

JUNE 1980 \$1.25

Popular Mechanics

SOLAR INSTALLATIONS:
How you can avoid
blunders and rip-offs

188-MPH SPORTS PLANE
you build from plans & kits

FOUR-WHEEL DRIVE:

- PM tests Datsun's new mini pickup
- Owners Report: Love the Jeep CJ-5 and 7

TV: 8 home cures
for wiggles,
ghosts and
snow



DARING CHALLENGE:
MACH.5
ON WATER

BUILD FOR SUMMER

- **COMPLETE PLANS:** Construct this classic colonial cupola
- **STEP-BY-STEP:** Weave this great rope hammock
- **HOW-TO:** 4 lattice garden retreats to make
- **PLUS:** Build our kids' foldaway art center

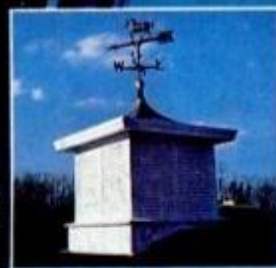

Less 'tar' and smooth taste
in one incredible light!

KOOL SUPER LIGHTS

- A light menthol blend.
- Only 7mg. 'tar'!
- An incredibly smooth taste.



At 7mg. 'tar'
we are lighter than all these.



16 mg. 'tar' 17 mg. 'tar' 11 mg. 'tar' 11 mg. 'tar'

Warning: The Surgeon General Has Determined
That Cigarette Smoking Is Dangerous to Your Health.

Kings, 7 mg. "tar", 0.7 mg. nicotine av. per cigarette by FTC method.

Save a cool \$100* at Sears

on Sears Central Air Conditioning System with five-year warranty on compressor

24,000 Btuh Model #52151

Now \$599

Other models also on sale at similar savings.
Thermostat, refrigerant tubing, installation extra.

Those hot summer days and nights aren't far off. So start making yourself comfortable right now. Because these efficient Sears Central Air Conditioners are on sale, with quality features like:

- "Silent Sentinel" Electronic Control
- Wrap-around condensing coil unit
- "Super Coil".

There's even more to the exceptional quality of Sears Central Air Conditioners. They're durably built to provide long-lasting comfort. That's why you'll find it hard to beat Sears warranties.

*Sears can arrange
Professional
Installation.
Ask us for
FREE estimate.*



Full one-year warranty on air conditioner.
When installed and maintained in accordance with our instructions, Sears will, within one year from the date of purchase, repair the central air conditioner, free of charge, if defective in material or workmanship.

Full five-year warranty on compressor.
For five years from the date of purchase, Sears will replace the compressor, free of charge, if defective in material or workmanship. To obtain warranty service, just contact Sears.

*These are the minimum savings nationally. Regular prices vary in some markets.

Available at most Sears retail stores. Prices and dates may vary in Alaska and Hawaii.

**You can
trust your
house to**

Sears

Where America shops
for Value



ON SALE June 1 thru 21

© Sears, Roebuck and Co. 1980

Материал, защищенный авторским правом

Everybody into the pool.



Trucks are what we're all about.

More and more people are discovering that a van pool is a great way to lower the cost of getting to work. By sharing gasoline, insurance, and other expenses, each person realizes a big saving in transportation cost. Even with gas over a buck a gallon, splitting the cost among a vanful of friends works out to a pretty cheap ride.

And for van pooling at its comfortable best, we respectfully suggest the GMC Rally Wagon. It offers many of the carlike options to which you've become accustomed. Tilt wheel. Cruise Control. Air. Stereo. And other passenger-pampering luxuries. But unlike a car, it carries five passengers in its standard configuration, or up to 12 with available second and third seats. Also uncarlike, a convenient, sliding side door opens wide for easy getting in and out.

All in all, the GMC Rally Wagon offers an excellent opportunity for you and your co-workers to start your own private "bus system," one that operates on your timetable and never requires anyone to stand in the aisle. And when you compare the per-person cost with that of driving individual cars to work, well, there's simply no comparison.

So, get the gang together and talk to your GMC dealer about buying or leasing a GMC Rally Wagon.



GMC is
a division of
General
Motors



1984 GM Corp.



On the cover

In a radically designed craft housing a full-blown rocket engine, driver Lee Taylor is trying to capture the world's on-water speed record—and may even push his boat to half the speed of sound (350-plus mph). Read how the design evolved on page 73

—PM painting by Ed Valigursky

Popular Mechanics

JUNE 1980

CONTENTS

VOLUME 153 NUMBER 6

INTERNATIONAL EDITIONS: CARIBBEAN, ITALY, MEXICO, SOUTHERN HEMISPHERE

Special features:

Avoiding solar rip-offs

Like any other area of growing consumer interest, the solar-energy field has its bad apples. Here's how to be sure you're getting what you paid for.

84

188-mph sports plane you can build

Plans and kit materials bring this sleek aircraft with an efficient lightweight engine within the reach of many home craftsmen.

82

Datsun's mini-pickup

PM finds new full-time 4x4 is rough and ready off-road, but no tiger on the highway.

92

Plans for summer projects

Rooftop cupola with colonial lines cools your house. Woven rope hammock, latticework and children's art-and-craft center also in this issue. Begins on . . .

102

PM Owners Reports

Jeeps CJ-5 and CJ-7, plus Dodge Mirada, get love letters from buyers.

90, 100

Home TV cures

Easy ways to clean up common picture flaws.

88

Automobiles and bikes

- 12 [The PM Garage](#)
- 30 [Imports and Motorsports](#)
- 34 [Fuel for the future: After](#)
47,000 miles on gasohol—
a clean engine
- 43 [Saturday Mechanic:](#)
Troubleshooting pollution-
control systems
- 49 [Detroit Listening Post](#)
- 50 [Car Clinic](#)
- 60 [Firsthand report: Driving](#)
the 1980 LeCar
- 86 [Living with an electric car](#)
- 87 [A handsome hybrid, but](#)
you can't live with it—yet
- 90 [PM Owners Report: Dodge](#)
Mirada
- 92 [Bashing through Baja in](#)
Datsun's new 4x4
- 94 [Bicycle commuting: It](#)
makes more sense than
ever
- 100 [PM Owners Report: Jeep](#)
CJ-5, CJ-7

Aviation

- 82 [500 miles on 15 gallons](#)
. . . in an air race!
- 96 [World War II in the air](#)
is alive and well
- 98 [Iron Annie: The "enemy"](#)
steals the show

Boating and outdoors

- 58 [All Outdoors](#)
- 73 [Rocket boat shoots for](#)
Mach .5
- 178 [Best knots for new fish lines](#)

Photography

- 56 [Photo hints](#)

Shop and crafts

- 14 [PM Workbench](#)
- 20, 40, 57 [Hints from readers](#)
- 54 [New Now: home and shop](#)
- 110 [Make your own hammock](#)
- 116 [Workshop Minicourse:](#)
The block plane
- 118 [Build PM's ultimate desk](#)
for the crayon set
- 124 [Build the GT-8: PM's grand](#)
tourer for 8-year-olds
- 137 [Nails: Still the handiest](#)
fasteners in the workshop

Home and yard

- 22 [Channel carries water off](#)
your driveway
- 24 [PM looks at rain disperser](#)
- 26 [PM looks at pump jug](#)
- 33 [Appliance Clinic](#)
- 70 [Homeowner's Clinic](#)
- 84 [How to avoid solar rip-offs](#)
- 102 [Great ways to use lattice](#)
- 106 [Build a cupola—the classic](#)
cooling system
- 196B [PM looks at mist blower](#)

Electronics, radio and TV

- 8 [PM Electronics Monitor](#)
- 88 [8 ways to beat TV](#)
interference
- 188 [Mix your way to better sound](#)

Science and engineering

- 29 [Science Worldwide](#)
- 76 [How we'll build a working](#)
human heart

Every month

- 6 [Letters](#)
- 16 [Notes from the Editor](#)
- 54, 80 [It's New Now](#)
- 67 [PM Briefs](#)

AS A SERVICE TO READERS. Popular Mechanics publishes newsworthy products, techniques and scientific and technological developments. Due to possible variance in the quality and condition of materials and workmanship, Popular Mechanics cannot assume responsibility for proper application of techniques or proper and safe functioning of manufactured products or reader-built projects resulting from plans published in this magazine.

POPULAR MECHANICS (ISSN 0032-4558) is published monthly by The Hearst Corporation, 224 West 37th Street, New York, N.Y. 10019, U.S.A. Subscription prices: United States and Possessions, \$6.97 for one year; \$16.97 for two years; \$24.97 for three years; Canada and all other countries, add \$6.00 for each year. Controlled circulation postage paid at Salem, Ill. Authorized as second-class mail by the Post Office Department, Ottawa, and for payment of postage in cash. Registered as second-class matter at the Post Office at Mexico D.F., Mexico, June 20, 1950, © 1980 by The Hearst Corporation. All rights reserved. Printed in U.S.A.

POSTMASTER: Please send Forms 3579 to Popular Mechanics, P.O. Box 10064, Des Moines, Iowa 50350.

SUBSCRIPTION SERVICE: Popular Mechanics Magazine will, upon receipt from its reader of a complete new or renewal subscription order, undertake fulfillment of that order so as to provide the first-copy delivery either to the Postal Service or

alternate carriers within six to twelve weeks. If for some reason this cannot be done, you will be promptly notified of the issue date that will begin your subscription, with a request for any further instructions you may have concerning your order. Please address all such orders to us at Popular Mechanics, P.O. Box 10064, Des Moines, Iowa 50350. * Should you have any problem with your subscription, please write or call Joan Harris, Customer Service Department, Popular Mechanics, P.O. Box 10064, Des Moines, Iowa 50350. Telephone: 800-247-5470. State of Iowa residents call 800-542-1272. To assure accurate service, please enclose your mailing label when writing to us or renewing your subscription. * Renewal orders must be received at least eight weeks prior to expiration to assure continued service.

Use this address for subscription orders & inquiries

POPULAR MECHANICS
P.O. Box 10064
Des Moines, Iowa 50350

POSTMASTER: Please send Forms 3579 to this address

GET THE COMPLETE PICTURE. IT'S EASIER AT THE INSURANCE STORE.

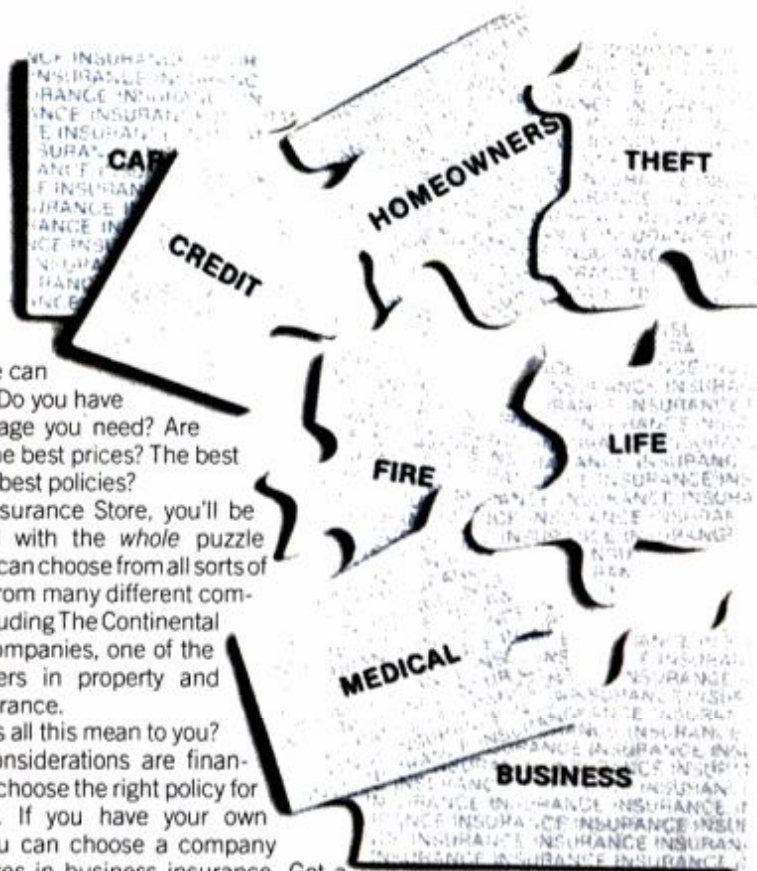

Insurance can be puzzling. Do you have all the coverage you need? Are you getting the best prices? The best service? The best policies?

At The Insurance Store, you'll be able to deal with the *whole* puzzle because you can choose from all sorts of insurance. From many different companies—including The Continental Insurance Companies, one of the world's leaders in property and casualty insurance.

What does all this mean to you?

If your considerations are financial, you can choose the right policy for your budget. If you have your own business, you can choose a company that specializes in business insurance. Got a boat? Choose the right boat policy. A plane? Choose your aviation insurance. Plus a whole range of policies for your home, life, car. It's all under one roof, sold to you by an independent agent.

You can't get that at State Farm because they sell only State Farm insurance. Same thing at an Allstate desk, or any other one-company operation.

So if you're looking for an easy way to solve the insurance puzzle, just call any agent listed under Continental Insurance in the Yellow Pages. They'll take all the pieces and come up with the perfect fit.



featuring

Continental Insurance

From The Continental Insurance Companies, subsidiaries of The Continental Corporation

Popular Mechanics®

Editor-in-Chief: John A. Linkletter
Executive Editor: Robin C. Nelson
Managing Editor: Bill Hartford
Art Director: Ira Herrick

Special Editorial Features: Sheldon M. Gallager, editor

Automotive: Tony Assenza, editor; Michael Lamm (West Coast); Gary Wizenburg (Detroit)

Science and Engineering: Gurney Williams III, editor

Home and Shop: Harry Wicks, editor; Joseph R. Provey, Penelope Angell, assistants

Boating, Outdoors and Travel: Wm. T. McKeown, editor

Electronics: Neil L. Shapiro, editor

Copy and Production: Gary Winter, chief; John Bostonian Jr., art; Peter Easton, Shannon K. Kelley, Daniel J. Oates, assistants

Art: Don Mannes, technical art director; Douglas Quinn, Alan Andresen, assistants

Special Publications: Clifford B. Hicks

Editorial offices: 224 West 57th St., New York, N.Y. 10019. We cannot be responsible for loss of unsolicited queries, manuscripts, or photos. For return, they must be accompanied by adequate postage.

Bureau of Information: Sophie Gronowicz, director; 224 West 57th St., New York, N.Y. 10019. (212) 262-4292

Associate Publisher,
Director of Advertising
Daniel J. Coleman

Advertising Offices:

New York: 224 West 57th St., New York, N.Y. 10019; (212) 262-4284

Chicago: 520 North Michigan Ave., Chicago, Ill. 60611; (312) 527-2400

Detroit: 377 Fisher Rd., Grosse Pointe, Mich. 48230; (313) 881-3520

Cleveland: 221 Mercantile Center, 3659 Green Rd., Cleveland, Ohio 44122; (216) 292-7334

Los Angeles: 460 East Carson Plaza Dr., Carson, Calif. 90746; (213) 532-8101

Production Manager: John A. Regina, (212) 262-4800

Classified Advertising Manager: H. E. Kappel, (212) 262-4825

Published by The Hearst Corporation

President

Frank A. Bennack Jr.

Chairman

Randolph A. Hearst

Vice Chairman

John R. Miller

President, Magazines Division

Gilbert C. Maurer

Publisher, Popular Mechanics

Joseph F. Kern

Publishing Consultant

Richard E. Deems

POPULAR MECHANICS IS PUBLISHED MONTHLY by the Hearst Corporation, 959 Eighth Avenue, New York, N.Y. 10019, U.S.A. Frank A. Bennack Jr., President; Randolph A. Hearst, Chairman; Harrison A. Mitnick, Treasurer; Harvey L. Lipton, Vice President and Secretary; Hearst Magazines Division: Gilbert C. Maurer, President; K. Robert Brink, Executive Vice President and General Manager; Raymond J. Petersen, Executive Vice President; Thomas J. Hughes, Resident Controller; William S. Campbell, Vice President, Director of Circulation; Joseph F. Kern, Vice President for Popular Mechanics.

IT'S EASIER

"I got the paint that beat the Weatherbeater.[®]"

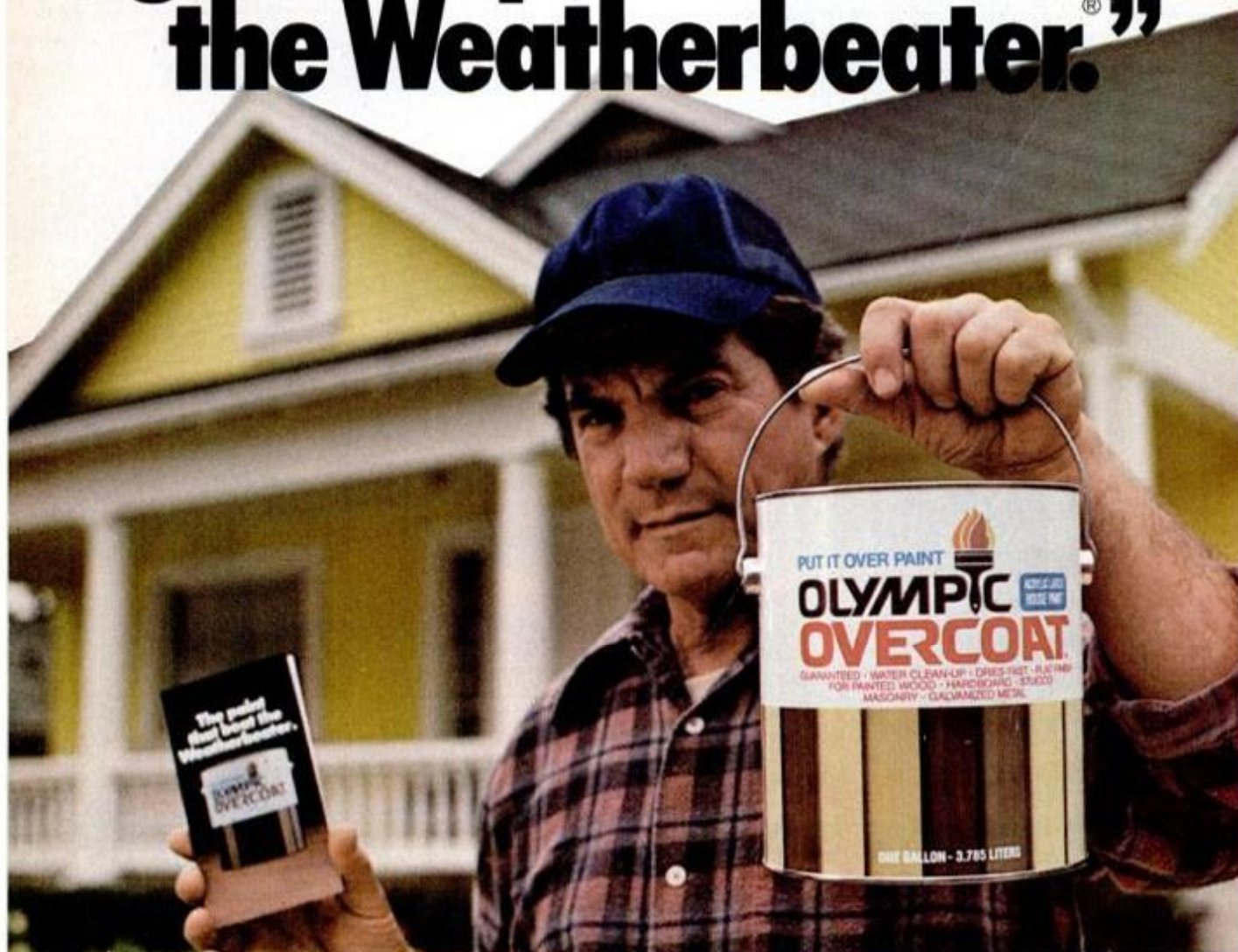

Olympic Overcoat outweathers Sears Weatherbeater.

That's what 94 out of 100 homeowners concluded when independent researchers asked them to compare weathered samples of both brands.

After examining white and red samples of each, most picked Overcoat as the one that looked better longer.

Here's what they said about Overcoat: "Fresher looking." "Less wear." "Less fading." "Looks newer."

Samples viewed were unlabeled and had been weathered for two years on the coast of Florida where the combination of ultraviolet rays, salt air and moisture create extra severe weathering conditions.

Read the facts about the paint that beat the Weatherbeater at your Olympic dealer.

It's all the evidence you'll need to buy Overcoat.

Olympic Overcoat[®]



Tests were conducted by D.L. Laboratories of New York City.

Материал, защищенный авторским правом

LETTERS TO THE EDITOR

A fleet of Fleets

In the April issue on page 107 (*Saving Lindbergh's First Plane*), you identify the biplane in the upper left photo as a Jenny. It is a Fleet biplane, powered by a Kinner five-cylinder engine. The correct name for it is a Consolidated Husky Jr.

JOSEPH B. WITKIN
PORTLAND, CONN.

I spent several years at the new Roosevelt Field in the mid-'30s where I obtained my A+E license and maintained the Roosevelt Aviation School aircraft. The Fleet airplane pictured was No. 7 of a group of nine or 10 similar trainers used by the school, along with a five-place open cockpit Standard biplane, two Aristocrats, a Fairchild 24 and a Stinson for flight training. I worked on all of them, and flew them on test flights after repairs or checks.

The photo appears to have been taken after 1929 at the old Curtiss Field, where the school moved after

the old Roosevelt Field was converted to an auto-racing course in the mid-'30s. The hangar in the upper right corner of the photo was destroyed in a fire shortly after the picture was taken, I believe.

RAYMOND C. POMASKI
FALLS VILLAGE, CONN.

Crowning achievement

In *Archimedes Would be Amazed* (*PM Briefs*, page 62, April '80), you state that the 12-foot-diameter screws were fabricated by Enviro Development Co. The screws were designed by EDC but were actually built by Crown Iron Works of Minneapolis. The screws weigh approximately 57,000 pounds each.

GARY D. SKELLENGER
CROWN IRON WORKS
MINNEAPOLIS

Row, row, row your bike

The Australian bike (*PM Briefs*, page 61, Apr. '80) is not really all new. It is a version of the four-

wheeled "Irish Mail." That model was steered with the feet on the front axle. Forward movement was produced by a rowing motion. Haven't seen any in many years—maybe it's time to bring it back. Keep up the good work.

FRANK WHITTLE
PHILADELPHIA

Can't find the handle

We very much enjoyed *Get the Big Picture: Pick of the Projection TVs* (page 104, Feb. '80). However, on page 105 in the upper right-hand corner, you show a couple playing the Atari Video Game. Unfortunately, this game (*Roadrace*) calls for a control stick different from the one they are using. They must be having a difficult time!

TOM AND MIKE WOLF
SPRINGDALE, OHIO

Danger warning

While we agree that with a cab, snow removal can be "almost fun"

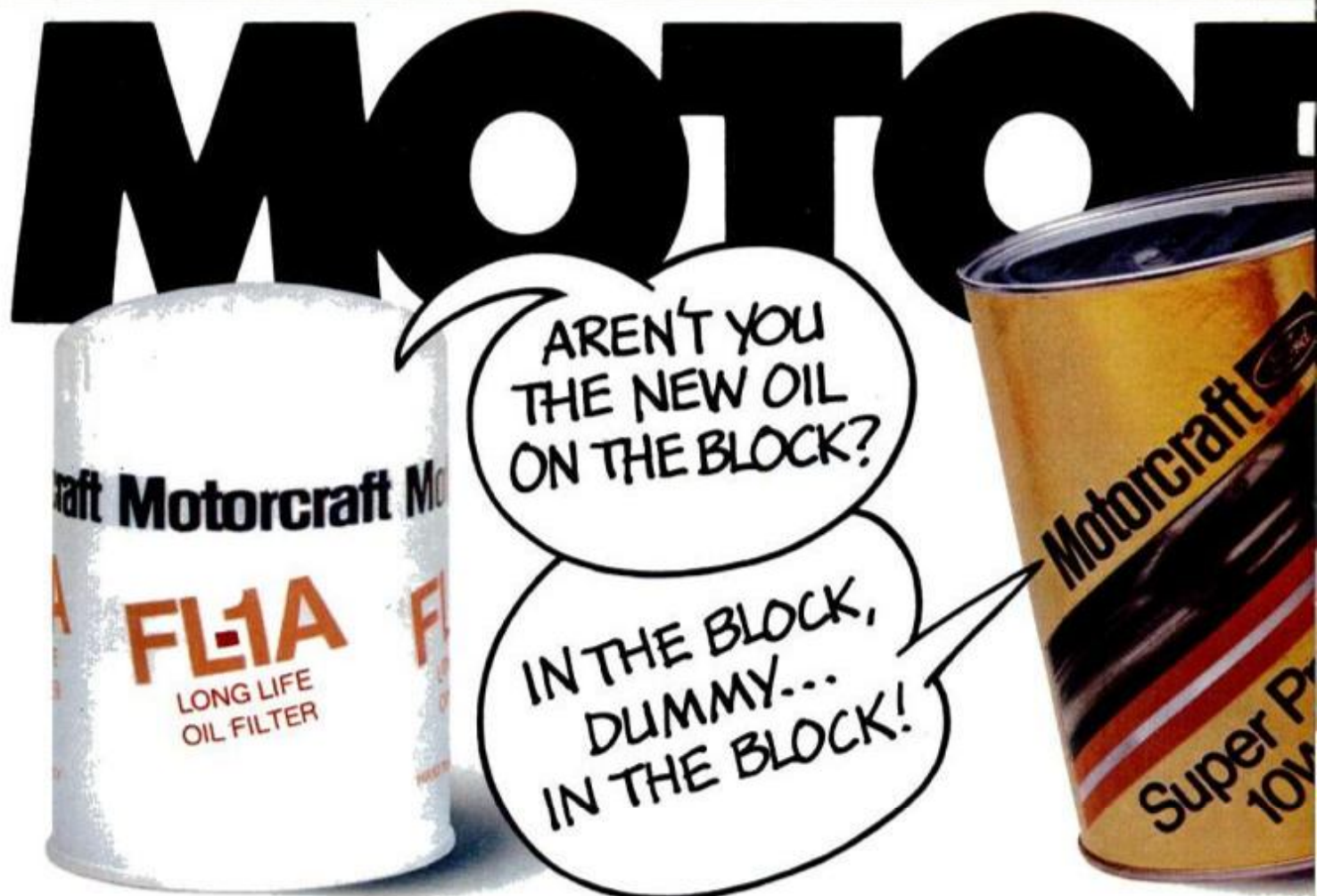

(Homebuilt Tractor Cab Takes the Bite Out of Snowblowing, page 76, Feb. '80), a word of caution is in order. Carbon monoxide build-up in such cabs can be significant. Exhaust-outlet modifications to minimize CO concentrations should be tested with accurate monitoring equipment. The vertical pipe and muffler shown in the photographs is of a kind not usually found on lawn and garden tractors. There are numerous complications with such a modification, not the least of which is that it does not guarantee a safe CO level inside the cab.

D.J. BURKHARDT
SIMPLICITY MFG. CO.
PORT WASHINGTON, WIS.

Geronimo!

I have never built an electronic device before, but I tried to build your TV silencer (*PM's Silencer Cuts Off Nagging TV Commercials*, page 162, Jan. '80) just for fun. The device worked and I love it. It's a great idea, but it does have a minor fault. When it is engaged, the only way to shut it off before the time limit has run out is to remove the battery. I spliced what I call a "bail-out switch" into one of the battery leads.

It's a simple on-off switch that allows you to stop the silencing at will.

DAVID WHALEN
CLEARWATER, FLA.

Safety first

You are to be congratulated for promoting home security with the article *PM Looks At: Floor Safe* (page 85, Nov. '79). I am a strong advocate of money safes being installed in the floor, embedded in concrete, under the carpet, for security as well as fire protection of personal property at home. However, your lead photo, with papers shown inside the safe coupled with the comment "peace of mind," is misleading. The safe shown, because of its design, will not protect the contents from fire damage. A comment like "not rated for fire protection" would have been appropriate.

EDWARD H. BARR
NIPOMO, CALIF.

Can't fuel him

I like the approach of your articles on muscle-powered yard tools, lightweight RVs, towing with compacts and so on; all are oriented toward using less fuel. Going "camping" in a 35-foot vehicle is a joke. After trying them all, I've gone back to car camp-

ing, with a hatchback that gets 35 mpg.

I feel closer to nature cooking and living outside; if I must have a bathroom and kitchen, I use a motel and get more satisfaction.

JAMES C. CRITTENDEN
PORTOLA VALLEY, CALIF.

Moped rules

In *What You Should Know Before You Start Commuting by Moped* (page 103, Mar. '80), some information was left out of the State Moped Laws table. The table says that any driver's license is sufficient to operate a moped in Pennsylvania. It should read "any driver's license with Class 6 stamped on it." Eye protection is also required on mopeds in Pennsylvania.

BARRY L. MASON
MODENA, PA.

Have one in your attic?

We've been searching for a copy of the Dec. 1940 issue of *PM*. We'd like to purchase one in reasonably good condition.

EDWARD F. KIBBLE
WALTER DORWIN TEAGUE ASSOCIATES
NEW YORK, N.Y. 10017

We're down to our last copy; can any readers help Mr. Kibble?

MOTORCRAFT



YEAH, AND WE'LL BE IN RETAIL OUTLETS SOON. WATCH FOR US!



...FOR SURE

PM ELECTRONICS MONITOR

But by any other name?

As the state of the electronic art continues to advance, repair and service technologies must also keep pace. Just as new electronic specialties have called for new vocabularies, so might we need a word for a shop devoted to fixing such specialized circuitry.

The name Digital Repair Service was proposed by Global Specialties Corp. a few months back. Since then, many in the electronics field are recognizing the need for such a specialized repair service.

Computers, clock radios, appliance controls, microwave ovens, thermostats and many other devices depend on *off* and *on* pulses to operate. Repairing such equipment calls for special tools, knowledge and education.

So far, specialists in this type of repairs have had no name for what they do, other than electronic repair, and this often makes them hard to find. As digital circuitry increases, perhaps a Digital Repair Service or DRS should be established.

Computerizing Gutenberg

In 1456, the Gutenberg Bible brought movable typefaces to the world and things have never been the same. Since those days of thick-bodied black-letter type styles, we have seen the bold-and-thin Bodoni styles; the sleek *sans-serifs*; the traditional Romans. In fact, there are hundreds of type styles now in everyday use. They have all had one thing in common—the designer invested many months of his life in balancing the form of every letter to a personal measure of perfection. Some designers have spent a whole lifetime perfecting a typeface.

Stanford University has now put the computer to work as a tool to help in typeface design. New typefaces may soon proliferate at an unheard of rate.

Donald Knuth invented the computer system which he details in his book *Tex and Metafont: New Directions in Typography*. Herman Zapf (who has hand-designed such popular typefaces as Optima) calls Knuth's computer system a breakthrough.

Simple English-style commands enable the computerized designer to see his new typeface instantly on the computer screen. Each letter can then be manipulated and reformed immediately. Thus, new



Make your own videotape graphics

Have you ever wished that you could create fancy graphics for your videotape extravaganzas? Well, you don't need to be an artist to do it.

We watched a demonstration of the above method with astonishment. The original design is painted on a transparent overlay, which is

attached to the TV screen. Then the camera is focused on the overlay. Now the image on the TV set consists of both the overlay and what the camera sees. By moving the camera back and forth, up and down, you can literally swirl the original design into a kaleidoscopic array of interlocking letters and graphics. Have fun!

fonts (a font is a complete assortment of type in one size and style) can be created quickly. Knuth only worries whether "font freaks will abuse this toy by overdoing it."

Video recorder update

Early videotape recorders cannot record/play for nearly as long as the new ones. People who bought them when they first came out are less than happy at how quickly they have been outmoded.

Sony is now offering at least a partial solution, in the form of an automatic videocassette tape changer for their Betamax models LV-1901/D, SL-7200/A, SL-8200 and SL-8600.

For \$125, recorders with this accessory can automatically play three tapes for up to nine hours.

Curses, Red Baron!

One of the most amazing programs we have yet seen for the home computerist is the FS1—Flight Simulator program from Sublogic. It's the next best thing to flying.

What makes this so unusual is the fully three-dimensional, animated display of the ground. You can land, dive, roll, climb, bank and "see" out the cockpit window, a view that is updated three to five times a second for a very believable movement. You can almost make yourself airsick.

Instruments such as altimeter and airspeed indicator are displayed as moving dials. Control is via the computer keyboard, or with game paddles or optional joystick.

The plane simulated is the venerable Sopwith Camel (although equipped with a radar screen and tricycle landing gear) of World War I vintage. Also simulated are five enemy aces who oppose you on a bombing mission.

More than a game, this is a true simulator. Every aspect of flying seems to be accounted for. After a few hundred hours of on-the-ground flight time, perhaps I'll look for someone who will take me up in a Piper Cub to see what I've learned.

FS1 is available from Sublogic, 201 West Springfield, Champaign, Ill. 61820, for \$25. It will run on an Apple and soon the TRS-80. **PM**

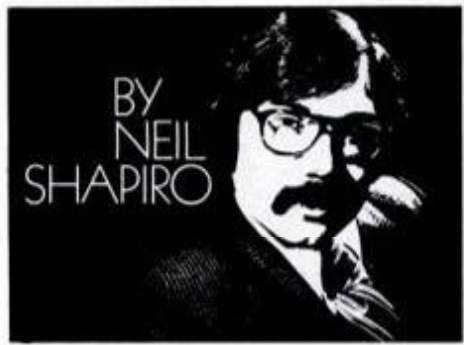

If you don't know roofing, know your roofer. And with Sears you do.

We've had plenty of practice in putting a roof over America's head. In fact, Sears has arranged the installation of thousands upon thousands of roofs in the past 30 years. So we're experts at the job.



We'll make a professional survey of your present roof, to recommend what should be done for best results. We'll also bring along samples of our Sears Glass Fiber Shingles.

Sears Glass Fiber Shingles have the highest fire-resistance rating — Class A — that Underwriters Laboratories can provide.



These shingles are protected with about 75% more weather-proofing asphalt than our conventional felt-based shingles. They resist curling and blistering. So they'll stand up to the weather for years and years.

Roofing has to be put on right, to protect right.

That's why we can arrange for Sears Authorized Installers to do the job professionally, neatly and thoroughly. That includes making sure your chimneys and vents are properly flashed.

Or, if you need new guttering...

Sears Continuous Aluminum Guttering and Sears Authorized Installers are your answer. The guttering comes in a



choice of durable finishes. It's made right on the job to the exact lengths needed, then checked for pitch, caulked, and fitted with new downspouts.

We'll stand behind what we do for you. And you can buy it all under Sears Modernizing Credit Plan.

The products and service described here are available at most Sears retail stores.

You can trust your house to

Sears

Where America shops
for Value

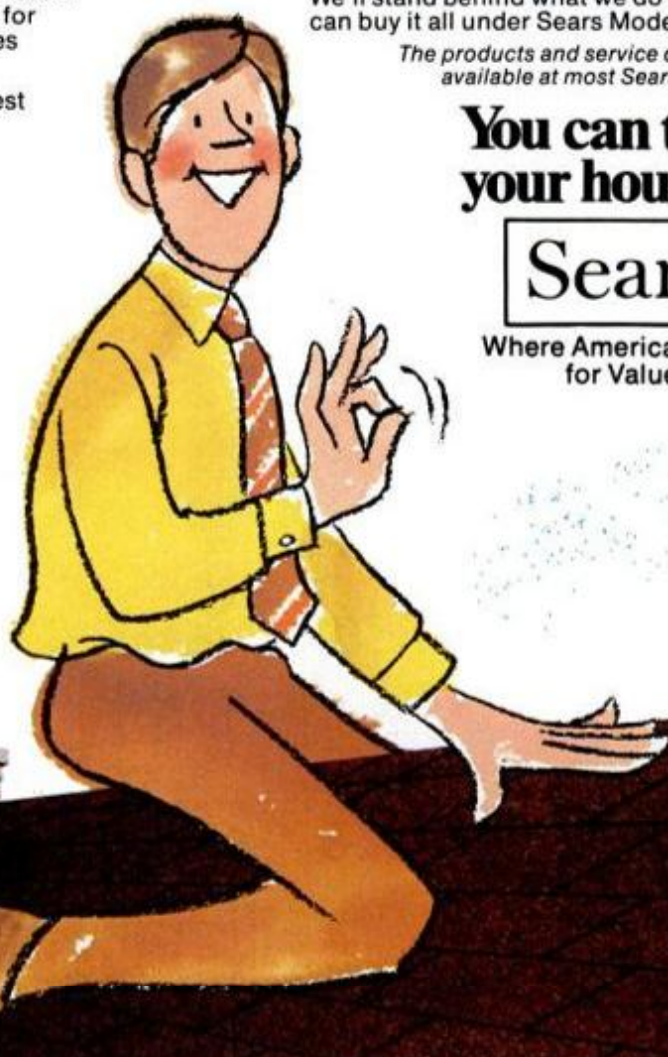



Salem

Warning: The Surgeon General Has Determined
That Cigarette Smoking Is Dangerous to Your Health.



Lively Light Menthol



Crisp
refreshing
taste in
a low tar.

Lights

LIGHTS: 11 mg. "tar", 0.8 mg. nicotine, LIGHT 100's: 11 mg. "tar",
0.9 mg. nicotine, av. per cigarette, FTC Report DEC. '79.

Материал, защищенный авторским правом

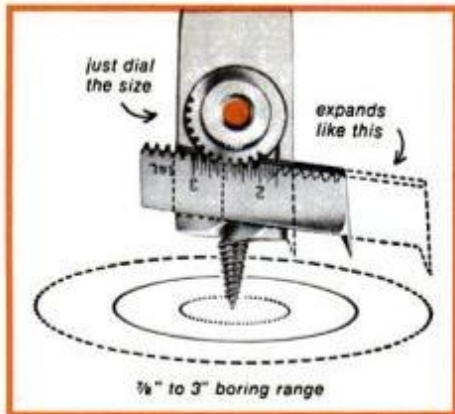

Irwin makes your 'Popular Mechanics' projects easier!

When you're building a cupola or any summer project, Irwin quality products can help!

There are good reasons to own an Irwin Micro-Dial... the expansive bit that lets you dial your size. Use it to bore holes up to 3" in any wood. Use it to bore as many as 35 standard hole sizes. Use it and save the cost of a whole tool box full of "single size" wood bits. Drop-forged from finest Irwin quality steel. Precision-engineered for accuracy. Heat tempered for long life. Machine-sharpened to cut fast and clean. No. 21 bores 1/8" to 1 3/4" (19 sizes). No. 22 bores 1/8" to 3" (35 sizes). Buy from your nearby hardware, building supply or home center store.



More power for small 1/4" drills & drill presses

Now easily bore holes up to 1 1/2" with the Irwin Speedbor® "88" electric drill wood bit. No wobble. No run-out. 1/4" shank chucks perfectly. Exclusive Irwin hollow ground point starts holes faster. Machine-sharpened cutters bore faster and cleaner. Forged in one-piece from Irwin quality tool steel. Heat tempered to last. 17 sizes. 1/4" to 1 1/2". Also available in attractive red plastic roll sets, 4, 6 and 13 bits.

Workshop special

Set of 6 Speedbor "88" bits with metal hang-up rack. Sizes 3/8", 1/2", 5/8", 3/4", 7/8", 1". No. 886M.



Strait-Line®

Chalk Line Reel Box—50 ft. & 100 ft. sizes. Popular-priced Irwin self-chalking aluminum alloy box. Easy action reel. Leak-proof. Practically damage-proof. Fits pocket or hand. Registered U.S. Patent Office



IRWIN every bit as good as the name
at Wilmington, Ohio 45177, since 1885

THE PM GARAGE REPORTS ON NEW AUTO PRODUCTS

The gloves, please

They laughed at me at the garage when I slipped on my Playtex rubber gloves. Mechanics aren't supposed to be afraid of dirty hands. But my feeling is: Why go out of your way to get greasy?

Barbed comments aside, I found



Super-grippy gloves let you handle even the greasiest parts. They are impervious to most automobile solvents and cleaners.

the heavy-duty Playtex gloves extremely useful for really dirty jobs. I tested them in the solvent bath while degreasing an old intake manifold and fuel pump. I was surprised to find they were very grippy. They also stood up to solvent. They cost \$2.99 wherever Playtex products are sold.—T.A.

Carb gauge set



Universal carburetor gauge set can be used for work on any American-made carb.

If you've ever tried to overhaul a carb without the right equipment, you know what a chore it is. Kent-Moore seems to have solved the

problem of getting your hands on the right tools with a Universal Gauge Set (part No. 9789-C).

The set, in a handy plastic case, includes 32 wire gauges; eight plug gauges; four flat gauges; an adjustable sliding scale for float-drop measurements; a linkage bending tool; two float-level gauges; and a choke-angle gauge. There's also an adjustable carb stand so you can work on the carb with both hands. Set is priced at \$67.20 by Kent-Moore, 29784 Little Mack, Roseville, Mich. 48066.—T.A.

Minigauges

Dashboards are getting smaller and ever more crowded with idiot lights. To really keep track of all your engine's functions, you need gauges, but sometimes that requires drilling



Plumbing and adapters make installation possible on all standard-thread engines.

holes in the dashboard or making up some special brackets. One solution might be to install the Stewart-Warner Mini-Panel.

The three gauges—voltmeter, water temperature and oil pressure—are the size of quarters and are housed in a plastic case measuring 4 inches wide, 2 inches high and 2 inches deep. The gauges are internally illuminated and, despite the small size, are very legible. The Mini-Panel costs \$59.95 and is available in most auto-parts and accessories outlets.—T.A.

Plug blaster

No matter how good you are at scraping and cleaning dirty spark-plugs, you can never get the result that a fine sandblaster would turn out.

Up to now, the one drawback to buying a sandblaster was the cost

(Please turn to page 176)



Monro-Magnum.[®] The ride keeps going after the road stops.

It's one thing to ride good on a smoothly paved highway. But it's a whole different ball game to also ride good when you're miles from anything that even resembles a road.

That's why we make Monro-Magnum[®] shocks.

Compared to the one-inch shocks that are standard on most pickups, 4x4s and vans, they're huge. Their bore is bigger. Their piston's bigger. And they've got nearly twice the oil capacity. To give you a ride that's far firmer and much more stable. Both on road and off.

In fact, we're so sure no standard shock will ride as well as Monro-Magnum, either on or off road, we're making this special



offer: "If in 60 days you don't agree four Monro-Magnums give you the best ride ever, Monroe will replace them, no charge, with any comparably-priced shocks." Offer extended to October 31, 1980. See your Monroe dealer for details.

So how about it? Get a set of Monro-Magnums and give 'em a real workout. You'll find the ride keeps going, and going and going.

AMERICA RIDES MONROE[®]

Monroe Auto Equipment
Division of Tenneco Automotive



PM WORKBENCH

PM EXAMINES PRODUCTS & SERVICES

Super sealer

Flecto now offers a sealer and clear finish made with its exclusive Envirosol system. The Varathane formulation is designed to penetrate wood fibers and achieve long-lasting stability. The result, the maker claims, is a reduced tendency of wood to ex-



Durability, quick drying and water cleanup are main advantages of Varathane Sealer.



The milky appearance is short-lived; it turns clear upon contact with the wood.



The top coat has a slight ambering effect, which brings out the beauty of the wood.

pand and contract with atmospheric changes.

The clear finish is available in gloss and satin, and dries up to three times as hard as a conventional varnish. Cleanup is with water. Made by Flecto Co., Oakland, Calif. 94604.—Rosario Capotosto

Stick with this one

The maker of Zar wood finishes has recently developed a strong, fast-drying glue that is perfect for all facets of woodworking, including cabinetry, toymaking, crafts and picture-frame making. It sets strong



Woodworking glue is available in quart bottles (left), also in 4-oz., 8-oz. and gallon containers.

enough for work to be unclamped in 30 minutes; that means clamps can be moved to next project. It reaches maximum strength overnight, and is available at hardware stores and home centers, from United Gilsonite Laboratories, Scranton, Pa. 18501.—H.W.

Router know-how

A new handbook describing how to use a portable router has been published by Black & Decker, the tool manufacturer. Priced at \$4.95 and sold through dealers handling Black & Decker tools, the 160-page manual includes over 125 photos and diagrams.

I particularly like some of the author's ideas for making fixtures that let you get more use from the tool. If



Well-illustrated book is handy reference.

you can't get the book locally, write Black & Decker Mfg. Co., 701 East Joppa Rd., Towson, Md. 21204. Ask for No. 76300.—H.W.

Books for your workshop

Frequent queries from readers indicate that today's how-to book buyer is becoming more discriminating. And he should. In my opinion, too many publishers offer do-it-yourself books of questionable value. Happily, there are a number of first-rate books around. Here are several that



Rockwell's series has nine book titles.

are worth considering for your workshop collection:

■ *Getting the Most Out of . . .* is a series from Rockwell Publications, 1004 East Brooks Rd., Memphis, Tenn. 38116. Each 128-page book deals with one subject; the first nine editions cover the table saw, drill press, bandsaw, radial saw, abrasive tools, three books of projects and finishing. Price is \$6 per book, postpaid.

■ *Creative Woodworking*, Dremel, Div. of Emerson Electric Co., 4915 21st St., Box 518, Racine, Wis. 53406. The book features more than 150 woodworking projects, ranging from a simple jigsaw puzzle to complex one-piece candelabra. The \$6.95 price tag includes postage.

■ *Do-It-Yourself Heating Supply Shop*, Solar Components Div., Kalwall Corp., Box 237, Manchester, N.H. 03105. This \$2 catalog is claimed to list everything required to design and build an efficient solar-energy system; most items are carried in stock for quick delivery. Catalog is available for \$2 postpaid from the above address.—H.W.

If you've come across a new product with some special features let us know about it. Write to PM Workbench, Popular Mechanics, 224 West 57th St., New York, N.Y. 10019.

FIGHT BACK AGAINST RISING GAS COSTS.

SCOUT® INTRODUCES THE WORLD'S FIRST TURBOCHARGED DIESEL WITH A 100,000 MILE WARRANTY.

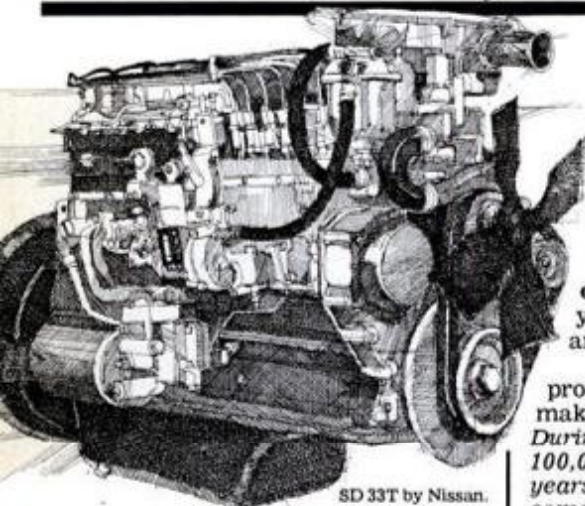

SD 33T by Nissan.

The new International Scout Turbo-Diesel engine gives you all the economy

Scout Turbo-Diesel fuel economy:

22 EPA EST MPG **24** EST HWY MPG

Remember use estimated mpg for comparison only. Mileage varies with speed, weather, trip length and your use of 4WD. Actual highway mileage will probably be less.

and dependability of a diesel with startling acceleration. Power to pass. Extra power when you want it...and need it most.

Diesel engines never need costly tune-ups, because they have no spark plugs or distributor points. Diesel dependability is unsurpassed. Many International Harvester truck engines getting 250,000 miles and more. Add turbocharging and you get the best mileage of any American 4-wheeler.

The warranty that separates our Turbo-Diesel from the Mercedes 300SD.

There's a promise that separates the Scout Turbo-Diesel not only from the Mercedes 300SD but from every other diesel car engine in the world. Our exclusive 100,000 mile engine warranty. *During the first 100,000 miles, or 5 years (whichever comes first), International® Scout will repair or replace without charge for parts or labor any*

*part of the engine block and all internally-lubricated engine components which are defective.**

Every Scout engine is a 100,000 mile engine. From our 196 cubic-inch four cylinder to our 304 cubic-inch and 345 cubic-inch V-8's.

The anti-corrosion warranty that separates Scout from ordinary cars. Scout gives you five years with no-rust-through. Clean and simple.

Our extensive 4-step rust-protection process lets us make this promise:

*During the first 100,000 miles, or 5 years (whichever comes first), International Scout will repair or replace any vehicle body component which suffers "perforation" due to corrosion without charge for parts or labor.**

Quality and security go hand-in-hand.

Our built-in quality will give you a sense of well-being you may never

experience in an ordinary car. It's a secure feeling of sitting in a vehicle that surrounds you with protective steel.

In a Scout you sit higher than a car. A vantage point that lets you see the road ahead more clearly and avoid trouble more easily.

Then there's our selective 4-wheel drive. It gives you the option of easily shifting from economical 2-wheel drive to 4-wheel drive, for extra stability and traction when the road or the weather looks rough.

How to fight back.

Before you even consider buying an ordinary car, test drive a 1980 Scout. It's as easy as dialing 800-IH-SCOUT for your local Scout dealer.

Dial Toll-Free **800-IH-SCOUT**
Illinois Residents 800-322-0821



INTERNATIONAL HARVESTER

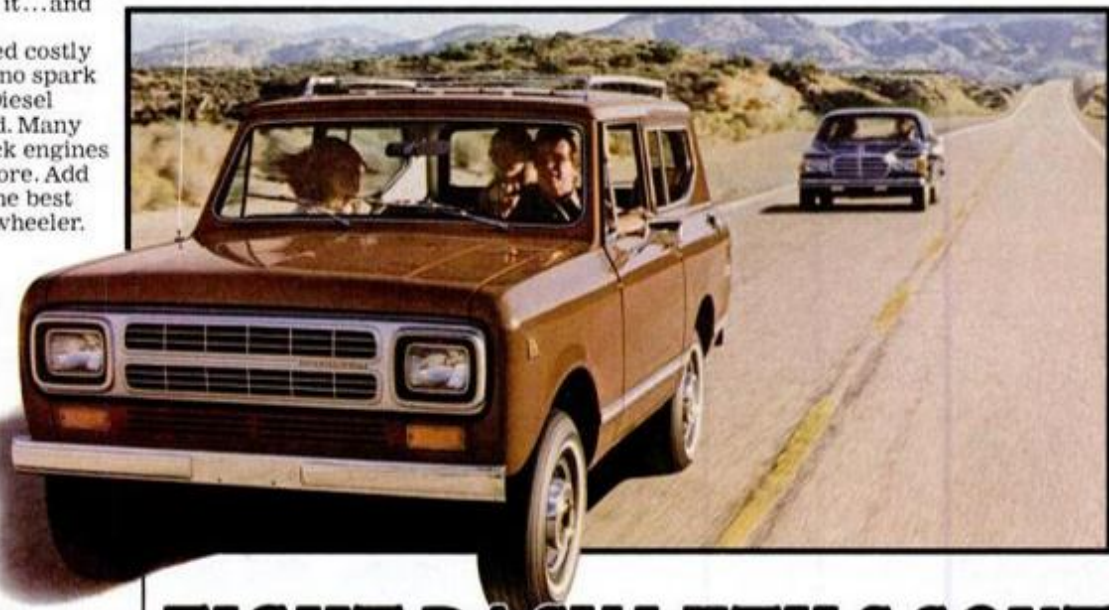

FIGHT BACK WITH SCOUT.

Anything less is just a car.

*Warranties are non-transferable, and assume customer's proper care and maintenance. See your dealer for details.

Материал, защищенный авторским правом

RISLONE HELPS ENGINES RUN BETTER



RISLONE acts fast to remove power robbing varnish, gum and deposits from engines. And RISLONE has been doing it for more than 40 years . . . That's dependability!

Most drivers feel an improvement in performance within a few miles of driving as RISLONE dissolves and disperses deposits from valve stems, lifters, piston rings and oil passages. The RISLONE treatment lasts, too, because a cleaner engine is better lubricated, runs cooler, longer, and gives better gas mileage.

Road test RISLONE yourself. You be the judge. Venture a dollar or so to find out if engine deposits are cutting your mileage and performance. You'll notice that RISLONE is a real bargain because it costs about the same as products in little cans but replaces a quart of motor oil.

GET RISLONE at your auto merchandise store now. We think you'll become a regular Booster if you give RISLONE a test drive!

Watch for these RISLONE super racers at your favorite drag strip . . . the Fabulous RISLONE Chi-Town Hustler, the stunning new RISLONE Jet of TV Tom Ivo, and the hot competition cars of John Lingenfelter and Bob Marshall!



RISLONE National Championship Racing Jacket . . . \$12.95 prepaid. Quality polyester & cotton wash/wear. RISLONE yellow with black & red emblems & stripes. S, M, L, XL. Send check or money order to: RISLONE Racing Jacket, The Shaler Company, Waupun, Wisconsin 53963

THE SHALER CO.

21 East Jefferson St.
WAUPUN, WISCONSIN 53963

In Canada: Warren Packaging Co.,
Scarborough, Ontario



NOTES FROM THE EDITOR

John A. Jinkletter

Lee Iacocca, president of Chrysler Corp., has introduced a new facet into the business of selling cars, we see. As you know, he has been spokesman for his firm in recent print and TV advertising. Now, for the first time in some 20 years of PM Owners Reports, we find that the *company president* ranks as a reason for buying a particular brand. Mr. Iacocca's style convinced at least two recent shoppers to buy the Dodge Mirada (page 90).

Step-by-step construction of projects in PM is such an accepted routine that we sometimes lose sight of the fact that the finished items can have another life after we finish our photography.

Such was the case with our Crayola Desk (page 118), which we knew, crammed full of tantalizing coloring gear donated by Binney & Smith (the Crayola people), just had to go where kids could get their hands on it.

It took only an inspired suggestion, from the staff—and it all wound up in the pediatrics area of Memorial Sloan-Kettering Cancer Center in New York City. We hope it's helping brighten the recreation hours of those spunky youngsters we saw at play there.



Accepting PM's Crayola Desk for the Sloan-Kettering Cancer Center is Diane Pinakiewicz, pediatrics administrator. On hand were Harry Wicks, Home & Shop Editor, and I.

While researching our artificial heart story (page 76), Science Editor Gurney Williams for a moment thought he had the caress that sets hearts beating faster. An artificial organ had suddenly jumped a bit over 100 beats a minute at his touch. His dream shattered when he learned engineer Gus Rosenberg had quietly "shifted" it into high just to display its speed.



Wedding of Dennis and Vonda MacDonald in a Ju 52 flying at 3000 feet over Indian River.

The nearest we've had to a real war correspondent in recent years is Robin Nelson, Executive Editor, who rode shotgun on a Ju 52 during a mock raid on Ti-Co Airport in Florida (page 96). Besides photographing attacking P51s and getting his beard singed during a low-level pass over exploding gasoline "bombs," Robin picked up the assignment of photographing a wedding aboard the pre-WWII German transport.

Get out of the rat race with your own TV or audio service business.

NRI will train you at home to service TV, audio equipment, video recorders, car stereo and more. Then show you how to run your own full- or part-time business.

Why stay stuck in a dead-end job when you can build your own future? You can learn to be a TV, audio and video technician right at home in your spare time. Get the training you need for a new career without quitting your job or traveling to and from night school. NRI makes it happen with exciting career training in TV and audio servicing.

Build TV, stereo, professional instruments

NRI training is practical training. Along with easy-to-digest theory in "bite-size" lessons, you get plenty of actual "hands-on" experience as you build our Master Course's big 25" computer-controlled color TV that lets you program a whole evening's entertainment, AM/FM solid-state stereo with speakers, transistorized volt-ohm meter, 5" triggered-sweep oscilloscope, TV color pattern generator, CMOS frequency



Start in your garage or basement and watch your business grow.



Be an audio specialist servicing home and auto stereo.

counter, and perform meaningful experiments with them and the NRI Discovery Lab.[®]

Business training as well as technical training

Of course, NRI training gets you ready to enter this field at many levels. You can start by working for an established service company, a dealer, or a manufacturer. But you can start working for yourself, too. NRI lessons show you how to set up and run a full- or part-time business. You learn job costs and billing, even how to set up a complete accounting system. That's how complete the program is.

The pros select NRI training

More than a million students later, NRI is still first choice. A national survey (summary on request) shows that more than half of practicing TV technicians have had home study training, and



Get into the booming video tape recorder market.

among them, it's NRI 3 to 1 over any other school.

You can't beat the value. All in one course you get *both* color TV and audio training, *plus* video cassette and disc systems. Send for our free catalog to see it all.

Free catalog...

No salesman will call.

Our big, 100-page catalog has all the facts. Descriptions of every course, each lesson and experiment, pictures and specifications of all the equipment you get. Send for it today, no salesman will ever bother you. If the postage-paid card has been removed, write to:



NRI Schools
McGraw-Hill Continuing
Education Center
3939 Wisconsin Avenue
Washington, D.C. 20016



You get all this professional equipment, build this 25" (diagonal) computer-programmed TV as you learn.

Dull tools can hack it

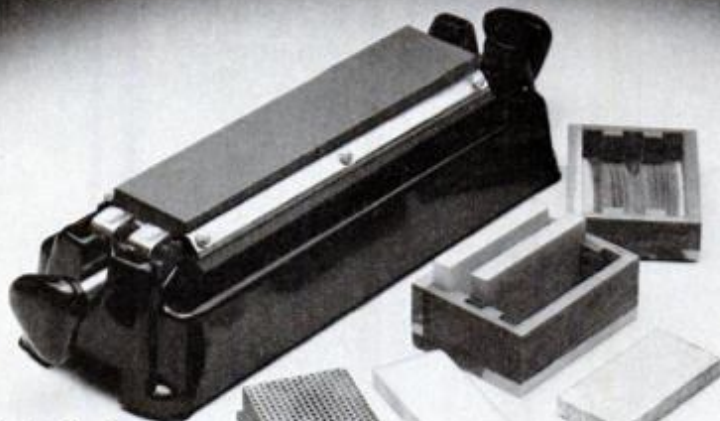

... But, is that what you really want? You'll never know how good a craftsman you can be until you have *really sharp* tools. Isn't it time you quit struggling with dull or average-sharp tools—and brought each tool to its *full potential* of sharpness?

- "The Sharpening Shop"—3 stones—fine, medium and coarse—mounted in revolving carriage. The 2 stones not in use are immersed in oil. Heavy, non-skid base. Cover and pint of oil included.

- **Diamond Hone.** The ultimate stone! Use indefinitely. Coarse grit.

- **3-Stone Set.** Washita, Soft and Hard Arkansas. In Cedar box.
- **Hard Arkansas Natural Stone.** In Cedar box.

For Credit Card Orders, call anytime, toll-free. 800-243-1037. In Conn., call 203-797-0772. For all other orders, mail coupon today.



The Fine Tool Shops, inc., 20-28 Backus Ave., Danbury, CT 06810
Dept. PJN8

Quantity	Item	Price, Ea.
_____	"The Sharpening Shop" Stone size: 11-1/2" x 2-1/2" x 1/2"	Specially Priced \$99.99
_____	Diamond Hone, 8" x 2" x 1-1/8"	60.00
_____	Diamond Hone (Fine), 6" x 2" x 3/4"	40.00
_____	3-Stone Set; stone size 4" x 2" x 1/2"	25.80
_____	Hard Arkansas Stone, 6" x 2" x 1/2"	25.00
_____	Soft Arkansas Stone, 6" x 2" x 1/2"	13.50

Send new color CATALOG OF FINE TOOLS. Free.

Add \$1.50 for first item, and 35¢ for each additional item for shipping and handling. Conn. residents add 7% sales tax.

Charge my _____ American Express _____ Visa _____
Master Charge (Bank No. _____)

Enclosed is my check for \$ _____

Account No. _____ Expires _____

Name _____

Address _____

City _____ State _____ Zip _____

HINTS FROM READERS

Renewing spring clamps



Renew old spring clamps with weakened hinge springs by bending the end of each spring leg so it's at a right angle to the handle (arrow).—A. Weber

Adjustable stilts

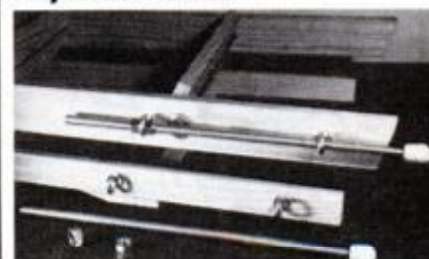

Two hex nuts hold stilt to the ladder.

I use a pair of threaded steel-rod stilts to level my ladder on sloped surfaces. To copy it, install two 5/16-in. eyebolts with two washers and a hex nut on each of the four ladder legs. Adjust the rod, then secure it with two free-running hex nuts. Use one stilt or both as needed.—Andrew Vena

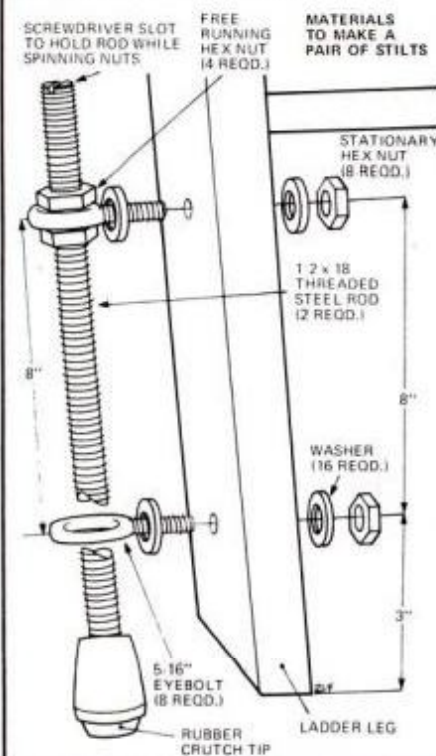



Olivetti Break- through

The world's smallest electronic printer will never run out of paper, ink or batteries thanks to Olivetti, JS&A and some incredible new technology.



The new pocket-sized Olivetti calculator slides open to unveil one of the most advanced printing heads ever developed.

It's a major breakthrough. That calculator shown above is the most advanced printing calculator in the world.

SLIP TOP PRINTER

The new Olivetti Logos 9 is only 1" x 2½" x 4½"—smaller than many cigarette packages. It has a full 12-digit liquid crystal display with add mode and full-floating or fixed position decimal.

To turn the unit into a printer, you simply slide up the top of the unit to expose the world's smallest and one of the most precise printing heads. The printing head prints letters and numbers, identifies each entry and even clearly separates groups of three whole numbers for easy readability.

PLENTY MORE

If its size and printing head are breakthroughs, so is its paper system. The paper is loaded in special cartridges with enough paper per cartridge for 1300 entries. All you do is simply pop a cartridge into the bottom of the unit each time you change rolls. It's the most convenient way ever designed to change a roll of paper for a printing calculator.

But if you're like most Americans, you'd be concerned about paper supply. Where do you get those special cartridges, and how do you know if you can get them years from now?

That's where JS&A comes in. A 32-roll supply—all you'll ever need for three full years—is only \$16. That's enough paper for 41,000 entries or approximately 52 line entries each working day for three full years.

But even more important, within one year stationery stores will stock the cartridges, and we predict that the Olivetti cartridge will become a standard in the industry.

NO INK CARTRIDGES

The paper is a new type that looks exactly like conventional paper. But the paper, when struck, leaves a clear sharp image without the use of ink. So there's no messy cartridge required and no space needed to store one. You'll never need ink again.

The rechargeable batteries last for 8,000 lines when you use just the printer and 80 hours using just the liquid crystal display. The batteries can be recharged 500 times, so theoretically the batteries should last for 300 rolls of paper, or more than nine times the life of your paper supply. The batteries can also be easily replaced.

POWERFUL COMPUTER

The features looked great. The world's smallest size, the paper roll convenience, the no-ink system, the battery life and the large 12-digit liquid crystal display were enough to convince us, but would the new Olivetti be considered a toy? Then we learned about its computational power and features which we feel are better than many of the most professional full-featured printing calculators.

Speed It's the world's fastest small printer with a speed of 2.1 lines per second. The unit also has a buffer so if you enter data faster than the unit, it will still print out each entry.

Memories The Logos 9 has two separate memories. One is an accumulating memory, and the other is a fully independent memory. And the display and printer indicate which memory is on the paper tape.

Printing Head The totally new printing head is a semi-alpha numeric system which labels all entries with letters to indicate the entry. For example LP is list price and CNT means item count.

Clock The unit is so complete, Olivetti even threw in a digital clock function. Your unit will display accurate time when the 12-digit display is not in use.

Gross Margin It automatically computes everything from gross margins to discounts and retail pricing. You just enter your percentage mark-ups in its memory, and it will automatically compute the results while retaining the formula and percentage in memory.

Plus More It has automatic round off, letting you select which figure to round off to. You can add a column of figures and then average your calculations automatically. The full-information liquid crystal display will tell you everything from when you're in the printer mode to whether you have something in memory and in which memory.

The technological breakthroughs in the Logos 9 were possible because Olivetti was able to eliminate the many interface components between the integrated circuit and the printing head. This was all made possible because Olivetti designed the entire system, not just a few of the components as is the case with most calculators.

So there it was. Great features, great convenience and great value for only \$89.95 complete with batteries, charger and 90-day limited warranty. For \$16 more, you can get 32

cartridges—all the paper you'll ever need for three years or for \$10 more you can get 16 cartridges. So impressed are we with the Olivetti Logos 9 that we are making the following offer:

FREE TRIAL OFFER

We urge you to test the Olivetti Logos 9 now. Order one for our 30-day no obligation trial. See the clear and easy-to-read paper tape and display. Use it as a pocket calculator, and carry it in your briefcase wherever you go. Experience the convenience of always having a printing calculator there whenever you need a permanent record of your transactions.

After 30-days of actual use, decide if you want to keep it. If you do you'll own the smallest, most advanced and convenient pocket printing calculator in the world. If for any reason you're not completely satisfied, simply return your unit within 30-days for a prompt and courteous refund, including your \$2.50 postage and handling. You can't lose.

Olivetti selected JS&A to exclusively introduce this exciting new product. With its solid-state design and high quality printing mechanism, the Olivetti should not require service. But if service is ever required, Olivetti maintains a convenient service-by-mail center as close as your mailbox.

To order your unit for our trial, simply send your money order or personal check for \$89.95 plus \$2.50 for postage and handling (personal check orders, allow 20 days to clear our bank) to the address below, or credit card buyers may call our toll-free number below. Add \$16 for 32 paper cartridges or \$10 for 16 cartridges. (Illinois residents please add 6% sales tax.)

Who would have imagined a printing calculator this small and this convenient with this much computational power just a few months ago? The Olivetti Logos 9 deserves your test. Order one at no obligation, today.

JS&A PRODUCTS
THAT
THINK®

Dept. PM One JS&A Plaza
Northbrook, Ill. 60062 (312) 564-7000
Call TOLL-FREE 800 323-6400
In Illinois Call (312) 564-7000

© JS&A Group, Inc., 1980

Jack McAlister had \$12,000 worth of power tools.

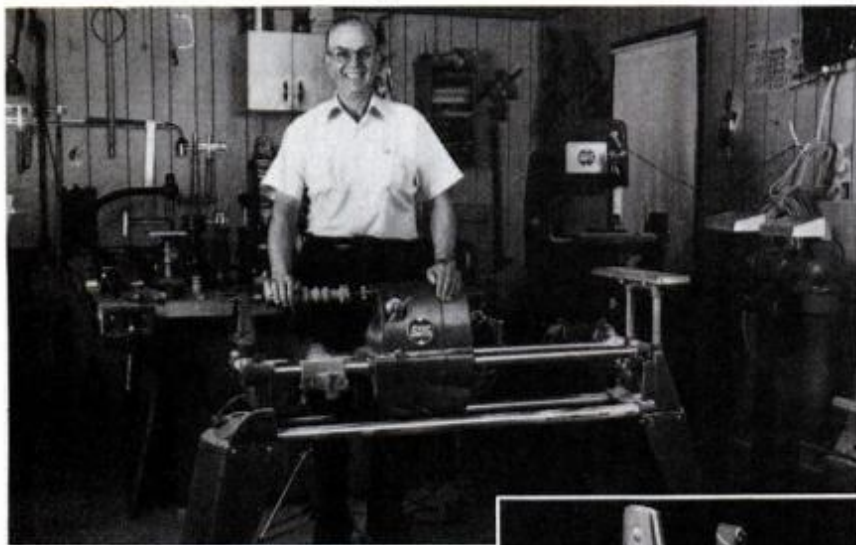

Here's why he sold them.

"My shop was equipped with commercial tools in which I had an investment of \$12,000 or more. I sold all my machines at a nice profit, and purchased one Mark V... I can do anything I was doing on all the machines, this gives me a lot more room and I have several thousand in the bank. What more could I ask for?"

— Jack McAlister, Tucker, Georgia



Jack McAlister found something out that a lot of woodworkers at all levels already know. You don't need a shop full of expensive power equipment to do just about any job you could imagine. All you need is a Shopsmith Mark V.

The 5-in-1 tool that does it all.

The Shopsmith Mark V is actually a complete workshop in a single, compact unit no bigger than a bicycle. It includes the five basic power tools no home shop should be without.

It's powered by a rugged precision-built motor that any power tool owner would be proud to own. And it can do more than your standard power tools because it actually lets you borrow features and set-ups from one tool to enhance the capabilities of the others. So you can tackle jobs you now wouldn't dream of doing yourself. And, thanks to the Mark V's built-in precision and control, you'll do them successfully.

Maybe it's time for you to find out what Jack McAlister and over 350,000 Shopsmith owners already know. Mail the coupon for all the facts today.

Don't you owe it to yourself to find out more about the Mark V — the single piece of equipment that can actually replace \$12,000 or more in power tools — yet costs less than 1/10 that figure?

**The Shopsmith Mark V —
the tool to start with...
the system you grow with.**



Shopsmith Inc.

Dept. 2522
750 Center Drive
Vandalia, Ohio 45377

Yes! Please mail me your FREE information kit on the Shopsmith Mark V. I understand there is no obligation.

Name _____
Address _____
City _____
State _____ Zip _____

Channel carries water off your driveway



Shop-built driveway channel eliminates flooding of the driveway at its low end.

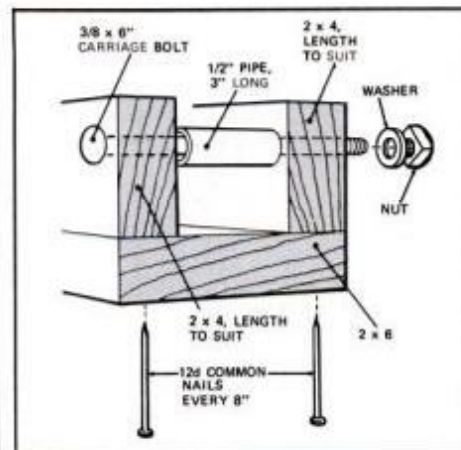

After a healthy rain, many homeowners have the problem of water running down the driveway into the garage. Lawrence Dodge of Penn Yan, N.Y., solved that problem by building this water diversion channel across his driveway.

For longevity, build the channel of pressure-treated lumber, available at most lumberyards. The rigid trough is constructed of 2x4 sides fastened to a 2x6 bottom piece. To assure that the 2x4s remain vertical, install 3-in.-long pipe spacers over carriage bolts located at 4-ft. intervals.

Install the channel diagonally, midway along the driveway, to divert water rapidly. Imbed the channel so its top edges are flush with the driveway surface. You'll be able to pass smoothly over the channel; yet it will carry surface water to one side of the drive.

To keep debris from entering, you can install heavy fence wire over the channel. You might also paint the top edges a bright color to alert pedestrians.—Ralph Wilkes

Heart Computer

Your heart can tell you three things that can help you live longer and stay healthier. The rest is up to you.

JS&A has never offered a pulse meter. And for good reason.

If you've ever used one, you'll quickly discover that your heart does not beat like a clock. It's irregular. It might beat at 40 beats per minute for one instant and at 120 the next. Since most pulse meters measure each beat as it occurs, you never feel confident that you're getting a very good reading.

We also considered size. Each pulse meter we examined was large or cumbersome and awkward to carry or store.

WE WAITED

We waited a few years. In the meantime, we discovered three ways your heart (through your pulse) helps you monitor your health.

Pulse Rate Your pulse rate can tell you if you are getting enough oxygen throughout your body. A high pulse rate indicates that your heart must pump faster to supply that oxygen and may indicate poor physical condition.

Target Zone Your pulse can tell you if your heart is beating fast enough during exercise. There's an area called the "Target Zone." Below this level, you're not exercising hard enough to do your heart or respiratory system any good. Above this level, you can be dangerously over-exerting yourself.

Cardiac Recovery Time The time it takes for your pulse rate to return to normal after you've exercised is the real measure of whether or not your exercise program is doing you any good. This time can be as healthy as one minute or as poor as several minutes.

The three things we learned convinced us that the ideal pulse meter must have the following features:

1. It must measure a series of heart beats and simultaneously compute the average to avoid the strange readings from irregular heart beats.
2. It must be small enough to use while exercising.
3. It should have a timing capability to determine the Cardiac Recovery Time.

It wasn't until a small Utah medical electronic instrument company created what we feel not only provides the capabilities listed above, but excels in other areas too.

FITS ON FINGER

The unit is called the Pulsetach, and it fits right over your finger. It weighs less than an ounce and can be worn easily during most exercise programs.

The large liquid crystal display can easily be seen in normal room lighting or in bright sunlight, and because liquid crystal displays consume very little power, the readily-available watch batteries will last for years. The Pulsetach automatically turns itself off in five minutes if you forget.

The heart of the system is a powerful micro-

computer CMOS semi-conductor integrated circuit that will take up to 4 pulse beats, compute an average pulse rate, and then flash that rate on the liquid crystal display.

FINGERTIP SCANNER

The sensor consists of a Gallium Arsenide infrared light-emitting diode which scans your fingertip hundreds of times a second to determine your pulse rate. This new system is one of the most accurate and is also used in sophisticated hospital systems.

The unit also contains a quartz-controlled timing circuit which will accurately time either your exercise period or your Cardiac Recovery Time. And you can switch back and forth between the pulse and chronograph mode while you are exercising.

We realize that the Pulsetach sounds like a very sophisticated unit. And it is. But as sophisticated as it is internally, it's an extremely easy unit to operate. There are just two buttons to press which operate the pulse reading and the chronograph timing circuit. A third button engages the audio circuit.



The Pulsetach system fits comfortably on your finger while it monitors your heart and determines your Cardiac Recovery Time.

HEAR YOUR PULSE

The audio circuit simply beeps every time your pulse beeps. This feature lets you monitor your pulse by hearing it as you run or exercise and it can be shut off by pressing the button a second time. The timing circuit is quartz-controlled and extremely accurate.

The Pulsetach not only has combined all of the most advanced technology in an extremely small size, but it costs less than many other systems lacking its advanced features.

The Pulsetach can be used for joggers, athletes, all forms of exercise and even cardiac recovery patients, as it operates quite effectively with pacemakers.

REAL WORKOUT

We suggest you order a Pulsetach for our 30-day no-obligation trial. When you receive your unit, give it a real workout. Notice how simple it is to operate and how easily you



The Pulsetach will shortly become the number one selling system of its type in the nation.



can read your pulse rate. Use it to stay in your Target Zone and to determine and then improve your Cardiac Recovery Time.

Monitor your Cardiac Recovery Time. Determine your Target Zone and see if you're really exercising in that area. Then use the Pulsetach to watch those important signs slowly improve thanks to the accuracy and information you get from the unit.

By knowing the important factors that help you monitor your health, you'll feel better, exercise more effectively, and many doctors feel you'll live longer.

TWO UNITS AVAILABLE

To order your Pulsetach pulse meter, send your check for **\$119.95** plus \$2.50 postage and handling (Illinois residents add 6% sales tax) to the address below. (Allow 20 days for personal checks to clear.) Credit card buyers may call our toll-free number below.

You can also order the more expensive hospital unit that averages 16 beats and has all the features including the small size of the previous unit. It costs **\$169.95**.

We'll send your Pulsetach pulse meter complete with 90-day limited warranty and instructions which include information on determining your Target Zone, Cardiac Recovery Time and other helpful information.

Then after your test, if you're not fully convinced that the Pulsetach is the best unit of its kind, the most convenient, and the greatest value, return it within 30 days for a prompt and courteous refund including the \$2.50 charge for postage and handling. You can't lose.

Your Pulsetach is totally solid-state so service should never be required, but if it is, the manufacturer has a national service-by-mail facility backing each unit. JS&A is America's largest single source of space-age products—further assurance that your Pulsetach is backed by a substantial company.

We've waited an awful long time to jump into the pulse monitoring field. But what a great entry. Order your Pulsetach at no obligation today.

JS&A PRODUCTS
THAT
THINK®

Dept. PM One JS&A Plaza
Northbrook, Ill. 60062 (312) 564-7000
Call TOLL-FREE 800 323-6400
In Illinois Call (312) 564-7000

© JS&A Group, Inc., 1980

LUBRIPLATE® "MARINE" LUBRICANTS

For protection beyond the call of duty!



LUBRIPLATE DIVISION / FISKE BROTHERS REFINING COMPANY / 129 LOCKWOOD STREET / NEWARK, N.J. 07105
MANUFACTURING PLANTS IN NEWARK, N.J. 07105 AND TOLEDO, OHIO 43605 / DISTRIBUTORS NATIONWIDE

LEARN TO THINK LIKE A PHOTOGRAPHER.

It is a rebirth of the mind. Simple surroundings take on a new meaning, a new dimension. It is the world of photography, and you can be an integral part of it through the innovative new McGraw-Hill Photography Workshop.

In the convenience of your own home, at your own pace, you'll learn to think like a photographer. You'll be given projects to utilize your newfound skills. A panel of profes-

sional photographers will critique your work and stimulate your photographic senses. You'll even have the opportunity to win photographic competitions.

For a complete packet of free information, call toll-free, **operator #203 at 800-648-5600** (in Nevada call 800-992-5710), or mail this coupon to McGraw-Hill Photography Workshop, 3939 Wisconsin Avenue, N.W., Washington, D.C. 20016.



Name (please print) _____

Address _____

City/State/Zip _____

3030-060

PM LOOKS AT RAIN DISPERSER



Rain disperser, installed in place of gutters, turns rainwater runoff from roof into droplets and prevents erosion.

Deflect Away rain dispersers perform the same functions as gutters and leaders—but with little or no maintenance, since they don't trap leaves. We installed a 10-ft. section a year ago and found that water running off the roof turns to fine droplets as



Brackets should be screwed to a fascia board as low as possible. Aluminum strips snap into place in the brackets.



A late-fall spraying with a garden hose keeps the dispersers free of debris.

it hits the disperser. This eliminated dirt splashing onto nearby siding, as well as erosion or trenching in the ground below the eaves. Dispersers are not suited to houses where poor drainage causes water to leak through basement walls. The manufacturer is Klenatron Co. Inc., 20 Hayward St., Ipswich, Mass. 01938. A 5-ft. section with hardware costs about \$10 at hardware stores.—J.P.

MAKE A CLEAN SWEEP OF SHOP-VAC® SAVINGS... AT K MART.

The Vacs that revolutionized heavy-duty cleaning are sale-priced now at K mart. With features like: • Double filtration system to pick up wet and dry material • Automatic shutoff to prevent overflow • Built-in drain • Powerful, heavy-duty .94-hp, 6-amp motor to power-clean workshop, basement, garage, car,

patio or home • Handy tool pouch to keep accessories with the vacuum cleaner • UL listed.

The Wet/Dry Shop Vac is available in two models: an eight-gallon dual deluxe with nine standard attachments (Model 600-14); and a five-gallon deluxe with five standard attachments (Model 600-07).

Both models include a four-wheel dolly with swivel casters for ease of maneuvering. On sale through June 28 at over 1,600 K mart stores across the U.S.A.



\$39⁹⁷
(Model 600-14)

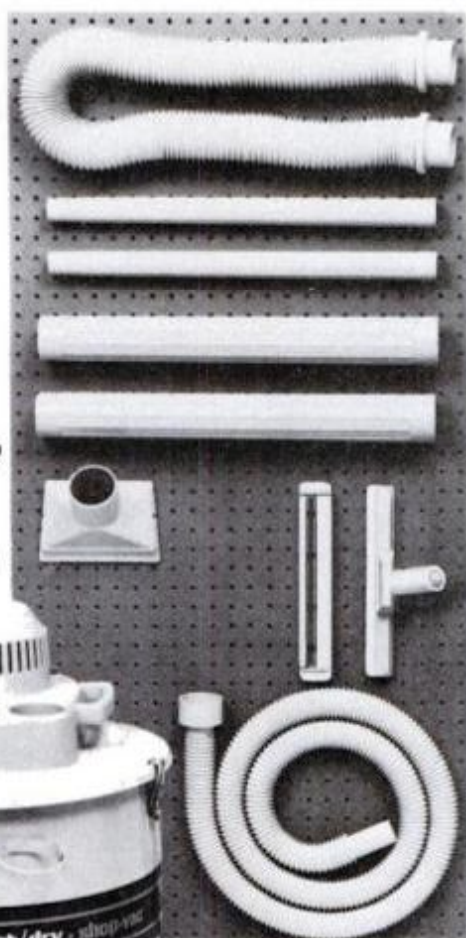

\$32⁹⁷
(Model 600-07)



Kmart®

The Saving Place

Copyright 1980

K mart Corporation

Troy, Michigan 48084

'What to do if you're teed off at athlete's foot.'

by Hale Irwin



"The only way I can keep my feet feeling up to par is to use Dr. Scholl's Solvex® Athlete's Foot Products."

When you feel the first itch of athlete's foot, just apply Dr. Scholl's Solvex Ointment or Spray. Solvex kills athlete's foot fungi on contact. And helps control the itching and burning of athlete's foot.

And, if you want to beat the itch before it starts, try regular applications of Dr. Scholl's Solvex Powder. It absorbs the moisture that athlete's foot thrives in and helps prevent reinfection.

"Face it, who knows more about feet than Dr. Scholl's? Their Solvex keeps my mind off my feet. And on the ball!"

Dr.Scholl's



© 1979 Scholl, Inc.

PM LOOKS AT PUMP-A-DRINK JUG



Plastic jugs with built-in pumps are available in ½- and 1-gal. sizes.

Large picnic jugs can be awkward to pour, especially on a picnic table crowded with goodies. You can leave this cold-beverage jug on the table and use your finger tips to dispense drinks. Press the pump top once or twice to fill an average-size glass.

The half-gallon jug costs \$14 and the one-gallon unit, \$17, at retail houseware outlets. They're from Aladdin Industries Inc., PM680, Box 100255, Nashville, Tenn. 37210.—H.W.



Pump mechanism is built into the jug lid. Unbreakable container keeps beverages cold, but isn't for hot drinks.



A gentle push on the lid top is all you need to pump liquid into the glass. Spout plug prevents spillage in transit.

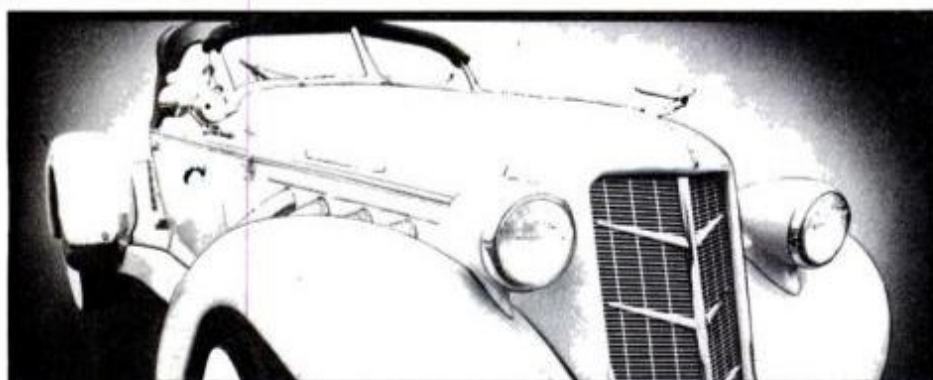

DON'T WAX YOUR CAR EVER AGAIN!

Chemists Develop New Glaze To Save Your Paint

A new discovery in the chemical industry *now makes car wax obsolete!* Wax, being soft, actually attracts and collects dirt — PROMOTING FADING AND PAINT ROT! CHEM-GLAZE is a unique, TEFLON® BASED POLYMER, SUPER HARD CURING RESIN SYSTEM, that will last up to 10 times longer than wax! By simply wiping on, CHEM-GLAZE will easily flow into paint pores, and completely seal paint against the destroying elements of the atmosphere.

Until now, CHEM-GLAZE has been used strictly by foreign import dealers, to protect costly custom paint finishes. It is also used on the body shells of race cars to cut wind resistance, and to give that "super-glossy" appearance.

WARNING!!!

CHEM-GLAZE — has been labeled and sold for double!
CHEM-GLAZE — has been recycled and sold for less, using inferior silicones, or acrylics, posed as our costly POLYMER-TEFLON® BLEND.

CHEM-GLAZE will actually stop and remove oxidation on a car that is not new. Also, extensive salt-spray tests in Florida prove that the CHEM-GLAZE laminating effect will put an impregnable "glaze" that will last 2-3 years on new paint!
WE GUARANTEE CHEM-GLAZE to be fully tested 100% SAFE AND EFFECTIVE! If you find

after using CHEM-GLAZE, that anything we say about this revolutionary product is untrue, return unused portion FOR A FULL REFUND! (minus shipping charges)

Invest \$14.95 today, for a 16 oz. bottle of CHEM-GLAZE, enough to treat three cars. These pennies will make you dollars in maintaining, or reselling a big investment — YOUR CAR!

— DEALERS INQUIRIES INVITED —

Call Collect — (313) 525-7747 for Instant Processing

To: **TRU-KEM CORPORATION**

P.O. Box 2324, Livonia, Michigan 48150

- Please rush one 16 oz. bottle of CHEM-GLAZE @ 14.95 (plus \$2 shipping and handling in U.S.A. — \$7 Foreign)
- SAVE \$5.00! Rush 2 bottles @ 24.95 (plus \$2 shipping and handling in U.S.A. — \$7 Foreign)
- Check or Money Order enclosed Charge my Credit Card
- BankAmericard/Visa Master Charge, Interbank No. _____

Credit Card No. _____ Exp. Date _____

Name _____

Address _____

City/State/Zip _____

We just called a halt to the horsepower race.

At Chrysler, we don't want to sell you any more outboard than you really need. And the outboard you need may be less than what you think you need.

Remember when the biggest engine you could get was 40 horsepower? And all you needed to win a boat race on that little lake back in Western New York state was a 25 horse motor? Or remember learning to waterski behind a 10 h.p.?

Something happened in outboard-ing since those golden summers years ago. It was the horsepower race. Every year, something bigger, something better. And, needless to say, more expensive. We stopped raising the ante at 140 horsepower. For the majority of single and dual engine

installations, we believe this is more than sufficient.

We recently worked with the manufacturer of a 17' semi-vee hull weighing 1175 pounds. *While it was rated at 115 h.p., the Chrysler 75 moves this hull easily.* It will tow a couple of skiers or carry a whole boatload of fishermen out to where they're biting.

Important to you is the fact that our 75 h.p. costs close to \$500 less than our 115.

With most boat and motor combinations, you reach a point of diminishing returns on the horsepower scale.

We ran our 75 in waterskiing acceleration tests against a Mercury 80. It was an even match, which left us wondering why someone would need 5 extra h.p.

In comparison runs between our 75 and a Mercury 90, the Merc won. It was 2 mph faster at the top end. The question you have to ask yourself is whether a 2 mph difference is worth having to pay for 15 extra horsepower and buying extra gasoline.

The Chrysler Marine line of 19 outboards—from 4 to 140 horse-

power—is hand-built in a small Hartford, Wisconsin plant that's been making outboards since 1944. We believe our range is adequate for most applications. If you must have more power, our stern-drives from 195 to 240 h.p. should suffice.

Chrysler outboards are designed and built to be simple.

Take off the engine cowling and you'll see what we mean. No expensive gimmicks to complicate or malfunction. Just good, solid engineering. Engineering that not all our competitors have. Forged crankshafts—not cast. Needle, roller and ball bearings, exclusively, in every powerhead. And a CD ignition that is unsurpassed in the industry.

A Chrysler outboard is the perfect mate for today's lighter, more fuel-efficient boats.

Get together with your Chrysler Marine dealer and decide how much horsepower you really do need.

See your Chrysler Marine dealer, soon. And call a halt to the horsepower race.

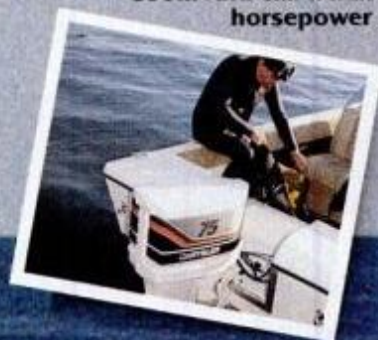

**OUTBOARDS
INBOARDS
INBOARD/
OUTDRIVES
DIESELS**

QUALITY ENGINEERED BY THE
NEW CHRYSLER CORPORATION



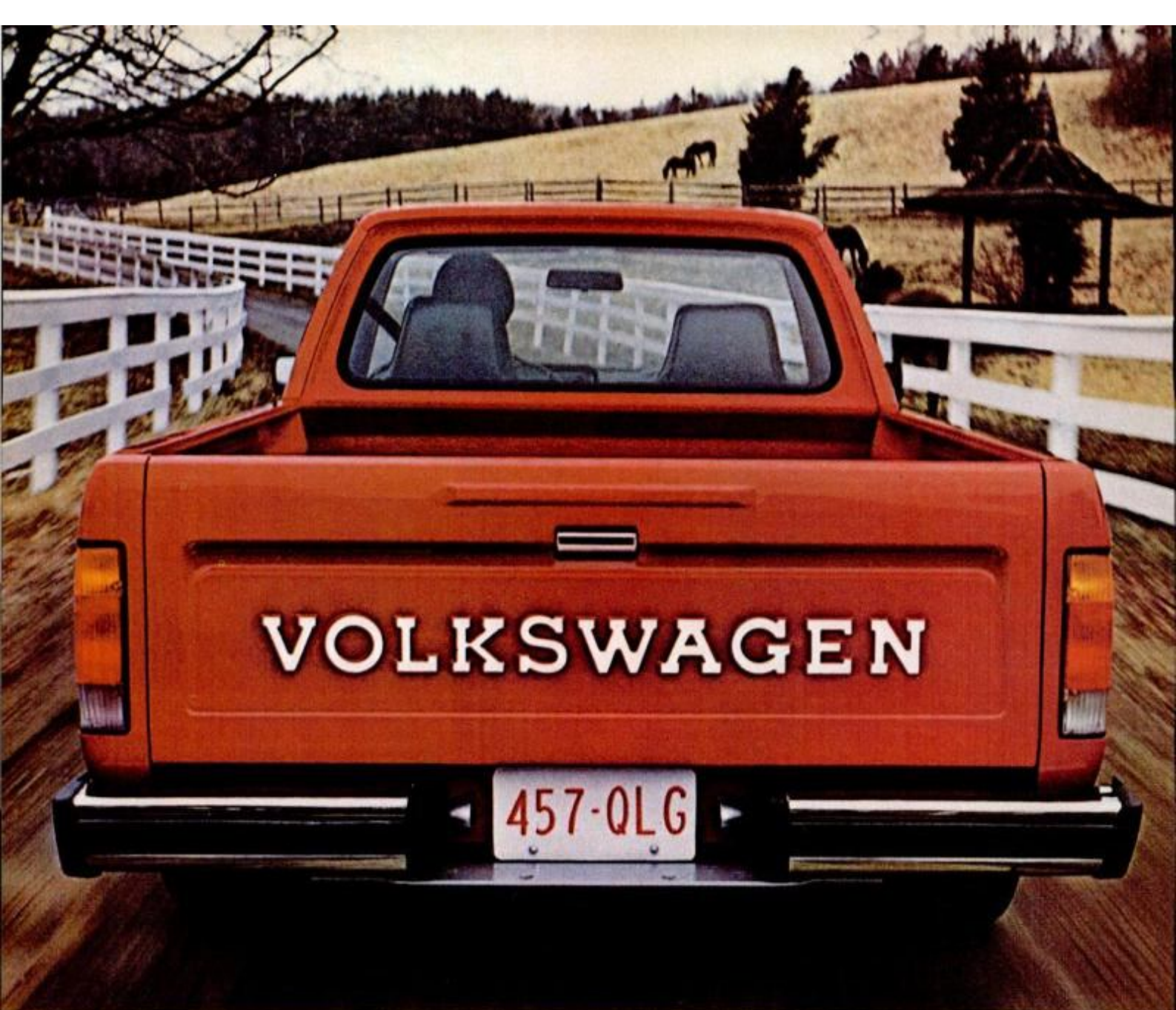

It has economy written all over it.

The Volkswagen Pickup.

Probably one of the most economical pickups ever invented with a fuel-injected gas engine. And if you want even more economy there's a diesel option that delivers mileage no one can beat.

(It gets an EPA estimated ²³mpg, 32 mpg highway, estimated ³⁹mpg diesel and 48 mpg diesel highway. Use "estimated mpg" for comparisons. Your mileage may vary with weather, speed and trip length.

Actual highway mileage will probably be less.)

But the engine's not the only thing that's economical.

It has front-wheel drive for economical power transfer from the engine to the wheels.

And, the engine is transverse-mounted for more economical use of cab space for passengers and better forward visibility for the driver.

What's more, it has an independently operating electric fan to cool the engine more economically, too.

In the back, it has double-wall construction so that if something you carry in its six-foot steel bed makes a dent on the inside, nothing shows on the outside. But the most economical thing of all about the Volkswagen Pickup is the fact that it's still a Volkswagen.

**VOLKSWAGEN
DOES IT
AGAIN**



принадлежит, защищенный авторским правом

SCIENCE WORLDWIDE

Power from the Dead Sea

Israelis are drawing solar energy out of water from the Dead Sea and using it to run a 150-kilowatt power plant.

Israel's Minister of Energy, Yitzhak Modai, inaugurated the system recently with the prediction that energy harvested from the lifeless sea, the saltiest body of water in the world, might someday provide most of the electricity for the country.

The solar pond is a shallow, black-bottomed basin filled with sea water. The high salinity prevents convection; when the sun shines, heat builds up in the lowest levels of the pond where salt concentrations are highest. This hot water, close to the boiling point, runs through heat exchangers, which extract energy to run turbines.

Deadly optical illusions

Why does the moon loom on the horizon, then seem to shrink as it rises? Why do pilots misjudge the distance of runways, sometimes with fatal results?

Dr. Stanley Roscoe, a psychologist at New Mexico State University, thinks the questions are related.

Roscoe's theory: When you gaze at the moon on the horizon, your eyes are focused at a distance, accommodating to faraway land or water features. For unknown reasons, this distance accommodation makes the moon look bigger. It also makes airports appear larger when pilots approach cities over water. Their eyes focus on faraway lights; runways

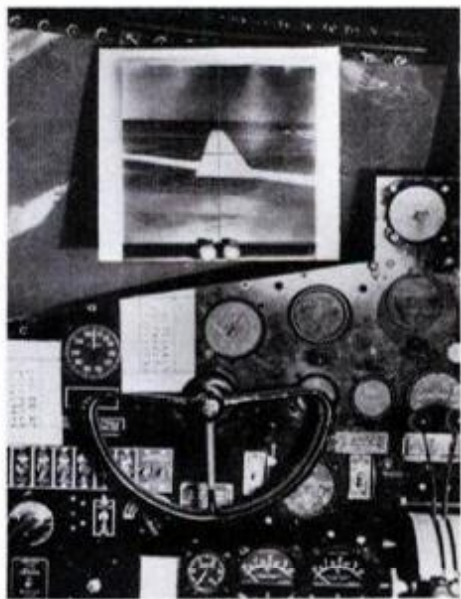

Periscope view (simulated here) made runways look too small. Result: overshooting.



Shallow pond, shown before filling with Dead Sea water, collects heat near briny bottom.

appear closer than they are; there's a temptation to drop below a safe altitude.

On the other hand, when the eyes adjust to seeing nearby objects—a dirty windshield, for instance—runways appear small and distant. The danger: overshooting.

Roscoe's theories aren't universally accepted, but experiments tend to support his idea that cockpit viewing conditions affect pilots' distance judgments. He began studying cockpit optical illusions more than 30 years ago when he outfitted a Cessna with a periscope. Pilots using it consistently judged the field to be farther away than it was—because their eyes were accommodating to the screen 15 inches in front of them. A slight magnification applied to the periscope corrected the problem. The research has aided the design of television control systems for remote-piloted vehicles and smart bombs.

Aspirin and heart attacks

A major clinical trial to find out whether aspirin can prevent heart attacks has produced discouraging results.

During the 3-year test, the National Heart, Lung and Blood Institute kept watch on more than 4500 persons who had already had a heart attack. Some subjects took a gram of aspirin a day; others in a control group took placebos.

Earlier clinical trials had raised optimism that the group taking aspirin would suffer fewer second heart attacks. But the regimen apparently didn't work: Not only were there about the same number of heart-attack deaths in the aspirin

and control groups, but those taking aspirin suffered more side effects, such as stomach bleeding.

Superbubble in space

Scientists have discovered an immense bubble of superheated hydrogen material centered in the prominent summer constellation Cygnus, the Northern Cross.

Dr. Webster Cash of the University of Colorado and Dr. Philip Charles at the University of California, Berkeley, found the glowing gas blob in data from a NASA satellite, HEAO-1, that collected X-ray emissions from space.

The bubble, some 6000 light years from Earth, is about 1200 light years in diameter, they said. Temperatures inside the bubble are about 3.5 million degrees F.

How did it get there? Cash suggests it began growing some three million years ago when a star exploded, battering a cloud of cool gas near Cygnus. The explosion compressed the gas, spawning other stars, which in turn exploded, blowing superheated hydrogen away from the cloud and into an expanding bubble. Our sun, Cash said, may have formed at the edge of a similar bubble.

PM

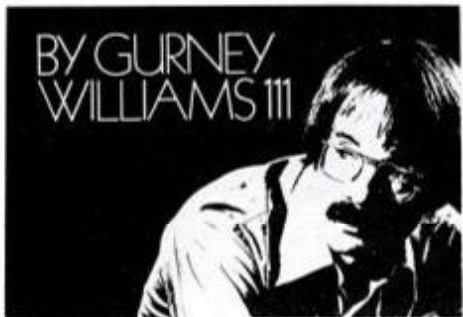

IMPORTS & MOTORSPORTS

Future wagon



Volvo idea car uses turbo on the B-21, ohc Four to provide 30-mpg highway economy.

Volvo is long overdue with an update of its popular station wagon. Nice changes under the skin have been made over the years, but the old 140-series body is essentially the same as when introduced in the late '60s. Why, even the taillight lenses on the 1980 wagon are identical to those on the first 145 wagon of a dozen years ago! That's why it would be nice if the striking wagon shown here were a 1981 model. But, no, it is, as the sign says, a "concept car."

Volvo engineers were turned loose to design a wagon for the future and they started by reducing the drag coefficient: The nose was wedged, the rear was chopped and a chin spoiler was designed to minimize airflow under the car at 55-mph speeds. In fact, the spoiler automatically lowers at that speed; at rest and low speeds it is retracted, so it won't tangle with high curbs. The lowered beltline fell into place as a result of the change in body shape for improved aerodynamics. Other features of the car include new passive belt system, aluminum body parts, turbo on the B-21 Four, tailgate cut into the roofline for easier loading and onboard computer. Enthusiasm for the design at auto shows in Europe this summer could mean production early in the '80s.

1981 Saab sedan

Saab has concluded that not everyone wants a hatchback. Notchbacks do appeal to buyers who require that



Sedan version of Saab 900 joins hatchbacks for the '81 model year.

their cars hold a trunkful of dignity. Four-door sedans like BMWs, Audis and Volvos give Saab its toughest competition here, and the Swedish automaker feels it better have its own sedan to go against the "up-scale imported segment of the market." The Saab 900 sedan will go on sale late this year as an '81 model. Like the hatchback, the sedan has a fold-down rear seat so you can have your dignity and versatility, too.

Ford's wagon idea



Ghia Studio built this better idea for Ford.

There's a Ford Fiesta front-wheel drive train underneath, but you'd never guess it. The GTK is a station-wagon design from Ford's Ghia Studio in Turin, Italy. The miniwagon is built on a 94-inch wheelbase and fits four, plus luggage. Like the Volvo wagon, it's an idea car and not scheduled for production—yet.

Another Honda model

Quint. What better name for a five-door hatchback? Honda does keep it simple, right down to the names it

pulls out of our dictionary for the cars it sells here. The nameplate is familiar in Japan, but the car is still not slated for shipment to the United States. The Quint is an all-new sporty sedan on a 93-inch wheelbase. It's 162 inches overall, 63.5 inches wide and 52.5 inches high. Fuel tank capacity is just over 13 gallons. Fuel mileage is reported to be 54 mpg at a steady 37.5 mph. Nice



Honda Quint features 1601-cc CVCC Four.

economy, but it doesn't seem to be the kind of car you would want to drive that slow.

More new diesels

The diesels keep coming. Latest addition to the list, the Volvo diesel-engine cars, went on sale here last month. The sedan and station wagon mount an in-line, six-cylinder diesel of 2386-cc displacement. The swirl-chamber design puts out 76 hp at 4800 rpm. Combined city/highway fuel mileage of these models is 28 mpg, 31 mpg for overdrive sedan.

Also available now, but only in Europe, is the Strada diesel (the car's called Ritmo, or rhythm, in Europe). Fiat's diesel Four displaces 1714 cc, and we suspect it will be an optional engine in '81 Stradas. **FM**

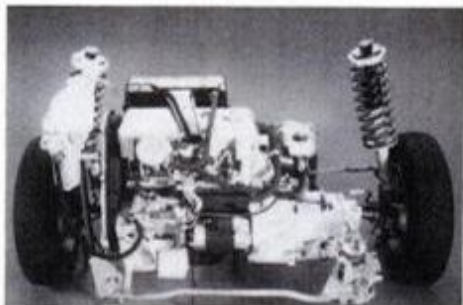

Fiat diesel Four may become Strada option.

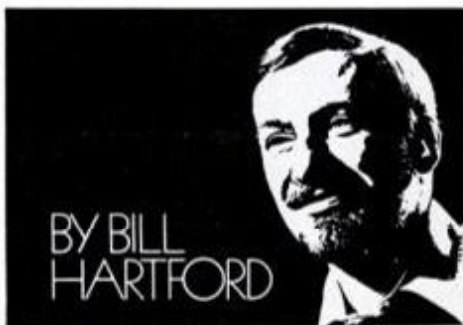



DEFENSIVE LINES.

AC Air and Oil Filters. When you're talking about filters, the name of the game is defense. AC Oil Filters help trap damaging particles and clean your oil. AC Oil Filters also help provide many thousands of miles of engine protection. Air filters are part of the defense story, too. AC Air Filters are designed to include an oil-wetted paper element to promote dirt-holding capacity and to help remove dirt that can cause engine wear. AC Filters are recommended replacements for General Motors cars and light trucks and are available for most other American-built vehicles. So keep your guard up. Wherever you go for parts or service, ask for reliable AC Filters for your car's protection.

AC-Delco Division of General Motors Corporation.

THANKS, AC.





“My boys mow 11 lawns a week, not counting our own, so we really depend on our John Deere.” Lucy Ellis, Dallas, Texas

Eleven lawns a week is a lot of mowing for one lawn mower. Especially in Dallas, where the lawns are Texas-size and the mowing season runs from March through October.

Nevertheless, the Ellis family's 21-inch self-propelled John Deere has been doing the job for 2 years now, and it's still running as strong as ever.

“We've been real pleased with how dependable it is,” says Lucy Ellis. “It always starts right up, which our last mower didn't. And we've had almost no repairs to speak of.”

What's more, it's as easy to operate as it is reliable.

It has a powerful 4-hp engine that zips through tall grass with ease. A rear-wheel gear drive provides superior traction, even on hillsides.

And an optional 2½ bushel rear bagger allows for close-in trimming around trees, flower beds, etc.

John Deere 21-inch mowers come in a self-propelled model with an electric-start option and in a push-type model. Push models are also available in 18- and 20-inch cutting widths.

Come in for a demonstration soon.



For more information, write John Deere, Dept. 62, Moline, Illinois 61265.

Nothing runs like a Deere®



APPLIANCE CLINIC

QUESTIONS ANSWERED

Leaky corner

I have a Sears Kenmore dishwasher, Model No. 587-779400. Every so often it leaks from the front left corner of the machine. It does this for several days and then stops. What could be the cause?—R.L. Alderman, Bennington, Vt.

First, you might look for a worn or loose door gasket. Check to make sure the gasket around the tub is snapped firmly into its mounting holes.

Pay special attention to the bottom left and right corners. Push the gasket so that it's tight against the tub. Remove any accumulation of food deposits at these corners with household vinegar.

If the gasket looks worn or flat, remove the two screws holding the door latch at the top of the tub. Remove a door shim behind the latch and reinstall it. Try the dishwasher and check it for leaks. Keep removing shims until the door is tightly sealed. If the door still leaks, the gasket should be replaced.

When the dishwasher is not being used, be sure to keep the door closed but not latched tightly. This will allow the gasket to breathe and swell to its normal size.

Running marathon

I have a General Electric refrigerator, Model No. TB304XB, which runs continuously, defrosting only when I manually defrost it. I replaced the thermostat and had a technician add more refrigerant gas to the system. It still continues to run. What can I do?—Edward Klein, Cedarhurst, N.Y.

If the refrigerator still gets cold and your only problem is that it runs continuously, check the following items: the refrigerator clearance space, the condenser, the door gasket and the light switch.

Make sure the space on top of the refrigerator is at least 4 in. away from cabinets and is free of all clutter and storage items. Check the static condenser at the rear of the refrigerator to make sure it is clean and clear of any papers that may have fallen between it and the box.

Test the door gaskets by simply opening the doors and closing them on a piece of paper. There should be a slight tug on the paper as you try to pull it out. Test various spots along the doors by repositioning the paper. If the paper slips by itself or

pulls easily, you should replace the door gaskets.

Next, open the doors and press the light switch in. The light should go out. If it doesn't, replace the switch.

If all of the above check out okay, then the problem rests in the sealed system, probably the compressor. This diagnosis should be made by a qualified GE technician. At that time, you will be able to decide whether to repair or replace the refrigerator.

Dishwasher vs. disposer

Is it true that a garbage disposer shouldn't be used while you have the dishwasher running? If so, why?

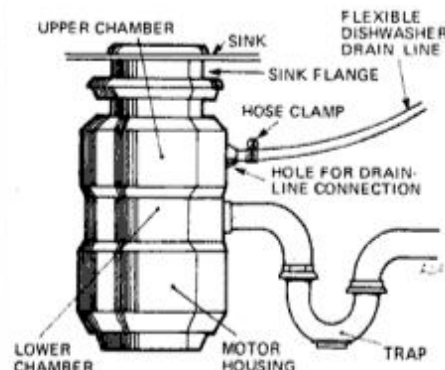

Dishwasher drain is connected to disposer through knockout hole in upper chamber.

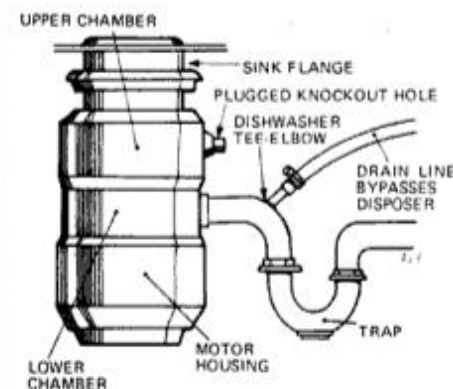

To bypass disposer, plug knockout hole, connect drain to dishwasher tee-elbow.

Would it be more efficient to attach the dishwasher to its own separate drain line?—Tim Pelzek, Milwaukee

There is no reason why both units cannot be running at the same time as long as each has its own electrical circuits, so that you don't run the chance of blowing a fuse. The dishwasher uses only hot water. A cycle can last from 15 to 30 minutes or

more. A disposer is used with cold water and is run for only a few minutes.

The only caution I'd advise is to watch when you batch-feed the disposer—when you scrape and load the disposer full of food and then turn it on. Worn or dull shredding knives can force some food into the dishwasher drain-line connection when the dishwasher drains into the disposer (see top drawing, left). This causes a partial or full restriction, with the result that the dishwasher will not pump out or will pump out very slowly.

A separate drain line for the dishwasher (see lower drawing, left) is more efficient because the water bypasses the upper and lower chambers of the disposer and drains directly into the trap itself.

You can purchase the dishwasher tee-elbow connection at a plumbing-supply store. This system would eliminate any potential problems from a clogged dishwasher drain line.

Knock, knock

We purchased an Amana refrigerator, Model No. TR16W, in June, 1976. In the last three months, the refrigerator has developed a loud knocking noise when the compressor shuts off. The dealer says this is a common compressor problem and replacing it will do little good in stopping the noise. Is this true?—Margaret S. Cutter, Lima, Ohio

Amana informs us that this is not a common problem with their refrigerator units. However, it is possible that a suspension spring in your refrigerator has either broken or slipped inside the compressor. This would cause the motor to lean to one side and knock loudly on start up and shut down, due to torque.

The only cure is to replace the compressor. Since this is a major job, have an authorized service agent confirm the problem before you have the job done.

You are still covered under the five-year, sealed-system warranty. So the only expense you will probably face for these repairs will be the labor cost.

PM

If you have a question about any appliance, send it to Appliance Clinic, Popular Mechanics, 224 West 57th St., New York, N.Y. 10019. Sorry, but letters cannot be answered individually. Problems of wide interest will be discussed in this column.

FUEL FOR THE FUTURE

After 47,000 miles on gasohol— a clean engine

by Mort Schultz

Confused by all the contradictory statements about the gasoline and ethanol mixture called gasohol? I was, too. So, I decided to find out for myself what, exactly, this fuel does to your engine.

I visited Buzz Marcus Toyota Co. in Glenside, Pa., because, up to now, probably no other outfit has operated cars more miles on gasohol than Marcus.

We disassembled an engine that had been driven since new on nothing but gasohol. In fact, it was operated most of these miles, not on the conventional mixture of 90 percent gasoline and 10 percent ethanol, but on an 80- to 20-percent blend.

The carburetor was like new. There was no dirt and no varnish, and metal and nonmetal parts showed no signs of corrosion. This is particularly interesting since the General Motors Research Laboratory in Warren, Mich., found that when testing gasohol in an engine on a laboratory test bench, some fuel system materials, notably elastomers, deteriorate more with gasohol than with gasoline.

When we pulled the head, there was no evidence of sludge or carbon buildup, although there was a thin layer of soot in the combustion chambers. The valves were clean.

Cylinder walls were shiny and so was the exhaust header. The only carbon present was on the tops of pistons. The amount was insignificant, and no more than would be present in an engine run 47,000 miles on gasoline and maintained properly.

I also removed the sparkplugs from another engine that had been running on gasohol for 15,000 miles. They were clean and showed practically no wear. The plugs on the 47,000-mile engine were changed every 15,000 miles; so when I saw them they had only a couple thousand miles on them.

As far as I could see, gasohol is
[\(Please turn to page 36\)](#)

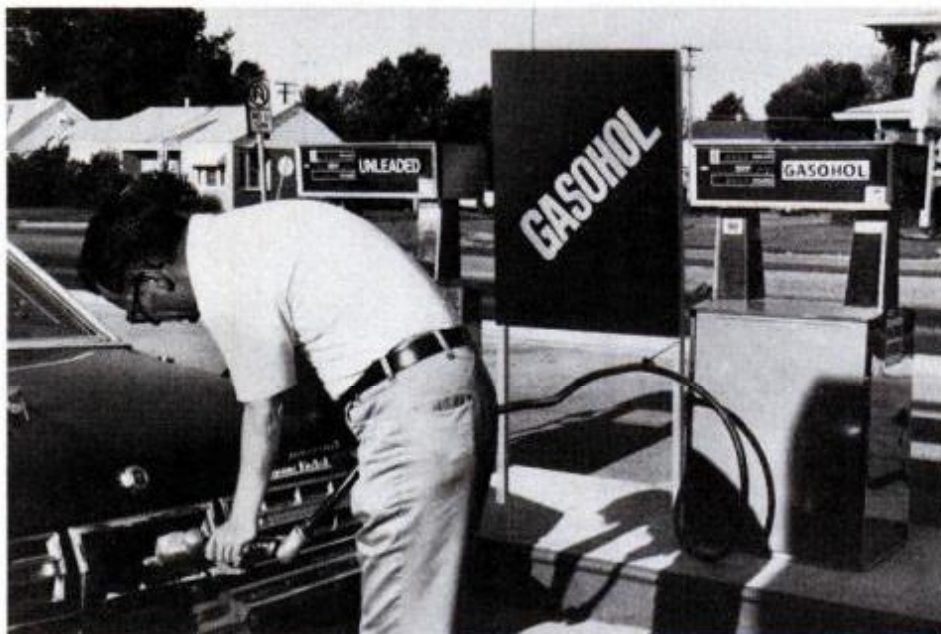

There are now only 2000 service stations in the country that are pumping gasohol. Due to certain government incentives, that number should double by sometime in 1981.



Changed every 15,000 miles on gasohol, the sparkplugs are free of carbon deposits.



The carburetor fuel bowl has no sludge after a total of 47,000 miles on gasohol.



Valves are clean and show little wear. Black deposit on combustion chamber is merely soot. Note wipe mark on No. 2 chamber.



The only carbon buildup occurred on the piston crown. But it was less than that found in engine run on straight gasoline.



KENTS
DON'T
HAVE
IT!



MERITS
DON'T
HAVE
IT!



MARLBORO
LIGHTS
DON'T
HAVE IT!



WINSTON
LIGHTS
DON'T
HAVE IT!



VANTAGE
DOESN'T
HAVE
IT!



BENSON &
HEDGES LIGHTS
DON'T
HAVE IT!

Only Tareyton has the best filter!

For a taste too good to be 5.

Why the best?
Because Tareyton's
unique charcoal filter
means taste that's
smooth. It means
flavor that's distinctive.
It means that no other
cigarette is quite like
Tareyton.



"We'd rather light than fight!"

TAREYTON LIGHTS



5
mg. tar
0.4 mg. nic.

Warning: The Surgeon General Has Determined
That Cigarette Smoking Is Dangerous to Your Health.

5 mg. "tar", 0.4 mg. nicotine av. per cigarette by FTC method.



Ford wagons and the option that could pay for itself.

A better protection idea from the Wagonmaster.

Just ask your Ford Dealer.

When you order your new Ford wagon, be sure to consider the one option that could pay for itself. Ford Motor Company's Extended Service Plan. It's available to help protect you against rising service costs. And it's backed by Ford Motor Company and honored by participating Ford Dealers nationwide.

To learn more about what this plan covers and what it costs, see your Ford Dealer.

The option that
could pay for itself.



EXTENDED
SERVICE
PLAN



Gasohol acts as a solvent and will dislodge dirt and rust from the fuel tank. Since this sludge can clog the fuel filter, check for it often to prevent stalling.

A CLEAN ENGINE

(Continued from page 34)

probably better for your engine than straight gasoline. Nevertheless, you may run into some problems when you make the switch. We'll discuss them later. First the good news.

Higher octane

The average octane quality of unleaded gasoline these days is 87. The average octane of ethanol is 98. When unleaded gasoline and ethanol are mixed at the 9-to-1 ratio to make gasohol, the average octane of the blend becomes 90. This is sufficient to eliminate pinging. If your engine timing is set correctly and you still experience some pinging, switching from straight gasoline to gasohol will probably cure it.

When you do switch to gasohol from gasoline you don't have to modify or adjust your engine at all. I've run my Pontiac V8 for several thousand miles on a 9-to-1 gasohol with no modifications. In fact, I tried a 20-percent mixture of gasoline and ethanol and had no difficulties.

Ethanol is an excellent motor fuel and very compatible with gasoline. It is made by fermenting and distilling crops such as corn, wheat, alfalfa and sugar cane. It differs from methanol, commonly referred to as wood alcohol, which comes mainly from natural gas and can be produced from coal.

Methanol *cannot* be used in present automobiles. For one thing, it is more corrosive than gasoline and ethanol-gasoline blends, and will quickly damage fuel tanks and carburetor parts. For another, methanol has less than twice the vapor pressure of gasoline. That means it doesn't vaporize very well

and tends to remain a liquid in engines. In testing methanol and methanol blends in engines, GM found that it created starting problems, poor warm-up performance, stalling and lack of acceleration. Such is not the case with ethanol. There are, however, other problems worth mentioning.

The water content in alcohol, for one, can give trouble, but I haven't experienced any. The alcohol in gasohol is 192 proof. Pure alcohol (no water) is 200 proof. Alcohol of 192 proof is 96 percent alcohol and four percent water, which isn't enough to cause a major problem. (To determine the percentage of water in alcohol, subtract the proof number from 200 and divide by two.)

However, some people are experiencing plugged fuel filters. The reason is that alcohol in gasohol may separate in cold weather and cause water to accumulate in the fuel tank. If a large quantity of water is pumped through the fuel line, the filter will clog. The alcohol in gasohol tends to act as a solvent. If there is dirt in the fuel tank or fuel line, alcohol may loosen particles and carry them through the fuel line to the fuel filter.

If you use gasohol and your engine becomes hard to start or begins stalling, the first thing to check is the filter.

Joseph Colucci, manager of the Fuels and Lubricants Dept. at GM Research Laboratories, cautions that you may experience other driving problems with gasohol, especially in models which do not have a closed-loop (feedback) fuel system. Some 1979 and many 1980 models possess this electronically controlled system.

"The oxygen in the fuel (ethanol is a partially oxidized hydrocarbon) causes vehicles to operate three percent leaner with gasohol than with gasoline," Colucci advises. "This leaner operation can increase problems such as surge, hesitation and stalls."

The ideal (stoichiometric) air/fuel ratio of gasoline is 14.5 to 1. That is, 14.5 parts of air for one part of gasoline. The ideal ratio for gasohol is 13.9 to 1. Therefore, when gasohol is run through your carb, which was designed for gasoline, the mixture will automatically be leaner than ideal for gasohol.

I haven't experienced any of these driving problems in the thousands of miles I've operated my car, which has a conventional fuel system, on 9-to-1 gasohol. But if I did, I would increase fuel/air mixture slightly.

Another potential problem you

(Please turn to page 38)

Ford. The best gas mileage of any wagons built in America.

But that's what you'd expect from the Wagonmaster.

On January 5, 1929, Ford's first Woody rolled off the production line and onto the American Road. In that year Ford began a journey fifty years long, building more station wagons than anyone else, earning the right to be called Wagonmaster.

Today the Wagonmaster is also the Mileagemaster. 1980 Ford wagons have the highest mileage ratings of any wagons built in America. From roomy full-size LTD Wagons to versatile mid-size Fairmonts to value-packed

BEST MILEAGE OF ANY WAGONS BUILT IN AMERICA.

WAGONS	EPA EST. MPG	EPA EST. HWY.	EST. RANGE	EST. HWY. RANGE
LTD (8-cyl.)	17	24	340	480
FAIRMONT (6-cyl.)	21	30	294	420
PINTO (4-cyl.)	23	38	322	532

Use these estimates for comparison. Your mileage may differ depending on speed, distance and weather. Actual highway mileage and range will probably be less than estimates. Calif. estimates lower. Comparison excludes diesels and other Ford Motor Co. wagons. Ranges are based on EPA mileage estimates and LTD's 20-gallon gas tank, Fairmont's and Pinto's 14-gallon gas tanks.

Pintos, Ford wagons are built to stretch your gas dollar.

And Ford wagons are the most popular of all. Since 1949, Ford has sold a million more wagons than anyone else.*

When it comes to wagons, Ford's better ideas just keep getting better.

And that's what it takes to be the Wagonmaster.



*Based on R. L. Polk & Co. registrations.



FORD WAGONS

FORD DIVISION



Wagonmaster - Mileagemaster. 1980 Ford.

A WORK TRUCK NEEDS A WORK TIRE



FIRESTONE STEELTEX RADIALS WORK.

Firestone Steeltex Radials for light trucks give you the long mileage, smooth ride, good traction and gas saving of a steel belted radial *plus* the hard nosed toughness of a real truck tire.

We built the Steeltex Radial to work. That's why the steel cord in Steeltex Radial belts is the same cord we use in the Firestone Transteel XR4s that roll on the 18 wheelers.

And that's why we build two of them. The regular Steeltex Radial and, for extra drive wheel traction, the Steeltex Radial Town & Country.

Firestone

STEELTEX RADIALS

Working Tires For Working Trucks

Remember, the safety of any tire depends on wear, load, proper inflation and driving conditions.

A CLEAN ENGINE

(Continued from page 36)

may encounter is an increase in vapor pressure that occurs when running on gasohol. Generally, gasoline has a vapor pressure of 10 pounds per square inch (p.s.i.). The addition of ethanol raises the pressure to about 10.7 p.s.i.

This increased vapor pressure can cause vapor lock in hot weather. A vapor lock condition occurs when fuel boils in the fuel pump or fuel line. The resulting vapor blocks the flow of fuel to the carburetor, causing the engine to shut down until things cool off.

As a precaution, if you are going to operate a car on gasohol in hot weather, carry a Thermos of cold water. Cold water poured on a fuel pump and fuel line will relieve the vapor lock.

Mileage increase is small

As for the question of fuel economy with gasohol, if there is an increase, my experience has been that it's too insignificant to notice. However, Marcus Toyota claims that its gasohol-driven Toyotas get a 3.5-percent increase in fuel economy compared to a similar car using gasoline.

Furthermore, Illinois Bell Telephone conducted a six-month experiment, running 15 vehicles on gasohol and 15 comparable vehicles on gasoline. A company representative told me they showed an increase in mileage of 4.3 percent for the gasohol-fed cars.

Conversely, the Solar Electric Research Institute (SERI) says, "Most tests indicate that cars achieve more miles per B.T.U. with alcohol. However, since alcohol contains fewer B.T.U.s of energy per gallon than gasoline (110,000 for gasohol; 114,000 for gasoline), the mileage performance of gasohol does not differ significantly from that of gasoline, especially in new cars."

Colucci of GM agrees with SERI. He says, "With an open-loop (conventional carburetor) fuel system, fuel economy can either improve, decline or remain the same, depending on the carburetor calibration. With a closed-loop system, our data suggest that the fuel economy penalty for gasohol is about three percent."

Let me leave you with a word of caution: If you own a new car and get your hands on some 192+ proof alcohol, don't exceed the 9-to-1 gasoline-to-alcohol ratio. New car warranties cover vehicles that use gasohol containing only up to 10 percent ethanol.

FM



We left our hearts in San Francisco ...and a case of Canadian Club.

San Francisco! What better place to hide a case of golden Canadian Club than the city where millions came to seek gold in the Gold Rush of 1849?

So, we boarded a cable car on our way to hide a case of the world's finest-tasting whisky in America's most beautiful city. Do you know San Francisco well enough to find the C.C.?

A BART ride, a street with a past.

Start at BART's last city stop, and take a 30-cent ride. Change to another mode of transit, and ride until you can transfer again. Do so, and head for the farthest terminus, but disembark at the first right-angle. Stroll a nearby street

till it suggests a profession. Then head back toward your latter mode of transportation one block closer to your former. Where idlers gather, note who stays longest.

Find a way out of town but stay in.

Now head straight to some rails and follow them as far as necessary to meet a way named for an important Gold Rush figure. Let it lead you to a way out of the city, but don't leave. (If you've made it this far, don't think things are looking up.) Now return to the last route you were directed to. Somewhere along it we hid our Canadian Club. Things you've seen should tell you where.

Tell the boss, "C.C., please!"

When you reach it, tell the man in charge "C.C., please!" You'll receive a case of Canadian Club, the world's finest-tasting whisky.

As you'll discover, C.C. is smoother and lighter than other whiskies. So try it on the rocks or in a sour or Manhattan. Millions know that Canadian Club is worth searching for. And 2,600 San Francisco Bay Area bars and restaurants know it's worth serving. So enjoy yourself. Say "C.C., please!"



© 1980 · 6 YEARS OLD. IMPORTED IN BOTTLE FROM CANADA BY HIRAM WALKER IMPORTERS INC., DETROIT, MICH. 86.8 PROOF. BLENDED CANADIAN WHISKY.

Canadian Club
"The Best In The House"®



"I ran out of Gillette TRAC II, so I tried another blade. The results weren't even close. I'll never run out of TRAC II again."

"If I buy bargain blades, I might get a shave I didn't bargain for. But I know I'll get a clean, smooth shave with Gillette TRAC II."

To Guys Who Use Gillette TRAC II,[®] No Other Blade Will Do.



"No wonder I'm always sold out of Gillette TRAC II"

**Gillette
TRAC II[®]
TWIN BLADES**

Gillette
WE GIVE YOU THE EDGE.

© 1980 The Gillette Company

HINTS FROM READERS

Turnbutton stops drawers



All too often, a shallow drawer is pulled completely out of its cabinet and its contents are scattered over the floor. To prevent this, I install a turnbutton on the top edge of the drawer back, as shown. When turned to the vertical position, the button strikes the case and the drawer cannot be pulled out.—*Howard Moody*

Stop a swinging door

Stop a door from drifting open or shut by removing its top hinge pin and wrapping it with clear plastic tape. When it is replaced, the friction of a tight-fitting pin will generally keep the door stationary.—*Lane Olinghouse*

Post pulling

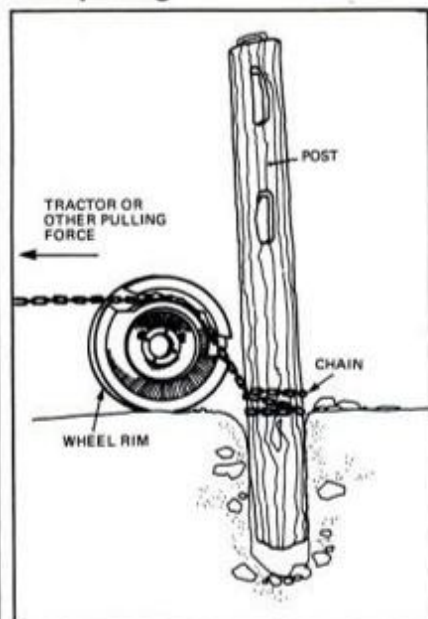

You can easily pull up posts with a length of chain and a wheel rim. Wrap the chain around the base of the post. Then string it over the wheel rim and attach it to a pulling force, such as a tractor or car.—*Jim Wallace*



The freezer. There's a Ford Granada in that block of ice - with Shell Fire & Ice motor oil in its crankcase. After we chopped through the ice, we turned the key. The engine started in four seconds.



The oven. Same test car, same Shell Fire & Ice, towing a 30-ton crane in the Mojave Desert 36 hours later. The oil temperature hit 270°F (well above normal). But Shell Fire & Ice protected the engine.

From the freezer to the oven in 36 hours: The Shell motor oil that had to earn its name.

Take a new Ford Granada and ask it to crank up fast, frozen in a huge block of ice. Then, after you've thawed it out, ask it to pull a 30-ton crane through several miles of Mojave Desert.

Do that and you aren't just asking the car to perform. You're demanding peak performance from its motor oil.

A frozen Ford gets a quick start

Shell Fire & Ice® 10W-40 is an *all-season* motor oil. And an all-season motor oil should be able to help cold engines start fast.

Enter "the freezer."

First we built a special mold to hold our Ford Granada.

Then we put it in a gigantic freezer at zero degrees and sprayed in gallon after gallon of water. Layer by layer, the water was frozen around the car.

Inside the Ford's crankcase, the oil temperature dropped to well below freezing.

When we removed the walls of the mold, the ice was so solid that it took us an hour with two pickaxes to hack our way into the passenger compartment.

Finally, we turned the key.



Immediately, the engine cranked. In four seconds, it started. We'd gotten our Shell Fire & Ice All Season Motor Oil down to subfreezing, and it *still* helped the engine start fast.

"The Oven"

An all-season oil also has to protect when the going gets hot. And the going that gets an oil the hottest is towing a heavy load.

So after we'd defrosted our test car (a 36-hour task), we hooked it up to the crane we'd used to lift the ice block out of its mold.

The crane weighed in at over 60,000 pounds—the Ford Granada, a mere 3,500 pounds.

We started towing. By the time we'd gone several miles, the oil temperature had hit 270°F. Well above normal.

Did Shell Fire & Ice protect? We tore the Ford's engine down the next day for a closer look. And after carefully examining its critical parts, our technical experts had the proof:

There was not one bit of abnormal engine wear. 36 hours after helping a cold engine start fast, the same Shell Fire & Ice Motor Oil had protected an extra hot engine.

Gas-saving formula.

Shell Fire & Ice All Season Motor Oil is formulated to save gasoline. Your mileage will depend upon car and conditions.

So change to Shell Fire & Ice 10W-40 Motor Oil today.



"Ten minutes in these rocks, but tough Stren® held him."



Jetty fisherman Harry Bode found out just how tough DuPont Stren® fishing line is.

"My plug was one foot from the rocks when a striper came out of the water and exploded on it," says Harry.

"I fought him in the rocks and on the rocks for ten minutes. I thought for sure he was going to wipe me out. I still landed him. There was nothing wrong with my line—25 pound-test Stren. That fish went a little over 30 pounds. It's hard to believe, but that stuff holds up."

Prove it to yourself. Fill your reels with Stren. And go get tough with a fish. Any fish.



**YOU NEED
TOUGH STREN.**



reenactment

Troubleshooting pollution-control systems

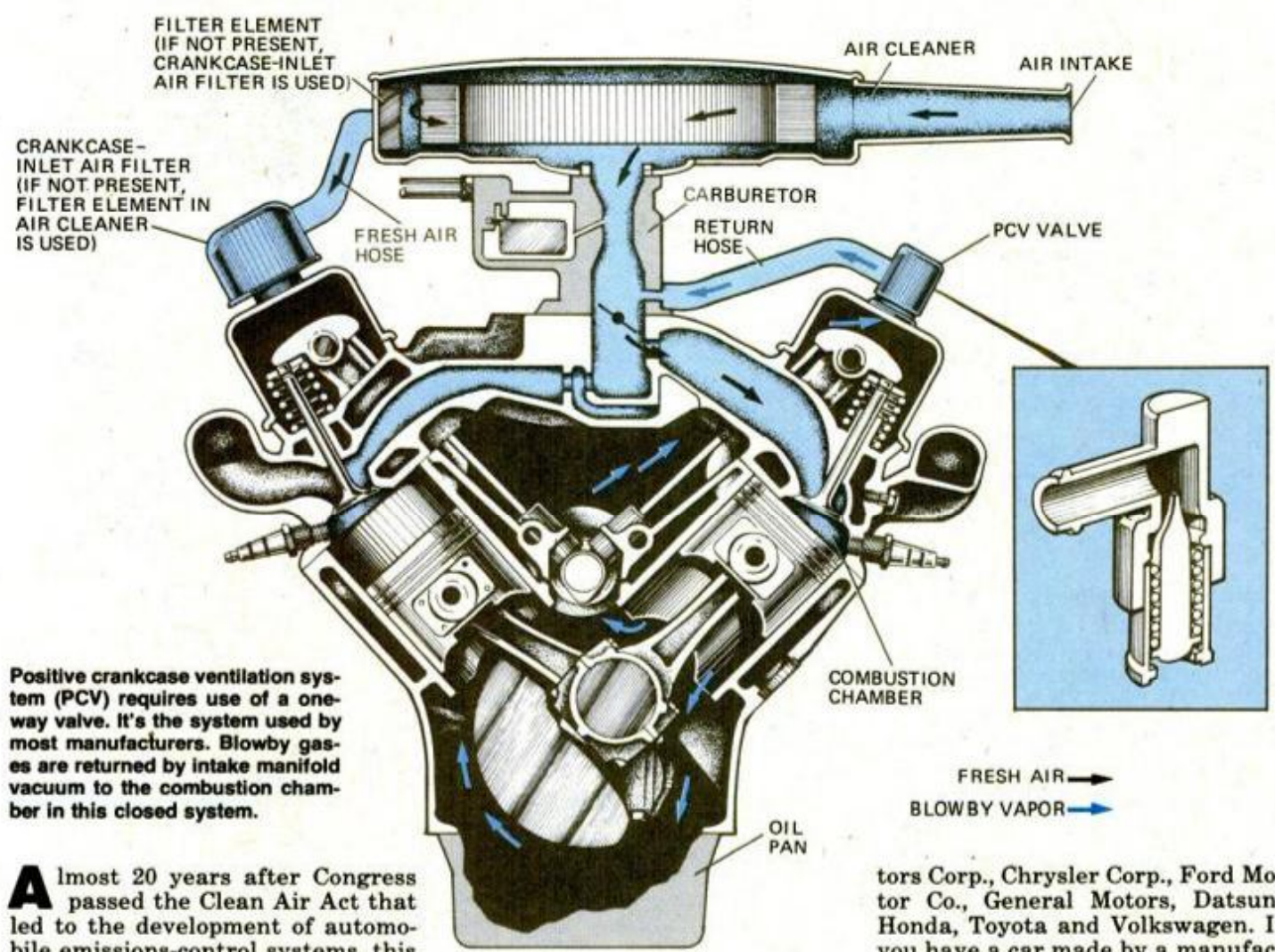

Positive crankcase ventilation system (PCV) requires use of a one-way valve. It's the system used by most manufacturers. Blowby gases are returned by intake manifold vacuum to the combustion chamber in this closed system.

FRESH AIR →
BLOWBY VAPOR →

Almost 20 years after Congress passed the Clean Air Act that led to the development of automobile emissions-control systems, this equipment still remains a mystery to many car owners. Consequently, emissions controls are blamed for a host of automobile problems they don't cause. On the other hand, they are rarely thought of as the source for many problems they *do* cause.

One reason for this confusion lies in the growing number of components. It started simply enough in 1963 with the crankcase ventilation system—a valve and a couple of hoses. However, in a 1980 Oldsmobile, for example, I counted over 50 pollution-control components. No wonder car owners are often confused about the exact functions of the various emissions systems.

Even more confusing is the fact that different manufacturers have adopted different methods of controlling the same pollutants. Differ-

ent methods have led to different hardware, calling for different service techniques.

However confusing the mass of emissions-control hardware seems, each piece fits into one of the only *three* systems. It is either part of the closed-crankcase ventilation system, the fuel-evaporation-emissions control system or exhaust-emissions control system.

This article discusses the closed-crankcase ventilation and fuel-evaporation-emissions control systems. Subsequent articles will deal with the exhaust-emissions control system.

We will concentrate on the systems employed by the eight leading manufacturers of automobiles sold in the United States: American Mo-

tors Corp., Chrysler Corp., Ford Motor Co., General Motors, Datsun, Honda, Toyota and Volkswagen. If you have a car made by a manufacturer other than one of these, your car uses a system similar to the emissions-control hardware used by one of the leading eight.

PCV system

You can call it positive crankcase ventilation (PCV), crankcase-emissions-control system, crankcase-vapor-control system, or crankcase ventilation system. It is the oldest emissions-control system and has the job of preventing blowby gases (hydrocarbons), which get past pistons into the crankcase, from entering the atmosphere.

Blowby gases can't stay in the crankcase. For one thing, they would mix with oil and produce sludge. They could also produce acid. In any case, they would limit engine life.

Before the advent of crankcase-emissions control, blowby gases were blown out the crankcase into the air through a tube. Blowby was a primary cause of unhealthy air.

There are two variations of closed-crankcase ventilation systems used by the eight leading manufacturers. Six of them (Honda and Volkswagen excluded) use a system that employs a PCV valve to regulate the flow of blowby gases to the engine.

Note: Several models made by some of these manufacturers in the past have not used PCV valves, but have employed fixed orifices (see below).

Blowby gases escaping past pistons are drawn by intake manifold vacuum back up through the rocker-arm cover, where the PCV valve is normally located. They go through the PCV valve into the intake manifold, and into the cylinders where they are burned.

The systems used by Honda and VW divert blowby gases into the intake manifold through a fixed orifice in the base of the carburetor. The fixed orifice takes the place of the PCV valve. As you'll see below, the Honda closed-crankcase ventilation system is a little more elaborate than the VW system, and requires more maintenance.

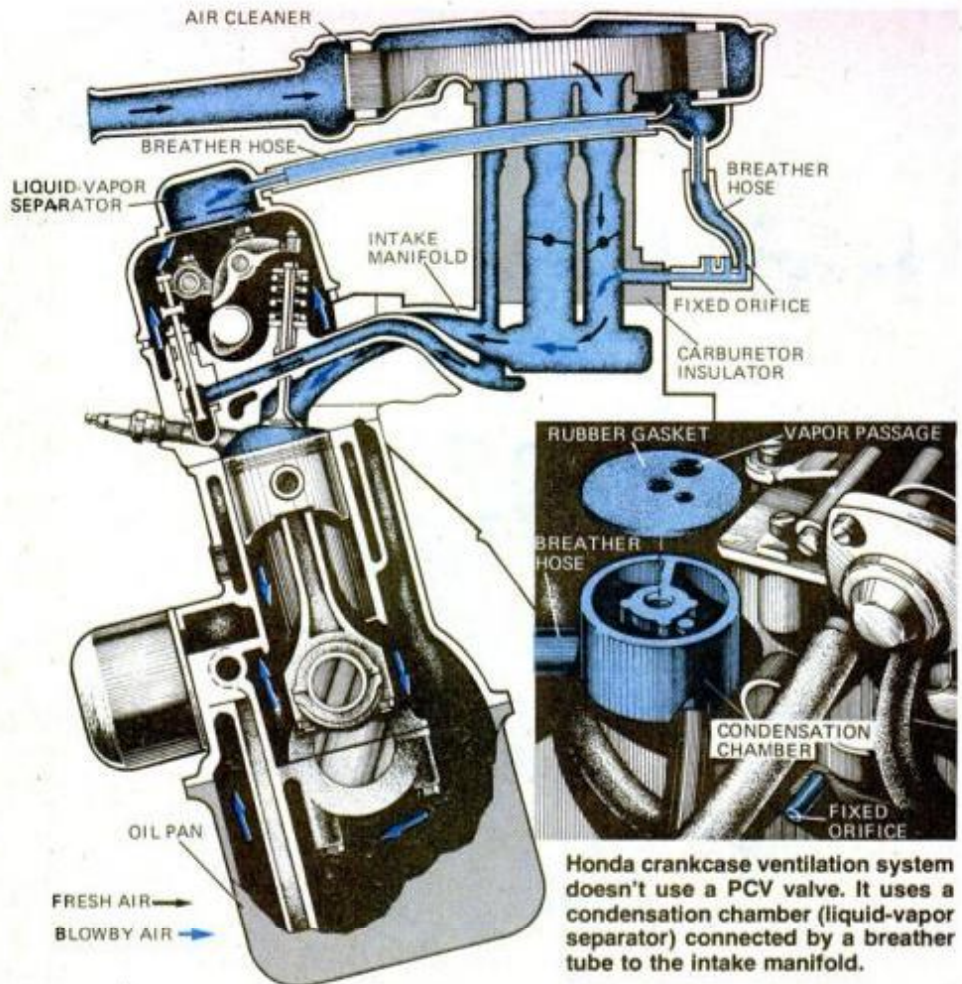

Honda crankcase ventilation system doesn't use a PCV valve. It uses a condensation chamber (liquid-vapor separator) connected by a breather tube to the intake manifold.

Blockage causes trouble

Whichever system you have on your car, it is subject to a buildup of sludge and other elements that can

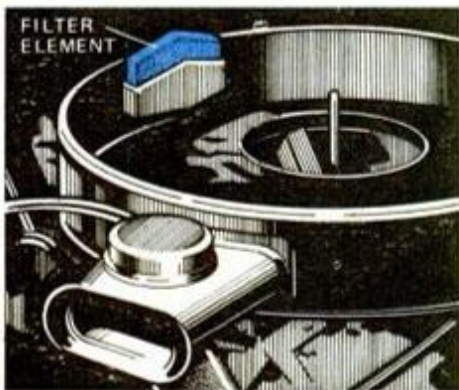

The PCV filter element located in the air-cleaner casing cannot be serviced. It must be replaced with a new filter element. To test the PCV valve (below), remove it and check for vacuum with your thumb.

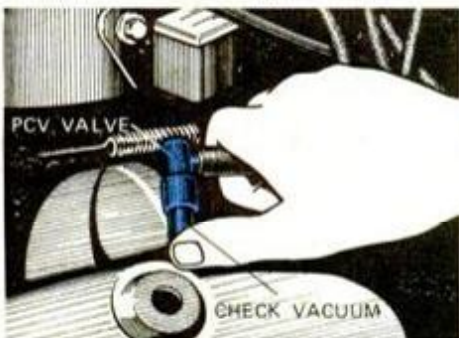

block the flow of blowby gases. After a period of time, the PCV valve, or the fixed orifice in particular, can get clogged badly enough to stop the flow of blowby gases entirely. This will affect engine performance. If allowed to continue, serious engine damage may result from the buildup of contamination and pressure.

An engine that has a clogged crankcase-ventilation system will demonstrate one or all of the following symptoms:

- Slow, unstable engine idle.
- Frequent stalling.
- Oil loss.

Pressure in the crankcase can blow oil up through rocker-arm covers and hoses into the carburetor air cleaner. A carburetor air-cleaner filter coated with oil is a sign that the PCV system needs servicing.

Servicing the PCV system

To service a closed-crankcase ventilation system that has a PCV valve, follow these steps:

1. Pull the PCV valve from the rocker-arm cover while the engine is running. If the system is working, you will hear hissing as air passes through it. Shake the valve.

2. Place your finger over the valve inlet. You should feel strong suction. If not, the system has a blockage. Chances are the valve is clogged, so

replace it and test again. If there is still no suction, proceed with servicing.

3. Remove the hoses and check them for cracking. Replace hoses, if necessary. If hoses are okay, place them in a solvent, such as trichloroethylene, and let them soak for 10 minutes. Then, ram a clean cloth through them using a wooden dowel as a rod. Let hoses dry.

4. Examine the return-hose fitting at the carburetor. To remove deposits that may have accumulated, twist the shank end of a suitably sized drill bit in the opening. Be careful not to enlarge or deform the opening.

5. The system has either a crankcase-inlet air-cleaner filter on the rocker-arm cover, a crankcase ventilating filter on the side of the carburetor air cleaner, or a ventilating filter inside the air cleaner. Wash a crankcase-inlet air-cleaner or crankcase-ventilating filter in solvent. Let them air dry. Don't dry them with compressed air. You may damage the filtering element.

Replace a small filter in the carburetor air cleaner.

Servicing the fixed orifice

To service the fixed-orifice system used by Honda, disconnect the breather hose from the carburetor

insulator and insert the shank end of an appropriately sized drill bit. Be careful not to enlarge or deform the opening.

Remove hoses and clean them in solvent, as explained above. Take the condensation chamber from the air cleaner. Remove the cover and inspect the vapor passage for a buildup of sludge. Clean out the vapor passage with solvent and a soft brush, if necessary.

Inspect the gasket. If it's damaged, replace it. Be sure the vapor-passage hole in the gasket is lined up with the vapor passage in the chamber. See that hose connections are tight.

To service the closed-crankcase ventilation system in the VW, clean hoses in a solvent. Clean deposits from them by shoving a wad of clean cloth through the hoses with a wooden dowel.

In 1976 a service notice was issued by Volkswagen which affected that model year's Rabbit crankcase ventilation system. As we mentioned, VWs don't use a PCV valve, but rather a restrictor with a 7-mm orifice. This system created hard starting and/or carb icing in cold weather by allowing moisture to collect in the intake manifold.

The service procedure outlined by VW included retrofitting a PCV valve and related plumbing to fix the problem. At the time, this was a "free fix" performed at all dealers. The fix is still in effect, but no longer free.

The installation requires two parts, a metal tube (part No. ZVP 202-851) and a PCV valve (part No. 211-129-101). It also requires the removal of the deflector in the air-intake elbow, and the removal of the restrictor in the valve cover to intake-elbow connecting hose.

If you find that your engine is

hard to start or icing occurs in cold weather, check out the crankcase-ventilation system. If the problem can't be cured by servicing the restrictor, then you'll probably have to retrofit the PCV system.

Evaporation system

The fuel-evaporation emissions-control system, which was introduced in 1970-71, prevents the escape of gasoline fumes (hydrocarbons) into the atmosphere. The system is reliable and requires little service. However, if it doesn't receive this minimal service when it's needed, you will get a constant odor of gasoline.

A canister filled with carbon is at the heart of the system. Fuel vapor from the gas tank is stored in this canister until it can be diverted to the engine, where it is burned. Servicing the system normally entails servicing the carbon canister. There are two ways to do this: Replace the filter in the canister or replace the canister.

To replace the filter, remove the canister, turn it upside down and remove the filter (in the base of the canister). This should be done every 25,000 to 30,000 miles, unless the air in your area is particularly dusty. In that case, replace the filter more often.

To test the Honda charcoal canister, use a vacuum pump on the fuel-tank fitting. If vacuum is formed, replace the canister.

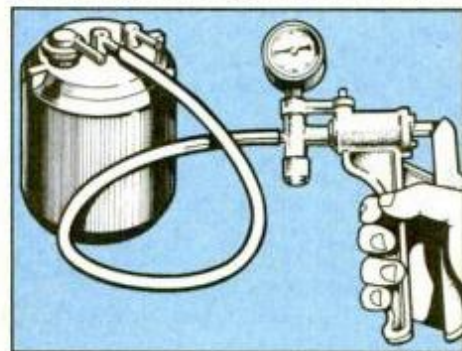

When you remove the canister, be sure to tag fuel hoses and their connecting points in some way, so hoses can be reconnected correctly. Incidentally, it is also a good idea to inspect hoses, which don't last forever. If a hose is cracked or dried out, replace it.

Important: Hoses used in this system are specially manufactured to withstand high concentrations of fuel vapors. When replacing a hose, be sure the replacement has the same markings as the old hose. Generally, hoses used in the fuel-evaporation emissions control systems are marked EVAP.

More sophisticated systems

Beginning in 1979, some fuel-evaporation emissions-control systems became more sophisticated to further curtail the escape of fuel vapors into the atmosphere. Chrysler, for example, has added a fuel-vapor-return system to the fuel filter of all four- and eight-cylinder engines for sale nationwide, and to the fuel filter of all cars sold in California.

This system makes use of an additional line that runs from the top of the in-line fuel filter back to the fuel tank. There are, therefore, three lines emanating from the fuel filter, instead of two, as in most Chrysler products. You have the line coming from the fuel pump and the line going to the carburetor. That third line you may see on your filter is the vent line back to the fuel tank.

The purpose of this vent line is to return fuel vapors that form during idle and slow-speed operation to the fuel tank, rather than passing them to the carburetor where some may escape into the atmosphere.

The addition of this vent line doesn't necessarily mean that you must replace the fuel filter more often—unless, of course, you get a

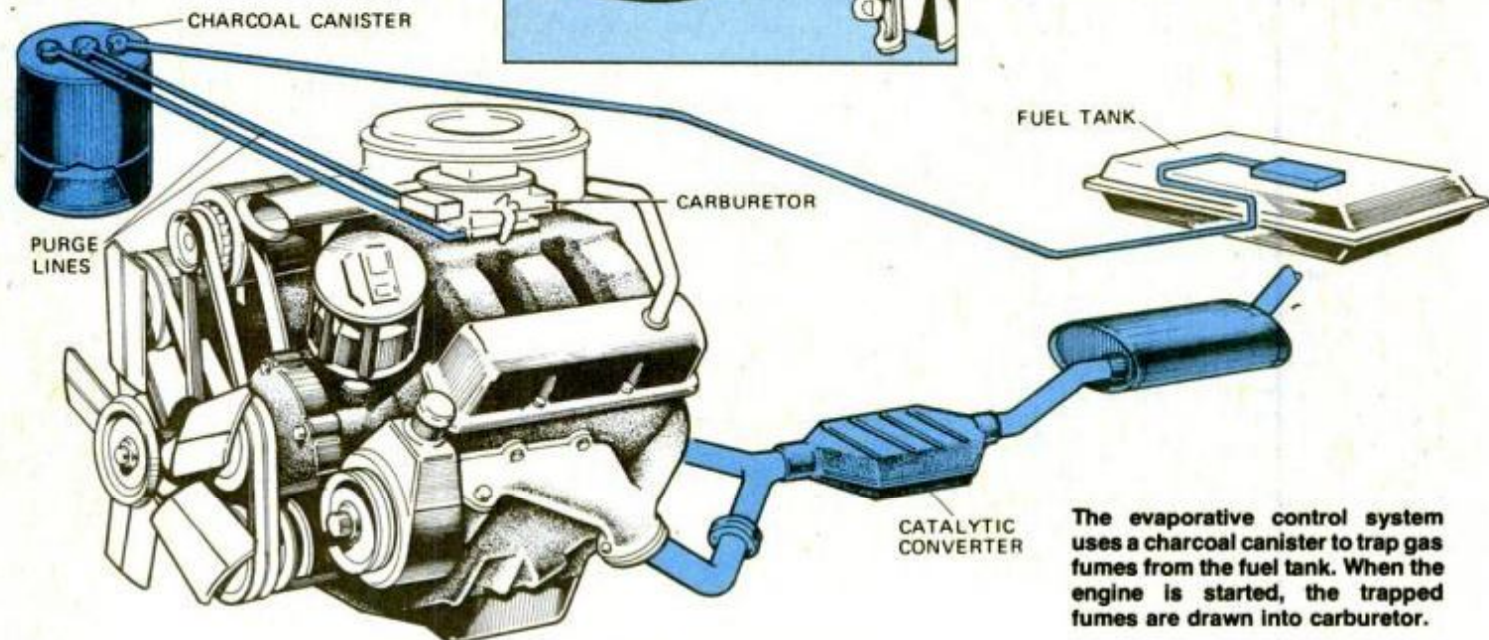

load of dirty fuel that clogs the element. Normally, replacing the filter every 30,000 miles will suffice.

Ford Motor Co. models with 2150-2V, 2700VV and 7200VV carburetors have fuel-bowl vent valves as part of their fuel-vapor emissions-control system. The valve, located in the carburetor fuel-bowl-vent line, closes off the vent line when the engine is running to prevent vapors from escaping.

An open valve is trouble

I mention this component for one reason. If you can't find the cause of a lean-fuel-mixture problem with one of these late-model carburetors, inspect this valve to make sure it is closing the vent line when the engine is running. If the valve remains in the open position, vacuum will affect air pressure in the carburetor, resulting in a lean fuel mixture.

Models 2700VV and 7200VV carburetors have an additional vent valve inside the fuel bowl. If this valve fails in the open position, it will result in a rich mixture that can affect engine performance.

Despite innovations such as these, probably the only servicing you will ever have to give the fuel-evaporation emissions-control system is to replace the canister filter, or the canister itself.

AMC, Chrysler, Datsun, Ford and GM use carbon canisters with replaceable filters. The only time it's necessary to replace the canister is if the canister cracks.

Honda, Toyota and Volkswagen use canisters which have to be replaced either periodically, or when tests show that they are clogged.

Volkswagen Beetle

Replace the canister every 30,000 miles. The canister is located under one of the rear fenders (usually, the right rear fender). Make sure hoses are connected correctly.

Volkswagen Rabbit

The following information *does not* apply to Rabbits with diesel engines.

Replace the charcoal canister, which is in the engine compartment, every 30,000 miles. The system uses a fuel-tank-breather gravity valve, which must be operational to assure performance of the overall system.

The purpose of the fuel-tank-breather gravity valve is to duct fumes that escape from the fuel tank to the charcoal canister. If the car rolls during an accident, the breather gravity valve closes to keep gasoline from leaking.

The valve is located on the car body, to the right and above the fuel

tank. To test its operation, proceed as follows:

1. Remove the valve from the car.
2. Attach a hose to connection A and place the other end of the hose in a pan of water.
3. On 1977 and earlier models, plug connection B.
4. Holding the valve vertically, blow into connection C. If air bubbles don't appear in the water, replace the valve.
5. Keep blowing into connection C as you gradually tilt the valve. Bubbles should stop when the valve reaches a 45° angle. If not, replace the valve.

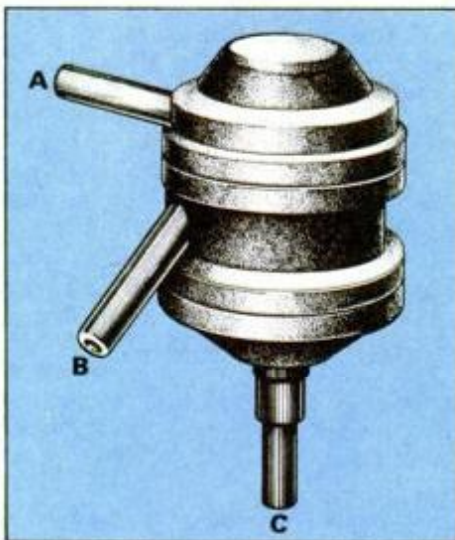

To test VW breather-gravity valve, attach hose to A and immerse in water. Plug B with finger and blow into C. If bubbles appear, the valve is faulty. To test a Toyota canister (right), plug B and blow through A. Air should flow freely through C.

Starting with the 1978 model Rabbits, a cutoff valve was installed between the activated charcoal-filter canister and the engine's air cleaner. The cutoff valve is supposed to remain closed while the engine isn't running, or running at idle. This prevents fuel vapors from entering the engine under those conditions and allows them to pass during wider throttle openings. In addition to trapping vapors, this valve also makes it unnecessary to disconnect the evaporative-emission-control hose from the air cleaner during adjustment of the idle mixture.

To check operation of the cutoff valve perform the following procedure:

1. Disconnect the cutoff valve at the air cleaner.
2. Blow air into the disconnected hose.
3. If the valve leaks or does not close completely when you blow into it, the valve is faulty and should be replaced.

Toyota

To determine if the charcoal canister has to be replaced, detach hoses from the canister. Be sure to identify them with their connections.

Hold your finger over connection B (see illustration) as you blow air through connection A. If the flow of air is restricted, or charcoal particles are expelled from connection C, replace the canister.

Honda

To test the charcoal canister in a Honda, you should proceed as follows:

1. With the engine at normal operating temperature, connect a tachometer and remove the fuel-tank filler cap.

2. Remove the canister air hose from the connection on the car frame. The air hose is the hose protruding from the base of the canister. Connect a vacuum gauge to the end of the hose.

3. Run the engine at 3500 rpm. Vac-

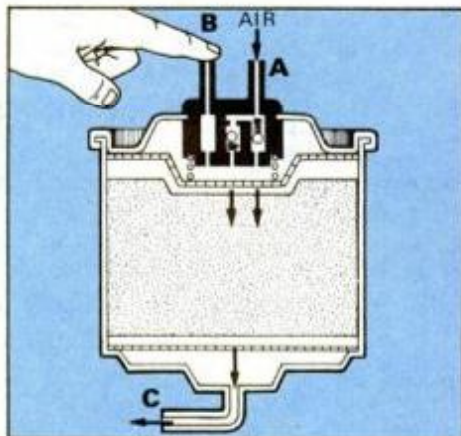

uum should be recorded on the gauge within one minute. If it isn't, replace the canister. If vacuum appears, go to the next step.

4. Remove the canister from the car and attach a hand vacuum pump to the fuel-tank hose fitting. Pump the vacuum pump. There should be no vacuum. If there is, replace the canister.

If your car wasn't included in this section, it probably has a pollution-control system similar to one of those we did cover. To find out which system your car has, check your owner's manual first. If it isn't cited there, get under the hood and start tracing down the components. Start with the carburetor and trace all vacuum hoses to their components. Find the PCV valve and begin tracing the vacuum hoses from there. Do the same for the charcoal canister. You might make a rough sketch of the pollution devices and use the above information to figure out how they work.

FM

19 mg. "tar", 1.3 mg. nicotine av. per cigarette, FTC Report MAY '78.

© 1978 R.J. REYNOLDS TOBACCO CO.

Satisfaction, Camel Filters style.

Some men taste it all: Rich warm flavor. Smooth even taste. Solid satisfaction.

Only from the Camel Filters blend of Turkish and domestic tobaccos.

Warning: The Surgeon General Has Determined That Cigarette Smoking Is Dangerous to Your Health.

Famous Camel Quality



TOUGH FORD COURIER

The Gas Mileage Champ of the best-selling compacts.

Ford Courier is the gas mileage champ of the best-selling compacts. Up to 29% better than the competition. Courier's EPA rating is better than Datsun, better than Toyota, better than Chevrolet LUV. And Courier beats the competition for the fourth straight year! Courier's built tough, too. With rugged ladder-type frame, 6-leaf progressive rear springs, standard front stabilizer bar, and power brakes... 2L and optional 2.3L engines. And see your Ford Dealer for full details on Ford's new corrosion perforation warranty. It's a no-cost 36-month limited warranty that excludes exhaust system components. Ask about Ford's Extended Service Plan, too.



Courier Sport Group. Package includes plaid buckets, woodtone instrument panel, sport steering wheel, gauges and carpet.



Free Wheeling Courier. Custom-ordered look. Black-painted GT bar and push bar. Add "B" Package for tape stripes, cast aluminum wheels and RWL tires.



For big loads. 1400-lbs. payload rating, 7-ft. box option.



OFFICIAL 1980 EPA RATINGS SHOW

	BEST MPG RATING		LONGEST RANGE	
	EPA EST.	HWY. EST.	EST. MILES	HWY. MILES
FORD COURIER	27	37	473	647
BETTER THAN TOYOTA	21	28	338	451
BETTER THAN DATSUN	25	32	423	541
BETTER THAN LUV	25	35	325	455

Use estimates for comparison. Your mileage and range may differ depending on speed, distance and weather. Actual hwy. mileage and range will probably be less than estimated. Fuel tank capacities (gal.) for LWB models. Courier 17.5, Toyota 16.1, Datsun 16.9, LUV 13.0. Calif. estimates lower.

FORD

FORD DIVISION



DETROIT LISTENING POST

Two new nameplates

It's official: Ford's so-called world car, named the Erika in Europe, will bow here this fall as the Ford Escort and Mercury Lynx. There will be a three-door hatchback and five-door wagon, to be followed by a notchback sporty coupe in mid-'81 and a four-door sedan for '82.

At its Dearborn, Mich., facility Ford recently talked about the computer design, analysis and development that are going into its new front-wheel-drive world car. Then engineers showed off the engine plant that's been completely revamped and enlarged to build Escort/Lynx engines at a maximum rate of 225 an hour.

Ford is claiming its 1.3- and 1.6-liter engines for the cars will give better fuel economy and better performance than VW's 1.5-liter gasoline



Computer-graphics model of Ford's Escort/Lynx is used to test its body rigidity.

engine in the Rabbit. That'll be something, since the Rabbit engine is recognized throughout the industry for its excellent performance and fuel-economy characteristics.

Small-car diesels coming

Chevrolet's Chevette will get two important additions to its option list this fall—a four-cylinder diesel engine (supplied by GM's Japanese partner, Isuzu) and a five-speed manual transmission for both gasoline and diesel versions.

This same diesel engine (or a version of it designed for transverse front-drive installation) will be offered in the Chevy and Pontiac J-car subcompact, scheduled to replace Monza and Sunbird early next year.

Not to be outdone, Ford will prob-

ably buy four-cylinder diesels from its own Japanese partner, Toyo Kogyo (which also makes Mazda cars and trucks), for installation in the Escort/Lynx front-drivers by mid-'82.

Chrysler plans to deal for diesels with Peugeot of France, while American Motors will get its oil-burners from compatriot (and Peugeot's rival) Renault. All this overseas buying does not mean, however, that the Detroit makers aren't cooking up their own small diesels—it's just a good way to get into the market quickly, while the domestic diesel projects are getting underway.

Ford tests PROCO

Ford has completed a trial production run of its 5.0-liter, V8 PROCO engine. The PROCO (for programmed combustion, a type of stratified charge) tested well, proving that mass-production of the fuel-efficient, gasoline-engine design is possible.

The chief concern about PROCO is the extremely fine production tolerances it requires, which could make it too difficult and expensive to build in volume.

PROCO is seen by Ford as an alternative to the diesel in future large and luxury cars, delivering comparable fuel economy without the traditional diesel drawbacks. The question of whether to go with PROCO engines or diesels in the company's mid-'80s smaller cars, however, is still to be decided by Ford executives.

GM serious about electrics

Encouraged by recent advancements in battery technology, GM has moved its electric-vehicle development to front stage by creating a "project center" to coordinate it. "In making this move," says GM president E.M. Estes, "we are attaching the same importance to the design and engineering of a small, battery-powered passenger car that we are giving to GM's other passenger cars of the future."

While work on electric vans continues separately at the GMC Truck and Coach Div. in Pontiac, the Warren, Mich., GM Tech Center-based project group should have its first small electric commuter car designed so it can be in production by 1985.

AMC "Eaglet" due this fall

Although it may be called something else, son of Eagle (internally called "Eaglet") is nearly ready for introduction this fall.

Sharp-eyed observers have spotted prototypes zipping around on road tests that look just as expected: high-ground-clearance Spirit sedans and coupes with Eagle-like fender flares and rocker skirts.

Nobody's talking details, but AMC chairman Gerry Meyers told me recently that the small four-wheel-drive car is aimed at "an entirely different market" from that of the family-oriented Eagle. In other words, it'll be a more youthful, sporty and fun vehicle, not to mention less expensive and more fuel thrifty. It will have a 2.5 liter, four-cylinder engine, manual transmission and part-time 4wd in base form. Meanwhile, Eagle itself will be offered in slightly more economical versions for '81, with at least two, and maybe all, of the above options.

Short notes

■ Complaining about new-car prices? The Automotive Information Council reports that the average new car today costs only 36 percent of the median family income vs. 38 percent in 1970, more than 50 percent in 1960 and 70 percent in 1950. You never had it so good.

■ Having lost their Japanese-built, L-body, sports-car project to the cost-cutter's knife, GM's Buick and Oldsmobile Divs. are now scheduled to get their own coupe and sedan versions of the front-drive J-cars about a year after they debut in Chevy and Pontiac showrooms.

■ Dodge Division's '81 front-drive K-car will be called "Aries" when it replaces the Aspen compact line this fall. No word on names for the Plymouth or later Chrysler versions. **PM**

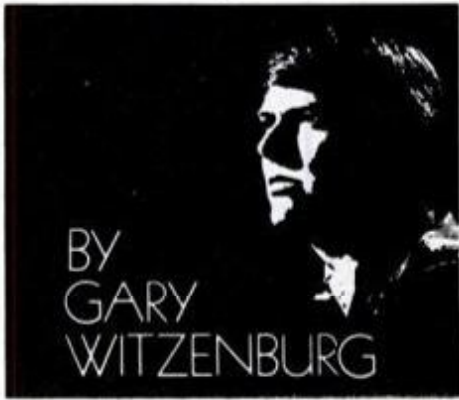

CAR CLINIC

SOLUTIONS
FOR MECHANICAL
HEADACHES

BY
MORT SCHULTZ



Paper rout

My 1979 Pontiac LeMans Grand Safari station wagon has contact-paper sides—the wood-grain look. What I'd like to know is how to care for it. I've seen the sides of some older wagons turn white. Some people I've spoken to tell me to wax the sides. Others say don't wax, just wash. I need the truth.—T.A. Martin Jr., Broussard, La.

One truth is that the "contact paper" sides of your wagon aren't contact paper. They're vinyl. Since they are vinyl, treat them as you would a vinyl top. Apply wax to them whenever you wax the rest of the car. In between the waxing jobs, wash the vinyl sides as you would the metal exterior parts of the car. And that, according to Pontiac, is the whole truth.

Marriage counseling

Please help. This is a serious problem, because my husband wants to dump our car. But I love our 1978 Ford Fiesta and I'm bucking him. If the car stands idle for a week or longer, its clutch freezes. Whenever this happens, the car has to be towed to the dealer for servicing. We were told by Ford, "You can't allow the Fiesta to stand for longer than a week since the clutch will freeze. This is characteristic of this vehicle, and nothing can be done." Is Ford right?—Mrs. Veronica Casciotta, Crystal River, Fla.

Yes and no. Yes, because if you let your Fiesta stand for a week or longer, then, as you've discovered, the clutch will freeze. No, because there is something you can do about it.

The problem occurs more frequently in hot, humid climates. For a reason that's too complicated to go into here, heat and humidity have an adverse reaction on clutch-disc material, which causes the disc to stick to the pressure plate. If the car is driven often, a buildup of "bonding material" won't take place.

On Oct. 2, 1979, Ford put a new clutch into use. It has been installed

in new Fiestas coming off the production line and has been distributed to dealers. A part number is not available as I write this, but the new clutch has yellow markings on its outer circumference.

Take the car back to your dealer and have the new clutch installed. It should be a freebie, because this problem was in your car since you bought it. The money you would have spent for the clutch can be used to buy your husband a present, so you can kiss and make up.

Low down

I've had a problem with my 1978 LeBaron since it was new. I've not been able to fill the gas tank more than ¾ full. I've had the car to two Chrysler dealers. One of them even replaced the gas tank and rollover valve, but no help. Any ideas?—S.E. Tennant, Addison, Pa.

How do you know the gas tank isn't being filled? If you're going by the fuel gauge, then I've got the solution to your problem.

Low fuel-gauge readings have been a problem with 1977-78 LeBaron, Diplomat, Aspen and Volare models built between March 21, 1977, and April 18, 1978—except Aspen and Volare six-cylinder two-door coupe and four-door sedan mod-

els with 18-gallon fuel tanks. The problem is inadequate air venting and is corrected by adding a notch to the lower end of the fuel-tank-filler tube which extends into your tank. The procedure is described in service bulletin 14-15-78 (7/24/78). Since the filler tube must be removed from the tank for the notch to be cut, leave the job to your dealer; it's a free fix.

Shivering Chevette

My 1978 Chevrolet Chevette has a small, but annoying problem. After hitting a puddle of water, there is a loud vibrating noise and shudder under the hood. If I depress the clutch and accelerate the engine, the vibration increases, so this rules out a drive train problem. The vibration gradually diminishes, and everything is fine until I go through another puddle. I've squirted a garden hose up under the car with the engine idling, but can't recreate the vibration. What do you think?—Donovan E. Radford Jr., Pittsburgh.

I think water is being splashed on the drive belt, causing it to slip. The alternate slipping and locking of the belt is producing the vibration.

Chevy admits that this has been a problem with the Chevette, but there doesn't seem to be a solution. A baffle plate has been tried, but the plate reduces air flow and may cause overheating. See that the belt is properly tensioned and is in good condition. This will minimize vibration.

Bad diet

On a recent trip to Canada in my diesel VW Rabbit, I was advised by two service-station operators, who also drive diesel trucks, that the best additive to diesel fuel is automatic transmission fluid (ATF). I was told to add a quart of ATF to 20 gallons of

(Please turn to page 52)



Tete-a-tete

Says Arnold D. Kastrup of Richfield, Ohio: "Ever run out of gasoline and go to a station where they give you a can of gas, but they don't have a funnel?"

Yes, Arnold. So what can I do?

"Save one of those long-neck plastic bottles that you otherwise discard. Cut a window into its side and put it in the car. Now, the next time your engine runs dry, instead of being left up the creek without a funnel, stick the neck of the bottle into the tank filler, hold the bottle with one hand and pour with the other."

Thanks, Arnold. Good idea for an emergency.

Try running with your hand over your nose and your mouth.

In seconds, you'll discover how the right air filter on your car can save you gas and money.

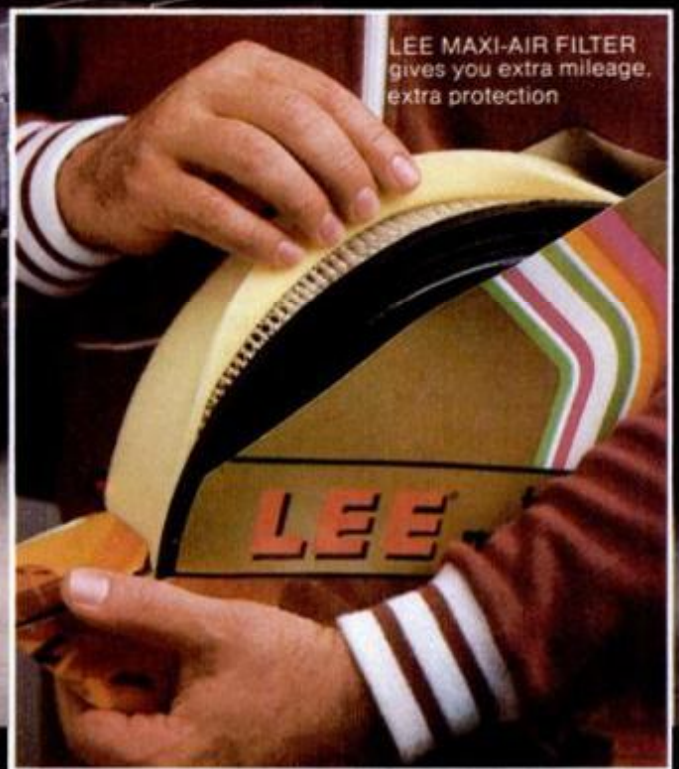

LEE MAXI-AIR FILTER gives you extra mileage, extra protection

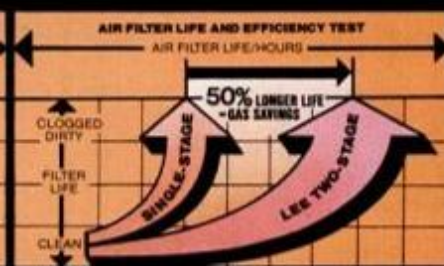

You can't run easily if you can't breathe easily. Neither can your car. And when your car can't breathe easily, it burns extra gas. Expensive gas.

To run well, your car's engine needs the right mix of gas

and air. If a dirty air filter chokes the air supply, your engine burns more gas. That costs you. In performance. And in dollars.

That's why it pays to have an air filter that stays cleaner longer. The LEE 2-stage Maxi-Air Filter.

We pack our LEE Maxi-Air Filter with the extra pro-

tection you need against dirt. By using two filters, one backing up the other, our LEE Maxi traps up to 50% more dirt than single-stage filters. And it stays cleaner up to 50% longer. That's Maxi protection.

It means that your car will have the air it needs to run better, longer on less gas.

You don't have to replace your filter as often, either. So you save money on filters and gas. That's double savings. Maxi savings... to let you breathe a little easier, too.

Pack maximum protection against dirt in your oil, too. Use LEE 2-stage Maxi-Oil Filters. They trap twice the dirt, last far longer than single-stage filters to save you money. And to save you worry about engine wear.



LEE MAXIFILTERS

NOW FOR IMPORTED CARS TOO.

CAR CLINIC

(Continued from page 50)

fuel once every two or three months, or 3000 to 5000 miles, to clean the injectors. What problems, if any, will I encounter?—R.E. Hommel, Annapolis, Md.

According to Robert Bosch Inc., which makes the injection system for the VW Rabbit, any dirt inadvertently introduced into the system with ATF could plug up the minute passages of the injection pump. Furthermore, I was told, this might bring about a chemical reaction that could cause deterioration of the pump seals.

An engineer for Robert Bosch told me, "If the fuel system is clean and free of water, there is no need for any additive." However, diesel No. 1 fuel which has been stored at service stations for a period of time can build up water and contamination. In fact, fungus will grow in diesel fuel if it sits long enough.

It seems, then, that the only fluid to put into a diesel engine is diesel No. 1 fuel, but even here you can encounter trouble if you aren't careful. It's a good idea to patronize service stations that pump a lot of diesel fuel. This means those stations that

you know are busy, such as highway truck stops. Then you know that fuel hasn't been sitting in the station tanks too long.

Break the smoking habit

The letter from Charles LaDow of San Diego in the Feb. '80 Car Clinic

caught my eye. He was having a problem with his 1979 Oldsmobile diesel engine smoking during uphill acceleration. I had the same problem with my 1978 Olds Custom Cruiser diesel at 36,000 miles. I found a cure. Maybe it will help Charles and others: Remove the air-breather filters

Resisting change

In case you've forgotten, cars with breaker-point ignition systems normally have a ballast resistor or a resistor wire incorporated into the ignition system to keep the points from getting maximum voltage.

Too many volts delivered to points will cause premature point failure. The resistor prevents this. But a resistor, if it changes value, can work in reverse. In other words, excessive resistance reduces the amount of voltage available to sparkplugs, leading to engine misfire, especially on acceleration.

A set of new plugs may eliminate the problem temporarily, but the condition will return when electrodes wear slightly and gap widens. So keep this tip in mind: If, for the life of you, you can't figure out why your engine is misfiring on acceleration, check the resistance value of the ballast resistor or resistor wire with an ohmmeter. Compare to the specified value allowed by the manufacturer. If it isn't the same, replace the resistor.

PM CAR CARE
TIP

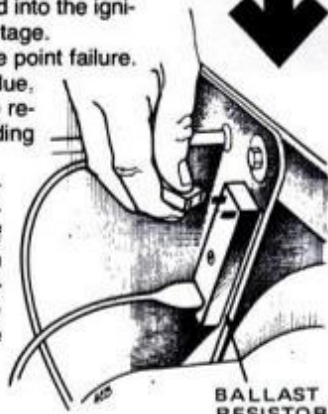

BALLAST RESISTOR



Robert Division, Parker Hannifin Corporation
Shelton, Connecticut 06484

Seeing is believing. I want more information
on this mirror and where I can buy it.

MODEL 809 MODEL 829 MODEL 850

NAME _____

ADDRESS _____

CITY _____ STATE _____ ZIP _____



ROBERK

electric remote mirrors

Enjoy the advantages of
electric controlled scanning



At last . . . simple, practical, economical
electric remote control mirrors. Eliminate
blind spots at a flick of a switch. Electric
scanning makes safer rear vision a reality.



809
truck & van

Power Scanning Eliminates Blind Spots

Epoxies made easy.

Finally. Epoxies that are neat, epoxies that are convenient. They're Duro™ E-POX-E® products packaged in the new Quick-Mix Syringe.™

The Quick-Mix Syringe measures an equal amount of resin and hardener every time. No more guesswork or waste. Just results.

DURO E-POX-E® 5 sets fast (only 4 to 6 minutes). Yet gives you one of the strongest bonds you can buy for wood, plastic, metal, ceramics and glass.

DURO E-POX-E® GLUE gives you a tough bond. Remains workable for 2 to 3 hours. Gives you time for large repairs.

DURO E-POX-E® STEEL FILLER chemically welds metals. Ideal for plumbing leaks, home appliances, fixtures. Can be drilled, tapped, threaded and filed.

Save trouble. Save time. Save mess. Duro E-POX-E Quick-Mix Syringe products are part of the fine Duro family of household and automotive repair products. Just ask your Duro representative or call SAM at

1-800-321-9188 for more information.

SAVE IT WITH DURO.



DURO
QUICK MIX SYRINGE

Woodhill Permatex
a Loctite Corporation subsidiary
Cleveland Ohio 44128

© 1980

(one on each valve cover) and wash them in a strong dishwasher soap and hot water. I do this at each oil change, and my car has stopped smoking. Warning: Do not use gasoline or any combustible solvent to clean air filters. Fumes are sucked directly into the air-intake manifold and could cause a problem.—Bill Kelso, Humboldt, Kan.

Simply superb advice, Bill. Thanks a million.

Meeting her Waterloo

I made a mistake. I purchased my 1980 Pontiac Phoenix without power steering and I'm finding it difficult to park the car. My dealer is willing to install power steering for me if I can supply the kit. Can you tell me where it can be purchased?—Mrs. Anthony L. Mazzoli, Waterloo, N.Y.

Right from Pontiac, but I'm sorry to say your "mistake," as you call it, is going to cost you a bundle to rectify.

If your car is equipped with a heavy-duty suspension system, tell your dealer to order power-steering kit 7832592. If your car doesn't have heavy-duty suspension, tell your dealer to order power-steering kit 7833701.

The kit costs \$299. To this, you

have the dealer's charge for installation. It is not farfetched to assume that the total price will come to \$500.

Service and safety tips

■ Chrysler Corp. has approved changes in the ignition timing from 12° BTDC to 8° BTDC to stop ping in federal (non-California) cars with 225-cu.-in. engines and two-barrel carburetors.

After making this adjustment, you should make sure that the carburetor speeds are set to the specifications on the vehicle emission label.

■ If you own one of the first 1980 VW Vanagons (built between July and Dec., 1979), you may have a problem. Improper torquing of the 10×16-mm ball-joint bolts may result in the bolts loosening. This could cause a ball joint to separate from the wishbone, leading to a loss of control.

The wise thing for you to do is to have the dealer check the bolt torque to make sure it is to specification.

■ If you're finding space too tight to get a new

GOT A PROBLEM WITH YOUR CAR?

Just ask Mort about it. Send your question to the Car Clinic, Popular Mechanics, 224 West 57th St., New York, N.Y. 10019. While letters cannot be answered individually, problems that are of general interest will be published in the column.

oil filter into place on your 1977-80 Ford Courier with 2.3-liter engine, Ford suggests you use Motorcraft oil filter FL-300. It's stubby enough for you to fit it in place without the likelihood of banging your knuckles on the fender-apron flange.

■ More than 70 percent of the auto tires that are sold in the United States are of the whitewall variety and we're willing to bet that many car owners don't know how to clean them.

Goodyear says that the best way to clean whitewalls is to wet them and scrub with heavy-duty liquid detergent and a stiff brush. Then, rinse. An oil-based product may make whitewall tires look just like new, but it will also cause the rubber to deteriorate, so don't use it.

■ When changing the oil filter of a 1980 Chevrolet Citation with 2.8-liter V6 engine for the first time, don't take your cue from the PF-40 oil filter you find. The PF-40 is installed in production because of a clearance problem in the plant during assembly of the car. Once the car is in your hands and ready for a new filter, use a PF-51. This model offers increased capacity.

■ Hey, motorcyclists: A new eight-page tire information service bulletin showing step-by-step instructions for the demounting and mounting of cycle tires with tubes has been issued by the Rubber Manufacturers Assn. It's free and can be ordered from RMA, 1901 Pennsylvania Ave. NW, Washington, D.C. 20006. **PM**

NEW NOW for home and shop



A These regrindable taps have a series of gashes that replace the nose taper that's found on conventional taps. When the tap becomes worn, you can use the gashes as templates to produce new gashes behind the worn ones, and then cut off and discard the worn section. The new tap can thread 25 to 50 percent more holes between grinds than a conventional, cold-forming tap threads in its entire life, according to the manufacturer. Taps are available in machine screw sizes 0 (\$13) to 3/4-in. (\$31), in both NF (fine) and NC (coarse) threads, from Detroit Tap & Tool Co., 8615 East Eight Mile Rd., Warren, Mich. 48090.

B The Solid State Electronic Dishwasher has computerized controls that allow it to keep tabs on energy consumption. You select the wash, rinse and dry options depending on the amount of soil on the dishes and the time available. An LED readout displays the amount of energy consumed. The Model GSD2500, which costs about \$700, also diagnoses potential problems via its fault code on the panel. A manual tells what should be done to correct a problem. A digital display shows the number of minutes remaining until the end of the cycle in progress. The machine is due on the market around October 1980. It's from General Electric, 2100 Gardiner Lane, Louisville, Ky. 40205.

C Four new Carrier heat pumps are in the through-the-wall Sierra line. The Energy Efficiency Ratio for the units ranges up to 9.6. Cooling capacities range from 9500 to 17,700 B.T.U. Heating capacities in the heat-pump mode range from 8100 to 15,000 B.T.U., while in the electric-heat mode they run from 5000 to 16,000 B.T.U. Pumps have solid-state, variable-speed fans and ultrasonically bonded, all-aluminum coils. Units (from \$800) are by Carrier Air Conditioning, Box 4808, Carrier Parkway, Syracuse, N.Y. 13221.

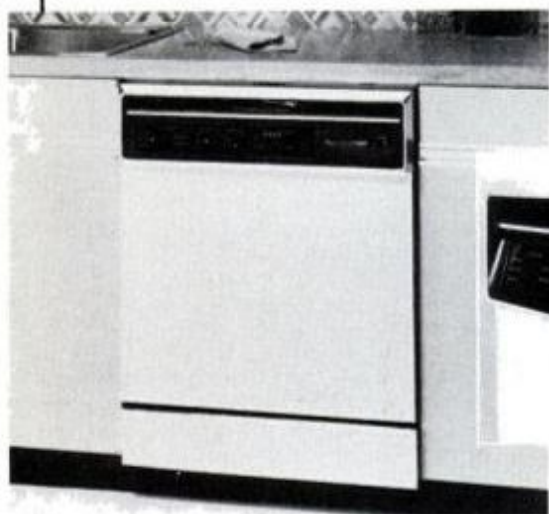

D A new vinyl wall-covering kit introduced by Red Devil contains a paste and sizing brush, a wide smoothing brush, a razor knife and a seam roller. Detailed instructions for application of the wall covering are printed on the back of each package. The vinyl wall-covering kit is available at houseware and hardware stores and is priced at \$7. There's a separate kit that's been designed for working with other types of wall coverings. Both kits are made by Red Devil Inc., 2400 Vauxhall Rd., Union, N.J. 07083.

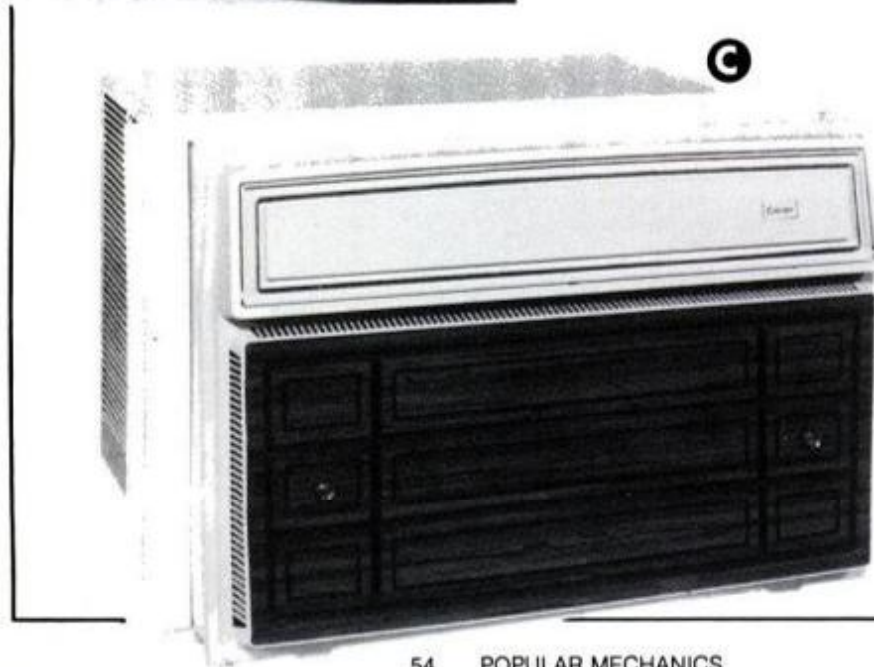

Go ahead, make something out of it!

Black & Decker is on sale at K mart.

Handy power tools at prices that are easy to handle. Now is the perfect time to add one or more of these popular tools to the worktable.

Circular Saw with 7 $\frac{1}{4}$ " blade. Spring guard for safer operation. Adjustable guide for angle cuts. $\frac{5}{8}$ -hp Router for precision cutting and decorative edging. (Bits not included.) $\frac{1}{2}$ -hp Jigsaw.

Variable speed allows slower cutting of metals, rapid cutting of woods. $\frac{3}{8}$ " Drill with reverse. Variable speed control makes starting holes easier and more accurate.

These work- and timesaving tools are on sale through June 28 at over 1,600 K mart stores across the U.S.A.

\$26.88

CIRCULAR SAW
MODEL 7308

\$23.88 ROUTER
MODEL 7600

\$23.88
DRILL
MODEL 7190

\$19.88
JIGSAW
MODEL
7580

Black & Decker quality at a K mart price. Nice.

Kmart®

The Saving Place

Copyright 1980

K mart Corporation

Troy, Michigan 48084

Dupli-Color-Quality spray paint For your car-For your home



Dupli-Color Auto-Spray® for your car is recognized as the finest automobile touch-up paint in the world. Dupli-Color Spray Enamels, Lacquers and Primers for the *home* give you that same assurance of quality and satisfaction.

For a multitude of things in and around your home, you can't beat Dupli-Color Enamels, Lacquers and

Primers. They are specially formulated to give a smooth, even finish on wood, fiberglass or metal. They are durable, long-lasting and available in a range of attractive decorator colors.

You know how good Auto-Spray is for your car. Imagine what Dupli-Color Spray Enamels, Lacquers and Primers can beautify in and around your home!

DUPLI-COLOR®

See it all in a
WINK
WIDE ANGLE MIRROR

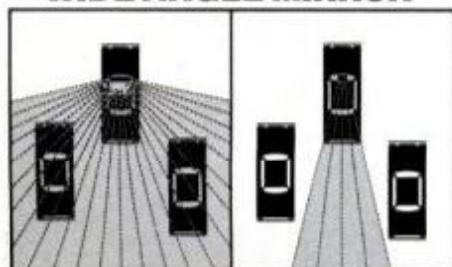

See this.

Not this.

- 160° "eyes front" rear vision
- Distortion & Glare free
- Eliminates blind spots

See your auto accessory dealer today!

WINK Corporation
20630-56th Ave. W. Room B 306
Lynnwood, WA 98036

PHOTO HINTS

How dry I am



Clean, dry hands are necessary to make sure enlarging paper doesn't become contaminated in the darkroom. A hair dryer fastened to a gooseneck or other stand allows you to hold your hands in the airstream for drying.—Ken Patterson

Thermometer holder



A clothespin will keep a thermometer from falling into a tall bottle when you take temperature readings.—Terry Huss

Scratch hider



Tiny scratches on a negative are big lines on an enlargement. A tiny amount of petroleum jelly applied to the negative with your finger will fill the scratch and keep it from showing on the enlargement.—Bob Berger

HINTS FROM READERS

Substitute clamps

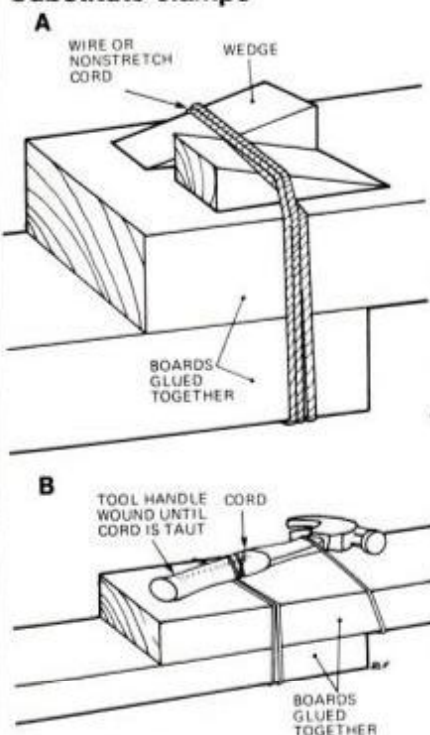

If you don't have a C-clamp or vise, here are two ways to clamp work that's just been glued. Method A needs cord and two wedges. B uses cord and a hand tool.—*Theodore L. Gaillard Jr.*

Hacksawing tubing

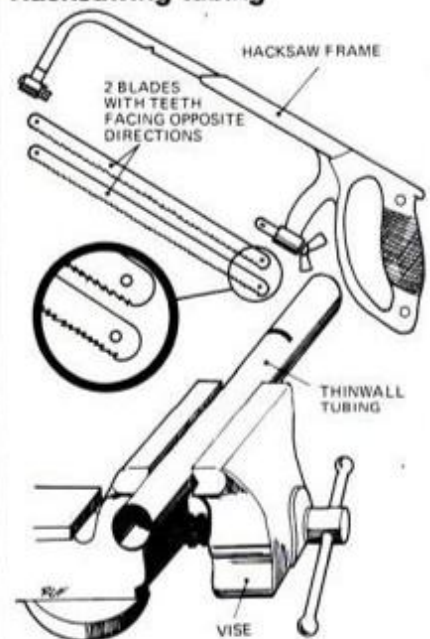

Use two saw blades to hacksaw thinwall tubing easily with less grab. Position the blades with their teeth facing in opposite directions.—*Howard Moody*



**Rain Dance[®]
lasts longer
than any other
leading car wax.**

Water beading proves it.
DuPont guarantees it.

Rain Dance[®] is guaranteed to shine longer, to bead water longer, to last longer. It's the car wax with the watertight guarantee.

America's #1 Premium Wax



GUARANTEE: "RAIN DANCE" is guaranteed to keep on beading and shining longer than the leading liquid or paste waxes. If not completely satisfied, return unused portion to 8-4233, DuPont Company, Wilmington, DE 19898, for full refund of actual purchase price and postage.

ALL OUTDOORS

Fixing afield

As if in answer to our recent complaints, a new on-the-go glue for outdoorsmen has just been put on the market, and it's worth tracking down at hardware and sporting-goods stores. It is called "Instant Krazy Glue for Fishermen, Hunters & Campers," and comes blister-packed in an .11-ounce plastic container, slightly larger than the little .07-ounce tube that seems to be on sale everywhere.

A number of these cyanoacrylates are available under a variety of brand names. They're the "miracle" glues that have tremendous bonding strength, but can be dangerous, if you're careless, since they will bond your fingers or eyelids together. (For eye trouble, wash only with water and see a doctor; fingers can be unstuck with acetone or nail polish remover.) We have tested an assortment of makes and all seem to perform equally well at home.

In the woods, it's been something else. Some tubes would get squashed in a pocket or leak in a tackle box, once they'd been opened, with disastrous results. Others can't be effectively recapped once they are opened, and may ooze during the pressure changes of an airline flight. The glues, with their rapid setting time and great strength, are ideal for fixing the broken tip-top of a fishing rod, resetting a splinter from a gun stock, securing a loose strap on a camera case, repairing the heel of a hiking shoe. But previously, the opening pin might break after one use, or the expensive little container wouldn't reseal and would have to be thrown away. Now Krazy Glue's Camper Model 815 has cured that with a pushpin that can travel successfully. A larger 20-gram supply is also available for \$7.98 from Krazy Glue, 53 West 23rd St., New York, N.Y. 10010.

These cyanoacrylates can cement mating pieces, but will not fill gaps satisfactorily, so it's still worthwhile to carry along a pair of moldable sticks of epoxy, as well. Consider small rolls of duct tape and strapping tape, needle-nose pliers and a couple of single-edge razor blades to round out your outdoor quick-repair kit. They can all help make a temporary fix until you have more time.

Catching your world record

The next fish you hook may be the largest ever landed with the partic-

ular strength of line you're using. Even if it's not, it still could be bigger than any of that type that have been weighed in before. Either way, some new rules make it easier than ever for you and your fish to apply for fame and a spot in the record books.

The International Game Fish Assn. is now the record keeper for both fresh and saltwater fish. In order to update their categories of game fish, they are staging an international contest this year that will run through Nov. 30.

Explains Elwood K. Harry, noted president of the I.G.F.A., "In order that the anglers throughout the world will have a chance to show us, through their fishing activities, the amount and kind of species that should be considered for permanent world record status in our charts, we have made the decision to accept all applications without any charge to the angler.

"This new program will result in a set of freshwater world records that have been established under the same type of angling rules, and will have credibility comparable to our existing saltwater records."

Any fish, from a one-pound bluegill to a 1000-pound marlin, is eligible. The new equipment and angling regulations give all fishermen an even chance.

While you can get the rule book and record entry application forms at no charge from the International Game Fish Assn., 3000 East Las Olas Blvd., Fort Lauderdale, Fla. 33316, the best way to enter is to send in \$15 (tax deductible) and become a regular member. Then, along with the free forms, you get a free copy of their excellent *World Record Game Fishes* book with its complete listings and articles by famous fishermen (\$5.95 postpaid to nonmembers).

And in addition to a bimonthly newsletter, jacket patch, membership decals and card, you're supporting a worthwhile, nonprofit organization.

Shooting to order

It's no secret that the safe and proper way to learn gun handling is to handle guns under proper supervision at a range. They are not always easy to find, and the answer can be a do-it-yourself group installation. Some recent case histories show it's not as hard as it sounds. You need a

place for a safe rifle and pistol setup, a number of interested people to do the organizing and the work, and money.

All, it turns out, are available in many communities. A new \$1 booklet from the National Shooting Sports Foundation, 1075 Post Road, Riverside, Conn. 06878, gives many of the answers or tells where they can be found.

Called *How to Develop New Places to Shoot*, the publication outlines the sources for planning, organization, construction and cost guidelines, and the all-important financing. It turns out there are a number of industry and federal, state and local funding programs that are available for dedicated groups. This booklet provides names and addresses. A community that is anxious to have a worthwhile facility should find the answers here.

Two additional sources of guidelines for scattergun enthusiasts are the Amateur Trapshooting Assn., 601 West National Rd., Vandalia, Ohio 45377, and the National Skeet Shooting Assn. Box 28188, San Antonio, Tex. 78338. For shooting competition and training, trap and skeet fields are unrivaled, and are not difficult to set up. With the shotgun's limited range, much less acreage is required.

Outdoor advisories

■ Want to build your own bicycle from scratch? *Designing and Building Your Own Frameset*, by R. P. Talbot, \$16.95 postpaid from the Magnet Guild, 310 Franklin St., Boston, Mass. 02110, will help to get you started.

■ Campsite reservations at 17 campgrounds in Yosemite, Sequoia-Kings Canyon, Grand Canyon, Rocky Mountain, Shenandoah, Great Smoky and Cape Hatteras National Parks can be made this year through 600 Ticketron offices, as well as by direct mail. **FM**

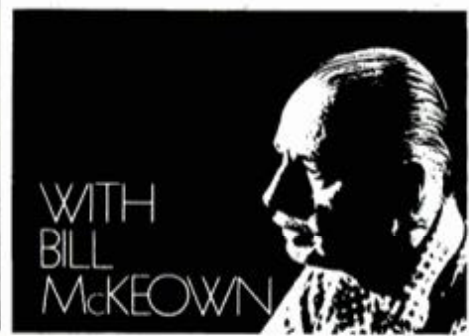

On Father's Day, live up to Dad's expectations.

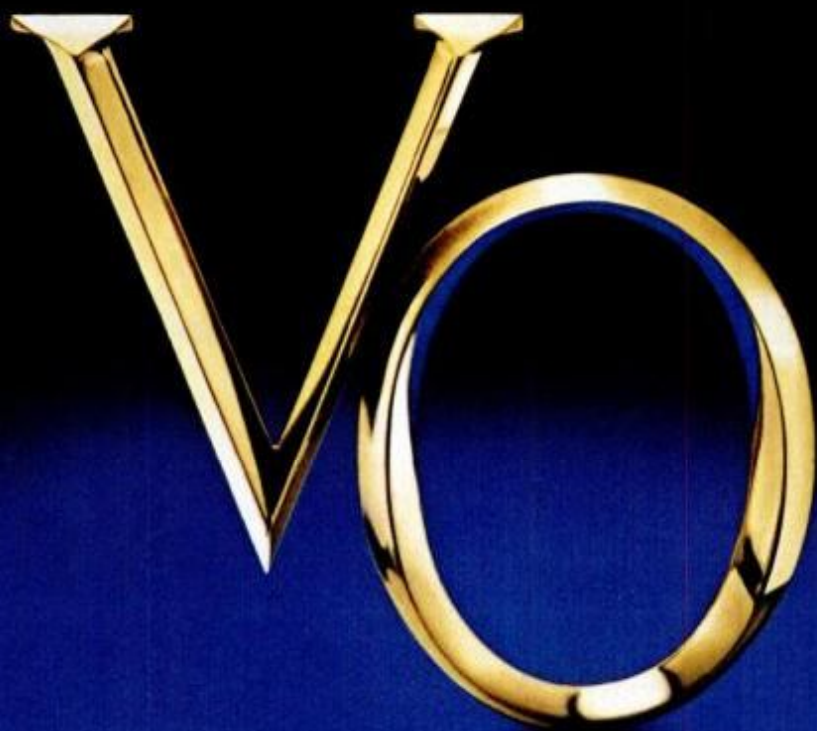
A large, three-dimensional gold logo consisting of the letters 'V' and 'O'. The 'V' is formed by two thick, parallel bars that meet at a sharp point. The 'O' is a thick, circular ring. The logo is set against a dark blue background and has a soft, dark blue reflection on the surface below it.

Seagram's V.O.
The symbol of imported luxury. Bottled in Canada.
Enjoy our quality in moderation.

Canadian whisky. A blend of Canada's finest whiskies. 6 years old. 86.8 Proof. Seagram Distillers Co., N.Y.C.

FIRSTHAND REPORT

by Gary Witzenburg
DETROIT AUTO EDITOR



Driving the 1980 LeCar

Our newest naturalized citizen gets a bigger engine and better mpg.

For 1980, LeCar benefits from several significant improvements. A larger, slightly torquier and, surprisingly, more economical 1.4-liter Four replaces the previous 1.3-liter Four; a new electronic ignition system improves performance and reduces maintenance costs; new damage-resistant fiberglass bumpers look better and save some weight compared to the old ones. In addition, there's an all-new instrument panel that looks much better than the previous bargain-basement design and features a more convenient control layout; larger side-window defogger vents have been added; and the combination of a larger

blower fan and more efficient air intakes provides much better interior ventilation and heating.

The 1980 LeCar, distinguished by a new set of rectangular headlamps, also boasts a number of small changes aimed at reducing noise and vibration. These include a quieter muffler; new rubber tailpipe mounts; reinforced engine and radiator mounts and air filter brackets; and sound insulation in the hood.

Zip and comfort

The larger engine provides snappy performance and impressive EPA fuel economy numbers—30-mpg city (compared to 27 for 1979) and 40-mpg highway. AMC won't release horsepower figures, but we'd guess the new 1.4 puts out about 65 hp, compared to the old 1.3's 58 at 6000 rpm in U.S. trim. That doesn't

sound like much, but it's enough for (front) tire-spinning starts and plenty of useful zip for fighting the urban commuter wars.

LeCar provides a remarkably smooth and comfortable ride, even on bumpy roads, and with its agile handling, LeCar has a high fun-to-drive quotient. The low-back front bucket seats are "specially engineered by Renault's Bio-Mechanics Dept. to decrease driving fatigue and maximize driver and passenger comfort." While this language is straight from the press release, the claim happens to be true. Seats also lift and slide forward for easier access to the rear compartment. However, the standard-model buckets don't have a backrest angle adjustment.

Standard LeCar equipment in-
(Please turn to page 62)



What it lacks in power, LeCar compensates in crisp handling. Its unique suspension produces an extremely smooth ride.

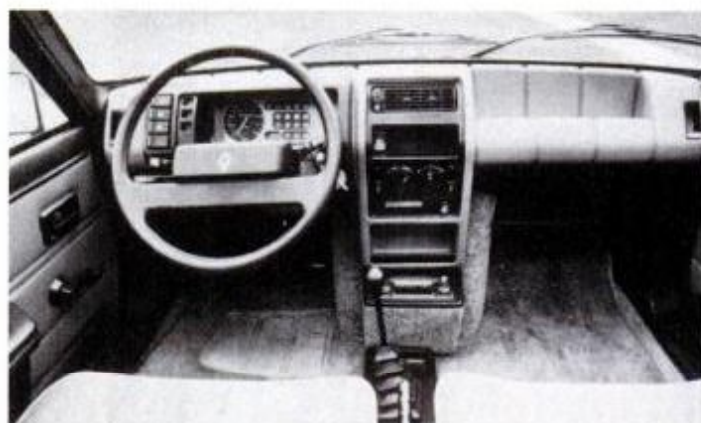

Redesigned dash gives the car a more luxurious look. All of the switches have been repositioned to provide easier access.



Who says the Toyota 4-Wheel Drive Truck is leading the off-road pack? *OFF-ROAD* and *PICKUP, VAN & 4WD!* Both magazines named it "4WD of the Year" when introduced!

One reason is a 2.2 liter engine. It's bigger than any other small 4WD. That's extra power to move you out front, on the road or off. Our machine also has the highest running

ground clearance of any small 4WD, to help save you from getting hung up on the hard stuff.

The Toyota's high-riding good looks and fancy interior haven't hurt its popularity any, either. The Sport Truck model has locking front hubs, full carpeting, AM/FM Multiplex stereo radio and full instrumentation —standard. Tilt steering wheel and

power steering are available options.

Surprised that a new design could be so good so soon? Don't be. The Toyota 4-Wheel Drive Truck is the "Son of a Land Cruiser." We put our 30 years of experience building one of the world's toughest 4-wheel drive vehicles into it.

So get a Toyota 4-Wheel Drive Truck. And lead 'em, off the road.

**THE TOYOTA 4-WHEEL DRIVE TRUCK.
IT'S LEADING EVERYONE
OFF THE ROAD.**

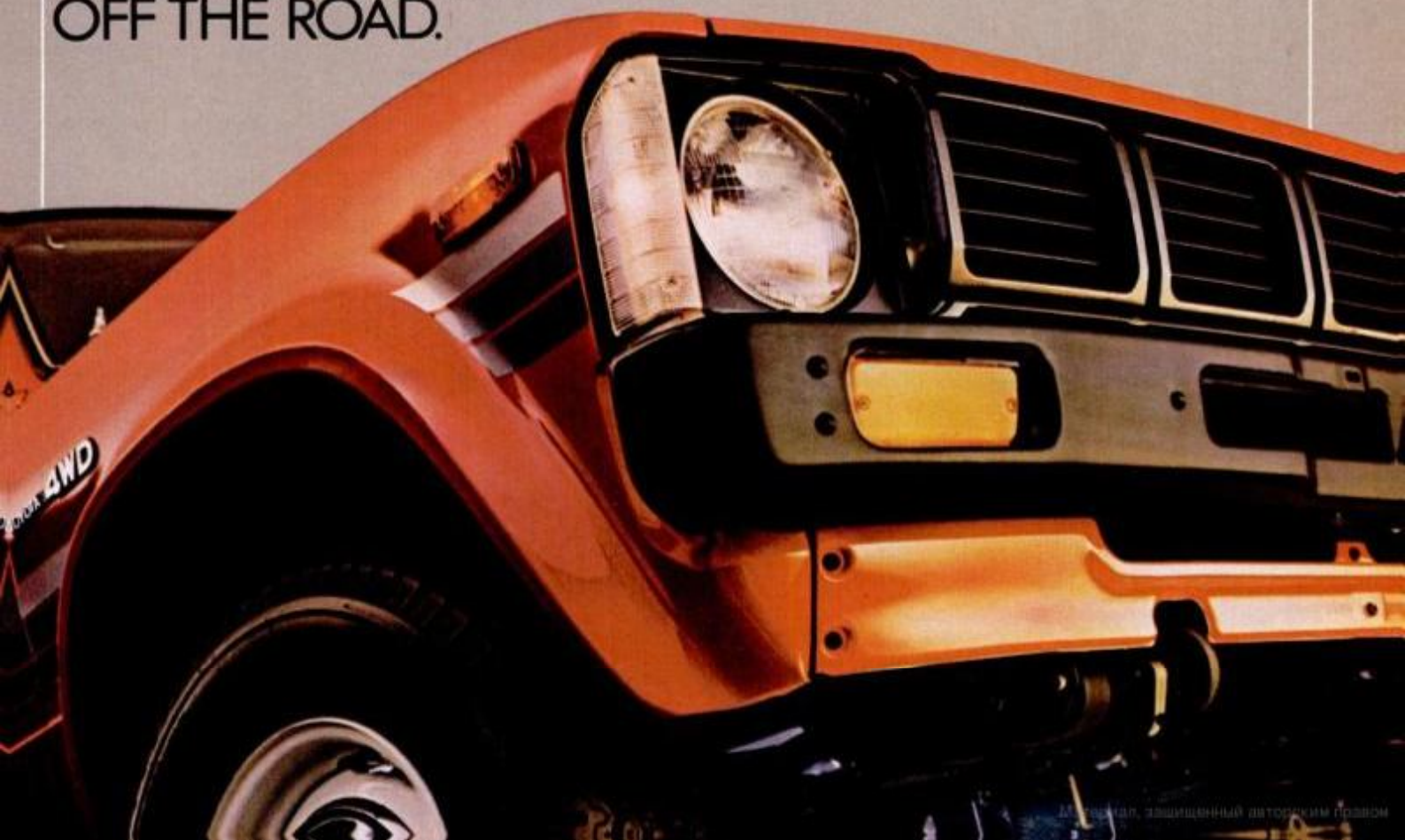

THE ONE ★ THE ONLY
★ THE ORIGINAL ★

VAUGHAN

SUPERBAR

The World's most
useful and versatile
hand tool!

IT PRIES! IT LIFTS!
IT SCRAPES! IT POUNDS!
IT PULLS NAILS
LIKE NOTHING YOU'VE
EVER USED BEFORE!

Deep,
smoothly curved
"shepherd's crook"
end easily
pulls the
biggest nails

Heavy
forged steel—
heat treated and
spring tempered
for toughness

SUPERBAR
Scrapes • Pries • Lifts • Puts

Full 15"
long for
good leverage;
three nail slots
for convenience

Sharp,
hand-ground
blades slip easily
under moulding
without marring

BEWARE
of inferior
imitations...
there's only
one Vaughan
Superbar!

VAUGHAN

VAUGHAN & BUSHNELL MFG. CO.
11414 Maple Avenue, Hebron, Illinois 60034

For people who take pride
in their work... tools to be proud of

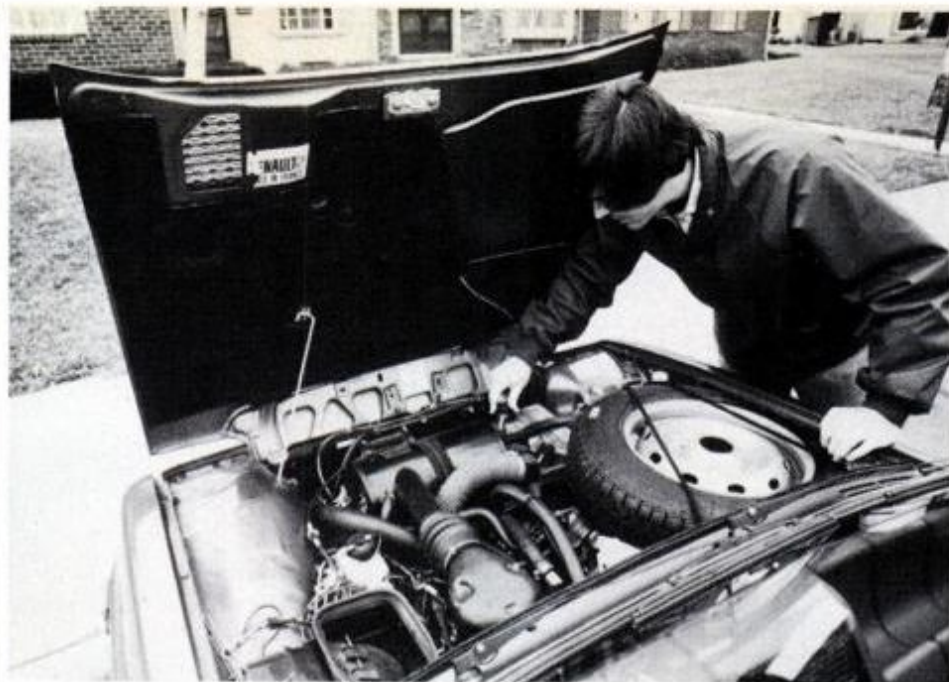

Unlike most front-wheel-drive cars, LeCar's engine is positioned longitudinally. Once the spare is removed, access to the plugs, distributor and oil filter is easy.

DRIVING THE 1980 LeCAR

(Continued from page 60)

cludes four-wheel independent suspension, with sway bars front and rear, front disc and rear drum brakes (balanced automatically by a load-sensitive proportioning valve), rack-and-pinion steering and Michelin steel-belted radial tires.

Although the wheelbase is long for the car's tiny overall dimensions (contributing to both ride and interior room), the turning circle is a very short 32 feet for easy parking and maneuvering in congested areas. There's no glove box, but nine pockets and bins of various sizes provide convenient storage space for most anything short of a picnic basket. The rear seat folds forward to more than triple LeCar's usable cargo room, and the rear hatch opens

down to bumper level for very easy loading and unloading.

With its manual choke, the little engine starts and drives away with ease on cold mornings, but there's no automatic shutoff and no temperature gauge to let you know when to shut it off. In fact, except for fuel and speedometer, there are no gauges—just "idiot" lights.

Considering LeCar's decade-old design, it's surprisingly contemporary and satisfying in most ways, and a good buy for the money at only \$4269 base. For \$600 more, the Deluxe version features reclining front buckets, power-assisted brakes, swing-out rear quarter windows, custom steering wheel, electric rear-window defroster, extra sound insulation, "rally" stripes and a removable rear cargo cover. Extra-cost options for the Deluxe include factory airconditioning, sunroof, rear window washer/wiper and clear metallic paint, but no automatic or five-speed manual transmission.

With more than two million LeCars on the road throughout the world, Renault seems to have it down right, because the car has achieved a first-rate reputation for durability and reliability. Every AMC dealer selling LeCars had to send his shop technicians through a special service training program.

LeCar should continue improving its popularity in fuel-conscious America. It has all the elements that made VW's Beetle so popular in the 1960s—controversial, but often endearing, looks and character, simplicity and outstanding fuel economy. Only this time, competition is a whole lot stiffer. **FM**



With the rear seat folded, the cargo area provides 35.1 cu. ft. of luggage space.

AIR FORCE EXPERIENCE:

Everybody knows you need experience to get ahead. But AIR FORCE EXPERIENCE can take you as far as you want to go. Great training. Responsibility. Skills you can use for a lifetime. Talk to your Air Force Recruiter about AIR FORCE EXPERIENCE before you make any choice. Do it for your country — and yourself. Call toll free 800-523-5000 (in PA: 800-362-5696), or mail in the card. It can be your ticket to . . .

A GREAT WAY OF LIFE.



AIR FORCE

WHY MORE AND MORE PEOPLE WILL BE MOVING UP TO A NEW MIDDLEWEIGHT THEY CAN'T EVEN PRONOUNCE.

Lots of guys are ready for a bigger saw.

And the new Poulan 3400

CounterVibe is the one they'll be moving up to. How come?

Because, feature for feature, dollar for dollar, there's never been a chain saw like it. With solid state ignition, all-position carburetor, 100% needle bearing construction, a powerful 56CC engine, an extra-quiet, spark-arresting muffler, a kickback-reducing sprocket nose bar and more.

And while it's got everything it takes to make cutting easier, it's also



The 3400 CounterVibe. Big enough to handle jobs most lightweights can't.

got everything it takes to make cutting easier on you.

Like an extra-large diameter, padded grab bar. A five-point fail-safe CounterVibe anti-vibration system that reduces cutting vibration by up to 78%. And a precision balanced crankshaft. So there's less noise, less vibration, less cutting fatigue and more comfort.

Of course, with the Poulan 3400 CounterVibe, you may have a harder time saying the name.

But you've never had an easier time cutting.

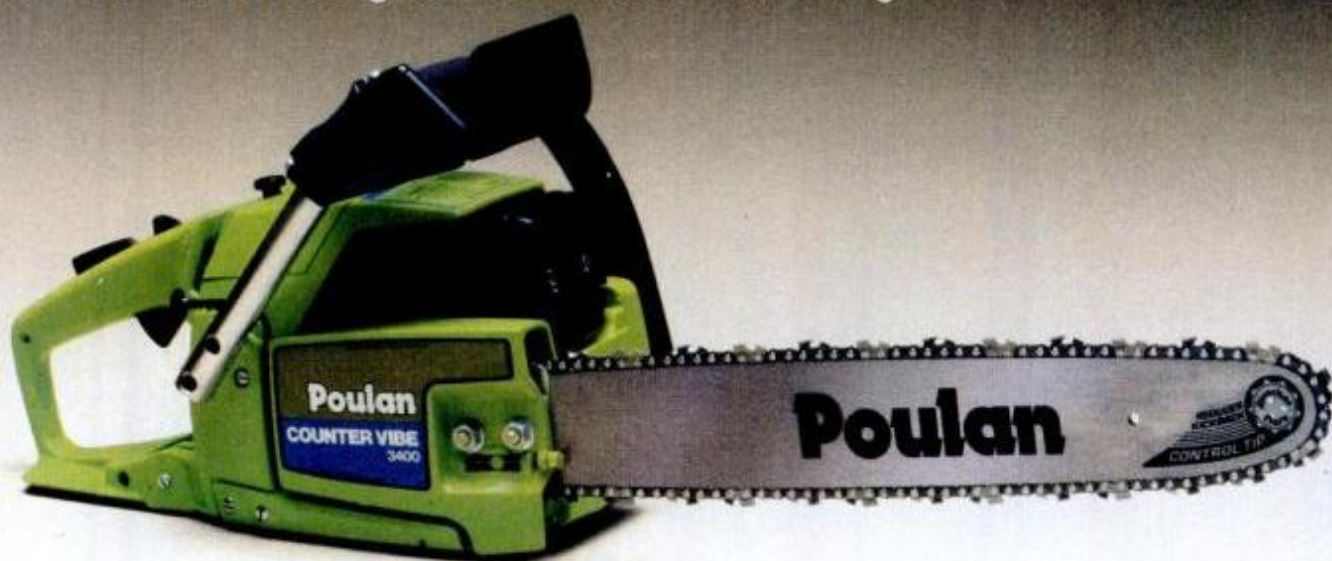

The New Poulan 3400 CounterVibe.



Beaird-Poulan Division, Emerson Electric Co., Shreveport, Louisiana. Look in the Yellow Pages under "Saws" for your nearest Poulan Dealer.



PM's Whatsit

What had 12 engines, a 157-foot wingspan, a 130-foot fuselage and flew 1370 miles nonstop 50 years ago? If you can't rattle off the name of this one of only three ever built, turn the page.

If I only had a vane

Engineer Jim Lentell, an agricultural equipment designer in Chelmsford, England, is making a name for himself with his modern scarecrow apparatus. The "Gentlemen Jim" model, at Lentell's left in the photo, consists of a fairly convincing human head model, a red nylon tailed coat and paddle-type "hands" that cause the arms to wave in the slightest zephyr. The taller device, called a "Securicrop," is just a triangular steel box with wind-catching vanes that rotates in the breeze—but Lentell vouches for this one, too, as well as the smaller "Squarescare" aimed at the gardener market. An alternating bright-red-and-blue-stripe paint scheme, oscillating in the wind, is said to be the key to the vane-type devices.

For best results, says Lentell, always put bird-scare devices out *before* the birds attack a crop, and rotate them to a different location every five to six days.



Time flies

In the opening segment of *Palmerstown*, a moderately acclaimed TV series based on *Roots* author Alex Haley's Tennessee boyhood, a mood-establishing shot of the old home clearly showed a jet contrail in the sky above. The setting was the 1930s.

Gray power

Next to the brand-new McDonnell Douglas F-18A "Hornet" fighter in this photo, a World War II military aircraft complete with insignia, squadron markings and painted mascot (see page 96) seems a gaudy warbird indeed. The reason: This Hornet is the first of its type to appear in today's "operational" paint scheme, which consists of three shades of gray accented only with very muted national insignia (on fuselage directly under cockpit). Ap-



parently even in the modern air-to-air combat regime, dominated by radar target acquisition and missiles guided by infrared-seeking, or even more sophisticated electronics, a low visual profile still can give a fighter an edge.



Earlier developmental model of Hornet appearing in nonoperational orange and blue paint scheme gets off a Sidewinder missile.

IPM BRIEFS

Whatsit revealed

Before the Dornier DO-X rattled off into obscurity, it amazed a lot of people. The plane could carry up to 169 passengers, and those were 525-hp Siemens-Jupiter engines placed back to back (pusher and puller) on mounts that kept them high and dry above the wing. The plane was designed by Claude Dornier, head of the German firm bearing his name. The test pilot on the flight shown here, from Switzerland's Lake Constance, bore the appropriate Teutonic moniker of Richard Wagner.

Magnetism and medicine still a gaussing game

Water for drinking and cooking in Russian hospitals is exposed to a magnetic field before use. Japanese authorities officially recognize magnetic devices as medical apparatus. Certain magnetic phenomena—such as the Hall effect (page 78)—still have theorists guessing as to their precise nature, but that has not kept "biomagnetism" from emerging as a prominent area of at least quasi-medical interest.

The marketing of devices such as the Magnetic Water Pencil (photo) is evidence of this interest. Consisting of no more than a cylindrical magnet a little more than an inch long encased in a ballpen-type plastic holder, the \$5.95 unit is intended to be used to "improve" the quality, taste—even the smell—of water "polarized" by stirring with the magnet. Our tests on New York City water (not that bad to begin with) yielded no noticeable results. Please do not send us your bad water for testing.



Aronson shows battery system; he stresses need for charging centers located in motels, shopping centers and service stations.

The luxury electric

Shown with the first production model of his \$28,500 electric passenger car—dubbed the Transformer I—is developer Robert Aronson, president of Electric Fuel Propulsion Corp. of Troy, Mich. Aronson claims his company can produce 5000 cars per year and deliver within six months on special orders (the car shown was bought by actor Lloyd Bridges). Aronson also says he is lining up dealers and envisions a network of 100 recharging stations (which would be required to lease an \$8500 mobile recharging unit from the company) for the Southern California area.

Aronson says his 180-volt cobalt battery system delivers more than twice the power per unit weight as ordinary lead-

acid batteries, giving the car cruising speeds of 55 mph or better with a radius of 100 miles. With the mobile recharging unit, a 45-minute charge is good for another 100 miles—or, an emergency fast charge of 10 minutes' duration gives the car a 20-mile range. Owners could also get a full charge overnight through a built-in slow charger plugged into a 110- or 220-volt outlet. Aronson estimates the cobalt batteries will take 800 charges, providing up to 90,000 miles per system.

Accessories on the luxury model include stereo; power brakes, power steering and power windows. The air conditioner is battery-powered but the heater-defroster requires liquid fuel.



4x4 INTRODUCING THE DATSUN OF 4-WHEEL DRIVE



Grab your gear – the first 4x4s by Datsun are here! With the biggest choice of compact 4-wheel drive truck bodies in America.

TOUGH IN THE ROUGH, SMOOTH ON THE ROAD
Datsun takes 4-wheel drive where the competition's never been. With the highest minimum ground clearance in the class. Solid steel plates to protect underbody parts. A powerful overhead cam engine. A separate high/low range 4x4 transfer stick. And enough built-in tough to tame the roughest road.
But there's plenty of beauty in the beast, too. The new Datsun 4x4s have independent front suspension and big 15-inch wheels to glide you in road-smoothing comfort.

ROOMIEST COMPACT 4-WHEELER IN HISTORY
The Datsun King Cab 4x4 has over 7.1 cubic feet of inside storage space – and optional jump seats inside! Now check out the standards: reclining buckets, tachometer, trip odometer, flip-out rear side windows, flip-down cargo light and the only standard 5-speed in the class. No 4x4 can treat you more like a king!
And if you're looking for a long bed, Datsun's the longest in the class with over 7 feet of cargo length.

REMINDER: BE GOOD TO YOUR LAND
Rugged as the new Datsun 4x4s are, it's important to respect the natural beauty of our wilderness land. Use 'em on the off-road roads, and in designated rec vehicle areas. That'll keep us all truckin' for a long time to come.
Visit your Datsun dealer, and test drive the hottest 4 wheels in America today – the 4x4s by Datsun!

DATSUN WE ARE DRIVEN

Some items shown are owner-installed custom options.



HOMEOWNERS' CLINIC

QUESTIONS ANSWERED

House too tight?

My husband and I bought a 20-year-old, Cape Cod-style house. In the last five years, to help conserve energy, we've added insulation, storm windows and doors, and caulked the exterior. We now have black mold appearing on walls and ceilings and condensation on the windows. If we can't control it, we'll be replacing windows again, this time because they'll have rotted. We run two dehumidifiers in the basement in the summer. My washing machine in the basement drains into a French drain, which carries the water to a drain field.

My husband says the mold is due to the fact that our house is now too tight. If that's the case, why aren't some of the newer, insulated houses I've seen affected by the mold, too?—Danielle Bloomberg, Northampton, Pa.

Mr. B is correct. Your house is now too tight. Before you did such a fine job of combating heat loss, cool, dry air could infiltrate under doors, windows and uncaulked gaps in the walls. This dryer air would offset the moisture in the air caused by normal, daily activities such as showers, baths and cooking.

You have to introduce cooler, dry air into your system and eliminate the moist air from your house. Start by getting rid of the French drain in the basement. Add exhaust fans in the kitchen and baths. Once a day, open a window slightly while you run these fans for 10 or 15 minutes. Also keep your dehumidifiers running in the winter. Opening the house will negate some of the good you've done conserving energy.

If you have a warm-air system, it is possible to duct fresh, outside air into your plenum. This should be dampered and connected to a humidistat to go on when your furnace motor starts. It is possible to pre-heat this air also, but if you do, you should consult a licensed mechanical engineer.

Another alternative is to run more dehumidifiers on the first floor. Read about the Airpliance in "Having and Eating Cake," on this page.

I doubt if the newer houses are tightened to the extent that yours is. Also consider lifestyle: Doors are constantly opened and closed in a house with children and pets. This seemingly short exposure to fresh,

dry air, when multiplied 20 times per day, adds up.

Popped nails

What's the best way to deal with popped nails that protrude or recede here and there on our modern drywalls? I've been a subscriber to Popular Mechanics for many years, but I don't recall a good answer to the question.—John Auer, Harvester, Mo.

I'll just assume that your wife got the July '78 issue of PM before you

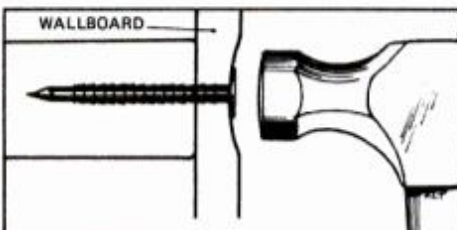

Last hammer blow sets nail and dimples adjacent wallboard without breaking paper.

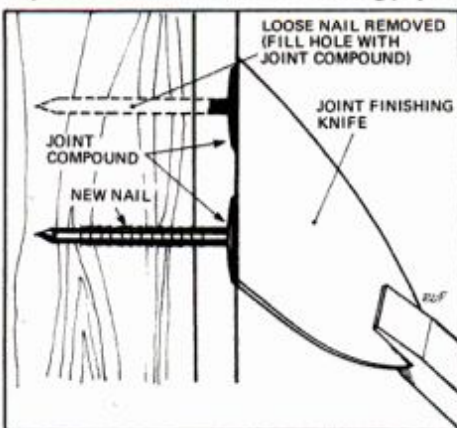

Use a wide joint-finishing knife to apply three feathered layers of joint compound.

dry air and maybe left it at the garden club (See "Camouflaging nail dimples," *Homeowners' Clinic*, page 40). I'm also assuming that my answer was good. As nail popping is a common occurrence, the remedy is worth repeating, this time with the sketches (above).

Those popped nails are usually caused by shrinking of the framing members as wood dries, by settling, or by using an insufficient number of nails during initial installation. (Spacing should be one nail every 7

in.) If the nail is protruding from the surface, try removing it with your fingers. If it's tight, drive it back in. If it's loose, remove it, as vibrations will only cause it to show again. In either case, drive new nails about 2 in. on both sides of the faulty one. The last blow of the hammer should dimple the drywall and set the nail. Take care that the nailhead doesn't tear the outside paper of the drywall.

Follow the nail setting with three applications of joint compound using a 4-in., joint-finishing knife. Be certain that you sand lightly between coats.

Having and eating cake

We'd like to know of a system for providing combustion air to our fireplace. When we have a fire in our tight, energy-efficient house, air is drawn from our gas furnace, which is separated but in the same chimney as our fireplace. When we have a fire in the fireplace, flue gas is forced into the basement if either our hot-water heater or furnace is running.—Gordon B. Carson, Midland, Mich.

Your problem is "kissin' kin" to "House Too Tight," the first letter on this page. The importance of supplying combustion air to fireplaces, furnaces and heaters is explained in a helpful pamphlet from the Minnesota Energy Agency, 980 American Center Building, East Kellogg Blvd., St. Paul, Minn. 55101. This illustrated, free booklet points out the dangers of not having enough combustion air.

There's an Airpliance Venting Kit made to supply heaters and fireplaces with combustion air. It's made by Basic Energy Conservation Services Inc., Dept. PM, 1296 Hudson Rd., St. Paul, Minn. 55106. The kit costs about \$80; it's easy to install. You may want to write the manufacturer in order to obtain a brochure. **PM**

Do you have a home maintenance or repair problem? Send it to Homeowners' Clinic, Popular Mechanics, 224 West 57th St., New York, N.Y. 10019. Letters cannot be answered individually, but problems of wide interest will be discussed in this column. For more home repair and maintenance help, get PM's Home Care Guide, \$4.95 postpaid. Send order(s) to PM, Dept. HCG, Box 1014, New York, N.Y. 10019.

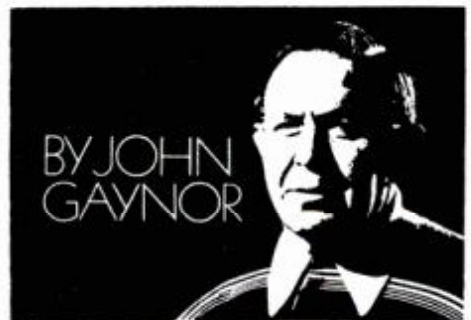

BY JOHN GAVNOR

Premium. Imported.



BLACK VELVET® BLENDED CANADIAN WHISKY, 80 PROOF, IMPORTED BY © 1979 HEUBLEIN, INC., HARTFORD, CONN.

Velvet Touchin'.



Marlboro

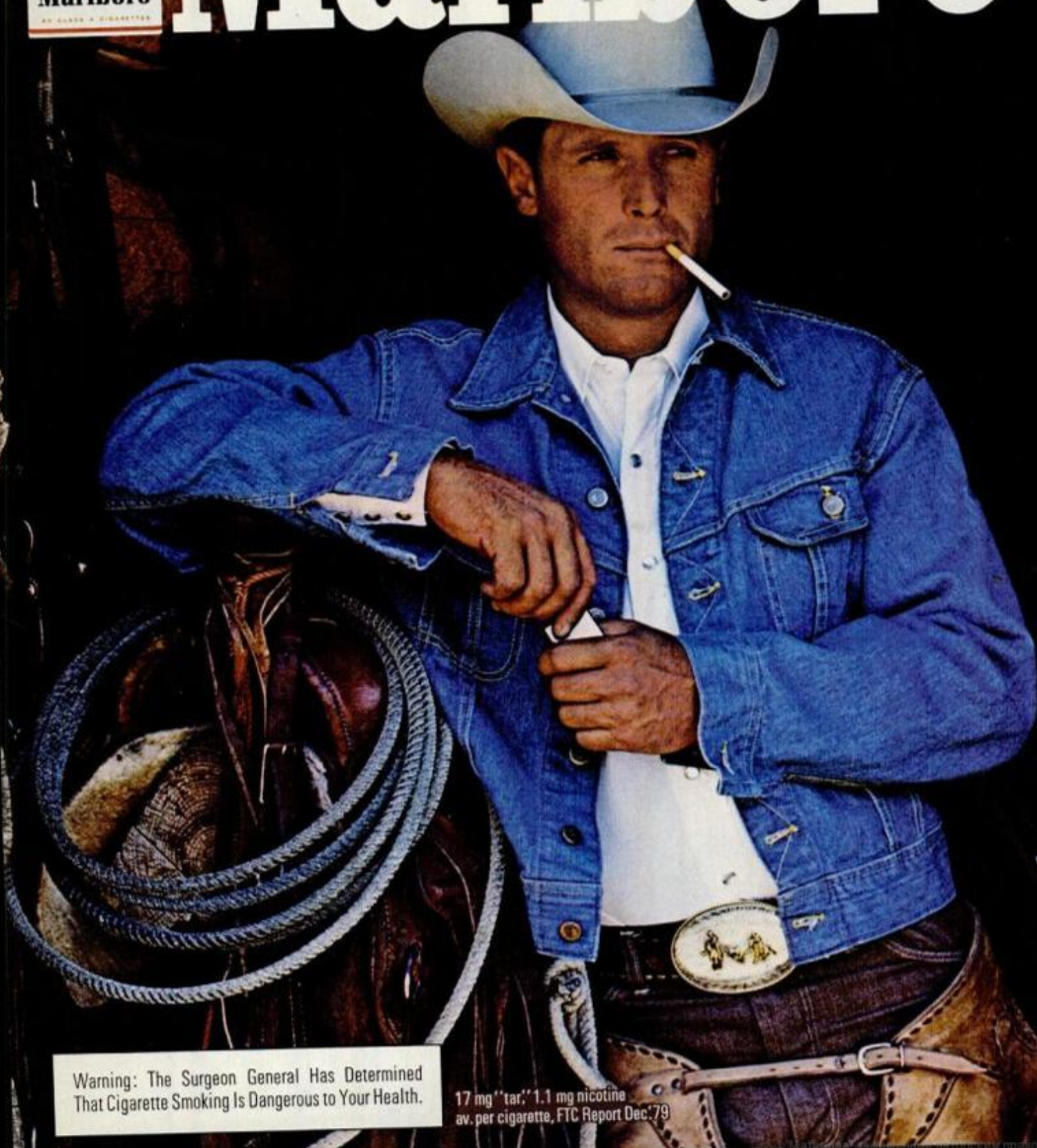

Warning: The Surgeon General Has Determined That Cigarette Smoking Is Dangerous to Your Health.

17 mg "tar," 1.1 mg nicotine av. per cigarette, FTC Report Dec. '79

Rocket boat shoots for Mach .5

Can the former record-holder bring the world boat-speed record back to the United States?

by Steven Parker

Speed on the water is going to approach the speed of sound if Californian Lee Taylor has his rapid way this spring. His gleaming missile-shaped rocket ship, U.S. *Discovery II*, is scheduled to take a first shot at the world record on Lake Tahoe at about the time you read this article. Sixteen-thousand horses of power have been harnessed into the 40-foot, 2500-pound craft to push it faster than any boat has ever gone before, and bring the speed championship back to the United States.

The current record is held by Ken Warby of Australia. In 1978, using a turbojet-powered racer that was somewhat similar to an earlier Taylor speedster, Warby broke the previous record that Taylor had held for 11 years with a new clocking of 317.60 mph on the lake behind Blowering Dam, Australia. But Taylor believes his new boat can do more than up the record and is planning for 350 miles per hour plus an eventual try toward transonic speeds.

Lee Taylor may regain his title as the fastest man on water—or disaster may strike as it did at Lake Mead, Ariz., in 1964, in an

accident that left him in a coma for 18 days. Now, at 45, Taylor has everything riding on his *Discovery II*. Working out of a building in an industrial park in Irvine, Calif., Taylor and his small band of volunteers have been up late nights for the past three years constructing this vehicle that more resembles a fighter rocket out of *Star Wars* than any kind of boat. The results, however, have convinced Taylor, his crew and his major sponsors, Ducommun Metals and the Sahara Tahoe Corp., that his target speeds of 350 and beyond are more than possible.

Discovery II's 40-foot hull is powered by a Woodruff rocket engine that is capable of 8000 pounds of thrust, approximately 16,000 incredible horsepower from a totally nonpolluting fuel of hydrogen peroxide. The working



Holding a model of his new U.S. *Discovery II*, Lee Taylor stands beside trophy he held 11 years, the prestigious Royal Motor Yacht Challenge Cup that goes to the world speed-record holder. Taylor has to top 317.6 mph to bring it back from Australia.

Airborne at rocket speed,



U.S. Discovery II patented (No. 4,095,549) by Arthur L. Williams

STAINLESS STEEL 150-POUND ENGINE: DELIVERS 16,000 HP

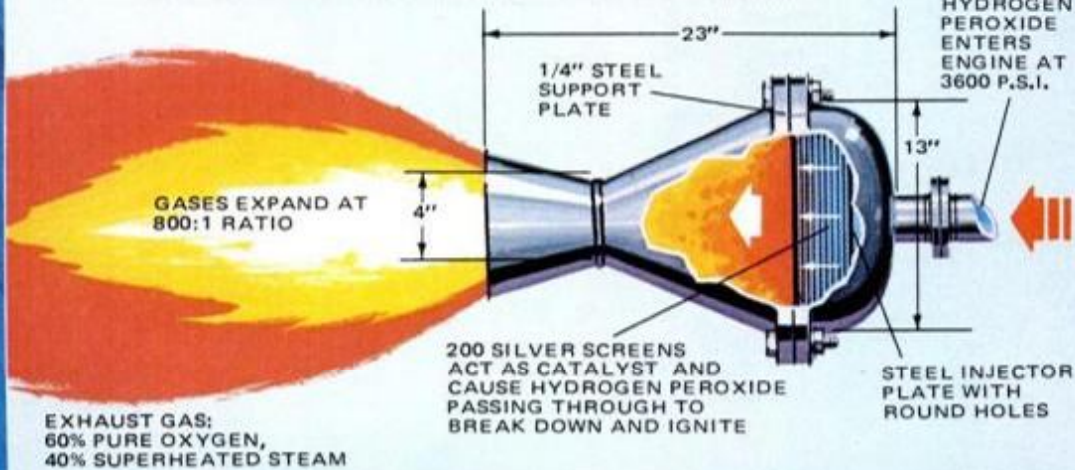

In the Woodruff engine, 200 12-inch-diameter circular silver-mesh screens, similar to window screens, fire off the hydrogen-peroxide fuel to develop the tremendous 8000 pounds of thrust. This "engine" inside its stainless-steel shell weighs only 26 pounds. Pilot's right-hand throttle controls the injection of the fuel/air mixture and its pressure.

Discovery II aims for world record.

core of the 150-pound engine weighs a mere 26 pounds, and is one of the smallest and lightest components of the vehicle. If the engine is working correctly, the critical factor of the rocket boat's success depends on the air-pressure force feeding the hydrogen peroxide to the silver-mesh-catalyzing screens in the engine that create the propelling explosion. This is no back-yard exercise in speed. The U.S. *Discovery II* combines the latest in boat and aircraft design in both engine and hull.

The craft carries two 50-gallon stainless-steel fuel tanks, one mounted for-

ward of the driver's compact cockpit, the other directly behind the driver. The all-important cylindrical air-pressure vessel is mounted 14 feet from the bow of the boat and will be able to maintain a constant pressure of 3000 pounds per square inch. Between this pressure tank and the fuel tanks are air/fuel regulators, block valve and check-valve system, all of which are pilot-controlled from the cockpit. The right-hand-mounted throttle with which Taylor will turn up the boost also feeds information to three separate gauges that monitor the air/fuel mixture and pressure. All fuel lines and fittings are of aircraft quality and

designed for the safety and protection of the pilot.

The steering system contains a rudder that sits in the water, as on any conventional boat, and also an aircraft-type steering rudder on the vertical stabilizing tail, rising 9 feet above the water. When *Discovery II* reaches high speed, it leaves the water, and only a 4-inch extended skeg below the boat's transom remains below the surface as a fixed guidance device. With all conditions right, everything else is in the air and the boat is a rocket-powered missile with essentially unlimited top speed under proper smooth-water conditions.

Once all this gets moving, it gets

(Please turn to page 158)

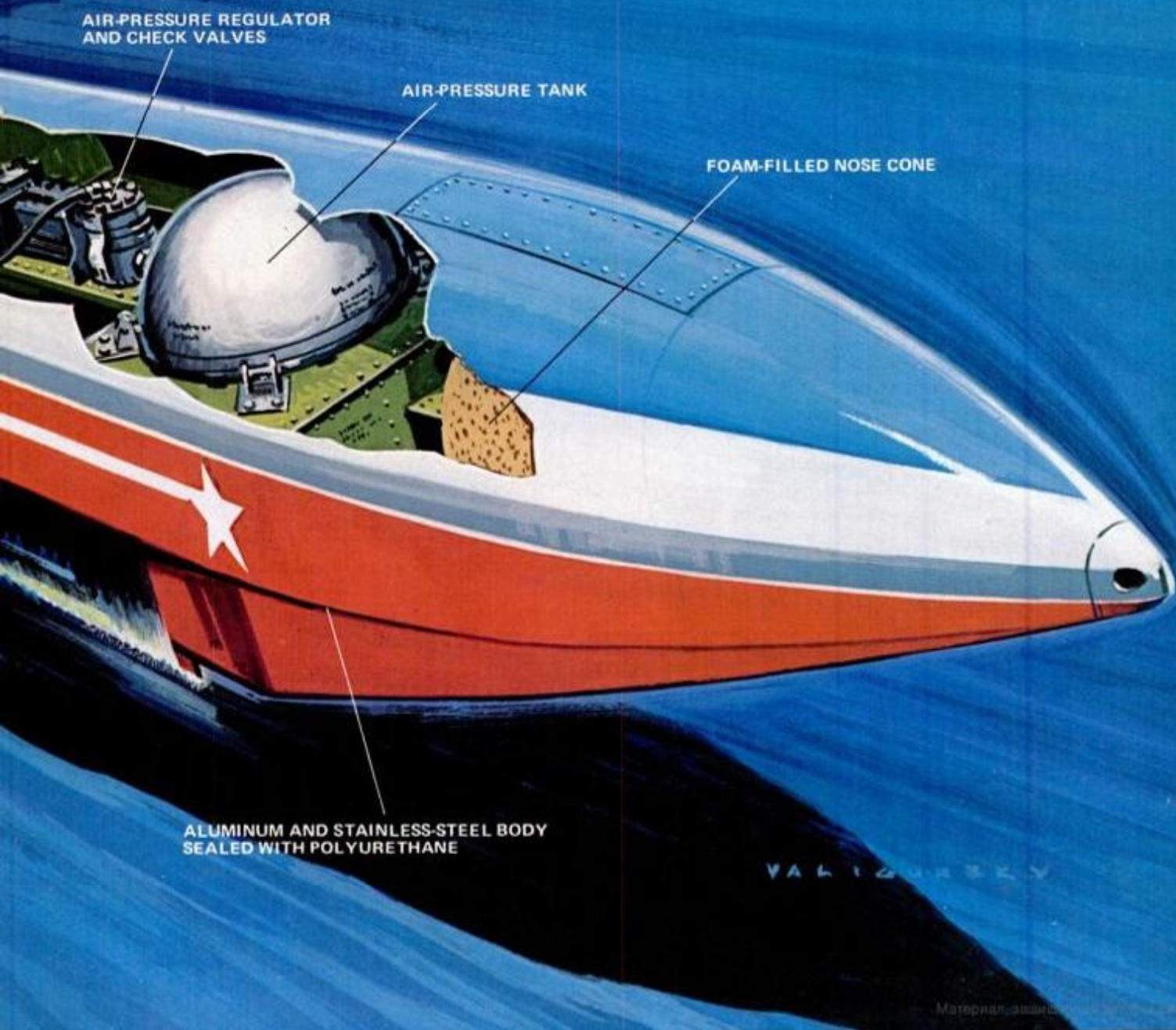

How we'll build a

The challenge: Build a zero-maintenance pump small enough to fit behind the ribs.

by Gurney Williams III

A 200-pound calf recently suffered a man-made heart attack at the Milton S. Hershey Medical Center in Pennsylvania after researchers injected tiny spheres into one of its arteries. But within a few days, its blood surged through its body at a normal 10-liter-a-minute pace. His appetite returned. He was able to stand.

The cure, like the cause, was man-made. A carefully engineered mechanical pump the size of a large fist helped thrust blood into the animal's main artery and out to its organs and muscles.

The pump, called a Left Ventricular Assist Device (LVAD), is a critical piece of hardware in a challenging, competitive research effort

(Please turn to page 78)

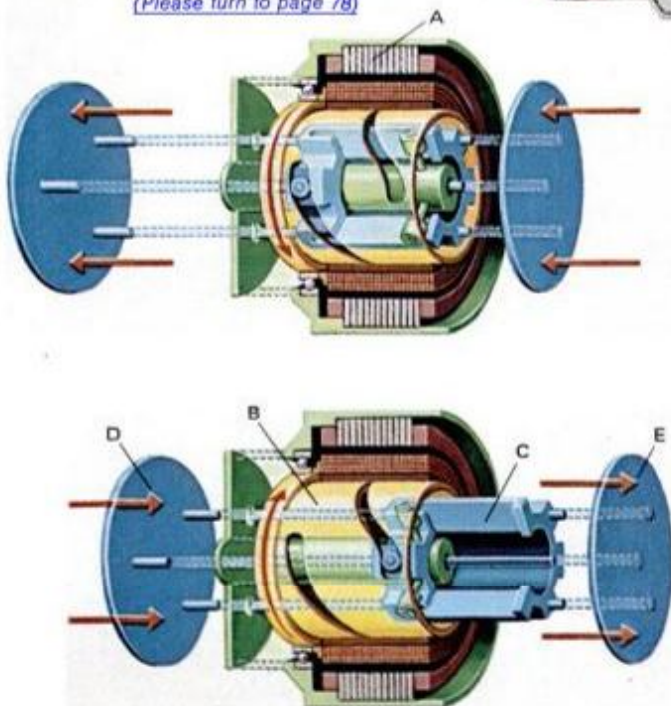
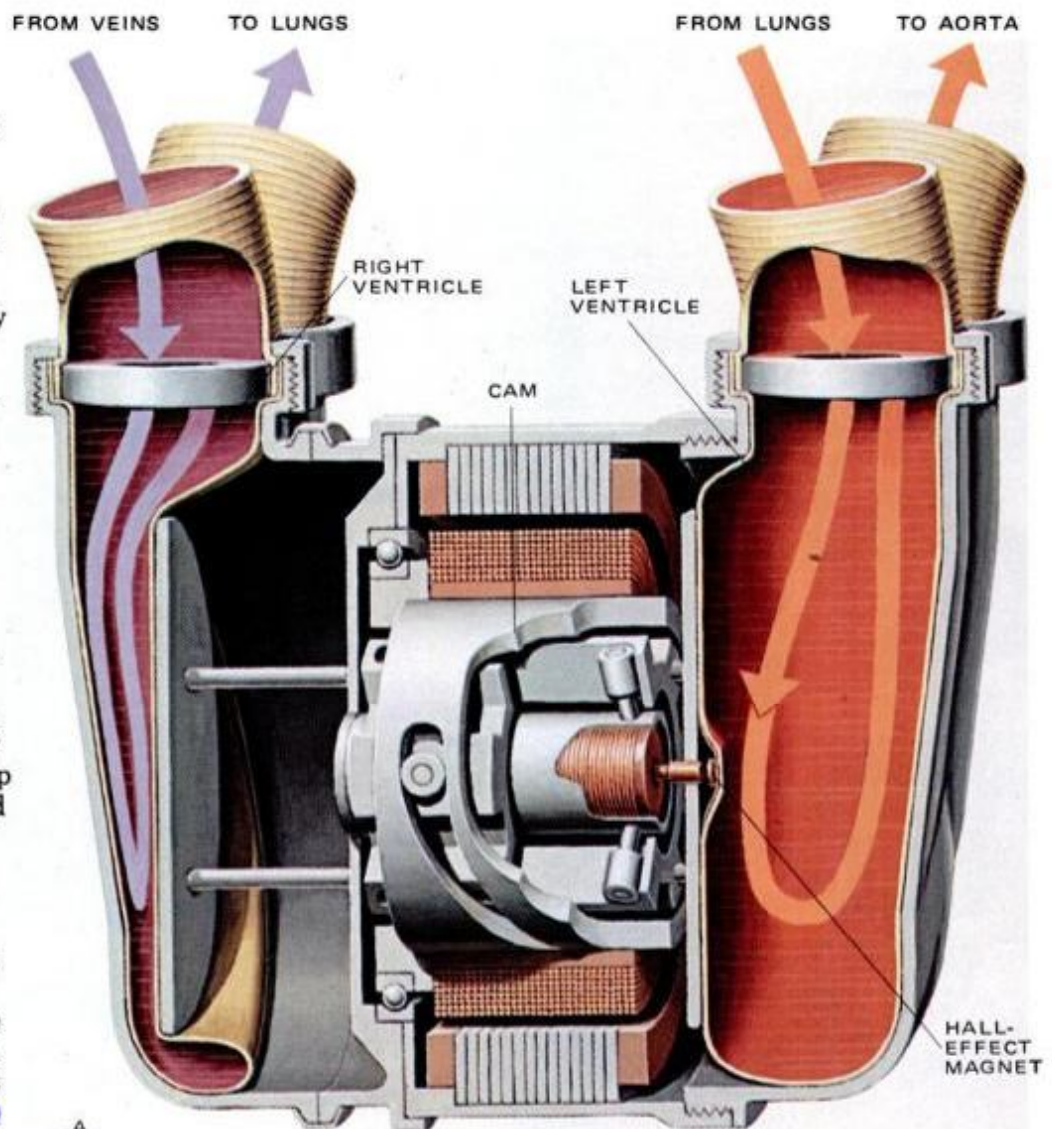

Prototype heart (in photo and cutaway, above) substitutes electric motor for heart muscle. In Hershey Medical Center design (left), stator (A) causes cam (B) to rotate 216°. As cam turns, it moves pusher-plate actuator (C) toward right or left depending on cam rotation. Pusher-plate actuator connects to pusher plates (D and E). Plates impinge on smooth polyurethane sacs duplicating chambers in human heart. After plate pushes blood out of one sac, cam reverses to pump blood from the other. In the biological heart (opposite page), both chambers contract at once.

working human heart

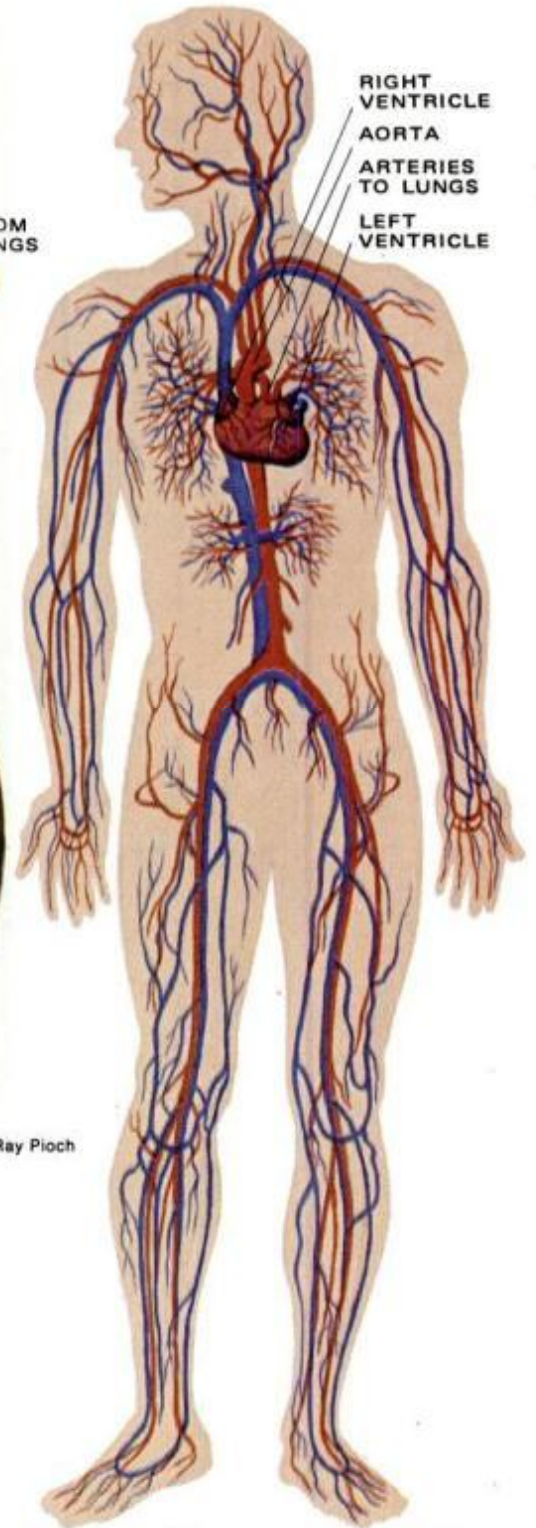
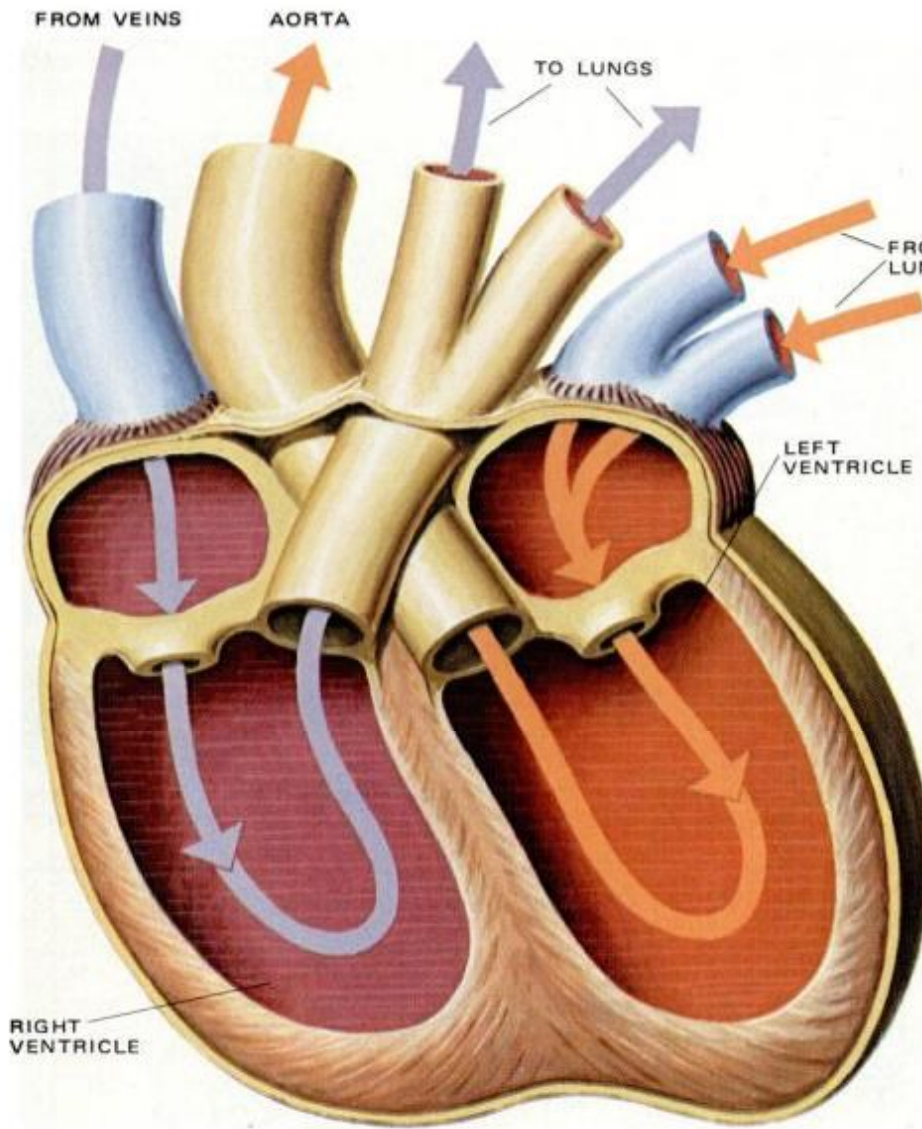

Illustrations: Ray Ploch



Hershey researchers adjust the Left Ventricular Assist Device on calf. Similar device has been used as a "crutch" for weakened human hearts.

In biological heart, left ventricle pumps oxygenated blood into aorta, body's main artery. After circulation, blood returns in veins to right ventricle. There, it is pumped to the lungs to receive new oxygen supply before entering the left ventricle. Pumping rate of Hershey artificial heart is set by devices continuously sensing the blood pressure in the circulatory system.

to build an implantable, artificial human heart. At least 20 centers here and abroad are working toward the creation of an almost perfect machine, a double-chambered, self-contained pump capable of moving roughly five liters of human blood every minute, or 2.6 million liters a year, with zero downtime for the years between replacement operations.

Despite these formidable specs, researchers have developed several different designs—including one for a nuclear-powered human heart—and kept animals alive for weeks on prototypes (the record is 7½ months, for a calf in Utah) after removing their natural hearts.

Fix it or remove it

Whirring, clicking hearts are dramatic evidence of a new direction in medical research. "Traditionally, medicine has attempted the alleviation of pain or of disability," said Dr. Pierre Galletti, a professor of medical science at Brown University. "Next came preventative medicine. Now we are at the threshold of substitutive medicine—'If you can't cure it, get rid of it and replace it.'"

Artificial body parts have come a long way from the ill-fitting, hand-carved wooden leg. Today's labs are building implantable internal or-

gans, as well as arms and legs, and keeping test animals alive with them:

■ Galletti himself is at work on a device to replace diseased lungs. In a typical experiment, he removes one lung from a sheep, then connects the animal to an artificial substitute lung made of teflon tubing coiled inside a plastic bag blown up with oxygen. The sheep's blood runs through

the tubing, porous enough to let the oxygen in without leaking blood. So far, it's worked on half a dozen sheep, he told us, although use in humans is at least a decade away.

■ Galletti has also connected rats and dogs to an artificial pancreas, developed in collaboration with researchers from Harvard, the Massachusetts Institute of Technology (M.I.T.) and Amicon Corp. The nor-

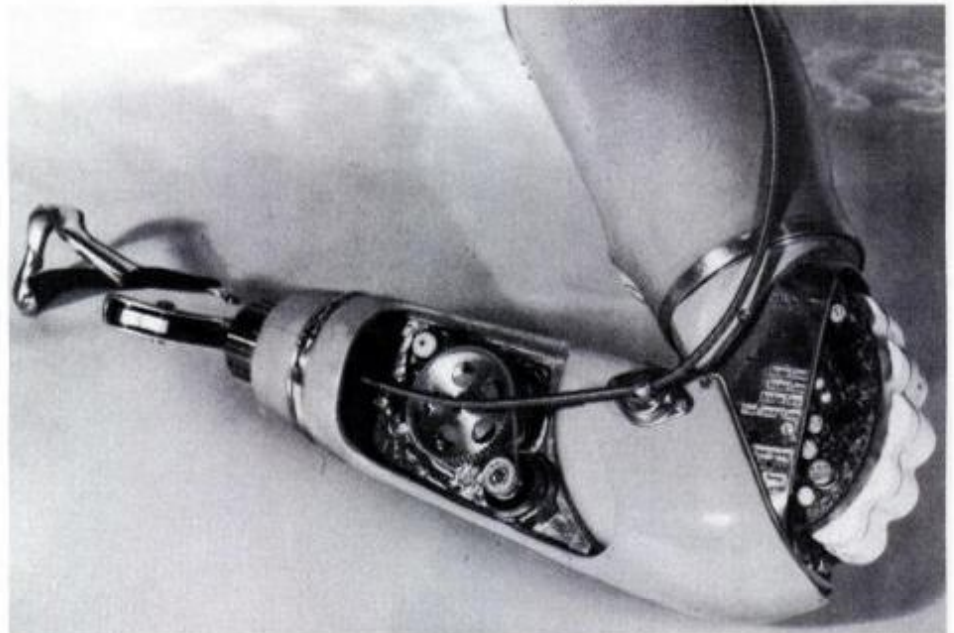

Artificial arm under study at the University of Utah contains computer circuitry to analyze electrical activity in shoulder muscles, and then control battery-operated motors.

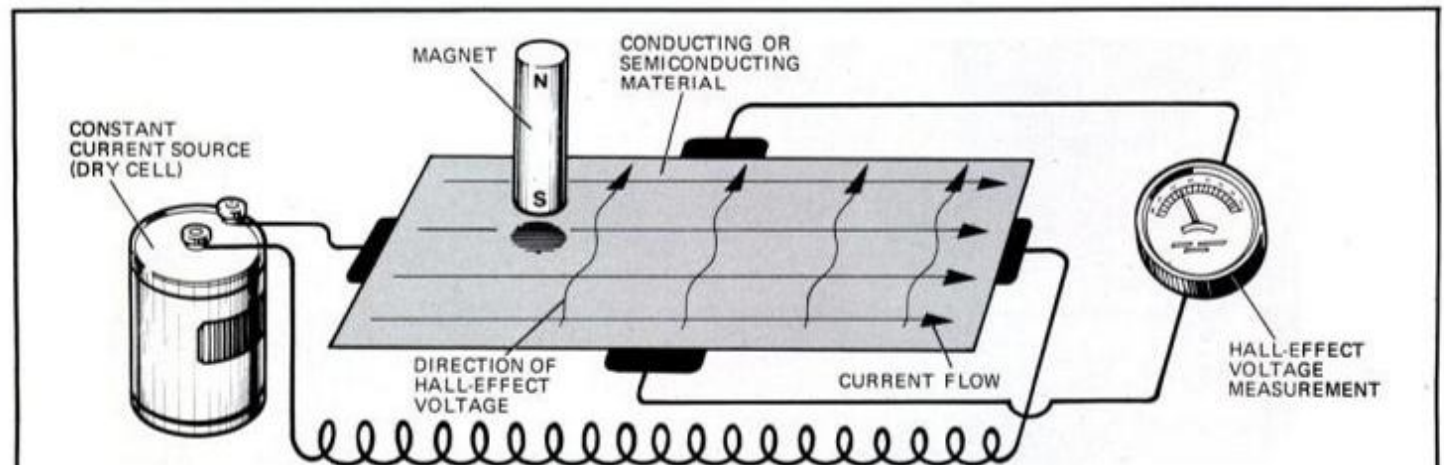

The Hall effect—a key to the heart

When considering a switching device to regulate pumping of an artificial heart, two factors come immediately to mind: reliability and durability. The human heart cycles about 40 million times a year—well beyond a reasonable operating life for mechanical switches. Fortunately, there are solid-state switches available that have *no moving parts* and therefore no wear. The one chosen for the Hershey heart is known as a Hall-effect device, developed by Micro Switch, a division of Honeywell.

The Hall effect, named for Edward H. Hall, the Johns Hopkins graduate student who defined it in 1879, has preoccupied a few theorists for nearly a century. Yet it is unknown to

the general public and had no commercial application until Micro Switch perfected a solid-state switch in 1968.

What Hall found was that if magnetic force lines were perpendicular to an electrical current flow (see diagram) and the magnet was brought close to a conductor (Hall used gold foil), a "pressure" to deflect the current in the conductor—later to be called Hall voltage—seemed to arise. It was as if some force were trying to push a noncompressible fluid like water to the side of the pipe in which it flowed. Hall found that this voltage increased with the strength (or proximity) of the magnetic field and also with the strength of the original current—and later experimenters found Hall

voltages even higher when certain semiconducting materials replaced the conductor.

It remained for Micro Switch to digitize a Hall-effect device, which meant that it would produce Hall voltage that is either "on" or "off," depending on whether the magnet has crossed a predetermined threshold.

Thus can a sensor the size of a pinhead "feel" the approach of a small magnet attached to the flexible wall of the Hershey heart's left ventricle, and accurately control the pumping rate. Tests at Micro Switch have Hall-effect switches operating reliably after 12 billion cycles. Computed in terms of human heartbeats, that's 300 years.

mal human pancreas, a long, rounded gland at the back of the abdomen, secretes enough insulin hormone to allow the body to use blood sugar efficiently. In diabetics, insulin levels are too low. To build an artificial pancreas, Galletti seeds the outside of a porous tube with live, insulin-producing pancreas cells. When the tube is spliced into an animal's circulatory system, these cells sense insulin levels in the blood. They secrete proper amounts of the hormone through the porous wall of the man-made tube. It's worked for up to a week on dogs, he told us, and might be available for diabetics before the end of the decade.

■ Johns Hopkins researchers have used artificial blood clots to treat more than 50 human patients. Natural blood clots, of course, can be a medical disaster, blocking off blood supply to the heart or the brain. But man-made clots, carefully placed, can help save lives. Before an operation on one 56-year-old Baltimore woman to remove a tumor from her liver, Dr. Robert I. White Jr. inserted a thin, hollow catheter into a vessel supplying blood to the growth. At the tip of the catheter was the artificial clot: a tiny, deflated balloon made of clear silicon. Using an X-ray dye, he monitored the movement of the catheter until the balloon was in a perfect position to dam the flow of blood to the tumor. Then he filled the balloon with dye to a diameter of about one-quarter inch, just enough to block the blood. The procedure guarded against life-threatening hemorrhage when surgeons successfully removed the tumor.

■ Other researchers have filled the plastic shells of artificial arms with

computer circuitry in recent years, to analyze electrical activity in shoulder muscles and direct motorized elbow flexions and grasping movements in artificial hands. One model, built by Dr. Stephen C. Jacobsen at the University of Utah, carries a battery pack good for at least 2500 elbow movements before recharging. The prototype picks up minute signals from two sensors on biceps and triceps muscles to control elbow movement. Motors in the arm can lift five pounds with the speed of a natural arm.

A crutch for heart patients

Some of the most imaginative work has gone into building components of a human heart, coronary parts that will eventually be fitted together to make a total artificial organ. In the meantime, doctors have used some of the components as a crutch for ailing hearts.

One patient at grave risk at the Hershey Center was a 39-year-old mother of four from northern Pennsylvania. Rheumatic fever had damaged a heart valve, preventing an unobstructed flow of blood into her left ventricle. This chamber on the left side of the heart receives oxygenated blood from the lungs, and pumps it up into the aorta, the main artery of the body. Dr. William S. Pierce put in an artificial valve, while a heart-lung machine took over the work of oxygenating and circulating her blood. The operation proceeded smoothly. But when the heart-lung machine was disconnected, her heart would not pump well enough to keep her alive.

Ten years ago she would not have survived. But by the time of her operation in 1977, Hershey research-

Artificial pancreas (left) has maintained insulin levels in rats and dogs. Inside device, blood circulates through porous tube (below) whose wall is coated with live pancreas cells. These sense hormone level in blood and secrete adequate insulin through wall to enable body to use blood sugar efficiently. Device may be used in humans within 10 years.

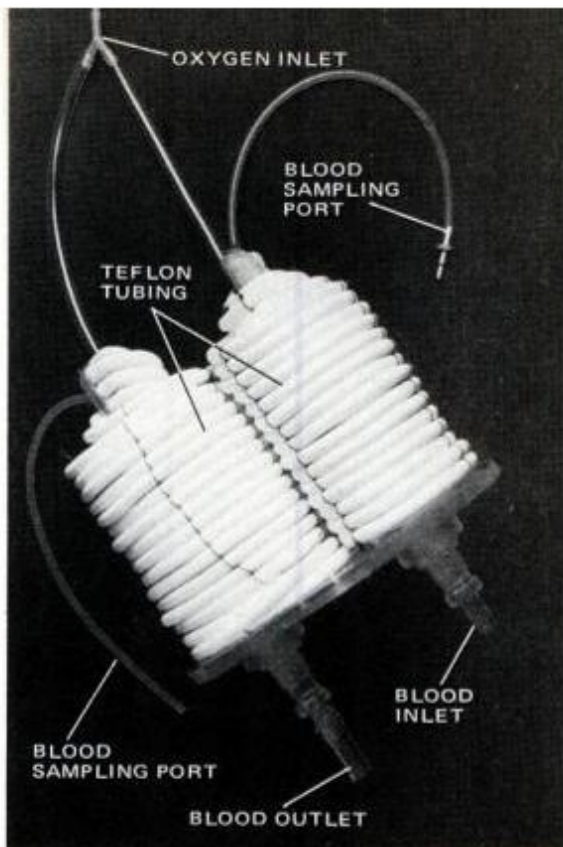
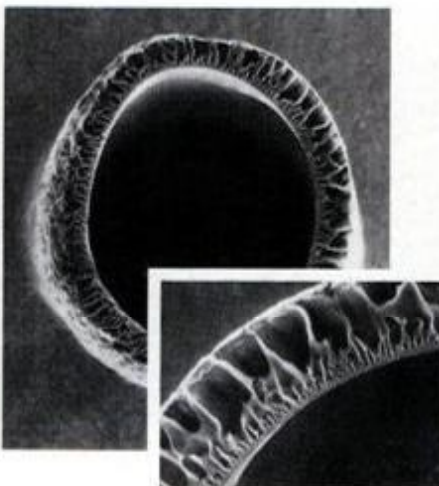
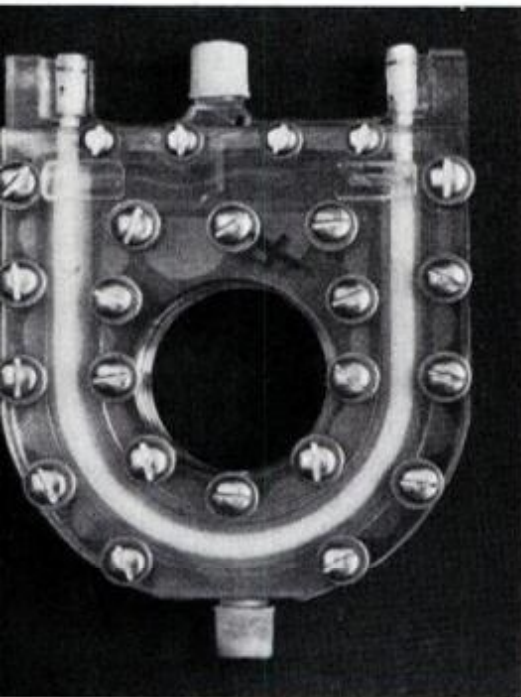

In artificial lung, a plastic oxygen bag (not shown) encases porous Teflon "vessels."

ers had perfected their LVAD enough to connect her to it. She wore the small pump outside of her body. Its polyurethane chamber received blood through a tube and then, powered by a pneumatic pump, it delivered a spurt of blood into the aorta at precisely the right time to complement the weak effort of her own heart. Pierce gradually weaned her from the device by reducing its pumping. After eight days, her own heart took over completely. She went home, and lived for more than a year. The cause of her death is unknown.

Since the first LVAD operations three years ago, the mechanical pumps have been connected to 14 patients at Hershey, all of them in imminent danger of dying. The woman and a man, discharged last summer and still alive, were the only survivors. Other medical centers, using different designs for the LVAD, have had about the same success. Of 15 patients attached to mechanical heart pumps at Children's Hospital Medical Center in Boston, there have been just three long-term survivors.

But small as it is, the survival rate among these critically ill patients is remarkable, considering the problems with such mechanical pumps that seemed insurmountable just a short time ago.

In his office overlooking the rolling farmland around the Hershey Center, affiliated with Penn State University, Pierce recalled some of

(Please turn to page 162)

IT'S NEW
NOW

Big wheel

Ken Wilson thinks tricycles may help solve the energy crisis. But he's not high on currently available three-wheelers, because they don't corner very well. Enter Wilson's Carriage Cycle. It's articulated in front, so the rider's part of the trike leans into a turn. Combined with a leaf spring

suspension (right), it permits riding on rough terrain; the three wheels give stability on ice, snow and in the rain. The inventor claims it's perfect for carrying loads like groceries. The Chenoa, Ill., resident uses a chain and sprocket (below right) for front-wheel steering.

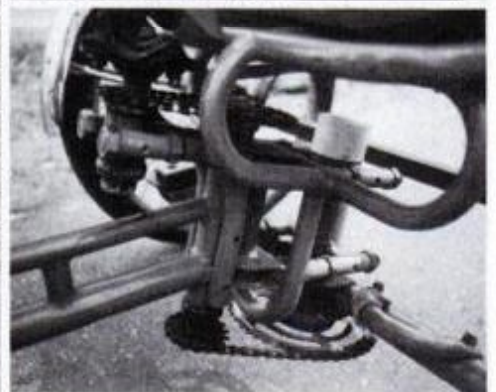

Electronic washer



A single-chip microcomputer controls this washing machine. The user punches in type of material being washed, degree of dirtiness and size of load; the machine picks the optimum washing program and lowest possible consumption levels of electricity, water and detergent. Made by AEG-Telefunken of Germany, the machine can make its own repair diagnosis.

Against the wind

High winds can accelerate heat loss from, and cause physical damage to, greenhouses. An artificial windbreak made of a material called Paraweb is said to be able to reduce heating costs as much as 25

percent in stiff winds. The webbing, made by ICI Ltd. in England, is claimed to be virtually indestructible and unaffected by weather. It is also used in crop protection, sand-dune control and snow fencing.



Riding on air



Called the world's first and only inflatable ice chest, the Nautilus comes in seven-quart size (seven cans plus ice cubes) and also in other sizes up to 48 quarts. When not used to keep drinks cold, it'll keep cameras and binoculars protected from travel bumps and important gear afloat, if a sudden rain should come or a canoe capsizes. Each of the five models is a different color; price ranges from \$14.50 to \$27.50. The chests deflate to stow compactly.

Digital delight

Electronic technicians and hobbyists can now purchase a logic probe as an inexpensive kit, and get high-quality performance in the bargain.

The probe is indispensable for use in troubleshooting digital electronics. It's available at \$19.95 from Global Specialties Corp., 70 Fulton Terrace, New Haven, Conn. 06509. (It's listed in their catalog as probe model LPX.)

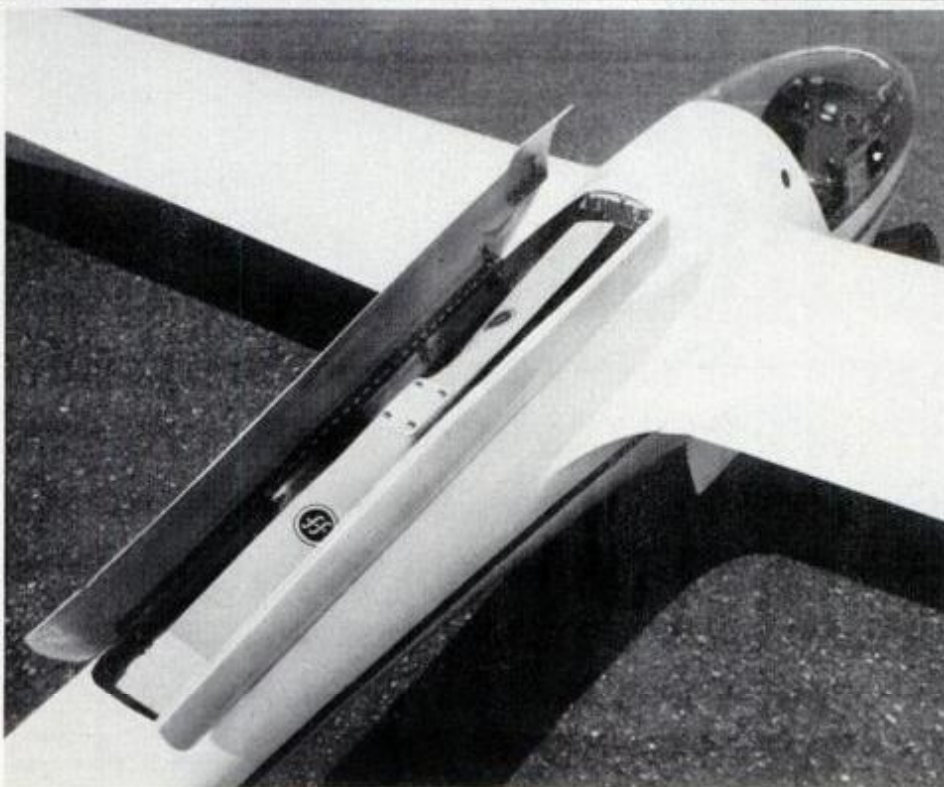
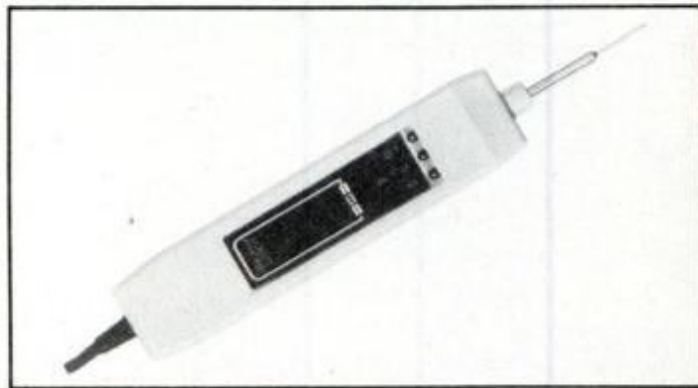

This glider can do it all

The Pik-20-E is the first production sailplane to sport a retractable engine. The powerplant obviates the need for a tow-plane and comes in handy in an emergency.

By hand-cranking the engine and the prop into the fuselage, the pilot turns the plane into a competitive, high-performance glider with a 15-meter-wingspan, the maker claims. Carbon fibers are used in the wing spars to save weight; empty, the plane is 640 pounds. The engine is a 500-cc, 43-hp two-stroke. Top speed is 174 mph.

Manufactured in Finland by Eiriavion, it is distributed in the United States by Smitty's Soaring Service in Clinton, N.Y. This aircraft may be purchased for \$43,000 complete.

500 miles on 15 gallons... in an air race!

This all-composite sports plane gets 40 miles to the gallon, hits more than 180 mph, and has already scored high in one air race. You can build it from plans and kits for under \$5000.

by Sheldon M. Gallager

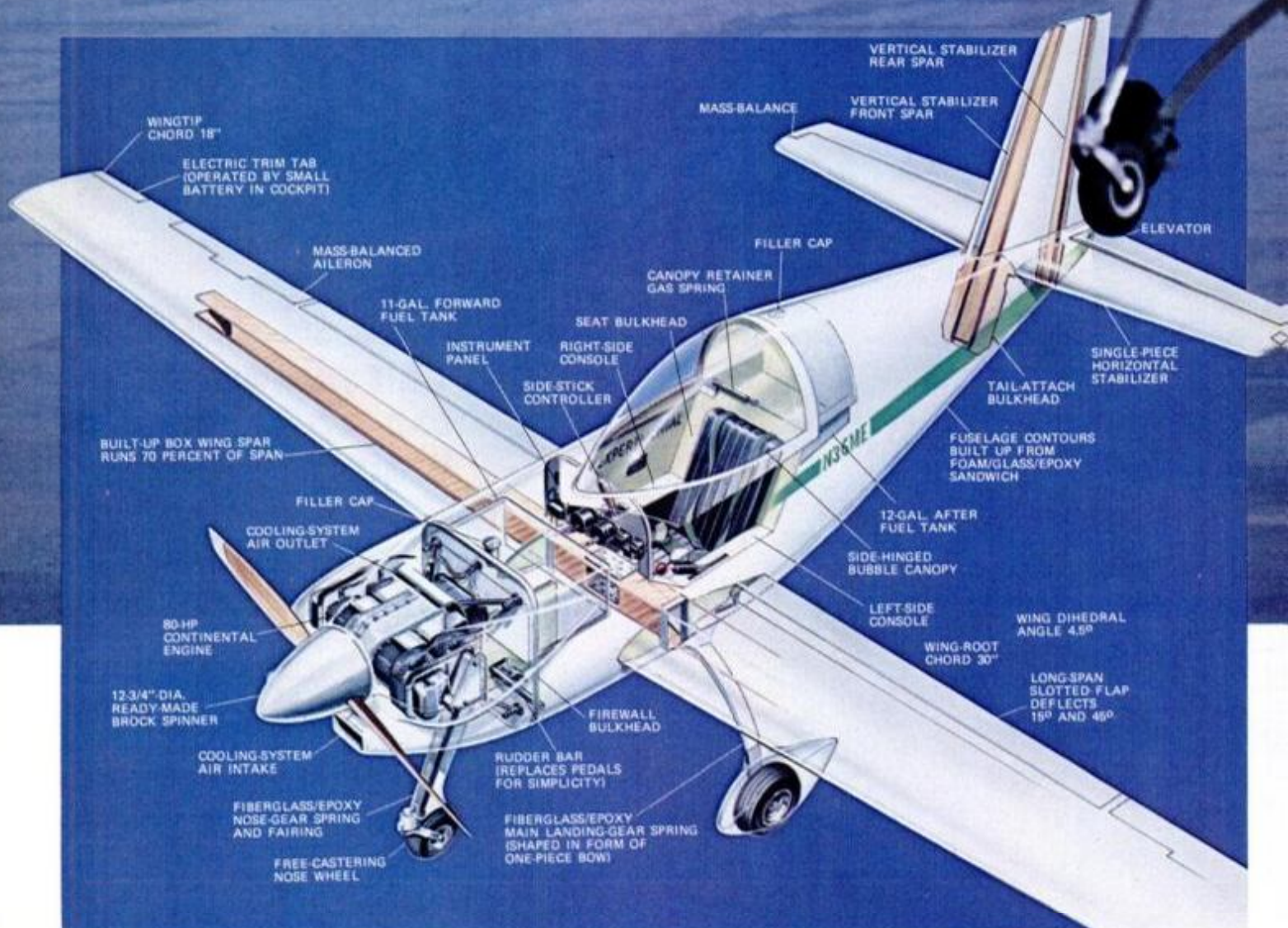

Low weight and clean lines give this all-composite speedster impressive performance on modest power. Streamlined wheel pants and fairing on the nose-wheel strut were added after photo (above, right) was taken, upping speed 10 mph. Ground steering is by differential braking; nose wheel is free-castering. To keep weight down, there's no radio or engine starter, though they can be added.



PM photo: Bill Pierce

George Mead didn't start out to build an air racer, but the trim little craft he came up with has been performing so well it's beginning to *think* it's a racer. George entered it in last summer's Oshkosh 500—a 500-mile, closed-course pylon race for sports planes—and surprised everyone, including himself, by coming in a respectable third in a field dominated by veteran race pilots. Mead's creation, aptly named Adventure, is a sleek, single-seat, tri-gear monoplane designed for easy construction, safe handling, economical operation and—are you ready?—high performance. High *what*? On the face of it, this last claim seems improbable. Easy-to-build, easy-to-fly airplanes aren't supposed to be inspiring performers. Yet George has managed to pack a remarkable amount of excitement into his tiny speedster. It hits 188 mph flat out, has a high-speed cruise of 175 mph, and climbs like an express elevator at 1600 feet per minute. While not intended for unlimited aerobatics, it romps nimbly through loops, rolls and most other maneuvers an adventuresome pilot would want to

(Please turn to page 153)



Ailerons are tiny—only 24 inches long—but are mass-balanced, highly effective. Numeral 4 on wing is plane's race number.

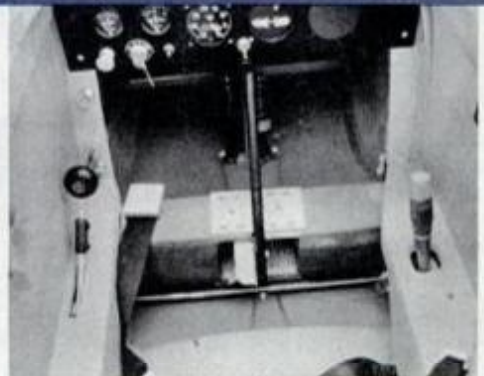

Fighter-style side-stick controller is at right in cockpit. Center handle is flap control, extra long to give good leverage.



Side-hinged canopy opens out of way for easy entry. Slot in nose cowl is exhaust port for novel forced-air cooling system.

DON'T GET BURNED BY

Lured by growth of the solar market, hundreds of novice installers are

Abraham M. Genen bought a solar system for his Orange County, N.Y., house that didn't work anywhere near as well as it was supposed to. The contractor promised a 50-percent efficiency. The actual performance, Genen estimates, is 10 to 15 percent.

What makes Genen's experience especially illustrative is that Genen is not just any buyer. He is a senior

consumer-fraud expert in the New York State Attorney General's Office. One of his specialties: solar energy. In fact, Genen, a 14-year consumer-fraud veteran, got his solar assignment about the same time he got his solar system. He could have been his first complaint.

"I asked a lot of questions," he said. "I got data and statistics. They were as phony as a \$3 bill." Now he's

suing the contractor. He says he would do it differently next time, but his first solar system has brought him nothing but, as he says, "tsouris," the Yiddish word for "aggravation."

Genen is part of a growing subculture that has found solar energy in practice to be far different from solar energy in theory. Even more ironic is that numerous complaints are surfacing while the quality of collectors is improving.

Two things are happening in the solar field. First, established manufacturers and installers are supplying high-quality solar systems that meet various standards. Second, hundreds of inexperienced manu-

Make sure the solar hot-water system you're considering incorporates features illustrated on schematic below. How it works: conventional hot-water tank at right connects to solar tank, core of a closed loop. Water from the solar tank is pumped up to collector, heated and returned. Fluid warms household water passing through submerged coil. Heating elements in the conventional hot-water tank further warm

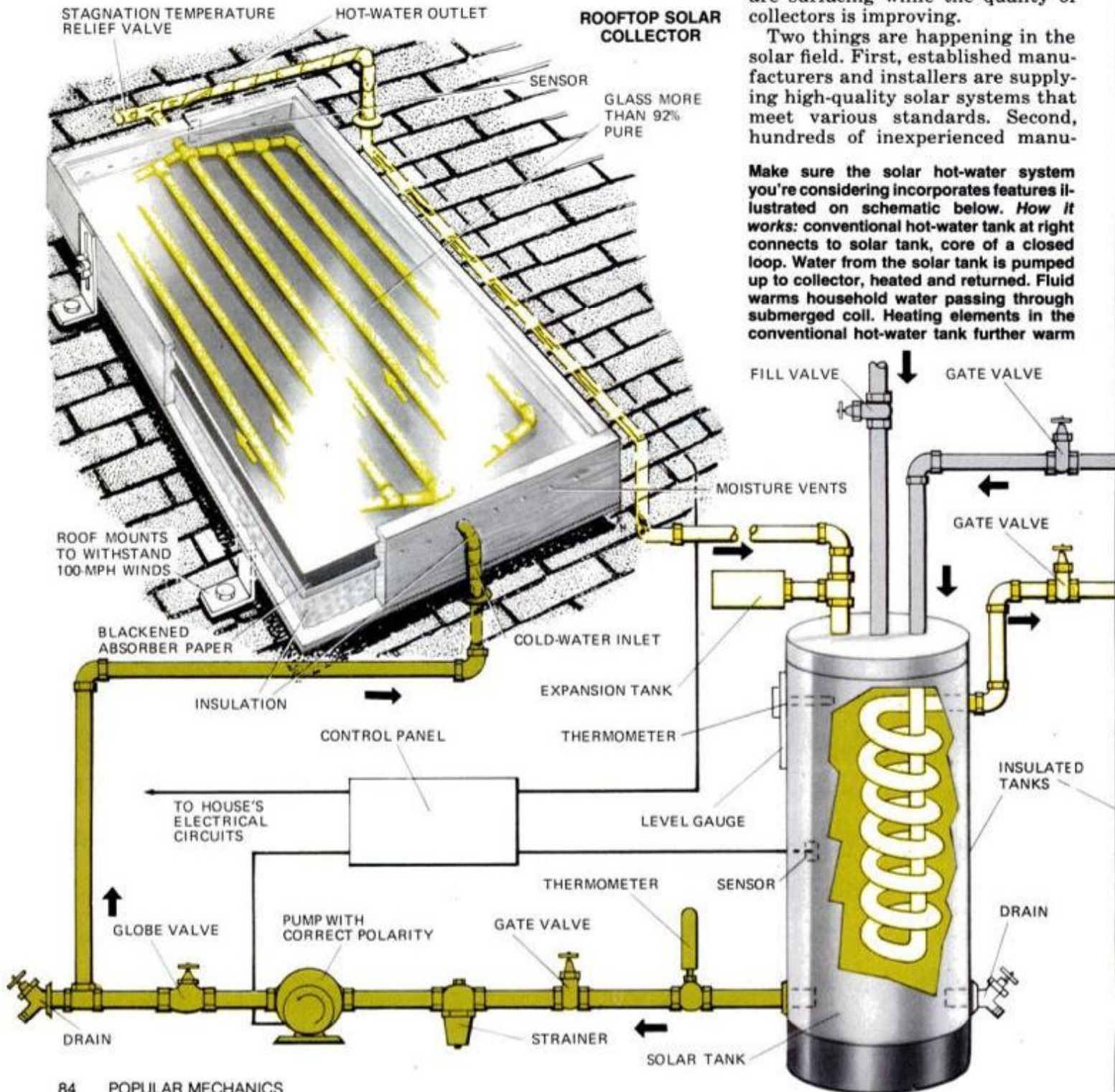

SOLAR RIP-OFFS

by Stuart Diamond

selling inferior systems.

Manufacturers and installers—attracted by the astronomical growth of the solar market—are profiting by selling inferior work. Today, perhaps 200,000 solar systems—largely domestic hot-water—dot this country, and the figure more than doubles each year. The number of competent solar firms has not kept pace with demand, experts say.

“When they opened the door, everyone came in, including the incompetents,” says Edward Bohrer, president of California’s Southwest Energy Management, which is highly regarded by federal officials. Bohrer said fully 20 percent of his business involves fixing systems installed by someone else.

the water as necessary. Sensors—one in the solar tank, one in the collector—turn on the pump when the collector temperature is at least 10° hotter than the temperature in the solar tank. Potential problems range from heat waste, caused by inadequate insulation on pipes or tanks, to blowouts, caused by pump failures and overheating. Good solar systems are able to save you as much as 80 percent of fuel bills.

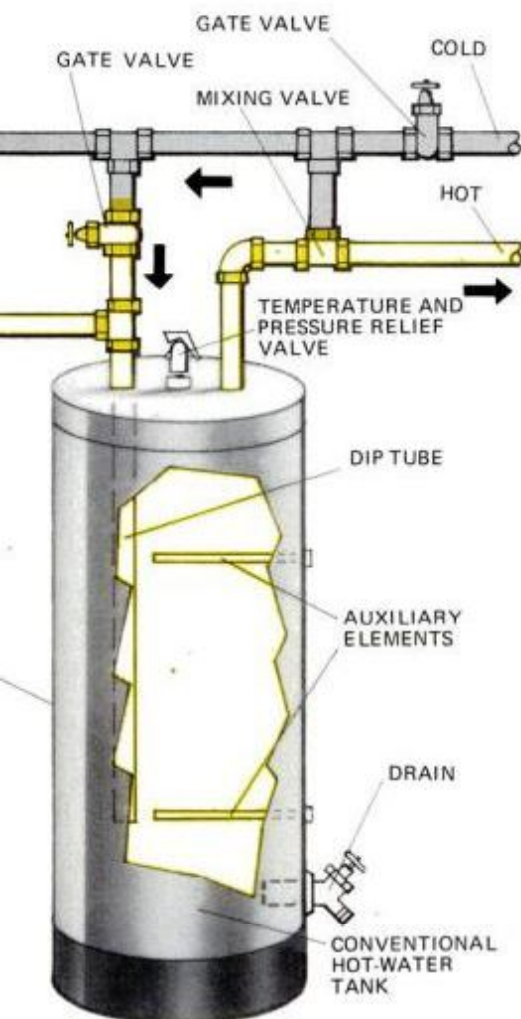

What’s wrong with the picture above? Haphazard orientation of collectors reduces efficiency. Ideally, collectors should face no more than 15° east or west of true south. Moldings lifting on collector surface (below) is evidence of poor construction.

Disheartening evidence of recent problems comes from an inspection of 60 systems early this year by the Florida Solar Energy Center, a state agency.

Only three of the systems checked were found to be problem-free. Fully 24 had more than routine design and installation problems, 13 had serious problems and seven didn’t work at all. Even Randy Dyer, associate director of the Solar Energy Industries Assn., conceded that inexperienced labor has proven to be a serious problem in a significant number of cases nationwide.

In a number of southern California houses, workers installed systems by following the manufacturer’s directions exactly: Install the collectors to the north, facing the sun. Unfortunately, the collectors came from Australia. In the United States, the sun comes from the south.

“The problems go from the ridiculous to the very subtle,” observed Lynda Connor, who manages solar consumer programs at the U.S. Department of Energy.

Large rewards possible

The rewards for selecting the right system are large: A tax credit (See *How Energy-Saving Home Improvements Can Save Tax Money*, page 136, Sept. ’79), thousands saved on fuel bills and a jump in a house’s resale value. A problem-free solar system is completely automatic. But to reap those rewards, consumers must first use sound buying prac-



tices, as they would for any major purchase.

Here, is how to avoid getting burned when you buy a solar system.

Collecting information

The first step is to gain as much detailed information as possible on solar systems—how they work, who makes them, performance data, economics, different designs, local installers, problems. Contact the federally funded National Solar Heating and Cooling Information Center (see page 134 for the address of the Center and other helpful agencies), perhaps the world’s largest such solar outlet. Almost everything they supply is free.

Make sure you ask for the *Domestic Hot Water Heater Installation Guidelines*, an invaluable document that will help you install—or scrutinize—any system.

Send for the Solar Energy Industry Assn.’s *Directory of S.E.I.A. Cer-*

(Please turn to page 131)



The Comuta-car's small size and quick reflexes enable it to zip through any traffic situation.

Living with an electric car

We take home a production electric car and get a charge . . . and some shocks.

by Tony Assenza AUTO EDITOR

Owning an electric car these days is probably one of the last great opportunities the average motorist has of exercising his pioneering spirit. The current state of development of these volt guzzlers is comparable to that of aviation a few years after the Wright brothers flew their first hundred yards. In that sense, anyone who buys an electric is embarking on a trip through uncharted territory. He leaves behind the automotive world as we know it and, like any pioneer, is left pretty much on his own, to sink or swim as best he can. I discovered this one evening when the batteries gave up, leaving me stranded in the middle of the Brooklyn Bridge.

In a gas-engine car, running out of fuel isn't yet a major problem. But who do you turn to when you need to revitalize 200 pounds of dead batteries? Have you ever tried calling the



PM photos: Ralph deMasi

AAA and asking for 12 batteries? I can guarantee that their answer is anything but encouraging.

The problem is that nobody in the entire country is able to provide this unique type of emergency road service. The only recourse is to ride home slung off the back of a tow truck. And that's a very uninspiring position, especially for a pioneer.

Fortunately, that night on the bridge I didn't need a tow truck. A good Samaritan named Serge from Trenton pushed me off the bridge to a gas station, one of the greatest institutions of the 20th century. Where else can you get anything from a loaf of bread to a rebuilt transmission . . . and a charge for a dead electric car?

I never got a chance to properly thank Serge from Trenton. He took off in his Beetle before I even got a chance to get his full name. So,

wherever you are, Serge, thanks for the push.

Getting stranded far from a plug was the worst that happened with the electric car. But once I got it safely home, life became less complicated and actually very enjoyable. All I had to be aware of was the state of charge and my mileage. As long as I stayed within the range limit, the car was as effortless to live with as a gasoline-engine car.

While tooling around the neighborhood I discovered something else about owning an electric. Short of passing out hundred dollar bills on a street corner, having this car is the best way of making friends ever invented. Park it and it will draw more crowds than the Super Bowl.

Tough as a football helmet

The object of all this attention on the street, our test vehicle, is called

Comuta-car. It is one of the few electric vehicles currently available for sale. There are dozens like it in various stages of testing and evaluation but none of those are on the market. The reason we picked this car was its availability and the reasonable price, just under \$5000. The few other electrics available cost a lot more.

What you get for the money is a sturdy, two-passenger car that carries 13 batteries in an aluminum floorpan, all wrapped up in a Cylolac ABS plastic body shell, the plastic used to make football helmets.

To meet the government's crash tests, the manufacturer placed four of the batteries in a tray in front of the car. In a head-on collision, the tray is designed to absorb most of the impact and prevent the batteries from being pushed into the passenger compartment. A similar arrangement is at the rear of the car.

To provide even more occupant protection, a roll bar is installed over the seats and another crash bar runs beneath the dashboard. There is still another bar that runs down both sides of the windshield. This roll-cage arrangement is similar to that used by race cars.

While the interior lacks most of the luxury touches found even in subcompacts, it is not uncomfortable. There is no seat adjustment, but anyone under 6 feet should have no trouble being comfortable.

In fact, no one should have much trouble adapting to driving this car. It works pretty much like any other car with automatic transmission.

To get the car under way, you insert a key and turn it. But, instead of hearing an engine turning over, there is silence. The red parking-brake lamp goes on. The parking brake is an interlock mechanism that prevents current from reaching the motor while the brake is engaged.

Forward and reverse are selected by a three-position toggle switch; forward is up, middle is neutral and reverse is down. The switch can't accidentally change position.

Once the switch is positioned, a tap on the accelerator will get the car rolling. The accelerator in this case is a conventional pedal that controls the amount of electrical power delivered to the engine. There are three forward and reverse speeds, each one automatically activated by relays when the accelerator is depressed. When you're driving, the only sound the car makes is the whine of the electric motor and the clicks of the relays as each one is activated.

The instrument package consists
(Please turn to page 173)

A HANDSOME HYBRID, BUT YOU CAN'T LIVE WITH IT—YET



Two rear axles are used to evenly distribute the weight of the batteries. On the road it cruises at over 60 mph. Diagram illustrates twin-engine layout.

Thus far, no fully practical vehicle that is entirely gasoline-free has been perfected. But after 18 months in the works, the Briggs & Stratton Corp. (the world's largest manufacturer of small internal-combustion engines) has unleashed the next best thing: the Gasoline/Electric Hybrid. This sporty, family sedan can be driven by either its 8-hp Baldor, series-wound d.c. electric motor or an 18-hp Briggs & Stratton gasoline engine. Or it can be driven by both together to produce variable gas mileage from 25 to 150 mpg.

While some of the major automobile manufacturers are just now receiving large government grants to experiment with such vehicles, the Briggs & Stratton Hybrid is already being tested. It's a roomy, contemporary, aerodynamically sound, good-looking car with passable performance, maximum fuel efficiency, and the one big thing all pure electrics have lacked: long-range capability. The car offers a range of approximately 60 miles under battery power, but when that cuts out, the driver just switches on the ignition and motors happily home under gasoline power. Combined range: over 300 miles.

When Briggs & Stratton undertook the hybrid project, one of the first choices to face project engineer Doug Janisch and then vice president of research and development Bob Harkness was between the two common approaches to combining gasoline and electric powerplants. The first—and simplest—



method is to add an engine-driven generator to the electric motor to recharge its batteries. This "series-hybrid" design adds nothing to the electric motor's performance, however, only its range, and suffers significant mechanical-electrical-mechanical conversion losses that make it an inefficient system. According to Harkness, "the series system loses energy at every step, and it takes a very complicated electrical circuit to take large inputs of energy from the generator and store them into the batteries."

Thus, Briggs & Stratton has employed the "parallel-hybrid" principle, whereby the heat engine is directly connected to the electric motor, applying its power mechanically to the driveline. In addition to acting as a reserve when the electric power is depleted, the gasoline can be—and usually is—used as a supplement to the electric motor to produce increased power.

On level ground the electric motor will propel the car at about 45 mph, the gasoline engine at about 44. Under hybrid power—gasoline and electric together—the car will cruise easily in the low 60s.

With the parallel-hybrid system, no attempt is made to recharge the batteries during the car's operation. That is accomplished at home, via two chargers, in anywhere from two to eight hours at a cost of anywhere from 75 cents to \$3.75, depending on the time of day (night rates are cheaper) and the cost per kilowatt in your area.

Driving the Hybrid differs very little from driving an ordinary car. Starting up is as easy as flipping on a light switch, in this case a toggle located on the lower left portion of the dash. What is disconcerting is that, even with the switch on, the car makes absolutely no sound. Press the accelerator, however, and it

PM photos: Dave Gooley



The little internal-combustion engine is hooked up directly to the electric motor.

(Please turn to page 173)

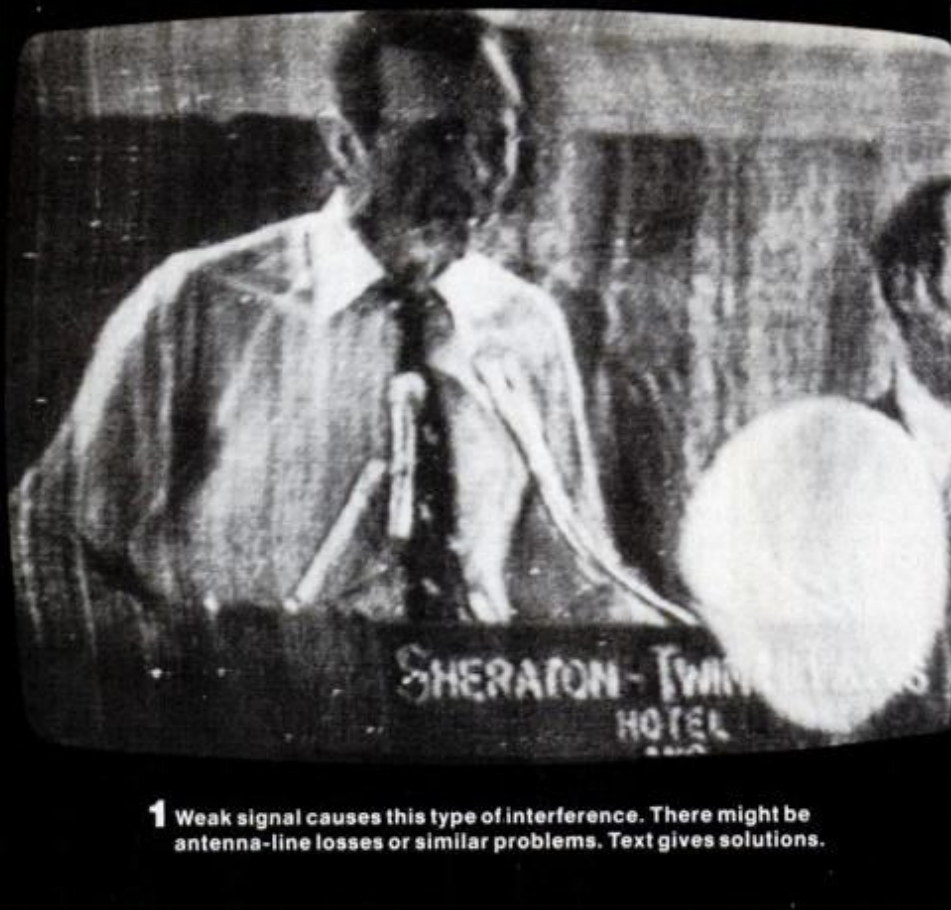

1 Weak signal causes this type of interference. There might be antenna-line losses or similar problems. Text gives solutions.



2 Electrical—bands of snow.



3 FM radio—hash-like stripes.

8 WAYS TO BEAT TV INTERFERENCE

by Jorma Hyypia

A few years ago, there was considerable hoopla about the alleged disruption of television by citizens band radio. Today, there are rumblings and grumblings that hobby computers are the real TV-interference culprits. Tomorrow, latter-day Don Quixotes bent on protecting the purity of TV transmissions may have reason to joust with *real* windmills, as well as with CB radio and computers.

1. Weak TV signals

These can be mistaken for television-interference (TVI) problems. If all channels have the same grainy, degraded appearance, look for corroded or broken connections all along the lead-in cable, from the antenna to the TV set. This type of maintenance is indicated if you formerly had good reception. If you have never had satisfactory picture quality, you may need a better antenna, or the existing antenna should be placed higher up and per-

haps be fitted with a signal amplifier for improved reception.

If only one or two channels have the overall grainy appearance, your cable connections are probably in good shape. Perhaps you are simply located in a fringe area with respect to the particular channels affected. Better antenna orientation (direction and height) and use of a signal amplifier should solve the problem.

2. Electrical interference

If very pronounced, this might be mistaken for a weak signal condition, although the two effects are ac-

tually quite easy to differentiate. A weak signal causes uniform degradation of the entire picture area. On the other hand, even severe electrical TVI tends to form changing bands of flickering, short, horizontal lines, or else more randomly spaced, bright pinpoints of white light. The latter effect is very common when an electrical storm is in the viewing area.

If you observe pinpoints of light dancing around on the screen when there is a breeze blowing outside but no storm, check the lead-in wire connections to the antenna. Odds are

High-pass filters can be useful if installed as shown here. Don't forget to put one on each side of a booster amp. Try the three cures at far right to solve the interference from appliances or dimmer switches—but be careful of a.c. wiring if you make modifications.

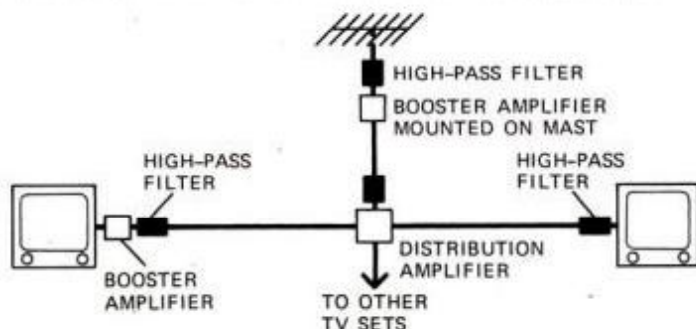



4 Computer—similar to radio.



6 CB radio—pulsing lines.



7 Co-channel—different images.



5 Ghosts—multiple imaging.



8 Airplanes—picture tears.

Recognizing what's wrong is the first step to improving poor TV reception. Here are the most common problems and the solutions.

you will find at least one connection either badly corroded or broken off.

To track down other intermittent electrical TVI, go around the house and turn off operating appliances one by one.

If a portable radio is affected by the same interference, carry it around your home area and see where it sounds noisiest. It's just possible that you will get loudest radio interference when you move closer and closer to a neighbor's property; maybe *his* appliance or engine is creating the problem.

If the interference is caused by a power drill or saw, you may live with the minor nuisance. However, any appliance that causes persistently annoying disruption of TV or stereo equipment performance should be corrected (see illustration).

3. FM radio interference

This can be caused by a nearby FM broadcast station and may create a herringbone pattern that is easy to confuse with a similar pattern caused by misadjustment of the TV set's fine-tuning control. If the tuning control is at fault, the inter-

ference pattern fluctuates with sound changes in the TV program; if FM interference is present, the pattern fluctuates with variations in the sound of the FM broadcast, *not* with the sound of the TV program.

FM TVI is usually most bothersome on Channel 6, although other channels in the 2 to 13 series may also be affected. Before attempting a cure, make certain that the FM interference is not caused by a nearby FM receiver.

To become familiar with FM interference, hold a portable FM receiver

(Please turn to page 126)

POWER CORD

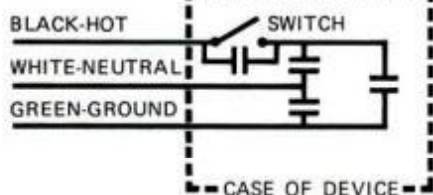

C=.001 MFD., DISC CERAMIC



.001 MFD., DISC CERAMIC

C=.001 MFD.; DISC CERAMIC

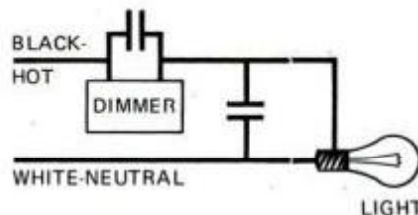

LIGHT

Never underestimate a pretty face. Nearly 80 percent of the Mirada owners we surveyed told us that its sheer good looks sold them on the car.

And after living with it for a while, 72.1 percent still listed appearance as the Mirada's best-liked feature.

A restaurant manager from Texas put it this way: "I initially went into the Dodge dealership to buy a new truck. When I saw the Mirada, though, it just took my breath away! The car's styling and roominess sealed the deal. The only regret I have is that I didn't buy a second Mirada for my wife. She's always taking mine!"

An Ohio computer operator rhapsodized, "I love the styling and am constant-



Chrysler designers acknowledge coffin-nose Cord's influence on Mirada's grille.

ly being bombarded with comments and questions about the car. It's incredible how many compliments I've received on my Mirada! From people I know to people I don't know, it's nothing but praise."

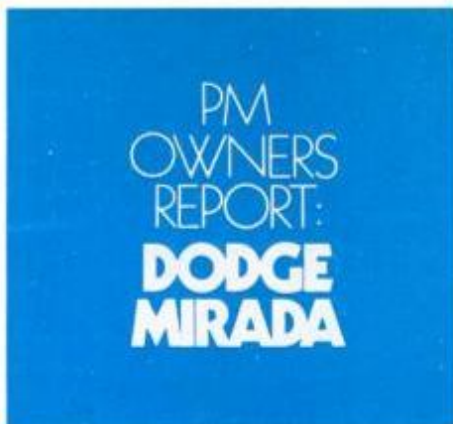

And praise for the Mirada's clean, brawny styling goes on and on.

"Sporty looking and sporty handling," wrote a Michigan boat builder.

A Wisconsin assembler: "I've always driven Chevrolets, but I liked the Mirada's styling much better than anything GM has to offer."

And an Illinois retiree with memories of that classic look: "I like everything about the Mirada's appearance, especially the Cord-like front-end design and the beautiful upholstery."

"It's a very classy car," penned an Ohio X-ray technologist. "I bought my Mirada for its style. I consider it one of the best-designed cars of the 1980 model year."

A 19-year-old female factory worker from Michigan confided, "Girls always

buy a car first for looks, then for things like comfort, gas mileage and so on."

A North Carolina company manager summed it up this way: "We needed a larger car, liked the Mirada's appearance, and felt we could get the best price from Chrysler because of its financial problems."

We noted an undercurrent of concern for Chrysler's business difficulties in many of the responses we received. A Pennsylvania administrative sales manager, for example, told us, "I bought my Mirada primarily on the basis of looks, but I also like Mr. Iacocca's style on television. He helped me decide to purchase my first Chrysler product since 1953."

And a Michigan electronics technician echoed: "I was impressed with the TV ads—Lee Iacocca puts forth a very sincere image."

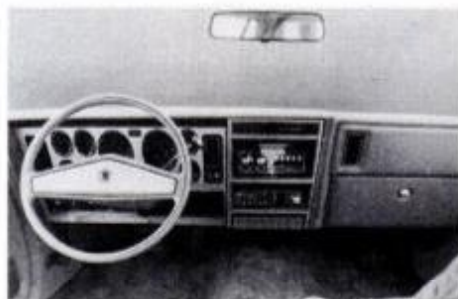

The luxurious car interior can be ordered with leather upholstery and a console.

BY MICHAEL LAMM WEST COAST EDITOR

Owners heap praise on the Mirada; its only fault seems to be poor mpg

Slant Six delivers best economy, owners say.

Last year's Magnum had same Cord-like face as the Mirada.

Suspension and basic chassis come from MoPar's J-body.



The restaurant manager, mentioned earlier, adds, "I have only praise for Dodge and Chrysler Corp. This car can help a troubled company. I looked at many different cars (T-Bird, Cougar, Grand Prix, Regal) but picked the Mirada and don't regret it one bit."

Some of the old Dodge virtues still shine through. For example, a Michigan truck driver volunteered, "I still like



Plenty of legroom in rear seat, owners tell us, plus easy entry via long doors.

Chrysler engineering," and an Arizona telephone man said, "I went back to Dodge because we needed dependable transportation."

But most owners praised the Mirada's specific virtues: styling, handling, comfort, ride and economy. The following are random, but typical, praises.

"The comfort of the Mirada cannot be exceeded by any cars of its size."—Indiana printing rep.

A Michigan department supervisor: "It's a very distinctive-looking car, gets fairly decent gas mileage, and the Mirada's price was within reach. My company buys new General Motors cars every year. In seven years, I've yet to see one delivered in perfect condition. But the Mirada has been so troublefree that, in the 4200 miles I've owned it so far, I haven't once had to open the hood."

Mechanically, the Mirada turns out to be one of the least troublesome American cars we've reported on lately. Fully 62.2 percent of the owners we surveyed said they'd had no mechanical problems of any sort. That's nearly 10 percentage points better than the Cadillac Seville, 17 points better than the Olds Toronado, and 19 points above the Omni-Horizon.

Dealer service garnered equally good reviews, with 70.7 percent deeming service satisfactory when needed and 72.2 percent rating their service staffs *good to*

(Please turn to page 150)

The mod Mirada

As youth goes, so goes the market. That's been a product planner's maxim dating back to 1955.

Today, as more and more young buyers slide into smaller and smaller economy cars, customers for big cars grow progressively older. It's a trend that Detroit—and especially Chrysler Corp.—wants to counter, at least for the next few seasons or until it, too, can produce smaller cars.

The Mirada's planning period predates \$1-a-gallon gasoline, so in some ways the car is an anachronism.

Yet Dodge finds it advantageous because the Mirada provides a flashy, larger model that sparkles with youth appeal. Very simply, Dodge wants to keep young buyers interested in this size category. Chrysler, after all, still manufacture a lot of cars with these dimensions.

As it turns out, nearly 55 percent of those owners we surveyed are under age 40—so the car seems to be doing its job.

The Mirada, identical to the Chrysler Cordoba in all but cosmetics, uses basically the same chassis and suspension introduced in the 1976 Aspen and Volare sedans. These underpinnings currently also support the Dodge Diplomat and Chrysler LeBaron.

So, while corporate designers have done a fine job of making the Mirada look new, all its mechanical components are tried and proven, including its three engines: the veteran Slant Six, the reliable 318 V8, and one of the industry's biggest remaining powerplants, the Mo-Par 360 V8.

A NATIONWIDE SURVEY BASED ON 476,456 OWNER-DRIVEN MILES

Plenty of headroom is achieved despite low overall vehicle height.

Large, squared-off trunk offers lots of luggage space despite intruding spare. Some owners objected to "corny" rectangular taillamps, said they don't go with rest of the Mirada's design.

Rear panes ought to open outward for ventilation, suggest owners.



Mirada shares 112.7-inch wheelbase with Aspen/Volare/LeBaron/Diplomat.



Bashing through Baja

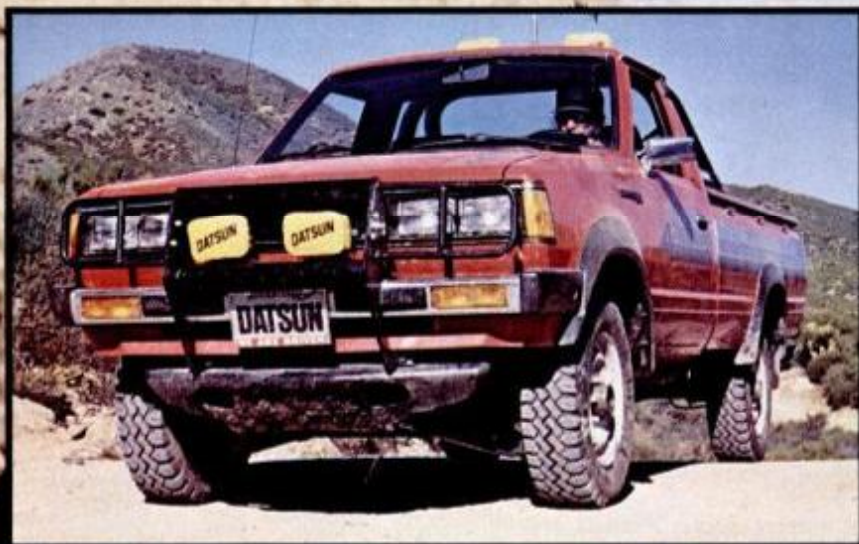
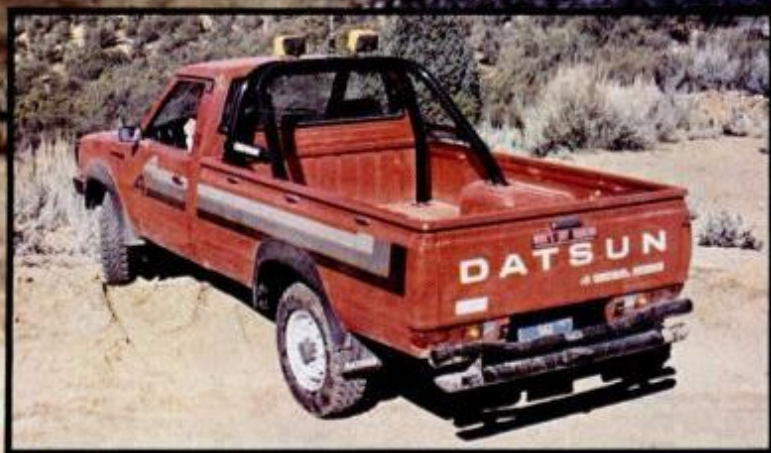

The Datsun longbed version (above) has payload rating of 1400 pounds. The rear tow hook is available as an option. Ground clearance (left) is a generous 8.8 inches, providing plenty of room for the serious off-roader. Accessories such as a push bar and auxiliary lights can be ordered from Datsun dealers. Hard as he tried, driver couldn't drown the engine (bottom left).



PM photos by the author

by Michael Lamm WEST COAST EDITOR

If it's off-roading you're after, the new Datsun 4x4 mini-pickup bounces your buns with the best. I don't believe there's a more rugged truck built in any size.

Datsun invited four dozen automotive journalists to try to destroy 14 production 4x4s in the spiny mountains of central Baja California. We tried but

in Datsun's new 4x4



The 1.9-liter, overhead-cam, four-cylinder engine produces 92 hp. Dash includes a tach, voltmeter and oil-pressure gauge.

failed—failed even to drown out an engine or to bring squeaks to any of the cabs.

Datsun flew us in three twin-engined Cessnas to the tiny village of Valle de Trinidad. We knew we were off on an adventure when one of the planes crashed on landing. Fortunately, nothing got hurt except the pilot's career and the belly of the Cessna it-

self (the pilot simply forgot to lower the landing gear).

From Valle de Trinidad we drove the Datsun 4x4s some 20 miles to Mike's Sky Ranch, 4500 feet above sea level. The climb took 1½ hours. The road consisted mostly of ruts and was liberally decorated with washes and boulders. Baja's big spring

(Please turn to page 170)

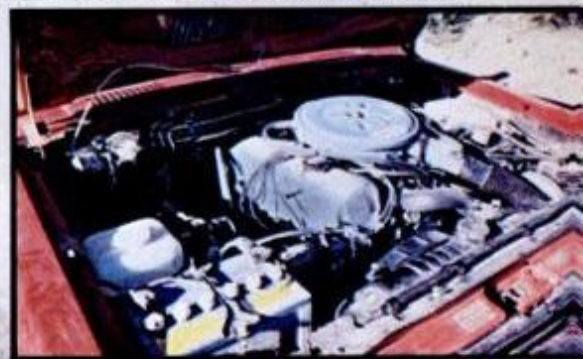



BICYCLE COMMUTING

It makes more sense than ever

The logical response to both the gas crunch and the fitness boom, commuting by bicycle is fun and saves money.

by Tom Sahagian

Bike commuting is becoming increasingly popular—there are a half-million commuters nationwide, according to Department of Transportation Secretary Neil Goldschmidt—and many more people will be discovering good reasons to ride to work.

In many ways, the bicycle is the ideal commuting vehicle. Nonpolluting, energy-efficient (more so than any other form of transportation), inexpensive and just plain fun, the bicycle could eliminate the crowding, noise and fumes of our auto-clogged streets. The frustration and anxiety that characterize most auto commuting would be replaced by smooth, healthful cycling.

Consider the advantages. Like a car, a bike is not subject to the rigid scheduling (or unreliability) of mass transit. But unlike a car, it can go almost anywhere, can't run out of fuel and never needs to warm up. Even an expensive bicycle is cheap compared to the smallest car. Most people could buy an exotic new bike every year with the money they spend on car insurance alone. And maintenance? All thoughts to the contrary, bikes are easy to maintain and repair, and hardly ever break anyway. Next time you're lying on your back with grease in your face under a precariously jacked-up car, think about that.

And don't forget fitness. Cycling is

The sign tells the story—the bicycle is the commuting vehicle of the future. Below, four ways to make commuting easier:

1. Slip-on shoe covers keep feet dry, warm in bad weather.
2. Leg strap keeps pants away from chain.
3. Lightweight rain chaps hang from belt.
4. Panniers provide greater carrying capacity than backpacks, handlebar bags.

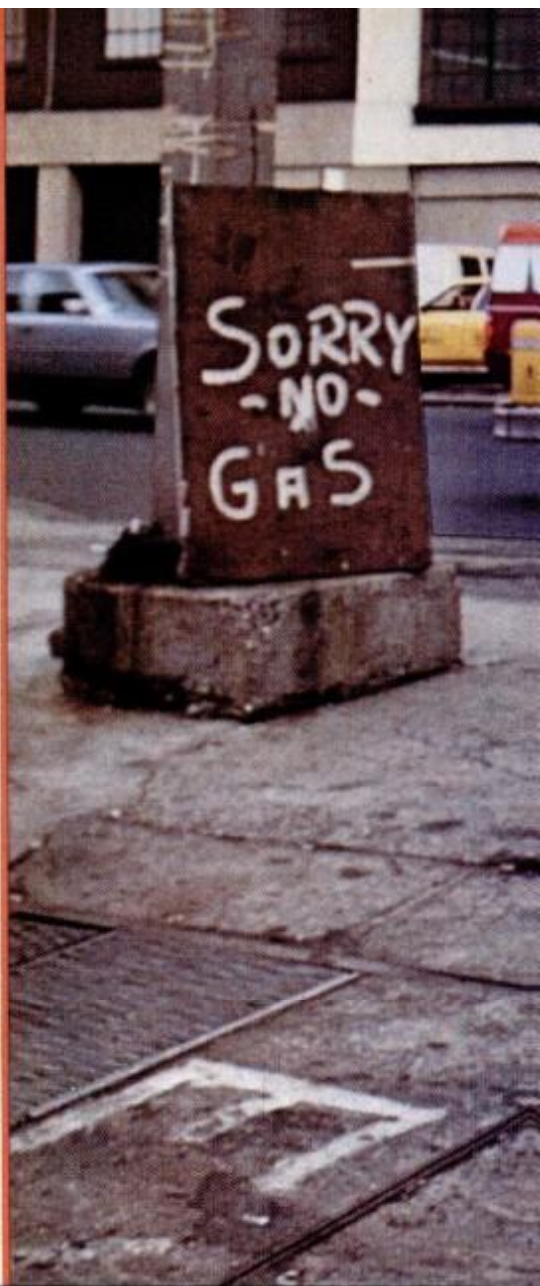
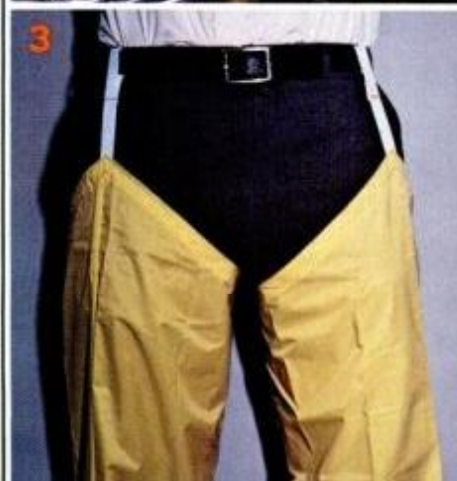



PM photos: Brad Hess

a great way to get into shape. Not only does bike commuting make more sense than ever, it's easier than ever, too, thanks to developments in bikes and accessories.

Bicycles themselves have not changed much, and, as is pointed out later, commuters use all types. Some innovative folding machines make taking a bike on a train or bus easier, but now large carrying bags are available for transporting 10-speeds. Just flip the quick-release le-

vers, remove the wheels and pop the bike into the bag.

Bike equipment *has* changed, though, and for the better. High-pressure (100-p.s.i.) tires are now available for the most common type of wheel rims and the rims themselves are lighter. The result is a smoother, easier, more efficient ride, although some experts claim the tires are easier to puncture.

That brings up the great fear of many an almost-commuter: flat

tires. Although flats are not really the problem most people think, several tire inserts and airless tires are now on the market, and most of them do eliminate flats. But almost all are flawed in some important way. It's probably easier to carry a spare tube for the few flats that occur. It's likely, though, that manufacturers will soon produce a more widely-accepted product.

In order to carry a spare tube,

[\(Please turn to page 146\)](#)

AS A WARM-WEATHER SPECTACLE
AT AIRPORTS ALL ACROSS THE UNITED STATES...

WORLD WAR II IN THE AIR IS ALIVE AND WELL

by Robin Nelson

Standing 100 yards from the runway with the rest of the crowd as the P-51s come across low and hot, you are suddenly amazed by the noise. You tend to forget how those Packard-Merlins sounded when they were wound up. But the growl and whine of airborne piston engines is the one thing that confirms that you're back there—back in World War II—and when a lone Mustang returns

even hotter and pulls up into a victory roll the crowd goes “aaahhh” and the goose pimples break out even on kids who have only ever seen it before in the movies.

Observers of popular culture are only guessing as to why, but it seems that as we approach the 40-year cycle on the anniversaries of major World War II events, both nostalgia and serious interest are peaking. And

on the local airport airshow circuit, promoters—including charity fund raisers in many instances—are finding out that “warbirds” will pull in the crowds as never before.

Warbirds of America, Inc., affiliated with the Experimental Aircraft Assn. and headquartered in Hales Corners, Wis., is an umbrella organization of World War II aircraft owners and buffs. Not all of its





Large photo: A flight of four P-51 fighters approaches the Ti-Co Airport near Cocoa, Fla., to participate in an airshow with the only war-vintage Junkers 52 (shown flying above) still intact. Below are a P-51 (far left) and a B-25 Mitchell bomber in desert paint with its "authentic" World War II mascot emblem, both of which participated in the Ti-Co airshow. All of these aircraft are maintained and flown by private owners.





Author Martin Caidin's unique JU-52 shown at TI-Co Airport with bicentennial colors flying (in 1980). A 50-year-old design, the plane's STOL performance, rugged simplicity and mechanical attributes still add up to an "advanced" flying package in terms of modern aircraft. Sketch below is one of several wartime configurations.

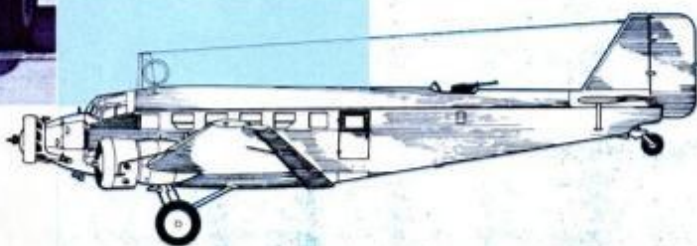

IRON ANNIE: THE 'ENEMY' STEALS THE SHOW

Two miles out from the runway, the *Luftwaffe* formation circles—two graceful single-engine Messerschmitts and a massive assembly of corrugated metal slabs towed by three engines and known as a Junkers-52—called *Tante* ("Auntie") *Ju* by wartime friends and, not quite as affectionately, "Iron Annie" by wartime enemies. But as she roars across the runway now in her long-awaited attack, Annie has no real enemies—the ground-triggered "bomb" blasts are from gasoline-filled milk containers—although the crowd already suspects that the orbiting swarm of Mustangs will bounce Annie and exact revenge on her next pass. They're right—the Messerschmitts are dispersed and Annie is savaged by the 'Stangs. White smoke pours from her two wing-mounted engines—vegetable oil pumped into hot exhaust stacks.

It's all in a day's play for Iron Annie and

the man who resuscitated her, Martin Caidin. One of the country's most prolific writers of aerospace fact and fiction, Caidin recently produced a book on his love affair with this only remaining wartime JU-52 (*The Saga of Iron Annie*; Doubleday) in which he documents her history as a Norwegian airliner, confiscated *Luftwaffe* transport—in which Adolf Hitler himself was airlifted, Ecuadorian roustabout cargo ship and, finally, derelict.

Additionally, Caidin will expound for hours on the airplane's virtues to anyone falling within epithet range. And most of it is true. I sat beside him in the right seat for a patented Iron Annie takeoff. Caidin jockeyed the throttles forward and the plane's huge tail lifted off the runway before we'd gone 2 feet. It seemed to me that we began to get unstuck at about 65 mph indicated—Caidin later said it was within 400 feet of where the roll began and I know it was less than 500. With about 75 mph showing we had enough ground clearance to put a wing down and roll into the tightest turn off a runway I ever want to see, much less fly. The JU-52 easily made a 180° turn, still accelerating, without getting farther than 1000 feet from where the brakes were released on the ground.

Conceived by Hugo Junkers and Kurt

Weil in 1929, the 52 was a huge commercial success before the first DC-3 ever flew. Unique—probably to this day—was the plane's rugged reliability as an airliner, in particular one that could take off, fully loaded, with one engine out. Its independence from ground services and return on investment because of minimal downtime—rather than any striking payload figures—were the keys to its success.

As a military aircraft, the 52's versatility and unbreakability made up for some inherent unsuitabilities—chief among which was the lack of self-sealing fuel tanks. German aircrews under tracer fire paid dearly and often for this discrepancy. While the nominal military load in transport configuration was 32 troops, it is documented that one JU-52 fled Stalingrad with 59 aboard, including one clinging—ultimately frozen—to the vertical stabilizer.

The usually ebullient but often exacting Caidin was instrumental in establishing the Confederate Air Force spin-off group in Florida known as the Valiant Air Command, and has been flying Iron Annie in shows where the VAC participates. Recently, he spoke of starting a new organization to be known as the Rebel Air Circus. Wherever Annie goes, however, and under whatever flag, she's a treat to see.—R.N.



As PM's Robin Nelson found out, the JU-52's dorsal gun turret is a great place for warbird watching. Ray Martin's ME-208 (right), the only one still flying, is also seen above off the Junkers tail as the Axis formation "attacks."



1300 members own or fly airplanes, and some are partners in shared warbirds—some own more than one. Jim McDonnell, a newspaperman long associated with the group, estimates that about 300 World War II aircraft are actively flown today.

"Bufs were always interested in restoring World War II planes," says McDonnell, "but sometime in the Seventies—maybe it had something to do with the Bicentennial—the public began to show a lot more interest in seeing them fly."

Which didn't bother the buffs one bit. One of the few things that defray the exorbitant costs of maintaining and flying a 40-year-old military airplane are airport operators who offer free fuel—a major inducement—to owners who agree to show up and fly an airshow routine. There are also some Internal Revenue Service wrinkles that apply to restored aircraft, but often planes are "donated" by individual owners to a cooperative group like the Confederate Air Force (CAF), which until recently was unique and pioneered the World War II airshow circuit. Former owners then get to fly the birds in the CAF Ghost Squadron's reenactments of Big War encounters. (At one point this included a B-29's simulated A-bomb run over Japan, but public outcry removed it from the agenda.)

CAF is headquartered in Harlingen, Tex., and flies its own big air show there each year in October (see calendar below). CAF has active "wings" in other states, but two years ago its Florida wing decided to become autonomous under the name Valiant Air Command. VAC members retain their own planes; the only things pooled are effort—to put on their own annual airshow at Ti-Co airport near Cocoa, Fla.—plus experience and expertise. Maintenance and parts problems continually haunt warbird owners. If a plane is one-of-a-kind or very rare, replacement parts may have to be fabricated from scratch—and even flight manuals may be nonexistent, making just starting an engine for the first time an adventure in itself.

When the mechanic who does most



Walk-around time is almost as good as the flying display. Above, an ME-108 flown by father/son team of Lee and Carl Dufrechou shares the ramp with an SNJ and other birds.

of the work on the CAF's B-17 Flying Fortress was transferred last year by the airline that employs him full time, the old bomber was moved to his new base right along with him—so critical is knowledgeable maintenance.

The big bombers are rare spectacles even in the newly enlivened skies of World War II remembered; there are only a couple of B-17s and just one B-24 Liberator currently on flying status—with overall expense, complexity and fuel capacity providing easy reasons why. The AT6 trainer (SNJ to Navy types) on the other hand, of which more than 17,000 were built in the U.S., is always present in handfuls where warbirds turn out—partly because of its simplicity and parts availability but also because it is, as it always was, a good airplane in which to get started flying World War II.

But by far the most popular aircraft among warbird pilots and spectators alike is the P-51 Mustang. Many authorities believe it was the consummate fighter of World War II, and it flew on even into Korea. A 'Stang holds the current world piston-powered speed record, at a fraction under 500 mph, and another has the cross-country record of six hours, 21 minutes, for Los Angeles

to Washington, D.C. Among 'Stang buffs, the coup is to spot rare "C" (prebubble canopy) or "H" (hottest of the hot) models.

You could have purchased a P-51 from a government surplus depot in 1946 for about \$3500. The asking price for a "clean" one today often exceeds \$200,000. Next to that, gold is a bum investment.

One of the best parts of a warbird show comes before the flying display, when the birds are parked for close-up inspection. "When a plane is taken down and rebuilt, bolt by bolt, then finished with today's paints in an authentic color scheme, it's a far more beautiful thing than ever came off the line in 1942," says Jim McDonnell.

Inevitably, the trivia nuts dominate the walk-around inspection conversation, dropping such gems as how the Zero got its name,¹ which frontline U.S. fighter was originally designed for the Royal Air Force (RAF)² or how the first ME-262 jet got off the ground³. Maybe you've heard it all before, but it's still a kick to stand in the shade of a wing and go through it again.

Sure, war is hell, the pilots say, and it always will be. But these machines are somethin' else. **PM**

WHERE TO SEE WORLD WAR II AIRPLANES FLYING THIS YEAR

June 7-8: London Intl. Air Show, London, Ont.
 June 21-22: Hamilton Intl. Air Show, Mount Hope, Ont.
 June 28-29: Blue Grass Air Show, Lexington, Ky.
 July 1: Summerfest (air show), Milwaukee
 July 12-13: Blue Angels Homecoming Show, Pensacola Naval Air Station, Pensacola, Fla.
 July 19-20: Dayton Air Fair, Dayton, Ohio
 July 26-27: Park District Air Show, Chicago
 July 27: Air show and display, Thief River Falls, Minn.

Aug. 2-9: Experimental Aircraft Assn. fly-in, Oshkosh, Wis.
 Aug. 9-10: Detroit City Air Show, Detroit
 Aug. 16-17: Warbird Air Show, Ogden, Utah
 Aug. 24: Grider Field Air Show, Pine Bluff, Ark.
 Aug. 30-31: Cleveland National Air Show, Cleveland
 Sept. 1: National Air Festival, San Diego
 Sept. 6-7: Metro Airport show, Nashville, Tenn.
 Oct. 9-12: Confederate Air Force Show, Harlingen, Tex.

¹Formally, it was designated A6M, indicating the sixth carrier aircraft designed for the Japanese Navy from Mitsubishi Co. The production model came out in the Japanese calendar year 2600 (1940) and was given the customary *sen* (type) number based on the last two digits of the initial production year. Hence, the A6M, Zero-*sen* fighter.

²The P-51. North American Aviation undertook all design and development costs without government help based on an original RAF order for 350 aircraft. Only after it saw the prototype fly did the U.S. Army Air Corps show any interest.

³Through either sheer panic or cool ingenuity: Barrelling down the runway in the first all-jet ME 262 (previous models had flown with an auxiliary piston engine), test pilot Fritz Wendel got absolutely no elevator response so he hit the brakes. This brought the tail up momentarily, the control surfaces became active and the plane flew without further incident. The maneuver became S.O.P.

Look around. Where else will you find a car that's going on 40 and still a teaser?

The Jeep sells mostly to young people—what Detroit calls the youth market. Nearly 90 percent of the owners in our survey weren't even born when the first American Bantam Jeep bounced across the mock battlefields of Camp Holabird, Md., in the fall of 1940.

Jeeping continues to be a state of mind. The Jeep became a cult car long before anyone dreamed up that concept. Not a nut nor bolt interchanges with the original, yet the 1980 American Motors Jeep *remains* an original. It's still the True Jeep, a direct descendant of Willie the Willys—oft copied and never matched.



Jeep owners praise open-air driving and the rock-solid construction of both models.

PM OWNERS REPORT: JEEP CJ-5, CJ-7

What we have here is the stuff of legend: veteran of three major wars, butt of countless jokes, hero of battles real and imagined. It's a vehicle that's just as serene accepting the Museum of Modern Art's award as one of the world's 10 all-time best automotive designs, as it is on the sands of Iwo Jima and North Africa.

We're dealing with a phenomenon beyond reason. The Jeep remains a workhorse, yes, but it's also a toy and an instrument of the owner's self-image. As it has been for almost 40 years, it's an imperfect, sometimes aggravating car that's always forgiven for one simple reason: It's fun to drive!

Jeep owners tend to be individualists. They're hard to pigeonhole, and for that reason, this Owners Report will deviate

slightly from our usual format. Instead of categorizing responses as we usually do, let's examine the comments of several diverse, but typical, Jeep owners.

First, here's a 22-year-old mechanic/electrician from Illinois. He drives a four-cylinder CJ-5 with four-speed.

"I buy new cars every year," he told us, "and found this AMC dealer tough on price. I had to be persistent and spent a lot of time dealing. I was presold on four-wheel drive from last winter's snows. I drive 24 miles to work and don't want to get stuck. Driving to and from my job is a top priority.

"So far, I've had only two mechanical problems with my CJ. The pin holding the shift lever onto the transfer case sheared off, and the speedometer cable broke. I replaced the broken pin myself; the dealer fixed the cable. I rate his service department as excellent. AMC mechanics give speedy, courteous service.

"I'd rate the Jeep's workmanship as good. For this day and age, I think it's pretty well constructed. But, as with all things, materials seem to get cheaper as prices go up. What I really wish they'd change, though, are the front lock-out hubs. It's a pain to have to stop, get out, and lock/unlock them everytime I switch into or out of 4wd.

"My specific praises of the Jeep include its 20/26-mpg gas mileage with the Four, its maneuverability, tall ride and control in

BY MICHAEL LAMM WEST COAST EDITOR

Jeep lives up to its rugged reputation, although owners would like better mileage



Owners would like a lockable compartment in the rear.

Stiff rear springs don't bottom out in the rough.

snow and rain. The only thing I don't like about it is the feel of the power steering with the Goodyear Tracker A-T tires."

Next, here's a Florida production-flow manager, aged 23, who drives a CJ-7 with the 258-cu.-in. Six and four-speed.

"We own property in the North Carolina mountains, and I haul my boat and like 4wd for trailering. One thing I especially like is that it's a simple vehicle. I can hose down the entire interior, including the instrument panel, after it gets muddy or dirty."

"Mechanical problems have involved



The no-frills interior provides drivers with adequate comfort and lots of legroom.

loose heater wires, a small leak at one front hub, and a broken clutch-return spring. All repairs were made quickly, and the dealer took time to explain why the

parts failed. Because of my working hours, this dealer also made special arrangements to allow me to drop off my Jeep after regular hours. All charges were covered by AMC's warranty.

"I shopped two different dealers. The first one was high-pressure and high-priced, but the second allowed me a full \$1000 discount and spent a lot of time showing me different models and features. I find workmanship excellent. The car takes a helluva beating and keeps going."

"I'm over six feet tall, yet have lots of legroom. It's an excellent-handling vehicle, with great versatility, very sturdy, good view of the road because of height. I get an open and free feeling with the top down. To me, Jeeps have classy lines. Nothing else looks like a Jeep. I definitely intend to buy another Jeep when this one wears out, but that'll be a long time, I'm sure."

Now to a California electronics engineer, aged 23, with a four-speed, six-cylinder CJ-5:

"I bought this Jeep for rough four-wheeling. What I especially like about it is its ruggedness. The thing goes like a mule. Also, it's simple. The only thing I don't like is the gas mileage. I'm getting 12 to 16 mpg.

"The dealer replaced a broken drive-shaft and mended a noisy clutch throwout

(Please turn to page 168)

Jeep: a living legend

Jeep again offers a four-cylinder engine. It's Pontiac's "Iron Duke," a 2.5-liter pushrod design that also powers GM's X-cars.

The Four is spunky, yet gives owners the option of fuel economy in the 20-mpg range. Additional Jeep engine choices include AMC's long-lived 258-cu.-in. Six and the 304 V8. Owners of Jeeps with these engines had more complaints about fuel mileage.

Jeeps come in two basic sizes: the CJ-5 on an 83.5-inch wheelbase, and the CJ-7 with a 10-inch-longer chassis. AMC offers three equipment/trim packages for both Jeeps: the Renegade, the Golden Eagle and the Laredo. All of them include upgraded tires and wheels, specific interiors and urethane wheel-lip moldings.

All Jeeps come with a folding windshield, rollbar, front disc brakes and the new four-speed transmission. Options include an automatic (except CJ-5) and part-time 4wd with automatic transmissions.

When you buy a new Jeep, you buy it topless. For the CJ-5, the factory offers a vinyl or denim soft top. Soft tops are now available with steel doors and roll-up windows. The CJ-7 can be had with a molded hardtop for 1980.

In addition to the CJ series, the full line of Jeeps also includes the J-10 pickups, plus the two-door Cherokee Wagon and the four-door Wagoneer.

For the first time in seven years, the Wagoneer will be available with either the full-time or part-time Quadra-Trac transmission, improving fuel economy considerably.

A NATIONWIDE SURVEY BASED ON 771,465 OWNER-DRIVEN MILES

High seat position gives excellent visibility.



The Pontiac-built, four-cylinder engine yields 20 mpg on the highway and 17 in city driving. Still, most buyers opted for the six-cylinder engine, which gives 17 mpg on the highway, and the V8, which averages only 15 mpg.

Power steering reduces steering wheel effort.

Locking hubs increase mileage on pavement.

Great ways to use airy, elegant lattice

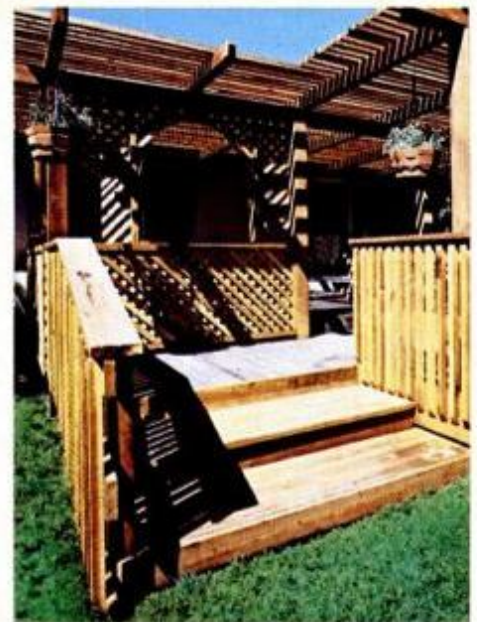

Cool and refreshing patio enclosure adds privacy to outdoor living area without sacrificing fresh air and sunlight.

1 Deck enclosure with arched windows

by Joseph R. Provey
ASSISTANT HOME AND SHOP EDITOR

For many people, latticework brings to mind garden trellises, bowers and summer cottages. It is commonly used to support climbing vines—or to screen unsightly footings. Architects and designers recognize that these simple patterned screens have decorative as well as functional applications.

The deck enclosure with latticework walls on this page is a good example. It's built of redwood and finished with a clear, water-repellent finish (with mildewcide) to maintain a mellow redwood color.

The latticework screens provide privacy for meals and parties. They are made of 1×2 boards for stability, but nominal 2-in. stock, ripped to 3/8-in.-thick strips, saves money.

The enclosure frame consists of posts and beams. Run posts through the deck to concrete piers and drift pins below, or fasten them to decking with angle fasteners (over a supporting member). Use 2×2s to frame openings between posts, and nail latticework to them.

To bend a 116-in.-long arch board

(clear redwood) for the 47½-in.-wide window shown, cut 3/32-in.-wide kerfs, ¼ in. deep and spaced 1 in. on center. To bend the 118-in.-long spine, cut 3/32-in. kerfs, 5/8 in. deep

and spaced 5/8 in. on center. Soak boards in water until they bend without splitting.

Next, preassemble and temporarily brace the arched windows to hold the shape until they are nailed in. Kerfs can be left exposed or filled with white glue and sawdust.

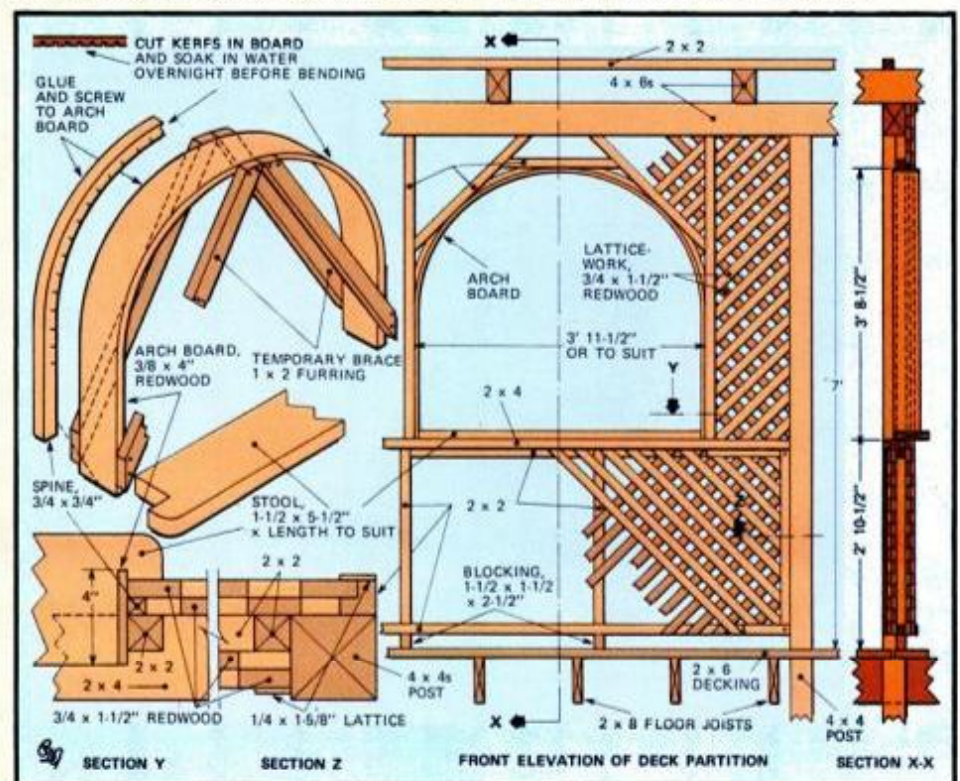



2 Window shutters and wall panels

A room plagued by too much sunlight was transformed into this cheerfully dappled setting by adding lattice panels to the bare wall and matching shutters to the win-

dows. Although the diamond patterns stimulate a lot of visual activity, the setting remains cool and visually relaxing.

To construct the wall panels, join

Latticework shutters and modular wall panels move garden spirit into this family room. Panels remove for painting.

members at corners with half-lap joints and screws. Install bottom layer of lattice in rabbet with glue and 1-in. brads. Space the lattice 1½ in. apart at 45° to the horizontal. Since each strip is a different length, you'll have to mark and cut as you go. Cut duplicates for the top layer and for other panels you plan to make. Nail down the top layer at 90° to the first and cover with trim.

To install the modular wall panels, fasten furring strips through dry-wall or plaster to wall studs with 10d common nails. Predrill lead holes in plaster to prevent cracks caused by nailing. Fasten the lattice panels to the furring with brass screws and washers. Using screws will let you easily remove the panels when it's time to repaint them and the wall behind.

Position filler blocks behind the lattice panel to provide a secure anchor wherever heavy hanging objects (such as potted plants) are desired. Both the filler blocks and the furring strips should be painted to

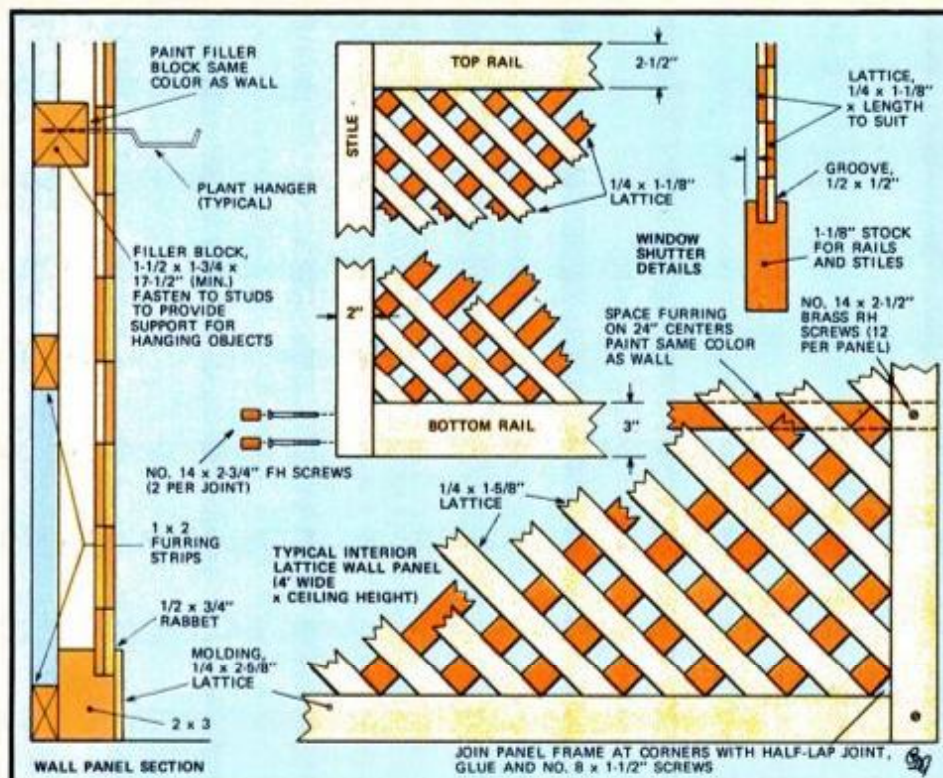

Patio design for 1, Robert Gallagher; patio and bar design for 3, Steve Morgan; photos for 1 and 3, Carl Riek courtesy of the California Redwood Assn.; photos for 2 and 4, Wood Moulding & Millwork Producers.

match the wall to make them "invisible."

Simple shutters with stiles and rails grooved for the lattice may be butt-joined at the corners—or use the joint shown on page 105 for long window shutters. Preassemble the latticework with glue and trim to size on a table saw using a veneer cutting blade. Next, apply glue in the stile and rail grooves and the rail ends. Assemble and clamp until dry. Then add screws to reinforce butt joints. To hide screwheads, counterbore and dowel-plug holes.

3 Patio bar

Frequent trips to the kitchen make it hard for a host to enjoy patio entertaining. A patio bar stocked with party provisions ahead of time will save you many round trips. It will also make a great place to serve buffets, as well as a counter at which meals can be eaten.

Bar construction is straightforward. Use 10d galvanized common nails to attach the sides to top cleats and the floor. Use 4d finishing nails to fasten lower cleats to the upright members and shelves to the cleats.

Allow 1/4-in. gaps between top and shelf boards to prevent water standing on surfaces. Another important consideration: The top should overhang the front at least 5 in. to provide legroom when the bar is being used by a person seated on a stool.

Rip 3/8-in.-thick strips from nominal 2-in. stock scrap for the latticework bar front (or use 1×2 stock and 6d nails). To assemble, fasten the horizontal strips to the vertical bar members first, using 4d galvanized finishing nails. Space them 1 1/2 in. apart. Then nail on the outside layer with 6d galvanized finishing nails (8d nails if nominal 1-in. stock) at top and shelf level. Stiffeners may be added at the bottom, between uprights.

A color brochure on redwood garden shelters and redwood deck finishes is available for 50 cents post-paid from the California Redwood Assn., 1 Lombard St., San Francisco, Calif. 94111.

3 GARDEN-GRADE REDWOODS

Construction Heart (all heartwood) is recommended for posts, joists, stringers and all near-ground applications.

Construction Common (contains sapwood) is good for decking, fencing, trellises, benches and trim.

Merchantable (has larger knots, more sap, but can be cut economically for small applications) is used mainly for planters and rails and may be ripped to provide boards for the latticework projects.

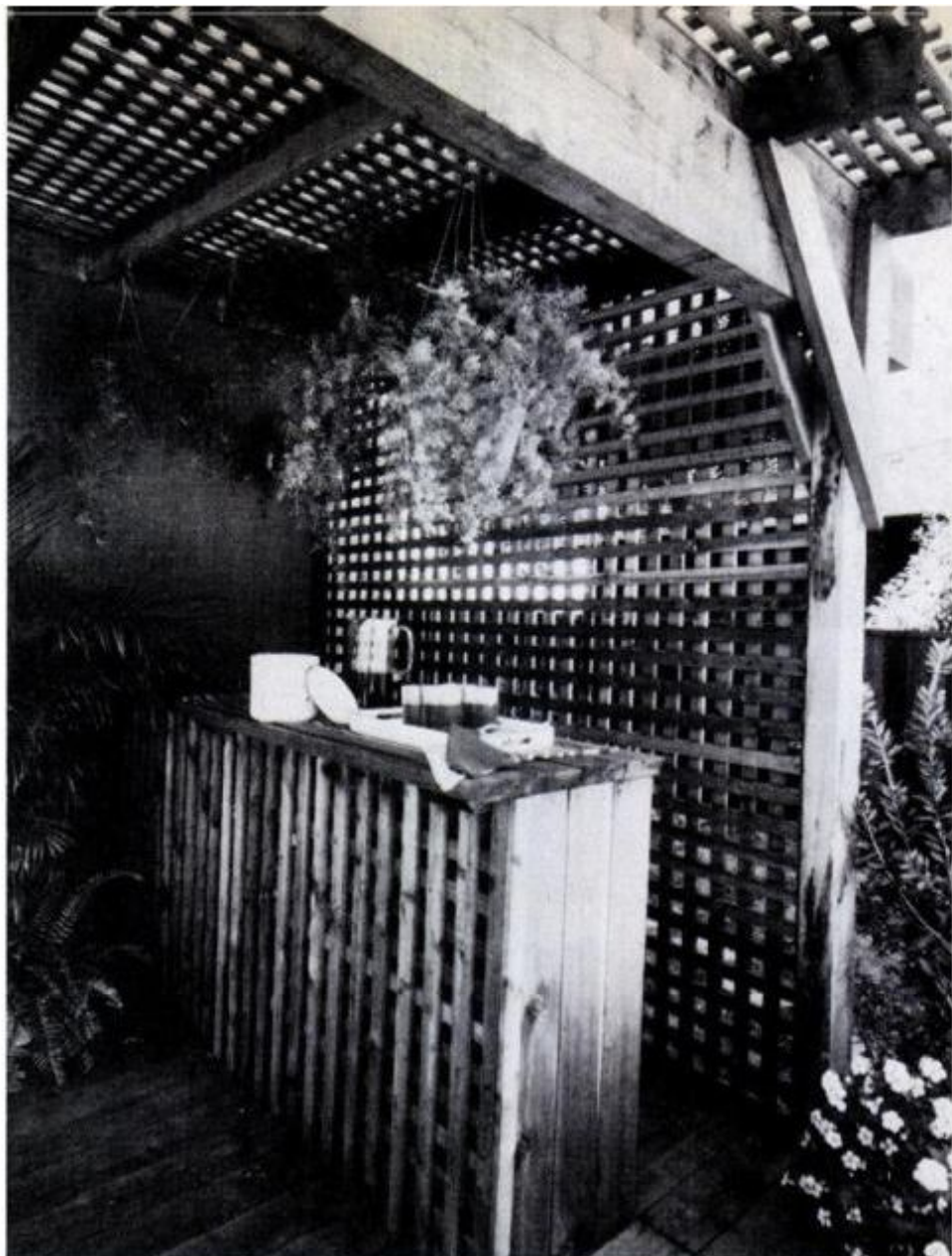

Redwood patio bar, fronted with a decorative latticework, makes this airy deck enclosure even more convenient for hosting your favorite back-yard parties and get-togethers.

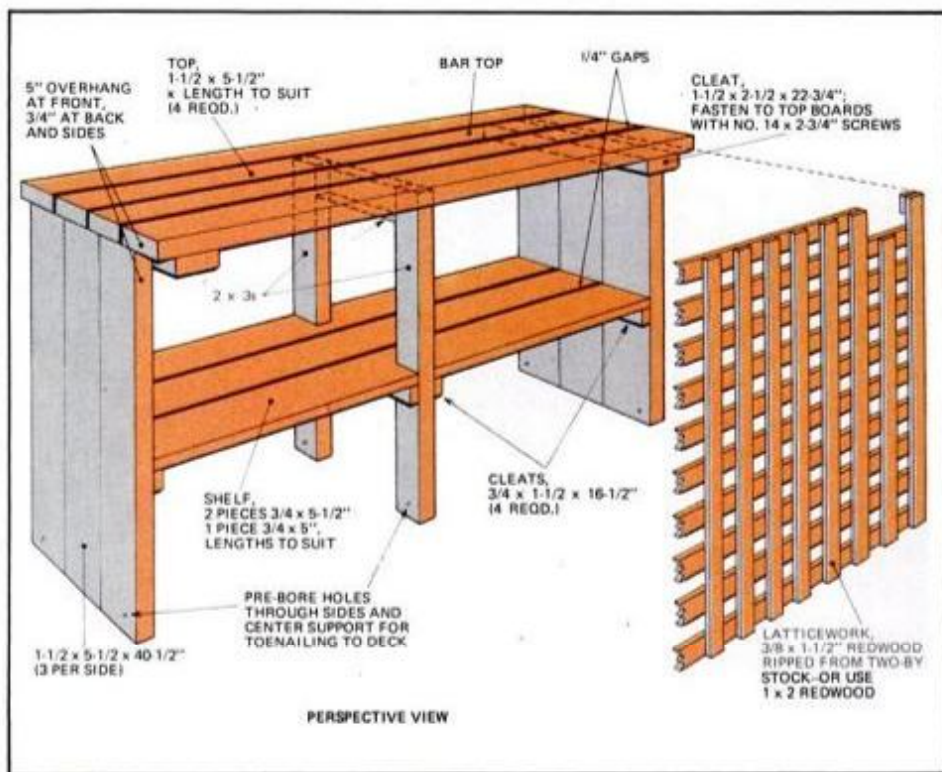

4 Door and window treatments

A room can look crowded if it includes too many nonunified elements. One solution is to streamline, as depicted in the vanity-closets ensemble and window screens below. This built-in eliminates a cluttered look and the diamond-lattice pattern helps to bridge visually the corners of the room.

The window screens provide a con-

tinuous sweep from floor to ceiling, hiding the windows and lower wall sections; they may also be used to hide an unpleasant view.

Before assembling the closet doors, preassemble the latticework insert using $\frac{3}{8}$ -in. staples on the unseen side. Space the lattice 3 in. apart at 45° to the horizontal. Then trim to size on a table saw.

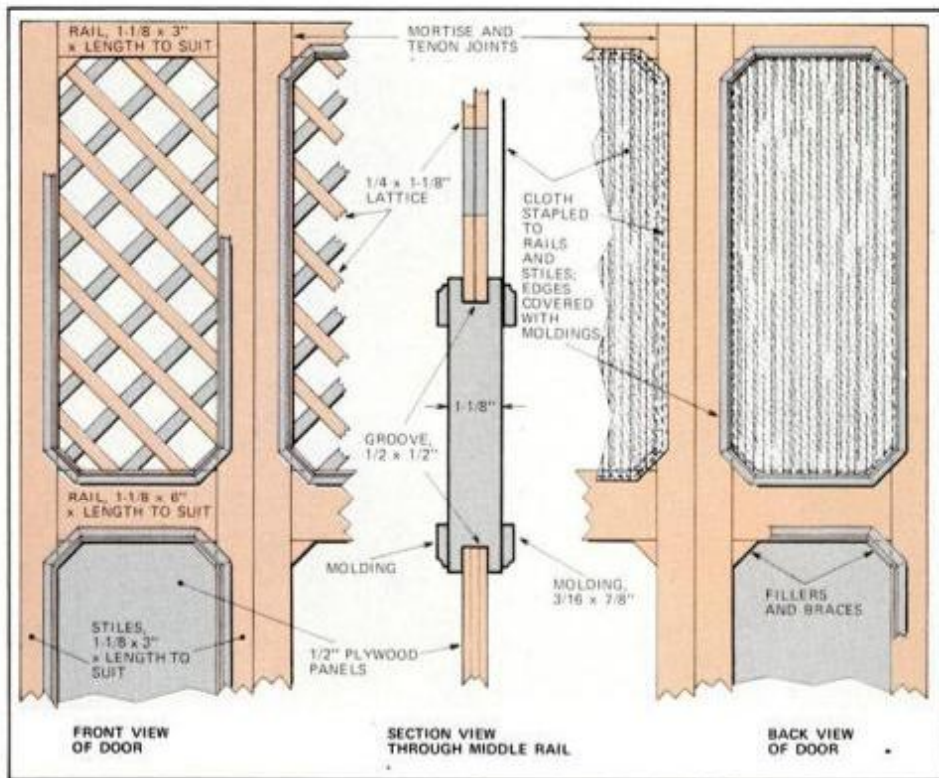

For formal indoor effects, lattice was used in closet (above) and floor-to-ceiling dining-room shutters (below).

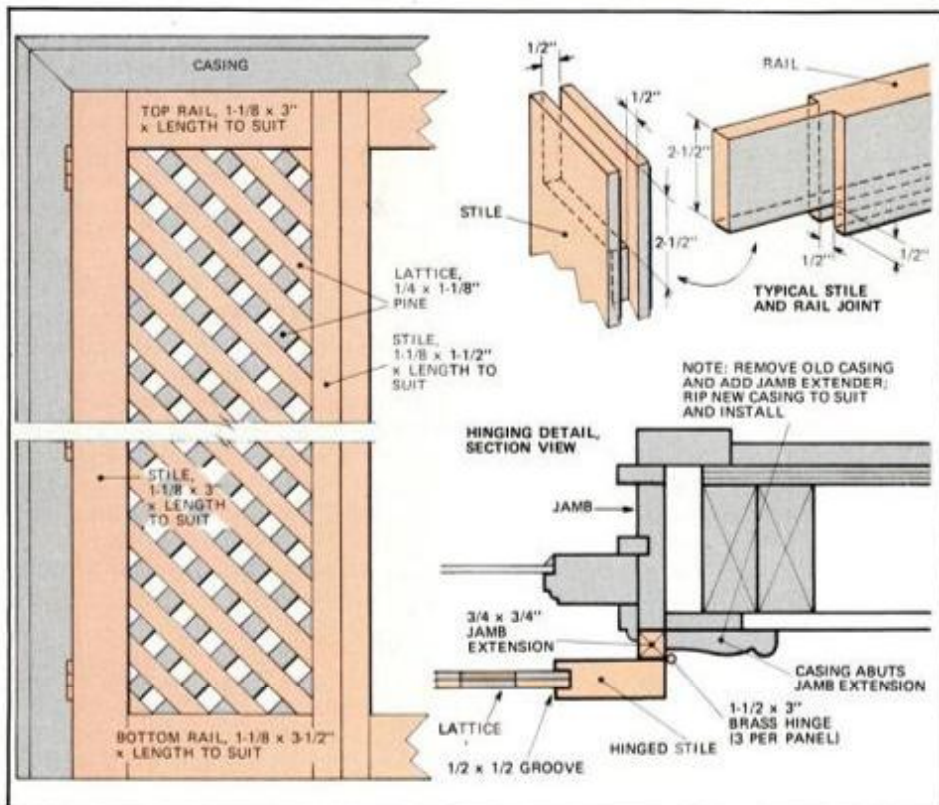

To install long shutters, a jamb extender must be used to provide clearance at the stool. The extender must be wider than shown in the plans for stools which extend more than $\frac{3}{4}$ in. from wall.

Remove the old casing and stool horns. Then attach the jamb extender with 6d finishing nails and glue. Replace lower window stops with stop molding wide enough to cover the joint. Next, hang the shutter units using three hinges per shutter. Add new casing, abutted to the jamb extender. Choose a factory-milled molding and rip its width to suit. Or, make up your own casing with 1x3 pine and back-band molding nailed to the outer edge for a finishing touch.

For a brochure on lattice, write to Wood Moulding & Millwork Producers, Box 25278, Dept. PM 680, Portland, Ore., 97225.

PM

Build a cupola—the classic cooling system

Here's an attractive solution to ventilation problems in your home.

by Rosario Capotosto

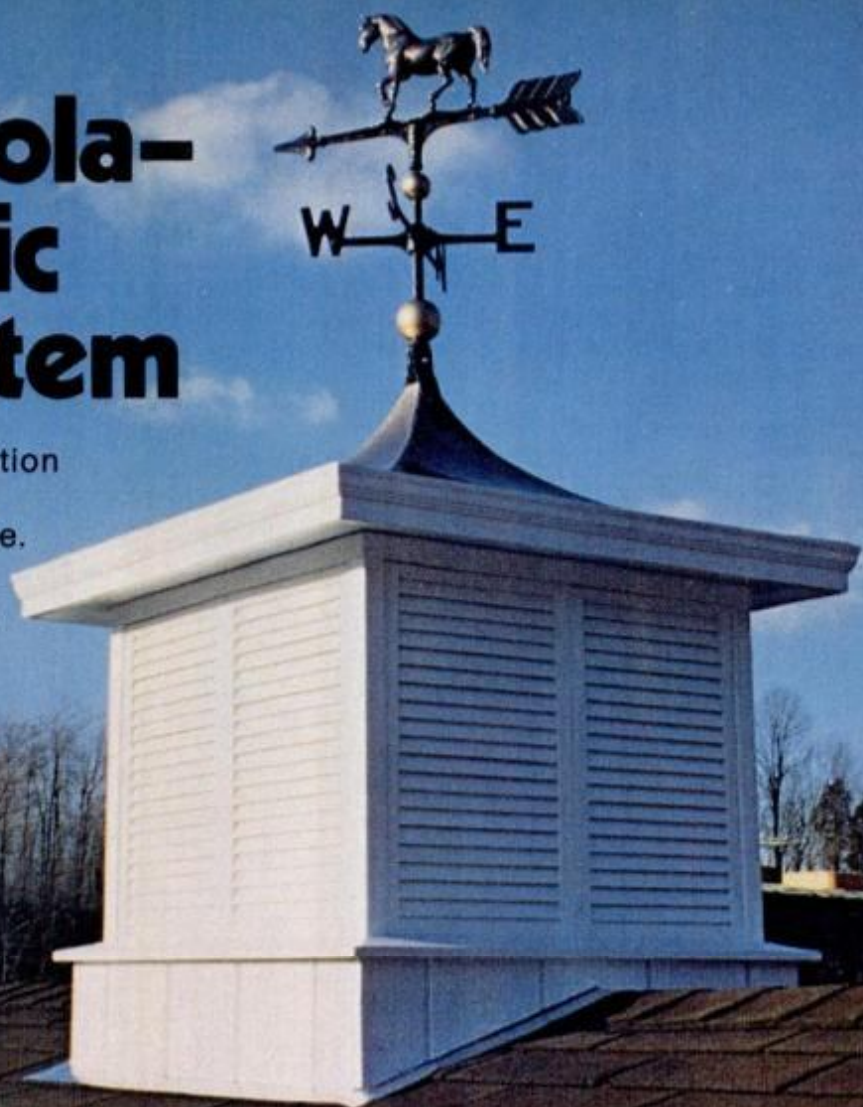

PM photos by the author

Installing a cupola is an effective way of ventilating an interior, and it also adds architectural interest to your home. Our version has an eye-catching, contoured copper roof that you can fabricate in your own shop. Follow the technical drawings on page 109.

The main frame of the cupola is constructed of 2×2 kiln-dried lumber and ¾-in. fir plywood. Its base is dimensioned for a roof with a 4-in-12 slope. If your roof line differs you can alter the design to suit.

Building the frame

Begin by cutting the vertical members (B) of the frame. Cut the four pieces to length, making the appropriate bevel angle at the bottom ends, which depends on the angle of your roof. Cut the dadoes in these members by making a series of sawkerf cuts or use a dado head.

Cut parts A with 45° miters on all ends. Assemble the square top of the frame using 8d common nails and glue. Use four bar clamps to assure squareness.

For superior holding strength and no rust stains, all nails used in the project should be hot-dipped galvanized. Use either waterproof resorcinol glue or plastic resin glue (the latter is less costly but also water-resistant).

Cut and attach crosspieces C to the verticals using glue and 3-in. (10d) finishing nails to form an H. Join the two H-ends to the remaining crosspieces. Then add the square top frame and bracing members D and G at the bottom.

Shaping the sills

The sills (J) are of ¾-in. pine stock. Cut the 45° miter first, then notch the rear corners so they'll seat into the corner posts of the frame.

Cutting the deep bevel on the upper face of the sill is a simple task on the table saw. Face two sill pieces back to back against the rip fence; then nail a piece of plywood across both to bridge them. This allows the pieces to slide past the blade without danger. After cutting the first bevel, you rotate the pieces so you can ta-

per the second. Then glue and nail the sills in place.

To prevent rain from entering, attach stops (L and M) to the four openings at the top, bottom and sides. Bore pilot holes in the stops for the screws to attach the shutters. One pair of the shutters is hinged to allow access to the roof from the attic.

Finishing the frame

The cupola base is sheathed with ¾-in. plywood (N and O). It is finished with Champion Building Products texture 1-11 plywood. However, you may choose to finish the base to match your house siding. Cut the siding to fit, but don't nail it in place. It must be removed later, during the cupola installation, to permit application of flashing.

Constructing the roof

The roof base (K) is a square of ¾-in. plywood with a center cutout. The top edge is built up of 2×2s (E and F) and 1×3 sidepieces (S and T) edged with a crown molding (U).

How to top your roof with a cupola



Disassemble the cupola before moving it to the roof. It takes two people on separate ladders to carry the copper cupola roof.



After boring four corner holes from inside, mark the proposed cutout with chalk. This view shows the truss framing.



A coarse blade in a sabre saw makes the cut. Pack extra blades in case you hit a nail. This view shows the truss framing.



Bore angled pilot holes for lagscrews through the frame and house roof after checking for plumb. Use quality caulking to seal the angled sides of the base. The straight sides don't need caulking.



Insert flashing and the facing boards.



After securing the cupola roof, screw the shutters in place and add center cleats.

Before cutting the roofing formers (P) which give contour to the roof, you'll find it is helpful to make a cardboard template. Then cut the plywood formers on the bandsaw or with a sabre saw. Cut a top center notch in one former and a bottom center notch in the other former so they will interlock.

The top edges of the formers should be beveled 45° both sides to form a common joint for the copper roof sections. This can be a tricky operation, but you can make the bevel using a piloted bevel cutter in a router as follows.

Adjust the router so the cutter projects just enough to cut 1/8-in. short of dead center of the plywood edge. When you make the second cut on the other side, the total remaining edge will be 1/8-in. This thickness is enough to guide the pilot (or the gully between it and the blade, depending on the particular bit you use). Try a few test cuts on scrap until you get the adjustment right on target.

Cut the roof-peak support blocks

(H) from 2×4 stock, then glue and nail them in place. To align them accurately, it helps to nail a strip of wood across the face that bridges the formers.

Fabricating the copper roof

Strips of copper (Q) can be nailed to the beveled top edge of the formers to provide a soldering base for the roofing. If you make a series of cuts along both edges of the strips you can bend them along the curved former without their buckling.

Make V-cuts with shears or make straight cuts with a jig or hacksaw. The saw kerfs will allow sufficient clearance, but simple straight cuts with shears won't provide the necessary clearance to prevent buckling.

Copper is normally sold in 3×8-ft. sheets at building material supply houses. This is more than you will need to fabricate the roof. However, if you take a full-size paper pattern of the roof section to a local roofing or sheet-metal contractor, you may be able to buy scraps the size you need.

To make an accurate pattern for the four sections (R) of the roof, trace directly over the roofing formers and make a cardboard template. Do this *before* you nail the copper strips on the top edges of the formers with 1-in. brass or copper escutcheon nails.

The four copper sections shouldn't butt tightly against one another. Instead, expose a 1/8-in. width of the copper strip below.

Use a sharp scribe against the template to mark the copper for cutting. Then cut the parts with shears.

Soldering the roof

Soldering the roof in place is a job for a heavy-duty soldering iron. A torch isn't recommended because it is difficult to control the heat of a torch.

Apply soldering flux; then tin the copper strips (Q). Tack-solder the four roof sections in place and nail the bottom of the sections to the roof frame with 1-in. brass or copper escutcheon nails. Start soldering at

Tips on building the cupola



Cut dado joints in vertical members (B) by making repeat, overlapping passes with saw. Note that the ends of these members are beveled to conform to the roof pitch.

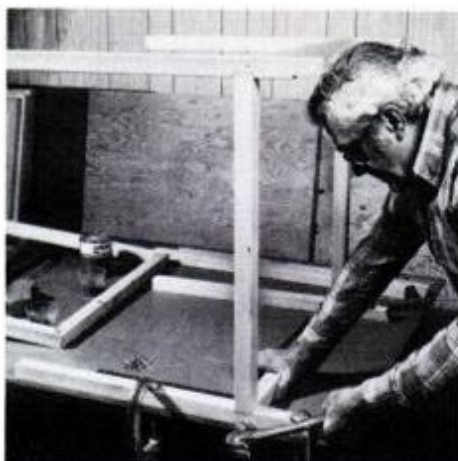

Assemble with glue and nails, as well as bar clamps if possible, to assure tight joints. Use square to check that assembly is true; otherwise, shutters won't fit.



Miter-cut the ends of the sill members (45°); then saw the deep bevels on the top surfaces using the setup shown. Reverse this assembly to cut second sill bevel.



Sill ends are notched to fit around the corner posts. Apply glue to all joints before fitting them in place. The base of the frame is now ready to be sheathed.



Attach rain stops; then bore pilot holes for screws that attach shutters. Don't add them yet, but do number each section to avoid confusion during installation.



Cut the roof formers with a band or sabre saw; shape the top edges by making two passes with router fitted with a 45° bevel cutter. See text for details.



Temporarily tack-nail a strip of wood perpendicular to the peak support blocks; this helps to align the blocks for nailing.



Make saw kerfs or V-cuts in copper strips (Q) so that they won't buckle when fitted along the top edges of roofing formers.



Fold the copper strips to conform to the roof formers and nail the strips in place. These provide soldering base for roof.



Use a template and scribe to outline the cuts for the copper roof sections. Carefully make cuts with snips or power shear.



Tack-solder the copper before nailing the bottoms with 1-in. brass or copper escutcheon nails; then finish the soldering. Use a heavy-duty iron (not a torch) on the 16-oz. copper. File off solder lumps.

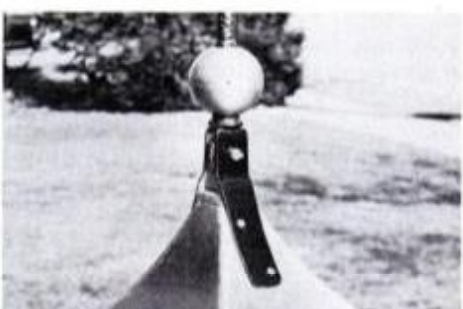

Weathervane bracket is made of 1/8-in. aluminum stock with stainless-steel screws.

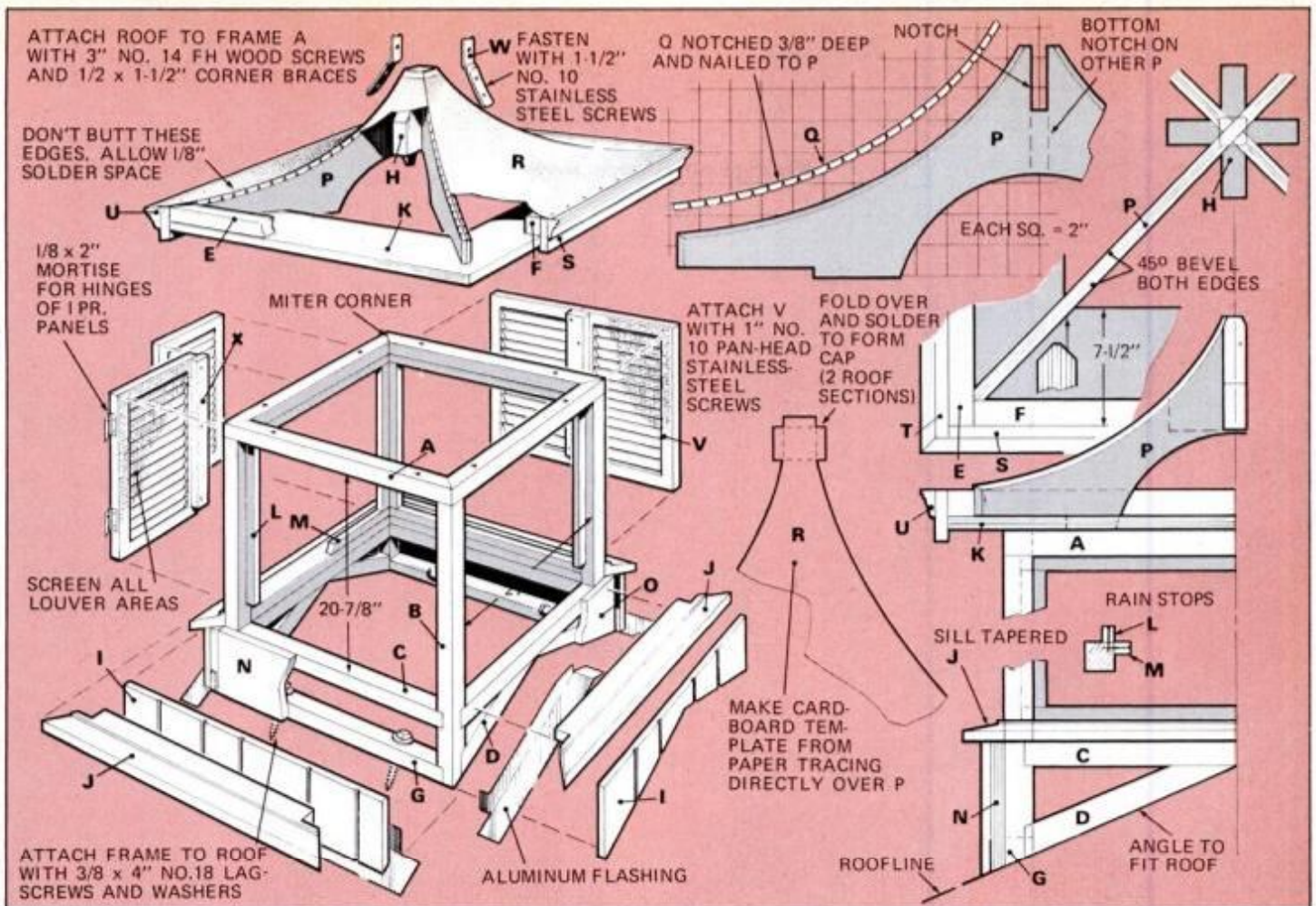

the top of the seams and work downward using 50/50 solder.

Heat won't properly transfer through the soldering tip if it isn't clean and tinned. As you work, continue to apply flux and solder regu-

larly to the tip to keep it tinned. Wipe off any excess solder with a

(Please turn to page 142)

Other classic cupolas you can adapt to your home

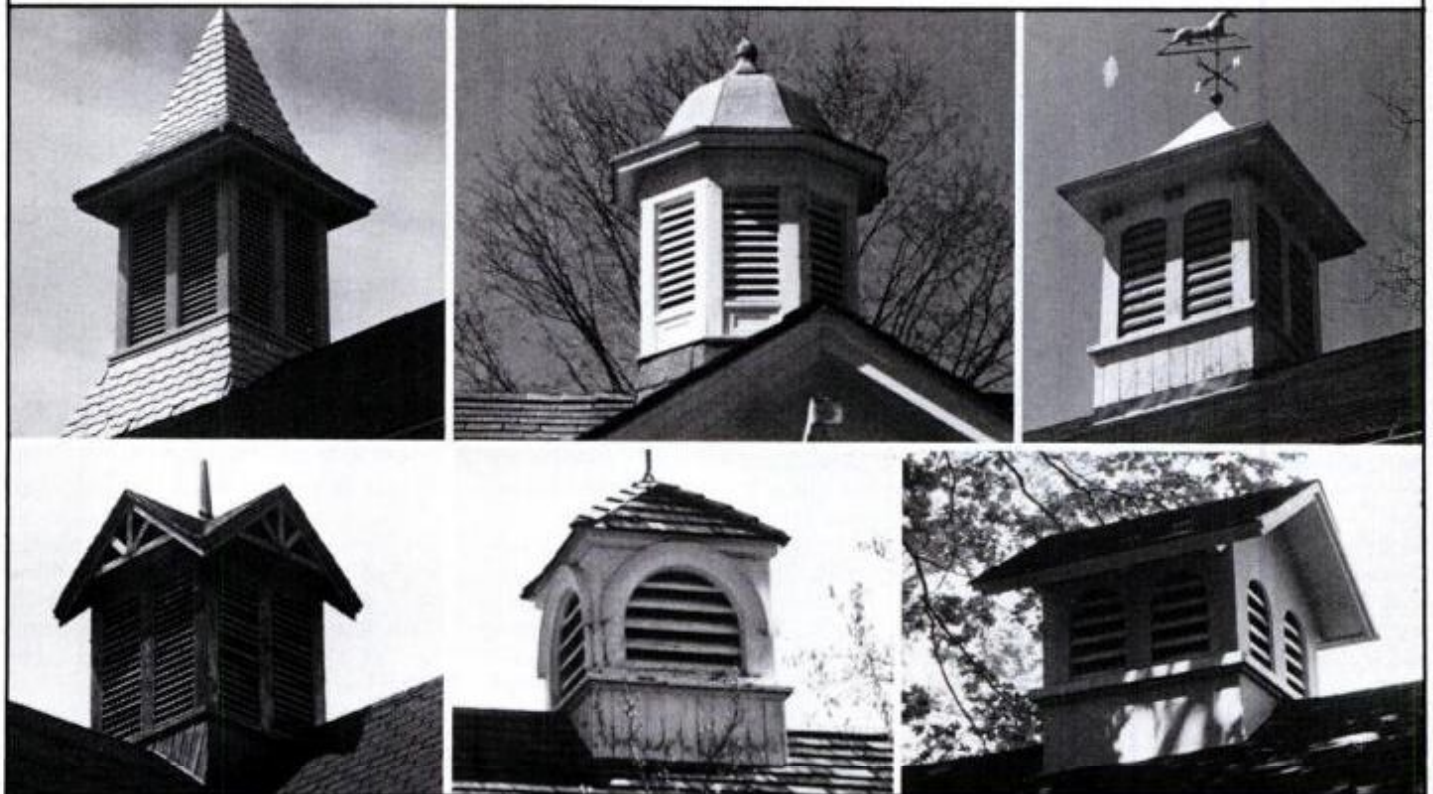

The basics for building a cupola are spelled out in text and art (top), and it's relatively easy to adapt other styles, if desired. Cupolas shown above are examples that have been popular in the United States for a century. To avoid building errors, draw plans first.

Photos: Frederick Paton for House Beautiful's Colonial Homes

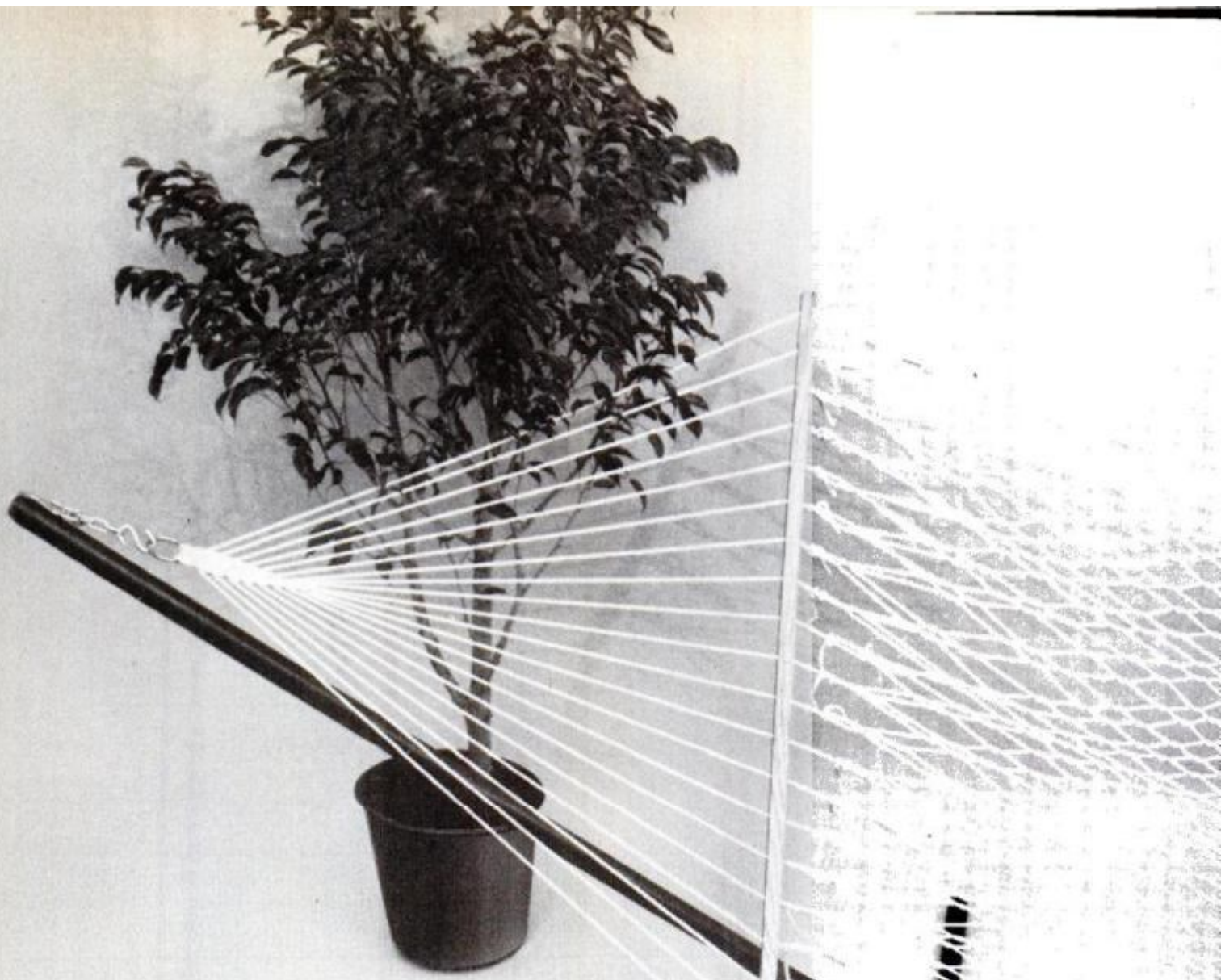

Pamper yourself this summer with this cotton rope hammock you can weave.

by Barbara H. Jacksier and Joseph R. Provey

Not since you were a baby have you been held the way this hammock can hug and gently sway you. Made of soft, absorbent cotton cord, our unit is big enough to let you stretch out crosswise or lengthwise. Hung outdoors, the open-weave pattern permits even a slight breeze to pass through to keep you cool. Indoors, it can be hung in a living room or recreation room. When not in use, hang it on the wall.

At first, making a hammock may seem complicated. It does take patience, but weaving is a forgiving art since you can unravel mistakes and

try again. Start off setting up the hammock loom shown on page 112.

Make two braids to form the hammock edges next. For each braid, cut two 220-in. lengths. Tie one pair at their middles to a loom pole using a square knot. Begin to braid by placing the rightmost strand over the one to its left. Then place the leftmost strand over the two strands to the right. Repeat these two steps, always working the right cord over one cord to the left and the left cord over two cords to the right, until the braid is 80-in. long, including the starting loop. Now, tie the loose end of the braid to the other dowel with a square knot. Insert 16 paper clips at the ends of the braid and at 4-in. intervals. Slip it down the poles to

make room for a second braid and for weaving of the body of your hammock.

When both braids have been completed, make a plywood shuttle as shown on page 112 and wind about a third of your cord onto it. Unwind about 9 ft. and bind the cut end. Then, starting at the right-hand edge of the top braid, thread the bound end from front to back through the braid at the first paper clip. Repeat this at each clip. Tie the bound end of the cord to the left dowel under the top braid when finished.

At the right dowel, pull the cord back through the braid until it's

PM photos by Eric Barnick; hammock stand is from Hammacher Schlemmer, 145 East 57th St., New York, N.Y. 10022, and sells for \$114.50 postpaid (in continental United States).

How to make your own hammock and hang it anywhere

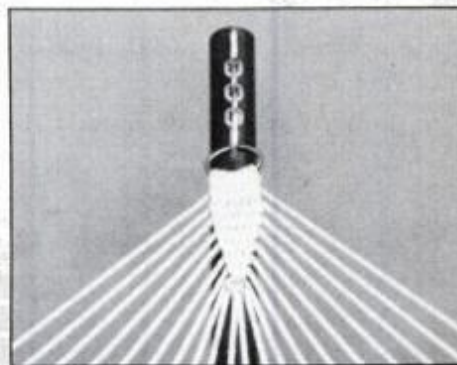

Twenty-strand harness allows the hammock to conform to shape of your body.



taut. Stretch the cord to the pole top and hold it there while extending the cord down to the X-mark. This point marks the total length (89 in.) of the first and all subsequent rows of cord. To register this point, wind it around the nail at the top of the pole and prepare to weave next row by dispersing slack equally to form loops.

All of the following rows are woven using the shuttle. Bring it around the outside of the loom pole and toward you, passing under the top braid. Then push it from front to back through the first loop and each

MATERIALS LIST—HAMMOCK

- | No. | Size and description (use) |
|---|--|
| 1 | 1/4" dia. x 1000' cotton cord (hammock body, edging and harnesses) |
| 2 | 1 x 1 x 60" oak (spreaders); rip and resaw from 1/4" stock |
| 2 | 2" dia. rings, brass or cadmium-coated (harness rings) |
| 2 | 1 1/4" dia. x 4" round stock (loom frame) |
| 1 | 1/4 x 5 x 24" plywood (shuttle) |
| Misc. White adhesive tape or string for binding cord ends; 5, 10d common nails; 32 large paper clips | |

remaining loop, making 15 passes in all. Pull the cord taut and once again register an 89-in. length using the X-mark. Wind it around the nail atop the second loom pole. Redisperse the slack and the second row is complete. Pass the shuttle around the dowel as before.

The first loop in the third row is formed by passing the shuttle from back to front through the leftmost loop. The end loops are easy to miss. *Be sure you make 15 passes per row.* Complete the third row, register the 89-in. length, and wind it around the nail on the loom pole after letting the first row's cord slip down over the dowel. Pass the shuttle around the dowel and repeat the instructions for weaving the second and third



Weaving the hammock

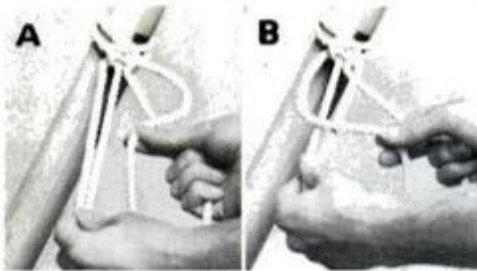

To make the braid, place rightmost cord over cord to left (A). Then place leftmost cord over two cords to the right (B).



Repeat steps A and B until the braid is complete. Pull the strands tight to assure a strong braid that won't stretch.



Use paper clips to mark intervals and thread first row of mesh into braid. Pointed dowel opens braid for threading.

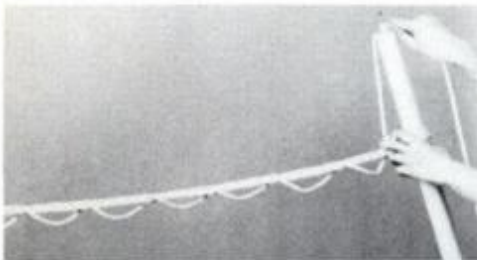

After first row is threaded and tied to left loom pole, measure length using X-mark and disperse slack to form loops.



Again, working from right to left, make the second row of mesh by passing the shuttle, front to back, through the loops.

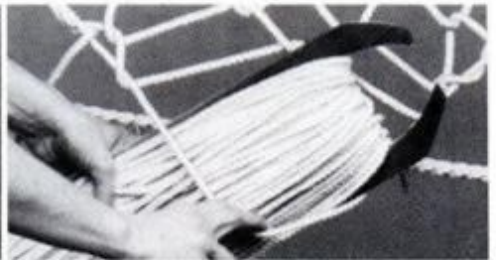

When you weave rows in opposite directions (from left to right), pass shuttle and cord back to the front through loops.



Weave the harness with the ring hanging on wall. Use a pair of nails to permit hanging woven strands out of the way.



To join hammock body to harness, tie loops of mesh, two at a time, to corresponding harness cords using a bowline (right).

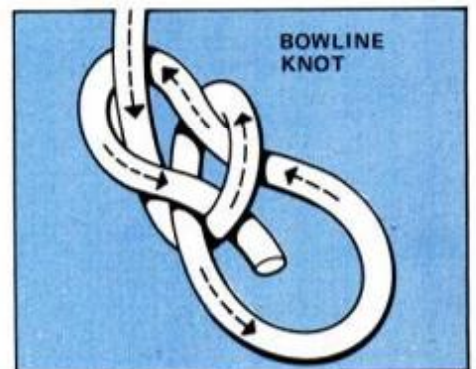

rows until you have 37 loops on each dowel, not including the braid loops.

To help locate loops through which you'll be weaving, go back to the loom pole around which you

most recently turned and pull up on the cord attached to the nail. This will put tension on the last row worked and make it easier to spot.

When the shuttle runs out of cord, rewind it with a new supply. Tie the

old and new together with a square knot at one of the loom poles so the knot won't end up in the middle of the hammock body.

When there are 37 rows, leave 9 ft. and cut the cord. Bind the end and

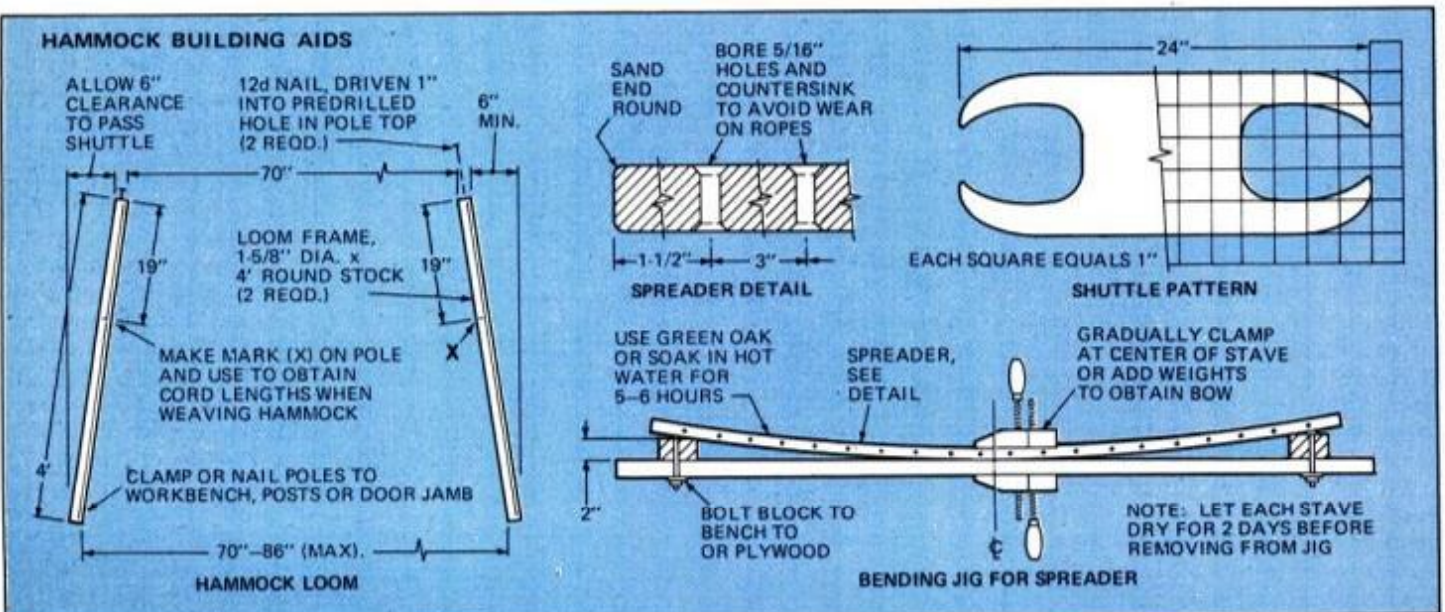

An in-depth look at the only "plug-in" remote control system you'll ever need for your home.

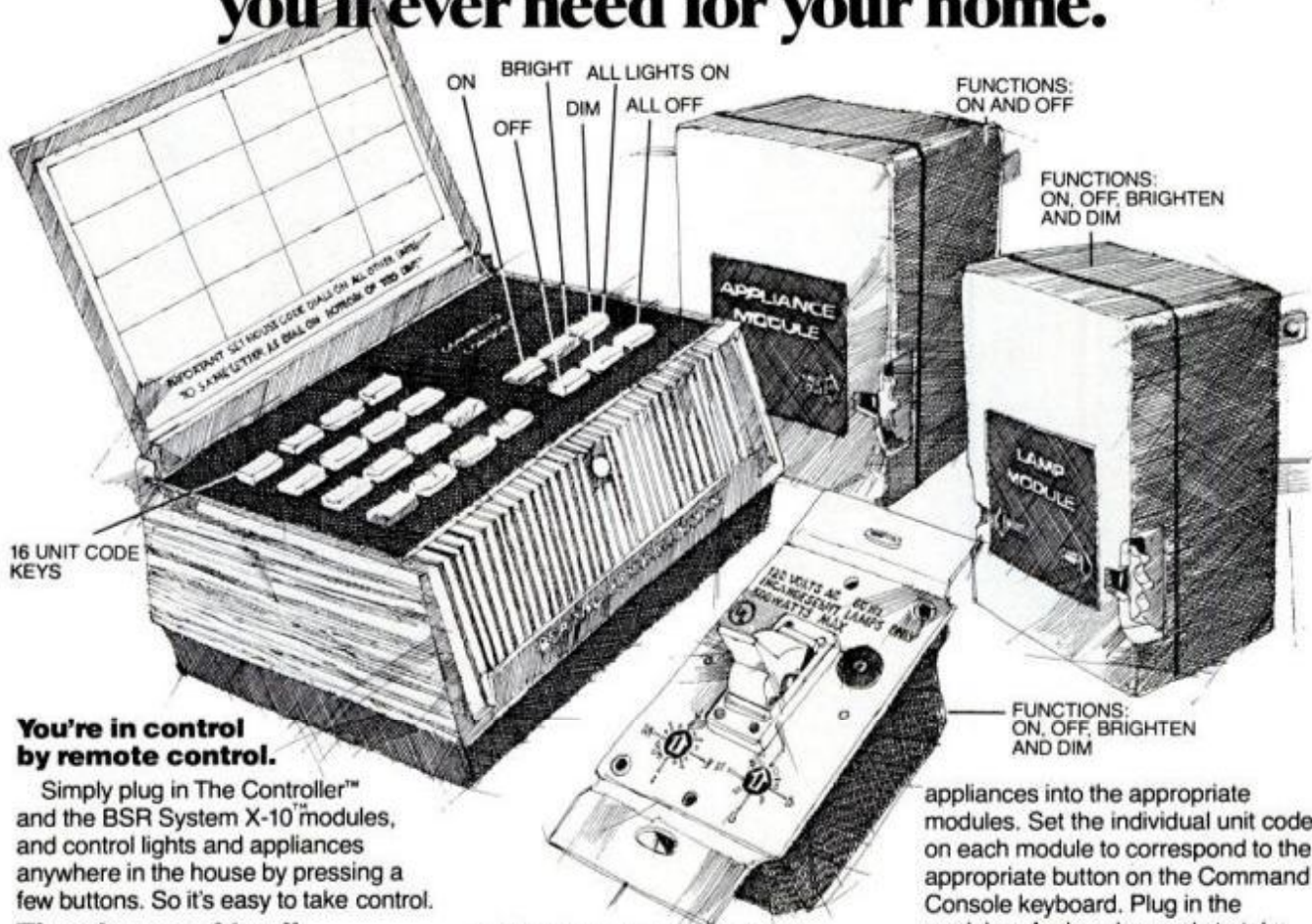

You're in control by remote control.

Simply plug in The Controller™ and the BSR System X-10™ modules, and control lights and appliances anywhere in the house by pressing a few buttons. So it's easy to take control.

There's no end to all of the control you've got.

You can turn on the TV, radio or stereo in the morning to help you wake up without getting up from bed. Or at night, turn on the lights before going downstairs so you don't have to fumble in the dark. Turn off unnecessary lights and help get your electric bill under control. Or, dim the lights and save energy, too.

And when it's time to turn in, just push a button and turn everything off. And sleep soundly. But, if you hear a strange noise in the middle of the night, you can press a button to turn on all the lights and scare the daylighters out of an intruder.

The Controller is designed to control every room in the house.

By pressing the buttons on the Command Console keyboard, command signals are transmitted over

existing household wiring to the module of your choice. The Lamp Module turns on, off or dims any incandescent lamp up to 300 watts. The Appliance Module turns appliances like TVs, window fans or stereos on and off. And the Wall Switch Module is designed to turn on, off or dim any light or lamp up to 500 watts normally operated by a wall switch.

There's even a Cordless Controller that transmits signals to an Ultrasonic Command Console from up to 30 feet away. So there's plenty of control for everyone.

Simplicity is built into the system.

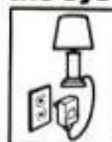

No special wiring is needed. Simply plug The Controller Command Console into any wall outlet in any room of the house.

Set your personal house code on the console. Then plug your lamps and

appliances into the appropriate modules. Set the individual unit code on each module to correspond to the appropriate button on the Command Console keyboard. Plug in the modules. And you're ready to take control.

For under \$100*, everything's under control.

The Controller Starter Kit comes with a Command Console and modules to control lights and appliances at three locations. The system is also sold separately, so you can add to it at any time. And stay in control.



BSR System X-10™
THE CONTROLLER.™
Everything's under control.

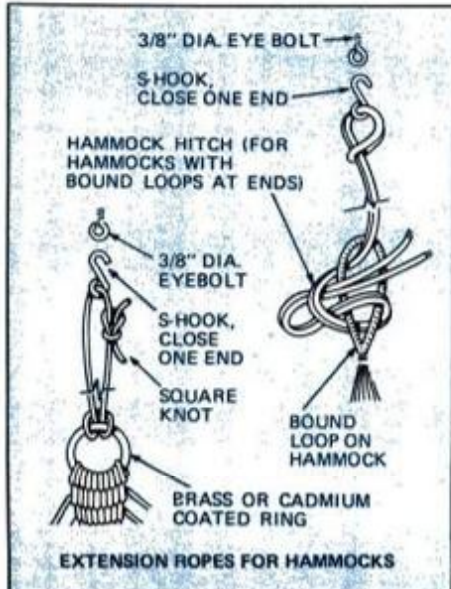
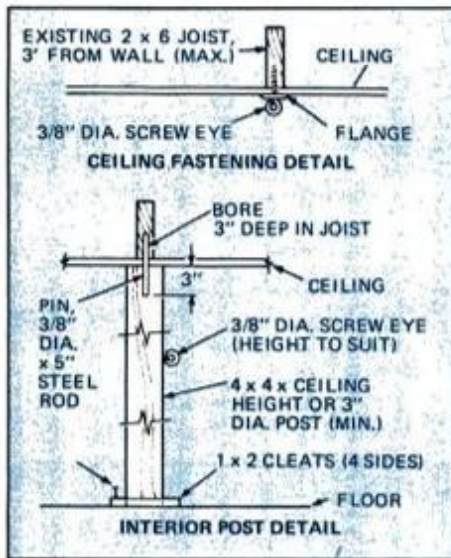
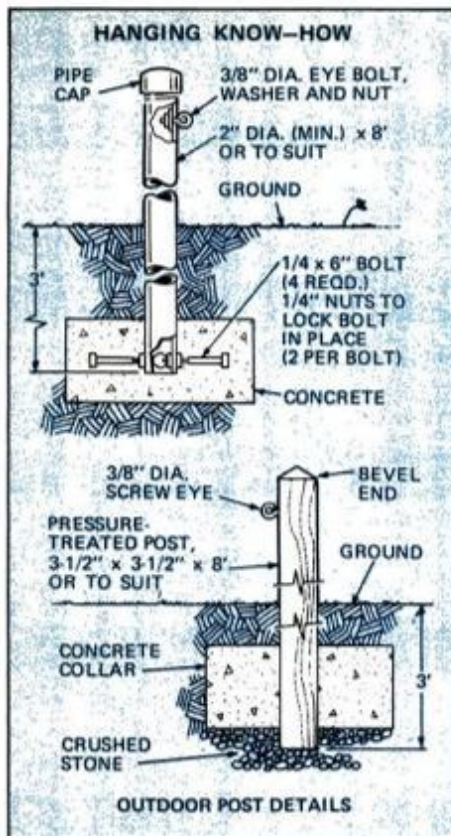

SHORT CUTS TO OWNING A HAMMOCK

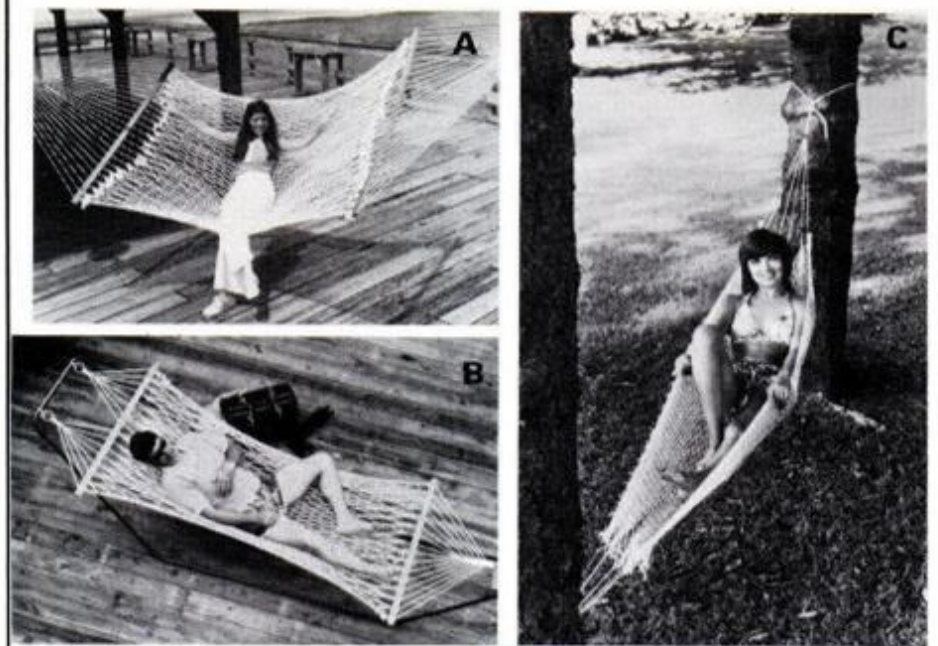

- A** Pawleys Island cotton or spun polyester woven hammock retails for \$60 to \$70, depending on its size.
- B** Three-point polyester rope hammock (43 x 76 in.) is priced at \$58 (not including stand) from Algoma.
- C** Several manufacturers market go-anywhere, easy-to-stow, synthetic net hammocks for less than \$10.
- D** Folding hammock (45 x 84 in.) stores in a compact, upright position. It's \$60, from Algoma.



If you decide to buy a hammock, be sure to get one that's big enough. The compact nylon hammocks that you can stow in a shoe box may be too confining. Next, check the rope material for comfort. Cool, absorbent cotton is hard to beat, but some spun polyesters are supple. Polyester is also mildew- and rot-resistant.

Hammock stands usually cost as much or more than the hammock. Choose one that either folds or knocks down for easy carrying. Three-point stands and bed-type

hammocks offer greater stability than two-points, but sacrifice swaying.—J.P.

MANUFACTURERS LIST

- Algoma Net Co., 310 Fourth St., Algoma, Wis. 54201 (all types of hammocks and hammock stands).
- Gold Medal Recreational Products, Div. of Blue Mountain Industries, Blue Mountain Rd., Blue Mountain, Ala. 36201 (synthetic camper hammocks).
- The Hammock Shop (Pawleys Island Hammock), Box 308, Pawleys Island, S.C. 29585 (rope hammocks and stands).
- Hatteras Hammocks Inc., Box 1602, Greenville, N.C. 27834 (rope hammocks and stands).

thread it through the first braid you made at the first paper clip, and then through the first loop in the 37th row. Continue to alternate until the edging is joined to the hammock body. Then tie the cord end to the loom pole.

Before removing the hammock body from the loom, pass a cord through all the end loops on each pole. Tie the ends of each cord together and remove the hammock body from the loom.

To make each harness, cut 10 130-in. lengths and pass them halfway through a ring. Hang the ring on the wall between two flanking nails, as shown in photo on page 112, and arrange the strands in order with a distinct front and back row. Bring the rightmost strand on the back row over the rightmost strand on

the front row. Then weave it under the next strand on the back row. Continue across in this manner and place the strand over the left nail when done.

Now take the leftmost strand and bring it under all front strands. Place it over the right side nail. Repeat for each strand until two remain. Make a square knot.

Pass the 20 strands of each harness through the 20 holes in each spreader. Make overhand knots. Then hang the harnesses and adjust knots to equal tension on all cords. Repeat for the other harness.

Finally, group end loops of the hammock (count braid ends as one loop) in pairs and tie one harness strand to each group using a bowline knot. Trim and bind all the ends to prevent unraveling.



Now! A Scientific Way to "SCRUB" the Air Clean!

Clear The Air with "NATURES-AIRE"

Makes dust, odor and pollutants vanish—leaves the air country fresh

Discover nature's own "secret" for fresh air...

Ever notice how wonderfully fresh and clean the air is after a good thunderstorm? Well, it wasn't the rain that cleansed the air... it was the negative ions generated by the storm. Now you bring that same natural phenomenon into your home, office or car with Natures-Aire, the ion generator that works like Mother Nature to cleanse, purify and refresh the air you breathe!

Natures-Aire—a controlled "thunderstorm"

That's right! Natures-Aire safely and electronically emits negative ions to create the same beneficial balance of ions found in the great outdoors—right in your home. You just plug it in and it silently and immediately begins to sweep unpleasant odors, smoke and pollutants from the air—leaves it refreshed and smelling sweet and country-fresh.

Unlike many similar products

Natures-Aire produces precisely the right balance of ions—25,000/cm³. Scientific research has shown that much more or less would not have the beneficial effect. In fact, Natures-Aire is now the standard by which Underwriters Laboratories measures other negative ion generators. It is the first ion generator to receive U.L. listing.

Negative ions—Nature's "Good Guys"

Though you can't see them working, negative ions actually grab on to particles of dust, smoke, organic and inorganic pollutants and sweep them from the air. Just as negative ions cleanse the air after a thunderstorm, Natures-Aire cleanses the air in your home with its gentle, controlled stream of negative ions—Nature's "good guys".

Natures-Aire—no matter where you live

Studies show that winds carry harmful pollutants everywhere—even to tucked-away communities. That's why Natures-Aire is so vital for everyone. In the near future, negative ion generators will undoubtedly be standard equipment in airplanes, office and apartment buildings. But you don't have to wait! You can start protecting your whole family from harmful pollutants and unwanted odors right now with Natures-Aire.

Perfect when you entertain

You'll love breathing purified air everyday, but imagine what a great benefit Natures-Aire will be when you have parties. No lingering cooking odors to embarrass you—no smoke filled rooms when the guests are gone! Yes, Natures-Aire will actually destroy stubborn odors, smoke, dust and other harmful pollutants in the air—not just cover them up with an artificial "freshener." Lets the whole family breathe easier! Just think what an important difference it will make to your personal environment.



listed by 

Proven safe and effective

Yes, Natures-Aire's graphite conductive fibers are so safe a baby could chew on them. And Natures-Aire sweeps any airborne micron-size pollutants from the air and deposits them in the wall or floor. So effective at eliminating smoke and odors, you'll notice the pleasant difference in just minutes!



Now—Mountain-Aire for your Car, Van, Truck or Boat

Natures-Aire has a "twin" that works wonders in your car, too. It's called Mountain-Aire. You just plug it into the cigarette lighter of your car and enjoy a smoke-free, odor-free, pollutant-free freshness wherever you go!

Put your nose to the test without risk!

You're probably a little skeptical. That's okay—we're so convinced that Natures-Aire and Mountain-Aire are the most effective, revolutionary air purifiers around that we're prepared to offer you a 30-Day Money-Back Guarantee. Prove it to yourself. Use Natures-Aire in your kitchen, bathroom, living room, bedroom (many say they actually sleep better!) and Mountain-Aire in your car and see for yourself if you don't notice the refreshing difference right away.

Small price—big reward!

You can own the product of the future for just \$79.95. What a small price to pay for clean, invigorating air for years to come! But remember—if you're not absolutely convinced that Natures-Aire and Mountain-Aire far out-perform other air purifying systems, simply return your order for a prompt, courteous refund.

Pure air... Pure value!

Imagine! For fresh, pure air every day of your life—you pay just \$79.95. A small investment when it comes to protecting the well-being of your whole family!

Safe enough for a baby... yet effective enough to rid your home of lingering smoke, odors and pollutants. Leaves it wonderfully refreshed and sweet smelling!

CAMBRIDGE INTERNATIONAL, Inc.

8700 Waukegan Rd. Morton Grove, IL 60053 (312) 966-5510

Credit Card Customers

Call Toll Free 24 hours a day

800-228-5440

(In Neb. 800-642-8777)

Clip & Mail to:

Cambridge International, Inc. Dept.—PM60
8700 Waukegan Road,
Morton Grove, Illinois 60053

YES! Please rush me _____ (quantity) Natures-Aire Ion Generator(s) at just \$79.95 plus \$3.95 for shipping and handling. (Ill. residents add 6% sales tax.) I understand that if I am not absolutely satisfied with my purchase, I may return it within 30 days for a prompt and courteous refund.

OPTION! Send me _____ (quantity) Mountain-Aire Ion Generator(s) for my car or van at just \$79.95 plus \$3.95 for shipping and handling.

Check or MO enclosed
 Charge to: American Express Diners Club
 Carte Blanche Master Charge Visa

Account # _____ Exp. Date _____

Name _____

Address _____

City _____ State _____ Zip _____

Signature _____

©Cambridge International, Inc. 1980

WORKSHOP MINICOURSE

THE BLOCK PLANE

Even if you own a shop that is fully equipped with stationary power tools, there are times when a plane is the tool you'll want. What better way to shave "whiskers" from end grain, or reduce a piece of wood to a carefully placed pencil line?

Though professional carpenters will often carry three or four different planes, the two that the average do-it-yourselfer need be concerned with are the block and jack planes. The latter is the larger of the two and is typically used for shaving swollen and stuck doors. We will discuss this plane in a future minicourse column. The block plane is a tool that you should try to master early in your woodworking career. This is one of the few tools—once you have become an expert in its use—that will assure you of having a neat, professional-looking finished project.

Keep a sharp iron

In order to use this tool to its fullest, you must know how to grind and hone its cutting edge. Maintain the bevel that comes on the iron, about 25°, and hone the cutting edge after each grinding to razor-like sharpness.

Check any plane iron for sharpness with the same technique that is recommended for testing chisel sharpness. That is, hold the iron at 90° to your thumbnail and scrape lightly. A sharp cutting edge will remove a scant amount of nail. *Never* test for sharpness by rubbing a finger across the cutting edge.

It takes practice to master a block plane, so start by working with scraps of soft wood (such as clear pine). Cutting strokes must be made with the grain; an against-the-grain stroke will cause the plane to chatter, or jump, which will result in chopping and uneven stock removal.

Once you have tried to cut with a plane against the grain, you will know why it is important to avoid this mistake. Also, practice by marking guidelines along a board's edge, just as you would to remove material from a door's edge. Vary the thickness of the material to be removed from, say, 1/8 in. to 1/32 in. This will help you develop a feel for setting the blade and stroking the tool across the work.

In general, the iron should be set



A block plane is the smallest smoothing tool that you're likely to have in your shop; it's also the one that you'll use most often. Iron is held rigidly by cap when the cam (arrow) is pushed to the right.

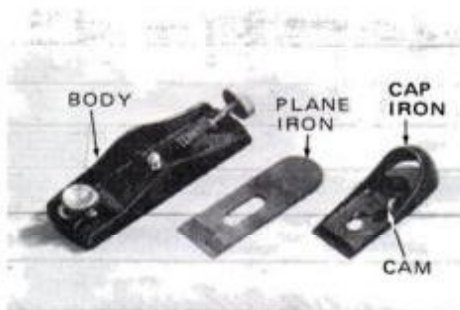

The basic tool consists of these three parts. As with its bigger cousins, the smoothing and jack planes, the tool's blade always should be kept razor sharp.

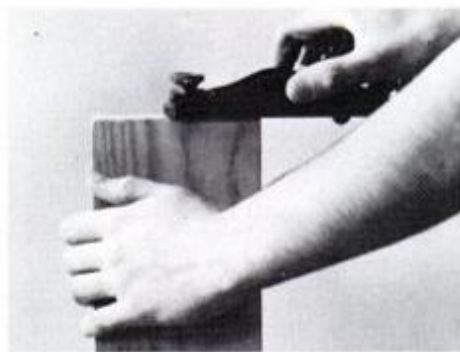

to a depth that produces scant stock removal. An attempt to remove too much stock in a single pass generally fouls the workpiece. Play it safe and try for thin continuous shavings.

When you plane the long edge of a vise-held board, you can guide the tool by extending several fingers down along the board's side.

Keep your tool in good shape; *always* retract the plane iron (to protect its cutting edge) after each use. Keep the tool clean and oil it occasionally to prevent any rust formation.



To remove the plane iron, push the cam to the left and simply lift off the cap piece.



Block plane is frequently used to smooth an end grain. If you try to make the cut in a single pass across the end, you'll likely cause splintering, as illustrated here.

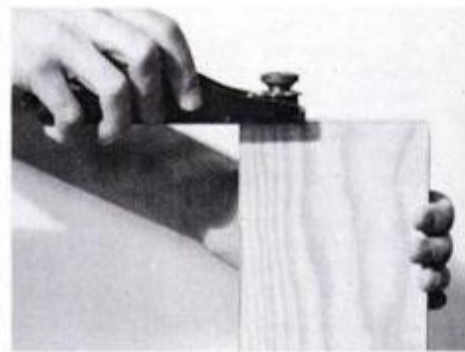

To avoid splintering, make the planing cut from the corner to the middle (left), then repeat the stroke from the second corner (above). You should *never* make strokes from the middle to the corners.

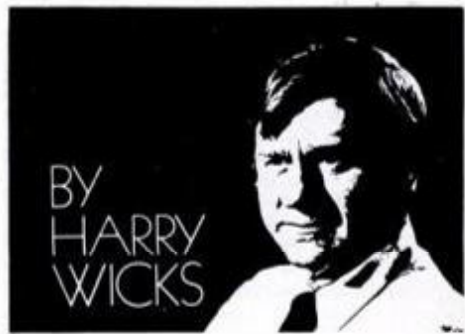



WILL POWER vs. WHEEL POWER

Wheel Power. That's what Black & Decker's incredibly versatile Workwheel™ Power Stripper and Sander gives you. The power to turn tedious sanding and stripping jobs into effortless work.

The Workwheel™ sands flat and contoured surfaces, removes paint and rust, polishes, buffs and even sharpens. All with its own versatile line of accessories.

And it has a virtually unlimited capacity for work. That's because the Workwheel™ combines the power and performance of four hardworking tools in one dynamic unit.

As a power sander, the Workwheel™ performs all kinds of difficult sanding operations on both flat and contoured surfaces.



As a power stripper, it removes stubborn rust and paint from metal surfaces easily.

There's also a polishing bonnet and cushion pad for big buffing jobs on cars and boats.

Or maybe you've got an ax to grind. The Workwheel™ can do that, too. Mount it on your Workmate® or workbench and use it to sharpen blades and knives. Its mounting bracket allows you to take the work to the tool.

The Workwheel™ from Black & Decker. It's the only civilized way to handle sanding, stripping, polishing, and sharpening.

When America has a job to do, it reaches for Black & Decker.

B-D **Black & Decker**
WORK WHEEL



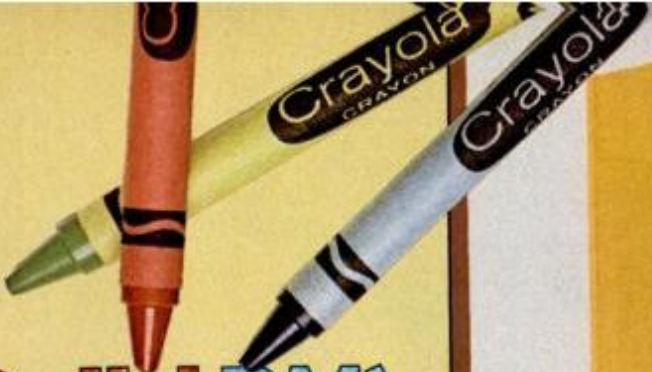

Build PM's ultimate desk for the Crayola set

We put a giant version of the famous Binney & Smith crayon box to use as a fully equipped kids' work center.

by Harry Wicks
HOME AND SHOP EDITOR

By popular demand, the names and logotypes of famous manufacturers are appearing on everything from T-shirts to bumper stickers. And now we introduce our giant crayon-box work center featuring the instantly recognizable Crayola logo—the manufacturer has approved its use by PM readers on a work center built for their own use.

All kids who have seen this intriguing "box" take to it right away because there is an instant recognition of the logo. The fact that they play "in" the work center will keep the youngsters happy for hours on end.

Rescaled 'crayon box'

We designed and proportioned the cabinet as close as possible to the scale of a real Crayola box, but the final dimensions were slightly compromised for practical considerations.

PM photos: color, Harry Hartman
black and white, Rosario Capotosto
Design: Douglas Eisman
Construction design: R. Capotosto and the author
Styling: Gabe Herrick
Desk accessories: Binney & Smith, Inc., 1100
Church Lane, Box 431, Easton, Pa. 18042



If we had scaled the box precisely—while assuming a 4-ft. width—the cabinet would have to be more than 7 ft. high. That's far too tall for safe and easy access to upper shelves by zealous youngsters of the age for which the unit is intended. The width

allows for ample desk space and a pair of doors wide enough to provide for a number of functions (as can be seen in the photos).

The unit is heavy enough for it to be freestanding. But, if the children who will use the desk tend to be overly



1 Opened, the desk provides all sorts of room for storage and kids' activities. Notice the roll of paper for painting mounted in the door at left.

2 Famous trademark shows when the doors are closed.

3 Caster-mounted doors on the box make its opening and closing a snap for youngsters.

gymnastic, you had better secure the cabinet to the wall by installing three or four screws of adequate length through the cabinet back into wall studs.

The deep doors ride on globe casters which take the strain off of the

hinges and provide stability, especially when the doors are closed. For the latter reason, the casters are positioned toward the front edge of the doors—instead of at the back where they would be almost out of sight. However, if you decide to mount the

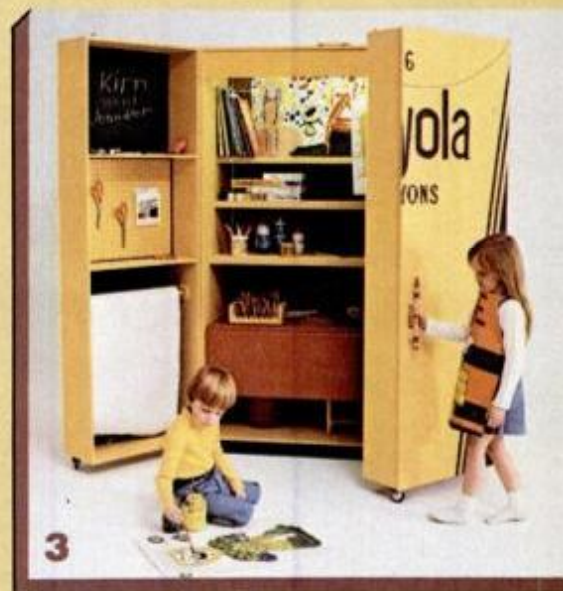
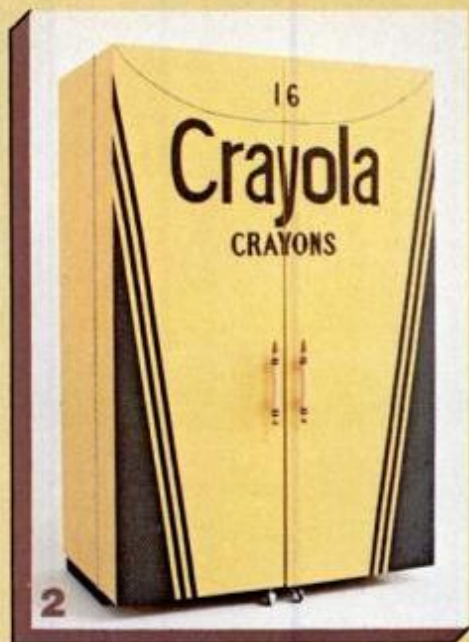

cabinet to the wall, you can place the casters in the set-back position.

The desk flap is supported by two swinging brackets that are positive-holding and safe. The space under the desk stores a combination bench/step stool. By standing on the middle or top step the average child can reach the upper areas easily. The 30-watt fluorescent lamp installed in the cabinet illuminates the cork display board as well as the desk work surface.

Except for the desk surface, which is made of $\frac{3}{4}$ -in. pine, the entire cabinet is built of plywood. We chose Duraply MDO (medium density overlaid) plywood for the prototype—even though it costs more. This is top-quality fir plywood with a resin-overlaid surface which is ideally suited for painting. It saws without splintering and consists of sound inner plies. *Note:* Use MDO plywood which is sur-

© 1980 R. J. Reynolds Tobacco Co.

DORAL II



But this much taste.



Warning: The Surgeon General Has Determined That Cigarette Smoking Is Dangerous to Your Health.

MENTHOL: 5 mg. "tar", 0.4 mg. nicotine,
FILTER: 5 mg. "tar", 0.5 mg. nicotine,
av. per cigarette, FTC Report DEC. '79.



Bore lead holes for following nails along the center of all butt-joint locations. This is done to make certain that the nails will center in the mating pieces.



Glued-and-nailed cleats help to support the shelves and simplify assembly. Use galvanized nails for good holding power.

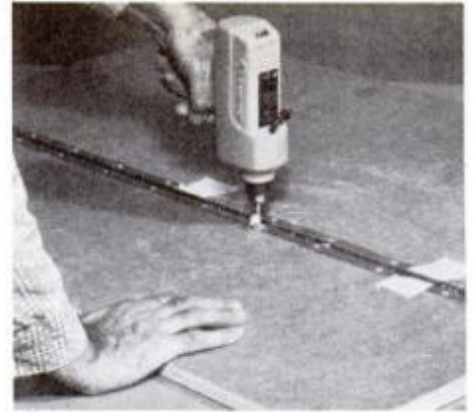

Fit the continuous hinge to the desk panel and flap before assembly. This beats working on your back and hoping for a good fit. Notice the spacing shim.

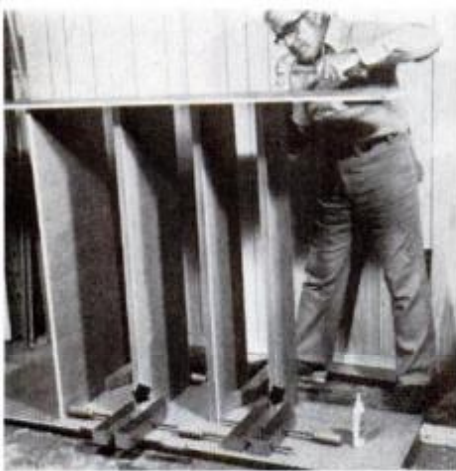

Parallel clamps are a must for holding the large shelves in place during first assembly stages. Start nails (to make locating holes) before you apply the glue.

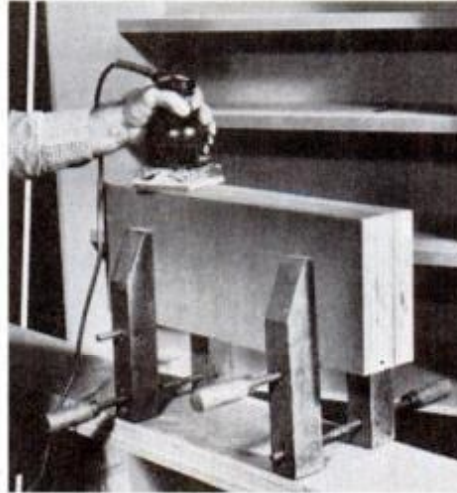

To speed the task, gang-sand front edges of door horizontal members. Later, ease all sharp corners slightly with sandpaper.



With the doors resting in place on the cabinet, attach the hinges. Shims are used to create a small gap at the hinge edges.

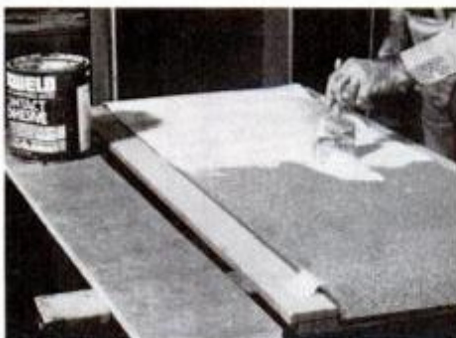

Make the cork bulletin board easily by contact-cementing sheet cork onto Homasote board. Apply cement to both surfaces. Cork is sold by the roll at home centers.

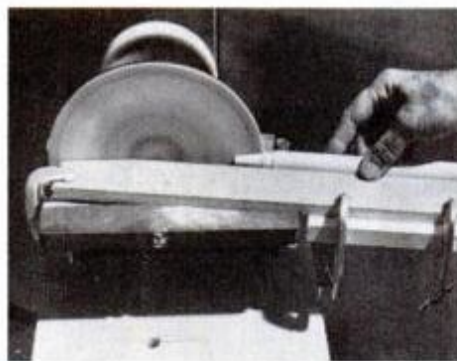

This simple jig lets you "turn" the crayon handles with a disc sander. A working angle of about 10° creates crayon tip

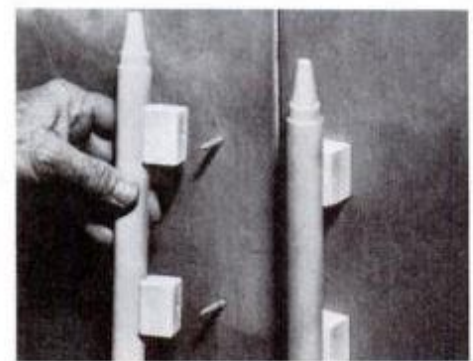

Use large screws that penetrate the stand-off blocks and enter the hardwood dowels. Maximum holding power is a must here.

faced both sides (S2S) for cabinetry.

Much of this project involves cutting large plywood pieces with a portable saw. Use a fine-tooth plywood blade and a good straightedge guide. When you cut a 6- or 8-ft. length, drive a few nails into the guide strip—and partly into the workpiece—to prevent bowing.

Start with cabinet cross members. Rip off 1 in. along a long edge so you have a sheet 47 in. wide. Next, cut the top, bottom, shelves and light-shield strip to size. If the 47-in.

width is cut accurately, these inside-fitting pieces will be the same length, and you will have trouble-free cabinet assembly. Desktop and shelf stiffeners must also be cut to the 47-in. dimension out of the 3/4-in. stock.

Cut the back and two side panels to size and mark positions of horizontal members on the insides of these pieces. Using a drill bit, bore pilot holes along centerlines.

For strength at butt joints, pre-

[\(Please turn to page 144\)](#)



Photo above shows the setup for boring perpendicular crayon holes in the holder's angled surface. The drill bit is the brad point type—perfect for this purpose.

SPACE AGE PROTECTION FOR YOUR CAR'S FINISH.
THREE LAYERS DEEP. 24 MONTHS LONG.



THE NEW POLYSHELL™ SYSTEM FROM TURTLE WAX.®

Weather. Pollution. Oxidation.

They all take turns beating the shine off your car's finish. But now the system is on your side—the PolyShell system from Turtle Wax.

An offshoot of space technology and Turtle Wax know-how, the PolyShell system locks three layers of protection between your car's finish and things that can kill it. Bonded

layers of Polymers and Silicones prime, shine and seal the finish.

There's even a Reactivator, which you apply every 6 months to bring the finish up to full shine and full protection for 24 months.

The PolyShell system is easy to apply. You don't need buffers or special tools. All the essentials are included. And it works for all car finishes.

Get the system on your side today. Ask for the PolyShell system from Turtle Wax.





PM's kids' version of the Grand Touring cars of old can be used safely on open fields (above) as well as on driveways and sidewalks. The car boasts an adjustable seat so vehicle can be used by Pop as well as Junior. The car's crank (below) won't start an engine but it does produce a child-satisfying clacker sound when it's turned.

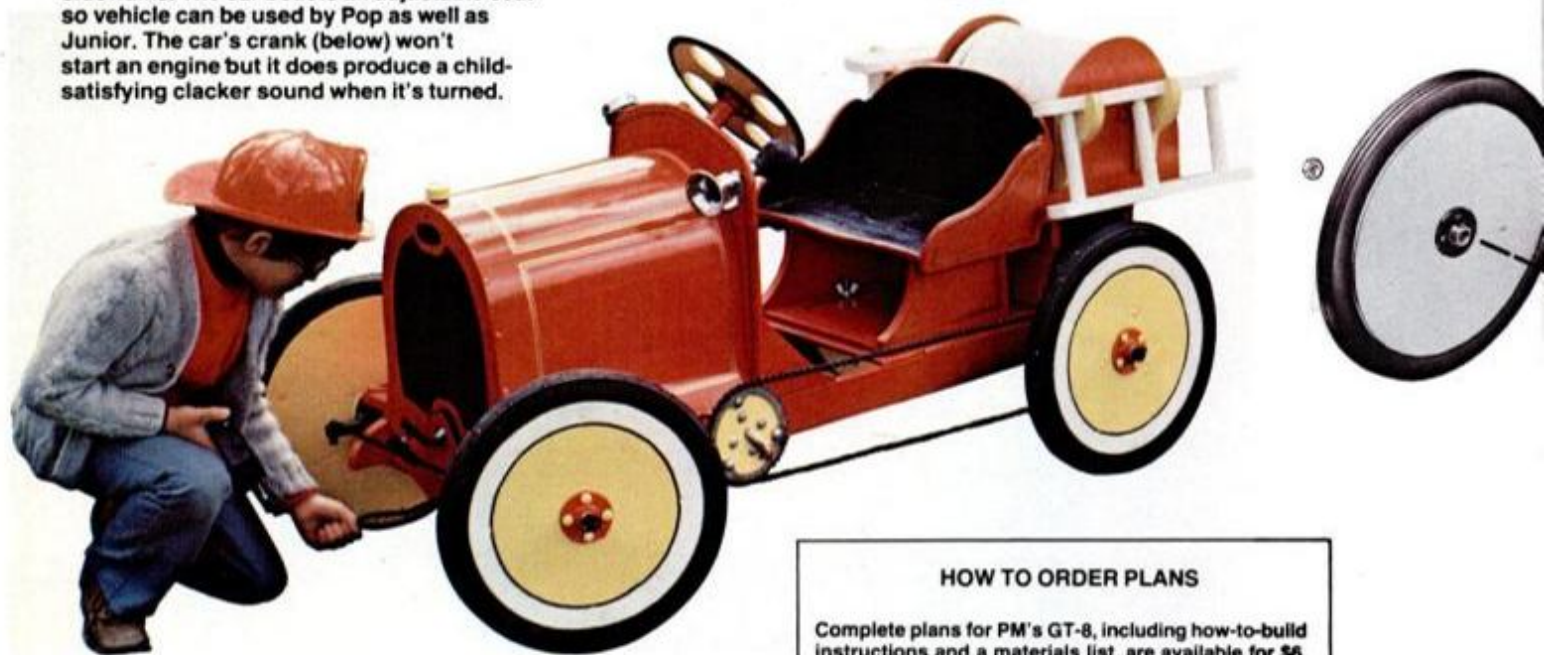

HOW TO ORDER PLANS

Complete plans for PM's GT-8, including how-to-build instructions and a materials list, are available for \$6. Send check or money order to PM GT-8, Stevenson Publications, Box 584, Del Mar, Calif. 92014. Allow two to four weeks for delivery for third-class mail; add 75 cents if you prefer faster first-class mailing.

Build the GT-8: PM's grand tourer for 8-year-olds

Build this classic and your child will draw a crowd wherever he pedals it.

by Harry Wicks HOME AND SHOP EDITOR

The talk about creating a pedal car such as this one—which PM's readers could duplicate—began more than five years ago. The major obstacle was the lack of lightweight, sturdy, old-style wheels at a reasonable price.

We decided to meet the problem head on and take a crack at creating built-from-scratch wheels. Designer Peter Stevenson successfully solved

the problem. His light, free-rolling wheels are made of laminated lumber and plywood, using standard bicycle hubs.

Parts for the car are easily purchased at lumberyards and plumbing-supply houses. The plans (see

following page) include a materials list to make shopping a snap. The car handles nicely and doesn't require any special tools or welding equipment to construct.

Depending on what materials you can salvage from an old bike, the cost to build the pedal car is about \$100, which is a neat investment for what will become a family pass-along heirloom. **PM**

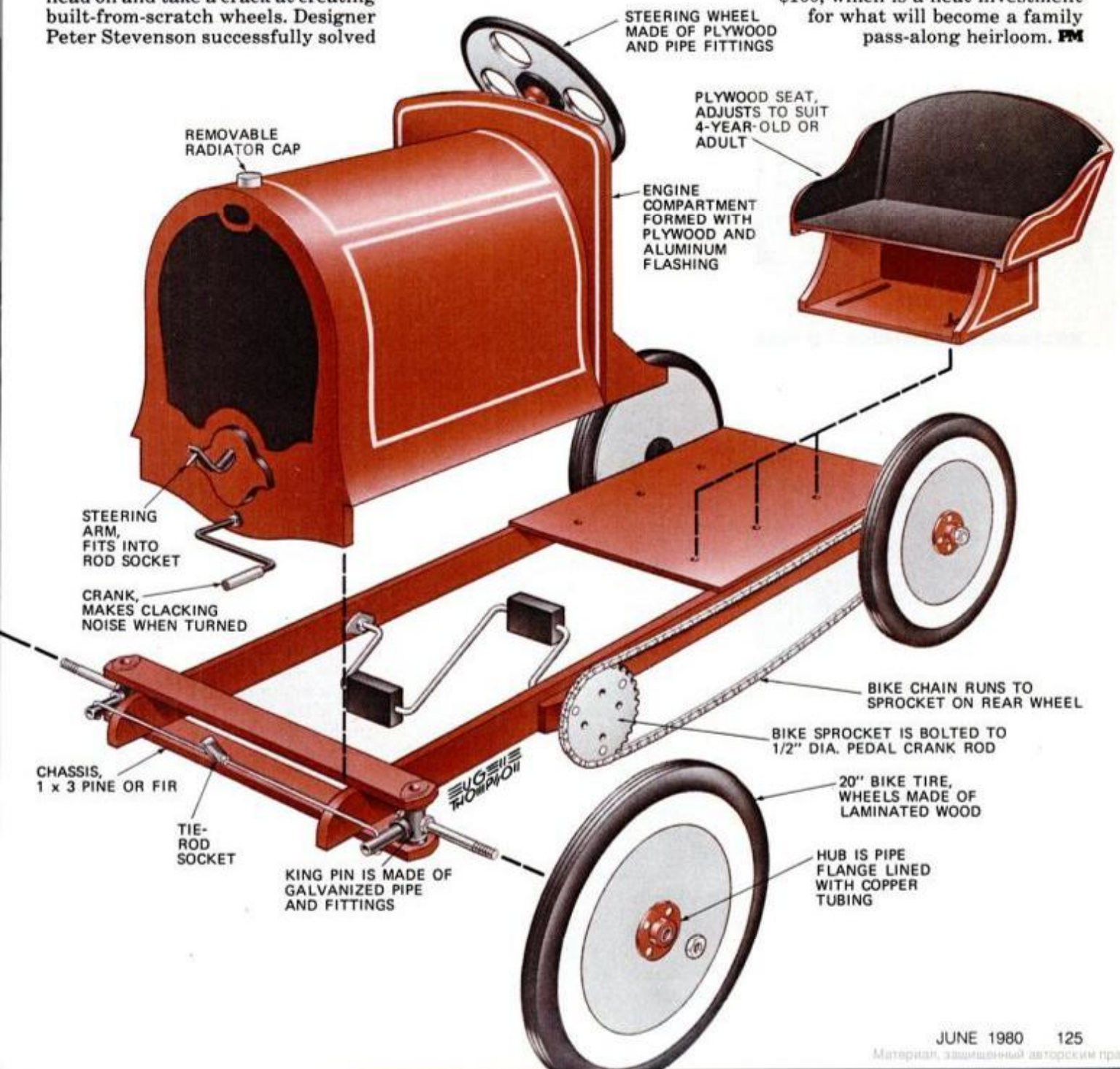

LYNCHBURG HARDWARE & GENERAL STORE

42 Main St., Lynchburg, TN 37352



JACK DANIEL'S COUNTRY CLUB CAP

This is a comfortable, practical sportsman's billed cap with a Jack Daniel's Country Club Patch and appropriate gold braid. It fits all head sizes and is guaranteed to start interesting conversations on the 19th hole or backyard barbecue. My \$7.50 price includes postage and handling.

Send check, money order, or use American Express, Visa or Master Charge, including all numbers and signature.

(Tennessee residents add 6% sales tax.) For a color catalog full of old Tennessee items and Jack Daniel's memorabilia, send \$1.00 to above address.

BEATING TV INTERFERENCE

(Continued from page 89)

near a TV set tuned to Channel 13. Dial the radio down to the 96- to 97-megahertz range and observe the variety of interference patterns on the screen.

If your own FM receiver is the problem, just move it a little farther away from the TV set. If the FM TVI is caused by a broadcast station, start by installing an inexpensive FM-band rejection filter at the rear of the TV set. Connect the filter to the antenna leads as instructed in the literature that comes with it. Use a connector cable of the same type as the existing antenna lead. This may be a simple twin-lead wire or a coaxial cable; just don't mix the two types.

If you have an antenna amplifier, install one filter before the amplifier and a second one ahead of the TV receiver input terminals. You may also be instructed to add a ground wire which should be kept as short as possible. If the filters don't solve the problem, call a serviceman for in-set modifications.

4. Computer-generated TVI

This is generally not a problem unless the computer is quite close to the TV set. During our tests, Channels 2, 4 and 13 were found to be most sensitive to computer radiation. However, the radiation put out by some other computer might affect a TV set differently, perhaps on other channels, and produce other types of interference patterns.

If a neighbor buys a hobby computer, don't be in a rush to blame him for all your TV interference problems. It's simple enough to check it out by turning the computer on and off while watching the TV set. Not all computers create TVI, even when operated next to the television receiver.

5. Ghosting

This is a formation of double images and occurs when the TV signal travels along two paths of different lengths from the broadcast tower to a receiving antenna. However, ghosting can also be caused by a poor TV antenna and/or lead-in wire, or merely improper aiming of a directional-type antenna. Check these possibilities first.

If the problem obviously relates to multipath reception of a reflected signal, try moving the antenna to a different location. If that doesn't cure the problem, replace the antenna with a more directional type, and be sure to use shielded-type lead-in wire.

If you observe ghosting and significant blurring or other distortion of the picture, this is a pretty good indication that the difficulty is two-fold: ghosting and a weak signal. Once again, the best solution may be either to aim the antenna more carefully or switch to a more directional antenna.

6. CB radio interference

This can be caused by citizens band and amateur "ham" radio transmissions, but also by transmissions by police and other public service radios.

Such TVI characteristically occurs in the form of dark parallel lines tilted slightly off the horizontal. These patterns are easy to confuse with similar effects caused by horizontal-hold problems in the TV set. But these aren't the only interference patterns produced by radio transmitters.

The actual effects vary greatly depending on many factors, including the strength of the radio signal and whether the radio operator is actually talking or merely sending out an unmodulated carrier wave.

If the TVI is, in fact, due to radio interference, the pattern will pulsate as the radio operator talks, and may even bounce back and forth between the parallel-line pattern and more random patterns.

You will not observe such pulsations if the parallel lines are caused by horizontal-hold problems; instead you may hear a high-pitched tone. To cure a hold malfunction, readjust the horizontal-hold control. If that doesn't work, have a serviceman replace a bad component.

Eliminating radio transmitter TVI can be a problem. You should begin by installing an inexpensive high-pass filter at the antenna terminals of the TV set. Be sure to use the same type of connecting cable as is used for the antenna lead-in (either twin-lead wire or a coaxial cable). Put one filter ahead of an antenna signal amplifier you may be using and a second filter at the TV set. If the filters don't fully cure the problem, consult your serviceman about possible modifications of the TV set's internal circuitry.

7. Co-channel images

This resembles ghosting, but is easily recognized because the second image is usually of a different program, which means it is coming from a second TV broadcast station. Remember, true ghosting involves a duplication of the same TV program material.

Co-channel interference is most

(Please turn to page 128)

Free! Edmund Scientific Catalog



Explore Astronomy, Biofeedback, Optics, Lasers, Magnets, Weather, Magnifiers, Microscopes, Photography . . . Over 4,000 Fascinating Products in Our FREE 100 page color Catalog! Send for your FREE Edmund Scientific Catalog, Today! 38 Years Of Service!

Yes! Rush me your FREE catalog!

Name _____

Address _____

City _____

State _____ Zip _____

Clip and Mail Coupon Today to:
Edmund Scientific Co., Dept. 2020 H-12
Edscorp Bldg., Barrington, N.J. 08007
No. 156 ©1980 Edmund Scientific Co.

Maintain Your Ford Motor Company Vehicle
"The Ford Way" with...

FORD SERVICE PUBLICATIONS

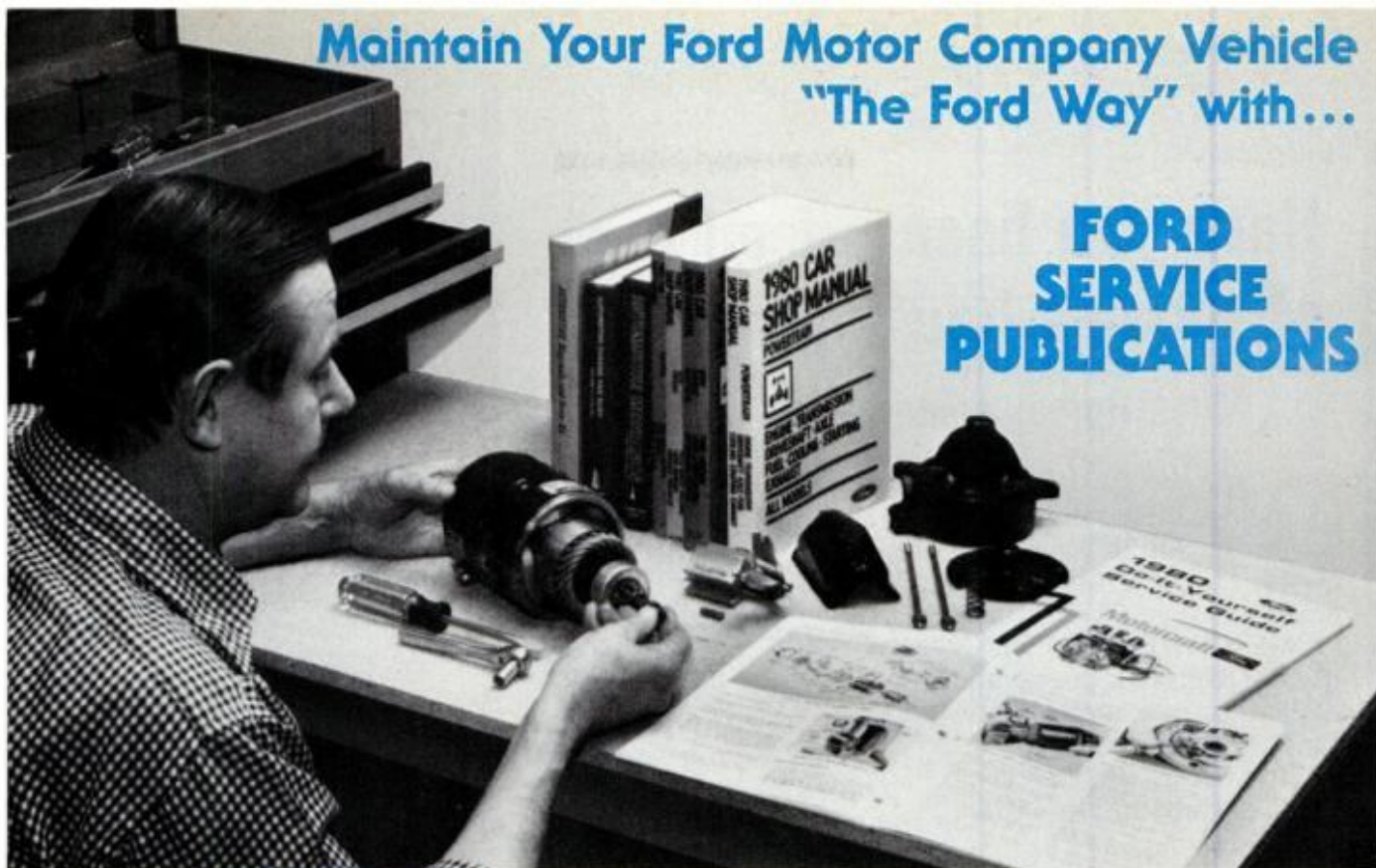

CAR SHOP MANUALS

SHOP MANUALS	1980	1979	1978
Shop Manual Set — Includes all car models except those listed in footnotes.	365-126-80ABC \$31.90 (1)	365-126-79 \$21.95 (2)	365-126-78 \$19.75 (3)
Shop Manual — Includes Lincoln Continental, Mark VI, Full-size Ford/Mercury	365-126-80A \$19.95	—	—
Shop Manual — Includes Fairmont, T-Bird, Zephyr, Cougar	365-126-80B \$19.95	—	—
Shop Manual — Includes Granada, Lincoln-Versailles, Mustang II, Monarch, Pinto, Bobcat, Capri	365-126-80C \$20.95	—	—
Shop Manual — Fiestas	365-315-80 \$9.50	365-317-79A \$8.95	365-315-78 \$8.95
Shop Manual — Full-size Ford/Mercury	—	365-327-79 \$10.95	Covered in 365-126-78

Footnotes: (1) All car models EXCEPT Fiesta: receive 80A, 80B, 80C Shop Manual

(2) All car models and Ranchero EXCEPT Fiesta, Full-size Ford/Mercury

(3) All car models and Ranchero EXCEPT Fiesta and Capri

VEHICLE SYSTEMS REFERENCE MANUALS

MANUAL	FORM NUMBER	PRICE
Air Conditioner Systems	3631-103 TXT	\$4.55
Air Conditioner Control Systems	3640-003 TXT	\$4.55
Alternator Service & Testing	3101-010 TXT	\$3.40
Battery Service & Testing	3102-005 TXT	\$3.40
Carburetor Service Manual, Vol. I	2400-016 TXT	\$4.55
Carburetor Service Manual, Vol. II	2400-018 TXT	\$4.55
Engine Tune-Up	0900-010 TXT	\$3.40
Automotive Ignition Systems	2301-005 TXT	\$3.40
Automotive Starting Systems	2801-001 TXT	\$3.40
Vehicle Emission Control, Vol. I	0901-021 TXT	\$4.55
Vehicle Emission Control, Vol. II	0901-021 TXTA	\$4.55

SIMPLIFIED DO-IT-YOURSELF MANUALS

MANUAL	FORM NUMBER	PRICE
1980 Thunderbird, Cougar XR-7, Mustang, Monarch, Zephyr, Fairmont, Granada, Pinto, Bobcat	365-130-80	\$4.50
1980 Full-size Ford/Mercury	365-131-80	\$4.50
1980 Fiesta	365-317-80	\$4.50
1980 Ford Econoline Van	365-132-80	\$4.50

ORDER INFORMATION

Please fill in this order form completely. Be sure to include form number and model year.

Make check or money order payable to:

FORD SERVICE PUBLICATIONS
P.O. Box 07150
Detroit, Mich. 48207

FORM NO.	QUANTITY	PRICE EACH	AMOUNT
Total Order			_____
Michigan Purchasers Add 4% Sales Tax			_____
All Materials prior to model year 1980 add \$.50 handling charge			_____
GRAND TOTAL			_____

—PLEASE PRINT— Prices subject to change without notice.

If you need any further information on Ford Motor Company's full line of service publications, phone (313) 865-5000 or write to address shown below.

NOTE: Purchasers outside domestic U.S.A., please write to same address for quotation.

Please allow up to 4 weeks for postal service.

IMPORTANT
THIS IS YOUR
SHIPPING LABEL
PLEASE PRINT

From ... **FORD SERVICE PUBLICATIONS**
P.O. Box 07150, Detroit, Michigan 48207

TO:
Name _____
Street _____
Address _____
City/State _____ Zip _____

Return Requested

Return Postage Guaranteed



FINANCING
NO
PROBLEM!

Have you been priced out of today's housing market?

Miles Homes could be the answer!

If you have the ambition and desire to build your own home, then the Miles Plan could be for you. **THE MILES HOME OWNERSHIP PLAN IS UNIQUE.** Your desire and dedication are more important than ready cash — start now to build the home of your dreams...the Miles Way.

- Liberal credit — Low monthly payments while building.
- Foundation assistance.
- Land may not have to be fully paid for.
- Pre-cut materials, blueprints, **step-by-step instructions.**

- 36 months to build.
- There is a representative near you. Phone: (612) 588-9700.

Miles has nearly 30 years experience helping over 15,000 families to build their own home. Send coupon today to see how Miles can help you.

Miles Homes

12 Inco A Division of Insilco Corporation

Send me your **FREE** Great Homes Idea Book

MILES HOMES, Dept. 0610
4500 Lyndale Ave. N., Minneapolis, MN 55412

Name _____

Address _____

City _____ State _____ Zip _____

County _____

Phone (_____) _____

I plan to do all or part of the work

\$1.00 enclosed for priority handling

BEATING TV INTERFERENCE

(Continued from page 126)

commonly caused by atmospheric conditions that permit signals from a very distant station to bounce back down from the upper atmosphere and thereby "skip" to receiving areas they normally wouldn't reach. There's nothing to do about a temporary problem except wait until the atmospheric condition clears, usually within an hour or two.

However, if you experience *persistent* co-channel interference, it means that you are located where it is possible to pick up signals regularly from two broadcast stations on the same channel. You may be able to cure or minimize the problem by installing a highly directional antenna. If some interference persists, try reducing the signal strength with a tunable signal attenuator that actually weakens the signal getting into the TV set.

8. Airplanes and windmills

Here are but two examples of miscellaneous outside sources of TVI. The whirring blades of a helicopter (eggbeater) or the wings of a banking 747 can cause TV interference. The display may tear badly, and there may be a temporary loss of color. The problem is really troublesome only near busy airports.

Some channels may be more sensitive than others to such disturbances, perhaps partly because of weak TV signals. The installation of a better antenna, use of a shielded coaxial lead-in cable, and addition of an antenna signal amplifier can greatly reduce the effects of aircraft.

A similar problem can be caused by windmills! People living in rural areas may already be familiar with this source of TVI, and the problem may become more widespread if windpower develops into a significant energy source in the years ahead.

Of course, there's also TVI that originates from malfunctioning equipment at the TVI broadcast station, and the broadcaster usually—but not always—announces that fact. If you observe bad color or other picture distortions during the presentation of field-recorded news broadcasts, for example, it may be due simply to a malfunction or inexperienced use of the broadcaster's portable camera equipment.

Additional tips

If a specific ham or CB transmitter in your area obviously relates to your TVI problem, work with the

(Please turn to page 130)



Enjoy Fireplace
Beauty
PLUS Both
Highest
Heat Output
and
Efficiency!

Unique design of THERMOGRATE® Free-Standing Fireplace/Stove produces more heat at high efficiency than any stove (55,000 BTU/hr. at 63.2% efficiency) . . . so you burn less wood while enjoying glass door elegance!

For **FREE** information, write: Thermograte Ent. Inc., Dept. 841-006 P.O. Box 43021 St. Paul MN 55164 Or **CALL TOLL FREE: 800-328-0882**

STEP FORWARD INTO THE PAST



FANTASTIC FACTS

- Saves up to 35% on air cond. costs
- Quality manufacturing since 1939
- **UL approved**
- 90 day \$ back and 3 yr. guarantee

To order call 1-800-241-7788

Ga. call coll. 1-404-498-1278

Send 25¢ for color catalogue

UNIQUE ENERGY PRODUCTS

P.O. Box 1009 - Dept. PM-6

Stone Mountain, Ga. 30086

SPECIAL PRE-SEASON OFFER! **9⁹⁵**
WHY SPEND \$39.95 TO \$100?... ONLY

**GUARANTEED TO KILL MOSQUITOES,
 GNATS, FLIES, MOTHS, ETC.
 ELECTRONICALLY,
 OR MONEY BACK**

Safe for Humans, Pets, Birds—
 Kills Flying Insects with No
 Poisons, Insecticides, Sprays

- SPECIAL ANGSTROM BULB ATTRACTS ALL TYPES OF FLYING PESTS—KILLS THEM ON CONTACT
- SAME EFFECTIVE ATTRACTING PRINCIPLE USED AT MANY STADIUMS, RACE TRACKS, RESTAURANTS, DAIRY BARNs, SWIMMING POOLS
- PRICED THE SAME AS ANY DECORATIVE PATIO LIGHT AND AS BEAUTIFUL TOO
- NO CLEAN-UP, NO BAGS TO EMPTY
- USE INDOORS OR OUTDOORS
- ECOLOGICALLY SAFE FOR TREES AND SHRUBS
- WILL NOT HARM BEES OR OTHER BENEFICIAL DAY-WORKING INSECTS

Now, after extensive research and field testing, comes news of a major break-through in pest control. The IC7 Insect Control Lamp, employing same attracting principle used for years by commercial enterprises, is now available for home and patio.

This amazing insect control lamp will rid your patio and home of those pesky flying insects, clear hundreds of square feet and really let you enjoy your summer evenings.

AMAZING SCIENTIFIC PRINCIPLE

The Attracto/Angstrom Black Light Bulb with its special wave length, attracts insects to the IC7 Lamp like a magnet. Once they come in contact, they are exterminated. (ADDITIONAL BULBS AVAILABLE). No clean-up needed.—The lamp is 100% safe for children, pets, birds, and is environmentally accepted.*

*Reg. with U.S. Environmental Protection Agency, No. 41681.

**LARGE 1 FT. TALL by
 8" IN DIAMETER!**
 MADE IN U.S.A.
 Patent Pending



**SPECIAL
 PRICE OFFER
 ONLY**
\$9⁹⁵

**DRAWS INSECTS
 LIKE A MAGNET
 AND KILLS THEM -
 ZAP!**

NOT SOLD IN STORES

AS
 SEEN ON **TV**

©1980 Media Marketing

CREDIT CARD HOLDERS CALL AT NO CHARGE
 TOLL-FREE NUMBER: 1-800-331-1000

SATISFACTION GUARANTEED OR MONEY BACK

INSECT CONTROL CO., INC. Dept. 551
283 Greenwich Ave., Box 464
Greenwich, Conn. 06830

Yes, I want to rid my home and patio of flying insect pests the 100% safe, effective way. Please send me _____ (qty.) IC7 Insect Control Lamp(s) at only \$9.95 each, plus \$1.50 ea. to help defray postage and handling.

SAVE: Order 2 Insect Control Lamps at only \$17.50 plus \$1.50 postage and handling for both!

I enclose full payment of \$_____ (Conn. residents, add sales tax.)

Charge to: Visa Master Charge, Interbank # _____

Card # _____ Expires _____

Signature _____

NAME _____

STREET _____

CITY _____ STATE _____ Zip _____

**INSECT TRAPS WITH 10 WATT BULB SELL AT \$69.95.
 THIS MODEL IS A FULL 75 WATT BLACK LIGHT!**

Order now, at this special price
 of only \$9.95. Hurry. Mail this
 no-risk coupon today.

INSECT CONTROL CO. INC.,
283 Greenwich Ave., Box 464
Greenwich, Conn. 06830

Own a DIXON ZTR mower and you might never get to use it yourself.



Once the family finds it's *mower fun* on a DIXON, you've lost the mowing job. Maybe forever.

DIXON mowers appeal to all kinds, all ages. A great many operators are *under 18 or over 65* and more than half are women; many are farm wives.

Big 42" cut or 30" town lawn size, all have Zero Turning Radius that easily cuts mowing time on many lawns in half. That's Mowbility!

Test drive one today; it might be the last time you get to drive it yourself!

Tell me more about DIXON Zero Turning Radius mowers. Please send a free brochure to:

NAME _____

ADDRESS _____

CITY _____

STATE _____

ZIP _____



I might like to be a DIXON Dealer; please tell me how:

TELEPHONE _____

DIXON INDUSTRIES, INC.
BOX 494, DEPT. PM2
COFFEYVILLE, KANSAS 67337
(316) 251-2000

© Dixon Industries, Inc.



The pride of your toolchest... Cabinetmaker's Screwdrivers from England.

Designed especially for wood screws, beautifully balanced for excellent control. Sheffield carbon steel blade is machined flat for extra leverage. Oval-shaped, lacquered Beechwood handles fit the palm of your hand. Bright steel ferrules... a handsome screwdriver set. Blades: 2, 3, 4, 5, 6".

5-Piece Cabinetmaker's Screwdriver Set \$19.95

Enclosed is \$19.95 plus \$1.50 Shipping/Insurance for The Screwdrivers. Include NEW catalog FREE.

VISA or MC, order toll free 1-800-343-6130

Name _____

Address _____

City _____

State _____

Zip _____

Enclosed find \$1.00 for NEW 79-80 Catalog only.

THE PRINCETON COMPANY

WE KNOW YOUR CAR INSIDE AND OUT.



Life—Protects, preserves, and beautifies all rubber, vinyl, and leather products.



Power Steering Fluid—Works in power steering systems to prevent leaks.

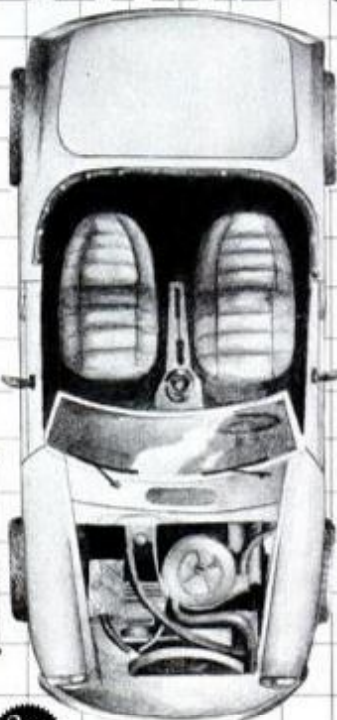

Tire White—Penetrates and removes all types of road soil on both whitewalls and blackwalls.



Puncture Seal—Safely inflates tires, sealing the puncture.



Engine Aid—Helps to reduce friction, retard oxidation, and extend the life of your oil.



Motor Flush—Cleans car engines in just 5 minutes.



Diesel Fuel Conditioner—Specially formulated to keep tanks free of the gum and varnish that form in diesel fuels.



Radiator Specialty Company
Charlotte, NC 28234

BEATING TV INTERFERENCE

(Continued from page 128)

operator to check his equipment for proper performance. See if the rig is properly grounded, test for harmonics and/or spurious emissions, and add a good earth ground if the transmitter cabinet radiates energy. Install a low-pass filter on the transmitter antenna circuit to see if the TVI pattern is affected by changes in harmonics and/or spurious emissions.

If these measures fail, go back to the TV receiver and recheck all antenna connections. If there's an antenna signal amplifier, remove it temporarily. If this eliminates TVI, reconnect the amplifier, but protect it against radio frequency (RF) pickup as follows: 1. Add grounding; 2. enclose the amplifier in a metallic RF-proof housing and ground the housing; 3. install a high-pass filter at the input to the amplifier; 4. install a second such filter in series if the first one is not adequate.

Add a purchased a.c. power-line RF filter to determine if the RF from the transmitter is entering the TV set by way of the power cord. If the TVI persists, even when the antenna is disconnected, look for the problem inside the TV set, especially at the tuner. Disconnect the antenna input lead inside the set at the tuner. If the TVI is eliminated, install a high-pass filter at the tuner. If this doesn't cure the problem, each stage of the TV must be tested—a job for a repairman.

Electrical TVI caused by sparking home appliances and tools can often be eliminated by adding capacitor bypasses. However, the modifications must be done with extreme care, especially when bypassing appliances having capacitors. Dangerous voltages may exist, the a.c. power line might accidentally be shorted and an inexperienced do-it-yourselfer can invite electrocution!

Arcing between the brushes and commutators of infrequently used power tools are best left alone. If the tools are in constant use, TVI can be reduced by bypassing each side of the line to the other side and to ground with capacitors. The on/off switch also should be bypassed.

Also, .001-mfd. capacitors may be used to bypass arcing contacts in such thermostatically controlled appliances as electric blankets and fish-tank heaters. Defective TVI-producing doorbell transformers should be replaced. Dimmer switches that utilize SCRs or triacs can cause much hard-to-eliminate TVI. However, bypassing with capacitors may help somewhat. **FM**

DON'T GET BURNED BY SOLAR RIP-OFFS (Continued from page 85)

tified Solar Collector Ratings, which evaluates the performance of a few dozen collectors. Contact the energy offices of any of the 10 northeastern states or Florida to find out which collectors have passed the performance standards set for the 10,000 hot-water grants of \$400 each, issued in the past three years by the U.S. Department of Housing and Urban Development. The Florida Solar Energy Center also has tested more than 150 collectors made by scores of manufacturers. Send for its summary data sheet.

Fully understand a solar system before proceeding. In theory, it's simple: The sun heats a black "absorber plate" in an insulated box, covered with glass or plastic to accept light and trap heat. Water or air flows to the collector, where it picks up heat for use in your house. In practice, however, solar systems are complicated.

How systems fail

As you examine the diagram on page 84, you can begin to see where problems might develop. For example, if sensors or pumps are installed backwards, systems can heat the collector (and thus the sky) and cool hot-water tanks. It has happened. In fact, in some badly designed systems, the collector was protected from freezing by pumping up warm water from the storage tanks—water already heated by the collectors or by conventional fuel. Instead, of course, the collector should be protected with antifreeze, or be automatically emptied (through the drain) into a pail or outlet when the temperature gets too cold. It would then be filled automatically when the outside temperature increased.

Good systems include safety features such as a stagnation temperature relief valve, expansion tank, or both, in case the pump fails. Without such safety features, the sun could raise the collector temperature to 400°, blowing out the collectors or causing other serious damage.

The size of the storage tank or bin is also critical. In Roanoke, Va., one man bought a domestic hot-water system with a 2000-gallon storage tank, instead of the usual 60 to 120 gallons. The tank collected a lot of B.T.U.s of heat, but they were spread out over so much water that the fluid only increased a few degrees in temperature. The system was useless without a smaller tank.

It almost goes without saying that energy conservation comes before solar energy. For a hot-water sys-

tem, insulate the tank and pipes. For heating, insulate the attic, buy storm windows and caulk and weatherstrip windows and doors.

Choosing a collector

California has a lot of swimming-pool heaters. One, a black hose, came in a coil and was installed on the roof. In one Palo Alto installation, a high wind unrolled the hose about 10 feet. It smacked into a second-floor window and emptied the pool into the bedroom.

Always choose a collector that (1) has been approved in a federal testing program, (2) looks good in the solar industry's rating booklet, or (3) is highly rated by an independent laboratory. All reputable collectors will have undergone stagnation-temperature tests. Ask for documentation.

First define your needs: domestic hot water, swimming pool or heating (air or water). Space heating usually requires higher collector temperatures than hot water. So heating systems often have double glazing and an electroplated black collector coating, to absorb more incoming light.

The longest-lasting collectors are copper. Galvanized steel and aluminum are subject to rusting, pitting or other corrosion. Add buffers to the water or antifreeze.

If you are a do-it-yourselfer, the specific collector you choose will probably depend on price and ease of installation. If you're hiring someone, depend on what's local: You don't want a dealer who's 200 miles away if you have a problem.

A final note on collectors: A recent study by the Solar Energy Research Institute in Colorado found a thermosiphoning system to be the most efficient of all. In such a system, the collector and the tank are on the roof, with the tank higher. The water circulates by siphoning; there is no pump. Of course, the system can't be used in freezing weather. But if you don't mind a tank on your roof and no solar-heated water on freezing days, consider it. The system costs less than \$1500.

Picking a contractor

The best solar system in the world is thoroughly useless when installed by an incompetent contractor. In Florida, a perfectly good pump was installed upside down, so it could not be oiled—and it needed to be oiled. In Miami, a solar installer put in high-temperature collectors for a low-temperature swimming-pool system. The plastic pipes melted.

(Please turn to page 132)

SEE YOUR DEALER TODAY

DEMAND THE ORIGINAL

'Firestik'

"THE FUEL-SEEKER"

**DON'T TAKE NO FOR AN ANSWER!!
THE #1 WIRE-WOUND AND MOST
COPIED ANTENNA IN THE WORLD!**

Rugged, Shatterproof Fiberglass . . .

CB

Antennas and accessories for marine, RV, truck, auto, van and motorcycles, etc.

SIX COLORS:

Clear, Spun-Gold,

Silver-Gray, Black, Red and White.



SEND FOR FREE CATALOG

'Firestik' Antenna Company
2614 East Adams/Phoenix, AZ 85034

Name _____
Street _____
City _____
State _____ Zip _____

Serving the CB and
Communications Market Since 1962.

5-YEAR REPLACEMENT WARRANTY

DO-IT-YOURSELF

FINE GRANDFATHER CLOCK KITS

STARTING UNDER

\$225

(including movement and dial)

- Factory direct prices
- Heirloom quality
- Solid ¾" hardwoods: black walnut, cherry, mahogany, oak
- Easy to assemble, parts pre-cut
- Solid brass West German chiming movements
- Money back guarantee
- Prompt shipment



MASTER CHARGE and BANKAMERICARD/VISA
ACCEPTED

Write for FREE color catalog

EMPEROR® CLOCK COMPANY

WORLD'S LARGEST MANUFACTURER
OF GRANDFATHER CLOCKS
Dept. 426 Emperor Industrial Park
Fairhope, Alabama 36532

AQUA DRILL

FOR WATER INDEPENDENCE

HAPPY HEALTHY LIVING REQUIRES A PLENTIFUL AND CONTINUOUS SUPPLY OF GOOD QUALITY WATER.

ODDS ARE IN YOUR FAVOR THAT THIS WATER SUPPLY IS LESS THAN 200 FEET BELOW THE SURFACE OF YOUR PROPERTY.

THE **AQUA DRILL**® IS THE INEXPENSIVE WAY TO ACHIEVE **WATER INDEPENDENCE**.

FOR FULL INFORMATION ON THIS APPROACH TO WATER WELL DRILLING CALL TOLL FREE

800-231-2735

OR WRITE

AQUA-WELL MFG. CO.

P.O. BOX 10839, DEPT. W-102
HOUSTON, TEXAS 77018



SOLAR RIP-OFFS

(Continued from page 131)

In one development near San Diego, rooftop collectors face east, west, south and in between. Installers apparently just followed the roofline, ignoring the direction from which the sun shines.

Usually, the dealer will also install the system. First, make sure he is experienced: Ask for the names of 10 customers, and visit at least three. If the dealer won't cooperate, leave.

Solder blocks a pipe

Grill the customers. Has the system leaked? Did the workmen kick the dog and track mud all over the carpets? Ask them how they know the system is saving money. One woman in Florida told researchers that she loved her system, but closer examination revealed it wasn't supplying any heat: A piece of solder was blocking a pipe.

Call agencies and ask for previous complaints: the local consumer affairs department and better business bureau, the state contracting license board. Consider asking your bank to do a credit check on the company principals and on the firm. The bank may do this as a courtesy or will charge a nominal fee, perhaps \$20. The credit check will determine how sound the company is and whether there are any major judgments against it.

Execute a contract, specifying the type, number and price of all materials to be used. This is important: A few southwestern solar-water heater distributors were caught switching—installing cheaper and less efficient collectors than what the customer paid for.

In all cases, get a collector warranty at least as strict as the one required by the U.S. Department of Housing and Urban Development for all systems installed under its grant program. That is a full one-year warranty on minor parts such as valves and sensors, and a five-year warranty on the collector, pipes and pump. There must also be a five-year guarantee against corrosion. Try to get a full year's warranty on the installation, too—California requires it—but settle for 90 days.

And consider requesting a performance bond, in which a bonding or insurance company guarantees both the collector and the system. After all, solar companies do go out of business—in which case all their guarantees are worthless. Usually the bond costs one percent of the to-

(Please turn to page 134)

HIGH TIME...

**Big in performance,
AM-FM with Alarm—
Small overall!**

Don't take another trip without it!

Next time you travel, take a little bit of home-style luxury with you in HIGH TIME, the deluxe analog AM/FM Alarm Clock Radio. Stylish twin circle front panel for easy viewing, outshines ordinary travel alarm clock radios. Quartz timekeeping never lets you down with accuracy to within 5 seconds per month. Top-mounted alarm switch gets you up and going in the morning! Tucks easily in your briefcase or pocket. Built-in telescoping antenna pull-in distant stations for sound that's powerful, crisp and clean. With custom travel pouch and earphone for private listening.

Just 5¼" x 3" x 2½".
Operates on four "AA" batteries.



Credit Card Customers
**Call Toll Free
800-228-5440**
(In Neb. 800-642-8777)

**CAMBRIDGE
INTERNATIONAL, Inc.**
8700 Waukegan Rd. Morton Grove, IL 60053 (312) 966-5510

Clip & Mail To Dept. PM60

Please send me _____ HIGH TIME AM/FM Clock Radio(s) at just \$39.95 each plus \$2.95 for shipping and handling. (Ill. residents add 6% tax.) I understand that if I am not satisfied, I may return my purchase within 30 days for a prompt refund.

Check or Mo enclosed Charge to:
 Visa Master Charge American Express

Account # _____ Exp. Date _____

Name _____

Address _____

City _____ State _____ Zip _____

Signature _____

© Cambridge International, Inc.

Until now, it wasn't just the birds that came back each spring.

Ever notice how the concrete cracks you repair one spring come back the next?

That's because most concrete repair products can't handle the expansion and contraction brought on by seasonal temperature changes. (Not to mention the constant exposure to day-to-day weather changes.)

But new DOW CORNING® Silicone Concrete Crack Sealant is different. It's 100 percent silicone rubber. So it forms a flexible, waterproof seal that won't crack, crumble or shrink as the seasons do their annual thing.

There's even a 10-year limited product warranty.

You won't get a patched look either. DOW CORNING Silicone Concrete Crack Sealant blends well with your sidewalk, patio, driveway, foundation and other masonry surfaces.

Ask for DOW CORNING Silicone Concrete Crack Sealant wherever home or auto repair products are sold. And soon.

Early birds get a \$1.00 refund offer from Dow Corning right on the cartridge.

DOW CORNING



© Copyright Dow Corning Corporation 1980.

NEW!

**DOW CORNING®
Silicone
Concrete
Crack
Sealant**



100% SILICONE RUBBER
• PERMANENTLY FLEXIBLE
• WON'T CRACK OR CRUMBLE
• WATERPROOF SEAL

NET 10.7 U.S. FL. OZ. (317 ml)

CAUTION! UNCURED SEALANT MAY
IRRITATE EYES. Avoid eye contact.
KEEP OUT OF REACH OF CHILDREN.



100% BLENDED SCOTCH WHISKIES, 86 & PROOF. IMPORTED BY SOMERSET IMPORTERS, LTD., N.Y., N.Y.

AT THE END OF THE DAY,
EVEN A BRIDGE SEEMS TO BE
HEADING HOME FOR RED.

JOHNNIE WALKER RED
THE RIGHT SCOTCH WHEN ALL IS SAID AND DONE



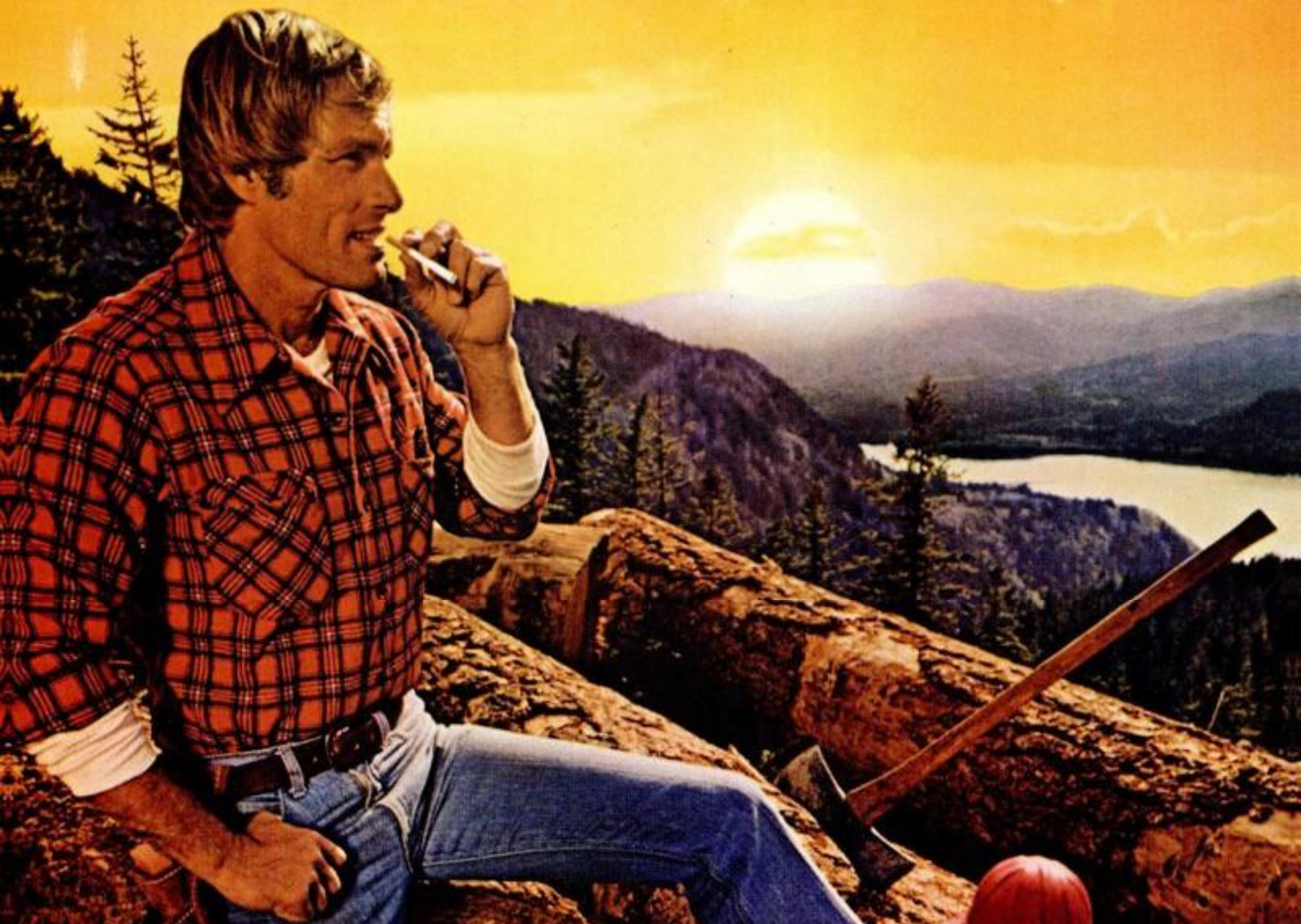

When your taste grows up, Winston out-tastes them all.

Only Winston's Sun-Rich™ Blend
of the choicest, richest tobaccos
tastes this full and satisfying.

Winston after Winston.

BOX: 17 mg. "tar", 1.2 mg. nicotine av. per cigarette by FTC method;
KING: 20 mg. "tar", 1.4 mg. nicotine av. per cigarette, FTC Report DEC. '79.



Soft Pack and Box

Warning: The Surgeon General Has Determined
That Cigarette Smoking Is Dangerous to Your Health.

Nails—still the handiest fasteners in the workshop

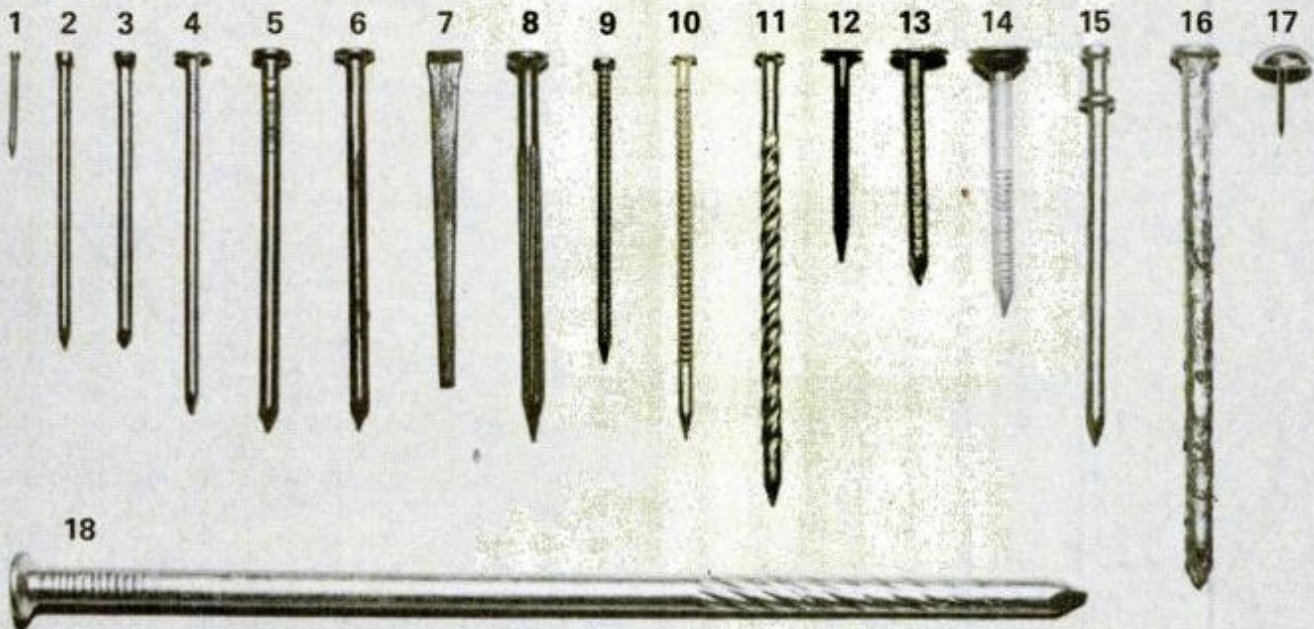

All nails were created for a purpose. Here's a guide to help you pick the one that's best for the task at hand.

by Rosario Capotosto

Nails provide one of the simplest and easiest ways to fasten things. But all nails are not the same. So in order to do a job properly and most effectively, you should know some basics about the variety of nails that are available. The following guidelines—prepared with the help of the nail-producing people at Armco's Western Steel Div.—will enable you to match the nail properly to the job.

Form follows function

Nails differ according to size, shape, material and finish. In various combinations, these factors have a direct bearing on the intended use of the nail.

Nail lengths are designated (somewhat confusingly) in both inch and "penny" sizes. The latter is indicated by a whole number followed with a small "d," which is an ancient abbreviation for penny (See *History of Penny-sizing*, page 139). Generally, as the length of a nail increases,

so does its diameter or gauge. Nail gauge refers to the diameter of the wire from which it is made. No. 1 gauge is the largest; 20 gauge, the smallest.

Shapes of nailheads, shanks and points vary considerably (see chart on page 138). Nail finishes can be bright, cement-coated or galvanized. Each of these characteristics serves a specific purpose.

For use around the home and shop, nails may be grouped in two categories: general-purpose and special-purpose. General-purpose nails are available in four types—box, common, casing and finishing.

Common nails have a large, flat head, smooth shank and diamond point. They are used for all types of general construction and rough carpentry where appearance is not of primary importance.

Box nails are similar to common nails with one important difference: The box nail has a larger-diameter head in relation to shank diameter. The large heads of both nails hold the nailed member securely by spreading the load or grip over a broad area. When nailing thin stock—which has a tendency to split with a thick-shank common nail—the thin-shank box nail is used instead. The alternative is to predrill holes in the top member, which is tedious and time-consuming.

A lineup of useful nails: (1) brad; (2) finishing; (3) casing; (4) box; (5) common; (6) cement-coated box; (7) cut flooring; (8) fluted masonry; (9) wood shingle; (10) asbestos shingle; (11) exterior hardboard; (12) drywall; (13) barbed roofing; (14) neoprene-seal roofing; (15) double head; (16) hot-dipped galvanized; (17) upholstery; (18) gutter spike (also comes with chisel point).

Casing and finishing nails have very small heads and are the choice for cabinet work, molding, window and door trim, and wherever a finished appearance is important. Both are available with either a cupped or flat brad head.

Cupped versions have a slight indentation in the head to accommodate a nail-setting tool. A nailset is used to sink the nailhead slightly below the surface. The hole is filled and sanded for total concealment.

Nails with flat brad heads are intended to be driven flush to the surface. They cannot be set properly because the nailset tends to slide off the smooth surface.

The difference between the casing and finishing nail is similar to the difference between the common and box nail—a casing nail is thicker than a finishing nail of equal length. Brads are small finishing nails sized from $\frac{3}{8}$ to 1 in. They're designated by inch length and gauge rather than penny size.

In general, the proper nail size is dictated by the thickness of the sur-

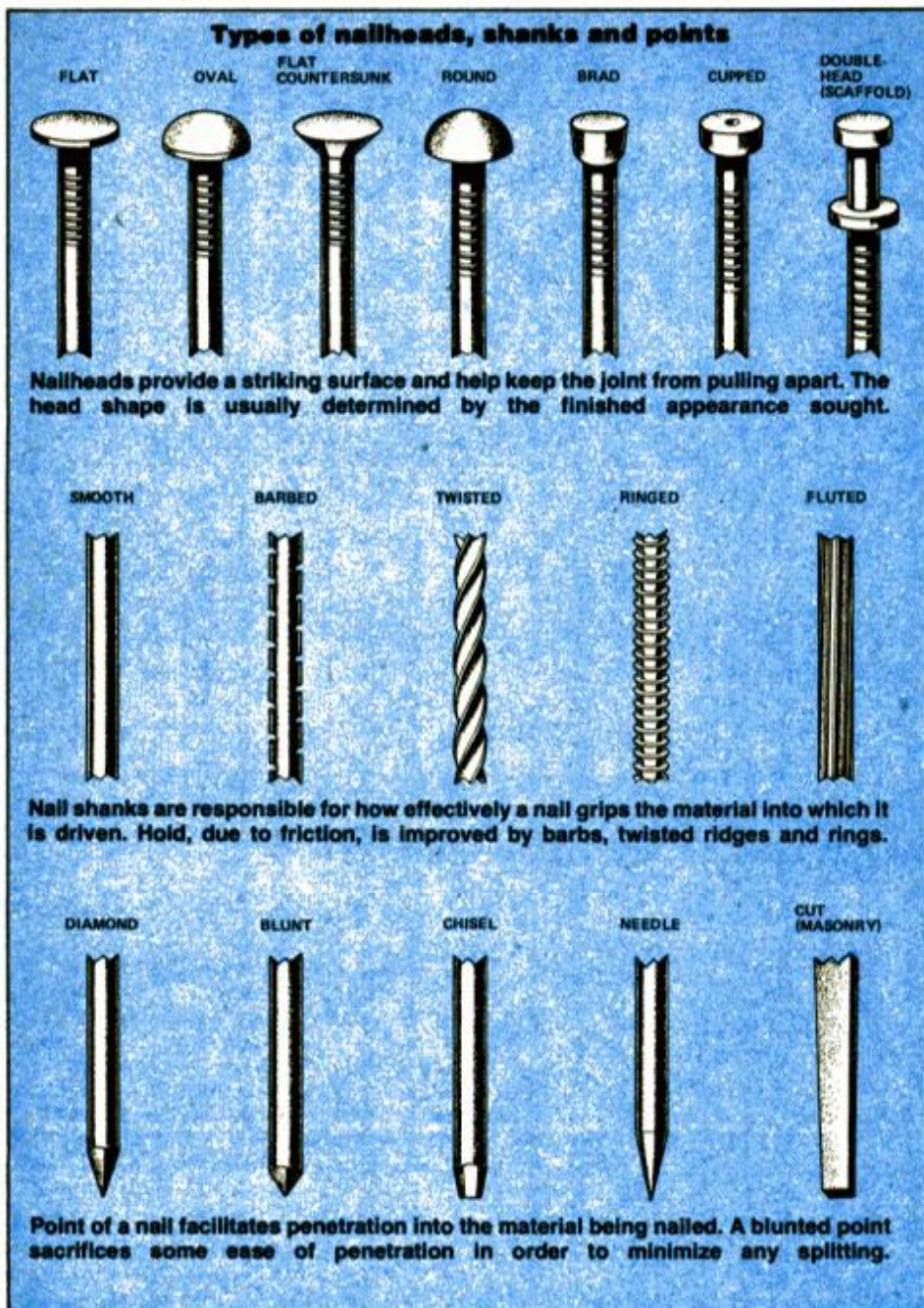

face board being nailed: The nail should penetrate two times the thickness of the top board to gain sufficient holding power. For example, when nailing through nominal 1-in. stock ($\frac{3}{4}$ in. actual), the nail should be at least $2\frac{1}{4}$ in. long (7d or 8d). Of course, there are exceptions to this rule. It won't hold when fastening $\frac{1}{32}$ -in. sheet metal, for instance.

Nails for special jobs

The above-mentioned nails will do fine for average nailing requirements, but they won't do when you need extra holding power or rust resistance, or when you want to attach plasterboard, hardwood flooring, roofing or wood to masonry. For these jobs, a variety of special-purpose nails have been developed with distinct advantages for particular applications.

Most special-purpose nails are named to signify their specific use, such as for roofing, drywall, underlayment and masonry. Others are named for significant characteristics, such as ringed, cement-coated, galvanized and double-head.

Different physical characteristics bring about the improvements in special nails. Extra holding power is achieved by special shank shapes, such as barbed, twisted, fluted and ringed. When an ordinary nail is driven into wood, the squeeze of the displaced fibers against the nail serves to hold it in place. However, a smooth-surfaced nail will have a tendency to withdraw slightly if the joint remains under stress for a period of time. In addition, as the wood ages, the wood fibers often lose moisture and shrink, thereby enlarging the nail hole and, in effect, shortening the nail depth. This results in

loosened nails or protruding nailheads. A common example of this is a "popped" drywall nail—one that has been pushed from its hole by green lumber that has dried and shrunk. Use of the newer drywall nails with ringed shanks helps to eliminate this. Other irregular-surfaced shanks are designed to prevent loosening.

Cement-coated nails have a resin coating that also provides more friction and greater holding power. However, they are not more effective than nails with shaped shanks.

To protect nails against atmospheric corrosion, a coating of zinc (galvanizing) is applied to the surface. When applied by an electrolytic process, the coating is smooth and thin and the nails are termed electrogalvanized. This treatment offers only moderate protection. For maximum resistance to rust, hot-dipped and tumbler-galvanized nails are recommended. Due to their very coarse surface of zinc flakes, these nails also possess remarkable holding power. They are, however, somewhat harder to drive than smooth nails.

Most nails have standard diamond points, but some special-purpose nails are characterized by blunt, needle and chisel points. Hardwood flooring nails come with blunt diamond points. These reduce the possibility of splitting because the point shears through the fibers instead of slicing through, as would occur with a regular diamond point. The slicing action spreads the fibers, resulting in a split.

Softwood fibers are more resilient so that a regular diamond point can penetrate without causing a split. A good trick when splitting occurs while driving ordinary pointed nails is to blunt the point with a light hammer blow.

Chisel points are found on heavy-gauge gutter spikes and heavy hinge nails. The shape of this point allows these extra heavy gauge nails to be driven into heavy timbers with relative ease.

Needle points are usually found on nails used on insulated building board and fiberboard. The sharp point makes penetration easier and reduces the chance of deforming the material.

12 popular, special nails

1. **Cement-coated:** Box, casing, common and finishing nails, as well as most other types, are available with optional cement coating.

2. **Concrete and masonry:** Several types of masonry nails are available for fastening wood or other

Actual-size nail reference chart

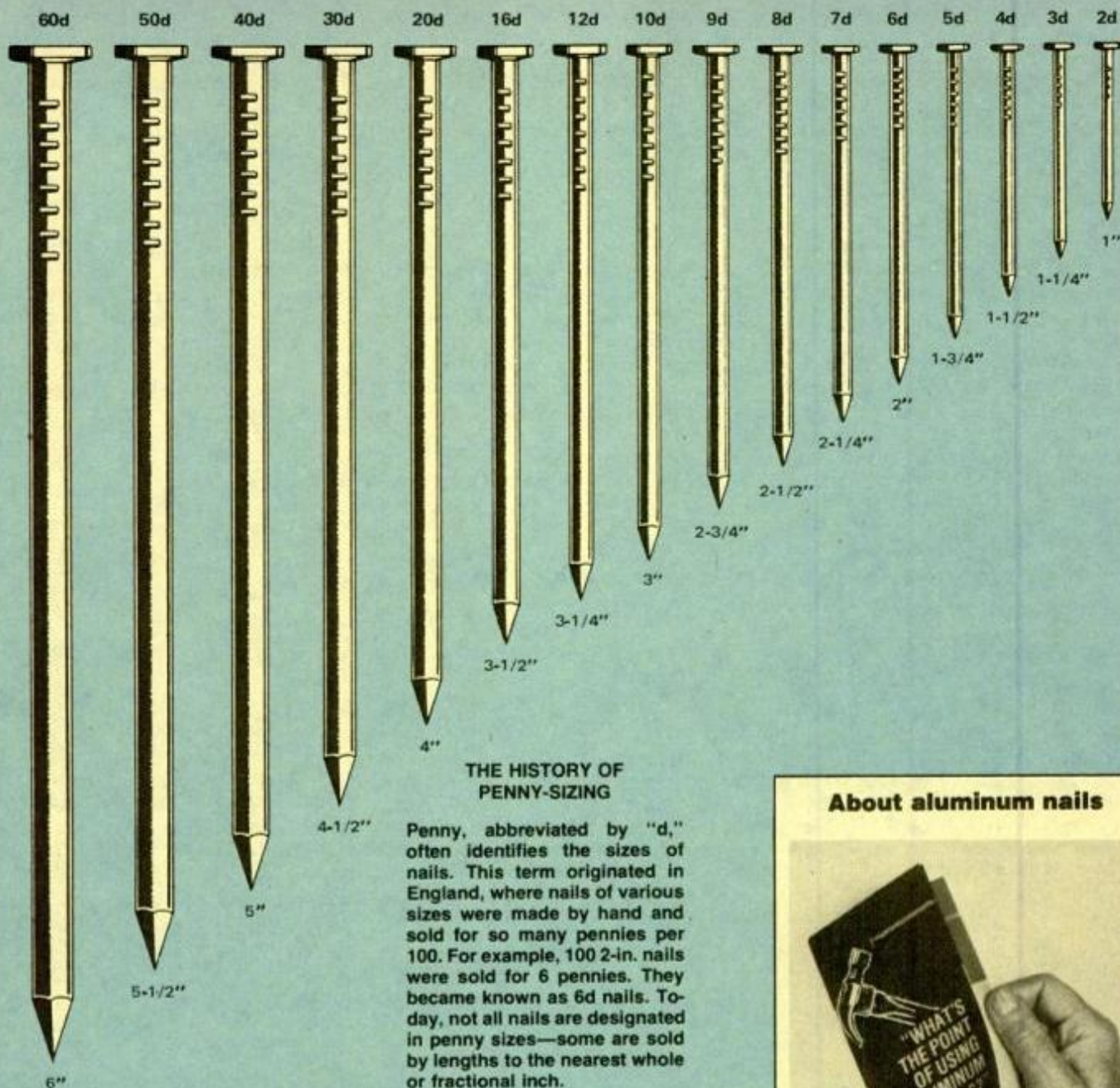

THE HISTORY OF PENNY-SIZING

Penny, abbreviated by "d," often identifies the sizes of nails. This term originated in England, where nails of various sizes were made by hand and sold for so many pennies per 100. For example, 100 2-in. nails were sold for 6 pennies. They became known as 6d nails. Today, not all nails are designated in penny sizes—some are sold by lengths to the nearest whole or fractional inch.

About aluminum nails



Aluminum nails can be used for: wood siding and shingles, asbestos siding and shingles, aluminum siding and trim, plastic panels and roofing, gutters and downspouts, porches and decks, outdoor furniture projects and for fencing. They are strong and durable—and will not cause rust stains when exposed to the weather. Styles and advantages of aluminum nails are described in a brochure, *What's the Point of Using Aluminum Nails?* Obtain a free copy by writing to the Aluminum Assn., Inc., Dept. PM 680, 818 Connecticut Ave. N.W., Washington, D.C. 20006.

materials to masonry walls and floors. They come with smooth and round, square and fluted shanks. The last two provide maximum holding power. All are hardened. Hardened nails are particularly susceptible to chipping at the head when struck with an erratic hammer blow. Therefore, wear safety goggles when driving hardened nails to protect your eyes, and use a heavier hammer or hand sledge to do the driving. Masonry nails have very little tensile strength (resistance to pullout), but do have good lateral strength (resistance to shear).

3. Drywall: This is the nail to use for attaching plasterboard sheets to interior wall studs, joists and rafters. The newest type has rings for superior holding power, a coun-

tersunk head that drives flush to the wallboard without cutting the paper, a depression in the head that ties in the joint cement, and a sharp point for easy nail starting. This type is far superior to the conventional drywall nail.

4. Double head: Intended for temporary lumber construction such as concrete forms and scaffolding, this nail is simply driven to the lower head for a solid assembly. The projecting upper head assures fast and easy withdrawal when dismantling is desired.

5. Flooring: There are several types of flooring nails, the oldest version being the cut nail. This has a rectangular cross section and a flat, blunt tip that is capable of penetrating hardwood flooring edges with-

out causing splits. A more widely used type has a twisted shank and blunt diamond point. Also available are smooth-finish and cement-coated types. Some are made of stiff steel to resist bending.

6. Gutter spikes: These are long nails used for attaching and supporting rain-gutter systems. They are available galvanized with flat or oval heads and diamond or chisel points.

7. Heavy hinge: This is a smooth-shank nail with a chisel point used for fastening hinges on heavy doors. It's available with an oval, or flat, countersunk head.

8. Lath: A thin-gauge nail with a flat head used for attaching wood lath to studs.

9. Roofing: There are two types of roofing nails made for residential applications. The most common is

the large, galvanized flathead nail with a barbed shank that is used for nailing asphalt shingles, roll roofing and felt.

The other is a sealing roofing nail. It has a neoprene washer under the large head and is used to secure metal and fiberglass roofing and siding sheets. The washer effectively seals the nail holes against rain and wind. Its ringed shank provides good holding power. Roofing nails are usually galvanized.

10. Siding: Siding nails are available for simulated masonry, wood and hardboard siding. Heads are flat except for the hardboard nail, which has a countersunk head. This nail is made of a stiff grade of steel to resist bending. All siding nails are galvanized.

11. Underlayment: This is a ringed nail with a small, flat, coun-

tersunk head and a diamond point. It's used to install plywood or untempered hardboard subflooring to joists.

12. Upholstery: Upholstery nails have a large, round or decorative head and are used to fasten upholstery. They are usually colored or plated so that they have an attractive appearance.

Choice of metals

All the nails described above are made of steel, but other metals are also used for making some types of nails, including aluminum, brass and copper.

It is important for you to match the nail to the metal you are working with. This prevents the problem of galvanic corrosion that results when dissimilar metals are brought into close contact. **PM**

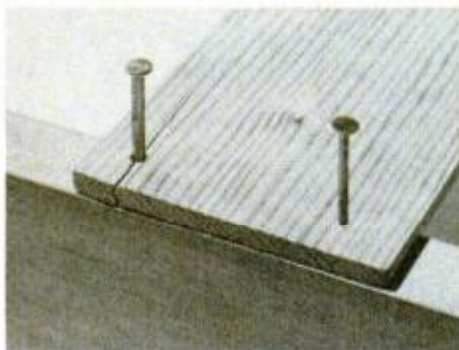

When a common nail (left) splits thin stock, a smaller-diameter box nail of equal length (right) will do job without splits.



Blunt-pointed, cut flooring nails minimize splits in flooring tongues. Use a blunt nailset to set all nailheads flush.



Drive hardened masonry nails into mortar joint using at least a 20-oz. hammer or a hand mallet. Since these nails chip and break easily, wear your safety goggles.



Nongalvanized or poorly galvanized nails will rust and stain siding. Eventually, disintegrating nailheads will lose holding power, causing the shingles to loosen.

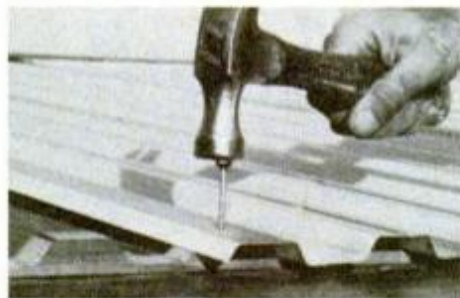

Corrugated fiberglass or metal-sheet roof materials are best attached with neoprene-washed nails. These will effectively prevent water leaks. They are ringed and available in aluminum and galvanized steel.

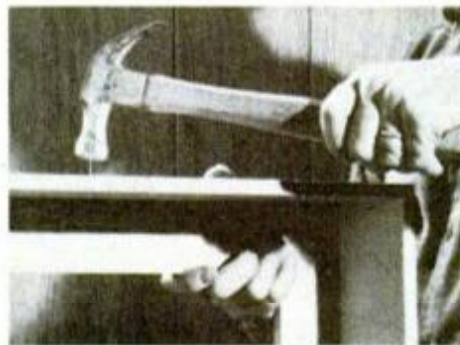

When gluing up workshop projects that are difficult to put clamps on, use finishing nails to secure joints as the glue dries.

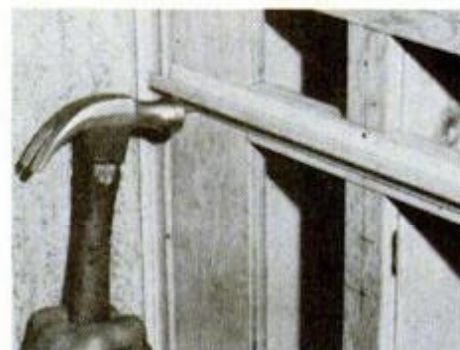

Choose cement-coated nails for installing wall-paneling molding strips, since they won't loosen to cause problems later.



Choose hot-dipped, galvanized common nails for outdoor wood construction to prevent the corroding effect of the weather.



Assemble temporary structures with double-head (scaffold) nails. Used on this sawhorse cross member, they are easily pulled to permit folding and flat storage.

**Trooper-tested
Protection.**

**Unbeaten
Mileage.**



**The two things
you want from your motor oil
are both in
Texaco's Havoline Supreme.**



Indy 500 race car driver Janet Guthrie knows that, today, drivers like you want more than a motor oil that just protects your engine.

You're also looking for a fuel economy tested oil. That's why Janet recommends that you use Havoline Supreme. Texaco's Havoline Supreme is the 10W-40 motor oil with a special friction fighter that's been proven in fuel economy tests. In fact, extensive tests showed that two leading 10W-40 motor oils advertising "extra gasoline mileage" couldn't beat Havoline Supreme.

What's more, in over a million miles of rugged state trooper testing, it delivered proven engine protection, too. Up-front protection backed by unbeaten mileage—two supreme reasons why you should change to Havoline Supreme.



Trust your car to the products with the Star.

BUILD A CUPOLA

(Continued from page 109)

rag. Hold the face of the soldering tip flush on the work to transfer maximum heat.

After soldering, use a file to smooth out any irregular lumps. Occasionally rub chalk in the file teeth to minimize clogging.

Use soapy water with a small amount of vinegar added to wash off the flux from the surface.

The bottom edges of the copper roof panels (R) will overhang the roof side pieces (S,T) by about $\frac{3}{8}$ in.

Apply caulking along these bottom edges of the copper where they meet the crown molding (U).

Weathervane bracket

The standard attachment bracket supplied with many weathervanes could not be used on this cupola roof, due to its sharp peak. However, you can shape a bracket (W) of $\frac{1}{8}$ -in. aluminum stock.

Form the slight curves by cutting the bracket strips through scrap 2x2. Sandwich the aluminum between the wood and squeeze the assembly in a vise. Make the sharper

bends by hammering the aluminum against an anvil or machinist's vise.

Finishing the cupola

Paint all of the exposed surfaces. However, leave the insides of the shutters bare so the wood can breathe to protect against decay.

Assemble the unit completely at ground level to check fit; then disassemble the roof, shutters and base facing boards to lighten the load for transporting the cupola to the roof of the house.

If your house roof is of truss construction (like the one shown in this installation), simply cut a 22-in.-square hole through the ridge. For a conventionally framed roof with a ridge board, see *How to Make Room at the Top* (page 180, Feb. '80) for details on framing an opening through a ridge.

See the photos on page 107 for details on installing the cupola.

After the cupola is attached to the house roof, aluminum flashing is installed and the face boards are nailed. Next, secure the copper roof. Finally, install the shutters (V) and nail center cleats (X) to brace the shutters at the joint line. Use a compass to locate true north for positioning the weathervane. **PM**

Why pay \$150 to have your car professionally poly-sealed? Now—in less than an hour you can do-it-yourself with Blue Poly, the revolutionary new one-step poly sealant that cleans, shines and seals all in one easy application.

Blue Poly bonds to the surface of your car with a finish so tough it protects against acid rain, blazing sun, snow, grease, road tar, automatic car washes, salt spray—all the elements. And you can save plenty of "green," \$135 or more, when you do-it-yourself with Blue Poly—the one-step poly sealant with the two-year guarantee.

**GUARANTEED TO PROTECT TWO YEARS
OR YOUR MONEY BACK!**

© 1980 Blue Coral Inc.

From the makers of

Blue Coral®

MATERIALS LIST—CUPOLA

Key	No.	Size and description (use)
A	4	1½ × 1½ × 30" kiln-dried fir (headers)
B	4	1½ × 1½ × 28-½" kiln-dried fir (corner posts)
C	4	1½ × 1½ × 27-½" kiln-dried fir (soleplates)
D	4	1½ × 1½" to suit roof slant, kiln-dried fir (brace)
E	2	1½ × 1½ × 37½" kiln-dried fir (roof frame)
F	2	1½ × 1½ × 34½" kiln-dried fir (roof frame)
G	2	1½ × 1½ × 27-½" kiln-dried fir, beveled to roof pitch (anchor brace)
H	4	1½ × 3¼ × 7½" fir (peak support blocks)
I	4	¾" Champion Building Products texture 1-11 plywood cut to fit (facing)
J	4	1¼ × 3¼ × 32" pine (sills)
K	1	¾ × 37½ × 37½" plywood (roof base)
L	8	1½ × 1½ × 20½" kiln-dried fir (vertical rain stops)
M	8	1½ × 1½ × 24" kiln-dried fir (horizontal rain stops)
N	2	¾ × 6¼ × 31½" plywood (sheathing)
O	2	¾ × 6¼ × 32¾" plywood (sheathing)
P	2	¾ × 14½ × 48¾" plywood (roofing formers)
Q	4	1½ × 29" 16-oz. cold-rolled copper sheet (former strips)
R	1	3 × 6 ft., 16-oz. cold-rolled copper sheet (4 roof panels; locate position of all panels on copper before cutting)
S	2	¾ × 2½ × 34½" pine (roof side pieces)
T	2	¾ × 2½ × 39" pine (roof side pieces)
U	4	1¼" solid crown molding (edging trim)
V	8	15 × 24" presanded shutters, trimmed to fit (see note 1 below)
W	2	¼ × 5" aluminum stock (weathervane brackets)
X	4	½ × 1½ × 19½" pine (cleats)

Misc.: Hot-dipped, galvanized 8d common nails; hot-dipped, galvanized 10d finishing nails; 4, 3" No. 14 fh wood screws; 1" No. 10 pan-head, stainless-steel screws; ¾ × 4" No. 18 lag-screws and washers; 4, ½ × 1½" corner braces; 2 pair of 1-½ × 2" solid brass hinges; 1" brass or copper escutcheon nails; plastic resin or resorcinol glue; aluminum flashing; aluminum screening; exterior paint.

Note 1: Shutters are available from J.C. Penney, item No. A-737-3731 A; trim them to 13½ × 20-½".

Note 2: Weathervane with three-dimensional horse figure is available from J.C. Penney, item No. A-847-3530 A horse.

for part-time extra money...
or a profitable full-time business...

YOU'LL LIKE LOCKSMITHING!

you learn fast... you profit fast!

ELECTRIC KEY MACHINE

and over 300 professional tools and supplies come with the course



Learn at home in spare time with the fine home study course of the original, accredited LOCKSMITHING INSTITUTE. It's practical training. You learn by doing real jobs on all kinds of locks, working with the tools and equipment that come with the course. Every step is spelled out for you, clearly diagrammed...easy and quick to learn.

START MAKING MONEY IN JUST A FEW WEEKS! After the first few lessons, you'll know how to do simple jobs for pay. Do small installations, make duplicate keys, change locks. Many students report spare time earnings, even while learning, that

add up to several hundred dollars extra income, just a sample of what's ahead!

BE A MASTER LOCKSMITH IN 6 MONTHS! Upon completion of the course, you receive the Accredited Diploma that certifies you as a Master Locksmith, qualified to do highly professional work, either as an employee or running your own lock shop. What a hedge this gives you against unemployment, inflation, strikes or layoffs! How great to have for extra income when you retire!

CASH IN ON THE URGENT, GROWING DEMAND! Locksmithing work has zoomed in these days of increased crime and vio-

lence. Everyone wants a locksmith...for homes, apartment buildings, cars, bikes, hospitals, vending machines, banks, businesses... wherever security is essential. As a Master Locksmith, with the professional know-how to do major installations as well as simple jobs, you will find your time well paid for...and interesting, too.

LOCKSMITHING INSTITUTE does not guarantee how much you'll make or be hired to do...but we do guarantee that our graduates are Master Locksmiths, qualified professionals. It's been that way since 1948. And that's a guarantee all by itself, isn't it?

WE LEARNED... AND WE LIKE IT!



"After completing a few lessons, I started doing small jobs...earned \$500 spare time. Now earning \$100 extra per week."
E. E. Neel, Houston, Tex.

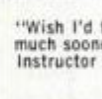

"Wish I'd taken the Locksmithing course much sooner. Earned \$380 while training! Instructor was very helpful and prompt."
John F. Lewis, Chicago, Ill.



"My main motivation was independence. Earned \$500 part-time while still studying. Definitely see more potential earnings."
Gerald Sesontovich, Pte. Claire, Que.

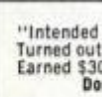

"Intended to make locksmithing a hobby. Turned out to be a source of extra income. Earned \$300 part-time while training."
Donald J. Brooks, El Monte, Calif.



**FREE BOOKLET AND
ALL DETAILS BY MAIL**



**NO SALESMAN
WILL CALL**

**MAIL POST-PAID
CARD OR COUPON**

TODAY!

LOCKSMITHING INSTITUTE

Division of Technical Home Study Schools
Dept. 110-060, Little Falls, N.J. 07424

• Licensed by N.J. State Dept. of Education
• State Approved Diploma • Approved for Veterans

Locksmithing Institute, Dept. 110-060
Div. Technical Home Study Schools
Little Falls, N.J. 07424

Please rush by mail your FREE booklet and all facts about the opportunities in locksmithing. I am under no obligation. No salesman will ever call.

(print)
Name _____

Address _____

City _____

State/Zip _____

Check if eligible for Veteran Benefits

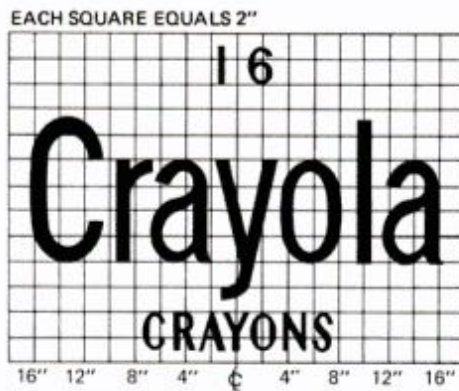
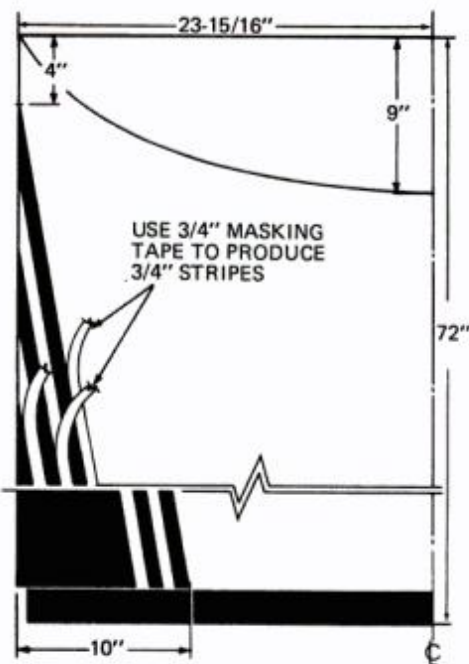

MATERIALS LIST—ULTIMATE DESK

Key	No.	Size and description use
A	1	1/2 x 48 x 72" plywood (back)
B	2	1/2 x 20 x 72" plywood (sides)
C	2	1/2 x 20 x 47" plywood (top, bottom)
D	1	1/2 x 8 1/4 x 47" plywood (shelf)
E	1	1/2 x 11 1/4 x 47" plywood (shelf)
F	1	1/2 x 15 1/4 x 47" plywood (shelf)
G	2	1/2 x 2 1/2 x 19" pine (base sides)
H	2	1/2 x 2 1/2 x 47" pine (base ends)
I	2	1/2 x 11 x 12" plywood (flap supports)
J	1	1/2 x 4 7/8 x 47" plywood (light shield)
K	2	1/2 x 23 1/8 x 72" plywood (door fronts)
L	4	1/2 x 8 1/2 x 72" plywood (door sides)
M	8	1/2 x 8 1/2 x 22 1/2" plywood (door tops, bottoms, shelves)
N	2	1/2 x 3 x 19" plywood (paper rack sides)
O	1	1/2 x 3 x 21 1/2" plywood (paper rack base)
P	2	1/2 x 3"-dia. plywood (paper roll rod discs)
Q	2	1/2 x 14 1/2 x 19" plywood (bench sides)
R	1	1/2 x 11 x 18" plywood (bench seat)
S	2	1/2 x 14 1/2 x 16" plywood (bench step, bottom)
T	2	1/2 x 2 1/2 x 18" pine (bench step stiffeners)
U	2	1/2 x 3 1/2 x 7" plywood (crayon holder sides)
V	1	1/2 x 1/4" x to fit, pine (cleats)
W	1	3/4 x 18 1/2 x 47" plywood (desk)
X	1	3/4 x 12 x 46 3/4" plywood (desk flap)
Y	2	3/4 x 1 1/2 x 3" pine (desk flap stops)
Z	3	3/4 x 1 1/2 x 47" plywood (shelf stiffeners)
AA	1	3/4 x 7 1/4 x 8 1/4" (crayon rack)
BB	1	1/4 x 13 1/2 x 22 1/2" plywood (paper rack, front)
CC	1	1/4 x 19 x 22 1/2" plywood (paper rack, back)
DD	1	1/4 x 6 1/4 x 8 1/4" plywood (crayon holder backup)
EE	2	1/4 x 18 1/2 x 22 1/2" Peg-Board
FF	4	1/4 x 3/4 x 18" pine (trim)
GG	4	1/4 x 3/4 x 22 1/2" pine (trim)
HH	4	1 x 2 x 18 1/2" furring (Peg-Board support)
II	4	1 x 2 x 19 1/2" furring (Peg-Board support)
JJ	2	3/4 x 1/2 x 12" hardwood (flap levers)
KK	1	3/4"-dia. x 22 1/4" dowel (paper roll holder)
LL	2	1"-dia. x 11" dowel (handles)
MM	4	1 x 1 1/2 x 1 1/2", cut from 2 x 3 fir
NN	1	18 1/2 x 45 1/4" Homasote
OO		5-mm x 18 1/2 x 46 1/4" roll cork
PP	4	1" x No. 10 fh screw, countersunk washer
QQ	2	1 1/2 x 72" continuous hinge
RR	2	1 1/2 x 11" continuous hinge
SS	1	1 1/2 x 46 1/4" continuous hinge
TT	2	Shepherd No. 9019 Noia, 2 1/2" ball caster
UU	2	Amerock T 9700 door catch
VV	2	Screw eyes
WW	1	5" cord
XX	9	Clothes pins
Y1	1	36" single fluorescent lamp fixture
Y2	1	Lamp cord and plug
Y3	1	1/2" hex nut
Y4	1	1/4" cord bushing
Y5	3	Solderless connectors
Y6	1	Pull chain switch

glue 1/2 x 3/4-in. cleats to the sides and back at positions below the shelves and desk panel. (Top and bottom cleats aren't needed.)

Before starting the cabinet assembly, attach shelf stiffeners to the shelves and sand the raw edges. Also, cut the desk flap to size (slightly smaller than the main desk panel's width).

Because the continuous (piano) hinge is on the bottom surfaces, this is easier to install before assembly. Insert 3/32-in.-thick shims between the flap and desk panel; tape hinge in place, mark hole centers with an awl and drill the screw pilot holes.

Assembly can be with white or aliphatic-type glue—if room temperature isn't too high and if you're used to working fast. Otherwise, use a slow-setting hide or animal glue to assure adequate working time.

Assembling the cabinet

Attach the shallow base to the bottom panel. Lay one side panel on two lengths of 2x4 (shimmed if the floor is uneven) so there will be no bouncing or rocking. Use parallel clamps to hold the shelves and desk panel upright. Add the top and bottom last. Lay the other side in place on the cross members and start a nail into each one.

Lift the side panel, apply glue to both surfaces and nail. Add the top and bottom; then remove the clamps below. With a strong helper, grasp both ends and flip the assembly over, being careful to keep the whole thing intact. Nail and glue the second side.

Lay the unit on the floor, back side up, and glue and nail in the back.

The predrilled lead holes will keep the nails on target. Set all nailheads and fill.

Next, do the doors. Because of their smaller size, you don't need cleats for the door assembly. However, work the same as with the cabinet: Mark, drill and use clamps to position and hold parts upright.

Hinge-fit the doors next. Lay the

cabinet on its back and attach the hinges to the sides. Tape cardboard shims about 3/32 in. on the edge adjacent to the hinge and position the doors in position. Mark the screw centers and bore pilot holes. (Note: Due to the hinge placement, clearance isn't required at the center where doors meet. However, a 1/8-in. clearance is indicated in the plans to prevent binding problems that could occur if the cabinet twists on an uneven floor.)

Hinged desk-flap supports must be positioned slightly lower than the flap to clear the hinge knuckle. Solid wood strips attached to the bottom surface of the flap make up the offset.

Nail Peg-Board inserts in the doors to 1x2 standoff strips to provide back clearance for the hooks. Cut thin wood strips, 1/4 x 3/8 in., to dress the inside corners around the perforated board, but do not attach them until after painting.

To make the cork bulletin board, roll cork is contact-cemented to Homasote fiberboard. Trim the board to size after the cork is laminated. Use flathead screws and finishing washers to attach it after painting.

The novel crayon-shaped handles can be turned on a lathe or you can make them with a disc sander. Using the simple jig shown, feed the dowel slowly against the disc while rotating it continuously.

To drill holes in the crayon holder, assemble it without the permanent 1/8-in. bottom panel in place (use a temporary one for backup). Mark hole centers with an awl; then place the rack on a flat board on the drill-press table. A brad-point drill bit will enter the slanted surface readily without slipping or drifting.

After sanding the raw edges, give the entire cabinet a coat of primer; then paint it. To color-match the Crayola box, we used PPG No. D 4213 Sardonyx and No. N 7914 Lacquer Green. Desk and bench were coated with No. U 7245 Really Rust. Use masking tape for a sharp border between colors. Paint trim strips around the perforated-hardboard panels and attach them with 3/4-in. brads.

To letter the box, make a full-size template as shown in the plans. Tape this on the box with pencil carbon beneath. Redraw the lines, using a straightedge and sharp pencil to transfer the logo. Use the green paint to fill the lines.

For a tough finish that you can wipe clean with water, let the paint cure several days, and then apply varnish as it comes from can. **PM**

LET US TAKE THE RISK.
We'll Hold Your Check, M.O.,
Visa Or M.C. Slip For A Full 30 Days!

Lose 4-6 Inches Of Bulging Fat BEFORE WE CASH YOUR CHECK!

WAIST AWAY will reduce the size of your waist & hips, without dieting, completely at our risk!

Just fill out the coupon below and postdate your check for 30 days from today! Or send us your m.o. or your Visa or M.C. account #. We'll hold your check, m.o. or credit card for 30 days, but we will send your **Waist Away NOW!** Try it. Use it. Watch inches disappear. If, for any reason you are not delighted, send it back. We will return your check or m.o. **UNCASHED!** We'll tear up your charge! Thousands of happy customers make us bold enough to make this **SUPER GUARANTEE!**

The original **WAIST AWAY** is no cheap cloth or elastic imitation. We know our quality materials and scientific design works. It has worked for years for athletes, taking the body's own heating effect, concentrating it on areas with bulging fat.

Lose 4-6 Inches In the First 24 Hours!

That's right! **Waist Away** can work on waist and hips that fast. This slimming action is due to our original design, which can be imitated but not duplicated. Our rubberized belt is soft and washable. The same quality athletes use to sweat away excess moisture that forms bulky fat... quickly. Imagine seeing a dramatic difference the very next day!

Don't Hold Fat In... LOSE It!

Waist Away is not a glorified corset and it needs no bothersome attachments. We don't just squeeze it in. Especially with our 5 minute exercise program, you will lose inches without dieting. It is working right now for some of the most famous athletes and entertainers in the world!

Waist Away Does More!

Our special construction creates a soothing massage effect which relieves back pain and tense muscles while trimming fat. Jog, do housework or office work wearing **Waist Away**. After you drop a few inches, **Waist Away** adjusts to allow you to lose more!

We take the risks—you lose nothing... but that unsightly fat! So order NOW!

Vibrant Sales P.O. Box 2521
Grand Central Sta., New York, N.Y. 10017



Vibrant Sales Dept. WA-705 P.O. Box 2521, Grand Central Sta., New York, New York 10017

Sirs: I have enclosed my check m.o.
 M.C. Visa info which you will hold
UNCASHED under your no-risk 30-day guar-
antee. (NY residents add sales tax)

Waist Size: _____ (Men's) _____ Women's)
_____ Rush 1 belt @ \$14.99 plus \$1.00 p&h
_____ (Save \$2) Rush 2 belts @ \$27.99 plus
\$2.00 p&h

Name _____

Address _____

City _____ State _____ Zip _____

Interbank # _____ Expir. _____

Acct. # _____

AMAZING
INCREASE GAS MILEAGE
50% AND MORE!
WITH NEW CONVERSION METHOD

"AMAZING!" SAYS FORMER NASCAR GRAND NATIONAL RACING GREAT



Jim Paschal (right) listens as Tommy Dillon explains first hand how he successfully converted the 400 cu. in. V8 engine of this 1975 Dodge Monaco to a V4 to go from 12 m.p.g. to 26.4 m.p.g.

Tommy Dillon, a mechanic of 25 years in High Point, North Carolina has perfected a method of converting V8 engines into V4's. His first conversion was on a 400 cu. in. 1975 Dodge Monaco, and the gas mileage jumped from a costly 12 m.p.g. to an amazing 26.4 m.p.g.!

"This is neither a gimmick nor a gadget," says Mr. Dillon. "It involves some simple internal engine work, and anyone with a small amount of mechanical ability can do it."

The procedure will work on any American made V8 engine. Dillon's second conversion was on a 318 cu. in. 1970 Plymouth Satellite. Again the gas mileage soared, going from 19.6 m.p.g. to 28 m.p.g.

According to Mr. Dillon, the change in the performance of both cars, other than the increase in gas mileage, was negligible at speeds over 30 m.p.g. with only a slight loss of power in acceleration.

Mr. Dillon has devised a do-it-yourself manual with written instructions, pictures and diagrams to help you convert your own engine. You can also take your car and the manual to your own mechanic and have him do the conversion for you. The total cost of parts required is approximately \$40.00.

Double your money back guarantee with proof that this procedure does not work! Send \$14.95 plus 75¢ postage and handling for your copy. Master Charge/Visa accepted. Credit card orders 1-800-327-9191 EXT. 717. In Florida 1-800-432-7999.

Convert-A-Car, Box 7226-C, High Point, N.C. 27264.

LEARN
MEAT CUTTING



Train quickly in 8 short weeks at Toledo for a bright future with security in the vital meat business. Big pay, full-time jobs—**HAVE A PROFITABLE MARKET OF YOUR OWN!** Time payment plan available. Diploma given. Job help. Thousands of successful graduates. OUR 57th YEAR! Send NOW for a big new illustrated FREE catalog. No obligation. G.I. approved. NATIONAL SCHOOL OF MEAT CUTTING, No. 71-02-01977, Dept. 50-1] 33 N. Superior, Toledo, Ohio 43604.

NEW FOREHEAD THERMOMETER



COMPUTERIZED! ACCURATE! Only \$198 Ea. Plus 52¢ Shpg. & Hndlg.

SAVE! 2 for \$3.95, 3 for \$5.95, Postpaid

• UNBREAKABLE — SAFER THAN GLASS • READS C AND F DEGREES AT THE SAME TIME • SAFE, PLEASANT TO USE — KIDS LOVE IT • HOSPITAL TESTED • SANITARY — CANNOT SPREAD GERMS

Send Check or Money Order (No CODs)

NATIONAL MERCHANDISE Dept. M
 P.O. Box 7746, Chicago, IL 60680

MOLDS

for making
 Ornamental Concrete
 Items...

Book about Aluminum Molds with prices and production trade secrets direct from world's largest mold manufacturer.



SEND \$5.00

CONCRETE MACHINERY COMPANY, INC.
 P. O. BOX A99 - HICKORY, N. C. 28601

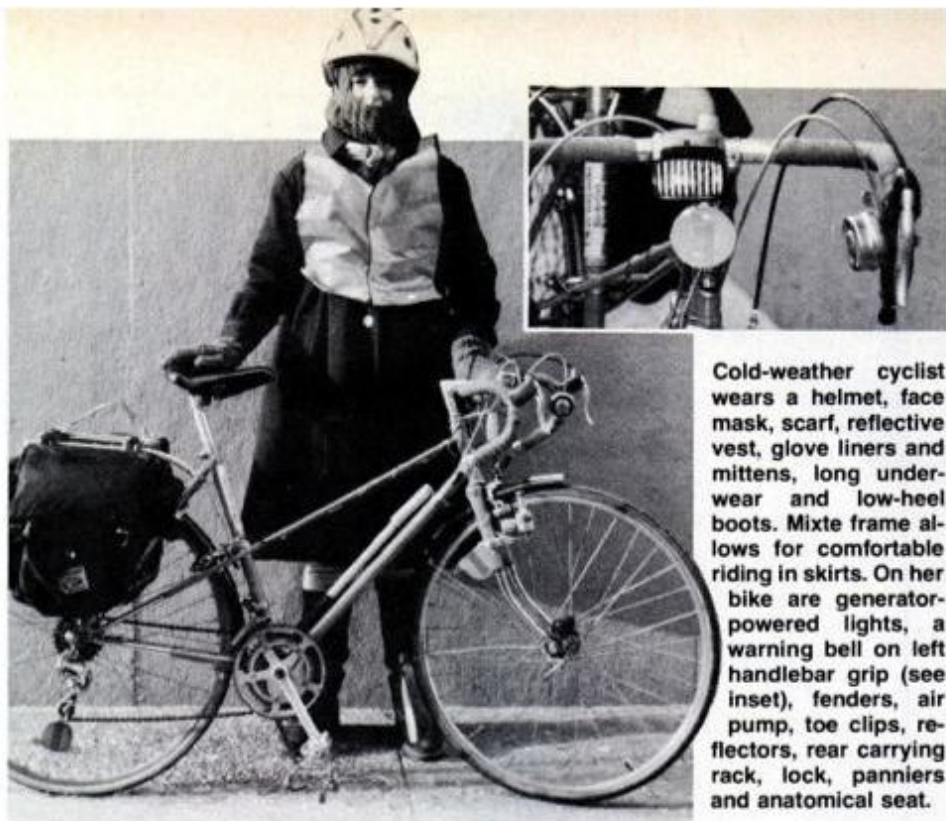

Cold-weather cyclist wears a helmet, face mask, scarf, reflective vest, glove liners and mittens, long underwear and low-heel boots. Mixte frame allows for comfortable riding in skirts. On her bike are generator-powered lights, a warning bell on left handlebar grip (see inset), fenders, air pump, toe clips, reflectors, rear carrying rack, lock, panniers and anatomical seat.

BICYCLE COMMUTING

(Continued from page 95)

along with a toolkit, rain poncho and other cargo, a wide range of products is available. Most, like handlebar bags and rear panniers, are borrowed from bike touring. Some of the gear can double as luggage.

As with every other popular phenomenon, biking has fostered its own high fashion. New garments for inclement weather should be of prime interest to commuters. While old standbys like folding ponchos still find plenty of favor, good-looking outerwear made of Gore-Tex provide superb weather protection for those who can afford it. Jackets, pants and gaiters made of the stuff keep you dry but still "breathe."

Safety equipment has improved, too. Jackets and pants (and even panniers) coated with a substance called Early Warning transform the bike rider into a giant reflector at night. Rear-mounted flashing lights also improve nighttime visibility.

Rider comfort hasn't been ignored either. Foam or leather padding for handlebars all but eliminates hand numbness during long rides. And so-called anatomical seats have replaced the traditional hard-leather saddle in many cycling circles.

If bike commuting makes so much sense, why isn't everyone doing it? There are many valid reasons, but all of them can be dealt with. Here's how to overcome the most commonly cited obstacles.

Advanced age. Provided your doctor doesn't object, there's nothing to keep any healthy person from riding a bike for all but the longest dis-

tances. Bike commuting isn't a race, so speed isn't important.

Poor physical condition. Again, given a doctor's okay, cycling is not only possible for out-of-shape riders, it provides an easy way to improve physical condition. Many experts believe cycling to be better exercise than jogging because the smooth pedaling motion doesn't abuse the legs like the constant pounding of running. Further, cycling is done sitting down, making it less fatiguing.

Too long a commute. Most people can manage 10 to 12 mph on a bicycle for long periods; 15 or 20 mph becomes easy with experience. Even a 10-mile commute would take an hour at most. Depending on where you live, that could be faster than public transit or car.

Most car engines take a good seven miles to warm up. That means short trips result in more pollution, higher fuel consumption and greater engine wear than does highway cruising—so save the car for long trips.

Inferior bicycle. Commuters use every kind of bike imaginable—1, 3, 5, 10, 12 and even 15-speed bikes, folding bikes and three wheelers. It's not necessary to have an expensive 10-speed, although many people do. If your commute it relatively flat, almost any bike will suffice. For gentle hills, the low gear(s) of bikes with three or five speeds should do. Many long-time commuters use such bikes. For extensively hilly riding, a 10-speed may be necessary.

Bad weather. Many dedicated commuters don't bike in rain and snow.

(Please turn to page 148)



Giant 1980 Buyers' Guide shows you how to Assemble and drive your own full-size sports car.

160 Colorful Pages • Over 500 Photos • More Than 100 Automotive Conversions

Be the envy of all your friends! For the price of an everyday compact car, you can own an authentically detailed 1936 Jaguar SS-100, a full-size Dino Ferrari look-alike or a gull-wing Porsche inspired street racer. Just imagine winding through the country behind the wheel of a car that looks like it came from a James Bond movie. These are serious handcrafted automobiles that sell for a mere fraction of their apparent value.

Read all about these unique sports cars plus dozens of re-creations of the most exciting antique, classic, and futuristic automobiles in the world. The pages of *The Complete Guide To Kit Cars* are filled with the amazing facts about these full-size "bolt-on" sports car bodies. All are enjoyable spare time projects designed to save you thousands of dollars. Virtually anyone can assemble one at home and no special skills or mechanical ability are necessary. Many are even available ready to drive.

The "kit car" concept is not new. For decades, custom coach builders have been designing stylish new bodies to replace those of existing automobiles. Previously they were available only to the privileged few. Now, modern production techniques and space age materials have spawned a new generation of speciality auto manufacturers. The public's overwhelming response to the wide variety of moderately priced automotive alternatives has created a booming industry. *The Complete Guide To Kit Cars* shows you how easily you can afford a highly personalized automobile for the price of a mass-produced compact.



Beat the energy crisis in style. If you've ever dreamed of owning a priceless antique, a handsome classic, or a modern GT, but have more time than money, *The Complete Guide To Kit Cars* will show you dozens of price conscious alternatives. You get all the solid advice you'll ever need to help select just the right car.



Style, performance and economy in one package. Why compromise when you can have all three? These hybrids combine the legendary styling you've always wanted with the mechanical reliability and performance you demand. They are durable automobiles, meant to be driven and enjoyed daily—not stored away like some fragile antique or temperamental exotic.



Publisher's No-Risk Money Refund Guarantee. *The Complete Guide To Kit Cars* has already opened the door to an exciting automotive adventure for more than a quarter of a million satisfied readers. As Publisher, I invite you to send for your copy today, at no obligation. Examine it at your leisure for 14 days. Then, if you aren't totally satisfied that this valuable publication is everything we claim—and more—return it postpaid for a prompt and courteous 100% refund.



ALL NEW for 1980

YES — please send me my copy of *The Complete Guide To Kit Cars*. I understand that I may return it within 14 days for a prompt 100% refund if not completely satisfied.

Mail Today To:

AUTO LOGIC, INC.
P.O. BOX 2073, DEPT PM68
WILMINGTON, DE 19899

- \$8 Postpaid
- \$11 Rush First Class Mail
- \$12 Foreign Air Mail

Visa Master Charge

Exp. Date _____

Signature _____

Name (print) _____

Address _____

City _____ State _____ Zip _____

Save Time! Phone Your Order TOLL-FREE

Visa or Master Charge Card Required. Call any time, 24 hours-a-day, 7 days-a-week (800) 331-1000. In Okla. call collect (918) 664-8300.



This is the only fact filled buyers guide devoted exclusively to these unique cars. It gives you all of the important information about the exploding do-it-yourself kit car revolution. As you examine the data-packed pages, you'll discover everything from 50 MPG roadsters to fire breathing mid-engine V8's that you can assemble from full-size sports car kits. Altogether, there are more than 75 manufacturers and 118 different models included. Never before has so much valuable "how-to," money saving information been packaged in one practical guide. It's all designed to help you get behind the wheel of your dream car at a price you can easily afford.

Easy! DRILLS WATER WELLS 50-100-200 FEET DEEP!

SAVES YOU HUNDREDS OF DOLLARS!!!

Did you know that vast quantities of fresh, sparkling clear water lie within 200 feet of the surface of the ground almost *everywhere*? In the city. In the suburbs. In the country. Pure, tasty water untouched by chemicals or pollutants.

Trouble is, until now, the only practical way to tap this wonderful supply of free water was to hire a professional driller—and that could cost you a thousand dollars or more.

But now YOU can drill your own well and save hundreds of dollars!

With the remarkable Hydra-Drill you can drill your own well. It's amazingly uncomplicated and simple to operate. More than 47,600 water wells have been drilled with Hydra-Drills by homeowners who have had no previous experience in well drilling.

You owe it to yourself to find out more about this practical economical way to provide good, year 'round water for your home and garden.

Write or call today for our FREE information package including the booklet "HOW TO DRILL YOUR OWN WELL". There's no obligation—ACT NOW! Call anytime including Sundays. No salesman will call.

Deeprock Mfg. Co., Opelika, Alabama 36801

FREE Phone Toll-Free
(800) 821-2280

(Ask for Extension 5091)
Call anytime including Sundays . . .

OR CLIP COUPON AND MAIL TODAY!

Deeprock Mfg. Co., Dept. PM60
Opelika, Alabama 36801

Please mail your free information kit immediately. I understand there is no obligation. No salesman will call.

Print Name _____

Address _____

City _____

State _____

Zip _____

© 1980 Deeprock Mfg. Co.

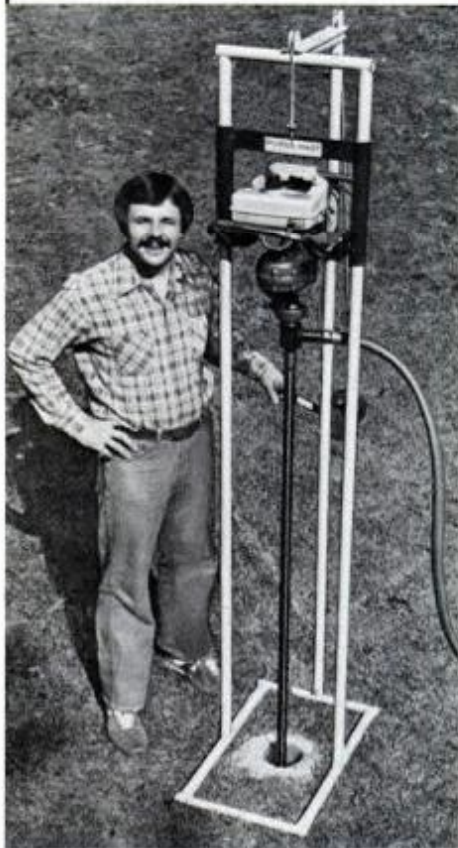

SPARE TIME INCOME? SELL KNAPP SHOES!

Sell famous Knapp Cushion Comfort Shoes full time or part time to supplement your income. Enjoy the financial success and security you've always dreamed about. Millions of repeat customers. Earn higher commissions plus bonuses. No investment. Free selling and training kit to get you started. America's No. 1 company in the direct selling shoe industry. Write: Knapp Shoes, Dept. L 612 Knapp Centre, Brockton, Mass. 02401.

KNAPP
The more for the money shoe.

FIND LOST TREASURE

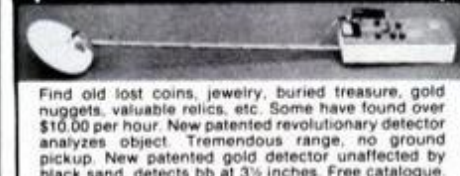

Find old lost coins, jewelry, buried treasure, gold nuggets, valuable relics, etc. Some have found over \$10.00 per hour. New patented revolutionary detector analyzes object. Tremendous range, no ground pickup. New patented gold detector unaffected by black sand, detects bb at 3 1/2 inches. Free catalogue.

GARDINER ELECTRONICS

Dept. 19 • 4729 N. 7th Ave. • Phoenix, Az. 85013

DOUBLE YOUR MONEY

That's our promise to you. Send now for our all new catalog full of many unique products that save you money and also conserve energy. All are easy to install. Just send us \$1 now to cover postage and handling and we'll send you our latest edition PLUS a certificate worth \$2 which you can use towards any purchase.

Send **Con-Serve Products, Dept PM-68**
To: 1225 Highland Avenue
Glenview, Illinois 60025

BICYCLE COMMUTING

(Continued from page 146)

It's unwise when there's much ice on the road. But riding in bad weather is not a trial, especially with new riding wear available.

Dirt and perspiration. Afraid you'll be sweaty and grease-covered after a bike ride to work? Well-dressed executives who commute by bike report fenders and leg straps are usually enough to keep you clean. With experience, it's easy to know how much clothing to wear. That usually means being just a bit cool upon departure so you warm up as you ride. Some commuters change clothes at work; a number of firms provide shower facilities.

Safety problems. Bike riding in traffic can be dangerous. But statistics show most cycling accidents involve young or inexperienced riders riding improperly or without sufficient light at night. A few precautions can eliminate most dangers:

■ **Always wear a helmet.** Even a low-speed collision could be fatal without head protection. A helmet may look funny and cost a lot, but scrambled gray matter looks worse and costs more to fix—if it can be fixed.

■ **Always ride with traffic.** Unlike pedestrians, cyclists should always "go with the flow" of traffic. Wrong-way cyclists cause innumerable accidents because no one expects them to come riding along from the wrong direction.

■ **Wear white at night.** Plaster your bike with reflectorized tape. Wear leg or arm lights or put a light on front or rear of the bike, or both. See and be seen.

■ **Ride prudently.** Obey the traffic laws—don't sail through red lights and stop signs. Don't weave crazily through traffic or cut off people. Ride several feet away from parked cars to avoid a suddenly opening door. And hand signal when turning.

■ **Keep your bike in shape.** A bike with bad brakes or loose nuts is an accident waiting to happen (see *Tune Up Your Bike For Riding Ease and Safety*, page 118, July '79).

Bike Security. Always lock up your bicycle. Many riders have psyched themselves past every possible objection to bike commuting only to have their bike damaged or stolen the first week. The long-term answer is employer cooperation to provide secure bike racks or even allow commuters to bring bikes into their factories and offices. Otherwise, the best bet is a U-shaped bike lock, posts and trees—and take your front wheel with you.

POWER TO CAMP OUT OR SHIP OUT.

When you're in the great outdoors, you never want to get in a position you're powerless to control. And that's where Honda comes in.

PORTABLE POWER.

The new EM-500 portable generator is the ideal companion for campers and hunters. It gives you a maximum 500 watts of power in a lightweight 40 lb. package about the size of a portable TV.

Whether you need to power your camping accessories, charge your RV battery or just warm-up under an electric blanket, the EM-500 does it quietly and economically—about 4 hours on a tankful of gas.

It's great for small power tools, barbecue motors and electric fans, too. And it can really light-up a camp site.

In addition to the EM-500, Honda has a full line of portable generators from 400 to 4,500 watts.

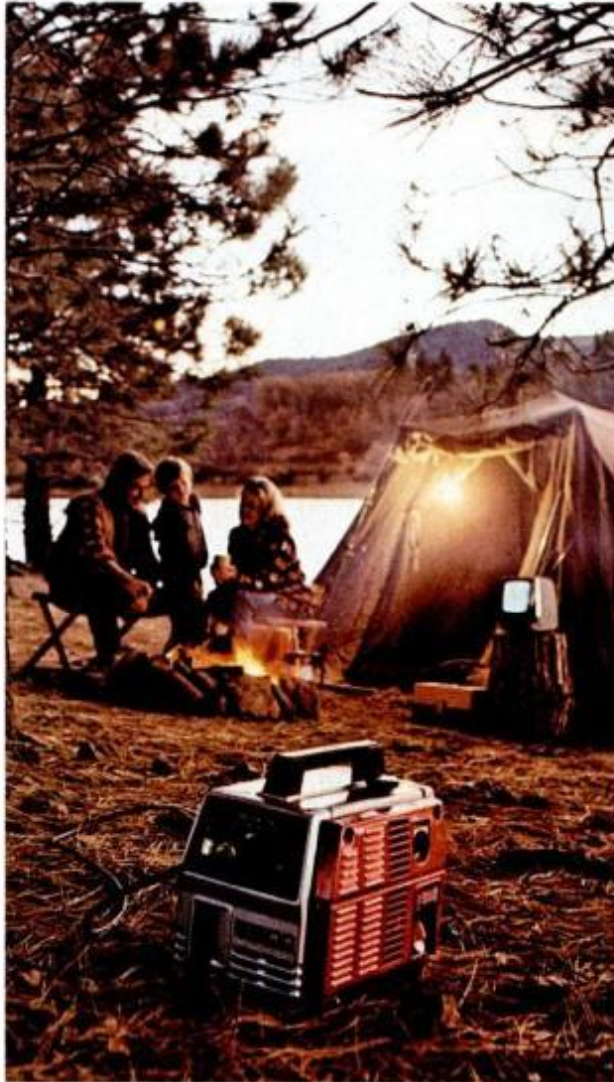

NAUTICAL POWER.

Honda has power for boaters and fishermen, too. A line of 4-stroke outboard engines that come in 7.5 and 9.9-hp models, both with short or long shaft.

Honda's 4-stroke design means quiet operation. Quick response and powerful acceleration. Maximum fuel economy—over three hours on a tankful of fuel under full throttle.

Smoother operation. And less pollution because there's less oil and smoke discharge.

These engines are ideal for trolling. They have the power to keep from drifting at low RPM's without fouling the plugs.

Before you head out on your next trip, let your nearby Honda dealer tell you about Honda power. Just look in the Yellow Pages or call toll-free 800-648-5311 (Operator 99).

IT'S A HONDA



excellent. Again, that's a cut above the American average, and proves that Chrysler Corp. is, indeed, trying hard to improve its total image on the grass-roots-owner level.

"I needed three transmissions in my 1978 Dodge Magnum, but haven't had any mechanical problems in my 1980 Mirada," stated a self-employed Wisconsin owner.

A Michigan store manager: "The wipers didn't work when I first tried them. The dealer changed the wiper motor in a half hour flat, and I didn't even have to get out of the car."

On the topic of general workmanship, the Mirada again received a hearty pat on the back, with nearly 80 percent in our survey rating it *good to excellent*. That's another healthy endorsement and, quite frankly, a radical change from our previous Chrysler Corp. reviews.

A Tennessee real estate agent: "Excellent workmanship. Quality superior to any car in its price range, in my opinion."

An Ohio CPA: "The doors and windows fit better than on other cars, making for less wind noise at highway speeds."

The Mirada's handling came in for another round of praise. "It's a peach to drive, and my wife agrees," declared a

sheet-metal worker from Arizona.

An Ohio pressman: "Great handling and maneuverability. I'm very pleased, too, with the acceleration and passing ability of the 225-cu.-in. Slant Six."

A Wisconsin RN: "Lots of get-up-and-go with the 318 V8." And you'll note in our data panel that only 0.8 percent of our respondents opted for the 360-cu.-in. V8, meaning that economy takes precedence over brute acceleration.

In the area of changes-we'd-like-to-see, here's a random sampling.

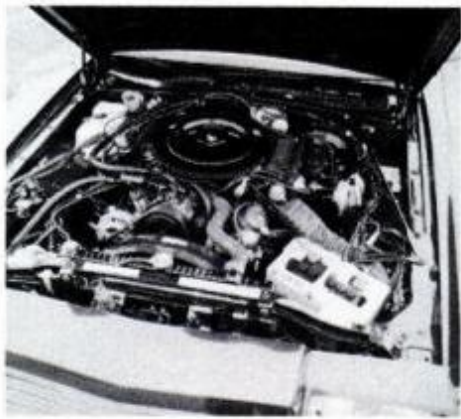

Most owners got the 318 V8; less than 1 percent ordered the 360-cu.-in. engine.

"Remove the fake louvers on the front fenders," suggested a Florida architect. And on the topic of styling, 8.1 percent of our respondents felt that the taillamps looked too rectangular and, as one person put it, "corny."

"How about a four-speed manual transmission to go along with the sporty look?" queried a Texas store clerk.

An Alabama chemical operator: "The rear swaybar ought to be standard equipment on this type of car, no matter which engine you choose." (In fairness, a heavy-duty suspension package is available for \$28 extra. The Open Road handling group costs an additional \$224. The Open Road package consists of front and rear stabilizer bars, alloy wheels, steel-belted radials and higher-effort power steering.)

A Michigan police officer: "The gas filler should be taken off the rear fender and hidden behind the license plate."

An Ohio salesman: "The front seats offer no thigh support."

And a South Carolina deliveryman: "The rear quarter windows ought to open up for better ventilation."

But the vast majority preferred to leave their Miradas just as they are. The following are the feelings of most owners.

New from Stewart-Warner

MINI-PANEL

The world's smallest instrument panel alerts you to car problems before they cause costly damage.

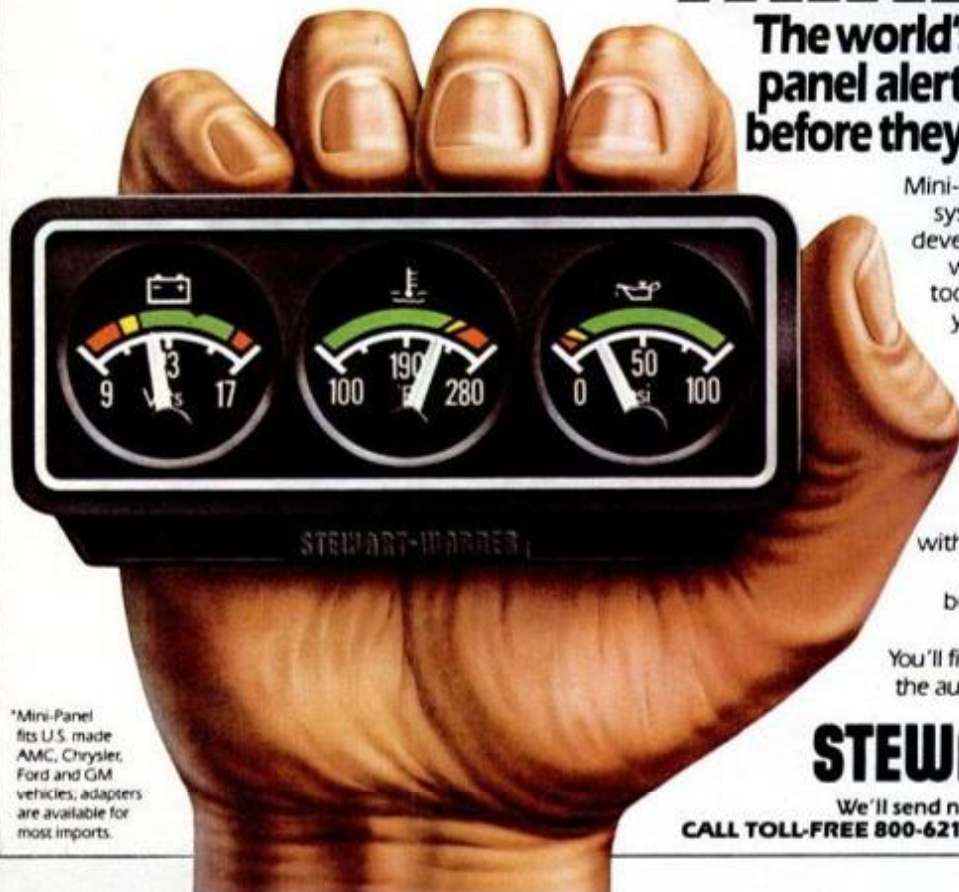

Mini-Panel is the miniaturized early warning system that helps you spot problems that develop while you drive. (Unlike traditional warning lights that don't go on until it's too late.) Catch those problems early, and you'll save yourself a lot of grief, as well as expense.

Each gauge serves an important function, enabling you to monitor electrical, cooling, and oil pressure systems at a glance.

Mini-Panel is so compact you can mount it on top of your dashboard—without obstructing your view of the road.

It's easy to install* with no drilling or bolting. No unsightly wires, so you have a professional-looking installation.

You'll find Mini-Panel at auto supply stores and the automotive section of leading retail stores.

STEWART-WARNER 

We'll send name and address of your nearest dealer.
CALL TOLL-FREE 800-621-5199. IN ILLINOIS 800-972-5855.

*Mini-Panel fits U.S. made AMC, Chrysler, Ford and GM vehicles; adapters are available for most imports.

"It's a beautiful, stylish car with lots of room," commented an Ohio educator. "I have nothing but good things to say about the Mirada. For example, my husband is very tall and this is the first car in which he's been able to sit up straight. It's very comfortable on long trips, and we're delighted with the Slant Six's excellent gas mileage. We're getting about 22 mpg in the city and 28 on the road."

And finally, from a Texas party-store manager: "The dealer had my car in tip-top condition when I took delivery. I watched him check it out from bumper to bumper.

Everything about the car fits well. There are no rough areas anywhere. I also like the large interior. There's plenty of roominess without everyone having to cuddle up. Plenty of space in the trunk, too. The

car handles great in tight situations, also in curves, parking and passing. I appreciate the maneuverability, the silence and the gas mileage. The mileage might seem average for a four-passenger car, but when you consider that it's possible to carry six people in the Mirada, the mpg is absolutely outstanding. I think it's one of the finest cars Chrysler Corp. has ever made." **PM**

SUMMARY OF 1980 DODGE MIRADA OWNERS REPORTS*

Total miles driven 476,456	Comfort 37.2	Very good 25.0	Good 27.7
Average miles per gallon	Ride 29.5	Good 11.8	Average 11.8
225-cu.-in. Six	Economy 23.3	Fair 2.9	Fair 7.6
In town 17.1	Specific dislikes:	Poor 0.7	Poor 8.4
Long trips 22.7	No complaints 38.2%	Comfort opinion (rear seats):	Number of vehicles owned:
318-cu.-in. V8	Mileage less than expected 11.4	Excellent 41.3%	Mirada only 52.6%
In town 14.7	Noises and rattles 8.1	Very good 33.9	Two cars 35.0
Long trips 20.0	Poor dealer service 5.7	Good 15.7	Three cars 9.5
360-cu.-in. V8	Poor workmanship 4.9	Fair 6.6	Four or more cars 3.0
(Sample too small to tabulate.)	Cold starts 4.9	Poor 2.5	Makes of other cars owned:
Engine choices:	What changes would you like?	Had any mechanical trouble?	Dodge 32.3%
225-cu.-in. Six 36.4%	No changes 22.6%	No 62.2%	Plymouth 13.8
318-cu.-in. V8 62.8	Better gas mileage 12.9	Yes 37.8	Ford 12.3
360-cu.-in. V8 0.8	Restyled taillamps 8.1	What type of trouble?	Chevrolet 10.8
Why did you choose the Mirada?	Better materials 5.6	Cold starting 19.6%	Age distribution of owners:
Styling 79.9%	Different seat shape/style 5.6	Carburetor 15.7	15-29 years 25.1%
Economy 15.7	Workmanship opinion:	Transmission 9.8	30-49 years 43.0
Size 12.7	Excellent 32.1%	Windshield wipers 7.8	50-plus 32.0
Price 10.4	Good 47.4	Dealer repairs satisfactory?	Would you buy another Dodge product?
Handling 10.4	Average 13.1	Yes 70.7%	Yes 87.3%
Specific likes:	Fair 5.1	No 29.3	No 12.7
Styling 72.1%	Poor 2.2	Dealer service opinion:	Would you buy another Mirada?
Handling 36.8	Comfort opinion (front seats):	Excellent 44.5%	Yes 86.0%
	Excellent 59.6%		No 14.0

*Percentages might not equal 100% due to rounding or insufficient data.

DREMEL 4" TABLE SAW DOES IT ALL! AND IT'S PORTABLE, TOO.

If you cut a lot of 1" or smaller stock...material that doesn't need a full sized table saw...this saw's for you. It has everything the big saws have, scaled down to a convenient 13" x 8 $\frac{3}{4}$ " x 11 $\frac{1}{2}$ " size. Blade tilts for bevels. Miter gauge has built-in stops. Rip fence is self-aligning. And there's a blade guard and other safety features, too. Handles just about every sawing job you can think of quickly, conveniently, accurately. The Dremel motorized table saw comes with a 32-tooth, 4" dia. combination blade. Dremel Division, Emerson Electric Co., Racine, WI 53406.



Cross Cuts



Bevel Cuts



Rips



MODEL 580SP



Miter Cuts



Cuts Tongue and Groove Joints



FREE EXTRA SAW BLADE

Look for the specially marked 580SP Table Saw cartons that contain this fine tooth blade. You get two blades for the price of one.

\$5.95 RETAIL VALUE

IT'S GOT EVERYTHING THE BIG SAWS HAVE, EXCEPT SIZE.

DREMEL

TAKE COMMAND OF ANY JOB WITH THE SKILTEAM.

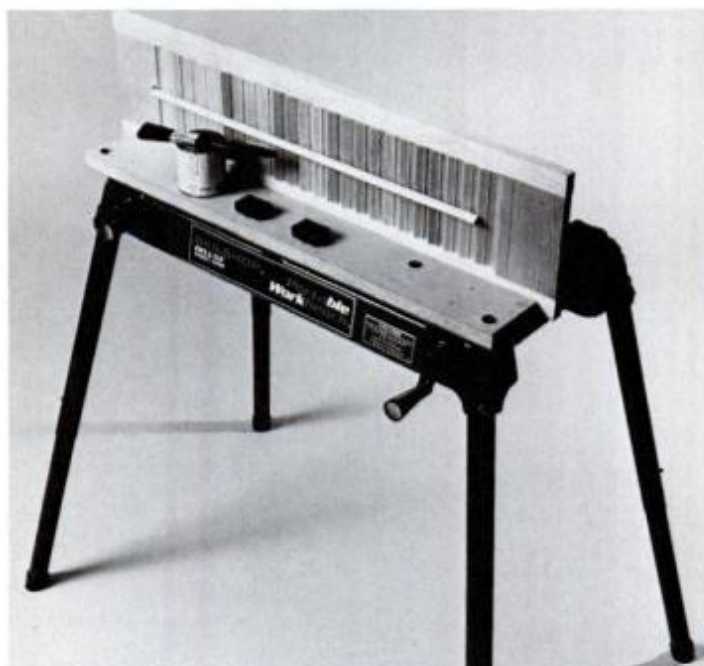

The new Skilshop Porta-Bench™ gets a solid grip on practically any job. It adjusts to 4 separate heights* and offers comfortable sit-down clearance. The tubular steel legs stand up to 350 pounds of workload.



The Skil® line of circular saws delivers smooth dependable power for fast cutting. Motors are burn-out protected against tough use. You can even cut through metal or concrete with appropriate blades. These double insulated saws include combination blade and blade wrench.

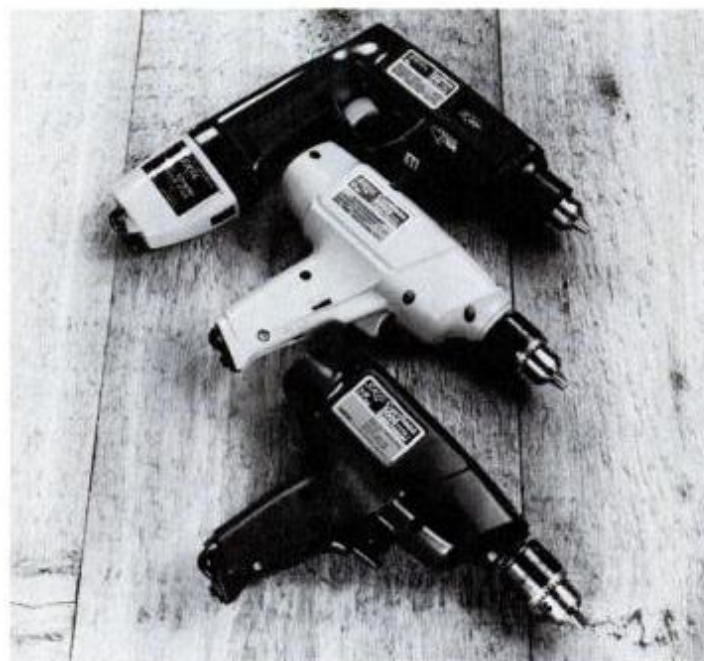

The Skil® line of cordless drill/screwdrivers provides portable muscle that goes wherever you need it. These reversible drills are equally at home in wood, metal and concrete. They're available in two-speed and variable speed models. Rechargers are included.



The amazing Skil Sandcat™ sander combines the power of a belt sander with easy handling of an orbital sander. Its light weight (only 4½ pounds) and low vibration take a lot of the strain out of jobs—especially when you're sanding overhead. Double insulated for safety.

* Only the deluxe Model 2200 has adjustable height.

Do it with **SKIL**. 

500 MILES ON 15 GALLONS

(Continued from page 83)

try. All this, mind you, is on a modest 80 hp from a small Continental A-80 powerplant (other engine options range from 65 to 85 hp).

How did George do it? He did it in part by borrowing liberally from the high-technology engineering developed by Burt Rutan for use in the now-famous VariEze (*VariEze: A Plane That Lives Up to Its Name*, page 74, Feb. '76) and Quickie (*PM's Pick: 10 Sports Planes You Can Build Yourself*, page 116, Feb. '79). Like the Eze and Quickie, Adventure is of all-composite construction using foam/fiberglass/epoxy laminations to build up wings, spars, fuselage, tail surfaces, even landing-gear struts. The method produces an incredibly strong, light, glass-smooth airframe capable of high performance on low power.

Mead's choice of composite construction is not surprising. A flight-test engineer for Cessna and former Air Force pilot, George worked with Burt Rutan during the final development stages of the VariEze, where he became convinced that the simple, moldless, foam/glass/epoxy process was the modern way to go. He found that many prospective sports-plane builders also liked the process, but wanted something not quite so far out as the canard-wing Eze or tandem-wing Quickie. He thus set out to see how the exotic Rutan mystique could be applied to a traditional-looking aircraft.

Enter Adventure, a sort of Ford built on a Ferrari chassis, uncannily quick and agile, but conservative in appearance. This is intentional and a major selling feature. In fact, George is billing the Adventure as "the first design to offer true sandwich composite structure in a conventionally configured airplane."

Docile but not dowdy

Most midget racers have short, stubby, low-aspect-ratio wings and tails, sacrificing some lift and stability for speed. Mead went in the opposite direction. Though only 13 feet long, his Adventure has a broad wingspan of 20 feet and a somewhat oversize tail group. Both wing and tail surfaces are of a graceful, thinly tapering, high-aspect-ratio shape—almost sailplane-like. Mead believes this is necessary for good lift, sure-footed stability and safe, easy handling. The large tail is designed to dampen out up-and-down pitching—a problem that typically plagues many small planes.

The result is a craft that's docile without being dowdy. "It's the kind

of airplane," says George, "that if you don't like what you are doing, you can let go of the thing and it will behave itself."

Racing the fuel gauge

In the classic Indianapolis 500, racing machines cover 500 miles in 2½ to 3 hours at speeds up to 200 mph. In the Oshkosh 500, racing machines cover 500 miles in 2½ to 3 hours at speeds up to 200 mph.

Apart from the fact that the Indy machines are cars and the Oshkosh machines are airplanes, there is one other important difference: The Indy racers consume up to 280 gallons of fuel, the legal maximum; the Oshkosh racers are limited to just 18 gallons for single-place planes and 22 gallons for two-seaters—up to 262 gallons less for the same distance.

The Oshkosh 500, officially known as the Lowers-Baker-Falck Competition, is a recently established event held annually at Oshkosh, Wis. Unlike other air races, it is a speed/efficiency contest in which the idea is to see how fast you can go on the least amount of gas—just to make things interesting. You thus race the fuel gauge as well as the clock.

George covered the 500 miles in two hours, 50 minutes and 17 seconds at an average speed of 176.32 mph—enough to win third place in a field of nine (famed professional race pilot Steve Wittman took first).

What's more significant, however, is that Mead used less fuel than any other contestant—a mere 15.1 gallons for an average of better than 33 mpg. (Wittman clocked 197.70 mph, but consumed 17.1 gallons.) Earlier, George flew 620 miles nonstop from Wichita, Kan., to Oshkosh on just 16 gallons for an average of nearly 40 mpg—not bad for a 180-mph-plus airplane.

Light and lively

One reason for Adventure's speed and economy is its low weight—only 460 pounds empty. Yet gross weight is 780 pounds, providing ample payload for a good-sized pilot and 23 gallons of fuel in two tanks.

While the landing gear is fixed, the penalty in drag is minimal, Mead feels, compared to the weight, cost and complexity that a retract-gear system would impose. The main-gear struts are in the form of a single, continuously curving fiberglass bow—a slick innovation adapted from Rutan's VariEze that provides simple mounting and a self-springing action without an elaborate suspension.

A fighter-style side-stick control-

(Please turn to page 154)

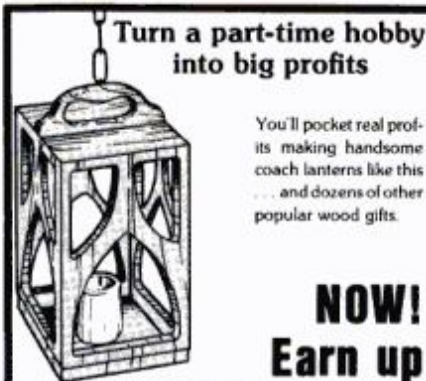

Turn a part-time hobby into big profits

You'll pocket real profits making handsome coach lanterns like this... and dozens of other popular wood gifts.

NOW!
Earn up to \$15 an hour making popular custom wood products

Now, a Free Information Kit tells how you can make \$5, \$10, even \$15 an hour or more in your spare time, in your own basement or workshop.

A patented, easy-to-use woodworking tool—the famous Shopsmith Router Arm—lets even beginners quickly turn out a big volume of beautiful wood products and gifts that sell themselves on sight, at handsome profits.

You'll have fun making and selling deep-etched custom signs for home or business, beautiful picture frames, decorator wall plaques, coach lanterns, serving trays, trinket chests, and dozens of other popular, fast-selling items. You can even start a money-making furniture repair and restoration business if you like. It's the perfect way to turn an enjoyable and satisfying hobby into extra cash while being your own boss!

FREE BUSINESS-ASSISTANCE PLAN

Mail the no-obligation coupon below to receive, by mail, a Free Information Kit, "Your 'Rout' to Woodworking Profits," that tells you all about this profitable opportunity. We help you get started with a complete, thoroughly researched "Blueprint for Success" that includes advertising materials, project ideas and patterns, production aids... the "works". And, we'll help your business grow by sending you a constant flow of new project plans and business-building ideas.

Don't miss getting the free facts about this unusually good money-making opportunity! Mail the coupon today!

FREE FACTS KIT



Shopsmith Inc.

Dept. 2523
750 Center Drive
Vandalia, Ohio 45377

Please mail me your Free Information Kit, "Your 'Rout' to Woodworking Profits" that tells how I can make money in my spare time with the patented Shopsmith Woodworking Router Arm—including the details of your complete "Business Plan". I understand there's no obligation.

Name _____

Address _____

City _____

State _____ Zip _____

Cabinetmakers' and professional woodworkers' inquiries welcome.

TODAY'S SIMONIZ WAX GIVES YOU HARD-WORKING SHINES WITHOUT HARD WORK.



You know you always get brilliant, hard-working shines with Simoniz wax. What you may not know is how hard we've worked over the years to take the hard work out of our Simoniz waxes. Today's new thicker-formula Simoniz pre-soft and liquid give you beautiful results—beautifully easy.

Look for them in their shiny new blue packages.

THE EASY SHINERS.

500 MILES ON 15 GALLONS

(Continued from page 153)

ler is located in the right-hand cockpit console—another touch taken from the VariEze. Rutan and Mead are both convinced from their military experience that the modern side stick offers more precise control, better arm support and less fatigue.

Clever cooling system

Most small planes merely have an opening in the nose to scoop in air and cool the engine, a method that works but at the cost of some speed-killing drag. Mead goes a step farther. His intake scoop is connected to a diverging duct that slows down incoming air while increasing its pressure. Thus the engine is bathed in high-pressure, low-velocity air for maximum cooling efficiency.

At the top of the engine, heated air is collected in a plenum chamber and channeled through a converging duct where it is accelerated back up to nearly its original inlet speed and expelled through an exhaust port. This highly effective flow of cooling air enables the intake port to be very small—about half the size normally used. Thus drag is likewise cut approximately in half.

The wings are built as two separate panels that merely "plug" into the fuselage through reinforced slots. Their single, massive spars carry through to the center and are joined by metal splice plates on the floor of the cockpit—that's all there is to the wing installation.

Long-span, slotted flaps extend from the wing root to the ailerons and deflect 15° for takeoff and approach and 45° for landing. Fully deployed, they reduce stall speed by 13 mph to a comfortably tame 57 mph. Approaches can be made at 80 to 85 mph, with touchdown at around 60. Takeoff run is about 800 feet; landing roll, 1500.

Mead estimates his Adventure can be built for a bit under \$5000, allowing \$2000 for engine cost. Construction plans, including engine installation and operating manual, are \$100 from Mead Engineering Co., Box 354, Colwich, Kan. 67030. An info brochure is \$5. A complete materials kit is available at an introductory price of \$1980 from Aircraft Spruce & Specialty Co., Box 424, Fullerton, Calif. 92632. Hard-to-make items like axles, engine mount and other welded parts will be supplied by Ken Brock Manufacturing, 11852 Western Ave., Stanton, Calif. 90680. The plastic bubble canopy and landing-gear struts can be obtained from Mead himself.

FM

Print For Profit

Cards; stationery; envelopes; advertising; labels; tickets; QSL cards; announcements; greeting, sympathy, prayer cards; tags, etc. Save money. **Own a Printing Business.** We supply everything direct from factory. Easy instructions. Also raised printing like engraving. Have home shop. Add to income. Send 25¢ for catalog.

Kelsey Process, 80-BF Meriden, CT 06450



ANYONE CAN SOLDER WITH KESTER SOLDER

DO-IT-YOURSELFERS!

Let Kester solder aid you in your home repairs or hobbies. A radio, TV, model train, jewelry, plumbing, etc. Save money—repair it yourself. Send self-addressed, stamped envelope to Kester for a FREE Copy of "Soldering Simplified".



KESTER SOLDER
4201 WRIGHTWOOD AVE.
CHICAGO, ILL. 60639



"SAVE
YOUR
HEART"

with a **STAIR-GLIDE** Stairway Lift
RENTAL-PURCHASE Program Available

America's largest selling stairway lift. Ideal for people who cannot or should not climb stairs. Easily installed in less than 2 hours without damaging stairway. Runs off household current. Choose from Deluxe or Economy models.

AMERICAN STAIR-GLIDE® CORP.
4001 East 138th, Dept. POP-060
Grandview, Missouri 64030

Kirsten



**FREE
COLOR
CATALOG**

Send for our free color catalog showing all of the Kirsten pipes, accessories and tobaccos.

KIRSTEN PIPE CO. INC.
P.O. Box 70526, Seattle, WA 98107
Dept. D

CANADA AT ITS BEST[®]

Light. Smooth. Imported Canadian Mist.[®]
The whisky that's becoming America's favorite Canadian.



Share some tonight.

IMPORTED BY B-F SPIRITS LTD., N.Y., N.Y., CANADIAN WHISKY—A BLEND, 80 PROOF, © 1979.

Photographed at Lake Beauvert, Jasper, Canada.

Whisky and whisky glasses are trademarks of B-F Spirits Ltd.

The inside of your engine

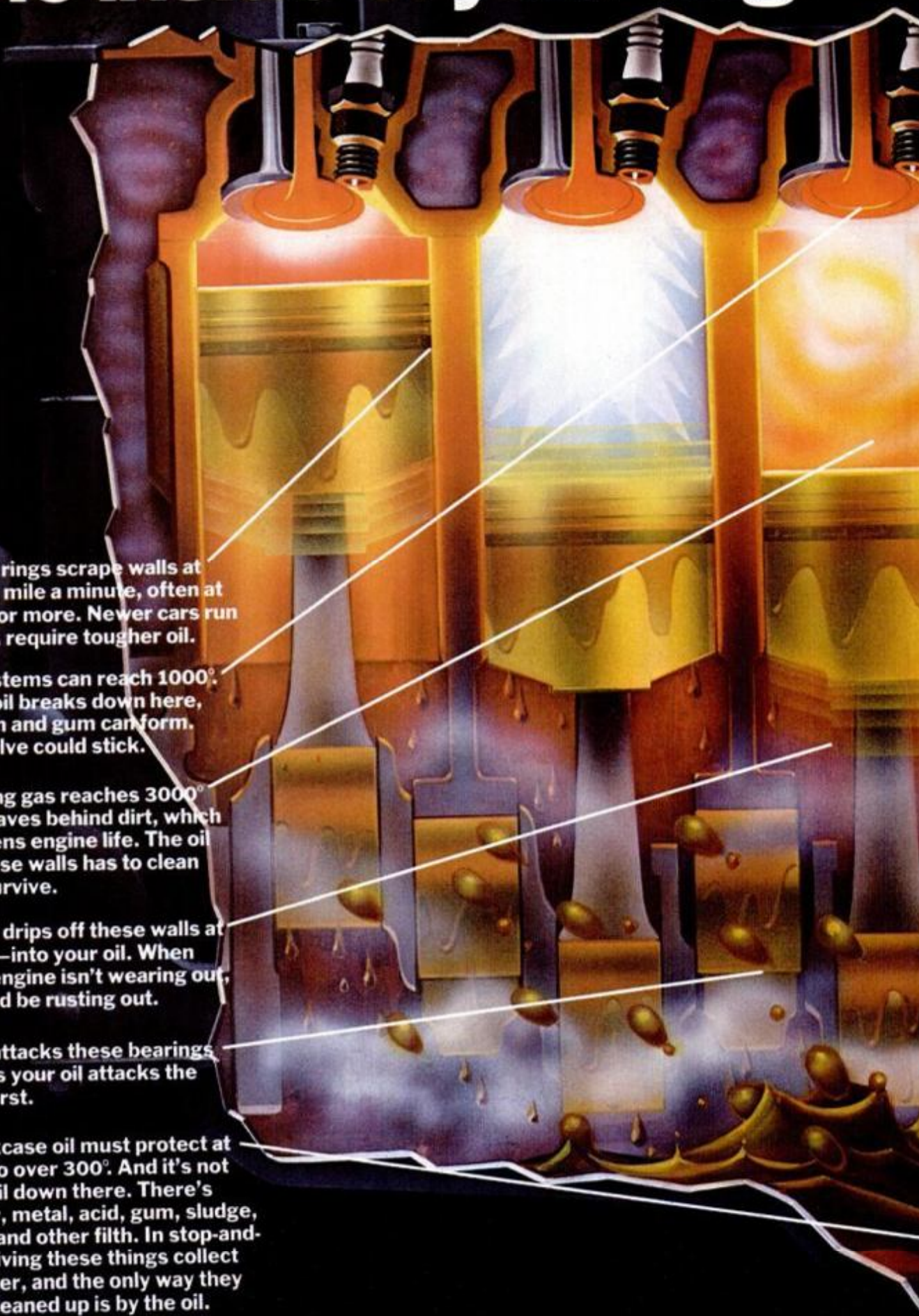

Piston rings scrape walls at up to a mile a minute, often at 1000° or more. Newer cars run hotter, require tougher oil.

Valve stems can reach 1000°. If the oil breaks down here, varnish and gum can form. The valve could stick.

Burning gas reaches 3000° and leaves behind dirt, which shortens engine life. The oil on these walls has to clean and survive.

Water drips off these walls at night—into your oil. When your engine isn't wearing out, it could be rusting out.

Acid attacks these bearings unless your oil attacks the acid first.

Crankcase oil must protect at -35° to over 300°. And it's not just oil down there. There's water, metal, acid, gum, sludge, rust, and other filth. In stop-and-go driving these things collect quicker, and the only way they get cleaned up is by the oil.

is an inferno.

There is only one oil that's good enough for the worst place on earth. The best.

And since 1928, Gulfpride has been our name for the best motor oil we make.

It has been used to set more than 200 World and U.S. Speed Records.

It has won the 24 Hours of LeMans, and the Indianapolis 500.

It has been the choice of people who know engines because it is made by people who know engines.

And the inferno that is the inside of an engine is why every new Gulfpride oil has no fewer than six ingredients to fight rust, acid, water, dirt and incredible heat.

Our newest oil – Gulfpride Super Premium – even has a new ingredient that increases gasoline mileage by actually making engine parts more slippery.

It also has a track record. It went over one million miles in tests with no engine failures.

So when you're looking for an oil, remember two things. First remember where it's been.

Then, remember where it's going.



New Gulfpride
The tough oil

THE WATER TORTURE. AND HOW TO AVOID IT.

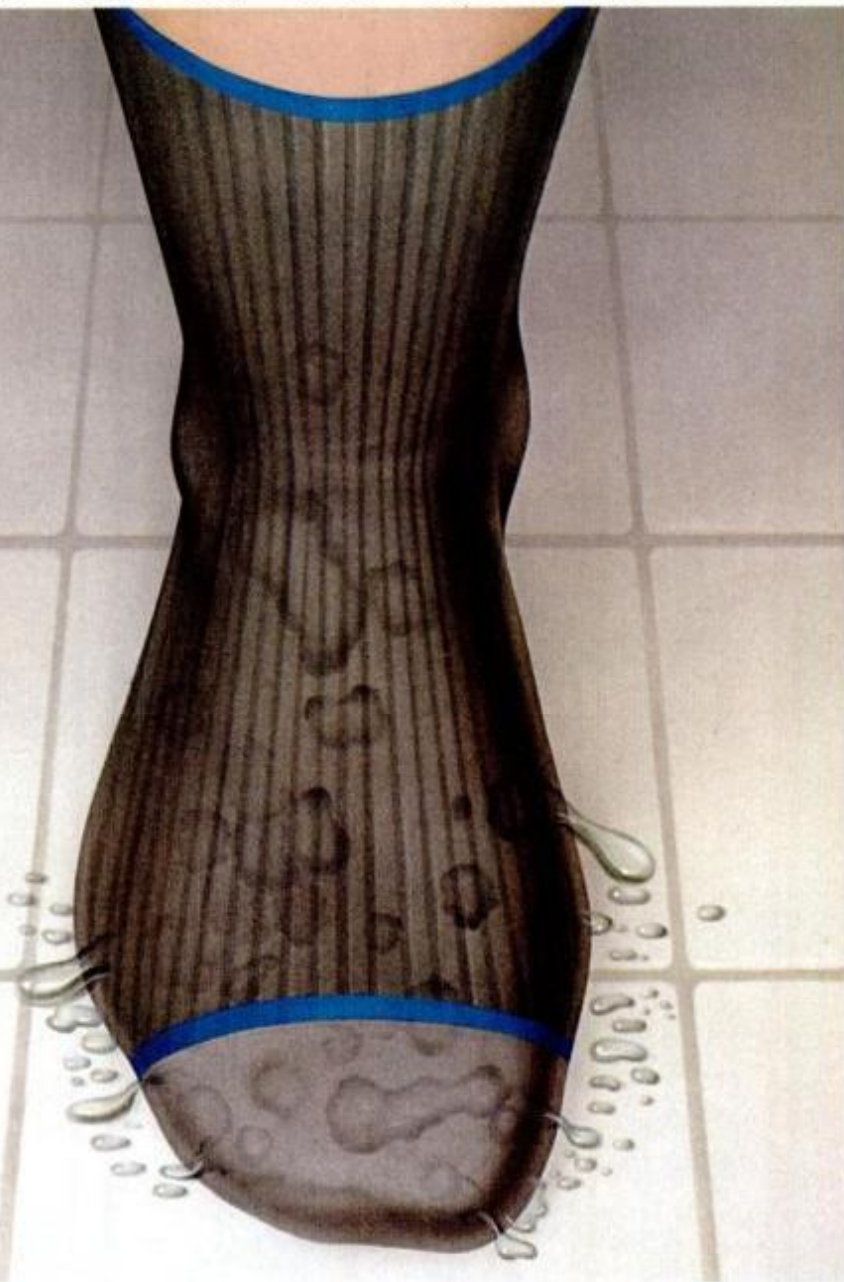

Bound and confined in shoes. Difficult to breathe. Forced to carry heavy loads. It's no wonder feet perspire. And that wetness can be torture for your feet.

Dr. Scholl's Foot Powder fights the special problems of foot wetness. Foot Powder absorbs perspiration. And when you avoid wetness, you avoid the uncomfortable, sweaty feeling.

It also helps stop other little "tortures" that come with wetness. Athlete's Foot and other fungi have less chance to get started because Foot Powder prevents dampness. And since it helps control wetness, it helps control odor.

Feet stay cooler, drier and fresher. So your feet are more comfortable. And you're more comfortable. A little shake in the morning or after bathing is all it takes.

And since it's applied directly to the skin, it controls moisture in a way insoles can't.

So why go on torturing yourself?
Use Dr. Scholl's Foot Powder every day.



Dr. Scholl's

© 1979 Scholl, Inc.

ROCKET BOAT

(Continued from page 75)

pretty hard to stop. That is what caused Taylor's crash in his craft, *Hustler*, at Lake Mead. He was running so fast that he simply ran out of water and ended up slamming against the side of a hill. Taylor's next ride in the *Hustler*, three years later, was slowed with a parachute, the first time one had been used to brake a boat. *Discovery II* will employ a dual Deist drogue-chute system, similar to those now used on drag boats and cars. The parachute, besides giving the pilot deceleration control, helps the boat avoid the sponson-jumping effect that caused the crash and death of Donald Campbell in his famous *Bluebird*, after Campbell had set seven records over a nine-year period.

A hull that will hold together at three times the force of gravity during tremendous acceleration and deceleration pressures is not easy to design. Lee Taylor has taken advantage of one of the latest aircraft technology advancements, a polyurethane bonding process that is applied much like spray paint and acts as a shrink-fit sealant. McDonnell Douglas and the U.S. Marine Corps, major developers of the system, have predicted that rivetless aircraft will be produced in a few years using this process. The *Discovery II* record attempt gives this innova-

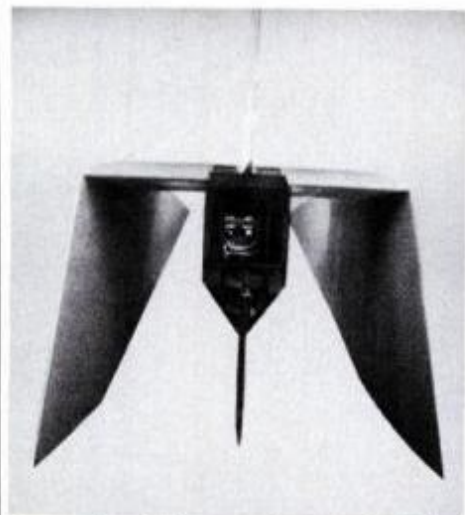

Stern view, before engine was installed, shows long rudder that has only four inches in water when craft is on plane.

tion a major tryout, and standard rivets are used as well for added safety. Test with a model showed that the rivet/bonding made the craft capable of holding together under an astounding 20.6 Gs of force, more than anything likely during actual speed runs.

When you first see the boat, you're
(Please turn to page 160)

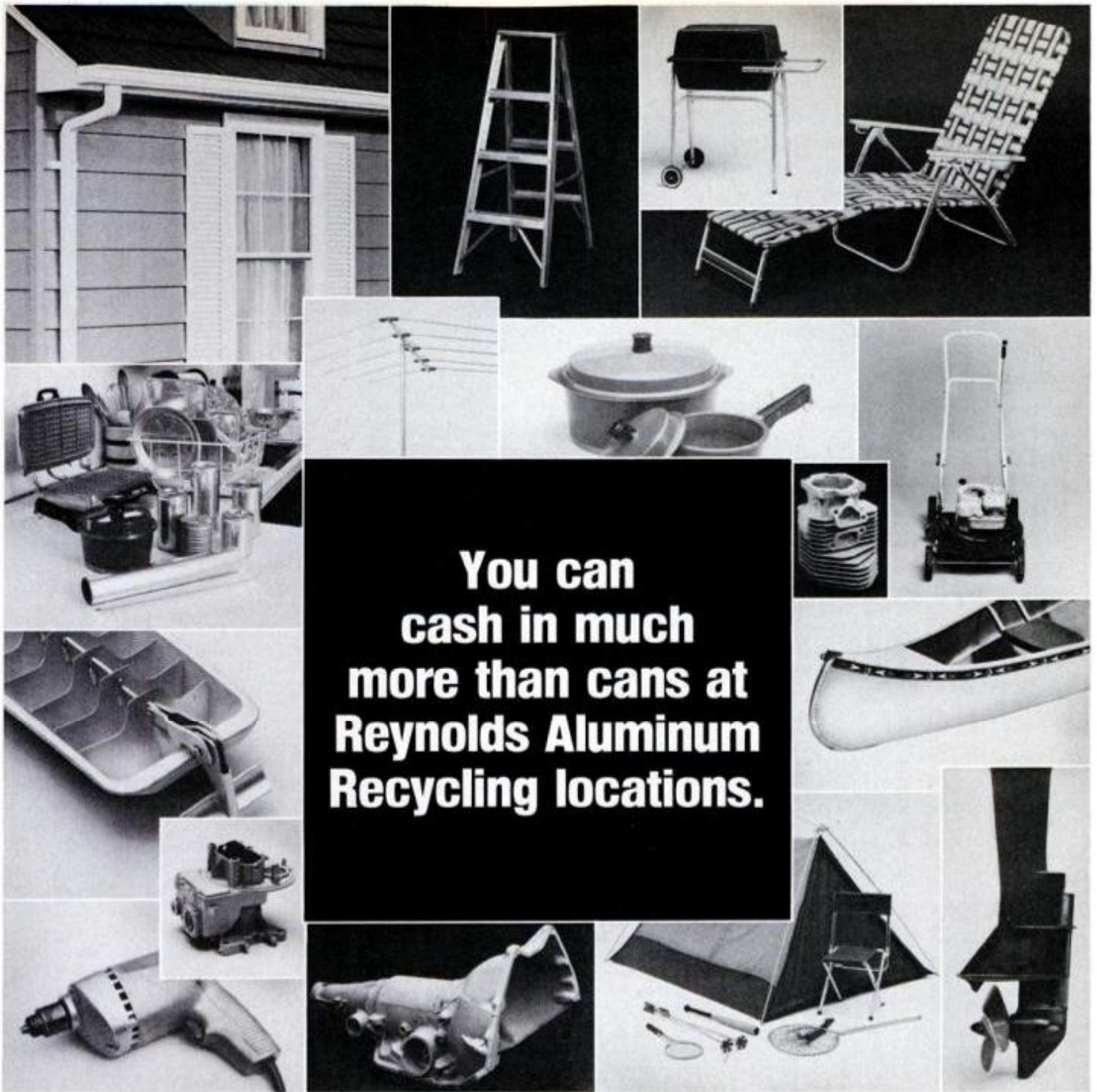

**You can
cash in much
more than cans at
Reynolds Aluminum
Recycling locations.**

The beauty of using things made with aluminum around the house is that even after you've stopped using them, they're valuable. You can recycle them for cash. And, if you look at the pictures above you'll get a good idea about the kinds of aluminum things that could provide a windfall for you.

Chances are there's valuable aluminum in a cupboard, in your garage or in your tool shed, right now, just waiting to be cashed in. All you need do is make sure your aluminum is properly prepared. It should be clean with no other material attached to it,

cut into 3 foot lengths or less, and separated from any cans you might be recycling.

Reynolds has over 1,000 recycling locations, coast to coast. And last year alone we paid our recyclers over \$45,000,000 for their used aluminum. So it really can be worth your while.

For more information on recycling with Reynolds check your yellow pages under Recycling Centers, or call this toll free number, 1-800-228-2525 and mention *Popular Mechanics*.

So start getting it together today. Cashing in old aluminum is as easy as cashing in cans and clearing it out will please everybody.



Important News For **BACKACHE SUFFERERS!** Momentum® is 50% stronger than regular tablets— Doan's, Bayer, Bufferin or Tylenol Tablets.

Before you take any regular strength tablet for muscular backache, remember this: Momentum Tablets are 50% stronger. That means Momentum gives you 50% more pain reliever per dose to relieve backaches.

For pain, inflammation, and stiffness of muscular backache, there's no stronger backache medication you can buy than Momentum.

Momentum does more than

reduce pain and soothe inflammation. It has extra medicine, too, to enhance the relief of muscle pain. As pain is reduced, stiffness eases, you move more freely in minutes.

If you are not getting all the pain reliever you need, get Momentum Tablets. For backache relief, 2 Momentum Tablets give you the strongest medication possible without a prescription. Take only as directed.

Make up to 8 GALLONS OF ALCOHOL FUEL AN HOUR for as little as 50¢ A GALLON!



ORDER THE COMPLETE
INSTRUCTION PACKAGE FROM
THE MOTHER EARTH NEWS® NOW!

The deluxe 6" still package costs just \$15 and includes:

- Complete bill of materials.
- Easy-to-follow diagrams and instructions for building every part of the still . . . from the mash cooking vat to the circulation system.

- Detailed instructions for operating the still.
- Recipe for cooking mash.
- Instructions for making the column collapsible so the still can be moved easily.
- Instructions for applying for a permit from the government so you may operate your still legally.

With these plans, you can build your still for under \$500 . . . after that, it's a simple matter to convert cars, tractors, and even furnaces to run on homebrewed fuel.

MOTHER's 6" Column Still Plans
84027 \$15.00

Also available: MOTHER's 3" Column Still Plans (to produce up to 1 gallon of alcohol per hour)
84016 \$15.00

NO-RISK GUARANTEE!

All of Mother's Plans come with a no-risk guarantee: If after 10 days you decide not to use your plans, you can return them for a full refund of your purchase price.

To order, send your name, address, and zip code along with a check or money order for \$15 to:

Mother's Plans
P.O. Box A
East Flat Rock, N.C. 28726

Or use your Master Charge or BankAmericard/VISA. Send the account number, expiration date, and Interbank Number (for Master Charge only) to the above address, or call in your order TOLL-FREE by dialing: 800/438-0238.

MOTHER'S PLANS, Dept. 400102, P.O. Box A, East Flat Rock, N.C. 28726

Enclosed is \$15.00. Please send me 6" Column Still Plans or 3" Column Still Plans. I understand that I have 10 days to examine the plans and if I decide not to use them, I can return them for a full refund.

Charge the plans to:

Master Charge (Interbank No. _____)
 BankAmericard/VISA

NAME _____

Name _____

ADDRESS _____

Account number _____

CITY _____

Expiration date _____

STATE _____ ZIP _____

Signature _____

Add \$1.00 to have plans sent first class. North Carolina residents add 4% sales tax. Canadian cash orders, add 15% surcharge. Sorry, no C.O.D.'s. Prices subject to change without notice.

ROCKET BOAT

(Continued from page 158)

likely to say, "Put wheels on it and set a new land speed record at Bonneville." Taylor isn't interested. A water man, he contends the obstacles faced trying for boat records are much more numerous and dangerous than ashore—a reason no one tries very often for the water record. Taylor's 1967 record, set at Lake Guntersville, Ala. (285.213 mph in the *Hustler*), went unchallenged for 11 years. At Guntersville, the late German rocket expert, Dr. Wernher von Braun, was an adviser.

Taylor had been attracted to southern California water sports since his youth. Friendship with speedboat designer Rich Hallett kept Taylor on water skis or in a boat, and he held the water ski record, 92 mph, in the 1960s ("For about 10 minutes," says Taylor) behind a boat driven by Hallett. Lee later became one of the top drag racers, driving Hallett boats.

A double rebuilding

Working with friends, and with the team spirit he had learned as a pro football player, it took Taylor a year to build his record-setting *Hustler*, and then another three years to rebuild it after his devastating Lake Mead crash. Lee also had to rebuild himself from what he calls "less than zero," including relearning to talk and walk. Taylor felt he owed much to the people who nursed him through the rough times after the accident, and was determined to try again. Fear is something he seems to have put in its place: "I've chased it down the street a long time ago. At over 200 miles an hour, you don't even have time to be scared."

What happened to *Discovery I*? The project just ran out of money, but the \$2.5 million effort of *Discovery II* with the support of Ducommun Metals and Sahara Tahoe appears ready for the test.

After the initial Tahoe record-go, Taylor plans further record attempts. Included are plans for a world tour, with record attempts on Lake Geneva, Switzerland, and perhaps Lake Baikal in the Soviet Union. After that, with a new and more powerful *Discovery III*, Taylor aims to take a waterborne shot at the sound barrier on Lake Tahoe.

These are no small plans, but they are from a man used to winning and determined to bring the prestigious speed title back to the United States. Lee Taylor is a man known for comebacks and success. With the *U.S. Discovery II*, he has a chance for both.

PM



**You can never thank your father enough,
but at least you can give him Chivas Regal.**

12 YEARS OLD WORLDWIDE • BLENDED SCOTCH WHISKY • 86 PROOF • GENERAL WINE & SPIRITS CO., NEW YORK, N.Y.

Minwax® Goes Outside

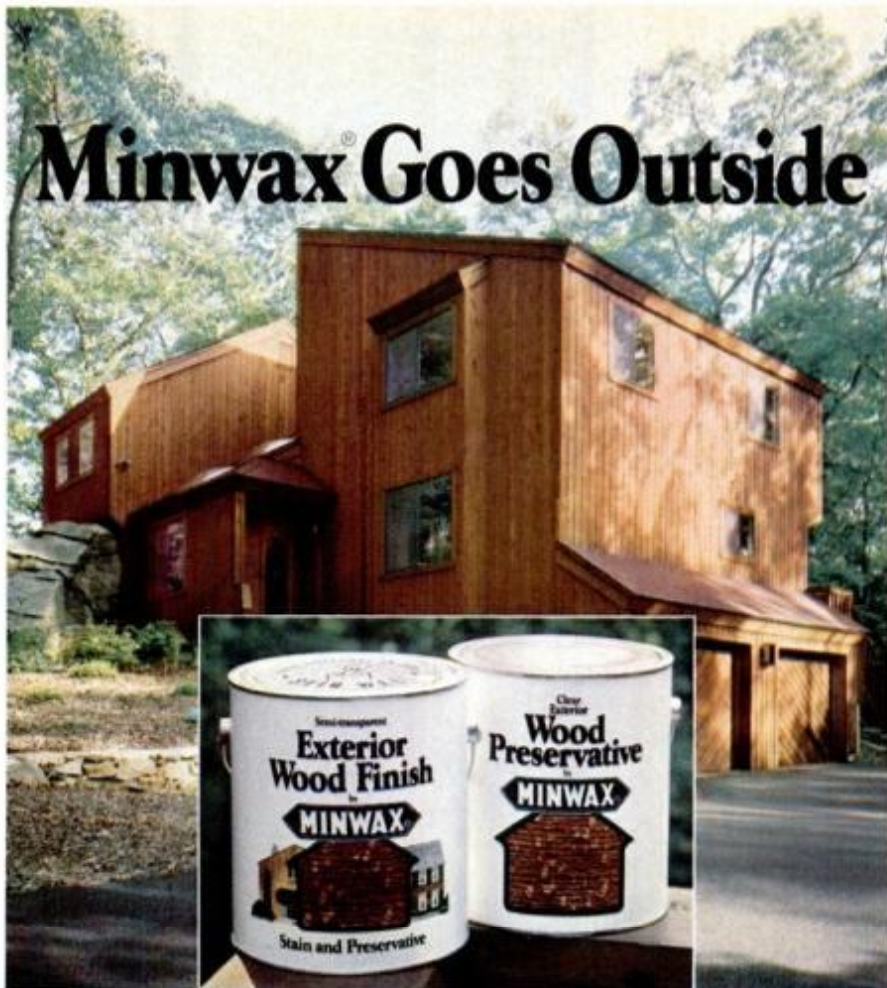

Now...Exterior Wood Finish and Wood Preservative by Minwax

For years, Wood Finishes by Minwax have enhanced the beauty of wood *inside* fine homes. Now you can apply the rich color and protection of a Minwax Finish *outside* as well.

Oil base Exterior Wood Finishes by Minwax color wood without hiding texture. They penetrate deep into wood fibers, sealing out moisture to guard against mildew and fungus.

Get your home ready for the wilds of weather and wear...with colorful Wood Finish or Clear Wood Preservative by Minwax.

Free Booklet! Send us the coupon below for a FREE 16-page booklet, *Tips on Wood Finishing*. Also, color card and name of nearest dealer.



Minwax Company, Inc., Dept. PM-60
Box 995, Clifton, NJ 07014

Name _____
Address _____
City _____ State _____ Zip _____
® Minwax is a registered trademark.

DO SOMETHING SPECIAL FOR YOUR CHILDREN WITHOUT SPENDING A LOT OF MONEY.

By following my material list and step by step instructions, you can build them a good, sturdy six piece living room set for as little as \$20 to \$25 dollars.

For complete information, send only four dollars to LIBERTY ENTERPRISES. We will also include simple upholstery instructions, and if you are not completely satisfied, simply return mailing within TEN DAYS FOR COMPLETE Refund.

© 1980 LIBERTY ENTERPRISES.

Please send check or money order to:
LIBERTY ENTERPRISES, P.O. Box 534
SOUTH BEND, INDIANA 46624

Name _____
Address _____
City _____ State _____ Zip _____

We take pride in responding promptly.

BUILDING A HUMAN HEART

(Continued from page 79)

the frustrating "early" experiments with total hearts—just seven years ago.

The early operations

In a typical operation, doctors removed a calf's heart and implanted in its place two chambers driven by puffs of air in flexible pipes running through the animal's chest. One chamber was the left ventricle, fore-runner of the LVAD. The other, the right ventricle, received blood from veins and pumped it out to the lungs to take on oxygen before entering the left ventricle.

"We did six calves between 1973 and 1976," Pierce said, "and every one of the animals bled to death." Success came tantalizingly close in animal No. 6. While a contract officer from a federal funding agency watched, Pierce implanted the pumps. The calf's circulation appeared normal for about 15 minutes.

"Then," Pierce told us, "something very drastic happened. The aortic pressure fell and the inlet pressure rose, and we diagnosed that a disc on one of the valves had fractured." The calf was put back on the heart-lung support system, and was never weaned from it. The officer from the National Institutes of Health went back to Washington.

The Hershey team approached calf No. 7 with little hope that its funding would continue. "We put the pumps in, closed him up and expected something terrible to happen," Pierce said. "We put him in a cage in the care area and I came up here to get something from my desk, and then I went back down."

He was astounded by what he found. "The animal was *standing up*. We thought we'd better get pictures while we could, so we called in photographers." A crowd of them soon gathered around the cage, plugged in flash equipment—and blew the circuit breaker for the electrical line supplying the calf's pumps. The artificial heart stopped. The calf dropped in a quivering heap.

The situation called for heroic action: Two of the Hershey researchers disconnected the air hoses supplying power to the implanted pumps and began blowing into them, forcing the chambers to pump some blood into the calf's vessels with their own lung power. At the same time, others hastily found an extension cord and ran it from an outlet in another room to the pumping machine. Plugged back into the

(Please turn to page 164)

Most people drive cars...
A few drive Legends



MiGi II

Finally, a sports car that expresses your individuality, your values. The MiGi II. An elegant, authentically detailed replica of the classic 1952 MG-TD.

Own a sports car custom-built for you. Or take pride in assembling it yourself on the dependable Volkswagen Beetle chassis. The lightweight, steel-reinforced fiberglass body insures improved gas mileage, performance, and years of carefree beauty. All from Fiberfab, the world's oldest and largest component sports car manufacturer.

The MiGi II unites classic design, mechanical simplicity and economical operation in a car that will never be out of date. Rediscover the legendary excitement of sports car driving: the MiGi II.

Send the coupon today. Or call TOLL FREE now for complete information: 800-328-5671.



FIBERFAB, INC.

1000 Turners Cross Road South
Minneapolis, MN 55416

CALL TOLL FREE: 800-328-5671

- Enclosed is \$2 for MiGi II color brochure.
- Enclosed is \$15 for color brochure and assembly manual.

PM6

Name _____ Age _____

Street _____

City _____ State _____ ZIP _____

Phone: Home () _____ Bus. () _____

Charge the above material to my VISA Master Charge account.

Card Number _____

Expiration Date _____

Signature _____

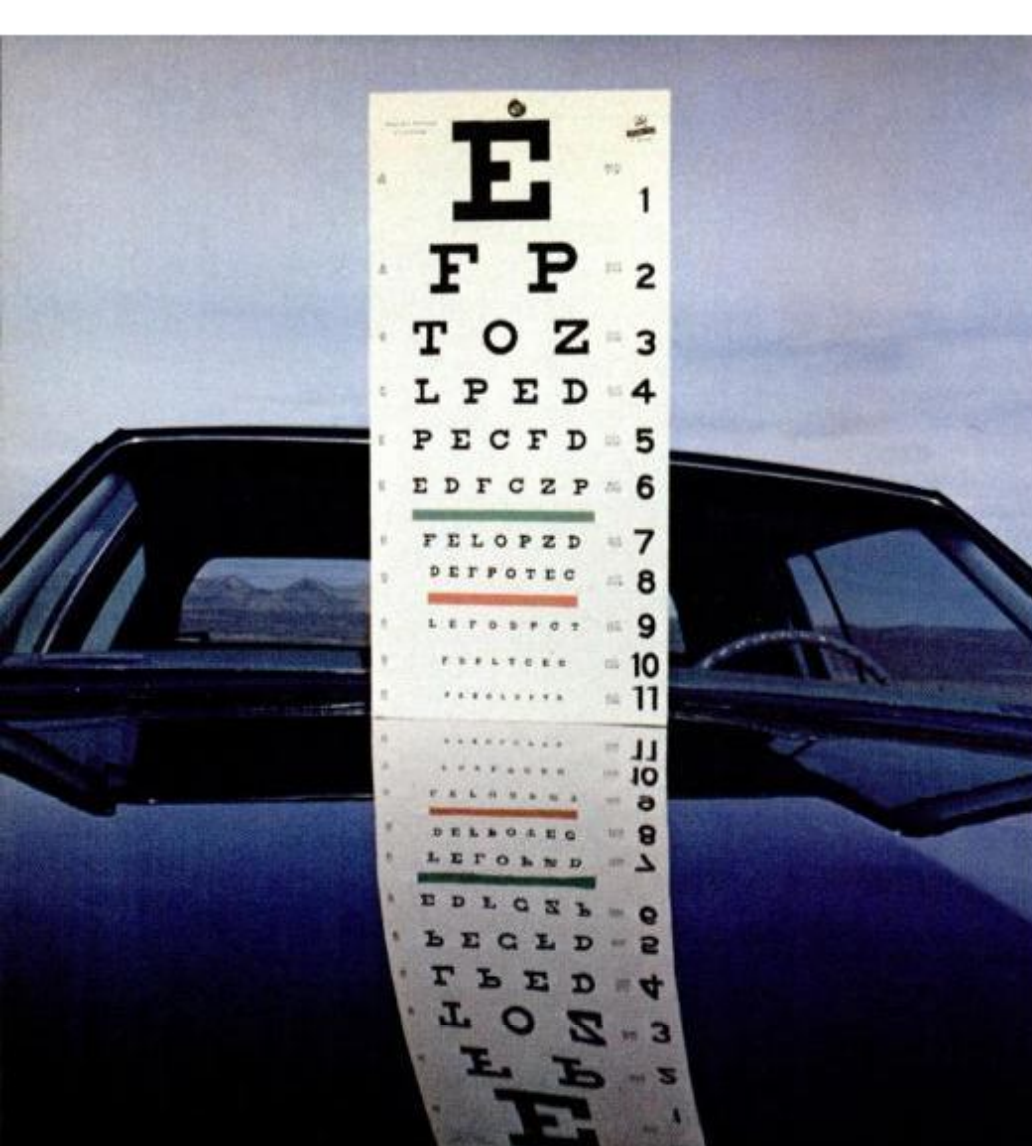

Great Reflections™ gives your car THE 20/20 SHINE

The eye chart says it all.

Great Reflections™ car wax gives you a shine so deep-down clear, you can actually read line number 8 — the 20/20 line. And that's the Great Reflections 20/20 shine.

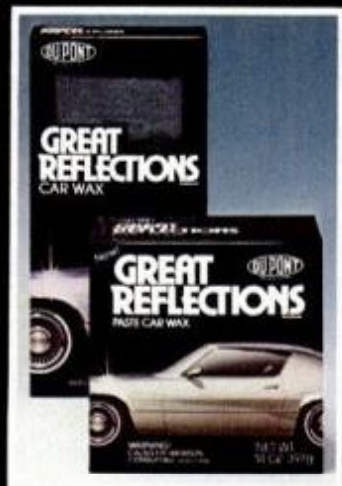

Test it yourself. Any way you look at it, your car can be a perfect vision with a Great Reflections™ shine.

Buy Great Reflections now and get \$1.50 refund from Du Pont.



GUARANTEE: GREAT REFLECTIONS CAR WAX is guaranteed to deliver a spectacular shine. If you are not satisfied, return the unused portion to the Du Pont Company, 8-4233, Wilmington, Delaware 19898, for a refund of your actual purchase price and postage.

BUILDING A HUMAN HEART

(Continued from page 162)

external power, the animal survived.

From this shaky start, Hershey researchers have successfully implanted externally driven artificial hearts in more than a dozen calves; one of them lived 157 days. And over the last few years, they have begun to attack one of the central challenges facing all developers of mechanical hearts: building a motor small enough so the entire heart (except batteries) can fit in the chest.

The \$1500 heart motor

The latest in a series of motors at Hershey weighs about 19 ounces (compared with a human heart's weight of roughly 12 ounces), takes up about the same space as a real heart and—in action—looks and sounds alive. In a working model of the motor in one of the Hershey labs, a chamber expands and contracts like an automated toy accordion. Pressing with two fingers on the chamber causes the heart to compensate for the extra load; it automatically resists the pressure, making whispered "whiff, whiff, whiff" sounds until pressure is released.

The works inside the heart are no more complicated than the inside of your car's engine. But the feedback and control systems are sophisticated. For one thing, the speed of the motor is regulated by a magnetically operated, solid-state switch built into the heart. As blood flows into the left polyurethane chamber, the chamber expands, thrusting a circular pusher plate sideways. A magnet at the center of this plate trips the Honeywell Hall-effect switch (see page 78) when the chamber is filled with blood. The filling time depends on blood pressure in the organism: the higher the pressure, the faster the fill—and the slower the heart should pump. So the Hall-effect switch enables the heart to "read" blood pressure continuously, and to pump at the right pace.

Initial versions of the motor weighed more than two pounds and cost around \$325, according to Dr. Gerson Rosenberg, a mechanical engineer who has worked on the design full time since 1975. Later versions cost more as they shed weight; the current model runs about \$1500.

Hydraulic and atomic hearts

There's more than one way to build a heart, or keep it beating. At the University of Utah, Dr. Robert Jarvik is experimenting with an electrically driven hydraulic heart. A direct-current motor, operating at

(Please turn to page 166)



IT'S LIKE GETTING FREE GASOLINE

**when you change to
Quaker State Sterling Motor Oil.**

Quaker State Sterling lubricates better than regular oils, so changing your oil to Sterling can get you better gas mileage. It's specially blended and fortified with new and improved additives to cut friction and improve wear protection.

With Quaker State Sterling in the crankcase your engine doesn't work as hard—so your gasoline goes farther. It's like having extra gas in the tank, for free!

Like all Quaker State Motor Oils, Sterling can help your car last and help you avoid expensive engine repairs.

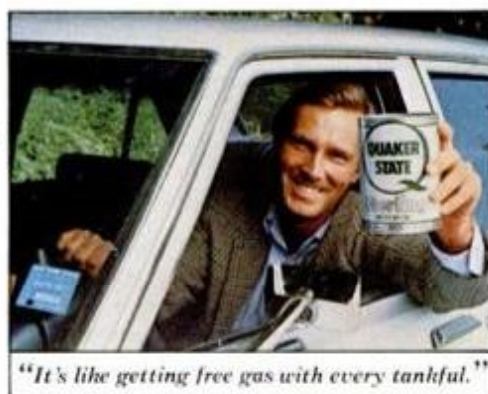



Now you can kill wasps and hornets in their nests from...

your way through Ralph Nader and the whole world." The prognosis for atomic-powered hearts: They probably won't come into widespread use until after several years' experience with more conventional power, electricity or heat. And it'll be some years before doctors implant even conventionally powered hearts in human chests.

The first patients

How many years? "People have been saying 10 years for 20 years," Pierce said. "I think we're farther away than 10 years." It depends largely on how the first LVAD implants work out; Pierce and others we interviewed were hopeful some human patients might begin wearing portable left-ventricle-assist pumps within the next four or five years. Jarvik's opinion: "The plan is to have LVADs ready about 4½ years from now, and the total heart could follow that closely."

And who will the first patient be? "The most obvious candidate," Pierce said, "is any patient who is now a candidate for heart transplantation. They only do 20 to 25 heart transplantations a year, and the need is for thousands a year."

The major problem with transplants is rejection: The body is programmed to cast out foreign proteins. But, ironically, the body won't reject the artificial plastic and metal hearts Pierce and others are building, because the mechanical versions are biologically inert.

So there is an eerie possibility that within a generation, for some patients who need a new heart, surgeons might pass up the real thing in favor of a custom-made, whirring, clicking machine. **FM**

BUILDING A HUMAN HEART

(Continued from page 164)

about 8000 to 12,000 rpm, connects to the impeller of a flow pump. Fluid driven by the pump pushes against diaphragms, driving the blood. One advantage of the Jarvik unit: It weighs only about 14 ounces, not including the electronics. Jarvik expects to implant the self-contained heart in a calf before the end of the summer.

The Hershey heart and the Jarvik device require batteries; Rosenberg said patients with an artificial heart would probably have to carry a 12-pound battery pack whenever they were away from a wall outlet. Nuclear power offers one way to run an artificial heart without external batteries. One design under consideration at the Joint Center for Graduate Study at the University of Washington uses either an electric heater or a 1000° F. radioactive isotope—plutonium 238—to provide heat for a Stirling engine. The heat causes helium enclosed in the Stirling to expand, driving a piston and moving hydraulic fluid to power a pump for the blood.

The thermal engine would be convenient for patients who don't want to lug their power supply around. And several researchers we talked to said it was safe, locked up in a kind of Thermos bottle of foil insulation.

But lately, a number of lab sources told us, the idea of a nuclear-powered heart is about as popular as a mineral spa at Three Mile Island.

"The real advantage is you don't have to fool around with batteries, and it's better for the patient," one scientist said. "The disadvantage is you have to fight

...12 ft. away!

Raid Wasp & Hornet Killer has a long-distance spray-nozzle to keep you at a good distance. You spray it directly on the nest. It kills on contact and saturates the nest to kill late-coming or returning insects. Use it once and the job is done.



Johnson
Wax

© 1978 S. C. Johnson & Son, Inc.

PROTECT YOUR CAR FROM THE ELEMENTS

FIRST TIME AVAILABLE TO THE PUBLIC

ORIGINAL PLASTIC COATING
GLO-SHIELDTM
MAKES WAXES AND POLISHES OBSOLETE

AS SEEN ON TV



Plastic Coat Your Car In Less Than 1 Hour FOR ONLY \$9⁹⁵

NEW CAR DEALERS CHARGE UP TO \$200

POLYMER ACRYLIC ACTUALLY RESURFACES AND RESEALS IN ONE SIMPLE STEP. GIVES YOUR CAR "SHOWROOM" BRILLIANCE THAT LASTS THREE YEARS—GUARANTEED!

Now at last you can put an end to corrosion, chalking, rusting, dulling, and pitting of your car's finish. GLO-SHIELD can protect your car's finish and restore it, too! You can bring back that new car look in less than 1 hour with hardly any effort at all! Too good to be true? Not with GLO-SHIELD, the miracle polymer plastic sealant that's guaranteed to protect and/or restore your car's finish for three years. Yes! you can revitalize and restore dull oxidized finishes...just wipe on — wipe off. Do away with compounding... dead paint is chemically removed. Just wipe on—wipe off. GLO-SHIELD removes old waxes, tar, stains, tree sap, road film, dirt, bird droppings, grime, grease, gasoline streaks, rusting, even tarnish. GLO-SHIELD deposits a plastic film that fuses to the surface and fills the pores to give your car a hard, high lustre, mirror-like finish. Just wipe on—wipe off.

NOTHING LIKE ANYTHING YOU'VE EVER USED BEFORE
Don't confuse this product with any wax or polish. GLO-SHIELD is a clear, transparent liquid, when, after it strips old wax and grime away, actually deposits a film that's very similar to the acrylic lacquer your car was originally painted with. And it works even if your car was painted with enamel. Acrylic sticks to anything... but nothing sticks to acrylic! Not tree sap, not

road salt, not grime or dirt, not even bird droppings, grease, gasoline — not even paint.

- THIS IS AN ACRYLIC PRODUCT DO NOT CONFUSE WITH IMITATIONS!
- NO RUBBING! NO BUFFING!
- CLEANS, COMPOUNDS, POLISHES, SEALS!
- USE ON ANY PAINT FINISH!
- FAST, ONE STEP WIPE-ON, WIPE-OFF!

And, GLO-SHIELD's protective coating that you apply in under one hour lasts three years. All you have to do to keep the finish beautiful is a light hosing...even a light rain, and road dirt, salt and grime roll right off, and dries streak free. GLO-SHIELD is detergent proof, contains no abrasives, invisible, non-yellowing, peelproof and crystal clear.

Here's an added plus. GLO-SHIELD works its magic on all painted and plated surfaces...chrome bumpers, mag wheels, appliances, motorcycles, fiberglass boats formica, marine hardware, brass, plexiglass, stainless steel, aluminum, etc.

So put an end to laborious waxing and polishing...get GLO-SHIELD the one step, wipe on—wipe off refinisher that gives your car a three year finish...free from dirt, grime, smudges. Order yours today!

Enough for 2 average cars. \$9.95 (less than \$5 per car). Fleet owners: write on letterhead for quantity prices.

3 YEAR GUARANTEE

If, after using GLO-SHIELD, you are not delighted, return the unused portion anytime up to three years, for a pro-rata product refund

© 1979 MEDIA MKTG.

ACCEPTED AND PROVEN FOR AIRPLANES AND BOATS

After extensive testing GLO-SHIELD has been accepted and used by America's leading aircraft manufacturers and leading boat builders. Desert sunshine labs report amazing results from testing (reports available on request). GLO-SHIELD has been shown to be especially effective while operating in a salt water environment and highly recommended by boat centers for use on all boats, including fiberglass.

CONSUMER NOTICE!

Beware of cheap imitations and the scare tactics of High Price Sealants — **ONLY GLO-SHIELD** is made with **ACRYLICS**. The same **ACRYLIC** that's on your car's original paint.

(Glo-Shield is a one step operation—you don't need so-called professionals to put it on for hundreds of dollars) You do it yourself easily—in less than an hour.

BEFORE YOU BUY—LOOK AT THE LABEL.

Only Glo-Shield Contains Acrylics
Not a wax—Not a Polymer-Silicone Polish **But an Acrylic Sealer**—that protects and shines...guaranteed for 3 years. Don't be switched—it's your money.

CREDIT CARD PURCHASE—CALL TOLL FREE 24 HOUR SERVICE: **800-453-2444**

SATISFACTION GUARANTEED OR MONEY BACK

GLO-SHIELD, Dept. 1452
10-10 44th Ave., P.O. Box 1464
Long Island City, NY 11101

Please send me GLO-SHIELD. I understand that if I am not delighted in every way, I can return the unused portion for a pro-rata refund, exclusive of postage and handling.

- One bottle only \$9.95 plus \$1 shipping.
- SAVE: Two bottles only \$18 plus \$1 shipping. Enclosed is \$_____ or charge my
- BankAmericard MasterCard
- MC Bank # _____ Exp date _____

Acct.# _____
Name _____
Address _____
City _____
State _____ Zip _____

N.Y. RESIDENTS ADD SALES TAX



**Makes Over \$60 EXTRA a Week
In Own Sharpening Shop!**

"My Belsaw Sharp-All made me \$3,500 last year just in spare time. Now I'm going full time. It's great to be your own boss."
David Swanson — Utica, Michigan



**Let Belsaw prove
YOU can do it, too! On our
30-DAY FREE TRIAL OFFER**

You risk nothing by accepting this offer to see how easily you can turn your spare time into Big Cash Profits with your own Complete Sharpening Shop. No selling . . . No previous experience needed. Our famous Sharp-All and show-how instruction set you up to make \$200, \$500, \$700 a month CASH sharpening SAWS, KNIVES, SCISSORS, LAWNMOWERS, Shop and Garden tools . . . all cutting edges.

Send coupon for FREE facts on this money-making business. How we'll even finance you.

No Obligation — No Salesman Will Call

BELSAW SHARP-ALL CO.

711H Field Bldg. Kansas City, Mo. 64111

**JOIN THESE SHARP-ALL
MONEYMAKERS**

"Think the world of my Sharp-All. Am grossing \$4,000 a year on a part-time basis."

*Lawrence Stevenson
E. Syracuse, New York*

"There's excellent profit in sharpening . . . we now do about \$600.00 a month."

*Ed Kistler, Jr.
Sarasota, Florida*

"I average \$5.00 an hour part time and business gets better all the time."

*Roy Jennings
Sandwich, Illinois*

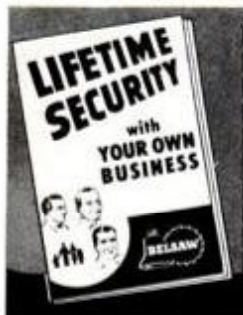

RUSH COUPON TODAY FOR FREE BOOK

BELSAW SHARP-ALL CO. Stan Field, Pres.
711H Field Bldg., Kansas City, Mo. 64111

Send details of FREE TRIAL OFFER and Free Book "Lifetime Security"

Name _____
Address _____
City _____ State _____ Zip _____

No obligation . . . No salesman will call

"Tilting" PICTURE FRAMING VISE

**Make Your Own Frames & Save
It's Fun & Easy**

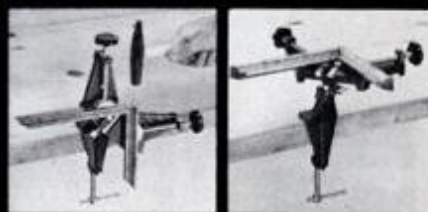

VERTICAL POSITION
PREDRILL HOLES FOR
DOWEL JOINTS OR
NAILING

FLIP TO HORIZONTAL
POSITION TO GLUE
AND CLAMP CORNERS

- CLAMPS TO ANY WORKBENCH OR TABLE
- TILTS FOR EASY ASSEMBLY OF PICTURE FRAMES
- LETS YOUR HANDS FREE TO GLUE, NAIL AND DRILL
- GREAT FOR PROFESSIONAL, HOBBYIST, DO-IT-YOURSELF
- FRAMES FOR PAINTINGS, DOCUMENTS, PHOTOS, DIPLOMAS, NEEDLEWORK AND MORE

H. R. Sales Co.
P.O. Box 175
Franklin Park, Illinois 60131

\$14⁹⁵

Please rush me _____ Tilting picture framing vise(s) at \$14.95 each plus \$2.00 shipping and handling per unit. Send check or money order. Illinois Residents include 6% sales tax.

Name _____
Address _____
City _____ State _____ Zip _____

PM OWNERS REPORT: JEEP CJ-5 AND CJ-7 *(Continued from page 101)*

bearing—I give him a rating of excellent. Other minor problems, like carburetor stumble and a stuck vent, I'll fix myself. Workmanship ranges from excellent to poor—excellent for the big things like engine and drive train and poor for such items as dashboard mounting. What the Jeep needs is a bigger gas tank, tube-type tires, a manual choke, locking storage bins, higher seatbacks and a handier emergency brake. But I'd buy another one without hesitation when and if this one ever wears out."

A Michigan computer graphics designer, 22, owner of a CJ-7 V8 with four-speed and these comments:

"It's a fun machine summer and winter. I like to do more with my transportation than just go back and forth to work. I enjoy the V8's power, but it's mighty thirsty. I get about 12 mpg on the highway.

"I've had a couple of problems with my Jeep. The clutch adjustment screw loosened and made for hard shifting. The carburetor also used to bog down at freeway speeds.

'Comfort rates very good front and rear, but you have to remember that this is a short-wheelbase vehicle."

An Arizona electrical engineer, 23, with a CJ-5 Six and four-speed:



For serious off-roading, the windshield is able to fold down flat right over the hood.

"This is my second Jeep. I moved to Arizona from Kansas and decided to buy one with the options I need. I know I'm going to do a lot of off-roading.

"I've had no mechanical problems these first 4000 miles, and I love Jeeps because of their ruggedness, reliability

and simplicity. As for workmanship, I can see some cut corners—sloppy paint, bad undercoating, and so on, but it's got good quality in the major components."

A 39-year-old Michigan steelworker with a four-cylinder, four-speed CJ-5:

"I needed economical transportation and also wanted to have a toy. I hunt, so I figured the Jeep would make that easier.

"When I took delivery, the engine had a slight dieseling tendency, and one headlamp didn't work. The service department was prompt and efficient and also gave me some tips on maintenance.

"I like the Jeep's overall design, and its workmanship inspires confidence. The great range of accessories lets me personalize my vehicle. It's comfortable in both seats, but short people and kids could use a step to help get in and out. My specific praises of the Jeep are its ruggedness, looks and versatility. I wish they'd put a lockable storage compartment under the back seat."

And finally, an Oregon lineman, aged 60, with a CJ-5 Six and four-speed:

"I've owned Scouts, Broncos and Chevy 4x4s, but the Jeep is still king. Back in the '40s I always had the four-cylinder models; then went to the V6. And al-

LEADERS HAVE TASTE

Even the look of the A&C Grenadier rewards the choosy smoker. It's long and lean. Touch a match to it, and here comes rich, exciting aroma, full and satisfying taste. At its heart, a richly rewarding blend of five fine imported and domestic tobaccos. All of this sealed in our Fresh Loc package. When you've got the taste for leadership, light up an A&C Grenadier. In light or dark natural wrapper.



A&C GRENADIERS—THE TASTE LEADER

though I like the 304 V8, I went for the in-line Six for 1980 and am delighted with its all-around performance and 14-to-18-mpg economy. I drive 68 miles five days a week, and my last 304 V8 was absolute murder on gas!

"I've purchased Jeeps in three different states, and all dealers were exceptionally good. Even so, I find that getting replace-

ment parts always takes 3 to 4 weeks. Of mechanical ills, the right front shock collapsed, and the clutch release bearing went out. Jeeps are famous for this. I've owned 21 Jeeps since 1946, and the defrosters have always been inadequate. The '80 model is no exception.

"That may sound negative, but you can tell I'm high on Jeeps. They're ruggedly

constructed, very easy to handle in tight rough spots, and have no rival in really brutal, off-road driving. It's amazing how much abuse they can take. I drive my Jeep in the rough every chance I get. In fact, in 1954 I lost one in a canyon. It's still down there! No questions, please. I made a bad mistake that day—but never a mistake buying any Jeep!" **PM**

SUMMARY OF 1980 JEEP CJ-5 AND CJ-7 OWNERS REPORTS*

Total miles driven 771,465	Recreational use 10.5	Comfort opinion (front seats):	Dealer service opinion:
Average miles per gallon	Past experience 9.9	Excellent 20.1%	Excellent 24.8%
Ohv Four (151-cu.-in., 2-bbl.)	Specific likes:	Very good 38.2	Good 26.1
In town 17.5	Handling 37.6%	Good 25.1	Average 20.6
Long trips 20.4	Styling 28.5	Fair 12.1	Fair 13.9
Ohv Six (258-cu.-in., 2-bbl.)	Roadability 22.6	Poor 4.5	Poor 14.5
In town 14.0	Economy 19.9	Comfort opinion (rear seats):	Number of vehicles owned:
Long trips 17.4	Performance 19.4	Excellent 6.9%	Jeep only 34.7%
Ohv V8 (304-cu.-in., 2-bbl.)	Specific dislikes:	Very good 27.7	Two cars 49.5
In town 12.3	No complaints 17.0%	Good 26.0	Three cars 11.7
Long trips 15.2	Gas mileage 17.0	Fair 24.9	Four or more cars 4.1
Engine choices:	Noise and rattles 11.2	Poor 14.5	Makes of other cars owned:
Ohv 151-cu.-in. Four 31.5%	Stiff ride 9.0	Had any mechanical trouble?	Ford 23.4%
Ohv 258-cu.-in. Six 54.8	Poor dealer service 6.4	Yes 60.0%	Chevrolet 22.7
Ohv 304-cu.-in. V8 13.7	What changes would you like?	No 40.0	Oldsmobile 10.9
Transmission choices:	No changes 16.7%	What type of trouble?	Buick 10.9
Four-speed manual 91.1%	Better gas mileage 7.5	Clutch 28.2%	Volkswagen 7.0
Three-speed automatic 8.9	Different seat shape 7.0	Shifter pin falls out 12.8	Age distribution of owners:
Series choices:	Larger fuel tank 5.9	Transmission 12.0	15-29 years 59.2%
Jeep CJ-7 52.0%	Different styling 5.4	Carburetor 11.1	30-49 years 36.2
Jeep CJ-5 48.0	Workmanship opinion:	Heater 7.7	50-plus 4.6
Why did you choose the Jeep?	Excellent 31.3%	Oil leaks 7.7	Would you buy another Jeep?
Four-wheel drive 32.6%	Good 41.9	Dealer repairs satisfactory?	Yes 89.4%
Economy 23.8	Average 14.6	Yes 56.4%	No 10.6
Roadability 21.5	Fair 7.1	No 43.6	
	Poor 5.1		

*Percentages might not equal 100% due to rounding or insufficient data.

TO COMPLETE
YOUR WORKSHOP

ATLAS BANDSAW

IT'S CONVERTIBLE



NOW
ONLY

\$235⁰⁰

plus \$30 handling and shipping

The Atlas Band Saw • Handles cut-off operations in a wide range of metals — from steel and iron, to aluminum, brass and copper • Comes complete with 1/2 hp, 1725 rpm motor • Takes any shape stock — bar, flat, square, hex, tubing structural shapes, and cuts it at any angle from 90° to 45°. Max. capacity is 4" x 6" • 3-speed V-belt and worm gear drive offers speeds of 90, 155, 250 rpm • Swiveling rapid approach/release type vise allows fast set ups. Set desired cut, and spring control feeds blade at proper speed for smooth, fast cuts • Has stock stop for repeat cutting • Converts to vertical position for contouring, notching, slitting, and other operations in metal or wood. Length 41", height 37", width 16 1/2". Extends to 43" length, 47 3/4" height in vertical position.

ATLAS BANDSAW

Mail To: ATLAS PRESS COMPANY, Dept. 280
2019 N. Pitcher, Kalamazoo, MI 49007

Please send me the Atlas Band Saw (Model 4359).
Enclosed is my check or money order for \$265.00.
(Includes shipping and handling) or charge my order to:

VISA Master Charge

Acct. # _____ Exp. Date _____

Name _____

Address _____

City/State/Zip _____

Send FREE Atlas Power and Hand Tool Catalog.

Michigan residents add 4% sales tax.

Available continental U.S.A. only.

Price subject to change without notice.

DATSUN'S NEW 4x4 IN BAJA

(Continued from page 93)

floods left us with four rivers to cross, plus innumerable streams and gullies that we had to tippy-toe through. The 14 pickups, each with a driver and passenger, were linked with CB radio.

Up at Mike's, which I can best describe as a well-stocked *cantina* that sleeps 40 (actually it also has a swimming pool, great *carne asada*, no phones and an abundance of solitude), off-road racer Jim Conner had laid out a course that included lots of soft riverbeds and sand.

We writers took turns tearing up the course and trying to tear up the Datsuns, but we failed on all counts. The 4x4s withstood all the abuse we could inflict on them—a great testimony to their ruggedness and overall quality of engineering and assembly.

Converted from 2wd

Basically, when you buy Datsun's new 4x4, you get the conventional pickup converted from two-wheel drive. Chassis, cabs, engines, transmissions and most other components are the same as the two-wheeler. So, you can go to any Datsun dealer or aftermarket accessory dealer and find parts, without having to worry about new-model stock shortages.

Front axles, independent front suspension, transfer case, axle ratios and the heft of some transmission gears in these Datsun 4x4s are new. They use torsion bars up front and overslung, heavy-duty, leaf springs aft, providing a payload capacity of 1400 pounds.

Also included in the 4wd package are 15-inch, all-weather tires on 5.5-inch wheels (radials on the King Cab); free-running front hubs; skid plates for the gas tank, catalytic converter and transfer case; front and rear towing hooks and an eight-inch ground clearance. Body mounts are about an inch taller than on Datsun's 2wd pickups, accentuating the tall look.

Inside, you get bucket seats (a bench is slated for later models), tach, voltmeter, oil-pressure gauge and 4wd indicator light. As in 2wd models, the Datsun 4x4s come in short- and longbed versions, with standard or King Cabs.

The King Cab boasts a five-speed overdrive transmission; standard-cab models use the four-speed. Air-conditioning, fancy interiors and several stereo options are all available in the new 4x4s.

Racer Jim Conner also sells two stages of off-roading equipment for

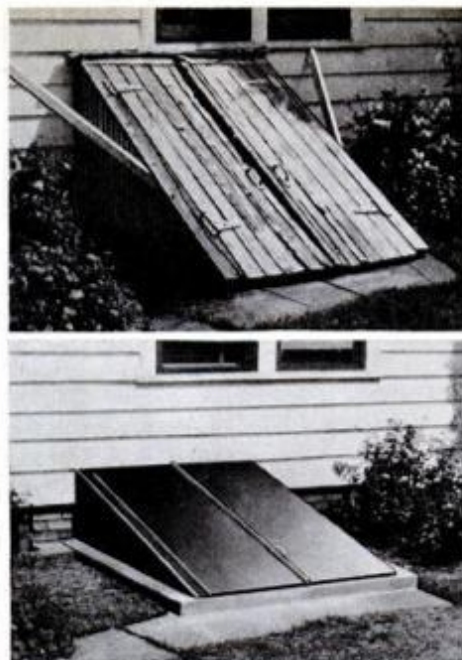

What a difference a Bilco Door makes!

Replacing that troublesome old wooden door with a modern BILCO Basement Door will add new beauty and convenience to your home. You'll like its neat, trim appearance and rugged construction. Long lasting, watertight, safe and secure, it pays for itself in savings on repair and replacement costs. ■ Ease of operation is a special BILCO feature. Torsion rods provide effortless opening and closing of the heavy gauge steel doors. ■ A BILCO Basement Door is also the ideal addition to your present home or the home you're planning. It saves tracking through first floor rooms, makes the basement useful, convenient, safe. Just like adding a whole new floor of valuable living space.

Bilco

AMERICA'S FINEST
BASEMENT DOOR

The BILCO Company Dept. PM60
New Haven, Connecticut 06505

Please send me:

- Information for replacing a wooden door.
 "How-To" booklet for adding outside entrance to present home.
 Data for new home to be built.

Name _____

Address _____

City _____

State _____ Zip _____

these burros—equipment that most Datsun dealers stock. The first stage uses heavy-duty, single shocks and wider radial tires. The second stage offers twin shocks and competition tires. Also available are additional underbody protection and urethane fender flares.

Driving these beasties

Two things need to be improved in the Datsun 4x4. First, there's an awful lot of steering feedback from the big front tires. Several drivers ended up with skinned knuckles as a result of the steering-wheel being wrenched from their hands. Crawling over rocks and rills causes the wheel to want to go its own way. Datsun needs to offer power steering for these 4wd pickups—an option that's under consideration.

The second problem involves engine power and final gearing. The two-liter (1952 cc) sohc Four might be rated at 92 hp net, but it doesn't feel that strong on the highway.

At 55 mph, pulling 4257 pounds (unloaded) and a 4.375:1 axle ratio, there's just not enough power for comfortable passing in direct two-wheel drive. I piloted a standard-cab, shortbed Datsun 4x4 back from Valle de Trinidad to San Diego, Calif., got caught behind several trucks and just couldn't find long enough open stretches to pass. And on freeway upgrades, forget passing altogether.

The 4x4 does a fine job at low speeds in the rough, but how often does the average driver travel in Baja-like surroundings? Most likely, he'll spend 99 percent of his time on pavement, and that's where this 4x4 falls short.

I had no problem off-roading. The front hubs lock manually, which means you have to climb out of the cab to get at them. Fine—no quibble with that. The transfer case has four gear-lever positions: 2wd, 4wd high, neutral and 4wd low. In low range, the Datsun is willing, and often able, to tackle sheer cliffs, either up or down. Four-wheel-drive high gives good ratios for snow, mud and gravel roads.

All Datsun pickups come with reclining bucket seats, but the recliners can't tip back far enough in the conventional cab to let a driver really stretch his legs. In the King Cab, however, the seat does tip back far enough to give even tall drivers a comfortable driving position—and you can also order inward-facing, foldaway jumpseats for the kids.

The EPA says that these Datsun 4x4 pickups average from 19.9 mpg in the city to 27.3 mpg on the road, depending on which cab and transmission you choose. The King Cab, with its five-speed gearbox, yields better mileage than the rest, despite weighing slightly more than its shorter *compadres*. **PM**

SPECIFICATIONS—DATSUN 4x4

Engine type: Sohc Four, cast-iron block, aluminum head.
Bore and stroke: 85 x 86 mm or 3.35 x 3.39 in.
Displacement: 1952 cc or 119.1 cu. in.
Compression ratio: 8.5:1
Net bhp @ rpm: 92 @ 5200.
Net torque @ rpm: 112 @ 2800.

	4wd Shortbed	4wd Longbed	King Cab
Wheelbase	101.4 in.	110.8 in.	110.8 in.
Overall length	171.7 in.	187.0 in.	187.0 in.
Ground clearance	8.8 in.	8.8 in.	7.9 in.
Fuel capacity	13.2 gal.	16.9 gal.	13.2 gal.
GVWR	4257 lbs.	4347 lbs.	4371 lbs.
Payload rating	1400 lbs.	1400 lbs.	1400 lbs.

HE MADE ME A

ZOMBIE!

It started out innocently enough. Frank offered me a glass and said, "Try this, Margie."

I took a tentative sip. I found the taste dangerously exciting—a captivating blend of apricots and rum.

I knew I'd never be quite the same.

I beseeched Frank to tell me how he created this compelling concoction. That's when I saw the exotic-looking bottle with a label that read: HEUBLEIN ZOMBIE.

I knew that it was destined to become one of my favorite drinks.

And I'll always be grateful to Frank for giving me my first taste of how truly delightful a Zombie can be.



THE LIQUORS
IN IT

Zombie—made with Rum, Natural Flavor and Caramel Color
35 Proof © Heublein, Inc., Hartford, CT

\$2 REFUND
Look for our offer on specially
marked Lufkin packages at partici-
pating tool outlets. Offer ends Nov. 30, 1980.



We wouldn't trust this job to anything but a Lufkin.[®]

My kids will play on this patio when it's finished. My wife will barbecue on it. And rock the baby carriage on it. That's why we won't trust this job to anything but a Lufkin measuring tape made by Cooper the Toolmaker.

Like this Lufkin Mezurlok.[®] It has a positive lock so the blade won't creep while I take my measurement and throw the job a little bit off.

And a patented bumper that helps keep the tip from breaking off.

Plus they made the case from the strong stuff football helmets are made of, so it'll be hard to break—even if I drop it, or step on it.

They've also made Lufkin tapes easier to locate in your local store. Because now all the quality tools from Cooper the Toolmaker are together in one spot: the Cooper Tool Center.

Look for Cooper next time you need tools you can depend on.



Boker • Crescent • Lufkin • Nicholson • Weller • Wiss • Xcelite
Friends you can trust...from Cooper the Toolmaker. 

of a voltmeter calibrated like a fuel gauge—F to E—and a d.c. ammeter. The ampere gauge indicates when the batteries are fully charged during plug-in periods.

The rest of the dash contains conventional auto controls like windshield wipers, defroster, headlights and high beams, directional signals, horn and heater.

Driving for two cents a mile

Despite its limited range of 40 miles, and its low top speed of 38 mph, learning to live with the Comuta-car is a remarkably pleasant experience.

The routine of plugging in every night and checking the electrolyte once a week becomes second nature very quickly. Unlike a gas engine, it has no sparkplugs to clean, oil to change or timing to be set. And best of all, you will never have to worry about the engine not starting. As long as the batteries are charged, you're always ready to go.

The greatest satisfaction of electric-car ownership is knowing you will never have to stop at a gas pump. Instead, you have the convenience of plugging in at your home

outlet. No special wiring is needed because the Comuta-car is charged on regular house current. And the cost? It's about the same as running a 40-watt bulb all night. In New York that works out to about 80 cents per charge. Given the 40-mile range the net cost per mile is *two cents*.

During the time that we had the electric car, my wife Lillian and I almost ignored our regular car. The Comuta-car fulfilled almost all of our local transportation needs and we only fired up the gas burner when a long trip was called for.

Ideal urban car

The Comuta-car, or any limited-range electric car, is an ideal urban car. Where a gasoline-powered car is most inefficient, stop-and-go driving, an electric is very efficient because it uses no power while stuck in traffic or waiting for traffic lights.

Because of its size, it can fit into parking spaces that are too small for even the tiniest subcompact cars. In addition, there is enough room behind the two seats for four grocery bags, which makes it great for shopping.

For short-range hauling, this little wedge has got to be one of the cheapest modes of transportation. But if you're thinking of buying one, my only word of caution is don't stray far from home.

For more information about this car, contact General Engines Co. Inc. 591 Mantua Blvd., Sewell, N.J. 08080. **FM**

A HANDSOME HYBRID

(Continued from page 87)

springs instantly into motion, accompanied by the quiet hum of an express elevator and the loud clicking of relays.

The Hybrid, rushed to completion, still has a few bugs in it. One is the noise. The gasoline engine sounds like a lawnmower and the clicking of the relays is annoying. Both can be easily remedied, however. The car also needs a buzzer to warn that the electricity is on, so the driver doesn't accelerate unless he means to go, and to warn him to turn it off again before exiting the car.

The dual capability of the Hybrid seems to be the perfect answer to the limitations of pure electric cars. While it won't free us completely from dependence on oil, it is certainly a step in the right direction.

Now, since Briggs and Stratton doesn't plan to manufacture the Hybrid, we'll just have to wait for a large auto manufacturer to produce it.—Virginia DeMoss

CRUEX®
RELIEVES
JOCK ITCH
 Chafing, Rash and Other Annoying Groin Irritations.

Itching? Chafing? Rash? Get fast relief with Cruex, the leading Jock Itch product in America. Cruex soothes. Relieves. And it's medicated to fight the causes of Jock Itch.

Use medicated Cruex spray powder or squeeze powder for easiest application, or Cruex cream for more concentrated medication. Use only as directed.

Get Cruex. There's nothing like it for Jock Itch.

© PENWALT CORPORATION 1979

ETHANOL CHEMURGY CORPORATION RELEASES IMPORTANT INFORMATION

HOW TO RUN Energy News YOUR AUTOMOBILE ON ALCOHOL FOR 10¢ TO 20¢ PER GALLON.

Did you know that:

- Nearly everyone can, with the proper permits, manufacture their own alcohol as a fuel.
- You can immediately run your car on alcohol with no major adaptations.
- You can produce alcohol fuel for a cost of 10¢ to 20¢ per gallon and up.
- Alcohol is an anti-knock agent.
- Engines run smoother with no crank case dilution.
- You do not have to pay \$1.00 per gallon to run your present automobile.

Instructions are available on how to build your own backyard still, providing you receive the necessary permits prior to constructing the still. The projected cost is around \$100 to \$150 and the still should produce 10 to 20 gallons per day.

For more than fifty years countless individuals have produced alcohol and used it as a fuel for internal combustion engines. These engines have worked superbly. Here are just a few of the many advantages of using alcohol as a fuel:

Using alcohol, an engine will develop 30 percent more power. Engine operation is smoother, and alcohol lets your engine operate under heavy loads and low speeds without "bucking." Alcohol also serves to loosen carbon accumulations.

Alcohol can be produced in a SOLAR STILL from grains, sugar beets, molasses, lawn clippings, weeds, sawmill waste, vegetables, fruits, etc.

For a limited time, Ethanol Chemurgy Corporation will send to all interested individuals: (1) A copy of their findings on alcohol as a fuel for internal combustion engines, (2) Instructions on where to apply for a permit to manufacture your own alcohol as a fuel, (3) Complete schematic drawings and instructions on how to build an inexpensive SOLAR STILL that you can put together in one afternoon, (4) A list of materials needed for the SOLAR STILL with approximate costs, (5) Basic recipe for producing your

own alcohol fuel, and (6) Information where you can obtain more literature on alcohol as a fuel.

To obtain this information, mail the attached order blank with a check or money order for \$9.95 payable to Ethanol Chemurgy Corporation, Dept. M-6, P.O. Box 220, Orem, Utah 84057. We will bill through your VISA or Master Charge account if you prefer. Or, call toll-free 1/800/528-6050, Extension 1020, and your order will be processed within 12 hours. Please have your VISA or Master Charge handy when you call. This information carries a 30-day 100% money-back guarantee.

Order toll-free by phone:
1/800/528-6050,
Extension 1020
Or mail this no-risk coupon:
Ethanol Chemurgy Corp.
Dept. M-6 • P.O. Box 220
Orem, Utah 84057

I'm enclosing \$9.95 check or money order. Please rush me the alcohol fuel information described above.

Name _____

Address _____

City/State/Zip _____

Please charge my order to
VISA or Master Charge.

Account Number _____

Expiration Date _____

Holder's Signature _____

NEXT MONTH IN PM

- **Ultralight revolution**
the homebuilt aircraft.
- **How to choose an**
inflatable boat.
- **Great 'stained glass'**
works that anyone
can produce.
- **How aerial fireworks**
are put together.

SUBSCRIPTION SERVICE: Popular Mechanics Magazine will, upon receipt from its reader of a complete new or renewal subscription order, undertake fulfillment of that order so as to provide the first-copy delivery to the Postal Service within six to twelve weeks. If for some reason this cannot be done, you will be promptly notified of the issue date that will begin your subscription, with a request for any further instructions you may have concerning your order. Please address all such orders to us at Popular Mechanics, P.O. Box 10064, Des Moines, Iowa 50350. Should you have any problems with your subscription, please write or call Joan Harris, Customer Service Department, Popular Mechanics, P.O. Box 10064, Des Moines, Iowa 50350. Telephone: 800-247-5470. State of Iowa residents call 800-532-1272. To assure quickest service, please enclose your mailing label when writing to us or when renewing your subscription. Renewal orders must be received at least eight weeks prior to expiration to assure continued service.

Popular Mechanics

P.O. Box 10060, Des Moines, Iowa 50350

YES! Please enter my subscription to POPULAR MECHANICS for:

- 1 year \$8.97
 2 years \$16.97

Payment of \$ _____ is enclosed.

Bill Me _____
initial here

Name _____ (please print)

Address _____

City _____ State _____ Zip _____

Your first copy will be on its way to you in six to twelve weeks. Watch for it!

Charge orders subject to publisher's acceptance.

(Above prices apply in U.S. & Possessions only. All other countries add \$6.00 per year.)

CHANGING ADDRESS?

If you're planning to move, please let us know at least eight weeks before changing your address. Attach current address label and fill in your name and your new address. This will serve to insure prompt service on your subscription.

Send old label with your name
and new address to:
POPULAR MECHANICS
P.O. Box 10064, Des Moines, Iowa 50350
or call toll free 800-247-5470
(State of Iowa residents call 800-532-1272)

NAME _____
(Please print)

NEW ADDRESS _____

CITY _____ STATE _____ ZIP CODE _____



“485 miles of land didn’t stop the U.S. Coast Guard when my town went under water.”

The folks in East Grand Forks, Minnesota are used to floods. Perched at the meeting point of the Red and Red Lake Rivers, they get a big one every spring as the snow swollen waters run into ice blocks up north. But the town’s mayor, Louis Murray knows how to handle it. As soon as the rivers begin to rise, he sees that the U.S. Coast Guard is notified.

“It’s really terrific,” Mayor Murray says. “Call the Coast Guard up at 9:00 AM and they’re here right on time...some twenty of them with half a dozen boats and all their equipment loaded up on trucks...their expertise is certainly welcome.”

For two, sometimes three weeks, the Coast Guard helps East Grand Forks fight their annual flood. They sandbag dikes, run a ferry-boat service between strategic points and rescue people—not to mention an occasional dog, cat or chicken—who have been stranded by the water.

The Coast Guard stays until



Mayor Louis Murray

the flood waters subside and everybody is safely returned to their homes. And East Grand Forks is grateful. As Mayor Murray puts it, “I don’t know what we’d do without the Coast Guard.”

But it’s all in a day’s work when you’re in the Coast Guard—protecting lives, helping others. Whether it’s fighting floods in East Grand Forks, Minnesota,

**HELP OTHERS. HELP YOURSELF.
THE COAST GUARD.**

preventing an oil spill in the Caribbean, or enforcing federal laws in our coastal waters. And when it comes to helping yourself, there are a lot of great jobs in the Coast Guard. In fields like electronics, mechanics, navigation, aviation, communications and seamanship. And the Coast Guard gives you all the training you need to get your career off the ground.

If you like the idea of helping yourself while helping others you’ll like the Coast Guard.

Coast Guard Opportunities

Post Office Box 3798
Abilene, Texas 79604

Please send me more information about the opportunities for men and women in the Coast Guard.

- Regular Enlisted Coast Guard O.C.S.
 Coast Guard Reserve Academy

Name _____ Age _____

Street _____ Apt No. _____

City _____

State _____ Zip _____

Phone Number _____

For more information send in the coupon or call toll free: 800-424-8883 except in Alaska, Hawaii or Washington, D.C.

56060



**Gold
Silver
Jewelry
Coins
Relics**

TECHNA

Can Put You in The Picture

Lost and hidden valuables are buried all around us! The Techna XR9, a sophisticated Transmitter/Receiver metal locator, reaches thru dirt, sand, even solid rock to help you *find* those valuables! And with Techna's unique (Patent Pending) Dual Phase Discrimination system, you don't waste time on junk! Everytime you discover something, the XR9's micro-computer circuit instantly analyses the find and flashes a *Green* indicator light for coins, jewelry, and other valuables, or a *Red* indicator light for nails, foil, bottle caps, and other junk!

With the XR9 you can find a *single* coin up to 10 inches deep, a bag of coins up to 2 feet deep, and larger objects up to 6 feet deep!

The XR9 is ruggedly constructed with an all aluminum case and control deck. Detector indication is with a large viewmaster meter, clear-tone loud speaker, and the exclusive Dual Phase lights. Features include built-in battery tester, headphone jack, comfortable hand grip, and adjustable aluminum stem. Tuning is fast and easy for anyone.



**TELL TREASURE
FROM TRASH!**

Whether for family fun or serious treasure hunting, XR9 is the one! If you are not entirely pleased, return the unit within 30 days for a full refund. Comes with Full one year Limited Warranty (Copy on request) and complete instructions.

TO ORDER: Send check or money order For \$189.95, plus \$6.00 for shipping and handling To:

DESIGN FORMAT, 11900 Montana, El Paso, TX 79936.

THE PM GARAGE

(Continued from page 12)

and inconvenience of large commercial units. Black & Decker has solved the problem with a compact plug blaster that offers the same results as larger units. And the best thing is you can plug it into the cigarette-lighter socket of your car. That means you can do all the plugs right on the fender without any running around.



Compact sparkplug cleaner gives professional results, plugs in lighter socket.

The plug blaster comes with enough grit for a dozen uses and a plug-gapping tool. It costs about \$20 and is available at auto-parts stores or in the auto departments of general merchandisers.—T.A.

Helmet security

At last you can leave full-face helmets with your motorcycle and rest assured that it will still be there when you return. A device called the



HelmetLock has room for two helmets and folds out of the way when it's not in use.

HelmetLock by CycleTogs clamps onto any tube on the bike and lets you lock the helmet in place. It uses triangular-headed bolts, which can't be removed without the use of a special tool that's supplied with the unit. It is priced at \$19.95, and is available from CycleTogs International, Box 19414, Portland, Ore. 97219—T.A.

Thousands across nation using Ohio man's sure-fire way to get rich quick

Are you an 8 hour a day working person? Do you have little or no savings in the bank? Are you in debt with mortgage, car payments and charge accounts? Do you have little experience at anything except the small specialty of your job?

If you've answered "yes" to all these questions, you are a prime candidate for a foolproof get rich quick system developed by a working man from Canton, Ohio. His name is Benjamin Swarez and he was in your exact same position not long ago. But, he changed all that by inventing a get rich quick system designed especially for the working man.

How did this system come about? You probably already know about Mr. Swarez and his system. Ads on his system and stories about Mr. Swarez have appeared in nearly every major newspaper and magazine in the country. Thousands of people across the nation have purchased the system and the stacks of letters from satisfied customers received by Mr. Swarez are overwhelming.

Mr. Swarez did not develop his system overnight. But his final, perfected version certainly does generate income overnight.

Mr. Swarez's first successful system netted him \$80,000 clear. What's it like to get \$80,000 almost overnight in one lump sum?

"It's almost impossible to verbalize. My wife and I just stared at the check for a long time. We had a two day celebration with a dinner and party. Then I went into work and told my smug boss, who thought he had me under his thumb, where he could stick his low paying, lousy job. Next we paid off all our bills including our house mortgage and had a burn-the-mortgage party.

The following day we went to an auto dealer's showroom and laid down cash for a new luxury car. I never had the experience of a new car even as a child."

"Then my wife and I went on a shopping spree for clothes. We had been making do with old clothes for so long they had become worn out. She always had to shop for clothes with very little money. I always joked with her that 'If I gave you \$5,000 to spend on clothes could you do it in one day?' She used to say 'I could do it in a couple hours.' So that's what I did. I gave her \$5,000 to go out and buy clothes. It ended up taking all day and she said she relished every minute."

"Finally, we took a long trip. In New York I bought her a large diamond at Tiffany's — another thing we always dreamed about."

"But I can tell you that the money was not the most important benefit in this. What money really does is give you precious time. Time to be with your wife and children before they grow up before you know it — and time to do things you really want to do. Another priceless thing you gain is your self respect. No more crawling and kneeling because you're dependent. The words of Frank Sinatra's song 'My Way' says it all."



Benjamin Swarez

How much money can you make and how fast can you make it? Mr. Swarez averages around \$200,000 for each system he produces. He says doing a system to make \$10,000 or \$20,000 is literally duck soup. "I

have these available to me all the time and don't even use them," he says.

How fast can you make money? Mr. Swarez stated, "You can actually make money within hours in some cases. You can compile a system in one afternoon one day and start having spendable money in your hands produced by the system the very next morning."

Who all can do it and how sure fire is it? Mr. Swarez says, "I've done it 14 times in a row now. I taught my younger brother and brother-in-law the system and they've already made over \$500,000 each. All you need is the ability to follow simple directions, common sense, and the ability to see a job through to completion."

This system is also perfect for people who are confined to homes, such as housewives. Mr. Swarez named his system "7 Steps to Freedom". He has been selling his system to others for a year now. The reason? "Why not?" he says. "First I thought I'd have to keep it secret. But then I found out the system can't be saturated, so why not sell it and make money by selling the system on top of the other money I am making using it."

People from every state in the union have purchased Mr. Swarez's system. What do these people have to say? Here are just a few comments:

"... It is such an excellent product that anyone who can read and follow instructions can be a millionaire. ..." — William J. Bontrager, Peoria, IL

"... This is the first time I have purchased a 'get rich' product that I sincerely feel will work." — Earl J. Davis, Chicago, IL

"... Adjectives alone cannot describe its hidden wealth. After many years, much money and a bellyfull of frustration, I believe I have found an honest man, and yes I truly mean it." — John T. Vaughn, Norridgewock, ME

"I have just received your system and have taken it to college. It has really lifted some eyebrows especially the first and last parts..." — Mark Kimble, Rockhill, SC

A word to the doubting Thomases. Of course there will be those who will doubt that the system is for real. Mr. Swarez has featured this system in nearly every newspaper in the country and he has sold his system to thousands of people across the nation and in every state of the union. The story has been checked repeatedly by newspaper reporters and government authorities at literally every level. The story checks out. Every word he has stated about his system is true or he would've been out of business long ago.

You can make \$100,000 in a matter of weeks or days. In some cases money starts in hours. Here's how it works...

1 You will receive Mr. Swarez's system in the mail which contains everything you need to complete one of your own systems. From anywhere, such as your kitchen table, you complete the preliminary steps. This involves filling out provided forms and following provided outlines.

2 The preliminary steps of the system are done only one time. After these preliminary steps, you can do the steps for each individual system anywhere, from your home, while you are traveling. (Mr. Swarez does his individual systems in his motorhome) or from a favorite vacation spot. Again, by following outlines and filling out forms, you complete your individual system (each of which is in two parts, Part A and Part B).

3 After completing Part A and Part B of the System, depending on the type of system you do, you may either phone in Parts A and B of your individual system, or you drop it in the mail. In the type of systems where you phone in Parts A and B, you can virtually complete a system one afternoon and have spendable money in your hands the very next morning.

4 In a matter of days or weeks, depending upon which system you do, you can receive \$100,000 for each system. In some cases, over 80% of the money will be in your possession in less than a week. Your money will either be deposited in your bank account or brought to you by mail to your home or your vacation spot.

For those who wish to purchase the N.P.G.S. System, called "7 STEPS TO FREEDOM", it is being distributed by mail only for the present. Mr. Swarez has kept the price of the system low so those who most need it can afford it.

To order: (1.) Get a blank piece of paper (2.) At the top of the paper, print the words "7 Steps to Freedom" (3.) Print your name and address (4.) Mail this along with \$20.00 in cash, check or money order to Quality Consumer; Dept. G-168 ; 706 Twelfth St. N.W.; Canton, Ohio 44703.

Or, if you want us to start processing your order immediately, phone in your order as follows: (1.) Dial this TOLL FREE number, 1-800-321-0888 (Ohio residents dial 1-800-362-0636) and ask for operator G- 162 ; (2.) Say the words "7 Steps to Freedom, N.P.G.S. system" (3.) Give your name and address (4.) Give the operator one of your following credit card numbers: Master Charge or Visa (also include your Interbank number). Or, if you don't want to use a credit card, tell the operator you want it mailed C.O.D. Operators are on duty right now and around the clock.

Direct any inquiries to (216) 452-0868. Please do not dial the toll free number for information. The operators are not permitted or qualified to answer questions.

Best knots for the new fishing lines

Four combinations fit to be tied for a tight, no-slip grip on the latest synthetics.

by Homer Circle

Here are four hot knots selected especially for the tough new fishing lines now being introduced. Improved plastics are making the latest lines tougher, longer wearing and more abrasion resistant, but some knots can slip and come untied or reduce rated test strength by cutting through as they tighten.

Many record fish have been lost because a knot failed at a crucial moment. An angler can buy the newest technology in fishing line, but it will only be as good as the knot that connects him to his catch. If your pet knots have never failed, fine. Try them with the new lines. A good test is to tie your knots on one lure and the ones shown here on another. Pull them against each other; then you can be certain. My four favorites should fill most fishing needs.

Bimini twist

The Bimini twist is my choice when you are fishing the newly popular ultralight tackle and using

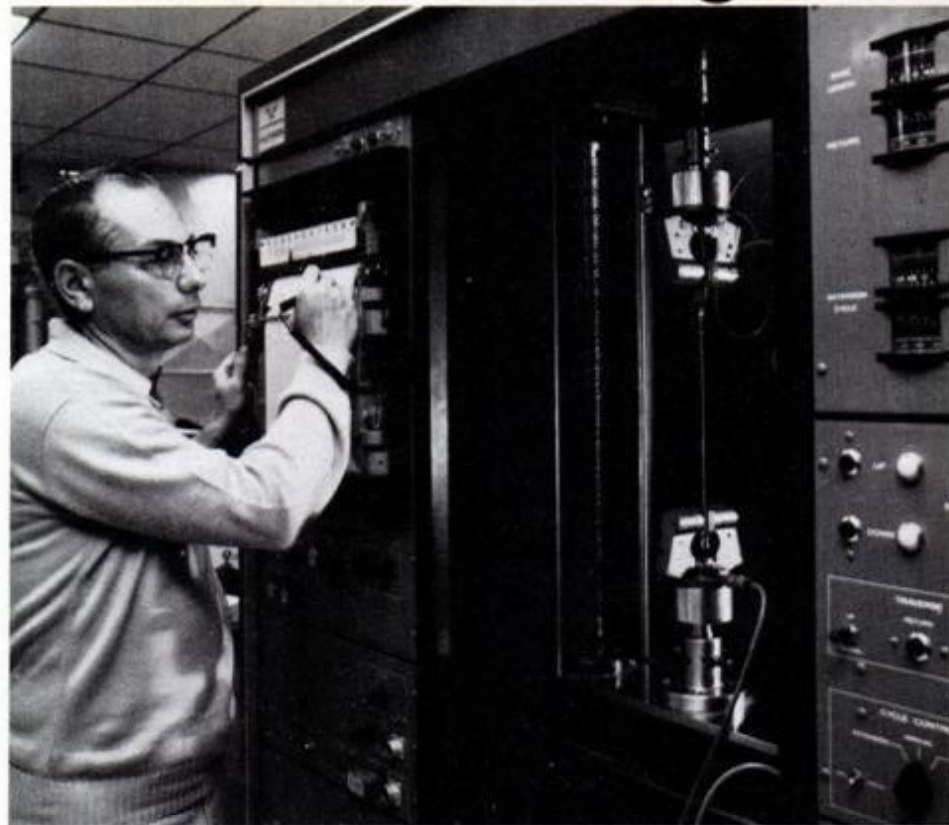

Testing Stren monofilament line, DuPont's Instron machine records break strength.

light lines which might break. It enables you to double the strength of the terminal end of your line. The knot originated in saltwater, is offi-

cial for record catches, and tests 100 percent of your line's pound-test.

It looks complicated, especially if

(Please turn to page 180)

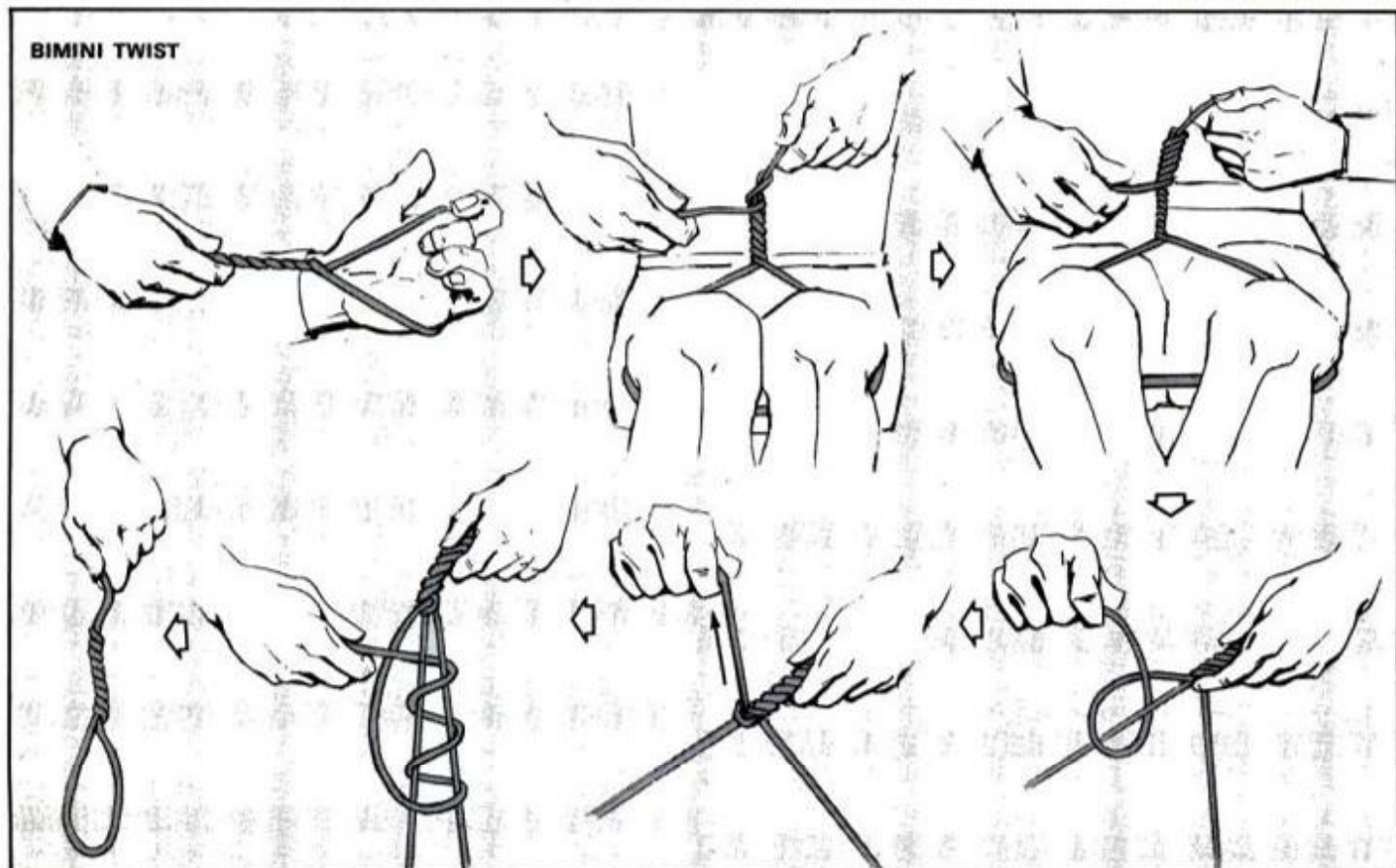

BIMINI TWIST



Imagine. An oil that goes 25,000 miles without a change.

Mobil 1* synthetic motor oil is the oil that saves you gas. It's also the oil that saves you oil changes.

Because with Mobil 1 you can go an incredible 25,000 miles or one year whichever comes first on one oil change.*

Now that's one incredible claim. But that's only fitting. You see, Mobil 1 is one incredible oil.

Mobil 1 lubricates better than premium oils to help your engine

run smoother and last longer.

And because it's a synthetic oil, Mobil 1 doesn't break down as fast. And that means you can go longer—a lot longer between oil changes.

Imagine an oil that goes 25,000 miles between oil changes and saves you gas to boot.

We can't imagine why someone would use anything else.

Mobil 1 The oil that saves you gas. And more.

*Adding oil as needed. New car owners follow warranty requirements. Diesel and Turbo owners follow manufacturer's instructions. © 1980 Mobil Oil Corporation.

Материал, защищенный авторским правом

Doctors Prove You Can Help Shrink Swelling Of Hemorrhoidal Tissues Due To Inflammation. Relieve Pain And Itch Too.

Gives prompt temporary relief from hemorrhoidal pain and itch in many cases.

Doctors have found a most effective medication that actually helps shrink painful swelling of hemorrhoidal tissues caused by inflammation. In many cases, the first applications give prompt relief for hours from such pain and burning itching.

Tests by doctors on hundreds of patients showed this to be true in many cases. The medication the doctors used was *Preparation H*[®]—the same Preparation H you can get without a prescription. Ointment and suppositories. Use only as directed.

BEST KNOTS FOR NEW FISH LINES

(Continued from page 178)

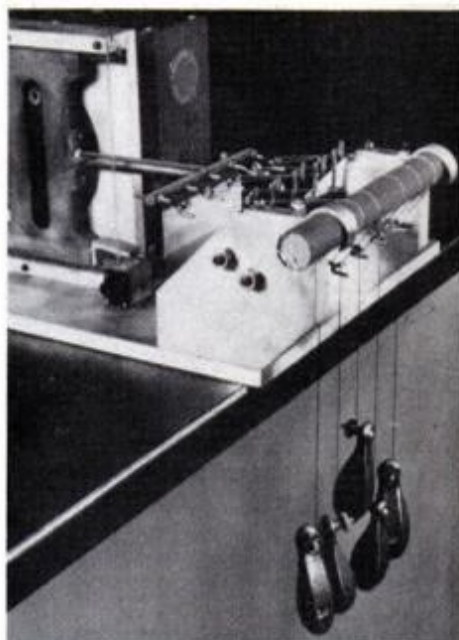

Abrasion resistance of new lines is found by pulling over sandpapered dowel.

What you don't know about these water and fuel savers could cost you over \$200 a year!



Easy-to-install kit dramatically cuts water and fuel costs!

Only \$29.95
plus \$2.50 handling

SHOWER

Patented shower head offers a forceful, pleasantly tingling shower, but uses only 2.1 gallons of water per minute rather than the 5.8 used with common shower heads, reducing those water and heating fuel costs up to 60%!

FAUCETS

Bath and Swivel-Kitchen faucet aerators cut water use from 3 gallons to 2.2 gallons per minute at normal household pressure. Fuel and water savings of up to 50%!

Figures above are based on average water and water heating usage for a family of four.

TANK

Toilet tank water saver cuts water use from 5.7 gallons per flush to only 3.3½ gallons per flush without loss of pressure! Saves up to 20% on water bills.

Don't wait, call toll free!
800/323-5038

In Illinois call (312) 272-3270 collect to place an order on your Visa, Master Charge or American Express.

Or send \$29.95 plus \$2.50 for shipping and handling to:
Resource Conservation Technology

P.O. Box 248, Northbrook, IL. 60062.
Illinois residents add 6% sales tax.

NO RISK! Refund if not totally satisfied, return within 15 days of receipt of product. If further information is desired, please write or call the above for complimentary brochure.

you're a tad fumblefingered, but it's worth the practice.

Double the end of the line to form about a 2-foot loop. Place loop over one hand and rotate it 20 times to put twists in line.

Holding in the twists, place your knees together and put the loop in the line over them. Hold tension on the main line as you pull back and down on the tag end, letting it drop over the twists.

Spread your knees apart, increasing tension, and pull slightly downward on the tag end as you increase knee pressure. As you ease tension on the tag end, it will wrap down over the twists entirely.

Place your index finger in the "V" of the loop and throw a half hitch over one side of the loop. Pull half hitch up tightly. The twists are now secure so you can relax pressure.

Make a three-wrap hitch around both lines and pull up snugly. Clip off the tag end right against the knot. With practice, you can vary the loop size to fit your needs.

Brinson knot

This knot was impressed upon me by another knothed, Billy Brinson, a fishing guide at Santee Cooper, S.C. It broke all my other pet knots, so I've been using it since. It tests to 95 percent plus of line strength.

First, insert the line through the eye of the hook; do it again to make a double loop. Lap a loop with the tag end against the standing line, holding it with thumb and forefinger. Make five wraps with the tag end

(Please turn to page 182)

STOP CAR THEFT— AUTOMATICALLY

Your car is an easy mark for the joy-riders and small-time strippers who account for 70% of all auto thefts. Locked car doors can be opened quickly and easily with a slim-jim. Ignition locks can be defeated with a slide-hammer in as little as 30 seconds. In other words, a thief can break into your car and drive it away without much risk of attracting attention. After its last ride, your car will be stripped and abandoned. That's a high price to pay for being a little easy.

What Can You Do? Until now, there wasn't much of a practical solution to the problem. You had to turn your car into a rolling electronic fortress to get the protection you wanted. That meant drilling holes, mounting locks, adding switches, stringing wires, and installing ugly alarm boxes. That's a lot of work, and a big mess.

Which Mess Is Best? In spite of the inconvenience, you still may not get the theft protection you want. What if you get lazy about turning the alarm on and off—especially when the weather is bad and you're "only going to be in the bank for a minute." A system that drains your car battery of its starting power while it's on standby isn't really protection at all. And, a sophisticated system that sounds off whenever a loud truck rolls by or when there's a random voltage drop in the car's electrical system doesn't exactly inspire confidence. After a few dozen false alarms, your neighbors may be convinced that you and your car are safer without an auto alarm.

In fact, with most auto alarm systems, the best thing you can hope for is to mess up your car's electrical system and appearance so much that nobody will want to steal it—or own it. What you need is a simple, effective alarm system that will discourage the would-be thief without discouraging you. You need to get ARMED™, the mobile alarm that won't mess up your car or your life.

Why? ARMED™, the ultimate mobile alarm, is a creation of computerized digital electronics, and it can think for itself: it doesn't need to be turned on or off. That means no added locks or control switches, and that means **no drilling**. Once the alarm is installed, you'll never see it or touch it. In fact, the ARMED™ alarm is so sophisticated that it has been granted 8 claims to patent by the U.S. Patent Office.

What Does It Do? Here is how the ARMED™ system works. When your car door is opened, ARMED™ begins counting down an owner adjustable Entry Delay. This Entry Delay allows you

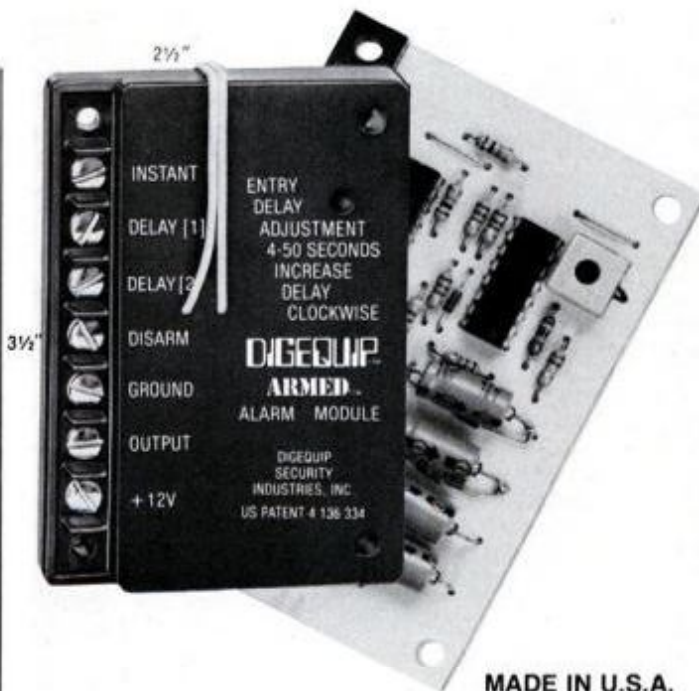

MADE IN U.S.A.

to enter your car and use your key to turn the ignition "on" (or to "ACC"). This stops the Entry Delay countdown and disarms the alarm. In other words, you enter, start, and drive your car as always. **When a thief breaks into your car, the Entry Delay will elapse and the alarm will begin sounding before he can break the ignition and manipulate it into an "on" condition. The alarm will attract attention and scare the thief away. The last thing these opportunists want is attention. Even if all the doors are reclosed, the alarm will sound for two minutes and then reset itself. If a thief decides to come back, he will get the same treatment.** When you turn the ignition off, the ARMED™ alarm begins an Exit Delay countdown of two minutes. This should be enough time for you and your friends to exit comfortably and close all doors. If you need more time, simply leave the ignition in the "on" position until the car is unloaded. At the end of the Exit Delay, the alarm sets itself and goes into standby condition, waiting to validate the next entry. You get constant automatic protection and freedom from extra locks and switches.

Inconspicuous Consumption: The ARMED™ alarm will not give you a dead battery. In standby condition, ARMED™ consumes only 1 microamp of current. At that rate it would take 2,000 years for ARMED™ to drain a typical car battery of its starting power. Statistics show that most cars won't even last that long.

Flexibility: The ARMED™ alarm is extremely versatile. It will accept addi-

tional **instant** alarm triggering from many sources, such as switches on hoods, trunk lids, glove boxes, storage compartments, gas flaps, CB's, sound systems, or any other equipment or enclosure you wish to protect. ARMED™ will also accept instant or delayed alarm triggering from seat switches, motion detectors or similar devices. The alarm output will activate any relay-controlled car horn or other type of noisemaker.

Easy to Install: The ARMED™ alarm was designed for the do-it-yourselfer. **No drilling or other vandalism is required.** The alarm module splices easily into the wiring system found in most cars. All connections are made with simple snap-on wire splicers, and a complete, fused, alarm wiring harness is supplied. Every clearly described installation step includes a built-in self-test to prevent mistakes. Even the test light is included. The alarm module has an adhesive backing for quick, secure, concealed placement under the dash.

Hi Tech = Low Price: In today's market the consumer is offered more technology for less money than ever before. The ARMED™ alarm (AL3B), complete with detailed instructions, fused wiring harnesses, snap-on splicers, test light, and window decals costs only \$49.95. That's cheaper than many less intelligent alarm systems; it's certainly cheaper than another car. For some Fords and a few imports without the necessary horn relay, a convenient relay package (RK1A) is available for \$9.98.

Discouragement Plus! Now you can add a new dimension to ARMED™ protection. Engine Lock™, the ultimate accessory, will not allow your car's engine to start once the ARMED™ alarm has begun sounding. Even though the alarm resets, Engine Lock™ will not release until the hidden remote reset is activated. You hide the remote reset wherever you like, and you'll never have to touch it unless someone has tried to steal your car. In that case, you'll be grateful for the minor inconvenience.

An Easy Option: Engine Lock™ attaches easily to your ARMED™ alarm system, and everything needed for a quick installation is provided. Engine Lock™ can disconnect either the starter circuit, electric fuel pump, or electronic ignition, or it can close a fuel solenoid or short out a Kettering point ignition. But remember, Engine Lock™ gets its operating signals from the ARMED™ alarm module, so it cannot be used by itself. Yet it can be added to your ARMED™ system at any time. The Engine Lock™ module (EL1A), complete with instructions, connectors, wiring and remote reset is \$34.95.

Insurance Discounts Possible: ARMED™ is known in the auto insurance world as a PASSIVE alarm because it offers constant, automatic protection. ARMED™, especially when used with Engine Lock™, may qualify for the comprehensive discounts offered by many insurance companies for PASSIVE alarm systems. These discounts can go as high as 15%. Sometimes being passive pays off. Check with your own company to be sure.

Satisfaction Guaranteed: If you don't like what we send you, you can send it back within 30 days. Units found defective in materials or workmanship will be repaired or replaced without charge for a period of 2 years from date of purchase.

CREDIT CARD BUYERS CALL
TOLL-FREE 1-800-323-1717
ask for operator #27 and mention product numbers (in Illinois call 800-942-8881) or send check or money order including \$2.50 for shipping and handling (Tenn. residents add 6% sales tax) to:

Hi-Tech Marketing
2 Vantage Way
Nashville, TN 37228
a division of
Digequip Security Industries, Inc.

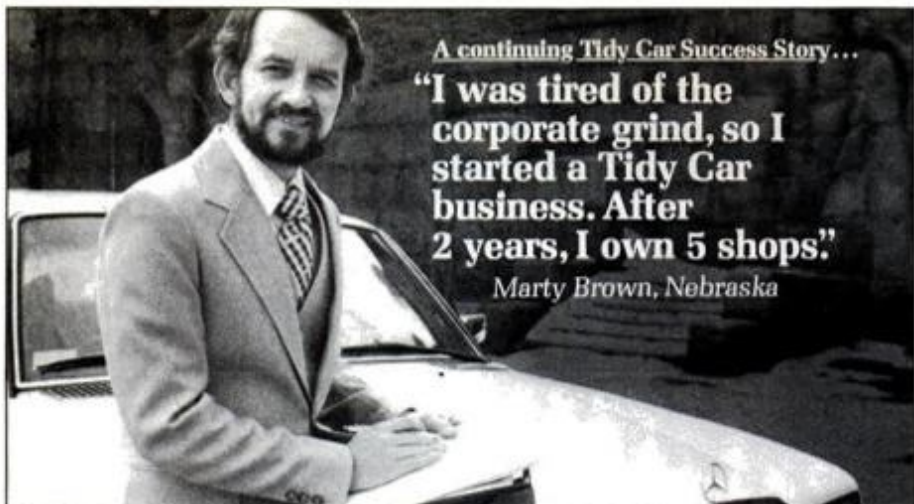

A continuing Tidy Car Success Story...

"I was tired of the corporate grind, so I started a Tidy Car business. After 2 years, I own 5 shops."

Marty Brown, Nebraska

Marty Brown's Tidy Car business has been a success almost from the very beginning. After only nine months in the business he started a second shop location. In two years he now has five Tidy Car locations, giving superior car appearance maintenance services to car owners throughout the Midwest.

Looking back a short two years, Marty still remembers working 65 hours a week in charge of cost accounting for a large company.

"I simply wasn't being compensated enough for the tremendous pressures of balancing budgets and preparing forecasts for 107 company branches," he explained. "Plus, when I considered the real hours I was working and the expense of my college education, it just wasn't worth it."

"I looked into starting my own accounting office, leasing vehicles, even owning a golf course. Then I read about Tidy Car."

Start for less than \$1500.

"The income potential was there... with almost no initial cash outlay. I could start the business for \$1500. I didn't have to borrow anything. In fact, I was able to generate enough income in the first three months to build my whole business."

"I don't shine cars myself anymore. In fact, after the first six months, I had eight operators working for me while I managed the business."

"What you know about cars initially doesn't matter so much as your ability

to manage. Tidy Car has a tested formula outlined in their owner's manual, so there's virtually no gamble to this business. There's nothing I've found to compare to it. The market is there, the numbers are there. People are keeping their cars longer so they need to maintain them better. We keep increasing the appearance maintenance services we provide.

"You can apply Tidy Car's Preserv-A-Shine® paint sealant; apply new car upholstery protection treatments; revitalize vinyl roofs; clean and protect fiberglass, plexiglass, you name it. And, while we're mostly talking about family cars, there's business in boats, RVs, even aircraft."

Mail Coupon Today!

The Tidy Car world-wide dealer network includes over 2,000 independent businessmen. If you'd like to join them, mail the coupon today to find out if you qualify. Find out more about how you can win with Tidy Car!

Gary Goranson, Pres.
Tidy Car Inc., Dept. PM6
3918 Broadway
Cheektowaga, NY 14227
(716) 856-2826



I'm interested in Tidy Car! Please send me your free 20-page brochure on how to win with Tidy Car!

Name _____

Address _____

City _____ State _____ Zip _____

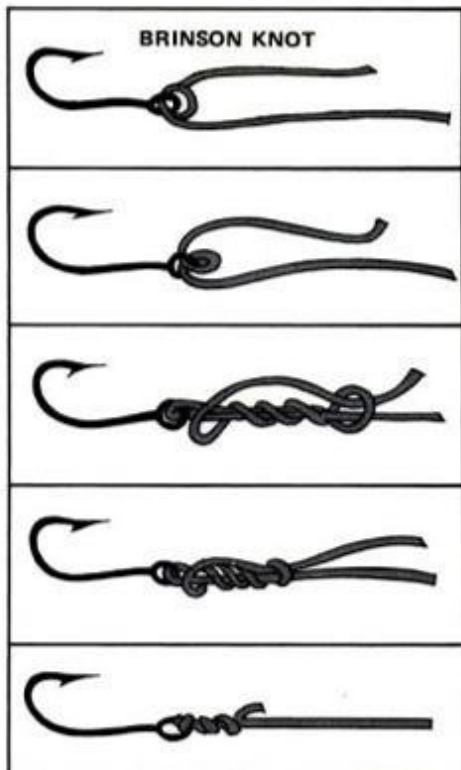

BRINSON KNOT

BEST KNOTS FOR NEW FISH LINES

(Continued from page 180)

and then run it through the loop.

Let the tag end hang free while you pull the hook and standing line in opposite directions. Loops should fold over themselves to form a neat, tapered knot against the eye of the hook. (Note: Occasionally, the loops just don't go together properly. You can tell because the knot will break as you snug it up tightly. Practice should enable you to do it properly nine times out of ten.)

Palomar knot

This knot, designed by a Californian named Chet Palomar, is so simple. (Please turn to page 184)

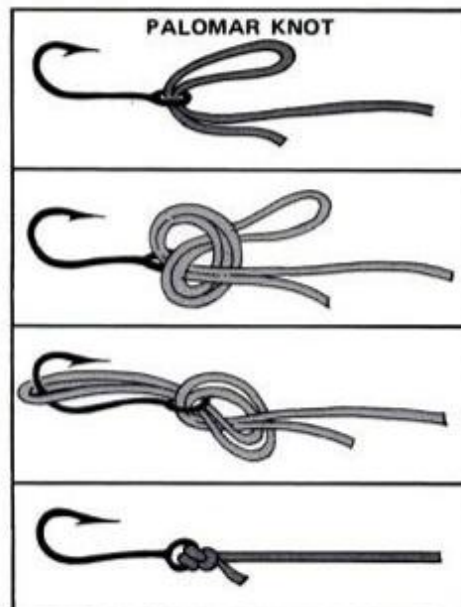

PALOMAR KNOT

BE A CHIMNEY SWEEP

Your Own Business: A chimney sweep can clean a chimney with the August West® System in one hour. Nationally, the average charge is \$40.00.

A Growing Need:

The energy crisis has resulted in a dramatic increase in wood burning. Wood smoke deposits (combustible creosote) in chimneys. Regular cleaning is necessary to prevent fire damage.

The August West® System:

More sweeps use it than any other method in the country.

Send for our free booklet, or call TOLL FREE any time and ask for "The August West Story."

800-648-5311

(In Nevada (800) 992-5710)

August West Systems, Inc.
Box 603 - Dept. PMR
Weyport, CT 06890



COIN GRAB BAG FREE!



GIANT SURPRISE COIN ASSORTMENTS packed grab-bag style from collectors* including rare, scarce and valuable coins up to 2000 years old! A real exciting treasure hunt; unsorted, unsorted—just as they are received—no 2 assortments exactly alike! Nobody knows what's in them, but each guaranteed to contain our guaranteed \$3.00 catalog value or more for only \$6.98 plus 75¢ p.p. each. Our Super Size \$18.00 minimum catalog value or more only \$13.49 plus \$1.00 p.p. each. FREE! Order 4 of either size, get 1 same size FREE! Ideal gifts for beginner or advanced collector. Handsome illustrated 32-page Guide, Catalog & Price List included FREE with order; otherwise 50¢.

*Partial List of Coins in Collections:
Half & Large Cents
Flying Eagle Cents
Indian Head Cents
Two Cents
Three Cents
Liberty Nickels
Shield Nickels
Buffalo Nickels
Half Dimes
Sealed Liberty 10¢
Barber Dimes
Sealed Liberty 25¢
Barber Quarters
Sealed Liberty 50¢
Barber Half Dollar
Walking Liberty 50¢
Civil War Tokens
Coins of the World

MATT NUMISS, Dept. PM6A, Great Neck, N.Y. 11022

HOW TO MAKE \$10,000 A MONTH AG FLYING!



**AND TAKE OVER SIX MONTHS VACATION A YEAR!
WITHOUT A COLLEGE EDUCATION OR EVEN A HIGH SCHOOL DIPLOMA!**

The pilot of the airplane in this picture can make \$10,000.00 in a month.

Sounds too good to be true, doesn't it? But I can make \$10,000.00 a month, and I never went to high school. So why can't you?

You don't need years of training to do what I do. You don't need large sums of capital. But there is a catch. You have to be able to fly an airplane. If you don't think you would like to fly—perhaps this is not for you.

But if you are already a pilot, or would like to become a pilot, then read on. This may be the best opportunity of a lifetime.

If you have a commercial pilot license, I can show you how you can prepare yourself to earn up to \$10,000.00 A MONTH, in just a few short weeks.

If you are not a pilot—don't despair—I will tell you how you can become one in 90 days or less!

Let me introduce myself: my name is Jim Ward. I have a very unusual occupation. My services are so much in demand that I can make \$5,000.00 to \$10,000.00 a month working four to six months a year. Then I take a six-month vacation!

I am an agricultural pilot. Ag pilot for short. Let me explode some myths about ag flying.

Perhaps you think it is dangerous? Wrong. There is no need for it to be dangerous, IF you have the proper attitude, and a little training in how to avoid the common hazards. I have been doing this work for over 23 years and I have never had any kind of accident! So, it can't be that dangerous, can it?

Maybe you have heard that it is a hard business to break into? Wrong again. I became an ag pilot just 20 days after deciding I wanted to get into this BIG MONEY occupation. I took a 10 day course, and 10 days later, I got my first job!

Previously, I was a starving flight instructor. I switched from instructing to ag flying and increased my earnings TENFOLD in the first week!

To be an ag pilot you do not have to be licensed to fly by instruments. You do not need a multi-engine rating. You do not need a lot of hours. 200 hours total flying time is enough in most cases. You do not have to do any aerobatics.

And yet you can make more money than most airline co-pilots. Even more than some captains.

Interested? O.K. To help people like you break into the BIG MONEY in a hurry—AND SAFELY—I have prepared the one and only indispensable guide on how to get into this profession. It is called, "HOW TO MAKE \$10,000.00 A MONTH—AG FLYING!"

In this guide, I lead you by the hand and reveal all the little secrets about this ag flying game that I have learned in my twenty three years of experience.

I show you:

- How to become a pilot in less than 90 days
- How to get training almost free if you are a veteran
- How to finance lessons if you are not
- How to prepare yourself for ag flying when you have your license
- How to fly low safely
- How to spray a field
- How to fertilize
- How to mix chemicals
- How to load your airplane
- How to make farmers happy
- How to make your boss happy
- How to get that first job
- How to get into the big money

AND MUCH, MUCH MORE!

Now if you have read this far, I want you to do yourself a favor and ACT NOW.

SEND FOR MY MATERIAL TODAY,

because tomorrow, or next month, may be too late. I can't promise that this ad will appear again. If you wait until another day, you may forget to order, or you may lose the magazine or the address. This moment, NOW, may be your one chance to find out what this ag flying business is really all about.

SO, ORDER NOW, while you're thinking about it. Take any piece of paper and write the words "HOW TO MAKE \$10,000.00 A MONTH—AG FLYING." Then put your name and address on it and send it with a check or money order for \$20.00 to:

**AGRICULTURAL PILOT SERVICES, INC.
DEPT. PM-1, P.O. BOX 650-929
MIAMI, FL 33165**

Or, if you prefer to use your MASTER CHARGE OR VISA CARD, CALL (TOLL FREE) 1-800-327-8456 and ask for EXTENSION 9. Give the operator your name, address and credit card number. (In Florida call (305) 444-7173). Sorry, but the operators are not qualified to answer questions about the material.

If you order my material TODAY, I will include, ABSOLUTELY FREE, a list of OVER 100 COMPANIES, and agricultural aircraft operators who hire ag pilots. (These lists are normally sold for \$10.00 to \$20.00. GET YOURS FREE, while they last. This offer may not be repeated.) So HURRY, order "HOW TO MAKE \$10,000.00 A MONTH—AG FLYING!", TODAY.

We also run an ag pilot school and complete training program, but that is another thing that you will learn about when you receive my material.

MONEY BACK GUARANTEE: You may examine my material for 10 days, and if you are dissatisfied for any reason, just send it back, in good condition, and we will cheerfully refund your money.

Copyright 1980 Agricultural Pilot Services, Inc.

Now you can cash in on the huge demand for SHARPENING SAWS and TOOLS.

BE YOUR OWN BOSS!

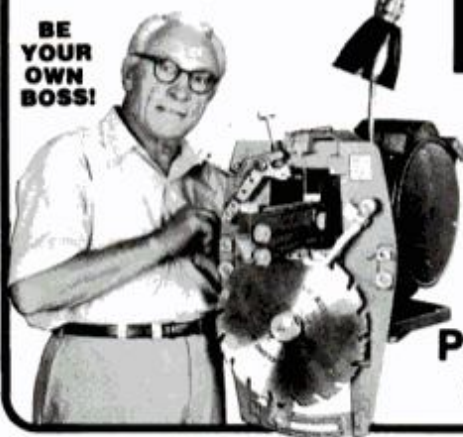

Make \$8⁰⁰ an hour...
 or more. Work part time, full time, right at home.
 No layoffs. No strikes.
 Provides a steady source of year round income.

This can be one of the most important decisions you ever make
 Going into business for yourself can be the most exciting and rewarding decision you're likely to make in your lifetime.

Owning your own business brings you a sense of independence. You're the boss, setting your own work hours. Your own effort builds the business for yourself and your family. You can achieve great satisfaction and profits, if you choose and manage your business wisely. That's why so many men, just like you, are cashing in on the big profits to be made in this fast-growing service field.

The sharpening business allows you to get started with only a minimum investment, requiring little space and effort for a successful operation. It lets you build and expand as fast, or as slowly as you like. You pocket most of the money you take in, because there are exceptionally high profits with no investment in merchandise.

If you need only \$200 or \$400 extra income each month, a sharpening business is ideal for spare time. The additional dollars can be SPENT for more of the good things of life. Or they can be SAVED in a rainy-day fund that the family can bank on.

More sharpening businesses are needed every year

As original equipment continues to climb in cost, owners are becoming more concerned that the equipment be maintained so that it performs like new. This means more companies, contractors, carpenters and home owners are having their old saw blades and tools resharpened many times, where in the past, they would have replaced them with new blades or tools. This is where you

can step in with the much needed service of sharpening saws and practically any kind of tool.

SEND FOR FREE FACTS TODAY!



This FREE booklet has helped thousands

Thousands of good men have been inspired by this fact-filled book into making that first important step of starting their own business. It can be yours just for the asking.

It covers these important subjects...

- How much money can you make
- Age, education not a factor
- No selling is required — customers bring their business to you
- Lawn mowers and chain saws
- Sharpening business is year-round
- Sharpening opportunities in small towns and large cities
- A sharpening business provides excellent retirement income
- How Foley helps you start
- No experience needed, any age can succeed

Act today, so you can have a brighter, more secure tomorrow

Right now, while this is still fresh in your mind, fill-in the coupon below. We will send your FREE copy of "Opportunities in a Sharpening Business of Your Own". There is absolutely no obligation and there are no franchise fees in starting your Foley Sharpening Business.

Send your name and address to: Foley Manufacturing Co. 3205 Foley Building, Minneapolis, Minnesota 55418

RUSH COUPON TODAY!

Foley Manufacturing Company
 3205 Foley Building
 Minneapolis, Minn. 55418



YES, I would like to receive complete details about how I can easily start a profitable, Foley-equipped sharpening shop. Please rush me your FREE booklet, without any cost or obligation, that gives me full details on how I can quickly start my own business.

NAME _____

ADDRESS _____

CITY _____

STATE _____ ZIP _____

BEST KNOTS FOR NEW FISH LINES

(Continued from page 182)

ple anyone should be able to tie it once he has seen it demonstrated. It checks out above 96 percent and should be used for tying line to a hook, swivel or snap. It is not quite as handy as the Brinson knot when tying to the eye of larger lures, since the loop must slide over the entire rig. But use it because it's a beaut.

Double the end of your line about a foot and insert the loop through the eye of the hook.

Tie a simple overhand knot in the double line. Slide the loop over the end of the hook or lure. Pull hook and line in opposite directions to snug the knot. Clip off the tag end.

Surgeon's knot

When you need to join two lines, or tie a leader to your line, this knot is as functional as it is simple, and can handle lines of different diameters. It makes a small knot that will not bump going through your guides and thus lasts much longer.

Lap the two lines for about a foot and tie a simple overhand knot in the doubled lines. Pull it up until it forms a small loop.

Hold the loop open and tie a second overhand knot, as illustrated

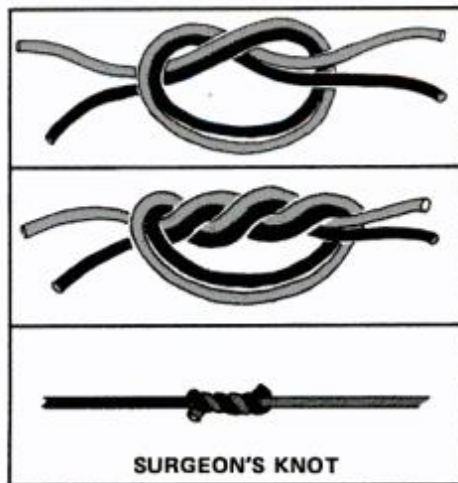

SURGEON'S KNOT

(above). Grip the double lines at each end of the loop and tighten slowly.

Snug the knot tightly. Then release the tag ends and tighten further by pulling on standing ends. Clip tag ends against knot. It won't slip.

When tying with a doubled line, keep the lines parallel and don't let them twist. As you make the final draw down, make certain the coils pull up in a neat spiral. Pulled up too quickly, they can overlap and cut each other. Tests on DuPont's Instron machine show that slippage in a loose knot is the main cause of failure. Snug each knot so tightly it won't slip.

FM



FREE BOOKLET

This little book has helped change the lives of thousands of good people, just

like you. Just complete the coupon, clip it out and mail it to us today. Get started now for a brighter, more prosperous tomorrow!

24-HOUR ANSWERING SERVICE

CALL TOLL FREE 1-(800)-328-7140

(Except in Hawaii or Alaska)

YOU can build this 75-mile-per-gallon

HYBRID ELECTRIC CAR from PLANS

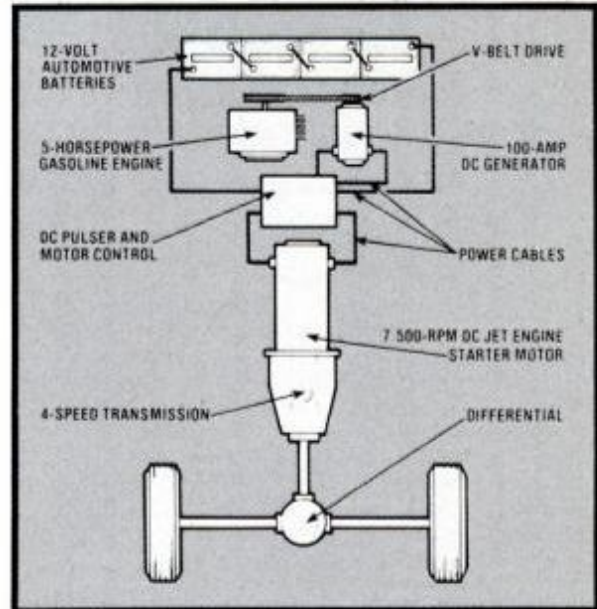

... developed from the car conversion by David Arthurs of Springdale, Arkansas which was described in **THE MOTHER EARTH NEWS®**.

David reports 75 miles per gallon from his vehicle. He began with a 1970 Opel GT, and the plans list 14 other makes and models among many that are suitable candidates for the conversion!

HERE'S HOW IT WORKS . . .

All you do is take your existing car (or buy a used body) and replace its original powerplant with a small gasoline-powered lawnmower engine. (That's right, a lawnmower engine!) This engine drives a 100-amp generator which supplies the vehicle's drive motor with electricity.

When more power is needed, four automobile batteries—hooked up in series and fed by the generator—give you plenty of kick for passing, for climbing hills, and for running at normal highway speeds.

GET ON YOUR WAY TO HIGH-MILEAGE MOTORING . . . NOW!

Your total conversion cost—when you buy the parts and build it yourself—is about \$1,500. Your first year's benefits alone—in fuel savings and in hassle-free driving—can more than repay the expense.

Because of the tremendous demand, THE MOTHER EARTH NEWS® now offers you a detailed, step-by-step set of plans for making the HYBRID ELECTRIC CAR. The complete package includes the plans, bill of materials, and list of suppliers . . . sells for \$15 . . . and comes with a no-risk guarantee: If after ten days you decide not to use your plans, you can return them for a full refund.

HERE'S HOW TO ORDER . . .

1. Fill in the coupon below. PRINT your name and address. If the coupon is missing, you may order on a separate sheet of paper, on which you write the words "HYBRID ELECTRIC CAR PLANS" and your name and address.
2. Make your check or money order payable to MOTHER'S PLANS. North Carolina residents add 4% sales tax. Canadian residents add 15% surcharge to cash orders. No charge for regular shipping, but please allow 6 weeks for delivery. (For faster service, add \$1 for first class postage.)
3. If you prefer to charge it to BankAmericard/VISA or Master Charge, include your name, your account number, the expiration date on the card, and your signature. (For Master Charge, give the Interbank Number.)
4. Mail your order and remittance to: MOTHER'S PLANS, Dept. 400101, P.O. Box A, East Flat Rock, N.C. 28726. (Sorry, no COD's, but you are fully protected by our 10-day, no-risk, money-back guarantee of satisfaction.)

YES! Please send me _____ sets of HYBRID ELECTRIC CAR PLANS. I understand that if for any reason I am not 100% satisfied with the plans, I may return them within ten days for a full refund.

Ship to:
NAME _____
(please print)

ADDRESS _____

CITY _____ STATE _____ ZIP _____

MY REMITTANCE OF \$15 PER SET OF PLANS ORDERED IS ENCLOSED. (N.C. residents add 4% sales tax. Canadian residents add 15% surcharge to cash orders.) If first class mail delivery is desired, add \$1 for extra postage, and check here .

PLEASE CHARGE TO MY: BankAmericard/VISA
 Master Charge (Interbank No. _____)

NAME _____
(please print)

ACCOUNT NUMBER _____

EXPIRATION DATE _____

SIGNATURE _____

Make check or money order payable to: MOTHER'S PLANS
Mail to: Dept. 400101, P.O. Box A, East Flat Rock, N.C. 28726
(Price subject to change without notice.)

Ion Fountain^{T.M.}

YOUR ULTIMATE AIR FRESHENING/
IONIZING SYSTEM. TOP QUALITY.
LOW PRICE. STATE OF THE ART.



Breakthrough. The new Ion Fountain™ is in a class by itself. This negative ion generator gives you power to saturate your home or office with billions of refreshing ions. Without fans or any moving parts it puts out a pleasant breeze. A pure flow of ions pours from the top like water from a fountain, filling your room. The result? Your air feels like fresh ocean air—pure, crisp, and wonderfully charged.

The price? **Only \$79.95.** That's a price breakthrough because no other company can offer you a unit with higher ion output or better quality than the Ion Fountain™, even at triple our price.

HOW CAN WE DO IT?

Six years of experience helps. Plus a lot of ingenuity, aggressive research and a personal commitment to give our customers the best we can.

UTP Ion Research Center is a branch of our educational publishing company. And our commitment in publishing to give birth to new ideas and methods that enrich humanity is part of the Ion Research Center too. We're in business to serve you and your environmental needs.

WHAT ARE IONS?

Ions are electrically charged atoms in the air with either a positive or negative charge. The sun and cosmic rays as well as lightning and fast-moving water (like waterfalls, surf) generate trillions of negative ions every day. The more negatively ionized the air, the fresher and more alive it is. Air pollution, artificially controlled climates (with air conditioning and heating) and electronic equipment all produce excess positive ions, depriving the air of these small negative air ions and creating dead "stuffy" air.

WHAT'S THE SOLUTION?

Our rapid-growth technology, which sometimes takes its toll on the quality of our air, has also come up with the solution. Following Nature's model of the thunderstorm which uses a high electrical charge to purify, revitalize and stimulate the air, the UTP Air Energizer has been developed imitating this process. Both the thunderstorm and the Air Energizer fill the air with negative ions, restoring the natural electrical balance to the polluted, energy-depleted air. But the Ion Fountain can be used indoors in the home, office, workshop, laboratory, etc., keeping a fresh supply of ionized oxygen available night and day. This new breakthrough in fresh air control is not a cover-up

which masks or deodorizes. The unit actually removes the dust, smoke, bacteria and pollen particles from the air by attaching ions to them and causing them to sink to the earth where they can be vacuumed up rather than inhaled. At the same time ions electrically stimulate the energy-stripped air.

YOUR CHOICE OF TWO TOP-QUALITY UNITS!

There's only one unit that's better than the Ion Fountain. That's our own Executive System Four™. It sells for \$159. It has an even higher ion output. Plus! Our special **Dial-An-Ion** feature allows you to adjust the ion output anywhere from low to high. Not everyone knows that the need for ions varies. A large smoky room will require higher output than a small room. And some people want fewer ions while sleeping than while working. The new Executive System Four is our answer to this need for output flexibility.

FACTS YOU NEED TO KNOW The Ion Fountain™—System Five

<i>Ion density:</i>	430,000 ions per cm ³ /sec. at 1 meter. 1.55 million ions per cm ³ at 50 cms.
<i>Use:</i>	Large room or office—9000 cu. ft.
<i>Warranty:</i>	1 year
<i>Output voltage:</i>	15KV
<i>Ozone:</i>	Less than 2 parts per billion
<i>Dimensions:</i>	5¾" x 4¼" x 2¾"

Executive System Four™

<i>Ion density:</i>	Low to maximum of 540,000 ions per cm ³ at 1 meter. 1.6 x 10 ⁶ ions per cm ³ at 50 cms.
<i>Output voltage:</i>	15KV
<i>Ozone:</i>	Less than 2 parts per billion
<i>Dimensions:</i>	11" x 5" x 4"
<i>Use:</i>	Large room or office 10,000 cu. ft.
<i>Warranty:</i>	1 year

If the Executive System Four is better, why did we bring out the Ion Fountain? Not everybody is willing to pay \$159 for an air ionizing unit, no matter how good it is. Just like not everyone drives Rolls Royces. Most drive less expensive cars. The Executive System Four is for the person who wants the

absolute best quality and doesn't mind paying a little extra to get it. If you want highest ion output, flexibility, and a beautiful oak paneled case, buy the Executive System Four.

If you want something at half the price of the Executive System Four, but still better than any other units costing up to \$250, buy the Ion Fountain.

HOW TO GET ONE

To place your order now just send a check for \$79.95 plus \$3 shipping for the Ion Fountain. Or send \$159 plus \$4 shipping for the Executive System Four. Tell us your full street address as we cannot ship to Post Office boxes. (California residents add 6% sales tax.)

Our unit is dependable and trouble-free, but if by rare chance any problems occur our service-by-mail center sends off your unit within 24 hours of receipt or sends a replacement so you are not without fresh air and can enjoy your dust-free environment. And each Air Energizer is backed by a full one-year limited warranty.

HOW TO GET ONE FAST

Credit card holders can call our toll-free number below. Order a unit now and if you are not satisfied with its effects within 10 days simply return it for a full cash refund. Order your Air Energizer today.

UTP

Read "The Golden Egg"

University of the Trees Press
ION RESEARCH CENTER, Dept PM6
Box 644 BOULDER CREEK, CA95006
Call Toll-Free . . . 800-538-0750
In California call (408) 338-6663
Send check or use your Master Charge,
Visa or American Express card.

DETECT YOUR IONS

This simple but accurate detector instantly gives you a reading of ion intensity.
The Econometer . . . (Pen Size) . . . \$7.50
[If ordering separately include \$2.00 for shipping.]

SURVIVAL! Spirulina is a new wonder food supplement higher in protein than any other natural source. Very high in other nutrients too. Find out how you can be a commissioned representative of the Light Force Family and distribute Spirulina in either bulk or as special vitamin supplements. Generous commissions and opportunities available. **Phone or write for your free information. (408) 338-9436.** Please do not use the toll-free number for information.

PUBLIC LIQUIDATION of MICROWAVE OVENS!

A MAJOR, POPULAR BRAND AT FAR BELOW DEALER COST!

FACTORY NEW! FACTORY PERFECT!

Save over \$400.00!

Fully programmable! Designed for home use
but made to pass strict commercial
standards for constant use!

APPROVED BY:

- U.L. - Meets rigid safety requirements of Underwriters Laboratories for home and commercial use.
- H.E.W. - Meets all the strict safety standards of the U.S. Dept. of Health, Education and Welfare!
- C.S.A. - Meets all safety requirements of Canadian Standards Association (stricter than U.S.)!
- N.S.F. - Commercially approved by National Sanitation Foundation (for restaurants, institutions).

Compare all the wonderful features of this superb oven with any other brand! Then compare our price. Prove to yourself what a sensational value this is! If you EVER thought of getting a new microwave oven, RIGHT NOW is the time to do it!

5 YEAR WARRANTY! Includes one year on parts and labor plus Free in-home service. Four additional years coverage on magnetron tube. Serviced by hundreds of centers that service other major brands such as Litton, Amana, Magic Chef, Panasonic, etc.

PATENTED BEAM STIRRER! For more even distribution of microwaves; more thorough, uniform cooking.

LARGE CAPACITY! Big, 1.30 cu. ft. interior can hold an 18 lb. turkey. Can cook entire meal at one time! Has a special pyro-ceram glass bottom for your convenience.

FULLY PROGRAMMABLE! A solid-state, electronic mini-computer lets you program cooking in advance!

5-STAGE MEMORY! Program up to 5 separate oven cycles at one time. Appropriate panel lights up to inform you as each new cycle starts. Oven works in proper sequence even if programmed in wrong sequence!

ELECTRONIC DIGITAL TIMER! Set cooking time for a few seconds or up to 99 minutes, 99 seconds. The five second buzzer signals completion of cycle.

L.E.D. DIGITAL CLOCK! Shows time of day, power level, cooking time, temperature setting of meat probe.

10 SEPARATE POWER LEVELS! For every type of cooking need... from slow cooking all the way to fast.

PROGRAMMABLE DELAYED COOKING! Leave the house for up to 12 hours and the oven will start all your programmed cooking instructions BEFORE you return.

DEFROST CYCLE! Quickly defrosts a roast, turkey, ham, etc., in a fraction of normal time.

4 SAFETY INTERLOCKS! Microwaves immediately shut off when door is opened.

EASY CLEANUP! Vinyl coated acrylic interior will not streak or stain; wipes off clean and new-looking. Cook on glass, china, paper, plastic, even ON aluminum foil.

SAVE ON LEFTOVERS! Leftovers are quickly heated to a delicious "just cooked" flavor! Dried out bread and bakery goods are restored to "just baked" freshness. Cold coffee reheats without a boiled, bitter taste.

GREAT NUTRITION! Microwaves' speedy cooking RETAINS MORE of the vitamins and minerals so essential to good health! Foods shrink less, too.

SAVE ON ENERGY COST! Save 40% to 90% on the energy cost of cooking (depends on type of food item).



Credit card holders can phone order:
Toll-Free: 800-328-5082
In Minn. call collect: 612-729-2345

C.O.M.B. Co.

THE NATION'S LARGEST AUTHORIZED MAIL
ORDER LIQUIDATOR OF CONSUMER PRODUCTS
3258 MINNEHAHA / MINNEAPOLIS, MN 55406
Phone: 612-729-2345 Toll-Free: 800 328-5082

PUBLIC NOTICE!

Because we are the nation's largest mail order liquidator of consumer products, famous manufacturers often come to us with special, big closeouts.

There are many reasons for their closeouts, such as: last year's models, discontinued products, financial difficulties, plant closings, etc., etc.

We liquidate huge inventories to the public at a fraction of the normal retail price! Sometimes we are allowed to advertise the brand name and reason for the closeout. Sometimes not.

In the case of these ovens, we had to replace the original major brand name with our own private label. But we can tell you this much: These are all brand new, factory perfect, made in U.S.A. Over 200,000 were sold under the original brand name at \$789.00!



CAN COOK A WHOLE MEAL AT ONE TIME! USES NORMAL HOUSE CURRENT.
Plugs into 15 amp., 110-120V outlet. Must be 3-prong, grounded outlet for proper performance.

We have liquidated over 9,000 microwave ovens, including these famous brands: Tappan, Panasonic, Toshiba, Caloric (made by Amana). But NEVER have we been able to offer such a sensational, money saving low price on an oven as superb as THIS one!

JUST TAP IT TO PROGRAM IT!

- L.E.D. DIGITAL DISPLAY** - Shows time of day, cooking time, power level... at your command.
- NUMBER SELECTION** - Tap the ones you want for cooking time, power level, meat probe temperature, time of day.
- SIMMER** - For medium energy.
- WARM** - For lowest power setting on sauces, yeast bread, to soften butter and cheese, to keep foods warm.
- POWER LEVEL** - Tap it before selecting any of 10 different power levels.
- TEMPERATURE PROBE** - Tap it before setting desired temp. for meat probe.
- REST** - Lets time pass between cycles.
- THAW** - Uses 50% of power for thawing or for cooking delicate foods.
- COOK** - Produces 700 watts power for fastest cooking cycle.
- CLEAR** - Cancels out any information you previously programmed.
- CLOCK** - Tap it to display time of day.
- DELAY** - To delay start of your cooking instructions up to 12 hours if desired.
- START** - Just tap to start the functions you programmed.



Over 200,000
formerly sold at:
\$789.00

OUT THEY GO AT ONLY:

\$339

160 PAGE COOKBOOK INCLUDED!
Lavishly illustrated with over 640 beautiful, full color photos! Shows step-by-step preparation of a wide selection of main course meals, side dishes, desserts, pastries, appetizers, etc. Like a complete home-cooking course! You'll love it! And you'll delight in all the wonderful, new, taste-tempting foods you can learn to prepare with your sensational new microwave oven!

C.O.M.B. Co. / Authorized Liquidators Dept. B-137
3258 Minnehaha Avenue S., Minneapolis, Minn. 55406

Send _____ Omega Microwave Oven(s) at the liquidation price of only \$339.00 each. I will pay shipping charges to the driver upon delivery. (Allow up to 5 weeks for delivery. If paid by personal check, allow extra 2 weeks for check to clear bank.) Sorry, no C.O.D. orders.

My check or money order is enclosed.
Charge to: Mastercharge VISA American Express
Account No. _____ Expires _____

PLEASE PRINT CLEARLY
Name _____
Address _____
City _____
State _____ ZIP _____ Phone _____

Now you can mix your way to better sound

Mixers have long been known to the serious audiophile, but you don't need a million-dollar system to use them. We show you how to choose—and use—these often neglected audio components.

by Bill Kanner



The Teac mixer/meter combination (above) solves all but the most complex mixing problems. There are inputs and outputs for nearly every purpose. With meters, mixer goes for about \$725. Audio-Kit 62 (left) is a build-it-yourself mixer that offers 6 inputs, 2 outputs for \$300.

To some people a "mixer" is something you put in a highball, while to others it means a certain kind of fraternity party. But mention the word "mixer" to a dyed-in-the-wool audio buff or a well-biased recordist and it means something else entirely. To them a "mixer" is a junction box for microphones and line inputs.

A typical mixer has sliders, buttons, knobs and often meters. It also has the remarkable ability to send into rapture any dedicated audio enthusiast. But why the ecstasy over something that's basically a junction box?

A mixer takes a signal, alters it only slightly and sends it on its way

(Please turn to page 190)

OWN YOUR OWN ELECTRIC CO.

SAVE THOUSANDS OF DOLLARS! It's Being Done Now!

Utilize Non-Polluting Wind Power for Home, Farm, Apartment!

Have ALL the power you need for light, heat, appliances at a cost of pennies
— and make money by selling surplus to your local utility!

WIND POWER "PROJECT INDEPENDENCE"

The Complete Guide that Gives You All the "How-To" Facts for Utilizing Non-Polluting Wind Power!

HOME OWNERS! APARTMENT DWELLERS! FARM OWNERS!

Create your own electric power for cooking, lighting, heating, hot water, washing, TV, etc. Forget about blackouts, power loss, costly utility bills. WIND POWER works for you FREE — saves you loads of money year after year, after year — gives you complete independence from utilities!

YOU CAN BUY A WINDMILL OR BUILD ONE YOURSELF!

This book tells you where to buy wind power systems — the cost — the best size for your city or farm home. It details how to build your own system. Frank Buyak of Pound Ridge, N.Y., built his own system in 1974 for under \$1500. Under today's tax credit for installing energy-saving devices (legislation now in Congress seems sure to raise this to 50%) you can get the government to pay up to half the cost of your installation.

BUILD A WIND POWER SYSTEM FOR UNDER \$200!

Comprehensive plans and detailed illustrations show you how an under \$200 installation, working on winds as low as 7 MPH can provide lighting, heating and pumping. The book also shows you how to utilize solar units when the wind is down.

PROVEN PERFORMANCE OF WIND POWER SYSTEMS!

- Norman Page of Pelham, Mass., spends \$30 a year (for parts) to run his windmill and it provides power for his lighting and appliance needs. When an electrical storm in Pelham blacked out all homes, offices, and factories, Mr. Page's personal wind power system kept right on working!
- A Windmill is now generating power for a five-story tenement building on East 11th Street in New York City (see photo) and they are selling their excess power to the Con Edison utility.
- Three wind machines are presently being installed in the State of Washington that will provide all the power needed for 2,000-3,000 homes.



It's easy to install a windmill next to your home that will provide light, heat & run all your appliances — plus a surplus to sell to your utility



Windmill atop apartment house in New York City

ONLY \$9.95

AS SEEN ON T.V.

CREDIT CARD BUYERS Call Toll Free 24 Hour Service

800-648-5600 Oper. 136

Order Today! 14 Day Money Back Guarantee!

WIND POWER, Dept. 1251
283 Greenwich Ave., Box 464, Greenwich, CT. 06830
Please send me your WIND POWER BOOK.
Enclosed is my check or M.O. for \$10.95
(\$9.95 plus \$1 for shipping). OR, charge to my

VISA MASTERCARGE Exp. Date _____

Acct. # _____ Interbank # _____

If not delighted with this book, I can return it in good condition in 14 days for a refund of purchase price.

Name _____

Address _____

City _____ State _____ Zip _____

Conn. residents add sales tax

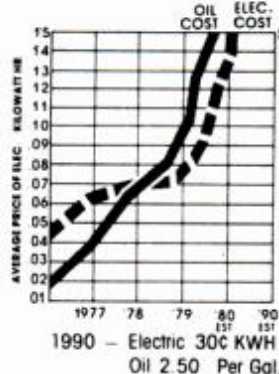

ACT NOW! SAVE! SAVE! SAVE!

In 1977 a kilowatt hour cost an average of 5 to 6¢. Today, it's more than twice as much — and the rates keep going up and up, dependent on the whims of OPEC, oil companies, natural gas consortiums, and air polluting coal suppliers. The wind is clean, and better yet, it's FREE! Did you know you can also store your surplus power and sell it to your local utility — thru your present utility meter. (Yes, it's being done right now.) Congress mandated it (Public Law 95-617).

S-K TOOLS VICTORY SPECIALS



SAVE \$35^{08*}
Over 50%

S-K 21 pc. 1/4" Dr. Socket Set
#4921-80

Only \$34⁸⁸

Indy Winners:



Rick Mears—
driver Jim McGee—
mechanic

and
American-made S-K Tools

Chief mechanic Jim McGee says,
"I used S-K Tools extensively in
preparing our winning car."

Right now take advantage of fantastic
savings on this and other championship
quality S-K Tools sets. They're available
at auto parts and hardware stores.

CHECK OUR GOLDEN WARRANTY



HAND TOOL DIVISION, DRESSER INDUSTRIES, INC.
3201 N. Wolf Rd., Franklin Park, Illinois 60131

Copyright 1980 DRESSER INDUSTRIES, INC.

*Savings are based on suggested user prices of
individual pieces.

Make up to
\$12⁵⁰ an hour
Start your own
money making business!



Hundreds of Belsaw trained men
have succeeded in this fascinating
and highly profitable field...

YOU Can Do It Too!

BE A LOCKSMITH

Never before have money-making opportunities been so
great for qualified Locksmiths. Now lucrative regular
lock and key business has multiplied a thousandfold as
millions seek more protection against booming crime.
Yet there's only one Locksmith for every 17,000 people!

Train FAST at Home—Collect CASH PROFITS Right Away.
You're "in business" ready to earn up to \$12.50 an hour
a few days after you begin Belsaw's shortcut training.
Take advantage of today's unprecedented opportunities
in Locksmithing for year-round EXTRA INCOME in spare-
time—or fulltime in a high-profit business of your own.
Hundreds we've trained have done it. So can YOU! All
tools, 100 professional Key Machine given you with
course. These 600 practice materials and equipment,
plus simple, illustrated lessons, plus expert supervision,
plus business-building guidance will ensure you to KEEP
THE MONEY COMING! (It's ideal for retirement—good
jobs too. SEND FOR EXCITING FACTS—No obligation!
ALL SPECIAL TOOLS AND EQUIPMENT INCLUDED!

PRO KEY
MACHINE
YOURS
TO KEEP!

This Pro Key Machine can
make up to 500 a
month in your spare
time—and it won't cost you a penny
to start with your training.
Find out all about it!



RUSH Send for your
COUPON! copy today!

Accredited Member
National Home
Study Council

10-DAY
NO RISK
TRIAL! BELSAW INSTITUTE
101H Field Bldg.
Kansas City, MO. 64111

RUSH COUPON!

There is NO OBLIGATION and NO SALESMAN Will Call—ever!

FREE! BELSAW INSTITUTE
101H Field Bldg., Kansas City, Mo. 64111
Please rush FREE Book "Keys to your Future."

NAME _____
ADDRESS _____
CITY, STATE, ZIP _____

ALL-GEAR CRAWLER

1st IN
KIT FORM

Full track power,
16 hp. EASILY
ASSEMBLED. Buy
factory direct. Over 30
attachments incl. dozer
blade, garden tools, loader.
Odd job and resale opportunities
are great. Send now, to:



STRUCK KIT, Dept. PM60, Cedarburg, Wis. 53012

CATALOG showing Magnatrac Kit construction
 & uses — 50¢.

PLANS for fabricating Magnatrac Tractor from
 local materials, \$7.00 (refunded on any pur-
 chase).

Name _____
Address _____
City, State, Zip _____ (Dealer Inquiries Invited)

\$300⁰⁰ wk

PAID

NO SELLING
CAMERA AVAILABLE for shooting
17 rolls film!

* NO PHOTO EXPERIENCE NEEDED
Great SPARETIME after your regular
job! Do shooting yourself or have others
work for you. Genuine opportunity!

WRITE FREE REPORT # PM-6
3110 Fulton Ave, Sacramento, CA 95821

NAME THAT TUNE!

OVER 120 TUNES AVAILABLE
FOR YOUR OWN MUSIC BOX CREATION!
Swiss Movements available from 16 to 72 notes from
\$7.50. Disc 11 per with over 98 music favorites to choose
from. Guaranteed for 1 year. Send \$1.00 for catalog
with tune selection (refundable).

WORLD OF MUSIC BOXES
412 Main St. Avon, New Jersey 07717 Dept. B



MIXING FOR BETTER SOUND

(Continued from page 188)

virtually unchanged. It simply
takes a signal at the input and lets it
out the other end as an output.

The answer is partly in the sex ap-
peal of the sliders, knobs and meters
and partly in what they allow you to
control. With an ordinary stereo
tape recorder, you can plug in two
microphones and have one picking
up signals for the left channel and
the other for the right. On most ma-
chines, there is no provision for
blending those channels or for add-
ing other microphones. A mixer
changes that. You can have a vari-
ety of microphones (or other input
sources) giving you signals that you
can blend together or keep relative-
ly separate. You can alter the vol-
ume or "gain" of each input and
even change the tonality of each in-
dependently.

Mixing at home

Mixers first came to prominence
with the development of rock music.
They had been used to balance re-
cordings before then, but the '50s
saw the coming together of a num-
ber of elements in popular music.
Les Paul's electric guitar and over
dubbing with a multitrack tape re-
corder meant that you could record
many instruments, voices or elec-
tronically produced sounds, keep
them separate for as long as you
wanted, and then combine them in a
desired fashion.

The mixer became the intermedi-
ary controlling element in recording
sessions. It kept the input sources at
given levels and combinations could
be grouped. Then, once the desired
material was on a multitrack
master, the mixer could be used to
take that information and combine
it into two tracks or channels for the
final stereo version.

That makes a mixer a necessity
for the professional recording engi-
neer, but why would the ordinary
audiophile want one?

As sound equipment has gotten
better, more and more people have
been getting into the act. They ei-
ther want to record themselves or
they have friends in a band. Increas-
ingly, audio gear that was originally
intended for use by professional
sound technicians has filtered down
to the amateur.

With a mixer, a good set of micro-
phones and a good tape deck, the en-
thusiastic hobbyist can make tapes
that are virtually indistinguishable
from a studio production. And with
today's musical styles, you can al-
ways connect two turntables to your

(Please turn to page 192)

JC. WHITNEY & CO. Introduces ... A Custom-Tailored CAR COVER for EVERY CAR!

With Exclusive **Enduralite®** Fabric . . .

- ★ LIGHTER ★ STRONGER ★ LONGER LASTING
- ★ FREE CUSTOM INSIGNIA ★ FREE STORAGE BAG

LOW AS **39⁹⁵**



1980 Models Included!

Exclusive **Enduralite®** fabric combines the best features of cotton and polyester for superior strength, durability and lightness. Stands up to constant use, wind, lasts longer. More resistant to sun-fade than all-cotton fabrics. It's water-repellent, yet fabric "breathes" to prevent moisture condensation under the cover. Mildew resistant, too.

So lightweight, even a child can handle it! Average cover weighs only 8 lbs. Lightweight and custom fit make fast, singlehanded installation and removal easy for anyone. Allows easier, more compact storage. Easier to launder, too.

Soft, gentle fabric won't scratch your car's finish. Safe for even the most delicate lacquer finishes. **Quality construction:** Superior fabric and workmanship assure shape retention over long use. Double-sewn seams for extra strength. Elastic sewn in to front and back for a snug, perfect fit. Cover stores compactly in its own storage bag, when not in use. **Launder it at home!** Light weight and compactness

let you wash and dry your cover in your home laundry . . . and water repellency won't wash out! Fade-resistant. Resists wrinkles, too.

Custom covers are tailored to fit the exact dimensions of your particular make, year and body style. These are not universal-type covers with only 2 or 3 available sizes. We have 7600 patterns—including the pattern for your vehicle, no matter how new, old or rare . . . and your cover is cut and tailored from your specific, custom pattern.

American made—not imported. **Enduralite®** car covers are custom tailored in our United States plant where we have full control over quality and fit.

Protects your car's paint, vinyl top, metal trim, rubber and interior trim from the fade, oxidation and damage caused by the sun's harmful ultra-violet rays, by smog, industrial pollutants and ozone, by wind-blown dust and sand, by rain, snow, sleet and ice, by tree sap and bird droppings. And it helps discourage vandalism.



FREE! Custom Insignia
Your car's own custom insignia included with your car cover.



Cloth bag matches car cover, has draw-string closure for neat, compact, protected storage of your car cover when it's not in use. *Yours FREE* with your custom car cover.

LIMITED 2-YEAR WARRANTY
Your Custom Car Cover is warranted for 2 full years against tearing, fraying or losing its shape or water repellency. Warranty does not include vandalism and is limited to the purchase price of the car cover.

ORDER BY PHONE—TOLL FREE
and charge your order on your Visa/BankAmericard or Master Charge.

Call **800-621-5809**
24 HOURS A DAY — 7 DAYS A WEEK
(In Illinois call 800-972-5858)

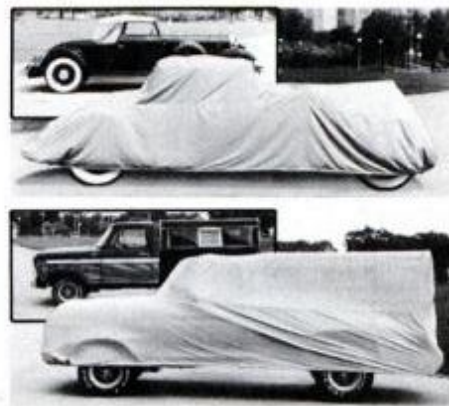
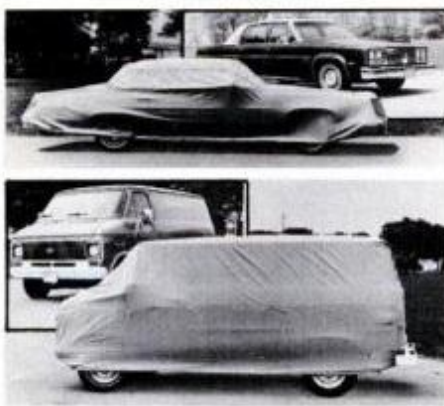

FOR ANY CAR LISTED BELOW

Alfa Spyder	Fiat 850, 124	MG, Midget, MGA,
Austin Healey	Soyder, 500,	MGB-GT, MGB-
Sprite	1100, 1200, 1500	Convertible
Datsun 1600-2000	Convertible	Morgan 2 Seat
Convertible	Honda 600 Coupe	Triumph Spitfire,
Any car listed above,	Lotus Elan Elite	TR2, TR3, TR3A
78-1432AF—	to 1971	

Each **\$39.95**

FOR ANY CAR LISTED BELOW

Accord	Cougar	Hupmobile	Oldsmobile
Alfa-Romeo Sdn.	Crown	Jaguar	Omega
American Motors	Cutlass	Jensen	Packard
Apollo	Dasher	Interceptor	Pantera
Aspen	Datsun	Jeep®	Peugeot
Aston Martin	all 2+2	Kaiser	Pierce-Arrow
Auburn	Z-cars	Lamborghini	Plymouth
Avanti	Datsun 810	Lancia	Pontiac
Bentley	Datsun 2005X	Landcruiser	Rambler
Bricklin	DeSoto	La Salle	Ranchero
Buick	Dodge	Le Baron	Rolls Royce
Cadillac	Camaro	Lincoln	Rover
Checker	Duesenberg	Mangusta	Seville
Chevelle	El Camino	Maserati	Skyline
Chevrolet	Essex	Maverick	Skylark
Chrysler	Excelsior	Mercedes-Benz	Studebaker
Citation	Fairlane	Mercury	Thing
Citroen	Ferrari	Model A	Thunderbird
Cordoba	Firebird	Model T	Torino
Corvette	Ford	Monarch	Versailles
	Frazier	Monte Carlo	Volare
	Granada	Nash	Volvo
	Henry J.		
	Hudson		

FOR ANY CAR LISTED BELOW

Alfa-Romeo Cpe.	Datsun 1200	Mustang II
Arrow	Datsun B210	Omni
Astre	Datsun F10	Opel
Audi	DKW	Pacer
Austin	English Ford	Pinto
Austin-Healey	Fairmont	Porsche
Beetle	Falcon	Rabbit
BMW	Fiat exc. 850, 124	Renault
Bobcat	Soyder, 500,	Saab
Capri	1100, 1200, 1500	Scirocco
Celica	Convertible	Simca
Chevette	Fiesta	Skyhawk
Cobra	Fox	Starfire
Coit	Gremlin	Subaru
Corolla	Hillman-Minx	Sunbeam
Corona	Horizon	Sunbird
Cortina	Isotta	Tiger
Corvaire	Jensen	Triumph exc.
Crocket	Karmann Ghia	Spitfire, TR2,
Crosley	Lotus exc.	TR3, TR3A
Daimler	Elan Elite to 1971	Vauxhall
Datsun 240Z, 260Z	Mazda	Vega
Datsun 280Z, 280ZX	Morris-Minor	Volkswagen
Any car listed above,	Mustang	Zephyr
55-2705WF—		

Each **\$52.95**

FOR ANY CAR LISTED ABOVE . . . Each **\$62.95**

55-2706UF— . . . Each **\$62.95**

FOR ANY OTHER AMERICAN CAR. . . . Each **\$62.95**

78-1435UF— . . . Each **\$62.95**

FOR ANY OTHER IMPORTED CAR. . . . Each **\$59.95**

78-1434XF— . . . Each **\$59.95**

ANY PICKUP TRUCK OR VAN (1 TON OR LESS) . . . Each **\$69.95**

78-1436BF— . . . Each **\$69.95**

ORDERING INFORMATION: State Make, Year, Model, Body Style, If Vehicle Has External Antenna and Stock Number.

MAIL TO:

JC. WHITNEY CO., Dept. LGYJ
1917-19 Archer Ave. • P.O. Box 8410
Chicago, IL 60680

Make my Custom-Fit Car Cover for the following car, truck or van and rush it to the address below. Include Custom Emblem and FREE Storage Bag.

Make _____

Year _____ Model _____

Body Style _____

Check if your vehicle has an external antenna. (Use additional sheet of paper if you are ordering Car Covers for more than one vehicle).

Stock No. _____ Car Covers @ _____ (Add \$4.50 per cover for postage and handling). Illinois residents add 6% sales tax.

I enclose \$ _____

Charge my order to my Visa/BankAmericard or Master Charge.

Acct. No. _____

Expiration Date _____

Name _____

Address _____

City _____

State _____ Zip _____

JC. WHITNEY CO. • 1917-19 ARCHER AVE. • P.O. BOX 8410 • CHICAGO, IL 60680

GAS SAVERS Cars-Trucks-Vans

ELECTRONIC WATER INJECTION SYSTEM

INCREASES
MILEAGE
UP TO 30%



- Ends spark knock
- Install yourself
- Allow the use of a low octane, more inexpensive gas.
- Helps cool engine.

NOW \$79.95
4,6,8 Cyl.

QUARTZ HALOGEN FOG & DRIVING LIGHTS



Rect. Amber or Clear (Chrome Bezel)
Round & Rect. Amber (Black Bezel)

NOW \$16.95 ea.

Light Covers \$2.95 ea.

MORE GAS SAVERS!!

Electronic Ignition Conversion Kit 6,8 Cyl Except Mopar	\$39.95
Cruise Control Unit	\$89.95
Air Cond. Cut-out (cuts off A/C during acceleration) 4,6,&8Cyl.	\$11.95
GM HEI Advance Curve Kit	\$ 6.95
Advance Curve Kit (spring ONLY)	\$ 2.95
Ford, GM, Mopar	
LED Digital Clock	\$16.95

Our Catalog specializes in many Gas Saver & Do-it-Yourself items, Performance parts for your Car-Truck or Van.

Gratiot AUTO SUPPLY

Mail Order Division
P.O. Box 870-PM60
Royal Oak, Michigan 48068

Send \$1.00 for the new '80 Catalog

Name _____
Address _____
City _____ State _____ Zip _____

PRICES GOOD FOR MAIL ORDER ONLY

VISA - MASTER CHARGE PHONE ORDERS (313) 885-5311
To Order: List quantity, price, desc., enclose 25% deposit, balance C.O.D.

Do your heels ache?



Why suffer from heel spurs, stone bruises, or sore heels when CUSHI-HEEL PILLOWS PROVIDE QUICK RELIEF WHILE YOU WALK OR RUN. Thick and gentle yet resilient, these (U.S. PAT. No. 3,994,926) pillows are exactly the right shape density and compression to best protect heels from the jarring and pounding they receive on hard surfaces. Excellent for jogging, football, tennis, basketball, racquetball, or jobs where you're constantly on your feet. They really work. IF NOT SATISFIED, RETURN WITHIN 10 DAYS FOR FULL REFUND. Send \$4.95 for one pair; \$9.00 for two; along with name, address, men's/women's shoe size to: CALDERON PRODUCTS CO., K-8 BOX 5117, AKRON, OHIO 44313. Visa-M/C accepted. Ohio residents add 4% sales tax.

"How to Get Your own Castle Built for 20 to 30% less than market price".

send
Name _____

Address _____

to Castle Builders Inc.
Rt. 2, Box 187
Springdale, Ar. 72764

FOR FUN AND PROFIT. A

Weekend money maker!

from **ATLAS**

With an Atlas lathe you can turn your garage, shop or basement into a profitable spare or part-time business!

This Atlas 12-inch (300 mm) back-geared metal turning lathe is engineered for both light industrial application and home-workshop projects. Priced to fit your budget, yet loaded with features—a full 12" swing, with 36" between centers. Equipped with reversible power cross and longitudinal feeds and a timesaving quick change gear box. Sixteen speeds, from 28 through 2072 RPM. Available in either inch or metric, bench and pedestal models. Made in U.S.A. Take advantage of the special promotional sales now in progress at all participating Atlas dealers.

grind
bore
ream
knurl
drill
mill
machine
thread
polish
crew cut
wood turn



Mail To: Atlas Tool Company, Dept. 270
2019 N. Pitcher, Kalamazoo, MI 49007
Please send free Atlas Catalog plus name and address of nearest Atlas dealer.

Name _____
Address _____
City _____
State _____ Zip _____

MIXING FOR BETTER SOUND

(Continued from page 190)

mixer and turn your next party into a disco.

Other than that kind of novelty, isn't a mixer an extravagance? Sure it is—unless you really intend to do some live recording. More and more audiophiles are finding that home studio-type recording is the next logical step for them. It provides a level of creativity not otherwise available. A mixer allows versatility and individual expression and need not be a big investment compared to the rest of the system.

A good open-reel tape deck (the kind most used for serious live recording and editing) will cost a minimum of \$500. If that's the kind of equipment we're talking about, then the additional cost of a small mixer is, on a percentage basis, no great investment.

Build it yourself

If you're willing to do a little work yourself, you can get a more than adequate mixer for under \$300. AudioKit 62 is a British mixer kit distributed by AudioMarketing of Stamford, Conn. As the name implies, it's a 6-in/2-out unit. That means that you can take up to six high-impedance inputs, mix them as desired, and end up with two channels at the output. The 62 takes about eight hours to build.

The AudioKit 62 has a variety of controls and features. Each input channel has a gain control that acts as a microphone amp, bass and treble controls, as well as cue and echo controls. The last two are for external equipment and are connected to outputs on the back panel. Each channel has a pan pot, which can apportion each input to either or both channels. A slider controls the amount of signal going to the output stage.

In addition to the cue and echo outputs, the 62 has main and auxiliary pairs of outputs. The main set (which you connect to your tape deck) is controlled via slider and its level is reflected in VU meters. The auxiliary outputs are knob-controlled.

The AudioKit 62 is flat and can be carried in a briefcase. And while its optimum power source is its 24-volt d.c. power supply adapter, it can run successfully for hours on two 9-volt batteries. The kit sells for \$265, including the power supply.

Want to play with a few more output channels? Teac has just the item for you. Its Model 2A accepts microphone or line inputs of either high or

(Please turn to page 194)



Attractive Air Alive unit measures only 4 1/2" x 4" x 1 3/4" and cleans a 20' x 15' x 8' room in up to 15 minutes.

AIR ALIVE

Uses "Nature's Air Cleaners" to electronically destroy odor, smoke, dust, and pollen. Now research shows it may do more!

Little-understood particles, called negative ions, are said to be nature's best air cleaners. They attach themselves to dust, smoke, pollen or anything else floating in the air, and cause it to fall harmlessly to the ground. Now there is growing proof that negative ions may affect your moods, health and sense of well being.

THE ION CONTROVERSY

For the past 20 years, scientists and scholars-world wide have been studying the effects of electronically charged particles in the air called negative ions.

Russian scientists have recently proven that the presence of ions in the air is essential to animal life. Research conducted at the University of California has shown that plant growth is stunted when the ion content in the air is decreased.

Some researchers claim there's evidence that negative ions can relieve allergic ailments and headaches, help control virus, retard the growth of bacteria, increase mental alertness and energy, reduce pain, tension, fatigue and depression and produce sound sleep.

Interestingly, while the number of those who believe that negative ions do, in fact, produce these benefits, has grown, the number of doubters has decreased over the years.

THE ION IMBALANCE

The air is made up of molecules that contain either a majority of electrons, making them negative particles, or a majority of protons, making them positive particles.

Although nature produces a nearly equal number of positive and negative ions, there are a number of reasons why we are surrounded by an over abundance of protons: air pollution depletes the number of negative ions in the air, the static charge from synthetic fibers produces positive ions and natural earth radiation, that would normally produce negative ions, is retarded by concrete and asphalt covering the land.

In effect, we are breathing air that nature never intended us to breathe ... air that has been depleted of negative ions. What is needed is a way to correct this ion imbalance.

NATURE'S AIR CLEANERS

There is almost no disagreement among scientists that negative ions are unmatched in their ability to cleanse the air of impurities. This is how they do it: negative ions attach themselves to dust, smoke and pollen, neutralize them and cause

them to fall harmlessly from the air.

Engineers and doctors have recently recognized this benefit and have begun to take advantage of it. Many now use commercial units that emit negative ions and effectively destroy odors and pollutants in the air.

It has only been during the last year that technology has developed an affordable consumer model. These units were first introduced in Europe where there is a high level of interest in the benefits of negative ions.

Now we are introducing one of the first consumer units to be sold in this country!

ONE OF THE FIRST UNITS UNDER \$100

When we were offered the opportunity to introduce Air Alive to the American market, we jumped at the chance! Why? Because it's one of the first consumer models in this country to be sold for under \$100. And because it's manufactured by Western Systems, Inc., a pioneer in the ion generation field.

MOST COMPACT UNIT ON THE MARKET TODAY

Air Alive measures only 4 1/2" x 4" x 1 3/4" and puts out 3 trillion negative ions per second per cubic centimeter. That's as many or more than larger, more expensive units now on the market. It is so powerful that it cleans a 15' x 20' x 8' room in up to 15 minutes. Air Alive brings you more cleansing power in its compact size.

WARRANTED FOR TWO FULL YEARS

Air Alive is an all solid state unit ... it has no moving parts. The unit is so trouble free that it is warranted by Western Systems, Inc. for two full years, in the unlikely event that anything should go wrong.



FREE BOOK JUST FOR TRYING AIR ALIVE

Just for trying the Air Alive unit, we are offering a 160 page book entitled "The Ion Effect".

Absolutely Free!

It is yours at no additional charge. It's yours to keep even if you should return the Air Alive unit during our 30 day trial period. "The Ion Effect" traces one man's 10 year effort to discover the truth about the effects of ions. Judge for yourself the benefits of negative ions.

OPTIONAL AUTO ADAPTER

Now Western Systems, Inc. brings something new to the American market that Europeans have used for years ... an optional auto adapter that allows you to use your Air Alive home model in your car, truck, van or RV. Hardware included for mounting under your dashboard and adapter plugs into your cigarette lighter.

30 DAY NO-RISK TRIAL

We believe Air Alive to be the most compact negative ion generator on the market today. It will destroy the dust, smoke, pollen and odors in the air in your home, office or car.

And we want you to decide for yourself whether or not you can benefit from the effects scientists are claiming that negative ions can have on your health and sense of well being.

We offer you a 30 day, no risk trial period on every Air Alive unit you order. If during that time you decide the Air Alive unit does not meet your expectations, for any reason, you can return it for a prompt refund of the purchase price.

TO ORDER YOUR AIR ALIVE

Simply fill out the coupon and send it, along with your check or money order, to the address below. For even faster service, call Toll Free: 1-800-527-7066. In Texas call (214) 349-3120.

MEDIA MARKETING, INC.

10155-9 Plano Road • Dallas, TX 75238

Yes! Send me _____ Air Alive units at \$79.95 ea. and _____ Auto Adapters at \$8.95 ea. Add \$3.50 postage, handling and insurance charge. Texas residents add 5% sales tax.

I UNDERSTAND I HAVE A 30 DAY NO RISK RETURN OPTION.

Name _____

Address _____

City _____

State _____ Zip _____

Check or Money Order enclosed.

Charge to:

Master Charge

VISA Expires _____

Account Number _____

Signature _____

Order Toll Free: **1-800-527-7066**

In Texas Call: **1-214-349-3120**

© MMI-1979 PM068

BELOW WHOLESALE! ELECTRONIC IGNITION MODULES

(BRAIN BOXES)



\$33.00
ALL FORD TYPES

MEET OR EXCEED FACTORY O.E. SPECS



\$17.50 ALL G.M. TYPES



\$13.95 ALL CHRY TYPES

ALL ITEMS ***90 DAY GUARANTEE** MADE IN USA

TESTERS

STYLE #1 FOR

CHARGING SYS
TESTS BATTERY
REG. ALT. AND
ALT. COMPONENTS

\$13.95

STYLE #1 SHOWN



STYLE #2 FOR

ELECTRONIC IGN.
TESTS ALL IGNITION
COMPONENTS AND
PINPOINTS DEFECTIVE
PART

\$16.95

POCKET SIZE - EASY TO USE
BOTH STYLE #1 & #2 FOR \$29.95
WHEN ORDERED TOGETHER

SHIPPED WITHIN 24 HRS** UPON RECEIPT OF ORDER. Replaces factory modules that are responsible for the majority of electronic ignition failures—even if your ignition is OK now, don't be caught without a spare module. EASY TO INSTALL. Other electronic auto parts at similar savings. WRITE FOR FREE BROCHURES COVERING FULL LINE. *Refund limited to purchase price or replacement. **ADD 3 wks. delivery time for personal checks

NAME _____
ADDRESS _____
CITY _____ STATE _____ ZIP _____

TO: AMERICAN COMPONENTS Please ship me _____ (qty.)
P.O. BOX #1529 module(s) for a 19 _____
TROY, MICH. 48069 (car make)

style # _____ (qty.) pocket size tester(s)
cert. ck. or chg. my _____ Please find enclosed money order.
Exp. date _____ for the advertised price of _____
+ \$1.50 per order shipping & handling, Mich. residents add 4% sales tax.

2 Signed _____

Order Eyeglasses by Mail and Save.



Yes, prescription glasses (or your present lenses duplicated) by mail and at big savings. As low as **\$14.95**—frames, lenses, and case! Satisfaction guaranteed. Write for free catalog.

Est. 1959

All lenses, all styles.

Prism Optical, Inc., Dept. PM60

10992 N.W. 7th Ave., N. Miami, FL 33168



FREE NEW 1980 GOLF CATALOG

44 PAGES OF SUPER VALUES

Sam's World Of Golf Dept. E.
7547 Mentor Ave., Mentor, O. 44060

Our 46th Yr.

Call Toll Free 1-800-321-7048



SELF DEFENSE KUNG-FU • KARATE

Learn unbeatable fighting power
BLACK BELT INSTRUCTORS

NEW HOME STUDY COURSE
CERTIFICATE AWARDED

For details write: NEW ORIENT KARATE SCHOOL
Dept. 9F Box 5, Avon, N.J. 07717

Your home workshop can PAY-OFF

BIG...

Earn Extra Income
Right At Home.

START
YOUR OWN
MONEY
MAKING
BUSINESS!



BELSAW
3-IN-1

Power Feed
Power Tool.

SEND FOR
FACTS TODAY!

Planer Molder Saw

Three power tools in one—
a real money-maker for you!

The BELSAW Planer/Molder/Saw is a versatile piece of machinery. It turns out profitable precision molding, trim, flooring, furniture...in all popular patterns. Rips, planes, molds separately...or all at once. Used by individual home craftsman, cabinet and picture framing shops, lumber yards, contractors and carpenters.

Never before has there been a three-way, heavy-duty woodworker that does so many jobs for so little cost. Saws to width, planes to desired thickness, and molds to any choice of patterns. Cuts any molding pattern you desire. Provides trouble-free performance. And is so simple to operate even beginners can use it!

30-Day **FREE Trial!** SEND FOR EXCITING FACTS
NO OBLIGATION—NO SALESMAN WILL CALL
RUSH COUPON BELSAW POWER TOOLS
TODAY! 901H Field Building
Kansas City, MO 64111

BELSAW POWER TOOLS Co.
901H Field Building
Kansas City, MO 64111

YES, please send me the FREE Booklet that gives me complete facts about Belsaw's Planer-Molder-Saw and full details on how I can qualify for a 30-Day Free Trial right in my own shop. I understand there is No Obligation and that No Salesman will call.

Name _____

Address _____

City _____

State _____ Zip _____

MIXING FOR BETTER SOUND

(Continued from page 192)

low impedance and has a mike attenuate position that cuts the microphone amp's power. Each input has its own bass and treble controls. Color-coded pushbuttons allow you to assign any input to any or all outputs, and pan pots allow you to control the output of any input channel relative to the output.

The back-panel outputs are equally versatile. The quarter-inch microphone-inputs are supplemented by standard RCA-type line-input jacks. Above the line inputs are cue outputs that give you the signal before the input fader. They can give you a check and some insurance for another mix should you need a backup.

The dual set of line and auxiliary jacks both come after the last amplification stage—after the master fader. They give you the final signal. But the 2A also has patch points for auxiliary equipment.

The 2A has yet another set of jacks labeled "Buss In." This set can be used to gang or stack a series of mixers and control them via one master fader. You might find that the initial six inputs on your 2A are not enough and you want to use a larger mixer.

You'll notice that while the Model 2A is a sophisticated piece of equipment, it has no meters. It's not that Teac feels meters are irrelevant. Quite the reverse. Teac makes the MB-20 meter bridge, which is basically a set of four VU meters with switching and inputs and outputs.

You can use the MB-20 quite effectively. Along with the 2A, it forms a control console. The mixer's line outputs feed the tape deck. A set of four tape-in jacks provide a monitor function (front-panel selection for each channel) and four jacks provide line signals for the mixer.

As professional-type mixers go, the combination of a Teac Model 2A mixer, at \$475, and an MB-20 meter bridge, at \$250, is a real bargain. It yields all the versatility and quality most of us are likely to need. If the combination ticket is a little steep, think about getting the AudioKit 62 or just starting out with the Teac mixer and using your deck's meters. Add the Teac meter bridge later.

If the idea of recording your own sound appeals to you and you're tired of the results you're getting with microphones through your tape deck, take a serious look at a mixer. It doesn't have to cost a fortune and can give you just the creative control you need. Besides, it could well be the life of your next party.

PM



**MODEL P34A -
ULTIMATE RECREATIONAL
FRIDGE AND
FOOD WARMER** **\$189.00**
(in Canada \$199.00)

The same size, color, weight and capacity as the P34 but includes food warming features, fully adjustable temperature control and low battery warning indicator.

The P34A is our top of the line portable. It heats, it refrigerates and with specially designed electronic circuit control (patent applied for) it allows you to dial a complete range of temperatures from very cold to very warm. You wine buffs will find it indispensable to chill up to 1 doz. wine bottles at just the right temperature. Low battery indicator warns you when you need a recharge and the sensing circuits efficiently control your power consumption to save on battery drain. This is our best-of-the-line, recreational fridge and food warmer with all the bells and whistles for the discerning buyer who demands quality, size and complete versatility. Use from a cigarette lighter receptacle or plugged into house current with our optional 110 volt adaptor.

Small Fridge. Big Deal.

FROM ONLY \$129.

Space age breakthrough creates a new line of Koolatron electronic portable refrigerators and food warmers.

You're nicely away on your long-awaited vacation, camping trip or long weekend with the family. You're comfortably cruising in your car, van or rec. vehicle along a busy interstate with few rest stops or restaurants. You guessed it... the kids want to stop for a snack. But your Koolatron P34 or P34A is full of sandwiches, cold pop, fried chicken... home made, fresh and cold. The family helps themselves and you've saved valuable vacation time and another expensive restaurant bill.

You're a commuter, a salesman or a trucker and you spend many hours in your vehicle daily. Now with your amazing Koolatron P10 plugged in beside you, you open the lid and instantly fresh food and drinks are at your fingertips. Just for the price of a good cooler and one or two seasons of buying ice, (or about 10 family restaurant meals), all the marvels of home refrigeration are available electronically. An amazing space-age miracle... the thermo-electric solid state module... makes these portable refrigerators possible.

These amazing heat pumps have not only gone to the moon, but have provided the breakthrough for Koolatron's portable fridge revolution.

THOUSANDS IN USE

Koolatron now has tens of thousands of electronic fridges in use worldwide using these same powerful solid state modules. Built to take it, two of these electronic modules are encased in tough, plastic insulated chests that are designed to be rugged and trouble-free. Non-rusting hinges and latches prevent corrosion in salt water environments. And with only one moving part (a small 12 volt fan) Koolatron's portables seldom see a service depot. Now you can enjoy Koolatron's whole family of electronic portable refrigerators and food warmers that eliminate costly ice and provide "home refrigeration" convenience at sane and sensible prices.

As a travel fridge the P10 keeps foods and beverages fresh and cold wherever you go. Carry insulin, medical samples, dietetic foods. Great for private planes and golf carts. Photographers use it for films. Mothers... now you can refrigerate baby's formula in your car then heat it with the flick of a switch or keep it cold. Powerboaters, just plug it into your boat's cigarette lighter to keep a day's food and drink ice cold without going ashore for ice. With your engine off, you can operate for up to 6 hours and still start your engine. "A low battery" indicator warns you when it's time to recharge. With the power off, your P10 keeps everything hot or cold for many hours in its well insulated case.

With our optional 110 volt adaptor you'll also find endless uses wherever house current is available... at your cottage... as a bar fridge... in your motel room for a midnight snack and drink... as a small office fridge... or beside your pool. Use as an auxiliary home fridge when you're having a party.

MODEL P34 - RECREATIONAL FRIDGE

\$169.00
(in Canada
\$179.00)



Holds over 40 lbs. of food and beverages or 48 pop cans. Refrigerates in air temperatures up to 95°F. Rugged ABS case in sand beige color with dark brown non-corroding latches and handle. Large 34 litre capacity (1.2 cu. ft.) weighs 17 lbs. empty. Ext. 21" L x 16" H x 16" W. Int. 16" L x 12" H x 11 1/2" W. Operates on 12 volts DC with supplied power cord or with optional 12VDC/110VAC power adaptor.

The P34 is the full-size member of the Koolatron family of portable electronic fridges. It is designed especially for the serious traveler and outdoorsman and will refrigerate more than 3 times the contents of the P10. As a hunter, camper, boater, you'll be amazed at the capacity and convenience. Fits into any boat, van or camper or back seat of your car. Plugs into your cigarette lighter receptacle and refrigerates over 40 lbs. of food (no space wasted by ice), yet it draws no more power than the P10. With our optional 110 volt adaptor, you'll find endless uses as a bar fridge, cottage fridge, office fridge. Your P34 has all the advantages of the P10 without the heating cycle or low battery indicator but with all the capacity needed by the outdoorsman.

MODEL P10 - CAR FRIDGE & FOOD WARMER

\$129.00
(in Canada **\$139.00**)



Holds approx. 17, 12 oz. pop cans - refrigerates in air temps. up to 95°F. Also keeps hot foods hot (150°F) at the flick of a switch. Deep rich blue Polypro plastic case. Ext. 16" L x 11" H x 11 1/2" W. Int. 11" L x 8" H x 8" W. with 10 litre capacity (11 qts.) weighs 10lbs. empty. Operates from supplied 12 volt power cord in vehicles or with optional 12VDC/110VAC power adaptor.

ORDER TODAY WITHOUT OBLIGATION!

Simply complete the attached order form or phone collect and we'll rush you your portable on our no risk 21 day trial offer. Each unit comes with complete instructions and a written 1 year warranty. In the unlikely event you ever need service, we have major service centres in New York, Arizona and Canada. When you receive your Koolatron, use it constantly for 3 full weeks without risk.

If you ordered our optional 110 volt adaptor, plug it in, then use your portable immediately as a bar fridge or around the patio or pool. Next plug the fridge into your car or RV. Take your family out for a weekend trip. Enjoy fresh home-cooked food as you thumb your nose at those expensive restaurant stops. If after you've thoroughly tested it, you don't agree that your Koolatron represents a major breakthrough that will save you time, money and bother for years to come, send it back for a full refund. You can't lose... we guarantee it.

So be among the thousands to discover that the ice age is over. Don't waste another dollar on ice... order your Koolatron with no obligation today!

For rush delivery phone your order in collect to:

0-705-737-0842

Koolatron Industries Limited
56 Harvester Ave., Batavia, New York 14020
230 Bayview Drive, Barrie, Ontario, Canada
Or use this handy order coupon.

Koolatron

Dept. 1161

Industries Limited
56 Harvester Avenue, Batavia, New York 14020
Canada: 230 Bayview Drive, Barrie, Ontario L4N 4Y8

Send me with full refund privileges:

- ___ Koolatron P10 at \$129.00 (\$139.00 in Canada)
 - ___ Koolatron P34 at \$169.00 (\$179.00 in Canada)
 - ___ Koolatron P34A at \$189.00 (\$199.00 in Canada)
 - ___ Koolatron 110V adaptor at \$29.95 (\$34.95 in Canada)
- Please add \$8.00 for handling and delivery per unit.
No charge for shipping adaptor if ordered with unit.
Add \$3.00 for shipping adaptor by itself.
(N.Y., Ont. and Quebec residents add sales tax.)

I understand that I may return any item undamaged within 21 days and receive a full refund if I am not satisfied.

I enclose my check or money order for \$ _____ or please charge it to my Visa Mastercharge American Express

Account Number _____

Expiry Date _____

Signature _____
(necessary to send merchandise)

NAME _____

ADDRESS _____

CITY _____ STATE _____

ZIP CODE _____ PHONE _____

Sharpen your chain saw like a pro!

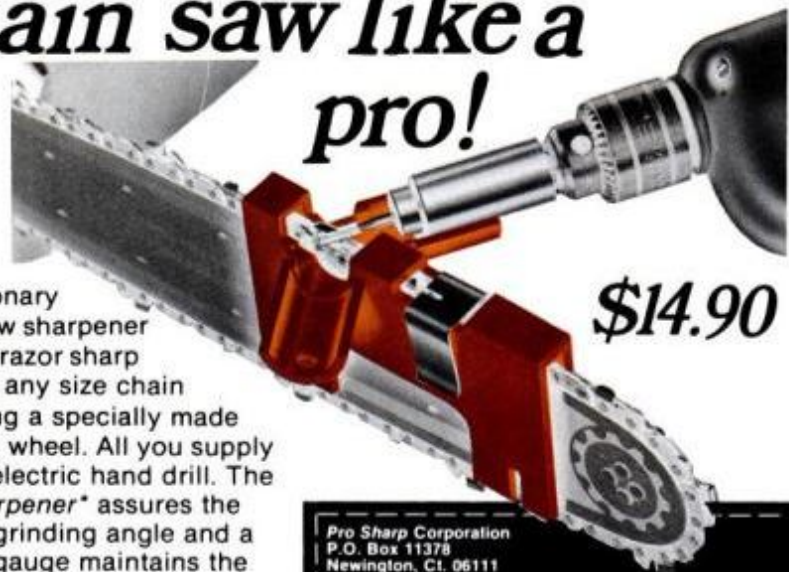

\$14.90

This revolutionary chain saw sharpener grinds a razor sharp edge on any size chain saw using a specially made grinding wheel. All you supply is a 1/4" electric hand drill. The *Pro Sharpener** assures the correct grinding angle and a built-in gauge maintains the proper guide height.

The *Pro Sharpener* produces a ground edge—much sharper than a filed edge. Comes complete with three grinding wheels (enough for up to 30 sharpenings) plus a hand file adapter.

*Patents pending

Pro Sharp Corporation
P.O. Box 11378
Newington, Ct. 06111

Please rush *Pro Sharpener(s)* at \$14.90 each plus \$1.95 postage and handling per unit (\$3.00 outside U.S.). Send check, money order or Master Charge. No C.O.D.'s.

M.C. # _____

Inter Bank No. _____ Exp. Date _____
Conn. Residents add 7% sales tax.

Name _____

Address _____

City _____ State _____ Zip _____

Important: To insure correct grinding wheel size
Indicate your Chain Saw Mfg.
Saw Model: _____

30 Day Unconditional money back guarantee.

Your

CONSERVE ENERGY

Electrify your Bike...

PEDALPOWER-Exciting new powerful electric drive for bikes. Tames tough hills. Be independent. Shop when you want. Fits all bikes and adult trikes. Easy to use and install. Beat high gas prices. Recharges overnight at home. Travel 100 miles for a dime.

Get your exercise without strain. Pedal easily with motor engaged to help improve your health. Visit friends. Travel to work or ride for fun. Starts without pedaling. Noiseless, non-polluting. Virtually maintenance-free operation!

Thousands in use today by senior citizens, students, housewives, workers, handicapped and professionals. Call today or write for free booklet with complete details on PEDALPOWER motors, Take-Apart Electric Bikes and Adult Electric Tricycles.



Call Toll Free
800-257-7955*

For this **FREE BOOKLET**
& Special Offer or Write:

PEDALPOWER

General Engines Co.
5807 Mantua Blvd.
Sewell, NJ 08080



* In AK, HI, NJ call collect (609) 468-0270

APPROVED FOR VETERANS Learn how to **MAKE MONEY** in **DRAFTING**

Train at home in spare time. No previous experience needed. Tools and materials included with course. No special talent required. We show you what to do, how to do it. **LEARN DRAFTING! AT HOME!**

FREE! "CAREER KIT" NAME _____ AGE _____
ADDRESS _____

Accredited CITY _____ STATE _____ ZIP _____
National NORTH AMERICAN SCHOOL OF DRAFTING,
Home Study 4500 Campus Dr., Dept. PB050, Newport Beach, CA 92660
Council

GARAGE DOOR OPENERS

Radio Controlled

• Buy Factory Direct and Save
• Thousands In Use • Free Brochure
• Easy Homeowner Installation
• Immediate Shipment by UPS or PP

HELPMATE Equipment Co. Dept. PM6-80 Baroda, MI 49101

BREW YOUR OWN FUEL

BROWN'S ALCOHOL MOTOR FUEL COOKBOOK

Contains step-by-step procedures for the making and using alcohol as a motor fuel. How to build your own home still, how to modify your car's carburetor to run on alcohol & other engine modification to get up to 100 miles per gallon, & much more. Loaded with large clear photos, you'll be amazed at how easy it really is. Don't hesitate order your copy today! 1 Book No. 300.....\$9.95 postpaid

DESERT PUBLICATIONS
DEPT. PM - CORNVILLE, ARIZONA 86325

SAVE GAS IN A FLASH!
"GAS LIGHT" VACUUM GAUGE.

Improve your driving habits. Maintain steady gas pedal pressure. Green, yellow and red lights flash indicating good, fair or poor gas mileage. Snap-out face-plate for horizontal or vertical mounting. Get maximum power from every drop of gasoline. You could improve gas mileage up to 30%!

Featured in the March Popular Mechanics. Money-back guarantee, if returned within seven days. **\$17.95**

PALPAC
P.O. Box 1172 Pacific Palisades, CA 90272

Send me _____ Gas Light Vacuum Gauges at \$17.95 each. Enclosed check or money order \$ _____. Add \$1.50 for postage and handling. Also send me the Tune-Up Guide (with 72 "How To" tune-up tips) for \$2.50. Add \$1.50 for guide postage and handling. Please allow four weeks for delivery.

Name _____
Address _____
City _____ State _____ Zip _____

Call toll free — 1-800-621-5809
Master Charge and Visa.
Card # MC _____
Visa _____

USE ZIP CODE WHEN ANSWERING

**PUBLIC NOTICE!
BANKRUPTCY**

**and Financially
Distressed Merchandise!**

We are authorized liquidators of large inventories that must be quickly sold at sacrifice prices because of a variety of reasons such as:

- Manufacturers' overproduction
- Last year's models
- Bankruptcy
- Sheriff's sale
- Bank loan foreclosure
- Insurance claim sale

If your company finds itself in any situation that requires it to sell large inventories for immediate cash, call us! Only products in perfect operating condition... or slight blemishes that do not affect operating performance... will be considered. Call toll-free: 800-328-5082.

**MUST LIQUIDATE
AT FAR BELOW DEALER COST!
3-Speed, Horizontal & Vertical
3/4 hp. 6" BAND SAW
Heavy-Duty for Steel, Iron, Copper, Wood, Plastic, etc.**

**CUTS STEEL UP TO 4 1/2" ROUND,
UP TO 4" X 6" RECTANGULAR!**

Here's a big, rugged, heavyweight band saw with plenty of power to slice through steel up to 6 inches thick! It saws easily through any shape stock — flat, bar, square, channel, tube. Use it to saw lumber, plastic, copper, brass, aluminum, iron, with proper saw blade. Comes with standard 1/2" blade, 64 1/2" long. Blade rides on big 7 1/2" bandwheel.

For horizontal cuts, you can vise-lock work in position and walk away. Automatic shut-off turns off machine when cut is completed. Tension control spring adjusts quickly to feed blade at proper rate of speed for smoothest cutting. It cuts in vertical position, too, so you can slit, notch or cut contour shapes! An ideal cutting tool for your workshop!

- 1 Cuts up to 4 1/2" round stock; up to 4" x 6" rectangular stock.
- 2 3/4 hp. capacitor start motor gives plenty of power. Three-prong plug fits 110V outlet.
- 3 Steel and bronze gears; worm gear drive for smooth, long-lasting performance.
- 4 Easy adjustment for blade tension.
- 5 Adjustable roller guides; ball bearing thrust guide to keep blade rigid for most effective cutting. Prevents loose blades that break.
- 6 Heavy duty stand for firm, sturdy support.
- 7 Heavily ribbed cast iron saw bow for mass weight and rigidity plus reinforcement.
- 8 Heavy duty metal work stop lets you repeat same length cut, time after time.
- 9 Handy tool shelf with slight V-shape to keep tools from falling off.
- 10 Head support allows for quick work change without lifting saw head all the way up.
- 11 Equipped with NEMA 56 motor frame.
- 12 Easy access for change of blade.

Includes 18-page operating manual!

\$470.00 value!

NOW... while they last:

\$198

AMERICAN EXPRESS

Master Charge

VISA

Credit card customers can phone their order:
Toll-Free: 800-328-5082
In Minnesota, call collect: 612-729-2345.

C.O.M.B. Co.

THE NATION'S LARGEST AUTHORIZED MAIL ORDER LIQUIDATOR OF CONSUMER PRODUCTS
3258 MINNEHAHA / MINNEAPOLIS, MN 55406
Phone: 612-729-2345 Toll-Free: 800 328-5082

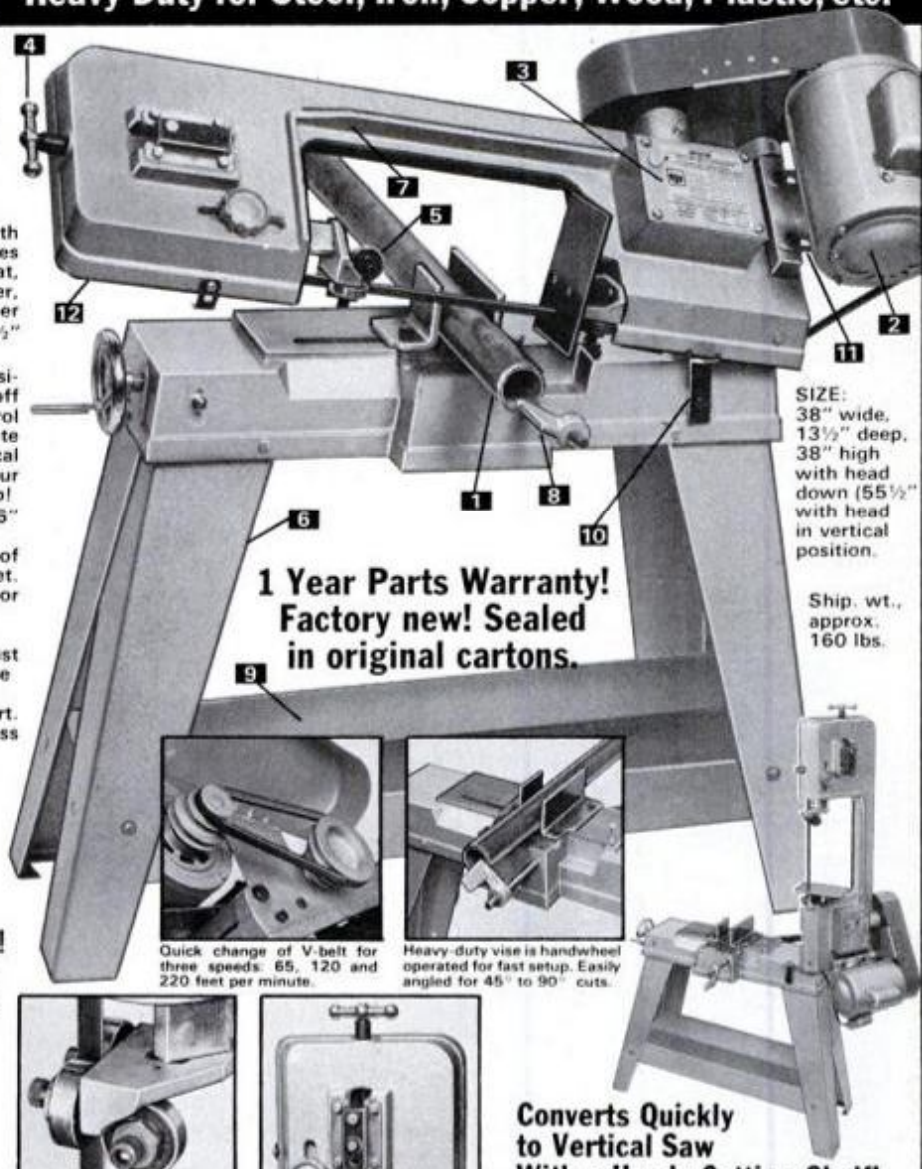

**1 Year Parts Warranty!
Factory new! Sealed
in original cartons.**

SIZE:
38" wide,
13 1/2" deep,
38" high
with head
down (55 1/2"
with head
in vertical
position.

Ship. wt.,
approx.
160 lbs.



Quick change of V-belt for three speeds: 65, 120 and 220 feet per minute.

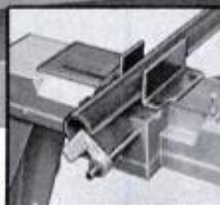

Heavy-duty vise is handwheel operated for fast setup. Easily angled for 45° to 90° cuts.

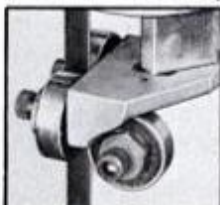

Blade guide arm adjusts for size of work; gives maximum rigidity to blade for squareness and accuracy.

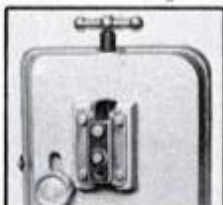

Idler bandwheel mounted on gibbs for alignment adjustment, accuracy and proper blade travel.

**Converts Quickly
to Vertical Saw
With a Handy Cutting Shelf!**

The saw head tilts back for use as a vertical saw! A handy cutting table is included. You can notch, slit or cut contour shapes using the shelf for support. It's like having two saws in one!

C.O.M.B. Co. / Authorized Liquidators Dept. B-136
3258 Minnehaha Avenue S., Minneapolis, Minn. 55406

Send me _____ Heavy Duty Band Saw(s) at \$198.00 each. I will pay shipping charges to the driver upon delivery. (Allow 5 weeks for delivery. If paid for by personal check, allow an additional 2-3 weeks for check to clear.) Sorry, no C.O.D. orders.

My check or money order is enclosed.

Charge to: Mastercharge VISA American Express

Account No. _____ Expires _____

PLEASE PRINT CLEARLY

Name _____

Address _____

City _____

State _____ ZIP _____ Phone _____

Rural Route Customer: If truck carriers do not normally deliver to your home, include a note with this order, stating nearest town address of store, friend, truck terminal where we can ship.



FREE BLUEPRINTS and TRIAL LESSON —for your greater success in Building

Beginners, craftsmen, even foremen and superintendents, have sent for these free blueprints and trial lesson in Plan Reading as a means of trying out Chicago Tech's home-study Builders training. See how you can learn Plan Reading, Estimating and the practical details of all types of construction in your spare time at home. Mail coupon or phone TOLL FREE today for your free ranch home blueprints, trial lesson and catalog on CTC Builders training.

• PHONE TOLL FREE (24 HRS.)
1-800-528-6050 Ext. 810

CHICAGO TECH/School for Builders
2000 S. Michigan Avenue, Chicago, Ill. 60616

CHICAGO TECH/School for Builders Veterans
Dept. PM-50 2000 S. Michigan Ave., Check
Chicago, Ill. 60616 Here

Please mail me a Free Trial Lesson, Blueprints and Builders Catalog. I understand there is no obligation—no salesman will call.

NAME _____ AGE _____
ADDRESS _____
CITY _____ STATE _____ ZIP _____

SUPER-TOUGH CLEAR FINISH.



SUPER-EASY WATER CLEAN-UP.

PEN-CHROME® SUPER V.

At last! A durable, crystal clear, non-yellowing wood finish that's water-based. Created by Fuller-O'Brien, Pen-Chrome Super V is a true urethane coating and comes in flat, satin and high gloss. It's super!

Available at your Fuller-O'Brien Pro Shop.

PM LOOKS AT ECHO'S MIST BLOWER



Large, 13-liter capacity of mist blower's chemical tank permits uninterrupted use.

Spraying my tall trees and thick shrubs had been frustrating because my equipment wasn't powerful enough. After trying the Echo MB 400 Mist Blower, I'm convinced that it's the way to go.

The gas-powered, back-pack unit is sturdy yet lightweight. The misting nozzle can be adjusted for a straight or wide spray pattern by shifting collar behind the nozzle.

A four-position discharge valve controls the rate of flow from 0.6 to 3.5 liters per minute. An optional dusting attachment, now under development, will soon be available.—Rosario Capotosto

SPECIFICATIONS—MB 400 MIST BLOWER

Weight: 25.4 lbs.
Engine: gasoline (2-cycle), air-cooled, single cylinder
Blower: centrifugal type, 8000 rpm
Chemical tank capacity: 3.4 gal. (13 liters)
Price: about \$300
Manufacturer: Echo Inc., 3150 MacArthur Blvd., Northbrook, Ill. 60062



A rubber plug covers the port for optional dusting attachment now being designed.



The chemical tank has a fine mesh filter and a wide mouth for easy filling.



Four-position valve controls flow rate. Collar behind nozzle sets spray pattern.



To start unit, pull 1/2 to 2/3 of the rope on the automatic-rewind recoil starter.

INTRODUCING THE

RotorWaycExec

THE LATEST ADDITION TO THE ROTORWAY FAMILY OF FINE HELICOPTERS

Ask any helicopter enthusiast and he'll tell you that the small gas turbine is what gave life to the present generation of executive helicopters. The turbine's high horsepower/weight ratio and the ability to fully enclose it in a streamlined fuselage made the helicopter go as fast as a fixed wing, but still with the ability to land most anywhere. Incredible speed and ultimate landing versatility along with the capability of birdlike power-off-landings makes the executive helicopter the ultimate transportation machine. There's only one drawback, it's expensive! Only large corporations seem to have the opportunity of utilizing these aircraft.

For years RotorWay's been working hard to change all this and finally it's happened! Oh yes, we're still using piston power, but there's no comparison to the aircraft engine of yesterday. We designed our power plant to be water cooled, so we can fully enclose it. The RotorWay engine is made of lightweight aluminum and it also has an impressive h.p./weight ratio, but it burns 30% less fuel than most turbines. Since we designed this engine specifically for helicopter use and since it's manufactured by us right down to its crankshaft, we had the opportunity to achieve this unparalleled efficiency.

It's not just the power plant that makes the Exec go fast, it's also a fully streamlined teardrop fuselage, coupled with an efficient, sturdy rotor system that has just the right disc loading and solidity ratio for feather smooth flight. Of course, the best news of all is the price. Now you don't need to be president of G.M. to own an executive helicopter. You can hangar the RotorWay Exec in your garage and you won't have to lease it out to pay for it. The Exec won't cost you \$5,000.00 to learn to fly, we'll teach you ourselves since the basic training is included. In addition, local RotorWay Service Centers are now being established to service your helicopter. Send for the RotorWay program evaluation package today.

Send me all the information on the RotorWay helicopters immediately.

Enclosed is \$10.00 (\$12.50 Foreign)

Charge to MasterCard VISA

(Acct. #) _____ (Exp. Date) _____

(Signature) _____

Name _____

Address _____

City _____ State _____ Zip _____

ROTORWAY AIRCRAFT INC.

14805 S. I-10, TEMPE, AZ 85284

OPM6

Send for the colorfully illustrated package of information on the RotorWay helicopters. 65 pages of exciting photos, diagrams, charts and information especially prepared to assist you in evaluating the RotorWay Exec and the Scorpion 133. Contains specifications, design and construction features, operational and cost comparison, the RotorWay Story, an extensive commentary on RotorWay and the history and development of helicopters, glossary of terms, synopsis of helicopter theory, principles of flight, time view drawings and price lists, and a copy of the current month's "Sport Helicopter" newsletter, plus a special offer.

TURBINE SPEED AND
SAVING ON INEXPENSIVE
PISTON POWER

RotorWay
AIRCRAFT INC.

14805 S. Interstate 10 • Tempe, Arizona 85284

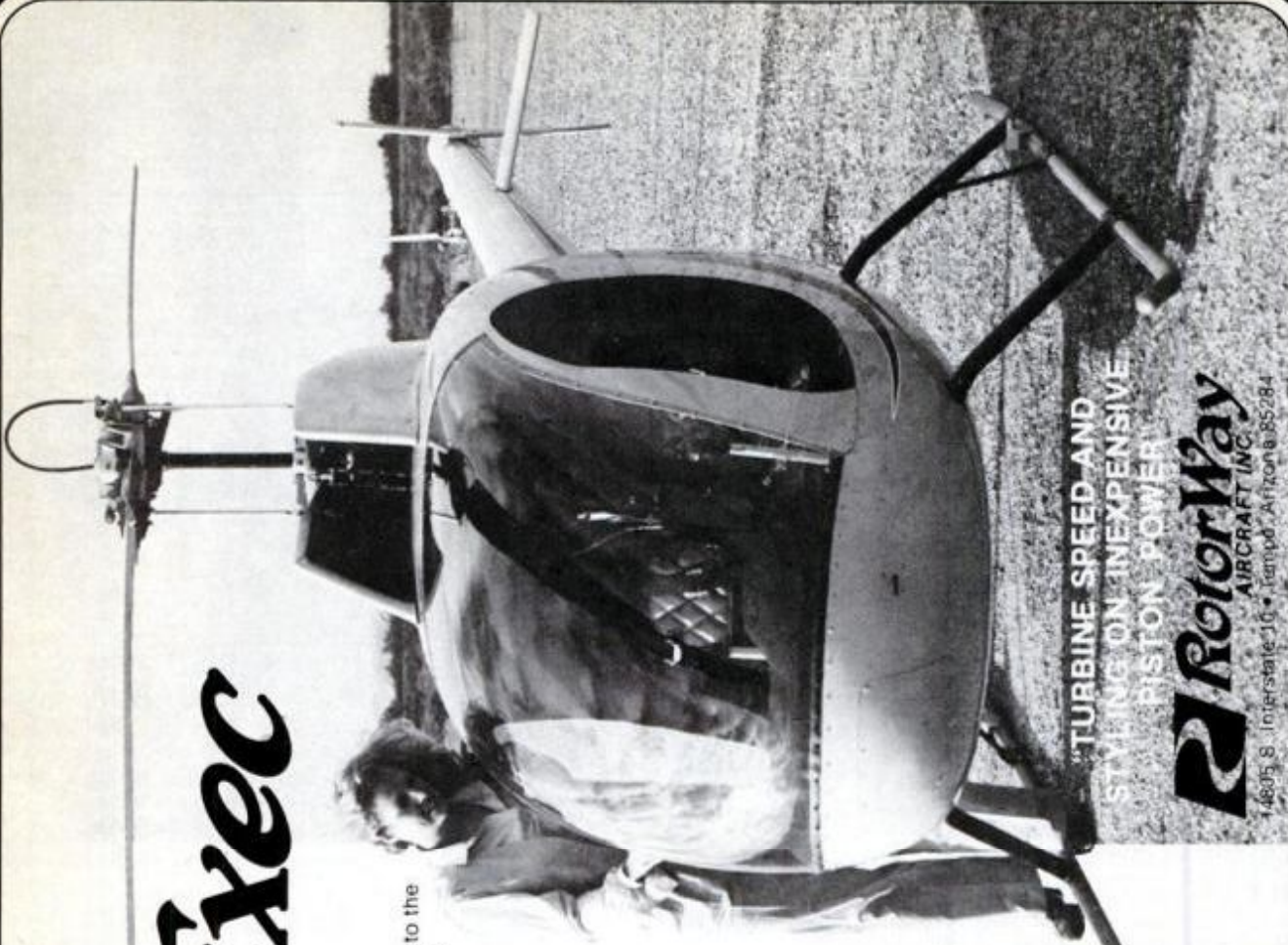

Bicycling Magazine

The Necessary Accessory

There's more to serious cycling than meets the eye. And unless you're already a bike expert, you'll need the authoritative advice you'll find in every issue of BICYCLING magazine.

- **Touring** — Where to go, how to get there, and how to plan, pack and train for your trip.
- **Road Tests and Consumer Guides** — Bike and equipment evaluations you can't afford to miss.
- **Maintenance and Repair** — How to keep your wheels rolling.
- **Cycling Technique** — Increase your riding efficiency!

BICYCLING magazine is necessary because it's your complete guide to bikes and biking. And, if you act now, you can "test ride" BICYCLING at a big savings — \$3.50 off the regular newsstand price.



SPECIAL INTRODUCTORY OFFER

YES! I'd like to give BICYCLING magazine a whirl. Please enter a one-year (9 issues) trial subscription in my name. If I like what I see in my first issue, I'll pay just \$10.00. If not, I'll write "cancel" on the invoice, return it, and owe nothing. The first issue is mine to keep regardless. 80085

NAME _____
 ADDRESS _____
 CITY _____ STATE _____ ZIP _____

SAVE MORE by ordering 18 issues for \$18.00.
 My payment is enclosed to speed processing.

BICYCLING, Emmaus, PA 18049

BUMPER STICKER PRINTING DEVICE

SIMPLE, CHEAP, PORTABLE
 ANY MESSAGE IN MINUTES
 SEND FOR **FREE DETAILS**

BUMPER—MAGIC
 P.O. BOX 22791 (GC)
 TAMPA, FLA. 33622

SATELLITE TV GET 50 CHANNELS!

It's all true! No matter where you live receive movies, sports, pay television, sports from around the world! 24-hour programming! Crystal clear reception! For complete information, sources and design information, send \$7.95.

SPACECOAST RESEARCH
 Dept. E, P.O. Box 442, Altamonte Springs, FL 32701



New Technology!

Cruise Director.

Enjoy a new sense of direction and get lost less often with an Airguide auto compass. Model 1601 (shown) is self-illuminated... has adjustable compensators and adhesive mount. At retail stores. Write for catalog A.



Airguide
 2212 Wabansia Chicago 60647

Telephone Listening Device

Record telephone conversations in your office or home. Connects between any cassette or tape recorder and your telephone or telephone LINE. Starts automatically when phone is answered. Records both sides of phone conversation. Stops recorder when phone is hung up. This device is not an answering service.



Each **\$18.95**
 Qty Disc Avail

Super Powerful Wireless Mic

10 times more powerful than other mics. Transmits up to 1/4 mile on any FM radio. Easy to assemble kit. 15V battery (not incl.)

Call (305) 725-1000 or send \$18.95 + \$1.00 shipping per item to USI Corp., P.O. Box PM-2052, Melbourne, FL 32901. COD's accept. For catalog of transmitters, voice scramblers and other specialty items, enclose \$2.00 to USI Corp.



PROPANE CONVERSION



Never enter a gas line again! Convert your vehicle to propane now... for under \$150. Made with locally available parts and common hand tools. Sound to good to be true? BELIEVE IT! It really works great, switch from gas to propane WHILE DRIVING! I figured out a way to do it, and I'll show you how. Send me \$10 and receive a detailed set of plans by return mail. If you're not COMPLETELY satisfied, return them within seven days, and I'll cheerfully refund your \$10. **DETAIL SPECIALTIES, P.O. Box 22, Dept. P-680, Torrance, CA 90507.**

Portable Steam Cleaner

Steam in 60 seconds
CLEAN: Engines, Air Filters, Lawn Mowers. 3 year guarantee on fire box, coils. Uses liquid soap, propane fired. Weight 120 lbs. Auxiliary pump required on low water pressure.



WEDCO MFG. INC., Dept. M-11
 Scott Lane • Box D, Jackson, WY. 83001

DELTA GLIDER

THE ORIGINAL GLIDER... \$3.25
 This is the most popular glider...
 Includes: 1. 1/2" x 1/2" x 1/2" glider...
 2. 1/2" x 1/2" x 1/2" glider...
 3. 1/2" x 1/2" x 1/2" glider...
 4. 1/2" x 1/2" x 1/2" glider...
 5. 1/2" x 1/2" x 1/2" glider...
 6. 1/2" x 1/2" x 1/2" glider...
 7. 1/2" x 1/2" x 1/2" glider...
 8. 1/2" x 1/2" x 1/2" glider...
 9. 1/2" x 1/2" x 1/2" glider...
 10. 1/2" x 1/2" x 1/2" glider...
 11. 1/2" x 1/2" x 1/2" glider...
 12. 1/2" x 1/2" x 1/2" glider...
 13. 1/2" x 1/2" x 1/2" glider...
 14. 1/2" x 1/2" x 1/2" glider...
 15. 1/2" x 1/2" x 1/2" glider...
 16. 1/2" x 1/2" x 1/2" glider...
 17. 1/2" x 1/2" x 1/2" glider...
 18. 1/2" x 1/2" x 1/2" glider...
 19. 1/2" x 1/2" x 1/2" glider...
 20. 1/2" x 1/2" x 1/2" glider...
 21. 1/2" x 1/2" x 1/2" glider...
 22. 1/2" x 1/2" x 1/2" glider...
 23. 1/2" x 1/2" x 1/2" glider...
 24. 1/2" x 1/2" x 1/2" glider...
 25. 1/2" x 1/2" x 1/2" glider...
 26. 1/2" x 1/2" x 1/2" glider...
 27. 1/2" x 1/2" x 1/2" glider...
 28. 1/2" x 1/2" x 1/2" glider...
 29. 1/2" x 1/2" x 1/2" glider...
 30. 1/2" x 1/2" x 1/2" glider...
 31. 1/2" x 1/2" x 1/2" glider...
 32. 1/2" x 1/2" x 1/2" glider...
 33. 1/2" x 1/2" x 1/2" glider...
 34. 1/2" x 1/2" x 1/2" glider...
 35. 1/2" x 1/2" x 1/2" glider...
 36. 1/2" x 1/2" x 1/2" glider...
 37. 1/2" x 1/2" x 1/2" glider...
 38. 1/2" x 1/2" x 1/2" glider...
 39. 1/2" x 1/2" x 1/2" glider...
 40. 1/2" x 1/2" x 1/2" glider...
 41. 1/2" x 1/2" x 1/2" glider...
 42. 1/2" x 1/2" x 1/2" glider...
 43. 1/2" x 1/2" x 1/2" glider...
 44. 1/2" x 1/2" x 1/2" glider...
 45. 1/2" x 1/2" x 1/2" glider...
 46. 1/2" x 1/2" x 1/2" glider...
 47. 1/2" x 1/2" x 1/2" glider...
 48. 1/2" x 1/2" x 1/2" glider...
 49. 1/2" x 1/2" x 1/2" glider...
 50. 1/2" x 1/2" x 1/2" glider...
 51. 1/2" x 1/2" x 1/2" glider...
 52. 1/2" x 1/2" x 1/2" glider...
 53. 1/2" x 1/2" x 1/2" glider...
 54. 1/2" x 1/2" x 1/2" glider...
 55. 1/2" x 1/2" x 1/2" glider...
 56. 1/2" x 1/2" x 1/2" glider...
 57. 1/2" x 1/2" x 1/2" glider...
 58. 1/2" x 1/2" x 1/2" glider...
 59. 1/2" x 1/2" x 1/2" glider...
 60. 1/2" x 1/2" x 1/2" glider...
 61. 1/2" x 1/2" x 1/2" glider...
 62. 1/2" x 1/2" x 1/2" glider...
 63. 1/2" x 1/2" x 1/2" glider...
 64. 1/2" x 1/2" x 1/2" glider...
 65. 1/2" x 1/2" x 1/2" glider...
 66. 1/2" x 1/2" x 1/2" glider...
 67. 1/2" x 1/2" x 1/2" glider...
 68. 1/2" x 1/2" x 1/2" glider...
 69. 1/2" x 1/2" x 1/2" glider...
 70. 1/2" x 1/2" x 1/2" glider...
 71. 1/2" x 1/2" x 1/2" glider...
 72. 1/2" x 1/2" x 1/2" glider...
 73. 1/2" x 1/2" x 1/2" glider...
 74. 1/2" x 1/2" x 1/2" glider...
 75. 1/2" x 1/2" x 1/2" glider...
 76. 1/2" x 1/2" x 1/2" glider...
 77. 1/2" x 1/2" x 1/2" glider...
 78. 1/2" x 1/2" x 1/2" glider...
 79. 1/2" x 1/2" x 1/2" glider...
 80. 1/2" x 1/2" x 1/2" glider...
 81. 1/2" x 1/2" x 1/2" glider...
 82. 1/2" x 1/2" x 1/2" glider...
 83. 1/2" x 1/2" x 1/2" glider...
 84. 1/2" x 1/2" x 1/2" glider...
 85. 1/2" x 1/2" x 1/2" glider...
 86. 1/2" x 1/2" x 1/2" glider...
 87. 1/2" x 1/2" x 1/2" glider...
 88. 1/2" x 1/2" x 1/2" glider...
 89. 1/2" x 1/2" x 1/2" glider...
 90. 1/2" x 1/2" x 1/2" glider...
 91. 1/2" x 1/2" x 1/2" glider...
 92. 1/2" x 1/2" x 1/2" glider...
 93. 1/2" x 1/2" x 1/2" glider...
 94. 1/2" x 1/2" x 1/2" glider...
 95. 1/2" x 1/2" x 1/2" glider...
 96. 1/2" x 1/2" x 1/2" glider...
 97. 1/2" x 1/2" x 1/2" glider...
 98. 1/2" x 1/2" x 1/2" glider...
 99. 1/2" x 1/2" x 1/2" glider...
 100. 1/2" x 1/2" x 1/2" glider...
 101. 1/2" x 1/2" x 1/2" glider...
 102. 1/2" x 1/2" x 1/2" glider...
 103. 1/2" x 1/2" x 1/2" glider...
 104. 1/2" x 1/2" x 1/2" glider...
 105. 1/2" x 1/2" x 1/2" glider...
 106. 1/2" x 1/2" x 1/2" glider...
 107. 1/2" x 1/2" x 1/2" glider...
 108. 1/2" x 1/2" x 1/2" glider...
 109. 1/2" x 1/2" x 1/2" glider...
 110. 1/2" x 1/2" x 1/2" glider...
 111. 1/2" x 1/2" x 1/2" glider...
 112. 1/2" x 1/2" x 1/2" glider...
 113. 1/2" x 1/2" x 1/2" glider...
 114. 1/2" x 1/2" x 1/2" glider...
 115. 1/2" x 1/2" x 1/2" glider...
 116. 1/2" x 1/2" x 1/2" glider...
 117. 1/2" x 1/2" x 1/2" glider...
 118. 1/2" x 1/2" x 1/2" glider...
 119. 1/2" x 1/2" x 1/2" glider...
 120. 1/2" x 1/2" x 1/2" glider...
 121. 1/2" x 1/2" x 1/2" glider...
 122. 1/2" x 1/2" x 1/2" glider...
 123. 1/2" x 1/2" x 1/2" glider...
 124. 1/2" x 1/2" x 1/2" glider...
 125. 1/2" x 1/2" x 1/2" glider...
 126. 1/2" x 1/2" x 1/2" glider...
 127. 1/2" x 1/2" x 1/2" glider...
 128. 1/2" x 1/2" x 1/2" glider...
 129. 1/2" x 1/2" x 1/2" glider...
 130. 1/2" x 1/2" x 1/2" glider...
 131. 1/2" x 1/2" x 1/2" glider...
 132. 1/2" x 1/2" x 1/2" glider...
 133. 1/2" x 1/2" x 1/2" glider...
 134. 1/2" x 1/2" x 1/2" glider...
 135. 1/2" x 1/2" x 1/2" glider...
 136. 1/2" x 1/2" x 1/2" glider...
 137. 1/2" x 1/2" x 1/2" glider...
 138. 1/2" x 1/2" x 1/2" glider...
 139. 1/2" x 1/2" x 1/2" glider...
 140. 1/2" x 1/2" x 1/2" glider...
 141. 1/2" x 1/2" x 1/2" glider...
 142. 1/2" x 1/2" x 1/2" glider...
 143. 1/2" x 1/2" x 1/2" glider...
 144. 1/2" x 1/2" x 1/2" glider...
 145. 1/2" x 1/2" x 1/2" glider...
 146. 1/2" x 1/2" x 1/2" glider...
 147. 1/2" x 1/2" x 1/2" glider...
 148. 1/2" x 1/2" x 1/2" glider...
 149. 1/2" x 1/2" x 1/2" glider...
 150. 1/2" x 1/2" x 1/2" glider...
 151. 1/2" x 1/2" x 1/2" glider...
 152. 1/2" x 1/2" x 1/2" glider...
 153. 1/2" x 1/2" x 1/2" glider...
 154. 1/2" x 1/2" x 1/2" glider...
 155. 1/2" x 1/2" x 1/2" glider...
 156. 1/2" x 1/2" x 1/2" glider...
 157. 1/2" x 1/2" x 1/2" glider...
 158. 1/2" x 1/2" x 1/2" glider...
 159. 1/2" x 1/2" x 1/2" glider...
 160. 1/2" x 1/2" x 1/2" glider...
 161. 1/2" x 1/2" x 1/2" glider...
 162. 1/2" x 1/2" x 1/2" glider...
 163. 1/2" x 1/2" x 1/2" glider...
 164. 1/2" x 1/2" x 1/2" glider...
 165. 1/2" x 1/2" x 1/2" glider...
 166. 1/2" x 1/2" x 1/2" glider...
 167. 1/2" x 1/2" x 1/2" glider...
 168. 1/2" x 1/2" x 1/2" glider...
 169. 1/2" x 1/2" x 1/2" glider...
 170. 1/2" x 1/2" x 1/2" glider...
 171. 1/2" x 1/2" x 1/2" glider...
 172. 1/2" x 1/2" x 1/2" glider...
 173. 1/2" x 1/2" x 1/2" glider...
 174. 1/2" x 1/2" x 1/2" glider...
 175. 1/2" x 1/2" x 1/2" glider...
 176. 1/2" x 1/2" x 1/2" glider...
 177. 1/2" x 1/2" x 1/2" glider...
 178. 1/2" x 1/2" x 1/2" glider...
 179. 1/2" x 1/2" x 1/2" glider...
 180. 1/2" x 1/2" x 1/2" glider...
 181. 1/2" x 1/2" x 1/2" glider...
 182. 1/2" x 1/2" x 1/2" glider...
 183. 1/2" x 1/2" x 1/2" glider...
 184. 1/2" x 1/2" x 1/2" glider...
 185. 1/2" x 1/2" x 1/2" glider...
 186. 1/2" x 1/2" x 1/2" glider...
 187. 1/2" x 1/2" x 1/2" glider...
 188. 1/2" x 1/2" x 1/2" glider...
 189. 1/2" x 1/2" x 1/2" glider...
 190. 1/2" x 1/2" x 1/2" glider...
 191. 1/2" x 1/2" x 1/2" glider...
 192. 1/2" x 1/2" x 1/2" glider...
 193. 1/2" x 1/2" x 1/2" glider...
 194. 1/2" x 1/2" x 1/2" glider...
 195. 1/2" x 1/2" x 1/2" glider...
 196. 1/2" x 1/2" x 1/2" glider...
 197. 1/2" x 1/2" x 1/2" glider...
 198. 1/2" x 1/2" x 1/2" glider...
 199. 1/2" x 1/2" x 1/2" glider...
 200. 1/2" x 1/2" x 1/2" glider...
 201. 1/2" x 1/2" x 1/2" glider...
 202. 1/2" x 1/2" x 1/2" glider...
 203. 1/2" x 1/2" x 1/2" glider...
 204. 1/2" x 1/2" x 1/2" glider...
 205. 1/2" x 1/2" x 1/2" glider...
 206. 1/2" x 1/2" x 1/2" glider...
 207. 1/2" x 1/2" x 1/2" glider...
 208. 1/2" x 1/2" x 1/2" glider...
 209. 1/2" x 1/2" x 1/2" glider...
 210. 1/2" x 1/2" x 1/2" glider...
 211. 1/2" x 1/2" x 1/2" glider...
 212. 1/2" x 1/2" x 1/2" glider...
 213. 1/2" x 1/2" x 1/2" glider...
 214. 1/2" x 1/2" x 1/2" glider...
 215. 1/2" x 1/2" x 1/2" glider...
 216. 1/2" x 1/2" x 1/2" glider...
 217. 1/2" x 1/2" x 1/2" glider...
 218. 1/2" x 1/2" x 1/2" glider...
 219. 1/2" x 1/2" x 1/2" glider...
 220. 1/2" x 1/2" x 1/2" glider...
 221. 1/2" x 1/2" x 1/2" glider...
 222. 1/2" x 1/2" x 1/2" glider...
 223. 1/2" x 1/2" x 1/2" glider...
 224. 1/2" x 1/2" x 1/2" glider...
 225. 1/2" x 1/2" x 1/2" glider...
 226. 1/2" x 1/2" x 1/2" glider...
 227. 1/2" x 1/2" x 1/2" glider...
 228. 1/2" x 1/2" x 1/2" glider...
 229. 1/2" x 1/2" x 1/2" glider...
 230. 1/2" x 1/2" x 1/2" glider...
 231. 1/2" x 1/2" x 1/2" glider...
 232. 1/2" x 1/2" x 1/2" glider...
 233. 1/2" x 1/2" x 1/2" glider...
 234. 1/2" x 1/2" x 1/2" glider...
 235. 1/2" x 1/2" x 1/2" glider...
 236. 1/2" x 1/2" x 1/2" glider...
 237. 1/2" x 1/2" x 1/2" glider...
 238. 1/2" x 1/2" x 1/2" glider...
 239. 1/2" x 1/2" x 1/2" glider...
 240. 1/2" x 1/2" x 1/2" glider...
 241. 1/2" x 1/2" x 1/2" glider...
 242. 1/2" x 1/2" x 1/2" glider...
 243. 1/2" x 1/2" x 1/2" glider...
 244. 1/2" x 1/2" x 1/2" glider...
 245. 1/2" x 1/2" x 1/2" glider...
 246. 1/2" x 1/2" x 1/2" glider...
 247. 1/2" x 1/2" x 1/2" glider...
 248. 1/2" x 1/2" x 1/2" glider...
 249. 1/2" x 1/2" x 1/2" glider...
 250. 1/2" x 1/2" x 1/2" glider...
 251. 1/2" x 1/2" x 1/2" glider...
 252. 1/2" x 1/2" x 1/2" glider...
 253. 1/2" x 1/2" x 1/2" glider...
 254. 1/2" x 1/2" x 1/2" glider...
 255. 1/2" x 1/2" x 1/2" glider...
 256. 1/2" x 1/2" x 1/2" glider...
 257. 1/2" x 1/2" x 1/2" glider...
 258. 1/2" x 1/2" x 1/2" glider...
 259. 1/2" x 1/2" x 1/2" glider...
 260. 1/2" x 1/2" x 1/2" glider...
 261. 1/2" x 1/2" x 1/2" glider...
 262. 1/2" x 1/2" x 1/2" glider...
 263. 1/2" x 1/2" x 1/2" glider...
 264. 1/2" x 1/2" x 1/2" glider...
 265. 1/2" x 1/2" x 1/2" glider...
 266. 1/2" x 1/2" x 1/2" glider...
 267. 1/2" x 1/2" x 1/2" glider...
 268. 1/2" x 1/2" x 1/2" glider...
 269. 1/2" x 1/2" x 1/2" glider...
 270. 1/2" x 1/2" x 1/2" glider...
 271. 1/2" x 1/2" x 1/2" glider...
 272. 1/2" x 1/2" x 1/2" glider...
 273. 1/2" x 1/2" x 1/2" glider...
 274. 1/2" x 1/2" x 1/2" glider...
 275. 1/2" x 1/2" x 1/2" glider...
 276. 1/2" x 1/2" x 1/2" glider...
 277. 1/2" x 1/2" x 1/2" glider...
 278. 1/2" x 1/2" x 1/2" glider...
 279. 1/2" x 1/2" x 1/2" glider...
 280. 1/2" x 1/2" x 1/2" glider...
 281. 1/2" x 1/2" x 1/2" glider...
 282. 1/2" x 1/2" x 1/2" glider...
 283. 1/2" x 1/2" x 1/2" glider...
 284. 1/2" x 1/2" x 1/2" glider...
 285. 1/2" x 1/2" x 1/2" glider...
 286. 1/2" x 1/2" x 1/2" glider...
 287. 1/2" x 1/2" x 1/2" glider...
 288. 1/2" x 1/2" x 1/2" glider...
 289. 1/2" x 1/2" x 1/2" glider...
 290. 1/2" x 1/2" x 1/2" glider...
 291. 1/2" x 1/2" x 1/2" glider...
 292. 1/2" x 1/2" x 1/2" glider...
 293. 1/2" x 1/2" x 1/2" glider...
 294. 1/2" x 1/2" x 1/2" glider...
 295. 1/2" x 1/2" x 1/2" glider...
 296. 1/2" x 1/2" x 1/2" glider...
 297. 1/2" x 1/2" x 1/2" glider...
 298. 1/2" x 1/2" x 1/2" glider...
 299. 1/2" x 1/2" x 1/2" glider...
 300. 1/2" x 1/2" x 1/2" glider...
 301. 1/2" x 1/2" x 1/2" glider...
 302. 1/2" x 1/2" x 1/2" glider...
 303. 1/2" x 1/2" x 1/2" glider...
 304. 1/2" x 1/2" x 1/2" glider...
 305. 1/2" x 1/2" x 1/2" glider...
 306. 1/2" x 1/2" x 1/2" glider...
 307. 1/2" x 1/2" x 1/2" glider...
 308. 1/2" x 1/2" x 1/2" glider...
 309. 1/2" x 1/2" x 1/2" glider...
 310. 1/2" x 1/2" x 1/2" glider...
 311. 1/2" x 1/2" x 1/2" glider...
 312. 1/2" x 1/2" x 1/2" glider...
 313. 1/2" x 1/2" x 1/2" glider...
 314. 1/2" x 1/2" x 1/2" glider...
 315. 1/2" x 1/2" x 1/2" glider...
 316. 1/2" x 1/2" x 1/2" glider...
 317. 1/2" x 1/2" x 1/2" glider...
 318. 1/2" x 1/2" x 1/2" glider...
 319. 1/2" x 1/2" x 1/2" glider...
 320. 1/2" x 1/2" x 1/2" glider...
 321. 1/2" x 1/2" x 1/2" glider...
 322. 1/2" x 1/2" x 1/2" glider...
 323. 1/2" x 1/

BARGAIN HUNTER SECTION

Make **BIG MONEY** Helping Motorists

SAVE GAS

up to \$2 per Tankful!



Slip it on
in minutes...

PROVEN FUEL SAVING SYSTEM invented by auto engineer offers quick, easy cash to spare timers! Patented **TURBO FLO** installs easily in most cars & trucks in minutes. Government certified labs verify up to 5 to 20% gas savings depending on make, age, condition and how car is driven (even more MPG with trick tuning). Soups-up performance, too! (Exc. pts in CA). Car life guaranteed. Sells fast at \$19.95, you pay just \$4.95 in quantity. Sample and sales kit \$14.95 p/d. Proof FREE! Write or order now. VISA or Master Charge welcomed. **SATISFACTION GUARANTEED!**

ALMQUIST MFG. LTD., Dept. PM-6D, Milford, PA, 18337

Splits
EASIER & FASTER!

**THE BOSS
LOG SPLITTER!**



Only \$49.95 plus \$5 p. & h. for adaptable cone, or \$99.95 plus \$8 ready-to-attach to hub of car or light truck (specify vehicle). Pa. — send 6% sales tax. Free info — send stamped self addressed envelope. **Good Products,**

Route 3 Box 88-A PM, Kutztown, Pa. 19530

GO-KARTS FACTORY DIRECT

Now you can afford an all welded tubular steel factory made Go-Kart— We have Go-Kart frame kits with all welding done, ranging from **\$29.95** to \$99.95 and complete Go-Kart kits with 3½ hp engines ranging from \$139.95 to \$199.95. Send \$1.00 for catalog and complete set of drawings to

Schmieder Motor Co. Rd. #1 Doylestown, Pa. 18901.

RICKA DUO-WHEEL CONVERSION KIT AND FIBERGLASS FENDERS



New wide tire adapters & fenders to fit most mini - ½, ¾ & 1 ton trucks. Simple bolt on installation. Increases traction, tire capacity & life.

The ultimate in safety protection for your family.

RICKA MFG. DEPT. RPM-6

Pequot Lakes, MN 56472

RE-LITE

2 bulb fixture duplicates the charm and increases the light output of a double mantle gaslight. Kit includes on-at-dusk, off-at-dawn photo control, fixture, bulbs, detailed instructions. Your energy savings will pay for this kit in less than 6 months. 115 volt kit \$29.95 postpaid, or safe 12 volt kit including UL approved transformer, \$44.95. Dealers and installers inquiries invited.

Yardlighting Systems, Inc.
1039 Charles
St. Paul, MN 55104

WEEDHOPPER—ULTIMATE FUN MACHINE!



No licenses required on plane or pilot; 40 hour construction time; complete kit \$2695.00; carries 220 lb up to 50

mph! Send \$5.00 for info-pak to:
WEEDHOPPER OF UTAH, INC.
Box 2253, Ogden, Ut. 84404

**THE TROUBLE-FREE
WIRE DISPENSOR**

By **WEDCO Manufacturing Inc.**, Dept. P-2, 175 So. Scott Lane, P.O. Box D, Jackson, WY 83001, (307) 733-2336

- Developed by an Electrician for Electricians
 - Saves Time — Wasted Wire
 - Speeds Handling of Several Colors
 - Moves Like a Hand Truck
 - Capacity is 5 — 2000 # 10 AWG Reels
 - Weights Just 72 Pounds
- WRITE FOR BROCHURE AND PRICES



- PLANS AND INSTRUCTIONS FOR**
- Go Kart \$2.50
 - Mini Bike \$2.00
 - Mini car \$3.00
 - 12' Sail Boat \$4.00
 - Front Traction Go Kart with Gearless Differential \$10.00
 - Mini Jeep \$3.00
 - Pedal Boat \$4.00
 - # H.P. Tractor \$10.00
 - Soup Box \$3.00

Mini Vehicles Plan Dept. C 1 Barb., N.Y. 12901

Ted Horsley is saving at least \$180 a year on his electric bill...

How is he doing it?

With the Efficiency II™ water heating heat pump. The Efficiency II attaches to the existing electric or oil water heater and draws heat from the surrounding air to heat the water, providing the same amount of hot water while using half as much electricity or oil.

Ted Horsley is pleased with the results:

"We do everything we can to save energy. The Efficiency II is an energy-saving device that works and pays back."

Find out more about the Efficiency II and how it can save you money. Call or write TODAY.



Mail to:

E-Tech, Inc.
Dept. PMB
3570 American Dr.
Atlanta, Georgia 30341
or

Call TOLL-FREE:
1-800-241-7755

Name _____

Address _____

City _____

State _____ Zip _____

Our home is heated by:

electricity oil gas wood

Our electric or oil water heater is located in the _____



THERE'S A HUNGRY BEAST UNDER THE HOOD OF YOUR CAR.

Feeding the beast breaking you? Let Mile-O-Matic throttle that appetite. Installs quickly and easily. Simple and gloriously effective. Improve your mileage **at least** 10% or we'll refund every cent. Order Mile-O-Matic now and drive like a mileage expert!

\$19⁹⁵*

USE OUR HANDY COUPON OR CALL TOLL FREE AMERICA (1-800-327-9009) AND ASK FOR EXTENSION 962. ORDER NOW!

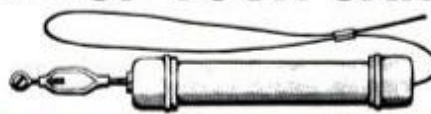

Name _____

Address _____

City _____ State _____

Mastercharge Zip _____

VISA

acct. no. _____

11650N Michigan Rd. Zionsville Indiana 46077

TILLER USERS...

Can your machine do all of this?

Save
\$143.80
NOW

- ★ Handle with just ONE HAND.
- ★ EVENLY break, turn & till soil.
- ★ Shred vegetation without tangling.
- ★ Leave NO WHEELMARKS or FOOTPRINTS.

The TROY-BILT® ROTO TILLER-POWER COM-POSTER can do all this and more! That's why serious gardeners consider it the finest tiller available. See for yourself! For complete details, OFF-SEASON SAVINGS, and FREE 24-page booklet clip this and mail today to:

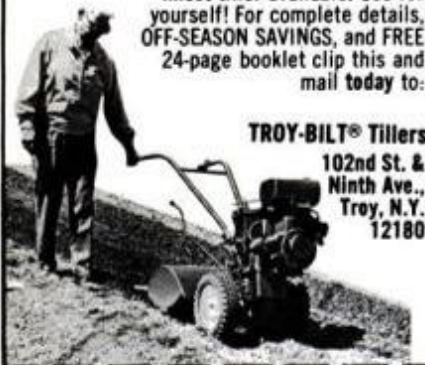

TROY-BILT® Tillers
102nd St. &
Ninth Ave.,
Troy, N.Y.
12180

TROY-BILT® Roto Tiller-Power Composters
Dept. A263
102nd St. & 9th Ave., Troy, N.Y. 12180

Please send the whole wonderful story of TROY-BILT® Roto Tillers including prices and OFF-SEASON-SAVINGS now in effect for a limited time. (Please Print Clearly)

Mr. _____
Mrs. _____
Ms. _____
Address _____
City _____
State _____ Zip _____

GAS SAVER

INCREASE MILEAGE BY 20-35%

The gas saver increases mileage by improving fuel vaporization. A simple gasket insert between the carburetor and manifold, the gas saver is constructed from quality materials to last the life of your car! Can be easily installed in your own garage. If not satisfied within 30 days you will receive a full refund.

\$9.95



for 1 bbl. carburetor

NO C.O.D. SEND CHECK OR MONEY ORDER

Or CALL TOLL FREE 24 HRS./DAY
1-800-821-7700 EXT. 105
in MO. 1-800-892-7655 EXT. 105

U.S. FUEL CONSERVATION, CORP.
300 E. Armour Blvd., Kansas City, Mo. 64111

Name (print) _____
Address _____
City _____ State _____ Zip _____
 Visa Mastercharge
C.C. No. _____ Exp. Date _____
Model _____ Year _____
Engine 4 cyl. 6 cyl. 8 cyl.
Combustion (U.S. cars and trucks only, no diesel or fuel injection)
 1 barrel send \$ 9.95 + \$1.00 handling
 2 barrel send \$14.95 + \$1.50 handling
 4 barrel send \$16.95 + \$1.75 handling



AT DEALERS OR ORDER DIRECT POSTAGE PAID
WS-1 STANDARD MODEL \$5.00
FS-1 COMPACT FOLDING MODEL \$7.00
S9 SLINGSHOT WITHOUT WRIST-BRACE \$4.00
RR-1 REPLACEMENT BANDS & LEATHER POUCH \$2.00
SA50 500 ROUNDS 1/2" DIA. AMMO. ONLY USA \$2.00
NO C.O.D. \$/ FOR AIR POST. FOREIGN ORDERS ADD PER ITEM \$2.00
TRUMARK SLINGSHOTS: P.O. BOX 1517 1, BOULDER, CO. 80506

DUNE-BUG

Complete plans & specs on how to build or buy - disc. prices on parts, kits, engines, & raw material.



Send \$2 for DUNE-BUG pkg to:
K & P Mfg.
330 S. Irwindale, Azusa P6
Calif. 91782

CLOCK COMPONENTS



Clock Movements: Battery, Quartz, Electric, Urgos Grandmother, Grandfather, Westminster & Triple Chime, 8 Day Key Winds & Westminster, Bin Bins, Barometers, Metal, Bezel, Paper dials, Hands, Brass & Plastic Numbers & Markers, Hundreds of Items, Quantity Prices. Send \$1.00 for 60 Page Catalog. Refunded on \$10.00 Order.

NEWPORT ENTERPRISES, INC. Dept. A
2313 West Burbank Blvd., Burbank, Calif. 91506

MAKE TOP MONEY IN STAINED GLASS



Learn at home in your spare time. Program includes your book of completely illustrated lessons, all professional tools, interesting projects and more. Our self study program gives you every thing needed to start you on your way to success. You can earn big money making stained glass lens shades, windows, jewelry, sun catchers and more. FREE 24-page 17x27 Retailer Carriers Ltd. - Publications Dept. PM660 33 E. Main St., Round Lake Park, Ill. 60073

SAVE GAS! SAVE MONEY!

'With the NEW'



verify the need To Replace Catalytic Converter



\$28.95

Federal state and local laws may prohibit use from leaving device on vehicle after testing is completed

- Test Fuel Economy
- Precision fit, do it yourself kit.
- Made of tough durable 16 gage steel.
- Available For 1975-79 ... GM: Cars, trucks, vans Ford: Cars, trucks, vans Chrysler: Vans only AMC: Jeeps only

Car Tech Products
6114-20 W. North Ave.
Suite 100 A
Chicago, Ill. 60639
(312) 889-9272

'ADAPTO'

Emergency fuel nozzle adapter



This self-service accessory will allow you, in an emergency, to add regular gasoline into an unleaded gas only fillerneck. No spills... No leaks...

\$5.00 TWO \$9.00 FOR

Dealer inquiries invited

Name _____
Address _____
City _____ State _____
Zip _____ Phone _____
 Car
 Truck
 Van Yr. _____ Make _____ Model _____ Eng. Size _____
 Check M.O. VISA Master chg.
Card # _____ Exp. _____
Signature _____

Please send me:
_____ Test Tube(s) \$28.95 ea. \$ _____
_____ Adapto(s) \$5.00 ea. \$ _____
6% tax (Ill. only) \$ _____
Shipping charges: \$ _____
Test Tube (\$2.00 ea.) \$ _____
Adapto (no charge) \$ _____
Total \$ _____
Phone toll free order 24 hrs. 1-800-441-7550 ext. 16



PM-180



America's fastest growing sports

PROFIT WITH A HOBBY!

read our customers stories about gold nuggets!

FIND GOLD, SILVER, COINS, RELICS AND MORE WITH WHITE'S. LARGEST MANUFACTURER OF ELECTRONIC MINERAL/METAL DETECTORS KNOWN WORLD WIDE. TAKE IT WITH YOU ANYWHERE WHEN TRAVELING. GREAT OUTDOOR FUN. Covered by U.S. Patents

For your nearest dealer, \$49.95 and up. Budget and free catalog call toll terms available. free 1-800-547-6911

white's electronics, inc.

AIRCRAFT KITS

Complete And Detailed Plans

Fuel-efficient & High-performance Aerobatic & Cross-country



MANY TYPES 1, 2 & 4 Seat
SEND TO: AIRCRAFT KIT CATALOG
Dept. A • P.O. Box 19826 • Houston, Texas 77024

110 VOLT A.C. GENERATORS

60 cycles, 3000 watts, WT. 27 pounds, 5" x 10" Fanbelt driven from car or pickup. Operates, T.V. All power tools. Over 17,000 in service. This is our 30th year. Guaranteed 6 months, \$169.00. Our X1200-watt generator needs no battery. Special price \$159.00. Add \$6.50 for postage & handling, per unit. Send for our free catalog.

VIRDEN PERMA-BILT Box 7160 PM
2821 Mays, Amarillo, TX 79109
Phone: 806/352-2761

Actual Photo!



mini-bike

New plans reveal step by step details how to build your own mini-bike. FREE discount coupons for parts.

RUSH \$2 for PLANS and everything to:

plans

Box 34422, Dept. PM6, Omaha, Nebr. 68134

EARN BIG COMMISSIONS

WORK FULL OR PART TIME!

Show big FREE SALES KIT featuring complete line low priced business printing and ad specialties to business people. Build profitable repeat business. Start now.

NATIONAL PRESS, INC.
DEPT. 064 NORTH CHICAGO, ILLINOIS 60064



Know your car inside and out.

Know how to fix it... to tune it... to service it... to keep it running right. The TOTAL SERVICE MANUAL for your car will show you how to do everything from a minor adjustment to a major repair.

factory workshop manuals. Each one is carefully re-written for use by the do-it-yourself car owner. Clear and easy to follow, yet complete and detailed enough even for professional use. You get all the important information plus hundreds of the best pictures, diagrams, and specifications.

TOTAL SERVICE MANUALS are digests of official

SATISFACTION GUARANTEED OR YOUR MONEY BACK

TOTAL SERVICE MANUALS

1713	ALFA ROMEO 67-78 for all Giulia, GT & Spider models	\$10.95
9641	ALFA ROMEO ALFETTA 73-78	\$10.95
8677	AMC GREMLIN, HORNET, PACER 71-79 for all models	\$10.95
8190	AMC REBEL 67-70 all models plus Marlin 71-74	\$9.95
0991	ARROW, PLYMOUTH 76-77 for all models	\$10.95
9404	ASPIEN, DODGE 76-78 for all models	\$8.95
7122	AUDI 100 70-77 for all models inc. 100i	\$10.95
0664	AUDI 5000 77-79	\$10.95
8749	AUDI FOX 73-79 covers all models	\$18.50
0916	AUSTIN ALFA 68-71 covers all models inc. 1100, 1300	\$10.95
1203	AUSTIN HEALEY 100/6, 3000 56-68 for all models	\$10.95
0752	AUSTIN MARINA 71-75 sedan and GT models	\$10.95
0379	BARRACUDA & CUDA 65-72 all 4 & 6 cyl models	\$8.95
8154	BLAZER, CHEVY 67-79 all models plus Suburban & GMC Jimmy	\$10.95
1042	BMW 2000, 2002 66-76 covers all models inc. CA, CS, 1/11	\$10.95
9813	BMW 320 70-79 covers all models	\$10.95
9326	BMW 75-79 inc. 530, 630, 633, 733 models	\$8.95
9760	BMW 2500, 2800, 3.0 all models inc. Bavaria & CS	\$11.95
0883	BOBCAT, MERCURY 70-79 covers all models	\$8.95
0504	BONCO, FORD 66-77 all 2 & 4 wheel drive models	\$8.95
0011	BUICK 66-68 factory shop manual must give year	\$18.95
0025	BUICK 71-79 shop manual must give year inc. 1972-73	\$18.95
0727	CADILLAC 68-74 all models except Eldorado	\$10.95
8678	CADILLAC 67-78 covers all 6 & 8 V8 models	\$10.95
9557	CAPRI 76-78 for a 2000, 2600, 2800 mds	\$10.95
0875	CAPRI 77-78 covers all models	\$10.95
0379	CHALLENGER 70-72 covers all 6 and V8 models	\$8.95
8331	CHARGER 67-70 for all models inc. 500 & R T	\$8.95
8212	CHARGER 71-75 covers all models	\$8.95
0383	CHEVILLE 64-79 inc. Malibu, Monte Carlo, El Camino	\$8.95
0838	CHRYSLER 76-78 covers all models	\$10.95
1038	CHEVROLET 29-40 covers all 6-cyl models	\$16.00
0888	CHEVROLET 49-54 reprint of factory shop manual	\$17.00
0051	CHEVROLET 55 or 57 reprint factory shop manual give year	\$19.95
8407	CHEVROLET 56 supplement to 55 manual	\$10.95
0870	CHEVROLET 68-79 for Bucyrus, Bel Air, Impala, Caprice	\$8.95
8187	CHEVY II 62-68 covers all 4, 6 & V8 models	\$9.95
0779	CHEVY LUV 72-77 covers all models	\$10.95
1661	CHEVY PICK-UPS 67-78 all models & GMC	\$10.95
1662	CHEVY VANS 67-78 for all models & GMC	\$10.95
1145	CHRYSLER 55-71 all inc Newport, 300, New Yorker	\$23.95
0020	CHRYSLER 72-79 factory manual must give year	\$23.95
9148	CITATION, CHEVY also covers Omega, Phoenix, Skylark	\$8.95
9588	CITROEN ID, DS 67-75 covers all 0519, 20, 21 mds	\$10.95
8539	CITROEN SM reprint of factory service manual	\$20.95
8264	COLT, DODGE 71-77 covers all models	\$10.95
9422	COMET 60-65 covers all models	\$8.95
8211	COMET 70-77 covers all models	\$8.95
8212	CORONET, DODGE 71-75 covers all models	\$8.95
0477	CORVAIR 60-69 covers all models	\$10.95
0478	CORVETTE 57-65 covers all 283 & 327 models	\$10.95
9481	CORVETTE 66-79 covers all 327, 350, 427, 454 models	\$10.95
1756	CRICKET, PLYMOUTH 70-73 also covers Hillman Avenger	\$10.95
9440	DART & DEMON 65-67 covers all models	\$8.95
8188	DART & DEMON 68-76 covers all models	\$8.95
1657	DATSUN F10 76-78 covers all models	\$10.95
1164	DATSUN 200SX 77-79 covers all models	\$10.95
9442	DATSUN 1200 70-73 covers all models	\$10.95
8065	DATSUN 210 74-78 covers all model inc B210	\$10.95
8127	DATSUN 240Z, 260Z, 280Z 70-78 covers all models	\$10.95
9152	DATSUN 280 79-80 includes 280ZC	\$8.95
1551	DATSUN 510 68-73 covers all sedn & wagon mds	\$10.95
1074	DATSUN 510 78-79 covers all models	\$10.95
9583	DATSUN 610 68-77 covers all models	\$10.95
0935	DATSUN 710 73-76 covers all models	\$10.95
8271	DATSUN 810 77-78 for all models	\$10.95
1258	DATSUN 311 1600 2000 SPL & SPL sports car mds	\$11.95

GENERAL INTEREST BOOKS

1264	CHILTON AUTO REPAIR 73-80 for all American cars	\$16.95
1226	CHILTON AUTO REPAIR 71-78 Reg. \$13.95 Special	\$8.95
7137	CHILTON AUTO REPAIR 94-71 for all American cars	\$17.95
1763	CHILTON AUTO REPAIR 54-63 for all American cars	\$17.95
7111	CHILTON TRUCK REPAIR 73-80 American & imported mds	\$17.95
8561	CHILTON TRUCK REPAIR MAN 61-71 for all 1/2-2 1/2 ton mds	\$19.95
9700	CHILTON IMPORT CAR MANUAL 73-79 for ALL pop imports	\$18.95
0445	CAR ECONOMY TUNING GUIDE getting most from the least	\$2.95
7125	AUTO AIR CONDITIONING... service & repair all	\$6.95
8726	TRANSISTOR IGNITION SYSTEMS covers them all	\$5.95
1067	MORE MILES PER GALLON GUIDE how to do it good & cheap	\$7.95
7110	WEEKEND MECHANIC'S HANDBOOK ideal manual for beginner	\$8.95
0622	HOW TO TUNE YOUR CAR good for all cars	\$5.95
8030	POWER TUNING your car, truck, van or RV	\$5.95
8859	GM DIAGNOSIS & REPAIR MANUAL 70-80 for all GM cars	\$19.95
1717	BASIC AUTO REPAIR MANUAL a must for any car	\$5.95
1707	BASIC BODYWORK & PAINTING	\$4.95
1711	BASIC CARBURETTORS & FUEL SYSTEMS	\$4.95
1706	BASIC CHASSIS, suspensions, brakes	\$4.95
0791	BASIC ENGINE HOTRODDING	\$4.95
1708	BASIC IGNITION & ELECTRICAL SYSTEMS	\$4.95
0680	BASIC AUTO TROUBLESHOOTING for all cars	\$4.95
8359	BRAKE SERVICE GUIDE for repairing all types & makes	\$5.95
3759	ELECTRONIC FUEL INJ MAN 70-77 for all imported cars	\$9.95
9411	HOLLEY carbs, all 2 & 4 bbl. tune & rebuild	\$9.95
9652	ROCHESTER carbs, all inc. 4MV Quadrajet	\$9.95
9666	SOLEX CARBURETTORS all 1 & 2 barrel down draft	\$2.95
6354	SU CARBURETTORS tune & rebuild all to 1976	\$8.50
9423	STROMBERG CD CARBS tune-rebuild all to 1976	\$8.50
6734	WEBER DOZE overhaul manual	\$4.95
1511	WEBER CARBURETTORS tune & rebuild all models to 1979	\$8.50
0827	AUTOMOTIVE REFINISHING best paint book yet	\$5.95
8425	MINOR AUTO BODY REPAIR step by step how to	\$6.95
5104	AUTOBODY REPAIRING & REPAINTING the best	\$9.95
5106	GLASS FIBER AUTO BODY construction & repair	\$5.00
1071	CREATIVE CUSTOMIZING how to do-it-like a pro	\$6.95
8491	PRACTICAL ENGINE SWAPPING how to do it right	\$5.95
9947	FRONT WHEEL DRIVE complete, detailed history analysis	\$7.95
6029	DIESEL GUIDE covers everything your buyer should know	\$8.95
0541	MODERN DIESEL CARS describes all models now sold	\$5.95
7128	DIESEL How to convert your car, van, pickup to	\$6.95
0632	GLENN DIESEL/GAS FI REPAIR 65-73 Bosch, Kuepferscher, Spicer	\$8.95
8423	DIESEL ENGINES, HOW TO REPAIR complete training course	\$7.95
1017	AUTOMOBILE ENGINE REBUILDING	\$13.75
9780	AUTO RESTORATION GUIDE best ever published 291 pgs	\$11.95
0595	CAR INTERIOR RESTORATION useful for all cars	\$3.95

9297	DATSUN PICK-UP 68-79 for all 571 & 670 models	\$10.95
1145	DODGE 55 71 all inc. Coronet, Monaco, Polara	\$10.95
0871	DODGE 72-77 for all Monaco & Polara models	\$8.95
1259	DODGE OMNI 78-79 covers all models	\$10.95
8708	DODGE RAMCHARGER 74-75 covers all models	\$8.95
1798	DODGE PICK-UPS 71-79 covers all models	\$10.95
8203	DODGE VANS 67-70 all 1 1/2 & 1 ton mds inc. Plymouth	\$8.95
6070	DODGE VANS 71-79 covers all models	\$10.95
8192	DUSTER 70-76 for all models inc. Scamp	\$8.95
8184	FAIRLANE, FORD 67-70 covers all models	\$8.95
8366	FAIRMONT, FORD 78-79 covers all models	\$10.95
9472	FALCON 60-64 covers all models inc. Mercury Comet	\$8.95
9874	FALCON, FORD 64-70 covers all 6-cyl models	\$8.95
0480	FALCON, FORD VB 65-71 covers all V8 models	\$8.95
9736	FIAT 124 67-77 for all models inc. v6, v6a, v6c, TC, spcl	\$10.95
0844	FIAT 124 SPORT 68-78 all coupe & convertible models	\$10.95
9640	FIAT 128 72-79 for all models inc. SL & Rally	\$10.95
8742	FIAT 131 75-79 covers all models inc. Mirafiori	\$10.95
1201	FIAT 850 64-74 all sedan, coupe & spider mds	\$10.95
0399	FIAT 1170 73-79	\$10.95
1023	Fiesta, Ford 72-79 for all models	\$10.95
0675	FIREBIRD covers all models-67-74	\$8.95
1149	Ford 55-67 all inc. Galaxie, LTD, Custom & wagons	\$10.95
0882	Ford 68-79 for Galaxie, LTD, Custom, XL & wagons	\$8.95
9369	Ford COURIER 72-77 covers all models -imported	\$10.95
8205	Ford PICK-UP 65-68 all 2 & 4 wheel drive, 1-2-1 ton	\$8.95
0451	Ford PICK-UP 69-79 covers all models	\$10.95
8204	Ford VANS 61-68 for all 1/2, 1, 1 1/2 ton models	\$8.95
0453	Ford VANS 69-79 covers all 4 & 6 V8 models	\$10.95
9436	GRANADA, Ford 75-77 covers all models	\$8.95
0644	Honda 60, 600, 67, 75 for all models inc. "Z"	\$10.95
0885	Honda ACCORD 77-79 covers all models	\$10.95
8694	Honda CIVIC, 73-79 covers all models inc. CVCC	\$10.95
8206	INTERNATIONAL SCOUT 67-73 800, A, B, II mds	\$8.95
8565	INTERNATIONAL 67-78 tune maintain Scout, wagon, pick-up	\$8.95
1206	Jaguar 55-69 sedan mds 2.4, 3.4, 3.8, 240, 340	\$10.95
1043	Jaguar E-TYPE 61-72 covers all 6-cylinder models	\$10.95
9612	Jaguar E-TYPE V12 71-74 covers all models	\$10.95
9395	Jaguar XJ6 68-78 covers all models	\$10.95
9617	Jaguar XJ12 72-77 for all models inc. Daimler	\$10.95
9769	Jeep 50-65 for 4 & 6 cyl station	\$16.95
8207	Jeep 66-79 for all Cherokee, Commander & Wagoneer mds	\$8.95
8205	Jeep WAGONEER series with 230 cfm eng.	\$16.95
9806	Jeep WAGON, C.J.2, C.J.3 reprint factory manual	\$16.95
0509	Jeep CJ-5, CJ-6, CJ-7, 55-79	\$8.95
8856	Jeep FC150, 170 covers all front cab models	\$16.95
8739	Jensen Healey reprint of factory manual	\$20.95
1254	Land Rover 59-77 covers 2, 2A, 3 gas & diesel models	\$10.95
1149	LINCOLN 55-70 covers all models	\$10.95
9773	LINCOLN 71-77 all models inc. Versailles	\$10.95
0481	Maverick 69-71 6 cyl, 170-200, 250 cu. in. eng.	\$8.95
1011	Maverick 72-77 covers all models	\$8.95
8550	MAZDA GLC 77-79 covers all models	\$10.95
0370	MAZDA RX2 70-75 covers sedan & coupe mds	\$10.95
0371	MAZDA RX3, 100-70, 74 covers all models	\$10.95
0444	MAZDA 71-78 includes RX4 and Cosmo models	\$8.95
0880	MAZDA PICK-UP 72-75 8, 1600 & rotary eng mds	\$8.95
0593	MAZDA 808, 818 72-78 covers all models	\$10.95
0781	MERCEDES-BENZ 190SL reprint of owner's manual	\$8.95
0745	MERCEDES-BENZ 220 covers all models	\$10.95
9483	MERCEDES-BENZ 220 68-72 mds except Diesel	\$10.95
1747	MERCEDES-BENZ 230 63-68 inc. 230S & SL	\$10.95
1748	MERCEDES-BENZ 250 65-68 covers all models	\$10.95
9484	MERCEDES-BENZ 250 69-72 covers all models	\$10.95
9485	MERCEDES-BENZ 280 68-72 covers all models	\$10.95
0416	MERCEDES-BENZ 68-73 inc. 280, 300 & 350, 450 V8 mds	\$9.95
8439	MERCEDES-BENZ 74-79 covers all models inc. Diesels	\$10.95

1149	MERCURY 55-70 covers all models	\$10.95
9773	MERCURY 71-77 for all models inc. Cougar	\$10.95
1105	MG TA, TB, TC, TD, TF 36 55	\$10.95
1098	MG MIDGET 58-78 covers all models	\$10.95
1106	MGA, MGB 55-68 covers all models inc. taxi cab	\$10.95
1720	MGB, MGBGT 69-79 for all roadster & coupe models	\$10.95
8296	MGC reprint of factory manual	\$20.95
0517	MINI 59-78 covers all models inc. Mini-Cooper	\$10.95
9436	MONARCH, MERCURY 75-77 for all models	\$8.95
0050	MONZA, CHEVROLET 77-79 factory manual give car year	\$13.95
9076	MUSTANG 65-73 covers all models	\$10.95
0479	MUSTANG V8 65-73 covers all models	\$10.95
8772	MUSTANG II 74-78 covers all 4, V6, & V8 models	\$10.95
8187	NOVA 69-79 covers all 4, 6 & V8 models	\$9.95
7107	OLDS CUTLASS 70-77 covers all inc. 442 models	\$8.95
0002	OLDS 68, 71, 74 factory shop manual must give year	\$11.95
0008	OLDS 75-79 factory shop manual must give year	\$17.95
1724	OPEL KADETT 62-73 1000, 1100, 1700 models	\$10.95
1752	OPEL KADETT 67-73, 1500, 1700, 1900 mds	\$10.95
8273	OPEL 66-79 for all models inc. 1960 Monza & Isuzu	\$10.95
9580	OPEL GT 68-73 covers all 1900 models	\$10.95
0876	PEUGEOT 504 68-74 includes diesel models	\$8.95
7124	PEUGEOT 504 68-78 for all gasoline models	\$10.95
0883	PINTO 70-79 covers all models inc. Mercury Bobcat	\$8.95
1145	PLYMOUTH 55-71 all inc. Belvedere, Fury, Satellite	\$10.95
0874	PLYMOUTH 72-76 Fury, Fury Gran, Suburban mds	\$8.95
1860	PLYMOUTH HORIZON 78-79 covers all models	\$10.95
0030	PONTIAC 69-75 factory manual, all models, give year	\$18.95
0489	PONTIAC TEMPEST 68-73 all mds inc. GTO, Le Mans	\$8.95
1650	PORSCHE 356 57-65 covers all A, B & C models	\$10.95
1591	PORSCHE 911 64-73 covers all models	\$10.95
8173	PORSCHE 911 74-77 includes N. S. Targa, Carrera	\$10.95
1590	PORSCHE 912 65-69 with 1582cc engine	\$10.95
9834	PORSCHE 914 70-76 all models inc. 914-E	\$10.95
0993	PORSCHE 924 76-78	\$10.95
8208	RAMCHARGER, TRAILDUSTER 74-75 all models	\$8.95
0372	RENAULT 5 72-78 for all models inc. Le Car	\$10.95
1224	RENAULT 8, 10 62-72 covers all models inc. 1100	\$10.95
9429	RENAULT 12 69-79 covers all models inc. auto trans.	\$10.95
0645	RENAULT 15, 17 71-78 all mds inc. TL 75	\$10.95
1554	RENAULT 16 65-78 covers all models	\$10.95
0395	ROADRUNNER & SATELLITE 68-73 all models	\$8.95
1121	ROVER 2000 63-75 for all models inc. 2300	\$10.95
0750	SAAB 99 69-76 covers all models inc. fuel injection	\$10.95
8440	SAAB 67-79 covers all models inc. Sunnet	\$10.95
1098	SPRITE 58-71 covers all Mk. 1, 2, 3 & 4 models	\$10.95
8058	SUBARU 71-79 all sedan, coupe, hardtop & wagon models	\$10.95
0845	SUNBEAM TIGER reprint of factory shop manual	\$29.95
0485	TEMPEST, GTO, LE MANS 68-73 all models	\$8.95
9773	THUNDERBIRD 71-77 covers all models	\$10.95
8189	TORINO 68-75 all models inc. Elte, Rancho	\$8.95
0912	TOYOTA CELICA 70-77 covers all models imported	\$10.95
0829	TOYOTA CELICA 78-79	\$10.95
7127	TOYOTA COROLLA 68-74 for all models	\$10.95
9812	TOYOTA COROLLA 75-78 all models plus 5-sp. trans.	\$10.95
1738	TOYOTA CORONA 65-68 covers all 4-cyl 1500 models	\$10.95
0926	TOYOTA CORONA 69-73 for all models inc. NW II	\$10.95
0886	TOYOTA CORONA 74-77 covers all 4-cyl models	\$10.95
0754	TOYOTA CORONA Mk 2 72-76 for all 5-cylinder models	\$10.95
0647	TOYOTA MR-LUX 65-77 covers all models	\$10.95
8524	TOYOTA LAND CRUISER 66-77 covers all models	\$10.95
1000	TRIUMPH SPITFIRE 69-78 covers all models	\$10.95
1231	TRIUMPH TR4 61-67 covers all models	\$10.95
1015	TRIUMPH TR5, TR6, 67-76 all models inc. TR250	\$10.95
8693	TRIUMPH TR7 75-79	\$10.95
8192	VALIANT 68-76 all mds inc. Scamp, Signette	\$8.95
8455	VEGA 70-71 covers all models	\$10.95
0567	VEGA 72-73 for 140 CID & GT 140 CID models	\$8.95
0884	VEGA 74-77 covers all models	\$8.95
9404	VOLARE, PLYMOUTH 76-78 for all models	\$8.95
1227	VOLKSWAGEN BEETLE 54-67 for all mds inc. K.G.	\$10.95
0140	VOLKSWAGEN BEETLE 68-77 covers all models inc. K.G.	\$10.95
8695	VOLKSWAGEN RABBIT, SCIROCCO 74-77 covers all models	\$10.95
6010	VOLKSWAGEN RABBIT, SCIROCCO 74-79 for all mds inc. Diesel	\$17.95
1547	VOLKSWAGEN BUS 54-67 all camper, van, transporter mds	\$10.95
7130		

MANUFACTURE THIS BEAUTIFUL CONCRETE OUTDOOR FIREPLACE Right In Your Back Yard

**\$10.00 Worth of Sand and
Cement Produces This
Attractive Fireplace.**

**Sells on Sight from
\$250 to \$300. Easy to
start your own Profit-
able Business.**

The RPT Mfg. Fireplace
Molds and Process are
the most amazing and
foolproof ever invented.
Simple to operate.

BIG DEMAND!!

Sell all you produce to
Department Stores,
Homeowners, Parks,
Nurseries and Picnic
Groves. Fireplaces sell
on sight. No experience
necessary. We supply
full operating instructions
and equipment plus the
know-how that spells
BIG PROFITS. This is an
outstanding opportunity
for men of vision and
small capital to get in a
busy rich paying field.
Don't delay. Mail coupon
at once for full details.



**RPT MFG. DEPT. PM60
3537 Limekiln Pike, Chalfont, PA 18914**

Name _____
Address _____
City _____ State _____ Zip _____



PAINT EASIER... FASTER WITH THIS PROFESSIONAL STAND-UP ROLLER BUCKET

Durable metal construction.
Holds 4 gallons. Curved
bottom lets roller get last
drop. Tip-proof base. Dou-
bles as wallpaper paste or
utility bucket. Removable
roller screen. Only \$11.95
prepaid in USA. No
phone orders. Mas-
tercharge, Visa,
check or MO
accepted. Free
brochure.



KONKURO, INC.
1313 Laurel St.
San Carlos, CA
94070

Satisfaction
guaranteed

SHEET METAL WORKER



**SPECIAL PRICE—
LIMITED QUANTITY OF FACTORY SAMPLES**
An all-purpose sheet metal forming
machine. Shears, press brakes, rolls
24" material up to 20 gauge mill steel
or equivalent.



PACIFIC ONE CORPORATION
410 West Coast Highway, Newport Beach, CA 92663

Celebrate July 4th & ALL Special Events

CARBIDE CANNONS



BIG BANG!
Mammoth cannons
shoot with terrific
bang! The larger the
cannon, the louder the
bang! Beautiful reproductions of
army field guns produce realistic
flash & bang. No gunpowder or
matches used. Uses low cost carbide powder. Machined brass
mechanism for easy loading & firing. Each made of rugged cast
iron & steel metal. Lasts a lifetime. Handsome decor when not
in use. Modern Cannons have heavy duty rubber tractor
wheels. World War I Cannons have large cast iron wheels.
Send check or money order or phone your order. Master or
Visa charge cards accepted by mail or phone (313) 791-2800.
Give card number & expiration. Orders shipped promptly.
Serving satisfied customers since 1914. Money back guarantee.
Not sold in Michigan.
Modern 60mm Cannon, 9" Long, 2 Tractor Wheels \$14.95
Modern 105mm Cannon, 17" Long, 4 Tractor Wheels \$25.95
Modern 155mm Cannon, 25" Long, 8 Tractor Wheels \$31.95
17" World War I Cannon (shown) 2 cast iron wheels \$23.95
25" World War I Cannon, 2 cast iron wheels \$31.95
Carbide Ammo, about 300 shots \$1.50, 3 packs for \$3.95
ADD \$3.00 SHIPPING & HANDLING EACH CANNON
Johnson Smith Co., 35075 Automation Dr.
DEPT. 106, Mt. Clemens, Mich. 48043

COUNTERFEIT GUNS

AUTHENTIC! FULL SIZE MACHINED METAL MODELS.
Museum quality precision machined metal classics weigh, look
and feel like real guns. Will fool experts. Perfectly legal—CANNOT
BE FIRED. Blued and gas-tempered like originals. Decorate your
den, office, rec-room. Send for FREE FULL-COLOR CATALOG.
Made of over 30 blued, hand-finished parts—DELIVERED FULLY
ASSEMBLED.

**SAME SIZE
AND WEIGHT
AS THE ORIGINALS!**
MONEY BACK IF NOT SATISFIED!
GOVERNMENT .45
STANDARD BOREM OF GRS. SLIDE WORKS LIKE ORIGINAL
WITH SAFETY THAT WORKS. LGTH. 9", WT. 2 1/2 LBS.
DISASSEMBLES. ADD \$1.50 POSTAGE/HANDLING
LIKE ORIGINAL. Model R300 \$44.95



**REPLICA MODELS, INC., P.O. BOX 1061
DEPT. PM060 800 SLATERS LANE, ALEXANDRIA, VA 22313**

Send R300 Send FREE COLOR CATALOG

Charge to: BAC Mastercharge Am. Express Diner's Club

NAME _____

ADDRESS _____

CITY/STATE/ZIP _____

MONEY BACK IF NOT SATISFIED

Build the world's most energy-efficient home.



And save for
years to come.

Your Monterey Domes geodesic shell package is delivered, ready to assemble using
simple tools. No skills necessary. Monterey Domes meet all building codes and VA/
FHA standards. Save on construction costs and up to 50% on energy costs! Priced
from \$3995. Send \$4.00 now for our 80 page catalog and planning kit!

Please rush me your 80 page full color catalog and planning kit. I am enclosing
\$4.00

Also send me the Monterey Domes Assembly Manual for an additional \$5.00

NAME _____

ADDRESS _____

CITY, STATE, ZIP _____

MONTEREY DOMES Mail to: Monterey Domes, Dept. 154
P.O. Box 5621, Riverside, CA 92517

Low-Cost Energy Saver!



Build this beautiful 3 br., 1140 sq.ft. home for \$6500
complete and cut your heating & cooling bills 50%.
Tanyons new do-it-yourself Home Kit '80' includes bidg
prints, material list & special instructions. See how easy
and inexpensive it is to build & own this **no-mortgage
home!** Want to price several low-cost energy saving homes
before choosing one? Then the Home Pricer Planning
Book is for you. It contains 49 home designs, floor plans &
material lists that show you exactly what you need for any
style you choose.

Money Back Guarantee.
Order both today and never make a mortgage payment
again! Send your Name, Address, City, State & Zip plus
\$58.00 for Home Kit '80', \$510.00 for Home Pricer,
\$515.00 for both, saving \$3.00! Or send \$1.00 for
information pkg. Mail Today To: TANYON PRESS, Dept.
PM103 2427 W. 25th St., Erie, Penna. 16506

This is the truck that Jack built.

He saved
\$1000.
You can too!

Easy-to-build semi-kit can save you money. Engine is
completely assembled; frame is welded and painted.
You just bolt everything together (using common
tools and our 22"x34", fully illustrated in-
struction sheet) and start hauling!

- 11 H.P. Briggs & Stratton engine
- Automatic transmission with forward and reverse.
- Electric start standard.
- Hydraulic disc brakes with parking valve standard.
- Full, one-quarter ton payload capacity.
- Dumping bed measures 44 1/2"x40"x11".
- Electric powered model also available.



For your FREE
color brochure write:
or phone (616) 849-3400.

Carl Heald, Inc.,
Dept. PM60 P.O. Box 1148,
Benton Harbor, Michigan 49022

TV TO STEREO

SOUND ADAPTER



GET SIMULATED STEREO SOUND FROM YOUR TELEVISION!

TELEADAPTER® easily connects to your own TV and stereo system to give you full rich simulated stereo sound through your amplifier and speakers. TELEADAPTER'S electronic circuitry matches the impedance between your TV and stereo amplifiers' aux., tape, or tuner input, while completely transformer isolating the TV's & stereo's chassis, for safety. The matrix circuitry provides two channels of output that plug directly into your stereo. Those ballgames and movies will never be the same after you hear the realistic thundering sound. Only \$19.95 postage paid, complete with hookup instructions, 2 year warranty.

To order: Enclose check • VISA or MasterCard # _____
 Expiration Date _____ Bank # _____
 NAME _____
 ADDRESS _____
 CITY _____
 STATE _____ ZIP _____

Satisfaction guaranteed or your money promptly refunded.

RHOADES National Corporation
 Dept. PM - P.O. Box 817
 Hendersonville, TN 37075
 (615) 824-1735

SEND COMPLETE CATALOG

GARDENERS

SAVE \$\$... GROW YOUR OWN FRESH FRUITS & VEGETABLES

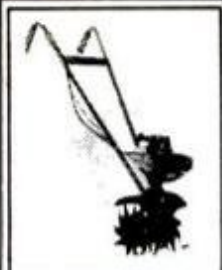

Weights 20 lbs.

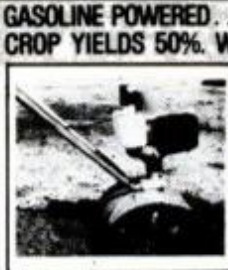

High Speed Till

GASOLINE POWERED... VERY GENTLE, EASY TO USE, MAY INCREASE CROP YIELDS 50%. WEIGHS 20 lbs. TILLS DEEP... WEEDS FAST! HELPS YOU EARN PART-TIME INCOME

one weeds gardens. When you own an AGCO you can get \$10 to \$25 per garden for weeding and trimming neat borders around walkways, gardens and ornamental shrubs. THE AGCO IS NOT SOLD IN STORES... You save money by buying direct... Liberal warranties 2 week money back trial period... For more information about this amazing gardening machine write to:

IMPROVES YOUR GARDEN 7 IMPORTANT WAYS

1. High speed tiger tines granulate toughest clays into sandy loam. Unique tilling action improves your soil, tills 6 to 8 inches deep without strain.
2. Makes weeding fast easy and fun, weeds 1 to 3 inches deep in narrow rows set 12 inches wide.
3. Gives you bumper crops of lush fruits and vegetables.
4. Gives you excellent flower beds helps your garden burst with beautiful blooms.
5. Gives you a garden others will envy.
6. Aerates and thatches your lawn.
7. Cuts neat borders around gardens, walkways, shrubs and trees.

Amazing new tiller makes gardening easy, it tills, it weeds, it aerates and cuts neat borders around walkways, gardens and shrubs.

Warranted unbreakable Tiger tines chew through the toughest soils and grass covers, power tills; you soil into super aerated sandy loam for healthy plant growth.

Weeds 1 to 3 inches deep, does a 20 by 40 ft. section in 20 minutes or less. Weeds well in narrow rows... May increase your crop yields 50%. Made by American Co. with over 55 years experience in the manufacture of tough reliable gardening tools.

MAY HELP YOU EARN \$10 to \$25 A JOB!
 You can hire lots of people to mow lawns... No



Weeds Narrow Rows



Used Commercially

AGCO Dept. P.M. P.O. Box 75 P-5
 SOUTHAMPTON, PA. 18966

I want more information, please send literature to:

Name _____
 Street _____
 City _____
 State _____ Zip _____
 For rush delivery of literature call:
 Tel. # 215 947-8855 - Mon - Sat. 9 AM - 4 PM

SWISS ARMY TYPE
 ALL PURPOSE

WONDER KNIFE

11 BLADES
 RED HANDLE
 3 1/2"

\$7.50

FOR

- FISHERMEN
- CAMPERS
- HOBBY
- HANDYMAN

Money Back Guarantee

CORK SCREW
 HOOK DISORDER
 CAN OPENER, CUTTING BLADE, SCISSORS,
 CAP LIFTER, SMALL CUTTING BLADE, FISH
 SCALER, HOLEPUNCH, SCREWDRIVER, NAILFILE

SEND CHECK OR M.O. NO C.O.D.s
 INCLUDE \$1.00 FOR POSTAGE & HANDLING
 ATLANTIC COAST DISTRIBUTORS INC.
 P.O. BOX 50588, JACKSONVILLE BEACH, FLA. 32250

THE "WIDE OPEN SPACE" CAPSULE

The latest generation of space capsule has arrived...perfect for exploring the wide open spaces you dream about!

Complete life support systems...water, heat, lights and fuel economy.

Scamp...the space age camper

Want to know more?
 Send us \$2 and your return address and we'll mail you our latest brochure, or call toll free 1-800-346-4962.

EVELAND'S
 Dept. PM 680
 Box 2
 Backus, MN 56435

Handbook of Small Standardized Components
 Metric Catalog #101

STOP FORTNIGHTING-

for Small Mechanical Parts

Giant new 768 page SDP Catalog features over 24,000 hard-to-find inch and metric off-the-shelf parts: Timing belts, pulleys, chain drives, gears, motors, speed reducers, couplings, shafts, bearings, counters, fasteners etc. for building, repairing, inventing any small machine, engine, model...Low prices. Catalog 747-just \$4.95 POSTPAID. Stock Drive Products 55A South Denton Ave., New Hyde Park, New York 11040. Free Metric/Inch Conversion Slide Rule Included!

THE FUN MACHINES

... that work, too!

SUPER BRONC

6 BIKE MODELS

7 TRYKE MODELS

• FUN TO BUILD!
• FUN TO RIDE!

These rugged off road vehicles are powered by 5 hp to 16 hp American-made engines. Engine is completely assembled, frame is welded and painted. You just bolt everything together and start riding. Kit priced from \$479.95 to \$999.95.

For a FREE color brochure with complete details, write today to:

Carl Head, Inc. Dept. PM-06, P.O. Box 1148, Benton Harbor, MI 49022
 From the largest Maker of Bike and Tryke Kits in the World - Carl Head, Inc.

the New Look from Elite

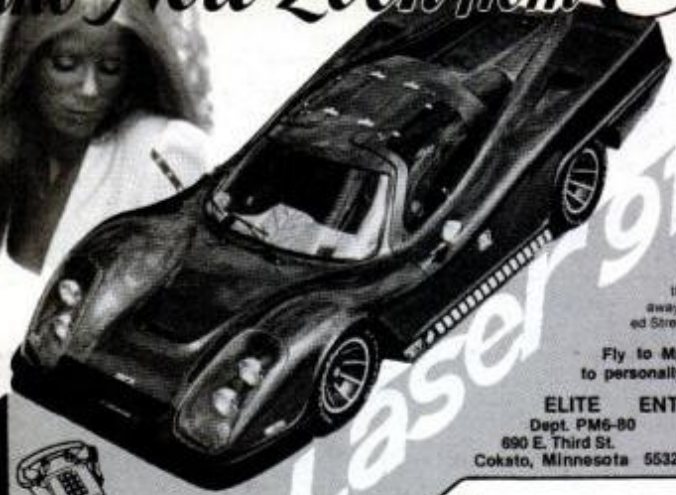

The ultimate in a GT Sports Car Kit. Take a VW chassis, combine it with your choice of power. Bolt on the LASER 917 Kit and drive away in the most uniquely designed Street Sports Car of the times.

Fly to Mpls. / St Paul **FREE*** to personally order your LASER 917

ELITE ENTERPRISES, INC.
Dept. PM6-80
690 E. Third St.
Cokato, Minnesota 55321 (612) 286-2660



To order \$29.95 Full Pack call Toll Free 1-800-328-8898. Refundable with Kit Purchase Major Credit Cards Accepted.

NAME _____ AGE _____
ADDRESS _____
CITY _____ STATE _____
ZIP _____ PHONE _____

\$3.00 LASER 917 Color Brochure, Ordering Information and Price List
\$29.95 Full Pack (Refundable with Kit Purchase) LASER 917 Color Brochures,
Ordering Information, Price List, Technical Engineering Manual and Construction Guide,
Dealer Information, Solid Color Chart, Metal Flake Color Chart, and Free Flight Information.

*This information included in Full Pack Only

HOME ENERGY COST-SAVING PLANS



2000 WATT SAVONIUS WIND-TURBINE SYSTEM: Operates more efficiently than conventional windmills, even in low windspeed areas! Ideal for homes, farms cottages! Simple, Economical Construction! **COMPLETE PLANS** include electrical charging circuit.



3000 WATT WOODBURNING STEAM TURBINE: Compact Radial Turbine delivers up to 2000 WATTS of generated electricity! Enjoy Plentiful, **FREE** Power from wood! Simple, Compact Design! **COMPLETE PLANS** includes battery and boiler configuration. **PLANS \$7.95 each, both for \$12.00**

**GLENVALE PRODUCTS, Dept. PM6, Box 358
Station D, Toronto, Ontario M6P 3J9**



BUY STAINED GLASS SUPPLIES DIRECT FROM MANUFACTURER

Came Leads, Glass, Solder & Tools! Everything you need for the professional or beginner. Wide selection of tools and materials with instructions all in our exciting new catalog. For your copy send \$3.00, refundable with first order.

CORAN-SHOLES INDUSTRIES
509 E. 2nd St., Dept. PM 50, Boston, MA 02127
(617) 268-3780

IF YOU WORK WITH WOOD GET...

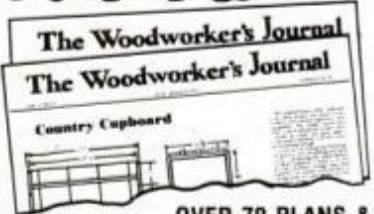

OVER 70 PLANS & PATTERNS FEATURED EACH YEAR

Each issue of Woodworker's Journal is filled with actual plans and patterns, shop tips, money-making ideas, antique repairing and cabinetmaking techniques. Whether you're a novice or a veteran you'll enjoy every page of detailed instructions for all types of practical woodworking projects. Build fine Early American, Shaker, Contemporary Furniture, Toys, Gifts, Clocks, Lamps and much more.

SUBSCRIBE NOW

1 YEAR (6 issues)—only \$7.00
2 YEARS (12 issues)—only \$13.00
Foreign Rates—Add \$2.00. Please make payment in U.S. Funds.

GUARANTEED: Full refund on all unmailed issues if not completely satisfied.

Send Check or M. O. to:
THE WOODWORKER'S JOURNAL, Dept 516
P.O. Box 1629, 25 Town View Drive,
New Milford, Ct. 06776

6 issues—\$7.00 12 issues—\$13.00

Name _____
Address _____
City _____ State _____ Zip _____

Learn Glass Etching



Transform your windows, mirrors and everyday glassware into works of art the easy way with the **New ARMOUR ETCH™** GLASS ETCHING METHOD. Complete including supplies, illustrated step-by-step instruction booklet, plus 45 full-size etching patterns.

ONLY \$9.95
(please add \$1.50 per kit postage & handling)
Armour Products, Dept. PM60
Hill St, Midland Park, NJ 07432 • 201/652-8895

Name _____
Address _____
City _____
State _____ Zip _____

Quality Pilot's Glasses Only from \$7.95 U.S. Optics.



- Polished Glass Lenses
- Metal Frames
- Impact Resistant
- Money Back Guarantee

To order, send check or money order (include \$1.00 for postage and handling) to: **U.S. Optics, Dept. 748, P.O. Box 14206, Atlanta, Georgia 30324.** (Specify gold or silver frames.)
SPECIAL: Order now and get two pairs for \$14.00 plus \$1.00 postage and handling. Credit cards accepted, include number and expiration date. **FREE!** During this limited offer from **U.S. Optics**, deluxe velour lined protective case with each pair. A \$3.00 value. Dealer inquiries invited.
NOTICE: Don't be fooled by cheap imitations. These glasses are made exclusively for U.S. Optics. To make sure you get the best, order now. 30-day money back guarantee.

FREE case with each pair.

PROPANE - CONVERSION

RUN CARS - TRUCKS - ON PROPANE
Return to gasoline anytime without even stopping vehicle! Completely **PROVEN** and **TESTED**—and very efficient. Build it yourself in 2 days for as little as \$50 with **LOCALLY AVAILABLE** parts. **EASY** to build—only hand tools and simple plumbing required. Uses ordinary gas stove tanks—refillable anywhere. For **COMPLETE** plans—drawings—part list, send \$10 to Fleming Engineering, PMD-6 Remsen, NY. Zip 13438. **SATISFACTION GUARANTEED**

"MAKER'S MARK" BRANDING TOOL

SEND FOR YOUR FREE INFO PAK! NO OBLIGATION

NOW! Brand your own name permanently on wood and leather hand-crafts! Simple to use. Long lasting U.L. approved electric handle. Brands full name. Guaranteed.

CRAFTMARK PRODUCTS, INC.
P.O. Box 6308-PM6 Marietta, GA 30065



TRAILER FOR THE 80's - Burro Travel Trailer kit sleeps four. Under 1,000 lbs. Fiberglass. Ready to tow. Finish interior only. Write Burro PM6, 14143 - 21st Avenue North, Plymouth, MN 55441. For full color catalog send \$2.00 to cover postage and handling.

HAVE FAMILY FUN AFLOAT WITH A PONTOON BOAT

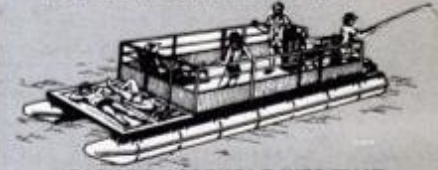

EASY TO ASSEMBLE KITS THAT SAVE YOU MONEY

Economical, safe, and practically indestructible. Ideal for family parties, fishing, or swimming. Kit contains pontoons, frame, motor mount, helm station, steering, railing, and hardware. Send \$2.00 for plans and pictures.

CALL TOLL FREE
1-800-351-1363 In Texas call: 915-643-2517
ROTOCAST FLOTATION PRODUCTS
P O BOX 1059, DEPT PM
BROWNWOOD, TEXAS 76801

IMPORTED LOCK BLADE

9" Overall Length **\$3.50 Ea.**
5" When Closed

- Sharp and Tough
- Stainless Steel Blade

Flips open instantly and locks automatically to prevent accidental closing. Razor sharp tough stainless steel blade for reliable use and hard long service. Send \$3.50 plus 50¢ to cover postage and handling.

Model # K-12-AL

Not for sale in areas where prohibited by law.

WESTBURY SALES CO.
373 MAPLE AVE. Dept. L-6-PM WESTBURY, N.Y. 11590

SAVE UP TO 85%
GOV'T SURPLUS and NEW EQUIP'T

ENERGY BOOSTER CENTRIFUGAL BLOWER
 200 CFM, 115-VAC
\$13.95 Normal Retail Over \$40.00

BIG, Equip't. Catalog
 Send 50¢ Cash or Stamp

EQUIPMENT CATALOG SURPLUS CENTER

DIRTY PRICED ON:
 WOOD OPERATING CABLE
 SHAW MOTORS - WINDMILL
 SPEED REDUCERS - PUMPS
 COMPRESSORS - TELEPHONES
 POWER PLANTS - BINOCULARS
 HYDRAULIC ELECTRONICS
 IMPROVED MOTORS - HOSES
 WELDS - MANY OTHERS

* (ITEM #16-922) ... Boost efficiency of woodburning stoves or heaters, circulate heat in solar systems, use for dozens of air conditioning, air intake, ventilating applications. Useful for forced draft, cooling, drying, etc.
 * 200 CFM, 115-VAC, 2.2-amp. motor, thermally protected. Dynamically balanced 6" diam. rotor. Inside 3" diam., rectangular discharge 3" x 3-1/4". Overall 8-1/2" x 8-1/4" x 7-1/8". Ship wt. 8 lbs.

SURPLUS CENTER PM-060 Lincoln, Nebraska
 Zip Code 68501

PUMPS BUY DIRECT AND SAVE
 Drain • Irrigate • Circulate • Spray

Heavy duty ball bearing pump. All metal, rust-proof Type XB. Stainless shaft. Use 1/4 HP or larger. 1 HP 1,200 GPH 60" high or 3,000 GPH 25" well. 5,200 GPH max., 1 1/4" in.; 1" out. Belt or direct drive. **\$19.95** Type P won't rust or clog. Bronze bearing. To 2,400 GPH. 1" in.; 3/4" out. **\$13.95** ADD \$2 pgs & hndg. Money back Guarantee.

LABAWCO, 80 Hwy 206, Belle Mead, N.J. 08502

LENAIR

WASTE OIL HEATER
 For Shop, Garage, Warehouse and Farm

Waste Oil Worth 80¢ per gallon as a heating fuel.

Pay Yourself not the fuel companies. Heat with any type of waste oil. LENAIR Waste Oil Heaters are a smart investment. Models 75,000 and 130,000 BTU Forced Air. **PROVEN • SMOKELESS ODOORLESS**

WRITE **LENAIR INDUSTRIES INC.**
 P.O. BOX 1017-C
 JANESVILLE, WI 53545
 DEALER INQUIRIES WELCOME

FREE PLAN WITH FIRST ORDER

BLUEPRINTS
 FOR WOODEN TOYS, GAMES, PLAQUES, PUZZLES
 CATALOG \$1.00 (REFUNDED WITH FIRST ORDER)
 DESIGN GROUP FULL SIZE • EASY TO READ BLUEPRINTS
 P.O. BOX 514, DEPT. F, Miller Place, N.Y. 11764

BEST "LEARN-IT-YOURSELF" BOOKS!

- The Bicycle Builder's Bible 378 p., 280 il. \$8.95
- Plumbing With Plastic 406 p., 269 il. \$8.95
- Handbook of Carpentry Plans/Projects 490 p., 533 il. \$9.95
- How To Repair Clocks 182 p., 90 il. \$5.95
- The Complete Handbook of Front Wheel Drive Cars 320 p., 235 il. \$7.95
- Practical Knots & Ropework 406 p., 305 il. \$9.95
- 21 Custom Speaker Enclosure Projects You Can Build 252 p., 177 il. \$7.95
- The Practical Handbook of Blacksmithing & Metalworking 448 p., 909 il. \$9.95
- The Woodworker's Furniture Construction/Repair Bible 448 p., 395 il. \$8.95
- The Encyclopedia of Homebuilt Aircraft 576 p., 315 il. \$12.95
- Rebuilding the Famous Ford Flathead 140 p., 101 il. \$5.95
- How To Design and Build Your Own Furniture 272 p., 302 il. \$7.95
- How To Repair Old-Time Radios 252 p., 162 il. \$7.95
- Basic Drafting 280 p., 251 il. \$7.95
- Collecting and Restoring Old Steam Engines 192 p., 93 il. \$7.95
- The Metalcrafter's Bible 434 p., 372 il. \$9.95
- How To Build Adobe Houses ... etc. 256 p., 204 il. \$7.95
- Collecting and Building Model Trucks 288 p., 448 il. \$9.95
- Wood Carving Made Easy 252 p., 169 il. \$7.95
- The Complete Handbook of Sewing Machine Repair 308 p., 238 il. \$8.95

SEND NO MONEY. We'll invoice you on 10-DAY FREE TRIAL. All paperback books. **TAB BOOKS, Dept. PM-680, Blue Ridge Summit, Pa. 17214**

AMAZING ELECTRONIC PRODUCTS

Lasers super powered, burning, cutting, rifle, pistol, pocket—see in dark—shotgun directional mike—screaming—silent Tesla—Stunwand—TV disrupter—energy producing, surveillance, detection, electrifying, chemical, ultrasonic, cb, zero, auto and mech devices, hundreds more—**ALL-NEW PLAN INFO UNITED PARTS SERVICE.**

CATALOG \$1. INFORMATION unlimited.
 DEPT. MB BOX 716 • AMHERST, N.H. 03031

CUT STRAIGHT WITH STRATE-CUT

A MUST FOR EVERY POWER TOOL USER

Use "STRATE-CUT" Cutting Guide with any portable circular saw, jig saw or router. **Extends to 8'6"**, reduces to 51" for short cuts and portability. Clamps to paneling, doors and other long work. Rip 4'x8' sheets down the center; trim 1/16" off a door. Make precision 90° cuts, tapers, angles, dados, bevels, grooves. Unbeatable for scoring wall-board. Guides utility knife. **Here's how this sturdy aluminum tool works:**

- (1) Patented connector joins and aligns
- (2) two 51" guide sections with four set screws (3) C-clamps (4) attach guide to work. Tool follows guiding edge (5) Clamps and illustrated instructions incl. only \$19.95 plus \$2.00 shipping and handling. U.S.A. only. Send check or M.O. to: **R.A.K. PRODUCTS, Department M-45 Box 23426, Milw., WI 53223. MONEY BACK GUARANTEE. Wis. Res. 4% tax.**

NEW! VERTICAL MILL

Write for free literature on our complete line of miniature tools and accessories.

The Ultimate Tool for the miniature machinist. From the makers of the famous SHERLINE 3" Lathe.

FULLY GUARANTEED MANUFACTURED IN U.S.A.

SPECIFICATIONS

- OVERALL SIZE: 12" x 14 1/2" x 17" high
- WORK TABLE: 13" x 1 1/4"
- TRAVEL: X Axis — 9"
- Y Axis — 3"
- Z Axis — 6 1/4"
- MOTOR: 1/5 Horsepower
- FEATURES: Precision spindle, adjustable pre-load bearings, anti-backlash feed screws, fully dovetailed, machined slide, adjustable gibs and more.

only \$289.50
 f.o.b. San Marcos

SHERLINE PRODUCTS
 INCORPORATED

170 NAVAJO SAN MARCOS • CA 92069 • USA
 ...the hobbyist's complete workshop

DISCOVER BADGE POWER AT A LOWER-THAN-EVER-BEFORE PRICE!

Discover the power to persuade, humor, surprise and identify. Make extra income by cashing in on the big demand for badges and buttons. Give your family an exciting hobby everyone will enjoy. **BADGE-A-MINIT**, gives you that power and more! Pin-back badges convey any message, slogan, emblem, or photo in an exciting and highly visible way. With the **BADGE-A-MINIT** system, you create badges for all your needs—quickly, easily, inexpensively. The color coded dies and hand die press are totally portable, simple to operate, and produce badges from parts that cost just pennies each. The large full color **BADGE-A-MINIT** catalog contains a wide range of resources for club, home and business applications. Send for yours today, it's **FREE!**

BADGE-A-MINIT announces the lowest price ever for a complete badgemaking system. The new starter kit is only \$17.95 and includes color-coded, **BUT-N-LOK** die set; sturdy Lexan, hand die press; quality, pin-back badge parts; and easy-to follow illustrated instructions. Everything you need to discover badge power for only \$17.95. Once again, **BADGE-A-MINIT** breaks the price barrier! Order your own **BADGE-A-MINIT** now.

BADGE-A-MINIT, Ltd.,
 Box 618, Dept. PM60
 Civic Industrial Park,
 LaSalle, IL 61301

I WANT BADGE POWER! Rush me the **BADGE-A-MINIT** starter kit for only \$17.95 plus \$1.75 shipping fee. (If I live in Ill. I'm including \$.90 sales tax)

My personal check or m.o. is enclosed.

Use my charge card checked below.

VISA Mastercharge Am. Express

SEND ME FREE THE 64-page, full color illustrated **BADGE-A-MINIT** catalog of ideas.

Credit Card # _____
 Interbank # (MC) _____ Exp. Date _____
 Signature _____
 Name _____
 Address _____
 City _____
 State _____ Zip _____

STARTER KIT \$17.95

CLASSIFIED ADVERTISEMENTS

Rate: **\$4.30** per word payable in advance each insertion. Minimum insertion ten words. Bold face capitalized words—**\$1.00** per word additional (First word set in Bold Face at no extra charge, Zip Code Free.) The next available issue to place an advertisement in America's No. 1 Classified Section is **AUGUST**. The closing is **JUNE 5th**.

Send remittance payable and order to Popular Mechanics, ATT.: Hildegard E. Kappel, Class. Adv., Mgr., 224 West 57th Street, New York, New York 10019. Please indicate Heading under which ad is to appear. As a consumer service and in cooperation with our mail-order advertisers who use post office box addresses for their convenience in handling your order, Popular Mechanics maintains a register of such mail-order advertisers containing their complete names and street addresses.

To avoid delay in the publication of your ad, please send descriptive materials with your request.

AUTOMOBILES

LEAVE YOUR LIGHTS ON? DEAD BATTERY? NO MORE, NOT IF YOU USE "LITE-REM." A child can attach. Money back guarantee. \$3.95 plus 90¢ mailing and handling. LITE-REM, Box 27, Elmira, Oregon 97437

CAR BATTERY SAVER. Leave your lights on and ignition off, this gadget reminds you. Guaranteed. \$6.95 plus \$2.00 handling. Battery Saver, Dept. PM-6, Box 548, Avilla, Ind. 46710

USED CAR BUYER'S GUIDE. Learn the secrets car dealers know and never buy another lemon! Money Back Guarantee. \$10.00. HAS Publications, Box 5489, Falmouth, Va. 22401.

FREE Trial Offer reduce your gas consumption with our new pedal spacer. Send \$1.00 for handling to: Pedal Spacer, Box 997, Flemington, N.J. 08822

"SAVE HUNDREDS"! — "KNOW THE SECRETS"!
Know sales techniques of automobile dealers "Before You Buy"!
Also "SAVE HUNDREDS" On your trade in! Sales Managers Report! \$4.00 to: Elliott Publications, Post Office Box 17155-P, Jacksonville, Florida 32216

ALCOHOL FUEL HOME BREW, Easy Plans and Information run Car 25¢ gallon. Send \$4.00 to: Fuel, Box 3194P, Redwood City, Calif. 94061

THE 100 MPH-PLUS CARBURETOR! Fact or Fiction? Details Free. Stamp Appreciated. Parks, Rt. 3, Box 350E, Lanett, AL 36863.

DISTILL LIQUID ENERGY, Outstanding Proven Alcohol Fuel Still. 200 Gallon Mash Capacity. Produces — 8-10 Gallons Per-Hour, Build for under \$1000. Complete Blueprints, Materials List. Hursand Associates, Box 213P, Wayzata, Minnesota 55391

GASOLINE MILEAGE INCREASED DRAMATICALLY, easily!! Details FREE!! Technering, Box 12191B, Norfolk, VA 23502.

PROPANE CARBURETION — Is it For You? Booklet covers Advantages and Disadvantages Written with 30 Years Experience. Save Hundreds of Dollars and Many Headaches. Send \$5.00 to: Propane Carburetion, Box 237-M, Loganville, Pa. 17342

ALCOHOL FUEL HOME MADE, Complete Instructions. Formulas to run Car or Furnace. \$4.00 to: Alcohol, Box 470P, Salem, UT. 84653 (Refundable).

PROPANE Conversion — Cars — Trucks. Return to gasoline anytime while driving. Uses regular refillable trailer tanks. No engine modifications. **COMPLETELY PROVEN — TESTED — THIS SYSTEM WORKS!** Uses inexpensive **LOCALLY** available parts. Engineered for amateur mechanics. Build for around \$50.00 in two days with ordinary hand tools. Satisfaction **ABSOLUTELY GUARANTEED** or immediate refund. For complete plans **RUSHED** First Class, send \$10.00. Fleming Engineering - PM-10, RD1, Remsen, New York 13438

MOTALOG Ring-Valve Replating Job—\$6.00. Money-Back Guarantee! Free Brochure! Arrow Products, Box 374M, Broken Arrow, OK 74012.

MPG INCREASED 30% + !! No gimmicks — no gadgets. Professional secrets revealed. Free details — Posco (#G86), Box 300, LaGrangeville, N.Y. 12540

LECTRICKAR — Convert VW's, Fiats to electric 50 mph plans \$25.00. Info. \$1.00. Robert Bucy, Box 28794, Dallas, Tx. 75228.

AUTOMOBILES Oil Dipstick Cleaner. Attaches instantly under any automobile hood. Insert Dipstick in Cylinder to clean. \$1.95 or Two \$3.70. Patton Enterprises, Box 3312, Early, Texas 76801

PROPANE/GASOLINE DUAL-FUELED AUTOMOBILE! Complete Plans, Instructions, and Parts Sources for converting your car. \$10.00. RDA, Box 873, Concord, NC 28025

MAGNETIC SIGNS For Your Car or Truck. Sunshine Crafts, P.O. Box 9692, Yakima, Washington 98909

HOW To Get FREE Motor Oil for your Car. Complete working instruction. \$5.00 — Bennett, Rt. 1, Dept. P, Danielsville, Georgia 30633

GASOLINE SHORTAGE? Keep running with Propane. Flip a switch while driving, engine runs on Propane. Two simple Propane systems to choose from. Build either for around \$50. Complete Plans-\$10. Fully Guaranteed. Also included: Professional Propane Conversion Information. Gac Engineering, Box 266M, Owis Head, Maine 04854

NO GASOLINE AVAILABLE!!! Prepare yourself. Build a woodgas-generator like the one which kept vehicles running during the - **NO GASOLINE** - period of W. W. 2. Old inventions, Re-discovered in the archives of Europe. Drawings and details \$5.95 to: **GEN-GAS**, Box 671, Chatsworth, California 91311.

SAVE Money — Auto Collision Repairs Book — \$4.95. Starco, 1817 West Touhy Ave., Park Ridge, Illinois 60068

SECRETS OF THE 200 MPG CARBURETOR! Patent Drawings and Instructions \$10.25—Money Back Guarantee. Roadrunner Publications, Raymondville, Texas 78580

RUN CAR, TRUCK, TRACTOR ON WOOD! Illustrated Report \$5.00. Sweat, Box 591, Titusville, FL 32780

ALCOHOL FUEL LEGALLY. Run Car or Furnace for 30¢ Gallon. New Plans, Instructions, Formulas \$3.00. Geans Publishing, Box 98P, Payson, Utah 84651

SAVE 60% On Auto, Marine, Regulators, Alternator Parts, Transistorized Ignition Modules. Send Legal-Size Stamped Envelope For Prices. L.E.S., Box 3629, Kent, WA 98031

SAVE YOUR CAR! Stop Rust, for Pennies Used, New, Instructions — \$3.25. GW Perrin, 117 Falcon, Johnstown, Pa. 15905

ALCOHOL FUEL STILL BUILT FROM SALVAGE PARTS. Plans \$3.99. Gasohol, Box 8646, Mobile, Alabama 36689.

MAKE MONEY With Secondhand Cars. Illustrated How-To Booklet \$3.95. Catalina Publications, Box 8205-CRB, Tucson, Arizona 85738

GAS SAVERS 214 page book gives patent drawings and explanations for 41 gas saving inventions. \$9.95 plus \$1 postage. U.S. Marketing, P.O. Box 06059, Portland, Oregon 97206

SAVE Gas! Simple Invention Improves Mileage 15% — Boosts Power. Complete Plans, Instructions - \$2.00. Rimar, Box 1144B, Berkley, MI 48072.

FREE INFORMATION! Fuel-economy tuning secrets explained. Technering, Box 12191B, Norfolk, VA 23502

FREE Oil For Your Car. Details \$1.00. Ideas Unlimited, 953 East River, Kankakee, IL 60901.

CRASH COSTLY AUTOBODY REPAIRS. Informative booklet helps eliminate hassle \$5.98. CJ Enterprises, Box 4302, Eastside, Oregon 97420

POWER Your Car with Wood. No Engine Modifications. Send \$3 for Patented Information. Alternate Energy Research, Box 1321, Manassas, VA 22110

INCREDIBLE MPG Increase!!! How To Build Water Injector Easily, Inexpensively!!! Free Details!!! Send 4"x9" Self Addressed Stamped Envelope. U&I, PM60, Box 4873, Boise, Idaho 83704

SAVE UP TO \$400/YEAR with Tuffon's teflon engine coating for just \$26.00. That's a 1540% return that carries lifetime, money-back guarantee to increase MPG. HBS Enterprises, 127 Crocus, Lake Jackson, Texas 77566

REMOVE Splattered Bugs Easily! Autos, Trucks & Vans. Guaranteed Results! Act Now and Be Ready! Send \$3.00 to: Rabie Enterprises, P.O. Box 12726, Tallahassee, Fla. 32308

GASOLIN GUIDE, PLUS Alcohol-Making Manual. Both only \$2.00. Alchogas, 5133 Fairhill, Philadelphia, Pa. 19120.

100% SYNTHETIC MOTOR OIL — WHY SUPPORT SPECIALLY AMERICAN MADE SYNTHETIC OIL IS BETTER THAN IMPORTED OIL — INCREASE MPG WITH CHEMOL — MILLIONS SPENT IN RESEARCH — NO GIMMICK — DETAILED INFORMATION: \$3.75 MERIDETH DIST. CO., 474 HAYWOOD RD. ASHEVILLE, N.C. 28818

MPG INCREASER! — lasting TEFLON oil treatment. Guaranteed. Petrolonsevern, 2246-M Grand, Connersville, Indiana 47331

SAVE GAS! AMAZING NEW INVENTION increases mileage up to 30%. Free information. Auto-Sciences, P.O. Box 6008, Orange, Ca., 92667.

THE-FUEL-MIZER-KIT. ULTIMATE Savings per Dollar. \$6.95. Box 240, Marcy, N.Y. 13403

PROVEN 30% MILEAGE INCREASE! WE SHOW YOU NOW. \$1.00 Information. Box 240, Marcy, New York 13403.

ATTENTION RADAR DETECTOR OWNERS — Keep your detector from being stolen. Let us turn it into a remote unit. For details send \$1.00 to: Randolph Electric, Box 4, Holyrood, Kansas 67450

MILEAGE INCREASED. PERMANENT INCREASED RPM, HORSEPOWER COMPRESSION, REDUCE OIL CONSUMPTION, TEMPS. Information \$2.00 Credit to Purchase 6-8 Cyl. — \$49.95, 4 Cyl. — \$29.95. Motorcycles — \$14.95. Al Wendel, 24 Roushey St., Shavertown, PA 18708

SAVE GAS AND DRIVE. What you know and NEED TO KNOW about saving gasoline. IT'S HERE NOW, seven page booklet \$2.00. Box 6271, El Monte, Calif. 91734

100 MPG Electric-Gas Combination, \$5.00. Homecraft, 2350 W47P Denver, CO 80211.

BEAT THE CAR DEALER! Sell your Old Car! Tips from 18 Years Experience! \$3.50. Box 11528, Kansas City, MO 64138

SIX Inch Lever Wrench. Many uses! Automatic sizing! Must for all car owners! Satisfaction guaranteed. \$8.95 Postpaid. Janken Co., P.O. Box 19555, Raleigh, N. C. 27619

PROPANE SURPLUS! — Low Prices!! — Convert Your Engine — Keep Gasoline Standby! — Easily Followed Book — \$4.95 — **GUARANTEED!!** — LPG Automotive, Box 1045MF, Newport Beach, California 92663. **DON'T BE MISLED!!** Legal Conversions Cost More Than \$50.

INCREASE The Value of your car. Proven method used by Dealers. Booklet \$3.00. Box 503, Barrie, Ontario L4M 4T7

VAPOR Carburetor 100+ M.P.G. Proven Patent Drawings, Details \$10.00. C.D.M., Box #90, Zimmerman, Minnesota 55398

WHEEL ALIGNMENT — Illustrated Instructions for making and using simple accurate tool. \$4.00. Almond, 601 Porter Street, Blacksburg, Virginia 24060

ALCOHOL-Detailed Information Concerning Still Plans, Recipes, Brewing, Vehicle Conversion Burning Both Alcohol or Gasoline. Easy Home Methods. \$5.00. ALCO, Box 1603, Plains, Pa. 18705

2 TON Hydraulic Axle Jack. Handle. \$10.00. **180 POUND** Double Headed Torque Wrench. S.A.E. And Metric. 1/2" Drive. \$8.00. **4 - PIECE** Adjustable Wrench Set. \$10.00. **WAREHOUSE TOOLMART,** Box 64303, Los Angeles, California 90064

GAS GADGETS DO THEY WORK OR NOT? Which Ones Do As Advertised, Which Ones Are RIP-OFFS. Receive your copy "GASSAVERS NEWS"™ Before you Buy One! Including Product Evaluations on Those That Work. Send \$2.00 To: Fuelexpanders, P.O. Box 17711-PMA, Irvine, California 92715

STOP YOUR CAR FROM BEING STOLEN! Installed in minutes. Money back guarantee. Can't be stolen even with keys. Mystifies thieves. Send \$14.95 Postpaid. Box 10952, #425, Houston, Texas 77018

JEeps Military Willys MB \$3,995.00 Restored. Duryea Ford, Brockport, N.Y. 14420

WATER INJECTION SYSTEM Burn water/alcohol with gasoline, improves mileage/performance. **FREE BROCHURE** Plans \$5.00 or Complete System; reservoir, fittings, tubing, hardware, instructions/illustrations \$19.95 Postpaid. **MONEY BACK GUARANTEE!** Waterflo Dynamics, Box 17172, Lansing, MI. 48901

150,000 MILE AUTOMOBILE !!! Maintenance, gas savings tips. Booklet \$2.00 (refundable). Automotive, Box 6064, Vero Beach, FL 32960

TRUE—or—FALSE: Oil in the Radiator indicates Cracked Cylinder Heads. — Undercoat and Vinyl Tops often Hide Collision Repairs. — "Book Value" averages \$1000. less than Retail. — Know All the Answers! — **READ "How To Buy A Used Car Like A Professional"** — Expert Troubleshooting Guide — Comprehensive Buyers Manual. — \$5.00 — Light Publications, P.O. Box 665-M, Westfield, Mass. 01086.

BIG GAS SAVINGS — Do-It-Yourself Manual By Professional \$3.99 — (Refundable.) XA Automotive, 113 Tupeilo, Ft. Walton, FL 32548

GAS \$2.50 A Gallon! What? By Next Year Get in on Alcohol Back-Yard Still Plans, Recipes, Laws, Permits, Engine Conversion, Complaint Manual. Mulco Industrial Services, 4631 Painters Street, New Orleans, Louisiana 70122

SAVE HUNDREDS/THOUSANDS on new cars. Expert report shows how. Guaranteed. \$10.00. TAB, P.O. Box 4358PM, Virginia Beach, Va. 23454.

(Continued on next page)

AUTOMOBILES

(Continued from preceding page)

STOP WASTING GAS! I'll tell you how. **MONEY BACK GUARANTEE.** Why Wait until gas is \$2.00 a gallon. Send \$3.00 to: B&D Enterprises, P.O. Box 16791, Jacksonville, Florida 32216

GASOHOL! "How to Build an Alcohol Still". Informative Book. \$2.00. Pioneer, Box 2507-G, Wichita Falls, Texas 76307

PROPANE/GASOLINE DUAL-FUEL AUTO! Conversion Plans and Instructions. Parts Sources. Only \$10.00! RDA, Box 873, Concord, NC 28025

REBUILD AUTO BATTERY Yourself, in 30 Minutes for Pennies. Send \$2. 4511 W. 64th St., Tulsa, Oklahoma 74132

ELECTRIC VEHICLES

GUIDE TO ELECTRIC AUTO CONVERSION. Comprehensive 64 page Conversion Manual. Includes Proven Diagrams, Parts Procurement, Contacts, and more! Loaded with information!! \$14.95. Information FREE. Bill Williams, IA6, Box 1548, Cupertino, CA 95014.

HYBRID GAS-ELECTRIC CAR Top speed of 90 MPH, 80 MPG, no plug-in. Simple conversion, easy instructions including list of parts. **BEAT OPEC.** Send \$9.95 to: Hybrid Cars, 640 Broadway, Denver, Co 80203

ELECTRIC Car Conversion: Simple, Easy To Follow Step-By-Step Instructions, 5 Years Research and 3 Working Cars. — \$27.00. — Manual Coverage Information \$2.00. Eilers, P.O. Box 2781, Santa Clara, CA 95051

ELECTRIC/HYBRID VOLKSWAGEN CONVERSIONS! Information—\$3.00. Book—\$9.50. Blueprints—\$15.00. **KAYLOR-KIT,** 3162A Bay, Redwood City, Calif. 94063.

MIDGET CARS

BUILD A RACING GO-CART. Enduro Go-Cart. Plans \$5.00. JMH, Ind., P.O. Box 2031, Southfield, Michigan 48037

AUTO SUPPLIES & EQUIPMENT

TIRED OF DEAD BATTERIES FROM FORGETTING TO TURN OFF YOUR LIGHTS? LITE-REM is guaranteed to solve your problem. Money back if not completely satisfied. \$3.95 plus 90¢ mailing and handling. **LITE-REM,** Box 27, Elmira, Ore. 97437

GASOLINE PRICES SOARING! SUPPLY SHORTAGES! Try the **MINI-SUPERCHARGER** for 30 days at **OUR RISK!** Up to 21% SAVINGS - LIKE EVERY FIFTH TANKFUL FREE! Install in minutes. \$18.95 postpaid. **SKEPTICAL?** Write for details. **DANLO,** Dept. M, 2906 Parkwood, Box 539, Lisle, Illinois 60532

PARTS: Army Jeep and truck parts. Spare Parts & Equipment Co., P.O. Box 751, Lexington, Kentucky 40501

ALTERNATOR/Generator Rebuilding Book. Details: Hedelund Engineering, 7505 Barkentine, Las Vegas, Nevada 89128.

AMERICA'S #1 Patented Gas Saver. Like having every Fifth Tank Full Free. Adds Clean Power, Faster Acceleration, Reduces Carbon Ping and Wear. \$19.95. Alpha Research, Box 345, Rodeo, CA 94572

AUTOMOTIVE BREAKTHROUGH! Varifold WATER INJECTION Eliminates Ping, Carbon Dieasing. Increases Mileage, Performance, Engine Life. (Guaranteed!) \$119.95. Free Brochure. Box 550P, Stanwood, WA 98292

HARDTOPS For Alfa, Austin Healy, Datsun, Fiat, Jaguar, Jensen Healy MGA, MGB, Midget, Spitfire, Sprite, Sunbeam, TR3, TR4, TR6, TR250—**DYNAPLASTICS,** P.O. Box 4907, El Monte, California 91734

YOUR CAR WILL RUN ON WOOD. Mine does. Complete instructions, plans, photographs, \$12.50. R&R, Box 458, Hillsboro, N.M. 88042

STOP OIL CHANGES. GUARANTEED. INFORMATION \$2.00. 98-1106 Kahapii, Alea, Hawaii 96701

BACKUP Alarm \$19.95 Prepaid. Don't run over a child. Kiddialert, Box 974, Barrie, Ont., Canada L4M 5E1

RECREATIONAL VEHICLES, PARTS & ACCESSORIES

BUGGED? Screening Plans for Vans, Detailed, \$3.95. P.O. Box 1411, Merrett Island, Florida 32952

MOTORCYCLES, BICYCLES, MOTORSCOOTERS & SUPPLIES

PLANS Go-Kart \$2.50, Mini Bike \$2.00, Three Wheeler \$3.00, Soap Box \$3.00, Mini Vehicle, Dept. C2, Chazy, N.Y. 12921

HONDAS, \$25.00, Schwinn's, \$21.00, Catalog 95¢ (Refundable). Surplus, 443, Bend, Oregon 97701

MOTORIZED BICYCLE . . . Proven! Simple Inexpensive Design!!! Two cycle lawnmower engine powered . . . Plans: \$2.00 . . . J-C Publishers, Box 135, Troy, N.Y. 12182

HANG GLIDING—AVIATION

JOIN THE ULTRALIGHT REVOLUTION. Build and fly your own powered Hang Glider! Kits, Engines, Accessories. Catalog \$2.00. Tricraft Aero, P.O. Box 488, Genoa City, WI 53128

AIRBOAT Propellers and hubs for all engines. Literature \$1.00. Airboats, Inc., 3855 Miller Avenue, Fort Worth, Texas 76119

ONE-MAN JET HELICOPTER — Easy, inexpensive to build! Detailed plans, drawings—\$7.00. **HELICOPTER EXPERIMENTER'S HANDBOOK**—\$4.00. Both—\$10.00. Helicraft, Box 3053, Redondo Beach, California 90277

INFLATOPLANE! Inflatable Rubber Airplane, Complete Story \$4.95. ESSCO, Akron Airport, Akron, Ohio 44306

HANG-GLIDERS — 24 flight-tested designs registered. Send \$5.00 to: Harmon's, Dept. S, 406 S. Main, Rock Port, MO 64482.

SPACE & ASTRONAUTS

ANTIGRAVITY Propulsion Device. Free Brochure! RDA, Box 873N, Concord, NC 28025

NASA Patches Sample and List \$2.00. Wagner, X860, New Haven, Ct. 06504

HOVERCRAFT

AERO-CAR Amazing Hovercraft built easily with ordinary tools. Lawnmower engine power. Carries one man plus. Hovers, flies forward, backward. Sideways over land/snow/water. Complete construction plans and brochure. \$8.95. Aero-Projects, Box 5118PM, Clinton, New Jersey 08809.

HOVERCRAFT Plan All Sizes. Catalog \$1.00. Universal Hovercraft, Box 281, Cordova, Illinois 61242

HOVERBIKE! Lawnmower Powered - Free Information, Dept. H06, 871A2 Moe, Akron, Ohio 44310

CB-RADIO, TV & HAM EQUIPMENT

POLICE Scanners, Crystals, Antennas, CBs, Radar Detectors. HPR, Box 19224, Denver, CO 80219

FREE Educational Electronics Catalog. EduKits Workshop, Department 806B, Hewlett, New York 11557.

GIANT SCREEN TV. Projection system kit includes lens, plans, instructions. \$16.00. Guaranteed. ADP Enterprises, Box AW-1, Brisbane, CA 94005

GOVERNMENT Surplus receivers, transmitters, snoopercoopers, parts, Catalog 25¢. Meshna, Nahant, Mass. 01908

49¢ RADIO + TV Tubes. Free Catalog. Cornell, 4213-17 University, San Diego, California 92105.

INCREASE YOUR CB RANGE — LEGALLY! Free information. "SKIPPER", Box 130-BS, Paradise, Calif. 95969

SATELLITE TV BUYERS GUIDE. Exclusive comparisons plus how to **INSTALL YOUR OWN** saving big \$\$ Worldwide movies, news, sports, religion, entertainment on your set. **WELL OVER 35 CHANNELS.** Book guaranteed. US funds please. \$12.95 postpaid or \$14.95 First class (Airmail). Reed Publications, Box 219-C, Maitland FL 32751

CB SPECIALTIES! PLL EXPANDERS, repair/modification books, range-boosters. Catalog \$1. CB City, Box 1030M, Woodland Hills, Ca. 91365

50 CHANNEL TELEVISION. Operate your own satellite receiver. Super-Clear pictures. Complete information. Refundable. \$5.95. Merit, 2307 Tyler Lane, Louisville, KY 40205

ELECTRONICS

MECHANICALLY INCLINED INDIVIDUALS! Assemble electronic devices in your home. Knowledge or experience not necessary. Get started in spare time. Above average profits. \$300-\$600/wk. possible. Sales handled by others. No investment - Write for free details: **ELECTRONIC DEVELOPMENT LAB, BOX 1560PM, PINELLAS PARK, FL 33565**

BOOKS — Learn Electronics, Lasers, Robotics, Computers, TV, Solar Etc. - Catalog 30¢ - DOT, 9719 Southwest Highway, Oaklawn, Illinois 60453

PRINTED CIRCUIT BOARDS from sketch or artwork. Kit Projects. **DAMOCINTHS** Inc., Dept. PM, Box 261, Westland, Michigan 48185

ELECTRONICS YOUR HOBBY? MAKE IT YOUR CAREER! Get Unique Booklet that will Open the Door. Send \$3.95 to: Files, Box 459-B, Massapequa, N.Y. 11758

STEREO, CASSETTE TAPES, ETC. . . .

FREE Catalog—Electronics Kits—Amplifiers—Pre-amplifiers—Psychedelic Strobes—SCA Adaptors—Color Organs—Digital Instruments—Guitar Amplifier. **FREE** Subscriptions, SWTPC, Box PM32040, San Antonio, Texas 78284.

OLDIES — 45 RPM Original Hits. Catalog \$1.00. C&S Record Sales, Box 197A, Wampsville, NY 13163

NAME Brand Stereo and Sound Equipment at World's Lowest Prices. Send \$1.00 for Bargain Packed Catalog. World's Stereo Center, P.O. Box 149 Longboat Key, Fl 33548

GOLDEN Oldies. Thousands of 45 Records. Send \$2.00 for catalog. Stewart Estep Records, Box 10243, Alexandria, VA 22310

MOTION PICTURES & SOUND EQUIPMENT

FREE HOME ENTERTAINMENT CATALOG. Hundreds of titles in videocassette, super 8 or 16 mm film. New releases from Paramount, Warner Bros., Columbia, MGM, Allied Artists, Disney and more. Specify film or video. Write: Niles, Box 1576-PM, South Bend, IN 46634.

16MM Films, Videotapes, Bargains. Urbanski, 8142 S. Kenneth, Chicago, Illinois 60652

CAMPERS & TRAILER KITS—PLANS

R-V KITS — PLANS — PATTERNS Campers — Trailers — Fifth Wheels — Vans — Covers — Motorhomes. Simple construction. Save! R-V Kits/Equipment catalog \$1.00. Glen-L R-V's, 9152PM Rosecrans, Bellflower, CA 90706

BOATS, OUTBOARDS, TRAILERS & KITS

BOATKITS — PLANS — PATTERNS — FRAMEPACS — FIBERGLASS — World's largest Catalogues — 300 — designs — 8'/80' — plywood — fiberglass — steel — **POWERBOATS** — inboard — outboard — jets — cruisers — sportfishers — hydroplanes — runabouts — **SAILBOATS** — Daysailers — Trailersailers — Multihulls — motorsailers — **(KYACK-CANOE)** — large selection wood — canvas — fiberglass) **BOATBUILDING** — materials — hardware — fastenings — rigging — sails — plywood — **FIBERGLASS** — polyester epoxies — foams — cloth — mats — C-Flex — special section boatbuilding with wood epoxy saturation system — catalogues \$2.00 (Book "One-Off Boatbuilding" \$6.00) **CLARKCRAFT,** 16-P Aqualane, Tonawanda, NY 14150

BOAT PLANS — FRAME KITS — PATTERNS — Huge 140-page catalog! Powerboats — Sailboats — Outboards — Jets — Rowboats — Houseboats — Runabouts — Dories — Workboats — Racing Boats — In plywood — Cold Molded — Wood/Epoxy — Fiberglass — 8' to 49'. Lowest cost, highest quality for 27 years. Easy, proven methods include instructions especially for amateurs. No lusting! **"BOATBUILDING SUPPLIES"** — Fastenings — Fiberglass — Resins — Glues — Equipment — Spars — Books — Boat Trailer Plans. Send \$2.00 for catalog plus free "Boatbuilding Supplies" brochure. "Inboard Marine Hardware" catalog also \$2.00. Glen-L Marine, 9152 Rosecrans, Dept. MP, Bellflower, CA 90706

PLANS (280), Patterns, kits, Catalogs: Powerboat \$2.00, sailboat, \$1.00. Marinecraft, Box 161-M, Brighton, Mass. 02135

EVINRUDE 1979 Bargains . . . all sizes . . . Scott McCulloch parts . . . \$1. handling . . . Electra Marine, 610 Merrick Road, Lynbrook, New York 11563

BOAT KITS - 22 trailerable models - **POWER** and **SAIL** - 16'-30'. Molded fiberglass hulls and decks come factory assembled - you install factory supplied interior. Save half factory-built cost. No experience required. **FREE** catalog. Luger, Dept. BC-80, 3800 West Highway 13, Burnsville, Minnesota 55337 —(612) 890-3000

CANOE, Kayak, Wood — Fiberglass. Plans \$10.00. Trailcraft, Concordia, KS 66901

BUYING A BOAT. How to get started in the best boat for you and your pocketbook. Satisfied or money back. Send \$2.95 to: **BOATS,** Box 415, Hampton, VA 23669

CAMPING EQUIPMENT & TENTS

HOW TO MAKE A ONE-POLE TEPEE — 12' — 16½' — Sleeps 4-7 Adults — Complete — Easy To Follow — Instructions — No Risk Offer — Send \$5.00 Check/MO to: Englemans Tepee, PM-6, 3615 Mt. Pleasant Rd., Kelso, WA 98626 — You must be Satisfied, or Return Book Within 15 Days for Full Refund!

FREE Catalog. Everything for camping. Campmor, Box 407N, Bogota, New Jersey 07603

CAMPERS TRAVELERS 4 convenient items for the price of 3! Emergency Siren Flashlight, Swiss Type Army Knife, Illuminated Pocket Map Magnifier. **BONUS** "Everything Tool" combination jar opener, screwdriver, wrench, tongs, shellfish cracker. \$19.95. Shipping charge \$2.70. Inside/Out, 1234 Arabella St., Dept.-J, New Orleans, LA. 70115

CAMPING

US MILITARY SURVIVAL MANUAL. Plus 530 Manuals on Carpentry — Auto Repair — Electronics — Etc. Complete Catalog \$3.95 (Refundable). Waiter, 411 Longmeadows, Wilton, CT 06897

ATHLETIC & BODY BUILDING COURSES

POWERFUL Muscles Fast!! Guaranteed! **FREE** Information. American Powerhouse, Box 667, Minneapolis, Minnesota 55440

PHYSICAL Fitness Newsletter, Dept. 40, P.O. 195, Western Springs, Illinois 60558, introductory copy.

(Continued on next page)

ATHLETIC & BODY BUILDING COURSES

(Continued from preceding page)

FREE Muscle Building Lesson, It Works! Send 50¢ Mailing Costs. **BODYSCULPTURE**, Box 125, Rockaway, NJ 07866

DEFENSE . . . Learn Block Hits . . . Illustrated Defense Against the Four Most Common Attacks. Send \$3 To: Larry Harris, P.O. Box 20397-PM, Sacramento, CA 95824

BUILD HUGE ARMS FAST! Guaranteed. \$4.00. Robert's, 241 Shore Drive, Eastlake, Ohio 44094

BUILD Massive 20" arms. Only \$3.00. Mus-L-Up, Box 982, Redondo Beach, Ca., 90278

SPORTING GOODS & EQUIPMENT

BOOMERANGS — INCREDIBLE RETURN! Exciting sport. **FREE** catalog. 30 designs, books. BoomerangMan, 306 Park, Monroe, LA 71201

SCUBA Catalog 50¢. All Brands. Fantastic Discounts. Scubasales, 2610 Merrick, Belmore, New York 11710

LUBRICANT AND CLEANER Impregnates Teflon Film into Pore Structure. **GUNS** — Increase Velocity, Extend Barrel and Action Life. **FISHING EQUIPMENT** Reels, Eyelets, etc. \$5.95. Al Wendel, 24 Roushey St., Shavertown, PA 18708

HOW TO WIN AT RACQUETBALL Instructional guide to match preparation \$3.95 (refundable). Rollout Publications, Box 2088, Michigan City, Indiana 46360

FISHING, TACKLE, LURES

FISH FLIES — Professional Dry Fly Assortment, Leather Case. Send \$8.98. — P. Gaymon Assoc., 6358 Stonewain Ct., Oxonhill, MD 20022

HUNTING, GUNS, DECOYS

LEARN GUNSMITHING-PISTOLSMITHING; Three Great Books, Home Gunsmithing Digest, Hobby Gunsmithing, Pistol Gunsmithing. Free Catalog—Edwards, Dept. MP, 2402 Alta Court, Midland, Michigan 48640

DOGS & KENNELS

COLLARS, Leashes, Harnesses, ID Plates. Write for Catalog: The Dog Collar Works, Maysville, Georgia 30558

PUPPIES MEAN PROFIT! \$1000.00 Month. Plan \$3.00. Dogs, Box 314, Hudson, Wisconsin 54014

BATTERIES, GENERATORS

MAGNETOHYDRODYNAMIC GENERATOR! Converts Burning Gas directly to Electricity. No Moving Parts! Simple, Easy to follow Plans/Instructions. Only \$10.00! RDA, Box 873, Concord, NC 28025

ENGINES, MOTORS, MAGNETS

ENGINES aircooled to 16 HP for Mowers, Tillers, Riders, Hobby. Tremendous discounts, illustration, prices. \$2.00 Refundable. Ashland Small Engines, Ashland, MO 65010

REWIRE Car Alternator for 110 AC. Plans for \$3.00. Sweett, Box 591, Titusville, Florida 32780

REPAIR ELECTRIC MOTORS! GENERATORS! ALTERNATORS! Details! Modequip, Box 7266, Kansas City, Missouri 64113

REWIND JUNK TRANSFORMERS for any voltage! Manual shows how. \$3.00 Guaranteed. Harrit, Box 495, Great Neck, N.Y. 11022

TOOLS FOR SALE

WOODWORKING Handtool Catalog, 88 Pages of Finest German Goodies. Frog Tool Catalog, 700 W. Jackson Blvd., Chicago, Illinois 60606

AIR TOOLS — Free Wholesale Catalog; Hoosier Distributing, 3009 Sample, South Bend, Ind. 46619

RODAC OR CHICAGO PNEUMATIC PROFESSIONAL 1/2" DRIVE AIR IMPACT WRENCH, 300' TORQUE \$69.96. 3/4" DRIVE PROFESSIONAL AIR RATCHET \$59.95. SPECIFY BRAND DESIRED. S-K 1/2" 8 PIECE DEEP IMPACT SOCKET SET 7/16"-3/4" \$26.95, S-K STANDARD SET \$16.95. TOOLS HOLD MANUFACTURERS GUARANTEES. ANDREQU INDUSTRIES, 22-69 23RD STREET, ASTORIA, NEW YORK 11005

NEWLY PATENTED. Vented oil can spout. Speeds oil from quart cans. \$3.00 Postpaid. TRJ Manufacturing, Box 984, Yucaipa, Calif. 92399

MACHINERY, TOOLS & SUPPLIES

MORTISING ATTACHMENT For Cummings, Enco, Continental or Similar Drill Presses. Send for Free Literature. Ted Vander Putten, 673 Hickory Road, Oneida, WI 54155

MILLING Cutters, lathe milling attachments, Catalog \$1.00. Potter, Box 73, Cedar Rapids, Iowa 52406.

MACHINEX - Unimat - Maximat - Sherline Lathes, Mills. Catalog \$1.00. Shop Supplies \$1.00. Campbell, 1424 Barclay, Springfield, Ohio 45505

BANDSAW BLADES, Carbide Tipped Saws, Any Size, Free literature. King Saw, 6541 Tidewater Drive, Norfolk, Virginia 23509

1600 CATALOGS listed and described. Sources for everything imaginable. \$3.00. Masterlog, Box 879, Fairfax, California 94930

BANDSAW BLADES, Any Size. Free Pricelist. Parker, 8921HY49, Sonoma, Cal. 95370.

CONVERT 3 PHASE MOTORS To Single Phase! 100% Power on 50% Juice. Easy Instructions and Illustrations. Send \$8.50 To: Tanyon Press PMM, 2427 W. 26th St., Erie, PA 16506

SMALL FOUNDRY Furnaces, Supplies. Free literature. Pyramid Products, 3736 South 7th Avenue, Phoenix, Arizona 85041

LUMBER/MAKER And your chain saw makes lumber and Cabins from Logs right where they lie—full details write: Haddon Tools, 4719 Route 120, McHenry, Illinois 60050

UNIMAT Owners. Get 10 Threads — Right, Left Hand! 5 Feeds Forward, Reverse with the Carico Quick-Change Threading and Power Feed Attachment! Free Brochure! Carico, 3551 Grant, Corona, CA. 91720

4" METAL Cutting Lathe \$72.65. Taig, 15048 Proctor, Industry, CA 91746.

30 LATHE Tool Projects, -Mill, Slot, Grind etc. -Catalog \$2.00. EJ Cafarelli, 4735 Hayman, Warren, MI. 48092.

ATLAS DRILL PRESS. Made in USA. Drills to center of 16" circle. Six speeds from 480-6200 rpm. 1/2" chuck. For more information, write: Atlas Press Co., Dept. 3CD, 2019 N. Pitcher, Kalamazoo, MI 49007

TREMENDOUS Value, 15 Precision Industrial Steel Drill Bits 1/16" — 1/2" \$14.95. Michael Hudak, 260 Nicholson St., Joliet, IL 60435

RUN three phase motors with single phase power. P-7 wiring diagram and instructions \$5.00. Advance Research, 3232 Shawnee, Fort Worth, Texas 76135

STEEL, Aluminum, Brass — Sheet — Bar — Tube, Shop Supplies. Plans. Write: CEI, Box 152A, Knoxville, Ill. 61448

BLACKSMITH & FOUNDRY SUPPLIES

SMALL Foundry Furnaces, Supplies, Information \$1.00. Kroeger Company, Le Claire, Iowa 52753

FORGES: gas, coal — hammers — tongs — anvils — anvil benches—all blacksmith supplies. Catalog \$1 (refunded first order). Mankel Blacksmith Shop, 7836 Cannonsburg, Cannonsburg, MI 49317.

ENERGY SAVING

104 Ways To Control Your Electric Bills! Send \$2.00 for Details. Electric Controls, Box #58, E. Bridgewater, Mass., 02333

GASOHOL Make your own legally plans, recipes, laws, \$5.00. Encon, P.O. Box 1663, Manassas, Virginia 22110

REDUCE AIRCONDITIONING COSTS; 75% possible with hybrid system **PATENTED** Details \$2.00; Rowe Engineering, Rt. 1, Box 13, Paradise, Texas 76073

LOG SPLITTER No Hammers, Screws, Cylinders. Detailed Drawings. \$3.00 SASE. Jimco, P.O. Box 295, Orrville, Ohio 44667

COMBINATION SOLAR HEAT HOT WATER HEATER AND FURNACE. Reducing Oil Consumption. Save up to 95%. Use Wood or Coal. Blueprint \$9.95. Write: Michaud, 1552 West Street, Southington, Conn. 06489

CENTRAL HEAT FROM WOOD! Wood-burning boilers heat whole house, yield hot water! Details: Tekton Corporation, Box 999, Conway, MA 01341.

SAVE Up to 75% on Heating, Fire Place Insert Plans \$5.00. Patented Wood Stove Plans \$25.00. S&W Wood Stoves, 587 West Market Street, York, Pennsylvania 17404.

INSULATION QUESTIONS? Official data about "R" values, comparisons, safety, installation, cost, and savings. Illustrations and charts. A wealth of information for only \$3.00 to: Solar Now, Box 4829, Mesa, Az. 85201

WOOD BURNING STOVE! Build for Under \$40.00. Plans \$5.00. Tammy, Box 66, Zeeland, Mich 49464

47 ENERGY Saving Ideas that can be used in the Average Home. Covers Heating, Electricity, etc. Guaranteed to Save Real \$\$\$ Send \$3.00 and SASE to: Energy, Box 936CF, Media, PA 19063

THE LAZY BUT SMART HOMEOWNER'S WAY To Cut Energy Bills in 7 Days. Quickly! Easily! Cheaply! Guaranteed. Free Details. Home Energy Enterprises, Dept. PM6, 68 Center St., Red Bank, N.J. 07701

FREE HEAT, 6 HOURS after Wood Stove Fire Burns out. \$10.00 for plans. NASCO, 166 Broadway, Saranac Lake, N.Y. 12983

BREAKTHROUGH Energy Home design. Without heating in winter, cools down **ONLY 20 DEGREES IN 3 WEEKS** — 95% Energy Independent! Send \$10.00: Research Systems, 3955 Blue Diamond, Las Vegas, Nevada 89118

99 WAYS TO SAVE ENERGY AND MONEY. Booklet Contains Everything you Need to Know. Send \$1.50 to: J.C. Enterprises, Box 295, Johnson City, New York 13790

AIR CONDITIONING Costs high? With simple tried and tested modifications, your home will stay cool without air conditioning. For easy do-it-yourself plans, send \$4.00 to: Mar-Mee-Co, Box 157, McFarland, WI. 53558

SMOKE STACK Heat Exchanger, Detailed Plans, Illustrations \$8.95. Arsenault, RFD 3, Colchester, CT 06415

SOLAR & ALTERNATE ENERGY

400-PAGE METHANE FUEL MANUAL! Plans, formulas, diagrams, equations, etc. Everything you need to know. Convert home, farm, etc. Generate fuel from garbage! **ONLY \$15.00!** RDA, Box 873, Concord, NC 28025

WINDPOWER'S Progress. Update Report. \$3.00. Windways, 304 Shirley, Winthrop, MA 02152

AIRCONDITION — Pennies per Month. Minor Investment, Plans \$5.00. Enemiser, Box 784, Anoka, Minn. 55303

AMAZING Forced-Air Wood Heater. Supplement your Furnace or use Alone. Write: Box 3, Rockton, Ill. 61072

SOLAR PANELS Diagrams and Specs. of Inexpensive and most Efficient Solar Heat and Hot Water Units—\$9.50 — **THEY WORK!** Solar Research, P.O. Box 933, Port Richey, Florida 33568

ENERGY INTEGRATION — Book on Alcohol, Methane, Electricity & Solar Systems for Homesite Energy Production. \$2. AIEnSy, Rt. 2, Box 43, San Marcos, Texas 78666

KALWALL'S SOLAR HEATING CATALOG! FULL Line of Solar Heating Components, including Sun-Lite® Glazing and Tubes. Order all Materials from one Source. Send \$2.00 for Catalog. Solar Components, Dept. M, P.O. Box 237, Manchester, New Hampshire 03105

UNDECIDED About SOLAR Energy? Simplified Design Method Sizes, Costs, Optimizes your Conversion — New Residential System. \$4.95. R. Brislin, 33 Oak Street, Wilkes-Barre, Pa. 18702

DARRIEUS ROTATING AIRFOIL System Generates 3Kw Electricity! Most Advanced Concept in Wind-power! Complete Plans: \$6.95. Glenvale, Box 358k Station D, Toronto, Ontario M6P 3J9

SOLAR Oven 2 sq. Simple, Efficient, Inexpensive Plans — \$5.00. Charles Post, 3200 McBride Road, Owosso, Michigan 48867

ACTIVE SOLAR SYSTEMS!! SAVE 50% or more. Solar Potential Evaluation Your Area Plus Needed Details. \$2.00. Solar Basics, Box 1031, Bellingham, WA 98225.

IS SOLAR YOUR ANSWER? A helpful, non-technical, beginner's guide to solar energy use in the home. \$2.50. Send check or money order to: Sunland Distributors Inc., P.O. Box 954, Gulf Shores, AL 36542.

NO FUEL MOTOR - PATENTED! Soon to obsolete fossil fuels, solar, wind, nuclear, - all other sources of energy. Details \$10. Includes copy of patent. Jim Stoddard, Dept. PMA, P.O. Box 22469, Robbinsdale, Minnesota 55422

PLANS, Solar Room Heater for Double-Hung Windows, \$5. Projects List, Free. SolaWorkshop, P.O. Box 974, West Cornwall, CT 06796

SOLAR COLLECTOR—Can be used in **HEATING SYSTEMS, HOME, POOLS,** etc. Build at low! low! cost from inexpensive household materials or scrap parts. Simple construction. Complete illustrated plans. \$4.95. New England Dynamics, Box 388, Greenville, RI 02828

BUILD YOUR OWN EFFICIENT WOOD HEATER—Living Room, Den, Basement. Engineered and Tested Design. Complete Plans and Instructions. \$5.95 plus \$1.00 postage/handling. RO-COM Research/Development, Dept. C-1, 522 E. 20th, Post Falls, Idaho 83854

SUN POWER IS FREE. Use it to heat your home, provide hot water, heat your swimming pool. **BEFORE YOU INVEST** find out which collection and storage system best fits your needs. (Only \$1.00) Bischoff, East 15508 Twenty Fourth, Veradale, Washington 99037

ALCOHOL Production Plans: Solar Powered Still (not just a Glass covered box), Solar mash fluid pre-heater, and Solar powered cooker pre-heater. Plans researched, tested, and complete. \$10.95 per set of 3. Solar Alcohol Book—First Edition \$9.95 plus \$3.00 Handling. RunFree Enterprise, Inc. P.O. Box 536, Ucon, Idaho, 83454. Satisfaction Guaranteed. Idaho Res. add 3% S.T.

FREE SKYLIGHT MATERIAL SOURCES, Installation . . . \$3.00. Ideas, E-2, Box 614, Warren, Ohio 44482

WINDGENERATOR PLANS, Stuart System. Highly recommended by leading engineers for efficiency. Produce your own **FREE ELECTRICITY.** \$9.00 includes Material list, sources, instructions, detailed plans. Systems Engineering, Box 514, Groton, CT 06340

SOLAR WINDOW FILM Apply Homes, Auto's, RV's Literature \$2.00: Solar Film, Box 3071, Evansville, Indiana 47730

WIND ELECTRIC GENERATORS + SOLAR CELLS In Stock. National Company Guarantees Lowest Cost. Latest Technology From 12 Volt DC to 5000 Watts AC. Dealers Wanted, Exclusive Territory, Send \$3.00 For Complete Distributor Price Catalog. c/o: Gregory Hamilton, P.O. Box 989M, Sun Valley, California 91352

(Continued on next page)

SOLAR & ALTERNATE ENERGY

(Continued from preceding page)

DISTILL Fuel Alcohol, Instructions, Diagrams. \$4.95, Murray, Box 16084, Fort Worth, Texas 76133

SOLAR PAC™ hot water system. Complete, pre-assembled, D.I.Y. package (609) 853-8276.

YOUR OWN SOLAR GREENHOUSE. Grow Vegetables, Flowers Year Round. Uses Minimum Auxiliary Energy. Follow our Simple Plans for 8' x 12' or Larger. \$12.95. L.H. Design Corp., Box 73, Louviers, Colorado 80131

NEW-SOLAR SIDING — Decorative — Cheaper than Aluminum, Highest Btu's per Dollar, Complete Instructions — \$7.00 — New York Solar Research Institute, 91-32 197th Street, Hollis, NY 11423

HOME HEATING, FUEL SAVERS

KERO-SUN Portable Kerosene Heaters, Heat your Entire Home, Garage, or Shop for Pennies per Hour. Safe Clean Burning, Will ship U.P.S. anywhere in U.S. For full Color Brochure and Complete Information send \$2.00 to: Pequea Woodworking, Ronks, Pa. 17572 (Refund Upon Purchase)

OUTDOOR Furnace Concept, Attaches To House, Safest \$5.00. Designs, P.O. Box 235, Kirkwood, New York 13795

HYDRAULIC Log Splitter, Complete Plans. Send \$6.00 to: Plans, P.O. Box 24497, Richmond, Virginia 23224

HOME CRAFTSMAN

SCREEN-DOORS FOR DOUBLE GARAGE DOORWAYS. Garage Becomes Recreation Room, Permits Auto use Either Side and Garage Door Closing with Screen-door Intact, Compact Storage, Inexpensive Materials. Easy Plans. Send \$5.00 to: Torgersons, 164 West Moreland, West St. Paul, Minnesota 55118

AMAZING AUTOMATIC DOOR OPENING SYSTEM For Homes, Offices, Workshops. Without Coming Near Door You Identify Visitors and Open Automatically. Details \$2.00. System \$49.95 (Refundable). Dealers Inquiries Welcomed. Checks, Money Order To: Parklite Technology, P.O. Box 11173, Portland, Oregon 97211

GLASS Cutting The Easy Way. Use Those Old Pieces of Glass You Have. Make Table Tops, Shelves, Fix Broken Windows. Glass Cutter And Easy to Read Instructions \$4.95 To: Joe Roden, Box 11201, Cincinnati, Ohio 45211.

BUILD BUTCHER BLOCK Complete Construction Details — \$10.00. Wolff Wood Art, 1945 Farragut, Chicago, IL 60640

NEW Special Mounting Hardware, Sample Packet \$5.00. MUKAM, 4950 Lander Road, Chagrin Falls, Ohio 44022

UNFINISHED picture frame moulding. Factory close-out. 50% discount. 200 styles. Write: Japs, 126-PF Seventh North, Hopkins, MN 55343

CATALOG FULL-SIZE FURNITURE PLANS — \$1.00. Refunded with first order. Traditional, Early American, over 150! Furniture Designs, 1425 Sherman, Dept. CP-80, Evanston, Illinois 60201.

WORLD'S LARGEST CATALOG? Three pounds 832 pages. Every Tool, Supply, Machine, Imaginable \$5.00. Refundable. McKilligan, PM-680, Johnson City, New York 13790

FREE HOBBY Tool Catalog, 1,000 Items below Wholesale! International Curio Shoppe, D-64, Box D, Mountaintide, New York 12763

CREATIVE HANDYMAN - EARN THOUSANDS Full or part time at home. Startling new discovery reveals simple method for beautiful wood and glass art creations from easily obtainable raw materials. Phenomenal ready market in all areas. Free Details. Universal Marketing Associates, Dept. F-1, 3350 West Catalina, Phoenix, AZ 85017.

101 PATTERNS, Gifts, Novelties, Action Windmills plus "Make Money Jig Sawing". Only \$4.00 Prepaid 1st. Class Mastercraft 65M, P.O. Box 631, Park Ridge, Illinois 60068

WOODWORKERS- Projects with plastics instead of wood, using woodworking tools, Instructions, Projects, and Sources, \$5.00. Westons, Box 7614, Greensboro, N.C. 27407

OVER 50 UNIQUE PATTERNS! Profitable, Wooden Gifts, Novelties, Plus "Shop Secrets". Only \$5.00. Accents (F-60), Box 262, Danvers, Massachusetts 01923

CABOOSE Playhouse Plans 8' Long \$6.00. 105 Warrior Drive, Tryon, NC 28782

BACKGAMMON BOARD, Build your own Elegantly Framed Set. Plans \$3. Edward's Designs, Box 973M, Avon, CT 06001

NEW! UNIQUE! Woodcraft Product. Make, Demonstrate. EASY! Solid MONEYMAKER! Details FREE. Glenn-Art, 202 Johns Ave., Lebanon, PA 17042

FREE! EXOTIC VENEER SAMPLE plus illustrated supply catalog with simplified instructions! Learn how to create beautifully veneered furniture quickly, easily! Exotic veneers, inlays, supplies. Hurry! Morgan, PO1K10, 1123 Bardstown Road, Louisville, Kentucky 40204.

A 10 Place Gun Cabinet For Under \$60.00. Plans And Material List \$3.00. G. Pistner, 154 Comet Rd., St. Mary's, PA, 15857

FURNITURE Plans, Instructions — Several Original Designs. send: \$3.00. Richard Webb, 6506 Sherl Dr., Huntsville, AL 35806

BUILD Your Own MULTIPLE And SPINDLE CARVERS, Plans \$24.95. Send M.O. To: W. Hill, Jr., Rt. 3, Box 784-A, Thomasville, N.C. 27360

TRADITIONAL Butcher Block! Build for Yourself, or Sell for Profit. Complete Illustrated Plans, \$3.00 - Heirloom Designs, P.O. Box 2365, Youngstown, Ohio 44509

INEXPENSIVE Basement Fallout SHELTER Pre-built components stove in Basement. ASSEMBLE QUICKLY IN EMERGENCIES. Step by Step Plans. \$3.00. J.H. Shelter Projects, Box 1462, Gilbert, Arizona 85234

FOLDING DOALL FRAMING SQUARE Adjustable Angles, Tee Square, Rule, Folds Flat. Make from Wood/Metal. Illustrated Plans \$2.00. VERSITOOLS, 25 Monroe Street, Westminster, Md. 21157

WOODWORKING JIGS AND TOOLS you can make yourself. An index to over 125 excellent plans. \$3. The Weekend Woodworker, Box 2042, Sunnyvale, California 94087.

BUILD Furniture With FREE Hardwoods. Information, Four Plans \$6.50. Designs, Box 208, Clawson, Mich. 48017

WOODEN Toy Plans, Picture Frame Ideas. Free Information. Christopher Michael's, 151PM6 Rio Grande, Seguin, TX 78155

WOODEN GEARED CLOCK Plans! Free Brochure. Gorden, 16321 SE Second, Bellevue, WA 98008

UNIQUE Clocks. Patterns \$3.00. Information \$1.00. Tennessee Rignals, P.O. Box 2181P, Bon Aqua, Tennessee 37025

INTRODUCING NEW EASY WAY YOU CAN BUILD TOY KITCHEN APPLIANCES YOUR CHILDREN WILL LOVE. They can be built in one weekend with basic woodworking tools. Plans include material list, cutting list, and detailed illustrations. Refrigerator, range, and sink plans cost \$5.00. Cupboard plan available for additional \$3.00. Weiers Woodcrafts, 850 East Second Street, Redwood Falls, Minn. 56283

WATERBED Frame & Pedestal. BUILD OWN, REALLY SAVE! For complete, easy-to-follow instructions, necessary hardware, FREE catalog, send today only \$8.95 to: Contemporary Products, 10403 West Patterson Place, Littleton, CO 80123

WOODWORKERS! \$13.00 Hourly. Constructing ATTRACTIVE Lawn Furniture. DRAWINGS. Marketing Instructions \$5.00. Mayer, 315 Taylor, Granby, Mass. 01033

SOLDERING Gun Tips — \$3.00 per Dozen. Guaranteed. Colt Delvers, Box #4577 Rochester, N.Y. 14613

WOODWORKERS 3 plans for home shop, \$2.00. Dec. Unlimited, 6743 Ewing N., Minneapolis, Mn. 55429

TOOL BENCH - Roll it around like a wheelbarrow and push the retractable handles out of your way. Build it yourself with our complete plans and material list. Send \$2.00 to: J. Tyler Corp., 6137 W. Fond du Lac Ave., Milwaukee, WI. 53218.

WOODWORKING - Catalog of Early American Plans and Kits available for gifts. Decorator items and furniture. Send \$1.00 to: SugarBranch Woodworks, P.O. Box 499, Rogue River, OR 97537

GRANDPA'S Toy Plans, Kits and Accessories. Send \$1.00 For Catalog. Grandpa's Plans, Box 3772, City of Industry, California 91744

CONSTRUCTION PLANS, BLUEPRINTS

ADD-ON SOLAR GREENHOUSE. Active or passive. Inexpensive, sturdy. Looks great! Grows great! Fits all. Full plans, illustrated builder's booklet \$12.50. Pilcher Ecosystems, Rt. 1, Box 355, Mead, WA 99021

BUILD "THE UTILITY BARN". 10'x20' Plus Loft. Plans \$5.50. MONTI, Box 1653, Tullytown, Pa. 19007

PLANS!!! Workshops, Garages, Storage Buildings. . . Select from Catalog! . . . \$2.98 - Whip-Poor-Will Publications, P.O. Box 339P6, South Boston, Va. 24592

POST AND BEAM Ranch and A-Frame. Both for \$6.00. YPB., Box 183, Delaware, Ohio 43015

GARDEN SHED PLANS, Popular Styles, Sizes. Free Details. Eljay Studio, Box 272, Buffalo, N.Y. 14224

LOG CABINS & "A" FRAMES

INVESTMENT CASTING, Build Complete Foundry from Junk. Detailed Information Book \$3.00 Smelter Plans \$6.00. Pemberton, Box 445, Wilsonville, Ore. 97070

HOME BUILDING & REMODELING

AMATEURS' GENERAL CONTRACTING MANUAL, save \$1000s, we did. Send \$8.95 to: Eggleton, 265 Ravenna Street, Hudson, Ohio 44236.

UNDERGROUND HOUSE PLANS Complete for Building. \$30.00. Structural Engineer Certified. No Heating, Cooling or Insurance Needed. Will not Burn or Blow away. All Air filtered. Waymon Rudder, Ramer, Ala. 36069

SAVE HUNDREDS Maybe THOUSANDS Before Having any Remodeling done on your Home. Know the Facts First. Send \$8.95 plus 60¢ Handling to: George Shampine, Box 312-C, Worth, Ill. 60482

IMPOSSIBLE to Build a Furnished 30' x 60' Two Story Home, with Basement and 24' x 30' Garage, with 95% Contracted Labor for under \$35,000? We did. For Details send \$5: Home, Box 196, Grant, Mich. 49327

ENERGY EFFICIENT PLANS you can afford. NATURAL APPROACH to healthful living. MONEYMAKING OPPORTUNITIES to supplement your income. Send one dollar for information, refundable. DESIGNS, Box 242, Berrien Springs, MI 49103

ROOFS, Is your three tab Shingle Roof installed properly? This 30 page booklet is a step by step explanation of proper installation. Do it yourself or supervise. Send \$2.95 to: Roofing, Box 29221, Minneapolis, Minn. 55429.

BUILD A 2000 sq. ft. home for under \$25,000. Complete instructions and plans. Send \$3 - AKT Enterprises, RR4 Box 332E, Hillsboro, Mo. 63050

GET LATEST UNDERGROUND HOMES INFORMATION! Two new books, manual, blueprints. Free color brochure! Underground Homes, 700 Masonic Building, Dept. PM6C, Portsmouth, Ohio 45662

WOODBURNING FIREPLACE Easily built professional masonry fireplace. No experience or expensive tools. Step-by-step instructions, detailed plans, materials list. Everything you need to know. Send \$10 to: Lyle, Box 9100, Odessa, Texas 79762.

INVESTMENT FOR YOUR FUTURE — EFFICIENCY, STYLE, COMFORT, SECURITY. EARTH SHELTER HOMES GUIDE. \$3.00. Box 1724, Wausau, WI 54401

PLASTICS

CASTOLITE Liquid Plastics. Crystal clear, colors. For casting, embedding, coating, fiberglassing; in industry, laboratories, craft work. Reproduce your designs with our mold materials. Profitable. Illustrated Catalog \$1.00. CASTOLITE, Dept. 80G/PM, Box 391, Woodstock, IL 60098.

AIR CONDITIONING

CUT COOLING BILLS UP TO 75% Revolutionary! Do It Yourself! Moneyback Guarantee! \$9.95 Per Plans Package. SKEPTICAL? Send 75¢ for Proof Positive Details. 30th Century Corp., Dept. 104, Box 505, Derby, KS. 67037

DO IT YOURSELF

IN-GROUND Swimming Pool Kit—Blue-prints—Vinyl Liner—Side-Walls—Skimmer—Filter—Pump—All materials Necessary for Construction—Except Local Materials—16' x 32' \$1,995.00—FOB. Cheswick Pool Sales Inc., Rte. 28, Cheswick, PA 15024. (412) 274-6400. Call Collect.

WELDING ALUMINUM and "POT METAL" is easy with LUMIWELD. For information — SASE to: Dept. HP Alumsmiths, P.O. Box 517, DeLand, Florida 32720

RECHARGING AUTO AIR CONDITIONING SYSTEMS. Why Pay a Shop for a Simple Recharge when you can Achieve the Same Results at Less than Half the Cost, in Less Time! Learn System Operation, Controls, Leaks and their Locations, Safety, and Steps to Charging. Send \$8.50 To: Safety and Proper Charging, Luger Publications, Box 652, Mineola, NY 11501

WRITE AND SELL YOUR OWN "HOW TO" BOOK or pamphlet! You're an expert in something. . . Write about it! Millions will see your ad here. YOUR experience qualifies! This acclaimed guide, \$4.95 ppd. (tax deductible, 15-day Satisfaction Guarantee). C. Alvez Publications, Dept. 48-PM, Melrose, NM 88124.

GROW BEAN SPROUTS. SOILLESS. Chop Suey. Instructions, Chinese Beans, \$3.00. JASCO, Box 1015, National City, CA. 92050

HOW TO MAINTAIN GALVANIZED ROOFS. Simplified method. Complete illustrated instructions. Send \$3.00 postpaid. Check or Money Order — Airmail to: Gallardo Reports, Box 2988, San Jose, Costa Rica, (Immediate Airmail Delivery).

ELECTROPLATING. Complete amateur's textbook. All metals Electroplate metallic/nonmetallic items \$9.95. Details free. Tropic, Box 95-P3, Palm Bay, Florida 32905.

CALIFORNIA Redwood burl wall clock kits \$35.00. The Burl Works, POB 24606, San Jose, CA 95154

HYDROSTATIC Pressure Test Salvage Water Heaters for Low Cost Air Compressor Tanks. Big Savings, Extra Income. Build Hydrostatic Pressure Pump for under \$5.00. Detail Plans, Test Instructions, List of Air Compressor Controls \$5.00. Can'Dair, 3232 Shawnee, Fort Worth, Texas 76135

WATERBED KITS — Build your own and save dollars! Natural sleep — no backaches. Complete plans, brochure, \$2.00. Waterbed Designers, Box 521P, Shelley, ID 83274

UPHOLSTERING SUPPLIES, Fabrics, Vinyls, Tools, Cane, Instruction Books, Free Catalog. Jim Dandy Sales, Box 3077P, Cincinnati, Ohio 45230.

BUILD AUTO PARKING GUIDE For Your Garage EASY, INEXPENSIVE. Plans \$2.00. Robbins Home, P.O. Box 52, Zion, Illinois 60099

(Continued on next page)

DO IT YOURSELF

(Continued from preceding page)

SAVE — Modern Section COUCH — Build for \$115.00. Simple! Complete Plans include Cushion Patterns, Finishing, Send \$4.95 Self Addressed Stamped Business Envelope to: Couch, Box 70008, Eugene, Oregon 97401

STEREO Hookup To TV. Plans \$3.00, Kit \$16.00. Bates, Box 51, Maynard, Iowa 50655

INSULATION Report, "How To" Booklet for The Homeowner. \$4.00. Insulation, Neltrix Research, P.O. Box 21, Burnt Hills, N.Y. 12027

HOW I lined my Chimney with Tile in 5 Hours for \$75.00. Instructions and Illustrations send \$4.00. B&B Chimney, Box 24, Hallowell, Maine 04347

BUILD Powerful Air Compressors From Old Lawn-mower Engines. SAVE Hundreds. Plans — \$5.00. Vandergrift, 437 Houston, Ambler, Pennsylvania 19002

75 MPG! Amazing Build-It-Yourself Hybrid Electric-Car can Travel at 90 MPH . . . takes less than 40 Hours to build . . . and costs just \$1500! Complete plans (including Schematics, Materials List, and Components Sources) are available from THE MOTHER EARTH NEWS. Send check or money order for \$15 to: MOTHER'S PLANS, Dept. 400103, P.O. Box A, East Flat Rock, North Carolina 28726.

REDUCE Food Costs Enjoyably—Grow Tasty Vegetables—Inexpensive, Easily Built Greenhouse Plans. \$4.50. Post Enterprises, Box 21, Torrance, CA 90507. (Californians add 6%.)

HOW To Test/Repair House Wiring. Make Testing Equipment. Illustrations. \$3.00. Bennett Enterprises, Box 116-PM, Atwood, TN 38220

GET 8 GALLONS OF ALCOHOL FUEL PER HOUR FROM YOUR 8" COLUMN STILL. Plans, instructions and recipe available for \$15. Send check, money order, Visa or Master Charge number to: MOTHER'S PLANS, DEPT. 400104, P. O. BOX A, EAST FLAT ROCK, NC 28726.

REPAIR Sprayed Ceilings Booklet \$1.50 To: Repairs, 170 Brittany Rd., Gaffney, S.C. 29340

CARPET—HOW TO INSTALL Your own, make it a business, \$20,000 to \$100,000 a year, detailed instructions \$2.50. Cedar Place, P.O. Box 261, Decatur, IN 46733

SAVE Money! Settle your automobile accident without a lawyer. Free details. Dept. PM60, A. C. Industries, 6400 Southwest Freeway, Suite 415, Houston, Texas 77074

RUSTIC Furniture. Simple but Beautiful. Plans \$3.00. Little, 3404 Noble, Edmond, Ok. 73034

TUNE UP your lawn mower with our easy photo-illustrated, step-by-step instruction manual. No special tools needed. \$4.95. Money back guarantee. Oriando Press, P.O. Box 7531, Orlando, Florida 32854.

DRAFT BEER - Detailed Instructions For Pressurized Bar From Used Refrigerator \$3.95. Kinzua Novelties, Kinzua Hts., Bradford, PA. 16701

CARPET YOUR HOME YOURSELF - Step-by-Step installation instructions \$1.00 - "HOW To Get The Best Buy On Carpet" \$1.50 - Both MONEY SAVERS \$2.00. Walter Wolfe, 3021 So. Mayflower, Arcadia, Calif. 91006

TOOL CONSOLES For Pickup Trucks, Super Storage, Inexpensive, Easily Built, \$5.00 for Detailed Plans. CB's, Rt. 1, Box 573A, Spring Lake, NC 28390

GIANT Screen TV Kits Selling For \$19.95. Your Cost: \$14.95! Plans \$2.00. KAM, Dept. B, 1638 10th Avenue, Honolulu, HI 96816

YOU, YES YOU; THE DO IT YOURSELF BUILDER. The Time has come. We want to introduce our New Fast and Time Saving Device. It will allow you to pick up your hedge trimmings while, retaining the beauty of your ornamental bark or stone. Our Easy To Follow Plans will give you this, and more. Send now for complete drawings, and design dimensions. Send only \$4.95 to: Better Dimensions, P.O. Box 134, Elma, New York 14059

HEAT House Free Breakthrough, \$4.00. Homecraft, 2350 W47P Denver, CO 80211.

ENERGY-MONEY-SPACE-SAVING 5-load REVOLVING clothesline carousel. Ceiling mounted. Plans \$3. CARROUSEL, Dept. PM, 1800 No. Dunlap, Roseville, MN 55113

PRACTICAL Landscape IRRIGATION Innovative DRIBBLE-MISER method Saves water and money. VERY LOW COST installation. Plans \$5.00. Money-back Guarantee. Dribble-Miser, 8813 Old Hwy. 99 SE, Olympia, Wa. 98501

SAVE Heating Costs. Simple Homebuilt Device Reduces Baseboard Heat Loss. Plans \$2.50. Ret, Box 798, Ripley, W. VA. 25271

APPRAISE YOUR GOLD YOURSELF. Simple, with this revolutionary new handbook. Send \$4.00 to: Goldscales, Box 1386, Sandpoint, Idaho 83864

20% PLUS INCREASED GAS-MILEAGE with the tested and reliable WATER-ALCOHOL VAPORIZER. Build it yourself with our buying sources and construction-installation booklet. The cost is only \$4.50. The complete unit ready to install is \$29.00 shipping incl. Money back guarantee. Send check or MO to: C.M. Research 75 Bank Str., Unit #20, Sparks, Nevada 89431

KEEP hands & body beautiful. Simple, inexpensive formulas, \$3.00. "GB", 2292 New St., Burlington Ont., Canada L7R 1J3

VENTURES — Repair Your Own — Start Your Own Business — Complete Instruction Manual. Send \$7.95. Oral Alternatives, P.O. Box 1113, Melrose Park, Ill. 60160

WHAT IS A HOME ALARM AND HOW DOES IT WORK? send \$3.50. River Valley Press, Box E, St. Paul Park, MN 55071

HOME IMPROVEMENT — Save thousands. Earn cash installing maintenance free aluminum exterior with easy illustrated guide \$2.95. Hadfield Publications, 9622 West Bradley Road, Milwaukee, WI 53224

BUILD This Well Vented Dog House. For Plans Send \$3.00 to: Hundal Enterprises, 3281 Eldon, Victoria, B.C., Canada V8Z 3R7

WATERBEDS BY MAIL! Complete plans for Frames, Headboards, Drawer Pedestals. Also offering Top Quality Guaranteed Mattresses, Heaters, Accessories. Catalogue \$1.00. Discount Waterbeds, 1805 2nd Street #H, Berkeley, CA 94710

CATALOG of Wooden Toy Patterns, Wooden Toykits and Toymakers Supplies. Send 75 cents to: Toy Designs, P.O. Box 441-P, Newton, Iowa 50208.

LANDSCAPE Yourself! **SAVE BIG!** \$4.95. Charlottebruce Enterprises, Box 15975-P, Covington, KY 41015

FOOD DRYER Build under \$25, Instructions \$3.50. Dehydrator, P.O. Box 87, Washington, MO 63090

YOU CAN TRAIN YOUR DOG! Easy! Inexpensive! Free Details. K9'er, POB 168T, Moxco, WA 98936

REPRODUCTION MOLDS

RUBBER, Fiberglass Molds for Ornamental Concrete (Birdbaths, Planters, etc.). Over 900 to Choose From. Free Information, SASE. Plycrete Mold, Elk Rapids, Michigan 49629

ARTS & CRAFTS

MAKE Figurines, Plaques, candles, lawn ornaments, Molds, plastercraft kits, liquid rubber. Sample and catalogue \$2.50. Wooley Company, Box 29, Peoria, Illinois 61650.

RECIPES! Hundreds of Southern Recipes, only \$3.95. Box 896, Greer, SC 29651

"GETTING Started in Stained Glass" 50¢. Whittemore, Box 2065Y, Hanover, Mass. 02339.

STAINED GLASS Supplies. Complete Catalogue. \$1.00. Craftsmen, 217 Main, Ridge Park, N.J. 07660

STAINED GLASS Catalog-P Send 50¢. Tools, Supplies, Books. Saylescrafs, 171 Main Street, Nyack, New York 10960

NINE Quick Craft Ideas. Send \$2 to: Quik Crafts, R. D. #1, Box 119A-PM-1, Wrightsville, PA 17368

LEATHERCRAFT Catalog, Tools, Leather, Dyes, Dressings, Saddle Stamps, Buckles much more. Send \$1.00 (refundable with order) to: MacPherson Bros., P.O. Box 99442, San Francisco, Calif. 94109

PORTRAIT MASTER - Inexpensive Original Pencil Portraits From Your Photos. Free Information, Peter Secora, 430 East O'Keefe Street, #107, Palo Alto, CA 94303

CARTOONING, COMMERCIAL ARTS & SIGN PAINTING

MODERN Cartooning taught by mail. Write for free brochure. Cartoonrama—Box 263-2F, Branford, Conn. 06405.

35 LESSON cartooning course. Cartoonist's Magazine, both \$3.00. Hartman, Box 30367, Lincoln, Nebraska 68503.

SIGN Painting—Easy method. Free catalogue. Kaufmann Company, Centertown, Missouri 65023

ANIMATION Course Kits. Catalog \$1.00. Heath Prods., 1700 N. Westshore, Tampa, FL 33607

MODELS—CARS—SHIPS—TRAINS—PLANES ETC.

HOT Air Balloon! Plans \$3.00. Participop Inc., 39 Meridene Cres., London, Ontario, Canada. NSX 1G4

HOT AIR ENGINE KIT — Lively Performance, Machinist Delight. Brochure 50¢. P.O. 1372, Concord, NH 03301

BOOMERANG 14" SQUARE. Send \$2.50: Jarvco, 1802 Sandalwood, Caldwell, ID 83605

BUILD museum-quality ships models, gun models, dollhouse room settings. 1980 Model Catalog features complete kits, fittings, plans, construction materials, tools. "How-To" books. 88 pages. Only \$1.00. James Bliss & Company, Dept. PM, Route 128, Dedham, MA 02026.

MODEL AIRPLANES — Huge Catalog. \$2.00. Sig Manufacturing Co., Inc., Montezuma, IA 50171

CIVIL WAR Model CANNON Plans: Catalog free. Green-PM-68, Box 892, Shalimar, Fla. 32579

RADIO CONTROL! Airplanes, Boats, Motorcycles, Helicopters, Supplies, Discount Catalog—\$3.00 (Refundable). Modelers Supply, Box 7185, Montgomery, AL 36107

TOYS, GAMES, PUZZLES, NOVELTIES

SUPERMAZE puzzles. \$2.00. Amelia Press, Dept. PM, P.O. Box 448, Amelia, Ohio 45102

"I'LL BUY THAT" World's newest game craze. Contagious — \$7.50 PPD. — Challenging 168 Cards, Score Pads and Rules. Martin Games, Box 483, Libertyville, Ill. 60048

PACHINKO MACHINES. Exciting original Japanese gambling device. Legal in U.S.A. Fun for all ages. FREE Catalog. Write: PPMC, 3525 Mt. Everest Blvd., San Diego, Ca. 92111

MAGIC TRICKS, JOKES, VENTRILOQUISM

FREE! World's Leading Novelty Catalog. 1800 Jokes, Tricks, Science, Sports, Hobbies, Johnson-Smith, C-10, Mt. Clemens, Mich. 48043

VENTRILOQUISM/Puppets! Catalog \$1.00 (Refundable). Maher, Box 420PM, Littleton, Colorado 80160.

PROFESSIONAL MAGIC Catalog, \$1.00. Same day Service, No Substitutes. Fabulous Magic, 3319 E. Charleston, Las Vegas, Nevada 89104

FREE! \$2.00 Trick, Huge Catalog, all 50¢. Abracadabra-MP, Scotch Plains, New Jersey 07076

VENTRILOQUISM! COURSES, DUMMIES. Brochure \$1.00. — Rizzy's, 6034 So. Pulaski, Chicago, Illinois 60629

JUGGLING For Beginners, Quick and Easy Method. Send \$2.00 to: A&D, 905 7th Ave., 308, Garner, NC 27529.

GRASS ROOTS JOKE CLUB - The Newsletter Of Stag Humor. 10 Issues \$15. 4065 North Massachusetts, PM180, Portland, Oregon 97227

"RATTLESNAKE Tails!" Thrill your friends with this Badlands Rattlesnake Tail Gag! Send \$1.50 to: "Gags", Box 562, Brookings, S.D. 57006

SWEETEST PRANK of my youth. Drive your whole Town Crazy. Harmless—\$2.00. GLM, 410 West King, Shippensburg, Penna. 17257.

HOBBIES & COLLECTIONS

DELUXE PLAYING CARDS from around the world plus tarot decks and tarot books. 32-page full color catalog. Send \$1.00. THE BEST OF CARDS CATALOG, Department PM, 38 East 32nd Street, New York, NY 10016.

"OLD Time Soldier Molds", Write for free information and special offering. Castings-PM, P.O. Box 542, Highland Park, Illinois 60035

COLLECT Military Medals. List 50¢. Vernon, Box 387 PM, Baldwin, New York 11510.

MARDI GRAS Authentic Carnival Parade Souvenir while they Last. \$2.50 each, limit 2 per customer. Cupid's Korner, Box 10554, Jefferson, La. 70181

COLLECT US Navy Nuclear Submarine Patches. List 25¢. Emblems, 608-860 Rogers, Waxahachie, Texas 75165

BEER CAN COLLECTORS — Write For Our New FREE Catalog. Box 3807-E, Stamford, CT 06905

FOR SALE: War Relics, Militaria, Head Gear, Field Equipment, Medals, Badges, Edged Weapons, Military Books and Records. Send 50¢ For Latest Lists. (Also Interested in Buying.) GLOBE MILITARIA, INC., 6752 5th Ave., Brooklyn, N.Y. 11220.

EXPOSITION COLLECTORS Club membership information. ECHO, 1436 Killarney, Los Angeles, CA 90065.

ANTIQUES, RELICS, INDIAN GOODS & CURIOS

LEARN Brass and Copper Stripping and Polishing. P.O. Box 346, Atlantic, Iowa 50022

INDIAN Relics. List 25¢, Arrowheads \$5.00 Dozen, Folsom \$10.00 each. C. Secrist, Deerfield, Missouri 64741

STAMP COLLECTING

500 Different World-Wide Stamps for \$2.00 Approvals included. Save 5% off all orders. RG. Sales, Dept. M, P.O. Box 1065, Jamaica, N.Y. 11431

100 Different U.S. 25¢ Approvals. Bradley, Box 425P, Midlothian, VA 23113

16 Foreign Stamps 54-86 Years Old. Only 10¢. (Adults Only). Goliath, CS-1, Bethlehem, New Hampshire 03574.

18 DIFFERENT U.S. Airmail stamps worth over \$1.00 Only 10¢. (Adults Only.) Limit One Set. Wonderful Lists included. Littleton Stamps, AN-1, Littleton, New Hampshire 03561.

TOPS! 100 Popular Poland Stamps (all different) only 25¢. Mystic, Dept. PS1, Camden, New York 13316.

FREE! 55 Different, Including Triangles, Space, Others! Request Approvals, Baird, PM-57, Box 8128, Portland, Oregon, 97207

U.S. 6 Commemorative Plate Blocks 1.00! Approvals. Gordon Davison, Contoocook, New Hamp. 03229

220 Beautiful, Exciting, Mysterious, Valuable, International Stamps only 10¢ with Approvals. Stamps-PM, 1427, Bellflower, CA 90706

(Continued on next page)

STAMP COLLECTING

(Continued from preceding page)

BREATHTAKING Beautiful. 50 Different mint Monaco pictorials commemoratives only \$1.50 with mint complete set approvals. Pagoda, Box 132P, Sidney, Ohio 45365.

GREAT Gift free with 1st purchase — fine United States approvals and want list service. Send \$5¢ for handling. The Stamp Boutique, Box 86M, Wheeling, Ill. 60090

SINGLE STAMPS 2¢ and up. Mounted in books. **TRUST STAMP COMPANY,** P.O. Box 100-P, Jamaica, New York 11435.

50 YEARS Old fifteen different United States, over fifty years old—25¢ with approvals. Jaxon, Box C11-P, New Rochelle, New York 10804.

50¢ BRINGS You 100 pictorial plus worldwide approvals. Capt. Shaw's Stamps, Box 277, Ocean Park, Maine 04063.

COINS, STAMPS, PAPERMONIES. Wholesale Offers. Investment Information \$1.00. **PROFITEER,** Dept. A, Box 11249, San Francisco, CA 94101

50 DIFFERENT Old U.S. between 1861 and 1939 — \$1.00. Ed Roush, 423 Shepard, Mansfield, Ohio 44907.

PENNY! Approvals! Regardless catalogue! Kioster, 4164 52nd St., San Diego, Calif. 92105.

2,000,000 Stamps—150 Countries—2¢ Each. Belden, Box 4149, Dearborn 48126

FREE Surprise collection sent with approvals. Gould, 1784 Union, San Francisco 94123.

FREE Worldwide packet. Penny approvals. Froelich, Box 412-A, Morton Grove, Ill. 60053.

100 INDIA 10¢. Approval Applicants. Gibson, Box T, Williamstown, N.J. 08094

OLD U.S. Stamps on Approval. Chester, Box 15414G, Philadelphia, Pa. 19149

FREE: 32 Page United States and United Nations Price List. Shelton, Box 610547C, North Miami, Florida 33161.

UNITED NATIONS 3 Complete Mint Sets 25¢. Approvals. Cornetta, POB 1509-M, Lake Placid, Florida, 33852

FIFTY Free Stamps with Approvals. J&D Stamps, Box 747, Melbourne Beach, Florida 32951

BARGAIN 100 World-wide Stamps 25¢. Quality Approvals. R. Parker, Box 143, West Brookfield, MA 01585

U.S. MINT Specials! Flag Set complete \$2.00; 1936 Army-Navy complete \$2.00. Free List. Brooks, 2601 Avenue "U", Brooklyn, New York 11229

CANADA. 50 different 25¢. Approvals. Oroszky, Box 1-C, Sarnia, Ontario, Canada N7T 7H8

\$5.00 Value. 100 Different United States Commemoratives \$1.00: Bryson, Box 8123, Toledo, Ohio 43605

HISTORIC Visit to U.S. of POPE JOHN PAUL II Commemorated by a Fantastically Beautiful first Time Cover with Official Postmarks and Lovely Engraved Portrait of His Holiness. Only \$1.25. K.M. WALSH, BOX 300A, TUCKAHOE, NEW YORK 10707

UNITED NATIONS. Free set with price list. Ftacek Stamps, Box 1023, Manteca, California 95336

PENNY APPROVALS. Regardless Catalogue. Zamora, 1 Méndez Liclaga, San Sebastian, Puerto Rico 00755

FREE Mongolia Camel Set. Request Approvals. Alpaugh, Box 225, Highbridge, New Jersey 08829

50 U.S. 25¢. With Approvals. Happy, Box 124, Springvale, ME 04083.

50 ARGENTINA — Different 10¢. Approvals. Gobestamps, Box 690, Saco, Maine 04072.

"WHOLESALE" U.S. - Foreign Pricelist and catalog Free! Everything Guaranteed. Schneider, Box 1240, Grand Rapids, Michigan 49501

FREE World Wide Stamps with Approvals. Chapmans, Box 487W, Galesburg, Michigan 49053

COMMEMORATIVES — U.S. Assortment 25¢. Approvals. Lee's, Box 2105, Albany, N.Y. 12220

\$10.00 CATALOGUE VALUE \$1.00 to General Foreign Approval Applicants. Bonus, Postpaid. **T&D STAMPS,** 139 Montrose, Grand Rapids, MI 49505

200 Different Worldwide, Plus Economical Beginner's Packet Approvals, \$1.00. Fies, 301P, Pleasantville, Ohio 43148.

100 STAMPS — 10¢ Sent with Approvals. Chubbuck, 71 Auckland, Dorchester, Mass. 02125

FREE Mint Set with each Dollar Spent! Howard, Box 3545, York, Penna. 17402

U.S. Bargain, 24 different Air Mails \$1.00 with beautiful worldwide approvals. Stamp Center, Kennebunk, Maine 04043

EVERYTHING Beginners need to know about stamp collecting \$3.50 total. Elster Enterprises, P.O. Box 13134, Indianapolis, IN 46234

UNBELIEVABLE ANIMAL COLLECTION From Wild, Mysterious Mongolia. Only 25¢ with approvals. Moleksi, Dept. 6PMO, 11 North Westview Avenue, Feasterville, PA 19047

WOW! 125 All Different plus Mystery Gift. Only 10¢. Approvals. Fayette Stamps, Dept. 418KA, Fayetteville, NY 13066

LOOK! 107 different Triangles, Sports, Topicals, etc. Only 10¢. Approvals. Jayto Stamps, Manlius, New York 13104

U.S. MINT S/S (1311) 10¢ with approvals. REM, 1122 Marabelle, Ft. Pierce, FL 33450

SPECTACULAR World Collection — 10¢. Vatican Ghana, San Marino U.S., Russia, Animals, Space. Over 100 different! Plus U.S. Catalog, Approvals. Global, Box 7429-P-28, Olympia, Washington 98507

1,000 DIFFERENT WORLD + 100 different MONGOLIAN BEAUTIES \$3.00. Approvals. Cancel service anytime. **ADULTS ONLY.** Gouge, Box 88-MH, Elizabethton, Tennessee 37643

FREE Catalog: 3,000 different Packets! Uilery, 1016 Meridian, Mishawaka, Indiana 46544

WOW! Bicentennial Souvenir Sheet Worth Over \$2.00 Plus 100 Different Worldwide 25¢ With Approvals. Tarheel Philatelics, Siler City, North Carolina 27344

COINS, TOKENS, CURRENCY

TEN Foreign Coins from Iceland, Israel, Pakistan, Algeria, etc. Only 10¢. (Adults Only.) Wonderful Price Lists included. Littleton Coins, MB-1, Littleton, New Hampshire 03561.

3 OLD Liberty Head Nickels Only \$1.00. Issued before 1913. Limit 1 Set. (Adults Only.) Plus price lists. Littleton Coins, HL-1, Littleton, New Hampshire 03561.

U.S. & FOREIGN COIN LIST, \$1.00. Southern Oregon Coin Brokerage, P.O. Box #4, Selma, Oregon 97538

OBSOLETE Coins, Indian head cent and buffalo nickel both for only \$2.00. Send check or money order: Dakota Gold, P.O. Box Z, Sioux Falls, S.D. 57101.

15 DIFFERENT (scarce) Buffalo Nickels \$7.00; 10 Different \$5.00. Coin Fair, Box 911, New York, NY 10008

CAMERAS & EQUIPMENT

PORTABLE CLOSEUP STUDIO — Mounts on Tripod. Holds Camera, Subject, Background. Completely Adjustable. \$17.95 PPD. Brochure 25¢. Idea Factory, Box 215, Valley Springs, CA 95252.

PHOTOS & PHOTO SUPPLIES

MAKE MONEY, SELL PHOTOS. MILLIONS bought by Newspapers, Magazines. LEARN Kind Wanted, How To Submit, Prices Paid, Laws, Regulations, WHERE TO SELL. REPORT #54P-6 \$1.50 POSTPAID. **TREASURE CHEST, 1117 THOMAS JEFFERSON PLACE, FREDERICKSBURG, VIRGINIA 22401**

SAVE MONEY. Build your own 750mm lens. Enlarges over 15 times your normal lens. Send \$3.00 for plans and instructions to: A & R Enterprises, Box 415, Sioux City, Ia. 51101.

"EARN cash with your camera." Part-Time/Full-Time. Amateur/Advanced. Over fifty ways, \$5.00. St. Clair Photography, Box 446, Princeton, Indiana 46760.

BOOKS & PUBLICATIONS

CRIME By Computer, \$6.95 Postpaid — 300 Pages — Quimtronix, Box 548-PMO, Seattle, Washington 98111

BECOME Author of "ROOTS" of Your Hometown. Free information. J. Mangini, 705 Kaweah, Exeter, Calif. 93221

SHOPPING By Mail — . . . Big Discounts, Vitamins, Books-Fat Catalog—\$1.00—Suburban Shopper, 8208, East Millstone, N.J. 08873

FREE LIST! 350 Self-Improvement books. Lyons, 4803 Lyons, Austin, Texas 78702.

FREE Magazine Featuring 500 Books . . . Natural Health, Gardening, other interesting Subjects. Provoker Press, St. Catharines-502, Ontario L2R 7C9

PUBLISH Your Book! Join our successful authors. Publicity, advertising, beautiful books. All subjects invited. Send for fact-filled booklet and free manuscript report. Carlton Press, Dept. PMF, 84 Fifth Avenue, New York 10011.

FREE Book, Prophet Elijah Coming Before Christ. Megiddo Mission, Dept. 63, 481 Thurston Road, Rochester, N.Y. 14619.

PUBLISHERS' OVERSTOCKS BARGAIN BOOKS, 3,000 titles, all subjects! Free catalog: Hamilton, 98-51 Clapboard, Danbury, CT 06810

1980 ANTIQUE & Flea Market Directory \$3.00. Nationwide. "Y-NOT", Box 8561, Fort Lauderdale, Florida 33310, Dealers Wanted.

WILDERNESS Living! Shelter, Food, Power, Self-Defense Books. Free Catalog. Aspen Cabin, Box 2517, Flagstaff, Arizona 86003

HUNDREDS Of Bargain Books. All Subjects. Free Catalogue. Eldon R. Nelson, 4100 E. 29, Tucson, Arizona 85711

FREE — Win Contest Brochure. 50¢ Postage. Jetco, 2308 Connemara Drive, Matthews, NC 28105

CIA AND GOVERNMENT MAPS Latest Releases. Over 300. Complete Catalog \$3.95 (Refundable). Walter, 141 Longmeadows, Wilton, CT 06897

306 FREE MAGAZINE SUBSCRIPTIONS! Details. Whitley, Box 5823PM, Bossier City, LA 71111

MANY Helpful, interesting titles. Gooch, 265 W. Robinson, Hernando, Ms. 38632

FREE Book Catalog — Solar . . . Finance . . . Self-Help — Over 400 Selections! Anderson Assoc., Box 214-PM, Esmond, ND 58332

VENTRILOQUISM Secrets! How To Throw Your Voice. \$3.00. Data, Box 344P, Dayton, OH 42240.

BOOK BARGAINS 400 titles, catalog \$1.00. Adelphi Enterprises, P.O. Box 643, Hopatcong, NJ 07843

INFLATION Hit You? Checklist of 300 Ways to Hit Back. \$3.95. Box 341, DeKalb, Il. 60115

WANT to understand your dreams? Chart your horoscope? Send \$2.00 for book on dreams or \$3.00 for horoscope plus 50¢ postage. Books, Box 1961, Alamogordo, New Mexico 88310

SELF IMPROVEMENT Books. 250 Topics. Details. Don Mar Specialties, P.O. Box 85, Yonkers, N.Y. 10710

MUSIC INSTRUCTIONS & INSTRUMENTS

ACCORDIONS — Famous Makes. 40 Models! Importer-to-You Prices. Save! Cordovox and Button Style. Home Trial. Trade-ins. Terms. Free Catalog! Accordion Corporation, Dept. R, 5535 Belmont, Chicago 60641

INTERNATIONAL Catalog valuable to makers, repairers of stringed instruments. Imported woods, parts, accessories, kits. Fine German-made violins, violas, cellos, basses and bows. Send 25¢ for catalog. 10% Credit Certificate will be enclosed. International Violin Company Ltd., Dept. LY, 4026 W. Belvedere Ave., Baltimore, Md. 21215.

POEMS AND LYRICS RECORDED. SOUTHSOUND, Box 5901-PM, Texarkana, Texas 75501

SAVE Gas. Learn to play bottles, glasses, tin cans, saw, inner-tube, steel guitar at home. Stamp to: Nova, Rt. 3, Box 291 M, Columbia, South Carolina 29206

BEST GUITAR Chord Book anywhere with Diagrams and Example Songs. A "Must" for Beginners! \$3.00. R. Burgess, Rt. 4, Aoshkie, N.C. 27910

GUITAR MUSIC FREE CATALOG. Ed Sale Guitar Co., Grand Island, Florida 32735

NEW PATENTED JEW HARP. Finest made. Illustrated instructions. \$4.95 ppd., guaranteed. Free brochure. Tru-Tone Harp, Dept. PM, 4805 S.E. 26th, Portland, Oregon 97202.

SUPER-SAVINGS Guitar Strings, Accessories, Effects Pedals, Microphones, etc. Free Catalog. Super-Save Music, Box 387, Boca Raton, Florida 33422

PIANOS, PLAYERS, PUMP ORGANS. Rebuild and repair. Catalog of "How-To" books, \$2.00 (refundable). Vestal Press, Vestal 11, New York 13850.

FREE Catalog! Kits and Completed. Harpsichords, Hammered and Appalachian dulcimers, guitars, banjos, mandolins, Hughes Dulcimers, 4419 West Colfax, PM, Denver, Colo. 80204.

MUSICAL SAW — If you can whistle, you can play the Saw. Produced since 1921. Details—Free "Sawing News of the World". Musseh-Westphal, 130PM South 4th Street, Delavan, Wisconsin 53115

ACCORDION Top Brands, Cordovox, Buy Direct. Tremendous discounts. Trades accepted. Free brochure. N.M. Accordion-O-Rama, 16 West 19th Street, New York, N.Y. 10011.

ELECTRIFY Player Pianos, Pump Organs Quickly. Inexpensively with Lee Silent Suction Units. Write: Lee Music, P.O. Box 308F, Culver, Oregon 97734

BANJO, GUITAR Cassette Lessons. Free Catalog. Bailey, 4005PM Lara, Chattanooga, TN 37416

POEMS Set To Music. Nashville Music Productions, Box 4001-PM, Nashville, Tennessee 37204.

STRINGS, ACCESSORIES, SCARCE PARTS, REPAIR BOOKS. Catalog 25¢. Stringking, Rifton, New York 12471

FINGER STYLE GUITAR — World's easiest Method — All good Finger — Pickin Hits from Great Artists. For Beginner or Advanced. Send \$10.95 For Volume to: Just Pickin, P.O. Box 3189, Freeport, Texas 77541

PLAY GUITAR in One DAY! ANY Song in Seven Days! **PROVEN** Method includes 100 Popular Songs, Chord Finder, **GUITARIST BOOK OF KNOWLEDGE, TUNER, COURSE #346P \$4.99 POSTPAID. TREASURE CHEST, 1117 THOMAS JEFFERSON PLACE, FREDERICKSBURG, VIRGINIA 22401**

EASY Play and Make! Quality Dulcimers, Banjos, Hammered Dulcimers, Instruments and Kits, from \$29. (Brochure) **HERE, INC. #P, 29 SE Main St., Minneapolis, Minnesota 55414**

PLAY Music by understanding musical structure and harmony built with chords. Two new books for beginners through advanced. Free information. Write: MSL Publishing, P.O. Box 2261, Dept. 1000, Mansfield, Ohio 44905

PLAY DRUMS! Without reading music — simple instructions & cassette . . . Money Back guarantee — Details & Sample \$1.00. Good Child Publishing, Box 366-PM, Spring Hill, Tenn. 37174

HOW-TO buy and care for **PIANOS!** — Pamphlets — \$1.00 — "Pianos", Box 61454A, Sunnyvale, CA 94088

(Continued on next page)

MUSIC INSTRUCTIONS & INSTRUMENTS

(Continued from preceding page)

HARPSICORD, FORTEPIANO and ORGAN KITS — Build reproductions of 17th and 18th century single- or double-manual instruments from our kits or let our experienced craftsmen build one for you. For 20 page brochure send \$1.00 to: Frank Hubbard Inc., 185 A-PM Lyman Street, Waltham, MA 02154.

TUNE YOUR OWN PIANO and save. Easy, fun! Kit includes tuning hammer, mutes, fork, 201 page book. \$19.95. Coastal Instruments, Box 3802, Wilmington, NC 28406

EDUCATION & INSTRUCTIONS

LEARN Law Enforcement, Patrol procedures, criminal investigation, making arrests and more. Course includes scientific kits—fingerprinting, crime photography, evidence collection. Free facts. Police Sciences Institute, Dept. PBC50, 4401 Birch, Newport Beach, CA 92660.

EARN HIGH SCHOOL DIPLOMA AT HOME IN 1 - 6 MONTHS!

STATE registered. Lowest tuition available. Individual counseling. Up to 1/2 of your credits awarded for job experience. Call free 1-800-327-8103. Cambridge Academy (PM-6), 409 E. Osceola, Stuart, FL 33494.

BLACKJACK "21". Charts show when to hit, stand, split, and double down. Guaranteed! Only \$5.00. Oceanview Enterprises, 8726 Sepulveda Blvd., No. 1211-A, Los Angeles, Ca. 90045.

BOOKKEEPING Or Accounting! Easy home-study plan prepares you quickly to do your own books . . . or others. Approved for Veterans. Free "Accounting Career Kit." Write: Accounting School, Dept. PBC40, Newport Beach, CA 92660.

INDIANA University Offers Over 275 Correspondence Courses which can lead to a High School or College Diploma. For information call 800-457-4434. In Indiana 800-822-4792, or Write: Independent Study Division, Owen Hall 005, Bloomington, IN 47405

EXTENSION And Post-Graduate Awards in Philosophy, Art, Science, Botanic, Medicine, Homeopathy, Radionics, and others. 30 subjects Curricular free (airmail \$1.00 refundable). Registrar, Sussex College of Technology, Highfield, Danehill, Sussex, England.

INSTANT MEMORY . . . NEW WAY TO REMEMBER. No memorization. Release "photographic" memory. Forget nothing! Liberates extraordinary knowledge, talents, ESP. Immediate results! Free information. Institute of Advanced Thinking, 845PM Vialapaz, Pacific Palisades, California 90272.

LEARN COMMERCIAL REFRIGERATION SERVICE. Free information. Practical Technology, 301c Marlin Street, Dix Hills, N.Y. 11746

COLEMAN CAMP GEAR Repair. Earn as you learn at home for profit or hobby. Lanterns, Stoves, heaters, all models. Modern Schools, Dept. PM, 4225 N. Brown Ave., Scottsdale, AZ 85251.

RADIESTHESIA, Radionics, Dowsing E.S.P. Courses and Equipment Illustrated Catalog \$1.00 (refundable) Established 27 years. Dept. PM/R, Bruce Copen, Highfield, Danehill, Sussex, England RH17 7EX.

AUCTIONEERING - Free catalog. Resident or Home Study Course. Nashville Auction School, Nashville, TN. Mailing address - P.O. Box 190, Lawrenceburg, TN 38464.

DETECTIVE Profession. Easy home study; free tielack or lapel pin, certificate future. Professional Investigators Training School, Dept. CP, P.O. Box 1890, San Pedro, CA 90733

UNIVERSITY DEGREES BY MAIL Programs! Bachelors, Masters, Ph.D.'s . . . Free revealing details. Counseling, Box 317-PM6, Tustin, California 92680.

HOW YOUR MIND CONTROLS HEALTH! Easy method sheds stress! American Meditation, 1232 Race Road, Baltimore, Maryland 21237

LEARN Asleep or awake. Records, tapes, equipment! Free catalog! Drawer PM-400, Ruidoso, New Mexico 88345

BARTENDING - Bar Management Home Study. Bartending Training, 3843-C San Fernando Road, Glendale, CA 91204

AUCTIONEERING: Mendenhall School of Auctioneering, High Point, North Carolina 27263. Free information.

REFRIGERATION or Aircraft Mechanics. Sample \$1.00. Box 13660, Portland, Oregon 97213

AUTOSUGGESTION. Sleep-learning headquarters! Tapes, records, books, Gigantic catalog free. Research Association, Box 24PM, Olympia, Washington 98501.

LEARN GAS TURBINES! Correspondence course covering all systems, maintenance, theory, operation. Established 1957. Valuable diploma awarded. American Jet School, Department 105B, Darby, Montana 59829

REISCH WORLD WIDE COLLEGE OF AUCTIONEERING, INC. World's Largest—46 years. Term soon. Free catalog, VA Approved, Modern Auction Library "FREE" with enrollment, 515-423-5242 — Col. Gordon E. Taylor, P.O. Box 949, Dept. 19, Mason City, IA 50401.

USED Courses! Books! Lists 25¢. Smith's, 124 Marisborough, Salem, Massachusetts 01970

LEARN Sewing Machine repairing. A profitable Trade, Easy to learn. Free details. Sewing Center, 187 FR, Rochelle, GA 31079

PIANO TUNING PAYS. Learned easily at home. Accredited NHSC, GI Approved. NILES BRYANT SCHOOLS, INC., Dept. P, 3631 Stockton, Sacramento, California 95820

NEW BABY? Infancy to First Grade Early Learning Program. Newsletter, 93 Webster, Arlington, Massachusetts 02174

SCREEN-Printing. Learn how to make money at home spare time printing signs, bumper stickers, T-shirts, more. Print on paper, plastic, glass, metal, fabric . . . for stores, realtors, mail order factories, politicians, etc. Write: Screen Printing Center 4401 Birch, Dept. PBC40, Newport Beach, CA 92660

UNIVERSITY DEGREES BY MAIL . . . OUR SPECIALTY. FREE Revealing details. Success, Box 13151-M6, Columbus, Ohio 43213.

PROFESSIONAL Technician Reports! "How to Avoid Major Appliance Repair Rip-Offs," plus, "How to Care For Your Major Appliances." **STOP GETTING RIPPED OFF!** Send \$9.95 to: D.P. Enterprises, Box 134, Leavittsburg, Ohio, 44430.

ELECTRONIC BLUEPRINT READING — Improve Job/Salary — Free Details!!! Blueprints, 7131 Owensmouth, Suite B58PM, Canoga Park, Calif. 91303

LEARN Commercial Art, Calligraphy, Corrections. Yenny, Box 1181-N, Piqua, Ohio 45356

NO SECRETS! Save money! Easy Step-by-Step guide. How to settle your automobile accident without a lawyer. Money-back guarantee. Written by a lawyer. \$9.95. Dept. PM6E, A. C. Industries, 6400 Southwest Freeway, Suite 415, Houston, Texas 77074

ELECTRONIC GAME REPAIR - COIN MACHINE TRAINING. Growing field needs qualified technicians. **BECOME ONE.** Call toll free 800-634-6537. Nevada Gaming School, 3100 Sirius Rd., Las Vegas, NV 89102 (Approved for Veterans.)

REPAIR clocks and watches (including digitals). Free catalog of helpful books. North American, Box 77ASA, Fox River Grove, Illinois 60021.

\$PRACTICALS Do-It-Yourself Success Seminar. Write: BT Seminar, Uplift Publications, Box 352, P-100, Palestine, Texas 75801

TRIG-DIAL Triangle and circle, students, designers. \$3.00. GS Service, 12910 Orme, Cleveland, Ohio 44125

IMITATE MILLIONAIRES! Brainwave Patterns! Simple! Scientific! Book \$2.00. Edemp, 600 Hunter's Trail, 23C, Glendora, California 91740

EMPLOYMENT INFORMATION

WORK OVERSEAS, DOMESTIC, OFFSHORE, ONSHORE, FREE DETAILS, JOBS, BOX 73542, HOUSTON, TX 77090

HOW TO BECOME A COMPUTER PROGRAMMER . Free Details: CP3, Box 5734-PM6, Pittsburgh, PA 15208

EQUAL Opportunity Guide to SKILLED TRADES - JOBS. \$3.00. Box 221907, Carmel, CA. 93922.

AUSTRALIA - NEW ZEALAND Want You! 75,000 jobs. All occupations. Big pay. Free transportation. Employer listings \$2.00. Plus information 68 other countries. Austco, Box 4116E, Hayward, CA 94540.

BROADCASTING CAREERS. Know what it takes to have a career in Radio or TV. Training, Qualifications, Earnings, and Places of Employment covered in this 25 page report. Send \$3.95 to: CAREERS, Dept. PM, C-4, Box 189-A, Pikeville, KY 41501

JOBS OVERSEAS . . . (Including Alaska.) Free Details, Global Employment, Box 808-PM, National City, California 92050.

ROCKY MOUNTAIN EMPLOYMENT NEWSLETTER! Colorado, Idaho, Montana, Wyoming!! Current Openings — All Occupations!! Free Details . . . Intermountain-L, 3506 Birch, Cheyenne, Wyoming 82001.

FLIGHT Time. Costs Pennies Per Hour, Information \$3.00. **FLIGHTIME**, Box 2464, Richardson, TX 75080

EMPLOYMENT WANTED

ARE YOU LOOKING FOR EMPLOYMENT? Try our Classified Section! It costs only \$4.30 per word. And, if you wish to run all or part of your ad in bold capital letters— you can do so for as little as \$1.00 per word additional. Act now! Send your ad to: **POPULAR MECHANICS, CLASSIFIED DEPT., 224 WEST 57TH STREET, NEW YORK, NY 10019**

HELP WANTED

OVERSEAS Employment . . . \$10,000-\$50,000 +. Free information! Employment International, Box 29217-AF, Indianapolis, Indiana 46229.

WE BUY NEWSPAPER CLIPPINGS of Obituary Notices for \$3.00 each. Instructions \$3.00. Clippings, Box 4755PM, Philadelphia, Pennsylvania 19134

EARN \$20,000, VACATION, HEALTH RETIREMENT BENEFITS. FOR DETAILS: **DOLAN, BOX 368, MOUNT HOLLY, NJ 08060**

FOR INVENTORS

MANUFACTURER SEEKING INVENTIONS. ADVANTER INTERNATIONAL, 1100 17TH NW, WASHINGTON, DC 20036.

INVENTORS — United States Patent Office Searches. Patent Development Engineering and Marketing of your inventions, ideas with manufacturers contracts. Send for **FREE INVENTION CERTIFICATES** and invention information. Serving inventors Since 1948. **GEORGE SPECTOR, LICENSED PROFESSIONAL PATENT ENGINEER.** Former **UNITED STATES PATENT OFFICE EXAMINER**—3615 Woolworth Building, New York, 10007

PATENT AND DEVELOP Your Invention. Registered Patent Agent and Licensed Professional Engineer. Send for **FREE PATENT INFORMATION** Every Inventor Should Have. Richard L. Miller, 3612 Woolworth Building, New York, New York 10007 (212) 267-5252

NONPROFIT Foundation helps inventors. Widest range of services. Free recording forms. Free evaluation. Affiliated Inventors Foundation, 501-B Iowa, Colorado Springs, Co. 80909.

U.S. PATENT Office Searches, 234 Broadway, Room 3615, New York 10007. Free invention certificates.

REGISTERED PATENT ATTORNEY Washington D.C. Suburb. Donald A. Kettiestrings, 414 Hungerford Drive, Suite 411, Rockville, Maryland 20850

REGISTERED PATENT ATTORNEY. Applications and Searches. Mail Service. Free Preliminary Review. Box 392, Millwood, N.Y. 10546

PATENT work done **PERSONALLY.** Economical. Free review. Registered Patent Agent, 1365-A Potomac Heights Drive, Oxon Hill, Maryland 20022.

DRAWINGS — for required Patent Office Filing. Box 365, Mayo, Maryland 21106.

PROTECT Your Invention. Registered Patent Attorney. Many Years Experience, all Fields. Individual Inventor's Problems Given Special Consideration. Very Reasonable Charges. Write for Free Information. Paul H. Gallagher, 105 W. Adams, Chicago, Illinois 60603

PATENTS, TRADEMARKS, COPYRIGHTS. Find out for yourself. Information booklet and start-up forms, \$1.00. Arts & Technology Law Center, Box 1513A, 1200 3rd Ave., San Diego, California 92101

INVENTORS Patent Your Invention. Free Initial Consultation. We are Registered by the U.S. Government. Victor J. Evans & Co., 4637 Eastern Ave. N.E., Washington, D.C. 20018. Since 1898.

NEW! "Patenting your Invention Yourself!" \$29.95. Moneyback Guarantee! Patent Attorney, Box 7400-PM, Washington, DC 20044

INVENTORS: Free information on offering your invention for sale. Kessler Sales Corporation, C-56-FI, Fremont, Ohio 43420

MANUFACTURE, Procurement, Finance, Patenting. Sales DO'S and DON'TS, \$5.00. **WAYNE COMPANY,** Maria Stein, Ohio 45860. **SMALL BUSINESS CONSULTANTS.**

SGADGETS. You Create Control-Idea To Patent. 15 years personal experience, research. \$1,000's? —No results? Complete procedure \$5.00 to: BFN, 5818 Grand Avenue So., Minneapolis, Minnesota 55419

INVENTIONS WANTED

IDEAS, inventions, new products needed by innovative manufacturers. Marketing assistance available to individuals, tinkerers, universities, companies with feasible concepts. Write for: **Kit-PM, IMI, 701 Smithfield, Pittsburgh, PA 15222.**

INVENTIONS MARKETED! Cash Royalties! **FREE INVENTION PROTECTION CERTIFICATES.** George Spector Manufacturers Representatives, Woolworth Building, New York, N.Y. 10007.

INVENTIONS WANTED FREE CONSULTATION NO IDEA TOO SMALL Disclosure registration. Potential cash or royalties from manufacturers seeking new ideas. For free information on how to register your ideas, Call or Write: **AMERICAN INVENTORS CORP., 59 Interstate Dr., Dept. PM, West Springfield, MA 01089. (413) 737-5376.** A Fee Based Marketing Company

INVENTORS: If you have an invention for sale or license, write for free booklet explaining how we can help you. Kessler Sales Corp., C-56-IW, Fremont, Ohio 43420

HONEST Invention Opportunities For Your Better Ideas. Discover: Boston Core Group, 77 Gibbs St., Brookline, Mass. 02146

PATENTS FOR SALE

PATENT Wellman Barbwire Reel for Rolling Up, Letting Out Wire. Royalty or Cash. Gerald Wellman, Box 1274, Rifle, Colorado 81650

REAL ESTATE & FARMS

CANADIAN LAND FROM \$47.00 AN ACRE. Low monthly payments. Choice properties across Canada. Ideal for cottages, hunting, fishing & investment. 6 month money back guarantee. 12 month exchange privilege. Catalogue, \$1.00. Write: Canadian Estate Land, Dept. 23C, 286 Lawrence Ave. West, Toronto, Canada M5M 3A8

FREE! Big Summer Catalog! Over 5,400 country properties described, pictured! Land, Farms, Homes, Businesses, Recreation. Retirement buys! Selected best throughout the U.S. Over 700 offices, 43 states All Across America! Yours **FREE** from the World's Largest! **STROUT REALTY, Inc., 7 S. Dearborn, Dept. 5800, Chicago, IL 60603.**

(Continued on next page)

REAL ESTATE & FARMS

(Continued from preceding page)

BIG . . . FREE . . . SUMMER CATALOG! Over 2,700 top values coast to coast! **UNITED FARM AGENCY**, 612-PM West 47th, Kansas City Mo. 64112

OFFICIAL UNITED STATES/CANADIAN DIRECTORIES!! \$1.25/Acre!! Complete Agricultural, Commercial, Residential, Waterfront Listings, Homesteading Availabilities Information. \$2.00 — National Center: United States, Canadian Lands, Hewitt-PC, Wisconsin 54441. (Copyright 1980)

CALIFORNIA Acreage, Lots. \$30 down, \$30 monthly. Box 35291, Los Angeles 90035

RECREATION Land Tracts, 5-40 Acres, Idaho — Washington — Montana. Timber — Views — Streams. Insured title — Access — Low down. Write: Western High Lands, Inc., Dept. A, Box 969, Hayden Lake, Idaho 83835

TAKE OVER 10 acres Texas ranchland, beautiful valley. No down. \$25.00 month. Box 2851-D, Van Nuys, CA 91404

COUNTRY LAND — How to buy and find it — Exciting report! \$5.00-refundable W. Kaufman, 149 Clearvale, Buffalo, N.Y. 14225

HOW TO LOCATE the best country property buys. Free details. Route 1, Box 77C, Abilene, Texas, 79601.

SAVE Thousands. Homeowners Guide for Selling your Home. \$4.95 to: Guide, Box 9300, New London, N.H. 03257

HOME-OWNERS - Save enough on your mortgage to buy another house. Professional research shows you how to restructure your mortgage. (Bonus-Country Land Report). Send \$6.50 to: MHI Publications, P.O. Box 174 - P, Garner, N.C. 27529.

HOW TO BUY AND SELL LAND. Your lifetime guidebook to success. \$5.00. Wiseman Opportunities, Route 1, Box 561, Elgin, Texas 78621.

COUNTRY LAND — Secrets in Choosing Good Country Land Anywhere, What to Look For, What Questions to Ask, \$5.00 Refundable. Treehouse Enterprises, Box 5439PM, Pine Bluff, AR 71611

FOR SALE BY OWNER — Florida Properties. Free Catalog. P.O. Box 1050, Tallahassee, FL 32302

SAVE BIG! Buy Property for Less! Send \$9.99 To: Informational Services, Box 2162, Butler, PA 16001

OWN LAND — How To Find And Purchase Good Country Land. Detailed Booklet. \$3.00. Hudson House Enterprises, P.O. Box 6565, Dept. PM-2, Odessa, Texas 79762.

EXPORT—IMPORT

GIANT Wholesale Catalog! "Thousands of Products." \$2.00 (Refundable). Phelps, Box 22401, Cleveland, Ohio 44122

IMPORT From Your Home . . . Complete Information. \$3.00. V-M Enterprise, P.O. Box 112, Warren, Mich. 48091

2500 "Fast selling" products. Free brochures! Balico, Box 91309-86, Cleveland, Ohio 44101

PLASTIC BAGS

PLASTIC BAGS WHOLESALE 350 Sizes Stocked. Catalog 50¢. Milvan, 7799-PM Enterprise, Newark, California 94560

BUY IT WHOLESALE

POLYETHYLENE Trash Storage Bags, Various Sizes. Lowest Prices. SASE. M. Zimmerman, P.O. Box 933-PM, Flushing, N.Y. 11354

HEARING Aids, Batteries. Wholesale. Catalog 25¢. Fiston, Box 1444, New Preston, Conn. 06777

FREE Catalog Jewelry, Wigs, Leather Goods, Perfumes. Closeout prices. Cash Sales Co., 203 E. Congress, Tucson, AZ 85701

REPLACEMENT PARTS, Service tools for Chain Saws, Small Engines. First Quality. Substantial savings. Free Catalog. Stores, shops, give sales tax number for dealer information. Repair Parts, Box 6329-K77, Erie, PA 16512

SAVE ON PARTS! Free catalog jammed with Motorcycle, Snowmobile, Small engine parts, Accessories. Manufacturer's Supply, Box 157-PM, Dorchester, Wisconsin 54425

BELTS And Buckles. Complete line fast sellers including truckers, motorcycles, CB's, westerns, etc. Big Profits. Complete dealer set up. Catalog, details free. Anchor Specialties, Box 3958-BPM, North Providence, RI 02911

WORLDWIDE Wholesale Bargains: Imports Closeouts Dropship Marnees, 9225PM Parkway, Highland, Indiana 46322

400,000 BARGAINS Below Wholesale! Many Free! Liquidations . . . Closeouts . . . Job Lots . . . Single Samples. Free Details. Bargainhunters Opportunities, Box 730-A, Holland, Michigan 49423.

CLOSEOUTS! Discounts! Below wholesale! Freebies! Samples! DDN, Box 20152-PM, Ferndale, Michigan 48220.

HAVE Own Business. World's largest wholesalers. American, foreign. Bargains. Free details. International Buyers, Box 16386-M, Portland, Oregon 97216

RINGS, Jewelry priced 130% below Retail Price. Catalog. \$1.00 (Refundable). Anka-PM, 95 Washington, West Warwick, RI 02893

BUY WHOLESALE for Yourself or Sell to Consumers for a Handsome Profit. All Lines of items. Over 2000 of them. All 30% off Suggested Price! Fully Guaranteed! We Pay All Postage and Handling! Send \$3.00 (Refundable First Order) for your 100 Page Full Color Catalog. **ROYAL ENTERPRISES**, P.O. Box 103, Dept P, Palmyra, Pa. 17078

WALLPAPER CLOSEOUTS!—50¢ Per Roll. Sell for up to \$10 per Roll. Free Details. Wholesale Decorating Warehouse, Dept. A-400, P.O. Box 953, Elyria, OH 44035

ADV. AGENCIES, ADV. SERVICES, MAILING LISTS

EXPERT Assistance for mailorder, advertisers. Ratebook leading newspapers, magazines \$1.00. Chicago Advertising Agency, 28-EM Jackson, Chicago 60604

MAILORDER ADVERTISERS!! CLASSIFIED ADVERTISING CAN BE MOST PROFITABLE AND REWARDING. PROBLEM IS TO KNOW WHAT TO DO, WHAT NOT TO DO. COLUMBIA CAN HELP YOU WITH YOUR MAILORDER PROGRAM. OVER 20 YEARS CLASSIFIED ADVERTISING EXPERIENCE. KNOWLEDGE OF BEST PULLING PUBLICATIONS. EXPERT COPY SERVICE IS ALL YOURS AT NO INCREASE OVER PUBLISHER'S STANDARD RATES. CHANCES ARE YOU WILL SAVE MONEY. WRITE TODAY FOR FREE DETAILS PLUS YOUR FREE COPY OF "MAILORDER ADVERTISER'S RATE GUIDE" COLUMBIA ADVERTISING AGENCY, BOX 1285-PM, RICHMOND, INDIANA 47373

BUSINESS SERVICES

INCORPORATE Yourself. Save Attorney Fees, Guide Tells How, Free Information. R. L. Co., P.O. Box 14453, Savannah, Georgia, 31406

AVAILABLE on Cassettes! — "How to Start a Business" — or — "How to Buy and Sell a Business" — \$8.95 each. Send to: Business Seminars, Inc., Box 2093P, Tampa, Florida, 33601

RUBBER STAMPS

POCKET Rubber Stamps, 3 lines \$2.50; Lypowy Rubber Stamps, 435 Ocean Ave., Beachwood, New Jersey 08722

RUBBER Stamp Catalog \$1.00, Refundable. Business Cards. Youngers Stamp Shop, Princeton, Iowa 52768

STAMPS Made To Order. Three Lines \$4.60. Send Now! Robert's Rubber Stamps, 2810 E-W Hwy., Washington, D.C. 20015

PERSONALIZED Pocket Rubber Stamp, 3 lines \$2.75; Bett-R Enterprises, 12100 Valley Spring Lane, #308-P, Studio City, California 91604

LOW Cost Rubber Stamps, 3 Lines \$2.10, 4 lines \$2.60, 5 Lines \$3.10. Pyramid Stamp Works, 1292 PM Maple Hill Rd, Castleton, NY 12033

OFFICE SUPPLIES

HOW TO MAKE MONEY THROUGH CLASSIFIED ADVERTISING. Booklet shows you how to start your own business with Classified Advertising. **ONLY \$1.00 FOR BOOKLET** — (\$2.00 coupon refundable with first order) **H.E. KAPPEL, PM, DEPT. P, 224 WEST 57TH ST., NEW YORK, NY 10019**

PRINTING PRESSES—RUBBER STAMP OUTFITS

PRINT YOUR OWN — Printing presses, type, supplies direct from factory. Send 25¢ for catalog and samples to: Kelsey Co., DM, Meriden, Conn. 06450.

PRINTING Presses, type, Supplies Lists, 20¢. Turnbaugh Service, Mechanicsburg, Pennsylvania 17055

RUBBER Stamp supplies catalog. Jackson, Brownsville Road, S-110, Mt. Vernon, Illinois 62864

COMPLETE Rubber Stamp Outfits, Supplies. Same day shipment. Sign Engraving Machines, Wholesale Catalog \$1.00 Deductible. Star Stamp, 732 S. Federal, Chicago 60605

TYPE Fonts, Hand Printing Presses, Supplies. 120 pages. \$1.00 deductible first order. Acme Type, 732 Federal, Chicago 60605.

PRINTING & SUPPLIES

100 BUSINESS CARDS \$1.95 Postpaid. MERRICK, Box 365, Dinuba, CA 93618

QUALITY BUSINESS PRINTING, Selco Products, Department 37, Danvers, Massachusetts 01923

QUICK Copy Printing. Low Prices. Write: Nationwide, 614 North Main, Bloomington, Illinois 61701

PERSONALIZED Stationery, Labels, Recipe Cards, etc. Low prices! Free Literature. Margaret Brown, Liberty Lane, Bethesda, Ohio 43719

GUMMED LABELS

1,000 Deluxe Gummed Address Labels \$2.00. Free Literature. Acme, 55 Tomoka, Pittsburgh, Pennsylvania 15229

GIFT SHOPPING

FREE Catalog of Gifts. Huge discounts. Kimmell's, Box 2177, Martinex, Ca. 94553

FREE Gift Catalog. B&W Enterprises, 1389H Munro Avenue, Campbell, California 95008

CLOCKS, WATCHES, OLD GOLD, JEWELRY

HIGHEST CASH for Gold, Jewelry, Gold Teeth, Rings, Diamonds, Watches, Silver, Platinum, Mail Articles Today. Free gift with information. Chicago Gold & Precious Metals, 6 E. Monroe, Dept. 1056, Chicago, 60603.

SILVER Salvage From Industrial Waste \$4.00. Blackett, 562-31 Street, Ogden, Utah 84403

HIGHEST CASH IMMEDIATELY For old gold, silver, platinum, jewelry, gold teeth, watches, diamonds, spectacles. Free information. Rose Industries, 29-A East Madison, Chicago 60602. Established 1934.

BUYING GOLD — SILVER ARTICLES! Any Condition! Absolutely No Risk! Free Details. Reliance, 48-C Margin, Salem, Mass. 01970

WATCH And Clock repairing books, tools, materials. Free Catalogs. North American, Box 77-AR, Fox River Grove, Illinois 60021

GOLD-SILVER-PLATINUM WANTED. For free information Write: Wilmots, 345 S. Glassell, Orange, Ca. 92666

IMMEDIATE CASH for DISCARDED jewelry, spectacles, dental gold, medals. Satisfaction guaranteed. complimentary information, write: **BURGREN & ASSOCIATES**, Dept. PM680, 14479 SW Arabian, Beaverton, Oregon 97005

HIGHEST CASH PAID within 48 HOURS for GOLD 10K-14K-18K, CLASS RINGS, SILVER coins, STERLING. Send items to: **INTERNATIONAL GOLD AND SILVER EXCHANGE**, 4 Lee Ave., Asheville, North Carolina 28804

BUYING 10K CLASS RINGS. Men's \$21.00, Women's \$11.00. Mail: Dakota Gold, P.O. Box Z, Sioux Falls, South Dakota 57101

GOLD

GOLDMINING — Instructions for Easily Constructed Portable Wooden Miner Rocker Box — \$8.00. Goldcol, P.O. Box 1124, Adams City, Colo. 80022

MINERS — How to Pan for Gold and Make It Pay. Send \$3.00 To: Mining Information N.W., 15012 82nd Ave. N.W., Gig Harbor, Washington 98335

GOLD RUSH '80 Unique illustrated manual REVEALS—panning, sluice techniques, deposit locations within streams! Sluice plans included. Don't miss out! Send \$5.00 today! Kalinowski, R.D. #7, Box 702, Dept. PM-6, Flemington, N.J. 08822

FIND GOLD — Guide tells how, free information. David Hunt, Roosevelt, Utah 84066

GOLD MAPS Show where its found in 21 gold producing states. Panning instruction, sluice-box plans \$6.95. Research, Box 639, Dept. 2, Fort Benton, Montana 59442

GOLD! Handy 48 page Prospector's Guide identifies 185 minerals in field. \$3.35 Postpaid. Ballew Associates, Box 5194-P, Redondo, WA 98054.

GOLD EXTRACTION AND PURIFICATION from Jewelry and Plated Objects. Kit Includes Lab Tested Process, Gold Extracting and Testing Solutions. Additional Readily Available Supplies needed for Process. Kit \$19.95, Process only \$9.95. D&B Labs, P.O. Box 4354, Bremerton, Washington 98310

GOLD PROSPECTING SECRETS! . . . How to Prospect For Profit. . . Panning, Sluicing, Drywasher Plans. . . \$3.00. Ole Swenson, 595 West Line St., Box 1598, Bishop, Cal. 93514

GOLD . . . How to test, buy, sell precious metals. Free details. Joal Enterprises, P.O. Box 6427, Lake Worth, FL 33461

DRYWASH, Gold extractor assembly kits, and plans. Information \$2.00; Drywash, P.O. Box 4637P, Las Vegas, Nev. 89106

FIND GOLD!!! — where to look — how to pan for GOLD! — \$3.95 — **PIONEER GOLD FINDERS**, Box 99, Elk Grove, California 95624

GOLD Dredge. You can build this inexpensive, Powerful, 3" Gold Dredge. Send \$1.00 for information or \$10.00 for Plans, Photos and Instructions to: Gold Dredge, S1-C55 Peters Road, RR#1, Westbank BC V0H 2A0

GOLD MINING — WEEKENDS! Complete Guide. \$3.00. Gold, P.O. Box 25, Big Bear Lake, CA 92315

PRECIOUS STONES & MINERALS

GET Free catalog no serious rockhound, gem Cutter, jewelry maker, hobbyist or craftsman can be without. Full of bargains, exclusive items, low prices from largest suppliers and authorities in the field. Free new catalog just off the press, yours for the asking. Write: Grieger's, Dept. C-12, 900 South Arroyo Pkwy., Pasadena, California 91109

500 Polished Gemstones \$7.00. Tumblecraft, 5401 North James, Minneapolis, Mn. 55430

TREASURE FINDERS

FIND Lost coins, jewelry, buried treasure, gold nuggets, relics. New revolutionary patented detector analyzes objects, tremendous range, no ground pick-up. Free catalog. Gardiner, 4729M N. 7th Ave., Phoenix, Arizona 85013

(Continued on next page)

TREASURE FINDERS

(Continued from preceding page)

TREASURE - Locate quarter mile away with ultra sensitive locator - brochure free. Research Products, Box 13441 - AMC, Tampa, Florida 33611

REDUCES PRICES! Manufacturing Overage Topline Metal Detectors. Contact: B-TEX, 614 Easy Street, Garland, Texas 75042

FIND buried Silver and Gold Coins 50% deeper than with conventional TR detectors. Free catalog. Compass Metal Detectors, Dept. PM60, 3700 24th Ave., Forest Grove, Oregon 97116.

PROFITABLE OCCUPATIONS

FREE Catalogs. Repair air conditioning Refrigeration. Tools, supplies, full instructions. Doolin, 2016 Canton, Dallas, Texas 75201.

FT. SMITH Auction School, Ft. Smith, Ark. 72901. Resident & Home study. Veteran Approved.

PLASTERCRAFT!!! Profitable home business. Molds available. Details: Lynnette, 6251C Mentor Park, Mentor, Ohio 44060

INSPECT House Structure and Systems for Buyers. Be your own boss. Operate from home. Exceptional Income. Details \$1.00. GNIH, Box 115, Orleans, Mass. 02653

LEARN TO LEAD. Leadership Training Program, 125 Pages, Produced by Leadership Psychologist. 2048 Copies used in Business and Government at \$40.00. Yours for \$35.00. **MORE MONEY MORE POWER, SECURE JOB.** Send \$35.00. AP Press, Box 352, Crawfordsville, Indiana 47933

WOODBURNING Booming! Make and Install Chimney Caps. Prevents Rust. 900% Profit using Local Materials. Blueprints \$4.50. Guaranteed. Southwest Chimney Sweep, P.O. Box 188, Rosedale, Va. 24280

AUTOMOBILES!!! Complete Guide Explains Buying, Repairing, Selling. Very Profitable!!! \$3.00 - Box 218-A, Leicester, Massachusetts 01524

BACKPACKERS, Canoeists, Earn \$1,200. Month. Information \$3. Wilderness Expeditions, P-306, Toronto, Canada M5R 2T1

START SUCCESSFUL TOOL RENTAL BUSINESS Sparetime, with Little Cash. Step-by-Step Instruction Manual, \$4.75 Lincoln PM14, Box 3053, Clifton, NJ 07012

FREE INFORMATION - Start your own cleaning business. No investment. Details: 3413 Stratton, Ft. Collins, CO 80525.

CAN You do most repairs around your house? Very profitable business in your neighborhood. \$4.00. Brad Bond, 615 Lewis, Billings, Montana 59102. Money Back Guaranteed.

SALESMEN—DISTRIBUTORS

SELL SENSATIONAL LOW-COST BURGLAR ALARM. Lightening seller. Exceptional margin. Samples for trial. Northwest Electric, Ave. 2117, Mitchell, S. DK. 57301

SOLAR ELECTRIC BATTERY CHARGERS - Barn Ventilators - Lighting Systems. Inexpensive - 3 Year Warranty. Technical Data \$1.00. Box 66b, Carpinteria, CA. 93013

AGENTS WANTED

SPARE TIME CASH. Sell famous Hanover Shoes. Samples, sales kit free. No experience needed. No age limit. Big commissions. Hanover Shoe, Dept. 2604, Hanover, Pa. 17331.

PRINTING Advertising Salesmen—Excellent money making sideline selling Decalcomania Name Plates, small quantities. Advertising Specialties, sign letters. Free samples. Raico XL, Boston, Mass. 02119.

STOVES converts 50 gallon drum to Efficient Home Heating Unit. \$32.50 post-paid. Dealers Wanted. Indian Country Inc., Deposit, N.Y. 13754.

BUSINESS OPPORTUNITIES

IMPORT-Export opportunity, profitable world-wide, mail order business from home, without capital. We ship plan for no risk examination. Experience unnecessary. Free Report. Mellinger, Dept. C2706, Woodland Hills, California 91367

STOP Wasting Money answering questionable advertisements. 1000 offers explained. Globe, Box 20588-PM, St. Louis, Mo. 63139.

BE your own boss! 1001 fast, easy ways to make money! Free! Rush name, address, zip. Money Making, 11071-F Ventura Blvd., Studio City, Calif. 91604

PREPARE Tax Returns - Housewife Jo Ann Netzley made \$5,500 last season. Train at home. VA Approved. National Tax School, Monsey, 2FM, New York 10952

ABANDONED INDUSTRIAL SILVER—Take It! Details: Metals, Box 548, Woodville, Texas 75797

F-A-N-T-A-S-T-I-C S-U-R-P-L-U-S BARGAINS! FREE DETAILS! "MONEYMAKER" BOX 98279-B2, SAN FRANCISCO, CALIFORNIA 94109.

AT LAST You can Buy any Mail Order Product or Merchandise without risking your Money. Send for Details. AFIMO, 3901 N. Mesa, Suite 103, El Paso, Texas 79902

WHOLESALE Opportunity profitable without capital, experience unnecessary. Over 2500 jewelry and gift items, below wholesale jobber prices. Send \$10.00 (refundable) for complete plan and catalogue. Shel-Ran Enterprises, 838 Garfield Ave., Dept. C801, Aurora, IL 60506

LOCK-KEYING Simplified 18" x 24" Illustrated Instructions \$4.00. Barch-Enterprises, 3730 Southview Drive, #426, San Diego, CA 92117

GASOLINE and **GROCERIES** Problems or Profit - Start your own Convenience Store with little or no investment. Choice Sites Available most Areas. Details \$5.00. Old World Enterprises Inc., Box 406, Clover, S.C. 29710

SILVER! - Salvage it for Profit - At Home! Complete Manual - \$5.00. Camek, Box 491P, Bethlehem, Pennsylvania 18016

MAILORDER Opportunity! Start Profitable Home Business without Experience or Capital. Write for Free Book, Case Histories, plus Complete Details. No Obligation. Mail Order Associates, Dept. 590, Montvale, NJ 07645.

FREE introduction to a monthly business starter bulletin. Full, part, spare time ideas and facts. Carlson Bulletin, P.O. Box 282, Quakertown, Pa. 18951

MAKE MONEY in Ornamental Iron. Illustrated Instruction Book \$13.95. Henry Rice, 1009 South A Street, Santa Rosa, CA 95401

YOUR own business Free! We furnish all equipment and expertise. Free particulars. Write: Roberts, Room RC-2-JE, 1512 Jarvis, Chicago, IL 60626.

\$534.00 Weekly Working Three Hours Daily at Home. \$356.00 Weekly Working Two Hours Daily. \$178.00 Weekly Working One Hour. Start Immediately. Paid Daily (Advance) - \$106.80, \$71.20, or \$35.60. Written Earnings Guaranteed. Free Bulletin/Application. FAS, Postal Unit 13703-F, San Antonio, Texas 78213

VINYL'S Where the money is! Professionally repair, refinish, recolor furniture, luggage, car tops. Quick, easy. Two small \$20 jobs a day earn you \$1,000 a month. Homes, cars, offices, restaurants, unlimited customers. Start earning after a few days practice. Sensational details Free. VIP, 2007 Montrose, Chicago 60618.

PICTURE Framing—Profitable full or spare-time business. Easy to learn with handbook-course "Guide To Picture Framing Profits." \$3.00 Guaranteed. Free framing-supplies catalog included. Japs, 126-PM Seventh North, Hopkins, Minnesota 55343.

TAKE Catalog orders. We drop-ship 2,500 best-selling specialty products. Lowest below wholesale prices. Immediate delivery. Spectacular home business opportunity. Free book. SMC, 6061 De Soto Ave., Dept. 20-90, Woodland Hills, CA 91365.

TURN Your Dreams Into Dollars! Everything You Need Furnished For Successful Mailorder Program. Free Details. Royal Mailorder, 3225 West 11th, Chicago, IL 60655.

ASSEMBLE PRODUCTS AT HOME. Many opportunities paying High Weekly Profits presently available without investment. Write: Businesses, 9286 Brighton 11th, Brooklyn, New York 11235.

VENDING Machines. No selling. Routes earn amazing profits. Big catalogue free. Parkway Machine Corporation, 1930PMB Greenspring Drive, Timonium, Maryland 21093.

GET RICH! Secret Law smashes Debts - brings Cash and Credit. Details Free! WealthKit, Box 350-B, Billings, New York 12510

ERASE DEBTS with little known law - CREATE Wealth! Details FREE! Blueprints, #B6, Box 100, LaGrangeville, N.Y. 12540

REPAIR HYDRAULIC JACKS - DETAILS FREE. WRITE: HYDRAULIC PARTS SUPPLY, BOX 4197, BROWNSVILLE, TEXAS 77820.

PIANO Tuning quickly learned with home study courses. Diploma granted. American Tuning School, 17050 Telfer Drive, Morgan Hill, Calif. 95037.

PHOTOSTAMP Agents Wanted! Make big Money From Home mailorder. Free Samples, Information. Postmatic-C7, East Providence, R.I. 02914.

AMAZING! \$265,000 Yearly with classified ads. Free Proof for Stamp. Moneycraft, PM-6, P.O. Box 845, Ceres, Ca. 95307

MONEY Available to start your business. Repay only if you succeed. Home-Operated Businesses, Welcome, Associates, Box 98-A3, Brooklyn, N.Y. 11235.

NOTICE: 500% Profit Repairing Vacuums! BaRon, Box 863, Portales, New Mexico 88130

FREE Report! "Making Bucks Selling Information By Mail." Quick, easy profits. Paramount, Box 1232 (PM6), Chickasha, Oklahoma 73018

WOODWORKERS - Turn \$4 material into \$34.95. Free Brochure! Pine Shop, 78P, West Petersburg, New Hampshire 03468

14K GOLD, Sterling Silver Jewelry. Make 250% Profit. Send \$1.00 (refundable) for Catalog. Courtesy Gems, 1634 Bogart, Bronx, NY 10462

BIG profits washing windows. Perfect "shoestring" business! SBIC, 473B Morris, Providence, RI 02906.

LEARN The secrets of repairing junk batteries "Fabulous Profits" small investment. Apex Engineering, 5454 Bolsa, Atascadero, Calif. 93422

START Profitable Service Business-Easily! Alena, Box "A", Farmingville, New York 11738

STARTING your own business. Free details, SASE. Tapes-PM, Box 45033, Houston, TX 77045.

CAN you afford \$35.00 to start your own mailorder business? Write: Neil H. Tasker, Shamokin, Pennsylvania 17872

\$500.00 MONTHLY clipping newspaper items. Experience unnecessary. Free Details. Colonial, 1108 Colonial, Inkster, MI 48141

EARN BIG FEES Easy-fascinating opportunity. Become Money Broker. Own hours. No experience. Proven success formula. Free Report: DFC, Dept. 10-P-6, 1145 Reservoir Avenue, Cranston, Rhode Island 02920

MAIL Order Representatives. \$100. for supplies. Free Brochure. AUDIT CONTROLS, Dept. 40, Box 23339, Fort Lauderdale, FL 33307

MAKE MONEY AT HOME. Report details seven profitable programs. Only \$1 and self-addressed stamped envelope. Cee-Oh Enterprises, 21090P Bayou Drive, Bend, Oregon 97701

"HIGH PROFIT" Investments of the 80's. 'FREE' Report S.A.S.A. J & H, P.O. Box 2540D, Falls Church, VA. 22042

HOW TO MAKE MONEY THROUGH CLASSIFIED ADVERTISING. Booklet shows you how to start your own business with Classified Advertising. ONLY \$1.00 FOR BOOKLET - (\$2.00 coupon refundable with first order). H.E. KAPPEL, PM, DEPT. P, 224 WEST 57TH ST., NEW YORK, NY 10019

THERE'S Money for you in jewelry. Details \$1.00 (refundable). Nasco, 310-ABS Lincoln, Fox River Grove, Illinois 60021.

BIG Earnings! Steady Income! Proven Mailorder Business. Free Profit Details. Garrison, 650 Wagner PM4, Greenville, OH 45331.

BARTER - "PROFITS" IN TRADING. Simple at Home Business. Free Details SASE. Write: BARTER, P.O. Box 483-A, Auburn, NY 13021

FREE TV-RADIO ADS!!! Details: FREE - CENTURY, Box 2571-PM2, Landover Hills, MD 20784

SELL Books By Mail. Complete Dealer Set-up—25¢. Midwest, Box 44-R2PM, Shawano, Wisconsin 54166.

\$480 Weekly. Home mailing program. Goodworld, Box 26233-R, Tamarac, Florida 33320

FREE Mailorder Dropship Business Journal! Mailer's World, Box 1355K, Sioux Falls, South Dakota 57101.

\$92.00 From Square Foot Plywood. (Huge Demand). Revealing Proof 25¢ (Refundable). Woodwin, Bridgewater, Mass. 02324

LEARN Sewing Machine Repairing. Men. Women. Lucrative Profits. Gresslin Correspondence School, Box 927, Spencer, Iowa 51301.

I MADE \$40,000 Year by Mailorder! Helped others make money! Details 25¢. Torrey, Box 3187Y, Ypsilanti, Michigan 48197.

\$58.90 DAILY PAY. \$353.88 WEEKLY. Homework. Immediate Income. Earnings Guarantee Certificate. Free Report/Application. AAHIP, Unit 29309-F, Medcena, Texas 78229

BOOMING Book Business!! Amazing 800% Profit. Dealer Packet Free! Mitchell, Box 1058PM-R, Benton, AR. 72015

BECOME REAL ESTATE INSPECTOR - \$100.00 HOURLY Potential. Be Boss. Part/Full Time. Home Operation Eliminates Investment. Simplified Instruction, Forms, Assistance. Free information. IOREI, Box 418-M10, Sullivan, MO 63080.

AVOID Mailorder legal problem. Read "Mailorder Laws and Regulations." Explains necessary licenses, different taxes, etc. Only \$3.00. Play safe. Order today. (Dealers Wanted.) JH Associates, Box 5123, Margate, Florida 33063

COMPLETE \$500.00 weekly mailing program. Universal Designs, Box 202-P, Medford, Minn. 55049

MAILORDER \$1,000.00 POSSIBLE MONTHLY Selling Information. Free Details: AR Enterprises, Box 92-AB, Bronx, New York 10465

MAKE \$2,000.00 MONTHLY. Spare time. Unique proven enterprises. No Selling. No Capital to start. Free brochure. Kashbulder. Box 1132-19K Indianapolis, Indiana 46225.

FREE Inflation-Beater Book "2042 Unique Proven Enterprises." Fabulous "Little Knowns." Work home! HAYLINGS-B, Carlsbad, Calif. 92008.

CHIMNEY SWEEPING is a High Paying Trade! Become a Professional CHIMNEY SWEEPER Quickly and Economically. Free Information. Michael James Chimney Sweeping, Box 1078, Dept. PM, Aptos, California 95003

FREE Details. "Mail Order Success". Shead's, Box 381315P, Germantown, TN 38138.

\$2000 Per Month Possible. Gifts, Carded Merchandise, 1001 Others. You Buy Below Wholesale. JAYCO, 6477 Atlantic 5333, Long Beach, California 90805

BIG PROFIT - Wholesale, Excellent Second Income, 2,500 Products. Free Details. Shanalee Company, POB 15696, Long Beach, CA 90815

"BUSINESS Opportunities", Good Money! If interested, Write for Free information. Me-Dor Enterprises, 302 Monte Vista Ave., Charlottesville, VA 22903. Send Self Addressed Envelope.

(Continued on next page)

BUSINESS OPPORTUNITIES

(Continued from preceding page)

PLASTERCRAFT! Moneymaking Home Business. Details. Mailway, Box 249498F6, Nashville, TN. 37202.

\$1400.00 MONTHLY CLIPPING NEWSPAPERS At Home!!! Start Now. No Experience Required. Valuable Free Information. Send self-addressed stamped envelope. Horizon, Box 1685-WBBD, Las Vegas, NV 89101.

PIANO Tuning learned quickly at home! Free information. Empire School, Box 450327, Miami 33145

\$500 Weekly! Work 10 Hours taking catalog orders! Midwest Wholesalers, Hwy. 35A, Siren, Wis. 54872

EASY! Proven — Wholesaling Opportunities . . . Unbelievable Large Profits! . . . "Experience Unnecessary." Details Free: Sunnyvale-PM2, 2627-19th Street, Rockford, Illinois 61109

PROFITABLE and Fascinating Home Business Importing Unique Jewelry. The Home Importers Guide tells How, Where, Sources, Techniques, **PLUS FREE JEWELRY SAMPLE.** Send \$5.00 to: Harris Marketing, P.O. Box 58363, Seattle, Washington. 98188

BUY Gift and Novelty Items below Wholesale. Spectacular Home Business Opportunity. G&K Sales, 7120 S. 86th Ave., Justice, Ill. 60458

MAILORDER MAKE \$2,000.00 MONTHLY SELLING INFORMATION! Free Details. UCI, 2385 Roscomare, D-11, Los Angeles, California 90024.

FREE! "Secrets of Mailorder's Easiest Business." LaPacifica's, 1704PM Carrere, Bakersfield, CA 93308.

TRS-80 Computers, LII-16K \$680.00, 16K Interface \$375.00, 70LPM Printer \$795.00. Brochure \$2.00 refundable. Microcomputer 7316B Matthews-Minthill Road, Minthill, North Carolina 28212.

PAY TV. Proven moneymaker in restaurants, coffee shops. For free information, write: Eldorado Products, 3645 Inglewood Avenue 3, Redondo Beach, California 90278

\$800 From sheet plywood. No jokes. Details \$4.50. Fidd-Wood, Box 928, Cuba, Illinois 61427.

HUGE MARKET of Vinyl Repair and Auto Reconditioning is yours with kit we supply. Free Brochure. K.L. Kent, Box 1052, Stephenville, TX 76401.

I FINANCE YOUR BUSINESS. Get \$500 to \$2 million. World's largest directory. Helped thousands—Free proof. Capital-17, Kerrville, Texas 78028.

EASIEST Way To Mail-Order Success. Proven. Free Details. Clarke, Box 2414, Boca Raton, FL 33432.

MAIL-ORDER—Get the truth. Write: Balgenorth, Dept. PM6, Box 10476, St. Petersburg, FL 33733.

HOW to earn money in **VINYL REPAIR.** Manual explains process done with materials bought locally—establishing route. \$6.95. Acu-Trim, Box 494, Gaithersburg, Md. 20760

BIG MONEY Selling Stereo Equipment. Price List \$1.00. Refundable; **JEWELRY**, Assorted \$10.00/doz. Apollo Sales, Box 379-P, Schenectady, N.Y. 12301

\$1200.00 MONTHLY ASSEMBLING PUZZLES at home!!! Start now. No experience required. Valuable free information. Send self-addressed stamped envelope. Careers, Box 225-WBBD, Concord, CA 94522.

I MADE \$1 Million Finding Capital for Local Merchants & Businessmen. Helped others start. No Selling. Write: FBA-12, Kerrville, Texas 78028.

80% profit! Unique **BIRTHDAY REMINDER CALENDAR** sells on sight. Calendars, Box 802-P, Brigham City, UT 84302

PATENTED GASOLINE SAVER BREAKTHROUGH by Automotive Engineer can earn you \$300.00 weekends! Lightning \$19.95 Seller—Keep \$15.00! Government certified laboratories verify 5-18% savings, more clean power. Minutes installation. Details Page 196E. Alquist Manufacturing, GT-6, Milford, PA 18337.

\$625/Weekly! Home mailing program. Free postage, supplies, \$20 bonus! V-J, 323 Franklin, 804/H-98, Chicago, IL 60606

GUARANTEED Weekly Income of \$238.00. Work at home. Earnings Guaranteed. SIA, Box 182PM, Quitman, Texas 75783

FREE Information - Start a successful Coupon Advertising Business. Treasures in Coupons, Box 442, Milford, Mich. 48042

\$300 Weekly. Using our Blackjack Computer Write: Research, Box 111, Unicoi, TN. 37692

INCREASE SALES. Effective daily use of business cards. \$3.50. PCR Enterprises, 1510 - 27th Ave., Missoula, Montana 59801

MAILORDER —The Easy Way! Free Details. Galaxy Enterprises, Box 73, Mamaroneck, N.Y. 10543

2000% PROFIT GUARANTEED!!! Mailorder Riches!!! No Gimmicks!!! Free Report Shows How!!! T&D Publications, Box 1672, Madison, WI 53701.

MAKE Money! Sell our popular "How To" Publications! Superior-PM-3, 2421 S. Fulton Place, Tulsa, OK 74114

PROVEN BUSINESS — T-SHIRTS. Send \$1.00 to: T-SHIRTS, 4913 Bradenton Rd. #209, Sarasota, Florida 33580

\$\$\$ in Sports Advertising. Details \$2.00. SASE. Box F, Uvalde, Texas 78801

MINIATURE GOLF BLUEPRINTS. Brochure. Walter Nugent Construction, Box 8709, Detroit, Michigan 48224.

BECOME A BUSINESS BROKER free details. Drawer 991, Dept-3, Hollywood, Florida 33022

EVERYBODY FORGETS. Earn Hundreds\$ Helping People Remember. Details \$3.00. Refundable. Dataminder, Box 2584, McAllen, TX 78501

PLATINUM IN THE JUNKYARD! Cash in on scrap Catalytic Converters! Details. \$3.00. Howse, Box 4358-(PM), Waco, Texas 76705

HOW TO MAKE MONEY THROUGH CLASSIFIED ADVERTISING. Booklet shows you how to start your own business with Classified Advertising. **ONLY \$1.00 FOR BOOKLET** — (\$2.00 coupon refundable with first order). **H.E. KAPPEL, PM, DEPT. P, 224 WEST 57TH ST., NEW YORK, NY 10019**

HOW To Make Extra Money At Home . . . Free Proof Write — One-Way Specialty Wholesalers, Box 591-PM, Juneau, Alaska 99802

MONEYMAKING OPPORTUNITIES

OVER 1,000 BUSINESS-OF-YOUR-OWN opportunities in 5 issues of Opportunity Magazine and they're yours free for the asking! Write Opportunity, Dept. 471, 6 N. Michigan, Chicago 60602.

FREE Brochure: Selling **INFORMATION** by Mail. High Profits. Brown's, 186 Church Street, Jonesboro, Georgia 30236.

CASH FOR TRASH. Fool-Proof Method Guaranteeing \$100 from Garage Sales. \$2.00. Dwyer Enterprises, Box 8267, Rochester, NY 14617

50 MONEYMAKING REPORTS: Reprint, Sell, 100% Profit! SASE. Grove Books, 8519 Hazen, Houston, Texas 77036.

14 TERRIFIC Money-Making Offers. Details. Young's, Box 38-P, Woodbridge, VA 22191

125 Low Investment Money Making Businesses . . . \$2.00 . . . Aquarius, Box 569, Vacaville, CA 95688.

WIN \$\$\$\$\$. . . Free Details: Dept. WC3, Box 5734-PM6, Pittsburgh, PA 15208

MAKE MONEY IN SPARE TIME. Earn generous commissions as a subscription representative for leading magazines. For free details, send this ad with your name and address to: **POPULAR MECHANICS**, Dept. AB-S, 250 W. 55th St., New York, N.Y. 10019.

SWEEPSTAKES - Contests - Crosswords! 60-page sample Free! Prizewinner-P, Box 10596, St. Petersburg, Fla. 33733.

VINYL'S Where The Money Is! Professionally repair, refinish, recolor furniture, luggage, car tops. Quick, easy. Two small \$20 jobs a day earn you \$1,000 a month. Homes, cars, offices, restaurants, unlimited customers. Start earning after a few days practice. Sensational details Free. VIP, 2062 Monroe, Chicago 60618.

\$358.00 Weekly possible. 2 hours daily at home. Start immediately. Massplan (A8), Box 1439, Edmonton, Alberta T5J 2N5

MAKE Statuettes, Novelties, Imitation Marble. Sell to stores or start gift shop. Details 25¢. Marbleizing, P.O. Box 1178, Ballwin, Missouri 63011

YOUR CHILDREN Can Be Earning Money this Summer! Proven Money Making Plans for kids. Only \$1.00. Satisfaction Guaranteed. American Publications, P.O. Box 3652, Honolulu, Hawaii 96811

NEW Discovery in Battery Reconditioning Means "Big Profits Fast". Electone, 7415 Gable Drive, Little Rock, AR 72205

INFLATION CAN MAKE YOU RICH . . . Unique Fresh Approach . . . Must Act Now . . . Free Details . . . Hilltop Manor, P.O. Box B-PM3, Tehachapi, California 93561

HOW TO MAKE MONEY THROUGH CLASSIFIED ADVERTISING. Booklet shows you how to start your own business with Classified Advertising. **ONLY \$1.00 FOR BOOKLET** — (\$2.00 coupon refundable with first order). **H.E. KAPPEL, PM, DEPT. P, 224 WEST 57TH ST., NEW YORK, NY 10019**

HOW TO BUY — HOW TO SELL . . . REAL ESTATE — Inside Know-How of an Expert! Two Booklets Packed with Hints, Definitions, Forms . . . Written by Broker, Builder . . . **MONEY BACK GUARANTEE!** \$3.00 each . . . both \$5.00 . . . to: Bell Publishing Company, Box 636, Ocean Springs, MS 39564

SILVER \$5.00 OUNCE. Send Stamp for Details: Globe, 5319 Grant St., San Diego, CA. 92110

HELP PRODUCE PORK And Make Money Doing It. Free Detailed Brochure. Lorenza Jewell, Box 196, Jamaica, N.Y. 11420

WE BUY NEWSPAPER CLIPPINGS of Wedding Announcements for \$1.00 each. Instructions \$1.00. Clippings, Box 491-PM, Gatesville, Texas 76528.

GARAGE SALE INFORMATION: Make more money! S.A.S.E. \$2.00. FISHER, 1342 Ridge, Homewood, Ill. 60430.

HOMEWORKERS Manual! Free Details. Drake, 450 Lucile Street, Bartow, FL 33830.

MAKE Money Writing Short Articles. Booklet \$1.50. Conrad House, 323 Franklin, #804P, Chicago, IL 60606

GOLD FORTUNE? Get hundreds more from dealers for old gold/silver. Detailed professional Guide, \$10. Free data on this lucrative field for beginners. Gold Research, 3140 S. Ocean Dr., 2210-P, Hallandale, FL 33009

\$4.30 Daily Starting Next Week. No Mailorder Swindle or Stuffing Envelopes Ripoff. Send 15¢ poststamp: SBIAEMKS, Drawer 4099, Valley Village, Ca 91607.

\$10,000!! Six Hours Work! Matching Yellow Pages, Classifieds. Easy! Instructions. \$5.00. Celluzzi, Box 7029-156, Riverside, CA 92513

MAKE EXTRA MONEY in your Spare Time. Copyrighted Report Shows How You Can Turn Hobby into Part Time Money Making Venture. Common Household Articles May Be Worth Hundreds of Dollars! \$1.50 + 59¢ Hndig. (CA Res. + 6%). REVCO, 21329 Lakeshore Dr., #35, California City, CA 93505

SELLING KNAPP SHOES IS EASY. Highest cash commissions immediately. Enjoy a steady income with satisfied repeat customers. Your own hours. No investment. Free sales kit. Knapp Shoes, K612 Knapp Centre, Brockton, Mass. 02401.

"PROFIT From Silver Recovery" . . . Methods to Recover Industrial Silver. SASE and \$5.00 for Complete Details. S - M Graphics, Box 2418-PM, So. Vineland, N. J. 08360.

TURN 5,000 Names into \$50,000, we buy all you collect. Detail \$1.00 (Refundable). Colbert, Box 674-A, Richmond, California 94808.

BEAT INFLATION - Earn \$100 daily, easily. Travel or work at home - You're the boss! Horizons, Box 1645, New Port Richey, FL 33552

NEED CASH? \$15 - \$25 for class rings. Also buying wedding bands. Send to: J&S, P.O. Box 2731, Lakeland, Florida 33803.

BIG PROFITS From **TURTLES.** Informative Instruction Booklet, \$6. **TERRAQUATIC**, Box 57B, Paradise, La. 70080

HOW TO BUY REAL ESTATE WITHOUT MONEY!! GUARANTEED. . . . \$3.50 . . . Reschke Enterprises, Box 1325, Port Huron, Michigan 48060

SUCCEED in Your Own Business! Proven Methods Anyone Can Use. Free Literature. RW Enterprises, 7610P Carissa, Laurel, MD 20810

\$800.00 WEEKLY MOONLIGHTER'S BONANZA! Write: Harmony House, Suite PMH, 162-16 85th Street, Howard Beach, NY 11414

EARN Over \$250 Every Weekend Texturing Ceilings. No Experience, \$2.75. Almand, Box 903, Windsor, Colo., 80550

CASH in on high interest rates! Details \$3.00 — Peridot, MP4, 618 Wooster Rd. N., Barberton, Ohio 44203

HOW TO WIN MAGAZINE and **TELEVISION CONTESTS.** Send \$5.95 Check or Money Order to: Thos. J. Jackson, Publisher, Box 11546, Bethabara Station, Winston-Salem, North Carolina 27106

FREE REPORT. SAVE THOUSANDS \$\$\$\$\$. Sell Your Own House. Professionals Secrets. 12 Easy Steps. Guaranteed. Janroy Associates, 51A Fourth Street, Providence, R.I. 02906

ENJOY Fresh Vegetables and Beautiful Flowers Longer. Make a Simple Coldframe and Grow your own. Save Money. Info and Plans \$2.00. Earthcraft Products, P.O. Box 3068, Youngstown, Ohio 44511

\$2,000. MONTHLY For Further Information Send \$2.00 to: **ATLANTIC MAIL ORDER**, P.O. Box 1802, Sackville, N.B., Canada E0A 3C0

\$350.00 Weekly! Home Program! Dolores, 104 East Third, Salem, Missouri 65560

NEW PROVEN System to Successful Blackjack **FIRST TIME** Introduced. **NOT AVAILABLE** in Stores. \$11. Send check or money order to: Creative Agency, 2301 El Camino, San Mateo, Calif. 94403.

EARN \$\$\$\$ From your **WOODWORKING HOBBY!** I did, I'll show you. Rush SASE for details. Lenny, Box 265, Athens, Tennessee 37303

HOW To Win Contests. 2.00 Refundable. Wait Baron Associates, 4609 Bond Street, Warren, Ohio 44483

HOW TO MAKE MONEY THROUGH CLASSIFIED ADVERTISING. Booklet shows you how to start your own business with Classified Advertising. **ONLY \$1.00 FOR BOOKLET** — (\$2.00 coupon refundable with first order). **H.E. KAPPEL, PM, DEPT. P, 224 WEST 57TH ST., NEW YORK, NY 10019**

\$60.00 PER HOUR LIFETIME INCOME IMMEDIATELY. Write: Williams, 1062P South Budlong, Los Angeles, 90044

TEN WAYS To Make **BIG MONEY** At Home \$3.00. **PHILLIPS**, Box 4813, St. Louis, MO 63108

"WEALTH THE ULTIMATE GOAL". Does this idea INTEREST you? Rush Stamped Addressed Envelope. J. W. Yates, Box 207, Shelby, Mississippi 38774

HOW To Earn Extra Money; \$50,000.00 Possible; \$2.98. Treasury, 409B West Lee, Enterprise, AL 36330

RABBITS—CHINCHILLAS—FUR BEARING ANIMALS

RAISE RABBITS SUCCESSFULLY 68 Page Booklet Tells How. 50¢. American Rabbit Assn., H1, P.O. Box 426, Bloomington, Illinois 61701

AMAZING Profits! \$10,000 Yearly Raising Rabbits for Wool and Breeding. Details—\$1.00. American Angora, Malta 12, Montana 59538.

\$500-\$1000 Month Plan raising Rabbits for us. Free details, White's Rabbitry, PM, Hudson, Ohio 44236.

EARTHWORMS, LIVE BAIT

FREE Literature Profitable Business Raising Fishworms, Crickets. We teach you how to Raise and Sell. Write Today. Carter Fishworms, Plains, Georgia 31780.

POULTRY & GAME BIRDS

BIG FREE CATALOG, all about growing birds at home, incubators, feeders, hatching eggs. Write: Marsh Farms, 14272-A Brookhurst, Garden Grove, CA 92643

OF INTEREST TO ALL

NO EUROPEAN Vacation? Amuse your Friends with six London Postcards, Airmailed to you for your Greetings, then Reposted to them from England. \$5.00. 37 Porchester, Kempton Walk, Croydon, England.

GOPHER PROBLEMS? Send \$3 for "Troubles with Gophers." **FOR SALE BY OWNER** "Tips on how to show and sell your home." \$2. REPCO, Box 23121, San Jose, Ca. 95153

TRIPLE INTEREST ON BANK DEPOSITS! Earn Double-Digit Interest on Every PAYCHECK! Complete Details: \$5.00. Cormac, Box 466M, Medina, NY 14103.

INSTANT HOSPITALIZATION. Broad Benefits, Low Cost. For those between jobs. Stevens, 185 North Wabash, Chicago, Illinois 60601

HOTTEST NEW COLLECTIBLE - RARE GEMS! Details Free! Taylor's, 113PM Martin, Indian Harbor Beach, Florida 32937

MEAT AND POTATO Lovers - 83 Recipes to Stretch Your MONEY. \$3.95. Holt, P.O. Box 2063, Burlington, North Carolina 27215

HOW TO MAKE MONEY THROUGH CLASSIFIED ADVERTISING. Booklet shows you how to start your own business with Classified Advertising. **ONLY \$1.00 FOR BOOKLET** - (\$2.00 coupon refundable with first order). H.E. KAPPEL, PM, DEPT. P, 224 WEST 57TH ST., NEW YORK, NY 10019

DOG LOVERS - Poison-Proof your Beloved Pet. Three Easy Steps - \$3.95. Byers, 4025 Lyon, Oakland, CA 94601.

BE Self-Insured. Stop Excessive Auto Premiums. Continental Marketing, 210 Fifth Avenue, New York, N.Y. 10010

CUT Insurance Costs in Half—Guaranteed—Free Details. EPS Publishing, Box B-2(M), 1108 Hooper Ave., Toms River, N.J. 08753

GET EVEN Without Getting Caught. Free Details. Wordwise, Dept. PM-2, Box 27, Uniondale, New York 11553.

SAVE Money! Settle your automobile accident without a lawyer. Free details. Dept. PM61, A. C. Industries, 6400 Southwest Freeway, Suite 415, Houston, Texas 77074

250 YEAR CALENDAR, \$4.00. KTP Products Co., Dept. 14, P.O. Box 87, Champlin, Mn 55316

LIFE & HEALTH INSURANCE: Answers to 50 most asked questions, \$3 handling charge to: P.J., Box 304, Los Gatos, CA 95030

HOW TO SAVE . . . Free Details: IB3, Box 5734-PM6, Pittsburgh, PA 15208

INFLATION BEATING BOOKLET. Over 250 methods including energy, shopping, transportation, etc. \$2 to: Economasters, P.O. Box 114, Catharpin, Va. 22018.

BARGAINS in imported goods! Manufacturer's list included free. \$2.00-Imports, Box 3063, Wescosville, Pa. 18106

COMPUTER PROCESSED BIORHYTHMS 1 Yr. Report \$5. Include Birth-Date. Computerized Data, Box 496, Southampton, Pa. 18966.

MECHANICALLY INCLINED? Boy, have we got two intriguing puzzles for you, a four piece T-shape plus a five piece Square! Sounds easy huh? Try it! Make nice gifts. \$3.00. Liffers, Box 458A, New Hartford, Conn. 06057

BLACKJACK. Simple, powerful new method. No card counting required. So EASY, a child can master it. Complete instruction booklet. Invest just \$14.95 TODAY! Be a WINNER! Olympic Systems, Box 35073M6, Edina, MN 55435

FREE Directory on Products, Plans, Recipes, Consumer Information, and Systems Supplied by Craftco Directory, Box 28993, Dallas, Texas 75228

OF INTEREST TO WOMEN

BOBBY WHISTLE. DIRECT FROM ENGLAND! Emits a loud shrieking sound—ideal for emergencies. Wear it around your neck or keep in purse. 3 1/4" long. \$5.25. ALVA HOUSE, 7700 Leesburg Pike, Suite 102B, Falls Church, Va. 22043.

MEAL PLANNING. Address Finder, Unique Luggage Tags, Tax Data Organizing Method. Information, Illustrations. \$3.00. Appleknockers, Beaver Falls, New York, 13305.

GARAGE GOLD SECRETS! GUARANTEED! SASE, \$2. KEYED, BOX 490286, KEY BISCAYNE, FLORIDA 33149

GOVERNMENT SURPLUS

MILITARY SURPLUS, CAMPING SUPPLIES. Free Catalog. Marmaton Enterprises, Box 585C, Nevada, Mo. 64772

DIRECTORY Your Area Plus Report How To Buy — \$2.00. Consumer Help, Dept. 4AA, Drawer 269, Lakeview, Oregon 97630

GOVERNMENT SURPLUS. Buy in your Area. How, Where. Send \$2.00. **SURPLUS HEADQUARTERS**, Box 926-PM, Lake Dallas, TX 75065

J-E-E-P-S — \$19.30! — C-A-R-S — \$13.50! — 650,000 ITEMS — GOVERNMENT SURPLUS — MOST COMPREHENSIVE DIRECTORY AVAILABLE TELLS HOW, WHERE TO BUY — YOUR AREA — \$2 — MONEY-BACK GUARANTEE — "GOVERNMENT INFORMATION SERVICES," DEPARTMENT B-6, BOX 99249, SAN FRANCISCO, CALIFORNIA 94109.

JEeps, Trucks, from \$52.40 . . . Boats, Airplanes, Automobiles, Motorcycles, Typewriters, Tools, Clothing, Sports, Camping, Photographic, Electronic Equipment . . . 300,000 Amazing Bargains direct from Government Nationwide . . . low as 2¢ on dollars! Surplus Catalog and Sales Directory \$2.00 (refundable). Surplus, Box 954-PPM, Muskegon, Michigan 49443

"GOVERNMENT SURPLUS DIRECTORY!" . . . Buy 500,000 items (including Jeeps) . . . low as 2¢ on dollar! Most complete information available — \$2.00 (guaranteed). SURPLUS DISPOSAL, Box 19107-AF, WASHINGTON, DC 20036.

GOVERNMENT LANDS FROM \$7.50 ACRE! Homesites, farming, vacationing, investment opportunities! "Government Land Buyer's Guide" plus current listings—\$2.00. Surplus Lands, Box 19107-AF, Washington, D.C. 20036.

1980 Surplus Army, Navy store 64 page illustrated catalog. Send \$1.00. Ruvel, 3037 North Clark, Dept. J-6, Chicago, Illinois 60657

O-F-F-I-C-I-A-L UNITED STATES DIRECTORY . . . Jeeps . . . \$37.22!! . . . 400,000 Listings!! . . . Your Immediate Area!! . . . UNEQUALLED!! . . . \$2.00 (INCLUDES G-LANDS, G-LOTTERIES INFO-GUIDE!!) . . . UNCONDITIONALLY GUARANTEED!! . . . United States/ Great Lakes Federal Surplus Depository B-807PB, Marshfield, Wisconsin 54449. (COPYRIGHT 1980)

MOTORCYCLES — JEeps — HELICOPTERS — AUTO-MOBILES . . . GOVERNMENT SURPLUS DIRECTORY—MONEYBACK GUARANTEE — How, where — \$2.00. GS Information, Department 16, Federal Building, Box 3913, Springfield, Massachusetts 01101

DISCOUNT Catalog — Viet-nam Boots, Canteens, Viet-nam Jackets, Knives, Jungle Hats, Packs, Helmets, C-Rations, Send \$1.00 Refundable. Dixie Military Surplus, Box 8149-PM, Nashville, Tennessee 37207

J-E-E-P-S . . . \$18.88! . . . 675,000 Items! Buy in Your Area! How! Where! — "Moneyback G-U-A-R-A-N-T-E-E-D 1980 Government S-U-R-P-L-U-S Directory" — Including: "Buy G-LANDS," — "G-Oil/G-Gas L-O-T-T-E-R-I-E-S," — \$2.00. GSURPLUS, Box 2009-E, Syracuse, New York 13220

JEeps \$52.40, Airplanes \$75.01, Typewriters \$6.70, Boats \$7.50, direct from government. Directory and Surplus Catalog \$1.00 (refundable). Midwest Surplus, Box 401-PM, Dayton, Ohio 45401

STRIKE It Rich Buying And Reselling Government Surplus!! Buy Airplanes \$75.02 . . . Jeeps \$13.20 . . . 850,000 Items!! Resell At Your Price! How? Where? \$1.50. Results Guaranteed. Campos Industries, 323PMJ Santana, Hollister, CA 95023.

BARGAIN Hunter's GOLD MINE. Complete personal property purchase guide. \$2. StyleArt Publications, 12-F, 2126 Fairway Circle, Atlanta, Georgia 30319.

GOVERNMENT Surplus — Buy Your Area. How, Where. Send \$2.00. JRS Enterprises, 91-969 Mallani St., Ewa Beach, Hawaii 96706

J-E-E-P-S . . . !! CARS . . . !! Less than 1¢ on dollar!! 650,000 items!! COMPREHENSIVE DIRECTORY tells how, where, YOUR AREA!! \$2.00!! MONEY BACK GUARANTEE!! Surplus America, Department C-6, Box 20390, Jackson, Mississippi 39209.

LOANS BY MAIL

BORROW FROM HOME. Any amount, any purpose, within 30 days. Competitive Rates. Also, you can earn unlimited income as our Money Agent. No experience—own hours. National Company to assist every way possible. No Gimmicks! Free Details: Financial, Dept. 10-C-6, 1145 Reservoir Avenue, Cranston, R.I. 02920

BORROW \$25,000 "overnight." Any purpose. Keep indefinitely! Write: Success Research, Box 29263-AS, Indianapolis, Indiana 46229.

FREE Details on How to Borrow up to \$10,000 entirely by Mail. Write: Postal Financial Services, Inc., Dept. 1382, 814 Pierce St., P.O. Box 268, Sioux City, Iowa 51102.

CASH Loans and Outright Grants to Individuals refused Elsewhere. No Collateral, Co-signers, interviews. 98% Accepted. Associates, Box 98-A4, Brooklyn, NY 11235

BORROW \$125,000 Interest-Free! Repay Anytime. Everyone eligible. Free Report: Executive PM-6, Box 996, Dundee, Florida 33838

THE ARABS HAVE MILLIONS to Loan, Invest, Business, Investment Purposes. \$25,000—\$10,000,000 Possible. (Not Iranian) Free Details. Arab Ventures, —PM, 935 Main, Vidor, TX 77662

BORROW \$30,000 fast! Repay anytime. Free report. Infohouse—PM6, Box 1004, New York, NY 10003.

NEED MONEY—instant cash no Credit investigation. Detail Free. Jersey Consultant, 3196-C Kennedy Blvd., Jersey City, N.J. 07306

LOANS! \$2,000 - \$5,000,000. Advise amount & purpose. Write: National, 507 - P Fifth Ave., New York 10017

PERSONAL

COLLEGE DEGREES BY MAIL. Renowned Universities offer full-accredited Bachelors, Masters, PH.D.'s . . . Free revealing details. Counseling, Box 317-MP-6, Tustin, California 92680.

COLLEGE Diplomas Without Classes. Accredited Degrees by Mail. Free Details. DACS, Box 33428, Seattle, WA 98133

HOW To preplan a funeral. SAVE: Money, time, emotions. Mail \$3.95 now to: Pearson, Box 6099, Santa Barbara, Cal. 93111

FINANCE YOUR DREAMS With Government and Foundation Grants. Free details. Tou-PM6, 432 PCH, Hermosa Beach, California 90254.

CONFIDENTIAL Chicago Mailing Address: Business, Personal. Since 1944! Mail Center, 323(K) Franklin, Chicago 60606

UNIVERSITY DEGREES BY MAIL . . . OUR SPECIALTY. FREE Revealing details. Success, Box 13151-T6, Columbus, Ohio 43213.

PSORIASIS SUFFERERS: DISCOURAGED? Write for Free important information that is helping thousands. Pixacol, Box 29277PM, Parma, Ohio 44129.

BIBLE Questions answered. Stamped envelope. Bylon, 17167 Bentler, Detroit, Michigan 48219

AMAZINGLY Different, Personal and original poems and parodies written for Birthdays, Anniversaries, any occasion by writer of Mississippi's Official State Song. Details, Davis, 214B Galvez, Jackson, Ms. 39209

HOW To Control PSORIASIS. Free Details. Bonanni, P.O. Box 9071, Albany, New York 12209

BIORHYTHMS - Yearly charts. Send birthdate, \$7.00. Bio-Charting, Box 396-PM Miamisburg, Ohio 45342

YOUR BIORHYTHM. Computerized!! FREE folder. Send SASE. OREB, 3700 Dean Dr., Suite 2607, Ventura, CA. 93003.

HOW TO BE AS SUCCESSFUL AS YOU WANT! New booklet reveals proven secrets. Send only \$3.00. Guaranteed. Guidance, 2919 Nancy Creek, Atlanta, Georgia 30327

COLOR Blind? Enjoy greater color perception with Color Aid™ glasses. Information: Color Aid, Ltd., Box 744, Dept. 103, Mundelein, Ill. 60060

CREDIT HASSLES? What's in your Credit File? Detailed Government Document Explains Everything. \$2.00 for Booklet. Home Library, P.O. Box 305, Fort Anne, N.Y. 12827

REMAILING SERVICE

UNLISTED ADDRESS. Discreet and confidential. Remail 50¢ Single. Mail Forwarding Service, 8050 S. Main, Houston, Texas 77025

CONFIDENTIAL MAIL And PHONE Calls Received and Forwarded Daily. Box 387PM, Claymont, DE 19703

PACIFIC Northwest Address. Discreet Remailing Service. Write: Jobal, Box 546, Woodinville, Wa. 98072

FLORIDA REMAHS Receiving-Forwarding. Allen, 6326 Autlan Drive, Jacksonville, Florida 32210

REMAILING DIRECTORY \$5.00. INTERNATIONAL REMAIL FORWARDING ASSOCIATION, BOX 1536M, HILO, HAWAII 96720

YOUR mail Received-Forwarded-Confidential. DAL Mail Service, P.O. Box 98, Southview Station, Binghamton, NY 13903

FREE! Remailers Listing. (New Agents Wanted): Box 471PM, Atlanta, Texas 75551.

CHARLOTTE Remails. Confidential. Stamped Singles 50¢. TLM, Box 220363, Charlotte, N.C. 28222

CONFIDENTIAL TEXAS ADDRESS, UNLIMITED POSSIBILITIES. ALEXANDER, BOX 17982, SAN ANTONIO, TEXAS 78217

INDY Remails - Stamped Singles 50¢. HIS, Box 19086, Indianapolis, Indiana 46219

MISCELLANEOUS

PHOTO ID. Sealed in plastic. All states, provinces. 24-hours. GUARANTEED. Free Social Security card. Send \$5.00 (2/\$8.00), photo, name, address, height, weight, hair, eyes, birthdate. CARDINAL, Box 5200-DR234, Jacksonville, Florida 32207.

ORNAMENTAL Iron Designs. Book of 1600 Beautiful, Practical Designs for Railings, Columns, etc. Free Literature. Cunningham, 3881 South 3200 West, Box 20005, Salt Lake City, Utah 84120

IDENTIFICATION Card Catalog. Free. Nipcom, 303 Main, Barstow, California 92311

PHOTO IDENTIFICATION CARDS . . . Certificates . . . GUARANTEED!! Samples 25¢ . . . Bascco, Box 3461-P-80, Providence, R.I. 02909.

MUSHROOM Lovers — Grow your Own. Even Earn Money. Send \$3.98 for Instructions. Mushroom, Box 2025, Universal City, Texas 78148

(Continued on next page)

MISCELLANEOUS

(Continued from preceding page)

PROTECT YOUR FAMILY! Don't die without a Will!! Blank will form, only \$2 — guaranteed! Services, Box 171, Dept. 1A6, Falkville, Alabama 35622

HORSEPLAYERS: You can beat the races. Consistent, easy method that works! Only \$30.00. W. White, 1042 Rosemont, Chicago, IL 60660

FAMILY Tree Genealogy History Can Become Heirloom Through Descendants. \$1.00 Refundable. A.C.B. 30 Sullivan Street, Cookeville, Tennessee 38501

MODIFY Your Kettle Style Grill. Bar-B-Q Bigger Meats, Turkeys! Easy! Cheap! Plans \$2.00. ABC, Box 244-M6, Herndon, VA 22070

TUNGSTEN Carbide, \$6.50 lb. Free Details. Box 12764-C, Phila., Pa. 19134.

IDENTIFICATION CARDS . . . CERTIFICATES . . . 52 SELECTIONS. Samples 25¢. Documents, Box 5684X, El Monte, Calif. 91731.

WANTED—MISCELLANEOUS

TRAINS: Toy Lionel American Flyer. Write: Schumacher, 2912 "O" Street NW, Washington, DC 20007

GOLD, Silver, Platinum, Mercury, Tantalum wanted. Ores assayed. Free circular. Wholesale Terminal, Norwood, Ma. 02062.

MODEL TRAINS: Lionel, etc. Top Prices. Tom Ryan, 81-45 Woodhaven Blvd., Glendale, New York 11385. (212) 849-8825.

BUYING Tungsten Carbide, Top Prices — Poley's Industrial Salvage, 12389 S. Minges, Battle Creek, MI 49017 (616) 979-4075.

PAINTINGS WANTED! Investors pay highest prices for fine old paintings. Ursula Armbruster, 1316 Fargo, Chicago, IL 60626. (312) 743-7644

ANTIQUE SPARKPLUGS, Old, Unusual. D. Christensen, 184 Carter Rd., Princeton, N.J. 08540. 609/921-1277

FOR SALE—MISC.

PIE-THROWING Greeting Card! Reader gets cream pie, flour or confetti in puss! Surprise Someone. Free Details. Crazy-Kard, Box 829, Valley Forge, PA 19481.

BEERDRINKERS!! Economical Home Draft Beer. Convert Refrigerator With Kit. 1108 Sharps, Bridgeville, PA 15017.

OVERSEAS Specialties "Discounted." Free Brochure! Productsco, Box 91309-K6, Cleveland, Ohio 44101

HEARING AIDS

HUGE SAVINGS. Eliminate dealer mark-ups. Free Trial. Batteries Wholesale. Terms arranged. Lloyds-PMC, Rockford, Illinois 61104.

FREE HEARING AID CATALOG — Save 1/2 by mail! Write: "MoneySavers", 9530-PM6 Langdon, Sepulveda, California 91343. Not sold in California.

TOBACCO

MAKE Pipes. Information: Pimo, Inc., P60, Box 59211, Chicago, Illinois 60659

FORMULAS, PLANS, ETC.

20,000 MONEYMAKING FORMULAS! CATALOG — \$2.00 — REFUNDABLE! GWA3, Box 193, Brookfield, WI. 53005

TRAVEL & RESORTS

TRAVEL THE WORLD at discount rates! Thousands save 75 to 90%. Special report tells how. Send \$3 today. Orchard Enterprises, P.O. Box 682, Lake Geneva, WI 53147

PAN AM "Two-for-One" discount coupons. Save \$thousands flying overseas. Limited supply. Order now! Only \$75. Wallace Company, Box 14032, Washington, D.C. 20044.

SPECIAL SERVICES

NEW — Nationwide Reminder Service. Forgetful? Let Us Remember For You. Inexpensive. Free Details. Write: Reminder, P.O. Box 483-F, Auburn, N.Y., 13021

INFORMATION On anything. Ferguson Research Specialists, 60-15 Woodside, Woodside, New York 11377.

HOW TO MAKE MONEY THROUGH CLASSIFIED ADVERTISING. Booklet shows you how to start your own business with Classified Advertising. ONLY \$1.00 FOR BOOKLET — (\$2.00 coupon refundable with first order) H.E. KAPPEL, PM, DEPT. P, 224 WEST 57TH ST., NEW YORK, NY 10019

BETTER HEALTH

GUARANTEED!! Achieve and maintain your best weight. FREE details. CD3, Box 5734-PM6, Pittsburgh, PA 15208

LOSE WEIGHT! Improve Your Figure. Author Reveals A Diet Plan that Works! \$2.00. D&J Gifts, 249 Forest St. NW, Warren, Ohio 44483

LIVE LONGER!!! Quit Smoking! . . . Free Details: QS3, Box 5734-PM6, Pittsburgh, PA 15208

ACNE AWAY! Start healing your first day. \$5.00. M.V.S. Research, P.O. Box 546NL, Highland Park, IL. 60035

FIGHT Inflation. 24 Marvelous Chicken Recipes. \$3. Berkel Books, P.O. Box 524051, Miami, Fla. 33152

TECHNIQUES FOR WEIGHT CONTROL! Easy Complete Program with Proven Methods for Maintaining Control Over Eating Habits. Only \$2.95. Control, Box 15, Kings Park, New York, 11754

SLEEP, Immediately, All Night, Awake Refreshed. Learn Sleeping Techniques By Cassette. Send \$9.95. Behavioral Management, Box 8024P, Roseville, Minnesota 55113

THE HEALING POWERS OF HERBS. Amazing book reveals remedies used since the dawn of history. Send \$3.50 to: J.C. Enterprises, Box 295, Johnson City, New York 13790

QUIT SMOKING!! With our Report — Your Desire — YOU CAN!! \$2.00 Refundable. Treehouse Enterprises, Box 5439PM, Pine Bluff, AR 71611

SLEEP BETTER — FEEL BETTER, A PROVEN FACT! The Truth about Flotation Sleep; health studies, engineering reports, consumers waterbed Handbook. \$3.00 (Refundable). Discount Waterbeds, 1805 Second Street, #G2, Berkeley CA 94710

THIS SERVICE COULD SAVE YOUR LIFE! . . . OR THE LIVES OF LOVED ONES! Thousands injured Weekly in Accidents or Due to Health Conditions! Most Complete Emergency Medical Information Service . . . When Seconds Count! Many Physicians Endorse! Confidential. Worldwide! Free Information. Medical Data Banc, P.O. Box 3242, Omaha, NE 68103

FOR THE HOME

SELLING Your home. Send \$2.00 for 2-color brochure "Getting Ready for an Open House" to: Vicki, 330 Second St., Los Altos, CA 94022.

FARM & GARDEN EQUIPMENT

ETHANOL, HOME MADE AUTO FUEL, Working Manual with Complete Plans and Instructions to build still inexpensively. Mash Formula, Government Regulations, Auto Conversion to Burn your Product. Much More, Satisfaction or Refund. \$12.95 Postpaid. Agline Farm, Route 2, Box 150, Tuttle, Oklahoma 73089

GARDENING & LAWN CARE

ORGANIC Fish Emulsion \$8.75. Garden Grow 8 qt. \$8.75, 16 qt. \$14.00 ppd. Natural Garden Supply, 64410 CR3, Wakarusa, Ind. 46573

FLOWERS, PLANTS & NURSERY SUPPLIES

LEARN Landscaping at home. Free booklet. Lifetime Career Schools, Dept. A-798, 2251 Barry Avenue, Los Angeles, California 90064

WINEMAKING & OTHER RECIPES

WINEMAKERS-BEERMAKERS . . . Free Supply catalog. Yeast, Equipment, Continental, Box 68016-PM, Indianapolis, Ind. 46268.

SOUTHERN Cookbook, 130 Original Recipes; \$3.98. Joyce Renda, Dept. PM 100, 721 Meadowdale, Shreveport, LA 71108

TRADITIONAL French-Canadian Recipes, Pea Soup, Meat Pie, Maple Syrup Desserts; \$3. Recipes, 2 Bloor St. W., 100-183 Toronto, Ont. M4W 3E2 Canada.

BEETS MAKE FINE WINE!! \$3.00, R-C-W Enterprises, 4750 Naniloa Dr., Holladay, UT. 84117.

ROMAINE SALAD RECIPE. Send \$2.00. TOM, P.O. Box 809, Lakeside, AZ 85929

ATTENTION BEER MAKERS: 6 lbs. Munton & Fison Hopped Malt Extract; Specify Light, Amber, Dark. Prepaid \$9.50. Money Order Only. Home Winery Supply, Dundee, MI 48131

MAKE BEER, Wine, Liqueurs. Free Catalog. Bacchanalia, Box 51, Central Village, Mass. 02790

WINEMAKERS-BEERMAKERS — Free Catalog—Fast Service—Large Selection: Kraus, Box 7850L, Independence, Missouri 64053.

WINEMAKERS-Beermakers: Free illustrated catalog of supplies. Semplex, Box 12276R, Minneapolis, Minnesota 55412.

FREE ENCYCLOPEDIA Winemaking, Beer-making, Supplies, Equipment, Ingredients, Vinox Industries, Box PM-7498, Rochester, New York 14615

WINE, Three Weeks; Beer, Two. Catalog, Supplies. Jim Dandy Sales, Box 30377PM, Cincinnati, Ohio 45230

WINEMAKING/BEERMaking Supplies, Equipment. Free Catalog. Wine Hobby, P.O. Box G-104, Greenwood, MA 01880.

BEER LOVERS — Brew your own. Delicious! Inexpensive! Free Catalog. Beer Gear, Box 25093M, Lansing, Michigan 48909

TEN Unusual Cookie Recipes Including Pavlovas . . \$2.00 . . . CIM, Box 926, Moorhead, Minnesota 56560

PINA COLADA RECIPE Delicious! S.A.S.E. \$1.00. FISHER, 1342 Ridge, Homewood, Ill. 60430.

TRAIL RIDERS CHILI, Hot, spicy. No tomatoes. Extra good, \$2 and SASE. Cook Shack, Box 9551, Tulsa, Oklahoma, 74107.

GENUINE Bavarian Soft Pretzel Recipe Plus Bonus, \$2.00. Munich, 6463 Alum Creek Dr., Groveport, Ohio 43125.

VAQUERO'S Bar-b-que Beans with a Southern Twang. \$2.00. S.A.S.E. Ed Carlson's, 8445 Roseway, El Paso, Texas 79907

PROFESSIONAL BARTENDING TOOLS. Complete Set for Home Bartending plus 25 most asked for Drink Recipes—\$14.95. Johnson's, Box 154, Roslyn, N.Y. 11576

SCRUMPTIOUS Cheese Straws Recipe. \$2.00 S.A.S.E. Ed Carlson's Gimcracks, 8445 Roseway, El Paso, Texas 79907

REVEALED. Great-Grandma's Liver Balls. You'll love them. \$2.00. — Post Enterprises, Box 21, Torrance, CA 90507.

MEN! — Women! Outdoor, indoor, 119 Pages Proven Winning Chicken Recipes. Budget Stretcher. Impress Spouse/Friends. Send \$2.00. SAM Sales, 1772 Laurel Brook, Birmingham, Al. 35215

DIAMOND Jubilee recipes from 1900's New England. Delicious, wholesome, easy and economical. Great collection. \$3.00. M. Sheer, 167 Injun Lane, Media, PA 19063.

BEERLOVERS! Finest homebrew ingredients, supplies. World Famous COMPLETE brewing outfits. Free details, handbook. Duane Imports Ltd., Department PM60B, 508 Canal Street, New York, New York 10013

TOM AND JERRY BATTER Time Tested Recipes with Complete Instructions. Prepare Now for the Holiday Season. Sell to Bars — Liquor Stores — Supermarkets. Unbelievable Profits. \$3.00. Tom & Jerry, Box 226, Rapid City, South Dakota, 57701

GASOHOL ALCOHOL NOW LEGAL! Distiller's Manual \$2.00. Homestils, 5133 Fairhill, Philadelphia, Pa. 19120.

ORIGINAL Sourdough bread recipe \$1.00 SASE. Box 1705, Plano, Texas 75074

ANCIENT MEAD — The LOVERS' POTIONS! CLASSIC honey wines EASY! SENSUOUS! \$2.95 to: Wilde Rose Press, Box 22-P, Barons, Alberta, TOL OGO

CASSEROLE CLASSICS Delicious! Nine recipes for \$3.00. SASE. Allen Publications, Box 7107, Duluth, Mn. 55807

101 BLUEBERRY RECIPES Delicious breads, cakes, jams, desserts. Send \$3.00: Blueberries -PM, Box 881 HSJ, Springfield, Mo. 65801

"DELICIOUS recipes and candies from HAWAII." For info send \$1.00 refundable on first order. Recipes, 2411 10th Ave., Honolulu, Hawaii 96816

BAKERS DOZEN PICKLE RECIPES \$3.00. SASE. Overstreet, Box 392, Rantoul, Illinois 61866

SUPERB HOMEMADE WINE Grape, Dandelion. Very Potent. Ready in Weeks. FAST FERMENT INGREDIENT and Recipes \$5.00. Andre, 10-A Marion Place, Saratoga Springs, NY 12866

CARMELA URICOLO'S molto bene italian recipes. \$2.50. Box 24858, Philadelphia, Pa. 19130.

TURNIP CASSEROLE. Send \$2.00. Impmart, 56 Norman Street, Milton, Mass. 02187

OLD-FASHIONED HOMEMADE BREAD RECIPE \$1.00. Margaret Brown, Liberty Lane, Bethesda, Ohio 43719

JALEPENOS! Stuffed - Fried - \$1 SASE. WeTexAnn, Box 252, Big Spring, TX 79720

FRUIT Jumble Cookies! Great for holidays or anytime. Send \$1.00 to: Family Recipes, 4459 Victoria Park Dr., Los Angeles, California 90019

REAL Italian Spaghetti Sauce Recipe . . . \$2.00 . . . Box 145, Winsted, Connecticut 06098

CUT FOOD BILLS! 14 easy homemade bread recipes, \$3.00. FREE BONUS! Fountain Valley, Box 5608, Security, Colo. 80931

SOUTHERN Homemade Recipes Quick and Easy — \$2.00 — Box 26636, New Orleans, LA 70126

DELICIOUS Beef Log Recipe for Parties or Snacks. Easy and inexpensive to make. \$2.00 S.A.S.E. Jay Enterprises, P.O. Box 5, Elwood, Indiana 46036

CASSETTE TAPES of the future!! Details. Hamilton's, 1320 East 112, Cleveland, Ohio 44106

DESSERT PIZZA. Cool, Delicious, Easy. \$2.00. Western Guild, Drawer F, Marysville, WA. 98270

BACHELOR COOKBOOKLET. Variety of delicious easy recipes. \$3.00 Hodges, 10358 Powderhorn, Fountain Valley, CA 92708.

HARD Cider or Wine from frozen juice. Recipe \$2. J. Stiff, 18 Bailey Cres., Scarborough, Ontario M1G 2P3.

BROCCOLI Quiche plus Lemon Sponge Pie — \$3.00 — SASE. Gourmet, Box 552, State College, PA. 16801

BEER-WINEMAKING-GASOHOL Supplies. 38 Imported Malts. Free Catalog. Wine & Brew Hobby, P.O. Box 1866, Allentown, Pa. 18105

BURGLAR ALARMS & HOME PROTECTION

PROTECT YOURSELF AGAINST CRIME. Report reveals latest techniques. Free Details. Helpful Publishers, Box 568, Pinellas Park, Florida 33565

POLICE DIALER \$29.95. Free Catalog. SASCO, 5619 St. John, Kansas City, Mo. 64123

BURGLARY PREVENTION: LEARN HOME PROTECTION, Send \$3.00. Windsor Press, Box 24-P, Suffern, New York 10901

FINEST Equipment! Save! FREE CATALOG! AAS, 186B Oxmoor Road, Birmingham, AL 35209.

CUT YOUR ELECTRIC BILL OVER 50%

SLICK BOOK LAUDED IN CONGRESS

As you're only too painfully aware, the cost of electricity is soaring. Every time you get your electric bill it really gives you a jolt. What's more, experts all agree that electricity costs are going *up!*—*UP!*—*UP!*

People have been driven to desperate measures: tampering with electric meters, tapping power off other people's lines, etc., etc., etc.

A book has been published called *Cut Your Electric Bill Over 50%*. It describes slick tricks for reducing the cost of electricity.

These are little-known, shrewd methods for reducing your electricity costs. With them, if your bill is big enough, you can *cut your electricity costs \$1,000 a year!*

It's little wonder that James E. Hall, the author of this remarkable work, has been praised on the floor of the United States Congress for his ingenuity—and for his contribution to the public welfare and the pocket-books of American consumers.

Read what one very highly regarded United States Congressman has had to say about *Cut Your Electric Bill Over 50%*:

What James E. Hall has done is show how the average American can reduce utility bills by 50%. Having saved 25,874 kilowatt hours of electricity in just nine months—and documented this achievement—Mr. Hall has proved that it can be done. In helping to conserve energy, he has done his country a great service. I have brought Mr. Hall's advice and methods to the attention of the appropriate government agencies.

The above high-powered, unqualified testimonial was not an offhand remark made during an idle conversation in a Capitol corridor; it was a formal statement introduced into The Congressional Record.

The Premier Publishing Company is proud to offer you, as a public service, copies of the historic, supremely utilitarian, enriching work entitled *Cut Your Electric Bill Over 50%—AT A PRICE OF ONLY \$3.98!*

When you consider that you'll probably save the cost of the book *a hundred times over in the first year*, you'll realize what a shocking bargain this is. We're giving you the book *practically free!*

And if our claims seem outlandish, get this: We offer the book with a *satisfaction-or-money-back guarantee!* If you're displeased for any reason whatsoever, just return the book for a full refund—no questions asked.

How can you lose?

To order your copy, just fill out and mail the coupon below.

Do so *immediately*. Your electric meter is running 24 hours a day, 7 days a week. Every day, every hour, every minute that you delay is wasting your hard-earned money.

PREMIER PUBLISHING CO.
BOX 7777, NEW YORK 10001

I enclose \$ _____ for _____
copies of ingenious, enriching,
Congressionally acclaimed
Cut Electric Bills Over 50%
at a mere \$3.98 (plus 85¢ ship-
ping; total, \$4.83).

NAME _____

ADDRESS _____

CITY _____ STATE _____ ZIP _____

© The Ad Agency mcmlxxx. PPM-1

CANADIAN WHISKY—A BLEND • 80 PROOF • IMPORTED AND BOTTLED BY THE WINDSOR DISTILLERY COMPANY, NEW YORK, N.Y.

ONE CANADIAN STANDS ALONE



WINDSOR



Материал, защищенный авторским правом.

Warning: The Surgeon General Has Determined That Cigarette Smoking Is Dangerous to Your Health.

Vantage

The ultimate point
in low tar taste

FILTER 9 mg. "tar", 0.8 mg. nicotine
av. per cigarette by FTC method.
MENTHOL 11 mg. "tar", 0.8 mg. nicotine,
FILTER 100's, 12 mg. "tar", 0.9 mg.
nicotine, av. per cigarette, FTC Report DEC. '79.

