

# Popular Mechanics

FEBRUARY 1980 \$1.00

1980 PROJECTION TVs:  
THE BRIGHTEST  
PICTURE YET!

PLUS: One you  
make from  
a kit

**NEW CURES  
FOR WET  
BASEMENTS**

**PM DRIVES 3  
NEW VWs: Pickup,  
Van & Convertible  
PLUS:**

**CROSS-COUNTRY TESTS:  
'80 Honda Civic,  
VW Rabbit Diesel**

**PM TESTS THE M.I.T.  
PEDAL PLANE THAT  
ANYONE CAN FLY**

**THE TOP 10 NEW BOATS**

**PM's attic remodeling:  
Full of ideas for you**

**CRAFTSMAN SPECIAL  
9 COMPLETE PLANS**

- Authentic copy of Lincoln's office bench
- 4 shop tools you can build
- 4 valentine gifts



**OVER THE IRON CURTAIN**

**DARING FLIGHT  
TO FREEDOM IN A  
HOMEMADE BALLOON**







Warning: The Surgeon General Has Determined  
That Cigarette Smoking Is Dangerous to Your Health.

Kings: 17 mg "tar," 1.0 mg nicotine—  
100's: 18 mg "tar," 1.1 mg nicotine av. per cigarette, FTC Report May '78

MARLBORO CIGARETTES © 1978 B&W T Co.



**Come to where the flavor is.  
Come to Marlboro Country.**



**Marlboro Red or Longhorn 100's—  
you get a lot to like.**

**This One**



**63XE-UYL-9U99**



**Some of the best things  
are measured by the ounce.**



**Seagram's V.O.**  
**The symbol of imported luxury. Bottled in Canada.**  
**Enjoy our quality in moderation.**

Canadian whisky. A blend of Canada's finest whiskies. 6 years old. 86.8 Proof. Seagram Distillers Co., N.Y.C.





### On the cover

A homemade balloon which carried eight members of two East German families to freedom in the West is depicted on its night flight. The full story of the balloon's creation, with sketches by the builders done exclusively for PM, begins on page 100.

—PM painting by Ed Valigursky

# Popular<sup>®</sup> Mechanics

FEBRUARY 1980

CONTENTS

VOLUME 153 NUMBER 2

INTERNATIONAL EDITIONS: CARIBBEAN, ITALY, MEXICO, SOUTHERN HEMISPHERE

## Special features:

### Olympic ski jumpers— human flying machines

Engineering of both the jumper's form and the hill he tries to beat make a spectacular but safe Olympic event.

91

### PM drives 3 new VWs

First extensive driving trials for the new Vanagon, plus pickup and convertible models.

98

### How to keep your basement dry

PM runs down the best ways to avoid the most common homeowner problem.

163

### Testing a pedal plane anyone can fly

M.I.T. biplane design advances human-powered flight technology.

120

### Attic remodeling

PM's model project gets the most from an unfinished attic.

134

### New projection TVs

Pick 'em for screen brightness, or build your own kit projector.

104

### Automobiles and bikes

- 14 Imports and Motorsports
- 35 Saturday Mechanic: How to find, service and replace your car's sensors
- 53 The PM Garage
- 58 Car Clinic
- 62 Detroit Listening Post
- 98 Driving the 1980 VWs
- 108 Driving the 1980 Honda Civic

### Electronics, radio and TV

- 9 PM Electronics Monitor
- 20 What to look for in new direct-drive audio gear
- 72 Hints from readers
- 88 Computerized sketch pad you build from a kit
- 104 Get the big picture: Pick of the projection TVs
- 107 Build a giant-screen TV—from kit or scratch

### Science and engineering

- 43 Science Worldwide
- 91 The Jump: Anatomy of the top Olympic spectacle
- 92 A human flying machine
- 100 The freedom balloon
- 103 100 ways to beat the border
- 110 Plastic gets tough

### Boating and outdoors

- 86 All Outdoors
- 114 PM's pick: 10 boats that are tops for 1980
- 117 Tabs to trim gas use by half!
- 119 New gear to go afloat

### Every month

- 6 Letters
- 13 Notes from the Editor
- 49 PM Briefs
- 26, 96, 113 It's New Now

### Home and yard

- 28 New storm door lets your front door show
- 40 Homeowners' Clinic
- 67 New heat pump lowers your hot-water bill
- 71 Appliance Clinic
- 76 Homebuilt tractor cab takes the bite out of snowblowing
- 78 UL pushes for safer appliance power cords
- 80 Shop-made hardness tester for metalworkers
- 134 How to make room at the top . . . with class
- 163 11 ways water gets into your basement—and how to stop it

### Shop and crafts

- 26 New Now for home and shop
- 30 PM looks at handle repair kit
- 32, 54, 65, 72 Hints from readers
- 47 PM Workbench
- 124 4 valentines from your shop
- 126 From Lincoln's law office: A handsome pine and maple bench you can build
- 130 Weekend workshop: 4 great projects for your shop
- 130 Automatic center finder
- 130 Pivotal radial-saw rip fence
- 131 Mobile accessory for tool cabinet
- 133 Rotary punch for neat holes
- 138 Workshop Minicourse: Installing a bandsaw blade

### Photography

- 68 Photo Hints
- 122 Six photo mistakes even the pros make—and how to prevent them

### Aviation

- 120 What it's like to fly the M.I.T. pedal-powered biplane

AS A SERVICE TO READERS, *Popular Mechanics* publishes newsworthy products, techniques and scientific and technological developments. Due to possible variance in the quality and condition of materials and workmanship, *Popular Mechanics* cannot assume responsibility for proper application of techniques or proper and safe functioning of manufactured products or reader-built projects resulting from plans published in this magazine.

POPULAR MECHANICS IS PUBLISHED MONTHLY by The Hearst Corporation, 224 West 57th Street, New York, N.Y. 10019, U.S.A. Subscription prices: United States and Possessions, \$8.97 for one year; \$16.97 for two years; \$24.97 for three years. Canada and all other countries, add \$9.00 for each year. Second-class postage paid at New York, N.Y., and at additional mailing offices. Authorized as second-class mail by the Post Office Department, Ottawa, and for payment of postage in cash. Registered as second-class matter at the Post Office at Mexico D.F., Mexico, June 20, 1950. © 1980 by The Hearst Corporation. All rights reserved. Printed in U.S.A.

POSTMASTER: Please send Forms 3579 to *Popular Mechanics*, P.O. Box 10064, Des Moines, Iowa 50350.

SUBSCRIPTION SERVICE: *Popular Mechanics Magazine* will, upon receipt from its reader of a complete new or renewal subscription order, undertake fulfillment of

that order so as to provide the first-copy delivery to the Postal Service within six to twelve weeks. If for some reason this cannot be done, you will be promptly notified of the issue date that will begin your subscription, with a request for any further instructions you may have concerning your order. Please address all such orders to us at *Popular Mechanics*, P.O. Box 10064, Des Moines, Iowa 50350. • Should you have any problem with your subscription, please write or call Joan Harris, Customer Service Department, *Popular Mechanics*, P.O. Box 10064, Des Moines, Iowa 50350. Telephone: 603-247-5470. State of Iowa residents call 603-532-1272. To assure quickest service, please enclose your mailing label when writing to us or renewing your subscription. • Renewal orders must be received at least eight weeks prior to expiration to assure continued service.

Use this address for subscription orders & inquiries

POPULAR MECHANICS  
P.O. Box 10064  
Des Moines, Iowa 50350

POSTMASTER: Please send Forms 3579 to this address



## FOR THE MAN WHO HAS EVERYTHING. SOMETHING TO CONTROL IT WITH.



### THE BSR SYSTEM X-10™ THE CONTROLLER



Just plug it in (no special wiring is needed), and you can control up to 16 lights and appliances

anywhere in the house by simply pressing a few buttons. And when you can turn on the TV, dim the lights or turn them all off without getting up from your easy chair, you're in control.

For under \$90\* the BSR System X-10 Starter Kit comes with a command console and enough modules to control lights and appliances at three locations. So the man who has everything doesn't have to have a lot of money to own one.

\*Manufacturer's suggested retail price.  
BSR (USA) Ltd., Blauvelt, N.Y. 10913  
BSR (Canada) Ltd., Toronto, Ont.

BSR



## The Controller

EVERYTHING'S UNDER CONTROL. THE BSR SYSTEM X-10.



VENTARAMA

## the plastic-domed ventilating skylight

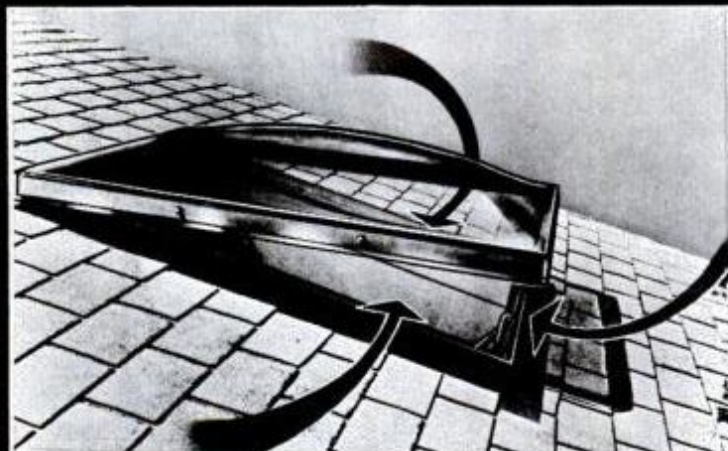

Bring more light and ventilation into your home. . . upstairs bedrooms, inside baths, porches and dark kitchens. Solve the dormer problem. One day installation. Weather-tight and waterproof. Please write or phone for illustrated literature.



VENTARAMA SKYLIGHT CORPORATION  
75 Channel Drive, Port Washington, N.Y. 11050 (516) 883-5000

## Popular Mechanics®

**Editor-in-Chief:** John A. Linkletter  
**Executive Editor:** Robin C. Nelson  
**Managing Editor:** Bill Hartford  
**Art Director:** Ira Herrick

**Special Editorial Features:** Sheldon M. Gallager, editor

**Automotive:** Bill Hartford, editor; Michael Lamm (West Coast); Gary Witzenburg (Detroit)

**Science and Engineering:** Gurney Williams III, editor

**Home and Shop:** Harry Wicks, editor; Joseph R. Provey, Penelope Angell, assistants

**Boating, Outdoors and Travel:** Wm. T. McKeown, editor

**Electronics:** Neil L. Shapiro, editor

**Copy and Production:** Garry Winter, chief; John Bostonian Jr., art; Peter Easton, Shannon K. Kelley, Daniel J. Oates, assistants

**Art:** Don Marnes, technical art director; Douglas Quinn, Alan Andresen, assistants

**Special Publications:** Clifford B. Hicks

**Editorial offices:** 224 West 57th St., New York, N.Y. 10019. We cannot be responsible for loss of unsolicited queries, manuscripts, or photos. For return, they must be accompanied by adequate postage.

**Bureau of Information:** Sophie Gronowicz, director; 224 West 57th St., New York, N.Y. 10019. (212) 262-4292

**Associate Publisher,  
Director of Advertising**  
Daniel J. Coleman

### Advertising Offices:

**New York:** 224 West 57th St., New York, N.Y. 10019; (212) 262-4284

**Chicago:** 520 North Michigan Ave., Chicago, Ill. 60611; (312) 527-2400

**Detroit:** 377 Fisher Rd., Grosse Pointe, Mich. 48230; (313) 881-3520

**Cleveland:** 221 Mercantile Center, 3659 Green Rd., Cleveland, Ohio 44122; (216) 292-7334

**Los Angeles:** 460 East Carson Plaza Dr., Carson, Calif. 90746; (213) 532-8101

**Production Manager:** John A. Regina, (212) 262-4800

**Classified Advertising Manager:** H. E. Kappel, (212) 262-4825

Published by The Hearst Corporation

### President

Frank A. Bennack Jr.

### Chairman

Randolph A. Hearst

### Vice Chairman

John R. Miller

### President, Magazines Division

Gilbert C. Maurer

### Publisher, Popular Mechanics

Joseph F. Kern

### Publishing Consultant

Richard E. Deems

POPULAR MECHANICS IS PUBLISHED MONTHLY by the Hearst Corporation, 959 Eighth Avenue, New York, N.Y. 10019. U.S.A. Frank A. Bennack Jr., President; Randolph A. Hearst, Chairman; Harrison A. Mitnick, Treasurer; Harvey L. Lipton, Vice President and Secretary. Hearst Magazines Division: Gilbert C. Maurer, President; K. Robert Brink, Executive Vice President and General Manager; Raymond J. Petersen, Executive Vice President, Advertising; Thomas J. Hughes, Resident Controller; William S. Campbell, Vice President, Director of Circulation; Joseph F. Kern, Vice President for Popular Mechanics.



# BEHIND THE GENIUS OF OLYMPUS CAMERAS IS A GENIUS.



*Maitani*

When he was ten he built his first camera. By the time he was a university student, he had four important camera patents to his credit.

His Name: Maitani. Chief camera designer for the Olympus Optical Company.

And without exaggeration, he is responsible for the 35mm SLR as we know it today.

Before Maitani got his hands on it, the 35mm SLR was a lumpy, leaden affair. Maitani took the camera and five years later transformed it into the light, compact, unexpectedly rugged Olympus OM-1.

Amazingly, as the camera shrunk, the critical features got larger. The viewfinder: big, bold and bright. The controls: roomy. The shutter release: designed with the forefinger in mind.

This was accomplished through the use of new materials. New design. And commanding it all; the startling vision of a true inventor.

Next came the OM-2. With an OM-1 actually built into it, the OM-2 goes on to offer a fully automatic function.

The OM-2 can measure the light during the actual instant of exposure.

For those who want to enter the world of 35mm SLR photography in the least intimidating manner, Maitani has created the Olympus OM-10. A fully automatic camera that lets you just focus, and shoot. And it's built with the Olympus quest for quality.

Yet there are those who maintain that Maitani's greatest contribution has been the OM System. A group of over 300 components that are as compact as the cameras themselves. Imagine, if you will, a 300mm lens you can hand hold! Pick up an Olympus camera. Is there not something in the feel, the heft, the lightness and toughness that sets it apart?

Long before these cameras were made, Maitani sculpted them in clay. And in wood. Thousands of hands from all over the world were studied for their size and shape. The devotion to detail can be documented in dozens of ways.

The Olympus OM-1, OM-2, OM-10. We can honestly say that few things in the world are designed and made this well.

And we can honestly say that no one else in the world could have designed and made them.

For information write Olympus, Woodbury, N.Y. 11797.

OLYMPUS ANNIVERSARY



# OLYMPUS®



# LETTERS TO THE EDITOR

## Up a tree

The October PM arrived exactly one week after Hurricane Frederic devastated Mobile, Ala., and I couldn't have been more relieved to see the article on tough cuts (*How to Make the Tough Cuts with Your Chain Saw*, page 126). With over 20 large pine trees either broken, uprooted or toppled, I was able to do the necessary tree work safely.

One problem in the article was the artist's drawings of the Treeman's knot on page 127 (figures 2 and 3). Shouldn't the tail from the waist loop wrap three times around the main tail and then pass between, not behind, the waist loop and the main tail rope?

DAVID B. DABNEY  
MOBILE, ALA.

Here in the Northeast, the standard tree-climbing rope is 1/2-in. dia. by 120 ft. long in manila. Anything larger is just too bulky to handle safely in a tree.

The power-saw rope should be put as high as the climber's safety line and in the tree's center. That way, you can reach either side of the tree easily.

Since I have been in the tree-work business for 18 years, I enjoyed this article very much.

LOYAL L. AVERY III.  
WAKEFIELD, MASS.

Never, never use a limb as a crotch for securing your safety rope. Pass the climbing rope around the main trunk—and use the limb only as a "stop."

R.G. CARMICHAEL  
BETTENDORF, IOWA

The technique shown on page 128 for pulling a limb clear of a building only shows a small part of this complex operation. Three bull ropes are needed to be tied to this one branch to safely maneuver the branch clear of the building. This maneuver requires the use of two or three ground men.

It takes years of experience to become a competent tree climber. . . If your readers attempt to remove a tree without proper equipment, knowledge and skill, they could possibly cause themselves serious injury.

JAMES EVANS, PRESIDENT  
MUNICIPAL ARBORISTS ASSN.  
STATE COLLEGE, PA.

Felling nuisance limbs is a hazardous task. We did not mean to leave our readers with the impression that it should be attempted without learning the skills beforehand. We'd like to

## TREEMAN'S KNOT

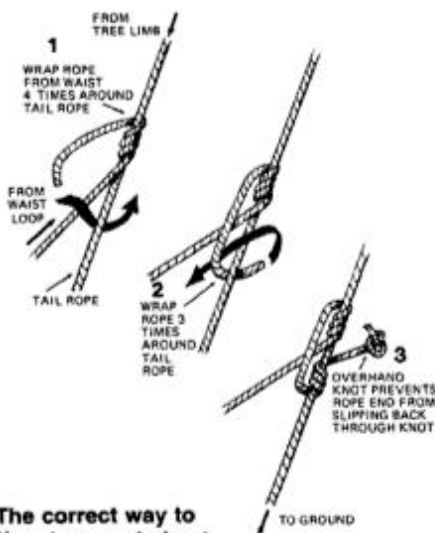

The correct way to tie a treeman's knot.

thank the readers who wrote with additional tips and cautions—and also for calling our attention to the artist's mistake on page 127 (figures 2 and 3). The diagrams above show the correct steps for tying a treeman's knot, properly called a taut-line hitch.

## Refreshing

The article on NASA's energy-conserving home (*Our Year in NASA's Far-Out House*, page 77, June '79) was one of the best I've read on the subject. Energy-efficient living has indeed become a necessary condition of future survival. It's refreshing to see that PM is as concerned with environmental problems as it is in sharing helpful hints from its readers. Keep up the good work.

J.E. POPOLIS  
BELLEFONTE, PA.

## Cone caveat

*Firewood: The Born-Again Fuel* in the September PM (page 125) did not make clear that the use of a cone-shaped splitter on a car equipped with a limited-slip differential is a highly dangerous procedure.

W. BERNHEIM  
OROVILLE, GA.

A cone-shaped splitter should never be used on a car equipped with lim-

ited-slip if the opposite wheel is on the ground. A person buys a car equipped with Positraction (or any other kind of differential lock) so that power will be applied to both rear wheels equally. This option will prevent the drive wheel from turning freely and could easily cause the car to jump the jack.

Owners of the cone-type splitters should read their manuals thoroughly before attempting to use the device. Install the emergency stop-button as directed.

## A missing engine

The article *PM Follow-Up: The DC-10* (PM Briefs, page 73, Oct. '79), regarding breakaway engines from wide-body jets, reminded me of an incident that occurred in 1971 or 1972.

An Air Force C-5A at Altus AFB, Okla., was running up its engines prior to takeoff. When takeoff thrust was reached, one of the outboard engines separated from the pylon, "flew" up and back over the wing, and finally landed in a field about half a mile away! To my knowledge, it did not strike the empennage (tail section). The Air Force probably will not want to admit to this incident, but perhaps other readers can supply more details. As a pilot, I appreciate your coverage of aviation safety topics.

E.S. SUMMERFIELD  
(FORMER) CAPT., USAF  
HIGHLAND, CALIF.

## Down-under devotee

I enjoyed your spread on the latest small computers (*Home Computers That Plug In and Go!*, page 66, Aug. '79).

In this country, all the most recent developments and technical information are slow to filter through to the average person. I'm thankful that PM allows me to keep my finger on the world pulse of inventions and innovative products.

MURRAY SMITH  
AUSTRALIA

## Correction

On page 106 of the article *Auxiliary Heaters Put Heat Where You Need It* (Dec. '79), the price given for Gold Bond's Panelectric ceiling panels was incorrect. Installed in a finished ceiling, the price is approximately \$1 per sq. ft. The panels alone are about 70 cents per sq. ft.

PM





# OMC TURNING SOLD ME.

Visiting new harbors with Jeanie and the kids . . . that's where I find my fun.

But sometimes things can get a little crowded. That's why I insisted on OMC for our new boat.

It all started when I used a friend's boat with an OMC. It let me turn in about half the distance of any stern drive boat I ever handled.

My dealer explained the reason . . . OMC Turning™. Other stern drives pivot 60° side to side. The OMC Stern Drive pivots up to 90° for tighter turns and more maneuverability.

So, my OMC really makes the difference—especially in

close quarters.

OMC Turning sold me. It could sell you, too.

You could also be sold on OMC's fingertip-controlled SelectTrim™ for pulling a skier or planing out with a boatfull. Or, have the boatbuilder install Pre-

**OMC makes the difference.**

# OMC STERN DRIVE

OMC STERN DRIVE  
A PRODUCT GROUP OF OUTBOARD MARINE CORPORATION  
3145 CENTRAL AVENUE, WAUKEGAN, ILLINOIS 60085  
FROM THE MAKERS OF EVINRUDE AND JOHNSON

set Trim™ for best overall performance.

And if you trailer a lot you'll want our exclusive 75° Hi-Tilt™. Easy in and easy out with 25% more clearance whether launching or changing a prop in the water.

OMC also offers you Tru-Course™, power or mechanical, steering that never "fights back" and Uni-Mount™ for less noise, vibration, and a more relaxed ride.

Ask an OMC owner. Write us for more information and go see your dealer. He's in the Yellow Pages under "Boats".

Then specify total performance. Specify OMC.



# INTRODUCING A YAMAHA WITH THREE WHEELS AND A DOZEN ADVANTAGES.

When we say our brand-new Yamaha Tri Moto will out-pull, out-run and out-fun anything in its class, we've got our reasons:



**1** For one, it's a nearly indestructible workhorse able to perform just about any job in anything from fresh plowed fields to sloppy mud and hardpack snow.

**2** For another, it's a quick, responsive recreational vehicle, capable of taking you up mountains, down valleys, even through swamps (if that's your idea of a good time).

**3** At the heart of this versatile machine is a 123cc two-stroke engine that gushes power and torque like an oil well. Rugged, reliable and simple, as only a two-stroke can be.

**4** And Yamaha's Autolube system relieves you of the responsibility and mess of pre-mixing the gas and oil, while maintaining the ideal oil/fuel mixture for longer engine life. There's even an oil reservoir light to tell you when it's finally time to fill 'er up.

**5** The transmission, kicked into life by an automatic centrifugal clutch, has five foot-operated forward speeds, including an ultra low with

tremendous pulling power. (Although it's not recommended, a Tri Moto has been known to pull a two-ton Chevy—with the Chevy's brake on.)

**6** A Capacitor Discharge Ignition means not only maximum performance and efficiency, but no breaker points to wear out or adjust.

**7** The riding position on a Tri Moto is the direct result of our unique seat and frame design.

The benefit is remarkable stability for a three-wheeler, even running side hill.

**8** Up hill or down, the specially designed front fender keeps mud from accumulating on the underside.

**9** Big, fat, cord-type tires provide amazing traction over terrain that would bog down lesser three-wheelers. They're also tougher to cut than low-pressure balloon-type tires.

**10** There's a disc brake in the rear for plenty of fade-free stopping power.

**11** And an ingeniously engineered system waterproofs the air cleaner and carburetor. Just one more example of perhaps the best advantage of all.

**12** It's a Yamaha.

## YAMAHA

*When you know how they're built.*

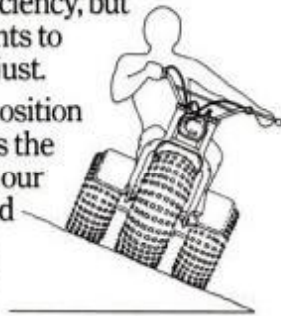



# PM ELECTRONICS MONITOR

## Hey, now I remember!

Calculators have evolved beyond being mute mathematicians for adding up the grocery receipts. Now they can function as a pocket-size memory for important dates, phone numbers and even messages.

Sharp and Toshiba have both announced alphanumeric calculators. Sharp calls its EL-6200 an "executive planner" and Toshiba refers to its new product as an "electronic diary." By whatever name, we predict these devices will catch on.

Both offer specially designed readouts that can display not only numbers but the English alphabet. Sharp offers 37 memories to Toshiba's 30 wherein the user can store all sorts of information.

Enter your wife's birthday, for example, and on the appointed day your pocket companion will stridently "beep" to alert you and display the spouse-related reason on its liquid-crystal face.

The Toshiba can even link up to four alarms to one message. If you want it to say TAKE PILL four times in a day, then you can set it to sound off at each appropriate time.

Keep business appointments, romantic rendezvous and memo-pad messages, all in unfailing electronic



These electronic memo pads from Sharp (top) and Toshiba (right) store and recall any message or personal reminder.

memories. (Just don't forget to take the calculator with you each morning.)

## Check out new checkmatters

Chafitz, in New York, recently unveiled a whole new line of chess computers to replace those we reported on in our May '79 issue (*PM Crowns the Computer Chess Champ*, page 118). Their flagship model, called an auto-response board, is truly an exciting innovation. Each square of the chessboard is equipped with an under-the-board sensor along with a

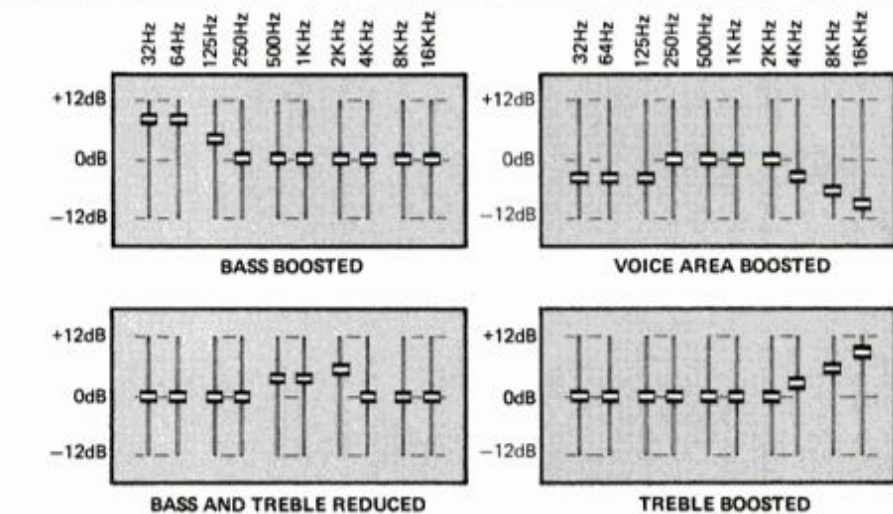

## The great equalizer

Frequency equalizers, if properly used, can be a welcome addition to many a stereo-ophile's equipment shelf. Each control governs one range of frequency response (some offer dual controls, one for each

speaker, in every range). As we show above, you can re-arrange your music to suit yourself or your acoustical environment. But be warned. A great equalizer can't compensate for poor speakers or faulty amplifiers!

visible light. Move a piece, and the computer senses it and responds by illuminating a light on the square it wishes to move to. This eliminates keyboard entry. Unfortunately, the list price is a very steep \$875.

Chafitz has also developed a modular game system, which includes chess, backgammon and checkers, to retail at \$375. The latest in the "Boris" series of chess games is the Boris Diplomat, selling at \$119.

Do the new machines play better? Well, we hope to try out some of them, as well as those from other manufacturers such as Fidelity (Chess Challenger). In particular, Fidelity's new Chess Challenger 7, with hundreds of preprogrammed openings, looks very interesting.

## Back to the shop blues

We receive a lot of unsolicited books for review—but we hardly ever read one so intently as we did Barry Deutsch's *How to Avoid TV Repair Rip-offs*. In the past I have had some horrendous experiences with TV repairs, but armed with this book, I think I could have avoided most of those problems.

Deutsch is a consumer lawyer who is the Director of Repair Services for New York City's Department of Consumer Affairs. He's heard it all when it comes to unscrupulous repair practices.

The book guides you through picking a repair shop, to understanding the contract, to knowing what to do if you're unhappy with the final re-

sults. While parts of the book's narrative may be a bit self-conscious, the information is indispensable.

The book is available by mail order for \$2.95 postpaid from Fight Back Publications, 2718 Ocean Ave., Brooklyn, N.Y. 11229. It includes a money-back satisfaction guarantee.

## Room for one more?

Believe it or not, even outer space can be used up. Currently, communications satellites must be at least five degrees apart for good Earthside reception—and almost all available space directly above the Earth's equator has been taken!

General Telephone and Electronics (GTE) has announced a new type of antenna for Earth receiving stations. Called a "low sidelobe system," it can separate signals from more closely packed satellites. As more satellites are launched, such antennas will have to be developed even further. After all, you just can't stack satellites like so much cordwood.

PM

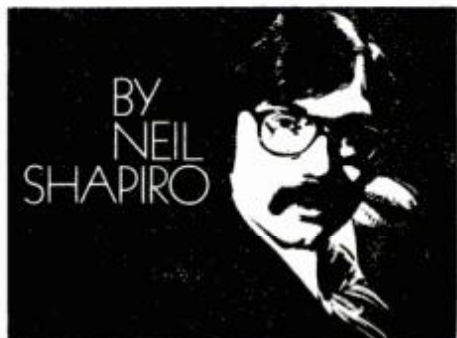

BY NEIL SHAPIRO



A man in an orange jacket is leaning over the side of a ship, holding a thick rope. He is smoking a cigarette. The background shows the ocean and a clear blue sky. The ship's structure, including a crane and various cables, is visible in the foreground and background.

# No compromise Winston Lights didn't compromise

Warning: The Surgeon General Has Determined  
That Cigarette Smoking Is Dangerous to Your Health.

LIGHTS, 13 mg. "tar", 0.9 mg. nicotine, LIGHT 100's, 13 mg. "tar",  
1.0 mg. nicotine av. per cigarette, FTC Report MAY '78.



on great taste to get low tar.  
Why should I?

Winston Lights taste good  
like a light cigarette should.







# Velvet Smoothin'

*Premium. Imported.*



BLACK VELVET\* BLENDED CANADIAN WHISKY. 80 PROOF. IMPORTED BY © 1990 HEUBLEIN, INC., HARTFORD, CONN.





## NOTES FROM THE EDITOR

John A. Spletter

**W**hen you want a job done, ask a man who's already busy, goes the old saying. It worked for us when we wanted to have three new Volkswagen models tested (page 98). Gary Witzenburg, Detroit Auto Editor, did the driving for us during the same week that he competed in the International ADAC 24 Hours at Nürburgring, Germany, and then (while shaking off jet lag) roared around the Lime Rock, Conn., track at the annual Test Day sponsored by the International Motor Press Assn. The new Volkswagens were up in Vermont—another trip for Gary—where he gamely put them through their paces in snow.

It may seem like too much, but publication of Gary's newest book occurred while all the traveling and driving was going on. The book, *Mustang, The Complete History of America's Pioneer Ponycar*, comes from an author who has served as main propulsion assistant on Navy ships, flown Navy planes and served on the General Motors engineering staff (including a stint as car test engineer for the Corvette). As they say, ask a busy man...



Gary Witzenburg.



His new book.



Tom Sahagian pedaling—without wings.

Tom Sahagian admits, and he credits it with his ability to make an unusually long flight in the *Chrysalis*.

Tom later observed with some wonderment that when the 96-pound biplane was trucked to the flying site, the air in the truck weighed more than the airplane.

PM

# Window replacement?

Introducing exactly what you need in a replacement window



Andersen Windows

# FREE

Don't replace your windows until you've read this fact-filled 16-page brochure.

Find out the answers to your most important window replacement questions. And learn how you can use original quality Andersen® Perma-Shield® windows instead of special replacement windows.

Please send your free booklet, "Introducing exactly what you need in a replacement window." Mail to Andersen Corporation, Box 12, Bayport, MN 55003

Name \_\_\_\_\_  
Address \_\_\_\_\_  
City \_\_\_\_\_  
State \_\_\_\_\_ Zip \_\_\_\_\_

The beautiful way to save fuel®  
**Andersen® Windowalls®**



026-020

©1981 Andersen Corp. Report MN 078



# IMPORTS & MOTORSPORTS

## Fiat Panda



Perfect bumper car for Italian traffic, Panda's rubber protection wraps completely around lower body.

Like the giant panda with its asymmetrical eye patches, Fiat's new mini is one of the few cars produced with half a grille. Slots on the Panda are designed into the left side only. They're all that's needed to provide the engine with cooling air: a two-cylinder, 652-cc mill doesn't require a whole lot of airflow around it to keep its operating temperature optimum.

The new fwd Panda, now available in Europe, is the first of a new generation of economy cars that stretch a gallon further than ever, and squeeze every last cubic inch of interior space out of modest overall dimensions. We won't see the Panda here—certainly not while gasoline is still so reasonably priced, and nowhere near \$3 a gallon, as it is in Italy.

## Volvo's GL concept

One of my pet peeves is how difficult—or downright impossible—it is to get luxurious, high-level appointments in a basic, standard-engine, economy sedan. All the plush options are offered in the high-powered, big-buck models only. This isn't the case, however, with Volvo's new-for-1980 GL model. It's four-cylinder under the hood, but elsewhere

Volvo combined 240 and 260 series to produce thrifty, luxurious GL model.



it's got the standard equipment of the luxurious six-cylinder models: power windows, central locking, air, power steering and more. The strong, economical Four has more than enough power for all the gear. The sensible luxury car is here!

## A Gemini for Citation?

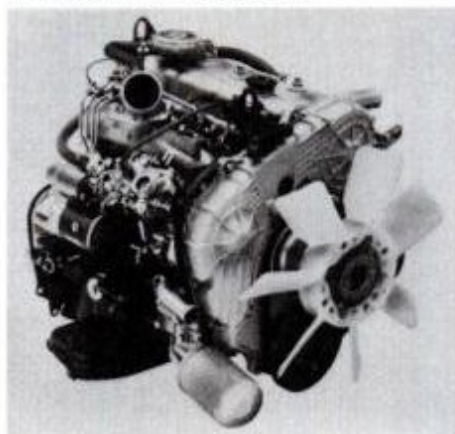

Isuzu diesel could power future GM cars.

Isuzu Motors of Japan has just introduced that country's first small, diesel-powered passenger car. General Motors has been taking a keen interest in this powerplant. Since GM has a significant financial interest in the Japanese company, it's not

at all farfetched to consider the possibility of diesel-powered LUVs and X-body cars (Citation, Phoenix, Skylark and Omega) in the near future. GM would surely have first dibs on exports of the 1.8-liter, compression-ignition Four. The engine features a 3.5-second start, even in subzero weather, with its QOS (Quick On System), and is claimed by the manufacturer to provide 60-mph-plus motoring. Stay tuned.

## Mercedes for the museum



Mercedes-Benz GP racer is now on view.

As Speed Weeks at Daytona get ready to roll and the 1980 motorsports season gets under way, many fans are already making plans for their Indy pilgrimage. Just added to the Indianapolis Motor Speedway Museum is this W165 front-engine race car, built for the 1939 Grand Prix of Tripoli. Two machines were built and they finished one, two. They were never raced again due to a rules change after the race, so the car still sits on its original, specially developed Continental tires, only one race on the treads.

## Good news department

The following items come from across the Atlantic and Pacific.

■ MGBs will continue to be available, production of the sports car having been extended to 1981 by BL Ltd.

■ Honda has just introduced an overdrive automatic transmission. For now, the "T-type" automatic is for home-market Preludes, but we're sure to see it here soon. **PM**

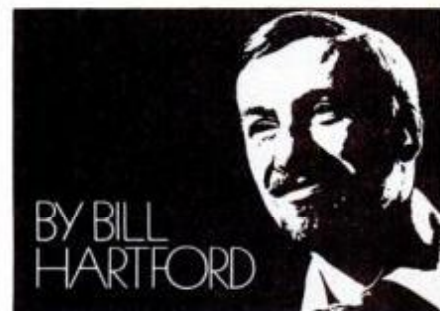





Introducing the first new truck of the 80's...

# TOUGH NEW 1980 FORD

with the best gas mileage rating of any American-built standard pickup:

Ford totally redesigned its pickups to help meet the fuel needs of the 80's: 19 MPG EPA estimate, 29 MPG highway estimate\*. No other American-built standard pickup has ever achieved such a mileage rating. Plus Ford has the longest estimated range of any 1980 pickup.

Tough '80 Fords give you more payload capacity than last year's models with comparable GVWR's. An all-new cab. Exclusive Twin-I-Beam front suspension. Aerodynamic styling. And more.

See all the new 1980 pickups at your Ford Dealer. New 4x4's with Twin-Traction Beam independent front suspension. Rugged new Six-Wheeler. Roomy new SuperCab.



**All-new cab interior.** More leg room than last year. New instrument panel. New anti-theft features like locking steering column, inside hood release. New options include AM/FM stereo with 8-track or cassette player, underhood tool box.

**BEST GAS MILEAGE RATING**  
of any American-built  
standard pickup

**19** EPA  
EST. MPG\*    **29** EST.  
HWY. MPG\*

Standard 4.9L (300 CID) Six with optional overdrive transmission.

**LONGEST RANGE**

**722**    **1,102**  
EST. MILES    HWY. MILES

Std. 72L (19-gal.) tank plus opt. 72L (19-gal.) auxiliary tank (on LWB Style-sides only). Total: 144L (38 gals.).

\*EPA estimates. Compare these estimates with others. Your mileage and range may differ depending on speed, distance and weather. Actual highway mileage and range will probably be less than estimated. California estimates lower. Diesels and car-trucks excluded.



**Ford pickups. America's best sellers of the 70's.** (based on R. L. Polk & Co. registrations)

**FORD**

FORD DIVISION





**LOOKING FOR  
THAT ONE BIG  
OPPORTUNITY?**

**NTS  
OFFERS YOU  
FOUR.**





NTS/HEATH H-89 Microcomputer

Now, more than ever, it makes sense to build new skills and cash in on them. NTS gives you that opportunity—with solid training and exciting equipment to train on.

NTS's special Project Method of instruction helps you quickly acquire practical know-how in these exciting fields:

**ELECTRONICS** We prepare you for the

booming micro-processor field by having you work with your own micro-computer at home. You'll not only learn how to



troubleshoot it, but how to program it to do what you want.

Or, work with your own



digital color TV or 2-meter FM transceiver in other courses.

Whichever of our 14 electronics programs you choose, count on working with the most exciting and innovative equipment offered by any home study school.

**HOME APPLIANCES** Excellent full or

part time income possibilities. Course covers repair and servicing of washers, dryers, ranges and small appliances. You'll work with top testing gear.

# ACT NOW TO DEVELOP YOUR POTENTIAL...WE GIVE YOU FOUR EXCITING WAYS TO DO IT, WITH EQUIPMENT AND TRAINING THAT MAKE HOME STUDY COME ALIVE!

**AIR CONDITIONING/HEATING** Prepare for one of the most essential industries in the world. Learn how to service commercial, industrial and residential heating and cooling equipment. We provide excellent specialized equipment while you learn.

**AUTO MECHANICS** Few technical fields can offer all the opportunities that the auto industry can. We offer "shop tested" instruction plus an impressive array of equipment, including a solid-state automotive oscilloscope. Learn engine diagnosis, motor overhaul and much more.



**ACT NOW! SEND FOR OUR FREE COLOR CATALOG ON THE OPPORTUNITY OF YOUR CHOICE - TODAY!**

## NATIONAL TECHNICAL SCHOOLS

TECHNICAL-TRADE TRAINING SINCE 1905  
Resident and Home-Study Schools  
4000 South Figueroa St., Los Angeles, Calif. 90037

**NO OBLIGATION. NO SALESMAN WILL CALL.  
APPROVED FOR VETERAN TRAINING.**

**NATIONAL TECHNICAL SCHOOLS** Dept. 201-020  
4000 South Figueroa Street, Los Angeles, CA 90037

Please send FREE color catalog

<input type="checkbox"/> MicroComputers/MicroProcessors	<input type="checkbox"/> Audio Electronics
<input type="checkbox"/> Communications Electronics	<input type="checkbox"/> Auto Mechanics
<input type="checkbox"/> Digital Electronics	<input type="checkbox"/> Air Conditioning
<input type="checkbox"/> Color TV Servicing	<input type="checkbox"/> Home Appliances

Name \_\_\_\_\_ Age \_\_\_\_\_

Address \_\_\_\_\_

Apt. \_\_\_\_\_ City \_\_\_\_\_

State \_\_\_\_\_ Zip \_\_\_\_\_

Check if interested in G.I. information.  
 Check if interested ONLY in classroom training in Los Angeles.





Dual CS521

Realistic  
Lab 500Realistic  
Lab 55Pioneer  
PL-630Eumig  
MetropolitanPioneer  
RT-707Realistic  
Lab 49

Dual 819

# What to look for in new direct-drive audio gear

The secrets of direct-drive turntables and cassette decks are simple to unravel. Understanding them can help you to choose your next turntable or deck.

by Art Zuckerman

**S**omething wonderful has been happening to turntables. They have been shedding most of their audio problems. Speed irregularities are being banished and so is the low, rumbling noise that's known,

appropriately enough, as rumble.

Audio engineers have been chipping away at these problems for many years. But now they have achieved new standards of excellence with a superior drive system. It is called direct drive, and in a relatively short time it has become dominant at the top end of most

turntable product lines. It has even made incursions into the medium- to lower-price ranges—and into cassette and open-reel decks.

Direct drive is just what its name suggests—a motor that operates at precisely the selected playing speed and drives the turntable directly. Conventional phonograph motors have always operated at speeds enormously higher than that of turntable rotation—1800 rpm versus 33½ rpm. At this great speed, a

*(Please turn to page 22)*



# Friendly Comparison



*Can JS&A offer a better telephone answering unit than the first one we introduced? Here's the story of American competition at its finest.*

We've seen them all. Every telephone answering unit has its advantages and disadvantages.

So when JS&A selected our first telephone answering unit three years ago and called it the best remote system available, it soon became one of the most popular units on the market. Since 1976, JS&A has sold thousands of them.

## SERIOUS COMPETITION

But that was three years ago. It finally took an enterprising company called Olympia to develop and introduce what we would call the first serious competition to our first telephone answerer.

So JS&A had a dilemma. Here we were, with an excellent relationship with a major supplier, and yet our reputation demands that we offer our customers only the most advanced products. Do we continue to carry both units, or do we break off relations completely and introduce a competitive model? To make the decision more difficult, you first have to understand the new technology in the Olympia unit.

## A FAIR COMPARISON

The Olympia Master Telephone Recorder is a microprocessor-based system with a few features that make it a more advanced unit than the industry leader.

But to provide a fair comparison, there are a few disadvantages with the Olympia. The Olympia does not have a call counter that tells you at a glance how many calls you've received. And its outgoing announcement is not recorded as fast as with our first unit. But there are so many other features and advanced technology that the Olympia deserves your consideration.

## ERASE OR SAVE

Most remote units and the Olympia have remote pagers. When you want to retrieve your messages, simply hold the pager up to the telephone, press a button, and the telephone answering unit rewinds to the start of your first message and plays them back.

That's great. But there was a disadvantage to the others. After you listened to your messages, you could not rewind. If you wanted to rewind to the beginning of the tape, you had to call your unit a second time. That's only a slight problem if you're calling locally from a phone booth, but very costly when you're calling long distance. And if you don't call back right away and rewind, you have another problem. Later, you'll have to listen to all those messages you previously heard because the unit doesn't know where the old messages stop and the new ones start.

The new Olympia Master Recorder has solved that problem. You have a choice. You can either hang up after you've heard your

messages or you can rewind them to the beginning while you're on the phone.

## NO MESSAGE/LAST MESSAGE

Let's say you call in and there are no messages for you. The Olympia has a special beep tone that tells you the moment you call in that there is no message. Or let's say there are three messages waiting for you. After the three messages are played back, another beep tone signals you that you've finished your last message. There is no provision like this on any of the popularly priced units.

## YOUR OWN TAPE

The Olympia uses one commercially available cassette tape that will last a few years with normal use. Today's most popular unit uses a built-in tape that will last five years, and costs \$17 to replace. With the Olympia unit, you remove the old cassette and pop in the new one which shouldn't cost more than \$2.

## TAPE SPEED

It costs time and money to listen to your old messages and to rewind. So the Olympia not only improved the concept by giving you a choice, they also improved the tape rewind speed. Now, when you retrieve your calls, your rewind time is faster than many other systems and as fast as the system we formerly sold.

Not only is the Olympia faster, but it measures only 2 1/4" x 6" x 10" and weighs only 36 ounces. You can place your phone on top of the unit or next to it without cluttering your desk.

We could probably present reasons why the Olympia Master Recorder will pay for itself with just the time you save retrieving messages—but there's more.

## SINGLE SYSTEM

You record your outgoing announcement on one track of the cassette tape and you receive your incoming messages on the other side. This single cassette approach reduced the costs of the Olympia below those of the conventional recorders that required two separate record and playback systems. And like other units, when you play back your tape, you hear only your incoming messages—never the outgoing announcement.

To record an outgoing announcement, you simply press the record button and talk into a microphone supplied with the unit. The unit will record a 17 second outgoing announcement and a 30 second incoming message. Our previous unit records a 20 second outgoing announcement and a 30 second incoming message.

## AND THEN THERE'S VALUE

Our previous unit sold for \$269.95. The Olympia sells for only \$169.95—a \$100 savings before you even start to use the system.

But don't take our word for it. Order an Olympia from us on our 30-day telephone answering test. Personally see how quickly you can retrieve or rewind your messages without having to call in twice. See how this compact unit fits on your desk. And above all, note the quality and workmanship of this fine piece of equipment.

Then after 30 days of messages, decide if you want to keep your unit. If not, no problem. Just return your unit for a prompt and courteous refund including your \$3.50 postage and handling.

If you decide to keep it, great. You'll own the most advanced unit of its kind. The Olympia Master Recorder is sold exclusively by JS&A. We're America's largest single source of space-age products, and we have sold more telephone answering units than many of our competitors combined. We know the market.

## MULTI-NATIONAL CORPORATION

Olympia is a multi-national corporation with eight national factory service and service-by-mail facilities—further assurance that your modest investment is well protected.

To order your Olympia, send a check for **\$169.95** plus \$3.50 postage and handling made payable to JS&A Group, Inc. (Illinois residents add 5% sales tax.) Credit card buyers may call our toll-free number below. We'll send your unit complete with recording microphone, one cassette tape, remote pager, AC adapter, instructions, and a 90-day limited warranty—everything you'll need for your 30-day test.

When we realized that the Olympia was the unit we should market, we called our previous supplier and told them of our decision.

In today's changing times, technology does not stand still. Despite our excellent relationship with our previous supplier, we felt it our obligation to introduce today's most advanced products—even at the risk of losing a valuable supplier.

If you're considering a new telephone answering unit, we can't recommend a better system than the Olympia Master Recorder. Why not order one at no obligation today?

**JS&A** PRODUCTS  
THAT THINK

Dept. PM One JS&A Plaza  
Northbrook, Ill. 60062 (312) 564-7000  
Call TOLL-FREE ..... 800 323-6400  
In Illinois Call ..... (312) 564-7000

©JS&A Group, Inc., 1979

FEBRUARY 1980 21

Материал, защищенный авторским правом



## NEW DIRECT-DRIVE AUDIO GEAR

(Continued from page 20)

motor generates vibrations of 30 hertz (Hz) and its multiples or harmonics. Power from the motor is transmitted to the turntable by a mechanical linkage, which may also transmit some of the 30 Hz/harmonic vibration to the pickup to create audible rumble.

Because direct-drive motors oper-

pulley diameter to rim diameter.

The belt acts like a filter, absorbing most of the low-frequency motor vibrations instead of transmitting them. As long as proper tension is maintained, a good belt won't create speed irregularities until it finally wears out.

Until just a few years ago, belt drives were employed in all higher-quality turntables. The introduction of good servomotors with effective

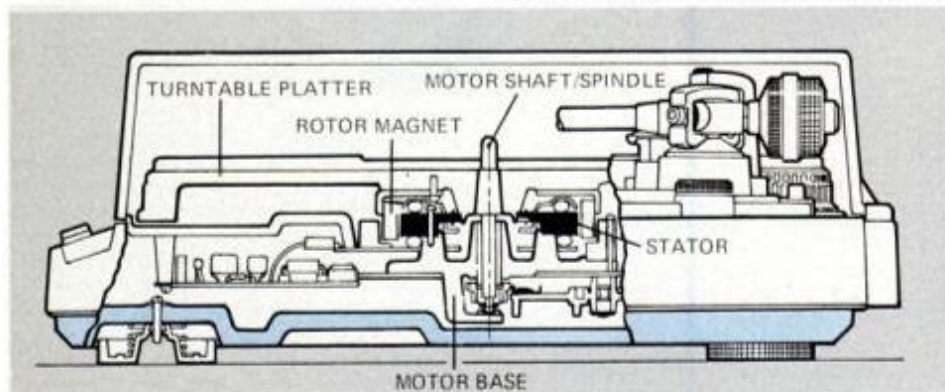

Technics makes its turntables so that the direct-drive motor is a part of the platter.

ate at speeds of no more than 45 rpm or, at most, 78 rpm, the vibrations they generate are at such low frequency that they fall well into the inaudible, subsonic range. In effect, such motors generate no rumble whatsoever.

On the other hand, rumble is a particularly severe problem in lower-priced changers, where the transmission device is a puck-like rubber wheel called an idler pulley. In operation, it presses against both the motor pulley and the inner rim of the turntable.

The motor pulley is mounted on the motor shaft, and along its length it has two or three different diameters, depending on number of speeds at which the changer is designed to operate. Positioning the idler wheel against one of these diameters establishes operating speed.

Because the idler wheel is a solid piece of material, it tends to transmit rumble-causing vibrations. If it is the least bit out of round, it will also create flutter-like speed variations. Leaving the idler wheel engaged when the power is off leads to this condition by creating flat spots on the idler at the points of stationary contact.

### From belts to direct drive

A far superior linkage is the belt drive, in which a precision-ground belt goes around either the rim or a special flange on the bottom of the turntable and also around the motor pulley. In this system, too, speed is usually changed by moving the belt from one diameter on the motor pulley to another, changing the ratio of

feedback-control systems began to change all that. The speed of such motors is controlled directly by electrical signals. Some form of reference signal for the chosen playing speed is provided, and the actual speed of the motor or platter is sensed in some way. The sensing circuit also generates a signal that varies indirect proportion to speed changes. This signal is compared with the reference. Any deviation between the two creates a difference signal, which is fed back to the motor to alter its speed.

A direct-drive turntable is not necessarily free of problems. Much depends on how it is engineered. If a speed variation is allowed to become too great before the system responds, the corrective action can lag far enough behind the problem to make it audible. Another problem is cogging, caused when the poles of the motor are spaced so far apart

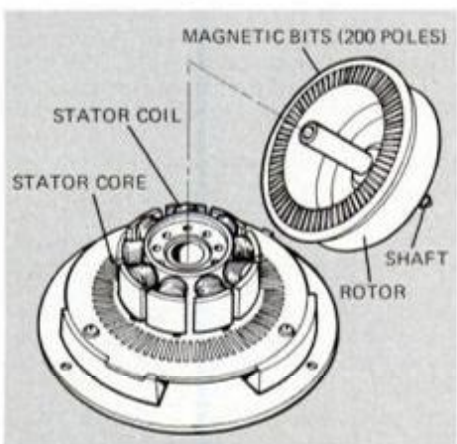

Magnetic bits on rotor are sensed to detect the speed of Pioneer table.



In the belt-drive turntables, moving the belt from one diameter of the pulley to another changes its speed.

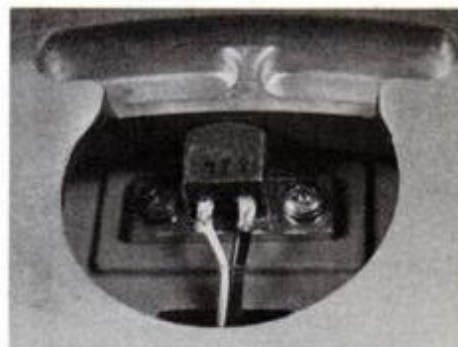

Denon's direct-drive turntables use a recording-style head to sense the speed of the platter.

that they impart a pulsing action, or flutter, to the turntable.

Almost universally, a heavy turntable is still a major defense against minor speed variations because its inertia tends to smooth out such variations. Better turntables also usually have high-torque motors that are more responsive to correction signals.

### Ideas in the field

There are a variety of approaches to speed-sensing systems. JVC offers what it calls a super servo frequency generator, an integral part of the servomotor assembly. It consists of a magnetic disc with either 90 or 180 slits around its periphery. The disc faces a round circuit board with an equal number of printed coil elements. As the disc rotates with the motor shaft, pulses are generated in the coils. According to JVC, the output of all the coils are integrated and averaged to create a wave form with constant pitch.

Many of Pioneer's direct-drive turntable motors have a rotor faced with 200 magnetic bits. A facing plate around the stator core of the motor has a matching array of 200 elements that detect magnetic fields and react to them by pulsing. As it rotates, the elements pulse a signal proportional to motor speed.

Magnetic detection is also employed in Denon turntables, but in this case the magnetic patterns are recorded on the inner rim of the

(Please turn to page 24)



# Bone Fone<sup>TM</sup>

*A new concept in sound technology may revolutionize the way we listen to stereo music.*

*The Bone Fone surrounds your entire body with a sound almost impossible to imagine.*



You're standing in an open field. Suddenly there's music from all directions. Your bones resonate as if you're listening to beautiful stereo music in front of a powerful home stereo system.

But there's no radio in sight and nobody else hears what you do. It's an unbelievable experience that will send chills through your body when you first hear it.

#### AROUND YOU

And nobody will know you're listening to a stereo. The entire sound system is actually draped around you like a scarf and can be hidden under a jacket or worn over clothes.

The Bone Fone is actually an AM/FM stereo multiplex radio with its speakers located near your ears. When you tune in a stereo station, you get the same stereo separation you'd expect from earphones but without the bulk and inconvenience. And you also get something you won't expect.

#### INNER EAR BONES

The sound will also resonate through your bones—all the way to the sensitive bones of your inner ear. It's like feeling the vibrations of a powerful stereo system or sitting in the first row listening to a symphony orchestra—it's breathtaking.

Now you can listen to beautiful stereo music everywhere—not just in your living room. Imagine walking your dog to beautiful stereo music or roller skating to a strong disco beat.

You can ride a bicycle or motorcycle, jog and even do headstands—the Bone Fone stays on no matter what the activity. The Bone Fone stereo brings beautiful music and convenience to every indoor and outdoor activity without disturbing those around you and without anything covering your ear.

#### SKI INVENTION

The Bone Fone was invented by an engineer who liked to ski. Every time he took a long lift ride, he noticed other skiers carrying transistor radios and cassette players and wondered if there was a better way to keep your hands free and listen to stereo music.

So he invented the Bone Fone stereo. When he put it around his neck, he couldn't believe his ears. He was not only hearing the music

and stereo separation, but the sound was resonating through his bones giving him the sensation of standing in front of a powerful stereo system.

#### AWARDED PATENT

The inventor took his invention to a friend who also tried it on. His friend couldn't believe what he heard and at first thought someone was playing a trick on him.

The inventor was awarded a patent for his idea and brought it to JS&A. We took the idea and our engineers produced a very sensitive yet powerful AM/FM multiplex radio called the Bone Fone.

The entire battery-powered system is self-contained and uses four integrated circuits and two ceramic filters for high station selectivity. The Bone Fone weighs only 15 ounces, so when worn over your shoulders, the weight is not even a factor.

#### BUILT TO TAKE IT

The Bone Fone was built to take abuse. The large 70 millimeter speakers are protected in flexible water and crush resistant cases. The case that houses the radio itself is made of rugged ABS plastic with a special reinforcement system. We knew that the Bone Fone stereo may take a great deal of abuse so we designed it with the quality needed to withstand the worst treatment.

The Bone Fone stereo is covered with a sleeve made of Lycra Spandex—the same material used to make expensive swim suits, so it's easily washable. You simply remove the sleeve, dip it in soapy water, rinse and let the sleeve dry. It's just that easy. The entire system is also protected against damage from moisture and sweat making it ideal for jogging or bicycling.

The sleeve comes in brilliant Bone Fone blue—a color designed especially for the system. An optional set of four sleeves in orange, red, green and black is also available for \$10. You can design your own sleeve using the pattern supplied free with the optional kit.

#### YOUR OWN SPACE

Several people could be in a car, each tuned to his own program or bring the Bone Fone to a ball game for the play by play. Cyclists,

joggers, roller skaters, sports fans, golfers, housewives, executives—everybody can find a use for the Bone Fone. It's the perfect gift.

Why not order one on our free trial program and let your entire family try it out? Use it outdoors, while you drive, at ball games or while you golf, jog or walk the dog. But most important—compare the Bone Fone with your expensive home stereo system. Only then will you fully appreciate the major breakthrough this product represents.

#### GET ONE SOON

To order your Bone Fone, simply send your check or money order for **\$69.95** plus \$2.50 postage and handling to the address shown below. (Illinois residents add 5% sales tax.) Credit card buyers may call our toll-free number below. Add \$10 if you wish to also receive the accessory pack of four additional sleeves.

We'll send you the entire Bone Fone stereo complete with four AA cell batteries, instructions, and 90-day limited warranty including our prompt service-by-mail address.

When you receive your unit, use it for two weeks. Take it with you to work, or wear it in your car. Take walks with it, ride your bicycle or roller skate with it. Let your friends try it out. If after our two-week free trial, you do not feel that the Bone Fone is the incredible stereo experience we've described, return it for a prompt and courteous refund, including your \$2.50 postage and handling. You can't lose and you'll be the first to discover the greatest new space-age audio product of the year.

Discover the freedom, enjoyment, and quality of the first major breakthrough in portable entertainment since the transistor radio. Order a Bone Fone stereo at no obligation, today. \*Pending FCC approval.

**JS&A** PRODUCTS  
THAT THINK<sup>®</sup>

Dept. PM One JS&A Plaza  
Northbrook, Ill. 60062 (312) 564-7000  
Call TOLL-FREE ..... 800 323-6400  
In Illinois Call ..... (312) 564-7000  
©JS&A Group, Inc., 1979



TO COMPLETE  
YOUR WORKSHOP  
**ATLAS  
BANDSAW**  
IT'S CONVERTIBLE



NOW  
ONLY

**\$235<sup>00</sup>**

plus \$30 handling and shipping

**The Atlas Band Saw** • Handles cut-off operations in a wide range of metals — from steel and iron, to aluminum, brass and copper • Comes complete with 1/2 hp, 1725 rpm motor • Takes any shape stock — bar, flat, square, hex, tubing structural shapes, and cuts it at any angle from 90° to 45°. Max. capacity is 4" x 6" • 3-speed V-belt and worm gear drive offers speeds of 90, 155, 250 rpm • Swiveling rapid approach/release type vise allows fast set ups. Set desired cut, and spring control feeds blade at proper speed for smooth, fast cuts • Has stock stop for repeat cutting • Converts to vertical position for contouring, notching, slitting, and other operations in metal or wood. Length 41", height 37", width 16 1/2". Extends to 43" length, 47 3/4" height in vertical position.

**ATLAS BANDSAW**

Mail To: ATLAS PRESS COMPANY, Dept. 145  
2019 N. Pitcher, Kalamazoo, MI 49007

Please send me the Atlas Band Saw (Model 4359).  
Enclosed is my check or money order for \$265.00.  
(Includes shipping and handling) or charge my order to:  
 VISA  Master Charge

Acct. # \_\_\_\_\_ Exp. Date \_\_\_\_\_

Name \_\_\_\_\_

Address \_\_\_\_\_

City/State/Zip \_\_\_\_\_

Send FREE Atlas Power and Hand Tool Catalog.

Michigan residents add 4% sales tax.

Available continental U.S.A. only.

Price subject to change without notice.

WHAT TO LOOK FOR IN NEW DIRECT-DRIVE AUDIO GEAR

(Continued from page 22)

turntable platter. There are 1000 such recorded pulses, and they are read by a magnetic head identical to those in tape recorders.

A totally different approach to a control-frequency generator is taken in Sansui's SR 929 turntable.

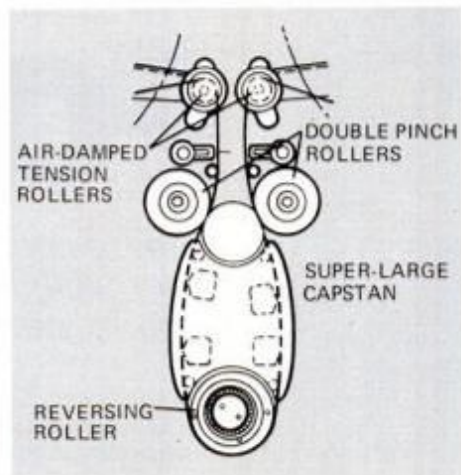

Technics' isolated-loop system uses single capstan to drive tape at two points.

Here, infrared light-emitting diodes (LEDs) cause a photo transistor to pulse as the drive motor turns.

Fisher's direct-drive turntables use the more customary magnetic-detection approach, but in a very unorthodox linear motor. The turntable platter is part of the motor. Attached to the platter's inner flange is a continuous band of ferrite material oriented into 120 magnetic poles.

Mounted atop the turntable base is a ring of matching electromagnetic drivers that alternately attract and repel the poles, causing rotation. Sensing coils arranged in a ring concentric with the drivers detect the revolving magnetic patterns as the flange goes by and generate a signal.

Although more conventional in their motor design, Technics direct-drive turntables are constructed so that the rotor element is an integral part of the turntable platter. As in the Fisher design, there is only one moving part in the entire motor assembly.

Dual's direct-drive model GS 721 has a motor with two overlapping layers of eight coils each. This eliminates even the briefest pause between magnetic pulses.

At the top of virtually every line of direct-drive turntables today are quartz-controlled models. These use a quartz crystal precisely the way quartz watches do, to provide an almost absolute time reference.

Most direct-drive turntables have

speed-adjustment controls so that you can tune pitch to a play-along instrument or hand-tweak the speed. Conventional turntables have a separate strobe pattern for checking each speed. More sophisticated models have only one pattern because the strobe lamp itself adjusts its pulse to the reference frequency for the playing speed that is in use. Pioneer's PL-630 does away with the strobe altogether but substitutes a pitch meter. Several JVC models even have digital speed readouts.

Servomotors are also coming into increasing use in tape decks to drive their capstans, either via belt or direct drive. Several of the better open-reel machines, such as Pioneer's low-profile RT-700 series, which can be rack-mounted, have direct-drive capstans. The innovative "isolated-loop" series of Technics open-reel machines not only have direct drive but also quartz-locked feedback control.



State-of-the-art direct-drive is used in this Fisher Model MT6225 turntable using linear direct-drive.

But relatively few cassette decks have gone the direct-drive route yet. One that has is particularly unusual, the Eumig CCD, top-loading deck. It senses the speed of the capstan, which is an extension of the motor shaft, optically via a lightweight disc that is photo-etched with 2500 radii.

Technics, taking a more customary approach, has already marketed direct-drive, front-loading cassette decks with a quartz-locked control system. The company says that, until recently, motors that were sufficiently compact for use in a front-loading, direct-drive system simply weren't available.

It is probably safe to say, judging from trends in turntable design, that as more manufacturers learn to make such compact motors, direct drive will also become the standard in cassette-deck, top-of-the-line offerings.

FM



## U.S. Government Report:

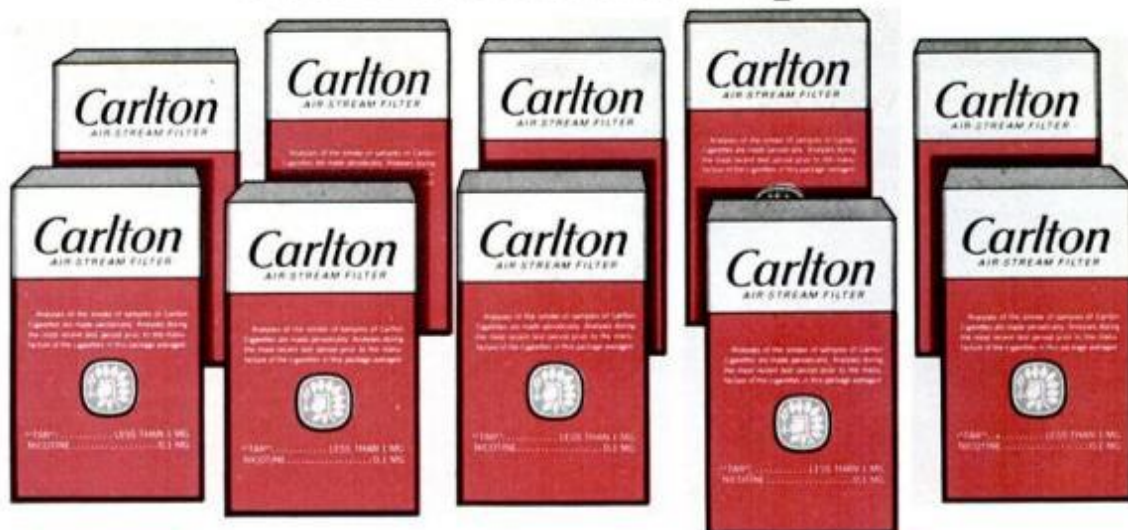

Box or menthol:

# Ten packs of Carlton have less tar than one pack of...

	Tar mg./cig.	Nicotine mg./cig.		Tar mg./cig.	Nicotine mg./cig.
Kent	12	0.9	Parliament Lights	9	0.6
Kool Milds	14	0.9	Salem Lights	10	0.8
Marlboro Lights	12	0.8	Vantage	11	0.8
Merit	8	0.6	Vantage Menthol	11	0.8
Merit Menthol	8	0.6	Winston Lights	13	0.9

# Carlton is lowest.

Less than 1 mg. tar,  
0.1 mg. nic.

Of all brands, lowest... Carlton Box: less than 0.5 mg. tar  
and 0.05 mg. nicotine av. per cigarette, FTC Report May '78.

Warning: The Surgeon General Has Determined  
That Cigarette Smoking Is Dangerous to Your Health.

Box: Less than 0.5 mg. "tar", 0.05 mg. nicotine;  
Soft Pack and Menthol: 1 mg. "tar", 0.1 mg.  
nicotine av. per cigarette, FTC Report May '78.



# NEW NOW for home and shop



**A** This  $\frac{3}{8}$ -in. variable-speed drill-screwdriver from Skil has a 0 to 250 rpm range for tough drilling and screw-driving, and a 0 to 750 rpm range for faster work. The tool shifts gears to deliver full power at either range, according to Skil. It also has a reversing switch and double-reduction gearing for added torque. The cordless drill runs on a rechargeable power pack. Model 2016 is \$100, including power pack and recharge unit. The manufacturer is Skil Corp., 4801 Peterson Ave., Chicago, Ill. 60646.

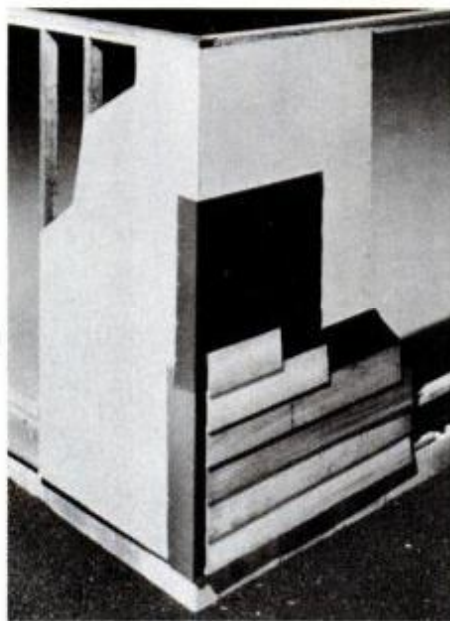

**B** Super 440 structural building board offers advantages as sheathing material. It eliminates the need for corner bracing or plywood at corners and provides twice the R-value insulation of wood, according to Homasote, its maker. Super 440 can also be used for carpet padding, porch ceilings, partitions and in other areas. It comes in  $\frac{1}{2}$ - and  $\frac{5}{8}$ -in. thicknesses, in 4-ft. widths and 8-, 9-, 10- and 12-ft. lengths. It's sold in lumberyards for 26 to 28 cents per sq. ft.; maker is Homasote Co., Box 7240, West Trenton, N.J. 08628.

**C** Kitchen range hoods custom-built of wood to match all styles of Quaker Maid kitchen cabinets are now available. The hoods feature a metal-lined interior with factory-equipped ventilating system and lights. The ventilator clears 300 cu. ft. of air per minute, according to the maker. A snap-out panel provides easy access for wiring and duct work on the installation. Hoods priced from \$780 will fit range areas from 30 to 60 in. wide in wall-mounted or island models. Quaker Maid, Rt. 61, Leesport, Pa. 19533.

**D** This full-size, playable harpsichord comes in a kit of precut wooden parts. It is a replica of a 1765 Baker Harris instrument. The harpsichord has five full octaves, measures  $2\frac{1}{2}$  x 6 ft. and weighs 100 lbs. The kit's preshaped parts are patterned after the parts on the original. Details of construction and decoration also closely follow those of the original. Harpsichord is priced from \$1200 for the basic precut kit to \$4200 for the built-up instrument. Frank Hubbard Inc., 185A Lyman St., Waltham, Mass. 02154.

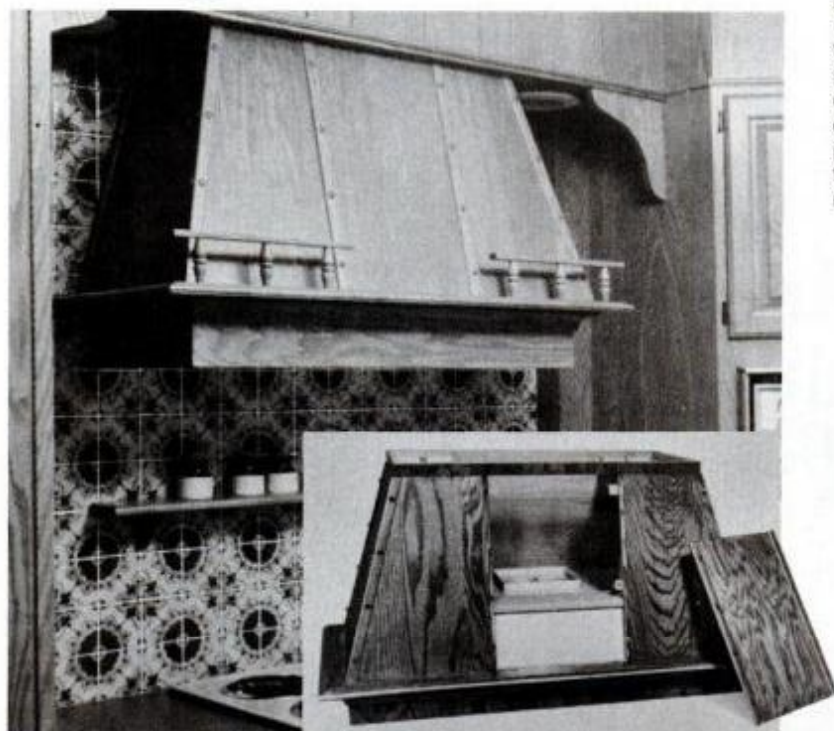



# Portable refrigeration price breakthrough!

## Last chance: \$134\*

**Solid State Refrigeration makes portable coolers as obsolete as grandma's kitchen ice box.**

The kindest thing you can say about ice boxes is they're better than nothing.

They fall down on the job in hot weather. They look more like swimming pools than refrigerators when the ice melts. And, every other day, you have to dig into your pocket to buy more ice. (If you can find it).

Koolatron's 12 volt portable refrigerators work on thermoelectrics, not ice. And maintain normal refrigeration temperatures.

So taking the Koolatron on your trip is like taking a small version of your home refrigerator. Everything — and everybody — stays cool.

### USES AEROSPACE REFRIGERATION MODULES

The Koolatron portable cools your food electronically with solid state thermoelectric refrigeration modules. These same powerful modules are used by military and aerospace scientists to cool critical components in rockets and satellites. They use thermoelectric cooling because of its *absolute reliability, insensitivity to motion or level, small size & weight and minimal battery drain.*

### WHY IS THE KOOLATRON PORTABLE SO MUCH BETTER THAN AN ICE CHEST?

An ice chest maintains an air temperature of 50-60 deg. F. Meat and milk spoil rapidly at temperatures above 50 deg. F. which is why the top of your meat will go bad even when it is sitting on ice. Koolatron portables maintain normal home refrigeration temperatures of 40-45 deg. F. even in 95 deg. F. weather.

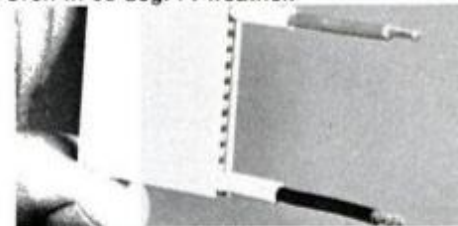

Two of these miniaturized thermoelectric modules replace all the bulky complex piping coils, compressors and motors in conventional portable refrigerators. The modules pump heat from your food into efficient heat sinks where it is dissipated by a quiet fan. They operate on a principal called the "Peltier Effect" — passing electricity through the junction of dissimilar metals causes heat to flow away from the junction.

### BOATING, FISHING, CAMPING, HUNTING

Fits into virtually any boat, van or camper. Carry it on the back seat during car trips. Ideal for fishing and hunting — bring your catch back home fresh (a few loads of fish fillets could pay for your portable). Use it for grocery shopping, medicines, carrying film, salesmen's samples. Take it to the drive-in movies, auto races and other sporting events. With an inexpensive battery charger you can use your

Koolatron as a bar fridge all winter and a patio fridge in the summer. Run it in your motel room at night and enjoy a midnight snack whenever you feel like it. We have customers using our portables on construction sites, in workboats, laboratories and even in locker rooms for a "cold one" after the game.

### THE ULTIMATE PORTABLE REFRIGERATOR

It weighs less than most coolers with a block of ice but holds over 40 lbs. of food or 48 pop cans in its large 36 qt. capacity. Plug it in a lighter socket in your car, boat or van or operate it from a 12 volt battery charger plugged into 110 volts. Cold contents will stay cold overnight with unit off. Draws a maximum of 4 amps., averages about 2 amps. at 70 deg. F. with the thermostat on. Keeps your food cold and dry. Exterior dimensions are 21"L x 16"W x 16"H. Interior dimensions are 16"L x 11-1/2"W x 12"H.

### BUILT-IN QUALITY AND DURABILITY

The rugged "ABS" case is filled with the best insulation available — rigid urethane foam. It has a "150 lb. test" handle and non-rusting polypropylene hinge and latches, with stainless steel fasteners. Your portable comes with a 9 ft. detachable cord which plugs into your cigarette lighter. It also has terminals for attaching wires directly from a battery or fuse panel. The same terminals are used for your battery charger clips when operating from a charger. A reverse polarity warning light & buzzer are included. Because of Koolatron's solid state construction your unit should never require any servicing unless physically damaged. If service is ever required, it is available through our service depots in Batavia, NY, or Barrie, Ont., Canada.

### GUARANTEE, 21-DAY MONEY-BACK TRIAL PERIOD

Your Koolatron comes with a written 1 year guarantee plus complete instructions and helpful information about batteries and chargers. If for any reason you are not totally satisfied, return it for a prompt refund in full.



### PAYS FOR ITSELF

If you are regularly using ice, your Koolatron portable will pay for itself with the money you save on ice, spoiled food,



**\*\$25 off-season saving ends with this ad.**

*The Koolatron portable keeps over 40 lbs. of food at household refrigeration temperature but weighs only 15 lbs. Only 21" x 16" x 16" ext. Model F1A shown.*

restaurant bills and the gasoline used looking for ice.

### SPECIAL OFF-SEASON DISCOUNT!

The Koolatron F1 has regularly been selling at \$159. (\$179 in Canada.) By ordering off-season you can save a full \$25 off these prices. You save! We keep our plant at an efficient operating level off-season! But you must order now.

### ADJUSTABLE THERMOSTAT OPTION

For an additional \$10.00 you can order the Koolatron portable with an adjustable thermostat in place of the standard fixed temperature thermostat — order Model F1A.

### OPTIONAL 110 VOLT ADAPTOR

This custom-made adaptor allows you to operate anywhere on 110 volt power... home, cottage, hotel, patio, pool, ... \$29.95 (\$34.95 in Canada) plus \$3 shipping. Special price if ordered with main unit only \$25.00 (\$30.00 in Canada). No shipping charges — save \$7.95.

Koolatron Industries Limited,  
56 Harvester Ave., Batavia, New York 14020

Phone your order in collect to

**705-737-0842**

Or use this handy order coupon.

<b>Koolatron INDUSTRIES LIMITED</b>	
56 Harvester Ave., Batavia, New York 14020	
Canada: 230 Bayview Drive, Barrie, Ontario L4N 4Y8	
Dept. 1048	
Send me ___ Koolatron F1 @ \$134.00	
(\$154.00 in Canada) + \$7.00 each for handling and delivery in USA or Canada (N.Y., Ont. and Que. residents add sales tax.)	
___ I want model F1A and have added \$10.00.	
___ I also want the power adaptor and have added \$25.00 (\$30.00 in Canada) shipping included. If I order separately it will be \$29.95 (\$34.95 in Canada) plus \$3 for shipping.	
I understand that I may return either item undamaged within 21 days and get a full refund if I am not satisfied. I enclose my <input type="checkbox"/> cheque	
<input type="checkbox"/> money order for \$___ or, please charge my	
<input type="checkbox"/> Visa <input type="checkbox"/> Mastercharge <input type="checkbox"/> American Express.	
Acct. No. _____	
Expiry Date _____ <input type="checkbox"/> Send brochure only	
Signature _____ (necessary to ship merchandise)	
Name _____	
Address _____	
City _____	
State _____ Zip _____	

P634

FEBRUARY 1980 27

Материал защищен авторскими правами



# DANDY DRAWERS

BUILD YOUR OWN STORAGE AND SAVE!!

**\$12.00**  
SPECIAL  
OFFER



MOLDED SLOTS  
FOR PARTITIONS



BUILT IN EASY  
SLIDER LIPS

ONE PIECE,  
INJECTION MOLDED,  
HIGH IMPACT, PLASTIC

MOLDED  
HANDLE

STACK

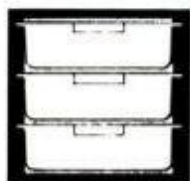

UNDER BENCH



Design and build your own custom storage with the easy sliding DANDY DRAWERS. Just cut slots (kerfs) in your standard 6", 8", 10" or 12" boards for the two drawer lips. Simple and fast.

Please send (check one or more), @ \$12.00 each. Selection:

- 4 Large DANDY DRAWERS (11" x 7-3/4" x 2-7/8")
- 6 Regular DANDY DRAWERS (9" x 5-3/4" x 2")
- 10 Small DANDY DRAWERS (7-3/16" x 4-7/16" x 1-1/2")
- 12 Dinky DANDY DRAWERS (5-3/16" x 3-3/16" x 1-1/8")

Color:  Red  Blue  Green  Yellow  Mixed

Enclosed is \$ \_\_\_\_\_ for \_\_\_\_\_ selections.

Cash  Check  Money Order. NO C.O.D.'s PLEASE.

Name \_\_\_\_\_

Address \_\_\_\_\_

City \_\_\_\_\_ State \_\_\_\_\_ Zip \_\_\_\_\_

All drawers shipped prepaid in continental USA. California residents add 6% sales tax.

Thousands in use in the kitchen, garage, camper, kid's room, industry, etc.

Dealer inquiries invited

BAUMBACH  
Engineering Co.  
640 National St.  
Mt. View, CA 94043

# New storm door lets your front door show

No longer do you have to hide your expensive, carefully chosen front door behind a storm door. The version shown (bottom photo) allows a picture-window view of your entry. It's available with a white, bronze, brown or black aluminum frame and clear, tempered safety glass. In standard front-door size—36x84 in.—it's priced at \$110.

For \$30 more, door also has PPG's Solargray tinted, tempered safety glass, shown, which cuts heat gain and brightness. Feather-Lite Manufacturing Co., 1210 East Maple St., Troy, Mich. 48099, makes it. **PM**



A handsome front door like this one is often hidden by a conventional storm door.



This storm door allows full view of expensive front door. Aluminum frame holds 30 x 70-in. panel of Solargray tinted glass.

# ARROW

presents

America's most **USEFUL** gift  
for the **Do-it-Yourselfer!**



No. T-50MP  
8-PIECE  
Multi-Purpose  
STAPLE GUN KIT

## SHOOT A STAPLE WHEREVER YOU'D DRIVE A NAIL!

You'll handle all of the 1,001 home fix-up fastening jobs faster, cheaper, better! It's a breeze: one *squeeze* and you've nailed it with Arrow's powerful T-50 Staple Gun! All steel construction, jam proof, lasting chrome finish. Uses six staple sizes.

No. T-50MP 8-PIECE MULTI-PURPOSE STAPLE GUN KIT includes Arrow's All-Purpose T-50 Heavy Duty Staple Gun plus all these extra accessories: slip-on Wiring Attachment; slip-on Screen Attachment; slip-on Shade Attachment; staple lifter; 1250 T-50 1/4" staples; 1250 T-50 1/2" staples; 1250 Ceatite staples. Complete with heavy duty molded storage case.

Sold at all leading Hardware, Home Center and Discount Department Stores everywhere.

ARROW FASTENER COMPANY, INC.  
271 Mayhill Street, Saddle Brook, N.J. 07662



## AND PERFORM.

This is a highly engineered chain saw for those people who are serious about woodcutting. The Stihl 028WB. A high performance, mid-size saw with all the design integrity of the big professional Stihl saws — which are the best-selling saws in the world! Like the pro saws, the 028WB is a saw you can count on to start right up, winter or summer, to run smoothly and handle easily. And to do the job you give it to do.



"With 15" bar and chain.

## AND PERFORM.

A combination of light weight, high-engine output and Anti-Vibration makes it one of the most versatile chain saws made. As well as one of the most advanced saws of its type, with features the competition can't touch. The 028WB is sure to turn in a first-class performance. Every time you use it. And at a manufacturer's suggested retail price of just **\$279.95\***. Get all the details on this great performer at your local Stihl dealer.

# THE 028 WB FROM STIHL. WATCH IT PERFORM.



# STIHL®

The World's Largest Selling Chain Saw.

\* Registered Trademark (pronounced "Steel") © Copyright 1979 Stihl Incorporated, Department 1076, 536 Viking Drive, Virginia Beach, Virginia 23452. For sales and service see the Yellow Pages under "saws."





## Irwin makes your 'Popular Mechanics' projects easier!

From furniture to a new family room, Irwin quality products can help!



You can easily bore holes up to 1½" with the Irwin Speedbor® "88". This is the wood bit that cuts clean, fast, accurately. Puts more boring power at the working end of your ¼" electric drill.

Irwin's exclusive hollow ground point has the power to start holes fast. Sharp spade type cutters power through any kind of wood (fast). ¼" shank chucks perfectly.

Every Irwin Speedbor "88" forged from solid bar of finest tool steel. Machine-sharpened. Heat tempered full length to last. 17 individual sizes, ¼" to 1½". Also sets of 4, 6 & 13 bits. Buy wherever fine hand tools are sold.



**Irwin workshop special**  
All metal rack & 6 bits, sizes ¼" to 1".

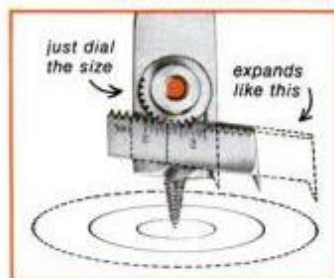

### Irwin Micro-Dial® bores 35 hole sizes

Just dial the size hole you want, up to 3 full inches. Taper square shank fits all hand braces. Machine-sharpened spur and cutters deliver clean, accurate boring action. No. 22 model (illustrated) combines 35 standard sizes in one precision-engineered wood bit, ⅝" to 3". No. 21 lets you dial 19 standard sizes, ⅝" to 1¾". Get an Irwin Micro-Dial soon.

### Irwin Screw Starter

Marks hole, starts hole, threads hole for screw to easily enter wood and non-metal materials. Handiest hand tool in years for housewife and handyman.

© Registered U.S. Patent Office

**IRWIN** every bit as good as the name  
at Wilmington, Ohio 45177, since 1885

## PM LOOKS AT HANDLE REPAIR KIT



Maul handle replacement (left) has fiberglass core and a molded polypropylene body for superior shock absorption. The unbreakable handle stops fracture from overstrike (above).

**A** new handle replacement system for hammers, sledges, hatchets, mauls and axes is good news for anyone who has ever tried fitting a wooden handle replacement. Mix epoxy glue in an unopened plastic pouch by working with fingers. Snip corner and squeeze glue like toothpaste into voids in tool's eye. No wedges are required. Kits are at hardware outlets from Decker Manufacturing Co., Keokuk, Iowa 52632. Prices are \$3.50 to \$10.—J.P.



Punch out broken handle from tool's eye; apply caulk to handle shoulder.

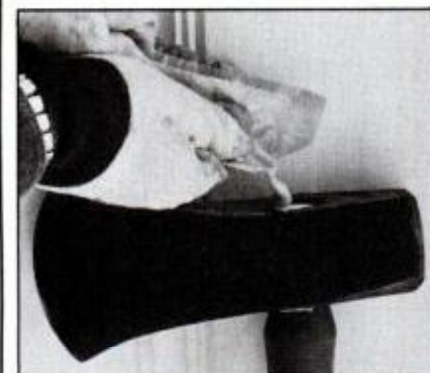

Lean tool against wall when pouring epoxy; drive a nail to support the head.

Turn a part-time hobby into big profits

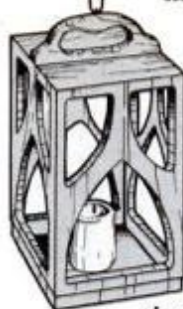

You'll pocket real profits making handsome coach lanterns like this ...and dozens of other popular wood gifts.

## NOW! Earn up to \$15 an hour making popular custom wood products

Now, a Free Information Kit tells how you can make \$5, \$10, even \$15 an hour or more spare-time in your own basement or workshop.

A patented, easy-to-use woodworking tool—the famous Shopsmith Bryco Router Arm—lets even beginners quickly turn out a big volume of beautiful wood products and gifts that sell themselves on sight, at handsome profits.

You'll have fun making and selling deep-etched custom signs for home or business, beautiful picture frames, decorator wall plaques, coach lanterns, serving trays, trinket chests, and dozens of other popular, fast-selling items. You can even start a money-making furniture repair and restoration business if you like. It's the perfect way to turn an enjoyable and satisfying hobby into extra cash while being your own boss! **FREE BUSINESS-ASSISTANCE PLAN**

Mail the no-obligation coupon below to receive, by mail, a Free Information Kit, "Your 'Rout' to Woodworking Profits," that tells you all about this profitable opportunity. We help you get started with a complete, thoroughly researched "Blueprint for Success" that includes advertising materials, project ideas and patterns, production aids... the "works". And, we'll help your business grow by sending you a constant flow of new project plans and business-building ideas.

Don't miss getting the free facts about this unusually good money-making opportunity! Mail the coupon today!

Mail to: Shopsmith Bryco Router Arm Div.  
Shopsmith, Inc., Dept. 1996  
750 Center Dr., Vandalia, OH 45377

### FREE FACTS KIT

SHOPSMITH, Dept. 1996  
750 Center Drive  
Vandalia, Ohio 45377

Please mail me your Free Information Kit, "Your 'Rout' to Woodworking Profits" that tells how I can make money in my spare time with the patented Shopsmith Bryco Woodworking Router Arm — including the details of your complete "Business Plan". I understand there's no obligation, and no salesman will visit.

Name \_\_\_\_\_

Address \_\_\_\_\_

City \_\_\_\_\_

State \_\_\_\_\_ Zip \_\_\_\_\_

Cabinetmakers and professional woodworkers inquiries welcome.



# It took me 30 YEARS to develop THE PERFECT PIPE... now you can smoke it FREE FOR 30 DAYS!

If you have searched, as I have, to find the perfect pipe, the one that smokes cool, sweet and clean from your very first puff, your search is over! Our newly patented AEROSPHERE Pipe Smoking System combines tiny internal chambers and proportioned fresh air to keep nicotine, tar and sludge from reaching your mouth, and eliminate tongue bite. It's the finest smoking pipe ever made. I can only prove it to you by letting you smoke it. That's why it's not sold in stores. They won't let you put a pipe in your mouth. But I will, for a 30-day free trial of pure smoking pleasure. It's good, or it costs you nothing.

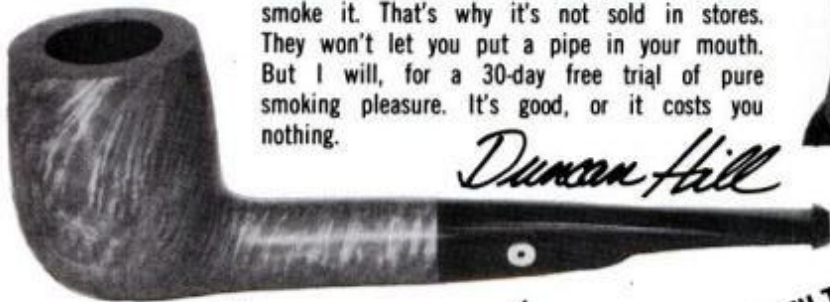
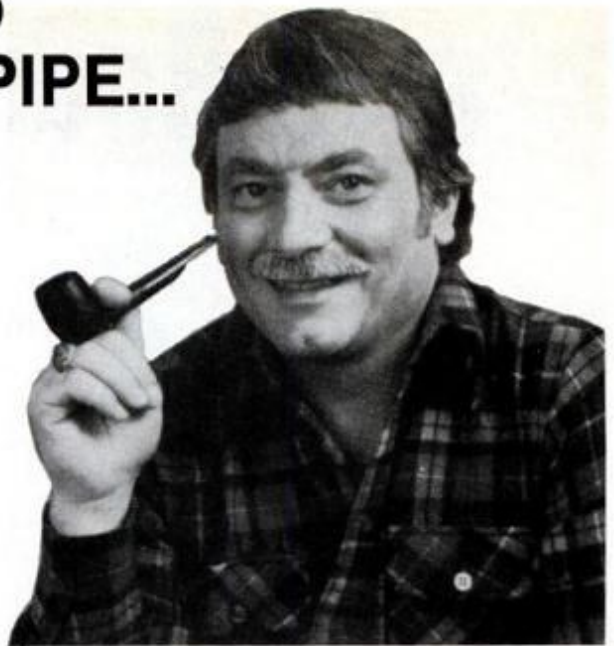

*Duncan Hill*

**NO BREAKING IN!**

**THE SECRET IS THE PATENTED AEROSPHERE CHAMBER!**

**NO FILTERS!  
NO INSERTS!**

To look at this handsome Algerian briar pipe with its unique tiny brass circle, you'd think it was just another of those good-looking pipes you've been buying, and trying, for years. You'd never guess that hidden within its bite-proof Ebonite stem is the secret that makes this the greatest smoking pipe you've ever had in your mouth.

## WHAT IS THE SECRET?

It's as old as science itself! Yes, the patented AEROSPHERE is an adaptation, in miniature, of scientific principles based on condensation and ventilation. Condensation, in the inner chamber of the AEROSPHERE, to trap moisture, tar and nicotine, plus a measured puff of air that draws the heat and bite away from your smoke. It sounds simple, but it's the result of intricate scientific achievement that you really can't believe until you light up my pipe in your mouth and take your first smooth, clean, mellow puff!

## COOL AND DRY, SMOKE AFTER SMOKE!

It's true, as often as you smoke your AEROSPHERE, pipeful after pipeful, from first to last. No breaking in, no tongue bite, no gurgling moisture! And all without inserts or filters or constant cleaning. You'll never know the true pleasure of

pipe smoking until you've tried the AEROSPHERE. And you'll find it the most comfortable pipe you've ever held in your mouth.

## PROVE IT YOURSELF WITH MY 30-DAY FREE TRIAL

It's the only way to learn that what I say is true. And if you think I'm taking a big risk in making such a PROVE-IT-YOURSELF FREE OFFER, I'm not! Because I know that once you try our pipe, and keep on smoking it for 30 days, you'll never want to be without it. This is the only way I've ever offered my AEROSPHERE pipe. It's the way so many smokers have finally found the perfect pipe they've always dreamed of smoking.

Do this right now. Mail the coupon. Send **no money**. Just your name and address. I'll send you a brochure showing our handsome, hand-fitted and hand-finished pipe styles so you can select the one you'd like to try. Then you can look forward to your 30 days of trying out my AEROSPHERE pipe and finding out how truly great pipe smoking can be. All without risking more than the stamp to mail this coupon. Do it today.

**DUNCAN HILL, LTD., Dept. 16B0  
70 West Drive  
Hartville, Ohio 44632**

## WE FOUND THE PERFECT PIPE WITH THE 30-DAY FREE TRIAL

"Many Thanks for sending me your Duncan Hill pipe. I work outside and I like to hunt and fish. For me a good pipe is necessary. No filters or inserts or things like that. Folks around here are about the same, too. They just want a good pipe to smoke. It's Duncan Hill for me!"

Robert R. Scales,  
Kokomo, Ind.

"Bravo! At last, I've found a pipe that's perfect. It's the quality of the Duncan Hill pipe that I like. All the other pipes I own, just sit and I reach for my Duncan Hill for pure quality of pipe smoking. My check is attached. Please send me another in smooth finished walnut."

John L. Gard,  
Mountain View, Cal.

"I've spent hundreds on imported pipes, as well as so-called 'cooled' pipes sold locally. Now, I don't even use them. You said I should smoke my Duncan Hill all the time, and that's the way it's turned out. Thanks for inventing the best pipe in the world."

Millard F. Crank-Landis,  
Boston, Mass.

"When I ordered my Duncan Hill pipe I just wanted a good smoke. It seemed to me that the Duncan Hill pipe was a better idea, and it is! You've really put a lot of thought into it. Your pipe is perfect. Thank you for the smoothest, coolest smoking pipe I've ever had."

William A. Young,  
Oak Brook, Ill.

## MAIL TODAY FOR 30-DAY FREE TRIAL

**Duncan Hill, Ltd., Dept. 16B0  
70 West Drive  
Hartville, Ohio 44632**

OK, Mr. Hill! Mail me your brochure so I can select the pipe style for my 30-day free trial.

Name \_\_\_\_\_

Address \_\_\_\_\_

City \_\_\_\_\_

State \_\_\_\_\_ zip \_\_\_\_\_



Yes!  
**TWO!**  
for all week  
and  
all weekend



# Working Man's Body Vest

THE "MACHO" COLD REMEDY

**2** for only **12<sup>95</sup>**

THAT'S RIGHT! 2 for 12<sup>95</sup>. The extra protection the active outdoor man needs! Whether you work hard or play hard, you've got to stay warm and comfortable. Haband's Body Vest is that protection!

### THREE LAYERS WARM!

- 100% textured nylon shell
- 100% nylon tricot lining
- 100% polyester fiberfill
- LARGE ARM HOLES
- 3 BIG POCKETS
- BIG HEFTY ZIPPER
- WASH and WEAR
- WATER REPELLANT



EXTRA  
LONG  
FULL  
BACK  
for  
KIDNEY  
WARMTH

### HABAND

A family business with 54 years experience in direct mail service! For fast, reliable service, please send your order to Duke Habernickel, Pres.

**HABAND COMPANY**  
265 N. 9th St., Paterson, NJ 07530

Gentlemen: Please send me \_\_\_\_\_ Body Vests for which I've enclosed \$ \_\_\_\_\_ plus \$.65 toward postage and handling.

Or To Charge It:  VISA  Master Charge

Exp. date \_\_\_\_/\_\_\_\_/\_\_\_\_ Acct. # \_\_\_\_\_

**GUARANTEE:** I understand that if upon receipt I do not choose to wear the vest(s) I may return them within 30 days for a full refund of every penny I paid Haband. 780-302

Name \_\_\_\_\_

Street \_\_\_\_\_

Apt. # \_\_\_\_\_

City/State \_\_\_\_\_

Zip \_\_\_\_\_

## Body Vests 2 for 12<sup>95</sup>

### AVAILABLE SIZES

S	M	L	XL	XXL*	XXXL*
34-36	38-40	42-44	46-48	50-52	54-56

\*Please add \$1 per vest for XXL & XXXL

COLOR	HOW MANY	WHAT SIZE
NAVY	a	
BROWN	b	
GREEN	c	

## 2nd MOST IMPORTANT TOOL FOR EVERY WOODWORKING SHOP...

VERSATILE  
**W&H**  
MOLDER-  
PLANER

Second only to a saw... molds, planes, rabbets.



FROM \$345

- Master Charge
- BankAmericard

SEND FOR FREE BROCHURE 2G

**WILLIAMS & HUSSEY MACHINE CORP.**  
Dept. 2E, Milford, New Hampshire 03055



### 12 V AIR COMPRESSOR — WITH BUILT-IN GAUGE...160 PSI

QUICK-AIR pumps air faster to higher pressure than other portable units. Plugs into veh. cigarette lighter socket. Built-in gauge shows pressure as you inflate tires, RV water systems, steel or rubber air shocks + other inflatables. Complete with 3' air hose, 15' power cord, on/off switch & 2 inflating adapters all in sturdy carry case. Money back guar. TO ORDER ITEM #101A send check or MO for \$49.95 + \$3.95 ship (CA res. add 6% tax) OR include VISA or M/C acct # & exp. date. Send to OMEGA, Dept. 81-PM, 733B Lee St., Des Plaines, IL 60016.

## HINTS FROM READERS

### Carbon transfers punch marks



When transferring hole positions from a pattern to wood, place carbon paper under the pattern, carbon side toward the wood, and use a punch or scriber. Sharpen the punch tip and tap it with a hammer. Pattern can be used many times; yet carbon will clearly transfer the marks.

—Walter E. Burton

### C-clamp is holder



A large C-clamp fastened between top and second steps of a stepladder provides a handy hanger for a hammer.

—Ken Patterson

### Carrying small drill bits



The only complaint I have with small bit cases is that bits fall out as case is opened. To stop this, embed bits in clay.—Frank Day





# Get in on the PROFITS in SMALL ENGINE service and repair Start your own money

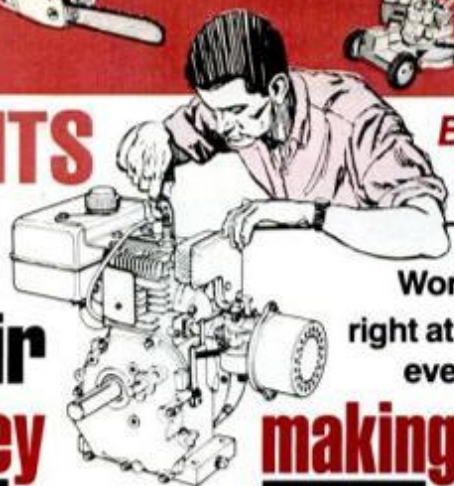

**BEAT INFLATION!**

Cash in on the huge demand for small engine repair.

Work part time, full time right at home - we help you every step of the way.

**making business!**

In just a short time, you can be ready to join one of the fastest growing industries in America...an industry where qualified men are making from \$10.00 to \$15.00 per hour...and that's just for labor. Parts, engines and accessories add even more to the profits.



Because the small engine industry has grown so quickly, an acute shortage of qualified Small Engine Professionals exists throughout the country. In fact, it's not unusual for a good small engine man to be three to four weeks behind in the summer and at least a week behind in the winter. When you see how many small engines are in use today, it's easy to understand why qualified men command such high prices—as much as \$17.50 for a simple tune-up that takes less than an hour!

## 46-million small engines are in service today!

That's right—there are over forty-six million 2-cycle and 4-cycle small engines in service across the U.S.A. That's the official count from the Engine Service Assn., and new engines are being built at a rate of one-million per month! With fully accredited and approved Belsaw training, you can soon have the skill and knowledge to make top money servicing these engines. Homeowners and businessmen will seek you out and pay you well to service and repair their lawnmowers, tillers, edgers, power rakes, garden tractors, chain saws, mini-bikes, go-carts, snowmobiles, generators, snowblowers, paint sprayers...the list is almost endless.



## No experience necessary.

You don't have to be a 'born mechanic' or need prior experience. If you can read, you can master this profitable trade right at home, in your sparetime, without missing a single paycheck. Lessons are fully illustrated—so clear you can't go wrong.

## You receive trade secrets and business plans

We guide you every step of the way, including tested and proven instructions on how to get business, what to charge, how to get free advertising, where to get supplies wholesale...all the "tricks of the trade"...all the inside facts you need to assure success right from the start.

### Increased Income

"I've had about 8 years experience repairing small engines... but repairs were only minor... until I started the Belsaw Course."



Walter H. Strick Campbell, California

With our famous 'learn-by-doing' training method, you get practical 'hands-on' experience with specialized tools and equipment that you'll receive with your training plus a brand-new 4HP engine—all yours to keep!

## SEND FOR FREE FACTS!

You risk nothing by accepting this offer to find out how Belsaw training can give you the skills you need to increase your income in a high-profit, recession-proof business of your own.

Just fill in and mail coupon below (or send postcard) to receive full information and details by return mail. **DO IT TODAY!**



**BELSAW INSTITUTE OF SMALL ENGINE REPAIR**  
510F Field Bldg., Kansas City, MO. 64111

**There is NO OBLIGATION and NO SALESMAN Will Call—ever!**

Send TODAY for this fact-filled **FREE BOOKLET!**



Tells how you quickly train to be your own boss in a profitable Sparetime or Fulltime business of your own PLUS complete details on our **10-Day NO RISK Trial Offer!**

BELSAW INSTITUTE, 510F FIELD BUILDING KANSAS CITY, MISSOURI 64111

YES, please send me the FREE booklet that gives full details about starting my own business in Small Engine Repair. I understand there is no obligation and that no salesman will call.

Name \_\_\_\_\_  
Address \_\_\_\_\_  
City \_\_\_\_\_  
State \_\_\_\_\_ Zip \_\_\_\_\_

Accredited Member National Home Study Council

You get all this Professional equipment with your course—and it's Yours to KEEP!



PLUS...  
**4 HORSEPOWER CLINTON ENGINE... YOURS TO KEEP!**



# World's First and Only Solar-Powered Watch\*

## Guaranteed to outperform any watch sold today... or it costs you nothing!

**The Sunwatch; acclaimed as the most accurate, most versatile, most rugged watch ever made.**

These features make all other watches obsolete:

- Clearly visible by day or night
- Natural side-view window simplifies reading
- 100% solar-powered, you never replace batteries
- No resetting of calendar, not even in leap years

#### Space age accuracy

Now you'll never worry about accuracy again. Because the Sunwatch will keep you on time for the rest of your life. (Accurate to within 1 sec. per month.)

#### Solar age efficiency

Miniature solar cells automatically convert sunlight, daylight or ordinary bulb light into usable energy for storage. The solar cells last virtually forever. So you'll never replace a watch battery again.

#### Programmed for over a century

The built-in computer on a chip will always display the correct time date and month. Also, it automatically adjusts the watch calendar for long and short months, leap years and it's programmed until the year 2100!

#### Easy to read

The natural side-view display lets you tell the time, day and date without twisting your arm into an uncomfortable position.

#### Numbers always visible

Four varying light intensities are built into the viewing display, allowing the Sunwatch to adjust automatically to any light. This means you can always read it, even in the brightest sunlight.

#### 10 Display functions

The Sunwatch is capable of displaying the following information: hours • minutes • seconds • months • date • day • leap year • speed calibration • AM/PM indicator • seconds count-off.

#### Extreme accuracy

Unlike other electronic watches using tuned crystals to control timing accuracy, the Sunwatch incorporates a unique, programmable, microcircuit synthesizer to make it the first watch in history that is accurate to less than 1 second per month. That's 5 times more accurate than the latest quartz Accutron.

#### The Power Source

Tiny silicon power cells, which are constantly being energized by natural sunlight, daylight or an ordinary light bulb keep the Sunwatch energy storage system charged. Should the watch not be exposed to light, it will continue to operate for months on stored power.

**The most indestructible watch in the world**  
The workings of the watch: solar panels, energy cells, quartz crystal, computer on a chip, etc., are all permanently sealed in a Lexan module. This module is so unique it's protected by U.S. and foreign patents.

#### Completely waterproof

Leave the Sunwatch in salt water for months. Dive with it in depths up to 750 feet. There are no openings — magnetic slide bars activate all functions. With Sunwatch's exclusive, permanently sealed Lexan module, there are no "O" rings or seals to leak.



#### Shock resistant to 25,000 G's

You can crash it into a rug-surfaced brick wall at 90 mph with no noticeable effect. Wear it while doing heavy work, exercise or any strenuous activity.

#### Temperature resistant

Put the Sunwatch in boiling water for 30 minutes, freeze it in a block of ice for a year. Extreme temperatures will not damage your Sunwatch.

#### Pressure resistant

There are no air spaces inside the Sunwatch. Therefore, it is not susceptible to high pressures such as might be encountered diving to great depths.

#### The perfect watch for a lifetime

Imagine split-second accuracy for the rest of your life. Sunwatch is a virtually indestructible, beautifully styled, space-age timepiece, and it's available in three exciting finishes: Brushed stainless steel, Gold plated stainless steel, or a Durable black finish on stainless steel. All Sunwatches come with a matching stainless steel band with removable links and adjustable clasp.

#### Made in the United States

The Sunwatch, designed by Roger Riehl, was being worn by its inventor nearly a year before the first electronic digital watch was even available to the general public. Since that time constant engineering evaluations and design improvements have been made on the Sunwatch to incorporate the latest in digital microcircuit and solar power technology. Thus the Sunwatch today represents state-of-the-art electronics technology. It is built to the same rigid standards practiced by the manufacturer in creating sophisticated computer micro for the U.S. Government and other major users of these components.

#### \* A word about other "Solar Watches"

Roger Riehl, designer of the Sunwatch, states that there is no other completely solar powered watch on the market today. Claims of solar power by other watch manufacturers are based on the use of a small solar cell. Due to their limited size, these cells can be proven, in technical terms, to be of virtually no significant value in extending the life of a watch battery. For this reason, all other so-called "solar watches" must have replaceable batteries. The Sunwatch's power storage system, however, need never be changed and is, in fact, permanently sealed to withstand abuse and the elements.

#### Unique and memorable gift

Available in a special gift box (see order form) the Sunwatch makes an ideal gift for special holidays, birthdays, graduation, Father's Day, etc. Perfect for business people, commuters, teachers, athletes and sportsmen, who require split second accuracy.

#### Free custom engraving

At your request, each Sunwatch will be hand-engraved with the name you specify.

#### Limited Warranty is your protection

The Sunwatch is covered by a 2 year limited warranty issued by Riehl Time Corporation (manufacturers of the prestigious Synchrona 2100) and included with your watch. A copy of the warranty may also be obtained free of charge by writing to Future Concepts, 41 Holiday Park Dr., Hauppauge, NY 11787. This warranty gives you specific legal rights, and you may also have other rights which vary from state to state.

#### 15 Day no risk trial offer

Order your Sunwatch today and use it for 15 days. Then, if you are not completely satisfied return it for full money back.

#### CREDIT CARD ORDERS CALL TOLL FREE 800-845-7252

N.Y. Residents Call Collect 516-822-4550

#### OR MAIL THIS NO RISK COUPON

**Future Concepts** 41 Holiday Park Drive  
Dept. 342  Hauppauge, New York 11787

#### Please send me:

- Brushed Stainless Steel Sunwatches at \$129.95 each
- Black Finish on Stainless Steel Sunwatches at \$159.95 each.
- Gold Plated Stainless Steel Case Sunwatches at \$179.95 each.
- 24 Hour (Military Time) \$10.00 Additional.
- Gift Boxes at \$4.95 each.

Please add \$3.95 per watch shipping and insurance.  
Enclosed is \$\_\_\_\_\_ Check or Money Order  
(N.Y. Residents add appropriate sales tax)

#### CHARGE IT: (Check One)

- American Express  VISA (BankAmericard)
- Master Charge  Diner's Club  Carte Blanche

Credit Card# \_\_\_\_\_ Bank# \_\_\_\_\_

Issue Date \_\_\_\_\_ Exp. Date \_\_\_\_\_

Signature \_\_\_\_\_

Name to be engraved \_\_\_\_\_

Name \_\_\_\_\_

Address \_\_\_\_\_

City/State/Zip \_\_\_\_\_



# How to find, service and replace your CAR'S SENSORS

by Mort Schultz

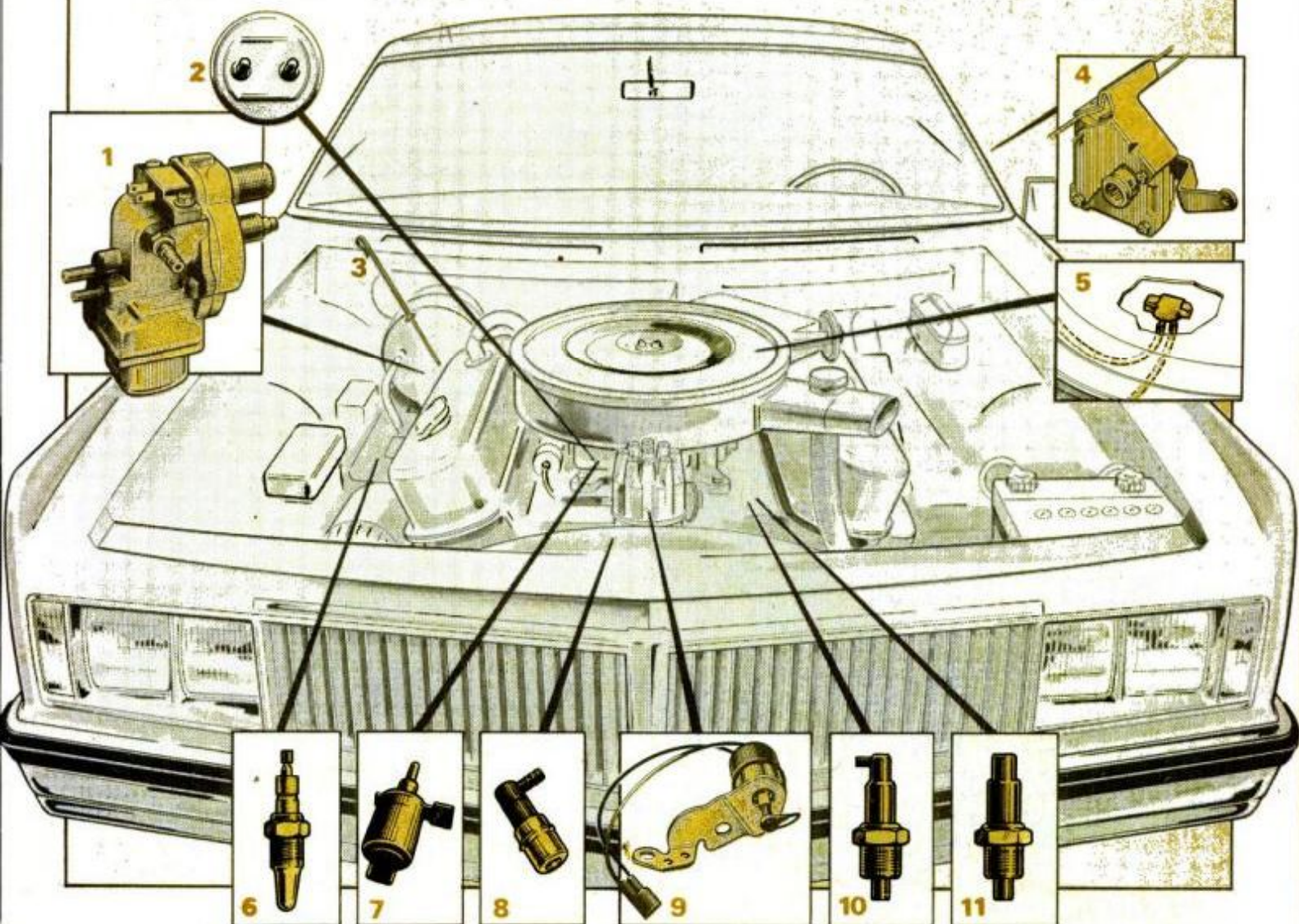

**1** Speed-control sensor in speedometer cable housing. **2** Carburetor-switch sensor. **3** Transmission-fluid-level sensor/dipstick. **4** Height sensor for level-control system on rear suspension. **5** Air-temperature sensor in air-cleaner. **6** Exhaust-gas oxygen sensor. **7** Throttle-positioner sensor. **8** Coolant-temperature sensor (in water-pump housing). **9** Start and run sensors in distributor. **10** Coolant-temperature sensing switch. **11** Oil-pressure sensing switch.

**D**epending on the make and model of your car, it has various sensors, each doing a particular job. How often have you given them a thought? If something goes wrong with a system a sensor serves, thinking "sensor" may help you avert time-consuming, frustrating trou-

bleshooting and, possibly, a needless repair. The cause of trouble is frequently a malfunctioning sensor.

## Engine-temperature monitor

Let me give you some examples of the problems you can avoid by thinking "sensor." Consider, first, the en-

gine-temperature sending switch.

This sensor is screwed into the engine to measure temperature. It transmits the "message" to a gauge to let you know when the engine overheats. The sensor does this by using a variable resistor, which can fluctuate in value as the tem-



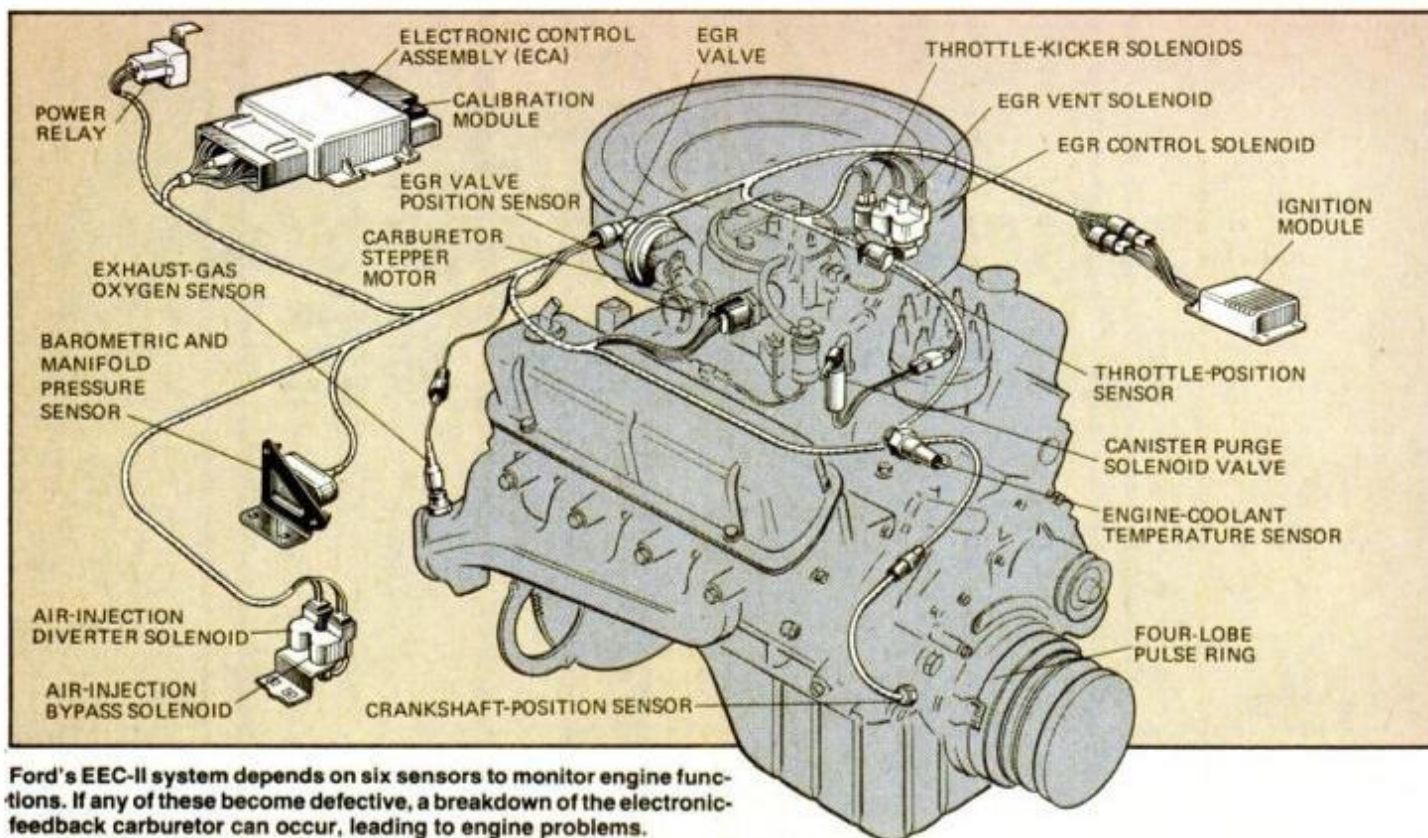

Ford's EEC-II system depends on six sensors to monitor engine functions. If any of these become defective, a breakdown of the electronic-feedback carburetor can occur, leading to engine problems.

perature increases and decreases.

When the engine is cold, the resistance of the sensor is high, which restricts electric current to the temperature gauge on the dashboard. This results in a low (or no) temperature indication. As the engine gets warm, the sensor resistance value decreases, and electric current is permitted to flow to the gauge. The temperature indicator needle rises.

Suppose, one day, the temperature indicator needle on the dash shoots up. Some people think the worst. They may even indiscriminately replace the radiator or water pump.

But the smart approach, instead, is to think "sensor" unless, of course, coolant is actually boiling over. If the engine isn't really overheating, the malfunction you're looking for is in the temperature-indicator circuit, quite probably with the temperature-sensing switch.

To test the switch, unscrew it from the engine and check resistance with an ohmmeter. (Many mechanics simply replace the sensor without testing. It's not an expensive part.) If the resistance reading isn't as specified in service data (usually 100 to 200 ohms, give or take a few), replace the sensor.

### Sensors affect engine

The engine-temperature sensing switches are simple to work with, but what about the sensors serving modern, highly complex automobile electronic systems—for example,

the exhaust-gas oxygen sensor of the electronic feedback carburetor system? The oxygen sensor is in the same ballpark as the engine-temperature sensing switch, except for one thing: If the oxygen sensor fails, it doesn't simply cause a gauge to show a malfunction. It disrupts the electronic-feedback carburetor system. Consequently, engine operation is affected and, as a result, the engine may:

- Detonate.
- Stall when cold or warm.
- Idle rough when cold or warm.
- Miss.
- Hesitate.
- Surge.
- Have poor gasoline mileage.
- Be hard to start when cold or warm.
- Emit an objectionable exhaust odor.

### Electronic-feedback carburetors

Few people now have electronic-feedback carburetors in their cars. The system is the newest one adopted by domestic carmakers to help meet the rigid clean-air standards for the 1980s. However, most cars will eventually have this system.

Credit for pioneering the electronic-feedback carburetor system here belongs to Volvo. The company applied the Bosch development to its 1977 California cars. In Volvos, it's used in conjunction with fuel injection and it's called Lambda-sond. Now, every American manufacturer has adopted a version of the system, which also requires use of a three-way catalyst.

Electronic-feedback carburetors started appearing on some U.S. models in 1979. Its use is more widespread on 1980 models. Next year, it will be standard on most models.

The development of electronic-feedback carburetors has resulted in new "letter-talk" used by manufacturers. Chrysler calls its unit EFC for Electronic-Feedback Car-

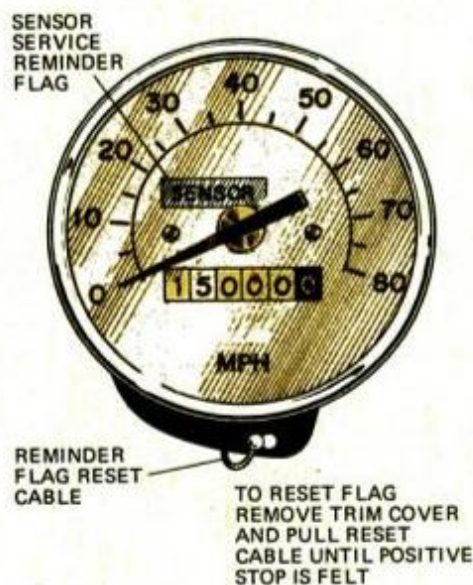

The exhaust-manifold oxygen sensor must function properly on cars equipped with the new, electronically controlled carburetors. Because of this, a warning light on the dash goes on after a specified number of miles, indicating a replacement for the sensor must be installed.



buretor. Ford calls its system EEC for Electronic Engine Control. The General Motors system is referred to as C-4, which shouldn't be confused with the Ford automatic transmission of the same name. The GM C-4 is taken from the four initial C's of Computer-Controlled Catalytic Converter. American Motors uses the Ford system on six-cylinder engines and the GM system on four-cylinder engines.

The purpose of the electronic-feedback carburetor is to keep the air/fuel mixture at a precise ratio. By keeping the ratio within narrow limits, the three polluting agents—hydrocarbons (HC), carbon monoxide (CO) and nitrogen oxides (NOx)—created when fuel is burned can be treated by a newly advanced catalytic system, known as a three-way catalyst.

The new catalytic system does a more effective job of controlling emissions than the older catalytic system. As the older converter does, the new one converts HC and CO to carbon dioxide (CO<sub>2</sub>, the same ingredient used in soda pop) and water vapor, but it also converts NOx into harmless nitrogen and oxygen, which the old converter doesn't do.

The older catalytic converter contains platinum or palladium and platinum. So does the new converter. But the new converter also contains rhodium, which does an effective job in breaking down NOx. Cou-

pled with the exhaust-gas recirculation (EGR) unit, the three-way catalytic converter is expected to remove, once and for all, NOx as a threat to the environment. (Incidentally, Chrysler and Ford use two catalytic converters, one to treat HC and CO and one to treat NOx. GM incorporates all functions into one converter.)

And what's at the heart of this sophisticated three-way catalytic system? A sensor, that's what—specifically, a sensor that measures the oxygen content of exhaust gas, compares it to the oxygen content of the atmospheric air and then transmits an electronic signal concerning this ratio to the carburetor control unit. Upon receiving the signal, the carburetor adjusts the air/fuel ratio to keep exhaust gases within the narrow bounds necessary for effective catalytic treatment of emissions.

As you can see by examining the illustrations of the EFC, EEC and C-4 systems accompanying this article, the oxygen sensor is not the only sensor these systems employ. A breakdown of any sensor can cause a breakdown of the electronic-feedback carburetor and lead to an engine problem.

### Testing oxygen sensors

Therefore, when something goes amiss, think "sensor." If the system has a sensor, or sensors, check it, or them, before making other repairs.

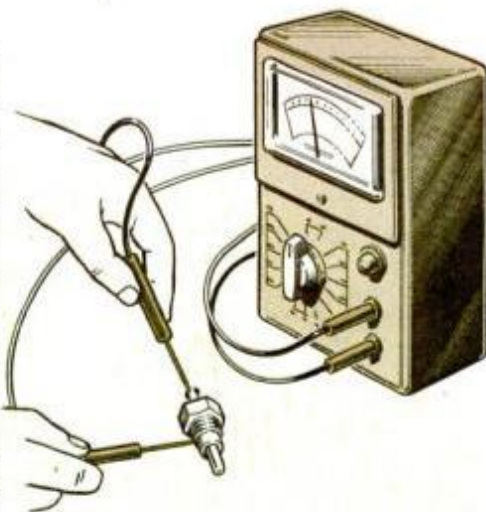

Ohmmeter is used to test sensors with electric resistance elements. The temperature-sensing switch, for example, usually has resistance of 100 to 200 ohms.

Testing the electronic-feedback carburetor sensors is within the expertise of advanced Saturday mechanics. However, you have to use specific testing procedures designated for your car model. Therefore, you need a service manual. Manufacturers of domestic cars are making manuals available for a reasonable charge.

To demonstrate the relative ease involved in testing a sensor, let's take as an example the Ford EEC exhaust-gas oxygen sensor. To test it, disconnect the wiring harness from the sensor.

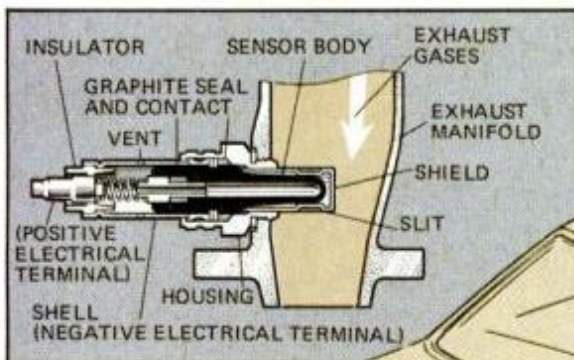

Chrysler's EFC system uses two catalytic converters (as does Ford's EEC): a regular oxidation catalyst controls HC and CO, a three-way catalyst controls NOx. Sensor (left) compares oxygen content of exhaust to that in atmosphere, signals electronic-feedback carburetor (below), insuring correct air/fuel ratio.

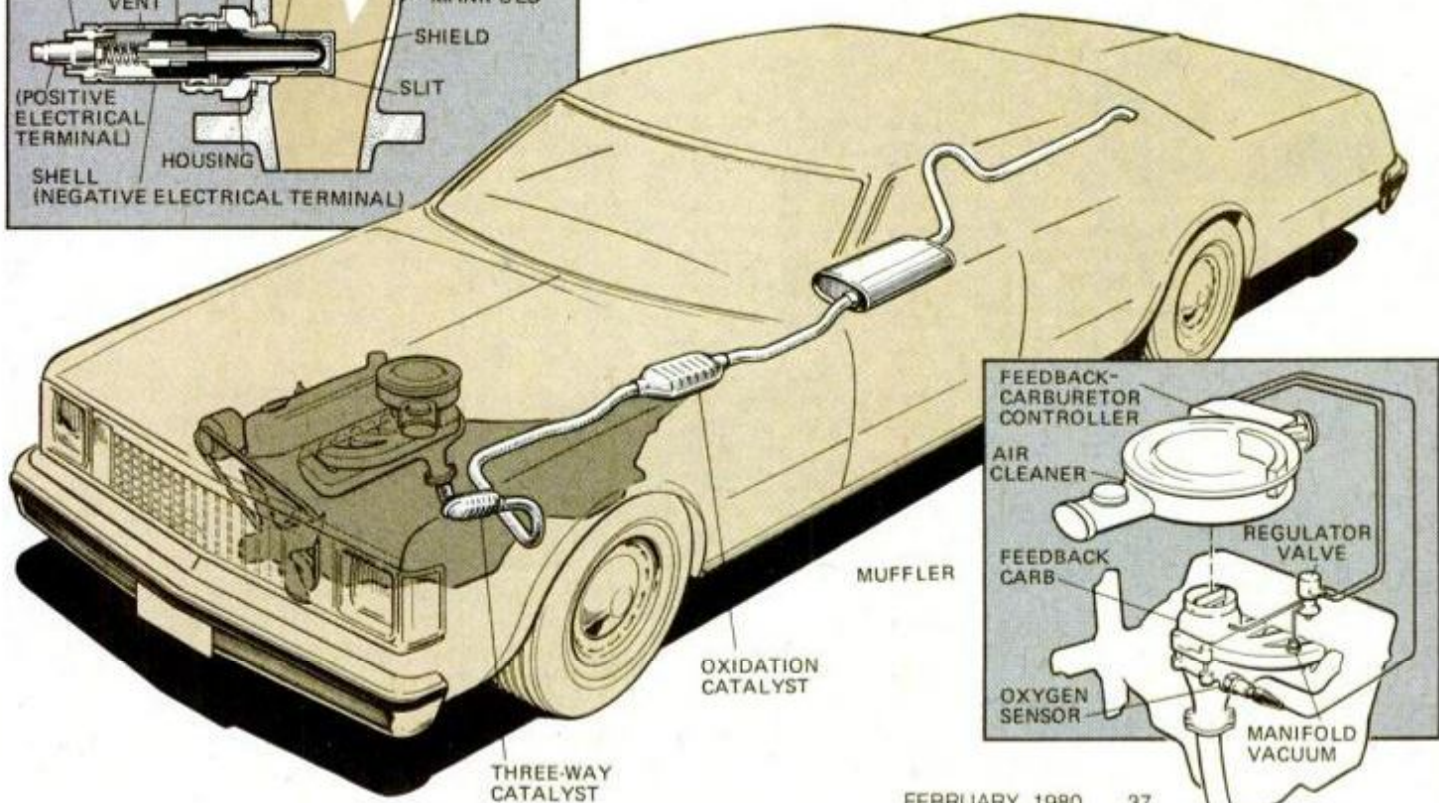



Connect the positive lead of a voltmeter to the sensor connector wire and connect the negative lead to ground. Start the engine and let it warm up to reach normal operating temperature.

Now, with the engine idling, a reading of 0.2 to 0.5 volt should show on the voltmeter low-voltage scale. Push down on the cold-start enrichment rod of the carburetor. Voltage should be 0.6 to 1.1.

If voltage is not within the specified ranges, the exhaust-gas oxygen sensor is faulty and should be replaced.

By the way, the exhaust-gas oxygen sensor is so important that a car with an electronic-feedback carburetor is equipped with a warning that displays itself every 15,000 miles to tell the driver to replace the sensor. The warning will not appear if the sensor fails before 15,000 miles.

### Monitoring lean-burn engine

Let's take another example of the simplicity involved in resolving a problem caused by a malfunctioning sensor. In 1976, Chrysler introduced its Electronic Lean Burn system to control exhaust emissions by allowing the engine to burn a leaner-than-usual fuel mixture.

Keeping the mixture at the leaner

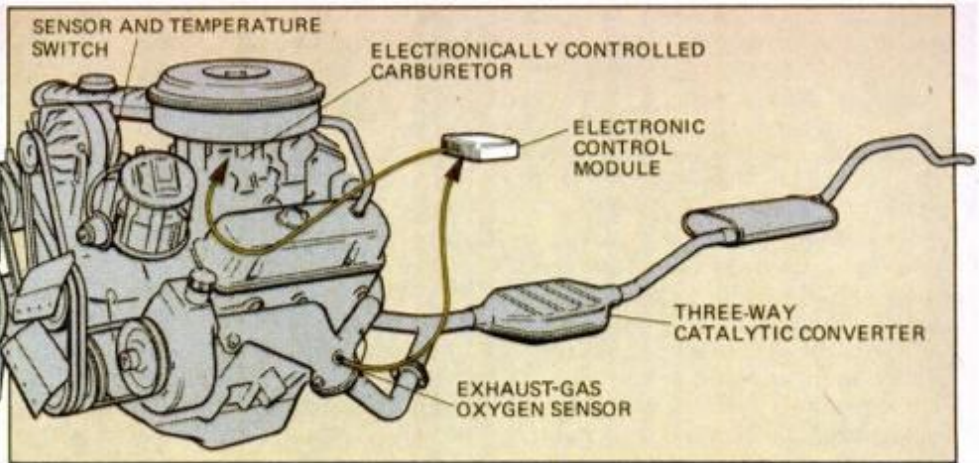

GM's C-4 (Computer-Controlled Catalytic Converter) system has a single three-way catalyst that—like other three-way units—only functions properly if the engine runs with a precise air/fuel ratio. A sensor in exhaust system measures oxygen and signals control module, which can perform carburetor adjustments as car is driven.

level eliminates several items of emissions-control hardware. They include the EGR system, orifice spark-advance control system, air pump, and conventional distributor vacuum advance.

To monitor constantly changing variables within the engine, the Electronic Lean Burn system uses six sensors: coolant temperature, ambient-air temperature, throttle position, carburetor switch, and vacuum and pickup coil. These send "messages" to the spark-control computer, which determines instantly when the fuel mixture is to be ignited.

In other words, ignition has to be rapid and precise to attain smooth burning of the lean mixture. Conventional mechanical methods of controlling ignition timing are too slow, whereas the electronic methods aren't.

Suppose a Chrysler with an Electronic Lean Burn system suddenly starts using an excessive amount of fuel and exhibits a high idling speed. Fault often lies with the coolant-temperature sensor, which (as the diagram on page 35 points out) is on the water-pump housing. Testing this sensor requires a simple ohmmeter, not a sophisticated digital analyzer. You don't even have to take the sensor out of the car.

The ohmmeter is connected to ground on the engine and to the sensor terminal. With the engine cold, there should be continuity. If not, replace the sensor. With the engine warmed to normal operating temperature, there should be no continuity. If continuity is present, replace the sensor.

### Air cleaners have sensors, too

Most cars have thermostatic air cleaners. These, too, have a sensor that can cause a problem.

Suppose there is a sudden increase in fuel consumption. As you know, there are many causes for this, but one cause, frequently overlooked, is a thermostatic air-cleaner damper door that binds. And what's the main reason for this? A defective temperature sensor!

The sensor controls a vacuum motor, which closes the damper door when the engine is cold and opens the damper when the engine is warm. To test for a bad air-cleaner temperature sensor, the engine has to be completely cold.

Remove the air-cleaner cover and place an accurate thermometer near the sensor. A photographic thermometer having a metal housing and long metal stem, or one like it, is usually accurate enough for this simple test.

Wait for the thermometer to stabilize, which takes five or 10 minutes. Then, reinstall the air-cleaner cover and start the car's engine, letting it idle.

The damper door should close over the snorkel at once. If it doesn't, the linkage or vacuum motor is at fault. As soon as the damper door starts opening, remove the air-cleaner cover and read the thermometer. The temperature should read between 95° and 135° F.

If the temperature exceeds this reading and the damper door hasn't opened, replace the sensor, which most likely is defective.

The thermostatic air cleaner temperature sensor is held by retaining clips. Remove the air cleaner and turn it upside down. Pry retaining clips off the sensor with a screwdriver to remove the sensor.

Sensors in most other areas of a car are screwed in place. They can be removed easily by simply engaging the hex of the sensor with an appropriate wrench. **FM**

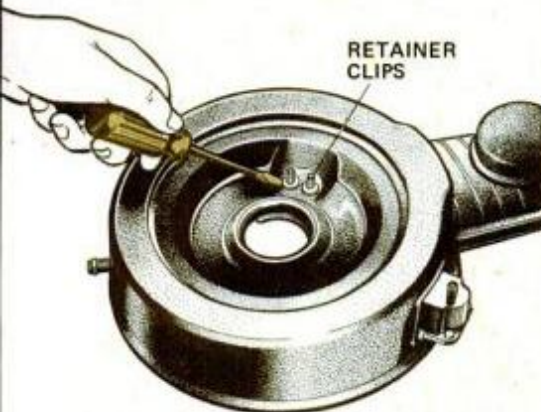

If damper door on air-cleaner housing doesn't open between 95° and 135° F., sensor must be replaced. To remove, pry off retaining clips with screwdriver. Be certain that the gasket (below) is in good condition before replacing the sensor.





# A NON-TECHNICAL LOOK AT THE TECHNICAL ADVANTAGES OF USING STP GAS TREATMENT

It all starts with this wonderful chemical called Alkylhydroxybenzylpolyamine.

Fancy name for something that looks like a balloon on a string. But, as the primary active ingredient, it does two important things in your car's fuel system:

First, it helps remove water from your gas tank by surrounding droplets of water, suspending them in your gas so they can pass harmlessly through your fuel system.



Second, it helps prevent grunge like gum and varnish from sticking to metal surfaces of the fuel system in two ways:

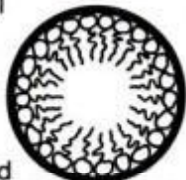

By coating the metal surfaces of the fuel system and by surrounding the gum and varnish to keep them from getting a toehold. This helps keep your carburetor clean and that helps maintain peak engine performance.

Still with us?

So far, all you've got to remember is that STP Gas Treatment fights back against bad guys in your fuel system.

Now for the second thing to remember: All this isn't fiction. It's fact. Results proven in scientific tests. For instance:

## FIGHTS RUST.

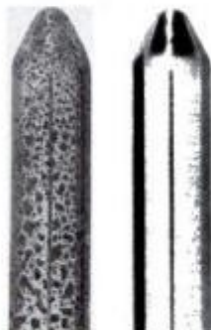

These two steel bars were both soaked in the same gas plus water. Only difference? The gas used with the bar on the right contained STP Gas Treatment.

## FIGHTS WATER.

Water causes more than rust. It can freeze, too. Brrrr! Regular use can lessen the likelihood of gas line freeze. Tests proved STP Gas Treatment increases the emulsification of water and that means it helps water get through your system, out your exhaust.

## FIGHTS CARB DEPOSITS.



Some carburetor openings are tiny enough to become restricted by gum and varnish, which can rob your engine of efficiency. We put clean metal sleeves in 28 engine

tests. Without us (left) nasty formations developed. With us (right) sleeves came out much cleaner. Take your pick.

## FIGHTS VALVE DEPOSITS.



For this test, we matched up six new cars in three matched pairs. After only 12,000 miles, look at the difference that can develop in valve deposit formation. (We're on the right.) That stuff on the

left? Would you want that in your car?

In summary.

Maybe you've never thought about using a gas treatment. Well, you should. Odds are, you've got some bad guys lurking in your fuel system. Things you ought to fight back against—if you want to keep your car running like it ought to.

STP Gas Treatment does exactly that.

It's the best selling Gas Treatment in America.

## FIGHT BACK! WITH STP GAS TREATMENT.

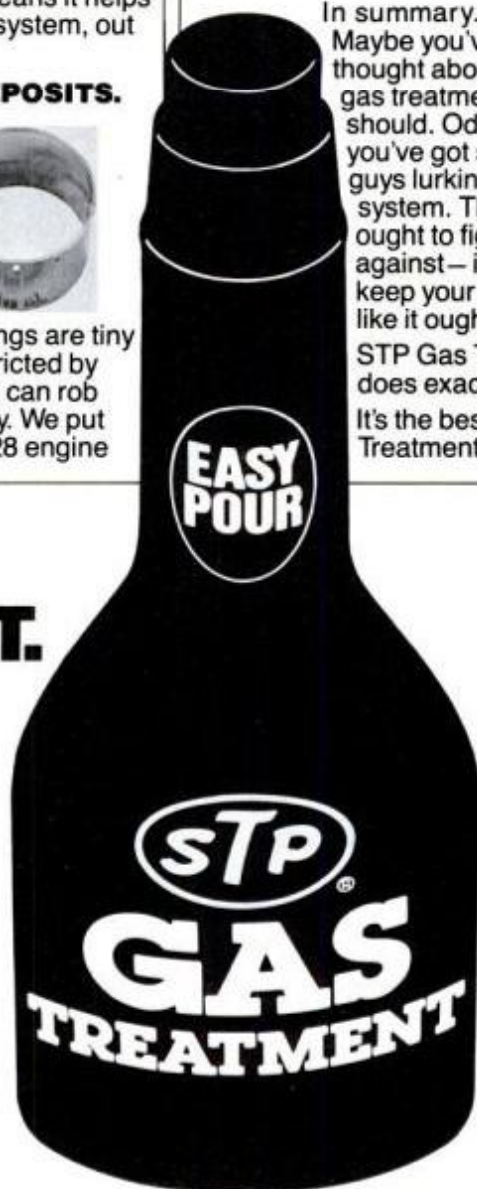



# HOMEOWNERS' CLINIC

## QUESTIONS ANSWERED

### Extra heat

I have a built-in metal fireplace. Behind the front brick veneer and in the area that encloses the fireplace is wasted warm air.

I was wondering if there's a chance I could connect this "compartment" to my regular warm-air heating plenum, to transfer the heat to other rooms. I'd use proper filters, of course.—Dennis Schimming, Houston.

My advice is not to tamper with the area surrounding the rear and sides of your zero-clearance fireplace.

Although it may appear to be a waste of heated air, the risk of introducing a fire into your air-distribution system isn't worth the trouble. You may also negate your fire insurance if you should make this alteration.

### Insulation comparison

I recall reading somewhere that rock wool has a higher R-value per inch than fiberglass. If this is true, why isn't rock wool available anymore? Also, what are the R-values of various insulating materials?—W. Kostellic, Granville, Ill.

One of the places you could have read about R-values was in *Insulation: How Much Is Enough?* (page 132, Sept. '78). Below are R-values as listed in the article (Table 1). The higher the number, the more effective the insulation.

### R-Values for various thicknesses of insulation

TABLE 1

Insulation	Maximum R-Value (per inch of thickness)
Vermiculite	2.08
Glass fiber loose fill	2.1-2.4
Rock wool loose fill	2.7-3.2
Cellulose	3.1-3.8
Glass fiber blankets/batts	2.7-3.7
Rock wool blankets/batts	3.1-3.6
Urea formaldehyde	4.1
Polystyrene, polyurethane	6.25

TABLE 2\*  
Batts or blankets

R-Value	Loose and blown fill	
	Glass fiber	Rock wool
R-11	3½"	3"
R-13	4"	3½"
R-19	6"	5"
R-22	7"	6"
R-26	8"	7"
R-30	9½"	8"

\*Source: Department of Energy.

I've also listed inches of insulation required to attain various R-values between R-11 and R-30, for both glass fiber and rock wool (Table 2). I prefer this chart as, depending upon where you live, it could cost less to add extra glass fiber for the same R-value in rock wool.

Rock wool is available. Write: Rock Wool Industries Inc., Premium Brand Insulation, Box 5170, Denver, Colo. 80217, for a distributor near you.

### Carpet-clearing hinge

I was told that there is a type of hinge that will raise a door to help clear the carpet, when the door is opened. The door must be flush when closed.—Eli Glumac, Mechanicsburg, Pa.

The hinge you're looking for is called a rising butt hinge. It is manufactured by Ball and Ball, Exton, Pa. 19341. By studying the photo,

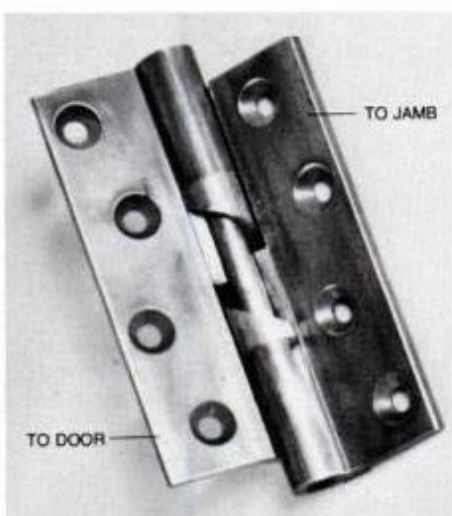

Rising butt hinge lets door swing over a plush carpet. Right-hand hinge is shown.

you can see how opening the door will also raise it.

In brass, a 3 × 2¾-in. set is \$42.90 per pair; a 4 × 2½-in. set is \$53.75 per pair. In aluminum a 3 × 2¾-in. set is \$26.10 per pair; a 4 × 2¾-in. set is \$29.75 per pair. Postage is \$2 per pair.

When you are ordering, specify a right-hand or left-hand hinge. To tell which type hinge you need, stand with your back to the door, so it swings toward you when opened. If the hinges are on your right, they are right-hand hinges.

### Overtreated wood?

For 16 years we have struggled with the 6×14-ft. deck on our church par-

sonage. When it was new we stained it with several coats. Finally, as a last resort, we painted it. Nothing we have tried will adhere to the wood. The paint seems to be oily on the wood side when peeled back.

Besides the fact that it is an eyesore, we are constantly replacing wood that is rotting, because the deck has no protection from the weather.

Someone said our wood may have been "over" treated. Is that possible? Will we have to tear it all down and start over?—James E. Conner, Belmont, Mich.

The initial stain and paint jobs most likely didn't cover the sides and bottom of the wood decking, allowing moisture to penetrate the pores of the wood.

When there is sunshine following rain, the warmth draws the moisture to the surface and from the wood. The painted surface is flaked off in the process. The fact that you also have rotting wood indicates that pressure-treated wood wasn't used.

Replace all rotted wood with pressure-treated, dry wood. Check your decking supports (joist and girders), too. If they have rotted, I'm afraid you'll have to tear down and start over, using dry, pressure-treated wood.

There are several brands available. Check with your local lumberyard or home center to learn what they carry.

[Ed. Note: John's article on where, when and why to use pressure-treated wood will be in the *PM Garden Guide* next month.] **PM**

Do you have a home maintenance or repair problem? Send it to Homeowners' Clinic, Popular Mechanics, 224 West 57th St., New York, N.Y. 10019. Letters cannot be answered individually, but problems of wide interest will be discussed in this column. For more home repair and maintenance help, get *PM's Home Care Guide*, \$4.95 postpaid. Send order(s) to *PM*, Dept. HCG, Box 1014, New York, N.Y. 10019.





Warning: The Surgeon General Has Determined That Cigarette Smoking Is Dangerous to Your Health.

Source comparative 'tar' and nicotine figures: FTC Report May 1978. Of All Brands Sold: Lowest tar: 0.5 mg. 'tar,' 0.05 mg. nicotine av. per cigarette. Golden Lights: 8 mg. 'tar,' 0.7 mg. nicotine av. per cigarette by FTC Method.



# Golden Lights<sup>TM</sup> taste astonishes first-time users.

Unbelievable taste from a low tar surprises smokers. Many switch to Golden Lights after trying just one pack.



**17**  
MG. TAR  
1.0 MG. NIC.



**20**  
MG. TAR  
1.3 MG. NIC.



**16**  
MG. TAR  
1.1 MG. NIC.



**17**  
MG. TAR  
1.4 MG. NIC.



**17**  
MG. TAR  
1.2 MG. NIC.



**16**  
MG. TAR  
1.1 MG. NIC.



**19**  
MG. TAR  
1.3 MG. NIC.



**8**  
MG. TAR  
0.7 MG. NIC.

Golden Lights.  
The taste high tar smokers  
want in a low tar.  
(Regular & Menthol.)



# THE GUTS AND BOLTS OF A TOUGH CHEVY BLAZER.

A 4-wheel-drive Blazer is guts-and-bolts tough and practical. On or off the road, it's a people mover, trailer tower, cargo hauler. And it has the new 1980 Chevrolet Three-Year Perforation-From-Corrosion Limited Warranty. See your Chevrolet dealer for details. Ask about leasing, too.

84.3%	87.2%	87.5%	92.6%	92.9%	94.3%	94.7%	95.5%	95.9%	99.9%
50	51	52	53	54	55	56	57	58	59

**A TOUGH RECORD TO BEAT.**  
 94.8% of Chevy Light, Medium, Heavy-Duty trucks and commercial vans in the ten most recent years recorded were still on the job. (Based on R. L. Polk & Co. model year registrations through July 1, 1978. 1979 statistics not available at time of printing.)

Part-time 4WD now available with optional automatic transmission. Freewheeling front hubs help improve rolling efficiency over last year, when in 2WD. Manual transmission standard. Aluminum wheels available.

Staged, 2-barrel carburetor on standard 4.1 Liter (250 Cu. In.) Six. Not available in California. One barrel is used for normal operation. The second, larger barrel is activated for more power.

No extra suspension equipment required for off-road use with 4-wheel-drive Blazer. Front stabilizer bar, leaf springs and power steering are standard. Rear shocks are counter angled to help control brake/power hop. Power-assisted brake system is also standard and computer-matched to Blazer's Gross Vehicle Weight Rating.

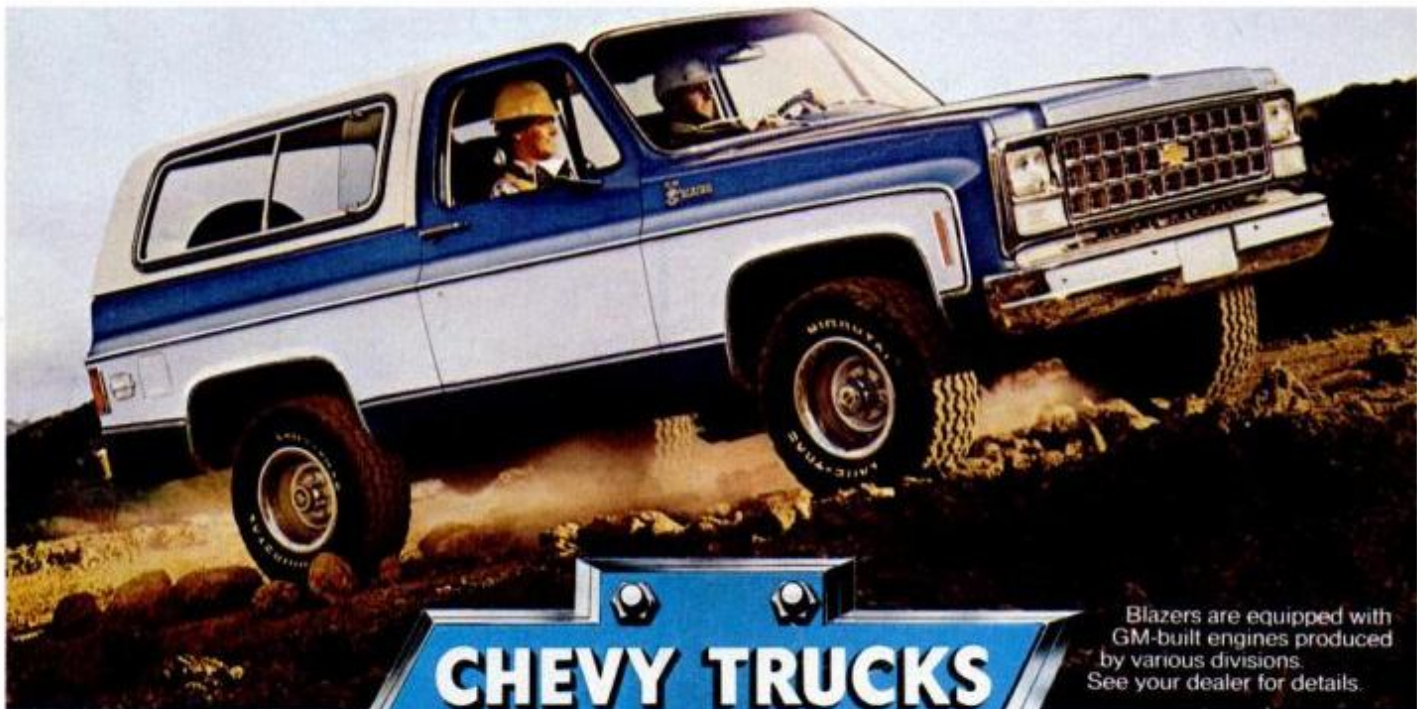

Blazers are equipped with GM-built engines produced by various divisions. See your dealer for details.

**BUILT TO STAY TOUGH**



# SCIENCE WORLDWIDE

## A sweeping of space dust

The dust particles in the photos at right may have been shed by a passing comet. And university scientists who analyzed the particles say they may contain new evidence concerning the formation of the solar system.

The particles (about 1/2500-inch in diameter) were collected on sticky plates carried by a NASA-operated U-2 aircraft and deployed at altitudes above terrestrial pollution. Scientists at California Institute of Technology and the University of Washington found several exotic extraterrestrial substances.

Some are fluffy clumps of different minerals. Others comprise crystals of a single mineral, and a few are hard spheres, apparently formed by melting in the atmosphere or outer space. Most interesting of all to the scientists, some particles

appear to contain slight chemical irregularities. Researchers are currently looking for more of the unusual features, evidence of nuclear reactions that occurred when the solar system was formed. If they find them, scientists will know that at least some of the dust has been cluttering the attic of space above us for the past 4.5 billion years.

The "comet dust" research comes at a time when NASA is planning a major mission to send an unmanned spacecraft to meet Halley's Comet when it next appears, in late 1985.

## Sun power at Winter Olympics

The rack of solar cells in the photo below may power communications for part of the Winter Olympics this month in Lake Placid, N.Y.

With the flick of a switch, the pho-

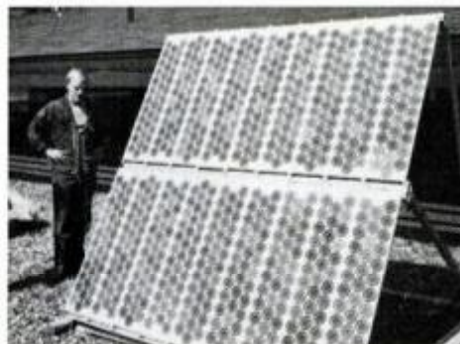

Panels may power communication lines.

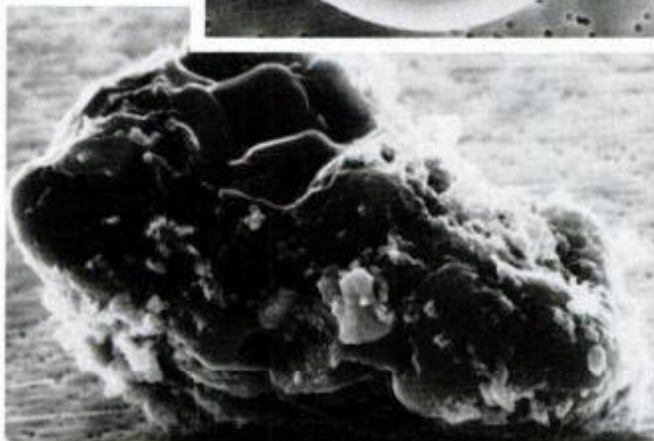
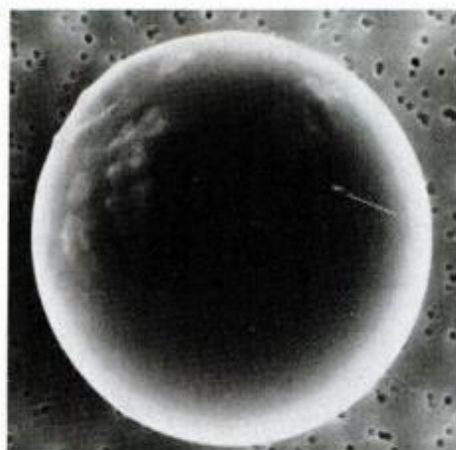

Tiny, hard sphere (top) was formed by melting in Earth's atmosphere or outer space. A second kind of space-dust particle (above) is crystal core flecked with debris.

tovoltaic cells can be hooked into the communications system connecting a command post with remote stations on the 4867-foot-high Whiteface Mountain.

The 20 panels, made by ARCO Solar Inc. of California, are most likely to be called into use during the giant slalom events on the mountain. During other events, the system will be available as a backup, in case the conventional power is interrupted. Each of the 20 panels can produce up to 20 watts. Power is fed to a battery system which could keep the system running for days if it's cloudy.

The solar installation is one of a number of advanced technological

*(Please turn to page 44)*

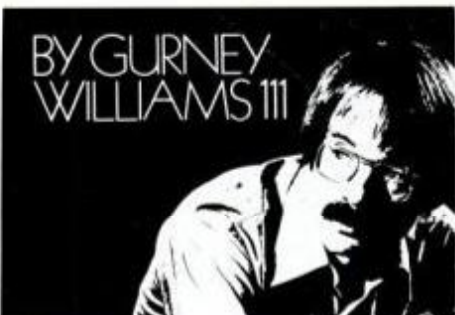

BY GURNEY  
WILLIAMS III



The pride of your toolchest...

## Offset Leverage Nipper

Throw away your old nipper. Offset jaws greatly increase draw capability on brads, tacks, finishing nails, etc. Especially good for working in tight corners. You bite, hold and draw with less force. Green lacquered handles lay comfortably in your hand. Made in Germany. Jaw width 1/2". Overall length: 7".

**Offset Leverage Nipper \$12.95**

Enclosed is \$12.95 plus \$1.50 Shipping/Insurance for **Offset Leverage Nipper**. Include NEW catalog FREE.

VISA or MC, order toll free 1-800-343-6130

Name \_\_\_\_\_

Address \_\_\_\_\_

City \_\_\_\_\_ State \_\_\_\_\_ Zip \_\_\_\_\_

Enclosed find \$1.00 for NEW 79-80 Catalog only.

**THE PRINCETON COMPANY**

P.O. Box 276-39, Princeton, MA. 01541

**WE DARE YOU TO COMPARE!**

**WESTWOOD OFFERS YOU MORE...**  
SAVE 20-50% OVER COMPARABLE FINISHED CLOCKS



**YOUR SELECTION OF:**

- CLOCKS
- 17 MODELS TO CHOOSE FROM
- MOVEMENTS
- 20 DIFFERENT MOVEMENTS AND DIALS
- OPTIONS
- BEVELED GLASS - HANDCARVING
- OAK OR CHERRY SOLIDS - RARE BURLS
- EASY-TO-ASSEMBLE
- PRE-CUT KITS
- ONLY THE FINEST QUALITY
- NEW FREE
- COLOR CATALOG

**WESTWOOD CLOCKS N KITS**

Uncompromised in quality  
Dept 004F  
3210 Airport Way  
Long Beach, Ca 90806  
(213) 595-4981



# Your CONSERVE ENERGY



## Electrify your Bike...

**PEDALPOWER**-Exciting new powerful electric drive for bikes. Tames tough hills. Be independent. Shop when you want. Fits all bikes and adult trikes. Easy to use and install. Beat high gas prices. Recharges overnight at home. Travel 100 miles for a dime.

Get your exercise without strain. Pedal easily with motor engaged to help improve your health. Visit friends. Travel to work or ride for fun. Starts without pedaling. Noiseless, non-polluting. Virtually maintenance-free operation!

Thousands in use today by senior citizens, students, housewives, workers, handicapped and professionals. Call today or write for free booklet with complete details on **PEDALPOWER** motors, Take-Apart Electric Bikes and Adult Electric Tricycles.

Call Toll Free  
800-257-7955\*

For this **FREE BOOKLET**  
& Special Offer or Write:

**PEDALPOWER**

General Engines Co.  
5636 Mantua Blvd.  
Sewell, NJ 08080



\* In AK, HI, NJ call collect (609) 468-0270

## YOU DON'T NEED CASTRO'S PERMISSION TO ENJOY THE UNIQUE HAVANA FLAVOR.



If you remember savoring and lingering over a fantastically mild and flavorful Cuban leaf cigar in the days before the Cuban embargo, you will be interested in this offer — and the story behind it!

When the Cuban embargo hit, we and other small manufacturers of fine custom-made cigars faced ruin. Our very existence depended on maintaining the same incomparable quality we had staked our reputation on.

The solution was pure cloak-and-dagger. One dark night a few years ago a group of daring Cuban expatriates put to sea carrying a precious cargo of Cuban tobacco seeds. After running a gauntlet of Cuban gunboats they finally reached their destination —

Honduras. Here under almost identical conditions of climate and soil, this prime tobacco flourishes to this day, far from its native land. This is the tobacco we use to make our superbly mild and flavorful cigars — cigars an expert can't tell from Havana.

### MY OFFER TO CIGAR LOVERS

I will send you postpaid a variety of 60 factory fresh cigars. Smoke one or a half-dozen with my compliments. If these cigars aren't all you expect and a great deal more, return the remainder by parcel post within 30 days and I'll refund your money. No questions asked. Your delivered cost is only \$10.90 for 60 Factory-Fresh Cuban Seed Leaf Cigars.

A384 To order, fill in and mail coupon to

### THOMPSON CIGAR CO.

200 N. Edison Ave., Dept. A384, Box 1839, Tampa, FL 33601

O.K., TOM! Ship me the Victory Sampler under your money-back guarantee for only \$10.90.

- Check for \$10.90 enclosed. (Fla. residents add 4% sales tax.)  
 Charge \$10.90 to my  
 Visa  Master Charge  
 American Express  
 Diners Club  
 (OFFER GOOD IN U.S. ONLY)

Credit Card No. (Print all digits)

Master Charge Also Enter EXP. DATE  
4 Digits Below Your Acct. No.

name

street

city

state

zip

CREDIT CARD HOLDERS USE  
44 POPULAR MECHANICS

**TOLL-FREE 800-237-2559**

## SCIENCE WORLDWIDE

(Continued from page 43)

systems to be used at the games. (See *The Jump: Anatomy of the Top Olympic Spectacle*, page 91.)

### Nature's own oil spill

Dr. George Harvey, a federal research oceanographer, smelled oil in a sample of Atlantic Ocean water collected from 600 feet below the surface. "Damn it," he said. "Someone's contaminated the sample with lube oil."

But when Harvey repeated the collection, traces of oil were still there. He continued to find oily water below the surface as his research vessel completed a month-long cruise. His conclusion: The continental shelf of Venezuela or Trinidad had leaked up to 30 million tons of toxic oil into the sea, a monstrous spill 800 nautical miles long, 300 feet thick and up to 30 miles wide. Previous estimates of annual oil leakage into the sea were only five or six million tons from all sources.

Harvey's work seems likely to intensify debates between petroleum companies and environmentalists. "Companies can argue their operations contribute only a small fraction of oil in water," Harvey told us. "Environmentalists can say there's more oil in the sea than we knew, so even small additional spills are highly dangerous."

### Radiation pill: a follow-up

A New Jersey drug firm plans to be first to market potassium iodide, which counters the effects of some radiation on the thyroid gland.

But the company, Wallace Laboratories of Cranbury, N.J., has no immediate plans to sell the pills or drops to the general public. A spokesman said initial marketing efforts would be directed toward cities, states and utilities that owned nuclear powerplants. The potassium iodide might be available to the general public, over the counter, at some point in the future, the spokesman said. Its price hasn't been set.

A spokesman for the Food and Drug Administration said Wallace's application to sell the anti-radiation drug would be approved as soon as the federal agency received a copy of the drug-container label.

As we reported here last July, the FDA is on record as encouraging applications to sell potassium iodide as protection against radioactive iodine 131. "As soon as we get that label, you'll see a turn-around time [for approving and application] so fast it'll make your head spin," an FDA spokesman told us. **PM**



# CANADA AT ITS BEST<sup>®</sup>

Light. Smooth. Imported Canadian Mist.<sup>®</sup>  
The whisky that's becoming America's favorite Canadian.



*Share some tonight.*

IMPORTED BY B-F SPIRITS LTD., N.Y., N.Y. CANADIAN WHISKY—A BLEND, 80 PROOF © 1979.  
Photographed at Bow Lake, Province of Alberta, Canada.



# THREE WAYS TO PASS A GAS PUMP.

You're looking at three of the most economical ways of getting from here to there on two less wheels than you're probably using now.

The Yamaha XS400 Special II. Mid-size and manageable and surprisingly quick, it'll also squeeze 64 miles from a gallon of gas.

The sporty XS650 Special II lives up to its British heritage by sipping petrol at a most conservative rate. It'll make a gallon go 58 miles.

With one big cylinder, the SR500 produces incredible power and torque. And also incredible mileage: over 60 miles to the gallon.



REGULAR	<b>1.05</b>
NO-LEAD	<b>1.09</b>
PREMIUM	<b>1.10</b>

CLOSED  
SATURDAYS, SUNDAYS,  
and HOLIDAYS

Those little signs outside the Exxons, Shells and Texacos of the world are trying to tell you something.

They're telling you to get a Yamaha.

**YAMAHA**  
When you know how they're built.

Mileage figures based on EPA testing for city riding. Your mileage may vary depending on the way you ride. Although not shown, one or two rear view mirrors are standard equipment. Always wear a helmet and eye protection.



# PM WORKBENCH

PM EXAMINES PRODUCTS AND SERVICES

## Old standby gets a facelift

Edmund Scientific, 7082 Edscorp Building, Barrington, N.J. 08007, has modernized the format of its world-famous catalog. The newly designed catalog—which presents more than 4000 products—contains 100 pages, with 50 of them printed in full color.

You will probably be surprised, as I was, to find that the catalog is no longer digest size, but now measures 9¾×8¼ in. Though some in our office expressed a sentimental preference for the old format, I think the move from small to big in this case is a change for the better.

The 1979 catalog can be obtained at no charge by writing to Edmund at the address above.—H.W.

## New drills from Millers Falls

The Millers Falls Div. of Ingersoll Rand, 253 East Washington Ave., Washington, N.J. 07882, has unveiled seven new drills that are labeled "Super Duty." Though I haven't yet tested one of the drills, I plan to do so soon.

The seven models of drills include: three ¼-in. drills with 1900 rpm, 0-1900 variable speed and reversing and 0-4000 rpm variable speed; three 3.8-in. drills with 600-rpm, 1000-rpm and 0-1000-rpm variable speed and reversing; and one ½-in. drill with 0-600-rpm variable speed and reversing.

All seven models include all ball



Tough drill comes with 10-ft., heavy-duty cord, and it is UL- and CSA-approved.

bearing/needle bearing construction, heavy-duty chucks, double insulation and a 10-ft. rubber cord. The drills are double insulated and require no grounding.—H.W.

## Ratchet chain wrench

Though the 360° ratchet chain wrench is truly a tool for the profes-

sional, it is also one that many homeowners who do their own piping work might want to know more about.

The ratchet chain wrench will grip both steel and plastic securely—yet it won't gouge the plastic. Since there are no jaws on this tool, it's great for working in close quarters.

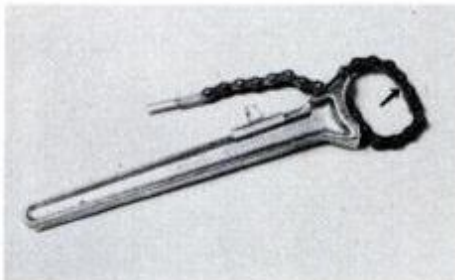

Ratchet chain wrench has serrated teeth on one side of chain (arrow) to grip large nuts and pipes without crushing them.



To use, wrap chain around pipe, feed end of chain under anchor pin (A), and hook to notch on spring-loaded pressure clip (B). Use like any ratchet-operated wrench.

The wrench sells for \$49 postpaid, and is available from Nicholson Distributing, 1324 Kingston Dr., Ogden, Utah 84403.—J.P.

## Big-hole woodbits

Many serious woodworkers prefer a bit with a center spur because greater drilling accuracy is assured. Now Leichtung Inc., 4944 Commerce Parkway, Cleveland, Ohio 44128, is offering four large-diameter versions. I've used all four—5/8, 3/4, 7/8 and 1 in.—and can report that they've earned a permanent place in my drill-accessory box.

The bits are priced at \$10.95, \$12.50, and \$13.95 and \$15.50 respectively, or \$39.95 for all four, plus \$1.75 postage.

They're good for use in either

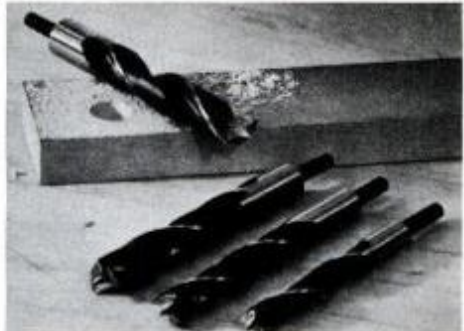

Big hole bits feature step-down shanks, can be used in 3/8-in. portable drill.

drill press or portable drill with 3/8-in. or greater chuck capacity.—H.W.

## Twist ties at your fingertips

Here's a handy product for both workshop and kitchen—a refillable, wall-mounted container that dispenses nonrusting, refillable ties for plastic bags and the like. In the shop, mine comes in handy for holding nails, screws and small tools. I've even used ties to hold small parts when gluing. My wife uses one (mounted in the pantry) for tying



To install refill (left), cover is removed and reel is inserted (above). The spring-steel piece at bottom is used to sever the tie at desired length.

of food-storage and garbage bags.

Dispenser is \$2.29, refills \$1.59, at general merchandise stores such as K-Mart. Weld Tron, 1532 South Washington Ave., Piscataway, N.J. 08854, makes it.—H.W.

If you've come across a new product with some special features, let us know about it. Write to PM Workbench, Popular Mechanics, 224 West 57th St., New York, N.Y. 10019.





## We wouldn't trust this job to anything but a Crescent.

If I strip these nuts, it'll probably cost more for the plumber to fix what I did, than to fix what went wrong.

That's why we won't trust this job to anything but a Crescent adjustable wrench and Crescent adjustable pliers.

My Crescent wrench adjusts to snug down tight on any size nut or bolt, so there's less chance for slipping.

And my Crescent pliers have "locking grooves" so I can adjust them for small, medium, or large size pipes or connections.

But be careful. Not every adjustable wrench or pliers is a Crescent. You'll find

Crescent products where they keep all the quality tools from Cooper the Toolmaker: the Cooper Tool Center in your local store.

Look for Cooper next time you need tools you can depend on.



**Boker • Crescent • Lufkin • Nicholson • Weller • Wiss • Xcelite**  
**Friends you can trust...from Cooper the Toolmaker.**



# IPM BRIEFS



## PM's Whatsit

A comely former secretary, now a design student, Stella Wain-Heapy hails from Goring-on-Thames, England. As if that were not enough, she's gone and invented some sort of jacket to fit on a jug. Why on earth would Ms. Wain-Heapy invest time that could well be spent in a disco to go and do something like that? Can't imagine? Turn the page.

## The census — this one counts

*The 1980 census is nearly upon us. On or about March 28, every household in the United States will receive the government's 20th Decennial Census of Population form in the mail. If you don't fill out the questionnaire and return it, you'll be visited by a census-taker.*

*It makes sense to cooperate. Federally funded programs in your area may depend upon updated 1980 figures on, say, farm population or income levels. Also, for every 1 percent of the population who do not fill out their questionnaires, follow-up costs — borne by all taxpayers — will amount to about \$2 million. Finally, the maximum penalty for refusing to cooperate with the Bureau of the Census is a fine of \$5,000.*

*Some people hesitate to fill out census questionnaires because they worry about how the information may be used. Federal laws covering the confidentiality of census information are quite specific and rigid, extending to all other government agencies. The FBI, for instance, or the IRS, cannot legally avail themselves of any data acquired through the census-taking process. Since the confidentiality provision was introduced, in 1870, no Census Bureau employee has ever been formally charged with divulging confidential information. Even the Bureau's computers are programmed to identify and refrain from printing out figures that might identify specific businesses or individuals.*

*Census data on individuals remains confidential for 72 years. People constructing family genealogies often make use of declassified data available from the Census Bureau after that period has elapsed.*

*The questions for 1980 will consist basically of the same ones regarding names, ages and marital status of householders. Some "extras" will be thrown in regarding energy usage and work—primarily commuting — patterns.*

## Also the final solution to the Philistine problem



John R. Polly, a retired painting contractor from Oxnard, Calif., is 51. Tim, a German shorthair, is 10. There is nothing that Tim likes better than for John to walk along the beach with him and chuck old tennis balls for him to fetch. John likes it, too, except

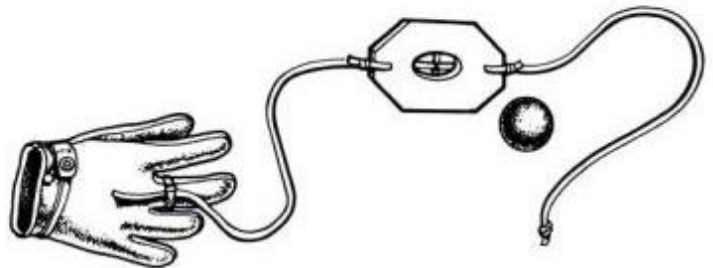

that whenever there was a touch of stiffness in the old shoulder the tennis ball never went far enough to give Tim a good run.

John eventually developed a solution, and it works so well he had it patented. It's a sling arrangement with a leather pocket that holds the tennis ball securely and an ingenious attachment of one sling strap to a finger on a glove worn by the slinger. This assures smooth, powerful releases when the other end — held between thumb and finger — is let go.

John's record tennis ball heave to date is about 225 feet. Tim has never been in better shape.





## Whatsit revealed

With a little flexible foam, a 100-watt heating element and a vinyl cover with a Velcro fastening, our Stella has gone and invented the answer to a home winemaker's prayer. The electrically heated jacket keeps wine-to-be at exactly the right temperature for fermentation, even though ambient temperature may vary right down to freezing. It's designed to fit a standard jug sold to grape fanciers in Britain.

## PM follow-up: Skate casualties roll on

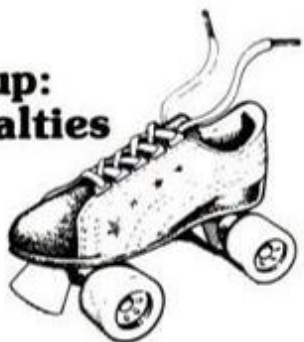

When PM talked about the technology behind the roller skating boom eight months ago (*The Roller Renaissance*) (page 94, June '79), injuries resulting from skating accidents were already shaping up as a statistical caution to the sport's newcomers. There is no question that contemporary urethane-wheeled skates are the safest ever made, but the sport is drawing great numbers of inexperienced persons. The seemingly forgiving nature of the soft plastic wheels and precision suspensions apparently combines with an aura of exhibitionism to produce a high risk potential. Skaters are trying things they can't do in places they shouldn't be trying anything — on streets, sidewalks and in shopping malls.

According to the Consumer Products Safety Commission, wrists, knees and elbows account for the overwhelming majority of skaters' injuries. Over 100,000 emergency room treatments for skating accidents were logged in 1979 — more than double the annual rate of five years ago.

Interestingly, about one-fourth of those injured and admitted for treatment are 25 years old or older. Many of them apparently thought the new soft-wheeled skates would let them "perform" safely on irregular surfaces. Not so. The crack in the sidewalk is still waiting to do you in, if you're not careful, and unless you've still got your baby teeth, the resulting repairs will keep your dentist in golf clubs for a long time.



Oscar Pumpin picks over the bumper crop . . .



. . . and takes torch in hand to create . . .

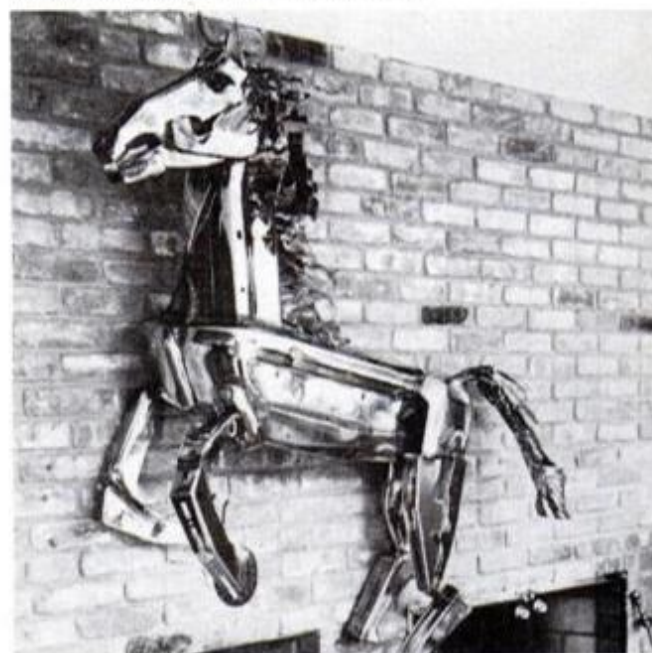

. . . a magnificent wall-mounted stallion.

## Oh, give me a chrome

The editors at PM have seen their share of sculpture done from automobile parts — and very little, frankly, we'd care to have in the house. But sculptor Oscar Pumpin, who currently haunts the junkyards of Long Island, N.Y., has got something going for him. Oscar works only with chrome — primarily bumpers. Oscar's tours-de-force are his chrome animals, often nearly life-size, in which he does a brisk business at art fairs in the Long Island area. But lest you think there's no message in a Pumpin work, be advised that the handsome horse shown here was deliberately fashioned (most of it) from a '71 Mustang. Far out.



Warning: The Surgeon General Has Determined  
That Cigarette Smoking Is Dangerous to Your Health.



# The Vantage Point

Where great taste and low tar meet



FILTER 100's: 10 mg. "tar", 0.8 mg.  
nicotine, FILTER, MENTHOL:  
11 mg. "tar", 0.8 mg. nicotine, av. per  
cigarette, FTC Report MAY '78.

© 1978 B&W TOBACCO CO.



# A lot of car for a lot of reasons.



## The Body by Fisher reason.

Life can be a lot tougher on a car than you might think. That's why Chevy Chevette's built solid. With a unitized Body by Fisher that's been welded to be rigid and structurally tight. With double-panel doors, hood and deck lid construction. And with extensive anti-corrosion treatments to help fight rust.

Let there be no mistake about it. Chevette's built to take some of life's hard knocks.

## The convenient service reason.

Dallas to Duluth... Cincinnati to Seattle... coast to coast. That's where you'll find neighborhood Chevy dealerships. And the kind of dedicated dealers and technicians who can provide you with the kind of service and maintenance you might need.

Who says good help is hard to find? No matter where you are in the U.S.A., you won't have to go far to find Chevrolet.

## The lower price reason.

The 1980 Chevy Chevette 4-Door Hatchback is:

\$340 less than '80 Toyota Corolla Deluxe 4-Door
\$321 less than '80 Datsun 210 Deluxe 4-Door
\$1,232 less than '80 VW Rabbit Custom 4-Door

Based on Manufacturers' Suggested Retail Prices. Tax, license and available equipment additional. Destination charges will vary by location and will affect the comparisons. Level of standard equipment will vary.

## The standard reasons.

Of course, then there are all those standard features for which Chevette has become so famous:

- White-stripe glass belted radial ply tires
  - Wheel trim rings
  - Bumper rub strips
  - Body side moldings
  - AM radio
  - 4-speed manual transmission
  - Reclining bucket seats
  - Cut-pile carpeting
  - Even more. (Many features are not standard on our lower priced Chevette Scooter.)
- See your Chevy dealer about buying or leasing a 1980 Chevy Chevette.

# 1980 Chevy Chevette

A lot of car for the money.





# THE PM GARAGE

## CAPSULE REPORTS ON NEW AUTO PRODUCTS

### Simple chain installer

Installing snow chains used to be a hassle for me until I discovered Sno-Bloc. Sno-Bloc is a yellow ramp made of tough polycarbonate plastic. It's 9½ inches wide by 21½ inches long, weighs just 2½ pounds and is divided into four sections. The first section raises the car's wheel 2 inches off the ground. The middle two sections are level. The last section acts as a brake so that you can tell when your tire is correctly positioned on the ramp.

To use Sno-Bloc, the chain is placed with its crosswise links in the ramp's indentations (which are between the four main sections). The car is then driven forward so that the wheel rests squarely on Sno-Bloc's middle sections. The chain can then be fastened easily because the indentations allow it to move slightly.

Each Sno-Bloc is so strong it can support 2000 pounds. Thus, they can be used on any vehicle that weighs less than 8000 pounds. It costs \$12.95 postpaid from Sno-Bloc Inc., 17981 G Sky Park Circle, Irvine, Calif. 92741.—*Moss Miller*

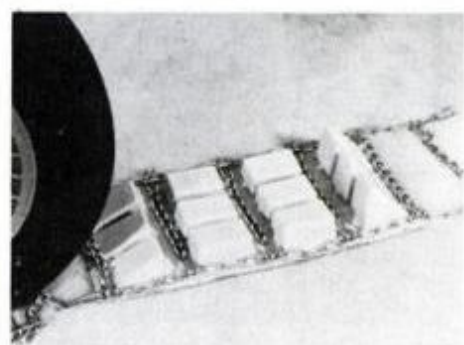

Links of chain are placed in Sno-Bloc's indentations; then you simply drive up.

### Windshield repair kit

To passersby, Tony Jacino appears to have lost his senses. There he stands, next to his 1968 Buick LeSabre in a Howard Johnson's Restaurant parking lot, calmly making cracks in the car's windshield with a metal ball.

But Tony isn't crazy. He's making the cracks on purpose to demonstrate to me how his new resin repair kit can fix a small "bull's-eye" crack in the Buick's laminated windshield.

First, he applies a special pedestal to the crack—it has a hole in its center so the resin can get to the glass.

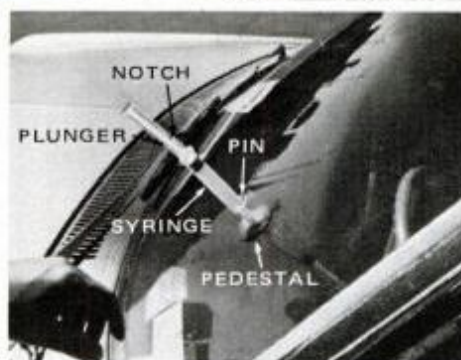

Top: When plunger is up, vacuum draws air out of solution in pedestal. Above left: "bull's-eye" crack before repair. Above right: After, it's resin-filled, hard to see.

The pedestal is mounted on an adhesive base.

He then attaches a large syringe to the pedestal (it comes without the needle). Two premeasured solutions, which come in their own small syringes, are squirted into the large syringe.

A plunger is then placed in the big syringe. A pin is removed so that the plunger can be pressed down very easily.

Next, the pin is replaced and the plunger is drawn up, creating a vacuum which draws most of the air out of the solution. After 10 minutes, the plunger is depressed until a notch is engaged that holds it firmly in place. This forces the epoxy solution into the crack under pressure.

After four hours at 50° to 70° F., the entire apparatus is removed and discarded. The repair, while not perfect, is certainly a big improvement. All that remains visible is the tiny point of impact, and glare is greatly reduced.

Unfortunately, the kit cannot repair cracks that have "spread." But Tony informs me he is working on this.

The kit can be ordered from Clear Star Products, Box 737, East Moriches, N.Y. 11940. It's \$13.95, plus \$2 for postage and handling.—*Moss Miller*

### Handy quartz-halogen light

Whenever I turn to my 6-volt, battery-powered lantern to illuminate something at night, it always seems

that the batteries have become weak or gone dead. Recently, though, I tested a compact (3½×6¼×4-inch) quartz-halogen spotlight made by Ushio Electric of Tokyo.

Dubbed Handy Light, the unit plugs into my car's cigaret-lighter socket, thus assuring a reliable source of power. Its light output is 90,000 candlepower, more than most regular headlights will put out on high beam.

Handy Light has a 12-foot cord and a built-in handle for easy use. It is available for \$14.95 postpaid from Ushio America, 140 East Savarona



Ushio's Handy Light plugs into cigaret lighter, has wallop of full-sized headlight.

Way, Carson, Calif. 90746.—*Moss Miller*

### Sparkplug lead puller

SK Tools' new sparkplug lead puller has a handle like a screwdriver's and a metal shaft with a special clip at the end. The shaft is bent at an



SK Tools' new sparkplug lead puller has clip on end to remove wires.

angle. Since there are no handles to squeeze together, as on a conventional plier-type lead puller, the SK puller can remove leads that are in very inaccessible places while preventing painful burned or bruised knuckles.

The SK lead puller is manufactured by Dresser Industries Inc., 3201 North Wolf Rd., Franklin Park, Ill. 60131. It is available at most auto-parts and hardware stores for \$4.49. Ask for SK part No. 73601.—*Moss Miller*



# 75 MPG!

**TOP SPEED OF 90 MPH!  
1,125 MILES OF DRIVING  
(from a 15-gallon fuel tank)!**

That's the kind of high-mileage, fuel-pinching performance you can get — right now — with the amazing **HYBRID ELECTRIC CAR!** What's more . . . *you can build it yourself!*

## HOW IT WORKS

All you do is take your existing car (or buy a used body) and replace its original power plant with a small gas-powered lawn mower engine. (That's right, a lawn mower engine!) This engine drives a generator which, in turn, supplies the vehicle's drive motor with electricity allowing you to travel at speeds up to 50 MPH.

When more power is needed, four automobile batteries — hooked up in series and fed by a 100-amp generator — give you plenty of kick for passing, climbing hills, and for running at higher speeds (up to 90 MPH) . . . and to help save normally wasted energy, a regenerative braking circuit automatically converts the drive motor into a generator that feeds and charges the batteries *while the vehicle is decelerating!*

Your total cost — by buying your own parts and building it yourself — is under \$1500. Your first year's benefits alone — in fuel savings *and* in hassle-free driving — will more than pay for the car!

## GET ON YOUR WAY TO HIGH-MILEAGE MOTORING . . . NOW!

THE MOTHER EARTH NEWS® — the national magazine long recognized as a leader in alternative energy — offers you a detailed, step-by-step set of plans for making the HYBRID ELECTRIC CAR. The complete package includes the plans, bill of materials, and list of suppliers. The plans sell for \$15.00 and come with a no-risk guarantee. To order simply fill in the coupon below and mail it — along with your payment — to: MOTHER'S PLANS, Dept MP, P.O. Box A, East Flat Rock, North Carolina 28726.

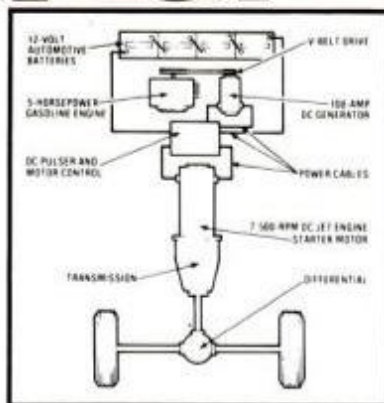

The layout of the new drive system.

Enclosed is \$15.00  
Please send me the HYBRID ELECTRIC CAR plans. I understand that I have 10 days to examine the plans, and if I decide not to use them, I can return them for a full refund.

Ship To:

NAME \_\_\_\_\_ ADDRESS \_\_\_\_\_

CITY \_\_\_\_\_ STATE \_\_\_\_\_ ZIP \_\_\_\_\_

CHARGE IT TO MY  MASTER CHARGE OR  VISA CARD

NAME \_\_\_\_\_ ACCOUNT NO. \_\_\_\_\_ EXPIRATION DATE \_\_\_\_\_

MASTER CHARGE INTERBANK NO. \_\_\_\_\_ SIGNATURE \_\_\_\_\_

Add \$1.00 if you wish to have your plans sent first class.

North Carolina residents add 4% sales tax.

MOTHER'S PLANS, DEPT MP, P.O. BOX A, EAST FLAT ROCK, NORTH CAROLINA 28726

## NEW RUBBER STAMP BUSINESS THIS LITTLE TABLE TOP MACHINE PAYS BEGINNERS UP TO \$16.50 AN HR. MAKES EVERYTHING SIMPLE & EASY Start at Home in Spare Time

The multi-billion dollar Rubber Stamp business—once controlled by a few big companies—is now being taken over by small operators—one in every community in the U.S. Men and women who have this inexpensive machine can turn out huge quantities of Rubber Stamps. Working full capacity it can earn as much as \$33.00 an hour for the operator. You don't need experience. We supply everything. And, can show you how you can have this business FREE. Cash in on the lucrative Rubber Stamp business in your community NOW! We'll mail full particulars FREE and no salesman will call. Rush coupon today or send your name on a postcard to:

Rubber Stamp Div. - Dept. R-2-JB  
1512 Jarvis Ave. - Chicago, IL 60626

FOR FASTER SERVICE—CALL TOLL FREE  
800-621-5809—24 hours a day—7 days a week  
In Illinois Call—800-972-5858



### Rubber Stamp Div.

1512 Jarvis Ave., Dept. R-2-JB, Chicago, IL 60626

Please rush full particulars that can get met started in the profitable Rubber Stamp business at home. Include details on how I can get the business FREE! Everything you send is free and no salesman will call.

Name \_\_\_\_\_

Address \_\_\_\_\_

City \_\_\_\_\_

State \_\_\_\_\_ Zip \_\_\_\_\_

Mail This  
↓  
**FREE!**

## HINTS FROM READERS

### Rubber-stamp aid



If a rubber stamp fails to make a good impression, try placing a folded cloth or handkerchief beneath paper being stamped. Four to eight thicknesses of cloth make a big difference.—Tom Clyde

### Dowel marking gauge

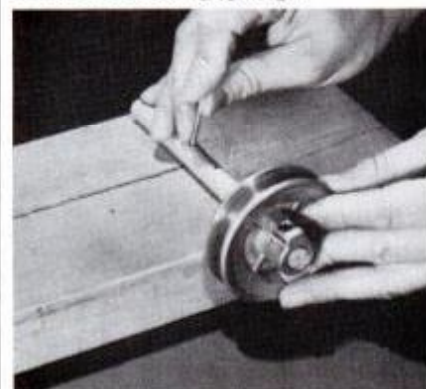

You can make a marking gauge for a specific job using a dowel, a 3-in. pulley and a nail. Bore several holes spaced at 1-in. intervals in the dowel. Insert dowel into pulley. Adjust dowel until a hole is in the correct position for the nail to mark the board. Then tighten the setscrew. Scribe as shown.—Ken Patterson

### Reinforcing chain links



Make the unsoldered links of chain jewelry less likely to come apart by filling the joint with a drop of epoxy or cyanoacrylate adhesive.—Walter E. Burton



# NOW! Learn to repair video cassette and disc systems with NRI's at-home training in TV and Audio Servicing.

NRI training keeps you up with the state of the art so you're thoroughly trained for professional TV and audio service work. New lessons cover the latest advances in home video tape and video disc units, even laser systems. And they're included at no extra costs as part of your NRI course.

## Learn at Home in Your Spare Time

You learn right at home, at your convenience, without quitting your job or going to night school. NRI "bite-size" lessons make learning easier...NRI "hands-on" training gives you practical bench experience as you progress. You not only get theory, you actually build and test electronic circuits, a complete audio system, even a color TV.

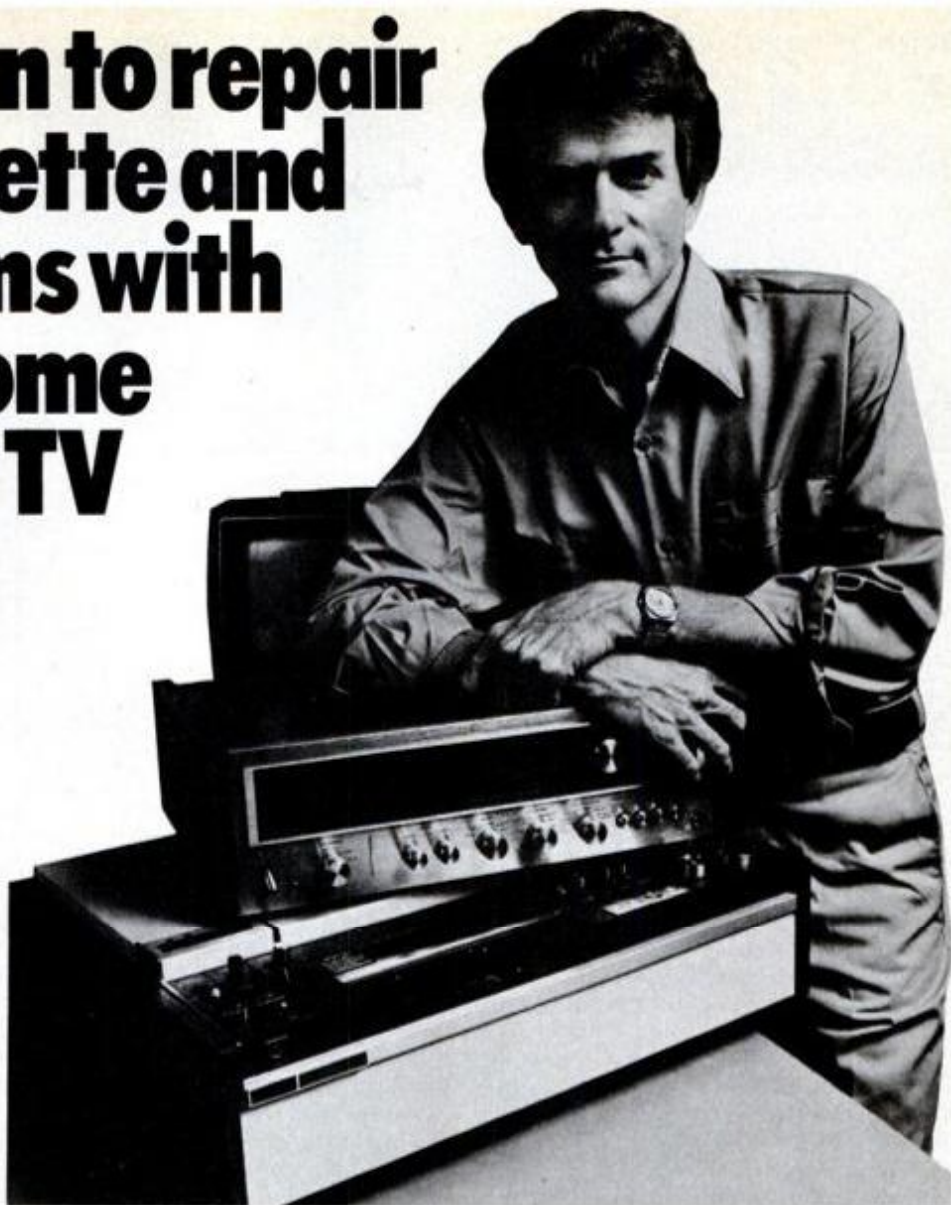

## Build Color TV with Computer Programming

As part of your training in NRI's Master Course, you assemble and keep NRI's exclusive, designed-for-learning 25" (diagonal) color TV, the only one complete with built-in computer tuning that lets you program an entire evening's entertainment. As you build it, you introduce and correct electronic faults, gain understanding and practical experience.

You also construct a solid-state stereo amplifier and tuner, complete with speakers. You even assemble professional test instruments, so you know what makes them tick, too. You build a transistorized volt-ohm meter... a CMOS digital frequency counter... integrated circuit TV pattern generator... even a solid-state triggered-sweep 5" oscilloscope. You use them in your course, keep them for actual TV and audio servicing work.

## Free Catalog... No Salesman Will Call

Send today for the 100-page catalog that shows all the lessons, all the equipment and training material you get. The catalog will show you other NRI opportunity fields like the new course in Microcomputers & Microprocessors, Complete Communications, and more. With the addition of video cassette and disc systems, television has taken on an exciting new dimension. NRI training can put you right in the center of that dimension.

If card has been removed, write to:



**NRI Schools**  
McGraw-Hill Continuing  
Education Center  
3939 Wisconsin Avenue  
Washington, D.C. 20016



# CAR CLINIC

SOLUTIONS  
FOR MECHANICAL  
HEADACHES

BY  
MORT SCHULTZ



## All keyed up

*I'm having a difficult time removing the ignition key from my 1974 Chevrolet Monte Carlo. Occasionally, it's also tough getting the engine started without jiggling the key. Can you help me, please?—Sam Nasca, Rochester, N.Y.*

Sure, Sam. The key probably has a burr, or two, causing it to catch as you pull it from the lock. The same burr, or two, can keep the key from seating and tripping all tumblers, necessary to complete the circuit for starting.

To knock off any sharp edges, buff the key with a wire brush. Then, shoot powdered graphite into the ignition lock. Work the deburred key back and forth a few times. This entire procedure should solve your problem.

## Fire and brimstone

*On uphill acceleration, my 1979 Oldsmobile Cutlass Brougham with diesel engine belches black smoke. There is no missing that I can feel, but there is an occasional light knock. Can you give me your opinion as to the cause?—Charles R. LaDow, San Diego, Calif.*

Considering the smoke and occasional light knock, my first thought is that an injector is sticking in the open position. However, since the car doesn't act up when driven on level ground, the injector theory may not prove to be true. What's another reason, then, for black smoke?

According to a spokesman at Oldsmobile, if injectors are performing properly and the engine is tuned up correctly, smoke at wide-open throttle may be normal. The amount of smoke a diesel engine creates when it's under load is related to the size of the engine.

Engines that have a smaller displacement (4.3 liter, say, like your Olds) will labor and smoke more at wide-open throttle than engines of larger displacement (for example, the 5.7-liter engine used in the Cadillac Seville). The density of the

smoke can be reduced by easing off the throttle as you go uphill, but then the engine has to negotiate hills under reduced power.

I want to add that Oldsmobile, although aware of the smoking-under-load situation, has not issued service instructions to combat the problem, other than to have injector functioning checked. It makes me believe that the condition has to be tolerated.

## One knock after another

*I, too, have fought the "ping" or "cackle" problem with my Chrysler Corp. car, just as Mrs. Gladys Porter described in your Oct. '79 column. The noise occurred during light acceleration of my 1978 Chrysler LeBaron (318-cu.-in. engine) with the transmission in high gear. The Chrysler dealer adjusted timing (as you suggested that Mrs. Porter do), re-routed vacuum hoses, considered replacing the spark control computer and so on.*

*Nothing helped until an assistant service manager referred to a service bulletin which recommended replacing the torque converter lock-up spring in the transmission. Success! The same solution worked for my*

*brother's 1979 Chrysler Cordoba. I think Mrs. Porter should tell this to her dealer. He must have the same service bulletin.—Jim Mershimer, Gibsonia, Pa.*

The service bulletin Jim refers to is 08-26-78, which discusses a spark knock of short duration on acceleration, just after the torque converter locks up.

The modification calls for you to install a new torque converter spring and/or lock-up valve (the parts called for are dictated by the transmission serial number). The repair raises torque converter lock-up speed sufficiently to keep cylinder pressure from increasing to a point which fuel octane can't handle. If the cylinder pressure rises above this point, gasoline explodes, which causes detonation (spark knock).

The lock-up torque converter acts as a clutch, which engages just after the transmission shifts to high gear. If torque converter speed is too low, the engine labors until torque converter speed increases. This momentary laboring causes cylinder pressure to rise, which can result in detonation.

The modification described in the Chrysler service bulletin prevents laboring by increasing torque converter lock-up speed to about 40 mph. On some cars, application of this service bulletin can get rid of spark knock. However, over the past several years, there have been a number of service bulletins issued by Chrysler to solve the spark knock problem.

The one that I reported in October is the latest advisory. If your Chrysler engine detonates, see that a mechanic consults *all* service bulletins under service bulletin index head-

*(Please turn to page 60)*

## Pennies from heaven

Our thanks to reader Paul Pollak (address unknown) for sharing this experience, which shows the importance of remembering a common, but often neglected, part. Paul writes:

"I recently checked the oil level of my 1973 Ford Pinto station wagon and was surprised to find it one inch above the FULL mark. Color was milky-gray. A mechanic told me I had 'big trouble'—that water was contaminating the oil. I decided to change oil and filter, and checked coolant level every day. Again, the oil level rose and color turned. Oddly, the radiator stayed full, discounting the loss-of-water theory. Other mechanics all blamed water contamination, but none could say where the water was coming from. Finally, someone said that maybe my PCV valve was clogged, preventing the crankcase from venting properly and causing moisture to condense and deposit water in the oil. Since I replaced the PCV valve, for pennies, I've had no more trouble."

PCV VALVE:  
SOURCE OF OIL-  
CONTAMINATING WATER

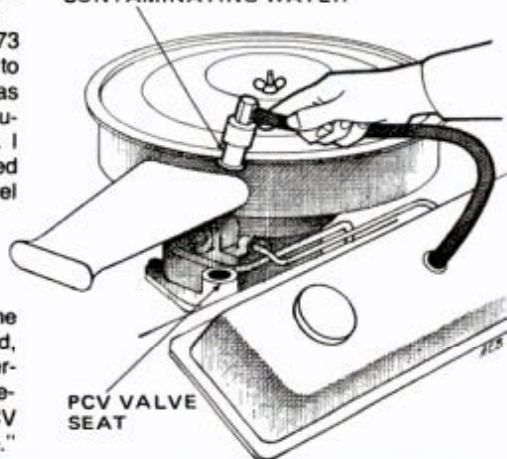





There's a reason so many sports car enthusiasts who own a truck, own a Toyota SR-5 Sport Truck. It's more than just the presence of a 5-speed transmission, or bucket seats. Call it a feeling, the way everything works together. Because "feel" is what sports cars, and the SR-5, are all about.

You'll know what we mean the moment you start the 2.2 liter engine.

It pulls hard, yet the 5-speed shifts into gear with a light, precise feel many genuine sports cars can't match.

The standard power assisted front disc brakes snug the SR-5 to a clean stop, but there's hardly a pip from the tight, all-welded cab. And the standard AM/FM stereo radio, full carpeting, and blacked-out

instrument faces enhance the sporty atmosphere inside.

Everything working in harmony—that's the feeling the Toyota SR-5 Sport Truck shares with good sports cars. *PICKUP, VAN & 4WD Magazine* got the feeling. They put it this way, "...this is how a small truck built by BMW would drive and feel if BMW built small trucks."

## THE SR-5 SPORT TRUCK. THE SPORTS CAR OF TRUCKS.

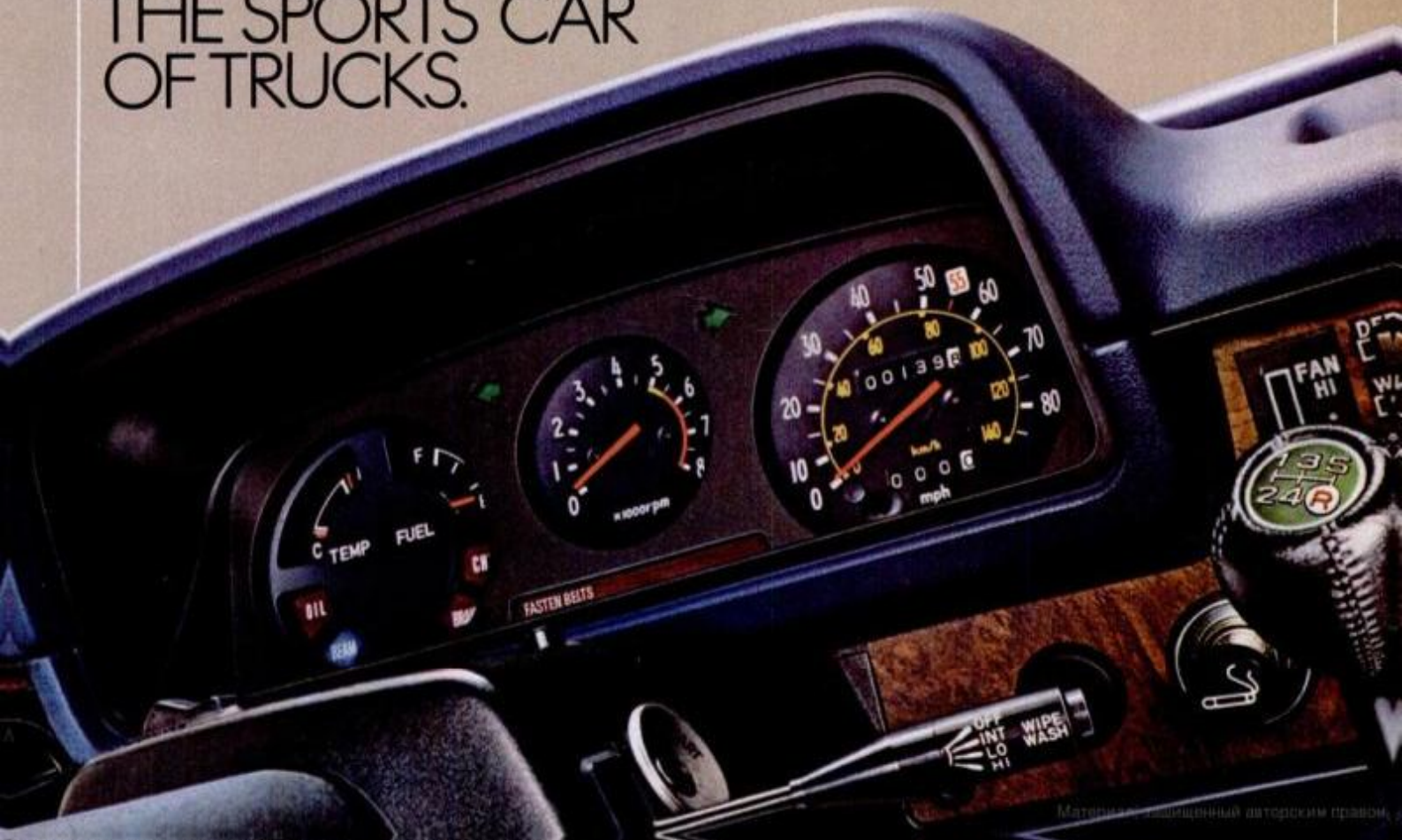



## CAR CLINIC

(Continued from page 58)

ing "Electrical" for those which apply to your vehicle.

### Precious problem

*I own a 1979 Buick Regal with the V6 turbocharged engine, and I'd like to know the best way of removing spark-plugs. Space is limited, especially on the passenger side of the car, and I've been told that the turbo pipes have to be removed before plugs can be removed.—John L. Precious, Long Island City, N.Y.*

Someone's pulling your leg, John. Well, maybe not. The job looks tougher than it is. Get yourself an offset ratchet and short extension, and you shouldn't have too much trouble removing plugs while avoiding the torture of first removing turbo pipes.

By the way, I know this has nothing to do with changing plugs, but it's a good time to remind you to faithfully follow manufacturer engine oil change period recommendations for this engine. Change oil every 3000 miles. A spokesman at Buick told me his department is starting to see turbochargers with bad bearings. Turbocharger bear-

ings fail, primarily, because oil breaks down. With a turbocharged engine, oil breakdown begins at 3000 miles.

### Scratching paint

*I have a problem with the paint job of a 1974 Ford Mustang II, which I recently bought used. I can scrape the paint off with my fingernail. People tell me that in 1974 Ford tested paint mixtures, and this led to a batch of bad paint jobs. Is the rumor true? What do you suggest I do?—Robert M. Runyon III, Drayton Plains, Mich.*

In 1974, Ford used new paints on the Thunderbird and Mark IV, not on the Mustang. Ironically, though, in 1974 Ford issued service instructions to dealers concerning peeling paint. However, as far as *Car Clinic* is concerned, there has not been an abundance of mail from Ford owners complaining of paint problems.

Service instructions suggest that if paint peels, a so-called flash primer should be used when repainting with acrylic lacquer. Says Ford: "This material provides the adhesion necessary for paint to adhere and prevent recurrence of peeling." Ford recommends two flash primers

### Good advice from Goodyear

According to a recent informal survey by *The Wall Street Journal*, the price of gasoline has forced more motorists to garage their cars and find alternate means of transportation. This raises an interesting point. Although a car may not be used as much as before, its rubber products continue deteriorating. So says Goodyear Tire and Rubber Co. The point is: Don't take drive belts and cooling system hoses for granted, just because you've cut your driving by 10, 25, 50 or 75 percent. Check hoses for cracks and a spongy feeling, and check belts for frayed edges and cracking as often as you did before. You can expect these parts to start breaking down two years after being installed, driving or no driving. So says Goodyear.

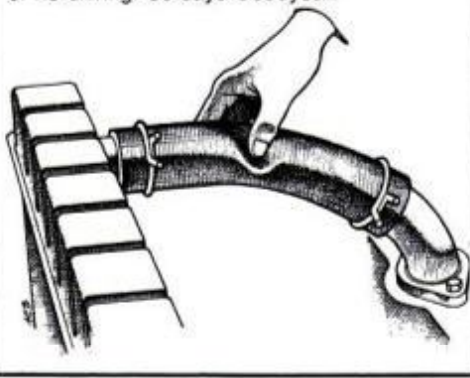

# Lok\*Backs

from  
**CAMILLUS**

Experience, skill and unparalleled pride is clearly reflected in this NEW line . . . each a true masterpiece. Ounce for ounce the finest folding lock-backs on the market today.

They come in 3 sizes, each with etched blade of high-carbon stainless steel that automatically locks in open position, functional design, and hand-contoured wood handle. No. 2 bolsters are solid nickel silver . . . No. 3 and 4 are solid brass. Gift packaged with top-grain leather pouch.

Available at your local sporting goods or hardware dealer. For complete catalog, send \$1.00 to:

**CAMILLUS CUTLERY  
COMPANY**

Dept. E, Camillus, New York 13031





made by Ditzler. They are primer sealer DL-1970, which is neutral gray, and primer sealer DL-1947, which is clear. Both are available from a Ford dealer. When using either of the two, you don't have to strip the finish. Just sand enough to smooth the area, and apply primer followed by acrylic lacquer.

#### The chair recognizes D.R.

Can I use your column to thank Chevrolet and also to offer your readers advice? I have a 1977 model equipped with a 305-cu.-in. engine that has been driven only about 6000 miles.

Starting when the car was new, the oil would turn completely black within 300 miles of an oil change. When I questioned the dealer service department about this, I was told that the color was normal and that this could be blamed on the pollution control gear.

A year after I bought the car, the engine developed a noise. When the mechanic removed the valve covers, he scolded me for not having changed oil, but I had service bills to prove that oil had been changed at three-month intervals and also that I had been complaining of a problem with the oil. At this point, I insisted that

the zone office send a factory representative to resolve the problem. This gentleman discovered a cracked valve guide, which was allowing gasoline and engine oil to mix. Repairs were made and the oil now looks great.

My advice to your readers is, if they buy a new car, they keep all service bills, no matter who does the work. With the bills, they can document complaints and maintenance, and have a leg to stand on when bringing a problem directly to the manufacturer. In my case, the engine was repaired free of charge, although the car was out of warranty six months. Please don't use my name or town if my comments appear. Just sign me—A Devoted Reader.

Thanks, D.R., but let me add something. If you do your own servicing, save the receipts for the products you buy, such as for oil and filters. Keep a diary of when services are done. This will help convince the

#### GOT A PROBLEM WITH YOUR CAR?

Just ask Mort about it. Send your question to the Car Clinic, Popular Mechanics, 224 West 57th St., New York, N.Y. 10019. While letters cannot be answered individually, problems that are of general interest will be published in the column.

man that recommended services were performed during the warranty period.

#### SERVICE TIPS

■ What do you do with an empty CO<sub>2</sub> tire inflator after pumping up the stowaway spare? GM offers three choices: Get the inflator refilled by the dealer; if he can't accommodate you, get it refilled at a fire extinguisher shop; if this fails, exchange the empty inflator for a filled one (the dealer should be able to do this for you).

■ If you hear what seems to be a transmission moan from your 1979 AMC Spirit, Concord or AMX with V8 engine—but only in winter when the heater is being used—have your dealer install a nylon restrictor (part No. 3219619) in the heater core inlet tube. The restrictor solves the problem without affecting heater operation.

■ Cadillac is advising mechanics that the knock you may hear from your diesel engine may not be the spark knock you think it is. It could be piston knock. To find out which it is, retard injection-pump timing as much as possible. This action will quiet down a spark knock, but not a piston knock.

■ Chrysler Corp. has an informative folder for you on how to save fuel when driving any size car. It's free and can be obtained by dropping your name and address to Gas Saving Tips, Box 970-A, Detroit, Mich. 48232. **PM**

## NEW DREMEL BELT SANDER & DISC SANDER IN ONE.

The ingenious combination of a quiet-running, 5" disc sander and 1" wide x 30" long sander-belt makes this the most useful power tool you'll ever own.

The disc handles rough sanding and shaping. The belt sander takes care of the finishing.

3" throat depth, easy belt adjustment make inside sanding simple. Has a platen that provides a rigid sanding surface if you need it but removes for flexible belt sanding.

Great tool if you don't have a workshop. Great tool if you do. Available wherever fine power tools are sold.

Dremel, Division of Emerson Electric Co., Racine, WI 53406.

## YOU'LL NEVER RUN OUT OF USES FOR IT.



MODEL 730



Sharpens, polishes, cleans, grinds metal, wood, some plastics.



Large tilting table, adjustable miter gauge for sanding accurate angles.



Compact. Weighs just 11 lbs. Only 15" high x 10" x 11".

# DREMEL



# DETROIT LISTENING POST

## Turbo Trans-Am pace car

Following on the heels of last year's 10th Anniversary Pontiac Trans-Am Daytona 500 pace car will be a specially designed, charcoal-on-white pace car for the 1980 Indianapolis 500.

With the exception of the unique paint and striping design, the car will be a basically standard, 4.9-liter turbo V8 Firebird Trans-Am. However, it also will have a special hood scoop and "fire-breathing" decal design, silver-tinted hatch-roof panels, white aluminum "airflow" wheels, 3.08:1 limited-slip differential and automatic transmission. The new turbocharged engine is rated at 210 hp at 4000 rpm and 345 foot-pounds of torque at 2000 rpm.

About 6300 replicas of the Indy pace car will be built for sale (except



Limited-edition, 210-hp, turbocharged Pontiac Trans-Am will be the pace car at the 1980 Indy 500. Top speed: 120 mph.

in California, where the turbo 4.9 is not certified for that state's tougher emissions standards), according to Pontiac general manager and General Motors vice president Bob Stempel.

The standard equipment will include four-wheel disc brakes, halogen headlamps, airconditioning, power windows and a specific interior with red instrument lighting, AM/FM stereo radio with cassette tape and a leather-wrapped Formula steering wheel. The Indy pace car decals will be available through Pontiac dealerships.

## Flywheel-powered bus

In the far-flung-future department, we have General Electric working on a petroleum- and pollution-free flywheel-powered city bus, under contracts from the federal Departments of Energy (DOE) and Transportation (DOT). The concept involves equipping a full-size transit bus with a 3000-pound steel flywheel operating in a sealed, low-pressure helium atmosphere. The flywheel is connected to a motor/alternator

that generates electricity to drive a 150-hp propulsion motor.

Range between flywheel charges will be only about 3.5 miles, but getting the flywheel back up to speed will take just 90 seconds, and curb-side recharging stations would be closely spaced. Claimed advantages are clean, quiet, efficient, exhaust-free operation, plus long operating life and low maintenance.

## News from GM and Ford

GM is planning an inexpensive, front-drive subcompact, smaller than the Chevette, for U.S. introduction in 1985. It's dubbed "S-car," and a version of it could be the first production electric car in GM showrooms.

Pontiac Div. is working on a mid-engine, two-seat sports car and looking for corporate approval to produce it in the mid-1980s. It would have a plastic body and use the 2.8-liter, V6 engine from the "X-car" (Phoenix), but it would be a mid-engine, rear-wheel-drive design, like Fiat's X 1/9. Considering the fate of previous sports-car proposals from GM divisions, it's unlikely to get the corporate nod, unfortunately.

Ford, meanwhile, is developing a smaller version of its fuel-saving, four-speed automatic overdrive (AOD) transmission for use in cars smaller than the 1980 Cougar and T-Bird. It should be ready by 1983.

## More on alternate fuels

There's a small but growing trend toward conversion of cars and trucks to either propane or natural gas, which can be accomplished at a cost of \$1000 to \$2000 per vehicle (See *Saturday Mechanic: Converting Your Car To Propane*, page 48A, Sept. '79, for details). Both are clean burning and cost less than gasoline, but their present use is mostly limited to large fleets, due to fuel availability and other problems.

There are only 25,000 propane dealers in the United States, and you'd have to build your own refueling station to run on natural gas. Also on the negative side, both natural gas and propane have less energy content than an equivalent amount of gasoline, meaning lower fuel mileage and performance; both can be highly dangerous if improperly handled; finding qualified service on the road for either system is

next to impossible. For the firsthand story, though, Mort Schultz will report in a future issue his experiences involved with finding and using propane.

More practical as a way to stretch gasoline supplies someday may be a product called HydroFuel, which is being tested by Avis Rent-A-Car System Inc. Developed more than 10 years ago by United International Research Inc. of Hauppauge, N.Y., HydroFuel is an unspecified mixture of unleaded regular gas and alcohol in solution with water, plus a special stabilizer, Hydrelate, which acts to prevent separation of the liquids.

Avis says test results have been encouraging so far in a fleet of 30 management cars, but there are no plans as yet to try the stuff in rental cars. No word on when or if HydroFuel might be marketed to the public.

## RV maintenance manual

There's no point in trying to sell that motor home as long as people are worried about fuel availability and cost. So you might as well keep it in tip-top shape and enjoy it when you can.

Toward that end, a new *Motor Home Chassis Service Guide* has been prepared by RV specialists at Chrysler. It puts into "layman's language" some of the more simple do-it-yourself maintenance and repair procedures that a motor-home owner can make on his recreational vehicle or chassis."

The booklet is being given away at Chrysler-sponsored service seminars at National RV Rallyes and shows; or send \$5 to Manager, Technical Services, Chrysler Corp., Service and Parts Div., Box 1718, Detroit, Mich. 48288. **PM**

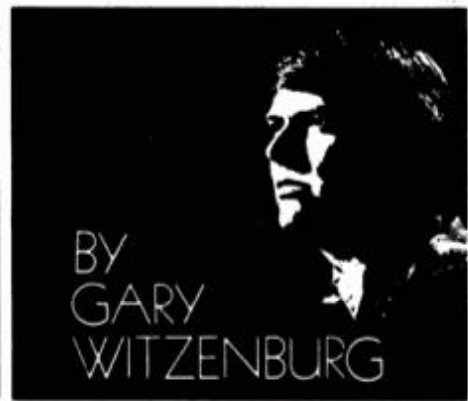



# Vertical thinking from Audiovox: the first complete, one-piece sound system for your 1980 Chevy Citation.

And some horizontal thoughts  
for the other GM X-body automobiles.

**GM only makes a vertical radio for the Citation. Audiovox makes the only vertical radio/cassette or radio/8-track unit for the Citation (and they make it in one piece).**

Audiovox engineering overcame the problems of space and gravity that GM couldn't. Not surprising – Audiovox produces auto sound systems, not automobiles. Instead of a separate under-dash tape player, the Audiovox units are designed in one piece. And it wasn't simply a matter of turning a conventional unit on its ear – gravity won't stand for that.

#### **Audiovox does – Detroit doesn't.**

When you buy a new car, Detroit offers countless options. When you buy a sound system for that new car, Audiovox offers more options than Detroit has ever heard of. So why settle for a car manufacturer's radio if you can choose an S.P.S. by Audiovox. Like the 5 different vertical one-piece sound systems for your 1980 Chevy Citation or one of 64 other S.P.S. systems for all



Available at new car dealers only.

new cars. And Audiovox guarantees your S.P.S. stereo for the life of your car, Detroit *doesn't!*

#### **All this and a lifetime warranty.**

Audiovox is the *only* manufacturer to offer a *lifetime* warranty on all of its S.P.S. auto sound components. Should a component from one of these systems malfunction during the warranty period due to a manufacturing defect, it will be replaced without cost, except for removal and installation costs. The lifetime warranty remains in effect for as long as you own the car.

*The Audiovox S.P.S. sound systems were developed in the audio research laboratories of Shintom Co., Ltd., Yokohama, Japan.*

*For further information, write to:  
R. Harris, Technical Director  
Dept. 10K, S.P.S. Division  
Audiovox Corporation, 150 Marcus Blvd.  
Hauppauge, NY 11787.*

© 1979, Audiovox Corp.





Got a ceiling problem?

## Cover it up! Dress it up! Light it up! Quiet it down! With a new Armstrong suspended ceiling.

Whatever your ceiling problem—covering up an old or damaged ceiling, adding a new room, or finishing off a basement—an Armstrong suspended ceiling is a problem-solver with style. Beautiful. Washable. Fire-retardant for extra protection. Acoustical to help quiet down any room. Preengineered for energy-efficient fluorescent lights.

Best of all, with an Armstrong suspended ceiling, like Royal Oak shown above, solving your ceiling problem is a do-it-yourself project. There are no staples or glue to mess with, no plastering or sanding. The big 2' x 4' ceiling panels simply drop into the color-matched Super White Grid. The ceiling is easy to install and easy to keep looking fresh and new. If a panel gets damaged, just lift it out, and lay in a replacement.



If lighting is a problem, you can install Armstrong fluorescent fixtures with the ceiling . . . for lighting where you want it, not just where the builder put it.

You can install a beautiful new Armstrong suspended ceiling almost anywhere in your home. Briefly, here's how:

Hang the Armstrong Super White metal runners about three inches below your existing ceiling or open joists (about six inches with light fixtures).

Snap the Armstrong Super White cross tees into the main runners, and lay in the ceiling panels. It takes some time, but it's easy. You can do it!

See your Armstrong ceiling retailer for a broad selection of suspended ceilings. Find him under "Ceilings" in the Yellow Pages. Or send us this coupon, and we'll send you his name and a free full-color brochure.

Armstrong, Dept. 02RPM  
Peoria, IL 61614

Please send me your new color  
brochure on suspended ceilings.

Name \_\_\_\_\_  
Street \_\_\_\_\_  
City \_\_\_\_\_  
State \_\_\_\_\_ Zip \_\_\_\_\_

**Armstrong**

CREATORS OF



THE INDOOR WORLD®

Материал, защищенный авторским правом



# HINTS FROM READERS

## Emergency tap wrench



A large turnbuckle can double as a tap-wrench handle in an emergency. Fit the square end of the tap into the turnbuckle. Then tighten the screws to hold the tap securely.—*Ken Patterson*

## Stamp storage



A small plastic storage box having compartments and a transparent lid is handy to store stamps by denomination for easy identification.—*A. A. Reyner*

## Solder secures blades

After you've coiled a bandsaw blade for storage, use short strips of solid, but soft, wire solder to hold the loops together. The solder will secure the blade without damaging the teeth—as regular wire can. When the solder finally does break from repeated use, it can still serve its original purpose.—*Howard E. Moody*

## File guide

If you file your own hand saws, particularly the fine-tooth saws, blacken the teeth with candle smoke before you begin work. If you are then interrupted in your work, the discoloration will indicate the teeth that remain to be filed.—*Robert Stuman*

# Important News For BACKACHE SUFFERERS!

Momentum® Tablets are 50% stronger than Doan's.

Before you take Doan's Pills for your muscular backache, remember this: Momentum Tablets are 50% stronger than Doan's Pills. That means Momentum gives you 50% more pain reliever per dose to relieve backaches.

For pain, inflammation, and stiffness of muscular backache, there's no stronger medication you can buy than Momentum Muscular Backache Formula.

Momentum does more than reduce

pain and soothe inflammation. It has a calmativite, too, to help relax tension that can cause muscles to tighten. Doan's has none. As pain is reduced, stiffness eases, you move more freely in minutes.

If you are taking Doan's, you are not getting all the pain reliever you get in Momentum Tablets. For relief of backache pain, just 2 Momentum Tablets give you the strongest medicine possible without a prescription. Take only as directed.



FINANCING  
NO  
PROBLEM!

## Have you been priced out of today's housing market?

Miles Homes could be the answer!

If you have the ambition and desire to build your own home, then the Miles Plan could be for you. **THE MILES HOME OWNERSHIP PLAN IS UNIQUE.** Your desire and dedication are more important than ready cash — start now to build the home of your dreams...the Miles Way.

- 36 months to build.
- There is a representative near you. Phone: (612) 588-9700.

Miles has nearly 30 years experience helping over 15,000 families to build their own home. Send coupon today to see how Miles can help you.

- Liberal credit — Low monthly payments while building.
- Foundation assistance.
- Land may not have to be fully paid for.
- Pre-cut materials, blueprints, **step-by-step instructions.**

Send me your **FREE** Great Homes Idea Book

**MILES HOMES, Dept. 0210**  
4500 Lyndale Ave. N., Minneapolis, MN 55412

Name \_\_\_\_\_

Address \_\_\_\_\_

City \_\_\_\_\_ State \_\_\_\_\_ Zip \_\_\_\_\_

County \_\_\_\_\_

Phone ( ) \_\_\_\_\_

I plan to do  all or  part of the work

\$1.00 enclosed for priority handling

**MPMO**

**Miles Homes**

12 Inslco A Division of Inslco Corporation





## Who could blame you?

CHIVAS REGAL • 1.75 LITER BOTTLE • 12 YEARS OLD WORLDWIDE • BLENDED SCOTCH WHISKY • 86 PROOF • GENERAL WINE & SPIRITS CO., N.Y., N.Y.



# New heat pump lowers your hot-water bill



Compact heat pump connects to an existing electric water heater, can rest on floor, mount on shelf or be hung from ceiling.

If you have an electric water heater, you can cut your operating costs in half or more. This is the good word for a new heat pump, the first of its kind, that attaches easily to any existing electric water heater. Called Efficiency II, it's a trim, compact add-on that looks and works much like an airconditioner. It extracts heat from the air and feeds it to the water tank, thus relieving the regular heating coils of much of their load.

According to its maker, E-Tech Inc., the heat pump can reduce a water heater's electric consumption by 56 to 70 percent, saving \$150 or more a year for a family of four. Installation takes only an hour or two, using ordinary tools. Price is \$549 from E-Tech Inc., 3570 American Dr., Atlanta, Ga. 30341.—S.M.G.

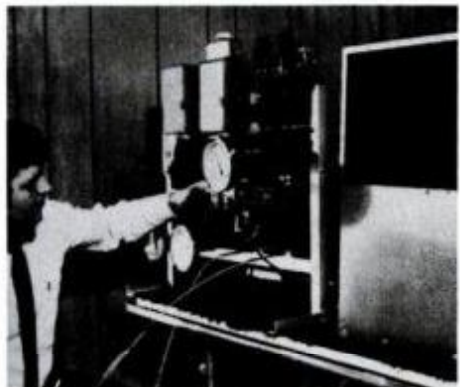

Test setup comparing heat pump with conventional electric hot-water heater shows unit can cut costs more than 50 percent.



## Quick! Name 13 energy savers!

**qb** ... your assurance of quality  
the GIBSON-HOMANS company  
1755 Enterprise Parkway • Twinsburg, Ohio 44087 • 216/425-3255

FACTORIES: Twinsburg, Ohio; Matawan, New Jersey; Conyers, Georgia; Tampa, Florida; Des Moines, Iowa; Gretna, Louisiana; Kansas City, Missouri; Portland, Oregon; Richmond & Vernon, California; Ennis, Texas; Malton (Toronto) Ontario, Canada; Boucherville (Montreal) Quebec, Canada.



### 24 inch Band SAW CUTS TO CENTER OF 48 inches

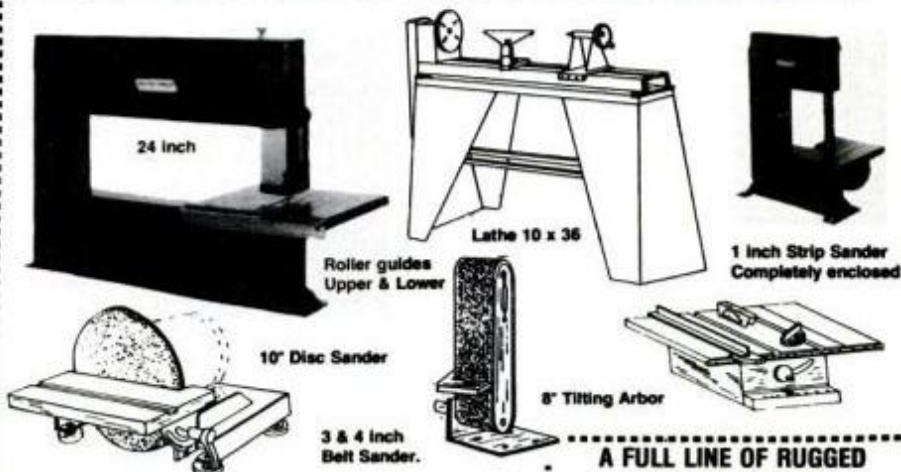

#### DU-ER TOOLS — RUGGED ALL STEEL — BALL BEARING — EXTRA VERSATILITY

Du-er's 24 inch Band Saw gives the handyman the versatility of an industrial tool at a price he can afford, the quality that is demanded by industry. The Band Saw, one of the best cutting principals for wood, metal or plastic, has been limited in use because of the depth of throat. The B-24's Big throat and new drive feature gives longer blade life, cuts metal, wood or plastic.

Du-er tools are fabricated of Heavy Gauge Steel, 30 years experience developed new engineering features with accuracy, and ball bearings for added quality. Extra features created by manufacturing know how makes Du-er tools available at exceptionally low prices, yet no quality is sacrificed.

You can order direct from Factory where there is no Dealer represented ... Free Information. F.O.B. factory

#### A FULL LINE OF RUGGED ALL STEEL TOOLS:

24 inch Band Saw	199.95
12 inch Band Saw	159.95
10 x 36" Rugged Lathe Ball Bearing	89.95
3 inch Belt Sander Ball Bearing	24.95
4 inch Belt Sander Ball Bearing	39.95
8 inch Tilting Arbor Saw	99.95
10 inch Disc Sander Table Model	69.95
1 inch Strip Sander	69.95
Deluxe Stand for all Tools	39.95

**DU-ER TOOLS, 5448 Edina Industrial Blvd., Minneapolis, Minn. 55435.**





# NOW, For The First Time- Use The WOODBITS The PROS Use!

PROFESSIONAL WOODBITS are NOT available in hardware stores. Stores only carry spade bits which tear grain, clog and bind; or metal-cutting twist bits that also bind and — what's worse — "skate" off the mark.

## Why is a WOODBIT Best?

A PROFESSIONAL WOODBIT has four features designed specifically for wood:

- A CENTER SPUR that locks your bit on course and so prevents "skating".
- TWO CUTTING SPURS that start and dimension a perfectly round hole.
- EXTREMELY SHARP FLUTES extend from the two cutting spurs and continue the cutting action all the way through the wood . . . shaving the sides smooth. Most important, the two spurs will not splinter the wood as the bit cuts through . . . as spade or metal cutting bits do.
- THE CUTTING FLUTES ARE ENGINEERED for maximum chip ejection so that your drilling machine won't bind and burn out.



LEICHTUNG'S PROFESSIONAL WOODBITS can be used in portable drills or drill presses with chucks of  $\frac{3}{8}$ " or more. 7 piece chrome-vanadium steel set includes  $\frac{1}{8}$ ,  $\frac{3}{16}$ ,  $\frac{1}{4}$ ,  $\frac{5}{16}$ ,  $\frac{3}{8}$ ,  $\frac{7}{16}$  and  $\frac{1}{2}$ " sizes. Lengths from  $2\frac{3}{4}$  -  $5\frac{3}{4}$ ". Made by German professionals for pros or "wood-be" pros.

**7 PIECE WOODBIT SET ..... ONLY \$15.95**

## Depth Adjusting Collars For The 7 Piece Set



Get the precision of a costly drill press for under \$10.00! Here's how they work: Figure the desired depth of the hole; slip the collar over the bit to that depth; fix the collar position with the set screw — and drill. 7 collar sizes,  $\frac{1}{8}$  -  $\frac{1}{2}$ ", fit each bit in the 7 piece woodbit set. Tool steel.

**7 Piece Depth Adjusting Collars ..... ONLY \$9.95**

**Buy Both Bits And Collars And SAVE \$2.00..... ONLY \$23.90**

## Complete Your Bit Set With These 4 BIG WOODBITS

Primarily for use in a drill press, these larger diameter bits can be used in any powerful portable drill with a  $\frac{3}{8}$ " or larger chuck. These are really top quality professional cutting tools. The  $\frac{3}{8}$ " bit is  $7\frac{1}{8}$ " long, the  $\frac{1}{2}$ " bit is  $11\frac{1}{8}$ " long, the  $\frac{3}{4}$ " bit is  $14\frac{1}{8}$ " long, and the 1" bit is  $17\frac{1}{8}$ " long. No collars available.

**Buy All 4 Big Woodbits (SAVE \$12.95)..... ONLY \$39.95**

**COMPLETE 18 Piece Drill Set (SAVE \$16.80)..... \$62.00**

18 Piece Set Includes:

7 Bits:  $\frac{1}{8}$  -  $\frac{1}{2}$ "; 7 Collars to match plus 4 BIG WOODBITS:  $\frac{3}{8}$ " - 1".



You Can Order Tools By Phone: **Call TOLL FREE 800-321-6840**  
Ohio Residents Call: (216) 831-6191

Yes Ric Leichtung, please send me:

- \_\_\_ 7 pc. Woodbit Set(s) @ \$15.95 .....
- \_\_\_ 7 pc. Depth Collars To Match Above Set @ \$9.95 .....
- \_\_\_ 14 pc. Bit and Collar Set(s) @ \$23.90 (SAVE \$2.00) .....
- \_\_\_  $\frac{3}{8}$ " BIG Woodbit(s) @ \$10.95 .....
- \_\_\_  $\frac{1}{2}$ " BIG Woodbit(s) @ \$12.50 .....
- \_\_\_  $\frac{3}{4}$ " BIG Woodbit(s) @ \$13.95 .....
- \_\_\_ 1" BIG Woodbit(s) @ \$15.50 .....
- \_\_\_ All 4 BIG Woodbits @ \$39.95 (SAVE \$12.95) .....
- \_\_\_ Complete 18 pc. Drill Set(s) @ \$62.00 (SAVE \$16.80) .....

Shipping, Handling and Insurance **\$1.75**

Method of Payment

Check  VISA  MasterCard

TOTAL

Card # \_\_\_\_\_

Good thru \_\_\_\_\_

Name \_\_\_\_\_

Address \_\_\_\_\_

City \_\_\_\_\_

State \_\_\_\_\_

Zip \_\_\_\_\_

**LEICHTUNG**  
"THE Workbench People"

4944 Commerce Parkway # 280PM  
Cleveland, Ohio 44128  
Phone 216-831-6191



Enclosed is my order for woodbits. As my BONUS, please

send your 68 page, 1980 color catalog of hard-to-find woodworking tools, PLUS all catalogs and new tool bulletins FOR THE NEXT TWO YEARS FREE!

Enclosed is \$1.00. Please send your 1980 color catalog PLUS all catalogs and bulletins FOR THE NEXT TWO YEARS!

# PHOTO HINTS

## Clamp support



A small camera may be supported on many surfaces with a spring photo clamp. The swivel-bolt device is fitted with a bolt, which is then screwed into the tripod socket.—Ken Patterson

## Chemical-depletion chart



This chart makes it easy to plot the depletion of photo chemicals. Using manufacturer's specs, compute the number of prints of each size obtainable from each batch of chemicals. Draw chart showing each print capacity and mark off the number of prints of each size as they are sent through each bath. When chart indicates solution is exhausted, replace with fresh batch.—Kenneth Brooks

## Tape trick



When using your camera's self-timer or when making long exposures, light may enter the camera through the eyepiece if you're not looking through the viewfinder. To eliminate the problem, cover the eyepiece with black tape after composing and focusing.—Bob Berger



# BEST BUY

TOP QUALITY AND POWER COMBINE  
TO GIVE YOU THE FIRST AIR FRESHENING/  
IONIZING SYSTEM THAT EVEN SAVES YOU MONEY



## SYSTEM FIVE

The Air Energizer shown above is the least expensive negative ion generator on the market, selling for only \$74.95. That's \$5 cheaper than our nearest competitor. It is also the best. If you are comparing units you need to know the facts. With the UTP Air Energizer you even get *more* for your \$5 /*less*. We can charge less and give you a higher quality unit because we are a common ownership company. And we are in business to serve you and your environmental needs. Our major competitor is a mail order house that promotes dozens of products every year, but the UTP Ion Research Center is a branch of an educational publishing company. For the past several years we have researched and developed one special electronic product: negative ion generators. This specialization enables us to be the industry's frontrunners. And the System Five Air Energizer is our latest breakthrough in Air Ionization.

### WHAT DO IONS DO FOR YOU?

Frankly, as marketing director I was pretty skeptical of our Ion Research team's work until one day two years ago when I was walking to work. The season's first thunderstorm had just ended. The air was sparkling clean and almost magically alive. I took a deep breath. The new energy in the fresh air made my head tingle. But as I walked into the office building where I work I immediately felt a drop in energy. The air was dull and lifeless—"stuffy feeling".

Was I experiencing what our Ion Researchers had been telling me all along for the last four years? I decided to test it. I put a UTP Air Energizer on my desk. Skepticism gave way to enthusiasm. I felt great. I still have that unit on my desk.

### WHAT MADE THE DIFFERENCE

Have you ever wondered what makes this kind of difference in the air? It isn't just our attitude when we're out in Nature versus being in a crowded city. It isn't that it's a weekend and not a workday.

The difference lies in the electrical balance of the air or the quantity of "ions" present.

### WHAT ARE IONS?

Ions are electrically charged atoms in the air with either a positive or negative charge. The sun and cosmic rays as well as lightning and fast-moving water (like waterfalls, surf) generate trillions of negative ions every day. The more negatively ionized the air, the fresher and more alive it is. Air pollution, artificially controlled climates (with air conditioning and heating) and electronic equipment all produce excess positive ions, depriving the air of these small negative air ions and creating dead "stuffy" air.

### WHAT'S THE SOLUTION?

Our rapid-growth technology, which sometimes takes its toll on the quality of our air, has also come up with the solution. Following Nature's model of the thunderstorm which uses a high electrical charge to purify, revitalize and stimulate the air, the UTP Air Energizer has been developed imitating this process. Both the thunderstorm and the Air Energizer fill the air with negative ions, restoring the natural electrical balance to the polluted, energy-depleted air. But the Air Energizer can be used indoors in the home, office, work-shop, laboratory, etc., keeping a fresh supply of ionized oxygen flowing from its emitters night and day. This new breakthrough in fresh air control is not a cover-up which masks or deodorizes, but the unit actually removes the dust, smoke, bacteria and pollen particles from the air by attaching ions to them and causing them to sink to the earth where they can be vacuumed up rather than inhaled. At the same time ions electrically stimulate the energy-stripped air.

### MORE FOR LESS

Why do we say you get more for less money? A typical marketing technique is to take your weakness and assert that it is one of your strengths. This is exactly what our competitor has done. Their ads proclaim the wonders of "miracle fuzz", the bronze fuzz ball emitter on their unit. But using bronze fuzz and calling it a new invention is really old hat. It was first introduced in England many years ago. In fact we ourselves brought out a bronze fuzz unit called System Three over a year ago because it's cheaper than needles. But we are discontinuing it because we want to maintain our reputation for the highest quality, and stainless steel emitter needles are so much better. A single, large fuzz ball emitter is difficult, if not impossible, to clean. It quickly gets so dirty that its efficiency is reduced. We are the only manufacturer we know of that uses *self-cleaning* stainless steel emitter needles.

### YOUR CHOICE OF TWO TOP-QUALITY UNITS!

There's only one unit that's better than System Five. That's our own System Four. It sells for \$159. It has an even higher ion output. Plus! Our special **Dial-An-Ion** allows you to adjust the ion output anywhere from low to high. Not everyone knows that the need for ions varies. A large smoky room will require higher output than a small room. And some people want fewer ions while sleeping than while working. The new System Four is our answer to this need for output flexibility. And we're the first and only ones to offer this special feature at this price. If System Four is better why did we bring out System Five?

Not everybody is willing to pay \$159 for an air ionizing unit, no matter how good it is. Just like not everyone drives Rolls Royces. Most drive less expensive cars.

System Four is for the person who wants the absolute best quality and doesn't mind paying a little extra to get it. If you want highest ion output, flexibility, and a beautiful oak paneled case, buy System Four.

If you want something at half the price of System Four, but still better than any other units costing up to \$250, buy System Five.

### HOW TO GET ONE

To place your order now just send a check for **\$74.95** plus \$3 shipping for System Five. Or send **\$159** plus \$4 shipping for System Four. Tell us your full street address as we cannot ship to Post Office boxes.

Our unit is dependable and trouble-free, but if by rare chance any problems occur our service-by-mail center sends off your unit within 24 hours of receipt or sends a replacement so you are not without fresh air and can enjoy your dust-free environment. And each Air Energizer is backed by a full one year limited warranty.

### HOW TO GET ONE FAST!!!

Credit card holders can call our toll-free number below. Order a unit now and if you are not satisfied with its effects within 10 days simply return it for a full cash refund. Order your Air Energizer today.

# UTP

Read "The Golden Egg"

University of the Trees Press  
ION RESEARCH CENTER  
BOX 644 PM, BOULDER CREEK, CA 95006  
Call Toll-Free . . . 800-538-0750  
In California call (408) 338-6663  
Send check or use your Master Charge,  
Visa or American Express card.

### WE HAVE ION DETECTORS!

Now you can prove to yourself which unit has the highest output. These high quality, low cost detectors enable you to do scientific tests and comparisons. Our **Econometer** contains a neon light that blinks in the presence of negative ions. The more ions, the faster it blinks. The **Ionometer** gives you a sensitive meter to compare readings between units. The **Ionoscope** gives you three sensitivity ranges for advanced and accurate detection.

**ECONOMETER . . . (pen size) . . . \$7.50**

**IONOMETER . . . (3" x 2" x 1 1/4") . . . \$49.95**

**IONOSCOPE . . . (5 1/2" x 3" x 1 1/4") . . . \$99.95**

Add \$2.00 per detector for shipping.



5 mg. "tar", 0.5 mg. nicotine av. per cigarette by FTC method.

© 1979 R. J. Reynolds Tobacco Co.

# DORAL II

Only 5 mg tar.  
No other cigarette with  
this little tar...

...has this much taste.

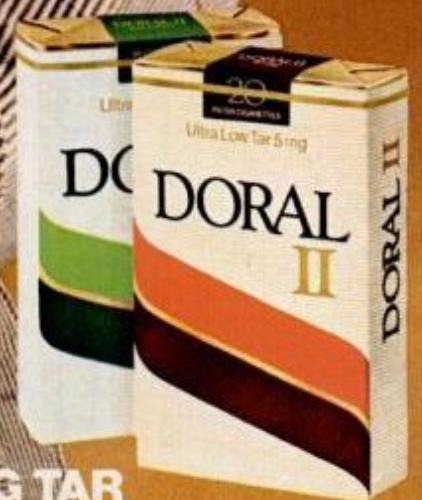

ONLY **5** MG TAR

Get what you never had before:  
Satisfaction with ultra-low tar.

Warning: The Surgeon General Has Determined  
That Cigarette Smoking Is Dangerous to Your Health.



# APPLIANCE CLINIC

## QUESTIONS ANSWERED

### Searching for universality

*Is there some all-universal home appliance parts storage depot where homeowners can purchase parts? It seems that five years after an appliance is marketed, you can't get parts. For want of some inexpensive components, consumers have to discard perfectly good washers, dryers, refrigerators—the list is endless.*

*Are some companies more accommodating than others? If so, you should tell us which they are, so we can buy from them and avoid the offenders of "planned obsolescence."—C.C. Cromley, Chantilly, Va.*

Most appliance manufacturers maintain an inventory of spare parts for a minimum of 10 years following discontinuance of a model. In fact, manufacturers usually provide parts for at least 15 years. Maybe you aren't going to the right supplier for your parts.

Although there is no single universal parts storage depot that stocks all parts (none that we've been able to uncover, anyway), there are many companies throughout the country that provide replacement parts for many models. A list of these was provided in the April '78 *Appliance Clinic*. If you can't find a supplier in your area, we suggest you get in touch with one from another area. Most of the companies on the list we provided have mail-order facilities.

### Facts on vacs

*I think I have a problem with a Sears Wet and Dry Pickup Home and Shop Vac. The first model I bought (758.17885) leaked air from the rim of the tank and cover. Sears service, saying the vac was defective, replaced the unit with a bigger model (758.17871). This one, too, has air escaping from around the full circle of the cover. However, suction is good. When I put my hand over the nozzle, the amount of air escaping from around the rim diminishes.*

*Neither the Sears sales staff nor the service department seems to have a solution. Everyone has a different opinion. Can you give me a straight answer? Is this machine defective, too?—Peter J. Canarelli, Bethpage, N.Y.*

No, and neither was the first vac you had. Sears vacs are supposed to "leak" air around the rim. In fact, the rim is part of the exhaust system

and the vac is designed to exhaust about 25 percent of its total exhaust from the rim.

Don't compare this Shop Vac with a conventional vacuum cleaner. The Shop Vac has tremendous force—in fact, it moves over 200 cu. ft. of air per minute (cfm), as compared to 70 cfm for the average home vacuum cleaner. Exhausting, therefore, plays an important part in the machine's operation.

When you put your hand over the nozzle, you are reducing the load on the vacuum, so it isn't moving as much air as it normally does. This accounts for the reduction in exhaust. When the exhaust is reduced, so is the amount of air escaping around the rim.

### Giving support

*Glasses in the upper rack of my KitchenAid Model KDR-66 dishwasher don't come clean most of the time. Neither do fruit dishes, saucers and plates. I feel there isn't enough water pressure to spray the upper rack. Repairmen have not corrected the problem. Please help.—Mrs. James E. Wallace, Webster Groves, Mo.*

Your theory about low water pressure may be valid, but the most common cause of this problem is low water temperature. Unless water is 140° to 160° F., the detergent won't break down, and food will remain on dishes.

If water temperature is at the proper setting, chances are the wash-arm support is loose, cutting down on the amount of water pressure the wash arm delivers. Replace the wash-arm support. This entails removing the wash arm, fine and coarse strainer assembly and wash-arm support. It is not a difficult job, but if you need help, write KitchenAid for service literature: Customer Relations Dept., KitchenAid Div., Hobart, Troy, Ohio 45374.

### Life begins at 20

*Our General Electric top-loading dishwasher Model 1SU-60P leaks water from the top of the tub. A new rubber gasket provided by GE was installed, but water still leaks when the machine starts its washing cycle and also during the rinsing cycle. What can I do? The machine works fine, except for the leak.—Mrs. Harry A. Sikma, Chicago*

That's saying something, since this dishwasher is about 20 years old. One or both of two problems may be present. First, perhaps the gasket wasn't installed properly. This gasket isn't the easiest to secure. If it isn't stretched sufficiently, it has a tendency to roll in toward the tub. Lacking the proper contour, the rubber gasket may be allowing the water to leak.

The second possible problem is that the spring of the spring-loaded top cover may have weakened in 20 years. If so, the cover may not be closing tightly enough to keep water from leaking, although you are pulling the lever that closes the cover as hard as you can.

On a hunch, I'd replace the spring, too. Who knows? The machine may be good for another 20.

### 'Boiling' refrigerator

*The compressor of my Whirlpool side-by-side refrigerator, which is only two years old, was recently replaced. Now, when it shuts off, a noise resembling the sound of boiling water comes from the tubing for about a minute. The noise wasn't there before the replacement. The serviceman tells me pressure is equalizing. Please advise me on how to solve this problem.—Ted M. Niec, West Middlesex, Pa.*

It's true that some equalization of pressure takes place in the system, but if you didn't hear noise before the refrigerator was repaired, you shouldn't hear noise now. The tubing may have accidentally been misrouted, or there may not be ample charge in the system.

If this repair was made by an authorized Whirlpool representative, call Whirlpool headquarters in Michigan. The company will contact the service technician. Together, they will make sure the refrigerator is operating as it should.

Call, toll-free, 800-253-1301. If the repair wasn't made by an authorized Whirlpool service technician, call anyway. Whirlpool may suggest an appropriate course of action for you to follow. **PM**

*If you have a question about any appliance, send it to Appliance Clinic, Popular Mechanics, 224 West 57th St., New York, N.Y. 10019. Sorry, but letters cannot be answered individually. Problems of wide interest will be discussed in this column.*



**These four matched volumes tell you and show you everything any building or carpentry job...from fixing a roof to building even building an addition or a house!**

# Take this 4-volume CARPENTERS AND BUILDERS LIBRARY

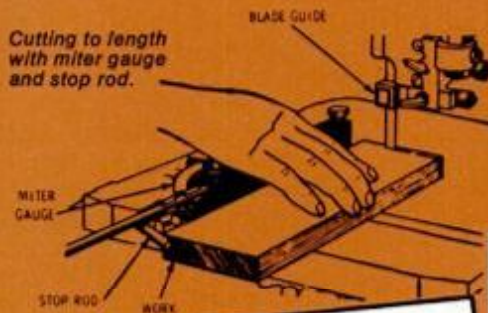

FOR ONLY **\$295** (regular price \$24.50) when you join Popular Science Book Club

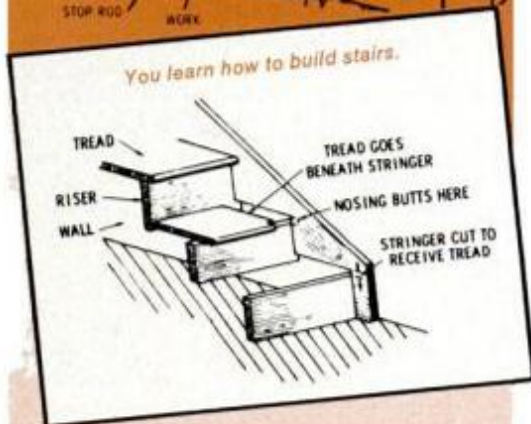

## How Popular Science Book Club Works

Just mail the postpaid card to get your \$24.50 4-VOLUME CARPENTERS AND BUILDERS LIBRARY. Send no money now. We'll bill you later for only \$2.95 plus delivery and handling.

Then, about every four weeks (15 times a year), you'll receive a Club bulletin describing the coming main selection and alternate books also available, all at Club discounts. If you want the main selection only, do nothing. It will be sent automatically. If you don't want the main selection, or want alternate books, or no books, please make sure to indicate your wishes on the Instruction Form and return it to us by the date shown. Club mailings are carefully scheduled to assure you of at least 10 days in which to do this. But in the unlikely event that you don't have 10 days, and you receive an unwanted selection, you may return it at our expense.

After receiving your joining shipment, your only obligation is to buy two more regular selections or alternates in the next year. After that, membership may be cancelled at any time, by either you or the Club.

DISCOUNTS UP TO 50%. All books are offered at substantial discounts—up to 50% or more. Yet virtually every book is identical to the publisher's edition. Same paper, printing, binding, jacket. The only difference is price.

**AS A CLUB MEMBER**, you'll have an opportunity to choose from more than 100 superb, up-to-date books on a wide range of popular science subjects every year—**AT DISCOUNTS OF UP TO 50%**. (And your only obligation is to buy two of them.) You'll be offered books on home improvement, repair and workshops, remodeling, house building, energy and insulation, wiring, plumbing, cars and car repair, electronics, appliance repair, furniture building, machines and technology and many other home handyman subjects.

This information-packed 4-VOLUME CARPENTERS AND BUILDERS LIBRARY brings you professional, easy-to-understand how-to on just about every build-it-yourself question you'll ever have . . .

- You get a complete how-to book on woods and woodworking tools, how to do all kinds of joinery and cabinetmaking joints, how to do kitchen cabinet construction . . . *and more.*
- You get a complete how-to book on all standard specs of every element in house construction, including how to read plans and make your own . . . *how to lay out a home workshop . . . and more.*
- You get a complete how-to book on laying out the foundation, how to do concrete block construction, house framing, chimneys, fireplaces, porches, patios, insulation . . . *and more.*
- You get a complete how-to book on every aspect of roofing, flooring, doors, windows, stairs, plus how to use stationary and portable power tools, plus tips on painting, maintenance, repairs, termite protection . . . *and more.*

You get step-by-step instructions on everything from reading a building plan to building a house (including the foundation), doing all the carpentry in it—and keeping the house in A-1 shape for a lifetime. And thousands of show-how pictures make it all amazingly easy, even for a novice. Let's look at a few of the remodeling and fix-it jobs you learn how to do . . . You learn how to replace worn or missing shingles. How to fix chimney flashing leaks. How to repair stairs (or build them from scratch).

If doors need fixing or fitting, you can find out how to do it from these books. If you want to lay new flooring, you can just turn to these books to find out how to do a first-rate job with wood-tile, linoleum, asphalt, rubber or ceramic tiles. If you want to build a fireplace, you'll find out exactly how from these books . . .

This marvelous 4-book library also tells you how to use all kinds of power tools to maximum advantage (most of them have great versatility). You learn about woods—their characteristics, strengths, best uses. You learn about fasteners—nails, screws, bolts, more—their holding power, size-strength ratio, and how to use each.

These books teach you scores of tricks and shortcuts used by carpenters for measuring, cutting, raising, fastening, finishing—every technique and job. They give you the answers to just about every carpentry question you'll ever have. And they can save you thousands of dollars in the years ahead.

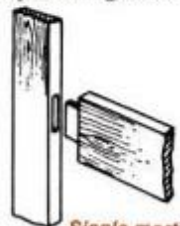
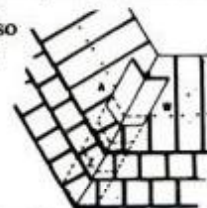

Single mortise and tenon joint.

Installing metal shingles under wood shingles.



**you need to know to do just about  
a foundation, installing new paneling,**

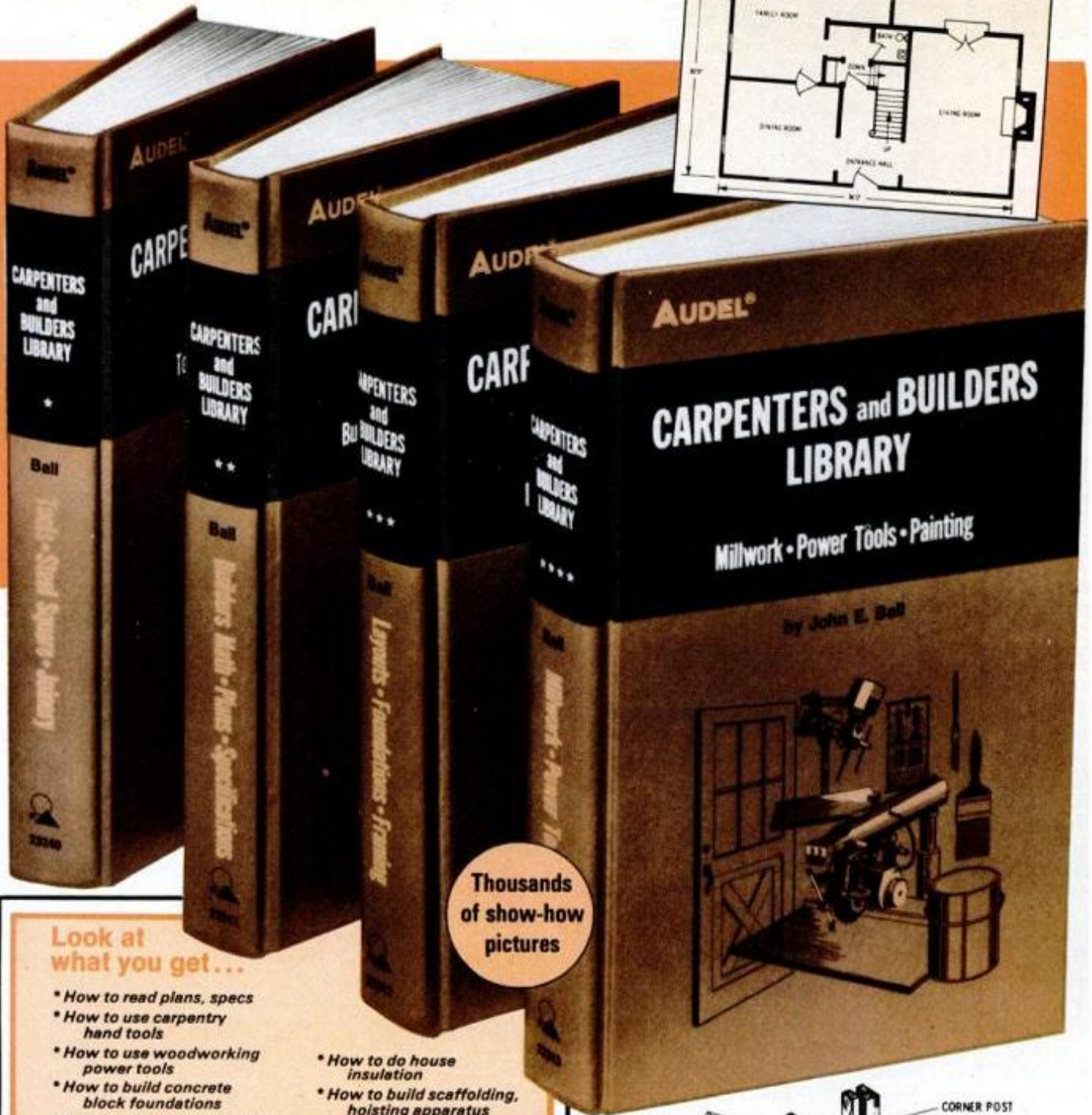
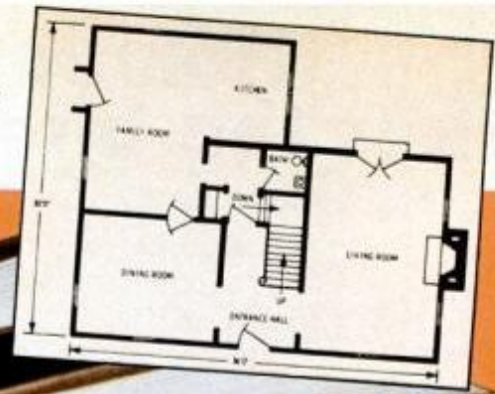

Thousands  
of show-how  
pictures

**Look at  
what you get ...**

- \* How to read plans, specs
- \* How to use carpentry hand tools
- \* How to use woodworking power tools
- \* How to build concrete block foundations
- \* How to choose best woods, materials, fasteners
- \* How to plan and build roofing, flooring
- \* How to construct walls, doors, windows
- \* How to make joints
- \* How to build stairs
- \* How to build chimneys and fireplaces
- \* How to use builders' math, do surveying
- \* How to make kitchen cabinets, counters
- \* How to do cabinetmaking joinery
- \* How to build A-frame, 1- and 2-story houses
- \* How to plan a home workshop
- \* How to do house insulation
- \* How to build scaffolding, hoisting apparatus
- \* How to do wood pattern-making (for castings)
- \* How to do sheathing and siding
- \* How to do cornice construction
- \* How to plan termite protection
- \* How to do interior-exterior painting
- \* How to build girders and sills
- \* How to make concrete forms (and molds)
- \* How to sharpen saws
- \* How to build skylights
- \* How to do house maintenance and repair
- ... and much more

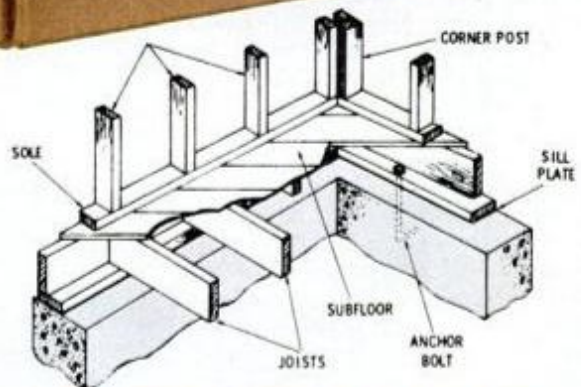

MAIL THE ATTACHED CARD OR WRITE TO:

**Popular Science** BOOK CLUB  
P.O. Box 2006, Latham, N.Y. 12111



# Homebuilt tractor cab takes the bite out of snowblowing



Easy-to-make plywood tractor cab keeps driver warm in severest Midwest winters.

**C**learing snow after a Michigan blizzard can be a cold, miserable job even with a tractor-propelled snowblower. After one rugged winter of braving freezing temperatures and facefuls of wind-whipped snow, I was determined not to go through another without some kind of tractor cab for protection. But cabs for small yard tractors aren't easy to come by. The few accessory cabs available for some models can't readily be adapted to fit other makes.

The answer was the homebuilt cab you see here. It's basically simple, yet sporty-looking, costs very little to make, and keeps me warm, dry and comfortable in the coldest, stormiest Midwest weather. And it's handy in summer, too. While it can be quickly removed if you wish, I find it offers welcome shelter against blazing sun and sudden cloudbursts.

## Planning the cab

The cab is designed to fit my particular tractor—a Pennsylvania model—but can be altered to suit most other tractors of the same general size and type. The main attachment member is a piece of 3/4-in. pipe fastened to the tractor frame just ahead of the footrests. Its length is determined by the width of the tractor at the rear wheels.

The front of the cab is supported entirely by this pipe and is anchored to it by metal straps, as shown in the

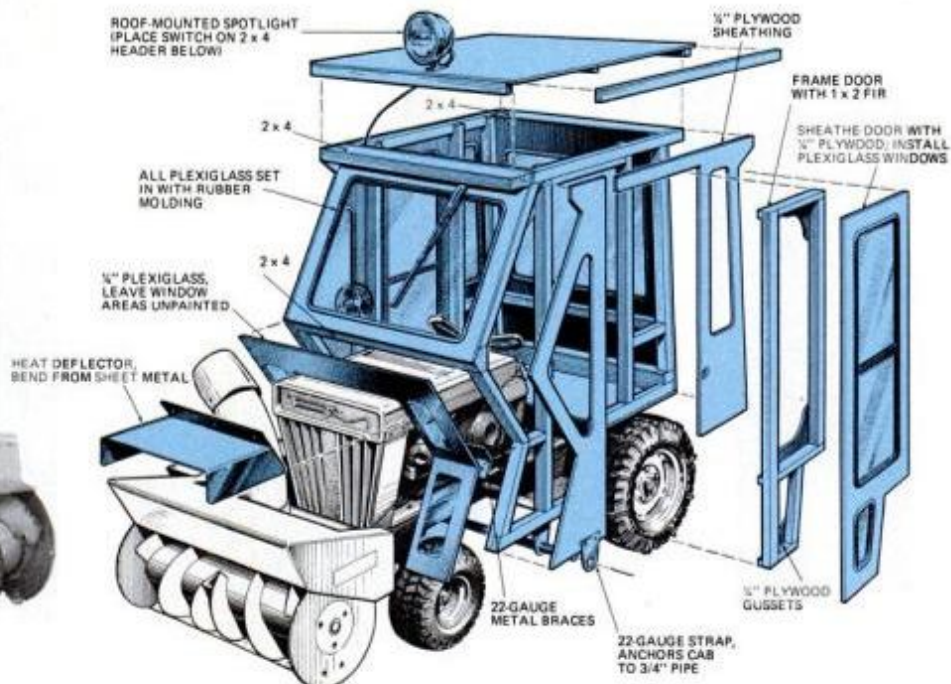

drawing above. The back of the cab merely rests on the tractor's rear-wheel fenders with no attachment necessary, making installation and removal simple. For tractors that have no fenders, or where the fenders aren't strong enough to take the weight, a second pipe can be fastened to the tractor's frame at the rear to support the back of the cab in the same way as the front.

To plan the cab's layout, I used a primitive but effective method that will work with any tractor. With the help of my son, I held a piece of 1/4-in. plywood up against the side of the tractor, level with the front support pipe, and traced on the locations of the control levers, footrest and rear fender. Then I sat in the seat to de-



Roomy cab encloses operating controls, is readily entered through large side door.

termine the desired headroom and other interior dimensions. The object here is to keep all controls inside the cab with plenty of room around them for your free, unobstructed movement.

## Framing the enclosure

The plywood sheet, with the various locations and dimensions marked on it, thus provides an accurate pattern for cutting out the sides of the cab. The edges of the side panels and door opening are reinforced all around with 1x2 cleats on the inside. Cross rails of 2x4 stock join the sides together and support the roof, windshield and rear window.

The door is cut from one side panel. Do not saw it out, however, until all framing is complete. This will keep the side intact for greater structural rigidity and easier handling during assembly.

The windshield and windows are made of 1/4-in. clear acrylic plastic set into rubber car-window moldings obtained at an auto junkyard. The moldings make a trim, weather-tight seal and allow the windows to be slipped out easily in summer for ventilation. A heat deflector made of sheet metal channels warm air from the engine cowling into the cab. In summer, this, too, is removed. An electric wiper from a junkyard keeps the windshield clear, and a roof-mounted spotlight shines where you're going. Now snow removal is almost fun.—Kenneth G. Poeder



# Long-range luxury. 1980 Ford LTD.



LTD Country Squire

## Best mileage of any full-size wagon.

Fifty years of Ford wagon technology come together in the 1980 LTD. It's versatile, good-looking and practical with even better mileage than last year—the best of any full-size wagon.

**17** EPA EST. MPG      **24** EST. HWY. MPG

For comparison excl. diesels and other Ford Motor Co. wagons. Your actual mileage may differ depending on speed, distance and weather. Actual hwy. mileage will probably be lower than est. Calif. mileage lower.

## Unsurpassed room.

No wagon sold in America has more passenger or cargo room than LTD. Based on EPA volume index (112 cu. ft. passenger, 53 cu. ft. cargo). And LTD Wagons are rated to tow up to 6,000 lbs. with an optional towing package.

See your Ford Dealer and ask about the Extended Service Plan.



Better ideas for the 80's FORD.

**FORD LTD**

FORD DIVISION



**340-Mile Est. Range; 480-Mile Est. Highway Range.** Based on LTD's 20-gallon gas tank and EPA mileage estimates. Your range may differ. Actual highway and California range will probably be lower.

P R N 0 3 1

**Automatic Overdrive Option.** First fully automatic transmission with the benefit of overdrive on an American car.



**LTD Luxury.** Optional Interior Luxury Group shown with rich velour cloth, available in super-soft vinyl or optional leather.



**Cargo Room.** With the tailgate down, you can actually slide in a 4' x 8' sheet of plywood . . . flat.



**3-Way Tailgate. Dual Facing Rear Seats.** Tailgate swings open like a door or down like a platform. Dual facing rear seats, an exclusive Ford Motor Co. option, provides seating for two or an extra 7.7 cu. ft. of under-floor stowage (with seat cushions removed).



**NEW  
INVENTION**



**Beat the Gas  
Pump and Improve  
Your M.P.G. with**

**Gastell™**

**The gas and money  
saver that really works!**

- Improves mileage up to 30%
- Government Tested
- Audio signal tells you of fuel wastes
- Quick and easy set-up

**Make any car more fuel-efficient  
with Gastell™**

You don't have to be told that gasoline costs are skyrocketing. And all of us want to help conserve. But now there's a low cost, truly effective way to stretch your mileage and your gas dollars *without driving less!* It's called **Gastell™**.

**How it works**

Simply stated, **Gastell** is a revolutionary new electronic vacuum gauge that emits an audible signal when gas is being wasted by improper acceleration. **Gastell** actually monitors the intake manifold pressure to tell you if pressure is too low to allow full combustion of the fuel entering the carburetor. *By correcting acceleration, you conserve gas that would otherwise be passed through the exhaust system as unburned vapor.*

**A constant and reliable fuel saver**

In start and stop traffic, driving up and down hill, going around corners, on the expressway, in virtually every driving situation, **Gastell** instantly tells you if you're wasting fuel. And because **Gastell** features an audio signal, as well as a visual one, your eyes never need leave the road. *For safety and savings, Gastell makes great sense!*

**Proven effective in independent tests**

Unlike many gimmicks and gadgets you may have seen advertised that try to capitalize on the gas crisis, **Gastell** is a low-cost, totally reliable fuel saver that independently-conducted tests have proven to be truly effective. **Gastell** provides an immediate solution to the problem of wasted gas—it can actually im-

*prove your miles-per-gallon by up to 30% without reduced engine performance!* What's more, **Gastell** also gives warning of faulty ignition, carburetion or spark plug performance. It's completely safe for any car engine.

**For every person, every car!**

**Gastell** is conveniently designed in preset 4, 5, 6 and 8 cylinder models and arrives with all electrical, vacuum and mounting hardware, as well as quick, 1-2-3 instructions. Very easy, 15 minute installation.

**Use it for 30 days—and SAVE!**

The remarkable fuel-saver **Gastell** is available during our special introduction for just \$39.95. Use it in your own car for 30 days and if not totally convinced that **Gastell** is THE ANSWER to the fuel shortage, simply return it and we'll send you a prompt, courteous refund.

**Credit Card Customers**

**Order Now—  
Call Toll-Free  
800-228-5440**

(In Neb. call 800-642-8777)

**CAMBRIDGE  
INTERNATIONAL, Inc.**

8700 Waukegan Rd. Morton Grove, IL 60053 (312) 966-5510

**Clip and Mail To: Dept. M12**

Please send me \_\_\_\_\_ Gastell(s) at \$39.95 each plus \$3.95 shipping and handling. (Ill. residents add 6% sales tax).

Please indicate number of car cylinders:

4  5  6  8

Check or Money Order enclosed.

Charge to:  Master Charge  Carte Blanche

Visa  American Express  Diners Club

Account # \_\_\_\_\_ Exp. Date \_\_\_\_\_

Name \_\_\_\_\_

Address \_\_\_\_\_

City \_\_\_\_\_ State \_\_\_\_\_ Zip \_\_\_\_\_

Signature \_\_\_\_\_

© Cambridge International, Inc. 1980

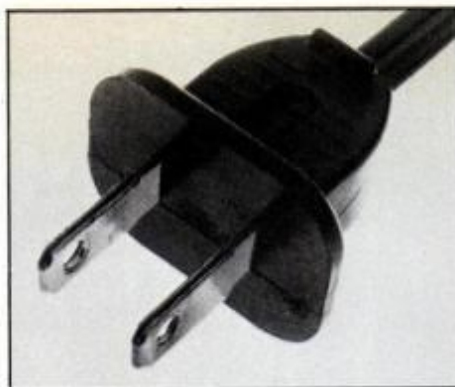

A protective front flange on the plug face and stricter specifications for blade dimensions are some new UL requirements.

**UL pushes  
for safer  
appliance  
power cords**

**S**pecial safety features on all indoor extension cords and supply cords for kitchen appliances are now required by Underwriters Laboratories. The requirements were made to minimize the risk of children sustaining electrical burns.

The program is intended to reduce accidents in which a teething child mouths the connection of an appliance cord and an extension cord, or sucks the unused end of an extension cord. It is also meant to reduce accidents in which an older child, who can't separate an appliance plug and an extension cord, yanks them apart with his mouth.

Specifically, the requirements call for designs that will: 1) ease mating an appliance plug to an extension cord; 2) make it easier to grip a plug and 3) reduce the likelihood of contact with live parts.

To accomplish these goals, UL engineers are requiring manufacturers to: 1) comply with stricter specifications for both blade dimensions and performance tests that monitor how easily a plug can be inserted into an outlet and how well it fits; 2) provide plug faces that are constructed with a front flange; 3) use larger outlets with contacts more deeply recessed in their slots than previously and 4) provide closures for unused extension cord outlets.

When purchasing extension cords and kitchen appliances, parents of young children should look for the features mentioned above. **FM**

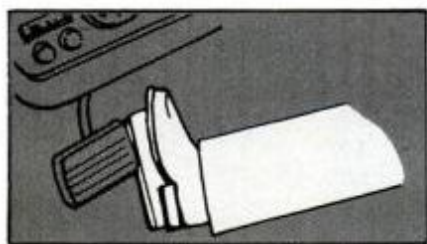

Improper acceleration can waste up to 30% of your car's fuel supply. Gastell prevents that with an audio signal that tells you you're wasting gas. It's the low-cost solution to the energy crisis!



# EARLY TIMES. THE WAY IT WAS, IS THE WAY IT IS.



**1870. The first transcontinental train trip.**

*On May 23, eight of the most elegant train cars America had ever seen steamed out of Boston for the Pacific Coast, with 129 distinguished guests aboard.*

*And when they gathered to celebrate in the mahogany-paneled smoker, what other Kentucky whisky would have been more appropriate than Early Times?*

*Today, its smoothness is just as prized. Because we're still slow-distilling it the same way we did in 1860. So you don't have to look back to the good old days. You can look forward to its great taste tonight.*

86 OR 80 PROOF, EARLY TIMES DISTILLERY CO., LOUISVILLE, KY.  
© 1979.



1860

TODAY



# Shop-made hardness tester for metalworkers

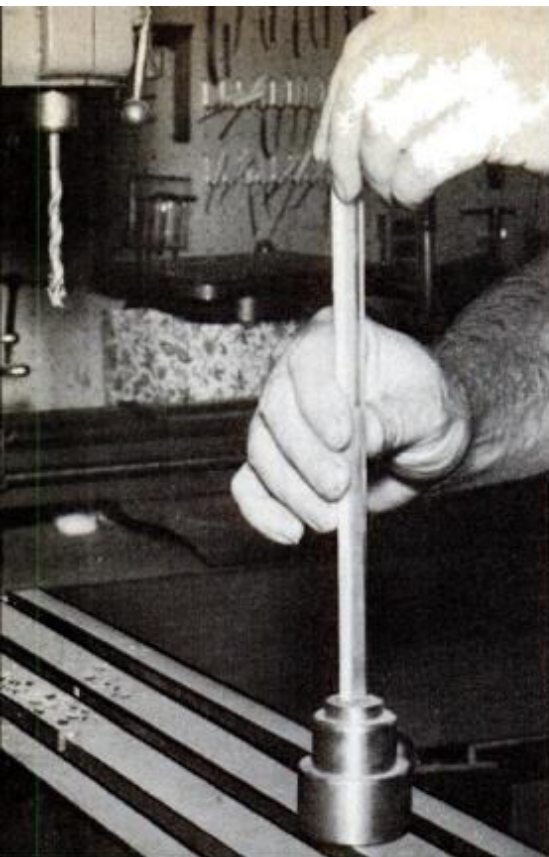

Easy-to-make, metal-hardness testing device is a must for serious metal shops.

Anyone who works with metals knows that a hardness tester is a very useful device. If you know the hardness of a piece of metal to be turned in a lathe, you can save valuable time setting the feed and speed. There is no guesswork in determining the correct rake and relief angles to be ground on the bit for the most efficient cutting. Knowing hardness will also let you look up the yield and impact strengths of welds and metals. When overhauling an engine, hardness tests on reground valves and shafts can save you time and heartache.

Although industrial hardness testers cost thousands of dollars, you can make a simple and inexpensive one in an hour for about \$1. It's portable so that you can take it to the job—and its accuracy is within 2 percent.

This testing device works because when a steel ball is dropped on a piece of metal, it will retain more energy and bounce higher the harder that metal is.

## Making the tester

Theoretically, such factors as length of tube, inside tube diameter and ball weight will not affect the results. However, for practical reasons we suggest the dimensions shown in the diagram. The plastic tubing is available at plastic-supply houses. The  $\frac{3}{16}$ -in.-dia. steel ball can be obtained from a discarded ball bearing.

## Using the tester

First you must calibrate your tester and draw up a graph like the one shown. The slope of the line on your graph may differ slightly from ours since the steel ball you select may not be as hard as the one we used.

To calibrate your tester, obtain two pieces of metal with known, but different, degrees of hardness. Then calculate the percent of rebound of each by noting the rebound height and dividing by the original height. Plot the percentages against hard-

ness and draw a straight line through both points.

Hardness of any metal can now be read on the graph. Follow these steps:

- 1 Remove all rough machining marks from test piece by filing.
- 2 Remove all rust, scale, grease, and dirt from the test piece.
- 3 Keep the test piece level and firmly supported.
- 4 Hold the tester vertical.
- 5 Pull trigger to drop the ball and observe rebound reading on the scale.
- 6 Test in six places to get the *maximum* reading. Do not use the average of all readings.
- 7 Calculate percent of rebound and use graph to find hardness.

Neither this nor any other tester will give a correct reading in two cases. One is when you test a thin piece of metal not firmly supported. The metal will deflect from the falling ball, and this spring effect will give a low reading.

The second is when a piece is either surface work-hardened or surface annealed due to improper machining, polishing or heat treating. If you suspect this, file or machine the top layer in a place that does not affect the looks or operation of the piece and test there.

The list on the facing page will

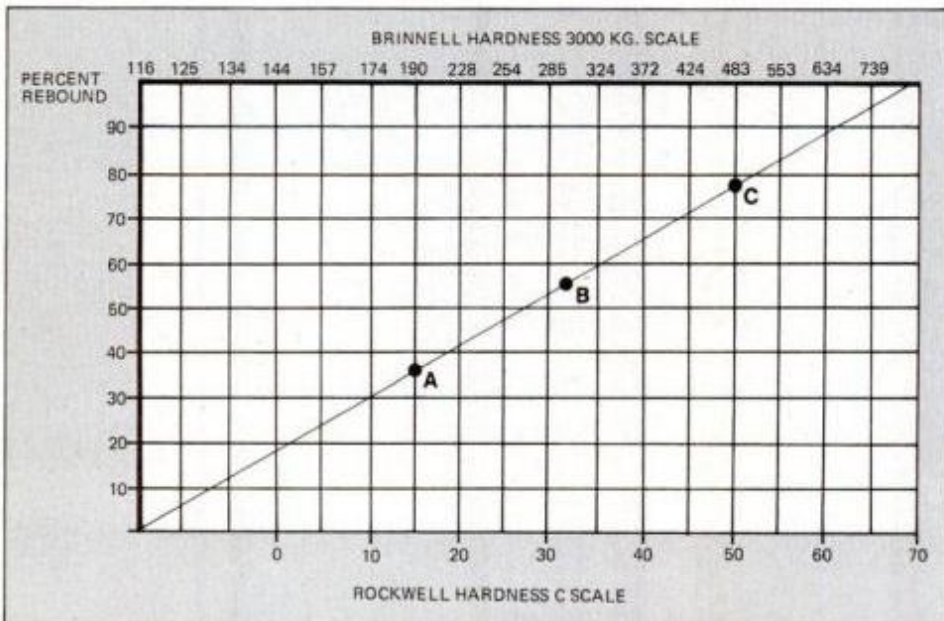

Plot the percent of rebound of samples (A and B) with known hardness. Draw line through points. Then determine hardness of C by plotting its rebound on the graph.

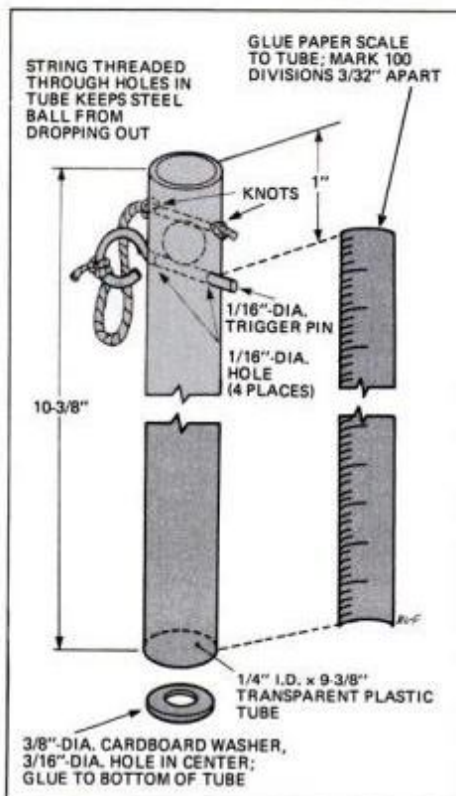



help you identify metals once you have determined their hardness.—  
*Villy Diernisse*

**Typical working hardness of some metals**

AISI Steels	Brinell Hardness 3000-Kg. Scale	Rockwell Hardness C Scale
1020 Hot-rolled or annealed	120	
1021 Cold-rolled	160	6*
1040 Annealed	130	
1040 Hot-rolled	135	
1040 Cold-rolled	210	19*
1040 Heat-treated	250	24
1340 Heat-treated and tempered at 400° F.	539	54
2340 Heat-treated and tempered at 400° F.	534	54
4140 Annealed	185	13*
4140 Heat-treated and tempered at 400° F.	545	54
4340 Heat-treated and tempered at 500° F.	540	54
4340 Heat-treated and tempered at 800° F.	447	47
4615 Heat-treated and tempered at 350° F.	634	60
5140 Heat-treated and tempered at 400° F.	545	54
6145 Heat-treated and tempered at 400° F.	555	55
8620 Heat-treated and tempered at 350° F.	705	63
<b>Tool Steels</b>		
A-2 Heat-treated and tempered at 500° F.	634	60
A-6 Heat-treated and tempered at 350° F.	634	60
A-7 Heat-treated and tempered at 300° F.	705	63
A-8 Heat-treated and tempered at 600° F.	584	57
A-9 Heat-treated and tempered at 900° F.	601	58
D-2 Heat-treated and tempered at 450° F.	634	60
D-4 Heat-treated and tempered at 600° F.	634	60
D-5 Heat-treated and tempered at 400° F.	705	63
D-6 Heat-treated and tempered at 900° F.	634	60
D-7 Heat-treated and tempered at 300° F.	739	65
H-13 Annealed	217	19*
H-13 Heat-treated and tempered at 1050° F.	496	51
H-13 Heat-treated and tempered at 1100° F.	457	48
H-13 Heat-treated and tempered at 1150° F.	382	41
H-13 Heat-treated, tempered with nitride case	71	
H-19 Heat-treated and tempered at 1050° F.	553	55
H-21 Heat-treated and tempered at 1100° F.	510	52
H-22 Heat-treated and tempered at 900° F.	510	52
H-23 Heat-treated and tempered at 1100° F.	424	45
L-2 Heat-treated and tempered at 500° F.	523	53
L-6 Heat-treated and tempered at 450° F.	634	60
M-2 Heat-treated and tempered at 1050° F.	739	65
M-3/1 Heat-treated and tempered at 1050° F.	739	65
M-3/2 Heat-treated and tempered at 1050° F.		67
M-7 Heat-treated and tempered at 1025° F.		67
M-10 Heat-treated and tempered at 1050° F.	722	64
M-42 Heat-treated and tempered at 1000° F.		70

*(Please turn to page 84)*

# Rich Lights

from Viceroy



The rich low 'tar.'

Kings and 100's.

Warning: The Surgeon General Has Determined That Cigarette Smoking Is Dangerous to Your Health.

9 mg. "tar", 0.8 mg. nicotine av. per cigarette by FTC method.



**New products.  
New features.  
New technology.**



# MERCURY OUTBOARD

**New for  
1980.**



1980 is the year of the breakthrough for Mercury® outboards. Four new engines, three of them loop charged for better performance and fuel economy. Backed by 40 years of engineering for maximum reliability, and mechanical improvements throughout the line.

### **New Black Max.®**

The new 225-hp Black Max V-6 Mercury delivers more power in a slimmer, lighter, more fuel-efficient design. And to handle all that power, it's engineered with a high-capacity, super-strong bearing system.

### **New Fishpower.™**

The new 3.6-hp, 18-hp and 25-hp Mercs are compact power packages, designed for easy handling. The Merc 18 and Merc 25 are loop charged for better performance and fuel economy. And they're





200 H.P.

150 H.P.

115 H.P.

80 H.P.

50 H.P.

20 H.P.

7.5 H.P.

4 H.P.

# BOARDS FOR 1980

specially engineered for fast and easy servicing — routine maintenance requires no special tools.

## Mid-range improvements.

The redesigned 40-hp Merc runs quieter than ever, but with more power and better performance. The 70-hp Merc, too, provides more performance with a new higher rpm range and a new gear ratio.

## For fishermen.

Sleek new slimline gearcase design and new prop designs for better weed-shedding. Engines that will troll for hours without fouling the spark plugs — and that includes the high-horsepower Mercs.

## Breakthrough in corrosion resistance.

All critical parts are stainless steel or other tough, high-impact corrosion-fighting materials. And

a multi-step metal protection process provides an extra-hard corrosion-resistant paint finish. The result — the most corrosion-resistant outboards on the market, in fresh or salt water.

## Match your needs exactly.

The 1980 Mercury line — more engines than ever before, and the broadest range of power in our history. Now you can match your needs exactly, for greatest fuel efficiency.

At Mercury, engineering leadership means we never stop making them better. We've given you just a few of the reasons here. Your Mercury dealer will be happy to give you the full story. Visit him soon.

**MERCURY  
OUTBOARDS**

A BRUNSWICK COMPANY

Mercury Marine, Fond du Lac, Wisconsin, Canada, Australia, Belgium



# How to cope with the high cost of heating:

**HANDLE WITH KERO-SUN!**

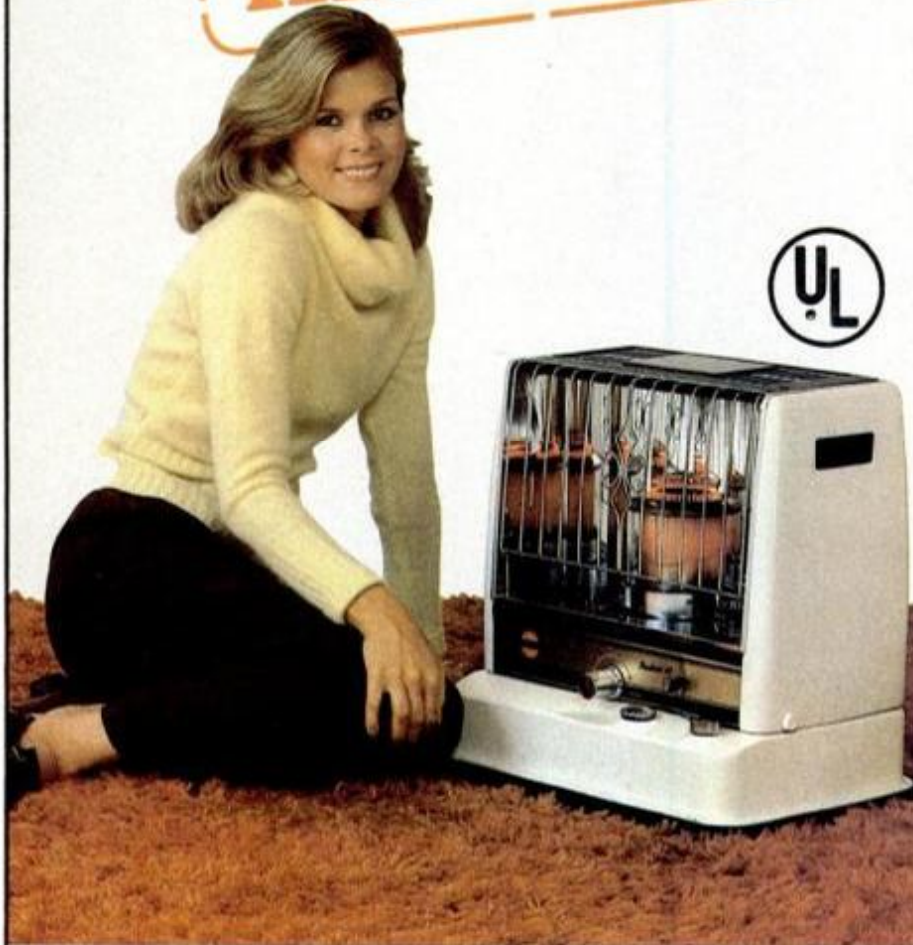

If you're frustrated by the high cost of heating, a Kero-Sun portable kerosene heater gives you low cost heat for only pennies an hour. Heats with almost 100% efficiency for 30 hours on less than 2 gallons of clean-burning, safe kerosene. Every Kero-Sun is thoroughly safety-tested. Each has a battery-powered igniter, so you need no matches to light it and each has an automatic shut-off — in case of tip-over. There's no smoke, no odor, and you need no chimney installation. This may be the winter when a Kero-Sun portable heater is your *only* way to handle the high cost of heating. Write for more information on the whole Kero-Sun line of heaters.

Please send me full facts about Kero-Sun portable heaters and the name of my nearest dealer.

Name \_\_\_\_\_  
 Street \_\_\_\_\_ City \_\_\_\_\_  
 State \_\_\_\_\_ Zip \_\_\_\_\_ Tel.# \_\_\_\_\_



KERO-SUN INC., MAIN STREET, KENT, CT 06757

P-20

## SHOP-MADE HARDNESS TESTER

(Continued from page 81)

Tool Steels (continued)	Brinell	
	Hardness 3000-Kg. Scale	Rockwell Hardness C Scale
M-43 Heat-treated and tempered at 1000° F.		70
O-1 Heat-treated and tempered at 400° F.	688	62
O-2 Heat-treated and tempered at 375° F.	688	62
O-6 Heat-treated and tempered at 400° F.	670	61
P-2 Annealed	100	
P-2 Heat-treated and tempered at 400° F.	688	62
P-4 Annealed	109	
P-4 Heat-treated and tempered at 1150° F.	634	60
P-20 Annealed	190	15*
P-20 Heat-treated and tempered at 1150° F.	300	32
P-20 Heat-treated and tempered at 400° F.	538	54
S-1 Heat-treated and tempered at 400° F.	568	56
S-2 Heat-treated and tempered at 300° F.	634	60
S-7 Annealed	197	17*
S-7 Heat-treated and tempered at 400° F.	601	58
S-7 Heat-treated and tempered at 500° F.	538	54
S-7 Heat-treated and tempered at 900° F.	483	50
T-5 Heat-treated and tempered at 1050° F.	739	65
T-8 Heat-treated and tempered at 1075° F.	739	65
T-15 Heat-treated and tempered at 1050° F.	739	65
W-1 Heat-treated and tempered at 200° F.		67
W-2 Heat-treated and tempered at 500° F.	634	60
<b>Other Ferrous Metals</b>		
Gray cast iron	150	3*
White cast iron	400	43
Malleable iron	120	
Maraging steel type 250 annealed	278	29
Maraging steel type 250 hardened	470	49
Maraging steel type 300 annealed	292	31
Maraging steel type 300 hardened	523	53
Maraging stainless steel annealed	254	25
Maraging stainless steel hardened at 900° F.	457	48
Maraging stainless steel hardened at 950° F.	445	47
Maraging stainless steel hardened at 1000° F.	435	46
420 Stainless annealed	175	10*
420 Stainless hardened, tempered at 600° F.	477	50
440 Stainless annealed	215	19*
440 Stainless hardened, tempered at 300° F.	560	56
<b>Nonferrous Metals</b>		
Aluminum	244	23
Brass (60% copper, 40% zinc) hardened	160	6*
High brass (66% copper, 34% zinc) hardened	183	12*
Red brass (85% copper, 15% zinc) hardened	163	7*
Bronze annealed	74	
Bronze hardened	166	7*
Beryllium copper 20 C cast	153	4*
Beryllium copper 20 C cast and aged	285	30
Beryllium copper 20 C annealed	112	
Beryllium copper 20 C annealed and aged	402	43
Beryllium copper 245 C annealed and aged	424	45
Beryllium copper 275 C annealed and aged	435	46

\*These values are given for comparison purposes only.



# The Easy Tugger™ Load Handler

profits soar from gear technology breakthrough.

**\$29.50**

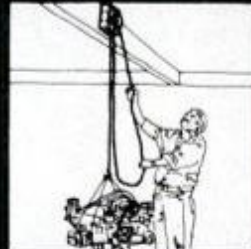
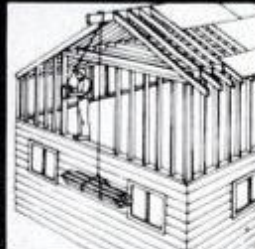

Gear breakthrough replaces ratchet catches.

Use it as a winch.

Use it as a hoist.

Use it with your electric drill or socket wrench.

With the Universal Mount, one winch does the job of many.

Two-speed transmission.

Totally rustproof.

Saves time and money.

With a small investment in an Easy Tugger™ load handler you will increase profits by saving time, money, and trouble. The safety, convenience, and low price of the Easy Tugger™ is made possible by a revolutionary new breakthrough in gears and power transmission protected by a variety of U.S. and international patents including U.S. Patent No. 3,895,540. This new technology puts the old-fashioned winch and hoist in a class with the dinosaur—clumsy, unsafe, heavy, out-of-date.

#### Safest

Easy Tuggers™ are much safer than ordinary winches and hoists. A case protects fingers and knuckles. A replaceable shear ring prevents accidental lifting of oversize loads that might break the cable. There is at least a 400% over-design on all parts. And our **Load Handling Handbook**, included free with each Easy Tugger™, will make you a pro at pulling and lifting.

#### Strongest

Tool Master's Easy Tugger™ has the highest strength-to-weight ratio of any winch. The Easy Tugger™ body is designed to take an 8,000 pound load, and its cable has a safety factor of four times its advertised rating, and it has a totally rustproof case and drive unit.

#### Saves You Money

The Easy Tugger™ costs less and does more than the old-fashioned winch or hoist. Use an Easy Tugger™ to help on those jobs which would ordinarily require expensive extra labor, or a serviceman, jobs like repairing your own car or moving things around the house. Carry one next to your spare tire to pull your car out of a ditch or to use as an emergency tow cable. The Universal Mount, available separately, allows one Easy Tugger™ to be moved easily and quickly from one job to another.

#### The Easiest to Use

The hand cranked Easy Tugger™ can be driven by an electric drill or socket wrench and will adapt to virtually any load handling problem. The cable automatically locks in position with no ratchet catches. The Easy Tugger™ has an easy lifting two-speed transmission which gives maximum efficiency in handling light or heavy loads. You never waste time winding in the cable and the Easy Tugger™ is instantly ready to lift a heavy load.

#### Use it Everywhere

The Easy Tugger™ can be mounted vertically or horizontally, on just about anything; it can be attached with bolts, a chain, a hook, rope, stake, or trailer hitch. This load handler is a boat winch, a utility winch, a chain hoist, a ratchet hoist, a load binder, all in one.

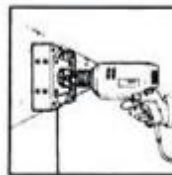
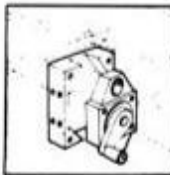

You can take the motor out of your car with the same Easy Tugger™ you use on your boat trailer.

If you use tools, you need the Easy Tugger. The Easy Tuggers™ come in five models for every application—hand powered in ½ and 1 ton models, 1 ton "endless chain" powered, and 1½ ton 110V AC electric "Home and Shop Model," and 1½ ton 12V DC electric "Outdoor Recreation Model." Information on options will be sent with each order. Even if you already own a winch, you should order a copy of our **Load Handling Handbook**, for \$3.50 just to find new ways to use it.

#### No Risk Guarantee

Too good to be true? Try an Easy Tugger™ for thirty days without obligation. If you're not satisfied, just return it and your money will be refunded.

For Credit Card orders, call toll free

**800 835-2246**

Kansas residents call 800 362-2421.

**Tool Master, Inc.**  
P.O. Box 2190  
Boulder, Colorado 80306



Please send me:

To: **Tool Master, Inc.**  
P.O. Box 2190  
Boulder, Colorado 80306

Check or money order enclosed.  
 Mastercharge  Visa Exp. Date \_\_\_\_\_

Acc't # \_\_\_\_\_  
Signature \_\_\_\_\_

Ship to:  
Name \_\_\_\_\_  
Street \_\_\_\_\_  
City \_\_\_\_\_ State \_\_\_\_\_ Zip \_\_\_\_\_

Because of demand please allow  
45 to 90 days for delivery.

Made in U.S.A.

\_\_\_\_\_ ½ ton Hand Powered Easy Tuggers™ with 12' cable @ \$29.50 \_\_\_\_\_  
\_\_\_\_\_ 1 ton Hand Powered Easy Tuggers™ with 30' cable @ \$39.50 \_\_\_\_\_  
\_\_\_\_\_ 1 ton Deluxe "Endless Chain" Easy Tuggers™ with 30' cable @ \$54.50 \_\_\_\_\_  
\_\_\_\_\_ 1½ ton 12V DC Electric Easy Tuggers™ @ \$99.50 \_\_\_\_\_  
\_\_\_\_\_ 1½ ton 110V AC Electric Easy Tuggers™ @ \$109.50 \_\_\_\_\_  
Shipping and handling add \$2.50 for each Easy Tugger™  
\_\_\_\_\_ Universal Mounts @ \$5.00 \_\_\_\_\_  
\_\_\_\_\_ Drill Adapter @ \$2.95 \_\_\_\_\_  
\_\_\_\_\_ Load Handling Handbook @ \$3.50 \_\_\_\_\_  
Colorado residents add 3% sales tax \_\_\_\_\_

Total Price \_\_\_\_\_

PM-2



# ALL OUTDOORS

## Family fishing

Probably one of the best family outdoor activities is fishing together. The kids want action, the adults like relaxation—and with today's new gear, the sport can provide both. By choosing suitable bait-casting, trolling, jigging, spin-casting, spinning or fly-casting equipment, the youngsters are challenged and can catch fish, as well. Those you won't eat may be released, and meanwhile the family small-fry have learned a life-time skill.

This spring many Evinrude motor dealers will be sponsoring "Take a Dad Fishing" activities, with instruction sessions, contests and clinics for parents and children together. It should be an ideal way to combine family companionship with a lot of outdoor fun.

## Tenting out

If it never rains on your campground, if it's never too hot in the sun, never too cold at night, there are never insects or crawling creatures or you never just feel you'd like a little privacy, you can always unroll your sleeping bag right on the ground. Otherwise, the answer is a tent, as so many people going outdoors for a bargain vacation are finding out.

Tents still look much the same as those Omar the Tentmaker was stitching up 800 years ago, and newcomers to the outdoors don't appreciate the improvements of the last 25 years. Unless you have gone out in the middle of a rainy night to tighten ropes that are letting the leaky canvas collapse, broken a toe on a tent peg, tripped over a guy line and landed face down in the mud in the dark, you don't know how far modern tents have come.

Today's smaller models can pack in your backpack without breaking your back. Larger ones, big enough for a big family, can stow easily in one corner of a car trunk. But best of all, nearly every tent manufacturer we have checked this year makes models that can stand on their own. There's no center pole to encumber the inside, no network of perimeter ropes to surround it (and hold it semi-erect as they stretch and shrink with moisture). The new free-standing tents are rigid and light enough to be picked up and moved, when you find there are rocks under the spot where you unrolled your sleeping pad. All have the civilized

addition of floors, and peg loops around the outside edge to stake down your shelter if a wind threatens.

This breakthrough for sleeping out in comfort started about 20 years ago, when Bill Moss invented the Pop-Tent with its flexible fiberglass pole ribs that flipped it up and open with a quick push. Moss Tent Works of Camden, Me., now makes free-standing models in assorted sizes—their six-sleeper Trillium weighs only 13 pounds. Moss and others currently use fiberglass and also hollow aluminum poles with



Free-standing, lightweight tents, like White Stag's Sky Country, now set up fast, have added headroom and no interior poles.

shock cord inside so that they snap quickly into place. Light fabrics allow inner moisture to evaporate, a waterproof rain fly can keep out a downpour and some tent makers are using expensive, breathable Gore-Tex, as well.

If you've never tented out or only remember it from Army days, you should take another look at the modern designs for economical and energy-saving camping this coming year.

## Snow shelter

Better than a tent for camping out in the winter is an igloo. It looks difficult to build, and is—unless you know the Eskimos' techniques. Then it becomes a warm and cozy shelter for snowbelt mountaineers, hikers, cross-country skiers, or anyone in a blizzard survival situation this time of year. The best instruction booklet is certainly *Igloo, Building Eskimo Snowhouses*, \$1.15 from Off Belay, 15630 Southeast 134th St., Renton, Wash. 98055. It tells such things as: how to get a snow saw, your most important tool (buy one, use a machete, or hacksaw one out of 2 x 18-inch stiff 1/8-inch alloy aluminum); how to build with pow-

der snow (tramp it down to pack it before cutting blocks); and how to make the quickest shelter (cover a trench with A-frame blocks).

## On-the-go guides

For warmer camping, Wayne Fears says that, "because swamps have suffered less from the pressures of progress than any other part of the American landscape, they constitute the last sportsman's paradise and nowhere will you find better hunting and fishing." To prove his point, he has just written *The Sportsman's Guide to Swamp Camping*, published by David McKay. Though it might not be your first choice for a vacation, Fears makes it sound more attractive as he explains how it is done.

Exceptionally attractive, and almost as welcome as a tax refund (which, in a way, they are), the new full-color publications for outdoorsmen from the U.S. Government Printing Office are special.

One example, *Stehekin*, is a description of Washington's North Cascade Mountains, prepared by the Interior Dept.'s National Park Service. It has 24 glowing wilderness photos and is the kind that would cost \$12 in a hard-cover bookstore. Instead, it's \$1.50. Another, from Interior's Fish and Wildlife Service, is *Migration of Birds*, a new \$4.25 update of an old standard. It includes modern radar measurements of geese that cruise at 60 mph and up to 29,000 feet and hawks that can dive at 200 mph. Long-distance records go to Arctic terns. They favor cool summers, and migrate over 11,000 miles between north polar regions and the Antarctic. Most of their lives are apparently spent in daylight in lands of the midnight sun.

Both books are available from the Superintendent of Documents, U.S. Government Printing Office, Washington, D.C. 20402. **FM**

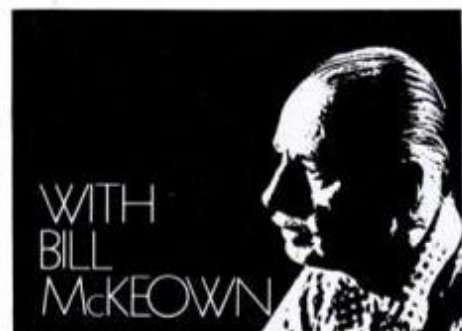



# Give any Manhattan the crowning touch.

Seagram's 7 Dry Manhattan.  
To 1 part dry vermouth add 3 parts  
Seagram's 7. Grace with  
a twist of lemon.  
Brilliant.



Seagram's 7 Classic Manhattan.  
To 1 part sweet vermouth add  
3 parts Seagram's 7 and a dash of  
bitters. Top off with a cherry. Tops!

Seagram's 7 Perfect Manhattan.  
To equal parts sweet and dry  
vermouth add 3 parts Seagram's 7.  
Bright idea!

Start out with the great taste of Seagram's 7 and  
you'll always end up with a great Manhattan.  
Any way you like them, enjoy our quality in moderation.

**Seagram's 7 Crown**  
Where quality drinks begin.

SEAGRAM DISTILLERS CO., N.Y.C.  
AMERICAN WHISKEY—A BLEND. 80 PROOF.





Handwriting is easily displayed with a computerized tablet like the Digikitizer.

## Computerized sketch pad you build from a kit

A graphics tablet is a computer accessory that puts drawings onto a computer's screen and into computer memory. This new one for home use is easy to put together.

by Neil Shapiro ELECTRONICS EDITOR

**D**rawing with a computer can be a ticklish, involved process. Often, the simplest appearing figures call for the most advanced programming techniques. Now, there is a better way to put the computer to work in the design studio.

The Digikitizer from Talos Systems (7419 East Helm Drive, Scottsdale, Ariz. 85260) hooks up to an Apple II computer, or TRS-80, and allows you to draw freehand—no programming involved. It brings the computer one step closer to being a perfect tool.

Nothing could be simpler than entering a drawing into the computer to be displayed on the screen. All you have to do is to draw the figure you want (with a pen-like transducer) on the surface of the tablet-shaped Digikitizer, and the drawing shows up on the display.

On the Apple II computer, you can

draw in 16 colors in its coarse, low-resolution mode or you can opt for exceedingly fine, high-resolution lines with only six working colors. We found the high-resolution mode to be the best to work with to draw realistic rather than impressionistic designs.

### Better than a speeding pen

The Digikitizer also calls upon the power of the computer to aid the artist. You can draw a straight line either by simply drawing it or (if you need a really *straight* one) by just touching the pen to the end points. The Digikitizer allows the computer to automatically connect the dots. This feature really speeds things up and makes for neater results.

But what is truly amazing is the feature of Computer Assisted Design (CAD). Here is something that,

*(Please turn to page 170)*

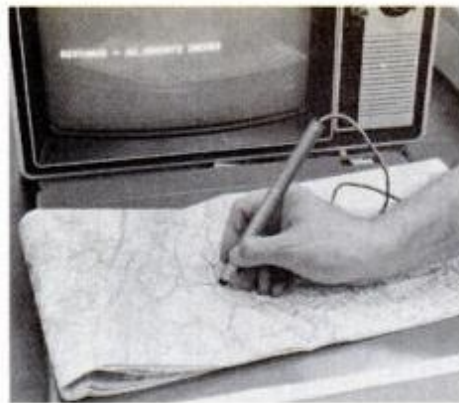

Figuring out mileage for a trip is simple using the Digikitizer. Just place map on top of tablet and trace over your route with the transducer pen. You get a distance read-out. Areas are also calculated.

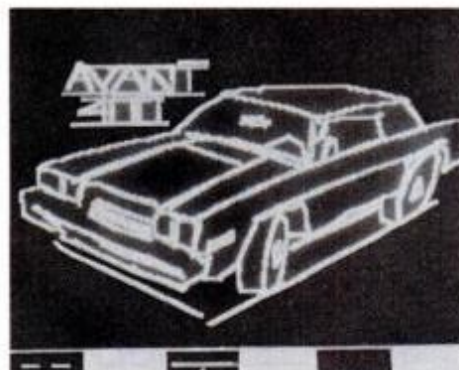

Drawing in high-resolution mode can be done in two ways: Car (above) was made from computer-connected dots, since straight lines were needed. Portrait (below) was done freehand for curves and detail.

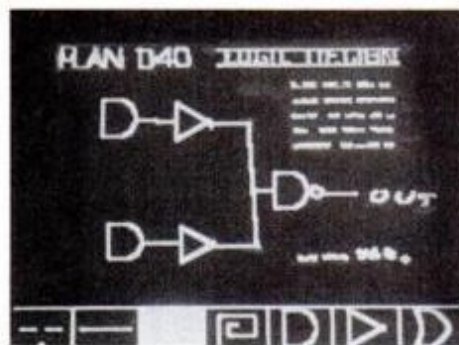

Computer-assisted design program allows you to literally "pick up" symbols from bottom row and transfer them onto screen. The symbols can be rotated before being placed, and if you make a mistake, they can be erased. You can then have computer assistance in drawing the connecting lines.





# 1980 DATSUN KING CAB— THE ROOMIEST SMALL TRUCK IN HISTORY.

## A DATSUN EXCLUSIVE! 2 REAR JUMP SEATS INSIDE THE CAB.

It took Datsun to come up with the biggest small pickup news in 20 years: the new Datsun King Cab® GL. With more space, legroom and luxury than you may experience in any small truck—including two reclining bucket seats up front and two jump seats behind that fold up to create more inside storage space than ever. That's "Grand Luxury" as only the King Cab GL can deliver it. With everything from cut-pile carpeting to a road-smoothing new ride.



## GO NNA PICK YOU UP LIKE NEVER BEFORE.

When you add up the standards, no truck's gonna pick you up like the new King Cab GL. Check out this check list: • Styled wheels • Radial tires • Quad rectangular headlamps • Engine compartment lamp • 5-speed over-drive • Full instrumentation including tachometer • Quartz clock • AM/FM radio • Electric rear-window defroster • Center console • Even a dome lamp that swings down to light the cargo area.

## DATSUN MILEAGE. MONEY IN THE BANK.

There isn't a bigger rig that can match Datsun pickups for economy. Yet Datsun trucks, with their gutsy 2-liter overhead cam engines, can haul 1400 lbs. of cargo and some bigger pickups. Now that's a truck you can drive all the way to the bank.

25

EPA ESTIMATED  
MPG

32

EPA ESTIMATED  
HIGHWAY

EPA estimates for comparisons. Actual mileage may differ, depending on speed, trip length and weather. Actual highway mpg will probably be less than est. California mileage lower.

## PERSONAL PICKUPS. THE RIGHT CAB, THE RIGHT BED.

For 1980, Datsun gives you choice like never before. From standard 6-foot beds... to the super-size Datsun long bed with over 7-feet of cargo length. And cabs ranging from Datsun's lowest priced Standard

Li'l Hustler to the luxurious King Cab GL. We're dedicated to building you the right truck for your trucking needs.

## THE TOUGH KEEP GETTING TOUGHER.

Over 37 percent of all small trucks on the road today are Datsuns. That's a tough act to follow—but durability is a Datsun tradition built on quality. We test and retest under demanding conditions until every pickup is Datsun-perfect, and ready for a tough life ahead. Datsun trucks: their first job is to last. Test drive the big news in small trucks at your Datsun dealer—the small truck expert.



# DATSUN WE ARE DRIVEN

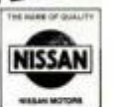



---

---

Latest Smoker Research Just In:  
**MERIT** undisputed victor over leading high tars  
in tests comparing taste and tar level.

---

---

# Smokers Prefer Merit 3 To 1!

---

---

**Smokers find the taste of low tar  
MERIT matches that of high tar cigarettes.**

New taste-test results prove it.

*Proof:* A significant majority of smokers rated MERIT taste as good as—or better than—leading high tar brands. Even cigarettes having twice the tar!

*Proof:* Of the 95% stating a preference when tar levels were revealed, 3 out of 4 smokers chose the MERIT low tar/good taste combination over high tar leaders.

**MERIT smokers rate low tar  
MERIT satisfying taste  
alternative to high tar brands.**

New national smoker study results prove it.

*Proof:* The overwhelming

© Philip Morris Inc. 1979

Warning: The Surgeon General Has Determined  
That Cigarette Smoking Is Dangerous to Your Health.

majority of MERIT smokers polled felt they didn't sacrifice taste in switching from high tar cigarettes.

*Proof:* 96% of MERIT smokers don't miss former high tar brands.

*Proof:* 9 out of 10 enjoy smoking as much since switching to MERIT, are glad they switched, and report MERIT is the best tasting low tar they've ever tried!

You've read the results. The conclusion is clearer than ever: MERIT delivers a winning combination of taste and low tar.

A combination that seems to be attracting more and more smokers every day and—more importantly—satisfying them long term.



Kings: 8 mg "tar," 0.6 mg nicotine—  
100's: 11 mg "tar," 0.7 mg nicotine  
av. per cigarette, FTC Report May '78

# MERIT

**Kings & 100's**



# THE JUMP: Anatomy of the top Olympic spectacle

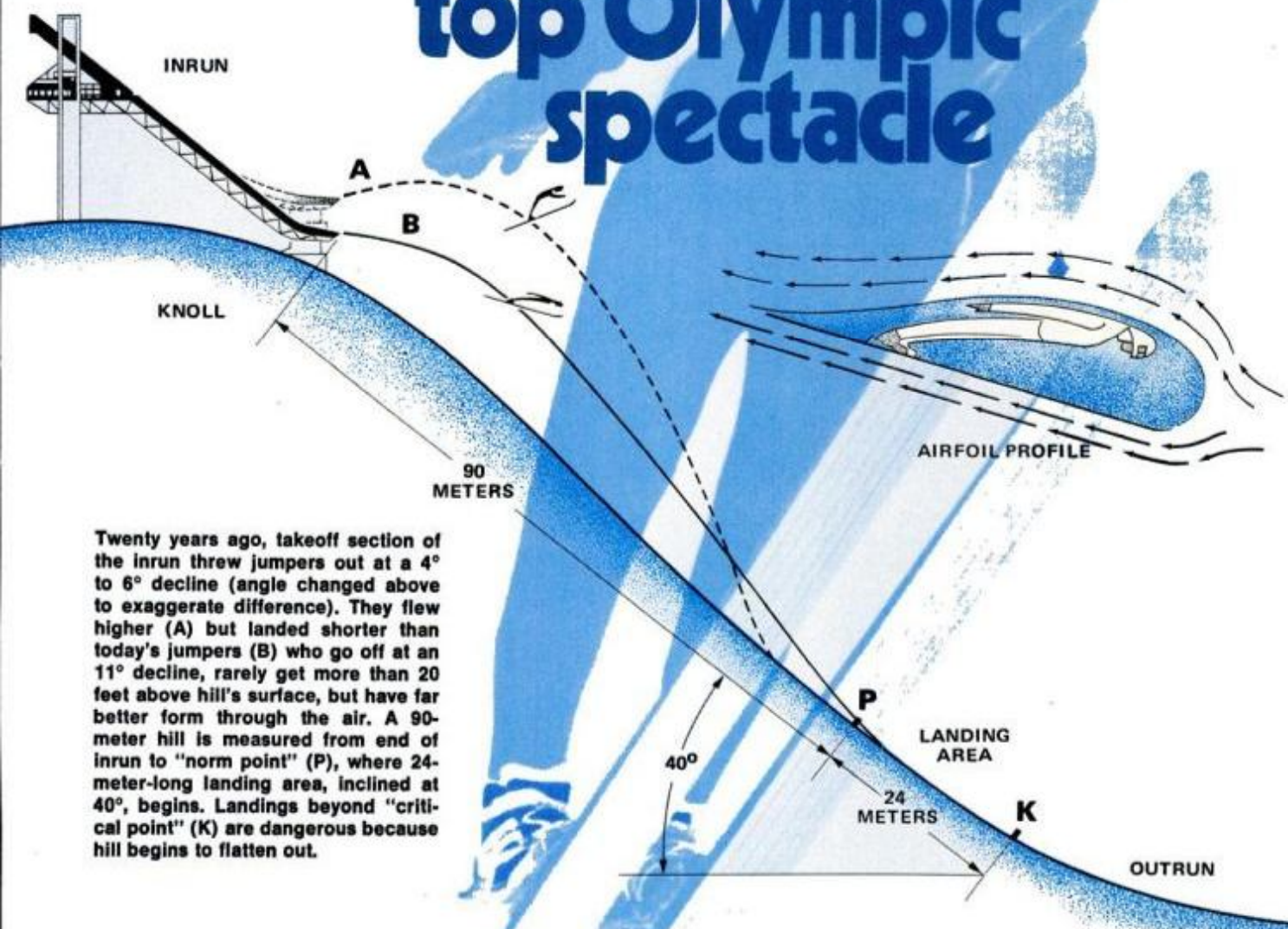

Twenty years ago, takeoff section of the inrun threw jumpers out at a 4° to 6° decline (angle changed above to exaggerate difference). They flew higher (A) but landed shorter than today's jumpers (B) who go off at an 11° decline, rarely get more than 20 feet above hill's surface, but have far better form through the air. A 90-meter hill is measured from end of inrun to "norm point" (P), where 24-meter-long landing area, inclined at 40°, begins. Landings beyond "critical point" (K) are dangerous because hill begins to flatten out.

It's still the biggest winter thrill, but a lot of needless risk has been engineered out of modern ski jumping.

by Charles Lehrsén

**B**efore the 1980 Winter Olympics are through, a crowd of 18,000—the largest for any of the Lake Placid events and maximum allowable by law—will have gathered in the sub-freezing cold, twice, to gaze with awe

upon one of America's least-played sports. In fact, were it not for the luge and biathlon, both of which have a drawing power that extends to their competitors' next of kin, Lake Placid's hottest ticket—the ski jump—would be the most exclusive event, from a participant's standpoint, of them all.

The fact of the matter is this: In all of the United States there are only about 50 men capable of handling a 90-meter hill, larger of the two Olympic jumps, with a reasonable degree

of competence. That is not to say that more Americans—maybe 150—won't *try* hills that big and bigger, up to 120 meters, but many of them will be ill-prepared. Perhaps 10 men form America's pool of potential world-class jumpers, and no women have ever qualified—not even for the tamer 70-meter hill.

Yet another unusual aspect of ski jumping rests solely with spectators. It's an appetite that yearns for total lapses of form—aerodynamic atroc-

(Please turn to page 94)



# A HUMAN



One-piece stretch-fabric suit is skin-tight; porosity must be uniform throughout fabric to preclude "parachute" effect (not permitted in Olympics).

Angle of attack: Jumper finds attitude to give lift-aided descent of about  $40^\circ$ . Too high an angle, he stalls and falls short, too shallow, he's in a dangerous dive.

Skis can be held up to six inches apart before air begins to flow between them. Slight spread increases "wing" area. Typical jumping ski is 8.5 feet long, of reinforced plastic construction with wood or composition core. Deep grooves are for straight tracking.



# FLYING MACHINE

**J**umpers say they try to "attack the hill" or "ride the air pressure." Either way, borrowing a phrase from another sport, it means trying to lead with your chin. The modern jumper tries to close the gap between his body and his skis, at the same time letting his upper profile curve enough to provide the cambered top surface that approximates an airfoil (wing) shape to give him added lift. With up to about six inches between them, the skis form a solid lower surface with little air flowing through the gap. Perfectly configured, a jumper could maintain his lift-assisted glide indefinitely. Shaping the hill so that he "runs out of it" safely is the job of the engineers.

Modern stress on streamlining exemplified by thumb-straps for sleeves. One hand deflected into airstream gives slight directional correction with differential braking effect.

At takeoff on the 90-meter hill (below), a jumper is hitting about 60 mph, will pick up an added 10 mph or more during the flight. Infinitely adjustable starting gate on Lake Placid's 90-meter jump will maintain long jumps while keeping competitors from dangerously "outjumping" the hill.

Bindings must permit extreme lean, allow skis to "work" in gusts and turbulence.

Built-up heels on ski boots help keep jumpers from "sitting back" on the inrun, getting air under his skis too soon.

JANIS





ties that will result in a reprise of the "agony of defeat" sequence from *Wide World of Sports*. "Television continually stresses the falls, and some of us don't like that," says Stan DuRose, head of the U.S. Ski Assn.'s Ski Hill Engineering Committee. "Each time we complain, though, we're told that is what the public wants."

Are we all sadists? Well, if we are, we're not every good at it. In fact, waiting for a spectacular ski-jumping spill these days can be a form of masochism, like searching for a good five-cent cigar. The sport has undergone a revolution, and you just don't get the wonderful wrecks that you used to. *Wide World's* famous fall—ultimately harmless, by the way—is nine years old. And the days when skiers "stalled out" 75 feet above the snow are gone forever.

### 'Riding' the air

Two things have happened. In the first place, ski jumpers have learned to fly. "It is not at all like in the old days," says Karl Martitsch, the architect who designed both of the Lake Placid jumps. "Skiers don't try to push the air or cut the air. Now, the object is to *ride* the air. In theory, if the hill kept going, they would never have to come down."

But—and this is the second break-

through—the hills do not keep going. Rather, they begin, end and undulate in exactly the right places. And they follow the flight curve so snugly that today's jumpers are never more than 15 or 20 feet off the ground, TV camera angles to the contrary. Thus, if an athlete fails to get "up on the air pressure," as they say, he doesn't have too far to fall. And if he succeeds in becoming the perfectly cambered airfoil, the jumper can fly 500 feet at 70 mph and land as softly as if he had hopped off a table.

"All this scientific stuff has made the sport absolutely safe," says Art Devlin, a former Olympian who competed in an era when the hip flask was some jumpers' best friend. "Not as spectacular, but safe." Indeed, several experts contend that, with all the improvements, jumping has become less hazardous than downhill skiing.

Devlin says he began hearing the "scientific stuff" in the early 50s, shortly after the first ski-flying hill was constructed in Oberstdorf, Germany. (Ski flying, a non-Olympic sport, is the name given to jumping from hills of 120 meters or more.) Built by the legendary jumper Heini Klopfer, with considerable help from the U.S. Army Corps of Engineers, the Oberstdorf hill had a "norm point" (expected jumping distance) of 120 meters. It attracted scores of

**With adjustable starting gates, variable decline takeoff sections and contours that exactly follow a jumper's correct flight path, Lake Placid's 90- and 70-meter hills cost \$6.5 million to fit out.**

jumpers from around the world—many of whom skulked home in embarrassment.

The huge jump magnified everyone's faults. "Things you could get away with on a small hill, you couldn't get away with there," Devlin recalls. "You could just *feel* what was wrong. It was great, though, because instead of blindly following the Norwegians, as we had for years, we began thinking, 'Hey, maybe there's a better way to do this.' And with the help of wind tunnels, we found out there was."

### Technique evolves

From the time ski jumping became organized, around 1860, until the mid 1950s, the sport's first commandment was "Jump high." Hills were designed accordingly. "The old inruns threw you straight up into the air," says Devlin. "From the top, they looked like a crazy loop-the-loop."

Actually, the upward tilt of the takeoff point was an illusion, created, most likely, by the fact that a steep (usually 38°) stretch of inrun lay between it and the skier. At its end, the ramp was much flatter, but if you viewed the hill from the side, it was obvious that the takeoff point did in fact go *downward*, if only 4 to 6°.

Using their well-developed thigh muscles, old-time jumpers would push off this slight incline for all they were worth. Add the element of a "knoll" area that dropped off sharply and you've got a jumper who was far off the ground. Devlin has an old photo-







Arm-waving jumper at 1905 Michigan event shows form that dominated sport's early years.

graph of himself—near the entrance of his Olympic Motor Inn, on Lake Placid's Main Street—in which he is 100 feet above planet Earth.

He considered the 30-year-old picture recently and was not pleased. "Arm's kind of cockeyed," he said.

A large, brightly lit trophy case has been built into one wall of the Olympic's lobby. Behind glass, little gold men dot the rugged landscape. The display is impressive—whole high schools have not reaped as much hardware as Devlin—yet it is slightly funny, too, for the tarnished skiers seem to be falling from their pedestals. Their legs are straight, their backs are straight, but they are bent

dangerously at the waist. If a little gold Olympic judge were to wander by, he would not be pleased to find them in the obsolete jackknife position.

In its time, the jackknife was a serviceable technique. By opening and closing their L shape, jumpers compensated for poorly designed inruns that sent them off too fast, or in an unnatural attitude. Before the engineers took over, improvising was the name of the game, as well as the downfall, quite literally, of skiers prone to panicky overadjustments. Remember the newsreels of jumpers who flapped their arms like birds? Those guys were searching desper-

ately for what aviators call the "angle of attack."

The 70- and 90-meter jumps at Placid's Intervale area, rebuilt for these Olympics at a cost of \$6.5 million, are probably the best in the world. Both have takeoff points that drop between 9 and 11°, depending on the snow cover. At that steepness, and with the new style of jumping, Olympians are virtually assured of falling into an aerodynamically correct posture.

Modern skiers begin their jump in a crouch called the egg position. On the way down the inrun, they keep their legs apart, so that air can pass through, and they can gain speed. If a man goes too fast, however, he can "out-jump" a hill, and wind up past the K (critical) point. On a 90-meter hill, the designated landing area, which stretches from P, the engineers' symbol for the norm point, to K, consists of a 24-meter stretch that drops at 40°. Between the takeoff point and P is what is called the knoll; the measurement of this expanse equals the official size of the hill. Beyond K, the hill becomes too flat, and is considered dangerous for landing.

To find out if a jump is running too fast, judges send down a number of noncompeting skiers known as forerunners. These brave souls are timed electronically at the 38° section of the inrun, where, ideally, they should be traveling between 56 and 58 mph. At that rate, they would

*(Please turn to page 140)*

## Welcome to Placid—would you like to see a venue?

For months now, Lake Placid, N.Y., has been festooned with banners that say "Welcome World, We're Ready." The 3000 residents of that Adirondack Mountain community take their Olympics seriously, and it is easy to see why. The 1932 games put Placid on the map.

In sharp contrast to the economy, the weather in 1932 was rather warm. Since there are no Olympic events involving slush, this caused problems. But no more. In 1980, everything that can be refrigerated will be, and there are machines standing by that can cover the entire downhill course of Whiteface Mountain with 16 inches of snow in 16 hours. In all, more than \$92 million in Federal and state funds have been spent to build housing and refurbish Olympic venues. Here are some of the high-points:

**Bobrun:** Some safety modifica-

tions have been made on this 1557-meter course since 1932, but according to Erich Scharer, a Swiss sledder, its strong point is that it is still not perfect. "We don't like 'computerized' runs," he says. "They present no challenge." The Placid bob-run has 16 curves, many of which will be taken at around 90 mph.

**Luge Run:** Once, during a Washington hearing, a U.S. Congressman asked if luge wasn't "something to eat." It is not. Sleds are light and extremely dangerous, since they travel, sans steering mechanisms, at 70 mph. The 1000-meter course in Placid is the only luge run in the Western hemisphere.

**Speed Skating Oval:** Located on the campus of Lake Placid High School, which will be closed during the games, the speed rink measures 400 meters. The price for refrigerating it was \$3 million—or about

three times the cost of the entire 1932 Winter Olympics.

**Fieldhouse:** The arena built 48 years ago is still in good shape, and it will be used this year, but it seats only 1200. The new \$16 million structure, right next door, houses 8500 spectators and two ice sheets.

**Whiteface Mountain:** In addition to the previously mentioned snowmaking equipment, a 6400-foot quad chair lift has been added to what will soon be rechristened Olympic Mountain. On the bottom, by games' time, will be a new lodge for 4000.

**Olympic Village:** Housing for 1800 athletes and officials has been built in the hamlet of Ray Brook, five miles from downtown Lake Placid. For security reasons, visitors will not be let in. Someday, no one will be allowed out, because after the Olympics the compound will become a Federal prison.—C.L. \*



## Mobile operating room



An inflatable tent system for medical use on the battlefield or in civil emergencies has been developed by a Swedish firm. The Field Medical Tent 80, made by Trelleborg AB, provides a spacious, light and sterile environment for surgery and/or recovery. Each module comprises four air-filled arches spaced by aluminum tubes and measures about 17 by 24 feet. The highly mobile unit goes up and dismantles quickly. At 400 pounds, it is easily carried by four to six men. Tent is said to offer more usable floor space and better hygiene than other designs.

## Who needs snow?

Winter may seem to last an eternity, but it never lasts long enough for ski-lift operators. To earn money when there's no snow, some Bavarian slopes offer rides on a Sloper, a four-wheeled, highly maneuverable vehicle powered only by gravity. Slopers can hook up to a ski lift and unhook with the push of a button. Steering is accomplished with foot pedals, and the handlebars pull toward the driver for braking. Both the foam wheels and braking plate are said not to harm turf. To avoid multivehicle collisions, only one goes down at a time.



## No more roar

Intended to compete with helicopters for use in seismic surveys, the 23-foot Tiger air-cushion craft operates much more quietly than most other hoverers. Its four-

blade propeller, which pushes and steers the craft, is housed in a specially designed duct to reduce noise. Because it is quieter, Tiger is also well suited for coast-

al and estuary survey work near wildlife. The 12-seater has a top speed of about 35 knots. It's said to cost one-tenth as much as helicopter used for same work.

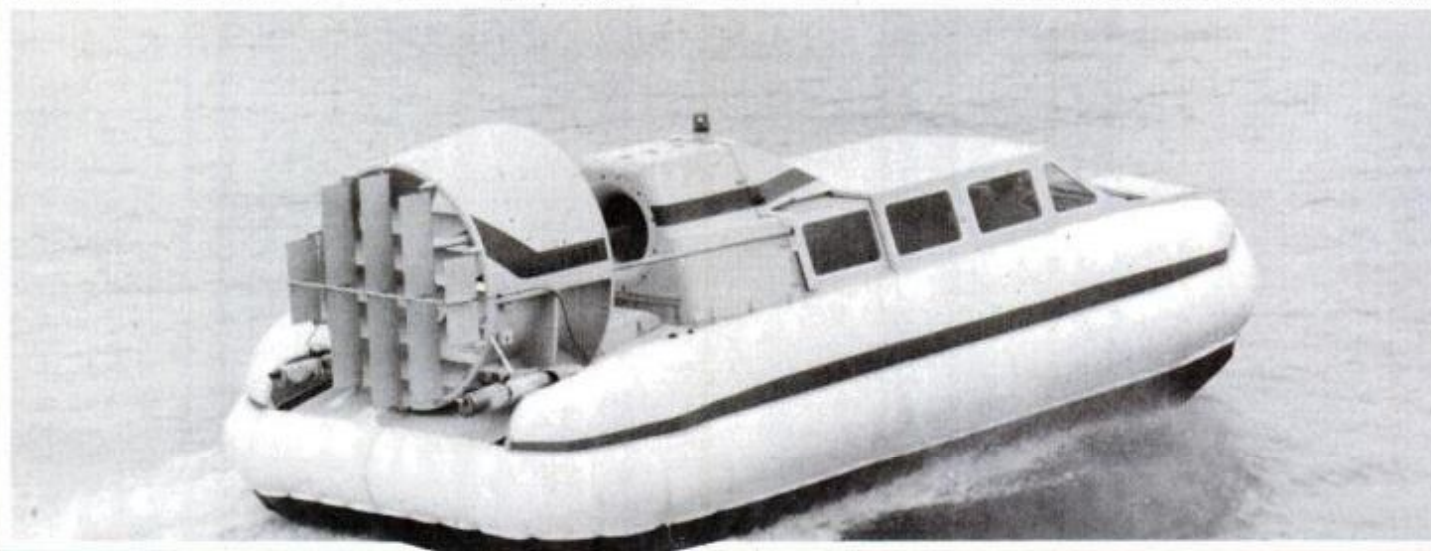



## Spider for safety

One look at Buchegg Square in Zurich, Switzerland, tells you it's a dangerous place for a pedestrian. But since the in-

stallation of an overhead walkway dubbed the Spider, pedestrian accidents have been reduced to zero. In fact,

there's a stiff fine for crossing at ground level. Another benefit: Pedestrians using Spider are exposed to less auto exhaust.



## Yakety-yak

The Yak Yeoman was designed to go anywhere and be cheap and easy to build. Its chassis is made of welded rectangular tube; the two side panels are the same, as are the four fenders. A limited-slip differential applies power to one rear wheel if the other starts spinning. Two

power takeoffs can be used to operate other equipment or haul the Yak out of a jam. It's available as a covered wagon, pickup truck or personnel carrier. The maker, Manchester Garages Ltd. in England, claims the Yak can be assembled by two workers in under a day.

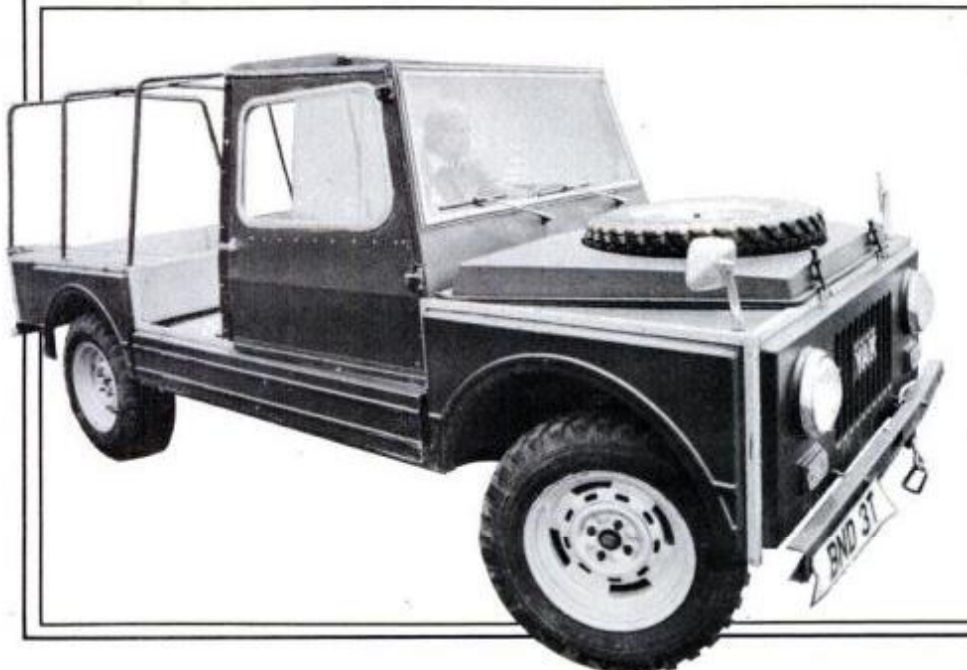

## Cordless phone



Like to move around the room when you talk? A cordless phone made by the German firm Siemens allows just that. Unlike models using radio frequencies, this unit employs infrared light. The portable receiver houses all controls while the rest of the works are mounted on a wall. Because of signal reflection, system can operate from any corner of the room, but will not interfere with other units in other rooms. Unit is still under development and is not yet commercially available.



## FIRSTHAND REPORT

by Gary Witzenburg  
DETROIT AUTO EDITOR



# Driving the 1980 VWs

**N**ow that Volkswagen of America has been cranking out Rabbits in Pennsylvania for nigh onto a couple of years, the U.S. engineering team, under vice president and director of engineering Duane Miller, has designed its first new vehicle . . . or, more accurately, two-thirds of a new vehicle. From the front bumper to the cab's rear wall, and except for unique front suspension struts, spring and shock rates, the new pickup is basi-

cally standard Rabbit. But from the cab back, it's all new.

Miller calls his group "the smallest major automotive engineering team in the country," and for that reason the initial design was done in conjunction with Sheller Globe engineers in Lima, Ohio. "But," he's quick to add, "we're also the most aggressive."

The bed is a full six feet long and has double-wall construction, so any

*(Please turn to page 158)*

### Truckin' with Volkswagen

Front-wheel drive with either gas engine or diesel, Rabbit pickup is seen from various angles, below left. Payload is just over 1100 pounds, bed length is six feet.

Vanagon retains air-cooled rear-engine, rear-wheel-drive powertrain of original VW bus. Handling is greatly improved, though, as is rear cargo capacity.







Convertible has glass rear window (inset) with electric defogger. Padded top folds down easily, doesn't take up cargo space.





# THE



With no experience either in flying or constructing balloons, two East German families collaborated to put together a successful escape vehicle of spectacular size. The test flight was also operational.



# FREEDOM BALLOON

They worked secretly, by night, in constant fear of discovery. But in only 18 months these two self-taught aeronauts fashioned Europe's largest hot-air balloon and soared, with their families, high over their captive society's walls to an epic escape.

by John Dornberg

**A**t 2:40 a.m. on an autumn Sunday morning, the West German town of Naila, population 7000, six miles from the East German border in Upper Franconia, was darker and quieter than a cemetery. All taverns and inns were shut, and the tourists, who stream in at that time of year to see the turning foliage of the idyllic Frankenwald, had long had their last beers and sausages and were slumbering in their featherbeds. Though it was the harvest season, dawn was more than three hours off and even the farmers were still asleep.

For Constables Walter Hamann and Rudolf Gölkel of the Bavarian State Police, cruising the country roads outside of town in their Audi "Foxbat" patrol car, it had been a routine night—except for a case of multiple hit-and-run driving which occurred shortly after they had begun their patrol duty.

Suddenly they spotted a strange light flickering and moving slowly in the starry, quarter-moonlit sky.

A meteor? Too slow and it wouldn't be visible that long. A UFO? Gölkel and Hamann laugh: "We don't believe in them." The two observed the light from the ground for a few more minutes, estimating that it was at an altitude of over 5,000 feet, then saw it mysteriously extinguished. But they were certain it was some kind of object coming down—fast—about two miles southwest of Naila. When they reached the estimated place they could see nothing at first. But suddenly two men—Peter Strelzyk, 37, and Günter Wetzel, 24, appeared like apparitions out of the dark, bursting through the bushes.

"Where are we?" they asked apprehensively in the accent of their native Thuringia, just across the border. "Are we in the West?"

Yes, the constables assured them. Strelzyk and Wetzel whooped with joy, then called out to their wives, Doris Strelzyk, 34, Petra Wetzel, 23, and their four children, aged 2 to 15, still hiding in a nearby shed: "Come out, we made it! And bring that champagne bottle. We can open it now. That's what the books said all balloonists do when they land."

Günter Wetzel's broken leg was only casualty of balloon's hard landing. It kept the hospitalized Wetzel (above, right) from joining a re-enactment take-off (below), in which Peter Strelzyk, his wife Doris (kneeling at left), Petra Wetzel and children of the two families packed the home-built "gondola" for a photo.





"A balloon?" Gölkel and Hamann, not entirely unaccustomed to encountering airborne defectors from East Germany, asked incredulously: "You came in a balloon?"

"Hot air. We built it ourselves," Strelzyk said proudly. "Come look, it's in a clearing back there."

Thus ended the most ingenious, courageous and bizarre escape ever made across the grim, tightly patrolled frontier between the two Germanys.

Communist East Germany was created out of what had been the Soviet zone of the occupied Nazi Reich after World War II and Hitler's defeat. It celebrated its 30th anniversary as a sovereign state, recognized by the United States and 120 other nations, just three weeks after the Strelzyks and Wetzels landed near Naila. Whatever else it may be, it has the dubious distinction of becoming the only country in world history that has ever built a wall to keep people in, rather than out.

Its 836-mile-long frontier with West Germany, plus the 28 miles that divide East from West Berlin, located like an island 110 miles inside East German territory, bristles with watchtowers, barbed wire and mesh fences, self-triggering shrapnel guns, land mines, vicious dogs, plowed strips, vehicle traps, searchlights and 60,000 machine-gun-toting soldiers (see facing page).

The border, fortified in this manner in 1961 in an attempt to halt the postwar hemorrhage of refugees from communism, and still being tightened and worked on every day, is a tragic symbol of authoritarian rule and of man's inhumanity to man. But it is also a tribute to his valor, fortitude and inventiveness, for despite the manner in which it has been systemically sealed, some 80,000 East Germans have managed to get over, under and around it during the past 18 years.

But not usually in homemade hot-air balloons—and at that, the biggest one ever built or flown anywhere in Europe, according to West German experts. That taxes the imagination even of those familiar with all the imaginative capers (see facing page) which have been pulled to travel illegally from East to West.

Even in an affluent, free country, it would be quite an achievement to build your own balloon with no previous experience or instruction, particularly one large enough to safely transport four adults, one nearly grown teenager and three smaller children. But it is hardly an imaginable undertaking in an economically mismanaged police state where the materials are barely available, must be bought and gathered surreptitiously, and all the work must be done in total secrecy at the risk of long imprisonment. And to fly it without testing? Almost madness!

Only two men with the gumption, guile, technical skills and sheer courage of Peter Strelzyk and Günter Wetzel could have done it.

### Why and how they did it

In an interview in Naila, only 35 miles south, but a political and ideological world removed from their erstwhile homes in Pösneck, East Germany, they told me why and how they did it.

They have been close friends since they met four years ago while both were scouring stores in search for one of the necessities usually in short supply in a com-

munist country—bathtubs and some bathroom fixtures.

Each had recently bought an old house and was remodeling it. Both were technically educated and incorrigible tinkerers, eager to solve mechanical problems.

Wetzel had wanted to be an automotive mechanic but could apprentice only as a bricklayer. The last few years, when not moonlighting as a repairman and electrician in partnership with Strelzyk, he drove a truck for a "people's-owned" transport enterprise.

Strelzyk, who apprenticed as a machine fitter, had hoped to become a pilot when drafted into the East German air force in 1963, but he served, instead, as an aircraft mechanic. After his discharge he trained as an electrician, then, with three skills to his credit, went to work for Pösneck's "people's-owned" plastics and synthetic fiber factory. There he rose quickly to become a foreman and then a department head in charge of automation control technology. By the time he quit three

years ago, to become a self-employed electrician—small craft shops being allowed in East Germany—he was earning well above the average and had collected 50,000 East German marks (\$7500) as premiums for suggestions he had made to improve production at the plant.

By East German standards the Strelzyks and Wetzels, with both wives also working, were well off. But both families

wanted out of what they describe as a "hermetically sealed workers' and farmers' republic."

"It wasn't the higher living standard in the West that appealed to us," Strelzyk explain, "but the hypocrisy of the whole system in the East that repelled us.

"You are subjected to constant propaganda and lying. You are not free to read what you please, to say what you think, or to travel anywhere except to other communist countries, and not always that. Worst of all, it turns your children into opportunists and hypocrites."

### The idea takes shape

Thus began talk of fleeing. Surface routes were immediately ruled out as impenetrable and too dangerous. Somehow flying over appealed to both men, and for a while they toyed with the notion of building a helicopter, only to rule it out when they realized they would not find a powerful enough motor to lift eight people.

Then, one evening in March 1978, one or the other—they do not remember who—said: "Why don't we build a balloon?" The idea seemed so great that they headed to Pösneck's only bookshop and the library the following morning and began reading all they could find even vaguely connected with the subject.

What they soon learned from their reading was that they would need a huge balloon. Four adults, Strelzyk's son Frank, the three smaller children, the gondola, the gas containers, the burner and the bag itself would probably total 1650 pounds.

Using the isobaric equation of state for air, they calculated they would need a balloon with a volume of 70,629 cu. ft., provided they could raise that much cold air from around 32° F to a temperature of 212° F. They figured the balloon would require at least 8,611 sq. ft. of material.

Two days after first thinking about it, they went out

*(Please turn to page 146)*

**We opened the bottle of champagne first. That's what all the books say balloonists do after they land.**



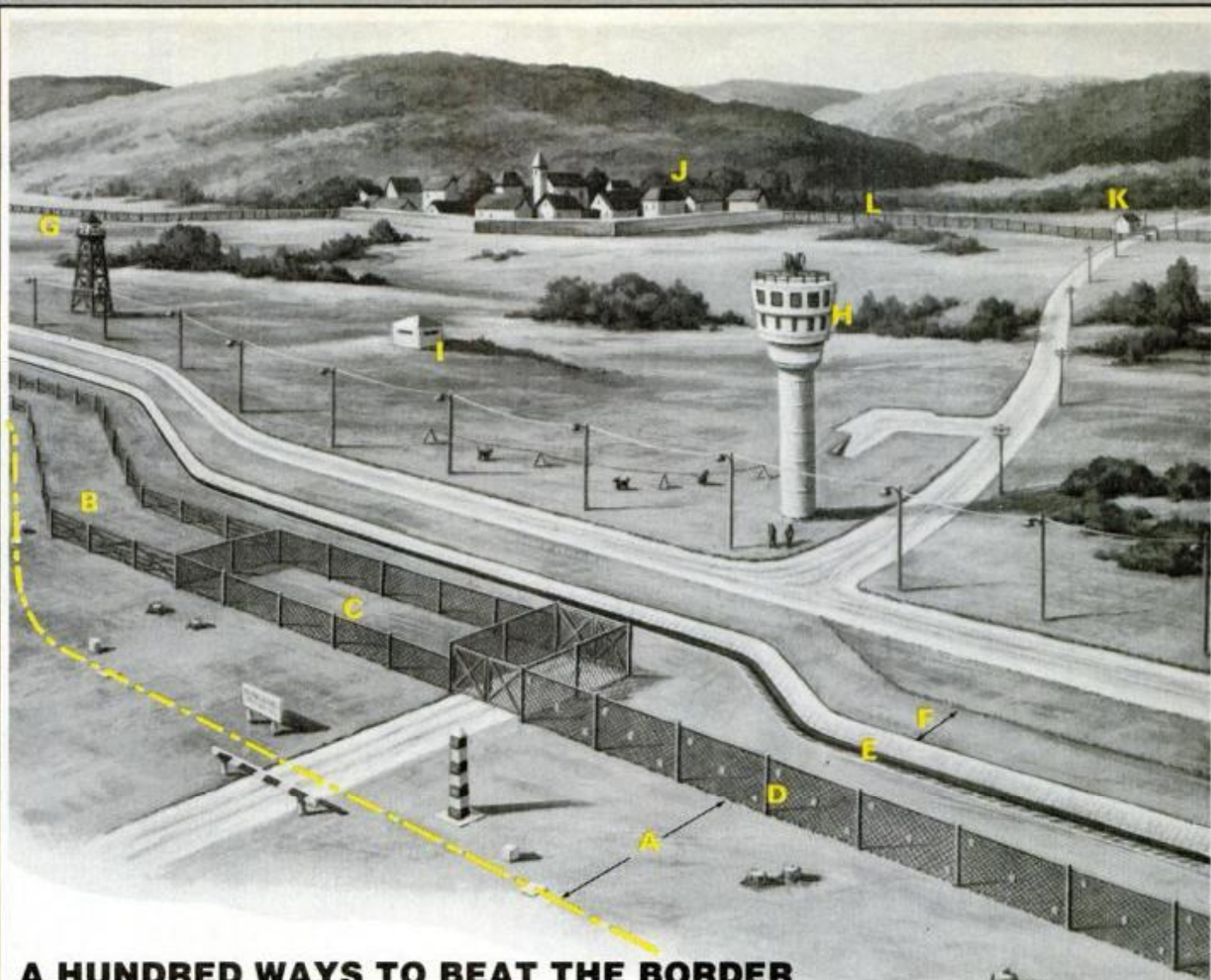

## A HUNDRED WAYS TO BEAT THE BORDER

Anyone with a strong desire to leave East Germany is standing at the end of a long, long line. Successful emigres have used just about every means except rockets.

Those who did not succeed were either shot and killed in the attempt—169 since 1961—or were imprisoned for up to 10 years for the unique crime of “trying to flee the Republic.”

Many have tunneled, and some have scuba-dived, under the border. One man, in 1968, built a mini-submarine that conveyed him, at 3 mph, from the East to the West German coast along the Baltic Sea. Others have rowed that route in rafts and dinghies, and one woman swam it—over 40 grueling hours.

Over the years, several dozens—a few not even trained as pilots—have used small planes to fly over it, and in 1962 an entire family, using helpers on the other side, crossed the Berlin Wall from one building to another on a tightrope cable with a roller and suspended sling seat.

East Germans are often smuggled out aboard the trucks traveling on the East-West transit routes. They jump their country's ships in neutral harbors or off friendly shores. They take advantage of the more relaxed rules in some other socialist countries, such as Yugoslavia, to escape while on “vacation” (although loved ones are often left behind, since the government discourages entire families from vacationing together—for obvious reasons).

Some have simply rammed through border fortifications with armor-plated trucks, buses and cars. And every year several dozens—no one really knows how—continue to make it across the mine-fields, past the tripwires and shrapnel guns, watchtowers and guards, through and over the fences on foot. Every land conveyance known to man has been used, from a tiny Isetta, rebuilt to hide one person under the seat, to a Cadillac, remodeled by a professional escape organization to stow one escapee between dashboard and firewall.

The “gentlemanly” way, though by no means less risky, has been

In an area typical of that where the Strelzyk-Wetzel balloon crossed, the actual East German border (red line) is backed by an astounding security array. Beyond the stone markers and demarcation signs is a space (A) up to 100 meters wide, cleared of trees and shrubs. The common double row of barbed wire fence (B) with land mines between is currently being replaced, either by a double row of wire-mesh fencing (C) and mined strip, or by single wire-mesh fence (D) 10 feet high with tripwire or remotely triggered shrapnel guns mounted at leg, midsection and head levels. Beyond fencing is a concrete trench (E) to trap vehicles attempting to ram their way out. Beyond that, a plowed security strip (F) 40 feet wide picks up all footprints. Back from the service and patrol road are old-style wooden guard towers (G), newer concrete tower command posts (H) and observation bunkers (I), plus leashed dogs on long wire runs. Even nearby villages (J) have their 10-foot-high walls and the border crossing checkpoint (K), up to three miles from the border, lies along a rear security line (L) with electronic, acoustical and tripwire sensing devices. On its first, unsuccessful balloon attempt, the Strelzyk family actually flew into this area and landed only yards from the “death zone.”

to simply outwit the border guards with passport flim-flams, fake documents or a straight face.

Thus, in the mid-1960s, some 180 East Germans were spirited out disguised as foreign diplomats, riding in long, black limousines from a car-rental agency, and displaying impressive-looking, leather-covered documents, originally printed as membership cards in a fancy West Germany Playboy-type club called “Confederation Diplomatique.” The initials “CD,” embossed on the cards, were misread by East German frontier guards as diplomatic passports.

*(Please turn to page 150)*



Big-screen TV turns a living room into a private theater. We used a videodisc system along with this two-piece Advent Model 761 projection TV (screen in background, console in foreground). You never have to worry about being entertained if you own such a system. With pre-recorded film or live TV, the giant screen brings the picture alive!



ADVENT 761

# Get the **BIG PICTURE:** Pick of the projection TVs

PM photos: Frank Lusk



Here are the best of today's projection TVs and a look at what tomorrow may offer. Only question left is—do you have a big enough living room?

by Stan Prentiss

**P**rojection televisions are more appealing buys than ever before. Their 50- to 78-inch washable screens often display excellent picture definition and color rendition.

The lenses have been improved for greater brightness, and the receiver itself has undergone improvements, both at the engineering and consumer levels. Engineers can appreciate such features as a comb filter for enhanced horizontal resolution—while the rest of us simply remark on how clear the big picture seems. Then there are features such as

timers, remote control, and the ability to easily plug your own stereo into the set in order to *really* hear the sound.

Some 50,000 sets were sold in 1979—that's \$125 million retail dollars—and by this year's end another 70,000 should be sold to homes and businesses. By 1980 many Americans will have their own home movie theaters and be royally entertained by video fare from broadcast programs, cable TV, video discs and cassette recorder/players.

Meanwhile, here's how to evaluate  
[\(Please turn to page 106\)](#)





ADVENT 710

The Advent 710 (above) is a two-piece set with optics (and price) slightly below that of the same company's Model 761 (left). Panasonic's CT-6000 (right) is a three-tube projection system of excellent quality. Mitsubishi's VS500 (bottom left) offers one of the brightest, true-to-life pictures we saw.



MITSUBISHI VS500



PANASONIC CT-6000



SONY KP5000

Sony's KP5000 is a one-piece set which uses two, rather than three, lenses to project the picture.





**The Giant Screen TV Center of New York, where all photos were taken, offers two one-tube systems of their own. The Mark 5 (left) has a glass lens, the Mark 4 (right) an acrylic one. Both perform well.**

the systems now on the market and compare the technologies they offer.

**The systems**

Contemporary models sell in one- or two-piece units, the difference being that projection screens are either mounted on the cabinet or are separate. All better sets, however, have three cathode-ray tubes (CRTs) for red, blue and green colors, and most operate at 30,000 volts (high voltage)—approximately the same as any direct-view 25-inch TV receiver. So, in this one respect, there's nothing new. The big differences are in optics, curved or flat screens, chassis features, remote controls, and excellent red, blue and green picture-tube beam convergence—without which the picture cannot be accurately and sharply defined, causing its resolution to suffer.

In one-piece units, distances between screen and optics have already been preset by the manufacturer. The result is a "compact" roll-around set whose basic limitation is screen size. In two-piece systems, the screen is separate, often larger, and is placed a carefully measured distance away from the electronics in the console. Six to seven feet is about maximum screen size for home use.

Common optics for most of these sets are of either the refractive or Schmidt type. The Schmidt type consists of two in-line mirrors, one with a center hole so that the light image may pass through and then be reflected back and onto a projection screen, doubling light output. Refractive ar-

rangements have increasingly "fast" single or dual lenses and are rapidly challenging the more expensive, usually precision-ground glass Schmidt optics for pure brightness—but not always giving the best contrast or overall picture sharpness.

The refraction term comes from the normal process of "bending" a light beam through any magnifying lens to

produce an enlarged image. Common lens speeds for plastic Fresnel discs are  $f/1.5$ , followed by  $f/1.85$  for aspheric acrylic and  $f/2.4$  for precision-ground glass—with even faster  $f$ -stops on the way for better brightness.

Two-piece projection sets usually shine red, blue and green beams, with actual blending of colors occurring on the screen itself. This is done to produce pictures with four to five times the brightness of single-tube systems. Single-piece sets ordinarily aim their CRT tubes at a silver-coated mirror (some front-coated, others rear-coated), which folds the three light paths, shortening the distance between tubes and screen by half and reducing overall brightness by only a few percent.

There are also a number of single-tube, single- or multiple-lens projection receivers that are ordinarily much less expensive and produce pictures of lower light level and less definition, roughly proportional to their

*(Please turn to page 145)*

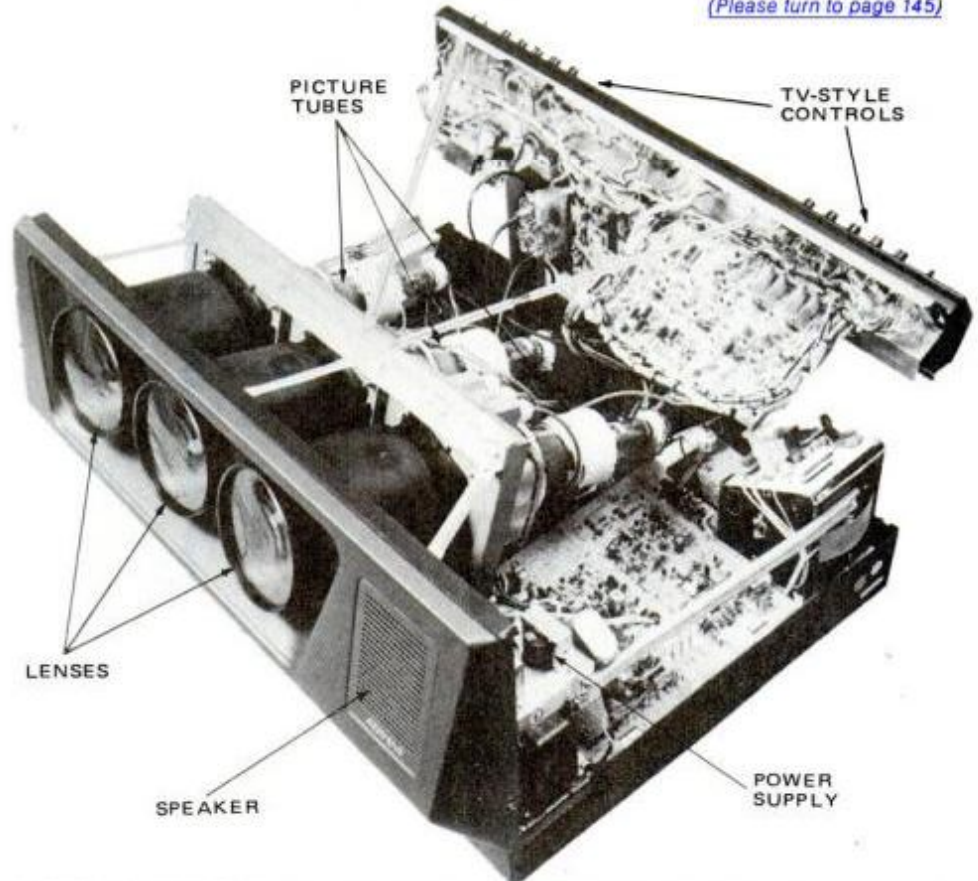

**Lenses in picture tubes of a projection TV are one-piece units (as shown above and at right). The best systems available use three picture tube/lens arrangements. One assembly projects red, the next blue and the third green. The three projected images are reflected from a mirror (left) and are combined visually on the large projection screen.**

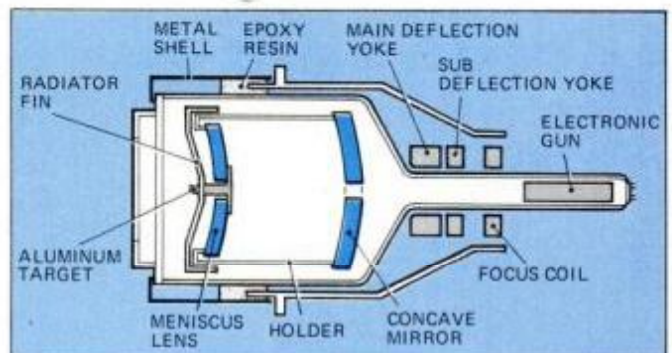



# Build a giant-screen TV— from kit or scratch

You can now build your own big-screen TV for less than \$500. It will provide you with all the pleasure and satisfaction of giant-screen TV sets that cost up to eight times as much. How? By using the new low-cost TV projection screens and lenses that have recently been developed.

Giant-screen television is not new. It had its beginnings with early black-and-white television. Some early sets used small picture tubes that projected the image through a lens onto a screen, similar to a slide projector. The giant-screen TVs of today use the same principle.

The problem with projection TV has been, and still is, brightness. How do you take an image produced by an ordinary color TV picture tube, project it through a lens to a screen and end up with a picture that is satisfactory for viewing under normal room light?

The problem has been a difficult one to solve. Most projection lenses can

Designing and building your own projection TV can be easy and relatively inexpensive. There's even a complete kit available.

by Robert Rupp

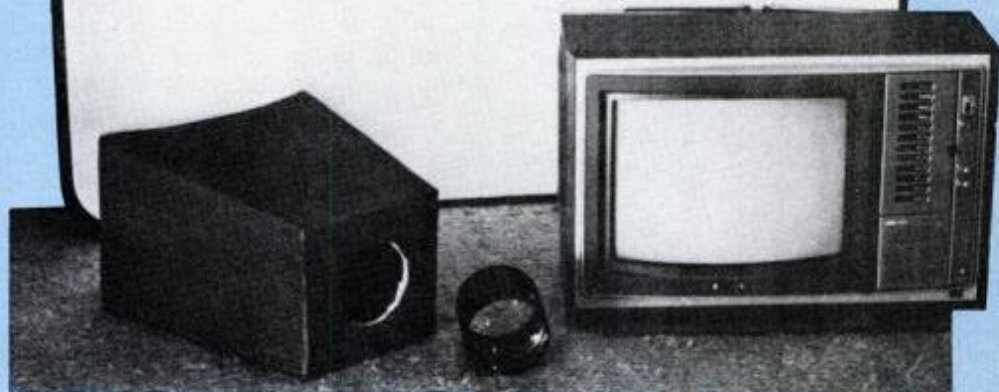

Building your own big-screen TV can be as simple as we show here. All you need is a good-quality lens and just enough cabinetry skills to fashion the cone that holds the lens in front of a TV screen. We show you how to figure out the critical dimensions.

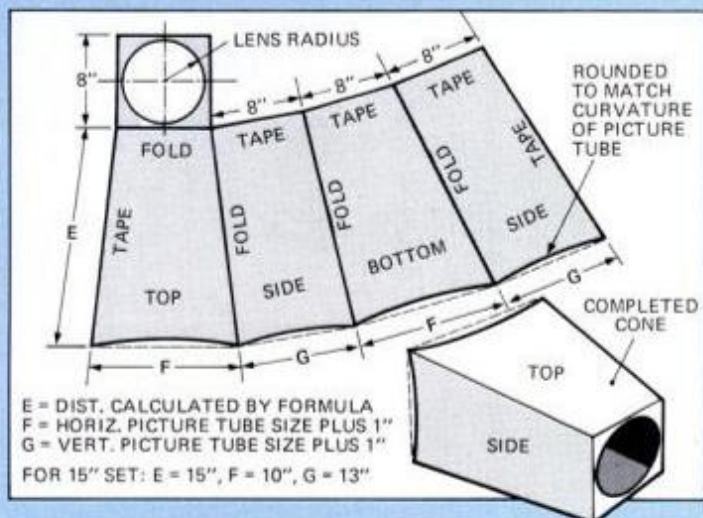

Our prototype version uses a cardboard cone to hold the lens; follow cutting guide (above) to fashion your own. Once it's designed, you may want to make one of wood.

The cone should fit snugly around the TV screen (above). Once made, TV/cone arrangement must be set at correct distance from a concave screen (right).

transmit only about 4 percent of the light produced by the picture tube. Some companies effectively attacked the problem by using three picture tubes instead of one. Each tube scans its own color—red, green or blue—and projects its own separate image. These images are then perfectly superimposed on a highly reflective screen. This system is capable of producing three times the brightness of a one-tube projection system.

Many low-cost giant-screen TVs use ordinary solid-state portable TV sets

as the picture source. By using special lenses and screens, they provide an adequate picture. This is the system that the average person can build.

To build your giant-screen TV, you should first know something about how projection lenses work. Normal camera lenses do not work because they cannot "see" enough of the TV picture tube to project it. The new lenses, designed for TV projection, are of the Cooke triplet design, and consist of two positive and one negative lens ele-

(Please turn to page 152)

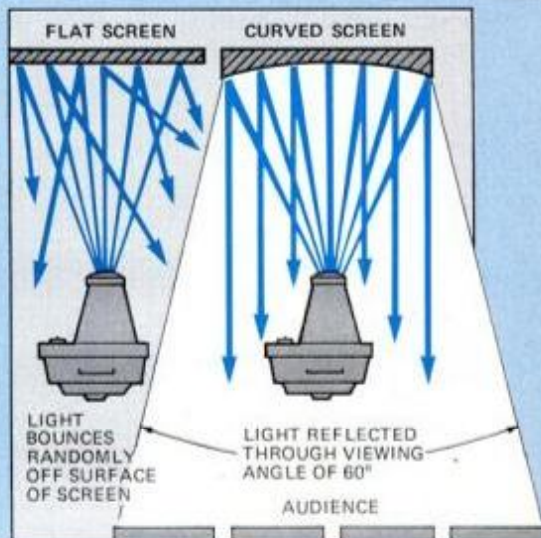



## FIRSTHAND REPORT

by Michael Lamm  
WEST COAST EDITOR



# Driving the 1980 Honda Civic

**L**ike the Volkswagen Beetle, the Honda Civic set a trend in this country. The Civic legitimized and popularized the smallest car acceptable to the American public.

Before the Civic, the Beetle held that distinction. Several import makers, including Honda, had tried to introduce smaller models here—

smaller than even the Civic. But these proved *too* tiny and failed.

In May 1973, Honda replaced its two-cylinder 600 minicar with the first Civic. The Arab oil embargo followed that December, and Honda dealers immediately found themselves in clover. Honda has since become a household name in motorcars. Before



Civic 1500 DX has simple, handsome styling, with well-integrated bumpers. Note flared wheel arches, which add to sporty look.

All of the controls are easy to reach in Civic's well designed interior.



Redesigned tailgate opens to bumper for loading.





the embargo, Honda's U.S. reputation centered on motorcycles.

Back in '73, the Civic represented Honda's biggest four-wheeled offering. Today it's the most petite. Even so, the Civic has grown slightly for 1980—up two inches in wheelbase, 2.5 inches in overall length, nearly three inches in width, 2.3 and 3.5 inches respectively in front and rear tread. The three-door hatchback has gained 13 percent in interior space, while the Civic wagon's carrying capacity is up 26 percent.

The '80 Civic keeps the same general shape and lines, but you'll notice some welcome changes. The liftgate on the three-door hatchback now dips to bumper level for easier loading. There's more legroom in the rear seat.

The front end borrows from the Prelude—a wide, uninterrupted grille with parking lamps in the bumper. The Civic's taillights are larger and more horizontal than for '79.

Front-wheel drive and transverse engine placement remain. The Civic again comes in two body styles, but this year there are two engine sizes and four models.

Body types are the three-door hatchback and a five-door wagon. Add to that 1300-cc and 1500-cc engines, four- and five-speed manual transmissions, the optional two-speed Hondamatic, and you have the overall picture on Civic choices.

The Civic's price leader lists for \$3699 and consists of the three-door hatchback with four-speed gearbox

and CVCC 1300-cc engine (CVCC stands for Compound Vortex Controlled Combustion—a stratified charge principle that allows all Honda engines to burn extremely lean fuel mixtures). The 1300 still sips regular *leaded* gasoline, but it's the only Honda that does, and it isn't sold in California or in some high-altitude regions.

Climbing the model ladder, all other Civics now use the new 1500-cc ohc Four. There's the plain-Jane Civic 1500, another unadorned hatchback with four-speed only, which costs \$4049.

Then comes the Civic DX three-door, in a 1300-cc, five-speed version for \$4175; with a 1500-cc engine and

*(Please turn to page 156)*



New 1500 DX, on a dirt road near Green River, Utah, averaged 33 mpg coast-to-coast.

## Coast-to-coast in a 1500 DX

From the moment I sat down at the wheel of the new 1980 Civic 1500 DX, I knew this car was no ordinary "econobox." I adjusted the backrest of the comfortable, cloth-insert bucket seat to its most upright position and slid the seat back. There was plenty of legroom.

I adjusted the integrated air conditioner (\$500) and left Los Angeles on route I-15, bound for New York. Seven hours later, I was in Mesquite, Nev., 353 miles away. I had spent those hours driving through the desert, and my road speed averaged 52 mph. Despite crosswinds of up to 40 mph that left many motorists stopped in despair, the car tracked easily, needing few steering corrections.

After a brief stop for dinner, I drove another 200 miles. The seats

were so comfortable that I never felt tired. I quickly became impressed with the Civic's excellent road manners as I piloted the car through twisty mountain passes in Utah. The steering was light and precise, acceleration swift, braking quick.

After driving through some beautiful mountain ranges in Utah and Colorado on the second day of my 2965-mile journey (and tackling some snow-covered highways at elevations of up to 14,000 feet without much difficulty), I reached the flat, wide-open farmlands of Nebraska on day three.

Now that the Civic was broken in fully, it was time to test its performance. The Civic impressed me with its quickness, especially during passing maneuvers. I was able to go

from 30 to 50 mph in a lightning quick 5.2 seconds in second gear. In third, I was able to go from 50 to 70 mph in only 8.7 seconds. And zero to 60 took a reasonable 14.2, although you'll never be able to duplicate this time using the 32- and 53-mph shiftpoints that are marked on the car's speedometer—they lie beyond the 1488-cc engine's 5000-rpm power peak.

The Civic turned in remarkable fuel economy. For example, on a 606-mile run between North Platte, Neb., and Geneseo, Ill. (with a third night stopover in Des Moines), the car got 39.77 mpg at an average speed of 61 mph.

Not only is the Civic comfortable, but it seems much larger from the driver's vantage point than its diminutive 148-inch length would suggest from the outside. Clever interior design certainly helps to make the car seem spacious: The windows are relatively large (especially the tall windshield) and the dash is set well back toward the firewall.

The test car did have a few flaws, the most noticeable being too many squeaks from various trim panels as the car traversed bumps (the ride, incidentally, was busy but not punishing). The defroster could not be shut off when the ventilation system was set in the "heat" mode, and it filled the upper areas of the interior with cold air at night. Finally, the backrest adjuster on the seat has click stops that are too far apart for fine tuning.

Other than these few quirks, the Civic was so much fun to drive that it could easily put many \$10,000 GT cars to shame. Its overall 33.3-mpg average fuel economy was respectable. I think I'll order mine in silver with a red interior. —Moss Miller



# Plastic gets

Modern lightweight composites are challenging steel and aluminum in applications from house walls to fighter wings.

by Robert L. Perry





# tough



On composite wing of McDonnell Douglas AV-8B: 1 auto wheel; 2 transmission support; 3 Corvette seat; 4 Maxim oven; 5 Hamilton Beach iron; 6, 7, 8 rackets; 9 driveshaft; 10 fishing rods; 11 clubs. (Composites 1-3, PPG Industries; 4-5, General Electric; 6-11, Celanese Corp.)

**D**eep in a basement room of what used to be a New Jersey high school, a technician engages a groaning, puffing machine that looks like a dry cleaner's steam press. The "press" rolls a brown, silky material into a tough but willowy fishing rod. Another technician nearby toils on what looks like a miniature carpet loom. He is winding an automobile driveshaft that weighs half as much as one made of steel. One major difference between this driveshaft and metal models: It's twice as strong as steel.

Both men at the Celanese Chemical Corp. research center in Summit, N.J., are testing supercomposites—modern materials similar to stuff in acrylic sweaters and polyester pantsuits, but chemically more complex. These new materials may cause a revolution in the auto industry as great as the one from wood to steel 50 years ago. And their potential for you and me may be as significant as the move from the Stone Age to the Bronze Age. Ancient man combined soft copper and brittle tin to make durable bronze; modern man mixes miracle materials, such as carbon fiber and plastics, to make strong composites. The challenge to traditional materials from tough, new composites has sent engineers for aluminum and steel companies scurrying to their calculators.

Man-made materials have come a long way from the nylon stocking and cheap plastic whistle. Today, advanced forms of nylon, for instance, are showing up in the strangest places: around the chests of police officers, for instance.

Bettendorf, Iowa, police officer David Schafer was wearing a lightweight vest of Kevlar, a Du Pont-made material similar to nylon, when he trapped a robbery suspect in a drugstore. The suspect tried to shoot his way out of the store, charging at Schafer and firing a .45 automatic. One of the slugs slammed into Schafer's stomach from less than a foot away. The Kevlar, a fiber five times as strong as steel pound for pound, stopped the slug. The suspect was fatally shot by another officer after a short chase. Schafer's only injury was a bruise. Without the Kevlar, he almost certainly would have died.

The common link among all plastics is a chemical building block called a polymer. A polymer is a repeated string of carbon, hydrogen and nitrogen molecules. How chemists arrange the string at different temperatures determines each polymer's properties.



The first polymers were short strings that make the most widely known plastics—common nylon, acetate and rayon. Many of today's longer polymers were "fallout" from other research. Robert Edelman, Celanese senior research chemist, says that carbon fiber, one of the major composite discoveries, was developed as British researchers sought stronger, lighter materials for jet aircraft bodies.

Carbon fiber masquerades under other names—graphite or graphite fiber. But they're the same thing—practically pure carbon produced in intensely hot, complex chemical reactions.

### The frustrating road to fiber

Like many advances in modern technology, the development of graphite fiber proceeded in small, sometimes frustrating steps. "To make carbon fiber, they first tried burning cellulose (as in cotton) and rayon (as in stockings). But cotton incinerated and rayon melted into a mess," Dr. Edelman says.

After trying many other materials, researchers found that burning the polymer polyacrylonitrile (PAN) at 2700° F. drove off every atom but carbon. Combustion left a residue easily woven into a flexible, fabric-like form with the addition of resins. PAN, a colorless, flammable polymer, also makes up the acrylic fibers often found in our clothing.

But there was another problem. To make a superstrength composite, the carbon residue, which does not naturally form fibers, had to be combined with an adhesive resin. Unless

refrigerated, the best resins have shelf lives only hours long. That meant an auto company couldn't economically use them. Dr. Edelman began a long search for the right resin.

Knowing the complex properties of polymers, Edelman's team tested polyester resin "recipes" in one-quart batches. With precise measuring devices, Edelman poured, mixed, stirred and sampled for more than three months. "Each time we finished a batch, we just let it stand at room temperature. If it thickened too fast, or started to smell, we just chucked it out and tried again."

After properly proportioning a host of ingredients called catalysts and inhibitors, Dr. Edelman created a resin with a shelf life of months instead of hours. Auto companies can easily and inexpensively store the resin until they combine it with carbon fibers.

Despite such progress, carbon fiber is still expensive: It costs \$18 a pound (down from \$1000 just 10 years ago). So scientists today are seeking ways to use as little fiber as possible, while maintaining its superstrength.

Luckily, carbon fiber is easily united with common fiberglass, epoxy or polyester resins. And the resulting material marries the best features of both materials.

Supercomposites are used in ways as far out as you can imagine. Carbon fiber composites are baked in ovens to make lightweight wings for the Marine Corps AV-8B VTOL (vertical takeoff and landing) fighter and Navy Hornet fighter aircraft. And researchers say the carbon fi-



Fiberglass strands, from PPG Industries, will combine with resin and chopped fibers to make tough, moldable composite.

bers are indispensable in such esoteric objects as complex frequency filters on RCA's SATCOM communications satellites. In the near future, the space shuttle is to carry 50-foot carbon fiber struts into outer space to build 100-yard-wide satellites.

On Earth, the smooth, dark brown, silky fiber—or other newly toughened polymers—may provide your plumbing, garage your motorcycle, or repair the crack in your swimming pool.

### New world of consumer products

The Celanese experimental steam press rolls out about 500 expensive carbon-fiber (marketed as "graphite") golf clubs and fishing rods an hour. I bent their light fishing rod as far as I could, trying to snap it. Only my ego did any snapping. The thin, light golf club seems ideal for helping women and elderly golfers make longer drives. Graphalloy Inc. makes these and graphite-fiber tennis racquets. The Shakespeare Co., too, uses Union Carbide's Thornel graphite fiber to make 24 models of its "Ugly Stick" fishing rod.

I also recently tested a new hand iron made with General Electric Corp.'s new composite, Valox. GE and Hamilton Beach use Valox in the handle and upper housing of their new 2-pound, \$19.95 hand irons. I compared the new irons to a standard 4-pound GE Steam and Dry Iron with a plastic and metal housing. On several shirts, the light iron did fine. At comparable temperatures with no more elbow grease, it got the wrinkles out as well as the heavier iron. The only disappointment is that the power cord, made of common plastic, connects to the right side of the iron,

(Please turn to page 174)

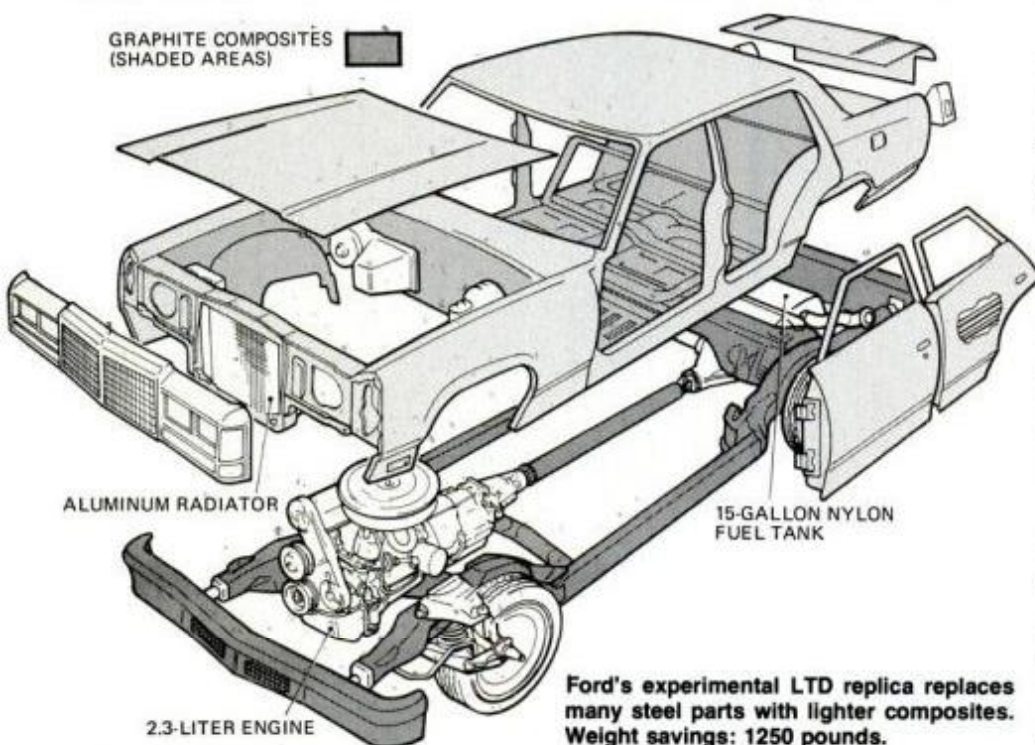



# IT'S NEW NOW

## Indoor antenna

TV reception in apartments can be difficult, especially if outdoor antennas are prohibited. The AT-5000 contains circuitry that allows element rods to be half usual length. Included with unit are a spring-loaded, floor-to-ceiling pole and plant-hanger hooks. About \$43 from Winegard Co., 3000 Kirkwood St., Burlington, Iowa 52601.



## Electric cart

Lectra Bug is a four-wheel, electric-powered vehicle that can be built in most home shops for about \$200 to \$400, says the maker. Because of its auxiliary chain drive, it can be licensed as a moped, maker claims. Top speed is about 15 mph. Plans cost \$15 and are available from Lectran Co., Box 1648, Largo, Fla. 33540.



## Close to you

The CU-70 kit is Polaroid's system for making close-up photos with SX-70 cameras. It includes three close-up lenses and focusing frames, plus an electronic flash. Lenses provide life-size, 2x and 3x magnification. Kit, with case, SX-70 Sonar One Step camera and accessories, is under \$600. Polaroid Corp., Cambridge, Mass. 02139.

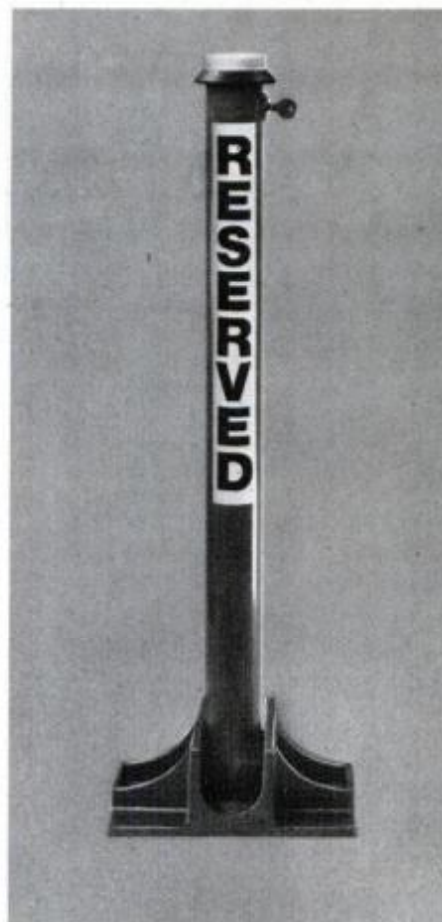

## Keep your place

Private parking spaces can be kept free of unwanted cars, says the maker of Safepark. Anchored or epoxied to ground, the solid-steel pole stands 32 inches high and can only be swung down when unlocked. It swings up again to prevent auto theft. About \$60. Progressive Systems Co., 6500 North California Ave., Chicago, Ill. 60645.

## Pop goes the vial cap

The RX Tool was designed for adults who have difficulty removing childproof caps from medicine vials, the elderly and handicapped especially. The tool is said to remove most types of snap caps regardless of cap position. It's about \$3 from RX Tool Co., 6750 South Clermont St., Littleton, Colo. 80122.

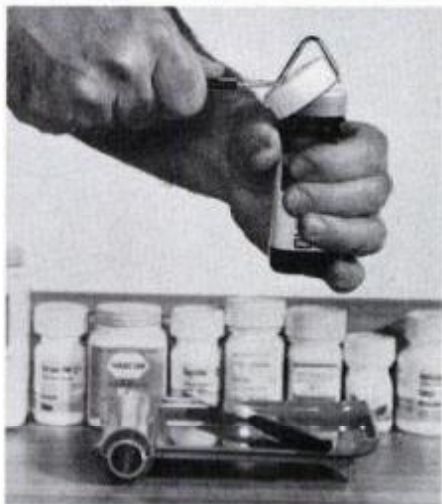

## Glue remover

The usual method for removing price stickers, decals and bumper stickers involves scratching them off with a fingernail. A more effective way is now available, according to the maker of Adhesive Remover, which you just brush on. It is said not to burn skin or remove automotive paint. A 4-ounce can is \$1.79 from Sierra Enterprises, 2134 Dicker-son Rd., Reno, Nev. 89503.





# 1980 BOATING



Wellcraft's high-performance 30-foot Scarab Sport can take twin new 300-hp Mercury motors.



## PM's pick:

A preview of styled-up water performers shows improved looks, speed and fuel economy.

by Bill McKeown  
BOATING EDITOR



Glastron runabouts, with decked-in bow (above) or open bow with extra seating (left), now use their SSV hull for 16-footers that claim the soft ride of a V-bottom and the added stability of a tri-hull. Outboard power ranging from 70 to 120 hp is recommended.





Phoenix Marine of Hialeah, Fla., offers latest Jim Wynne double-deckrise performance hull with "propeller pockets" (visible in the transom above) that require only a 22-inch draft with twin gas or diesel engines.

# 10 boats that are tops for 1980

**N**ew power, hull designs, construction materials, styling and performance will be the boating developments to watch this coming year.

Boat shows are already revealing trends that should hold down fuel consumption, while keeping up comfort, sea-

worthiness and dependability in pleasure craft.

Light weight is one way to cut down on the mass that must be pushed through the water, and plastics and metals that have more strength for the same or less poundage are being used. They cost more, but

the makers claim that you'll eventually save the difference in lowered maintenance, gas consumption, and impact on waves, since they skim over rough water instead of through it.

Aluminum, graphite, Kevlar aramid fiber and even exotic space-age metals



Latest Forest Wood Ranger Bass Classic model features "Mr. BASS" (Ray Scott) driving. Wiring for remote tilt is built in.



Formulae Super Cat from Formulae Racing Sailboats, Riviera Beach, Fla., is claimed to be world's fastest at speeds to 25 mph.

Birchbark look, redwood seats, aluminum gunwales and fiberglass hulls style new 12- 15- and 17-foot canoes from Sears.



Multiple features of Hammond V-1940XL St. Tropez include open foredeck, cushioned sundeck aft, transom platform over drive.



Thunderbird's Formula One, its newest high-styled 17-footer, has OMC, Mercruiser or Volvo power options, transom platforms.



Excalibur Executioner, a limited edition 32-footer from racer Reggie Fountain, has turbocharged 475-hp Mercruisers, 87 mph.





Famous gaff-rigged Friendship sloop is now duplicated in fiberglass by Liberation Yachts, Centerville Rd., Warwick, R.I.



Claimed to be legal on lakes where "powerboats" aren't, Fin & Feather's \$995 Bass Barge is pushed by two electric motors.

Glastron V-243 SeaFury offshore fisherman has walk space around cabin, molded bow pulpit. It can take outboards to 280 hp.



One of 46 Bayliner models for 1980, this 25-foot Sunbridge mounts a MerCruiser 145 diesel with a water-cooled turbocharger.



The Kat 416, an inflatable catamaran from Semperit/Steyr-Daimler-Puch, is 13 feet long, weighs 125 pounds, can carry 1000.



Mounting the new three-stage Eliminator Jet from Snake River Marine, Starcraft Islanders are now on Coast Guard patrol.



Good, quick stability test for small hull (if you're a good swimmer) is to stand on one gunwale. Grumman's 3.8 passes easily.

are going afloat more often, and should have the strength to handle the higher outboard and inboard horsepowers and turbocharging that have arrived.

#### Fuel-saving sailboats

Sailboats are a popular way to save fuel, and catamarans and scows are rated fastest of all by sailors who want speed. When choosing your windjammer, you may have more fun by picking one from a class that is popular locally for racing. There's more chance for tuning sailing skills in competition, and a higher resale value when you're ready to trade.

Little boats take less gas or muscle to run, and are suitable for most sheltered waters. Inflatables, particularly, are becoming the answer for boatmen with limited storage space, and some of the latest

models are testing the use of high-strength Kevlar and graphite filaments, as well as synthetic coatings, to give the inflated fabric added durability and abrasion resistance. Vee bottoms are being designed into larger blowups, so there is less slap and pounding as these light-weights plane over choppy seas.

#### Keep weight aft

Power options with turbocharged diesels, conventional gas inboards, stern-drives and outboards all offer more ranges of performance. The trend in engine placement today is to keep weight aft, and the deep-V hulls allow even standard inboards to be stowed astern for easier planing and ride. Boats burn only a small fraction of fuel used today, and may deliver the most fun per gallon. **PM**



# Tabs to trim gas use by half!



With trim tabs full up and engine trimmed out (above), boat can ride bow-high through head seas. With tabs down and engine in (left), hull planes evenly. Left tab up and right down (below) shields against beam seas.



WATER PRESSURE ON  
TRANSON TAB LIFTS STERN  
TO RAISE HULL ON PLANE

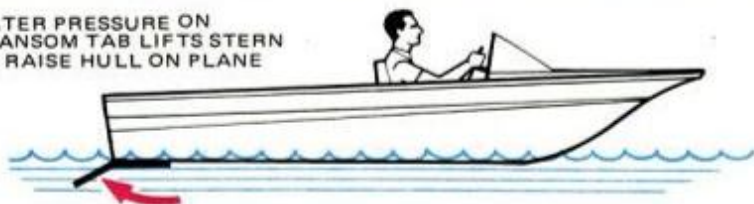

Safer, softer rides and big fuel savings are the bonus benefits of install-yourself hull adjusters.

by Bob Stearns

**T**rim tabs—sometimes called afterplanes, shims, transom wedges or stern planing boards—have been around almost as long as power boats. However, until prices soared at the fuel dock, they were used only to correct hulls that did not perform properly. Today, though, if properly designed and installed, they

can smooth out the ride while saving a remarkable amount of fuel. Here are five trimming systems, listed in order of effectiveness, that should save you many bonus dollars at the marina gas pump.

### Transom shims

These are the most basic form of trim control, and the least expensive, but they are also the most time-consuming to install. A pair of these wedges, secured at the extreme aft end of the boat, with one on each side under the transom (or transom bait wells, if the boat has them), can provide extra lift. Since almost all planing hulls, especially outboards and

sterndrives, are heaviest in this area, the added lift tends to bring the bow down for a smoother, more level ride. It can also stop the tendency of some boats to buck and porpoise up and down as they run.

The primary disadvantage of this system is that a lot of time is consumed in experimenting with different sizes and shapes of these wedges before the best compromise is reached. And because it is necessary for these wedges to be glued or screwed to the bottom of the hull, they cannot be removed easily for adjustment.

If you have to try several different sets before the best are found, you



may find the process is messy. There is a better approach, however, which I worked out a few years ago when I had a boat with an aggravating tendency to porpoise. I installed a pair of simple adjustable shims, one under each transom baitwell. They solved the problem neatly and allowed me to "fine tune" my boat's performance. Fuel consumption tests revealed that in some conditions these shims improved my rig's fuel economy from 5 to 10 percent.

They were simply a pair of 6-inch x 4-inch L plates made of .030-inch stainless steel at a local metal fabricator for about \$20. Four screws at the leading edge of each plate hold it securely under the transom, and each extends astern just enough to allow vertical adjustment with a setscrew. It takes only a few minutes of trial and error running to find the best setting.

The disadvantage of the shim system is that the ideal adjustment is limited to average running conditions. Too much lift and you might get in trouble as your bow started to bury in a steep, following-sea situation.

#### Preset (manual) trim tabs

These operate in the same way as the adjustable shims, but with an ad-

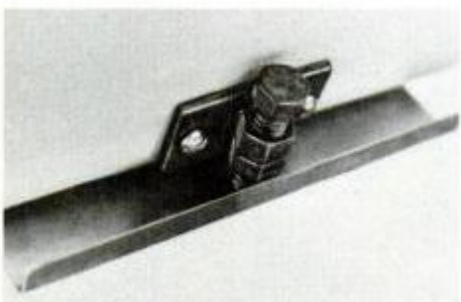

Adjustable homemade tab is controlled by a bolt threaded through brazed nut on L.

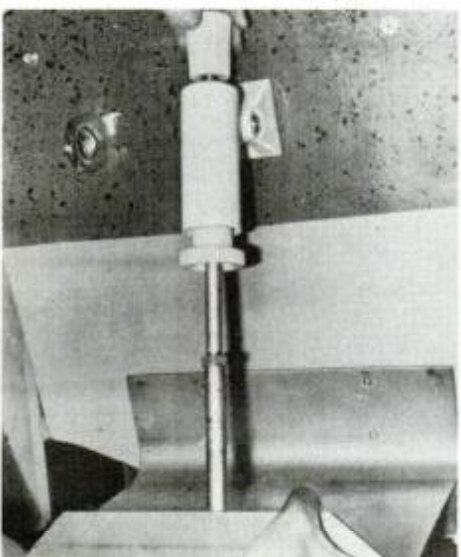

"Automatic" tab is spring-loaded, extends down at slow speeds, pushed up by water.

vantage: They are mounted on the transom and extend aft, increasing the effective length of the hull without adding more weight. While offering more lift at the transom, they also increase the planing surface in the area where the load is heaviest and often raise the cruising speed. Obviously, more speed from the same throttle setting means more miles per gallon.

These tabs are available in a wide variety of sizes, shapes and materials. Some are stainless steel, others are aluminum, and a few are space-age plastics. Some are "automatic adjusting"—they are spring-loaded, so that at slow speed the pressure of a spring forces the tabs down for more lift. As speed increases, water pressure hinges them up so that they don't tilt the bow down excessively.

Most preset tabs are adjusted with tools for average running conditions and cannot be changed while underway. One set, however, called Dolphin Trim Tabs, are manually adjustable via a spring-loaded support arm and a series of notches on the upper surface of the horizontal tab. To achieve more lift, you simply stop the boat and reach over the transom, pushing the trailing edge of each tab as far down as you wish. The lever arm

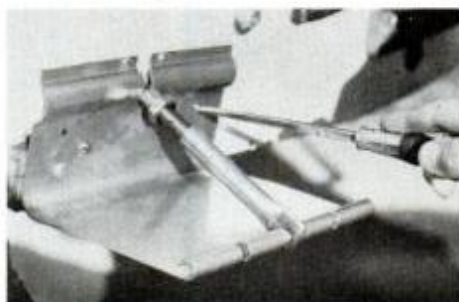

Boat must be stopped for manual or tool adjustments for change in trim-tab angle.



Shown in maximum "up" position, Bennett tab is remotely controlled from the helm.

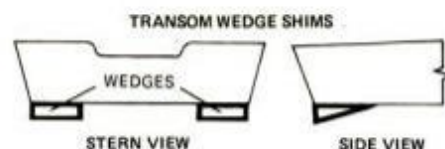

Fixed wedges require trial-and-error fit.

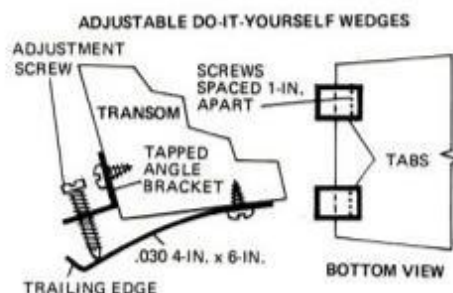

Stainless-steel tabs are bent up at rear trailing edge for stiffness, could be cut 5 x 8 inches, or 6 x 10 for larger boats.

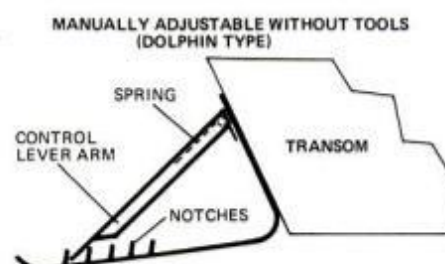

Arm is lifted or pushed for adjustments.

drops into the corresponding notch and stays there until another adjustment is made.

The advantage of this system is that each tab can quickly be adjusted individually. If you are faced with a long ride home in a nasty cross wind chop, the tab on that side can be depressed further than the downwind tab, thus keeping the boat in a more level and dryer attitude. For a head sea, both tabs can be raised to lessen the possibility of burying the bow when topping a steep wave, and plunging down into the trough.

The disadvantage is that the boat must be stopped each time you make an adjustment. But all the preset tabs can save you as much as 10 to 30 percent on your fuel bill, if they are the correct size for your boat and properly installed and adjusted. Results with every boat will differ somewhat because of variations in hull design, power, load and sea conditions. Cost of these tabs ranges from about \$35 to \$120, depending upon size, materials and design. They are simple and quick to install.

#### Engine power trim

Available for almost all outboards over 40 hp, as well as many sterndrive models, this adjustable, propeller-angle trim can give extensive control over hull attitude in the water. The

(Please turn to page 143)



# New gear to go afloat

Even marine accessories are being made lighter to help cut down fuel-consuming weight aboard. Plastics and stainless steel are helping to reduce maintenance. Smaller engines are lowering the cost of rigs and the gas required for them.

In addition to the small outboards from the big producers—Outboard Marine's Evinrudes and Johnsons, Brunswick's Mercurys and Mariners, and the Chryslers—there are new modest-horsepower, fuel-efficient motors from well established mini-mill producers. Aquabug, Clinton, Eska, Honda, Mighty Mite, Seagull, Sears, Spirit, Suzuki and Wards supply two-cycle outboards that are light, economical and muscular for their size. Often they make a better (and easier to stow) standby engine than a big pair of thirsty twins.

Even electronics is going afloat in small rigs, and no craft is too small this year for a depthfinder and CB or VHF portable radio. **PM**

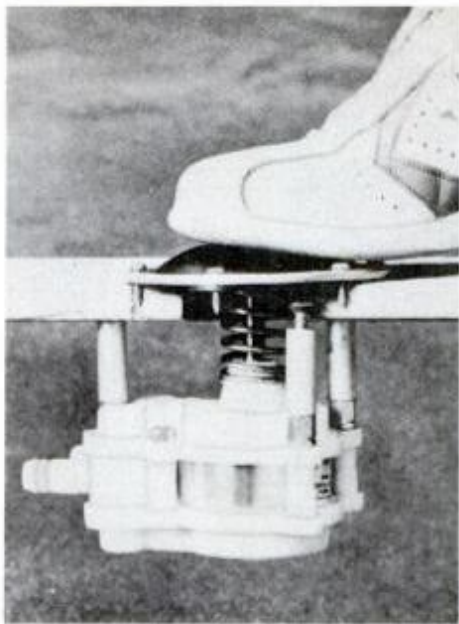

An out-of-sight pump to fill a sink or drain the bilge of a dinghy while your hands are busy, the small, 2.5-gpm Flush Mount is from Rule Inc., Gloucester, Mass.



With craft up to 30 feet now being hauled on a trailer, Dutton-Lainson, Hastings, Neb., has a StrongArm electric winch to power or hand crank boats up to six tons.



Running shoal water up to six inches thin without tearing up the prop is possible by raising the outboard and attaching a Riffle Runner by Water World, Roseburg, Ore.



A "Fire Blanket" for boats that should work equally well ashore, this safety item from Goldbergs' Marine, Philadelphia, is said to smother a galley or engine blaze.

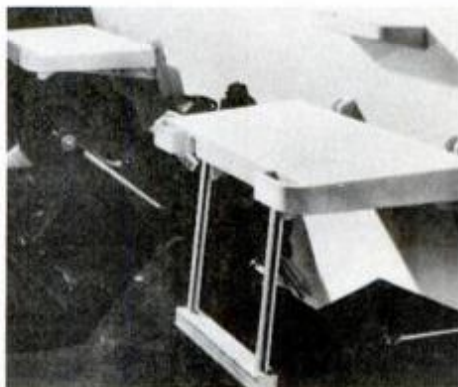

For convenience and safety, a stern step makes reboarding easier, and the Transom Platform from Tempress, in Seattle, adds a teak step, can fold up out of the way.



Handi-Mate is made by Bush Products in Lynnwood, Wash. The device clamps on an outboard motor tiller and extends both throttle and steering all the way up to center seat.

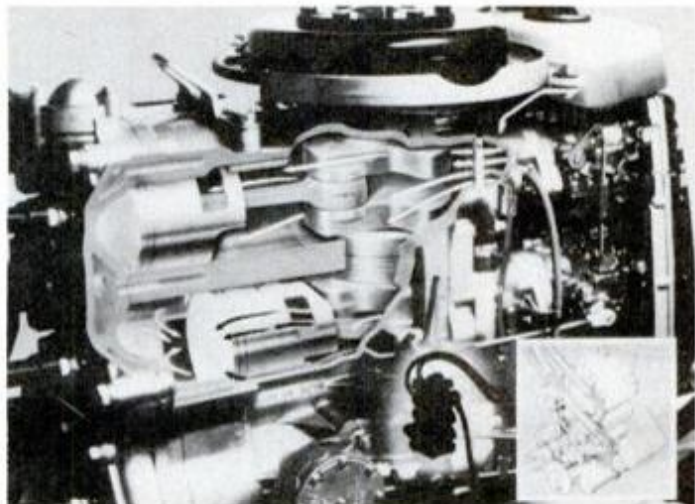

Mix of gas and outboard oil is provided automatically by metered oil injection into new Spirit 85, top of 12-model line. Just fill the oil reservoir and the engine does the rest.



# WHAT IT'S LIKE TO FLY PEDAL-POWERED

Human-powered flight for everyone moves a step closer with this M.I.T.-designed biwinger.

by Tom Sahagian

A photograph of a man pedaling a human-powered aircraft on a runway. The aircraft is a biplane with a large propeller and a cockpit. The man is sitting in the cockpit, pedaling. The aircraft is being run along the runway by a crew member. The background shows a grassy field and a line of trees under a clear sky.

The author pedals his way to a 63-second flight; maximum altitude was about 15 to 20 feet. Flight crewman runs along with the airplane to stabilize wings during takeoff and landing.



# THE M.I.T. BIPLANE

Wings are mostly space—a combination of aluminum tubing, Styrofoam, balsa and Mylar (right). Air inside weighs about half what wing does. One tough technical problem was stretching Mylar over framework, keeping it taut.

Pilot's view of cockpit (top) shows prop, plastic chain, rpm meter. Marks on tube record total flights.

Author receives some assistance with "custom fitting" of his seat (far right).



The ground crew shuddered. "Right! Right!" one of them shouted, as the airplane banked left at a steep 30°. The plane's controls no longer seemed to respond, and the pilot was much too tired to fly properly. A wing-shattering crash looked imminent. As the plane inexorably lost altitude, the pilot closed his eyes and waited for the splintering impact.

But it never came. Somehow, the wings straightened out and the landing became nothing more than a stiff bump. A collective sigh of relief from the ground crew and spectators sounded across the airfield. The pilot collapsed in the cockpit, exhausted.

So ended my last flight in the *Chrysalis*, a human-powered airplane designed, built and flown by students at the Massachusetts Institute of Technology (M.I.T.). Some think high winds (a seven-knot breeze is a stiff gale to *Chrysalis*) made the plane uncontrollable, while others credit pilot incompetence. No matter; it was my most memorable flight.

## Flight for the masses

*Chrysalis* hasn't won any prizes or crossed any channels, but it may have done what its famous cousin *Gossamer Albatross* couldn't do—bring human-powered flight within the capability of almost everyone.

Sometime after Paul MacCready's *Gossamer Condor* won the long-sought Kremer Prize (see *I Pedaled the Mile to Aviation's Big Prize*, page 100, Dec. '77), a group of model-airplane enthusiasts at M.I.T. thought they'd try to fly a previous unsuccessful student-built plane. When they failed, they decided it would be easier to design something from the ground up.

Unlike the *Gossamer* group, the *Chrysalis* people did not seek any prizes or records; rather, they wanted to build a plane that everyone involved in the project could fly. Thus, high performance became secondary to ease of control, stability, durability and ease of construction.

That decided, the basic layout of

the plane came readily: front-mounted prop, rear-mounted control surfaces, and a biplane wing configuration. The design was strictly conventional.

Why a biplane? Because the designers didn't have access to a hangar wide enough to accommodate the 96-foot wingspan of a monoplane design. Also, a biplane could be made stronger.

Most design verification was done on a 1/8-scale model flown inside the M.I.T. gym. Bob Parks and Harold Youngren, the two chief designers, were members of the award-win-

(Please turn to page 172)

A good pilot can easily outdistance ground crew—unless they ride bicycles. Tail position shows plane is still climbing. Note Air Force Thunderbirds in background.





REWIND KNOB

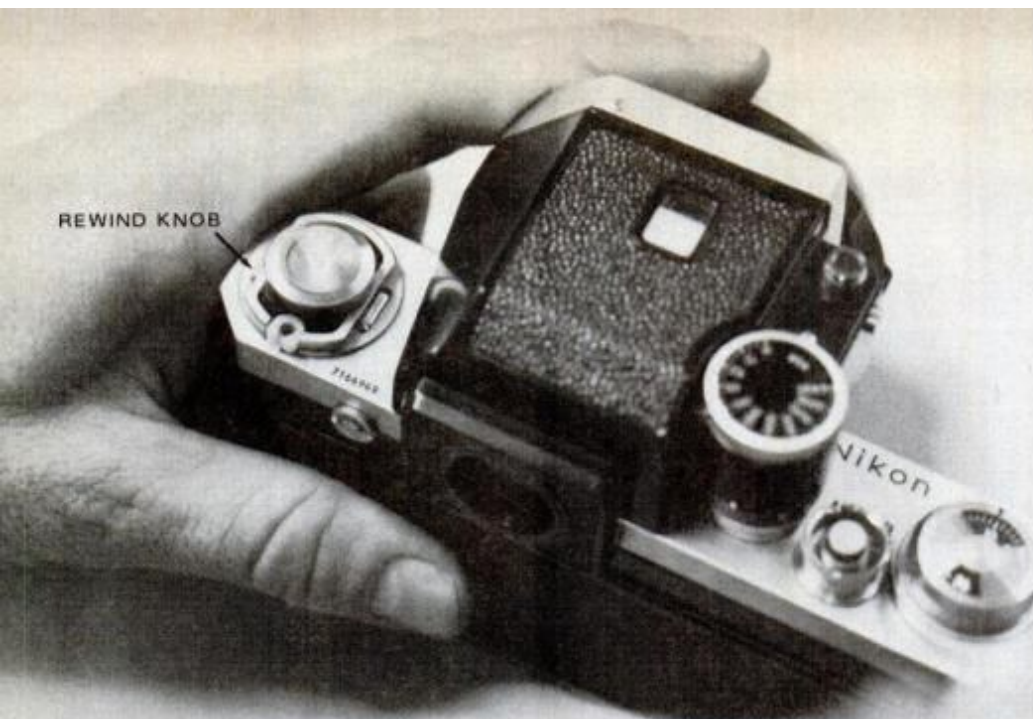

**P**rofessional photographers are human; they make mistakes. But since a pro can't goof too often and remain a pro, he usually devises a system to make sure errors don't recur.

Amateurs need not worry about some of the more esoteric boo-boos the pros make, and many photos are ruined by failures in the camera. Such mechanical foul-ups occur more often in equipment that sees everyday use—and sometimes abuse—by a working pro than in amateur gear used twice a month.

We've selected six of the most basic blunders that everyone makes. If you acquire the habit of going through a mental checklist each time you shoot, you'll minimize your goofs. If you do make a mistake, don't be too upset—you're in good company. **PM**

**1** No film in the camera. Few goofs can cause more embarrassment than this one, but it happens all the time, even to professionals. Jon Naar, who has published several books, recalls the time he happened upon a raging fire at a hotel in London. He whipped out his Leica and began shooting. Many of the "exposures" were highly dramatic, but the camera wasn't loaded. He and many other pros always watch the rewind knob to see if it turns when the film-wind lever is advanced (see photo, above). A related problem can also be solved this way: Sometimes the film is loaded but doesn't advance. If the knob moves, you're okay. Don't be afraid to waste a frame making sure the film is moving—it's worthwhile insurance.

## Six photo mistakes even the pros make—and how to prevent them

A pro will goof once, and then make sure he doesn't do it again.

by Tom Sahagian

**2** Reshooting a roll of film. Many photographers, especially those who do their own processing, do not rewind the film all the way into the cassette. That way, they can squarely cut off the narrow leader strip in the light, instead of fumbling in the dark before winding the film on a developing reel. But you need a way to distinguish between used and unused film. In the photo at near right, one roll of film has been exposed and the other hasn't—can you tell which is which? You could easily reshoot the used film. Solution: Crimp the end of the leader after rewinding (far right). Some pros go one step further and tear the leader off.



**3** Wrong film-speed setting. With today's fast 400 ASA films in both color and black-and-white, many photographers just set the film-speed dial at 400 and forget it. But what's more likely is that you'll shoot color slides at ASA 64 one day, and then perhaps "push" 400 ASA to an exposure index of 800 indoors the next. It's easy to forget to change the dial, and the next roll will almost certainly be wildly over- or underexposed. The best thing to do is to tape the end flap from the film box on your camera back (far right). It will remind you to adjust the film-speed setting. Some cameras now have holders made specifically for an end flap (near right). Other photographers even stuff part of the end flap of the film box into the camera's hot shoe.





**4 Incorrect flash synchronization.** This is a common problem because modern flash units are so automatic it's easy to forget that the shutter speed still must be set for proper synchronization. That is, the shutter must open fully as the flash fires. On cameras with focal-plane shutters, proper electronic flash sync is  $\frac{1}{60}$  or  $\frac{1}{125}$  second, although a few synchronize somewhere in between. Cameras with leaf shutters can sync up to  $\frac{1}{500}$  second, but few amateurs use them.

At shutter speeds above proper sync, part of the frame will be unexposed (right) except for ambient light. With some cameras, the entire negative will be black. A small label affixed to the flash unit reminding you to set sync speed should do the trick.

What happens if you set too slow a sync speed? Not much, unless you shake the camera. If there's a lot of ambient light, it could affect the exposure. In fact, it's possible to create an interesting effect by shooting a moving object at a very slow shutter speed ( $\frac{1}{30}$  or less) with flash.

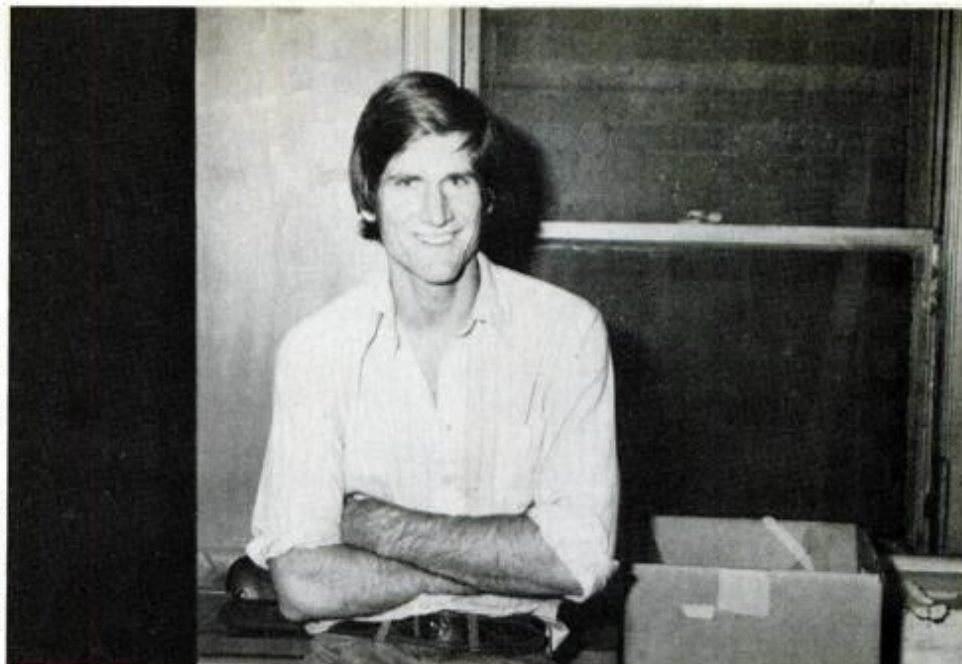

**5 No lens shade.** Many photographers neglect to use lens shades because they think the anti-reflective coating on modern lenses renders a shade useless. Not so. Unwanted light rays can spill into the image area and cause washing out or spurious reflections. Note that even though the image area is rectangular or square, the lens projects a circle. A bright light may not be visible in the viewfinder but still be in the

circle. In the photo above, no shade was used. Much of the top of the picture is washed out, even though the sun was not visible in the viewfinder. In the photo below, a shade was used. Details are much clearer. When the lens is stopped down, little hexagons or octagons can appear in a photo; these are reflections of the lens diaphragm. Often a shade on a lens can eliminate these annoying reflections.



**6 Low batteries.** As cameras become more and more electronic, and as motor winders proliferate, more camera systems depend on batteries. Some manufacturers have incorporated flashing LEDs or other warnings to tell you when the batteries are running low. Even so, it's possible to be caught with your energy down. The obvious solution is to carry a fresh set with you at all times. Some photographers have two sets of nicads and keep one set always in the charger. Others wrap batteries in a plastic bag (to keep out humidity) and stick them in the freezer. After taking them along as a backup, they are returned to the freezer to prolong life. Make sure cells are brought up to room temperature before use.

If you still manage to become stuck without a backup, here's a possible way to squeeze another shooting session out of a battery: Clean its contacts with a pencil eraser (above). Wipe with a cloth to remove fingerprints and reinstall without touching the contact surfaces. It's wise to change batteries annually, whether you think you need to or not.





# 4 valentines from your shop

by Harry Wicks HOME AND SHOP EDITOR

Here are four attractive easy-to-make projects useful the year round.

By spending a couple of Saturdays in your workshop building these delightful items you are sure to create the most pleasant Valentine's Day your family has ever enjoyed. We asked designer C.J. Castelberry to come up with some Valentine gifts that our woodworking readers could create for their wives and daughters. Her successful results are shown on the facing page.

To assure surprise, you'll have to keep your shop off limits while the projects are in the works, but the secrecy will only add to the enjoyment when the recipients open their presents.

## Construction is easy

Happily, we were able to retain the boutique-like look that the designer wanted — even though the goal was to create the prototypes in wood with the least amount of effort. The result is that

sanding and/or planing, use a hollow ground planer (or finer) blade to cut out all parts on the table saw.

■ For cuts made with jigsaw or bandsaw, use the finest-possible blade that won't break when turning a sharp radius.

■ Sanding of scrolls (heart shapes) goes very quickly if you use a flap-type sander (such as Merit Abrasive's Sand-O-Flex) in either portable drill or drill press.

■ Seal all parts before painting with a thinned coat of shellac; thin 3-lb.-cut shellac one part shellac to three parts denatured alcohol. A pigmented shellac, such as Bin or Enamelac, is an even better primer. These can go on full strength as they come from the can.

■ For the multicolored items — mirror and varicolor jewelry box — our designer used acrylic paints which are available in artists' supply stores. The acrylic paints are water soluble. When completely dry

### MATERIALS LIST—RING CADDY

No.	Size and description (use)
1	1/4 x 6 x 10" plywood (hand)
1	1-3/4 x 2-3/4 x 5-1/2" hardwood block (base)
Misc:	Felt, 1/4" brass cup hooks, sandpaper, acrylic paints, clear sealing spray.

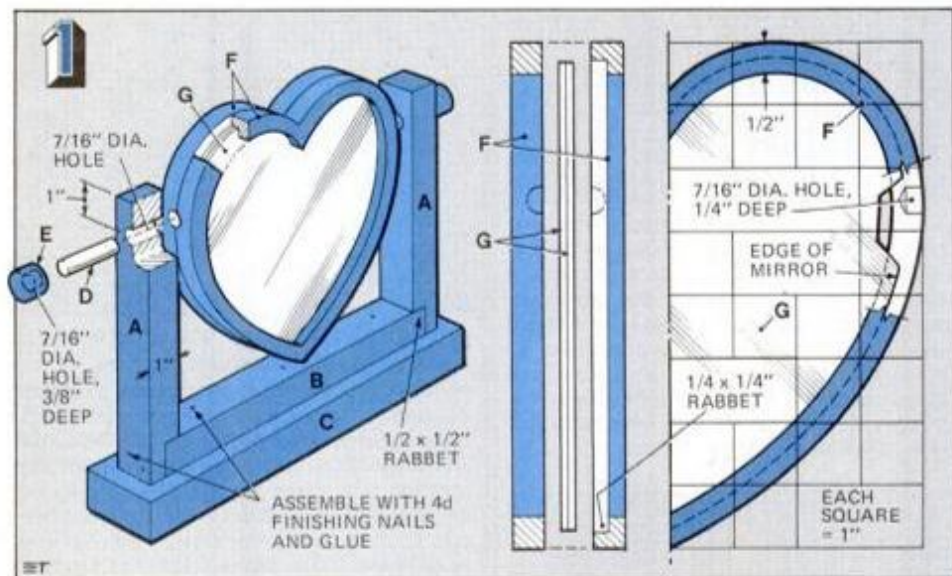

all of the projects can be easily reproduced by anyone with a typical home workshop. The mirror project requires the greatest carpentry skill — and certain tools — (you will need handscrews to hold vertical legs and mirror in alignment when boring the dowel hinge holes). Before starting any of the projects, take the time to study the construction drawings provided, and *do* read through all instructions.

## General instructions

■ To minimize the time needed for

### MATERIALS LIST—MIRROR

Key	Pcs.	Size and description (use)
A	2	1 x 1 x 8-1/2" pine (uprights)
B	1	1 x 1 x 10-3/4" pine (sub-base)
C	1	1 x 2 x 11-3/4" pine (base)
D	2	7/16 x 1-3/4" dowel (hinges)
E	2	3/4 x 3/4" dowel (hinge caps)
F	2	1/2 x 8 x 8" plywood (heart)
G	2	Custom-cut heart 1/8" mirrors
Misc:		4d finishing nails, shellac, sandpaper, acrylic paints, Krylon clear spray (No. 1301).

they should be protected with several coats of a clear, compatible sealer. I used Krylon's No. 1301 clear spray on the projects shown.

■ For projects where a high gloss is

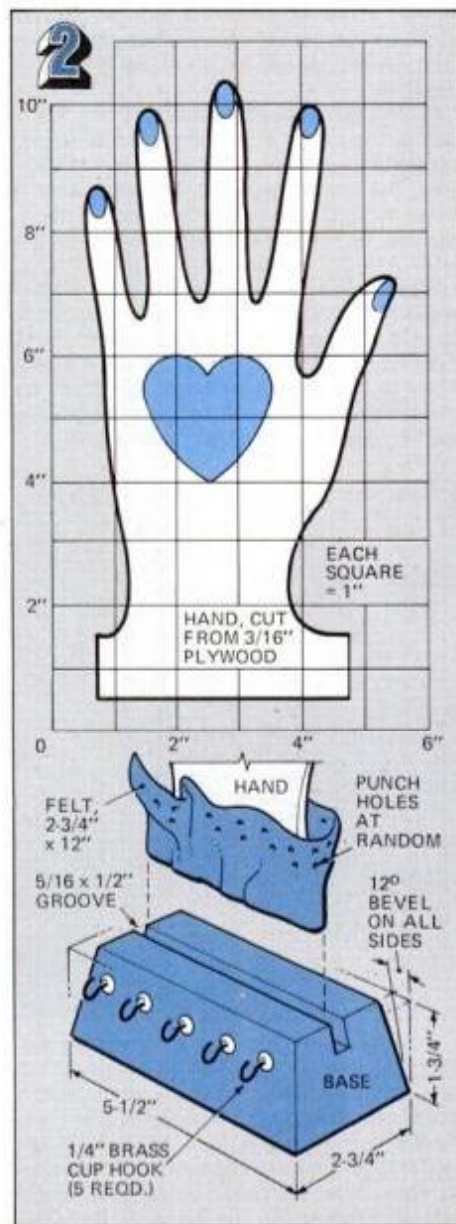

Stylish ring caddy (above) is a super-easy valentine to make. The mirror (at left) requires a little more skill.

desired, use enamel. For the red jewelry box and the crayon holder I opted for a relatively new aerosol paint called LeSpray. Though the paint produces a very high gloss finish, it is a water-soluble coating. Thus, cleanup is fast and easy. The same product is also available in a brush-on form called LeBrush, if you prefer brushing on to aerosol cans. (Available at hardware and paint stores, both versions of this paint are manufactured by Sensico Inc., Oakland Calif. 94608.)

(Please turn to page 193)

Project designs: C.J. Castelberry  
Construction by the author  
PM color photo: Harry Hartman





**1** Frame for tilting heart-shaped mirror is constructed of 1/2-in. plywood. The tilt action is made possible by force fit.



**2** Our attractive ring caddy keeps rings, small jewelry convenient on a vanity. A felt cuff holds earrings in full view for easy selection.

**3** Solid-wood, linked hearts bored with many holes become a handy crayon holder for your youngest valentine.

**4** Layered-pine jewel box can be painted in stripes or solid as shown. A circular cutout is affixed to top's underside to assure alignment when the box is closed.



**3**



**4**





*A PM Reproduction*

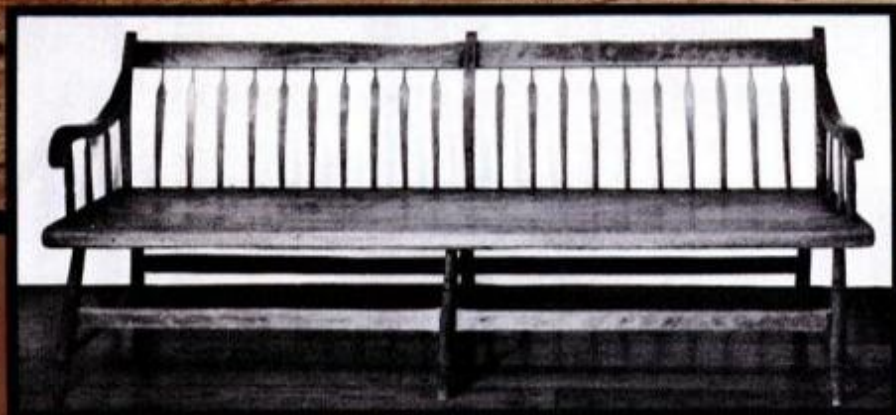

Reproduction (top), is a ringer for the original (above) minus years of wear as a resting place for weary clients who visited Lincoln's law office. Details such as the coves on the bench leg (left) have been carefully and exactly duplicated.



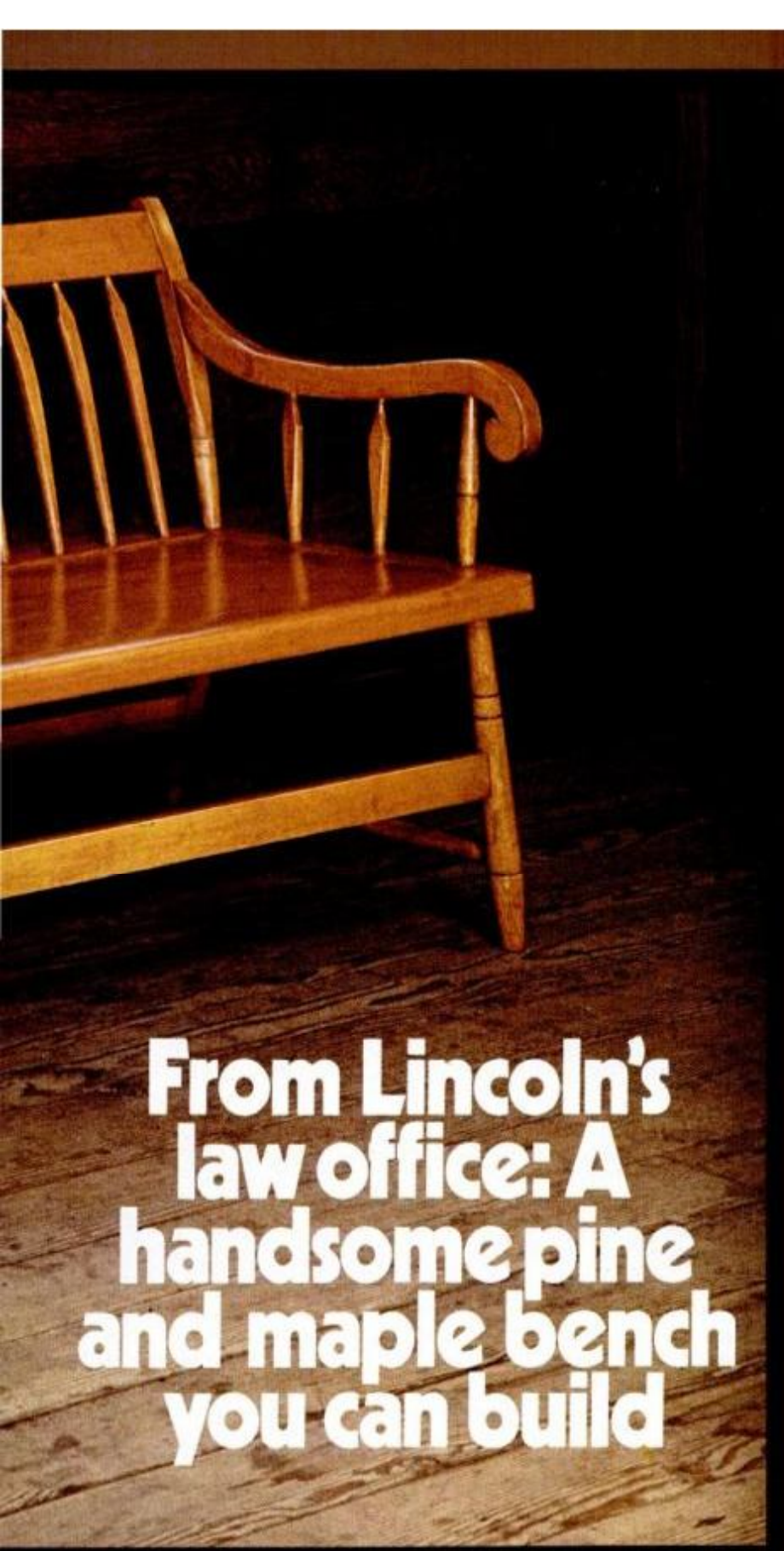

# From Lincoln's law office: A handsome pine and maple bench you can build

The original is preserved in the Law Library of the Old State Capitol Building in Springfield. The Illinois State Historical Library has granted PM permission to reproduce the piece exactly.

by David Warren

**B**y the early 1840s, Abraham Lincoln had become a successful Springfield, Ill., attorney. His practice had grown rapidly, in recognition of his abilities in law, his quick grasp of argument, his sincerity and his lucidity of speech. However, Lincoln possessed another important attribute—he had a genuine appreciation of good design in furniture.

The bench he picked for the waiting area of his law office is a real beauty. It is constructed of pine and maple and is 19 inches wide by 78 inches long. We used the same woods to build the reproduction. Design features include a plank seat, Windsor arrow back and trestle leg assembly.

Before you begin construction, make several construction aids to assure accurate cuts and tight-fitting joints.

First, make a full-scale drawing of an end view, showing leg- and back-support angles and the spacing of the arm stays. Then make a full-scale drawing of the front and back of the seat ends. Next, draw a bottom view of the settee from the end to the center, showing legs, stretchers and angles. Save time by drawing only half, since the remaining half is a mirror image and locations and angles are merely flopped during construction. Finally, draw a full-scale top view of the same half, showing back-support and arm-rest locations and angles, and the spacing of arrow-back pieces.

Templates are also necessary for the Lincoln settee. On heavy cardboard, draw one for scooping out the seat area. Draw one of a back leg and one of a front leg. Also, make a template for the front and back corners of the seat. Then cut out the shapes using a utility knife.

Use the full-scale drawings as an aid to make sight guides that let you line up holes to be bored at proper angles. You will need a sight guide for each rear leg and for each front leg. Note that the borings for the corner legs are at compound angles. Cut the guides from 2x4 scrap, six inches long.

## Begin construction

Using the drawings, lay out and turn the arrow-shaped arm and back stays. Then plane the flat areas as required while the workpiece is held rigid in the lathe.

## Bending the stays

Make the bending jig as shown in the photo. It will bend two stays at a time. Soak them for four hours. Then

PM photos: Matt Doherty  
Cabinetmaker: Ray Peterson



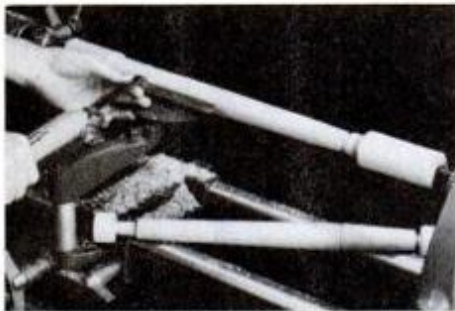
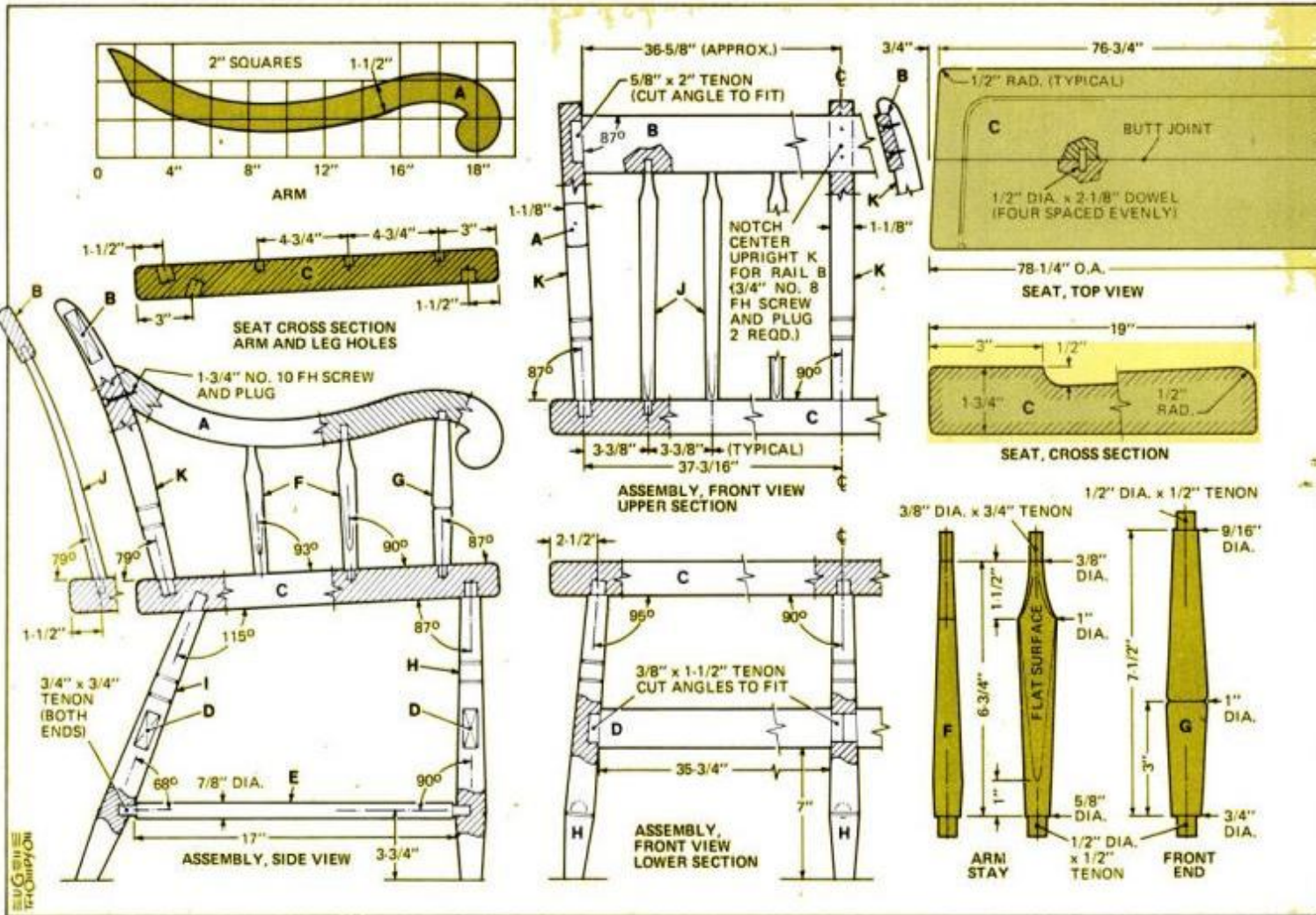

Rough square stock to round for arm stays using a gouge. Then use skew to turn to final diameter as shown in plans.



After stay has been turned and coves have been cut, sand smooth with 220-grit paper while workpiece turns in the lathe.



Turn 20 arrow-shaped back stays, using a cardboard template to check contour and to assure uniformity during the turning.

Before you remove stay from the lathe, plane two flats on opposite sides of the workpiece as indicated in the plans.

Use a shop-made jig constructed like the one shown below to bend and clamp each water-soaked back stay until dry. The jig

should bend the curve slightly tighter than exact contour of the back to allow for spring-back upon release from the jig.

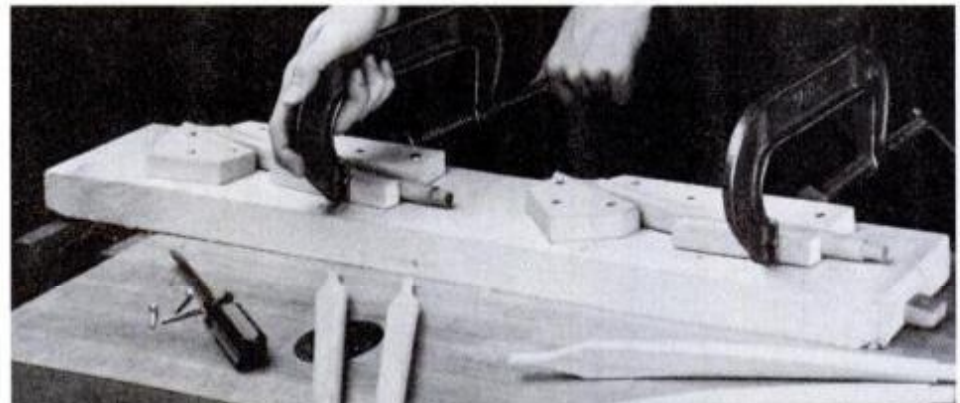



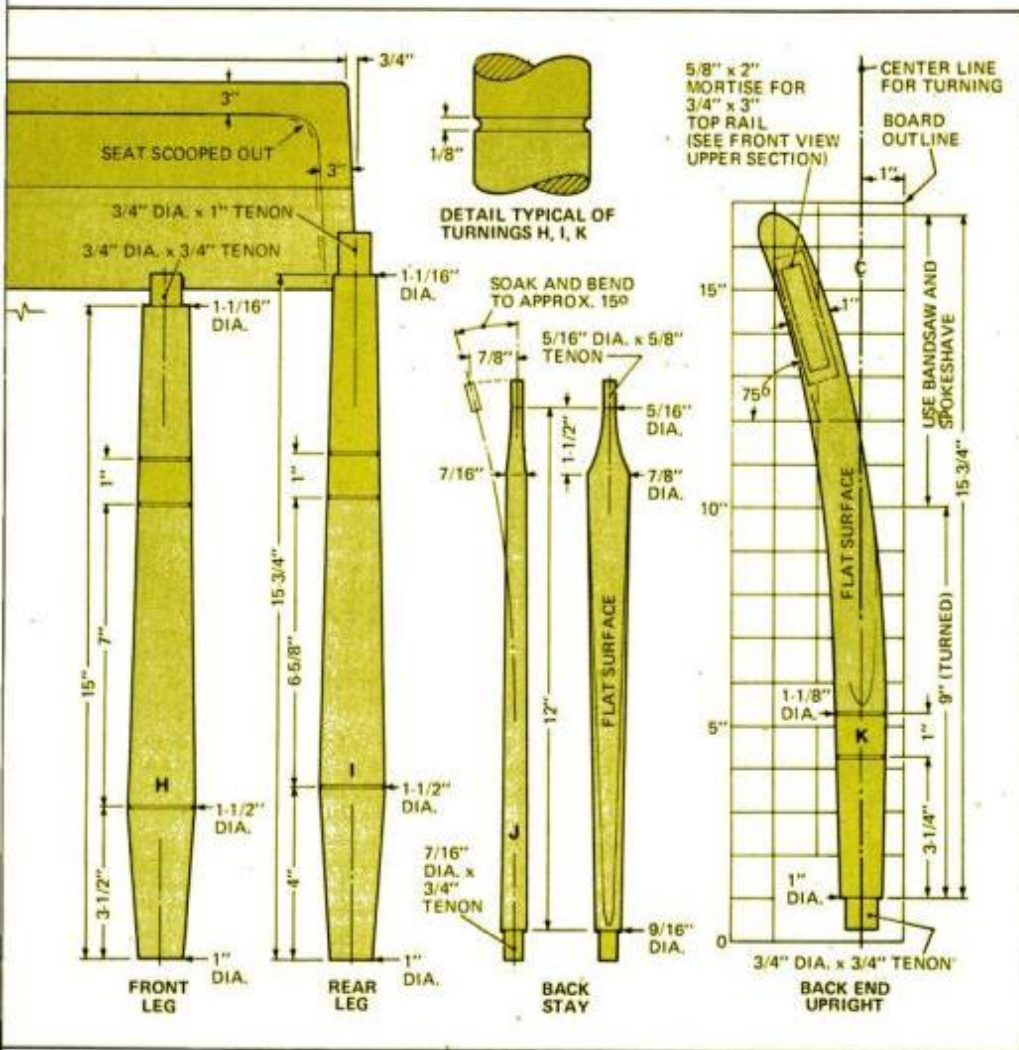

place them in the jig and clamp overnight, until dry. Since bending stays will take at least 10 days, continue working on other parts in the meantime.

Turn the three back posts (K) next. Run the lathe at slow speed because of their out-of-balance shapes. Use the bandsaw and spokeshave to shape parts after turning the lower portions.

Using the full-scale drawing, proceed to lay out the two arms (A) and cut out on a bandsaw. Save the cutout waste pieces so they can be used to support the armpieces while boring the required holes later. Smooth the arms using a fine wood rasp.

We joined two boards with glue and dowels to make the seat (C). Each

*(Please turn to page 184)*

#### MATERIALS LIST—LINCOLN BENCH

Key	Pcs.	Size and description (use)
A	2	1½ x 6 x 18" maple (armrest) cut to shape
B	1	¾ x 3 x 73¼" pine (top rail)
C	1	1¾ x 19 x 78¼" pine (seat) glue-up from two boards
D	4	¾ x 2 x 36½" pine (bottom rail)
E	3	7/8"-dia. x 17" maple (rung)*
F	4	1"-dia. x 8" maple (arm stay)*
G	2	1"-dia. x 8½" maple (front end stay)*
H	3	1½"-dia. x 15¼" maple (front leg)*
I	3	1½"-dia. x 16¼" maple (rear leg)*
J	20	7/8"-dia. x 13¾" maple (back stays)*
K	3	1½ x 3½ x 17" maple (back posts) cut to shape

Misc.: Plastic resin glue, paper for patterns, cardboard for templates, 2 No. 10 x 1¾" fh brass screws, 2 No. 8 x ¾" fh brass screws, wood plugs cut to suit, Minwax Ipswich stain, orange shellac, Carnuba wax.

\*These are final dimensions. Allow enough extra stock to facilitate turning.



Three back posts (K) are offset-turned prior to sawing them to shape and using a spokeshave to round them off. Turning should be done at slow speed because of out-of-balance configuration of workpieces.

You should use a piece of 2x4 scrap with the end cut to the proper compound angle as a sight guide for boring holes at the rear corners on the plank seat.



Draw full-scale pattern from plans for armrest and trace onto board. Cut out the shape with a bandsaw, using a fine-tooth blade to shorten sanding time. The guard is raised for photo clarity only.

Since the concrete floor of a shop or garage is rarely flat and level over a 4x8-ft. area, it's a good idea to shim a full sheet of plywood level, checking with the aid of

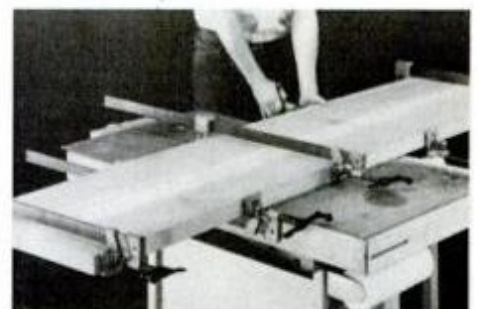

Plank seat may be glue-and-dowel joined from several boards. Alternate direction of annual rings to help neutralize warping. Apply glue to mating surfaces; alternate bar clamps on both sides to prevent cupping.

a long spirit level. This will provide a surface on which you can mark final length of the legs in order to prevent a wobbly bench later.

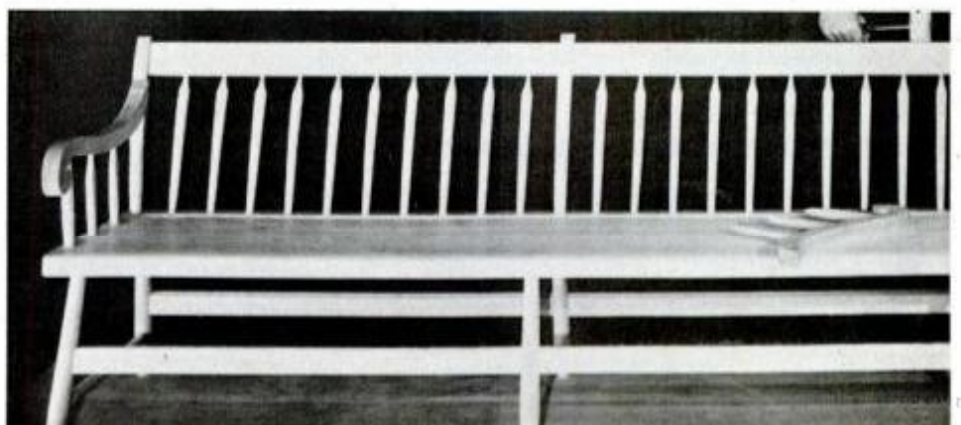



# WEEKEND WORKSHOP: 4 great projects

## Automatic center finder

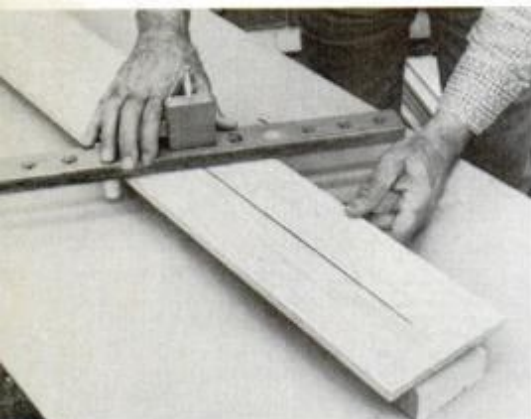

In use, pencil marks centerline when gauge straddles workpiece and underside pegs remain in contact with the board's edges.

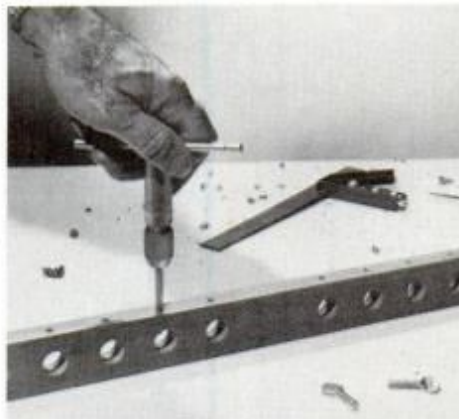

Tap the 3/16-in. holes in the center finder's edge for thumbscrews which lock guiding 3/4-in. dowels into position.

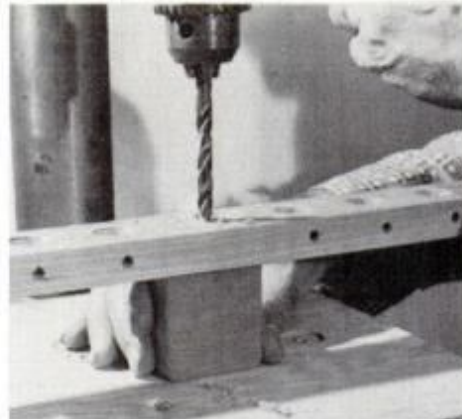

Use drill press to bore 5/16-in. center hole, as well as 3/4-in. dowel holes. All holes must be perfectly centered.

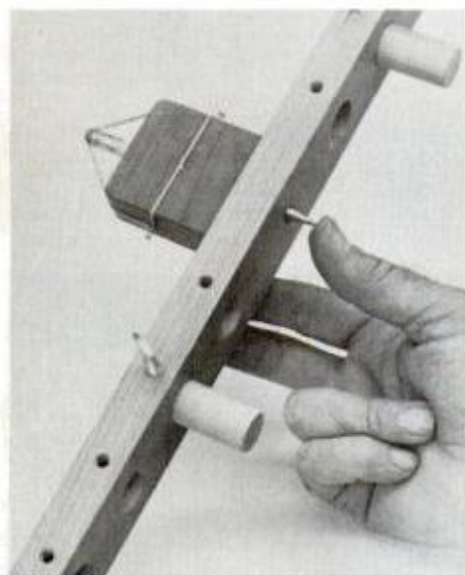

Rubber band acts as spring to put pressure on pencil for marking workpiece. Fixed pencil would make finder arm rock.

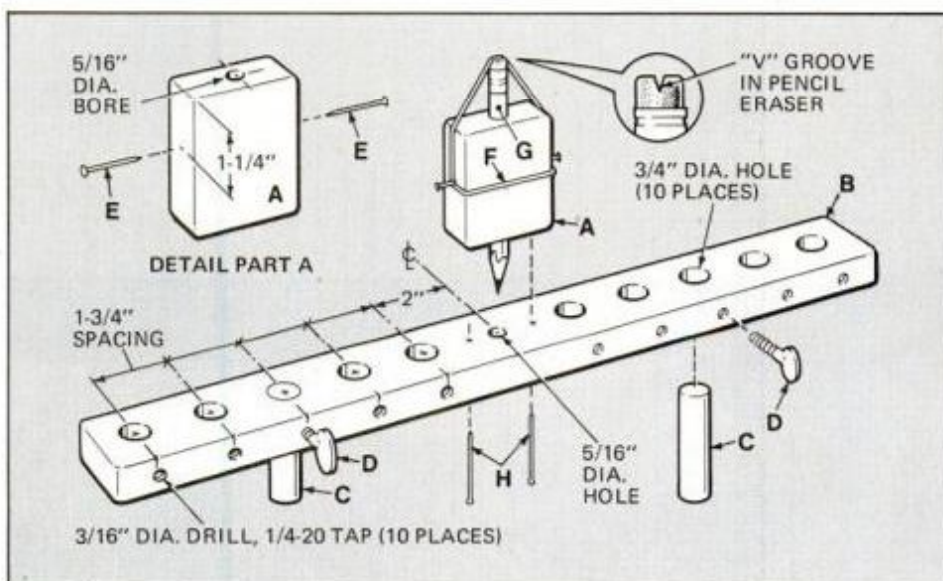

This handy tool finds centers and marks centerlines on boards and panels up to 17 in. wide. To use it, adjust pegs (C) to suit board width as closely as possible, and pivot arm (B) until the pegs press against the edges of the workpiece. The spring-loaded pencil will mark the center as you push the tool along the length of the board.

When making the center finder, keep in mind these tips:

1. Each dowel hole must be bored precisely the same distance from the pencil hole as the corresponding hole on the opposite side.
2. All holes must be perfectly centered.
3. Use a brad-point bit in your drill press to bore holes accurately.
4. Use a thin, weak rubber band (No. 18) to provide gentle spring action for pencil.

### MATERIALS LIST—CENTER FINDER

Key No.	Size and description (use)
A	1 1-1/16 x 1-3/4 x 2-1/2" hardwood (pencil block)
B	1 1-1/16 x 1-3/4 x 20" hardwood (arm)
C	2 3/4"-dia. x 2-1/4" dowel
D	2 1/4-20 x 1" thumbscrew
E	2 1" escutcheon
F	1 No. 18 rubber band
G	1 pencil with rubber eraser
H	2 6d finishing nail

Misc: White glue, tack (optional), oil finish (optional)

A V-notch cut into the tip of the eraser or a tack will hold the rubber band in place.

— Robert Bessmer

## Pivoting radial-saw rip fence

This versatile, long-lasting fence pivots and can be adapted to cut any right- or left-hand angle. To build it, cut a board the length of your saw table. Install it in the table slot and mark the location of the saw blade's path. Next, lay out and center-

punch the four holes to be bored (see plans). Use a drill press to bore holes and then rip the fence in half lengthwise. Glue dowels into holes in the top half of the fence, letting them protrude at the bottom. When they're dry, align the dowels

with holes in the bottom fence half and assemble. Cross cut the assembly at the blade path mark.

### Aligning fence with blade

Clamp the fence halves into the table



# for your shop



Hardwood fence has dowel hinges which allow it to pivot for cutting angles.

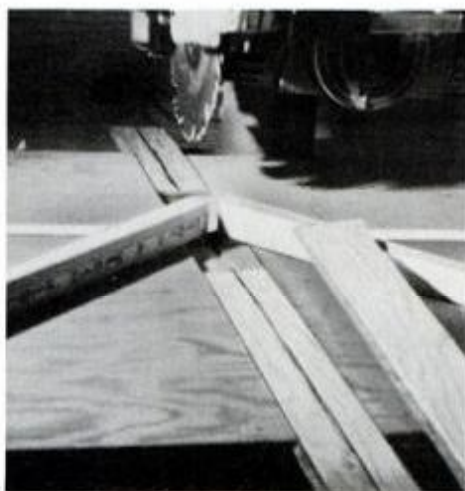

Removable section can be replaced after many cuts (which destroys the surface).

slot and install your widest-kerf-cutting blade. Then slide the fence sections to allow 1/16 in. blade clearance. Mark the fence ends flush with the table ends, remove and trim. Slightly round the corners at the pivoting ends of the fence.

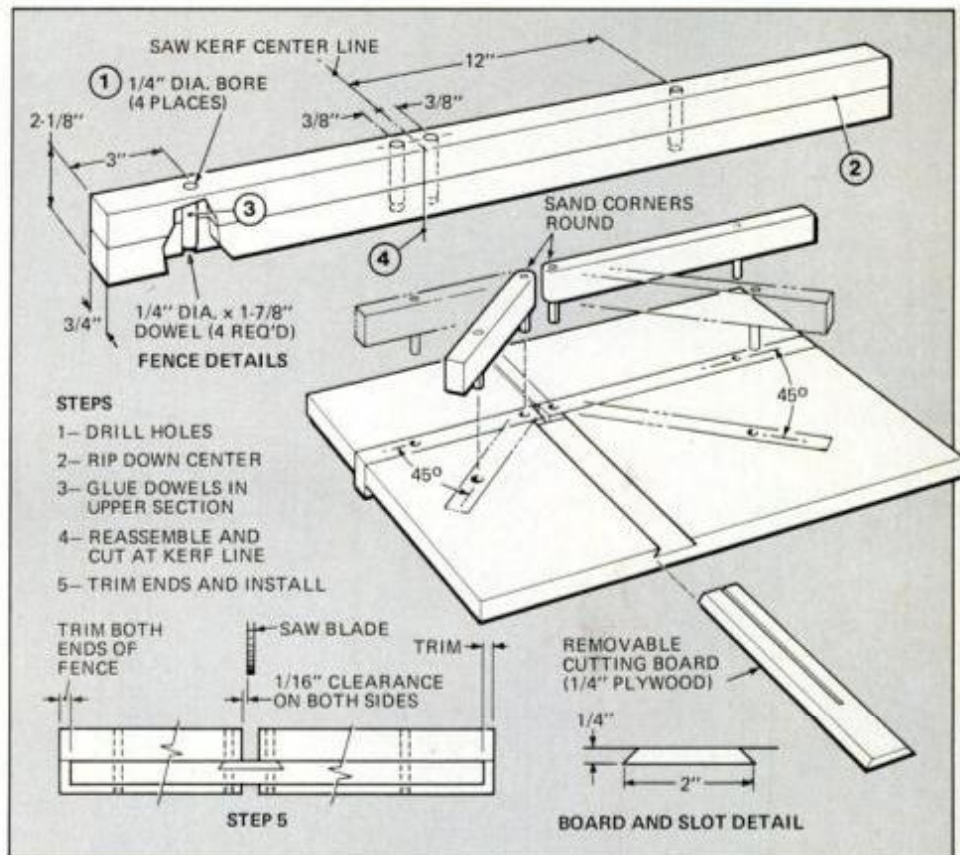

If desired, a rule can be marked on each fence section. The tapes from a discarded tape measure can also be used. Cut tape at the 1-in. mark and fasten it to the fence section, so that the tape begins precisely 1 in. from the blade.

## Bore holes in table

To lay out holes in the saw table which

lock the fence for cutting at 45° or at another angle, pivot the fence into the angle position, mark the hole, centerpunch and bore, using guide to keep the hand drill vertical.

**Note:** When using your saw to cut bevels and compound angles, slide fence to the right, so that the blade will pass through the opening.—*Dr. C. D. Smith*

## Mobile accessory or tool cabinet



Compact cabinet (above) organizes tools or accessories in drawer and pull-out shelves; it also has door pockets for manuals (left).

**T**his mobile cabinet was designed to store accessories for a radial-arm saw. It was sized to fit under the radial-saw

table extensions which were featured in *Build PM's Compact Table for Your Radial Saw* (page 122, Feb. '79). The cabinet can also be used to store an assortment of portable power tools. Casters let you roll the cabinet to any work station.

### How to build the cabinet

Construct the cabinet as shown in the plans. Install the pull-out shelf slides and the drawer slides prior to joining the sides (A) and back (B) to the top (C). Use glue and finishing nails to make the final assembly. Check for squareness as you go.

Next, make the drawer and pull-out shelves. The dividers can be arranged to suit the tools which you will be storing.



# WEEKEND WORKSHOP:

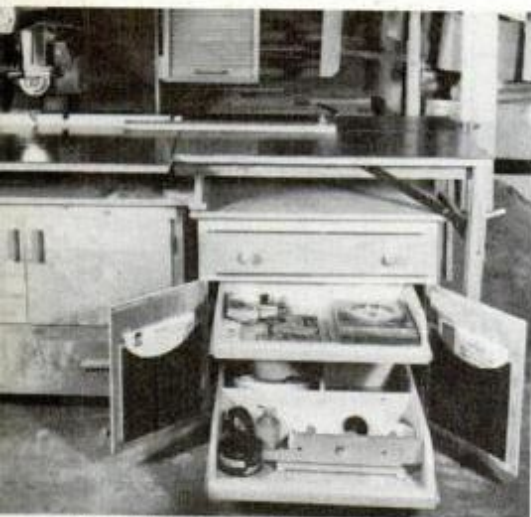
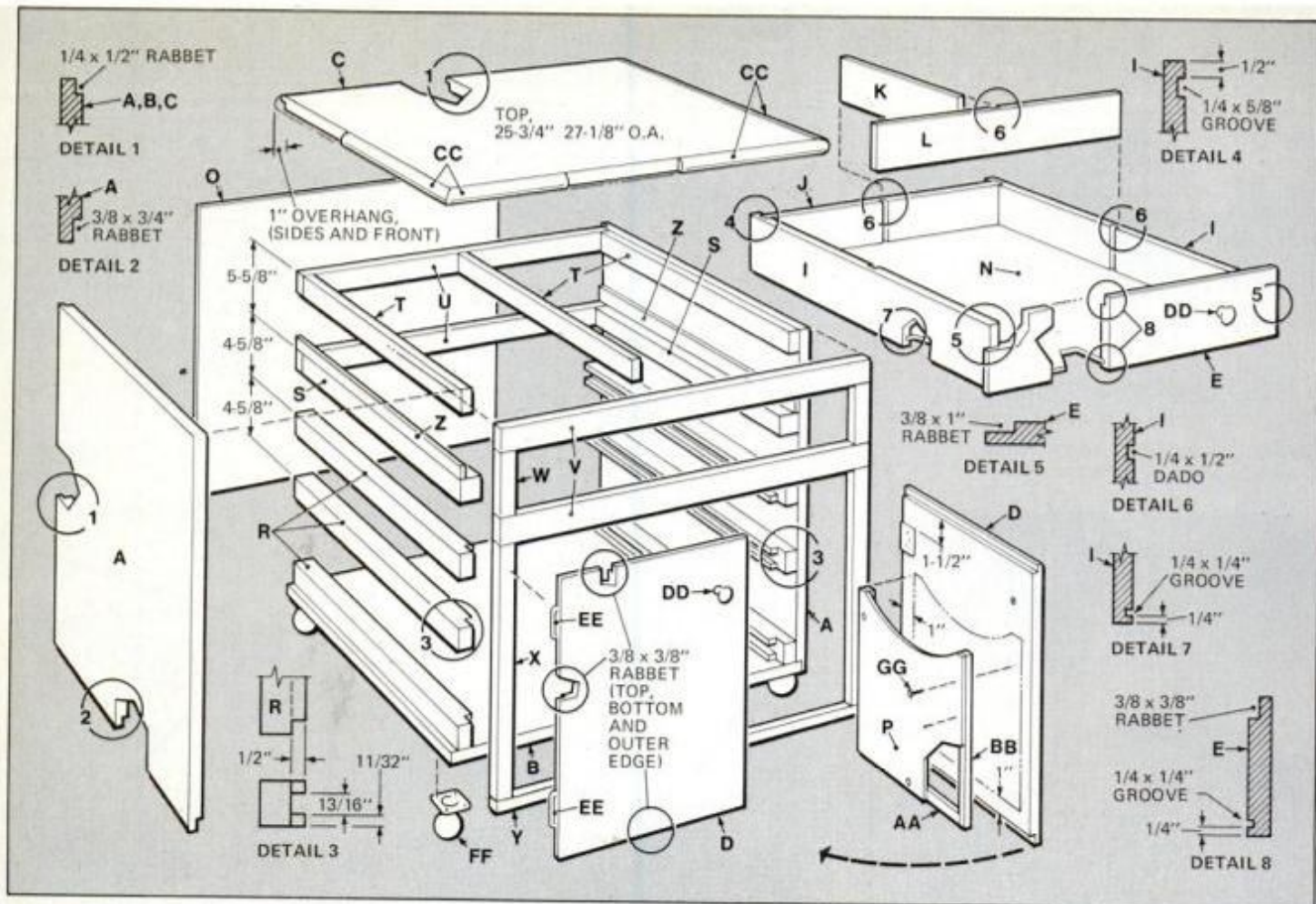

Accessory cabinet can be parked under extension to radial-arm saw table. Note that parts G2 and H2 (not shown in drawing) refer to bottom pull-out tray dimensions.

letely. The drawer slide ends must be notched as shown in the plans to avoid interference with the door pockets.

The choice of hardware is optional. We used wooden knobs with self-closing, 3/8-in. offset hinges.

Finally, add plate-type casters to the 3/4-in. plywood bottom and coat with clear, gloss polyurethane for a durable finish.—C. E. Banister

## MATERIALS LIST—MOBILE CABINET

Key No.	Size and description
A	2 3/4 x 23-3/8 x 24" plywood
B	1 3/4 x 24 x 24-5/8" plywood
C	1 3/4 x 25 x 26-1/8" plywood
D	2 3/4 x 11-7/8 x 16-1/8" plywood
E	1 3/4 x 4-3/8 x 23-3/4" plywood
F	3 3/4 x 21-1/2 x 22" plywood
G1	4 5/8 x 3-1/2 x 22" pine (planed from 3/4" stock)
G2	2 5/8 x 4-3/4 x 22" pine (planed from 3/4" stock)
H1	2 5/8 x 3-1/2 x 19-3/4" pine (planed from 3/4" stock)
H2	1 5/8 x 4-3/4 x 19-3/4" pine (planed from 3/4" stock)
I	2 5/8 x 4 x 23" pine (planed from 3/4" stock)
J	1 5/8 x 4 x 22-1/4" pine (planed from 3/4" stock)
K	1 1/2 x 3-1/2 x 10" plywood
L	1 1/2 x 3-1/2 x 22-1/4" plywood
M	3 1/2 x 3-1/4 x 19-3/4" plywood
N	1 1/4 x 22 x 22-1/4" plywood
O	1 1/4 x 22-7/8 x 24-5/8" plywood
P	2 1/8 x 10 x 10-1/2" pegboard
Q	3 1-1/2 x 1-1/2 x 20-1/2" fir or pine
R	3 1-1/2 x 1-1/2 x 23-3/4" fir or pine
S	2 1-1/2 x 1-1/2 x 23" fir or pine
T	3 3/4 x 1-1/2 x 23" fir or pine
U	2 3/4 x 1-1/2 x 25-5/8" fir or pine
V	2 3/4 x 1-1/2 x 25-1/8" fir or pine
W	2 3/4 x 1 x 4-1/8" fir or pine
X	2 3/4 x 1 x 15-1/2" fir or pine
Y	1 3/4 x 3/4 x 25-1/8" fir or pine
Z	2 1/4 x 3/4 x 23" fir or pine

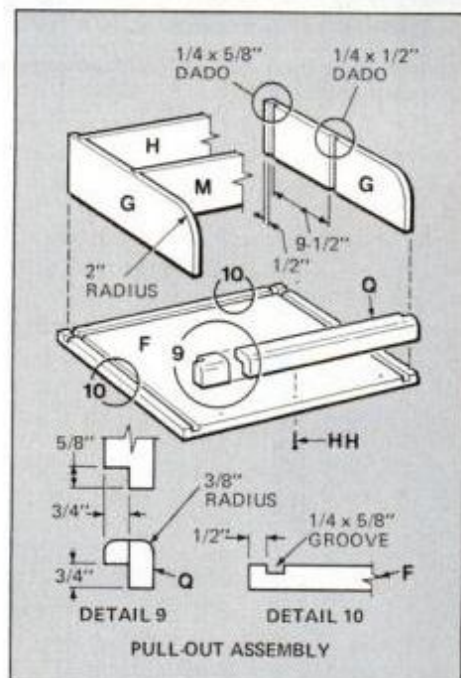

AA	4 1/2 x 1/2 x 10-1/2" fir or pine
BB	2 1/2 x 1/2 x 9" fir or pine
CC	as reqd. 3/8 x 3/4" half round
DD	4 1" dia. wood pulls
EE	4 3/8" offset, self-closing cabinet hinges
FF	4 2" dia. plate-type casters
GG	6 No. 6 x 1" fh screw
HH	9 No. 12 x 1-1/4" fh screw

Misc: White glue, finishing nails as reqd., zip clips for extra partitions (zip clips are available from Craftsman Wood Service, 2727 South Mary St., Chicago, Ill. 60608).



## Rotary punch for neat holes



Rotary punches can be used to cut 1/2-in. holes in cardboard with a drill press (left), or 1/4-in. holes in leather by twisting punch held in tap wrench (above).

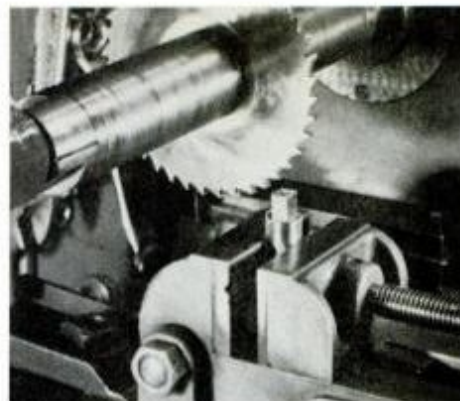

After cutting blank for punch, mill square tip so punch can be used in tap wrench.

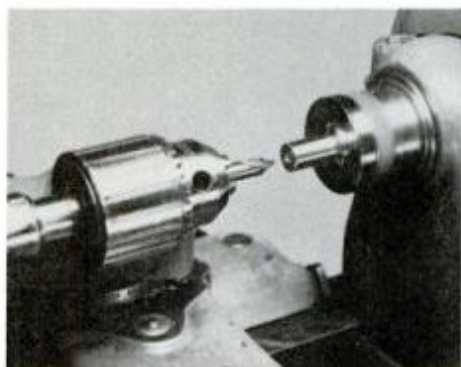

Use a center drill to insure precise start of twist drill in punch blank.

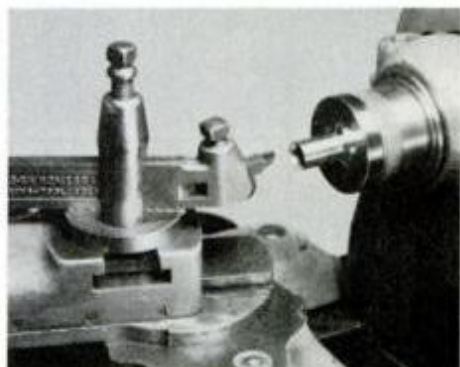

For machining inside bevel, compound slide, set at 65°, controls tool travel.

**R**otary punches make neat, round holes quickly in thin materials. Instead of pounding them to make them perform, they are rotated, either by hand or power, and act as clean-cutting circular knives. A rotary punch can cut clean holes in felt, cardboard, leather, paper, plastic upholstery, cork, cloth and balsa wood.

The punches are made from high-carbon drill rod, to be used in a conventional tap wrench or a 1/2-in. drill press chuck. They can also be adapted for use in portable electric drills or hand-cranked drills by turning their shanks to suit your drill.

A punch can be made with either an inside or outside bevel on the cutting edge. An inside bevel (see plans) will make holes equal to the cutter's diameter. Outside bevels will make discs or plugs to the cutter's diameter. Since the cutting edge is so thin, however, holes punched by outside-bevel punches will be practically the same diameter as the punch bore.

Begin making a punch by machining a blank true and flat at each end. Then square one end to fit a tap wrench, using a milling machine or by grinding or filing.

A collet chuck holds the punch for drilling and machining the bevels. Spot hole with a center drill. Then drill to the desired diameter. After the hole is made, use the lathe compound slide, set at 65°, for machining the inside bevel with a tool bit slender enough to enter the hole without dragging. For outside bevels, set compound slide at 80°, invert tool bit in its holder and feed into the punch blank from rear. Take successive cuts until a sharp cutting edge is formed. Then hone with an abrasive stone.



For outside bevels, invert tool bit, set slide at 80° and feed against blank.

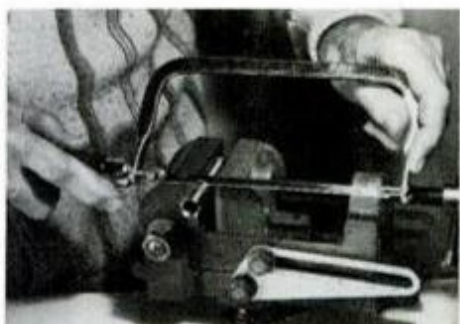

Cut notch in punch with hacksaw to permit ejection of cut discs with aid of wire.

After the lathe work is done, clamp punch in a vise, and saw and file smooth a V-shaped notch at the shank-end of the bore. This opening is necessary for removing cut plugs from the punch bore. A handy tool made of No. 10 copper wire (see plans) is ideal for pushing out the cut plugs through the notch opening.

Harden and temper cutting end of each punch by heating to bright red and plunging it into cold water. Repeat the end until a straw color appears on a brightened area at the cutting edge; douse in water. Polish entire punch with abrasive flap wheel.

Material to be cut by your rotary punch should be supported by something that won't yield too readily, but will not damage the punch edge. White pine and linoleum make good surfaces. — *Walter E. Burton*

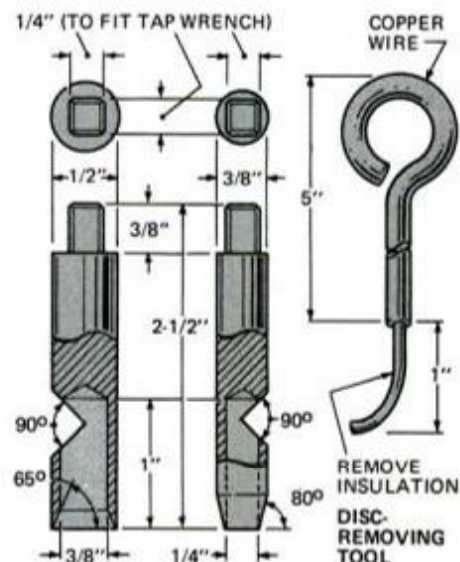



# HOW TO MAKE Room at the top... with class



With careful planning this homeowner turned a cramped, makeshift attic studio into a spacious room used by the entire family.





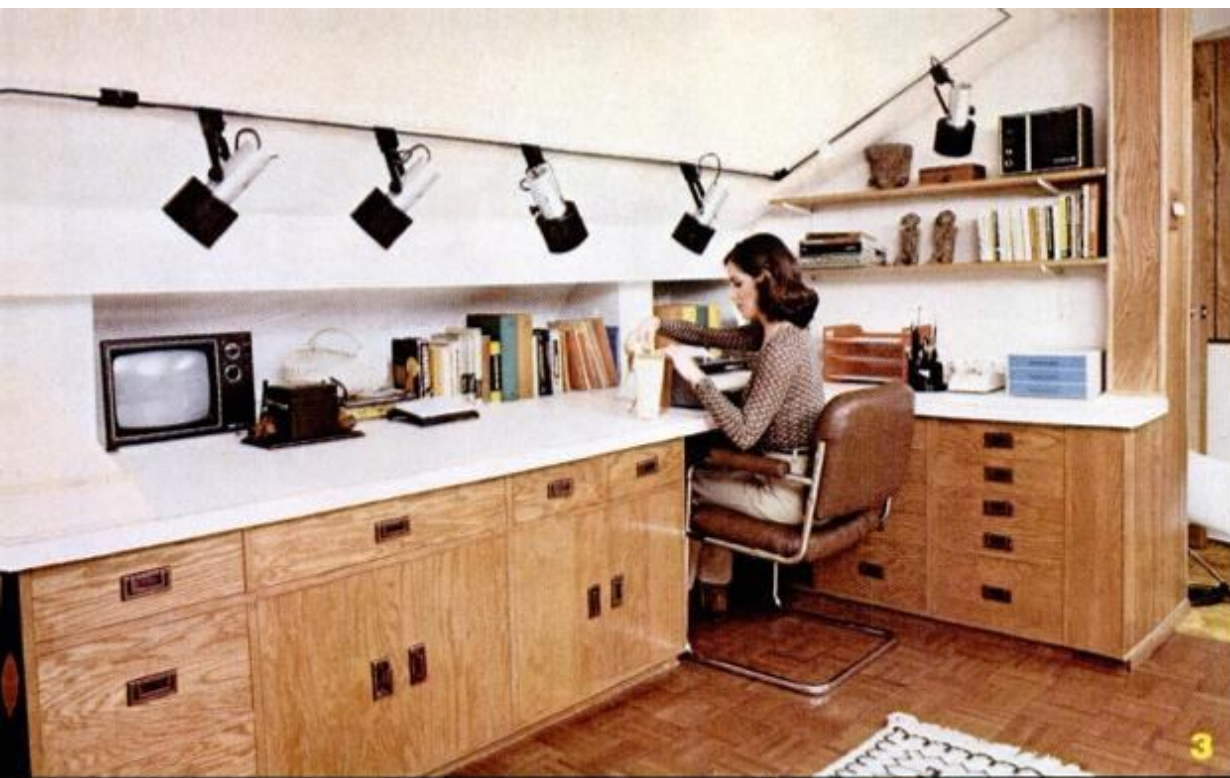

**1** Prior to remodeling, attic space served as a combination storage room and den.

**2** In about 10 months' worth of doing-it-himself on weekends and occasional weekday evenings, homeowner transformed room into multi-use space.

**3** Large, well-lit work surfaces with recessed wall storage and cabinets below provide couple with enough elbow room for independent, varied pursuits.

**4** Couch with roll-out trundle bed becomes a cozy resting place for overnight guests.



**A**n attic is not generally thought of as a spacious, airy, abundantly lit, well-organized room, but *PM* staffer Don Mannes, with design help from architect Ira Grandberg, has succeeded in creating one. The primary reason for the remodeling was to provide in-house office space. Don, an artist, required a drawing board and lots of counter and storage space for art supplies. His wife, Barbara, a schoolteacher, also needed a lot of desk area, plus plenty of room for files.

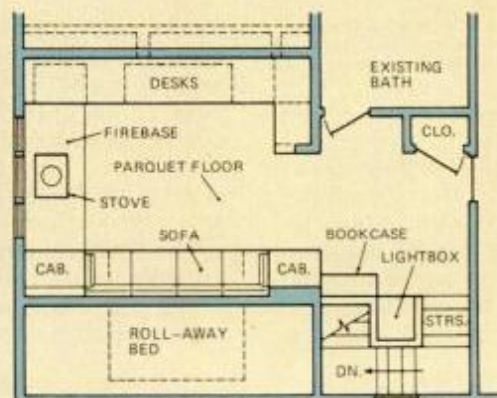





**5** Cabinets at either end of sofa can be used for record albums or for storing bar equipment and beverages. They are large enough to accommodate a small refrigerator, if desired.

**6** Area around the stair landing serves as a library/gallery for books, graphics and wall hangings.

**7** An ingenious in-floor fluorescent plant lamp, installed in shaft between the stairs also serves as effective night light.

#### SHOPPING INFORMATION

For buying information or the nearest dealer, write directly to the manufacturers listed below.

**Carpet**, Delicious style in Crown gold color, Bigelow-Sanford, Inc., Box 3089, Greenville, S.C. 29602; **Chairs**, Crown Discount Corp., 3128 Queens Blvd., Long Island City, N.Y. 11101; **Counter laminate**, White, WilsonArt, Ralph Wilson Plastics Co., 600 General Bruce Dr., Temple, Tex. 76501; **Fireplace**, Venus model, The Majestic Co., 245 Erie St., Huntington, Ind. 46750; **Sofa fabric**, Saddleback Naugahyde in Nutmeg, Uniroyal Inc., 1230 Avenue of the Americas, New York, N.Y. 10020; **Parquet flooring**, Cumberland II oak parquet in chestnut brown, E.L. Bruce Co., Inc., 4255 LBJ Freeway, Dallas, Tex. 75234; **Lighting**, Continental and Universal style track lights, wall-wash floods and recessed-eye recessed lights and Vienti series spheres, Halo Lighting, 400 Busse Rd., Elk Grove Village, Ill. 60007; **Textured paint** on ceiling, Easy-Tex, Gold Bond Building Products, Div. National Gypsum Co., 325 Delaware Ave., Buffalo, N.Y. 14202; **Wood paneling**, Capri Elm, Weyerhaeuser Co., Tacoma, Wash. 98401; **Slate hearth**, A. Dally & Sons Corp., Box 27, Pen Argyl, Pa. 18072; **Windows**, Carclad casements, Caradco Window & Door Div., Box 920, Rantoul, Ill. 61066; **Accessories: Afghan kit**, Bucilla Co., 30-20 Thomson Ave., Long Island City, N.Y. 11101; **Desk accessories**, Bouton's, Spring Valley, N.Y. 10965; **rug**, Victor Henshel, Inc., 1061 Second Ave., New York, N.Y. 10022; **Wallhanging/baskets**, Judy Deming of Loomworks, New York, N.Y. 10956.

The room is so well-organized and pleasant to relax in, that by adding a prefab fireplace, it also serves as a family room and place for parties. It can even be used as a guest room. A built-in sofa with trundle bed, which pulls out from behind the wall,

makes the transformation quick and easy.

Originally, the attic was chopped up with small closets and unnecessary partitions. Natural light came only from a pair of double-hung windows. The stairwell was narrow and a shaft that ran up its center to the ceiling obstructed light from the only other window on the floor.

The first remodeling step was to demolish the unwanted partitions. Then old windows were replaced with larger units. Removal of the

central stairwell shaft walls, brought light from the previously obstructed window to the gallery/library area.

The key, however, to making the most of the space, was built-in furniture. The built-in sofa/bed and recessed wall boxes made use of behind-the-wall space which under normal circumstances is difficult to utilize.

#### Space-saving sofa, trundle bed

The aim was to make use of be-



hind the wall space for bedding only used occasionally. Begin by framing the rough openings for the wall recesses and trundle. Construct the bed frame as shown in plans, sizing it to suit your needs.

The sofa is framed with 2x4s and skinned with paneling. Cabinets flanking the sofa are of plywood over 1x2 cleat framing.

Recessed wall boxes above the sofa can be preassembled prior to installation. Glue and nails will assure strong joints. Secure these units to the rafters above and studs at ends with finishing nails.

### Build a wall-length desk

Before you build the desk, cut and frame the rough opening for the shelf

recesses. If you're not sure whether the attic knee wall is a bearing wall, have an engineer decide for you. If it is, adequate headers must be installed over all openings. Next, construct the cantilevered fluorescent-light-fixture supports by fastening 2x4s with lag screws to the rafters. At this time, you should have the wiring installed

*(Please turn to page 180)*

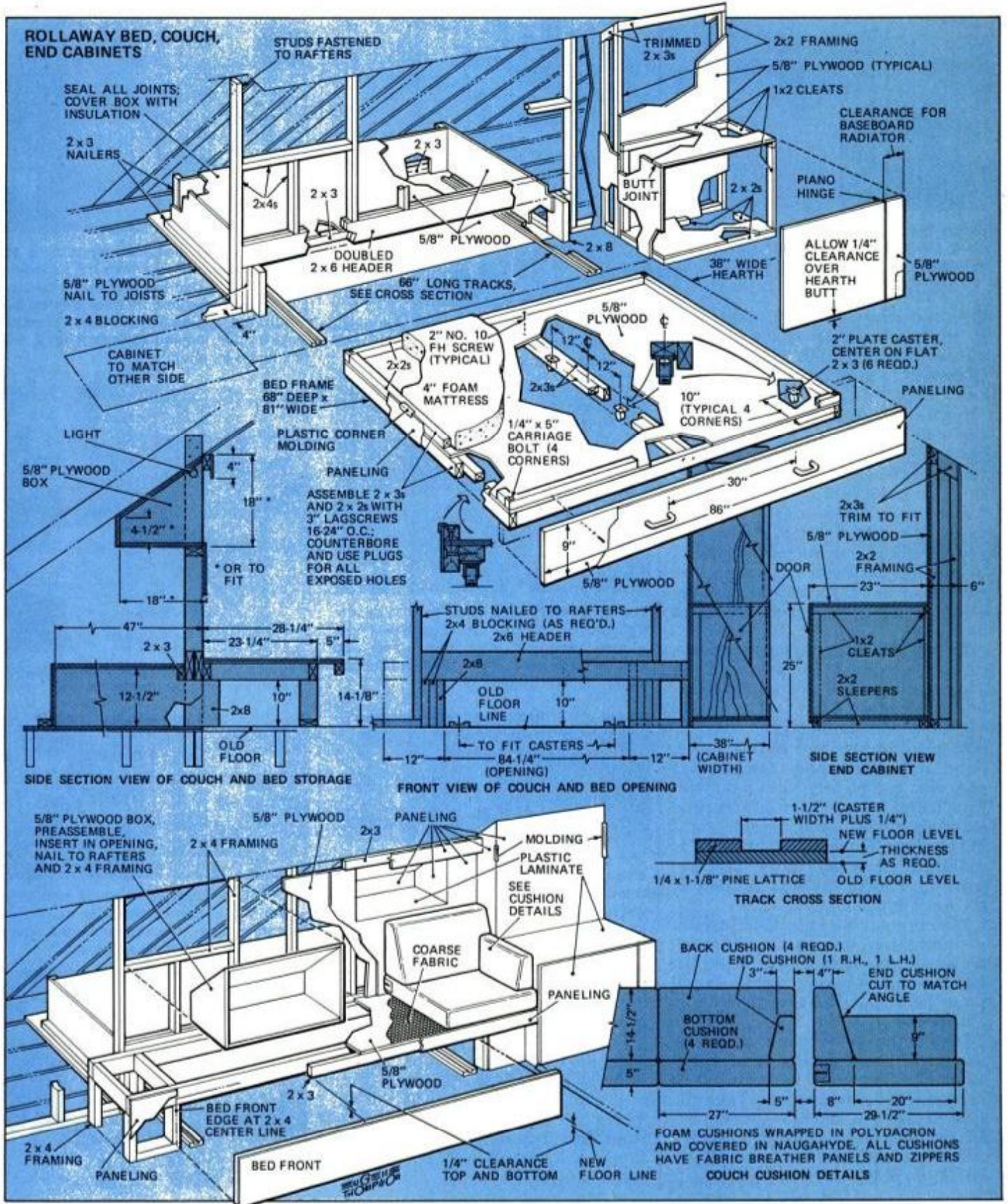



# WORKSHOP MINICOURSE

## INSTALLING A BANDSAW BLADE

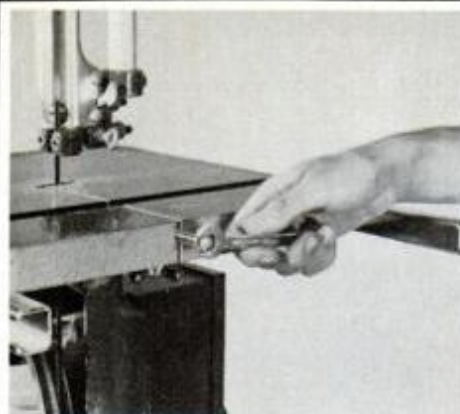

Before blade can be changed, table alignment pin must be removed. Though it's threadless, a wrench does it best.

In an earlier column, I mentioned that the bandsaw is one of my favorite shop tools, but I didn't have the space to spell out just why. For one thing, it is a particularly comfortable tool to work with. Using common sense and a little practice, you can quickly learn the basic skills required for safe bandsaw operation. In addition, you can easily make straight cuts with a bandsaw using the appropriate guide, and you have the built-in advantage of being able to cut curves, scrolls and the like. I would hate to have to operate in my wood shop without a bandsaw.

As with all stationary power tools, setup is extremely important. Even a top-quality tool won't deliver if you fail to maintain it properly.

All manufacturers provide good instructions for use and maintenance. Read and understand them so that you are completely familiar with your tool. I keep the manufacturers' manuals (for *all* my shop tools) right in the shop. When an adjustment is required, or some other problem pops up, I have the information at my fingertips.

When removing an old blade or installing a new one on the bandsaw, always disconnect power first. In fact, the blade cover guards should *never* be removed when the saw is plugged in.

Depending upon brand, your saw table will have some sort of alignment pin that must be removed so the blade can go in or out. Take the time to use a wrench as shown, because there is too much of a chance of burring the head (i.e., rounding it off) if you pull it out using a pliers. If

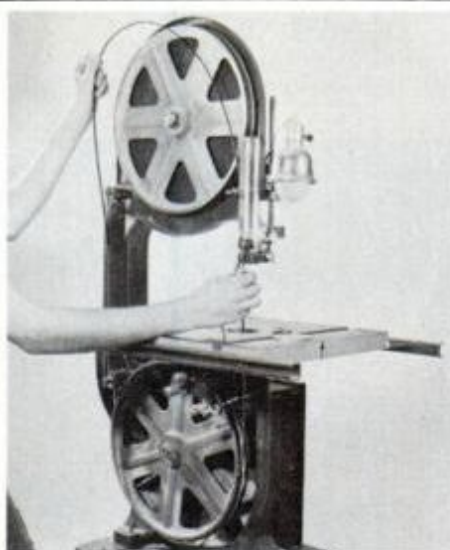

Blade is slipped through slot and positioned on center of both wheels. Teeth travel downward at blade's cutting point.

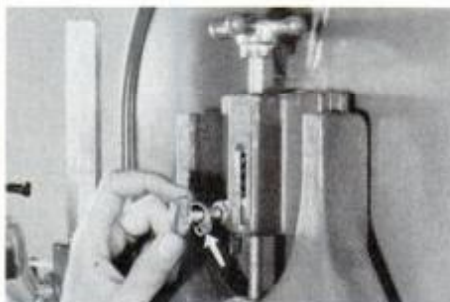

The blade must then be tracked to assure it's running on the center of the upper wheel. Disconnect saw from power and turn wheel by hand. When blade tracks correctly, tighten wingnut (arrow).



The guide pins are adjusted so they are close enough to blade to prevent it from twisting as work is fed in. Guides should not rub the blade sides. With pins as close as possible, they are adjusted forward or back to ride behind gullets of saw teeth.

that happens, you face an aggravating task each time you want to change blades.

The photographs shown on this page illustrate basic steps for adjusting a bandsaw. Though your brand may sport a nut or bolt of different configuration or size, the rules for setup remain basically the same. *But, remember, check your manual before starting.* **FM**



Blade must be tensioned by turning star wheel as shown. Some saws have a tension scale (arrow) that permits quick tensioning—you simply line up fiber washer with the correct tension on indicator. If your saw lacks a scale, tension blade so it has a 1/4-in. flex in a 6-in. span.

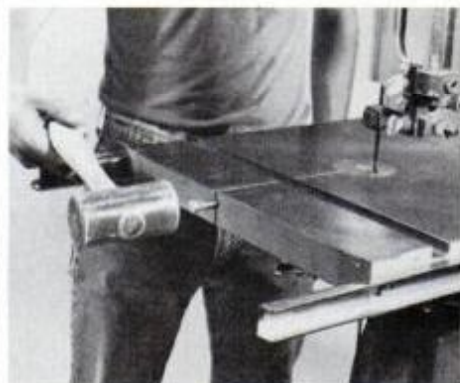

Replace the table alignment pin by tapping in with a plastic or wooden mallet.



Next, blade support wheel is positioned about 1/64 in. behind blade spine. Finally, bottom guides—located below the table—are adjusted in similar fashion.

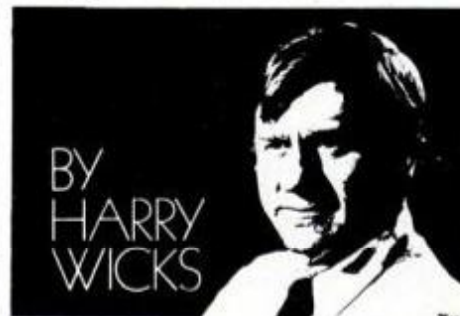



# Your home workshop can PAY OFF ... ... BIG!



This One Low-Cost Power Tool—

**SAWS** to desired Width...  
**PLANES** to desired Thickness...  
**MOLDS** all popular Patterns...

—All at once or separately... All By Power Feed!

Try The  
Belsaw In Your  
Own Shop On Our  
**30-DAY FREE  
TRIAL OFFER**

Mail Coupon Below  
For Complete  
Details!

*The Only Complete Workshop Tool Of Its Kind In The World!*

**From The Day It Arrives...** the Belsaw will make and save you money. With shortages and inflation driving lumber prices sky-high, this versatile power tool easily pays for itself by quickly converting low cost rough lumber into high value finished stock. In just one pass turn out your own quarter-round, door and window stop, casing, tongue-and-groove... all popular patterns. Other Belsaw operators are making cases for grandfather clocks, furniture, picture frames, fencing, bee hives, bed slats, surveying stakes... all kinds of millwork.

**Built For Pros... Priced For Home Craftsmen...** it is engineered and built to industrial standards, but factory-direct selling keeps the price low. Handles tough oak and walnut as easily as pine, and so simple to operate even beginners with no experience can use it.

Start  
Your Own  
Business!  
Earn Extra  
Income  
Right At  
Home.

With just this one low cost power-feed machine in a corner of your garage or basement, you're set up to supply lumberyards, cabinetmakers, carpenters, remodelers, contractors and hobbyists in your area with custom-planed lumber, trim, molding... ALL of their millwork requirements. You can supply picture molding to art shops, hardware and department stores, or sell direct to framing shops. All standard patterns are available from stock, or we'll custom grind a knife to your own special design or sample.

## Does The Belsaw Pay? YOU BET!

### READ WHAT OTHER BELSAW OWNERS SAY:

**A Good Investment** • Robert Sawyer, Roseburg, Oregon: "I believe that the Belsaw is the best investment I ever made. I've been a planer man for years and am now retired. The Belsaw has earned me over \$60,000 extra income in the past eleven years."

**Pays For Itself** • R. S. Clark, Springfield, Ohio: "I bought a batch of walnut in the rough, and after planing it on the Belsaw I figured up the money I had saved. It was enough to pay for two-thirds the cost of the Planer. It really does a good job."

**More Than Expected** • Stephen Schultz, Orangeville, Penna.: "This machine pays for itself by making money out of scrap boards. It is a very well built machine and I confess it is more than I expected for the price. It does everything you say it will."

### ... And Belsaw Is The Choice Of Professionals:

"I recommend Belsaw's Planer-Molder-Saw as the most useful shop tool that any craftsman could own. We use ours every day in the WORKBENCH model shop, and couldn't get along without it."

JAY HEDDEN—Editor of WORKBENCH Magazine

**You Take NO RISK! The Belsaw  
Is Backed By Our Exclusive 100%  
Guarantee of Satisfaction:**

• "Try the Belsaw in your own shop for a full 30-Days and put it to work for you. Give it a thorough test and make it prove that it can do everything we say it will... use it just as much as you want. Then if you are not completely satisfied, just send it back and we'll return every penny you sent. And YOU are the sole judge! There are no questions asked... there are no fine print 'use' charges. Our flat guarantee is that YOU must be 100% satisfied or you get your money back."

**FREE  
BOOKLET!**

Get FREE  
Book with  
facts and  
full details  
... RUSH COUPON TODAY!



**Just Mail Coupon...  
NO OBLIGATION and  
NO SALESMAN Calls!**

**ACT NOW!  
Coupon  
Brings  
Full Details!**

*If coupon has been removed, just send postcard with name and address to:* BELSAW POWER TOOLS Co.  
900F Field Building  
Kansas City, MO 64111

BELSAW POWER TOOLS Co.

900F Field Building  
Kansas City, Missouri 64111

**YES**, please send me the FREE Booklet that gives me complete facts about Belsaw's Planer-Molder-Saw and full details on how I can qualify for a 30-Day Free Trial right in my own shop. I understand there is No Obligation and that No salesman will call.

NAME \_\_\_\_\_

ADDRESS \_\_\_\_\_

CITY \_\_\_\_\_ STATE \_\_\_\_\_ ZIP \_\_\_\_\_





## You Can Build This Clock!

only with a  
Craft Clock Kit

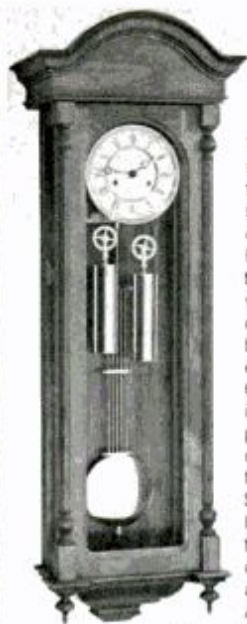

You will always remember the satisfaction that you felt in building your own clock. Our new Vienna Regulator is one of the most magnificent wall clocks ever produced, yet you can build it easily and economically using a Craft kit. We make the intricate cuts and preassemble all difficult parts. Your satisfaction is guaranteed. Send today for catalog which contains the largest selection of kits, movements and dials available in America.

**New for 1980!**

**Vienna Regulator in black walnut**

### CRAFT PRODUCTS COMPANY

Dept. 01, 2200 Dean St., St. Charles, IL 60174

116-Page Catalog \$1.50     FREE Brochure

Name \_\_\_\_\_

Street \_\_\_\_\_

City / State / Zip \_\_\_\_\_

*Serving America's Craftsman Since 1940*

## STEP FORWARD INTO THE PAST



### FANTastic Facts

- Saves up to 35% on heating costs
  - Quality manufacturing since 1939
  - **UL approved**
  - 90 day \$ back and 3 yr. guarantee
- To order call 1-800-241-7788  
Ga. call coll. 1-404-498-1278  
Send 25¢ for color catalogue

### UNIQUE ENERGY PRODUCTS

P.O. Box 1009 - Dept. PM-2  
Stone Mountain, Ga. 30086

## TOP OLYMPIC SPECTACLE (Continued from page 95)

reach the takeoff point of the Olympic inruns at the recommended 60 mph. Excessive inrun speeds are remedied by having the skiers move down the ramp to a lower gate, in the case of the 70-meter hill, or using the 90-meter's unique movable starting platform.

### A good takeoff earns points

Judging for style begins at the moment of takeoff. Once jumpers thought it was really keen, and very Norwegian, to stick their arms out on either side, like swan divers. Today that maneuver could cost you a medal. Instead, the contemporary jumper puts his arms back and leans forward, as far as he can, over his skis.

And with good reason. Air travels faster over his gently curved body than under his flat skis. To put it another way, the pressure from below becomes greater than the pressure from above. He has lift.

From its work with computers and wind tunnels, the International Skiing Federation has determined that if a jumper left the ramp pigeon-toed, he would create a large triangle beneath him that would be completely air-resistant. He would find it much easier to fly. The bad news is that it would be impossible to land. Nevertheless, the discovery was not without its practical applications. "We now know," Martitsch says, "that if a jumper keeps his skis separated by about 6 inches, no air will flow through, and he will be carried by the entire area, from the outside of one ski to the outside of the other." In the old days, if you did not keep your skis tightly together, you lost style points.

### From wood to plastic

Compared to their Alpine counterparts, jumping skis are long (8½ feet) and heavy, grooved at the bottom so they will stay straight after landing. Once made of 100 percent hickory, they are now mostly plastic, with a wood core. Boots, attached by loose bindings that allow air currents to play with the skis, have experienced a revolution of their own. The newfangled type come up high in the back, so that jumpers will be less likely to "sit down" on the inrun, allowing air to get under their skis. (For details on the latter subject consult Vienko "Agony of Defeat" Bogatej, the Yugoslavian immortalized on *Wide World*.)

On a higher plane, helmets have replaced woolen ski caps, and the once-macho "baggy" look has given way to the finely cut jumping cos-

tume. Before each competition, apparel is tested to make sure air flows through freely. It seems that a few years ago, some jumpers got the idea that if their suits had extremely porous fronts, and rubberized backs, they could "balloon" themselves a few extra meters.

Even if cheating were allowed in this Olympics, it would be hard for America to add to the one ski-jumping medal we've won since the winter games began in 1924. Our greatest hope in the event, though, is 22-year-old Jim Denney of Duluth, Minn. Denney is a fair country lander, but according to Devlin, who will handle the TV commentary for ABC, the United States won't be a world power in ski jumping until our entire team learns to come down more stylishly. Landings are supposed to be accomplished in the telemark position, a shock-absorbing pose in which the knees are bent and one foot is placed slightly ahead of the other one.

### Safety over distance

Although distance counts as much as form in each competition, there is no steady assault on the world record—176 meters—as in other sports. "If you want to go farther you just build a bigger hill," says Martitsch. "There is nothing mysterious about it. Of course, there is a limit, a point where the jumper would lose control, just as a cat, if you throw him far enough, will somewhere lose the ability to land on his feet. But do we care where that point is? No. We care only about safety."

Olympic ski jumping is still conducted on good old-fashioned snow, but scientists are working on that, too. Mats of shredded plastic—variously described as looking like spaghetti, a hula skirt and a thatched roof—have been used on European hills for years, and are just now being introduced in the United States. With this innovation, winter is no longer necessary; all you do is water down the plastic and go.

Devlin has never seen a hill wearing a hula skirt. Still, he likes the idea. "We've got to get those things over here," he says. "Then we could practice more. Heck, we might even find us a good jumper in Alabama, and it wouldn't cost us anything! I'll bet Coca-Cola would buy us a mat if we let them put their name on it."

Considering that Coke's colors are red and white, and that the mats remind some people of spaghetti, that would be a most remarkable sight indeed.

## WHOLESALE LOCKSMITH SUPPLIES



ORDER YOUR  
GIANT  
CATALOG



.....jam packed with the latest in Locksmith Tools, Key Machines, Key Assortments, Deadbolts, Foreign Car Key Blanks, complete line of Safes, Closed Circuit TV Systems, Alarm Systems, High Security Locks, Electronic Lock Card Systems, I.D. Cards, Technical Manuals, Code Machines, and much, much more! National's Your One-Stop Locksmith Supply Supermarket. Most orders shipped within 24 hours. We welcome locksmiths, student locksmiths and industrial accounts. To order National's catalog send \$5.00 (refundable after first purchase of \$25.00 or more). Your catalog will be rushed to you by first class mail!

NATIONAL LOCKSMITH SUPPLY P.O. BOX 31598 DALLAS, TEXAS 75231



# To the men & women who want to quit work, someday.

Isn't it about time, you found out, the misunderstanding that most people have about becoming Financially Secure?

As incredible as this may sound, there is a way to accumulate great wealth without working sixteen hours a day, every day, for the rest of your life. But, because of the bold implication of this statement, I would like you the reader to be the judge.

My name is Robert E. Shindler. I wrote a book entitled "The Get Rich Report," but I am **not** going to tell you how to become a millionaire. Furthermore, I am **not** going to show you how to become rich overnight. What I am going to tell and show you are ideas and methods that have made people from all walks of life successful, independent and financially secure for the rest of their lives.

If you are still with me this far, and I hope you are, I would like to share with you some of my accomplishments that I have included in my new book.

Now I know that you expect me to tell you about some "secret success formula", that I found in the attic of some old mansion. Or that I spoke to and studied the richest and most powerful men in the country. **Not true.**

## Quite the Opposite

What I learned over the past five years about success and financial independence was quite the opposite from any formulas that you may have heard or read about.

Take Robert Gorman, a middle-aged man from Alexandria, Virginia. He works as a carpenter restoring old houses, because he likes it, and has a net worth of over a million dollars. He owns two office buildings and twenty-five houses (all of which he accumulated over the past seven years starting with nothing).

And then there is Alice Ragan who is a widow with four children from Arieta, California. Five years ago she was flat-broke and so heavily in debt that she came very close to applying for welfare. Today she has over \$250,000 in the bank and 35% ownership in one of the states largest corporations. All of this was acquired by using the same ideas and methods that Mr. Gorman used.

I found that these two cases were not isolated by any means. From one end of the country to the other I talked to small groups of people from all walks of life (all applying and using the same ideas and methods). All starting without any capital and all becoming financially secure.

## Definitely Different

The methods and ideas were definitely different. The concept was unique and far superior to anything in any book I had ever read.

I began by putting the information and methods I had learned into practice, revising and improving them to work even faster. I was amazed at the results in just six months.

Today I am my own boss and I am spending a lot of time traveling around the country doing things that I only dreamed about before.

In the first six months of operation, with just one of my methods, I earned over \$100,000. The second half of the year I doubled that figure. After three years of perfecting my methods, I am the president of my own corporation which planned a series of acquisitions back in 1978 which by 1980 should surpass the \$6 million dollar mark.

I'll tell you one thing: anyone can make

\$200,000 a year using my methods and ideas and they would be a fool not to try. Things are tough for people living on salaries. Tomorrow they'll be even tougher.

All over America new fortunes are being created. People from all walks of life are embarking on an adventure that few experiences in life can match: A journey into excitement, success and — just possibly — great wealth and the kind of personal freedom that few others will ever enjoy.

## The Real Proof

But you will find the real proof of my accomplishments in the last eleven chapters of my book. I will show you that you don't have to be a genius. I'm definitely not. You will find that you don't have to live in any particular part of the country. Nor do you have to have experience or outside financing.

My book "The Get Rich Report" will show you more than how to make a substantial income and become financially secure. It will stimulate your mind and reveal to you NEW ideas and methods that will work for you NO MATTER what kind of job or business you are in. I have already received many letters from housewives, lawyers, businessmen, doctors and government elected officials who have thanked me and profited from the ideas and suggestions in my book.

## \$2,800 in Twenty-Eight Days

*"I am a retired railroad man 75 years of age. I used to just sleep all day and watch TV at night. Now that I received your Get Rich Report, I have something to do with my time and making money besides. Last month I made \$2,800 using your methods. I could easily double that if I were a younger man. I feel useful again."*

Thomas Sheehan  
Saginaw, Michigan

## A Blueprint for Success

*"I am a school teacher. Before that I was in show business — New York, Dallas, Europe. Also wrote for Broadway shows. After seeing a sample of your work I can only say: your systems are like a blueprint for becoming successful. You can count on me. My goals are set very high!"*

John McCall  
New York, N.Y.

## \$24,000 in Four Months

*"It seems all my life I've been faced with bills, bills, and more bills. I was always up to my ears in debts, and there never seemed to be any let up. If it wasn't one thing, it was another. I just couldn't get my head above water. Since I started using your methods in your book I've gained a second income of \$24,000 in just four months, besides my regular salary. I am now free and clear of unpaid bills. I have \$34,000 in savings in the bank and I have just purchased a new home \$125,000. It seems like I have a new lease on life."*

John Seals  
Indianapolis, Indiana

## \$14,028.77 in One Week

*"Five days after your book arrived I set one of your plans into action. I made \$14,028.77. I have never in my life time, seen a program work so fast. PS. I still don't have a job."*

Joseph Altizer  
Springfield, Illinois

## \$32,000 in Just Three Months

*"Three months ago I took what you taught me in chapter 10 to heart. The results were remarkable. I made \$32,210.00. Not bad for a person with a seventh grade education."*

Samuel Thornton  
Riverside, California

Those were just some of the comments from people, just like yourself, from all walks of life and various parts of the country. The only difference between them and you is their use of certain basic principles taught in The Get Rich Report. In just one week from now you can know what they know.

I have written the book in plain English to make it easy to read and easy to follow. If you are asking yourself about now, "I wonder if his book is about mail-order?" let me answer you by saying you are dead wrong. The Get Rich Report has ABSOLUTELY NOTHING to do with or about mail-order.

You will find twenty-one chapters that are full to overflowing with facts, methods, ideas and techniques, that are working for me and several hundred others across the country. Methods like: A six month step-by-step plan for building a \$200,000 income without having a job or business. Or the system that allows you to receive \$10,000 two weeks after the book arrives.

You will find that you don't need an education to make these methods work. Nor do you need lots of experience. Both men and women, all ages, are acting on my seasoned advice. What is required? A willingness and a determination to put this knowledge to work for you and your family. Believe me when I say, it does not require you to leave your present job or business and there is positively No Selling or buying of any products. In fact, you don't need to have or rent an office to get started. You can do it anywhere — out or your house or in your apartment. With my methods and ideas you will be able to earn an extra \$5,000 to \$100,000 in a matter of months.

## 30 Day Free Trial

But I would like you to be the judge. Order your copy of "The Get Rich Report" from NVP Publishing Company on a 30-day trial basis. Make your own test of my ideas and methods. See if they work for you under your everyday conditions. Then if you aren't convinced that "The Get Rich Report" is a good investment, return it within 30 days for a full, courteous and prompt refund. Absolutely no questions asked.

For those who are still a little skeptical — I will go one step further: POSTDATE YOUR CHECK FOR 30 DAYS FROM NOW. I won't cash your check or money order for 30 days after I've sent you my book. Use my methods and ideas for that period and if you don't like them, just send the book back and I'll return your check UNCASHED.

"The Get Rich Report" is published by NVP Publishing Company — a substantial company — additional reassurance that your prudent investment is well protected.

To order your copy at no obligation, simply write the words "The Get Rich Report" on any plain sheet of paper, along with your name, address and zip code. Enclose a check or money order for \$12. Mail your check along with your order to me, Robert E. Shindler c/o NVP Publishing Company, Dept. KK, One NVP Plaza, Box 607, Herndon, Virginia 22070

NVP Publishing Company, 1979



# Discover Camel Lights satisfaction.

The Camel World of satisfaction comes to low tar smoking.

This is where it all started. Camel quality, now in a rich tasting Camel blend for smooth, low tar smoking. Camel Lights brings the solution to taste in low tar.

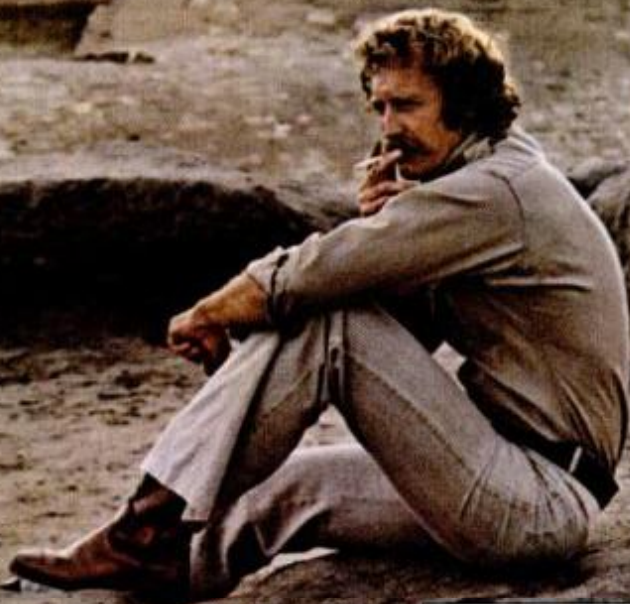

LIGHTS: 10 mg. "tar", 0.8 mg. nicotine, av. per cigarette by FTC method.  
100's: 13 mg. "tar", 1.0 mg. nicotine, av. per cigarette by FTC method.

Warning: The Surgeon General Has Determined That Cigarette Smoking Is Dangerous to Your Health.



## TABS TO TRIM GAS USE BY HALF!

(Continued from page 118)

skipper actually aims the angle of thrust, and he can do it while underway at any speed. Not only do you push the bow down to stop the pounding when heading directly into a nasty chop, but you can also raise the bow higher than normally possible at medium to slow speeds, making it possible to keep "your nose in the air" when running before a steep following sea.

Better still, the helmsman can, by the momentary touch of a button, adjust the craft's running attitude to the optimum for that particular speed and sea condition. Obviously, the power-trim system can also be combined with shims or preset tabs to increase control combinations considerably. Fuel savings possible with a tab-and-power-trim system can run as high as 30 percent, we've found in our test.

### Power trim tabs

Power tabs can do everything preset trim tabs will do—plus a lot more. One of their many advantages is the way they can be controlled while underway at any speed. You can also raise one and lower the other individually, and the boat's running attitude responds immediately.

Because the skipper, using simple dash-mounted control levers or buttons, has such precise control over the attitude of his craft, the danger of over-control is almost eliminated. This allows installation of much larger tabs than would be safe or practical with preset trim tabs. The largest power tabs that will fit your boat, in fact, should be used.

You can install these tabs yourself and save money. The pair of 9 x 12-inch Bennett Trim Planes I installed on my 17½-foot Hewes Redfisher took me about four hours of work. The job wasn't complicated, due to their simple design, complete instructions, and prerigged plug-in wiring harness.

The most immediate effect was a noticeable increase in top speed. Without the Bennetts, tops for my rig with a 75-hp Johnson Stinger was 36.7 mph. After the power tabs were installed, it promptly jumped to 39.5. I also measured an improvement in fuel economy that ranged from 10 percent in smooth water to as much as 40 percent when it is rough. Since I can power-adjust the hull's underwater "geometry" at will, I also get a far smoother and dryer ride in all sea conditions. And in addition to the fuel savings, I have less wear and tear on the boat

and on its equipment—radio/telephone, depthfinder, control console and the rest. The result will be improved resale value because of better condition and performance, plus the value of the tabs themselves.

Quality power-trim tabs aren't cheap. Typically they range from \$300 to \$400, plus installation. Because of the fuel they save, however, they could pay for themselves in a few years for an active boatman, without even figuring the probable increases in gasoline prices over that period.

### Power trim and power tabs

Combine both systems and you get a result that outperforms either method alone. Now you have precise fore-and-aft control, plus side-to-side trimming which only the tabs can provide. You can now use the trim tabs primarily to offset a crosswind that otherwise would be drenching you with spray. Meanwhile, your engine's power trim can angle your hull up or down for a smoother ride.

You cannot raise your bow with trim tabs. By raising the tabs, however, as far as they would go (slightly above the horizontal), and trimming the engine to the full outward extent of its power trim range, I found that my boat could attain a much higher bow attitude. That would allow running in up to a six-foot following sea, with no tendency to dig in her bow and broach.

Fuel economy, as expected, is increased even more, which my test records clearly show: Without the Bennett power tabs, my fishing boat begins to fall off plane at 3400 rpm and 17 miles per hour. As the hull starts to mush, my miles per gallon drop from 5.6 to 3.5, and my speed from 17 to 10.5 mph. With the power Trim Planes installed, I found I could stay on plane at speeds as low as 11.03 mph and 2600 rpm, as long as both tabs were in the maximum down position and the lower unit trimmed out as far as it would go. Without the tabs, but at the same throttle setting, the boat fell off plane to 7.67 mph, and the miles per gallon dropped 44 percent from 5.0 to 3.4. At the same time, my rpm dropped from 2600 to 2300. If I then moved the throttle back to 2600 without tabs, my speed picked up to only 9.0 mph, and my gas mileage dropped even further—to 3.3. That's 2.03 mph slower, and 52 percent lower fuel economy than the same tachometer speed with the trim tabs.

Obviously, the poorer the sea

conditions, the more dramatic the fuel economy with these two power trim systems. During adverse sea conditions, where it was previously impossible to stay on plane at 17 to 18 mph without punishing my boat and myself, I can now drop to 11 or 12 mph, still stay on plane, and thus save a large amount of fuel—while slogging through conditions when it would be particularly unfortunate to run dry.

Even at my normal 25 to 30 mph cruising speed, the effect of the two trim systems is noticeable. Without them, my best miles-per-gallon is 6.4. Adding power trim alone boosts that to 6.9 mpg, and when I added the Bennett Trim Planes, it jumped to 7.9 mpg. My average cruising speed has also increased by three miles an hour. That's not bad for a 17½-foot boat (18 when you include the length of the tabs). In fact, it's better than some cars.

### Safety benefits are a bonus

Safety improvement is also a trim tab bonus you should not overlook. Getting home ahead of a storm through choppy and gas-consuming headseas can be a worrisome problem. Reducing the punishment of a pounding ride, plus the chance of a broach, make tabs even more worthwhile.

Your boat will produce different results than mine—every craft does, because of differing hull designs, size, loading, power and water conditions. But by using these principles, you should be able to reduce your fuel consumption and improve performance to a significant degree. Your percentages may even trim mine! **FM**

### MANUFACTURERS LIST

#### Manual or preset

Diversified Products Co., 1136 Venice Blvd., Los Angeles, Calif. 90015. Preset.  
Dolphin Marine Sales, 5901 Northeast 14th Ave., Fort Lauderdale, Fla. 33334. Manually adjustable with tools.  
Glen L. Marine Designs, 9152 Rosecrans, Bellflower, Calif., 90706. Preset.  
Olson Industries, Box 2520, Sarasota, Fla. 33578. Automatic adjusting (spring-loaded).  
Scott Molding Co., Box 2958, Sarasota, Fla. 33578. Flex-A-Trim flexible plastic, automatic adjusting.  
Tempo Products, 8200 Cochran Rd., Solon, Ohio 44139. Automatic and preset.

#### Remote controlled

Bennett Marine, 550 Northwest 12th Ave., Deerfield Beach, Fla. 33441. Electric-hydraulic.  
Boat Leveler Mfg., 7305 Natural Bridge St., St. Louis, Mo. 63121. Electric-hydraulic.  
Glen L. Marine Designs (see above).  
Hummel Mfg., 164-02 95th St., Howard Beach, N.Y. 11414. Air-operated.  
ICM Marine Products, 1140 West 15th St., North Vancouver, B.C. Hydraulic.  
Kiekhaefer Aeromarine, Box 1458, Fond du Lac, Wis. 54935. K-Planes hydraulic.  
L. Saraga Inc., 121-26 Dupont St., Plainview, N.Y. 11803. Electric-hydraulic.



# NOW YOU CAN GET JUICED AT A YAMAHA DEALER.



EF1200

EF2600

EF1800

Yep. Yamaha makes portable generators. The kind of portable generators that you would expect Yamaha to make.

Technically advanced, simple to operate, lightweight, compact and exceedingly reliable.

A capacitor discharge ignition produces a strong spark under any working condition. And virtually no maintenance is required.

Few, if any, manufacturers offer C.D.I. throughout their entire generator line. Yamaha does.

A feature completely unique to Yamaha is an oil warning system which automatically stops the engine when the oil drops below a certain level.

There's a D.C. outlet so you can conveniently recharge a battery. Large intake silencers and mufflers for exceptionally quiet operation. High-capacity fuel tank for long hours of smooth, continuous power.

These are the things that make a generator a Yamaha. In places where a generator

is often the only source of power and there's not a drop of gasoline to waste, Yamaha is the name people rely on.

The Yamaha EF1200, EF1800 and EF2600.

Portable electric power to run anything from campsite to a construction site.

See your Yamaha dealer and get all the juicy facts.

## YAMAHA

*When you know how they're built.*



## PICK OF THE PROJECTION TVs

(Continued from page 106)

cost; some sell for as little as a few hundred dollars.

In the last several months there have been two very new picture-display advances, one of which is just reaching the general market. The other may be confined to higher priced military-industrial sets and may not be enjoyed at all by the consumer (at least not in its present, expensive form).

For right now, Henry Kloss and his Kloss Video Corp. have developed a brand-new Novatron picture tube, having extra-sharp magnetic focusing, a long deflection angle, and a mirror system somewhat akin to the highly successful Schmidt optics. The beam shines through the center of an optical mirror, strikes a small, phosphor-coated center target, then is reflected around the target assembly and out through a final correction lens to the viewing screen—one tube, of course, for each color. Kloss claims a system optical speed of  $f/0.7$ , just about the fastest in the industry, and brightness of at least 80 foot-lamberts. A 19-inch TV measures about 150 foot-lamberts.

### An unconventional system

Meanwhile, Aquabeam, the most unconventional new system of all, has been introduced by Art Tucker of Electronic Systems Products Inc. Tucker designed a four-window plastic box, mounted a pair of individual-wave-length dichroic mirrors inside, then filled the box with special liquid to defeat refractive mirror distortion. The result is a single red, blue and green beam of very high intensity that can be projected by only one lens on any suitable viewing display, the image size depending solely on distance between projector and screen. Unfortunately, startup manufacturing costs for this system are high. Consumer production units would have to sell for between \$5000 and \$7000.

Japan's Mitsubishi (MGA) is also showing a new tri-picture tube system. MGA claims a brightness level 10 to 15 times greater than that of conventional tubes and a maximum resolution of 350 lines horizontal and 400 lines vertical at 25 kilovolts.

### Available now

With more than minor improvements immediately available, at least four of the newer sets are well worth consideration by anyone who has that extra buck available to invest in big-screen TV.

Kloss Video Corp. markets its Novabeam two-piece system with No-

vatron tubes at the relatively modest price of \$2495. This includes: a 6½-foot screen; 80 foot-lamberts of brightness; a Magnavox 4-MHz comb filter; very high resolution chassis; electronic random access; channel scan; remote-control tuning; a built-in test pattern generator to adjust focus and convergence; equalized power amplifier for the speaker; separate sound output; and both 300- and 75-ohm antenna inputs—an excellent buy in most respects.

There is also MGA's current VS-500U and more recent VS-505U and VS-510U models, which are just appearing in some major cities. The VS-500U has: a 50-inch (diagonal) screen of washable vinyl;  $f/1.3$ , four-element precision-ground glass optics; five stages of video amplification (gain) with super resolution; varactor pushbutton tuning; two 5x7-inch oval speakers capable of being switched to a 10-watt external amplifier; and 300- and 75-ohm antenna inputs. There are also video and audio input jacks, and the cabinet is vinyl-clad wood veneer—another solid buy, even at \$3700, considering this is a very deluxe set with excellent convergence and superior optics.

Another new and very presentable single-unit projection TV that's also just being introduced to the market is Advent's new VideoBeam Model VB125. Featuring a low-profile cabinet of solid hardwood and walnut veneer, this set (as do other Advents) uses: a Canadian Electrohome TV chassis to drive three 5-inch, four-element picture tubes with  $f/1.3$  lenses; a five-function remote control for on/off; random access and sequential channel selection; hi-fi loudspeaker; video/audio outputs; two direct video inputs; 300- and 75-ohm antenna inputs; a 300-ohm UHF outlet; and customer controls on the lip of the cabinet mirror drawer. Price: \$4000.

All of the projection TVs we mention can be used with video-cassette decks, the new videodiscs and electronic games, as well as for normal TV fare. Many so-called "media rooms" feature a projection TV screen along one wall, with numerous accessories from the list above for an all-around home entertainment center.

Is this all? For the time being, probably yes. But by next summer, more U.S. and perhaps even foreign manufacturers may be in the market with laser-beam projection sets and 6-foot screens that will literally dazzle the eyeballs. **PM**

## BE YOUR OWN BOSS!



### Start a MONEY-MAKING SMALL ENGINE REPAIR BUSINESS of YOUR OWN

Earn EXTRA CASH income working at home—SPAREtime or FULLtime

#### Small Engine Repair Is A Wide Open Field

Over 65-Million small engines are in use today, and a million new units are being built each month. This means there's plenty of business and big profits available for qualified men who can service and repair them. Industry growth has been so fast that there is a shortage of small engine repair pros. That's why NOW is the time for you to get into this profitable field where you can command hourly rates equal to any other skilled craft. The sale of parts, engines and accessory items add even more profits... profits YOU earn and keep in YOUR pockets, not someone else's.

#### Start A Fulltime Business Or Work Spare Hours For Extra Cash Income

When you're the boss in a fulltime business of your own there's never a worry over strikes or layoffs, and you earn year round profits repairing chain saws, tillers, tractors, mowers, mini-bikes, power rakes, generators, snowmobiles, snowblowers and many more items. There is no huge investment for equipment, no expensive inventory. Work right out of your garage, basement or a spare room. Ideal for sparetime income too. In just evenings and weekends you can earn extra cash for a rainy-day or retirement fund, or use the extra money for the things you want NOW.

#### It's Easy To Learn—No Experience Needed

You can learn this craft at home in your spare hours with our time-tested "hands on" training methods. Age, education, minor handicaps are no barrier. You get latest text materials, special tools and 3½HP Briggs & Stratton engine, but that's not all. We also help you with detailed data on how to get started, where to get business, what to charge, where to get parts at wholesale... all the shortcuts and proven methods you will need to get your business off to a fast, profitable start.

#### Send TODAY For FREE Facts There is NO Obligation —NO Salesman Calls

Our FREE information Kit tells how to quickly start your own business, how to grow, and how you can inspect the Foley Small Engine Repair Course on our 15-Day NO RISK Trial Offer. Mail coupon (or send postcard) to:

Foley Small Engine Repair  
4681 Foley Building  
Minneapolis, Minnesota 55418



YOU GET THESE QUALITY TOOLS AND INSTRUCTIONS PLUS THIS 3½ HP BRIGGS AND STRATTON ENGINE YOURS TO KEEP!



Foley Manufacturing Co.  
4681 Foley Building  
Minneapolis, Minn. 55418

RUSH COUPON TODAY!

YES, please send FREE Data Kit and full details on how I can start a profitable Small Engine Repair business of my own, and facts about Foley's exclusive 15-Day No Risk Trial Offer. No obligation. No salesman will call on me.

NAME \_\_\_\_\_  
ADDRESS \_\_\_\_\_  
CITY \_\_\_\_\_  
STATE \_\_\_\_\_ ZIP \_\_\_\_\_



## THE FREEDOM BALLOON

(Continued from page 102)

to look for material. Since Posneck, population 20,000, has few stores and they were well known in town, they drove 30 miles to a department store in the larger city of Gera where they found a cotton cloth they thought would do the job. To allay any suspicions on the part of the clerk, who was speechless when they told her how much of it they wanted, they said they were from a camping club and wanted it as tent-lining.

### Sewing under cover

For the next two weeks Wetzel ensconced himself in his upstairs bedroom, always hiding everything if visitors came, to do the sewing on a 40-year-old, foot-pedal sewing machine. Working each day until his hands and feet were swollen, he produced a bag measuring 50 feet wide and 66 feet long.

Strelzyk, meanwhile, working in Wetzel's downstairs hobby shop, constructed the gondola and burner system.

His first burner rig, later to prove inadequate, consisted of two 11.8-inch-diameter, 24.2-pound, 1.45-gallon bottles of liquid propane household gas hooked by hoses to a ½-inch waterpipe with a control petcock, topped by a 4-millimeter-diameter nozzle leading into a sheet-metal stove pipe that measured 39 inches long and 5 inches in diameter.

The gondola was a 4.6 by 4.6-foot welded frame of 1.57-inch angle-irons, strengthened by two diagonally welded 1-inch iron struts. He drilled holes in the frame at 6-inch intervals to bolt in a fitted piece of sheet-metal flooring .03-inch thick. At each corner he bolted a 1-inch-square, 31.5-inch long steel post and also drilled holes in it at 6-inch intervals. Through the holes he passed 8-millimeter-thick nylon clothesline, surrounding the gondola, like the ropes in a prize-fight ring, as a

guard rail. On top of each of the four posts he welded a ½-inch open hook to which the lines (the same type of nylon clothesline material) securing the bag to the gondola (three lines per hook, 12 in all) could be secured.

By early April 1978 Strelzyk and Wetzel were ready for testing. They spent several days hunting for a safe place where they could try out the balloon, finally finding a secluded clearing in a forest about 18 miles south of Posneck and 6 miles from the border. Under cover of darkness they spread out the bag, lit the burner (whose flame was only a disappointing 1.5 feet long), held up the opening and attempted to inflate the balloon with it. Nothing happened.

"We thought it was because the bag was lying flat on the ground and probably ought to be vertical," Wetzel remembers.

They spent several weeks hunting for a place where they could do that secretly, finally discovering an isolated rock quarry with a 75-foot cliff, from which the bag could be suspended and inflated from below. Again, nothing happened.

Wetzel and Strelzyk then designed and built an ingenious blower—figuring that the bag should first be filled with cold air—and a portable "flame-thrower" that would help heat it before igniting the burner on the platform.

The blower consisted of a homemade fan with six blades, each about 3 feet long, powered by a 14-hp, 250 cc "Zwickauer Motorenwerke" motorcycle engine. The blades were fashioned of sheet steel. The blower had a capacity of 17,657 cu. ft. of air per minute. The engine was equipped with a starter from an East German Trabant automobile, which they could switch on by jump cable from the battery of Strelzyk's Soviet-made Moskvitch sedan. To avoid possible detection in the clearing, because of the motorcycle engine's noise, they silenced it with a Trabant muffler.

The "flame-thrower," also fed by two 11-kilogram

Strelzyk and Wetzel collaborated on these sketches exclusively for PM. Top view of gondola (Gondel) below indicates dimensions in millimeters, including sheet-metal (Blech) thickness, length of sides and diameters of gas bottles (Gasflaschen) and burner

pipe (Brennerrohr). Profile sketch (not to scale) shows 40 x 40-mm angle-iron frame, iron corner rods drilled with five holes for 8-mm nylon clothesline (Nylonseile) and hooks (Haken) on top, each with three clotheslines attached securely to the balloon.

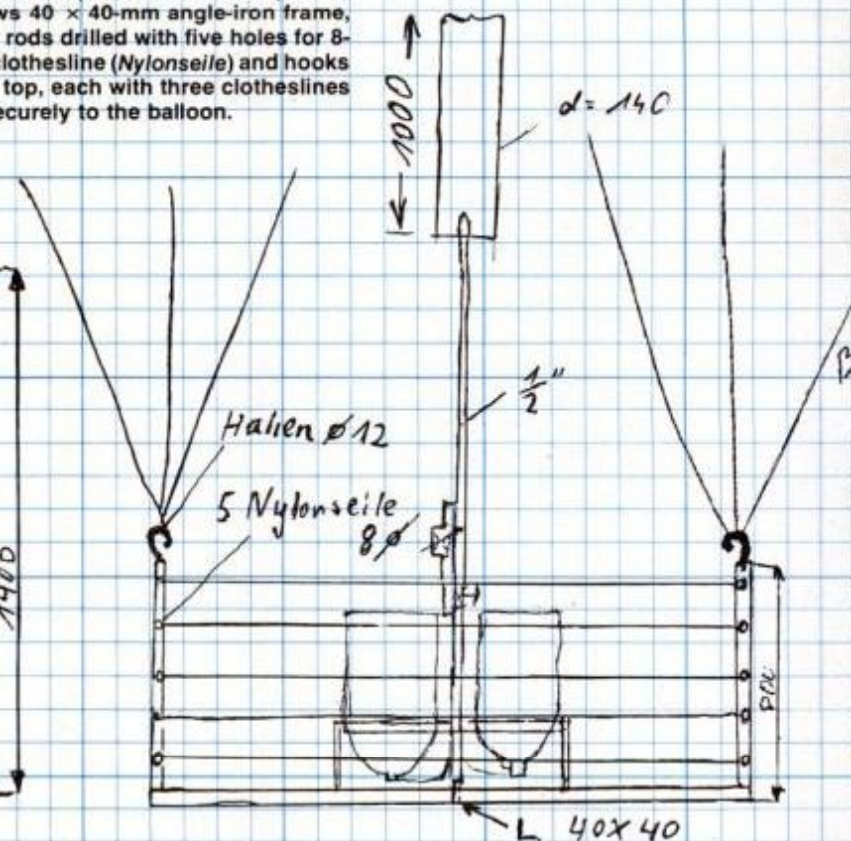
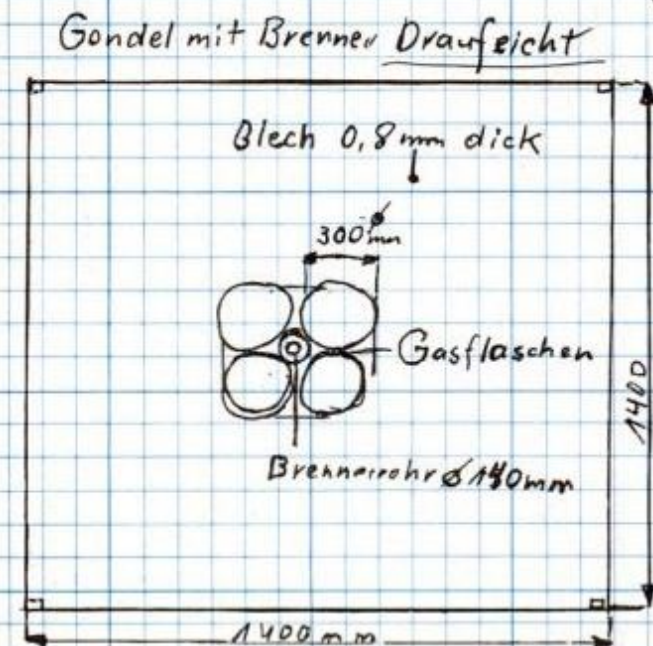



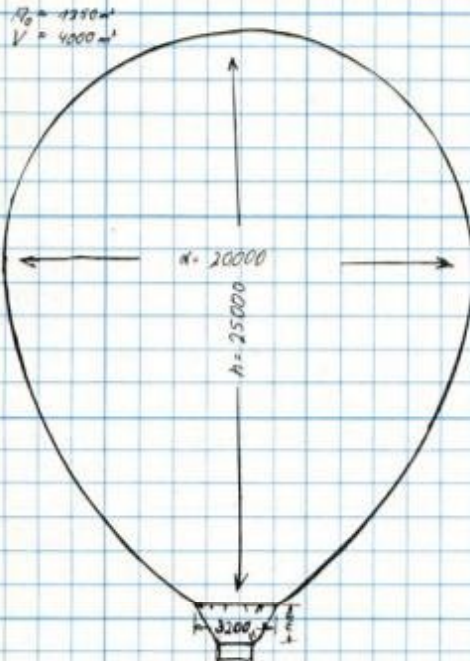
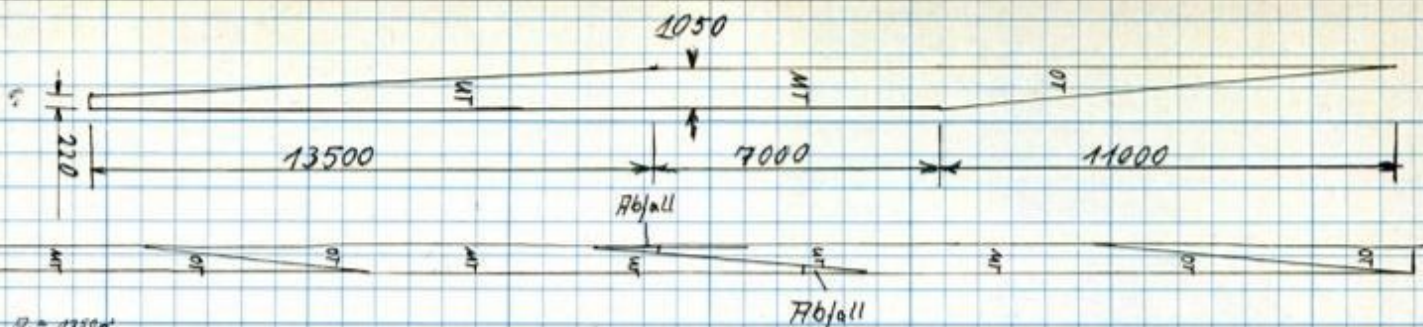

Drawing above shows shape of individual fabric sections (top) and how careful planning allowed each section to be cut from rolls of fabric with the least waste (Abfall). Dimensions in millimeters refer to upper (OT), middle (MT) and lower (UT) segments of each piece of fabric. At widest part, each section is 1050 mm wide. At left is Strelzyk's sketch for the assembled balloon, with the surface area and the cubic contents written above.

placed the various samples over the mouth of the hose and switched the cleaner on. The denser the material, the more the suction would deflect the water in the tube. The umbrella covering proved best, but was also the most expensive. Strelzyk and Wetzel settled on one of the taffetas.

To buy it without arousing suspicion, they drove more than 100 miles to Leipzig, East Germany's second largest city, and placed their order in a big department store, this time claiming they were from a sailing club and the material was ideal for sailmaking.

"They didn't have that much in stock," Strelzyk explained, "and told us it would take a day. We were afraid that the purchase might be reported to the State Security Service, but when we went back to the store the next day, there was our taffeta; all 800 running meters of it, a meter wide, but alas, in four different bright colors. We took it, paid 4,800 marks (\$720) for it,

(Please turn to page 148)

propane gas bottles, was simply a portable version of the balloon's platform-mounted burner.

The new equipment finished, Strelzyk and Wetzel set out again one dark night for the little clearing to try once more. The results, however, were the same. The bag wouldn't inflate, but thanks to the powerful blower, the two men realized why. The material was too porous. The air rushed right through it.

### Disappointed but determined

They packed up the bag and all their equipment and headed back to Posneck, sorely disappointed, 2,400 East German marks (\$360—the cost of the material) poorer and weary for all their efforts, but determined not to give up.

First they had to destroy the evidence. Over the next few weeks Strelzyk cut up and burned the 800 square yards of balloon bag in the furnace of his house. Then they began scouting for a denser and more suitable textile. In stores in Posneck they picked up various samples: umbrella covering, several grades of synthetic taffeta, and nylon jacket lining.

They tested the materials for heat resistance by baking them at various temperatures in the oven of a kitchen range. To determine density they devised a simple but clever system: They drilled a quarter-inch hole in the side of the plastic suction hose of a floor-type vacuum cleaner, inserted a U-shaped tube of glass into it so that it would be air-tight. They painted markings on the glass and filled it partly with water. Then they

Balloon's powerplant is the converted stovepipe (Ofenrohr) sketched at right and rotated (Ansicht 90° verdreht) below to show flat iron bracket (Bügel aus Flacheisen), which is 30 mm wide. Nozzle (Düse) diameter is 4 mm. Strelzyk and Wetzel used a double-valve arrangement to regulate the burner; a pneumatic valve type NW 6 (Pneumatikventil) was the primary control, installed in circumvention of a ½-inch water petcock (Wasserhahn) that was opened to give full gas flow. For precise regulation during flight, smaller valve was to be used, but soon after takeoff on the actual escape the balloon top ripped and the full-bore petcock was opened until the gas ran out.

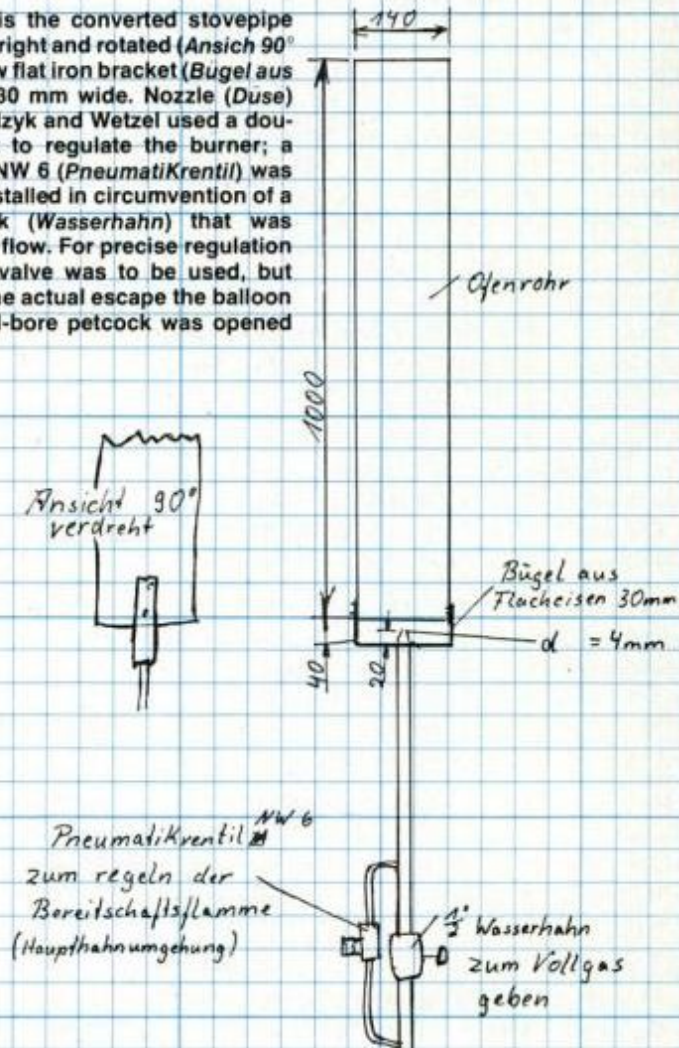



## THE FREEDOM BALLOON

(Continued from page 147)

and then dashed back to Pösneck."

Wetzel meanwhile had attached an electric motor to his wife's aged sewing machine and within a week had the new bag, identical in its 15-by-20-meter dimensions to the old one, ready.

The two men drove back to the little clearing with all their gear late the next night, made their preparations, spread out the balloon on the ground, started the blower, ignited the "flame-thrower," and within five minutes or so the bag was nearly full, standing tall, and the air stayed in it. But Strelzyk's burner was too weak and gave it too little lifting power.

By now it was almost winter, too late and too cold to make a flight, even if the balloon would rise. Strelzyk and Wetzel spent the last months of 1978 trying to devise a more powerful burner. They added two more 11-kilogram propane gas bottles, they experimented with gasoline and with gasoline-propane mixtures. But the results were still unsatisfactory. Four people might make it, and then only with luck, but never eight.

That was one reason why Wetzel decided at the time to back out. Another was that he had started building a large model airplane with a gasoline motor and began toying with the idea—far-fetched, as he now concedes—of constructing a large enough version in which he, Petra and their two small children could flee.

Thus Strelzyk tinkered on alone, still dissatisfied with the burner and its lifting power. Then suddenly, in June, 1979, came the break. He was trying to empty a half-full propane tank in his garden by holding it upside down. When he opened the spigot the gas shot out in a huge cloud.

"The pressure with the bottles held upside down, I figured, ought to give me the flame length and burning propensity I wanted—24,000 kilocalories per 1 cubic meter of gas," he explained, adding that 1 cubic meter of gasified propane is equal to 1 liter or 2 kilograms in liquid form.

He quickly made alterations on the gondola to provide an angle-iron rack in the middle of it, on which he could mount four propane tanks upside down and, together with his elder son, headed once again for the forest to test the burner. On ignition, a 40-foot flame shot out of the stove pipe. Sixteen months after they had just gotten the idea, the balloon was ready and the Strelzyks

began waiting for the right weather and wind conditions.

### Aloft on Independence Day

Both came on the night of July 3. The family headed with balloon to the clearing and at 1:30 a.m. on July 4, lifted off, rising at 13 feet per second to an altitude of 6,600 feet—according to the barometer which Strelzyk had converted into an altimeter.

The northerly wind blowing them toward West Germany was good—almost 20 miles per hour. But then disaster struck. They entered a cloud. The vapor condensed into water on the balloon's surface, soaked the material and made it heavier and heavier.

"Before I really realized what was happening," Strelzyk recalled, "and before I had the presence of mind to increase the gas flow, we were sinking too fast."

They came down safely but still in East Germany a scant 200 yards from the border and freedom. They were right in the "death strip" and within sight of the wire-mesh fence that, as they now know, bristles with tripwire-triggered shrapnel guns.

The tale of how they spent the next nine hours gingerly picking their way out of the 500-meter-wide border area with its hidden tripwires, and out of the three-mile-wide restricted area behind it without being seen, caught or shot by border patrols, is a harrowing one. But they made it to the clearing where they had abandoned their car with trailer, the blower, the auxiliary flame-thrower, and the lines and spikes that had held the balloon until lift-off. The balloon and gondola, of course, remained as glaring evidence of their escape attempt, right where it had landed in the death strip. According to reliable West German border police sources, it was discovered that same morning.

The hunt for the balloon escapees was on and Strelzyk became panicky.

He destroyed all evidence—the blower, the flame-thrower and even his calculations. Fearing that they might have been seen that day in their unmistakable orange Moskvitch, he sold the car and bought a used East German-made Wartburg. He also tried to make contact with Western embassies in East Berlin in the hope of finding a diplomat who might hide them in a car or truck and drive them to West Berlin.

"I knew it was just a matter of time before the search would close in, not only on us but the Wetzels," he explained. "I went to him, told him what had happened and he

agreed our only hope was to build another, bigger, better balloon that would take all eight of us out—and to build it faster than the plodding, bureaucratic secret police apparatus would expect us to."

### Back together once more

This time, working together again, they designed a bag with twice the volume—141,256 cu. ft., measuring 65.6 feet in diameter, and 82 feet in height, and requiring 13,453 sq. ft. of material. To find the material they drove more than 2000 miles crisscross all over East Germany, buying small amounts here, small amounts there, aware that any large order anywhere would alert the police. What they ultimately came up with looked like a rainbow-colored patchwork quilt of synthetic textiles, some of them patterned and flowered and intended as bedding. They even bought the clothesline needed in different towns.

Wetzel went back to his creaky sewing machine, after cutting the wild array of material first into equal widths of 3.3 feet, and then wedge-shaped pieces 103.3 feet long. Strelzyk built a new blower, flame-thrower, gondola and burner, to the exact same specifications of those he had abandoned in the border death strip or dumped in a panic after that harrowing mishap. Within only six weeks they were ready to go again.

The new balloon bag weighed 403 pounds together with its clothesline. The gondola, burner, propane bottles and the two families of four came to another 1209 pounds. Total weight to be lifted: 1612 pounds.

"But I knew that with the new bag's volume we would have plenty of reserve," Strelzyk says. He knows the calculations by heart and did them for me.

"At the normal density of air, at 0° C., 4000 cubic meters of air has a weight of 5172 kilograms. At 100° C., the air density is only 3785.4 kilograms on a volume of 4000 cu. meters. Thus, the density difference between the cold and the heated air is 1386.6 kilograms. That was my lifting power. Subtract the 733 kilograms of the bag, gondola and passengers, and we had a reserve lift-power of 653.6 kilograms."

### Skyward for good

All they needed was the right wind and weather again. It came on the evening of Sept. 15. Wasting no time on tests but certain that it would work, the two families, with only the clothes on their backs, packed their balloon and equipment into the trailer hitched to Strelzyk's

(Please turn to page 150)



# When your taste grows up, Winston out-tastes them all.

Only Winston's Sun-Rich™ Blend  
of the choicest, richest tobaccos  
tastes this full and satisfying.

**Winston after Winston.**

BOX: 19 mg. "tar", 1.3 mg. nicotine, KING: 20 mg. "tar",  
1.3 mg. nicotine, av. per cigarette, FTC Report MAY '78.

Warning: The Surgeon General Has Determined  
That Cigarette Smoking Is Dangerous to Your Health.





## LYNCHBURG HARDWARE & GENERAL STORE

Box 342, Lynchburg, Tenn. 37352



### Old-time Riverboat Playing Cards

Both of these decks are prettier than a painting, and so is the antique tin card case. Each card is a bit larger and thicker than normal—like those used on riverboats in the 1890's. There's a black and a green deck—both with an antique gold "distillery design." The face cards are reproduced from 100-year-old artwork. So it's a real unusual set of cards for the serious player. Twin deck in antique case: \$8.50. Postage included.

Send check, money order, or use American Express, Visa or Master Charge, including all numbers and signature.

(Tennessee residents add 6% sales tax.)  
For a color catalog full of old Tennessee items, send \$1.00 to above address.

## MOLDS

for making  
Ornamental Concrete  
Items...

Book about Aluminum  
Molds with prices and  
production trade secrets  
direct from world's largest  
mold manufacturer.



SEND  
\$5.00

CONCRETE MACHINERY COMPANY, INC.

P. O. BOX A99 - HICKORY, N. C. 28601



"SAVE  
YOUR  
HEART"

with a **STAIR-GLIDE** Stairway Lift  
RENTAL-PURCHASE Program Available

America's largest selling stairway lift. Ideal for people who cannot or should not climb stairs. Easily installed in less than 2 hours without damaging stairway. Runs off household current. Choose from Deluxe or Economy models.

**AMERICAN STAIR-GLIDE® CORP.**

4001 East 138th, Dept. POP-020  
Grandview, Missouri 64030

## THE FREEDOM BALLOON

(Continued from page 148)

recently-purchased Wartburg car. Wetzel and young Frank got on a motorbike, the women and children into the car, and they headed for their "launch pad to freedom"—the same little clearing in the forest.

It was 1:30 a.m. Sunday, Sept. 16, by the time they arrived and started setting up. The gondola was secured with ropes and spikes in the ground, the bag spread out. Wetzel and Frank held up its 10-foot diameter opening. Strelzyk turned on the blower. In just 10 minutes it was full. In another three minutes the air within it was heated, and the burner blazing. Shortly after 2:00 a.m. they lifted off, taking only nine minutes to attain an altitude of more than 6,500 feet, and moving at 18 miles per hour toward West Germany again. The air temperature at that altitude was 18° F. The women and children huddled, shivering, on the gondola floor around the four propane bottles, which took up 40 percent of the floor space. The only protection against falling was the clothesline guard rail.

As short and ultimately successful as the 28-minute flight was, it was not without mishap and near disaster. The meter-long stovepipe of the burner, Wetzel and Strelzyk lateral calculated, was about 10 percent too long, with the result that the flame was too high and pressure too great inside the bag.

Shortly after takeoff, and still well within East Germany, a rip appeared in the top of the bag. The gush of air out of it extinguished the burner and Wetzel began frantically trying to rekindle it with a pack of matches brand-named, ironically, *Freie Welt*—Free World. It ignited, only to go out several more times.

Just before crossing the border, they later realized, their strangely illuminated conveyance must have been spotted in the night sky by East German patrols. Searchlights were trained on them from the ground but were probably not powerful enough to make them completely visible. Just to be on the safe side, Strelzyk turned the petcock to full, the flame reached a frightening length of more than 50 feet inside the bag, and the balloon rose by another 1,640 feet to its maximum altitude of 8,202 feet.

"I didn't know whether the altimeter I had fashioned was accurate," Strelzyk said, "but West German air controllers later told me that they were getting radar blips... at that time from something they couldn't identify. That was us."

Soon the gas ran out and they came down, fast and hard, near Naila, 460 feet from high-voltage wires.

Wetzel, who broke his leg in the landing and was the only casualty, estimates the kilocalorie output of the burner at 480,000 to 500,000 during the brief ride, and believes that "we could have made it as far as Bayreuth (30 miles further southwest) had not the top blown out and made us consume so much gas."

Now much celebrated and trying to settle down in Naila, where they intend to live, when I interviewed them, the Wetzels and Strelzyks still could neither quite believe their good fortune nor face squarely the risks they had taken.

But they were sure of two things.

They want to register their balloon in West Germany, join a club and go ballooning again—"for fun and in daytime when you can see something." They were also sure, sadly, that no one in East Germany would be likely to duplicate their escape for a long, long time. Border patrols are now even more watchful.

Indeed, within a day of the successful flight, all small airports close to the border in East Germany were closed, the planes transported further inland. Along a broad 18-mile band, from Lübeck on the Baltic Sea to Hof, near Naila, and where East Germany's border meets Czechoslovakia, security tightened.

"No one," conjectured a Bavarian official, "will ever again be able to buy enough materials in East Germany with which to make a balloon—even by shopping every department store in the country." **PM**

## BEATING THE BORDER

(Continued from page 103)

Four East Germans once passed through Berlin's "Checkpoint Charlie" wearing homemade Russian officers' uniforms and driving a Soviet-make car which they had painted regulation olive green. The East German guards actually saluted them as they left.

One East Berliner even managed to escape backward. A professional photographer, he hired several beautiful girls as models, took them to "Checkpoint Charlie" and told border officials he was on assignment from an East German magazine to take publicity pictures of the frontier arrangements, which are ballyhooed by Eastern propaganda as a "defensive measure against capitalist-imperialism." He asked several of the guards to pose with the girls and, with his back to West Berlin, began taking scores of pictures, moving one or two steps backward—closer to freedom—with each shot until he was standing on the white demarcation line. He then turned and bolted into the arms of American MPs, who had been watching his antics with great amusement.—**J.D.**



Start your own money making business!

Make up to \$12<sup>50</sup> an hour—  
even while learning!

Train FAST  
at home!

Get into this booming high-profit business that's  
Easy to learn—Easy to do—Easy on You!

Never before have money-making opportunities been so great for qualified Locksmiths. Now lucrative regular lock and key business has multiplied a thousandfold as millions seek more protection against zooming crime. Yet there's only one Locksmith for every 17,000 people!

**Start Collecting CASH PROFITS Right Away**

You're "in business" ready to earn up to \$12.50 an hour a few days after you begin Belsaw's shortcut training. Take advantage of today's unprecedented opportunities in Locksmithing for year-round EXTRA INCOME in-spares-time—or fulltime in a high-profit business of your own. Hundreds we've trained have done it. So can YOU! All tools plus professional Key Machine given you with course. These plus practice materials and equipment, plus simple, illustrated lessons, plus expert supervision, plus business-building guidance will enable you to KEEP THE MONEY COMING IN! Ideal for retirement—good jobs too.

**SEND FOR EXCITING FACTS—No Obligation**

Discover what's in Locksmithing for you—how Belsaw's Master-Locksmith-approved training can give you the skill you can depend on to EARN MORE—ENJOY LIFE MORE.

No Extra Cost! Included With Your Locksmith Training



**BURGLAR ALARM and SECURITY SYSTEMS** training. Covers all phases of Burglar, Hold-Up and Fire Alarm servicing and installation. This valuable and timely instruction includes all special tools and supplies. ONLY Belsaw offers such extensive training in this rapidly expanding field as a part of your Locksmith training.

**ADVANCED Locksmithing!** How to change combinations, in stall and service Safe, Vault and Bank Safe-Deposit Box locks. You learn-by-doing on the locks that we supply. You'll find it fascinating and highly profitable work.

Be Your Own Boss!



# BE A LOCKSMITH!

"I began earning right after starting... made \$1,200 while I was still learning."

HARVEY COLE Charlevoix, MI 49720



10-DAY NO RISK TRIAL!

Send for details!

**THIS PRO KEY MACHINE IS YOURS TO KEEP!**



This Pro Key Machine can alone add up to \$200 a month to your income... and it won't cost you a penny extra with your training.

ALL SPECIAL TOOLS AND EQUIPMENT INCLUDED!



Find out all about it! Send for **FREE** Facts TODAY!

Just fill in and mail coupon below (or send postcard) to receive full information and details by return mail. **DO IT TODAY!**

**RUSH COUPON!**

**BELSAW INSTITUTE**  
100F Field Bldg., Kansas City, Mo. 64111

Hundreds of Belsaw trained men have succeeded in this fascinating and highly profitable field...

"I opened my own business, spare time, seven months after I enrolled and made a profit of \$329 for the first week."  
**B. A. Deberry Littleton, Colorado**



"No more hard, nasty work for me. Now I have my own business and with hardly any effort I average around \$50 a day. Thanks for my new start in life."  
**Sam Walker Prichard, Alabama**



There is **NO OBLIGATION** and **NO SALESMAN** Will Call—ever!

**RUSH COUPON TODAY FOR THIS FACT-FILLED**

**FREE BOOKLET!**

Tells how you quickly train to be your own boss in a profitable Sparetime or Fulltime business of your own **PLUS** complete details on our **10-Day NO RISK Trial Offer!**



Send for your copy today!

BELSAW INSTITUTE, 100F FIELD BUILDING KANSAS CITY, MISSOURI 64111

**YES**, please send me the FREE booklet that gives full details about starting my own business in Locksmithing. I understand there is no obligation and that no salesman will call.

Name \_\_\_\_\_

Address \_\_\_\_\_

City \_\_\_\_\_

State \_\_\_\_\_

Zip \_\_\_\_\_

... YOU Can Do It Too!



SEE YOUR DEALER TODAY

# DEMAND THE ORIGINAL 'Firestik'<sup>®</sup>

"THE FUEL-SEEKER"

**DON'T TAKE NO FOR AN ANSWER!!  
THE #1 WIRE-WOUND AND MOST  
COPIED ANTENNA IN THE WORLD!**

Rugged, Shatterproof Fiberglass . . .

**CB** Antennas and accessories for marine, RV,  
truck, auto, van and motorcycles, etc.

Also Marine, 2 Meter and Land Mobile Antennas.  
Five Colors:

Spun Gold, Silver-Gray, Black, Red and White.

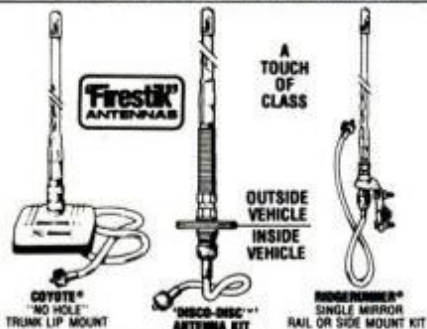

SEND FOR FREE CATALOG

"Firestik<sup>®</sup>" Antenna Company  
2614 East Adams/Phoenix, AZ 85034

Name \_\_\_\_\_  
Street \_\_\_\_\_  
City \_\_\_\_\_  
State \_\_\_\_\_ Zip \_\_\_\_\_

Our 17th Year Serving  
the CB & Communications Market

**5-YEAR REPLACEMENT WARRANTY**

# DO-IT-YOURSELF FINE GRANDFATHER CLOCK KITS

STARTING UNDER

# \$220

(including movement and dial)

- Factory direct prices
- Heirloom quality
- Solid 3/4" hardwoods: black walnut, cherry, mahogany, oak
- Easy to assemble, parts pre-cut
- Solid brass West German chiming movements
- Money back guarantee
- Prompt shipment

MASTER CHARGE and  
BANKAMERICARD/VISA  
ACCEPTED

Write for FREE  
color catalog



## EMPEROR<sup>®</sup> CLOCK COMPANY

WORLD'S LARGEST MANUFACTURER  
OF GRANDFATHER CLOCKS  
Dept. 335, Emperor Industrial Park  
Fairhope, Alabama 36532

## BUILD A GIANT-SCREEN TV (Continued from page 107)

ments. This design allows the lens to "see" images that measure up to 17 inches wide.

Other lens designs are available, such as aerial camera lenses and plastic Fresnel lenses. The latter lenses tend to project an image of

rather inferior quality. Most lenses used for projection TV have focal lengths of about 12 inches, and this will be considered standard for our uses.

What about lens speed and focal ratios? The focal ratio is the lens's

### . . . And here's a kit

If you already own a 13-inch color TV, there is a kit available to turn it into the heart of a one-piece projection TV. The kit is called the KD50 and retails for \$350 from VSR Sales (433 Airport Blvd., Suite 419, Burlingame, Calif. 94010).

The KD50 will not perform as well as one of the \$2000 units with three-lens optics, but it does offer a relatively inexpensive route to big-screen TV. It uses a plastic Fresnel lens to project the image from your TV set onto the big screen. The picture is

This one-lens system from VSR Sales is a kit—all you add is a 13-inch color TV. It uses a Fresnel lens and we found it to be acceptable.



TV must be set exactly within cabinet or you'll see distorted picture.

best viewed in a room with very muted lighting, and it does lack some of the resolution of the more expensive units.

Still, we found the performance to be adequate for casual viewing. If you're looking for a way to watch a movie or a football game on a big screen, the KD50 might be a way to go.

Assembly was very easy. It took us less than five hours to progress from three large boxes to the finished unit. Construction was aided by the evident attention to prefabrication paid by the manufacturer. Every tab and hole matched its mate perfectly!

It will be necessary to modify the TV used in conjunction with the KD50 system. Wires to the verticle deflection yoke must be reversed so that the image on the TV appears both upside down and as a mirror image.



Closing cabinet gives neat appearance, blending with room's decor.

The projection system rights it via the plastic lens. Don't forget to do this and, if you don't feel at home working on a TV set, almost any qualified technician should do it for a small fee.

### Don't bump the cabinet

Alignment proved critical. The 13-inch TV set (that you supply) must be exactly positioned in the cabinet. The slightest bit off results in a partially defocused picture. As the TV just sits in the cabinet, once it is aligned, try to keep people from bumping into the unit or—as happened to us—you'll have to do it all again.

All in all, the KD50 seems a good buy and VSR Sales told us they'll offer a money-back guarantee to readers of *Popular Mechanics*.—Neil Shapiro



focal length divided by its aperture. This ratio gives the relative speed of the lens, and is usually used to compare how bright one lens will project an image as opposed to another lens. *Lower focal ratios let more light pass through the lens and increase brightness.* This can be deceiving, however, because some lenses that pass a lot of light may lack sharpness or contrast, which are also important factors to consider.

Do not be misled by claims of brightness. Generally, you can follow these simple rules: 1. Glass lenses provide the sharpest images, but must be viewed under low room light. 2. Plastic lenses of the three-element design produce brighter images, but lack sharpness and contrast. 3. Plastic Fresnel (pronounced Fray-nel) lenses produce very bright images, but lack definition and contrast except the Z element used by Schudel with a lens speed of f/1.6.

### Projection screens

Without the proper projection screen, you won't see an image bright enough for long periods of viewing. Your eyes require a certain level of brightness to avoid eye-strain. Except for the three-tube projection systems, few commercial giant TVs have met the required standards. You can get close to these standards if you follow our instructions.

To increase brightness, a special screen can be used. This screen is usually molded into a spherical shape and covered with highly reflective aluminum foil. When light is projected on this screen, it is reflected back to the audience in a cone of light known as the viewing angle.

### Which lenses and screens?

Refer to the list of manufacturers at the end of this article. All these companies make quality products, and the selection of a lens/screen combination really is dependent on just how the final TV system will be used.

For maximum brightness and audience viewing angle, the f/1.9 lens from U.S. Precision Optics and the 4-foot screen from Siva Products are the best combination.

For a combination of maximum sharpness and contrast, a glass lens and the Schudel screen are recommended.

### How to calculate distances

You can use a solid-state portable TV with a picture tube diagonal of 12 to 17 inches. With this TV and a cardboard cone to hold the projec-

tion lens, you can make a simple but adequate giant-screen TV projector.

To calculate the proper distances between TV tube, lens and screen, use the following formulas:

$$C = \frac{A}{B} \quad D = C \times 12" + 12"$$

$$E = \frac{D}{C}$$

A = diagonal of projection screen, in inches.

B = diagonal of TV picture tube, in inches.

C = ratio of the above (A divided by B).

D = distance from focal point of lens to screen, in inches.

E = distance from focal point of lens to TV picture tube, in inches.

These formulas will work 90 percent of the time. They work best with small-diameter (3-inch) lenses. Bigger lenses will blow up the image in a shorter distance.

### Adapting the TV

If you project an image using an ordinary TV, you will see the picture upside down and backward. To obtain the correct image, you'll have to flip and reverse the TV picture electronically. This can be done easily by reversing the wire leads going to the vertical deflection yoke at the rear of the TV picture tube. You must refer to the schematic of the set or consult a local TV service shop for help. To avoid shock, *observe the proper precautions* when working around the picture tube.

### Making the projection cabinet

The cabinet to hold the TV and lens need not be elaborate to work properly. A cardboard cone taped over the front of the TV picture tube will provide as good a picture as a cone made out of solid oak.

For good results, the lens should be mounted perpendicular to the picture tube and in line with its center. If the lens is slightly out of alignment, proper focusing of the final projected image cannot be achieved. This is especially critical when you are using large-diameter lenses.

Note that distance E in the formula is from the focal point of the lens, which is somewhere in the middle of the lens barrel. If the retaining ring for the lens is placed at this point, proper focusing should be achieved without having the lens fall out.

Illustrated here (page 107) is a simple cardboard cone made for a

(Please turn to page 154)

## WOODWORKERS Do-it-Yourself CATALOG

with **20**  
**WOOD**  
**SAMPLES**



**104** giant pages  
—finest veneers,  
cabinet & furniture  
woods, carving blocks, inlays, period hardware,  
carved moldings, pic. framing, Sliding, revolving  
hdwe. Coffee mill kit. Wood finishes, cane,  
lamp parts. Marquetry kits. Specialty wood-  
working tools. Over 2,000 hard-to-find practical  
products. Woodworking books and plans.

TEAR OUT AD. MAIL TODAY.

**CONSTANTINE** Est. 1812  
2051 Eastchester Road, Bronx N.Y. 10461

Enclosed \$1 for Woodworkers Catalog with 20 samples of beautiful veneers. All identified. Helpful when buying woods.

Dollar refunded on first order.

Enclosed 50c for catalog without samples.

ALSO enclosed \$1.95. Send practical instruction manual—"Creative Veneer Craft." How to create decorative veneer designs. Techniques, patterns, projects. It's the perfect supplement to Constantine's big Catalog.

New York State residents please add tax on \$1.95

Name \_\_\_\_\_

Address \_\_\_\_\_

Zip \_\_\_\_\_

## SAVE YOUR FLOORS

Easy-to-install, long-lasting Shepherd Casters with resilient wheels make all kinds of household furniture and appliances easy to move without scratching or denting hardwood and tile floors.

For quality casters in a variety of styles and sizes, look for the Shepherd name wherever hardware is sold.

Insist on the best

**shepherd**  
**casters**





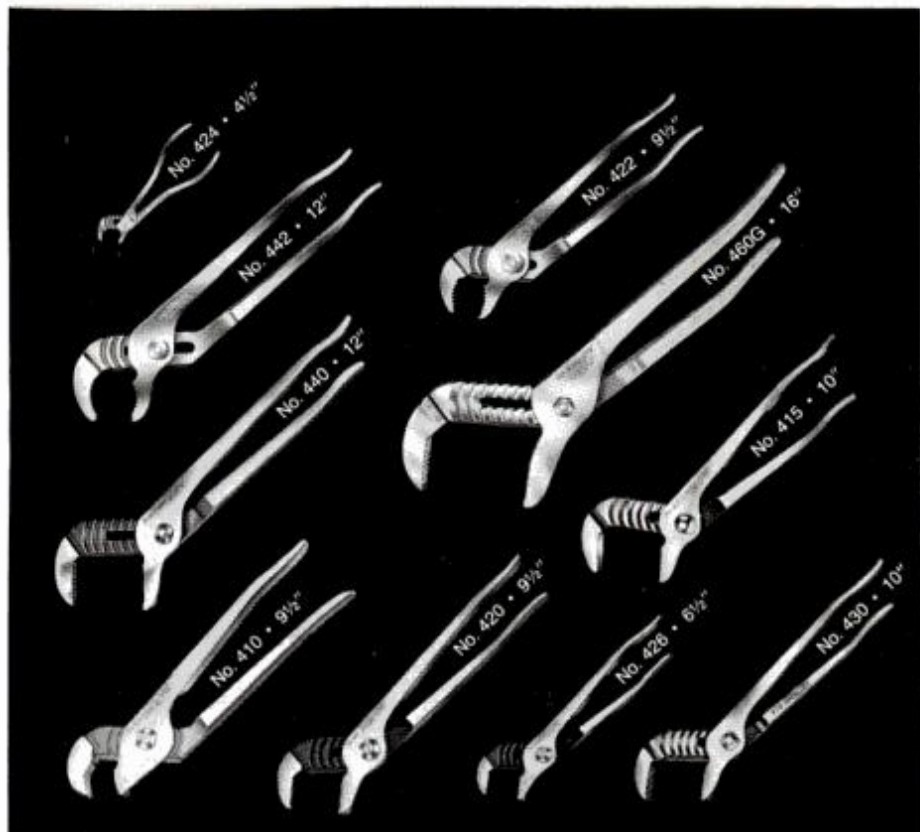

## Who Says Ours Are The Best? YOU Do.

Year after year, you tool users buy more CHANNELLOCK tongue and groove pliers than any of the imitator brands. By far. It's your way of telling us that CHANNELLOCK, the original, the first of its kind, is best of its kind. Thank you. We're going to keep it that way.

CHANNELLOCK, INC. • Meadville, Pennsylvania 16335

# CHAN NEL LOCK

Meet the Rest of the Family. Send For Free Catalog.

## BUILD A GIANT-SCREEN TV

(Continued from page 153)

typical 15-inch TV set. The actual picture tube size is 9 by 12 inches. The cone is made slightly larger so it can be taped to the lip that protrudes from the face of the TV set. You'll have to adapt the cone according to your set. Once you get the cardboard cone to work properly, you may want to remake it out of wood to obtain a more professional look.

The completed projector arrangement can be mounted on a piece of plywood for more stability or built into a wooden box to match the room furniture.

### Using the projection screen

The screen can be mounted easily on the wall by using ordinary shelf brackets. It can then be removed and stored when not in use. For maximum enjoyment, the projector should be located at a level just below screen-viewing height. If the projector is tilted at too great an angle, distortion of the projected image will result.

You should be certain to use a screen that has been designed especially for projection TV.

Projection TV screens are curved, as opposed to flat, movie-style screens. As shown in the diagram on page 107, the curvature of the screen helps to "concentrate" the light into an image that appears brighter to the viewer.

Do not skimp on the screen—a most important part of the system.

The screen should be tilted at an angle that reflects the brightest image to the audience viewing area. Remember that the screen works like a mirror. If light strikes it at an angle, the light will be reflected at an equal opposing angle. **FM**

## Don't get caught next year without a Thermograte® wood heating appliance!

If you wanted a Thermograte® Fireplace Furnace insert or Fireplace/Stove this year . . . but were disappointed because there weren't enough to go around . . . don't wait 'til it's too late again!

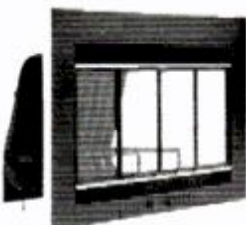

Order now. We'll guarantee delivery by Oct. 1, 1980. 6-month trial & 12-month 'no interest' terms.

**SATISFACTION GUARANTEED!**

### IT WORKS!

Cool air in tubes is heated, expands and rises. Heated air flows into your home . . . naturally!



For FREE information, write:  
Thermograte Ent., Inc. Dept. 840-002  
P.O. Box 43021 St. Paul, MN 55164  
Or CALL TOLL FREE: 1-800-328-0882

© 1980 TEI ST. PAUL, MN 55113. ALL RIGHTS RESERVED.

### MANUFACTURERS LIST

Buhl Optical, 1009 Beach Ave., Pittsburgh, Pa. 15233, manufactures small f/3 and larger f/2.8 lenses. Prices range from \$125 to \$180; lenses are sharp and work best with Schudel screen.

Optical Science Group, 24 Tiberon St., San Rafael, Calif. 94901, manufactures plastic Fresnel lenses, mostly as proprietary products for other companies. Prices range from \$40 to \$140; lenses are good for economical systems.

Schudel & Associates, 6973 Consolidated Way, San Diego, Calif. 92121, makes high-quality, very bright 50- and 66-inch (diagonal) screens that work best with glass lenses. Prices: about \$100 for 50-inch, \$250 for 66-inch. Other screens from 50 inches to 7 feet are available from \$80 to \$250; company also sells lenses.

U.S. Precision Optics, 3997 McMann Rd., Cincinnati, Ohio 45245, makes a large, 6 1/2-inch, three-element plastic lens (Beta II), which projects bright images of average sharpness and contrast. Lens works best with Siva screens; price is about \$135.

For more information about building giant-screen TVs from kits, write to the following: Edmund Scientific, 101 East Gloucester Pike, Barrington, N.J. 08807; Extron, 8831 Sunset Blvd., West Hollywood, Calif. 90069; and Televue Optics, 15 Green Hill Lane, Spring Valley, N.Y. 10977. They offer various kits, lenses, screens and information about systems that use special mirrors and other hardware.



# YOUR QUICK WAY TO EASY MONEY!



# VINYL REPAIR

## GIVE "on-the-spot" SAME DAY SERVICE GET "on-the-spot" SAME DAY PAY!!!

### You can be in business IN A FEW DAYS!

Sensational! That's the **MONEYMAKING POWER** of VIP Professional Vinyl Repair . . . the business of your own that can be part or full time for **QUICK AND GROWING PROFITS!** You need no study — no training — just a few hours' practice and you're ready to do repairs for pay, — **BIG PAY!** You can be in business practically overnight.

### Start for less than you make in 1 hour on first job!

With just a small down payment, you get the complete VIP going-into-business kit . . . all equipment, materials, complete step-by-step instructions, business-building helps . . . everything you need!

**\$513<sup>00</sup>**  
in first 10 days!  
"The first 10 days I made \$513. Now getting business from 15 car dealers, 6 furniture stores, 4 restaurants and bars, and clothing stores."  
H. Whaley, Wash.



### HERE'S THE VIP VINYL REPAIR KIT that puts you in your own HIGH-PROFIT BUSINESS

### ALL FACTS FREE BY MAIL — NO SALESMAN WILL CALL. MAIL COUPON NOW

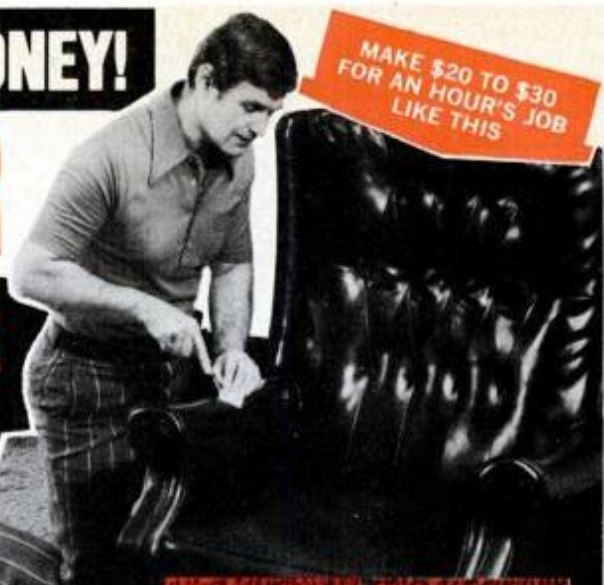

MAKE \$20 TO \$30 FOR AN HOUR'S JOB LIKE THIS



**"Wherever I see vinyl, I can do business"**  
"I've made as much as \$60 in 3 hours."  
C. Herrera, Jr., Ariz.

**9 HOLIDAY INNS FOR HUSBAND/WIFE TEAM**  
"These Inns have put us on a monthly allotment. We are busy every day. Wonderful to be one's own boss. We are putting on one repairman to handle business other than Holiday Inns. With our setup, we have weekly checks coming from just the Inns."  
Mr. & Mrs. Bechtel, Ohio

**STEADY WORK FOR 20 CAR DEALERS**  
"20 car dealers give me all their repair work. I call on two or three every day, take care of what's needed. No matter what the repair is, it's easy to do with VIP."  
R. Lanning, Ky.

**\$440 IN 9 HOURS!**  
"I repaired 55 chairs at the NCO Club at \$8 each — \$440 for 9 hours' work. Materials and transportation cost only \$35!"  
D. Gagnon, S.C.

### UNLIMITED CUSTOMERS FOR YOUR SERVICE

Auto dealers, car shops, restaurants, motels, bars, clubs, hospitals, bus companies . . . these are just a few of the places that need vinyl repairs, repeatedly. The business is there, waiting for you. And a repair job that takes 1/2 an hour to an hour can mean a quick \$15 to \$30 for you . . . most of it **PURE PROFIT!**

### MEN, WOMEN, HUSBAND/WIFE TEAMS FIND VIP QUICK, CLEAN, EASY, PROFITABLE!

Both women and men enjoy this easy, profitable way to make good money fast and steady. The VIP exclusive process is so easy, the directions so simple, that anyone who can read plain English can do it. And what a money-maker! A sure way to have an independent income, or build to a business as big as you want to make it. There's no end to the demand!

**GET ALL INFORMATION FREE BY MAIL. NO SALESMAN WILL EVER CALL.**

MAIL THE COUPON BELOW OR PHONE  
TOLL FREE **800-621-5809**  
In Illinois 800-972-5858

**VIP VINYL INDUSTRIAL PRODUCTS**  
2021 Montrose Ave., Dept. 181  
Chicago, Ill. 60618

Vinyl Industrial Products, Dept. 181  
2021 Montrose, Chicago, Ill. 60618

PLEASE RUSH BY MAIL FREE FACTS about VIP Vinyl Repair and how I can start making money within a few days! No salesman is to call. I am under no obligation.

Print Name \_\_\_\_\_  
Print Address \_\_\_\_\_  
Print City/State/Zip \_\_\_\_\_



## DRIVING THE 1980 HONDA CIVIC

(Continued from page 109)

a five-speed, the DX is priced at \$4599.

The Civic 1500 GL five-speed represents the top of the line—a sportier version of the hatchback, with (among many other standard goodies) tach, steel-belted radials, quartz digital clock, rear wiper/washer and upgraded trim, all for \$4949.

The five-door Civic wagon has the 1500-cc engine and a five-speed transmission as standard for \$4849. Two-speed Hondamatic is optional

on the 1500 DX and the wagon for \$150.

All 1500-cc Civics use a small catalytic converter this year, which means they do need unleaded fuel—something previous Civic owners happily lived without. On the plus side, though, the 1500 engine delivers not only dramatically better performance than last year's non-catalyst version, but its gas mileage is EPA-rated higher: an estimated 36 mpg city for 1980 versus 33 for 1979. California cars, like the one we drove from Los Angeles to New York City, are rated at 32 mpg city, up 4

mpg from their EPA rating in 1979.

## Driving impressions

I liked the old car, but this new one is definitely better. I drove a DX five-speed recently and found a lot to appreciate.

The 1500's performance comes through as the car's most noticeable change. The previous Civic had a good deal of punch—at least with a manual gearbox. But this one's got a lot more snap off the line and plenty of power for passing. Third gear is good to an easy 75 mph, and the engine gets stronger as rpm goes up.

Because of its size, the Civic scoots into parking spaces you wouldn't even look at with most cars. I found the rack-and-pinion steering light and manageable—3.3 turns lock to lock. There's a slight amount of torque steer toward the left on hard acceleration, but it's not bothersome.

Upright, firm seats have adjustable backrests that let them suit most drivers. If you're over six feet, though, you'll find headroom and legroom a little tight. Yet the back seat has been civilized and is now quite acceptable.

The DX has an open steering wheel that leaves the instruments easy to see. Other Civic models use a four-spoke wheel that tends to block the lower portion of the instrument pod.

The five-speed is fun to use, but the stick tends to be a tad wobbly, and I'd like the detent spring for fifth and reverse to be a little less forceful. It takes a definite effort to sink those two gears.

## A quiet ride, overall

Out on the highway, the Civic feels solid and glides along in relative silence. Honda engineers have managed to quiet the car in all details but two. I found the Japanese Goodrich polyester tires noisier than necessary, and the five-speed tends to emit a soft whine in its top gears—a fact made more noticeable by the hush of the rest of the car.

The wagon uses a rigid rear axle and leaf springs, but other Civics share a modified MacPherson independent rear-suspension system. Overall riding qualities are excellent. The Civic doesn't feel choppy despite its very short wheelbase.

Like other Hondas, the Civic comes with a vast assortment of nice touches and unexpected extras.

An assortment of sound systems is available, and the Civic's optional air conditioner fits into the normal vents. It's a car that once again proves that good things come in small packages.

PM

Men - Women! Make Money In Your Own Home Business!

## "I STARTED WITH \$100 AND MADE MILLIONS IN MAIL ORDER"

You can make a Mail Order Fortune much easier today. I want to help you but: If you are looking for a get-rich-quick-scheme... please turn the page. I did not get rich overnight. But I can tell you that within a short time in mail order I was making more money than any of my friends. The millions came later... and I owe every penny of it to mail order! If you are ambitious and willing to follow directions... I will help you get started on your way to mail order success!

### YOUR HOME MAIL ORDER BUSINESS

Just a few hours a week part time at the start! Then branch out into full time! Keep present income while adding welcome "second income." Use Mail Order profits for travel, savings, education, retirement. It's up to you.

I learned long ago the success secret in Mail Order is picking the right product. I reveal in my Free Course 3 tests your product must pass to be a Mail Order winner! I'll show how to make up simple little ads that bring in orders and cash. Everything I tell you is based on my own success. I know it works.

### BUY BELOW WHOLESALE FOR BIGGEST PROFITS

Imports are great for Mail Order. I travel the world searching out new imports you can turn into quick profits. Start with 24,221 best selling imports. Deal in one or many. Buy Below Wholesale direct from overseas supplier. You keep all the profit. I will also

ACTUAL CUTS OUT GREEDY I.T. MEMBER STRIKES REPORTS MIDDLEMEN. "Can make 80% more profit importing merchandise. The Mellinger Plan gave me new home, new car, own store." Bill Theissen, Canada

reveal my Drop Ship Plan that starts you with little or no product investment. Buy one at a time or in quantity.

### 1000's NEW PRODUCTS EVERY YEAR

With my Plan you get free Membership in International Traders. Vast world wide organization keeps you supplied with new products every month to sell by mail or other ways. Members also attend my personal seminars held in cities near you. Mail coupon for Course and home business report. No charge or obligation. No salesman will call! Find out what Mail Order holds for you!

**FREE MAIL ORDER COURSE**



B. L. MELLINGER, Famous World Trader, Internationally known Mail Order Expert.

I started in Mail Order a few years ago, part time in my garage. I had less than \$100. I discovered how to make Mail Order pay big. Today my business empire spans the globe... 1,253 acres of land, office buildings, warehouses. My Plan lets you use my experience to make a fast start in your own big profit home business.

## FREE MAIL ORDER COURSE COUPON

The MELLINGER Co., Dept. C2252  
6100 Variel Avenue, Woodland Hills, CA 91367

Send Free Mail Order Course... Show me how I can start a Mail Order/World Trade Business of my own. There is no obligation; no salesman will call.

Name \_\_\_\_\_  
Address \_\_\_\_\_  
City \_\_\_\_\_ State \_\_\_\_\_ Zip \_\_\_\_\_

\*Save 3 days, give ZIP for fast reply!

## ANYONE CAN SOLDER WITH KESTER SOLDER

### DO-IT-YOURSELFERS!

Let Kester solder aid you in your home repairs or hobbies. A radio, TV, model train, jewelry, plumbing, etc. Save money—repair it yourself. Send self-addressed, stamped envelope to Kester for a FREE Copy of "Soldering Simplified".

KESTER SOLDER

KESTER SOLDER  
4201 WRIGHTWOOD AVE.  
CHICAGO, ILL. 60639



## SELF-DEFENSE KUNG-FU • KARATE

Learn unbeatable fighting power  
BLACK BELT INSTRUCTORS

NEW HOME STUDY COURSE  
CERTIFICATE AWARDED

For details write: NEW ORIENT KARATE SCHOOL  
Dept. 9B Box 5, Avon, N.J. 07717



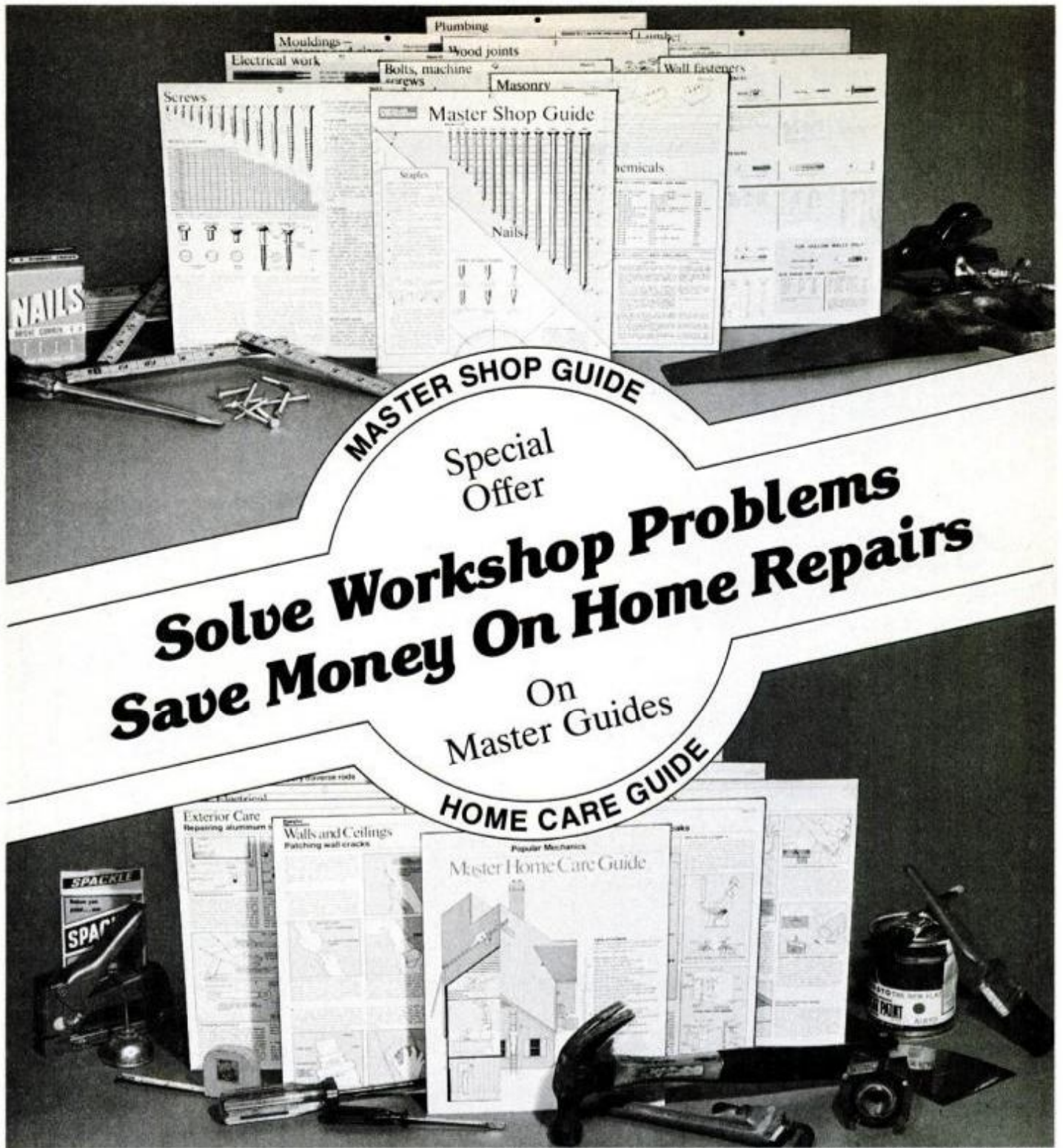

**Solve Workshop Problems  
Save Money On Home Repairs**  
On  
Master Guides

Take advantage of this special offer on Popular Mechanics' famous Master Guides.

The POPULAR MECHANICS MASTER SHOP GUIDE has helped hundreds of thousands of do-it-yourselfers solve workshop problems. We think it is one of the most important tools you'll ever buy.

The Shop Guide lays out everything you need to know, graphically and ready-to-use. All about nails, screws, bolts, wall fasteners, drills, abrasives, lumber, plywood, gypsum, adhesives, paneling, shop math, stair construction, masonry, wood finishing, plumbing, pipe fittings, electrical work, gutters,

concrete, remodeling measurements plus a built-in ruler, protractor, 45° triangle and compass.

The perfect companion to the Shop Guide is the POPULAR MECHANICS MASTER HOME CARE GUIDE. The Home Care Guide will enable you to tackle common home repair jobs like an expert. You'll be able to patch wall cracks, paint your house or apartment, hang wallpaper, hang drapery rods, hang a door and install a lockset, repair scratches in furniture and much more. The Guide also instructs you on methods of saving energy to help cut your fuel bills.

By using the coupon that appears on this page you can order both Guides for

\$7.95 postpaid. You'll save \$2.95 off the regular price. ORDER NOW! They also make great gifts.

**PM MASTER GUIDE OFFER**, Dept. 280  
Box 1014, Radio City Station  
New York, N.Y. 10019

Yes! Please send me the POPULAR MECHANICS MASTER GUIDES that I have indicated below:

\_\_\_ Set(s) of both Guides at \$7.95 per set \$ \_\_\_\_\_

\_\_\_ Home Care Guide(s) only at \$5.45 per Guide \_\_\_\_\_

\_\_\_ Shop Guide(s) only at \$5.45 per Guide \_\_\_\_\_

TOTAL AMOUNT REMITTED \$ \_\_\_\_\_

Name \_\_\_\_\_

Address \_\_\_\_\_

City \_\_\_\_\_ Zip \_\_\_\_\_

Make check or money order payable to Popular Mechanics.

Popular Mechanics is a publication of Hearst Magazines, a Division of THE HEARST CORPORATION



special offer  
Buy The **ATLAS**  
6" Screw Cutting Lathe  
and get a  
**\*Free Chuck**



ONLY **\$395<sup>00</sup>**

PLUS \$30 SHIPPING & HANDLING

ACCURACY AND DEPENDABILITY  
AT A SENSIBLE PRICE...

**ATLAS 6" Lathe**

has 8 spindle speeds. 6" swing over bed, 6" swing over saddle wings. 19 1/4" between centers. Spindle turns in Timken tapered roller bearings. Reversible power longitudinal feed. Lathe is 11" high, 17 1/2" wide, 34" long. Cuts 8 to 96 threads per inch, right or left-hand. Comes complete with graduated compound rest, tool post assembly, change gears, threading dial, V-belt, motor pulley with 3/8" bore, two 60° lathe centers, wrenches.

**\*Four-Jaw, 4" Dia. Chuck**

Holds irregularly shaped work. Each hardened steel jaw operates independently. Reversible jaws, has 1" - 10 threads. Wrench included. A \$71.00 value.

- No risk offer. Return purchase within 15 days for full refund if not satisfied.
- Full one year guarantee.

Price subject to change without notice.

Mail To: **ATLAS PRESS COMPANY, Dept. 80**  
2019 N. Pitcher, Kalamazoo, MI 49007

Please send me the Atlas 6" Lathe and 4-Jaw Chuck. Enclosed is my check or money order for \$425.00 (including shipping/handling) or charge my order to:

Visa  Master Charge

Acct. # \_\_\_\_\_ Exp. Date \_\_\_\_\_

Name \_\_\_\_\_

Address \_\_\_\_\_

City/State/Zip \_\_\_\_\_

Send for **FREE Atlas Lathe Accessories Catalog.** Michigan residents add 4% sales tax.

Available U.S.A. only. Lathe comes via motor freight, shipping/handling to west coast. Alaska and Hawaii require additional freight to final destination. This offer expires 3/31/80.

**DRIVING THE 1980 VWs** (Continued from page 99)

cargo banging around inside won't dent the outside. The tailgate folds down with ease and can be removed completely (without tools) for carrying long loads. Maximum interior bed width is 64.4 inches and maximum payload is just over 1100 pounds.

Rear suspension is a tubular "live" axle with elliptical leaf springs, a stiffer "helper" spring below the bottom leaf and a "soft-entry" compression bumper above the axle that effectively acts as a third-stage spring when the truck is loaded beyond its gross vehicle weight.

This design (instead of coil springs) provides the necessary ground clearance without intrusion into the cargo bed, according to Miller. The rear tubular shocks are staggered to provide axle control on

washboard roads and when braking on rough surfaces. A 15-gallon fuel tank (4.4 gallons larger than the one in Rabbit cars) is mounted forward of the rear wheels and between them, to minimize handling differences as the fuel load changes.

Brakes are power-assisted, with discs in front and self-adjusting drums in the rear. More importantly, there's a load-sensing proportioning valve in the system to prevent any rear-wheel locking under braking at all load conditions.

**Pickup choices varied**

Like the car, the Rabbit pickup offers your choice of a 1.6-liter, 78-hp (76 in California) gasoline engine or a 1.5-liter, 48-hp diesel. The former is EPA-rated at 23 mpg city and 32

(Please turn to page 160)

**A Rabbit Diesel's cross-country hop**

Ask the average guy in the street what car he'd pick if he had to drive it 2950 miles in only five days, and he'd probably opt for a Caddy. Or maybe a Mercedes, if he was knowledgeable about foreign cars.

I'd pick a VW Rabbit Diesel, based on the experiences I've had driving these cars from New York to San Diego on two separate occasions.

Last year, I headed west in a four-door Deluxe that was made in Germany. This year, I drove the Pennsylvania-built two-door Custom—the least expensive Rabbit Diesel you can buy for 1980. The only options it had were the new five-speed tranny (\$175) and extra sound insulation (\$40). It was the quietest diesel I have driven—barely any engine noise while cruising in fourth or fifth gears—but it was expensive for such a simple, no-frills machine: It cost \$6490 delivered, not including sales tax.

The tan car appeared so plain that one San Diego resident described it as being "vanilla." Even though it was vanilla, it was still comfortable, even after 12 hours of driving.

The seats don't have separate head restraints like the ones on the Deluxe model, but they're firm and offer good lower back and thigh support. However, since their backrests are flat, upper back support is lacking and there's little lateral restraint during hard cornering.

**Superb over long distances**

The Rabbit Diesel has excellent ride and handling characteristics, making it perfect for long-distance driving. The ride is smooth, but has just enough firmness so you get a good feel for the road. The Rabbit's steering is precise and has enough self-centering so the car will track a straight course without constant corrections.

The only handling problem I found with the test car was with the five-speed transmission: It was easy to find fifth gear (to the right and up), but downshifting from third to second was difficult.

Last year's test car accelerated briskly for



**Rabbit Diesel got 38.7 mpg on 2950-mile trip from New York to San Diego.**

a diesel (0 to 60 mph in 17 seconds), but the 1980 model didn't develop much power (this bunny had been fed some dirty diesel fuel and its fuel-injection timing was way off, according to Gene Thompson Motors of Richmond, Ind., the dealer who gave her a check-up after 690 miles).

Even after the car spent three hours in the shop, with injection timing set to specs and a new fuel filter, she still didn't want to hop up to speed as fast as her 1979 sister. The best I could do was 0 to 60 mph in 26 seconds, but heading into the wind it took as long as 44.5 seconds! Thirty to fifty mph was a leisurely 14.2 seconds, while 50 to 70 was a very slow 37.5.

At least fuel economy was excellent: 38.7 mpg overall, with a high figure of 47.3 mpg at an average speed of 53 mph. At a steady 60 mph, I got 36.4 mpg in fourth gear, 46.9 in fifth gear (four-speed Rabbits will get better mileage in fourth gear than five-speed models will, since they have higher final-drive ratios—3.9:1 compared to 4.17:1 in five-speed cars).

If you like your cars plain vanilla, you'll love the Rabbit Diesel, no matter which color you pick. And for \$345 more, you can opt for the more luxurious Deluxe version. But hurry—these Rabbit Diesels are so nice to drive and drink so little that they'll all be adopted by spring. —Moss Miller



# SAVE YOUR BACK AND SAVE SOME MONEY, TOO...

as you split firewood the easy way with POPULAR MECHANICS great new log splitter. You build it yourself and then sit back to reap the rewards of a roaring fire. The rig on this hydraulically operated log splitter exerts some 10,000 lbs. of pressure and will easily split 2 ft lengths of maple and ash logs 12 to 14 inches in diameter. With an I-beam backbone, double acting hydraulic cylinder, control valve oil filter, 3 hp gasoline engine and more features, you'll find this log splitter a delight to build and a pleasure to use. And, you'll save your back from aching as well as saving money by splitting that wood yourself. So, have some more time to enjoy the warmth from your fireplace. Send for complete plans and step by step instructions now. Just \$8.95



---

#### PM Plans Library **Log Splitter**

Box 1014, Radio City Station N.Y., N.Y. 10019

Please send complete plans and instructions. I enclose a check or m.o. for \$8.95. Make check payable to Popular Mechanics.

Name \_\_\_\_\_

Address \_\_\_\_\_

City \_\_\_\_\_

State \_\_\_\_\_

Zip \_\_\_\_\_

Please allow 3-4 weeks for delivery.

PM280

Popular Mechanics is a Publication of Hearst Magazines, a Division of THE HEARST CORPORATION

---



**DRIVE WITH SAFETY—ARRIVE RELAXED**  
**P-A-N-O-R-A-M-I-C, WIDE ANGLE**  
**REAR-VIEW MIRROR Only \$5<sup>98</sup>**



**NOW SEE 6 LANES AT ONCE!**

- 43 square inch oversized mirror 3 times more vision than smaller mirrors
- Special control switch cuts dangerous high-beam glare from behind

How many close calls have you had because you failed to see the other car in your "blind spot"? You leisurely start to turn, suddenly a horn blasts behind you as you swerve back to your lane. Where did he come from? You never even saw him. Well now you can put an end to "blind spot" bedlam with our 6 lane, rear-view mirror.

This new extra-wide angle mirror measures 13½" wide and is over 3" high . . . giving you 43 square inches of panoramic viewing that instantly reveals the hidden danger of cars coming from the right or left as well as from behind. This new extra-vision eliminates the danger of your taking your eyes from the road in front of you to twist around and see what's coming from the right or left. It reduces the strain and tension of avoiding "blind spot" catastrophes. You'll find long distance driving less tiring, more pleasant and definitely safer. Possibly for the first time in your life you'll arrive at your destination completely relaxed.

**MAIL COUPON TODAY MONEY BACK GUARANTEE**  
 The cost of this Extra-Wide Angle Rear-View Mirror is ONLY \$5.98 . . . less than half the price of smaller mirrors sold in 1978! Remember it slips over your present mirror in seconds and is ready for instant use. If for any reason you are not completely delighted, simply return for full refund (except postage & handling). But don't delay. The safety of you and your family is at stake. Mail coupon today. You'll be glad you did.

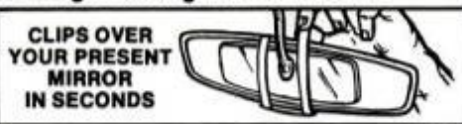

© 1979 Nat'l Home Prods., 60 Wilton Rd., Westport, CT 06880

**MAIL NO-RISK COUPON TODAY**  
**NATIONAL HOME PRODUCTS, Dept. WA-246**  
 60 Wilton Road, Westport, CT 06880

Please send me the new EXTRA-WIDE ANGLE REAR-VIEW MIRROR for only \$5.98 plus 95¢ postage & handling on full money back guarantee (except postage & handling) if I am not completely delighted.

Enclosed is \$\_\_\_\_\_ Check or money order, no C.O.D.'s please. CT residents add 7% sales tax.

Name \_\_\_\_\_

Address \_\_\_\_\_ Apt. # \_\_\_\_\_

City \_\_\_\_\_ State \_\_\_\_\_ Zip \_\_\_\_\_

**SAVE MORE!** Order two mirrors for only \$10.98 postpaid and save \$2.88! Same Money Back Guarantee.

**DRIVING THE 1980 VWs**  
 (Continued from page 158)

mpg highway with the standard four-speed, 21 city and 29 highway with the optional automatic, and a very respectable 23 and 35 mpg with the optional five-speed (give or take a mile-per-gallon in California).

The diesel, fairly snappy for an oil-burner, offers 41 mpg in the city and a whopping 54 on the highway, with the five-speed, according to EPA ratings.

Driving the Rabbit pickup is little different from driving any other Rabbit, with one major difference: Squeezing a six-foot bed into 170 inches of overall length has short-changed the cabin to the point where this six-foot driver had to get out after only a few minutes' incarceration. If you're a bit shorter or don't mind knees-up, elbows-out driving, however, it may not be a problem for you.

Otherwise, all the usual Rabbit attributes are there: uninspired but legible and logical instrument panel, complete with some of the handiest stalk controls in the business, zippy performance, spirited handling, surprisingly smooth ride for such a small vehicle (and a truck to boot) and interior quietness at least as good as the car.

**Traction best with light loads**

What about the loss of driving traction at the front wheels when the bed is loaded? "Marketing studies," says Miller, "showed that 93 percent of the time small pickups operate at 120 kilograms (265 pounds) of load or less. At that loading, the Rabbit has equal or better traction compared to rear-drive small pickups." In other words, the front-drive Rabbit starts with far better slippery-surface drive traction unloaded than its conventional competition. However, at some point of loading it loses that advantage, and as the load increases beyond that point will be at a disadvantage. Obviously, this problem is of more importance to the buyer who intends to load his truck heavily more than once in a while.

At this point, it's the only small pickup with front-wheel drive and the only one available with an optional diesel engine. Also unique are its low overall and load floor heights (made possible by unibody construction), its car-like ride and handling and its excellent economy/performance compromise with the available five-speed transmission. That's because first through fourth gears are designed for acceleration, while the 0.76:1 overdrive fifth is strictly

**SECOND INCOME?**

**EASY WITH A  
 STRUCK-KIT  
 CRAWLER  
 TRACTOR!**

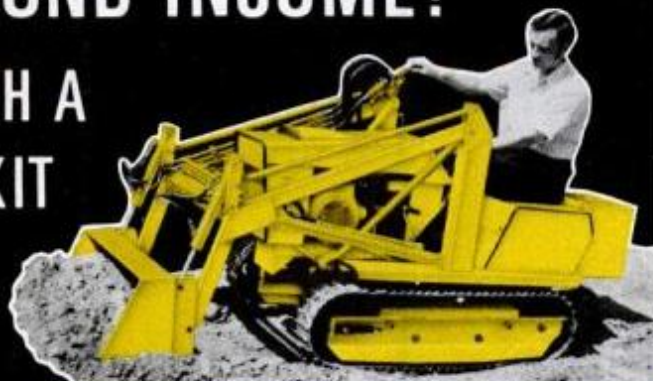

Full track Magnatrac outpulls, outpushes, outworks wheeled garden tractors especially in slippery conditions. Kit type tractor (can be easily assembled on a weekend) saves you money (buy factory direct), 16 hp., 4 speeds forward and 1 reverse. Over 30 heavy-duty attachments incl. moldboard plow, dozer blade, snowblower, mower, tiller, hydraulic or electric front-end loader, backhoe. Similar attachments available for our lower cost, highly popular Mini-Dozer. Both Tractors offer you great odd job and resale opportunities. Send now, to:



**MINI-DOZER**

**STRUCK KIT, Dept. PM20 Cedarburg, Wis. 53012**

Catalog showing Struck Tractor Kit construction & uses (specify Mini-Dozer or Magnatrac) — 50¢. Both catalogs — 75¢.

Plans for fabricating Struck Tractor (specify Mini-Dozer or Magnatrac) from local materials — \$7.00. Both plans — \$10.00 (Refunded on any purchase.)

Name \_\_\_\_\_

Address \_\_\_\_\_

City, State, Zip \_\_\_\_\_

(DEALER INQUIRIES INVITED)



mileage. And the 49-state gasoline engine does not need a converter, since federal emissions standards for trucks are still a little more reasonable than those for cars, and so they can run on cheaper leaded regular fuel.

While the base truck is a bit of a stripper, the LX version comes with deluxe trim, wider wheels, steel-belted radial tires, AM/FM radio and vent windows.

Other options that are available include alloy wheels, airconditioning, remote control outside mirror, western mirrors, cargo bed tie-down rails, sliding rear window, special instrumentation, a trailer hitch with wiring and a "Sport Truck" graphics package. Rated towing capacity is 1500 pounds with trailer brakes and 1000 pounds without.

### Vanagon handles better

For only the second time since VW invented it, the camper/bus has been completely redesigned. Introduced in 1949, it was first redone in 1967, and some 5.5 million have been built and sold worldwide in 30 years of production.

Compared to its predecessor, the 1980 VW "Vanagon," as they call it, has a wider track and a lower center of gravity for vastly improved handling and stability, much more glass area for better visibility, and improved aerodynamics for fuel economy and highway performance. What it doesn't have, unfortunately, is a new engine with more power to push it up the hills.

Still, the old, trusty, tried-and-true air-cooled flat Four is fuel-injected these days and puts out an honest and reliable 67 hp all day long from its 2.0 liters. VW says that most people in Europe buy the bus with an even smaller 1.6-liter engine for the extra fuel economy, so it figures we should be happy here with the 2.0.

You might wonder why VW didn't go to a modern, front-mounted, water-cooled engine with front-wheel drive like every current VW passenger car, or even to conventional front engine/rear drive like the company's larger European-market vans and trucks. Fact is, it looked at 12 different configurations and a variety of engines, ranking each in terms of space utilization, comfort, performance, economy, handling and other factors. And when the tallies were made, sure enough, the old air-cooled, opposed Four in the back came out the winner.

While the front-drive configuration works great for a small car and even a small truck designed for light

loading, it wouldn't work so well for the Vanagon. Weight distribution, for instance, whether loaded or unloaded, works out to nearly 50/50 because the driver, spare tire and fuel tank are up front, and most of the cargo weight ends up between the axles.

The vile handling characteristics of VW's original bus were improved somewhat with the 1967 design, but the latest version is head and shoulders above that, thanks to the wider treads, lower center of gravity, revised rack-and-pinion steering geometry and all-new front suspension with upper and lower control arms, coil springs, tubular shocks and a sway bar. An improved version of the '67-'79 model's semi-trailing-arm, double-jointed-axle independent rear suspension with progressively wound coil springs and tube shocks holds its own in back. Brakes are ventilated discs in front and drums in the rear, complete with a pressure regulator to prevent rear-wheel lockup under hard braking.

Other comparisons to the previous model include: a 2.4-inch lower floor and two-inch higher roof; eight-inch lower cargo floor over the engine; 75 percent larger rear cargo room and a nearly five-foot shorter turning circle. Wheelbase is increased by 2.3 inches, front track by 6.9 inches, rear track by 4.5 inches and overall width by 3.3 inches. But in spite of all this increased capacity, the pop-top camper version (at 77.2 inches overall height) will still fit into the average garage.

### A convenient dashboard

Mounting the high seats in the forward-control cab leaves no doubt that this is a van, but once buckled up inside you'll find it much more comfortable and carlike than the older versions. The instrument panel is plain but pleasant, with everything easy to see and reach, including the long gearshift handle. The steering wheel angle is far less bus-like than before. Although the standard seats don't fully recline, they do have 25 percent more fore-aft travel and a few notches of backrest angle adjustment to help you find the best seating position.

It's no sports car, but the thing is amazingly agile and stable in cornering maneuvers. VW says it generates 0.7 lateral "Gs" on a skid pad vs. 0.63 for the '79 version. Crosswind stability is also improved (35 percent at 62 mph), steering effort is reduced by 50 percent, heating and ventilation are significantly better and interior noise levels are three to five decibels lower than before, de-

pending on the speed. Improved aerodynamics should just about cancel the added size and weight, giving fuel economy similar to last-year's model... 17 mpg EPA city, 23 mpg highway for the four-speed, 49-state version.

Imported from West Germany, the 1980 Vanagon is available as a standard wagon (seven or nine-passenger), a semicommercial Kombi van or a full-fledged Camper with pop top, swiveling front seats, table, wardrobe, pantry, two double beds, water hookup and (in the deluxe version) refrigerator and two-burner stove.

### Rabbit convertible is fun

Following in the footsteps of VW's homely but lovable Beetle convertible is its logical successor, the Rabbit convertible. The only Rabbit model not built in the United States this year, it's basically a loaded and expensive (\$8895) ragtop version of the deluxe Rabbit sedan, complete with vinyl-covered roll bar and heavily padded and lined top that folds into an unsightly lump nearly as tall as the windshield.

Surprisingly, rear vision with the top down isn't as bad as you might expect; keeping it above the beltline leaves the space underneath available for cargo, accessible through a small hatch door in back or from the inside via a folding rear seat. Adding to the car's top-down visual discord are the rear quarter windows, which roll down only about halfway.

Aesthetics aside, however, the little topless Rabbit is even more fun to drive than the tin-top versions, and it's quicker, more economical and roomier inside than the aged Beetle it replaces. Top up, it's quiet and snug inside, and there is very little noticeable wind noise or leakage.

The five-speed transmission, twin remote control outside mirrors, a glass rear window with electric defogger, vent windows, reclining front seats, console, sport instrumentation, AM/FM stereo radio with cassette tape and a choice of cloth or leatherette upholstery are all part of the standard package. Airconditioning, alloy wheels, sport steering wheel and sport seats are optional. Bodies for the limited-production convertible are built by Karmann coachworks in Osnabrück, West Germany.

German-built Scirocco sport coupe and Dasher sedans and wagons are continued with only minor engineering improvements for 1980. The diesel-engine Rabbits now come from VW's Pennsylvania plant instead of from Germany. **FM**



# Fantastic Price Break! Only \$5.98

**NOW AVAILABLE  
TO THE PUBLIC**



## KEEP THAT "SHOWROOM SHINE" FOR 3-YEARS AND NEVER WAX, POLISH or BUFF AGAIN!



### POLYMER GLASS MIRACLE SEALANT APPLIES IN LESS THAN 1 HOUR!

**Not a wax! Not a polish!  
A miracle of modern chemistry!**

You simply wipe it on to "wrap" your car in a protective glass-smooth surface! Just as acrylic finishes revolutionized the paint industry... just as epoxy adhesives made ordinary glues obsolete overnight... now a breakthrough in chemical science has produced an incredibly hard, super glossy, non-stick "polymer glass" sealant that can "glass in your car's showroom shine" virtually for its lifetime!

#### The Famous "Shock Test" Dealers Use

Dealers who have been charging an arm and a leg for this fabulous treatment have a standard sales pitch. They wipe a bit of this amazing formula on your car and then, while you're watching, deface it with a marking pen. Almost before you can scream in protest, they simply wipe it clean again! And while you're still speechless, they sell you a complete "glassing" for anywhere from \$85 to \$200 — whatever they think they can get!

#### The Secret is Simple — The Magic is in the Product

Glasscote's polymer glass formula

literally fuses itself to the finish of your car by "molecular bonding". And it contains a formulation similar to that used to make those "non-stick" frying pans, so it's so glossy smooth that practically nothing will stick to it! Even bird droppings and crushed insects simply slide off with the touch of a damp cloth.

**It takes less than 60 minutes  
to Glasscote your car**

Now you can get the identical protection for your car with Glasscote, and all you need do is all the dealer does — wipe it on, let it dry, and wipe it off! So why pay somebody \$85-\$200 an hour to do it for you? Why not buy Glasscote direct-by-mail for only \$5.98 — enough for three years treatment for a small car — more than enough to Glasscote even the biggest Mercedes, Rolls, or Cadillac for 12 full months! Simply wipe it on once a year and forget about all that waxing, polishing, and buffing forever! A simple soap and water washing or a wipe with a damp cloth restores the gloss!

**Even if your used car is already dingy looking** from oxidation, Glasscote helps remove it and restore a brighter color and more glossy shine.

**PROTECT NEW OR USED  
CAR PAINT AND BRIGHTWORK  
AGAINST ALL THESE HAZARDS!**

SNOW	SMOG & POLLUTION	BUGS	MUD
RAIN	OCEAN SPRAY	TREE SAP	ROAD
SUN-WIND	AIRBORNE SOOT	BIRD DROPPINGS	SALT

— EVEN VANDALISM FROM MARKING PENS!

Once you seal your car in Glasscote, its finish and chrome is immune to the worst conditions nature or man can devise! You're protected against:

- ... oxidation that can fade or change paint color
- ... corrosive smog, acid precipitation, industrial pollution, oily airborne soot
- ... road tar stains and smudges
- ... sticky tree sap, crushed insects, bird droppings
- ... salt sea air or road salt splashes that can pit, corrode and destroy chrome.

**Save Gasoline — Add Resale Value to your Car**

Experts say the smoother your car's finish, the less wind resistance it has, which means it can go farther on a gallon of fuel. And when you come to sell your car, you know what a difference appearance makes. A car with "showroom gloss" three, four, or five years old is bound to bring hundreds of dollars more than the same car with dingy, oxidized finish. So release yourself forever from the bondage of constant waxing and polishing, and insure yourself of top dollar on your trade in years from now! Mail coupon now!

## 3 YEAR GUARANTEE!

Simply use Glasscote as directed. If its "showroom shine" is not maintained for a period of 36 months, if the Glasscote surface doesn't totally and completely please you, its glossy, dirt-repellent qualities are not instantly apparent and noticeably superior, if you're not delighted in every way, return the unused portion to National Home Products, Customer Service, 60 Wilton Road, Westport, CT 06880. Our refund check for the full purchase price (except postage & handling) will promptly be sent to you!

\*\*\*\*\* MAIL NO-RISK COUPON TODAY \*\*\*\*\*

**NATIONAL HOME PRODUCTS, Dept. GCS-293**  
60 Wilton Road, Westport, CT 06880

Please send me \_\_\_\_\_ bottle(s) of Glasscote at \$5.98 plus \$1 shipping and handling per bottle.

If at any time in the next 3 years my car loses its "showroom shine", I may return the unused portion for full refund (except shipping and handling).  
**SAVE:** Order 2 bottles for only \$10.98 postpaid.

Total amount enclosed \$\_\_\_\_\_ CT residents add 7% Sales Tax.  
Check or money order, no C.O.D.'s please.

Charge it please to:  American Express  Visa  
 Master Charge (Bank Number \_\_\_\_\_)

Card No. \_\_\_\_\_ Expiration Date \_\_\_\_\_

Name \_\_\_\_\_

Address \_\_\_\_\_ Apt. # \_\_\_\_\_

City \_\_\_\_\_ State \_\_\_\_\_ Zip \_\_\_\_\_



# 11 ways water gets into your basement—and how to stop it

A chronically wet basement can be one of the toughest problems for a homeowner—or professional—to diagnose. PM prescribes the cures.

by John H. Ingersoll

**A**nyone who has pumped out and mopped up a basement flood knows the hopeless feeling it generates and the damage water leaves in its wake. Out-of-season clothes, shoes, books, dry firewood, golf clubs, oil-pump motors—all suffer from a forced bath.

Listed below are 11 common situations which potentially lead to a wet basement. Find those cases which resemble your own and read what you can do about them.

**1. Seepage from basement window wells** occurs when rainwater collects in the wells and enters

through cracks around the window or through the foundation itself.

*Cures:* Build up the curb around a window-well perimeter with masonry or corrugated metal. Where no drain exists, install one attached to piping leading away from the foundation as shown on page 164.

**2. Poor grading around the foundation** accounts for most basement water problems. Faulty grading is described as any soil condition that dumps water against a foundation wall. The water eventually builds enough pressure—called hydrostatic pressure—so that no matter how

well foundation walls are protected against seepage, it will find a way in.

The commonest form of poor grading is ground leading away from the house on the level, or worse, inclined uphill. These situations are not too hard to correct. The toughest problem occurs when a builder fails to provide ground-water drainage for a house built into a hillside or he digs a swale (depression) at the base of the hill, but underestimates the amount and force of water coursing down the hill toward the house.

*Cures:* Raise the grade around the

There are many causes of a wet basement; 11 of the most common are: (1) basement window wells with clogged drain or no drain at all; (2) improper grading; (3) clogged drain—or none at all—in outside basement stairwell; (4) below-grade foundation cracks or missing mortar; (5) high water table or underground spring; (6) root-clogged drain tile; (7) downspout disconnected from gutter; (8) garden bed at foundation wall; (9) clogged dry well or no splash block at downspout; (10) infrequently cleaned gutter; (11) missing gutters, downspouts.

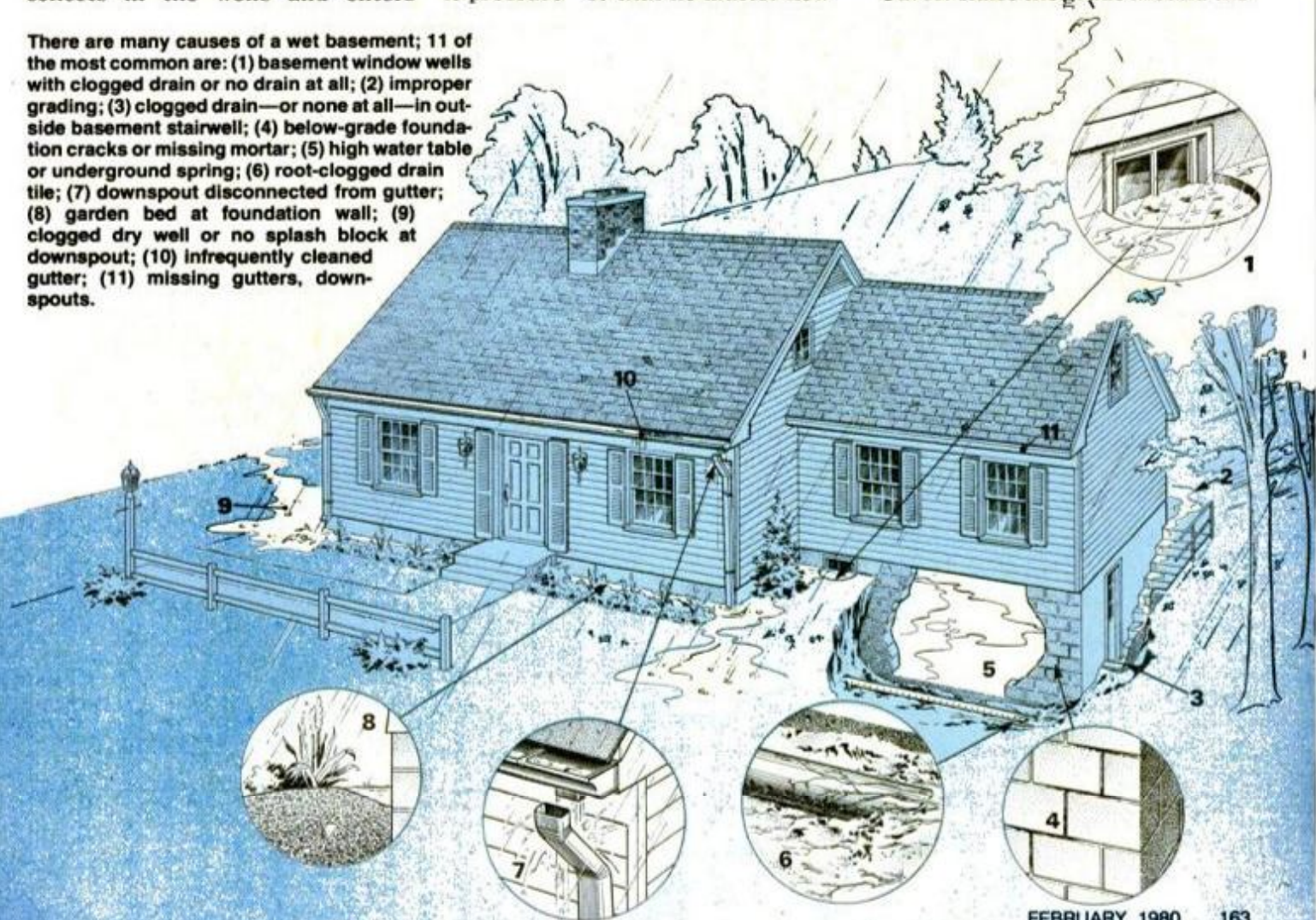



foundation so that a fall of at least 1/2 in. to the foot continues down and away from the house at least 6 ft., and preferably 10. With fresh mortar, parge bare masonry around the foundation before packing new soil against it, or adhere a layer of 6-mil black polyethylene to the masonry surface. Over the new soil, plant a thirsty ground cover, such as pachysandra, vinca minor or periwinkle—or put down sod.

For the hillside house at the foot of a virtual waterfall during a rain-storm, the cure takes more time and energy. Redirect water around the house and downhill by a French

drain—a ditch filled with crushed stone. This water-absorbing ditch parallels the line where hill and level lot meet.

Viewed from a helicopter, the drain looks like a U around the house, its base on the uphill side. Depth and width of the ditch will vary. Minor runoff from a mild incline may need a ditch only 6 in. wide and 6 in. deep. Steeper hills require larger ditches. Hard clay soil needs more drainage than sandy soil. Cover the stone-filled trench with straw, topsoil and sod. At the line below the hill, sod cover should be at the center of a slight swale, so hill-

## SIMPLE DRAINS FOR COMMON PROBLEMS

DRAIN PIPE LAYOUT FOR WINDOW WELL

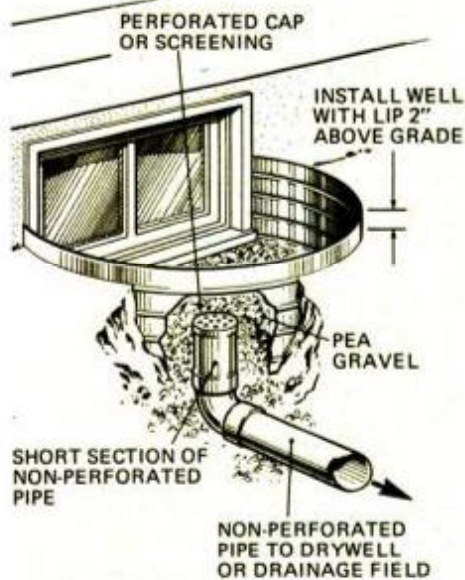

DRAIN PIPE LAYOUT AT DOWNSPOUT

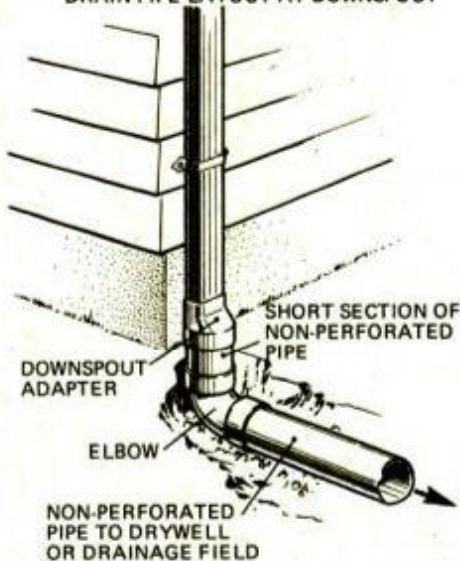

Install drain in basement window wells (left) which fill up with water during storms and cause seepage into basement. Downspout runoff (above) carries water away from house to prevent pooling at wall.

## New water-sensing alarm system

Touch Flood Alert's sensors to moist surface and it will sound an 85-decibel beep (at 10 ft.). Used in laundry rooms, bathrooms, kitchens or basements, it can warn of leaky or broken pipe connections or rising ground water. It's \$15 postpaid from Datasonic Inc., 150 West Pine St., Long Beach, N.Y. 11561.—J.P.



Alarm, placed at base of furnace, will sound if basement floor becomes wet.



Solid-state alarm, powered by 9-volt battery, has UL-approved sound device.

## If all else fails . . .

When all efforts at stemming basement leaks have failed, consider the use of a pressure-relief system. If you're really ambitious you may attempt to do it yourself. Use a cold chisel and hand sledge (the long hard way) or a rented jackhammer to break open a 12-in.-wide trench around the perimeter of the basement floor. Once through the slab, dig and remove soil to a depth of at least 12 in. If the trenches slope at all, the drop should be toward the sump. Level trenches, however, are adequate. Fill 1-ft.-deep trenches with 2 in. of crushed stone, continuous 4-in. perforated plastic pipe (with elbows at the corners), and then add more stone to the floor level. Leave the trench open and form a slight swale (depression) at its center.

For floors which persist in puddling up, or for those with existing sump pumps that are located away from the wall, additional trenches can be cut (see diagram). Lay in the same stone/perforated pipe/stone combination, attaching the pipe to the perimeter sections with tees. Then cover these trenches with fresh concrete so that you have use of the basement floor again. Covering the perimeter trenches is an option to consider.

If you don't already have a quality sump pump, you should purchase and install such a unit (see *Prevent Basement Flood Damage With a Sump Pump*, page 162, Feb. '79). Lead the evacuating pipe to an area drain, a dry well that's located at least 25 ft. away from the house, or to an open outfall on the downhill side of your property.

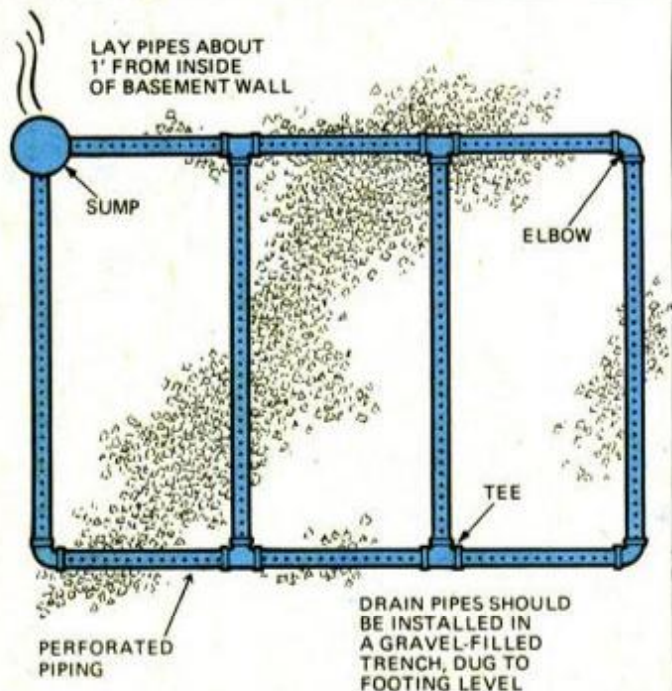



draining water has a chance to soak into the French drain.

As added insurance to catch a large volume of water, lay drain pipe over 2 in. of stone at the base of the ditch before backfilling with the remaining stone.

At lower ends of the drain lines, divert outfalling water with rock so the current doesn't carve furrows in the lawn. Or, connect the drains to solid piping that carries water underground to drainage.

**3. Exterior basement entries are often water routes to basements.** You may have too low a curb around your stairwell opening, a clogged drain, or may lack a drain in the stairwell. Double metal cellar doors that have been climbed upon or banged with a heavy object may have damaged runoff channels that direct water into the basement.

*Cures:* Same as for No. 1. Use caulking to seal around metal cellar doors. Bend deformed channels back in position if possible.

**4. Cracks in masonry or at masonry joints** are a common cause of

water infiltration. Masonry that is porous and subjected to ground-water pressure is also a sure candidate.

*Cures:* If you have eliminated water against the foundation wall as much as possible and still have moisture or seepage, consider applying an interior masonry sealer.

Two types of sealers are readily available: Portland cement with additives such as synthetic rubber, and epoxy compounds. A third type, Xypex, which entered the U.S. market last year, contains Portland cement, finely-ground silica and several active organic chemicals. Mixed with water, this batch penetrates wet masonry, forming crystals within the masonry pores. Once formed, the crystals block seepage. A comparison of the three types appears in the chart on page 166. Follow manufacturers' directions for wall preparations to the letter.

**5. A high water table** or an underground spring are the rarest sources of basement floods, and are most difficult to stop. If water in

your basement is essentially clear, it probably flows from one of these sources.

*Cures:* The pressure-relief system described on page 164 should handle the problem.

**6. Clogged drain tile** around the foundation footing forces ground water against the foundation or beneath the footing into the space below the floor slab. Old clay drain tile laid in sections is usually to blame. Silt and soil build up between sections that have worked apart. A tree root may have broken through a tile (and could do the same to newer plastic drain piping).

Diagnosing this problem is difficult; the only sure way is to dig down, unearth the tile and examine it. That's time-consuming, and should you have it done, expensive. A simple test, however, tells you the direction from which water comes. If water lying on the basement floor is muddy or laced with silt, it's a 99-to-1 bet it came from the ground around the foundation, and just possibly seeped into the basement be-

## HOW TO SEAL YOUR BASEMENT WALLS FROM THE INSIDE



Before applying sealer, use wire brush to remove loose debris; then plug all holes and floor/wall seams with patching mix.



Apply single-coat, Portland-cement-type sealers with a stiff brush to get the granules into masonry pores.



Spread two-part epoxy sealer with a polyester brush. Do not mix more than you can handle—or compound will begin to set.

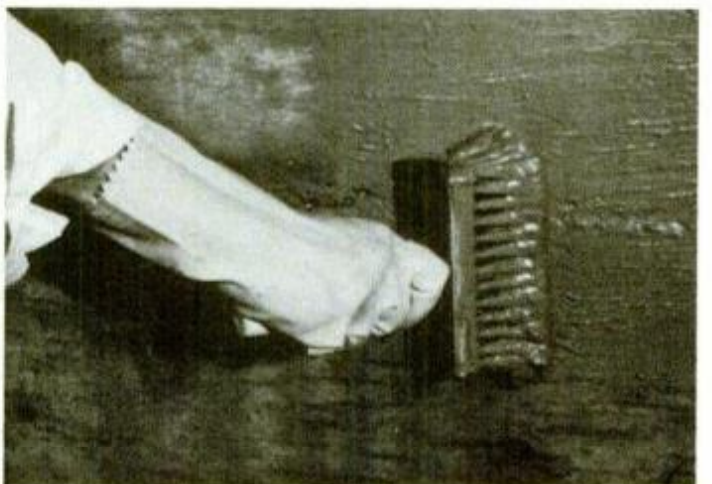

Xypex sealer, new on the market, is brushed onto a wall that has been wetted. Compound penetrates concrete to form seal.



## BASEMENT WALL AND FLOOR SEALERS

Material	Before Applying, Fill Holes and Cracks With	Apply Over Paint?	Apply Over Wet Wall?	Coverage	Masonry Penetration	Recommended Number of Coats	Warranty	Paint Over It?	Approx. Cost (1600 sq. ft.)
Drylok (Portland cement plus additives, i.e. synthetic rubber)	Hydraulic cement	Only over a cement-base paint in good condition	No, but okay over damp wall	75 to 100 sq. ft. per gallon	Deeper than paint	2	Five years when applied correctly	Yes	\$210
Devcon (Two-component epoxy compound)	Hydraulic cement or Portland cement mortar	Only if paint condition is very good	No, but okay over damp wall	150 to 200 sq. ft. per gallon	Forms tough outer coating	2	None	Yes	\$350
Xypex (Portland cement, silica, organic chemicals)	Thicker mix of Xypex	No	Yes; will not work otherwise	6 sq. ft. per gallon	Several coats, thickness of foundation wall	2	Warranty by applicator who does job	Yes	\$385

### Where to get professional help

If you decide that you need outside help, call in a professional for a diagnosis and estimate. But be wary. Over the years, basement waterproofing has been a profit bonanza for gyp artists. One of their favorite gambits is to convince an owner they will waterproof the outside of a basement wall without digging up a spoonful of soil. How? By inserting a hose into the ground at intervals along the foundation and pumping in a surefire formula that is meant to spread and seal the masonry successfully.

"Absolute nonsense," says the president of the oldest waterproofing company in New

York City, a company engaged in sealing commercial buildings, tunnels and bridge supports.

The technique was originally based on a passable idea: pumping bentonite into the soil around a basement. Bentonite is a clay-like substance derived from volcanic ash. As the material absorbs water, it expands. In the soil, bentonite is intended to draw off ground water aimed at the foundation wall, and simultaneously expand, in theory, pressing dry backfill against the foundation wall.

In practice, the bentonite scheme failed enough times to give the method a shaky

reputation. And more than a few owners learned later to their dismay that the formula injected around their house wasn't even bentonite, but a cheap, worthless imitation of the clay-like substance.

But don't give up. There are reputable contractors. Find one the way you would locate any professional—by asking friends for recommendations, then checking out the contractor's stated reputation. A good place to start looking? Call the nearest chapter of the National Home Improvement Council. Or write the national office of NHIC at 11 East 44th St., New York, N.Y. 10017.

cause of blocked drain tile. Clear water usually indicates a spring or high water table.

**Cure:** Double check water sources through 3. If you can divert ground water from the drain tile, whether the tile is blocked or not becomes irrelevant.

Having completed your checking and correcting only to discover during the next downpour that the basement still leaks, proceed to the next least-expensive step: Seal the basement walls, the periphery of the floor.

In the unlikely event your basement still leaks, review your latest work. Have you missed anything? Skimped on application? If not, you need the pressure-relief system.

**7. Broken or rusted-out downspouts and gutters** that fail to carry off water are obvious trouble sources.

**Cure:** By all means, repair breaks and replace rusted-out sections of the rain-carrying system. Often, the weak point is the right-angle gutter beneath a roof valley. During a hard rain, valleys can catch and send more water coursing than a gutter will carry. If possible, cut a downspout into the system at the angle, and divert the outflow.

**8. Flower beds parallel to the foundation** are a form of poor grading that can also lead to water where you don't want it. Gardens crested in the center are the worst

offenders—they invite water to pool and seep along the foundation wall.

**Cure:** Get rid of the garden. Build up the grade as noted in No. 2, and plant ground cover or lay down sod.

**9. A downspout that pours water only a few inches from the foundation wall** is little help. It may cause the soil to become saturated (boggy) with water, thereby increasing the likelihood of basement seepage. A stopped-up or flooded dry well close to the house produces the same effect.

**Cures:** At least, put a stone or concrete splash block under the downspout. Better, attach a rolled vinyl hose to the downspout end. Force of the flow unrolls the hose and deposits water some distance away from the foundation.

Best of all, connect the downspout with solid piping leading to an area drain, or a dry well excavated at least 25 ft. from the foundation. (A dry well is 6 to 8 ft. deep, 4 to 6 ft. in diameter, and walled with unmortared stone or concrete block. The top is closed with a stone slab or cast concrete lid. Then covered with a layer of topsoil and sod to match the lawn.)

If you suspect an existing drywell is clogged, open it and use a power or hand-operated bilge-style pump to suck out the water.

Dig out the base of the dry well

another foot or so, and replace the soil with crushed stone. That's minor surgery.

If your yard resembles a swamp, dig trenches for at least two drain lines leading from the base of the dry well away from the house. Rest the drain pipe on 4 to 6 in. of crushed stone, and cover the piping with straw or insulation before backfilling so the pipe perforations don't clog with dirt.

**10. Clogged gutters** resemble Nos. 7, 8 and 9 in their damaging effect. They are, however, a lot easier to remedy.

**Cure:** Climb to the roof and, using a garden trowel or gloved hand, scoop gutter-muck into a bucket or to the ground. Install "bird-cages" or screening at top openings of all your downspouts to prevent the possibility of clogging with twigs and leaves.

**11. The lack of gutters and leaders** can cause ground beneath the eaves to erode. During a rain, the depressions fill with water that eventually will find its way inside your basement.

**Cure:** Install a rain-carrying system. PSE

#### SEALER MANUFACTURERS

Devcon Corp. (Devcon Epoxy Sealer), 61 Endicott St., Danvers, Mass. 01923  
 United Gilsontite Laboratories (Drylok Ready-mixed Sealer), Scranton, Pa. 18501  
 Xypex Chemicals Ltd. (Xypex) 12520 Vickers Way, Richmond, B. C. V6V 1H9



# What's so hard about building a Heathkit product?

**nothing!**



**JUST PICK A KIT... ANY KIT**  
Whether you're a beginner or an experienced kit builder, you'll find it's easier than you'd dreamed!



**STEP-BY-STEP, CHECKING AS YOU GO** — you can't go wrong when you do one step at a time and check your work!

**GET STARTED**



**ALL THE PARTS ARE INCLUDED** — even solder — so all you need are a soldering iron, wire cutter, pliers and a screwdriver!

**THE EASY-TO-FOLLOW INSTRUCTIONS** even show you how to solder perfect connections!

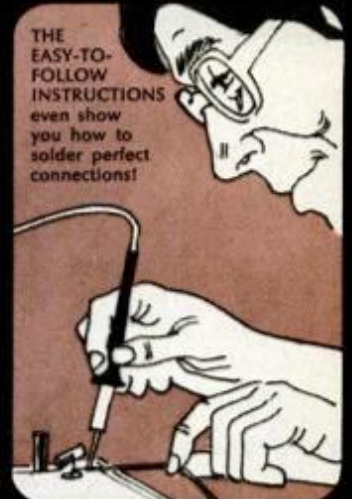

**ALL FINISHED**

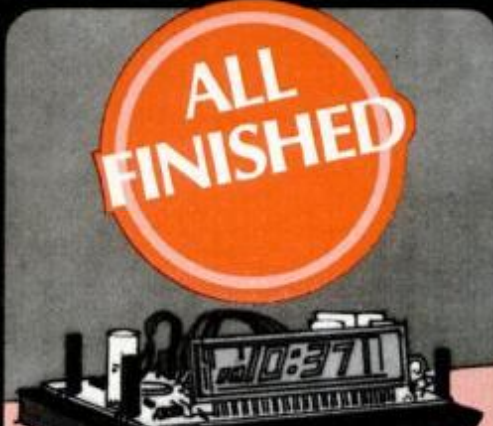

**ONE LAST CHECK** that all the connections are made right, and you're ready to turn it on...

**IT WORKS**



**AND TO THINK YOU BUILT IT YOURSELF!** It's a great feeling. You saved money — you enjoyed it — and you ended up with a great, hand-crafted product!

**You can start right now...fill in the coupon and mail it today!**

**FREE** **HEATHKIT® CATALOG**

Heathkit products are displayed, sold and serviced coast-to-coast at Heathkit Electronic Centers (Units of Veritechnology Electronics Corporation). See the white pages of your phone book for the store nearest you.

If coupon is missing, write:  
Heath Company, Dept. 017-622  
Benton Harbor, MI 49022



Read about nearly 400 money-saving, easy-to-build electronic kits — stereo, color TV, clocks and weather instruments, auto and aircraft accessories, Amateur Radio Equipment, Personal Computer Systems and much more! Simply mail the coupon below or take the coupon to your nearby Heathkit Electronic Center.

**Heathkit** Heath Company,  
Dept. 017-622  
Benton Harbor, MI 49022

Please send me my FREE Heathkit Catalog.  
I am not now receiving your catalogs.

Name \_\_\_\_\_

Address \_\_\_\_\_

City \_\_\_\_\_ State \_\_\_\_\_

CL-725B Zip \_\_\_\_\_



# solar saves

The World's Largest & Most Comprehensive Buyers' Catalogue of Solar Energy Products! State of the Art Solar Products, Ideas and "How To" Information on Solar Principles, Installation and Tax Credits & Advantages. An exciting, Giant 350-Page Money-Saving Sourcebook! Send For Our Catalog Today.

**Credit Card Buyers . . .**  
**Call Toll Free (800) 537-0985**  
 In Ohio Call (419) 937-2226

Now Only \$5.00



## Solar Sourcebook

**YES!** Enclosed is my check or money order for \$5.00. Send me the **Peoples' Solar Sourcebook**.

Name \_\_\_\_\_

Address \_\_\_\_\_

City \_\_\_\_\_ State \_\_\_\_\_ Zip \_\_\_\_\_

Mail to: **Solar Usage Now**  
 450 E. Tiffin Street  
 Department E-2  
 Bascom, Ohio 44809

## Print For Profit

Cards, stationery, envelopes; advertising, labels, tickets, QSL cards, announcements, greeting, sympathy, prayer cards, tags, etc. Save money.

**Own a Printing Business.**  
 We supply everything direct from factory. Easy instructions. Also raised printing like engraving. Have home shop. Add to income. Send 25¢ for catalog.

**Kelsey Presses, 80-BN Meriden, CT 06450**



## BASEMENT TOILET

Flushes up to existing sewer or septic tank by powerful, self-contained pump operated by normal water pressure. No digging up floors. Clog resistant, easily installed. Make basement into game room, den, apartment with private bath. Write for free literature. Dealer inquiries invited.

**DOSS MFG. Dept. J-25, Box 10947, Houston, Texas 77018**



## BUY DIRECT! MINI-BIKE FRAME!

New bolt-together frame. No welding. Complete with plans. Fits 3 1/2 hp gas engine.  
 Send only \$39.95 for your frame. Also available are new engines, wheels and etc. Send \$2 for plans.

**BIRD, Box 34422, PM2, Omaha, Nebr. 68134**

## Enjoy Your Own Business

Start Earning at once—No special experience required  
**A SHOP IN ITSELF**  
**STAND-ALL Model 7**



**SMITH-NIELSEN EQUIPMENT CO.**  
 Mfg of Saw Grinders  
 Distributor of Complete Saw Shop Equip  
 509-535-9811  
 Box 2505 Terminal Annex, Spokane, Washington 99220

Sharpens & Retools Hand Saws 3 point through 18 point.  
**SHARPENS—BAND SAWS—HACK SAWS—WOOD AND METAL CUTTING SAWS**  
 with straight back and identical tooth profile. **CROWNS**—adjusts to any standard crown. **HOOKS** 5" to 21" **BEVELS**—0° to 30°

# POWER KING one tough tractor!

Mows grass at 3 acres per hour; 48", 60" mowers, 5' sickle bar. Plows, tills, bulldozes, clears snow, splits logs and more. 25 attachments. 12, 14, 16, 18 hp. All-gear drive gives more usable power, saves gas.



Free catalog Engineering Products Co., 1005 K-2 Anoka Ave., Waukesha, WI 53186.

C-65C

NAME \_\_\_\_\_  
 ADDRESS \_\_\_\_\_  
 CITY \_\_\_\_\_ STATE \_\_\_\_\_ ZIP \_\_\_\_\_



## AFFORDABLE TRACK POWER

**NEW—Utility Crawler Tractor**; high flotation steel cleated rubber tracks. Buy Factory Direct in KIT or Completely Assembled. Over 30 attachments—backhoe, loader, blade, garden plow, etc. Send for 16 pg. Catalog . . . 50¢, or for "Build-it-yourself" plans . . . \$7.00 (refunded on any order).  
**Dahco Corp. Dept. PM20 Cedarburg, WI 53012**

## Learn ACCOUNTING at home

Learn about careers in Accounting, Bookkeeping, Tax Returns. Send for **FREE "ACCOUNTING CAREER KIT."** **INCLUDED WITH COURSE**  
 Veterans benefits.

NAME \_\_\_\_\_ AGE \_\_\_\_\_  
 ADDRESS \_\_\_\_\_  
**FREE BOOK** CITY \_\_\_\_\_ STATE \_\_\_\_\_ ZIP \_\_\_\_\_  
**NORTH AMERICAN SCHOOL OF ACCOUNTING, Dept. PB010**  
 4500 Campus Dr., Newport Beach, CA 92663

## Portable Steam Cleaner

Steam in 60 seconds

**CLEAN:** Engines, Air Filters, Lawn Mowers. 3 year guarantee on fire box, coils. Uses liquid soap, propane fired. Weight 120 lbs. Auxiliary pump required on low water pressure.

**WEDCO MFG. INC., Dept. M-10**  
 Scott Lane • Box D, Jackson, WY. 83001



## Create a Family Treasure as Thousands Have Since 1916

Handcrafted by our own grandfathers, our grandfather clock kits are semi-assembled, easy-to-build, of solid 3/4" walnut, cherry, mahogany or oak. Kits include beveled glass. We handcraft our spun brass Lady Florentine and Goddess Diana Lyre pendulums. Tubular bell or Westminster rod chimes. Hand painted moon wheels. Send for free color literature of all kits and movements or send \$2.50 for 3 plans: **AMERICAN CLASSIC, SPIRIT OF MOUNT VERNON and SPIRIT OF THE CENTURY**, plus literature.



**KUEPPEL CHIME CLOCK WORKS & STUDIO, PM-01**  
 21195 Minnetonka Blvd., Excelsior, MN 55331.

## COMPUTERIZED SKETCH PAD

(Continued from page 88)

until now, has only been available on the most expensive computers.

Enter the design mode and the computer displays a blank screen with the working area outlined and a row of electronic symbols at the bottom edge. Move the pen to touch one of the electronic symbols and you have "loaded" it with that symbol. Touch it to the tablet and you display the symbol on the relative spot on the computer display.

This CAD mode can be adapted for all sorts of things, such as architectural design and flow charting or anywhere the same symbols are used time after time. Right now, Talos makes available only the software for electronic symbols, but you can program your own or wait until others are released.

The Digikitizer not only draws figures and lines, it can help you to understand geometrical relationships as well. Suppose you have a complicated two-dimensional figure for which you need to find the area. All you have to do is trace the figure, or a scale representation of it, on the surface of the tablet. As soon as you have defined a closed shape, the computer will not only display the shape but automatically calculate the area. The same principle is applied for calculating straight-line distance, such as routes on a map.

## The inside story

The main reason Talos can sell this unit at \$499, less than 50 percent of competitively priced tablets, is that it's a kit. It's an easy kit to assemble but requires painstaking attention to detail. It is not for the beginner, but the instructions are as good as the more complex Heathkits. It took us four evenings to assemble, about 16 hours in total.

The circuitry is, unsurprisingly, quite complex. The basic idea is that the pen is held above a gridwork of fine, copper lines atop a printed-circuit (PC) board just beneath the plastic tablet top. The pen sends out high-frequency energy and the circuits inside the Digikitizer sense which copper lines the pen is above. Then, this data is translated into computer-display information and put in the computer.

We found the Digikitizer to be an exciting computer peripheral (accessory). Its low cost and ease of use contribute to the enjoyment.

Home computers are coming down in price and peripherals such as this one cannot fail to make such computers ever more popular. It sure does beat a crayon and paper! **PM**



# SEAMLESS SPRAY PUTS YOU IN AN INFLATION-PROOF BUSINESS!

## SELL PART-TIME MAKE FULL-TIME INCOME

**\$500 ON JUST  
ONE ORDER...**

**LOTS MORE  
IF YOU WANT IT.**

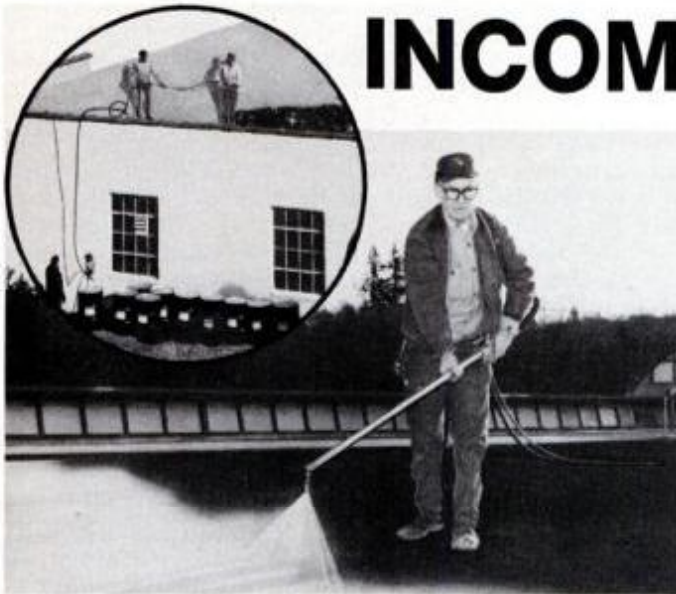

Make over \$500 on average Seamless Spray sale to schools, factories, shopping centers, etc. Many orders pay over \$1,000 commissions.

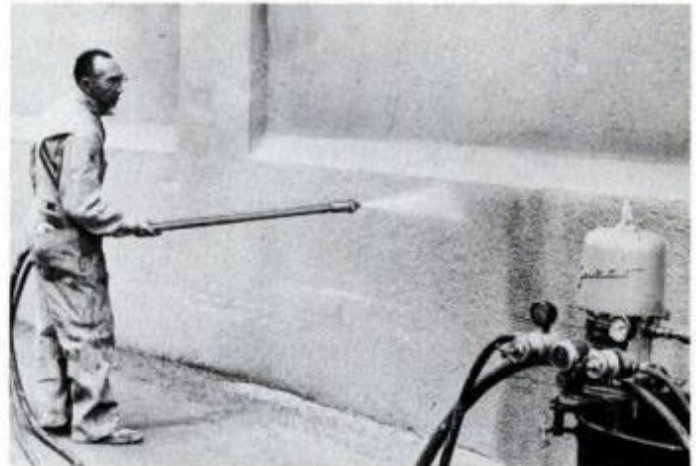

Make \$748 on a 10 barrel Seamless Spray order for Liquid Metallic Sidings. The easy, fast way to waterproof, caulk and insulate building exteriors.

**Through a series of circumstances created by inflation, I can now offer one of the most unusual opportunities in the history of direct selling. And best of all, you need no specialized experience to handle it. Absolutely none whatsoever!**

If you've done any selling at all you know you can't make it anymore selling nickel and dime items. You can't afford to bust a gut selling a half dozen orders a day and wind up making \$25 to \$30. You need a necessity that everybody needs—that's quickly and easily sold because it solves problems born out of the inflation.

We call our process SEAMLESS SPRAY. It fills a vacuum created by the soaring price of new roofs. Roofs everywhere are leaking—in desperate need of repair. Using our Seamless Spray Equipment, factories, plants, shopping centers, schools, hospitals, apartment complexes use their own maintenance people to renew, waterproof these roofs at a cost of less than 12 cents per square foot. We loan equipment absolutely free. On the average Seamless Spray order you make over \$500. You need absolutely no experience in our

business. Our program is organized step-by-step for easy, successful use whether you sell General Motors (they are Seamless Spray users) or the corner garage.

When I tell you, PACE saved one school \$28,400 with Seamless Spray roof renewal, you'll understand how fast you eliminate sales resistance. Your market is pre-sold. Roof contractors with their exorbitant prices hand you the business on a silver platter.

Give PACE as little as 8 hours a week—that's all we ask. Once you start making \$500 and more on one Seamless Spray order, then you'll consider full time PACING. In addition to Seamless Spray you'll also get our Siliconized PARK-KING Blacktop Sealer—our Liquid Metallic Siding—and a complete line of highly specialized Labor-Saving One-Coaters designed to save big money on all kinds of building maintenance. Each meets the BIG SELL concept, where you can make a Big Paycheck everyday you make calls with Pace.

**"WRITE ME TODAY FOR ALL THE FACTS!"**

**R. H. Rogers,**  
PRESIDENT

Read about the Big Checks other new Pacemen are regularly receiving—how quickly they learn our business with no prior experience. How PACE helps them every step of the way. See how one satisfied Pace customer tells another. Write us a letter or mail the coupon. You'll get "Same Day Action" with all the exciting facts upon which you can make an intelligent decision.

**SHOW ME HOW TO USE INFLATION  
TO MAKE OVER \$500 ON SINGLE ORDERS!**



**PACE PRODUCTS, INC.**

81st & Indiana Dept. PM-280  
Kansas City, Missouri 64132

Name \_\_\_\_\_

Address \_\_\_\_\_

City \_\_\_\_\_ State \_\_\_\_\_ Zip \_\_\_\_\_



## Time to test your skill.



Now you can build your own Mason & Sullivan heirloom quality, antique reproduction clock.

Over 20 different models available in do-it-yourself, pre-cut or semi-assembled form for all levels of skill. Grandfather, Grandmother, wall, desk, mantle and more. All solid 3/4" hand-matched kiln-dried hardwood in walnut, oak, cherry or Honduras mahogany. Imported precision movements and chimes. Solid brass dials. Clocks you'll find challenging to make and at a savings you can appreciate. So, if you're looking for the finest clocks around... don't waste another minute. Build a Mason & Sullivan. It's well worth the effort.

Send for our new 32 page catalog today.



- Please send me your new color catalog of top quality antique reproduction clocks I can build.  
 I enclose \$1.00 for catalog.

Name \_\_\_\_\_

Address \_\_\_\_\_

City/State \_\_\_\_\_ Zip \_\_\_\_\_

**Mason & Sullivan Co.**

Dept. 1116 Osterville, MA 02655

## WHAT IT'S LIKE TO FLY THE M.I.T. PEDAL-POWERED BIPLANE

(Continued from page 121)

ning M.I.T. model rocket club and had a lot of model-making experience. They designed the plane in about a month last winter.

All the principals signed up for the same special projects course under Prof. Eugene Larrabee. They received about \$2500 to build the plane. Of that, about half went for aluminum tubing for the airframe. The tubing presented a problem: with .02-inch walls, it was too thick! A one-day chemical milling operation was set up to eat away metal to the required .013- to .018-inch thickness.

Despite a seemingly endless variety of obstacles, first construction to first flight took only 91 days. (Example: They couldn't find Styrofoam sheets thin enough, so Parks had to invent a special cutter.) As many as 30 different volunteers worked long hours, sometimes as much as 18 hours straight, to assemble the craft. One wing-covering session lasted three days. "We lived on Coca-Cola the whole semester," said Bruno Mombrin, a volunteer.

One of the keys to *Chrysalis's* success was the shape of the propeller. Hyong Bang, one of the principals, wrote a computer program based on Prof. Larrabee's design equations and used it to find the most efficient configuration. The 14-foot prop weighs only 3 pounds. More interesting, perhaps, is that the English Channel-crossing *Gossamer Albatross* used the M.I.T. group's prop design, as well. According to Parks, it was one of several factors crucial to *Albatross's* achievement. There was a lot of interchange of ideas between the two groups; MacCready's basic design concepts were the starting point for *Chrysalis*. Parks says both *Albatross* and *Chrysalis* evolved from *Condor*, but developed in different directions.

On June 5, 1979, on its first attempt, *Chrysalis*, piloted by Youngren, flew successfully. The 30-foot flight lasted 15 seconds at a height of about three feet. Since then, the craft has flown more than 350 times without major mishap. In fact, *Chrysalis* has weathered so many landings (and crashes) so well that most of the excess aluminum tubing thought to be needed for repairs was never used.

True to the intent of its builders, *Chrysalis* has been flown by a wide variety of pilots, most of them with no special training. Men and women from 18 to 60 years of age, ranging in weight from 100 to 200 pounds, have flown. Youngren has made the most

spectacular flights, often reaching a 36-foot altitude and staying aloft for a few minutes at a time.

### My flights

A disappointingly gray dawn broke over the Hanscom Field airstrip and my stomach churned as we wheeled the plane out of its hangar. It was so big, and yet so light—just a 96-pound model airplane. I wondered if I could fly it without destroying it or myself, or both. I served as a wing stabilizer with the ground crew and rang along as Bang took *Chrysalis* up for a brief shake-down flight. Then it was my turn.

I climbed into the Mylar-covered cockpit and tried not to step anywhere but on the pedals; one slip and my foot would shoot through the fragile balsa and Styrofoam structure. Seat "adjustment" was simple—Bang stuffed several foam pads behind me until I felt comfortable. In front of me a small meter told me my pedaling speed. "Just keep the meter pinned and you'll be okay," I was told.

Strapped to the pedals and mashed into the foam padding, I listened carefully to a quick lecture about the control stick. Pull back to climb. Pull left if veering right. Pull right if veering left. Don't pull too hard. And—oh, yes—make sure to keep pedaling. My heart quickened with each instruction.

Bang sealed me in the cockpit; I began to pedal slowly. The ground crew was in position, and Bang raised the tail. "Pedal faster!" he yelled as he began to push the plane forward. "Now, smoothly, POWER!"

In seconds I was pedaling close to 80 rpm and the plane surged ahead. Suddenly the wings were out of everyone's reach—I was airborne! The transition had been butter-smooth. I was so excited I stopped pedaling long enough to lose most of my altitude; a burst of effort brought me up again, but now I was veering right. I pulled left much too hard on the stick and swung too far left. My legs were tiring quickly, so I slowed down. The plane landed almost as smoothly as it had risen.

As I gasped for air, I was quickly surrounded by crew members congratulating me on my flight. Tired but exhilarated, I asked, "How high was I?"

"Oh, your wheel was maybe four or five feet up," came the reply. I was surprised and crestfallen. Only five feet! It had felt like 15 or 20. I later learned that everyone experiences the same illusion.

### HIGH FLYING THRILLS!

The amazing rotating airfoil

## ROLL-O-KITE

\$5.00 each sent prepaid

The unusual design of this rapidly spinning airfoil causes strong lifting forces in the wind. A GREAT FLYER! Quick, easy to assemble without glue or tools. 17" wide, 7" diameter. COMPLETE KIT includes fittings, instructions, 100 yards of flying string — all handsomely boxed for gift giving.

\$5.00 each, 3 for \$13.50, 10 for \$25.00

Calif. residents add 6% tax

Hawaii, Alaska, Puerto Rico, Mexico, Canada & any USA rush orders, add \$1.50 per order for air shipment. All other countries: minimum order 10 for \$30.00 — boxed & shipped by sea, prepaid.

Send check or Money Order to:

**RAFCO**, Dept. PM-20

3136 Kashiwa St., Torrance, CA 90505

THE ORIGINAL

## BASEMENT TOILET

Genuine Porcelain

FLUSHES UP TO SEWER OR SEPTIC TANK

-No Digging Up Floors- INSTALLS EASY. ANYWHERE!

Write **McPHERSON, Inc., Dept. PM**  
 Box 15133 Tampa, Florida 33684





My first flight had been a good one, but it had been difficult to get the feel of the controls and remember to keep pedaling all at once. Armed with a firmer grasp of the necessary flight techniques, I felt certain I could vastly improve my flight.

### Easier, with practice

After a good rest, I took off again, this time pedaling over 100 rpm—the meter was indeed pinned. Carefully husbanding the controls, I climbed higher and higher. With a better feel for the stick, I flew much straighter. My legs flagged briefly, but I summoned hidden reserves to keep going. Finally, I could pedal no longer. I settled to the ground, spent.

But it had been glorious! Despite the frenzy of pedaling, the flight was smooth, even peaceful. The beating of the propeller and my own grunts were the only sounds.

I'd been aloft for 63 seconds and had traveled about a quarter of a mile about 20 feet above the ground. Bang approached and congratulated me again. "You're among the

group of elite pilots," he exclaimed.

That puts me in pretty good company, I'd say. Bryan Allen, powerplant of the *Gossamers*, has also flown *Chrysalis*. He said it was a more stable plane; he probably could fly it a lot farther than I could, too.

### The future

Despite the euphoria induced by the day's flying, there were some disappointments. After my last flight—the one in which I snatched a safe landing from a sure crash—the prop shaft sheared and the prop fell off just after takeoff. It was the only major damage sustained during more than 350 flights, although Parks says it could have been fixed in a day. But the plane was scheduled to be dismantled that weekend anyway, because there would be no place to store it.

Also, we'd had no opportunity to make turns in flight; the appropriate runway was crowded with the Air Force Thunderbirds and a C-5A.

The future of human-powered flight seems bright, however. Parks,

Youngren, and John Langford, another principal, now work for Lockheed in California, about 40 miles away from Paul MacCready's group. There is talk of a joining of forces to design the next generation of planes. A brief glimpse of a rough drawing showed what looked like a cross between *Gossamer* and *Chrysalis*—a monoplane with puller prop and rear tail.

The goal is to make the plane easy to assemble and disassemble, so a large hangar isn't needed for storage. There's a chance such a plane, whatever its configuration, would be made of graphite tubing and would be available in kit form in a couple of years or so.

But it takes a well-trained athlete like Bryan Allen to keep one of these birds aloft for an appreciable length of time; *Gossamer* required 0.25 to 0.3 hp to stay up and *Chrysalis* needed 0.4 hp. How could a less athletic person do it?

The answer may lie in low-cost solar cells and an electric motor. With a solar assist, pollution-free, human-powered flight for everyone may become reality. **FM**

## If you like a Chevy Pickup,

## you'll love it with Tilt-Wheel.



"Tilt-Wheel's really great in my Chevy pickup!"  
Larry B. Malles  
Fort Wayne,  
Indiana

Tilt-Wheel is available on all GM light-duty pickup trucks. Tilt-Wheel means easy in and easy out. And, it helps fit the truck to you. You can put the wheel

where you like it for driving. Tilt-Wheel makes a big difference for a small price. Ask for a demonstration, the next time you go to buy a GM pickup.





# Get a grip on your work ...instantly



...with new "Jaws" woodworkers clamp, the quicker gripper. Simply slide movable, ratchet arm along the notched steel beam, then tighten to fit the work. Serated jaws hold flat, round or tapered work pieces. Jaw on sliding arm floats to accommodate shape of workpiece. A novel ratchet system makes the jaws easy to position, even in the most confined areas. Throat depth is an ample 2 3/4".

In two largest sizes, *both* arms are movable. They can be reversed to exert outward pressure, similar to a spreading jack. The most useful, lightweight, versatile clamps we have ever seen.

For Credit Card orders, call anytime, toll-free 800-243-9844. In Conn., call 203-375-4629. For all other orders, mail coupon today.

## PLASTIC GETS TOUGH

(Continued from page 112)

where it gets in the way if you happen to be a lefty.

Du Pont's Zytel ST, a nylon resin, is being stamped into one-piece, five-spoke bicycle wheels. It's lighter than aluminum and, according to the venerable chemical company, tougher than steel. (The ST stands for "supertough.") A Du Pont spokesman said the company has aggressive plans to market Zytel ST and other hard-to-crack chemical materials in applications where metals can't even compete—possibly in pipes carrying exotic fuels for advanced spacecraft, for instance.

Supercomposites have already entered the plumbing market, although they haven't yet won full acceptance from plumbing professionals and consumers. "Plumbing is a very traditional industry," says James Beltz of Celanese. "It takes 7 to 10 years' faultless performance to convince the industry to adopt plastics." That experience is building now.

Celanese uses an advanced polymer called Celcon for faucets and bathroom fixtures. Its selling points: It withstands 180° F. and 1000 pounds of water pressure and comes in "decorator" colors. Its weakness: I've found that if you use abrasive cleaners on composite fixtures, you can scratch away the finish. Composite plastic is a bit harder to clean than porcelain, and a sticky film develops when it is cleaned in hard water.

## Walls of composite

Houses of the future may use composites extensively behind the walls. And if present trends continue, the walls themselves may be made of composites.

Two new composites in particular show promise for home construction. One, a special cement combined with a secret polymer and reinforced with a fiberglass fabric, is called Tapecrete. Two Canadian engineers developed it to prevent the destructive freeze-thaw cycle on Canadian highways. Successfully tested on Toronto bridges, Tapecrete is useful for surface repair for swimming pools, driveways, sidewalks and walls. Compared to concrete installed six months later, a 2-year-old Tapecrete test patch on a New York City sidewalk was far less worn.

PPG Industries wants to replace wooden and plaster wall construction with its fire-resistant, lightweight, fiberglass-reinforced product, Envirez. According to Factory Mutual Test Center experiments,



The Fine Tool Shops, Inc., Carriage Hill, Westport, CT 06880  
Dept. PMF8

Please send the following "Jaws" Instant Action Clamps. If I am not satisfied in every way, I may, within 30 days, return for complete refund, including round-trip postage.

Quantity	Size	Price, Ea.	Quantity	Size	Price, Ea.
_____	6"	\$6.70	_____	30"	11.60
_____	12"	7.60	_____	36"	12.60
_____	18"	8.40	_____	Extra Pair of Jaw Pads	.50
_____	24"	9.25			

Send new 96-page color CATALOG OF FINE TOOLS. Free.

Add \$1.50 for one item, and 35 cents for each additional one except the extra pads, for shipping and handling. Conn. residents add 7% sales tax.

Charge my \_\_\_\_\_ American Express \_\_\_\_\_ Visa  
Enclosed is my check for \$ \_\_\_\_\_ \_\_\_\_\_ Master Charge (Bank No. \_\_\_\_\_)

Account No. \_\_\_\_\_ Expires \_\_\_\_\_

Name \_\_\_\_\_

Address \_\_\_\_\_

City \_\_\_\_\_ State \_\_\_\_\_ Zip \_\_\_\_\_



Envirez walls have a smoke rating of 50 compared to polyester's 500. Wood's rating is higher yet. Envirez panels may not be in your home for a while, but you can look for them in schools and aboard new passenger jets.

### 'Bread and water' cars

Probably, you'll first become familiar with supercomposites in your future automobile. After downsizing, the best way for Detroit automakers to meet stiff federal mileage regulations by 1985 is to put the "fat" American steel car on a "bread and water" diet of supercomposites and aluminum.

Frank Daley, who is General Motors' manufacturing development director, says composites are fuel efficient. A steel car-fender liner, he says, weighs 13 pounds, aluminum 5 pounds, and composites 6 pounds. To manufacture and carry the part for five years takes the energy equivalent of 14 gallons of gas for the steel liner, 10 for aluminum, and only 7 for composites.

The aluminum industry questions the figures supporting composites' superior energy conservation. A recent Aluminum Assn. report, comparing *lifetime* energy require-

ment of aluminum, steel or composite auto hoods, says that the aluminum hood saves nearly 43 gallons of gas compared to a steel hood, compared to 7 gallons for a composite hood.

"The plastic hoods have only one life cycle," an association spokesman explains. "Aluminum can be recycled into new parts again and again for only a fraction (about 5 percent) of the energy required to make parts the first time." And he points out that plastic can't be used to make every part of the car. There will still be a role for aluminum—in engine blocks, for instance.

The steel industry isn't letting composites and aluminum steal the field, either. A U.S. Steel spokesman notes that new, inexpensive, high-strength steel will contribute to car-weight reduction. "One of our advances reduces weight and corrosion," the spokesman says. "One side of the high-strength steel sheet receives paint while the other side has been galvanized to prevent rust." So steel foresees it will maintain its competitive position during the 1980s.

Despite the competition from metals, supercomposites have already begun to appear in cars as "structural components"—body panels,

wheels, bumper beams and radiator supports. Until recently, they had been confined to noncritical parts such as doorknobs and display panels. Now, Ford has placed plastic hoods weighing 35 percent less than metal ones on 60,000 1980 Econoline Vans, and is testing 1000 carbon-fiber airconditioner brackets. GM is considering a plastic station-wagon tailgate.

Celanese and PPG have married fiberglass and carbon fiber with new resin and new winding techniques to make the composite driveshaft. A composite driveshaft is one 17-pound piece; in steel, it weighs 40 pounds and comes in three pieces. The composite shaft requires one production cycle, while the metal shaft may require 20 different steps, plus assembling the pieces. The composite shaft must be replaced if it tears. But its makers say the composite shaft is stronger and more resistant to damage.

If the plastic industry is right, the car you buy a decade from now will carry a lot of composite parts. Fancy polymers will also strengthen your driveway, house walls and appliances. And—if the industry is right—you'll never miss the metal replaced by tough new plastics. **PM**



**FREE Drafting Aptitude Test You Grade Yourself!**

Discover if you have ability for drafting—send for free Aptitude Test plus Drafting "Career Kit." No cost or obligation! No salesman will call. Drafting requires no special drawing skill or technical ability. Everything you need supplied with course—plus easy-to-follow, step-by-step lessons and personal guidance from our instructors.

Men! Women! Learn at home in spare time with no previous experience.

# Be a DRAFTER!

**3 BIG DRAFTING KITS INCLUDED WITH COURSE**

When you train at home with us for a job in Drafting.



**TRAIN AT HOME!**

For "spare-time" study, there's no place like home! No schedules, no time lost going to class or "getting ready." Everything is always at your fingertips. Go at your own pace. Learn more **FASTER...** because you're a "class of one"!

**READ WHAT 2 OF OUR BEST STUDENTS SAY!**

We are proud of these comments sent to us by students when we asked them to evaluate our course. They may or may not be typical, but show what can be done by those who set their goals high and go after what they want.

**SALARY INCREASED BY 56%.** "Upon earning this diploma, I was made senior draftsman and my salary increased by 56%. I owe such an achievement to North American School of Drafting and its wonderful staff."

**Mr. Eirie Farrell**

**MAKES UP TO \$200 A WEEK.** "The training I have gained from North American School of Drafting has enabled me to work independently. I am now an assistant architect of Summit Development Company, and make up to \$200 a week. The course was very helpful to me."

**Mr. Copeland Moxey**

**Get into a Career Where Pay Has Been GOING UP!**

Salaries for draftsmen climbed 23% during the 3 years from 1973 to 1976, according to 1977 survey of 12,000 draftsmen by American Institute for Design & Drafting. Graduation from this course does not insure that you will get a job. To find out how our graduates have done, send for our job placement record. And because opportunities vary from one area to another, check the job market in your area and see how many jobs are available in the field of drafting.

**RUSH COUPON FOR FREE "DRAFTING CAREER KIT."**

Color Brochure, "Careers in Drafting"—jam-packed with revealing facts on opportunities in drafting and how to train at home in spare time...plus, valuable 5-way Drafting Instrument. Everything sent **free** and **without obligation.**

**MAIL COUPON TODAY**

Accredited Member, National Home Study Council **Careers by Home Study**

**NORTH AMERICAN SCHOOL OF DRAFTING, Dept. PB010**  
4500 Campus Dr., Newport Beach, CA 92660

Rush aptitude test and drafting career kit...**ALL FREE**  
No salesman will call. Check here for GI or VA

NAME \_\_\_\_\_ AGE \_\_\_\_\_

ADDRESS \_\_\_\_\_

CITY \_\_\_\_\_ STATE \_\_\_\_\_ ZIP \_\_\_\_\_

**APPROVED FOR VETERANS**

North American School of Drafting  
4500 Campus Dr., Dept. PB010, Newport Beach, CA 92660



# LIQUIDATORS OF INVENTORY

## NOW YOU CAN BUY DIRECT FROM A LIQUIDATOR!

Begin your own wholesale business or purchase the products for your own use. Bailey Sales Corporation, Liquidators of Inventory, offers Giant savings to you, not by large volume buying or cheap imports. Our method is simple! We buy excess and bankrupt inventory from companies all over the U.S. Many items can be purchased from us below manufacturing cost alone. Pictured below are just a few of the hundreds of items which appeared in a recent publication.



**Tubeless Rib Tire & Wheel**  
 Assy. 15 x 6.00-6  
 Sug. List \$29.95  
 Our Price \$13.95 Ea.  
 10 Or More \$11.95 Ea.



**Toro Trimmer-Edger**  
 Sug. List \$69.95  
 Our Price \$29.95 Ea.  
 10 Or More \$24.95 Ea.



**Bosch Spark Plugs**  
 Sug. List \$1.49 Ea.  
 Our Price \$.59 Ea.



**Lawn Mower Blades**  
 Sug. List \$4.69  
 Our Price \$1.49 Ea.  
 10 Or More \$1.00 Ea.



**12 Volt Lawn & Garden Battery**  
 Sug. List \$41.95  
 Our Price \$20.95 Ea.  
 10 Or More \$18.95 Ea.



**Mini Bike Clutch**  
 Sug. List \$22.95  
 Our Price \$8.95 Ea.  
 10 Or More \$7.95 Ea.



**Onan 18 H.P. Twin 4 Cycle Engine**  
 Sug. List \$729.00  
 Our Price \$389.00 Ea.

The catalog that you receive is sent to over 40,000 manufacturers, distributors, and wholesalers within and outside the U.S. These products are offered to you and are listed in a monthly publication, "LIQUIDATORS OF INVENTORY." These items are constantly changing every month. If you are in business and your products relate to lawn and garden, motorcycles, tools, agriculture, all types of industrial and wholesale items, this catalog can be an asset to your company.

Bailey Sales Corporation offers volume buying with substantial discounts to wholesalers and manufacturers. It's also a great opportunity to get into the wholesaling business. Check our prices above; they tell the story. Buying at these prices you can make money.

Fill out the handy order blank below and send for your "LIQUIDATORS OF INVENTORY" catalog today for \$13.50 per year. Outside the U.S., \$27.00 per year.

**Bailey Sales Corporation**

BOX 127  
 CORUNNA, MI. 48817

ENCLOSED IS MY CHECK OR MONEY ORDER FOR \$13.50 for ONE YEARS SUBSCRIPTION  OUTSIDE U.S. \$27.00

NAME \_\_\_\_\_ PM

ADDRESS \_\_\_\_\_

CITY \_\_\_\_\_ STATE \_\_\_\_\_ ZIP \_\_\_\_\_

# HINTS FROM READERS

## Washer holds wires

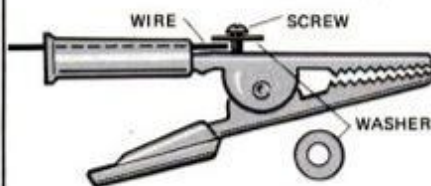

Many hobbyists or repairmen use alligator clips to join a component or wire in a circuit, temporarily, but wires tend to slip from the screw—especially the less-flexible wires of resistors and capacitors. Put a thin metal washer between wire and screwhead to widen the contact area and strengthen its hold.—*R. Krishnaswamy*

## Keeping components neat



Any builder of an electronic kit knows how important it is to keep parts neat. A cardboard lid and scrap of Styrofoam plastic can make a good parts organizer. Styrofoam is used to half-fill the lid. Resistors and capacitors are then put in order. The other half of the lid can hold switches or controls.—*Ken Patterson*

## Remove leaking fluid



Do you still get wrong answers on your pocket calculator—even after replacing the battery? If so, check for leakage from an exploded cell. The fluid can cause metal parts to corrode or, worse, short out the printed-circuit board. Remove fluid with a cotton-tipped applicator.—*Arden Bomeli*

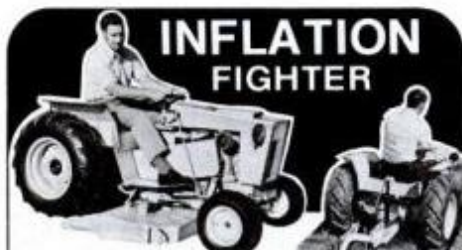

## INFLATION FIGHTER

Assemble 16 hp. Big Wheel Tractor Kit for yourself or resell for profit. Factory direct savings. 30 attachments — 57" mower, plow, loader, backhoe, snowblower, etc. Catalog, 50¢. "Build-it-Yourself" Plans, \$7 (refunded on any purchase). Struck Kit, Dept. PM20T Cedarburg, Wis. 53012

## NO MORE BACKACHES!

Rugged Bluebird Cultivator

### CUTS TIME AND WORK

Powered Wheels — Simple Controls  
 Power-oscillating tines (Pat.)  
 Throws no dirt on seedlings  
 Works close to plants

Eliminates weeds — easily

MONEY-BACK WARRANTY.

Unit includes: depth control, fold-down handles, oil, wrench, Briggs & Stratton engine, shipping box.

DIRECT FROM FACTORY. Brochure Free

**PRECISION VALLEY MFG. CO.**

Box 9112 Springfield, VT 05156



# Henry Morgan says: "If NRI can turn me into an appliance repairman, think what they can do for you!"

Did you know that there are over a billion appliances in use in the United States today? And three repairmen. At least that's the way it seems when one of mine goes on the blink. With more than two dozen electrical gadgets in my house going snap, crackle and pop, I finally got tired of trying to locate a guy with enough ambition to take my money and I decided to learn how to make the repairs myself.

When a well-aged comic like me decides to go back to school, you can bet the family jewels it won't be back at P.S. 93. I'm going to learn at home, or not at all. So I sent away for NRI's home-study course in Appliance Servicing... and I took the course.

With a mechanical aptitude slightly below that of King Kong, I needed a course that started at the beginning and didn't move ahead too fast. Well, NRI did just that. They started with electricity — what it is and what it does — and went from there. You proceed at your own rate of speed. Whip through it if you want to, or take your time. What counts is the fact that you learn, in a way that it sticks with you.

You learn to repair appliances — from food processors and microwave ovens to refrigeration and air conditioning equipment — the real professional way. It's the kind of training you need to be a pro or a really hot-shot do-it-yourselfer. If NRI can turn old ten-thumbs Morgan into a reasonable facsimile of a repairman, think what they could do for you!



NRI's no fly-by-night outfit. They've been training people for more than sixty-five years... and they've had over a million students. It's the oldest and largest home-study school in the field of electronics and electricity, so they know it better than anyone else around.

The NRI course is really easy to understand... with lots of pictures to show you what they're talking about. They even send you the tools you need at no extra cost. Depending on which level of training you select, you'll get professional hand tools, test meters, and demonstration equipment that lets you see the circuits you've been reading about.

In just a few months, you'll be fixing your own appliances like I do. Then, you'll move ahead into bigger stuff like washers, trash mashers, garbage disposers, freezers, solid-state controls, and more — the heavyweight professional training, all in "bite-size" lessons to make it as easy as possible for you.

Take my advice and mail the postage-paid



card for a free catalog describing the courses, tools, and lessons in detail. Even if you don't know which end of a screwdriver is the handle, they can give you the training to become a professional repairman and appliance technician. NRI's training is one of the few things I've ever sent for that was even better than they said it would be. The NRI catalog is free and there's no obligation. No one will knock at your door or bug you at home. NRI doesn't use salesmen. They don't need them.

Take it from Henry Morgan, the appliance repair field could sure use some good men. Now if somebody else beat you to the postcard, write to NRI at the address below.

*Henry Morgan*

## Other Opportunities from NRI.

### Small Engine Repair

Learn to service and repair lawn mowers, garden tractors, chain saws, tillers, outboards, mopeds, motorcycles and other small engines. NRI training includes professional tools... inductive tachometer, volt-ohm meter, torque wrench, valve spring and ring compressors and more. And you learn by doing, actually building a 3-1/2 HP engine as part of your training. Choice of Basic and Advanced Courses. Check postcard for catalog.

### Air Conditioning/ Refrigeration/Heating Including Solar Technology

Covers entire field, including lessons on solar heating, heat pumps, etc. Course is complete with professional tools, including top-grade professional vacuum pump, key to the proper servicing of refrigeration and air conditioning

units. Two courses to choose from. Check postcard for free catalog.

### Auto Repair and Servicing

NRI "hands-on" training covers what you need to know from headlight to taillight. Includes professional tools like inductive timing light, ignition analysis and tune-up instrument, vacuum test pump, and the latest advance in diagnostic instruments, a digital read-out tune-up analyzer. Approved by Richard Petty, America's winningest stock car driver and NRI automotive consultant. Choice of two courses, check postcard for catalog.



**NRI Schools**  
McGraw-Hill Continuing  
Education Center  
3939 Wisconsin Avenue  
Washington, D.C. 20016



## HOW TO MAKE ROOM AT THE TOP

(Continued from page 137)

for all outlets and light fixtures.

You can buy cabinets ready-made, have them custom-built or make them yourself. For basic cabinet-making plans, see *How to build your own kitchen cabinets*, page 141, Apr. '78. Screw cabinets to wall studs af-

ter they have been shimmed at wall and floor for level and plumb.

Once the cabinets are rigid, cut the plywood or particleboard panels for the desk top, notching for studs if necessary. Glue and nail a pine strip for the front edge to each panel.

Plastic laminate can be installed after the top panels have been fastened to cabinets, but it's easier to

apply it beforehand. Start at front edges, cutting the laminate strips 1/8-in. oversize so they can be trimmed with a flush-trimming carbide router cutter. Then bond the laminate to the top surface, again cutting the piece slightly oversize and trimming afterward.

Fasten the laminated top to the

(Please turn to page 182)

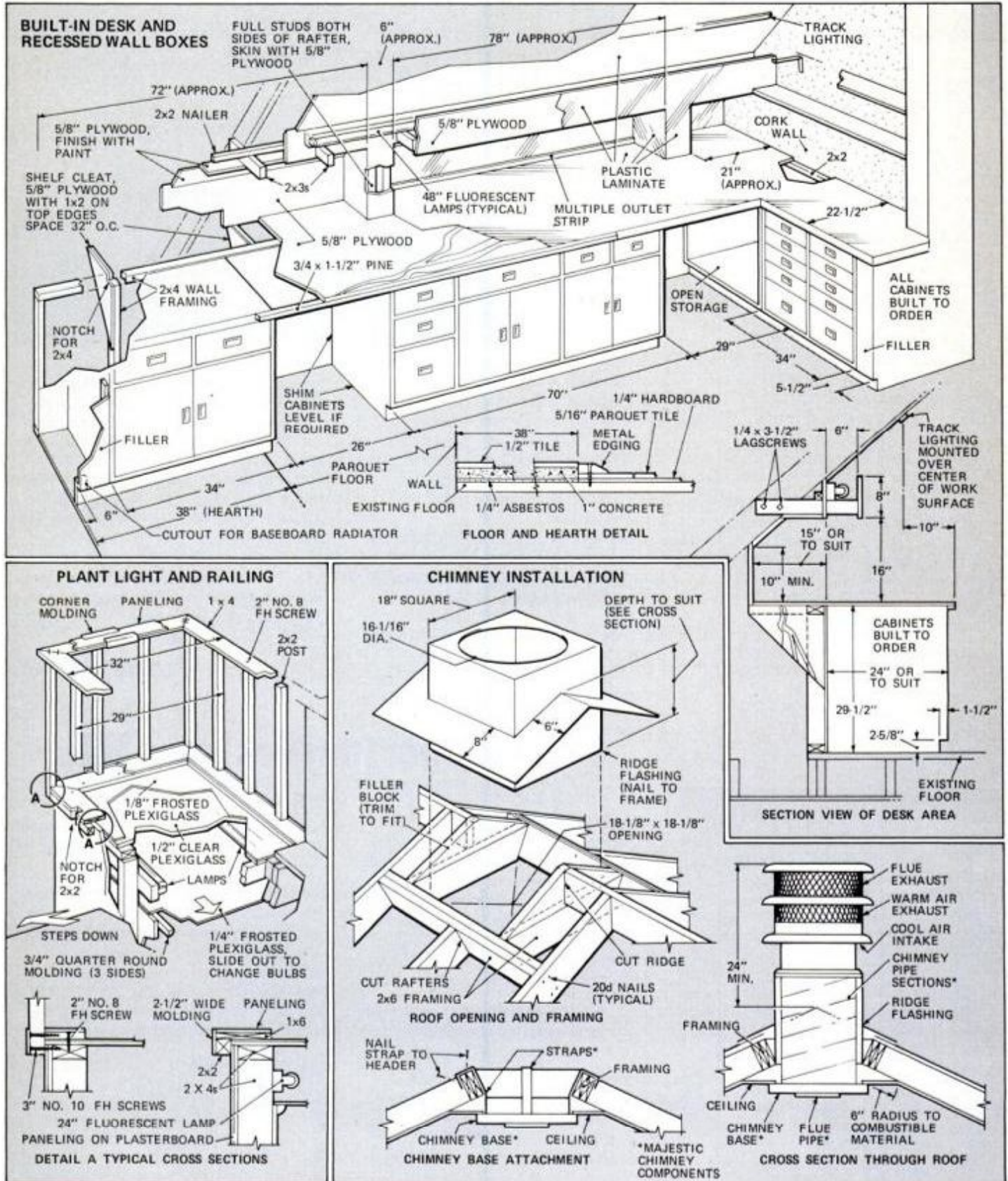



BE YOUR  
OWN  
BOSS!

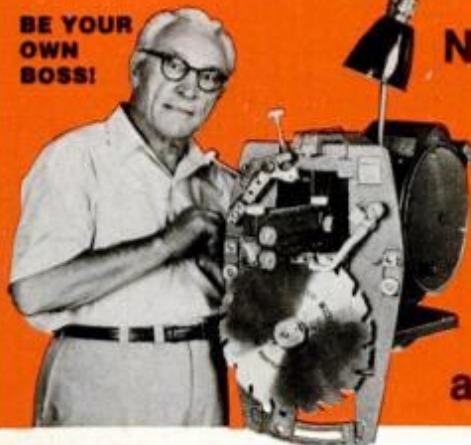

Now you can cash in on the huge demand  
for SHARPENING SAWS and TOOLS.

**Make \$8<sup>00</sup> an hour...**

or more. Work part time, full time, right at  
home. No layoffs. No strikes. Provides  
a steady source of year round income.

**Head What These Foley  
Shop Owners Say:**

**Shop will gross \$40,000 ...  
... likes being independent**  
*"I worked in various industrial jobs for years, and always wondered if I could make money for someone else, why I couldn't do it for myself. So after losing my regular job, I opened my Foley sharpening shop in the basement of my home. I only had a minimum of cash to start with, but Foley financed the balance. My shop will gross over \$40,000 this year, and I like the feeling of running my own shop without answering to someone else."*

**William Wescott  
Willoughby, Ohio 44094**



**Husband and wife have a  
going spare  
time shop**

*"I'm a construction foreman, and my wife is a nurse's aide. Our Foley shop fits in nicely with our regular jobs, and we earn extra money. Our sons help out too, so ours is a real family business."*

*"I'm still too young to retire, but when I do I'll have a very good business built up. Foley equipment helps us to do good work and brings customers back with more jobs on a regular basis... we have a lot of repeat business the year around."*

**Victor Kosloski  
Sturgis, Michigan 49091**



**Glad he  
chose Foley  
for his saw  
shop**

*"I worked as a carpenter all my life, but when a back injury forced me to quit I decided to go into sharpening full time. I'm very proud of my shop and glad my choice was Foley equipment... it is superb. I made over \$48,000 last year, and this year it will go more than \$50,000."*

**Victor Johnson  
Lincoln, Nebraska 68507**

**This can be one of the most  
important decisions you ever make**

Going into business for yourself can be the most exciting and rewarding decision you're likely to make in your lifetime.

Owning your own business brings you a sense of independence. You're the boss, setting your own work hours. Your own effort builds the business for yourself and your family. You can achieve great satisfaction and profits, if you choose and manage your business wisely. That's why so many men, just like you, are cashing in on the big profits to be made in this fast-growing service field.

The sharpening business allows you to get started with only a minimum investment, requiring little space and effort for a successful operation. It lets you build and expand as fast, or as slowly as you like. You pocket most of the money you take in, because there are exceptionally high profits with no investment in merchandise.

If you need only \$200 or \$400 extra income each month, a sharpening business is ideal for spare time. The additional dollars can be SPENT for more of the good things of life. Or they can be SAVED in a rainy-day fund that the family can bank on.

**More sharpening businesses are  
needed every year**

As original equipment continues to climb in cost, owners are becoming more concerned that the equipment be maintained so that it performs like new. This means more companies, contractors, carpenters and home owners are having their old saw blades and tools resharpened many times, where in the past, they would have replaced them with new blades or tools. This is where you

can step in with the much needed service of sharpening saws and practically any kind of tool.

**SEND FOR FREE FACTS TODAY!**

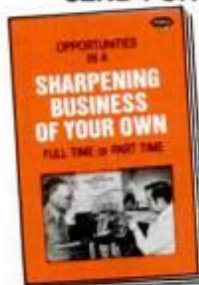

**This FREE  
booklet has  
helped  
thousands**

Thousands of good men have been inspired by this fact-filled book into making that first important step of starting their own

business. It can be yours just for the asking.

*It covers these important subjects ...*

- How much money can you make
- Age, education not a factor
- No selling is required — customers bring their business to you
- Lawn mowers and chain saws
- Sharpening business is year-round
- Sharpening opportunities in small towns and large cities
- A sharpening business provides excellent retirement income
- How Foley helps you start
- No experience needed, any age can succeed

**Act today, so you can have a  
brighter, more secure tomorrow**

Right now, while this is still fresh in your mind, fill-in the coupon below. We will send your FREE copy of "Opportunities in a Sharpening Business of Your Own". There is absolutely no obligation and there are no franchise fees in starting your Foley Sharpening Business.

Send your name and address to: Foley Manufacturing Co.  
3201 Foley Building, Minneapolis, Minnesota 55418

**CLIP OUT AND MAIL THIS COUPON TODAY — OR CALL TOLL FREE 1-(800)-328-7140,**  
(Except in Hawaii or Alaska). 24-HOUR ANSWERING SERVICE.

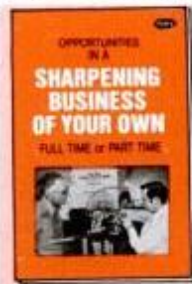

**FREE  
BOOKLET**

This little book has helped change the lives of thousands of good people, just

like you. Just complete the coupon, clip it out and mail it to us today. Get started now for a brighter, more prosperous tomorrow!

**Foley Manufacturing Company  
3201 Foley Building  
Minneapolis, Minn. 55418**



**YES**, I would like to receive complete details about how I can easily start a profitable, Foley-equipped sharpening shop. Please rush me your FREE booklet, without any cost or obligation, that gives me full details on how I can quickly start my own business.

**NAME** \_\_\_\_\_

**ADDRESS** \_\_\_\_\_

**CITY** \_\_\_\_\_

**STATE** \_\_\_\_\_ **ZIP** \_\_\_\_\_

**AREA CODE** \_\_\_\_\_ **PHONE NO.** \_\_\_\_\_





## FREE BLUEPRINTS and TRIAL LESSON —for your greater success in Building

Beginners, craftsmen, even foremen and superintendents, have sent for these free blueprints and trial lesson in Plan Reading as a means of trying out Chicago Tech's home-study Builders training. See how you can learn Plan Reading, Estimating and the practical details of all types of construction in your spare time at home. Mail coupon or phone TOLL FREE today for your free ranch home blueprints, trial lesson and catalog on CTC Builders training.

• PHONE TOLL FREE (24 HRS.)  
1-800-528-6050 Ext. 810

**CHICAGO TECH/School for Builders**  
2000 S. Michigan Avenue, Chicago, Ill. 60616

**CHICAGO TECH/School for Builders** Veterans  
Dept. PM-20 2000 S. Michigan Ave., Check  
Chicago, Ill. 60616 Here

Please mail me a Free Trial Lesson, Blueprints and Builders Catalog. I understand there is no obligation—no salesman will call.

NAME \_\_\_\_\_ AGE \_\_\_\_\_  
ADDRESS \_\_\_\_\_  
CITY \_\_\_\_\_ STATE \_\_\_\_\_ ZIP \_\_\_\_\_

## Underground Homes



□ **The Primer To Earth Sheltered Living** — 24 Page Booklet gives basic information on underground homes — advantages, site selection, planning, financing, building tips, construction and landscaping. 83.00 ppd.

□ **Plans For The Future** — 44 Page Book features full color renditions of 25 different underground home designs, plus floor plans. Blueprints available. 86.95 ppd.

Order Today! Satisfaction Guaranteed.  
**Underground Homes • Dept. PM2**  
229 Masonic Bldg. • Portsmouth, OH 45662

## MIRACLE TOMATO Yields 2 BUSHELS To A Vine



Now—You can grow the world's most amazing Tomato right in your own garden and get from 2 to 3 bushels of delicious, ripe tomatoes from every vine. Tomato grows 16 to 20 ft. high. Huge,

### BURGESS CLIMBING TRIP-L-GROP

meaty, solid fruit, wonderful flavor. Some weigh as much as 2 pounds. Unsurpassed for canning and slicing. Blight free — drought and disease-resistant. Grows any place. Outyields all other varieties.

**TRIAL PACKET 10¢**  
Postpaid. Order Today!  
Jumbo Packet 25¢

Write for FREE complete Catalog listing many unusual Seeds, Plants and Bulbs even if you don't order tomato seeds. Order Cat. No. 56711

**BURGESS SEED & PLANT CO.**  
DEPT. 4951-68  
905 FOUR SEASONS ROAD  
BLOOMINGTON, IL. 61701

## HOW TO MAKE ROOM AT THE TOP

(Continued from page 180)

cabinets with corner braces or by screwing up through cabinet corner brackets. Then build plywood dividers and enclose back and top of the recess with plywood. To make skinning recess easier, screw recess back to the desktop prior to sliding the top into position. Apply plastic laminate to dividers. Paint top and back of recesses. Install a multiple-outlet strip and light fixtures.

### Recessed floor/ceiling lamp

Removal of the stairway shaft partitions created a perfect spot for a through-the-floor fluorescent light. This provides subtle under-lighting for showing off plants and a night light for the stairs and room below. The ½-in. plexiglass will support 150 lbs. Access to bulbs is through a sliding plexiglass panel.

### Prefab fireplace slate hearth

Since the fireplace unit we selected has a 7-in. clearance from the floor, noncombustible floor material beneath and around it was a must. We used slate tiles set in a 1-in. bed of mortar over a ¼-in. sheet of asbestos millboard. To build such a hearth, nail asbestos millboard and a layer of wire mesh to the floor. Use 2x2s to build form for mortar at sides. Experiment with tile patterns and make a dry run before mixing mortar. Then shovel a mixture of 1 part mortar mix to 1 part sand mix into form to a depth of 1 in. Level and smooth the mix and tap slate lightly into position using a hammer and wood block. We used a simple brickwork pattern with 5/16-in. spaces and worked from front to back, starting with full-width tiles. The mortar mix should be thick to keep tiles from settling too low. If they do, put some mix under them and retamp in place. Point space between tile using joint filler.

To cut tiles for fitting in the last rows, use a portable circular saw with a masonry cutting blade. Prepare a simple jig to hold two sides of the tile snug. Lay a piece of plywood on top to hold tiles in place and cut along exposed area about three quarters through for a clean break. Cut on the exposed side of tile.

Since we wanted to center the fireplace in the room, the chimney passes through the roof at the ridge. See framing details and the design for the custom-built ridge-flashing assembly in the plans. At the roof opening, a triple wall pipe circulates outside air around the inner flue to insulate and prevent ignition of nearby rafters.

PM

If You Need

# RUBBER

Super Quick

Anytime Day or Nite **STAMPS**

CALL Toll Free 1-800-547-8678

# QUARTZ

BATTERY CLOCK  
MOVEMENTS - NEW  
LARGER  
SELECTION  
at the Lowest  
Prices Ever  
From KLOCKIT



### QUARTZ #202 & 203

Dimensions 2 7/8" L x  
2 7/16" W x 1" D.

#202 - for dials up to  
1 1/4" thick.

#203 - for dials up to  
7/8" thick.

Prices: For 1 Mvt. \$10.50,  
5 mvts. \$8.75 ea.,  
10 Mvts. \$7.65 ea.

Free Hour & Minute Hand!  
Second hand 5-300 — 35¢ ea.  
Shipping Extra.

- Pendulums!
- Dials!
- New "Mini-Quartz"
- Numerals!
- Chime Movements!
- Wt. Shells!

Add : Shipping & Handling!

1 unit \$1.50, 5 units, \$2.00

PHONE ORDERS WELCOME!



### SAVE with #154

American made 4 jewel  
Battery Clock Movement  
Free Hr. & Min. hand -  
Low prices: 1 Mvt. \$6.95  
5 Mvts. \$5.85 ea., 10  
Mvts. \$5.40 ea.

For dials up to 1/4" thick -  
long shaft available - at  
slight extra cost, shipping  
extra.

For a Free Catalog - Write KLOCKIT, P.O. Box 629 • Lake Geneva, WI 53147  
or Call: [414] - 245-6902 - [For 1st class catalog delivery - send 50¢]



Turn Extra Time Into **Extra Income!** Earn \$5 TO \$8 an Hour

Be your own boss  
in a money-making  
business of your own.

No  
Experience  
Needed

# Sharp-All

lets you

# Sharpen Saws

garden and shop tools  
for home and industry

Start Earning FAST—No Experience Necessary.

With SHARP-ALL it's easy to start your own business. No selling is involved, no inventory. People bring in their work... you take in year round CASH Profits and keep 90¢ out of every dollar you earn. Work sparetime or fulltime right at home in your garage, basement or tool shed. Work the hours you want—FREE Book tells how to start your own business even while working at your regular job.

Big PROFITS In Sharpening.

Every home and business has saws and tools that need periodic sharpening. There's plenty of business waiting for the man who can sharpen saws, planer knives, jointer blades, wood chisels, scissors, pinking shears, snips, lawnmowers, axes and other garden, shop and home tools. SHARP-ALL does ALL these jobs and more... quickly, and at a big profit. You will be sharpening headquarters for carpenters, builders, lumberyards, factories, home workshops and hobbyists... hundreds of jobs right in your own neighborhood.

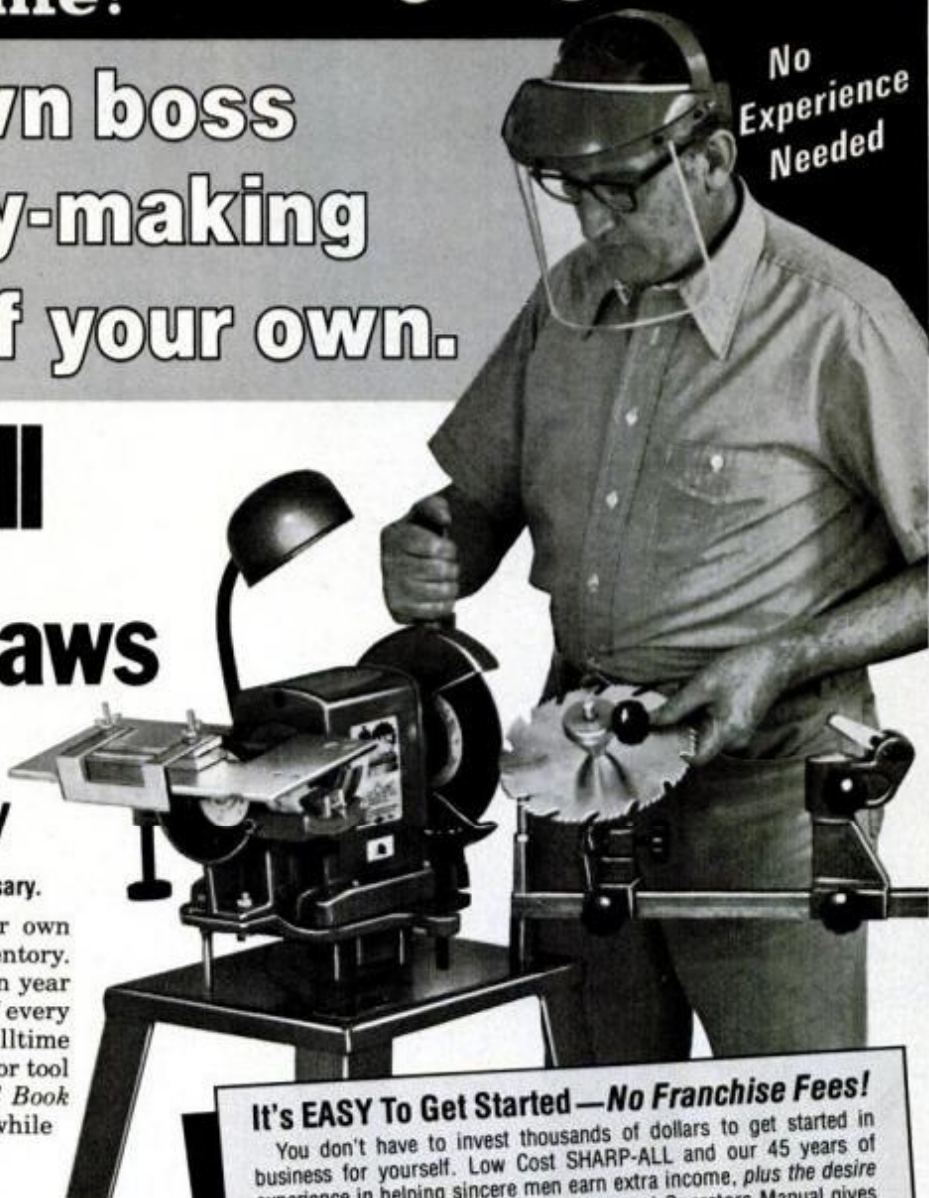

It's EASY To Get Started—No Franchise Fees!

You don't have to invest thousands of dollars to get started in business for yourself. Low Cost SHARP-ALL and our 45 years of experience in helping sincere men earn extra income, plus the desire to get ahead is all you need. Fully illustrated Operators Manual gives clear, step-by-step instructions, shows exactly how to sharpen each tool, where to get business, what to charge, how to get free advertising... all the "tricks of the trade". And, SHARP-ALL does the kind of precision job that brings customers back time after time.

Send for FREE Book "Lifetime Security." Do It Today!

There is NO OBLIGATION and  
NO SALESMAN Will Call!

ACT NOW!  
Coupon  
Brings  
Full Details!

SEND FOR FREE FACTS TODAY!

You risk nothing by accepting this offer to see how easily you can turn your spare time into Big CASH Profits with your own Complete Sharpening Shop. Send coupon or mail postcard for full details on our exclusive

30-Day FREE Trial Offer!

FREE Booklet gives full details—

Our Free Book tells how to start a profitable, lifetime home sharpening business, how we help you grow, how we'll finance you.

Send for  
your copy  
today. No  
obligation.



No Obligation... No Salesman



BELSAW SHARP-ALL CO.  
710F Field Bldg.  
Kansas City, MO 64111

FREE  
BOOK

RUSH  
COUPON  
TODAY!

Please send my FREE copy of your book  
"Lifetime Security" and full details on  
your 30-Day Free Trial Offer!

Name \_\_\_\_\_

Address \_\_\_\_\_

City \_\_\_\_\_

State \_\_\_\_\_

Zip \_\_\_\_\_

BELSAW SHARP-ALL Co., 710F Field Bldg., K.C., MO 64111



# IF YOU WORK WITH WOOD GET...

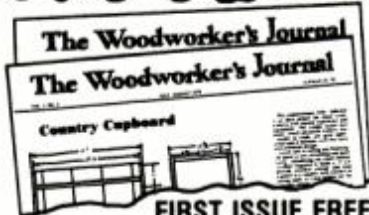

**FIRST ISSUE FREE**

When you subscribe to the next 12 issues of the Woodworker's Journal. Each issue is filled with actual plans and patterns, shop tips, money-making ideas, antique repairing and cabinetmaking techniques.

**OVER 70 PLANS & PATTERNS  
FEATURED EACH YEAR.**

Whether you're a novice or a veteran you'll enjoy every page of detailed instructions for all types of practical woodworking projects. Build fine Early American, Shaker, Contemporary Furniture, Toys, Gifts, Clocks, Lamps and much more.

**SUBSCRIBE NOW**

1 YEAR (6 issues)—only \$7.00
2 YEARS (12 issues)—only \$12.00
Foreign Rates—Add \$2.00. Please make payment in U.S. Funds.

**GUARANTEED:** Full refund on all unmailed issues if not completely satisfied.

Send Check or M. O. to:  
**THE WOODWORKER'S JOURNAL**, Dept. 512  
P.O. Box 1629, 25 Town View Drive,  
New Milford, Ct. 06776

6 issues—\$7.00     12 issues—\$12.00

Name \_\_\_\_\_

Address \_\_\_\_\_

City \_\_\_\_\_ State \_\_\_\_\_ Zip \_\_\_\_\_

## SPARE TIME INCOME? SELL KNAPP SHOES!

Sell famous Knapp Cushion Comfort Shoes full time or part time to supplement your income. Enjoy the financial success and security you've always dreamed about. Millions of repeat customers. Earn high commissions plus bonuses. No investment. Free selling and training kit to get you started. America's No. 1 company in the direct selling shoe industry. Write: Knapp Shoes, Dept. L 612 Knapp Centre, Brockton, Mass. 02401.



## QUICK START

250  
AMPS  
12 VDC

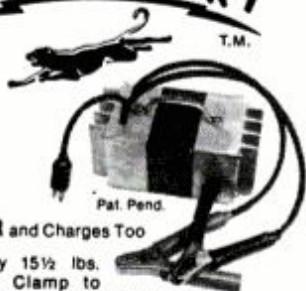

100%

**STARTER** and Charges Too

Weights only 15½ lbs.  
Easy! Just Clamp to  
Battery and Plug into 120 V Outlet.

**Quick Start Will Start your Engine in Seconds.**

Only \$97.50 and we pay the freight.

**GREAT PLAINS PRODUCTS**

P.O. BOX 82632 Okla. City, OK 73148 PM

## NEXT MONTH IN PM

- **Minisubmarines take on big underseas jobs.**
- **New camping gear goes backwoods with the RVs.**
- **Annual garden and outdoor living guide.**
- **Vacuum gauge—an economy driving tool.**

**SUBSCRIPTION SERVICE:** Popular Mechanics Magazine will, upon receipt from its reader of a complete new or renewal subscription order, undertake fulfillment of that order so as to provide the first-copy delivery to the Postal Service within six to twelve weeks. If for some reason this cannot be done, you will be promptly notified of the issue date that will begin your subscription, with a request for any further instructions you may have concerning your order. Please address all such orders to us at Popular Mechanics, P.O. Box 10064, Des Moines, Iowa 50350. Should you have any problem with your subscription, please write Joan Harris, Customer Service Department, Popular Mechanics, P.O. Box 10064, Des Moines, Iowa 50350. To assure quickest service, please enclose your mailing label when writing to us or when renewing your subscription. Renewal orders must be received at least eight weeks prior to expiration to assure continued service.

## Popular Mechanics

P.O. Box 10060, Des Moines, Iowa 50350

**YES!** Please enter my subscription to POPULAR MECHANICS for:

- 1 year \$8.97  
 2 years \$16.97

Payment of \$ \_\_\_\_\_ is enclosed.

Bill Me \_\_\_\_\_  
initial here

Name \_\_\_\_\_ (please print)

Address \_\_\_\_\_

City \_\_\_\_\_ State \_\_\_\_\_ Zip \_\_\_\_\_

Your first copy will be on its way to you in six to twelve weeks. Watch for it!  
A publication of The Hearst Corporation  
Charge orders subject to publisher's acceptance.  
(Above prices apply in U.S. & Possessions only. All other countries add \$6.00 per year.)

## CHANGING ADDRESS?

If you're planning to move, please let us know at least eight weeks before changing your address. Attach current address label and fill in your name and your new address. This will serve to insure prompt service on your subscription.

Send old label with your name and new address to:  
**POPULAR MECHANICS**  
P.O. Box 10064, Des Moines, Iowa 50350  
**FOR CHANGE OF ADDRESS ONLY**  
CALL TOLL FREE 800-247-5470  
(State of Iowa residents call 800-532-1272)

For any other subscription inquiries, please write Joan Harris, Customer Service Dept., POPULAR MECHANICS, P.O. Box 10064, Des Moines, Iowa 50350.

NAME \_\_\_\_\_ (Please print)

NEW ADDRESS \_\_\_\_\_

CITY \_\_\_\_\_ STATE \_\_\_\_\_ ZIP CODE \_\_\_\_\_

## HANDSOME BENCH YOU CAN BUILD

(Continued from page 129)

piece should be ripped ¼ in. wider than necessary to allow for planing and joining. Plane the edges to allow a sliver of light to show at the center. When they have been glued and clamped, this will assure a tight fit at the ends.

### Shaping the seat

After the planks have been joined, cut the ends of the seat to conform to your drawing. Round the corners and scoop out the seat, using a 1-in. gouge and block plane. Test frequently with a cardboard template and use 80-grit sandpaper for the initial sanding. Finish the sanding step with 120-grit paper.

On the bottom of the seat, lay out the locations of the legs (H and I). Use the appropriate sight gauges to bore holes. Next, cut the rails (D). When you cut the tenons, pay particular heed to angles at the tenon shoulders to be sure you have a tight fit.

Mortises in legs can be cut with mortising attachment on your drill press, or by grouping bored holes to mortise dimensions and chiseling out the waste. Use the V-block jig, shown in *Try These Two Projects from A. Lincoln, Handyman* (page 118, Feb. '79), to hold the legs to proper angle while mortising. Also bore the holes in the legs for the rungs (E). Trim the tenons to fit the mortises.

### Build bench from bottom up

To assemble the seat and legs, prepare plastic resin glue and glue legs to seat, rungs to legs, and rails to legs. Clamp to hold all parts in position and to square rails to rungs. Allow the completed assembly to stand for 24 hours before continuing. Then cut the leg bottoms at the proper angle and length.

With the bottom half assembled, proceed with parts for top half. Start by propping arm with cut-off pieces and make bores. A light pencil line on the side of the arm will help you to align the bit with the required angle.

Rest the assembled lower half of the bench on a full sheet of plywood, shimmed, leveled and fixed on the shop floor. Then locate and bore holes in the seat top, using a portable drill and sight gauge.

Cut away excess stock from the ends of the three posts (K). Finish shaping with a spokeshave and wood rasp. Then, sand with 100-grit, 150- and, finally, 180-grit paper.

Cut the top rail (B) to length and

(Please turn to page 186)



## PUBLIC NOTICE! BANKRUPTCY

### and Financially Distressed Merchandise!

We are authorized liquidators of large inventories that must be quickly sold at sacrifice prices because of a variety of reasons such as:

- Manufacturers' overproduction
- Last year's models
- Bankruptcy
- Sheriff's sale
- Bank loan foreclosure
- Insurance claim sale

If your company finds itself in any situation that requires it to sell large inventories for immediate cash, call us! Only products in perfect operating condition . . . or slight blemishes that do not affect operating performance . . . will be considered. Call toll-free: 800-328-5082.

# MUST LIQUIDATE AT FAR BELOW DEALER COST! 3-Speed, Horizontal & Vertical 3/4 hp. 6" BAND SAW Heavy-Duty for Steel, Iron, Copper, Wood, Plastic, etc.

## CUTS STEEL UP TO 4 1/2" ROUND, UP TO 4" X 6" RECTANGULAR!

Here's a big, rugged, heavyweight band saw with plenty of power to slice through steel up to 6 inches thick! It saws easily through any shape stock — flat, bar, square, channel, tube. Use it to saw lumber, plastic, copper, brass, aluminum, iron, with proper saw blade. Comes with a standard 1/2" blade, 65" long. Blade rides on big 7 1/2" bandwheel.

For horizontal cuts, you can vise-lock work in position and walk away. Automatic shut-off turns off machine when cut is completed. Tension control spring adjusts quickly to feed blade at proper rate of speed for smoothest cutting. It cuts in vertical position, too, so you can slit, notch or cut contour shapes! An ideal cutting tool for your workshop!

- 1 Cuts up to 4 1/2" round stock; up to 4"x 6" rectangular stock.
- 2 3/4 hp. capacitor start motor gives plenty of power. Three-prong plug fits 110V outlet.
- 3 Steel and bronze gears; worm gear drive for smooth, long-lasting performance.
- 4 Easy adjustment for blade tension.
- 5 Adjustable roller guides; ball bearing thrust guide to keep blade rigid for most effective cutting. Prevents loose blades that break.
- 6 Heavy duty stand for firm, sturdy support.
- 7 Heavily ribbed cast iron saw bow for mass weight and rigidity plus reinforcement.
- 8 Heavy duty metal work stop lets you repeat same length cut, time after time.
- 9 Handy tool shelf with slight V-shape to keep tools from falling off.
- 10 Head support allows for quick work change without lifting saw head all the way up.
- 11 Equipped with NEMA 55 motor frame.
- 12 Easy access for change of blade.

Includes 18-page operating manual!

## \$470.00 value!

NOW . . . while they last:

# \$198

AMERICAN EXPRESS

Master Charge

VISA

Credit card customers can phone their order:

Toll-Free: 800-328-5082

In Minnesota, call collect: 612-729-2345.

## C.O.M.B. Co.

THE NATION'S LARGEST AUTHORIZED MAIL  
ORDER LIQUIDATOR OF CONSUMER PRODUCTS  
3258 MINNEHAHA / MINNEAPOLIS, MN 55406  
Phone: 612-729-2345 Toll-Free: 800 328-5082

Copyright 1979 C.O.M.B. Co., Inc.



SIZE:  
38" wide,  
13 1/2" deep,  
38" high  
with head  
down (55 1/2"  
with head  
in vertical  
position.

Ship. wt.,  
approx.  
160 lbs.

**1 Year Parts Warranty!**  
Factory new! Sealed  
in original cartons.

Quick change of V-belt for three speeds: 65, 120 and 220 feet per minute.

The heavy duty vise is hand-wheel operated for fast setup. Easily angled for miter cuts.



Blade guide arm adjusts for size of work; gives maximum rigidity to blade for squareness and accuracy.



Idler bandwheel mounted on gibbs for alignment adjustment, accuracy and proper blade travel.

**Converts Quickly  
to Vertical Jig Saw  
With a Handy Cutting Shelf!**

The saw head tilts back for use as a vertical jig saw! A handy cutting table is included. You can notch, slit or cut contour shapes using the shelf for support. It's like having two saws in one!

C.O.M.B. Co. / Authorized Liquidators Dept. 178  
3258 Minnehaha Avenue S., Minneapolis, Minn. 55406

Send the 3/4 hp. Heavy Duty Band Saw for only \$198.00. I will pay shipping charge to the driver upon delivery. (Allow 2-3 weeks for delivery. If paid by personal check, allow additional 1-2 weeks for check to clear the bank.)

My check or money order is enclosed.

Charge to:  Mastercharge  VISA  American Express

Account No. \_\_\_\_\_ Expires \_\_\_\_\_

PLEASE PRINT CLEARLY

Name \_\_\_\_\_

Address \_\_\_\_\_

City \_\_\_\_\_

State \_\_\_\_\_ ZIP \_\_\_\_\_ Phone \_\_\_\_\_



## SAVE HEATING DOLLARS

**HOT PIPES**  
Converts 38" of 3" flue pipe, 19" of 8" flue pipe into a finned heating radiator.  
Installs in minutes, no tools needed.  
**\$6.95 plus \$.95 shipping.**  
WIL-MOR, INC. Dept. C  
P. O. Box 30182  
Cleveland, Ohio 44130 Ohio residents add 5% Sales Tax.



## Order Eyeglasses by Mail and Save.



Yes, prescription glasses (or your present lenses duplicated) by mail and at big savings. As low as **\$14.95**—frames, lenses, and case! Satisfaction guaranteed. Write for free catalog.

Est. 1959

All lenses, all styles.

**Prism Optical, Inc., Dept. PM20**  
10992 N.W. 7th Ave., N. Miami, FL 33168

## USE THOSE BABY FOOD JARS

SnapCaps attach to "4" pegboard to hold your baby food jars. Provide neat, visible storage for small shop items, sewing and craft supplies. 4 SnapCaps—\$1.00  
36 SnapCaps—\$7.50 72 SnapCaps—\$14.00 144 SnapCaps—\$26.00 Post-paid, no COD Check or money order.  
**WICKLIFFE INDUSTRIES**  
Box 286, PM-20  
Wickliffe, OH 44092



NEW  
NEW  
NEW  
NEW  
NEW

**THE WATERFRONT EQUIPMENT AND HARDWARE STORE**

1849 Annapolis Street • Annapolis, MD 21401

Quality Boat Handling and Waterfront Equipment

**NEW CATALOG**  
CATALOG \$5.00 Refundable FREE DETAILS

## LEARN MEAT CUTTING



Train quickly in 8 short weeks at Toledo for a bright future with security in the vital meat business. Big pay, full-time jobs—HAVE A PROFITABLE MARKET OF YOUR OWN! Time payment plan available. Diploma given. Job help. Thousands of successful graduates. OUR 5th YEAR! Send \$1.00 for a big new illustrated FREE catalog. No obligation. C.E. approved. NATIONAL SCHOOL OF MEAT CUTTING, No. 71-02-01977, Dept. 50-2, 33 N. Superior, Toledo, Ohio 43604.

## NAME THAT TUNE!

OVER 120 TUNES AVAILABLE FOR YOUR OWN MUSIC BOX CREATION!  
Seven Menorahs available from 18 to 22 notes from \$7.50 Disc Type with over 80 music favorites to choose from. Guaranteed for 1 year. Send \$1.00 for catalog with tune selection (refundable).  
**WORLD OF MUSIC BOXES**  
412 Main St. Avon, New Jersey 07717 Dept. B



## Make Money in SCREEN Printing HOME BUSINESS!

PRINT WITHOUT A PRINTING PRESS!  
Print without a printing press! Signs, bumper stickers, T-shirts, banners, posters. Print on paper, plastic, glass, wood, metal, fabric... almost any surface—every color of the rainbow... for stores, realtors, mail order, factories, politicians, etc. Easy home-study course starts you fast. We show you what to do, how to do it... guide you step-by-step. Send name, address, age for free facts.  
**SCREEN PRINTING CENTER, 4401 Birch St., Dept. 98010, Newport Beach, CA 92663**

## At Last a New Amazingly Simple GAS TURBINE JET ENGINE

Build from easy to follow plans. Length 15", Dia. 6 1/2", Wt. 15 lbs. Fuel: Gasoline or Kerosene.  
"Screaming Demon" develops 20 H.P. Ideal project for serious-minded hobbyists, students, scientific and industrial attachment. For use on small racing boats, midget cars, etc. Full size assembly drawings with critical dimensions, bill of materials and photos. Price \$7.900. No. G.O.D.  
1510 28th St., Box 1398  
**SAVOY SCIENTIFIC SANTA MONICA, CALIF. 90408**



## WEEDHOPPER—ULTIMATE FUN MACHINE!



No licenses required on plane or pilot; 40 hour construction time; complete kit \$2695.00; carries 220 lb up to 50 mph! Send \$5.00 for info-pak to:  
**WEEDHOPPER OF UTAH, INC.**  
Box 2253, Ogden, Ut. 84404

## LANDSCAPING

Growing demand—good income for trained Landscape Contractors and Garden/Nursery personnel. Start your own business part- or full-time or hobby. Home study course prepares you in 6 months. Certificate awarded. Free booklet describes opportunities. No salesman.  
**LIFETIME CAREER SCHOOLS Dept. A-843**  
2251 Barry Ave., Los Angeles, CA 90064



Name \_\_\_\_\_  
Address \_\_\_\_\_  
City \_\_\_\_\_ State \_\_\_\_\_ Zip \_\_\_\_\_

## REPAIR CLOCKS

Home Study Course prepares you for Good Income—Professional Status. Free Details. No salesman will call.

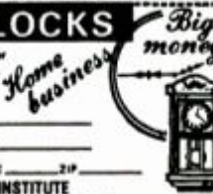

NAME \_\_\_\_\_  
ADDRESS \_\_\_\_\_  
CITY \_\_\_\_\_ STATE \_\_\_\_\_ ZIP \_\_\_\_\_

**CLOCKMAKERS INSTITUTE**  
P.O. BOX 448, LEWISTOWN, PA. 17044



## STAINED GLASS

Send 50c for fascinating catalog of kits, tools, ideas, books and supplies.  
**BIG STARTER KIT**  
Only \$16.95 ppd.

**WHITTEMORE,**  
BOX 2065EM, HANOVER, MASS. 02339

## An ATLAS BODY? In 7 days

my method of DYNAMIC-TENSION starts giving results you can feel and your friends will notice. Big, useful muscles. Gain weight, if needed. Lose "pot belly." Send your name and address for 32-page book—FREE.  
**CHARLES ATLAS, 49 West 23rd St., New York, N.Y. 10010 Dept. PB**



## BREW YOUR OWN FUEL

**BROWN'S ALCOHOL MOTOR FUEL COOKBOOK**  
Contains step-by-step procedures for the making and using alcohol as a motor fuel. How to build your own home still, how to modify your car's carburetor to run on alcohol & other engine modification to get up to 100 miles per gallon, & much more. Loaded with large clear photos, you'll be amazed at how easy it really is. Don't hesitate order your copy today!  
Book No. 390... \$9.95 postpaid  
**DESERV PUBLICATIONS**  
DEPT. PM — CORNVILLE, ARIZONA 86325



## GARAGE DOOR OPENERS

• Radio Controlled  
• Buy Factory Direct and Save  
• Thousands in Use • Free Brochure  
• Easy Homeowner Installation  
• Immediate Shipment by UPS or PP  
**HELPMATE Equipment Co. Dept. PM2-80 Baroda, MI 49101**



## BE A CHIMNEY SWEEP

Your Own Business: A chimney sweep can clean a chimney with the August West® System in one hour. Nationally, the average charge is \$40.00.

### A Growing Need:

The energy crisis has resulted in a dramatic increase in wood burning. Wood smoke deposits form a malleable creosote in chimneys. Regular cleaning is necessary to prevent fire damage.

### The August West® System:

More sweeps use it than any other method in the country.

Send for our free booklet, or call TOLL FREE any time and ask for "The August West Story."

**800-648-5311** Add for operator 51

Or Nevada (800) 952-5710

**August West Systems, Inc.**

Box 603 — Dept. PMN  
Westport, CT 06880



## HANDSOME BENCH YOU CAN BUILD

(Continued from page 184)

cut tenons on both ends as per shop drawing. Lay out and cut mortises on both end back posts. Then notch the center post to accept the rail. Follow by laying out the 20 holes for the back stays (J). The holes should allow the pieces to slip in and out easily to facilitate the assembly process later.

## Dry assembly

Next, round the arms with a rasp and scraper and sand when the proper contours are reached.

You are now ready for dry assembly of the arms and back. Expect some filing and trial-and-error matching until a good fit is achieved in all mating pieces. While the bench is dry-assembled, hold each end post tightly to the arm and bore the holes for brass screws. Then counterbore, insert screws and tighten, drawing the arms to the posts. Do the same to fasten the centerpost to the top rail. Disassemble.

## Prepare for final assembly

Have a bucket of warm water and a cloth handy to wipe away excess glue. Begin by fitting and gluing the back posts and stays to the seat, then to the top rail. Secure with a band clamp. Glue and assemble the arms and their stays (F and G). Cover all screw heads with wood plugs cut to match.

Use band clamps wherever needed, especially in joining posts to the seat and to the top rail.

## Finishing the bench

Allow the assembled unit to stand for 24 hours. Then, using the 180-grit sandpaper, sand all surfaces and break (round slightly) all sharp corners. Prepare all surfaces for staining by wiping with a tack rag. We used Minwax Ipswich stain for the finish shown in the lead photo on page 126.

Allow the first coat to stand undisturbed overnight before applying the second coat. Again, allow overnight drying. Then apply a coat of orange shellac. After four hours, rub all surfaces with No. 0000 steel wool and wipe down with a tack rag before applying a second shellac coat. Allow this coat to dry completely overnight.

Finally, rub gently with No. 0000 steel wool and wipe down with tack rag. Polish with a clean soft cloth and Carnauba wax.

Your Lincoln settee reproduction is now complete and should become a treasured possession in your family for generations to come. **PM**



## 4 VALENTINES FROM YOUR SHOP

(Continued from page 124)

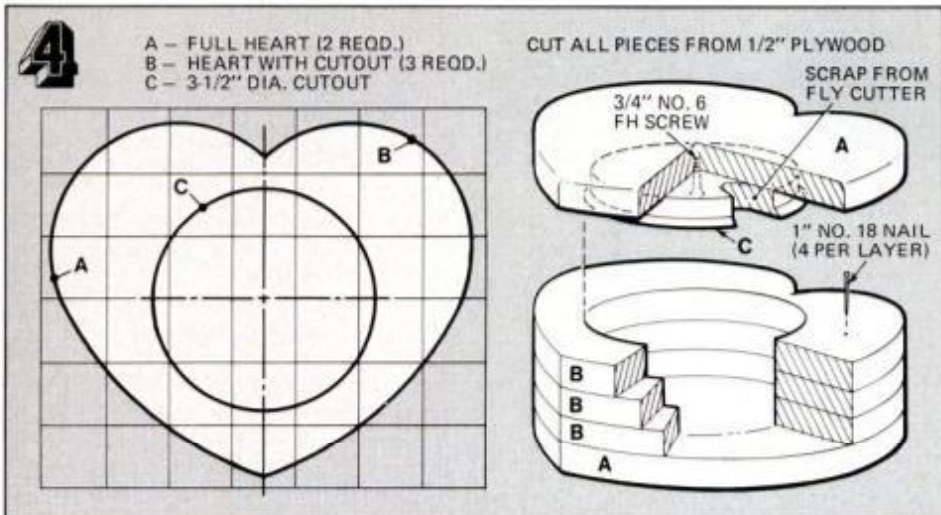
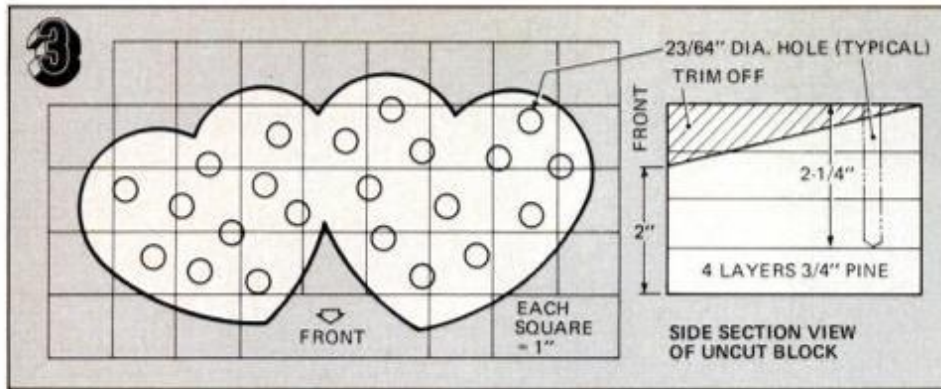

No complicated hardware is used to hold the mirror in a tilt position. Our version is designed with dowel "hinges" which are merely a force fit.

The mirror pretty much stays at the angle to which it is tilted. It will not, however, stand out at extreme angles (i.e., parallel to the base). The force-fit design works perfectly for any of the typical dresser-top mirror uses.

### Beginning work on the mirror

Start by laying out the heart shape on either cardboard or 1/8-in. hardboard. Cut out the template and transfer the design to one of the pieces of plywood. Tack this piece to the second piece of plywood and then cut out both of them at one time, using either a scroll saw or a bandsaw.

While the pieces are still tacked together, use a rabbet cutter in your router to cut the mirror-holding rabbet. Once you've gone this far, you can bring the cutouts to your local glazier and order the 1/8-in. mirror

### MATERIALS LIST—JEWELRY BOX

No.	Size and description
5	1/2 x 6 x 6" clear pine (or A-D grade plywood)

Misc.: Sandpaper, shellac, assorted spray paints, white glue.

### MATERIALS LIST—CRAYON HOLDER

No.	Size and description
1	3 x 5 x 9" pine (or glue up blocks of thinner stock to desired thickness)

Misc.: Sandpaper, paint.

hearts. The glazier can't cut a perfect heart—as you can with wood—but he should cut it close enough so all rounded spots will be hidden in the rabbet when the halves are joined. Remember to sand all of the edges before you separate the hearts.

Cut the remaining parts for the stand and assemble, using glue and nails. Separate the tacked-together heart pieces and temporarily reassemble them as they will be when they hold the mirror. Using a pair of hand screws, clamp the heart in position with the stand. With the setup held rigid in a vise, bore the holes for the hinge dowels. Then make a test assembly and, when satisfied, permanently assemble the mirror.

Seal all parts and paint with acrylic paints using the color photo on page 125 as a guide. Seal with Krylon No. 1301 spray.

### Ring caddy

Start by gluing up wood for the base (unless you have a suitably

(Please turn to page 194)

## Free! Edmund Scientific Catalog



Explore Astronomy, Biofeedback, Optics, Lasers, Magnets, Weather, Magnifiers, Microscopes, Photography... Over 4,000 Fascinating Products in Our **FREE** 100 page color Catalog! Send for your **FREE** Edmund Scientific Catalog, Today! **38 Years Of Service!**

Yes! Rush me your **FREE** catalog!

Name \_\_\_\_\_  
Address \_\_\_\_\_  
City \_\_\_\_\_  
State \_\_\_\_\_ Zip \_\_\_\_\_

Clip and Mail Coupon Today to:  
Edmund Scientific Co., Dept. 2020 H-04  
Edscorp Bldg., Barrington, N.J. 08007  
No. 156 ©1980 Edmund Scientific Co.

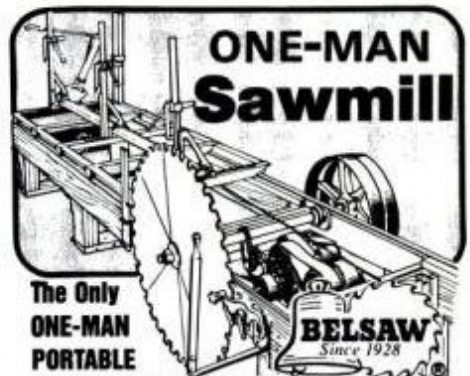

The Only  
**ONE-MAN  
PORTABLE**

**SAWMILL** Of Its Kind In The World!

If you need good, high-quality lumber, don't let inflated lumber prices stop your important building projects. The Belsaw goes right to the trees and turns out smooth, true-cut lumber... even beginners get excellent results. Just one man (no crew needed) can easily cut enough on weekends to save hundreds of dollars over high lumberyard prices. For power use tractor PTO or other low HP diesel or electric unit. Factory-direct selling keeps price low, and convenient time payments may be arranged.

Send for **FREE BOOK!** Just mail coupon below for "How To Saw Lumber" booklet and complete facts on the One-Man Sawmill. There is **NO** Obligation and **NO** Salesman Will Call on you. **Do It TODAY!**

**FREE BOOK** **BELSAW MACHINERY CO.**  
3124 FIELD BUILDING  
KANSAS CITY, MO 64111

Please send all facts and details in your **FREE BOOK** "How To Saw Lumber". I understand there is **No Obligation** and that **No Salesman** will call on me.

Name \_\_\_\_\_  
Address \_\_\_\_\_  
City-State \_\_\_\_\_ Zip \_\_\_\_\_



# Bargain Hunter

4 VALENTINES FROM YOUR SHOP

(Continued from page 193)

sized hardwood block in your scrap box). Do use hardwood for the base because you need its weight for stability.

Shape the block on the table saw, locate and bore cup-hook holes, sand, set aside. Lay out the hand on the 1/4-in. plywood and cut it out with a coping saw, scroll saw, sabre- or bandsaw. Sand all of the edges and surfaces and then seal them with shellac.

After checking parts for fit—remember that the hand should be “sloppy” in the kerf to allow for the flannel cuff—paint all parts, using the color photo on page 125 as a guide. When dry, assemble the cad- dy using glue.

## Crayon holder

To get the desired thickness, I created a laminated block by gluing up four layers of 3/4-in. pine. Use carpenter's glue and clamps—no nails are needed—and allow the block to dry for at least 24 hours.

It is easiest to do a neat job if you bore the crayon-holding holes and cut the slanting front *before* cutting the hearts to shape. You can do the first on the drill press and the second on either a radial or table saw using conventional cutting techniques.

In case you should forget to cut the angle first, use a belt sander and coarse-grit paper to shape the slanted front.

Sand the holder smooth, dust and apply spray paint. Some paint will fill the crayon holes a bit; you may have to use a rattail file to bring them back to easy-fit crayon-holding capacity.

## Jewelry box

You can use either 1/2-in. pine or plywood to make the heart layers. The former takes the paint better but the latter is stronger.

If you should decide to go with pine, you can increase its stability by alternating the grain direction of the hearts so each successive layer will have its grain at 90° to the one below it.

The three middle layers are cut out using a circle cutter (often called fly cutter) in the drill press. The cutter should be used with drill press at a slow speed and the workpiece must be clamped rigidly for safety. Set one of the circular cutouts aside for use as the cover's guide. This is simply glued and screw-fastened, using a single flathead screw.

Sand the box well, dust it off and then finish as per general instructions. **PM**



Annual Buyer's Guide  
160 Pages  
Over 500 Photos



## ASSEMBLE & DRIVE YOUR OWN FULL-SIZE SPORTS CAR

For the low price of an ordinary compact car, you can own an authentically detailed MG-TD replica, a full-size Dino Ferrari look-alike, or a gull-wing Porsche-inspired street racer. Altogether, there are more than 100 stylish antique, classic and modern coach reproductions known as “kit-cars.” Virtually all are simple one-for-one bolt-on body replacements designed to fit a variety of popular everyday cars.

Now you can get all the important details about these practical do-it-yourself money-saving conversions with the newest, largest, most comprehensive super catalog ever published. *The Complete Guide To Kit Cars* gives you 160 fact-filled pages of information about these revolutionary automobiles that can be assembled for a fraction of their apparent value. This giant buyer's guide is packed with everything from 40 MPG roadsters to fire breathing mid-engine V8's • All the models • All the Manufacturers • More than 500 photos • In-depth articles • Prices • Specifications • How-to features plus much more!

★ 14 Day Money Back Guarantee ★



\$7 Postpd.  \$10 Rush 1st Class  
 \$11 Foreign Air Mail

Bill to my:  Master Charge  VISA

Send Today To: **AUTO LOGIC, INC.**  
P.O. Box 2073, Dept. 703  
Wilmington, DE 19899

# \_\_\_\_\_ Exp. Date \_\_\_\_\_

Signature \_\_\_\_\_

Name (print) \_\_\_\_\_

Address \_\_\_\_\_

City \_\_\_\_\_ State \_\_\_\_\_ Zip \_\_\_\_\_



Order TOLL-FREE by phone.  
Master Charge or VISA REQUIRED!  
(800) 331-1000 Day or Night.  
(918) 664-8300 in Okla. call collect.

## NOW COMES IN 2 SIZES: PONY FOR SMALL GARDENS, HORSE FOR LARGE GARDENS.



## JUST ONE HAND!

So easy to handle you guide it with just one hand. And now the Troy-Bilt Roto Tiller-Power Composter is yours in 14 1/2" and 20" tilling widths. For complete details, prices, off-season discounts, send coupon below for free booklet.

Troy-Bilt, 102nd St. & 9th Ave., Troy, N.Y. 12180

Troy-Bilt Roto Tiller-Power Composters, Dept. A23  
102nd St. & 9th Ave., Troy, N.Y. 12180

Please send the whole exciting story of Troy-Bilt® Roto Tiller-Power Composters, including prices, specifications and off-season savings.

Mr. \_\_\_\_\_ (Please Print Clearly)

Mrs. \_\_\_\_\_

Miss \_\_\_\_\_

Address \_\_\_\_\_

City \_\_\_\_\_ State \_\_\_\_\_ Zip \_\_\_\_\_

## START MAKING CHEAP "HOMEMADE FUEL."

## STOP WASTING MONEY ON GAS.

Step-by-step instructions how to:

- convert your car's engine to operate on alcohol.
- produce your own cheap "Homemade Fuel."

Send only \$10.80 for the "Homemade Fuel" Book.

## SEGO ENERGY

Box 1290A Palsade, Colorado 81526

## 110 VOLT A.C. GENERATORS

60 cycles, 3000 watts. WT. 27 pounds. 5' x 10" Fanbelt driven from car or pickup. Operates. T.V. All power tools. Over 17,000 in service. This is our 30th year. Guaranteed 6 months. \$169.00. Our X1200-watt generator needs no battery. Special price \$159.00. Add \$6.50 for postage & handling, per unit.

VIRDEN PERMA-BILT Box 7160 PM  
2821 Mays, Amarillo, TX 79109  
Phone: 806/352-2761

## TILLS & HOES & SAVES

### KEEPS GARDEN CLEAN, PRODUCTIVE

Low priced, multi-purpose tiller/hoe. A joy to operate. 30-day home trial. Shipped prepaid (ex. AK, HI). Free information.



AUTO HOE,  
P. O. Box W121A2, De Pere, Wis. 54115

## EARN BIG COMMISSIONS

### WORK FULL OR PART TIME!

Show big FREE SALES KIT featuring complete line low priced business printing and ad specialties to business people. Build profitable repeat business. Start now.

NATIONAL PRESS, INC.  
DEPT. 021 NORTH CHICAGO, ILLINOIS 60064



## DRIED FLOWERS ARE 'IN'...

All your favorite flowers for dried arrangements are in Herbst Bros. FREE 72-page seed catalog. Send today.

## HERBST BROTHERS SEEDSMEN, INC.

1031 N. Main St. Brewster, NY 10509 (914) 279-2971

## Burglar-Fire Protection



Protect Your Life, Home, Business, Auto, etc.

- Our catalog shows how. Install your own alarm systems and devices and save \$555. We offer FREE write-in engineering service.

FREE CATALOG Lowest Prices on Reliable, High-Quality Alarm Systems and Devices

Burdex Security Co. Box 82802-PM Lincoln, Ne. 68501





### SAVE HUNDREDS OF DOLLARS

Imagine yourself the builder of this attractive ALL PURPOSE BARN 24' by 36' by 18' high with easy to follow plans. Appealing to the eye in suburban, farm, ranch, lake area. Many uses as 3 or 4 car garage, boats, campers, store, lodge. Plans call for concrete floor, ceiling joist, plywood loft flooring, suggested window and door locations. Send \$10.00 for plans and material list 24' x 36' HORSE BARN PLANS showing 3 stalls, tack room \$12.00. Send 50¢ for brochure and other projects to build.

**HAMMOND BARNs, Dept. PM802**

Box 584, 3130 Hardacre Court, New Castle, Indiana 47362.



### WASTE OIL HEATER

For Shop, Garage, Warehouse and Farm

Waste Oil Worth 80¢ per gallon as a heating fuel.

Pay Yourself not the fuel companies. Heat with any type of waste oil. LENAIR Waste Oil Heaters are a smart investment. Models 75,000 and 130,000 BTU Forced Air.

PROVEN • SMOKELESS ODORLESS

WRITE  
**LENAIR INDUSTRIES INC.**  
P.O. BOX 1017-C  
JANESVILLE, WI 53545  
DEALER INQUIRIES WELCOME

### BELOW WHOLESALE! ELECTRONIC IGNITION MODULES

(BRAIN BOXES)



**\$33.00**  
ALL FORD TYPES

MEET OR EXCEED FACTORY O.E. SPECS



**\$17.50** ALL G.M. TYPES



**\$13.95** ALL CHRY TYPES

ALL ITEMS **\*90 DAY GUARANTEE** MADE IN USA

### TESTERS

STYLE #1 FOR

CHARGING SYS.  
TESTS BATTERY  
REG. ALT. AND  
ALT COMPONENTS

**\$13.95**

STYLE #1 SHOWN



STYLE #2 FOR

ELECTRONIC IGN.  
TESTS ALL IGNITION  
COMPONENTS AND  
PINPOINTS DEFECTIVE  
PART

**\$16.95**

POCKET SIZE - EASY TO USE  
BOTH STYLE #1 & #2 FOR \$29.95  
WHEN ORDERED TOGETHER

SHIPPED WITHIN 24 HRS. UPON RECEIPT OF ORDER. Replaces factory modules that are responsible for the majority of electronic ignition failures—even if your ignition is OK now, don't be caught without a spare module. EASY TO INSTALL. Other electronic auto parts at similar savings. WRITE FOR FREE BROCHURES COVERING FULL LINE \*Return limited to purchase price or replacement.

NAME \_\_\_\_\_  
ADDRESS \_\_\_\_\_  
CITY \_\_\_\_\_ STATE \_\_\_\_\_ ZIP \_\_\_\_\_

TO: AMERICAN COMPONENTS Please ship me \_\_\_\_\_ (qty.)  
P.O. BOX #1529 modules for a 19\_\_\_\_\_  
TROY, MICH. 48099 (car make)

style # \_\_\_\_\_ (qty.) pocket size tester(s)

cert. ck. or chg. my: Master chg. Visa acct# Please find enclosed money order.

Exp. date \_\_\_\_\_ for the advertised price of \_\_\_\_\_

+ \$1.50 per order shipping & handling. Mich. residents add 4% sales tax.

Signed \_\_\_\_\_

### TV TO STEREO SOUND ADAPTER



### GET SIMULATED STEREO SOUND FROM YOUR TELEVISION!

TELEDAPTER® easily connects to your own TV and stereo system to give you full rich simulated stereo sound through your amplifier and speakers. TELEDAPTER'S electronic circuitry matches the impedance between your TV and stereo amplifiers' aux., tape, or tuner input, while completely transformer isolating the TV's & stereo's chassis, for safety. The matrix circuitry provides two channels of output that plug directly into your stereo. Those ballgames and movies will never be the same after you hear the realistic thundering sound. Only \$19.95 postage paid, complete with hookup instructions, 2 year warranty.

To order: Enclose check • VISA or MasterCard # \_\_\_\_\_

Expiration Date \_\_\_\_\_ Bank # \_\_\_\_\_  
NAME \_\_\_\_\_

ADDRESS \_\_\_\_\_  
CITY \_\_\_\_\_

STATE \_\_\_\_\_ ZIP \_\_\_\_\_

\*Satisfaction guaranteed or your money promptly refunded.\*

**RHOADES**  
NATIONAL CORPORATION

Dept. PM - P.O. Box 817  
Hendersonville, TN 37075  
(615) 824-1735

SEND COMPLETE CATALOG

### PORTABLE ELECTRIC POWER

Build your own 110-Volt Electric Plant from used parts. Will operate lights, power tools, heating units, brush-type elect. motors, plus charge batteries and arc weld. Ideal for boats, campers and portable shops. Plans \$9.95 check or M.O. **CHAPALA CO.**  
1020 E. Irvine, Dept. M. Tustin, Calif. 92680

### COUNTERFEIT GUNS BLANK-FIRING (STARTER PISTOLS)

AUTHENTIC! FULL-SIZE MACHINED METAL PISTOLS CANNOT BE MADE TO FIRE REAL AMMUNITION. These blank firing pistols are NOT firearms! No federal license required. Purchaser MUST be 18 years or older. Money back (less postage) if not satisfied.

SAME SIZE & WEIGHT AS ORIGINAL **\$47.95** PLUS POSTAGE

**POLICE .357 MAGNUM**  
Length: 9.25" Weight: 2.2 lbs.  
U50-2061 **\$47.95**

U50-228C. Blank cartridges. Box of 100 **\$4.95**

Add \$1.50 POSTAGE/HANDLING TO EACH ORDER

UNIQUE IMPORTS, INC., Dept. PM020  
800 SLATERS LANE, ALEXANDRIA, VA 22313

Send  U50-2061  U50-228C  FREE COLOR CATALOG

Charge to: VISA  MC  AX  CB  DC

\* LIST ALL NUMBERS ON CARD. INCLUDE EXP. DATE:

NAME \_\_\_\_\_  
ADDRESS \_\_\_\_\_  
CITY / STATE / ZIP \_\_\_\_\_

MONEY BACK (LESS POSTAGE) IF NOT SATISFIED

### BUILD YOUR OWN POWER TOOLS

SAVE \$50 TO \$300

METAL PARTS KITS AT LOW FACTORY DISCOUNT PRICES FOR:

- 12-IN. BAND SAW
- 18-IN. BAND SAW
- 6-IN. BELT SANDER
- SPINDLE SHAPER
- 10-IN. TILT/ARBOR SAW

PLANS Full Size Patterns **\$2.50** EACH REDUCTIBLE

KITS FROM  
• COMB. DRILL PRESS-LATHES \$32.99 to \$124.99

Step-by-step plans, photos show how. No machining or welding. 78,000 in. use. 5-Year Guarantee. Send \$3.00 for plans (Ppd.) or 50¢ for Catalog. **GILLIOM MFG., INC.** Dept. PM-2, St. Charles, Mo. 63301

## Add bolts and love and what do you get?

### A quality machine that YOU built!

7 Tryke Models, and 6 Bike Models. Many accessories, including bench seat

**SUPER BRONC**

**SUPER TRYKE**

**SUPER TRYKE**

Easy-to-build semi-kit saves you money. Engine is completely assembled, frame is welded and painted. With common tools and our 22" x 34", fully illustrated instruction sheet, you just bolt everything together and start riding!

- Rugged vehicles powered by 5 hp to 16 hp American-made engines.
- All have torque converters (no shifting), four-shock suspension and tough, tubular steel frames.
- Can be licensed for street riding in many states.
- Can be registered as farm machinery.
- Kit priced from \$399.95 to \$799.95, less accessories.

For exploring, hunting, fishing, and occasionally even for work, these machines bring a lot of pleasure. If backwoods riding is your kind of fun, write today for a FREE color brochure, to:

**Carl Heald, Inc.** Dept. PM-02 P.O. Box 1148, Benton Harbor, MI 49022

From the Largest Maker of Bike and Tryke Kits in the World — Carl Heald



Heats 25-48 hours on just  
1 gallon of fuel!  
**THE SUPER BLUE FLAME  
PORTABLE KEROSENE HEATER**

Similar heaters sell  
for \$100 — ours only  
**\$42<sup>95</sup>**

- Saves fuel dollars!
- Non-electric!
- No odor!
- No smoke!
- Doubles as cooker and humidifier!
- No chimney venting!



## CHEAP HEAT!

- Kerosene heat is the most inexpensive supplement to permanent household heat.
- Turn your thermostat down & turn your Blue Flame Heater on in just the room you are in!

Our 12,000 BTU kerosene-burning space heater keeps a large 12' x 18' room comfortably warm. Raises temperature of smaller 12' x 15' room by approximately 50°F! Supplies intense, even, quick-starting heat. Economically heats colder rooms — or garage, workshop, basement, cabin, boat, greenhouse, etc. One gallon of kerosene burns 25 hours on highest flame, up to 48 hours on lower setting. **A FRACTION THE COST OF ELECTRIC HEATERS!** Depending on flame height, burns full 9¼ to 18 hrs. per 3 pt. tank-full — a long time without refueling!

Top functions as cooking surface and humidifier (moist air retains heat). Has air-cooled coil handle, wide no-tip base, corrosion-resistant fuel tank, fuel gauge. Lightweight (approx. 5½ lbs.), portable. Can secure in one place. Baked enamel. 19½" high x 11½" diam. at base. Wick cleaner included. Wick lasts approx. 3 months if used daily. (Extra wicks \$4.95 ea.). **SUPER HEATERS:** One for \$42.95, two \$83.90, three \$122.85. Add \$3.50 per unit shipping & handling. N.J. Res. add 5% sales tax. Master Charge & Visa welcome. **ORDER TODAY!**

DORSAY, 142 MacArthur, Dept. 275,  
Garfield, N.J. 07026. (201) 546-5507.

**(Dealer  
Inquiries  
Invited)**

**30-DAY NO-RISK GUARANTEE**  
You must be fully satisfied with your Blue Flame Heater, or return it in 30 days for a refund. No questions asked.

**CREDIT CARD CUSTOMERS MAY  
CALL TOLL FREE TO ORDER —**  
24 hrs. a day, 7 days a week

**DIAL 1-800-241-0604**  
(In GA. 1-800-282-7418)

ASK FOR  
OPERATOR  
111

DORSAY, 142 MacArthur Ave., Dept. 275,  
Garfield, N.J. 07026. (201) 546-5507

Please send me \_\_\_\_\_ **SUPER HEATER(S)** #241  
(one \$42.95, two \$83.90, three \$122.85)  
Send \_\_\_\_\_ Extra Wick(s) #324 at \$4.95 ea.

Add \$3.50 per heater shipping & handling.  
N.J. Res. add 5% sales tax. Enclosed is \_\_\_\_\_

Charge my  MC  VISA Exp. date \_\_\_\_\_

Name \_\_\_\_\_  
Signature \_\_\_\_\_

Name \_\_\_\_\_  
Address \_\_\_\_\_  
City \_\_\_\_\_  
State \_\_\_\_\_ Zip \_\_\_\_\_

©1979 Dorsay

Fuel-Thrifty ATV's

It only takes  
\$2710 to become  
an exclusive **MAX**  
All Terrain  
Vehicle Dealer\*



6 WHEEL  
DRIVE

AMPHIBIOUS

And that includes your vehicle  
delivered to you Freight Free!

Get the Facts on the Fuel-Thrifty ATV  
Write **MAX**, Dept. A-3, 60 Depot St.  
Buffalo, N.Y. 14206 • (716) 855-2226

Name \_\_\_\_\_

Address \_\_\_\_\_

City \_\_\_\_\_

State \_\_\_\_\_ Zip \_\_\_\_\_

\*If the territory is still open.  
(YOU MUST BE 21 YEARS OF AGE)

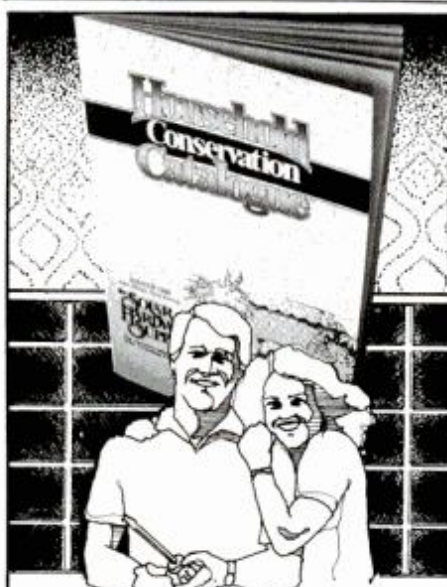

## Give yourself a Housewarming.

The new Household Conservation Catalog is full of products and ideas to help you save money as you save energy — in every room of your home.

From caulking to solar hot water, we've got you covered.

Send \$1.00 (refundable with first purchase) to:

**SOLAR  
HARDWARE  
SUPPLY** Dept. PM  
2160 Clay  
Denver, Colorado 80211

It's more than a catalog, it's an energy education.  
The Consumer Sales division of Solar Technology Corporation

**CHOOSE YOUR  
FREE BUTTON!**  
(OVER 1,000 CHOICES)



**PROMOTE • RAISE FUNDS  
MAKE PROFITS • IDENTIFY**

It's America's most extensive line of badge and button making equipment. Useful for clubs, schools, business, individuals. Basic kit contains hand die press, color coded dies, badge parts and illustrated instructions. All for just \$24.95.



SEND TODAY

**BADGE-A-MINIT, Ltd.,** Box 618, Dept. PM-20  
Civic Industrial Park, LaSalle, IL 61301

Yes, I want to choose my FREE Sample Button. Send your 48-page color catalog.

I'm convinced, send me the complete **BADGE-A-MINIT** system. I've enclosed \$24.95 plus \$1.75 postage. Ill. Residents add 5% sales tax.

Use my credit card indicated below:

VISA (BankAmericard)  Master Charge

American Express

Credit Card # \_\_\_\_\_ Exp. Date \_\_\_\_\_

Inter Bank # \_\_\_\_\_ Signature \_\_\_\_\_

Name \_\_\_\_\_

Organization \_\_\_\_\_

Address \_\_\_\_\_

City \_\_\_\_\_ State \_\_\_\_\_ Zip \_\_\_\_\_

**UNCONDITIONAL MONEY-BACK GUARANTEE**



**WHAT'S THIS?  
PUT VENEER  
ON WITH AN  
IRON?**

**FREE:** Send for free iron-on veneering instructions and colorful veneer craft catalog today!

Announcing! Use new iron-on veneering technique and Bob Morgan's wood veneers to create beautifully veneered furniture quickly and easily! Just put new hot melt glue sheet between veneer and other wood surface. Then apply heat with an iron. Veneer is ironed in place in only 2 minutes. Guaranteed foolproof! Send now for free catalog. Catalog lists 101 varieties rare veneers, needed supplies, tools, and hot melt glue sheet at reasonable prices. Bargain starter offers also included. **SAVE 25%. Hurry!**

**BOB MORGAN WOOD, DEPT. PO1K6**  
1123 Bardstown Rd., Louisville, Ky. 40204

**INVENTORY ADJUSTMENT SPECIAL!**

**PILOT'S GLASSES AT  
UNBELIEVABLE PRICES!**

**ONLY  
\$6.95**

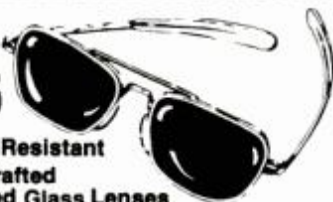

- Impact Resistant
- Handcrafted
- Polished Glass Lenses
- Hardened Metal Frames
- Money Back Guarantee

To order, send check or money order (include \$1.00 for postage and handling) to U.S. Optics, Dept. 306, P.O. Box 14206 Atlanta, GA 30324. (Please specify gold or silver frames.) **SPECIAL:** Order now and get **TWO PAIR** for \$13 plus one dollar handling charge.

**FREE! During this limited offer.**  
Deluxe velour lined protective case. A \$3.00 value.

**LIMITED OFFER FROM U.S. OPTICS**



3 BOOKS COUNT AS 1 SELECTION—972/982/993: 566 p.—Customizing Your Pickup; Fixin' Up Your Van on a Budget & Super Vans (\$15.85 paperbacks)

**CUSTOMIZING YOUR PICKUP**

**FIXIN' UP YOUR VAN ON A BUDGET**

**SUPER VANS**

**HOW TO MAKE HOME ELECTRICITY FROM WIND, WATER & SUNSHINE**

1128-252 p.—How to Make Home Electricity From Wind, Water and Sunshine (\$9.95)

**Outdoor Projects for Home & Garden**

1116-512 p.—Outdoor Projects for Home & Garden (\$12.95)

**HOW TO PUT UP YOUR OWN POST-FRAME HOUSE AND CABIN**

1154-378 p.—How to Put Up Your Own Post-Frame House & Cabin (\$12.95)

**MAKING TOYS IN WOOD**

2 BOOKS COUNT AS 1 SELECTION—318/915: 490 p.—Making Toys in Wood & The Build-It Book of Learning Playthings (\$18.90)

**THE BUILD-IT BOOK OF LEARNING PLAYTHINGS**

2 BOOKS COUNT AS 1 SELECTION—1084/1086: 1184 p.—Handbook of Home Improvements/Remodeling & Encyclopedia of Do-It-Yourself Projects (\$32.90)

**THE FAMILY HANDYMAN HANDBOOK OF HOME IMPROVEMENT & REMODELING**

**The Family Handyman Encyclopedia of Do-It-Yourself Projects**

1196-280 p.—Adding Solar Heat to Your Home (\$12.95)

**ADDING SOLAR HEAT TO YOUR HOME**

**THE STONEMAKER'S BIBLE**

1226-294 p.—The Stonemaker's Bible (12.95)

**WORKING WITH PLYWOOD, Including Indoor/Outdoor**

1144-384 p.—Working With Plywood, including Indoor/Outdoor Projects (\$12.95)

3 BOOKS COUNT AS 1 SELECTION—906/1036/1063: 552 p.—Homeowner's Guide to Solar Heating/Cooling; How to Cut Your Electric Bill & How to Install Your Own Home/Mobile Electric Plant (\$13.85 paperbacks)

**Homeowner's Guide to Saving Energy**

2 BOOKS COUNT AS 1 SELECTION—903/904: 566 p.—Guide to Modern Heating/Cooling Systems & Homeowner's Guide to Saving Energy (\$18.90)

1168-182 p.—How to Repair Clocks (\$9.95)

**HOW TO REPAIR CLOCKS**

**SMALL APPLIANCE REPAIR GUIDE—Vol. 2**

715/745: 406 p.—Small Appliance Repair Guide & The Home Appliance Clinic: Controls, Cycle Timers, Wiring & Repair (\$15.90)

**THE HOME APPLIANCE CLINIC: Controls, Cycle Timers, Wiring & Repair**

**HOMEOWNER'S GUIDE TO SOLAR HEATING & COOLING**

**HOW TO INSTALL YOUR OWN HOME OR MOBILE ELECTRIC POWER PLANT**

**How to Cut Your Electric Bill and Install Your Own Emergency Power System**

**HOW TO BUILD YOUR OWN UNDERGROUND HOME**

4773-512 p.—TWO BOOKS IN ONE BINDING—How to Build Your Underground Home & How to Build Adobe Houses . . . etc. (\$24.90)

**How To Build Adobe Houses**

**THE COMPLETE LIBRARY OF METAL WORKING, SOLDERING, & BLACKSMITHING**

378-434 p.—The Complete Library of Metal Working, Soldering & Blacksmithing (\$24.85)

**66 WEEKEND WOOD FURNITURE PROJECTS**

2 BOOKS COUNT AS 1 SELECTION—974/1188: 840 p.—66 Weekend Wood Furniture Projects & 66 Children's Furniture Projects (\$23.90)

**66 Children's Furniture Projects**

1087-182 p.—How to Repair Briggs & Stratton Engines (\$7.95)

**How to Repair Briggs & Stratton Engines**

1044-448 p.—The Woodturner's Bible (\$14.95)

**THE WOODTURNER'S BIBLE**

925-406 p.—Practical Electrical Installation, Repair & Rewiring (\$12.95)

**PRACTICAL ELECTRICAL INSTALLATION, REPAIR & REWIRING**

An Extraordinary Offer to introduce you to the benefits of Membership in

# HOW-TO BOOK CLUB

take any **6** (UP TO 14 DIFFERENT BOOKS) of the selections on this page **99¢** for **ALL SIX**

with a Trial Membership in the Book Club that guarantees to save you 25% to 75% on a wide selection of how-to books.

## Facts About Club Membership

● The 6 introductory selections (up to 14 different books) of your choice carry publisher's retail prices of up to \$141.35. They are yours for only 99¢ for all six (plus postage and handling) with your Trial Membership ● You will receive the Club News, describing the current selection, alternates and other offerings every 4 weeks (13 times a year) ● If you want the selection, do nothing: it will be sent to you automatically. If you do not wish to receive the selection, or if you want to order one of the many alternates offered, you simply give instructions on the reply form (and in the envelope) provided, and return it to us by the date specified. This date allows you at least 10 days in which to return the form. If, because of late mail delivery of the Club News, you do not have 10 days to make a decision and so receive an unwanted selection, you may return it at Club expense ● To complete your Trial Membership, you need only buy four additional monthly selections or alternates during the next 12 months. You may cancel your Membership any time after you purchase these four books ● All books—including the Introductory Offer—are fully returnable after 10 days if you're not completely satisfied ● All books are offered at low Member prices plus a small postage and handling charge ● Continuing Bonus: If you continue after this Trial Membership, you will earn a Dividend Certificate for every book you purchase. Three Certificates, plus payment of the nominal sum of \$1.99, will entitle you to a valuable Book Dividend of your choice which you may choose from a special list provided Members.

Let us send you your choice of 6 (up to 14 different books) of these practical book selections as part of an unusual offer of a Trial Membership in How-To Book Club.

Here are quality volumes, each designed to help you increase your know-how, save you money, and make your leisure hours more enjoyable. Whatever your needs, How-To Book Club offers books you can put to immediate use and benefit.

This extraordinary offer is intended to prove to you, through your own experience, that you can keep up with new books, and save while so doing! As part of your Trial Membership, you need purchase as few as four books during the coming 12 months. You would probably buy at least this many anyway . . . without the substantial savings offered by the Club.

To start your Membership on these attractive terms, simply fill out and mail the coupon today. You will receive the 6 selections (up to 14 books) of your choice for 10-day inspection. YOU NEED SEND NO MONEY! If not delighted, return the books within 10 days and your Membership will be cancelled without obligation.

HOW-TO BOOK CLUB, Blue Ridge Summit, Pa. 17214

## HOW-TO BOOK CLUB

Blue Ridge Summit, Pa. 17214

Please open my Trial Membership in HOW-TO-BOOK CLUB and send me the 6 selections (up to 14 books) circled below. I understand the cost of the books I have selected is only 99¢ for ALL 6, plus a small shipping charge. If not delighted, I may return the books within 10 days and owe nothing, and have my Trial membership cancelled. I agree to purchase at least four additional books during the next 12 months, after which I may cancel my Membership at any time.

318/915 378 715/745 903/904  
906/1036/1063 925 972/982/993  
974/1188 1044 1084/1086 1087 1116  
1128 1144 1154 1168 1196 1226 4772

Name \_\_\_\_\_ Phone \_\_\_\_\_

Address \_\_\_\_\_

City \_\_\_\_\_

State \_\_\_\_\_ Zip \_\_\_\_\_

(Valid for new Members only. Foreign and Canada add 15%.) PM-280



You can have a happier life  
— an excellent income  
perform a service  
everyone needs  
— work part time or full time

You can make good money from the growing demand for on-location cleaning. Every home and building are potential customers. Every customer represents repeat business. Clean carpet, upholstery and walls on-location using Von Schrader professional cleaning equipment, the finest of its kind. No special skills or experience needed. You can start part time with just one machine. As your business grows you can add the other two and thus offer a complete cleaning service. Equipment is light and portable. This is not a franchise. You pay no fees, dues or royalties. You own the equipment (amazingly small investment) keep all you earn. And we help you every step of the way. For 46 years we have helped thousands of users to enjoy a steady, growing business. We'll send you full information—learn



how others became financially independent. So—take that first important step by mailing the coupon or call Toll Free

1-800-558-2484  
(except in Wisconsin, Alaska, Hawaii).

**VON SCHRADER company**

1020 Place, Racine, WI 53403  
Send for information. (No salesman will call.)

Name \_\_\_\_\_  
(Please print)  
Address \_\_\_\_\_  
City \_\_\_\_\_ State \_\_\_\_\_ Zip \_\_\_\_\_

**USE  
ZIP CODES  
WHEN  
ANSWERING  
ADS**

**HOME-BUILT ALTERNATE ENERGY PLANS**

Build these simple home systems from local parts & tools and enjoy FREE heat, light & power! COMPLETE PLANS: \$6.00 EACH, ANY 3 FOR \$15.00

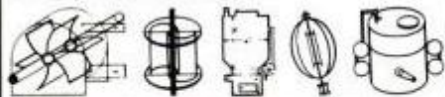

**3000 WATT WOODBURNING STEAM TURBINE.** Convert wood to valuable Electricity! Includes Boiler & battery details.  
**2000 WATT VERTICAL SHAFT SAVONIUS WINDTURBINE.** Offers simpler construction & efficiency than conventional windmills.

**PORTABLE GASOLINE GENERATION SYSTEM.** Uses Negative combustion to run any gas engine, even vehicles! Produces 1 liter gas equivalent from only 2 kg. of wood!  
**2000 WATT DARREIUS VERTICAL SHAFT ROTATING AIRFOIL.** Most advanced concept in Windpower! Offers high efficiency, low cost!

**METHANE GAS GENERATOR.** Produce Methane gas to heat & light city homes or farms from normally wasted resources! Cook with Methane & even run gas engines!

**GLENVALE PRODUCTS Dept. PM2, Box 358 Station D, Toronto, Ontario M6P 3J9**



*Steuben?*

No! Your glass, etched by you with **Armour Etch™**, an exciting new do-it-yourself kit that revives the ancient art of etching. With it, you can create rich, permanently etched designs — as beautiful as collector's items — on any glassware, windows or mirrors. You won't believe how easy it is!

*No art talent necessary*  
Just trace, cut, apply Armour Etch. Use our patterns or any that strike your fancy from magazines, newspapers, craft books, etc.

*Now you can etch:*  
All Glass Windows, Mirrors, Household Glassware, Stained Glass, Lamps, Fish Tanks, Terrariums, Storm Doors, Auto Glass, Fireplace Doors, China Cabinets.



*Kit contains:*

Armour Etch Cream, applicator brush, Armour Cleaner Concentrate, hobby knife, masking vinyl, reusable vinyl gloves, step-by-step illustrated instruction book. **PLUS 45 full size etching patterns.**

*only \$9.95*

**ARMOUR PRODUCTS** PM20  
Hill St., Midland Park, N.J. 07432, U.S.A.  
Please send me \_\_\_\_\_ Armour Etch kits at \$9.95. Add \$1.00 for postage and handling. (New Jersey residents add 5% sales tax.)

Name \_\_\_\_\_  
Address \_\_\_\_\_  
City \_\_\_\_\_  
State \_\_\_\_\_ Zip \_\_\_\_\_

**PARKS 12" THICKNESS PLANER**



The PARKS NO. 95 is a compact, modestly priced planer with mill planer precision and ruggedness. More than 40,000 in use around the world. Write NOW, for complete details!

**THE PARKS WOODWORKING MACHINE CO.**  
Dept. PM, 1501 Knowlton St., Cincinnati, Oh. 45223  
"Mfrs. of Quality Woodworking Machines Since 1887"



**IF YOU USE A VISE - YOU NEED KANT-SCRATCH VISE GRIPS** Created, tested and approved by expert mechanics for precision work! No slipping no "jiggling". Cannot scratch or mar the surface. Holds threaded and round material securely with perfect safety. Eliminates the damage to high polished or finished objects held in the vise. Sizes 3 - 3 1/4 - 3 1/2 - 3 3/4 - 4 inches - \$4.00. Sizes 4 1/4 - 4 1/2 - 4 3/4 - 5 inches - \$4.50. All taxes and shipping included. Allow 15 days for delivery. **FEST SPECIALTIES, 443 BRENDA, WEST COVINA, CA 91791**

**Laser 917. A Unique Sports Car Kit**  
FOR VW. FUN, EASY TO BUILD.  
Send \$3 for color brochure  
Send \$29.95 for brochure and assembly manual  
Credit card ordering  
**CALL TOLL FREE 1-800-328-8898**

**Elite Enterprises Dept. PM2801**  
690 East Third St. Cokato, MN 55321

**AUTOMATIC SAW SET**  
Set saw teeth automatically—100 per minute without effort. Perfect hammer and anvil action sets teeth uniformly—no tooth breakage.

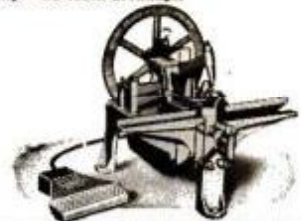

**FOR HAND SAWS AND BAND SAWS**  
Write for details  
**BURR MANUFACTURING CO.**  
8931 Venice Blvd.  
Los Angeles, Calif. 90034

**neova II** VW HOVERCRAFT  
uniquely different  
land - water 40 mph  
info pack \$8  
plans - kits available

**NEOTERIC - USA - INC.**  
Terre Haute, Indiana, 47780  
Ph. (317) 466 2303

**Wooden Toy Patterns Catalog**

**OVER 200 DESIGNS  
FREE PATTERNS & WHEELS  
WITH CATALOG PURCHASE  
ONLY \$1.00 REFUNDABLE**

*Low-Built Toys & Crafts*  
2907 Lake Forest Rd.  
P.O. Box 5459-133 Tahoe City, Ca. 95730

**IMPORTED LOCK BLADE**

9" Overall Length  
5" When Closed  
**\$3.50 Ea.**

- Sharp and Tough
- Stainless Steel Blade

Flips open instantly and locks automatically to prevent accidental closing. Razor sharp tough stainless steel blade for reliable use and hard long service. Send \$3.50 plus \$6 to cover postage and handling.

Model # K-12-AL  
Not for sale in areas where prohibited by law

**WESTBURY SALES CO.**  
373 MAPLE AVE. Dept. L-2-PM WESTBURY, N.Y. 11590





# Know your car inside and out.

Know how to fix it... to tune it... to service it... to keep it running right. The TOTAL SERVICE MANUAL for your car will show you how to do everything from a minor adjustment to a major repair.

factory workshop manuals. Each one is carefully written for use by the do-it-yourself car owner. Clear and easy to follow, yet complete and detailed enough even for professional use. You get all the important information plus hundreds of the best pictures, diagrams, and specifications.

TOTAL SERVICE MANUALS are digests of official

## TOTAL SERVICE MANUALS

SATISFACTION GUARANTEED OR YOUR MONEY BACK

1713	ALFA ROMEO 62-78 for all Giulia, GT & Spider models	\$9.95
9641	ALFA ROMEO ALFETTA 73-78	\$9.95
9643	AMC AMBASSADOR 68-74 covers all models	\$9.95
8677	AMC PACER 75-77 covers all models	\$9.95
0991	ARROW PLYMOUTH 76-77 for all models	\$9.95
9404	ASPEN DODGE 76-78 for all models	\$9.95
7122	AUDI 100 70-77 for all models inc 100L	\$9.95
0664	AUDI 5000 77-79	\$9.95
8749	AUDI FOX 73-79 covers all models	\$17.50
0916	AUSTIN AUSTIN 68-71 covers all models inc 1100, 1300	\$9.95
1203	AUSTIN BEALEY 100VA, 3000 56-68 for all models	\$9.95
0752	AUSTIN MARIN 71-75 sedan and GT models	\$9.95
0379	BARRACUDA & CUDA 65-72 all 6 & V8 models	\$7.95
0503	BLAZER, CHEV 59-77 for all 2 & 4 wheel drive models	\$7.95
1007	BMW 1600 66-73 covers all models	\$9.95
1042	BMW 2000, 2002 66-76 covers all models inc CA, CS, TI	\$9.95
9813	BMW 320 75-78 covers all models	\$9.95
9760	BMW 2500, 2800, 3.0 all models inc Bavaria & CS	\$10.95
0883	BOBCAT, MERCURY 76-79 covers all models	\$7.95
0504	BRONCO, FORD 66-77 for all 2 & 4 wheel drive models	\$7.95
0024	BUCIK 66-74 factory manual must give car year	\$12.95
0727	CADILLAC 68-74 all models except El Dorado	\$9.95
8678	CAMARO 67-78 covers all 6 & V8 models	\$9.95
9557	CAPRI 70-76 for all 2000, 2600, 2800 models	\$9.95
0379	CHALLENGER 70-72 covers all 6 and V8 models	\$7.95
8331	CHARGER 67-70 for all models inc 500 & R/T	\$7.95
8212	CHARGER 71-75 covers all models	\$7.95
0383	CHEVELLE 64-77 inc Malibu, Monte Carlo, El Camino	\$7.95
0638	CHEVETTE 76-78 covers all models	\$9.95
1038	CHEVROLET 29-40 covers all 6-cyl models	\$15.00
0888	CHEVROLET 49-54 reprint of factory shop manual	\$16.00
0051	CHEVROLET 55 or 57 reprint of factory manual, give year	\$19.95
8407	CHEVROLET 56 supplement to 55 manual	\$9.95
0870	CHEVROLET 68-77 for all full size models	\$7.95
8187	CHEVY II 62-77 covers all 6 & V8 models	\$7.95
0779	CHEVY LUV 72-77 covers all models	\$9.95
1661	CHEVY PICK UP 67-78 all models & GMC	\$9.95
1662	CHEVY VANS 67-78 for all models & GMC	\$9.95
1145	CHRYSLER 55-71 all inc Newport, 300, New Yorker	\$9.95
0020	CHRYSLER 72-79 factory manual must give year	\$22.95
9588	CITROEN ID, DS 67-73 for all models 19, 20, 21	\$9.95
8539	CITROEN SM reprint of factory service manual	\$19.95
8264	COLT, DODGE 71-77 covers all models	\$9.95
9422	COMET 60-65 covers all models	\$7.95
8211	COMET 70-77 covers all models	\$7.95
8212	CORONET, DODGE 71-75 covers all models	\$7.95
0477	CORVAIR 60-69 covers all models	\$9.95
0478	CORVETTE 57-65 covers all 283 & 327 models	\$9.95
9481	CORVETTE 66-76 covers all 327, 350, 427, 454 models	\$9.95
1756	CRICKET PLYMOUTH 70-73 also covers Avenger	\$9.95
9440	DART & DEMON 55-67 covers all models	\$7.95
8188	DART & DEMON 68-76 covers all models	\$7.95
1657	DATSUN 110 76-78 covers all models	\$9.95
1164	DATSUN 200SX 77-79 covers all models	\$9.95
8065	DATSUN 2000, 8210 68-78 covers all models	\$9.95
8127	DATSUN 240Z, 260Z, 280Z 70-78 covers all models	\$9.95
1551	DATSUN 510 68-73 covers all sedan & wagon models	\$9.95
1074	DATSUN 510 78-79 covers all models	\$9.95
9583	DATSUN 610 68-76 covers all models	\$9.95
0935	DATSUN 710 73-77 covers all models	\$9.95
8271	DATSUN 810 71-78	\$9.95
1258	DATSUN 811 1600-2000 SPL & SRL models	\$10.95
9297	DATSUN PICK UP 68-77 covers all 521 & 620 models	\$9.95
1145	DODGE 55-71 all inc Coronet, Monaco, Polara	\$9.95
0871	DODGE 72-77 for all Monaco & Polara models	\$7.95
1259	DODGE OMNI 78-79 covers all models	\$9.95
8208	DODGE RAMCHARGER 74-75 covers all models	\$7.95
8564	DODGE PICK UP 65-75 service/maintain all 2-wheel drive	\$7.50
8371	DODGE PICK UP 65-75 Service/Maintain all 4-wheel drive	\$7.50
8203	DODGE VANS 67-77 all 100, 200, 300 mds & Plymouth	\$7.95
8192	DUSTER 70-76 for all models inc Scamp	\$7.95
8189	FAIRLANE, FORD 62-70 covers all models	\$7.95

9422	FALCON 60-64 covers all models inc Comet	\$6.95
9874	FALCON, FORD 64-70 covers all 6-cyl models	\$7.95
0480	FALCON, FORD V8 65-71 covers all V8 models	\$7.95
9776	FIAT 124 67-77 all inc sdn, vta wgn, TC, spd	\$9.95
0844	FIAT 124 SPORT 76-78 for coupe & spider mds	\$9.95
7118	FIAT 124 SPORT 66-75 for coupe & spuer mds	\$9.95
9640	FIAT 128 69-77 for all models inc SL & Rally	\$9.95
8742	FIAT 131 75-77 covers all Maraton models	\$9.95
1201	FIAT 850 64-74 all sedan, coupe & spider mds	\$9.95
0399	FIAT X1/9 73-77	\$9.95
1073	FIESTA, FORD 77-79 for all models	\$9.95
0675	FIREBIRD covers all models—67-74	\$7.95
1149	FORD 55-67 all inc Galaxie, LTD, Custom & wagons	\$9.95
0872	FORD 68-77 inc Galaxie, LTD, Custom, XL & wgn	\$7.95
9369	FORD COURIER 72-77 covers all models imported	\$9.95
0451	FORD PICK UP 69-79 covers all models	\$9.95
8204	FORD VANS 66-68 covers all models	\$7.95
0453	FORD VANS 69-79 covers all 6 & V8 models	\$9.95
9436	GRANADA, FORD 75-77 covers all models	\$7.95
8677	GREMLIN & HORNET 71-77 covers all 6 & V8 models	\$9.95
0644	HONDA 360, 600, Z— all models	\$9.95
0885	HONDA ACCORD 76-77	\$9.95
8694	HONDA CIVIC, CIVIC CVCC 73-77 covers all models	\$9.95
8206	INTERNATIONAL SCOUT 67-73 800, A, B, II mds	\$7.95
8565	INTERNATIONAL 62-75 tune & maintain all mds	\$7.95
1207	JAGUAR XK120, 140, 150 48-61 also Mk 7, 8, 9	\$9.95
1206	JAGUAR XJ 2.4, 3.4, 3.8, 240, 340	\$9.95
1043	JAGUAR E-TYPE 61-72 covers all 6-cylinder models	\$9.95
9612	JAGUAR E-TYPE V12 71-74 covers all models	\$9.95
9399	JAGUAR XJ6 68-78 covers all models	\$9.95
9617	JAGUAR XJ12 72-77 for all models inc Daimler	\$9.95
9769	JEEP 50-65 for 4 & 6 cyl station	\$15.95
8207	JEEP 66-79 for all Cherokee, Commando & Wagoneer mds	\$7.95
9805	JEEP WAGONEER J-series with 230 cih eng	\$15.95
9806	JEEP UNIVERSAL C-2, C-3 reprint of factory manual	\$15.95
0509	JEEP CJS, Cj-6, Cj-7, 55-79	\$7.95
8856	JEEP FC150, 170 covers all front cab models	\$15.95
8739	JENSEN HEALEY reprint of factory manual	\$19.95
1719	LANDROVER 1, 2 48-61 for all models	\$9.95
1254	LANDROVER 59-76 covers 2, 2A, 3 gas & diesel models	\$9.95
1149	LINCOLN 55-70 covers all models	\$9.95
6773	LINCOLN 71-77 all models inc Versailles	\$9.95
0481	MARINER 69-71 6 cyl 170, 200, 250 cu in eng	\$7.95
8211	MAVERICK 72-77 covers all models	\$7.95
1550	MAZDA GLC 77-78 covers all models	\$9.95
0370	MAZDA RX2 70-73 covers sedan & coupe mds	\$9.95
0371	MAZDA RX3, 1000 70-74 covers all models	\$9.95
0444	MAZDA 71-78 inc dats 844 and Cosmo models	\$7.95
0880	MAZDA PICK UP 72-75 8, 1600 & rotary eng mds	\$7.95
0593	MAZDA ROK 818 72-78 covers all models	\$9.95
0573	MAZDA 1500, 1800 67-74 covers all models	\$9.95
1009	MERCEDES-BENZ 190 59-68, B, C & 200 models	\$9.95
0781	MERCEDES-BENZ 190SL reprint of owner's manual	\$7.95
1746	MERCEDES-BENZ 220 59-65 covers all mds	\$9.95
9483	MERCEDES-BENZ 220 68-72 mds except Diesel	\$9.95
1747	MERCEDES-BENZ 230 63-68 inc 230S & SL	\$9.95
1748	MERCEDES-BENZ 250 65-68 covers all models	\$9.95
9484	MERCEDES-BENZ 250 69-72 covers all models	\$9.95
9485	MERCEDES-BENZ 280 68-72 covers all models	\$9.95
0416	MERCEDES-BENZ 68-73 inc 280, 300 & 350 450 V8 mds	\$9.95
8439	MERCEDES-BENZ 74-79 covers all models inc Diesels	\$9.95
1149	MERCURY 55-70 covers all models	\$9.95
9773	MERCURY 71-77 for all models inc Cougar	\$9.95
1105	MG TA, TB, TC, TD, TF 36-55	\$9.95
1098	MG MIDGET 58-78 covers all models	\$9.95
1106	MGB, MGB 55-68 covers all models inc twin cam	\$9.95
1720	MGB, MGBGT 69-79 all roadster & coupe models	\$9.95
8396	MGC reprint of factory manual	\$19.95
0917	MINI 59-75 covers all models inc Mini-Coooper	\$9.95
9436	MONARCH, MERCURY 75-77 for all models	\$7.95
0050	MORGAN, CHEVROLET 77-79 factory manual, give car year	\$12.95
1109	MORGAN 30-77 covers all 4-cyl models	\$9.95

8395	MUSTANG 65-73 covers all 6-cylinder models	\$9.95
0479	MUSTANG V8 65-73 covers all models	\$9.95
8272	MUSTANG 67-74 covers all 4, V6, & V8 models	\$9.95
8187	NOVA 69-77 covers all 6 & V8 models	\$7.95
7107	OLDS CUTLASS 70-77 covers all inc 442 models	\$7.95
0678	OLDSMOBILE covers all models—55-74	\$9.95
0008	OLDSMOBILE 75-79 factory manual give year	\$16.95
1724	OPEL KADETT 62-73 1000, 1100, 1200 models	\$9.95
1752	OPEL KADETT 67-73, 1500, 1700, 1900 mds	\$9.95
0859	OPEL 1900 MANTA 70-74 covers all coupe mds	\$9.95
8273	OPEL 75-77 covers all models inc Isuzu	\$9.95
9589	OPEL GT 68-73 covers all 1900 models	\$9.95
9872	PEUGEOT 304 covers all models—70-73	\$9.95
1546	PEUGEOT 404 60-75 covers all models	\$9.95
0876	PEUGEOT 504 68-74 includes diesel models	\$7.95
7124	PEUGEOT 504 68-76 for all gasoline models	\$9.95
0482	PINTO 70-73 covers all models	\$9.95
0883	PINTO 74-79 covers all models inc Bobcat	\$7.95
1145	PLYMOUTH 55-71 all inc Belvedere, Fury, Satellite	\$9.95
0874	PLYMOUTH 72-76 Fury, VIP, Gran Suburban mds	\$7.95
1660	PLYMOUTH HORIZON 78-79 covers all models	\$9.95
0030	PONTIAC 69-75 factory manual, all models, give year	\$17.95
0489	PONTIAC TEMPEST 63-73 all mds inc GT, Le Mans	\$7.95
1650	PORSCHE 356 57-65 covers A, B & C models	\$9.95
1591	PORSCHE 911 64-73 covers all models	\$9.95
8173	PORSCHE 911 74-77 includes N, S, Targa, Carrera	\$9.95
1590	PORSCHE 912 65-69 with 1582cc engine	\$9.95
9834	PORSCHE 914 70-76 all models inc 914-6	\$9.95
0993	PORSCHE 924 75-78	\$9.95
8208	RAMCHARGER, TRAILDUSTER 74-75 all models	\$7.95
0372	RENAULT 5 72-78 for all models inc Le Car	\$9.95
1224	RENAULT 8, 10, 16 72-78 covers all models inc 1100	\$9.95
9429	RENAULT 12 69-79 covers all models inc auto trans	\$9.95
0645	RENAULT 15, 17 71-78 all mds inc TL, TS	\$9.95
1554	RENAULT 16 65-78 covers all models	\$9.95
0395	ROADRUNNER & SATELLITE 68-73 all models	\$7.95
1121	ROVER 2000 63-75 for all models inc 2200	\$9.95
9493	SAAB 96 66-75 covers all V4 models	\$9.95
0750	SAAB 99 69-76 covers all models inc fuel injection	\$9.95
8440	SAAB 67-79 covers all models inc Sonnet	\$9.95
1098	SPRIT 58-71 covers all Mk 1, 2, 3 & 4 models	\$9.95
8058	SUBARU 70-77 covers all models	\$9.95
0853	SUNBEAM ALPINE 55-65 Mk. 2, 3, 4 & Raper	\$9.95
0845	SUNBEAM TIGER reprint of factory shop manual	\$19.95
0489	TEMPER, GTO, LE MANS 68-73 all models	\$7.95
9773	THUNDERBIRD 71-77 covers all models	\$9.95
8189	TORINO 68-75 all models inc Elite, Ranchero	\$7.95
0912	TOYOTA CELICA 70-77 covers all models imported	\$9.95
0829	TOYOTA CELICA 78-79	\$9.95
7127	TOYOTA COROLLA 68-74 for all models	\$9.95
9812	TOYOTA COROLLA 75-77 including 5-speed	\$9.95
1738	TOYOTA CORONA 65-68 covers 4-cyl 1500 models	\$9.95
0526	TOYOTA CORONA 69-73 for all 4-cyl models inc Mk II	\$9.95
0886	TOYOTA CORONA 74-77 covers all 4-cyl models	\$9.95
7332	TOYOTA CORONA 68-76 covers all 4-cyl models	\$9.95
0754	TOYOTA CORONA Mk 2 72-74 for all 6-cyl mds	\$9.95
0647	TOYOTA HILUX 68-77 covers all pick-up models	\$9.95
8524	TOYOTA LAND CRUISER 66-77 covers all models	\$9.95
0687	TRIUMPH SPIT 70-74	\$9.95
1200	TRIUMPH SPITFIRE 69-78 covers all models	\$9.95
1016	TRIUMPH GT6 62-74 for all models plus Vitesse	\$9.95
1225	TRIUMPH TR2, TR3, 52-62 covers all models	\$9.95
1231	TRIUMPH TR4 61-67 covers all models	\$9.95
1015	TRIUMPH TR5, TR6, 67-76 all models inc TR250	\$9.95
8693	TRIUMPH TR7 75-77	\$9.95
8192	VALIANT 68-76 all mds inc Scamp, Signette	\$7.95
0567	VEGA 72-73 all 140 CID & GT 140 CID models	\$7.95
0884	VEGA 74-77 covers all models	\$7.95
9404	VOLARE, PLYMOUTH 76-78 for all models	\$7.95
1122	VOLKSWAGEN BEETLE 54-67 for all models inc K.G	\$9.95
0140	VOLKSWAGEN BEETLE 68-77 covers all models inc K.G	\$9.95
6010	VOLKSWAGEN RABBIT, SCIROCCO 74-79 all mds inc Diesel	\$16.95
1547	VOLKSWAGEN BUS 54-67 all camper, van, transporter mds	\$9.95
7130	VOLKSWAGEN BUS 68-78 all camper, van, transporter mds	\$9.95
9582	VOLKSWAGEN TYPE 3 62-73 for squareback, fastback	\$9.95
9639	VOLKSWAGEN 411 68-72 covers all E, L, LE models	\$9.95
9778	VOLKSWAGEN 412 71-74 covers all models	\$9.95
8748	VOLKSWAGEN DASHER 74-78 covers all models	\$14.95
9444	VOLVO P1800 60-73 all models inc E & ES	\$9.95
1722	VOLVO 122 61-70 for all models inc GT	\$9.95
1754	VOLVO 142, 144, 145 66-74 for all models inc 5 & L	\$9.95
9558	VOLVO 164 68-74 for all models, inc fuel injection	\$9.95
3729	VOLVO 242, 244, 245 75-78 for all inc fuel inj	\$9.95
8311	VOLVO 262, 264, 265 75-78 all models inc fuel injection	\$9.95

## GENERAL INTEREST BOOKS

1264	CHILTON AUTO REPAIR 73-80 for all American cars	\$16.95
0743	CHILTON AUTO REPAIR 72-79 for all American cars	\$14.95
1775	CHILTON AUTO REPAIR 68-75 Reg. \$12.95, Special	\$6.95
1763	CHILTON AUTO REPAIR 54-63 for all American cars	\$17.95
8561	CHILTON TRUCK REPAIR MAN 61-71 for all 1 1/2-2 1/2 ton mds	\$19.95
9700	CHILTON IMPORT CAR MANUAL 73-79 for ALL pop imports	\$18.95
9839	MOTOR'S AUTO REPAIR 74-79 for all U.S. built cars	\$16.95
0445	CAR ECONOMY TUNING GUIDE getting most from the least	\$2.95
7125	AUTO AIR CONDITIONING... service & repair all	\$6.95
8726	TRANSISTOR IGNITION SYSTEMS covers them all	\$5.95
1067	MORE MILES PER DOLLAR GUIDE How to do it right	\$5.95
1509	INTRODUCTION TO TUNING what it is & how to do it	\$2.95
9622	HOW TO TUNE YOUR CAR good for all cars	\$4.95
8859	GM DIAGNOSIS & REPAIR MANUAL 70-80 for all GM cars	\$9.95
1712	BASIC AUTO REPAIR MANUAL a must for any car	\$5.95
1707	BASIC BODYWORK & PAINTING	\$3.95
1711	BASIC CARBURETORS & FUEL SYSTEMS	\$3.95
1706	BASIC CHASSIS, SUSPENSIONS, BRAKES	\$3.95
0791	BASIC ENGINE HETRODODING	\$3.95
1708	BASIC IGNITION & ELECTRICAL SYSTEMS	\$3.95
0680	BASIC AUTO TROUBLESHOOTING for all cars	\$5.95
8359	BRAKE SERVICE GUIDE for repairing all types & makes	\$5.95
3759	ELECTRONIC FUEL INJ MAN 70-77 for all imported cars	\$9.95
0889	FUEL INJECTION MANUAL covers all systems through 1972	\$14.95
9411	HOLLEY carbs, all 2 & 4 bbl, tune & rebuild	\$5.95
9625	ROCHESTER carbs, all inc 4MV Quadrajet	\$9.95
9666	SOLEX CARBURETORS all 1 & 2 barrel downdraft	\$2.95
6354	SU CARBURETORS tune & rebuild all to 1976	\$6.50
9423	STROMBERG CO CARBS tune/rebuild all to 1976	\$6.50
0734	WEBER DCOE overhaul manual	\$4.95



# KEEP MAGAZINES, CATALOGS, MANUALS, JOURNALS NEAT and ORGANIZED in HOME, OFFICE, WORKSHOP!



## ALL POPULAR SIZES AVAILABLE

From digest size to newspaper size! Popular letter and magazine size (9" X 11 1/2", 3 3/4" box width) — 8 for \$12.95, 25 for \$28.97 postpaid. Sturdy heavy-duty fiberboard will last for years! Charge it! Mail coupon below.

## END CLUTTER! FIND IT FAST ... THE FIRST TIME WITH HANDY, HUSKY, HEAVY DUTY FIBERBOARD SHELF FILES

Eliminate the mess of loose magazines, newspapers, catalogs, etc. at home, in the office, in garage or workshop. Find what you want when you want it by using these handy shelf or desk top files. Ends personal paper pollution problems once and for all! Adhesive ID labels included.



Professional Aids Co., Suite 220  
3685 Commercial Ave., Northbrook, IL 60062

Please rush postpaid Fiberboard Desk and Shelf Files as checked below:

How Many	Qty.	Size	Price	Total Price
	8	Letter Size	\$12.95	
	25	Letter Size	28.97	

Charge it to  Visa  Mastercharge TOTAL: \_\_\_\_\_

Acct. No. \_\_\_\_\_ Exp. Date \_\_\_\_\_

Name \_\_\_\_\_

Address \_\_\_\_\_

City/State/Zip \_\_\_\_\_

Illinois Residents add 5% Sales Tax, please. Other sizes from digest to newspaper available.

Check for Free Catalog.

I enclose \$ \_\_\_\_\_ full payment. Ship postpaid.

## COVERALLS

**2 FOR  
\$9.95**



Great for work or those around the house jobs, made from a material called Tyvek which has been used in industry

for years. Tyvek is a tough reusable clothing material that can cut those dirty job apparel cost. Completely durable, water resistant, chemical resistant and comfortable. Can be laundered or drycleaned. Satisfaction guaranteed. Send check or money order for 9.95 plus 50¢ shipping to **BAY COUNTRY DISTRIBUTORS INC.** P.O. Box 1568 Easton MD. 21601

Name \_\_\_\_\_  
Address \_\_\_\_\_  
Size: M \_\_\_ L \_\_\_ XL \_\_\_ Color: White \_\_\_ Blue \_\_\_

PLANS AND INSTRUCTIONS FOR	
Go Kart	.....\$2.50
Mini Bike	.....\$2.00
Mini car	.....\$3.00
12" Sail Boat	.....\$4.00
Front Tractor Go Kart	.....\$10.00
with Gearless Differential	.....\$10.00
Mini Jeep	.....\$3.00
Pedal Boat	.....\$4.00
8 H.P. Tractor	.....\$10.00
Soap Box	.....\$3.00

Mini Vehicles Plan Dept.-C  
Chazy, N.Y. 12921

## NO INVESTMENT! INSTANT INCOME!

Run your own profitable 'shoe store' business from home in spare or full time. We give you — FREE — complete Starting Kit that makes you \$217.00 EXTRA each month for just 2 easy orders a day. You feature 350 fast-selling dress, sport, work shoe styles for men and women. Air-cushioned insoles, and 75 years of shoemaking craftsmanship! Sizes 4-16 — widths AA-EEEE. Draw on 500,000 pair stock. Earn prizes, bonuses, shoes for yourself. Rush postcard for your FREE Starting Kit today... Now!



**MASON SHOE MFG. CO.,**  
Dept. H-426  
Chippewa Falls, WI 54729



## TUNE YOUR GUITAR Like A Professional

This new invention is ideal for every guitarist — beginner or professional. Six precision tuned reeds make exact tuning a snap. Just clamp onto your guitar, then adjust the strings. When the proper pitch is reached, the corresponding reed vibrates. Just as easy as that! Ideal for bands or combos. Tunes all instruments to exactly same pitch. **\$8.95 plus \$1** shipping and handling. Money back guarantee.

ED SALE Studio 834-P, Grand Island, Fla. 32735

# The Workshop Heater.

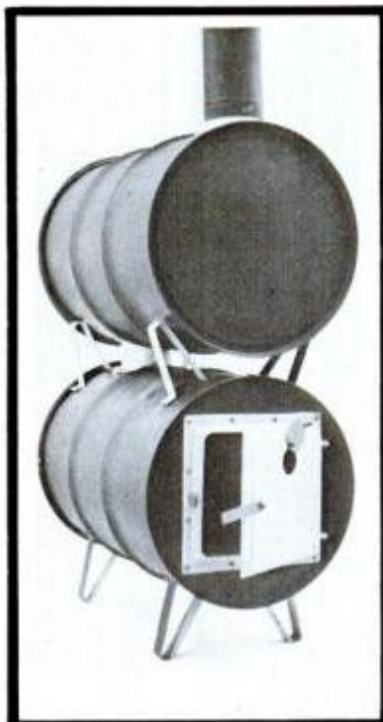

## SAFE CONTROLLED EFFICIENT HEAT

This kit converts a 55 gallon drum (not supplied) into a high capacity woodburner. Internal draft channel, spark proof, air tight design, allows safe, controlled, efficient heat while limiting metal temperature of drums to prevent burn through. Use draft control for heating large or small areas. Easily heat your entire home. Burns over 24 hours. Heavy steel kit bolts together quick and easy. Top drum squeezes 60% more BTU's from heat normally lost up chimney. Before you spend \$500 or \$600 on a wood heater, try the Sotz Heater Kit for under \$60. Within 10 years, if the kit cracks, warps or burns up, or if within 1 year the drum shows any sign of burning up, your money back.

Thousands are used by the U.S. Army, U.S. Forestry Service, Federal, State and local government agencies. Learn to heat water at lowest cost, easiest, safest and automatically. Season/dry wood in days instead of months.

Bottom Kit: Send \$34.95 (delivered U.P.S.)  
Top Kit: Send \$20.95 (delivered U.P.S.)

Send for the Sotz News.

Sotz Corp. • 13610 Station Rd. • Columbia Sta., Ohio 44028

## COUNTERFEIT GUNS

**AUTHENTIC! FULL SIZE MACHINED METAL MODELS**  
Museum quality precision machined metal classics weigh, look and feel like real guns. Will fool experts. Perfectly legal — **CANNOT BE FIRED.** Blued and disassemble like originals. Decorate your car, office, rec-room. Send for **FREE FULL-COLOR CATALOG.** Made of over 30 blued, hand-finished parts — **DELIVERED FULLY ASSEMBLED.**

**SAME SIZE AND WEIGHT AS THE ORIGINAL!**  
MONEY BACK IF NOT SATISFIED!  
**GOVERNMENT .45**



STANDARD SIDEARM OF G.I.S. SLIDE WORKS LIKE ORIGINAL WITH SAFETY THAT WORKS. LGTH. 5 1/2"; WT. 2 1/2 LBS.  
DISASSEMBLES ADD \$11.50 FOR FACE-HANDLING LIKE ORIGINAL. Model R300 ..... **\$44.95**

**REPLICA MODELS, INC.,** RO. BOX 1061  
DEPT. PM-020 800 SLATERS LANE, ALEXANDRIA, VA 22313  
Send  R300  Send **FREE COLOR CATALOG**  
Charge to:  SAC  Mastercharge  Am. Express  Diner's Club

(LIST ALL NUMBERS ON YOUR CARD)

NAME \_\_\_\_\_  
ADDRESS \_\_\_\_\_  
CITY/STATE/ZIP \_\_\_\_\_  
MONEY BACK IF NOT SATISFIED

## THE TROUBLE-FREE WIRE DISPENSER

By WEDCO Manufacturing Inc., Dept. P-1, 175 So. Sior Lane, P.O. Box D, Jackson, WY 83001 (307) 732-2336

- Developed by an Electrician for Electricians
  - Saves Time — Wasted Wire
  - Speeds Handling of Several Colors
  - Moves Like a Hand Truck
  - Capacity is 5 — 2000 # #10 AWG Reels
  - Weights Just 72 Pounds
- WRITE FOR BROCHURE AND PRICES



**Rockwell Speed-Bloc Sander** — Palm grip design for one hand use. Thumb control switch, offset pad for 4 way flush sanding, 12,000 OPM, 100% Ball Bearing, 5/64" Orbit, 115 V. Direct Motor to pad design. Pad size 4 1/2" x 4 1/4". Add \$2.00 for shipping. Reg. \$69.99  
4480(330)-R7 ..... \$53.98

## SILVO (BRAND NAME) TOOL CATALOG

**THOUSANDS OF EXCITING TOOL VALUES:** Stanley, Wen, Speedy-Sprayers, Milwaukee, Rockwell, Dremel, Skil, Nicholson, Disston, Millers Falls, Helios, Wellsaw, Plumb, Kennedy, Huot, Ridgid, Crescent, Vise-Grip, Audel Books, Unimat, Wiss, Channel-lock, General, Pony Clamps and many Nationally Advertised brands of tools and supplies. We ship Coast to Coast at prices hard to beat. Send \$1.00 for our big **SILVO TOOL CATALOG** today.

## SILVO HARDWARE CO.

2205 Richmond St., Dept. PMO-2 Phila., Pa 19125



## Build the world's most energy-efficient home.

And save for years to come.

Your Monterey Domes geodesic shell package is delivered, ready to assemble using simple tools. No skills necessary. Monterey Domes meet all building codes and VA/FHA standards. Save on construction costs and up to 50% on energy costs! Priced from \$3995. Send \$4.00 now for our 80 page catalog and planning kit!

Please rush me your 80 page full color catalog and planning kit. I am enclosing \$4.00.

Also send me the Monterey Domes Assembly Manual for an additional \$5.00.

NAME \_\_\_\_\_  
ADDRESS \_\_\_\_\_  
CITY, STATE, ZIP \_\_\_\_\_

Mail to: Monterey Domes, Dept. 150  
P.O. Box 5821, Riverside, CA 92517

## SATELLITE TV

### GET 50 CHANNELS!

It's all true! No matter where you live receive movies, sports, pay television, sports from around the world! 24-hour programming! Crystal clear reception! For complete information, sources and design information, send \$7.95.

SPACECOAST RESEARCH  
Dept. E, P.O. Box 442, Altamonte Springs, FL 32701

New Technology!

## OFFER EXPIRES MAY 31

Hardened Steel. For filing, drilling, milling, carving, routing any metal or wood. Cutting edges from 1/4" to 1", all shanks 1/4". Brand new in air-tight G.I. packs.

32-Tool Set, G.I. cost \$275 now... \$22.00  
14-Tool Set, G.I. cost \$114 now... \$16.00  
Save Even More, Both Sets now... \$33.00  
Two \$32 Sets (Limited Time) \$52.00  
100% Guaranteed. Add \$2.50 for shipping. Texas orders add 5% tax. Export orders add \$3.

U.S. SURPLUS CENTER, Dept. 503  
715 Camden, San Antonio, Texas 78215

## DUNE-BUG

Complete plans & specs on how to build or buy - disc, prices on parts, kits, engine, & raw material.

Send \$2 for DUNE-BUG pkg to:  
K & P Mfg.  
330 S. Irwindale, Azusa P2  
Calif. 91702

## wood patterns

FULL SIZE LAYOUTS ★ OLD TIME RACERS

★ TOYS  
★ CRAFTS

catalog 25¢

ANTIQUE TROLLEY  
NOVEL TUNNEL TOY

CRISS-CROSS BOX 324 F WAYNE, N.J. 07470

## PUMPS

BUY DIRECT AND SAVE  
Drain • Irrigate • Circulate • Spray

Heavy duty ball bearing pump. All metal, rust-proof Type XB. Stainless shaft. Use 1/4 HP or larger. 1 HP 1,200 GPH 60" high or 3,000 GPH 25" well. 5,200 GPH max., 1 1/4" in; 1" out. Belt or direct drive. \$19.95  
Type P won't rust or clog. Bronze bearing. To 2,400 GPH. 1" in; 3/4" out. \$13.95  
ADD \$2 pkrge & hndng. Money back Guarantee.

LABAWCO, 80 Hwy 206, Belle Mead, N.J. 08502

## 10 YEAR Guarantee

### \$450

A GREAT all purpose knife for the outdoorsman. Offers you the quality of CUSTOM made models selling for much more! Hand polished imported surgical steel blade has SAFETY LOCK to prevent accidental closing. Expensive Pecca wood handle. SOLID BRASS bolsters and liner. Popular 4" size (7 1/2" open). IF BROKEN IN 10 YEARS WE WILL REPLACE AT NO CHARGE! Use 30 days, money back if not pleased. Send \$4.50 plus 48¢ postage & handling TODAY! Midwest Knife Co., Dept. W-2608 9043 S. Western Ave., Chicago, Ill. 60620. Mail orders only.

## Fabulous Folbotting NOW

Avoid the risks and discomfort of flippy canoes, skimpy kayaks, wobbly inflatable rafts! NOW, you GLIDE securely in perfected Folbot, completely relaxed in EXCLUSIVE swivelback COMFORT. America's foremost small craft in various styles and colors from 1 to 4 seaters. GLIDE smoother, faster with EASIER lightweight double blades, efficient yacht smart sails, small motors. Perfect for nature study, scouting, float cruising, supreme in White Water, Surf, Marsh and Sea. Most INEXPENSIVE in EASY PREFAB KITS or ready FACTORY BUILT, also travel smart FOLDING types to fit inside trunk of aircraft!

## FOLBOT

Super Craft at BIG SAVINGS  
Easy PREFAB Kits from \$134 or cartop FACTORY BUILT from \$249  
FOLDING from \$439

Smart Economic BASIC KITS  
12 foot Single \$34  
14 foot Double \$46  
Big Sailer 16 foot \$57

## FREE

Action Color Catalog With Facts & Figures  
For rush inc. \$1 First Class Postage  
Mail coupon or address to: FOLBOT CORP. PM280 Charleston, S. C. 29405

Print Name \_\_\_\_\_  
Address \_\_\_\_\_  
City \_\_\_\_\_ State \_\_\_\_\_ Zip Code \_\_\_\_\_

## "PAY" YOURSELF \$1000+ to BUILD THIS NEW 4-WHEEL HAULER

- 16 or 11 H.P. Briggs & Stratton electric start engine • automatic torque converter transmissions
- 500 lbs. payload plus two passengers • dump box 44 1/2" x 40" x 11" • steering wheel, foot pedal controls
- forward and reverse gear • rear dual hydraulic disc brakes

Tough Mark Series Haulers lug 500 lbs. of cargo plus you and a passenger almost anywhere. 16 H.P. opposed Twin-Cylinder or 11 H.P. Synchro-Balanced Briggs & Stratton engine, automatic torque converters (no manual shifting), alternator and electric start. Steering wheel, foot pedal accelerator and brake (rear dual hydraulic disc), forward and reverse gear let you maneuver easily with speeds up to 25 MPH. Dump bed 44 1/2" x 40" x 11" extends to over 4' with tail gate opened. Many accessories.

Build it yourself and SAVE \$1000+. Engine mounts to welded & painted frame. Tires mounted on rims. You bolt parts together and pocket assembly costs. Only simple tools needed. Thousands from eight to 80 have built a Carl Heald Kit.

For more information call 616/849-3400 or write for FREE brochure today:

Heald Hauler Mark 4 Model HH-416 shown with optional headlights and knob tires.

Also 3-wheel models and with steel cab.

## Carl Heald, Inc.

Dept. PM-20  
P.O. Box 1148, Benton Harbor, MI 49022

## Select Your LOG HOME

AMERICA'S BEST INSULATED HOMES! Pre-cut "EXTRA INSULATED" log home kits in select, treated and hand peeled Northern White Cedar or Lodge Pole Pine priced from \$3900. Use your custom plan or select one of ours. We manufacture kits for any log structure. Send for Plan Book \$3.50, or a Dealership Information Package \$6.00

## Wilderness Log Homes

Route 2 - PMC20 Plymouth, Wis. 53073

Please Send:  Plan Book \$3.50  Dealership Information Pack w/Plan Book \$6.00

Name \_\_\_\_\_  
Street \_\_\_\_\_  
City \_\_\_\_\_ State \_\_\_\_\_  
Zip \_\_\_\_\_ Phone ( ) \_\_\_\_\_



## NEW PORTABLE POWER SEWING MACHINE WITH "WALKING FOOT"

FOR UPHOLSTERING AND HEAVY SEWING  
READY TO USE

HALF THE PRICE OF OTHER MACHINES THAT DO THE  
SAME WORK

SPECIAL INTRODUCTORY PRICE: ONLY \$450.00 (as shown)

For use at home or shop  
to make or repair:

- Auto Seat Covers
- Boat Seats
- Van Interiors
- Boat Sails
- Draperies
- Light Leather
- Tarps
- Trampolines
- Floor Mats
- Heavy Clothing
- Furniture Upholstery

Forward and Reverse sewing  
Total Weight—36 lbs.

Available at your Local Dealer  
or, Order Direct.

THOMPSON  
MINI-WALKING  
FOOT  
MODEL  
PW103-A



### Dealers Contact:

HUEY SEWING  
MACHINE CO.  
P.O. BOX 75212  
OKLAHOMA CITY,  
OK. 73147

PHONE # 405/943-5793

To: Datho Mfg., Inc.  
P.O. Box 12110  
Lubbock, Tx. 79452  
(806) 745-6031

### DIRECT ORDERS

- Cashiers Check or Money Order
- Personal Check (allow 20 days to clear)
- Texas Residents add \$22.50 sales tax

Name \_\_\_\_\_ Address \_\_\_\_\_  
City \_\_\_\_\_ State \_\_\_\_\_ Zip \_\_\_\_\_

# Monster Maul

WOOD SPLITTING CAN BE EASY...WITH THE SOTZ MONSTER MAUL

Total weight: 15 lbs. (Head—12 lbs.)



- Splits most logs in one lick—won't stick.
- Rugged all-steel tool guaranteed 10 years.
- Split 'em where they fall.
- No struggling or lifting heavy logs up to mechanical splitters.
- Ends broken handles, stuck axes, flying wedges.
- No stooping over, stands upright on flat end.
- All around fastest, easiest hand splitter made or your money back!

# \$22.98

(delivered U.P.S.) included in price

Send for the Sotz News.

Sotz Corp. 13610 Station Rd. Columbia Sta., Ohio 44028

## Low-Cost Energy Saver!



Build this beautiful 3 br., 1140 sq. ft. home for \$6500, complete and cut your heating & cooling bills 50%. Tanyons' new do-it-yourself Home Kit "80" includes bldg prints, material list & special instructions. Home Kit shows how easy it is to build this home. Think of the money you'll save with this **no-mortgage home!** Want to price several low-cost energy saving homes before choosing one? Then our Home Pricer Planning Book is for you. It contains 49 home designs, floor plans & material lists.

### Money Back Guarantee.

Order both today and never make a mortgage payment again! Send your Name, Address, City, State & Zip plus: \$8.00 for Home Kit "80", \$10.00 for Home Pricer, \$15.00 for both, **saving \$3.00!** Or send \$1.00 for information pkg. **Mail Today To: TANYON PRESS, Dept. PM2, 2427 W. 26th St., Erie, Penna. 16506.**

## SLASH ENERGY COSTS!

Very Controversial Survival Publications (over two dozen) on Electric, Gas and Water meters, Phones, TV, Guns and Ammo and Other Vital Topics, including Monthly News-letter. By John J. Williams, M.S.E.E., as seen on CBS "60 Minutes" (13-5-78). **ONLY YOU CAN ASSURE YOUR OWN SURVIVAL!** Send \$1 (apply to first purchase) for our Super Brochure to:

**CONSUMERTRONICS CO.**  
P.O. BOX 475 ALAMOGORDO, NM 88310

## How (and where) to find Almost Anything—By Mail

New 176 page directory of over 2000 mail order catalogs. Absolute money back guarantee. (Order within 15 days to get free newsletter subscription.) Send \$9.95 or for details write to:  
**Pinkerton Marketing Inc.**  
1355 Oak Terrace  
Lake Bluff, IL 60044



## GREAT SAUSAGE RECIPES AND MEAT CURING

227 Page illustrated book explains sausage making plus home curing and smoking of meat, fowl and fish. Over 100 Recipes. Free equipment and supply catalog has more information. For yours, send to:

**The SAUSAGE MAKER** 1067 Grant St.  
Dept. F12 Buffalo, N.Y. 14207

EASY TO READ • SAME SIZE

**BLUEPRINTS**  
FOR WOODEN TOYS,  
GAMES, PLAQUES, PUZZLES

CATALOG \$1.00 (REFUNDED WITH FIRST ORDER)

DESIGN GROUP  
P.O. BOX 514, DEPT. F  
MILLER PLACE, N.Y. 11764 N.Y. 405 5495 182

WOOD PLANS  
COURTESY

## RE-LITE

2 bulb fixture duplicates the charm and increases the light output of a double mantle gaslight. Kit includes on-at-dusk, off-at-dawn photo control, fixture, bulbs, detailed instructions. Your energy savings will pay for this kit in less than 6 months. 115 volt kit \$29.95 postpaid, or safe 12 volt kit including UL approved transformer, \$39.95. Dealers and installers inquires invited.



**Yardlighting Systems, Inc.**  
1678 Hewitt  
St. Paul, MN 55104



Build this 3/4 Size 1901 Ford as a Father & Son Project for \$100.00. For Blueprints and construction information send \$7.50 to

**Devore Enterprises**  
P.O. Box 22314 Indianapolis, IN 46222

## GO... HUNTING



with a White's  
electronic mineral/metal detector

Locate gold, silver, coins, rings... from \$59.95

U.S. Patented • Call Toll Free for nearest Dealer Up...  
(800-547-6911)

**ELECTRONICS...Free Literature...DEPT. PO**  
1011 Pleasant Valley Rd., Sweet Home, OR 97386



- FOR • KITCHEN
- WORKSHOP • BOAT
- TRAILER • CAMP
- GARAGE MAGNETIC



## Solve your HANG-UPS

Magnabar Mark XII. Lifetime guarantee, convenient, practical, versatile, trouble-free. Fashioned in 12" hardwood, singly boxed. Mounts quickly on any surface. Excellent gift. Model SS-12: **\$5.95** p.p. each. Send check or M.O.

Complete Catalog on request.



Phelon Magnagrip Company, Inc.  
Dept. F-503 East Longmeadow, Mass. 01028

## RICKA DUO-WHEEL CONVERSION KIT AND FIBERGLASS FENDERS



New wide tire adapters & fenders to fit most mini - 1/2, 3/4 & 1 ton trucks. Simple bolt on installation. Increases traction, tire capacity & life.

The ultimate in safety protection for your family.

RICKA MFG.  
DEPT. RPM-2  
Pequot Lakes, MN 56472

Splits EASIER & FASTER!

## THE BOSS LOG SPLITTER!



Only \$49.95 plus \$3 p. & h. for adaptable cone, or \$99.95 plus \$5 ready-to-attach to hub of car or light truck (specify vehicle). Pa. — send 6% sales tax. Free info—send stamped self addressed envelope. Good Products, Route 3 Box 88-A PM, Kutztown, Pa. 19530



## YOU CAN BUILD THIS CABIN

1184 SQ. FT. FLOOR SPACE: \$3,200

Purchase the material locally, and build this beautiful "A" FRAME CABIN. Complete plans, illustrated instruction manual and material list: ALL FOR \$5.00 on a MONEYBACK GUARANTEE. Send \$5.00 for plan #412 to:

DEPENDABLE PRODUCTS CO.  
P.O. box 1645, Vista, Calif. 92083.

## MAKE MONEY! REPAIR HYDRAULIC JACKS



Earn while you learn at home. Millions of jacks in gas and auto service stations, trucking firms, body shops, riggers, factories and farms need servicing... most of which you can learn to repair. We show you HOW. Start spare time in your basement or garage. Big opportunity for mechanics. ACT NOW. Write for Folder No. PM-2 and free brochure.

Hydraulic Jack Repair Manual Co., Inc.  
G. P. O. Box 3 • Staten Island, N.Y. 10314

## MAKE TOP MONEY IN STAINED GLASS



Learn at home in your spare time. Program includes your book of completely illustrated lessons, all professional tools, interesting projects and more. Our self study program gives you every thing needed to start you on your way to success. You can earn big money making stained glass lamp shades, windows, jewelry, sun catchers and more. FREE INFO: Write to Regina Carver Ltd., Publication Dept. PMG20 33 E. Main St., Round Lake Park, Ill. 60073

## BUILD YOUR OWN MOTORHOME



- 5th WHEEL
- CAMPER
- TRAILER
- COVER
- VAN



## KITS • PLANS • FULL SIZE PATTERNS

GLEN-L component kits, plans, and full size patterns make it easy AND YOU SAVE \$\$\$! Factory-like methods adapted for amateurs assure professional results you'll be proud of. Pictorial instructions cover frame construction, undercarriages, cabinetry, framing, electrical, plumbing, aluminum skin, and more! Building is fun! No special skills or tools required. Dozens of models PLUS equipment, parts, aluminum skin all available at DISCOUNT PRICES! Send \$1 today for illustrated catalog showing RV PLANS, KITS, & EQUIPMENT.

GLEN-L RV's 9152 Rosecrans Bellflower CA 90706

GLEN-L RV's  
9152P Rosecrans Bellflower CA 90706  
Enclosed is \$1.00. Please rush RV KITS & PLANS catalog  
Van Conversion Plans (all models) only \$5.00  
Name \_\_\_\_\_  
Address \_\_\_\_\_  
City \_\_\_\_\_ State \_\_\_\_\_ Zip Code \_\_\_\_\_

## BUILD YOUR OWN BOAT

Join the thousands who build each year AND SAVE \$\$\$! GLEN-L's proven methods are especially intended for amateurs. Step-by-step pictorial and written instructions with material listings assure PROFESSIONAL RESULTS! HUGE 128 page catalog describes over 150 designs, 8' to 49'. Sailboats, powerboats, boat trailers, boating books, AND MORE! Order catalog now and also receive FREE "BOATBUILDING SUPPLIES" brochure.

## KITS • PLANS • PATTERNS



GLEN-L 9152 Rosecrans Dept T Bellflower CA 90706



GLEN-L MARINE DESIGNS  
9152 Rosecrans Dept T Bellflower CA 90706

Rush \_\_\_\_\_ GLEN-L catalogs @ \$1.00 ppd. (\$2 CANADA)  
..... "BOATBUILDING WITH PLYWOOD"..... @ \$8.95 ppd.  
..... "INBOARD MOTOR INSTALLATIONS"..... @ \$6.95 ppd.  
..... "HOW TO FIBERGLASS BOATS"..... @ \$5.95 ppd.  
..... "HOW TO BUILD BOAT TRAILERS"..... @ \$4.95 ppd.  
..... "RIGGING SMALL SAILBOATS"..... @ \$4.95 ppd.

NAME \_\_\_\_\_  
STREET \_\_\_\_\_  
CITY \_\_\_\_\_  
STATE \_\_\_\_\_ ZIP \_\_\_\_\_

## CUT STRAIGHT WITH 'STRATE-CUT'



A MUST FOR ALL POWER TOOL USERS

Use "STRATE-CUT" Cutting Guide with any portable circular saw, jig saw or router. Extends to 8'6", reduces to 51" for short cuts and portability. Clamps to paneling, doors and other long work. Rip 4'x8" sheets down the center; trim 1/16" off a door. Make precision 90° cuts, tapers, angles, dados, bevels, grooves. Unbeatable for scoring wall-board. Guides utility knife. Here's how this sturdy aluminum tool works:

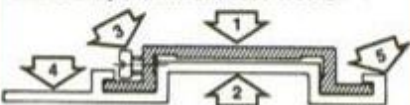

(1) Patented connector joins and aligns (2) two 51" guide sections with four set screws (3) C-clamps (4) attach guide to work. Tool follows guiding edge (5) Clamps and illustrated instructions incl. only \$19.95 plus \$2.00 shipping and handling. U.S.A. only. Send check or M.O. to: R.A.K. PRODUCTS, Department M-41 Box 23426, Milw., WI 53223. MONEY BACK GUARANTEE. Wis. Res. 4% tax.

## NEW! VERTICAL MILL

Write for free literature on our complete line of miniature tools and accessories.

The Ultimate Tool for the miniature machinist. From the makers of the famous SHERLINE 3" Lathe.

FULLY GUARANTEED



MANUFACTURED IN U.S.A.

### SPECIFICATIONS

- OVERALL SIZE: 12" x 14 1/2" x 17" high
- WORK TABLE: 13" x 1 1/4"
- TRAVEL: X Axis - 9"
- Y Axis - 3"
- Z Axis - 6 1/2"
- MOTOR: 1/5 Horsepower
- FEATURES: Precision spindle, adjustable pre-load bearings, anti-backlash feed screws, fully dovetailed, machined slides, adjustable gibs and more.

only \$289.50  
f.o.b. San Marcos

SHERLINE PRODUCTS

170 NAVAJO SAN MARCOS • CA 92069 • USA

INCORPORATED... the hobbyist's complete workshop







# CLASSIFIED ADVERTISEMENTS

Rate: \$4.00 per word payable in advance each insertion. Minimum insertion ten words. Bold face capitalized words—\$1.00 per word additional (First word set in Bold Face at no extra charge, Zip Code Free.) The next available issue to place an advertisement in America's No. 1 Classified Section is APRIL. The closing is FEBRUARY 5th.

Send remittance payable and order to Popular Mechanics, ATT.: Hildegard E. Kappel, Class. Adv., Mgr., 224 West 57th Street, New York, New York 10019. Please indicate Heading under which ad is to appear. As a consumer service and in cooperation with our mail-order advertisers who use post office box addresses for their convenience in handling your order, Popular Mechanics maintains a register of such mail-order advertisers containing their complete names and street addresses.

To avoid delay in the publication of your ad, please send descriptive materials with your request.

## AUTOMOBILES

**GASOLINE MILEAGE INCREASED DRAMATICALLY!** Details FREE! Toll-free recording, 1-800-446-8289 anytime. Techneering, Box 12191B, Norfolk, VA. 23502.

**INCREASE, even DOUBLE your car's life and economy!** 52 page manual shows how. Guaranteed. Order NOW! \$3. Prestige Enterprises, Dept. PM28, 2316 McCormick, Great Bend, KS 67530.

**HOW TO SAVE GASOLINE.** 25¢. HenCo, Box 3804, Seminole, Fla. 33542

**DISTILL LIQUID ENERGY.** Power your vehicles and home. Outstanding wood burning alcohol fuel still. Detailed plans, materials list, and farmers mash formulas included. \$15.00 — Hursand Associates, Box 213, Wayzata, Minnesota 55391

**BUY — SELL — TRADE any car, RV, etc.** Hundreds available/wanted. Current Listings book \$1.00. **FINDERS AUTO EXCHANGE**, Box 2245, Springfield, Virginia 22152

**14" TOW CABLE, 1/4" Galvanized Aircraft Cable 5/16" Forged Hooks \$7.95 P.P.** — Tow-Tek Industries, P.O. Box 161A, Abington, Conn. 06230

**MPG INCREASED 30% + !!** No gimmicks — no gadgets. Professional secrets revealed. Free details — Posco (#GB2), Box 300, LaGrangeville, N.Y. 12540

**NEW Car Free Yearly! Workable Secret Method—** Free information! Supercar, Box 28101PM, St. Louis, MO 63119

**MINI-TRUCK INTERIOR KITS!!!** Plush SEAT COVERS & DOOR PANELS \$75.00, CARPETS \$35.00. Also Carpets, Headliners, Tops, Sportscar Seat Covers, etc. for all Cars. **THE TUFTER**, Box 971, Fallbrook, Calif. 92028

**THE ALCOHOL BOOK —** New Fuel For Your Car. Make Your Own. \$9.95. White Specialties, Box 1300, SCR, Big Spring, Texas 79720

**RUN CAR, TRUCK, TRACTOR ON WOOD!** Illustrated Report \$5.00. Sweatt, Box 591, Titusville, FL 32780

**MOTALLY** Ring-Valve Repeating Job—\$6.00. Money-Back Guarantee! Free Brochure! Arrow Products, Box 374M, Broken Arrow, OK 74012.

**"SPERRY-OWENS TEFLON MOTOR TREATMENT."** Free Details. Write: Handley, Box 216PM, Magnolia, Texas 77355

**NEW! SCIENTIFIC DISCOVERY GUARANTEE'S** Better Gas Mileage and Increased Horsepower. Free Details. Motor-Life, P.O. Box 30053, Chicago, Illinois 60630

**GASOLINE SHORTAGES!** Run your car on Propane or Gasoline by Flipping a Switch. Choice of two Propane Systems. Cost Around \$50.00. Installation Details—\$10.00. Gac Engineering, Box 266, Owis Head, Maine, 04854

**PROFITABLY SELLING YOUR CAR, TRUCK, RV!** Booklet \$3.50. Rork Enterprises, 3320 Glendora, Bay City, Mich. 48706

**AMAZING NEW INVENTION INCREASES MILEAGE UP TO 25%.** Start saving gallons of gas every week with the **MILEAGE-MINDER**. Installs in two seconds. No tools or connections required. **IT REALLY WORKS!!** Money back guarantee. Send check or M.O. for \$14.95 plus \$1.50 for mailing costs to: **AUTO-SCIENCES**, P.O. Box 6008, Orange, Ca. 92667

**STOP Battery Corrosion—Eliminate Corrosion** Buildup on Automobile Batteries. Construction Equipment, Semi-Trucks, Boats, etc. A Liquid Product. Non-Toxic, Non-Irritant, Non-Flammable Money-back Guarantee. Send \$5.00 Check or Money Order. Konkor Krode Inc., P.O. Box 162, Midvale, Utah 84047

**LECTRICKAR —** Convert VW's, Fiats to electric 50 mph plans \$25.00. Info, \$1.00. Robert Bucy, Box 28794, Dallas, Tx. 75228.

**SPACE-AGE AUTOMOTIVE BREAKTHROUGH!** One-Time-Only Permanent Engine Treatment increases gas mileage while reducing engine repairs. Six iron-clad, unconditional guarantees. Amazing Details. **RFD Enterprises**, 2320 Southwood, Dallas, Texas 75224.

**FREE Brochure, UNKNOWN FACTS** Why your car is a gas Guzzler! Hartnell Diagnostic Clinic, Box 446, Centralia, IL. 62801.

**75 MPG! Amazing Build-It-Yourself Hybrid Electric Car** can Travel at 90 MPH... takes less than 40 Hours to build... and costs just \$1500! Complete plans (including Schematics, Materials List, and Components Sources) are available from **THE MOTHER EARTH NEWS**. Send Check or Money Order to: **MOTHER'S PLANS**, Department PMC, P.O. Box A, East Flat Rock, North Carolina 28726.

**SAVE GASOLINE — SAVE MONEY —** Excellent manual tells how — Pictures, Tables, Sketches. Outstanding text. Act Now, send \$2.95 to: **Management Energy Resources Inc.**, Drawer T, Dept. PM-2, Cape Canaveral, Florida 32920

**SECRETS OF THE 200 MPG CARBURETOR!** Patent Drawings and Instructions \$10.25—Money Back Guarantee. Roadrunner Publications, Raymondville, Texas 78580

**MAKE ALCOHOL FUEL LEGALLY!!** Solar/conventional still plans and formulae. Details on Federal Permits! Only \$10.00. **RDA**, Box 873, Concord, NC 28025

**ALCOHOL Cookbook —** Your complete Alcohol Fuel Manual. Free Details. Tormon's, Box 788, Asheville, NC 28802

**FORGOTTEN Carburetor Patents!** Write! Lindsay, Box 12-IL, Bradley, IL 60915

**THE COMPLETE CAMARO BOOK** from A through Z-28. Hardcover, 144 pages, 312 photos. Satisfaction positively guaranteed. \$16.95 postpaid. **Lamm-Morada Publishing Co.**, Box 7607-FC, Stockton, Calif. 95207.

**PROPANE Conversion — Cars — Trucks.** Return to gasoline anytime while driving. Uses regular refillable trailer tanks. No engine modifications. **COMPLETELY PROVEN — TESTED — THIS SYSTEM WORKS!** Uses inexpensive **LOCALLY** available parts. Engineered for amateur mechanics. Built for around \$50.00 in two days with ordinary hand tools. Satisfaction **ABSOLUTELY GUARANTEED** or immediate refund. For complete plans **RUSHED** First Class, send \$10.00. **Fleming Engineering - PM-6, RD1, Remsen, New York 13438**

**NO GASOLINE AVAILABLE!!!** Prepare yourself. Build a woodgas-generator like the one which kept vehicles running during the - **NO GASOLINE** - period of W. W. 2. Old inventions, Re-discovered in the archives of Europe. Drawings and details \$5.95 to: **GEN-GAS**, Box 671, Chatsworth, California 91311.

**GASOLIN GUIDE PLUS Alcohol-making Manual.** Both, only \$2.00. Gourmet, 5133 Fairhill, Philadelphia, PA 19120.

**HEADLIGHT Alarm.** Free information. C&C Industries, POB 804, Forked River, NJ. 08731.

**STOP AUTO THEFT WITH GARD-A-CAR.** Stalls Engine Dead in 8 Seconds, Easy Installation, Satisfaction Guaranteed. \$19.95 each, Illustrated Report \$2.00. **Deloris Gang**, Dept. PM2, 7084 Erie S.W., Navarre, Ohio 44662

**NEW! QUICK MORNING START.** Heavy 3 Amps. **OVERNIGHT CHARGE** Without raising Hood—Freezing Weather. Three parts. **PLANS—\$4.00** German Patent. **TELEVID INTERNATIONAL**, P.O. Box 970, Vancouver, Washington 98666

**CONVERT V/8 ENGINES TO V/4** Possible saving 50%, for \$30.00. Simple proven instructions, by Auto Instructor, 30 years exp. Send \$10.00 for complete instructions. **Auto Conversion**, P.O. Box 153, Madison, AL 35758

## ELECTRIC VEHICLES

**BUILD —** Amazing 4 Wheel Electric Moped! Plans \$15.00. Details \$2.00. **Lectran**, Box 1648, Largo, Fla. 33540

**CONFIDENTIAL Hybrid Car Plans.** Information. Get 75 mpg. \$1.00. Catalog included free. Ideal, Box 1237-EG, Melbourne 32935

**ELECTRIC Car conversion manual breakthrough.** Exact Step-by-step instruction, Diagrams Drawing. Conversion approx. \$1300.00. Five years Research/Development. \$39.00. Information \$2.00. **Mr. Eilers**, Box 2781, Santa Clara, Ca. 95051

**UNUSUAL Electric Automobile Publications!** Write! Lindsay, Box 12-IM, Bradley, IL 60915

## AUTO SUPPLIES & EQUIPMENT

**PARTS:** Army Jeep and truck parts. Spare Parts & Equipment Co., P.O. Box 751, Lexington, Kentucky 40501

**GASOLINE Auxiliary Tanks.** Pick-up Trucks. Below Retail. Free Details — **SASE**, National Clearinghouse, 2148 Evans, Flossmoor, Illinois 60422

**ALTERNATOR/Generator Rebuilding Book.** Details: Hedelund Engineering, 7505 Barkentine, Las Vegas, NV 89128.

**HARDTOPS** For Alfa, Austin Healy, Datsun, Fiat, Jaguar, Jensen Healy MGA, MGB, Midget, Spitfire, Sprite, Sunbeam, TR3, TR4, TR6, TR250—**DYNAPLASTICS**, P.O. Box 4907, El Monte, California 91734

**RINGS —** Valve jobs — Driving. Free Details, Motaloy, 2532 Superior, Chicago 60612

**SNOW PLOW WING:** At last, a wing for snow plows on Jeeps, Pickups & other small 4 x 4's. Keep your plowing easy. **MINI-WING™** keeps snow banks pushed back, leaves room to plow the next storm. Manual & Hydraulic models to fit Fisher, Meyer, Western and most others. Send for complete information. **C.W. Storey & Co., Inc.**, **MINI-WING** Div., P.O. Box 242, Dept. 2, Englewood, Ohio 45322

**EMERGENCY Adapter.** Use Regular Gas in Un-Leaded Tank. \$2.00 to: **Webeco**, P.O. Box 10943, Pittsburgh, PA 15236

**STOP AUTO THEFT! NOT AN ALARM!** Simple, Low-Cost, Do-It-Yourself — Guaranteed! Free Details. Write: **Pinehurst Mart**, 280 Dundas E. (822), Toronto, Ontario M5A 3W1

**MAKE YOUR OWN GASOLIN —** Requires only 8 Square Feet Garage or Backyard Space. Easy. Engines Run Cooler, Powerful, Longer. Instruction Manual — \$10., with all needed Equipment \$25. We've used it 15 Years. **Gross Racing Enterprises**, 1086 Magie, Fairfield, Ohio 45014

**PREVENT THEFT** How To Make Automobile and Van Hub Cab Locks. Simple Instructions \$1.75. **Charles W. Hunter**, P.O. Box 176, Brooklyn, New York 11212.

## MOTORCYCLES, BICYCLES, MOTORSCOOTERS & SUPPLIES

**HONDA \$25.00, Schwinn, \$41.00.** Details 95¢ (Refundable). Surplus, 443, Bend, Oregon 97701

**PLANS** Go-Kart \$2.50, Mini Bike \$2.00, Three Wheeler \$3.00, Soap Box \$3.00. Mini Vehicle, Dept. C2, Chazy, N.Y. 12921

**GO-KARTS —** Blueprints, Kits or Completely Assembled. Catalog \$3 (Refunded First Order). **Gross Racing Enterprises**, 1086 Magie, Fairfield, Ohio 45014

## HANG GLIDING—AVIATION

**SPORTPLANES, MINI-HELICOPTERS, MOTORIZED—HANGGLIDERS.** Plans/Kits/Complete. Many Types. Catalog \$3.00. **LFP**, Dept. A, Box 19828, Houston, Texas 77024

**CUSTOM WOOD PROPELLERS** For Home-built Aircraft, Airboats, Decoration. **Legger**, 6 Khedive Ave., Toronto, Ontario, Canada M6A 2G2

**ONE-MAN JET HELICOPTER —** Easy, inexpensive to build! Detailed plans, drawings—\$7.00. **HELICOPTER EXPERIMENTER'S HANDBOOK—\$4.00.** Both—\$10.00. **Helicraft**, Box 3053, Redondo Beach, California 90277

## SPACE & ASTRONAUTS

**ANTIGRAVITY Propulsion Device.** Free Brochure! **RDA**, Box 873M, Concord, NC 28025

## HOVERCRAFT

**AERO-CAR** Amazing Hovercraft built easily with ordinary tools. Lawnmower engine power. Carries one man plus. Hovers, flies forward, backward, sideways over land/snow/water. Complete construction plans and brochure. \$7.95. **Aero-Projects**, Box 5118PM, Clinton, New Jersey 08809.

**HOVERCRAFT Plans** All Sizes. Catalog \$1.00. **Universal Hovercraft**, Box 281, Cordova, Illinois 61242

**HOVERCRAFT Plans, Components—Free Information—**Venture, 871A2 Moe, Akron, Ohio 44310

## CB-RADIO, TV & HAM EQUIPMENT

**GOVERNMENT** Surplus receivers, transmitters, sniperscopes, parts, Catalog 25¢. **Meshna**, Nahant, Mass. 01908

(Continued on next page)



## CB-RADIO, TV & HAM EQUIPMENT

(Continued from preceding page)

**POLICE** Scanners, Crystals, Antennas, CBs, Radar Detectors. HPR, Box 19224, Denver, CO 80219

**36¢ RADIO + TV Tubes.** Free Catalog. Cornell, 4213-17 University, San Diego, California 92105.

**INCREASE YOUR CB RANGE — LEGALLY!** Free information. "SKIPPER", Box 130-82, Paradise, Calif. 95969

**CB TUNER/MODIFICATION REPORTS.** Simple, non-technical. \$6.00 each, specify model. Free catalog! Plans, kits, books. **CB CITY**, Box 1030M, Woodland Hills, CA 91365

**FREE Educational Electronics Catalog.** EduKits Workshop, Department 802B, Hewlett, New York 11557.

**GIANT SCREEN TV.** Projection system kit includes lens, plans, instructions. \$16.00. Guaranteed. ADP Enterprises, Box AW-1, Brisbane, CA 94005

## ELECTRONICS

**TRS-80 INTERFACING.** 254 Page Book Tells All, \$9.95 Postpaid. Group Technology, Box 871, Check, Virginia 24072.

**PRINTED CIRCUIT BOARDS** From Sketch or Artwork. Kit Projects. **DANOCINTHS, INC.**, Box 261, Westland, Michigan 48185

**MECHANICALLY INCLINED INDIVIDUALS!** Assemble electronic devices in your home. Knowledge or experience not necessary. Get started in spare time. Above average profits. \$300-\$600/wk. possible. Sales handled by others. No investment - Write for free details: **ELECTRONIC DEVELOPMENT LAB, BOX 1580PM, PINELLAS PARK, FL 33565**

**SPEAKERS!!!** Sources List. \$1.00! Reaser (PM), Box 4951, Montgomery, AL 36103

## HIFI, TAPES, PHONOGRAPHS, RECORDS

**RECORD-TAPES!** Discounts to 73%; all labels; no purchase obligations; newsletter; discount dividend certificates; 100% guarantees. Free details. Discount Music Club, 650 Main St., Dept. 1-0280, New Rochelle, New York 10801.

**BUILD Beautiful 30" Speaker Cabinets.** Professional Design. You Select Speakers. Plans \$3.50. **ALLWEST PRODUCTS, P.O. Box 822, Chino, CA 91710**

**OLIDES- 45 RPM Original Hits.** Catalog \$1.00. C&S Record Sales, Box 197, Wampsville, New York 13163

**FREE Catalog—Electronics Kits—Amplifiers—Pre-amplifiers—Psychedelic Strobes—SCA Adaptors—Color Organs—Digital Instruments—Guitar Amplifier.** FREE Subscriptions. SWTPC, Box PM32040, San Antonio, Texas 78284.

## MOTION PICTURES & SOUND EQUIPMENT

**16MM Films, Videotapes, Bargains.** Urbanski, 8142 S. Kenneth, Chicago, Illinois 60652

**SUPER 8, 16mm & 8mm Full-Length Features and Digest Films in Color and Black/White.** Rock Movies. Jack Nicholson, Sherlock Holmes, Bogart, Selznick. Hundreds of Titles. FREE Illustrated Catalog. **MILES, Box 1576PM, South Bend, Indiana 46634.**

## CAMPERS & TRAILER KITS—PLANS

**R-V KITS — PLANS — PATTERNS — Campers — Trailers — Fifth Wheels — Vans — Covers — Motorhomes.** Simple construction. Save! R-V Kits/Equipment catalog \$1.00. Glen-L R-V's, 9152PM Rosecrans, Bellflower, CA 90706

## BOATS, OUTBOARDS, TRAILERS & KITS

**BOATKITS — PLANS — PATTERNS — FRAME-PACS — Materials — World's largest catalogues — 300 "Oneoff" designs 8' — 80' in fiberglass and plywood etc. POWERBOATS — inboards — outboards — jets — cruisers — Sportfishers — hydroplanes — runabouts — SAILBOATS — Daysailers — Trailer-sailers — Motorsailers — (KYACKS — CANOES — 40 models) BOATBUILDING MATERIALS — Hardware — Fastenings — Sails — Plywood — SPECIAL SECTION ON FIBERGLASS — resins — foam — epoxies — mats — Cloth. Catalogues \$1.00 (with Boat-builder's Guide \$2.00). **CLARKCRAFT — 16-P — Aqualane — Tonawanda — NY 14150****

**KYACKS — CANOES — PLANS — KITS — Patterns — Materials 40 models in fiberglass — plywood — canvas — Catalogues with "Boatbuilder's Guide" \$1.00 — **CLARKCRAFT — 163 Aqualane — Tonawanda — NY 14150****

**BOAT PLANS - For amateurs - Catalog \$2.00** Naval Architect, Box 2551-P, LaHabra, CA 90631.

**EVINRUDE 1979 Bargains . . . all sizes . . .** Scott McCulloch parts . . . \$1. handling . . . Electra Marine, 610 Merrick Road, Lynbrook, New York 11563

**BOAT PLANS — FRAME KITS — PATTERNS —** Huge 140-page catalog! Powerboats — Sailboats — Outboards — Jets — Rowboats — Houseboats — Runabouts — Dorries — Workboats — Racing Boats — In plywood — Cold Molded — Wood/Epoxy — Fiberglass — 8' to 49'. Lowest cost, highest quality for 27 years. Easy, proven methods include instructions especially for amateurs. No lofting! **"BOATBUILDING SUPPLIES" — Fastenings — Fiberglass — Resins — Glues — Equipment — Spars — Books — Boat Trailer Plans.** Send \$2.00 for catalog plus free "Boatbuilding Supplies" brochure. "Inboard Marine Hardware" catalog also \$2.00. Glen-L Marine, 9152 Rosecrans, Dept. MP, Bellflower, CA 90706

**FIBERGLASS — RESINS — Foams — glass — epoxies — mat — etc. Factory prices — Catalogue \$2.00 — Book "Complete Fiberglassing" \$5.00 — **CLARKCRAFT — 16-P1 Aqualane — Tonawanda — NY 14150****

## GAS SAVER DORY SKIFFS

**FREE Plan "Gloucester Gull" Rowing Dory with Brochure/Photos — 50 Plans 15/45 Ft. Power & Sail — Only \$1.00, Air Mail \$2.00.** Texas Dory, Box 720, Galveston, Texas 77553

**BOAT KITS - 22 trailerable models - POWER and SAIL - 16'-30'. Molded fiberglass hulls and decks come factory assembled - you install factory supplied interior. Save half factory-built cost. No experience required. FREE catalog. Luger, Dept. BC-80, 3800 West Highway 13, Burnsville, Minnesota 55337—(612) 890-3000**

**AUTOMATIC Reverse Lock:** Johnson, Evinrude. Info: \$2.00. Box 368-H, RT. 2, Pierre Part, Louisiana 70339

**PLANS (280), Patterns, kits, Catalogs: Powerboat, \$2.00, sailboat \$1.00. Marinecraft, Box 161-M, Brighton, Mass. 02135**

## CAMPING EQUIPMENT & TENTS

**ALCOHOL** cook stove. For emergencies, backpackers, outdoorsmen. Efficient, lightweight. No moving parts. Send \$10.70 to: TWM Enterprises, Box 266P, Wilton, CT 06897

**FREE Catalog.** Everything for camping. Campmor, Box 407N, Bogota, New Jersey 07603

## ATHLETIC & BODY BUILDING COURSES

**INCREASE Height!** Details 35¢. Tail-Up (30010), Box 32307, Louisville, Kentucky 40232

**PHYSICAL Fitness Newsletter,** Dept. 40, P.O. 195, Western Springs, Illinois 60558, introductory copy.

## SPORTING GOODS & EQUIPMENT

**BOOMERANGS — INCREDIBLE RETURN!** Exciting sport. **FREE** catalog. 30 designs, books, BoomerangMan, 306 Park, Monroe, LA 71201

**ARCHERY** Lowest Discount Prices. All top brands. Orders shipped same day received. Money-back guarantee. World's Largest Supplier. Free catalog. Anderson Archery Corporation, Grand Ledge, Michigan 48837

## BATTERIES, GENERATORS

**SURPLUS A.C. Generators 110V., 60CY. Catalog \$2.00 (Refundable).** Box 3904, Las Vegas 89030

**ENGINE Generator 1250 Watts, \$299 Postpaid,** Other Sizes. JJ Enterprises, Box 693, Oshkosh, Wisconsin 54902

## ENGINES, MOTORS, MAGNETS

**REWIRE** Car Alternator for 110 AC. Plans \$3.00. Sweatt, Box 591, Titusville, Florida 32780

**REPAIR ELECTRIC MOTORS! GENERATORS! ALTERNATORS!** Details! Modequip, Box 7266, Kansas City, Missouri 64113

**GRAVITY TURBINE,** Functioning without Gas. Power Cars. Send \$1.- for Information & Drawings. Eddy Saballos, Apartado 2877, Caracas 101-Venezuela

**REWIND** JUNK TRANSFORMERS for any voltage! Manual shows how. \$3.00 Guaranteed. Harrit, Box 495, Great Neck, N.Y. 11022

## TOOLS FOR SALE

**UNIVERSAL Wrench, 3/4"-13/16", \$4.98.** Lakewood Ltd., Box 9026-W, Reno, Nevada 89503

**ALL-IN-ONE WRENCH.** Adjusts automatically 3/4" to 1 1/2". Ratchet like action. Chrome plated steel. Guaranteed. \$5.95 postpaid. White Mountain Gifts, 21P Adams St., Berlin, N.H. 03570

## MACHINERY, TOOLS & SUPPLIES

**1600 CATALOGS** listed and described. Sources for everything imaginable. \$3.00. Masterlog, Box 879, Fairfax, California 94930

**LOG SPLITTER Hydraulic 5HP 12 Second Cycle.** Free Brochure. Paragon Splitters Inc., 3601 Cindy Lane, Seven Hills, Ohio 44131

**4" METAL Cutting Lathe \$68.90.** Taig, 15048 Proctor, Industry, Calif. 91746

**BANDSAW BLADES, Any Size.** Free Pricelist. Parker, 8921HY49, Sonora, Cal. 95370.

**MACHINEX - Unimat - Maximat - Sherline Lathes, Mills.** Catalog \$1.00. Shop Supplies \$1.00. Campbell, 1424 Barclay, Springfield, Ohio 45505

**BANDSAW BLADES, Carbide Tipped Saws, Any size, Free literature.** King Saw, 6541 Tidewater Drive, Norfolk, Virginia 23509

**COMPLETE MITERING EQUIPMENT** for Perfect Picture Frames for under \$250.00. Hobby or Pro. Pootatuck, Box 18, PM2, Windsor, Vermont 05089

**TAP ALUMINUM WITH EASE!** Tapping Solution Complete with Instructions Send \$5.95 To: Scherrer Instruments, Inc., 7170 Manchester, St. Louis, Missouri 63143

**TECHNICAL Publications!** Lathes, hydraulics, blacksmithing, steam engines! More! Catalog! Lindsay, Box 12-IP, Bradley, IL 60915

**SMALL FOUNDRY Furnaces, Supplies.** Free literature. Pyramid Products, 3736 South 7th Avenue, Phoenix, Arizona 85041

**MILLING Cutters, lathe milling attachments, Catalog \$1.00.** Potter, Box 73, Cedar Rapids, Iowa 52406.

**LUMBER/MAKER®** And your chain saw makes lumber and Cabins from Logs right where they lie—full details write: Haddon Tools, 4719 Route 120, McHenry, Illinois 60050

**MILLING MACHINES, Affordable, QUALITY PROJECTS, Vertical \$4.95, Horizontal \$4.95, Both \$7.95, (Vise Plans included). NU-DESIGN COMPANY, Box 6344-F, Santa Ana, California 92706**

## BLACKSMITH & FOUNDRY SUPPLIES

**FORGES:** gas, coal—hammers—tongs—anvils— anvil benches—all blacksmith supplies. Catalog \$1 (refund first order). Mankel Blacksmith Shop, 7836 Cannonsburg, Cannonsburg, MI 49317.

## ENERGY SAVING

**METHANE, WIND, SOLAR, FUEL CELLS,** Enjoy free heat & power send for energy encyclopedia. A list of mfg., costs, specs, on alternate sources of energy. Plus catalog of plans, books, & energy saving devices for the do-it-yourselfer. Send \$4.00 to: Energy Service, 14a Hughey Ave., Nashua, N.H. 03060

**WOOD Stove — Weld your own Attractive High Efficiency Stove.** Complete Instructions \$6. Sea Wind Supply, 15668 Virginia Pt. Rd. N.E., Poulsbo, WA 98370

**SOLAR POWERED INDOOR CLOTHES DRYER, and In-door Garden.** Fresh Vegetables Year 'Round. Easy Plans \$3.00. Guaranteed. Dadson, 3218A Shasta Way, Klamath Falls, Oregon 97601

**CONCERNED ABOUT HEAT LOSS FROM YOUR RESIDENCE OR COMMERCIAL BUILDINGS?** Send for informative booklet which describes principles utilized in modern Alaskan building designs. \$4.00. Northern Technologies Engineering, Box 73916, Fairbanks, Alaska 99707

**SAVE ELECTRICITY. NEW NASA INVENTION. HAWS,** 400 W. 4th, Odessa, Texas 79761

**HEAT YOUR HOME FOR \$40.** Energy Guide \$1.50. Energy Institute, 37 Hamilton Street, Boston, Ma. 02125

**CENTRAL HEAT FROM WOOD!** Wood-burning boilers heat whole house, yield hot water! Details: Tekton Corporation, Box 999, Conway, MA 01341.

**INCREASE Your Fuel Economy.** I'll show you how. Send \$3.98 to: Gas Saver, 17244 Barbee, Fontana, CA. 92335

**SAVE up to 25% on Heating Bills.** Plans \$5.00. Heatco, Rt. 6, Box 432, Staunton, Virginia 24401

**HOW to cope with rising energy costs? ENERGY MANAGEMENT DECISIONS** offers proven dollar-saving solutions monthly. Sample copy \$2.00. BRI Publications, Dept. MC, Box 9430, Phoenix, Ariz., 85068.

**SAVE MONEY!** Easy Thermostat Plans \$3.50. Joyce, Box 41454M, Chicago 60641

## SOLAR & ALTERNATE ENERGY

**AMAZING Forced Air Wood Heater.** Supplement your Furnace or use Alone. Fiberglass Storage Tanks 100 to 6,000 Gallons. Write: Box 3, Rockton, Illinois 61072

(Continued on next page)



## SOLAR & ALTERNATE ENERGY

(Continued from preceding page)

**PREPARE FOR THE COMING SOLAR BOOM!** Read Solar Energy Digest, Box 17776-PM, San Diego, CA 92117.

**SUN TRACKING SOLAR COLLECTOR!** World's Most Efficient System. Send for—Plans/Parts/Complete units. Ross Solar Systems, Medina, Washington 98039

**ENERGY INTEGRATION** — Book on Alcohol, Methane, Electricity & Solar Systems for Homesite Energy Production. \$2. AlEnSy, Rt. 2, Box 43, San Marcos, Texas 78666

**SOLAR Heating with Easily Obtained, Inexpensive Materials.** For Plans Send \$3.00 to: Miller, 5801 West Cascade Drive, Franklin, Wisconsin 53132.

**SAWDUST Burning Heaters.** Plans \$4.95. Arpad Gelanyi, P.O. Box 382, Los Banos, California 93635

**SAVE MONEY!** Heat Water, Home with Solar Energy. Complete Monthly Coverage of Plans, Government Subsidies. **SOLAR HEATING NEWSLETTER.** Year \$6.50; Money-Back Guarantee. 39 Whipoorwill, Bethel, Connecticut 06801

**PLANS** — Solar Heater for Less than \$3 Total. Plan Cost \$2.50. Dan, Rt. 1, Box 193-C, Cochrane, WI 54622

**MAKE AND TEST Your own SOLAR COLLECTOR** NASA engineer writes manual simple enough for science fair projects. Send \$4.95 to: 422 Shadow Creek, Seabrook, TX 77586

**KALWALL'S SOLAR HEATING CATALOG!** Full Line of Solar Heating Components, Including Sun-Lite® Glazing and Tubes. Order all Materials from one Source. Send \$2.00 for Catalog. Solar Components, Dept. N, P.O. Box 237, Manchester, New Hampshire 03105

**DOES YOUR WOOD STOVE MAKE ELECTRICITY? IT CAN!** Simple Wood Stove Powered Electrical Generator. Assemble with local parts for under \$100.00. No Machining or Welding. Plans, Pictures, Instructions, \$10.00 US. Brochure of Steam Engines and accessories \$3.00 US. **STEAM POWER PRODUCTS**, Rt. 2, Dept. PM, Koskonong, Missouri 65692

**SOLAR Window Thermosyphon Saves Fuel Costs.** Construction Plans \$5.00. 2032 Park, Baltimore, Maryland 21217

**BUILD Electric Automobiles.** Woodstoves, Windmills! More! **TECHNICAL CATALOG!** Lindsay, Box 12-IN, Bradley, IL 60915

**BUILD A SOLAR WATER HEATER** — 40 Page Instruction Manual With Blueprints \$8.00. Sunwise, Box 1433, Alamosa, Colorado 81152

**SOLAR ENERGY Opportunities Report**—\$3.00. Satisfaction Guaranteed. William Brace, 8225 Encino, Northridge, California 91325

**1980 SOLAR DIRECTORY**—Your guide to the Industry! Examines Current Technology, Lists Manufacturers of Greenhouses, Pool Heaters, Complete Systems and More. \$6.25. **INTERNATIONAL SOLAR CONSULTANTS**, 177 MacDougal, New York, New York 10011

## HOME HEATING, FUEL SAVERS

**"FREE" Heat** — Burn used Crankcase Oil/Free at many Service Stations/In your Home-Built Stove. Inexpensive, Easy to Build. Instructions \$10.00. D. Lindell, Box 48, Oak Park, Minnesota 56357

**FUEL OIL SAVER!** Oilburning additive saves 20%! Formula, Instructions, \$2.00. Gourmat, 5133 Fairhill, Philadelphia, Pa. 19120

**WOODSTOVE/FIREWOOD** manual. Buying, safety, 100 Do's/Don'ts. \$2.50 postpaid. McM Publishing, 3531 SW 57th, Portland, Oregon 97221

## HOME CRAFTSMAN

**TURNING SQUARES:** Cherry, Maple & Ash. Brochure 50¢ Refundable. Cryder Creek Wood Shoppe, Box 19, Dept. PM-2, Whitesville, W.V. 14897.

**WOOD LATHE COPY DEVICE** — Easy To Build — Plans \$7.00. Marshall Woodworking, 2829 Agricola Street, Halifax, Nova Scotia, B3K 4E5

**CREATIVE Fun Building Child's Safe.** Changeable Combination. Instructions \$4.00. Box 166, Turlock, California 95380

**WOOD!** 40 varieties Hardwoods! 4000 Items - Woodshop Tools, Supplies, Kits, Hardware. 152 page 50th Anniversary catalog. 50¢. Craftsman, Dept. AX-20, 1735 Cortland Ct., Addison, IL 60101

**PICTURE Framing Supplies**—Save 50% making your own frames. Catalog \$1.00. Japs, 126PP Seventh North, Hopkins, MN 55343.

**WORLD'S LARGEST CATALOG?** Three pounds, 832 pages. Every Tool, Supply, Machine, Imaginable \$5.00. Refundable. McKilligan, PM280, Johnson City, N.Y. 13790

**CATALOG FULL-SIZE FURNITURE PLANS** — \$1.00. Refunded with first order. Traditional, Early American, over 150! Furniture Designs, 1425 Sherman, Dept. CP-80, Evanston, Illinois 60201.

**50 UNUSUAL PATTERNS!** Profitable Wooden Gifts, Novelties. Plus "Shop Secrets". Only \$4.00. ACCENTS, 374 Boston (P-2), Topsfield, Mass. 01983

**BUILD Magnificent Floral Display Shelves.** Special Lighting Encourages Growth. Fun/Profit. Blueprints \$3.00. Floraglow, Box 1234, Taylors, South Carolina 29687

**QUICK "Steps" to Accurate Stair Building.** \$3.00. "Stairbuilder", P.O. Box 1512, Post Falls, Idaho 83854

**FREE HOBBY Tool Catalog.** 1,000 Items below Wholesale! International Curio Shoppe, D-64, Box D, Mountaintale, N.Y. 12763

**BUILD Your own lathe from old car parts.** Plans \$2.80. Free supplement of money making projects included. Lindsay North, Box 251, Oroville, Washington 98844

**WOOD FINISHING AS EASY AS 1-2-3** with the famous Sealacel process acclaimed by craftsmen for over 50 years! Send for free Facts booklet and catalog of wood finishing supplies. General Finishes, Box 14363P, Milwaukee, WI 53214

**UNIQUE PLANS.** Toy Chest, Table and Chairs. \$3.00. **GOUT BOARD.** \$1.00. **FREE** brochure. William Davison, 2238E East Karen, Phoenix, Arizona 85022

**CALIFORNIA HOT TUBS** — Build for \$150. Also Pumps, Filters, Heaters, Hydrojets at Distributor Prices. Complete Blueprints, Instruction Manual — \$7.50. Tubs, Box 22511B, Robbinsdale, Minnesota 55422

**PLYWOOD Aquarium Plans** - Instructions \$1.00. DUR-E-SHEL, 6902 Prairie, Middleton, Wisconsin 53562

**WOODEN BEARED CLOCK** plans! Details. Gordon, 16321 SE Second, Bellevue, Wa. 98008

**HOW To Make 100 Decoupage** at one time. 12 Pages, easy instructions. \$3.00. Jay's, Box 442, Kennesaw, GA 30144

**BUILD** — Stereo Stand — Bookshelf 2x6 feet, from one piece plywood plus trim pieces. Complete plans and instructions \$3.00. Peter Morash, Moneycave, Middle Road., Paget, Bermuda 6-06

**101 PATTERNS.** Gifts, Novelties, Action Windmills plus "Make Money Jig Sawing". Only \$4.00 Prepaid 1st. Class. Mastercraft 25M, P.O. Box 631, Park Ridge, Illinois 60068

**CRADLE** plans, full size, \$5.00. Furniture plans, illustrated offering \$1.00. Refunded with first order. Williams, Fine Furniture Designer, P.O. Box 8626, Newport News, VA 23606

**DRAFTING Table Plans** \$6.00 Postpaid 37 1/2"x60", Information — Photos 50¢ Refundable With Order. Anders Designs, Dept. PM, P.O. Box 678, Garner, North Carolina 27529

**100 JIG SAW PATTERNS.** Full Size Toys, Windmills, Letters, Birdhouses, Shelves, Animals, etc. \$3.00 ppd. 1st class. Hayes Patterns, 6F Willow, Woburn, Ma. 01801.

**BRICK or FIELDSTONE BEAUTIFUL WALL FACINGS.** Use inexpensive plaster with our realistic molds. Easy directions. Write: Bricmold, 152 Rim Lane, Hicksville, N.Y. 11801

**OLD TIME WOODEN TOYS.** Plans and Construction Details for 20 Imaginative Action Toys. \$3.00. Coast Publications, Box 221, Shawngigan Lake, British Columbia, Canada V0R 2W0.

**TOY Plans.** Easy, Profitable. List 25¢. Christopher Michael's, Dept. PM2, 151 Rio Grande, Seguin, Tex. 78155

## CONSTRUCTION PLANS, BLUEPRINTS

**PHOTOGRAPHERS!** Save Money, Darkroom Time! Build Your Own Professional Quality Paper Safe. Amazingly Easy! Unique, proven design. Simplified Construction. Step-by-Step Foolproof Plans! \$2.00. Page Diversity, Dept. A2, Box 561, Seabrook, Maryland 20801

## HOME BUILDING & REMODELING

**ARCHITECTURAL** Consultation, Design, Drafting Services thru Mail. Write: Panu Architects, 34-14 87 Street, Flushing, New York 11372.

**EARTH INTEGRATED HOMES.** Beautiful Greenhouse Designs. Cuts Heating and Cooling Bills 100%. Write: Terrasol Systems Inc., RD 2, Box 4166, Newton, New Jersey 07860

**CUT COST.** Don't waste! Finishing Recroom? Cabin? How many Tiles? Panels? Kit contains new drafting material to work efficiently. Free information or complete Kit ppd. \$12.00 Instructions, Satisfaction Guaranteed. Plan-Kit, P.O. Box 278, Montvale, NJ 07645

**LAY your own STONE** - easy FormPress Method. Instructions \$2. Stonehouse Stoneworks, Rt. 3, Box 244A, Salem, VA. 24153

**BASEMENT WATERPROOFING**— Save Thousands—It's easy to do it yourself! You can have a dry basement this spring! Step by step method for any wet basement problem in one easy to follow booklet. Send \$3.95 check or M.O. to: Kaye Co. Inc., P.O. Box 14368, Philadelphia, Pennsylvania 19115.—Pa. residents add 6% sales tax. Allow 3-4 weeks delivery.

**SAVE 95% . . . GUARANTEED!!!** Installing Overhead Light Fixtures? Save at least 95% of Cost of Hiring Electricians to Install Wall Switches in the Conventional Manner. Unpublished Method Requires no Special Skills. Request **FREE** Copy of Guarantee or Send \$7.95 to: SWITCHES, P.O. Box 766 -A2, Englewood, New Jersey 07631.

**GET LATEST UNDERGROUND HOMES INFORMATION!** Two new books, manual, blueprints. Free color brochure! Underground Homes, 700 Masonic Building, Dept. PM-C2, Portsmouth, Ohio 45662

## PLASTICS

**CASTOLITE** Liquid Plastics. Crystal clear, colors. For casting, embedding, coating, fiberglassing; in industry, laboratories, craft work. Reproduce your designs with our mold materials. Profitable. Illustrated Catalog \$1.00. **CASTOLITE**, Dept. 808/PM, Box 391, Woodstock, IL 60098.

## DO IT YOURSELF

**FILES** — **HOMES SHARPENING** for information send \$2.39. Files, Box 256, Ashville, New York 14710

**WELDING ALUMINUM** and "POT METAL" is easy with LUMIWELD. For information — **SAVE** to Dept. HP, Alumsmiths, P.O. Box 517, DeLand, Florida 32720

**AMAZING TV REPAIR BOOK** . . . Fix your own . . . Guaranteed. Write: Publications, Box 517B, Brea, CA 92621

**PERSONAL Federal Income Tax, Condensed Instructions, Simplified Steps** \$2.50. Tax Pamphlet, P.O. Box 763, Sheboygan, Wisconsin 53081

**MAPLE TREE TAPS**, \$1.75 each. Foote-Crafts, Box 1932, Saginaw, Michigan 48605

**BUILD HYDRAULIC LOG SPLITTER!** Component Sizing, Frame Drawing, Circuits, \$4.00. — CPC, Box 101-C, Marengo, Illinois 60152

**NOW AVAILABLE.** Ingenious Design for Bridge across your own Stream for Fishing, Fun, or Motorcycle Access, all without Wetting your Feet. Instructions, Plans, Pictures, \$5.00. Spacraft, Box 379, Stayton, Oregon 97383

**MONEY, Credit Problems!** Don't give up! Help Yourself, only \$10.00 will get you Step By Step Information that Works. Randy Armstrong, 6655 Gunn, Brown City, Mich. 48416

**CHIMNEY** Cleaning from Inside — Avoid hazardous climbing. Do-it-yourself. Brushes, fiberglass rods, accessories. Illustrated catalog \$1.00. Chimney Care, P.O. Box 426P, Cavendish, Vermont 05142

**IN-GROUND Swimming Pool Kit**—Blue-prints—Vinyl Liner—Side-Walls—Skimmer—Filter—Pump—All materials Necessary for Construction—Except Local Materials—16' x 32' \$1,995.00—FOB, Cheswick Pool Sales Inc., Rte. 28, Cheswick, PA 15024. (412) 274-6400. Call Collect.

**FIREPLACE** and Flue Construction. How to Construct. Complete Booklet, Diagrams. \$4.95. Creations, P.O. Box 1623, Marion, N. C. 28752

**UNIQUE TOYBOX.** Accessible, Versatile, Simple. Plans \$1.50. S.S.A.E. Jidimira Enterprises, 35 Warner Place, Jamestown, N.Y. 14701.

**CONDO / HOME OWNERS INCREASE STORAGE!** Easy to Build — Free Standing Garage Locker. Instructions, Drawings, \$5.00. Edventures, PM-1, P.O. Box 1123, Evanston, Illinois 60204

**BASEMENT WATERPROOFING** — Step-by-step procedures revealed for the first time by America's leading Waterproofing Expert enables you to save minimum \$1900 on normal cost for average size basement. Send only \$4.00 for 45 Page Manual to: BDS Inc., 2520 Brice Rd., Akron, OH 44313

**ELECTROPLATING.** Complete amateur's textbook. All metals Electroplate metallic/nonmetallic items \$9.95. Details free. Tropic, Box 95-P3, Palm Bay, Fla. 32905.

**PROJECTION TV** . . . Convert your TV to project 7 Foot picture . . . Results equal to \$2,500 projector . . . Total cost Less than \$200 . . . **PLANS & LENS** \$16.00 . . . Illustrated information **FREE** . . . Macrombe, Washington Crossing, Pennsylvania 18977

**TURN YOUR IDEAS** into Patents, Step by Step Procedure used by Inventor \$3.00. R.A. Smith, Box 361, Welcome, N.C. 27374

**TIRED** of paying professional framers? You can do it yourself with the Elko Picture Frame Clamp. Clamps 4, 6, 8 sided frames. Clamps all sides simultaneously in 1 to 3 minutes. Clamps frame for stamp or frame large as twelve feet. Adjusts to any size in seconds yet fits in shirt pocket. Satisfaction guaranteed. \$13.95 postpaid. E-Z Clamp Corp., 19800 Woodpecker Road, Petersburg, Virginia 23803.

**"CRAWFISH"** Delicious! Build your own Trap for \$5.00. Plans \$4.00. Box 80871, Seattle, Washington 98108.

**UPHOLSTERING SUPPLIES,** Fabrics, Vinyls, Tools, Cane, Instruction Books, Free Catalog. Jim Dandy Sales, Box 30377P, Cincinnati, Ohio 45230.

**GASOLINE ADDITIVES.** Combustion/Acceleration Improver, Dry Gas, Anti-Knock, Carbon Remover. Nothing Mysterious, Common, Inexpensive Ingredients. Recipes \$3. Gas-Add, P.O. Box 1255, New Britain, CT 06050

(Continued on next page)



## DO IT YOURSELF

(Continued from preceding page)

**TELEPHONES UNLIMITED, EQUIPMENT, SUPPLIES, ALL TYPES, REGULAR, KEYS, MODULAR.** Call (714) 563-5555 or Mail \$1.00 (Refundable). Box 11478, San Diego, California 92112

**GLUE!** Make your own in minutes from discarded material. Strong, durable bond for wood, metal, plastic. Proven formula \$1.00. TAC, Box 241, Hemet, CA. 92343

**MAGNETS** — Genuine Alnico Magnets — 3/4" Diameter. Hundreds of uses in Home and Shop. \$10.00 per dozen. Udico, 1557 7th Street, Santa Monica, Calif. 90401

**FREE Standing Fireplace** — Wood Burning, Under \$30.00. Easy Instructions — 4 Hours Work. \$2.00. Fuel, P.O. Box 235, Portage, MI 49002

**CUT Heating Cost with New Method.** Old Crankcase Oil, inexpensive to do. Send \$3.00 for Details. Monahan & Sons, P.O. Box 3, Carmel, New York 10512

**BUILD Scale Model Family Home!** Plans \$7.95. Lakehurst's, Box 1956P, Wichita, Kansas 67201

**COMPRESS Leaves, trash, etc. into Stove-Size logs.** Plans \$4. Firewood, P.O. Box 435, Spokane, Washington 99210

**POCKET BIG SAVINGS!** Make your own Household Products for Pennies!! Numerous formulas only \$2.00. Order today. Taylor, 2144 Coastland Ave., San Jose, CA 95125

**ELIMINATE Hated TV Commercials!** Forever! Install "AID". Easily. Complete Kit \$5.95. Guaranteed. Box 68431, Seattle 98188

**WATERBED Frames.** Detailed plans \$1.95 for material list and instructions. SLEEPLAND, Box 810, Carberry, Manitoba, Canada R0K 0H0

**PHOTO INVENTORY YOUR HOME AND BELONGINGS.** Professional photographer's step-by-step instructions show you how. Needed in case of fire or theft. Supplies identification to police, ownership proof for insurance company. Special safekeeping album stores prints and slides. Send \$10.95. MC and Visa o.k. Smart Set, 225 East 17th Street, Santa Ana, CA 92706

**BUILD Powerful Air Compressors From Old Lawn-mower Engines.** SAVE Hundreds. Plans — \$5.00. Vandegrift, 437 Houston, Ambler, Pennsylvania 19002

## REPRODUCTION MOLDS

**RUBBER, Fiberglass Molds for Ornamental Concrete (Birdbaths, Planters, etc.)** Over 900 to Choose From. Free Information, SASE. Plycrete Mold, Elk Rapids, Michigan 49629

## ARTS & CRAFTS

**MAKE Figurines, Plaques, candles, lawn ornaments, Molds, plastercraft kits, liquid rubber.** Sample and catalogue 25¢. Woolley Company, Box 29, Peoria, Illinois 61650.

**"GETTING Started in Stained Glass"** 50¢. Whittemore, Box 2065Y, Hanover, Mass. 02339.

**STAINED GLASS Catalog-P** Send 50¢. Tools, Supplies, Books. Saylescrafts, 171 Main Street, Nyack, New York 10960

## CARTOONING, COMMERCIAL ARTS & SIGN PAINTING

**LEARN Cartooning.** Fun or profit. Cartooning, Box 7069G, Colorado Springs, CO. 80933

**SIGN Painting Learned At Home.** No Special Talent Needed. Free Proof. Watson's, Phillips, Nebraska 68865

**SIGN Painting—Easy method.** Free catalogue. Kaufmann Company, Centertown, Missouri 65023

**MODERN Cartooning taught by mail.** Write for free brochure. Cartoonorama—Box 263-2B, Branford, Conn. 06405.

**35 LESSON cartooning course.** Cartoonist's Magazine, both \$3.00. Hartman, Box 30367, Lincoln, Nebraska 68503.

**CARICATURE, CARTOONING!** Earn money now! Six different professional illustrated instruction books \$3. K. Harris, P.O. Box 1567, Portland, Oregon 97207

## MODELS—CARS—SHIPS—TRAINS—PLANES ETC.

**BUILD museum-quality ship models, gun models, dollhouse room settings.** 1980 Model Catalog features complete kits, fittings, plans, construction materials, tools. "How-To" books. 88 pages. Only \$1.00. James Bliss & Company, Dept. PM, Route 128, Dedham, MA 02026.

**MODEL AIRPLANES** — Huge Catalog. \$2.00. Sig Manufacturing Co., Inc., Montezuma, IA 50171

**CIVIL WAR Model CANNON Plans:** Catalog free. Green—PM28, Box 892, Shalimar, Fla. 32579

**RADIO CONTROL!** Airplanes, Boats, Motorcycles, Helicopters, Supplies, Discount Catalog — \$3.00 (Refundable). Modelers Supply, Box 7183, Montgomery, Alabama 36107

**SHIP MODEL Kits, Plans, Fittings from our own Workshop.** Big Illustrated Catalog: \$1.00. Bluejacket Shipcrafters, 50V Water Street, South Norwalk, CT 06854

**LIVE steam engine kits.** Marine, stationary, walking beam. Boilers, fittings. Fascinating modeler's hobby. Catalog \$2.00. HPK, Centuck 34, Yonkers "U", New York 10710

## KITES, GAMES, PUZZLES, NOVELTIES

**"I'VE HAD ENOUGH CHAP-A-QUID-A-GATE"**. This Slogan printed on four by fifteen inch bumper sticker. Two for \$3.00 or Six for \$5.00. Order from: Jones Novelty Co., RD. 3, Box 98A, Laurel, Del. 19956.

**BULLSHIT - REPELLENT!** Aerosol Cans — Stop Your Buddies From Telling You Those "Tall" Fishing And Hunting Tales! Only \$3.95 Postpaid. S&S Distributors, P. O. Box 10741, Dept. PM, Birmingham, Alabama 35202.

## MAGIC TRICKS, JOKES, VENTRILOQUISM

**VENTRILOQUISM/Puppets!** Catalog \$1.00 (Refundable). Maher, Box 420PM, Littleton, Colorado 80160.

**FREE!** World's Leading Novelty Catalog. 1600 Jokes, Tricks, Science, Sports, Hobbies. Johnson-Smith, C-10, Mt. Clemens, Mich. 48043

**FABULOUS MAGIC Catalog 50¢.** Same day service, no substitutes. Fabulous Magic, 3319 E. Charleston, Las Vegas, Nevada 89104

**BRAND NEW FUN CATALOG. HUNDREDS OF SUPER GIFTS, GIMMICKS, AND NOVELTIES. SEND 25¢ TO: FUN FACTORY, INC., DEPT. 1181, 41 SMITH STREET, ENGLEWOOD, N.J. 07631**

**VENTRILOQUISM Learned!** Details .50¢. Dummies. Hartz, Box 556, Beaufort, South Carolina 29902

**FREE!** \$2.00 Trick, Huge Catalog, all 50¢. Abracadabra-MP, Scotch Plains, New Jersey 07076

**VANISHING Leprechaun, Easy Magic Catalog, \$1.00 Credit Coupon.** All for \$1.00. Elliott, 212 Adelaide Street West, Toronto, Canada M5H 1W7

## HOBBIES & COLLECTIONS

**COLLECT Military Medals.** List 50¢. Vernon, Box 387 PM, Baldwin, N.Y. 11510.

**TEXAS Flintstone—Generous Sample & Prices \$3.00.** Box 15392, Austin, Texas 78761

**COLLECT Military Patches.** Free Catalog. Emblems, 212428-B Hamilton, Newport News, Virginia 23602

## ANTIQUES, RELICS, INDIAN GOODS & CURIOS

**INDIAN Relics.** List 25¢, Arrowheads \$5.00 Dozen. Folsom \$10.00 each. C. Secrist, Deerfield, Missouri 64741

**OFFICIAL Guide to Antiques.** 448 Pages, \$8.98. Lakewood Ltd., Box 9026-A, Reno, Nevada 89503

## STAMP COLLECTING

**110 World-Wide 10¢ when ordering Colorful Approvals.** Jey-Lyn Stamps, Box 178-I, Chittanningo, New York 13037

**100 DIFFERENT Fascinating Turkey Stamps Only 25¢.** (Adults Only.) Goliath, Y-1, Bethlehem, New Hampshire 03574.

**PENNY!** Approvals! Regardless catalogue! Kloster, 4164 52nd St., San Diego, Calif. 92105.

**50 DIFFERENT Old U.S. between 1861 and 1939 - \$1.00.** Ed Roush, 423 Shepard, Mansfield, Ohio 44907.

**U.S. BARGAIN** — 25 Different Air Mails \$1.00, with Beautiful World Wide Approvals. Stamp Center, Kennebunk, Maine 04043

**BREATHTAKING Beautiful.** 50 Different mint Monaco pictorials commemoratives only \$1.50 with mint complete set approvals. Pagoda, Box 132P, Sidney, Ohio 45365.

**16 DIFFERENT U.S. Airmail stamps worth over \$1.00 Only 10¢.** (Adults Only.) Limit One Set. Wonderful Lists included. Littleton Stamps, AH-1, Littleton, New Hampshire 03561.

**50¢ BRINGS You 100 pictorial plus worldwide approvals.** Capt. Shaw's Stamps, Box 277, Ocean Park, Maine 04063.

**500 DIFFERENT Stamps, \$2.00.** Smith, 508A Brooks, College Station, Texas 77840.

**FREE:** 32 Page United States and United Nations Price List. Sheiron, Box 610547C, North Miami, Florida 33161.

**75 DIFFERENT US Free with Approvals.** Princess City Stamps, P.O. Box 908, Mishawaka, Indiana 46544

**CANADA Ten Late Commemoratives 10¢—Canadian Approvals.** Harley Boardman, Little Valley, New York 14755

**GREAT Gift free with 1st purchase** — fine United States approval and want list service. Send .15¢ for handling. The Stamp Boutique, Box 86M, Wheeling, Ill. 60090

**TOPS!** 100 Popular Poland Stamps (all different) only 25¢. Mystic, Dept. PS1, Camden, New York 13316.

**SINGLE STAMPS 2¢ and up.** Mounted in books. TRUST STAMP COMPANY, P.O. Box 100-P, Jamaica, New York 11435.

**50 YEARS Old fifteen different United States, over fifty years old—25¢ with approvals.** Jaxon, Box C11-P, New Rochelle, New York 10804.

**FREE Worldwide packet.** Penny approvals. Froelich, Box 412-A, Morton Grove, Ill. 60053.

**FREE U.S. \$1.00 Stamp, Older Issues, Commemoratives, Airmail, Virgin Islands, Others — Catalog Value over \$5.00.** U.S. Bargain Price List. All Free! Send 10¢ for Mailing. Empire Stamp, Toronto, Ontario M4V 2M2

**FREE U.S. LIST Mint Singles, Plates.** Minnesota Stamp Company, Box 131, Shakopee, Minnesota 55379

**220 Valuable, Beautiful, Exciting, Mysterious, International Stamps — Only 25¢ with Approvals.** Stamps, PM, Box 1427, Bellflower, California 90706

**FREE 100 Different with Approvals.** Lawrence Stamons, 41 Kimberly Lane, Bristol, Conn. 06010

**WOW!!! Free Gift!!! With Approvals.** Meinhardt, Box 2205, Carbondale, Illinois 62901.

**BEST in the West! We'll Prove It!** Five Beautiful Sets, \$1.00. Approvals. Pioneer Stamps, Box 842, Provo, Utah 84601

**CANADA.** 50 different 25¢. Approvals. Oroszky, Box 1-C, Sarnia, Ontario, Canada N7T 7H8

**FREE — Mammoth Collection — Scotts Master Global Albums.** When you Buy Approvals. Bargain Service, Box 5345, Santa Ana, California 92704

**WILL ROGERS — Olympic Games - Vietnam Veterans newest United States Commemoratives on lovely, cacheted First Day Covers.** 70¢ each or all three \$2.00. K.M. Walsh, Box 308J, Tuckahoe, N.Y. 10707

**FREE!** 55 Different, including Triangles, Space, Others! Request Approvals. Baird, PM-56, Box 8128, Portland, Oregon 97207

**U.S. 6 Plate Blocks — \$1.00!** Approvals. Gordon Davison, Key Largo, Florida 33037

**U.S. Bargains!** Pre-1930 used stamps with defects. High values at great savings! Worthwhile approvals for adults only. Rivertown, Dept. 152PB, Ada, Michigan 49301.

**DIFFERENT:** 500 Foreign, \$1.50; 650 U.S., \$6.00; 125 U.S., \$1.00. Futrell, Spartansburg, Pa. 16434

**PLATE BLOCKS.** Six Different 4¢ Only \$1.00. FREE WHOLESALE PRICELIST. AMPBCO, Box 26066P, St. Louis, Missouri 63136

**100 Different U.S. 10¢ approvals.** Bradley, Box 385P, Middlethian, VA 23113

**\$5.00 Value.** 100 Different United States Commemoratives \$1.00: Bryson, Box 8123, Toledo, Ohio 43605

**2,000,000 Stamps—150 Countries—2¢ Each.** Belden, Box 4149, Dearborn 48126

**FREE Surprise collection sent with approvals.** Gould, 1784 Union, San Francisco 94123.

**FREE!** Big Bargain Catalog - New Edition listing thousands of bargains including U.S. & B.N.A. stamps, packets, albums, accessories and supplies. Also fine stamps from our approval service, buy any or none, return promptly, please. Jamestown Stamp, Dept. E20PM, Jamestown, NY 14701

**1000 DIFFERENT Stamps \$3.90; 3000 \$16.70.** Free Packets Catalog. Ullery, 1016 Meridian, Mishawaka, IN 46544.

**WOW!** 110 All Different Germany 10¢. Commemoratives, Airmails, High Values, Big Catalog, bargain lists. Also, fine stamps from our approval service, any or none, return promptly, please. Jamestown Stamp, Dept. A20PM, Jamestown, NY 14701

**POPE John Paul's historical visit highlights spectacular introductory worldwide collection featuring:** Lake Placid Olympics Commemorative, American Bicentennial Painting, Interplanetary Space Station, Germany Baby Animals, Anguilla United States Inverted Airplane, Friedrichshafen Zeppelin, Zaire Fish plus 100 different worldwide. Only 25¢ when requesting approvals. State age. Douglas Cook, Dept. PM-7, Las Vegas, Nev. 89119.

**OLDER U.S.A.** 409 Different \$20.00 Value \$3.95. Krubeck, Route Two, Mount Carroll, Illinois 61053

**CLEARANCE 10 Worldwide Packets \$1.00.** Collections, Box 291, Portland, Connecticut 06480

**ISRAEL 15 Different 10¢ Approvals.** Sam Chazen, Box 666, Deiray Beach, Florida 33444

**"WHOLESALE" U.S. - Foreign Pricelist and catalog Free!** Everything Guaranteed. Schneider, Box 1240, Grand Rapids, Michigan 49501

**WOW!** Bicentennial Souvenir Sheet Worth Over \$2.00 Plus 100 Different Worldwide 25¢ With Approvals. Tarheel Philatelics, Siler City, North Carolina 27344

**FREE Mongolia Camel Set.** Request Approvals. Alpaugh, Box 225, Highbridge, New Jersey 08829

**50 SPORTS PICTORIALS 35¢.** Approvals. Arbour, 3727M Downeydale, Randallstown, MD 21133

**POLAND OUTSTANDING PICTORIALS 25 Different 10¢ with Approvals.** Kamco, P.O. Box 338A, Flushing, New York 11367

**50 ARGENTINA — Different 10¢.** Approvals. Gobestamps, Box 690, Saco, Maine 04072.

(Continued on next page)



## STAMP COLLECTING

(Continued from preceding page)

**BARGAIN 100** World-wide Stamps 25¢. Quality Approvals. R. Parker, Box 143, West Brookfield, MA 01585

**SPECTACULAR World Collection** — 10¢. Vatican Ghana, San Marino U.S., Russia, Animals, Space. Over 100 different! Plus U.S. Catalog, Approvals. Global, Box 7429-P-24, Olympia, Washington 98507

**88 DIFFERENT U.S. 50¢** Pope, 230 Union Street South, Concord, North Carolina 28025. Approvals.

**UNITED NATIONS 3** Complete Mint Sets 25¢. Approvals. Cornetta, POB 1509-M, Lake Placid, Florida, 33852

**345 Different Stamps \$1.00.** New Issues Approvals. Kloendike, Harrisburg, Illinois 62946

**U.S. MINT Specials!** Flag Set complete \$2.00; 1936 Army-Navy complete \$2.00. Free List. Brooks, 2601 Avenue "U", Brooklyn, New York 11229

**UNITED NATIONS.** Free set with price list. Ftacek Stamps, Box 1023, Manteca, California 95336

**FIFTY Free Stamps with Approvals.** J&D Stamps, Box 747, Melbourne Beach, Florida 32951

**100 INDIA 10¢.** Approval Applicants. Gibson, Box T, Williamstown, New Jersey 08094

**210 WORLDWIDE.** Only 25¢. Including Antique Cars, Wild Animals, Unusual Issues, Approvals. Act Today! Palmour, Dept. 821, Box 1358, Pleasanton, CA 94566

**SPECIAL 400 U.S. 30¢.** Approvals. Wright, Box 753M, Hagerstown, Maryland 21740

**FREE World Wide Stamps with Approvals.** Chapmans, Box 487W, Galesburg, Michigan 49053

**OLD U.S. Stamps on Approval.** Chester, Box 15414G, Philadelphia, Pennsylvania 19149

**GIGANTIC LIQUIDATION!** 50% Discount Approvals. Gaines, Box 788-G, Mattoon, Illinois 61938

**LOOK!** 107 different Triangles, Sports, Topicals, etc. Only 10¢. Approvals. Jayto Stamps, Manlius, New York 13104

**FREE U.S. Mint Set.** Approvals. Hildebrand, Box 4867, Santa Clara, California 95054

**89 DIFFERENT RUSSIA!** 25¢. Approvals. Milehigh, 3445 Quitman, Denver, Colorado 80212

**10¢ Stamp Assortment.** Inexpensive Approvals. Lee's, Box 2105, Albany, N.Y. 12220

**PENNY APPROVALS.** Regardless Catalogue. Zamora, 1 Méndez Liciaga, San Sebastián, Puerto Rico 00755

**200 Different Worldwide** — 25¢! Approvals. Boyd, Drawer 849, Saugatuck, MI 49453

**WOW!** 125 All different plus Mystery Gift. Only 10¢. Approvals. Fayette Stamps, Dept. 418KA, Fayetteville, NY 13066

**HISTORIC** Visit to U.S. of POPE JOHN PAUL II Commemorated by a Fantastically Beautiful First Time Cover with Official Postmarks and Lovely Engraved Portrait of His Holiness. Only \$1.25. K.M. WALSH, BOX 308A, TUCKAHOE, NEW YORK 10707

## COINS, TOKENS, CURRENCY

**3 OLD Liberty Head Nickels** Only \$1.00. Issued before 1913. Limit 1 Set (Adults Only.) Plus price lists. Littleton Coins, HL-1, Littleton, New Hampshire 03561.

**INDIAN Cents!** 7 Different — \$5.00 Postpaid. LAKEHOUSE Coins, 201 Broad, Lake Geneva, Wisconsin 53147

**HONG KONG DOLLAR** Only 10¢. Uncirculated cupronickel dollar. Limit One. (Adults Only.) Plus price lists. Littleton Coins, KH-1, Littleton, New Hampshire 03561.

**MINI-COINS.** Cent Through Dollar Die Cast six-piece Set. Send \$2.50: Gregco, Inc., Box 60, Carmel, Indiana 46032

**WHEAT PENNIES** — 50 Different — Average Circulated \$3.00. Emporium Sales, Box 263, Arcadia, California 91006

## PHOTOS & PHOTO SUPPLIES

**WALLET Sized Outdoor Exposure Guide.** Eliminates Meters. Five Film Speeds \$1.00. 400 Film Speed add \$1.00. RAN, 11722 Cherry, Los Alamitos, CA 90720

**PAINTED Backgrounds** for professional results. Photo Supplies. Two catalogs, pictures \$1.00 (refundable). Pierce, PMCO, 9801 Nicollet, Minneapolis, MN 55420

## COLOR SLIDES

**TRAVEL Color-Slides** World-wide Catalog 60¢. Worldwide, 7427M Washburn, Minneapolis, Minnesota 55423

## BOOKS & PUBLICATIONS

**HOMEMAKERS! SAVE WORK-MONEY-TIME.** "Helpful Homemaker Hints" in rhyme. 104 page book. IDEAL GIFT — \$2.95 plus 50¢ postage. Apple-Gems, P.O. Box 16292-P, San Francisco, Ca. 94116. Thirty Day Money-Back Guarantee.

**FREE Book.** Prophet Elijah Coming Before Christ. Megiddo Mission, Dept. 63, 481 Thurston Road, Rochester, N.Y. 14619.

**PUBLISHERS' OVERSTOCKS BARGAIN BOOKS.** 3,000 titles, all subjects! Free catalog: Hamilton, 98-51 Clapboard, Danbury, CT 06810

**PUBLISH Your Book!** Join our successful authors. Publicity, advertising, beautiful books. All subjects invited. Send for fact-filled booklet and free manuscript report. Carlton Press, Dept. PMB, 84 Fifth Avenue, New York 10011.

**OPPORTUNITIES UNLIMITED** — Free Catalogs. J. Henderson, Route 1, Box 358-B, Enterprise, Alabama 36330

**WILDERNESS Living!** Shelter, Food, Power, Self-Defense Books. Free Catalog. Aspen Cabin, Box 2517, Flagstaff, Arizona 86003

**FREE PUBLICITY FOR YOUR NEW PRODUCT!** How To Get It! The Beginner's Guide To New Product Publicity. Free Details. DD Enterprises, Box 488A, Lenox Hill Station, New York, New York 10021

**MILITARY Books** — WWII, Korea, VN. All Branches. Catalog 50¢. Keystone Patchco, Box 2726, Philadelphia, Pennsylvania 19120

**REPAIR CLOCKS AND WATCHES.** Free catalog of helpful books. North American, Box 77AQA, Fox River Grove, Illinois 60021.

**COMPUTER CONTROLLED Citizens;** Laser Tattooing Plan — exposed! Free report. Write: Spiral, Box 80323-P, Lincoln, Nebraska 68501

**CITY OF WORLD CHAMPIONS—Cookbook—Tasty Notes from Celebrities. . . Public Officials. . . Ethnic Families. . . Restaurants. . . Attractive Gift. . . \$4.95—Non-Profit Organization. . . TN, Box 2261, Pittsburgh, PA 15230**

**SUCCEED! How-to-Guide.** \$2.00, Foster, Box 975, Coronado, CA 92118

**HOW TO BUY A GUITAR.** \$3.00 Giftfinder Enterprises, 23 Dolphin St., Regina, Sask., Canada, S4S 3J7

**CASH REWARDS! OVER \$98,700.00 FOR INFORMATION ON MISSING PERSONS; PROPERTY; HEIRS. NEXT TWELVE ISSUES FOR THIS AD WITH \$10.00: REWARD NEWS HOTLINE, P. O. DRAWER 192, LIBERTY, TEXAS 77575**

**BOOKFINDING** Librarians search worldwide titles or subjects plus 150,000 indexed stock. PAB, 2917p Atlantic, Atlantic City, N.J. 08401 (609-344-1943)

**600 News Bibles—Today's Version;** Information \$1.99. Bridges, Box 4413, Hollywood, Florida 33023

**RARE Old Unusual Occult Books.** 900 Titles. Catalog 50¢. Marshall, Box 7169PM, Baltimore, Maryland 21218

**OCULT Metaphysical, Self-Improvement Books.** Free Lists. Collings, Drawer 589, Appalachia, Virginia 24216

**"GIVE A Man A Fish, You Feed Him For A Day. Teach Him to Fish, You Feed Him For Life."** Robert Mammen's Newest Book, THE SUCCESS IMAGE Teaches You to Fish in the River of Success, and how to Catch the Big Ones. Send \$6.00 check or money order: Ridgeview Press, Dept. PB, P.O. Box 192, Littleton, CO 80120. Money Back Guarantee.

**SUCCESS! Money! How to sell yourself (ideas, products).** \$4.95 guide. Office Dynamics, 1612 Shield, Laramie, Wyoming 82070

## PLAYS, SONGS, MANUSCRIPTS

**POEMS, SONGS:** Your Song or poem may earn you money. Free Examination. Columbine Records, 6430 Sunset Blvd., Suite 1221, Dept. PM, Hollywood, California 90028

## MUSIC INSTRUCTIONS & INSTRUMENTS

**MUSICAL EAR!** Play Easy Tunes on Violin in 2 Weeks. New Technique. Send \$12.00 for Course. Broadview, 76 Norwood, Plainfield, New Jersey 07060.

**INTERNATIONAL Catalog** valuable to makers, repairers of stringed instruments. Imported woods, parts, accessories, kits. Fine German-made violins, violas, cellos, basses and bows. Send 25¢ for catalog. Credit certificate worth \$1.25 enclosed with catalog. International Violin Company, Dept. AE, 4026 W. Belvedere Ave., Baltimore, Md. 21215.

**ACCORDIONS** — Famous Makes. 40 Models! Importer-to-You Prices. Save! Cordovox and Button Style. Home Trial. Trade-ins. Terms. Free Catalog! Accordion Corporation, Dept.R, 5535 Belmont, Chicago 60641

**PIANOS, PLAYERS, PUMP ORGANS.** Rebuild and repair. Catalog of "How-To" books, \$2.00 (refundable). Vestal Press, Vestal 11, New York 13850.

**ACCORDION Top Brands, Cordovox, Buy Direct.** Tremendous discounts. Trades accepted. Free brochure PM. Accordion-O-Rama, 16 West 19th Street, New York, N.Y. 10011.

**SUPER-SAVINGS** Guitar Strings, Accessories, Effects Pedals, Microphones, etc. Free Catalog. Super-Save Music, Box 387, Boca Raton, Florida 33432

**POEMS Set To Music.** Nashville Music Productions, Box 40001-PM, Nashville, Tennessee 37204.

**EASY PLAY** Dulcimers, from \$66.00. **EASY MAKE KITS,** from \$27.00. Mandolins, Banjos, Whistles, more; catalog. HERE, Inc., #P, 29 SE Main St., Minneapolis, Minnesota 55414

**BANJO, GUITAR** Cassette Lessons. Free Catalog. Bailey, 4005PM Lara, Chattanooga, TN 37416

**STRINGS, ACCESSORIES, SCARCE PARTS, REPAIR BOOKS.** Catalog 25¢. Stringing, Rifton, New York 12471

**HARMONICA KIT.** Learn to play the harmonica in just one evening. Kit includes harmonica and instruction book featuring over 35 popular songs. Send \$3.98. T.S. Magille, 3411 Carlton, Amarillo, Texas 79109

**P.M.I. — 1980 MUSICAL INSTRUMENT CATALOG** — \$2.00 — Credited on 1st Purchase America's most complete source of major brands instruments and accessories at Low, Low, Prices. Write: P.M.I., Dept. PM, P.O. Box 827, Union City, N.J. 07087

**ELECTRIFY** Player Pianos, Pump Organs Quickly. Inexpensively with Lee Silent Suction Units. Write: Lee Music, P.O. Box 308F, Culver, Oregon 97734

**GUITAR HOME STUDY COURSE, UNIQUE, ACCLAIMED BY 100,000 STUDENTS WORLDWIDE.** WRITE FOR BROCHURE: MAIC, BOX 39122, WASHINGTON, D.C. 20016

**IMPRINTED GUITAR PICKS** For sample of 18 different picks & prices, send \$1.50 to: Sound & Stage, P.O. Box 34, Fanwood, NJ 07023

**FREE Catalog.** Build harpsichord, harp, hammered dulcimer or Appalachian, banjo, mandolin. Also completed. HDC, 4419 West Colfax, PM, Denver, Colorado 80204

## EDUCATION & INSTRUCTIONS

**WELDING TRAINING.** Basic and Advanced for Major Processes - Arc (Stick), MIG, TIG, Gas Pipe all processes. A non-profit school. Accredited member NATTS. Approved Ohio 70-12-0064 HT. Write for school bulletin and course schedule. **NOBART SCHOOL OF WELDING TECHNOLOGY,** Box 80, Troy, OH 45373.

**BETTER ENGLISH** Can increase career opportunities. Improve your grammar in 12 hours. Easy, effective, unusual method. Box 5532, Evansville, Indiana 47715

**COLEMAN CAMP GEAR** Repair. Earn as you learn at home for profit or hobby. Lanterns, Stoves, heaters, all models. Modern Schools, Dept. PM, 4225 N. Brown Ave., Scottsdale, AZ 85251.

**UNIVERSITY DEGREES BY MAIL** Programs! Bachelors, Masters, Ph.D.'s . . . Free revealing details. Counseling, Box 317-PM2, Tustin, California 92680.

**SCREEN - Printing.** Learn how to make money at home spare time printing signs, bumper stickers, T-shirts, more. Print on paper, plastic, glass, metal, fabric . . . for stores, restorers, mail order, factories, politicians, etc. Write: Screen Printing Center, 4401 Birch, Dept. PBCC9, Newport Beach, CA 92660

**HIGH SCHOOL** At home, no classes. Diploma awarded, low cost. Information FREE, call toll free anytime 1-800-621-5809 (Illinois 800-972-5858) or write: American School, Dept. 30245, 850 E. 58th St., Chicago, Illinois 60637

**DETECTIVE Profession.** Easy home study; free tielack or lapel pin, certificate future. Professional Investigators Training School, Dept. CP, P.O. Box 1890, San Pedro, CA 90733

**INSTANT MEMORY . . . NEW WAY TO REMEMBER.** No memorization. Release "photographic" memory. Forget nothing! Liberates extraordinary knowledge, talents, ESP. Immediate results! Free information. Institute of Advanced Thinking, 845PM ViaLapaz, Pacific Palisades, California 90272.

**BARTENDING - Bar Management** Home Study. Bartending Training, 3843-C San Fernando Road, Glendale, CA 91204

**VETERINARY Assistant** — Train at home for exciting animal care career. Send for Free "Career Kit." North American School of Animal Sciences, Dept. PBCC9, Newport Beach, CA 92660.

**REISCH WORLD WIDE COLLEGE OF AUCTIONEERING, INC.**—World's Largest—46 years., Term soon. Free catalog, VA Approved, Modern Auction Library "FREE" with enrollment, 515-423-5242 — Col. Gordon E. Taylor, P.O. Box 949, Dept. 19, Mason City, IA 50401.

**EXTENSION** And Post-Graduate Awards in Philosophy, Art, Science, Botanic, Medicine, Homeopathy, Radionics and others. 30 subjects Curricular free (airmail \$1.00 refundable). Registrar, Sussex College of Technology, Highfield, Danehill, Sussex, England.

**AUTOSUGGESTION.** Sleep-learning headquarters! Tapes, records, books, Gigantic catalog free. Research Association, Box 24PM, Olympia, Washington 98501.

**LEARN Law Enforcement, Patrol procedures,** criminal investigation, making arrests and more. Course includes scientific kits — fingerprinting, crime photography, evidence collection. Free facts. Police Sciences Institute, Dept. PBCC9, 4401 Birch, Newport Beach, CA 92660.

**LEARN Sewing Machine** repairing. A profitable Trade. Easy to learn. Free details. Sewing Center, 187 FR, Rochelle, GA 31079

**AUCTIONEERING** — Free catalog. Resident or Home Study Course. Nashville Auction School, Nashville, TN. Mailing address — P.O. Box 190, Lawrenceburg, TN 38464.

**HOW Your MIND CONTROLS HEALTH!** Easy method sheds stress! American Meditation, 1232 Race Road, Baltimore, Maryland 21237

(Continued on next page)



## EDUCATION & INSTRUCTIONS

(Continued from preceding page)

**CUSTOMIZE** Vans, Exteriors, Interiors. Learn at home in spare time. GI/VA Approval. Free Facts. Customizing Center, Dept. PBCC9, Newport Beach, CA 92660.

**FASCINATING FINGERPRINTS.** Learn how to take, identify, classify, photograph fingerprints. And much more. Over 200 Pages with Hundreds of Photographs. Money-back Guarantee. Only \$10.00 to: Globe Enterprise, P.O. Box 1085, Glen Burnie, Maryland 21061

**FREE NEWSLETTER!** Powerful, easily-stimulated brain hormones increase brainpower instantly! Guaranteed! EDEPS, 600 Hunter's Trail, 23C, Glendora, Ca. 91740.

**RADIESTHESIA, Radionics, Dowsing E.S.P. Courses and Equipment** illustrated Catalog \$1.00 (refundable) Established 27 years. Dept. PM/R Bruce Copen, Highfield, Danehill, Sussex, England RH17 7EX.

### EARN HIGH SCHOOL DIPLOMA AT HOME FAST!

**STATE Registered.** Lowest Tuition Available. Individual Counseling. Credits Awarded for Job Experience and previous Courses. Free School Ring. Call Free 1-800-327-8103. Cambridge Academy (PM-2), 409 East Osceola, Stuart, Florida 33494

**BOOKKEEPING** Or Accounting! Easy home-study plan prepares you quickly to do your own books . . . or others. Approved for Veterans. Free "Accounting Career Kit." Write: Accounting School, Dept. PBCC9, Newport Beach, CA 92660.

**AUCTIONEERING BID CALLING** — Cassette tape by experienced auctioneer and instructor. Send \$24.95 to: Vince Simmons, P.O. Box 67, Lakeland, Florida 33802

**LEARN** Asleep or awake. Records, tapes, equipment! Free catalog! Drawer PM-400, Ruidoso, New Mexico 88345

**AUCTIONEERING:** Mendenhall School of Auctioneering, High Point, North Carolina 27263. Free information.

**GLAMOROUS** Radio Announcing, my 25 Years Experience may Help You. Send \$3.95 to: **RADIO BOOKLET**, Dept. P, P.O. Box 1565, Indianapolis, Indiana 46206.

**PRIVATE INVESTIGATION CAREER!** Free details! Shaw Investigation, Box 716, Provo, Utah 84601

**PIANO TUNING PAYS.** Learned easily at home. Accredited MHSC. GI Approved. **NILES BRYANT SCHOOLS, INC.**, Dept. P, 3631 Stockton, Sacramento, California 95820

**USED Courses!** Books! Lists 25¢. Smith's, 124 Marlborough, Salem, Massachusetts 01970

**TRAVEL Agent/Tour Guide!** Home-study plan explains exciting Travel Careers, how to qualify for Travel Benefits. Approved for Veterans. Free Brochure. Travel School, Dept. PBC10, Newport Beach, CA. 92660

**BE A BARTENDER** Professional Home Study Course. College of Cocktails, Box 35132-M, Los Angeles, Calif. 90035.

**UNIVERSITY DEGREES BY MAIL . . . OUR SPECIALTY.** FREE Revealing details. Success, Box 13151-M2, Columbus, Ohio 43213.

**LEARN GAS TURBINES!** Correspondence course covering all systems, maintenance, theory, operation. Established 1957. Valuable diploma awarded. American Jet School, Department 105B, Darby, Montana 59829

**INFORMATIVE CHARTS**— Engineering Constants, Measures, Weights, Belts, Pumps, Hydraulics \$2.00. Standards, Box 5303, Statesville, North Carolina 28677

**DRAFTING** — Blueprint Reading (Mechanical, Electronic, Architectural). Home Courses \$25.00. Send \$2.00 first lesson. Prior, Inc., 23-09 169 Street, Whitestone, New York 11357

**BASIC REAL ESTATE** Guide. Terms, Hints, Explanations. \$3 to: Broker, Box 363, Fort Atkinson, Wisconsin 53538

**BE A RADIO ANNOUNCER!** Former Radio Program Director Tells How To Get Started — Where To Get Training. Send \$2.00: Gatehouse Publications, Box 65, Proctor, West Virginia 26055

## EMPLOYMENT INFORMATION

**JOBS OVERSEAS . . . (INCLUDING ALASKA)** Free Details, Wages, Countries, How To Apply. Globalemploy, Box 808, National City, California 92050

**A-U-S-T-R-A-L-I-A . . . N-E-W-Z-E-L-A-N-D WANTS YOU!!** — 17,900 JOBS!! — PAID TRANSPORTATION!! — NEW REPORT!! — \$2 — MONEYBACK GUARANTEE!! — "AUSTRALIA COMMISSION," DEPARTMENT 894-72, NATIONAL PRESS BUILDING, WASHINGTON, DC 20045

**JOURNEYMAN LEGITIMATE CREDENTIALS GRANTED!** Write: National Craftsmen Union, 210 Fifth Avenue, Suite 1102, New York, NY 10010

**1980s' HOTTEST CAREERS!** Guide \$2.00. Knowhow, Box 261-PM2, Monroe, North Carolina 28110.

**RENO GROWING** Like Crazy! Jobs Galore! Several Pages Classified, \$1.00 Greenback. Crampton, 905 West Center, Fallon, Nevada 89406.

**JOBS! HOW TO GET THEM!** Professional Guidelines for Resume Writing, Interviews, Job Hunting. \$2.00. Success, Box 15185, Fort Wayne, Indiana 46815.

**CASINO Dealers Make Big Money; Become One.** Simple Method. \$3.00. Sunny, Box 5786D, Reno, Nevada 89513.

**EXCELLENT OILFIELD OPPORTUNITIES, EXCELLENT PAY** Onshore and Offshore. Opportunities Unlimited in all 50 states and the three coasts that surround them. For information and employer addresses send \$7.00 to: MKT Services, P.O. Box 14006, Fort Worth, Texas 76117

**ROCKY MOUNTAIN EMPLOYMENT NEWSLETTER!!** Colorado, Idaho, Montana, Wyoming!! Current Openings — All Occupations!! Free Details . . . . Intermountain-L, 3506 Birch, Cheyenne, Wyoming 82001.

**JOB HUNTING? "How-To"—Complete Guide.** FREE Details. Jim Glunt Publications, Box 299, Dept. PM, Bedford, PA 15522

**WORK FOR A WEEK IN WAIKIKI,** Or Anywhere you Wish! Exciting Job Exchange — Vacation Plan Program. Hundreds of Jobs Available! For Complete information Send Name, Address, Occupation and \$5.00. National Employment Services, 1100 Quail St., Suite 200, Newport Beach, CA 92660

**OFFSHORE JOBS** Unskilled \$330.00—\$450.00 per week skilled much higher. Complete information \$5.00. Oushore Jobs, Box 378M, Mary Esther, FL. 32569

**JOBS! Direct Mail Approach.** Avoid Competition Of Published Market! Low Cost!! Northeast USA. Roger, Box 612-B, St. Johnsbury, VT 05819

**AUSTRALIA - NEW ZEALAND** Want You! 75,000 jobs. All occupations. Big pay. Free transportation. Employer listings \$2.00. Plus information 68 other countries. Austco, Box 4116E, Hayward, CA. 94540.

**AUSTRALIA-NEW ZEALAND** Need You! 55,000+ Positions. Free Passage. Job Listings \$2.00. Jobco, Box 4055, Fullerton 92631.

**JOBS—JOBS—JOBS! ALL TYPES AVAILABLE IN TEXAS.** LOWEST UNEMPLOYMENT Rate in the NATION. Send \$2.00 for CLASSIFIED SECTION of SUNDAY NEWS-PAPER. Specify Dallas, Fort Worth, Houston or San Antonio. AAXTON, Dept. 501, Box 28439, Dallas, Texas 75228

**STUDY** and Work Opportunities Abroad. Send \$2. for Catalog and Instructions. Student-Travel, Box 21064, Seattle, WA 98111

## EMPLOYMENT WANTED

**ARE YOU LOOKING FOR EMPLOYMENT?** Try our Classified Section! It costs only \$4.00 per word. And, if you wish to run all or part of your ad in bold capital letters— you can do so for as little as \$1.00 per word additional. Act now! Send your ad to: **POPULAR MECHANICS, CLASSIFIED DEPT., 224 WEST 97TH STREET, NEW YORK, NY 10019**

## HELP WANTED

**TEXAS REFINERY CORP.** offers PLENTY OF MONEY plus cash bonuses, fringe benefits to mature individual in your area. Regardless of experience, write: W. D. Pate, Pres., Texas Refinery Corp., Box 711, Fort Worth, Texas 76101

**PARTTIME** Piece work. Webster, America's foremost dictionary company needs home workers to update local mailing lists. All ages, experience unnecessary. Send name, address, phone number to: Webster, 175 Fifth Ave., Suite 1101-1303-B, New York, N.Y. 10010

**OVERSEAS** Employment . . . \$10,000-\$50,000 +. Free information! Employment International, Box 29217-AB, Indianapolis, Indiana 46229.

## FOR INVENTORS

**INVENTORS** Patent Your Invention. Free Initial Consultation. We are Registered by the U.S. Government. Victor J. Evans & Co., 4637 Eastern Ave. N.E., Washington, D.C. 20018. Since 1898.

**WRITE:** Crane & Associates, Consultants, 819 E. El Camino, Box 834, Santa Maria, CA. 93456

**INVENTORS PROTECT** INVENTION with documentary Record of Invention Kit, instructions, samples how to record and protect your idea. Patent information. \$3.95 plus 75¢ postage. Jack C. Wright, 57 Lindbergh Blvd., Bloomfield, N.J. 07003

**U.S. PATENT** Office Searches, 234 Broadway, Room 3615, New York 10007. Free invention certificates.

**INVENTORS** — United States Patent Office Searches. Patent Development Engineering and Marketing of your Inventions, ideas with manufacturers contracts. Send for FREE INVENTION CERTIFICATES and invention information. Serving Inventors Since 1948. **GEORGE SPECTOR, LICENSED PROFESSIONAL PATENT ENGINEER, FORMER UNITED STATES PATENT OFFICE EXAMINER**—3615 Woolworth Building, New York, 10007

**NONPROFIT** Foundation helps inventors. Widest range of services. Free recording forms. Free evaluation. Affiliated Inventors Foundation, 501-B Iowa, Colorado Springs, Co. 80909.

**PATENT AND DEVELOP** Your Invention. Registered Patent Agent and Licensed Professional Engineer. Send for FREE PATENT INFORMATION Every Inventor Should Have. Richard L. Miller, 3612 Woolworth Building, New York, New York 10007 (212) 267-5252

**REGISTERED PATENT ATTORNEY.** Applications and Searches. Mail Service. Free Preliminary Review. Box 392, Millwood, N.Y. 10546

**INVENTORS:** If you have an invention for sale or license, write for free booklet explaining how we can help you. Kessler Sales Corp., C-52-FI, Fremont, Ohio 43420

**PATENT ATTORNEY** Serves Inventors by Mail. Box 405, Medfield, Massachusetts 02052

**REGISTERED PATENT ATTORNEY** Washington D.C. Suburb. Donald A. Kettlstrings, 414 Hungerford Drive, Suite 411, Rockville, Maryland 20850

**PATENT** Applications at Reasonable Rates. Edwin Uren, Registered Patent Agent, 430 Kelvin Court, Spring Hill, Florida 33526.

**NEW!** "Patenting Your Invention Yourself!" \$29.95. Moneyback Guarantee! Registered Patent Attorney, 7400PM Benjamin Franklin Sta., Washington, DC 20044

**PROTECT** Your Invention. Registered Patent Attorney. Many Years Experience, all Fields. Individual Inventor's Problems Given Special Consideration. Very Reasonable Charges. Write for Free Information. Paul H. Gallagher, 105 W. Adams, Chicago, Illinois 60603

**WAIBER & ASSOCIATES, INC.** Will Draw, Describe, and Submit your Product/Idea to 100 Manufacturers within Four Months, Write: Box 313, Lake Bluff, Illinois 60044

## INVENTIONS WANTED

**INVENTIONS MARKETED!** Cash, Royalties! FREE INVENTION PROTECTION CERTIFICATES. George Spector Manufacturers Representatives, Woolworth Building, New York, N.Y. 10007.

**IDEAS,** inventions, new products needed by innovative manufacturers. Marketing assistance available to individuals, tinkers, universities, companies with feasible concepts. Write for: KIT-PM, IMI, 701 Smithfield, Pittsburgh, PA 15222.

**INVENTIONS WANTED. FREE CONSULTATION. NO IDEA TOO SMALL.** Disclosure protection. Cash or royalties from manufacturers seeking new ideas. For free information on how to protect your ideas, Call or Write: **AMERICAN INVENTORS CORP.**, 59 Interstate Dr., Dept. PM, West Springfield, MA 01089. (413)737-5376. A Fee Based Service Company.

**LEARN** How to offer your invention for sale or license. Free booklet outlines procedures, royalty rates, requirements. Kessler Sales Corporation, C-52-IW, Fremont, Ohio 43420

## REAL ESTATE & FARMS

**FREE!** Big Spring Catalog! Over 5,400 country properties described, pictured! Land, Farms, Homes, Businesses, Recreation, Retirement buys! Selected best thruout the U.S. Over 700 offices, 43 states All Across America! Yours FREE from the World's Largest! **STROUT REALTY, INC.**, 7 S. Dearborn, Dept. 5800, Chicago, IL 60603.

**CANADIAN LAND** from \$47.00 AN ACRE. Low monthly payments. Choice properties across Canada. Ideal for cottages, hunting, fishing & investment. 6 month money back guarantee. 12 month exchange privilege. Catalogue \$1.00 Write: Canadian Estate Land, Dept. 23C, 286 Lawrence Ave. West, Toronto, Canada M5M 3A8

**OPTION** Your Way To Wealth. Send \$10.00 (Refundable — 60 Days). Option-P, P.O. Box 2308, Melbourne, Florida 32901

**CALIFORNIA.** Acreage. Lots. \$30 down. \$30 monthly. Box 35291, Los Angeles 90035

**BIG . . . FREE . . . SPRING CATALOG!** Over 2,700 top values coast to coast! **UNITED FARM AGENCY,** 612-PM West 47th, Kansas City, Mo. 64112

**OVER 1500** Properties in the South Central Ozarks, Mild Climate, Low Taxes, Productive Long Grazing Season. Free Brochure. Graven Realty, Inc., 120PM West Second, Mountain Grove, Missouri 65711. (417) 926-4200.

**42,000,000 ACRES** Valuable Government land available low as \$3.50 per acre. Campsites, farms, homesites. Fabulous business opportunities. Latest report! Send \$2.00. Satisfaction Guaranteed. American Land Disposal, Box 730-A, Holland, Michigan 49423.

**10-20 ACRES** in fabulous Northern IDAHO. Choice land in beautiful timbered settings. In the heart of lake, hunting & recreation country. Reasonably priced. Terms. Parcels with domestic water and power available. A unique opportunity for country living at its best. Write for free information: **NATIONAL ASSOCIATED PROPERTIES,** Dept. GC, 1121 Sherman, Coeur d'Alene, ID 83814 (208/664-8161)

**RECREATION** Land Tracts. 5-40 Acres, Idaho — Washington — Montana. Timber — Views — Streams. Insured title — Access — Low down. Write: Western High Lands, Inc., Dept. A, Box 969, Hayden Lake, Idaho 83835

**HOW TO FIND AND PURCHASE GOOD COUNTRY LAND.** Send \$2.50 — Free Bonus Offer Now! S&S Investments, P.O.Box 10741, Dept. PM, Birmingham, Alabama 35202

**HISTORIC** Western Town in beautiful Southern Utah. Hunt, fish, camp yearound. Huge valley rimmed by mountains. Lots \$695 full price, \$10 down. Complete information \$1.00. Southwest, Box 37 (N), Beryl, Utah 84714

**SAVE** Thousands! Sell your own Home. FREE Details. EZ Home, 53 Park Place, New York, New York 10007

**BEAUTIFUL** Small Waterfront Lot \$5.00 — Ideal Gift. John Jackson, Jr., 680 Muscogee Dr., A3, N. Ft. Myers, Fla. 33903



## EXPORT—IMPORT

"DISTRIBUTE Products From Manufacturers World-wide." Free Brochures! Ballico, Box 9130982, Cleveland, Ohio 44101

## BUY IT WHOLESALE

**IMPORTS** Closeouts Liquidations  
Job Lots. 500,000 Products! Rock-Bottom prices!  
Free Samples! Insiders, Box 879, New Hyde Park,  
N.Y. 11040

**BELTS** And Buckles. Complete line fast sellers  
including truckers, motorcycles, CB's, westerns, etc.  
Big Profits. Complete dealer set up. Catalog, details  
free. Anchor Specialties, Box 3958-BPM, North  
Providence, RI 02911

**REPLACEMENT PARTS**, Service tools for Chain  
Saws, Small Engines. First Quality. Substantial  
savings. Free Catalog. Stores, shops, give sales tax  
number for dealer information. Repair Parts, Box  
6329-K77, Erie, PA 16512

**SAVE ON PARTS!** Free catalog jammed with Motor-  
cycle, Snowmobile, Small engine parts, Accessories.  
Manufacturer's Supply, Box 157-PM, Dorchester,  
Wisconsin 54425

**AMERICAN** Jewelry Manufacturer in Thailand!  
**GUARANTEED** Gold and Silver Jewelry with  
**GENUINE** Rubies, Sapphires. Low **WHOLESALE**  
Prices. No U.S. Customs Charges. Catalog \$3 Refun-  
ded with Purchase. Gems Unlimited, 159/14  
Soi Pramote, Bangkok, Thailand, 5

**HAVE** Own Business. World's largest wholesalers.  
American, foreign. Bargains. Free details.  
International Buyers, Box 16386-M, Portland, Oregon  
97216

**RINGS**, Jewelry priced 130% below Retail Price.  
Catalog, \$1.00 (Refundable). Anka-PM, 95  
Washington, West Warwick, RI 02893

**WORLDWIDE** Wholesale Bargains: Imports  
Closeouts Dropship Marnees, 9225PM  
Parkway, Highland, Indiana 46322

**400,000 BARGAINS** Below Wholesale: Many Free!  
Liquidations Closeouts Job Lots  
Single Samples. Free Details. Bargainhunters  
Opportunities, Box 730-A, Holland, Michigan 49423.

**HEARING Aids**, Batteries. Wholesale. Catalog 25¢.  
Fiston, Box 1444, New Preston, Conn. 06777

**FREE CATALOG**. Indian Jewelry Wholesale.  
Manufacturer, Box 27230-P, El Paso, Texas 79926

**CLOSEOUTS!** Discounts! Below Wholesale! Free-  
bies! Samples! DDN, Box 20152 PM, Ferndale,  
Michigan 48220.

**WHOLESALE** Guide: Office Supplies . . . Printing . . .  
Envelopes . . . Jewelry (African, Indian) . . . Candy . . .  
Gifts . . . Records, Tapes . . . Etc . . . \$3.00. Information,  
Box 3913-AB, Springfield Massachusetts 01101

**JEWELRY** Luggage. Gifts at Discounts Up to 40%.  
Wholesale Catalog—\$3.00. Aspc, Box 407-P, New  
York, New York 10038

## ADV. AGENCIES, ADV. SERVICES, MAILING LISTS

**EXPERT** Assistance for mailorder, advertisers.  
Ratebook leading newspapers, magazines \$1.00.  
Chicago Advertising Agency, 28-EM Jackson, Chicago  
60604

**MAILORDER ADVERTISERS!** CLASSIFIED ADVERTISING  
CAN BE MOST PROFITABLE AND REWARDING.  
PROBLEM IS TO KNOW WHAT TO DO. WHAT NOT TO  
DO. COLUMBIA CAN HELP YOU WITH YOUR MAIL-  
ORDER PROGRAM. OVER 20 YEARS CLASSIFIED  
ADVERTISING EXPERIENCE. KNOWLEDGE OF BEST  
PULLING PUBLICATIONS. EXPERT COPY SERVICE IS  
ALL YOURS AT NO INCREASE OVER PUBLISHER'S  
STANDARD RATES. CHANCES ARE YOU WILL SAVE  
MONEY. WRITE TODAY FOR FREE DETAILS PLUS YOUR  
FREE COPY OF "MAILORDER ADVERTISER'S RATE  
GUIDE". COLUMBIA ADVERTISING AGENCY, BOX 1285-  
PM2, RICHMOND, INDIANA 47374

## BUSINESS SERVICES

**HOW TO START AND OPERATE A SMALL BUSINESS**.  
Complete guide to management, sample forms, copy-  
righted. \$5.00. Baker & Associates, Inc., Dept.-P,  
P.O. Box 524, Newport, Oregon 97365

## RUBBER STAMPS

**RUBBER** Stamps. Free Catalog. Jackson's,  
Brownsville Rd., G-101, Mt. Vernon, IL 62864

**PERSONALIZED** Pocket Rubber Stamp. 3 lines  
\$2.75; Bett-R Enterprises, 12100 Valley Spring Lane,  
#308-P, Studio City, California 91604

**UNIQUE** Plastic Stamp your Return Address on 3  
Lines and Stamp Pad \$6.00 postpaid. Dixie, Box  
202, Jackson, Mississippi 39205

## OFFICE SUPPLIES

**PROFITS FROM CLASSIFIED ADVERTISING!** Booklet  
shows you how to start your own business with  
Classified Advertising. Only \$1.00 (Refundable with  
first order.) H. E. KAPPEL, POPULAR MECHANICS,  
DEPT. P, 224 WEST 57TH STREET, NEW YORK, N.Y.  
10019.

## PRINTING PRESSES— RUBBER STAMP OUTFITS

**SIMPLE-X RUBBER STAMP PRESSES**. Hydraulic  
operated electrically heated. Sizes 5" x 8", 8" x  
12", 10" x 15". Starting outfits. Order for presses,  
supplies shipped day received. Send \$2.00 for  
Catalog and Brochure. Custom Manufacturers, Box  
211-PM, Springfield, MO 65801.

**TYPE** Fonts, Hand Printing Presses, Supplies. 120  
pages. \$1.00 deductible first order. Acme Type, 732  
Federal, Chicago 60605.

**COMPLETE** Rubber Stamp Outfits, Supplies. Same  
day shipment. Sign Engraving Machines, Wholesale  
Catalog \$1.00 Deductible. Star Stamp, 732 S.  
Federal, Chicago 60605

**PRINTING** Presses, type. Supplies Lists, 20¢.  
Turnbaugh Service, Mechanicsburg, Pennsylvania  
17055

**PRINT YOUR OWN** — Printing presses, type,  
supplies direct from factory. Send 25¢ for catalog  
and samples to: Keisey Co., DM, Meriden, Conn.  
06450.

**RUBBER** Stamp supplies catalog. Jackson,  
Brownsville Rd., S-110, Mt. Vernon, IL 62864

**WHOLESALE** Rubber Stamp Outfits, Supplies. Cata-  
log \$1.00. Martine, 1432 Major, Jefferson City, MO  
65101

## PRINTING & SUPPLIES

**QUICK** Copy Printing. Low Prices. Write:  
Nationwide, 614 North Main, Bloomington, Illinois  
61701

**PRINTING** — Stamp Cuts Made. DeLouise, Box  
106, Islip Terrace, NY 11752

## GUMMED LABELS

**1,000 DELUXE PERSONALIZED GOLD STRIPE**  
**GUMMED** Address labels. Prompt delivery. \$2.00  
Postpaid. Jamada International, P.O. Box 161,  
Brooklyn, N.Y. 11230

**1,000 Deluxe Gummed Address Labels** \$2.00. Free  
Literature. Acme, 55 Tomoka, Pittsburgh,  
Pennsylvania 15229

## GIFT SHOPPING

**EXCITING** Gift Catalog. B&W Enterprises, 1389B  
Munro Avenue, Campbell, California 95008

**TALKING EXECUTIVE TEDDY BEAR**. Pull the String  
and the Bear says, "You Are A Born Leader. You Are  
On Your Way To The Top. There is Nothing You Can't  
Do. You Are A Winner". P.J.'s Enterprise, 2345  
Woodbridge, Dept. 117, Roseville, Mn. 55113

**FREE CATALOG!** Unusual Gifts for all Ages! Novak,  
Box 1516-MC, Troy, Michigan 48099

## CLOCKS, WATCHES, OLD GOLD, JEWELRY

**HIGHEST CASH** for Gold, Jewelry, Gold Teeth,  
Rings, Diamonds, Watches, Silver, Platinum. Mail  
Articles Today. Free gift with information. Chicago  
Gold & Precious Metals, 6 E. Monroe, Dept. 658,  
Chicago, 60603.

**HIGHEST CASH IMMEDIATELY** For old gold, silver,  
platinum, jewelry, gold teeth, watches, diamonds,  
spectacles. Free information. Rose Industries, 29-A  
East Madison, Chicago 60602. Established 1934.

**GOLD-SILVER-PLATINUM WANTED**. For free infor-  
mation Write: Wilmots, 345 S. Glassell, Orange, Ca.  
92666

**WATCH** And Clock repairing books, tools, ma-  
terials. Free Catalogs. North American, Box 77-AO,  
Fox River Grove, Illinois 60021.

**DIGITAL WATCH REPAIR** — \$19.95 — All Makes  
and Models — LCD, LED, 90 Day Warranty. Act Now  
for Free Battery Replacement — Module Replace-  
ment Extra. Digitronics, P.O. Box 643PM, Old Bridge,  
New Jersey 08857

**CLOCKS** Handcrafted Wood Brochure \$1. Fisk, 631  
Union, Middlesex, New Jersey 08846

## GOLD

**FIND GOLD** — Guide tells how, free information,  
David Hunt, Roosevelt, Utah 84066

**WEEKEND GOLD**, Looseleaf book, **PLANS**, \$10.00.  
J. Bruun, 1275 Terry, Idaho Falls, ID 83401

**GOLD** — — STRIKE IT RICH! HOW TO EXTRACT  
**GOLD FROM OCEAN, RIVER, LAKE OR BAY WATER!**  
Not a Gimmick — — But a **SIMPLE** Scientific  
**PROCESS**. Order U.S. Patented Plans Showing How.  
Send \$11.95 To: D & D Enterprises Inc., P.O. Box  
32934, Dept. M2, San Jose, California 95152. Avoid  
the Rush. **ORDER NOW!** 1980C, D & D Enterprises  
Inc.

## PRECIOUS STONES & MINERALS

**GET** Free catalog no serious rockhound, gem  
Cutter, jewelry maker, hobbyist or craftsman can  
be without. Full of bargains, exclusive items, low  
prices from largest suppliers and authorities in the  
field. Free new catalog just off the press, yours for  
the asking. Write: Grieger's, Dept. C-12, 900 South  
Arroyo Pkwy., Pasadena, California 91109

**FREE** Indian Necklace. SASE. Walton Wholesale,  
201½ 5th Street, Fowler, Indiana 47944

**800 POLISHED** Gemstones \$5.00. Tumblecraft,  
5401 James North, Minneapolis, Minn. 55430.

## TREASURE FINDERS

**TREASURE** - Locate quarter mile away with ultra  
sensitive locator - brochure free. Research Products,  
Box 13441 - AMC, Tampa, Florida 33611

**FIND** Lost coins, jewelry, buried treasure, gold  
nuggets, relics. New revolutionary patented detector  
analyzes objects, tremendous range, no ground pick-  
up. Free catalog. Gardiner, 4729M N. 7th Ave.,  
Phoenix, Arizona 85013

**REDUCES PRICES!** Manufacturing Overage Topline  
Metal Detectors. Contact: D-TEX, 614 Easy Street,  
Garland, Texas 75042

## PROFITABLE OCCUPATIONS

**AMAZING!** \$265,000 Yearly with classified ads.  
Free Proof. (Stamp Appreciated). Moneycraft, PM-2,  
2316 Dale, Ceres, Ca. 95307.

**INSPECT** House Structure and Systems for Buyers.  
Operate from Home. High Hourly Return. Free De-  
tails. GNH, Box 115, Orleans, Mass. 02653

**PLASTERCRAFT!!!** Profitable home business. Molds  
available. Details: Lynnette, 6251C Mentor Park,  
Mentor, Ohio 44060

**RENTAL AGENT** Prestigious profitable home busi-  
ness. Complete guidelines \$3.00. Relief, P.O. Box  
32248, Minneapolis, MN 55432

**FT. SMITH** Auction School, Ft. Smith, Ark. 72901.  
Resident & Home study. Veteran Approved.

**MAKE MONEY IN SPARE TIME**. Earn generous com-  
missions as a subscription sales representative for  
leading magazines. For full details and instructions,  
send this ad with your name and address to:  
**POPULAR MECHANICS**, Dept. AB-M, 250 W. 55th St.,  
New York, NY 10019

**FREE** Catalogs. Repair air conditioning Refrigera-  
tion. Tools, supplies, full instructions. Ooolin, 2016  
Canton, Dallas, Texas 75201.

## SALESMEN—DISTRIBUTORS

**MAKE EXTRA MONEY DURING YOUR SPARE TIME!**  
Show our New Line of Calendars, Pens and Popular  
Advertising Gifts to Local Firms. Prompt, Friendly  
service from small town AAA-1 Company in our 71st  
year. No investment or collection. Weekly com-  
missions. Be your own Boss. Full Time potential. No  
Experience Necessary. Write: Richard Lowe, **NEWTON**  
**MFG., CO.**, Dept. PMC2, Newton, Iowa 50208

**SELL SENSATIONAL LOW-COST BURGLAR ALARM**.  
Lightening seller. Exceptional margin. Samples for  
trial. Northwest Electric, Ave. 2113, Mitchell, South  
Dakota 57301

## AGENTS WANTED

**MAKE** Big Money selling to friends and neighbors.  
No Investment! No Risk! Instant cash. Free Catalog  
and Selling kit. Mason Shoes, K-525, Chippewa  
Falls, WI 54729.

**PRINTING** Advertising Salesmen—Excellent money  
making sideline selling Decalomania Name Plates,  
small quantities. Advertising Specialties, sign  
letters. Free samples. Ralco XL, Boston, Mass.  
02119.

**SPARE TIME CASH**. Sell famous Hanover Shoes.  
Samples, sales kit free. No experience needed. No  
age limit. Big commissions. Hanover Shoe, Dept.  
2603, Hanover, Pa. 17331.

**SPARE TIME CASH** - Show Brand New 50-Page Sign  
Catalog and Samples to Local Businessmen, Write  
orders, Collect Deposit, we do rest. Details: Signco,  
1715 W. McNichols, Detroit, MI 48235

## BUSINESS OPPORTUNITIES

**IMPORT-Export** opportunity, profitable world-wide,  
mail order business from home, without capital.  
We ship plan for no risk examination. Experience  
unnecessary. Free Report. Mellinger, Dept. C2702,  
Woodland Hills, California 91367

**MAILORDER** Opportunity! Start Profitable Home  
Business without Experience or Capital. Write for  
Free Book, Case Histories, Plus Complete Details.  
No Obligation. Mail Order Associates, Dept. 507,  
Montvale, NJ 07645

**ABANDONED INDUSTRIAL SILVER**—take it! Details:  
Metals, Box 548, Woodville, Texas 75799

**BECOME A WHOLESALER!** RBB Enterprises, 4555  
Carmen, Chicago, Illinois 60630

**MAKE BIG MONEY** - up to \$28.00 an HOUR. Send  
\$4.95 for Complete Course and Manual, to: Frank's  
Steak House, P.O. Box 703, Niagara Falls, New  
York 14302.

**BUSINESS** Opportunity Newsletter. Professional  
Advice. Extra Income. Argonaut, Box 1688-PM2,  
Springfield, Ohio, 45501

**FREE POLISHED REDWOOD BURL GIFT**. 25¢ postage,  
packaging. RB, Dept. 12, 4829 Bel Aire, Arcata,  
Calif. 95521

**HOW To Sell Books by Mail** — \$5.95. Phillips  
Co., 1873 Plaza, (Suite 1301), Garland, Texas 75041

**TAKE** Catalog orders. We drop-ship 2,500 best-  
selling specialty products. Lowest below wholesale  
prices. Immediate delivery. Spectacular home  
business opportunity. Free book, SMC, 6061 De Soto  
Ave., Dept. 20-86, Woodland Hills, CA 91365.

(Continued on next page)



## BUSINESS OPPORTUNITIES

(Continued from preceding page)

**MAKE BIG MONEY** By Selling What You Know. \$10.00. Fowler, Box 137-B, Lake Dallas, Texas 75065

**TURN THOUGHTS INTO CASH!** Write Short Newspaper Paragraphs. Easy! FREE Details. O'Dell, 3131-K Stanwood, Philadelphia, Pa. 19136.

**"ADS 'M' ANSWERS"** has current "Business Opportunities" classified answers. We answered 'em all for you. Send long, self addressed stamped envelope: Consumer Assistance Corp., "The Consumer's Watchdog", Box 13102, St. Petersburg, Florida 33733

**PROFESSIONAL BUSINESS START-UP MANUALS.** Prepared by Leading Financial Institution. Used by Business Investors, Banks, Etc. Magnus, 6201 -M2 Hartford Road, Baltimore, MD 21214

**PROFITS FROM CLASSIFIED ADVERTISING!** Booklet shows you how to start your own business with Classified Advertising Only \$1.00 (Refundable with first order.) H. E. KAPPEL, POPULAR MECHANICS, DEPT. P, 224 WEST 57TH STREET, NEW YORK, N.Y. 10019.

**COST REDUCTION FOR SMALL BUSINESSES.** Engineer Shows how to save Thousands. \$5.00 — BRL Systems, 1409 Carriage Lane, Westmont, Illinois 60559

**A FANTASTIC business!!!** \$9.95. Anyone can do it!!! Free details!!! Turner, Box 2971, Spokane, Wa. 99220.

**BE YOUR OWN BOSS!** Free Details. Mailorder, P.O. Box 1804, Manassas, Virginia 22110

**BIG Earnings!! Steady Income!!** Proven Mailorder Business. Free Profit Details. Garrison, 650 Wagner, Greenville, OH 45331.

**BUMPER STICKER PRINTING DEVICE.** Cheap, Simple, Portable. Free details. Bumper, POB 22791 (GG), Tampa, Florida 33622

**300% Profit Possible Selling Gift Items.** Novelties, Toys!! Minimum investment! Full Profit Details. Hughes Giftworld, Box 9016PM, Newark, New Jersey 07104.

**MAKE Durable Building Plastic Easily Waterproof.** Fireproof, Economical. Bays Laboratory, 2086 - 2075 Drive, Cedaredge, CO 81413.

**PREPARE Tax Returns -** Policeman Albert Myers made \$2,000 his very first season. Train at home. VA Approved. National Tax School, Monsey, 28M, N.Y. 10952

**NEW TAX LOOPHOLES DISCOVERED.** Everyone Eligible. Free Facts. ULC, Box 3598L, Clarkston, GA 30021

**PICTURE Framing—Profitable full or spare-time business.** Easy to learn with handbook-course "Guide To Picture Framing Profits." \$3.00 Guaranteed. Free framing-supplies catalog included. Japs, 126-PM Seventh North, Hopkins, Minnesota 55343.

**VENDING Machines.** No selling. Routes earn amazing profits. Big catalogue Free. Parkway Machine Corporation, 1930PMB Greenspring Drive, Timonium, Maryland 21093.

**REPAIR HYDRAULIC JACKS — DETAILS FREE.** WRITE: HYDRAULIC PARTS SUPPLY, BOX 4157, BROWNSVILLE, TEXAS 77520.

**ERASE DEBTS** with little known law — CREATE Wealth!! Details FREE! Blueprints, #B2, Box 100, LeGrangeville, N.Y. 12540

**GET RICH!** Secret Law smashes Debts — brings Cash and Credit. Details Free! WealthKit, Box 350-B, Billings, New York 12510

**WOODWORKERS -** Start Profitable Business making Unusual Gifts, Decorative Novelties. Easy!!! Everything explained!!! Free details. Williams, 32P Titus, Glen Cove, NY 11542

**MAILORDER \$1,000.00 POSSIBLE MONTHLY** Selling Information. Free Details: AR Enterprises, Box 92-Z, Bronx, New York 10465

**LEARN** The secrets of repairing junk batteries "Fabulous Profits" small investment. Apex Engineering, 5454 Boisa, Atascadero, Calif. 93422

**JEWELRY SALES CAN MAKE YOU RICH!** Full or spare time. Starter kit \$1.00 (Refundable). Nasco, 310-AOB Lincoln Avenue, Fox River Grove, Illinois 60021.

**VINYL'S** Where the money is! Professionally repair, refinish, recolor furniture, luggage, car tops. Quick, easy. Two small \$20 jobs a day earn you \$1,000 a month. Homes, cars, offices, restaurants, unlimited customers. Start earning after a few days practice. Sensational details Free. VIP, 2007 Montrose, Chicago 60618.

**\$700 Per month earnings possible** filling out income tax forms at home or tax office during tax season. We show you how. Simple, quickly learned. Details mailed free. No salesmen. Hurry. Big demand. Federated Tax, 2065 Montrose, Chicago 60618.

**"MAILORDER Laws and Regulations"** explains necessary licenses, different taxes etc. \$3.00. Wonderful dropship proposition free. Neil H. Tasker, Shamokin, Pennsylvania 17872

**ASSEMBLE PRODUCTS AT HOME.** Many opportunities paying High Weekly Profits presently available without investment. Write: Businesses, 92-B2 Brighton 11th, Brooklyn, New York 11235.

**PHOTOSTAMP Agents Wanted!** Make big Money From Home mailorder. Free Samples, Information. Postermatic-C7, East Providence, R.I. 02914.

**MAKE \$15.00 hourly building custom luggage/cases** at home. Huge nationwide demand. Fill mail orders. We supply materials, instructions . . . everything. Free details. Customcase, 6075 De Soto Ave., Dept. X20-86, Woodland Hills, CA. 91365.

**PIANO** Tuning quickly learned with home study courses. Diploma granted. American Tuning School, 17050 Teffer Drive, Morgan Hill, Calif. 95037.

**AMAZING!** \$265,000 Yearly with classified ads. Free Proof (Stamp Appreciated). Moneycraft, PM-2, 2316 Dale, Ceres, Ca. 95307

**HOT —** Stamper Prints Gold Leaf. Personalize everything. Print Business Cards, Pencils, Matches. Free Details. Gold Magic, POB 24986 (GC), Tampa, Florida 33623

**\$500 WEEKLY GROOMING Dogs!** Your Home . . . Anyone Can Learn. Free Details!! Winewood, Box 322PM, Waupaca, Wisconsin 54981

**BUSINESS Opportunities Clearinghouse,** the magazine for ideas, contacts, and free ads. Write: BOC, Box 538, Morton Grove, Ill. 60053

**BIG Profits** in becoming a supplier to major industry through electroplating small parts and metalizing non-metals. Write for free particulars: Mason, Room MC-2-IA, 1512 Jarvis, Chicago, Ill. 60626.

**MAKE 200%-300%** on hundreds of products. Gift Items, novelties, toys, carded merchandise, 1001 others. Giant Catalog \$2.00 (refundable). J&L Enterprises, Box 7021A, Los Angeles, CA 90022

**SURPRISE EVERYBODY.** Become Notary Public now. We guide you, free. We sell notary needs. Raise your image, job value, income. Assistance nationwide. Brochure: Gulf, 234 Club-A, San Antonio, Texas 78201

**\$88.90 DAILY PAY. \$383.88 WEEKLY.** Homework. Immediate Income. Earnings Guarantee Certificate. Free Report/Application. AAHIP, Unit 29309-F, Medcensta, Texas 78229

**A GUIDE TO STARTING IN MAIL ORDER — \$1.00 Refundable.** CTD, Box 15585, Fort Wayne, Indiana 46885

**"OBTAIN Capital"**. Become Broker! Profitable. (Booklet \$2.00). Financial, Box 99PM2, Uleta, Florida 33164

**MAKE 2 to 3 times your cost!** Gifts, Novelties, 1001 Others. Giant catalog \$3.00 (Refundable). Wholesalers, Box 15784-M2, Austin, Texas 78761

**ASSEMBLE** Wood Lamps for Cash. Long SASE. Multiserv, Box 164M, Lincoln, Massachusetts 01773

**PROFITABLE BUSINESS** due to PETROLEUM SHORTAGE. Send \$8.00 for Details. D.P.D. Enterprises, P.O. Box 89 Auburn, Alabama 36830

**LEARN HOW YOU** can take less than \$90.00 and turn it into HUNDREDS every week. No Gimmicks or tricks, unique. \$3.95. Box 2324, Garland, Texas 75041

**PHOTO LAB Agents wanted!** We Develop Anything — Discreetly. Send for Free Information. API, Box 4815-P, Philadelphia, Pennsylvania 19124

**BE YOUR Own Boss!!** "999" Easy. Spare Time. Proven Home Businesses. Write: MJT, 7545 Edison, Tucson, Arizona 85715

**SCRAP GOLD YOUR WAY RICH.** Amazingly Simple. Details \$1.00. Kenlines, Box 14281, Savannah, Georgia 31406

**MAKE Big Profits** on Hundreds of Products. \$2.00 brings Giant Catalog (Refundable). Earl Phelps Company, 19016 Lanbury Ave., Cleveland, Ohio 44122

**"999 SUCCESSFUL Little Known Businesses"**. Information, write: D. Baskin, 3066-D, Glendale Ct., Decatur, Georgia 30032

**FREE Inflation-Beater Book** "2042 Unique Proven Enterprises." "Fabulous "Little Knowns." Work home! HAYLINGS-B, Carlsbad, Calif. 92008.

**PIANO Tuning** Learned Quickly at Home! Free Information. Empire School, Box 450327, Miami 33145

**SELL Books** By Mail. Complete Dealer Set-up—25¢. Midwest, Box 44-R2PM, Shawano, Wisconsin 54166.

**MAILORDER Profit Newsletter -** Professional Advice, Advertising Recommendations. Free Report. Communications, Box 405PM, Boston, Mass. 02199.

**SYNTHETIC LUBRICANTS.** Dealers wanted. Unlimited earnings. Free exciting details. Cresbrite, 6026-F Waggoner, Dallas, Texas 75230

**WE PAY \$1 EACH PHOTO** done! \$12.50 hr. Easy! Write FREE Report, #PM-2, 3110 Fulton, Sacramento, CA 95821

**SELL Books** By Mail. Jones, Box 24484, Vancouver, B.C., Canada V5T 4E1

**GOT Something to Sell?** Do it Through the Mail - the Most Inexpensive Way. Free Details. Send #10 SASE, Plante Co., 143 1/2 N. Market, Paxton, IL 60957.

**INSURANCE —** Be an Agent — See Auto — Homeowners. Free Details. Mr. Agent, POB 60205, Nashville, Tennessee 37206

**UNLIMITED Profits Possible!** Sell Exquisite Jewelry: Large Selection. Full Color Catalog - \$2.00 (Refundable). McCloud Enterprises, 96 Arcade, Calumet City, IL 60409

**BECOME REAL ESTATE INSPECTOR - \$100.00 HOURLY Potential.** Be Boss. Part/Full Time. Home Operation Eliminates Investment. Simplified Instruction, Forms, Assistance. Free Information. IOREI, Box 418-M6, Sullivan, MO 63080.

**CONSULTING Business!!** \$100.00 Plus/Hour Possible! Establish your Own. Easy! No Need To Be Expert. Complete Instructions, Guidance. Write Today; Free Details. ICOA, Dept. CH-2, 563 West Westfield Blvd., Indianapolis, IN 46208.

**BIG Money.** Monument Sales. Free Details. Box 846, St. Cloud, MN 56301

**START Profitable Service Business—Easily!** Alena, Box "A", Farmingville, New York 11738

**I MADE \$40,000 Year** by Mailorder! Helped others make money! Details 25¢. Torrey, Box 318YY, Ypsilanti, Michigan 48197.

**BOOMING Book Business!!** Amazing 800% Profit. Dealer Packet Free! Mitchell, Box 1058PM-N, Benton, AR. 72015

**AMAZING Profits!** Wholesale Merchandise. No Investment. James Clines Co., Uniontown, Kentucky 42461

**FREE Jewelry Sales Kit.** Make 233% Profit. Courtesy Gems, 1634 Bogart, Bronx, New York 10462

**FREE Giant Catalog —** business plans — reveal how to become wealthy wholesaler — from home full/spare time — Carwal, 6009-PM020 Hillcrest, Tacoma, Washington 98499

**MAIL ORDER Riches Revealed . . .** Learn to sell books "Lazy Boys" way . . . Fantastic Formula!! Free Details: Elan Publications, Box 7025, Dept. PM-1, Tulsa, Oklahoma 74105.

**SELL Oil Portrait Painting** From Photos. Dealership \$1.00 (Refundable). Merlin-PM28, 86 Valmonte, Banning, CA 92220.

**I MADE \$1 Million** finding capitol for local merchants & businessmen. Helped others start. No selling. Write: FBA-12, Kerrville, Texas 78028

**CHIMNEY SWEEPING** is a High Paying Trade! Become a Professional CHIMNEY SWEEPER Quickly and Economically. Free Information. Michael James Chimney Sweeping, Box 1078, Dept. PM, Aptos, California 95003

**MAKE \$2,000.00 MONTHLY.** Spare time. Unique proven enterprises. No Selling. No Capital to start. Free brochure. Kashbuilder, Box 1132-19K Indianapolis, Indiana 46225.

**\$82.00 From Square Foot Plywood.** (Huge Demand). Revealing Proof 25¢ (Refundable). Woodwin, Bridgewater, Mass. 02324

**REPAIR HYDRAULIC AND PNEUMATIC JACKS —** and Power Tools earn Big Money. Short Course \$3.95. Auto Jack, Box 10301, Orlando, Florida 32809

**LEARN Sewing Machine Repairing.** Men. Women. Lucrative Profits. Gremlin Correspondence School, Box 927, Spencer, Iowa 51301.

**\$480 Weekly.** Home mailing program. Goodworld, Box 26233-R, Tamarac, Florida 33320

**WOODWORKERS -** Turn \$4 material into \$34.95. Free Brochure! Pine Shop, 78P, West Petersborough, New Hampshire 03468

**RESTAURANT RECIPES BUILD SALES. START A RESTAURANT. PROFESSIONAL, TESTED, PROVEN RESTAURANT SIZED RECIPES FOR TODAY'S "IN" FOODS.** FREE INFORMATION. Creative Food and Restaurant Consultants, Box 62, Wilmette, Illinois 60091

**EARN UNLIMITED Extra Income** Taking Catalog Orders. Unique Import Items. Free Details! World's Best Inc., 8047A Caminito De Pizza, San Diego, California 92108

**\$356.00 Weekly** Guaranteed. Work 2 Hours Daily at Home (\$178.00 for One Hour). Free Brochure. R.C., P.O. Box 534, Saint Joseph, Missouri 64501

**VENDING Machine Profits: Begin Home.** Authoritative Manual Instructs. Details, Free Directory Machine Manufacturers. Clifco, Drawer 7519pm2, Alexandria, Virginia 22307

**FANTASTIC Way to Start your own Import-Export Business** from your Own Home Without Investing in Merchandise. World Traders Digest and Directory of Foreign Suppliers. Reveals U.S. Governments Help. Report \$5.00. Write: Can-Am Enterprises, Dept. P.M., 464 Bruce Avenue, P.O. Box 970, Nanaimo, B.C., Canada

**FREE Mailorder Dropship Business Journal!** Mailer's World, Box 1355K, Sioux Falls, South Dakota 57101.

**999 Low Capital Businesses.** Free Details. Horn, 542 Seneca, Dept. 280PM, Aurora, Illinois 60506

**FREE Details on High Profit Mail Order Book Business.** Vantage, Box 224-PM, Hyde Park, Mass. 02136

**MANUFACTURER NEEDS MAN** To Assemble product at home and supply national sales crews, full or part time. Should desire business of their own. Five-figure income potential. S.K.R.M. Manufacturers, River Bend Plantation, Broadway, North Carolina 27505

**\$2,000.00 Monthly Possible!!** Over 2,100 Items Available. Huge Profits Every Sale!! Free Brochures. Derst Company, 629-P2 Mosby, Savannah, Georgia 31405

**MAKE MONEY AT HOME:** Many Profitable Programs. Rush \$1. and SASE. Shukr, Box 174-PM Ahuntsic, Montreal, Quebec, Canada H3L 3N7

(Continued on next page)



## BUSINESS OPPORTUNITIES

(Continued from preceding page)

**26 UNUSUAL** Ways Mechanically Inclined People Make **EXTRA CASH!** Free Details. Write: Entrepreneur, 2311 Pontious Ave., Suite B-416, Los Angeles, CA 90064

**EXPLOSIVE!** Dynamic! Breakthrough! New Hand-capping Angle! First Time Revealed! Be One Of The Fortunate Ones! Jump On The Band Wagon! Seize This Lucrative Opportunity Now! Rewards Unlimited! Wager \$10.00 On This One! No Ripoff! Lifetime Opportunity! Box 19166, Cleveland, Ohio 44108

**"HOW To Pick A Successful Home Business Venture", \$2.00.** REN, 24 Hillsdale, Scott Depot, West Virginia 25560

**ASTOUNDING** Moneymaking, Recession-proof Mail-order Business! Exciting Details. Cummins, Box 20683, San Diego, California 92120.

**MAILORDER: FREE DROPSHIP DIRECTORY.** Clifco, Box 7519pm2, Alexandria, Virginia 22307

**PROFITS FROM CLASSIFIED ADVERTISING!** Booklet shows you how to start your own business with Classified Advertising. Only \$1.00 (Refundable with first order.) H. E. KAPPEL, POPULAR MECHANICS, DEPT. P, 224 WEST 57TH STREET, NEW YORK, N.Y. 10019.

**MAILORDER MILLIONS.** Expert Reveals Proven, How to Method For Success. Free Details. S. Enterprises, 508 Maple Street, San Mateo, California 94402

**BUSINESS Loans! Repay from profits. 98% Accepted!** Associates, Box 98-A3, Brooklyn, NY 11235

**BIG Profits** Striping Parking Lots. Huge Demand! Start without investment. SBIC, 473 Morris, Providence, Rhode Island 02906

**BUSINESS Ideas.** Self-Improvement Newsletter. Details. Impressions, 6569 Main, Williamsville, NY 14221

**PROFITABLE** Mailorder Plans. Kenmar, PM, Box 15266, Fort Wayne, Indiana 46815

**FREE** Brochure "Starts" \$100.00 Daily Marketing Program! Balico, Box 91309P2, Cleveland, Ohio 44101

**WHOLESALE** Opportunity. Hundreds of Items. Fast Sellers. Information. Shurlaine, 1939P Guernsey, Beaverton, MI 48612

**GUARANTEED \$238.00 Weekly.** Homework! Earnings Guaranteed. SIA, Box 182PM, Quitman, Texas 75783

**WORK** At home. Let us help you begin your mailorder business. Personal assistance. Details \$1.00. Home Business Opportunities, Box 283, Clarington, Ohio 43915

**MAKE** Thousands in Mail Order. Free Details. Coto, 3351 Hull Avenue, Williamsbridge, New York 10467

**BECOME YOUR OWN BOSS** — Home Improvements Information \$10.00 — Resume. Contractors Training of Illinois, Box 21, 101 E. Healey, Champaign, Illinois 61820

**\$100/DAY TABLETOP ELECTRIC FACTORY** Earns Big Profits! Knowledge, investment unnecessary. Prospectus \$3.00 (Refundable). Sweatt, Box 591, Titusville, Florida 32780

## MONEYMAKING OPPORTUNITIES

**HOW TO WIN CONTESTS!** Send \$2.95 Postpaid — Free Surprise — Bonus if You Order Now! S&S Investments, P.O. Box 10741, Dept. PM, Birmingham, Alabama 35202

**DEALERS** Wanted. Large Profits. Unique Proven Business. Argonaut, Box 1688-2MP, Springfield, Ohio 45501

**FIRST TIME OPPORTUNITY** Start Business for less than \$200.00. No Competition yet! For information Send \$5.00 to: Series 1, P.O. Box 32, Rocheport, Missouri 65279

**MAKE** Statuettes, Novelties, Imitation Marble. Sell to stores or start gift shop. Details 25c. Marbleizing, P.O. Box 1178, Ballwin, Missouri 63011

**"HOW to Become Rich Subconsciously.** Biblically Oriented." \$10.00. Global Publications, Box 32186, Minneapolis, Minnesota 55432

**OVER 1,000 BUSINESS-OF-YOUR-OWN** opportunities in 5 issues of Opportunity Magazine and they're yours free for the asking! Write: Opportunity, Dept. 467, 6 N. Michigan, Chicago 60602.

**DOLLARS FOR YOUR JUNK.** Junk Dealers Secrets Revealed \$3.00. Tesar's, Box 73, Christmas, Florida 32709

**PROFITS FROM CLASSIFIED ADVERTISING!** Booklet shows you how to start your own business with Classified Advertising. Only \$1.00 (Refundable with first order.) H. E. KAPPEL, POPULAR MECHANICS, DEPT. P, 224 WEST 57TH STREET, NEW YORK, N.Y. 10019.

**\$480.00 WEEKLY POSSIBLE!** Unique Mail-Order Opportunity. "Guaranteed Program." Interested? FREE Details: Freedom, Box 30224-PP, Denver, Colorado 80230

**DEALERS** wanted - full or part time - new product, details, sample \$3.00. Puglisi Enterprises, Box 4507, Manchester, N.H. 03108

**INSTANT** Win. Now available first instant prize \$Million Lottery. Free details and membership; Canadian Money Club, Dept. PM, P.O. Box 1006, (Adelaide Stn.), Toronto, Canada M5C 2K4

**CASH Loans "Overnight."** Wipe out Debts! Enjoy AAA-1 Credit! Free Report! "Research," Box 29263-AB, Indianapolis, IN 46229.

**VINYL'S** Where The Money Is! Professionally repair, refinish, recolor furniture, luggage, car tops. Quick, easy. Two small \$20 jobs a day earn you \$1,000 a month. Homes, cars, offices, restaurants, unlimited customers. Start earning after a few days practice. Sensational details Free. VIP, 2062 Montrose, Chicago 60618.

**SWEEPSTAKES** - Contests - Crosswords! 60-page sample Free! Prizewinner-P, Box 10596, St. Petersburg, Fla. 33733.

**PROFIT** From Inflation, Guaranteed Results. Report \$2.00. Midwest Consultants, Box 733, Rochester, Indiana 46975

**HOW INFLATION CAN MAKE YOU RICH NOW!** Send \$3.50 Postpaid; S&S Investments, P. O. Box 10741, Dept. PM, Birmingham, Alabama 35202

**LET** Me show you how you can have your own Rubber Stamp Business Free! Write: Roberts, Room RC-2-JA, 1512 Jarvis, Chicago, IL 60626.

**SELL PHOTOS** — Make money with your camera. Booklet tells how. Includes directory of where to sell your pictures. Your camera could provide a second income. Only \$1.50. A. Harsen, 500 Park Drive, Box 116, Belmawr, N.J. 08031

**\$48.85** Daily Starting next week. No Mailorder Swindle or Stuffing Envelopes Ripoff! For Information Mail 20¢ Poststamp: Sbiamek, Drawer 4099, Valley Village, CA 91607

**STOP** Wasting Money answering questionable opportunity ads. 1000 offers explained. Globe, Box 20588-PM, St. Louis, Mo. 63139

**FREE** Report. New Discovery in Battery Reconditioning Means "Big Profits Fast." Electone, 7415 Gabie Drive, Little Rock, Arkansas 72205

**GAMBLERS** — FREE! WIN lifetime income from dice, roulette, thoroughbred, harness, dog racing. Guaranteed! Research, Box 551PM43, Mineola, NY 11501

**CLIPPING NEWSPAPERS** — Earn \$150 weekly at home. Free Details! Box 1626, Waterbury, Connecticut 06721

**MAKE MONEY!** Collect GOLD and SILVER coins. Booklet tells how. Send \$2.00 Val-Lue Enterprises, Dept. 102M, 1923 19th Lane, Brooklyn, NY 11214

**101 PRACTICAL** Ways to Make Money at Home. Details Free. Fugate Enterprises, 1312 Lindell, PM, Hannibal, MO 63401

**HOW** To Make Money Writing Short Fillers. Report \$1.50. Easy Mailer's, Box 9803-2PM, St. Thomas, V.I. 00801

**FREE** Details! Proven Money Making Mail Order System. Money Minder's, 295 Mobil, Suite 3, Camarillo, CA 93010

**WIN** at Roulette!! Winners' System. Winning Almost Guaranteed Instruction Booklet \$2.00. Plante, 1434 1/2 North Market, Paxton, IL 60957.

**APPRAISING** Real Estate. Fantastic Profits. Free Report. AAR, Box 6125 PM, Hayward, CA 94544

**WE BUY** NEWSPAPER CLIPPINGS of Wedding Announcements for \$1.00 each. Instructions \$1.00. Clippings, Box 491-PM, Gatesville, Texas 76728.

**MONEY!** MAKING IT! ... WINNING IT! Write: KNOWHOW, Box 261, Monroe, North Carolina 28110

**TABLES** Using Free Construction Scraps. Attractive, Sturdy, Quickly Built. Complete Instructions. \$2.00 to: Basics, Box 1766, Dillon, Colorado 80435

**MAKE** Money Selling Photos. Instructions \$2.00. 135 Walter Avenue, Thornwood, New York 10594

**MAILORDER BEGINNERS.** \$50.000 Yearly Potential! Sell Information. At Home, Part Time. Free Brochure. Alpha Omega Enterprises, 416A Jeffries, Monrovia, CA. 91016

**SUCCESS BOOKS RENTED!** Inexpensive! Opportunities. Wholesale Gifts! Gee's, 288 N. Livingston, Livingston, NJ 07039

**FREE** List of Moneymaking Booklets. Ideal Specialities, 673-A Grove St., Rahway, N.J. 07065

**HAVE FUN AND MAKE MONEY TOO! WIN MONEY AT THE RACE TRACK, POKER, BLACKJACK, AND DICE.** Amaze your friends at BILLIARDS. Send Now for FREE Catalog of Information That Tells You How!! YOU CAN BE A WINNER! Shaw, 7217 University, E8, Peoria, IL 61614

**NEW** - Proven Plan For The 1980's - "JOIN IT" - Extra Money For You. Satisfaction Guaranteed. Send \$10.00 Today. Mardou, 1307 PM, Laurelton Drive, Endicott, NY 13760.

**PROFITS FROM CLASSIFIED ADVERTISING!** Booklet shows you how to start your own business with Classified Advertising. Only \$1.00 (Refundable with first order.) H. E. KAPPEL, POPULAR MECHANICS, DEPT. P, 224 WEST 57TH STREET, NEW YORK, N.Y. 10019.

**END** Money worries forever! I made \$77,000 last year. Paid Hardly any taxes. You can too. Free proof! Sterne, 8361-M Vickers, San Diego, California 92111

**MAKE MONEY FROM HOME!** Start your own profitable business! Free Details! Patrick's, 912 Summit, Downers Grove, Ill. 60515

**50 MONEY-MAKING REPORTS YOU CAN REPRINT, SELL FOR 100% PROFIT.** GROVE BOOK COMPANY, PM280, 8519 HAZEN STREET, HOUSTON, TEXAS 77036.

**INCREASE YOUR INCOME \$350.00 Weekly** Home Business. Free Details. G+K Enterprises, P.O. Box 1097-B, Cleveland, Texas 77327

**\$200.00 Possible** Immediately from Government Oil and Gas Leases. Details \$1.00. Energy Resource Company, 1013 Westchester Court, Evansville, Indiana 47710

## RABBITS—CHINCHILLAS—FUR BEARING ANIMALS

**AMAZING** Profits! \$10,000 Yearly Raising Rabbits for Wool and Breeding. Details—\$1.00. American Angora, Malta 12, Montana 59538.

**\$500-\$1000** Month Plan raising Rabbits for us. Free details. White's Rabbitry, PM, Hudson, Ohio 44236.

## EARTHWORMS, LIVE BAIT

**FREE** Literature Profitable Business Raising Fishworms, Crickets. We Teach you how to Raise and Sell. Write today. Carter Fishworms, Plains, Georgia 31780.

**GREY** Nightcrawlers — Raise/Retail — Free Literature. Fain's Earthworms, Edison, Georgia 31746

**REDWORMS** Bedrun 5,000-\$22.00; 20,000-\$57.00 including postage. Raising instructions. Brazos Worm Farms, P.O. Box 4185PM, Waco, Texas 76705

## POULTRY & GAME BIRDS

**BIG FREE CATALOG**, all about growing birds at home, incubators, feeders, hatching eggs. Write: Marsh Farms, 14272 Brookhurst, Garden Grove, CA 92643

**QUAIL** And equipment catalog. Also booklet "How to Produce and Sell Quail Year Around". Send 25¢ to: GOF Mfg., P.O. Box 1552, Dept. 1552-L, Savannah, Ga 31402

**999** Picture Color Catalog \$1.00. "Everything—You Name It!" Swans, Peacocks, Bantams, Pigeons, hobby supplies. Stromberg's Pets Unlimited, Pine River 59, Minnesota 56474

## OF INTEREST TO ALL

**RID** Fleas, Roaches and other Household Pests yourself. Eliminate Costly Pest Control Agencies. Product Information \$2.95. — Preferred Products, 414 Woodward Avenue, Jacksonville, Alabama 36265

**DIAMONDS—DO IT RIGHT** — By a simple test learn to Tell the Difference between genuine Diamonds and Simulated ones. Send \$2.95 to: Helpful Hints, P.O. Box 8672, Orlando, Florida 32806

**FREE FIREWOOD**, Plus get PAID! Complete Details, \$2.00. J. Lord, 641 Belair, Augusta, GA 30907

**SAVE** Hundreds Buying From The Manufacturers. For Details Send Stamped Envelope: Wrench Publications, P.O. Box 4277, San Leandro, California 94579

**HOW TO PREPARE OWN SIMPLE WILL** - Instructions, Samples - \$10.00. Wills, Box 42, Sedan, Kansas 67361

**STOP OVERPAYING YOUR FEDERAL INCOME TAX!** Easy to Read Report Prepared by Professionals. Money Back Guarantee. Send \$3.95 to: TAXES, P.O. Box 1654, Corpus Christi, Texas 78403

**SHORT** Time Only, Gather Coins Double Face Value, Last Chance, How, \$5.00. Rudys, 901 Lawndale, Royal Oak, Michigan 48067

**HOTTEST NEW COLLECTIBLE - RARE GEMS!** Details Free! Taylor's, 113PM Martin, Indian Harbor Beach, FL 32937

**BURGLARIES ARE SKYROCKETING!** Your House, Apartment or Farm May Be Inviting A Theft! Complete Manual of Home Security: \$4.00. Glenvale, Box 358p Station D, Toronto, Ontario M6P 3J9

**SNOW REMOVAL MADE EASY! FREE BROCHURE.** McLean's, Box 562, Statesville, North Carolina 28677

**FREE FUELS!** Guide to obtaining 7 heating fuels absolutely free! \$2.95. SAVE, Box 810, Carberry, Manitoba, Canada R0K 0H0

**SELF** Improvement Books, Free Catalog. Shaw, 7217 University, Peoria, Illinois 61614

**PRODUCE YOUR OWN GAS** From Beans! Entertaining Details \$2.00 SASE. Expressway, Box 6339, Ventura, California 93003

**PROFITS FROM CLASSIFIED ADVERTISING!** Booklet shows you how to start your own business with Classified Advertising. Only \$1.00 (Refundable with first order.) H. E. KAPPEL, POPULAR MECHANICS, DEPT. P, 224 WEST 57TH STREET, NEW YORK, N.Y. 10019.

## OF INTEREST TO WOMEN

**STUDIO** Home Knitting Machines are a profitable hobby. Credit available. Send \$1, for information to: Studio, Box PM46017, Seattle, WA 98146.

## GOVERNMENT SURPLUS

**GOVERNMENT LANDS FROM \$7.50 ACRE!** Homesites, farming, vacationing, investment opportunities! "Government Land Buyer's Guide" plus current listings—\$2.00. Surplus Lands, Box 19107-AB, Washington, D.C. 20036.

(Continued on next page)



## GOVERNMENT SURPLUS

(Continued from preceding page)

"GOVERNMENT SURPLUS DIRECTORY!" . . . Buy 500,000 items (including Jeeps) . . . low as 2¢ on dollar! Most complete information available — \$2.00 (guaranteed). **SURPLUS DISPOSAL**, Box 19107-AB, WASHINGTON, DC 20036.

1980 Surplus Army, Navy store 64 page illustrated catalog. Send \$1.00. Ruvel, 3037 North Clark, Dept. J-2, Chicago, Ill. 60657

J-E-E-P-S — \$19.30! — C-A-R-S — \$13.50! — 650,000 ITEMS — GOVERNMENT SURPLUS — MOST COMPREHENSIVE DIRECTORY AVAILABLE TELLS HOW, WHERE TO BUY — YOUR AREA — \$2 — MONEY-BACK GUARANTEE — "GOVERNMENT INFORMATION SERVICES," DEPARTMENT B-2, BOX 99249, SAN FRANCISCO, CALIFORNIA 94109.

O-F-F-I-C-I-A-L UNITED STATES DIRECTORY . . . Jeeps . . . \$37.22!! . . . 400,000 Listings!! . . . Your immediate Area!! . . . UNEQUALLED!! . . . \$2.00 (INCLUDES G-LANDS, G-LOTTERIES INFO-GUIDE!!) UNCONDITIONALLY GUARANTEED!! . . . United States/Great Lakes Federal Surplus Depository, B-807-P, Marshfield, Wisconsin 54449. (COPYRIGHT 1980)

JEEPS \$60.00 — Send for Directory Today. \$1.50. MONEYBACK GUARANTEE. Jeans, Dept. PM2, R. 1, Box 8, Hoschton, Georgia 30548

GOVERNMENT SURPLUS. Buy your area. How. Where. Send \$2.00. **SURPLUS HEADQUARTERS BUILDING**, Box 30177PM, Washington, DC 20014

J-E-E-P-S!! \$33.30!! 525,000 Items! Buy in Your Area! How! Where! - - "Moneyback G-U-A-R-A-N-T-E-E-D 1980 Government S-U-R-P-L-U-S Directory" - Including: "Buy G-LANDS," - - "G-Oil/Gas L-O-T-T-E-R-I-E-S," - - \$2.00. **GSURPLUS**, Box 2009E, Syracuse, New York 13220.

HOW to Make Money on Government Surplus. Send \$1.75. Bob Rees Products, R.D.#1, Emporium, Pa. 15834.

MOTORCYCLES — JEEPS — HELICOPTERS — AUTOMOBILES . . . GOVERNMENT SURPLUS DIRECTORY—MONEYBACK GUARANTEE—How, where—\$2.00. GS Information, Department 12, Federal Building, Box 3913, Springfield, Massachusetts 01101

JEEPS, Trucks, from \$52.40 . . . Boats, Airplanes, Automobiles, Motorcycles, Typewriters, Tools, Clothing, Sports, Camping, Photographic, Electronic Equipment . . . 300,000 Amazing Bargains direct from Government Nationwide . . . low as 2¢ on dollars! Surplus Catalog and Sales Directory \$2.00 (refundable). **SURPLUS**, Box 954-PPM, Muskegon, Mich. 49443

DISCOUNT Catalog — Viet-nam Boots, Canteens, Viet-nam Jackets, Knives, Jungle Hats, Packs, Helmets, C-Rations. Send \$1.00 Refundable. Dixie Military Surplus, Box 8149-PM, Nashville, Tennessee 37207

JEEPS \$52.40, Airplanes \$75.01, Typewriters \$6.70, Boats \$7.50, direct from government. Directory and Surplus Catalog \$1.00 (refundable). Midwest Surplus, Box 401-PM, Dayton, Ohio 45401

B-A-R-G-A-I-N-S !!! Jeeps—4WD Trucks!—Tractors!—Typewriters!—Tarps!—Government Sales, Your Area —E-X-P-E-R-I-E-N-C-E-D—B-U-Y-E-R-S Guaranteed R-E-P-O-R-T, \$2.—TJB, Box 157-P, Vernon Hills, Illinois 60061

PROFIT FROM GOVERNMENT SURPLUS \$3.00. **SURPLUS REPORT**, Box 7067, Cleveland, Ohio 44128

GOVERNMENT Surplus Directory \$2. Money Back Guarantee. Same as the best directories, except you receive within seven days or money back. Try Us! Sunshine Books, Dept. 40, Route 2, Box 698, Rustburg, Virginia 24588

GOVERNMENT SURPLUS, How and where to buy in your area. Complete Information \$2.00. DCI Sales, Box 1144, Salina, Kansas 67401.

JEEPS . . . 499,999 other bargains!!! Inside track!!! Fully guaranteed directory. Government sources near you!!! \$1.75 today . . . Herb, 127 Lake Street, Englewood, N.J. 07631

## GOVERNMENT BENEFITS

H-O-W T-O COLLECT TO \$112,501 GOVERNMENT BENEFITS OWED YOU!! — NEW REPORT!! — \$2.00 — MONEY-BACK GUARANTEE!! — "BENEFITS ADMINISTRATION," DEPARTMENT 894-B2, NATIONAL PRESS BUILDING, WASHINGTON, D.C. 20045.

VETERANS! DOES UNCLE SAM OWE YOU? "How To Get What U.S. Government Owes Veterans" Can Help You Find Out. \$3.00. The Mail Sack, 600 Welch Blvd., Dept. PM802, Flint, Michigan 48503

## LOANS BY MAIL

BORROW FROM HOME. Any amount, any purpose, within 30 days. Competitive Rates. Also, you can earn unlimited income as our Money Agent. No experience—own hours. National Company to assist every way possible. No Gimmicks! Free Details: Financial, Dept. 10-C-2, 1145 Reservoir Avenue, Cranston, R.I. 02920

ARAB MONEY TO LOAN, Invest For Business, Investment Purposes. \$10,000 — \$10,000,000. FREE Details. Arab-PM, 935 Main, Vidor, TX 77662

GET Cash Grants—From Government. (Never Repay.) Also, Cash Loans. All Ages Eligible. Complete Information, \$2.00. (Refundable). Surplus Funds-PM, 1629 K Street, #502, Washington, D.C. 20006

BORROW \$25,000 "overnight." Any purpose. Keep indefinitely! Write: Success Research, Box 29263-AN, Indianapolis, Indiana 46229.

BORROW \$1,000-\$50,000 secretly—"overnight." Anyone! Credit unimportant. Repay anytime. Incredibly low interest. No interviews, collateral, co-signers. Unique "Financier's Plan." Full information, \$2 (refundable). Spectrum, 79 Wall St.-7, New York 10005

UNSECURED Loans \$4,000 Up. Details \$2.00. Fiesta-PLM, Springfield, Illinois 62708

FREE Details on How to Borrow up to \$10,000 entirely by Mail. Write: Postal Financial Services, Inc., Dept. 1381, 814 Pierce St., P. O. Box 268, Sioux City, Iowa 51102.

BORROW \$125,000 Interest-Free!! Repay Anytime. Everyone eligible. Free Report: Executive PM-2, Box 996, Dundee, Florida 33838

CASH Loans and Outright Grants to Individuals refused Elsewhere. No Collateral, Co-signers, interviews. 98% Accepted. Associates, Box 98-A4, Brooklyn, NY 11235

CASH'S LOANS! Personal, Business, Consolidation. Any purpose. Write: NATIONAL, 507P Fifth Ave., New York 10017

## PERSONAL

INFORMATION/Assistance on Anything. USA/— Worldwide: International Research Service, Box 225, Blue Bell, Pennsylvania 19422.

CUT GROCERY BUDGET INFLATION 15-60% WITHIN 60 DAYS. DETAILED MANUAL \$10.00. D-M Enterprises, Box 529, Manhattan, Illinois 60442

GOD'S MIRACLES ARE FREE. PAUL, BOX 2466, CLARKSBURG, WEST VIRGINIA 26301

HOW To Take Charge of your life — Inquire: Life Planning Institute, Box 2020, Breesport, New York 14816

COLLEGE DEGREES BY MAIL. Renowned Universities offer full-accredited Bachelors, Masters, PH.D's . . . Free revealing details. Counseling, Box 317-MP-2, Tustin, California 92680.

COLLEGE Diplomas Without Classes. Accredited Degrees by Mail. Free Details. DACS, Box 33428, Seattle, WA 98133

CONFIDENTIAL Chicago Mailing Address: Business, Personal Since 1944! Mail Center, 323(k) Franklin, Chicago 60606

FINANCE YOUR DREAMS With Government and Foundation Grants. Free details. Tou-PM2, 432 PCH, Hermosa Beach, California 90254.

MEN! WHERE ARE YOU? "What it Means To Be A Man". Profitable, Powerful, Guaranteed. Send \$2.00 to: SEeco, OralMae P.O. 2129S2000E, Salt Lake City 84106

IMPROVE Your Memory. Details Free: Memory, Box 77, Palco, Kansas, 67657.

DIVORCE. Beat the racket! Fight all discrimination! Literature, attorneys. Information Free. Please disseminate. MEN'S RIGHTS ASS'N., B189, Forest Lake, Minn. 55025.

NERVOUS — Serenity Recipe, \$4.98. B. Gallo, Box 42903, Las Vegas, Nevada 89104

BIBLE Questions answered. Stamped envelope. Bylon, 17167 Bentler, Detroit, Michigan 48219

PSORIASIS SUFFERERS: DISCOURAGED: Write for Free important information that is helping thousands. Pixacol, Box 29277PM, Parma, Ohio 44129.

STARTLING . . . Life and Death facts about your **WOOD HEARTERS** . . . Write: DPI, P. O. Box "F", Albemarle, N. C. 28001

SAVE ON YOUR INCOME TAXES WITH ULTIMATE TAX SHELTER Method of Super-rich in Special List of Legal Tax Deductions and procedures for business and personal returns. Send \$2.00 REFUNDABLE. Wilson's TRA, 706 West McCalliard, Muncie, Indiana 47303

HAY-FEVER SUFFERERS . . . Easy RELIEF without drugs—\$3. Spencer Enterprises, Box 111, Spencer, West Virginia 25276

A LIST OF ONE-Liners that will promote a friendly argument at any gathering. \$2.00. Specialized Works, P.O. Box 7751, Stockton, California 95201

## REMAILING SERVICE

CONFIDENTIAL MAIL and PHONE Calls Received and Forwarded Daily. Central, Box 387PM, Claymont, DE 19703

PACIFIC Northwest Address. Discreet Remailing Service. Write: Jobal, Box 546, Woodinville, Wa. 98072

TORONTO Remails - Confidential Service. Write: Williams, Box 835, Adelaide St., Toronto, Canada M5C 2K1.

VIRGIN ISLANDS MAIL SERVICE. Our exclusive address is yours. Prompt remailing forwarding. Inquire: St. Croix Island Company, Dept. 1, P.O. Box 1081, Frederiksted, St. Croix, U.S. Virgin Islands 00840

UNLISTED ADDRESS. Discreet and confidential. Remail 50¢ Single. Mail Forwarding Service, 8050 S. Main, Houston, Texas 77025

REMAILING DIRECTORY \$5.00. INTERNATIONAL REMAIL FORWARDING ASSOCIATION, BOX 1536M, HILO, HAWAII 96720

LETTERS Remaild and Forwarded. Details 25¢: Box 8, Buffalo, New York 14212

FREE! Remailers Listing. (New Agents Wanted): Box 471PM, Atlanta, Georgia 75551.

BOSTON Remails. Stamped Singles 50¢. Jarman, 299 Nahant Road, Nahant, Mass. 01908

YOUR mail Received-Forwarded-Confidential. DAL Mail Service, P.O. Box 98, Southview Station, Binghamton, New York 13903

SUPERFAST, Confidential, Reliable, Economical 45¢. Webb's, Box 16369, Rocky River, OHIO 44116

NASHVILLE CONFIDENTIAL Personal business remailing, phone services. Prompt, dependable. Mailway, Box 24949PM, Nashville, TN. 37202.

NEW MEXICO Remails—Immediate re-mail 50¢. Anthony, 200 E. 22nd St., #44, Roswell, New Mexico 88201

MAIL RECEIVED — FORWARDED DAILY. Monmouth Management Associates, P.O. Box 401, Keansburg, New Jersey 07734

FLORIDA REMAILS Receiving-Forwarding. Allen, 6326 Autlan Drive, Jacksonville, Florida 32210

## MISCELLANEOUS

QUALITY CERTIFICATES, serious, comic/award yourself, friends, five/\$3.00. Documents, 2022-A W. Cholla, Phoenix, Az. 85029

PHOTO ID. Sealed in plastic. All states, provinces. 24-hours. GUARANTEED. Send \$5.00 (additional IDs \$4.00), photo, name, address, height, weight, hair, eyes, birthdate. CARDINAL, Box 5200-DR46, Jacksonville, Florida 32207.

TUBING: Vinyl, Latex, Neoprene, Colors: Catalogue: Canal Rubber Supply, 329 Canal Street, New York, New York 10013

IDENTIFICATION CARDS. Send for information. 929 University Ave., Berkeley, CA 94710.

AUTOMOBILE Drivers, Male-Female. Drive Late Model Cars, Pick-up Trucks all over the United States. Details \$5.00 plus self-addressed envelope with stamp. R.J.C., Box 583, Hancock, Michigan 49930

ORNAMENTAL Iron Designs. Book of 1600 Beautiful. Practical Designs for Railings, Columns, etc. Free Literature. Cunningham, 3881 South 3200 West, Box 20005, Salt Lake City, Utah 84120

PHOTO IDENTIFICATION CARDS . . . Certificates . . . GUARANTEED!! Samples 25¢ . . . Bascco, Box 3461-P-80, Providence, R.I. 02909.

FREE \$10.00 Surprise — \$2.00 Handling to: Box 841, Waterloo, Ontario N2J 4C3

HISTORICAL CASSETTE TAPE: "KENNEDY PRESIDENCY". Mail \$5.00. Tower, Lewes, Delaware 19958

## WANTED—MISCELLANEOUS

BUYING Tungsten Carbide, Top Prices - Poley's Industrial Salvage, 12389 S. Minges, Battle Creek, MI 49017 (616) 979-4075.

GOLD, Silver, Platinum, Mercury, Tantalum wanted. Ores assayed. Free circular. Wholesale Terminal, Norwood, Ma. 02062.

I BUY Old Fountain Pens. Evans, Box 1499, Santa Monica, California 90406

## HEARING AIDS

HUGE SAVINGS. Eliminate dealer mark-ups. Free Trial. Batteries Wholesale. Terms arranged. Lloyds-PMC, Rockford, Ill. 61104.

TRY before you buy! Rhodes Hearing Aids, 132-G, Brookport, ILL. 62910

## TOBACCO

MAKE Pipes, Information: Pimo, Inc., P20, Box 59211, Chicago, Illinois 60659

## FORMULAS, PLANS, ETC.

ONE HUNDRED EASILY PREPARED PRODUCT FORMULAS. Rush \$1.00. Distributor, R7B68, Milton, Florida 32570.

YOUR FORTUNE in Moneymaking Formulas! Thousands available at bargain prices—manufacturing secrets—easy money methods—details \$2.00 (Refundable)—GWA3, Box 193, Brookfield, Wisconsin 53005

NEW MONEymaking FORMULAS! Catalog — \$1.00 — Refundable! — Innovel, Box 53, Custer, WA 98240

## SPECIAL SERVICES

INFORMATION On anything. Ferguson Research Specialists, 60-15 Woodside, Woodside, New York 11377.

INFORMATION On Anything. Thorough, Reasonable, Fast! - Global Research Associates - PM, Box 182, Yalesville, Connecticut 06492.

PROFITS FROM CLASSIFIED ADVERTISING! Booklet shows you how to start your own business with Classified Advertising. Only \$1.00 (Refundable with first order.) H. E. KAPPEL, POPULAR MECHANICS, DEPT. P, 224 WEST 57TH STREET, NEW YORK, N.Y. 10019.

RESEARCH/INFORMATION any item, subject, service. Free details. Mailway, Box 24949PM, Nashville, TN. 37202



**BETTER HEALTH**

**NEGATIVE ION GENERATORS** and Accessories. (Assembled/Kits). (Fascinating details—\$1.00). Golden Enterprises, Box 1282-PM, Glendale, Arizona 85311

**HEMORRHOIDS** Cured permanently. Information free. Young, Box 9542-PM, Seattle, WA 98109

**HOW To Stop Smoking!** Secret Reveals All you Need to Know to Do-It-Yourself. Send \$3.95. Ashton's, Dept. 3, Box 2216, Pasco, Washington 99302

**SMOKING?** Stop! Tested Detailed Booklet \$3.95. Money Back Guarantee. Parkhurst Associates, United Penn Bank, Wilkes Barre, PA. 18701

**STOP SMOKING WITHOUT GAINING WEIGHT!** 32 page book \$2.00. Bailey Morgan, Box 654, Windsor Locks, CT 06096

**FLOWERS, PLANTS & NURSERY SUPPLIES**

**LEARN** Flower Arranging and Floristry. Start business or hobby. Free information on home study course. Lifetime Career Schools, Dept. B-584, 2251 Barry Avenue, Los Angeles, California 90064

**GROW** Ginseng! \$50 Pound. Have Seeds, Roots. Goldenseal. Full information. K. Collins, Viola, Iowa 52350

**LEARN** Landscaping at home. Free booklet. Lifetime Career Schools, Dept. A-794, 2251 Barry Avenue, Los Angeles, California 90064

**PARSNIP** Seed Sale. \$1.15 Each. Postpaid. SASE. O. Thorpe, P.O. Box 415, Ellensburg, Washington 98926

**WINEMAKING & OTHER RECIPES**

**WINEMAKERS-BEERMAKERS** . . . Free Supply catalog. Yeast. Equipment. Continental, Box 68016-PM, Indianapolis, Ind. 46268.

**HOME** Practice of the Brewers Art. Send \$4.00 To: Spectro Services Corporation, P.O. Box 9386, Norfolk, VA 23505

**MR. FRANK'S RECIPES** for King Crab Legs and Breaded Fan-Tailed Shrimp. Send \$2.00 to: FRANK'S STEAK HOUSE, P.O. Box 703, Niagara Falls, N.Y. 14302.

**WINEMAKERS** -Beer-makers: Free illustrated catalog of supplies. Semplex, Box 12276R, Minneapolis, Minnesota 55412.

**MAKE BEER,** Wine, Liqueurs. Free Catalog. Bacchanalia, Box 1PM, Dartmouth, MA 02714

**WINEMAKERS-BEERMAKERS**—Free Catalog—Fast Service—Large Selections: Kraus, Box 7850L, Independence, Missouri 64053.

**BEERMAKERS,** Winemakers, Free Catalog, Recipe. Finest Ingredients, Equipment, Service. SPI, Box 784M, Chapel Hill, North Carolina 27514

**BEERLOVERS!** Brew American and European Beer. Complete Kits, Equipment, Supplies. FREE Details. Duane Imports Ltd., Department PM20A, 508 Canal Street, New York, New York 10013

**BACHELORS'** Cookbook. 100 quick, economical recipes for fish, beef, pork, poultry. \$3.50 and self-addressed envelope. M. Hale, P.O. Box 18347, Wichita, Kansas 67218

**SAVORY MESQUITE SMOKED RANGE BBQ** — Absolutely Delicious. Your Friends Will Envy You — Fact, No Brag! Directions, Recipe, Mesquite \$3.00. Warnke Ranch Ent., 8034 Antoine, 106PM, Houston, Texas 77088

**MOM'S** Dollar Saving Recipes. \$3.00. Large SASE. Delightful Products, P.O. Box 567A, Sunnymead, California 92388

**WINEMAKING/BEERMAKING** Supplies, Equipment. Free Catalog. Wine Hobby, P.O. Box G-104, Greenwood, MA 01880.

**EVERYTHING** For Wine, Beer, Catalog: Jim Dandy Sales, Box 30377P, Cincinnati, Ohio, 45230

**BLEND OF WINES** — Unique Recipe — Fantastic Tasting — All Occasions — \$2.00. M.N.C., Box 38, Elwyn, PA 19063

**FREE RECIPES** — BEER, WINE. Make Better Beer at Home than you can Buy. Also Excellent Wine. Have Fun—Save Money. The Winery, Dept. M, 60 South Cooper, Memphis, TN 38104

**BEER-WINEMAKING** Supplies, 38 Imported Malts Free Catalog. Wine & Brew Hobby, P.O. Box 1866, Allentown, Pa. 18105

**"LIQUEURS/HOR D'OUVERS"** Eight Popular Liqueurs \$3.50. Do ahead hor d'ouvers Famous Cooking School Recipes \$3.00/Box 3041, La Jolla, California 92038.

**CHAMPAGNE,** Connoisseur's Delight. Homemade, Sparkling, Citrus. Recipe \$1. Drex, Box 4404, Charleston, WV 25304.

**BREW Your Own Beer!** Instruction and recipe \$1.00. Satellite Shopper, 5702 W. Ridgeway, Houston, Texas. 77053

**TWELVE** Favorite Recipes \$3.00. Old Fashion Recipes, RT.4, Box 195, Winchester, Virginia 22601

**FREE ENCYCLOPEDIA** Winemaking, Beer-making, Supplies, Equipment, Ingredients. Vynox Industries, Box PM7498, Rochester, New York 14615

**BEER LOVERS** — Brew your own. Delicious! Inexpensive! Free Catalog. Beer Gear, Box 25093M, Lansing, Michigan 48909

**ELEVEN** delicious Peanut Butter Recipes! \$3.00 SASE. Carole, Box 991-HSJ, Springfield, Missouri 65801

**LIQUEURS,** 6 You Make — \$3.50. Sweet Mel's, Box 9002, Boise, ID 83707

**MOONSHINE!** Whiskey, Gin, Vodka Making. Illustrated Manual, Recipes, \$2.00. Gourmay, 5133 Fairhill, Philadelphia, PA 19120.

**DELICIOUS CHOCOLATE PIE RECIPE.** Original \$3.00. Marge Smith, 1531 Northwest 29 Street, Oklahoma City, Oklahoma 73106

**WINEMAKING** —Using Balloon Fruit Juice Jugs—Recipe \$2.00 Blackett, 562-31 St., Ogden, Utah 84403

**OLD FASHIONED RECIPES** —Clam Chowder, Chicken Soup—\$2.00 each. P.O. Box 63-4703, Margate, Florida 33063

**EXCELLENT!!** Old-world Recipe using inexpensive Chuck Roast. Superb House Specialty for the Restaurateur or Family Gourmet. \$3.00. SASE. Hilltop Enterprises, Box 1363, Granite City, Illinois 62040

**BURGLAR ALARMS & HOME PROTECTION**

**PROFESSIONAL EQUIPMENT.** Compare Prices!!! Catalog/Decals — \$1.00. (Refundable). Preventor, 5602PF Santa Anita, Arcadia, 91006

**POLICE DIALER** \$29.95. Free Catalog. SASCO, 5619 St. John, Kansas City, Mo. 64123

**BURGLARY VICTIMS: NEVER AGAIN!** Learn "How to Repel Burglars" \$2.00. Prevention, Box 3151C, Culver City, CA 90230

**ULTRASONIC** - Wireless - Perimeter. Quality Selection. Catalog \$1: EAC, Box 7881J, Colorado Springs, Colorado 80933

**Popular Mechanics**

224 West 57th Street, New York, N.Y. 10019  
Classified Advertising Dept. (212) 262-4825 Order Form

**DEADLINE FOR ADS:** Copy and Payment must be in by the 5th day of the 2nd preceding month for the issue in which the ad is to appear. See Head of Classified Section.

**HOW TO COUNT WORDS:** Name and address must be included in counting the number of Words in your ad. Each initial or number used counts as 1 word: H.E.Kappel, 224 West 57th Street, New York, New York 10019: 9 WORDS. Zip codes are not counted. Phone #: 2 Words. Symbols used as keys are charged for. City or State count as 1 word each.: New Brunswick, New Jersey: 2 Words. Abbreviations such as C.O.D., F.O.B., R.P.M., U.S.A., P.O., 5x7, 16mm are counted as 1 word. (P.O.Box 392 counted as 3 words) Webster's International Unabridged Dictionary will be used as our authority for spelling, compound words, Hyphenations, abbreviations, etc. Please make checks payable to POPULAR MECHANICS.

Only \$40 for 10 word minimum  
\$4.00 each additional word  
BOLD FACE CAPS add \$1 per word  
(First Word: No Charge For Bold Face)

Remittance of \$ \_\_\_\_\_ is enclosed to cover \_\_\_\_\_ insertion(s) in the \_\_\_\_\_ issue(s) \_\_\_\_\_ Classification

1	2	3	4
5	6	7	8
9	10	11	12
13	14	15	16
17	18	19	20
21	22	23	24
25	26	27	28
29	30	31	32

**YOUR NAME** \_\_\_\_\_ **PHONE:** \_\_\_\_\_  
(PLEASE PRINT)

**FIRM (NAME IN AD)** \_\_\_\_\_

**YOUR ADDRESS** \_\_\_\_\_

**CITY** \_\_\_\_\_ **STATE** \_\_\_\_\_ **ZIP** \_\_\_\_\_

**DATE:** \_\_\_\_\_ **YOUR SIGNATURE** \_\_\_\_\_  
(PLEASE PRINT OR TYPE COPY • FOR ADDITIONAL WORDS ATTACH SEPARATE SHEET)



# Subscription price Slashed to \$2.97!

**M**oneysworth monthly has stunned the magazine world by announcing an offer of full-year subscriptions for just \$2.97. This is as little as some magazines charge for a single issue.

"We're doing this to celebrate our Tenth Anniversary," a spokesman said, "and to solidify Moneysworth's position as America's Number One Biggest Publishing Bargain. Ever since it began publication in 1970, Moneysworth has consistently lowered subscription rates, while other periodicals have raised theirs. We started out at \$10 a year and now we are offering Tenth Anniversary Special Subscriptions at *THE UNREAL PRICE OF ONLY \$2.97!*"

Moneysworth, which tells how to get the most for your money and the most out of life, is read by an estimated 5,000,000. Its chief competitors are Consumer Reports, which sells for \$12 a year, and Money magazine, for \$14.95.

## How to place your order

Readers of this magazine who wish to take advantage of this unparalleled offer should send their name and address along with \$2.97 to: Tenth Anniversary Special Subscriptions, Moneysworth, 251 W. 57th Street, New York, NY 10019.

Typical of the savvy, wallet-fattening articles Moneysworth prints are these:

**Recession-Proof Jobs**

**Cars that Are Stingiest with Gas**

**How to Earn 10½% on Your Savings**

**Canada's FREE Land Giveaway**

**How to Qualify for Food Stamps**

**The Only Diet that Really Works**

**The Long and Short of Hair Transplants**

**How to Collect Social Security from the**

**U.S. and Canada—BOTH**

**Are Hay Fever Shots Pointless?**

**Mercedes' New "Lifetime" Car**

**How to Reduce Exorbitant Doctor Bills**

**States with Best Unemployment Pay**

**How to Get a Low-Cost Divorce**

**The Kinds of Cars Mechanics Own**

**How to Hold On to Your Auto Insurance**

**How to Turn Botox into Gold**

**Contact Lenses that CURE Poor Vision**

**Happiness Is a Hick Town**

**A Gourmet's Guide to Free Cookbooks**

**How to Stop Snoring**

**Air Travel at 50% Off**

**Today's Soldiers Command High Pay**

**Prosperity in Alaska**

**Low-Cost Insurance for Non-Smokers**

**Mattresses to Turn Handsprings Over**

**How to Save 20% on Your Food Bill**

**Scholar Dollars for the Middle Class**

**Where Retirement \$\$ Goes Farthest**

**The "Yurt": Incredible \$350 House**

**How to Get 7 Bestsellers for Price of 1**

**Ski Areas Without Steep Prices**

**How to Burn Wood Efficiently as Fuel**

**Resumes that Get Jobs**

**How to Avoid Alimony**

**How to Travel and Get Paid for It**

**Fifteen Fabulous Free Maps**

**Don't Sneeze at This Cold Remedy**

**Starting a Retirement Business**

**Videotape: The Last Word in Wills**

**The World's 100 Best Free Calendars**

**Landing an Executive Job After 40**

**How to Cope with Dunning Letters**

**Sailboats that Are Real Winners**

**Getting a Job as a Forest Ranger**

**The Amazing New Two-Engine Car**

As you can see, Moneysworth is an easy-to-follow instruction manual for building a better life. Each day, it is inundated with ecstatic testimonials like:

• "You're not going to believe this, but I have parlayed \$146 into \$90,000, due to your informative article on how to break into real estate. How can I ever express my gratitude sufficiently?"

—H.T. Pinrose; Montgomery, Iowa.

• "Your advice on Social Security resulted in a \$3,135 lump-sum cash payment to my wife and \$171 monthly pension. The best investment I ever made was my subscription to Moneysworth." —Dr. Herman Hortop; La Grange, Ill.

• "Your tip on flying to Europe via Afghanistan saved me \$450. You've made me a subscriber for life."—Charles B. Fager, M.D.; Harrisburg, Pa.

• "Your article on high interest paid by foreign banks has enabled me to retire in style. I cannot thank you enough."—E. Svenson; Fallbrook, Cal.

• "Your news reports on investments have brought me, in just months, \$12,996 profit, tripling my money. You can bet I'll be a Moneysworth subscriber for life."—L. Grey; Ypsilanti, Mich.

• "Your article 'Inaccurate Billing by the Phone Company' led me to discover four years of overcharges. I got a \$1,593 refund!"—A. DiRienzo; Bristol, Pa.

• "Moneysworth's product ratings sure stretch the dollar. I bought the 35mm camera you recommended, saving 30%."—R. Goodrich; Tucson, Ariz.

• "Your article 'How to Avoid Paying an Exorbitant Doctor Bill' saved me \$65. Here's my subscription extension." —C. Wagner; Yorktown Heights, N.Y.

• "Thanks to your article 'How to Buy a New Car for \$125 over DEALER's Cost,' I just bought a Chevy at a saving that I conservatively estimate at \$350." —Rudy L. Grange; Anita, Iowa.

• "Moneysworth is aptly named. To paraphrase Churchill, never have so many paid so little for so much."—Dave Alpern; Pittsburgh, Pa.

## To take advantage

To take advantage of this *GIVEAWAY* offer, readers of this magazine should send their name and address with \$2.97 to: Tenth Anniversary Special Subscriptions, Moneysworth, 251 W. 57th Street, New York, NY 10019.

If ever a publication was accurately named, it's Moneysworth. This offer is highly recommended.

© Moneysworth mcm1xxx. TM reg.



# HOW MUCH FISHING CAN HOMER CIRCLE DO WITH EVINRUDE'S NEW 7½ AND 5 GALLONS OF FUEL?

**NOTE FROM EVINRUDE:** Miles per gallon and gallons per hour figures are fine for boat testers and engineers. But they don't mean much to ordinary troll-and-search, stop-and-cast fishermen. So we invited noted fishing writer Homer Circle, Angling Editor of Sports Afield, to run the 7½ for a week — doing what he would typically do fishing an unfamiliar lake — and report on what he did and how much fuel he used.\* His report follows:

"It takes a heap of running to find fish during dog-day doldrums. And this was the challenge we faced when invited to 'wring out' Evinrude's new 7½ hp outboard.

"A week's fishing on less than a gallon of fuel a day? The way I fish, without the help of an electric motor? Frankly, I doubted it. maybe four, but surely not six days.

"Gayle, my 'childbride' of 42 years, and I have fished together over three continents, and rarely have we found the fishing tougher.

"Using a topographic map of Wisconsin's Namekagon Lake, we systematically sought out bottom structures using a sonar flasher. We did not skimp on fuel but probed as we normally would under such conditions.

"We fished as we did 25 years BE, before electrics. We either let a friendly breeze waft us along an area, or anchored to fish out select spots, or trolled from one point to another.

"To catch enough fish to eat, we had to hit it hard to ferret out four holding areas from one to four miles from the dock. Then, putting aside



thoughts of fuel frugality, we deep-trolled during midday hours seeking a suspended lunker.

"Not only did we use just 5 gallons of gas during the week, we experienced the flawless performance of a thoroughbred. It powered our 14-foot Alumacraft from flat to scat in seconds.

"I found especially handy two features at the tip of the control handle: a kill button, and a knurled ring to fine-tune idling.

"Only on three occasions did this motor fail to start on the first pull. All were my fault for forgetting to put the handle control on 'start.' I liked the dock manager's comment: 'Sounds like my mother's sewing machine.'

"Summarizing: we put Evinrude's new baby to the test and found it totally adequate to all our fishing needs. In short: it's a gas-hoarding honey!"

*\*Of course, your fuel consumption will depend on conditions and your use of the outboard.*

**EVINRUDE**  
PRODUCT GROUP, OUTBOARD MARINE CORPORATION first in outboards  
©Outboard Marine Corporation 1979. All rights reserved.

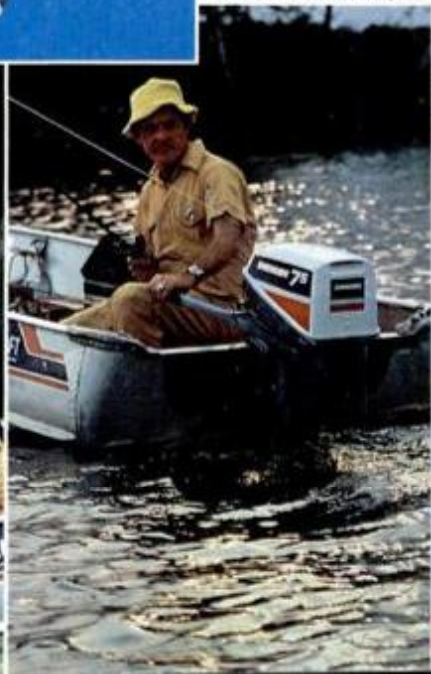



19 mg. "tar", 1.3 mg. nicotine av. per cigarette, FTC Report MAY '78.

© 1978 R. J. REYNOLDS TOBACCO CO.

## Satisfaction, Camel Filters style.

Some men taste it all: Rich warm flavor. Smooth even taste. Solid satisfaction.

Only from the Camel Filters blend of Turkish and domestic tobaccos.

Warning: The Surgeon General Has Determined That Cigarette Smoking Is Dangerous to Your Health.

