

AUGUST 1979 \$1.00

Popular Mechanics

CARS FOR THE FUEL CRUNCH:

Complete guide to diesel and regular-gas models

PM DRIVE REPORTS:

- Audi diesel
- Honda Prelude
- 84-mpg turbo diesel

HOME COMPUTERS:

4 models you just plug in and use

A master woodcrafter's 10 top secrets

COMPLETE PLANS:

- Lemonade stand
- Pewter tableware
- Luxurious platform bed



TERROR PLUNGE

WHAT FLIGHT RECORDERS REVEAL



© 1973 R.J. REYNOLDS TOBACCO CO.

Discover Camel Lights satisfaction.

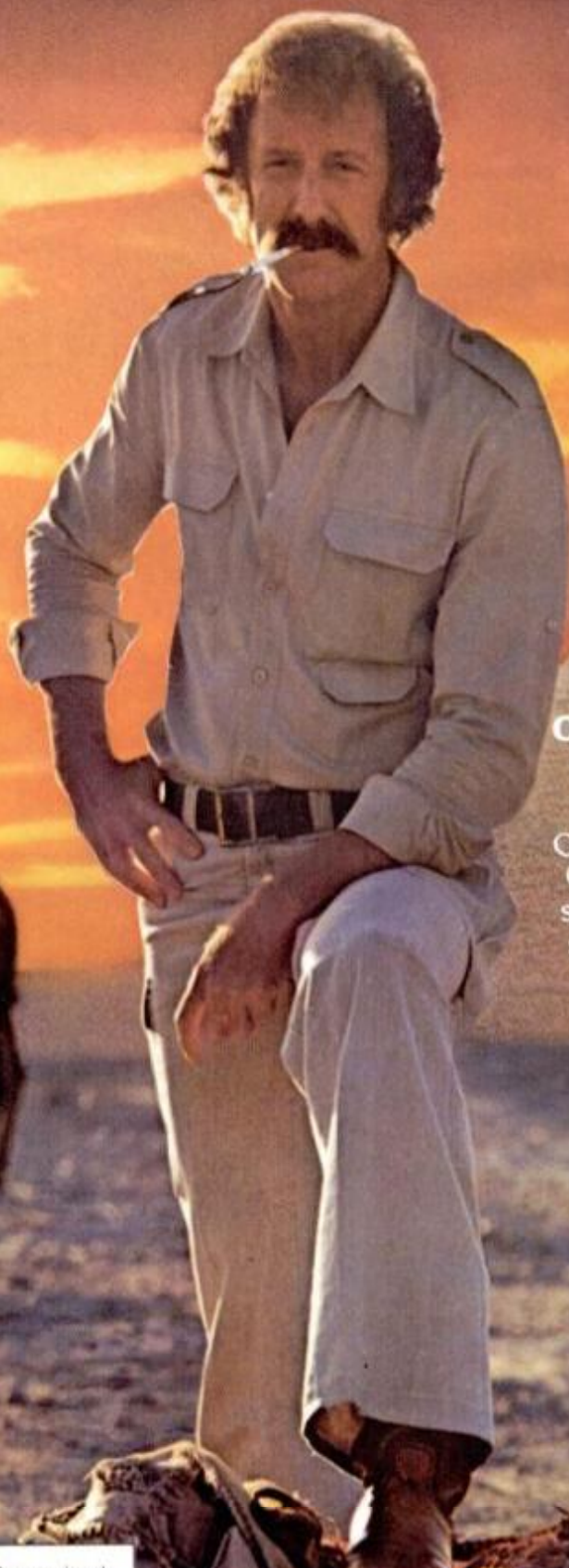

The Camel World
of satisfaction comes
to low tar smoking.

This is where it all started.
Camel quality, now in a rich tasting
Camel blend for smooth, low tar
smoking. Camel Lights brings the
solution to taste in low tar.



Warning: The Surgeon General Has Determined
That Cigarette Smoking Is Dangerous to Your Health.

LIGHTS: 10 mg. "tar", 0.8 mg. nicotine, LIGHTS 100's:
13 mg. "tar", 1.0 mg. nicotine, av. per cigarette by FTC method.

Your insulation's effectiveness can be reduced if you don't have a vapor barrier.

Now, a latex vapor barrier that goes on like paint.

Why you need a vapor barrier...



1. Warm moisture from inside your house penetrates exterior walls. This moisture can condense and freeze inside cold outer walls. Insulation and building materials get wet, frost forms, and heat is conducted to the outside.



2. One coat of Insul-aid™ puts a vapor barrier on your interior walls. Keeps most of the warm, moist healthful air inside. Your insulation stays drier, more effective. Helps keep fuel bills down!

Your family produces gallons of moisture a day.

That's right, the average family of four produces 4 or more gallons of moisture each day. Just from taking showers.



Washing dishes. Washing and drying clothes. Cooking. Breathing and perspiring. And if you have a humidifier, you'll produce *gallons more moisture every 24 hours.*

Independent tests show one coat of Insul-aid can cut heat loss through walls up to 20%.

If you're planning on painting, plan on using Insul-aid. And remember... you can do it just a room at a time, and only the interior walls that face the cold outside. In most rooms, that's just one or two walls plus the ceiling (but only if beneath cold attic space). *And you'll cut heat loss through those walls up to 20%.*

Insul-aid helps protect exterior damage, too.

Vapor from inside your home - penetrating exterior walls - also causes ex-

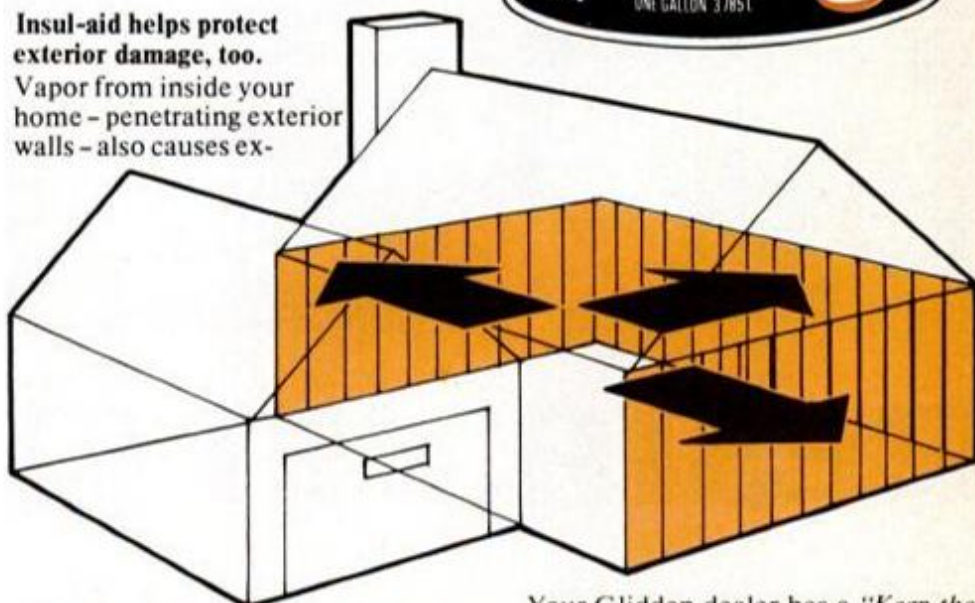

terior damage. The lack of a vapor barrier inside is the major cause of paint failure on the outside: peeling, blistering, staining can occur. *Insul-aid keeps up to nine times more moisture inside.*

Insul-aid exceeds FHA standards.

Minimum property standards of the Federal Housing Administration call for a vapor barrier having a vapor transmission rate not exceeding *1 perm* to be installed on the warm side of the walls (except for unfurred masonry walls). *Insul-aid more than meets this standard.*



Your Glidden dealer has a "Keep the Warm Inside" brochure with the whole story. And he has the Insul-aid you need to do it.



SCM GLIDDEN COATINGS & RESINS
SCM CORPORATION, CLEVELAND, OHIO 44115



**TRACTION OF
FRONT WHEEL DRIVE**



**QUICK
ACCELERATION**



**EXCELLENT
FUEL ECONOMY**



BUILT IN GERMANY



RACK AND PINION STEERING

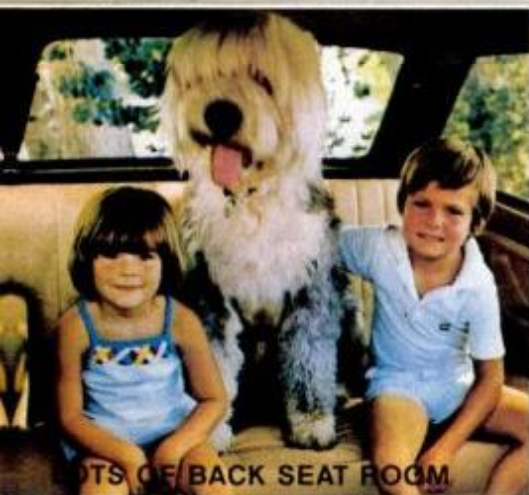

LOTS OF BACK SEAT ROOM



**SOLD AND SERVICED AT OVER
5,000 FORD DEALERS**



WIDE HATCHBACK DESIGN

FIESTA. WUNDERCAR!

Imported From Germany.

Ford Fiesta is Europe's most successful new car in history. (Based on new car nameplate sales in the first 24 months.) It's an import buyer's dream. A car that's at home on the San Diego Freeway as well as on the high-speed autobahn. Fiesta—Wundercar.

Excellent Performance.

Performance is what Ford Fiesta is all about. With front wheel drive and Michelin steel-belted radials to help take you up hills, through mud and over ice and snow.

Rack and pinion steering for direct response. And acceleration that will absolutely move you. In Ford tests, 1978 Fiestas accelerated from 0 to 50 MPH in an average of about 9 seconds.

Excellent Fuel Economy.

Fiesta gives you excellent fuel economy. EPA estimated mpg: [28]. Highway estimate: 39 mpg. Compare this to other cars. Your mileage may differ depending on speed, weather and trip length. California mpg is lower. Actual highway mileage will probably be lower than estimate.

At Over 5,000 Ford Dealers.

Fiesta is built in Germany and a success throughout Europe, but it's sold and serviced at over 5,000 Ford Dealers and backed by Ford Motor Company, Dearborn, Mich. Test-drive a Fiesta and see why we call it Wundercar.



FORD FIESTA

FORD DIVISION



Материал, защищенный авторским правом



On the cover

How could an airliner on a routine flight—as in the recent case of a 727 over the midwestern United States—go suddenly, violently out of control into a near fatal dive? Sometimes it takes months of electronic detective work to find the answer in that amazing little black box—the flight recorder. See page 57 for a report on what we can learn from flight recorders. —PM painting by Ed Valigursky

Popular Mechanics®

AUGUST 1979

CONTENTS

VOLUME 152 NUMBER 2

INTERNATIONAL EDITIONS: CARIBBEAN, ITALY, MEXICO, SOUTHERN HEMISPHERE

Special features:

Cars for the fuel crunch

PM looks under the hood of a specially tuned diesel to find out how a veteran racing mechanic gets 84 mpg out of it. Plus list of cars that burn regular gas and diesel fuel.

42

Other fuel-crunch cars: First-hand driving reports on Audi Diesel, Honda Prelude

43, 85

Master woodcrafter's 10 top secrets

Professional tips and shortcuts you can use in your shop today.

88

Home computers that plug in and go

PM analyzes, compares the models that can turn you on to personal computing now.

66

New gear for underwater fun

Diving product roundup, plus how to get complete plans for PM's Scuba-Tow II

72

Build a lemonade stand for cool customers

There's both fun and profit for kids in an old idea whose time is right now.

86

Automobiles and bikes

- [22 Imports and Motorsports](#)
- [25 Detroit Listening Post](#)
- [33 The PM Garage](#)
- [35 Car Clinic](#)
- [42 More miles for your money!](#)
- [42 An 84-mpg turbodiesel](#)
- [43 Driving the 34-mpg Audi Diesel](#)
- [62 PM Owners Report: Ford Pinto](#)
- [76 PM Owners Report: Jaguar](#)
- [82 Saturday Mechanic: How to select and replace shock absorbers](#)
- [85 Driving the Honda Prelude](#)
- [114 Your motorcycle: Time for chain maintenance](#)
- [120 Driving PM's electric car](#)

Electronics, radio and TV

- [14 PM Electronics Monitor](#)
- [66 Home computers that plug in and go!](#)
- [69 Games on computers](#)
- [78 Programmed scanning brings back CB excitement](#)
- [134 Now: Computers in speakers give super sound!](#)

Boating and outdoors

- [16 All Outdoors](#)
- [70 Small boats: Fun with less fuel](#)
- [72 Great new gear for underwater fun](#)
- [172 New Now for outdoors](#)

Photography

- [18 Photo Hints](#)
- [166 PM tests a revolutionary new 3-D camera](#)

Science and engineering

- [26 Science Worldwide](#)

Shop and crafts

- [13 PM Workbench](#)

28, 118, 136 Hints from readers

- [86 Build the best lemonade stand on your block](#)
- [88 10 great shop tricks from a master craftsman](#)
- [91 New Now for home and shop](#)
- [92 Gleaming pewter tableware you can make](#)
- [96 Quick framing with ready-made moldings](#)
- [100 Build a platform bed](#)
- [104 Workshop Minicourse: More about bench saws](#)
- [123 PM looks at better wood boring](#)
- [170 PM looks at sander-polisher-scrubber kit](#)

Home and yard

- [8 Appliance Clinic](#)
- [48 Homeowners' Clinic](#)
- [51 Super bowl for chain-saw champs](#)
- [98 Quick fixes for small appliance problems](#)
- [102 How to troubleshoot solid-state appliances](#)
- [159 PM looks at new energy-saving lamp](#)
- [162 New ways with nylon-cord lawn trimmers](#)

Aviation

- [57 What we're learning from airplane flight recorders](#)
- [61 From worst U.S. crash, an incomplete record](#)

Every month

- [7 Letters](#)
- [53 PM Briefs](#)
- [64, 81, 91, 174 It's New Now](#)

Worth writing for

Looking for more ideas and information? See page 151.

AS A SERVICE TO READERS. Popular Mechanics publishes newsworthy products, techniques and scientific and technological developments. Due to possible variance in the quality and condition of materials and workmanship, Popular Mechanics cannot assume responsibility for proper application of techniques or proper and safe functioning of manufactured products or reader-built projects resulting from plans published in this magazine.

POPULAR MECHANICS (ISSN 0032-4558) is published monthly by The Hearst Corporation, 224 West 57th Street, New York, N.Y. 10019, U.S.A. Subscription prices: United States and Possessions, \$8.97 for one year; \$16.97 for two years; \$24.97 for three years. Canada and all other countries, add \$6.00 for each year. Second-class postage paid at New York, N.Y., and at additional mailing offices. Authorized as second-class mail by the Post Office Department, Ottawa, and for payment of postage in cash. Registered as second-class matter at the Post Office at Mexico D.F., Mexico, June 20, 1950. © 1979 by The Hearst Corporation. All rights reserved. Printed in U.S.A.

POSTMASTER: Please send Forms 3579 to Popular Mechanics, P.O. Box 10064, Des Moines, Iowa 50350.

SUBSCRIPTION SERVICE: Popular Mechanics Magazine will, upon receipt from its reader of a complete new or renewal subscription order, undertake fulfillment of

that order so as to provide the first-copy delivery to the Postal Service within six to twelve weeks. If for some reason this cannot be done, you will be promptly notified of the issue date that will begin your subscription, with a request for any further instructions you may have concerning your order. Please address all such orders to us at Popular Mechanics, P.O. Box 10064, Des Moines, Iowa 50350. • Should you have any problem with your subscription, please write or call Joan Harris, Customer Service Department, Popular Mechanics, P.O. Box 10064, Des Moines, Iowa 50350. Telephone: 800-247-3470. State of Iowa residents call 800-532-1272. To assure quickest service, please enclose your mailing label when writing to us or renewing your subscription. • Renewal orders must be received at least eight weeks prior to expiration to assure continued service.

Use this address for subscription orders & inquiries

POPULAR MECHANICS
P.O. Box 10064
Des Moines, Iowa 50350

POSTMASTER, Please send Forms 3579 to this address



Chivas Regal • 12 Years Old Worldwide • Blended Scotch Whisky • 86 Proof •
General Wine & Spirits Co., N.Y.

Popular Mechanics®

Editor: John A. Linkletter
Executive Editor: Robin C. Nelson
Managing Editor: Arthur J. Maher
Art Director: Ira Herrick

Special Editorial Features: Sheldon M. Gallager, editor
Automotive: Bill Hartford, editor; Michael Lamm (West Coast); Gary Witzenburg (Detroit)
Science and Engineering: Gurney Williams III, editor
Home and Shop: Harry Wicks, editor; Joseph R. Provey, Penelope Angell, assistants
Boating, Outdoors and Travel: Wm. T. McKeown, editor
Electronics: Neil L. Shapiro, editor
Copy and Production: Garry Winter, chief; John Bostonian Jr., art; Peter Easton, Shannon K. Kelley, Daniel J. Oates, assistants
Art: Don Mannes, technical art director; Douglas Quinn, Alan Andresen, assistants

Special Publications: Clifford B. Hicks

Editorial offices: 224 West 57th St., New York, N.Y. 10019. We cannot be responsible for loss of unsolicited queries, manuscripts, or photos. For return, they must be accompanied by adequate postage.

Bureau of Information: Sophie Gronowicz, director, 224 West 57th St., New York, N.Y. 10019. (212) 262-4292

Director of Advertising
Daniel J. Coleman

Advertising Offices:

New York: 224 West 57th St., New York, N.Y. 10019; (212) 262-4284

Chicago: 520 North Michigan Ave., Chicago, Ill. 60611; (312) 527-2400

Detroit: 377 Fisher Rd., Grosse Pointe, Mich. 48230; (313) 881-3520

Cleveland: 221 Mercantile Center, 3659 Green Rd., Cleveland, Ohio 44122; (216) 292-7334

Los Angeles: 460 East Carson Plaza Dr., Carson, Calif. 90746; (213) 532-8101

Production Manager: John A. Regina, (212) 262-4800

Classified Advertising Manager: H. E. Kappel, (212) 262-4825

Published by The Hearst Corporation

President

Frank A. Bennack Jr.

Chairman

Randolph A. Hearst

Vice Chairman

John R. Miller

President, Magazines Division

Gilbert C. Maurer

Publisher, Popular Mechanics

Joseph F. Kern

Publishing Consultant

Richard E. Deems

POPULAR MECHANICS IS PUBLISHED MONTHLY by the Hearst Corporation, 224 West 57th Street, New York, N.Y. 10019, U.S.A. Frank A. Bennack Jr., President; Randolph A. Hearst, Chairman; Harrison A. Mitnick, Treasurer; Harvey L. Lipton, Vice President and Secretary. Hearst Magazines Division: Gilbert C. Maurer, President; Raymond J. Peterson, Executive Vice President, Advertising; K. Robert Brink, Vice President and General Manager; Thomas J. Hughes, Resident Controller; William S. Campbell, Vice President, Director of Circulation; Joseph F. Kern, Vice President for Popular Mechanics.

THE SCOUT FRAME. WE OVERBUILD IT IN CASE YOU OVERLOAD IT.

*All-welded
box frame construction
for extra rigidity.*

*Heavy-duty axles
for increased towing
and load-hauling
capacity.*

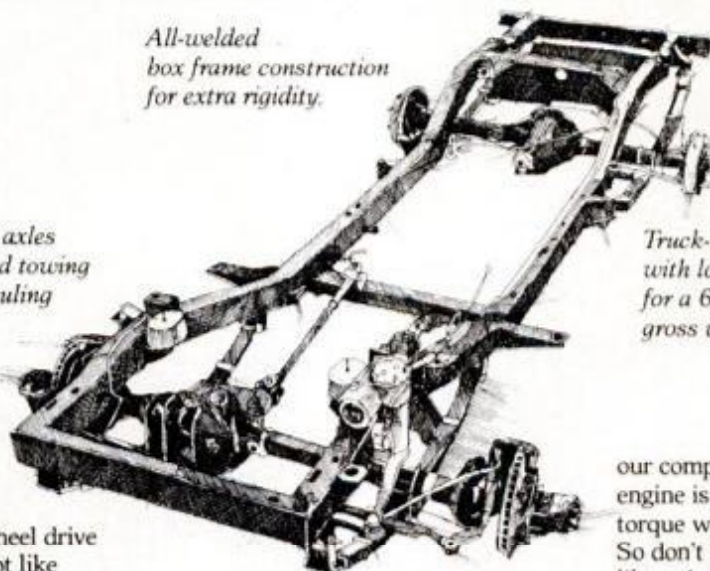

*Truck-type suspension
with long-leaf springs
for a 6,200-pound
gross vehicle rating.*

Strip away the rugged exterior, and some 4-wheel drive vehicles might look a lot like the family car. But not the International Scout. We build it from the ground up as a sports/utility vehicle, with parts strong enough to take the 4-wheeling, heavy hauling and all the other things a Scout does best.

Strong from the start. Take the Scout steel box frame, for example. It's all-welded, instead of riveted, for the extra rigidity to hold up

under heavy loads and bumpy roads. The things that can bend ordinary frames out of shape.

Heavy-duty help. The frame is just the start of Scout's built-in durability. Our heavy-duty axles are rated to carry heavier loads than

our competitors. And the Scout engine is built to provide more torque with less effort. So don't buy something that *looks* like a 4-wheel drive vehicle. Buy something that's *built* like one. See your International Harvester Scout dealer and test drive a Scout II, SSII, Traveler® or Terra®. Because, from the frame up... anything less is just a car.



INTERNATIONAL HARVESTER

SCOUT.®

Anything less is just a car.

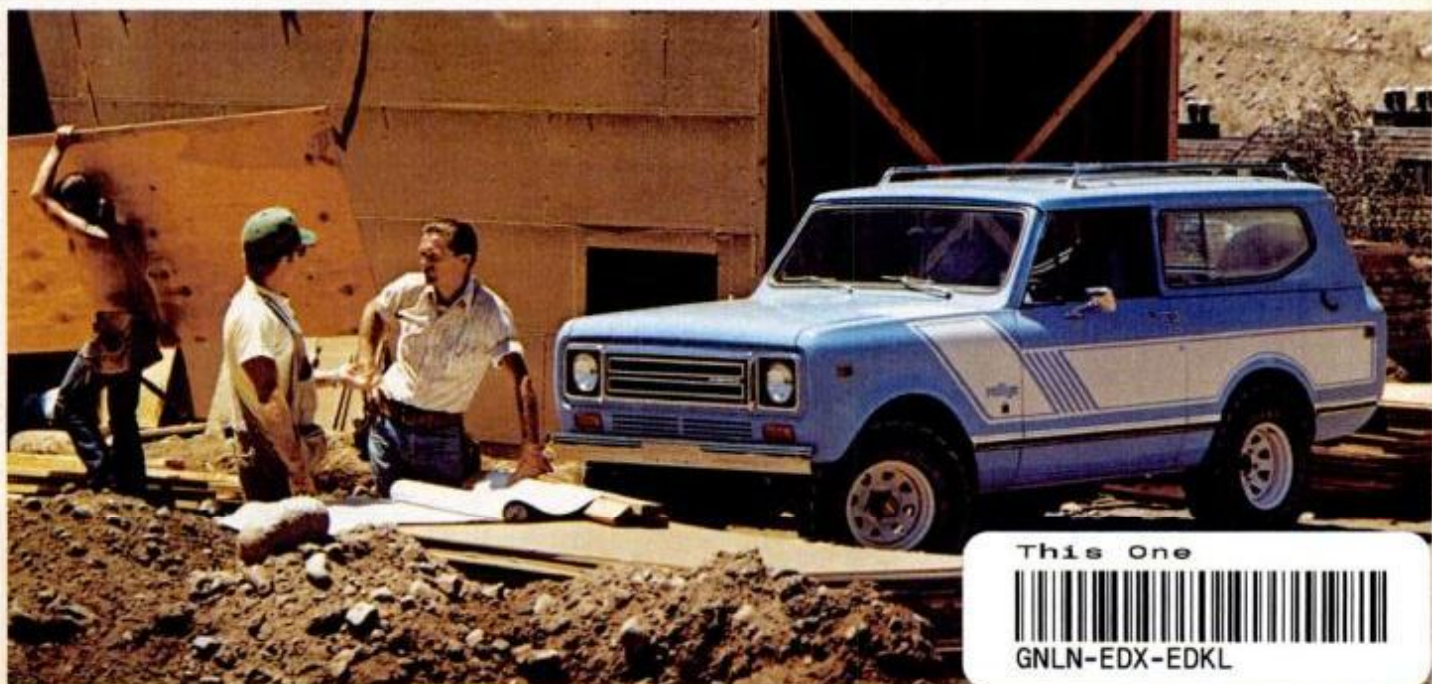

This One



GNLN-EDX-EDKL

TASTE WINSTON LIGHTS



**Best taste.
Low tar.**

13 mg. "tar", 0.9 mg. nicotine av. per cigarette, FTC Report MAY '78.

Warning: The Surgeon General Has Determined
That Cigarette Smoking Is Dangerous to Your Health.

LETTERS TO THE EDITOR

Coast Guard deserves credit

I know it was just an oversight, but you forgot to mention the Coast Guard in your otherwise fine article *Modern Search and Rescue: Call Out the Computers!* (page 103, May '79). You mentioned everyone from the Air Force to the Civil Air Patrol, but neglected the Coast Guard, even though it was one of their helicopters that made the rescue referred to in the story.

TIMOTHY REID
ST. LOUIS

We certainly didn't mean to slight the exemplary work of the Coast Guard in the case. As a tragic footnote to the story, the two Coast Guard helicopter pilots in the Vermont rescue last December were killed Feb. 18 when their helicopter plunged into the Atlantic 180 miles east of Cape Cod during another rescue mission. Capt. G. Richard Burge and Lt. Cmdr. James D. Stiles died trying to pick up an injured member of a fishing boat crew. Their deaths are another reminder that no rescue mission is ever routine.

Your move

I noticed with amusement Shelby Lyman's comment concerning Chess Challenger's eighth move in its game with Boris (*PM Crowns the Computer Chess Champ*, page 118, May '79). He wondered why Challenger did not "simply castle." I know the answer. Challenger was deliberately programmed not to castle, except in "mate in two" situations. I called the manufacturer and they said that they had encountered "programming problems" with castling and en passant, but that the machine would perform such moves if the user would apply the special move keys. Being an avid chess player, this upset me, because if these moves were not part of the program, the machine could not make the best moves.

D.G. BROYLES
DUNKIRK, OHIO

The manufacturer acknowledges that earlier models of the Chess Challenger did not castle often enough, and that player instructions in the manual for en passant were incorrect. Both problems were fixed as of January '79, they say. Owners wishing to correct the problems on older

machines may call the company's customer service department collect at (305) 888-1000.

At last

Gotcha! Finally, after reading *PM* since the Fifties. The captions for the Chrysler Airflow and the DeSoto (*Yup, Car Care Really Is Easier Than Ever!*, page 158, May '79) on pages 160 and 161 are transposed.

PM is beneficial reading.

ROBERT E. WINTERS JR.
RALEIGH, N.C.

Praise from across the pond

I must write and thank you for the excellent reading and information contained in *Popular Mechanics*. It's truly a must for all do-it-yourselfers and craftsmen. Being a carpenter and joiner myself, I have learned quite a bit of useful knowledge from your articles.

I was a subscriber in the late '50s and early '60s. Your present editions are far, far better than in those years. Your publication puts all the do-it-yourself magazines produced in Great Britain to shame.

M.J. FARMAN
SHROPSHIRE, ENGLAND

It's nice to know we have fans on both sides of the Atlantic.

Update on a lean-to

I am sending you this OSHA bulletin in reference to the scaffolding story (*Speed Up House Painting On a Scaffold You Build*, page 139, May '79).

MARK CARROLL
ALBUQUERQUE, N.M.

The safety bulletin sent by reader Carroll says that lean-to scaffolds (like the one in the story) are prohibited in the construction industry by OSHA regulation 1926.451 (a) (2). The designer of the scaffold suggests securing the scaffold to a cleat that's temporarily nailed to the house.

Evolving controversy

With reference to the *Letters* column in the May issue (page 12): I am at a loss to understand just what you mean by a Divinely-directed process of evolution, as there is absolutely nothing divine in the so-called process of evolution. I happen to have several versions of the Bible, and in each one it says that God created

man after His own image. After reading the Bible from cover to cover on many occasions, I find absolutely nothing from which one could possibly relate evolution to the teachings of this book. I agree with Mr. Brannigan 100 percent in his remarks relating to his ancestors.

However, I won't go so far as to threaten the cancellation of my subscription, as its prime purpose relates to mechanics.

HOWARD H. FOGGAN
SENECA, PA.

Bits and pieces

You write about a Stanley power wood bit (*Workshop Minicourse*, page 104, Jan. '79). I've looked high and low and no one seems to know anything about it. Can you help?

WILLIAM H. SCRUGGS
MILLSTADT, ILL.

The Power Bore bits referred to in the story are code No. 105 from Stanley. If your local dealer can't order them for you, write to: Edward Benfield, Mgr., Press Information, The Stanley Works, 195 Lake St., New Britain, Conn. 06050 for the nearest local source.

Good memory

In your October 1970 issue you featured a prototype AMC Jeep vehicle, called the XJ001, on the cover and in an article on page 120 (*A Jeep in 'Wolf's' Clothing*). You may find it interesting that *Motor Trend* magazine, on page 35 of its April 1979 issue, shows a similar AMC Jeepster II that AMC is rumored to be introducing in 1980. It looks as though very few changes have been made from the prototype that you featured nine years ago.

HAROLD O. HOLIMAN
GREENVILLE, MISS.

You're right. Stay tuned as we continue to keep our readers a step ahead of developments that are taking place in the automotive world and other fields.

Correction

In the baseball game project in the April issue (*Play Ball! You Can Make This Game In a Weekend*, page 122), two items in the materials list are incorrect. Item J should be 1 pc. $\frac{1}{16} \times \frac{1}{2} \times 5\frac{1}{2}$. Item K should be 6 pc. $\frac{1}{16} \times \frac{1}{2} \times 1\frac{1}{2}$. **PM**

APPLIANCE CLINIC

QUESTIONS ANSWERED

7-year-old spinster

Our seven-year-old Speed Queen washing machine wants to spin, regardless of the control dial setting. What's wrong?—Stephen C. Coffman, Melbourne, Fla.

If your unit has a reverse motor, the fluid drive may not be operating and it will have to be replaced. Another possibility is that the main bearing, which acts as a brake, may not be engaging. In that case, the bearing will have to be disassembled for repairs, or it will have to be replaced.

If your machine has a solenoid system that controls the spinning phase, the fluid drive may not be operating or the machine may have an electrical problem, such as a bad solenoid. The solution is to call a Speed Queen service technician, to troubleshoot and fix the unit.

More on refrigerator noise

We received two cogent comments about "Tracing Refrigerator Noise" (*Appliance Clinic*, page 84, Feb. '79). One reader revealed his experience with a Tecumseh compressor. (The refrigerator discussed in the February Clinic was a Sears model.)

"Discussion with the regional repair people indicated that this design has a high degree of defective compressor mounts," the reader wrote. "Since Sears has a five-year warranty, they will replace the compressor with a new one having a better mount design."

According to Sears, however, there has been a "very low number of mount failures." Mounts are not included under the five-year warranty with the sealed system, but have a one-year warranty.

The second letter came from P.L. Raugh, operations manager of R.P.R. Repairers in Altoona, Pa. He wrote:

"Our company services Amana, Frigidaire, Kelvinator and Crosley. The problem described in your article is one all companies have been experiencing.

"According to our current service information and our own experience, thumping is caused by the compressor shutting off in the middle of a compression stroke. Replacing the compressor will not correct the situation.

"This problem has become more apparent in recent years, with the

new manufacturing techniques that use foam, rather than fiberglass, as the insulating material in refrigerator walls. Foam, though it is very effective when it comes to heat transfer, has a tendency to magnify normal operational noises."

Drying freezer cabinets

What can I do about a GE small-size freezer that sweats profusely on the outside cabinet?—Charles H. Durning, Oxnard, Calif.

The specific causes of sweating are no secret. Here's how to prevent them:

■ Consider location. Keeping a freezer or refrigerator in a damp area, such as a basement, can result in cabinet perspiration. Also, putting the unit too close to a wall may cause sweating.

■ Test for a burned-out heater. Units generally are equipped with low-wattage, wire-type heating elements called stile and mullion heaters. They supply just enough heat to

the cabinet to keep the temperature above the dew point. This prevents cabinet perspiration due to humid room air.

■ Check for wet insulation. This is a result of air leaking into a freezer or refrigerator through a defect in the outside cabinet. Air passes in through the unsealed area, depositing vapor on insulation. Wet insulation is the same as no insulation. If insulation is wet, replace it and fix the defect in the cabinet.

■ Look for missing insulation. If you find a void area, pack in more material. Sweating occurs when warm outside air hits the cabinet surface and comes in contact with cold inside air filtering out through gaps in insulation.

Grease

My Westinghouse electric range has developed vertical streaks which look like grease between the oven door window panes. I want to clean the glass. However, I was told by White-Westinghouse that there's no way of getting inside the glass and that I should call a serviceman. Is there an alternative?—David W. Caldwell, Winnipeg, Man.

Yes. Here's what to do:

■ Open the door at about a 30° angle and lift up. The door should slide off its hinges.

■ Lay the door on its face and remove the two corner screws and handle assembly. Screws holding the handle are accessible from the backside of the door.

■ Lift off the back cover to reveal the glass frame. Remove this to pry the two panes of glass apart.

■ Clean the glass with ammonia if you can. Streaks caused by splattering can be eliminated, but streaks caused by heat are virtually impossible to get off. If the glass is heat-streaked, you may want to replace it. A replacement window consisting of the two panes costs about \$35.

■ After putting the glass and frame back into position, seal the frame outside with silicone sealing compound to prevent heat, or anything else, from causing future streaking. **FM**

SERVICE TIP

Word from a colleague in the small appliance repair profession is that power cords of appliances drawing 1000 watts or more do not hold up because they get too hot. As a result, the plug or cord insulation melts, creating a fire hazard. This is reportedly happening to UL approved cords.

Keep on top of the situation by examining your appliance cords often. If a plug has a high spot, or has cracked, particularly around the prongs, replace the cord assembly. If cord insulation is charred, especially near the plug, replace the cord. Use a heavy-duty cord, instead of the type that came with the appliance. Your appliance or hardware dealer can advise you.

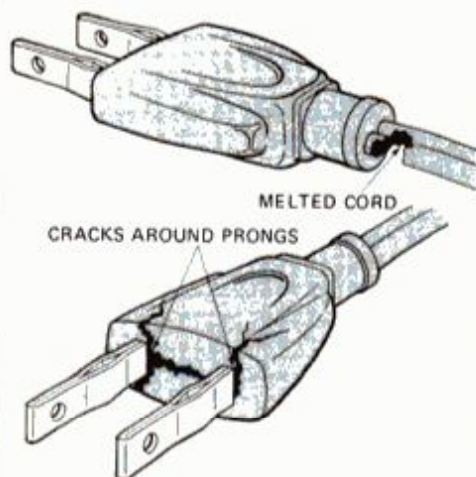

Cords and plugs damaged by overheating are fire hazards. They must be replaced.

If you have a question about any appliance, send it to Appliance Clinic, *Popular Mechanics*, 224 West 57th St., New York, N.Y. 10019. Sorry, but letters cannot be answered individually. Problems of wide interest will be discussed in this column.

New from NRI! 25" color TV that DIAGONAL tunes by computer, programs an entire evening's entertainment.

Just part of NRI's training in servicing TV, stereo systems, video tape and disc players, car and portable radios.

Only NRI home training prepares you so thoroughly for the next great leap forward in TV and audio... digital systems. Already, top-of-the-line TV's feature digital tuning, computer programming is appearing, and new digital audio recording equipment is about to go on the market.

NRI is the only home study school to give you the actual "hands-on" training you need to handle servicing problems on tomorrow's electronic equipment. Because only NRI includes this designed-for-learning, 25" diagonal color TV with electronic tuning, built-in digital clock, and computer programmer as part of your training. With this advanced feature, you can pre-program an entire evening's entertainment... even key lock it in to control children's viewing.

Exclusive Designed-for-learning Concept

The color TV you build as part of NRI's Master Course looks, operates, and performs like the very finest commercial sets. But behind that pretty picture is a unique designed-for-learning chassis. As you assemble it, you perform meaningful experiments. You even introduce defects, troubleshoot and correct them as you would in actual practice. And you end up with a magnificent, big-picture TV with advanced features.

Also Build Stereo, Test Instruments

That's just a start. You demonstrate basic principles on the unique NRI Discovery Lab,[®] then apply them as you assemble a fine AM/FM stereo, complete with speakers. You also learn as you build your own test instruments, including a 5" triggered sweep oscilloscope, CMOS digital frequency counter, color bar generator, and transistorized volt-ohm meter. Use them for learning, use them for earning as a full- or part-time TV, audio, and video systems technician.

Complete, Effective Training Includes Video Systems

You need no previous experience of any kind. Starting with the basics, exclusive "bite-size" lessons cover subjects thoroughly, clearly, and concisely. "Hands-on" experiments reinforce theory for better comprehension and retention. And your personal NRI instructor is always available for advice and help. You'll be prepared to work with stereo systems, car radios, record and tape players, transistor



radios, short-wave receivers, PA systems, musical instrument amplifiers, electronic TV games, even video tape recorders and tape or disc video playbacks.

Send for Free Detailed Catalog... No Salesman Will Call

Mail the postage-paid card today for our free 100-page catalog with color photos of all kits and equipment, complete lesson plans, convenient time payment plans, and information on other electronics courses. You'll also find out about NRI's new Computer Technology Course that includes your personal microcomputer. Or Complete Communications with 2-meter transceiver. If card has been removed, write to:



NRI Schools
McGraw-Hill Continuing
Education Center
3939 Wisconsin Ave.
Washington, D.C. 20016



\$49.88
Model XEL-12

\$99.88
Model XL-12

Homelite chain saws cut the worktime.

K mart cuts the price.

We've cut the price on two quality chain saws made by Homelite, the chain saw king. There's the Homelite 12" electric saw (Model XEL-12) with lightweight handling and quiet operation. It's double insulated and features a 1.5-hp 11-amp motor, plus push-button oiling for longer chain life. The Homelite 12" gas saw (Model XL-12) is

a great take-along for rounding up firewood. It features fingertip controls for easy handling and all-weather ignition. Both saws feature Homelite's exclusive SAFE-T-TIP to prevent kickback and protect the saw tip. On sale through September 1, 1979 at over 1,400 K mart stores across the U.S.A.

Kmart

The Saving Place

Copyright 1979

Kmart Corporation

Troy, Michigan 48084

Материал, защищенный авторским правом

PM WORKBENCH

PM EXAMINES PRODUCTS AND SERVICES

Woodman, spare that handle

Just as the woodchopping season looms ahead, along comes a low-cost device to help you save your ax and sledge handles. A hard-rubber "do-

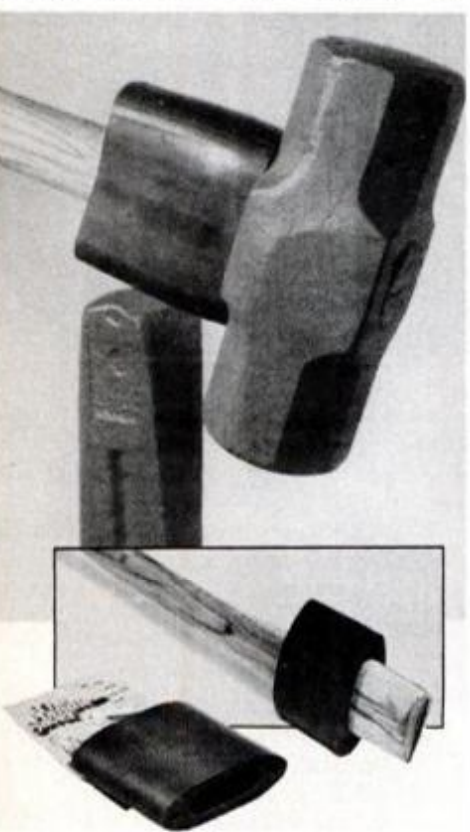

Since Handle Saver should fit handle snugly, make certain you specify the size when ordering. Use liquid soap to get it on.

nut" slips on under the toolhead, where most breakage from missed blows occurs. The device is available in four sizes—regular, large, ax eye and ax—and each costs \$2.98 postpaid from The Handle Saver, Box 26725, San Jose, Calif. 95159.—H.W.

New 'Plywood Encyclopedia'

The American Plywood Assn. has just published a revised and expanded *Plywood Encyclopedia* with more information in it than ever, including nail-size recommendations, an explanation of what a wood foundation is, and tips on building a floor or wall system.

The 64-page publication, so comprehensive it leaves nothing to guesswork, explains finishing, refinishing and plywood siding, and includes a complete guide to plywood grades and recommendations for their proper application.

The new edition of the *Plywood*

Encyclopedia is available for \$1 from the American Plywood Assn., Box 11700, Tacoma, Wash. 98411. Ask for Form X505—H.W.

For that hand-rubbed look

The latest interior oil-based wood finish from Glidden Coatings & Resins, 900 Union Commerce Building, Cleveland, Ohio 44115, is formulated to give the soft, pleasing look of a hand-rubbed finish. It seals well in one coat on untreated or stained wood. (The stool shown has Glid-



The stool above took on an instant "antique" look after one coat of honey maple.

Tone only applied to it.) Walnut, black walnut, French provincial and honey maple stains are priced at \$2.99, \$4.79 and \$11.49 respectively for pint, quart and gallon sizes. At paint stores and home centers.—H.W.

Nifty little carving book

Everyone seems to be interested in the zodiac; its diagram can be seen



Design is transferred using carbon paper.

now on everything from ashtrays and jewelry to fashions. Dremel has jumped on the bandwagon by offering a 16-page zodiac pattern book that sells for \$2. The book shows how to carve plaques with a Dremel Moto-Tool and a couple of cutters. So far, I've made two (and my 15-year-old son, one) and they've been admired by all who have seen them. The pattern book is available at stores handling Dremel products. Dremel Div., Emerson Electric Co., 4915 21st St., Box 518, Racine, Wis. 53406.—H.W.

Get the bugs out

Garden spraying is a lot easier since a Bugwiser 6220 compression sprayer has been added to my arsenal of



Spray pattern is controlled by turning nozzle cap clockwise for fine spray, to the left for long-distance stream.

yard tools. It holds 2 1/4 gal. of liquid, which is effectively expelled in a fine mist or long-distance stream. In use, turn the pump handle counterclockwise so spray materials can be poured into the tank; pump is pressurized by stroking its handle. Galvanized steel tank is epoxy-coated to resist corrosion. At hardware stores and garden centers, \$33.39. H.D. Hudson Manufacturing Co., 500 North Michigan Ave., Chicago, Ill. 60611.—R. Capotosto

If you've come across a new product with some special features, let us know about it. Write to PM Workbench, Popular Mechanics, 224 West 57th St., New York, N.Y. 10019.

PM ELECTRONICS MONITOR

Computers quiz TV students

Many people have taken college-level courses via two-way television. However, such courses have always required waits for test results and have given a student little idea of how he's doing compared to other students. Now, the University of Michigan has applied computers to this problem, replacing a whole team of teachers with one computer.

The system uses a sophisticated, but relatively inexpensive, mini-computer to keep track of all variables, such as test scores, questions and answers, and student feedback. During a video-taped lesson, the computer is programmed to interrupt and ask a multiple-choice question every two to five minutes.

The answers from every student are displayed. Then the computer informs the students what percentage of the far-flung class has chosen each answer. A "quick quiz" is given at the end of the lesson.

The computer calculates and displays each individual's average for the day, then each student's running average for the whole test series. Calculations and feedback are, of course, computer-instantaneous.

University of Michigan researchers are convinced their study proves that two-way computer-TV education is cost-feasible and effective.

Students in the project are the firefighters of Rockford, Ill., chosen because they undergo daily training and retraining, much of it classroom oriented.

The student firefighters "log-in" (enter their initials into the computer via personal terminals). The terminal, by the way, was fashioned from a cable-TV channel box, at a cost less than half that of more complex terminals.

So, if you already have cable TV, how long before you can take a two-way college course on it? Development is still in the tentative stages. What makes the Rockford project so interesting is that it is the first time a major university has shown a computer-run, two-way TV course to be an effective teaching tool.

Prime time extinct?

Ever since the start of TV, there has been the concept of "prime time"—the hours from 8:00 to 11:00 p.m., when most people who watch TV are at home and watching. It costs more to buy ad spots during those hours to reach that large audience and that's when the networks schedule

Remember Ohm's Law!

Now you'll never have to worry again about recalling Ohm's Law. Just remember that an Indian sees an Eagle over a Rabbit!

(Or, $I = \frac{E}{R}$.) I stands

for current in a circuit in amperes; E for the force in volts; R for the resistance in ohms. Given any two values, it is simple to calculate the third one. Just visualize it all properly!



the majority of their new shows.

Morton J. Fink, a senior vice president of Sony, has predicted that the videotape recorder (VTR) will make every hour of the day or night "prime." Fink, looking at things from a Sony point of view, sees videotape recorders (Sony's among them) gradually working their way into almost as many homes as there are TVs. Once a person has the capability of setting a timer to tape a show—what difference does it make what time the show comes on?

You could as easily follow the exploits of *Mork and Mindy* if they were shown at 3:00 a.m. as you could during prime time. Fink sees this possibility as providing "networks" for every taste. "There'll be time for art," he says, "for religion, for science, for tennis lessons, for a host of other subjects which today are neglected."

We hope he's right. But then again, perhaps it will only mean another eight hours' worth of violence, jiggly girls and macho detectives. Ultimately, the choice will lie with the audience.

New video disc contender

Panasonic (Matsushita) has a video disc machine in the works, but they're trying their best to keep the lid on its specifications. Latest rumor has it that it will use a nine-inch disc and a quartz stylus.

Unlike the existing Magnavox system that uses a laser for pickup and does not actually contact the disc, the Panasonic system would require disc-to-stylus contact—like an LP record. This would have to result in some wear on both disc and needle. The prototype does not offer

such features as freeze-frame and fast-forward, but a marketable version would be priced \$200 below laser units.

Will the video disc system you finally buy be a laser or quartz pickup? Only time—and the quality of the delivered images—will tell!

Hand-held computers on tap

Panasonic, in another move, announced at press time that they will soon be making available the first hand-held personal computer. A spokesman claimed it "will give birth to an entirely new field of consumer electronics."

The calculator-sized unit will feature a built-in keyboard and offer peripherals ranging from a printer to a voice-synthesizer. More interestingly, Matsushita claimed that the unit will be able to accept all memory chips, those that are now available and any that will be released later—including bubble memory. This would result in a fantastic capability to store and process information.

We will feature a more detailed report after we actually examine the unit. **PM**

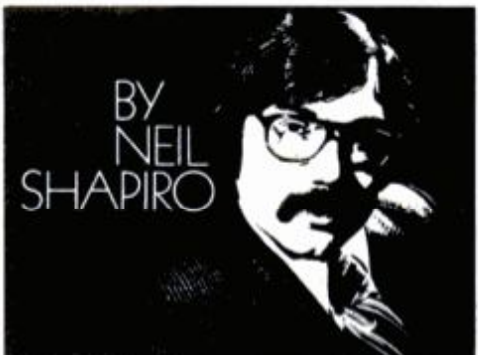

18 mg. "tar", 1.3 mg. nicotine av. per cigarette, FTC Report MAY '78.

© 1979 R. J. REYNOLDS TOBACCO CO.

Satisfaction, Camel Filters style.

Some men taste it all: Rich
warm flavor. Smooth even
taste. Solid satisfaction.

Only from the Camel Filters
blend of Turkish and domestic
tobaccos.

Warning: The Surgeon General Has Determined
That Cigarette Smoking Is Dangerous to Your Health.



ALL OUTDOORS

Building better fishing

Small trees, brush and old tires tied or chained together and anchored underwater in bays and coves have been found to make ideal fish attracters. Minnows like the shelter of these constructions, and bigger fish like the minnows. Fishermen like the concentrations of action, and recently the Tennessee Wildlife Resources Agency, with the help of the Young Adult Conservation Corps, has started to install 282 of these fish attracters in the Norris and South Holston Reservoirs. Each is

being noted on maps available from the TVA, so an angler can head right for a spot where the fish ought to be.

Certificates and shoulder patches are being awarded to fishermen in Manitoba who crimp or cut off the barbs of their hooks and then release any trophy fish they won't be eating. The "Go Barbless" campaign is expected to make it easier to remove fish from hooks and increase the record-size fish in the province's many notable streams.

Want to get youngsters, or anyone

else, started fishing? Instructor and student guides for group classes are now available from the American Fishing Tackle Manufacturers Assn. at nominal cost. Write Bob Bluth, AFTMA Sport Fishing Educational Foundation, 2625 Clearbrook Dr., Arlington Heights, Ill. 60005.

Or, if you'd like to set a world record, join the International Game Fish Assn., 3000 East Las Olas Blvd., Fort Lauderdale, Fla. 33316. Among the advantages is a free copy of their handsome new volume, *World Record Game Fishes*, which now includes freshwater and fly-rod, as well as saltwater records. Nonmembers can order it for \$5.95 postpaid.

Dual-fuel energy option

Providing an old answer to a new problem, Winnebago is installing a converter to burn LP gas, instead of gasoline, as an option in some of their new Winnebago and Itasca motor homes.

Engines will shift from one fuel to the other with the flip of a dashboard switch. Since most motor homes already come equipped with LP tanks to supply stoves, water heaters, furnaces and refrigerators, adding the necessary conversion is simplified. Cost: about \$600 to \$800.

The new conversion includes a vacuum fuel lock, propane converter heated by hot water from the engine, gas/air mixer and carburetor. In addition to saving gasoline, use of LP gas is expected to reduce engine maintenance, lower emission levels, provide smoother starts and performance with the 110-octane fuel and supply longer life for engine oil. In many areas, LP gas is priced lower than gasoline and, with 25,000 retail LP outlets, a dual-fuel RVer should be able to cover more miles with less worry and cost.



Outside: Itasca with kit looks standard.



Inside: Conversion is a compact unit.

Conversion supplies 110-octane-type fuel, shuts automatically when engine stops.

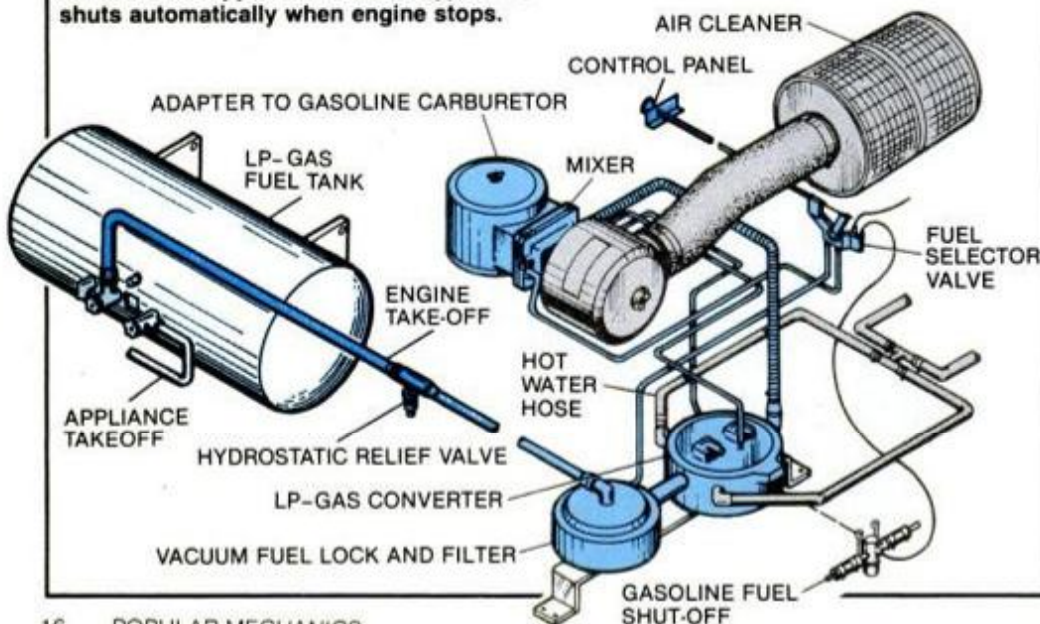

Off-road and on

Drivers who like to head away from the beaten track have had more than their share of neglect and abuse. But now there is a book just for them. Called *International Scout Four-Wheel-Drive North American Trail Guide*, the volume features articles, maps and where-to-go suggestions. It was prepared by Rand McNally's outdoor expert, Dick Dunlop; check International Scout dealers for a copy.

For RV travelers without a rig, both Coachmen Industries, Middlebury, Ind., and Winnebago Industries, Forest City, Iowa, have rental plans. And for travelers looking for gas savings, there's the new *Ryan's Gas Guide*, a coast-to-coast directory of discount self-service gas stations. It's \$2.50 postpaid from RMS, Box 20995, Billings, Mont. 59104.

Things to come

Old boat and motor lovers will head for Clayton, N.Y., Aug. 18-19, for the annual Shipyard Museum Antique Boat Show. And the sportsman's big date next month will be National Hunting and Fishing Saturday, Sept. 22.

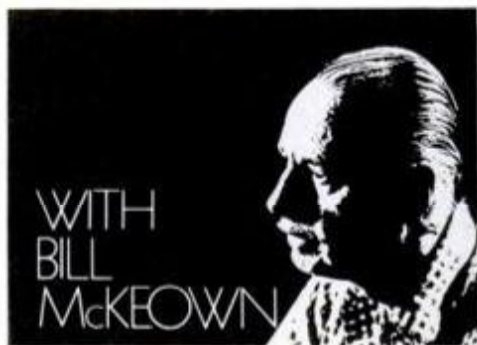

V.O.

Some people set their sights higher than others.

Seagram's V.O.

The symbol of imported luxury. Bottled in Canada.

Enjoy our quality in moderation.

Canadian whisky. A blend of Canada's finest whiskies. 6 years old. 86.8 Proof. Seagram Distillers Co., N.Y.C.

You wouldn't go on vacation without a sweater—

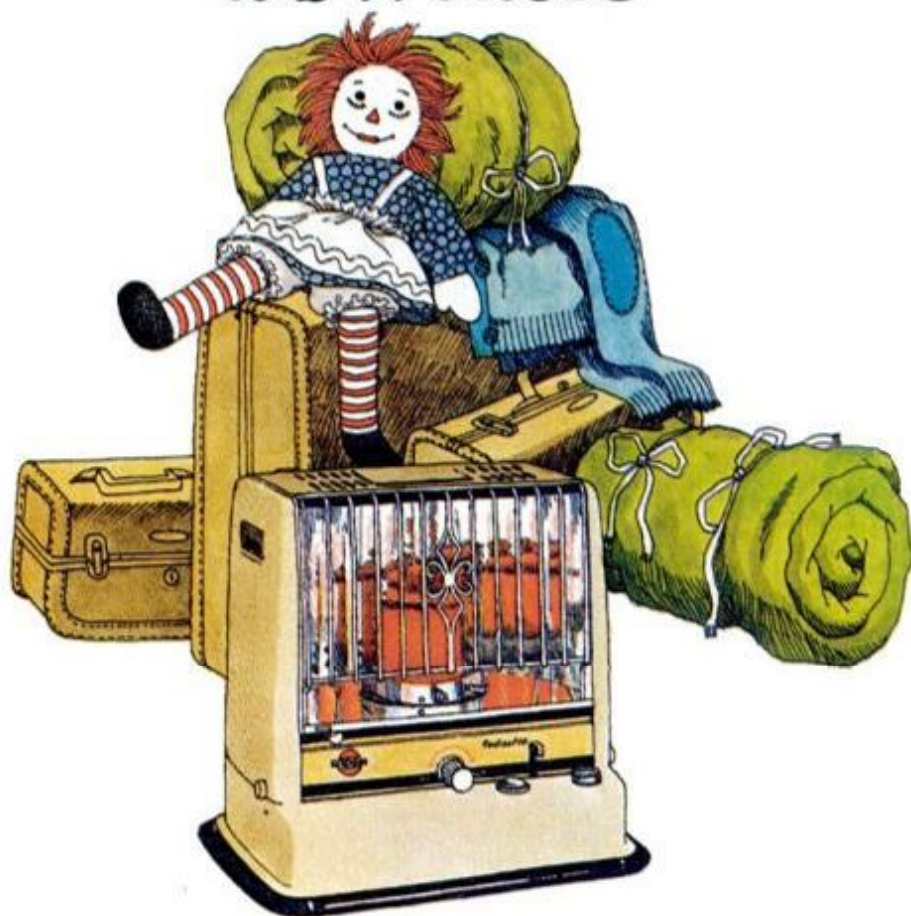

Kero-Sun— a sweater for the whole family.

The Kero-Sun Radiant 10 kerosene heater is so lightweight, you can take it anywhere. And there are some chilly summer evenings when a bit of extra heat is mighty welcome. A Kero-Sun operates in places where electricity is only a fond memory. Like an unheated mountain cabin. Or on a boat. Or in a beach house.

There's no smoke, no odor, and each model has been safety-tested. Each has an automatic, battery-powered igniter, so you don't need matches to light one, and an automatic shut-off in case of tip-over. You get 9,400 BTUs/hr. for 30 hours on 2 gals. of fuel.

If you're going off on vacation, don't go without a Kero-Sun heater. (That way, you won't have to worry even if you forget to pack the sweaters!)



PORTABLE HEATERS

Copyright 1979, Kero-Sun, Inc.

Please send me full facts about Kero-Sun portable heaters and the name of my nearest dealer.

Name _____
Address _____
City _____ State _____ Zip _____

KERO-SUN, INC., DEPT. M-89, KENT, CT 06757

PHOTO HINTS

Labels that don't come off



Make waterproof labels for dark-room bottles with 2-in.-wide adhesive tape. Use ballpoint pen for marking; felt-tip writing usually washes away.—*Terry Huss*

Lens-mark lightener



Index marks and other engraved lines and characters on a lens barrel can be made more visible through the application of light-colored lacquer. Try the white fluid used to correct typing mistakes. Apply with small brush or toothpick.—*Walter E. Burton*

Jugs for developing



Two-gallon plastic jugs can be cleaned out to make rockable 8x10 developing trays. Handles make agitation easier. Spouts reduce spillage when you pour back chemicals.—*David W. Roberts*

THIS IS THE ARMY

BACK HOME, I WOULDN'T MIND DOING THE WORK I'M DOING HERE." E-5 Larry Sarver, Fort Bragg, N.C.

In the modern Army people learn modern skills. Sophisticated skills that are often valuable in civilian life as well.

THE SKILL YOU WANT

If you enlist in the Delayed Entry



Program, you can get your choice of training guaranteed in writing. Then you wait (up to 12 months for high school graduates) until it



becomes available. If you join right away, your choice is limited by what's needed. Either way, the training you choose and qualify for will be guaranteed in writing.

HANDS ON

Most soldiers work in the specialty for which they're trained and get daily hands-on experience. You learn teamwork, responsibility, and the pride of doing a job right.

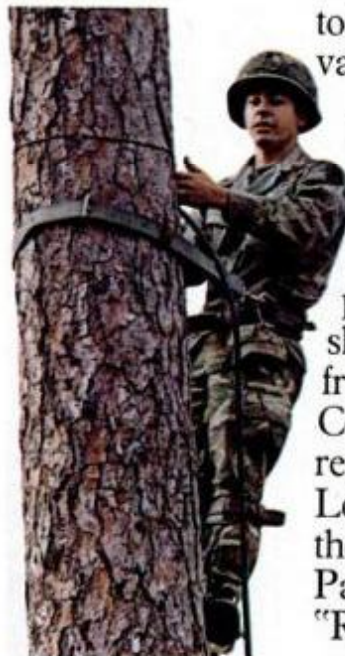

IT'S NOT ALL WORK

The Army really helps you enjoy your free time. Most posts have gyms, swimming

pools, libraries, and clubs to help you relax.

PAY & BENEFITS

Starting pay is more than \$419.00 a month, before deductions. Plus room, board and health care. And a chance

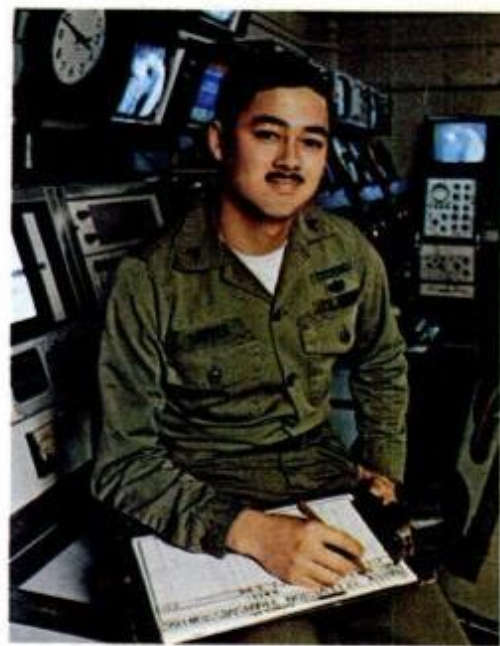

to take up to 30 days paid vacation. Even your first year.

PEOPLE

There's no military hardware to replace the human heart, no computer to out-think the mind. We need people. We are people. So share the pride that comes from serving your country. Contact your local Army representative.

Look in the Yellow Pages under "Recruiting"



JOIN THE PEOPLE WHO'VE JOINED THE ARMY. 800-431-1976

In N.Y., call 800-243-5614.

IMPORTS & MOTORSPORTS

Mid-engine Vector V8



Vector sports car may go into production in California.

It's a case of California dreamin' all right, but if Vehicle Design Force in Venice, Calif., can get its \$100,000 Vector sports car into production, it'll give Lamborghini and Ferrari some domestic competition. The goal is 50 cars a year starting in 1980.

The exotic styling and construction of the mid-engine car are matched by its performance. The



Note rear-view mirror on roof of Vector.

unitized body and chassis are of honeycomb aluminum. The off-the-shelf V8, a Chevy 350-cu.-in. block, is fitted with fuel injection and twin turbochargers. With an output in the 800-hp range and appropriate gearing, the Vector is good for over 200 mph. Yes, speed limits and fuel shortages are a fact of life, but so is the demand for cars that offer extraordinary performance.

Classy Corollas

If you wonder how much longer Toyota will crank out the same old, nondescript, bread-and-butter Corollas, the answer is . . . no longer. All-new sedans, coupes and liftbacks

1980 Corollas, to be here soon, will include this Sprinter coupe.



are on the way. The Sprinter 1500 SE (below) is the sportiest of the new line. Toyota calls the styling of the Corollas "modified wedge." The four-door sedan, even though it bears quite a resemblance to the Alfa Romeo Sport Sedan, has a personality all its own, as do all the new models.

Base engine is an ohc, 1500-cc Four. Optional in the Japanese market are a 1400-cc Four and a high-performance, dohc, fuel-injected, 115-hp, 1600-cc Four. Four-speed, five-speed and automatic gearboxes are available. We'll have to wait until fall to see U.S. models.

Peugeot 505

There's no mistaking this rakish sedan for anything but a Peugeot. The front-end sheet metal and grille are clearly updated from the 504. The 504 models, with their diesel-engine



The 505 joins Peugeot line next month.

option, may not be replaced by the 505 right away. The 505 will be introduced next month at the Frankfurt Auto Show with a two-liter Four (one version carbureted and another fuel-injected) and a new turbodiesel. The only turbodiesel available here now

is the Mercedes 300SD (see *Diesel Mercedes With Muscle*, page 80, Aug. '78), and chances are Volkswagen will have its version available before the Peugeot arrives—unless, of course, the U.S.-built turbodiesel Moodymobile (see page 42) beats them both to market.

Audi 4000 update

Since doing our early story on *Driving the Audi 4000* (page 32, June '79), which reported on the European version, we've driven the U.S. model. Beefy bumpers, dual headlights



Audi 4000 front end is U.S. version.

and small side markers, shown above on a U.S. car with German plates, are the major differences. These changes (to meet U.S. safety specs), a sharper interior, and other touches make a much snappier 4000. Germans who examined the car agreed that the U.S. version was the one they preferred.

The 4000 models, in Audi showrooms now, use a catalytic converter and require unleaded fuel in all states. Early next year, a five-speed transmission will be available. **PM**



Rally 4000 is after European title.

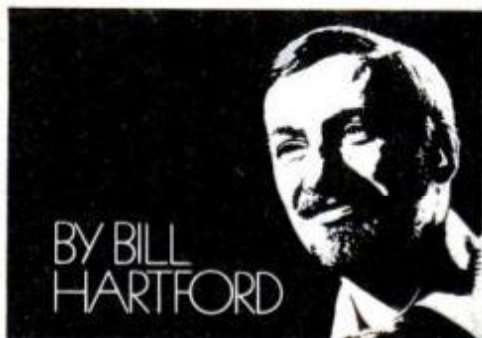



Tough Ford pickups: America's No.1 sellers.

Ford pickups were America's No. 1 sellers again in 1978 according to R. L. Polk & Co. registrations. And, for the third straight year, a Ford F-100 is the gas mileage champ, too!

Ford pickups are built tough. With tough Twin-I-Beam front suspension, an all-welded cab, extensive rust protection, and a double-wall box on every Styleside. They're tested tough at Ford's Arizona Proving Ground over miles of truck-jarring bumps, chuckholes, salt sprays.

Ford pickups offer choice, too: the roomy SuperCab, handsome Ranger Lariat and a full line of 4-wheelers.

Ford pickups. See why they're America's best-selling pickups. At your Ford Dealer.



F-100 SuperCab



Ford's Arizona Proving Ground

HIGHEST PICKUP GAS MILEAGE RATING IN AMERICA!

18

EPA est. MPG with 6-cyl. eng. and opt. 4-spd. man. OD trans.

Best EPA estimate of any full-size pickup excluding Diesels and car-trucks. Compare this estimate to the "estimated MPG" of other trucks. Your mileage may differ depending on speed, distance and weather. Six-cyl. eng. not available in Calif.

FORD

FORD DIVISION



9 mg. "tar", 0.8 mg. nicotine av. per cigarette by FTC method.

Warning: The Surgeon General Has Determined
That Cigarette Smoking Is Dangerous to Your Health.

Introducing
Rich Lights from Viceroy.



The first low'tar' cigarette
good enough to be called rich.

Kings and 100's.

© 1979 B&W T Co.

Материал, защищенный авторским правом

DETROIT LISTENING POST

Tipple in your tank

Gasohol, a one-in-ten mix of alcohol to gasoline that stretches every gallon of the precious petrol, is becoming available in many parts of the nation. Recognizing the fact that many motorists will be using the blend in late-model cars, Detroit's Big Four automakers have extended their warranties to cover engines fueled with gasohol. By the time you read this, new-car dealers should have more details available on the extensions.

Car preservation

Tuff-Kote Dinol, the Warren, Mich., based company well known for its new-and-used-vehicle rustproofing, is branching out into auto "grooming." Already the world's largest rustproofing company, Tuff-Kote Dinol will begin opening complete Car Preservation Centers throughout the country. Specializing in car painting and both interior and exterior cleanup preservation work, as well as rustproofing, these outlets will cater to owners interested in restoring and preserving their aging cars. A new training facility at the Warren headquarters will instruct Preservation Center owners and technicians.

Friendly fenders

Watch for damage-resistant and rustproof plastic fenders that bounce back after minor impacts on certain Ford and General Motors cars beginning this fall. A limited number of 1980 Ford Fairmonts and Mercury Zephyrs will get front fenders made of a new plastic "to gain manufacturing and over-the-road experience," according to Ford car engineering vice president Thomas J. Feaheny. The new plastic is called RRIM, for Reinforced Reaction Injection Molding.

GM's Oldsmobile Div. also will be trying plastic fenders on 5000 or more 1980 sporty Starfire models.

Meanwhile, Pontiac Div. will in-



Ford's Pinto replacement for '81 is fwd.

roduce an all-plastic station wagon tailgate on one of its larger models this fall, and Buick Div. is working on a new process for making plastic front ends for Rivieras and Regals as well as its X-body Skylarks.

GM update

GM's front-drive replacements for the current Monza, Sunbird, Starfire and Skyhawk subcompacts are scheduled for the spring of 1981 and will most likely be designated 1982 models. The MPS (multipurpose carrier) van/wagon vehicles, and variations of this year's front-drive X-car chassis may not be built at all: "It was just too expensive," laments one GM engineer. "We had to put our money where it would do some good on fuel economy."

There is also a mid-engine sports car proposal using X-car engines and transaxles, but that too is likely to be a casualty of Detroit's new necessity to plan everything around the Corporate Average Fuel Economy (CAFE) rules. If it doesn't lower the company's CAFE, it isn't worth doing.

'80 Chrysler Cordoba, Mirada; '81 La Scala

Chrysler's smaller Cordoba and Dodge Mirada personal luxury coupes are coming off the drawing boards. They will share the current 112.7-inch wheelbase, LeBaron/Diplomat chassis and mechanicals, while the L/D two-door models themselves are also slated to be stepped down in size one notch.

Cordoba sports a formal, upright, radiator-shell-type grille, single rectangular headlamps and an opera-type third window in the "C" (third) pillar. Mirada, which replaces Magnum, retains a variation on the Magnum's sexy, slanted horizontal-slot grille design, quad rectangular headlamps under clear plastic covers and a wide, louvered C-pillar. These new cars will compete with the smaller '80-model Ford Thunderbird and Mercury Cougar, as well as GM's popular Chevy Monte Carlo, Pontiac Grand Prix, Olds Cutlass Supreme and Buick Regal. A third, ultraluxury version of this basic car, called La Scala, is scheduled to go up against Cadillac's new front-drive Seville and Lincoln's Versailles beginning with the 1981 model year.

UFO (unrestrained flying objects)

It's not *Star Wars* or *Close Encounters*, but it is one of the better "UFO" films around, using a combination of starship fantasy and proving-ground crash tests to "debunk major arguments by car occupants for not wearing seatbelts." Showing it to your club or organization could save a friend's life. It can be obtained from the Public Relations Film Library, General Motors Corp., Detroit, Mich. 48202.

Air bags

You may not be ready for air bags yet, but they'll soon be ready for you. By mid-1981, according to GM president E.M. Estes, the exploding face cushions will be available options on all 1981 full-size GM cars. Ford and Chrysler, too, will get into the act with optional air bags on Lincolns, LeBarons and Diplomats for '81.

Passive belts, now on certain U.S.-built VW Rabbits and Chevy Chevettes, will also become available on '80-model Ford Mustangs and Mercury Capris. If, for some reason, you don't wear seat belts and would like to be part of the field tests, watch for these passive-restraint-equipped cars to go on sale and then rush out and buy one of your choice. Unless Congress overrules the National Highway Traffic Safety Administration (NHTSA), passive restraints will be mandatory on large cars beginning in 1982, on mid-size models the next year, and on all cars by 1984.

It may be coincidence, incidentally, but GM renamed its air-cushion restraints "Inflatable Restraint Systems" (IRS) just a few days before this year's federal tax forms were due.

FM

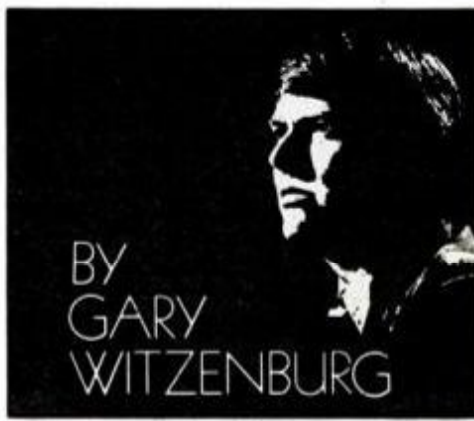

SCIENCE WORLDWIDE

The shape of future SSTs?

In a multiple-exposure photo (right), the wing of a NASA wind-tunnel model appears to be flapping. A researcher working with the model at Langley Research Center told PM that planes of the 1990s and beyond might be designed with permanently bent wingtips, resembling the wings of a seagull in a glide.

Some military planes might even have the capability to lower their wingtips in flight, according to Dr. Paul L. Coe at the center. The model has shown that bending the tip reduces the hazard of rolling when the plane is subjected to crosswinds at low speed. The roll problem becomes significant in planes designed to travel at well over twice the speed of sound.

Langley researchers have also learned from their work with the model that small changes in the leading edge of the plane's wing can produce significant improvements in lift capability. That, in turn, means pilots can climb on less thrust, saving fuel and reducing noise at subsonic speeds.

Piercing the mirage

Bell Labs researchers recently blurred their company's image to show how a new technique could make the image clear as a bell again.

They distorted the Bell System symbol by passing it through a piece of wavy glass. Then they processed the blurred bell in a laser system to remove mirage-like distortion and bring back the original, clean lines.

The researchers say the technology used to clean up the bell could improve light-wave communication, which now is prey to distortion from changes in densities or temperatures of optical devices through which the light waves must pass.

The heart of the system, according to researcher Paul Liao, is a pilot beam that scouts for distortion along the path of a transmission. In communication by light wave, information is sent from a transmitter along an optical path to a receiver. Temperature changes in devices along the path can deform the signal, just as heat in a desert can modify light waves so much that travelers are fooled into seeing mirages.

In the Bell system, the pilot beam is fired from the receiver to the transmitter. Along the way, it registers distortion and instantly cor-

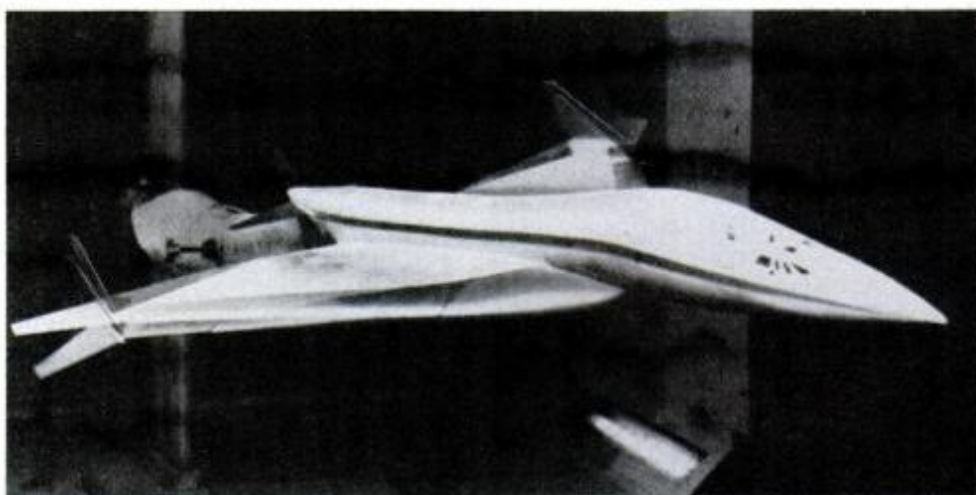

NASA wind-tunnel tests suggest bent wingtips may be standard on aircraft of 1990s.

rects the outgoing signal to allow for conditions on the light path.

Liao said the techniques were still highly experimental. But some day they may greatly increase the capacity of hair-thin fibers used to carry signals in telephone systems.

The principle behind the Bell

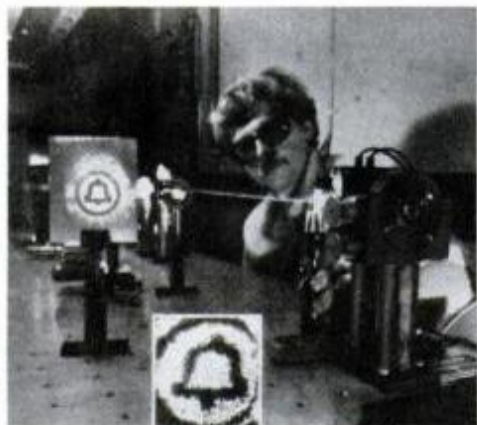

Distorted bell symbol (inset photo) is cleared up in the Bell Labs' laser device.

equipment, Liao said, could also be used to build new medical scanning devices that would allow doctors to peer a few millimeters beneath skin without X-rays or needles.

Can a cow predict a quake?

California researchers with a federal grant have begun a controlled study to settle a long-standing question about whether animals can help science predict earthquakes.

For years, the Chinese have claimed that shortly before a quake, cows shun their stalls, snakes leave their holes and hens flap nervously off their roosts. In at least one case—the Haicheng earthquake of Feb. 4, 1975—a forecast based on animal behavior was made 24 hours be-

fore the first major rumbles. Evacuation saved thousands of lives.

To find out whether such forecasts are a fluke, scientists at SRI International in Menlo Park have lined up 600 volunteers who live near seismically active fault lines in California. They call in regularly to report their observations of farm animals, including any nervous behavior in the barnyard. The data form a background pattern which can be used for comparison if there's a sudden flurry of odd activity among the animals. The research is supported by the Department of the Interior, U.S. Geological Survey.

Second thoughts on first aid

Despite what you may have heard in the past, don't put an ice pack on a snake bite. Don't give water or milk to burn victims, and don't apply a tourniquet unless you're trained.

Those are some of the revisions in first-aid rules detailed in the most recent American Medical Assn. First Aid Guide. In addition to re-writing some traditional medical guidelines, the manual contains sections on applying cardiopulmonary resuscitation to infants, as well as on injuries from piercing. It costs 50 cents from the AMA's Order Department, Box 821, Monroe, Wis. 53566.

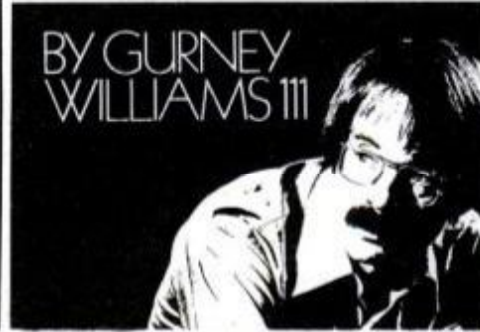

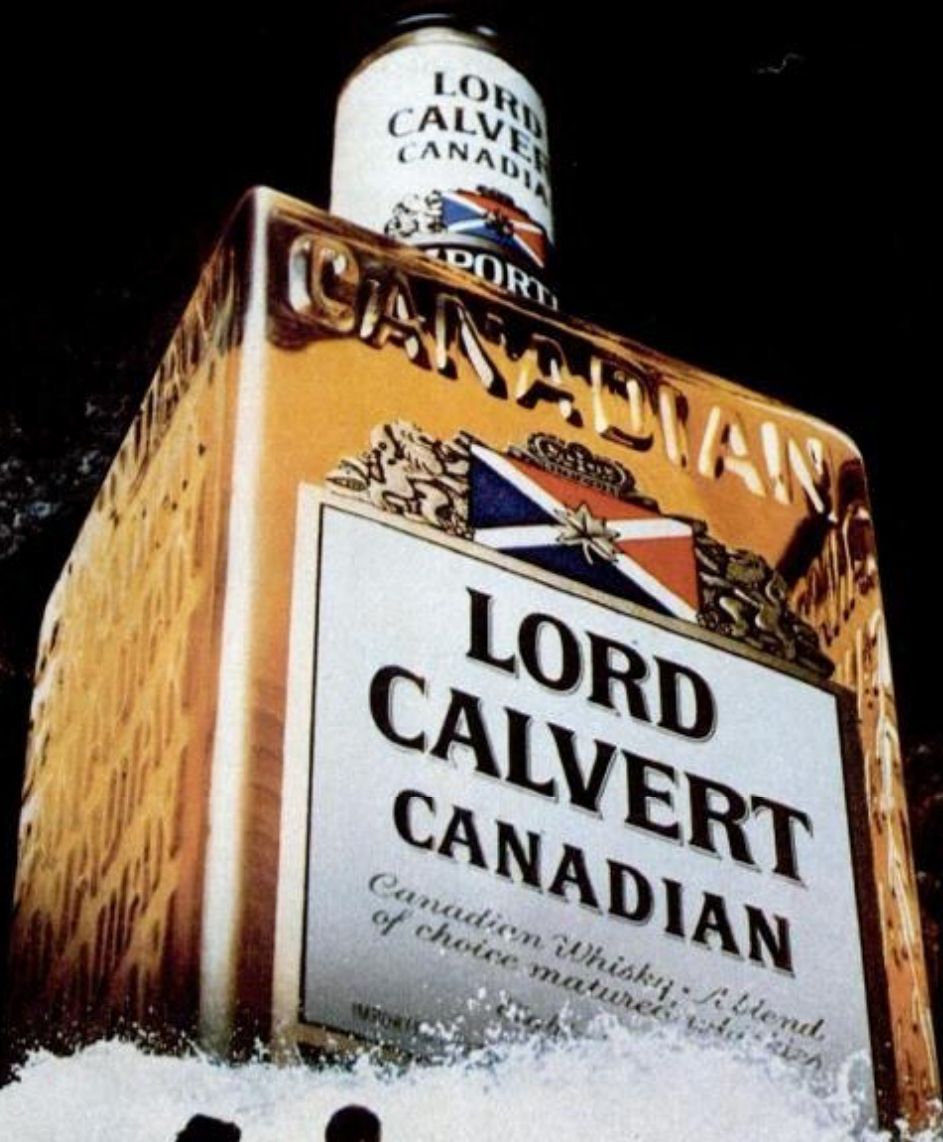

Right to the finish, its Canadian spirit stands out from the ordinary. What keeps the flavor coming? Super lightness. Superb taste. If that's where you'd like to head, set your course for Lord Calvert Canadian.

The unique spirit of Canada:
We bottled it.

Portable POWER for Pennies an HOUR

Kawasaki, the folks known for quality and performance, now offer you a full line of portable generators.

Portable electricity for . . .

- CAMPING
- CONSTRUCTION
- HOME EMERGENCIES

or wherever dependable power is needed.

Check your power needs and see your local Kawasaki Dealer.

Kawasaki
Don't let the good times pass you by.

'What to do if you're teed off at athlete's foot.'

by Hale Irwin



"The only way I can keep my feet feeling up to par is to use Dr. Scholl's Solvex® Athlete's Foot Products."

When you feel the first itch of athlete's foot, just apply Dr. Scholl's Solvex Ointment or Spray. Solvex kills athlete's foot fungi on contact. And helps control the itching and burning of athlete's foot.

And, if you want to beat the itch before it starts, try regular applications of Dr. Scholl's Solvex Powder. It absorbs the moisture that athlete's foot thrives in and helps prevent reinfection.

"Face it, who knows more about feet than Dr. Scholl's? Their Solvex keeps my mind off my feet. And on the ball!"

Dr. Scholl's



© 1979 Scholl, Inc.

HINTS FROM READERS

Chucking small bits

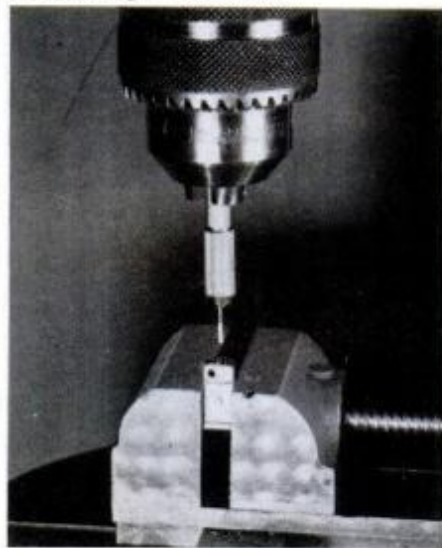

When the chuck of a drill press or hand drill can't hold small-diameter bits securely, chuck a pin vise to hold the bit. If necessary, cut off the swivel head on the vise. Its jaws will hold the smallest bits.—*Howard E. Moody*

Checking a level's accuracy

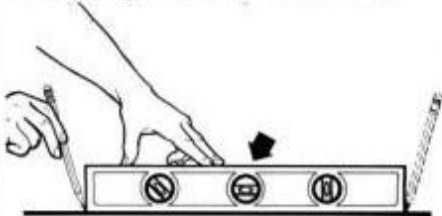

You can check a spirit level's accuracy by placing it on a tabletop or other flat surface. Note the position of the level bubble (arrow) and mark the locations of the level's ends. Then, precisely reverse the ends and read the bubble again. If it is in exactly the same position as on the first reading, you have a true-reading level.—*Harvey Muller*

Boring hardened steel

You can use copper tubing to bore holes in tempered steel. Cut a short length of tubing with an outside diameter that equals desired hole diameter. Drive a snug-fitting piece of drill rod inside the tubing to keep the chuck from collapsing it and chuck the tube. Use an automotive valve-grinding compound between the rotating tubing and the workpiece. Lift the tubing frequently to add compound. Use light pressure and bore slowly.—*Henry Miller*

**Somebody needs what you've already got.
Pass it on.**



You came out of the service with a lot going for you. Skill. Knowledge. And experience. And much of it didn't come out of a book or a tech manual. It came from somebody else. Somebody who took the time to pass along what he knew.

Well, what about you? You've got a lot to give, too. And you can do it. Part-time. In the Army National Guard.

In the Army Guard, you can make a difference. By working with people who



want to know what you know. By showing them the ropes. And watching them grow.

It's a satisfying job. The pay's good, too. And you'll be putting time against retirement benefits.

Check it out. There are a lot of people who want what you've got. Pass it on. In the Army National Guard.

See your local recruiter or call toll-free 800-638-7600 (except in Alaska, Hawaii, Puerto Rico and the Virgin Islands). In Maryland, call 728-3388.

**Help somebody.
Including yourself.**



The Guard belongs.

How many mpg does your muffler get?

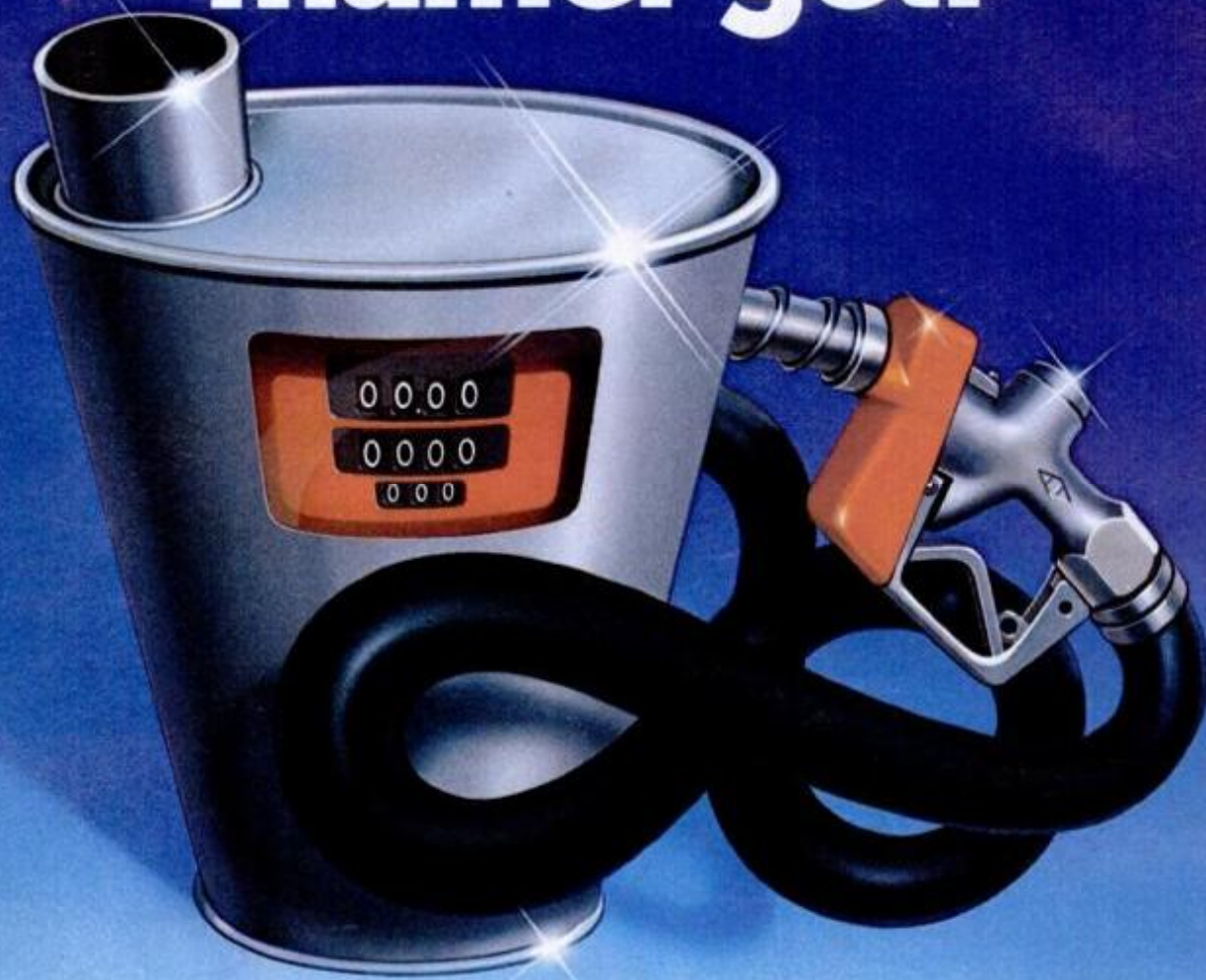

A strange question? Not at all. Take a Walker muffler. Over the years, it helps your engine run efficiently.

Why? Because we design exhaust systems specifically for each individual car—over 2,300 different systems. So a Walker system helps your car perform at its best. No wonder Walker is the world's best-selling muffler.

Just look for the Walker sign... at service stations and garages everywhere. Or look in the Yellow Pages under "Mufflers."

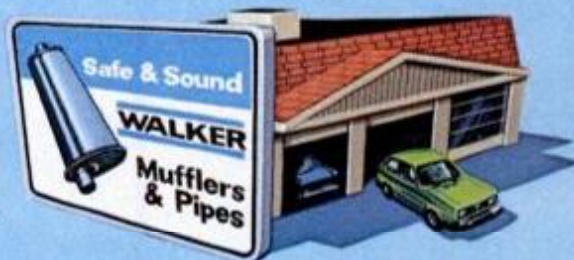

**Get a Walker muffler. A sound investment
for your gasoline dollars.**

WALKER

Walker
Manufacturing
Division of
Tenneco Automotive
1201 Michigan Blvd.
Racine, Wis. 53402



THE PM GARAGE

CAPSULE REPORTS ON NEW AUTO PRODUCTS

Battery dollars and sense

They do die hard. My DieHard storage battery is six years old this month and still cranking. I had to check my car's logbook to remember that I paid \$38 for the battery, which was warranted for five years. How much more can I get out of it? Another winter? Maybe two? More than that?

I don't intend to find out. After six



Retire your battery to light-duty service after it's cranked for six years.

years of reliable get-up-and-go, I'm putting it out to pasture. Not to the glue factory, mind you, but into light-duty service. I could get a couple of bucks for old catalog No. 4324 on a trade-in, but I'd rather it live out its last years providing warm cabin lighting on a buddy's boat.



Replacement DieHard is maintenance-free, but caps come off for hydrometer checks.

A DieHard replacement for my car now costs \$60, but it's still an investment I make gladly. The current DieHards have 390 to 550 amps. of cold cranking power, depending on size of battery for your car (a reserve capacity of 80 to 159 minutes at 25 amps.), and the traditional 60-month warranty. All Sears top-of-the-line DieHards are now maintenance-free, which should make my new battery very easy to forget about—for the next six years, anyway.—*B.H.*

Maintenance-free charger



Charger for maintenance-free batteries has a cutoff voltage of 14.87.

Maintenance-free charger

Maintenance-free car batteries—the new calcium/lead batteries *without* caps—have a cutoff voltage of 14.87, instead of the normal 12.75 volts for conventional batteries, so a regular battery charger can't fully charge a maintenance-free battery. A maintenance-free battery has a "memory," and if you undercharge the one in your car often enough, it "forgets" how to accept a full 14.87-volt charge.

So, it's always best to charge a maintenance-free battery with a charger that can give it a full charge. We tested one made by the Schumacher Electric Corp. of Chicago (sold by Western Auto and Best Products, among others. Price of the WS-40M: \$44 to \$50).

To charge a maintenance-free battery, you set the charger switches to 12-volt and then *Maintenance Free*. Charge is regulated automatically and tapers as battery stores up energy.—*M.L.*

New battery cables

Battery jumper cables, except for the quality of the cable and clamps, wouldn't seem like candidates for the better mousetrap theory. But we used a new set that is indeed

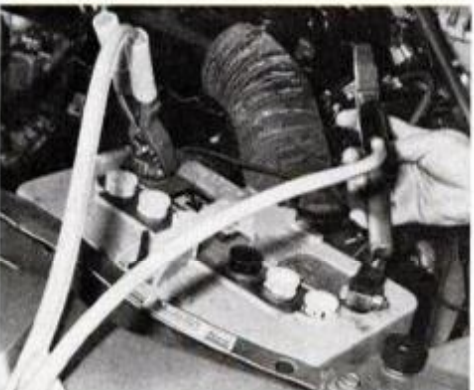

New jumper cables have indicator light.

unique. One of the two cables has an indicator light built into a clamp handle at one end, to prevent an incorrect connection which is always possible when it's dark.

It works this way: Set the clamp with the indicator light aside and connect the jumper cables to the good battery. Then bring the other cable ends over to the dead battery. First check the indicator light by touching its contact tab on the clamp against the other cable's clamp. The lamp lights, and you can proceed safely. Next, hook up the cable that doesn't have the indicator to one of the dead battery terminals. Before you make the final connection (with the clamp with the indicator), touch the contact tab on the clamp to the remaining battery post. If you've made a wrong connection, the indicator will light as a warning, so you can just reverse the connections to recharge.

The cables themselves are a tangle-resistant design that come in a carton handy for storage. Cost is \$12, maker is Associated Equipment Corp., 1555 Salzman Ave., St. Louis, Mo. 63133.—*Paul Weissler*

Ball-peen hammer



Dead-blow ball-peen doesn't bounce back.

The ball-peen hammer is the top choice for automotive work. You use it with a chisel and you need it for splitting rusted nuts, cutting away exhaust parts, even whacking out minor dings. For safety, there's nothing like a dead-blow hammer filled with lead shot. When it makes impact, it *stops!* It doesn't bounce, so there's less danger of injury. Now you can get a ball-peen in a dead-blow design, and it has a handle of molded compothane, a super-plastic. At about \$18 for a 16-ouncer, it's not much more than a ball-peen with wood handle. From Compo-Cast Div., C.E.S. Inc., 2222 North Olney St., Indianapolis, Ind. 46218.—*Paul Weissler*

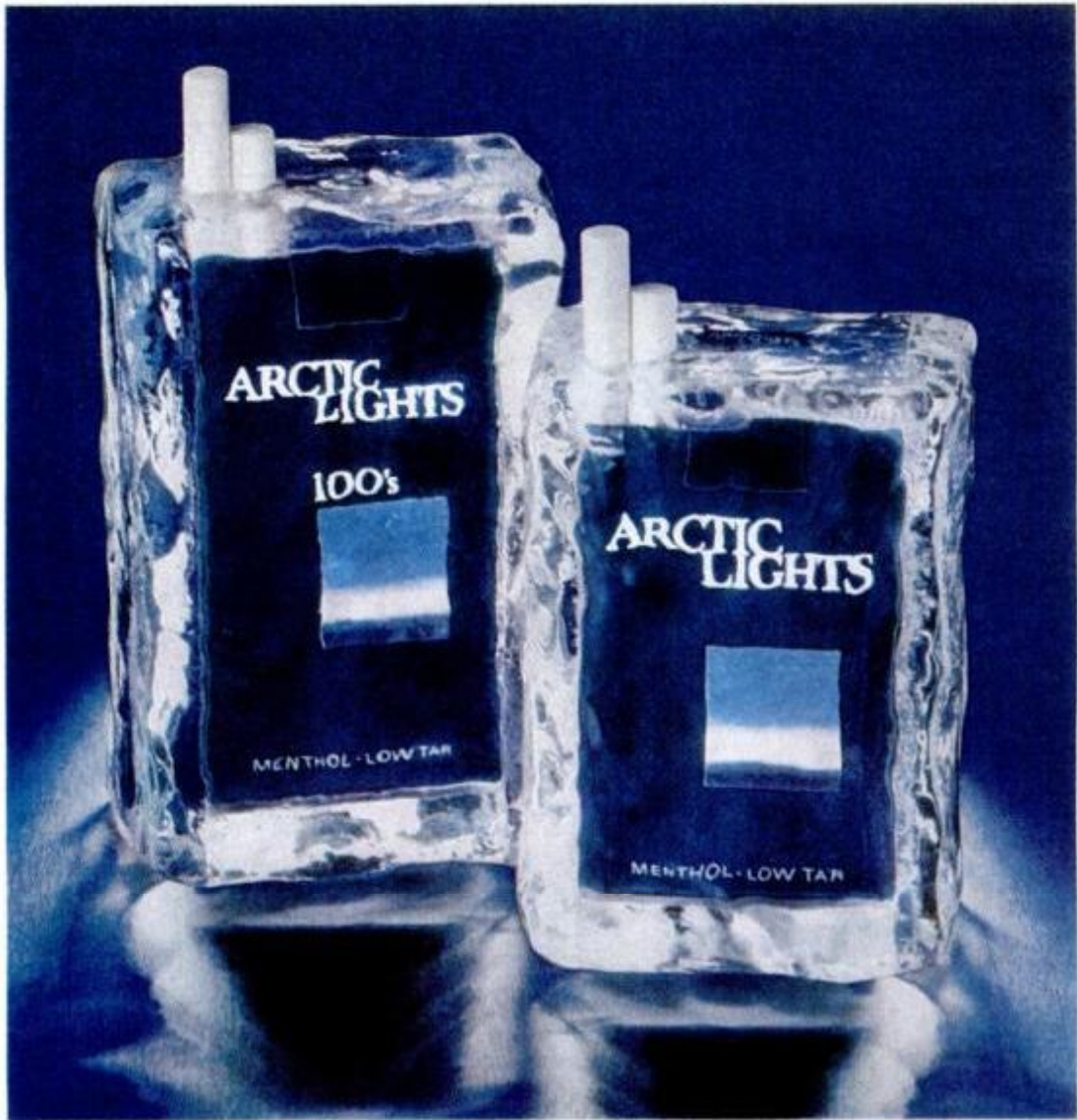

Discover
Arctic Lights
—more menthol refreshment than
any other low 'tar' cigarette.

Full menthol refreshment. That's what ARCTIC LIGHTS delivers.

A very special kind of menthol refreshment you just won't find in any other low 'tar' menthol cigarette.

You see, while the filter holds back 'tar,'

the unique new ARCTIC LIGHTS menthol blend comes right through. Result? You get the iciest, brightest taste in menthol smoking—puff after puff. Light up your first ARCTIC LIGHTS. **You just won't believe it's a low 'tar' menthol.**

Arctic Lights: Kings & 100's

© 1978 B&W T Co.

Warning: The Surgeon General Has Determined
That Cigarette Smoking Is Dangerous to Your Health.

9 mg. "tar", 0.8 mg. nicotine av. per cigarette by FTC method.

CAR CLINIC

SOLUTIONS
FOR MECHANICAL
HEADACHES

BY
MORT SCHULTZ



Artesian well

While inflating tires at a service station, I noticed bursts of oily water coming from the air pump chuck. Apparently, some oil got inside the tires. Is it harmful? Where does the oil come from?—Wallace Beck, Artesia, N.M.

The oil is air-compressor lubricant. It mixes with condensed water in the air tank, and is shot through the air hose and chuck into tires as they are being inflated. Oil can be detrimental to the tire's inner liner compound and result in reduced tire life. The price of tires being what it is, you may want to dismount the tires and wipe them out. One way to avoid this inconvenience is to buy a hand-operated air pump and inflate tires in your driveway.

Socket to me

A replacement power valve in the Motorcraft model 2100 carburetor of my 1975 Ambassador leaks gas, presenting a potential for fire in the engine compartment. It is the second power valve my mechanic has installed. Any cure?—Pete Parizzi, Pennsville, N.J.

Is your mechanic using the right tool to install this power valve? If he's using arc-joint pliers, for example, he could be warping the valve's housing, which allows gas to leak around the diaphragm. The special power-valve socket tool he needs fits a 3/8-inch drive. Tell your mechanic it is tool J-10175 and can be ordered from his supplier of Ford special service tools. (Motorcraft is a Ford carburetor.) Using the socket, he should tighten the valve as much as possible.

Where there's smoke . . . ?

Is there any truth to the story that the Chevrolet-made 305-cu.-in. engine is experiencing camshaft failure?—J.G., Milwaukee.

J.G. is probably referring to a recent article in the *Milwaukee Journal* alleging camshaft bearing failure in the 305 that can cost owners

as much as \$1000 to repair. The 305 engine was introduced in late 1976 and is used in Chevy, Pontiac, Buick and Oldsmobile cars and GMC trucks. About three and a half million have been built.

The *Journal* said there "may be a very small" number of failures. The exact number can't be verified, because "Chevrolet is unable or unwilling to provide a figure." Chevrolet has issued denials, although a Chevy spokesperson was quoted in the *Journal* as saying, "Bearing knock is one of the engine's characteristics. But in our reliability monitoring, the 305 engine does not show up as having bearing problems."

Car Clinic's investigation of the problem indicates: (1) yes, knocking 305 engines have been reported by customers at dealerships we surveyed; (2) where there has been engine failure, it resulted from the owner not changing motor oil when specified in the owner's manual.

GM has assured *Car Clinic* that any complaints our readers have will be investigated. Follow the complaint procedure outlined in the owner's manual; that is, first dis-

cuss the situation with the dealer. If this fails to resolve the problem, contact the nearest zone office (there's a listing in the manual). Finally, get in touch with the maker (address and phone number in the manual).

Unregulated failure

Can you tell me why my car, a 1976 Datsun B210, has experienced three cases of voltage regulator failure in 10,000 miles? Each failure caused battery overcharging. The electrical system has been gone over and no contributing condition has been found. Can you help?—Bradford L. Patterson, Glen Head, N.Y.

Datsun has used this particular voltage regulator on most of its models for several years. It is a reliable unit. Datsun says so. And so do I, based on your letter being the only one I recall getting to voice a complaint about this regulator. What can be causing the trouble? You may be getting defective regulators if you aren't using original Datsun parts. A Datsun regulator has a 90-day or 4000-mile warranty.

Other than this possibility, an electrical malfunction may have escaped diagnosis. Perhaps there's a short in the alternator, or a poor ground that is being activated by road movement. Either can cause electrical surging that can damage the regulator. Your choices are limited to these, so it shouldn't be too tough to track down the cause.

Hushing harsh shifts

My 1978 Dodge Omni has one drawback—harsh shifting. Is this an inherent condition?—Robert J. Hickey, South Wales, N.Y.

Chrysler says no. The company

(Please turn to page 36)

Roll the drum

When the pads of front disc brakes wear out and have to be replaced, it's time to check your rear brake linings. This usually requires removing brake drums, since the rear brakes of most cars are drum brakes. If the drums are tight and won't come off, look for an access hole in the drum. It may be covered up by a rubber cover or tab. Pry off the rubber cover or knock out the tab. Hold adjusting lever away from the self-adjusting screw with a narrow screwdriver, while using a brake-adjusting tool to back off the adjusting screw. After you've reinstalled the drum, adjust brakes by tightening the adjusting screw until there's a slight drag on the drum. Then, back off the screw 10 to 12 notches until wheel rotates freely. Remember to cover the access hole to keep moisture and dirt from entering the brake and botching up mechanisms.

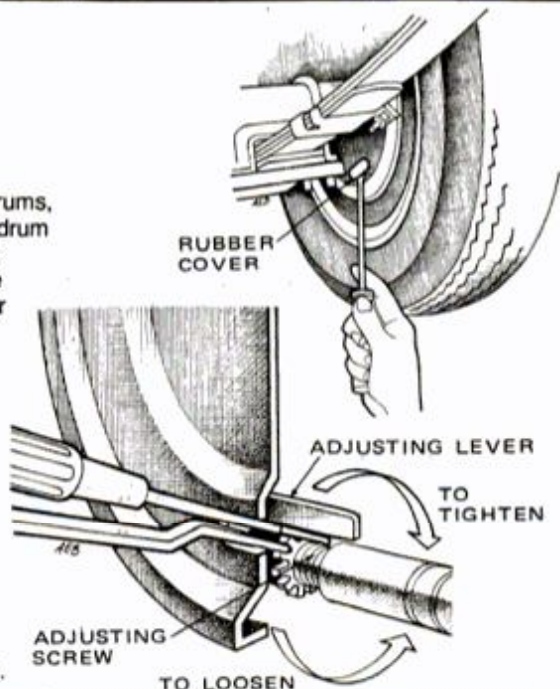

CAR CLINIC

(Continued from page 35)

contends that harsh shifting can be corrected by seeing that transmission fluid level is correct, and by properly adjusting the throttle rod linkage and gearshift linkage. If you have a Dodge dealer do the work, he can refer to service bulletin 21-03-79. If not, check the fluid level as outlined in your owner's manual. Then, you should adjust gearshift linkage as follows:

1. Place the gearshift lever in PARK.
2. Loosen the adjustable swivel block, which must move freely. If it doesn't, disassemble and clean the assembly.
3. Move the shift lever on the transmission as far as it will travel to the rear detent, which is PARK position.
4. Tighten the adjustment swivel lock bolt to 90 inch-pounds.

Now, adjust the throttle rod linkage by warming the engine to normal operating temperature. Make sure idle speed is within specification and the fast-idle cam is not engaged. Loosen the adjustment bracket lock screw at the transaxle end of the transmission throttle rod

cable. If the adjustment bracket does not slide freely, disassemble and clean the bracket. Holding the throttle lever firmly against its internal stop (toward the driver side of the car), tighten the adjusting bracket lock screw to 105 inch-pounds.

Module behavior

Seven months after buying a new 1978 Oldsmobile Cutlass, the engine wouldn't start. The HEI electronic module, which had failed, was replaced. Four months later—same problem. Again, the dealer replaced the module, along with the distributor cap, rotor and sparkplugs. I'm fed up. How do I convert to conventional ignition?—Kermit L. Hoffman, Johnstown, Pa.

You tear out the HEI distributor and secondary cables and replace them with a compatible breaker point distributor, ignition coil and secondary cables. Regap sparkplugs to .035 inch. But before you go through the hassle and expense, listen a minute. An honest friend of mine at GM told me there has, indeed, been a rash of electronic module complaints. He's in a department that gets "failed" parts for study.

Exhausting possibilities



A periodic inspection of the exhaust system is a swell idea, but get into the habit of checking the entire system. There is one spot which often is overlooked. It's the exhaust manifold-exhaust pipe joint connection. Exhaust gas leaking from here is as deadly as exhaust gas leaking from a rusted-out muffler or pipe. With the engine cold, look for white deposits resembling corrosion. This signifies a leak. Leaks occur when the manifold-exhaust pipe joint gasket goes bad. To replace the gasket, remove bolts, remove the old gasket, clean surfaces, apply a bead of gasket sealer to each surface, lay in a new gasket and tighten the bolts.

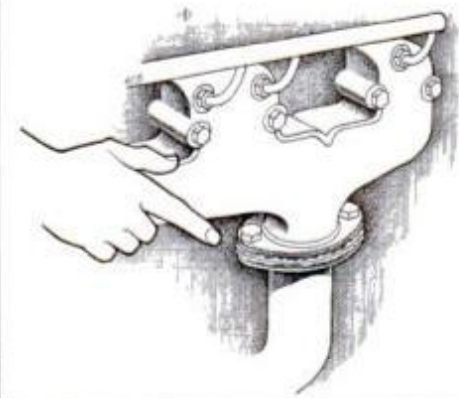

New from STP.
**An improved
carburetor
spray cleaner.**



New STP Carb Spray Cleaner contains an improved formula that removes gum, varnish and sludge from dirty carburetors, linkage, automatic chokes and PCV valves... even better than the old familiar STP Carburetor Cleaner formula.

Clean carburetors help engines run as they should... STP Carb Spray Cleaner cleans carburetors.

Get The Dry Look... and don't be a stiff.



The Dry Look leaves hair feeling as soft and natural as it looks.

The Dry Look gives you more than a great look. It leaves your hair feeling soft and natural, too — not too stiff. The Dry Look in pump spray or aerosol — with a formula that's right for your hair. Get The Dry Look... and don't be a stiff!



© The Gillette Company, 1979

Available in pump or aerosol.

According to my friend, "Nine out of 10 modules 'fail' because of loosely connected wires that attach to the module. Mechanics are too quick to pull out the module."

I have to agree that many mechanics are still not familiar with the HEI system. Your case is a good example. Why did your dealer indiscriminately replace a module, rotor, distributor cap and sparkplugs? It's not likely that all these parts failed at the same time.

The next time you experience an electronic module "failure," tighten wires connected to the module. Even the conventional ignition systems won't deliver if a primary wire should work loose, which frequently does happen.

Rubber marbles

When wheel balancing and inspections failed to cure a vibration in my car that occurred at above 45 mph, I pulled tires and looked inside. I found tiny globs of rubber, which I cleaned out. Now, no more vibration. The rubber marbles apparently upset balance. Thought you'd like to know.—Horace Mazet, Carmel, Calif.

You bet I do, and so do readers of *Car Clinic*. Thanks, Horace.

"Surge-ary"

I don't have a problem, but would like to share a solution. It concerns my Lincoln Mark IV, which experienced surging when the speed control was engaged. I took the car to a Lincoln-Mercury dealer, who said the trouble was caused by bad parts. I was charged \$10 for this diagnosis, which would be credited to my bill when I brought the car in for repair.

A few days later, I stopped at Burton Ford, a small town dealer. I explained the problem to Ralph, the service manager. A man of few words, Ralph said, "Humph," jacked up the front end and pulled, cleaned and lubricated the speedometer cable. The charge was \$2.50. The speed control is still operating perfectly, many thousands of miles later.

How's this for a tip?—Robert C. Lawrence, Montross, Va.

Ralph may not talk much, but he doesn't have to. His actions speak loud and clear. Thanks for sharing your experience, Bob.

GOT A PROBLEM WITH YOUR CAR?

Just ask Mort about it. Send your question to the *Car Clinic*, *Popular Mechanics*, 224 West 57th St., New York, N.Y. 10019. While letters cannot be answered individually, problems that are of general interest will be published in the column.

Safety and service tips

■ Not enough clearance between the choke plate and carburetor air horn causes the valve to stick in the open position, preventing easy starting of some of the 1978 Pontiac Grand Prix and Grand Ams with 301-4V engines. Remove the choke plate valve and use a file to shave .010 inch from each end. Deburr surfaces and reinstall the valve, using Loctite No. 75 on assembly screw threads.

■ The Department of Transportation is investigating an alleged braking defect in 1975-76 VW Rabbit and Scirocco, and 1974-76 Audi Fox and VW Dasher. The problem involves the possibility of faulty seals in the master cylinder, causing fluid loss and reduced stopping ability. Check the fluid level more frequently than usual. If you run into the problem, write the National Highway Traffic Safety Administration, Office of Defect Investigation, Washington, D.C. 20590, or call the toll-free hot line, 800-424-9393.

■ Chrysler reports that undercharged batteries in 1978 and 1979 Omnis and Horizons may result from a loose connection at the field terminals of the alternator. Service bulletin 08-09-79 explains how to test for electrical continuity and replace a loose connection.

■ A Ford Fiesta that doesn't start because of ignition failure may have a distributor armature (trigger wheel) loose on the distributor shaft. Get thread locker (part No. D5AZ-19554-A) from a Ford dealer and place a drop on the expansion-type drive pin holding the armature to the shaft.

PM

YOURS FREE!

**FEIRER
CABINETMAKING
AND MILLWORK**

**CABINETMAKING
AND MILLWORK**

Thousands of explanatory drawings illustrate important points and show you exactly how to do hundreds of woodworking jobs...

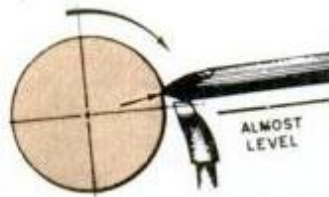
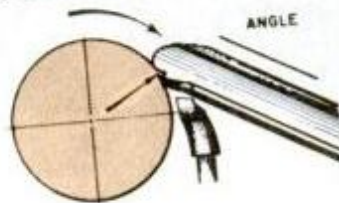

The two basic methods of turning on a lathe: cutting (top) and scraping.

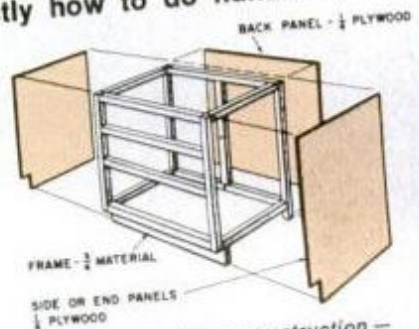

This is frame construction—often used in kitchen cabinets.

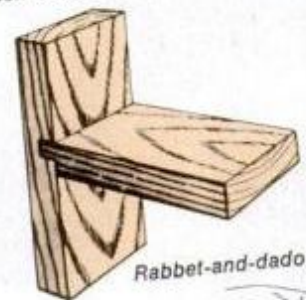

Rabet-and-dado joint.

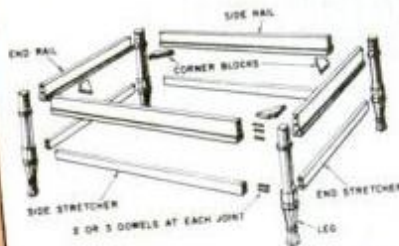

Exploded view of coffee table showing leg-and-nail construction using dowels and corner blocks.



When sharpening a hand saw, make sure the file is level as the stroke is made.

- ★ Master cabinetmaking techniques.
- ★ Become an expert at using hand and power tools—even lathes, routers, shapers.
- ★ Learn how to build furniture, do fine interior work.

• 928 PAGES
• THOUSANDS OF EXPLANATORY PICTURES

MAIL ATTACHED CARD TODAY OR WRITE TO:

Take this giant \$24.95 treasury of creative woodworking

FREE

when you join Popular Science Book Club

If you're like most do-it-yourselfers, you probably do most of the routine woodworking jobs around the house yourself and *pay* to get the fancier work done. Yet the real satisfaction of woodworking comes from doing those fancy jobs yourself: making a wall of handsomely grained built-ins . . . wood-panelling an entire room . . . constructing a table with a perfectly matched veneer top. Yes, you can do all of these fancy jobs yourself *even without experience* when you've got a copy of **CABINETMAKING AND MILLWORK** as your guide.

Thousands of show-how pictures guarantee success!

This excellent, 928-page volume is a complete education in fine woodworking. It teaches you exactly how to do every step of every woodworking job you'll ever want to do. Thousands of explanatory pictures (including many full color photographs), charts, assembly drawings, finishing illustrations, construction details and more make this book very easy to use . . . *even for a novice!* (Think of the money you can save by building, repairing, finishing and refinishing all kinds of home woodworking projects *yourself!*)

Super clear how-to on tools, wood, construction, materials, finishing and much more!

CABINETMAKING AND MILLWORK is such a giant how-to book that it takes more than 1700 separate index listings just to tell you *where to look* for each step-by-step answer. You get more than 200 pages on how to use hand tools, power saws, shapers, routers, drills, boring machines, lathes and more, including how to sharpen and care for tools and make a variety of jigs for power tools.

CLUB MEMBERSHIP SAVES YOU UP TO 50% ON THE BEST NEW DO-IT-YOURSELF BOOKS!

• home improvement and repair
• house building • cars and car repair
• home workshop • appliance repair
• electronics • how things work
• protection • masonry and carpentry
• mathematics • science and technology
• space • more

More than 300 pages of specific construction plans for built-ins, kitchen cabinets, room dividers, tables, bookcases, furniture of every description. You even get a big wood finishing section with more than 100 pages of step-by-step how-to for all kinds of fine hardwoods and practical softwoods, plywood, composition, hardware, plastic laminates, etc. There's much, much more on how to read blueprints, how to make construction drawings, estimate costs, purchase materials at big bargains. Every detail you need to know is given the complete, clear-cut treatment in this excellent do-it-yourself book. You'll use it for years as one of your favorite "handyman's tools".

HOW POPULAR SCIENCE BOOK CLUB WORKS

- First, you get **CABINETMAKING AND MILLWORK** (Regular price \$24.95) FREE, and your first Club selection, **BASIC HOUSE WIRING** (regular price \$10.95) for just \$7.95 plus delivery and handling. That's \$35.90 worth of books!
- Then, about every four weeks, 15 times a year, you'll receive a bulletin describing the main selection and alternate books also available. If you want the main selection only, do nothing. It will be sent to you automatically. If you don't want the main selection or want an alternate book, just indicate your wishes on the form that comes with the bulletin and return it by the date indicated. You will always have at least ten days in which to do this but in the unlikely event that you don't, and you receive an unwanted selection, you may return it at our expense. In addition, you may return any book within ten days, after examining it, if you're dissatisfied with it.
- Your only obligation is to buy two more books within your first year of membership. You may cancel your membership any time after that. To retain all membership benefits, you need buy only a book a year thereafter.
- You save up to 50% on every selection. Yet virtually every book is identical to the publisher's edition. Same binding, paper, print, jacket. Same everything except price.

Your first Club selection is BASIC HOUSE WIRING

This excellent book was custom written especially for Popular Science Book Club. It tells you everything you need to know to install, repair, improve and troubleshoot the entire electrical system in your home.

How to determine wiring needs. How to draw up plans for "go-aheads". How to install complete systems. And how to wire low-voltage devices (intercoms, etc.), rural buildings, service entrances, workshops, heavy-duty machines, appliances—everything!

For example, how to rewire an old house inside and out. Hang a chandelier. Put in handy closet fixtures. Install dimmer switches, convenience outlets, three-ways. Set up an intercom. Install door chimes.



Ground your TV or radio antenna.

And this new book makes all these things easy. More than 500 illustrations guide you through each job step by step.

This is the latest, most complete book of its kind available. It regularly sells for \$10.95. Your PSBC price is only \$7.95 plus delivery and handling.

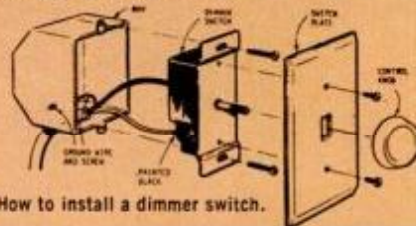

How to install a dimmer switch.

POPULAR SCIENCE BOOK CLUB, P.O. Box 2006, Latham, N.Y. 12111



Moodymobile is Capri with new drive train.

An 84-mpg turbodiesel

Ralph Moody once prepped cars for speed; now he's designing them for more mpg.

by Mort Schultz

Last December, when Secretary of Transportation Brock Adams called on automobile manufacturers to "reinvent the car" by the year 2000 to get 50 miles per gallon, Ralph Moody was getting 84 mpg from a 1979 Mercury Capri. As you might expect, the Moodymobile became an overnight celebrity.

Ralph and his partner, Mike Shetley, could have become overnight millionaires. They say they received "six different bona fide buy-out offers of \$100 million."

"Nuts to that," Moody said to me when I visited his shop in Oak Hill, Fla., to test the Capri. "We're not interested in offers. I don't want this put on a shelf. I want it in the hands of the American people."

My road test of the turbocharged diesel Capri did away with any

doubts I had. The Moodymobile does everything Moody and Shetley say it does.

I drove the car on exactly one-half gallon of diesel fuel, south from Oak Hill on Interstate 95, and mostly at 55 mph. The fuel finally ran out near Melbourne. I had covered 41.7 miles.

Dramatic test results

Several weeks later, the car's fuel achievements were confirmed by William T. Gordon, chairman of the automotive department at Daytona Beach (Fla.) Community College. Using a miles-per-gallon gauge, Gordon tested the car on a dynamometer and on the highway with these results: 84.6 mpg at 35 mph, 83.8 mpg at 40 mph, 82.9 mpg at 45 mph,

(Please turn to page 156)

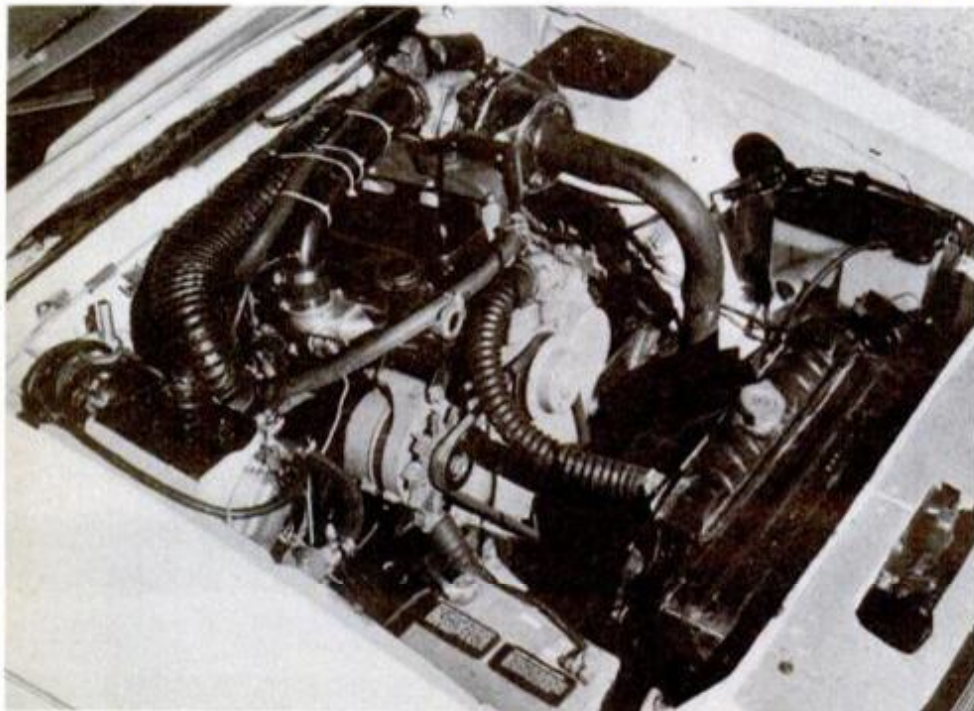

Capri's engine is a modified 108-cu.-in. Perkins diesel with exhaust turbocharging.

PM lists the models without on cheaper, easier to obtain

This chart will help you select a new or late-model used car that doesn't require unleaded gasoline. The difference in price between unleaded and regular gas is as much as 10 cents a gallon; it's even more between unleaded gas and diesel fuel. And shortages of unleaded gasoline are forecast by the Petroleum Industry Research Foundation.

What the chart numbers and abbreviations mean:

■ **(1)** designates cars that meet standards for exhaust emissions in all states except California without needing unleaded gasoline.

■ **(2)** identifies cars that meet standards for exhaust emissions in all 50 states without having to use unleaded gas.

■ **(3)** refers to cars that, when new, weren't sold in California.

■ **A/T** stands for automatic transmission.

■ **M/T** stands for manual transmission.

■ **Car descriptions** designate, in order, engine size in cubic inches, fuel system and number of cylinders. Thus, 258, 1V, 6-cyl. means an engine of 258 cubic inches having a one-barrel carburetor and six cylinders; 114, FI, 4-cyl. means an engine of 114 cubic inches with fuel injection and four cylinders. A diesel engine is so named.

■ **"Some with . . ."** in a car description indicates that some of the vehicles can use leaded gas while others require unleaded. To determine which have to use unleaded gas, check for the presence of a catalytic converter in the exhaust system or a label stating "Use unleaded fuel only" placed on the dashboard or near the gas filler cap.

1975

ALFA ROMEO (3)

Alfetta: 120, FI, 4-cyl.
2000 Spider: 120, FI, 4-cyl.

AMERICAN MOTORS

Gremlin (1): 232, 1V, 6-cyl.; 258, 1V, 6-cyl.
Hornet (1): 232, 1V, 6-cyl.; 258, 1V, 6-cyl.
Hornet station wagon (1): 232, 1V, 6-cyl.; 258, 1V, 6-cyl.
Metador (1): 258, 1V, 6-cyl.
Metador station wagon (1): 258, 1V, 6-cyl.
Jeep (2): 232, 1V, 6-cyl.; 258, 1V, 6-cyl.

AUDI (1)

Fox: 97, FI, 4-cyl.
Fox station wagon: 97, FI, 4-cyl.
100LS: 114, FI, 4-cyl.

AUSTIN (1)

Marina: 91, 1V, 4-cyl.

BMW (2)

2002: 121, 2V, 4-cyl.
530i: 182, FI, 6-cyl.
3.0i: 182, FI, 6-cyl.

BUICK (1)

Opel 1900: 116, FI, 4-cyl.
Opel 1900 station wagon: 116, FI, 4-cyl.
Manta 1900: 116, FI, 4-cyl.

CHEVROLET (2)

Luv pickup: 110, 2V, 4-cyl.

CHRYSLER (1)

Cordoba: 318, 2V, 8-cyl. (some with A/T)

money!

analytic converters that run
aded gasoline or diesel fuel.

HATSUM

B-210 (1): 85, 2V, 4-cyl.
610 (1): 119, 2V, 4-cyl.
610 station wagon (1): 119, 2V, 4-cyl.
710 (1): 119, 2V, 4-cyl.
710 station wagon (1): 119, 2V, 4-cyl.
280Z (1): 168, FI, 6-cyl.
Pickup (2): 119, 2V, 4-cyl.

ODGE

Colt (2): 98, 2V, 4-cyl.; 122, 2V, 4-cyl.
Colt station wagon (2): 98, 2V, 4-cyl.; 122, 2V, 4-cyl.
Dart (1): 318, 2V, 8-cyl. (some with A/T); 360, 4V, 8-cyl.
Coronet (1): 318, 2V, 8-cyl. (some with A/T)
Charger (1): 318, 2V, 8-cyl. (some with A/T)

ERRARI (2)

308 GT: 179, 8V, 8-cyl.

IAT (1)

128: 79, 2V, 4-cyl.
128 station wagon: 79, 2V, 4-cyl.
131 Mirafiori: 107, 2V, 4-cyl.
131 Estate Wagon: 107, 2V, 4-cyl.
124: 107, 2V, 4-cyl.

ORD

Pinto (1): 140, 2V, 4-cyl.
Pinto station wagon (1): 140, 2V, 4-cyl.
Mustang II (1): 140, 2V, 4-cyl.; 302, 2V, 8-cyl. (early production models)
Maverick (1): 250, 1V, 6-cyl. (early production models); 302, 2V, 8-cyl. (those with M/T)
Granada (1): 250, 1V, 6-cyl. (early production models); 351, 2V, 8-cyl.
Courier pickup (2): 109, 2V, 4-cyl.
Pickup (1): 360, 2V, 8-cyl. (those with A/T); 390, 2V, 8-cyl.
Econoline/Club Wagon (1): 351, 2V, 8-cyl.
Ranchero (1): 351, 2V, 8-cyl.

ONDA (2)

Civic: 78, 2V, 4-cyl.
Civic CVCC: 91, 3V, 4-cyl.
Civic CVCC station wagon: 91, 3V, 4-cyl.

INTERNATIONAL HARVESTER (2)

Scout II: 196, 1V, 4-cyl.; 304, 2V, 8-cyl.; 345, 2V, 8-cyl.
Travelall + pickup models 150: 304, 2V, 8-cyl.; 345, 2V, 8-cyl.; 392, 2V, 8-cyl.
Travelall + pickup models 200: 304, 2V, 8-cyl.; 345, 2V, 8-cyl.; 392, 4V, 8-cyl.

INCOLN-MERCURY (1)

Bobcat: 140, 2V, 4-cyl.
Comet: 250, 1V, 6-cyl. (early production models); 302, 2V, 8-cyl. (those with M/T)
Monarch: 250, 1V, 6-cyl. (early production models); 351, 2V, 8-cyl.

ASERATI (2)

Merak: 181, 6V, 6-cyl.
Khamain: 301, 8V, 8-cyl.
Bora: 301, 8V, 8-cyl.

AZDA (2)

808: 97, 2V, 4-cyl.
808 station wagon: 97, 2V, 4-cyl.
RX-3: 70, 4V, 2 rotors
RX-3 station wagon: 70, 4V, 2 rotors
RX-4: 80, 4V, 2 rotors
RX-4 station wagon: 80, 4V, 2 rotors
B1600 pickup: 96, 2V, 4-cyl.
Rotary pickup: 80, 4V, 2 rotors

MERCEDES-BENZ (2)

240D: 147, FI, 4-cyl. diesel
300D: 183, FI, 5-cyl. diesel

IG (1)

Midget: 91, 1V, 4-cyl.

EUGEOT (2)

504: 120, 2V, 4-cyl.
504 station wagon: 120, 2V, 4-cyl.
504D: 129, FI, 4-cyl. diesel
504D station wagon: 129, FI, 4-cyl. diesel

LYMOUTH (1)

Valliant/Duster: 318, 2V, 8-cyl. (some with A/T); 360, 4V, 8-cyl.
Fury/Road Runner: 318, 2V, 8-cyl. (some with A/T)

[\(Please turn to page 44\)](#)

Driving the 34-mpg Audi 5000 Diesel

by Bill Hartford AUTO EDITOR



Audi 5000 Diesel, like the gas-engine 5000, is a luxurious four-door sedan with front-wheel drive. The diesel version of the five-cylinder car can get 34 mpg on the highway.

Over 600 miles on a tankful of fuel! If you said nothing else about the diesel version of the Audi 5000, that would be enough. The range of the 5000 Diesel—from its 34-mpg highway economy and 19.8-gallon tank—ranks close to that of the Mercedes-Benz 240D with its somewhat larger tank and similar fuel economy. These two cars can go farther without a pit stop than any other cars on the road.

Mobility for five

Driving range hasn't mattered much to car buyers in the past, but now, not having to make as many fuel stops can save you waiting on long lines. A full tank on Friday night may mean you are going away for the weekend, instead of being a shut-in.

Until the day comes when the pumps run dry—for good—the 5000 Diesel will get you where you want to go economically, and will get you there in style. The front-wheel-

drive, four-door sedan with "Diesel" on its trunk lid is essentially the same superbly crafted car introduced in 1977 with gasoline engine (see *Driving the Five-Cylinder Audi*, page 106, Nov. '77). In the roomy and comfortable sedan, you'll find that you're very much at home, whether you're used to driving domestic or foreign cars—such is the meld of Mercury and Mercedes that Audi achieves with its interior design.

Mph for mpg

There's a trade-off when you go diesel, of course. Maybe it doesn't even deserve mentioning anymore, because car buyers are making the compromise so willingly: Just getting where you want to go now gets top priority.

Practical top speed of the 5000 Diesel we found to be somewhere between an indicated 80 and 85 mph. If Audi claims more, it's because it has convinced a test driver to sacrifice a

[\(Please turn to page 157\)](#)



Among the indicators and controls that you'll spot from the wheel of the 5000 Diesel are a start indicator light and idle-speed

adjuster. The two-liter, in-line Five is tilted 27° in order to maintain low hood profile and fuel-saving aerodynamics.

PORSCHE

914 (1): 109, FI, 4-cyl.; 120, FI, 4-cyl.
911S/Carrera (2): 164, FI, 6-cyl.

RENAULT (3)

17 Gordini: 100, FI, 4-cyl.

SAAB (2)

99: 121, FI, 4-cyl.

SUBARU (2)

Subaru: 83, 2V, 4-cyl.
Subaru station wagon: 83, 2V, 4-cyl.

TOYOTA

Corolla (1): 97, 2V, 4-cyl.
Corolla station wagon (1): 97, 2V, 4-cyl.
Corona (1): 133, 2V, 4-cyl.
Corona station wagon (1): 133, 2V, 4-cyl.
Celica (1): 133, 2V, 4-cyl.
Hilux (2): 133, 2V, 4-cyl.

TRIUMPH (1)

TR-6: 152, 2V, 6-cyl.
TR-7: 122, 2V, 4-cyl.
Spitfire: 91, 1V, 4-cyl.

VOLKSWAGEN (1)

Beetle: 97, FI, 4-cyl.
Thing: 97, FI, 4-cyl.
Bus: 109, FI, 4-cyl.

VOLVO (1)

240: 121, FI, 4-cyl.
245 station wagon: 121, FI, 4-cyl.
160: 182, FI, 6-cyl.

1976

ALFA ROMEO (1)

Afetta: 120, FI, 4-cyl.
2000 Spider: 120, FI, 4-cyl.

AMERICAN MOTORS (1)

Gremlin: 232, 1V, 6-cyl.; 258, 1V, 6-cyl.
Pacer: 232, 1V, 6-cyl.; 258, 1V, 6-cyl.; 258, 2V, 6-cyl.
Hornet: 232, 1V, 6-cyl.; 258, 1V, 6-cyl.
Hornet station wagon: 232, 1V, 6-cyl.; 258, 1V, 6-cyl.
Matador: 258, 1V, 6-cyl. (those with A/T)
Jeep: 232, 1V, 6-cyl.; 258, 1V, 6-cyl.

AUDI (1)

Fox: 97, FI, 4-cyl.
Fox station wagon: 97, FI, 4-cyl.
100LS: 114, FI, 4-cyl.

BMW (2)

2002: 121, 2V, 4-cyl.
530i: 182, FI, 6-cyl.
3.0i: 182, FI, 6-cyl.

BUICK (1)

Opel: 111, 2V, 4-cyl.

CHEVROLET (1)

Vega: 140, 1V, 4-cyl.
Vega Kammback: 140, 1V, 4-cyl.
Monza: 140, 1V, 4-cyl.
Luv pickup: 111, 2V, 4-cyl.
Pickup: 454, 4V, 8-cyl.

CHRYSLER (1)

Cordoba: 318, 2V, 8-cyl. (some with A/T); 400, 4V, 8-cyl. (some with A/T)
Chrysler: 400, 4V, 8-cyl. (some with A/T)
Chrysler station wagon: 400, 4V, 8-cyl. (some with A/T)

DATSUN (1)

B-210: 85, 2V, 4-cyl.
F-10: 85, 2V, 4-cyl.
F-10 station wagon: 85, 2V, 4-cyl.
610: 119, 2V, 4-cyl.
610 station wagon: 119, 2V, 4-cyl.
710: 119, 2V, 4-cyl.
710 station wagon: 119, 2V, 4-cyl.
280Z: 168, FI, 6-cyl.
Pickup: 119, 2V, 4-cyl.

DODGE

Calste (available in Puerto Rico only): 98, 2V, 4-cyl.; 122, 2V, 4-cyl.
Colt (2): 98, 2V, 4-cyl.; 122, 2V, 4-cyl.
Colt station wagon (2): 98, 2V, 4-cyl.; 122, 2V, 4-cyl.
Dart (1): 318, 2V, 8-cyl. (some with A/T); 360, 4V, 8-cyl.
Aspen (1): 318, 2V, 8-cyl. (some with A/T)
Aspen sta. wagon (1): 318, 2V, 8-cyl. (some with A/T)
Coronet (1): 318, 2V, 8-cyl. (some with A/T); 400, 4V, 8-cyl.
Coronet station wagon (1): 400, 4V, 8-cyl.
Charger (1): 318, 2V, 8-cyl. (some with A/T); 400, 4V, 8-cyl.
Monaco (1): 400, 4V, 8-cyl.
Monaco station wagon (1): 400, 4V, 8-cyl.

FERRARI (2)

308 GT: 179, 8V, 8-cyl.

FIAT (1)

128: 79, 2V, 4-cyl.
128 station wagon: 79, 2V, 4-cyl.
131 Mirafiori: 107, 2V, 4-cyl.

11 WAYS TO REDUCE FUEL WASTE

Whether your car uses leaded or unleaded gas, or diesel fuel, you'll want to squeeze every mile you can get from every tankful. Here's how:

- Keep your car fine-tuned. On the average, a tuned-up vehicle gets about 5 percent more mileage than one not in tune.
- Make sure there are no fuel leaks.
- Keep tires inflated to the manufacturer's recommended pressure—even higher as long as you don't exceed the maximum pressure stamped on the sidewalls.
- Don't top off the fuel tank, especially in hot weather. Fuel expands and may drip from the fuel-tank filler neck. Have the attendant stop pumping as soon as the fuel-pump automatic shut-off trips.
- Observe or drive below the 55-mph speed limit. It saves fuel.
- Accelerate as if there is an egg between your foot and the gas pedal. Slow, steady pressure saves tires as well as fuel. Don't accelerate like a jackrabbit.

■ Drive smoothly when cruising. Backing off and then hitting the accelerator causes unnecessary fuel consumption.

■ Anticipate stops at traffic signals. Ease up on the accelerator when a red signal appears. Try to time your approach so you don't have to stop. The greatest amount of fuel is used when a car has to be accelerated from a dead stop.

■ Don't warm up the engine any longer than necessary, even in cold weather. An idling engine consumes fuel. Start it, let it idle a few seconds and then drive at a speed not in excess of 25 mph for the first mile or two.

■ Try combining several short trips into one long one. Trips of less than five miles don't let an engine reach the normal operating temperature which is best for fuel economy.

■ Turn off the engine when you have to wait, for example, for a freight train to pass or for a drawbridge to open and close.

131 Estate Wagon: 107, 2V, 4-cyl.
124 Sport: 107, 2V, 4-cyl.
Lancia Beta: 107, 2V, 4-cyl.

FORD

Courier pickup (1): 109, 2V, 4-cyl. (some with M/T)
Courier pickup (2): 109, 2V, 4-cyl. (those with A/T)
Pickup (1): 360, 2V, 8-cyl. (those with A/T); 390, 2V, 8-cyl.
Econoline/Club Wagon (1): 351, 2V, 8-cyl. (some with M/T and A/T)

GMC (1)

Pickup: 454, 4V, 8-cyl.

HONDA (2)

Civic: 76, 2V, 4-cyl.
Civic CVCC: 91, 3V, 4-cyl.
Civic CVCC station wagon: 91, 3V, 4-cyl.
Accord CVCC: 98, 3V, 4-cyl.

INTERNATIONAL HARVESTER (2)

Scout II/Terra/Traveler: 196, 1V, 4-cyl.; 198, FI, 6-cyl. diesel; 304, 2V, 8-cyl.; 345, 2V, 8-cyl.

LINCOLN-MERCURY (1)

Capri: 140, 2V, 4-cyl. (some with M/T)

MASERATI (2)

Merak: 181, 6V, 6-cyl.
Khamain: 301, 8V, 8-cyl.
Bora: 301, 8V, 8-cyl.

MAZDA

Coamo (2): 80, 4V, 2 rotors
608 (1): 96, 2V, 4-cyl.
808 station wagon (1): 96, 2V, 4-cyl.
RX-3 (2): 70, 4V, 2 rotors
RX-3 station wagon (2): 70, 4V, 2 rotors
RX-4 (2): 80, 4V, 2 rotors
RX-4 station wagon (2): 80, 4V, 2 rotors
Rotary pickup (2): 80, 4V, 2 rotors
B1600 pickup (1, 2): 97, 2V, 4-cyl. (some early production models made for California)

MERCEDES-BENZ

240D (2): 147, FI, 4-cyl. diesel
300D (2): 183, FI, 5-cyl. diesel
230 (1): 141, 1V, 4-cyl.

MG (1)

Midget, 91, 1V, 4-cyl.

PEUGEOT (2)

504: 120, 2V, 4-cyl.
504 station wagon: 120, 2V, 4-cyl.
504D: 129, FI, 4-cyl. diesel
504D station wagon: 129, FI, 4-cyl. diesel

PLYMOUTH

Cricket (available in Puerto Rico only): 98, 2V, 4-cyl.; 122, 2V, 4-cyl.
Arrow (2): 98, 2V, 4-cyl.; 122, 2V, 4-cyl.
Valliant (1): 318, 2V, 8-cyl. (some with A/T); 360, 4V, 8-cyl.
Volare (1): 318, 2V, 8-cyl. (some with A/T)
Volare station wagon (1): 318, 2V, 8-cyl. (some with A/T)
Fury (1): 318, 2V, 8-cyl. (some with A/T); 400, 4V, 8-cyl.
Fury station wagon (1): 400, 4V, 8-cyl.
Gran Fury (1): 400, 4V, 8-cyl.

Gran Fury station wagon (1): 400, 4V, 8-cyl.

PONTIAC (1)

Astre: 140, 1V, 4-cyl.
Astre Safari Wagon: 140, 1V, 4-cyl.
Sunbird: 140, 1V, 4-cyl.

PORSCHE

914 (1): 120, FI, 4-cyl.
911 (2): 164, FI, 4-cyl.
912E (2): 120, FI, 4-cyl.
Turbo Carrera (2): 183, FI, 6-cyl.

RENAULT

5 (1): 79, 2V, 4-cyl.
12 (1): 100, 2V, 4-cyl.
12 station wagon (1): 100, 2V, 4-cyl.
15 (1): 100, 2V, 4-cyl.
17 (1): 100, 2V, 4-cyl.
17 Gordini (3): 100, FI, 4-cyl.

SAAB (2)

99: 121, FI, 4-cyl.

SUBARU (2)

Subaru: 83, 2V, 4-cyl.; 97, 2V, 4-cyl.
Subaru station wagon: 83, 2V, 4-cyl.; 97, 2V, 4-cyl.

TOYOTA (1)

Corolla: 97, 2V, 4-cyl.
Corolla station wagon: 97, 2V, 4-cyl.
Corona: 133, 2V, 4-cyl.
Corona station wagon: 133, 2V, 4-cyl.
Celica: 133, 2V, 4-cyl.
Hilux: 133, 2V, 4-cyl.
Land Cruiser: 258, 2V, 6-cyl.

TRIUMPH (1)

TR-6: 152, 2V, 6-cyl.
TR-7: 122, 3V, 4-cyl.
Spitfire: 91, 1V, 4-cyl.

VOLKSWAGEN (1)

Beetle: 97, FI, 4-cyl.
Dasher: 97, FI, 4-cyl.
Dasher station wagon: 97, FI, 4-cyl.
Bus: 120, FI, 4-cyl.

VOLVO (1)

240: 130, FI, 4-cyl.
245 station wagon: 130, FI, 4-cyl.
260: 163, FI, 4-cyl.
265 station wagon: 163, FI, 4-cyl.

1977

ALFA ROMEO (1)

Afetta: 120, FI, 4-cyl.
2000 Spider: 120, FI, 4-cyl.

AMERICAN MOTORS (1)

Gremlin: 232, 1V, 6-cyl. (some with A/T); 258, 2V, 6-cyl. (those with A/T)
Hornet: 232, 1V, 6-cyl. (some with A/T); 258, 2V, 6-cyl. (those with A/T)
Hornet station wagon: 232, 1V, 6-cyl. (some with A/T); 258, 2V, 6-cyl. (those with A/T)
Pacer: 232, 1V, 6-cyl. (some with A/T); 258, 2V, 6-cyl. (those with A/T)

(Please turn to page 46)

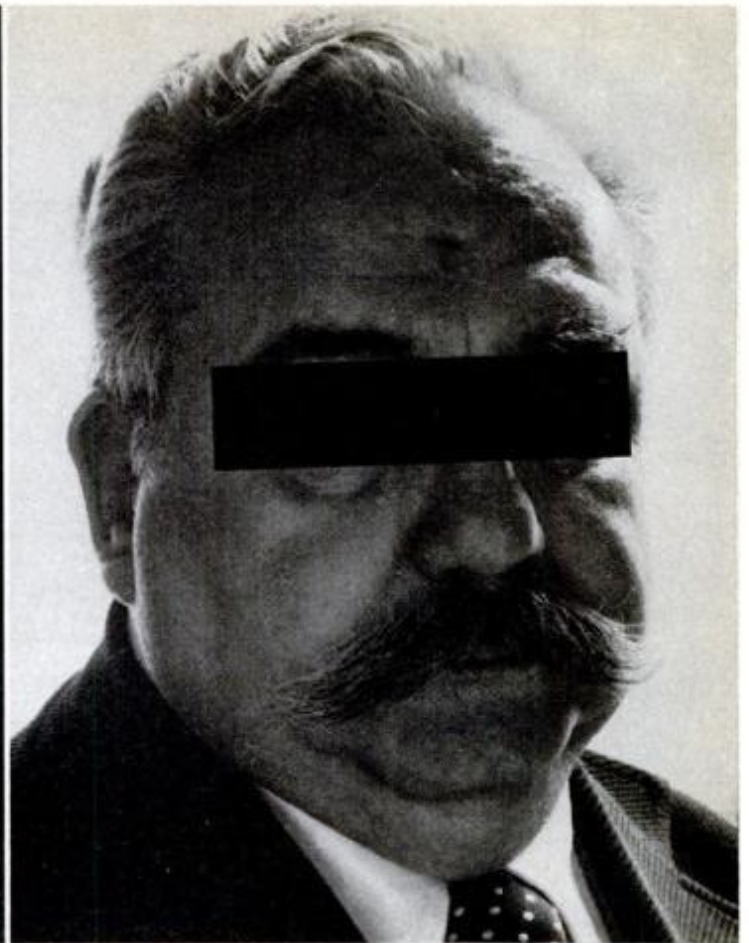
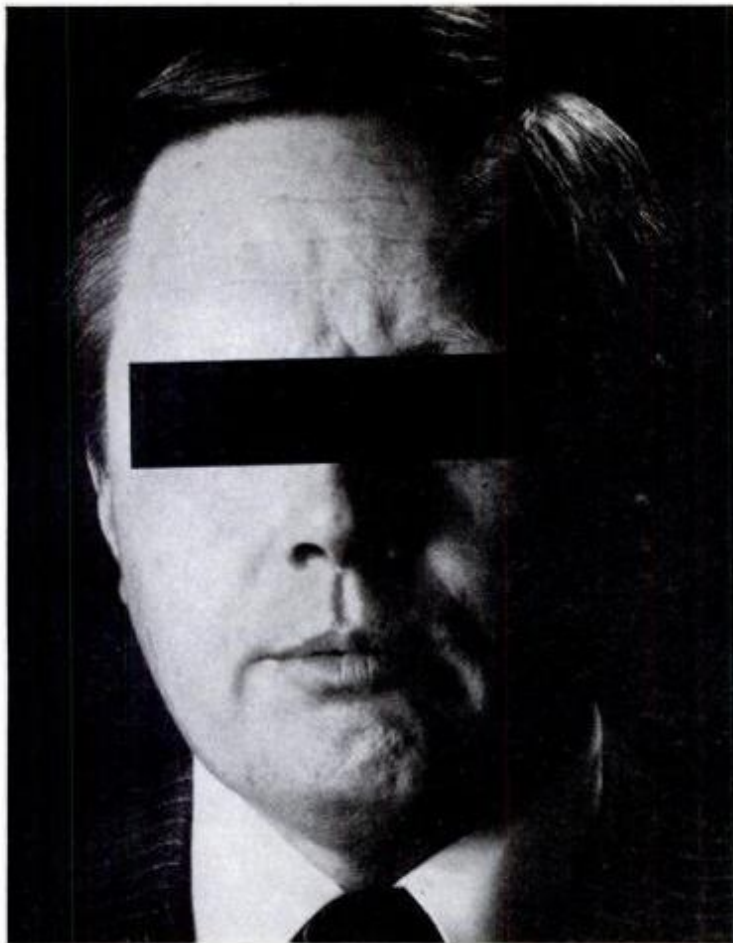

One of these men had a business that went into a slump, into the red and up in smoke.

He had a fire of a "suspicious" nature, but arson could not be proved. So, he was able to collect a substantial amount on his insurance. He turned his business loss into a profit for himself but into an additional expense for the insurance company and the policyholders.

Arson has become the "hottest" crime in the nation. Who are these arsonists? They range from small, one-time offenders, like the man on the left, to organized professional "torches." Many have found arson a profitable crime. Shocking! Even more shocking are the losses related to arson—700 lives and an estimated \$1.6 billion in insured fire losses in 1977. When you consider lost jobs, property taxes and higher costs in consumer goods, the total economic loss is a staggering \$10 billion!

We're a major group of property and casualty insurance companies and we're alarmed by the rise in this violent, costly and dangerous crime. Not only does arson jeopardize lives and property, it costs policyholders a lot of money—approximately 40¢ of every claim dollar paid for fire losses. That's four times more than ten years ago.

Recently, the FBI re-classified arson as a major crime, in the same category as murder, rape and grand larceny. This re-classification will result in greater attention by federal, state and local law enforcement agencies. We

in the insurance industry urged the government to take this action. We will continue working with law enforcement agencies to stop the spread of this vicious crime.

Here's what we're doing:

- Trying to take the profit out of arson by more extensive investigation of claims and by cooperating in the prosecution of more persons involved in "suspicious" fires.
- Supporting the Insurance Crime Prevention Institute's investigations of insurance fraud.
- Conducting arson-detection seminars for insurance personnel.
- Developing the Property Insurance Loss Register—a computerized file of previous loss claims which will alert investigators.
- Encouraging state legislators to pass stricter laws that carry heavier punishments for arson.
- Encouraging community and state arson task force programs to deal with arson problems on a local level.

Here's what you can do:

- Report any suspicious persons or activity to the police, fire department or fire marshal.
- Support efforts in your community to fight arson.

This message is presented by the American Insurance Association, 85 John Street, New York, N.Y. 10038.

Affordable insurance is our business...and yours.

© 1979 American Insurance Association.



RISLONE . . . It's Been Helping Engines Run Better for Over 40 Years

RISLONE acts fast to dissolve and disperse power robbing varnish, gum and deposits from valve lifters, stems and guides, pistons and rings, cylinder walls and oil passages. Most engines with average mileage and condition will run smoother, quieter and more powerfully within a few miles after adding RISLONE to the crankcase oil.

You be the judge. Road test RISLONE yourself. Get a can at your auto merchandising store. It's the best buy on the shelf, in the big yellow, red and black QUART can. Enough product to do a good job for you, as it has for millions of motorists for over 40 years.

Watch for these RISLONE super racers at your favorite drag strip . . . the Fabulous RISLONE Chi-Town Hustler, the stunning new RISLONE Jet of TV Tom Ivo, and the super cars of John Lingenfelter and Bob Marshall!

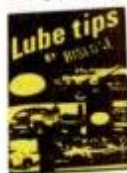

Send a stamped self-addressed envelope for your Free Copy of our 32 page LUBE TIPS booklet. It will answer some of your questions about engine lubrication.

THE SHALER CO.

21 East Jefferson St.
WAUPUN, WISCONSIN 53983

In Canada: Warren Packaging Co.,
Scarborough, Ontario

MORE MILES FOR YOUR MONEY! (Continued from page 44)

Pacer station wagon: 232, 1V, 6-cyl. (some with A/T); 258, 2V, 6-cyl. (those with A/T)

Jeep: 232, 1V, 6-cyl.; 258, 1V, 6-cyl.

AUDI (1)

Fox: 97, FI, 4-cyl.

Fox station wagon: 97, FI, 4-cyl.

100LS: 114, FI, 4-cyl.

BMW (2)

320i: 121, FI, 4-cyl.

530i: 182, FI, 6-cyl.

630CSi: 182, FI, 6-cyl.

BUICK (1)

Opel: 111, 2V, 4-cyl.

CHEVROLET (1)

Luv pickup: 111, 2V, 4-cyl.

Pickup: 454, 4V, 8-cyl.

DATSUN (1)

B-210: 85, 2V, 4-cyl. (except high-fuel-economy models with catalytic converter and 5-speed M/T)

F-10: 85, 2V, 4-cyl.

F-10 station wagon: 85, 2V, 4-cyl.

200 SX: 119, 2V, 4-cyl.

710: 119, 2V, 4-cyl.

710 station wagon: 119, 2V, 4-cyl.

810: 146, FI, 6-cyl.

810 station wagon: 146, FI, 6-cyl.

280Z: 168, FI, 6-cyl.

Pickup: 119, 2V, 4-cyl.

DODGE (2)

Celeste (available in Puerto Rico only): 98, 2V, 4-cyl.; 122, 2V, 4-cyl.

Coit: 98, 2V, 4-cyl.; 122, 2V, 4-cyl.

Coit station wagon: 98, 2V, 4-cyl.; 122, 2V, 4-cyl.

FERRARI (2)

308 GT: 179, 8V, 8-cyl.

FIAT (1)

128: 79, 2V, 4-cyl.

128 station wagon: 79, 2V, 4-cyl.

131 Mirafiori: 107, 2V, 4-cyl.

131 Estate Wagon: 107, 2V, 4-cyl.

Lancia Beta: 107, 2V, 4-cyl.

X 1/9: 79, 2V, 4-cyl.

124 Sport: 107, 2V, 4-cyl.

FORD (1)

Courier pickup: 110, 2V, 4-cyl.; 140, 2V, 4-cyl.

GMC (1)

Pickup: 454, 4V, 8-cyl.

HONDA (2)

Civic: 76, 2V, 4-cyl.

Civic CVCC: 91, 3V, 4-cyl.

Civic CVCC station wagon: 91, 3V, 4-cyl.

Accord CVCC: 98, 3V, 4-cyl.

INTERNATIONAL HARVESTER (2)

Scout II/Terra/Traveler: 196, 1V, 4-cyl.; 198, FI, 6-cyl. diesel; 304, 2V, 8-cyl.; 345, 2V, 8-cyl.

MASERATI (2)

Merak: 181, 6V, 6-cyl.

Bora: 301, 8V, 8-cyl.

Khamain: 301, 8V, 8-cyl.

MAZDA

Coemo (2): 80, 4V, 2 rotors

RX-3 (2): 70, 4V, 2 rotors

RX-4 (2): 80, 4V, 2 rotors

RX-4 station wagon (2): 80, 4V, 2 rotors

808 (1): 97, 2V, 4-cyl.

808 station wagon (1): 97, 2V, 4-cyl.

Rotary pickup (2): 80, 4V, 2 rotors

B1800 pickup (1): 110, 2V, 4-cyl.

MERCEDES-BENZ (2)

240D: 147, FI, 4-cyl. diesel

300D: 183, FI, 5-cyl. diesel

PEUGEOT (2)

504D: 141, FI, 4-cyl. diesel

504D station wagon: 141, FI, 4-cyl. diesel

PLYMOUTH (2)

Arrow: 98, 2V, 4-cyl.; 122, 2V, 4-cyl.

Cricket/Lancer (available in Puerto Rico only): 98, 2V, 4-cyl.; 122, 2V, 4-cyl.

PORSCHE

924 (1): 121, FI, 4-cyl.

911S (2): 164, FI, 6-cyl.

Turbo Carrera (2): 183, FI, 6-cyl.

RENAULT

5 (1): 79, 2V, 4-cyl.

12 (1): 100, 2V, 4-cyl.

12 station wagon (1): 100, 2V, 4-cyl.

15 (1): 100, 2V, 4-cyl.

17 Gordini (3): 100, FI, 4-cyl.

SAAB (1)

99: 121, FI, 4-cyl.

SUBARU (2)

Subaru: 97, 2V, 4-cyl.

Subaru station wagon: 97, 2V, 4-cyl.

TOYOTA

Corolla (1): 97, 2V, 4-cyl.

Corolla station wagon (1): 97, 2V, 4-cyl.

Corona (1): 134, 2V, 4-cyl.

Corona station wagon (1): 134, 2V, 4-cyl.

Celica (1): 134, 2V, 4-cyl.

Hilux (1): 134, 2V, 4-cyl.

Land Cruiser (2): 258, 2V, 6-cyl.

VOLKSWAGEN

Beetle (1): 97, FI, 4-cyl.

Dasher (1): 97, FI, 4-cyl.

Dasher station wagon (1): 97, FI, 4-cyl.

Dasher (2): 90, FI, 4-cyl. diesel

Dasher station wagon (2): 90, FI, 4-cyl. diesel

Rabbit (1): 97, FI, 4-cyl.

Rabbit (2): 90, FI, 4-cyl. diesel

Scirocco (1): 97, FI, 4-cyl.

Bus (1): 120, FI, 4-cyl.

1978

AUDI (1)

Fox: 97, FI, 4-cyl.

Fox station wagon: 97, FI, 4-cyl.

5000: 131, FI, 5-cyl.

BMW (2)

320i: 121, FI, 4-cyl.

530i: 182, FI, 6-cyl.

630CSi: 182, FI, 6-cyl.

730i: 182, FI, 6-cyl.

CHEVROLET (2)

Pickup: 350, FI, 8-cyl. diesel

DATSUN (1)

B-210: 85, 2V, 4-cyl. (except high-fuel economy models with catalytic converter and 5-speed M/T)

200SX: 119, 2V, 4-cyl.

F-10: 85, 2V, 4-cyl.

F-10 station wagon: 85, 2V, 4-cyl.

510: 119, 2V, 4-cyl.

510 station wagon: 119, 2V, 4-cyl.

810: 146, FI, 6-cyl.

810 station wagon: 146, FI, 6-cyl.

280Z: 168, FI, 6-cyl.

Pickup: 119, 2V, 4-cyl.

FIAT (1)

128: 79, 2V, 4-cyl.

128 station wagon: 79, 2V, 4-cyl.

131 Mirafiori: 107, 2V, 4-cyl.

131 Estate Wagon: 107, 2V, 4-cyl.

Lancia Beta: 107, 2V, 4-cyl. (those with M/T)

X 1/9: 79, 2V, 4-cyl.

124 Sport: 107, 2V, 4-cyl.

GMC (2)

Pickup: 350, FI, 8-cyl. diesel

HONDA (2)

Civic: 76, 2V, 4-cyl.

Civic CVCC: 91, 3V, 4-cyl.

Civic CVCC station wagon: 91, 3V, 4-cyl.

Accord CVCC: 98, 3V, 4-cyl.

INTERNATIONAL HARVESTER (2)

Scout II/Terra/Traveler: 196, 1V, 4-cyl.; 198, FI, 6-cyl. diesel; 304, 2V, 8-cyl.; 345, 2V, 8-cyl.

MASERATI (1)

Merak: 181, 6V, 6-cyl.

MERCEDES-BENZ (2)

240D: 147, FI, 4-cyl. diesel

300D: 183, FI, 5-cyl. diesel

300CD: 183, FI, 5-cyl. diesel

300SD: 183, FI, 5-cyl. diesel

OLDSMOBILE (2)

Delta 88: 350, FI, 8-cyl. diesel

98: 350, FI, 8-cyl. diesel

Custom Cruiser Wagon: 350, FI, 8-cyl. diesel

PEUGEOT (2)

504D: 141, FI, 4-cyl. diesel

504D station wagon: 141, FI, 4-cyl. diesel

PORSCHE

911 (1): 183, FI, 6-cyl.

911 (2): 201, FI, 6-cyl.

924 (1): 121, FI, 4-cyl.

928 (1): 273, FI, 8-cyl.

RENAULT (1)

LeCar: 79, 2V, 4-cyl.

17 Gordini: 100, FI, 4-cyl.

SAAB (1)

99: 121, FI, 4-cyl. (except turbo)

SUBARU (2)

Subaru: 97, 2V, 4-cyl.

Subaru station wagon: 97, 2V, 4-cyl.

Brat: 97, 2V, 4-cyl.

VOLKSWAGEN

Beetle convertible (1): 97, FI, 4-cyl.

(Please turn to page 154)

Fuel Economy You Can Bank On*...

With an **ECONOMASTER** Carburetor by Holley®

If your car is like many on the road, a worn or poorly maintained carburetor may be gobbling up your gas dollars. If so, you can stop the dollar drain with a replacement carburetor specifically designed to improve fuel efficiency...an **ECONOMASTER** carburetor by Holley.

Holley has redesigned **ECONOMASTER** carburetors by adding new style booster venturii to some models, enlarged metering ports or a two stage power valve to others. Engineering improvements such as these can pay off in more MPG for millions of cars produced since 1960.

You'll find that installation has been made simpler, too, because **ECONOMASTER** carburetors use existing throttle, choke and emission control hookups. Complete, step-by-step instructions guide you along the way. Holley Replacement Parts Division, P.O. Box 749, Warren, Michigan 48090.



Holley **ECONOMASTER** carburetors are available at leading auto parts dealers. *Actual fuel economy may vary, due to application and driving conditions.



For our latest pamphlet and where-to-buy list write to: Dept. PM-12, P.O. Box 3683, Center Line, Michigan 48015. Allow 45 days for handling.

* Registered Trademark
C-476

Holley
Replacement Parts Division

Colt Industries



HOMEOWNERS' CLINIC

QUESTIONS ANSWERED

Wavy floor

Without thinking, we rented our 80-year-old, one-floor house to a feed dealer who stacked feed bags 4 ft. high on our pine floor. The joists sagged. Now we have wavy floors and can't rent the house. The old house doesn't have vents to allow airflow around the joists. I've thought of tearing out the floor and filling the area with concrete, but this would cost a small fortune. Please suggest a solution.—R.C. Friggeri, Wichita, Kans.

The fact that your house is 80 years old just shows that there were errant builders in "the good old days," too. I'd say first, by all means, vent the crawl space! You may have joists that are slowly rotting from excessive moisture. The seed weight was the last straw. There are two methods of correction. Both assume that your joists are sound.

One method is to jack the joists level (from your basement or crawl space) and temporarily support

them so you can slip in new joists next to the old ones. Spike-fasten them to the existing joists at 8-in. on-center nail intervals as shown in the drawing (below). As you're concerned only with deflection (sag), the new joists do not have to bear fully on the foundation walls.

The second method: After the joists are temporarily leveled and supported, add doubled-up 2x8s or 2x10s (girders) below joists at center of span as shown. Use pressure-treated lumber to prevent rot. Once the girder is solidly supported by steel support posts on concrete blocks, the temporary supports can be removed.

Aluminum wiring accessories

Since my house is wired with aluminum wiring, I decided to take your very sound advice (Homeowners' Clinic Service Tip, page 23, Mar. '79) and install CO/ALR receptacles and switches. I called nine electrical supply houses. None carried the items,

nor did they know where I could obtain them. Are they still available?—David E. Nead, Fairport, N.Y.

Inquiries reveal that CO/ALR items aren't fast sellers. Many electrical supplies stores do not stock them. Surprisingly, one maker I spoke to was extremely polite but reluctant to have it known that it had them available. Another was happy to say they made the approved devices. If your supplier doesn't stock them, write Marketing Communications Manager for Electrical Distribution, Leviton Manufacturing Inc., 59-25 Little Neck Pkwy., Little Neck, N.Y. 11362, for the nearest dealer who does.

Can you top this?

We've received many queries from readers who want to know if existing cracked basement concrete slabs can be topped using an epoxy to bond the separated surfaces together. The main consideration is the original cause of the cracks. They are usually the result of moisture penetration or settlement of the base on which the slab was poured. Therefore, no matter what the bonding agent, an added topping will also crack.

A check with the Portland Cement Assn. confirmed these thoughts. However, the association has known of cases where 1½-in. topping (with 6x6-in. No. 10 wire mesh) has lasted when poured over broken slabs subject to foot traffic only.

I recommend removing the old slab, tamping the base firm and repouring a 4-in. slab using the above mesh.

PM

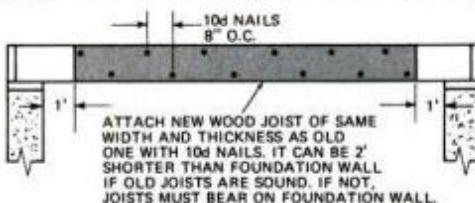
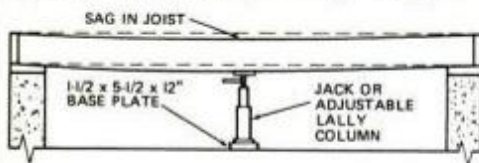

Sagging joist must be leveled and supported before you add new joist to reinforce it.

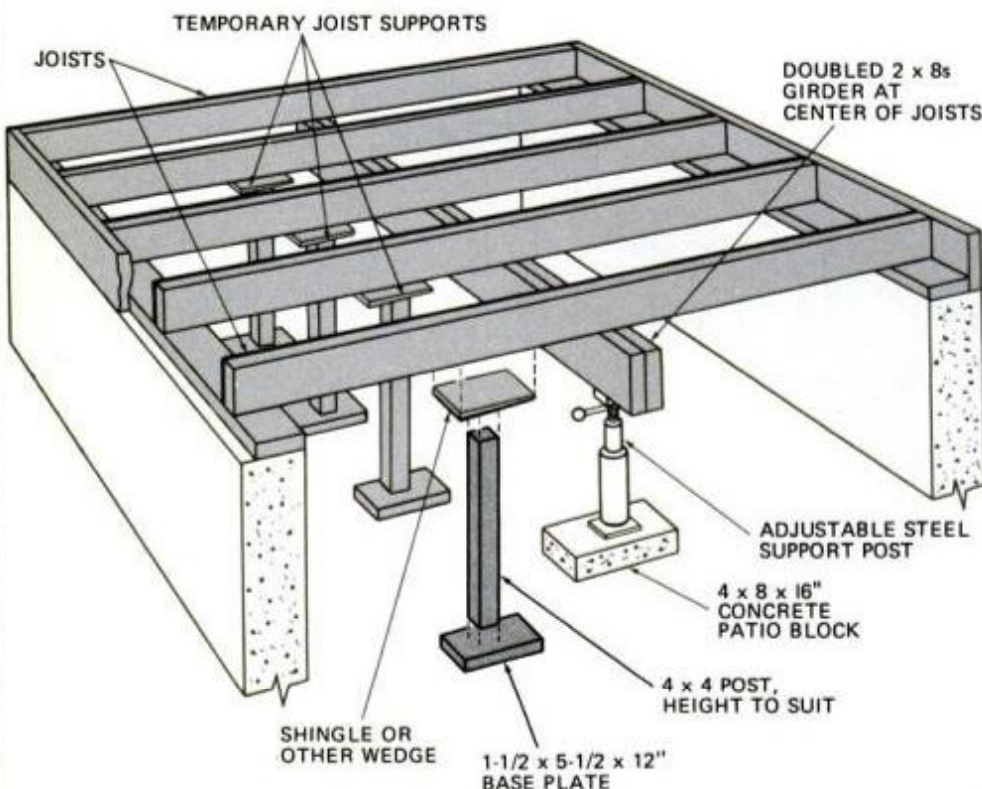

To correct sagging joists, temporarily level them and install a new beam (girder).

Do you have a home maintenance or repair problem? Send it to Homeowners' Clinic, Popular Mechanics, 224 West 57th St., New York, N.Y. 10019. Letters cannot be answered individually, but problems of wide interest will be discussed in this column. For more home repair and maintenance help, get PM's Home Care Guide, \$4.95 postpaid. Send order(s) to PM, Dept. HCG, Box 1014, New York, N.Y. 10019.

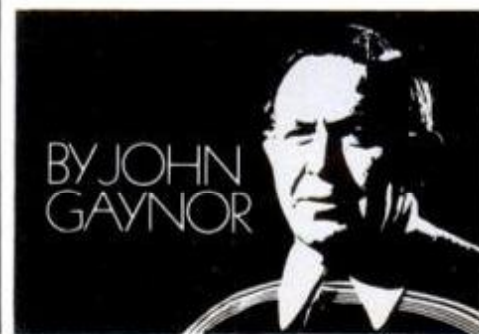

KOOL SUPER LIGHTS "100's"

Smooth & fresh
all the way.

A light menthol blend gives low "tar" smokers the smooth taste they want. Never harsh tasting. Make the smooth move to KOOL Super Lights.

KOOL SUPER LIGHTS
20 CLASS A CIGARETTES

KOOL

SUPER LIGHTS

100'S
LOW TAR · MENTHOL

At only 9 mg. 'tar,'
it's lower
than all these.

Smooth taste in
Kings and "100's,"
both at only 9 mg. 'tar.'



19 mg. 'tar'

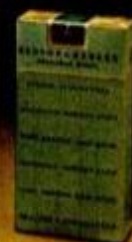

17 mg. 'tar'



10 mg. 'tar'



13 mg. 'tar'

9 mg. "tar", 0.8 mg. nicotine av. per cigarette by FTC method.

Warning: The Surgeon General Has Determined
That Cigarette Smoking Is Dangerous to Your Health.

**SEARS
SUPER VALUES**

CRAFTSMAN® 10-INCH TABLE SAW OUTFIT

Here are choice savings on Sears Cast Iron Top 10" Table Saw (#29815) that miters, bevels, rips, crosscuts and more. Outfit includes leg set, one extension and a permanently lubricated 100% ball bearing 1 HP motor that develops 2 HP. Plus, a manual reset overload-protector. And Sears exclusive Exact-I-Cut feature that lines up the cut ahead of the blade. Table Saw comes partially assembled. Save \$130.04, Now \$299.88.

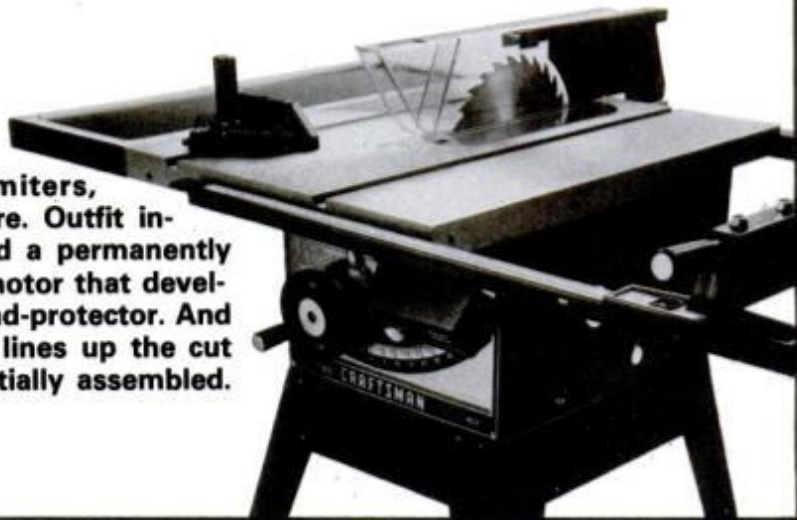

CHOICE SAVINGS \$115 to \$130 OFF



CRAFTSMAN® 10-INCH RADIAL SAW OUTFIT

Here's another choice value on America's best selling radial saw (#19775) that crosscuts, rips, miters, bevels and more. Has a powerful 1½ HP motor that develops 2½ HP. And a single lever miter arm control for one handed single step setups. Leg set included. Radial Saw comes partially assembled. Save \$115.06, Now \$299.88.

Sears

**WHERE AMERICA SHOPS
FOR VALUE**

© Sears, Roebuck and Co. 1979

ON SALE AUGUST 5-25

Available in most Sears Retail Stores.
Prices and dates may vary in Alaska and Hawaii.

**Full One Year Warranty on Both
Table Saw and Radial Saw**

If, within one year from date of purchase, either this Craftsman Table Saw or Craftsman Radial Saw fails due to a defect in material or workmanship, contact Sears and Sears will repair it free of charge.

EITHER SAW \$299⁸⁸

Super bowl for chain-saw champs

On September 21 and 22, the second annual Tournament of Kings chain-saw competition will take place at Carowinds Theme Park, located on the border of North and South Carolina. According to

Webb Maddux, president of Homelite, this year's contest "has been expanded to include champions from 13 major U.S. logging shows and five from Australia, Belgium, Canada, Finland and South America." The



Competitors can custom-file their saw's chain for the speed-cutting event only.



Steeplechase event has five stations. Each presents a different cutting problem.



Roy Booth Sr., a LaGrande, Ore., logger, won the \$1000 first prize in 1978.

contestants compete in six events—tree felling, steeplechase, boring, precision cutting, disc stacking, and speed cutting. For contest information, write Homelite Div. of Textron Inc., Charlotte, N.C. 28217.—H.W.

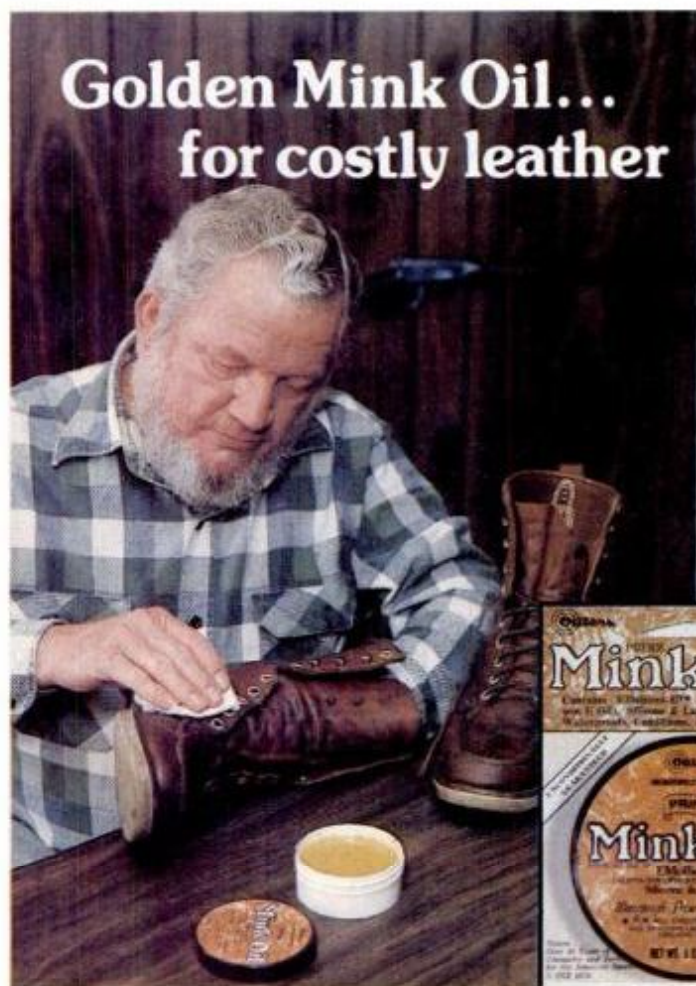

Golden Mink Oil... for costly leather

Leather is expensive, but now there's a way to protect your investment. When used regularly, Outers Golden Mink Oil with EMollient-E™ Silicone and Lanolin will prolong the life of fine leather and keep it newer looking indefinitely. The secret is EMollient-E™ (Vitamin E oil). Due to its unique properties, it not only softens leather fibers and keeps them pliable, it retards the aging process. It halts the loss (through oxidation) of vital oils and prevents premature stiffness and brittleness.

See your dealer or write:

Outers®
LABORATORIES, INC.
P. O. Box 39-P
Onalaska, WI 54650

Outers Golden Mink Oil Solid comes in 4 oz. tubs and 2 oz. push-ups. Complete kits also available. All Outers Leather Care products are unconditionally guaranteed; your money back if not satisfied.





National Unlimited Champion, Reno: Modified P-51 Mustang — Red Baron, Pilot — Steve Hinton, Owner — Ed Browning

The National Champion asks for Pennzoil.

When you want top-flight performance,
ask for Pennzoil quality.

There's a Pennzoil lubricant for almost every kind of engine.
So whatever you drive — and wherever you drive it — you can
depend on Pennzoil to give you the performance you demand.

Asking for that bright yellow can of Pennzoil has become
a time-honored tradition to millions of motorists.

And a lot of pilots, too.

Pennzoil has a history of quality you can count on.





Pathological skyjacking

Maybe some people just have it in for flying machines. Seven years ago Gary Trapnell tried to hijack a jet airliner and was sentenced to a life term in the Federal Penitentiary at Marion, Ill. Recently Trapnell tried to escape from prison by having a female accomplice—who was killed in the attempt—hijack a helicopter to fly him and two fellow inmates out. The judge was not impressed by Trapnell's avocational perseverance. He tacked on another life sentence plus 110 years.



Stretching it too far?

Good instructors and well designed equipment have made sport parachuting a lot safer than it looks. In the photo, a group known as the West Coast Pelicans is having some fun over Mojave, Calif.

But we're not sure that the introduction of "human air races"—known as tracking contests—such as were held at the recent Mojave National Air Races constitutes real progress or unnecessary thrill seeking.

By assuming the proper body position, like that of a ski-jumper but with toes extended and streamlined, a 'chutist in free fall can cover horizontal distances—as much as a foot over the ground for every two feet of altitude lost. The longest "track" wins the race.

We would hope contestants' chutes must be set to open automatically at a comfortable minimum altitude with a good safety margin in these formal competitions. Nobody wants to see a game of "chicken" with terra firma as the goal line.



TGV train on test run.



TGV interior during simulated commercial service test.

No way to run a railroad

Just at a point when the energy squeeze could bring intercity travel by rail back to its former vogue, lack of public acceptance and shaky finances seem to dictate substantial reductions in passenger rail service and even abandonment of thousands of miles of right-of-way. Lack of anything approaching consistent on-time performance and maintenance problems, meanwhile, continue to tarnish the image Amtrak was supposed to build up. A new low may have been reached recently when one Washington-to-New York Amtrak train simply separated in mid-run. One passenger returning from the dining car to his seat in one of the rear cars told PM he almost walked off the speeding train at the door where the cars had come apart.

The contrast between this sad state of affairs and what rail travel can be was demonstrated to PM recently on a rail tour in France. Over a period of several days, with some 20 hours spent on regular French trains, we witnessed *no* departures that were more than 30 seconds off the scheduled times, and only one arrival more than two or three minutes off schedule.

Passenger comfort, at speeds of 80 mph, was superb on the new Corail trains that now account for 25 percent of intercity traffic in France. Well-thought-out amenities, such as folding tables that recess after meal service and turn a "dining" car back into a coach, add to the comfort on crack trains.

The oil shortage will not spare the European trains. The French TGV (very high speed) trains soon due in service were originally expected to be powered by turbolocomotion (gas turbines driving alternators to produce current for electric traction motors). But fuel requirements were ultimately too high; the trains will now be all-electric (d.c. motors), with the problems of "collecting" current from power lines at high speeds—up to nearly 200 mph—having already been solved.

With an 18 percent gain in fuel efficiency over the turbotrain concept, the new French TGVs will still have the speed to keep intercity rail travel competitive with feeder airlines. The trains will use about one-fifth as much fuel per passenger mile as a transport aircraft, and about one half as much per passenger mile as a private car. Unfortunately, projections for the application and acceptance of similar energy-saving rail technology in the United States are nonexistent.

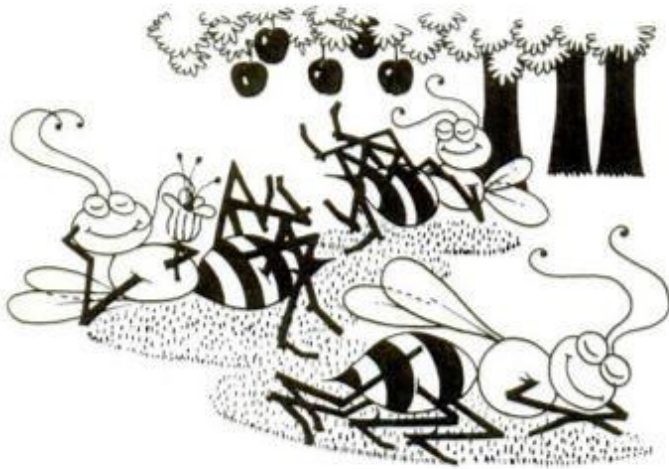

Lazy son of a bee

A Cornell University researcher, looking into why apple trees of the Delicious variety yield only an average of about 40 to 50 percent of their fruit potential, has come up with a shocking conclusion:

Some honeybees are lazy.

Entomology graduate student Willard Robinson has demonstrated how the structure of the Delicious apple blossom, differing from most other well known varieties, permits bees to enter from the side and tap its nectar without much of the "legwork" that normally pollinates the flower—and makes fruit possible—if the bee enters the blossom from above.

What's worse, experiments show that bees seem to acquire foraging techniques by experience, rather than through pure instinct. If they learn the side-entering technique and later approach a different blossom that doesn't yield to that easy method, most of them, Robinson notes, "get really disgusted and fly away."

Screeching halt

Shopping cart theft and vandalism can add heavily to the cost of operating a large retail operation—so heavily that a Winnetka, Calif., firm called ComputerCart Corp. can justify adding sophisticated electronics to an ordinary grocery cart.

Once installed, the equipment lets the cart operate normally unless someone tries to remove it from an area that has been electronically designated. When that happens, the device senses the cart is passing a boundary and . . . simply collapses the front wheels. From then on, until the wheels are reset by a specially coded key, the cart must be dragged wherever it goes. It almost sounds like a practical joke, but so long as it doesn't inspire frequent gag demonstrations on the part of customers, it can doubtless save some businesses some money.



I know we're best friends, but this is ridiculous

See Burke Ewing fly his hang-glider off the 300-foot cliffs at Torrey Pines, Calif. See Curtiss, Burke's 14-year-old mutt, make a terrible whining fuss when Burke soars off and leaves him. See Burke pondering the problem. See the solution.



Photos: John R. Hamilton.

How to fill your 2-car garage.



More and more people today are finding the best way to fill a 2-car garage is with a shiny new GMC pickup.

It can do everything from bringing home Rover's new house to hauling around garden supplies. Lots of loads you could never cram into a car.

You say you're a trailer hauler or a boat puller? A GMC pickup, properly equipped, can haul much more than most new cars these days.

But, of course, GMC has had over 75 years of experience with trucks that are downright muscular. GMC pickups, for instance, have lots of double-wall construction. You can even order a V-8 diesel. (GMCs are equipped with GM-built engines produced by various divisions. See your dealer for details.)

Yet for all its ruggedness, a GMC pickup is also smooth and comfy. There are even models with velour seating, and bucket seating with a center console is also available. And the luxury options include available AM-FM radio, Cruise Control, tilt steering wheel, power steering, power brakes and air conditioning.

So, see your dealer soon. And don't be surprised if your favorite car turns out to be your new 1979 GMC truck.



Trucks are what we're all about.

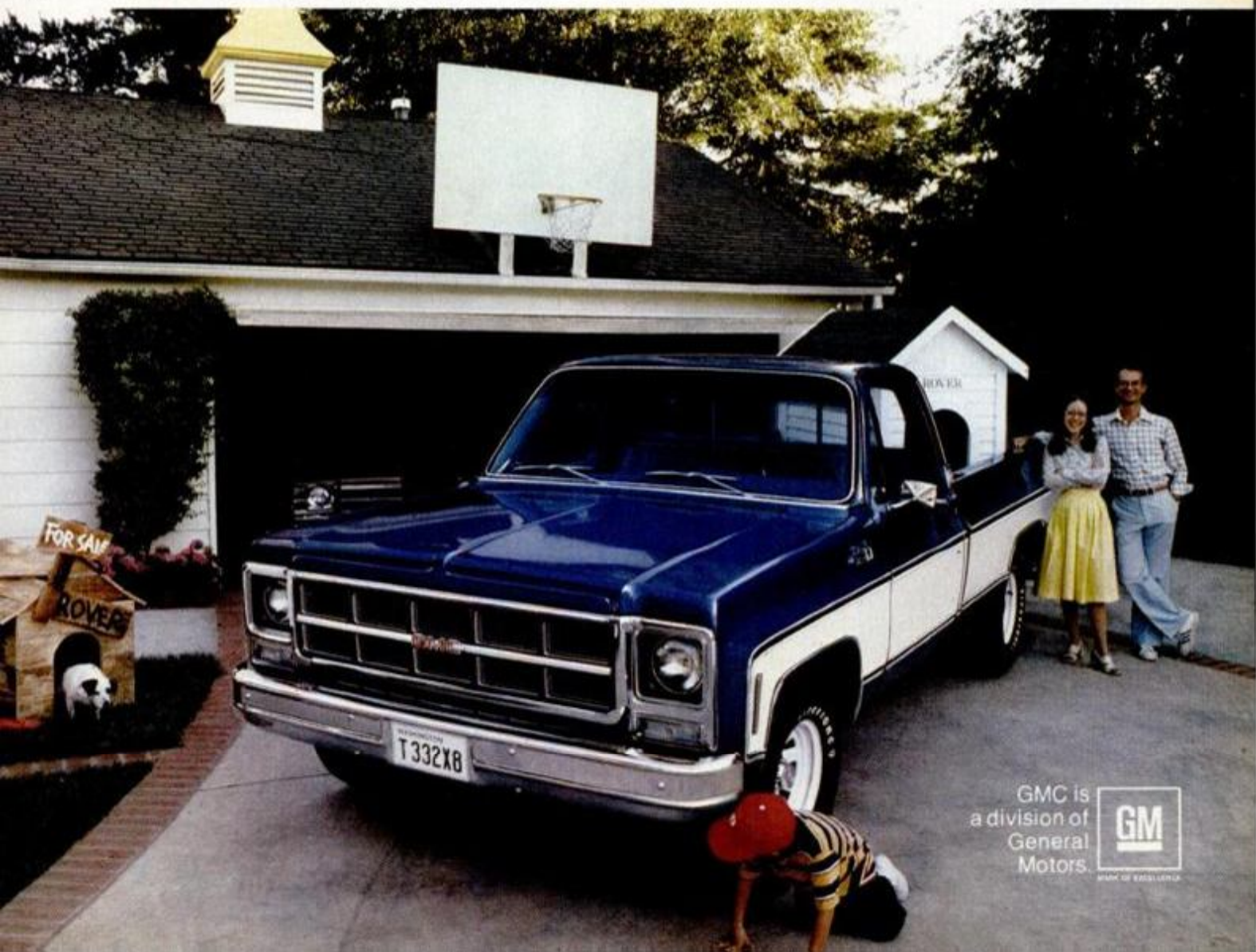

GMC is
a division of
General
Motors.



Come to
**Marlboro
Country.**

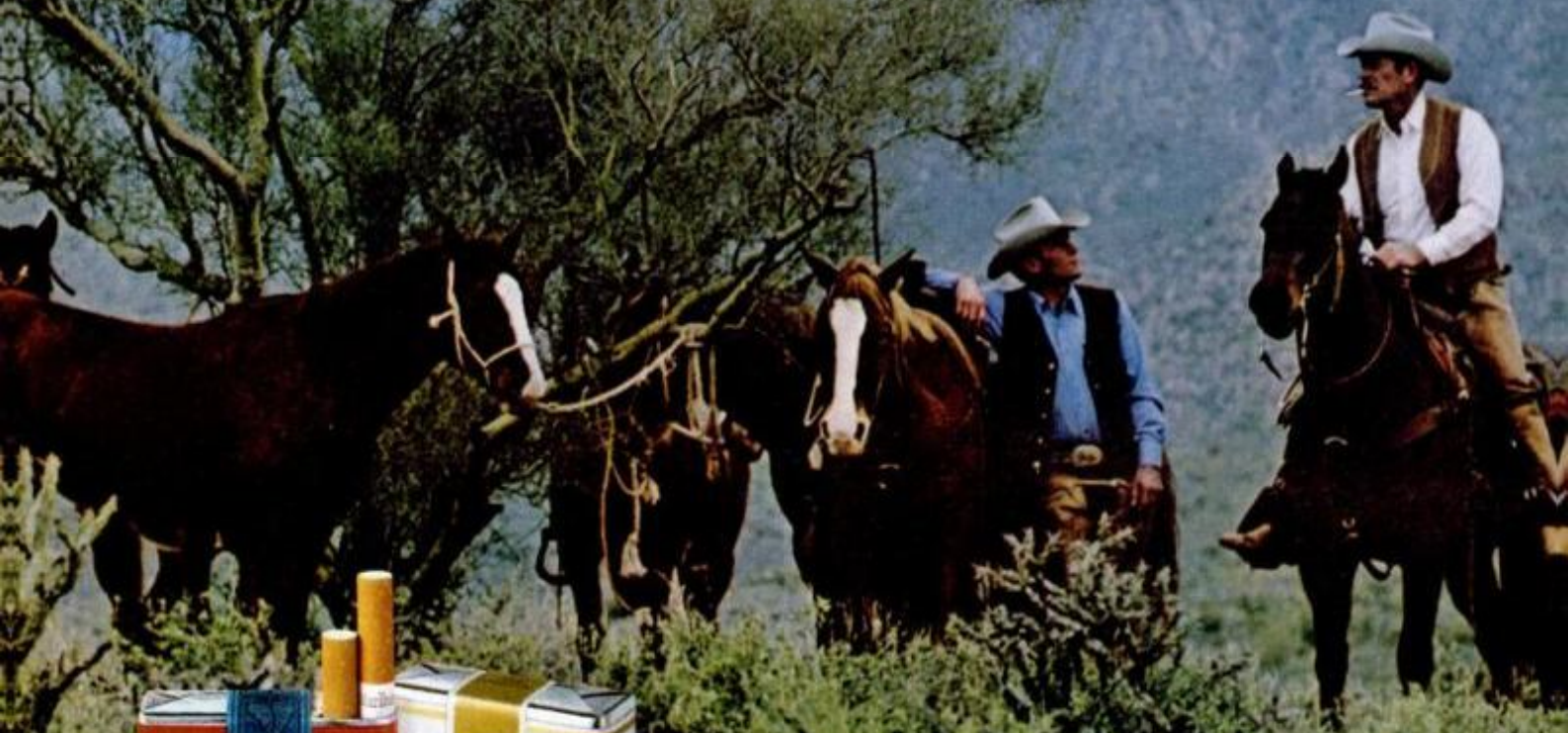

Famous Marlboro Red and Marlboro Lights—
either way you get a lot to like.

Lights: 12 mg "tar," 0.8 mg nicotine—Kings: 17 mg "tar,"
1.0 mg nicotine av. per cigarette, FTC Report May '78

Warning: The Surgeon General Has Determined
That Cigarette Smoking Is Dangerous to Your Health.

What we're learning from airplane flight recorders



Microphone in cockpit voice recorder is centered above pilots' heads. Pressing button for a few seconds erases magnetic tape.

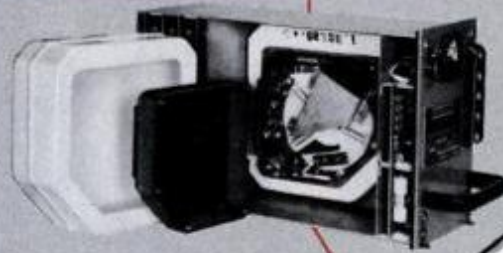

Cockpit voice tape is housed near the tail in container designed to protect it. Water in shield around tape would boil off in a fire, removing heat.

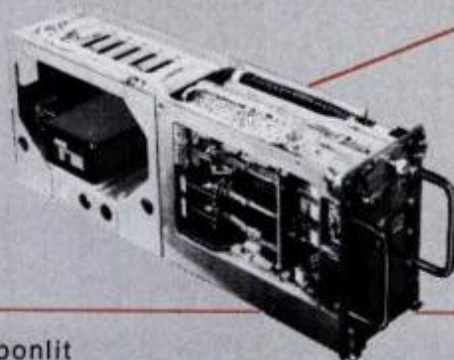

Styluses in foil recorder near tail scratch data about aircraft onto a fireproof metal strip. Second by second, the unit records altitude, speed, heading, vertical acceleration from remote sensors in plane.

Sometimes, only recorders survive to reveal what went wrong in the air.

by Gurney Williams III

with delicate tracings. It showed what the plane had done, as recorded by moving styluses. Hopper flattened the strip under a 35x microscope. Controlling the movements of the scope with a small joystick, he followed the tracings like a pilot flying over parallel railroad lines. Near the end of the strip, the lines—recording altitude,

speed, course and acceleration—became a twisted jumble as the plane went into its dive. Hopper's job was to make sense of the jumble.

In another office of the same laboratory, electronics engineer Paul Turner played the tape from the second recorder, the one that monitored cockpit sounds through a small microphone above the crew's heads. He was surprised by what he found. There were about nine minutes of conversation between crew members from Flight 841. But the recording had been made on the ground. All trace of talking and other sounds from the air had vanished from the tape. Pilot Gibson later told federal investigators that he didn't recall pushing the erase button.

In some ways, the mystery of Flight 841 is typical of cases handled by the small laboratory crew charged with analyzing flight recorder data. Hopper and Turner often

High over Michigan on a moonlit night, Trans World Airlines Flight 841 trembled, dropped its nose and began to spiral toward the ground. Passengers screamed and cried as speed approached Mach 1. Acceleration compressed them so forcefully in their seats that they had trouble breathing.

Pilot Harvey "Hoot" Gibson called on every reserve of skill collected in more than three decades of flying. He fought for control, but he had the clear impression that the airplane did a barrel roll at least once as it dropped some 30,000 feet in about 60 seconds. Finally, in desperation, he lowered the landing gear. The wheels provided enough drag to bring the plane under control at 9000 feet, seconds before it would have crashed with 87 persons aboard. He made a hard but safe landing in Detroit. No one died.

Within a few days of the incident last April, researchers at the National Transportation Safety Board, working in a windowless lab in Washington, began trying to relive the near disaster. They opened two sealed containers, each the size of a small suitcase, that had been taken from near the tail of the 727. From one, the flight data recorder, technician Billy Hopper withdrew a silvery metal strip etched

The final minute of a 747



Lightning strikes near cockpit, explodes left wing fuel tank.



Explosion blows off 16 feet of wing. Plane yaws to right.

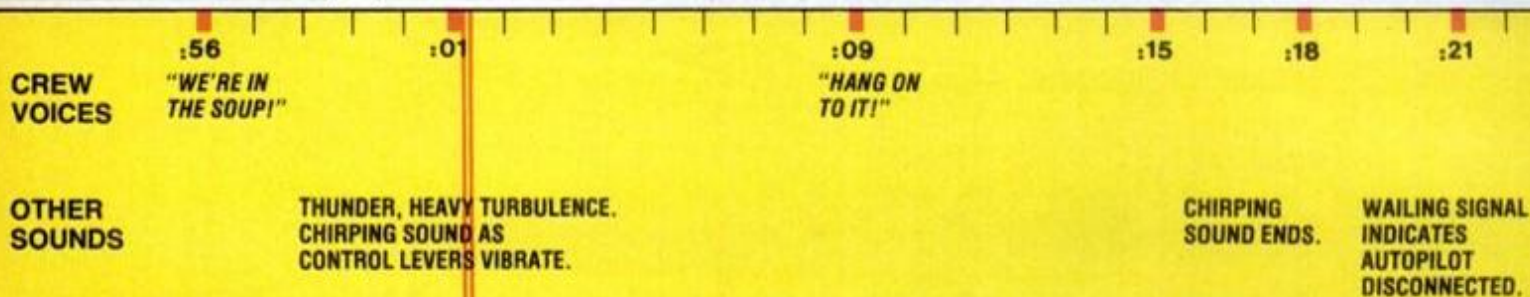

A cockpit voice recorder tape from Imperial Iranian Air Force Flight 228 helped investigators to reconstruct the last seconds of a 747 on May 9, 1976. Oscilloscope screen (right), displaying a picture of signals from cockpit tape, shows critical split second.

Top line, a graph of 400-cycle electrical interference caused by plane's generators, dips and jumps as lightning passes through plane's wiring system. Six thousandths of a second later, noise of strike—graphed by lower line—reaches cockpit mike. From time lag, investigator concluded that bolt hit about 6 feet from cockpit.

U.S. report later said that lightning was "plausible source of ignition" for fuel tank in left wing, setting off sequence illustrated above time line. Plane disintegrated over Spanish farmland. All 17 persons aboard the 747 were killed.

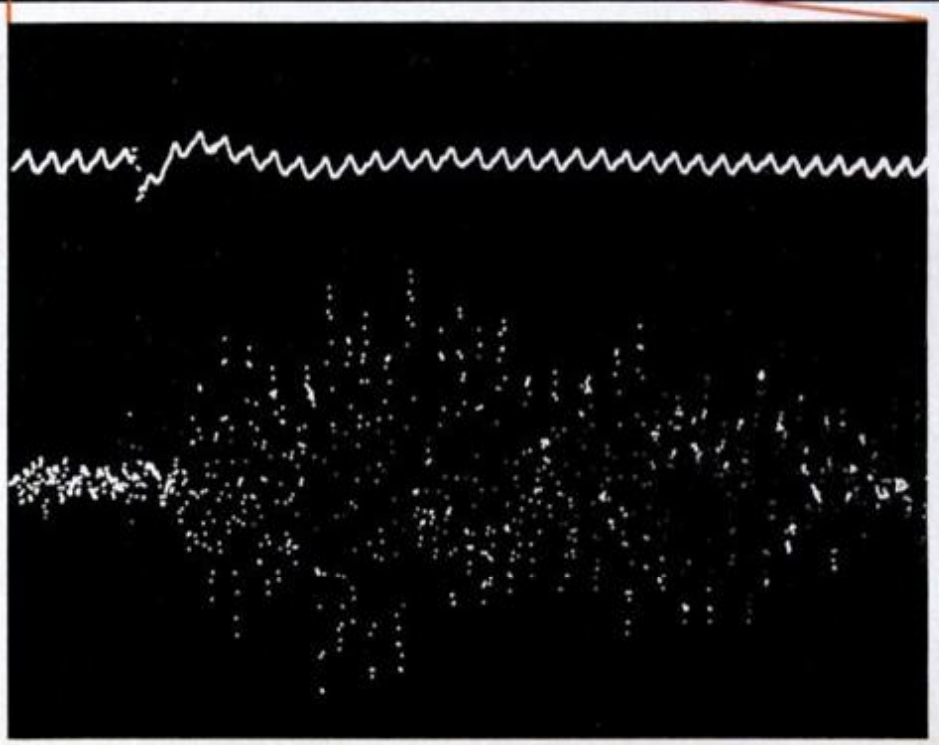



Flames weaken tail structure. Control problem worsens.

Almost a minute after strike, second explosion separates wing.

:31

"LOOK AT THE FLIGHT CONTROL."

:35

"IT IS NOT WORKING!"

"THE FLIGHT CONTROL IS NOT WORKING!"

:38

"WHAT THE _____'S GOING ON WITH THE CONTROLS!"

:42 :43

"LOOK AT THE CONTROL COLUMN!"

CONTINUOUS TONE WARNS SPEED IS BELOW 250 KNOTS.

:53

EXPLOSIVE SOUND. CREW MEMBER SWEARS. WOMAN'S SCREAM FROM CABIN. RECORDING ENDS.

:56

have to read between the lines. Like archeologists sifting ruins, they have to pull hypotheses from mere shreds of evidence, sometimes from instruments so battered and scorched they look like ancient artifacts.

The work is often slow. A month after 841's dive, for instance, a TWA official told the researchers that the voice recorder might have been wiped clean by some stray electrical pulse as the plane was switched from internal to external power on the ground. A spokesman for the airline told *PM* that engineers of the company's overhaul team in Kansas City had suggested the possibility of "some weird or spurious signal that would start the erasure mode." The suggestion would set off a new set of tests that would add weeks to the investigation. Federal officials were still trying to solve the mystery as we went to press.

But the painstaking lab work using recorders has frequently paid off in disclosing what happened in the final seconds of a flight headed for disaster. And recorder work often reveals why accidents happened, and suggests what could be done to prevent them.

Listening for stray noises

A cockpit voice recorder, for example, helped Paul Turner to suggest what might have gone wrong in one case involving a 747 owned by the Iranian Air Force. In his

analysis, Turner listened to much more than the voices of the crew as the plane approached Madrid, Spain, in 1976. Some of the most significant data came from Turner's study of odd sounds in the cockpit during the flight's final minute.

Imperial Iranian Air Force Flight 228 had been delayed for two hours in Iran while mechanics fixed a leaking fuel heater. But once over Spain, carrying 10 crew members, seven passengers and 100,000 pounds of fuel, the plane was running about 10 minutes ahead of schedule. The crew of Americans and Iranians sounded relaxed.

At one point as the plane soared over Spanish soil, the Madrid tower asked them to try to contact a French airliner. An Iranian crew member made the radio call in English. "Do you read?" he asked.

"Negative," answered the Frenchman, unwilling to respond to any language but his own. The Iranian laughed and tried again in English. "Negative!" said the French pilot, and now the 747 cockpit filled with laughter at the chauvinism.

The final minutes of the cockpit voice recorder tape of Flight 228 begin with a humdrum exchange of radio transmissions as the pilot requests a course change to avoid a cloud. The tower has cleared the plane to drop to 5000 feet. There is no apparent tension in the crew's voices as



An F.A.A. official examines the housing of the landing gear of a TWA 727 jet damaged last April as it spiraled out of control over Michigan. Plane landed safely.

the plane begins its descent. But on the ground, residents along the flightpath of the 747 are awed by the severity of the thunder and lightning passing south of Valdemoro. They will long remember May 9, 1976, as "the day of the storm."

'We're in the soup!'

Up in the plane, the first warning that something might be wrong is a crew member's voice. He swears and says, "We're in the soup!" The plane has apparently entered a cloud.

Five seconds later, the crew hears a crack like a nearby rifle shot. And suddenly the cockpit tape is filled with rumbling and, above it, a high-pitched chirping as control levers quiver in their slots. For seven seconds the speech of the crew is unintelligible against a turbulent background of distant cracking and breaking.

"Hang onto it!" the pilot yells, eight seconds after the first report.

Then, "Watch your autopilot!" Inexplicably, the chirping ends. Wailer signals, like a police car siren, warn that the autopilot has been disconnected.

The wailing stops and then, eerily, the cockpit sound is almost normal. The crew is silent.

Not for long. Now one of the Iranians shouts "Look at the flight control. . . . It is not working! The flight control is not working!" Within seven more seconds, a steady pervasive tone signals the crew that the airspeed has dropped below 250 knots without proper preparation for landing.

"Look at the control column!" someone yells. Forty-two seconds have passed since the initial rumbling.

Nine seconds later, the cockpit fills

(Please turn to page 142)



Cockpit voice recorder expert Paul Turner at work: Audio gear helps him dissect clicks, hums, rattles, engine roar for clues.



A technician runs the computer center where digital flight data recorders yield dozens of details about planes in flight.

How a recorder exposed a hidden killer

Wind shear is analogous to murder by icicle: The evidence disappears. Perhaps many times, accident investigators have blamed "failure to maintain flying speed" for crashes actually caused by wind shear.

But within a few years, new digital flight data recorders—collecting data on up to 100 details about a flight, second by second—have identified the potential killer and helped pilots learn evasive action.

Wind shear has probably claimed hundreds of lives. In the most widely publicized case, an Eastern 727 crashed into the approach lights at Kennedy International Airport, New York, in June of 1975. The plane was destroyed, and 113 of 124 passengers died. The cause: "the aircraft's encounter with adverse winds associated with a

very strong thunderstorm," according to the National Transportation Safety Board. The plane went down because of a sudden change in the direction or speed of the wind flowing over its aerodynamic surfaces—wind shear.

A headwind, for example, suddenly becomes a tailwind. Indicated air speed falls off. Lift declines. Unless the pilot increases thrust immediately, the aircraft will drop.

One wind shear case in December, 1973, was fortuitous in two respects. First, no one aboard the Iberia Air Lines DC-10 died after the plane struck an approach light and broke in two as it hit the runway at Boston's Logan Airport. Secondly, a digital flight recorder—a silent sentry near the tail—picked up enough data to reconstruct the plane's final minute with more precision than a camera would have provided. From thousands of electronic digital pulses on a silvery tape, computer expert Dr. Carol A. Roberts extracted information on control settings, fuel flow, landing gear lever position, altitude, autopilot mode—and more than 90 other systems on the jumbo jet. The effect of the shear appears nine seconds after the autopilot is disconnected. Then, suddenly, the rate of descent jumps to 1060 feet per minute. Three seconds later, the landing gear smashes on the runway.

Investigators compared the detailed picture of the disastrous approach with normal DC-10 landings. Computer information from the recorder helped them sort out precisely the shear's effects on the flight. They could then program a flight simulator to behave like the Iberia plane.

The Eastern 727 focused attention on the wind shear problem, but the flight recorder on the DC-10 enabled airlines to do something about it. Today pilots are routinely taught how to handle shears. And they practice flying through them on simulators containing the electronic model built with the help of a digital flight recorder.

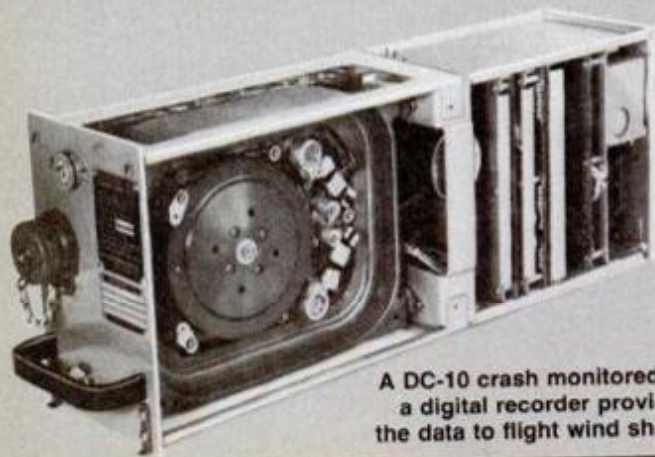

A DC-10 crash monitored by a digital recorder provided the data to flight wind shear.

From the worst U.S. crash, an incomplete record

The worst air disaster in the United States occurred on May 25, this year, when an American Airlines DC-10, which had one of its three engines rip entirely free of its wing mount and fall to the runway on takeoff, crashed less than a minute after leaving the ground at Chicago's O'Hare Airport.

Among passengers and crew aboard the DC-10, all 272 were killed on impact, as were two residents of the mobile home community which narrowly missed being obliterated by the plummeting airliner.

Arriving on the scene within a few hours, the National Transportation Safety Board's "go team" had to accomplish its priority goal—recovery of the aircraft's flight data recorder—amid a spectacle of smoldering ruin that was even more numbingly grim than in most crashes, because of the nearly inverted attitude in which the huge plane had apparently struck the ground. There were immediate doubts, as there always are in the bad ones, that the \$30,000 digital recorder could have survived intact. There were very few pieces of wreckage even large enough to be immediately recognizable as aircraft parts. And the recorder's mounting position in the tail assembly, normally an intact area even after the worst nose-in or belly-down crashes, looked like a liability in this one.

Yet within three days after the tragedy, the NTSB was able to make public certain tentative conclusions about the incident, based in part on data recovered from the flight recorder.

The crash occurred on the Friday of a holiday weekend. By Saturday afternoon, the flight data recorder, with a hole slashed in its cover, had arrived in Dr. Carol Roberts' computer lab at the National Transportation Safety Board. She had to have the recorder cut open. The view inside didn't raise optimism that the device would conclusively show what had happened: Lab workers found that the silvery metal tape in the Sunstrand recorder had broken into four or five pieces. And it was torn in several other places. But by Saturday night, Roberts and others had spliced the tape, plugged it into the computer and extracted a printout of preliminary data.

The Sunstrand spewed information on some 25 different flight parameters, includ-

ing pitch, roll, thrust from the three engines and control surface positions. Roberts used these data to piece together this preliminary account of the takeoff and brief flight.

The takeoff roll began normally, and speed built up to the point of "rotation," enough for the pilot to pull back on the yoke and raise the nose. The disaster began then:

"Thrust from the engines is sampled every four seconds," Roberts told *PM*. "The last indication of thrust from the No. 1 engine comes during the rotation. Four seconds later, there's no thrust." It appears, she said, that the engine on the left wing broke loose during the first few seconds of flight, carrying the flight recorder's sensor with it. The plane continued to climb to 300 feet, wings level.

Then, Roberts said, indications on the tape showed that the leading edge slat (flap) on the DC-10's left wing was retracted. This condition, known to pilots as "split flaps," would have set up a lift differential that could easily account for the violent left bank and subsequent out-of-control situation. "The loss of signal—indicating a retracted slat—might have been the result of an electrical problem which begins to affect recorder data at that point," Roberts told *PM*. Investigators did find the aircraft's left leading edge slat in a retracted condition amid the wreckage.

The plane continued to rise, but the recorder indicates that it also began to roll to the left, to a maximum of 118°—28° beyond the vertical. The data revealed that the pilot tried to control the roll by raising the aileron on the right wing. "There were control inputs, certainly," she said. "And the controls were responding, but I think the situation was beyond control at that point."

The plane reached about 600 feet of altitude, the recorder shows, before nosing down. The printout shows a slight recovery from the roll—it decreased to 112°—before the recorder stopped working, approximately 40 to 45 seconds after rotation, while the plane was still in the air.

Why did the recording stop? That's one of many questions investigators faced as we went to press. There was an apparent failure of the aircraft's main bus, affecting the entire electrical system. Why aren't flight recorders independently powered by



Dr. Carol Roberts (from left), NTSB chairman Jim King, audio lab chief Paul Turner examine flight recorder tape from DC-10 that crashed in May killing 274.

battery? *PM* was told that the NTSB had considered making a recommendation to that effect, but the idea has never been followed through officially.

Under further analysis, the digital recorder may help to answer some of the questions. (First indications were that the cockpit voice recorder—the other recorder on the plane—wouldn't offer much information. The cockpit mike picked up only a thumping sound, followed by a crew member's "Damn!" Then all voice recording ended, 30 seconds before the data recorder was cut off.)

While analysis continued, all DC-10s were grounded by the FAA, for inspection of the pylons attaching the engine to the wings. Federal Aviation Administrator Langhorne Bond said, in announcing the grounding, that inspectors had found "grave and potential deficiencies" in the structure on which the engines hang. Bond also ordered a review of pylon attachments in all wide-bodied jets, including the 747, L-1011 and A300 Airbus.

The administrator said he could not explain why the problem in mounting assemblies had not been discovered earlier, before the loss of scores of human lives.

"Somewhere along the way, we didn't do it right," he said.—G.W.

Housed near tail section, the flight recorder survived airframe-shredding impact.



Plane's 9000-lb. left engine, which separated on takeoff, is recovered from field.

Pintos have had their ups and downs these past few years, the worst downer coming in 1978 during the great gas-tank controversy.

Ironically, gas-tank problems involved 1971-76 Pintos, not '78 models. Ford had revised the subcompact's tank and fuel system in 1977.

Even so, 1978 was the year the Pinto went to court. People weren't buying. Pinto sales fell to 1.2 percent of the U.S. market that season, down from 1.8 percent in the car's heyday.

But then three things came along to turn the Pinto around for 1979: 1) dealers



Owners like instrument layout and controls, but wish ashtray was in dash center.

pursued a vigorous campaign to make the 1971-76 models safer; 2) the shrinking dollar caused imported cars to become relatively more expensive, and 3)

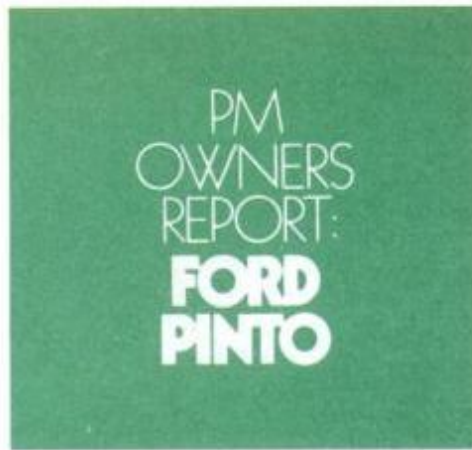

the 1979 Pinto received an extensive facelift—one that makes the front of the new car look totally unlike its former self.

So by early 1979, Pinto sales again headed upward and began breaking previous records. The marque's market penetration reached 2.2 percent last February, and Pintos have been selling briskly ever since.

The 1979 Pinto owners we surveyed agreed that it's a very nice car, BUT . . . And it's a big BUT in this case.

Dealer service came in for a thorough drubbing, with 23.7 percent of our respondents rating it poor. Not that Pinto owners needed all that much service—only 44.7 percent reported any sort of mechanical problem, and that's fairly low. But over

half of those who did need sick calls expressed dissatisfaction with Ford's physicians.

An Alabama mechanic reports, "The dealer kept the car two days to correct dieseling and a rain leak, but when I got it back it died and leaked just the same."

A Kentucky military employee: "The service department's main concern is moving out so many cars a day. If a problem hasn't reached the critical stage, they try to repair it by ignoring it. Example: My Pinto was chewing up starter gear teeth. The mechanic kept insisting he could find no problem. So, after three trips to the dealer, I let it get so bad that the simplest fool mechanic could recognize it."

Now there might be an interesting connection between Pinto service and Pinto



Pinto shows first major restyle since 1971, and owners report that they like it.

BY MICHAEL LAMM WEST COAST EDITOR

Pinto owners wish that dealer service was half as good as their cars

Pinto shares Fairmont's rectangular headlights and parking lamps.

Owners appreciate rack-and-pinion steering and the nimble handling.

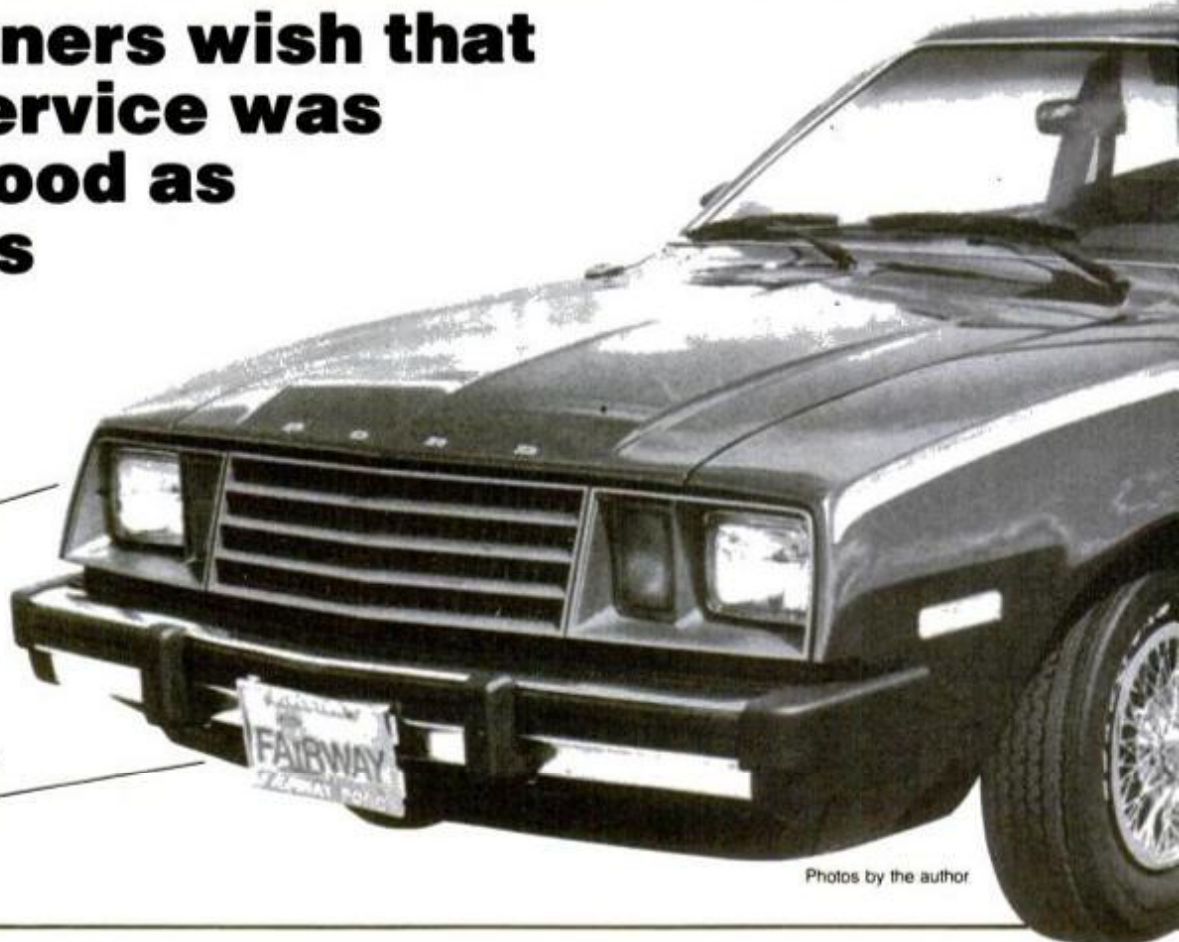

Photos by the author

sales. This is speculation, but it's worth noting.

Our survey shows that the main reason people purchased Pintos was for economy, with low initial price being a big sales factor.

Ford has a lot riding on the Pinto to help the company meet the government's CAFE (Corporate Average Fuel Economy) requirements. Ford wants very much to sell a lot of Pintos and has made it attractive for dealers to discount them to customers. Many dealers are more willing than usual to give generous trade-ins and to be flexible on sticker prices.

But, having "given away" those discounts on sales, dealers seem reluctant to "give away" additional amounts on service, especially warranty service.

And that's quite possibly one reason owners notice stalling and other aggravations by some dealers' back-shop departments.

It's interesting to contrast owner comments on the way they were treated by sales, versus service personnel. A Wisconsin foreman states, "The salesman who sold me my Pinto wagon was terrific. He really knew his stuff. But the service boys are another thing. I really had to argue to make them admit what was right and what was wrong."

An Alabama service-station attendant: "The dealer was hot to sell me the car. He even brought it over to where I work. But

my complaints about transmission leaks were to no avail, and after taking the car in six times, I've still got the same problem."

In fairness, too, *not all* Ford dealers took gas from our respondents on the service question. A Colorado supervisor wrote, "Excellent, prompt service by nice people," and he wasn't alone in that observation.

(Please turn to page 160)



Rear "buckets" limit seating space, but owners knew this when they bought car.

A decade of Pintos

The first Pinto arrived in 1971, with a base price of \$1919. Today, a comparable Pinto lists for \$3664—still one of the lowest tags around.

Henry Ford II promised not to change the Pinto basically for at least five years—a promise he's more than kept. Pintos received minor facelifts in 1974 and '76, then a major one in '79. Improvements beneath the skin included fender liners to help fight rust, and plastic shields between the fuel tank and rear axle to guard against explosions caused by rear-end collisions.

From 1971 through '73, only the 1600-cc and 2000-cc Fours were available in Pintos. Then in '74, the 2300 Four and 2.8-liter V6 were added—an engine lineup that's unchanged today. Pinto spinoffs include Mustang II of 1974-78 and Mercury Bobcat of 1975.

The 1979 Pinto comes as a two-door sedan, wagon, and three-door Runabout hatchback. The Runabout can be ordered with or without metal framing around the large rear glass.

In May, 1979, Ford introduced a Rallye version of the Runabout and wagon, with special suspension, styled steel wheels, bold paint and decals, front and rear spoilers, and more complete instrumentation. The Rallye wagon has porthole side windows, black luggage rack, and a carpeted cargo deck.

Industry sources speculate that by 1981, both the Pinto and the Fiesta will be replaced by a European-built fwd model (code-named Erica) that Ford is currently developing. For a look at the car, see the photo in *Detroit Listening Post* on page 25.

A NATIONWIDE SURVEY BASED ON 658,355 OWNER-DRIVEN MILES

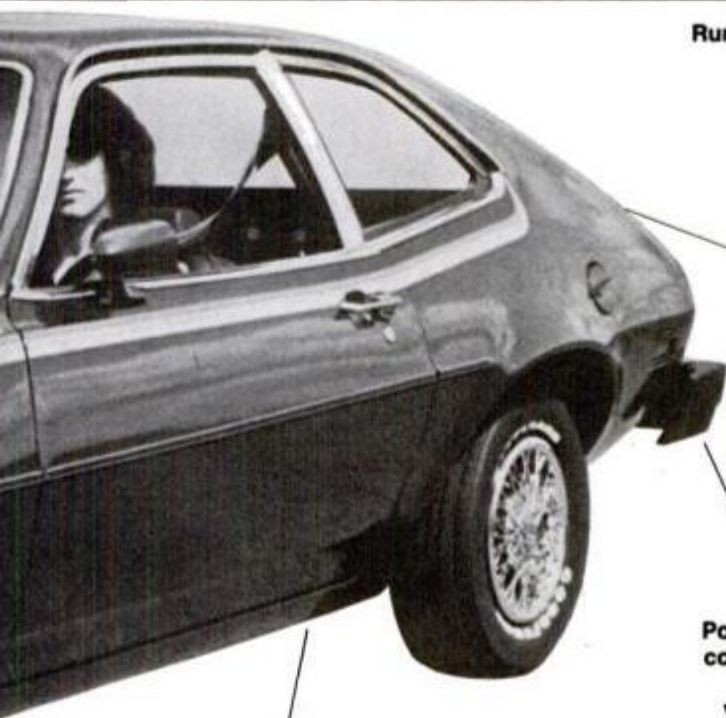

Wagon's wheelbase, is 0.3 inch longer than sedan's 94.5.

Runabout hatchback can be ordered without metal frame around window. Hidden storage area would be welcome.



A few owners reported leaks at the top of the hatch.

Post-1976 Pintos corrected earlier fuel-tank vulnerability.



High-speed copter sports twin rotors

The Sikorsky Advancing Blade Concept (ABC) research helicopter is said to combine low-speed and vertical flight characteristics of the helicopter with the high-

speed efficiency of fixed-wing craft. Powered by its counter-rotating blades and outboard-mounted turbojets, it recently flew 235 mph. The unique blade configura-

tion eliminates the need for a tail rotor and can be made to act like a fixed wing at certain airspeeds. Top speed of the ABC should eventually reach about 345 mph.



Windbreaker for bullets



Since our mention in January of Smith & Wesson Nyclad nylon-jacketed bullets (*All Outdoors*, page 13), study data have shown that people who frequent indoor firing ranges often have elevated blood levels of lead. The problem can be greatly reduced by using no-lead primers in cartridges, and nylon or copper cladding on slugs. In the top photo, lead from an unclad slug pours forth. Below, a Nyclad bullet spews up to 89 per cent less.

A more balanced view

It's difficult enough to hold a pair of binoculars steady when you're standing on solid ground; flying in a helicopter or plane, it's even harder. The Steadyscope, made by British Aerospace, is a gyroscopically controlled monocular that permits relatively steady viewing from moving or vibrating vehicles. Primarily military in application, it weighs about 4½ pounds and is powered by one D cell. It provides 7X magnification and can pan without jittering at up to 6° per second.

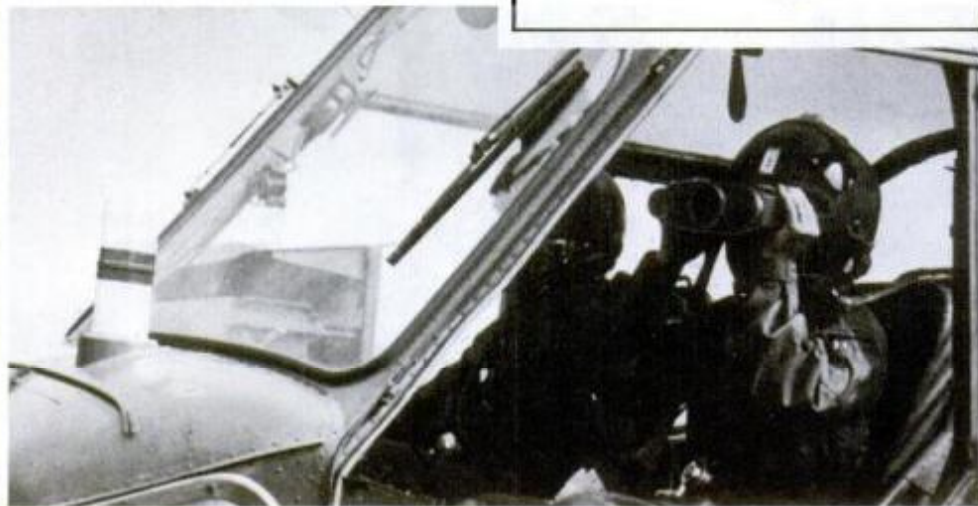

Cargo ship carries its own loading ramp



The cargo ship above isn't the victim of a stern-mangling collision, but is one of a new breed of so-called SuperCarriers. The ship, one of six built by the Oslo-

based Barber Blue Sea shipping consortium, can carry 32,000 tons of cargo. Its most unusual feature is a 40-foot-wide unloading ramp, designed to speed cargo

turnaround. The ramp (right photo) permits two-lane traffic at a maximum rate of 800 tons per hour. To further speed unloading, the ship has its own forklifts.

Portable kidney machine

Kidney dialysis patients usually can't travel because their machines are too big to carry and it is difficult to set up dialysis appointments away from home. This German man is undergoing dialysis in his New York hotel room, however, thanks to the portable unit in front of him. It weighs 33 pounds and fits in a suitcase. The unit should be out in 1980 for about \$8000.

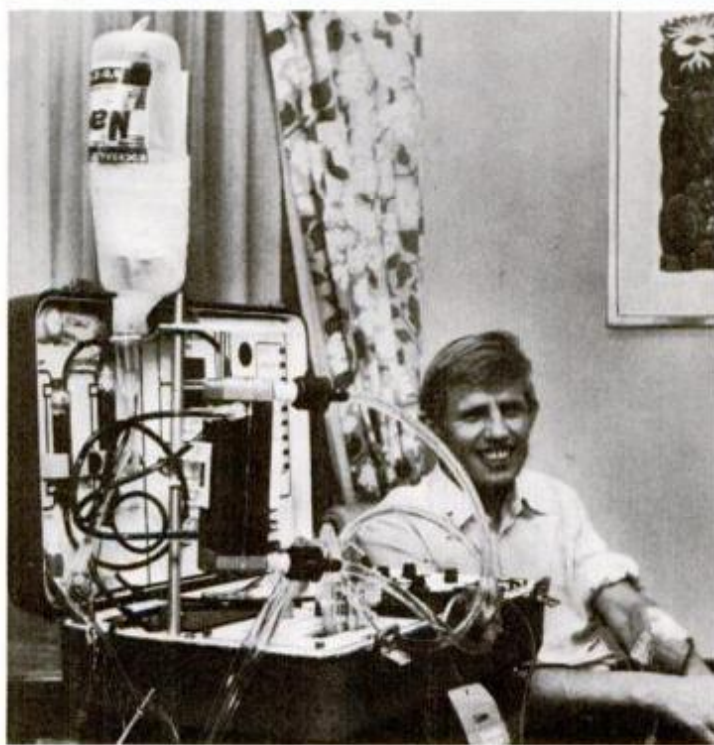

All wet

Thirteen-year-old boys don't usually play with dolls, but in this case it helped Jeff Bowles of Columbus, Ohio, win a superior rating in the Central Ohio Science Fair. Jeff designed a resistance detector and coupled it to a garage-door opener to make a moisture alarm. He originally wanted to demonstrate the device by having it turn on a motor, like a sump-pump switch, but his mother suggested that the wet diaper application might attract more attention. Jeff says he's been interested in electronics since he was 6; the project took him two days to complete. He might have gone to the State Science Fair, but they don't allow seventh graders.



In case of flood, lower bridge



The Dutch have constructed a network of outer and inner dikes to protect them from disastrous floods. If the outer dikes should fail, the inner dikes are supposed to offer a backup. Where inner dikes intersect with major roads (left), overpass lowers to road level to check waters.

Now it's easier than ever before to get in on the fun and excitement of personal computing. These four machines require no assembly or electronic skills. Take a *byte* of home computing!



1. MOUNTAIN HARDWARE ON-BOARD CLOCK
2. HEURISTIC SPEECHLAB

3. MOUNTAIN HARDWARE A.C. CONTROLLER
4. 6502 CENTRAL PROCESSOR UNIT (CPU)
5. INPUT/OUTPUT SLOT
6. CASSETTE INPUT/OUTPUT
7. RF MODULATOR

15. POWER SUPPLY

8. ACCESSORY ROM MEMORY

14. BASIC IN ROM MEMORY

13. RAM MEMORY

APPLE II

11. CONTROL KEY

12. ESCAPE KEY

16. PROGRAM ON CASSETTE

PM photos: Frank Lusk

1 This plug-in clock from Mountain Hardware gives the Apple a continuous time reference. **2** Heuristics offers the Speechlab add-on that lets you talk to the computer via a microphone. **3** Also from Mountain Hardware, this AC Controller allows the Apple to

run all your household appliances. **4** The CPU is the brain of the computer—everything else supports it. **5** These input/output slots let you plug in various accessories from different manufacturers. **6** The cassette recorder plugs in here to allow you to save and

load programs. **7** An RF modulator lets you attach the Apple directly to your home TV. **8** Permanent programs in special ROM (Read-Only Memory) chips can be plugged in here. We show the Superchip explained in the text. **9** The reset key instantly stops all computer operations. **10** The return key is most important. Whenever the computer asks a question, any typed-in answer must be followed by hitting this key. **11** The control key gives many other keys special, secondary meanings. **12** The escape key lets you use one or two other keys in combination to tell the com-

puter to accomplish special routines. **13** RAM (Random-Access Memory) is that which contains user programs; it changes what is stored when a new program is read in via tape or other means. **14** The ROM memory that comes with the computer contains the basic language and other, permanent programs. **15** Power supply must be strong enough to cope with any future add-ons or peripherals. **16** A computer program is stored on audio cassette tape. It can be a prerecorded program, like the one shown, or it can be one that you have recorded yourself.



RADIO SHACK TRS-80

The Apple II, the Commodore PET, Exidy's Sorcerer and Radio Shack's TRS-80 all promise to open the hobby of personal computing to more people than ever before—and to bring small computers into more and more small businesses. All of these computers offer special features to choose between, but they have many things in common as well. It's not that hard to understand a little about how they work, and such an understanding is needed to do comparison shopping. Computers are as varied as cars!

HOME COMPUTERS THAT PLUG IN AND GO!

by Neil Shapiro ELECTRONICS EDITOR

If you're considering getting into the personal computing hobby, then you're likely on the lookout for a dream machine that is easy to use, won't cost an arm and a leg, will not be quickly outmoded and is supported by reputable manufacturers in this still-infant field.

Here are four machines that are ready to use just as they come out of the box, and all are exceedingly good values. They are the TRS-80 from Radio Shack, Apple Computer's Apple II, Commodore's PET 2001 and the newest entry, the Sorcerer from Exidy. These computers are made for the hobbyist rather than just the technician. Purchasing any of them will open new doors to excitement and imagination.

How to choose

Picking a computer can only be compared to deciding which car to buy. All computers will compute just as all cars will get you where you're going. Your choice must

depend on more than obvious styling details. You must understand a little of what goes on under the hood, and the different ways each model "handles." One of the best ways to go about buying is to learn a few facts and then visit the various showrooms.

Speaking its language

You may have heard that computer programming is complicated and time-consuming. It is not as easy as, say, training the family dog, though it does have some of the same qualities! An unprogrammed computer is *much* more stupid than an untrained dog. A computer can do almost nothing until it is programmed. However, these computers instantly understand English-like commands.

The BASIC computer language was originally developed at Dartmouth College just to help beginners program computers. It is now the most popular language



in the hobby, and although other languages abound, BASIC is here to stay.

Almost everyone's first program is to have his computer print out the word "hello." Using BASIC, the program is typed in as: 10 PRINT "HELLO." Of course, complex tasks—such as in most computer applications—

The TRS-80 is shown (left) in a home environment. With recorder, monitor and keyboard enclosure, it fits in a small space.

call for much more complicated programs. But it is easy to catch on to the BASIC language.

The Sorcerer and the PET already speak extended BASIC, the most complete "dialect." The TRS-80 Level I is short a few commands and the Apple II does not automatically compute in decimal numbers.

The TRS-80 Level I is therefore simpler to learn on. To convert the language into an extended BASIC

(Please turn to page 150)

TURNING YOUR HOME COMPUTER INTO AN OFFICE MACHINE

A personal computer can be at the heart of a small business system. Many advertisements, however, imply that you will instantly be able to use a home computer for such things as figuring a payroll for 50 employees, keeping the inventory of a moderate-sized store or storing a complete set of complex books. It's not so easy.

A home computer requires many peripherals as add-ons before it can be used in any but the smallest business functions. You will at least need one (or even two) floppy discs and a good printer.

The floppy-disc system replaces the cassette tape recorder as your means of storing and recalling data and programs. It is much faster than tape and is almost never subject to loading problems.

Suppose you were searching an inventory record on cassette tape. It might take you up to half an hour, perhaps more, to find the item because tape travels slowly and you have to progress from one end to the other in search of the item.

A floppy disc, however, uses *random access*. If you are searching for an item, it will go immediately to that item. There is no appreciable waiting time with a floppy disc

This floppy-disc drive from Apple goes for \$595, including necessary connections.



when you are recalling or storing data. (Many hobbyists also buy floppies because of their speed in loading programs and maintaining home accounts.)

Two disc drives support each other as you enter correction data on one, merge the information and come up with a corrected inventory, for example, in an instant.

Computers can be used to print both inter-office reports and correspondence. They can also print just about anything else if equipped with a good printer. The best printers can print at speeds much faster than the eye can follow.

The cheaper printers are slower and the

quality of the printout may not be as good. Even an inexpensive printer is over \$400. Expensive ones are in the \$2000 to \$3000 range. A floppy which can go for \$400 to \$600. It depends on which computer it mates with and which manufacturer is determining the price for it.

So, to turn a home system into a business system may cost an additional four grand. Yet, in many applications, this is very cost-effective compared to buying a "business system" (or leasing it). Check with a reputable computer store and find out if such a system can save you more money than it costs to buy.

The Teletype Model 43 is one of the more deluxe printers and is priced at \$1350.

A Telpar printer makes a good backup—or even primary—printer. It retails at \$795.

A video monitor, such as this one from Koyo, gives you clear readability for around \$200.

Some systems might need two floppy discs to keep complete inventories and records.

Equipment courtesy of Computer Mart of New York



GAMES ON COMPUTERS

Computers do more than add and subtract; they can amuse you with intricate games. Some are thinking games, others reward quick reflexes.

by Neil Shapiro
ELECTRONICS EDITOR

While IBM may never admit it, computers are the most fun-loving machines that technology has ever developed. Home computers can take you into realms of imagination you never dreamed existed, and make them seem every bit as real and challenging as you could wish. Whether you want a game of chess, to walk the bridge of the starship *Enterprise*, or have any of a hundred different adventures, there is a computer program that makes it happen.

Other worlds, other places

There are a lot of computer games on the market these days that are designed for all of the major home computers. The game programs, supplied on audio cassettes, need

(Please turn to page 146)

The *Apple 21*, from Softape, is an amazingly realistic blackjack game for Apple II.

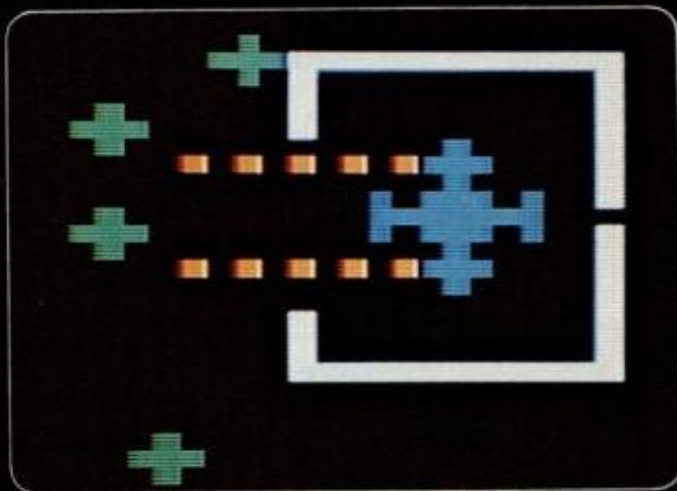

In *Pirates*, from Programma (above), you can blow the sails off a pirate scow. Fail, and you walk the plank. *Galactic Battle* (left), also from Programma, challenges you to destroy a space station. *Gunslinger*, from G/2, (below) is High Noon with you versus the computer. Games use Apple II computer's multicolor graphics. Some suppliers offer similar units for the black-and-white home computers.

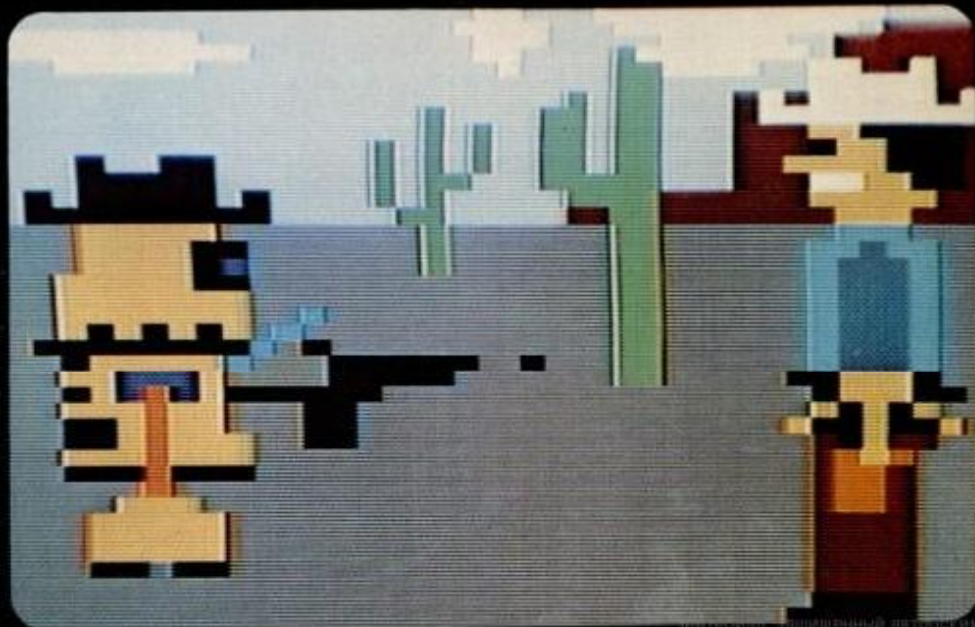



You can quick-change a standard Coleman 17-foot canoe into a white-water model with new snap-on vinyl and nylon spray cover.

SMALL BOATS: Fun with less fuel

New compact rigs with minipower are water-sporting bargains.

by Bill McKeown BOATING EDITOR



Broad beam and stable ride of wide multi-keel designs like the Boston Whaler make a good fishing boat or swimming raft. The 11½-foot hull, rated to 20 hp, easily handles Johnson 4.5.



Lightweight hulls need less power, are easier to cartop and launch. Grumman's 12½-foot aluminum 3.8 weighs 170 pounds, can do 22 mph, is rated for 10-hp motors, like this Mercury 9.8.

Boat owners, and engineers, too, are seeking ways to get more performance from the little rigs.

We've learned how fast and far big motors and large hulls can go. The new challenge is to take a mini model and fit it out for the most action it can safely handle, while using the lightest power and least fuel—or none at all.

Paddle power uses no gasoline, and is suitable, as well, for certain waterways that do not allow boats with engines. Specially designed

skiffs, canoes, kayaks and inflatables are now produced for running rapids and white water, but Coleman and Grumman also offer new cockpit covers to keep out water that might splash aboard.

A cover will not make an average, all-purpose canoe design the equal of the no-keel fast-water models, but it can keep gear dry during long open water passages and helps when things get rough unexpectedly.

Most small skiffs, prams and

dinghies can be rowed, but many were planned for outboard or sail, and are difficult to handle comfortably with oars. Fuel economy may bring back some of the fine old guide boats and rowing craft that seemed to glide along and were a delight to handle.

Meanwhile, small motors are packing more muscle. Outboards of 25 horsepower and less can push small craft up to 30 mph, and smaller mills will easily troll along all day

(Please turn to page 106)



Two skiers behind five hp? Ski instructor Jim McCormick tows talented sons Pat, 3, and Mike, 5, with a 106-pound Alumacraft 12-foot Cartopper, powered by Johnson's new 4.5-hp motor.

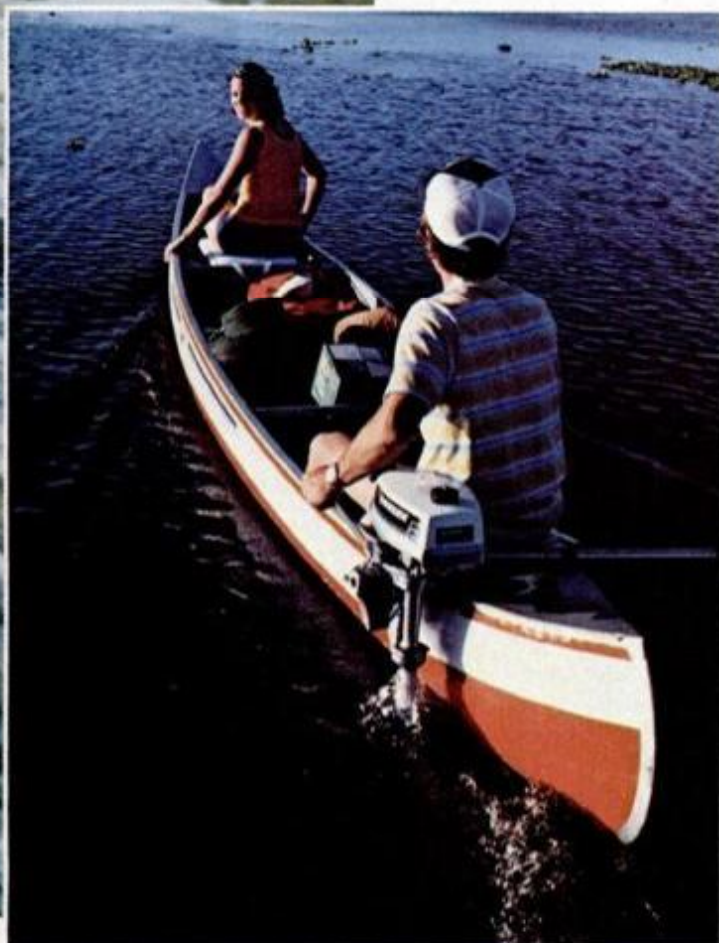

Mini-motors that troll almost all day on a tank of fuel are ideal for clamping on canoes. Most canoe makers have a square stern model or this cross-thwart type, shown with Evinrude 2.



Light and shoal-draft enough to explore the thinnest shallows, inflatables like the Maravia are made of rugged new fabrics.



Shown water skiing under power, the Wetbike is a speedy water sport machine. A Beach Buddy accessory (left) roll-launches it.

Scooters that go afloat

With features of a motorcycle, a bareback bronco, a moped—and a firehose in the face if you fall off—the motorized water sled provides you with the sensations of water skiing without much of the work.

Two prominent models—the Wetbike from Arctic Enterprises, Thief River Falls, Minn., and the Jet-Ski, Kawasaki Motors, Santa Ana, Calif.—offer speeds of up to 30 miles an hour. Since they use water jet power, there is no danger from propeller blades. And, if you should happen to take a spill, safety shutoff “kill” switches close the throttles and stop the motors.

Initially, the rigs were popular as a challenge to try over choppy water and through slalom courses. Now, an occasional owner will add a backpack, stow minimum gear aboard and head off for an overnight beach campout. Competitions have been organized, too, with races and distance runs in open water among the events.

Various trailers and accessories are newly available. Prices run approximately \$2500 for the 250-pound Jet-Ski, \$2800 for 350 pounds of Wetbike. Caution: Rent one first to try it out before you buy one.

Great new gear for

BUILD THIS EXCITING UNDERWATER SCOOTER FROM PM PLANS

You fly through the water with the greatest of ease when pulled along by PM's new self-powered sea scooter, Scuba-Tow II. An outgrowth of PM's highly successful original design, this latest version is even easier to build and offers added features. Made of stock aluminum tubing with two small electric fishing motors for thrust, it can be constructed for less than \$300 from PM's detailed, inexpensive, simple-to-follow plans.

Exciting things are happening in the underwater world of diving gear. From the simple masks and snorkels of not too long ago we've come to such exotic new devices as wrist-worn dive computers that do practically everything for you but breathe. Some of the latest advances in this fast-growing water sport are shown on these pages.

Also making its appearance is PM's own Scuba-Tow II, a self-propelled, electric-powered diving scooter that whisks you effortlessly through the water for hours of

undersea exploration or lazy surface snorkeling. You just hang on and let it pull you wherever you want to go. You steer with two handles that work like bicycle handlebars. With a little practice, it's possible to execute surprisingly intricate "aquabatic" maneuvers like steep banking turns, zooming dives and climbs, graceful wingovers, corkscrew rolls, even inside and outside loops—almost like a fighter pilot or air-show stunt flier.

Commercial underwater scooters sell for \$800 to \$1200 or more, but you can build this homemade model

Pressure-activated Bottom Timer (right) automatically starts as you dive, records elapsed time, is priced under \$60.



Ultimate in scuba instrumentation is Dacor wrist computer (below). Digital readouts tell depth, decompression times, warn of dangers.



Dual-beam dive light pinpoints distant objects and illuminates broad foreground area at same time, is said to eliminate claustrophobic "tunnel" effect of narrow beams. Called Captain Nemo, it boasts 300,000-candlepower brightness.

New dive knives, like these from Wenoka, sport brightly colored handles for added eye appeal as well as easier spotting if dropped underwater. Blunt-tipped style makes rugged prying tool, has line-cutting notch. Pointed type is small survival knife, can be worn on forearm.



underwater fun

7 slick diving aids you can buy—plus an all-new 1980 model of PM's famous Scuba-Tow you can build.

by Sheldon M. Gallager



Compact, easy-to-handle Scuba-Tow II is readily lifted into and out of a dive boat. In water, scooter is buoyant, will safely surface if you let go of it.

PM photos: Mike Fuller
Photo settings:
Silver Springs, Fla.
Cypress Gardens, Fla.



Slick new Sea Otter scuba rig from U.S. Divers combines air-tank backpack with buoyancy compensator vest in a single harness you just slip on and fasten with one buckle. There are no shoulder or leg straps to fuss with. Vest inflates from tank, mouth or CO₂ cartridge. One-hand inflation-deflation controls allow easy adjustment of buoyancy. About \$180.

Versatile wet suit by Henderson doubles as casual deck wear. Zippered folds in legs, arms and jacket open for loose-fit comfort when worn topsides. For diving, suit zips snugly, gives flotation, warmth.



Slip your camera into a plastic pouch like this and you can shoot pictures under water. The new soft enclosures from Ewa cost less than rigid housings, fold flat for easy carrying and storing, have optical-glass lens and viewfinder ports. A molded-in "glove" lets you operate camera controls from outside. In assorted styles and sizes for SLR and movie cameras, they're about \$55 to \$100 from Pioneer & Co.

from PM plans for under \$300—and have it ready to go in a weekend or two of work. Scuba-Tow II is a second-generation descendant of PM's popular original design introduced in 1974. This latest version incorporates advanced engineering, simplified construction and added convenience.

Its smartly styled, tubular shape is easy to produce, because it consists of three sections of stock 8-inch-diameter aluminum irrigation pipe, readily cut with a sabre saw. The circular pipe is stronger than wood, resists underwater pressures better and eliminates the need for fabricating a built-up shape. A bright, sealed-beam headlight in the nose provides underwater illumination, as well as adding a sporty touch. A sloping panel at the stern

successful underwater craft to his credit: PM's *One-Man Sports Sub* (page 90, June '68) and PM's *Two-Man Sub* (page 94, June '71).

Complete plans for building Scuba-Tow II are available from PM for \$8.95 (see ordering information on page 75). The plans include large-size drawing sheets, an illustrated instruction manual and sources for special components.

To test out and photograph the new scooter, PM editors took it to two of central Florida's most beautiful tourist attractions—Silver Springs, near Ocala, and Cypress Gardens, near Orlando. Here, in the remarkably clear waters of these famous marine facilities, we were able to evaluate its performance and also take a

accept standard 3/4-inch plumbing pipe. An ordinary pipe flange and short pipe nipple are all you need to attach each motor to the side of the scooter hull. Sections of aluminum tubing safely shroud the prop blades and give the craft the rakish look of a miniature rocket ship. Overall length is 42 inches, with a span of 22 inches across the motor shrouds.

Parts readily available

By special arrangement with the manufacturer of the motors, PM readers will be able to buy just the power heads, without tiller shafts and other hardware, thus saving money. The cost of both units together comes to about \$160. Electricity is supplied by two small, 12-volt motorcycle batteries, readily available from Sears and other sources for around \$30 each. The 8-inch aluminum pipe used to form the hull and motor shrouds can be ordered by mail if it is hard to find locally.

While the scooter is especially effective when used with scuba gear, you actually don't have to be an accomplished scuba diver to have fun with it—that's one of its big advantages. Since it relieves you of the exertion of swimming, you can stay down much longer and travel much farther on a lungful of air than you would normally be able to. Thus you can enjoy long, effortless dives without the need for an auxiliary air supply. You can also cruise along the surface with just a mask and snorkel, watching the magical world of marine life as it passes by below you.

Scooter won't sink

The scooter is designed to have slight positive buoyancy, so it will float when not in use or rise to the surface if you let go of it, with no danger of sinking. Its trim can be easily adjusted by sliding the batteries forward or back to shift weight toward the nose or stern. For diving, a little nose-heavy trim will help you guide the scooter downward. For surface snorkeling, it can be trimmed level or slightly nose-high to plane smoothly over the water. For extra down trim or negative buoyancy, a ballast compartment in the nose can be flooded, although this was not found to be necessary in PM tests.

In intermittent use, the batteries will give several hours of operation per charge and can be recharged overnight from an inexpensive home charger. A thumb-operated "kill" switch on one steering handle automatically stops the motors the instant you release your grip, so there's no danger of the scooter accidentally running away from you. A switch in the other handle controls the headlight.

For maximum safety, be sure to follow the precautions outlined in the instruction manual for Scuba-Tow II. The batteries, for instance, *must* be recharged in a well ventilated open area to avoid concentrations of possibly explosive hydrogen gas given off in the charging process (the danger is remote, but don't take

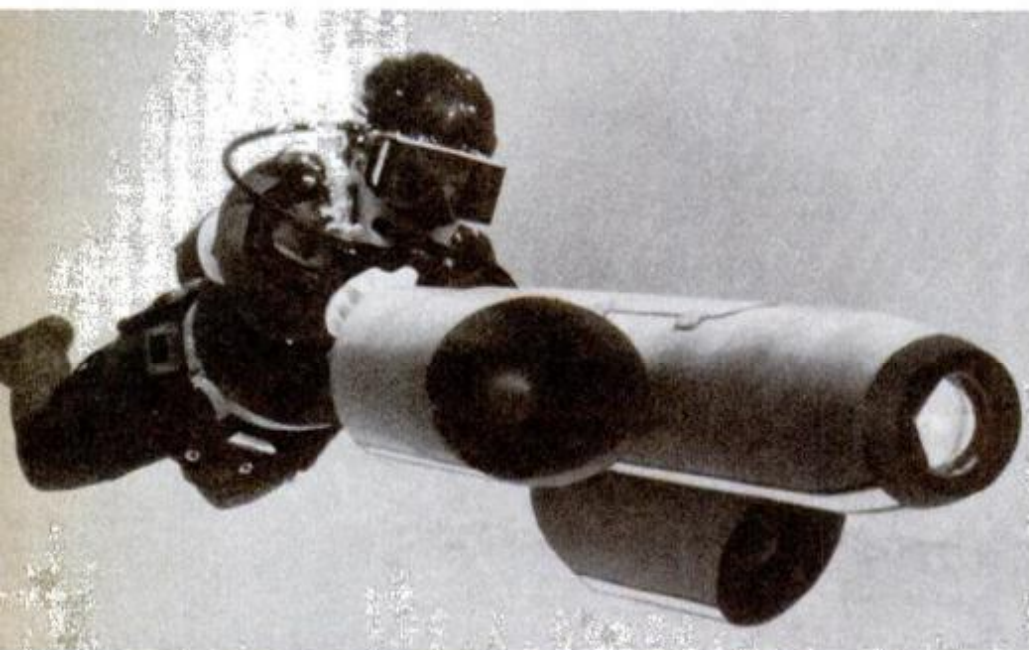

PM's electric diving scooter is easily guided through the water with bicycle-like hand grips. New features include headlight in nose (lower left) and instrument panel in stern (lower right). Hinged hatch cover opens for access to batteries and trim adjustments.

mounts a depth gauge, compass, thermometer and other diving instruments.

Easy to build and use

Like PM's earlier model, Scuba-Tow II was designed by Kent Markham, a marine construction expert and teacher at John Gorrie Junior High School in Jacksonville, Fla. Markham also has two other

closer look at other new diving gear.

The scooter is powered by two small electric fishing motors that develop a combined thrust of 40 pounds, or a little under 1 hp. This is enough to pull you along at about 3 mph—a brisk walking pace. Under water, that's a good clip. The motors are easy to mount because their housings are conveniently threaded to

chances). When operating the scooter with scuba gear, it is important to observe proper breathing practices, especially when ascending. Since the scooter may take you up faster than your normal swimming rate, remember to exhale as you rise to prevent excessive buildup of pressure within the lungs. Used with care, PM's Scuba-Tow II offers safe, exciting sport for the whole family.

New underwater automation

Other new equipment PM looked at reflects a growing trend toward greater sophistication in scuba gear for the sport diver. You can't forget to time your dives with an ingenious self-operating underwater stopwatch called Bottom Timer.

Unlike the usual dive watch, it has no outer timing ring you must remember to pre-set. Activated by water pressure, it automatically starts ticking as soon as you descend about six feet, and indicates elapsed time in both minutes and sec-

HOW TO ORDER PLANS FOR PM'S SCUBA-TOW II

For large, detailed plans plus an illustrated instruction manual on building this electric-powered underwater scooter, send \$8.95 in check or money order to Popular Mechanics, Dept. UW, Box 1014, Radio City Station, New York, N.Y. 10019. Please make payable to Popular Mechanics. Allow three to four weeks for third-class mail delivery. For faster first-class mail, add 75 cents to your remittance.

onds up to one hour. As you surface, it stops. Because it records only actual bottom time, it can keep a running total of repetitive dive times without your making mental calculations. It has luminous, easy-to-read numerals and hand, comes in three dial-face colors—orange, blue and black—and sells for under \$60 from Princeton Tectonics, Box 764, Hightstown, N.J. 08520.

For the ultimate in sophisticated scuba instrumentation there's Dacor's new diving computer, small enough to strap on your wrist. Programmed to operate on official U.S. Navy Decompression Tables, it takes most of the thinking—and danger—out of complicated diving situations.

(Please turn to page 132)

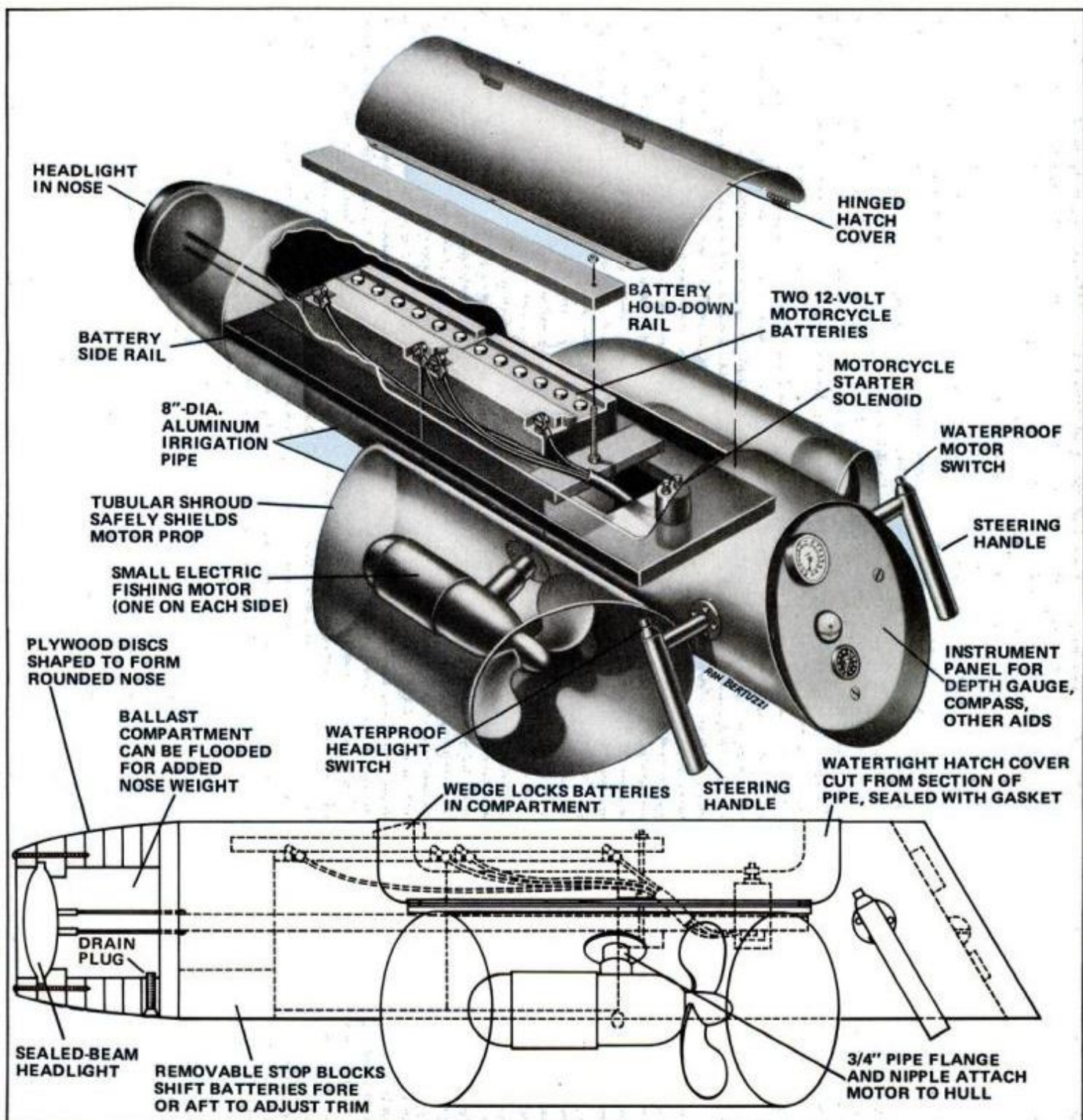

A California businessman scrawled across the top of his questionnaire, "You can understand a Jaguar only if you drive one."

Quite so; very true; yes. Owners indulge themselves in the luxury of owning Jaguars and find that, in return, their cars demand some indulgences, too.

Back in the days of XK-120 roadsters and Mark VII sedans, Jaguars used to be the precocious children of autodom—



Jaguar sedan's classic front end inspired 1970½ Camaro and Chrysler Cordoba.

troublesome, but delightful. In the early 1950s, when British cars were still recognized as worldbeaters, certain Jaguar facets needed to be overlooked and were; others demanded constant repair and attention, and those items were constantly repaired and attended to. It was part of the Jaguar mystique.

The question today is: What's changed?



We're talking here about 1979 cars. The six-cylinder models, which formed two-thirds of our sampling, use a basic engine design that's 31 years old. Even so, it was light-years ahead of its time in 1948, when its double overhead cams and hemispherical combustion chambers burst on the scene.

This engine has been updated steadily, and today it uses Bosch-Lucas L-Jetronic fuel injection, plus electronic ignition. Even so, it's one of the world's few hold-outs against cogged-belt drive for its ohcs.

The Jaguar sedan's body arrived in 1968 and has changed very little since. The famous, race-winning Jaguar sohc V12 made its first appearance in 1973 sedans, with the XJ-S coupe bowing in 1975. Six-cylinder Jags, of course, also

won umpteen hundred races back in the marque's glory days—but the point is that Jaguar Rover Triumph (formerly British Leyland) has had time aplenty to hone and massage all Jaguars into the stellar productions that their price tags (\$22,000 and up) would suggest. But have they?

"When it's running right," says a South



Though introduced in 1968, Jaguar styling looks fresh and still prompts most sales.

Carolina physician of his XJ-S coupe, "there's absolutely nothing like it in the world. But when it's not, it's downright awful."

A Georgia service rep states flatly, "I would rather buy one new Jaguar *and take care of it* than own three new Monte Carlos."

And a California attorney writes, "Although I was hesitant to purchase the Jaguar because of its rumored mechanical unreliability, my fuel-injected XJ6L

BY MICHAEL LAMM WEST COAST EDITOR

Jaguar owners enjoy their cars—sometimes through gritted teeth

Owners would prefer vinyl rub strip to ward off dings.

Several parts of Jag exhaust system are stainless steel.



Photos by the author

has been virtually troublefree. The design and craftsmanship of the Jaguar are, in my opinion, superior to any domestic automobile. And when compared to a Mercedes or BMW, the Jaguar proves a better value."

Emotionally, the Jaguar owner still seems torn between indulging himself and indulging his car. It's a demanding mistress; however, the rewards more than compensate for the annoyances.

An Illinois executive calls his XJ6 "a superb driving car." A California airline pilot opines, "My third Jaguar—a pure, classic machine. Nothing comes near it in styling."



Jags use GM's Turbo Hydro. Leather seats, real wood set off full instrumentation.



Interior comfort, convenience are aided by tilt seats, many storage compartments.

A California computer systems engineer: "Absolute luxury inside and out, and a real pleasure to drive." A California real estate broker: "Sexy four-door with the feeling of sportiness." And a New York secretary: "This is my third Jag—it's the only way to fly!"

Not surprisingly, styling came in No. 1 in terms of the Jaguar's best-liked attributes. Handling ranked a close second, and owners said some very nice things about their Jaguars' roadability and ride.

"Best-handling car I've ever driven," writes a California loan broker. A California housewife: "Very good handling, without the stiffness or effort of the Mercedes.

(Please turn to page 116)

The legendary Jaguar

Jaguar offers two different engines in two distinctive body styles. You can order the Jaguar sedan with either the dohc Six or the sohc V12 (one cam per bank). Sedans are designated XJ6 and XJ12 respectively. The XJ-S sport coupe comes only with the V12.

The aluminum 60° V12 displaces 326 cubic inches (5.3 liters) and develops 244 hp at 5250 rpm. The Six pulls 176 bhp at 4750 rpm from 258 cu. in. All Jaguars offer only one transmission: GM's Turbo Hydra-Matic.

Jaguar's long list of standard equipment includes airconditioning, AM/FM multiplex stereo with tape, leather upholstery, rack-and-pinion power steering, four-wheel power disc brakes, power door locks, fuel injection, steel-belted radial tires and limited-slip differential, among other features.

Inside, there's automatic temperature control, walnut instrument panel, console with glovebox, reclining front bucket seats, adjustable steering wheel and door-mounted speakers.

The XJ-S coupe weighs 3936 pounds, with the sedans tipping the scale at 100 to 400 pounds more. Bob Tullius recently captured the SCCA Trans Am Category I championship in an XJ-S.

Recent restyling of the XJ6 and XJ12 sedans (see *Imports & Motorsports*, page 64, June '79) gave them more headroom and slight exterior changes. Also added are new features, like cruise control and electrically operated sliding steel sunroof that were not available when we photographed the car here and surveyed Jaguar owners who bought their cars in November and December of 1978.

A NATIONWIDE SURVEY BASED ON 479,271 OWNER-DRIVEN MILES

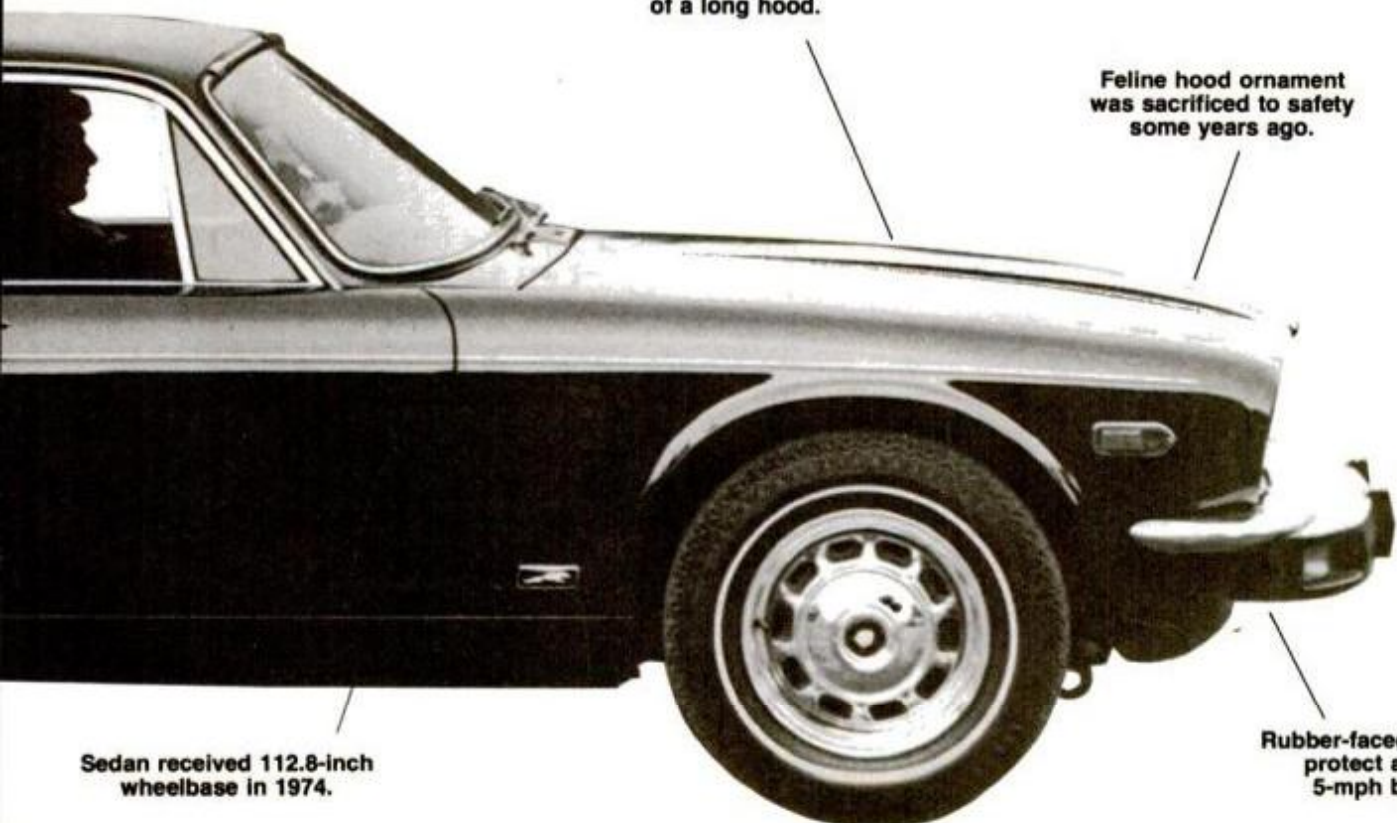

Jaguar drivers enjoy the rare vista of a long hood.

Feline hood ornament was sacrificed to safety some years ago.

Sedan received 112.8-inch wheelbase in 1974.

Rubber-faced bumpers protect against 5-mph blows.

Programmed scanning brings back CB excitement!

Microprocessor-controlled CBs offer capabilities undreamed of a few years ago—right at your fingertips. Around town or on the road, CB is better than ever!

by Herb Friedman

Citizens band sets with built-in microprocessors are changing the future of CB operations. These computerized sets let you operate on two, five or even 10 channels at once and can also help you cut through today's crowded band conditions. If you use a CB to monitor highway conditions or talk to channel buddies, these new sets are going to add even more excitement to your hobby and may even bring about something of a CB renaissance!

Two places at once

With very few exceptions, a non-computerized CB can keep track of the action on only one channel at a time. If you monitor a highway channel such as 19, without a CB set having a microprocessor inside, you can't tell what is happening on other channels. This can be serious for a motorist in an area with more than one highway channel. For example, in the New York City area, one superhighway uses Channel 19 while an immediately adjacent, limited-access highway uses Channel 10. In another area, there are three interconnecting roads and three highway channels—not to mention the emergency Channel 9.

Channel hopping at highway speeds used to mean leaning over and switching with one hand while steering with the other, which could get downright scary. It always seemed as if there should be a better way—and now there is. A computerized CB can watch over several channels simultaneously. It can search out busy channels if you live in a sparsely populated area and are looking for a contact. If you live in a big city, it can search out a clear channel. This searching mode is referred to as scanning.

Some CB models also provide automatic monitoring of an alternate



Radio Shack's Realistic line is one of the best-known brands in CB and its new TRC-459 is a base/mobile that will enhance its reputation. A single-sideband rig, it offers five memories and LED readout.

The SBE Key/Com 1000 has 10 computer memories, along with digital readout. An AM rig, it boasts a hot receiver section, as well as easy keyboard entry of its various computer functions.

channel. The set will keep track of a channel different from the one you are talking on; often the alternate channel will be 9, the national emergency channel.

You may also use alternate-channel monitoring almost as a private telephone. Suppose you are listening to Channel 19 (a highway channel) on your way home from work. Meanwhile, you have programmed your CB set to keep tabs on Channel 39, which is relatively quiet. If your home station calls you on 39, you will hear the call. Every 10 seconds, the computer in your CB briefly checks on Channel 39 (or whatever channel you have programmed). If the CB's





The A.R.F. 2001 is a handsome-looking base station offering fine, computer-enhanced performance. It has 20 computer memories. Receiver is as resistant to adjacent channel "splash" as any we've seen.



The Pace 8117 can be used as a base or mobile. An AM rig with digital readout, it has 10 computer memories, also slow/fast manual scanning controls.



Robyn's SB-54D offers SSB operation under microprocessor control, five memories, digital readout, excellent receiver sensitivity of three-tenth microvolts.

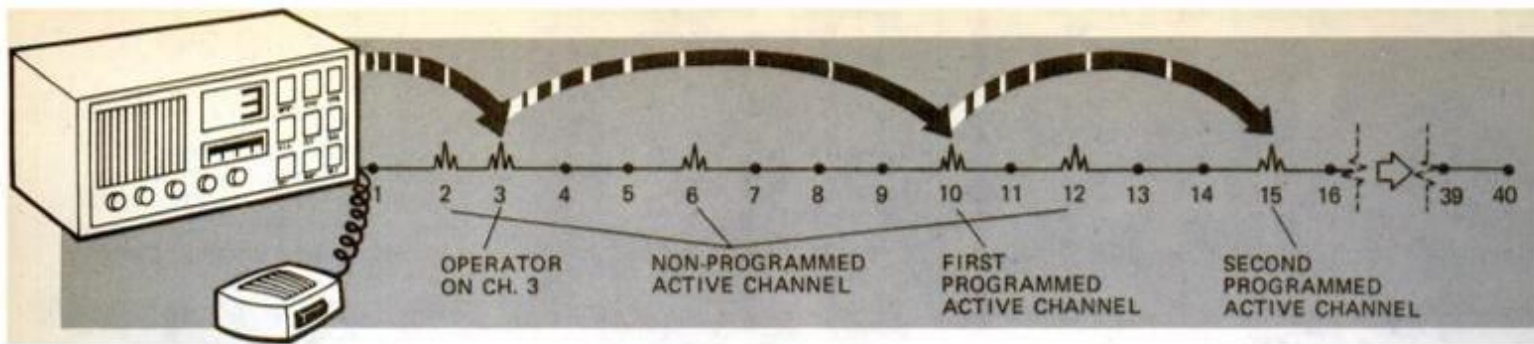

Programmable CBs will "jump" from channel to channel on the band and alert you to an incoming call on a memorized channel.

microprocessor notes any activity on the alternate channel, it will let you hear the signal or, in some models, will automatically switch both your transmitter and receiver to the alternate.

CB programmability

There is considerable variation between computerized CB sets now available—and more are appearing every day. However, one common feature was found among all five of the sets PM tested—high performance. As our test results show,

even leaving aside their computer functions, these are really hot rigs.

All the sets use some sort of keypad that looks like the one on push-button telephones. You can use the keys for many purposes other than choosing a channel. You just hold down the proper button to "step" through channels one after the other until you get the one you want—indicated on a bright LED (red numbers) readout. The buttons are also used to set the transceiver's scanning functions, to make it stop on either a clear or busy channel.

Here we see the first difference in design philosophies of the five rigs we tested. The A.R.F., Pace and SBE sets have 10-channel scan memo-

ries. The Cber may program any 10 channels to be scanned, in any sequence, for conversation or clearness. Then there is the five-channel, direct-access memory used by Radio Shack and Robyn. These transceivers have individual keys for each of five memories. While the five memorized channels are being scanned, you can immediately reach any one of the channels in memory by activating one of the memory buttons labeled M1 through M5.

Other computer functions found among the models we tested were: dual-speed (slow or fast) scanning (A.R.F., Pace); instantaneous operation on emergency Channel 9 by

(Please turn to page 126.)

FIVE LABORATORY-TESTED SCANNING CB SETS

FEATURE	A.R.F. 2001	Pace 8117	Robyn SB-54D	SBE KEY/COM 1000	Realistic TRC-459
Basic function (primary use)	Base station	Base (mobile)	Base (mobile)	Mobile	Base (mobile)
Power supply	120 v.a.c.	120 v.a.c./13.8 v.d.c.	120 v.a.c./13.8 v.d.c.	13.8 v.d.c.	120 v.a.c./13.8 v.d.c.
Accessories supplied	Microphone	Microphone	Microphone, d.c. power cord	Microphone, mobile mount, power cable	Microphone, d.c. power cord
Channel indicator	LED digital	LED digital	LED digital	LED digital	LED digital
Number computer memories	10	10	5	10	5
Memory type	Nonvolatile as long as line cord is connected	Volatile	Nonvolatile as long as line cord is connected	Nonvolatile (separate memory power)	Nonvolatile as long as line cord is connected
Size (height, width, depth)	7 x 18 x 15"	4 x 12 x 9.5"	6.2 x 16.75 x 11"	2.1 x 5.9 x 8.8"	3.8 x 15.3 x 11.8"
PERFORMANCE					
AM RF output	4.0 watts	4.0 watts	4.0 watts	3.6 watts	4.0 watts
SSB RF output	12.0 P.E.P. watts	No SSB	12.0 P.E.P. watts	No SSB	12.0 P.E.P. watts
Modulation sensitivity (0 dB = normal voice)	Off to +24 dB	+9 dB	Off to +13 dB	+10 dB	+27 dB
Nominal receiver sensitivity for 10 dB signal plus noise ratio	0.7 uV	0.4 uV	0.3 uV	0.3 uV	0.4 uV
Adjacent channel interference rejection	69 dB	65 dB	64 dB	57 dB	64 dB
SSB alternate sideband interference rejection	50+ dB	No SSB	40+ dB	No SSB	48 dB
Automatic gain control action, input signal range of 2-10K uV	14 dB	3 dB	6 dB	13 dB	3 dB
Input signal level required for S9 meter indication	280 uV	100 uV	100 uV	80 uV	150 uV

Note: All measurements are the "worst-case" condition, or the typically average condition for which there is no appreciable variation. As a general rule: The higher the modulation sensitivity (+13 dB is higher than +10 dB), the lower the voice level that can be used and still maintain 100-percent modulation; the lower the receiver sensitivity figure, the greater the receiver sensitivity; the higher the adjacent channel rejection figure, the greater the receiver's ability to reject "splash" from adjacent channel signals; the smaller the AGC

figure, the better, as it represents less of a volume change from the speaker when you're receiving weak and strong stations; the S-meter sensitivity for S9 meter reading has no effect on performance as S-meter readings are only a convenience for the operator. SSB stands for single sideband. This is a means of transmission that offers an effective increase in power and also requires half as much frequency space. This results in the seeming use of 80 channels instead of 40.

IT'S NEW NOW

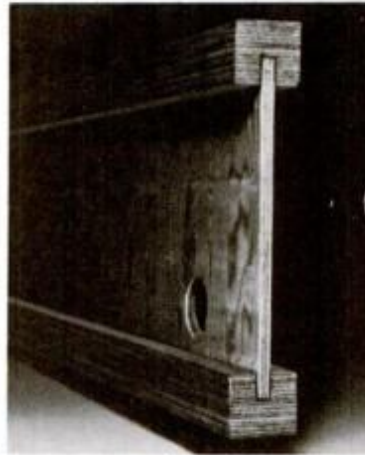

Plywood I-beams

Steel I-beams have been commonplace in construction for decades, but not wooden ones. The one shown at left is designed to replace 2x10 joists in home construction. The Residential TJI I-beam is said to be about 50 percent lighter than a 2x10 and stronger. The beam is made by gluing two laminated flanges to a $\frac{3}{8}$ -inch plywood web. A TJI costs about 30 percent more than a 2x10, but its in-place costs are said to be lower because it can be used at a wider spacing and in longer lengths. Trus-Joist Corp., 9777 West Chinden Blvd., Boise, Idaho 83702.

Shock absorber for light bulbs

Bulb-Miser reduces light-bulb-killing thermal shock from full current flow at switch-on. Its resistance is high when cold and decreases as it heats up. The metallic oxide wafer increases bulb life up to 300 percent, maker claims. Bulb-Miser is \$2. American Electro-Dynamics Corp., 1 Penn Plaza, New York, N.Y. 10001.

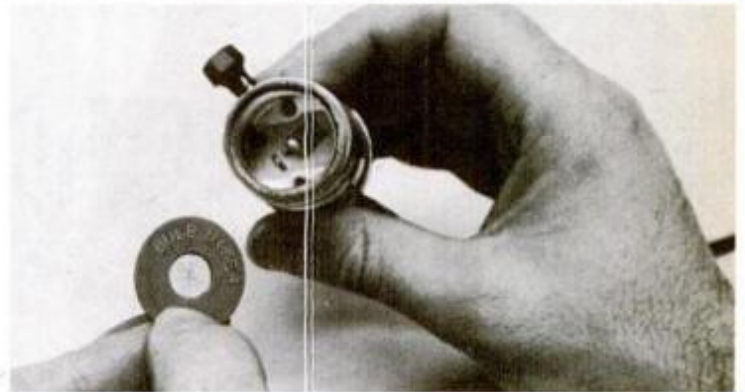

Beeper aids heart patients

With the CardioBeeper heart monitor, cardiac patients can leave the hospital earlier and transmit to their doctor a daily electrocardiogram from home. Two electrodes are placed under the armpits, and the battery-powered unit is held by the phone. The signal is decoded at the doctor's office or hospital. Unit costs \$350 with special heart-drug injector and is available by prescription. From Survival Technology Inc., 7801 Woodmont Ave., Bethesda, Md. 20014.



Fanning out in all directions

The Gyro-Aire fan is said to provide 360° air circulation with its rotating front louver. A second shaft on the fan motor turns the louver at 1/120th fan speed; louver can also be held stationary. The unit provides infinitely variable speeds from 0 to 1500 rpm. About \$60, from Mistral Fans Inc., 1311 Blue Gum, Anaheim, Calif. 92806.

All mixed up

Mix concrete, mortar or plaster with the Porta Mix. The portable mixer runs on house current, has a 160-pound capacity, and weighs only 50 pounds. Polyethylene mixing drum, with eight vanes, is said to be virtually indestructible and easy to clean. About \$160. Porta Mix Inc., 1083 Bloomfield Ave., West Caldwell, N.J. 07006.



HOW TO CHECK, SELECT AND REPLACE SHOCK ABSORBERS

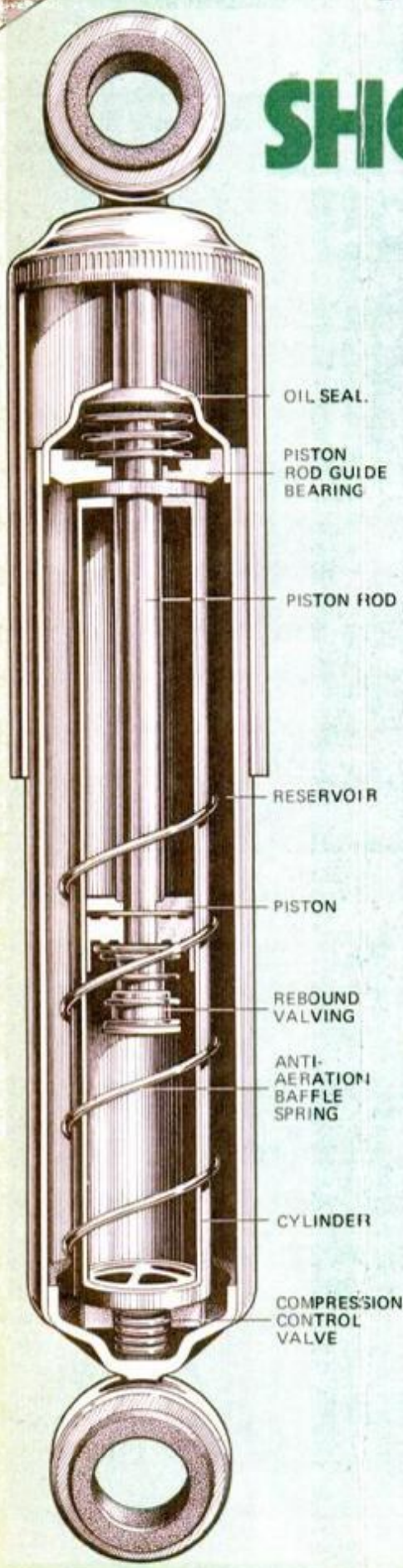

OIL SEAL.
 PISTON ROD GUIDE BEARING
 PISTON ROD
 RESERVOIR
 PISTON
 REBOUND VALVING
 ANTI-AERATION BAFFLE SPRING
 CYLINDER
 COMPRESSION CONTROL VALVE

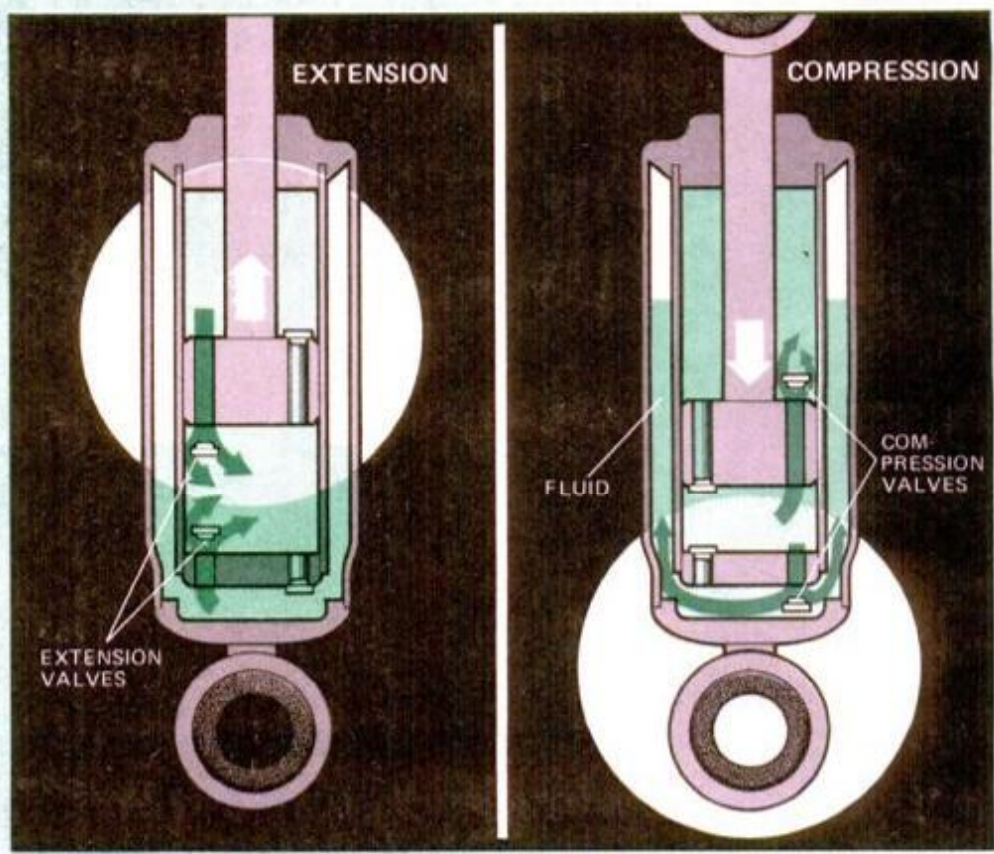

Typical shock absorber (left) contains hydraulic fluid that quickly dampens the continuous up-and-down motion of a car on its springs. System of valves (above) controls flow of the hydraulic fluid through rapid compression and extension cycles.

by Mort Schultz

Shock absorbers are often taken for granted. Yet these relatively simple little devices are vital to your safety and comfort. Poor shocks cause a rough ride and sloppy road handling. Bad shocks can be downright dangerous. Fortunately, failing shocks are comparatively easy to detect and replace.

Oddly enough, shock absorbers do not themselves absorb shock—they control the action of your car's springs, which in turn absorb road shock. Without shocks, your springs would not function properly.

Technically, shocks are direct-acting, velocity-sensitive dampening devices—direct-acting because they're mounted directly between a car's frame and axle; velocity-sensitive because the faster they move,

the more resistance they offer. As the speed of a typical shock is increased on a shock-absorber dynamometer from 30 to 85 to 170 cycles per minute, control on rebound (extension) increases from 165 to 285 to 430 pounds, respectively. Control on compression (jounce) increases from 60 to 185 to 275 pounds, respectively. Greater extension control is needed to compensate for the more powerful springing action that takes place during rebound.

The term "dampening" refers to the fact that shocks dampen, or restrict, the action of a vehicle's springs. If there were no shock absorbers, springs would bounce and rebound freely, making steering difficult, causing wheels to lift off the road, reducing braking efficiency

and shaking up the car's passengers.

Shock absorbers convert mechanical energy of up and down motion into a heat energy that is dissipated through the shock. The principles of fluid displacement are employed.

During compression, the piston rod and piston move down in the working cylinder, which causes a pressure drop in the upper part of the cylinder. The volume of the lower part is reduced.

To correct the pressure imbalance, hydraulic fluid follows the path of least resistance. This route is up through the upper compression valve, which is unseated by the force of the fluid. Thus the upper part of the cylinder is filled.

However, all the fluid which was originally in the lower part of the working cylinder cannot fit into the upper part because the piston rod has filled some of the void. This fluid is forced down through the lower compression valve into the reservoir area.

The amount of compression (jounce) control is dictated by the amount of force needed to transfer hydraulic fluid from the working cylinder into the reservoir.

During extension, the piston and piston rod move toward the top of the working cylinder. The volume of the upper cylinder is therefore reduced, forming a high-pressure area. To correct this pressure imbalance, fluid flows down from the upper cylinder into the lower cylinder, through the upper extension valve.

In addition, the volume of the lower cylinder is increased because the piston and piston rod have withdrawn. Since the amount of fluid coming from the upper cylinder is not sufficient to fill the lower cylinder, the pressure in the lower cylinder falls below the pressure in the reservoir. The lower extension valve is forced off its seat, allowing fluid from the reservoir also to flow into the lower part of the working cylinder. The amount of extension (rebound) control is the force required to pass fluid through the extension valves.

Do you need new shocks?

Shock absorbers deteriorate gradually, especially shocks originally installed by the automobile's manufacturer and replacement units that are warranted for a specific period rather than "life." Deterioration is deceptive. It doesn't happen suddenly. Drivers become accustomed to the gradual changes in driving "feel" that take place.

However, being aware of trouble

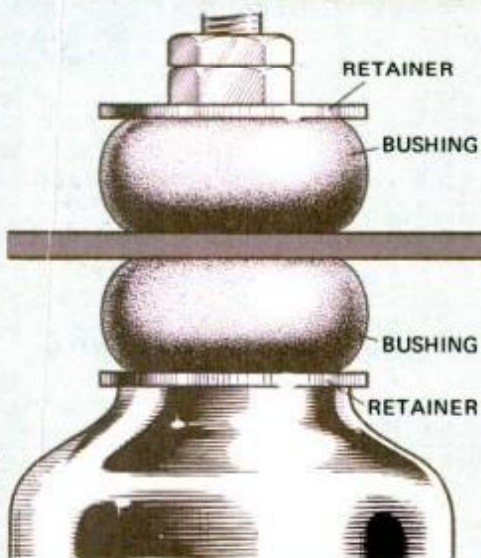
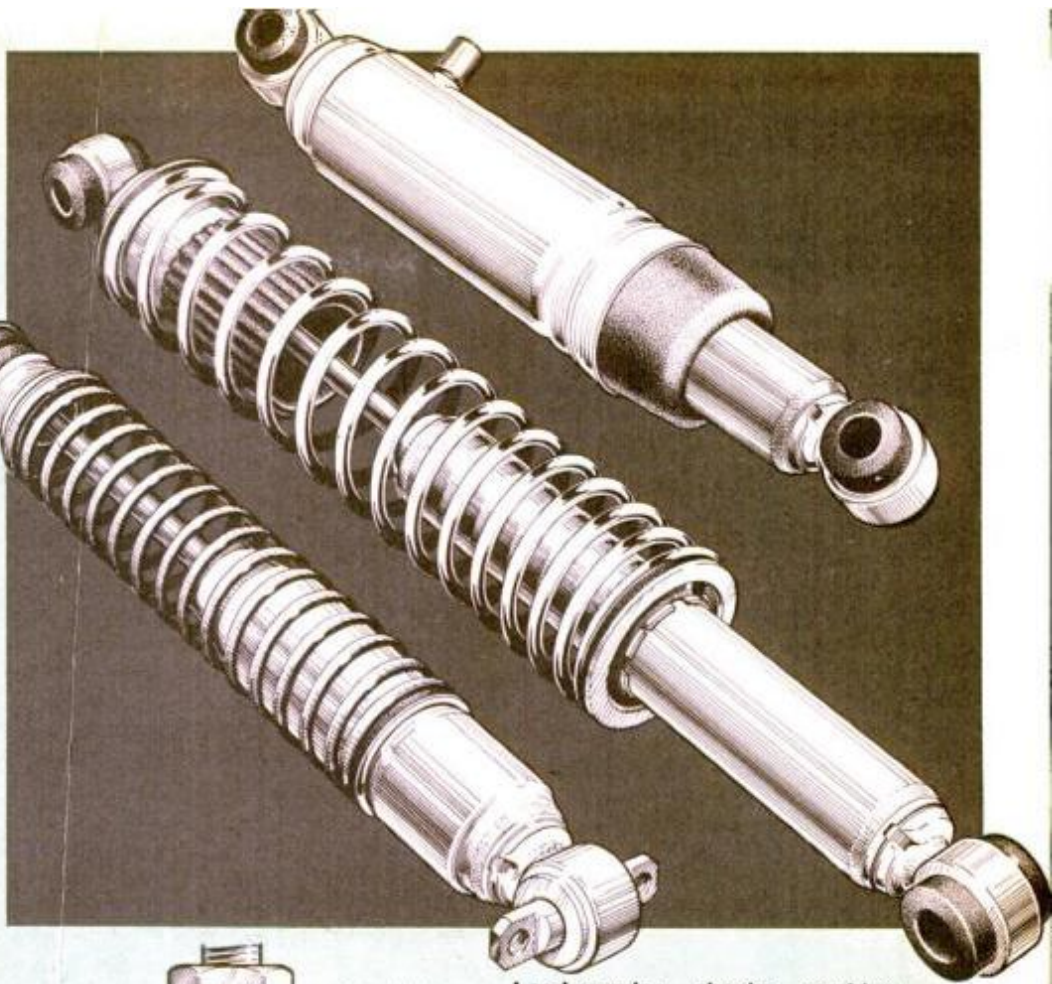

Load-carrying shocks combine springs with shock absorber. The left shock (above) is a front-load carrier, center is a rear-load carrier, right is an air-adjustable shock. Drawing (left) shows stud-type mounting. Tighten nut only until bushing spreads to the same diameter as retainer.

signs will allow you to spot worn shocks before they cause too many problems. Problems include loss of stability, driver control and braking efficiency; decreased tire life; premature damage to springs, suspension and steering-linkage components; and a decrease in your riding comfort.

The following are signs which indicate that your car may need new shocks:

- Shocks that have seen 20,000 to 25,000 miles if they are original equipment, or replacement units that have exceeded the mileage warranty set by the manufacturer.
- Oil on a shock's barrel, which signifies seal deterioration.
- Worn bushings. Test by trying to shake the shock. A shock that shakes is one that either has loose

mountings or bushings that are worn.

- Physical damage. A broken rod that you can see by lifting the car, so shocks are extended, is physical damage. Also, large dents in the case.

- Scuffed or badly spot-worn tires.
- The car bottoms out when negotiating harsh bumps or when coming to a sudden stop.

- The car is hard to handle, swaying on turns, bouncing on smooth roads, and/or lacking control on curves.

- Shocks that fail the push-and-bounce test. Push down hard at each corner of the car two or three times. Let go on the end of a downstroke. If the corner bounces more than 1½ cycles, the shock should be replaced.

Two important tips

1. If one shock needs to be replaced, the other shock on the same axle should be replaced. The other two can be left in service if they aren't damaged or worn.

2. Replacing shock absorbers won't cure riding and driving problems caused by other conditions. According to Gabriel, a maker of shocks for J.C. Penney and K Mart, "Excessive

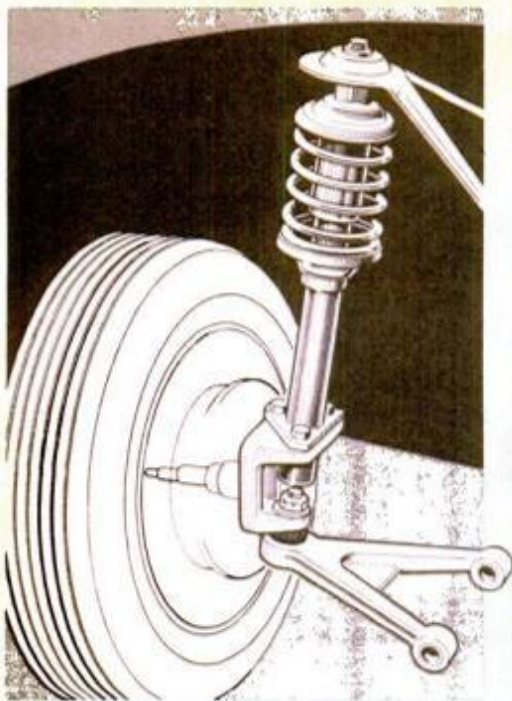

The replacement cartridges for MacPherson-strut, front-suspension shocks make do-it-yourself work easy.

bottoming due to weak or sagging springs can't be helped by new shock absorbers. Nor can they (shocks) correct shimmy caused by unbalanced tires, bad front-wheel bearings or worn front-end parts."

Picking a shock

Shock absorbers come in three general types: replacement, load-carrying or special purpose.

Replacement shocks look like original-equipment shocks. Some are comparable. Others have larger cylinder bores and pistons, greater-diameter piston rods and heavier valving. These heavier-duty units compensate for wear to the car's suspension system, withstand more rigorous driving conditions, and/or support heavier loads.

Replacement shocks may be classified as OEM-comparable (original equipment), heavy-duty, extra-heavy-duty, adjustable or MacPherson. Here, in general, is the purpose of each:

■ OEM-comparable shocks are similar to the vehicle's original equipment. They are designed for normal driving and light loads. Being the least expensive units available, they usually carry a specified rather than "lifetime" warranty.

■ Heavy-duty shocks can provide longer life than OEM-comparable units. They normally have a "lifetime" warranty and cost more. They should be used on a car with suspension parts that have "set." Heavy-duty shocks allow the car to handle heavier loads and more high-speed driving.

■ Extra-heavy-duty replacement shocks are designed for light trucks, recreational vehicles, station wagons and cars that pull lightweight trailers of the boat and camper types.

■ Adjustable shock absorbers are

offered by a few manufacturers. They allow you to set the shocks for various conditions, permitting regular, firm or extra-firm support.

■ MacPherson replacement cartridges allow you to replace original equipment cartridges without discarding strut housings. MacPherson units are used on most imported cars, including Arrow, Audi, Capri, Colt, Datsun, Honda, Mazda, Porsche 914, Toyota, Volkswagen and Volvo 240 and 260.

Load-carrying shocks are front and rear units that have the shocks combined with coil springs. Air-adjustable shocks also fall into this classification. Front and rear load-carrying units help you maintain maximum vehicle control and prevent damage to the suspension when hauling house trailers.

Air-adjustable shocks provide the occasional trailer-towing driver with flexibility. When towing your trailer, adding air to the shock provides maximum support. When the trailer isn't being towed, air should be bled from the shocks.

An air-adjustable unit is the same as a regular replacement shock absorber with the exception of the added air chamber. Owners of vans, recreational and off-road vehicles who vary the weight of the load they carry from one time to another will also find air-adjustable shocks useful.

Special-purpose shock absorbers
(Please turn to page 122)

How the modern shock absorber evolved

It started back when the horse-drawn carriage became horseless. Devices similar to the Hartford friction shock were used to control body and axle movement. The friction shock was adjusted by tightening a bolt that pressed a friction disc between two arms. The shock did a job, but too well. The metal-to-metal contact which was necessary to create friction also caused early failure.

Then, in 1904, a fellow by the name of Claud H. Foster invented the first direct-acting shock absorber, which he called the Gabriel Rebound Snubber. Gabriel was the name of Foster's company, which made musical horns.

The Rebound Snubber was a hydraulic device consisting of a heavy cast-iron body that contained a piston. The earliest models had the unit's body attached to the axle. The piston was operated by a leather or cotton strap that extended from the shock's piston to the frame.

The Rebound Snubber provided control in one direction—on rebound (up). When leather and cotton straps gave way to a metal link, control could be executed in both the rebound and compression (down) directions of the shock.

None of the old names in automobiles—Hupmobile, Jordan, Ford, Peerless, Stutz, Marmon, Elcar or Nash—offered the shock

absorber as standard equipment. Just as with today's stereo systems and power windows, the customer had to pay extra for the option.

This began to change in 1932 when the Hudson Motor Car Co. introduced the first automobile having four direct-acting shock absorbers as standard equipment. Auburn, Reo, Chrysler, Packard and Terraplane soon followed suit.

These early shock absorbers, beginning with Foster's design, had a common characteristic. They could be serviced and refilled

with hydraulic fluid. The shock absorber as a unit seldom had to be replaced.

This concept disappeared in 1937 when Gabriel introduced the forerunner of the modern sealed shock absorber, which had to be replaced when it wore out or sprung a leak. (In 1962, Maremont Corp. acquired the assets of the Gabriel Co. However, the shocks still bear the Gabriel name.)

One other fact may interest you: It wasn't until 1949 that Ford made the direct-acting shock absorber standard equipment on its cars, followed in 1950 by Chevrolet.—M.S.

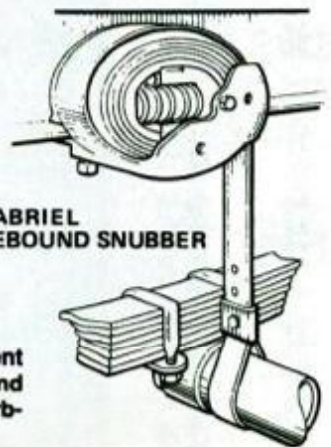
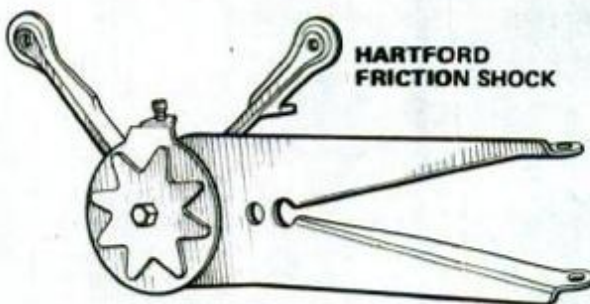

Early carriages used friction disc and arm arrangement (above) to control body and axle movement. Rebound snubber (right), patented Dec. 3, 1907 as a "shock absorbing device for vehicles," acted on rebound (extension).

FIRSTHAND REPORT

by Gary Witzenburg
DETROIT AUTO EDITOR



Driving the Honda Prelude



Large tires, short wheelbase and a well-designed suspension system give the new Honda Prelude excellent high-speed handling.

The question I kept asking myself during the auto writers' preview of the new Prelude sport coupe was "Why is Honda adding this car to its lineup?"

In just a handful of years, Honda has become No. 3 in U.S. import car sales and is gaining fast on second-place Datsun and sales leader Toyota. And Honda has accomplished this with only a few variations of just two basic cars: Civic and Accord. The tiny Civic, in sedan, hatchback and wagon form, has sold briskly since its introduction here in 1973. The aptly named Accord has been a sellout ever since its debut over three years ago, and a four-door sedan version introduced last fall has been equally successful.

Why the Prelude now?

Why then does Honda feel it needs a new sport coupe at this time, especially since the two-door Accord is a VW Scirocco-like hatchback coupe itself, and the company can't begin to produce or import enough of its existing models to satisfy the demand for them? And is this new Prelude really any different, or is it

just a notchback Accord with a trunk?

Well, here's an attempt at some answers: First, Honda sees the Prelude as appealing to a different sort of person, which is why they call it a "sports car for grown-ups." It's no accident that the Prelude's roofline and general profile make it almost a dead ringer for Mercedes' 450SL hardtop when viewed from the side. It's not intended as an affordable Mercedes, but it is supposed to conjure up images of refined German sporting efficiency for those who prefer quiet, solid, comfortable, steel-roofed "sports cars" over the traditional buzzy ragtop.

Second, the Prelude *is* a different car from the Accord inside and under its new body, although it uses the same transversely mounted 1751-cc, stratified-charge (CVCC), four-cylinder engine and five-speed or Hondamatic transmission and drive train, and feels much the same in everyday driving character. Except for an almost 2½-inch shorter wheelbase, the fully independent suspension layout is also similar, with coil springs over MacPherson struts, front and rear, and power-assisted front disc and rear drum brakes. The major difference is that the Prelude's larger 175/70 SR13

(Please turn to page 108)



Prelude in profile is a near copy of the Mercedes 450SL two-seater with hardtop.

Build the best lemonade

*** 'THIRST' AID

10¢

STAND

Easy to set up, this colorful, slip-together lemonade stand becomes an instant neighborhood attraction—all the kids on the block will be stopping by for a cool one. Plywood wings fold out quickly into a U shape (1). Seat and shelf then slide into slots to lock the structure rigid (2). Stakes and safety rope brace stand against unexpected gusts of wind (3).



Stand on your block

In a weekend work session, you can create this stand and be the hero on your block.

by Rosario Capotosto and Harry Wicks

Create this lemonade stand for your youngster and he or she will have a leg up on becoming the most successful entrepreneur in the neighborhood. We sized our prototype to fit kids from ages 6 to 8, but dimensions can be increased slightly if you want your version for a slightly older child. If you do, make certain you plan your layout carefully before cutting the plywood pieces.

The stand is lightweight, quite strong, easy to knock down and set up, and folds into a compact package for easy garage storage. To make it a snap for youngsters to maneuver the stand from storage to business site and back again, we have also included plans for an easily made hauling "crate."

To prevent the lemon from being blown over, our design includes holes in the uprights (see Photo 3, below) for lashing the unit securely. Stout cord looped through these holes and tied to either small stakes or tent pegs keeps the stand in business, even on windy days.

Building the stand

For convenient handling and easy storage, our lemon is halved and hinged. It's made of $\frac{3}{8}$ -in. exterior plywood, while the remaining parts are fashioned from $\frac{1}{2}$ -in. exterior plywood. Since several parts require just small pieces of plywood, check your scrap pile before ordering new plywood. If you must buy, get a 4 x 6-ft. sheet of $\frac{3}{8}$ -in. plywood for the lemon and a 4 x 4-ft. sheet of $\frac{1}{2}$ -in. plywood for the uprights, seat and counter.

Start the project by laying out the lemon



When it's time to close up shop, lemonade stand is folded neatly in half and toted in our rugged but lightweight "lemon crate." Unit takes little storage space in garage.

on the $\frac{3}{8}$ -in. plywood. Using a ruler, pencil and straightedge, mark off 4-in. squares so you can enlarge the pattern shown on page 130. Tip: Draw the lines lightly in the general outline of the lemon. Use a flexible aluminum yardstick, braced against partially driven nails, to draw the final, smooth, sweeping curves. Then draw the centerline. If you use a hollow-ground plywood blade in your sabre saw, you can do the drawing and cutting from the front (rather than having to reverse the artwork and draw on the back). On this project, the very slight splintering you

might get will be acceptable because you later round over the exposed edges.

Lay out the window and bore four large holes exactly on the four corners. Then, using a straightedge to insure accurate lines, cut the window out with your sabre saw. Sand all edges to remove any saw ripples.

To prevent any chance of splinters in small hands, ease all exposed edges slightly. Insert a $\frac{1}{4}$ -in. rounding-over bit in the router and adjust bit depth for a $\frac{1}{8}$ -in. cut. (This will leave a flat against which the bit's pilot can ride when you rout the second side.)

Cut the lemon in half, but do not rout the center edges because the joint must close tightly when the lemon is in the open position. Cut the counter, uprights and seat from the 4 x 4-ft. piece of $\frac{1}{2}$ -in. plywood. Sand and rout all but the lead edges of the uprights (where the hinges will be fastened). A $\frac{3}{16}$ -in.-deep rounding-over cut can be made on these parts. The slots for the counter and seat must be cut with accuracy. These should be just a shade over $\frac{1}{2}$ in. wide to allow clearance for easy fitting when pieces are joined.

Carefully lay out the slots and make the cuts. You can make a simple jig (as

[Please turn to page 129](#))



Concept and graphics: Doug Eisman
Construction design: the authors
PM photos: George Ancona, color
R. Capotosto, black and white

10 great shop tricks from a master craftsman



This is the fourth in a series of articles by noted woodworkers who have devoted much time to perfecting the craft. This month's expert is C.E. 'Doc' Banister. Doc restores treasured antiques sent to him from around the country; he also designs and builds custom pieces of all types, including music centers and other cabinets, special lathe turnings and workshop accessories.

Adjusting center-opening doors that overlap or gap

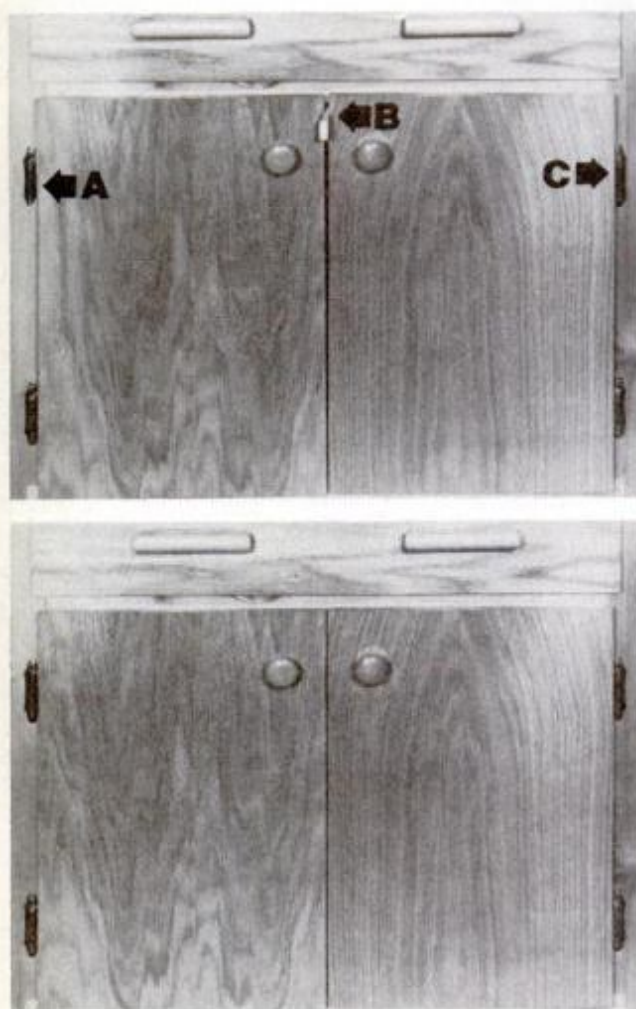

To adjust pairs of doors that open from the center and overlap each other, loosen the hinge screws of one door (here, A) and between the doors place a shim (B) that is thick enough to force the doors past their normal locations. Then retighten the hinge screws. Repeat this process with the other door (C) if the two still overlap. Conversely, if there is an unwanted and excessive gap between the doors, loosen the hinge screws and place the shims between the stile and door rabbet. Then close the door and retighten the screws.

Jig for repeat bench-saw cuts

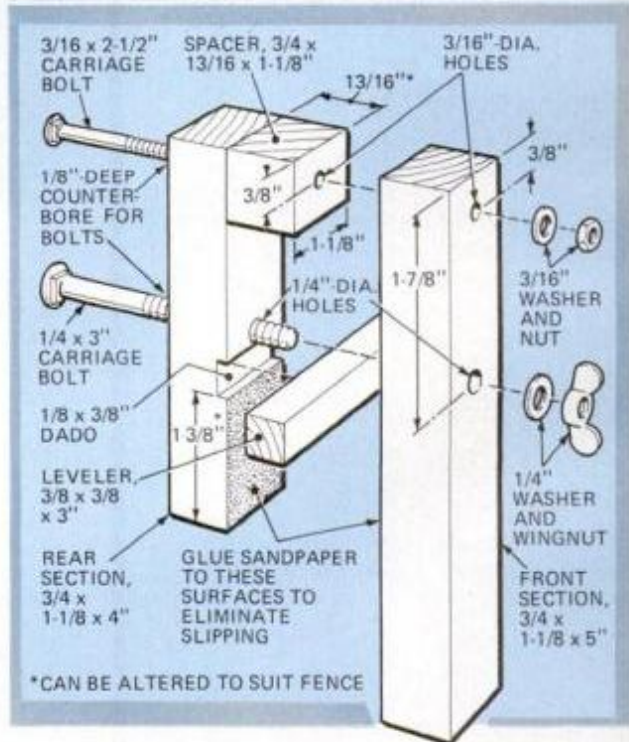
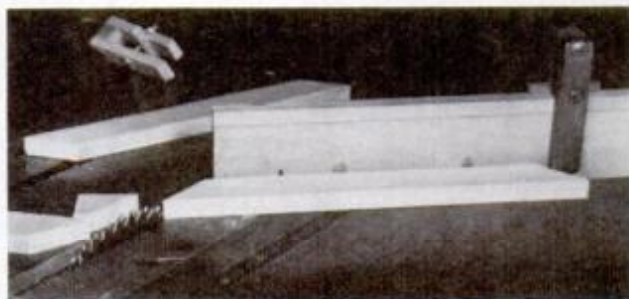

This stop for repetitive crosscutting on the table saw is easy to make and requires few materials. Yet it's a very helpful shop accessory. It fits on a board attached to the miter gauge and functions as a clamp and a stop. Length of the lower part of the rear section is governed by the width of the auxiliary miter board on which it's placed. If there is a tendency for the stop to slip, glue sandpaper to the inner surface of the lower leg of both the front and rear sections to keep the stop secure when boards are positioned against it.

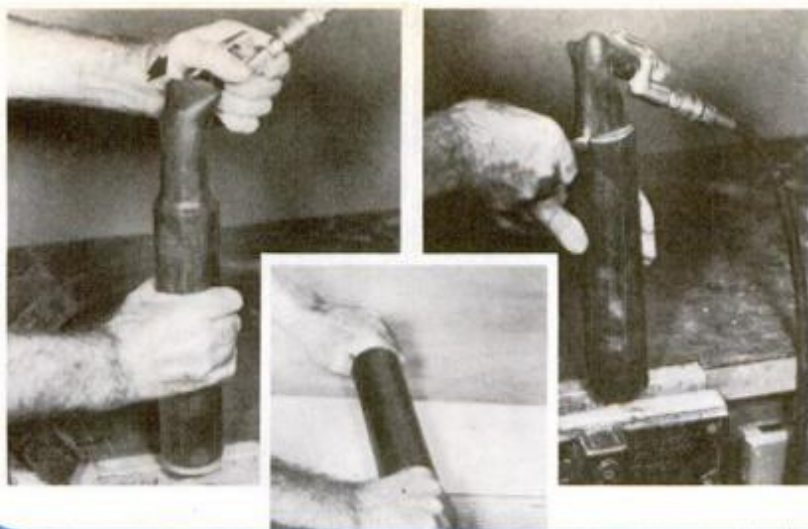

Tool for flattening laminate and veneer

This is a fine tool for flattening plastic laminate and wood veneer or mounting posters. It's simply a wooden rolling pin, which you can purchase or turn on a lathe, with a section of bicycle inner tube stretched over it. An air gun makes it easy to slip the tube on the cylinder. Stretch one end of the tube over the rolling pin. Use electrical tape to seal the other tube end to the nozzle of an air gun. The compressed air stretches the rubber so it can be positioned on the rolling pin. The tube virtually slides down the cylinder on a cushion of air with little effort from you.

Stove bolt aids turning

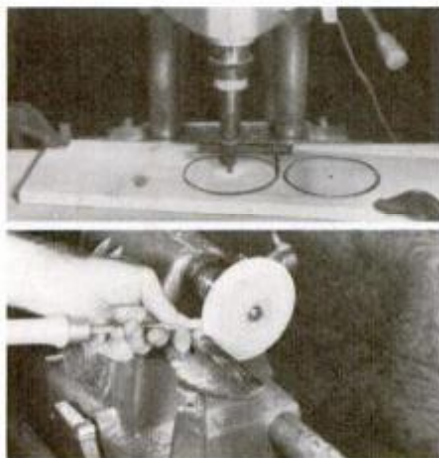

When lathe-turning wooden jar caps, wheels or discs up to 8 in. in diameter that require center attachment holes, cut the discs on a drill press with a fly cutter. Replace screw in lathe's screw center with a 1/4x2-in. flathead stove bolt. The 1/4-in. hole in the disc center fits neatly on the bolt. Secure disc with a washer and hex nut and turn.

Squaring a case

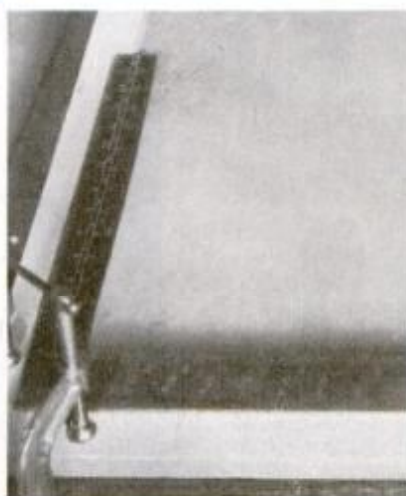

Here's a foolproof way to square a small or medium-sized case. Start by laying out and clamping a square corner on your workbench (left). Then use bar clamps to "rack" the case square. Clamp the cabinet top to the squared corner. Then run a clamp from top to bottom of the square. In extreme cases, insert a spacer in the corner opposite the latter clamp and pull the case *past square* and leave overnight. If needed, add more clamps after applying glue to joints.

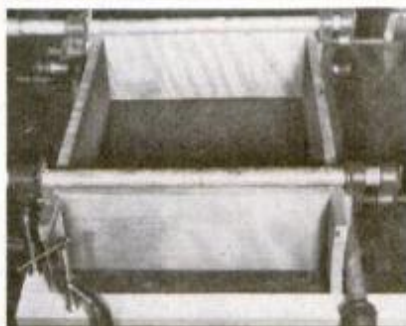

Cleaning saws and files

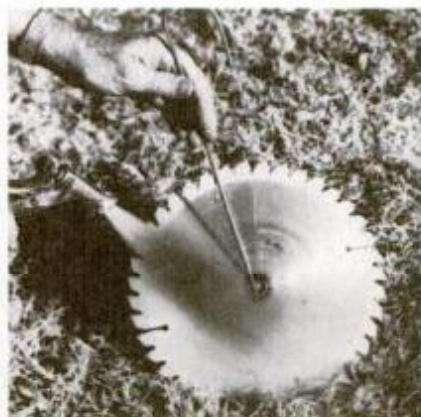

To clean pitch and scorch off saw blades, use an earthen, enamel or glass container that will hold a blade flat. Mix three tablespoonfuls of Drano with two quarts of water. Loop a wire through the arbor hole of the blade and lower the blade by the wire into the solution. Soak the blade for about five minutes. Then hose it off and thoroughly dry it. The blade should be as shiny as new. This solution also does a good job of cleaning wood rasps and files. However, soak these 10 to 15 minutes. Wash with a hose and clean any remaining material with a file card. As with any caustic or poison, store it in a place where children can't reach. Wear eye protection and follow the instructions for use on the label.

10 great shop tricks

Assembling furniture with glue

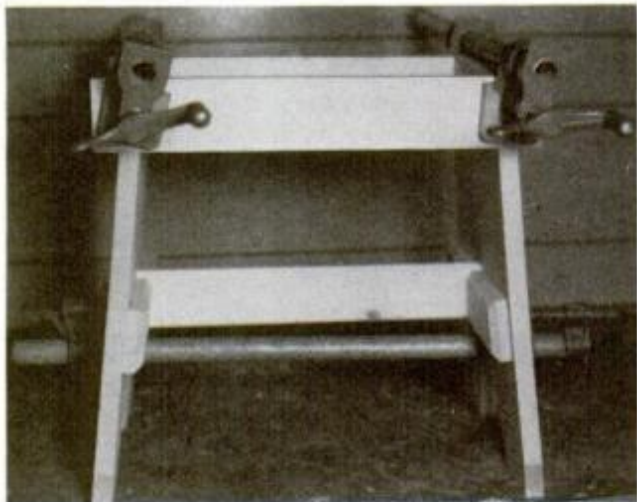

You can assemble cabinets and other furniture using only clamps and glue. Clean off glue squeeze-out with a damp sponge before it has a chance to dry. Using this method not only results in a need for minimal squaring, but the squaring can usually be done merely by shifting the clamps. Assemble chairs and stools on a flat surface. Check to see that all legs are plumb or, if splayed, are canted to the same angle.

Fastening screws during assembly



When installing wood screws, dip them in glue or spread glue on them before turning them into the wood. This stunt increases their holding power. The method is particularly effective when working with soft woods. After gluing the joints, keep the project in clamps for at least 12 hours, even if you use screws along with glue. Don't subject the work to undue strain for 24 hours to give the glue a chance to cure sufficiently.

Removing dents in wood



To remove hammer dents or other wood-crushing injuries, thoroughly wet a paper towel, fold it and place over the dented area. Apply a household iron set on "high." Steam will penetrate the dented wood and it will swell back to its normal level, filling the depression. Pass the hot iron over the wood to evaporate the excess moisture. Even large-size dents will respond to this treatment. Do be sure, however, that the wood is dried afterward before applying a new finish or coat of wax over it.

Cutting sandpaper, cardboard and other shop materials

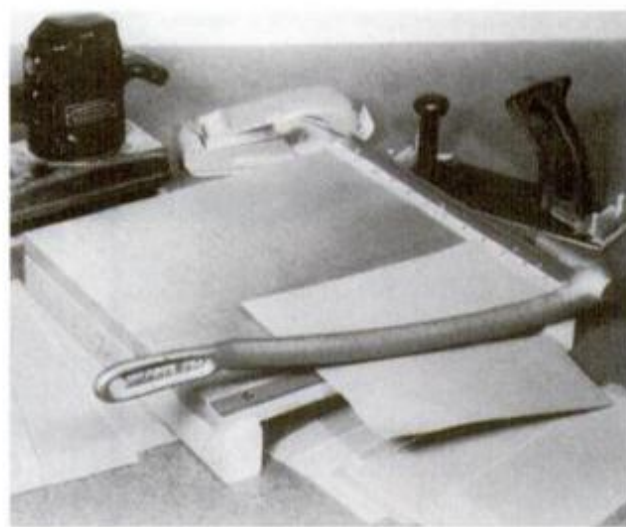

A good-quality paper trimmer will prove an invaluable aid around your workshop and home. You can use it to cut sandpaper to size accurately, neatly and quickly or to cut cardboard for templates, masks for painting trim and countless other projects. A good trimmer will even shear thin metal stock for use as shims.

NEW NOW for home and shop



A

A Skylights have become popular among do-it-yourselfers, but some cause heat loss. The Skywindow is said to reduce those problems through the use of a vinyl curb and an elastomeric weather gasket. The vinyl curb is designed to reduce heat loss through the skylight's periphery, and the gasket is made to reduce air infiltration. Dormer-shaped model DA is about \$200 for a 30x30-in. single-dome unit; model GA, with flat laminated safety glass, is about \$240 for a double dome. Wasco Products Inc., Box 351, Sanford, Me. 04073 makes it.

B For those with a yen for the past, the old-fashioned pull-chain toilet is once again available. Though it boasts an elevated tank, the unit is of modern construction throughout, including an insulated tank lining that is said to reduce condensation and dripping. Brass plumbing and pull-chain are available in chrome or 24-carat gold finish. The seat, cover and chain handle are made of oak, with a moisture-sealed finish. A white tank with chrome plumbing is about \$360; colors and gold plating are extra. From Kohler Co., Kohler, Wis. 53044.

C A spongy rubber O-ring allows the Twist-Lok cleanout fitting to install easily and seal tightly, the maker claims. The fitting, made of polypropylene, is said to be unaffected by solvent cements and thus cannot be accidentally solvent welded to its hub. The unit fits all standard plastic DWV (drain, waste and vent) hubs, without the need for cleanout adapters, and mounts with two self-tapping sheet metal screws. A 1½-in. fitting is \$1.95, while the 2-in. is \$2.49; 3-in., \$3.29; 4-in., \$4.95. Available from Genova Inc., 7034 East Court St., Davison, Mich. 48423.

D Walnut Antique Oil Finish is said to provide a simple way to achieve the effect of a hand-rubbed wood finish, but without a lot of effort. The liquid wipes on in one application and furnishes both color and protection. After application, buff the finish while it is still tacky to touch; it's said to be heat and stain resistant. Badly soiled surfaces can be restored by rubbing on the liquid with steel wool in the direction of the wood's grain. Finish is available for \$5.30 per quart. Minwax Co. Inc., 72 Oak St., Clifton, N.J. 07014.

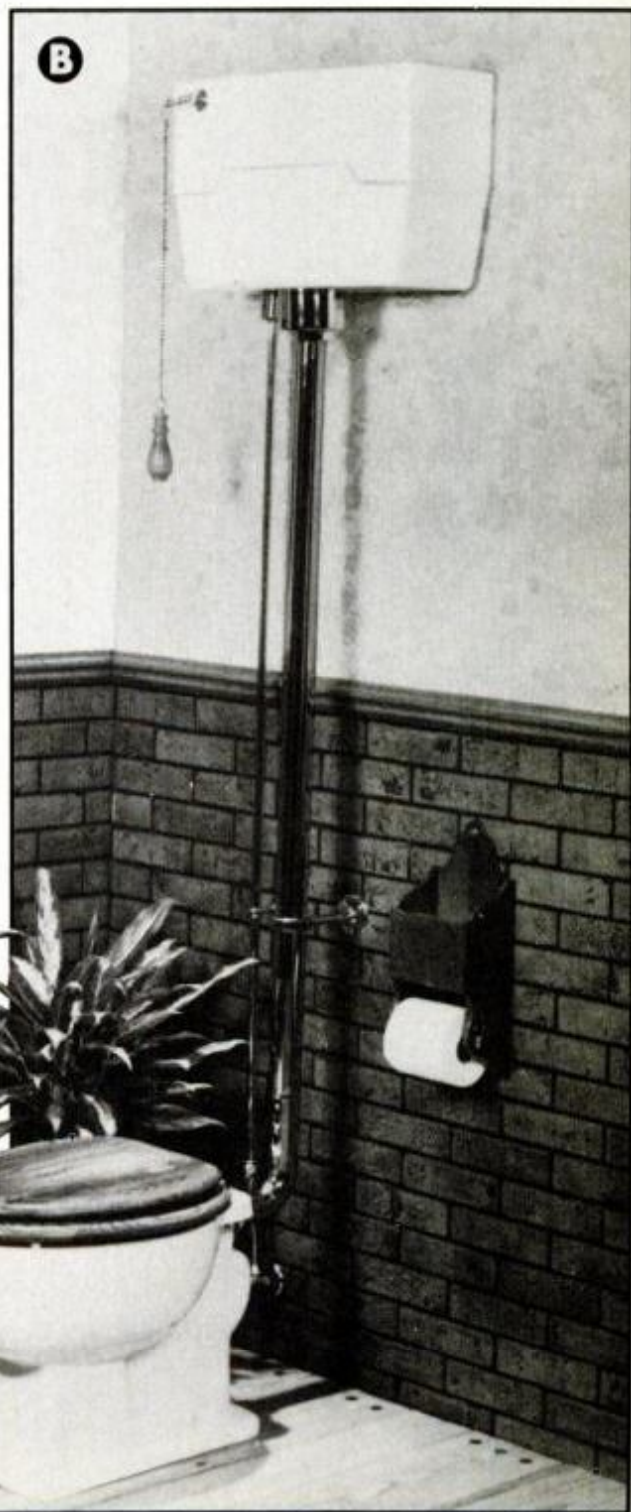

B



C

Antique
Oil Finish

MINWAX

Hard Finish
Soft Luster

WALNUT

D

Gleaming pewter tableware you can make

by Bruce R. Guyot

Here are basic techniques for the crafting of this easy-to-work metal, plus four handsome projects.

Although pewtersmithing is an age-old craft, the pewter objects crafted today have a contemporary appeal, thanks to updated designs and materials. Modern pewter sheet comes from the mill with a highly-polished finish that will remain untarnished indefinitely with proper care.

Aside from the attraction of the finished objects, you'll find that working with pewter is a pleasure in itself. Pewter is soft enough to be shaped by pounding with plastic mallets. It has a relatively low melting point so that it is easy to solder. (This low melting point, however, rules pewter out for making



Pewter objects accented with cherry wood make up this still life. Create your own handsome results by following instructions for making the salt and pepper shakers, the fruit bowl, box and tankard.

ovenwear.) For the most part you can use the woodworking tools you already have to make pewter items. In fact, about 75 percent of the tools that I use professionally are woodworking tools.

The four projects shown are designed to give you an introduction to the basic techniques for working with pewter. Instructions for the projects follow in increasing degrees of difficulty from the easiest piece, the fruit bowl, to the most difficult project, the tankard. Suppliers of materials and tools are listed at the end of the story.

Cutting pewter

Pewter is a soft metal that's quite easy to cut in any number of ways, depending on the tools you have. The pewter should be supported on both sides of the cut as you work. *Note:* Be sure to wear safety goggles and, if

The author is a professional pewtersmith. His studio is located in upstate New York.



PM photos: Carl Weese

SCORING, CUTTING, SHAPING, FILING, SOLDERING



Use either a commercial scoring tool or a common nail to scribe the pewter. Be sure to apply only a light pressure to this soft metal.



A hand sheet saw will make fine straight cuts. Take care to support the metal on both sides of the cut with plywood underneath it.



Best way to cut the outside curves is with a bandsaw, but a sabre, scroll or coping saw can also be used.



Sandwich the pewter disc in a wood form. Clamp assembly to bench; then pound to shape using a mallet.



Begin pounding around perimeter of the bowl, and continue to work in circles that become smaller in diameter each time until you reach the center.



To make a cylinder of pewter, just clamp the hardwood form in a vise; then bend the pewter by hand and lightly tap the ends together.



If cylinder fits loosely on a form, file seam edges by rubbing on a saw spine covered by 220-grit abrasive.

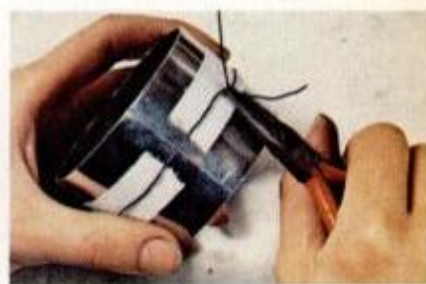

Twisted iron binding wire keeps edges together for soldering. Sheet asbestos shield under the wire is optional.



Hang cylinder by a rod secured in a vise. Brush flux inside on the seam and deposit solder bits on the flux.



Melt solder by applying torch heat under seam. Keep the torch moving to heat both sides of the seam evenly.

you cut for long periods, also wear ear protection.

The most accurate way to make a straight cut is with either radial-arm or bench saw. Use a plywood- or veneer-cutting blade. A hand sheet saw also makes straight cuts. This is a special hacksaw without a thick spine that allows deep cuts into sheet stock.

Making curved cuts requires other tools. A bandsaw makes clean outside curves. A scroll, sabre (with fine blade only), coping or jig saw make both outside and inside cuts.

Shaping pewter

You can shape sheet pewter by pounding it into or bending it around a hardwood form. These

forms can be turned on your lathe.

When you pound a pewter bowl or other concave shape into a wood form, start at its perimeter and work in gradually diminishing circles until you reach center. Then work from the center back to the perimeter. Repeat the process, feeling for bumps with your fingers to smooth the metal surface.

To make a pewter cylinder, or truncated cone shape, such as the tankard, bend the metal around a hardwood form. The form should be longer than the pewter piece, so it can be gripped in a vise. The pewter should close snugly around the wood form or leave a gap of no more than $\frac{1}{16}$ in. If the metal fits loosely on the form, sand the edges to fit. If the gap is larger than $\frac{1}{16}$ in., cut and try another piece. Seam edges must be even to solder.

SURFACE FINISHING, SOLDERING BOTTOM PIECES



File diagonally across the seam with a half-round file until all the solder points are removed. Then force the cylinder over the hardwood form to reshape it.

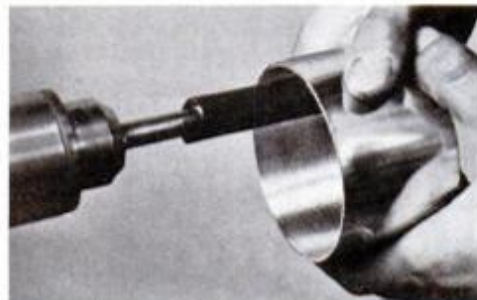

To finish interiors, chuck a $\frac{1}{4}$ -in.-dia. steel rod; tape 220-grit abrasive, rough side out. Move pewter in circular motion. Repeat with 400-, 600-grit types.



Sand the bottom and top edges of the cylinder by placing it on 220-grit paper and working in a circular motion.



Before soldering a bottom to the cylinder, cover seam (inside and outside) with ochre mixed with water until it's creamy.



Set the oversize bottom on a flameproof surface, apply flux carefully to the cylinder bottom, position cylinder on disc and place bits of 63-37 solder on lip.



Heat the bottom seam area. Keep light pressure on the cylinder with a block of wood to assure a tight seam. The flux will boil; then the solder will melt.

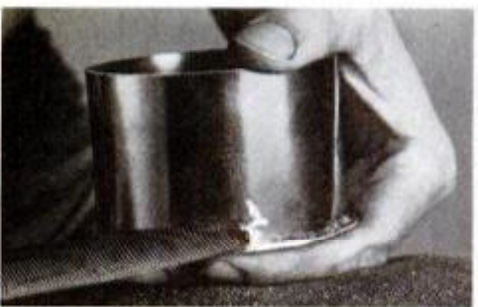

File off the bottom lip and excess solder; smooth vertical seam. Remove file marks with 220-, then 400-grit sandpaper.



Rotate the buff at 3500 rpm and apply tripoli cutting compound. Move the cylinder on the buff's lower front quadrant.

Soldering pewter seams

Iron binding wire wrapped around the pewter shape keeps the seam edges together when you solder. Cut one or more wire lengths and wrap them near the ends.

Into a clean glass dish, cut as many $\frac{1}{16}$ -in. bits of 60-40 solder as you'll use in one working session. Hang the pewter piece on a rod, seam side down. Brush flux on the inside of the seam and deposit solder bits on the flux at $\frac{1}{2}$ -in. intervals and at each end, so they straddle the seam.

Set the torch to a low flame and apply heat under the seam outside the cylinder. The solder will melt soon after the flux begins to boil. *Keep the torch moving. Pewter melts at close to the same temperature as solder does.*

Finish the inside of the pewter (see instructions) before you solder the top and bottom pieces.

Cut both top and bottom pieces oversize. Brush-finish bottom with 400-grit abrasive. Rest the bottom disc on a flameproof surface. Protect all seams and soldered areas from heat by brushing on a creamy mixture of ochre and water. Flux the bottom of the cylinder, center it on the disc and position $\frac{1}{16}$ -in.-long bits of 63-37 solder on the seam. This solder melts at a lower temperature than that used on the vertical seam.

Finishing the metal

As you solder, keep light pressure on the cylinder top to assure a tight seam. If the piece is to hold liquid, fill it with water to check for leaks. If you must patch a leak, cover other soldered areas with ochre.

If the interior of the piece won't be visible, as in a salt shaker, for exam-

ple, just remove the solder residue from the inside seam by filing diagonally across the seam with a half-round file. If the finished piece is open, finish it with 220-, 400- and 600-grit sandpaper. A steel rod chucked in a lathe or drill press with a length of sandpaper taped to it makes a good tool for fine-finishing the interior of the piece (see photo, page 94).

Reshape the piece by forcing it over the hardwood form. Sand the bottom and top edges of the cylinder, or other shape, by placing it on 220-grit sandpaper and moving it in a circular motion.

After the bottom and top of the piece are soldered in place and the excess pewter filed off, smooth the outside of the seams by wet sanding with 220-grit abrasive. Sand the en-

(Please turn to page 111)

MATERIALS LIST—BOX

Key	Pcs.	Size and description (use)
A	1	1-1/8" x 9-1/2" 18-ga. pewter (side)
B	1	3-1/4" dia. 18-ga. pewter disc (bottom)
C	1	3/4" x 3-1/2" dia. cherry wood (top)

Misc.: 2 7/8"-dia. x 4" maple cylinder form; tung oil; 2 7/8"-dia. suede disc (optional).

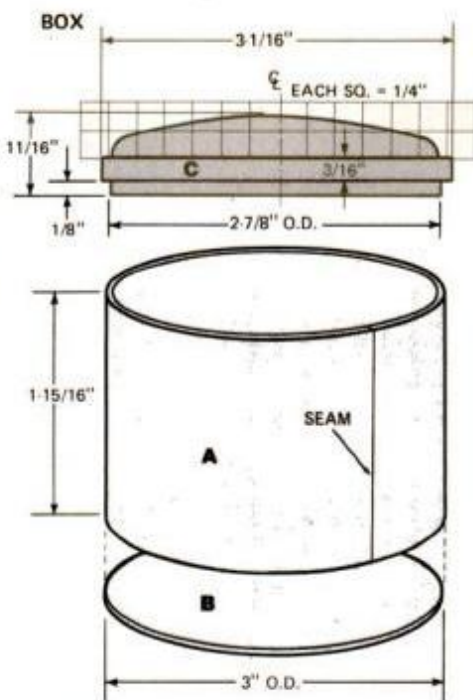

BOWL FORMS

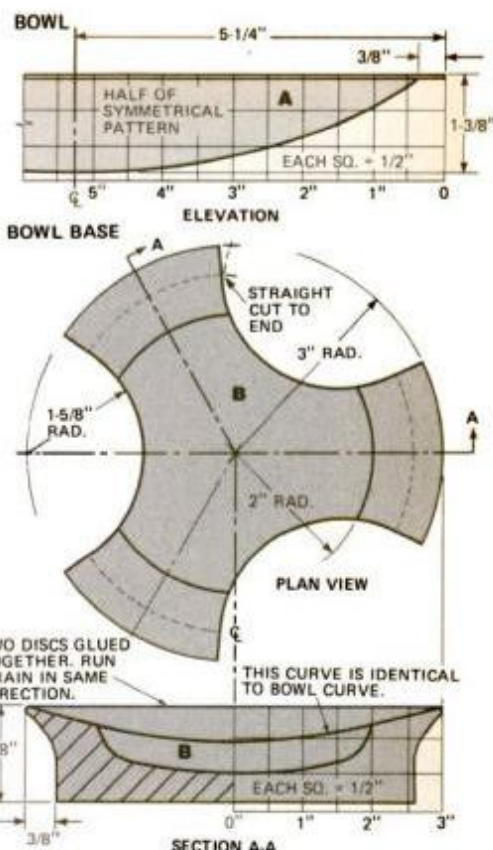
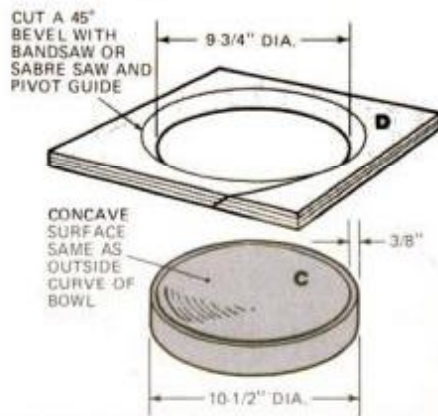

MATERIALS LIST—BOWL

Key	Pcs.	Size and description (use)
A	1	10-1/2"-dia. 18-ga. pewter disc (bowl)
B	1	1-1/2" x 6-1/4"-dia. cherry wood disc (base); glue up 2, 3/4-in. pieces
C	1	1 1/2" x 11"-dia. maple disc (form)
D	1	3/4" x 12"-sq. plywood (form top)

Misc.: Glue, masking tape, tung oil.

What you'll need

TOOLS AND EQUIPMENT

Nonmetallic mallet (plastic, rawhide or nylon).
Scoring tool (awl) or nail to mark metal.
Saws to make straight cuts: radial arm, bench saw or hand sheet saw.
Saws to make curved cuts: band, scroll or coping saw.
Torch that produces a small, conical flame.
Drill.
Center punch.
Wood lathe.
Motor spindle, as on a lathe, for buffing.
C-clamps.
Needlenose pliers.
Files: 6-in. flat and 6-in. half-round; should be single (cadillac) cut; straight cut makes for easy cleaning.
Outside calipers.
Buff rake, to raise nap of new buff; you can make a rake of 3/4 x 3 x 8-in. scrap wood and 18 roofing nails spaced 1/2 in. apart at one end of the rake.
Small paintbrush for applying ochre.
Small paintbrush for applying flux.
Goggles.
Ear protectors.
Cotton gloves.

SUPPLIES

18-gauge sheet pewter (see individual projects for size).
Ochre (a powdered clay mixed with water. Brushed over a seam that's already soldered, ochre prevents the solder from melting when heat is applied to a nearby area).
60-40 tin-lead solder to secure joints; it melts at 370° F.
63-37 tin-lead solder to attach the bottoms; it melts at 358° F.
Glass dish or ashtray to hold solder.
Pewter flux. (You can make this yourself using one oz. of glycerine and adding 10 drops of hydrochloric acid. Get the chemicals from your pharmacist or ask him to prepare it.)
20-gauge iron binding wire to hold cylinders together for soldering. Molten pewter won't adhere to the iron.
Thin sheet asbestos to protect pewter from binding wire scratches during soldering (optional).
Asbestos or Transite pad.
1/4 or 1/2-in.-dia. steel rod (long bolt) to hold pewter shapes while soldering them.
220-, 400-, 600-grit wet-or-dry sandpaper.
6-in.-dia. muslin buff and a means to mount it on a motor spindle.
Tripoli compounds: a cutting compound and a polishing compound (get compounds designed for nonferrous, soft metals).

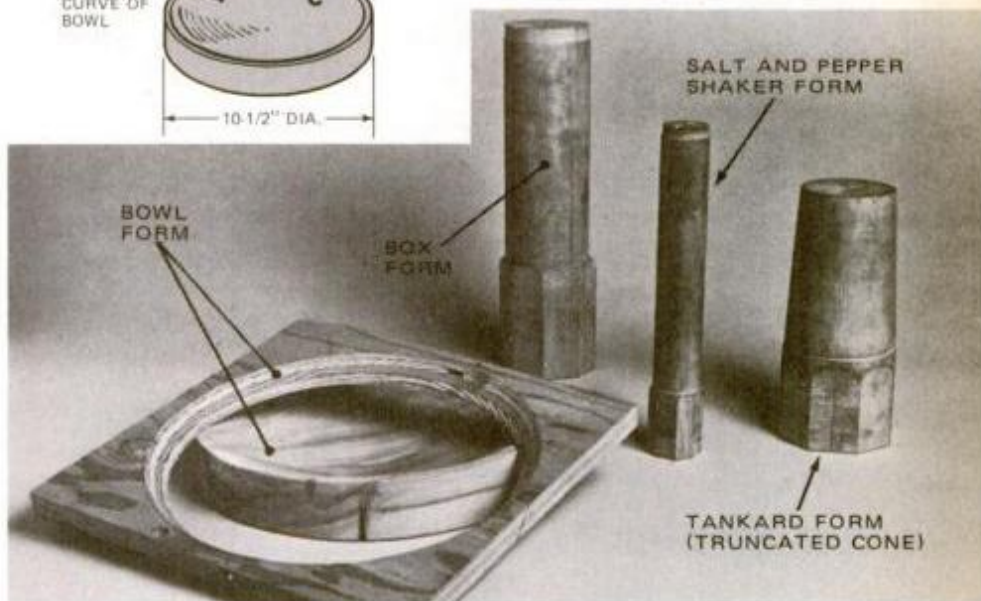

To shape sheet pewter, bend or pound it to conform with hardwood forms like these.



Two woodturning techniques are: spindle turning (left) to make cylindrical forms and faceplate turning (right) to make dish forms. For directions on making these shapes see *The Secrets That Make You a Woodturning Expert*, page 144, May '79.



1 These frame moldings by Klise are a few of the available designs. They let you create the effect you want at much lower cost than made-to-order frames.

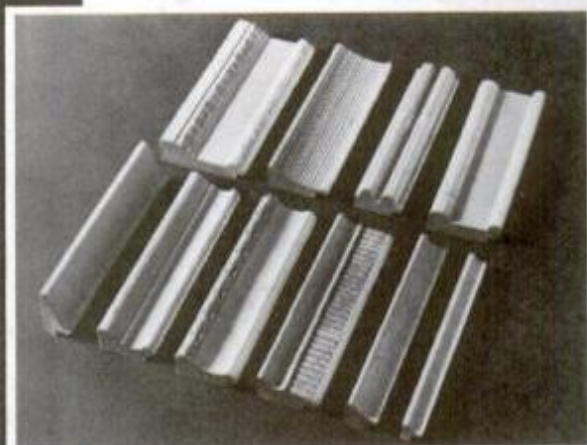

A special photograph or painting deserves a special frame. One way to get that custom job is to frame the art yourself.

Using unfinished picture-frame moldings to make your own frames combines the two benefits of any do-it-yourself project: You save money and you get custom work. Costs for at-home framing of the four prints shown here were about one-fourth the amount that was quoted by a professional framer. By doing your own framing, you not only enhance the art, you also assure that it blends appropriately with the room decor.

You can choose from a variety of moldings. With imagination and a little woodworking effort, you can combine moldings for still other creative effects.

Unfinished hardwood-frame moldings are available nationally in hardware stores and home centers. If you have a problem locating a do-it-yourself source, write Klise Manufacturing Co., 601 Maryland Ave. N.E., Grand Rapids, Mich. 49505, for

Quick framing with ready-made moldings

You can create custom frames with very little effort.

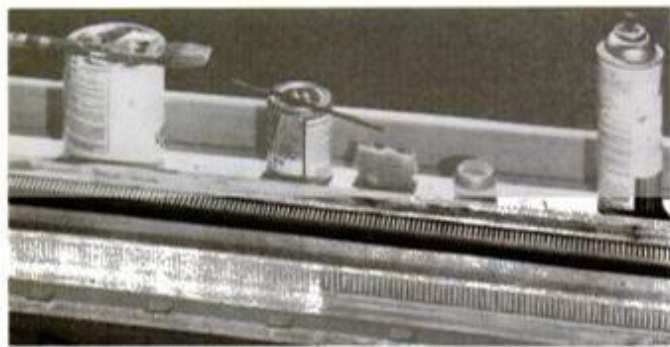

2 The top molding has a four-step finish. Results of the steps are shown in the bottom molding, left to right. The first step is to paint on a champagne-white basecoat.



3 After the white paint dries, grain the cove and fill the crevices with walnut stain applied with a sponge. Next, add gold highlights. Then finish with spray varnish.

4 Measure for length on the back of the molding. Mark it about $\frac{1}{16}$ in. oversize so the glass will fit in easily. Cut the 45° miter with a backsaw. Here, a corner clamp is used as saw guide to cut the miter.



the location of the nearest dealer. A mat border enhances most framed pictures. These four prints are unified with moss-green mats—a color that's found in all of the scenes pictured.

Framing accessories

Take the art you want framed to your local framing store along with knowledge of the color and texture of the wall on which it will hang. You can select a mat that picks up or complements a color in the art or furnishings in the room. The frame shop will cut the mat to order.

Glass or acrylic glazing protects prints from dust and keeps them flat. Nonglare picture glass costs extra, but cuts unwanted reflections.

Finishing the hardwood molding is the final creative touch. The finish applied to these frames is antique white with gold highlights to complement the scenes in the pictures and to contrast with a dark brown wall. See the photos and numbered captions to learn how these frames were made and finished. **FM**

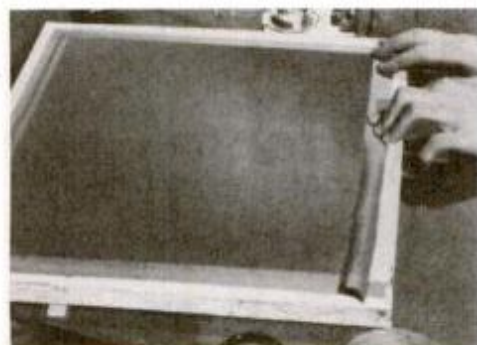

8 Insert corrugated cardboard so the back is flush with the frame. Secure the cardboard with water-activated gummed tape.

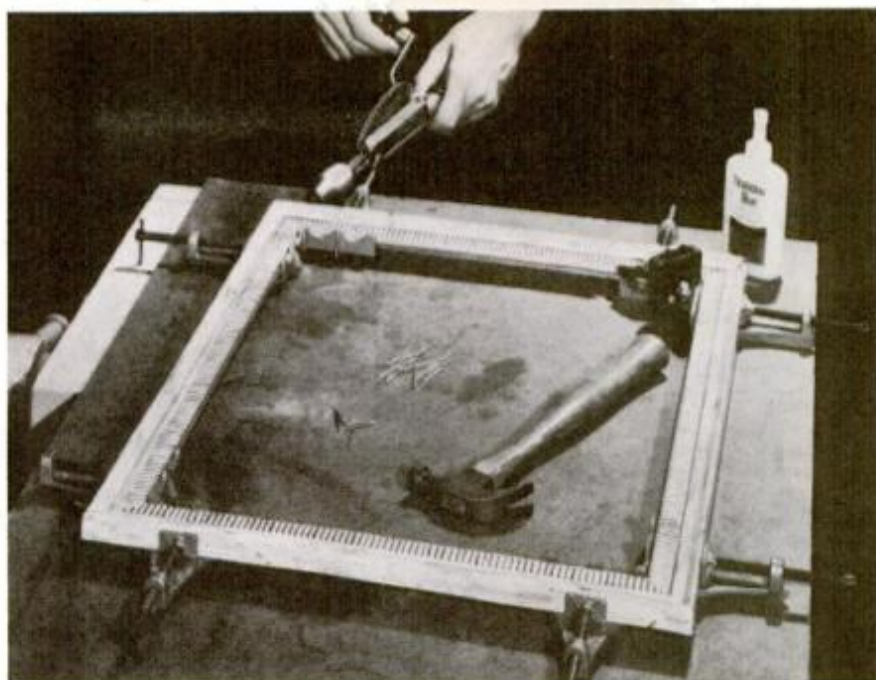

5 Glue and clamp the four mitered corners together. When dry, bore two nail holes at each corner. Nails should be toed slightly, not parallel to the

grain. The two nails should also be of different lengths. Use either ringed or rosin-coated nails for a superior holding power.

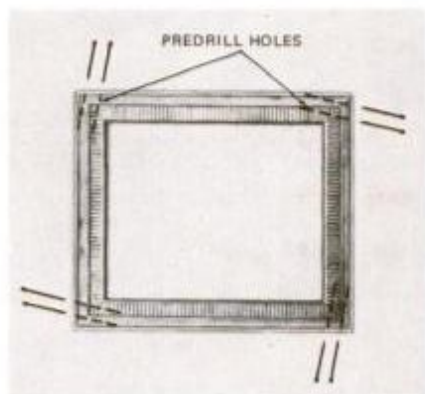

6 Slightly angle two nails of different lengths in each corner as shown.



7 When the frame is finished and assembled, insert the glass and the art which is spot-fastened to its mat with masking tape. Ordinary staples pressed in with a screwdriver secure the materials. This method eliminates the chance of nicking the glass by driving in brads with a hammer.



9 Use white glue and kraft paper to seal the back of the frame. Before gluing, dampen the paper with a wet sponge. It will expand, then later contract to produce a taut surface.



10 Trim off the excess paper with a knife. Complete the frame by installing eyehooks about a third of the distance from the top to the bottom. Then attach picture-hanging wire.

Quick fixes for small-appliance problems

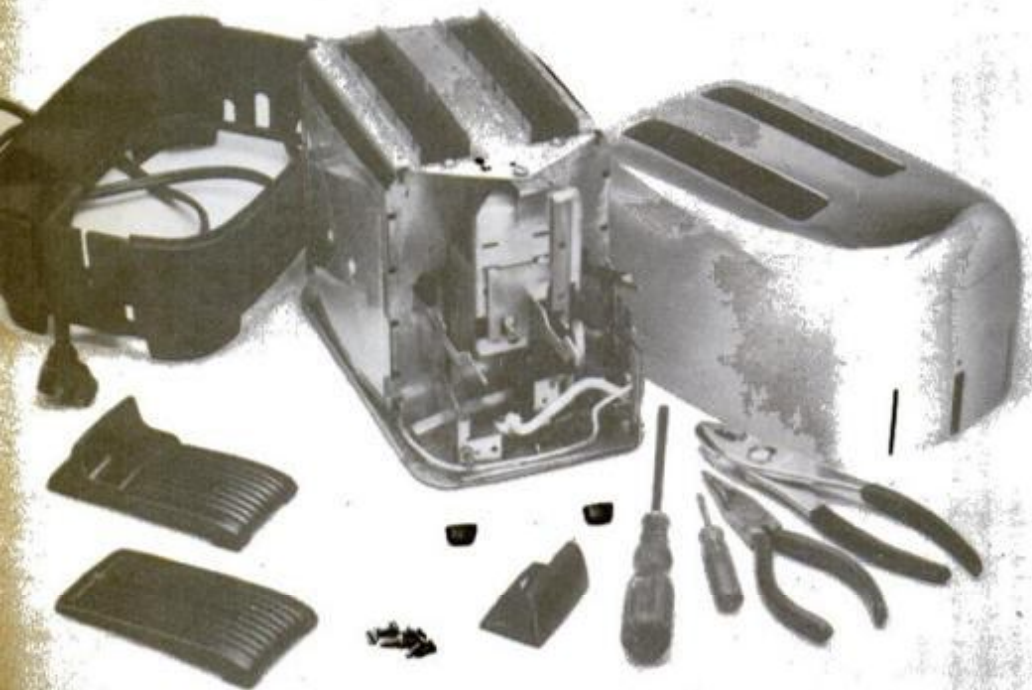

You can extend life of your appliances by learning how to spot common problems.

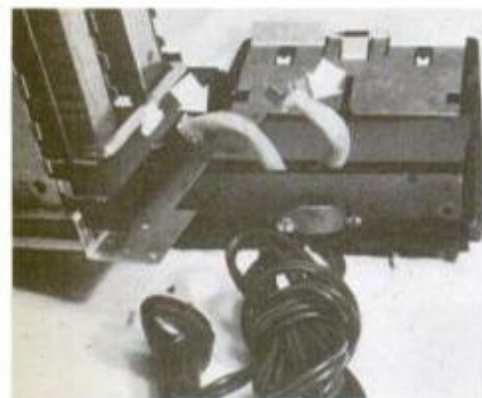

To test or replace a power cord, disassemble the appliance to get at the cord's terminals (shown here by arrows).



If ohmmeter reads infinity (∞) with leads connected one way and 0 when connected in the opposite way, power cord is okay.



There are two basic kinds of resistance heating elements—a closed element (left) and an open element (right).



Test a closed element by connecting the ohmmeter to the element's terminals. A zero reading indicates a sound element but a ∞ reading shows a bad element.

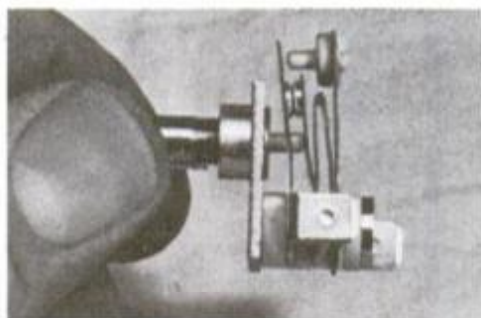

Thermostat (shown removed from appliance) is a switch which opens and closes to disrupt or permit current to flow—depending on need to produce heat.



Sometimes dirty or pitted points hamper thermostat operation. To clean the points, stroke lightly with an ignition point file. Be sure to brush away dust.

Labor costs being what they are, it is often impractical to have small, broken kitchen appliances fixed by a professional. It's a different story if you can do it yourself, because you can usually replace defective parts for a few dollars. The important thing is to know what you're doing, so you don't waste your time or further damage the appliance.

Safety note: If you do decide to attempt the repair of one of your appliances, keep in mind that the power cord should be unplugged from the power outlet while the unit is disassembled and while making tests with the ohmmeter.

The two types of kitchen appliances that you will be dealing with are those that heat and those that don't. The former predominate, and include toasters, toaster ovens and fry pans.

Checking heat-type appliances

Appliances that heat have two of three major components in common—a power cord (either the attached or the detachable kind) and a heating element. They may or may not have the third common component, a thermostat. When an appliance doesn't get hot, barely gets warm or overheats, the trouble is usually with one of these three components. Before examining the com-

ponents, however, check for loose connections or a defective outlet or plug.

Test the outlet by disconnecting the appliance and plugging in a lamp. If the lamp lights, the outlet is okay. If it doesn't light (and the bulb isn't defective), either the fuse or circuit breaker serving the outlet has flipped, or circuit wiring is bad.

Testing a power cord

To test a detachable power cord, connect another power cord (of the same gauge and known to be good) to the appliance. Does the appliance work now? If not, the problem may rest with the thermostat and/or heating element. Testing these components will be discussed later.

To test an attached power cord, unplug it from the wall outlet and open the appliance to reveal the other end of the cord. Now check to make sure a terminal hasn't come off a connector. If it has, you have discovered the problem. If a terminal is corroded or burned, or if the power cord is frayed at either end, replace the cord. It is in danger of failing and starting a fire.

Power-cord terminals are normally held to contacts by spade connectors, which are slide-on, slide-off parts, or by small nuts and bolts. To test a power cord for internal failure, once again make sure the appli-

(Please turn to page 124)



Ohmmeter in top photo shows that this toaster does not have a short. In photo above, however, we created a severe short to show that ohmmeter needle will swing to 0. Any movement of the needle from infinity (∞) indicates a short.



The two most common types of small-appliance motors include shaded-pole motor (left), used in can openers and electric knives, and a two-part universal motor (right). Universal motor consists of an armature (bottom) and field coil. Appliances need not be discarded when motors go bad, since the motor or motor components are available as replacement parts.

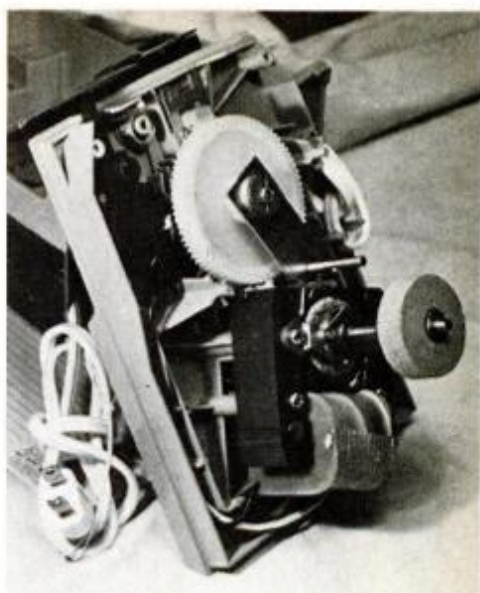

Maze of gears and wire becomes clear once you know what you're looking for. With the back pulled off this can opener, the essential parts, such as motor and power cord, are easy to spot for testing.

TOOLS TO HAVE ON HAND FOR REPAIR WORK

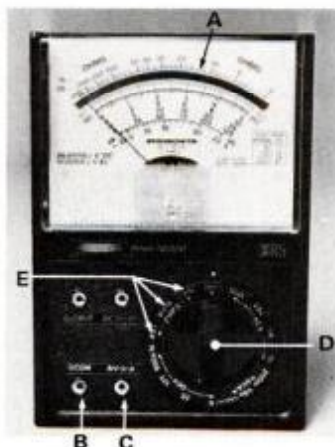

Ohms scale A on VOM (volt-ohm-milliammeter) is normally the only one you'll need to read while repairing small appliances. To test for circuit continuity, plug the black and red test leads into the correct jacks, B and C respectively. Set range switch D to appropriate ohms position E. Then touch probes on test leads across circuit. A reading of infinity means circuit has no continuity.

A toolkit like the one shown at right is worth the investment if you hate to throw away a hair dryer or mixer, just because it would cost more to fix it at a repair shop than to buy new. See below for complete list of tools to include in your small-appliance repair toolbox.



To get an accurate idea of what tools you need for repairing small appliances, we asked a pro. Jack Fletcher, who runs the All Appliance Service Center in Norwalk, Conn., says that the tools of his trade are surprisingly simple. A well rounded assortment begins with a soldering iron *(1); assorted screwdrivers (2), both short and long, and in flat-tipped and Phillips-head types, are also essential; small screw-holding screwdriver (3) is optional, but may save hours; cyanoacrylate-type glue (4) is great for mending. You should also include assorted Allen wrenches (5),

hammer with interchangeable head ** (6), wire stripper (7), pliers (8), wire cutter (9), and longnose pliers (10). The small socket and ratchet set (11) is handy, but optional. So are the VOM meter *** (13) and riveting tool (14).

—J. Provey

*Soldering kit shown is new from General Electric and includes a 30-watt, 120-v. iron with Nichrome element, flat and pointed tips, rosin-core solder and an iron rest. It's available at hardware outlets. **Hammer set is manufactured by X-acto, 45-35 Van Dam St., Long Island City, N.Y. 11101. It is at many art supply and hardware stores. ***Micronta VOM lists for \$16.95 at Radio Shack outlets.



Build a platform bed that's the living end

by Harry Wicks
HOME AND SHOP EDITOR

A simple studio bed, covered to match the walls, takes on a very special "platform look" from the surrounding U-shaped structure that you can build from our plans. The wooden add-on provides a number of creature comforts, such as a spot to park a TV set and/or hi-fi gear, or pillows for extra seating the next time your teen-ager has the gang over.

The entire room is a do-it-yourself project. The walls are decorated with a self-adhesive wall covering which is easy to install. Its pattern takes charge of the walls, alternating its silvery shimmer with a bright blue tile-like design.

Interesting touches that complete the happy feeling in the room are the magazine rack, hanging basket and wood-tubbed cactus. All accessories offer an expensive-looking textural interest that is inexpensively achieved.

Building the bed surround

The framework for the surround is constructed of 1x3 material assembled as

shown. The cantilevered platform gets its sturdiness from the 10x10-in. corner irons that secure it to the vertical wall framing members spaced 16 in. on centers. When the wall and seat are skinned with the diagonal 1x6 tongue-and-groove boards, the structure achieves full rigidity.

Since the structure must be built to suit the bed it will contain, start by taking careful measurements of the bed. Make a sketch on graph paper and note all measurements thereon. Refer to your drawing when you lay out the framework—*make certain you allow some space* (I.E.; if bed is 36 in. wide, the inside measurements of the U-shaped frame should be a minimum of 36½ in. wide). Allow similar spacing for the length dimension.

Your drawing should show locations of the various framing members. On the prototype, vertical members (studs) are located 16 in. on center to provide adequate nailing for the tongue-and-groove boards used on the surface.

You can use pine or other softwoods,

such as spruce or fir, but make certain you bore lead holes for any fastening with nails. Since, for the most part, the structure is built of ¾-in.-thick stock, the pre-bored holes are a must to prevent splits and weak, poorly fastened joints.

Cut all parts for the walls and temporarily tack them together so the unit can be checked for fit with the bed. If you've built too close for comfort, now is the time to sneak in a filler strip or two, if needed, because they will be hidden when the framework is skinned with the tongue-and-groove boards.

When satisfied with the fit, disassemble the walls and haul the parts back to your workshop. Reassemble the three wall units using finishing nails and carpenter's glue. All assembly of the ladder-like wall frames should be with 6d or 8d finishing nails; the rule of thumb is to use the largest size that won't cause splitting.

When dry, stand the units in position and check the corners for square; hold them that way with diagonal braces

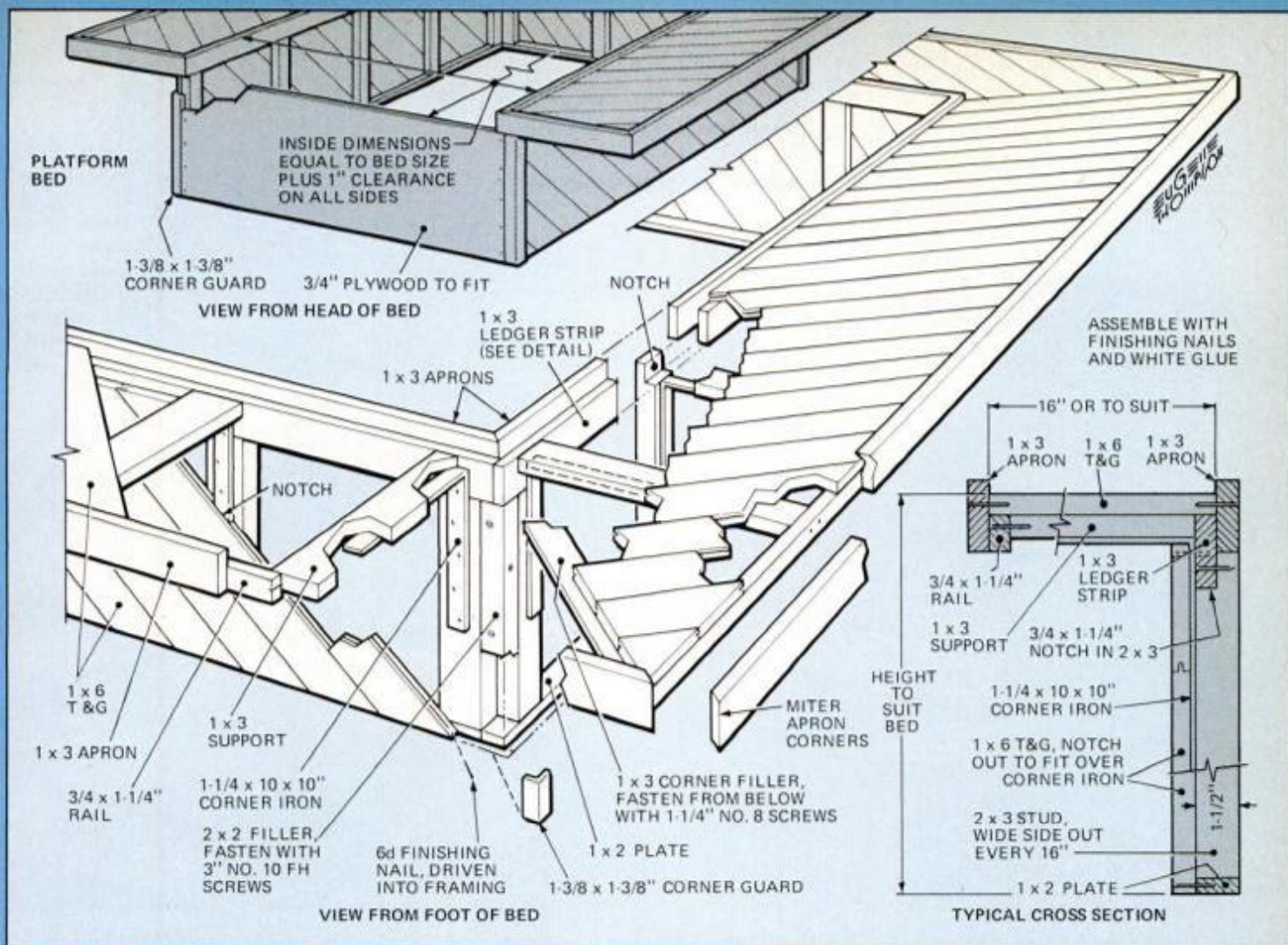

tacked at the corners. You will need one long straightedge tacked to the sides near the head of the bed structure. Install the filler strips at the corners with screws, and then join the corners with screws *only*. The idea here is to build a unit that will be relatively easy to move should the need arise.

Construct the cantilevered shelves using the technique shown above. The corner irons provide the fastening and the strength for the shelves. These may not be readily available, even in an otherwise well-stocked hardware store. But the dealer can get them on special order.

Since the diagonal lumber goes on over the brackets, it is necessary to plow out grooves in back to receive the hardware. You can make the groove with a router, straight cutter and clamped-on guides, or handsaw and chisel. Grooves do require careful layout and cutting.

You can eliminate this task by using 8x8-in. (or larger) shelf brackets. If you make the switch, keep in mind that the shelf brackets will be mounted on the face of the diagonal boards; thus, they will be somewhat in view on the finished project.

Install the shelf framework on the walls using glue, screws and nails. If you want to retain the take-apart advantage, the U-shaped platform can be built as a unit and completely screw-fastened to the walls.

Make certain that you predrill lead

holes in the tongue-and-groove boards for the shelf. If you do too much banging with a hammer, you are apt to do more destroying than building. In fact, it is recommended that you do a minimum of nailing from above and complete the shelf fastening task by using screws in pre-drilled holes from below.

Covering the walls

The application of peel-and-stick wall covering is a relatively easy way to refinish your walls. Start by estimating your needs. Keep in mind that a running yard of vinyl self-adhesive 18 in. wide contains 4½ sq. ft. of material. Thus, measure your walls to determine square footage (width x height). Divide the total square footage by 4½ and you have the number of running yards required to do the job. For example, an 8x10-ft. wall will require 18 running yds: $8 \times 10 = 80$ divided by $4\frac{1}{2} = 17.7$ or 18 running yards.

The surface to be covered should be clean, smooth and firm. Walls, whether wood, plaster or drywall, should be sealed with either shellac or a good quality paint. Nonporous surfaces such as metal, glass or plastic laminate do not have to be sealed.

Since walls usually aren't perfectly straight, start by establishing a true vertical with a plumb bob and chalkline. Tack the line near the ceiling and suspend the

bob. When movement ceases, hold the line secure against wall at bottom and snap the chalkline. If you start near a corner, snap the line 17½ in. away, giving a ½-in. overlap on the adjoining wall.

Unroll the wall covering on a flat surface and cut to length. Each sheet should equal floor-to-ceiling height plus 2 in. This allows 1 in. at both top and bottom; the extra length is trimmed off later.

Peel 6 to 8 in. of backing paper from the top and apply the paper to the wall, starting at the ceiling joint. Continue removing backing paper and run your hand down the face to make certain the wall covering is running straight without air bubbles.

Continue in this fashion around the room after checking corners for plumb with a level. Trim paper to suit any uneven corners. Con-Tact Brand adhesive paper is available at paint and department stores; the design shown here is Odyssey.

If you like the look of the structure but feel that all this framing and building is beyond your immediate skills and/or needs, consider building a simpler frame and then skinning it with ¾-in. plywood. This simplifies the construction to a great degree and you can still have the diagonal wood look by covering the plywood with a wood grain self-adhesive wallcovering. Con-Tact Brand's Woodgrain was used on the shelf shown.

PM

How to troubleshoot

Don't be scared off by computer-age technology—You can track down some malfunctions yourself.

by Mort Schultz

There's no time on a solid-state washing machine's control panel, because the functions are selected by the touch



If you're the owner of one of the new solid-state electronic washing machines or clothes dryers and you know your way around a VOM (volt-ohm-milliammeter), then you shouldn't have a problem troubleshooting its microcomputer control system.

To find out how to handle a problem with these controls, I visited Whirlpool and learned that no esoteric equipment is needed. You use the same VOM you use to troubleshoot electromechanically controlled (timer-type) clothes dryers and washers. I also learned that accurate troubleshooting demands an orderly approach. Every microcomputerized Whirlpool dryer and washer contains a "tech sheet" inside the console.

Since it isn't possible to discuss how to troubleshoot every problem that may strike electronic control systems of washers and dryers, let's walk our way through two common failures.

Washer runs, but where's water?

The only electronic component that may cause this problem is the electronic control unit. To get at the problem, open the console. With Whirlpool microcomputerized washing machines, the console is opened by removing screws at the lower

front corners of the console, pulling the console forward about 1/2 in., lifting and then tilting the console unit forward.

The electronic control, which is a printed circuit board assembly, has two connectors attached to it—one in the upper right corner and one on the left side. The "edge" connector on the left side is the one to work with. The one on the right is the connector from a relay, which provides the on/off and high/low motor-speed functions.

Important: Before beginning the following sequence, look for more common causes of this problem. Make sure: water faucets are open; water hoses run straight (no kinks); and water-hose filter screens aren't clogged (disconnect water hoses at inlet end to check).

Now, begin procedures. Note, however, that if the electronic control tests okay, there is probably a defective water inlet valve. Steps A through K are described below and keyed to symbols for steps in Diagram A on page 103.

Steps A, B: Connect a voltmeter across terminals P and W of water-level switch B. Start washing machine A and wait eight seconds. Check voltmeter.

Step C1: If voltmeter shows 120 volts, proceed to steps D, E and F.

Step C2: If voltmeter shows 0 volts, proceed to steps G, H, I, J and K.

Step D: Replace water-level switch.

Step E: Retest.

Step F: Water should now enter washer. If not, water inlet valve is malfunctioning.

Step G: If voltmeter shows 0 volts (C2), turn off washer and pull off edge connector. Connect voltmeter between terminal BR-OR of edge connector and terminal HV of electronic control, then between terminal BR-OR of edge connector and terminal CV of electronic control. Terminal HV coincides with terminal BR-R of edge connector. Terminal CV coincides with terminal YR of edge connector. Start washer and read meter.

Steps H, I: If meter shows 0 volts (H), electronic control is okay (I). Look elsewhere to solve the problem by rechecking components above and testing for faulty wiring.

Steps J, K: If meter shows 120 volts (J), electronic control is faulty and should be replaced (K).

Dryer runs, but where's heat?

Electronic components that may cause this problem are the "push-to-start" relay, which also controls heater functions, and the electronic

solid-state appliances



New microcomputerized clothes dryer doesn't have timer either. Buttons are pressed to select length of drying period and temperature and to start the unit.



The electronic control board (above) is beneath the touch control panel of a solid-state washer. Touch signals are transmitted to control board, which uses integrated circuits to control wash cycles.

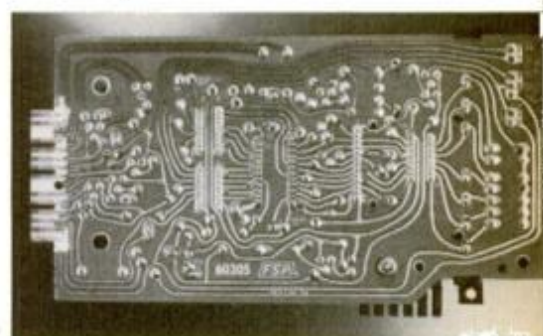

The printed circuit or "foil side" of the electronic control board is the side at which all troubleshooting sequences are carried out using a multimeter.

control. The two are connected by a wiring harness which has a quick-disconnect connector that fits into the bottom of the machine's electronic control.

The console of the dryer is opened the same way as the console of the washer. Before troubleshooting, let the dryer run at high heat for five minutes to warm up the electronic components. This procedure is necessary to obtain accurate voltmeter readings.

Steps A through K are described below and keyed to symbols in the steps in Diagram B. *Steps A, B, C, D, E:* Disconnect the relay connector at the electronic control and connect a voltmeter across terminals coinciding with CH1 and CH2 on E. Set temperature-selector switch on "heat" position A. Set cycle selector switch on the "timed" position B. Set the push-button selector of your machine's electronic control on "10" (C). Then start machine (D).

Steps F1, G: If voltmeter shows no voltage (F), electronic control is faulty. Replace G.

Step F2: If voltmeter shows 30 ± 5 volts, turn off the power and be sure to reconnect the quick-disconnect relay connector.

Step H: Connect voltmeter across terminals RS and RH1 of relay. Turn on power.

Steps I1, J: If voltmeter reads 240 volts (electric dryer) or 120 volts (gas dryer) (I), relay is faulty. Replace the relay (J).

Steps I2, K: If voltmeter reads 0 volts (I2), the cause of the problem is not with an electronic component, but with the heating element, gas burner, fuse, thermostat, wiring, centrifugal safety switch or motor. Locate the problem and make the needed repairs (K).

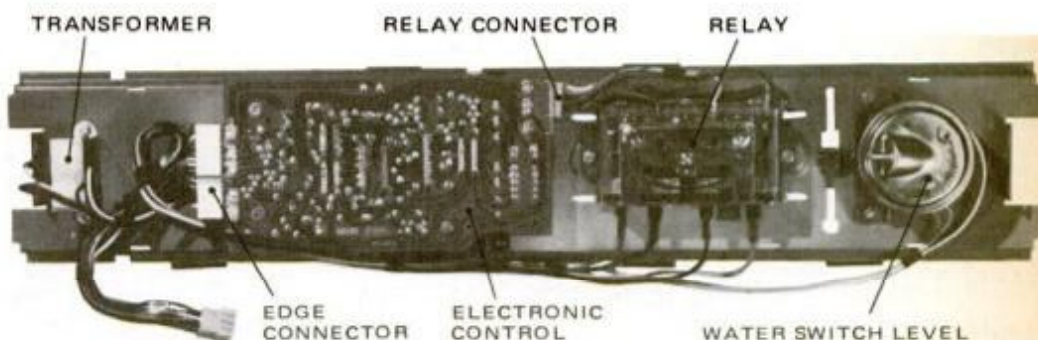

All terminals on the control board and all other components are clearly distinguishable, as shown above. You should have no problem making the correct connections.

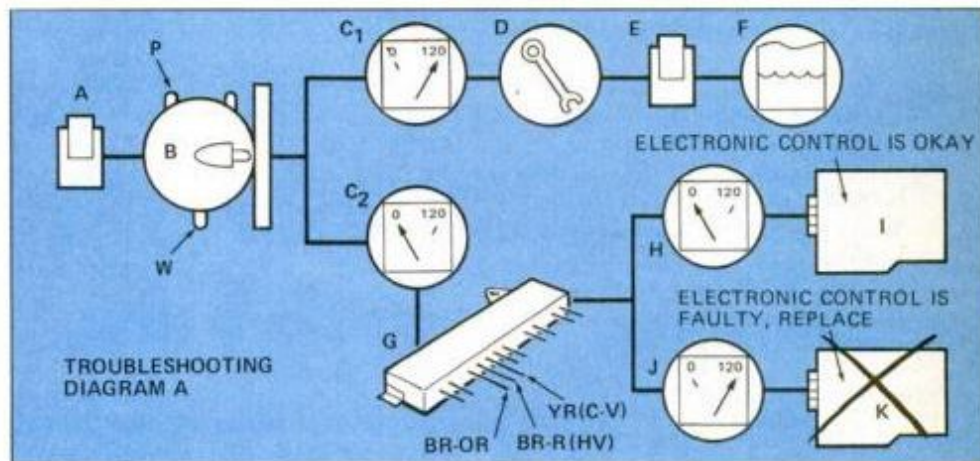

Troubleshooting sequence above is used if washer runs, but water doesn't fill.

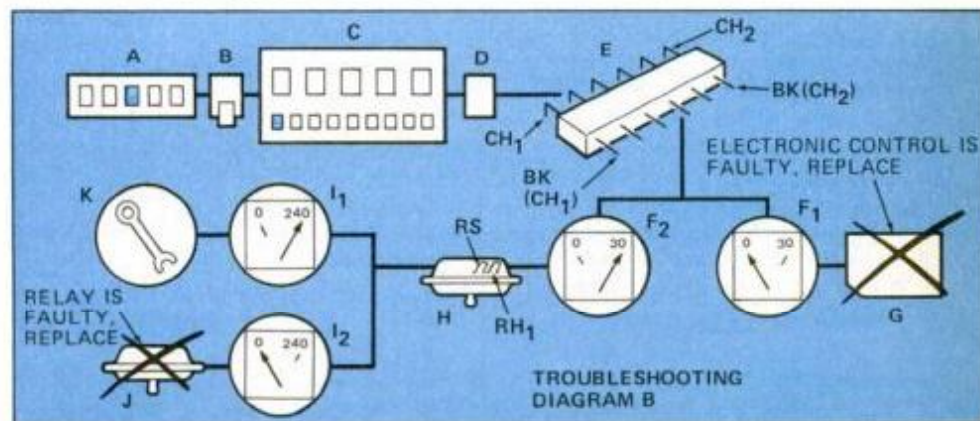

Diagram above shows troubleshooting sequence if dryer runs, but there is no heat.

WORKSHOP MINICOURSE

MORE ABOUT BENCH SAWS



Chamfer cutting is done with cut made along edge of workpiece that is away from rip fence. When fence is to left of blade, the bottom edge is chamfered.

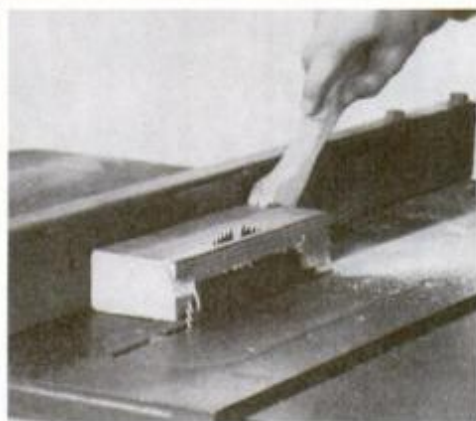

When the rip fence is to the right of the blade, the top edge is chamfered.

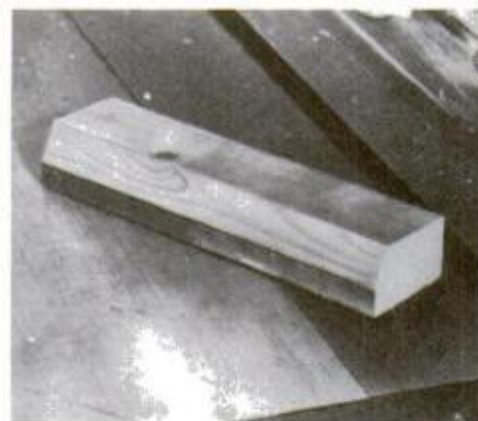

Push stick was used while cutting this simple chamfer the length of the board.

Cutting a chamfer on a board's edge is one of the simplest sawing techniques. To make the cut, you just tilt the saw blade to the required bevel angle, adjust the rip fence to correct width and push the board through. For safety, the edge being chamfered should be the one away from the fence. If the cut must be made along the inside edge, remember to install an auxiliary wood fence (see *Workshop Minicourse*, page 114, July '79), so the blade will contact it instead of the metal fence when it exits the workpiece.

You can use a combination blade to cut most chamfers, but if smoothness doesn't matter, switch to a rip blade for quicker cutting. No matter which blade you use, push the work through at a reasonable feed rate and make certain it stays in close contact with the fence so it doesn't bind between the tilted blade and fence.

Resawing—with care

Resawing is the technique of making a rip cut through a thick board's edge to create two thinner boards. This sounds simpler than it really is. Make no mistake; resawing is difficult and one of the more hazardous bench-saw cuts because the splitter and guard must be removed.

A narrow board can be resawed in one pass; you raise the blade until it is $\frac{1}{8}$ in. above the board's top plane. On wider stock, the blade is raised so it will cut slightly more than half-thickness and the first—and easier—cut is made. The board is rotated 180° for the second, more difficult pass. It is best to use the setup as shown when doing resawing. The hold-down and hold-in jigs enable you to feed the stock without expos-

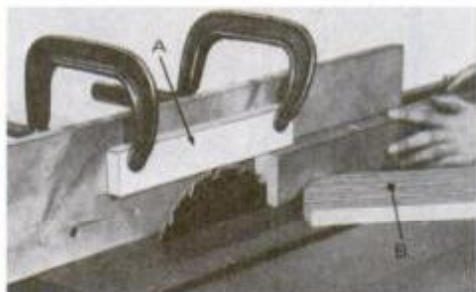

To insure a straight cut when resawing, use both a hold-down (A) and hold-in (B). The latter is clamped to the saw table.



To complete the cut, use a push stick and work from side of table. The hold-down prevents pushing through with stick; thus you must pull work to finish the cut.

ing your hands to blade danger. The spring stick's pressure should be on the workpiece, clear of the blade toward the operator (the pressure most not be exerted on the work at or after the blade). The stick shown can be made in 15 minutes or less and is a worthwhile addition to your bench-saw accessories.

If smoothness of cut isn't critical, there is a safer way to resaw a wide board. Elevate the saw blade to slightly less than half-thickness, so that the second pass will not separate the two boards. The finish, or separating cut, is made on a band-



Narrow boards can be halved in one pass, as shown. To resaw wider material, flop material 180° after first pass and make the second cut. Use a slow feed rate.

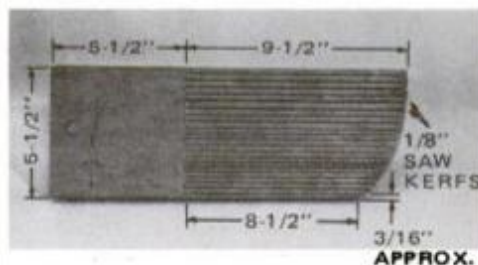

Wood spring is made by running a series of bench-saw cuts into a 15-in. length of 1x6 pine. Shape lower edge as shown on a bandsaw and use the spring clamp with its legs under tension, as at left.

saw, where greater operator control is possible. For safety, use the band-saw's rip fence to make the parting cut.

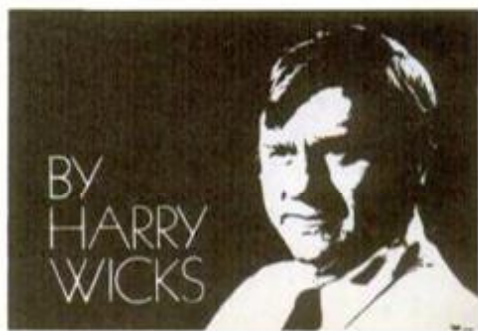



IT DOESN'T HAVE TO BE A FORD TO GET THE MOST OUT OF AUTOLITE SPARK PLUGS.

You probably know that Autolite makes plugs for Fords.

But what you may *not* know is that Autolite makes the same high efficiency plugs for almost every car ever made, American or imported.

So if you drive something as luxurious as a Chrysler Cordoba or as simple as a Chevy Chevette, now you know that you won't have to drive too far to find good plugs.



Fram and Autolite are Bendix Companies
Fram Corporation, Providence, Rhode Island 02916

SMALL BOATS

(Continued from page 70)

on one self-contained tank of gas.

How much power is enough? Your hull should have a Boating Industry Assn. (BIA) capacity plaque listing the top horsepower and weight of passengers and gear that it can handle. But less than maximum may still be plenty. The new Johnson 4.5, for example, when mounted on a small, light hull, can water ski two youngsters at once. Evinrude has a similar model. And since outboards under 10 hp can often be used where larger models are banned, all manufacturers have motors in this low fuel-consumption category. Craft that can fit on a cartop rack, inside a station wagon or on a small trailer all match up well with mini-motors.



Bonair Boat's 16½-foot Brute 500 mounts up to 60 hp, has vee bottom for smoother ride, can even be ordered with a scuba diving window mounted in the boat's bottom.



Tippy tendencies of canoes like stretch-formed Michi-Craft L-12 and other boats can be stabilized with pontoons.



This 2-hp tow unit for swimmers and divers comes from Aqua-Scooter, Springfield, N.J. It's also a small outboard.

Boats that may benefit the most from a trend to gas economy should be the already popular inflatables. Easy to store, convenient to carry, seaworthy and versatile, they offer bargains in watersport activities, though their prices will seem high. A quality blow-up boat will cost as much as, or more than, similar ones with rigid sides. Figure you'll pay over \$1000 for a 12-footer and up to \$6000 for a 20. These prices take them out of the swimming pool-toy field, where they never belonged.

New nylon fabrics with PVC polymeric coatings and, in some cases, even kevlar filaments, are giving inflatables more puncture and abrasion resistance. Rugged rigidity and low centers of gravity are making the new models safe enough for larger outboards, yet strong enough to pull water skiers and handle off-shore waters.

Small conventional boats are also making news these days. Cruising, fishing, camping, day boating and exploring sheltered shallow backwaters that the big boats never reach—these are just a few of the pleasures awaiting small-craft boatmen. **PM**



A canoe you can fold up into a 31-pound backpack unit, the Ally Collapsible from Vogue Industries, LaSalle, Que., uses aluminum ribs, PVC skin, assembles in 20 minutes.



Low center of gravity for passengers and gear, plus independent flotation chambers in case of puncture, make quality inflatables like this, with Chrysler 7.5, extra safe.

New Chemical Science Achievement... Prevents and removes oxidation... Even restores original luster to used models!

Polymer 'glass' sealant

Revolutionizes car-finish protection and keeps your car showroom bright for years — You'll never have to put wax on it again!

Available only as a service by new car dealers for \$100 to \$200. Now do it yourself in less than an hour for only \$29.95!

The original GloSeal with Polyglass!* (Offered by direct order only, not available in any store, 16 oz. bottle, enough for 2-3 average-sized cars.)

Professionally recommended for: ■ Cars ■ Trucks ■ Buses ■ Boats ■ Surfboards ■ Airplanes ■ All metals ■ Appliances ■ Fiberglass surfaces ■ Skateboards ■ Motorcycles & Bicycles ■ 4-wheel & Off road vehicles ■ RV's & Vans ■ Industrial uses

The elements vs. your once beautiful car... You've probably experienced it. Your treasured, shiny new automobile gradually fades and dulls. Oxidation sets in and the once brilliant, glossy finish turns chalky and washed out. Even hours of waxing and buffing can't recapture that new car look... Until this new chemical science discovery...

Never put wax on your car again... GloSeal* is not anything like a simple wax or polish. It is actually a miracle polymer glass formulation serving as a powerful sealant and a beautiful exterior finish. When applied to your car's finish and chrome its **Electromolecular Action** literally fuses it to the surface, locking in a brilliant shine for years. GloSeal* with Polyglass actually changes the molecular structure of your car's finish. It penetrates through the old wax and binds itself with the surface.

GloSeal* with Polyglass is impenetrable, non-porous and virtually impervious to damaging air pollutants, car-wash detergents, salt air and water, hot burning sun, cold winter winds, grease, wax, acids contained in eggs and shaving cream, ultraviolet rays and even fire damage. It also provides a brilliant, rich shine to your car's finish, keeping up the appearance and the value of your expensive investment.

Prevents oxidation from starting on new cars...and actually removes it from used models! GloSeal* is literally a *Glass Shield* that becomes part of your car's finish. Your new car's paint is guaranteed not to oxidize... for up to 3 Years! Then GloSeal* it again for

years more of protection. On used cars, GloSeal* will actually remove the surface oxidation, add gloss, and stop normal oxidation for 1 year before you need to reapply. It is similar to covering your car with an impenetrable coat of polyurethane.

Important:

Many other "polymer" car care products are ordinary silicone-based formulations, similar to a synthetic wax, as evidenced by their wax-like feel. GloSeal with Polyglass is an entirely different product. It is far more advanced, glass-like, slicker, providing a better, "electromolecular" adhesion. The result is a richer, deeper gloss than you have ever seen before, plus months of extra "Glass enclosed" protection!*

Enamel spray paint can't even get through the clear glass shield... When this new professional automotive product is demonstrated to car dealers, the "spray paint test" is used. GloSeal* is applied to a car's hood following the instructions. Then enamel paint is sprayed directly on it, along with Magic Marker and

other solvents. Then, to the observers' astonishment, all of these are wiped off the hood with a mere cloth. Nothing, not even dirt and dust can adhere to the surface!

No rubbing, labor, or buffing equipment needed... GloSeal* goes on easily and quickly. You wipe it on, let dry, and then wipe it off. It takes only a few minutes — less than an hour. Between washes just wipe your car with a damp cloth to reactivate its brilliant dirt and dust-repelling shine.

The incredible GloSeal* "Brilliance and Protection Guarantee"... If after using it, you are not pleased for any reason, return the unused portion within 2 weeks of receipt for a prompt refund of the entire purchase price. Further, if you apply and maintain according to the instructions and GloSeal* does not protect your new car for 3 years or your used car (90 days old or more) for 1 year, we'll return your small investment on a prorated basis. (Note: GloSeal* is 100% safe to use — it can be removed with mineral spirits).

CALL TOLL FREE FOR INSTANT PROCESSING: 1-800-235-6945, or if busy 1-800-235-6951. Calif. res. please call 805-966-7187. Or send coupon:



GloSeal* with Polyglass. Already on thousands of vehicles.

Promptly ship the following order. If not 100% satisfied I can return the unused portion within 2 weeks for a quick refund of purchase price (less shipping cost).

Check One:

- PG1 - ship 1 bottle @ \$29.95 and \$2.00 shipping & handling. Save \$5.00 per bottle on multiple bottle purchases
- PGM - ship _____ bottles @ \$24.95 ea. and \$2.00 shipping & handling ea.
- Check or Money Order enclosed (CA res. add 6% sales tax).
- Charge my credit card number below.
- BankAmericard/Visa Master Charge (interbank No. _____)
- American Express Diners Club
- Carte Blanche

Credit Card No. _____ Exp. Date _____

Name _____

Address _____

City/State/Zip _____

Starshine Group.

924 Anacapa St., Dept. GS13, Santa Barbara, CA 93101

* Trademark

© Starshine Inc., 1979

STOPS YOUR ROOF LEAK

In Just 5 Minutes!

It's pouring rain and your warm, dry home is invaded by a slow drip, drip, drip of water leaking through your roof. You call your local roofer and are shocked to learn how much roofing repairs cost these days.

While you wait for the next rain to come, the wife is worried about the new sofa being ruined from the down pour of rain water . . . from your leaky roof . . .

But, now at last, the new and truly revolutionary *U.S. Polycoat Roof Coating!* Imagine! A coating so efficient, so unique, that it waterproofs and protects your roof from rains or snow all year long. U.S. POLYCOAT can be brushed or rolled on over almost any surface and dries to a rubber sheet-like film in minutes—no heating—no mixing—use straight from the can. U.S. Polycoat adheres to asphalt shingles, rolled roofing, wood, brick, plywood, cement, tar, aluminum, metal, asbestos, insulation board and even urethane foam. U.S. Polycoat comes in seven colors to match your roof.

U.S. Polycoat protects driveways, sidewalls, patios, mobile homes and parking areas, too. But, if your roof is leaking send for U.S. Polycoat today. You'll have a worry-free waterproof roof that will last for years and years. Waterproof with U.S. Polycoat before you insulate!

U.S. POLYCOAT, INC., 2928 Malmo Drive • Arlington Heights, Ill. 60005 • (312) 364-5010



DRIVING THE HONDA PRELUDE

(Continued from page 85)

tires and tighter chassis tuning help to make it a better high-speed handler.

It's also slightly shorter, wider and lower than the Accord two-door, and as a result has less usable room inside, especially in the near-useless rear seats. There's a strong family resemblance in the styling, yet just enough difference to set it apart and give it a character of its own. The grille opening is aggressively wide



Rear view of the Prelude is dominated by large taillamps and a squared-off deck.

and flanked by single rectangular headlamps, instead of the Accord's quad round lights. There's a subtle "chin" spoiler, and the squared-off rear deck sports fat, oddly shaped taillamps in place of the handsome, Mercedes-like, horizontal Accord units.

Panel is cluttered

Probably the Prelude's worst feature is its cramped, cluttered and confusing instrument panel design. The tachometer dial is inside the speedometer, with a warning light module sitting dead-center in front of both, and the odometer offset to the left. The only gauges (fuel and temperature) are on the left, with a door-ajar and taillamp check panel on the right and a quartz digital clock and a super-strange rotary radio at far right.

The clock has pushbutton setting controls under a lift-up panel marked "push display," but it seemed to display all the time, whether pushed or not. The unique AM/FM stereo radio is certainly compact, but it's confusing to operate and hard to see around the steering wheel rim and spoke, and the rotary dial is difficult to read in daylight.

Delightful to drive

The obvious object of all this is to use space efficiently and to put everything in easy view and reach of the driver, but it's unattractive and confusing. We'd gladly trade for the Accord's far more handsome and practical panel, with its handy flat shelf on top.

Otherwise, the Prelude is a delight

Материал, защищенный авторским правом

U.S. POLYCOAT, INC. Dept. PM89
2928 Malmo Drive • Arlington Heights, Ill. 60005

Gentlemen: Please rush me _____ gallons of U.S. Polycoat.
 1 Gal. - \$13.95 2 Gal. - \$26.40 5 Gal. Bucket - \$63.50 Include \$1.50 Per Gallon for Postage and Handling. Enclosed is Check Money Order for total of \$_____ Charge my order to: VISA/BankAmericard Master Charge Acct. No. _____ Exp. Date _____

Color: Clear Silver Black White Green Red Brown

One gallon covers approx. 50 to 100 square feet. Two gallons covers approx. 100 to 200 square feet. Five gallons cover approx. 250 to 500 square feet. Coverage depends on type of surface.

Print Name _____

Address _____

City _____

State _____

Zip _____

DEALER AND APPLICATORS INQUIRIES INVITED • (312) 364-5010

© 1979, U.S. Polycoat

Cruise Director.

Enjoy a new sense of direction and get lost less often with an Airguide auto compass. Model 1601 (shown) is self-illuminated . . . has adjustable compensators and adhesive mount. At retail stores. Write for catalog A.



Airguide
2212 Wabansia Chicago 60647



Folding Saw Horses

\$49.95
PAIR

plus \$9.85
shipping
continental
USA

Unbelievably strong - sturdy - easy to store, carry, and transport. Simple set up. Weight 17 lbs., working surface 1" x 8" x 42" Kiln dried yellow pine for non-warp, permanence and safety.

CENTRUM INDUSTRIES INC.

443 Century, S.W., Grand Rapids, Michigan 49503

to drive, whether zipping through the mountains or cruising down the freeway. A bit more seat travel would improve the legroom for long-limbed drivers, but the nicely contoured and upholstered, fully adjustable bucket seats are as comfortable as they are supportive. The three-valve-per-cylinder CVCC engine is strong, willing, and peppy enough to make the car lots of fun to drive (it also runs on regular gas), and the five-speed transmission's only flaw is an uncomfortably long throw into the overdrive fifth gear. Handling, both fast and slow, is a cut above the already good Accord and as sure-footed and agile as any front-drive car available.

Standard equipment includes a lovely power "moonroof" with sunshade, electric rear window defroster, side window defogger outlets, remote trunklid release, intermittent windshield wipers; a maintenance reminder and a whole lot more. There are also plenty of useful and interesting options, such as airconditioning, cassette player, four-speaker stereo system, cast-aluminum wheels, and even an engine-block heater for cold climates.

The Prelude is indeed a new and different car, embodying most of the Accord's better qualities, along with a few of its own (both good and not so good), in a sportier, classier-looking package. Whether it will sell as well depends on those "grown-ups" who are looking for a sports car. **FM**

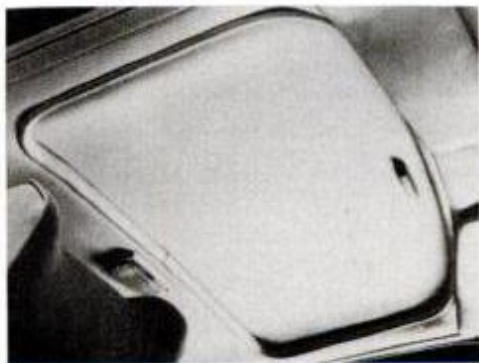

Sunshade (above) is operated manually. When it's pushed back, the power-operated moonroof (below) is exposed.



Now you can cash in on the huge demand for **SHARPENING SAWS and TOOLS.**

BE YOUR OWN BOSS!



Make \$8⁰⁰ an hour...

or more. Work part time, full time, right at home.

No layoffs. No strikes. Provides a steady source of year round income.

This can be one of the most important decisions you ever make

Going into business for yourself can be the most exciting and rewarding decision you're likely to make in your lifetime.

Owning your own business brings you a sense of independence. You're the boss, setting your own work hours. Your own effort builds the business for yourself and your family. You can achieve great satisfaction and profits, if you choose and manage your business wisely. That's why so many men, just like you, are cashing in on the big profits to be made in this fast-growing service field.

The sharpening business allows you to get started with only a minimum investment, requiring little space and effort for a successful operation. It lets you build and expand as fast, or as slowly as you like. You pocket most of the money you take in, because there are exceptionally high profits with no investment in merchandise.

If you need only \$200 or \$400 extra income each month, a sharpening business is ideal for spare time. The additional dollars can be SPENT for more of the good things of life. Or they can be SAVED in a rainy-day fund that the family can bank on.

More sharpening businesses are needed every year

As original equipment continues to climb in cost, owners are becoming more concerned that the equipment be maintained so that it performs like new. This means more companies, contractors, carpenters and home owners are having their old saw blades and tools resharpened many times, where in the past, they would have replaced them with new blades or tools. This is where you

can step in with the much needed service of sharpening saws and practically any kind of tool.

SEND FOR FREE FACTS TODAY!

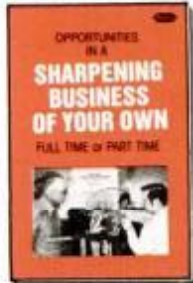

This FREE booklet has helped thousands

Thousands of good men have been inspired by this fact-filled book into making that first important step of starting their own

business. It can be yours just for the asking.

It covers these important subjects...

- How much money can you make
- Age, education not a factor
- No selling is required — customers bring their business to you
- Lawn mowers and chain saws
- Sharpening business is year-round
- Sharpening opportunities in small towns and large cities
- A sharpening business provides excellent retirement income
- How Foley helps you start
- No experience needed, any age can succeed

Act today, so you can have a brighter, more secure tomorrow

Right now, while this is still fresh in your mind, fill-in the coupon below. We will send your FREE copy of "Opportunities in a Sharpening Business of Your Own". There is absolutely no obligation and there are no franchise fees in starting your Foley Sharpening Business.

Send your name and address to: Foley Manufacturing Co. 1707 Foley Building, Minneapolis, Minnesota 55418

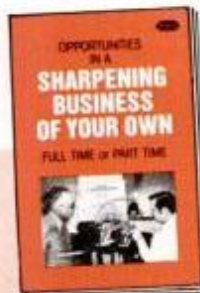

FREE BOOKLET

Send NOW For Your Free Copy!

This little book has helped change the lives of thousands of good people, just like you. Just complete the coupon, clip it out and mail it to us today. Get started now for a brighter, more prosperous tomorrow!

24-HOUR ANSWERING SERVICE
CALL TOLL FREE 1-(800)-328-7140
(Except in Hawaii or Alaska)

RUSH COUPON TODAY!

Foley Manufacturing Company
1707 Foley Building
Minneapolis, Minn. 55418



YES, I would like to receive complete details about how I can easily start a profitable, Foley-equipped sharpening shop. Please rush me your FREE booklet, without any cost or obligation, that gives me full details on how I can quickly start my own business.

NAME _____
ADDRESS _____
CITY _____
STATE _____ ZIP _____

Get Up To 4 Extra Miles Per Gallon... 100 Extra Miles Between Fill-Ups... SAVE Up To \$200 A Year On Gas...

OR DOUBLE YOUR MONEY BACK!

See our guarantee

Think of it! Thanks to an amazing automotive discovery, every single car owner, every fleet operator, every truck or camper owner... everyone who operates a gas-powered internal combustion engine, can now save up to 20% and more on their gasoline bills!

Yes, you'll actually get up to 70... 80... 90... even 100 extra miles from every single tankful! No matter how old or run-down your car may be... no matter how many gallons of gas it now devours each week... FROM THE VERY INSTANT YOU INSTALL THE BALL-MATIC™ GAS SAVER VALVE IN YOUR CAR, YOU WILL EXPERIENCE A DRAMATIC DECREASE IN GAS CONSUMPTION!

Here's why:

With all the advances made in automotive technology, the carburetor is literally 50 years behind the times! It is possibly the most inefficient component in the entire engine and is responsible for an incredible waste of gasoline! You see, the carburetor is present at the factory for idle conditions. This means that it is most efficient in regulating the gas-to-air mixture when the car is standing still and up to speeds of 35 mph. When you drive over that speed... or start up from a dead stop... or negotiate grades and steep hills... or pull a trailer or camper... or carry a full load of passengers, too much gas feeds into the carburetor and you get incomplete combustion. Every time that happens, it's just like pouring your money down the drain.

The Most Significant Automotive Breakthrough Of The Past Ten Years!

Adding the BALL-MATIC GAS SAVER VALVE to your engine is like having a "mini computer brain" which actually monitors the air-to-fuel balance on a constant basis. As soon as it senses an over-rich condition, it opens to permit a precise measure of additional air to enter the system. The result: more efficient combustion and a fuel savings of up to 20% or more!

Controlled Tests Confirm Big Dollar Savings

In the Spring of 1978, we arranged for a local Shell Service Station to conduct a controlled, supervised, test using seven different cars owned and driven by non-professional drivers. Each car was fitted with a locked gas cap and the keys kept in the possession of the testers.

After establishing base mileage consumption data for the various cars, the BALL-MATIC was installed and miles-per-gallon figures were re-checked. Every single car in the test showed dramatic improvement.

Year/Make Of Car	MPG Improvement
1970 Cadillac Eldorado	21%
1970 Chrysler Imperial	28%
1969 Cutlass	8%
1974 Vega	10%
1972 Gran Torino	19%
1967 Camaro	16%
1973 Cadillac Eldorado	40%
OVER-ALL AVERAGE	18%

Start Saving Immediately

As of now, tens of thousands of motorists all over the country have put the BALL-MATIC GAS SAVER VALVES in their cars. It takes only 60 seconds to install and no special tools are required (easy-to-follow instructions are provided) — it's so easy, anyone can do it! But best of all, the BALL-MATIC works immediately. There's no "breaking-in period" — you experience a significant savings with the very first tankful.

The BALL-MATIC fits all American made cars (except diesel or fuel injection) and all foreign cars except Volkswagen.

READ THE RESULTS FOR YOURSELF!

The BALL-MATIC (gas saver) that I purchased has proven itself. I drive a 1970 Oldsmobile, now I get four miles more per gallon.

C. T. — Orange, California

Just a short note to inform you of the performance of your BALL-MATIC unit that I have installed in my 1972 Ford station wagon. Prior to using your device, I averaged 12 to 13 MPG, now that I have installed your unit my mileage has gone up to 16 MPG around town.

A. Coultis
Sherriff, Orange County, California

Before it was installed on my 1973 Ford L.T.D. I was getting 9 miles to the gallon, since installation of the BALL-MATIC I am getting almost 15 miles to the gallon.

R. B. — Hickman, Nebraska

After installing the BALL-MATIC on my 1972 Oldsmobile Toronado I increased from 7.5 to 10.5 miles to the gallon.

Seeing this I took my station on as a BALL-MATIC dealer and within the first week sold over 100 valves.

This is the kind of extra income producer that other service stations should consider during this energy crisis to service their customers.

Louis Michaud
Mobile Service, New Britain, Connecticut

I want to express my thanks for the BALL-MATIC. Since it has been installed in my car, my gas mileage has not been under 18 miles per gallon. This is an increase of 5.5 miles per gallon.

Rev. R. N. Claremont, California

LOOK HOW EASY IT IS TO INSTALL THE BALL-MATIC YOURSELF

All you do is simply slip the BALL-MATIC onto the line leading from the PCV valve and twist into place. (It's as easy as screwing in a light bulb). In fact even if you never lifted the hood of your car before... you can install the BALL-MATIC in just a few moments (no special tools required). Easy to follow instructions are included.



GUARANTEED SAVINGS

We firmly believe the BALL-MATIC to be one of the best investments you can make to save money this year. The exact savings you will receive may vary significantly depending on the kind of car you drive, the condition of your engine, weather, your driving habits and the amount of driving you do; however we guarantee that you MUST SAVE AT LEAST FIVE TIMES the amount you paid for your BALL-MATIC in the very first year or WE WILL GIVE YOU DOUBLE YOUR MONEY BACK! (Double refunds limited to one unit per household or business).

OVER 100,000 ALREADY IN USE

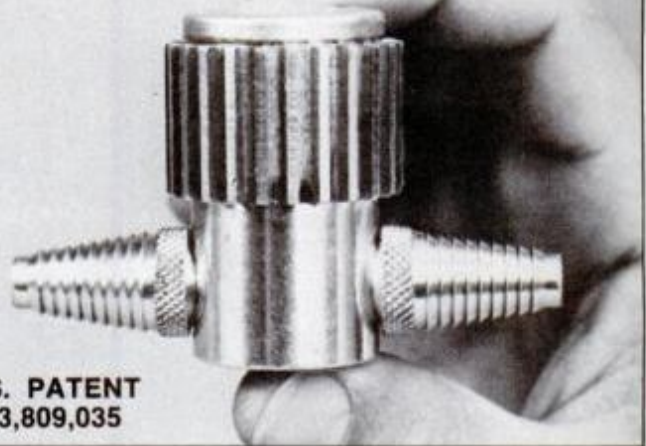

U.S. PATENT #3,809,035

Order One Today Entirely At Our Risk

There may be a reason why you don't install a BALL-MATIC on your car immediately. But, for the life of us, we can't figure it out! If after reading this ad you have any doubts whatsoever, just drop a note and we'll gladly forward a copy of our test reports for your inspection.

Test the BALL-MATIC yourself entirely at our risk. Install it in your own family or company car and if it doesn't deliver everything we say it will — starting with the very first tankful, just return it and we'll refund double your money. We wouldn't make that kind of guarantee in writing if we weren't positive of the performance of the BALL-MATIC!

Please don't delay. Every day you drive without a BALL-MATIC GAS SAVER VALVE in your car costs you money and needlessly wastes precious gasoline. Call or send in your coupon today.

24 HOURS A DAY - 7 DAYS A WEEK FOR MASTER CHARGE AND VISA ORDERS

CALL TOLL FREE 1-800-331-1000

IN OKLA CALL COLLECT (918) 664-8300

SEND NO-RISK COUPON TODAY

CLIFFDALE MOTORS, Dept. BMT-895
2055 McDonald Ave., Brooklyn, NY 11223

Please RUSH me the BALL-MATIC GAS SAVER VALVE(S) ordered below along with easy-to-follow installation instructions. I must get immediate improvement in pick-up and better gas mileage starting with my next fill-up and I must save at least five times my purchase price in the first year of use or I may return my valve for a refund of double my purchase price (excluding postage and handling, of course).

- Enclosed is \$_____
- \$12.95 plus 85¢ postage and handling for ONE BALL-MATIC
 - \$24.95 for TWO BALL-MATICS ppd. (You save \$2.65)
 - \$36.50 for THREE BALL-MATICS ppd. (You save \$4.90) Add \$12 for each additional valve.

CHARGE IT:

Visa Master Charge

Exp. Date _____ Bank # _____

Card # _____

Print Name _____

Address _____

City _____

State _____ Zip _____

CANADIAN CUSTOMERS Please add \$1.00 extra. Order from KYCAM, Dept. BMT, 510 Coronation Drive, West Hill, Ont. M1E4X6

DEALER INQUIRIES INVITED

PEWTER TABLEWARE YOU CAN MAKE (Continued from page 95)

tire piece with 400-, then 600-grit, sandpaper.

Next, set up a buffing wheel to spin at 3500 rpm. Apply Tripoli cutting compound and buff the pewter. Then reduce the wheel speed to 175 rpm and use polishing compound on the pewter. Keep the piece moving so it won't overheat. *Note:* wear a mask and cotton gloves.

Shaping the bowl

Turn the wooden dish form C and cut the plywood top form D according to plan on page 95. Cut the pewter bowl disc A, sandwich and tape it between the form parts and clamp the assembly to a bench.

Pound the pewter to bowl shape. Wear ear protectors when you pound. Unclamp the bowl and sand it smooth with 400-grit sandpaper.

File and use 400-grit abrasive on the bowl edge (with bowl in form). Buff the inside of the bowl (still in the form), then buff the outside of the bowl.

Glue discs together to make base B. Mount on a faceplate and turn to shape. Remove from lathe, cut the excess off the bottom, then sand and oil.

Making the box

Cut the box side A and bottom B of pewter (see materials list on page 95). Cut top C. Turn the hardwood cylinder form. Shape A into a cylinder and solder the seam. Finish the inside and bottom, then solder on B. Finish the outside.

Turn the top, being careful to

check with calipers for a snug fit in the cylinder; oil the wood.

Salt and pepper shakers

Cut sides A, tops C and bottoms B of pewter (see materials list). Bore holes for corks in B.

Turn the maple cylinder form. Shape the cylinder A and solder the seam. Position and solder the bottoms. Mark the hole locations on the top pieces. Center-punch lightly and bore holes. Solder tops to the shakers and finish. Be sure not to dent tops when polishing.

Cut the tankard pieces to size (see materials list). To plot paper pattern for A, plot the top and bottom curves, centerline, then the seam edge. Glue the pattern over pewter

(Please turn to page 112)

SUPPLIERS

Prices for pewter are constantly fluctuating. At press time, 1 sq. ft. of 18-ga. pewter costs about \$30. Enough material to make each project is available from Guyot Designworks, Box 23C, Fly Creek, N.Y. 13337. Approximate postpaid prices are: Fruit bowl pewter (wood base not included), \$22.50; box pewter and solder (wood top not included), \$7; salt and pepper shaker pewter, solder and two corks, \$8.50; tankard pewter and solder (wood handle not included), \$18. Write for current prices; make certain you include a self-addressed, stamped envelope.

Anchor Tool and Supply Co. Inc. (tools, materials), Box 265, Chatham, N.J. 07928 (catalog, \$2).
T.B. Hagstoz and Son Inc. (tools, materials), 709 Sansom St., Philadelphia, Pa. 19106 (catalog free).

Modern Pewter, by Shirley Charron, gives helpful information about pewter designs and fabrication techniques. For paper edition, send check for \$7.95 to Litton Education Publishing Inc., 7625 Empire Dr., Florence, Ky. 41042 (Kentucky residents add state sales tax).

SALT AND PEPPER SHAKERS

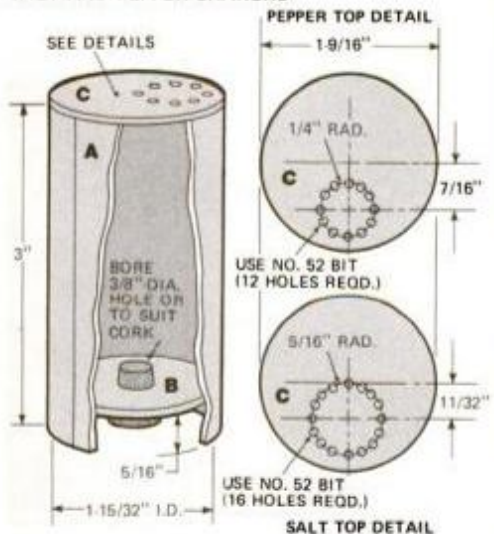

MATERIALS LIST—SHAKERS

Key	Pcs.	Size and description (use)
A	2	3 x 4 1/4" 18-ga. pewter (side)
B	2	1 1/2" dia. 18-ga. pewter disc (bottom)
C	2	1 3/4" dia. 18-ga. pewter disc (top)

Misc.: 1 1/2" dia. x 5" maple cylinder form, 2 corks (available in several sizes in hardware stores).

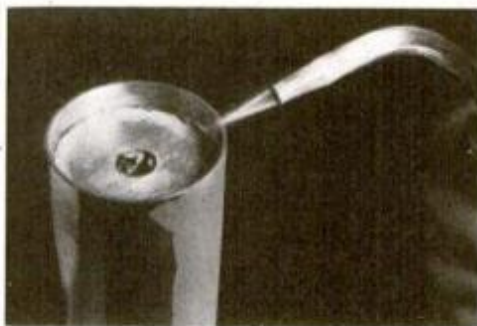

Put wood shaker form in vise vertically and slide cylinder over it, protruding 3/8-in. Insert and solder bottom piece.



Center-punch lightly and bore holes through the soft metal. Clean off any burrs with sandpaper; solder to cylinder top.

NOW! Get in on the PROFITS in SMALL ENGINE REPAIR!



Start your own money making business!

Work part time, full time—right at home—we help you every step of the way.

No doubt about it... as a small engine pro, you can cash in on the huge demand for qualified men in one of America's fastest growing industries. You'll be able to command top hourly rates of from \$10.00 to \$15.00 per hour—and that's just for labor. A simple tune-up earns as much as \$17.50 for less than an hours work, and parts, engines and accessories will add even more to the profits.

Plenty of business waiting for qualified men. 46,000,000 Small Engines Are in Use Today!

That's the official count from the Engine Service Assn., and one-million new engines are being built each month. With fully accredited Belsaw training, you can soon have the skill and knowledge to make top money servicing these engines. People will seek you out and pay you well to service their lawnmowers, tillers, edgers, power rakes, garden tractors, chain saws, mini-bikes, snowmobiles, generators, go-carts, paint sprayers, snowblowers... the list is almost endless.



NO EXPERIENCE NECESSARY!

You don't need to be a 'born mechanic' or have any prior experience. You can master this profitable trade right at home in your sparetime. Lessons are fully illustrated... so clear you can't go wrong, and with our famous 'learn-by-doing' method you get practical 'hands-on' experience. We also show you how to get business, what to charge, where to get supplies wholesale... all the inside tricks of the trade you need to assure success right from the start.

Send for FREE Facts—Do It TODAY!

NO Obligation—NO Salesman Calls!
You risk nothing by accepting this offer to see how easily you can learn the skills you need to increase your income in a high-profit business of your own. Just fill in and mail coupon below (or send postcard with name and address) to receive full information by return mail.

RUSH COUPON TODAY
BELSAW INSTITUTE
510P FIELD BUILDING
KANSAS CITY, MO 64111



BELSAW INSTITUTE
510P FIELD BUILDING
KANSAS CITY, MO 64111

Accredited Member
National Home Study Council



YES, please send me the FREE booklet that gives full details about starting my own business in Small Engine Repair. I understand there is No Obligation and that No Salesman will call on me.

NAME _____
ADDRESS _____
CITY _____
STATE _____ ZIP _____

FREE! EDMUND SCIENTIFIC CATALOG

Explore Astronomy, Biofeedback, Computers, Health, Lasers, Magnets, Microscopes, Optics, Photography, Weather... Over 4,000 Fascinating Items.

More Than 160 Colorful Pages... The Exciting, FREE Edmund Catalog!



38 Years of Service!

No. 108

Edmund Scientific Co. 1979

Yes! Rush me your FREE Catalog so that I can explore Edmund's World of Science.

Name _____

Address _____

City _____

State _____ Zip _____

Clip and Mail Coupon Today to:

Edmund Scientific Co., Dept. H-16
Edscorp Building, Barrington, N.J. 08007

FULL SIZE KIT AIRPLANE



the CUBy

- *Outstanding Trainer
- *Aerobatic Capabilities
- *Two Place
- *Economical
- *Cross-Country Performance

Available in kit form providing ease of construction.

SEND FOR INFORMATION PACKET

Photos and 3-view illustrations, complete list of assembly kits... \$3

COMPLETE BUILDER CONSTRUCTION DRAWINGS

Fully illustrated for the novice builder... \$65

Wag-Aero INC.

Box 181, 1216 North Road
Lyons, WI 53148
Phone 414/763-9586

Send 75c for
Aircraft Parts Catalog

PEWTER TABLEWARE

(Continued from page 111)

with rubber cement and cut out parts. Turn hardwood form.

Bend A around wood form, solder seam, smooth inside, brush-finish and attach D. Fit trim B and C around the body, solder ends together then solder trim to body.

Cut handle F and sand the outside surface square. Shape E around wood, trim and solder joint. Coat the inside of E with epoxy glue and attach to F. Sand and buff the handle and tankard before joining them.

Secure the tankard on its side, vertical seam down. File a small flat where the handle will attach. Shape wire solder in a double coil and flatten it with a hammer. Sand the top and bottom surface to remove dirt. Sandwich flux, solder coil, move flux and handle in place and secure with tape.

Paint the trim and joint E with ochre. Quickly remove the torch after the solder melts. Apply tung oil only to the wood. **PM**



Position trim piece to check fit. Remove and solder ends together. File excess solder, reposition and solder to body.



Cut pewter handle and cherry wood insert. Sand outer wood surface square. Bend around wood, remove and solder joint.



Apply flux and solder, tape handle in place. Paint rim with ochre, then solder. Handle drops slightly as solder melts.

TANKARD

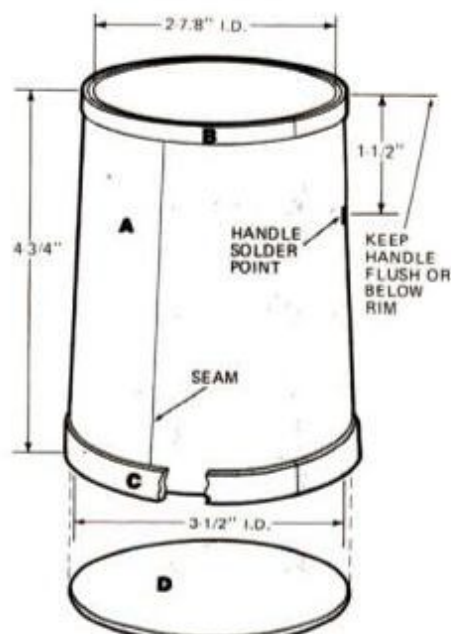
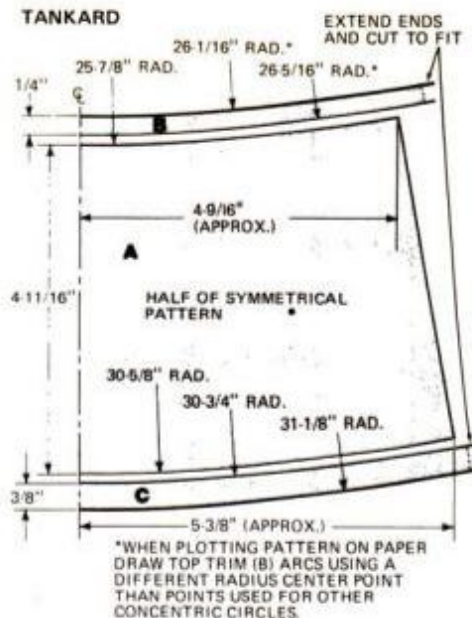

NOTE: MAPLE FORM FOR SHAPING HAS O.D. EQUAL TO TANKARD'S I.D.

TANKARD HANDLE

TO CUT F, MAKE INSIDE CUT FIRST WITH SABRE OR JIGSAW, THEN CUT OUTSIDE LINE WITH BANDSAW

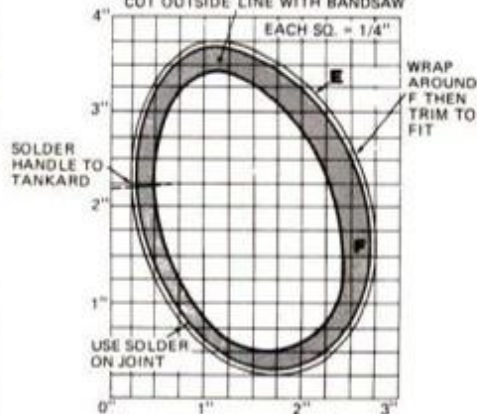

MATERIALS LIST—TANKARD

Key	Pcs.	Size and description (use)
A	1	4 1/16" x 10 3/4" 18-ga. pewter (side)
B	1	1/4" x 9 1/2" 18-ga. pewter (top trim)
C	1	3/8" x 11 1/4" 18-ga. pewter (bottom trim)
D	1	3 1/2"-dia. 18-ga. pewter (bottom)
E	1	1 3/4" x 9 1/2" 18-ga. pewter (handle)
F	1	3/4" x 2 1/2" x 3 1/2" cherry wood (handle)

Misc.: Maple truncated cone form (use i.d. and height on tankard drawing above; add extra height for vise grippage), glue, tung oil, masking tape.

Материал, защищенный авторским правом

What's so hard about building a Heathkit product?

nothing!



JUST PICK A KIT... ANY KIT
Whether you're a beginner or an experienced kit builder, you'll find it's easier than you'd dreamed!

GET STARTED



ALL THE PARTS ARE INCLUDED — even solder — so all you need are a soldering iron, wire cutter, pliers and a screwdriver!

THE EASY-TO-FOLLOW INSTRUCTIONS even show you how to solder perfect connections!

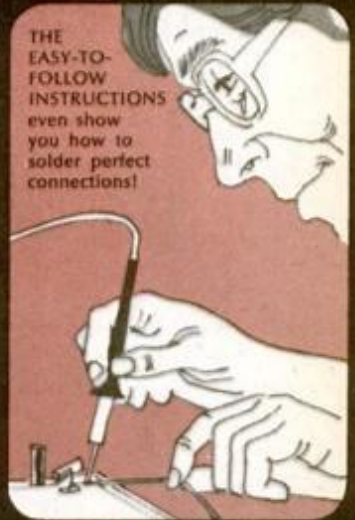

ALL FINISHED

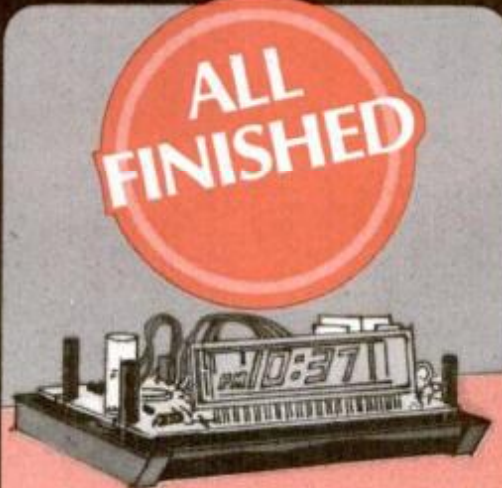

ONE LAST CHECK that all the connections are made right, and you're ready to turn it on...

IT WORKS



AND TO THINK YOU BUILT IT YOURSELF! It's a great feeling. You saved money — you enjoyed it — and you ended up with a great, hand-crafted product!

You can start right now...fill in the coupon and mail it today!

FREE **Heathkit**

HEATHKIT® CATALOG



Heathkit products are displayed, sold and serviced coast-to-coast at Heathkit Electronic Centers (Units of Schlumberger Products Corporation). See the white pages of your phone book for the store nearest you.

If coupon is missing, write:
Heath Company, Dept. 017-560
Benton Harbor, MI 49022

Read about nearly 400 money-saving, easy-to-build electronic kits — stereo, color TV, clocks and weather instruments, auto and aircraft accessories, Amateur Radio Equipment, Personal Computer Systems and much more! Simply remove the card along the perforated line, fill in and mail today.

HEATH
Schlumberger

Heath Company, Dept. 017-560
Benton Harbor, MI 49022

Please send me my **FREE** Heathkit Catalog.
I am not now receiving your catalogs.

Name _____

Address _____

City _____ State _____

Zip _____

CL-705

Time for chain maintenance

If you don't take proper care of your chain, it won't take care of you.

by Bill Hampton

If you're like most motorcyclists, you'd rather spend your time behind the handlebars than fiddling with your bike's rear chain. But that "string of links" takes a beating. And it needs a certain amount of attention, in the way of proper adjustment and lubrication. This is especially true if you're a hard-charging dirt rider or a tire-smokin' street jockey. Even if you're a conservative rider, you'll find that "conveyor belt" still needs more attention than other components on a motorcycle.

Check that chain

But first, before we find out what that *attention* is, are you making do with a worn chain? It's false economy to run a chain beyond its useful service life. A worn chain is murder on sprockets. What's more, a worn-out chain will make the bike perform in a jerky manner and rob power from the engine.

Without removing the chain, you can make a quick test to see just how worn it is. At axle height, grasp the chain between your forefinger and thumb and pull it away from the sprocket. If more than two-thirds of the height of the teeth is exposed, replace the chain. Adjustment involves tensioning the chain, so it's neither too tight nor sloppy. A tight chain is particularly bad. It and the sprockets all wear faster. Furthermore, a tight chain will overload the countershaft and rear-wheel bearings. Better to have it a little on the slack side, rather than too tight.

The chain should have about 3/4-inch up-and-down travel, midway between the sprockets. This is with rider weight on the seat and the rear tire resting on the ground. Because slack varies as the chain travels, check for the proper tension at the chain's tightest point of travel.

Keep in mind that a worn chain will have more variance in tension as it travels. Sprocket concentricity



Roller chain links (from left): pin link, roller link, master link (pin link with removable linkplate and clip) and half link.



Chain tension is checked by pushing up or down on chain midway between sprockets. Amount of play depends on loading.

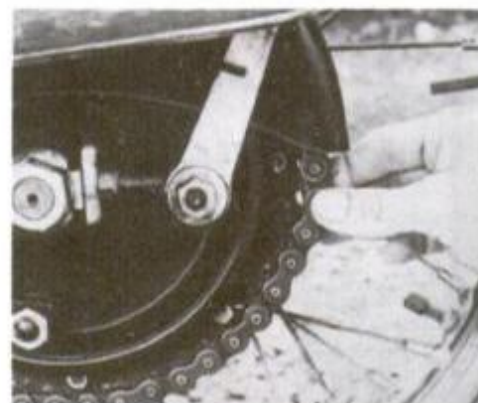

Check for worn chain by pulling it away from sprocket at axle height. If over two-thirds of teeth height shows, replace it.

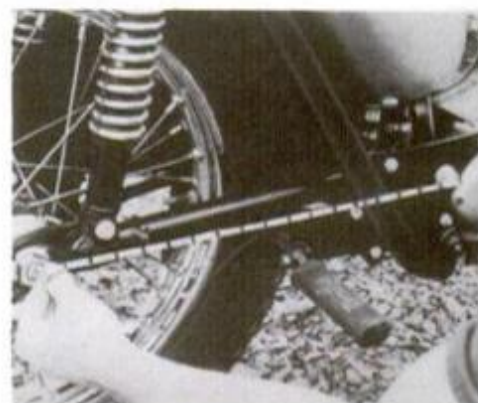

Rear wheel should be centered in swing arm. Measure from axle center to pivot on both sides to see if they're equal.

and wear also affect chain tightening or loosening during its travel.

If tension is checked while the bike is on its centerstand, allow 1/4 to 1/2 inch of play. When tensioning the chain, move each wheel adjuster an equal number of turns. Careless turning of the adjuster will result in misalignment of the rear wheel.

To insure precise alignment of the

rear wheel, move each adjuster by "flats." A flat is one side of an adjuster. For example, a hexagonal-shaped adjuster will have six sides, or flats. By keeping track of the number of flats you turn each adjuster, you won't cock the wheel to one side.

To determine if the rear wheel is
(Please turn to page 140)



PM's COMPLETE GARDENING GUIDE (Tools not included)

SPECIAL TWO-IN-ONE OFFER

Spruce Up Your Yard Slick Up Your Workshop

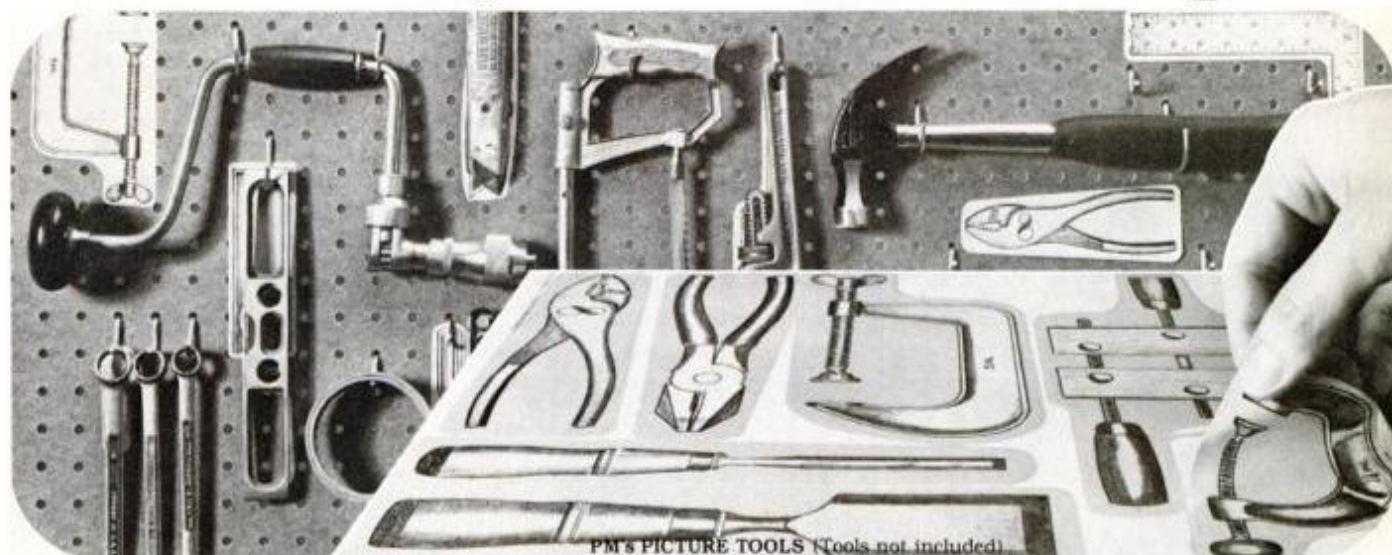

PM's PICTURE TOOLS (Tools not included)

Here's a special bargain that's hard to beat: Two of Popular Mechanics' famous home aids at a combined price that saves you over half the cost of either one alone. Here's what you get:

PM's COMPLETE GARDENING GUIDE — 24 big fact-packed pages put everything you need to know for a beautiful lawn, yard and garden at your fingertips. Dozens of charts, tables and how-to drawings cover landscaping, lawn care, growing plants, trees, shrubs, flowers, fruits and vegetables, pruning, transplanting and grafting, building walls, walks, patios — even pools, play areas and yard structures. Printed on heavy, plastic-coated stock and spiral-bound for easy, flip-to-find-it reference.

PM's PICTURE TOOLS — A neat, new way to organize, identify and keep track of your shop tools. Kit includes more than 70 brightly colored, self-adhesive silhouettes of common hand and portable power tools — plus a blank sheet for cutting your own shapes. Just peel them off their backing, stick them on your toolboard, and

you'll never wonder again what tools go where or which are missing.

The Gardening Guide and Picture Tools regularly sell for \$5.45 each, but now you can get both for only \$7.95 — a saving of \$2.95. Use the coupon below to order yours now.

Send check or money order to:

PM SPECIAL TWO-IN-ONE OFFER
Box 1014, Radio City Station, New York, N.Y. 10019

Please send me _____ set(s) of both the PM Complete Gardening Guide and PM Picture Tools at \$7.95 per set \$ _____

I would like to purchase separately:

_____ PM Complete Gardening Guide(s) at \$5.45 each \$ _____

_____ PM Picture Tool set(s) at \$5.45 each \$ _____

TOTAL AMOUNT REMITTED \$ _____

Name _____

Address _____

City _____ State _____ Zip _____

Please make check or money order payable to Popular Mechanics

Popular Mechanics is a publication of Hearst Magazines, a Division of THE HEARST CORPORATION Copyright 1979

PM OWNERS REPORT: JAGUAR

(Continued from page 77)

The XJ-S also gives a smooth ride and fast acceleration." And a California physician: "It runs, rides and handles like the smoothest rocket ship. It takes the light-

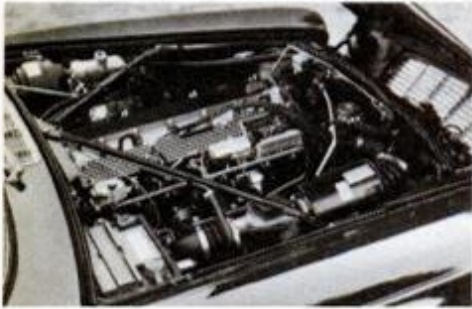

Race-bred ohc Six (above) and V12 sport electronic ignition and fuel injection.

est touch and is the most responsive car I've ever owned."

There's a darker side to the Jaguar also, represented in large measure by the Lucas electrical system. Britishers, in fact, call Lucas the "Prince of Darkness." Electrical defects topped our list of the Jaguar's ills, and if we include alternator/voltage-regulator problems, nearly 40 percent of our respondents admitted hav-

ing experienced some electrical troubles.

These tended to be mostly minor—like nonfunctioning gauges, burned-out bulbs and so forth. But a number of owners did report major woes—like shorts in the electronic ignition and failures in the Bosch-Lucas fuel-injection system. These brought the cars to total halts. Still others complained of hard starting when their engines were hot.

The aluminum V12, by and large, gave



Carpeted trunk will hold lots of luggage, but must be operated with a third key.

more grief than the ohc Six. One V12 owner, a retired publisher in California, said, "It [the V12] proved so detrimental to my health and well-being that I demanded that the dealer either give me my money back or issue me a new car. He



Nothing cramped here. Low headrests plus large windows give excellent visibility.

did neither, so I eventually traded the Twelve for a new Six and am pleased thus far, although any Fairmont or Malibu could be driven the same 2750 miles with far less trouble."

LOOK SHARP!

Stant caps protect your cooling system like no others can

When your car is checked for fall, whether you do it or your service station does, take a good look at the radiator cap. This important component is easy to overlook. But a faulty cap, or one of low quality, may not keep your cooling system pressure within safe limits. So when you replace the cap, take another good look. Look for Stant. Don't settle for just any cap. And for extra safety, install a Stant Lev-R-Vent® Pressure Cap... the safest, most dependable radiator cap available anywhere. And for expert tips on cooling system care, write for "The Stant Cooling System Fact Book." Send 25¢ to:

STANT
STANT MANUFACTURING CO., INC.
Connersville, Indiana 47331
A Purolator Products Company



Another respondent suggested the V12 be outlawed.

Nearly 25 percent of Jaguar owners we surveyed listed dealer service as the aspect of their cars they liked least. "Jaguar needs better-trained dealers," comments a California urologist, "and their mechanics invariably miss when it comes to troubleshooting."

Workmanship scored well overall, al-

though we did hear some grumbles about paint chipping, low-fidelity radio speakers, and fast-wearing seats. Several owners suggested changing the door locks so the car could get by with two, instead of three keys. The trunk and driver's door have to be locked with two different keys—a pain in the rain.

Jaguars come with tremendous amounts of standard equipment, but

cruise control wasn't available when we conducted our survey. We heard from a number of owners who installed their own (new Jags now offer cruise control).

In such areas as comfort, luxury, ride, handling, acceleration and performance, the Jaguar received nothing but praise. As an actor in California puts it: "The good features far outweigh the bad. It's an absolute dream to drive." **FM**

SUMMARY OF 1979 JAGUAR OWNERS REPORTS*

Total miles driven	479,271	Handling	56.1	Very good	20.5	Good	38.1
Average miles per gallon:		Comfort	34.1	Good	1.2	Average	16.7
Jaguar XJ6		Ride	30.5	Fair	2.4	Fair	10.7
In town	13.8	Performance	18.3	Poor	0.0	Poor	14.3
Long trips	17.0	Specific dislikes:		Comfort opinion (rear seats):		Number of vehicles owned:	
Jaguar XJ12		Poor dealer service	23.4%	Excellent	69.6%	One car	8.4%
In town	9.8	Poor gas mileage	16.9	Very good	13.9	Two cars	41.0
Long trips	12.3	No complaints	15.6	Good	2.5	Three cars	31.3
Jaguar XJ-S		Poor quality of materials	11.7	Fair	6.3	Four or more cars	19.3
In town	9.8	What changes would you like?		Poor	7.6	Makes of other cars owned:	
Long trips	12.5	Improved door locks	11.4%	Had any mechanical troubles?		Chevrolet	18.4%
Model choices:		Add cruise control (this feature is now available)	11.4	Yes	68.3%	Mercedes	15.8
Jaguar XJ6 sedan	66.3%	No changes	8.9	No	31.7	Cadillac	14.5
Jaguar XJ-S coupe	20.0	Better brakes	8.9	What type of trouble?		Pontiac	11.8
Jaguar XJ12 sedan	13.8	Better workmanship	8.9	Electrical	29.1%	Toyota	10.5
Why did you choose the Jaguar?		Workmanship opinion:		Airconditioning	14.5	Age distribution of owners:	
Styling	59.8%	Excellent	43.2%	Brakes	10.9	Under 20-29 years	10.5%
Handling	24.4	Good	38.3	Transmission	9.1	30-49 years	68.4
Performance	15.9	Average	7.4	Alternator	9.1	50-plus	21.1
Comfort	13.4	Fair	4.9	Dealer repairs satisfactory?		Would you buy another Jaguar?	
Past experience	12.2	Poor	6.2	Yes	62.3%	Yes	77.9%
Specific likes:		Comfort opinion (front seats):		No	37.7	No	21.1
Styling	68.3%	Excellent	75.9%	Dealer service opinion:			
				Excellent	20.2%		

* Percentages might not equal 100% due to rounding or insufficient data.

Your home workshop can PAY-OFF ...

...BIG!

3-in-1 Power Tool!

This one power-fed tool—
SAWS to desired Width ...
PLANES to desired Thickness ...
MOLDS all popular Patterns ...
—all in one fast operation!

Only Complete Workshop Tool Of Its Kind In The World!

From the day it arrives the Belsaw will make and save you money. With shortages and inflation driving lumber prices sky-high, this versatile power tool quickly pays for itself by easily converting low cost rough lumber into high value finished stock. Make your own quarter-round, base mold, door and window stop, casing, tongue-and-groove ... all popular patterns. Other Belsaw operators turn out picture frames, fencing, clock cases, furniture, bee hives, bed slats, surveyor's stakes ... all kinds of millwork. Handles tough oak and walnut as easily as pine using only one small motor, and so simple to operate even beginners can use it.



Try The Belsaw In Your Own Shop On Our **30-DAY FREE TRIAL OFFER**

Mail Coupon Below For Complete Details!

Send TODAY for this fact-filled **FREE BOOKLET!**

There is **NO OBLIGATION** and **NO SALESMAN** Will Call—ever!

YOUR OWN BUSINESS Part Time or Full Time—Right At Home!

Men and women everywhere are using this one low-cost power-feed machine to start and build their own new businesses...and YOU can do the same. Supply lumberyards, carpenters and contractors in your area with door and window trim...base shoe...bed mold...cove and quarter round...ALL of their trim. You can sell picture frame to custom framing shops, paint stores, department stores and direct to users. All patterns available or design your own. **Get FREE Booklet with facts and full details... RUSH COUPON TODAY!**

Does The Belsaw Pay? YOU BET!

READ WHAT BELSAW OWNERS SAY:

"I bought a batch of walnut in the rough, and after planing it on the Belsaw I figured I saved enough money to pay for two-thirds the cost of the Planer. It really does a good job."
R. S. Clark—Springfield, Ohio

"This machine pays for itself making money out of scrap boards. It is a very well built machine and I confess it is more than I really expected for the price. It does everything you say it will."
Stephen Schultz—Orangeville, Penna.

"I've been a planer man for years and am now retired. The Belsaw has earned me \$60,000 in eleven years...it's the best investment I ever made."
Robert Sawyer—Roseburg, Oregon

"I recommend the Belsaw as the most useful shop tool any craftsman could own. We use one every day in the Workbench model shop... couldn't get along without it."
Jay Hedden, Editor Workbench Magazine

BELSAW POWER TOOLS Co.
900P Field Building
Kansas City, MO 64111

FREE BOOK

YES, please send me the FREE Booklet that gives me complete facts about Belsaw's Planer-Molder-Saw and full details on how I can qualify for a 30-Day Free Trial right in my own shop. I understand there is No Obligation and that No Salesman will call.

Name _____
Address _____
City _____
State _____ Zip _____

FOR ANOTHER \$143* IT'LL ACTUALLY MOVE

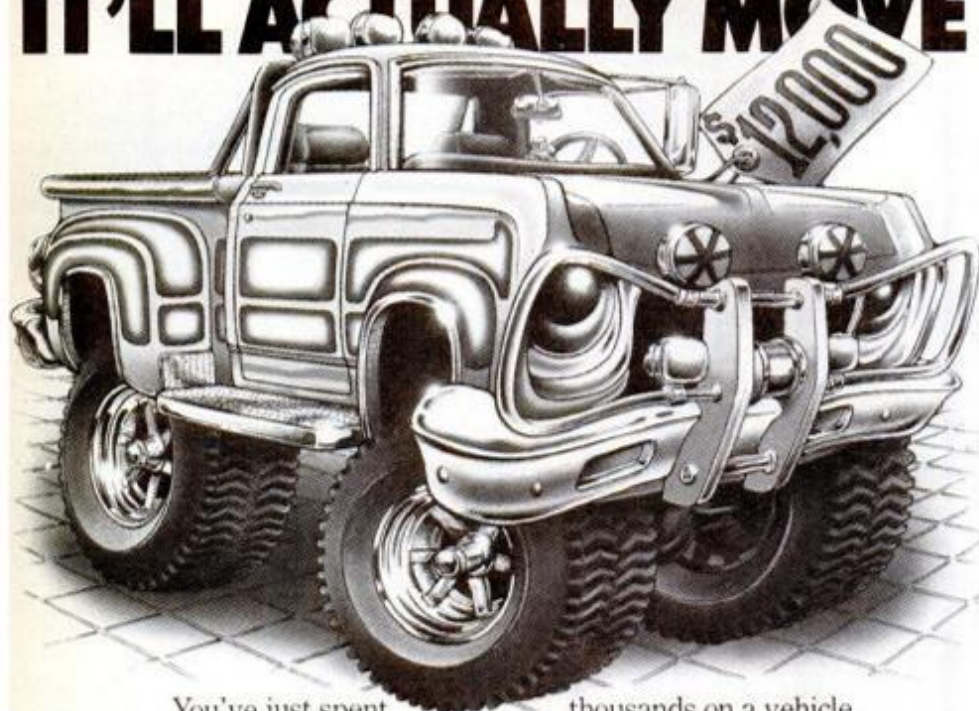

You've just spent thousands on a vehicle that looks as if it'll go like gangbusters. Now comes the big disappointment. Acceleration is sluggish. Power is weak. All are typical problems with late model V8's, harnessed by low rpm and emissions equipment.

Fortunately, there's an inexpensive solution. Replace your intake manifold with an Edelbrock S.P.2-P. Retaining all stock parts, it's easily hooked up to the standard engine by you or your mechanic. *Average S.P.2-P. cost: \$143.39 based upon 1979 consumer net prices.

You feel the difference the first time you touch the accelerator. The engine gives a sharp response. Extra power. Smoothness. Better mileage, provided you drive the same as you did before.

For more information on Edelbrock's S.P.2-P. manifolds, visit your nearest auto parts store or send \$2.00 for our full catalog including the installation brochure, decals, and an embroidered patch, to Edelbrock Corp., Dept. PM879, 411 Coral Circle, El Segundo, California 90245.

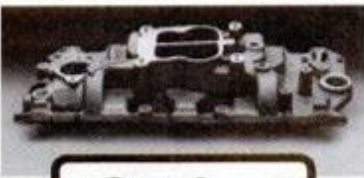

**OUR INTAKE MANIFOLD GIVES YOU
THE POWER YOU'RE MISSING**

Edelbrock

HINTS FROM READERS

Transporting items by car roof



Use thin, strong rope to tie rooftop load to hinge arms of the trunk and hood.



When hood and trunk are closed, the ropes become taut, grip the load tight.

Here's a good way to secure a load of lumber or other large item to a car roof. Raise the hood and trunk lid and snugly, but not tightly, tie rope around the load to the hood and trunk-lid hinge arms. Shut lid and hood so the load is secured. If load overhangs the rear, fasten a red attention flag on it.—
Rosario Capotosto

Hammering another tool

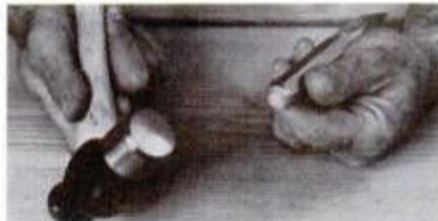

When you use a hammer to strike another tool, it's important to use the proper type and size. Use a ball-peen hammer or small hand sledge on struck tools. If you work with a common nail hammer, you'll risk chipping the struck tool. To be safe and to deliver a solid blow, the hammer-head diameter should be at least 3/8 in. larger than the head of the struck tool. Wear safety goggles.—
Frank Burgmeier

BRITISH SPORTS CAR PARTS
Steel/fiberglass body panels, upholstery, carpets, tops, wire wheels, grilles, bumpers, wiring harnesses, headers & exhaust systems, mech. parts, rubber trimmings. Catalog \$3.

AUSTIN-HEALEY
MG
TRIUMPH
JAGUAR Dept. PJ
512 BOSTON POST RD
DARLEN, CT 06820
(203) 645-8731/2

SPORTS & CLASSICS

NAME THAT TUNE!

OVER 120 TUNES AVAILABLE
FOR YOUR OWN MUSIC BOX CREATION!
Swiss Movements available from 18 to 72 notes from \$7.99 Disc Type with over 90 music favorites to choose from. Guaranteed for 1 year. Send \$1.00 for catalog with tone selection (refundable).

WORLD OF MUSIC BOXES
412 Main St. Avon, New Jersey 07717 Dept. B



BEAT Inflation
...and **HIGH Lumberyard Prices!**
Portable Belsaw goes right to the trees — turns out smooth, true-cut lumber every time. No experience required. Saw your own logs or lumber for others and make excellent sparetime income—no crew is needed. For power, use tractor PTO or other low HP diesel or electric unit. A size to meet every requirement and pocketbook—time payments may be arranged.

ONE MAN SAWMILL

BELSAW
Since 1922

Send postcard for FREE detail. No Obligation. No Salesmen Will Call
BELSAW MACHINERY Co., 3832 Field Bldg., Kansas City, Mo. 64111
SEND TODAY!

NOW! Turn Trees Into Valuable Lumber!

(We need your opinion)

A system with remote for less than the other people charge for just a telephone answering machine

This ad's a test. A kind of consumer survey. With a special Free Offer. To see if the low price of the new Call Jotter remote telephone answering system can turn one of the biggest selling business items into one that's successful with consumers, too.

Ordinarily, information like this comes from a consumer panel. Focus groups. But the manufacturer wasn't about to commit for the enormous sum required based on talk. He wanted facts. And came to us, as one of the largest mail merchandisers, for help. Because orders are facts he could act on.

Quality Features

For our part, we tested the Call Jotter thoroughly. And can tell you it's exceptionally well made. (It has to be to get our guarantee.) With solid state, microprocessor technology and plug-in simplicity. It's F.C.C. approved. And delivers the freedom and convenience you get with systems selling for \$299.95—which is the going price, as you know, for remote telephone answering machines.

One thing we did tell the manufacturer: something extra should be given to those who participate in this test. He agreed. So, you'll receive with your order a FREE professionally recorded tape that answers and records 30 messages... a FREE blank tape for recording your own messages or for when you're using the machine as a cassette recorder and player... plus a FREE adapter for connecting the Call Jotter to your telephone jack.

An Extraordinary Convenience

Now, we ask you, how much would it be worth to you, to your wife, even your teen-age children to never miss or worry about a phone call again? And to get your messages without having to wait until you get home—from any phone, anywhere in the world. Resetting the machine to take 30 more messages by touching a button on the Tele-Key remote control.

Of course, you'll use your Call Jotter to answer the phone when you're working outside and when you're in a part of the house where there's no telephone.

How much would you spend for an answering machine when the phone rings and you're up on a ladder painting the house? It's true—isn't it—the phone always seems to ring at exactly the wrong time. Like the critical moment in your favorite show and whenever you're taking a nap.



Get your message from any phone anywhere in the world.



Think of the time you've spent just waiting for someone who's promised to call. And what value do you place on your privacy... on working without interruption?

Because your Call Jotter has a monitoring system that lets you listen without answering, you can go back to what you were doing the instant you know it's a nuisance call or for someone who's out of the house. Naturally, you can take any call that's important.

Two For The Price of One

For additional value, Call Jotter works with a single cassette, like a pocket recorder or dictating machine, so you'll use it to listen to your favorite tapes and for recording your own tapes, for dictating letters and memos to be transcribed at the office.

Save \$130.00!

You'll use your Call Jotter, then, when you're away—whether it's running to the corner store or spending a month in Europe.

Still—we agree, you probably wouldn't want to spend \$299.95 for something that isn't business related. With Call Jotter, though, you save \$130.00! And that's a different story.

At \$169.95 (plus \$4.35 shipping and handling) Call Jotter's the lowest priced remote telephone answering machine you can get. (Without the remote, it's even less, only \$99.95 plus \$4.35 shipping and handling.)

Now, we invite you to discover the convenience and freedom it brings—especially if you're an active family—without risking one cent.

You can order either model with any national credit card simply by calling the toll free number below at any time. If you prefer, send your check to Douglas Dunhill at the address below. (Illinois residents are required to add the sales tax.)

Call 800-621-5554

Illinois Residents Call 800-972-5858
In operation 24 hours, 7 days a week

Remember, the low, down-to-earth price includes the Tele-Key remote control and the two FREE tapes plus the FREE adapter that fits your telephone jack. (If you don't have a phone on a jack, the telephone company will install one for a modest, one time charge when your system arrives.)

You Must Be Satisfied

Use your Call Jotter for 30 days. If you're not completely satisfied return it to us for a complete refund, no questions asked. Simply use the carton it comes in and follow the simple procedure in the directions we send you.

If this test is successful, the manufacturer will go into full production and you'll be seeing the unit in stores everywhere in six to nine months. You'll have played a part in this success—for which we thank you. Meanwhile, we'll be filling orders while we can from the supply on hand.

- Approved for connection in accordance with telephone company filed F.C.C. regulations
- Uses standard 60-minute cassettes
- Plugs into any phone on a jack with adapter supplied free
- Dynamic microphone, full fidelity speaker, push-button tape controls, call light, recorder-player operates on standard A.C. current
- Tele-Key complete with 9V battery for remote control from any phone anywhere in the world (2" x 3" x 1"—4 oz.)
- Hi-fi styling. Black and walnut color. Just 9½" x 10½" x 2¾"

The convenience and freedom you want... At the price you've been waiting for.

Douglas Dunhill
INC. AFFORDABLE QUALITY

Dept. 50-4078
Ten Douglas Dunhill Drive, Oak Forest, IL 60452
© Douglas Dunhill Inc. 1979

Driving PM's electric car in Iceland

by Bill Kilpatrick



Icelander Steinn Sigurdsson (left), winner of PM's electric-car contest (see Aug. and Dec. '75 issues), has his car built and on the road. As seen above, in front of the Icelandic Airlines Hotel in Reykjavik, the car is an eye-catcher.



I was somewhat startled when Steinn Sigurdsson drove his PM-award-winning electric car up in front of the Hotel Loftleidir in Reykjavik, Iceland . . . startled because the car's appearance triggered the thought that its "pilot" could well be wearing some sort of space suit. The car looked every bit as other-worldly as something out of NASA.

I confess to having thought of most electric cars as little more than gussied-up golf carts. But Sigurdsson's trim and sprightly little two-seater—which he calls "Rafsi"—turned out to be an honest-to-gosh automobile that feels and responds like one of those mini-Fiats and Renaults we used to see in the '50s.

The most immediate and striking difference between those ill-advised and unlamented imports and Rafsi is noise, the main source of which in the latter is the "singing" of its tires as it wafts along.

The other obvious difference is, of

course, in the way Rafsi looks. Those first little Fiats and Renaults were more or less bulbous miniatures of equally bulbous bigger models in their respective lines. But Sigurdsson's design reflects his having started out with a clean and unfettered sheet of paper, the result being a car that is at once very much for tomorrow, yet practical today.

What, in fact, Sigurdsson *did* start out with was some aluminum sheeting, tubing and extrusions, glass and plastic panels, strip and channel steel, and the bare-bones chassis he won in PM's electric-car design contest. The chassis, built in Italy by Carrozzeria Zagato, features a 12-volt, eight-battery pack powering a 3½-hp, 2000-watt motor capable of developing from 6 to 7 hp—all of which boils down to a between-charges running range of about 30 miles at speeds of up to 40 mph. It also features independent coil-spring suspension up front, a semi-independent rear suspension, and shocks all around anchored to a frame fabricated from 11-gauge channel and angle steel. Tires are Michelin X2 145 SR10s.

Basic controls—switches, "gear-shift" and so on—are mounted atop a squarish post that rises from the floor pan like a miniature high-rise office building.

Those, then, in general, are the "givens." It's what Sigurdsson has done with them that makes Rafsi special. (By the way, a road test report on the chassis appeared in the Aug. '75 issue of PM, page 47.)

A lot of the electric car body de-

signs I've seen so far seem to apologize for the limitations of the chassis upon which they are mounted. Unlike the earliest electrics, which in most respects resembled their gasoline and/or steam-powered peers, many of today's small electric cars look somewhat cobbled up—assemblies of unrelated afterthoughts.

Rafsi, on the other hand, seems to stand on its own as a vehicular design, period, and quite apart from whatever its source of motion.

Each aspect of Sigurdsson's design comes together beautifully the moment the car is actually driven. You pop into it, flip the appropriate switches, and off you go, mindful only of the absence of engine noise. Oh, you're aware of the motor working to get you up to cruising speed, but once the speedometer hits about 55 kilometers per hour, things settle down to a quiet, steady hum. Otherwise, you could be driving anything, flipping direction signals and all.

It rained on and off the day I drove the car, and I came to appreciate one of Sigurdsson's many thoughtful touches—the windshield wiper arrangement: With the exception of the right-angled corners, the wiper's single long blade sweeps the entire safety glass panel by spinning through a 360° circle.

PM

Editor's note: At the time of PM's electric-car contest, the chassis awarded to Mr. Sigurdsson was available from a company now out of business. PM is not aware of any similar chassis now on the market. Designs that might become available in the future would be known by the Electric Vehicle Council, 90 Park Ave., New York, N.Y. 10016, from which you could receive more information.

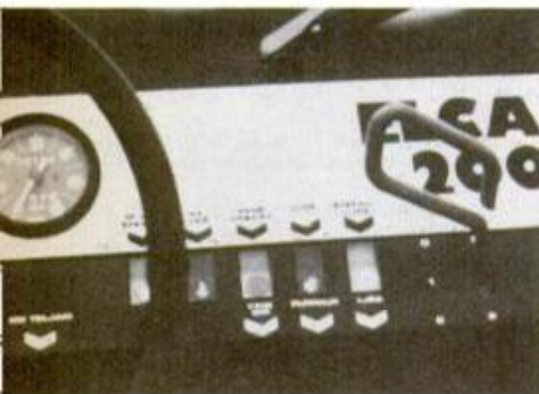

Cockpit of Sigurdsson's winning design has row of switches, monitoring lights.

Warning: The Surgeon General Has Determined That Cigarette Smoking Is Dangerous to Your Health.

FILTER 100's, 10 mg. "tar", 0.8 mg. nicotine, FILTER, MENTHOL.
11 mg. "tar", 0.8 mg. nicotine, av. per cigarette, FTC Report MAY '78.



The Vantage Point

Where great taste and low tar meet.



Great taste once belonged only to high tar cigarettes. Not any more. The secret? The specially designed Vantage filter works together with our rich 'Flavor Impact'™ tobacco blend to deliver satisfying flavor in every puff. That's Vantage. Low tar with a uniquely satisfying taste. And that's the point.

Regular, Menthol and Vantage 100's

SHOCK ABSORBERS

(Continued from page 84)

include those for racing cars, medium and heavy trucks, and buses.

Replacing shocks

Don't buy shocks unless they are accompanied by instructions. In addition to the manufacturer's suggestions, here is a list of "dos" and "don'ts" you should keep in mind when replacing shocks.

■ Just before you begin work, lay out all parts from the packages. Make sure the mounting components of each shock are present. Take each shock in hand, hold it ver-

tically, and pump it up and down to work air out of the chambers.

■ Make sure the car is firmly supported. You don't want it dropping on your head. If you are replacing rear shock absorbers of a car equipped with rear coil springs, don't let the rear wheels hang. The rear axle must be supported by a jack stand close to the shocks to keep springs in place when old shocks are removed, because shock absorber tension holds springs in position. Springs may also be supported by placing wedges between the suspension and axle.

Caution: If shocks are removed without the axle being supported,

the axle can drop suddenly and may injure you and damage vehicle components.

■ Don't twist studs off old shocks. You can damage the threads of the mounting seat, which is a part of the car. If nuts are rusted, give them a liberal dose of penetrating oil a day or two before you are going to do the job. Before applying oil, use a wire brush to remove rust and dirt from the mount threads.

■ As you remove the mounting hardware, notice the order of position. Be sure to reassemble new mounting hardware in this order.

■ Normally, to remove front shocks, hold the upper stem so it doesn't turn as you remove upper hardware. Then remove hardware holding the lower mounting and pull the shock out from the bottom.

Note: Lower hardware of front shocks is accessible from below. Upper hardware may not be. If not, get to it through the engine compartment. Hardware is either atop the fender housing or is reached by removing a rubber splash shield over the housing.

■ Normally, to remove the rear shocks, disconnect upper, then lower hardware. If upper hardware is not visible, get to it via the trunk.

■ In some cases of front shock installation, you may have to enlarge the hole in the lower suspension arm slightly to permit insertion of the shock's stem. Do this by tapping the inside edge of the hole, or by filing or grinding. Enlarge the hole just enough to accept the stem. You must never file or grind the shock.

■ When installing rear shocks, see that brake and fuel lines and exhaust pipes clear the units. Clearance should be checked with the car's body extended up and then pushed down after shocks have been installed—that is, with the wheels hanging and then by pressing down on the corners of the car. If necessary, move lines and pipes to obtain clearance.

■ Never grip the piston rod of a new shock with any tool. Just a small nick or scratch in the rod can cut the seal. This will allow fluid to leak out.

■ When installing shocks having stud-type mountings, don't over-tighten the nut. The rubber bushing should be squeezed only enough to give it the same diameter as the retaining washers.

■ Replacing air-adjustable shocks is similar to replacing standard shocks. However, there are additional steps to observe. For one, you have to disconnect air connections. Make sure you know these steps. They are listed in the instructions that come with the shocks.

There's a new-fashioned hardware store in town.

Sentry Hardware. With a brand-new sign, and some old-fashioned ideas. Because Sentry is more than a store able to provide you with exactly the right tools and supplies you need, at a price that's fair and reasonable. Sentry is people. Friendly, helpful, knowledgeable people.

So when you're ready to do-it-yourself, start off at the hardware store where people are ready to help.



SENTRY Hardware When you're ready to do-it-yourself.

Check the Yellow Pages under Hardware for the Sentry Store nearest you.

Interested in becoming a Sentry Hardware dealer? Contact us at Sentry Hardware Corporation, One Union St., New Canaan, CT 06840.



PM LOOKS AT BETTER WOOD BORING

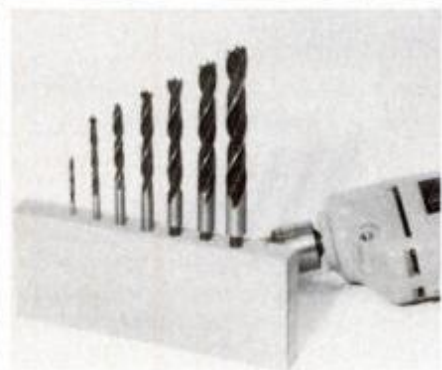

Author protects his bits by storing them in pine block kept on workbench.

I think it is safe to say that at some time everyone—from beginner to professional woodworker—has had a drill bit wander and damage a costly piece of wood. I am constantly on the lookout for new bit shapes that overcome the wandering tendency. The ones shown here are among the best I've used. Called Woodbit No. 3500, the seven-piece chrome-vanadium alloy set priced at \$15.95 plus \$1.75 postage includes 1/8-, 3/16-, 1/4-, 5/16-, 3/8-, 7/16-, and 1/2-in. sizes. Available from Leichtung Inc., 701 Beta Dr., Suite 17P, Cleveland, Ohio 44143.—H.W.



Bit's brad point keeps the bit on spot to be bored when the drill is started.



Woodbit's sharp flutes deliver a straight and perfectly round hole every time.



This VET Did It – and YOU Can Do It Too!

"War injuries left me badly handicapped, but now I'm a financial success as a Locksmith, thanks to your training. Besides, the work is fascinating. If I can do it anybody can." — Glen Johnson, Larned, Kan.

Make Up to \$10 an Hour—even while learning!

Train FAST at Home!

Be a LOCKSMITH!

If you enjoy fixing things, you're a "natural" to make hundreds of EXTRA DOLLARS a year in the fascinating business of Locksmithing. Rising crime has increased demand for service a thousandfold. Yet there's only one Locksmith for every 17,000 people!

COLLECT CASH PROFITS ALMOST AT ONCE!

You're "in business" ready to make \$5 to \$10 an hour a few days after you begin Belsaw's shortcut training. Easy, illustrated lessons complete with ALL practice equipment PLUS

- ALL TOOLS YOURS TO KEEP
- KEY MACHINE YOURS TO KEEP
- EXPERT PERSONAL ASSISTANCE
- BUSINESS-BUILDING HELP

enable you to get your share of this always-profitable business. Hundreds we've trained are doing it. So can YOU.

MAIL COUPON to discover how Locksmithing can keep the extra money coming in during spare time—or in your own full-time business. Ideal for retirement—good jobs, too.

BELSAW INSTITUTE, 100P Field Bldg.
Kansas City, Mo. 64111
Accredited Member NHSC.

N. Hunt, Wilmington, Del.—"I make \$50 a week extra."

R. Davis, St. Louis, Mo.—"I cleared \$110 last Saturday."

Ed Boyle, Pittsburgh, Pa.—"My business going at top speed. I'm moving to bigger quarters."



FREE

MAIL THIS COUPON • NO SALESMAN WILL CALL

BELSAW INSTITUTE, 100P Field Bldg.
Kansas City, Mo. 64111

Rush **FREE** book, "Keys to your Future."

Name _____

Address _____

City _____

State _____

Zip _____



THIS DO-ALL PRO KEY MACHINE YOURS TO KEEP!



Can add \$25 to \$40 a week to your income... and doesn't cost you a penny extra!

Give your tools a new lease on life with GUNK & SOLDER SEAL products

LIQUID WRENCH
NUMBER 20
STOPS SQUEAKS
PROTECTS METAL
LOOSENS
RUSTED PARTS
DRIES
WET ENGINES

RADIATOR SPECIALTY COMPANY
Charlotte, NC 28223

COLEMAN® INFLATE-ALL™ 150



No air? No sweat!

Operates from 12-v auto
cigarette lighter...
pumps up to 150 p.s.i.

For passenger tires...
4WD, pickup and RV tires...
motorcycle and bike tires...
air shocks... footballs,
basketballs, volleyballs...
dozens of other uses.

And it's the one with
Coleman quality. So you
know you can count on it
in the clutch.

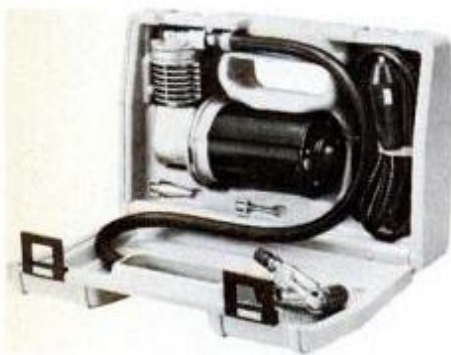

Coleman

The Coleman Company, Inc.
Wichita, Kansas 67201

NOW IN LEADING AUTOMOTIVE DEPARTMENTS

QUICK FIXES

(Continued from page 99)

ance is not plugged in and disconnect one of its terminals.

Attach an ohmmeter lead to one of the cord plug prongs. Attach the other ohmmeter lead to either the disconnected or attached power cord terminal. The ohmmeter (set on the Rx1 scale) will either show continuity (0 or a slight rise off 0) or resistance (an infinity reading, identified on the ohmmeter scale by the symbol ∞). Now, transfer the ohmmeter lead to the other power-cord terminal. The ohmmeter needle should swing to the opposite end of the scale from where it was, reading 0 if it had shown ∞ or ∞ if it had shown 0. If it doesn't, the cord is defective.

To satisfy yourself further, connect the ohmmeter lead to the power cord terminal which gave a meter reading of 0. Then keep your eye on the ohmmeter as you pull, bend and twist the power cord over its entire length. If the ohmmeter needle suddenly swings to infinity, there is a power-cord break. Replace it.

Power cords for small electric appliances are specially constructed. They are designed to carry heavy electrical loads, so be sure you get a cord made to meet the appliance demands, by sending to the manufacturer or visiting an appliance repair center. Failure to do so could result in a fire. When reattaching a power cord, make certain that terminals are tightly connected.

Trying the heating element

There are two types of heating elements: open and closed. Open elements are visible. They are spring-type components, which are stretched over the appliance and held by ceramic insulators.

A closed element is a coil inside a metal housing. The element is separated from the housing by manganese, which acts as an insulator.

Open elements are tested by unplugging the appliance, disconnecting one terminal and attaching an ohmmeter (set on the Rx1 scale) to it and to the other end. If the ohmmeter doesn't show 0 or a slight rise, but goes to ∞ , replace the element.

The open element you get as a replacement may have to be stretched to fit the appliance. Do this by holding one end in a vise and pulling the element until it's the same length as the old element. Don't stand directly in front of the element as you stretch it; it can come loose from the vise and spring back toward you.

Examine ceramic insulators. Replace those that are broken, along with those that are loose and can't

be tightened. If an insulator fails to hold the heating element securely, the element may loosen and become grounded against the appliance case, causing a short and creating a safety hazard to the user.

To test a closed heating element, remove the element, set the ohmmeter on the Rx100 scale and connect ohmmeter leads across the element terminals. The meter should show 0 or a slight rise above 0—not ∞ .

Rating the thermostat

A bad thermostat can prevent an appliance from heating or cause erratic heating (overheating or not hot enough). Check by unplugging the unit and carefully spreading the thermostat points apart to see if they are pitted or dirty. If they are, run an ignition point file (available at automobile parts counters) over the points. Make two passes. If points require more than this amount of filing to be cleaned, replace the thermostat. Excessive filing removes too much metal from the points, ruining them anyway.

To test for a defective thermostat in an appliance with an attached type of power cord, place a jumper wire across the prongs of the power-cord plug. The jumper wire should have an alligator clip on each end to keep the wire securely in place on the prongs. Connect the ohmmeter leads across the thermostat terminals. Then, with the ohmmeter set on the Rx1 scale, turn on the appliance on-off switch. The meter should show 0, or a slight rise above 0. Now, turn the on-off switch off. The needle should swing to infinity (∞). If it doesn't, replace the thermostat.

If you are testing the type of thermostat that is part of a detachable power cord, such as that used with skillets, fry pans, hot trays and the like, place a jumper wire across the prongs of the power-cord plug. Insert the ohmmeter test lead prongs into the two holes in the thermostat housing. The meter should show continuity (0 or a slight rise above 0). If it doesn't, replace the cord/thermostat assembly.

Testing for shorts

When you have completed repairs and reassembled the appliance, check for grounds (shorts). This is important. Do the same if someone using the appliance gets a "tickle" shock. A short occurs when a wire touches the appliance case.

With the appliance disconnected from the wall outlet, set the ohmmeter at its highest scale (Rx100, Rx1000 or Rx10,000). Attach the positive ohmmeter lead to one of the

(Please turn to page 126)

NASA'S INNER SPACE PROJECT TRIPOLYMER®



The space is inner space, those nooks and crannies between the walls of your home that need protection against heat and cold.

The experts at NASA understand this space. That's why they contracted us to insulate their model home in Virginia with Tripolymer insulation.

Tripolymer can solve *your* inner space insulating problems too; *protecting against heat and cold, soundproofing for silence, retarding flames if fire breaks out.*

For economy, quiet and safety see your Tripolymer dealer today. For more free information mail coupon.

C.P. Chemical Co., Inc., 39 Westmoreland Avenue, White Plains, N.Y. 10606

PM2

NAME _____

ADDRESS _____

ZIP _____

- I would like my local dealer to contact me.
- Send me more information on "Your Home's Inner Space"
- Send me NASA's brochure on their model home.

© ® C.P. Chemical Co., Inc. 1978

"Be sure you use a certified Tripolymer® dealer and ask for his consumer contract."

Convert your fireplace into a functional furnace

Cut your home heating bills by half or even more!

Insure your comfort in case of blackout or fuel shortage.

THERMOGRATE Fireplace Furnace

Tubular heat exchanger with Thermoshield heat amplifier maximizes heat output & efficiency.

Exclusive Stainless Steel heat exchanger tubes guaranteed 5 yrs. . . . should last a lifetime!

Installs easily into your existing fireplace. No modification needed.

• U.L. Tested & Listed.

- Unique full-view 'picture window' glass doors w/ 'Stay-Clean' design.
- High heat output even without blower.
- Swing-wide doors for easy ash clean-out.
- Burn coal, wood or paper waste.

Performance & Satisfaction MONEY-BACK GUARANTEED

Write for FREE color brochure with specifications & performance data:

THERMOGRATE ENTERPRISES, INC.
2785 N. Fairview Ave., Dept. 840-908
P.O. Box 43021, St. Paul, MN 55164
Or CALL TOLL FREE 1-800-328-0882

THERMOGRATE®

© 1979 TEI St. Paul MN 55113. All rights reserved.



QUICK FIXES

(Continued from page 124)

power-cord plug prongs and press the common lead firmly against the appliance housing. Turn on the on-off switch. The ohmmeter needle should *not* show any deflection from ∞ . If it moves off ∞ , disassemble the appliance, locate and fix the short.

Motorized appliances

Small kitchen appliances that do not use heat have motors that do the work. In this category are blenders, can openers, mixers, knives and food processors. If a motor runs (hums), but the appliance doesn't work, look for mechanical damage, particularly a broken gear or a binding bearing. Repairing these parts is not difficult if you note carefully how parts fit together during disassembly.

The most common problem when it comes to motorized appliances, however, is a motor that doesn't run and makes no sound. The cause is a defective a.c. outlet or power cord, a faulty motor, or a loose connection. If the a.c. outlet and power cord test out okay (as described earlier) and connections have been checked for tightness, turn your attention to the motor.

A damaged motor is no reason to discard an appliance. New motors cost about \$10. In some cases, you don't have to replace the entire motor—just a part of it. Universal motors, for instance, have by two separate components—armature and field coil. Either can be replaced at appliance part dealers.

The field is the more likely of the two units to fail, but to make a sound diagnosis inspect the armature, especially the commutator end. If the commutator is not burned or dirty, the armature is probably okay and you can replace the field coil. If the commutator is burned, examine the brushes. They are two independent units that sit on either side of the commutator. Replace brushes if they are worn (less than 1/4 inch long). Dress the commutator by rubbing it lightly with emery cloth.

One sign that brushes are defective is visible electrical arcing around the commutator as the appliance runs. Brushes give fair warning before they get so bad the appliance won't work. If the brushes are okay, but the commutator is burned, replace the armature.

Another type of motor widely used in small kitchen appliances is a shaded-pole motor. It usually comes as a complete unit, so if it seems to be the cause of appliance failure, check with an appliance store and get the correct replacement. **FM**

PROGRAMMED SCANNING

(Please turn to page 80)

pushing one button (A.R.F., Pace, SBE); one-button return to a user-programmable alternate frequency (Pace, SBE); continuous 40-channel scanning with no stop other than a short delay if channel meets the user-programmed criteria of busy or clear (Pace); and regular scanning of one selected channel every few seconds while monitoring another channel (Pace, SBE).

Memory programming

An aspect of computerization that is not often prominently featured in the published specifications is memory (programming) retention. Most of the new sets have *nonvolatile* memories—which means the memory or programming is *not* lost when the power to the transceiver is turned off.

Either the microprocessor's memory is kept "alive" by a separate power connection or by a small transistor-radio battery mounted on the back or within the cabinet.

At least one of the computerized sets has a *volatile* memory—which means that all programming is lost whenever the power is turned off. While programming a CB may not take more than a few seconds (once you get the hang of it) nonvolatile versus volatile memory is something to keep in mind while shopping for one of these new CBs. (Warning! Don't rely on the salesman. He may not know what you're talking about. Read the manual before buying if you find that the set is not listed on our chart.)

Prices are as follows: The A.R.F. 2001 goes for \$1095; Pace's 8117 is \$250; Robyn is bringing the SB-54D to market at \$530; SBE offers its Key/Com 1000 at \$260, and Radio Shack sells its Realistic TRC-459 for \$440.

Where there's a large cost differential between computerized models, prices generally reflect added features other than the computer microprocessor. A built-in digital clock ups the price and a single-side-band rig (SSB) will cost more than an AM one. However, all computerized sets are outstanding. You need not compromise performance for computerization. They presently go hand in hand.

As our chart will show, these sets have tested out as excellent in all areas of performance. You can buy with confidence. Just decide which computer features you need, which other options you might want, and go compare. You'll agree—CB is back. **FM**

Build a Grandfather Clock Case for \$99.

QUALITY GRANDFATHER CLOCKS AT FACTORY DIRECT PRICES.

- Completely finished and assembled
- Kits with pre-cut parts
- Beautiful solid woods (walnut, oak, or cherry)
- Brass West German movements
- Antique furniture reproductions
- Money back guarantee

Send \$1.00 for Color Catalog

VIKING
CLOCK COMPANY

P.O. Box 490, Dept. PM, Foley Industrial Park, Foley, Alabama 36535

"My friend showed me the way."

Ever wish you had a friend who could tell you how your car works and show you how to care for it? It sure would cut down on repair bills. Well, meet a new friend—*Saturday Mechanic's Basic Car Care Illustrated*. Over 500 pages and 800 illustrations that will take you step-by-step through most of the service repairs your car will ever need.

It's the first completely illustrated guide for the beginning auto do-it-yourselfer.

Basic Car Care Illustrated is written so you understand it. It gives you illustrations and captions rather than a lot of dense text. It shows you how every step of the way. No confusion. No mystery.

Plus *Basic Car Care Illustrated* has all these features:

- "Quick Fix" tips for temporary repairs
- "Pro-Shop" tricks of the trade
- Complete specifications

- Trouble shooting for every system
 - Lists of tools and equipment for every job.
- And because we recognize the do-it-yourselfer has limited tools, time and experience, we'll tell you when a job is too complex and difficult. But we'll also give you enough

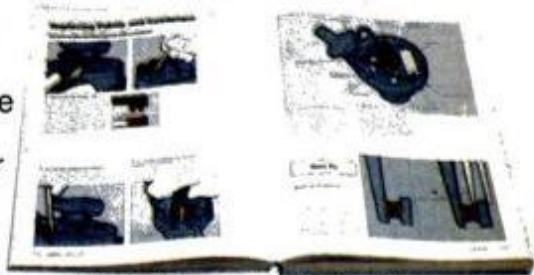

background so you can talk to a professional with confidence.

You'll find the *Saturday Mechanic Basic Car Care Illustrated*, a real friend, wherever auto accessories are sold. Or for the name of the dealer nearest you write to Saturday Mechanic, 1790 Broadway, New York, N.Y. 10019.

**SATURDAY
MECHANIC**

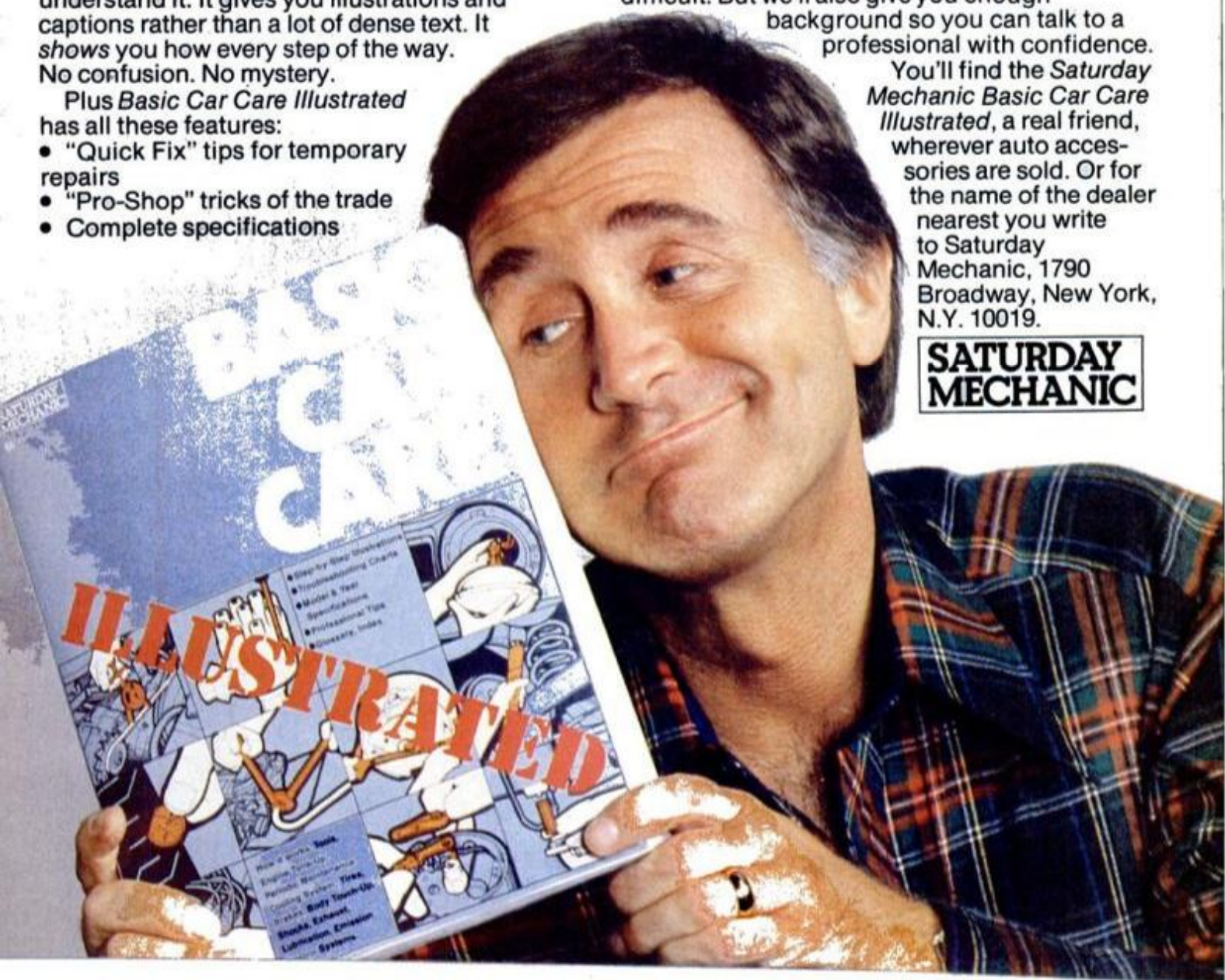

Available at

WALGREEN'S
DISCOUNT AUTO CENTER

HOWARD'S

Parts
Plus
autore



and these other fine stores: Aid Auto - Al's Auto Supply - 'Appy's - Arizona Jobbers Supply - Auto King - Auto Shack - Babcock Bros. - Bradlees - Buy-Wise - Caldor - Claber's - Clarkins - Clarks - Click - Clover - Cooks - Dahkemper's - Fisher's Big Wheel - Fred Meyer - Glosser Bros. - Gee Bee - Goffstown Auto Parts - Grand Auto - Harts - Hick's - Hill's - Honey's Auto Parts - K's Merchandise Mart - Ken's Distributing - Kozel Auto Parts - Majors - Masters - Modell's Shoppers World - National - National Auto - Nichols - Ontario - Parts City (Hawaii) - Parts World - Pep Boys (California) - Phil's Home & Auto - R & S - Rose Auto - Schuck's - Service Merchandise - Silverman Brothers - Sky City - J. M. Smith Auto Parts - Stephens Parts & Equipment - Strauss Stores - Strum Auto Supply - Tehan's - The Andersons - Thrifty Auto - Times Square Stores - Two Guys - Uncle Bill's - Whitlock Auto Parts

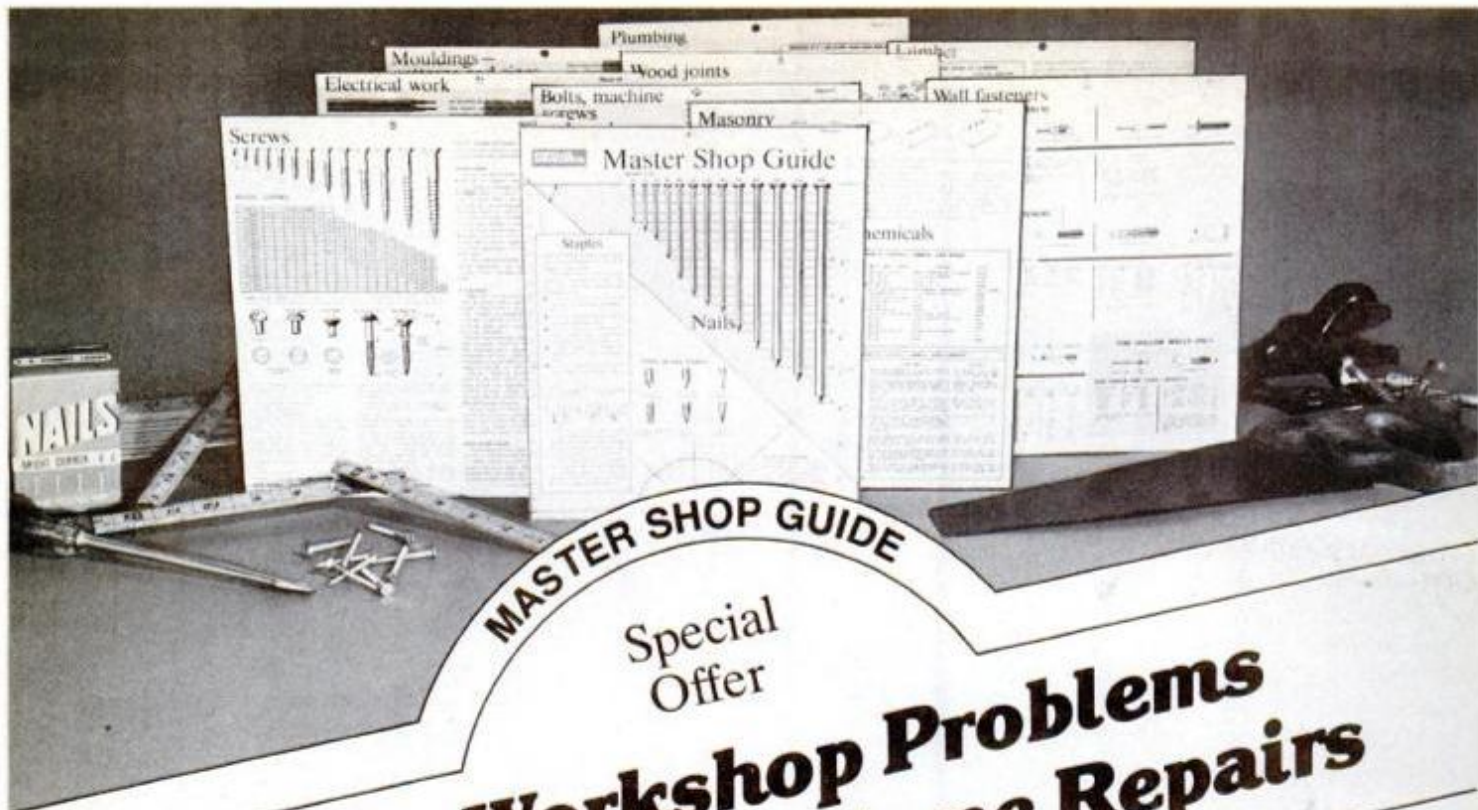

MASTER SHOP GUIDE

Special Offer

Solve Workshop Problems Save Money On Home Repairs

On
Master Guides

HOME CARE GUIDE



Take advantage of this special offer on Popular Mechanics' famous Master Guides.

The POPULAR MECHANICS MASTER SHOP GUIDE has helped hundreds of thousands of do-it-yourselfers solve workshop problems. We think it is one of the most important tools you'll ever buy.

The Shop Guide lays out everything you need to know, graphically and ready-to-use. All about nails, screws, bolts, wall fasteners, drills, abrasives, lumber, plywood, gypsum, adhesives, paneling, shop math, stair construction, masonry, wood finishing, plumbing, pipe fittings, electrical work, gutters,

concrete, remodeling measurements plus a built-in ruler, protractor, 45° triangle and compass.

The perfect companion to the Shop Guide is the POPULAR MECHANICS MASTER HOME CARE GUIDE. The Home Care Guide will enable you to tackle common home repair jobs like an expert. You'll be able to patch wall cracks, paint your house or apartment, hang wallpaper, hang drapery rods, hang a door and install a lockset, repair scratches in furniture and much more. The Guide also instructs you on methods of saving energy to help cut your fuel bills.

By using the coupon that appears on this page you can order both Guides for

\$7.95 postpaid. You'll save \$2.95 off the regular price. ORDER NOW! They also make great gifts.

PM MASTER GUIDE OFFER, Dept. 879
Box 1014, Radio City Station
New York, N.Y. 10019

Yes! Please send me the POPULAR MECHANICS MASTER GUIDES that I have indicated below:

___ Set(s) of both Guides at \$7.95 per set \$ _____
___ Home Care Guide(s) only at \$5.45 per Guide _____
___ Shop Guide(s) only at \$5.45 per Guide _____

TOTAL AMOUNT REMITTED \$ _____

Name _____

Address _____

City _____ Zip _____

Make check or money order payable to Popular Mechanics.

Popular Mechanics is a publication of Hearst Magazines, a Division of THE HEARST CORPORATION

LEMONADE STAND

(Continued from page 87)

shown in drawing, page 130) to cut the slots out with your sabre saw.

To determine the jig's slot width, measure the distance from each side of the blade to the edge of the saw shoe (they differ). Add both dimensions, plus 1/2 in.

(Please turn to page 131)

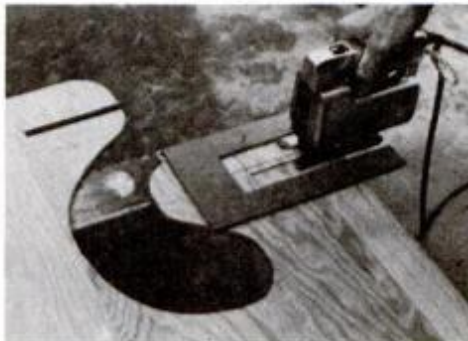

5 The only practical way to cut slots on the shelf, seat and uprights is with a sabre saw and simple jig that guides the saw for two parallel cuts (see drawing).



6 Careful spacing must be made when attaching the upright hinges. Spacing must be equal to the distance from inside to inside of the slots in the seat and counter. (Note: The centerline of the lemon should be cut before this step.)

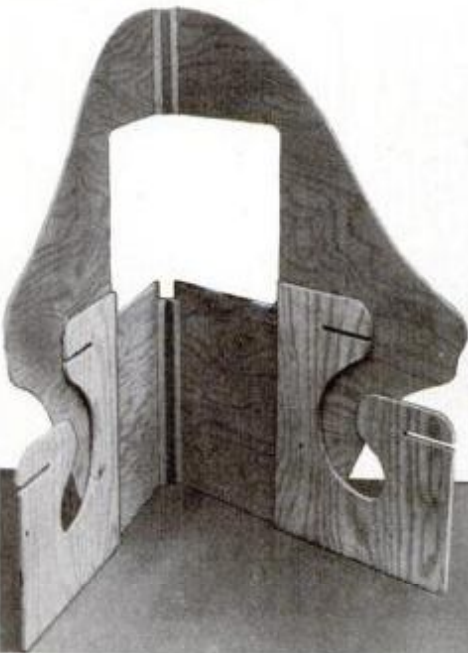

7 Center hinges are attached to glued-in-place standoff strips. These permit lemon halves to be folded parallel.

1 Using drawing on page 130 as a guide, lightly draw lemon's outline on plywood. Next, use a flexible strip, braced with nails, to draw a firm outline.



2 Use a smooth-cutting, hollow-ground blade in your sabre saw to cut outline with minimum of surface splintering.



3 Bore four large holes in the window's corners. Use a guide to saw the straight lines tangent to the bored holes.



4 To spare kids from splinters, round all plywood edges with a 1/4-in. rounding-over bit set to a depth of 3/16 in. Rounded edges also improve appearance.

At Last! **A Full-Feature Workbench at an Affordable Price!**



- Huge 12 1/2 sq. ft. surface area
 - Solid rock maple construction (225 lbs!)
 - 2 large-capacity vises
 - Rugged 2" thick laminated top
 - Massive 9" x 18" vise jaw will hold even delicate work
 - Adjustable leg levelers adjust workbench to uneven floor surfaces
 - Easily disassembles for moving
 - Available in kit form, too!
 - Optional tool well & tool drawer also available
- Until now, quality workbenches have usually been too expensive and too small. This huge, extremely versatile bench is available direct from the factory at an incredibly low price.

Made in U.S.A.

Garden Way Research, Dept. 90298W
Charlotte, Vermont 05445

TO: Garden Way Research, Dept. 90298W
Charlotte, VT 05445

Please send me your free information about the New Garden Way Home Workbench, including details on the build-it-yourself kits.

Name _____

Address _____

City _____

State _____ Zip _____

FANTastic
Energy saving
and Elegant

Save up to 35% on air conditioning and heating cost! Displaces up to 8500 cfm, yet uses less electricity than a 75w light bulb. **Quality fan manufacturing since 1939.** Cast aluminum motor, not a plastic imitation. Aluminum blades (wood see below). 3 year warranty. White or brown. **48" fan only \$118** post paid. Glass globe add \$15. Solid teak wood blades with brass bracs. \$48 ea. set. For Visa, MC or AmEx, give card number and expiration date or send check or MO. **Phone free continental US 1-800-241-7788.** Georgia only call collect 404-498-1278. **Send for free catalog.**

Unique Products Co. Dept. P.M.
P.O. Box 1009/Stone Mountain, GA 30086
Georgia res. add appl. sales tax.

WHOLESALE LOCKSMITH SUPPLIES



ORDER YOUR
GIANT
CATALOG

NATIONAL
LOCKSMITH
SUPPLY
N-79
CATALOG

jam packed with the latest in Locksmith Tools. Key Machines, Key Assortments, Deadbolts, Foreign Car Key Blanks, complete line of Safes, Closed Circuit TV Systems, Alarm Systems, High Security Locks, Electronic Lock Card Systems, I.D. Cards, Technical Manuals, Code Machines, and much, much more! **National's Your One-Stop Locksmith Supply Supermarket.** Most orders shipped within 24 hours. We welcome locksmiths, student locksmiths and industrial accounts. To order **National's catalog send \$5.00** (refundable after first purchase of \$25.00 or more). Your catalog will be rushed to you by first class mail!

NATIONAL LOCKSMITH SUPPLY P.O. BOX 31598 DALLAS, TEXAS 75231

LEMONADE STAND, EXPLODED VIEW

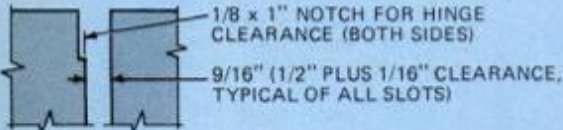
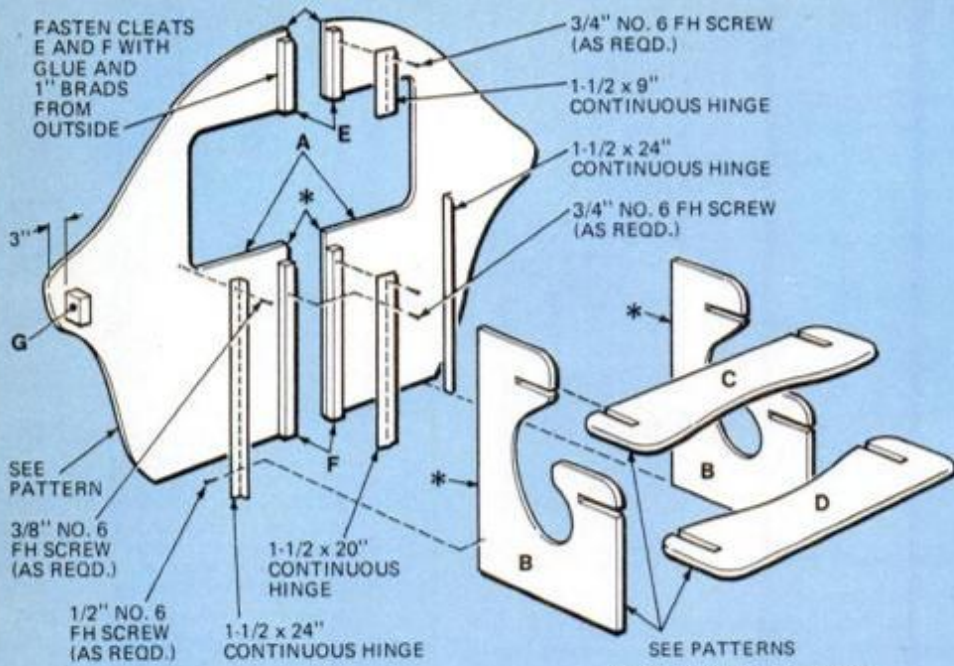

NOTE: ROUND ALL EDGES WITH 1/4" ROUNDING-OVER BIT IN ROUTER. DO NOT ROUND EDGES MARKED WITH AN *

FOR PLYWOOD CUTTING PATTERN INSTRUCTIONS SEE TEXT

PATTERN FOR SIDES, B

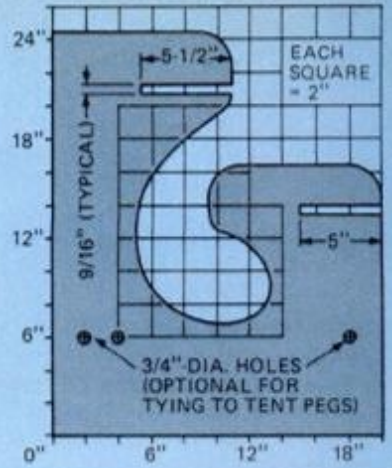

JIG FOR CUTTING SLOTS WITH SABRE SAW

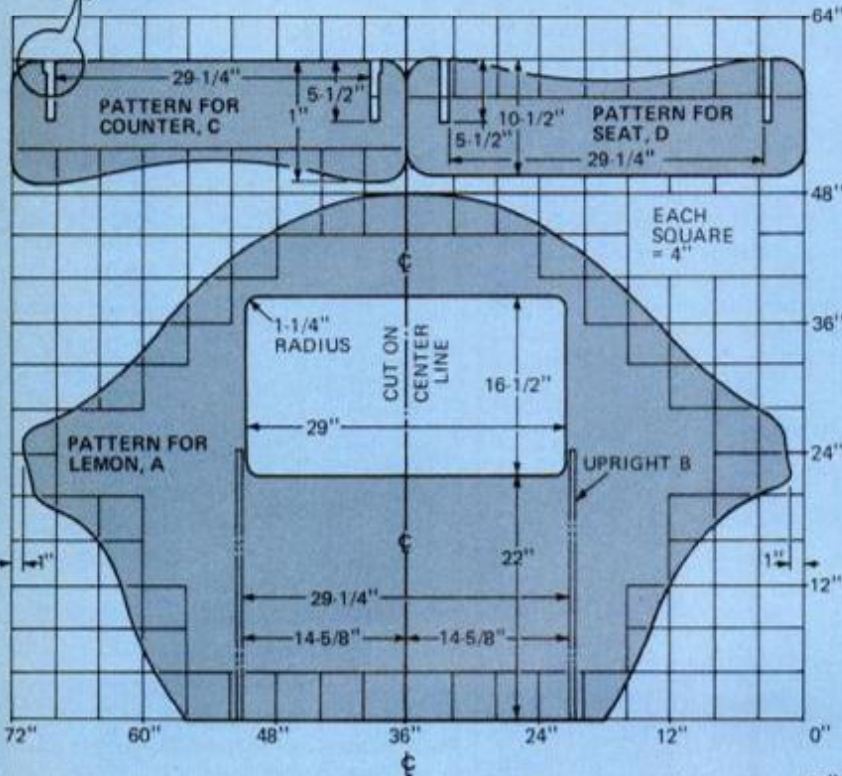
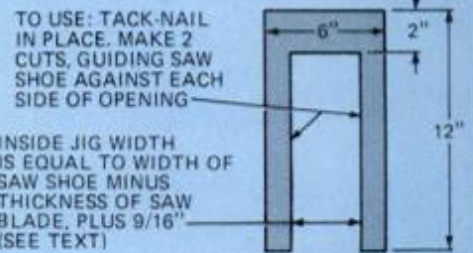

CART, EXPLODED VIEW

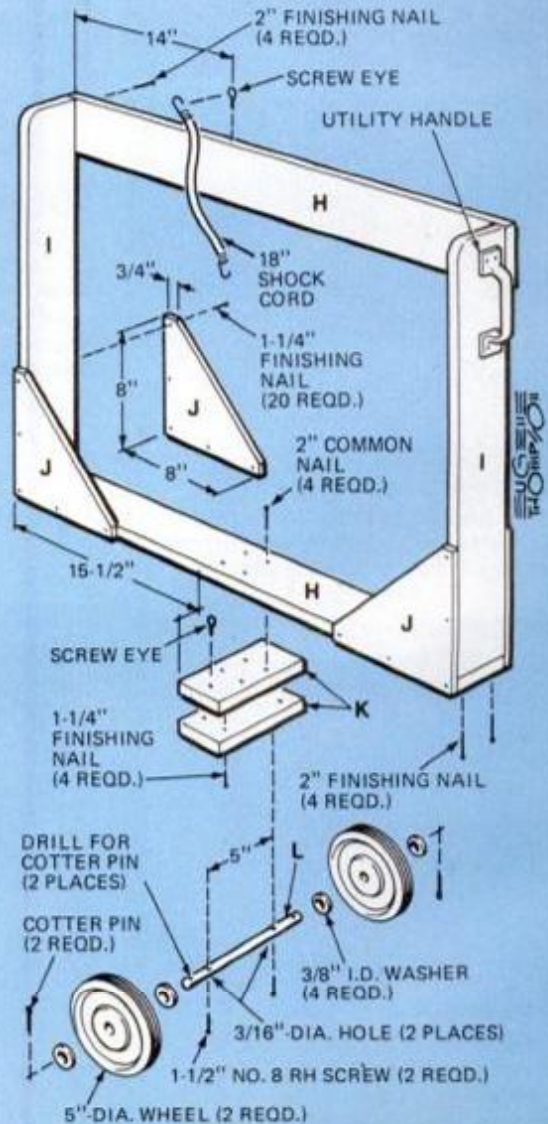

LEMONADE STAND

(Continued from page 129)

for stock thickness, and allow $\frac{1}{16}$ th in. or so clearance. Make test cuts on scrap to check the fit of the joint. Notice that the legs of the jig are made overlong so that the saw base is being guided as the blade makes contact with the workpiece. Tack-nail the jig to the work and make two parallel cuts, alternately guiding the saw against each edge of the jig's slot. Use a coping saw to make the bottom cut and drop out the waste.

The wheeled storage cart is made as shown in the plans on page 130. It is a simple frame constructed of 1x4 pine braced at the bottom corners with triangular gusset plates made of $\frac{3}{8}$ -in. scrap plywood. The two small wheels that are located under the frame at the center will make it easy for the kids to roll the cart all around the yard.

The wheels, which can be of the inexpensive type sold as replacements for a child's wagon, are mounted on a $\frac{3}{8}$ -in. steel rod that serves as an axle. Washers and cotter pins hold the wheels in place on the axle. An 18-in. shock cord secures the stand in the cart.

Construction hints

■ Notice that standoff cleats are glued along both hinge edges of the lemon. This added dimension permits the two halves to lie parallel when they are folded.

■ Make certain you bore holes for lashing the lemon upright. Play it safe and insist that your youngster use cord and tent pegs. If you were not to have a tie-down system, a strong breeze could bowl over your stand.

■ Before painting, prime all plywood surfaces with pigmented shellac, such as BIN or Enamelac. Do not prime inside edges of the slots.

■ Apply the lemon-yellow paint to all primed surfaces and allow to dry completely before adding the decorative touches shown in the illustrations. You can use the color photos as a painting guide. **PM**

MATERIALS LIST—LEMONADE STAND

Key	Pieces	Size and description
A	1	$\frac{3}{4}$ x 48 x 72" exterior plywood
B	2	$\frac{1}{2}$ x 20 x 24 $\frac{1}{2}$ " exterior plywood
C	1	$\frac{1}{2}$ x 11 x 36" exterior plywood
D	1	$\frac{1}{2}$ x 10 $\frac{1}{2}$ x 36" exterior plywood
E	2	$\frac{3}{4}$ x 1 x 9 $\frac{1}{4}$ " pine
F	2	$\frac{3}{4}$ x 1 x 20" pine
G	1	1 $\frac{1}{2}$ x 1 $\frac{3}{4}$ x 2 $\frac{1}{2}$ " pine
H	2	$\frac{3}{4}$ x 3 $\frac{1}{2}$ x 37 $\frac{1}{2}$ " pine
I	2	$\frac{3}{4}$ x 3 $\frac{1}{2}$ x 24" pine
J	4	$\frac{3}{8}$ x 8 x 8" exterior plywood (use scrap from A)
K	2	$\frac{3}{4}$ x 3 $\frac{1}{2}$ x 6 $\frac{3}{4}$ " pine
L	1	$\frac{3}{8}$ " dia. x 9 $\frac{3}{4}$ " steel rod
M	1	$\frac{1}{4}$ x 6 x 12" exterior plywood

Misc.: Utility handle, 18" shock cord, 2 screw eyes, 4 $\frac{3}{8}$ " I.D. washers, 2 5"-dia. wheels, 2 cotter pins, 1" brads, 2" and 1 $\frac{1}{4}$ " finishing nails, 2" common nails, $\frac{3}{8}$ " No. 6 fh screws, $\frac{3}{4}$ " No. 6 fh screws, $\frac{1}{2}$ " No. 6 fh screws, 1 $\frac{1}{2}$ x 20" continuous hinge, 1 $\frac{1}{2}$ x 9" continuous hinge, 2 1 $\frac{1}{2}$ x 24" continuous hinges.

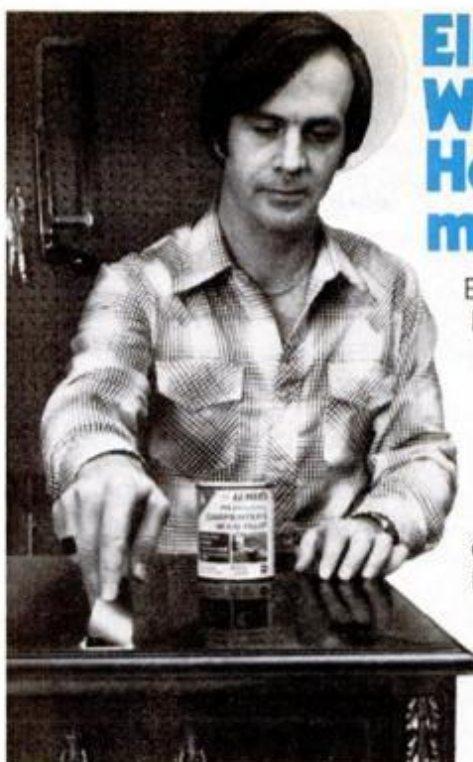

Elmer's sands, stains and disappears better.

Elmer's Carpenter's Wood Filler. How the pros make it look easy.

Ever wonder how the pros do it? With Elmer's® Carpenter's Wood Filler. It's easy to "work" and won't pull out while being applied. And it gives a smooth application that reduces sanding time. Besides, you can sand, drill, nail, cut, varnish or stain Elmer's. And its special latex formula resists cracking and shrinking. Of course, Elmer's is safe and non-toxic,* moisture and solvent repellent, and workable up to 10 minutes. It even washes up with water before drying. Now that's clean and easy.

*As defined by Federal Hazardous Substances Act



Elmer's.
When results count.



If you have anything that needs a good all-purpose lubricant that will last, **LUBRIPLATE®** is for you!

Sprays like a fluid, congeals into grease! Ideal for cars, hood latches, battery cables, door hinges, trunk locks, household uses, lawn and garden equipment, boats, winches, pulleys, gears, etc.

In fact, these are all for you!



LUBRIPLATE LUBRICANTS
A Pound of Performance in Every Ounce!

LUBRIPLATE DIVISION / FISKE BROTHERS REFINING COMPANY / 129 LOCKWOOD STREET / NEWARK, N.J. 07105
MANUFACTURING PLANTS IN NEWARK, N.J. 07105 AND TOLEDO, OHIO 43605 / DISTRIBUTORS NATIONWIDE

24 inch Band Saw cuts To center of 48 inches:



Du-ers 24 inch Band saw gives the handyman the versatility of an industrial tool at a price he can afford. Du-er tools are fabricated of Heavy gauge steel. 30 years experience has developed new engineering features in our full line at popular prices. F.O.B. Factory.

A FULL LINE OF RUGGED ALL STEEL TOOLS

24 inch Band Saw	199.95
12 inch Band Saw	149.95
10 x 36" Lathe — Ball/B. ...	89.95
3 inch Belt Sander — Ball/B.	24.95
4 inch Belt Sander — Ball/B.	39.95
8 inch Tilting Arbor Saw	99.95
10 inch Disc Sander	69.95
1 inch Strip Sander	69.95
Deluxe Stand for all Tools ..	39.95

You can order direct from factory where there is no dealer • Free information.

DU-ER TOOLS

5448 Edina Industrial Blvd.,
Minneapolis, Minn. 55435

GREAT NEW GEAR FOR UNDERWATER FUN (Continued from page 75)

Bright digital readouts show depth, bottom time, surface time, repetitive dive times and both the depth and duration of required decompression stops. Warning lights indicate the need for decompression and signal an unsafe ascent rate. Price is about \$425 from Dacor Corp., 161 Northfield Rd., Northfield, Ill. 60093.

Clever wet suit, tank pack

Two slick ideas in increased diver convenience are Henderson's multi-purpose Zip-On Exposure Suit and U.S. Divers' Sea Otter air-tank backpack. The Henderson Zip-On is actually a wet suit that you can also use out of water, as foul-weather deck wear when boating in chilly or stormy seas. A clever system of zippered folds in the legs, arms and chest lets you expand the suit into a casual jacket-and-slacks affair for loose-fitting comfort topsides. For diving, the folds zip tightly for a snug, body-hugging fit.

In an emergency, the suit also provides flotation and thermal protection. Tests show that, in 32° F. waters, it can extend the normal survival time of less than 10 minutes to as much as eight hours. The suit comes in bright orange or blue and is festooned with special pockets for a knife, tools, gauges and other diving gear. Matching boots, gloves and hood are available. It's about \$262 from Henderson Aquatics Inc., Buck and Sassafras Sts., Millville, N.J. 08332.

The Sea Otter B.C.V. is a nifty new two-in-one scuba rig that pairs an air-tank backpack with a buoyancy compensator vest in a single harness that makes it easy to put both on at the same time. There's only one strap to buckle and you're all set to dive. The three-way vest can be inflated from your tank, from an oral inflator tube or from an emergency CO₂ cartridge. Buoyancy is easily and precisely adjusted by one-hand inflation-deflation controls. For snorkeling, the tank pack can be removed and the vest used by itself. About \$180 from U.S. Divers Co., 3323 West Warner Ave., Santa Ana, Calif. 92702.

Knife overboard!

The next time you drop your knife overboard or lose it while diving, you may be able to find it more quickly. The latest dive knives are blossoming out with brightly colored handles to make them easier to spot underwater. The colors—high-visibility yellow and international orange—match other scuba accessories and help to add a bit of sparkle to a sport that, until recently, has been dominated by dismal black. We found the knives both attractive and sensible. They look particularly classy on a matching-color weight belt.

The knives shown here are from Wenoka Cutlery, 85 North Ave., Natick, Mass. 01760. Dacor and U.S. Divers are also offering knives in colors now, as are other

makers. Prices run about \$10 to \$35.

Other features to look for in dive knives are line-cutting notches—especially valuable in an emergency—serrated edges for sawing, screwdriver tips and blades marked with measuring scales. The blunt-ended blade, a recent innovation, makes a sturdy prying tool with less chance of tip breakage. The traditional sharp-pointed, general-purpose survival knife is also out in a new form—a scaled-down mini version with a 4- or 4½-inch blade. It's small enough to be worn on your forearm or can be piggybacked on top of a larger knife, in a double sheath.

Bag your camera

Whoever thought up the idea of putting a camera in a plastic bag to shoot underwater pictures hit on a good one. We tried it and it works. Imported from West Germany, Ewa's new soft-type enclosures are essentially plastic pouches sealed watertight at the top with screw-on metal clamps. They're not only cheaper than rigid underwater camera housings, but actually resist leaks somewhat better because of their collapsible design. The deeper you go, the more outside water pressure squeezes the plastic and inside air pressure keeps water out.

You can use the pouches down to about 30 feet—ample for the casual sport diver, especially since it's hard to shoot well-lighted underwater photos at much below 10 to 15 feet anyway. The bags will remain watertight at much greater depths, but the plastic becomes too stiff and compressed for easy handling. You work the camera's controls through an ingenious "glove" molded into the side of the enclosure. Optical-glass ports for the lens and finder assure a clear field of view.

The Ewa housings are available in the United States from Pioneer & Co., 900 Haddon Ave., Collingswood, N.J. 08108. There are styles for both SLR and movie cameras and sizes to hold such accessories as flash and motor drives. Prices range from about \$55 to \$100.

Double-beamed light

We also liked the new Captain Nemo diving light from Underwater Specialty Co., 55 Bartlett Place, Brooklyn, N.Y. 11229. Its brilliant quartz halogen lamp and specially designed reflector provide a dual-beam effect—an intense narrow beam for deep penetration, plus a broad peripheral beam for general illumination. You thus can pinpoint distant objects, while seeing what's around you at the same time—which makes for a warm, welcome feeling when you're exploring dark waters. Delivering 300,000 candlepower, the light is two to three times more powerful than most comparable models. At about \$250, it's not cheap, but it's an impressive development. **PM**

DO-IT-YOURSELF FINE GRANDFATHER CLOCK KITS

STARTING UNDER
\$220



(including movement and dial)

- Factory direct prices
- Heirloom quality
- Solid 3/4" hardwoods: black walnut, cherry, mahogany, oak
- Easy to assemble, parts pre-cut
- Solid brass West German chiming movements
- Money back guarantee
- Prompt shipment

MASTER CHARGE and
BANKAMERICARD/VISA
ACCEPTED

Write for **FREE**
color catalog

EMPEROR® CLOCK COMPANY

WORLD'S LARGEST MANUFACTURER
OF GRANDFATHER CLOCKS

Dept. 126, Emperor Industrial Park
Fairhope, Alabama 36532

Now Havoline is Supreme.



UNBEATEN MILEAGE



Havoline Supreme is Texaco's 10W-40 motor oil with a special friction fighter that has been proven in fuel economy tests.

Extensive tests showed that 2 of the leading 10W-40 motor oils advertising extra gasoline mileage couldn't beat Havoline Supreme.

What's more, Havoline Supreme is the motor oil that gives your car trooper-tested protection.

In fact, Havoline Supreme exceeds *all* car manufacturers' warranty requirements for gasoline-powered cars.

No wonder we call *this* Havoline Supreme.

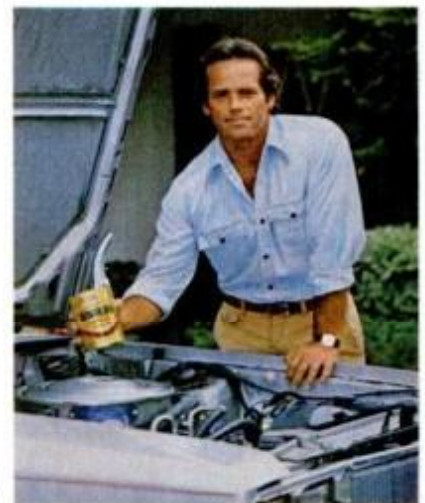

If you do it yourself, do it with Havoline.

Now: Computers in speakers give super sound!

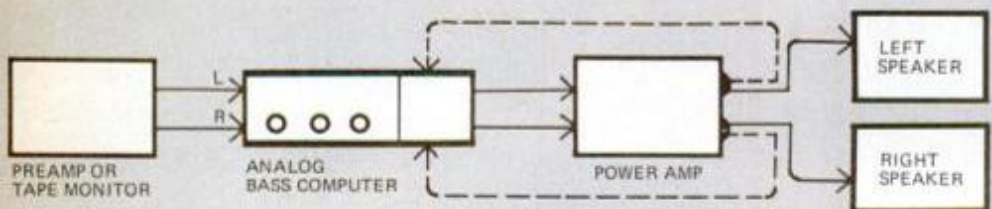

The Analog Bass Computer senses the output of the power amp and compares that output to what it knows the speakers can take. The output is adjusted accordingly.

With a computer's help, these small speakers give distortion-free sound from bass notes that would destroy ordinary speakers of the same size.

by Neil Shapiro
ELECTRONICS EDITOR

We believed our ears—but not our eyes—when we heard the tiny speakers that KLH demonstrated in New York. The speakers, in cabinets only a bit more than 12 inches high, with 6-inch woofers, were pouring out a lovely sound all out of proportion to their size. First came puzzlement, then a realization that here was a breakthrough in technology.

The KLH-3 speakers we saw use state-of-the-art electronics to get around one of the oldest problems in speaker design. This problem is that of a small speaker breaking up, or “blowing,” if it is made sufficiently responsive to deliver true bass.

Computer makes the beat go on

KLH has placed its “Analog Bass Computer” between the amp and the specially engineered speakers. The computer is programmed to know exactly how these particular speakers respond to any signal.

If the excursion—movement of the woofer's speaker cone—is forecast by the computer to be at a level the speaker can't take, the computer attenuates (reduces) the signal. One company spokesman referred to this as “electronic stiffness.”

Think of the computer as a sound-

system policeman. If the bass level is too strong—a deep transient—then the computer weakens it, and the computer always knows what the speakers it is tailored for are capable of standing.

At the speaker end

The speakers have been engineered to work in harmony with the computer. The cone is made of polypropylene, which, KLH claims, makes the music truer to life. However, most important is the oversized, huge magnet on the back of each cone.

The magnet is one of the things that govern bass response. Magnets on these speakers are tremendous relative to woofer size. They're almost the diameter of the speaker cone. Magnets this size would make ordinary 6-inch woofers self-destruct as soon as a strong-signal, bass transient came along. An unprotected speaker would turn itself into audio confetti.

But the Analog Bass Computer, a constant babysitter, knows when enough is enough and lowers the signal. Therefore, these speakers have the benefit of outrageously responsive bass at all signal levels.

How good are they?

The KLH-3 speakers we heard are priced at \$425 for the system—two speakers and computer. The company claims that they are as responsive as any other speaker in their price range—even though they are far, far smaller.

We have not as yet run lab tests—though we will—but our ears tend to support that claim. The sound must be heard to be believed—and these speakers will be available from audio dealers some time next month.

KLH is also coming out with two larger systems to challenge even the most immense speakers. If these KLH-3 units are any indication, speakers may soon become the smallest component in an audiophile's dream system.

Good sound no longer has to mean big sound! **PM**



The magnet on one of these speakers is almost as big in diameter as the cone!

Материал, защищенный авторским правом

“I want the best taste
I can get.
I get it from Winston.”

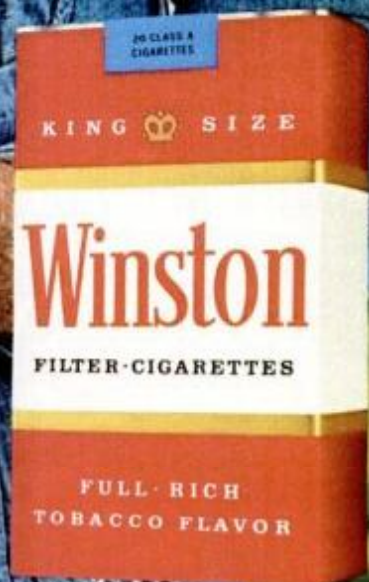

BOX: 19 mg. "tar", 1.3 mg. nicotine,
KING: 20 mg. "tar", 1.3 mg. nicotine, av. per cigarette, FTC Report MAY '78.

Warning: The Surgeon General Has Determined
That Cigarette Smoking Is Dangerous to Your Health.

Soft Pack or Box.

Friction destroys tools.

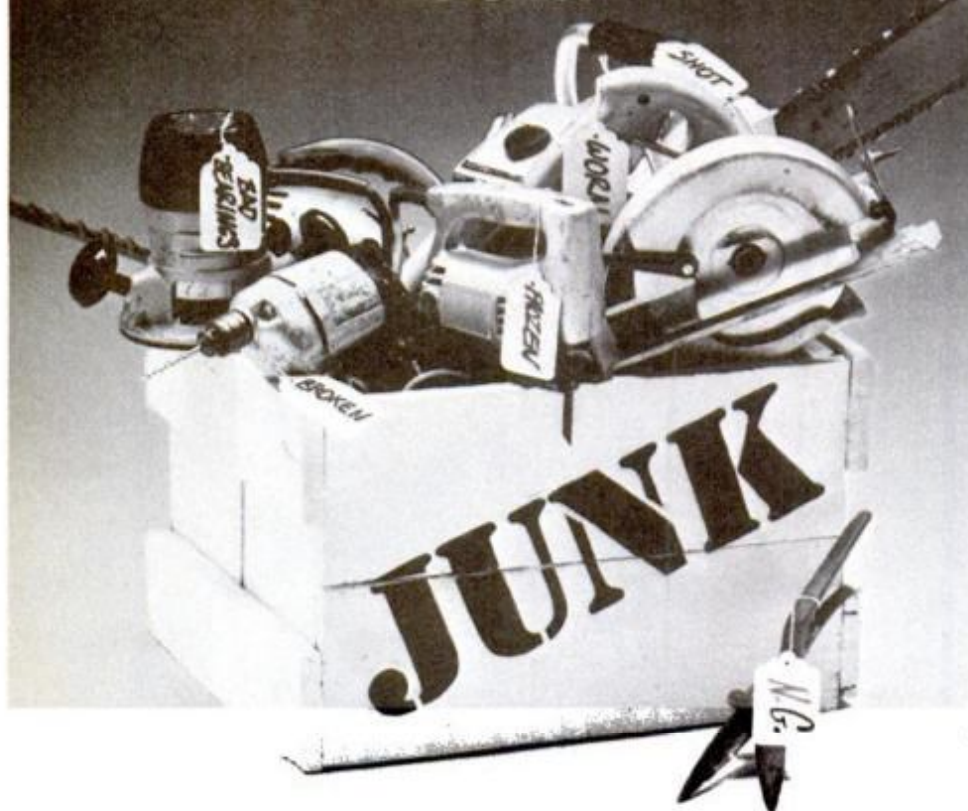

TRI-FLON fights friction longer and better than ordinary lubricants.

Tri-Flon™ is a complete system to fight friction and protect things around the home or shop from rust and corrosion. One spray carries millions of "wet" Teflon* beads that penetrate and displace grime, rust and moisture.

Try this test: Spray Tri-Flon on your grass clippers, then wipe the surface with a cloth. You'll discover that they're cleaner and

work smoother than ever. It works on all your hand and power tools.

Tri-Flon fights friction up to 10 times longer than ordinary lubricants. It loosens frozen parts fast. And its Teflon* film repels friction-causing grime and moisture.

Don't let friction destroy your valuable tools. Fight friction with Tri-Flon.



TRI-FLON
with TEFLON*
THE FRICTION FIGHTER

© 1979 The Tri-Flon Company, Costa Mesa, CA
*Registered Trademark of E.I. DuPont de Nemours & Co. (Inc.)

HINTS FROM READERS

Handy gluing clamp

GLUING CLAMP
(HALF OF SYMMETRICAL DESIGN)

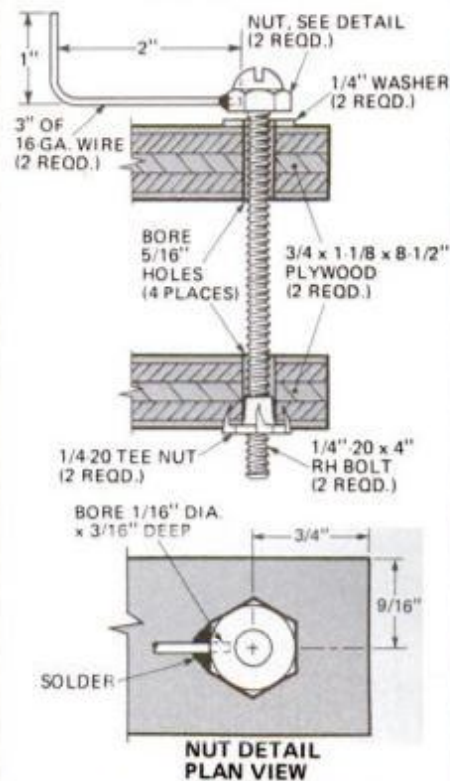

Use this clamp to exert pressure on glued joints. Although handles tighten bolts quickly, you'll get more pressure if you make last few turns with a screwdriver or wrench.—Walter E. Burton

Reinforcing joints



To increase a screw's holding power in end grain, first install a dowel in second board as shown. Bore a pilot hole through dowel and insert screw.—C.E. Rhine

Energy crunch creates new jobs for trained technicians.

Learn at Home in Your Spare Time as NRI Trains You for Heating, Air Conditioning, Refrigeration, and Solar Technology

As energy requirements increase and supplies tighten, as demands on established technologies increase and new ones are developed, the need for skilled technicians will continue to grow. And you can get a head start in this booming career field with NRI home training. You learn in your spare time, develop the professional know-how and skills that help you move ahead.

Practical Training Includes Professional Vacuum Pump

Along with the basic theory you need, you get the practical servicing tips and actual "hands-on" experience with NRI demonstration kits. You get necessary working tools like a system analyzer, leak detector, tubing and joint tools, and more. You even get a top quality



vacuum pump, a professional "must" for evacuating and recharging refrigeration systems properly.

Includes Optional Postgraduate Training at York Institute

Graduates of NRI's Master Course are eligible for a week of resident training at the world-famous York Institute. You'll get concentrated training on advanced industrial equipment under the guidance of expert instructors. There's no extra charge for tuition or training materials... an opportunity only offered by NRI.

Send for Free Catalog... No Salesman Will Call

Get all the details in NRI's free catalog. It shows lessons, equipment, and more about this exciting, big field. NRI home training works, as over a million students can tell you. Mail the postage-paid

card today and take advantage of your opportunities. If card has been removed, write to the address below.

Or check out these other growing fields

Small Engine Repair

There's plenty of opportunity for the man who can service power mowers, garden tractors, chain saws, tillers, outboards, mopeds, motorcycles, and other small engines. NRI training includes professional tools... inductive tachometer, volt-ohm meter, torque wrench, valve spring and ring compressors, and more. And you learn by doing, actually training on a 3½ HP engine we include as part of your training. Choice of basic or advanced courses. Check postcard for catalog.

Electrical Appliance Servicing

Good appliance technicians are hard to come by. NRI trains you for your own full- or part-time business in fixing everything from toasters to refrigerators and microwave ovens. Step-by-step training includes professional tools and instruments like clamp-on ammeter and appliance multimeter. Check postcard for catalog.

Auto Repair and Servicing

A good mechanic can work just about anywhere he wants to. NRI "hands-on" home training covers what you need to know from headlight to taillight. Includes professional tools like inductive timing light, ignition analysis and tune-up instrument, vacuum test pump, and the latest advance in diagnostic instruments, a digital readout tune-up analyzer. Approved by Richard Petty, America's winningest stock car driver and NRI automotive consultant. Choice of two courses, check card.



NRI Schools

McGraw-Hill Continuing Education Center
3939 Wisconsin Avenue
Washington, D.C. 20016

Some people
have money
to
burn!

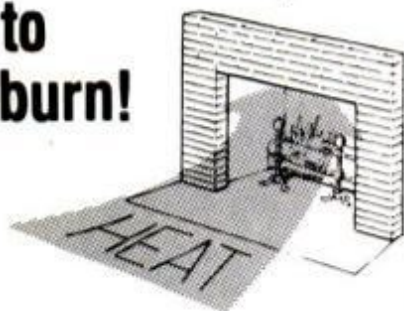

Others save
60% and more
on heating costs
with

Hearth Mate
the Fireplace Stove

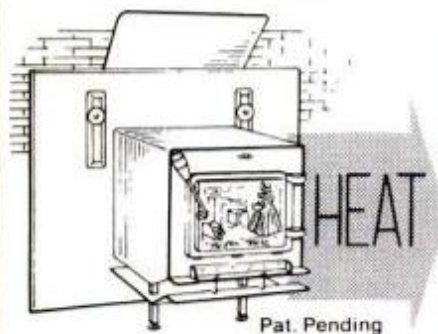

Installs in minutes



LISTED
for your safety

Send for complete Hearth
Mate Brochure

C & D Distributors, Inc. Dept. 422
P.O. Box 766 Old Saybrook, CT 06475

NAME _____

ADDRESS _____

CITY _____

STATE _____ ZIP _____

Please send me the Hearth Mate Brochure
that shows how I can save up to 60% on
home heating costs.

1979

CHAIN MAINTENANCE

(Continued from page 114)

centered in the swing arm, measure from the axle center to the swing-arm pivot center on both sides. If there's any difference in the measurements, use either adjuster to center the wheel. Then you should be sure to use *both* adjusters to tension the chain.

Lube that chain

It's probably the most distasteful part of chain maintenance, but lubrication is essential to the performance and life of the chain.

Little and often is the rule here.

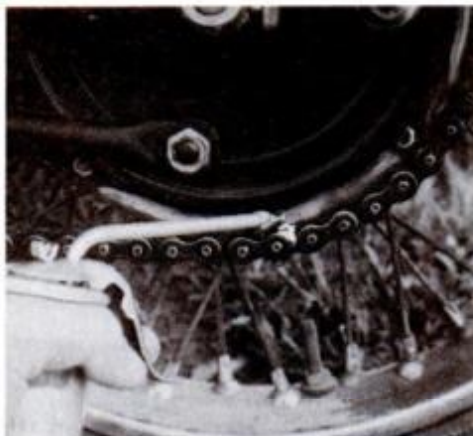

Lubricant is best applied by placing tip of applicator against sprocket adjacent to link plates and slowly turning wheel.



Closed end of spring clip on master link should lead in direction of travel chain, so it's less likely to be knocked off.

That is, apply enough lube to the chain without drowning it, and do it frequently. How frequently depends on how much and how hard you ride. And under what conditions.

The manner in which you apply the lubricant is important, too. Apply it to the *edges* of the linkplates, where it can seep into the areas between the rollers, pins and bushings. Dumping it onto the middle of the rollers won't do much good; it'll just be thrown off during operation.

It's also a good idea to let the lube soak into the chain's innards before you ride. This way there'll be less

lube thrown off before it gets a chance to settle in those crevices.

Allowing the bike to sit overnight after you've lubed the chain will let the lube settle inside the spaces between the rollers, pins and bushings. In addition, apply the lubricant right after the day's ride, while the chain is still warm. This will permit even better penetration of the lube.

Although the chain is more accessible midway between the sprockets, you may end up with more lube on the ground than on the chain. So if you can reach the rear sprocket, try this: First, elevate the rear wheel so you can turn it. Then direct a stream of lubricant against the upper edges of the linkplates as you slowly turn the wheel. The sprocket acts as a backstop, allowing overspray to seep down inside the links. Or you can place the tip of a spray can's plastic tube or the nozzle tip of a squeeze can against the sprocket, adjacent to the lower run of the chain. Lubricant will flow readily down into the links.

Getting to the inner row of linkplates on the other side of the sprocket may be a little tricky. If you're using a long-nosed applicator, you can poke it between the spokes from the other side of the wheel. Of course, the wheel can only be turned a few degrees at a time, until you withdraw and reinsert the nozzle. Or, you can position yourself behind the rear wheel and lube the links in much the same way you do the outer side.

If you're using a spray can with a plastic-tube extension, here's a neat trick: Take a match and carefully heat the tube about 1/2 inch from the end of the tip, until it sags to form about a 45° angle. This angled end will make it easier to reach the inner row of linkplates on the sprocket.

For the most effective lubrication and protection, use a commercial chain lube. It'll contain such substances as molybdenum disulfide, graphite, even teflon. But ordinary engine oil can be used, too. If so, use a No. 20 in cold weather, No. 40 in warm weather.

After you're done lubing, take a cloth and wipe off the excess lubricant. Wiping the chain will spread a film of lube over the links and prevent rusting. Lubing also gives you the opportunity to inspect the chain for defects. And, if a master link is fitted, check to make sure that its spring clip is seated and that the closed end is facing in the direction of chain travel. If the open end leads, there's always the possibility the clip could be dislodged by something.

"I can do it!"

Now you can do it! Even if you've never repaired anything in your life. You can do over 100 maintenance and repair jobs on your car with the help of a *Saturday Mechanic Car Care Guide*. And you'll save money every time.

Anything from just changing your oil, to doing a complete tune-up. Anything from replacing your wiper blades to doing your own brake job. And Saturday Mechanic tells and shows you how on *your* particular car.

Your Car Care Guide will:

- take you through every job step-by-step
- tell you what to do in clear and simple language
- show you where and how with nearly 200 drawings and photos

Saturday Mechanic has 14 different *Car Care Guides*. One for each of America's most popular U.S. and foreign cars. So there's bound to be one for your car.

Available wherever auto accessories are sold. Or for the name of the dealer nearest you write to Saturday Mechanic, 1790 Broadway, New York, N.Y. 10019.

You'll feel so confident about doing car repairs that you'll say, "I can do it!"

**SATURDAY
MECHANIC**



Available at

HECK'S

Hi-Gear
DISCOUNT AUTO CENTERS

Hills

and these other fine stores: 'Appy's - Aid Auto - Al's Auto Supply - Brill's Auto Supply - Cash & Carry Parts - Ciaber's - Clarks - Clover Stores - Cooks - Gee Bee - Goffstown Auto Parts - Gold Circle - Honey's - Modell's Shoppers World - National Auto - Nichols - Ontario - Parts City (Hawaii) - Parts Plus (Michigan) - Phil's Home & Auto - R & S Auto - Rickels - Rose Auto - Schuck's - See n Save - Serv-U - J. M. Smith Auto Parts - Sterling Automotive Supply - Strauss Stores - Strum Auto Supply - The Andersons - Times Square Stores - Thrifty Auto - Two Guys (East) - Uncle Bill's - Wonder World Auto

The Hearst Corporation
135 West 43rd Street
New York, N.Y. 10018

Attention Shopsmith Owners

Are you enjoying all the "privileges" of Shopsmith ownership?

If you're a Shopsmith owner, you already know that Shopsmith's versatile multi-purpose power tool system is the *only economical* way to own a *complete* home shop. But did you realize that in recent years Shopsmith ownership entitles you to many additional privileges?

For instance, as a member of the huge "Family" of Shopsmith owners, you're entitled to:

- Call our **Toll-Free Service "Hot Line"** for the answers you need . . . when you need them.
- A **Free subscription** to "Shavings," the Shopsmith publication that brings you dozens of great project ideas and valuable home maintenance tips in every bi-monthly issue.
- **Exclusive offers** on unique Shopsmith tools and supplies offered through our seasonal mailings.
- The opportunity to participate in our limited enrollment **Shopsmith Woodworking Academy**—the most comprehensive course offered anywhere!
- **Personal invitations** to attend demonstrations by factory experts in convenient locations all over the U.S.

And There's More to Come

In addition to these valuable privileges, you'll soon have *more* to look forward to including:

- Owner's Club
- Project Plan Contests
- Owner Referral Programs . . . and many more!

So, if you own a Shopsmith, whether it's new or used, and haven't been getting all of the Shopsmith benefits you are entitled to, use the coupon below to make sure we have you on record. After all, we want you to enjoy all of the "privileges" or belonging to the Shopsmith "Family".

Shopsmith Inc.

750 Center Drive,
Vandalia, Ohio 45377

I'm missing out on some of the Shopsmith privileges. Here are the serial numbers of Shopsmith equipment I own!

Jigsaw _____ Shopsmith _____
Band saw _____
Jointer _____ Belt Sander _____

I'm not a Shopsmith owner yet, but I'd like to know more about joining the Shopsmith "Family". Please send me information on the Shopsmith Mark V multi-purpose power tool system. There's no obligation and no salesman will call.

Name _____

Address _____

City _____ State _____ Zip _____

1890

AIRPLANE FLIGHT RECORDERS (Continued from page 60)

again with an explosive roar. A crew member swears. A woman in the passenger section behind the cockpit screams. Her thin voice is rising as the tape ends.

The wreckage of Flight 228 was scattered over an area of Spanish farmland more than five miles long and two miles wide. All 17 persons on the plane were killed. Spanish investigators on the scene pulled the cockpit voice recorder and flight data recorder out of the wreckage, and sent both to Washington.

'Scratch' vs. digital records

Initially, U.S. investigators were optimistic that the flight data recorder, in particular, would help determine why the plane disintegrated. The 747 was carrying the latest in data recorders, a whole generation beyond the foil recorders found on 727s.

In foil recorders, designed in the late 1950s, information is scratched into metal by styluses slightly larger than a capital "I" typewriter key. Foil recorders are usually limited to monitoring altitude, speed, vertical acceleration and heading. Jumbo jets today carry new digital recorders, designed within the past decade, that collect data for later "reading" by a computer. The new digitals cost about three times as much as the older "scratch" recorders (about \$30,000 compared with \$10,000) but they can hold more than 20 times the data. For any instant of time, they can deliver information on close to 100 details about the flight, from engine thrust to the position of an anti-ice switch.

The data recorder from Spain was passed to Dr. Carol A. Roberts, a computer expert in the National Transportation Safety Board lab who is an instrument-rated pilot herself. When she opened the battered recorder, she found that the shiny, silvery tape inside had broken into five long pieces during the accident. She spliced the tape back together, matching ends by comparing the shapes of the breaks like pieces of a jigsaw puzzle. Then she plugged the tape into her computer.

The silent computer

No data came out. "I thought, 'Maybe the electronics aren't working,'" she recalled recently. "I played with it." Still, the computer produced nothing. Eventually, Roberts went back through 25 hours of tape. The digital recorder produced no clues: It had apparently stopped working, for unexplained reasons, hours before the flight to Madrid.

Now the cockpit voice recorder tape of the final agonizing minute of Flight 228 took on new importance. There were dozens of questions to be answered. How fast was the plane going when it disintegrated—fast enough for turbulence to break it apart? Did lightning strike the

plane? Where? Or was there a bomb aboard? Turner began a second-by-second analysis of the sounds of the final minute in an attempt to answer the questions.

The voice recorder had long since proved itself as a sturdy witness in such disasters. Its most obvious use has been in providing a record of what was said in the cockpit. Sometimes the words alone have been enough for federal investigators to establish the cause of an accident.

Chatter on Flight 212

The crew on Eastern Flight 212 in September, 1974, for example, dropped clues about what went wrong as their DC-9 approached Charlotte, N.C. A transcript from the voice recorder shows, according to official findings, that the crew was lax. They chatted about politics ("Well, what ya think of old Ford givin' a pardon to Nixon?" "I was surprised.") and told dirty jokes. Extraneous conversation continued during the descent in heavy fog. One of the last fragments of conversation: "Now we're all ready—all we've got to do is find the airport." Six seconds later the plane crashed three miles from the runway, killing 71 persons on impact. The official report, drawing heavily on the tape, determined that the probable cause was "lack of altitude awareness at critical points during the approach due to poor cockpit discipline. . ."

Sometimes, naturally, pilots disagree with official findings about the significance of cockpit conversation. The Air Line Pilots Assn. sharply challenged the Safety Board's findings after the Eastern crash. The association said the board had ignored several references to pilot fatigue, for instance, while reading into the tape other things about the crew's attitude that weren't there. "Do they want pilots to hold a death grip on their yoke?" grumbled one source in the association who argued that banter in the cockpit didn't mean the pilots weren't flying well.

Clue was a click

In other cases, Turner has dissected apparently extraneous sound, plumbing clicks and stray vibrations for clues. In one accident over Sweden several years ago, several microphones placed around the cockpit fed different channels into the cockpit recorder. In listening to the channels, investigators heard a distinct click shortly before the crash. By noting time differences in when the click arrived at different microphones, they were able to triangulate the location of the click within inches. They discovered that the tiny noise had been made when a crew member turned off the de-icing switch for the tail. The subsequent buildup of ice caused the crash.

Turner showed *PM* recently how he

had explored the tape from Flight 228. In his cramped studio, he put on the tape from the 747 once again—he has listened to it hundreds of times—and fed the signal to a screen that displayed audio signals visually. Now the normal background noise from the cockpit made a ragged, jumping line on the screen. Another line above the first was thin and regular by comparison, a steady wave like the edge of a serrated knife.

A helpful glitch

This second wave, he explained, was something of a glitch in the flight recorder system—a small amount of interference caused by minor leakage from the plane's 400-cycle-per-second generators. It was similar, he said, to the faint 60-cycle hum sometimes heard on AM radios. But it was a useful glitch, he said.

Turner waited near a switch as the tape unrolled once again toward the final minute. "We're in the soup," the crew member said, setting off a five-second countdown in Turner's mind. The explosive sound came on the fifth second after "soup." At that instant, Turner hit the switch, freezing the rough pattern of cockpit sound—and the separate 400-cycle signal—on the screen.

"Now look at this," he said, shutting off the tape.

The 400-cycle signal had taken an almost imperceptible dip, then risen above its normal level, then returned to a steady hum.

When he first saw the change in the pattern, Turner called on airlines to help him find out what it meant. He asked: Could lightning have caused the line to whip like this?

Lightning has struck planes in flight thousands of times. The 747 alone has been hit at least 100 times. So airlines were able to pull out several cockpit voice recorder tapes of strikes and look closely at the generator wave. The investigators found that lightning has a signature: a dip, a jolting rise, a descent to normal hum. The patterns matched. A bolt had made its distinctive mark on Turner's screen.

A matter of timing

Now it was clear that lightning had struck the plane. But Turner read more into his screen than that. The wrinkle in the generator wave, he noticed, was located about an inch to the left of the noise pattern. This reflected the fact that it took time for the sound of the strike to reach the mike after the bolt had shaken the electrical system. How much time? Turner measured carefully on his screen and found that it took about six *thousandths* of a second (milliseconds). To Turner, the tiny delay was significant: Sound travels at about one foot per millisecond. So, six milliseconds translates to

(Please turn to page 144)

Guaranteed To Last Longer

Guaranteed To Last Longer

RAIN DANCE PASTE CAR WAX

Keeps on Beading and Shining longer after Rain. Wash after Wash.

Guaranteed

NET WT. 14 OZ.

Special Applicator Included

RAIN DANCE CAR WAX

Keeps on Beading and Shining longer after Rain. Wash after Wash.

Guaranteed

16 FL OZ (1 PT)

Rain Dance® lasts longer than the leading car waxes.

Water beading proves it.
DuPont guarantees it.

Rain Dance® is guaranteed to shine longer, to bead water longer, to last longer. It's the car wax with the watertight guarantee.

DU PONT

GUARANTEE: "RAIN DANCE" is guaranteed to keep on beading and shining longer than the leading liquid or paste waxes. If not completely satisfied, return unused portion to B-4233, DuPont Company, Wilmington, DE 19898, for full refund of actual purchase price and postage.



Now you can kill wasps and hornets in their nests from...

AIRPLANE FLIGHT RECORDERS *(Continued from page 143)*

six feet from the microphone located in the cockpit. "So from this," Turner concluded, "we know the lightning passed near the cockpit. And that's not unusual. A lot of strikes hit near the radome, or below cockpit windows."

Turner has used the technique in other cases, including an investigation of a 720 crash about three years ago in Saudi Arabia. He noticed a delay of about 20 milliseconds between the time there was a stray signal in the electrical system on the plane and the instant when the cockpit voice recorder picked up an explosive sound. And he discovered a disruption in the captain's radio channel—which also fed the recorder—a split second before the disruption affected the copilot's channel.

He passed on his findings to others exploring pieces of the plane. "I told them to look about 20 feet aft of the cockpit on the captain's side and see what you've got," he said. So investigators focused on pieces from the area pinpointed by Turner, and soon discovered a hole, apparently made by a bomb in the forward baggage compartment.

Sounds helped Turner suggest other hypotheses after the 747 crash near Madrid. How fast was the plane going? To try to answer that question, he took a tape recorder up in two 747s supplied by TWA and Pan American. While pilots changed speed in 10-knot increments, Turner picked up different noise levels in the cockpit: The faster the flight, the more noise. Back in his lab, he compared the test noises with the background sounds on the tape. He was able to estimate that the plane had been traveling between 330 and 350 knots when it entered the cloud—slightly above recommended air speed, but probably not enough to cause the accident.

The Iranians—including the Shah himself—had taken a keen interest in Turner's work. And at this point in the investigation, they raised an objection. Their Air Force 747, they pointed out, had been rigged as a cargo plane. There were

few passenger seats, all located in the "bubble" behind the cockpit. Most of the plane was a giant cargo bay. Perhaps the way it was modified had changed the characteristics of the sound, distorting Turner's calculations. The Shah sent a sister ship to the one that had crashed. Turner climbed aboard at a New Jersey airport, and repeated his tests during a two-hour flight over the Atlantic. The results were the same.

The official report on Flight 228 concluded that lightning was "a plausible source of ignition" of a fuel tank in the left wing. Most of the evidence to support the lightning hypothesis came from Turner's analysis of the sounds in the cockpit. The report, which came out last year, suggested that the bolt entered the plane "perhaps on top of the cockpit," flowed through the fuselage and out the wing. There, near the tip, other investigators found evidence of an explosion.

The final minute

Questions still hang over the flight, and the best that investigators can do is suggest what might have happened. Turner thinks that after the initial loss of its tip, the left wing lost much of its lifting power. To try to compensate, the autopilot sent up spoilers and flaps on the right wing, reducing lift and at the same time forcing the plane to yaw to the right. Flame from the left wing then arced back and inward, curling around the tail like a giant blowtorch. In the last seconds, the tail broke off.

As a result of the suggestion that lightning destroyed flight 228—and from experience with other lightning strikes—the Boeing company has improved shielding on the wires connected to fuel pumps in the 747 since 1976. The changes have made an already safe plane safer from freak accidents.

So the hidden messages in the tape, decoded by Turner, have helped to give us more security in the air. Thanks largely to the recorder in Flight 228, the 17 who fell from the sky on the day of the storm did not die in vain.

FM

...12 ft. away!

Raid Wasp & Hornet Killer has a long-distance spray-nozzle to keep you at a good distance. You spray it directly on the nest. It kills on contact and saturates the nest to kill late-coming or returning insects. Use it once and the job is done.



Johnson
Wax

© 1978 S. C. Johnson & Son, Inc.

Merit Replacing High Tar Brands.

—National Smoker Study

Majority of 'Enriched Flavor' smokers show no regrets about leaving former high tar favorites.

Do smokers attracted to low tar MERIT stay with the brand, or "backslide" to former high tar favorites? Read what MERIT smokers had to say in a nationwide research effort.

Confirmed: 85% of MERIT smokers say it was an "easy switch" from high tar brands.

Confirmed: Overwhelming majority of MERIT smokers say their former high tar brands weren't missed.

Confirmed: 9 out of 10 MERIT smokers not considering other brands.

And in research conducted among smokers who taste-tested MERIT against leading high tar brands:

Confirmed: Majority of smokers rate MERIT taste equal to—or better than—leading high tar cigarettes tested! *Cigarettes having up to twice the tar.*

Confirmed: Majority of smokers confirm taste satisfaction of low tar MERIT.

Kings: 8 mg "tar," 0.6 mg nicotine—
100's: 11 mg "tar," 0.7 mg nicotine av. per cigarette, FTC Report May '78

This ability to satisfy, and especially to satisfy over long periods of time, could be the most important evidence to date that MERIT is the first real alternative for high tar smokers.

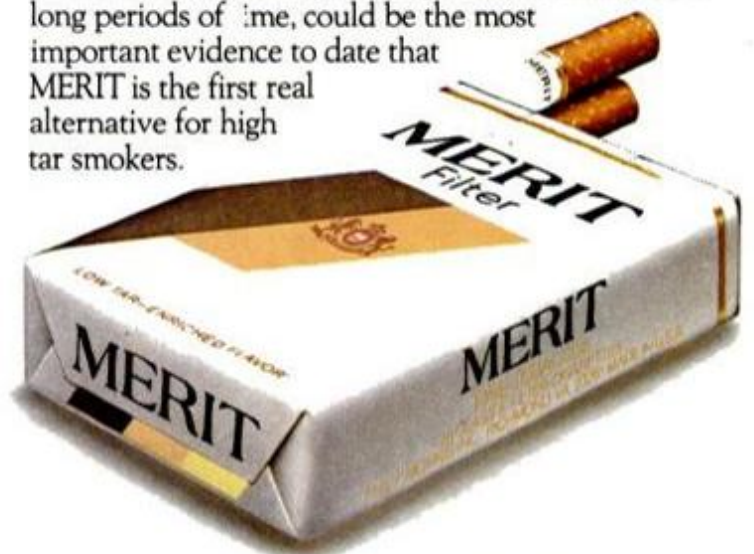

MERIT

Kings & 100's

Warning: The Surgeon General Has Determined That Cigarette Smoking Is Dangerous to Your Health.

© Philip Morris Inc. 1979

Материал, защищенный авторским правом

Telephone Listening Device

Record telephone conversations in your office or home. Connects between any cassette or tape recorder and your telephone or telephone LINE. Starts automatically when phone is answered. Records both sides of phone conversation. Stops recorder when phone is hung up. This device is not an answering service.



Each
\$18.95

Qty. Disc Avail.



Qty. Disc Avail.

Super Powerful Wireless Mic

10 times more powerful than other mics. Transmits up to 1/4 mile to any FM radio. Easy to assemble kit. 15V battery (not incl.)

Call (305) 725-1000 or send \$18.95 + \$1.00 shipping per item to USI Corp., P.O. Box FM-2052, Melbourne, FL 32901. COD's accept. For catalog of transmitters, voice scramblers and other specialty items, enclose \$2.00 to USI Corp.

Print For Profit

Cards; stationery; envelopes; advertising; labels; tickets; OSL cards; announcements; greeting, sympathy, prayer cards; tags, etc. Save money. Own a Printing Business.

We supply everything direct from factory. Easy instructions. Also raised printing like engraving. Have home shop. Add to income. Send 25¢ for catalog.

Kelsey Presses, 79-BH Meriden, CT 06450



LEARN MEAT CUTTING

Train quickly in 8 short weeks at Toledo for a bright future with security in the vital meat business. Big pay, full-time jobs — HAVE A PROFITABLE MARKET OF YOUR OWN! Time payment plan available. Diploma given. Job help. Thousands of successful graduates. OUR 36th YEAR! Send approved, NATIONAL SCHOOLS OF MEAT CUTTING, No. 71-02-0197T, Dept. 50-T, 33 N. Superior, Toledo, Ohio 43604

SAVE HUNDREDS OF DOLLARS

Build your patio with a PORTA-MIX® portable mixer. Home/commercial uses-plaster, cement, potting soil. Mixes up to 100 lbs. weighs 50 lbs. 115 volts. Fits in most cars. Only \$199 shipping included or send \$1 for catalog. 10-day money back guarantee. FREE patio stone mold with order.



PORTA-MIX, INC., Dept. DB, 1083 Bloomfield Ave., West Caldwell, NJ 07006

REPAIR CLOCKS

Home Study Course prepares you for Good Income — Professional Status. Free Details. No salesman will call.

NAME _____
ADDRESS _____
CITY _____ STATE _____ ZIP _____

SCHOOL OF PROFESSIONAL CLOCKSMITHS
DEPT. PH, FRANKSTON, TX 75763



LEARN DRAFTING AT HOME

Train at home in spare time. No previous experience necessary. Send for FREE Drafting "Career Kit" GI & VA Benefits. No salesman will call.

NAME _____ AGE _____
ADDRESS _____
CITY _____ STATE _____ ZIP _____

FREE! NORTH AMERICAN SCHOOL OF DRAFTING, Dept. PB079
"CAREER KIT" 4500 Campus Dr., Newport Beach, Calif. 92663

BASEMENT TOILET

Flushes up to existing sewer or septic tank by powerful, self-contained pump operated by normal water pressure. No digging up floors. Clog resistant, easily installed. Make basement into game room, den, apartment with private bath.



Write for free literature. Dealer inquiries invited.
DOSS MFG. Dept. J-25 Box 10947, Houston, Texas 77018

Gold & Silver Scrap

Available Everywhere. Buy scrap gold & Silver for Big Profit. Write for Free Details.

I. C. Meredith

P.O. Box 11216 Reno, NV 89510

USE ZIP CODES WHEN ANSWERING ADS

GAMES ON COMPUTERS

(Continued from page 69)

only be loaded into a home computer to be enjoyed. The computer can keep track of hundreds, even thousands of variables so that the games can be complex and challenging, as well as fun. Many of the best programs take advantage of the computers' various graphic displays.

Games can be divided into general categories. There are reflex games,

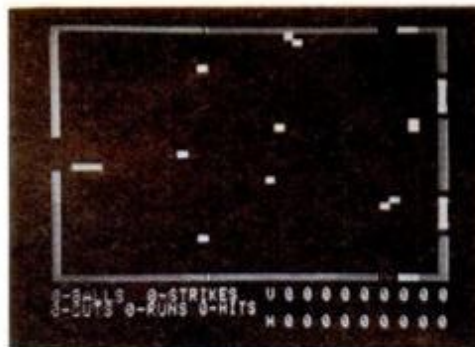

The game *Baseball*, from Creative Computing, lets one player control the pitcher and fielders while the other bats the ball.

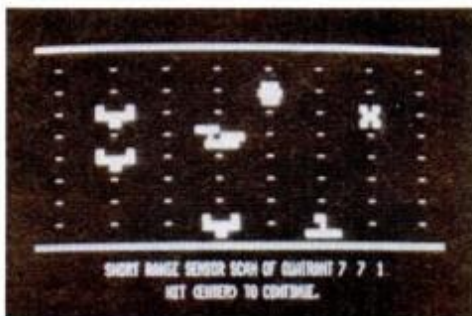

ENTERPRISE AND CREW
AWAITING YOUR ORDERS, CAPTAIN.

- 0 STATUS
- 1 DAMAGE CONTROL
- 2 SCIENCE COMPUTER
- 3 SHIP'S COMPUTER
- 4 LR SENSORS
- 5 SR SENSORS
- 6 IMPULSE ENGINES
- 7 WARP DRIVE
- 8 PHASERS
- 9 PHOTON TORPEDOES
- 10 ALERT
- 11 REPAIR

ORDERS? -

The best version of *Star Trek* we've seen is *Star Trek 3.3* from the TRS-80 Software Exchange. Watch out for those Klingons!

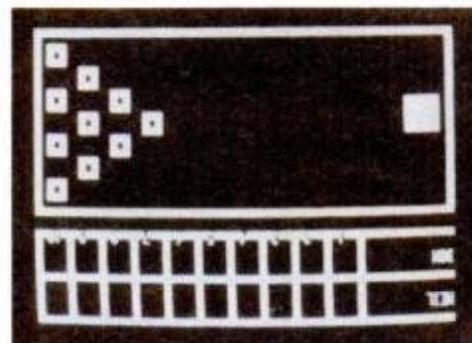

You can throw a gutter ball or a strike when you play *Bowling* on a computer. The program is from TRS-80 Program Exchange.

leaving the comfort of your easy chair.

Many computer games are based on popular stories or movies. Quite a few games require the player to somehow do as well as or better than the hero of a popular romance. Thousands of computer freaks have rescued Princess Leia from the evil Darth Vader! One game even recreates killer bees taking over the country, a la *Swarms* by Arthur Herzog.

Maze games are found in great variety. A classic in the field is the game of *Wumpus*, which has been redone innumerable times for just about every computer there is. In *Wumpus* you descend into a maze-like series of caves looking for the wumpus, a somewhat shy creature. Many games now offer very complex mazes, some guarded by various dangers, or even three-dimensional

(Please turn to page 148)

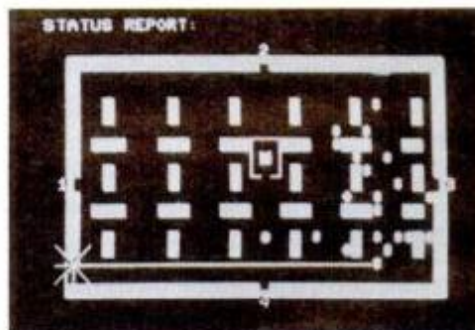

You must *Escape from the Death Planet*, and also rescue the princess, in this exciting game from Fantasy Games Unlimited.



From Hayden Books, *Sargon* plays a beautiful game of chess—beautiful in its display and in the quality of its moves.

in which the player's quick response in, say, hitting a key or moving a paddle, is the determining factor.

Then there are old favorites, such as chess and backgammon, played against the computer.

Science-fiction games abound, and one of the most popular games around is *Star Trek*. There are dozens of versions in which the player commands the *Enterprise* in a Klingon-ridden universe. Then there are the sports simulations; you can play golf, bowl, or shoot darts without

Turn the Inflation into the Best Earning Year of your life with paychecks of \$500 and more... week after week after week!

Dick Rogers



The Man Behind Seamless Spray

SELL PACE'S SEAMLESS SPRAY... THE PROCESS DEMANDED BY TODAY'S BUSINESS CONDITIONS!



Join PACE and immediately you put yourself right in the middle of the most profitable business you can engage in during the inflation. Consider these

Inflation-Proof possibilities. There are hundreds of plants, factories, schools, hospitals, shopping centers, etc., right in your area confronted with the worrisome problem of leaky roofs. They can't function without repairing them. But they also can't afford the unbelievable cost of putting on new roofs. Roof contractor prices have soared into orbit. With our SEAMLESS SPRAY, you give them an inflation-proof solution. At a cost of less than 12¢ a square foot, you

supply Pace waterproofing sealants which they apply with Pace's equipment furnished on a Free Loan basis. And that's not all! You back each job with Pace's Maintenance Policy which provides the *continuous product service* that saves the exorbitant cost of a new roof for the life of the building.

You're able to offer the one sensible, economical answer to roof problems...the plan proven in continuous use by thousands of the biggest companies in the USA, including General Motors, Madison Square Garden, Inc., Green Giant and Brunswick Corp. Best of all, you're profiting from a big Ticket sale where the average order pays commissions of over \$500.



\$11,000 A big check on a big order. You get used to thinking BIG in our business. This Seamless Spray order was worth over \$11,000 in commissions on a sale made to an aluminum rolling mill for our SILVERLEAF sealant.



\$1,757.25 A mighty nice day's work resulted in this new Distributor's first sale. This Seamless Spray order for LIQUID METALLIC SIDING paid commissions of \$1,757.25. The Distributor had no prior knowledge of our business.

You need no previous experience in our business. Our most successful men have come to us from all walks of life. Experience in Direct Sales is helpful but not essential. Age is no factor. Many men 60 and older make it big. Our program is ideally suited to part-time selling because the commission on each Seamless Spray order averages over \$500. For full information write Dick Rogers Dept. PM-879 or send coupon to:

RUSH DETAILS ON SEAMLESS SPRAY ENERGY SAVERS PAYING \$500 AND MORE ON A SINGLE ORDER!

TO: DICK ROGERS
 PACE PRODUCTS, INC. — Dept. PM-879
 81st & Indiana • Kansas City, Missouri 64132

Name _____
 Address _____
 City _____ State _____ Zip _____



Dept. PM-879 81st and Indiana • Kansas City, Mo. 64132

now in our 3rd decade of dynamic growth!

Материал, защищенный авторским правом

forth. So most home computers make themselves very useful—as we will show in future articles.

The computer-game field is still quite new, and the best games are likely to come in the future. Perhaps someday an Olympic event will not only be shown on TV, but *played* on TV as well! **PM**

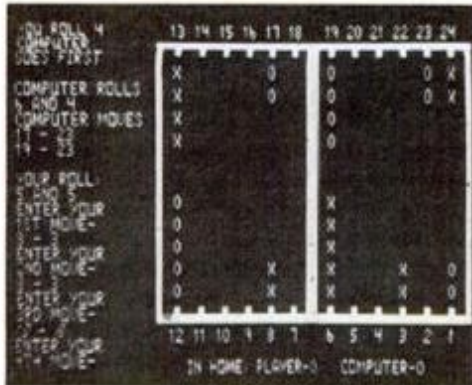

There's a fast backgammon game in *Fastgammon* from Quality Software. Its moves are surprisingly fast and accurate.



In Speakeasy Software's *Warlords*, up to four players can run small, warring kingdoms until only one monarch survives.

MANUFACTURERS LIST*

- Creative Computing (A, P, S, T), Box 789-M, Morristown, N.J. 07960.
- Fantasy Games Unlimited (P), Box 1683, Madison, Wis. 53701.
- Hayden Books (A, P, T), 50 Essex St., Rochelle Park, N.J. 07662.
- Holistic Data Systems Inc. (A), 2210 Wilshire Blvd., Santa Monica, Calif. 90403.
- Instant Software, c/o Kilobaud Microcomputing (A, P, S, T), Peterborough, N.H. 03458.
- Muse Software (A, P), 7112 Darlington Dr., Baltimore, Md. 21234.
- Powersoft Inc. (A), Box 157, Pitman, N.J. 08071.
- Programma International Inc. (A, P, S, T), 3400 Wilshire Blvd., Los Angeles, Calif. 90010.
- Quality Software (A, P, T), 10051 Odessa Ave., Sepulveda, Calif. 91343.
- Softape Inc. (A, P, T), 10432 Burbank Blvd., North Hollywood, Calif. 91601.
- Speakeasy Software (A, P, T), Box 1220, Kemptville, Ont., Canada, K0G-1J0.
- TRS-80 Program Exchange (T), 17 Briar Cliff Dr., Milford, N.H. 03055.

*In the above list, the letters A, P, S and T stand for the four most popular computers—the Apple, PET, Sorcerer and TRS-80. Almost all of the listed manufacturers offer software for small business and home finance use, as well as games. No matter what your interests, it might pay to write and ask for a catalog.

IF YOU TREAT YOUR TRUCK LIKE A TRUCK.

Treat it to Firestone hard working truck tires for hard working trucks.

The Transport 1 Wide Oval, for wide tread stability and traction, wet or dry.

The Steeltex Radial, for radial handling, traction, and economy plus steel belted strength.

The All Terrain, with a deep-biting aggressive tread that's quiet on the road, rugged off the road. Plus a bold raised white letter sidewall design.

All three are tough, all three are available in extra traction tread versions, all three are priced right.

Check them out at your nearest Firestone retailer. He'll show you how to treat your truck like a truck.



Transport 1
Wide Oval®

Steeltex Radial™

All Terrain™

Firestone

LIGHT TRUCK TIRES

JIG-SAW FURNITURE



Tough, Durable, **Light-weight** Furniture in a kiff! Has that new home depleted your savings account? Do you need furniture for your kid's rooms? How about some light-weight knock-around, take-to-the-beach furniture for your van?

These handsome, extremely durable chairs are constructed of heavy-duty PVC tubing and the cushions and supports are of open mesh polyester that is rot and mildew resistant.

Your furniture is delivered to you unassembled — You put it together and save. Assemble the frame, put on the cushions and your chair is ready for years of hard use!

We have a couch available at extra cost. Your choice of yellow, blue, red, white or green.

Mail coupon today for more information.

EVER-WEAR PRODUCTS, INC.
1202 North Howard Ave., Tampa, FL 33607

Chair — \$79.50 Couch — \$149.95

Name _____

Address _____

City _____

State _____ Zip _____

Dealer inquiries welcome.

Enjoy the warmth and beauty of a fireplace ... PLUS the high efficiency of a wood stove!



NEW! The first economical and highly efficient alternative to a built-in fireplace: THERMOGRATE

Free-Standing Fireplace/Stove

- 5-Way system delivers more heat output from less wood.
- Costs less to buy & install.
- Deluxe full-view 'picture window' glass doors.
- Integral Stainless Steel tubular heat exchanger ... delivers high heat output w/o blower!
- Antique Red or Satin Black.

Performance & Satisfaction MONEY-BACK GUARANTEED

Write for FREE Brochure:

THERMOGRATE ENTERPRISES, INC.
2785 N. Fairview Ave., Dept. 840-908
P.O. Box 43021, St. Paul, MN 55164
Or CALL TOLL FREE 1-800-328-0882

Thermograte®

© 1979 TEI St. Paul MN 55113. All rights reserved.

HOME COMPUTERS (Continued from page 68)

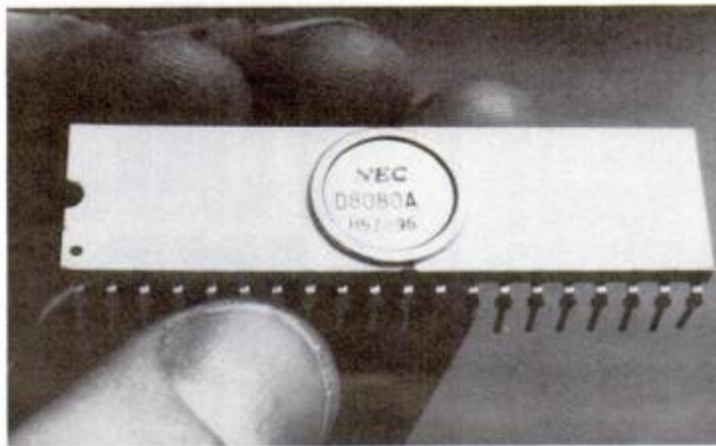

This is a computer's CPU "chip," or central processing unit. It is the "brain" of the computer, and all other chips and components work to support it. Once very expensive, CPUs now sell for less than \$10 in quantity. Unfortunately, it takes more than a CPU to make a functioning computer. The 6502, Z-80 and 8080 are the most widely used CPUs in the industry.

requires a \$100 modification. Or, you can buy the advanced TRS-80 Level II, with the extended BASIC included. The Apple II doesn't bother with decimals in its integer BASIC mode, as it can operate much more quickly that way. This allows fast animation of graphics. The Apple does come with extended BASIC as a program on tape (included free). Or, you can buy a \$180 accessory which allows extended BASIC to "come up" when you turn on the computer.

Extended BASIC is an absolute must for home finance or statistical summaries. The fact that these four computers offer extended BASIC is a prime reason for our recommending them.

If memory will serve . . .

When you program a computer, you are telling it how to do one task, and it will perform that task over and over again whenever the program is run.

Naturally, the more complicated the task, the more complex the instructions—your program—must be. A very long program requires more memory than a short program.

Memory is measured in thousands of "bits." A bit is the smallest unit of information understood by the computer. Usually a "bit" is a 1 or a 0. Eight of these bits make one computer word, called a *byte*. An 8K computer has approximately 8000 bytes of memory. Likewise, a 48K machine has over 48,000 bytes available for a program.

How much memory do you need? That depends on your application. An 8K capacity is an absolute minimum, 16K is good and everything over that is great. Why? Because as you get more advanced, your programs will get longer—requiring more memory.

The TRS-80 and the PET arrive with 8K of memory, the Sorcerer and the Apple with 16K. On all of the computers, adding more memory

(up to a certain limit) is simply a matter of plugging in "chips," which are rectangular black boxes containing the integrated circuitry of thousands of transistors. The Apple's main case will hold up to 48K. The other computers require expansion cabinets to go beyond 16K. You can buy additional memory chips separately.

By the way, there are two types of memory, referred to as RAM and ROM. RAM stands for Random-Access Memory. This is memory the computer can use over and over again, and the computer can also get to any portion of it right away. ROM, or Read-Only Memory, is a permanent memory that can never be changed.

Your programs are stored in the RAM (which can be reprogrammed at any time with a new set of instructions). ROM is used to store the BASIC language and can't be altered. It is the RAM you will wish to expand.

Draw, partner!

One thing that sets these computers apart from the others is their graphic capabilities—the way they can generate pictures, charts and other such computer artwork on the display screen. This is more than a styling difference; it will really affect how you use the machine.

The Apple is the only way to go if you are interested in color graphics. The other computers just display black and white. This is one reason the Apple costs more. If you saw our May 1979 issue (*Art by Computer*, page 128), you have already seen the beautiful color graphics the Apple II can produce. If not, suffice it to say that the color output is very striking and effective.

The TRS-80 divides the screen into points (rectangles, really), and allows you to turn *on* each point (making it white) or *off* (black). So, you can draw lines and graphs and some artistic graphics.

(Please turn to page 152)

LOOKING FOR IDEAS ON HUNTING, FISHING, CAMPING, BUILDING, TOOLS, ETC.? CHECK THESE LISTINGS. THEN USE THE COUPON BELOW.

WORTH WRITING FOR

137 Tools for the Mechanic

A 24-page catalog of hand tools from Channellock, Inc., gives full information about their popular tongue-and-groove slip joint pliers, precision cutting pliers, adjustable wrenches, screw drivers, hammers, tin snips, clamping tools and more. Free.

138 Solving Problems on the Road

A 40-page glove compartment guide tells drivers how to spot trouble while on the road and solve it. Featured are trouble-shooting tips for dozens of common car ailments and proper maintenance practices. Also included are sections on safe driving and fuel saving. 50¢ from Fram.

139 Cut Lumber Costs

Money saving booklet from Belsaw Machinery Co. tells how to convert low-cost rough boards into high-value lumber, trim and furniture. Easy to use power tool rips and planes boards to size and molds to choice of patterns in just one movement. Shows you how to match any existing molding or custom design your own patterns. Free.

140 Maintenance Guide for Specialty Vehicles

Light recreational and utility vehicles work harder and drive hotter than conventional cars. Frequent checks and extra precautions are in order. Here is a check list of maintenance tips from Purolator. Free.

141 Tools, Tools and More Tools

All 196 pages of the U.S. General Supply Corp. catalog are filled with top-name tools and handyman supplies—6,000 of them! Discounted prices, too. \$1.00 (refundable on first order).

142 Take the Hassle Out of Your Car Maintenance

Save time, money and trouble when you keep your car's parts clean and lubricated. Here's a guide from Gold Eagle illustrating their full line of automotive products, including lubricants, sealers, engine cleaners and more. Explains how to use each product to keep your car running smoothly. Free.

143 For The Sporting Man

Browning has been serving Sportsmen for a century and would like you to examine its beautiful catalog. Over 150 pages covering Browning's full line of rifles and shotguns, as well as fishing and archery equipment, accessories, and sportswear. And it's free.

144 Lower Your Gas & Tune-up Costs

A free booklet from Delta Products gives all the facts on their electronic ignition system. Learn about the possible savings in gas and elimination of tune-ups. Easy to install. Fits all cars, trucks, boats, and bikes.

145 Time on Your Hands

Build Mason & Sullivan clocks from kits carefully tailored to your skill level. Wide selection, including Heirloom, Contemporary, Antique and Shaker clocks. New color catalog also offers the tools to build them. Only 50¢

146 Well, Picture That

Here is a 12-page pamphlet from Kodak that shows you how to photograph the picture on your television screen. Capture the many important and enjoyable events offered on television right in your own home. 75¢

147 Build It and Save Money

Carl Heald, Inc. offers a color brochure describing money saving build-it-yourself kits for utility and recreational vehicles. There are kits for constructing your own trail bike, 3-wheel ATV, Dump Cart, ¼ ton hauler, tiller and more. Free.

148 Your Own Beautiful Beast

Schrade Cutlery, makers of Old Timer Knives, now offers the 1st edition of the Old Timer Knife Almanac. Offers a wealth of information on knife making, care and collecting and includes an Old Timer Beautiful Beast iron-on. Send for your collector's item Almanac and be able to wear your own rugged Beast on your T-shirt or anywhere you like. Free.

149 The Complete Machine System

Emco-Lux would like you to have its brochure covering the many uses of the Unimat 3. This is a miniature universal machine tool for metal, wood and plastic. For the beginner or experienced craftsman. Get all the facts—free.

150 A Money Saver

Fix almost any part of almost any U.S. car (1973-78) with easy "one-step-at-a-time" help from *Basic Car Care Illustrated*. Simplified instructions, "pro-shop" tips and hundreds of diagrams, illustrations and specs make this comprehensive volume a real money saver. 528 pp. Hardbound. Just \$14.95.

151 A Hot Item

Crosstech Torch develops flame temperature up to 3700°. Can be used for both brazing and soldering. General Regulator offers brochure describing the high performance and safety features of this torch. Works on either MAPP or propane fuels and can be used for unlimited repair and hobby projects. Free.

152 A Real Work Horse

The Hirsh Company offers information on the Iron Horse, a heavy duty, portable sawhorse. Super strong, it is ready to use when you need it and folds for storage. Get details on its many uses and information on other time and work saving Hirsh Products. Free.

153 Mow 'Em Down

Lawn mowing made easy. Woods offers a complete line of tractor-powered undermount and rear-mount lawnmowers. Choice of cutting widths in models to fit most tractors from 12 to 40 hp. Free color brochure from Woods Division of Hesston Corp.

154 Looking for a Challenging Career

Jet Mechanic, Computer Programmer, Electronic Instrument Repairman. The Marine Corps can train you for one of nearly 300 skilled jobs in 36 occupational fields. If you are between 17 and 28 and want more information, send for the Marine Corps Opportunity Book now. Free.

Popular Mechanics 8/79
Box 1718, Sandusky, Ohio 44870

Please see that I receive the items checked below

- | | | | |
|-------------------------------------|----------------------------------|--------------------------------------|---|
| <input type="checkbox"/> 137 | <input type="checkbox"/> 142 | <input type="checkbox"/> 147 | <input type="checkbox"/> 152 |
| <input type="checkbox"/> 138 50¢ | <input type="checkbox"/> 143 | <input type="checkbox"/> 148 | <input type="checkbox"/> 153 |
| <input type="checkbox"/> 139 | <input type="checkbox"/> 144 | <input type="checkbox"/> 149 | <input type="checkbox"/> 154 (Ages 17-28) |
| <input type="checkbox"/> 140 | <input type="checkbox"/> 145 50¢ | <input type="checkbox"/> 150 \$14.95 | |
| <input type="checkbox"/> 141 \$1.00 | <input type="checkbox"/> 146 75¢ | <input type="checkbox"/> 151 | |

Total items requested _____

Name (Please Print) _____

Address _____

Town _____

State _____

Zip Code _____

(Please send cash, check or money order made out to POPULAR MECHANICS. No stamps, please.)

Note: Popular Mechanics processes your requests for the above information and forwards these inquiries to the organization making the offer. Each company mails the material directly. Your order will be on its way to you within 90 days.

This coupon Expires Oct. 31, 1979

Total money for priced items \$ _____

Service Charge \$ _____ .35

Total money enclosed \$ _____

**For
fresher air.
Everywhere.**



Everyone would love a home or office with air as fresh and sweet as all outdoors. And now you can have it. Electronically.

The Modulon™ electronic air freshener generates negative air ions to counteract the dirt, smoke, dust, pollen, soot and other particles that pollute our indoor environment. And it does it silently and reliably, with no chemicals and hardly any electricity.

For information on the full line of Modulon air fresheners for home, auto and business, please fill in coupon below.

AMCOR

P-8

The Amcor Group Ltd.
Empire State Building
19th Floor
New York, N.Y. 10001

Please send information on Modulon air fresheners to:

Name _____

Address _____

City _____ State _____ Zip _____

**NEW High Branch
TREE SAW**

**Outreaches
and
Outworks
any
Pole Saw!**



**CLOSEUP OF
PATENTED
CUTTING CABLE**

Easily clear branches hanging over roofs, windows, play areas, gardens and pools. Revolutionary new "saw on a rope" cuts small and large branches, live or dead, up to 30' and higher while you stand safely on the ground. New concept has flexible steel cutting cable with round carbon steel saw teeth. Cable is attached to control lines and safety sandbag throwing weight. Simply toss weight over the branch you want to cut down, cable automatically positions itself in place, and then pull alternately on each control line to saw down branch. **Avoid the hazard of climbing ladders with a hand saw or a chain saw. Avoid the expense of hiring a tree service.**
HOMEOWNER MODEL—3 Foot flexible steel cutting cable, two 25-ft. control lines. Total length 53-ft. **\$14.97** plus \$2 shpg.
DELUXE PROFESSIONAL MODEL—4 foot flexible steel cutting cable, two 45-ft. control lines. Total length 94-ft. **PLUS ADDED BONUS**, 2 sturdy hand straps. **\$24.95** plus \$3 shpg.
Both models come complete with storage pouch, safety throwing weight and instructions.
Send check or M.O. 20 day money back guarantee.

HOLST, INC.

Dept. PM-89, 1116 W. Lake, Box 370
Tawas City, Mich. 48763

HOME COMPUTERS

(Continued from page 150)



A good book, like this one by Leslie Solomon and Stanley Veit, guides you over common hurdles to computer enjoyment.

The PET uses a different approach in that each of the keys has not only a letter, but a graphic symbol associated with it. Checkers, boards, lines, dots, hearts, clubs and more are all there for you. The TRS-80 offers more versatility as far as creating your own graphics, but the PET's graphics are clearer than the TRS-80's in many applications.

Exidy's Sorcerer has combined the two systems. You can program either way—with graphics right off the keyboard or you may design your own. Another point to ponder is how easy it is to program graphics. The Apple and the PET seem to have the easiest programming commands in their graphic modes.

Your best bet is to visit a local computer store and try the different computers out. (By the way, don't be afraid to play with the machines. If the store doesn't like it, find another store. Willingness to demonstrate is a good index as to how that store will treat you should you need help in the future!)

Looking to the future

It's best to have a computer which is supported by manufacturers other than the one that made the original machine. This leads to two things—a greater variety of available add-ons, and prerecorded programs with pricing that is more competitive.

The TRS-80 is the leader here, with many reputable manufacturers offering both accessories and prerecorded programs for it. The PET and Apple II have also attracted their share of "secondary" manufacturers. The Sorcerer is still too new to have aroused much interest among other manufacturers, but we should see such interest develop

shortly in software and add-ons.

Picture the best computer in the world with as much memory as you might hope for—but without a keyboard or a display. Deaf and dumb, the computer would be no more than a box, not functional, hardly decorative or useful.

Communicating back and forth

All of the four computers have self-contained keyboards. Once again, you have to try them yourself to see which you would like to type on the best. Some people have complained that the PET's keyboard is crowded—and it does take some getting used to. However, Commodore is now offering the PET (for more money) with a more businesslike keyboard.

The TRS-80 and the PET both come with their own monitors (TVs) for display. The Apple II requires a simple hookup to a home TV (a color TV for color graphics). The Sorcerer requires the purchase of an accessory video monitor (which you'll find varies in price as you shop from dealer to dealer).

In one area, all these computers need improvement. That is the *cassette interface*. When you program a computer, you don't want to type in the program every time. Such a feat could take hours. Instead, all these computers let you save a program on magnetic tape—cassette tape that is exactly the same as you use in your hi-fi. To read in a program *should* be as simple as plugging the tape recorder into the computer and turning both on.

Unfortunately, all these computers (as well as all others) can be balky and refuse to load properly. We found the Apple to be the most reliable when used with the recorder recommended by the company. The Sorcerer and PET were about equal, with around a 20-percent failure rate. The TRS-80 was the worst with almost a 50-percent failure rate.

At no time were we completely unable to load a program, but it often took more than two tries before we succeeded.

Here is one place where there is much room for design improvement in the construction of these computers. Programming sometimes can be annoying enough without tape-loading hassles!

What more do you need?

As mentioned, many different manufacturers offer many different accessories for these computers. What you will need will be a function of what you will be using the machine for. Still, we have seen a few

outstanding accessories, some so good we would think they should be purchased right along with your new computer.

For the Apple II, you could not go wrong purchasing either the Screen Machine from Softape or the Superchip from Eclectic Corp. Both give the Apple lower-case characters and easier graphics. The Screen Machine (for about \$16) is a program on cassette tape, while the Superchip is a plug-in ROM device (sells for about \$100).

The difference here is that a tape program uses up memory. The ROM device leaves all user-programmable memory in the computer free for programming.

Also, the Superchip adds editing functions—ways to correct your programs. Check both out if you buy an Apple II. One of them will be right for you.

The PET, for a long time, was without a good instruction manual. Recently, Commodore released one that many people may find a bit too technical to learn from. Total Information Services (TIS) makes a series of manuals for the PET that are tutorial and well done—a must for the new PET master.

Floppy discs and printers are also available (see page 68 for further explanation of these peripherals). You will find that there is always an add-on you could use!

Taking one home

The TRS-80, the Apple, the PET and the Sorcerer are all available now. With the advent of machines such as these, the personal computer is within everyone's reach. Will it make good on its promise and actually become as accepted as the CB set or hi-fi? With machines like these, usable with only a minimum of effort, it would seem only a matter of time. **PM**

MANUFACTURERS' LIST

Computers:

- Apple Computer Inc. (Apple II), 10260 Bandley Dr., Cupertino, Calif. 95014
- Commodore Business Machines (PET 2001), 3330 Scott Blvd., Santa Clara, Calif. 95051
- Exidy Inc. (Sorcerer), 969 West Maude Ave., Sunnyvale, Calif. 94086
- Radio Shack (TRS-80), 1300 One Tandy Center, Fort Worth, Tex. 76102

Accessories:

- Eclectic Corp. (Superchip), 2830 Walnut Hill Lane, Dallas, Tex. 75229
- Heuristics Inc. (Speechlab), 900 San Antonio Rd., Los Altos, Calif. 94022
- Mountain Hardware Inc. (AC Control), 300 Harvey West Blvd., Santa Cruz, Calif. 95060
- Softape (Screen Machine), 10432 Burbank Blvd., North Hollywood, Calif. 91601
- Telpar Inc. (printers), 4132A Billy Mitchell Rd., Box 796, Addison, Tex. 75001
- Total Information Services (PET manuals), Box 921, Los Alamos, N.M. 87544

Relieves Tormenting Rectal Pain And Itch, Helps Shrink Swelling Of Hemorrhoidal Tissues

...Due to inflammation. Gives prompt, temporary relief from such burning itch and pain in many cases.

The burning itch and pain caused by inflammation in hemorrhoidal tissues can cause much suffering. But there is an exclusive formulation that in many cases gives prompt relief for hours from this itch and pain. It helps shrink swelling of such tissues caused by inflam-

mation. Tests by doctors on hundreds of patients reported similar successful results in many cases. This medication is *Preparation H*®.

There's no other formula like Preparation H. Ointment and suppositories. Use only as directed.



Save Water With A Toilet Tune-Up.

Just one leaking toilet can waste up to 78,000 gallons of water each year due to a defective tank mechanism. Why go on wasting water? Write for your free Tune-Up Brochure.

FLUIDMASTER, INC.
P.O. Box 4794, 9800 Van Ness St., Dept. PM, Ashburn, California 94013

BIG MONEY IN T-SHIRTS!



Our book tells all! How to get started with little capital and make big money printing T-Shirts for schools, clubs and businesses! Beginners, earn up to \$50 per hour at home in your spare time! Everything explained step-by-step. Not a course! **SEND FOR FREE DETAILS!** Southwest Screen Print Ind., Inc. P.O. Box 423, Dept. PM, Scottsdale, Arizona 85252

Free Guide to Building Your Own Home

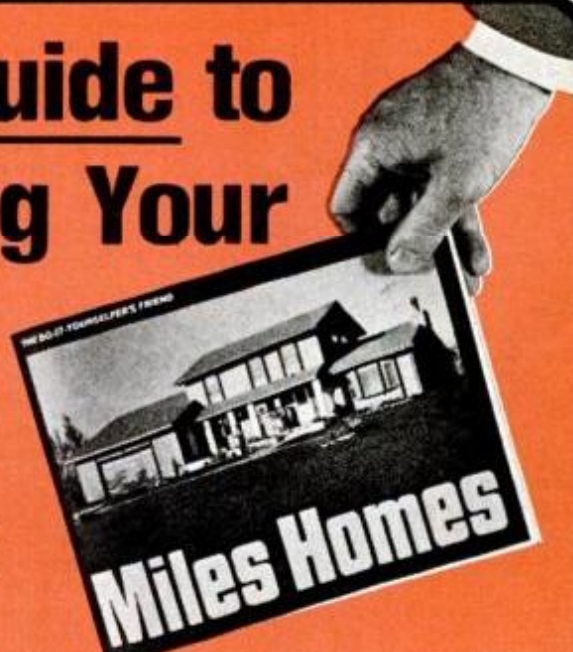

Special Financing for Do-it-yourselfers

Do-it-yourselfers! Find the answer to your prayers for a new home in this book. Join the thousands of families who have beaten inflation by building their own home The Miles Way.

The Miles Way is different. It's based on trust in people who are low on cash but high on ambition. Miles furnishes blueprints, pre-cut materials, step-by-step instructions and lots more. There's no big down payment...and you make low monthly payments while building. What's more, you may be able to start building without a paid-for lot.

Are you serious about having a new home? Are you willing to do all or most of the building? If so, don't pass up this opportunity to learn about The Miles Way.

Get our Great Home Ideas book. It tells the whole story. Eighty-four full-color pages of valuable information featuring our special, affordable financing for do-it-yourselfers, energy savings, decorating...plus fifty exciting build-it-yourself home designs.

Send coupon for your free copy today! There's no obligation...just a chance to begin a new life in your own new home. Allow 4 weeks for catalog delivery or send \$1.00 for priority handling.

There's a representative near you.
Phone: (612) 588-9700

Miles Homes

The Do-It-Yourselfer's Friend

Send me your FREE Great Home Idea Book
MILES HOMES Dept. MN 200
4500 Lyndale Ave. N. Minneapolis, Minn. 55412

Name _____
Address _____
City _____ State _____ Zip _____
County _____
Phone () _____

I plan to do all or part of the work
 \$1.00 enclosed for priority handling

NEW! DRILLS WATER WELLS 50-100-200 FEET DEEP!

SAVES YOU HUNDREDS OF DOLLARS!!!

Did you know that vast quantities of fresh, sparkling clear water lie within 200 feet of the surface of the ground almost *everywhere*? In the city. In the suburbs. In the country. Pure, tasty water untouched by chemicals or pollutants.

Trouble is, until now, the only practical way to tap this wonderful supply of free water was to hire a professional driller—and that could cost you a thousand dollars or more.

But now YOU can drill your own well and save hundreds of dollars!

With the remarkable Hydra-Drill you can drill your own well. It's amazingly uncomplicated and simple to operate. More than 47,600 water wells have been drilled with Hydra-Drills by homeowners who have had little or no previous experience in well drilling.

You owe it to yourself to find out more about this practical economical way to provide good, year 'round water for your home and garden.

Write or call today for our FREE information package including the booklet "HOW TO DRILL YOUR OWN WELL". There's no obligation—ACT NOW!

Deeprock Mfg. Co., Opelika, Alabama 36801

FREE Phone Toll-Free **(800) 821-2280**
(Ext. 86)

Call anytime including Sundays.
OR CLIP COUPON AND MAIL TODAY!

Deeprock Mfg. Co., Dept PM89
Opelika, Alabama 36801

Please mail your free information kit immediately. I understand there is no obligation.

Print Name _____

Address _____

City _____ State _____ Zip _____

© 1979 Deeprock Mfg. Co.



MORE MILES FOR YOUR MONEY!

(Continued from page 46)

Dasher (1): 97, FI, 4-cyl.
Dasher station wagon (1): 97, FI, 4-cyl.
Dasher (2): 90, FI, 4-cyl. diesel
Dasher station wagon (2): 90, FI, 4-cyl. diesel
Rabbit (1): 89, FI, 4-cyl.
Rabbit (2): 90, FI, 4-cyl. diesel
Scirocco (1): 89, FI, 4-cyl.
Bus (1): 120, FI, 4-cyl.

1979

AUDI (1)

Fox: 97, FI, 4-cyl.
Fox station wagon: 97, FI, 4-cyl.
4000: 97, FI, 4-cyl.
5000: 131, FI, 5-cyl.

BMW (2)

320i: 121, FI, 4-cyl.
633CSi: 196, FI, 6-cyl.
733i: 196, FI, 6-cyl.

CADILLAC (2)

Seville: 350, FI, 8-cyl. diesel
Eldorado: 350, FI, 8-cyl. diesel
DeVille/Brougham: 350, FI, 8-cyl. diesel

CHEVROLET (2)

C10 pickup: 350, FI, 8-cyl. diesel

DATSUN (1)

200SX: 119, 2V, 4-cyl.
210: 85, 2V, 4-cyl. (except high-fuel-economy models with catalytic converter and 5-speed M/T)
210 station wagon: 85, 2V, 4-cyl.; 91, 2V, 4-cyl.
310: 85, 2V, 4-cyl.
510: 119, 2V, 4-cyl.
510 station wagon: 119, 2V, 4-cyl.
810: 146, FI, 6-cyl.
810 station wagon: 146, FI, 6-cyl.
200ZX 2+2: 168, FI, 6-cyl.
280ZX: 168, FI, 6-cyl. (except 1979 1/2 models)
Pickup: 119, 2V, 4-cyl.

FIAT (1)

128: 79, 2V, 4-cyl.

GMC (2)

Pickup: 350, FI, 8-cyl. diesel

HONDA (2)

Civic: 76, 2V, 4-cyl.
Civic CVCC: 91, 3V, 4-cyl.
Civic CVCC station wagon: 91, 3V, 4-cyl.
Accord CVCC: 98, 3V, 4-cyl.
Prelude CVCC: 98, 3V, 4-cyl.

INTERNATIONAL HARVESTER (2)

Scout II/Terra/Traveler: 198, FI, 6-cyl. diesel

MASERATI (1)

Merak: 181, 6V, 6-cyl.

MERCEDES-BENZ (2)

240D: 147, FI, 4-cyl. diesel
300D: 183, FI, 5-cyl. diesel
300CD: 183, FI, 5-cyl. diesel
300SD: 183, FI, 5-cyl. diesel
300TD station wagon: 183, FI, 5-cyl. diesel

OLDSMOBILE (2)

Cutlass: 260, FI, 8-cyl. diesel
Cutlass station wagon: 350, FI, 8-cyl. diesel
Toronado: 350, FI, 8-cyl. diesel
Delta 88: 350, FI, 8-cyl. diesel
98: 350, FI, 8-cyl. diesel
Custom Cruiser Wagon: 350, FI, 8-cyl. diesel

PEUGEOT (2)

504D: 141, FI, 4-cyl. diesel
504TD station wagon: 141, FI, 4-cyl. diesel

RENAULT

LeCar (3): 79, 2V, 4-cyl. (some early production models)
17 Gordini (1): 100, FI, 4-cyl.

SAAB (1)

99 GL: 121, FI, 4-cyl.
900: 121, FI, 4-cyl. (except turbo)

SUBARU (1)

Subaru: 97, 2V, 4-cyl.
Subaru station wagon: 97, 2V, 4-cyl.
Brat: 97, 2V, 4-cyl.

VOLKSWAGEN

Beetle convertible (1): 97, FI, 4-cyl.
Dasher (1): 97, FI, 4-cyl.
Dasher (2): 90, FI, 4-cyl. diesel
Dasher station wagon (1): 97, FI, 4-cyl.
Dasher station wagon (2): 90, FI, 4-cyl. diesel
Rabbit (1): 89, FI, 4-cyl.
Rabbit (2): 90, FI, 4-cyl. diesel
Scirocco (1): 97, FI, 4-cyl.

FM

BE A CHIMNEY SWEEP

Your Own Business: A chimney sweep can clean a chimney with the August West® System in one hour. Nationally, the average charge is \$40.00.

A Growing Need:

The energy crisis has resulted in a dramatic increase in wood burning. Wood smoke deposits form milable creosote in chimneys. Regular cleaning is necessary to prevent fire damage.

The August West® System:

More sweeps use it than any other method in the country.

Send for our free booklet, or call TOLL FREE any time and ask for "The August West Story."

800-648-5311

in Nevada (800) 992-5710

August West Systems, Inc.
663PM, Weston, CT 06880



BEAT GAS PRICES

Specifications Plus Pre-Production License or Right to Utilize Sublabs' Vapor Injection Design (For Your Personal Use Only, Not For Resale).

This might become the best Automotive Investment You Will Ever Make.

Send \$19.95 to: Fuel Research Div. PMA,
Submarine Research Labs Inc., Porters Cove
Island, Hingham, Ma. 02043

Sublabs' 20th Year

TABLE STROKE SANDER

\$350.00
Assembled
less motor



N.C. Residents
Shipping
Weight 175 lbs.

Ball Bearing - 190" Sandbelt
"Build Your Own" Kit, plans, \$160.
F.O.B. 30 lbs. You furnish wood,
motor, time. Original in use over
3 years. (2 models Sidestroke
& String also available)

McCall House, Box 1950-B
Lenoir, N.C. 28645

"I want my 'Popular Mechanics' projects to look professionally done. Irwin products help."

Mike Todd, School Principal and Do-It-Yourselfer



IRWIN every bit as good as the name
at Wilmington, Ohio 45177, since 1885

You can easily bore holes up to 1 1/2" with the Irwin Speedbor "88." This is the wood bit that cuts clean, fast, accurately. Puts more boring power at the working end of your 1/4" electric drill.

Irwin's exclusive hollow ground point starts holes fast. Sharp spade-type cutters power through any kind of wood. 1/4" shank chucks perfectly.

Workshop special
Set of 6 Speedbor "88" bits with metal hang-up rack. Sizes 3/8", 1/2", 5/8", 3/4", 7/8", 1".

Strait-Line Chalk Line Reel Box -50 ft. & 100 ft. sizes. Popular-priced Irwin self-chalking aluminum alloy box. Easy action reel. Leak-proof. Practically damage-proof. Fits pocket or hand.

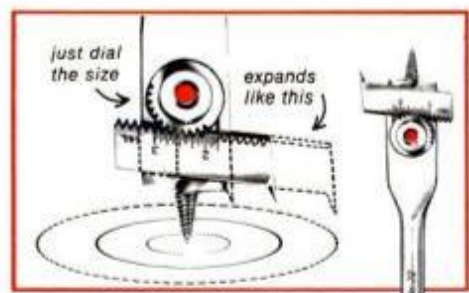

Irwin Micro-Dial bores 35 hole sizes
Just dial the size hole you want up to 3 full inches. Taper square shank fits all hand braces. Machine-sharpened spur and cutters deliver clean, accurate boring action. No. 22 model (illustrated) combines 35 standard sizes in one precision-engineered wood bit, 7/8" to 3". No. 21 lets you dial 19 standard sizes, 5/8" to 1 1/4".

MOLDS

for making Ornamental Concrete Items...

Book about Aluminum Molds with prices and production trade secrets direct from world's largest mold manufacturer.

SEND \$5.00

CONCRETE MACHINERY COMPANY, INC.
P. O. BOX A99 - HICKORY, N. C. 28601

EYEGLASSES BY MAIL

From **\$14.95**

FRAMES, LENSES & CASE, Complete.

DOCTOR'S PRESCRIPTION OR YOUR PRESENT LENSES DUPLICATED. Large selection of latest fashion frames and lenses.

QUALITY, ACCURACY, FIT, 100% GUARANTEED

SEND FOR FREE FAMILY CATALOG TODAY

PRISM OPTICAL INC. Dept. PM-89 Est. 1959
10992 NW 7th Ave., No. Miami, Fla. 33168

BE A LOCKSMITH

\$49.95

COMPLETE COURSE

Today a trained Locksmith can just about write his own ticket. Locksmiths average \$15.00 an hour. Learn at home - Earn as you learn. Fast easy course that trains you by doing. All keys, locks, picks, car locks and special equipment supplied. Zooming crime is everywhere, everyone is seeking greater protection. Cash in at once, train at home - Earn extra \$\$\$ right away. Send for exciting facts and a Free Lesson - No obligation or Send \$39.95 for complete kit & \$1.75 shipping & handling. Texas residents add sales tax. C.O.D. accepted. 10 Day money back guarantee.

NATIONAL LOCKSMITH SUPPLY CO. INC.
P.O. BOX 31598 DEPT P2
DALLAS, TEXAS 75231

SEND COURSE SEND INFORMATION AND FREE LESSON

NAME _____
C.O.D. _____
ADDRESS _____
CITY _____
STATE _____ ZIP _____

TO ORDER, CALL COLLECT
214-235-1811

MASTERCARD BANKAMERICARD



Does The Belsaw Pay? YOU BET!

\$5-\$6 an hour

100% Disabled

Wanted to Retire

"On Saturdays, my big day, I take in \$45 to \$55. Other days I average less, but I figure I make between \$5 to \$6 per hour... and sometimes more. I am presently enlarging my shop, and thank BELSAW and their fine equipment for making it possible."
V. O. Miller Hubert, North Carolina 28539

"I was disabled by an accident while employed as an iron worker. They declared me 100% disabled and said I'd never work again. I don't think I could work for anyone else but I started my sharpening business part-time and now it's turned into a full-time job with more work than I can do."
Rez Stage Tampa, Florida 33614

"I had dreamed of retiring for years, but was afraid to quit my salaried job. I had never used this type of equipment, but the SHARP-ALL was real easy to learn. I sharpened 30 blades my first week - without advertising at all. Now, for the first time in my life, I can say that I am content."
Farris Cornelius Wellington, Texas 79095

Makes Over \$60.00 EXTRA a Week In His Spare Time Sharpening Shop!

"My Belsaw Sharp-All made me an extra \$3,500 last year. Now I am going full time. It's great to be your own boss."
DAVID SWANSON - Utica, Michigan

Let Belsaw prove YOU can do it, too! On our 30-DAY FREE TRIAL OFFER

SEND FOR FREE FACTS! Our Free Book tells how to start a profitable, lifetime home sharpening business, how we help you grow, how we'll finance you.

You risk nothing by accepting this offer to see how easily you can turn your spare time into big Cash Profits with your own Complete Sharpening Shop. No selling... no previous experience needed. Our famous Sharp-All and show-how instruction set you up to make \$200, \$500, \$700 a month CASH sharpening Saws, Knives, Scissors, Lawnmowers, Shop and Garden Tools... all cutting edges.

FIND OUT ALL ABOUT IT No Obligation - No Salesman Will Call

BELSAW SHARP-ALL CO.
710P Field Bldg.
Kansas City, Mo. 64111

No Obligation... No Salesman Will Call

BELSAW SHARP-ALL CO. 710P Field Bldg., Kansas City, Mo. 64111
Send details of FREE TRIAL OFFER and Free Book "Lifetime Security"

NAME _____
Address _____
City _____ State _____ Zip _____



RED WING SHOES

The fittin'est safety boots for busy feet

- Heel-hugging Pecos pull-ons with steel toes
- Full-grain, water repellent leather



- "Sweat-Proof" leather insole—won't crack or curl
- Sizes 5 - 15, Widths B-EEE... not all sizes in all widths

IN THE
YELLOW PAGES
UNDER "SHOES"

GARAGE DOOR OPENERS

- Radio Controlled
- Buy Factory Direct and Save
- Thousands In Use
- Free Brochure
- Easy Homeowner Installation
- Immediate Shipment by UPS or PP

HELPMATE Equipment Co. Dept. PM779 Baroda, MI 49101

Send 25¢ for Details

LEARN Coleman CAMP GEAR REPAIR

MODERN SCHOOLS
Dept. No. PMC
4225 North Brown Avenue
Scottsdale, Arizona 85251

LANTERNS
STOVES
HEATERS
COOLERS
(All Models)
TENTS
CONVERSIONS
BACK PACKS

25,000 students
since 1946

"A dream business"

Mother Earth News

Make \$100-200 a day as a chimney sweep. Energy crunch and increasing wood-burning causing soaring demand. Have your own business with low investment using our modern methods. Call or write for free details.

**Black Magic
Chimney Sweeps**
Dept. PM, Stowe, VT 05672
802/253-4867



MOODY 84-MPG TURBODIESEL

(Continued from page 42)

82.6 mpg at 50 mph and 84.1 mpg on the road at 40 mph.

For Gordon's road test, the Capri carried a 500-pound passenger weight, a full fuel tank (18 gallons) and normal vehicle equipment (jack and spare tire). Using his highway result as the example, the Moodymobile can travel 1513.8 miles between fill-ups.

The car was also tested by government officials in city driving conditions. Carrying a full passenger load, with tires underinflated, and making 116 stops that varied from 20 seconds to two minutes, the car attained 57.2 mpg.

"Moody and Shetley have taken on a task of a factory team of 500 engineers and have done a phenomenal engineering job," Gordon states.

What's the secret, and where are Moody and Shetley going with it?

"There is no secret," says Shetley. "This is something domestic car companies can do. The Germans and Japanese have diesels that are getting mileage close to what we're getting with the Capri."

Standard Capri used

Moody and Shetley took a standard equipped Capri, pulled out the engine, transmission, driveline and rear axle, and installed a power train that is designed for maximum fuel economy.

Says Larry Johnson of the L and V Engine Service in Pinellas Park, Fla., who, with his brother Vic, worked on the turbocharging unit: "Ralph used established mathematical tables to determine the most efficient rpm and load range of the engine. He modified an engine, transmission and rear end to attain this level."

An example of the mathematical tables Johnson refers to are "pounds of fuel per horsepower per hour" tables, which are available for every engine.

The engine is a Perkins four-cylinder, in-line 108-cu.-in. diesel, which has been used for 20 years to run irrigation pumps and sailboats. At 17 inches high, the engine is one of the smallest and lightest around. Its original weight is 510 pounds. Moody shaved 50 pounds off that.

"One thing we did was install a steel flywheel that has a different thickness and diameter from the original," Shetley explains. "We also modified the bell housing, manifolds and exhaust system."

The result has been a total engine and transmission weight of 450

pounds. The original Capri engine weighs 555 pounds without a transmission.

Turbocharger a key

Internal modifications made to the engine allow it to run slower and cooler. To increase performance under these conditions, the engine has been outfitted with a modified Rajay 25 turbocharger.

A turbocharger is a device that uses a turbine driven by exhaust gases to drive a supercharger on an engine. It increases engine power without affecting fuel mileage.

Turbochargers are widely employed on racing cars. Its use on the Moodymobile comes as no surprise. Ralph Moody headed Ford's racing division from 1955 to 1976.

The modified turbocharger helps the Moodymobile maintain its high fuel mileage. By providing more air for combustion, the turbocharger permits the engine to burn 99 percent of the fuel charge. There is little lost fuel and there is a significant reduction in emissions, to boot.

"Ralph Moody's car is four times cleaner than any engine now on the market," says auto expert William Gordon.

Gordon's tests revealed a negligible 50 to 90 parts per million hydrocarbons and .01 to .02 percent carbon monoxide.

The car had not been tested for oxides of nitrogen (NOx) at the time this article was being prepared. However, Shetley says, "Our interpolation of data reveals that the engine will put out only .08 grams per mile oxides of nitrogen." General Motors has formally petitioned the Environmental Protection Agency for a waiver of the 1981 NOx standard for diesel engines, which calls for 1.0 grams per mile. The .08 expectation would better any NOx standard being considered.

Part-time fan electrically driven

The Capri diesel is water-cooled, but it doesn't have an engine-driven fan. This reflects another technique used by Moody to take as much load off the engine as possible. The engine doesn't overheat on the highway. To keep it from overheating in city traffic, the car is equipped with an auxiliary electric fan that Moody turns on by flipping a switch. Production cars would have the fan thermostatically controlled.

Moody and Shetley become very quiet when the subject of transmission and rear axle is broached. The standard four-speed transmission is

a Ford WT unit having an original 3.98 ratio in first gear, 1.97 in second, 1.37 in third and 1.00 in fourth. The rear end is a Ford C2 which has a 6 $\frac{3}{4}$ -inch-diameter ring gear and a 3.18 ratio. Those gear ratios have been altered in the Moodymobile.

"We modified the drive train drastically," Shetley says, "and that's all we'll say about it."

Decreased gear ratios

However, it is no secret that to attain better fuel mileage, gear ratios have to be decreased. Thus, the C2 rear end was probably modified by Moody to a ratio of perhaps 3.07 or 2.75—somewhere around that. The purpose is to dovetail the engine and drive-train torque to get the most efficient rpm for the speed at which the car is normally driven.

Another interesting note is that the front of the Moody-made car has been lowered two to three inches to reduce drag, and set up so handling would not be affected. As for the handling, I found it to be as good as that of any small car I have ever driven, with the exception of some low-end vibration that Ralph assures me will be eliminated in production models.

"The engine in the test car is mounted on stiff mounts because of all the abuse the car's been getting," Moody explains.

I went from 0 to 60 mph in about 17 seconds and held a top-end speed between 80 and 85 mph. Like any diesel, the car was noisy with the windows lowered, but I can put up with a lot of noise for 84 mpg.

What's next?

Where do Shetley and Moody go from here? Lincoln-Mercury has indicated interest in providing them with all the Capri, Monarch and Versailles bodies they need. In anticipation of this, the two are considering opening five production plants to meet the demand, which has already started. At this writing, they have received 40,000 orders.

The five plants they're looking at—in Titusville, Fla.; Denver; Detroit; Charlotte, N.C. and Baton Rouge, La.—will produce 10,000 cars the first year and 50,000 the next. Thereafter, they will be mass-produced at greater rates.

According to Ed Gorman of Lincoln-Mercury, "We are interested in the Moody car, but several details must be worked out. However, I am cautiously optimistic."

The "details" Gorman refers to are the certification of the Moody-

mobile by the Environmental Protection Agency, sharing of the warranty responsibility for the car by the three major component suppliers (Lincoln-Mercury, Perkins and Rajay), and arrangements by Perkins and Rajay to provide the Lincoln-Mercury dealers with replacement parts and service training of mechanics.

The Capri, with optional five-speed transmission, airconditioning and AM/FM radio, is expected to sell for \$8900. With AM radio and a four-speed transmission, the price would be \$8000. The Monarch, which gets 65 mpg on the highway, would sell for \$10,700. The Versailles (55 mpg on the highway) would sell for \$16,900. The Monarch and Versailles will be equipped with automatic transmission and airconditioning.

Prices aren't exactly cheap, representing from \$2000 to \$4000 above the sticker price for the three models. However, when you consider that with a full tank of fuel in the Capri, say, you can go from New York City to Miami, from Chicago to Salt Lake City, or from Los Angeles to San Antonio without making a fuel stop—well, maybe the price isn't so bad after all.

Up-to-date information about ordering the Moodymobile may be obtained from Moody and Shetley at Performance Proven Inc., Box 178, Oak Hill, Fla. 32759.

Incidentally, Moody and Shetley are building a two-passenger roadster with a fiberglass body. The car weighs 1450 pounds. Its mpg?

Would you believe 150?

"We guarantee it," Shetley states flatly. **PM**

34-MPG AUDI 5000 DIESEL

(Continued from page 43)

few days of his life sitting stupefied, pedal to the metal, while the speedometer needle slouches slowly toward 90.

If you're new to diesels, your passing technique for two-lane roads would benefit from studying stock-car sling-shot maneuvers. Jack-rabbit starts, like 50-cents-a-gallon diesel fuel, you can forget.

No vibro-massage

Tuning out diesel engine vibration is an art carved in rubber. Engine mounts for the new five-cylinder diesel are hefty enough so the seat of your pants won't tell you that you're driving a Mack, when the badge and the velour say Audi. Un-

(Please turn to page 158)



the
best darn
STUDFINDER
in the world

All the tools you've ruined because of striking a hidden nail could have been saved if you owned a Conover Metalspy.

This remarkable electronic tool can find hidden nails in boards, or pipes and wires buried in walls. It's also the world's best studfinder! Metalspy scans a six inch wide area, which is the largest of any tool on the market. Adjustable sensitivity, however, allows pinpointing metal objects to within a half inch circle.

Conover Metalspy comes to you with nine-volt transistor battery, complete instructions and warranty card. Don't chance ever again striking a nail with one of your valuable tools. Buy Metalspy today!

Conover:

Send me _____ Metalspy metal detectors @ \$15.95 each (One resident add 4% sales tax)

_____ Just send me your latest catalog of Conover unique handmade tools.

_____ Check or M.O. _____ Mastercharge _____ Visa

Card No. _____ Exp. Date _____

Name _____

Address _____

City _____ State _____ Zip _____

Conover Woodcraft Specialties
18125 Madison Road, Parkman, Ohio 44080
Phone: (216) 548-5591

"ROAD GLUE."



BOBBY
UNSER

2 TIME
USAC CHAMP

"KYB Gas-a-just Shock Absorbers give you superb control, even around sharp curves or over rough roads. You feel like you're glued to the road."

"I know, I use them on my personal cars and trucks."

Find shocks to fit most cars, light trucks, and vans where you buy parts.

Gas-a-just

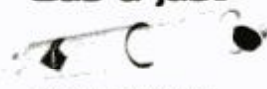

Write for free brochure:

KYB

KYB CORPORATION OF AMERICA
207 Eisenhower Lane South
Lombard, Illinois 60148

Built under license of Dr. deCarbon system.

Select Your LOG HOME



Use your custom plan or select one of ours. Cedar or Pine Log homes, leisure homes, and cabins from \$3900. Plan book \$3.50. Dealership information pack \$5.00.

Wilderness Log Homes

Route 2-PMC89 Plymouth, WI 53073

Please send Plan Book \$3.50 Dealership Info. Pk. \$5.00

Enclosed is \$ _____

Name _____

Street _____

Town _____

State _____

Zip _____

NEVER BUY GAS AGAIN!



CALL FREE
800-257-7955

Free
Booklet

ELECTRIFY YOUR BIKE!

PEDALPOWER exciting new bike drive tames tough hills. Be independent. Shop when you want. Fits all Bikes, Adult Trikes. Installs in minutes. Thousands sold. Recharges overnight. Travels 100 miles for a dime.

MONEY BACK GUARANTEE.

Call toll free: 800-257-7955*

Or send today for

FREE ILLUSTRATED BOOKLET.

General Engines Co.

5387 Mantua Blvd.

Sewell, N.J. 08080

*In N.J., Alaska, or HI. Call Collect: (609) 468-0270

Create a Family Treasure as Thousands Have Since 1916

Handcrafted by our own grandfathers, our grandfather clock kits are semi-assembled, easy-to-build, of solid 3/4" walnut, cherry, mahogany or oak. Kits include beveled glass. We handcraft our spun brass Lady Florentine and Goddess Diana Lyre pendulums. Tubular bell or Westminster rod chimes. Hand painted moon wheels. Send \$2.50 for 3 plans, AMERICAN CLASSIC, SPIRIT OF MOUNT VERNON and SPIRIT OF THE CENTURY, plus full color literature of all kits and movements.

KUEMPEL CHIME CLOCK

PM-98

21195 Minnetonka Blvd.,
Excelsior, MN 55331.



DRIVING THE 34-MPG AUDI 5000 DIESEL (Continued from page 157)

fortunately, you're made aware of this soft drive-train mounting by the violent whipping of the five-speed shift lever in your right hand when you do not accelerate and decelerate very smoothly.

Other adjustments you have to make at the wheel of the 5000 Diesel are twofold: Cold starts require a brief wait while glow plugs warm up things in the five cylinders for the low-volatility diesel fuel, and you have to get used to the fine-tune control for idle speed. This idle speed adjuster is a knob to the left of the steering column on the lower edge of the dash. It's designed to increase idle speed for cold starts and can also be used to fine-tune idle in city traffic, if you're especially sensitive to a slight diesel clatter at one specific rpm range or other.

VW's diesel family

The diesel Five is the latest in Volkswagen's family of in-line diesel powerplants (Audi is one of the car lines in the VW family). The first to be introduced was the Four currently used in Rabbit and Dasher models. It's a derivative of the gasoline Four.

The Five, too, is a "gas-block" diesel that has its origins in the gasoline Five developed specifically for the 5000 sedan. A Six is in production for light trucks and is for sale to other European automakers. We'll soon see the Six here in a Volvo sedan.

The Five uses a swirl chamber lo-

cated above the cylinder proper where fuel ignites instantly upon being injected. Ignition is caused by the intense heat in the chamber, the air there having been squeezed hot by the 23-to-1 compression ratio.

The swirl chamber design allows complete burning of the fuel for lower emissions and good economy, lower loads on drive-train components and, as we found on the Autobahn, very smooth and quiet running. Long engine life is also an expected benefit, and Audi appropriately places no mileage limit on its 12-month new-car warranty.

Supply, demand and dollars

Audi's supply of diesel versions this year will be only one for every four 5000s imported. PM expects the demand to exceed this supply and result in some shifted production schedules back in Ingolstadt. Demand would be higher still if the diesel were to be made available in California.

Audi has elected not to market the car there because of the prohibitive expense in meeting California's requirements for emissions certification of diesels, which are reported to be more stringent than the federal standards.

Prices for 5000 models start at \$9725. The 5000S, with Audi's luxury package, is \$11,360. The 5000 and 5000S Diesels are \$10,475 and \$12,110, respectively, reflecting a \$750 premium on the diesel Five engine. **PM**

AUDI 5000 DIESEL SPECIFICATIONS

Engine

Type: 5-cylinder, in-line
Bore: 76.5 mm (3.12 in.)
Stroke: 86.4 mm (3.40 in.)
Displacement: 1986 cc (130.8 cu. in.)
Compression ratio: 32.0:1
Horsepower (SAE net): 67 at 4600 rpm
Maximum torque (SAE net): 123 NM at 3000 rpm

Engine design

Cylinder block: Cast iron, tilted 27°
Cylinder head: Aluminum alloy
Valve arrangement: Belt-driven single overhead camshaft
Cooling system: Water-cooled, thermostatically controlled electric fan
Fuel system: Mechanical fuel injection with automatic controlled warm-up provision

Electrical system

Battery: 12-v./88-amp. hr.
Alternator: 55 amp. maximum
Firing order: 1-2-4-5-3

Drive train:

Type: Front-wheel drive
Clutch: Single, dry disc, hydraulic
Transmission: 5-speed, fully synchronized
Gear ratios: 1st, 3.60:1; 2nd, 2.12:1; 3rd, 1.36:1; 4th, 0.96:1; 5th, 0.778:1; reverse, 3.50:1; final drive, 4.30:1

Chassis and suspension

Frame: Unitized construction
Front suspension: Independent MacPherson struts with coil springs, single control arm, stabilizer; negative roll radius

Rear suspension: Torsion crank-axle, panhard rod, stabilizer; coil-spring struts

Foot brakes: Hydraulic dual-diagonal, power-assisted vented discs, front; finned drums, rear (self-adjusting)
Hand brake: Mechanical, on rear drums
Total brake-swept area: 76.4 sq. in.

Wheels

5½Jx14 (6Jx14 alloy wheels optional)

Tires

185/70 HR 14 steel-belted radials

Steering

Type: Rack-and-pinion, power-assisted
Turning circle: curb to curb, 33.8 ft.
wall to wall, 37.4 ft.

Capacities

Engine: 5 U.S. qts.
Transmission and differential, 5.5 U.S. pts.
Fuel tank: 19.8 U.S. gal.
Cooling system: 8.5 U.S. qts.
Trunk: 22.6 cu. ft.

Dimensions

Wheelbase: 105.7 in.
Front track: 57.9 in.; rear track: 56.9 in.
Overall length: 189.4 in.
Overall height (unloaded): 54.8 in.
Overall width: 69.4 in.
Curb weight: 2899 lbs.

Fuel consumption:

City: 26 mpg; highway: 34 mpg

PM LOOKS AT NEW ENERGY-SAVING LAMP

A new, long-life, screw-in fluorescent light lets you replace incandescent bulbs *and* save energy. The 44-watt Circlite provides the same amount of light as a 100-watt incandescent bulb—and also matches its warm color. Adapter and tube will pay for themselves during the first three years of use.—*J.P., H.W.*



Light "wheel" fits over adapter. Plug-in spoke slides forward to engage adapter.



With power cord disconnected and lamp's harp removed, screw adapter into socket.



Harp is replaced to fit between spokes. Light may be rotated slightly to suit.



With shade replaced, 10-in.-dia. fluorescent tube gives even light distribution.

SPECIFICATIONS—CIRCLITE

Lumens: 1750
 Estimated life, fluorescent tube: 7500 hours (about 3 yrs.)
 Estimated life, adapter/ballast: 50,000 hours (about 27 yrs.)
 Weight: 1.6 lbs. (tube and adapter)
 Price: Will retail for \$18 to \$20 at department, discount, drug and hardware outlets in September '79.
 Maker: General Electric Co., Nela Park, Cleveland, Ohio 44112.



CRUEX® RELIEVES JOCK ITCH

**Chafing, Rash and Other
Annoying Groin Irritations.**

Itching? Chafing? Rash? Get fast relief with Cruex, the leading Jock Itch product in America. Cruex soothes. Relieves. And it's medicated to fight the causes of Jock Itch.

Use medicated Cruex spray powder or squeeze powder for easiest application, or Cruex cream for more concentrated medication. Use only as directed.

Get Cruex. There's nothing like it for Jock Itch.

© PENNALT CORPORATION 1979

(Continued from page 63)

We asked owners to list the aspects of their Pintos they liked best or enjoyed most. Here's a representative sampling.

A California electronics assembler: "My wagon handles real well on corners. It's a handy size, sporty, economical."

A Georgia weapons mechanic: "The 2.3-liter Four has a lot of punch with the four-speed, and its gas mileage is good. I get 29-30 mpg on the highway. The Pinto also has a nice ride, and the 1979 models are pleasing to the eye."

An Ohio teacher: "It's easy to drive, very cooperative. And roomy inside. It looks sportier than previous models. The car suits my needs and I enjoy it."

An Alabama cotton-mill worker: "It handles like a big car, but maneuvers like a little one. I also like the styling."

And a professional auto mechanic from Florida: "Pintos are inexpensive and durable. This is our third one."

We also asked owners to list those things they don't like about their cars. Again, here's a cross-section of responses.

A Florida naval officer says, "The back seat is of little value, and the pressed cardboard cover over the spare tire in my Pinto wagon seems like an insult!"

A New York librarian: "My gas mileage isn't so good as I'd expected—only 14 around town and about 21 on the highway. The dealer says it will improve, though, as the car gets broken in."

And an Illinois student: "Needs more sound insulation; too many rumbles and rattles for a brand-new car. Goodness



Almost all buyers chose 2300-cc Four, gave it good marks for punch and economy.

knows, Ford has had enough years to work these out."

Owners suggested any number of changes that might improve their cars. Some of their recommendations included the following:

"Put a turbocharger on the option list," proposes a Kentucky lab technician.

"Make a five-speed overdrive transmission optional," seconds a Michigan grocery clerk.

An Ohio student: "Add hidden storage compartments in the Runabout and wagon to make them less vulnerable to theft." A Texas chemist: "Change the oil-filter angle, so oil doesn't spill when the filter drops down." An Arizona building inspector: "The rear-view mirror is too low on the windshield."

Front-seat comfort in the Pinto was generally judged *good to excellent*, although we did hear complaints about the lowness of the front buckets and the height of the seatbacks. Short drivers said it was difficult to see out over the dash sill, and even harder to grab a quick glance over their shoulders.

Rear-seat legroom and the bucketish shape of the rear "bench" made this area comfortable only for children. Even so, most owners anticipated this when they bought their Pintos. The folding rear seatbacks in wagons and Runabouts were roundly praised.

Workmanship was judged *good to excellent* by 41.9 percent of our respondents, as against 76.4 percent for the Dodge Omni and 75.2 percent for the

You'll have to take care of rust now or later...

and when that time comes, you'll want **Derusto Minute Finish Spray**. Derusto puts a special rust-inhibitive primer in the color. That means each application primes, beautifies and gives extra protection against corrosion. You can use it to renew rusted lawn furniture, wrought iron and mowers. It dries quickly to an attractive high gloss, and there are 17 colors plus white to choose from. It's also available for brush-on application.

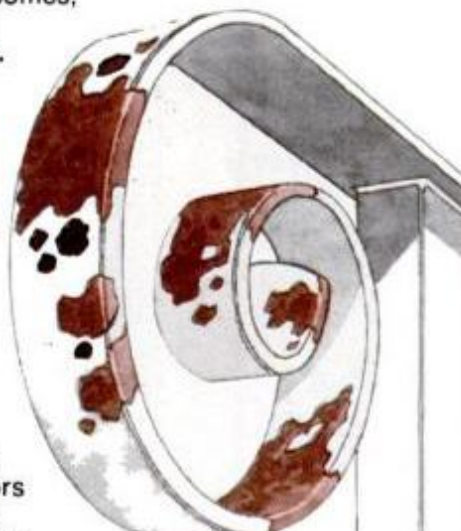

Derusto makes other special paints for your needs. To prime and protect gutters and downspouts, apply **Derusto Galv-A-Grip™**. It covers in one coat. And it won't crack or peel like ordinary paint. To prevent or stop rust on metal surfaces, use **Derusto Protective Coating**. The built-in, rust-inhibiting primer lets you protect with each semi-gloss coat. To renew rusty, weathered barbecue grills and hoods, ask for **Derusto Barbeque Black Spray**. A special heat-resistant paint, it dries quickly to a black matte finish.



and when you do...
all you gotta know is

DAP
Derusto

© 1979 DAP Inc. DAP and Derusto are trademarks of DAP Inc. DAP Inc., General Offices: Dayton, Ohio 45401/Subsidiary of Plough, Inc.

AMC Spirit. So praise in this area wasn't overwhelmingly in favor of the Pinto.

An Illinois real estate agent comments, "Why can't Americans make a *smooth* four-cylinder engine? The Japanese do it every day." An Illinois broadcaster: "I notice rough welds on the dashboard, tar spots on the seats, an ill-fitting decklid, and glue runs on the door panels. I'd call that average-to-fair workmanship."

And a record of 40.8 percent of our sampling told us they would not buy another Pinto next time. That's higher than any such response in recent memory. However, it can't be taken as a direct comment on the car—most Pinto owners said their families would have grown, and their needs would be different by the time they'd want to replace this car. Many mentioned that they definitely were inter-

ested in a larger Ford product.

A Michigan housewife exudes, "Yes, I'll buy another Pinto—I just love mine. It's exactly the right size. In fact, my only complaint is that I can't keep it home."

And a Minnesota computer programmer: "Yes, I'll take another Pinto—this is my fourth one. I drive 80-plus miles a day and make car payments out of fuel savings. I used to drive a gas guzzler." **FM**

SUMMARY OF 1979 FORD PINTO OWNERS REPORTS*

Total miles driven 658,355	Specific likes:	Comfort opinion (front seats):	Dealer service opinion:
Average miles per gallon:	Economy 51.7%	Excellent 21.6%	Excellent 17.8%
2.3-liter Four	Handling 36.9	Very good 32.1	Good 30.4
In town 20.3	Styling 32.2	Good 28.4	Average 13.3
Long trips 25.2	Comfort 14.1	Fair 14.8	Fair 14.8
2.8-liter V6	Size 13.4	Poor 3.1	Poor 23.7
In town 19.3	Specific dislikes:	Comfort opinion (rear seats):	Number of vehicles owned:
Long trips 23.5	No complaints 22.4%	Excellent 5.4%	One car (Pinto only) 39.2%
Body style choices:	Gas mileage lower than expected 11.9	Very good 10.2	Two cars 47.5
Two-door sedan 46.5%	Workmanship 9.1	Good 31.3	Three cars 7.6
Station wagon 30.3	Rattles and noisiness 7.7	Fair 28.6	Four or more cars 5.7
Three-door Runabout 23.2	Rough ride 7.7	Poor 24.5	Makes of other cars owned:
Engine choices:	What changes would you like?	Had any mechanical trouble?	Ford 38.5%
2.3-liter Four 95.5%	No changes 12.9%	No 55.3%	Chevrolet 22.9
2.8-liter V6 4.5	Different seat height 12.2	Yes 44.7	Buick 8.3
Transmission choices:	Better workmanship 7.5	What type of trouble?	Dodge 8.3
Four-speed manual 62.2%	Better gas mileage 7.5	Carburetor 14.3%	Age distribution of owners:
Automatic 37.8	Better quality materials 7.5	Transmission 11.4	Under 20-29 years 35.1%
Why did you choose the Pinto?	Workmanship opinion:	Airconditioner 7.1	30-49 years 38.3
Economy 47.5%	Excellent 11.7%	Sticky gas pedal 7.1	50-plus 26.5
Price 28.1	Good 30.2	Oil leaks 7.1	Would you buy another Pinto?
Size 18.1	Average 24.1	Dealer repairs satisfactory?	Yes 59.2%
Past experience 16.3	Fair 22.2	No 52.5%	No 40.8
Styling 15.6	Poor 11.7	Yes 47.5	

* Percentages might not equal 100% due to rounding or insufficient data.

Black & Decker announces the amazing Jack Rabbit hand pump.

It pumps or sprays almost anything.

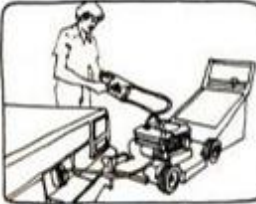

With a Jack Rabbit, you never need to keep gas cans around your house. Just pump fuel directly from your car to your lawnmower. Or from one car to another.



The Jack Rabbit pumps water out of hard-to-get-at places in boats. And it comes with an extra-thin intake tube that will pump oil directly out of inboard engines.

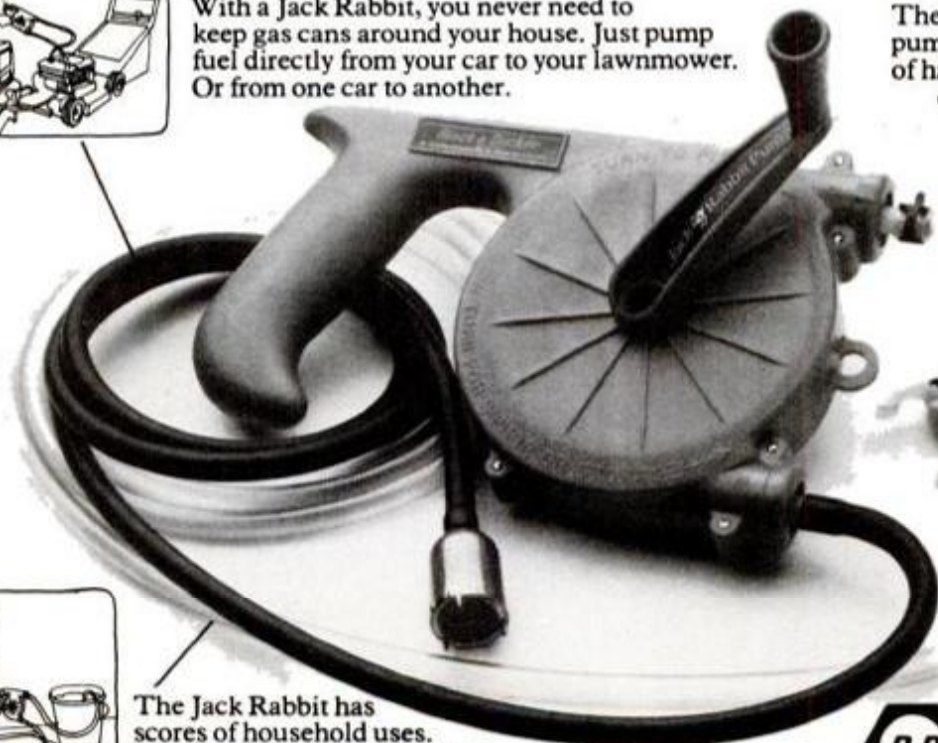

The Jack Rabbit has scores of household uses. It gets water—or any liquid—out of hard-to-reach places.



Every Jack Rabbit comes with a sprayer nozzle to spray liquid fertilizers or insecticides on gardens, shrubs, anything.

B-D Black & Decker
Towson, Maryland 21204.

Confidential loans to build that project you've always wanted.

Up to \$5,000.

Whatever your dream may be. A workshop. Perhaps an airplane. Or anything else. Home Credit can help make that dream come true now. You can get a personal, private loan for as much as \$5,000. Just pick-up the phone and call toll-free anytime. Or write, sending name, address, zip code, phone number, and tell us the best time to call you, in confidence. Call now. The lines are always open at 800-551-6572. (In Louisiana call collect (318) 335-1162, 8 a.m.-8 p.m.)



HOME CREDIT COMPANY

190 South 10th Street, Oakdale, LA 71473

Name _____

Address _____

City _____ State/Zip _____

Telephone () _____

1C-PM 8/79

New ways with nylon-cord lawn trimmer



This year's selection of nylon-cord lawn trimmers features new models with power increase switches, improved nylon cutting

cords and automatic line feeders. They can tackle even tougher yard chores and some cost less than last year's models.

Nylon-cord weed and grass trimmers are a good buy in '79—PM tells you what to look for.

by Glenn S. Hensley

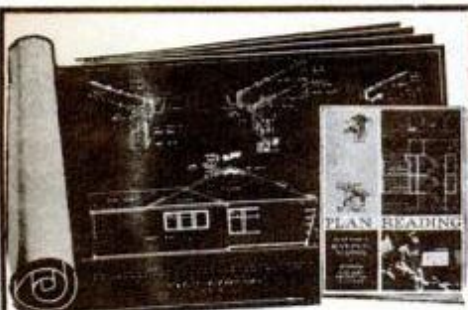

FREE BLUEPRINTS and TRIAL LESSON —for your greater success in Building

Beginners, craftsmen, even foremen and superintendents, have sent for these free blueprints and trial lesson in Plan Reading as a means of trying out Chicago Tech's home-study Builders training. Learn how you can master Plan Reading—Estimating—and the practical details of all types of construction in your spare time at home. Mail coupon below or phone TOLL FREE—see how you, too can prepare for a better job—higher income, or start your own contracting business.

• PHONE TOLL FREE (24 HRS.)
1-800-528-6050 Ext. 810

CHICAGO TECH/School for Builders
2000 S. Michigan Avenue, Chicago, Ill. 60616

CHICAGO TECH/School for Builders
Dept. PM-89 2000 S. Michigan Ave.,
Chicago, Ill. 60616

Veterans
Check
Here

Please mail me a Free Trial Lesson, Blueprints and Builders Catalog. I understand there is no obligation—no salesman will call.

NAME _____ AGE _____
ADDRESS _____
CITY _____ STATE _____ ZIP _____

In these days of constantly soaring prices, there's something you can buy today that's actually better than before, but sells for less money than it did last year. That useful product is a nylon-cord weed and grass trimmer.

A year or so ago, one popular light-duty electric trimmer that would cut an eight-in. circle would have retailed for \$29.95. You can buy an improved model this year for about \$15. Prices then range upward to close to \$300 for a gasoline trimmer/edger that will handle the toughest tasks.

To handle most of the trimming chores in a fair-sized yard, choose

one of the middle-of-the-line machines which range in price from \$40 to \$70. This is also less than comparable models cost a year ago.

Manufacturers explain that increased competition has made "cost adjustments" necessary, but the decrease in price can also be attributed to the fact that those manufacturers have amortized their start-up and tooling costs. In addition, some of them have boosted volume so extensively that unit costs have come down.

Using trimmers

If you've never owned or used a monofilament line weed trimmer, you're in for a pleasant surprise the first time you get your hands on one and flip the switch.

Line trimmers cut grass, weeds

A veteran weed fighter, the author is the editor of *Farm and Power Equipment*, a publication that serves farm and power equipment dealers.

Материал, защищенный авторским правом

Careful cutting in tight spots



New units with power-increase switches at full throttle can chip finishes from wood surfaces. Be careful to avoid marring surfaces.



Trimmers work well in tight spots, but prolonged use against concrete eats cord away and requires frequent line replacement.



Cleaning cracks and edging walks takes practice. You'll appreciate automatic line feed while you are working on jobs like these.

and other vegetation with a spinning cord of specially treated nylon monofilament line, spinning up to 12,000 rpm. In all units, the line is carried in the cutting head. As use shortens the cord, more can be fed out either automatically or pulled out manually. The line guards contain automatic built-in line cutters.

The units work easily and efficiently along walls, around rocks, trees and posts, under fences and shrubs. They are also adept at reaching into tight corners and awkward places where your lawnmower can't go, yet they do all this while you stay comfortably on your feet. There's no need to crawl around on your knees.

Designed so that the motor and shaft are protected from impact and stalling, they will work up against walls, walks and masonry with no danger of gouging. As a result, nylon cord trimmers will help you handle a variety of lawn trimming chores with speed, freedom and safety.

Most of them are electric-powered and require almost no maintenance. With no blades to sharpen, you can forget that chore. The majority of models don't even require lubrication. They are quiet, nonpolluting, easy to store, always ready and an extremely safe power lawn tool.

Be careful, though, for the spinning cord is still capable of flinging a small pebble or an occasional stick. No nylon-cord trimmer, however, will cut off a finger or a toe, nor will it slice its own electric cord.

Don't try to mow large patches of grass with your electric trimmer. It's just not meant for that task. Neither will it trench as neatly and precisely as steel-blade edgers.

New for trimmers in 1979

As with all new products, second and third generations benefit from

the field testing of earlier units. As a result, trimmer engineers and designers have eliminated miscellaneous bugs and problems that cropped up in previous years' units. Production procedures and quality control have been refined this year.

It appears that cutting lines are better for 1979, too. Manufacturers claim they are tougher and longer-lasting and that you will have a wider choice of cutting diameters.

For 1979, motors are said to be better than before. You'll notice not much is ever said about horsepower in connection with trimmer and edger motors when classifying them into large, medium and small units. There's a reason. Most units show a horsepower rating somewhere on their name plates, but unfortunately, these figures give you no accurate guide to their comparative performance. Different types of motors are rated differently. Advertised horsepower, torque, peak load, ampere ratings and the like can be misleading. Your best guide to a trimmer's performance is the size circle it is designed to cut. You can safely assume that a unit built to cut a 16-in. circle will outperform one that is designed to trim a 12-in. circle.

You can also get a clue from the size cutting cord. Trimmers built for prolonged, heavy cutting have cords of .065-in. dia. or larger.

Some of the confusion about horsepower ratings comes from the different types of electric motors used on cord trimmers. Many of the early models were built around permanent magnet motors. Those who use them claim that a permanent magnet motor produces expected torque at lower revolutions per minute, uses less current and is highly resistant to burn-out.

The horsepower rating of a perma-

nent magnet motor reflects the power output the motor can maintain indefinitely. This is the actual working speed. Other types of motors, though, are rated at the maximum horsepower they achieve only at peak output. Thus, it is possible that a permanent magnet motor rated at .4 hp may well outperform another type rated at $\frac{3}{4}$ hp.

Choosing a line trimmer

You have a dazzling variety to choose from in line trimmers for 1979. More manufacturers are getting into this growing field and they offer a wider range of sizes, prices and designs. Machines are available in electric, gasoline and cordless models.

Industry statistics show that there may be as many as 12 million cord trimmers now in use. So well accepted has been the cord trimmer that manufacturers are gearing up to deliver about 11 million more units in 1979 and 1980. If you'll be one of those 11 million purchasers, here are some tips to help plunk your credit card down for the right machine.

The larger ones, which cut a circle of 15 to 16 inches and which use a cutting cord of .065 in.-dia. or heavier, will trim all grass with ease and make quick work of heavy weed patches. They have the power and heavier cord to enable them to scalp through grass right down to bare ground. They'll edge your walks and curbs, even dig a trench when the earth is soft. Some are actually three tools in one, with interchangeable heads and can convert from line trimmers, to edgers, to metal-bladed saws to thrash through weeds or lop off limbs.

Due to their weight of 8 to 12 lbs., most of them are equipped with a helper handle to provide two-hand control. Toro's heavy-duty line trimmer, for instance, has a fully adjustable support handle.

Many of this year's large models have a feature that doubles the usable power of the unit to provide instant extra muscle for particularly tough cutting chores. Be careful when you use such a power booster, for the machine can raise painful welts on bare skin and even sting your toes if you allow it to whip over light shoes.

Try them out

When you try various machines at a dealer's store, you can get a good feel for the actual power of a trimmer equipped with a booster by running it at normal speed, then flipping on the power-increase switch.

(Please turn to page 164)

We scaled down the weight, put steel where it counts, developed a brilliant SL·II. finish, and wrapped it all up in a new package called **Steel·Lite II.**

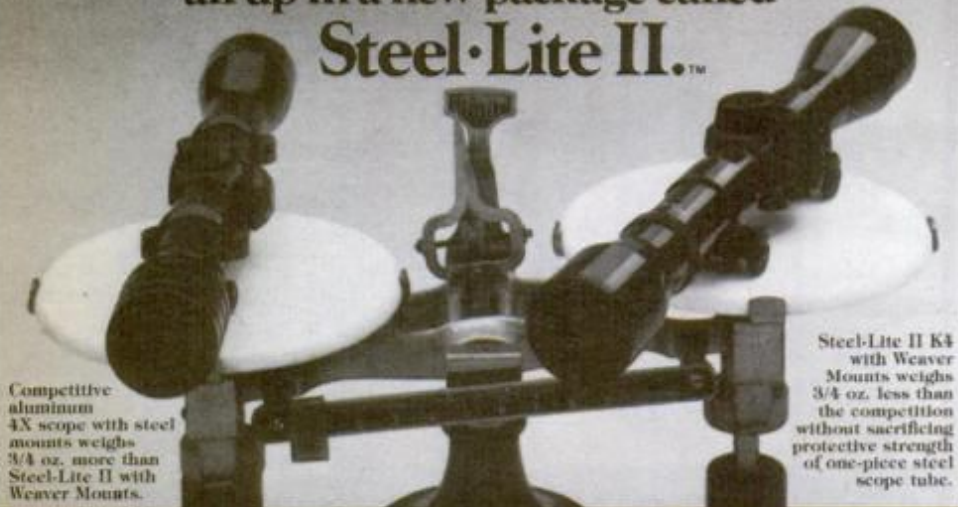

Competitive aluminum 4X scope with steel mounts weighs 3/4 oz. more than Steel-Lite II with Weaver Mounts.

Steel-Lite II K4 with Weaver Mounts weighs 3/4 oz. less than the competition without sacrificing protective strength of one-piece steel scope tube.

When you consider Weaver's Micro-Trac® Adjustment System, optical precision, improved fogproofing, and meticulous quality control, we think you'll agree: Steel-Lite II is an all-around winner in performance and style.

See the complete line of Weaver's fixed power, variable, and wider-view scopes at your nearest dealer. Ask for Steel-Lite II in '79.



Weaver Scope

A new dimension in American Craftsmanship.

For complete, full color 1979 catalog, send 50¢ to: W. R. Weaver Company, Dept. 91, El Paso, Texas 79915.

Build This Popular Mechanics Air Compressor.

It adds a new dimension to your home workshop.



When you build the rugged Popular Mechanics air compressor, you'll get one of the most versatile shop tools around. It's a tough workhorse that can tackle jobs you never dreamed of doing before — riveting, sandblasting, spray painting, inflating and countless other projects. And, unlike ordinary compressors, the PM air compressor can evacuate your car's air conditioning system. But best of all, it's affordable. With plans from the Popular Mechanics Plans Library, you can build the PM air compressor yourself and save up to \$200.

Send today for your Popular Mechanics Air Compressor plans, and add a new dimension to your workshop. Only \$5.95 (add 75¢ for first-class mailing).

Send check or money order to: 879
Air Compressor, Popular Mechanics Plans Library,
Box 1014, Radio City Station, New York, NY 10019.

(Make checks payable to Popular Mechanics.)
Please send me _____ sets of Popular Mechanics air compressor plans at \$5.95 each (add 75¢ each for first-class mailing). I enclose my check or money order for _____

Name _____

Address _____

City _____ State _____ Zip _____

Please allow four to six weeks for delivery.

Popular Mechanics is a publication of Hearst Magazines, a Division of THE HEARST CORPORATION

NYLON-CORD LAWN TRIMMERS

(Continued from page 163)

On better units, the surge of extra force will be obvious.

Choose a large unit only if you have a big yard and need it for use along walls, chain link fences, around rocks and trees. Prices for these models can be expected to range up to about \$80.

There are even several models that fit onto chain saws in place of bar and chain. One conversion unit, made by Weed Eater, weighs less than 6 lbs., cuts a 17-in. swath and sells for \$70.

Medium-size trimmers cut circles of 10 to 13 inches. You'll find most of these use cutting cords of .051-in. dia. They'll do the same work as the larger units, but do it slower. They're lighter and easier to handle, weighing between 3 and 5 pounds.

How automatic feed works



During average use, especially when unit is used near abrasive surfaces, the trim line becomes shorter and shorter.



With an automatic line feed feature, you merely have to tap the unit head lightly on the ground to release more line.



As the fresh cord is fed out from spool, it is cut to proper length by a blade that is affixed to the trimmer's safety shield.

Материал, защищенный авторским правом



35-mm prototype lacks many of the niceties production models will have.

effect was impressive, although somewhat eerie. I could push my finger "through" the parts of the picture that seemed to appear in front of the picture plane.

The photos also had good depth of field, good detail and sharpness, and generally compared favorably with conventional snapshots. Nimslo does not seem to have greatly sacrificed any important conventional qualities for the sake of 3-D. In fact, Nims claims his prints show less grain than 2-D prints. (Unfortunately, because of the plastic coating, it's not possible to reproduce one of the pictures in PM.)

The photos were not perfect, however. Unless a print is held steady, certain parts of the picture may seem to shift back and forth. And those portions that are out of focus are more annoying to the eye than they would be in a conventional photo.

Early efforts at 3-D

The magnitude of the Nimslo achievement should not be understated, however. Previous attempts at 3-D photography have been only slightly successful. Early systems required special viewers. Near the turn of the century, French scientist Maurice Bonet made 3-D pictures that needed no viewer, but required a one-ton camera that moved on a semicircular track. Also, much of the picture was out of focus.

Other efforts worked along similar lines. In the mid-sixties, Cowles Communications, Eastman Chemical and Harris-Intertype developed the X-ograph process (remember the 3-D covers of *Venture* magazine?), but the camera was still big; the pictures still contained unacceptably blurred areas.

The natural question arises: Why should Nimslo succeed where others failed? They claim they were able to learn from mistakes of others, and to

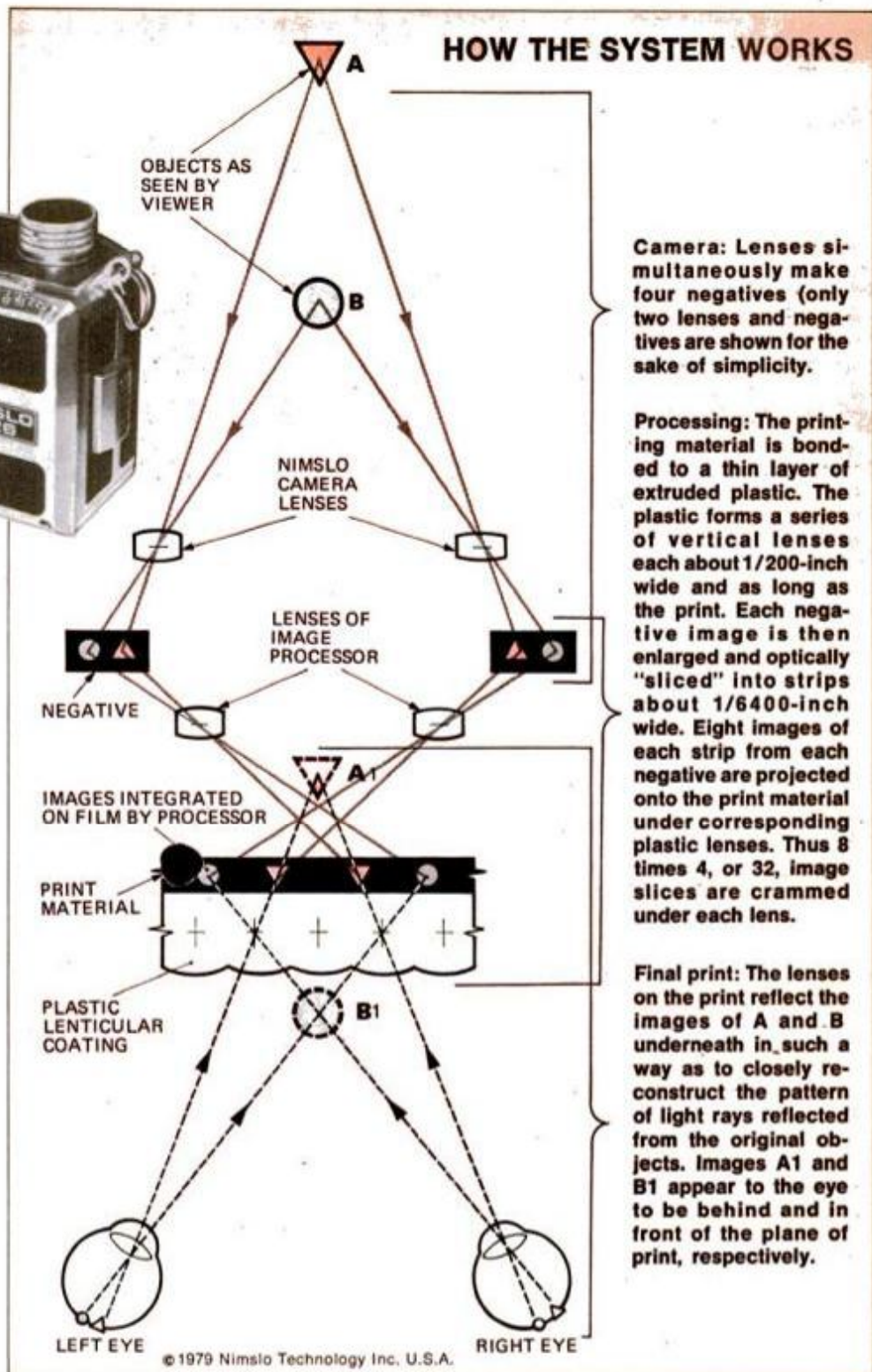

HOW THE SYSTEM WORKS

Camera: Lenses simultaneously make four negatives (only two lenses and negatives are shown for the sake of simplicity).

Processing: The printing material is bonded to a thin layer of extruded plastic. The plastic forms a series of vertical lenses each about 1/200-inch wide and as long as the print. Each negative image is then enlarged and optically "sliced" into strips about 1/6400-inch wide. Eight images of each strip from each negative are projected onto the print material under corresponding plastic lenses. Thus 8 times 4, or 32, image slices are crammed under each lens.

Final print: The lenses on the print reflect the images of A and B underneath in such a way as to closely reconstruct the pattern of light rays reflected from the original objects. Images A1 and B1 appear to the eye to be behind and in front of the plane of print, respectively.

© 1979 Nimslo Technology Inc. U.S.A.

assemble enough experts in enough different fields to solve the "three-dimensional jigsaw puzzle."

The first Nimslo amateur camera, which will probably be marketed in Europe next year, will use 35-mm film and have a programmed-shutter for automatic exposure control and fixed-focus lenses. According to Nimslo, however, future cameras can have variable focus, variable aperture and even interchangeable lenses. In fact, any feature conventional cameras have can be put on the Nimslo, according to the company. "Technical barriers are not a problem," Lo says, "what we put on the cameras will be the result of a marketing decision." Similar logic

would apply to the introduction of a 110 Nimslo camera.

The Nimslo process can handle both prints and transparencies. In fact, for the last three years, Nimslo has been test marketing a system closely related to their amateur process, called Computrak, that makes 3-D pictures with any standard 35-mm camera. From 6 to 11 negatives are required for a given picture, however, so its applications are limited. But the principles that led to the development of Computrak comprised the breakthroughs needed to produce the Nimslo camera.

Nimslo's first venture into the 3-D
(Please turn to page 168)

Sharpen your chain saw like a pro!

This revolutionary chain saw sharpener grinds a razor sharp edge on any size chain saw using a specially made grinding wheel. All you supply is a 1/4" electric hand drill. The *Pro Sharpener** assures the correct grinding angle and a built-in gauge maintains the proper guide height.

The *Pro Sharpener* produces a ground edge—much sharper than a filed edge. Comes complete with three grinding wheels (enough for up to 30 sharpenings) plus a hand file adapter.

*Patents pending

\$12.95

Pro Sharp Corporation
P.O. Box 11378
Newington, Ct. 06111

Please rush *Pro Sharpener(s)* at \$12.95 each plus \$1.95 postage and handling per unit (\$3.00 outside U.S.) Send check, money order or Master Charge. No C.O.D.'s.

M.C. # _____

Inter Bank No. _____ Exp. Date _____

Conn. Residents add 7% sales tax.

Name _____

Address _____

City _____ State _____ Zip _____

Important: To insure correct grinding wheel size

Indicate your Chain Saw Mfg. _____

Saw Model: _____

30 Day Unconditional money back guarantee.

PM-89

3-D CAMERA

(Continued from page 167)



Computrak 190 (top), forerunner of Nimslo system, allows 3-D photography with conventional cameras. Pictures are taken at precomputed points on track (below).

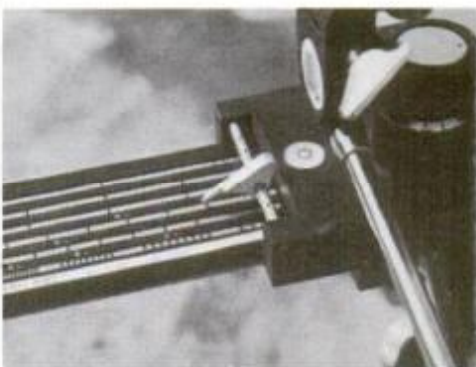

market in the United States could be in the portrait field, where they will find a growing number of competitors. Nims claims they all use variants of the X-ograph or other older processes. Nimslo's portrait cameras are expected to be more like their 35-mm prototype than like the large, bulky units of the others. A competitor, Walker Color Inc., is said to be working on an amateur camera, as well.

Improvements ahead

The quality of the Nimslo prints is good, but needs improvement. "The pictures you've seen are still prototypes. We're working on a number of mechanical developments, and a lot of improvements will be happening," Nims says. For example, the company currently has photos with 300 lenses per inch, instead of 200.

When will you be able to buy a Nimslo camera in the United States? Probably within a year, assuming things go well in Europe. How much will it cost? Between \$200 and \$400, depending on extra features. Prints should cost about 50 cents for a 3 1/2 x 4 1/2 in color. Will it be worth it? Nimslo thinks so.

PM

A Revolutionary Sleeping Experience



The Original Velveteen



\$49.95
from

Lightweight...Sensual...Adjusts to your comfort. An experience in rest or play unmatched by any other support structure. Takes the seasickness, immobility, and weight out of waterbeds, yet offers the same "give and take" sensation. Two people can sleep on a full, queen or king size bed undisturbed by the other's movements. The air coil construction, with multiple controlled air chambers, supports your body evenly and independently.



The AIR BED is the most revolutionary and luxurious way to spend a third of your life. You are gently but firmly supported by 100% air instead of metal springs and stuffing. Many chiropractors agree the structured Air Bed has unprecedented orthopedic value as a permanent mattress.

Store it on a shelf, take it camping, use it in your van, boat, summer home, on a floor or in a frame. Sunbathe and float on it. All 8" high standard sizes: Twin-39"x74", Double-54"x74", Queen-60"x80", King-74"x80". Inflates in minutes with any air pump or canister vacuum. (Bed comes with adapter) Durable 20 gauge poly vinyl cleans with soap and water. Repair kit included. High Powered Air Pumps. AC pump operates from standard electrical outlet. DC pump operates from auto cigarette lighter. \$29.95 each.

Do not be confused by inferior imitations. This is the original, permanent, red velveteen airbed...once priced as high as \$119.95. Try it for 10 days at our expense. If you are not satisfied, return it within 10 days for a refund.

Please send me the following AIR BED(S):

- Twin-39" x 74" (Item 2339) \$49.95
 Full-54" x 74" (Item 2354) \$89.95
 Queen-60" x 80" (Item 2360) \$79.95
 King-74" x 80" (Item 2374) \$99.95

Add \$4.95 per bed for shipping and insurance.

- AC Air Pump (Item 0004) \$29.95
 DC Pump-plugs into auto cigarette lighter. (Item 0005) \$29.95

Illinois Residents include 5% sales tax.

- Check or M.O. Enclosed
 Charge My Credit Card:
 American Express Mastercharge Carte
 Bank Amer./Visa Diners Club Blanche

Card No. _____ Exp. Date _____

Name _____

Address _____

City _____

State _____ Zip _____

Signature _____

PMCC-213

©CMI 1979203

CREDIT CARD ORDERS CALL TOLL FREE 800-323-2272 Illinois: 312 595-0461 Telex Orders: 25-5268

790 Maple Lane Bensenville, IL 60106

Contemporary
Marketing Inc.



I'll guide you step by step into your own thriving business

● While keeping your present job, would you like to gross \$14 or \$21 profit per hour?

a true story by Bob Ferrel

many things we could not afford before. My efforts were so much more productive. I scheduled my time to my own liking. When we wanted a day or two off, we took it. I worked hard but, if I wanted to be home early or quit at noon, I did.

This is not a business for a lazy man. But if a man is ambitious and will work to deserve those nice things in life we all want, this business is made to order for such a man.

I became so enthusiastic about this business and so appreciative of what it had brought my family that, whenever a man opened a dealership near me, I helped him get a quick start.

The company learned about this and had each new dealer in my section of Michigan spend a day with me. One day the president of Duraclean Company asked me how I would like to move to Headquarters and spend my entire time helping dealers to increase their sales and profits.

That was good news to my ears. Since then I have worked with hundreds of our dealers in their own towns and at regional meetings, conventions and dealer group meetings. But much of the time I am right here at my desk in touch with our dealers by letter and telephone.

Incidentally I sold my dealership at a good profit. Dealers sell their Duraclean businesses for up to ten times their cost. After 30 months, Leo Lubel sold for \$7,116 above his cost. If for any reason a dealer wants to sell, we maintain a service to locate buyers and help him sell.

Our job here at headquarters is to show each individual Duraclean dealer how to use his own abilities to bring him greatest success. I know hundreds of our dealers on a first name basis. We work together as one happy family. If you become a Duraclean dealer, I'll be as close to you as your telephone or mail box.

It's Easier than You Think To Build Your Own Business

If you've wanted to BE YOUR OWN BOSS... to become financially independent and have a fast growing income, now YOU CAN. And you own a Nationally Advertised business.

You can stay at your present job while your customer list grows... then switch to full time, lining up jobs for your servicemen to do. One job a day brings a good starting income.

If you hire two servicemen (full or part time) while you keep your job, the national price guide provides you a gross profit of \$14 an hour on their work and this is much easier to do than you think. We show you how... step by step. That's \$490 for a 35 hour week.

Your gross profit on three servicemen is \$21 per hour. Duraclean dealers find it easy to gross \$7 per hour on EACH serviceman plus \$12 an hour on any service they themselves render. The 24 page illustrated booklet we'll mail you (with no obligation) explains how most of your gross profit becomes clear net profit. Your income is limited only by the number of servicemen you employ.

You can operate from a shop, office, or your home. Equipment is light and portable.

At the start, you may want to render service yourself... or you can start with full or part time servicemen. This business is easy to learn... easy to start... so easy to service that women dealers do it. We prefer you have no experience... not have to "unlearn" old ways.

We are NOW enlarging this worldwide system of individually-owned service businesses. If you are reliable, honest and willing to work to become financially independent, we invite you to mail the coupon.

When you receive our illustrated booklet, you will see the way we show you step by step how to quickly get customers... and still more customers from their recommendations.

You have 7 superior services that are rendered "on location" in homes, offices, hotels, theaters, clubs, motels and institutions.

These are not ordinary services. You have

the prestige and endorsement of leading furniture makers and carpet mills, of Parents' Magazine and McCall's, of Research and Testing Laboratories.

National magazine advertising explains superior merits of your services, builds your customer confidence and brings job leads to you.

We and a Duraclean dealer will train you and assist you. He'll reveal his successful, proven methods. You have pre-tested newspaper and yellow-page ads, commercials, and a full mailing program.

Stores, upholsterers, insurance adjusters, and decorators refer jobs to our dealers. These year 'round services are in constant demand.

Start Small, Grow Big in this Booming Business

Many men have said to us, "I can't afford to give up my job till I know I have a sure thing... a sound business that will provide both security and a better living for my family."

That made sense to us so we worked out such a plan... and those same men are now enjoying a Duraclean dealership in many communities. You don't experiment. You use tested, proven methods. You have our backing and "know how."

Does this appeal to you? Don't decide now. Mail the coupon so you'll have the facts to decide wisely. There is no obligation. You'll then know whether this is what you want.

You can start small and grow big. A third century ago Duraclean was an idea... but it caught fire and spread to a world wide service. Why did it spread? (1) superior processes. (2) proven customer-getting methods (3) Day to day guidance from Headquarters.

Our first service, the care of upholstery and carpets not only cleans, it enlivens the fibers... revives dull colors. Pile rises with new life. There's no harsh machine scrubbing. No soaking. Mild aerated foam lightly applied lifts out dirt, grease, many unsightly spots like magic. Furnishings are used again in a few hours.

Government figures show service businesses are growing faster than industries and stores... \$750 million yearly potential just in rug and furniture cleaning. Your 6 other services are explained in the free booklet we'll mail you.

Only \$2188 starts you in YOUR OWN business. And we have enough confidence in your success that we finance the balance of the total cost of \$6500, with no interest or finance charges.

We furnish electric equipment and, with first shipment, enough materials to return your TOTAL investment. If you have good habits and know the importance of customer satisfaction, you can likely qualify for a Duraclean dealership.

TODAY is the time to reserve a Duraclean dealership, before someone takes your location.

It's been said, "Opportunity knocks but once at every man's door." This could be that one rare opportunity in your life.

It is surprisingly easy to learn this business. You can decide from the information we will send you whether to apply for a dealership. So, with no obligation whatever, mail the coupon TODAY. Cut it out NOW so you won't forget to mail it.

Mail this coupon TODAY
It may put you in business

Duraclean International
9-178 Duraclean Bldg., Deerfield, Ill. 60015

With no obligation, mail 24 page illustrated booklet telling how and why I can quickly increase my income and family security while still employed, how you'll help finance me. No salesman will call on me.

Name _____
Address _____
City _____
State & Zip _____
Telephone (area code) _____

SOME YEARS AGO I was a printer in a small Michigan town. I drew a pretty fair pay check but it wouldn't stretch far enough to provide the kind of living I wanted for my wife and five children.

Then one day I was reading a magazine just as you now are and I saw an ad. It intrigued me. It offered me the steadily growing income I had always hoped for. It said I would have greater security and personal independence... and that's what I had been wanting.

I was a little skeptical, but I said to myself, "for a postage stamp I can find out." So I mailed the coupon. In a few days, I got a letter with a booklet that gave the whole story. It opened my eyes. I could see why owning my own business was so much easier than I had always thought... why the day to day guidance of a successful worldwide organization could assure my own success.

I read the booklet several times. It just seemed too good to be true. I talked it over with my wife. We decided that now was the time to make the forward step... there was no reason to keep postponing an income increase.

So, I applied for a Duraclean dealership and I was accepted. I stayed with my job... ran a few ads... sent some mailings... contacted a few stores and told my friends about the superior services I was now equipped to give them. Evenings and Saturdays, I rendered the service. As the business grew, I added servicemen.

I found that I didn't have to develop a single idea myself. Every step had been prepared for me and pre-tested. Hundreds of other men had already proven my methods successful.

It didn't take long to see that I was making three to four times (yes, 3 to 4 times) as much per hour in my own business as in my printing job. So, after only seven months with a good following of customers, I quit my job to go full time on my own. In the meantime, I had enjoyed all this extra income on top of my salary.

Each day, we realized what a serious mistake not mailing that coupon would have been... and how that little act that seemed so trivial at the time actually changed our lives.

The steadily growing income brought us

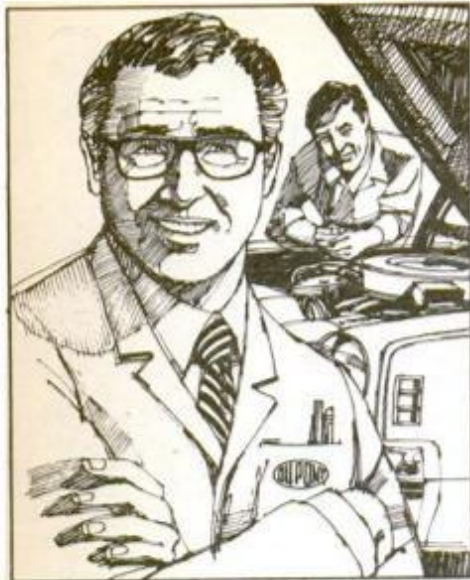

Car have an ailment that's got you stumped?

Ask the DuPont Car Doctor

He knows how to make a sick car well; keep a healthy car healthy. And the Du Pont Car Care Products he prescribes are good medicine for any car.



You and Du Pont. There's a lot of good chemistry between us.



Q. A compression gauge gave me the bad news that compression is way down on my six. Any way of telling whether it's the rings or the valves?

A. Sure is. Pull the plugs, and squirt a little engine oil into each cylinder. Now check the compression again. If the readings are about the same as before, it's probably only the valves. (The oil will temporarily seal up sloppy rings, but has little or no effect if the rings are OK.)

Q. My wagon's transmission got quite a workout this summer—including hauling a boat trailer 200 miles almost every weekend. Now the transmission is starting to shift a little noisily. Have I done it any damage?

A. Hard to say. But before you have it torn down, check the fluid level. If it's low, try a can of DuPont T-Seal.[®] That's often all it takes to quiet noisy shifting. Prevents leaky seals, too. (Not for use in Citroens.)

Q. Bought an old MG which I'm going to restore. Guy I know says I'll need a set of Whitworth wrenches to do the job. What's he talking about?

A. Many older English automobiles use bolts sized in the Whitworth system: by the diameter of the shank, not the head. Try a specialty tool house, or check the ads in one of the enthusiast magazines.

Q. Anything I can spray on my car's seat runners to keep the seats from sticking? Taking seats out to grease the runners is a real hassle.

A. DuPont Slipspray[®] is what you need. Keeps those runners moving smoothly with a dry, slippery film. And if your aim isn't perfect, don't worry. Slipspray won't hurt your carpets, rubber floor mats or vinyl upholstery.

Q. Know of anything I can use to keep grease and oil from grinding their way into my hands when I work? I've tried gloves...but they sure get in the way.

A. Try the "invisible glove": DuPont Pro-Tek.[®] It's a cream you rub in before you start work. Makes cleaning your hands quick and easy—even under the fingernails.

PM LOOKS AT SANDER-POLISHER-SCRUBBER KIT



Scrubber pad lets you use this versatile tool for tough scouring jobs.

This multiuse tool can clean and polish everything from kitchen floor to car. The off-center, padded head oscillates with an eccentric motion, prevents streaks, swirls or burns when sanding and polishing. Light tool is easy to handle, needs little pressure to run.—J.P.

MODEL X425 SPECIFICATIONS: Polished aluminum housing, phenolic inner housing, 120-v.a.c., 3.5-amp., 1/2-hp, 1200-rpm, 25-60-Hz motor. About \$63 at hardware stores. Electro Engineering Products Co., 1801 North Central Park Ave., Chicago, Ill. 60647.



To wax car, use scrubber pad to remove wax residue, then polish with buffer.

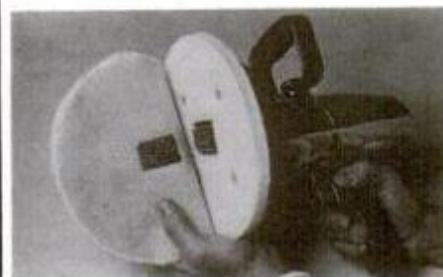

Velcro fasteners on accessory discs and toolhead make changes easy.



Kit includes 8-in. scrubber, two polishing pads, two sanding discs.

NO MONEY AT ALL

O.K.! So you're not a shoe salesman! You don't have to be, when you show the folks in your neighborhood the money they save and the quality they get with Hanover Shoes.

You just show them our full-color catalog... the shoes do the selling for you... and you pick up an extra \$200, \$300 or more in a month's spare time... any month, every month. What makes it so easy and so exciting is the downright, honest value you offer with Hanover Shoes. These are all-leather, finely crafted, top quality shoes you'll see only in the finest men's stores... well below the price they charge... actual savings of \$15 to \$20 per pair.

You see how quickly you can build a steady business? The people who buy once will come back for more of these values, every time they need shoes... for work, dress, casual wear, or roughing it outdoors. Boots, too... the finest!

Talk about a no-risk business that doesn't take

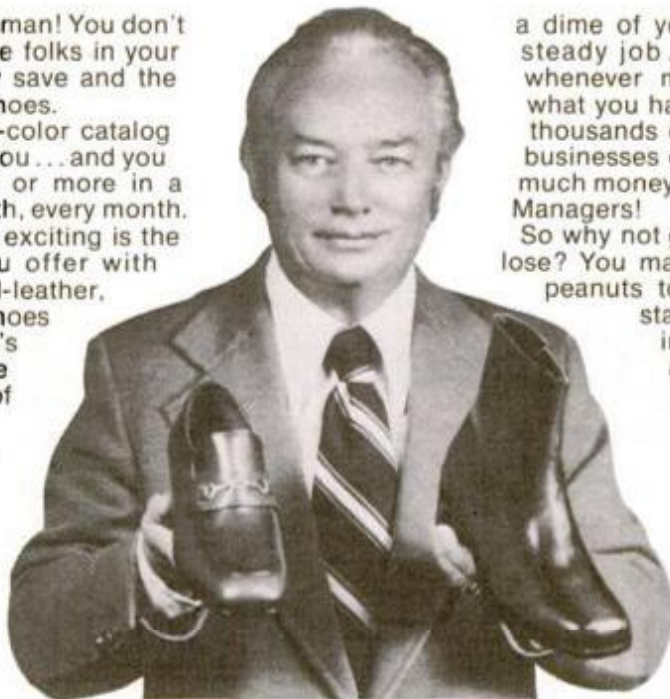

a dime of your money... lets you keep your steady job... and gives you extra income whenever money gets a little tight! That's what you have with Hanover... that's the way thousands of men have started independent businesses of their own. Some have made so much money they've become full time Hanover Managers!

So why not give it a try? What do you have to lose? You may find that \$300 a month is just peanuts to what you make once you get started. And that's what I'm counting on... why I'm staking you to a 30-day trial with our exclusive Hanover Sure-Sell Kit and catalog... and offering a free pair for you with the first ten orders you send me during this free trial period.

I'm sure you'll be my friend for life once you've started! The starting point is the postage-free coupon below. Just fill it out and get it in the mail to me today.

President

Yes, with your first 10 orders during your 30-day trial, you may pick a pair of boots or shoes from your Hanover catalog (the kind that sell for \$15 to \$20 more in fine stores). This pair is on me - your bonus for selling your first 10 pairs of Hanover Shoes. At the same time, of course, you'll pocket the commissions of \$70 or more for the orders you've sent in. How's that for a double payoff and really great start on your no-risk, no-investment Hanover business? Just fill out this coupon, cut on dotted line, fold and seal edges with glue or tape, and put it in the mail. **No salesman will call or phone you.**

111 N. Forney Avenue ■ Hanover, PA 17331

PLEASE PRINT

Name _____

Address _____

City/State/Zip _____

Dept. 2498

cut on dotted line, fold here, glue or tape edges, mail today



NO POSTAGE
STAMP
NECESSARY
IF MAILED IN THE
UNITED STATES

BUSINESS REPLY MAIL
FIRST CLASS PERMIT NUMBER 54 HANOVER, PA.

POSTAGE WILL BE PAID BY:

THE HANOVER SHOE, INC.
Gordon King, President
111 N. Forney Ave.
Hanover, Pa. 17331

NEW NOW for outdoors



More-mileage mini-camper conversion

Stretching each gallon of gas is easier with Chinook's aerodynamic camper for small pickup trucks. It will be available

this fall, factory installed, through Datsun, Toyota and Ford dealerships, and is expected to rival station wagon prices.

Pick-up tailgate for pickup trucks

For handling up to 1000-pound loads, hydraulic Hy-Tech Liftgate can be home-installed with hand tools in six hours. It's \$795 from Hy-Tech Industries, 705 North Seventh Ave., Phoenix, Ariz. 85000.



Airboat kit

A 25-mph airboat that you can build for \$350, the Hydro-Rat weighs 150 pounds, is powered by an 8-hp engine, and is constructed from \$10 plans from Rocky Mountain Airboats, Morgan, Utah 84050.



Take-along generator weighs 19 pounds

It's been called the world's lightest and smallest generator. Weighing in at 19 pounds and having the capability to turn out either 115-volt a.c. or 12-volt d.c. power, it is also one of the most convenient. Whether you're a camper, boatman, recreational-vehicle owner or just a general outdoorsman, this little mill can handle a host of chores for you.

Has the battery in your outboard-motor starter, car or trailer run down? This Model AQB-300 can build up enough of a charge in several hours to get an engine going again.

Do you require an emergency light, or power for a drill in the boonies, or current for the kid's portable TV on a rainy day at the campgrounds? This little AquaBug

two-cycle kicker might be a most convenient answer.

For a small soldering iron, hedge trimmers, portable water pump, tire inflater, fan, mini-vacuum cleaner or small power tools, its 300 watts of a.c. or 12 amperes of d.c. can do the job. There is an easy rope starter. An electromagnetic governor speeds up or slows down rpm as needed to deliver the necessary output.

This unit is just not beefy enough to power an air conditioner, a refrigerator, heater, clothes iron, oil burner, heavy-duty chain saw or power tools. But for \$275 sent to AquaBug International, 100 Merrick Rd., Rockville Centre, N.Y. 11570, you will receive a lot of power for the money.—*Bill McKeown*





"GRIT-EDGE" BLADES CAN CUT IT

Remington tungsten carbide "Grit-Edge" blades cut materials you wouldn't or couldn't cut with ordinary saw blades.

MATERIAL	ROD SAW	HACK-SAW	SABER SAW	CIRC. SAW	BAND SAW
Asbestos-Cement	•	•	•	•	•
Beryllium	•	•			•
Carbon	•	•		•	•
Cast Iron	•	•			•
Composites	•	•	•		•
Composition Board	•	•	•	•	•
Fiberglass	•	•	•	•	•
Foamed Glass	•	•			•
Friction Materials	•	•	•	•	•
Glass	•	•			•
Hardened Steel	•	•			•
Honeycomb Materials	•	•			•
Marble, Natural	•	•	•		•
Marble, Synthetic	•	•	•	•	•
Plaster			•	•	•
Plastic Laminates	•	•	•	•	•
Plywood			•	•	•
Stainless Steel	•	•	•		•
Stranded Cable	•	•			•
Superalloys, Iron-base	•	•			•
Superalloys, Nickel-base	•	•			•
Tempered Hardboard			•	•	•
Tires, Steel-Reinforced					•
Titanium	•	•			•
Tile, Ceramic	•	•	•		•

*Requires coolant and variable-speed machine

GRIT EDGE When ordinary blades can't cut it. **Remington.**  Remington and "Grit-Edge" are trademarks registered in the U.S. Patent and Trademark Office.

MODEL HOME BY "GRIT-EDGE"

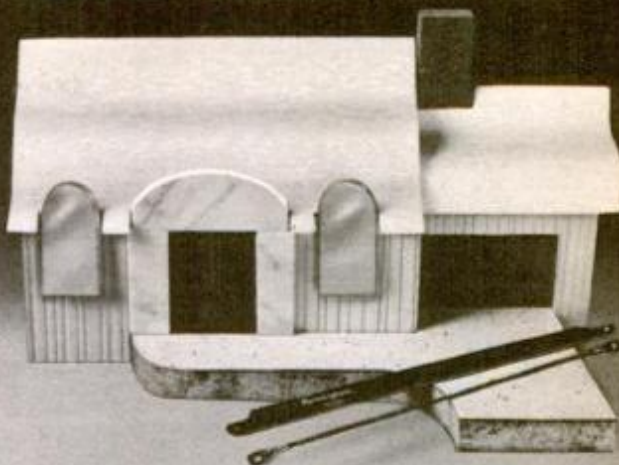

If keeping your house in model home condition means cutting fiberglass, slate, tempered hardboard, plastic laminates, particle board, marble, metals and other tough, hard-to-cut materials, Remington "Grit-Edge" rodsaw and hacksaw blades belong in your tool box.

The tungsten carbide "Grit-Edge" blades have no teeth to dull or break. Cut on the forward and backward strokes. Fit standard hacksaw frames. Leave edges smooth. Cut faster and last longer than ordinary blades.

See your hardware dealer or write Abrasive Products, Remington Arms Company, Inc., Bridgeport, Conn. 06602.

GRIT EDGE when ordinary blades can't cut it.

Remington.  Remington and "Grit-Edge" are trademarks registered in the U.S. Patent and Trademark Office.

LOOK FOR THIS LABEL



The Popular Mechanics Product Feature Mark. You'll find it on tools, home and car care supplies, workshop accessories and much more. Products displaying the Mark let you know they've been featured in the pages of Popular Mechanics.

And for over 75 years, readers have been turning to Popular Mechanics' pages to find reliable, authoritative information on a vast array of topics ranging from home maintenance to outdoor leisure activities to automotive care. The reason—a solid reputation built on a tradition of dependable reader service.

The Product Feature Mark is one more way Popular Mechanics serves its readers.

Popular Mechanics is a publication of Hearst Magazines, a division of the Hearst Corporation.

Popular Mechanics is a publication of Hearst Magazines, a Division of THE HEARST CORPORATION.

**Enjoy a roaring fire . . .
the easy way, with
PM's Log Splitter!**

What could be more pleasant on a cold, cold day than the warmth of a roaring fire. And, you can have all the firewood you need and save time and money by splitting that firewood yourself. POPULAR MECHANICS LOG SPLITTER exerts some 10,000 lbs. of pressure and will easily split 2 ft. lengths of maple and ash logs 12 to 14 inches in diameter. With an I-beam backbone, double-acting hydraulic cylinder, control valve oil filter, 3-hp. gasoline engine and other features, you'll find this log splitter easy to build and a fun thing to use. And, you'll save your back from aching as you split logs the easy way.

Have more time to enjoy the crackling fire in your fireplace. Use it through this year, or start getting ready for next winter. Either way, it's a very sound investment. Send for complete plans and step by step instructions for just \$8.95. Send a check or money order to PM Plans Library-Log Splitter, Box 1014 Radio City Station, N.Y. N.Y. 10019

PM LOG SPLITTER

Popular Mechanics is a publication of Hearst Magazines, a Division of THE HEARST CORPORATION

IT'S NEW
NOW



Turn a tripod into a handy luggage caddy

Tri-Caddy converts a camera tripod into a two-wheeled caddy. The accessory carries your photo equipment case or other luggage and keeps it handy while you're shooting. Its wheels have locks to keep the tripod sturdy. The caddy assembly is said to install and remove easily. Made of lightweight aluminum, the Tri-Caddy has a capacity of about 30 pounds. The Model TCD shown here is about \$22 from Welt/Safe-Lock Inc., 2400 West Eighth Lane, Hialeah, Fla. 33010.

For seat-of-the-pants driving

Sitting a long time is said to be more comfortable with Alphaned cushion. Its cells alternately inflate and deflate so no part of your body touches a cell more than 5 to 8 minutes. About \$55; air pump (battery, 12 v.d.c. or 110 v.a.c.), about \$150. Huntleigh Group, 41 W. 58 St., New York, N.Y. 10019.

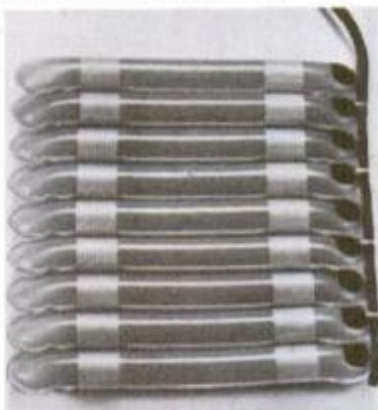

Fingertip wheelchair control

The Justa Finga is a fingertip-operated wheelchair brake. While useful for all braking purposes, it is said to be handiest when moving up or down a ramp. About \$60 from KGB Research and Development, 7025 Duncan Rd., Punta Gorda, Fla. 33950.

Cutting corners

The short, stainless-steel blades of the ShortCut are said to permit agile maneuvering in tight quarters. Springy plastic handles reduce cutting effort. Scissors cut equally well both left- and right-handed. About \$5 from Normark Corp., 1710 East 78th St., Minneapolis, Minn. 55423.



ASSEMBLE YOUR OWN BOAT KIT

and earn from it too!



PMB

G-22

SEND FOR FREE INFORMATION

Glassline

18305 MINNETONKA BLVD. • DEEPHAVEN, MN • 55391

NAME _____ AGE _____

ADDRESS _____

CITY _____

STATE _____ ZIP _____

PHONE _____

HOME () _____ BUSINESS () _____

CHECK ONE: SAILBOAT BASSBOAT

Celestron[®]

Telescopes...
Telephoto Lenses...
Binoculars...

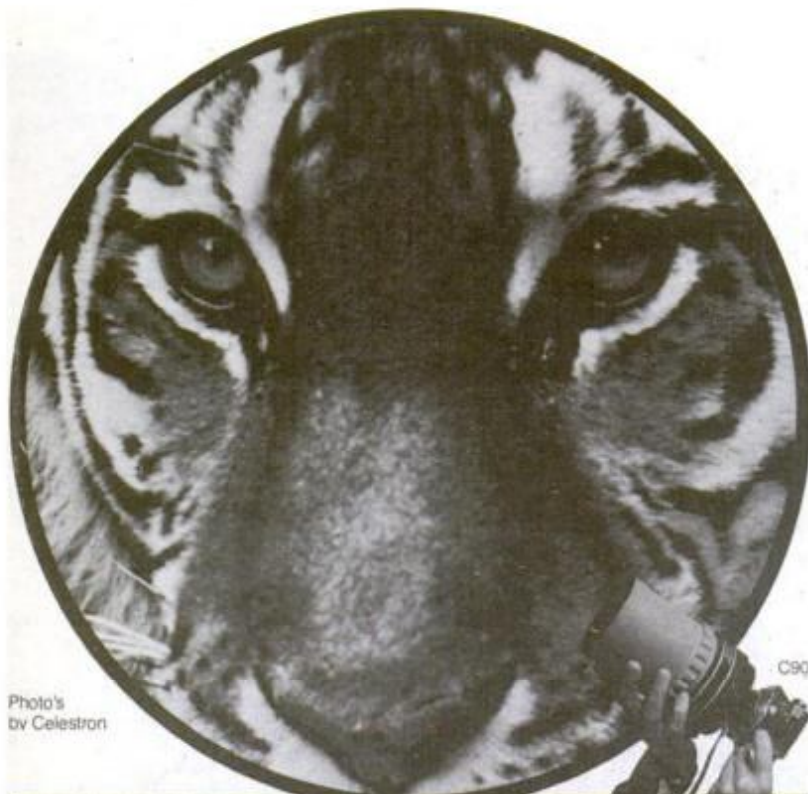

Photo's
by Celestron



Dealers
Inquiries
Invited



Send \$2.00 for 32 page
full color catalog on how to
select and use a Celestron
telescope.

Celestron

Celestron International
2835 Columbia, Box 3578-4
Torrance, CA 90503

NEXT MONTH IN PM

- **4wd Eagle**—revolutionary new car from AMC.
- **PM's annual Home Energy Guide.**
- **Killer trucks must go.**
- **Videodiscs enter the TV recording picture.**
- **The mystery of gravity waves.**

SUBSCRIPTION SERVICE: Popular Mechanics Magazine will, upon receipt from its reader of a complete new or renewal subscription order, undertake fulfillment of that order so as to provide the first-copy delivery to the Postal Service within six to twelve weeks. If for some reason this cannot be done, you will be promptly notified of the issue date that will begin your subscription, with a request for any further instructions you may have concerning your order. Please address all such orders to us at Popular Mechanics, P.O. Box 10064, Des Moines, Iowa 50350.

Should you have any problem with your subscription, please write or call Joan Harris, Customer Service Department, Popular Mechanics, P.O. Box 10064, Des Moines, Iowa 50350. Telephone: 800-247-5470. State of Iowa residents call 800-532-1272. To assure quickest service, please enclose your mailing label when writing to us or when renewing your subscription. Renewal orders must be received at least eight weeks prior to expiration to assure continued service.

Popular Mechanics

P.O. Box 10060, Des Moines, Iowa 50350

YES! Please enter my subscription to POPULAR MECHANICS for:

W8FD

- 1 year \$8.97
 2 years \$16.97

Payment of \$ _____ is enclosed.

Bill Me _____
initial here

Name _____ (please print)

Address _____

City _____ State _____ Zip _____

Your first copy will be on its way to you in six to twelve weeks. Watch for it!

A publication of The Hearst Corporation
Charge orders subject to publisher's acceptance.
(Above prices apply in U.S. & Possessions only. All other countries add \$6.00 per year).

CHANGING ADDRESS?

If you're planning to move, please let us know at least eight weeks before changing your address. Attach current address label and fill in your name and your new address. This will serve to insure prompt service on your subscription.

Send old label with your name
and new address to:

POPULAR MECHANICS
P.O. Box 10064, Des Moines, Iowa 50350
or call toll free 800-247-5470
(State of Iowa residents call 800-532-1272)

NAME _____ (Please print)

NEW ADDRESS _____

CITY _____ STATE _____ ZIP CODE _____



Own This \$100,000 Classic Mercedes Replica for as little as \$1995.

The original 1929 Mercedes Benz SSK would cost at least \$100,000 or more if one was available.

But now, Classic Motor Carriages, the World's largest manufacturer of Replicar Assemblies, offers this remarkably affordable copy for the auto enthusiast with average mechanical skills, using ordinary tools.

The Gazelle, replica of the nostalgic Mercedes, is a technological triumph. It is easily adapted to either VW or Ford components.

Classic Motor Carriages' World-Wide factories utilize the latest in modern Fiberglass excellence combined

with superb handcraftsmanship to produce the finest custom replicar assemblies money can buy.

All parts are meticulously engineered and inspected. The lustrous Gelcoat finish lasts a lifetime. No rusting—ever!

And remember all Replicar Assemblies are fully warranted by a company that cares.

Complete the coupon below to begin the most rewarding experience of your life. The thrill and satisfaction of building one of these cars yourself. A pride of ownership that money alone can't buy.

MAIL THIS TODAY TO START PLANNING ONE OF THE MOST REWARDING DO IT YOURSELF PROJECTS EVER.

Enclosed is \$3.00 for your 20 page color catalog, full information & consumers buying guide.

Enclosed is \$20.00 for assembly manual plus 20 page catalog; full information & consumers buying guide. Ford VW

Please charge my

Master Charge ___/___/___/Exp. date _____

Bank Americard ___/___/___/Exp. date _____

American Express ___/___/___/Exp. date _____

Name: _____

Address: _____

City: _____

State: _____ Zip Code: _____

Home Phone No.: _____

Office Phone No.: _____

Classic Motor Carriages, Inc.

200-K South Federal Highway, Hallandale, Florida 33009

Telex: Replicar HALA 519225

Tel.: (305) 456-1500

Factories and Sales Offices: Florida • California • Canada • Mexico • Brazil • United Kingdom

SAVE YOUR BACK AND SAVE SOME MONEY, TOO...

as you split firewood the easy way with POPULAR MECHANICS great new log splitter. You build it yourself and then sit back to reap the rewards of a roaring fire. The rig on this hydraulically operated log splitter exerts some 10,000 lbs. of pressure and will easily split 2 ft lengths of maple and ash logs 12 to 14 inches in diameter. With an I-beam backbone, double acting hydraulic cylinder, control valve oil filter, 3 hp gasoline engine and more features, you'll find this log splitter a delight to build and a pleasure to use. And, you'll save your back from aching as well as saving money by splitting that wood yourself. So, have some more time to enjoy the warmth from your fireplace. Send for complete plans and step by step instructions now. Just \$8.95



PM Plans Library **Log Splitter**

Box 1014, Radio City Station N.Y., N.Y. 10019

Please send complete plans and instructions. I enclose a check or m.o. for \$8.95. Make check payable to Popular Mechanics.

Name _____

Address _____

City _____

State _____

Zip _____

Please allow 3-4 weeks for delivery.

PM879

Popular Mechanics is a Publication of Hearst Magazines, a Division of THE HEARST CORPORATION

THE Bargain Hunter

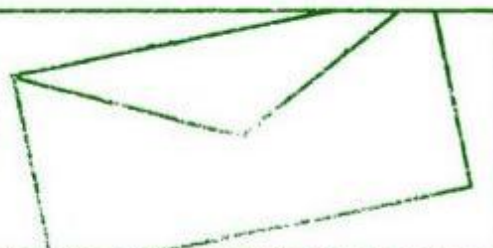

AMAZING ELECTRONIC PRODUCTS

Lasers super powered, burning, cutting, rifle, pistol, pocket—see in dark—shotgun directional rifle—unscramblers—giant Tesla—Stunwand—TV disrupter—energy producing, surveillance, detection, electrifying, chemical, ultrasonic, cb, aero, auto and mech devices, hundreds more—ALL NEW PLUS INFO UNITED PARTS SERVICE

CATALOG \$1. INFORMATION unlimited
DEPT. M8 BOX 718 • AMHERST, N.H. 03021



REPAIR AIR COMPRESSORS

Very few trained in this field. Thousands need repairing. In industry, Farm and Automotive. Illustrated Manual Tells How. Directory Included. \$4.95 Post-paid.

Air-Power, P.O. Box 1411, Hickory, N.C. 28601



MAKE TOP MONEY IN STAINED GLASS

Learn at home in your spare time. Program includes your book of completely illustrated lessons, all professional tools, interesting projects and more. Our self study program gives you every thing needed to start you on your way to success. You can earn big money making stained glass lamp shades, windows, jewelry, sun catchers and more.

FREE INFORMATION
Regina Careers Ltd. - Publication Dept. PM289
33 E. Main St., Round Lake Park, Ill. 60073

WISH BOOK CAN BE YOURS FREE

Three pound, 832 page catalog, as big as a Sears catalogue, but devoted to tools, supplies and machines, for every trade or craft. If you work with wood, metal, plastics, electricity, electronics, graphics, ceramics, leather, gardening, science, drafting, service trades, auto or home repair, or art and crafts, you need this giant of a catalog with over 60,000 items. A valuable reference, name brands, discount prices—catalog comes with \$5.00 merchandise refund coupon. Send \$5.00 or credit card number to get your catalog.



McKilligan Supply, PM8279, Johnson City, N.Y. 13790

An ATLAS BODY? In 7 days

my method of DYNAMIC-TENSION starts giving results you can feel and your friends will notice. Big, useful muscles. Gain weight, if needed. Lose "pot belly." Send your name and address for 32-page book—FREE. CHARLES ATLAS, 49 West 23rd St., New York, N.Y. 10010 Dept. HB



PUMPS BUY DIRECT AND SAVE

Heavy duty ball bearing pump. All metal, rust-proof Type XB. Stainless shaft. Use 1/4 HP or larger. 1 HP 1,200 GPH 60" high or 3,000 GPH 25" well. 5,200 GPH max. 1 1/4" in; 1" out. Belt or direct drive. \$19.95 Type P won't rust or clog. Bronze bearing. To 2,400 GPH. 1" in; 3/4" out. \$13.95 ADD \$2 pstge & handling. Money back Guarantee. LABAWCO, 80 Hwy 206, Belle Mead, N.J. 08502

110 VOLT A.C. GENERATORS

60 cycles, 3000 watts, WT, 27 pounds, 5" x 10" Fanbelt driven from car or pickup. Operates, T.V. All power tools. Over 17,000 in service. This is our 29th year. Guaranteed 6 months, \$149.00. Our X1200-watt generator needs no battery. Special price \$139.00. Add \$6.50 for postage & handling, per unit.

**VIRDEN PERMA-BILT Box 7160 PM
2821 Mays, Amarillo, TX 79109
Phone: 806/352-2761**

JET - GAS TURBINES

LEARN NOW! Train in your own home, in your spare time theory, construction, service, repair, all systems Jet-Gas Turbines. Multi-fuel power units for generators, aircraft, trains, buses, ships, etc. Write for complete details.

AMERICAN JET SCHOOL

Dept. PM6A Darby, Montana 59829

TV TO STEREO SOUND ADAPTER



GET SIMULATED STEREO SOUND FROM YOUR TELEVISION!

TELEDAPTER® easily connects to your own TV and stereo system to give you full rich simulated stereo sound through your amplifier and speakers. TELEDAPTER'S electronic circuitry matches the impedance between your TV and stereo amplifiers' aux., tape, or tuner input, while completely transformer isolating the TV's & stereo's chassis, for safety. The matrix circuitry provides two channels of output that plug directly into your stereo. Those ballgames and movies will never be the same after you hear the realistic thundering sound. Only \$19.95 postage paid, complete with hookup instructions, 2 year warranty.

To order: Enclose check • VISA or MasterCard # _____

Expiration Date _____ Bank # _____

NAME _____

ADDRESS _____

CITY _____

STATE _____ ZIP _____

*Satisfaction guaranteed or your money promptly refunded.



Dept. PM - P.O. Box 817
Hendersonville, TN 37075
(615) 824-1735

SEND COMPLETE CATALOG

COUNTERFEIT GUNS

AUTHENTIC! FULL SIZE MACHINED METAL MODELS. Museum quality precision machined metal classics weigh, look and feel like real guns. Will fool experts. Perfectly legal—CANNOT BE FIRED. Blued and disassemble like originals. Decorate your den, office, rec-room. Send for FREE FULL-COLOR CATALOG. Made of over 30 blued, hand-finished parts—DELIVERED FULLY ASSEMBLED.

SAME SIZE AND WEIGHT AS THE ORIGINALS! MONEY BACK IF NOT SATISFIED! GOVERNMENT .45



STANDARD S&WARM OF G'S. SLIDE WORKS LIKE ORIGINAL WITH SAFETY THAT WORKS. LGTH. 9", WT. 2 1/2 LBS. DISASSEMBLES ADD \$1.50 POSTAGE/HANDLING LIKE ORIGINAL. Model R300 \$44.95

REPLICA MODELS, INC., RO. BOX 1061

DEPT. PM-089 800 SLATERS LANE, ALEXANDRIA, VA 22313

Send R300 Send FREE COLOR CATALOG

Charge to: BAC Mastercharge Am. Express Diner's Club

NAME _____

ADDRESS _____

CITY/STATE/ZIP _____

MONEY BACK IF NOT SATISFIED.

TUNE YOUR GUITAR Like A Professional

This new invention is ideal for every guitarist... beginner or professional. Six precision tuned reeds make exact tuning a snap. Just clamp onto your guitar, then adjust the strings. When the proper pitch is reached, the corresponding reed vibrates. Just as easy as that! Ideal for bands or combos. Tunes all instruments to exactly same pitch.

\$8.95 plus \$1 shipping and handling. Money back guarantee.

FD SALE Studio B34-G, Grand Island, Fla. 32735

SAVE up to 90% GOVT. SURPLUS

Surplus and other bargains galore! Industrial, mfg, marine, aircraft, auto, hardware. A must for hobbyist, mechanic, handyman, outdoorsman. Our 34th Annual Catalog. Send 50¢ today (or \$1 for extra fast delivery).

AIRBORNE SALES CO.
8501 Steller Dr., Dept. PM79
P.O. Box 2727, Culver City, CA 90230

Name _____
Address _____
City _____
State _____ Zip _____

WOODWORKERS!

At Last!
A publication for both the novice and veteran, bringing you OVER 70 PLANS AND PATTERNS PER YEAR. Build fine Early American, Shaker, Contemporary furniture, Toys, Gifts, Clocks, Lamps and much more...

Each issue of The Woodworker's Journal is packed with practical projects plus Shop Tips, Jig Building, Money-making ideas, Antique Repair, Cabinetmaking Techniques.

6 Issues per year for only \$7.00
12 issues for only \$13.00
Foreign rates, add \$2.00

Send check or money order to:

The Woodworker's Journal Dept. 518
Sunset Lane Washington Depot, CT. 06794

Name _____

Address _____

Zip _____

BURRO Fiberglass Travel Trailer Kit

Build Yourself! Save Gas



Sleeps 4. Compact, lightweight. Weighs approximately 900 lbs., about 85 lbs. hitch weight. Easily pulled by small and big cars. Assembled in about 3 days with manual. All hardware completed at factory. No special tools. Summer cushions, winter warmth with dual wall construction. Fully equipped. Furniture moulded into interior walls. No screws or rivets to loosen.

Write BURRO, Dept. PM8, 14143 21st Ave. No., Plymouth, MN 55441 for full color catalog. Please enclose \$2.00 for postage and handling.

USED CORRESPONDENCE COURSES

Save up to \$600 on these up to date courses from major schools. Auto Mechanics, Air Conditioning, Electronics, Van Customizing, Gun Repair, Locksmithing, Motorcycle Mechanics, Small Engine Repair, Piano Tuning, Upholstery and many more. None over \$25. Free giant catalog.

**Budget Books / 5395 Kendall Drive
Miami, Florida 33156**

FREE! HARDWOOD VENEERS & LUMBER CATALOG

98 varieties world's rarest veneers and lumber at reasonable prices. Simplified veneering instructions plus full color wood selector included. Send for free catalog now and get special bonus starter offers. SAVE 25% Hurry!

**BOB MORGAN WOOD, Dept. P01K97
1123 Bardstow Rd., Louisville, Ky. 40204**



NEW...
Just Published!

**Walking
Lawnmower
Service Manual**

SLASH Lawnmower REPAIRS!

Complete guide to care, repair, tuneup: 128 pgs., dozens of exploded views & diagrams—8 leading engines used on dozens of mowers; PLUS blade sharpening, adjustments; Step-by-step instruction. Money-back guarantee.

Use your VISA or MASTER CHARGE Just send card no. & expiration date. Or send check for \$7.95. We pay postage.

INTERTEC Technical Publications, Dept. PM-8
P.O. Box 12901—Overland Park, KS 66212

In Canada contact: Lenbrook Industries, Ltd., Scarborough, Ontario M1H 1H5

**HAVE FAMILY FUN AFLOAT
WITH A PONTOON BOAT**

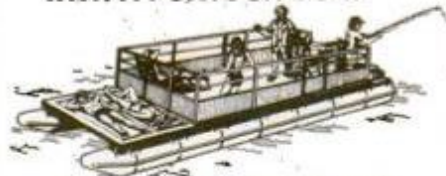

**EASY TO ASSEMBLE KITS THAT
SAVE YOU MONEY**

Economical, safe, and practically indestructible
Ideal for family parties, fishing, or swimming.
Kit contains pontoons, frame, motor mount,
helm station, steering, railing, and hardware.

Send \$2.00 for plans and pictures

**CALL TOLL FREE
1-800-351-1363**

**ROTOCAST FLOTATION PRODUCTS
P O BOX 1059, DEPT PM
BROWNWOOD, TEXAS 76801**

TILLER USERS...

Can your machine
do all of this?

Save
**\$215.80
NOW**

- ★ Handle with just ONE HAND.
- ★ EVENLY break, turn & till soil.
- ★ Shred vegetation without tangling.
- ★ Leave NO WHEELMARKS or FOOTPRINTS.

The TROY-BILT® ROTO TILLER-POWER COM-
POSTER can do all this and more!



That's why serious gardeners consider it the finest tiller available. See for yourself! For complete details, OFF-SEASON SAVINGS, and FREE 24-page booklet clip this and mail today to:

TROY-BILT® Tillers, Dept. 90198
102nd St. & Ninth Ave., Troy, N.Y. 12180

FREE HOT WATER



To supplement your hot water heating system. As you enjoy your fireplace, your systems' water will circulate through the Water-Grate greatly reducing your heating cost. Plans are such that this unit can be built to fit any size fireplace or Franklin stove. All parts are available at local hardware. No special tools needed!

**WATER-GRATE®
PLANS
\$3.00**

Water Grate P.O. Box 45206
Westlake Ohio 44145

**THE SPRENCH
3/8" SPEED WRENCH**



No more "knuckle busting"!

11° squeeze turns socket 90°.

Perfect for auto, aircraft, marine, plumbing, home maintenance jobs. At local hardware outlets, or send \$21.95 plus \$1.50 handling to:

SPRENCH

21133 Costano St.
Woodland Hills, CA 91364

Name _____

Address _____

City _____ State _____ Zip _____

(Calif. residents add 6% sales tax)

**RICKA DUO-WHEEL CONVERSION
KIT AND FIBERGLASS FENDERS**



New wide tire adapters & fenders to fit most mini - 1/2, 3/4 & 1 ton trucks. Simple bolt on installation. Increases traction, tire capacity & life.

The ultimate in safety protection for your family.



**RICKA MFG.
DEPT. RPM-8**

Pequot Lakes, MN 56472



EARN SHOES FOR YOURSELF!



If you will take just five Mason Shoe orders a month, YOU NEED NEVER BUY ANOTHER PAIR OF SHOES! The "Earn Shoes for Yourself" plan makes it EASY! With our catalog of 350 fast-selling styles (dress, work, sport shoes) you'll have no trouble getting the orders. And you'll have your own private "shoe store" from which to select your FREE SHOES. You don't invest one cent, yet you earn up to \$100 a week, showing friends and neighbors Mason Shoes. Fine quality air cushion shoes, in sizes 4 1/2 to 16, widths AA to EEEE.

Rush postcard for FREE Starting Kit, plus exciting Prize and Bonus Offers TODAY!

MASON SHOE MFG. CO., DEPT. H-334, Chippewa Falls, WI 54729



INVENTORY ADJUSTMENT SPECIAL!

**PILOT'S GLASSES AT
UNBELIEVABLE PRICES!**

**ONLY
\$6.95**



- Impact Resistant
- Handcrafted
- Polished Glass Lenses
- Hardened Metal Frames
- Money Back Guarantee

To order, send check or money order (include \$1.00 for postage and handling) to U.S. Optics, Dept. 306, P.O. Box 14206 Atlanta, GA 30324. (Please specify gold or silver frames.) SPECIAL: Order now and get TWO PAIR for \$13 plus one dollar handling charge.

FREE! During this limited offer.
Deluxe velour lined protective case. A \$3.00 value.

LIMITED OFFER FROM U.S. OPTICS

**Build this beautiful Dome
Home by
yourself!**



Monterey Domes' geodesic shell package is the least expensive, most energy-efficient home available. Can be easily assembled by one or two people. Saves up to 60% of building costs and 50% or more on utilities. Prices start at \$3795. Our Planning Kit has 96 exciting pages of affordable home packages from 700 to 4,500 square feet. Send for yours today!

- Please rush me your new 96 page full color Catalog and Plans Book. I am enclosing \$4.00
- Also send me the Monterey Domes Assembly Manual for an additional \$5.00.

NAME _____

ADDRESS _____

CITY, STATE, ZIP _____

Dept 156, P.O. Box 5621
Riverside, CA 92517



**THE TROUBLE-FREE
WIRE DISPENSER**



By WEDCO Manufacturing Inc., Dept. P-1, 175 So. Scott Lane, P.O. Box D, Jackson, WY 83001 (307) 733-2336

- Developed by an Electrician for Electricians
- Saves Time — Wasted Wire
- Speeds Handling of Several Colors
- Moves Like a Hand Truck
- Capacity in 5' — 2000' — #10 AWG Reels
- Weighs Just 72 Pounds

WRITE FOR BROCHURE AND PRICES

**FAMOUS RITTENHOUSE
HOME COMMUNICATOR**

Install it yourself! Exclusive surface-mounted design.

No holes to cut. Advanced solid state devices. Simple clip-to-wall wiring. Complete installation instructions included. Safe, low-voltage plug-in transformer. Door answering security combined with total in-house communications. Walnut finish. American made. Master station with fine AM/FM radio and built-in antenna, 3 Room Stations, 1 entrance station, wire, Model 6001-1 \$219. Perfect for a do-it-yourself project or as a gift for the handyman. Send Money Order, Visa, or Master Charge number. Florida residents add 4% sales tax. Allow 30 days for delivery. Send \$1.00 for color brochure.

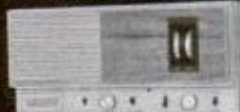

SARASOTA GIFTS
BOX 3855, SARASOTA, FLA. 33578 DEPT. PM8

**FREE!
POWERFUL MUSCLES
FAST!**

Ultra Modern Muscle Building Method adds inches of Powerful Muscles to arms, shoulders, chest, back and legs. "Learn waist" trimming secrets. Get fast results. Send 50c coin for mailing costs. Write today!

FREE!
Send name and address for Muscle Course

Olympic Musclebuilders (Dept. DMP1)
Box 125, Rockaway, N.J. 07866

The Touch By **Regency**
THE ULTIMATE IN POLICE SCANNER RADIOS



List Price \$279.95

**SPARKY'S PRICE
\$199.95**

Regency expertise in space age computer technology now brings the versatility of a totally synthesized scanner within anyone's reach. By merely touching the pressure pads, you can receive any one of 15,757 frequencies in the public service and amateur bands. You can search through entire bands for an active frequency. You can continue to search or stop and store the new frequency which will be automatically displayed in the LED digital readout. The display will also inform you of Power Failures, All Channel Lockouts, Programming Errors and Scan Delay Function Status. The K100 covers 30 to 50 mhz, 144 to 174 mhz and 440 to 512 mhz. Use your Master-charge, VISA card for faster service. Personal checks are held for bank clearance. Price does not include shipping charges. K100 has 10 Channels and a 1 Yr. factory warranty. Order your Toll Free dial 1-800-255-6389 or write to us at

SPARKY'S Home Electronic Center
11489A Oak Park Mall, Overland Park, KS 66214

THERE'S A BETTER WAY TO GO.

Energy shortages tell us we have to change our driving style.

Now! It doesn't mean we have to go back to horse and buggy days. But it does mean we have to make

every drop of gas give us the most go for our money. Anyone with horse sense knows that a well-tuned car gets better mileage, and in times of fuel shortages, better mileage means a lot.

The Mark Ten B Capacitive Discharge System keeps your car in better tune so it burns less gas.

Using Mark Ten B is more than horse sense. It's the

smart move under the hood, helping a nation survive an energy crisis and keeping you on the road. Delta Mark Ten. The best way to go.

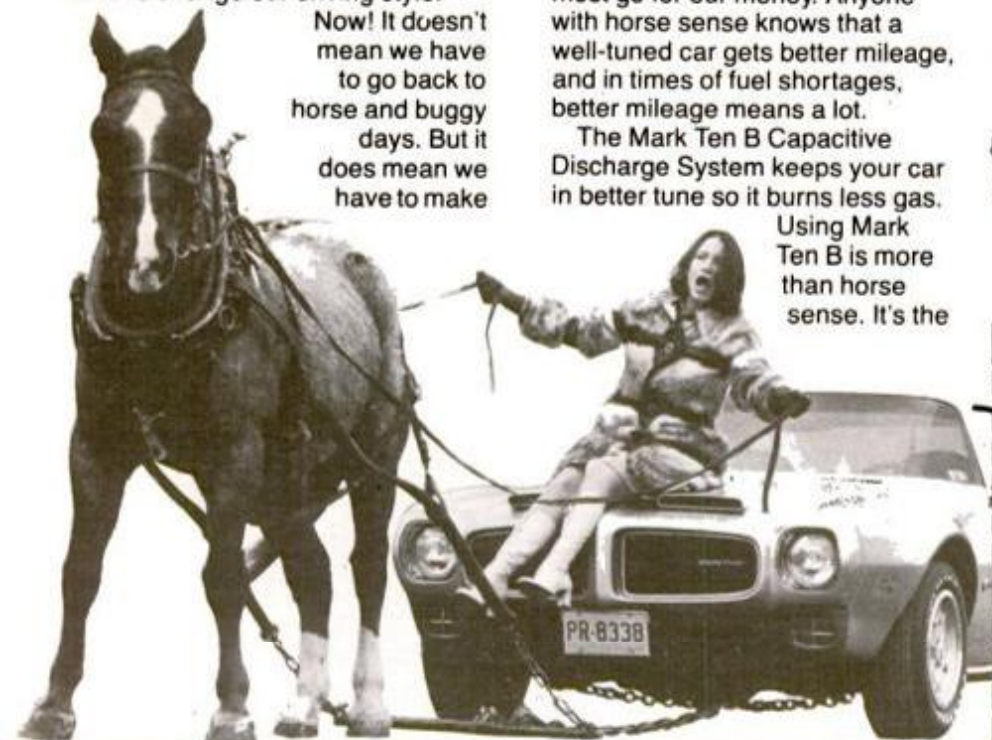

DELTA PRODUCTS, INC.

One Delta Way, Dept. PM
Grand Junction, Colo. 81501
(303) 242-9000

I want to know more about Mark Ten CDI's. Send me complete no-nonsense information on how they can improve the performance of my car.

Name _____

Address _____

City _____ State _____ Zip _____



Drain Flooded Cellar Fast

Needs No Electric Motor or Gas Engine

To drain out a cellar, pool, vat, cistern, excavation, boat, don't break your back hand-pumping or bailing. Just connect your garden hose to nearby water faucet and free end to intake side of DRAIN-DRI. Connect another length of hose to discharge side, turn on faucet, and normal water pressure makes the Drainer work. This siphon pump has no moving parts to wear, jam or break down. Only \$3.98 plus 80c handling and postage. Satisfaction guaranteed or money back.

LARCH, Dept. 209-A, Box 770 Times Sq. Sta. N.Y. 10036



3000 WATT SAVONIUS WINDMILL SYSTEM

"Build this Savonius Wind-Turbine from simple parts and generate up to 3000 Watts of valuable electricity! Ideal for homes, farms, cottages! Operates more efficiently than conventional windmills, even in low windspeed areas! Simple, Economical Construction! Complete Plans & Parts Catalogue: \$6.95."

Glenvale Products Dept WP,
Box 358 Station D,
Toronto, Ontario M6P 3J9

BUY STAINED GLASS SUPPLIES DIRECT FROM MANUFACTURER

Came Leads, Glass, Solder and Tools!

Everything you need for the professional or beginner. Wide selection of tools and materials with instructions all in our exciting new catalog. For your copy send \$2.00, refundable with first order. Satisfaction guaranteed.

CORAN-SHOLES INDUSTRIES

509 E. 2nd St., Dept PM So Boston, Mass. 02127
(617)268-3780

RATCHET SCREWDRIVER SET

LATEST DESIGN - HIGH TORQUE - COMFORT GRIP
4 BLADES (1/4 & 3/16 regular, #1 & #2 Phillips) STORED IN HANDLE

Send \$4.75 plus \$1.25 shipping and handling

AMERICAN CALCO, INC., Dept PM89
P.O. BOX 7000-47, PALOS VERDES PENIN., CA 90274

BEST BUY!

EASY-TO-ASSEMBLE KIT

ONLY \$355 F.O.B.

For 3'6" diam. Other diams. from 4' to 6' at comparable savings. All diams. adjust to floor-to-floor hts. of 8'1/2" to 9'6".



©The Iron Shop 1977

People who've looked everywhere tell us there isn't another spiral stair around that touches our combination of price and quality of materials and workmanship. We believe it! CALL OR WRITE FOR FREE BROCHURE:

To: The Iron Shop, Dept. 258 Box 128, 400 Reed Road
Broomall, Pa 19008 Our Tel: (215) 544-7100.

Name _____

Street _____

City _____ State _____ Zip _____

We accept Master Charge and BankAmericard.

THE IRON SHOP

MANUFACTURERS

JUST PUBLISHED THE COMPLETE GUIDE TO KIT CARS

160 Pages

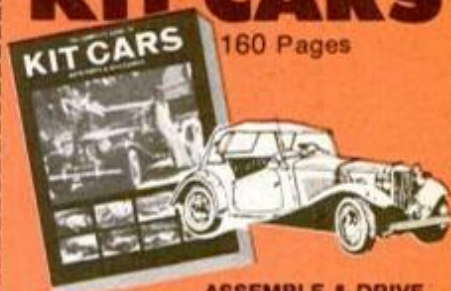

ASSEMBLE & DRIVE YOUR OWN FULL-SIZE SPORTS CAR

The 'All-New' 1979 KIT CAR GUIDE has it all! More than 110 exciting full-size sports car kits • In-depth articles • Detailed reviews • A giant New Directory Section • Hundreds of photos never before published • Up-to-date price comparisons • How-to's • Specifications • Do-it-yourself features • Parts • Gadgets • Accessories • And much more...



REPLICARS • EXOTICS • ANTIQUES • VANS
ROADSTERS • TRUCKS • BUGGIES • RODS

\$7 Postpaid \$9 Rush Mail & Foreign

Send Today To: **AUTO LOGIC, INC.**
P.O. Box 2073, Dept. PM-89
Wilmington, DE 19899

name (print) _____

address _____

city _____ state _____ zip _____

14 Day Money Refund If Not Completely Satisfied

CUT STRAIGHT WITH 'STRATE-CUT'



A MUST FOR ALL POWER TOOL USERS

Use "STRATE-CUT" Cutting Guide with any portable circular saw, jig saw or router. Extends to 8'6", reduces to 51" for short cuts and portability. Clamps to paneling, doors and other long work. Rip 4'x8' sheets down the center; trim 1/16" off a door. Make precision 90° cuts, tapers, angles, dados, bevels, grooves. Unbeatable for scoring wall-board. Guides utility knife. Here's how this sturdy aluminum tool works:

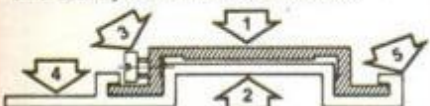

(1) Patented connector joins and aligns (2) two 51" guide sections with four set screws (3) C-clamps (4) attach guide to work. Tool follows guiding edge (5) Clamps and illustrated instructions incl. only \$19.95 plus \$1.50 shipping and handling, U.S.A. only. Send check or M.O. to: R.A.K. PRODUCTS, Department M-35 Box 23426, Milw., WI 53223. MONEY BACK GUARANTEE. Wis. Res. 4% tax.

CHOOSE YOUR FREE BUTTON!

(OVER 1,000 CHOICES)



PROMOTE • RAISE FUNDS MAKE PROFITS • IDENTIFY

It's America's most extensive line of badge and button making equipment. Useful for clubs, schools, business, individuals. Basic kit contains hand die press, color coded dies, badge parts and illustrated instructions. All for just \$24.95.



SEND TODAY

BADGE-A-MINUT, Ltd., Box 618, Dept. PM-89 Civic Industrial Park, LaSalle, IL 61301

- Yes, I want to choose my FREE Sample Button. Send your 48-page color catalog.
- I'm convinced, send me the complete BADGE-A-MINUT system. I've enclosed \$24.95 plus \$1.75 postage. Ill. Residents add 5% sales tax.
- Use my credit card indicated below:
 - VISA (BankAmericard)
 - American Express
 - Master Charge

Credit Card # _____
 Inter Bank # _____ Exp. Date _____
 Signature _____
 Name _____
 Organization _____
 Address _____
 City _____ State _____ Zip _____

UNCONDITIONAL MONEY-BACK GUARANTEE



Rockwell Speed-Bloc Sander—Palm grip design for one hand use. Thumb control switch, off-set pad for 4 way flush sanding. 12,000 OPM. 100% Ball Bearing, 5/64" Orbit, 115 V. Direct Motor to pad design. Pad size 4 1/2" x 4 1/2". Add \$2.00 for shipping. Reg. \$69.99 4480(330)-R7 \$49.98

SILVO (BRAND NAME) TOOL CATALOG
 THOUSANDS OF EXCITING TOOL VALUES: Stanley, Wen, Speedy-Sprayers, Milwaukee, Rockwell, Dremel, Skil, Nicholson, Disston, Millers Falls, Helios, Wellsaw, Plumb, Kennedy, Huot, Ridgid, Crescent, Vise-Grip, Audel Books, Unimat, Wiss, Channel-lock, General, Pony Clamps and many Nationally Advertised brands of tools and supplies. We ship Coast to Coast at prices hard to beat. Send \$1.00 for our big SILVO TOOL CATALOG today.

SILVO HARDWARE CO.

107 Walnut St., Dept. PM-8 Phila., Pa. 19106

Telephone Answering and Recording System

Eliminate those obscene telephone calls



Retail Price \$279.95

Sparky's Price \$199.95

Model 1400 is a low cost telephone answer and recording system featuring "Positive Call Control", which allows the user to rewind or fast forward to any individual message on the tape. It features variable outgoing announcement length between 2 to 20 seconds. The channel index keeps track of calls received-up to 20 messages of 30 seconds in length. A ring delay switch adjusts to answer on one of four rings. The convenient volume control allows the user to monitor incoming calls and answering only those of immediate importance, eliminating the possibility of Obscene Phone Calls. The handy pocket coder enables you to check your phone for messages from any telephone in the world. Model 1400 has a 90 day factory warranty. Use your Master Charge, VISA card for fast service, personal checks are held for bank clearance causing a lengthy delay in shipment. Order yours today, phone toll free

1-800-255-6369

Sparky's Home Electronic Center

11489A, Oak Park Mall

Overland Park, Kansas 66214

Send \$2.00 for our Electronic Products Catalog

WATER SHORTAGE?

INTRODUCING THE EXPLORER 2000 COMPLETE - SELF-CONTAINED WATER WELL DRILLING RIG



The "EXPLORER 2000" can be purchased and operated for less than the average cost of one commercially drilled water well. Furthermore, the "EXPLORER 2000" can be used to drill an unlimited number of water wells for home or commercial use.

Gasoline powered, all hydraulic drive-Industrial grade Construction-One man operation-2" to 8" diameter wells-Up to 600' depth-Fully self-contained-Pickup or trailer mounted-High speed drilling-Complete line of accessories.

Send \$3.50 (Refundable)
 To: Piper Hydro Drilling
 P.O. Box 237
 Alamogordo, N.M. 88310

THE FUN MACHINES

... that work, too!



6 BIKE MODELS

- FUN TO BUILD!
- FUN TO RIDE!

These rugged off road vehicles are powered by 5 hp to 16 hp American-made engines. Engine is completely assembled, frame is welded and painted. You just bolt everything together and start riding. Kit priced from \$399.95 and \$799.95.

For a FREE color

brochure with complete details, write today to:

Carl Heald, Inc. Dept. PM-98, P.O. Box 1148, Benton Harbor, MI 49022
 From the largest Maker of Bike and Tryke Kits in the World — Carl Heald, Inc.



7 TRYKE MODELS

SUPER TRYKE

THE ULTIMATE IN HEADPHONES



4 in 1 System

- TV Sound 2-13
- FM Radio
- WB Radio
- Stereo

THE VERY LATEST IN PORTABLE SOUNDS. THESE UNIQUE HEADPHONES HAVE TV SOUND CHANNELS 2-13, FM RADIO, WB RADIO, COMPLETELY BUILT IN! NO WIRES! LISTEN TO YOUR FAVORITE TV SPORTS OR PROGRAMS IN COMPLETE PRIVACY. TV RANGE IS APPROX. 20-30 MILES. ALSO INCLUDED IS A STEREO CORD TO PLUG IN TO YOUR OWN STEREO SYSTEM OR TAPE DECK TO LISTEN TO THOSE RICH SOUNDS! DON'T MISS THE SOUNDS OR EVENTS!

SEND \$39.95 (Plus \$2.00 for shipping) TO: IMC (Innovative Marketing Co.) P.O. Box 66 Plainfield, Ind. 46168

10 YEAR Guarantee \$4.50



A GREAT

all purpose knife for the outdoorsman. Offers you the quality of

CUSTOM made models selling for much more! Hand polished imported surgical steel blade has SAFETY LOCK to prevent accidental closing. Expensive Peaco wood handle. SOLID BRASS bolsters and liner. Popular 4" size (7 1/4" open). IF BROKEN IN 10 YEARS WE WILL REPLACE AT NO CHARGE! Use 30 days, money back if not pleased. Send \$4.50 plus 48¢ postage & handling TODAY. Midwest Knife Co., Dept. W-2308 9043 S. Western Ave., Chicago, Ill. 60620. Mail orders only.



Know your car inside and out.

Know how to fix it... to tune it... to service it... to keep it running right. The **TOTAL SERVICE MANUAL** for your car will show you how to do everything from a minor adjustment to a major repair.

factory workshop manuals. Each one is carefully rewritten for use by the do-it-yourself car owner. Clear and easy to follow, yet complete and detailed enough even for professional use. You get all the important information plus hundreds of the best pictures, diagrams, and specifications.

TOTAL SERVICE MANUALS are digests of official

SATISFACTION GUARANTEED OR YOUR MONEY BACK

TOTAL SERVICE MANUALS

1713	ALFA ROMEO 62-78 for all Giulia GT & Spider models	\$9.95
9641	ALFA ROMEO 73-78 for all Alfa Romeo models	\$9.95
9643	AMC AMBASSADOR 68-74 covers all models	\$9.95
8677	AMC PACER 75-77 covers all models	\$9.95
0991	ARROW, PLYMOUTH 76-77 for all models	\$9.95
9404	ASPEN, DODGE 76-78 for all models	\$6.95
7122	AUDI 100 70-77 for all models inc 100i	\$9.95
8749	AUDI FOX 73-79 covers all models	\$17.50
1229	AUSTIN AMERICA 68-71 covers all models	\$9.95
1203	AUSTIN HEALEY 100/6, 3000 56-68 for all models	\$9.95
0752	AUSTIN MARINA 71-75 sedan and GT models	\$9.95
0379	BARRACUDA & CUDA 65-72 all 6 & V8 models	\$6.95
0503	BLAZER, CHEV 59-77 for all 2 & 4 wheel drive models	\$7.95
1007	BMW 1600 66-73 covers all models	\$9.95
1042	BMW 2000, 2002 66-76 covers all models inc CA, CS, TI	\$9.95
9813	BMW 320 75-78 covers all models	\$9.95
9760	BMW 2500, 2800, 3.0 all models inc Bavaria & CS	\$10.95
0978	BOBACAT, MERCURY covers all models thru 76	\$7.95
0506	BONICO, FORD 66-77 all 2 & 4 wheel drive models	\$7.95
0024	BUICK 66-74 factory manual - must give car year	\$17.95
0041	CADILLAC 61-63 factory shop manual - give year	\$14.95
0727	CADILLAC 68-74 all models except El Dorado	\$9.95
0032	CADILLAC 76-77 factory manual - must give year	\$14.95
8678	CAMARO 67-78 covers all 6 & V8 models	\$9.95
9557	CAPRI 70-76 for all 2000, 2600, 2800 models	\$9.95
0379	CHALLENGER 70-72 covers all 6 and V8 models	\$9.95
8331	CHARGER 67-70 for all models inc 500 & R-1	\$9.95
8212	CHARGER 71-75 covers all models	\$6.95
0383	CHEVELLE 64-77 inc Monte Carlo El Camino	\$6.95
0838	CHEVETTE 76-78 covers all models	\$9.95
0881	CHEVROLET 49-54 reprint of factory shop manual	\$16.00
0055	CHEVROLET 55-57 reprint factory manual give year	\$19.95
8407	CHEVROLET 58 supplement to 55 manual	\$9.95
0870	CHEVROLET 68-77 for all models inc 500 & R-1	\$6.95
8187	CHEVY II 67-77 covers all 6 & V8 models	\$6.95
1090	CHEVY LUV 77-77 covers all models	\$9.95
1661	CHEVY PICK UPS 67-78 all models & GMC	\$9.95
1662	CHEVY VANS 77-78 for all models & GMC	\$9.95
1145	CHRYSLER 55-71 all inc Newport, 300 New Yorker	\$9.95
0029	CHRYSLER 75-77 factory manual - give year	\$19.95
9588	CITROEN DX, DS 67-73 for all models 1.9, 2.0, 2.1	\$9.95
8539	CITROEN SM reprint of factory service manual	\$19.95
8264	COLT, DODGE 71-77 covers all models	\$9.95
9422	COMET 60-65 covers all models	\$6.95
8211	COMET 70-77 covers all models	\$6.95
8237	CONCORD, DODGE 75-75 covers all models	\$6.95
0472	CORVAIR 60-69 covers all models	\$9.95
0478	CORVETTE 57-65 covers all 283 & 327 models	\$9.95
9481	CORVETTE 66-76 covers all 327, 350, 427, 454 models	\$9.95
5756	CRICKET PLYMOUTH 70-73 also covers Averager	\$9.95
8188	DART & DEMON 68-76 covers all models	\$6.95
8251	DATSUN 101 76-78 covers all models	\$9.95
1164	DATSUN 200SX 77-78 covers all models	\$9.95
8065	DATSUN 1200, 8210 68-78 covers all models	\$9.95
1726	DATSUN 240Z/260Z 70-74 covers all models	\$9.95
8127	DATSUN 260Z, 280Z 75-78 covers all models	\$9.95
1551	DATSUN 510 68-73 covers all vdn & wagon models	\$9.95
1074	DATSUN 510 1978 models	\$9.95
9583	DATSUN 610 68-76 covers all models	\$9.95
0935	DATSUN 710 73-77 covers all models	\$9.95
8271	DATSUN 810 77-78 covers all models	\$9.95
1258	DATSUN 311 1600 2000 SR & SRL models	\$10.95
8430	DATSUN PICK UP 68-74 for all 521, 620 models	\$9.95
9297	DATSUN PICK UP 75-77 covers all PL620 models	\$9.95
1145	DODGE 55-71 all inc Coronet, Monaco, Polara	\$9.95
0871	DODGE 72-77 for all models inc Scamp	\$6.95
1259	DODGE OMNI 1978	\$9.95
8208	DODGE RAMCHARGER 74-75 covers all models	\$7.95
8564	DODGE PICK UP 65-75 service manual all 2 wheel drive	\$7.50
8371	DODGE PICK UP 65-75 service manual all 4 wheel drive	\$7.50
8203	DODGE VANS 67-77 for all 100, 200, 300 models & Plym	\$9.95
8192	DUSTER 70-76 for all models inc Scamp	\$6.95

8189	FAIRLANE 62-72 covers all models	\$6.95
9422	FALCON 60-64 covers all models inc Comet	\$6.95
9874	FALCON, FORD 64-70 covers all 6 cyl models	\$4.95
0480	FALCON, FORD V8 65-71 covers all V8 models	\$9.95
9276	FIAT 124 67-77 all inc sdn, sta wgn TC, spcl	\$9.95
7118	FIAT 124 SPORT 66-75 for coupe & spider mds	\$9.95
0844	FIAT 124 SPORT 76-78 for coupe & spider mds	\$9.95
9640	FIAT 128 69-77 for all models inc SL & Rally	\$9.95
8742	FIAT 131 75-77 covers all Mirafiori models	\$9.95
1201	FIAT 850 64-74 all sedan, coupe & spider mds	\$9.95
0399	FIAT XJ/9 73-78	\$9.95
1073	Fiesta, FORD covers all models	\$9.95
0675	FIREBIRD covers all models-67-74	\$7.95
1149	FORD 55-67 all inc Galaxie, LTD, Custom & wagons	\$9.95
0822	FORD 68-72 inc Galaxie, LTD, Custom, XL & wgn	\$6.95
9369	FORD COURIER 72-77 covers all models imported	\$9.95
8205	FORD PICK UPS 70-78 for all models to 3.4 ton	\$7.95
8204	FORD VANS 66-77 Econoline, 100, 200, 300 mds	\$7.95
9436	GRANADA, FORD 75-77 covers all models	\$6.95
8677	GREMLIN & HORNET 71-77 covers all 6 & V8 models	\$7.95
0644	HONDA 350, 600, 2- all models	\$9.95
0885	HONDA ACCORD 76-77	\$9.95
8694	HONDA CIVIC, CIVIC CVCC 73-77 covers all models	\$9.95
8206	INTERNATIONAL SCOUT 67-73 800, A, B, E mds	\$7.95
8565	INTERNATIONAL 62-75 tune & maintain all mds	\$6.95
1207	JAGUAR XK120, 140, 150 48-61 also Mk 2, 8, 9	\$9.95
1206	JAGUAR 58-78 covers mds 2, 4, 3, 8, 240, 340	\$9.95
1043	JAGUAR E TYPE 61-72 covers all 6-cylinder models	\$9.95
9612	JAGUAR E TYPE V12 71-74 covers all models	\$9.95
9399	JAGUAR XJ6 68-78 covers all models	\$9.95
9617	JAGUAR XJ12 72-77 for all models inc Diamler	\$9.95
9769	JEEP 50-65 for 4 & 6 cyl station	\$6.95
8207	JEEP 66-79 for all Cherokee, Commando & Wagoneer mds	\$7.95
9805	JEEP WAGONEER 78-78 covers all models	\$14.95
9806	JEEP UNIVERSAL CJ 2, CJ 3 reprint factory manual	\$14.95
0509	JEEP CJ 5, CJ 6, CJ 7, 55-79	\$7.95
8856	JEEP FC150, 170 covers all front cab models	\$14.95
8739	JENSEN HEALEY reprint of factory manual	\$19.95
1719	LANDROVER 1, 2 48-61 all models	\$9.95
1243	LANDROVER 59-76 covers 2, 2A 3 gas & diesel models	\$9.95
1145	LINCOLN 55-70 covers all models	\$9.95
9773	LINCOLN 71-77 all models inc Versailles	\$9.95
8190	MATADOR, AMC 71-74 covers all 6 & V8 models	\$6.95
0481	MAVERICK 69-71 6 cyl 170, 200, 250 cu in eng	\$6.95
8211	MAVERICK 72-77 covers all models	\$6.95
9512	MAZDA GLC 75-78 covers all models	\$9.95
0370	MAZDA RX2 70-73 covers vntn & coupe mds	\$9.95
0371	MAZDA RX 3, 100 70-74 covers all models	\$9.95
0444	MAZDA 71-78 includes RX4 and Cosmo models	\$7.95
9441	MAZDA RX 7 78-79	\$9.95
0880	MAZDA PICK UP 72-75 8 1500 & rotary eng mds	\$7.95
0593	MAZDA RX8, 814 72-78 covers all models	\$9.95
0573	MAZDA 1500, 1800 67-74 covers all models	\$9.95
1009	MERCEDES-BENZ 190 59-68; B, C & 200 models	\$9.95
1027	MERCEDES-BENZ 57-67 190S, 190D, 100d, 600	\$6.94
1746	MERCEDES-BENZ 220 59-65 covers all mds	\$9.95
9483	MERCEDES-BENZ 220 68-72 mds except G500	\$9.95
1747	MERCEDES-BENZ 230 63-68 inc 230S & L	\$9.95
1748	MERCEDES-BENZ 250 65-68 covers all models	\$9.95
9484	MERCEDES-BENZ 250 69-72 covers all models	\$9.95
9485	MERCEDES-BENZ 280 68-72 covers all models	\$9.95
0426	MERCEDES-BENZ 68-73 inc 280, 300 & 350, 450 V8 mds	\$8.95
8439	MERCEDES-BENZ 74-79 Covers all models inc Diesels	\$9.95
1149	MERCURY 55-70 covers all models	\$9.95
9273	MERCURY 71-77 for all models inc Cougar	\$9.95
1105	MG TA, TB, TC, TD, TF 36-55	\$9.95
1088	MG MIDGET 58-78 covers all models	\$9.95
1106	MGA, MGB 55-68 covers all models inc Twin cam	\$9.95
1720	MGB, MGBGT 69-79 all roadster & coupe models	\$9.95
8396	MGC reprint of factory manual	\$19.95
0917	MINI 59-75 covers all models inc Mini-Cooper	\$9.95
9436	MONARCH, MERCURY 75-77 for all models	\$6.95

0050	MONZA, CHEVROLET 77-79 factory manual - give car year	\$12.95
1109	MORGAN 36-77 covers all 4-cyl models	\$9.95
9876	MUSTANG 6 65-72 covers 200 & 250 engines	\$9.95
0479	MUSTANG V8 65-73 covers all models	\$9.95
8272	MUSTANG II 74-76 covers all models	\$8.95
8187	NOVA 69-77 covers all 6 & V8 models	\$6.95
7207	OLDS CUTLASS 70-77 covers all inc 442 models	\$6.95
0678	OLDSMOBILE covers all models-55-74	\$9.95
0008	OLDSMOBILE 75-79 factory manual - give year	\$16.95
1724	OPEL KADETT 62-73 1000, 1100, 1200 models	\$9.95
1752	OPEL KADETT 67-73, 1500, 1700, 1900 mds	\$9.95
0859	OPEL 1900 MANTA 70-74 covers all coupe mds	\$9.95
0273	OPEL 75-77 covers all models inc Insignia	\$9.95
9589	OPEL GT 68-73 covers all 1900 models	\$9.95
9872	PEUGEOT 304 covers all models-70-73	\$9.95
1546	PEUGEOT 404 60-75 covers all models	\$9.95
0876	PEUGEOT 504 68-74 includes diesel models	\$7.95
7124	PEUGEOT 504 68-76 for all gasoline models	\$9.95
0482	PINTO 70-73 covers all models	\$9.95
0883	PINTO 74-79 covers all models inc Bobcat	\$7.95
1145	PLYMOUTH 55-71 all inc Belvedere, Fury, Saboteur	\$9.95
0874	PLYMOUTH 72-76 Fury, VIP, Gran, Suburban mds	\$6.95
1660	PLYMOUTH HORIZON 1978	\$9.95
0876	PONTIAC 55-74 all inc Catalina, Buick, Ventura	\$9.95
0489	PONTIAC TEMPEST 68-73 all mds inc GTO, Le Mans	\$6.95
1650	PORSCHE 356 57-65 covers A, B & C models	\$9.95
1591	PORSCHE 911 64-73 covers all models	\$9.95
8173	PORSCHE 911 74-77 includes N, S, Targa, Carrera	\$9.95
1590	PORSCHE 912 65-69 with 1582cc engine	\$9.95
9834	PORSCHE 914 70-76 all models inc 914 6	\$9.95
0993	PORSCHE 924 76-78	\$9.95
8208	RAMCHARGER, TRAILDUSTER 74-75 all models	\$7.95
8190	REBEL 67-70 covers all 6 & V8 models	\$6.95
0372	RENAULT 5 72-78 for all models inc Le Car	\$9.95
1224	RENAULT 8, 10 62-72 covers all models inc 1100	\$9.95
9429	RENAULT 12 69-79 covers all models inc auto trans	\$9.95
0645	RENAULT 15, 17 71-78 all mds inc TL, 15	\$9.95
1554	RENAULT 16 65-78 covers all models	\$9.95
0395	ROADRUNNER & SATELLITE 68-73 all models	\$6.95
1121	ROVER 2000 63-75 for all models inc 2200	\$9.95
9493	SAAB 95, 96 66-75 covers all V4 models	\$9.95
1759	SAAB 99 69-71 covers all models	\$9.95
0750	SAAB 99 72-76 for all models inc EMS	\$9.95
8440	SAAB 67-76 covers all models inc Sonnet	\$9.95
1098	SPRITE 58-71 covers all M 1, 2, 3 & 4 models	\$9.95
8058	SUBARU 70-77 covers all models	\$9.95
0833	SUNBEAM ALPINE 55-56 Mk 1, 2, 3 & 4 Roper	\$9.95
0845	SUNBEAM TIGER reprint of factory shop manual	\$19.95
0489	TEMPEST, GTO, LE MANS 68-73 all models	\$6.95
9773	THUNDERBIRD 71-77 covers all models	\$7.95
8189	TORINO 68-75 all models inc Elite, Ranchero	\$9.95
0912	TOYOTA CELICA 70-77 covers all models imported	\$9.95
7127	TOYOTA COROLLA 68-74 for all models	\$9.95
9812	TOYOTA COROLLA 75-77 all including 5-speed	\$9.95
7132	TOYOTA CORONA 68-76 covers all 4-cyl models	\$9.95
0754	TOYOTA CORONA Mk 2 72-74 for all 6 cyl models	\$9.95
0647	TOYOTA HI-LUX 68-77 covers all 4-cyl mds	\$9.95
8524	TOYOTA LAND CRUISER 66-77 covers all models	\$9.95
0687	TRIUMPH STAG 70-74	\$9.95
1200	TRIUMPH SPITFIRE 69-78 covers all models	\$9.95
1016	TRIUMPH GT6 62-74 for all models plus Vitesse	\$9.95
0927	TRIUMPH TR2, TR3, TR4 52-67 for all models	\$9.95
1015	TRIUMPH TR5, TR6, 67-76 all models inc TR250	\$9.95
8693	TRIUMPH TR7 75-77	\$9.95
8192	VALIANT 68-76 all mds inc Scamp, Signette	\$6.95
0567	VEGA 72-73 all 140 C/D & GT 140 C/D models	\$6.95
0884	VEGA 74-77 covers all models	\$6.95
9404	VOLARE, PLYMOUTH 76-78 for all models	\$6.95
1227	VOLKSWAGEN BEETLE 54-67 for all mds inc K.G	\$9.95
8456	VOLKSWAGEN BEETLE 68-71 all mds inc K.G	\$9.95
7201	VOLKSWAGEN BEETLE 72-77 all mds inc K.G	\$9.95
6010	VOLKSWAGEN RABBIT, SCIROCCO 74-79 all mds inc Desert	\$16.95
1547	VOLKSWAGEN BUS 54-67 all camper, van transporter mds	\$9.95
7130	VOLKSWAGEN BUS 68-78 all camper, van transporter mds	\$9.95
9482	VOLKSWAGEN TYPE 3 62-73 Squaback, Fastback	\$9.95
9639	VOLKSWAGEN 411 68-72 covers all L, L.L, L.L. mds	\$9.95
9778	VOLKSWAGEN 412 71-73 covers all models	\$9.95
8748	VOLKSWAGEN DASHER 74-78 covers all models	\$14.95
9444	VOLVO P1800 60-73 all models inc E & L S	\$9.95
1722	VOLVO 122 61-70 for all models inc GT	\$9.95
1254	VOLVO 142, 144, 145 66-74 for all models inc S & L	\$9.95
9558	VOLVO 164 68-74 for all models, inc fuel injection	\$9.95
3729	VOLVO 242, 244, 245 75-78 for all inc fuel inj	\$9.95
8311	VOLVO 262, 264, 265 75-78 all models inc fuel injection	\$9.95

GENERAL INTEREST BOOKS

0743	CHILTON AUTO REPAIR 72-79 for all American cars	\$14.95
1775	CHILTON AUTO REPAIR 68-75 Reg. \$12.95, Special	\$6.95
1763	CHILTON AUTO REPAIR 54-63 for all American cars	\$17.95
8561	CHILTON TRUCK REPAIR MAN 61-71 for all 1 1/2-1 1/2 ton mds	\$19.95
0445	CAR ECONOMY TUNING GUIDE getting most from the least	\$2.95
0979	FLAT RATE MANUAL 66-75 all mech & elec reprs US cars	\$14.95
7125	AUTO AIR CONDITIONING... service & repair all	\$6.95
8726	TRANSISTOR IGNITION SYSTEMS covers them all	\$5.95
1067	MORE MILES PER DOLLAR GUIDE How to do it right	\$5.95
9622	HOW TO TUNE YOUR CAR good for all cars	\$4.95
8859	GM DIAGNOSIS MANUAL for all GM built cars	\$4.95
1712	BASIC AUTO REPAIR MANUAL a must for any car	\$9.95
1707	BASIC BODYWORK & PAINTING	\$3.95
1711	BASIC CARBURETORS & FUEL SYSTEMS	\$3.95
1706	BASIC CHASSIS, SUSPENSIONS, BRAKES	\$3.95
0791	BASIC ENGINE TROUBLESHOOTING	\$3.95
1708	BASIC IGNITION & ELECTRICAL SYSTEMS	\$3.95
0680	BASIC AUTO TROUBLESHOOTING for all cars	\$3.95
8359	BRAKE SERVICE GUIDE for repairing all types & makes	\$5.95
0889	FUEL INJECTION MANUAL covers all systems through 1972	\$14.95
9411	HOLLEY carbs, all 2 & 4 bbl, tune & rebuild	\$5.95
9652	ROCHESTER carbs, all inc 4MV Quadrajet	\$9.95
9656	SOLEX CARBURETORS all 1 & 2 barrel down draft	\$2.95
6354	SU CARBURETORS tune & rebuild all to 1976	\$6.50
9423	STROMBERG CD CARBS tune/rebuild all to 1976	\$6.50
0734	WEBER DCOE overhaul manual	\$4.95
1153	WEBER CARBURETORS theory & design	\$3.95
9803	WEBER CARBURETORS tuning & rebuilding all	\$3.95
0827	AUTOMOTIVE REFINISHING best paint book yet	\$5.95
8425	MINOR AUTO BODY REPAIR step by step how to	\$6.95
51		

PLANS AND INSTRUCTIONS FOR

- Go Kart\$2.50
- Mini Bike\$2.00
- Mini Car\$3.00
- 12" Self Boat\$4.00
- Front Traction Go-Kart with Gearless Differential\$10.00
- Mini Jeep\$3.00
- Pedal Boat\$4.00
- 8 H.P. Tractor\$10.00

Mini Vehicles Plans Dept.-C
Cheney, N.Y. 12921

CLOCK COMPONENTS

Clock Movements: Battery, Quartz, Pendulum, Mantle, Key Wind, Electric, Grandmother Westminster Triple Chime, 31 Day School Clock, Metal, Bezel, & Paper Dials, Brass, and Plastic Numbers, Markers, Clock Hardware, Hundreds of Items, Quantity Prices, Send \$1.00 For 50 Page Catalog, Refunded on \$10.00 order.

NEWPORT ENTERPRISES, INC. Dept. A
2313 West Burbank Blvd., Burbank, Calif. 91506

FREE SAMPLE IMPORT

START MAIL ORDER IMPORT BUSINESS. Get free sample import from Orient. Shows big money you can make spare/full time in home business. No investment in stock. World famous mail order/world trade expert guides you. Clip ad. Good for one free sample import and big Free Report. Offer limited to adults. Mail ad today. **THE MELLINGER CO., Dept. P2258**, 6100 Varial Ave., Woodland Hills, CA 91367.

Portable Steam Cleaner
Steam in 60 seconds

CLEAN: Engines, Air Filters, Lawn Mowers. 3 year guarantee on fire box, coils. Uses liquid soap, propane fired. Weight 120 lbs. Auxiliary pump required on low water pressure.

WEDCO MFG. INC., Dept. M-10
Scott Lane • Box D, Jackson, WY. 83001

**NEW EDITION
POPULAR MECHANICS
CATALOG OF PLANS
PUBLICATIONS
PROJECTS**

A must for all homeowners and do-it-yourselfers. Build projects the whole family can enjoy!

To mark the 75th Anniversary of Popular Mechanics, we have published a brand new edition of our famous catalog of *Plans, Publications, Projects*.

For the past seventy-five years Popular Mechanics Magazine has been the leading publisher of plans and special publications for the do-it-yourselfer. Now we have listed our most popular plans, and all our famous special publications, in this brand new illustrated catalog.

PM's new catalog is loaded with photos and illustrations. You'll find listings for over 800 plans and publications along with complete ordering instructions.

Send for your catalog today! Only 50¢ postpaid.

To order send coin, check or money order to: Popular Mechanics Catalog, Dept. C77, Box 1014, Radio City Station, New York, N.Y. 10019.

Popular Mechanics is a publication of Hearst Magazines, a Division of THE HEARST CORPORATION.

RE-LITE

2 bulb fixture duplicates the charm and increases the light output of a double mantle gaslight. Kit includes on-at-dusk, off-at-dawn photo control, fixture, bulbs, detailed instructions. Your energy savings will pay for this kit in less than 6 months. 115 volt kit \$29.95 postpaid, or safe 12 volt kit including UL approved transformer, \$39.95. Dealers and installers inquiries invited.

Yardlighting Systems, Inc.
1678 Hewitt
St. Paul, MN 55104

WASTE OIL HEATER

• Proven • Smokeless • Odorless

You can beat the energy crisis in shop, farm, home, or business and Heat FREE...use any type waste oil. DEALERS INVITED

LENAN ENTERPRISES
Info **BOX 94**
\$1.00 **MILTON, WISC. 53563** 87,000 BTU

**SATELLITE TV
GET 50 CHANNELS!**

It's all true! No matter where you live receive movies, sports, pay television sports from around the world! 24-hour programming! Crystal clear reception! For complete information, sources and design information, send \$7.95.

SPACECOAST RESEARCH
Dept. E, P.O. Box 442, Altamonte Springs, FL 32701

HORNS
MAKE PEOPLE MOVE

- Tune Playing Air Horns! • Sounders for Burger and Fire Alarms
- Unique Animal Sounds
- 400-500 Gals. and 4000 Wires
- The Most Advanced Vehicle Alarm Systems
- European Police and American Sirens
- High Power Deafner Signals
- 1000's of Sounds

KOLIN INDUSTRIES, INC.
Box 357M-09 Bronxville, New York 10708
(914) 961-5065

FREE CATALOG

**IMPORTED
LOCK BLADE**

9" Overall Length
5" When Closed **\$3.50 Ea.**

- Sharp and Tough
- Stainless Steel Blade

Flips open instantly and locks automatically to prevent accidental closing. Razor sharp tough stainless steel blade for reliable use and hard long service. Send **\$3.50 plus 50¢ to cover postage and handling**

Model # **K-12-AL**

Not for sale in areas where prohibited by law

WESTBURY SALES CO.
373 MAPLE AVE. Dept. L-8-PM, WESTBURY, N.Y. 11590

Change your Luck Instantly!

enjoy instant riches, success, love, health, power.

There can be no success without LUCK! Luck can be controlled and changed, resulting in Power and Wealth beyond imagination. (Warning: You will receive powerful information. It is not to be misused.) If interested, write at once for this fantastic free report.

MARK-M ASSOC., Dept. PM-II, P.O. Box 98, Brooklyn, NY 11235

EASY TO READ • SAME SIZE

BLUEPRINTS FOR WOODEN TOYS, GAMES, PLAQUES, PUZZLES

CATALOG \$1.00 (REFUNDED WITH FIRST ORDER)

DESIGN GROUP, P.O. BOX 514, DEPT. F, MILLER PLACE, N.Y. 11764 NY add sales tax

Laser 917. A Unique Sports Car Kit

FOR VW FUN, EASY TO BUILD

Send \$3 for color brochure
Send \$29.95 for brochure and assembly manual
Credit card ordering

CALL TOLL FREE 1-800-328-8898

Elite Enterprises Dept. PM879
690 East Third St. Coakato, MN 55321

NEW! VERTICAL MILL

Write for free literature on our complete line of miniature tools and accessories.

The Ultimate Tool for the miniature machinist. From the makers of the famous SHERLINE 3" Lathe.

FULLY GUARANTEED

MANUFACTURED IN U.S.A.

only \$289.50
f.o.b. San Marcos

SHERLINE PRODUCTS
INCORPORATED

170 NAVAJO
SAN MARCOS • CA
92068 • USA

...the hobbyist's complete workshop

Burglar - Fire - Smoke Alarm Catalog

• Billions of dollars lost annually due to lack of protective warning alarms.

FREE CATALOG Shows you how to protect your home, business and person. Wholesale prices. Do-it-yourself. Free engineering service.

Burdex Security Co.

Box 82802 PM089 Lincoln, Ne. 68501

Hydraulic Log Splitter

PARTS ALSO AVAILABLE TO "BUILD YOUR OWN"

- Take the back breaking drudgery out of woodsplitting. Split logs for your own firewood. Split logs on a portable skidsteer. Use your log splitter to earn money for you on a rental basis. Splits pre-cut lengths up to 26" with 10.5 ton force. Fast splitting cycle time, 10 seconds.

BRAND NEW

F.O.B. Lincoln \$749.50

- Powered by 5-HP Briggs engine. Powerful 2-stage pump. Detent control valve automatically returns to neutral at end of force stroke and return stroke. All top quality components and construction. (Shop. Wt. 300 lbs.)
- "BUILD-YOUR-OWN" and save. We can furnish top quality components to build other sizes. Write us for description and prices. Send for our catalog. 100's of other items.

SURPLUS CENTER PM089 Lincoln, Nebraska
Zip Code 68501

GO... HUNTING
with a White's

electronic mineral/metal detector

Locate gold, silver, coins, rings... from \$59.95

U.S. Patented • Call Toll Free for nearest Dealer Up
•••800-447-4700 (in ILL., Call 800-322-4400)

ELECTRONICS •••Free Literature•••DEPT. P9
1011 Pleasant Valley Rd., Sweet Home, OR 97386

CLASSIFIED ADVERTISEMENTS

Rate: \$4.00 per word payable in advance each insertion. Minimum insertion ten words. Bold face capitalized words—\$1.00 per word additional (First word set in Bold Face at no extra charge, Zip Code Free.) The next available issue to place an advertisement in America's No. 1 Classified Section is **October**. The closing is **August 3rd**.

Send remittance payable and order to Popular Mechanics, ATT.: Hildegard E. Kappel, Class. Adv., Mgr., 224 West 57th Street, New York, New York 10019. Please indicate Heading under which ad is to appear. As a consumer service and in cooperation with our mail-order advertisers who use post office box addresses for their convenience in handling your order, Popular Mechanics maintains a register of such mail-order advertisers containing their complete names and street addresses.

When answering advertisements please use the zip code number

AUTOMOBILES

ZERO-COST AUTOMOBILE OWNERSHIP!! Details FREE. Techneering, Box 12191BZ, Norfolk, VA 23502

HYDROGEN - ALCOHOL Automobile Conversion and Fuel Generator Plans. Refundable. \$6.00. Merit, 2307 Tyler Lane, Louisville, KY 40205

MOTALOY Ring-Valve Replating Job—\$6.00. Money-Back Guarantee! Free Brochure! Arrow Products, Box 374M, Broken Arrow, OK 74012.

MPG INCREASED 30% + !! No gimmicks—no gadgets. Professional secrets revealed. Free details—Posco (#GB8), Box 444, Bronx, NY 10471

LECTRICKAR—Convert VW's, Flats to electric 50 mph plans \$25.00. Info \$1.00 Robert Bucy, Box 28794, Dallas, Tx. 75228.

PROPANE: Convert Your Engine—Keep Gasoline Standby!! How-to Book (Handtools!). \$4.95. Guaranteed! LPG Automotive, Box 1045MB, Newport Beach, California 92663

MOT Engine? Secret New Cooling Invention Discovered! So Ingenious Anyone can Install it. Guaranteed—\$7.85—Aljac, Box 3504-P2, Redondo Beach, California, 90277

RAMEX Ezeon. Exhaust Enhancer Increases MPG. \$5.95. Guaranteed. Gasaver, Box 989, Tacoma, WA 98401

RETUNING FOR MAXIMUM ECONOMY: Average mileage increase 55%, horsepower 5-10%. Details FREE. Techneering, Box 12191B, Norfolk, VA 23502.

MIRACLE Carburetor Vaporizes gas 100+ MPG. Drawings and Details \$6.00. Satisfaction guaranteed. Carbu, RT1, Box 79M, Hitchcock, South Dakota 57348

USE REGULAR GASOLINE INSTEAD OF NO-LEAD, PREMIUM. Simple, Inexpensive Formula. Send \$3.00 Arness Associates, Box 190-PM, Van Nuys, CA 91408

FORGOTTEN Carburetor Patents! Seven Unusual! Detailed drawings! Vaporize Gases, Gasoline, Diesel! Imagine the possibilities! \$5.00 Guaranteed. Lindsay, Box 12-1B, Bradley, IL 60915

HIDE ANY RADAR DETECTOR. Waterproof, Remote Mounting behind Grill or Below Bumper. Step by Step Instructions, Photos, Drawings, Parts List, \$5.00. VISA, Mastercharge (supply expiration date). TESE, Box 965-M, Gaffney, SC 29340

POWERFUL HORNS! Make people move! Hundreds of sounds! For cars, trucks, motorcycles, boats! Free Catalog. Kolin, Box 357-PM89, Bronxville, NY 10708

GAS Crisis! Simple Engine Modifications Increase MPG! Details: Supercar, Box 28101MM, St. Louis, MO 63119

POWER Your Car with Wood, no Engine Modifications. Send \$3 for Patented Information - Alternate Energy Research, Box 1321, Manassas, VA 22110

AVOID Radar Traps and Speeding Tickets. Results Guaranteed. Send \$2.00 To: Upland, 11 Lincoln, Maynard, Massachusetts 01754

RUN Car, Truck, or PROPANE! Switch back to Gasoline Instantly. Build yourself in two days. Only Hand Tools, Simple Plumbing required. Use Inexpensive Parts Available Anywhere. Satisfaction ABSOLUTELY Guaranteed! For plans—Send \$10.00. Fleming Engineering, Remsen, NY 13438

SAVE GASOLINE U.S. Government Patent Information. Henco, Box 3804, Seminole, Florida 33542

LOWER PRICE GAS - save 30¢, 40¢ or more per gallon. For information about alternate sources of Lower Price Gas for Cars & Trucks, Send \$9.99 to: S.I.P. Enterprises, P.O. Box 4873, Shreveport, LA 71104

SAVE MONEY — Cut Fuel Bills. Convert Car or Truck Engines to Propane. For information send \$1.50 to: Propane, 6108 Rue Des Amis, San Antonio, Texas 78238

GAS Mileage Improved 50 to 100 Percent. Learn Patented Method. For Info. Send \$3.00 to: Dynotherm Co., P.O. Box 61, Eagle, Idaho 83616

GASOHOL! New gasoline-saving motor fuel. Home-making guide, \$1.00. Gormet, 5133 Fairhill, Philadelphia, Pa. 19120

GASOHOL. Discover how to make the Alcohol that goes into newly developed Gasohol. Easier to make than beer and Wine made at Home. Send \$3.95 to: Energy, 8401 Leeward, Huntington Beach, California 92646

GAS-A-HOL Make your own Fuel—Less than 15¢ Gallon—Complete Plans—\$10.00. Information \$2.00. Designers Den, 750 North Main, Cedar City, Utah 84720

SLICK 50 — One Time Teflon Engine Treatment GUARANTEED TO INCREASE Gas Mileage. REDUCE Wear, Friction, Oil Consumption, Operating Temperature. Send \$20.95. Visa, Master. GFW, Box 38329, Dallas, Texas 75238

BURN WATER WITH GAS. MORE MILEAGE more power. As seen on Television: Free Info! Complete Plans and parts list \$25.00. Goodman Engineering Co., 685 N. Loudoun St., Winchester, Va. 22601

SCOTTISH GENIUS. Run Your Car Without Gasoline, Not Propane, or Steam, No Alterations to Engine. Free Details, Coldcast Laboratory, 43 Ogilvy Place, Arbroath, Scotland

KNOW The Dealers Cost of New Car, before You Buy. Send \$2.00. Box 1326, Linwood, Pennsylvania 19061

WHITEWALLS dull? Protect your investment with **SHOWROOM BRITE.** Guaranteed! \$9.95 ppd. White-wall, Box 633, Phoenixville, PA 19460

ELECTRIC VEHICLES

BUILD LECTRA BUG! Amazing 4 Wheel Electric Moped! Plans \$15.00. Details \$1.00. Lectran, Box 1648, Largo, Florida 33540

ELECTRIC CAR Conversion: Comprehensive instructions, Diagrams, Circuits, Wiring, Parts procurement, improvising, etc. Follow-up available. \$39.00. Battery Charger Diagram \$5.00 (6 1/2% Tax — California). Box 2781, Santa Clara, Calif. 95051

MIDGET CARS

BUILD "THE BUG" Your own personal sports car, completely different than anything else on the street! Engineered to make construction as simple as possible. Photocopy of article available as it appeared in Popular Mechanics past issues. Available for \$2.25. Send order to: Popular Mechanics, Box 1014, Dept. HE, Radio City Sta., New York, NY 10019

AUTO SUPPLIES & EQUIPMENT

ALTERNATOR/Generator Rebuilding Book. Details: Hedlund Engineering, 7505 Barkentine, Las Vegas, NV 89128.

PARTS: Army Jeep and truck parts. Spare Parts & Equipment Co., P.O. Box 751, Lexington, Kentucky 40501

WINDSHIELD Remover Kit for Gluein's \$8.95. Free Information. Self-addressed stamped envelope. C&D Distributors, P.O. Box 23, Elmont, NY 11003

FREE CATALOG Of License Plate Frames — Novelty. Personalized, Custom. STRAND ART CO., Dept. M, 350-12 Orangethorpe, Placentia, California 92670

AUTOMOTIVE Tools & Equipment Nationally Advertised Brands at Discount Prices for Mechanics. Send Stamped Envelope for Current Specials. Associated Distributors, 401 Augusta St., Cincinnati, OH 45202.

HARDTOPS For Alfa, Austin Healy, Datsun, Fiat, Jaguar, Jensen Healy MGA, MGB, Midget, Spitfire, Sprite, Sunbeam, TR3, TR4, TR6, TR250 — **DYNAPLASTICS**, P.O. Box 4907, El Monte, California 91734

SIRENS, Emergency Lights, Free catalogue. NSA, 2212B Shannondale, Libertyville, Illinois 60048

MOTALOY Ring Valve Job while driving. Guaranteed. \$6.75, two \$12.25. Andris Associates, Box 34081, San Francisco, CA 94134

STOP Auto Theft! Protect CB, Stereo, Guns. Do-it-yourself Burglar Alarm for under \$5.00. Plans—\$1.00 + Stamp. James Jones, Box 542, Chico, Texas 76030

(**DIRECTORY** Of Wholesale Auto parts sources). Details 15¢ Stamp. Brannon C. Specialties, 700 Brown, Lafayette, Ind. 47904

RECREATIONAL VEHICLES, PARTS & ACCESSORIES

RV AWNINGS — Discounts to 50%. "Awnings", Box 11357, Tampa, FL 33680

MOTORCYCLES, BICYCLES, MOTORSCOOTERS & SUPPLIES

HONDAS (Surplus), \$50.00. Mail 95¢ (Refundable). Motorscooter, 443, Bend, Oregon 97701

BEAUTIFUL MOPED MOTOR-BIKE In Crate to-you. **BIG SAVING.** E.J. Sales, Box PM3084, Centerline, Michigan 48015

OLD Motorcycles Wanted, parts, sidecars, literature. Contact: Bill McMenany, 920 Martin Avenue, Santa Clara, California 95050

BICYCLE REPAIRMEN — Tired of Bending over to work on Bicycles? Consider a Bicycle Work Stand Fully adjustable with "No-Mar" Vice Jaws. Write or Call: J.H. Maize, Co., P.O. Box 1321, Hamilton, Montana 59840. (406) 363-4980.

SCHWINN Parts Accessories Catalog 50¢. Schwinn, Dept. P, 688 Route 17, Paramus, New Jersey 07652

HANG GLIDING—AVIATION

BOOMERANG—INCREDIBLE RETURN! Exciting sport. **FREE** Catalog. 30 designs, books. BoomerangMan, 306 Park, Monroe, LA 71201

HELICOPTER KITS \$495.00, Jet helicopter kits \$995.00. Information \$1.00. BW Rotor, Inc., Towanda, Kansas 67144

SPORTPLANES, MINI-HELICOPTERS, MOTORIZED—HANGGLIDERS. Plans/Kits/Complete. Many Types. Catalog \$3.00. LFP, Dept. A, Box 19828, Houston, Texas 77024

SKYCYCLE - Flying Motorcycle. Information Package \$7.00. Liahona Aircraft Corp., Box 6761, San Jose, CA 95150

BECOME AN AIRLINE PILOT: Others will be glad to help pay for your training! Learn how. \$2.00. Air Capitol Pilots, Box 12621, Wichita, KS 67277

MOTORIZED HANG GLIDERS - Industry Leader. Hundreds Flying World-Wide! Complete Motorgliders, Kits, Propellers, Accessories. Catalog/Photos \$5.00. Rotec Engineering Inc., Dept. 8M, Box 124, Duncanville, TX 75116

DESIGN/Build Airplanes/Hang Gliders. Simplified Publication. Brochure 20¢. McCoy Aircraft, 12820 S. Figueroa, Los Angeles, CA 90061

BUILD — One-Man **JET HELICOPTER!** Easy, inexpensive. Detailed Plans, Drawings — \$7.00. **HELICOPTER EXPERIMENTER'S HANDBOOK** — \$3.00. Both — \$9.00. Helicraft, Box 3053, Redondo Beach, California 90277

SKYDIVE! Manual — Guaranteed. Free Details! Airtight, Box 161, Minier, Illinois 61759

SPACE & ASTRONAUTS

ANTIGRAVITY Propulsion Device. Free Brochure! RDA, Box 873N, Concord, NC 28025

ASTROPHYSIC Food! Never Run Out. Plans — \$5.00. — Rafco, Box 134, Broken Arrow, Oklahoma 74012

HOVERCRAFT

AERO-CAR Amazing Hovercraft built easily with ordinary tools. Lawnmower engine power. Carries one man plus. Hovers, flies forward, backward. Sideways over land/snow/water. Complete construction plans and brochure, \$7.95. Aero-Projects, Box 5118PM, Clinton, New Jersey 08809.

HOVERCRAFT Plans All Sizes. Catalog \$1.00. Universal Hovercraft, Box 281, Cordova, IL 61242

CB-RADIO, TV & HAM EQUIPMENT

GOVERNMENT Surplus receivers, transmitters, sniperscopes, parts, Catalog 25¢. Meshna, Nahant, Mass. 01908

RADAR — Beat it without a Detector, No Gimmicks, Easy to Follow Instructions. \$3.00. Box 3474, Providence, Rhode Island 02909

ENJOY 7 Foot Theater Television! Precision Lens and Plans, \$16.00. Guaranteed!! Free Details Write: D&D Distributors, P.O. Box 1766, Largo, FL 33540

REPAIR/MODIFY CBs. Build Linear Amplifiers, Speech Processors, Antennas. Free Catalog. CB City-P, 6241 Glade, Suite L303, Woodland Hills, CA 91367

FREE Educational Electronics Catalog. EduKits Workshop, Department 796B, Hewlett, New York 11557.

36¢ RADIO & TV TUBES. Free Catalog. Cornell, 4213-17 University, San Diego, California 92105.

POLICE Scanners, Crystals, Antennas, CBs, Radar Detectors. HPR, Box 19224, Denver, CO 80219

(Continued on next page)

CB-RADIO, TV & HAM EQUIPMENT

(Continued from preceding page)

ANTENNA ACCESSORIES CATALOG FOR HAMS, CBers and Home TV Innovators has Application Data. Send 15¢ Stamp to: Dept. PM2, Unadilla/Reyco, Box 280, East Syracuse, New York 13057

ELECTRONICS

MECHANICALLY INCLINED INDIVIDUALS ASSEMBLE ELECTRONIC DEVICES IN YOUR HOME. Investment, knowledge, or experience not necessary. Get started in spare time. Above average profits: \$300-\$600/week possible. Sales handled by others. Write for free Details. Electronic Development Lab., Drawer 1560PM, Pinellas Park, Fla. 33565

CALCULATORS

VIDEO CALCULATORS For Conversion of Count Intervals to Playing Time On VHS VIDEO RECORDERS. Free Details! Calcu-Products, P.O. Box 3209, York, Pennsylvania 17402

HIFI, TAPES, PHONOGRAPHS, RECORDS

FREE Catalog—Electronics Kits—Amplifiers—Pre-amplifiers—Psychedellic Strobes—SCA Adaptors—Color Organs—Digital Instruments—Guitar Amplifiers. FREE Subscriptions. SWTPC, Box PM32040, San Antonio, Texas 78284.

OLDIES—45 RPM Original hits. Catalog \$1.00. C&S Record Sales, Box 197, Wampsville, N.Y. 13163

RECORD-TAPES! Discounts to 73%; all labels; no purchase obligations; newsletter; discount dividend certificates; 100% guarantees. Free details. Discount Music Club, 650 Main St., Dept. 1-0879, New Rochelle, New York 10801.

MOTION PICTURES & SOUND EQUIPMENT

16MM Films, Videotapes. Bargains. Urbanski, 8142 S. Kenneth, Chicago, Illinois 60652

SUPER 8, 16mm & 8mm Full-Length Features and Digest Films in Color and Black/White. Rock Movies. Jack Nicholson, Sherlock Holmes, Bogart, Selznick. Hundreds of Titles. FREE Illustrated Catalog. NILES, Box 1576PM, South Bend, Ind. 46634.

VIDEO Cassette Owners—See first run movies, G-PG-R-X, for only \$4.95 after library subscription. VHT Library, Box 874, Valley Forge, PA 19481. 800-523-0343, in PA 215-935-9425. Free information, NO obligation.

CAMPERS & TRAILER KITS—PLANS

BUILD—IT—YOURSELF — Campers — Trailers — Fifth Wheels — Motorhomes — Pickup Covers — Camping Trailers — Kits — Plans — Full Size Patterns — (Van Conversion Plans \$5.00) — Send \$1.00 for R-V Kits/Equipment catalog. Glen-L R-V's, 9152PM Rosecrans, Bellflower, CA 90706

BOATS, OUTBOARDS, TRAILERS & KITS

BOATKITS — PLANS — PATTERNS — FRAMEPACS — FIBERGLASS — MATERIALS — "World's Largest Catalogues" — 300 "ONEOFF" DESIGNS — 8' — 80' — in fiberglass — plywood — steel — aluminum — **POWERBOATS** — Inboards — outboards — jets — cruisers — Sportfishers — houseboats — hydroplanes — tunnel — runabouts — **SAILBOATS** — Daysailers — Trailersailers — motorsailers — multihulls — (KYACK — CANOES — 40 models) — **BOATBUILDERS MATERIAL** — Hardware — fastenings — sails — masting — plywood — books — **SPECIAL SECTION ON FIBERGLASS** — resins — foams — epoxies — polyesters — mats — cloth — C-Flex — Airex etc. **CATALOGUES 1.00** — (With Boatbuilder's Guide \$2.00) — **CLARKCRAFT** — 16-P Aqualane — Tonawanda — New York 14150

KYACKS — CANOES — PLANS — KITS — Patterns — Material 40 models in fiberglass — plywood — canvas — Catalogues with "Boatbuilder's Guide" \$1.00 — **CLARKCRAFT** — 163 Aqualane — Tonawanda — New York 14150

EVINRUDE 1979 Bargains . . . all sizes . . . Scott McCulloch parts . . . \$1. handling . . . Electra Marine, 610 Merrick Road, Lynbrook, New York 11563

FIBERGLASS—RESINS—FOAM— Etc. — Complete line Catalogue with "How To"—\$1.00. **CLARKCRAFT** — 16-P-1 Aqualane — Tonawanda — New York 14150.

NEW — Used Johnson Motors — Parts. Antique Motors — Parts. Advise Needs. No Lists. Bill's Marine, 215 N. Main, North Syracuse, NY 13212

BOAT PLANS — FRAME KITS — FULL SIZE PATTERNS — Huge 128-page catalog! Powerboats — Sailboats — Inboards — Outboards — Jets — Cruisers — Houseboats — Runabouts — Dories — Workboats — Hydroplanes — Tunnels — Pontoons — 8' to 49'. Low cost, high quality plans for over 25 years. Easy, proven methods especially for amateurs include step-by-step pictorial instructions. Boatbuilding Supplies — Fastenings — Fiberglass — Resins — Glues — Hardware — Equipment — Boat Trailer Plans — Boating books. Send \$1.00 (\$2 Canada) for catalog plus Free "Boatbuilding Supplies" brochure. Glen-L Marine, 9152 Rosecrans, Dept. MP, Bellflower, CA 90706

SAILBOATS KITS - Save Half. Trailerable, factory molded fiberglass. 16' - \$1489; 21' - \$2460; 26' - \$3425; 30' - \$8675. Hull, deck assembled - you install interior. Terms. FREE color catalog. Lugar, Dept. BC-79, 3800 West Highway 13, Burnsville, Minnesota 55337.

FREE PLAN "Gloucester Gull" Rowing Dory With Brochure/Photos 48 Plans 15'/45' Power & Sail. Only \$1.00, Air Mail \$2.00. Texas Dory, Box 720, Galveston, Texas 77553

CAMPING EQUIPMENT & TENTS

FREE Catalog. Everything for camping. Campmor, Box 407N, Bogota, New Jersey 07603

ATHLETIC & BODY BUILDING COURSES

SECRETS Of the 300, 400, 500, 600 lb. Bench Press. Other Feats of Ultimate Strength. Powerlifting USA Magazine, Box 467A, Camarillo, California 93010. 12 issues \$10.

PHYSICAL Fitness Newsletter, Dept. 40, P.O. 195, Western Springs, Illinois 60558. Introductory copy.

POWERFUL Body Fast! Guaranteed! Free Information. American Powerhouse, Box 667E, Minneapolis, MN 55440.

INCREASE Muscle Size in One Day! . . . Free Information. Box 396PM, Wilmette, Illinois 60091

18 INCH + Arms — 90 Days or Refund — \$4.00 Complete! Westpubco, Box 4777-PM8, Vancouver, WA. 98662

SPORTING GOODS & EQUIPMENT

BOOMERANGS — INCREDIBLE RETURN! Exciting sport. FREE catalog. 30 designs, books. BoomerangMan, 306 Park, Monroe, LA 71201

ARCHERY Lowest Discount Prices. All top brands. Orders shipped same day received. Money-back guarantee. World's Largest Supplier. Free catalog. Anderson Archery Corporation, Grand Ledge, Michigan 48837

TRAPPERS Send 50¢ for our Catalog of Famous Trapping Supplies. E.J. Dailey's, Box 38M, Union Hill, NY 14563

GOLFERS New Product Improves Your Game Fast. Details: Aithom, P.O. Box 253, Rochester, New York 14601

POOL TABLE Plans \$4.00. Build for under \$100.00. Armco, 2387 Indiana, Columbus, Ohio 43202

FISHING, TACKLE, LURES

KADER Trolling Plates for In-Board, Out-Board Motors. None Higher \$55.00. 464 East 33 Street, Erie, PA 16504

TROUT Fishing in North America. Guide to 1300 Top Spots. \$8.95. Oakleaf Press, 33 Union Square West, New York, NY 10003

DOGS & KENNELS

INSULATED DOG HOUSE PLAN. Floor slides out for easy cleaning. Roof is water proof. Photocopy of plan as it appeared in P.M. available for 50¢. Send order to: Popular Mechanics, Dept. HE, Box 1014, Radio City Sta., New York, NY 10019

ELECTRICAL SUPPLIES

RUN 3 Phase Machinery on Single Phase lines. Plans and Wholesale parts list \$5.50. Convert-A-Phase, 3590 16th, Wyandotte, Mich. 48192

BATTERIES, GENERATORS

BATTERY Reconditioning Kit, includes molds, materials, instructions. Apex Engineering, 5454 Bolsa, Atascadero, Calif. 93422

GENERATORS A.C. 60CY 110V-120V 3,000W \$129.00 Belt Driven Others Available. Box 3904, Las Vegas 89030

NICAD Rechargeable batteries with solder tabs. SASE.—ROVA, Dept. PM8, Route 2, Box 258, Fort Atkinson, Wisconsin 53538

ENGINES, MOTORS, MAGNETS

REWIRE Car Alternator for 110 AC. Plans \$3.00. Sweett, Box 591, Titusville, Florida 32780

MAGNETS—FREE—SAMPLES — DNL Associates, Box 8041-P, Cranston, RI 02920

TRANSFORMERS — Rewind Them for any Voltage. Manual shows how. Easy! \$3.00 Guaranteed. Harrit, Box 495A, Great Neck, New York 11022

TOOLS FOR SALE

400 Black & Decker Tools. Catalog, \$1.00 — Refundable. Amalgamated Service Corp., 707 S. Lakehoma Drive, Mustang, Oklahoma 73064

MACHINERY, TOOLS & SUPPLIES

PRESSURE GAUGES —100, 200, 300 Pound, \$5.00 each Postpaid, 1000 Pound \$7.00. Fred Hines Company, Box 65-MG, Fair Grove, MO 65648

MILLING Cutters, lathe milling attachments, Catalog \$1.00. Potter, Box 73, Cedar Rapids, Iowa 52406.

BANDSAW BLADES, Any Size. Free Pricelist. Parker, 8921HY49, Sonora, Cal. 95370.

COMPLETE LINE Of high quality, low-priced CUTTING TOOLS, HOLDING FIXTURES, PRECISION INSTRUMENTS, METAL CUTTING LATHES, DRILL PRESSES, MILLING MACHINES, BANDSAWS AND MUCH, MUCH, MORE. Most items delivered free. Send \$3. for 316 page 1979 catalog, refundable with first order. **KABACO TOOLS, INC.**, P.O. Box 343, Sterling Heights, Mich. 48078

4" METAL Cutting Lathe \$68.90. Taig, 15048 Proctor, Industry, California 91746

MACHINEX - Unimat - Maximat - Sherline Lathes, Mills. Catalog \$1.00. Shop Supplies \$1.00. Campbell, 1424 Barclay, Springfield, Ohio 45505

BANDSAW BLADES, Carbide Tipped Saws, Any size, Free literature. King Saw, 6541 Tidewater Drive, Norfolk, Va. 23509

SMALL FOUNDRY Furnaces. Supplies. Free literature. Pyramid Products, 3736 South 7th Avenue, Phoenix, Arizona 85041

VERTICAL Or HORIZONTAL MILL PLANS \$5.00 Each, Both \$8.00. **FREE MILL VISE PLANS** With Order! **NU-DESIGN COMPANY**, 220 So. Center, Santa Ana, CA 92703

1600 CATALOGS Listed and described Sources for everything imaginable. \$3.00. Masterlog, Box 24413A, Oakland, CA 94623.

STAINLESS STEEL Wood, machine, tapping screws. Nuts, washers, boat nails. Free 12 page price sheet. Fastening Products, Box 151H, Cheltenham, PA 19012

COMPLETE MITERING EQUIPMENT for perfect picture frames for under \$250.00, hobby or pro. Pootatuck, Box 18PMK 2, Windsor, VT. 05089

DRILL PRESSES Precision Production Models from 10" - 14" to 40". Prices start at only \$173.00 with motor. For Details Write: Pacific One Corp., Dept. HM, 410 West Coast Highway, Newport Beach, California 92663

BLACKSMITH & FOUNDRY SUPPLIES

ARC WELDING Wall Chart, Proper: AMP settings, Electrodes, Filter lenses, wealth of information. \$3.00. DPIC, POB 941, Kingston, Ohio 45644

COAL Forges (or gas) — anvils, anvil benches, hammers, tongs, all blacksmith supplies. Order your Mankei catalog — \$1.00 — refunded on first order. Mankei Blacksmith Shop, 7836 Cannonsburg Road, Cannonsburg, Michigan 49317

WELDING, SOLDERING, PLATING

ARC WELDING BASICS YOU CAN MASTER IN SIX HOURS. Tells you how! Includes four projects to get you started. Photocopy of article as it appeared in P.M. available for \$1.75. Send orders to: Popular Mechanics, Dept. HE, Box 1014, Radio City Sta., New York, NY 10019

ENERGY SAVING

INCREASE Your gas mileage by 30%! Details, \$3.00. Brin, Tracen, Centest, Governors Island, NY 10004

85 GUARANTEED ways to lower electric bills! \$5.00 postpaid. For more information write: Legion, 9376-PB Saddle, Yuma, AZ 85364

SAVE up to 25% on cooling costs. Water cool your central air conditioning. Easy to install kit. \$79.95. Details FREE. Pierce Industries, Inc., P.O. Box 26391-M, Birmingham, Alabama 35226

DUAL-PURPOSE ENERGY EFFICIENT HOME. Easy. Inexpensive. Plans \$3.00. "Premiere Security Products", P.O. Box 5727, Daytona Beach, Florida 32018

STOP HIGHWAY ROBBERY —Fight Oil Co. Blackmail! Bold new T-shirt says it all! Free details: Visions, 22 Petaluma Blvd. N. - A, Petaluma, California 94952.

SLOW DOWN YOUR ELECTRIC METER —Perfectly Legal. Send \$3.00. Arness Associates, Box 190-PM, Van Nuys, CA 91408

ENERGY METERS, Electric Gas, Water, Phone, etc. Many very frank Survival Publications. Brochure 25¢. Consumertronics, Box 475PM, Alamogordo, NM 88310

WIND GENERATORS 120 Volts, 4, 10, & 20 Kilowatts. Upwind, Direct Drive. Info. Packet \$2.00. Dealer Inquiries Invited. Dakota Wind and Sun, Ltd., P.O. Box 1781-F, Aberdeen, SD 57401

CUT OIL BILLS 50% Plans \$5.00: Fuel Associates, POB 968, Schenectady, NY 12301

101 WAYS TO SAVE MONEY And Energy Heating Your Home. Includes Work Sheet. Charts. \$3.00. Professional Publications, P.O. Box 319P, Huntington, New York 11743

SOLAR & ALTERNATE ENERGY

"WATER Storage Tanks—Life Time Fiberglass—100 Gallon to 6000 Gallon Capacity". Write: Box 3, Rockton, Ill. 61072.

(Continued on next page)

SOLAR & ALTERNATE ENERGY

(Continued from preceding page)

SOLAR BOOKS
FULL LINE OF SOLAR HEATING COMPONENTS. INSTALL SOLAR HEAT YOURSELF AND ORDER ALL MATERIALS FROM ONE SOURCE. BY MAIL. SEND \$2.00 FOR CATALOG AND PRICE LIST. SOLAR COMPONENTS DIVISION, P.O. BOX 237, MANCHESTER, NH 03105

SOLAR CATALOG THIRD EDITION — Complete Systems in Stock. Technical Information. Install your-self. Dealer Programs Available. Send \$2.50. Solar Shop, P.O. Box 337, Clay, KY 42404

SOLAR POWERED ART-FORMS. Hand-Crafted Brass and Copper. Includes Oil Pump, Still, Airplane. Brochure 25¢. Jona of Springboro, PM-S, 285 Kesling Drive, Springboro, Ohio 45066

AMAZING Wood Heater—Automatic Forced Air—Heats Entire Home—2 Models from \$249.00—Write: Box 3, Rockton, Illinois 61072.

WOODBURNING RADIAL STEAM TURBINE Generates Electricity! Easy Construction! Compact! Complete Plans: \$6.95. Glenvale, Box 358F Station D, Toronto, Ontario M6P 3J9

PARABOLIC CURVE PATTERN For solar reflectors. Any size. Easy instructions. \$3.00. "Guide-Kit", Box 332H, Rialto, California 92376

POWER Your Automobile with Home Distilled Diesels on Vegetable Oil. Free Details. Box 302, North Dayton Station, Dayton, Ohio 45404

WOODBURNING STOVE KIT — Airtight. Heat 1500'. \$250.00 Delivered. Details \$1.00. Steamboat Stove-works, Box 1946, Steamboat Springs, Colorado 80477

INSIDER SOLAR HEATERS. \$23.95. Hangs Inside Window. Brochure, 7777 Green Valley, Mt. Vernon, Ohio 43050

SOLAR Heat your Mobile Home. Most components already built into your Trailer. Info. \$3.00. Ricks Works, Rt.3, Box 524-B, Las Cruces, New Mexico 88001

HOME CRAFTSMAN

CATALOG FULL-SIZE FURNITURE PLANS — \$1.00. Refunded with first order. Traditional, Early American, over 150! Furniture Designs, 1425 Sherman, Dept. CP-79, Evanston, Illinois 60201.

WOOD — Domestic and Imported Hardwoods! 4000 Items! Clock, musical instrument kits. Tools . . . discount prices! Hard-to-find hardware. 152 page catalog. 50¢. Craftsman, Dept. AX-89, 2729 Mary, Chicago, Illinois 60608

BE ADMIRER! GET FREE PUBLISHED RECOGNITION Showing off your handiwork, crafts, hobbies. Free details. Achievers International, Box 902-PM8, Tustin, California 92680.

WOOD FINISHING? . . . For professional results look to General Finishes' Sealacel 1-2-3 penetrating wood finishing process. Sealacel wipes on. Eliminating brushes and brushmarks. Even in a dusty environment, Sealacel will give you a smooth finish. For your free General Finishes catalog, write: General Finishes, P.O. Box 14363, Milwaukee, Wisconsin 53214

WORLD'S LARGEST CATALOG? Three pounds, 832 Pages. Every Tool, Supply, Machine, Imaginable, \$5.00. Refundable. McKilligan, PM879, Johnson City, N.Y. 13790

WOODWORKERS . . . New, novel animal-shaped minibox for children. For kit, send \$5.00 to: Pet Box Kit, P.O. Box 14802, Columbus, Ohio 43214

AMAZING CAT DOOR Lets your Cat in Electronically. Strays, Rodents, etc. are kept out. Inexpensive. Simple to Build. Plans \$3.00. A. Jones, Box 428, St. Lambert, Quebec J4P-3P8

WOODWORKERS! . . . Save \$ \$ on Plans. Nationally circulated publication features over 70 plans per year. Early American, Shaker, Contemporary furniture, clocks, toys, jigs, income ideas, \$7.00 brings 6 issues per year. Woodworker's Journal, Dept. 51C8, Sunset Lane, Washington Depot, Ct. 06794.

BUILD Your own lathe from old car parts. Plans \$2.80. Free supplement of money making projects included. Lindsay North, Box 251, Oroville, Washington 98844

WOODWORKERS Unique Three-Level Chessboard. Plans \$2.00. P.O. Box 142, Clearwater, Florida 33517

1887 TROLLEY — Wood Replica Nostalgic—Plans \$3.00. Catalog 25¢. Criss-Cross, Box 324D, Wayne, NJ 07470

SECRET Revealed! Master Furniture finisher Retires. Tells secret of worlds most beautiful, easy and tough finish. Send \$4.98. Wallace Moran, RT4, Box 93, Ruston, La. 71270

PLANS, Plans, Plus! 1914 Government Bulletin Reprinted—Bird Houses and How to Build Them. \$2.95. Refund if No Fun! Hendricks, 108P, Box 404, Hiram, Ohio 44234

YOUR HOME WORKSHOP Can earn you \$200.00 each weekend. Enroll with **HOME CRAFT CLUB LTD.** and receive your enrollment certificate and catalog of **HOME CRAFT** designs. Enrollment fee \$2.00. **HOME CRAFT CLUB LTD.**, Box 2620, Stn. A, Edmonton, Alberta T5J 2G3

WOODCRAFT Catalog: Direct—factory. Kits, Hardware, Toy Parts 50¢. Larson Wood Mfg., Box 672, Park Rapids, Minnesota 56470

CHOICE APPALACHIAN HARDWOODS: Cherry, Oak, Maple; Special Sizes; Standard Packages; Prompt Shipment; Free Information; Weidners, Dept. PM, 4379 South Shore Drive, Erie, PA. 16511

101 PATTERNS, Gifts, Novelties, Action Windmills, plus "Make Money Jig Sawing". Only \$3.00 Prepaid 1st. Class. Mastercraft 85M, P.O. Box 631, Park Ridge, Ill. 60068

FREE HOBBY Tool Catalog, 1,000 Items below Wholesale! International Curio Shoppe, D-64, Box 674, So. Fallsburgh, New York 12779

PM'S FAMOUS MASTER SHOP GUIDE. One of the most important tools you'll ever own! Lays out everything you need to know about nails, screws, bolts, drills, adhesives, lumber, masonry, plumbing and electrical work. 24 stand-up, hang-up, wipe-clean laminated pages. 56 charts plus a built-in ruler, protractor and compass. Solid value at \$4.95 + 50¢ to cover postage + handling. PM Master Shop Guide, Dept. HE, Box 1014, Radio City Sta., New York, N.Y. 10019.

DESIGNS UNLIMITED! — New Catalog! 50¢ (Refundable), Solar, Furniture, Buildings, Etc. — Systems & Designs, 8039 Kingston Pike 74, Knoxville, TN 37919

KITS And Patterns for Animated Wooden Toys. Free Pamphlet. Kits, P.O. Box 351, Encino, California 91316

WOODEN TRAIN . . . Attractive. Durable! Engine, six cars. Plans — \$4.50; Box A, Austin, Minnesota 55912

CREATE A CLOCK For Fun or Money movements components. FREE Instructions. P.O. Box 1966P, Daytona Beach, Florida 32015

CONSTRUCTION PLANS, BLUEPRINTS

LOG SPLITTER PLAN. Hydraulically operated. Exerts some 10,000 lbs. pressure. Splits with ease 2 ft. length of Maple and Ash Logs 12" to 14" Diameter. Uses 3-HP Gas Engine. Plans + instructions \$8.95. Send order to: Popular Mechanics, Dept. HE, Box 1014, Radio City Sta., New York, NY 10019

LOG CABINS & "A" FRAMES

MOUNTAIN GEM LOG HOMES — Your Plans or Ours — Form Fitted — Easy Assembly — Low Prices — Information Pack \$3.00. Box 230196, Tigard, Oregon 97005

BUILD YOUR OWN STONE HOUSE! Gather rocks free. Need pickup, hand tools — no experience! Guaranteed "HOUSE OF STONE" manual, \$3. Stonehouse, 8658, Sweet, Idaho 83670.

HOME BUILDING & REMODELING

SAVE 75%. MAKE TEN GALLONS FOR THE PRICE OF ONE. "Proven Miracle Paint Formula". Porous surfaces absorb the paint permanently. Join Masons, Painters and Contractors all over the country. **MONEY BACK GUARANTEE.** Send \$19.95 for YOUR Formula. EVANS, 407 East Broadway, Wetumka, Ok. 74883

IMPROVE ENERGY-EFFICIENCY, SECURITY of your entrance Door with a Beautiful Door Design! Many Styles. Easy DIY Installation. Free Catalog. DoorDecor, Box 615, Waxahachie, TX 75165

"PATTERN SCRIBING" for difficult installations on floorcovering, tile and paneling. Instructions: \$2.00. Braco, Box 161P, Reedsport, Oregon 97467

GEODESIC Domes, Kits, Plans. Catalog \$3.00. Timber-Line Geodesics, 2015 Blake Street, Berkeley, California 94704

ELECTRICAL Wiring Devices - Low Prices. Cable, Switches, Connectors, Everything for Wiring. Catalog 25¢ - Box 344621, Dallas, Texas 75234

EARTH SHELTERED HOMES. Energy efficient, low maintenance, blueprints available, details free! Underground Homes. P.O. Box 1346M, Portsmouth, Oh. 45662

PLASTICS

CASTOLITE Pours like water, hardens like glass without heat. Crystal clear, colors. Embedding, coating possibilities unlimited; for industry, laboratories, craft work and gifts. Reproduce your designs with a variety of mold materials. Profitable. Illustrated Manual Catalog \$1.00. **CASTOLITE**, Dept. 791/PM, Box 391, Woodstock, IL. 60098.

SAVE 50% on LUCITE Furniture. Build it Yourself with our Kits. Catalog plus Home Fabrication Manual. \$2.50 Refundable. CVD, P.O. Box 70, New York, NY 10031

AIR CONDITIONING

REPAIR Your own Window Units! Old Pro's tell-how Fix-it Manual PREVENTS OUTRAGEOUS RIP-OFFS! Details: Ronay, 11914-B 25th, Alta Loma, Texas 77510

DO IT YOURSELF

KEEP A Sparkling Clean Windshield. \$2.00. A Must for all Drivers. Formula, Box 1493M, Dayton, Ohio 45414

ELECTROPLATING. Complete amateur's textbook. All metals Electroplate metallic/nonmetallic items \$9.95. Details free. Tropic, Box 95-P3, Palm Bay, Fla. 32905.

ANNOUNCING New How-To Information Index. Monthly Review of Leading How-To Periodicals. Free Details, Sample Issue. Self-Reliance Index, Box 304-M2, La Crosse, WI 54601

CANNON Made from Inexpensive, Easily Obtained Materials. Harmless — complete Plans \$3.00. Cannon, 29 Wendell Street, Battle Creek, MI. 49017.

SECRETS OF THE 200 MPG CARBURATOR! Patent Drawings and Instructions \$10.25. Money back Guarantee. RoadRunner Publications, Raymondville, Texas 78580

TELEPHONES - Free Discount Catalog. Alcove, Box 460M, Bayshore, NY 11706

"FIRE-PROOF" VALUABLES BOX. Build your own. Any size. Inexpensive materials available any town. keep photos, documents, money, jewelry, etc. safe from fire. If house burns down, box and contents survive intact! Easy instructions. \$3.00. "Guide-Kit", Box 332D, Rialto, California 92376

UPHOLSTERING SUPPLIES, Tools, Cane, Instruction Books. Free Catalog. Jim Dandy Sales, Box 30377, Cincinnati, Ohio 45230

TELEPHONES UNLIMITED, EQUIPMENT, SUPPLIES. ALL TYPES, REGULAR, KEYED, MODULAR. FREE CATALOG. Call Now Toll Free — (800) 824-7888 in California (800) 852-7777 Alaska-Hawaii (800) 824-7919 Ask for Operator 738

ENERGY Saving Plans. Water Wheels, Windmills, Electric Cars, Home Power Plans, Free info, plans list. Goodman Associates, 4 Berryville Pike, Summit Point, WV 25446.

WOODEN STORAGE BUILDING PLANS. Information: Barnes Products, Box 726, Kalamazoo, MI 49005

MOTION DETECTOR — Many Spectacular Uses. Transistorized. Complete Plans and Drawings — \$4.95. D. Dahlin, 7310 So. Tamarac Court, Englewood, Colorado 80112

CHIMNEY Cleaning from Inside. Avoid hazardous climbing. Do-it-yourself. Brushes, fiberglass rods, accessories. Illustrated Catalog \$1.00. Chimney Care, P.O. Box 426P, Cavendish, Vermont 05142

MODIFY Old Telephones For Fun, Profit. Learn How; Write: Gray, Box 9710E, Kansas City, MO 64137

WOOD-STOVE KITS — Plans — accessories. Details \$1.00. Sherwood Stove Mfg., 750 North Main, Cedar City, Utah 84720

PM'S GREAT, NEW MASTER HOME CARE GUIDE. The latest and greatest in the Popular Mechanics Master Guide Series. Lays out all you need to know about home repairs, from basement waterproofing to roof repair. 24 laminated, wipe-clean sheets on 12 stand-up, hang-up boards. 150 charts and illustrations. Properly used, it can save thousands of dollars. \$4.95 + 50¢ to cover postage and handling. PM Master Home Care Guide, Dept. HE, Box 1014, Radio City Sta., New York, N.Y. 10019

COMPLETELY NEW PICTURE FRAME CLAMP Automatically Squares and Clamps all Four Corners at Once By Tightening One Wing Nut. Precision Made. Simple Adjustment. Satisfaction Guaranteed. \$19.95 postpaid. Lambert Designs, 2090 Great Highway, San Francisco, California 94116

REPRODUCTION MOLDS

RUBBER, Fiberglass Molds for Ornamental Concrete (Birdbaths, Planters, etc.). Over 900 to Choose From. Free Information, SASE. Plycrete Mold, Elk Rapids, MI 49629

ARTS & CRAFTS

MAKE Figurines, Plaques, candles, lawn ornaments. Molds, plastercraft kits, liquid rubber. Sample and catalogue 25¢. Wooley Company, Box 29, Peoria, Illinois 61650.

LIQUID LATEX Paratol. 706-G compounds for making rubber mold. Toughest, finest quality. Instructions. Money-back guarantee. Postpaid \$5.00 quart, \$15.70 gallon. Testworth Laboratories, Inc., 401 S. Main St., Columbia City, IN 46725.

STAINED GLASS Catalog-P, Tools, Supplies, Books. Send 50¢. Saylescrafts, 171 Main Street, Nyack, N.Y. 10960.

WHERE TO BUY HANDICRAFT SUPPLIES-RETAIL DEALERS DIRECTORY with 16 \$1 coupons \$4.00 each. Wholesale Arts & Crafts Supply Dealers Directory with 16 \$1 coupons \$5.00. Special: Both for \$8.50. First Class mailing, add 50¢ per directory. Handicrafts, 924 Winter St., Stamford, CT 06905

"GETTING Started in Stained Glass" 50¢. Whittemore, Box 2065Y, Hanover, Mass. 02339.

CARTOONING, COMMERCIAL ARTS & SIGN PAINTING

MAKE Money in Commercial Art, Yenny, Box 1181, Piqua, OH 45356

(Continued on next page)

CARTOONING, COMMERCIAL ARTS, & SIGN PAINTING

(Continued from preceding page)

MODERN Cartooning taught by mail. Write for free brochure. Cartoonorama—Box 263-1H, Branford, Conn. 06405.

35 LESSON cartooning course. Cartoonist's Magazine, both \$3.00. Hartman, Box 30367, Lincoln, Nebr. 68503.

SIGN Painting—Easy method. Free catalogue. Kaufmann Company, Centertown, Missouri 65023

MODELS—CARS—SHIPS— TRAINS—PLANES ETC.

RADIO CONTROL! Airplanes, Boats, Helicopters, Supplies. Big Discount Catalog—\$3.00 Refundable. Modelers Supply, Box 7185, Montgomery, AL 36107

MODEL AIRPLANES — Huge Catalog. \$2.00. Sig Manufacturing Co., Inc., Montezuma, IA 50171

SHIP MODEL Kits, Plans. Fittings from our own Workshop. Big Illustrated Catalog: \$1.00. Bluejacket Shipcrafters, 50V Water Street, South Norwalk, CT 06854

CIVIL WAR Model CANNON plans. Catalog free. Wm. Green, P.M.B. Box 892, Shalimar, Fla. 32579

KITES, GAMES, PUZZLES, NOVELTIES

CHESS PLAYERS! Win Cash playing postal chess. Free details. CHESS SYSTEMS, Box 11955-PM7, Baltimore, Maryland 21207

MAGIC TRICKS, JOKES, VENTRILOQUISM

VENTRILOQUISM/Puppets! Catalog \$1.00 (Refundable). Maher, Box 420PM, Littleton, Colorado 80160.

FREE! World's Leading Novelty Catalog. 1600 Jokes, Tricks, Science, Sports, Hobbies. Johnson-Smith, C-10, Mt. Clemens, Mich. 48043

VENTRILOQUISM Learned! Details .50¢. Hartz College of Ventriloquism, Box 556, Beaufort, S.C. 29902

FABULOUS MAGIC Catalog 50¢. Same day service, no substitutes. Fabulous Magic, 3319 E. Charleston, Las Vegas, Nevada 89104

MAGIC, Novelty Catalog, plus three tricks. \$1.00. Elbee, 230-PM, San Antonio, Tex. 78291.

HOBBIES & COLLECTIONS

OLD Time Miniature Soldier Molds, Free Catalog. Castings, 43 Turnbull, Highland Park, Illinois 60035

COLLECT Military Medals. List 50¢. Vernon, Box 387 PM, Baldwin, N.Y. 11510.

BEER CAN COLLECTORS — We've got the Toughies! Only \$1.00 each. Write for **FREE CATALOG**. Orders sent postpaid. Write: Stamford Imports, Box 3807A, Stamford, Connecticut 06905

GOLD Mine 1906 Stock. History \$2. Kemco, Box 469, Yreka, California 96097

AQUARIUM AND SUPPLIES

BUILD YOUR OWN COFFEE-TABLE AQUARIUM. Photocopy of article as it appeared in PM available for \$1.50. Send orders to: Popular Mechanics, Dept. HE, Box 1014, Radio City Sta., New York, NY 10019

DECALS, EMBLEMS, PATCHES

WWII Patches—Army, A.F., ETO Pacific, others. List 50¢. Keystone Patchco, Box 2726, Philadelphia, Pa. 19120

ANTIQUES, RELICS, INDIAN GOODS & CURIOS

INDIAN Relics. List 25¢. Arrowheads, \$5.00 doz. Folsom \$10.00 each. C. Secrist, Deerfield, MO 64741

STAMP COLLECTING

2,000,000 Stamps—150 Countries—2¢ Each. Beiden, Box 4149, Dearborn 48126

100 DIFFERENT Fascinating Turkey Stamps Only 25¢. (Adults Only.) Goliath, Y-1, Bethlehem, New Hampshire 03574.

50 DIFFERENT U.S. Stamps. Includes 1943 Flag Stamp of Occupied Nations. Only 25¢ Approvals included. Willett Company, Box 338-M, Yorktown Heights, N.Y. 10598.

50 YEARS Old fifteen different United States, over fifty years old—25¢ with approvals. Jaxon, Box C11-P, New Rochelle, New York 10804.

FREE Worldwide packet. Penny approvals. Froelich, Box 412-A, Morton Grove, Ill. 60053.

SPECIAL 400 U.S. 30¢ Approvals. Wright, Box 753-M, Hagerstown, Maryland 21740

18 DIFFERENT U.S. Airmail stamps worth over \$1.00 Only 10¢. (Adults Only.) Limit One Set. Wonderful Lists included. Littleton Stamps, AH-1, Littleton, New Hampshire 03561.

LOW priced foreign approvals with sensational ten set bonus. Only 10¢. PFS Stamps, Box 27, Fremont, Michigan 49412

NUDES! 50 Different \$1. Ace, Jamesburg, NJ 08831. **FREE WORLD CATALOG.**

PLATE BLOCKS. Six Different 4¢ Only \$1.00. **FREE WHOLESALE PRICELIST.** AMPBCO, Box 26066P, St. Louis, Missouri 63136

TOPS! 100 Popular Poland Stamps (all different) only 25¢. Mystic, Dept. PS1, Camden, New York 13316.

FREE Surprise collection sent with approvals. Gould, 1784 Union, San Francisco 94123.

500 DIFFERENT Stamps, \$2.00. Smith, 508A Brooks, College Station, Texas 77840.

100 BRITISH EMPIRE 10¢ Approvals. Gibson, Box 34A, Lansdowne, PA 19050.

SINGLE STAMPS 2¢ and up. Mounted in books. **TRUST STAMP COMPANY**, P.O. Box 100-P, Jamaica, New York 11435.

BREATHTAKING Beautiful. 50 Different mint Monaco pictorials commemoratives only \$1.50 with mint complete set approvals. Pagoda, Box 132P, Sidney, Ohio 45365.

50 DIFFERENT Old U.S. between 1861 and 1939 - \$1.00. Ed Roush, 423 Shepard, Mansfield, Ohio 44907.

ARCHITECTURE — ENDANGERED FLOWERS — SEEING EYE DOGS — Newest U.S. Commemorative stamps on Lovely, Cacheted, Official First Day covers — 70¢ each or all 3 for \$2.00. K.M. WALSH, Box 308H, TUCKAHO, NY 10707

PENNY APPROVALS. Regardless catalogue. Zamora, 1 Méndez Liciaga, San Sebastián, Puerto Rico 00755

U.N. 8 Mint Sets \$1.00! Approvals. Gordon Davison, Contoocook, New Hamp. 03229.

200 Unsorted Worldwide Stamps 25¢ Approvals. White, Box 24211ET, Indianapolis, Indiana 46224

HUGE Collection! 1000 Different **WORLD + 50** Different **RUSSIAN BEAUTIES.** \$3.00. Approvals. Gouge, Box 88-MD, Elizabethton, Tennessee 37643

AN UNUSUAL U.S. Approval Service. Sherman, Box 15355G, Philadelphia, Pa. 19111.

FREE World Wide Stamps with Approvals. Chapmans, Box 487W, Galesburg, Michigan 49053

FREE: 32 Page United States and United Nations Price List. Shelron, Box 610547C, North Miami, Fla. 33161.

U.S. Bargain - 100 different commemoratives, \$1.00, with beautiful worldwide approvals. Stamp Center, Box 37, Kennebunk, Maine 04043

FREE Congo Animal Set. Approvals included. Alpaughco, Box 225, Highbridge, N.J. 08829

50¢ BRINGS You 100 pictorial plus worldwide approvals. Capt. Shaw's Stamps, Box 277, Ocean Park, Maine 04063.

70,000 Different! \$2.50 per week. Free details! Hertie, 5329 So. Millard, Chicago, Illinois 60632

200 Different Argentina, Plus inexpensive Country Packet Approvals, \$1.58. Fies, A6P, Thornville, Ohio 43076

FREE! "MONEY SAVING" U.S. Price list. Scotco, X4455-PM8, Hollywood, Florida 33023

107 DIFFERENT Triangles, sports, topicals, etc. Value \$4.00. Only 10¢. Bargain approvals. Free coupon worth \$1. Jayto Samps, East Syracuse, New York 13057

50 ARGENTINA — Different. 10¢ Approvals. Gobestamps, Box 690, Saco, Maine 04072.

U.S. MINT Specials! Flag Set complete \$2.00; 1936 Army-Navy complete \$2.00. Free List. Brooks, 2601 Avenue "U", Brooklyn, N.Y. 11229

100 Different U.S. 10¢ approvals. Bradley, Box 385P, Midlothian, VA 23113

PENNY! Approvals! Regardless catalogue! Kloster, 4164 52nd St., San Diego, Calif. 92105.

50 U.S. 25¢. With Approvals. Happy, Box 124, Springvale, ME 04083.

FREE Bicentennial Souvenir Sheet Worth Over \$2.00 with 100 Different Worldwide—25¢ with Approvals. Tarheel Philatelics, Siler City, North Carolina 27344

OLD U.S. on Approval. Chester, Box 15414P, Philadelphia, PA 19149

"WHOLESALE" U.S. - Foreign Pricelist and catalog Free! Everything Guaranteed. Schneider, Box 1240, Grand Rapids, Michigan 49501

FREE! Big Bargain Catalog—New Edition Listing Thousands of Bargains including U.S. & B.N.A. Stamps, Packets, Albums, Accessories and Supplies. Also, Fine Stamps from our Approval Service which you may return without Purchases and Cancel Service at any time. Jamestown Stamp, Dept. E89PM, Jamestown, NY 14701

RUSSIA! Five sets 25¢ Approvals. Milehigh, 3445 Quitman, Denver, Colorado 80212

WOW! 110 All Different Germany 10¢. Commemoratives, Airmails, High Values, Big Catalog, Bargain Lists, Also, Fine Stamps from our Approval Service, which you may return without Purchases and Cancel Service at any time. Jamestown Stamp, Dept. A89PM, Jamestown, NY 14701

225 DIFFERENT Worldwide 25¢ Approvals. Tibbets, 8675 Meadow, Downey, California 90242.

FREE Animal Set. Request Worldwide Approvals. Alpaughco, Highbridge, N.J. 08829

25 DIFFERENT Unused Mainland China 25¢ with Approvals. Fred & Lily's, 2931 N. Monitor Ave., Chicago, Ill. 60634.

RUSSIAN Space Collection including Souvenir Sheet, \$1.00. Russian Approvals. Snedco, Waldwick, N.J. 07463

FREE Canadian with approvals. Stamps Unlimited, Box 2295, Kalamazoo, Michigan 49003.

FREE Catalog; 3,000 different Packets! Ullery, 1016 Meridian, Mishawaka, Indiana 46544

COINS, TOKENS, CURRENCY

HONG KONG DOLLAR Only 10¢. Uncirculated cupronickel dollar. Limit One. (Adults Only.) Plus price lists. Littleton Coins, KH-1, Littleton, New Hampshire 03561.

MERCURY DIME SPECIALISTS. Send \$2.00 For Two Extra Fine Mercuries and Our Price List. Mercury Associates, P.O. Box 105, Pinehurst, Mass. 01866

BUYING SILVER COINS, 618-847-2291, Nation Galleries, Box 391PM, Fairfield, IL 62837

40 PAGE list and VF Indian Cent Only \$1.00. A-Z Coins, 4201 Coldwater Road, Fort Wayne, Indiana 46805

3 OLD Liberty Head Nickels Only \$1.00. Issued before 1913. Limit 1 Set. (Adults Only.) Plus price lists. Littleton Coins, HL-1, Littleton, New Hampshire 03561.

WANTED Gold and Silver Rare Coins. George Stafford, P.O. Box 334, Kennett, Mo. 63857

BINOCULARS, TELESCOPES, MICROSCOPES, MAGNIFIERS

FREE Information on the World's most Versatile Telescope. Priced under \$200.00. Couiter Optical, Box K1, Idyllwild, California 92349.

PHOTOS & PHOTO SUPPLIES

DARKROOM SINK WITH A BUILT-IN PRINT WASHER. Make it Yourself, it's Easy! For 75¢ you can buy a Photocopy of the Article as it appeared in PM. Send Orders To: Popular Mechanics, Dept. HE, Box 1014, Radio City Sta., New York, NY 10019

BOOKBINDING

REBIND YOUR DAMAGED BOOKS. With a few common tools and a homemade book press (plan included) you'll be able to handle anything from a torn hinge to a complete rebinding. Photocopy of article as it appeared in P.M. available for \$1.75. Send orders to: Popular Mechanics, Dept. HE, Box 1014, Radio City Sta., New York, N.Y. 10019

BOOKS & PUBLICATIONS

CLOCK And watch repairing books, tools, materials. Free catalog. North American, Box 77-AHA, Fox River Grove, Illinois 60021.

FREE Book. Prophet Elijah Coming Before Christ. Megiddo Mission, Dept. 63, 481 Thurston Road, Rochester, N.Y. 14619.

PUBLISHERS' OVERSTOCKS. Over 3,000 bargain books, all subjects. Free catalog. Hamilton, 98-51 Clapboard, Danbury, Ct. 06810

WILDERNESS Living! Shelter, Food, Power, Medical, Self-defense, Military. Books—Vital, Fascinating. Extraordinary! Free catalog. Adobe Hacienda, RFD 3, Glendale, Arizona 85301.

FREE! Copies leading mail order trade journals. Send 50¢ postage & handling. Best, Morrero, LA 70073.

FREE! CATALOG, Self-Improvement Books—400 Selections. The Mail Sack, Dept. PM879, 600 Welch Blvd., Flint, Michigan 48503

PRACTICAL MACHINE DESIGN — Self-study Guide, Everthing Explained. Illustrations, Tables. Satisfaction Guaranteed. \$18.90. Limpert, 2748 Dearborn Street, Salt Lake City, Utah 84106

BACKACHE RELIEF! Scientific Information. Order Booklet Now! \$3.00. Terry Associates, P.O. Box 126, San Pablo, California 94806

70 CITIES COMPARED. Charts on Weather, Unemployment, Crime, much more. Order Report Now! \$2. Terry Associates, P.O. Box 126, San Pablo, California 94806

BEAT INFLATION! Hundreds of Ideas. Order Booklet Now! \$4.00. Terry Associates, P.O. Box 126, San Pablo, California 94806

LOSE WEIGHT Permanently! No Gimmicks. Safe. Order Booklet Now! \$2.50. Terry Associates, P.O. Box 126, San Pablo, California 94806

ALCOHOL BOOK — Monzert's Practical Distiller—Detailed Instructions and Diagrams For Constructing STILLs For Producing ALCOHOL. \$12.00 —To: Tech. Dev. Ent., P.O. Box 404, West Haven, Connecticut 06516

RARE Occult Books. Catalog 50¢. Marshall, Box 7169PM, Baltimore, MD 21218

BOOKS & PUBLICATIONS

(Continued from preceding page)

GOOD News Bible: Today's English Version; \$8.00. Bridges, Box 4413, Hollywood, Fla. 33023

REDUCE Your Income Tax Legally. Free Brochure. Send SASE. SEGD, 5531P Los Santos Way 10, Jacksonville, FL 32211

PLAYS, SONGS, MANUSCRIPTS

SONG Poem Authors. Have a Melody Written. Send \$10.00 per Poem to: Mark McCowen, 2313 West 16th, Odessa, Texas 79763

POEMS, SONGS: Your Song or poem may earn you money. Free Examination. Columbine Records, 6430 Sunset Blvd., Suite 1221, Dept. PM, Hollywood, California 90028

SONG POEMS Needed. Free Appraisal. Free Monthly Recording Awards. Free Publishing. Selected Material. Geo. Liberace, 6381-C, Hollywood Blvd., Hollywood, CA 90028

MUSIC INSTRUCTIONS & INSTRUMENTS

ACCORDIONS - Famous Makes. 40 Models! Importer-to-You Prices. Save! Cordovox and Button Style. Home Trial. Trade-ins. Terms. Free Catalogs! Accordion Corporation, Dept. R, 5535 Belmont, Chicago 60641

INTERNATIONAL Catalog valuable to makers, repairers of stringed instruments. Imported woods, parts, accessories, kits. Fine German-made violins, violas, cellos, basses and bows. Send 25¢ for catalog. Credit certificate worth \$1.25 enclosed with catalog. International Violin Company, Dept. AL, 4026 W. Belvedere Ave., Baltimore, Md. 21215.

ORGAN or PIANO instruction. 19 Lessons \$7.95. Lenina Music, 22685 Ulrich, Mount Clemens, Michigan 48043, Dept. 16.

PIANOS, PLAYERS, PUMP ORGANS. Rebuild and repair. Catalog of "How-To" books, \$2.00 (refundable). Vestal Press, Vestal 11, New York 13850.

FREE Details. Learn easily, play strum-along Guitar. TODD, 8265PM Mission, Riverside, CA 92509

MAGIC CIRCLE! Instant Chords, Introductions, Endings, Transposing, Modulation. Easy! Fun! \$5. MCK, 2301 Karakul, Ft. Collins, CO 80526

TENOR BANJO Self teacher; beginner to soloist, complete in 33 simple lessons; \$11.95 pp. SASE for details. BanjoP, Box 1225, Metairie, Louisiana 70004.

ACCORDION Top Brands. Cordovox, Buy Direct. Tremendous discounts. Trades accepted. Free brochure PM. Accordion-O-Rama, 16 West 19th Street, New York, N.Y. 10011.

GUITAR, Banjo, violin, Mandolin Making Materials, Accessories, Books, Piano Tuning Kits, Catalog 50¢. International Luthiers Supply, Box 15444, Tulsa, OK 74112

HANDCRAFTED Lutes, Harpsichords, Violins, etc. KITS—Dulcimers, Banjos, Mandolins. Oakhurst Luthier, 51096 Rusty Lane, Oakhurst, California 93644

EASY PLAY Dulcimers, from \$66.00. **EASY MAKE KITS,** from \$27.00. Mandolins, Banjos, Whistles, more; catalog. HERE, Inc., #P, 29 SE Main St., Minneapolis, Minnesota 55414

KITS! Build dulcimers, guitars, harps, Banjos, Mandolins. From \$2.95. Finished instruments from \$23.95. Free Catalog. 4419 West Colfax, PM, Denver, Colo. 80204.

POEMS Set To Music. Nashville Music Productions, Box 40001-PM, Nashville, Tennessee 37204.

P.M.I. 78-79 MUSICAL INSTRUMENT CATALOG - \$2.00 - Credited on 1st Purchase America's most complete source of major brands instruments and accessories at Low, Low Prices. Write: P.M.I., Dept. PM, P.O. Box 827, Union City, N.J. 07087

STRINGS, ACCESSORIES, SCARCE PARTS, REPAIR BOOKS. Catalog 25¢. Stringking, Rifton, NY 12471

ELECTRIFY Player Pianos, Pump Organs Quickly. Inexpensively with Lee Silent Suction Units. Write: Lee Music, P.O. Box 308F, Culver, Or. 97734

BANJO, GUITAR Cassette Lessons. Free Catalog. Bailey, 4005PM Lara, Chattanooga, TN 37416

TEACHERS DISCOUNTS. All Music, Music Makers, 4189 Snapfinger Woods, Decatur, Georgia 30035

EDUCATION & INSTRUCTIONS

WELDING TRAINING - Basic and Advanced for Major Processes - Arc (stick), MIG, TIG, Gas, Pipe all processes. A non-profit school. Accredited member NATTS. Approved Ohio 70-12-0064 HT. Write for school bulletin and course schedule. **NOBART SCHOOL OF WELDING TECHNOLOGY,** Box 79, Troy, OH 45373.

UNIVERSITY DEGREES BY MAIL Programs! Bachelors, Masters, Ph.D.'s. Free revealing details. Counseling, Box 317-PM8, Tustin, California 92680.

DETECTIVE Profession. Easy home study; free tielack or lapel pin, certificate future. Professional Investigators Training School, Dept. CP, P.O. Box 1890, San Pedro, CA 90733

BARTENDING - Bar Management Home Study. Bartending Training, 3843-C San Fernando Road, Glendale, CA 91204

VETERINARY ASSISTANT - Train at home for exciting animal care career. Send for Free "Career Kit." North American School of Animal Sciences, Dept. PBC49, Newport Beach, California 92663.

BOOKKEEPING OR ACCOUNTING! Your own business or work for others. Easy home-study plan prepares you quickly. Veteran-Approved. Free "Accounting Career Kit." Write: Accounting School, Dept. PBC49, Newport, California 92663.

BE AN AUCTIONEER. World's Largest Auction College! VA Approved. Write: Col. Gordon E. Taylor, Reich World Wide College of Auctioneering, Inc., P.O. Box 949, Dept. 19, Mason City, IA 50401

INSTANT MEMORY . . . NEW WAY TO REMEMBER. No memorization. Release "photographic" memory. Forget nothing! Liberates extraordinary knowledge talents, ESP. Immediate results! Free information. Institute of Advanced Thinking, 845PM ViaLapaz, Pacific Palisades, California 90272.

LOANS - Former bank executive explains how to obtain loans from banks, other lenders. \$3.00. Businessman's supplement \$2.00. Sylvan Press, P.O. Box 18212, San Jose, CA 95158.

SMALL ENGINE REPAIR Learn at home for profit or hobby. Money-back Trial Offer. No salesman will call. 25¢ Brings details. Modern Schools, Dept. PMCE, 4225 N. Brown Ave., Scottsdale, AZ 85251.

LEARN Asleep or awake. Records, tapes, equipment! Free catalog! Drawer PM-400, Ruidoso, New Mexico 88345

AUTOSUGGESTION. Sleep-learning headquarters! Tapes, records, books, Gigantic catalog free. Research Association, Box 24PM, Olympia, Washington 98501.

AUCTIONEERING: Mendenhall School of Auctioneering, High Point, N.C. 27263. Free information.

AUCTIONEERING - Free catalog. Resident or Home Study Course. Nashville Auction School, Nashville, TN. Mailing address - P.O. Box 190, Lawrenceburg, TN 38464.

LEARN Sewing Machine repairing. A profitable Trade, Easy to learn. Free details. Sewing Center, 187 FR, Rochelle, GA 31079

EXTENSION And Post-Graduate Awards in Philosophy, Art, Science, Botanic, Medicine, Homeopathy, Radionics and others. 30 subjects. Curricular free (airmail \$1.00 refundable). Registrar, Sussex College of Technology, Highfield, Danehill, Sussex, England.

EARN High School Diploma Spare Time. College-Recognized. Credits given for Previous Courses, Job Experience. Low Tuition. Exams Repeated Free. Individual Counseling. State Registered. Cambridge Academy, Dept. PM89, 409 East Osceola, Stuart, FL 33494.

RADIESTHESIA, Radionics, Dowsing, E.S.P. Courses and Equipment Illustrated Catalog \$1.00 (refundable) Established 27 years. Dept. PM/R Bruce Copen, Highfield, Danehill, Sussex, England RH17 7EX.

MARKETSMITH'S EMPIRE BUILDER - "How To" Newsletter for Small Investors. \$24/yr. Marketsmiths, Inc., 2615 Broadway, Galveston Island, Texas 77550

REFRIGERATION. 40 Lessons \$52.00. Brochure, Sample \$2.00 Deductible. Box 13660, Portland, Oregon 97213

USED Courses! Books! Lists 25¢. Smith's, 124 Marlborough, Salem, Massachusetts 01970

BE A BARTENDER Professional Home Study Course. College of Cocktails, Box 35132-M, Los Angeles, Calif. 90035.

PIANO TUNING PAYS. Learned easily at home. Accredited NHSC. GI Approved. **NILES BRYANT SCHOOLS, INC.,** Dept. P, 3631 Stockton, Sacramento, California 95820

LEARN Pastel Portrait Painting. Easy, New Method, earn Big Money. Free Details. Polin, P.O. Box 295M, Gatlinburg, TN 37738

HIGH SCHOOL At home, no classes. Diploma awarded, low cost. Information FREE, call toll free anytime 1-800-621-5809 (Illinois 800-972-5858) or write: American School, Dept. 30845, 850 E. 58th St., Chicago, Illinois 60637

EARN COLLEGE Degrees by Mail. Informant Pub. Co., 222 N. 9th St., Phoenix, Arizona 85034

SELL! Filler Articles to Magazines. Earn while you Learn. \$6.95. Act Now! Dorothy, Inc. 4316 Boyar, Long Beach, Calif. 90807

EMPLOYMENT INFORMATION

EXCITEMENT Available!!! Become a Scuba Diver or Shiphand! Company training provided - Education no factor. Excellent wages! Unlimited opportunities! For complete information and directory send \$5.00 to: Seaworks, Department 3, Box 10199, Milwaukee, Wisconsin 53210

JOURNEYMAN LEGITIMATE CREDENTIALS GRANTED! Write: National Craftsmen Union, 210 Fifth Avenue, Suite 1102, New York, NY 10011

AUSTRALIA-NEW ZEALAND Want You! 60,000 jobs! Free transportation. Employment listings \$2.00. **AUSTCO,** Box 4116-E, Hayward 94540.

RESUME Kit—Simple Instructions!! G-u-a-r-a-n-t-e-e-d!! \$2.00. Johnson, Box 8599-1W8, Beaumont, Texas 77711

HAWAII Jobs, Business Opportunities—\$3.00. RAF, Box 30793, Honolulu, HI 96820

IMMEDIATE JOB OPPORTUNITIES, Throughout United States and Canada. Details \$1.00. Employment Information, 208 South 4th, DeSoto, Missouri 63020

TEXAS Employment—Plenty of Jobs!! G-u-a-r-a-n-t-e-e-d!! \$2.00. Johnson, Box 8599, 1H8, Beaumont, Texas 77711

WRITE YOUR OWN RESUME. Unique Brochure Shows Right And Wrong Way — \$3.00 (Guaranteed). The Perfect Impression, 10411 Menhart, Cupertino, California 95014

250 Ways to Earn A Living Working At Home: Witty and Timely Compendium. Send \$2.95. Horbine Publications — (8-P), 191 Horbine Road, Rehoboth, Massachusetts 02769

RESUMES, Cover Letters, Searches. Dolin, 600 Bloomfield Avenue, Bloomfield, New Jersey 07003

EMPLOYMENT WANTED

ARE YOU LOOKING FOR EMPLOYMENT! Try our Classified Section! It costs only \$4.00 per word. And, if you wish to run all or part of your ad in bold capital letters - you can do so for as little as \$1.00 per word additional. Act now! Send your ad to: **POPULAR MECHANICS, CLASSIFIED DEPT., 224 WEST 57TH STREET, NEW YORK, NY 10019**

HELP WANTED

OVERSEAS Employment . . . \$10,000-\$50,000 +. Free information! Employment International, Box 29217AH, Indianapolis, Indiana 46229.

\$150.00 Weekly! Webster, America's authoritative dictionary company needs home workers to update local mailing lists. All ages, experience unnecessary. Free details. Send Name, address and phone number to Webster, 245BY East 25th., New York, NY 10010

FOR INVENTORS

INVENTORS - United States Patent Office Searches. Patent Development Engineering and Marketing of your Inventions, ideas with manufacturers contracts. Send for **FREE INVENTION CERTIFICATES** and Invention information. Serving inventors since 1948. **GEORGE SPECTOR, LICENSED PROFESSIONAL PATENT ENGINEER.** Former **UNITED STATES PATENT OFFICE EXAMINER—3615 Woolworth Building, New York 10007**

NONPROFIT Foundation helps inventors. Widest range of services. Free recording forms. Free evaluation. Affiliated Inventors Foundation, 501-B Iowa, Colorado Springs, Co 80909.

PATENT AND DEVELOP Your Invention. Registered Patent Agent and Licensed Professional Engineer, Send for **FREE PATENT INFORMATION** Every Inventor Should Have. Richard L. Miller, 3612 Woolworth Building, New York, New York 10007 (212) 267-5252

EXPERIENCED Product Development Consultants are available! Write: Designers' Choice, Inc., Box 148C, Oakland, New Jersey 07436

PATENT APPLICATIONS. Save \$\$\$ Write: Zekun Products, Box 1283, Ontario, California 91761

U.S. PATENT Office Searches, 234 Broadway, Room 3615, New York 10007. Free invention certificates.

PATENT ATTORNEY Serves Inventors by Mail. Box 405, Medfield, MA 02052

REGISTERED PATENT ATTORNEY Washington D.C. Suburb. Donald A. Kettlestrings, 414 Hungerford Drive, Suite 411, Rockville, Maryland 20850

FREE information and instructions, "How To Sell Or License Your Invention/New Product Idea." We Charge **NO FEES!** . . . Of Any Kind . . . At Any Time! Brandon & Associates, 17925 Sky Park Circle, Suite G3, Irvine, CA 92714

PATENT APPLICATION prepared of your invention by Patent Agent and Consulting Engineer. Reasonable Rates. Howard Podell, Beachfront Lane, New Rochelle, New York 10805.

BECOME INVENTIVE. Methodically. Only \$2. DeLila 1161, Box 56000X, Miami, Florida 33156

MR. INVENTOR: America's foremost development firm offers a complete service. For free details write: Charles S. Prince Co., Inc., Empire State Building, Suite 3308A, NYC 10001

REGISTERED PATENT ATTORNEY. Applications and Searches. Mail Service. Free Preliminary Review. Box 392, Millwood, N.Y. 10546

INVENTORS: If you have an invention for sale or license, write for free booklet explaining how we can help you. Kessler Sales Corp., C-58-F1, Fremont, Ohio 43420

INVENTORS We want your Environmentally Harmonious innovations. Send \$1.00 for our Magazine. United Inventors of Canada Ltd., P.O. Box 4659, Station 'C', Calgary, Alberta, Canada T2T 5P1

INVENTIONS WANTED

IDEAS, inventions, new products needed by innovative manufacturers. Marketing assistance available to individuals, tinkerers, universities, companies with feasible concepts. Write for: Kit-PM, IMI, 701 Smithfield, Pittsburgh, PA 15222.

MANUFACTURER SEEKING INVENTIONS. ADVANTEK INTERNATIONAL, 1100 17TH NW, WASHINGTON, DC 20036.

INVENTIONS MARKETED Cash, Royalties FREE INVENTION PROTECTION CERTIFICATES. George Spector Manufacturers Representatives, Woolworth Building, New York, N.Y. 10007.

LEARN How to offer your invention for sale or license. Free booklet outlines procedures, royalty rates, requirements. Kessler Sales Corporation, C-58-1W, Fremont, Ohio 43420

REAL ESTATE & FARMS

NEW! FREE! Big Fall-Holiday Catalog! Over 5,400 country properties described, pictured! Land, Farms, Homes, Businesses, Recreation, Retirement buys! Selected best throughout the U.S. Over 700 offices, 43 states All Across America! Yours FREE from the World's Largest! **STROUT REALTY, Inc.**, 7 S. Dearborn, Dept. 5800, Chicago, IL 60603.

CANADIAN LAND FROM \$47.00 AN ACRE. Low monthly payments. Ideal for cottages, hunting, fishing, investment! Free catalogue. Canadian Estate Land, 286 Lawrence Avenue West, Toronto, Canada M5M 3A8, Dept. 23C. 416-789-4536.

"CANADIAN Country Properties." Our 63rd year. Catalogue - 6 Issues \$2.00. Tax Sales Service, Suite 404-PM, 85 Bloor Street East, Toronto, Ontario M4W 1B5.

BIG . . . FREE . . . FALL CATALOG! Over 2,600 top values coast to coast! **UNITED FARM AGENCY**, 612-PM West 47th, Kansas City, Mo. 64112.

SELLING Your Home? Save Several Thousand Dollars. Information \$10. Colonial Homes, P.O. Box 60556, Los Angeles, California 90060

"FREE CATALOG!" All Types Property! Photos! (Offices in 12 States). **SAFE-BUY Real Estate Agency, Inc.**, Box 589-PM, Little Rock, Ark. 72203 1-800-643-8341

CALIFORNIA. Acreage. Lots. \$30 down. \$30 monthly. Box 35291, Los Angeles 90035

SAVE Thousands Selling your own Home. Complete Guide by Licensed Broker. \$10 Postpaid. Realty Services, Box 5891P, Phoenix, Arizona 85010

RECREATION Land Tracts. 5-40 Acres, Idaho — Washington — Montana. Timber — Views — Streams. Insured title — Access — Low down. Write: Western High Lands, Inc., Dept. A, Box 969, Hayden Lake, Idaho 83835

EXPORT—IMPORT

SELF "Selling" Products! Free Brochures! Allrightco, Box 9130988, Cleveland, Ohio 44101

BUY IT WHOLESALE

BELTS And Buckles. Complete line fast sellers including truckers, motorcycles, CB's, westerns, etc. Big Profits. Complete dealer set up. Catalog, details free. Anchor Specialties, Box 3958-BPM, North Providence, RI 02911

REPLACEMENT PARTS, Service tools for Chain Saws, Small Engines. First Quality. Substantial savings. Free Catalog. Stores, shops, give sales tax number for dealer information. Repair Parts, Box 6329-K77, Erie, PA 16512

GENUINE Indian Jewelry Wholesale. Details \$2.00 (Refundable). Langlemp, 6301 North 7th Street, Phoenix, AZ 85014

RINGS, Jewelry priced 130% below retail price. Catalog, \$1.00 (refundable). Anka-PM, 95 Washington, West Warwick, RI 02893

HAVE Own Business. World's largest wholesalers. American, foreign. Bargains. Free details. International Buyers, Box 16386-M, Portland, Oregon 97216

400,000 BARGAINS Below Wholesale: Many Free! Liquidations . . . Closeouts . . . Job Lots . . . Single Samples. Free Details. Bargainhunters Opportunities, Box 730-A, Holland, Michigan 49423.

FREE CATALOG. Indian Jewelry Wholesale. Manufacturer, Box 27230P, El Paso, TX 79926

SAVE ON PARTS! Free catalog jammed with Motorcycle, Snowmobile, Small engine parts, Accessories. Manufacturer's Supply, Box 157-PM, Dorchester, Wisconsin 54425

CLOCK — 6 Inch Round Movement. Roman Numerals. Guaranteed 1 Year. Movement only \$8.45. Movement Set in Ornate Wood (unfinished) or Ceramic (Mahogany, Deep Red, Tan, White) Base Only \$14.95. Measures 11" by 16", Weighs only 10 lbs. Beautiful Mantelpiece! (\$3.65 Shipping for Ceramic). Electro Products, Box 1215, Cartersville, Georgia 30120

WHOLESALE Leather Goods — Wallets, Belts, Buckles, Hats, Bags, etc. \$2. Brochures (Refundable). Handmade, Box 806, Conyers, Georgia 30207

ADV. AGENCIES, ADV. SERVICES, MAILING LISTS

MAILING LISTS — New Names every Issue. Ideal for Business/Moneymaking Opportunist. On Quality Perforated Gummed Labels. 200/\$10; 500/\$20. Postpaid. OWEN, P.O. Box 324, Markham, Ontario, Canada L3P 3J7

EXPERT Assistance for mailorder, advertisers. Ratebook leading newspapers, magazines \$1.00. Chicago Advertising Agency, 28-EM Jackson, Chicago 60604

MAILORDER ADVERTISERS!! CLASSIFIED ADVERTISING CAN BE MOST PROFITABLE AND REWARDING. PROBLEM IS TO KNOW WHAT TO DO. WHAT NOT TO DO. COLUMBIA CAN HELP YOU WITH YOUR MAILORDER PROGRAM. OVER 20 YEARS CLASSIFIED ADVERTISING EXPERIENCE. KNOWLEDGE OF BEST PULLING PUBLICATIONS. EXPERT COPY SERVICE IS ALL YOURS AT NO INCREASE OVER PUBLISHERS'S STANDARD RATES. CHANCES ARE YOU WILL SAVE MONEY. WRITE TODAY FOR FREE DETAILS PLUS YOUR FREE COPY OF "MAILORDER ADVERTISER'S RATE GUIDE". COLUMBIA ADVERTISING AGENCY, BOX 1285-PM, RICHMOND, INDIANA 47374

RUBBER STAMPS

RUBBER Stamps Free catalog. Jackson's Brownsville Rd., G-101, Mt. Vernon, IL 62864

PERSONALIZED Pocket Rubber Stamp. 3 lines \$2.50; Bett-R Enterprises, 12100 Valley Spring Lane, #308-P, Studio City, CA 91604

OFFICE SUPPLIES

PROFITS FROM CLASSIFIED ADVERTISING! Booklet shows you how to start your own business with Classified Advertising. Only \$1.00 (Refundable with first order.) H. E. KAPPEL, POPULAR MECHANICS, DEPT. P, 224 WEST 57TH STREET, NEW YORK, N.Y. 10019.

MULTIGRAPH, MIMEOGRAPH

NEED AN INEXPENSIVE COPY MACHINE. Make a dry printer yourself. Buy a photocopy of the plans as they appeared in P.M. Price 75¢. Send order to: Popular Mechanics, Dept. HE, Box 1014, Radio City Sta., New York, NY 10019

PRINTING PRESSES—RUBBER STAMP OUTFITS

SIMPLE-X RUBBER STAMP PRESSES. Hydraulic operated electrically heated. Sizes 5"x8", 8"x12", 10"x15". Starting outfits. Order for presses, supplies shipped day received. Send \$2.00 for Catalog and Brochure. Custom Manufacturers, Box 211-P, Springfield, MO 65801.

SAME Day Shipment. Rubber Stamp Outfits, Supplies. Wholesale Catalog \$1.00 deductible. Star Stamp Supply, 732 Federal, Chicago 60605.

RUBBER Stamp supplies catalog. Jackson, Brownsville Rd., S-110, Mt. Vernon, IL 62864

PRINT YOUR OWN— Printing presses, type, supplies direct from factory. Send 25¢ for catalog and samples to: Kelsey Co., DM, Meriden, Conn. 06450.

PRINTING Presses, type, Supplies Lists, 20¢ Turnbaugh Service, Mechanicsburg, Pennsylvania 17055

TYPE Fonts, Hand Printing Presses, Supplies. 120 pages. \$1.00 deductible first order. Acme Type, 732 Federal, Chicago 60605.

PRINTING & SUPPLIES

QUICK Copy Printing. Low Prices. Write: Nationwide, 614 N. Main, Bloomington, IL 61701

GUMMED LABELS

1,000 Deluxe Gummed Address Labels \$2.00, Free Literature. Acme, 55 Tomoka, Pittsburgh, Pennsylvania 15229

GIFT SHOPPING

HORSE HEAD COAT HOOK Made of Golden Brass. Large and Strong to hang many things on it. Decorative everywhere. \$9.98, PAIR \$18.98. Sonto Mail Order Associates, 3509 N. Damen Ave. 2/FI. Rear, Chicago, Illinois 60618

FREE GIFT CATALOG. Temple House, P.O. Box 5721, Sarasota, Florida 33579

FREE GIFT CATALOG! Multi-National Services Inc., 457 Sunshine Ave., Youngstown, Ohio 44505

CLOCKS, WATCHES, OLD GOLD, JEWELRY

HIGHEST CASH For Gold, Jewelry, Gold Teeth, Rings, Diamonds, Watches, Silver, Platinum, Mail Articles Today. Free gift with information. Chicago Gold & Precious Metals, 6 E. Monroe, Dept. 1258, Chicago 60603.

HIGHEST CASH IMMEDIATELY For old gold, silver, platinum, jewelry, gold teeth, watches, diamonds, spectacles. Free information. Rose Industries, 29-A

WATCH And Clock repairing books, tools, materials. Free Catalogs. North American, Box 77-AH, Fox River Grove, Illinois 60021.

GOLD-SILVER-PLATINUM WANTED. For free information Write: Wilmots, 345 S. Glassell, Orange, Ca. 92666

BUYING GOLD — SILVER ARTICLES! Any Condition! Absolutely No Risk! Free Details. Reliance, 48 Margin, Salem, Mass. 01970

CLOCKS Handcrafted Wood Brochure \$1. Fisk, 631 Union, Middlesex, NJ 08846

CHRONOGRAPH WATCHES — Men's and Women's — "Sanyo". 9 Functions. Special Sale \$21.60. No Cash. Suazo, 144-58 87 Road, Jamaica, New York 11435

HIGHEST CASH IMMEDIATELY For Gold: Rings, Jewelry, Teeth, Watches - Silver, Platinum, Coins. Mail Articles Today! Free Information, Gift. THE CONSTANT HOPKINS CO., P.O. Box 71C, Verona, WI 53593

GOLD

THE Ultimate Possession — GOLD! A Unique Opportunity to own Genuine, Raw, Placer GOLD just as it comes from the Earth in its Natural Form. Make Jewelry YOURSELF, Collect or Show as the Ultimate Possession. This Natural Alaskan Placer Gold is Being Offered in 48 Grain Vials at \$55 Each. Satisfaction Guaranteed or Money Back. Send \$1 for Full Color Brochure & Description. Littlefield Mines, Box 558-PM2, Merlin, Oregon 97532

PRECIOUS STONES & MINERALS

GET Free catalog no serious rockhound, gem Cutter, jewelry maker, hobbyist or craftsman can be without. Full of bargains, exclusive items, low prices from largest suppliers and authorities in the field. Free new catalog just off the press, yours for the asking. Write: Grieger's, Dept. C-12, 900 South Arroyo Fwy., Pasadena, California 91109

500 POLISHED Gemstones \$5.00. Tumblecraft, 5401 James North, Minneapolis, Minn. 55430.

TREASURE FINDERS

FIND Lost coins, jewelry, buried treasure, gold nuggets, relics. New revolutionary patented detector analyzes objects, tremendous range, no ground pick-up. Free catalog. Gardiner, 4729M N. 7th Ave., Phoenix, Arizona 85013

TREASURE - Locate quarter mile away with ultra sensitive locator - brochure free. Research Products, Box 13441 - AMC, Tampa, Florida 33611

METAL DETECTORS: Twenty Major Brands. LOWEST DISCOUNT PRICES! IMMEDIATE PREPAID DELIVERY. PHONE (315) 789-0809. Panna's Electronics, Box 167, Geneva, New York 14456

REDUCED PRICES! Manufacturing Overage Topline Metal Detectors. Compact: D-TEX, 614 Easy Street, Garland, Texas 75042

PROFITABLE OCCUPATIONS

FREE Catalogs. Repair air conditioning Refrigeration. Tools, supplies, full instructions. Doolin, 2016 Canton, Dallas, Texas 75201.

FT. SMITH Auction School, Ft. Smith, Ark. 72901. Resident & Home study. Veteran Approved.

START Service Contracting Business. Details. Alena, Box "A," Farmingville, New York 11738.

PLASTERCRAFT!!! Profitable home business. Molds available. Details: Lynnette, 6251C Mentor Park, Mentor, Ohio 44060

MAKE MONEY IN SPARE TIME. Earn generous commissions as a subscription sales representative for leading magazines. For full details and instructions, send this ad with your name and address to: POPULAR MECHANICS, Dept. AB-M, 250 W. 55th St., New York, N.Y. 10019.

INVESTIGATORS, POLICE, MECHANICS — Learn Profitable Traffic Accident Reconstruction, \$50/Hour Possible, Self-study Program, \$65.00. Money Back Guaranteed . . . Limpert, 2748 Dearborn Street, Salt Lake City, Utah 84106

HOW TO OPERATE A SUCCESSFUL NEIGHBORHOOD BARI! Send \$3.00. Jeffries, 2517 S.W. 64th, Oklahoma City, Oklahoma 73159

SALESMEN—DISTRIBUTORS

INSTANT CASH COMMISSIONS Full or part time. Free sales Kit features America's largest line low priced Business, Printing, Advertising Specialties, sign, calendars and other necessities used daily by business people. Profitable repeat order. No experience. No investment. No collections or deliveries. Write today. National Press, Dept. 957, North Chicago, IL 60064.

MAKE EXTRA MONEY DURING YOUR SPARE TIME! Show our New Line of Calendars, Pens and Popular Advertising Gifts to Local Firms. Prompt, friendly service from small town AAA-1 Company in our 70th year. No investment or collection. Weekly commissions. Be your own Boss. Full Time Potential. No Experience Necessary. Write: Richard Low, NEWTON MFG. CO., Dept. PMCB, Newton, Iowa 50208

FREE Details, Automatic Fishhooks. Profitable Samples \$3.00 Refundable. Aronmarine, 61-A, Mastic Beach, New York 11951

SALESMEN—DISTRIBUTORS

(Continued from preceding page)

BE FIRST! HOT NEW PRODUCT! NOTHING LIKE IT! Unusual Fast-selling Greeting Gift! \$3.50 Retail. Sample \$1. Living Love Leaf, Box 1280-PM, Kingshill, St. Croix, U.S. Virgin Islands 00850

SELL SENSATIONAL LOW-COST BURGLAR ALARM. Lightening seller. Exceptional margin. Samples for trial. Northwest Electric, Ave. 107, Mitchell, S. Dk. 57301

AGENTS WANTED

SPARE TIME CASH. Sell famous Hanover Shoes. Samples, sales kit Free. No experience needed. No age limit. Big commissions. Hanover Shoe, Dept 2483, Hanover, Pa. 17331

PRINTING Advertising Salesmen—Excellent money making sideline selling Decalcomania Name Plates, small quantities. Advertising Specialties, sign letters. Free Samples, Raico XL, Boston, Mass. 02119.

MAKE Up to \$11.50 per pair selling America's finest shoes. No investment! No experience necessary! Free catalog and selling outfit! Mason Shoes, K-491, Chippewa Falls, WI 54729

HANDSOME. Chrome-Plated Paper Welder@ "Welds" Paper without Staples, Clips! Big Profits! Other Items. Write: Cormac, Box 466-M, Medina, New York 14103

BUSINESS OPPORTUNITIES

IMPORT-Export opportunity, profitable worldwide, mail order business from home, without capital or travel abroad. We ship plan for no risk examination. Experience unnecessary. Free Report. Mellinger, Dept. S2708, Woodland Hills, California 91367

MAKE MORE MONEY THAN A PLUMBER! Fix fiberglass bathtubs. Big demand. Also boats, RVs, etc. Full or sparetime. Learn quickly at home. \$20 gets you started. Dept. HAF, FIBERTEX, 412 S. Lyon, P.O. Box 10300, Santa Ana, CA 92711

AUTO INTERIOR CUSTOMIZING AND UPHOLSTERING are today's high demand skills - yet easily learned at home! Fabulous profit potential. Send for FREE Opportunity Kit, details. Auto Upholstery Institute, 412 S. Lyon St., Dept. HAH, Santa Ana, CA 92701.

SECRET FORMULA FOR INFLATION FIGHTING 900% profit business. No parent company, no investment, no competition, no special training. Potential gold mine. Money back guarantee. Instructions \$2.00 SASE. Progress Reports, Box 1176M, Denham Springs, LA. 70726

MAIL Order Distributorships \$100 for supplies. Free Booklet. Audit Controls, POB 23339, Dept. 40, Ft. Lauderdale, FL. 33307

DISTRIBUTORS Wanted — Five Figure Income Potential. Free Details. Ecodine Associates, P.O. Box 348, Agincourt, Ontario, Canada M1S 3B9

FREE! 80 Page Report Revealing Exciting, Spare-time, Low Capital Business Opportunities you've never seen before! SPC, Box 3886, Bellevue, WA 98009

BROKERS REVEAL SECRETS To Real Estate Profits. \$3.00. Schreco, Box 58010, Louisville, Kentucky 40258

SELECTING—PROFITABLE SMALL BUSINESS—Publication—Proven Business Successes—Pitfalls—Described—\$4.95. Small Business Consultant, Box 234, Elm Grove, Wisconsin 53122

MAKE Rubber Stamps for profit. Inexpensive machines. Free Details. Stamper, POB 22809 (GC), Tampa, FL 33622.

MAILORDER Opportunity! Start profitable home business without experience or capital. Write for free book, case histories, plus complete details. No obligation. Mail Order Associates, Dept. 793, Montvale, NJ 07645

BUMPER STICKER PRINTING DEVICE. Cheap, Simple, Portable. Free details. Bumper, POB 22791 (GG), Tampa, FL 33622

HOT — Stamper Prints Gold Leaf. Personalize everything. Print Business Cards, Pencils, Matches. Free Details. Gold Magic, POB 24986 (GC), Tampa, FL 33623

FANTASTIC Home Business! Huge Potential. Details. LNSPM, RFD Box 429, Heber, Utah 84032

PICTURE Framing—Profitable full or spare-time business. Easy to learn with handbook-course "Guide To Picture Framing Profits." \$3.00 Guaranteed. Free framing-supplies catalog included. Japs, 126-PM Seventh North, Hopkins, Minnesota 55343.

REPAIR HYDRAULIC JACKS — DETAILS FREE. WRITE: HYDRAULIC PARTS SUPPLY, BOX 4137, BROWNSVILLE, TEXAS 78520.

VENDING Machines. No selling. Routes earn amazing profits. Big catalogue Free. Parkway Machine Corporation, 1930PMB Greenspring Drive, Timonium, Maryland 21093.

ERASE DEBTS with little known law — **CREATE Wealth!** Details FREE! Blueprints #88, Box 900, Bronx, NY 10471

CLASSIFIED Advertising pays! Write: Virgil Davis, Route 2, Hackleburg, AL 35564

PREPARE Tax Returns - Policeman Albert Myers made \$2,000 his very first season. Train at home. VA Approved. National Tax School, Monsey 2HK, N.Y. 10952

TAKE Catalog Orders. We drop-ship 2500 best-selling specialty products. Lowest below wholesale prices. Immediate delivery. Spectacular home business opportunity. Free book. SMC, 6061, De Soto Ave., Dept 20-80, Woodland Hills, CA 91365.

BE Your own boss! 1001 Fast, easy ways to make money! Free! Rush name, address, zip. Money Making, 11071-F Ventura Blvd., Studio City, Calif. 91604

BEAT the races! Free Booklet! "Unlimited Lifetime Income from Thoroughbreds -Harness". Elias, Box 47F, Brooklyn, New York 11219.

PIANO Tuning quickly learned with home study courses. Diploma granted. American Tuning School, 17050 Telfer Dr., Morgan Hill, Calif. 95037.

MECHANICALLY INCLINED Individuals desiring ownership of Profitable Small Manufacturing Business. Many spare/full time opportunities presently available Without investment: Businesses, 92-88, Brighton 11th, Brooklyn, New York 11235.

BECOME A CONSULTANT. Earn \$20-\$40/Hr. being in Business for Yourself. For Detailed Information on Starting or Expanding your own Technical Consulting Business write: Dr. S. Tomczak, ST&A, Box 480530, Los Angeles, CA 90048

PHOTOSTAMP Agents Wanted! Make big Money From Home mailorder. Free Samples, Information. Postermatic-C7, East Providence, R.I. 02914.

\$200.00 Monthly Spare time Making Novelty Items from scrap lumber. Workshop Five, 3800 Harney, Vancouver, Washington 98660.

BE Your own boss. Your own metalizing business free. We supply all equipment and know how. Free details. Write: Mason, Room MC-2-1H, 1512 Jarvis, Chicago, IL 60626.

AMAZING! \$265,000 Yearly with classified ads. Free Proof. Moneycraft, PM-8, 2316 Dale, Ceres, CA. 95307

"MAILORDER Laws and Regulations." Explains necessary licenses, different taxes, etc. Only \$3.00. Neil H. Tasker, Shamokin, Pennsylvania 17872

PROFITS FROM CLASSIFIED ADVERTISING! Booklet shows you how to start your own business with Classified Advertising. Only \$1.00 (Refundable with first order.) H. E. KAPPEL, POPULAR MECHANICS, DEPT. P, 224 WEST 57TH STREET, NEW YORK, N.Y. 10019.

100,000 BUYERS!! Classified ads — \$.15/word. Details FREE!! Salco, 1432 Birch, Lewiston, ID 83501

FRANCHISE DIRECTORY. Most Complete, Current. \$4.55. Box 5564, San Mateo, CA 94402

DEALERS Wanted! Huge profits selling books by mail. No inventory required. Free Details. Coastal Book Supply, Box 130PM, Jamesville, NC 27846

PIANO Tuning Learned Quickly at Home! Free Information. Empire School, Box 450327, Miami 33145

WOODWORKERS - Start Profitable Business making Unusual Gifts, Decorative Novelties. Easy!!! Every thing explained!!! Free details. Williams, 32P Tivvy, Glen Cove, NY 11542

HORSE Racing Fans—Lifetime Income—Predicting Today's Speed of the Thoroughbred Race Horse—Webster, Box 2486A, Renton, Washington 98055

BIG PROFITS! BIG SAVINGS! Buy Direct from Overseas Companies—Eliminate Middle Man. Send \$5.00 for Booklet Listing Over 500 Companies, Their Addresses and Major Products Offered. Byrd Enterprises, P.O. Box 8043, Greensboro, NC 27410

MAILORDER Dealers Wanted. Earn Outstanding Profits Using Tested Promotions! Executive Type Business. Details: Argonaut, Box 1688PM8, Springfield, Ohio 45501

GUARANTEED Weekly Income of \$238.00. Work at home. Earnings Guaranteed. SIA, Box 182PM, Quitman, Texas 75783

\$1200.00 MONTHLY CORRECTING PUPILS' LESSONS!!! Start immediately. Free Report. Send self-addressed stamped envelope. Home, Box 9201-SBJR, San Diego, CA 92109

BEAT INFLATION!!! Second income from home!!! Write: Coady, 5808F Lemay, Detroit, Michigan 48213

SELL Books By Mail. Complete Dealer Set-up—25¢. Midwest, Box 44R2PM, Shawano, Wis. 54166.

BIG Profits Buying, Selling Old Books. Free Information. Bazaar, Box 496, Chico, California 95927

\$200.00 + Weekly!! N-o G-i-m-m-i-c-k-s!!! Big Demand. Johnson, Box 8599-1K8, Beaumont, Texas 77711

REAL ESTATE LICENSING COURSE!! \$45. "PRA", Box 891, Auburn, Washington 98002

WIN At Football! We beat the pointspread an incredible 70% last 11 years! CBS-TV called us No. 1 football prediction newsletter! Guaranteed winner! Free: game by game record last 4 years. Winners Sports, 5711-D 14th Ave., Brooklyn, N.Y. 11219.

\$1,200.00 Monthly Raising Earthworms For Us. Free Details. Baker Enterprises, Box 193, Sparta, Ohio 43350.

FREE Giant Catalog — business plans — reveal how to become wealthy wholesaler — from home full/spare time — Carwal, 6009-PM8 Hillcrest, Tacoma, Washington 98499

FREE!! Mailorder Business Newsletter. Latest — Dropship — Opportunities. Publishers, 4887-D Trail, Salt Lake City, Utah 84120

BOOMING Book Business!! Amazing 800% Profit. Dealer Packet Free! Mitchell, Box 1058PM-H, Benton, AR. 72015

MAIL Baby Catalogs to New Mothers for Big Profits! Details \$1.00. Volz PM, Ypsilanti, Michigan 48197

SCREEN-Printing. Learn at home spare time. Make money printing signs, bumper stickers, T-shirts, more. Print on paper, plastic, glass, metal, fabric... for stores, reators, mail order, factories, politicians, etc. Write: Screen Printing Center, 4401 Birch, Dept. PBC79, Newport Beach, CA 92663

MAKE More Money By Mail. Haco, Box 846, Nashua, NH 03061

MAKE \$2,000.00 MONTHLY. Spare time. Unique proven enterprise. No selling. No capital to start. Free brochure. Kashiholder, Box 1132-19K, Indianapolis, Indiana 46225.

\$300. -\$700. Monthly Possible Raising Rabbits For Us. Details 25¢. Laboratory Animals PM Inc., P.O. Box 2467, Grand Rapids, MI. 49504

FREE Jewelry Sales Kit. make 233% Profit. Courtesy Gems, 1634 Bogart, Bronx, N.Y. 10462

BADGE PARTS. We stock 8 Sizes. Write: Debbeler Co. Manufacturer of Badge and Mug Machines, 1532-H North Jackson, Milwaukee, Wisconsin 53202

\$92.00 From Square Foot Plywood. (Huge Demand). Revealing Proof 25¢. (Refundable). Woodwin, Bridgewater, Mass. 02324

\$1.00 Lists Your Name Sent to 1,000 Importers, Jobbers, Mailers for One Year. California Pacific Mailers, Clayton, Calif. 94517

MAILORDER Profit Newsletter - Professional Advice, Advertising Recommendations. Free Report. Communications, Box 405PM, Boston, Mass. 02199

START YOUR OWN WHOLESALE BUSINESS. Complete Business Plan, Product Catalog \$10.00 (Refundable). Gibson, Dept. 1-79, 12830 Prairie, #209, Hawthorne, CA 90250

PHENOMENAL Earnings - 1979 Bestseller. New, Vital Product can make \$50,000 for you. Get free "Success That Never Fails" kit. Homesellers' Helpers, 3196AF Kennedy Blvd., Jersey City, NJ 07306

INCREASE YOUR INCOME! Spare/Full Time. Mail Order Guide Shows How. FREE Details. Globus, Box 443-PM8, Bartlett, IL 60103

LEARN Sewing Machine Repairing. Men. Women. Lucrative Profits. Gresslin Correspondence School, Box 927, Spencer, Iowa 51301.

FREE Mailorder Dropship Business Magazine! Mailer's World, Box 1355K, Sioux Falls, South Dakota 57101.

WOODWORKERS - Turn \$4 material into \$34.95. Free Brochure! Pine Shop, 78P, West Peterborough, NH 03468

LIFETIME INCOME At the Dog Track. Reliable Winnings every Week. Money Back Guarantee. \$5.00. R. Kobzina, 615 93rd, Naples, Florida 33940

I MADE \$1 million. Find Capital for Local Merchants & Businessmen. Tested Plan—No Selling. Free Details: FBA-12, Kerrville, Texas 78028

GIANT Income Men—Women! Set Ceramic Tile Successfully, Professionally. Book Explains All \$14.95. "Tile-O-Rama", Rainbow Publishing Co., Box 4158, Auburn Heights, Michigan 48057

BUILDING HOUSES-MAKING MONEY and Enjoying Life. Free Details. Construction Reports PM-8, P.O. Box 232, Lampe, Mo 65681

SELL SENSATIONAL LOW-COST BURGLAR ALARM. Exceptional margin. Samples for trial. Northwest Electric, Ave. 119, Mitchell, S.D. 57301

EARN Extra Money!! . . . New Interesting Way . . . Free Information: Hager Enterprises, Box 763PM1, Palacios, Texas 77465

MAILORDER WEALTH! Easy if you follow this Millionaire's detailed advice. Free information. KRC Associates, Box 5315, Ottawa, Canada K2C 3J1

SURPRISE EVERYBODY. Become Notary Public now. We guide you, free. We sell notary needs. Raise your image, job value, income. Assistance nationwide. Brochure: Gulf, 234 Club-A, San Antonio, Texas 78201

FREE BROCHURE! Amazing NEW Dealership helps Beginners receive CASH orders daily! Complete set-up. Enterprises, 16661 Ventura #215P1, Encino, CA. 91436

SUPER Profits applying never wax finish to auto's. Work from home. Little competition. Details free. Arius Auto, Box 20212, St. Petersburg, FL. 33742

\$58.90 Tomorrow, \$353.88 Next Week. Guaranteed. Free Report. AAHIP, Unit 29309, Medcensta, TX 78229

(Continued on next page)

BUSINESS OPPORTUNITIES

(Continued from preceding page)

PROFITABLE PICTURE FRAMING Complete mitering equipment for perfect frames — under \$250.00. Pootatuck, Box 18PML 2, Windsor, VT. 05089

PART-Time—Sell Auto Parts Wholesale. SASE, Details. Suburban, Box 544, Merrick, NY 11566

\$2,000.00 Monthly Possible!! Over 2,000 items Available. Lowest Possible Prices. Huge Profit Every Sale. Free Details! Derst Co., 629 Mosby, Savannah, GA 31405.

LOANS By Mail!! No Credit, No Collateral!! Free Details SASE. NCASPM, Box 1132, Friday Harbor, WA. 98250.

PROVEN Profitable Mailorder Business!! No Inventory, Shipping, Big Profits Every Sale. Free Details. AJF, 323 Franklin Blvd. South, Suite 804/A-53, Chicago, IL 60606.

HIGH PROFIT HOME BUSINESS. Exceptional Big Money. Free Details. DCS, 1633 So. Bundy, #6, Dept. P1089, Los Angeles, California 90025

"BECOME Mortgage Broker." Obtain Capital!! Sources, Box 99-PM8, Uleta, Florida 33164

CHOOSE \$100.00 Daily Wholesaling Programs. Free Brochures! Allrightco, Box 91309PB, Cleveland, Ohio 44101

GET RICH. Inflation will make you a Millionaire. Send \$10 for our Proven Program. Sun Industries, P.O. Box 1143, New Braunfels, Texas 78130

MAILORDER MILLIONS. It's true. Expert reveals Success Secrets. Helped others make money. Make yours now. Free Details. S. Enterprises, 508 Maple Street, San Mateo, CA 94402

\$24.00 Per Hour. Learn Professional Screen Repair Business. Write: Schafer. PM8, Box 128, Del Mar, Calif. 92014

PROFITS FROM CLASSIFIED ADVERTISING! Booklet shows you how to start your own business with Classified Advertising. Only \$1.00 (Refundable with first order.) H. E. KAPPEL, POPULAR MECHANICS, DEPT. P, 224 WEST 57TH STREET, NEW YORK, N.Y. 10019.

EARN BIG PROFITS DAILY. Successful trade secrets are revealed on money-making opportunities. For free details send to: Cook's Ideal Gifts Co., 11419 So. New Hampshire, P.O. Box 15945, Los Angeles, California 90015.

WHOLESALE Opportunity Over 1800 Products. Free Details. Gomez, P.O. Box 4855, Panorama, California 91402.

FREE Details on High Profit Mail Order Book Business. Vantage, Box 224-PM, Hyde Park, Mass. 02136

\$356.00 WEEKLY GUARANTEED. Work two hours daily at home (\$178.00 for one hour). Free Brochure. FAS, Box 13703, San Antonio, Texas 78213

MONEYMAKING OPPORTUNITIES

CONTEST - Sweepstakes News. 60 Exciting pages. 3-Month trial, \$1.00. Prizewinner, Box 10596, St. Petersburg, Fla. 33733.

SELLING KNAPP SHOES IS EASY. Highest cash commissions immediately. Enjoy a steady income with satisfied repeat customers. Your own hours. No investment. Free sales kit. Knapp Shoes, K612 Knapp Centre, Brockton, Mass. 02401.

MAKE Statuettes, Novelties, Imitation Marble. Sell to stores or start gift shop. Details 25¢. Marbleizing, P.O. Box 1178, Ballwin, Missouri 63011

MAKE Money in your Spare Time. \$1.50. Kery, 20 Godstone Rd., #702-PM8, Willowdale, Ontario M2J 3C5

BEAR RUG KITS With Mounted Heads. Look just like the Real Thing. Send 25¢. Lawrence Edward, P.O. Box 35129, Houston, Texas 77035

VENDING Machines. No selling. Routes earn amazing profits. Big catalogue Free. Parkway Machine Corporation, 1930PMM Greenspring Drive, Timonium, Maryland 21093.

FORECLOSED HOMES —Fortunes are made from distressed Real Estate. We show you how. Free literature. Sherman, P.O. Box P742, Hermosa Beach, CA 90254

\$47.50 Daily starting next week. No mailorder rip-off or stuffing envelopes swindle. Send Self-addressed stamped envelope: Sblamek, Drawer 4099, Valley Village, CA 91607

INSTANT Win. Now available first instant prize \$Million Lottery. Free details and membership: Canadian Money Club, Dept. PM, P.O. Box 1006, (Adelaide Stn.), Toronto, Ontario, Canada M5C 2K4

PROFITS FROM CLASSIFIED ADVERTISING! Booklet shows you how to start your own business with Classified Advertising. Only \$1.00 (Refundable with first order.) H. E. KAPPEL, POPULAR MECHANICS, DEPT. P, 224 WEST 57TH STREET, NEW YORK, N.Y. 10019.

EARN PART-TIME INCOME Supplying Friends and Stores with Bookshelves and Liquor Cabinets Made From Simple Instructions And Your Materials. Selling Tips. \$3.95. Comtel, Box 6252, Philadelphia, PA 19136

MAKE MONEY IN BIG MAIls! \$4.00. Details for SASE. Donald F. Ford, RD#2, Georgetown Rd, Oxford, NY 13830

UNITED STATES Government Needs Researchers and Pollsters! Many Fields. Every State. Experience Unnecessary. Excellent Compensation. Details \$2.00. Federal Research Associates, SR1902, Tower, MN 55790

NEED MONEY? Try our million dollar idea that works! It's "Better Than A Chain Letter - And Legal Too". Guaranteed or your money back. Try it, \$2.99. RoadRunner Publications - Raymondville, Texas 78580

MAKE MONEY IN MAIL ORDER. New, Exciting. Write: Publications, Box 235W, Brea, California 92621

BIG EARNINGS with your CHAINSAW! Start your own business. Details \$1.00. Chainsaw, Drawer A, Rainelle, WV 25962

PROFIT FROM ENERGY CRUNCH. Make, Use, Sell Alcohol. Send \$14.95 for Book with Complete Easy to follow Directions. White Company, Box T30G SCR, Big Spring, Texas 79720

MAKE \$16.50 Hourly. Produce rubber stamps. Equipment, know-how furnished. Free particulars. Write: Roberts, Room RC-2-1H, 1512 Jarvis, Chicago, IL 60626.

WE BUY NEWSPAPER CLIPPINGS of Wedding Announcements for \$1.00 each. Instructions \$1.00. Clippings, Box 491-PM, Gatesville, Texas 76528.

LEARN The secrets of repairing junk batteries "Fabulous Profits," small investment. Apex Engineering, 5454 Bolsa, Atascadero, Calif. 93422

\$2,000.00 Month Spare Time Possible! Unique Plan. Knight, Box 32242-M, Charlotte, NC 28232

CASH In On Rising Crime, HIGH PROFITS. NEW PRODUCT. Send \$2.00 (Refundable) to: P. Ranger Co., F58G9, GPO Box 2205, New York, N.Y. 10001

SPENDING MORE FOR LESS? Discover Ways to Get More for your Money. Introductory Issue \$1. 2's Inflation Fighters, Dept. 10, Box 3094, Clinton, Iowa 52732

INFLATION PINCH!! Earn extra money! Learn Import Drop-ship method. No merchandise investment. \$2.00. Lexington Enterprises, Dept. P11, 36 Lexington Avenue, South River, N.J. 08882

EARN Extra Income—Begin Successful Painting Business. Details \$4.00. R&T Associates, Box 4572, Waterbury, CT 06710

WEALTH Builders Rainbow Collection Listing Quality Wealth Programs. \$1.00. LaPacifica's, P.O. Drawer 5877PM, Bakersfield, CA 93388.

HOW TO MAKE \$300 A Day with Fiberglass Repair. \$5.95. ATW, 1008 W. Mitchell #231, Arlington, Texas 76013

RICHES, HAPPINESS, SUCCESS — Can Be Yours. Write: Success, P.O. Box 388, Rosehill, KS 67133

SUCCESSFUL Moneymaking Plans For Homeworkers. There's One Just Right For You. FREE DETAILS. Sarff Products, Box C-8415, Ann Arbor, Michigan 48107.

FREE - Easy Ways to make money selling exciting new products—Full - spare time. Send name, age for 5 months free subscription. Opportunity Magazine, 6 N. Michigan, Dept. 354, Chicago 60602.

PROFITS FROM CLASSIFIED ADVERTISING! Booklet shows you how to start your own business with Classified Advertising. Only \$1.00 (Refundable with first order.) H. E. KAPPEL, POPULAR MECHANICS, DEPT. P, 224 WEST 57TH STREET, NEW YORK, N.Y. 10019.

FREE Report. New Discovery in Battery Reconditioning means "Big Profits Fast." Electone, 7415 Gable Drive, Little Rock, Arkansas 72205

NEW. Good Income Plans. Free. Homecraft, 2350 W-47-P, Denver, Colorado 80211

RABBITS—CHINCHILLAS—FUR BEARING ANIMALS

AMAZING Profits! \$10,000 Yearly Raising Rabbits for Wool and Breeding. Details—\$1.00. American Angora, Malta 12, Montana 59538.

\$500-\$1000 Month plan raising rabbits for us. Free details. White's Rabbitry, PM, Hudson, Ohio 44236.

RAISE Chinchillas, Guaranteed income. Send \$3.00 for literature. DeShon's Windy Acres Ranch, Route 4PM, Ossian, Indiana 46777

PETS—BIRDS, CATS, HAMSTERS, ETC.

HATE To Let The Cat In? Look Under "HOME CRAFTSMAN".

EARTHWORMS, LIVE BAIT

GREY Nightcrawlers—Raise/retail—Free Literature—Fain's Earthworms—Edison, Ga. 31746

FREE Literature Profitable Business Raising Fishworms, Crickets. We Teach you how to Raise and Sell. Write today. Carter Fishworms, Plains, Georgia

REDWORMS Bedrun 5,000—\$22.00; 20,000—\$57.00 including postage. Raising Instructions. Brazos Worm Farms, P.O. Box 4185PM, Waco, TX 76705

RAISE Grey Hula Redworm Soilless Method. Three Oaks, Dresden, Tenn. 38225.

RED WIGGLERS Bedrun 5,000-\$20.00; 20,000-\$55.00. Includes Postage, Overcount, Instructions. Spring Creek Worm Ranch, 23010 Squirrel Tree, Spring, Texas 77379

POULTRY & GAME BIRDS

999 Picture Color Catalog \$1.00. "Everything—You Name It!" Swans, Peacocks, Bantams, Pigeons, hobby supplies. Stromberg's Pets Unlimited, Pine River 59, Minnesota 56474

OF INTEREST TO ALL

MECHANICAL TREASURE TROVE IN JUNKYARDS! What you can find; where; tips on buying. \$3.00. Fred Hines, Box 65M, Fair Grove, MO 65648

WIN Contests! Information you need to win. Booklet \$2.00. Southwest Specialty Products, Box 30084, Parma Hts., Ohio 44130

BIORHYTHMS Personalized on Useful, Attractive Calendars. Free Brochure. Charles, Box 64, Flossmoor, Illinois 60422

NOVELTY CARDS - "Better Service Earns A Bigger Tip!" 10 for \$1.00. Winsher Limited, Box 49165, Atlanta, Georgia 30359.

PROFITS FROM CLASSIFIED ADVERTISING! Booklet shows you how to start your own business with Classified Advertising. Only \$1.00 (Refundable with first order.) H. E. KAPPEL, POPULAR MECHANICS, DEPT. P, 224 WEST 57TH STREET, NEW YORK, N.Y. 10019.

AVOID TAXES! Legally! Accepted IRS Procedures. Information free. Infohouse - PM8, Box 1004, New York, NY 10003

SURVIVE What may almost eliminate mankind. You, your child or grandchild can have a chance. Send us one dollar and become a member of our group. As a member you may both teach and learn. Survival Students, P.O. Box 246, Manitou Springs, CO 80829

SAVE GAS! On your Present Car 20 Ways. Research Tested. No Gimmicks. \$3.00. IMPEX, P.O. Box M, Dept. A. Glenham, N.Y. 12527

DISCOUNTED GIFTS (2500)! LATEST INCOME OPPORTUNITIES. Freebies! Gee's, 288 N. Livingston, Livingston, New Jersey 07039

WIN Consistently, Poker, Races, Dice. Free Brochure. Timberhill, Chestnut Road, Box 51, East Aurora, New York 14052

ROACHES Bugging you? Try my trap—\$2.00. Rodco, Box 5024, Hilo, Hawaii 96720

GOVERNMENT SURPLUS

"GOVERNMENT SURPLUS DIRECTORY." . . . Buy 500,000 items (including Jeeps) . . . low as 2¢ on dollar! (most complete information available — \$2.00 (guaranteed). SURPLUS DISPOSAL, Box 19107-AH, WASHINGTON, DC 20036.

J-E-E-P-S . . . !!\$59.30!! . . . CARS . . . !!\$33.50! . . . 450,000 ITEMS!! . . . GOVERNMENT SURPLUS!! MOST COMPREHENSIVE DIRECTORY AVAILABLE tells how, where to buy!! . . . !! YOUR AREA!! \$2.00!! MONEYBACK GUARANTEE!! "Government Information Services," Department 88, Box 99249, San Francisco, California 94109

1979 Surplus Army, Navy store 64 page illustrated catalog. Send \$1.00. Ruvel, 3037 North Clark, Dept J-8, Chicago, Ill. 60657

J-E-E-P-S . . . !!\$33.30!! . . . 475,000 Items! Buy In Your Area! How! Where — "G-U-A-R-A-N-T-E-E-D 1979 Government Surplus Directory"—Including: "Buy Government Lands Guide"—Including: "Government Oil-Gas Lottery Guide"—\$2.00. GSURPLUS, Box 2009, Syracuse, New York 13220.

GOVERNMENT LANDS FROM \$7.50 ACRE! Homesites, farming, vacationing, investment opportunities! "Government Land Buyer's Guide" plus current listings—\$2.00. Surplus Lands, Box 19107-AH, Washington, D.C. 20036.

GOVERNMENT SURPLUS. Buy your area. How. Where. Send \$2.00. SURPLUS HEADQUARTERS BUILDING, Box 30177PM, Washington, DC 20014

DISCOUNT Catalog — Viet-nam Boots, Canteens, Viet-nam Jackets, Knives, Jungle Hats, Packs, Helmets, C-Rations. Send \$1.00 Refundable. Dixie Military Surplus, Box 8149-PM, Nashville, Tennessee 37207

JEEPS \$52.40, Airplanes \$75.01, Typewriters \$6.70, Boats \$7.50, direct from government. Directory and Surplus Catalog \$1.00 (refundable). Midwest Surplus, Box 401-PM, Dayton, Ohio 45401

O-F-F-I-C-I-A-L UNITED STATES DICTIONARY . . . Jeeps . . . \$37.22!! . . . 400,000 Listings!! . . . Your Immediate Area!! . . . UNEQUALLED!! . . . \$2.00 . . . (INCLUDES G-LANDS, G-LOTTERIES INFO-GUIDES!) . . . UNCONDITIONALLY GUARANTEED!! . . . United States/Great Lakes Federal Surplus Depository, B807PD, Marshfield, Wisconsin 54449. (COPYRIGHT 1979)

MOTORCYCLES—JEEPS—HELICOPTERS—AUTOMOBILES — GOVERNMENT SURPLUS DIRECTORY—MONEYBACK GUARANTEE— How, where—\$2.00. GS Information, Department 18, Federal Building, Box 2013, Springfield, Massachusetts 01101

LOANS BY MAIL

BORROW FROM HOME. Any amount, any purpose, within 30 days. Competitive Rates. Also, you can earn unlimited income as our Money Agent. No experience—own hours. National Company to assist every way possible. No Gimmicks! Free Details: Financial, Dept. 10-C-8, 1145 Reservoir Avenue, Cranston, R.I. 02920

BUSINESS Loans—Any Amount, Any Purpose. K. Finance, 814-723-9597

BORROW \$25,000 "overnight." Any purpose. Keep indefinitely! Write: Success Research, Box 29263-AV, Indianapolis, Indiana 46229.

SBA Loan Application Instructions. \$14.95 or Brochure Free. Box 15877L, New Orleans, LA 70175

BORROW \$25,000 interest-free! Repay Anytime. Everyone eligible. Free Report: Executive PM-8, Box 1308, Duluth, Georgia 30136

ARAB MONEY TO LOAN. Invest. For Business. Investment Purposes. \$10,000 — \$10,000,000. FREE Details. Arab-PM, 935 Main, Vidor, TX 77662

FREE Details on how to Borrow up to \$10,000 Entirely by Mail. Write: Postal Financial Services, Inc., Dept. 0590, 814 Pierce St., P. O. Box 268, Sioux City, Iowa 51102

NOW! MONEY-INTEREST FREE. \$1,000-\$30,000 on signature. Anyone. Use indefinitely. Write: Baker-PM8, Box 460, Ramona, CA 92065

CAPITAL Acquisition, Expansion, \$100,000. Up. Cruckshank, 75 Prospect Street, Hingham, Mass. 02043

BUSINESS Loans. \$5,000 — \$10,000,000. Any purpose. Lewis Hamilton, Box 205, Palmer, Texas 75152

\$CASH\$ Loans! \$2,000 — \$5,000,000. Advise amount — Purpose. Write: National Advertising Agency, 507P Fifth Avenue, N.Y. 10017

PERSONAL

INFORMATION/ Assistance on Anything. USA—Worldwide: International Research Service, Box 225, Blue Bell, Pennsylvania 19422.

FINANCE YOUR DREAMS With Government and Foundation Grants. Free details. Tou-PM8, 432 PCH, Hermosa Beach, California 90254.

COLLEGE DEGREES BY MAIL. Renowned Universities offer full-accredited Bachelors, Masters, Ph.D.s Free revealing details. Counseling, Box 317-MP-8, Tustin, California 92680.

FUNERALS! —Pre-arrangement Forms. Complete Instructions \$3.50. Funeral Counselors, Box 16086, Portland, Oregon 97216.

VITAMINS! Reasonable Prices. Quimette, Box N1043-1, New Bedford, MA 02746

PSORIASIS SUFFERS: DISCOURAGED: Write for Free important information that is helping thousands. Pixacol, Box 29277PM, Parma, Ohio 44129.

BIBLE Questions answered. Stamped envelope. Bylon, 17167 Bentler, Detroit, Michigan 48219

COLLEGE Diplomas Without Classes. Accredited Degrees by Mail. Free Details. DACS, Box 33428, Seattle, WA 98133

REMAILING SERVICE

UNLISTED ADDRESS. Discreet and confidential. Remail 50¢ Single. Mail Forwarding Service, 8050 S. Main, Houston, Texas 77025

FLORIDA REMAILS Receiving-Forwarding. Allen, 6326 Aulian Drive, Jacksonville, Florida 32210.

TORONTO Remails—Confidential Service. Write: Williams, Box 835, Adelaide St. Toronto, Canada M5C 2K1.

FREE! Remailers Listing. (New Agents Wanted): Box 471PM, Atlanta, Texas 75551.

1979 REMAILING DIRECTORY \$5.00. International Remailing Forwarding Association, Box 1536M, Hilo, Hawaii 96720

CONFIDENTIAL Service. Write: Pony Express House, 1391 Archer, Live Oak, Ca. 95953.

COLORADO Mail Forwarding. Write: Mail Forwarding, 1425 Brentwood, #18, Denver 80215-

MISCELLANEOUS

PHOTO BUTTONS. Your Photo on a 2 1/4 inch Button ONLY \$1.00. Photo Not to Exceed 3 x 3. John Leising, 2032 North 13 1/2 Street, Terre Haute, Indiana 47804

ORNAMENTAL Iron designs. Book of 1600 beautiful, practical designs for railings, columns, etc. Free literature. Cunningham, 3881 South 3200 West, Box 20005, Salt Lake City, Utah 84120

SUPER Giant Washer 15 Foot with 4 Special Attachments—Only \$29.98—Guaranteed. K & B Enterprises, POB 1412, Camden, New Jersey 08101

PHOTO IDENTIFICATION CARDS . . . Certificates GUARANTEED! Samples 25¢ . . . Bascco, Box 3461-

FREE — Knapp Shoe Catalog — Prices Discounted — Knapp, 207 Kensington Road, Lynbrook, NY 11563

MILITARY Stuff - 1000s of things. 65 pages full of Jackets, Boots, Metals, Wings, Ribbons, Insignia plus outdoor stuff. Send 50¢ (\$1 First Class rush) to: Ken Nolan, 16901-A Milliken, Irvine, CA 92713.

IDENTIFICATION CARDS. Send for information. 929 University Ave., Berkeley, CA 94710.

STYME! Itch Eraser. Press Tiny Device on Bite. Presto! Instant Relief. \$2.00. DB Enterprises, Box 566, North East, Pa. 16428

HOUSE Fly Trap with Chemical \$7.95, Satisfaction Guaranteed. M & S Merchandise, Box 1345, Milwaukee, Wisconsin 53201

PHOTO IDENTIFICATION CARDS. Free Samples. Documents, Box 5684T, El Monte, California 91731

WANTED—MISCELLANEOUS

GOLD, Silver, Platinum, Mercury, Tantalum wanted. Ores assayed. Free circular. Wholesale Terminal, Norwood, Ma. 02062.

BUYING Older Baseball Cards. Steve Coerper, 8115 Troost Avenue, N. Hollywood, California 91605

HEARING AIDS

SAVE Half or more on Nationally Known Hearing Aids. Rea Company Inc., Box 364, Bridgeport, Ohio 43912

NEW —Hearing aids, Batteries, Discount Prices. Free Details. Write: Rhodes, Dept. 132-S, Brookport, Illinois 62910

FREE HEARING AID CATALOG —Save 1/2—by mail! Write: "MONEYSAVERS," 9530PM-8, Langdon, Sepulveda, CAL 91343

REPAIR Hearing Aids. "Prompt, Reliable Service". Monmouth, 2A W. Front St., Red Bank, N.J. 07701.

TOBACCO

MAKE Pipes. Write to: Pimo P89, Box 59211, Chicago, Illinois 60659.

SCIENCE & CHEMISTRY

LASER Plans—Five for \$10.00, Catalog—\$2.00. Solaser, Box 1015, "PM879", Claremont, Calif. 91711

DISCOUNTS! Laboratory Chemicals, Glassware, Apparatus. Catalogue \$1.00. Deluxe Scientific, 507 Huron, Manitowoc, Wisconsin 54220

FORMULAS, PLANS, ETC.

20,000 MONEymaking Formulas Available—Bargains! Catalog/Manufacturing Secrets \$2.00 (Refundable): GWA3, Box 193, Brookfield, Wisconsin 53005

TRAVEL & RESORTS

USE A POSTAGE STAMP To Plan your Perfect Vacation. Complete addresses for FREE Brochures, Pamphlets, Maps — all American. \$3.00 Brings Official-Listing Booklet. Annie's, Box 31-P, Mountain Center, California 92361

HAWAII Vacation Apartments. Reservations. Hawaii, Suite 210, 910 Ala Moana Boulevard, Honolulu 96814. Toll Free 1-800-367-5205.

40 DISCOUNT Coupons to Major Florida Attractions. Orlando Disneyland Area. Send \$1.00. Vacation Kits, P.O. Box 201, Butler, Pennsylvania 16001

SPECIAL SERVICES

CRAFT-JOURNEYMAN REGISTER - Forming national register. Listing member names under trades. Prized publication to industry. Send \$5.00 for application and details to Craft-Journeyman Register, P.O. Box 21108, St. Petersburg, FL 33702.

INFORMATION On anything. Ferguson Research Specialists, 60-15 Woodside, Woodside, New York 11377.

PROFITS FROM CLASSIFIED ADVERTISING! Booklet shows you how to start your own business with Classified Advertising. Only \$1.00 (Refundable with first order.) H. E. KAPPEL, POPULAR MECHANICS, DEPT. P, 224 WEST 57TH STREET, NEW YORK, N.Y. 10019.

BETTER HEALTH

GH-3 NOW AVAILABLE BY MAIL—\$45! Free Information—Holistic Center, Box 600129 (P), N. Miami Beach, Florida 33160

STAY-SLIM. Secret of the Orient. \$2.95. P.O. Box 1146, Kissimmee, Florida 32741

HOW TO LIVE LONGER —Secrets Remain Healthy, Alert. \$1.50. Order Now. Ricky's Gifts, 1 Virginia Avenue, Huntington, New York 11743

DIETING Free Information. Kenneth Javorsky, 1918 1st Avenue West, C14, Williston, North Dakota 58801

ECONOMEAL — Increase Your Protein Intake By Proper use of Food Additive. \$4.95. Box 173, West Acton, Massachusetts 01720

NEGATIVE ION GENERATORS and accessories. (Assembled/Kits). (Fascinating details — \$1.00). Golden Enterprises, Box 1282-PM, Glendale,

FOR THE HOME

AUTOMATIC HOME FIRE PROTECTION. Illustrated Instructions \$3.00. LEEDON, Dept. PM8, 440 Henderson Street, Grass Valley, California 95945

SAVE \$15,000.00 OR MORE ON YOUR MORTGAGE!! Learn How . . . \$3.00. C & M Enterprises, Box 247-PM, New Berlinville, PA 19545

REPAIRS & SERVICING

WINDOW AIR CONDITIONER SERVICE GUIDE! Illustrated New Edition! All Makes! Send \$5.00 To: Stahl Air Conditioning, Box 195, Maspeth, NY 11378

GARDENING & LAWN CARE

BUILD A WINDOW GREENHOUSE— Converting a window in your home to a mini-greenhouse amounts to little more than attaching a box-like plexiglass enclosure to the outside. The beauty is that you don't do a thing to the window other than add screws to the frame—the window stays intact. No drafts in winter, no need for caulking. For plan send \$2.95 to: Popular Mechanics, Dept. HE, Box 1014, Radio City Sta., New York, NY 10019

FLOWERS, PLANTS & NURSERY SUPPLIES

LEARN Landscaping and the growing of plants. Start a profitable business part or full time. Free information without obligation. Lifetime Career Schools, Dept. A-573, 2251 Barry Avenue, Los Angeles, California 90064.

GROW Ginseng! \$50 Pound. Have Seeds, Roots. Goldenseal. Full Information. K. Collins, Viola, Iowa 52350

KNEE Pads. Sponge Rubber. Eliminate Soreness, Scratches. Adjustable Straps. \$3.98. DB Enterprises, Box 566, North East, Pa. 16428

WINEMAKING & OTHER RECIPES

WINEMAKERS-BEERMAKERS . . . Free Supply catalog. Yeast. Equipment. Continental, Box 68016-PM, Indianapolis, Ind. 46268.

WINEMAKERS-BEERMAKERS —Free Catalog—Fast Service—Large Selection. Kraus, Box 7850L, Independence, Missouri 64053.

WINEMAKERS - Beermakers: Free illustrated catalog of supplies. Semplex, Box 12276R, Minneapolis, Minnesota 55412.

MAKE Wine, Beer, Liqueurs, Beekeeping supplies. Free catalog. Bacchanalia, 273PM, Riverside Westport, CT 06880.

CORN Soup Recipe. Send \$2.00. P.O. Box 343, Wakefield, Quebec J0X 3G0

AMARETTO. Easy, Fast, Free information: Spirits, Box 1012, Pacifica, California 94044

GARDEN GASPACHO. Icy Opener for Summer Meals. Original Spanish Soup Recipe. Perfection! Easy Instructions \$2.00. Annie's, Box 31-P, Mountain Center, California 92361

FREE ENCYCLOPEDIA Winemaking, Beermaking, Supplies, Equipment, Ingredients. Vynox Industries, Box PM7498, Rochester, NY 14615

BEERMAKING — Learn How — Call 800-538-7936 — Toll Free.

EVERYTHING For Wine, Beer, Catalog: Jim Dandy Sales, Box 30377, Cincinnati, Ohio. 45230

HOW to Make Sourdough Bread to Rival San Francisco's Best. Hungry for that Fisherman's Warf Treat but Live too Far From Bay Area. Easy Recipe. \$1.00, SASE. Swit-Z Enterprises, P.O. Box 836, Oak Harbor, WA 98277

18 PICKLE And Relish Recipes—1944 Government Pamphlet Reprint, \$1.95. Refund if No Fun! Hendricks, 138P, Box 404, Hiram, OH 44234

BEEF IS TOO EXPENSIVE — 100 Chicken Recipes. \$3.00. LeRoy, R.D. 5, Shavertown, Pa. 18708

WINEMAKING/BEERMAKING Supplies, Equipment. Free Catalog. Wine Hobby, P.O. Box G-104, Greenwood, Ma. 01880.

BEER LOVERS! Brew premium American and European beers at home. Easy - Delicious - Fun. Great Savings. Free Details. Duane Imports, Ltd., Dept PM89, 508 Canal Street, New York, New York 10013

DELICIOUS Buttermilk Pie Recipe \$3.00. Jerri Cox, 188 McArthur, Denison, Texas 75020

BEERMAKERS, Winemakers, Free Catalog, Recipe. Finest ingredients, Equipment, Service. SPI, Box 784M, Chapel Hill, North Carolina 27514

BURGLAR ALARMS & HOME PROTECTION

QUALITY Burglar - Fire Alarm Equipment at DISCOUNT - Prices!!! COMPLETE Catalog \$1.00!! Steffens Alarm Supply, Box 624J, Cranford, NJ 07016

SUNBEAM Door Stop Alarm. Easy Installation — No Wires. No Batteries. \$9.95. Guaranteed Satisfaction or Money Back. M&S Merchandise Co., Dept. 61PM, P.O. Box 1345, Milwaukee, Wisc. 53201

PROFESSIONAL Quality Alarm Systems for your Home. For free catalogue write: EAC, Alarm Department, Box 7881A, Colorado Springs, Colorado 80933

Portable refrigeration breakthrough makes ice chests obsolete!

New Solid State Refrigeration Modules no bigger than your watch, have More Cooling Power than a 10lb. Block of Ice.

Your ice chest is bulky, awkward to carry, messy and inefficient at keeping its contents cold. You have to buy ice every day, if you can find it, throw away the spoiled soggy food and drain off the water repeatedly.

Conventional portable refrigerators are either too heavy, too noisy, drain your battery too quickly or need to be kept level.

These problems and inconveniences have finally been resolved in one totally new product - the Koolatron 12 volt portable electronic refrigerator. We believe the Koolatron portable represents such a dramatic advance in refrigeration for recreational use that all existing methods are now outmoded.

USES AEROSPACE REFRIGERATION MODULES

The Koolatron portable cools your food electronically with solid state thermoelectric refrigeration modules. These same powerful modules are used by military and aerospace scientists to cool critical components in rockets and satellites. They use thermoelectric cooling because of its absolute reliability, insensitivity to motion or level, small size & weight and minimal battery drain.

WHY IS THE KOOLATRON PORTABLE SO MUCH BETTER THAN AN ICE CHEST?

An ice chest maintains an air temperature of 50-60 deg. F. Meat and milk spoil rapidly at temperatures above 50 deg. F. which is why the top of your meat will go bad even when it is sitting on ice. Koolatron portables maintain normal home refrigeration temperatures of 40-45 deg. F. even in 95 deg. F. weather.

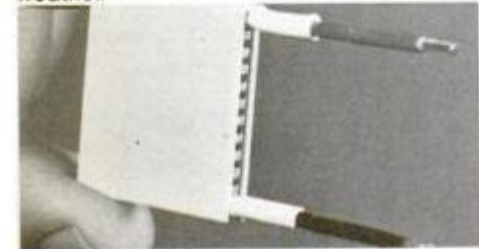

Two of these miniaturized thermoelectric modules replace all the bulky, complex piping coils, compressors and motors in conventional portable refrigerators. The modules pump heat from your food into efficient heat sinks where it is dissipated by a quiet fan. They operate on a principle called the "Peltier Effect" - passing electricity through the junction of dissimilar metals causes heat to flow away from the junction.

BOATING, FISHING, CAMPING, HUNTING

Fits into virtually any boat, van or camper. Carry it on the back seat during car trips. Ideal for fishing and hunting - bring your catch back home fresh (a few loads of fish fillets could pay for your portable). Use it for grocery shopping, medicines, carrying film, salesman's samples. Take it to the drive-in movies, auto races and other sporting events. With an inexpensive battery charger

you can use your Koolatron as a bar fridge all winter and a patio fridge in the summer. Run it in your motel room at night and enjoy a midnight snack whenever you feel like it. We have customers using our portables on construction sites, in workboats, laboratories and even in locker rooms for a "cold one" after the game.

THE ULTIMATE PORTABLE REFRIGERATOR

It weighs less than most coolers with a block of ice but holds over 40 pop cans or 40 lbs. of food in its large 36 qt. capacity. Plug it in a lighter socket in your car, boat or van or operate it from a 12 volt battery charger plugged into 110 volts. Cold contents will stay cold overnight with unit off. Draws a maximum of 4 amps., averages about 2 amps. at 70 deg. F. with the thermostat on. Keeps your food cold and dry. Exterior dimensions are 21" L x 16" W x 16" H. Interior dimensions are 16" L x 11-1/2" W x 12" H.

BUILT-IN QUALITY AND DURABILITY

The rugged "ABS" case is filled with the best insulation available - rigid urethane foam. It has a "150 lb. test" handle and non-rusting polypropylene hinge and latches, with stainless steel fasteners. The exterior is harvest gold with a white interior and has 4 non-slip rubber feet. Your portable comes with a 9 ft. detachable cord which plugs into your cigarette lighter. It also has terminals for attaching wires directly from a battery or fuse panel. The same terminals are used for your battery charger clips when operating from a charger. A reverse polarity warning light & buzzer are included. The Koolatron was designed so that the fan motor can be replaced by you with only a screwdriver. No other service should ever be required except for physical damage which can be repaired at our depots in Batavia, N.Y., or Barrie, Ontario.

GUARANTEE. 21-DAY MONEY-BACK TRIAL PERIOD

Your Koolatron comes with a written 1 year guarantee plus complete instructions and helpful information about batteries and chargers. If for any reason you are not totally satisfied, return it for a prompt refund in full.



BUY NOW AT OUR NEW LOW PRICE

Good news. Our increased sales have overcome mounting material costs. So for now we can pass on a



The Koolatron portable keeps 40 lbs. of food at household refrigeration temperature but weighs only 15 lbs. Only 21" x 16" x 16" ext. Model F1A shown.

saving of \$10.00 per unit. Formerly \$169.00. Now \$159.00 + \$7.00 handling and shipping (\$179.00 in Canada).

ADJUSTABLE THERMOSTAT OPTION

For an additional \$10.00 you can order the Koolatron portable with an adjustable thermostat in place of the standard fixed temperature thermostat - order Model F1A.

PAYS FOR ITSELF

If you are regularly using ice, your Koolatron portable will pay for itself with the money you save on ice, spoiled food, restaurant bills and the gasoline used looking for ice.

Don't Waste Another Dollar on Ice!

Phone your order in collect to

705-737-0842

Koolatron Industries Limited,
56 Harvester Ave., Batavia, New York 14020
230 Bayview Drive, Barrie, Ontario, Canada
Or use this handy order coupon.

Koolatron INDUSTRIES LIMITED

Dept. 679

56 Harvester Ave., Batavia, New York 14020
Canada: 230 Bayview Drive, Barrie,
Ontario L4N 4Y8

Send me ___ Koolatron F1 @ \$159.00 (\$179.00 in Canada) + \$7.00 each for handling and delivery in USA or Canada. (N.Y., Ont. and Que. residents add sales tax.)

___ I want model F1A and have added \$10.00. I understand that I may return it undamaged within 21 days and get a full refund if I am not satisfied. I enclose my check money order for \$_____, or, please charge my Visa Mastercharge American Express.

Acct. No. _____

Expiry Date _____ Send brochure only

Signature _____
(necessary to ship merchandise)

Name _____

Address _____

City _____

State _____ Zip _____

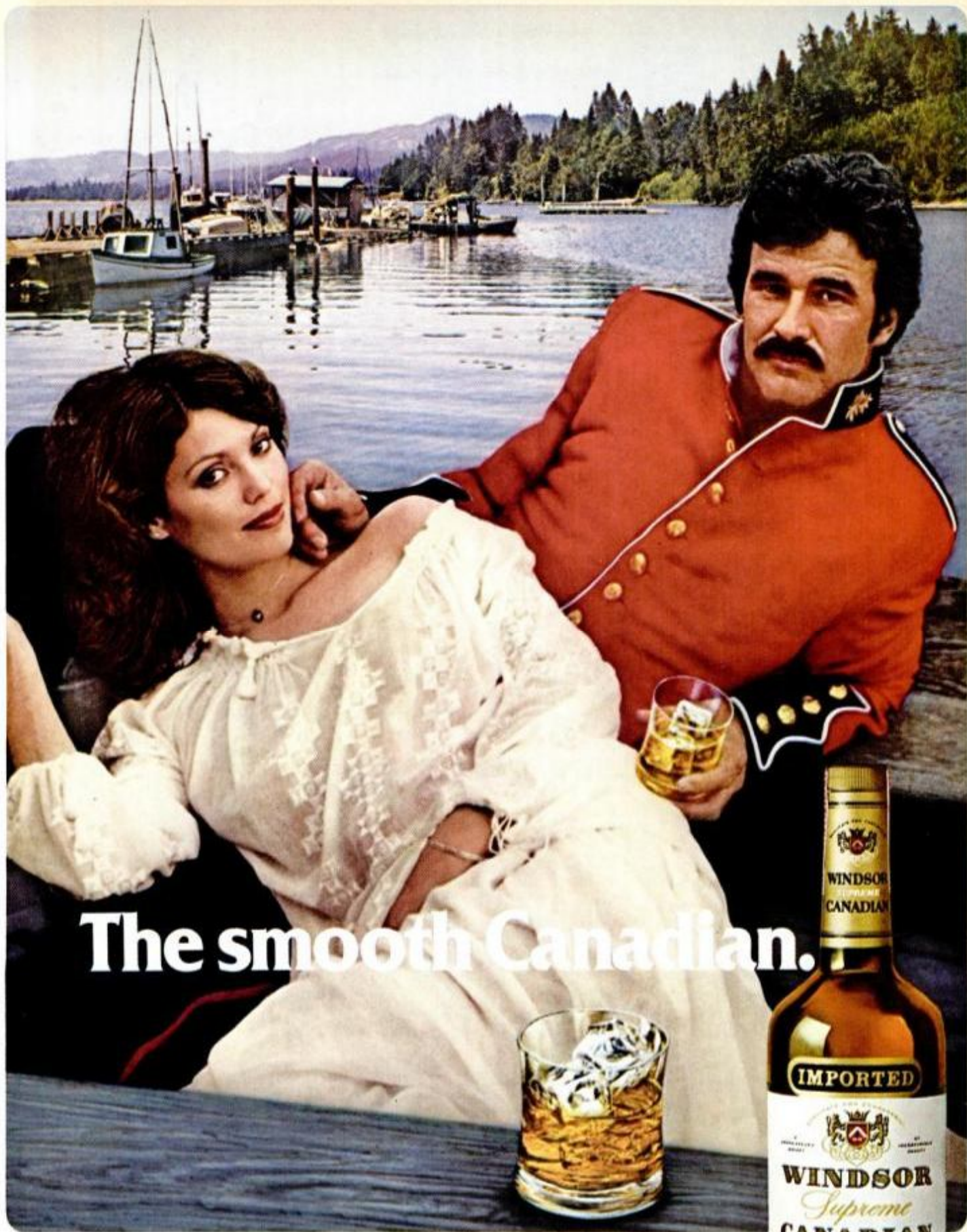

CANADIAN WHISKY - A BLEND - 80 PROOF - IMPORTED AND BOTTLED BY THE WINDSOR DISTILLERY COMPANY, NEW YORK, N.Y.

The smooth Canadian.

This Canadian has a reputation for smoothness. So you won't catch him drinking anything less than the smoothest whisky around.

Windsor. A whisky made with glacier-fed spring water and aged in the clear, clean air of the Canadian Rockies.

WINDSOR CANADIAN.
It's got a reputation for smoothness.



Материал, защищенный авторским правом

U.S. Government Report:

Carlton is lowest.

Box or Menthol:
**10 Carlton have less
tar than 1:**

	tar mg./cig	nicotine mg./cig
Kent	12	0.9
Marlboro Lights	12	0.8
Merit	8	0.6
Salem Lights	10	0.8
Vantage	11	0.8
Winston Lights	13	0.9
Carlton Soft Pack	1	0.1
Carlton Menthol	less than 1	0.1
Carlton Box	less than 0.5	0.05

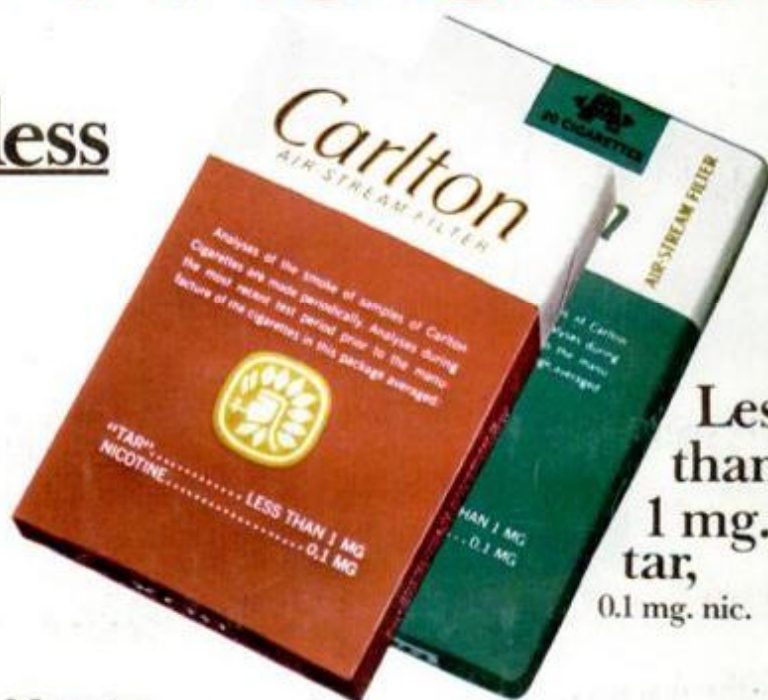

Less
than
1 mg.
tar,
0.1 mg. nic.

Of all brands, lowest... Carlton Box: less than 0.5 mg. tar and 0.05 mg. nicotine av. per cigarette, FTC Report May '78.

Carlton.
Filter & Menthol
**The lighter
100's.**

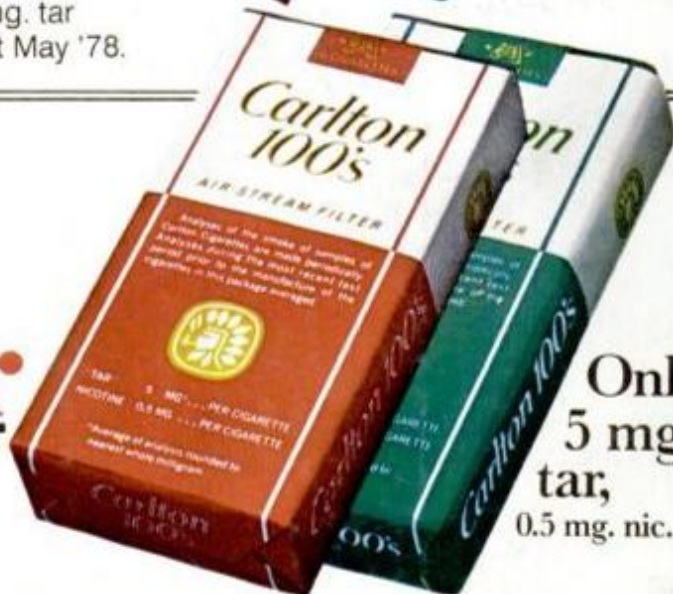

Only
5 mg.
tar,
0.5 mg. nic.

Warning: The Surgeon General Has Determined
That Cigarette Smoking Is Dangerous to Your Health.

Box: Less than 0.5 mg. "tar," 0.05 mg. nicotine;
Soft Pack and Menthol: 1 mg. "tar," 0.1 mg. nicotine
av. per cigarette, FTC Report May '78. 100 mm: 5 mg.
"tar," 0.5 mg. nicotine av. per cigarette by FTC method.