

JANUARY 1976 75 CENTS

Popular Mechanics

Create gems from stones with a \$50 homemade polisher

2 shops that pack a lot into a small space

DIESELS: PM drives the new ones—and Mercedes owners tell pros and cons

Mini subs now in quest for North Sea oil

9 budget speakers: Some sound great!

Make an old-time rolltop desk

New keep-warm outdoor gear

**WIND
DISASTER
PLANE CRASHES
SHED NEW FACTS!**



Come to Marlboro



Warning: The Surgeon General Has Determined
That Cigarette Smoking Is Dangerous to Your Health.

Kings: 17 mg. tar, 1.1 mg. nicotine—
100's: 18 mg. tar, 1.1 mg. nicotine av. per cigarette, FTC Report Apr. 75

Country.

Marlboro Red
or Longhorn 100's—
you get a lot to like.



This One



N1F7-8L3-OE3H

AUTOMOBILES AND BIKES

- 43 [Detroit Listening Post](#)
- 46 [The PM Garage](#)
- 60 [Here come the diesels](#)
- 62 [PM Owners Report: Mercedes diesels](#)
- 70 [You'll get real bargains buying 'recycled' car parts](#)
- 76 [Car safety and style: You'll be getting both!](#)
- 86 [Saturday Mechanic: How to replace disc-brake pads](#)
- 114 [Imports and Motorsports](#)
- 134 [Driving the Renault 5](#)

SHOP AND CRAFTS

- 80 [For nostalgia buffs: A rolltop desk you can build](#)
- 90 [Beginner's drill press](#)
- 91 [Parts cleaner](#)
- 102 [Speedy gem polisher you can build](#)
- 104 [Perfect circles every time](#)
- 104 [Motor-reversing switch you can make](#)
- 148, 150, 152 [Hints from readers](#)
- 162 [Router adapter for drill stand](#)

HOME AND YARD

- 73 [A room with nautical flavor](#)
- 98 [Two mini workshops for small spaces](#)
 - 98 [Shop No. 1](#)
 - 100 [Shop No. 2](#)
- 138 [Gardener's blower](#)

PHOTOGRAPHY

- 26 [Photo hints](#)
- 69 [Slide-copy illuminator for less than \\$1](#)
- 74 [New gadgets turn your pocket cameras into photo systems](#)
- 79 [Easy home color prints from slides](#)

SCIENCE AND ENGINEERING

- 54 [For big jobs in deep water—call a small sub](#)
- 84 [Striking it rich—oil in your own back yard](#)

AVIATION

- 49 [Weather demons in the sky](#)

BOATING, OUTDOORS

- 56 [Cool action](#)
- 57 [Warm gear](#)
- 96 [Build this raft boat for under \\$450—with power](#)

ELECTRONICS, RADIO, TV

- 66 [PM tests budget speakers: Some give rich sound.](#)
- 92 [Invisible revolution in your phone](#)
- 95 [Cassette tapes can be fixed](#)

WORTH WRITING FOR

Looking for more ideas and information?
[See page 182](#)

ON THE COVER

Wind disaster—plane crashes shed new facts about invisible air turbulence. See page 49. *Illustration: Ed Valigursky*

AS A SERVICE TO READERS. *Popular Mechanics* publishes newsworthy products, techniques and scientific and technological developments. Due to possible variance in the quality and condition of materials and workmanship, *Popular Mechanics* cannot assume responsibility for proper application of techniques or proper and safe functioning of manufactured products or reader-built projects resulting from plans published in this magazine.

Popular Mechanics®

JANUARY 1976 • Vol. 145 No. 1

INTERNATIONAL EDITIONS: Australia, Caribbean, Mexico, Southern Hemisphere

SPECIAL FEATURES:

A special five-page DIESEL section including reports on VW's test diesel; an In-Use Report on Mercedes 240D; one man's drive conversion. Page 60.

A rolltop desk you can build. Detailed plans for constructing a turn-of-the-century piece of furniture that's a natural for any room decor. Page 80.

You'll get real bargains buying 'recycled' car parts if you have solid knowledge about shopping and saving at auto wreck yards. Page 70.

Have you ever thought about drilling for oil? Well, one couple did. Their frustrating and grueling story starts on page 84.

Unraveling the mysteries of cassette tape repair can be easy if you know that snarled and broken cassette tapes can be fixed. Page 95.

Two mini workshops for small spaces let you have a dreamed-about shop in a space-stingy apartment or small home. For unique plans, see page 98.



Back-yard oil well 84



Buying parts from wreckers 70



Warm gear 57



Beginner's drill press 90

EVERY MONTH

- 8 [The Bicycle Shop](#)
- 12 [Letters](#)
- 16 [All Outdoors](#)
- 22 [Car Clinic](#)

- 32 [Homeowners' Clinic](#)
- 34 [Appliance Clinic](#)
- 36 [Science Worldwide](#)
- 53, 59, 65, 89 [It's New Now](#)

SUBSCRIPTION SERVICE: Mail all subscription orders, changes of address with your latest label, to Popular Mechanics, P.O. Box 646, New York, N.Y. 10019. All other correspondence relating to your subscription: James Gable, Customer Service Department, Popular Mechanics, P.O. Box 1567, New York, N.Y. 10019.

POPULAR MECHANICS IS PUBLISHED MONTHLY by the Hearst Corporation, 224 West 57th Street, New York, N.Y. 10019, U.S.A. Single copy for the United States and Canada, 75 cents. Subscription prices: United States and Possessions, \$7.00 for one year; \$13.00 for two years; \$18.00 for three years. Canada, add \$3.00 for each year. All other countries, add \$5.00 for each year. Second-class postage paid at New York, N.Y., and at additional mailing offices. Authorized as second-class mail by the Post Office Department, Ottawa, and for payment of postage in cash. Registered as second-class matter at the Post Office at Mexico D.F., Mexico, June 20, 1950. © 1975 by The Hearst Corporation. All rights reserved. Printed in U.S.A.

POSTMASTER: Please send Forms 3579 to Popular Mechanics, P.O. Box 646, New York, N.Y. 10019.

Материал, защищенный авторским правом

**Mercury introduces
the meanest, toughest,
most beautiful machine
we've ever built.**

BLACK MAX™

175 HP

Meet the ultimate outboard: the Black Max.
A whopping 175-hp outboard that's ready to tame the toughest water. Yet it's stingy on gas and compact in design.

The new Black Max is built with rugged dependability. Count on quick, easy starts with the Thunderbolt® CD ignition system. There's no tinkering with the carburetor. Fewer tune-ups. The plugs won't foul. And even in choppy water, you get smooth, sure control with Mercury Power Trim.

There's a bit of the Black Max in every Merc®.

For your nearest Mercury dealer showing Black Max... call

800-447-4700.

Illinois 800-322-4400.



BLACK MAX™

New Mercury symbol of power and dependability.



Mercury Marine · Fond du Lac, Wisconsin
Canada/Australia/Belgium

JOHN A. LINKLETTER
Editor
SHELDON M. GALLAGER
Executive Editor
DANIEL C. FALES
Managing Editor
WAYNE C. LECKEY
Home and Shop Editor
ALVIN KIETZ
Art Director

BILL HARTFORD
Automotive
JOHN F. PEARSON
Science and Engineering
WM. T. MCKEOWN
Boating, Outdoors and Travel
IVAN BERGER
Electronics and Photography
MICHAEL S. McCLINTOCK
Associate, Home and Shop
STEPHEN WALTON
Assistant, Home and Shop
MICHAEL LAMM
West Coast
ROBERT LUND
Detroit Automotive
GARRY WINTER
Copy Chief
RICHARD H. FUNK
Production
ALFREDO VEGA
Assistant, Production
IRA HERRICK
Associate Art Director
DAVID KOMITAU
Assistant Art Director
DON L. MANNES
Assistant Art Director
ED MENTKEN
Assistant Art Director
CLIFFORD B. HICKS
Special Publications
LUDWIG ARONS
Special Projects
SOPHIE GRONOWICZ
Director, Bureau of Information
EVERETT JOHNSON
Cabinetmaker

DANIEL J. COLEMAN
Director of Advertising

ADVERTISING OFFICES: New York: 224 W. 57th St., (212) 262-4282; Chicago: 520 N. Michigan Ave., (312) 527-2400; Detroit: General Motors Bldg., (313) TRinity 5-8711; Cleveland: 20310 Chagrin Blvd., Shaker Heights, Ohio, (216) 283-7788; Los Angeles: 601 N. Vermont Ave., (213) 666-6263.

JOHN A. REGINA
Advertising Production Manager

Published by The Hearst Corporation

JOHN R. MILLER
President
RANDOLPH A. HEARST
Chairman
RICHARD E. DEEMS
President, Magazines Division
JOSEPH F. KERN
Publisher

POPULAR MECHANICS IS PUBLISHED MONTHLY by the Hearst Corporation, 224 West 57th Street, New York, N.Y. 10019, U.S.A. John R. Miller, President; Randolph A. Hearst, Chairman; Harrison A. Mitnick, Treasurer; Harvey L. Lipton, Vice President and Secretary, Hearst Magazines Division; Richard E. Deems, President; Gilbert C. Maurer, Executive Vice President, Operations; Raymond J. Peterson, Executive Vice President, Advertising; William S. Campbell, Vice President and General Manager; John F. D'Avolio, Vice President and Resident Controller; Albert A. Rachol, Vice President and Director of Circulation; Joseph F. Kern, Vice President for Popular Mechanics.

ADDRESS ALL EDITORIAL COMMUNICATIONS to 224 West 57th St., New York, N.Y. 10019. For additional sources of information on the articles and products in this issue, write to the Bureau of Information, Popular Mechanics, for free "Where-to-Find-It" List.

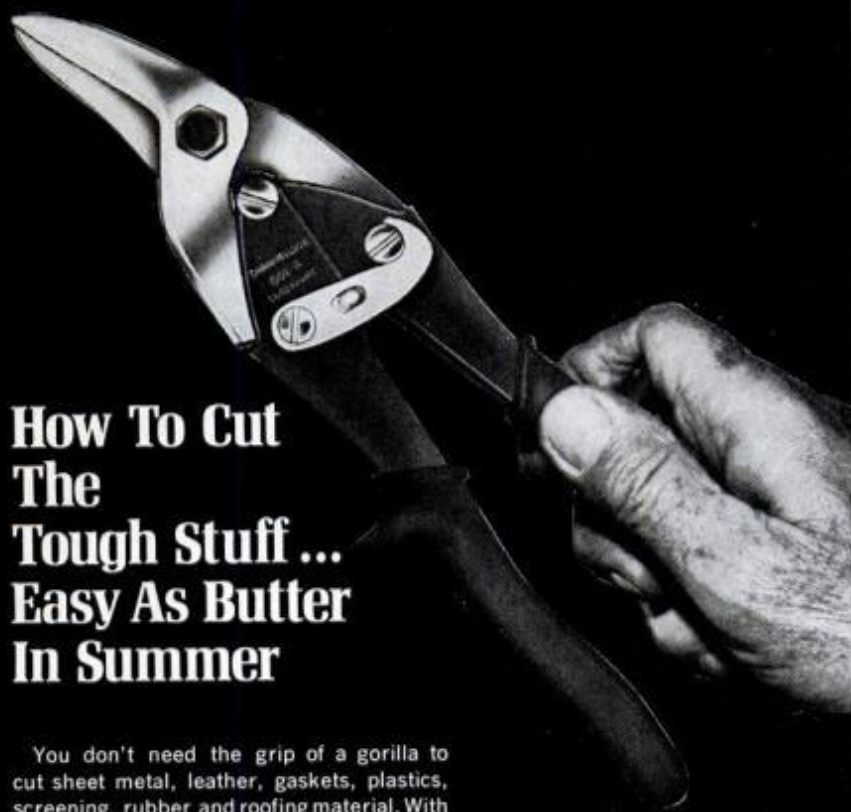

How To Cut The Tough Stuff ... Easy As Butter In Summer

You don't need the grip of a gorilla to cut sheet metal, leather, gaskets, plastics, screening, rubber and roofing material. With the perfectly mated, precision cutting edges of a CHANNELLOCK snip, you'll ease through such "tough stuff" . . . smoothly; accurately, positively. And happy day! No more blisters. The handles are cushion coated with durable, blue dipped plastic. Drop forged of highest grade tool steel, scientifically heat treated . . . your assurance of tough, dependable service for years to come.

CHANNELLOCK, INC., • Meadville, Pennsylvania 16335

CHAN NEL LOCK

Precision Made Snips



Send For Our Free Catalog

GET INTO THE STEAM OF THINGS

This steam engine kit is an ideal project for these cold winter evenings. It machines on a very small lathe such as the Unimat or the Sears/Atlas 6" and will prove that you are a better machinist than you think. Or, it makes a great project for school shop. The kit has all the parts you'll need, including complete drawings and instructions. It's a lot for \$6.95, postpaid.

Want to READ about Steam? MODEL STATIONARY & MARINE STEAM ENGINES, \$7—MODEL BOILERS & BOILERMAKING, \$7—EXPERIMENTAL FLASH STEAM (The hottest steam going.), \$11.

This is only 1 of 40 steam engine kits in our catalog—\$1 or FREE with order from this ad.



CALDWELL INDUSTRIES
BOX 170, 609 E. Davis St.
LULING, TEXAS 78648



An Easy Way to Change Jobs

'This system is simple, straight forward and quick — but it works. Do it right and you can have the highest earnings of your career!'

I've got something that can help you earn a great new living and perhaps even make you rich!

Now, I know this seems hard to believe, but I can also *prove* it to you!

I say this because I've got letters from *thousands* of satisfied customers, . . . and a product which has been praised by *50* leading media!

What's more, at \$12, it's an incredible bargain, and I'll even give it to you without asking you to risk *one penny!*

However, first let me tell you what I have.

I've got a *copyrighted job changing system* that you can use to move up in your field, or out to another field, but at significantly higher earnings.

It took myself and five other professionals two years and \$250,000 to develop—but it works!

Furthermore, it doesn't require "genius" and it doesn't require "luck." All you have to do is put it into action.

The reason we developed it was because with 84 million employed, and 15 million circulating resumes each year, this area was ready for some revolutionary ideas.

We knew more people than ever owned prestige cars & yachts, summer homes and international retreats, as well as having securities, real estate holdings and lots of cash in the bank.

In short, many people in the U.S. are living good lives!

At the same time, however, the great majority have no excess cash, little job security, and are frequently restless, bored with their jobs, commuting long hours, and harrassed by inflation!

We asked ourselves how do people get to live the "good life"?

Well, we found that most successful people were there because they never wasted time in dead-end situations!

What these people did was to make crucial job changes, and *parlay* their higher earnings into small fortunes!

Take a look at the economics!

Do you realize that if you were to change jobs every 4 years, at an average annual increase of \$4,000, and then put the increases in the bank at 6%,—that in 20 years you'd accumulate an extra *half million dollars!*

Getting raises is one thing, but getting significant increases because of job changes is a very important source for wealth!

The next question then, is how can you easily change jobs? This is where the unique system we've developed fits in.

Our system can work for anyone from \$8,000 to \$80,000. Do it right and you'll gain higher earnings, lifelong job security, but most of all, *everlasting self confidence!*

This is because once you've used it, you'll know you can *always* get a new job,—quickly and predictably.

Perhaps you're wondering why our system works? Well, it works because it's a *completely different approach*, based on totally new concepts.

But, also because it's simple, practical, and self-tailoring. You could start next week—and do it *without strain, confusion or worry.*

But, there is one catch! You won't be a success if you use old methods for dealing with recruiters & agencies, for answering ads & sending out letters, for handling interviews & negotiating salary.

To make more money without a hassle, you'll have to be willing to change. You'll also have to follow our system, have an open mind & have faith in yourself.

However, do this and a better life will be yours!

With our system, whatever you seek—a better job, a new career, higher pay, more satisfaction,—*I believe nothing can stop your success!*

Not age, sex, education, or even low earnings or past working history.

Personnel Magazine said we have a "breakthrough."

Business Week devoted a full page article and called it "indispensable."

The National Public Accountant even said it was "capable of catapulting any average person into a position offering much greater rewards."

However, your best proof of our system is that we've already received thousands of letters from grateful customers.

Letters like one from a gentleman in California who wrote: "In 4 weeks I changed jobs and raised my salary 33%! I wish I had it 10 years ago!"

Another man from New York said "I used one of your letters, sent 24 out, and got 13 interviews and 3 job offers!"

Still another from California said "In just 11 days I received an offer of \$7,000 more!"

I know this sounds almost too easy and I can't promise that you will do as well. But, then again you may do better!

Even the largest business magazine in the U.S., **Nation's Business**, said our materials were "incredibly effective."

Now, if you're serious about wanting to move up, then I know that our system is something you've got to have!

In fact, I'm so convinced that you'll agree that it's worth *hundreds of times the cost*, that I'll make sure you have nothing to lose.

First of all, when your order arrives, we'll ship within 24 hours. No delays!

Secondly, you can examine our system for 10 days.

Third, if at the end of that time you are dissatisfied, return it, & I personally guarantee your 100% refund will be mailed in 3 working days—with no questions asked!

To let me prove everything I've said, and to take advantage of this nothing-to-lose offer, just fill in and mail me the coupon below.

Performance Dynamics Inc.
Attn: Mr. Robert Jameson, President
17 Grove Avenue
Verona, New Jersey 07044

Dear Mr. Jameson:

Your offer sounds great! Please rush me your Professional Job Changing System right away, but on one condition. I understand I may examine it for 10 days, & if at the end of that time I return it, you will mail my full refund within 3 working days, with no questions asked. On that basis, here's my \$12, plus .50 for postage and handling.

Enclosed is my check or money order
 Chg. Bank Amer. Chg. Amer. Expr.
 Chg. Master Chg. Chg. Diners Club.

Acct. # _____ Exp. Date _____

Name _____

Street _____

City _____ State _____ Zip _____

Please note: Shipment is via parcel post. For spec. del. add \$2.00; for U.S. air add \$3.50; for fgn. air add \$7.00

PM

— New Jersey residents add sales tax —

Mr. Jameson's ideas have been the subject of more than five hundred articles, ranging from 600 words in *Business Week* to 3,000 words in *Chicago Today*. This material has also been nationally advertised in leading media including *The Wall Street Journal*, *Scientific American*, *Nation's Business*, *Signature*, *The New York Times*, *Newsweek International*, *The Los Angeles Times*, *American Scientist*, *Income Opportunities*, *Time*, *Specialty Salesman*, *Success Unlimited*, *Chemist*, *The Army Times*, *New York*, *The Chicago Tribune*, *True & others.* © 1975 Performance Dynamics, Inc.

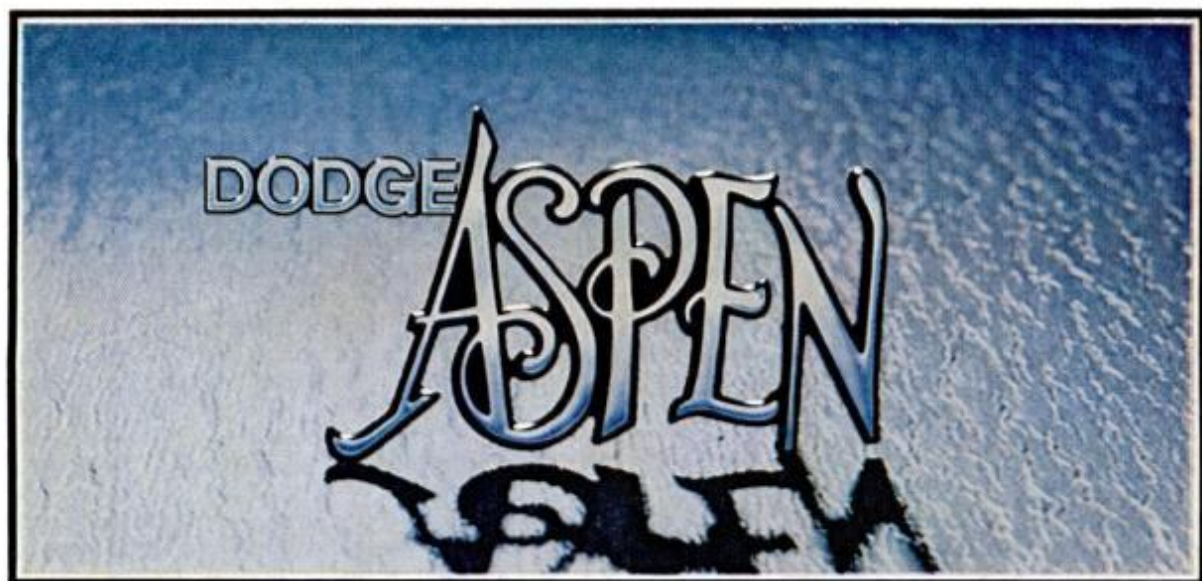

We took the things you said and engineered them into

This new kind of car was developed for those people who wanted the economy and maneuverability of a small car, but did not want to sacrifice comfort and ride.

It is available in two versions: Dodge Aspen and Plymouth Volaré.

To give you a big-car ride, we invented a new suspension.

This new kind of small car called for a new suspension. So, our engineers invented an Isolated Transverse front suspension (Patent Pending). It's truly unique. Road shock is kept as far away from the driver and passengers as possible.

For greater quiet, we engineered two noise-reducing systems.

Most people take noise for granted in a small car. But not our engineers. They developed two special sound systems. A sealing system that minimizes wind noise and an insulation system that reduces road noise.

Dodge Aspen and Plymouth Volaré are roomier than many larger cars.

We reserved smallness for the outside. Our sedan models offer more total headroom and legroom than many bigger cars. The two-door coupes seat five passengers, comfortably. The four-door and the station wagon models seat six, comfortably.

There was no small-car scrimping on comfort.

Getting in and out of some small cars can be a problem. In these cars, our engineers developed wide door openings that make it easy. There's even an optional seat that gives the driver a greater amount of comfort adjustment than conventional seats, and also in two-door models a pull-strap seat-back release that lets you get in and out of the back seat using only one hand.

Plymouth Volaré and Dodge Aspen are designed to make it easier to see the road.

We evaluated the relationship between the driver, the steering wheel and the seat to put you in a comfortable position to see the road, and large windows and windshield make it even easier to see.

Aspen and Volaré achieved E.P.A. rated highway mileage of up to 30 m.p.g.

According to official E.P.A. estimated mileage results, Aspen and Volaré with Slant Six engines and manual transmissions got 30 on the highway and 18 in the city with their wagon models, and 27 on the highway and 18 in the city with their coupes and sedans.* We did this by designing the shape to reduce wind friction. Then we reduced weight to about a thousand pounds less than a full-size car. That all helps increase economy. Of course, your actual mileage may differ depending on your driving habits, the condition of your car and optional equipment.

*In California, see your dealer for E.P.A. mileage figures for California equipped cars.

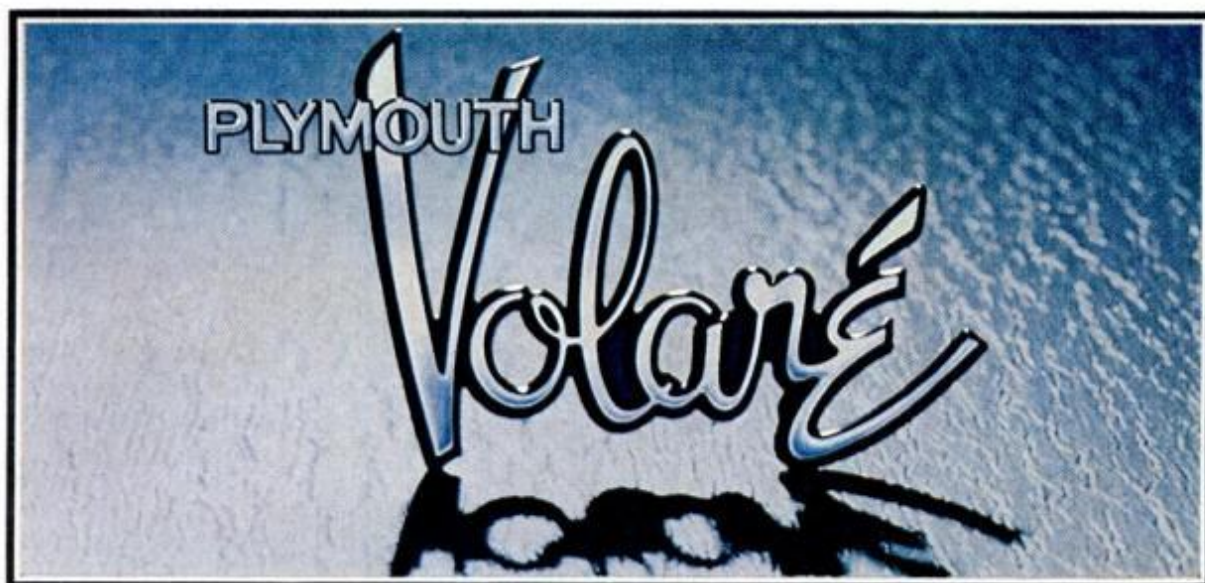

were important in big cars a new kind of small car.

Plymouth Volaré and Dodge Aspen are covered by The Clincher.

This means that for the first 12 months of use, any Chrysler Motors Corporation dealer will fix, without charge for parts or labor, any part of your 1976 Dodge Aspen or Plymouth Volaré we supply (except tires) which proves defective in normal use, regardless of mileage. Of course, the owner is responsible for normal maintenance such as changing filters and wiper blades.

With three body styles, your choice is not restricted.

These new small cars are offered as a 2-door coupe, a 4-door sedan and a 4-door station wagon—in several versions. Our new-size wagon weighs up to 1,200 lbs. less than some bigger ones. That means you'll save gas and even though it's two feet shorter than a full-size wagon, you can carry 92% as much weight and up to 76% as much bulk. Compare what you can carry with competitive wagons.

SIZE	LENGTH OVER-ALL	TOTAL LOAD CAP.	CU.FT. CARGO SPACE	PAS-SENGGERS
FORD COUNTRY SQUIRE	18.8 ft.	1,200 lbs.	94.6	6
CHEVELLE WAGON	18.0 ft.	1,100 lbs.	85.1	6
OUR NEW WAGON	16.8 ft.	1,100 lbs.	71.9	6
PINTO WAGON	14.9 ft.	850 lbs.	57.2	4

They're even easy to service.

We included all of our electronic advances. That means you can forget about replacing points and condensers. And, under normal driving conditions, there is no recommended transmission maintenance.

We wanted you to be able to order the options you wanted.

Many small cars are limited in the number of convenience options you can add. Ours can take all the important ones. For example, air conditioning engineered to provide comfort levels comparable to larger cars, power seats, power windows, electric door locks, tilt steering wheel, 4-speaker stereo, sun roof, power steering, power disc brakes, 50,000-mile battery, Sure-Grip axle, 4-speed manual overdrive transmission.

The price may be the biggest surprise of all.

You will find it hard to believe that you can get so much car, so much value for such a low price.

We made two versions . . . with two names . . . Dodge Aspen and Plymouth Volaré.

Aspen at your Dodge dealer's. Volaré at your Chrysler-Plymouth dealer's. See them now.





THE BICYCLE SHOP

GENE ANSWERS READERS THIS MONTH

Out of round

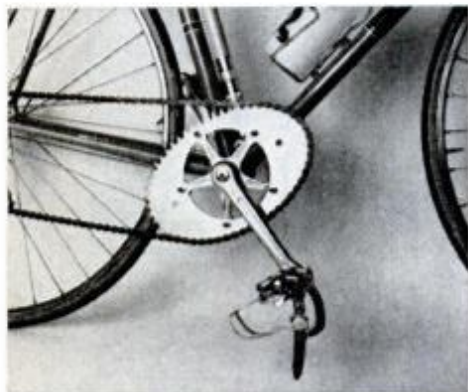

I have seen ads for an elliptical chainwheel. The idea seems attractive, but I hate to spend the money without advice. Any ideas?—Henry White, Manteno, Ill.

I have used an elliptical chainwheel and can report that it does indeed smooth out the pedal stroke. The elliptical sprocket flats out in speed at the top of the pedal position for more torque application. Racing and long-distance cyclists report faster rides and less fatigue and muscle soreness after long, hard rides. I found less tendency to stall on hills. You can order one for \$17.50 post-paid from the manufacturer, Durham Bicycles, 3944 Marathon St., Los Angeles, Calif. 90029. Be sure to give make and model of your current chainwheel set.

Avoiding dupe gears

I've noticed that whenever you talk about 15-speed bikes, you specifically recommend a freewheel with 14, 17, 22, 28 and 34 teeth. However, when it comes to chainwheels, you never give any specifics in terms of the number of teeth there. I'm planning to buy a triple-plateau chain set, preferably one with 30, 42 and 52 teeth. What do you think of this combina-

tion?—Restee Refuerzo, Baguio City, Philippines.

From the chart below, you will note I have indicated (with bold face type) several almost duplicate gears in the combination you mention. For example, the 14-42 gears give a gear number of 81, and the 17-52 pair a gear of 82.6. Since the 81 gear will, at 70-rpm pedal cadence, drive you at 16.87 mph and the 82.6 gear at 17.10 mph, this is almost a duplicated gear. Also, the 22-42 combination gives a gear of 51.5, and the 28-52 pair a gear of 50.1—same story. The chart shows an even worse situation with the 26 chainwheel, with 14-26 and 28-52 both giving the same 50.1 gear, and 17-26 and 34-52 both giving 41.3; so changing the 30 to a 26-tooth chainwheel obviously isn't the solution. You can have another too-close match if you go to a 54-tooth chainwheel. The answer is to use the 14, 17, 22, 28, 34-tooth freewheel with a 30, 42, 50-tooth chainwheel, avoiding really close duplications, as the chart shows.

For cold dogs

How do you beat cold feet in winter?—T. A'Hearn, Billings, Mont.

Up where you live, probably nothing will keep feet warm. In more moderate climates, as in the Midwest and New England, I recommend double-thick ski socks in one-size-large fleece-lined bike booties, the chukka style, available from bike stores that cater to racing cyclists. You could also use Polar Pals—plastic covers that strap to pedals. You can get them from your bike store or by mail from Eco-Cyclery, 8505 No. SR 48, Waynesville, Ohio 45068, for about \$2.50. Please note: If you use larger shoes, you may have to use a larger size toe-clip or shim out your clips with aluminum bar stock to maintain proper foot position on pedals. ★★★

If you have any questions about bicycling send them to The Bicycle Shop, Popular Mechanics, 224 West 57th St., New York, N.Y. 10019. Sorry, but letters cannot be answered individually. Problems of wide interest will be discussed in this column.

REAR	FRONT*					
	26	30	42	50	52	54
14	50.1	57.9	81	96.4	100.3	102.2
17	41.3	47.6	66.7	79.4	82.6	85.8
22	31.9	36.8	51.5	61.4	63.8	66.3
28	25.1	28.9	40.5	48.2	50.1	52.1
34	20.6	23.8	33.4	39.7	41.3	42.9

*FOR 27-IN. WHEELS. GEAR NUMBER = $\frac{\text{FRONT}}{\text{REAR}} \times 27$
 EXAMPLE: $\frac{26}{14} \times 27 = 50.1$

65,000 more technicians needed by 1980*

Learn Air Conditioning, Refrigeration and Heating.

Learn at Home With NRI's Master Course Program In Your Spare Time

Start a well-paid career in the field of air conditioning, refrigeration & heating with practical at-home training from NRI. The NRI program was developed with technical assistance from the York Division of the Borg-Warner Corporation and it uses bite-size texts, fine professional instruments and tools, and "hands-on" kits to make learning easy.

Air Conditioner System comes with Course for Trouble Shooting.

You get a Circuit Demonstrator, Control Simulator, tubing and joint-making demonstrator, leak detector, system analyzer, and a window air conditioner unit for hands-on experiments.

Optional Resident Training at Famous York Institute

Graduates of the Master Course may take advanced work at the world-famous York Institute Resident School at no extra charge. Working with expert instructors you will receive practical experience equal to months of on-the-job work.

Send for your free catalog.

Just check the card opposite. No salesman will call.

Approved for career training under GI Bill.



*U.S. Dept. of Labor Bulletin 1824

Four different schools give you this 25" hobby-kit TV...

DIAGONAL



Only NRI gives you this 25" designed-for-learning Color TV... plus complete Quadraphonic Audio Center!

DIAGONAL



No other home training school gives you both a solid state color TV and SQ® Quadraphonic Receiver complete with four speakers . . . all in one course. You get both for less than the tuition cost of TV or Audio alone from the next leading school. And only NRI's Master Course in Color TV/Audio servicing lets you train on equipment designed specifically for training.

NRI doesn't give you hobby kits. We invested the time and money to design equipment with learning in mind. It's the only way you can (1) get the feel of typical commercial circuitry, (2) learn bench techniques while building complete units from the "ground" up, (3) perform over 35 "in-set" experiments during construction, and (4) end up with a 25" diagonal solid-state color TV with cabinet and a 4-channel Audio Center.

NRI passes the savings on to you

Our engineering eliminates the cost of buying from an outside source. We pay no salesman's commission. Students are enrolled by mail only. The savings are passed on to you in the form of low tuition fees, extras like the TV's console cabinet and the Quad

System; professional test instruments like a 5" triggered sweep oscilloscope, CMOS digital frequency counter, and integrated circuit color TV pattern generator. You can pay hundreds of dollars more for a similar course and not get a nickel's worth more.

More know-how per dollar

It all boils down to the quality of training you get for your money. In our 62-year history, more than a million students have come to NRI and we're fully approved for career study under the G.I. Bill. We must be teaching something right.

Some of those "right" things are bite-size lessons to ease understanding and speed learning . . . personal grading of all tests, with comments or explanations where needed . . . a full-time staff of engineer/instructors to help if you need it . . . plenty of kits and experiments to give you hands-on training . . . and fully professional programs oriented to full or part-time career needs.

Also CB, Computer, & Other Courses

NRI offers not one, but five TV/Audio servicing courses so you can tailor

your training to your budget. Or you can study other opportunity fields like Digital Computer Electronics, Citizens Band Radio, Communications, Aircraft or Marine Electronics, Mobile Radio, and more. Send for our free catalog and see for yourself that no one gives you more training and equipment for your dollar. There's no obligation, and no salesman will call.

If card is missing, write to:



NRI SCHOOLS
McGraw-Hill Continuing Education Center
3939 Wisconsin Avenue,
Washington, D.C. 20016

* Trademark of CBS, Inc.

LETTERS

TO THE EDITOR

Let Navy build GM cars

In *Detroit Listening Post* (page 50, Nov. '75) Robert Lund mentioned GM's "New Theory on Cause of Rust." Where has GM been?

When I was in the Navy in 1969, I took a training course in aviation mechanics. In it we learned about the reaction of dissimilar metals and called it "galvanic corrosion." It occurs when dissimilar metals are in contact and an external circuit is provided by the presence of moisture. Maybe GM should have the Navy build their cars.

STEPHEN J. PUGLISI
BROOKLYN, N.Y.

More on tabletop hockey

I am considering building the tabletop hockey game (*Build This Tabletop Hockey Game for Family Fun*, page 94, Nov. '75), but there is one detail that is not clear to me.

Author George Kaler mentions that he "selected a used Vent-a-Hood range exhaust fan with two 1/25-hp, 1550-rpm motors, each driving a 3 1/2 x 4 1/2-inch squirrel-cage blower." What is the C.F.M. rating on this arrangement?

B. MORGAN FULTON
ERLANGER, KY.

The blowers in the Vent-a-Hood range exhaust fan put out a total of 290 C.F.M., which enters the 2-inch plenum through a 4 3/8 x 7 1/4-inch opening.

Don't burn old oil

In *How to Set Up an Auto-Repair Cooperative* (page 30B, Nov. '75), you describe a possibly hazardous means of disposing of engine oil.

Burning engine drain oil in the home furnace may liberate quantities of metal particles into an already dismal atmosphere. The metal particles are from the engine that the now "dirty" oil lubricated.

Maybe the coop members have had no problems with their burners, but they are not helping us "breathers"!

PAUL G. KOUTNIK
DOWNERS GROVE, ILL.

Even though the man shown has been using old engine oil for something like 25 years, we doubt if we would do it. The metal particles are

more likely to settle at the bottom of the tank than go elsewhere, but there's always the chance of clogging the burner nozzles—or, as you point out, releasing metal particles into the air.

Tip for winter drivers

In reference to *10 Tips for the Road This Winter* (page 70, Nov. '75), this tip might help your readers.

Numerous times when I have gone to the trunk to get some sand for a helping hand, I found it frozen solid. I tried everything to keep it from freezing, but to no avail. I found something else that does a much better job.

I fill my old, dry antifreeze jugs or milk jugs with cat litter and keep them in the trunk or on the car floor. When I get stuck, I open the top and pour the cat litter where I want it. Since it's coarser than sand, it gives superb traction and never freezes.

KENNETH GOEBEN
PASADENA, MD.

Turn the chisel

Permit me to compliment you on your well-written article *Your Tools—One of the Best Investments You'll Ever Make* (page 104, Nov. '75). I agree with the wording, but the picture on page 107 killed the article entirely.

A craftsman never lays his chisels on the cutting edges. Chisels should always be laid flat with the bevel down (and planes should be on their sides). Reason for this is very obvious: You avoid nicking.

JAMES S. HICKEY
HOUSTON, TEX.

Yes, it's good practice to keep the cutting edge off the surface. We should have turned the chisel bevel side down.

About amateur auto painters

Having worked in a body shop for three years and having done a number of home car-painting jobs, I disagree with parts of your October '75 *Saturday Mechanic* (*How to Repaint Your Car Yourself*, page 58).

You stressed that one could come out dollars ahead by painting his car himself. Using prices in my area, my estimate for the materials you men-

tioned is \$75 to \$85. That takes into consideration the tools involved, which the ordinary person wouldn't have. Also, an inexperienced painter would get exactly what he paid for: runs, fisheyes and chicken tracks. More than likely, he'd end up chucking the whole deal, just to have someone else paint it and spend even more money.

The article was correct in its instructions, but every painter has to learn *how* to paint. It is a technique, not something that comes out great with the right ingredients.

GEORGE P. DICKERSON
GARY, IND.

But don't underestimate the skills of Popular Mechanics readers. With correct instructions at their disposal, they can do just about anything—and well.

How to keep firewood dry

Have you ever piled cordwood or split wood to dry outside? The photos in *How to Cut Firewood and Use a Fireplace* (page 60, Oct. '75) show split wood piled with the bark on the bottom. As a boy I learned to pile wood with the bark side on top because it then sheds water rather than absorbing it under the bark.

R. NORMAN LUNDBERG
POPLAR, WIS.

Gas mileage and big cars

In 1956 and 1961 I bought full-size Dodge station wagons. Each was equipped with 318-c.i.d. engine and automatic transmission; neither had airconditioning. During that time Alaska had a 50-mph speed limit and each of those cars, carrying my family of six and camping gear, would consistently deliver 23 and 25 mpg. Some models in between and in later years had less attractive mileage.

Detroit can put out a full-size car with competitive mileage results compared to the smaller car class. Look what could be done on an intermediate size. I understand that the '75 models had most of the smog gear removed so mileage should be good. Why does Detroit refuse to give the public efficient engine operation that is available and proven?

PAUL W. ROHWER
ANCHORAGE, ALASKA

**Decisions...decisions...
Make your decision**

Pall Mall Gold 100's

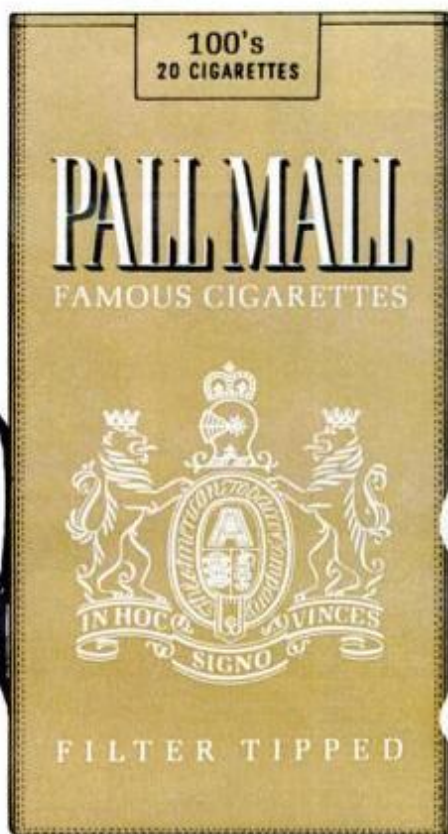

**Good rich flavor,
yet lower in tar
than the best-
selling short
(70 mm.)**

Not too strong
not too light
not too long
tastes just right.

PALL MALL GOLD 100's "tar" 20 mg. nicotine, 1.4 mg.
Best-selling regular size (70mm) "tar" 25 mg. nicotine, 1.6 mg.
Of all brands, lowest "tar" 2 mg. nicotine, 0.2 mg.

**Warning: The Surgeon General Has Determined
That Cigarette Smoking Is Dangerous to Your Health.**

20 mg. "tar", 1.4 mg. nicotine av. per cigarette, FTC Report April '75.

NOW! THERE'S A DIFFER

Adjustab

Fit the power to the job with the Powermatic™



Fix shades.



Repair screens.



Staple carpet.



Stretch canvas.



Install insulation.



Put up shelf trim.



Reupholster furniture.



Decorate with fabric.



Put up ceiling tile.

ENCE IN STAPLE GUNS:

1e Power!

Adjustable power means you can do more jobs with your staple gun. Turn the knob to the left for lower power and the Powermatic will drive short leg staples into soft wood, fabric and shelf paper. Turn the knob to the right and increase power to drive 9/16" leg lengths for jobs like insulating, ceiling tile, reupholstering. All the way

right and it can even drive into hardwoods like oak. The Powermatic staple gun builds, fixes, covers. Fires five staple sizes. Window on side signals when to reload and shows staple leg size. Loads fast and easy, too. Swing-open bottom means there's no jam problem cause it's so easy to clear and load. There's even a built-in staple remover! Handsome vinyl carrying and storage case, too. Perfect for pro or do-it-yourselfer!



Swingline®

The Swingline Company, A Division of Swingline Inc., 32-00 Skillman Avenue, Long Island City, N.Y.

ALL OUTDOORS

WITH BILL McKEOWN



Even the most avid outdoorsman spends some January days inside during bone-chilling weather. So now is a good time to look up or track down information on products and places you've been meaning to find out about and tricks and techniques you have wanted to try. Those special items of equipment you once admired are almost certain to be for sale somewhere. Here are sources for further research.

Mail-order catalogs listed in PM's display and classified ads are often free or may cost a dollar that's frequently refunded with your first order. From these you'll get a look at the latest in gear and usually good instruction on how to use it as well. The following are ones we have found useful.

For shooters

Try your local sporting goods or gun shop for useful recent digests, catalogs and directories like *Winchester-Western's Ball Powder Loading Data* guide for handloading of shotshells and rifle and pistol cartridges. The new *Handloader's Digest*, from Digest Books, covers both equipment and methods in well illustrated detail for \$7.95. The *Shooter's Bible Gun Trader's Guide*, \$3.95, gives a good basis for judging the value of your guns. Getting started in muzzle loading? Check *Lyman's Black Powder Handbook*. It's \$6.95 at gun shops or \$7.95 direct postpaid from Lyman, Middlefield, Conn. A pamphlet on *Federal Target Loads* is available free from Federal Cartridge dealers. Collectors can get the *Arco Gun Collector's Fact Book* in paperback for \$5.95, and contact Cherry's Sporting Goods, Geneseo, Ill., for antique and recent models.

For boatmen

Ever wonder what your used boat is worth, or how much a dealer is likely to allow on it? If you're willing to wonder \$30 worth, or can talk several boat club members into chipping in, you can order the *Used Boat Directory* from BCU International, Fort Lauderdale, Fla. In addition to covering 160,000 pleasure craft dating back as far as 1929, it also lists outboard motors from 1965.

New boating gadgets and gear?

Chris-Craft, Algonac, Mich., has a catalog that is a good source. For hardware and general fitting out and marine repair supplies, Defender Industries, New Rochelle, N.Y., provides a comprehensive catalog for \$1. Gifts and mementos of the sea may be selected from the catalog of Mystic Seaport, Mystic, Conn. And for an excellent reference afloat or ashore, covering everything from emergency procedures to regulations and seamanship, the \$4.95 *Boatman's Handbook* by Tom Bottomley is available from Motor Boating & Sailing Books, 224 West 57th St., New York, N.Y. 10019.

For RV owners

Tracking down trailer and camper equipment can be difficult; there are not yet many RV supply stores around and mail-order may be your best answer. Well-equipped outlets we can recommend include Fredson Trailer Supply, 815 North Harbor Blvd., Santa Ana, Calif.; Camping World, Beech Bend Road, Bowling Green, Ky.; Viking Camper Supply, 99 Glenwood Ave., Minneapolis, Minn.; and W & W Vacation Trailers, Highway 68, Haubstadt, Ind. All have catalogs for about \$1 and carry extensive stocks of those many accessories that seem so hard to find.

For fishermen

Anglers who don't have a chance to head south will find an admirable selection of new how-to-do-it books and pamphlets waiting for off-season study. What-to-use volumes include *Fishing With Natural Baits* by Vlad Evanoff, and *Bass Guide to Fishing Lures* for good coverage of how to choose and how to rig and use both live bait and artificials. For building your own, check through *Fiberglass Rod Making*, a Winchester Press book by Dale Clemens, with directions for designing, constructing and customizing your own. Then, once you've caught some trophy fish, consider the advantages of mounting your own. Don't wait to start with that trophy, though, advises W. E. Moore in his well-illustrated *Mount Your Own Fish Trophies*, from Doubleday. Instead, begin with some small species, follow the simple directions carefully, and your success

will show you what to do once you land that keeper lunger.

For assembling, or making, your own tackle and other sporting goods as well, invest \$1 for the extensive catalog from Herter's, Mitchell, S. Dak. Sports Liquidators, Sun Valley, Calif., and Cabela's, Sidney, Neb., are additional sources.

How to be the best fisherman around? Just become another A. J. McClane. His fishing encyclopedia is considered the standard in the field, and now we can find how he found out so much in an admirable collection of his writing edited by George Reiger, PM's former resident angling ace. The book, *Fishing with McClane*, covers 30 years and endless streams and ocean adventures. From Prentice-Hall, it's \$12.95, and after reading it all, if you could force yourself to part with it, the book would also make a handsome present for another fisherman.

Another gift possibility is a highly informative book from Bill Wisner, famed fisherman and fishing writer. Titled *How to Catch Salt-Water Fish*, this 584-page illustrated book gives you tips on tackle, baits, lures and techniques for catching 23 of the most popular Atlantic Coast sport fish from blues, blacks and flounder up through mackerel, pollack and striped bass and on to marlin, tuna and swordfish. Doubleday & Co. publishes the book which sells for \$8.95.

For campers and travelers

Outdoorsmen looking for general equipment catalogs and guides are in luck. We've found a wide assortment of good ones available. Pick almost any pastime or destination and there's likely to be companies offering what you need. The latest in clothing is carried by Recreational Equipment of Seattle; L.L. Bean in Freeport, Me.; Norm Thompson, Portland, Ore.; or Eddie Bauer in Seattle, Wash., just to name a few.

For finding new places to go, consult *Adventure Trip Guide*, \$4.50 postpaid from Adventure Guides, 36 East 57th St., New York, N.Y. 10022. *Hiking Trails in the Southern Mountains* and *Hiking Trails in the Midwest* give details for \$6.60 from Great Lakes Living Press, 435 North Michigan Ave., Chicago, Ill. 60611. ★★

In the Coast Guard you'll learn the mechanics of saving lives.



When there's a family marooned by a flood, a sail boat in trouble on San Diego Bay, a boating accident on the Intracoastal Waterway, the Coast Guard goes.

It could be by helicopter, a motor lifeboat, or a sleek Coast Guard cutter. Whatever the way, we can't afford any mechanical failures.

We're in the business of saving lives, and we're proud of the job we do. Last year, we answered over 67,000 distress calls, and saved or otherwise prevented the loss of over \$280,000,000 worth of property.

We need people with mechanical aptitudes in the Coast Guard. Young people who want to help others while they help themselves.

There are dozens of skills you can acquire: become an expert on gas and diesel engines, helicopter repairs, small boats, hydraulics.

Or, you can learn navigation, electronics, communications, or any number of useful, career-oriented vocations. Most importantly, you can learn at our expense.

The pay is good, too. Over \$360 a month to start, with your first raise right after boot camp. And that's money you won't have to budget to room and board because we furnish those free. Plus free dental and medical care, and 30 days of paid vacation every year.

If you want to further your education and get college credits, we'll help. We'll also provide GI benefits when you get out. Or, if you decide to stay in, you'll get a bonus for re-enlisting plus excellent retirement benefits at an age when you can do something with them.

If you've got a way with things mechanical, give the Coast Guard serious thought. We want bright, young, eager people who want to do something with their lives. While you're helping others, you help yourself.

So, if you're a young person thinking hard about a good future, or between the ages of 17 and 26 and wanting that good future right now, call us toll free.

**HELP OTHERS
HELP YOURSELF.
800-424-8883
THE COAST GUARD.**

The better the training the better you'll

Send for one of these **FREE** Illustrated

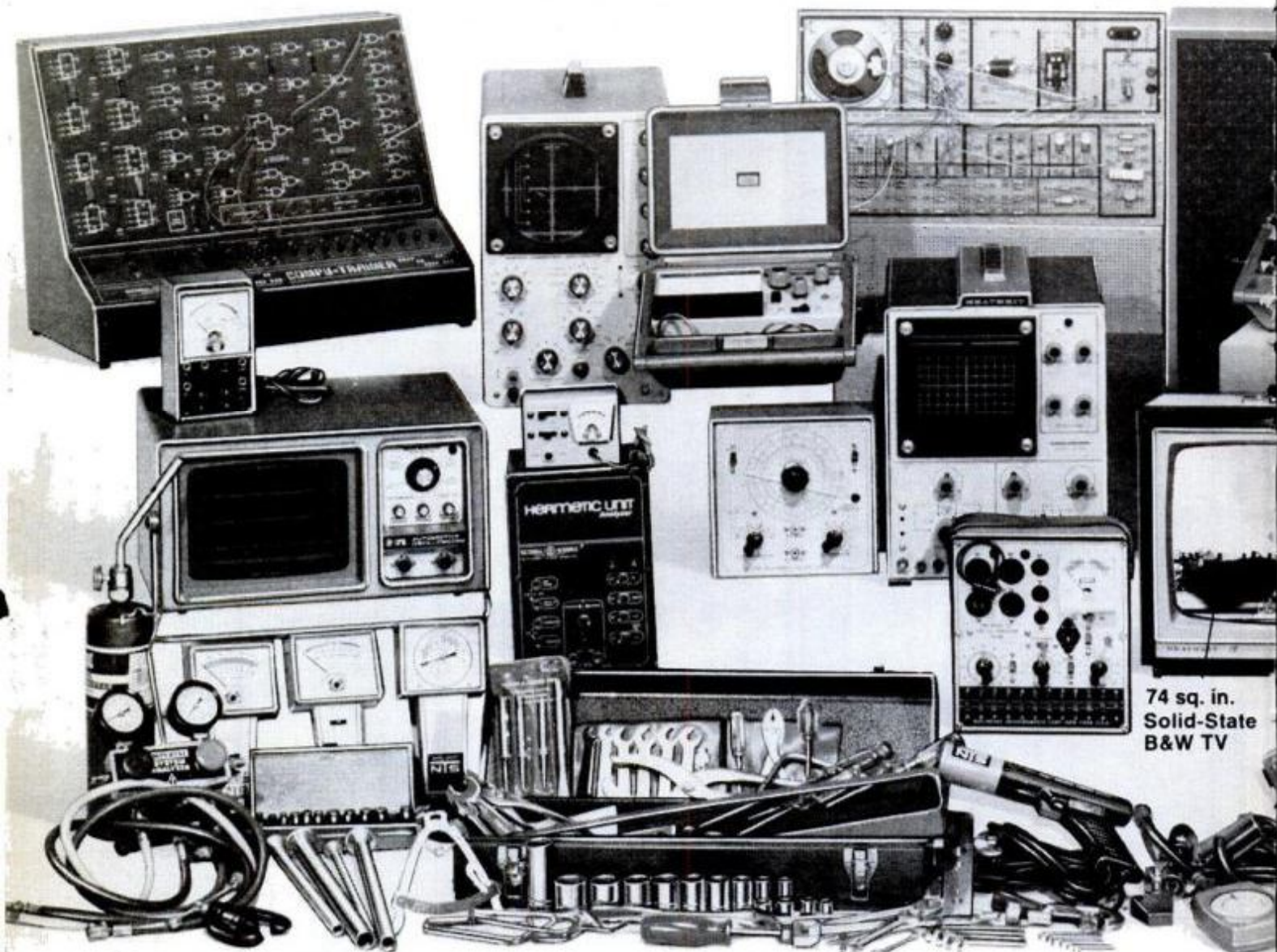

74 sq. in.
Solid-State
B&W TV

Build and keep some of the finest technical equipment made when you train with an NTS Project-Method home study course. And it's usually the same type of equipment you'll meet in the field and use on the job. It will help you acquire first-hand experience and skill — help prepare you better for a variety of exciting technical careers:

ELECTRONICS DIVISION: Courses include professional equipment like 5" solid-state oscilloscope, transistor and tube-tester, vector monitor scope, 74 sq. in. B&W TV, and solid-state stereo AM-FM multiplex receiver, speakers. Color TV courses feature advanced NTS/HEATH DIGITAL GR-2000 Color TV with silent varactor diode tuning; digital read-out channel selection (with optional digital clock), big 315 sq. in. screen.

MECHANICS DIVISION: Learn engine diagnostics, motor overhaul, transmissions, automotive maintenance. Courses include 9 in. solid-state automotive oscilloscope, testers, tools, mechanic's steel tool box, & more.

AIR CONDITIONING, REFRIGERATION/HEATING DIVISION: Learn servicing of commercial, industrial and residential heating and cooling equipment. Courses include hermetic unit analyzer, leak detector, charging testing-purging manifold set, tools and more.

HOME APPLIANCES DIVISION: Courses cover repair and maintenance of washers, dryers, ranges, smaller appliances. Equipment includes NTS Circuit-Trainer and professional multimeter.

and the equipment be equipped.

Career Guides:

COMPARE OUR
KITS AND LESSONS.
COMPARE OUR
TUITION.



(Simulated TV Reception)

LOWER TUITION FOR YOU: We employ no salesmen, pay no commissions. You receive all home-study information by mail only. Make your own decision, your own comparisons. Send card today or write for illustrated catalog in field of your choice, all details.

NO OBLIGATION. NO SALESMAN WILL CALL.

APPROVED FOR VETERAN TRAINING
Get facts on new 2-year extension.

NATIONAL TECHNICAL SCHOOLS

TECHNICAL-TRADE TRAINING SINCE 1905
Resident and Home-Study Schools
4000 So. Figueroa St., Los Angeles, Calif. 90037

NATIONAL TECHNICAL SCHOOLS Dept. 201-016
4000 South Figueroa St., Los Angeles, Calif. 90037

Please send **FREE** Color Catalog and Sample Lesson.
NO OBLIGATION. NO SALESMAN WILL CALL.

- Electronics Division
 Mechanics Division
 Air Conditioning/Refrigeration/Heating Division
 Home Appliances Division

NAME _____ AGE _____

ADDRESS _____

CITY _____ STATE _____

Please fill in Zip Code for fast service _____

- Check if interested in G.I. Bill information.
 Check if interested **ONLY** in classroom training in Los Angeles.

CAR CLINIC

BY MORT SCHULTZ



Straight answers

Either I misunderstood the salesman or he gave me a bum steer, but I've been under the impression I must use nonleaded gasoline only in my 1974 Malibu Classic. Yet last time out I tried a tank of premium gas and determined that my highway mileage went from 13.8 miles per gallon to 14.5 miles per gallon. Disregarding the difference in cost, is it okay for me to use premium instead of nonleaded regular? Are there advantages?—J. Henry Burgess, Gloucester, Mass.

Yes, it's okay. But beginning with '75 cars, only nonleaded gasoline can be used. That's the law. However, I should warn you Chevy says leaded gas may shorten sparkplug life.

Tell me—what kind of sensitive fuel per mileage gauge did you use to make your test run, because only with such equipment is it possible to determine a difference of 7/10ths of a mile in test runs. But even if you are accurate, we'll say for argument's sake, a small difference can be accounted for by variations in road conditions and wind resistance between one test run and another.

Advantages in using premium in your car? I see none!

Me—man in the middle

I have a 1975 Chrysler New Yorker Brougham, driven about 5000 miles. Recently the car develops a clunk-type noise in both rear wheels whenever I go over bumps, up or down driveways, and when turning corners. I've taken the car to dealerships and finally lodged a complaint with the factory. In every instance I'm told that the condition is normal and nothing can be done. However, independent mechanics have told me that they feel the car is dangerous to drive, and that I should demand the dealership install a new rear axle. I feel Chrysler is stalling until my warranty runs out. I would appreciate your point of view.—Monte Kurtyka, Redford Township, Mo.

I do not think the condition is normal; neither do I think it is dangerous. I think Chrysler should remedy the condition, which may be caused by one of the following:

1. Loose spring shackles.

2. Bad shock absorbers—the dealer should install two new heavy-duty shocks in the rear.

3. If the car is equipped with a sure-grip differential, the noise could be caused by a damaged clutch assembly. A new one should be installed.

Never on time

I own a 1975 Plymouth Fury custom equipped with a 318-cu.-in. engine, which I bought new. I've had problems with ping from day one. It's been back to the dealer three times and to an independent mechanic once for a solution to the problem with no results. Timing has been checked and rechecked. Premium gasoline helps, but doesn't completely eliminate the ping. Any suggestions?—M.A. Roach, Lynchburg, Va.

I suspect the damper pulley has been stamped improperly with respect to timing marks. I've seen marks off by as much as 20°, so there's no way to get correct timing by setting ignition to specification.

I would therefore set the ignition in your car until the ping has been eliminated. Stamp in a chisel mark on the damper pulley in line with the index marker, and take this as your timing reference from now on.

Tanked up

I had to replace the fuel filter after driving my Ford Granada only 5000 miles because it clogged with dirt. The fuel tank was flushed. However, the filter plugged again at 8000 miles. Is it possible that my gas cap isn't sealing tight enough and dirt is being drawn in? My dealer says no.—Gene S. Bontrager, Kalona, Iowa.

The dealer, I feel, is right. It's unlikely that the problem is being caused by an ill-fitting gas-tank cap. The solution, I feel, is to remove the fuel tank and blow out the fuel line all the way to the carburetor. When a fuel filter gets as badly clogged as you indicate yours is getting after relatively short mileage, flushing the gas tank is hardly likely to relieve the situation. Steam cleaning might do the job. If the dealer is willing to again drop the tank and replace it if steam cleaning doesn't work, let him. But I think that as long as the tank

has to be dropped to clean out the fuel line anyway, the tank might as well be replaced, so everyone can go away happy.

A better solution

Why does my 1974 Opel Manta 1900 with automatic transmission stall on acceleration after a stop or acceleration after coasting through a turn when the engine is warm and the weather is hot—never under "cold"?

(Please turn to page 24)

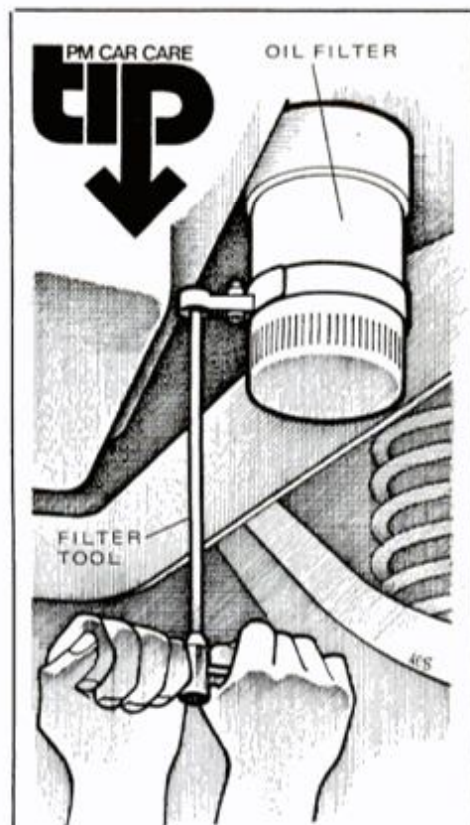

Hands only

Oil-filter tools are for loosening only—not tightening. When replacing your filter, strap the tool tightly around it and turn counterclockwise until the filter is free. Make sure the contact surface is clean of old gasket material and coat the gasket of the new filter with oil. Place the filter in position, taking care not to cross-thread, and *hand-tighten* the filter until the gasket meets the contact surface. Then, tighten the filter by *hand* only a half turn more. Tightening a filter with your wrench can result in distortion and an oil leak.



Taste the good times with
RALEIGH.
 Rich satisfying tobacco taste
 in a golden Kentucky blend.

Warning: The Surgeon General Has Determined
 That Cigarette Smoking Is Dangerous to Your Health.



Make a date with Seiko's Day/Date self-winding watch. It's yours for B&W coupons, the valuable extra on every pack of Raleigh. To see over 1000 gifts, write for free Gift Catalog: Box 12, Louisville, KY 40201.

CAR CLINIC

(Continued from page 22)

engine conditions? It doesn't stall at idle either. We've taken the air-conditioner out of the car, installed four new carburetors, and replaced the vacuum advance control. I'm ready to give up.—Dr. Russell S. Hill, Jr., Chesterfield, Mo.

Don't give up yet. Find a dealer who will use Opel Service bulletin 74-T-02, which explains how to set the carburetor correctly using a water-manometer and how to correctly set the accelerator pump linkage. I also think you should try a different brand of fuel. Some are more volatile than others and more apt to percolate.

Encountering resistance

What's the difference between resistor and nonresistor sparkplugs? What happens if you use resistor plugs in an engine calling for nonresistor plugs, or vice versa?—Gerald Cronin (address not given).

A resistor sparkplug has a resistor built into the center electrode near the firing tip that meters energy stored in the sparkplug. It was developed to eliminate static emissions caused by electric spark discharge. These emissions would cause radio, stereo and television frequency interference were it not for the presence of resistor elements.

An added advantage to resistor sparkplugs is the reduction of plug electrode erosion that the resistor provides. The AC Spark Plug Div. of General Motors tells us that resistor sparkplugs in an ignition system, "with or without other static suppression components, can increase electrode life 30 to 50 percent."

Practically all automobiles now in production use a form of resistance in the secondary circuit other than resistor sparkplugs. Other forms of resistance include a resistor in the rotor or distributor cap, or resistance-type sparkplug cables. Resistor sparkplugs are employed primarily in cars having two-way radios to provide the maximum in noise suppression. However, car owners who replace resistance-type sparkplug cables with metallic conductor cables for longer cable life frequently install resistor sparkplugs to obtain the necessary suppression.

You won't harm anything by installing resistor sparkplugs in an engine using another means of suppression, and you will get longer electrode life. However, you will pay about 40 cents more per plug. In a V8, then, you will pay approximately \$3.20 by switching from nonresistor to resistor sparkplugs.

Feeling the heat

Please indicate the temperature at which the cooling system of my 1970 Buick (350-cu.-in. engine) will boil over. No one knows.—Eugene P. Hagemann, Huntington, N.Y.

About 262° F.—assuming that everything is working properly.

You should be using a mixture of ethylene glycol in your radiator which protects the engine from freezing down to -20° F. (if more or less, change the numbers I'm about to give you accordingly). The boiling point of ethylene glycol (good quality) mixed thus is 224° F. However, the radiator pressure cap raises the boiling point of coolant 2.5° F. for every pound of pressure at which it's rated. Your car uses a 15-lb. cap. Therefore, the boiling point of coolant is raised by 38° F. Addition: 224° + 38° = 262° F.

Traffic 'jamitis'

I have a 1965 Chevrolet with a 283-cu.-in. V8 engine. Owners and service manuals tell me to use a 180° thermostat. I do a great deal of city driving in the summer and often get caught in traffic where coolant bubbles and boils away. The cooling system is clean and unobstructed. Should I switch to a 160° thermostat?—Charles W. Maynard, Carteret, N.J.

Switching to a 160° thermostat won't solve anything. The purpose of a thermostat is to let an engine warm to operational temperature as fast as possible by keeping coolant in the engine where it benefits from engine heat. Once this temperature is reached, the thermostat valve opens and coolant is free to flow through the radiator where it dissipates excess heat. Thus, engine temperature remains relatively constant unless an extraordinary operational condition, such as a city traffic jam, causes a temperature increase.

For those who drive often in heavy city traffic and have a problem, I suggest installing a coolant recovery system. This will cost about \$15, but it's worth the money. You'll make up the cost in coolant saved.

Rather than having coolant boil over and out through the overflow tube onto the pavement, it will flow into a plastic tank where it will be stored until the hot engine condition subsides. You can purchase a coolant recovery system from a dealer of automotive supplies and install it yourself. It's a simple job.

SERVICE TIPS

■ Ford Motor Co. has issued the following repair for '75 models that won't start in wet or high-humidity conditions: Wipe moisture and dirt from exposed areas of

the distributor cap and coil tower without disturbing wires. Replace damaged wires and attempt to start the engine. If the engine won't start, remove the distributor-to-coil high-tension cable and wipe out the coil tower and center tower of the distributor. Wipe off the cable. Now, apply Dow 4X or General Electric G-624 silicone grease to the outer surface of the coil tower and center tower of the distributor. Reinstall the cable firmly in both towers. If this doesn't work, replace the coil-to-distributor high-tension cable. The problem is being caused by the cable's boots not sealing tightly.

■ Is your 1974 or '75 Dodge Colt 2000-cc engine knocking slightly when started? The trouble may be caused by slack in the timing-chain tension damper, especially if the noise diminishes after a few seconds of engine operation. There's a new tension damper available—part No. MD-021227. Ask your dealer to consult service bulletin 09-10-75 for authorization. ★★

Jump right

Incorrect use of jumper cables and booster battery can damage the electrical system and cause personal injury. Now's a good time, at the start of real cold weather, to review the five-step proper procedure: 1. If boosting a battery in another car, make sure the two cars are not touching. 2. See that everything which runs on electricity is off, set parking brakes and place automobile transmissions in Park and manual transmissions in Neutral. 3. Remove vent caps from both batteries and cover vent holes with a cloth. 4. With engine off, connect one end of a jumper to the positive terminal of the weak battery, and then the other end of the same cable to the positive terminal of the booster battery. 5. Connect the other jumper to the negative terminal of the booster battery and then to a ground, such as the engine block, on the disabled car. Start the engine of the car possessing the booster battery and turn on the disabled car's ignition. When the disabled car starts, reverse procedure to disconnect jumpers. And no smoking or any other spark or flame!

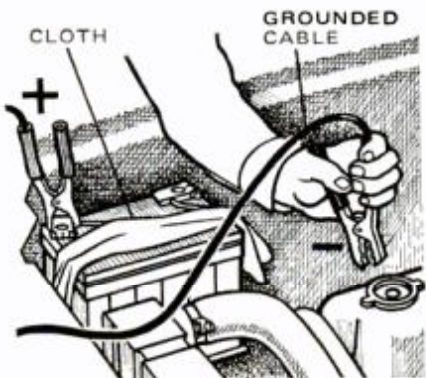

This is living.



This is Chrysler's 135: More power per pound!



Bring our 135 into your life and you can really live it up. With just about the most powerful outboard you could want. A hair-trigger performer with the action to accelerate with a competitive 150 (with comparable props) from a standing start, as shown in our 1975 test data. Yet it has the lightest weight per horsepower of any comparable 4-cylinder outboard—actually weighs less than competitive 115's. It comes with advanced features like high compression, race-style crankcase, specially calibrated carbs and exclusive fuel-saver throttle. You get Magnapower C-D ignition for instant starts, satin-smooth performance from idle to full throttle. And it's clean and uncluttered under the hood to make service and maintenance a cinch. Check the Yellow Pages for your Chrysler outboard dealer. And start living!

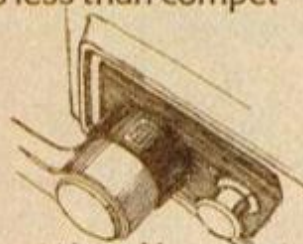

This is Chrysler's 75: More punch per piston!



Bigger pistons give you bigger performance punch from Chrysler's 75. Up to 22.5 cu. in. more piston displacement than any American 3-cylinder outboard. Our 1975 test data shows it easily out-runs other U.S.-built "3's," with faster acceleration for skiing, higher top speeds on light or extra-heavy hulls. You get the economy of high compression, efficient 2:1 gear ratio and tuned air intakes. Magnapower C-D ignition with electronic distributor adds quick starts, smooth performance. No points, no more costly ignition tune-ups. For even more punch, get Chrysler's 90, the ultra-hot 3-cylinder that gives you extra performance for every water sport, yet weighs the same as our 75. Check the Yellow Pages for your Chrysler outboard dealer. And start living!



Chrysler makes a complete family of marine power: inboard, outboard, jet, and stern drive; and a complete fleet of powerboats and sailboats. Live it up with Chrysler on "Water World" and "The Fishin' Hole." Check your local TV listing for times and dates.



Omega Pro-Lab B66

The last word in medium-format enlargers.

For sheer ease of operation, no photo enlarger surpasses Omega's Pro-Lab B66 for 35mm and 2 1/4" negatives.

The spring-loaded negative carrier opens wide when you lift the lamphouse, letting you advance negatives without disturbing their alignment. The lamphouse assembly is counterbalanced for smooth, easy movement. And a sliding panel allows instant access to the lamp, condensers and filter drawer. The rigid, inclined girder keeps negative and baseboard perfectly aligned, and leaves maximum room to center your easel.

CARRIER OPENS EASILY



SLIDING FRONT PANEL

Yet the whole unit will come apart quickly and easily for storage.

The B66 comes with three condensers, for optimum light distribution with negs to 35mm; or switch to two condensers to match the 2 1/4" format optical requirement. Or get the optional dichroic color head and dial in the exact filtration needed for color or variable-contrast printing.

Priced as sensibly as it's designed, and for even greater savings, there's our "Two-Lens Outfit" for 2 1/4"-square and 35mm formats.

Write for literature to Omega Division, Berkey Marketing Co., Inc., Woodside, N. Y. 11377. In Canada, Berkey Photo (Canada) Ltd., Ontario.



RIGID GIRDER DESIGN



OPTIONAL COLOR HEAD

Ω OMEGA

The Greatest Name in Your Darkroom.

PHOTO HINTS

FROM READERS

Tobacco pouches for accessories



Organize those small, loose accessories that get lost at the bottom of your gadget bag: just slip them into tobacco pouches. But don't use old pouches. They're likely to be just too dirty.—*Kenn Oberrecht, Coos Bay, Ore.*

Pencil eraser marks slides



A pencil eraser makes a handy rubber stamp for imprinting position spots on color-slide mounts. Just press the eraser on an ink pad then on the appropriate corner of the slide. Worn erasers make smaller spots, new erasers make larger ones.—*Walter E. Burton, Akron, Ohio*

Memory aid for double exposures



If you're shooting deliberate double exposures with a 2 1/4 x 2 1/4 reflex, mark the layout of the first shot on a 2 1/4-inch square of transparent acetate—it will make composing the second shot easier.—*John Koncewicz, New Britain, Conn.*



Konica won't let those once-in-a-lifetime shots get away.

Those once-in-a-lifetime shots are here one moment, and gone forever the next.

Which is why you should be there with a Konica automatic camera. It lets you squeeze off a perfectly exposed shot that will capture a moment forever, instead of letting life pass by while you're busy setting exposures.

Konica is the world's most experienced maker of automatic 35mm cameras, and offers you more features for the price, whether you want to spend under \$100 or over \$1000.

Let your dealer help you choose the right Konica for you. Or write for literature to: Konica Camera, Woodside, N.Y. 11377.

The Konica Automatics
From under \$100 to over \$1,000.



Berkey

From VIKING, the most striking offer ever made by a clock company!

WEST GERMAN BRASS CLOCK MOVEMENTS NOW SALE PRICED. COMPARE AND SAVE.



OUR SERIES 111 MOVEMENT WITH TEMPUS FUGIT DIAL.



OUR SERIES 111 MOVEMENT WITH MOVING MOON DIAL.

This is your chance to own fine genuine West German brass clock movements at the lowest prices being offered by anyone! An exciting opportunity for both clock buyers and clock builders.

These are the same precision movements we sell every day as part of the famous Viking heirloom quality floor clock Series 235D. Each movement has been tested by us to assure faultless performance and accuracy.

Select either the Tempus Fugit (Time Flies) dial or the Classic Moving Moon dial with lunar calendar. Both feature a permanently polished Brass dial and Black Serpentine hands, surrounded by embossed overlays. Beautiful in every detail! And just look at all you receive:

- Heavy Brass Dial
- Quality Brass plates and gears
- Hardened Steel pinions, pivots, and pallets
- Weights, pendulum, chimes, brass weight shells, brass bob
- Easy step-by-step instructions for installation and adjustment
- FULL ONE YEAR UNCONDITIONAL GUARANTEE
- BONUS: Free spare parts kit of suspension spring with every movement

AUTHENTIC WESTMINSTER CHIMES

These movements are weight driven, and strike the famous Westminster chimes. Chimes play 4 notes on the 1/4 hour, 8 on the 1/2 hour, 12 on the 3/4 hour and the full Westminster Melody of 16 notes on the hour. The chime notes are struck on 4 musically tuned rods. The hour is struck on 4 additional rods. Hands can be moved forward or backward to set time.

SPECIFICATIONS

- Dial Size—9-13/16" wide, 13" high
- Diameter of pendulum bob—4"
- Movement plate size—5-1/8" wide, 5" high
- Length of pendulum—31 1/2"
- Size of weight shells—1 1/2" diameter, 10 1/2" long
- Length of hand center shaft to hand nut—1 1/2"
- Movement plate thickness—.062 inch, 1.56 Millimeter

OUR SERIES 111 MOVEMENT WITH TEMPUS FUGIT DIAL, WESTMINSTER CHIMES AND ROMAN NUMERALS REG. \$109

SALE PRICE **\$99**

OUR SERIES 111 MOVEMENT WITH MOVING MOON DIAL, WESTMINSTER CHIMES AND ROMAN NUMERALS REG. \$124

SALE PRICE **\$114**

TOLL FREE CUSTOMER SERVICE 1-800-633-3057, Monday through Friday, 8:00 a.m.—5 p.m. Central Standard Time. Alabama customers call collect 1-943-5081.

HURRY—OFFER POSITIVELY ENDS FEBRUARY 29, 1976 AND MAY NEVER BE REPEATED.

USE THIS ORDER FORM FOR YOUR CONVENIENCE.

Description	Weight	Reg. Price	Sale Price	Qty.	Total
(All cabinets in solid 3/4" Native American Black Walnut)					
Series #111 Movement with Tempus Fugit Dial for series #235 clock. Roman Numerals standard. Check here for Raised Arabic Numerals, add \$5.	33	\$109	\$99		
Series #111 Movement with Moving Moon Dial for series #235 clock. Roman Numerals standard. Check here for Raised Arabic Numerals, add \$5.	33	\$124	\$114		
Series #235A Cabinet Kit without movement. Check here for pre-cut mirrors, add \$10.	53	\$149	\$99		
Series #235D Completely assembled and finished clock. (Check one) With Tempus Fugit Dial \$349 With Moving Moon Dial \$364 Both Sale Priced! Check here for Raised Arabic Numerals, add \$5.	91	\$399 & \$414	\$349 with Tempus Fugit Dial \$364 with Moving Moon Dial		

Charge to my Master Charge BankAmericard
 Enclosed is my personal check money order for \$_____

Card Number _____ Expiration Date _____

Master Charge ICA No.

Name _____

Address _____

City _____ State _____ Zip _____

Cost of Item(s) \$ _____

Residents of Alabama add 4% Sales Tax _____

Grand Total \$ _____

Shipped promptly — freight collect

We accept personal checks

PLEASE SEND ME YOUR FREE COLOR BROCHURE.

YOU MAY USE OUR TOLL FREE NUMBER WHEN ORDERING BY MASTERCARD OR BANKAMERICARD.



Dept. CM6 The Viking Building
Foley, Alabama 36535

References:
 South Baldwin Chamber of Commerce, Foley, Al.
 Baldwin County Bank, Bay Minette, Al.
 State Bank of the Gulf, Gulf Shores, Al.

SPECIAL \$99



DO-IT-YOURSELF KIT
3/4" SOLID NATIVE AMERICAN BLACK WALNUT

Complete with all wood parts, hardware and instructions

Series #235
 75" x 16" x 10"
 Reg. \$149

IF NOT 100% SATISFIED, return your order to us in original carton, within 30 days. Money back refund in full.



How to start making it early in life.

(A TRUE STORY)

Since he got out of the Navy, John Muirhead of Gales Ferry, Conn., has provided well for his family.

Two cars. A new house going up alongside a wooded lake. Even a handsome Great Dane named Sherman. But John has bigger ambitions.

"I want my own air-conditioning business doing installations and repairs. For homes, office buildings, restaurants, small factories, motels.

"That's no dream. With the training I've gotten from ICS, I know I can do it.

"In fact, my ICS training helped me get the first job I ever applied for. I won out over two other guys, even though I had no experience.

"Naturally, I was nervous at first. So I took my lesson diagrams with me on the job. And I found I could lick any problem.

"Pretty soon, they asked me to head up the air-conditioning department. I also picked up some business of my own on the side. That's what's helping to pay for the new house."

John Muirhead is one of our outstanding graduates. He's hard working. He's in a growing field. And he has good training.

Of course, we can't promise you'll be as successful as John—no school can guarantee jobs for its graduates. But ICS *can* give you the first-rate training you need—especially if you're interested in one of the growing careers where ICS concentrates its training.

AN IDEAL WAY TO LEARN

As an ICS student, you study at home, on your own schedule. You waste no time traveling to and from class. And you never have to miss a paycheck.

But you're never alone. If you ever want to talk to an instructor, you can call ICS from anywhere in the continental United States, using our toll-free Dial-a-Question® service.

Since 1890, millions of men and women around the world have turned to ICS for career training.

More than 70 of America's largest 100 corporations (including Gulf Oil, Bethlehem Steel, 3M, Westinghouse, and International Paper) use ICS training for their own employees.

And the ICS Center for Degree Studies is authorized by the Pennsylvania Department of Education to grant the Associate in Specialized Business degree in Accounting and Business Management, and the Associate in Specialized Technology degree in Civil, Mechanical, Electrical, and Chemical Engineering Technologies.

These degree programs are not mere stepping-stones to higher education nor are they intended for transfer toward more advanced degrees. They are practical, career-oriented programs designed to help you reach your objectives without further academic training.

If you already have some college education, you may be able to receive advanced standing toward your degree. With a degree from ICS, you'll be able to apply with pride for jobs that call for career training.

FREE DEMONSTRATION LESSON

No one can promise success, but if you *want* more—more money, more security, more day-to-day satisfaction and more future—our free Career Booklet and free Demonstration Lesson can help you get started in the right direction.

Remember, it's your life. You might as well make the most of it. © 1975 Intext, Inc. C

FOR A FREE CAREER BOOKLET & DEMO LESSON, CHECK BELOW.

- | | |
|---|---|
| <input type="checkbox"/> Electrician | <input type="checkbox"/> Automotive Mechanics |
| <input type="checkbox"/> Engineering | <input type="checkbox"/> Business Management |
| <input type="checkbox"/> Accounting | <input type="checkbox"/> Civil Engineering |
| <input type="checkbox"/> Drafting | <input type="checkbox"/> Interior Decorating |
| <input type="checkbox"/> Electronics Technician | <input type="checkbox"/> Construction Electrician |
| <input type="checkbox"/> TV Service & Repair | <input type="checkbox"/> Appliance Service & Repair |
| <input type="checkbox"/> Surveying & Mapping | <input type="checkbox"/> Income Tax |
| <input type="checkbox"/> Diesel Mechanic | <input type="checkbox"/> Motel/Restaurant Mgt. |
| <input type="checkbox"/> Air Conditioning & Refrigeration | <input type="checkbox"/> Mechanical Engineering |
| | <input type="checkbox"/> High School |

EARN A DEGREE WITHOUT GOING TO COLLEGE

The ICS Center for Degree Studies is authorized by the Pennsylvania Department of Education to offer career programs at home leading to Associate in Specialized Business and Associate in Specialized Technology degrees. For information, check the field of your choice below.

- | | | |
|--|-------------------------------------|-------------------------------------|
| Business Programs: | Engineering Technologies: | |
| <input type="checkbox"/> Accounting | <input type="checkbox"/> Civil | <input type="checkbox"/> Electrical |
| <input type="checkbox"/> Business Management | <input type="checkbox"/> Mechanical | <input type="checkbox"/> Chemical |

Name _____ Age _____

Address _____

City _____

State _____ Zip _____

Phone _____

XA804M

ICS

INTERNATIONAL CORRESPONDENCE SCHOOLS
SCRANTON, PA. 18515

VETERANS: TAKEN FOR CAREER PURPOSES, ICS PROGRAMS QUALIFY FOR V.A. BENEFITS. CANADIAN RESIDENTS USE SCRANTON, PA. ADDRESS FOR SERVICE FROM ICS CANADIAN, LTD. IN HAWAII: 931 UNIVERSITY AVE., HONOLULU, HAWAII 96814.

HOMEOWNERS' CLINIC



Think twice

When my home was built, 4 in. of insulation was poured between the attic floor joists. I have access to Styrofoam sheets used as packing. Could I use these between joists, or would it be better to add blow-in insulation, and how much more?—Royce Watson, Bryan, Tex.

I would add, say, 3 in. of poured insulation for a total depth of about 7 in. In time, this should return its cost in fuel savings. Be leery about using the styrene foam sheets. Styrene insulation is used in home construction but the variety used for packing may not have the fire-retardant qualities or insulating rating that you need. Be sure you know what you have before you use it.

Feathering patcher

I've always had trouble troweling a concrete patcher when making a shallow patch. I can never get it quite flush, smooth and neat. How is this done?—J. Erickson, Moline, Ill.

Ordinarily, you don't trowel a patch when edges require shallow

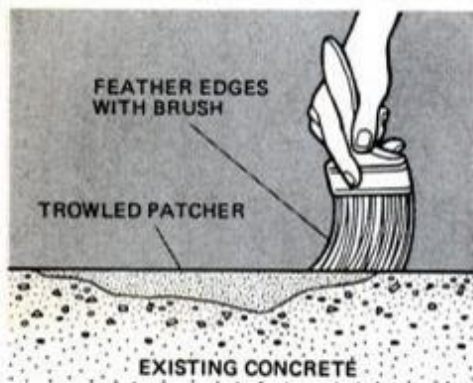

filling. Instead, smooth and level these edges with a brush as indicated. Use an old paintbrush or the coarser-bristle kind for masonry paint. Cover such a patch with coarse fabric and keep it damp for several days while the patching cures.

Condensate on floor

The floor in my basement recreation room is tiled and walls are paneled. The poured-concrete foundation forms two walls of the room. The floor is drawing water along these walls. How do I stop this leak without taking up the tiles along the

baseboard?—Robert Ash, Cleveland.

"Drawing water" is an unfortunate term—it does not describe what is happening. Water you see along the baseboard is condensate that will form on any surface at a lower temperature than the room air. Usually, improved ventilation is the cheapest cure; screen the basement windows and open them on cool days to let cooler, dryer air circulate freely. If there are no windows, use an automatic dehumidifier to lower moisture level of the air.

Warped paneling

I've installed paneling over the poured-concrete foundation in my basement, gluing the furring strips to the walls without insulation as there was no seepage or dampness. Now the paneling is warped and furring has loosened in several places. Would small vents at the floor and ceiling correct the trouble?—Frank Larson, West Point, N.Y.

Warping and loosening seem too far advanced. The vents might be a temporary, emergency remedy, but ultimately you will have to replace both paneling and furring, installing foil-faced insulating blankets (with the foil facing out, not in) between the furring strips.

Changing laminate color

Is it possible or practical to change the color of plastic laminate to a lighter shade by painting? The present color is a gold which seems rather dark and unattractive.—Mrs. F. T. Bruce, Arcade, N.Y.

Paints do not bond readily to smooth, hard laminate surfaces, and no air-drying finish can match the durability of the laminate itself. You could try roughening the surface with a medium-coarse steel wool to provide a "tooth" for paint, but don't be surprised if the coating doesn't hold up well.

Filling blisters

Paint has blistered and peeled in several small areas on wide siding, leaving ugly spots that show shadow lines in sunlight. Is there any practical way to conceal these defects?—Edwin True, Detroit.

I have concealed such defects successfully with spackling compound. Brush away any dust, then force the compound into place with a wide putty knife or joint knife, smoothing and flattening it. Let this dry thoroughly and then sand it flush. Protect the filling immediately with one or

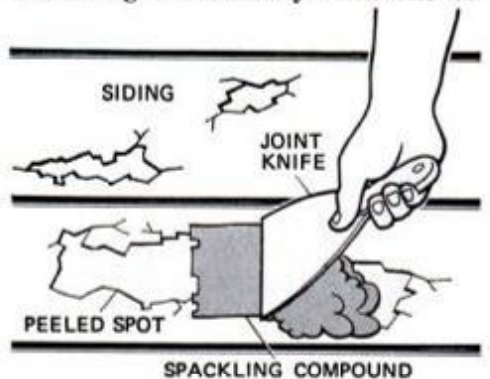

two coats of paint. I recommend this procedure only where there are relatively few defects. It is no substitute for a new paint job.

Below-grade tile

I plan to retila a 14x30-ft. basement room where there is humidity and foundation moisture. After old tile is removed and adhesive scraped away, should I wash the floor with a cleaner such as trisodium phosphate for better adhesion? The old tile is asbestos and I intend to replace it with vinyl.—Bud Haak, West St. Paul, Minn.

I favor asphalt tile for installation on concrete floors below grade. It wears well and is less subject to harm caused by the moisture conditions found in most basements. But I know of asbestos-tiled basement floors—including one that has been flooded twice—that are 25 years old and still in good condition. In any case, you'll need to clean the floor thoroughly to remove all cement residues, dust and dirt before laying new tile. It must also be dry before you lay tile. ★★

Do you have a home maintenance or repair problem? Send it to Homeowners Clinic, Popular Mechanics, 224 West 57th St., New York, N.Y. 10019. Letters cannot be answered individually, but problems of wide interest will be discussed in this column. For more home repair and maintenance help, get PM's Home Care Guide, \$4.49 postpaid. Send orders to PM, Dept. HCG, Box 1014, New York, N.Y. 10019.

Warning: The Surgeon General Has Determined
That Cigarette Smoking Is Dangerous to Your Health.

Start fresh with Belair.

Light menthol
to make your smoking
fresh and free again.



The light touch of menthol.

Windproof Ronson Butane lighter with adjustable flame. Yours for free B&W coupons, the valuable extra on every pack of Belair.

To see over 1000 gifts, write for your free Gift Catalog: Box 12, Louisville, Ky. 40201.



Kings, 15 mg. "tar," 1.0 mg. nicotine; Longs, 17 mg. "tar," 1.2 mg. nicotine, av. per cigarette, FTC Report Apr. '75

© B&W T Co.

Материал, защищенный авторским правом

APPLIANCE CLINIC

BY PAUL MANN



For openers

My General Electric Deluxe Toast-R-Oven is burning my toast and me to a crisp. I have to sit, watch and manually operate the thing, because the door won't open automatically. What's wrong?—A. J. Borg, Elmira, N.Y.

A defective solenoid, a defective switch or a defective mechanical spring coil. The solenoid works like a thermostat. It monitors heat, shuts down at a preset point and allows the door to open. If the solenoid is bad, the door stays shut. The switch activates the solenoid, so if it's bad, the solenoid won't work. The spring coil actually opens the door; if it's binding or stuck, the door may not open.

Whatever the origin of the problem, you should be able to make the repair at home, but you will need a schematic, instructions and parts for your model—GE has been making Toast-R-Ovens for about 10 years, and models do differ. Get the catalog number of your unit from the bottom of the crumb tray and send it to Frank Frumento, Service Center Manager, GE, 7100 Airport Highway, Pennsauken, N.J. 08101, with a note reminding him of this discussion. Frank told me he would send you a schematic and step-by-step repair instructions. After troubleshooting, you can write him again to let him know which parts you need.

Steady problem

The blades of our electric knife won't hold steady. They come loose while carving. They don't come out of their socket, but they are sloppy.

Would new blades help?—Thomas W. Peery, Waverly, Ohio.

The answer to your question depends on where the sloppiness is occurring. Look in two places. First, at the tip of the blade. As shown in the illustration, one blade has a small metal rivet that locks into a slot in the other. This rivet can wear down and become oblong in shape, causing blades to exhibit sloppiness instead of holding firm when moving. If that rivet looks oblong, the problem can be solved by replacing the blades.

If the blade lock is okay, check the blade holder or rocker arm inside the case. This part is usually plastic and can wear; blades then will not lock positively or at all. The part is easily replaced—the problem in getting a new one depends on the age of your knife. Consult a dealer who represents the manufacturer, or check your local directory for a small-appliance parts dealer.

Scour skipper

I have a Whirlpool dishwasher that has the Super Scour cycle which heats water in the first wash and final rinse while circulating the water. Is there any way to adjust the machine so the pump motor won't run until the water reaches its maximum heat?—R. Pierce, DuBois, Pa.

You're putting me on—either that or you haven't read the instruction manual that came with the dishwasher. The Super Scour cycle has a definite purpose—it's for pots and pans that need strong scouring to get rid of heavy deposits; prolonged water circulation accomplishes this.

If you don't want the Super Scour

cycle, you don't have to use it. Simply use the Super Wash cycle—this achieves the same result you would get by doing what you asked, and with *much* less trouble.

Plugging away

I own a Hotpoint clothes washer about 9 years old. It works fine except that the transmission leaks fluid. The company serviceman told me that when all fluid is gone, so is the washer. Why can't a person drill a hole in the transmission case, refill the transmission with fluid, and plug the hole?—Harold E. Roberts, Sylmar, Calif.

According to General Electric, there's a threaded plug in the top of the transmission case that can be unscrewed so the transmission can be refilled. But two difficulties arise: First, pulling the transmission from the machine so you can get to the threaded plug—this is a big job. Second, getting the fluid, which is a special 90-weight transmission oil—get in touch with the GE and Hotpoint Regional Parts Center in Burlingame, Calif., to find where to buy it in your area.

Sooner or later, you'll reach a point of no return with your washer. Leakage will get to the point where fluid is coming out as fast as you can pour it in, and you'll find that taking a couple of hours to pull the transmission for each refill isn't worth the effort. You then have two options: having the transmission overhauled and new seals installed for about \$150 (the figure I was quoted here on the East Coast), or buying a new washer.

Where's Waring?

Could you tell me the address of the maker of the Waring blender?—Charles G. Babian, Athens, Tenn.

Sure—Waring Products Div., Dynamics Corp. of America, New Hartford, Conn. 06057. ★★★

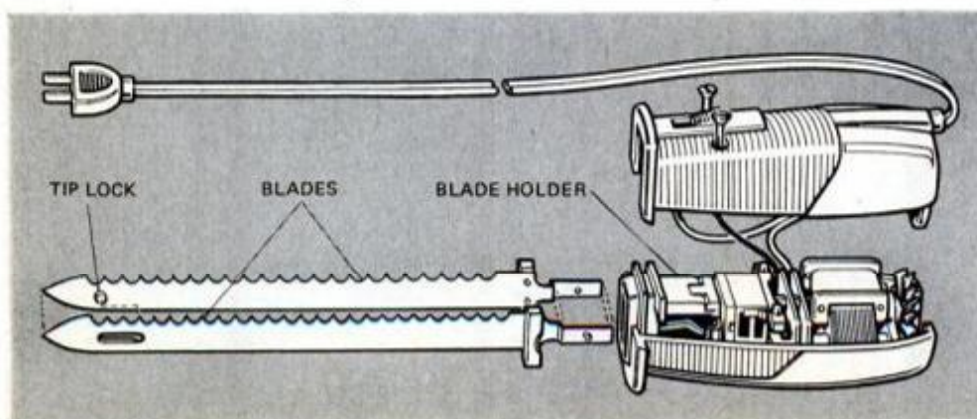

If you have a question about any appliance, send it to Appliance Clinic, Popular Mechanics, 224 West 57th St., New York N. Y. 10019. Sorry, but letters cannot be answered individually. Problems of wide interest will be discussed in this column.

ASTOUNDING SUCCESS-NATIONWIDE JOIN THE NUMBER 1 TEAM

A MESSAGE FROM THE PRESIDENT . . .

Here is your Golden Opportunity to own and operate one of the most successful business opportunities ever offered! Once again, we're expanding our National operation, making it possible for people just like yourself to enjoy a happy and prosperous future.

When you become part of the Guarantee Team, you'll understand why we're Number One in our field. Customers coast-to-coast know and respect our high degree of service and reliability.

For years now, you've watched the other guy get all the breaks . . . and make all the money. Now, it's your turn! Make your move TODAY by sending me the coupon below.

Frank Woodruff



Frank Woodruff, President Guarantee System

New Home Office Building

JOIN US IN A WELL PROVEN SUCCESSFUL BUSINESS!

We're a National company, No. 1 in our field . . . we're looking for a husband and wife team to join us in the rapidly expanding carpet cleaning and dyeing business.

Through development of our exclusive process, we have rapidly become the recognized industry leader. Our successful and proven methods are reaping outstanding profits in over 200 cities from Hawaii to Florida.



Our success is legitimate, documented, and easily verified.

If you're willing to work, we'll teach you our exclusive system of using color to dye, tint and clean carpets. No competition - We train - protected area.

Guaranteed Success! Solid buy-back agreement! Isn't it time you went to work for yourself?

DON'T DELAY - WRITE TODAY



This is your Golden Opportunity to establish yourself in a business where employment is guaranteed now and for years to come.

Please send me full details on the opportunity you offer qualified men to start a business of their own.

Member: International Franchise Association

GUARANTEE SYSTEM

GUARANTEE CARPET CLEANING & DYE CO.

2953 Powers Avenue / Dept. PM / Jacksonville, Fla. 32207

NAME _____

ADDRESS _____

CITY _____ STATE _____ ZIP _____

AREA CODE _____ PHONE _____

AREA DESIRED _____



SCIENCE WORLDWIDE

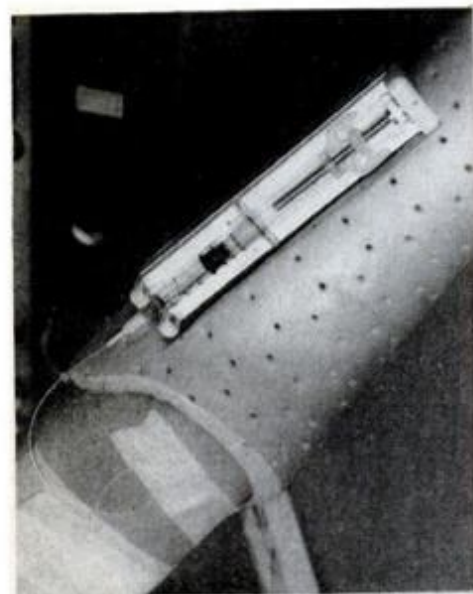

Motorized syringe

Certain medical conditions require large doses of drugs to be given intravenously. A mechanical pump or "drip" setup is used at bedside, causing the patient to remain immobile for long periods of time. Yet physicians think it's better for most patients to remain mobile.

Now British researchers claim to have solved the problem with the invention of a portable motor-driven syringe. A small battery-run motor is linked to a rod that pushes the syringe plunger. A timer controls the rate at which the syringe is emptied. Instead of the usual needle, pliable tubing connects the syringe with the patient's vein. The entire unit is strapped to the forearm so the patient can carry on normal activities while receiving the drug.

Land sinking in some states

Land subsidence—sinking of the land surface—occurring in parts of the nation could become more prevalent in the future, according to the U.S. Geological Survey. One USGS report, prepared with the California Department of Water Resources, notes that at least 4300 square miles of the San Joaquin Valley in California has subsided more than a foot since the 1920s.

Another report discloses that an area near Houston has subsided more than eight feet since 1920 and could

sink three more feet by 1980. Similar problems have developed in Louisiana, Arizona and Nevada. Most are caused by large withdrawals of ground water and petroleum, say USGS scientists. Though sunken land can never be raised to its former level, subsidence can be slowed and even stopped by recharging the ground with surface water.

Shock absorbers for skyscraper

The 60-story John Hancock Building in downtown Boston, due for completion in 1971, may finally welcome its first occupants this year. The delay was created by wind sway. In 1972 windows began to pop out; eventually all 10,344 were replaced. The framework was also beefed up with extra steel.

Now two huge shock absorbers, similar in principle to those on cars, are expected to dampen the effect when strong winds hit the building. Each will have a damper made up of a big steel box filled with lead that slides on a 30-foot steel plate. The damper will be connected to stiff springs anchored to structural columns on the 59th floor. Big hydraulic cylinders, also part of the system, will help to absorb motion. The two shock absorbers will cost about \$3 million.

Fats good for muscles

Fats create more weight for your muscles to move around, but some fats are vital to the health of muscles, says Dr. Charles D. Tweedle, a zoologist at Michigan State University. Normally, each fiber within a muscle—and there can be thousands of fibers in a large muscle—is connected to a single nerve cell. If that connection is broken because of injury or disease, the muscle fiber slowly withers and dies.

The connection can be reestablished, however, by a fatty compound discovered by Dr. Tweedle. The compound is released by nerveless muscle fibers and acts as a distress signal, which in turn is answered by nerve cells connected to undamaged, adjacent muscle fibers. "The nerve cells sprout threadlike branches, which eventually connect to the muscle fiber

sending the message," explains Dr. Tweedle. Once the new nerve connection is made, the muscle fiber works again, returning the muscle to almost normal strength.

Sniffing for gas with radar

Airborne radar that's already been used to discover valuable resources outside the United States is now at work searching for hidden pockets of natural gas in Virginia, West Virginia, Ohio and Kentucky. Carried aboard a jet at 40,000 feet, the side-looking radar cuts through clouds and weather as it "views" terrain from an angle. Electronically processed, the return signals are used to form a maplike image (see below) far superior to a conventional photo in revealing faults and other earth formations.

The other photo shows radar gear aboard the jet used by Litton Industries' Aero Service Div., which is making the four-state survey. De-

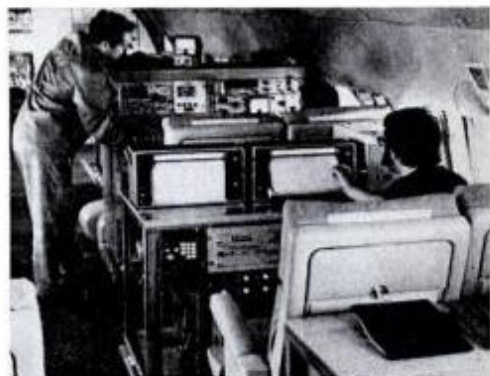

veloped by the Goodyear Aerospace Corp., the radar system has been used to map huge areas in South America. One set of maps led geologists to the discovery of a major iron-ore deposit in Venezuela. ★★★

YOU DON'T HAVE TO WIND UP AN EVINRUDE 200 TO MAKE IT GO.

Some people were surprised when we announced a new 200 horsepower V-6 instead of some lesser horsepower number. Until they found out why.

The why is simply that we saw the need for an outboard big enough and strong enough to deliver a high level of performance at economical cruise throttle; avoiding the penalty of sustained full throttle operation.

When the Evinrude 200 is run at cruising speed (a few mph below top speed), it uses up to 45% less fuel than when being run wide open. When throttled all the way down to the equivalent of 135 hp, it compares in fuel economy to a 135 running full out. And you still have 200 horsepower performance in reserve.



At cruise throttle the engine is running easy, even though it may be running stronger than any outboard has ever run before. It runs smoother and quieter, and lasts longer.

With 2.4 liters of displacement (149.4 cu. in.), the 200 can be broad-tuned for the full operating range. There's no need to go for broke at the top end.

The Evinrude 200 develops high torque in the critical planing range where offshore boats running in offshore seas need all the throttle response they can get.

It cruises efficiently faster than most motors can run.

You don't have to wind it up to make it go.



EVINRUDE
DIVISION OF OUTBOARD MARINE CORP.
first in outboards

If you can use any of these tools...

You can gain exciting new skills as an electronics troubleshooter in Bell & Howell Schools' fascinating learn-at-home program that includes building and experimenting with the new generation color TV.

Simulated TV test pattern



You may already have some of the skills you need.

Most of us at one time or another have put a screwdriver, a pair of pliers or some other basic tool to work. Fixing a bicycle wheel, tightening a window latch, putting up a bookshelf, or what have you.

But here's a thought.

Using these same simple tools as a starting point, you can develop the ability to put them to work for you in far more ways than you ever dreamed of. And Bell & Howell Schools' fascinating home learning adventure in electronics will show you how.

These days when it seems like there's an "electronic everything," it makes good sense to have occupational skills in the servicing and repair of such products as TV's and other home electronic equipment. Bell & Howell Schools is ready to help you develop the specialized abilities you need to become an electronics troubleshooter. While no assurance of income or employment can be offered, we try to assure you that no better-at-home training in electronics is available anywhere.

We have an exciting way for you to pick up these specialized skills in your spare time.

Don't think for a moment that we want you to spend your off-hours just reading a bunch of "how-to" books. That would bore anyone after awhile. What we at Bell & Howell Schools offer is the modern way to learn... a very different approach from the way you've been used to.

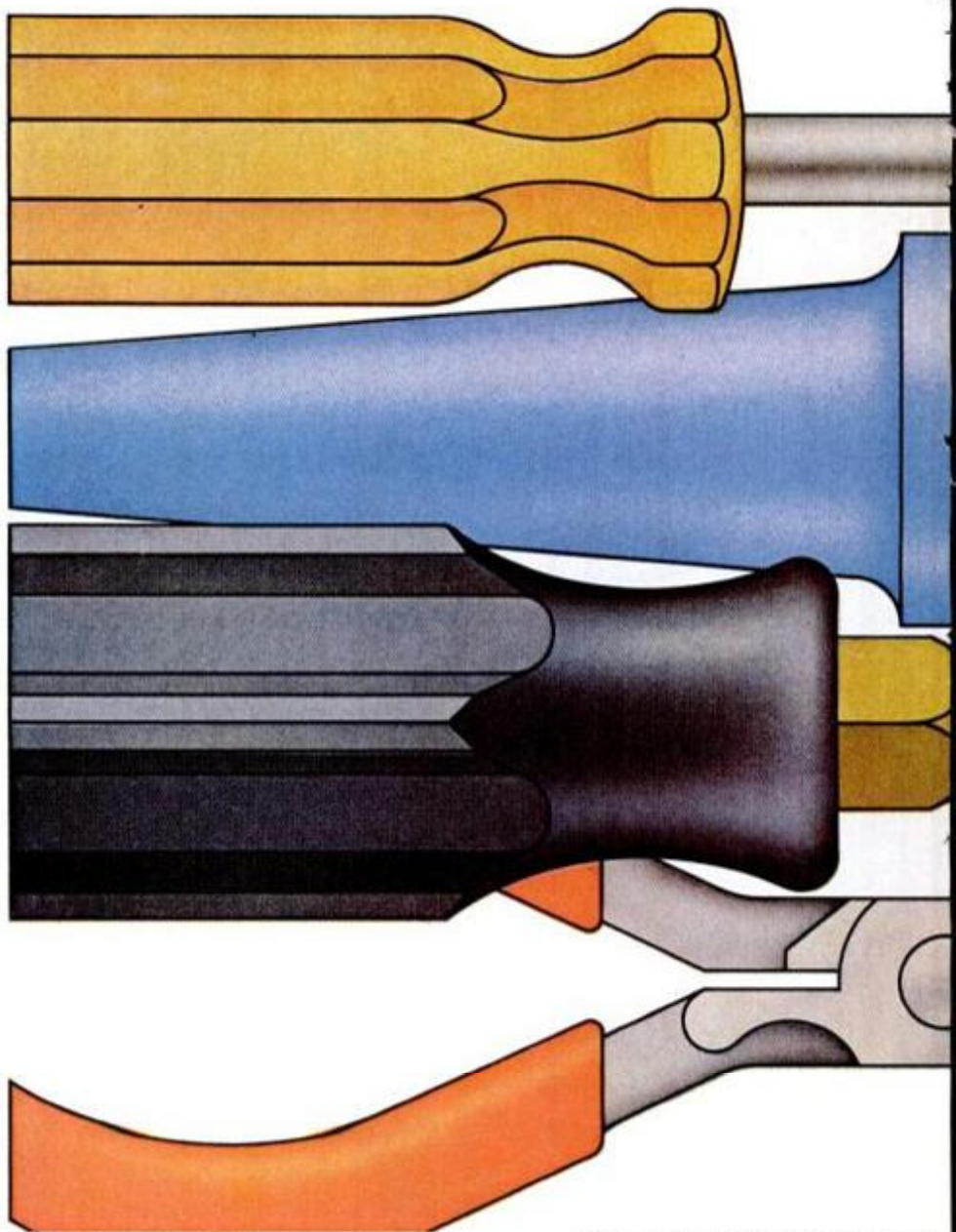

First of all, we believe that when you're exploring a field as fascinating as electronics, reading about it is just not enough. That's why throughout this learning adventure you'll get lots of "hands on" experience with some of the latest electronic training tools available today. You'll test and experiment with them and gain exciting new skills all along the way.

While no assurance of income opportunity can be offered, once you've completed this program a number of directions are open to you.

1. Use your training to seek out a job in the electronics industry.
2. Use your training to upgrade your current job.
3. Use your training as a foundation for advanced programs in electronics.

No electronics background necessary.

That's one of the many attractions of this program. We start you off with the basics and help you work your way up one step at a time. As a matter of fact, with your very first lesson you receive a special Lab Starter Kit to give you immediate working experience on equipment as you are picking up the fundamentals.

It makes the learning process faster and certainly a lot more interesting.

You'll build and perform exciting experiments with Bell & Howell's Electro-Lab® electronics training system.

You build this Electro-Lab® system step-by-step, too. First, the design console. After you assemble it, you'll be able to set up and examine circuits without having to solder them in place.

Next, you'll enjoy building a digital multimeter. This important instrument measures voltage, current and resistance and displays its findings in big, clear numbers like on a digital clock. Far easier to read than "needle pointer" meters.

Then comes the solid-state "triggered sweep" oscilloscope which is similar in principle to the kind used in hospital operating rooms to monitor heartbeats. You'll use it to analyze tiny integrated circuits. The "triggered sweep" feature locks in signals for easier observation.

You'll actually build and work with Bell & Howell's new generation color TV... investigating features you've probably never seen before!

This 25" diagonal color TV has digital features that are likely to appear on all TV's of the future. Features made possible by the applications of digital electronics

to home entertainment.

You'll probe into the technology behind all-electronic tuning and into the digital circuitry of channel numbers that appear big and clear, right on the screen!

You'll also build-in a remarkable on-the-screen digital clock, that will flash the time in hours, minutes and seconds. Your new skills will also enable you to program a special automatic channel selector to skip over "dead," channels and go directly to preselected channels.

You'll also gain a better understanding of the exceptional color clarity of the Black Matrix picture tube, as well as a working knowledge of "state-of-the-art" integrated circuitry and the 100% solid-state chassis.

Having actually built and experimented with this TV, you'll come away equipped with the kinds of skills that could put you ahead of the field in electronics know-how.

We try to give more personal attention than other learn-at-home programs.

1. Toll-free phone-in assistance. The program is designed so that you can proceed through it smoothly, step-by-step. However, should you ever run into a rough spot, we'll be there to help. Many schools make you mail in all your questions. We have a toll-free line you can call when you have a question that can't wait.
2. In-person "help sessions." These are held in 50 major cities at various times throughout the year where you can talk shop with your instructors and fellow students.

Why wait?

Find out more on how you can pick up new skills in electronics troubleshooting as you work with Bell & Howell's new generation color TV. You've got the tools to do it!

Mail the postage-paid card today for full details!

Taken for vocational purposes, this program is approved by the state approval agency for Veterans' Benefits.

If card has been removed, please write to:

An Electronics Home Study School
DeVRY INSTITUTE OF TECHNOLOGY

ONE OF THE
BELL & HOWELL SCHOOLS
4141 Belmont, Chicago, Illinois 60641

698R4



Channel numbers that flash on the screen



On-screen digital clock



Automatic pre-set channel selector

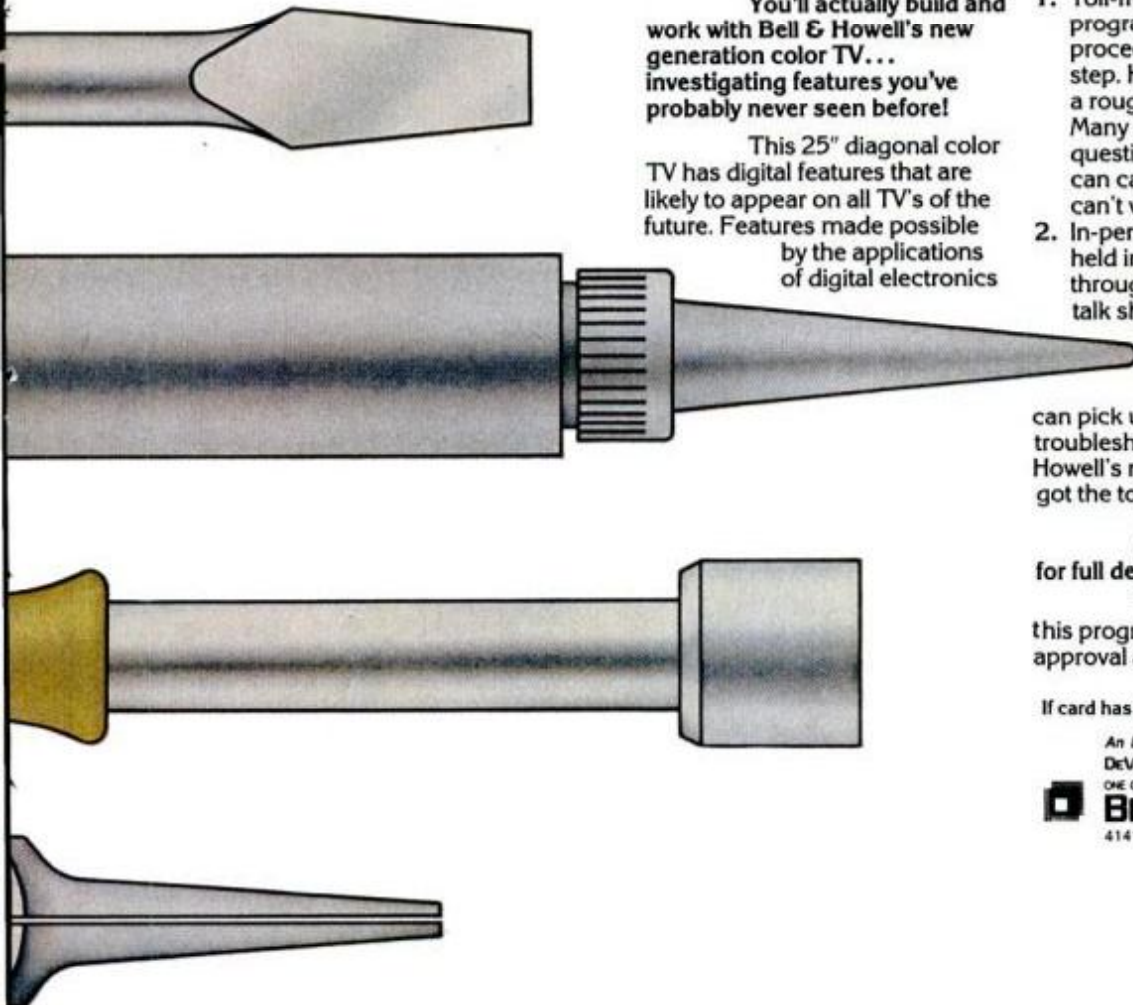

Your menthol
letting you down?

Come up to the consistently
smooth taste of extra coolness.
The taste that only KOOL has.

Come up to KOOL.



Warning: The Surgeon General Has Determined
That Cigarette Smoking Is Dangerous to Your Health.

DETROIT LISTENING POST



GM to divvy up sub-Chevette

GM sources now say four GM divisions will get a crack at the smaller-than-Chevette car coming in 1979. Chevette is still favored to get a one-year jump on the other divisions in selling the car. But Buick, Olds and Pontiac will have copies no later than the second year, if that long.

Although the car will be smaller than Chevette by at least six inches (Chevette has a wheelbase of 94 inches), it may not be GM's lowest-price car. Chevette may retain that claim, because even though the new car will be smaller, it will be a more luxurious package. But trying to peg the price of the car this far in advance is just plain guessing. Nobody really knows what the new cars will be selling for three or four years from now.

Chrysler tags mini a '78

Chrysler dealers who chide company execs for not having a subcompact to sell against competing cars are told they will have a small car in 1978. But Chrysler doesn't specify whether that's the '78 calendar year or the model year beginning in fall of 1977. The company would like to make it by the earlier date, but doesn't want to commit itself and then not be able to deliver.

GM, VW, Ford hot on diesel

GM has now confirmed it is working on a light-duty diesel for a passenger car, as PM reported in October. It will be a 280-cu.-in. Eight. (For a complete report on diesels, see page 60.) GM says the engine in its present state of development can't meet pollution-control standards for 1978. Even so, the company has bids out for tooling to produce the engine. Oldsmobile has the assignment to do the development work and is expected to turn out job one—engine No. 1, not a car you will be able to buy—by late 1977.

GM is contemplating a fairly expensive car, say around \$10,000 to \$12,000, that will give it an opportunity to build up experience with the diesel. Experience in producing it and experience with diesels in the hands of owners. Along with the

Eight, GM is testing four and six-cylinder diesels.

GM isn't the only automaker with high hopes for the diesel. Volkswagen discloses it is working on a dieselized version of its 1.6-liter Four. In trial runs at the Environmental Protection Agency lab at Ann Arbor, Mich., the VW diesel scored 50 miles to the gallon!

Ford is also cranking up a diesel development program. It's doing the work in Europe.

Tracking the turbine

While GM was confirming production of a diesel, Chrysler nailed down an item in last month's DLP on the turbine. We said the turbine is a good bet for 1980-81. George Huebner Jr., former director of research for Chrysler, says the engine possibly may be ready in three to four years. Huebner, who retired from Chrysler a few months ago, is the father of the turbine in this country. He has worked on the engine for 30 years.

The turbine that Chrysler has now, Huebner says, will have the fuel economy of a Six combined with the power and performance of an Eight. When Huebner says Chrysler will have a turbine in three to four years, he's talking experimental cars. I still think it will be in the 1980s before the company offers a turbine you can drive home.

No fat boy label for Ford

Ford has put itself on a crash program to remove as much weight as possible from its full-size cars in 1977 without benefit of new bodies or any appreciable change in overall size. It's not just coincidence that's the year GM will bring out a new line of full-size cars. The GM products will be 500 to 700 pounds lighter than comparable '76s. Ford says it isn't going to be caught napping if there's a fat boy contest.

Meanwhile, GM has asked Pontiac to work up a Phoenix II car. Phoenix, a two-door Ventura, is GM's lab-on-wheels for reducing weight. On the first version of the car, Pontiac trimmed off 700 pounds through use of lighter materials. Pontiac doesn't expect to equal that on Phoenix II,

but it could lop off another 300 to 400 pounds.

Speaking of GM's full-size cars, a company staff man who has seen the '77 products says they have virtually no grille. The hood slopes down to a narrow opening, giving the cars a very light look in front.

GM automatic a winner

Chevette is getting all the attention, but it's not the only winner GM has come up with this year. The company has another hit on its hands in the three-speed automatic transmission that's offered as an option on Chevette.

Dubbed the Turbo Hydramatic 200, it's the most compact, lightest unit GM has ever offered. Every GM car division except Cadillac is asking for dibs on the 200. Buick and Olds are even interested to the extent that they want to try the unit in their big cars. American Motors would also like to buy the 200 for use in its small cars.

Radial-tire claims punctured

Carmakers are having some second thoughts about radial tires, but not from a durability standpoint. Radials outlast bias-belted and bias-ply tires by 25 percent—40,000 miles with a set of radials versus 25,000 to 30,000 with bias tires. But that's not such a bargain when you figure radials cost 35 to 40 percent more than regular tires. The car companies are disappointed with radials because they have turned out to be not as puncture proof as the tire companies led Detroit to believe.

One tire engineer I talked with at Ford told me it has been his experience that the steel cord used in the radials acts to channel objects into the tire, instead of diverting objects away and preventing punctures. He said that radials are neither worse nor better than the bias-ply, bias-belted tires in this respect. "If you're going to get a flat, you're just as likely to get it with a radial as with a nonradial. The radial is still the best tire for most cars, but it's far from being the supertire it's supposed to be." ★★

If you can use a screwdriver you can create a classic family heirloom to enrich your home

HENTSCHEL Grandfather Clocks brings you its famous quality and craftsmanship in this unique **Pre-Cut Kit**.

Step-by-simple-step, you build your own beautiful, enduring Grandfather Clock designed to last for generations.

Nothing adds so much to your home as a stately Grandfather Clock. Its majestic height, the polished beauty of its solid wood, the gleaming brass of its face and works, all have a stunning effect.

No wonder families cherish these enduring timepieces from generation to generation. Fine homes everywhere echo their deep, mellow chimes. Collectors prize them more and more with the years.

Build an Heirloom—Yourself!

You may find it hard to believe that you can create such an heirloom yourself. But now it's made possible—easy—by the finest clock kit you can buy: the **HENTSCHEL Grandfather Clock Kit**.

This unique Kit took us years to develop. It had to have the same quality and craftsmanship **HENTSCHEL** has been perfecting since 1890. With no production shortcuts... no compromises in material. Yet it had to be quickly and easily assembled by almost anybody. A tall order; but our new Kit fills it.

The Finest Material—from Solid 3/4" Walnut to Polished Brass.

You'll find only one kind of hardwood in your **HENTSCHEL Kit**: kiln-dried, 3/4" solid walnut.

No plastics, no veneers.

The movements (which you order fully assembled) come from the hands of world-famed Black Forest craftsmen whose mastery goes back three generations.

Solid, polished brass; precision-cut, hardened steel. The estimated life of these movements is 100 years.

Every piece of wood in a **HENTSCHEL** Clock Kit is precision pre-cut. All miters are pre-drilled. And dowelled for extra strength. Corner blocks and other parts are pre-drilled and counter-sunk. And every piece of wood is sanded on **both** sides, visible or not.

Exactly the way custom clocks are made.

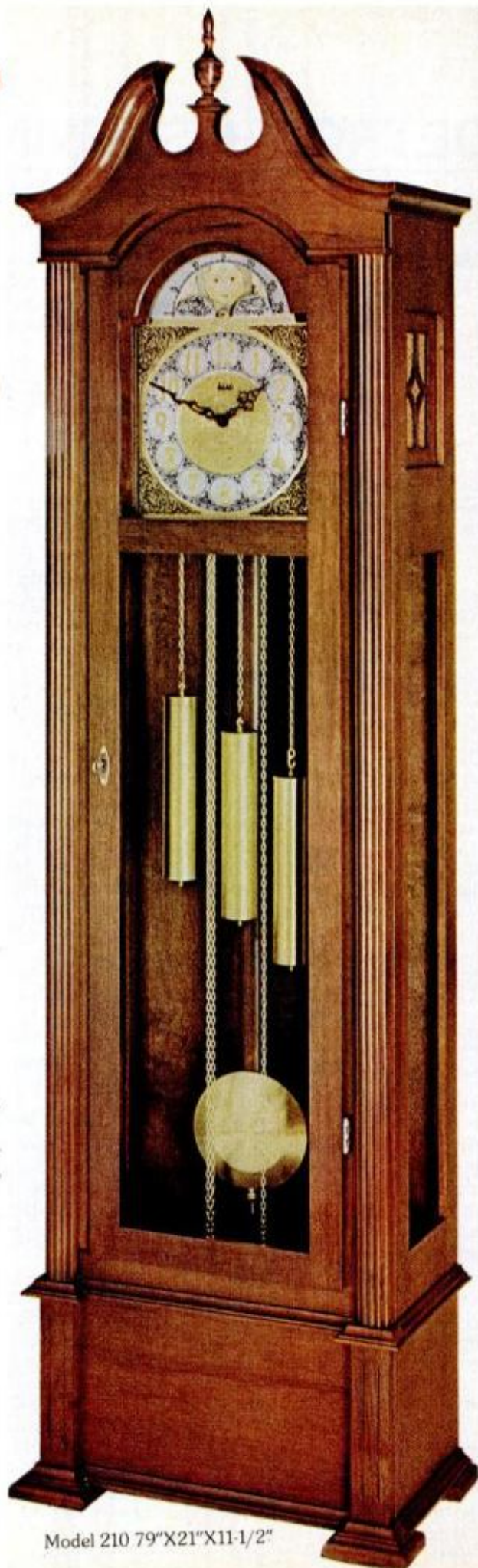

Model 210 79"X21"X11-1/2"

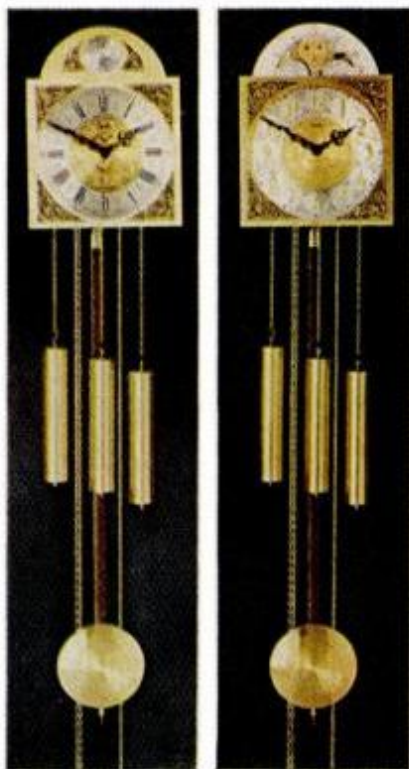

1000-W

1000-T

Choose from Two Movements by World-Renowned Craftsmen:
HENTSCHEL Movements are made in West Germany by craftsmen whose tradition of excellence and pride of craftsmanship goes back three generations. These precision movements are 8 day—weight driven—polished brass shells and bob—solid brass plates with hardened steel pinions.

1000-W Westminster Chime-Tempus Fugit Dial Chimes the 1/4 hour, 1/2 hour, 3/4 hour, and hour, with a Big Ben strike on the hour. Solid brass deeply engraved dial with "Tempus Fugit"—"Time Flies" overpiece... \$139.50.

1000-T Triple Chime-Moving Moon Dial Chimes three famous traditional melodies: Westminster, Whittington, and St. Michael. The solid brass polished dial, shows the changing phases of the moon... \$169.50.

The Finest Guarantees in the Industry

30-Day Guarantee If you are not completely satisfied with your **HENTSCHEL CLOCK KIT WITHIN 30 days**, simply return it in the original shipping carton for a complete refund. In fact, so confident are we of **HENTSCHEL** quality, we will even pay return shipping charges!

One Year Movement Guarantee: Every movement you order from **HENTSCHEL** is also guaranteed for a full year against defects in materials or workmanship. So you take absolutely no risk!

Mail the coupon today!

Unique Step-by-Step, Picture-by-Picture Instructions. If you own a screwdriver, you're ready to tackle a **HENTSCHEL Kit**. Step-by-step instructions take you every inch of the way. Exploded views show you how each part fits, and where. Photographs show you exactly how the finished product looks. You'll feel as if one of our master clockmakers is looking over your shoulder.

Mail Your Order Today. Enjoy the beauty, the elegance, the long-lived craftsmanship built into a **HENTSCHEL Grandfather Clock** soon. Begin with the pleasure of working with fine walnut. Then savor the interest and admiration of everyone who sees this handsome heirloom timepiece in your home. Enjoy the unique satisfaction of explaining that it's the product of your own hands. Mail the coupon today!



REMEMBER, ONLY HENTSCHEL'S GIVES YOU YOUR BEST FEATURE-FOR-FEATURE VALUE. JUST COMPARE!

	HENTSCHEL	OTHERS
1. A true 6' 7" tall Grandfather Clock case for less than \$150.	Yes	No
2. Lumber sanded on All sides.	Yes	No
3. All parts including miters precision pre-cut.	Yes	No
4. Miters pre-drilled and dowells provided for maximum strength.	Yes	No
5. Corner blocks and other parts pre-drilled and counter-sunk.	Yes	No
6. All Hardware Plus all screws included.	Yes	No
7. Some sub-assemblies stapled for production short-cuts.	No.	Yes
8. Possibility of costly errors in cutting miters.	No.	Yes
9. Complete glass kit (including bevelled front door) available for only \$19.95.	Yes	No
10. Free, solid brass personalized nameplate included, a \$3.95 Value.	Yes	No

\$139⁵⁰

Toll-FREE—Customer Service Number
 For your convenience as a Bank Americard or Master Charge card holder telephone your order on our Toll Free number. All U.S. except Mass. 800-225-2366. Mass. only 800-882-2048.

(Clock case only Movement extra)

..... Order Today Without Risk

HENTSCHEL CLOCK COMPANY (Allow 2 to 3 weeks for delivery. shipping charges collect.)
 Dept. 602-J
 16 Atlantic Avenue, So. Dennis, Mass. 02660

YES, please send me _____ Grandfather Clock Case Kit(s),
 Model No. 210, at each \$139.50 _____

Please send me the checked movement for my clock at price indicated.

Model 1000-W Westminster Movement and Tempus Fugit Dial at \$139.50 _____

Model 100-T Triple Chime Movement and Moving Moon Dial at \$169.50 _____

Complete Glass Kit (including lower beveled door panel) each \$ 19.95 _____

Mass. residents add 3% sales tax _____

Send illustrated 4-color brochure

Enclosed is my Check or Money Order Total _____

Charge to my Master Charge Bank Americard _____

Card Number _____ Exp. Date _____ Master Charge Interbank No. _____

Signature _____

Name _____

Address _____

City _____ State _____ Zip _____

I understand that if not fully satisfied I may return the kit(s). I have ordered within 30 days for a full refund—including return shipping charges.

H-002

THE PM GARAGE

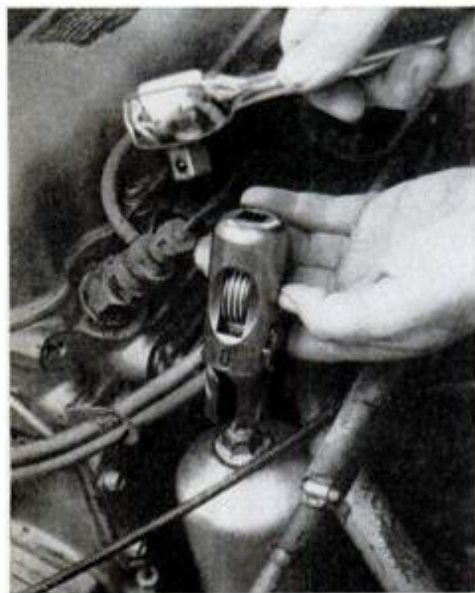

Dial-a-bolt

I have the perfect engine problem for the Gripall solution. I have a diesel in which all engine bolts are metric and all the bolts on accessories are English. The correct-wrench problem is obvious when changing the fan belt. I have to break loose two metric bolts on the engine and two English bolts of the American-made alternator. The Gripall Dial-A-Socket is a hefty steel socket (or impact) wrench attachment that's adjustable to fit any bolt from $\frac{1}{8}$ in. to $1\frac{1}{8}$ in. and metric equivalents in size. The two-point head of the Gripall permits good purchase on bolt heads and nuts. I was quite impressed with the sturdy unit that works with any $\frac{1}{2}$ -in. drive (or you can get from any hardware store a $\frac{1}{2}$ -in. adapter to fit your $\frac{3}{8}$ -in. drive). The one problem I noticed is that the unit requires clear access to all bolts. The Gripall is a little more than four inches long. So don't throw away your open-end or narrow socket wrenches. But for \$24.95 you can add a useful and well designed tool to your kit, especially as we go metric. Schlesinger's For Tools, Ltd., 1257-61 Utica Ave., Brooklyn, N.Y. 11203.—D.F.

Redecorate with spray

If you're tired of your car's upholstery color, by all means change it. It's super-simple with the vinyl spray paints now on the market.

I sprayed the interior of my Ca-

maro convertible in 1969, changing it from black to avocado. Everything has stood up amazingly well these past seven years; no regrets. I have, though, had to touch up worn areas on the seats and armrests twice.

The trick to spraying auto upholstery is to get everything absolutely clean. I use Formula 409 and scrub with a fingernail brush first, then hose that off and go over all surfaces with rubbing alcohol.

More recently I sprayed the front bench of my wife's Dodge wagon with Tony Nancy's Vinyl Spray. Again, the job turned out fine. For the single bench, it took three cans of paint, costing \$10.41 (\$3.47 per can). Tony Nancy Vinyl Spray is available at most car parts stores or from Sperex Corp., 16131 South Maple Ave., Gardena, Calif. 90248.—M.L.



Voltage booster

If you need household current outside your house, Tote-A-Volt can convert your car's 12-volt alternator to 110 direct current. You can run most electric tools on it, plus kitchen and bathroom appliances.

Tote-A-Volt offers several different models ranging from about \$15 to \$88. I chose the mid-priced Model 250-A (\$26.95) and found it easy to install and simple to use. Installation takes about half an hour and requires only common hand tools.

Being 110-volt d.c. (not alternating current), there are some electrical items that Tote-A-Volt won't power. It won't operate motors without brushes: pumps, refrigerators, washing machines and the like. Nor will it run appliances that use transformer power supply: TV sets, radios and conventional battery chargers. Also, since Tote-A-Volt's output varies with car engine speed,

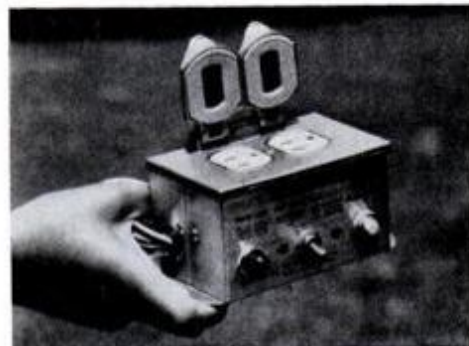

110-volt record players and tape recorders give an extreme wow-wow effect. You have to hold the throttle at a steady 2200 rpm (about 50 mph equivalent) to generate 110 volts. Tote-A-Volts are available at most car parts stores or from the manufacturer: Cliff Granberry Corp., Box 9505, Dallas, Tex. 75214.—M.L.

Glove-box bible

I've always carried a loose-leaf book in the glove box, and I've faithfully recorded all gas purchases and scribbled in oil changes and other maintenance or repairs. The looseleaf approach is better than keeping no record at all, but there's an even better way: Kay's 100,000 Mile Auto Maintenance Record. I would have been reluctant to recommend a \$2.95 (plus 40 cents for postage and handling) book just to keep track of your car's



health and appetite, but I came close to scoring my rear brake discs simply because my loose-leaf method doesn't remind me to check everything. The Kay book does. It has a maintenance section, mileage section and more. Kay Publications, 3103 North Monticello Avenue, Chicago, Ill. 60618.—B.H. ★★★

SOME STRONG REASONS WHY DATSUN IS THE NUMBER ONE SMALL PICKUP.



Two bed sizes. Datsun gives you two tough choices. You can get our Li'l Hustler with a 6-ft. bed. Or our Li'l Hustler Stretch with a longer 7-ft. bed.

Outstanding economy. Datsun Saves. If you harbor doubts, just witness Li'l Hustler's gas mileage figures: 31 MPG highway, 22 city. These are EPA mileage estimates with manual transmission. Of

course, your actual MPG may be more or less, depending on the condition of your truck and how you drive.

Strength in features. Our truck buyer's checklist begins: all-steel body and bed. Muscular 2000cc overhead cam engine. Rugged ladder-lattice frame. Tough torsion bar front suspension. Heavy-duty truck tires. And more, too numerous to mention.

Strong backing. To keep your Datsun trucking, there are nearly 4,000 factory-trained service technicians coast-to-coast. Plus a vast computerized parts network. That's how we plan to **stay** number one.

We figure the longer your Datsun survives, the longer you'll save.

Datsun Saves



The proud smoke

Product of a proud land.

Tobacco. It's as proud a part of the American tradition as the Statue of Liberty. At Liggett & Myers, we've made tobacco into a cigarette worthy of that tradition. The rich, mellow, distinctively smooth L&M. Smoke it proudly.

For color poster of New York Harbor without commercial identification, send 2 L&M pack bottoms and 75¢ to P.O. Box 60-1904, Minneapolis, MN 55460. Offer void to persons under 21 years of age. Good in U.S. only, except where prohibited, licensed, taxed or restricted by law. Offer expires December 31, 1976. Allow four to six weeks for delivery.

Warning: The Surgeon General Has Determined That Cigarette Smoking Is Dangerous to Your Health.



Filter King: 18 mg. "tar", 1.2 mg. nicotine av. per cigarette, by FTC Method.

Материал, содержащий информацию о табаке

Weather demons in the sky



Charred hulk is all that remains of Flight 66, an Eastern 727 that crashed and burned at Kennedy last June, killing 114. Cause is believed to be wind shear, producing sudden loss of lift during landing attempt.

Recent plane crashes are triggering new research into a pilot's nightmare—invisible air turbulence.

by Mort Schultz

Until recently, the term "wind shear" was little known outside aviation circles. Then, last June, came the tragic crash of an Eastern Airlines 727 jet, Flight 66, which plunged to a fiery end while attempting a landing in heavy turbulence at New York's Kennedy International Airport. The crash—the worst single-plane disaster in U. S. history—took the lives of

114. It was blamed on a strange phenomenon called wind shear.

Actually, wind shear is the greatest meteorological menace facing people who fly. It's known to have caused at least three other accidents since 1973 and perhaps one other in which 38 people died.

Even among aviation experts wind shear is a relatively new phenomenon.

"We began defining wind shear and identifying it as hazardous only in the past decade," says Charles Miller of the Flight Safety Foundation.

The Federal Aviation Administration's *Aviation Weather* manual defines wind shear as "a change in wind speed and/or wind direction in a short distance, resulting in a 'tearing' or 'shearing' effect.

"A narrow zone of wind shear, with its accompanying turbulence, is often encountered when an aircraft climbs or descends through a temperature inversion," the manual states. "It is a potential hazard to aircraft immediately after takeoff or on the final approach for landing . . . an aircraft may encounter a large loss of airspeed . . . this situation can be dangerous since the zone is only a few hundred feet above the ground."

Suddenly you're out of control

Blind to the presence of wind shear, or even if he knows it's around, a pilot who encounters the phenomenon may be unable to control his aircraft. He may have his plane flawlessly stabilized on an approach, with thrust

THE FIERY END OF FLIGHT 66

The sky was black, lightning flashed ominously and heavy rain lashed the field as Eastern Airlines Flight 66 turned on its final approach to New York's Kennedy International Airport. It was June 24, 1975—a day long to be remembered for a massive tragedy that touched off outrage, controversy and renewed efforts to establish the causes of mysterious air crashes. As the big 727 jet neared its assigned runway, 22L, it was caught in a sudden, violent downdraft—that invisible menace "wind shear"—and

dipped far below its normal glide slope. Hopelessly low, it sheared off several approach-light towers as its pilot fought vainly to pull up, then nosed into marshland short of the runway and burst into flames. Of the 124 on board, 114 perished. The time was 4:06 p.m.—lucky for some—for part of the wreckage skidded out onto Rockaway Blvd., a busy roadway skirting the airport. If the crash had occurred an hour later, the wreckage would have slammed into heavy rush-hour traffic, undoubtedly killing even more.

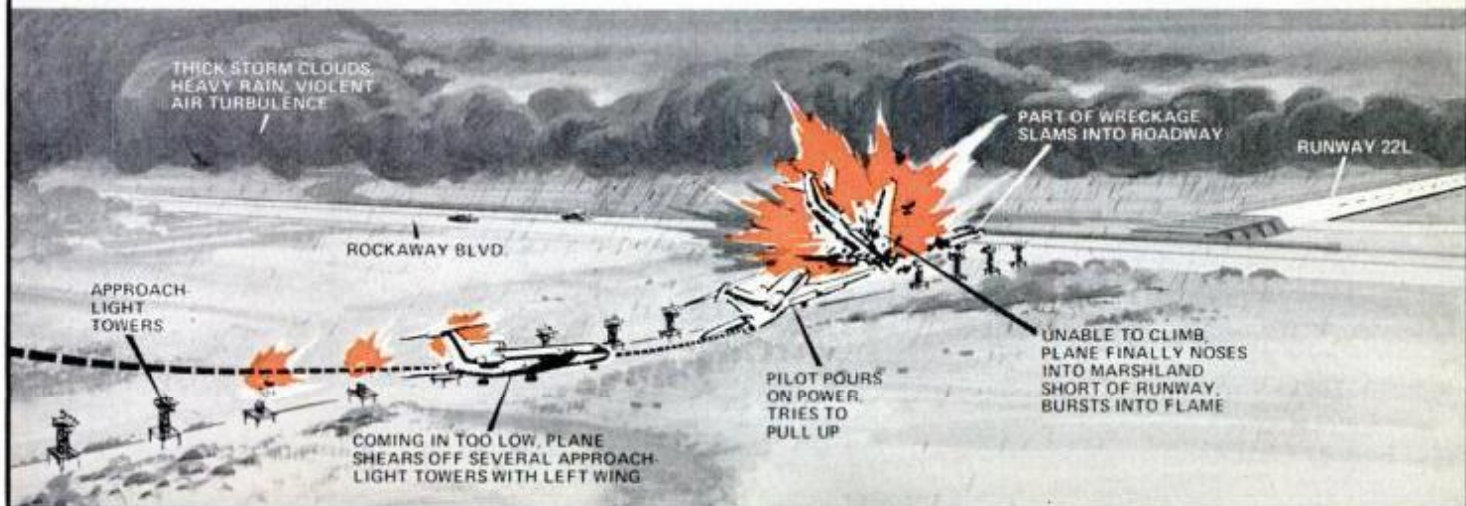

setting, airspeed, flaps and rate of descent all coordinated.

Then the plane will hit a tremendous vertical gust, or a gust from the rear. A head wind becomes a tail wind, or vice versa, and the aircraft gets caught in a violent downdraft, with its rate of descent suddenly accelerated.

The effects of wind shear are more hazardous during a landing than during a takeoff. On approach, a plane's power is substantially reduced. During takeoff, full thrust is being applied, which is usually sufficient to overcome the violent pull down.

According to reports, wind shear velocities in which the ill-fated Flight 66 found itself were in the order of 90 mph. Winds of 75 mph constitute a hurricane.

Two pilots who flew through the same zone several minutes before Flight 66 also found themselves in deep trouble.

Capt. C. L. Nickerson was landing his Eastern Airlines L-1011 jumbo jet, but had his airspeed upped 20 knots above the norm in anticipation of "hazardous air currents." He wanted the cushion so his aircraft would have enough momentum to overcome any sudden downdraft, allowing him to "go around."

Still, Nickerson's airspeed dropped from 150 to 118 knots in just two seconds and stayed at this low level for a dangerous period of time.

"A change in airspeed is not uncommon," Nickerson explains, "but to have it stay there and not move, and not be able to move it, is something I hope never to experience again."

Perhaps because of the extra 20 knots he had tacked on during his descent, Nickerson was able to overcome the pull-down effect. He pulled

Major types of

WIND SHEAR

Violent turbulence occurs in a narrow zone between two air masses moving in different directions, often in a temperature inversion situation where warm upper air moves across a stationary layer of colder air below it. Resulting wind velocities can reach or exceed hurricane force, causing extreme buffeting and loss of lift. If close to ground, as in making a landing approach, aircraft may lose too much altitude and airspeed to regain control and avoid a crash, as apparently happened to Flight 66.

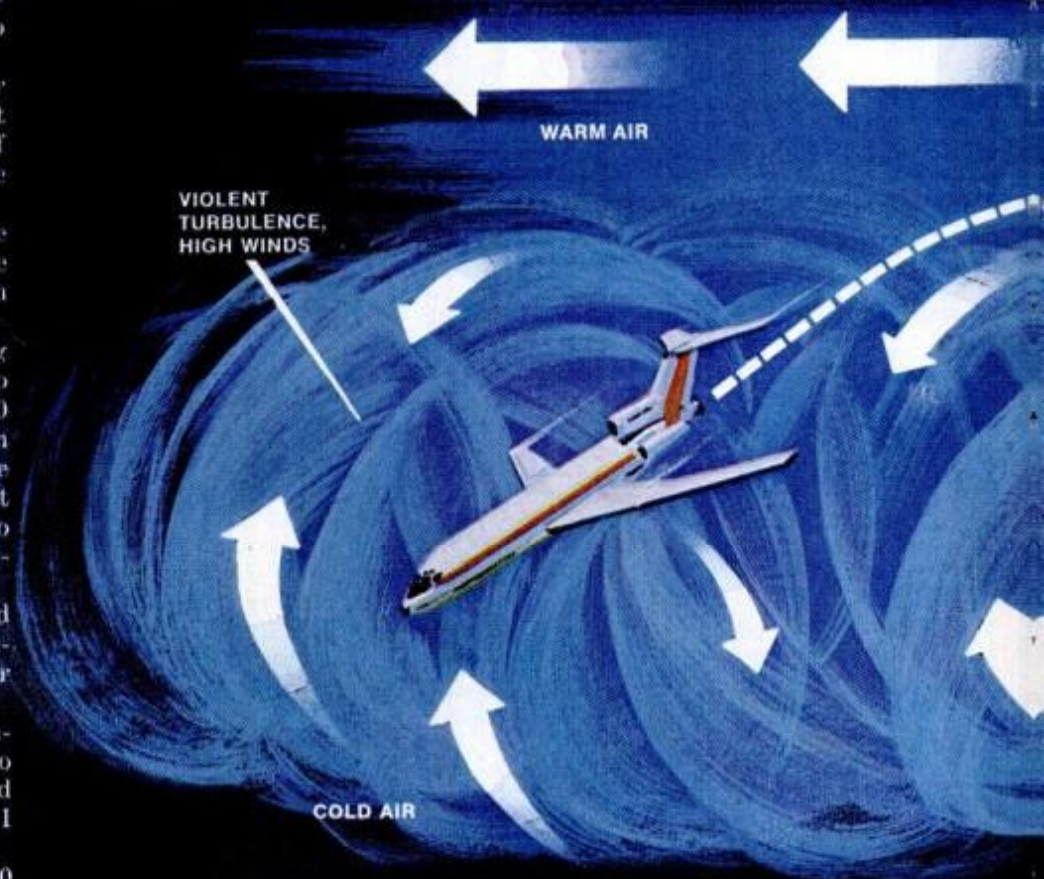

CONVECTION TURBULENCE

Sudden changes in air currents can be caused by temperature differentials of land features, such as cool bodies of water, rising heat from cities. As pilot approaches runway, unexpected downdraft can result in undershooting, updraft in overshooting.

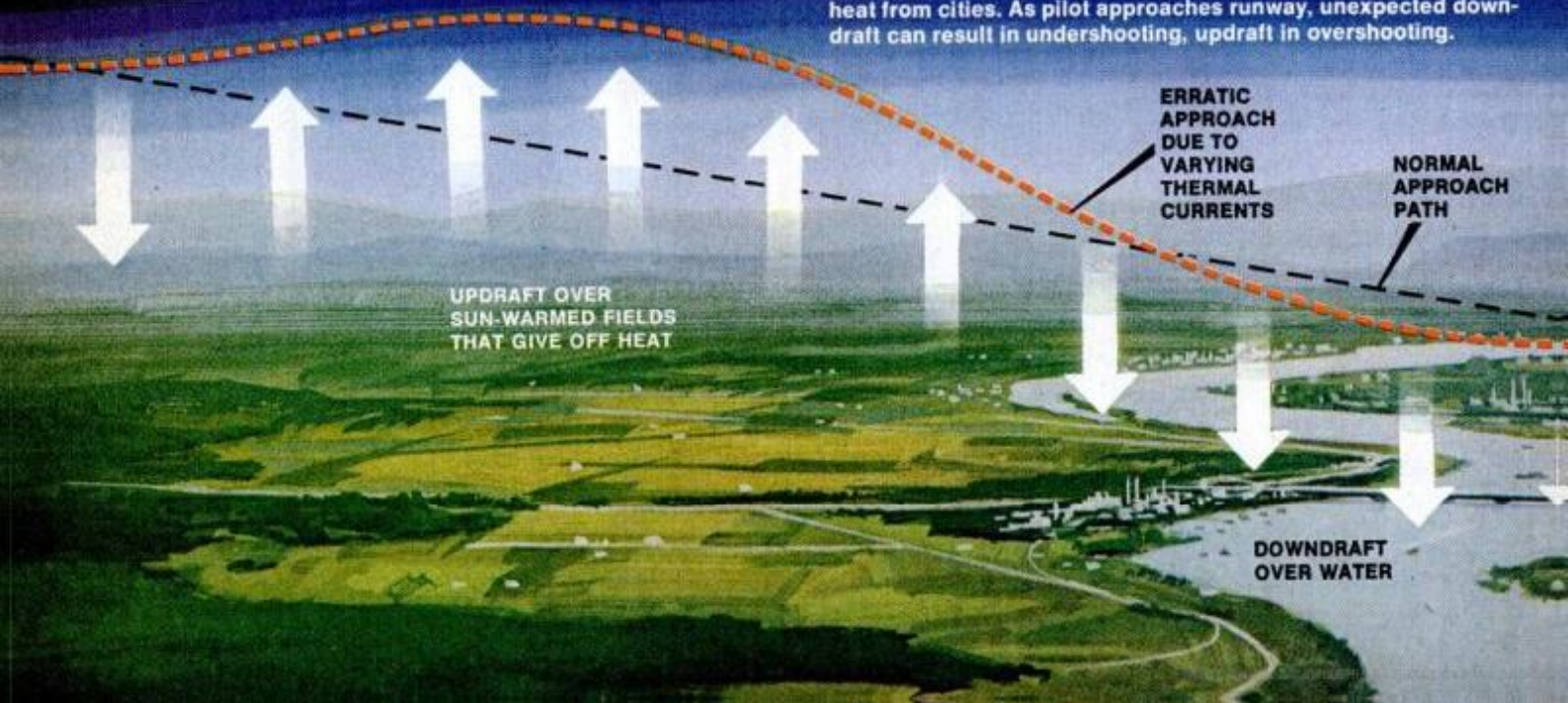

air turbulence

VORTEX TURBULENCE

Planes create turbulence themselves, especially today's giant jumbo jets. Spiraling wake, much like waves from a boat, sets up powerful counter-rotating air currents trailing hundreds of feet behind. A smaller, lighter plane following too close can be caught in this swirling "vortex" and violently buffeted, even flipped upside down.

TURBULENT WAKE FROM JUMBO JET

SMALL PLANE CAUGHT IN VORTEX EFFECT CAN BE FLIPPED UPSIDE DOWN

MOUNTAIN DOWNDRAFT

Cold air spilling down over the lee side of a mountain range can create a severe downdraft and loss of lift. A pilot attempting to clear the peaks or land on the ground below may lose sufficient altitude and airspeed to go out of control and crash.

COLD DESCENDING AIR CREATES STRONG DOWNDRAFT

UPDRAFT OVER CITY

AIRPORT RUNWAY

Art: Ed Valigursky



In Denver crash of Continental 727 last August, jet was pushed into ground on takeoff by strong downdraft thought to be the effect of wind shear. Fuselage broke into three sections, causing some injuries but fortunately no fatalities.

his giant jet up and headed for Newark Airport, 30 miles away.

Several passengers on Nickerson's flight complained about "poor service" resulting from the diversion. They were lucky. Those on Flight 66 never got a chance to complain.

Maybe they would have if warnings by Capt. Jack Bliss had been heeded. Bliss landed his Flying Tiger DC-8 cargo jet about eight minutes before Flight 66 started its approach.

Sounds warning

He admits to a seat-of-the-pants landing, diving his aircraft at a 20° bank so one main gear hit the runway first, then the other.

"If I had flown by the book, I would have been in real trouble," Bliss claims. "If I had slowed to 'bug' speed, I would have been in serious trouble."

Bringing his aircraft safely to taxi speed, Bliss warned the tower of a "tremendous wind shear."

Secrets a flight recorder can tell

Inside every commercial airliner are two small but vital "black boxes." These are the flight recorders that help investigators determine the cause of an accident and what to do to keep it from happening again. One type is called the flight data recorder.

Newest versions, like the Lockheed model shown partly disassembled above, can record on magnetic tape up to 64 separate functions continuously throughout an entire flight right up to the final second of impact. Some of these functions include altitude, speed, acceleration, engine operation, flight control movements, heading, time and temperature—important clues to what might have gone wrong. The second type is a voice recorder that tapes cockpit conversations for later playback and analysis of crew reactions during an emergency. Tremendously rugged, flight recorders can withstand an impact force of 1000 Gs and temperatures of 2000° F.—conditions seldom encountered in even the severest crashes. Where are these little boxes located? In the tail, because that's the part of a plane least likely to be damaged in a crash. The secrets they reveal can save many lives on safer future flights.

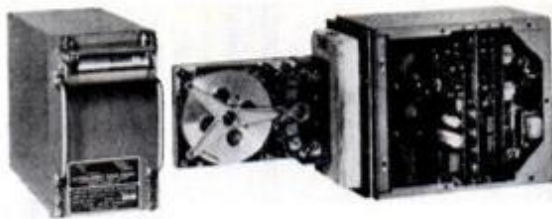

As it descended toward runway 22L, Eastern Airlines' Flight 66 dropped to "bug" speed—for a Boeing 727 about 130 knots.

"Bug" speed is the setting on the airspeed indicator signifying to a pilot the minimum speed he is to maintain on his landing approach.

Flight 66, from New Orleans, carried 116 passengers and a crew of eight. The time was 4:06 p.m. The blackness, broken only by bolts of lightning flashing from cumulonimbus clouds reaching 40,000 feet into the air, necessitated an instrument landing approach.

As the plane got closer to touchdown, Flight Attendant Mary E. Mooney was belted in her seat when

suddenly, she recalls, "The plane rolled to the left and full thrust power was applied. We lifted up, then we leveled out and hit."

Flight 66 had struck three towers supporting approach lights 2300 feet from the outer marker. The plane rose as Capt. Jack Kleven apparently applied full power in a vain attempt to save his aircraft. The jet cleared three other towers, plunged into four more and then to the ground. The burning wreckage was strewn over five acres of Long Island marshland.

Questions but few answers

Many questions have been raised. Who, if anyone, was to blame? Who

(Please turn to page 111)

What they're doing about turbulence to make flying safer

Barrel-like devices, shown below installed at New York's Kennedy Airport, were originally designed to detect and measure vortex turbulence, are now being modified to monitor wind shear effects as well. Tilted at various angles, they contain highly sensitive microphones that pick up acoustic impulses produced by turbulent air. Type and intensity of impulses indicate height and severity of turbulence. This information is then fed to a computer, giving an instantaneous readout that can be radioed to an incoming pilot to warn him to expect turbulence at a particular point in his landing approach or to advise him to abort landing attempt entirely. Dramatic evidence of vortex turbulence is shown in photos at right of NASA test. At top, smoke generator in tower spews stream across runway as plane lands below it. Seconds later, smoke is swirled into violent eddies (lower photo), indicating strong turbulence produced by plane's wake. Results of such research have led to possibility of installing deflector plates on wingtips to help break up turbulence before it gets dangerous.



IT'S NEW NOW



It's an oddball, but it goes

This rolling ball is one of 51 winners out of a surprising 4935 entries in Honda's annual employee design contest in Japan. Workers have use of company facilities, are encouraged to come up with new ideas—however far out—that might lead to practical improvements in vehicular engineering. The motor-driven ball, operating on the principle that a sphere can roll in any direction, can be steered forward, backward or sideways merely by turning wheel at the top.



Handy carryall for drill and accessories

This take-anywhere toter keeps your electric drill and accessories neatly organized and ready to carry to the job. Plastic tray holds $\frac{1}{4}$ or $\frac{3}{8}$ -inch drills, has 25-hole rack for bits from $\frac{1}{16}$ to $\frac{1}{2}$ inch. Other compartments take tools and attachments, while two drawers store screws and small parts. Drill-Mate is \$7.25 postpaid from Popular Mechanics Master Workshop Organizers, Box 1014, Radio City, N.Y. 10019.



Wall-hung work center

Virtually any size and shape of work center can be put together from these modular wall-mount bench and storage units. Three sizes include a 24-inch width for \$34.95, 48-inch width for \$59.95 and 24 by 24-inch corner section for \$17.95. Units feature perforated toolboards, overhead cabinets, undercounter drawers. Electrical knockouts in wall supports permit installing power outlets. Wall-mount design provides clear floor space for free movement, easy cleanup. Where wall mounting isn't desired, alternate base units are available. Also available is 20 by 30-inch mobile work center (left) with locking casters. Hirsh Co., 8051 Central Park Ave., Skokie, Ill. 60076.

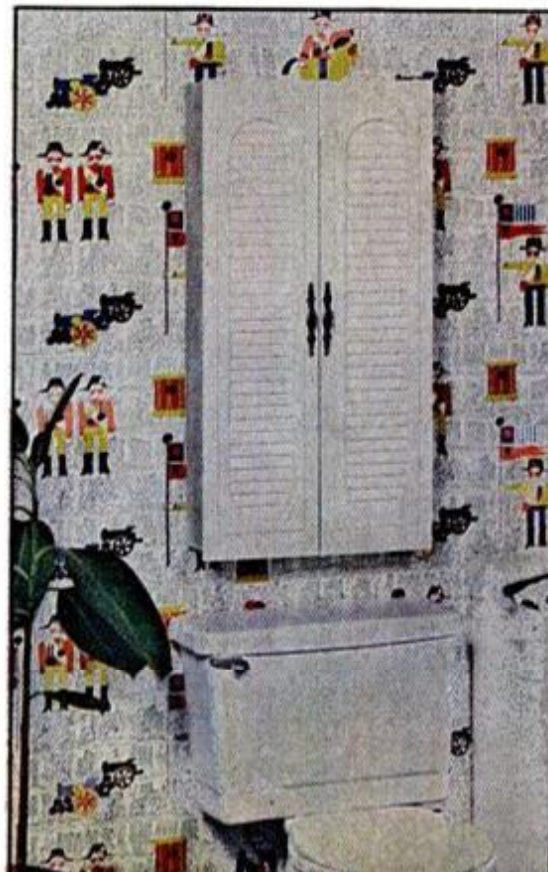
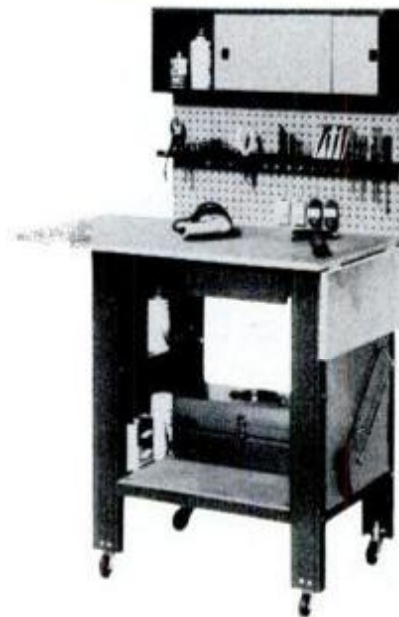

Bath cabinet for narrow wall space

Waste space in a bathroom can be put to use with this tall, slim wall cabinet designed especially for mounting above a toilet. The storage unit measures 36 inches high, 18 inches wide and $5\frac{1}{4}$ inches deep. Four shelves provide $2\frac{1}{2}$ square feet of space for concealing towels, toiletries and other bath items. The Wall-Ette comes in three styles: colonial (shown here), Mediterranean and French Provincial. Price is \$64. Matching vanities in choice of sink colors are also available in the same three styles. Universal-Run-dle Co., 217 North Mill St., New Castle, Pa. 16103.

**For big jobs
in deep water—
call a
small sub**

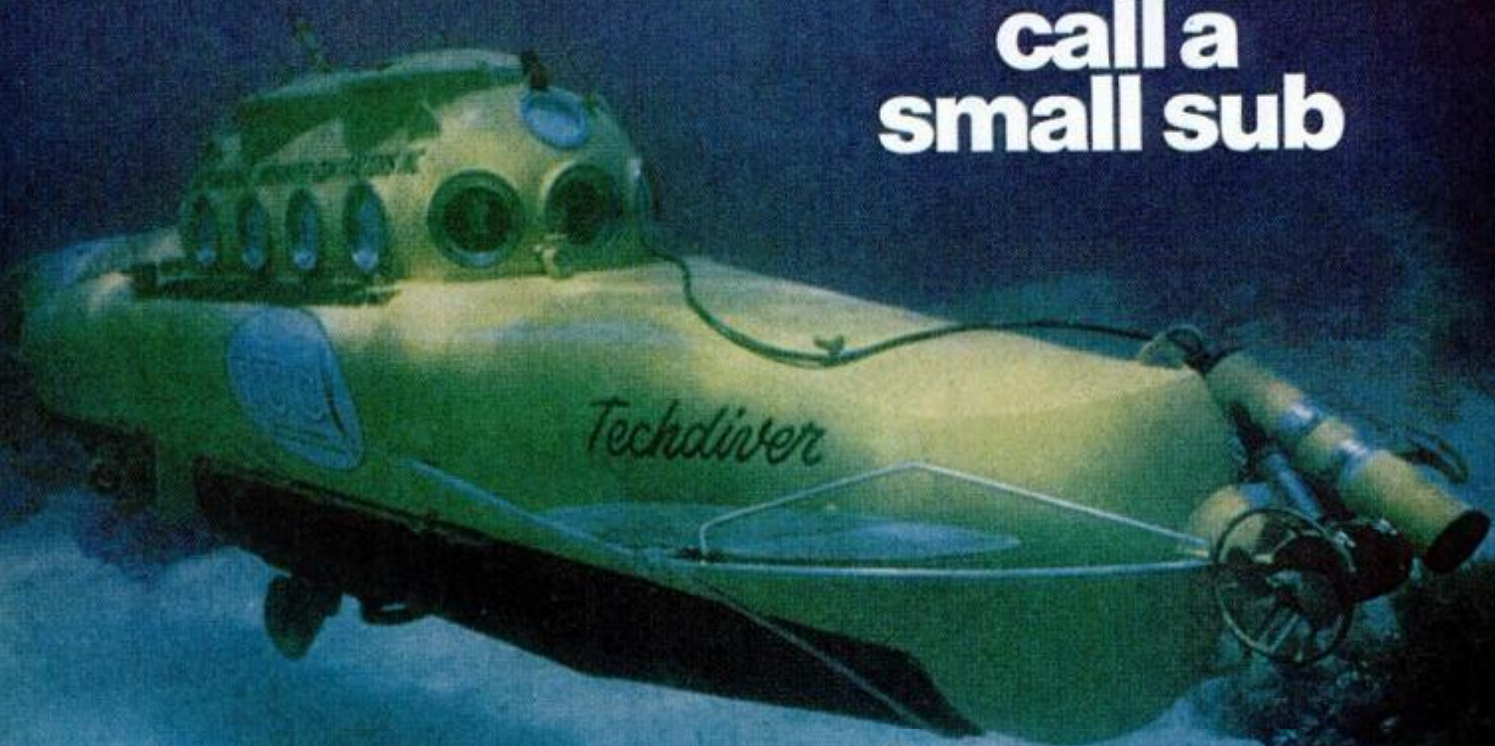

The sleek *Techdiver* (top photo) is a 22-foot, two-man sub operated by International Underwater Contractors. Equipped with a closed-circuit TV system, the sub has been used to inspect pipelines in many parts of the world. It joined in the search for the H-bomb lost off the coast of Spain in 1966. *Beaver Mark IV* (above and right) has a working depth of 2700 feet, carries a crew of two plus three passengers or divers and has a 2½-knot cruising speed.

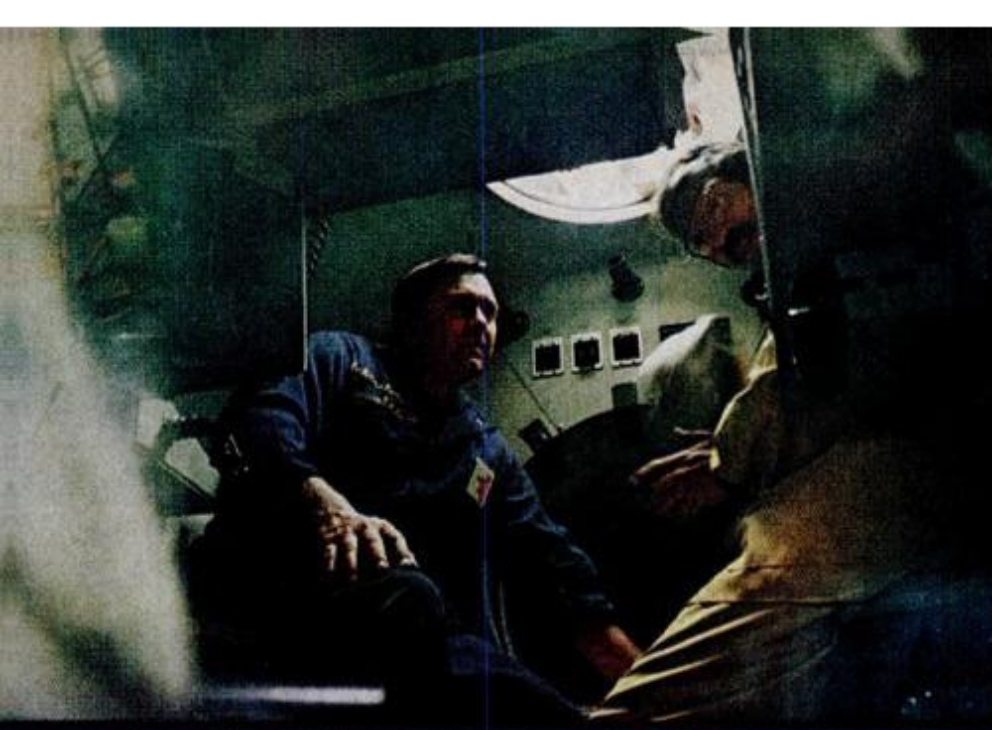

For maximum strength, *Beaver's* crew and passenger compartments are spheres. Interior of crew sphere is shown above. VOL L1 (below) permits crew to inspect pipelines through acrylic window. Divers can leave sub through lock-out hatch to make needed repairs. Divers (right, bottom) work on pipelines. The sub shown at the right, *Pisces III*, is launched and retrieved from "A" frame.

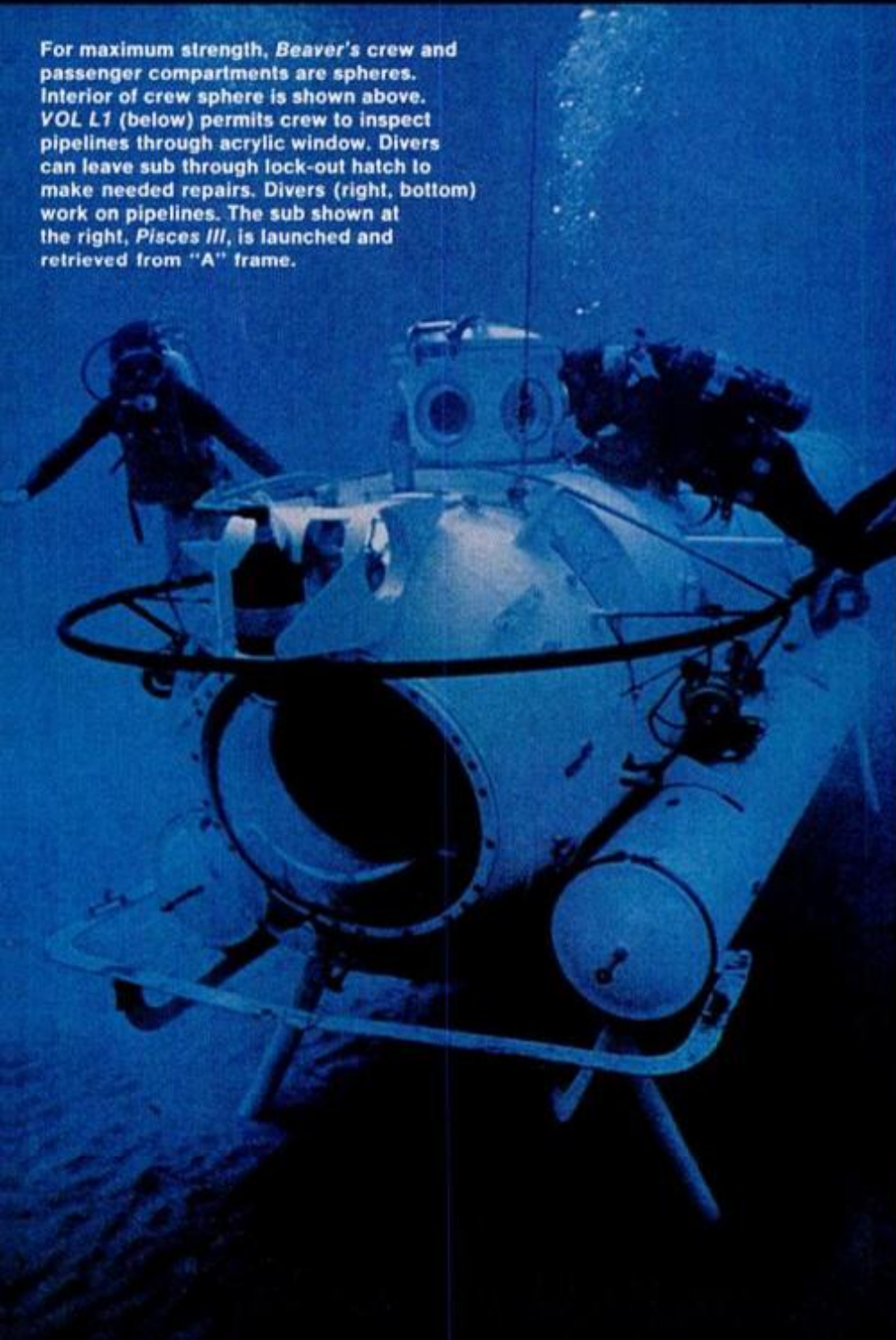

by Dan Hall

Tiny *Pisces III*—a 20-foot-long vessel with barely enough room for a crew of two—is part of a growing fleet of submersibles that have invaded parts of the Atlantic and the North Sea. Unlike most other undersea craft that have appeared in these waters, notably the silent marauders of the German navy during World War II, these pocket-sized subs work for a living.

On Aug. 29, 1973, *Pisces III*, operated by Vickers Oceanics of England, was engaged in burying a section of newly laid transatlantic telephone cable. The site was some 150 miles southwest of Cork, Ireland, and *Pisces III* was working at a depth of about half a mile. A nozzle held in the sub's manipulator arms ejected a powerful jet of water that cut a trench in the seabed. As the trench was formed, the cable sank into it. In time, current action would cover the cable with seabed material.

It was a routine job. After eight hours, the two pilots aboard *Pisces III* brought the craft to the surface, where a diver connected a towline to it from the support ship, the *Vickers Voyager*. Soon after the *Voyager* began winching in the sub, *(Please turn to page 124)*



Improvements in this year's snowmobiles are the result of growing pains—developmental aches probably felt more severely in the snowmobile business than in any other industry. People have loved—or hated—them so much that builders have entered crash programs to make them better.

The results are impressive. Models are quieter and well below the 78-dB sound level required for '76, easier to ride—even faster if you buy the biggest engines. New trends include liquid-cooled engines claimed to make less noise, hold more uniform temperature and provide better performance with lower fuel consumption. Suspension is divided between slide-rail for flatter trails and race tracks or bogie wheels when the going gets uneven.

Manufacturers are down to less than a dozen that seem to want to stay—not long ago there were over 100. New well-groomed trails help drivers head away from private property, and new insulated clothes make long runs less cold, more fun. The new snowmobiles are probably safer than many drivers who run them.

Racing helped start the sport, and now a number of builders are making models for competition. John Deere's new 340/S (right) is one example. Other new performers include Merc Trail-Twister (below); Ski-Doo Elan, Olympique and T-N-T (lower right), Massey-Ferguson entries (bottom).

Cool action

More horsepower, less overheating, higher styling are new snowmobile features.

by Bill McKeown

OUTDOORS EDITOR

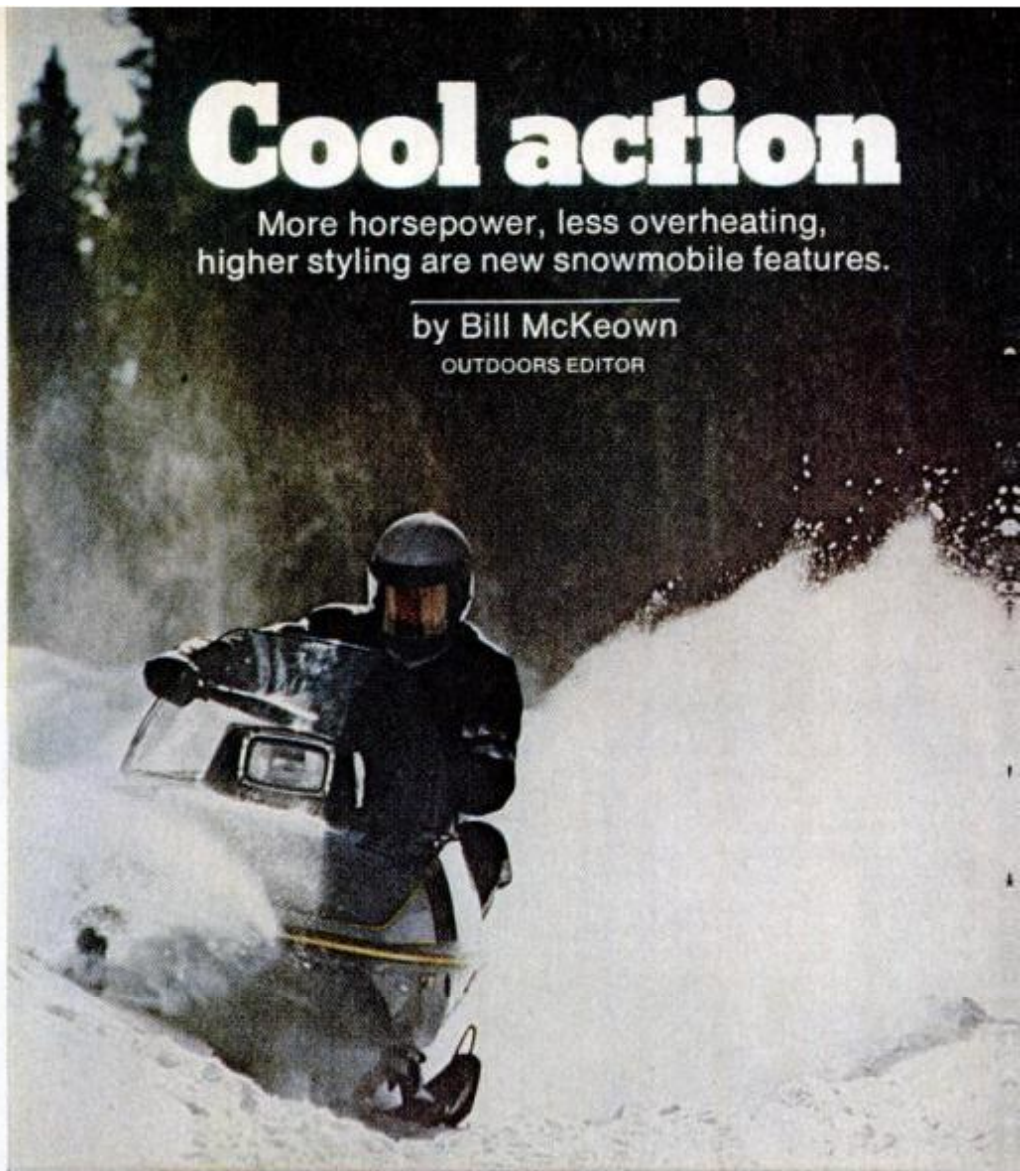

HOT PERFORMERS



Future look is forecast by prototypes like Brooks Stevens design for Evinrude (above). Enclosed cockpit and rear stabilizer are features. Manta (below) also has twin tracks, and adds rear engine, roll bar, plus wide stance for front steering skis. Single-seaters appear to be trend for competition models. Windshields are minimal.

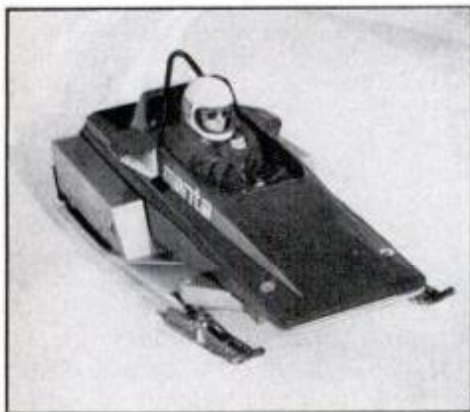

Race classes are being organized so that lower-power machines also have suitable classes, like Polaris (above), while professional drivers and factory teams can compete with free-air high-performance machines like Scorpion's special Odd Job (below). Several makers are fielding factory teams for the first time in '75-'76.



Warm gear

Try light clothing layers for air-space insulation that keeps out the cold.

by Jack Galub

Want to keep comfortable outdoors this winter as the mercury starts falling, or any other time when a chill wind blows? Then line your body with layers of warm air.

That's the message coming out of the Natick Development Center in Massachusetts. Natick is headquarters for the Army Clothing, Equipment and Materials Engineering Laboratory, the units responsible for the development of Arctic weather clothing used by GIs.

Although the center's work is combat-oriented, there is considerable similarity between the conditions faced by field soldier and civilian outdoorsman.

"All you do is hurry up and wait," is the centuries-old gripe of the chilled infantryman trying to keep warm. Similarly, you may find yourself sitting in the cold for hours watching for deer or waiting for fish below the ice. Or you may be frozen by wind blast while snowmobiling, or sitting in the stands during a football game. Research in the physiology of the body and impact of cold on it at Natick has reinforced some of the folk knowledge accumulated by Eskimos over the ages, and added some new hard medical facts to build on as well.

Where your heat goes

Body warmth is generated in the torso as a product of metabolic action and is carried by the bloodstream to the arms, legs and head. When heat loss begins to build up at these points, the blood vessels constrict, cutting down the flow of blood to protect the torso. The next thing you know, your feet and fingers become uncomfortably cold, your nose turns blue, your ears start hurting. Shivering sets in as an instinctive reaction that steps up your heart's pumping action and the flow of blood. Goose bumps dot your body surface and your body hair starts standing up, trying to build up pockets of warmer air. This is a waste of energy since we swapped our body fur for clothing eons ago.

What to do

Natick's field and laboratory experiments with various types of cold

weather clothing have resulted in the formulation of three basic principles followed by the Army when outfitting troops for winter combat. They are water-repellent shell, layer insulation and ventilation, says Ted Bailey, chief of the Natick Clothing and Equipment Div.

■ **An outer shell**, tightly-woven and water-repellent, protects layered insulation from rain and wind.

■ **Insulation** reduces heat loss; by adjusting the amount of insulation worn you can regulate heat retained against the body or allowed to escape to adjust to temperature changes. Layering is the most efficient form of insulation. Several layers of medium-weight, loosely fitting clothing are more effective than one heavy garment as thick or thicker than the combined layers.

■ **Ventilation** helps keep body temperature level, lets perspiration evaporate. Trapped perspiration fills your



Air warming mask from 3M, formerly white, now comes in tan so wearer no longer can be mistaken for a white-tailed deer.

clothing with moisture, reducing its insulation effectiveness. The easiest way to cool an overheated area is to open cuffs or collars, or take off a layer of clothing.

What to wear

If you are going to be exposed to the severe weather of mountain altitudes or northern snow-belt states for any extended period, your first layer of clothing should be cotton underwear worn under long johns. Quilted dacron is excellent for deep north country, double-layered cottons for more temperate areas. Wool-



Head warmth, essential for chill protection, is easier with convertible pull-down cap like Scottish balaclava, under \$5 in various colors by Recreational Equipment.

blend shirt and pants, and over them a water-repellent hunting jacket or parka with a removable insulating layer will protect your body and arms. Down or fiber-filled parkas and pants are particularly useful for maximum warmth and lightness. Note that most ski clothing is designed for active sport and may not offer the insulation needed for other activities.

WIND CHILL INDEX

TEMPERATURE	WIND SPEED M.P.H.		
	10	20	30
40	28	18	13
30	16	4	-2
20	4	-10	-18
10	-9	-25	-33
0	-21	-39	-48
-10	-33	-53	-63
-20	-46	-67	-79
-30	-58	-82	-94
-40	-70	-96	-109

DEGREES IN FAHRENHEIT

It's colder than thermometer shows when air or outdoorsman is moving. Wind-chill factor brings rapid frostbite to unprotected skin that's exposed to cold plus breezes.

The Army uses one pair of padded wool-blend socks, instead of the two tighter-fitting pairs advocated by some outfitters. These are worn under vapor-barrier insulated boots for Arctic conditions. The Army did not solve the problem of foot frostbite during the Korean war until it developed the vapor-barrier boot, Ted Bailey says. Until the old leather combat boots were replaced, troop

commanders expected half of their fighting strength to be lost through frostbite instead of enemy action.

Keeping hands warm remains a continuing research headache, the Army has found. Mittens are better than conventional fingered gloves. But in the search for lighter, warmer hand covering, the Army now is working on the use of heat-reflective materials or electric heat in mittens.

Face and head coverings

For face protection, the cold-weather face masks used on the Alaska pipeline project along with the synthetic fur-lined hoods do a good job. But if you plan only to sit and ice-fish, ride a snowmobile or watch a football game, an air-warming mask may be all you need. Especially if you have respiratory problems, the mask protects nose, cheekbones and mouth, and its use raises the temperature of inhaled air to an average of 60°F. and 95 percent humidity when the temperature outside the mask is -20° and the humidity 10 percent. It can make breathing comfortable instead of sometimes agonizingly painful.

Proper head covering during cold weather is a must, especially the kind that can be pulled down over the ears. A state-trooper-type hat, knitted ski hat or Navy watch hat will do the job under many conditions.

One hazard of cold, dry weather is wind chill, something TV weathermen like to talk about. Strong winds make low temperatures seem even colder, increasing the need for body insulation. When it's a comfortably cold 10° outside, even a moderate 10 mph breeze, for instance, drops the effective temperature down to -9° so far as the body is concerned. Increase that wind to 20 mph and the wind chill equals a bitter -25°. With the wind-chill index chart shown you can easily calculate what the effective cold can be when you are skiing or snowmobiling rapidly, or a strong wind is blowing.

The most effective protection against wind, other than a wall or armor plate, is the tightly woven outer shell of a well-made jacket or

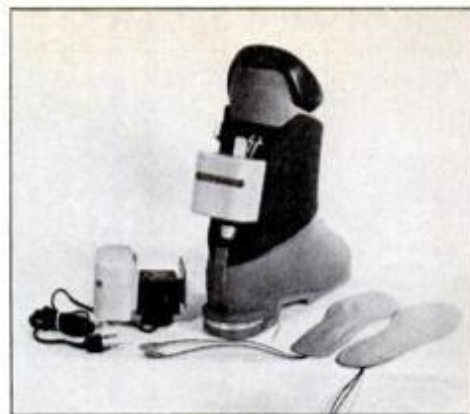

Electrically warmed insoles for shoes and boots plus gloves with space-suit features are being developed by Comfort Products, Aspen, Colo., to use rechargeable packs.

parka. Usually these shells are also water repellent. If yours has drawstrings or bottom buttons, use them to keep the wind from seeping through or blowing up inside.

Dressing for cold weather

How can you tell if you are dressed correctly for a cold-weather outing—before you start sweating? A basic rule of thumb calls for feeling cool when you get out in the open. Then, when you start moving, your body heat will warm the air pockets trapped inside your insulating layers of clothing.

The Army recommends, however, that you put on your full complement of clothing insulation layers at the start. Then when you get warmed up, you can peel off some of the layers before you work up a sweat.

Fortunately, the same kinds of clothing used by the Army can be bought locally at sporting goods stores or from mail-order outfitters.

Recently, cold-weather camping and extended high-altitude hikes and mountain climbing have become a challenge, and for these activities special study is necessary. Extended exposure to cold lowers the body core temperature, and as this occurs, judgment can be impaired and additional danger incurred. Hypothalnia is the technical term for this gradual cooling off, and the hiker needs to learn the symptoms so that he can watch his companions and himself and prevent the onset of this lethal chill. With care, however, and proper equipment, the cold weather need no longer stop the sportsman. Eskimos had the answer. ★ ★ ★



GumShoe, latest adaptation of famous Maine hunting boot by L.L. Bean, has waterproof bottom, laced low leather top.

IT'S NEW **NOW**

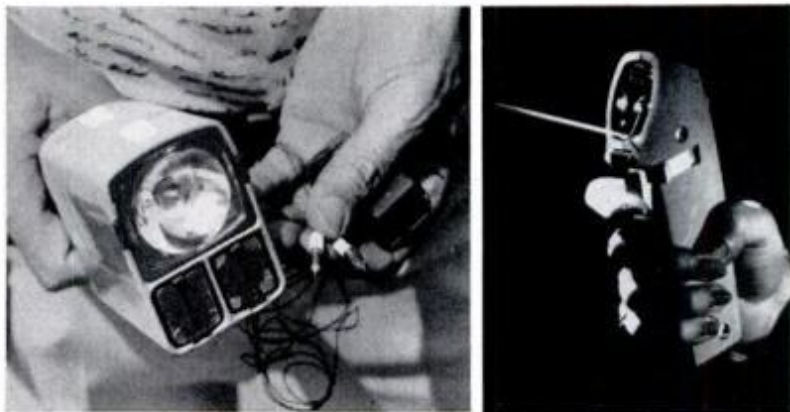

Bang—you're zapped

They look like harmless flashlights, but they can give an assailant a stunning surprise. Both offer nonlethal protection from muggers and other criminals. Taser device (left) fires tiny electrically charged "harpoons" that stun an attacker with 50,000 volts. Guardian (right) shoots a stream of chemical repellent. Both incorporate flashlight beams to aid aiming at night, work up to 15 feet. Taser is \$200 at department and specialty stores. Guardian is \$8.95 ppd. from Stanley's, Box 14030, West Omaha Station, Omaha, Neb. 68114. (Such devices may be illegal in some areas; check with local authorities before use.)

Wedge-shape stereo has eye, ear appeal

The wedge-shaped cabinet of Zenith's new Allegro Series III makes its controls easy to see and use from many angles. And it makes room for more controls: In addition to its FM-stereo and AM (with tuning meter), 8-track stereo tape cartridge recorder and phonograph, it has a high filter, FM muting and AFC switches, and a matrix for simulated four-channel sound, plus sliding bass, treble, loudness and balance controls. From Zenith, Chicago, Ill.



Computer catches forgeries

Nobody can sign your name as you do—not even the best forger. Time and pressure variations form a pattern as unique as your fingerprints. Using this principle, a British firm has developed an electronic system for verifying signatures at banks. You sign on a pad that records your "print" and stores it in a computer for future comparison when you sign again. Verisign NPL, Teddington, England.



Battery pack for Kodak sound cameras

The batteries powering this camera won't go dead till it has shot between 40 and 60 50-foot film rolls. Super-batteries? No—just a big pack of ordinary nickel-cadmium cells clipped to the photographer's belt. The pack is designed to power Kodak's Supermatic 200 (shown) and Ektasound sound movie cameras, can be recharged at least 500 times, and costs \$50 including charger.

Sound slides into this projector, too

That's no slide being inserted into the side of this slide projector. It's a continuous-loop sound cartridge for a sound-synchronizer small enough to fit in a standard Kodak projector. IAV Standard sells the sound system and projector together—\$300 for the Sound-Slide Six playback-only version, and \$330 for Sound-Slide Seven that lets you record your own narration and effects together with the slide-synchronizing pulses. The maker is at 3070 Lake Terrace, Glenview, Ill. 60025.

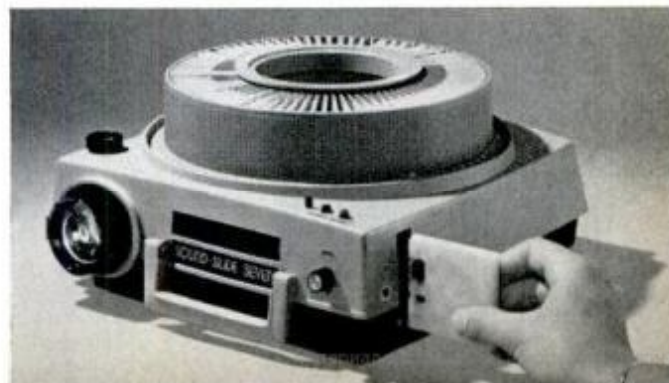

Here come the diesels

Special five-page diesel section

- **The new ones:** Now you can get a diesel-powered International Scout, and it looks as if GM and VW may soon offer diesels.
- **One man** who couldn't wait converted his pickup to diesel.
- **Owners** tell what it's like to live with the Mercedes 240 diesel sedan.

by Michael Lamm WEST COAST EDITOR

Forty years a stepchild, the diesel automobile finally appears to be coming of age. Mercedes, Peugeot, and International are currently marketing diesel cars in this country, and Volkswagen and General Motors stand on the verge.

There's a brisk demand for diesel automobiles. Mercedes and Peugeot can hardly keep them in stock. This demand was heightened by the gasoline crisis of December, 1973. Diesel fuel now is up to 25 percent cheaper than gasoline, so for people who put lots of miles on a car, fuel savings can make up for even the high initial cost of an expensive automobile like the Mercedes diesel (see Owners Report, page 62).

Whether diesel fuel will continue relatively inexpensive remains to be seen. If enough owners want it, demand and taxes could push up the price to that of gasoline. So for fuel economy, the attraction of diesel cars might be short-lived.

Diesel engines have certain inherent quirks, too, that make them hard to live with. Powerplants have to be

Volkswagen's Rabbit (left) has been fitted with a diesel and is being tested. International Scout (below) is now available with a diesel option.



VW Rabbit diesel engine is, like the gasoline engine, mounted transversely.

International Scout diesel engine is a six-cylinder in-line, displacing 198 cu. in.



HERE'S ONE DRIVER WHO DIESELED HIS OWN

heavier than their gasoline counterparts—thus more expensive—because compression ratios of 20:1 aren't uncommon so that reciprocating parts get more strain. To counter rough running, the diesel's flywheel has to be large and heavy also, as do the head and block. A 200-bhp gasoline engine weighs about 600 pounds, while a diesel of the same power rating weighs three times as much.

It's no secret that diesels are noisy and smelly, but still the average automotive diesel fulfills current U.S. smog requirements without such hang-ons as catalytic converters, pumps, electronic ignition, EGR, and the like. Still, diesels put out 3.8 times as much sulphur dioxide as gas engines and 7.8 times as many particulates (soot and lead). So if the government ever decides to restrict smell and soot, the diesel's pollution advantages might go up in smoke.

Another diesel handicap is relatively sluggish performance. Now, though, diesel cars like the Mercedes and Peugeot will keep up with normal American traffic. And while drivers have to compensate for slower acceleration, they soon learn to adjust and drive accordingly.

But none of the drawbacks of

(Please turn to page 126)

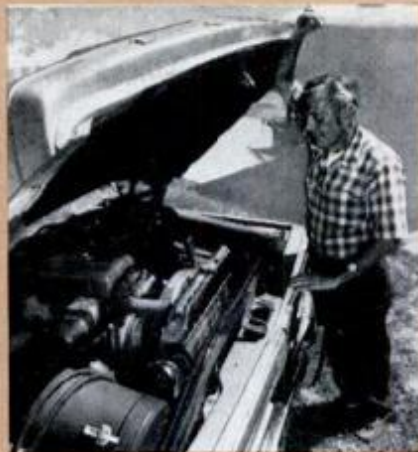

Marvin Haynie inspects the three-cylinder GMC diesel in his 1971 pickup.

This past summer, Marvin Haynie of Stockton, Calif., yanked the V8 from his 1971 Ford ¾-ton pickup and slipped in a three-cylinder GMC diesel.

Haynie is one of a growing number of engine swappers who are going for diesels to help beat the rising cost of gasoline. Several garages and shops around the country now specialize in diesel swaps. The average conversion can take up to 100 hours of work at normal shop rates, with the cost of the engine additional.

Owners of motorhomes and one-ton trucks are the more anxious customers for diesel swaps, but car and truck drivers are also among those switching to diesels.

Haynie, who's a shade-tree mechanic par excellence, has worked on diesels for 40-odd years. He did all his own conversion work in this instance, so he saved considerable money. Even so and despite the fact that he puts 45,000 miles a year on his pickup, it'll take him several years to recover costs.

\$3050 investment

His total investment, excluding labor, stands at about \$3050. This breaks down to \$1000 for the engine itself, which he bought used and immediately overhauled to the tune of \$600; \$300 for the turbocharger; \$150 for the Chrysler TorqueFlite automatic and \$1000 for incidentals.

The engine is a Series 3-53 GMC diesel (the "3" in the designation means three cylinders, the "53" denotes displacement per cylinder, for a total of 159 c.i.d.). It's a two-stroke unit that originally powered a railroad track-bed tamping car. In that form it was unturbocharged and rated at 78 bhp. Haynie concluded that 78 bhp wouldn't give his pickup enough oomph, especially since he wanted to keep its original power steering, power brakes and airconditioning. So he decided to hop the engine up a bit.

Tricky turbocharger

After the overhaul, he replaced the stock 40-mm fuel-injector nozzles with 55-mm and added the turbo. This last came via quite a bit of cut-and-try. It ended up being half from a Cessna 220

and half D-6 Caterpillar. Both halves are Airesearch, but the cold end came out of the Cessna and the hot end from the Cat.

Haynie machined his own engine-to-transmission adapter to mate the GMC diesel to the TorqueFlite. The reason he chose Chrysler's automatic is that it doesn't depend on vacuum to signal shift points. Ford's and GM's automatics do use vacuum. And while diesels produce vacuum via a vacuum pump, it's of a different order than that of gasoline engines and makes for rough shifting. The TorqueFlite uses governors and shifts smoothly with a diesel.

Accessories bolted on engine

Haynie figures, too, that since the diesel will outlast his Ford pickup, he wants to be able to transplant it in a newer vehicle in the future. Toward that goal, he's bolted all accessories directly to the engine—the turbo, all filters, plus the power units for air, steering and brakes. This way he can remove the entire powertrain as a unit and re-install it in a new pickup when necessary.

Meanwhile he was careful not to make any frame or sheet-metal changes to the '71 Ford pickup, and any time he wants to reinstall the original V8, he can.

Haynie's two biggest headaches in this conversion were routing the exhaust for a free gas flow, and discovering and compensating for the fact that Ford engineers had originally offset the V8 1½ inches to the right. Had he known that before he started, Haynie could have saved himself the trouble of remaking new engine mounts twice.

Driving impressions

The engine fires with a roar and settles down to a remarkably smooth, yet noisy, idle. Drop the selector into "Drive," and the pickup moves out with the sound of a big rig. There's a combination of diesel rap, turbo whine and throaty exhaust roar. It's louder than any normal passenger vehicle, but the sounds aren't annoying, and at 55 mph, wind noises cancel out the engine noise.

Acceleration feels more than ample. Chassis dynamometer checks show 100 to 105 bhp at the rear wheels—about the same as the 351-c.i.d. V8 used to deliver. At 60 mph, the turbo is putting out 6 to 8 p.s.i., so the diesel gives good passing acceleration.

The three-cylinder GMC engine weighs 230 pounds more than the Ford V8, so there's a little more front heaviness, but you'd never notice it in normal cornering. If you hot-dog it through turns, you feel a little more understeer than usual, but nothing drastic.

There's relatively little engine braking with a diesel, and that's something that takes getting used to. Another odd feature is that the engine doesn't die when you switch off the key. You have to hit a separate kill button.

All in all, it's a pleasure to drive this pickup, and even more so when you realize you're saving about \$3 on every tankful of fuel.—Michael Lamm





The 240D is Mercedes' least expensive model, just under \$10,000 for '76. Owners like clean lines, ample interior space. The 240D shares basic body with other 200 series sedans, so only way to tell it from 230, 300D and 280 models is by the "240D" on trunk lid.

A nationwide survey based on 4,449,779 owner-driven miles.

PM OWNERS REPORT: MERCEDES 240D DIESEL

The pleasure and pain of owning a diesel

by Michael Lamm WEST COAST EDITOR

Mercedes introduced its first diesel-powered passenger car in 1936—the 260D. This, in fact, became the first mass-produced diesel car in the world.

Owners of diesel automobiles have always been a breed apart. Surveys show they're generally more knowledgeable about cars. They drive longer-than-average distances (some of our correspondents put as many as 95,000 miles a year on their cars), so they're more interested in long engine life and fuel costs.

On the other hand, they're willing to put up with or ignore such diesel traits as low horsepower, noise, high initial cost and searches for diesel-fuel stations.

Most people don't regard Mercedes as an economy car. The 240D currently retails for \$9930 East Coast port of entry, and that's with four-speed transmission and minus transportation, taxes, license and any accessories. Equipped with automatic and air, a new 240D rolls out the showroom for over \$11,000.

An expensive car like the Mercedes can be economical if you drive it far enough. The diesel's low maintenance and depreciation help make it so over the years.

Yet in our survey, 72.2 percent of 240D owners put down **economy** as their primary reason for buying. And no fewer than 64.7 percent listed **economy** as the one thing they like most about their Mercedes diesels.

How do owners rationalize economy with so expensive a car?

"I used to own a large car that gave five miles per gallon when gas was short. This 240D gets 28 out on the highway," says a New York merchant.

A retired colonel in Florida sees it this way: "I'm 76 years old and don't expect to buy another car. This one is good for 15 years, is economical, well built and meets pollution requirements years ahead."

And a self-employed Texan: "Fuel economy and low depreciation are why I keep buying Mercedes. This is my third. I've driven each one five years and then sold it for about what I paid new."

An Illinois machinery salesman: "I bought



Photos by the author

To start cold engine, driver must wait for glow-plug to light—a minute or so in really cold weather. Some owners want the windshield wiper/washer controls changed.

my car for the long life of the diesel engine, no tune-ups, minimal maintenance, good mileage, inexpensive fuel and prestige."

Economy is, of course, a relative thing, but if the diesel owner drives his car long enough, he surely can realize a saving in fuel. Take this example. Compare the 240D with a full-sized American car, both driven 20,000 miles a year. Say the Mercedes averages 28 mpg on diesel fuel costing 45 cents a gallon. The U.S. car averages 14 mpg on gasoline costing 60 cents a gallon. The diesel owner, then, spends \$535.50 less annually for fuel. Over five years, that's \$2677.50.

Five-year-old Mercedes diesels still bring nearly \$4000 on the used-car market. Used full-sized American sedans, on the average, are worth perhaps \$1500 at age 5. So you can see that the combination of high resale value and good fuel economy can, indeed, turn the expensive Mercedes into an economy car.

A retail salesman from Bay Harbor, Fla., observes: "No matter what the price, America

One 240D owner said that like Hudsons and Studebaker enthusiasts, diesel owners are a breed apart.

Lack of a carburetor and ignition system eliminates conventional tune-ups.

Expensive parts, long waits for service, and steep periodic maintenance irk a number of Mercedes owners.

cannot produce a car that approaches the quality, safety, engineering, road stability and dependability of a Mercedes-Benz. The diesel is phenomenal at highway speeds, and I feel safer in my 240D at 90 mph than at 40 mph in any American car. And the Mercedes can run forever at 90!"

Such boundless enthusiasm seems to be typical. Comments a semiretired Arizonan: "I can't praise this car highly enough. It's my first Mercedes—wish I'd found out about it 20 years ago. My 240D rides like a stiff Cadillac, so I can drive 500 to 600 miles a day and not be tired (I'm 63 years old). The diesel is almost foolproof—I've seen some with 500,000 miles and still running fine."

And a Virginia communications manager: Excellent workmanship—absolutely zero flaws in the car when it was delivered. Nothing needed fixing. I'd ordered my car shipped directly from Germany, too. The arrangements were handled by the North American distributor, but my local dealer handles warranty items agreeably. I'm especially impressed with the durability of the diesel engine, low fuel costs, excellent handling and roadability, and low depreciation."

It can't all be roses, though, and it's only fair to consider owners' complaints as well. Here are representative samples:

"Poor passing capability, noisy when idling, smoky and a short disc-brake-pad life," says an Illinois business owner.

An Iowa sales engineer: "Sluggish performance in the mountains make this car nearly impossible to drive in those regions. I'd also like to see other sources of service besides the dealers."

"Brake pads don't last more than about 12,000 to 14,000 miles," says a Chicago commodity broker, and he's echoed by nearly 10 percent of our correspondents.

A Wisconsin furniture contractor: "Noise level is a bit high when talking back to front during highway cruising. I also consider the cost of parts too steep for both mechanical and body items."

We should point out that a full 25 percent of our owners said they had no complaints at all with their cars. That's an extremely high percentage in this day and age. But moving

Summary of Mercedes-Benz 240D Owners Reports* (Owners surveyed bought their 240Ds in January 1974)

Total miles driven 4,449,779	Workmanship 12.0	Good to excellent 98.0%	Loose fanbelts 14.3
Average miles per gallon	Specific dislikes:	Average to poor 2.0	Brakes 9.5
Manual transmission	Lack of power 22.2%	Rear seat	Transmission 8.3
Local driving 26.5	Poor or expensive service 12.5	Good to excellent 88.0%	Electrical 8.3
Long trips 30.0	Brake wear 9.7	Average to poor 12.0	
Automatic transmission	Rattles 6.9	Number of vehicles owned:	
Local driving 24.2		Mercedes only 23.1%	
Long trips 27.8		Two cars 57.1	
Transmissions	What changes would you like?	Three cars 14.7	
Automatic 57.1%	Increased power 19.0%	Four or more cars 5.1	
Manual 42.9	Better tires 7.0	Makes of other cars owned:	
Why did you choose the M-B diesel?	Better materials 5.6	Mercedes-Benz 22.5%	
Economy 72.2%	Is buying diesel fuel inconvenient?	Volkswagen 17.5	
Performance 17.2	Yes 10.4%	Chevrolet 14.2	
Quality 9.9	No 89.6	Ford 10.0	
Past experience 7.9	Dealer sales policy:	Buick 7.5	
Comfort 7.9	Good to excellent 75.1%	Had any mechanical trouble?	
Specific likes:	Average to poor 24.8	Yes 53.8%	
Economy 64.7%	Workmanship opinion:	No 46.2	
Handling 42.0	Good to excellent 97.4%	What type of trouble?	
Comfort 40.7	Average to poor 2.5	Airconditioner 19.0%	
Performance 18.7	Comfort opinion:		
	Front seat		

*Percentages might not equal 100% due to rounding or insufficient data.



Front buckets rate tops in comfort, and most praise rear seat as well. Some say vent wings would improve air circulation.

This four-cylinder diesel gives long, trouble-free life, say owners, and many plan to keep driving well past 300,000 miles.

along to something very different, let's hear comments about general comfort.

From a professional chauffeur in Tempe, Ariz.: "For six months I was employed as a chauffeur for a Phoenix businessman. He had occasion to ride in my 240D when his Cadillac limousine was being repaired. He's 6-2, with long legs, yet he commented several times how comfortable the car is. Even I like the back seat when others drive!"

"The back seat is more comfortable than the front," observes an Iowa sales consultant, and several other owners agree. Yet a Michigan cattleman counters: "We have a Cad Coupe de Ville. The Mercedes rides better, but the rear seat is a little tight for big passengers (it's fine for the grandchildren)."

And a North Carolina textile engineer: "This car is like an orthopedic mattress. It's hard, but after 500 miles behind the wheel, I can get out and walk away with ease."

In the area of dealer service, nearly two-thirds of the owners we surveyed gave it a mark of *good to excellent*. That's on a par with responses we received from owners of, for instance, the AMC Pacer, the Chrysler Cordoba and GM's Nova and Ventura.

Here are some comments about the Mercedes dealers' service departments:

"My dealer makes you make an appointment," says a self-employed Miamian, "and some parts aren't on hand. My dealer had to replace my engine mounts due to a drivetrain vibration. The vibration is still there, but the factory rep is going to re-examine the car next week."

A Louisiana chain-store owner: "My dealer was 20 miles distant until he lost the M-B franchise. Now there's only one mechanic left in this area, with the nearest dealer 55 miles away. Yet I rate service satisfactory."

A Tennessee sales engineer: "Service is generally good here. I do think, though, that they are too anxious to replace rather than adjust something."

An Oregon petroleum jobber: "A small Mickey Mouse cap on the back of the fuel injector disintegrated, allowing diesel fuel to run down into the clutch. Ever since, I haven't been able to start out smoothly. Even though the car was on warranty, the factory man refused to put a new clutch plate in. The dealer took the clutch apart and charged me \$38. The mechanic forgot to tighten the rear engine

mounts, so by the time I got home, I could hardly move the car. If any other manufacturer made a comparable diesel, I would buy it over the Mercedes merely because of M-B's attitude concerning the clutch."

A Virginia accountant says of Mercedes' service: "Expensive—but good."

Relatively few owners maintain their Mercedes themselves, but those who do complain that the oil filter is very hard to get at—and messy once it finally drops. Another persistent complaint—the one about the soft front disc-brake pads—irked a majority of maintain-it-yourselfers. A minister from Oregon wrote: "They put in these soft brake pads so they won't squeak, but they definitely wear too rapidly."

"More power," urges an Illinois administrator, "because at 5000 feet in the Rockies the car will hardly go." Fully 19 percent of our correspondents concur.

A Virginia attorney: "A larger fuel tank—20 to 25 gallons—would give the car a great range at no sacrifice of trunk space." The present tank holds 17.2 gallons plus a 2.4-gallon reserve.

A North Carolina Navy chaplain: "Reposition controls. Starter very inconvenient. Glow-plug light can't be seen."

A Michigan pharmacist: "I'd like to see a turbocharger offered, at least optionally, and especially in the higher altitudes."

A Minnesota diesel mechanic: "Put vent windows back in the front doors. Wind noise is excessive when front windows are rolled down any amount at all. I'd also suggest turbocharging the engine."

"Better tires," says a retired Oregon doctor, "because I had to replace my original set at 22,000 miles. The rears, especially, wear erratically under varying loads with the independent rear suspension."

And what do owners think of the 240D's general workmanship?

A retired nurse from Virginia muses: "We thought about this question for a long time and couldn't come up with a single complaint. It's a marvelous automobile. We're proud to own a Mercedes and thank the Germans for their impeccable design and engineering."

A Virginia dentist "Excellent quality—car is really tight."

A Florida elevator serviceman: "Excellent;

(Please turn to page 127)

Owners who change their own oil would prefer a spin-on filter, and those who take their cars in for service say that oil changes can sometimes take four hours.

Fuel-tank capacity on the 240D and 300D is greater for '76—up to 20.6 gallons.

One owner says, "I'd like quality steel-belted radials as original equipment instead of the lousy rayon radials." Several others echoed this sentiment.

It's hard to find good mechanics in smaller communities.

IT'S NEW NOW

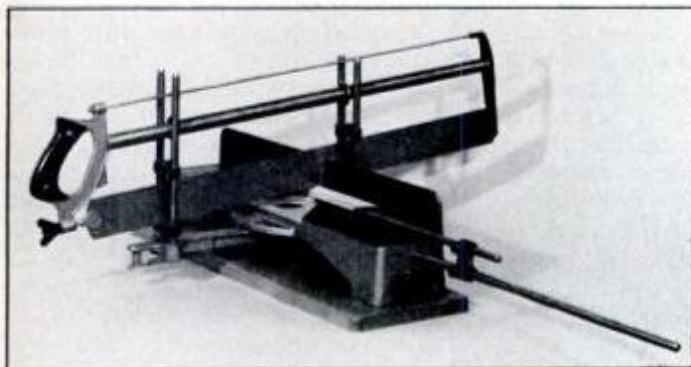

Miterbox with unique blade has great capacity

Depth of cut with this miterbox is not limited to saw-blade width. Instead, a hacksaw-like frame holds a thin, flexible blade under adjustable tension. The relatively narrow blade produces fine cuts and less friction when buried in a cut, and is fully supported by guides front and rear. These have rubber bumpers to eliminate shock at the end of a stroke and a device to hold the blade up so stock can slide under freely. Saw frame rides in practically frictionless Micarta bearings. Accurate locking is provided at 45°, 60° and 67½° right or left and 90°. Beechwood box has adjustable stop rods, comes in 17½ and 24½-in. lengths; \$103 and \$141 postpaid from Woodcraft Supply Corp., 313 Montvale Ave. Woburn, Mass. 01801.



Compact food and beverage center

You can keep just about anything in this smartly styled compact refrigerator from Frigidaire. It has space above for glassware, utensils or a cheese board. The unit provides 4.3 cu. ft. of refrigerated space, including a freezer compartment with ice tray, has a spreads compartment, condiment shelf, egg nests and three interior shelves. Its handy serving surface can even double as a desk. "The Male Box" is suggested for den, family room, patio, college dorm or office, and sells for about \$270.

Scraper goes where sandpaper can't

To get at tight spots on furniture or window frames for refinishing or repainting, Shape-Skrape has six quickly interchangeable blades to fit virtually any surface contour. Handle and long shank assure positive control; blades are hard-tool steel and reversible. Shape-Skrape sells for about \$3 retail or \$3.99 postpaid from Connecticut Valley Mfg. Co., 265 Newington Ave., New Britain, Conn. 06051.

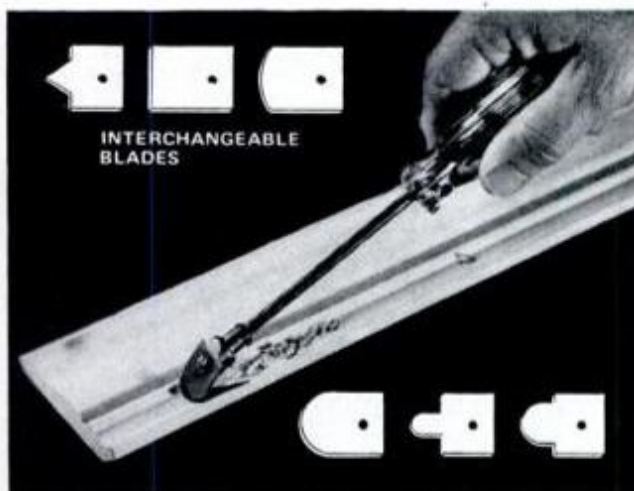

Graphite lubricating 'paint' for home, yard

Suitable for a variety of household lubrication tasks, Slip-Plate is a dry graphite paintlike coating that cuts friction without attracting dirt, is unaffected by temperature, impervious to corrosion and works equally well on wood, plastic or metal. Won't come off on hands or rub off in use; a 14-oz. aerosol can is about \$3 retail or \$3.99 postpaid from Superior Graphite Co., 20 North Wacker Dr., Chicago, Ill. 60606.



Thermostats update steam heat

For fuel economy and comfort, new individual thermostatic valves control steam radiators to maintain desired room temperature. The thermostats require no wiring, can be installed with their control dials separately mounted and can be used with hot-water and two-pipe steam systems as well as on radiators. In angle and straight-through styles for ½ or ¾-in. pipes, Honeywell, Inc., Minneapolis, Minn. 55408.

PM tests budget speakers:

If you've been going without lunches to save up for a stereo system, here's a bunch of speakers that may put you on a regular diet again. PM checked out nine models that offer respectable sound at price tags under \$80 and found that the best of them are very good indeed. As a group, these speakers give the pleasures of good audio for the lowest prices.

As the actual voice of your sound system, speakers—more than any other component—determine what

you hear. And if you are short on cash, the choice is all the more important for speakers are often the biggest item in your audio budget. With this in mind, we've tried to pinpoint the best buys among current low-cost speakers.

All speakers in this group are two-way systems, with woofers for the lower frequencies and separate tweeters for the highs. All are compact, some

hardly bigger than a shoebox. Smallness is one reason for their low price; it takes less material to make them. Also, the woofers in these units range in diameter only from 6 to 8 inches—about 4 to 6 inches smaller than in full-size speakers; that, too, is an economy. As for the tweeters, most of them are cone-shaped rather than dome-shaped, which reduces cost, though it also reduces the angle of treble dispersion slightly.

We found considerable difference between the various models tested. But on the whole, most of them produced pleasing and musically acceptable sound. Only one was clearly below par. And two were clear stand-outs in terms of naturalness and clarity of sound and outperformed some of the larger systems selling at twice the price.

Granted, the lowest reaches of the orchestra, the thump of the bass fiddle and the deep pedal notes of the organ, don't come through with the same solid thrust as in larger systems. Nor does the limited power-handling capacity of these speakers let you shake the walls with hard rock or Wagnerian thunder. But the best of the group had a very natural tonal balance, an adequate bass, sweet highs and enough treble dis-



Hegeman H-80, \$72

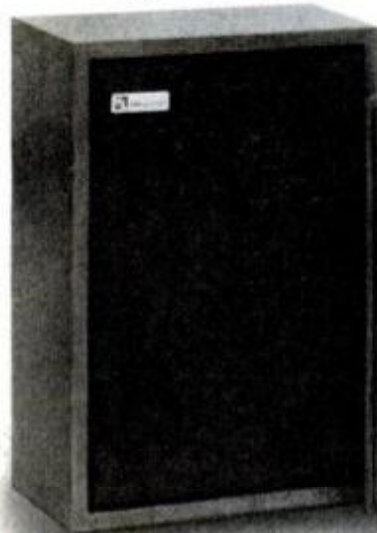

Advent 2, \$74



Acoustic Research AR-7, \$75

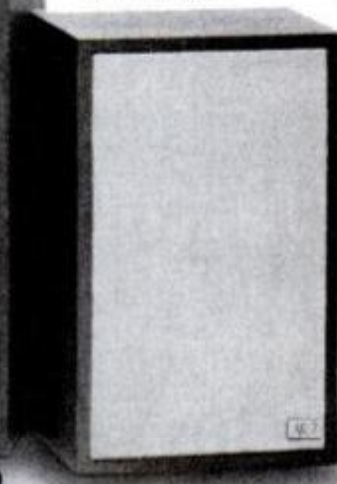

Dynaco A-10, \$60



Avid 60, \$60



Some give rich sound

by Hans Fantel

persion to give the sound a spacious and open feeling.

Test methods

The performance of a speaker can't be accurately pinned down by purely technical measurements. Frequency response and other specifications—even when correctly measured and honestly reported—don't really tell what a speaker sounds like. So the judgment is necessarily personal. But to gain a measure of objectivity, I didn't rely on my ears alone but asked two other experienced and knowledgeable audio fans to rate the speakers independently. As it turned out, all three of us noticed the same variations in tonal color.

In our test setup, all speakers were hooked to a switching device permitting instant A-B comparison of any two pairs of speakers. We drove the speakers with a high-quality Yamaha amplifier rated at a moderate power output of 15 watts per channel. We deliberately picked such a low-powered amplifier because budget speakers are most often used in low-cost installations where available power is limited.

We set up all of the speakers in a room larger than the typical living room to toughen the test conditions. In our case, the room measured 18 by 25 feet. If a speaker could fill a room this size with ample sound, we figured that it would have no trouble in most homes. Nearly all speakers in the group put out more than adequate sound levels under these

conditions—even in heavy orchestration—without budging into distortion.

Equalizing loudness

In comparing speakers, all speakers under test must be heard at exactly the same loudness. Otherwise, a slightly louder speaker will always sound better rather than louder, regardless of its true merit. We therefore equalized the loudness of all speakers through a special set of controls on the switching comparator. To obtain the most accurate possible loudness match, we made these adjustments with a "white noise" test signal, which contains all audible frequencies in a random mix. ("White noise" is the kind of sound you hear on FM sets between stations.) On speakers having a separate tweeter level control, we set these controls in the position providing "flat" response—neither stressing nor softening the highs.

We checked out all speakers with different types of music: a heavily orchestrated symphony, a concerto for guitar and orchestra with a very transparent sound texture, vocal music, jazz and rock. The object was to see how each speaker handled these different types of sound.

Test results

The two standouts in the group were the Advent 2 and Hegeman H-80. All types of music sounded lifelike and convincing. Even the big orchestral climaxes stayed clear and

undistorted, the rock bass had a sharp punch and real presence, and the highs were remarkably natural and spread nicely all around the room. It was the kind of sound that lets you forget the speakers' low cost.

The Electro-Voice E-V 13B just about equaled these high standards, especially in its clean, natural bass. The only negative comment was that the treble sounded just a trace hollow when an operatic soprano cut loose with some high notes. (And it wasn't just the timbre of her voice—we checked that against the other speakers.)

The Acoustic Research AR-7 and Dynaco A-10 speakers sounded quite similar to each other, nicely balanced, with an unobtrusive but ample bass and clear highs. Because of their rather softly rounded highs, both these speakers produced a very smooth impression of orchestral strings, but they lacked just a bit of punch for jazz and rock. They would appeal mainly to classical listeners.

The BIC-Venturi Formula 1 had a nice, punchy bass and crisp highs, while the Sylvania AS 3708 sounded a little tubby in the lows—but its highs were clear.

The KLH 32 had a "big" sound. This may appeal to some listeners, but to us it seemed boomy—like a jukebox. An effort to make the speaker sound more

KLH 32, \$63

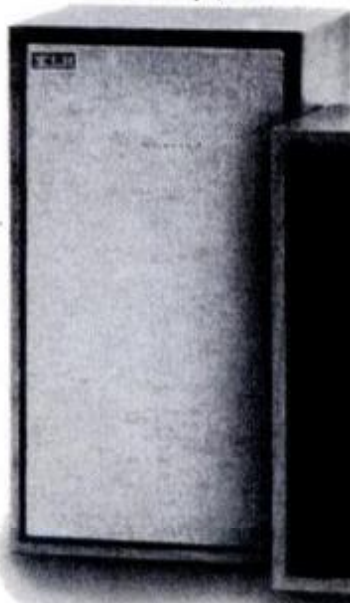

BIC-Venturi
Formula 1, \$75

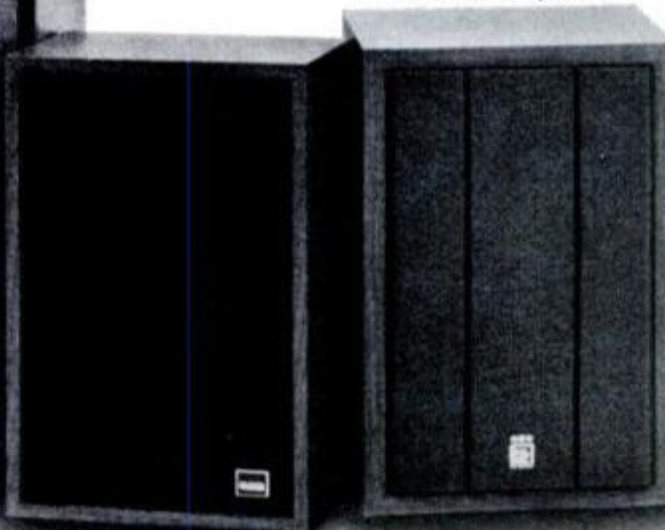

Sylvania AS 3708, \$65

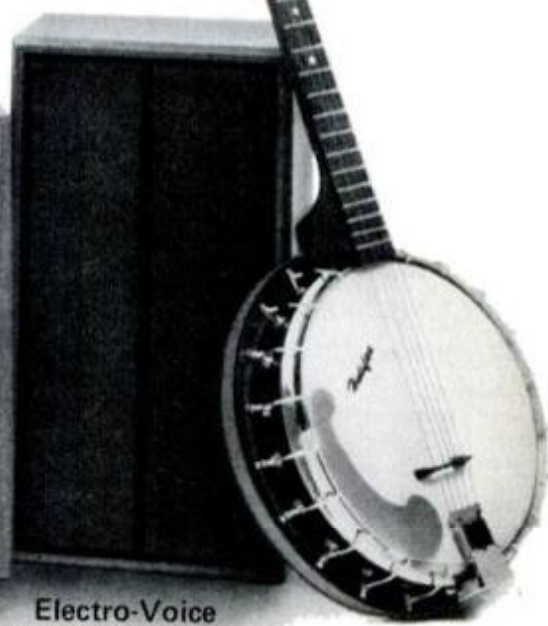

Electro-Voice
E-V 13B, \$80



Our test equipment included this Advent speaker switcher, which let us compare all of the speakers at the same sound level, and this Yamaha amplifier.

full-bodied apparently resulted in too much bass resonance.

The only seriously flawed speaker tested was the Avid 60, with a honky resonance in the midrange, rather weak bass and muddy highs.

Efficiency ratings

Because speakers in this price range are mostly used with low-powered amplifiers in inexpensive systems, we also measured their efficiency. Keep in mind that efficiency has nothing to do with a speaker's sound quality; it merely tells how much sound is put out for a given amplifier wattage. In fact, the most efficient model tested was the Avid, which flunked out on all other counts. Our ratings in the table below show how many decibels softer than the Avid each speaker would be when fed the same amount of amplifier power. Since 3 decibels (dB) is the smallest readily perceptible sound change, differences of less than 3 dB are insignificant.

Next to the Avid, the BIC-Venturi and the Hegeman were most efficient and would probably produce plenty of sound with amplifiers rated as low as 8 watts per channel. The Advent, AR and Dynaco were the

least efficient, but even they put out plenty of sound when fed by 15 watts per channel, and would probably work well on 12 watts. The rest had medium efficiency and would need about 10 watts per channel for satisfactory use in a large room. Maximum amplifier power these speakers can handle safely is probably around 25 watts per channel. All are rated at an impedance of 8 ohms, except Advent (4 ohms). But this makes no practical difference.

Design details

Some models offer interesting design. The BIC-Venturi differs from the rest by using a horn tweeter rather than a cone tweeter. It also features a modified bass-reflex enclosure (the "Venturi" design) to maximize bass output. Both factors contribute to its high efficiency. The Hegeman uses an aluminum tweeter cone to gain crisper transient response, sharpening the impact of drum-beats and the plucking of strings; an aluminum insert in the woofer cone smooths and extends the high end of the woofer's response.

Tweeter-level controls on some of these speakers help match their tweeter outputs to the acoustic properties of the listening room by adding or subtracting treble. But the amplifier's treble control does about the same thing, so the absence of a tweeter-level control is no handicap.

Speaker placement

Unavoidable limitations of small speakers at the low end can be partially overcome by placement tricks and in setting amplifier controls. Putting speakers on the floor and in corners will greatly increase bass output and efficiency. These small speakers can also use help from the amplifier to project more bass. Therefore, it's often wise to set the bass control on the amplifier for a slight boost, but not so much as to make the sound boomy. These simple items of audio know-how will help you make the most of these excellent speaker bargains. ★★★

A KIT SPEAKER



I BUILT IT: Speakerlab's instructions are simple, fun and thorough. They make assembly easier than changing a light bulb—and with less chance of getting burned. Wiring is preassembled, speaker openings pre-cut, and the only tools you need are a scout knife and sandpaper (though a stapling gun can cut assembly time from 90 minutes to 60).

But if you still have any problems—directions that seem confusing or parts that seem to be missing—Speakerlab offers the ultimate in kit convenience (and courage): a free long-distance number you can call for advice.

Once your speakers are ready to hook up Speakerlab is ready too with an eight-page operating manual (*Technical Compendium & Hot News Gazette*) that gives everything from a tongue-in-cheek graph of power requirements vs. your age (20 watts if you're 50 or over, 200 watts if you're a 20-year-old rock fan) to frequency-response graphs that help you pick the best speaker locations.

Dimensions of the \$59 Speakerlab S1's are 9½ x 11¼ x 18¼ inches; it's a two way system (woofer and tweeter) with a tweeter level control. My only regret was that with an engineer waiting to give me free advice over the phone, the instructions were so complete that I had no excuse to call him.—*Bill McKeown*

I HEARD IT: Unfortunately, the S1 came too late for our full-dress test. But in comparison with one of our top-ranked speakers, I found the S1 has a fine open treble, and medium efficiency. Its only failing is a slight bass resonance which made the lows fairly impressive at first hearing, but might sound muddy on extended hearing; but it's not enough to be annoying, and does add a bit of punch to rock.—*Hans Fantel*

Who makes it: Speakerlab, 5500 35th N.E., Seattle, Wash. 98105.

BUDGET SPEAKERS COMPARED

Make and Model	Price* Per Speaker	Dimensions	Efficiency (see text)	Tweeter Level Control
Acoustic Research AR-7	\$75.00	6¼ x 8¼ x 15¾"	-10 dB	Yes
Advent 2	74.00	7½ x 11 x 19½"	-9 dB	No
Avid 60	60.00	8¼ x 8¼ x 28"	-0 dB	No
			(Reference)	
BIC Venturi Formula 1	75.00	10 x 11 x 17"	-7 dB	Yes
Dynaco A-10	59.50†	8 x 8½ x 15¼"	-12 dB	No
Electro Voice E-V 13B	80.00	8¼ x 10 x 19¼"	-7.5 dB	Yes
Hegeman H-80	72.00	8 x 11 x 17½"	-8 dB	No
KLH 32	62.50†	7 x 11 x 19½"	-12.5 dB	No
Sylvania AS 3708	64.50	6¼ x 10¼ x 16½"	-13.5 dB	No

*List price (often discounted by local dealers)

†Sold only in pairs

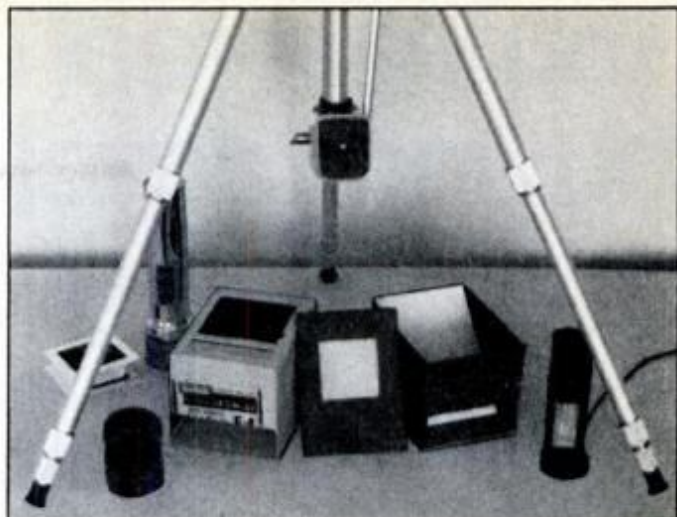
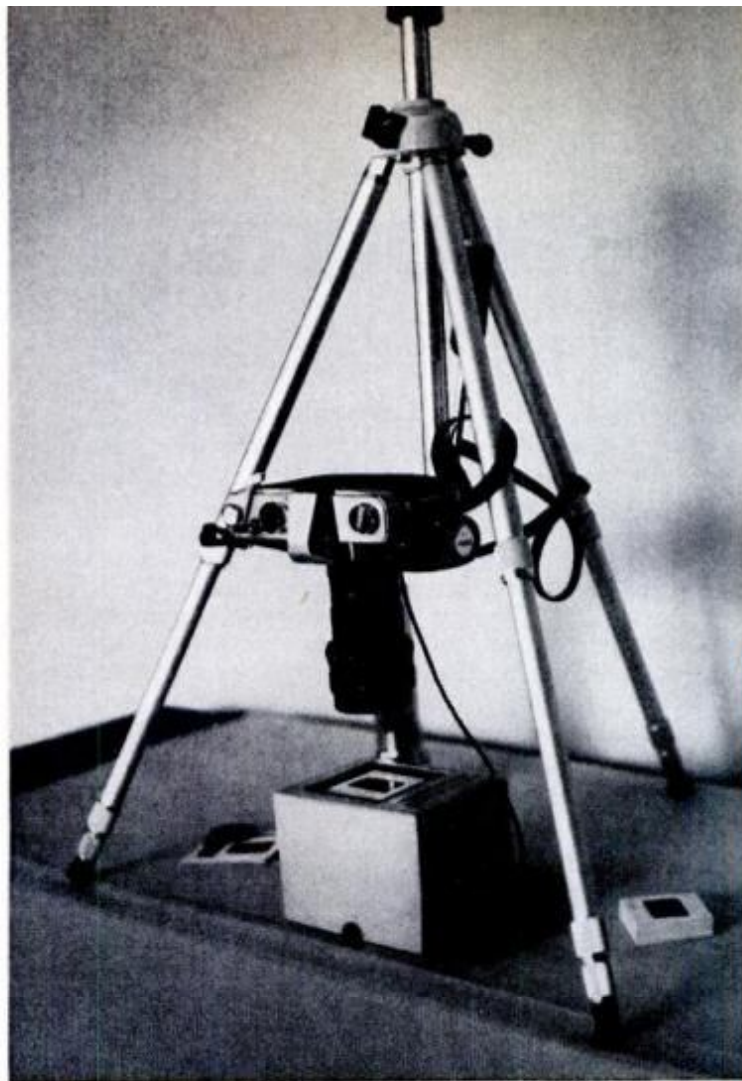

Slide-copy illuminator for less than \$1

by James L. Abbott

Photos by the author

Call this box a "slide converter" because it lets me shoot with slide film all the time. Then I can convert the results into any other type of film: black-and-white, color negative or duplicate slides. I can also make 35-mm copies of 126 (Instamatic) or $2\frac{1}{4} \times 2\frac{1}{4}$ (120) slides, and sandwich negatives or positives for unusual effects. But the best of all is the box's cost: less than a dollar.

The box originally held $3\frac{1}{2} \times 5$ -inch photographic printing paper. If you don't use it in sufficient quantity so you have a box this size, you can get one from your local film processor, usually for nothing. But any box of similar size and construction will do—you could even make your own in a pinch. The $3\frac{1}{2} \times 5$ -inch card that goes just below the lid and the 45° matte-white reflector both can be cut from scraps of poster card stock. A

piece of diffusion plastic is available from plastic dealers, among others, for a few cents. You may be able to do without the plastic entirely; but if you try it, make test shots to be sure the opening is evenly illuminated without dark corners. Just a few minutes spent cutting and assembling the components will quickly produce a valuable and versatile accessory for your single-lens reflex.

Cardboard box is sturdy

You can make the box from more substantial materials, but it's hardly necessary. The cardboard version should have many hours of use, and another can be made in short order.

To use the box, slip your flashgun into the slot, mount your camera

above the box with extension tubes or bellows to let you get close enough, and drop the slide you want to copy into one of the holes on top of the box. The 2×2 -inch lower opening will block off part of a $2\frac{1}{4}$ -square slide—but not as much as you think: just $\frac{1}{16}$ inch from each edge of the visible image area. If you use only $2\frac{1}{4}$ -squares, you can do without the inner adapter plate. (If you don't make $2\frac{1}{4}$ -square slides, then you simply can cut a 2×2 -inch hole in the box top, and do without the inner adapter.)

One last tip: Since the flashgun illuminates only the slide as you shoot, keep a flashlight handy to light up the slide as you focus and frame your camera. ★★★

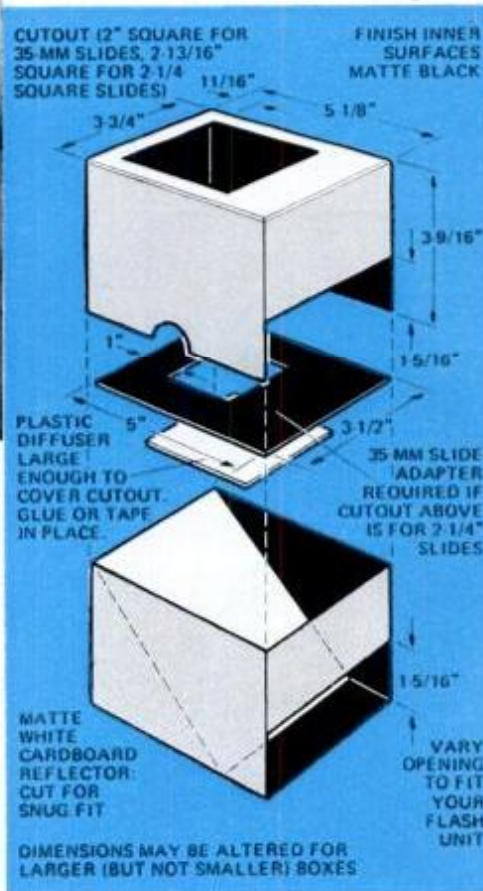

All you need to copy slides is a camera having close-up gear, an electronic flash and this box—which you build for about \$1. The disassembled view (above) shows simplicity of construction: just a photo paper box, a white cardboard reflector, a cardboard mask and a piece of plastic diffuser. The flashlight is used to illuminate the slide for focusing. The dimensions shown at left aren't critical, but smaller box might not fit your flash.

You'll get real bargains buying 'recycled' car parts

Solid tips on shopping and saving at auto wrecking yards

by Michael Lamm
WEST COAST EDITOR

An auto part bought at a wrecking yard costs you a third to half what you'd pay for it new through a franchised dealer. For older cars, the dismantler's price comes down as low as 10 percent.

Even so, some people wouldn't stoop to shop for car parts at a wrecking yard. Too tacky, they'll tell you; also too risky and too messy. Besides, you get no guarantee, and

you usually end up with the wrong part anyway. On top of that, they'll argue, wrecking-yard owners love to haggle, and they're unfriendly because they won't let you go "out back."

The purpose of this article is to dispel some of these myths and to tell you the ways auto dismantlers really work—how you can save money and time by using wrecking yards, which types are least expensive, how you can help them help you and what sort of service to expect.

Since so many people have never been to a wrecking yard and haven't even considered going, this primer might break some ice.

First, the dismantling business has come a long way since the old greasy sneaker days. "We're now a lot like any uptown store," one owner told me. His clean, well inventoried, medium-sized yard gives a 30-day exchange warranty on all parts and has three "hot lines" to help find items he himself doesn't stock.

He and others in the business pre-

Photos: Irv Dolin



It's a sea of car doors, but a good parts dismantler will have all the doors marked and will have the locations of doors for specific makes and models indexed in his office. Good

sheet metal and window glass bring relatively high prices, although nowhere near what you'd pay for the parts new. Check the new-part price before visiting a dismantler.



A dismantler's hot line will locate a part that he doesn't have in stock. This saves running around, but hot-line parts cost more than in-yard parts. The hot-line setup shown here is at Mid-Island Auto Parts in Deer Park, N.Y. Dave Marro helps a customer to find parts he needs for his Datsun 510.

fer the term *dismantler* but accept *auto wrecker*, although they say, "You wreck, we dismantle." They don't accept the term "junkyard," and dismantlers aren't scrap or metal salvage dealers.

The more progressive yards around the country currently use concrete aisles, space-saving pigeon-hole stacking in wire racks, forklifts for retrieval, pneumatic tools for removal and computerized inventory systems. Today there's a general atmosphere of a department store about them.

The Association of Auto and Truck Recyclers (AATR), based in Washington, D.C., estimates that there are 10,000 dismantlers in the country. The average parts yard covers five acres, employs three to seven people, stocks 300 cars and grosses \$500,000 a year.

Dismantlers are of several types. Some sell late-model parts only; others specialize in imports, older cars and even in single makes of cars. Some, of course, don't specialize in anything and carry a smorgasbord.

The dismantling business has been booming of late. Economic hard times mean good times for wrecking yards because people who hang onto their cars in tight-money times would rather fix than switch.

How to get the best prices

For the best prices and service from a dismantler, remember these three rules:

- Phone around to find the part you need;
- Get price quotes before you see the part;

- Bring in your old part to be sure the new one matches.

Let's say you need a decklid for your 1970 Torino sedan—your present decklid's been bent out of shape by some minor rear-ender.

Begin by phoning your local Ford dealer's parts department to get an idea of what the decklid costs new. Then, using your local directory call half a dozen wrecking yards to see if they have the part or can get it via their "hot lines."

Ideally, you want to find the yard that has the part in stock and at the lowest price. Hot-line prices are



higher than in-stock prices. I'll explain why in a moment. While you're phoning, comparison-shop by getting quotes before you leave your home. It often helps, too, to locate several decklids, because the first one might not pan out for some reason. And you might stumble onto one that's your color, so you might save re-painting it.

An important point is to establish

Small parts that you may need, like side-view mirror above or gas-cap door spring at left, may be hard to buy separately because the dismantler wants to keep the door or panel intact so he can sell it as a unit.





Good deals on engines removed from low-mileage wrecks can be had, but be careful and be sure that you obtain a written warranty.



For some parts, such as axles, alternators and so on, bring in your old part for comparison.

price early—before you drive to the yard—because once the counterman hands you the part, if you *then* ask him for its price, it will likely be more expensive than if you had asked beforehand.

How hot lines work

All larger yards have so-called “hot lines”—radiotelephone hookups to other yards. Hot lines operate like the old country party line or like a huge intercom system. The intercom is always open, and everyone on the line listens in continuously. By pressing a button, any yard in the system can talk to all the rest.

Currently some 120 hot lines are crisscrossing the nation, linking approximately 4000 yards. Most larger dismantlers have three hot lines: a local one that covers 20 to 30 other wreckers within, say, a 15-mile radius, plus two regional lines that span much larger territories. Regional lines often overlap but link up two different sets of yards. In other words, Regional Line A might tie together 80 dismantlers in upstate New York, and Regional Line B might cover another 80 yards, also in upstate New York, but these last 80 will be a different set. In any given town, perhaps four yards will belong to Line A and another four to Line B.

Local lines usually cost the dismantler \$15 to \$30 a month; regional ones \$125 to \$200, depending on the number of terminals and the size of the territory.

There are statewide and nationwide hot-line hookups. Rarely,

though, will a part be shipped farther than 200 miles because freight charges become prohibitive. National hot lines are viewed as something of a luxury.

If the yard you're phoning doesn't have your Torino decklid in stock, a good counterman will say, “Let me put out a call on my hot line.” He'll ask you for your name and phone number and will call you back within the hour.

Keep in mind, though, that hot-line parts are about 25 percent more expensive than parts in stock. That's because of shipping, overhead, time spent in locating and the local yard's commission. So, avoid hot-line parts if you can. Sometimes, of course, it's

the only way to find something, especially in a hurry.

The price of parts

Prices vary from area to area. Big-city parts are more expensive than ones in rural wrecking yards. A \$25 part in Stockton, Calif., brings \$40 in Los Angeles. Why? Because land costs more in bigger cities. So does labor. Also, there's simply more demand for used parts in population centers like Los Angeles—more people trying to keep older cars on the road. Too, big cities have more wrecking yards bidding on insurance salvage.

To give you an idea how prices vary, here are the results of a 16-yard survey taken across the country by the AATR last May.

Part	High	Low	Average
1971 Chevrolet 350 V8	\$375	\$250	\$310
1970 Chrysler TorqueFlite trans	150	75	110
1969 VW Bug transaxle	125	75	90
1971 Pinto rear axle assembly	75	45	65
1969 Cadillac driveshaft	85	45	65
1971 GMC 15-inch wheel	10	7	9

Prices vary locally, too, but not to so great an extent. The size of the yard makes little difference, because the hot line represents a great educator. Every yard on a line knows what every other yard is charging, so if the counterman at a small yard overhears what a large yard is getting for a part, why should he charge less?

Generally speaking, the later model the part, the more it will cost. That's
(Please turn to page 156)

Used wheels from a dismantler are a good buy, even if they are the cast-alloy type.



A room with nautical flavor

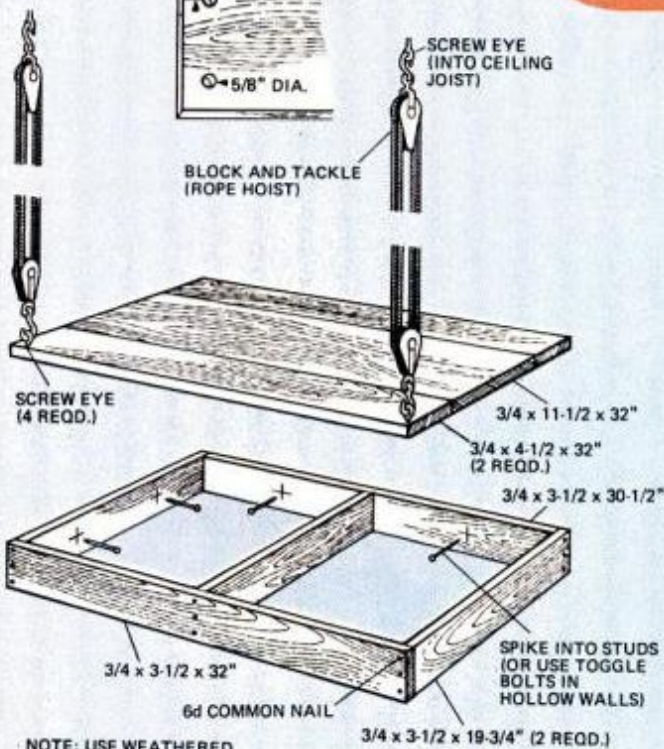
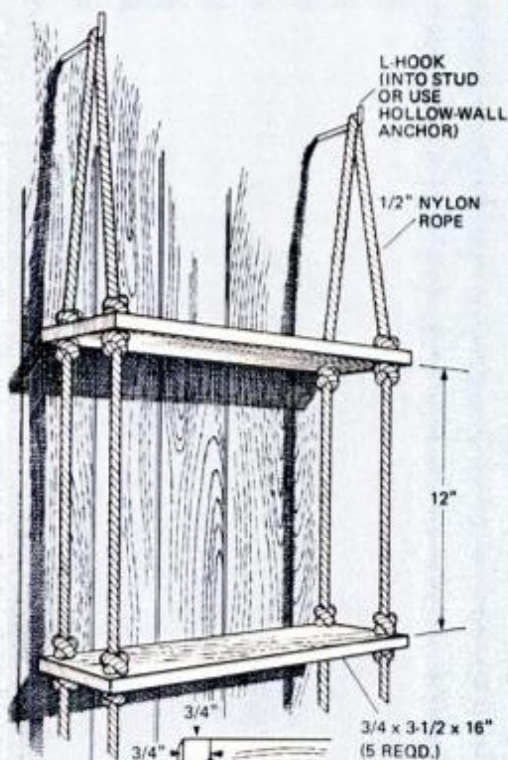

NOTE: USE WEATHERED BOARDS IF POSSIBLE. OR, USE COMMON PINE, THEN FINISH TO SIMULATE BARN SIDING.

Sheltered haven for youngster or dad gets its mood from weathered paneling and the hanging desk and shelf we show you how to build.

Interior designers know that a home decorating scheme stands a far better chance of being successful when a basic theme is adhered to—and if elements within the room are kept relatively simple. Because both rules were followed here, this room with seagoing theme is both appealing and functional. Two panelings from the Masonite Corp. help to create the mood: Chapel White Stone applied to one end wall, and Driftwood (from the Forrester series) on the remaining three walls and ceiling. Hefty, but false, rafters overhead complete the feeling of seashore and ships.

The clever room accessories, for which we've drawn plans, are at once charming and practical. To build them, you can use low-cost common pine which can quickly be made to look like driftwood. After cutting parts to size, distress the lumber by beating with a chain. Next, sand the parts smooth and apply a latex stain. Finally, brush on two coats of semigloss varnish. Assemble and hang the pieces as shown, using nylon rope and hoists which are available from Sears stores and catalog outlets. *Caution:* Make certain hooks are well anchored in wall and ceiling.—Harry Wicks

New gadgets turn your pocket cameras into photo systems

by Ivan Berger
PHOTOGRAPHY EDITOR



Pocket camera lenses (from rear): Tiffen HCE telephoto, Burleigh Brooks Computer tele, Kodak 608 with built-in tele, Sedic wide-angle.

What if cameras that took the new, tiny 110-size film were as versatile as their bigger, heavier 35-mm cousins? Camera buffs have been asking that question ever since they first learned how good 110-film photos (especially slides) could be.

Since such cameras aren't in production yet (though they could be very close), accessory manufacturers—and at least one camera company—are doing what they can to make pocket cameras more versatile. Already you can get skylight filters, adapter rings for other filters, close-up lenses, copy stands, electronic flashguns, rubber eyecups, wide-angle and telephoto lens attachments—even motor drives—to fit various 110-camera models.

How many of these attachments you can use depends on which 110 camera you own: Since Kodak's Pocket Instamatic line seems to be the best-selling 110 series, more accessories are made for various Kodak models than for any other makes. (But not by Kodak—which makes only a Magicube extender



for its older models, and an electronic flash and an off-camera flash extender for its new Trimlite series.) But the cameras with the widest range of accessories are the new Sedic 110 cameras—because Sedic designed its cameras for them. About the only attachment that you can be sure to find for any 110 model is electronic flash—there are almost as many 110-flash units around as there are 110 cameras to fit them to. (As we went to press, Vivitar announced one to fit Trimlite and other cameras using the new FlipFlash bars.)



Two dream accessories

Telephoto and wide-angle lenses are the dream accessories, the ones that convert cameras from mere snapshotters' delights to versatile, system cameras. That's probably why Kodak seems to be concentrating its current efforts around the Tele-Instamatic 608, a \$35 camera that switches from normal to a mild telephoto lens with 1.7X magnification—about equivalent to an 85-mm lens on a 35-mm camera—at the flick of the lever just in front of its chrome-plated shutter-release button.

For simpler Pocket Instamatics and Trimlites, Willoughby-Peerless sells Tiffen's HCE telephoto (\$10), a big-lens attachment that gives a moderate 1.6X magnification (equivalent to a 35-mm camera's 80-mm lens). Burleigh Brooks's Computar kit (\$40) fits Kodak's fancier Pocket

Instamatic 60 with a wide-angle and a telephoto lens; the wide-angle is moderate (its 0.85X magnification equates to a 41-mm lens on a 35 reflex), but the telephoto's 1.85X magnification is equivalent to a satisfactory 92-mm telephoto on a 35. And for \$25 each, Sedic offers an 0.7X wide-angle (like a 35's 35-mm lens) and a 1.5X telephoto (equivalent to a 75-mm).



Instamatic 60 with a wide-angle and a telephoto lens; the wide-angle is moderate (its 0.85X magnification equates to a 41-mm lens on a 35 reflex), but the telephoto's 1.85X magnification is equivalent to a satisfactory 92-mm telephoto on a 35. And for \$25 each, Sedic offers an 0.7X wide-angle (like a 35's 35-mm lens) and a 1.5X telephoto (equivalent to a 75-mm).

(Please turn to page 116)

Safety and style: You'll be getting both!

by Michael Lamm
WEST COAST EDITOR

PEDESTRIAN BAR RAISES TO TRAP VICTIM ON SOFT "HOOD" SURFACE. NOTE CLEAR PLASTIC CENTER SECTION ALLOWING DRIVER FORWARD VISIBILITY WHEN BAR IS ACTIVATED. SOFT TRAMPOLINE "HOOD" IS STRETCHED OVER LARGE CAVITY. THIS IS PART OF PEDESTRIAN SAFETY SYSTEM.

CAR-WIDE REAR-VIEW MIRROR GIVES PANORAMIC VIEW. ADJUSTS FROM DASHBOARD.

FRONT WINDSHIELD HINGES UP TO ALLOW ACCESS TO COWL WIRING, HARNESS, DASHBOARD AIR-BAG MECHANISM, WIPERS, ETC.

ALL SEATS HAVE SEE-THROUGH HEADRESTS AND AIRCONDITIONING OUTLETS THAT DIRECT AIR UPWARD FOR BETTER BACK-SEAT CIRCULATION.

SEAT CUSHIONS ARE VERY THIN (3 INCHES). STUDIES SHOW THAT THICK PADDING ADDS TO FATIGUE FACTOR AND HAS CONFINING QUALITY. EXCELLENT NEW SYNTHETICS WILL PROVIDE HIGH DEGREE OF COMFORT.

Passengers might have walked away from 70-mph rollovers, 50-mph head-ons and 30-mph side impacts, but the fact remains that America's first generation of ESVs (experimental safety vehicles) weighed too much, cost too much and guzzled too much.

Those early ESVs of the 1950s and '60s by AMF, Liberty Mutual, Ford, GM and the like tried to protect their occupants by sheer weight and bulk. They were heavy, unwieldy, expensive, thirsty and never very practical for actual production.

Now a second generation of ESVs is taking an entirely different approach. These lightweight, compact, stingy, fairly inexpensive research-and-idea cars try to be genuinely practical for production. They are aimed toward the mid to late 1980s and they achieve safety through innovation rather than by bulk. A number of

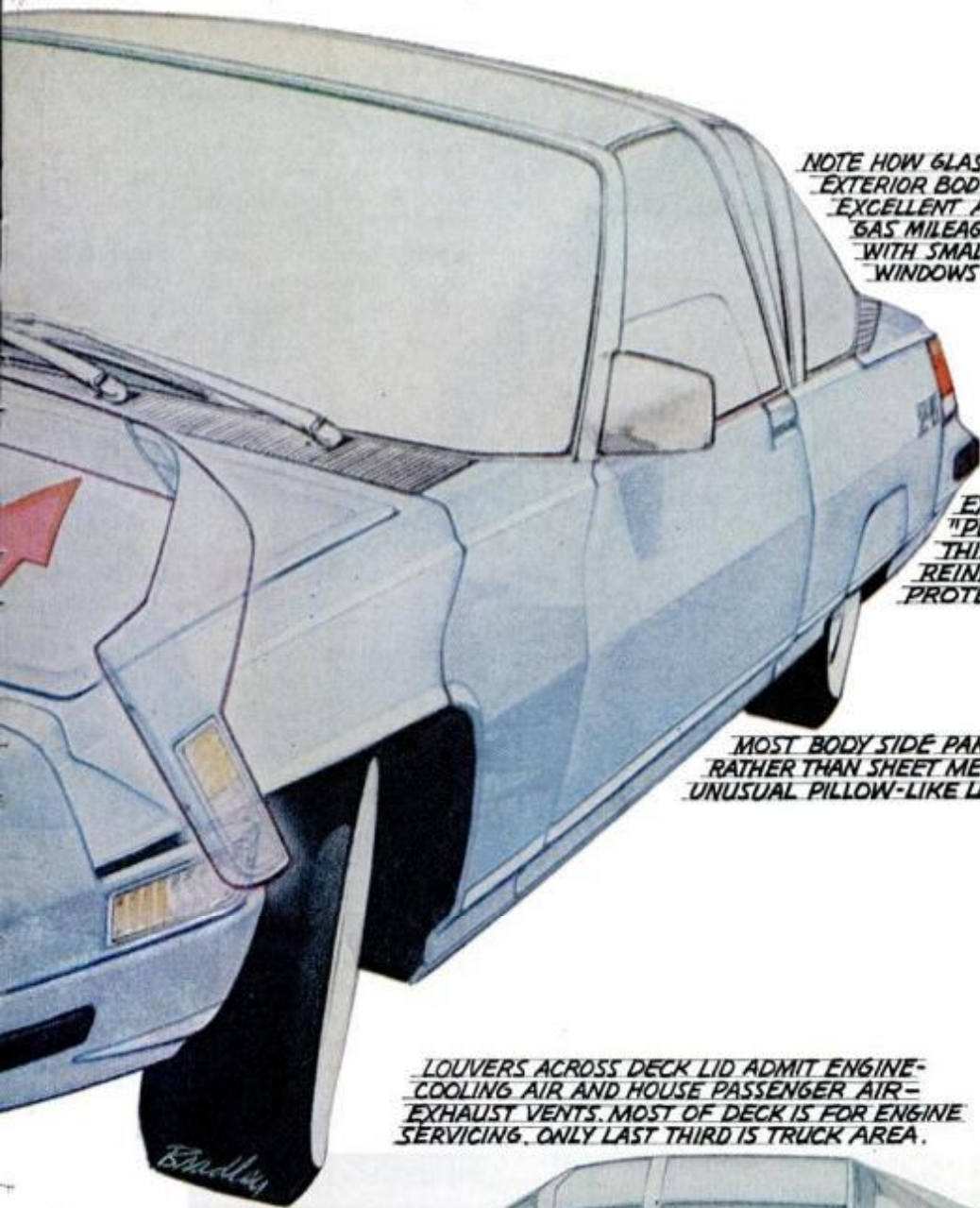

NOTE HOW GLASS IS NEARLY FLUSH WITH EXTERIOR BODY ELEMENTS. THIS PROVIDES EXCELLENT AERODYNAMICS AND INCREASED GAS MILEAGE. ALL WINDOWS ARE FIXED WITH SMALL, HAND-OPERATED ACCESS WINDOWS ON DRIVER AND PASSENGER SIDES.

EXTERIOR IS SLAB-SIDED WITH NO "PULL UNDER" AT ROCKER PANELS. THIS PERMITS EXTENSIVE SIDE REINFORCING AND IMPACT PROTECTION.

MOST BODY SIDE PANELS ARE VINYL SKINS RATHER THAN SHEET METAL. THIS GIVES AN UNUSUAL PILLOW-LIKE LOOK.

LOUVERS ACROSS DECK LID ADMIT ENGINE-COOLING AIR AND HOUSE PASSENGER AIR-EXHAUST VENTS. MOST OF DECK IS FOR ENGINE SERVICING. ONLY LAST THIRD IS TRUCK AREA.

EXTENSIVE GLASS AND MULTIPLE THIN PILLARS PROVIDE EXCELLENT VISIBILITY PLUS GREAT ROLL-OVER STRENGTH.

TIRES ARE THINNER ACROSS TREAD TO REDUCE ROLLING FRICTION. THERE'S NO SPARE WHEEL AS TIRES ARE VIRTUALLY "FLATPROOF".

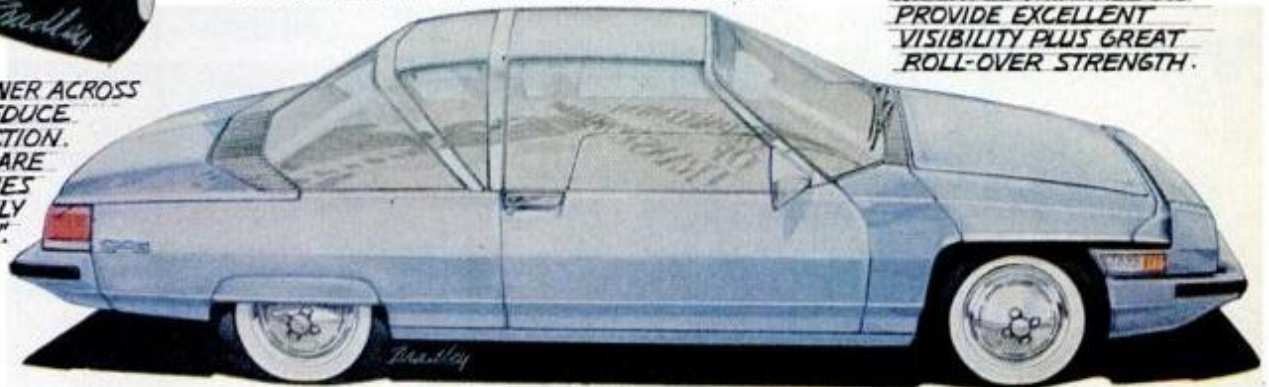

Art: Harry Bradley

these innovations are noted in the drawings on these pages.

Though the first-generation ESVs proved impractical, some design features did, in fact, filter down and now appear in today's cars. Slant-nose front-ends, big bumpers and decisions to eliminate hardtop models came from the first ESVs. So regardless of the second ESV's destiny, some of the research ideas you see here will actually find their way to Detroit's production lines within the next decade.

Designing the second generation ESVs has aroused international interest. Companies in Japan and Europe are getting involved voluntarily, including Austin, Audi and Volkswagen. Their ideas will be presented to our government along with ideas from a number of our own companies.

Last July 20, the federal government com-

LOWER BODY IS SELF-SKINNING, COLOR-IMPREGNATED FOAM OVER LIGHT-GAUGE METAL. THIS IS DENT-RESISTANT AND PROVIDES GOOD SIDE-IMPACT PROTECTION.

THE 1980s LOOK STYLED FROM 2ND GENERATION SAFETY CAR. NOTE CONVENTIONAL RATHER THAN GULL-WING DOORS.



missioned two independent contractors to plan and build the "mules" (working prototypes) of this second generation of safety cars: Mini-Car of Goleta, Calif., and Calspan of Buffalo, N.Y. Calspan is associated with Cornell Aeronautical Labs in Ithaca, N.Y.

The main thought behind these multimillion-dollar contracts: Build a true safety car that can really be mass-produced at a reasonable price. Calspan is working with Chrysler Corp. and is essentially modifying the Simca 1307/1308, making that car sophisticated and producible.

Mules are just starting to take shape, and most of my information comes from unofficial sources regarding Mini-Car's work. Mini-Car will supply 25 test-vehicle structures. Some will be styling mockups, others ride/handling protos, braking cars, configuration studies and crash structures.

Basically, Mini-Car is proposing a

relatively high sills, something like a big bathtub made of .018-inch sheet metal and foam-filled around the periphery. Fenders are solid foam except for wheel wells. It's a so-called "self-skinning" foam, which means its surface forms a natural glaze—smooth or grained—in any color injected into it. The surface is soft to the touch, and the foam's crush rate can be varied by changing density. This, along with the crushable sheet-metal "tub," lets passengers walk away from 50-mph barrier crashes.

The "pedestrian catcher" includes a soft, giving "trampoline" where the hood ought to be. Tests in England have shown pedestrians normally get hit below thigh level and are tossed up onto the hood. As the driver panic-brakes in reaction, the victim slides violently forward again onto the road where he usually cracks his skull or gets run over by the car that hit him or one passing by. So the pedestrian catcher uses

tempered glass. Fixed windows eliminate the weight and complexity of roll-up mechanisms. There's only one small openable window so the driver can reach out to pay tolls. Ventilation is by forced air.

To ward off side impacts, door inners are filled with lightweight, honeycombed sheet metal. Inside the proto, small airbags protect front riders, and all four passengers wear three-point harnesses. In the Mini-Car, seats are of thin section, with a clear polycarbon head restraint that suspends the seatback from the car roof. Seats have flexible nylon spines and are upholstered conventionally. To allow entry to the rear compartment, the seat roof suspensions detach, and the entire buckets flip forward. In other cars, no roof suspension is planned. Pedal-operated front seats slide forward.

Relatively thin roll bars—three hoops—are mounted over the windshield and at the B and C pillars,

PILLARS ARE INTEGRATED INTO OVERALL STYLING SO THEY DON'T LOOK LIKE THEY WERE TACKED ON.

FRONT SEAT HAS NO MOVABLE BACK. PEDALS MAKE UNIT MOVABLE FOR BACK-SEAT ACCESS. STEERING WHEEL IS ADJUSTABLE.

OUTSIDE REAR-VIEW MIRRORS ARE BREAKAWAY TYPE IN SOFT HOUSINGS. LENSES ARE SLIGHTLY CONVEX FOR BETTER VISION.

TAILLIGHT LENSES ARE SOFT, YIELDING, TRANSPARENT PLASTIC WHICH IS UNBREAKABLE. REAR VALANCE PANELS ON EITHER SIDE OF LICENSE PLATE ARE ALSO SOFT PLASTIC.

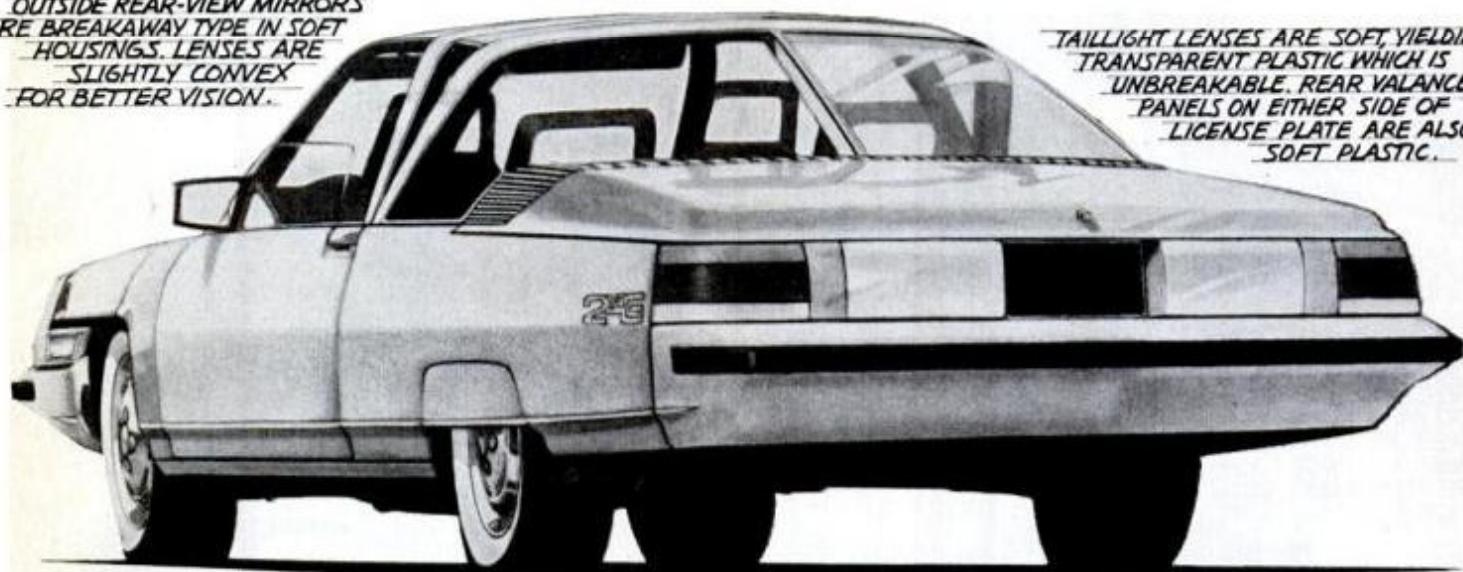

ONE-PIECE WHEEL WITH EXPOSED FOUR-LUG BOLT PATTERN. WHEEL-COVER STYLING IS BUILT INTO WHEEL DESIGN.

NO BRIGHT TRIM OR EMBLEMS ON BODY SIDES TO REDUCE WEIGHT. TAILLIGHTS ARE ALSO WITHOUT BRIGHT MOLDINGS.

1900-pound four-seater with foam-filled steel construction. It is a little larger than today's Pinto, with a 104-inch wheelbase, 175 inches overall, and 55 inches tall.

Mini-Car's revolutionary car will have a pedestrian catcher in front, self-skinning crushable foam for the body, radar-coupled four-wheel antiskid disc brakes, all-independent suspension, gull-wing doors, transverse midship engine, front airbags, thin-section fixed glass and three integral roll bars.

The main supporting structure has

the trampoline to soften slamming onto the car hood, then moves a "gate" that comes up to keep the victim from flying back out into traffic.

Below the trampoline is a small trunk compartment with a foot-thick foam floor that's part of the front crash/crush structure. In a 60-mph head-on, the entire front end collapses at a predetermined rate. Bumpers—also foam—are part of the system.

To help keep weight down, all glass is of a new thin section about half as thick but just as strong, as today's

with a center brace running down the rear glass.

Suspension in the Mini-Car mule is Fiat X-1/9, and the antiskid brakes are basically Porsche as modified by Tevis. Engine is a reworked Honda CVCC with the Honda five-speed overdrive gearbox.

Cost analysis studies show that the Mini-Car concept shouldn't be any more expensive to build or buy than conventional production compacts. Finished, running cars are supposed to be ready for evaluation by the government by May, 1978. ★★★

Easy home color prints from slides

by Ivan Berger

PHOTOGRAPHY EDITOR

Color photo and print by the author

Making my own color prints from slides didn't exactly scare me, you understand, but I must admit I let a lot of months go by between the time I got my first sample pack of Cibachrome and the time I took it out of my freezer to use it. Now I'm kicking myself for not starting sooner. It took me only one night to begin to get the hang of Cibachrome, and one more to start turning out good prints like this.

Actually, a reproduction on a printed page can't show you quite how good a Cibachrome print is. Unlike most color papers, Cibachrome has its dyes already in the emulsion, rather than forming them chemically during processing. That gives it really rich and luscious colors and—because the dyes act as filters to minimize light scattering—increased sharpness. Combine that with the rich colors and grainless sharpness you can get from slides, and the results are well worth 12 minutes of your time and \$2 of your money (for an 8x10)—especially when you consider that Cibachrome's dye chemistry makes it more fade-resistant than ordinary color-print materials, too.

You get custom results

Then there's the quality advantage that comes from doing it yourself: Only *you* know precisely the tones you want in your final print. And only you know when you want to print the whole slide; when you want to fill the 8x10 frame with just a portion of the slide, as I did in the color shot here (compare the full-slide version partially shown at right), and when you want to frame your picture in some other proportion than 8x10 as in my Eiffel Tower shot, also shown at right.

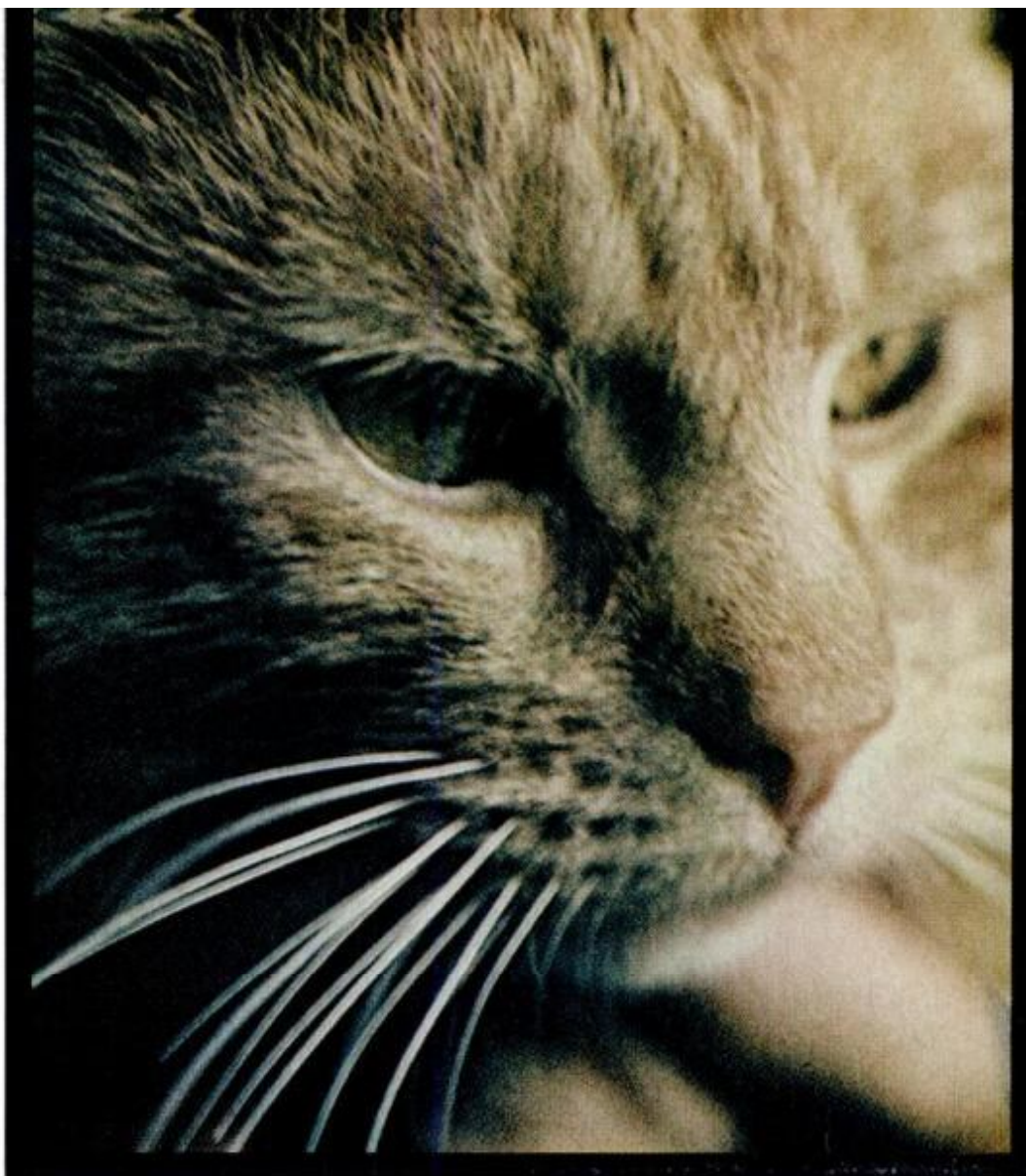

Color prints like this are easy with new Cibachrome. Useful accessories for this or any color process (right): Brantronics Temp-Set bath (top) for temperature control, Falcon Air-Evac bottles (in bath), Chromega drum and agitator printing base, Unicolor Jingle Bell programmable timer. Prints show custom cropping (see text).

If you're an experienced darkroom worker, you can add still further custom touches, such as "dodging" some areas by partially blocking the light to darken them, or "burning in" other areas with extra exposure to make them lighter. You can even alter color balances of selected areas by waving gelatine filters above them during exposure.

Since you're working from slides, you can see just what colors you're trying to reproduce or change, and check the print against its original. It's easier to judge framing and cropping with slides than with negatives, too.

It's easy

And Cibachrome itself is easy. Processing takes just nine minutes until you can see what you've done,



Photo: Benn Mitchell

just 12 until the print is ready to hang up to dry (its triacetate base won't curl as paper would). You need just three chemicals (developer, bleach and fix), plus a water wash. The recommended temperature of 75° F. (24° C.) is easy to maintain, especially with a 3° leeway up and down, and the steps are each short

[\(Please turn to page 117\)](#)



For nostalgia buffs... a rolltop desk you can build

Turn-of-the-century charm
makes this piece a natural for any room decor

by Rosario Capotosto

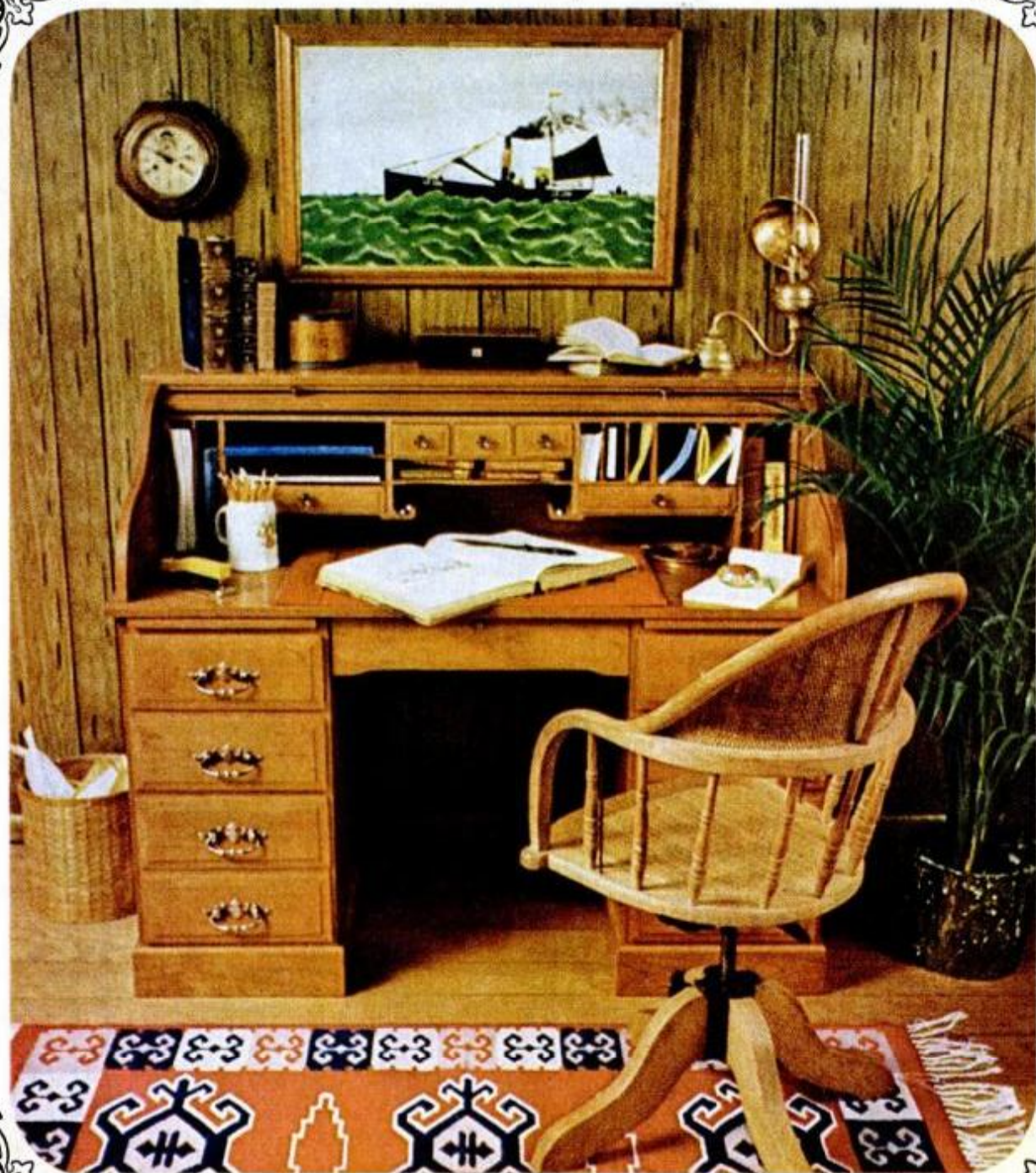

Back in the era of the trolley car and Model-T, the rolltop desk was popular in both home and office. Today, it's a cherished antique and you can pay as much as \$1300 and more for a store-bought reproduction. Build it yourself in fine cherry and you can own the charming heirloom you see here for a material cost of about \$380. You build it as two separate units, a base and a rolltop. Here's how:

Step-by-step construction

1. Rip the strips for all the frames: upper, lower and center. Use cherry where visible, poplar otherwise.

2. Cut tongues in ends of frame side members (use table saw with spacer between two outer blades of dado set to form two parallel cuts in same time). Tenonner or homemade jig should be used.

3. Cut 1/4-in. grooves in all side and end frame members, 1/4 in. deep. Cut dust covers from 1/4-in. gum plywood. Make a bit scant to allow space for glue.

4. Cut the pedestal side panels to size from veneer plywood.

5. Use straightedge guide to cut veneer panels to exact size. Since pieces are too large to handle on the average table saw, a portable circular saw is the best. Use great care in setting up the guide and use a smooth-cutting blade. Cuts must be

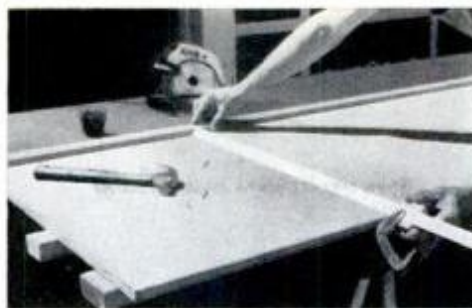

Block clamped to rule assures accurate straightedge placement to saw plywood.

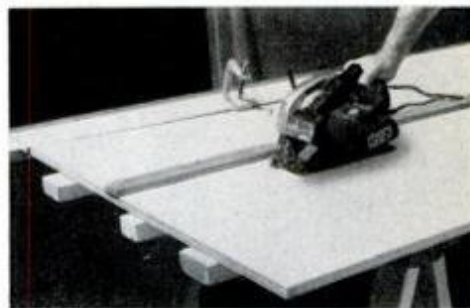

Good side of panel is placed down and panel is supported by 2x3s on sawhorses.



Identical dado cuts are made before moving jig. Outboard work support is *must*.



Tenon jig and pair of same-size blades with spacer are used to cut frame tongues.



Grooved end members are added to sidepieces after latter are on dust panel.



Corner notches are formed by gluing short 1/4-in.-thick strips to the front edges.

Styling: Gabe Herrick
Art: Fred L. Wolff

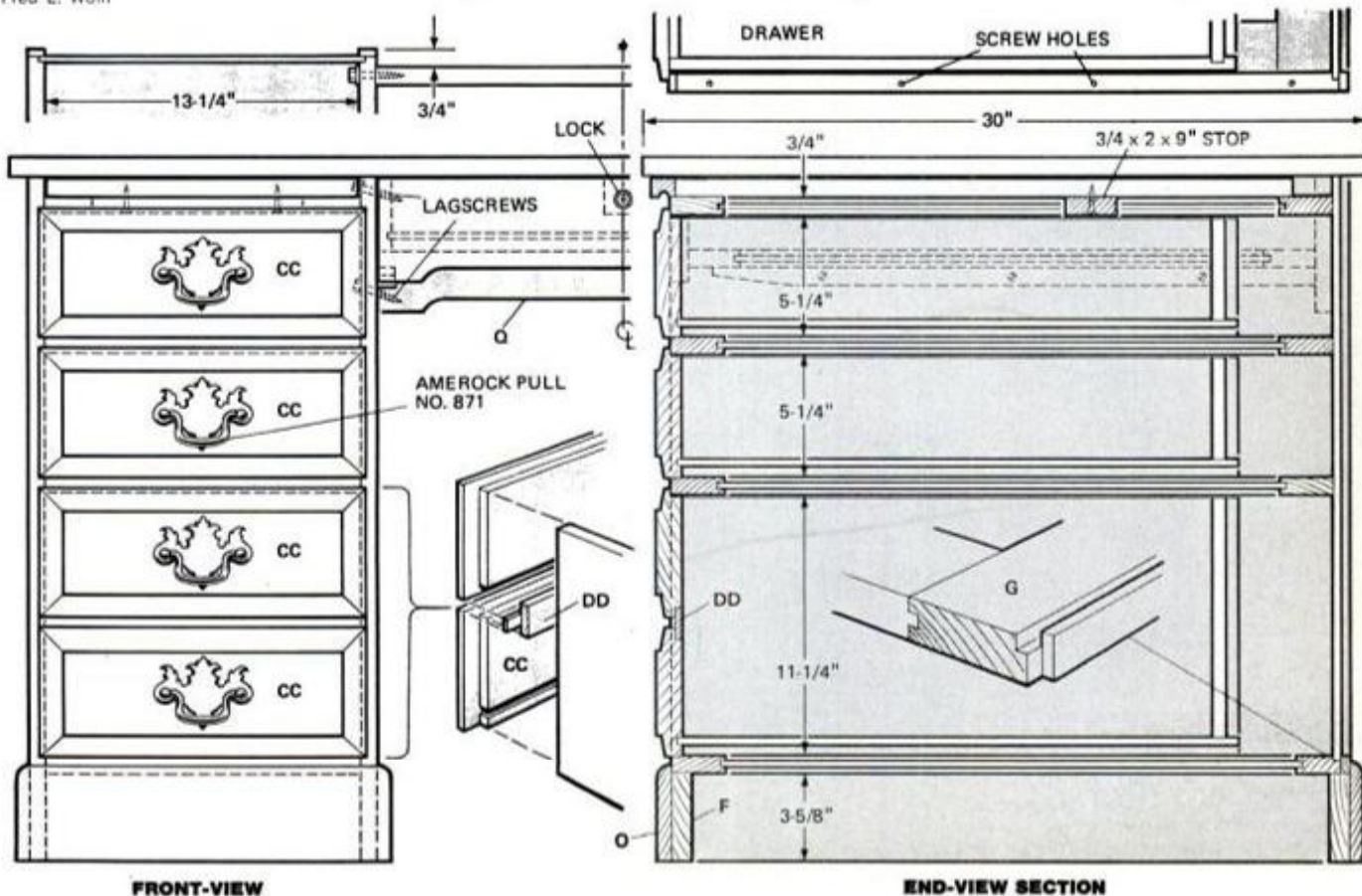

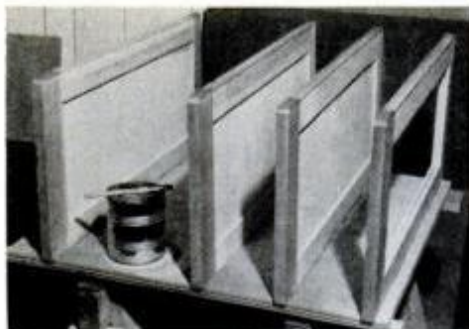

Use a slow-setting resin glue rather than white to allow ample assembly time.

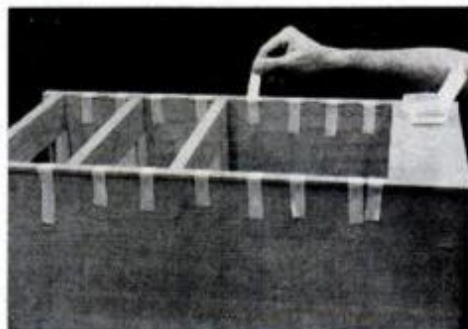

Toothpick standoffs keep tape away from glue line on inside pedestal surfaces.



Center frame is set in place without glue, then drilled for screw pilot holes.

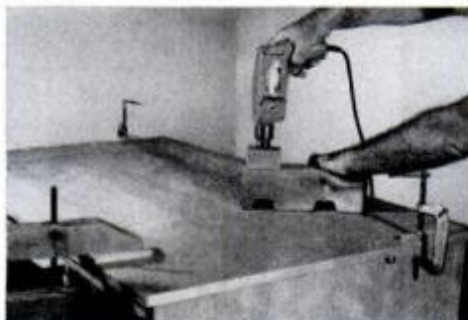

Counterbored holes for wood plugs are drilled at right depth with homemade jig.

finish cuts. Note: Tack nails are okay for saw guide because all cutting must be done from the back surface of panel in order to obtain clean, sharp edges on the face of the panel with a portable saw.

6. Method of notching corners of front frame members to allow the installation of facing strips on the veneer side panels is optional: It can be done with dado cutter or by adding $\frac{1}{4} \times \frac{3}{4}$ -in. strips to the fronts of the frames. The strips are cut short at both ends and must be glued perfectly centered.

7. Use dado head to cut the four dado grooves in the four pedestal panels. Mark all panels for advantageous grain orientation and make each cut on each panel before repositioning rip fence.

8. Don't use white glue or aliphatics; both set too fast for assembling the pedestals. Plastic resin is okay because it allows about 25 minutes assembly time at 70° F. Scrape off all glue run-off with a

(Please turn to page 144)

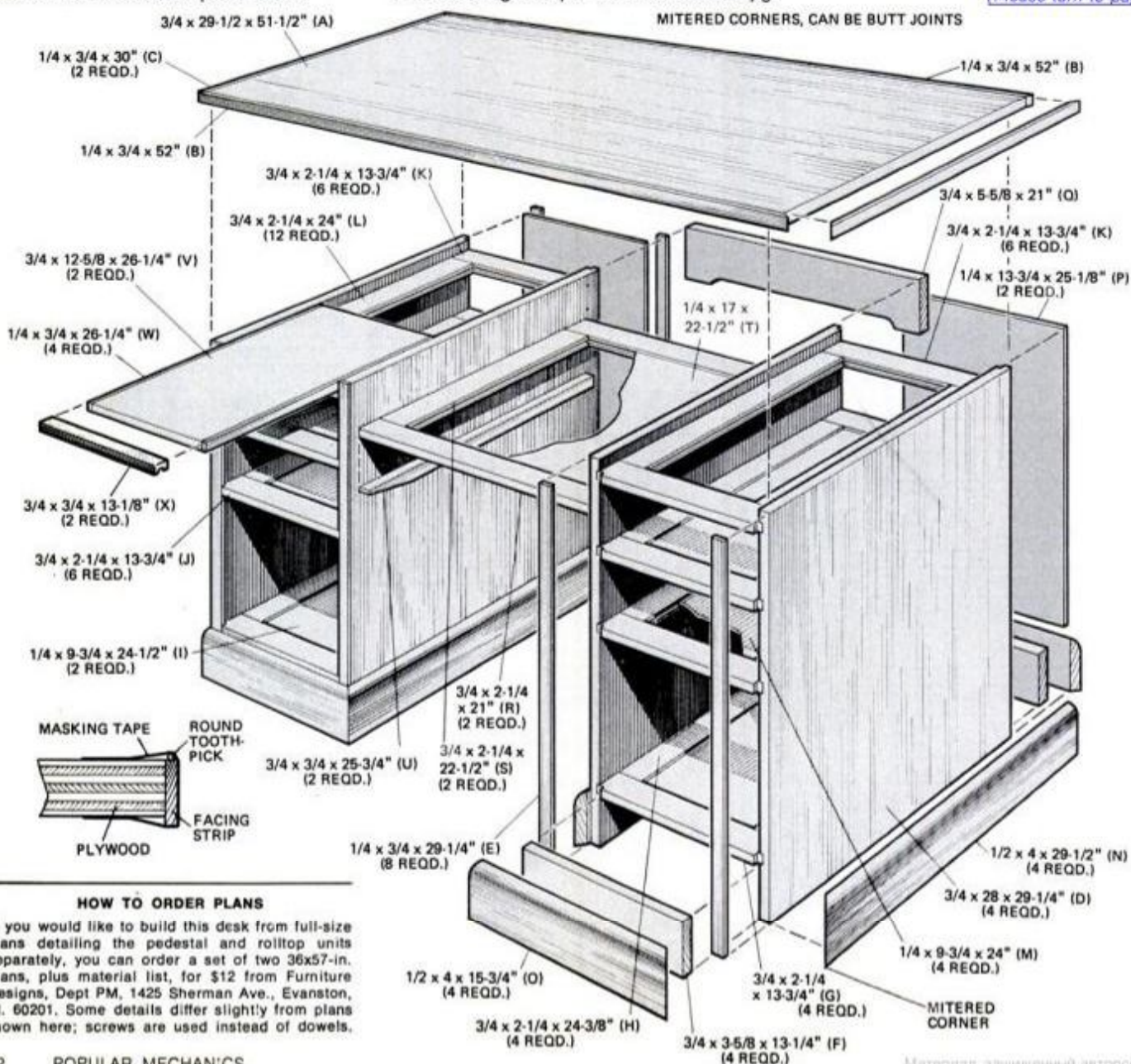

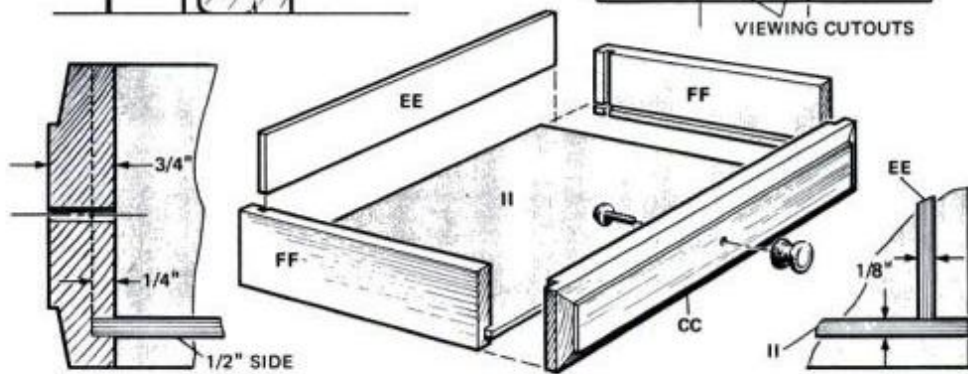
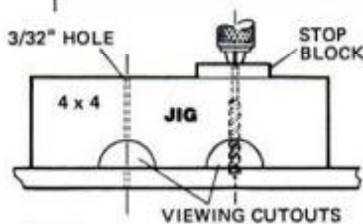
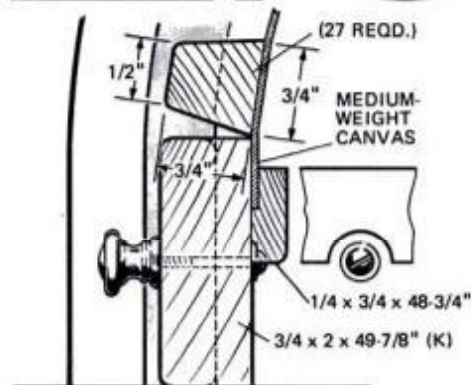
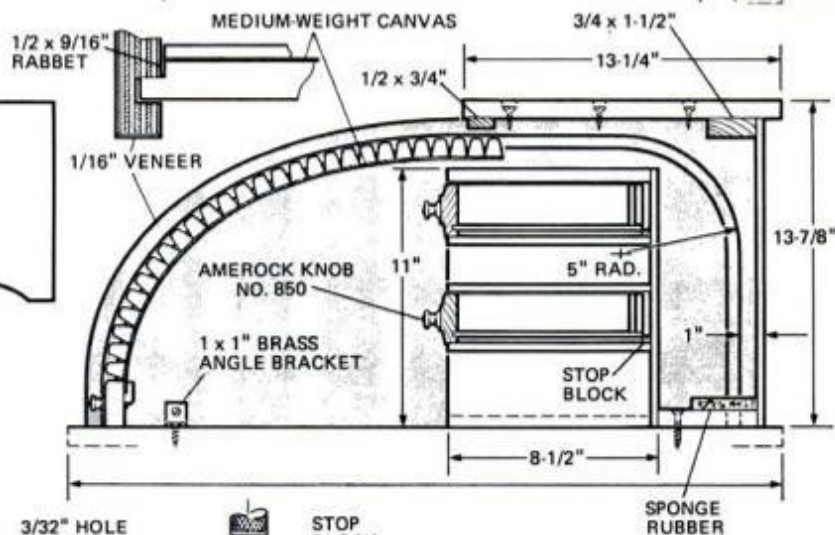
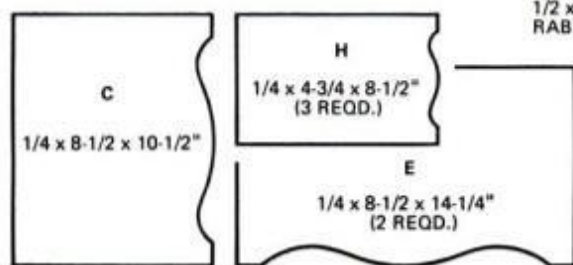
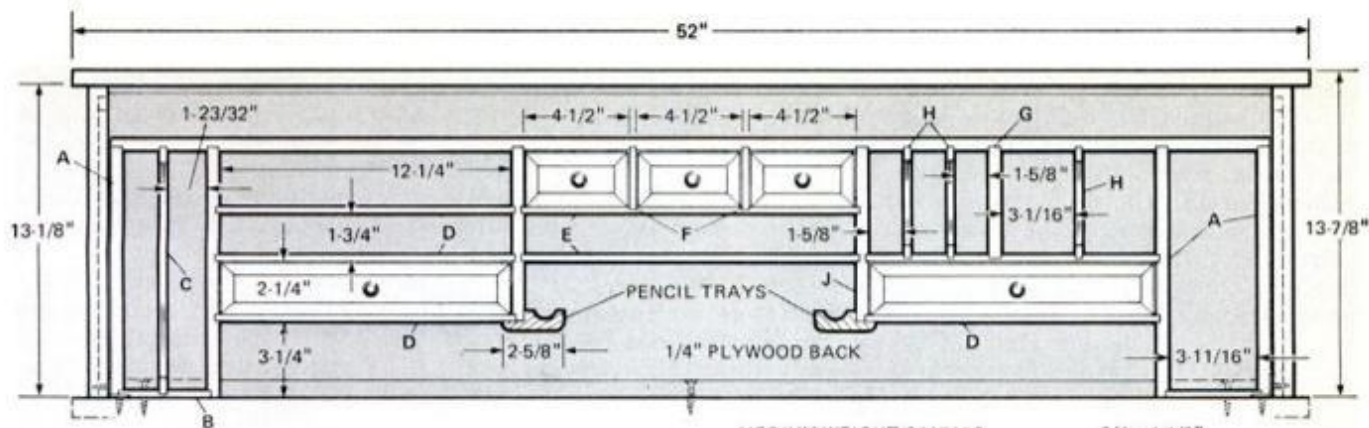

Drawer faces are beveled with saw blade set at 8° angle. Keep hands safe distance.

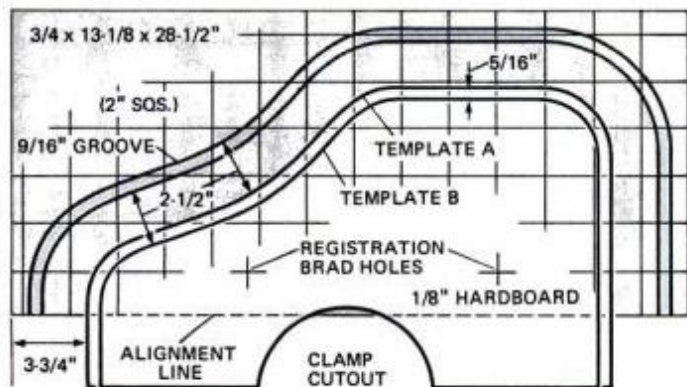

Two templates guide router to form 9/16-in. groove with 1/4-in. straight bit. Remaining 1/16 in. between 1/4-in. grooves is removed by guiding router freehand.

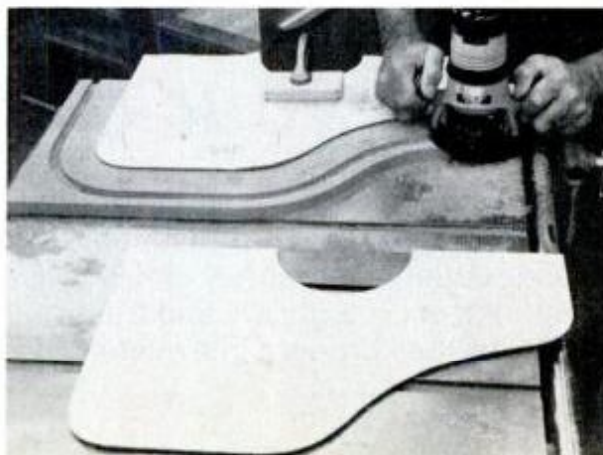

You've seen it in the movies: They've been drilling for oil for ages. They're broke, ready to quit. Then all of a sudden the well comes in a gusher, pouring down on them like black rain. Their troubles are over; they're rich. Delirious with joy, they splash and roll in the oily muck. Cut.

With slight changes in the script, this could be the true-life story of the Douglas Mitchell family living near Bartlesville, Okla. When Doug, a forestry expert turned amateur prospector, recently struck oil in his back yard, the Mitchells didn't romp in the muck, nor did they become rich overnight. Though the well was pumping a healthy 76 barrels of oil a day at \$11 a barrel, it would be a long time before the Mitchells could begin to enjoy their good fortune—they'd be paying off mounting bills and loans.

While more people are finding oil in odd places, not everyone can expect to. It helps, of course, if your back yard happens to be in Oklahoma, a state known to contain oil deposits. The first oil discovered there was at Bartlesville, the Mitchells' home town. That's why Doug's father, a long-time oilman with Phillips Petroleum, acquired the mineral rights to the property when he bought the land. His foresight paid off.

Long, tough road ahead

But it wasn't easy. Before Doug went into prospecting, he had been holding down two jobs and his wife, Linda, taught school to make ends meet. When he decided to take the gamble, he had to give up his jobs and the family of six had only Linda's teaching for support. They grew as much food as possible and tried raising cattle, but crop and cattle losses added to their troubles. Doug worked 16-hour days while other family members helped with farm chores. Linda, whenever she

wasn't teaching, was out back with Doug slinging well pipe around like a toughened, seasoned oilman. They sweat night and day for a year. Doug borrowed on his life insurance and took out every bank loan he could wangle. He scrounged second-hand equipment, much of it old and outmoded. He had bet his last buck on a hole in the ground.

The first step was installing a K-type Star spudder—an antiquated cable-tool drilling rig used in the earlier days of prospecting. It cost \$500, kept falling apart and spent almost as much time in the repair shop as on the job. The crown sheave, a heavy pulley wheel, fell off one day,

nearly killing Doug. Cable-tool equipment has now largely been replaced by modern rotary drilling rigs. But rotary drills are expensive.

Slow going

A cable-tool rig consists of a heavy steel mast with a pulley at the top. The drill stem and bit are suspended on the end of a steel cable that runs over the pulley and is spooled around a motor-driven drum at the base of the mast. The drill is raised by power and drops by gravity, continually rising and falling in the well casing as the bit chisels away the rock.

Doug doggedly drilled away for two months in the bitter cold of mid-

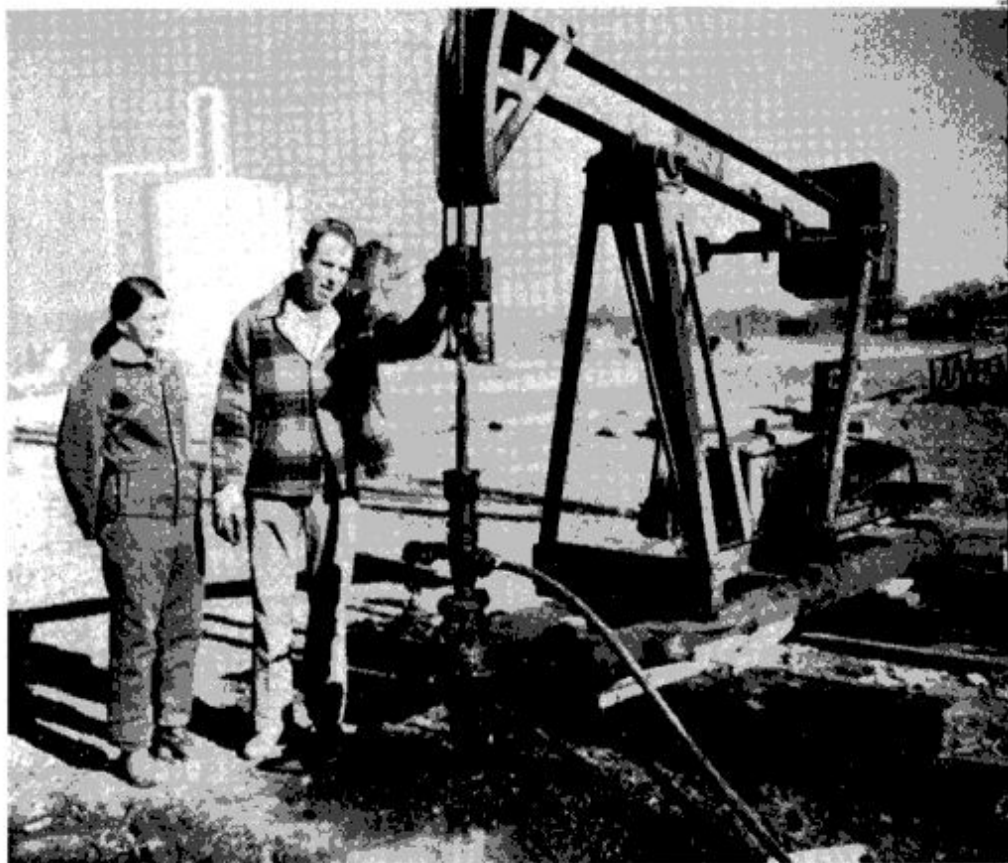

Old rocker-arm pump pours out a steady flow of oil from Mitchell ranch near Bartlesville, Okla. Well is now paying off after much time, sweat and money.

Striking it rich— oil in your own back yard

They laughed when a young couple decided to try for oil on their small ranch in Oklahoma. Their equipment was antiquated, their money almost gone. Then finally, after months of grueling toil and frustrating moments of near failure, they brought in a gusher. Nobody's laughing now.

by James M. Liston

winter as the bit inched slowly down. Son Jim, 13, became a helper on the "crew." A drill crew on such a rig usually consists of the driller who operates the equipment and a "tool dresser" who sharpens bits and washes sand samples. The wind blowing across the Oklahoma prairie in January can be vicious, but says Doug: "No man ever had a better crew. Linda and Jim kept me going."

He kept going until he had reached 1287 feet by the end of February. Now came the crunch. He needed more pipe and pumping equipment. He was out of money and there was nothing left to borrow on. If he didn't complete the well, they'd be

hopelessly in debt and would lose the ranch. It began to look as if he had dug a hole he couldn't get out of.

Help comes running

But word got around among friends and neighbors, even people they had never heard of: The Mitchells had problems. Suddenly things started happening. One stranger offered the use of a winch truck. Others contributed tools, tubing, rods, a pump and two 100-barrel storage tanks.

"With help like that, we felt we just had to succeed," says Doug.

The well looked promising. Minute traces of oil were beginning to show

up on the drilling tools and in bottom samples. Some oilmen rub a pinch of sand between their fingers while holding it up to an ear and claim they can "hear" oil—a difference in the grittiness of the sand. Watching for oil traces on the tools is called "catching teardrops." The Mitchells were definitely catching tears.

It was time to call in a contractor to "treat" the well—prepare it for production. The 4-inch steel casing first has to be cemented in place at the bottom. Then a probe is lowered that produces a radioactive log of the well. This gives a cross-sectional "map" of the various formations, helping to determine the best depth

(Please turn to page 151)



THREE STEPS TO MAKING A WELL PAY OFF

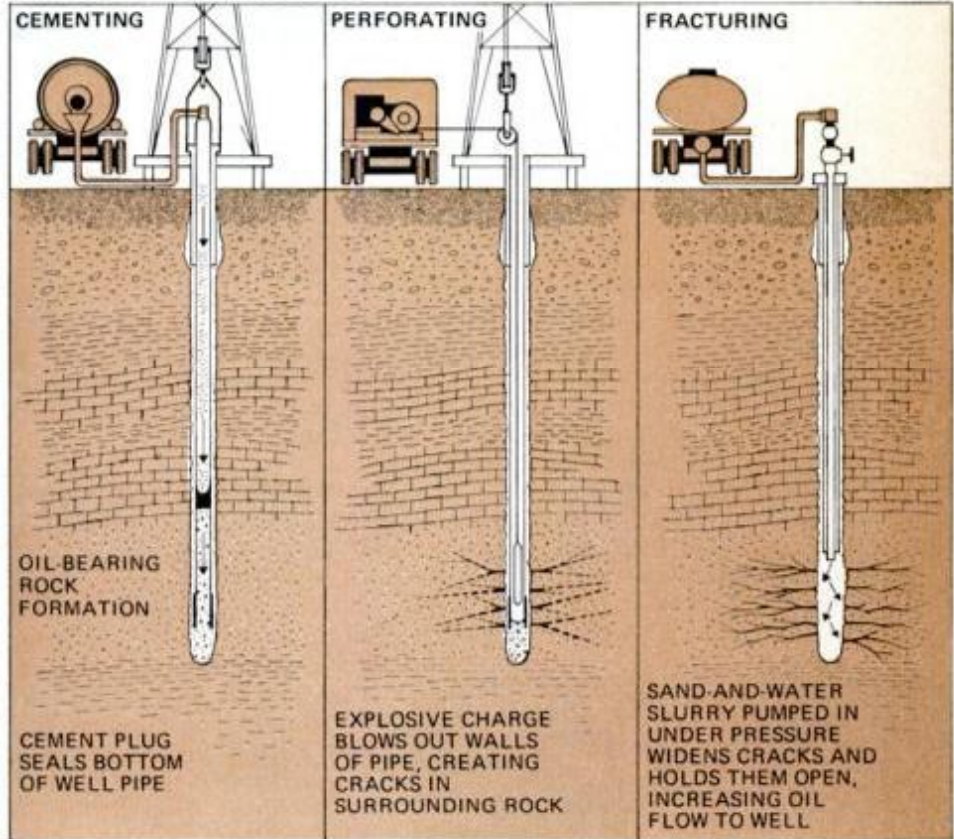

Dulled drill bits must be constantly hammered back to shape with a sledge, then resharpened—called tool dressing—as shown in upper photo. In lower photo, Mitchell family poses in front of ancient cable-type drill rig that brought in the well. Drawings show steps in opening well bottom so oil flows in.

Linda Mitchell guides section of well pipe into place as husband Doug lowers it (near right). Two worked together as team during long drilling ordeal. At far right, Doug climbs ladder to check oil level in storage tank with a simple "dipstick"—a long pole. Instrumentation isn't fancy.

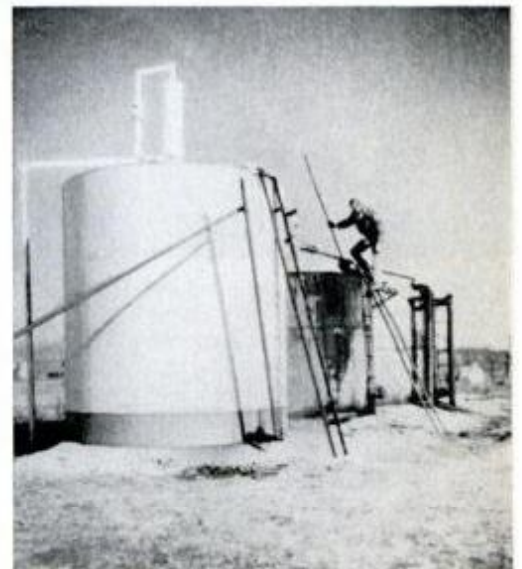

How to replace

Your biggest problem with disc brakes is worn pads. Inspecting and replacing pads isn't difficult when you know tricks the pros use, and follow an orderly procedure.

Frequent brake-pad inspection pays dividends. If you do it every time you're supposed to rotate tires, you should never have to resurface or replace rotors (discs).

A brake-pad replacement kit, which generally consists of four pads—two for each of the two front wheels—and other necessary parts, costs \$8 to \$13, depending on the car. But remember that the main cause of rotor failure is the wearing down of pads, leaving metal scraping against metal.

Pistons and pads

Disc brakes have one, two or four hydraulically driven pistons that force pads against revolving rotors. Except for some trucks, two-piston units are passé. They were used on 1963-66 Studebakers, first in the United States to offer discs.

Except for 1970 AMC models, 1970-72 Dodge Darts and Plymouth Valiants, and Corvettes and Camaros with disc brakes at all four wheels, all cars with discs since 1970 use

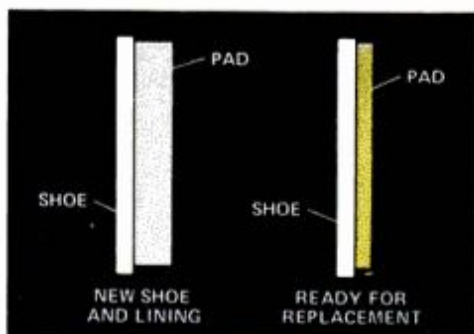

Check the thickness of the disc-brake pads periodically so you don't score discs.

trate on Delco-Moraine and Kelsey-Hayes one-piston units, used in nearly 98 percent of all cars with disc brakes built in the '70s. Only Pinto, Mustang II, Maverick and Comet use the Bendix one-piston unit. If your car's disc-brake unit is other than the two discussed here, you should have little trouble changing its worn pads if you follow these procedures, with slight variation.

Delco-Moraine one-piston units

Cars using this system are:

- Buick intermediate and compact models, 1969-76, and Buick full-size models, 1970-76.

- All model Chevrolets (except those noted), Cadillacs, Oldsmobiles and Pontiacs, 1969-76.

Inspect the outer pad: Look in each end of the caliper, where wear is usually greatest. Check inner pad by looking through the inspection hole in the top of the caliper.

If either pad is worn to about the same thickness as the metal shoe to which it's riveted, replace both pads and those on the disc unit of the other wheel. All-around replacement assures braking equalization.

Seat piston in bore using C-clamp (Delco-Moraine single piston, Step 4).

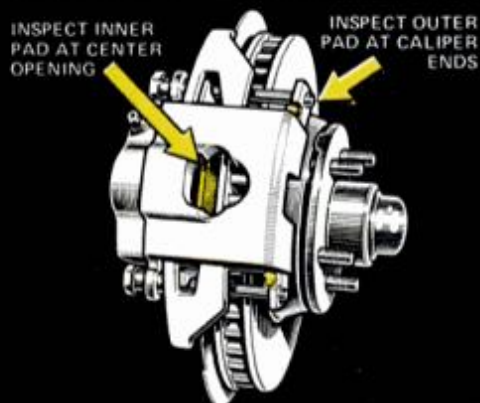

Pad inspection can be done without having to remove calipers on Delco-Moraine assemblies and on some Kelsey-Hayes units.

either Delco-Moraine, Kelsey-Hayes or Bendix one-piston units. Discs with four pistons were mostly used before 1970 and on the above exceptions.

Disc brake types

We don't have space to discuss repadding all types, so let's concen-

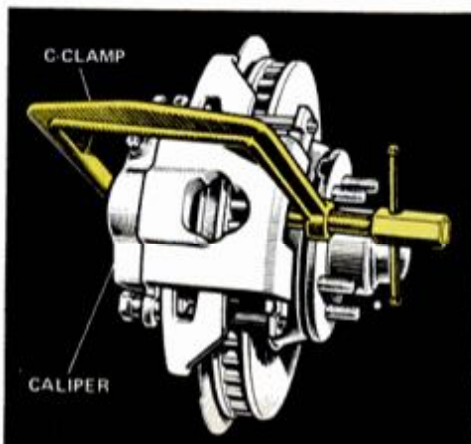

Steps in replacing the pads of a Delco-Moraine single-piston setup:

1 With a clean spoon, dip brake fluid from the master cylinder reservoir so it remains about one-third full. Discard fluid. Make sure you're not taking fluid from the wrong reservoir by tracing brake lines to see which feeds front discs and which feeds rear drum brakes.

Don't unscrew the brake line to draw off fluid, and don't empty the master-cylinder reservoir of all its fluid. Doing so will make it necessary to bleed air from the hydraulic system when you're done, and who wants to get involved with that!

2 Jack up the front of the car, making sure everything is secure. Remove the front wheel assemblies.

3 Put a seven-inch C-clamp on the caliper so the solid side of the clamp rests against the back of the caliper and the screw end rests against the metal side of the outer shoe.

4 Tighten the C-clamp as much as you can to move the caliper out away from the car and push the piston to the bottom of the bore.

5 With the caliper moved out and the piston bottomed, remove the C-clamp.

6 Unscrew the two mounting bolts which attach the caliper to the support bracket. Note that bolt heads

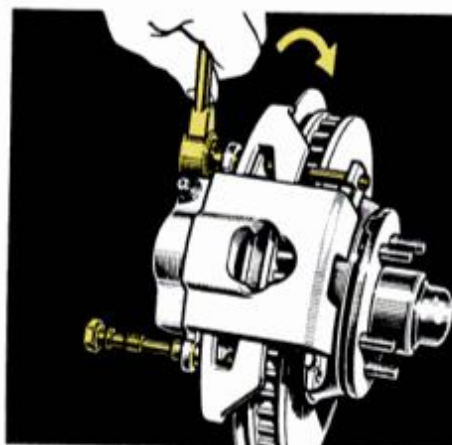

Release the calipers from the support brackets by unscrewing the bolts.

are behind the caliper. Use a socket and ratchet, if you have them, but you can also work an open or box-end wrench into position.

7 Lift the caliper off the disc. You needn't disconnect the brake

disc brake pads by Mort Schultz

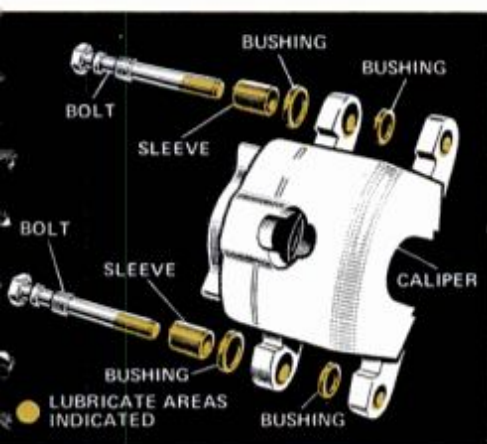

Lubricate the parts of the caliper assembly as indicated in color above.

hose, but be sure that you don't put stress on the hose.

8 You can now remove inner and outer pads. If either is stuck, pry it off carefully with a screwdriver, but watch out that the tool doesn't slip and damage the caliper.

9 Remove antirattle (shoe support) spring—it will be lying either in the piston cavity or on the inner shoe. Place this spring with the new pads. It will be reused.

10 Turn to the two inner ears of the caliper. Push out and discard the sleeve from each. Remove and discard the rubber bushings in the grooves of the *four* caliper ears.

You should have four new bushings and two new sleeves in the pad replacement kit you've purchased. Make sure they are the right pads for your Delco-Moraine unit.

11 Clean holes and bushing grooves in the caliper ears with a rag and wipe dirt from mounting bolts. Do not use an abrasive cleaner. It will rub away the plating.

Four disc-brake-pad types that vary depending on configuration of the calipers.

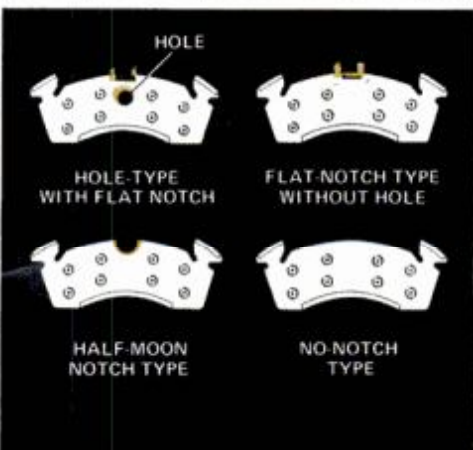

If bolts are corroded or bent, replace them. Clean inside of the caliper.

12 If fluid is apparent on the piston dust boot, the caliper should be overhauled. Otherwise, wipe the boot clean with a rag.

13 Use good-quality silicone lubricant to lubricate entire surface of new sleeves, new rubber bushings, bushing grooves and tips of mounting bolts. Install rubber bushings in caliper ears by hand.

14 By hand, install sleeves, positioning them so the ends that face the pad assemblies—the inner ends, that is—are flush with the machined surfaces of the ears.

15 Four variations of inboard pad assemblies are made for Delco-Moraine units: no-notch, half-

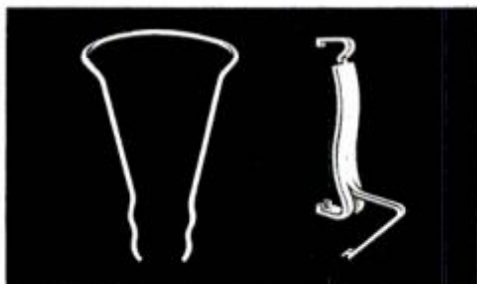

Springs that hold disc-brake pads: At left is the spring-wire, antirattle spring; the clip type is shown at right.

moon notch; flat notch without hole, and flat notch with hole. Your variation depends on the caliper your car uses. Examine the setup to identify that and proceed with installation. Be sure to note that no-notch and half-moon notch pads have a spring-wire antirattle spring and the other variations use a spring-wire antirattle spring or clip-type spring.

16 If your unit has a spring-wire antirattle spring, place it in the center of the piston so the spring's two tangs point up and toward the front of the caliper. Put the new inner-pad assembly in the caliper so the bottom edge of the shoe rests against the spring's tangs. Shift spring, if necessary, so its tangs will fall in the center of the shoe.

Press down on the ears of the shoe to get it to lie flat against the piston. With the assembly properly seated, the spring's tangs won't extend more than 0.100 inch above the base of the shoe.

Art: Peter Trojan

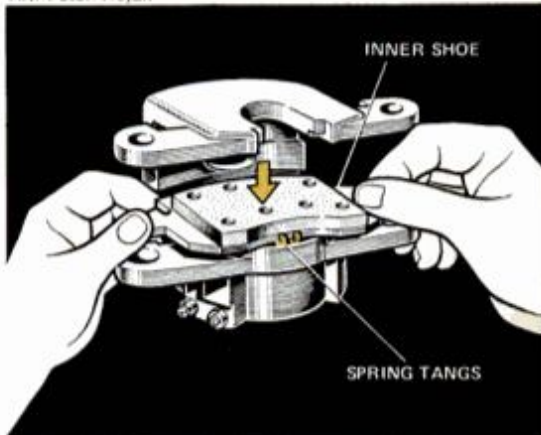

Inner pad is installed with the help of the spring-wire, antirattle spring.

17 If your units use a clip-type spring, place its top tang over the notch in the center of the inner shoe or into the hole from the rear of the shoe and press the spring on. It should fit the shoe securely at top and bottom.

Place the pad assembly on the caliper and press down on both ends until the shoe falls into a flat position, resting on the piston.

18 With inner-pad assembly in place, put the outer-pad assembly in the caliper so ears of the shoe line up with caliper ears.

19 Lift the caliper and rest bottom edge of the outer-pad assembly on outer edge of the disc. See that *no* clearance exists between tab of the outer shoe and caliper.

20 You should have a clean piece of $\frac{1}{4} \times 1 \times 2\frac{1}{2}$ -inch metal stock handy for use as a bridge across the cutout in the caliper. Bridge the cutout and reattach the C-clamp, making sure it's clean to keep from transferring dirt to the pad.

Do not tighten the C-clamp too much—just enough to hold the bridge securely and press the *outer*-pad assembly against the caliper with moderate pressure.

21 With Vise-Grip or Channel-lock pliers, clinch both ears of the outer shoe. Hold pliers $\frac{1}{8}$ to $\frac{1}{4}$ inch away from the outer edges of the ears.

Ears must be clinched flat against the caliper housing so no clearance exists. If there is clearance, do the clinching again.

22 Remove C-clamp and place caliper over the rotor, lining

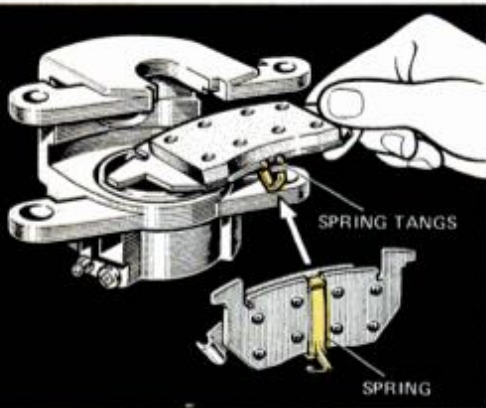

After spring is fitted securely, the inner pad can be fitted to the caliper.

up holes in caliper ears with holes in the support bracket. Be sure the brake hose is straight.

23 Insert mounting bolts through sleeves in the inboard caliper ears and push bolts through to engage bushings in the outboard ears, starting bolt threads into the support bracket carefully. Don't cross-thread. Tighten bolts with a torque wrench to 30-35 ft.-lb.

24 After installing new pads on both wheels, put on wheel and tire assemblies and fill the master cylinder with brake fluid meeting heavy-duty standard SAE J1703. Pump the brake pedal a few times and recheck fluid level. Add fluid if necessary to bring level within 1/16 inch of the reservoir top.

Kelsey-Hayes single piston unit

Cars using this system are:

- All AMC models, 1971-76.
- Plymouth Fury, Belvedere, Satellite and Barracuda; Dodge Monaco, Polara, Charger, Coronet and Challenger; Chrysler (except the 1969 Imperial), 1969-76.

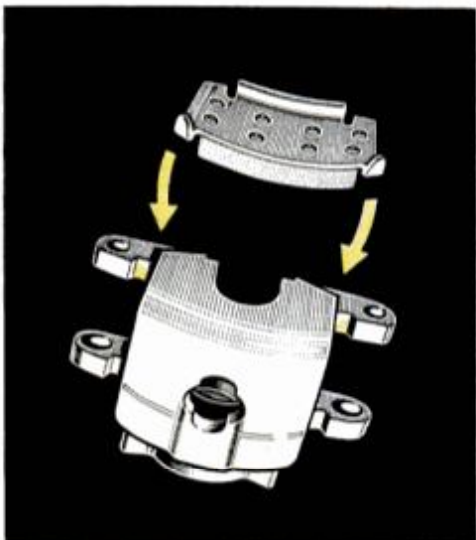

Outer pad assembly is fitted and attached to the caliper as shown here.

■ Ford; Mercury; Mark III and IV; Thunderbird, 1968-76.

■ Lincoln, 1970-76.

■ Cougar and Mustang (except Mustang II), 1968-76; Montego and Torino, 1968-76; Fairlane and Falcon, 1968-70; Comet, 1968-69.

Let's start with the Kelsey-Hayes unit on Chrysler and AMC models. Inspection of pads is the same as for the Delco-Moraine brake. So are preliminary steps of removing brake fluid and raising the car. Now proceed:

1 With a socket, remove the caliper guide pins and positioners to separate caliper and adapter.

2 Slowly move caliper out and away from the rotor.

3 Fashion a hook from a wire coathanger. Hook one of the ends through caliper, the other around a suspension member so caliper hangs without straining brake hose.

4 Remove the inner and outer pad assemblies, and the antirattle spring. Save the spring.

5 Use a drift to remove and discard outer bushings from caliper holes.

6 Slide inner bushings off guide pins; remove positioners.

7 Be sure there is no fluid leak. Use a clean hand to push piston back in place if you can. If not, use a clean C-clamp.

8 Install two new inner guide-pin bushings from your pad replacement kit in the caliper with the flanged end of the bushing on inner side of the caliper.

9 Compress flanges of the two outer bushings and work them into their respective holes in the outer holes of the caliper. Press in place, if necessary, with the flat side of a screwdriver tip.

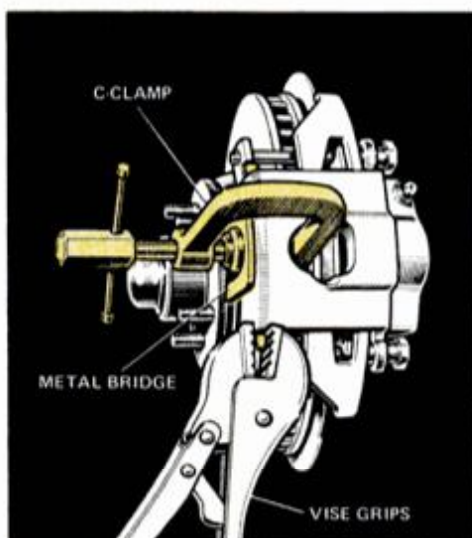

For installation of the outer shoe (Step 21, page 87), "vise-grip" pliers are used.

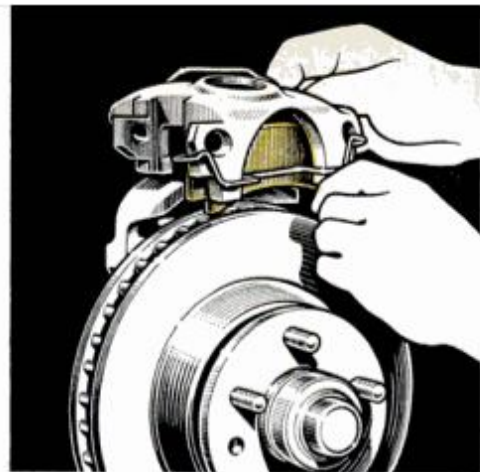

Caliper is replaced on disc by aligning guide pin holes. (This is the Kelsey-Hayes single-piston unit).

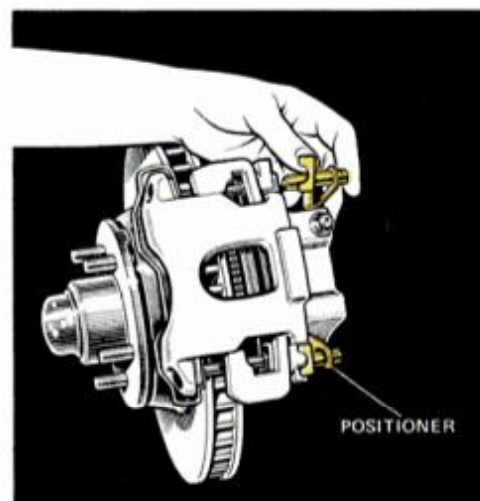

Guide pins are installed, as you make sure that the positioners are in place.

10 Slide new inner-pad assembly into adapter. Metal shoe must be seated fully in adapter recess.

11 Slide the new outer-pad assembly into caliper so the antirattle spring slides over outer part of the caliper. Be sure metal shoe is seated fully in caliper recess.

12 Hold inner-pad assembly in place and carefully slide the caliper in position on adapter and over rotor. Align guide-pin holes.

13 Install new positioners on guide pins with the stamped arrows on the positioners pointing upward. Working from the inboard side, install positioners and guide pins through the bushings and holes.

14 Press on ends of guide pins and thread them in place. Take care not to cross-thread. Tighten guide pins to 30-35 ft. lbs.

15 Refill master cylinder with brake fluid meeting Department of Transportation standard 3. Mopar brake fluid is recommended. Press brake pedal a few times and recheck master-cylinder fluid level.

The Kelsey-Hayes single-piston disc-brake system used on Ford Motor Co. cars is repadded similarly. The major difference is that two antirattle clips are used. ★★★

IT'S NEW **NOW**

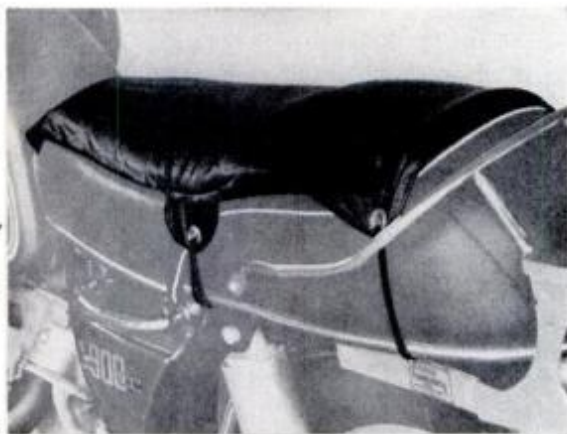

Hydraulic shock absorber for cyclists

If you've got a waterbed at home and yearn for the same kind of comfort on your motorcycle, you can install a Travel Ease Water Cushion on its seat. For winter riding, fill it with hot water—but add rubbing alcohol for antifreeze. Rider and passenger cushions are individually adjustable. \$24.95 ppd. JML Products, Box 3708-A, Milwaukee, Wis. 53217. Specify make, model, year of bike.

Bolt-on bike engine is self-starting

This mini gas engine for bicycles needs no starting rope to get it going—it starts itself as you roll along. Basically the same engine as AquaBug's outboard motor, it hits up to 18 mph, gets over 200 miles to the gallon. \$174.95. AquaBug International, 100 Merrick Rd., Rockville Centre, N.Y. 11570.



New generators for stand-by power

Power insurance for the home is given by Onan's new series of portable generating sets that produce 120/240-v. power. Used with Onan's transfer switch, they can meet a house's electrical needs during a short or extended outage (see *Your Own Electric Power—Whenever You Need It*, page 102, July '74). P-series sets have tubular carrying frame or hood and dolly shown, with wattages from 2000 to 5500. Prices: \$616 to \$1280. Onan Corp., 1400 73rd Ave. N.E., Minneapolis, Minn. 55432.



Multipurpose drive kit

Easy-driver toolkit has reversible ratchet in Lexan ball that gives large grip for lots of torque, includes heavy-duty blade, drive-shaft, screwdriver bits, 1/4 and 3/8-in. drive socket adapters; \$11.95. Creative Tools, 309 County St., Bennington, Vt. 05201.



Fast oil finish

Tru-Oil gives hand-rubbed finish without rubbing. Works on stained or unstained, old or new wood. Needs no separate filler, dries in 60 to 90 minutes; 8-oz. can \$3.50, spray can \$2.19, plus \$1 postage and handling, from Birchwood Casey, 7900 Fuller Rd., Eden Prairie, Minn. 55343.

Pipe wrenches for the do-it-yourselfer

Four pipe wrenches designed especially for homeowners feature full-floating hook jaw, forged hardened steel jaws and I-beam handles with comfortable grips. The tools are patterned after the Ridgid line of heavy-duty professional pipe wrenches. Sizes available are 8, 10, 14 and 18 inches. Suggested retail prices range from \$3.99 to \$11.49. The 14-inch model shown here is \$7.99 suggested retail. Ritco Hardware Div., Ridge Tool, 321 Summer St., Elyria, Ohio 44035.



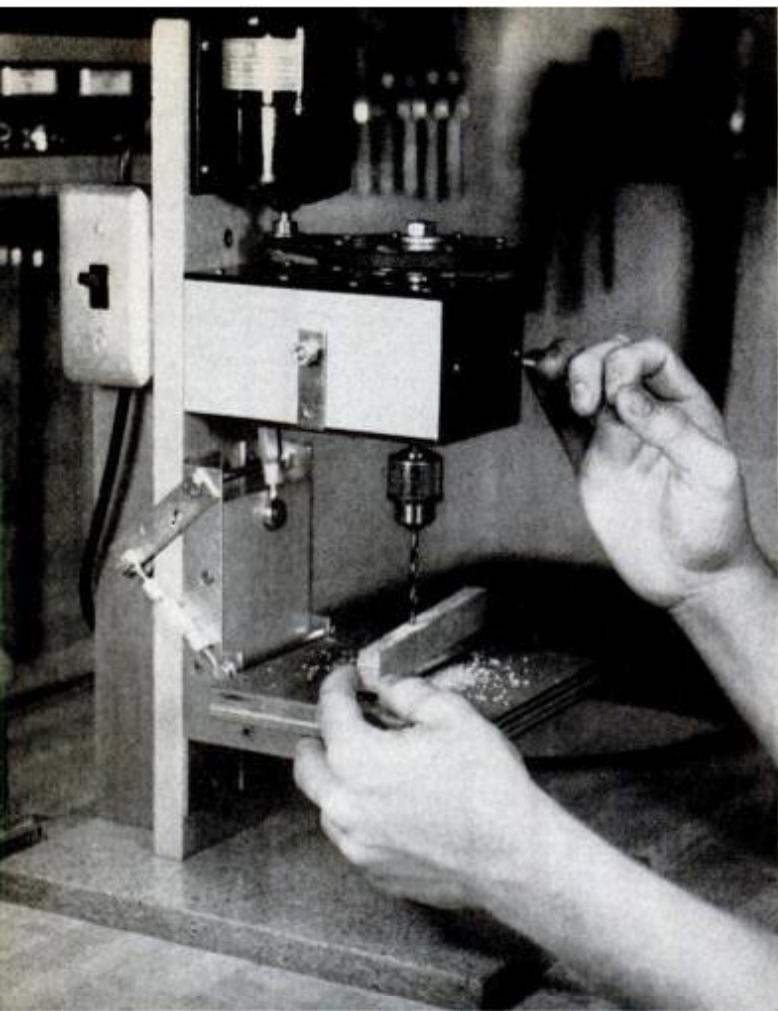

TWO SHOP TOOLS YOU CAN BUILD

Beginner's drill

This simple drill press, designed for the person who needs an inexpensive machine for small projects, can be built with common hand tools.

If you have an old sewing-machine motor and a 1/4-in. drill chuck, you can build the drill press for about \$15. Despite low cost and simple construction, it will drill 1/4-in. holes in hardwood or light metal without overloading, and work with enough precision for the delicate drilling many hobbyists require.

The ball-bearing spindle for the drill press is a bicycle axle, hub and bearing assembly made by Union and sold by Schwinn dealers for about \$5. Axle threads fit 3/8-24 thread commonly found on 1/4-in. chucks. Spindle and motor are fixed in place and the table moves to feed the work to the drill bit. Table height is adjustable by means of a turnbuckle, which is also a depth stop. The metal plates are standard items and already have the holes required, although some of these may have to be enlarged. Ends of wood parts must be square, as final alignment will depend upon them. Use a miterbox or allow extra material for truing with coarse sandpaper.

Start building with the spindle assembly. Assemble parts with the hub in place and mark locations for six 6-32 bolts to hold the hub. Disassemble, drill 9/64-in. holes for bolts, reassemble with eyebolts and other hard-

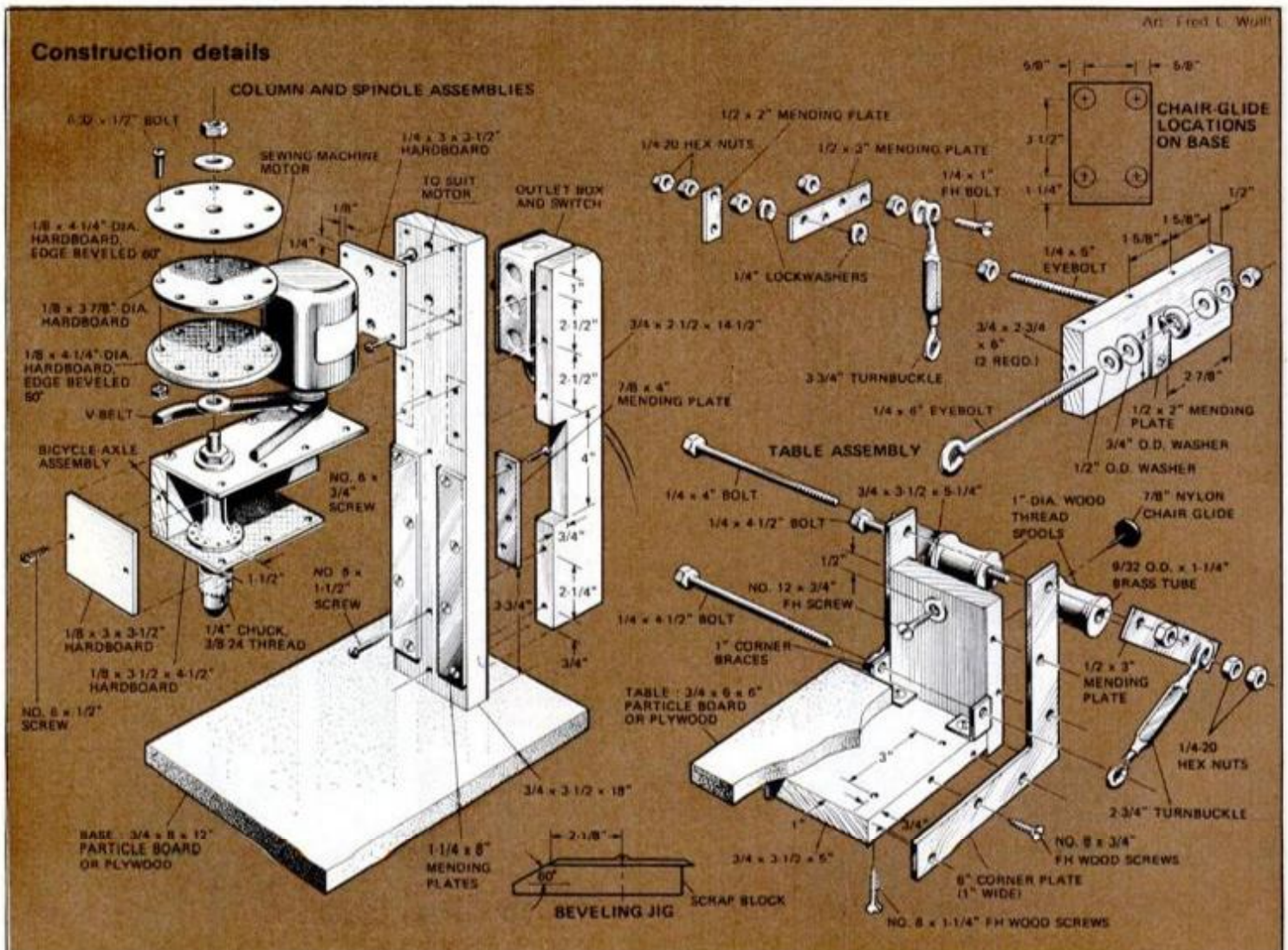

press by Richard F. Cutler

ware in place. Holes in the bike hub may require slight enlarging to accept bolts.

Make the column assembly next, then begin the table assembly by attaching nylon chair glides to the backboard. Glides must not be more than 3/16 in. thick; I used Hancock-Gross type 1336C. Attach corner plates to the backboard and subtable; since some screws must be placed near board edges, clamp boards near the screw holes to keep the wood from splitting as screws are driven. Attach corner braces, turnbuckle and table. Turnbuckle size is measured between centers of eyes in fully closed position.

Epoxy brass tubing (from a hobby shop) into spools with 1-in. dia. rims (Coats & Clark and Star are best). The table assembly may now be attached to the column. Adjust turnbuckles so the table moves freely, without excess binding or play. Fast-

en the spindle assembly to the column and hook up the table-lifting hardware; adjust if necessary.

Build up the pulley, and drill eight equally spaced 9/64-in. holes around the edge. Coat inside surfaces with epoxy, bolt together. Coat V-groove with epoxy and place in warm (150° F.) oven until cured; repeat coating until groove looks glossy. Drill centerhole to 3/8 in., attach pulley to axle with hardware supplied with hub.

Most motors used with a standard Singer belt (part No. 198651) will require a 1/4-in. spacer (two pieces of 1/8-in. hardboard). Spacer thickness should make the belt snug but not tight. Most sewing-machine motors are rated at 1/15 hp at 5000 rpm; this gives a bit speed of about 1000 rpm. Install the outlet box and switch after the motor is mounted. After adjustments are made, the drill press may be taken apart for sanding and finishing. ★ ★ ★

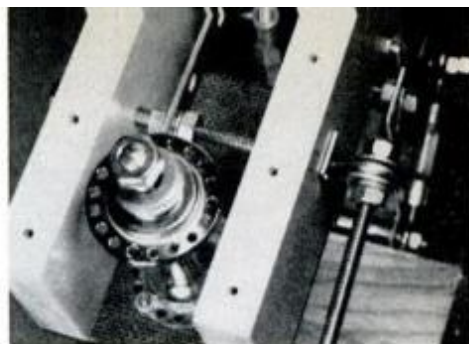

Spindle assembly contains a bicycle-hub bearing and table-lifting linkage.

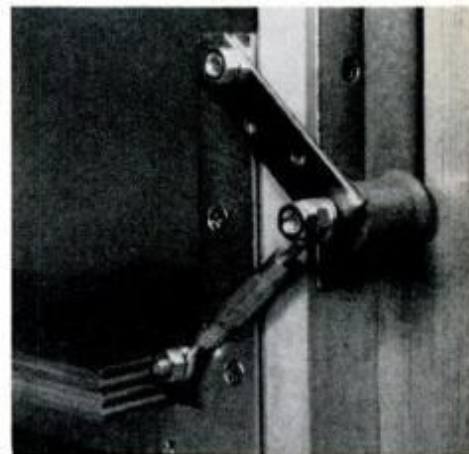

Thread spools serve as rollers for table movement; turnbuckles permit adjustment.

Parts cleaner

After working on a car or lawnmower, you want something better than a pan of kerosene to clean parts in. I built a parts degreaser like those used in garages, holding costs down by using a portable electric drill and an inexpensive drill pump. The basin is a radiator drain pan, supported by three angle-iron legs attached with aluminum straps Pop-Riveted in place.

Three angle-iron braces bolted or welded to the legs form a shelf for the kerosene tank, a 2 1/2-gal. gas can held in place by the 1-in. drain tube. (Handle and fill vent on the can are removed. A 1-in. tub drain goes at the center of the pan, with a matching threaded fitting soldered to the drain tube—which is soldered to the tank when the rest of the assembly is complete. Drill mounts on the

platform with a U-bolt of 1/4-in. steel rod threaded at the ends (or threaded rod). Clamps shaped from 1/8 x 3/4 in. aluminum bar stock hold the pump. The discharge tube is 1/4-in. copper tubing, the splash shield is galvanized sheet metal Pop-Riveted to the pan (with standoff brackets for a lipped pan). Suction and discharge lines to the pump are vinyl tubing.—Douglas Blodgett

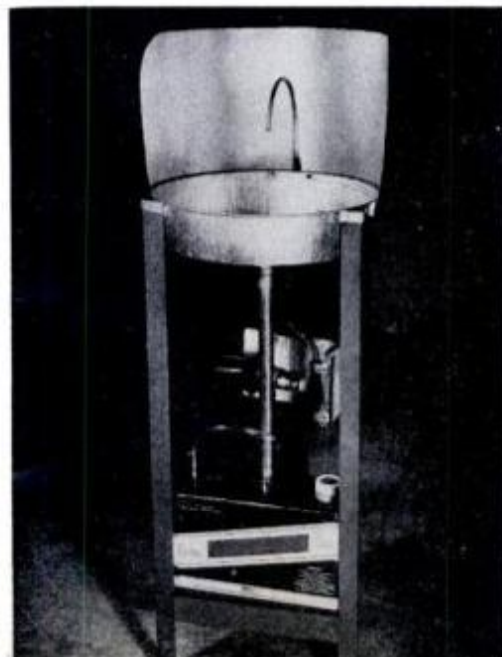

Degreaser circulates kerosene from tank to basin and back for cleaning grime-laden parts—and an old toothbrush is a good scrubbing tool. Unit is powered by 1/4-in. portable electric drill driving a small pump. Platform of 3/4-in. plywood allows removal of drill or pump for other use, separately or together.

"Call me from that phone over there," said Gerald Kruse, equipment supervisor at a large San Francisco telephone exchange. I did, and his phone began to ring even as I pulsed out the last digit on the push-button phone I was using.

"That's electronic switching at work," Kruse started to explain; but before he could finish, I heard a short beep tone on the line. "This is a call coming in for you," he said.

I pushed down my switch hook, then released it. Kruse was on hold, and I heard another voice: "We're ready for the next demonstration," it told me.

I hit the switch hook again to put that call on hold and bring back Kruse. Then we all hung up to try a new trick: three-way calling. I phoned Kruse and put him on hold by hitting the switch hook. I heard a pulse interruption, then a new dial tone. Pulsing a second number brought back my other caller, a maintenance man elsewhere in the Pacific Telephone building. After I touched the switch hook again, Kruse was on the line with us.

"You can go on doing this almost indefinitely," he explained, "as long as each new line you bring into the circuit is equipped with the three-way calling feature.

Our conference call over, I hung up and punched out a special code. Then Kruse and I went to another part of the building, knowing that any calls we got would follow us there.

Not futuristic—they're here

There was nothing futuristic about the telephone services I'd just been using. They—and other features like Speed Calling and International Direct Distance Dialing—are already available to millions of U.S. telephone subscribers as part of improved switching systems. After 1978, even mobile telephone users should have some of these custom calling services.

Yet these improvements will all take place behind the scenes, as part of a new revolution in telephone central-office design called the Electronic Switching System, or ESS for short.

Few of us realize that the tele-

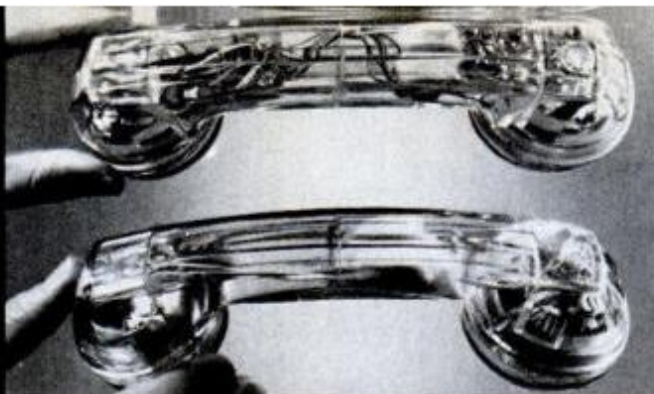

Amplified handset (top; note extra circuitry compared to standard model below it) will bring clearer reception to rural customers.

Invisible revolution inside your phone

by Joseph Zmuda

phone sitting on our desk or hanging on the wall is merely the first link to a vast, invisible switching network that provides communication to all parts of the world. While the telephone instruments in our homes change little over the years, modern technology is making big changes in the rest of the network. For example, the invention of the transistor at Bell Laboratories 28 years ago has led down a long road of research and development to ESS.

ESS takes the place of conventional switching systems that rely primarily on electromechanical call processing. In ESS, call switching is still performed by mechanical (though ultramodern) relays. But its control and memory sections use solid-state components—122,700 transistors in the metropolitan-type No. 1 ESS I was visiting—all mounted, together with other circuit compo-

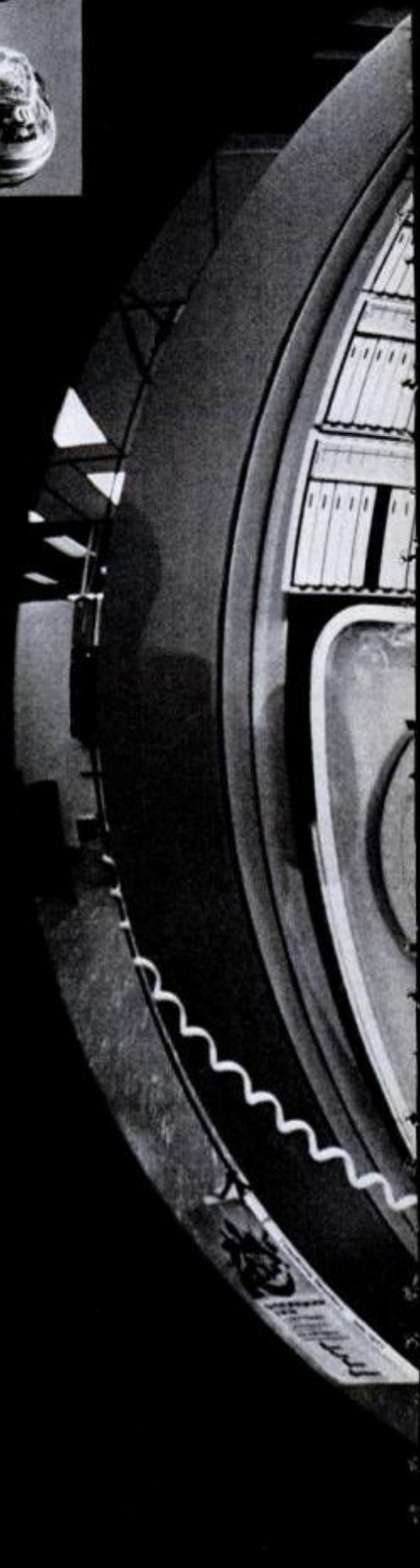

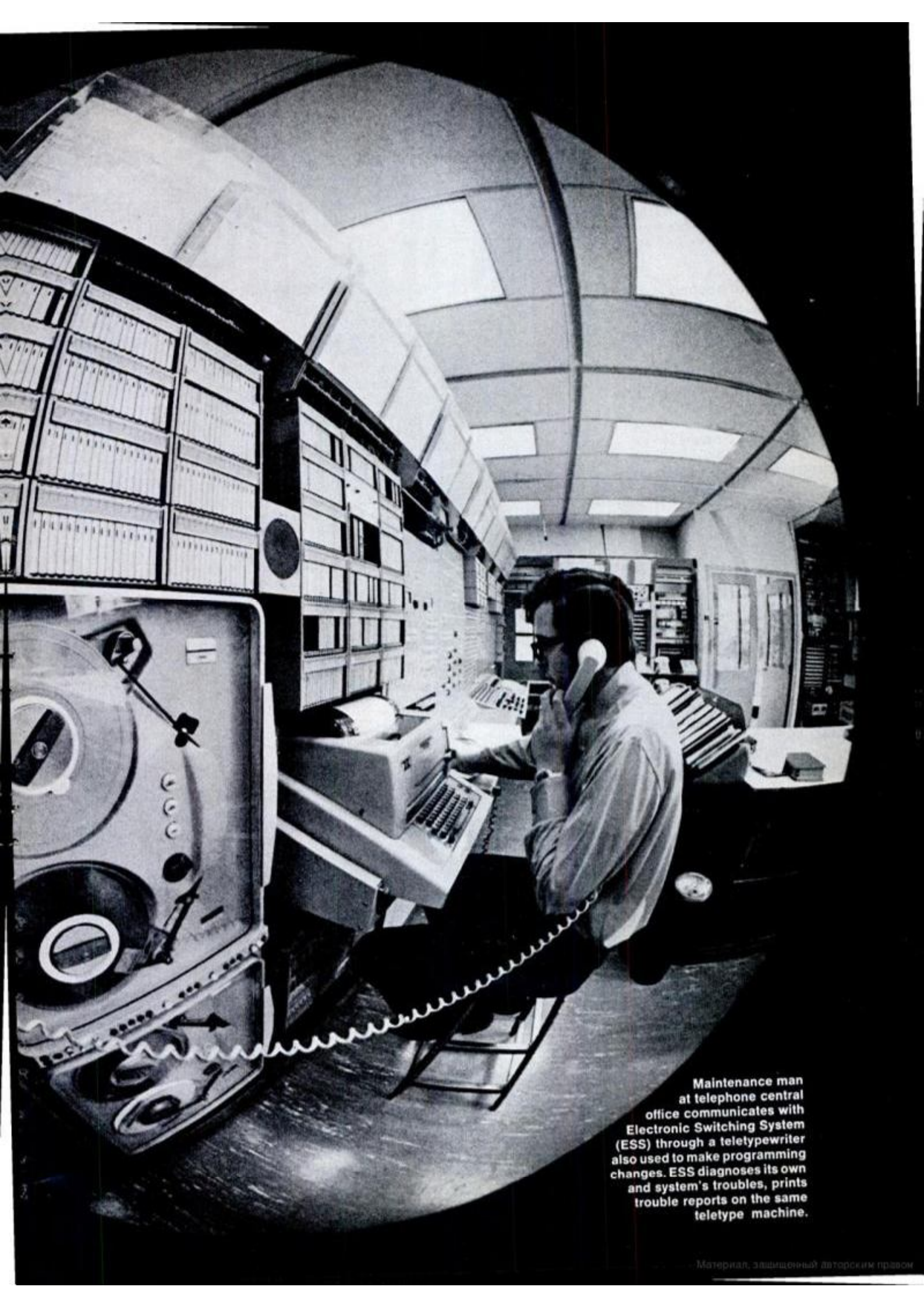

Maintenance man at telephone central office communicates with Electronic Switching System (ESS) through a teletypewriter also used to make programming changes. ESS diagnoses its own and system's troubles, prints trouble reports on the same teletype machine.

nents, on plug-in modules that are easily replaced in event of failure.

Along with the reliability and the rapid action of near-total automation, ESS also saves money through more efficient maintenance procedures. It's more compact, too: this particular ESS machine, capable of handling up to 110,000 calls per hour, occupies just half of one floor of the building. The neat and aesthetically pleasing banks of modern equipment give the office room the feel of a data processing center.

Touch-Tone and beyond

There is one revealing sign in our homes and businesses of the change in telephone technology, the push-button Touch-Tone phone. While all switching systems can be adapted to Touch-Tone calling, ESS features it as part of its program design. But even in the way it handles Touch-Tone calls, ESS is different, because it responds *instantly* to Touch-Tones and dial



Information operator uses computer-controlled microfilm for instant access to as many as 15 million listings.

pulses. That's how my call to Kruse got through so quickly—operating more than 2 million separate operations in the time it takes to complete a call.

A switchboard you 'talk' with

ESS has still another virtue: easy programmability. Conventional exchanges must be rewired in order to change your phone number or the type of service you require. With ESS, the phone company can alter the programming of any line through teletypewriters located in the central office and plant service center. This means quicker service changes, since phone company clerks can now program ESS directly, rather than having to wait for maintenance personnel to make needed wiring changes.

It also gives the customer some in-



Manual switching, as shown in this 1879 engraving, contrasts starkly with the speed, efficiency, accuracy and low manpower needs of today's ESS exchanges.

stant programming capability, using his pushbutton (or dial) phone instead of a teletype. Phone in an activation code and a phone number, and your calls are automatically transferred to that number till you dial the deactivation code.

With this Call Forwarding feature, you don't have to risk missing important calls, whether you're going next door or even out of town. When calls are forwarded, the calling party is billed the normal rate to your phone while you pick up the additional message units—or toll charges—to the forwarded location.

Speed Calling, too

Speed Calling, another ESS service, allows an individual to reduce the number of digits needed to dial frequently called numbers. Depending on which service you order, you can store up to eight or up to 30 commonly called numbers in the ESS memory system, and then dial them (even long distance numbers) by entering only three or four digits instead of the usual seven or ten. Aside from its speed, this service cuts down on misdialing.

Inside ESS

But the advantage of ESS may be less in the extra services it can provide than in the efficient way that it performs them. Mechanical switch-

ing machines delegate pieces of common equipment to customers for the duration of each call. But ESS cuts down equipment needed by constantly scanning every line it handles and switching only when it senses it can perform a useful function. The semiconductor logic circuitry of ESS's Central Control (CC) interrogates each line five times a second, sensing when a customer has picked up his phone, needs a dial tone, or has begun to dial, then moves on to see what everyone else's phone is doing before coming back to the first customer—200 milliseconds later.

Information about calls in progress and about the condition of equipment is continuously updated in a temporary memory called the Call Store. CC even checks itself; and data about troubles there or elsewhere in the ESS system is immediately printed out on the same teletype that the ESS personnel use in communicating their instructions to the machine. In addition, should a major trouble occur in Central Control, a duplicate CC is ready to take over until repairs are completed.

How CC will operate in any given situation is determined by information stored in a semipermanent memory, the Program Store. Thousands of thin, aluminum memory cards, each containing thousands of mag-

(Please turn to page 129)

Optical fibers (shown here being made by a new Bell Labs process) carry modulated beams of light instead of electricity. They may replace wires in underground telephone cables of the not-too-distant future.





Too's for cassette repair include: Audio Accessories kit (far left) with spare shell, splicer, and splicing tabs; 3M kit (top left) shown in more detail below; Editall splicing block (left) with splicing tabs, special tape-marking crayon, and razor blade. 3M kit (photos below) includes strips that fish broken tape ends out of cassette shell, splicing block to repair broken ends, winder to take up slack in tape after completion of repairs.

Snarled and broken cassette tapes can be fixed

by Robert Charolais and Ivan Berger

Cassette tapes don't break or snarl as often as they used to—improvements in cassette construction have seen to that. But the cheaper cassettes still are often troublesome, and even the better ones cause occasional problems—invariably on recordings that simply can't be duplicated.

Those problems may seem baffling—curlicues of tape snarled in your recorder's works, broken tape ends hiding shyly inside the cassette's plastic shell, even seemingly intact ones whose tape refuses to budge—but they can be cured. All it takes is a little knowledge, a steady hand, and the right tools.

The most common cassette problem is the jammed cassette whose tape won't move. The cause usually is friction inside the cassette, and an uneven "pack" of tape

(Please turn to page 128)

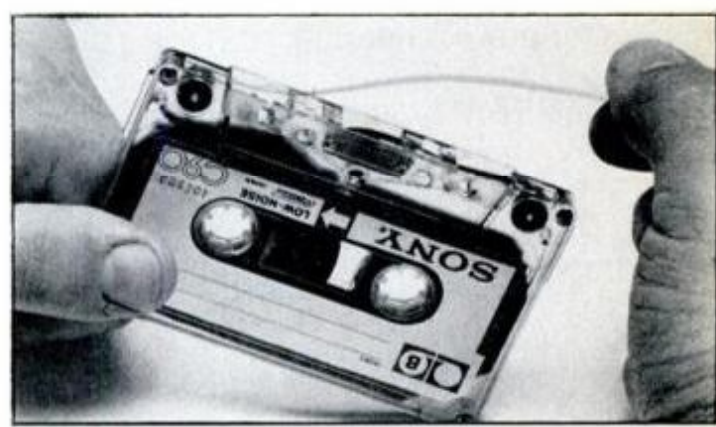

Build this raft boat for under \$450 —with power

Art: Fred L. Wolff

It took only a week of evenings and \$385.65 to build this simple and handsome pontoon deck boat. That price includes two electric outboard motors for power, steering.

by Michael McDougall

In several evenings' work you'll be ready to launch, once you start building this attractive pontoon boat. It is simple to construct, performs well, and the price is right. My cost was \$385.65, and though prices have gone up, you can still build yours for under \$450, including twin-screw electric power.

One key to the low cost is the availability of plastic-covered foam pontoons originally designed for a catamaran sailboat. I ordered each of them for \$65 plus \$5 handling f.o.b. from the Formex Corp., Box 812, 505 Belvedere Rd., Elkhart, Ind. 46514. They are now \$85 plus \$5 handling apiece, and worth it. The ABS covering of the Styrofoam gives the pontoons a handsome look, and fittings recessed fore and aft into each make them easy to attach. With a simple 6 by 8-foot plywood platform, reinforced by a supporting frame of 2x4s, the strong but lightweight pontoons will support a whole family or two couples.

Use two electric motors

I chose two trolling electric outboard motors to provide a comfortable 2 to 3-knot speed and a method of steering without a rudder. Mounted on the platform as far apart as possible, the motors will turn the boat in one direction or the other; you simply switch off the motor on the inside of the turn. To turn in one boat length, you reverse one motor.

You can't pull a water skier with

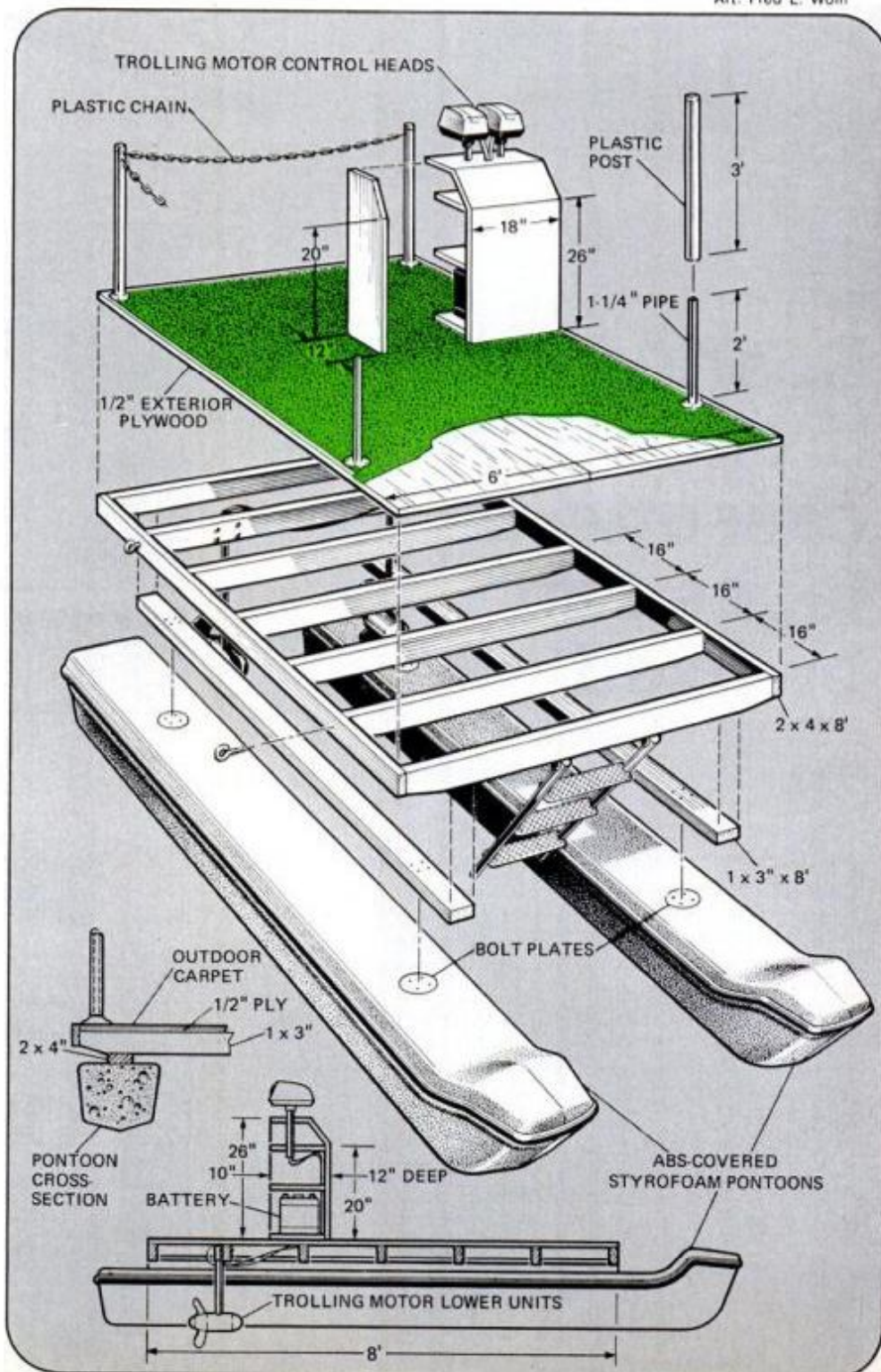



this arrangement, but you can keep up with some sailboats. A rudder and tiller can be purchased from the pontoon manufacturer.

Construction is simplified by the aluminum castings molded into the top of the Formex pontoons. They contain four $\frac{3}{8}$ -inch tapped holes to which the platform can be bolted. The 6 by 8-foot platform, reinforced by the 2x4s on 16-inch centers, provides a good compromise between weight and strength. One and a half sheets of $\frac{1}{2}$ -inch exterior plywood are used for the deck, and the remainder can be used for the control console. Coat everything liberally with wood preservative and marine paint.

Mounting the motors

To mount each motor, saw in half the tube connecting the control box and the lower unit. Splice No. 14 or heavier wire to the wires coming from the lower unit. Bring them through a hole drilled in a crutch tip that fits the motor shaft and seal with silicone adhesive. Run wiring from motors along the bottom of the platform and up through the console.

The console contains the battery and controls. Drop-front doors can enclose the shelves. Drill holes in the door enclosing the battery compartment to provide ventilation while charging. A lock on one compartment and a cutoff switch inside can pre-

vent unauthorized operation. I included a waterproof plug on the outside of the console to make hooking up a battery charger easy.

Construction is simplified by the aluminum castings molded into the top of the Formex pontoons. They contain four $\frac{3}{8}$ -inch tapped holes to which the platform can be bolted. The 6 by 8-foot platform, reinforced by the 2x4s on 16-inch centers, provides a good compromise between weight and strength. One and a half sheets of $\frac{1}{2}$ -inch exterior plywood are used for the deck, and the remainder can be used for the control console. Coat everything liberally with wood preservative and marine paint.

Finishing off

Cover the platform with indoor-outdoor carpeting and trim the edges with aluminum carpeting threshold. The safety stanchions are $1\frac{1}{2}$ -inch pipe screwed into pipe flanges. I covered them with plastic posts from a garden supply store and added plastic chain. Swimming steps are mounted forward and fold back under the deck. Install more rugged railings for fishing, or gas outboards for added speed. And get ready for questions and compliments. ★★★

Simplified steering requires only turning power knobs on control console (right). A drop-leaf door becomes a shelf for drinks.

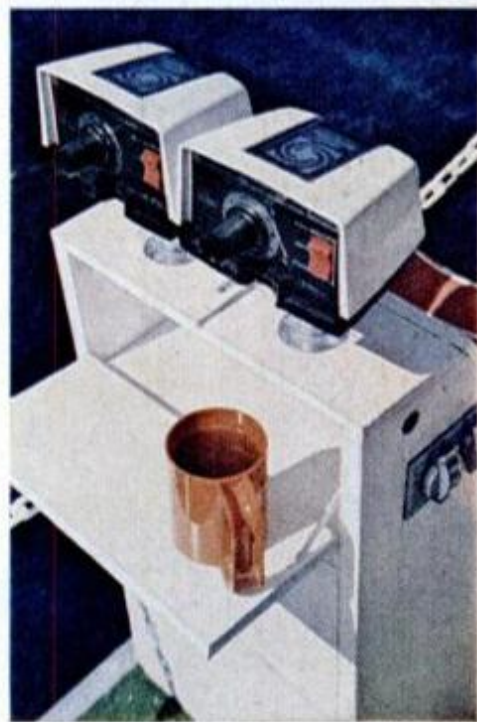

RAFT BOAT PARTS LIST

Lumber		4 $1\frac{1}{2}$ " pipe flanges	4.76
7 pcs. 2x4—8'	\$ 6.16	22' plastic chain	4.14
2 pcs. 2x4—8'	2.00	Miscellaneous	
2 pcs. 1x3—8'	3.68	2 electric trolling motors	80.00
2 4x8' pcs. $\frac{1}{2}$ " exterior-grade plywood	11.00	2 ABS-covered Styrofoam Formex pontoons, \$65 each plus \$5 handling (f.o.b); now \$85 plus \$5	140.00
Accessories		Heavy-duty 12-volt battery	41.25
Carpeting (felt polypropylene)	34.00	Wood preservative and paint	20.00
Double-stick tape (attach carpet)	2.50	Hardware	16.00
4 8' sections aluminum threshold	12.00		
4 pcs. $1\frac{1}{4}$ " x 2' threaded pipe	8.16		
		Total cost	\$385.85



Photo: Stephen Fay

© авторским правом

Two mini workshops for small spaces

Here and on the following pages are two ways you can get more shop than you ever thought possible into an apartment or small house.

1 We asked designer Tom Fung to give us a bench that would be really practical for a serious hobbyist but wouldn't spoil the looks of an attractively decorated room. His solution is a roomy workbench-cabinet that looks good enough to keep in the living room.

It's not for large-scale woodworking, of course, but the range of hobbies it can accommodate is impressive—try modelmaking, electronics, tabletop photography, movie or slide editing, microscopy, bookbinding and jewelry-making for a start. It's great for just about any kind of kit-building. Say you've got one of those Pocher 'd Italia car kits with 2199 parts—definitely not a one-evening project. With our mini-shop, you can leave parts set out as you like them on the rear section of the work counter, close up the drop leaf when you're done for the evening, and know those parts will still be there, undisturbed, when you come back.

Enough room for everything

We told Tom the bench must provide enough storage room so that all tools and materials for a hobby or

(Please turn to page 106)

It's a place (left) to keep everything for your hobby, with a well-lighted work area—but when it's closed (inset) our mini-workbench is beautiful furniture.

Construction: Rosario Capotosto
 PanaVise: Colbert Industries
 Stool, chair: Laverne Enterprises Ltd.
 Rug: Regal
 Model trains, tools: Roundhouse II, New York
 Styling: Shari Green



When you finish a project, you can snap its picture right at the workbench—seamless paper for tabletop photography unrolls from dowel rod near top of work area. Clamp-on photographic lights with "barn doors" are from Spiratone.

Car model: Anthony J. Arons

Art: Tom Fung

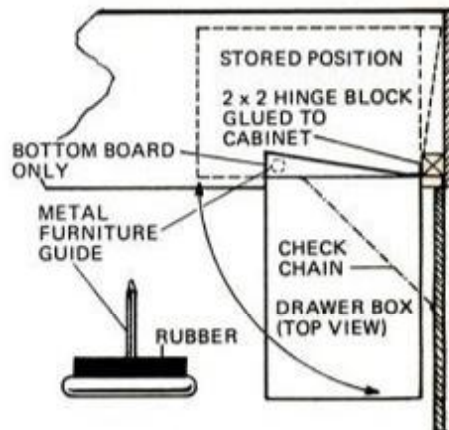
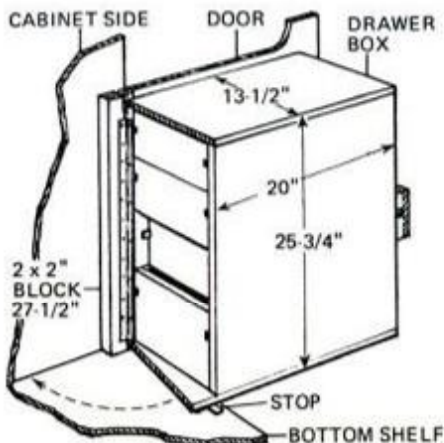
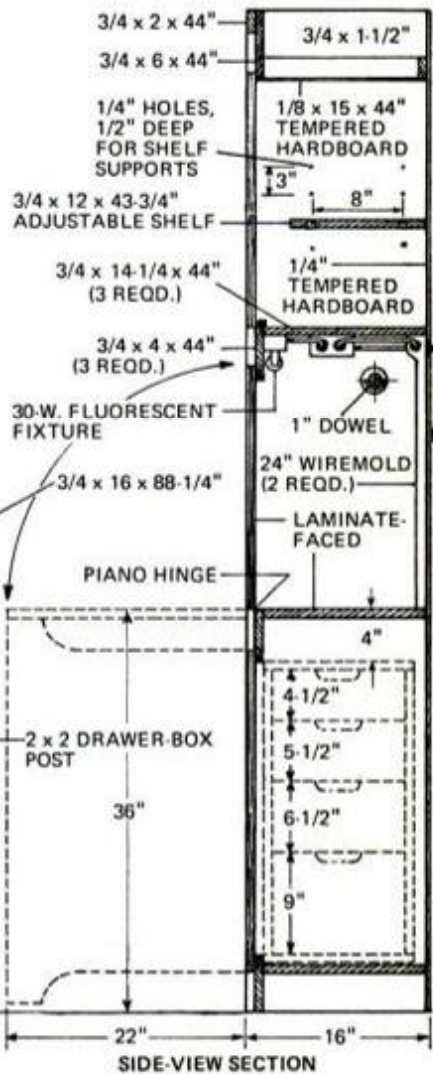
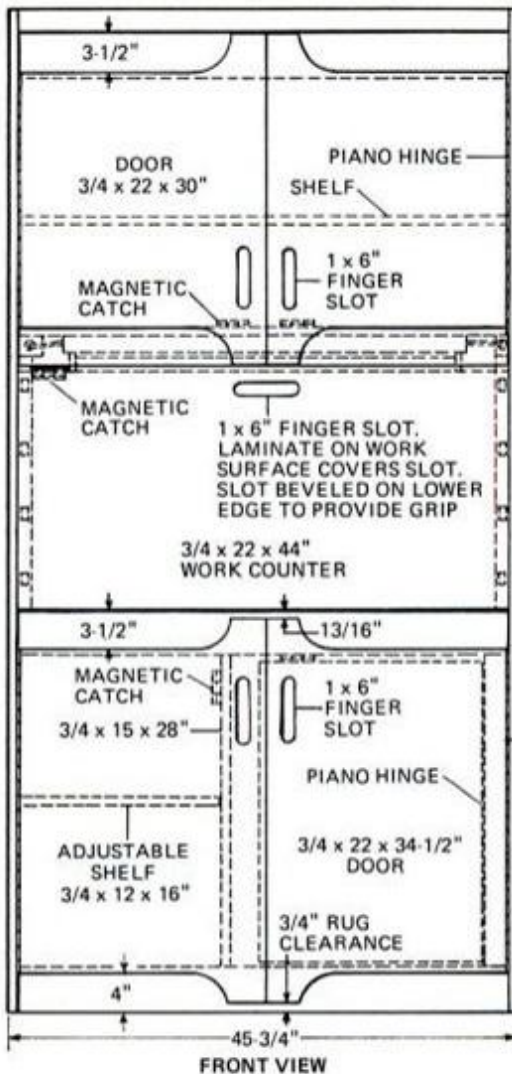
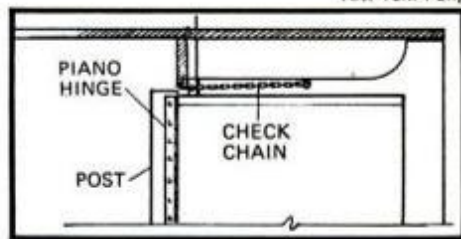

Two mini workshops for small spaces

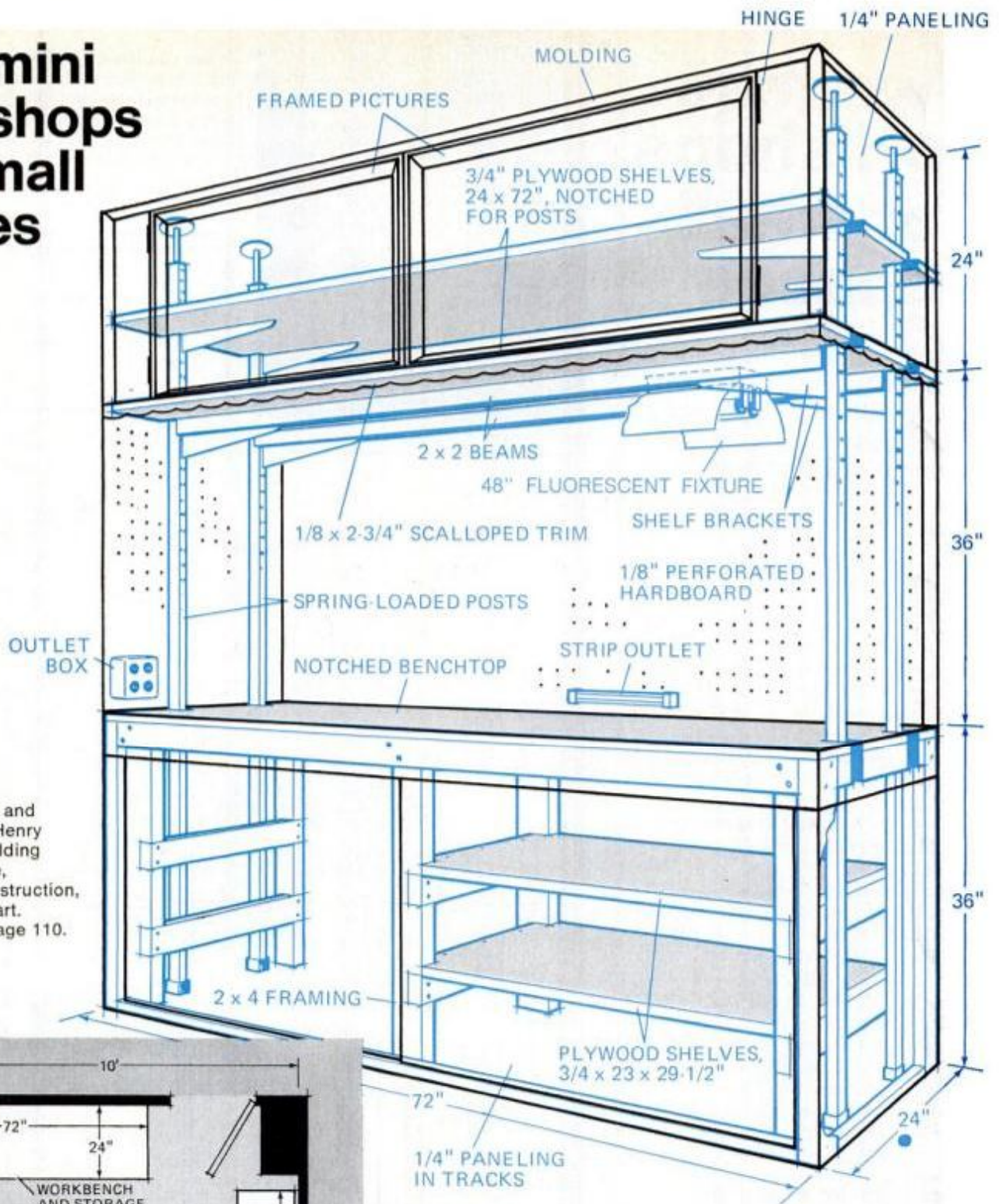

Main workbench and storage area in Henry Iken's model-building shop is of simple, freestanding construction, can be taken apart. See details on page 110.

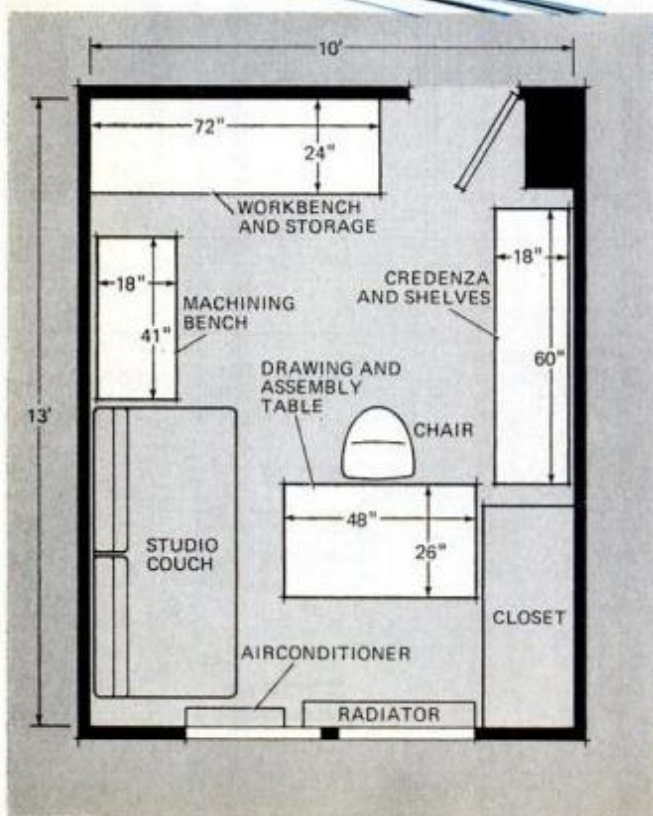

2

When Henry Iken's oldest daughter married, he acquired something he had wanted for a long time—a room in his family's three-bedroom apartment he could turn into a small shop. After years of building detailed ship models on the kitchen table—and having to clear the table for meals—he now began, after first paneling a wall and laying a new vinyl floor, to set up a really versatile shop for small-scale projects.

His use of the available space was clever, especially considering that the family insisted that the room remain usable as a guest room. All parts of the shop are freestanding or supported by spring-loaded poles, with no permanent installations to which the landlord might object. The main workbench was scratch-built, but the other units are ready-made office furniture, attractive and durable, with tough laminate tops. The



Compact shop includes everything Iken needs for modelmaking, as well as for furniture repairs, other light maintenance chores. Here he shapes a ship-model hull with a Surform tool.

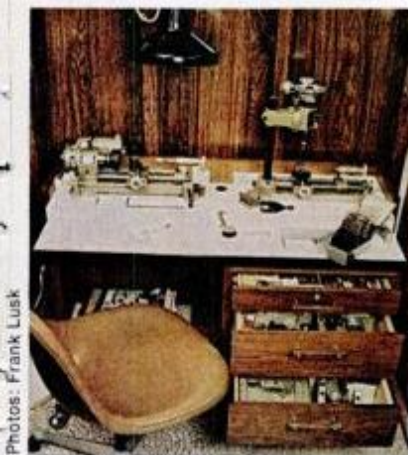

Machining bench has two Unimat lathes, full set of accessories.



Swivel vise handles large workpieces near the support post.



When reversed, wall picture is screen (above) for slide projector on shelf above credenza (right).



machining bench is a typewriter table—"just the right height," Iken says—with three-drawer pedestal on casters; the drawing and assembly table is a simple desk, and the credenza provides both an auxiliary work surface and additional drawers for storage of small tools and supplies. All are in the Departure Series from Designcraft Corp., 111 Kero Rd., Carlstadt, N.J. 07072. Cost when Iken bought them was about \$750.

Shelves within the main bench provide storage space for materials, kits, paints and glues—with enough room left for a Shop-Vac and attachments. Shelves above the credenza hold a large file of slides of prototype ship details and a projector. Iken can conveniently sit at the drawing table to sketch details of a model projected on the reversible picture screen on the opposite wall. Lighting supplied by the bench-mounted fluorescent fixture is supplemented by a combination incandescent-fluorescent Luxo floor lamp; its usual position is beside the machining bench.

Iken's full-time work is as a technical illustrator and partner in the firm of Walken Graphics. The drawings opposite and on page 110 are his.—*Stephen Walton, Assistant Home and Shop Editor*

(Please turn to page 110 for construction details)

Speedy gem polisher you can build

by R. S. Hedin



You're off to a fast start in lapidary with a home-built vibrating polisher that works four times faster than anything you can buy for the money.

By polishing the rocks you collect with progressively finer grades of abrasive, you can turn them into glowing gemstones. Inexpensive tumblers do the job well enough, but slowly—requiring at least one month per load. Vibrating rock polishers do it in one-quarter the time.

Commercial versions cost \$200 and up, but you can build this one for about \$50. It is basically a shaker table, with a platform, which holds the rock bowl, suspended on four coil springs and vibrated by eccentric weights on a rotating shaft attached to its underside. The base supports springs and drive motor.

The rock bowl is made from two Melmac mixing bowls (No. 118 by Texas Ware) fastened mouth-to-mouth. The bottom of the upper one is removed. Grinding is the best method—use eye, nose and mouth protection. Pencil a cutting line on the outside of the bowl and grind with the corner of the wheel. Silicone-rubber caulking is used to cement the bowls together (sand the glaze off the rims) and to line the lower one. The rubber needn't be smooth, but pockets that could trap grit should be filled. The lining should be about 1/16-in. thick.

Springs specified in the hardware list are just about right to support the load and isolate the base from vibration. If they're too stiff, the base will tend to walk; if too light, they may buckle under the load.

The pillow blocks for the shaft include ball bearings and can be bought most conveniently from a bearing supply house or well-stocked hardware store. Weight arms are held to the shaft with setscrews. Tapped holes in the shaft ends are for screws and washers that act as safety stops in case the arms loosen.

Defer buying pulleys and belt until the polisher has been assembled, then measure the distance between shafts—from this and pulley size you can determine belt length. *Without* the bowl and rocks in place, it should be necessary to compress the springs about 1/4 in. to install the belt.

Setting up the first run

For a first run, set the weight arms 90° apart, two weights on each. Fill the lower bowl with 10 lbs. of rocks (to assure correct motion and circulation), a cup of water and a few tablespoons of detergent, and, if starting with rough stones, 1/4 cup of 120 or 220-grit abrasive. Get the abrasive from your local rock store or hobby shop, which can provide more information on technique than can be presented here. To begin in lapidary, you can use this basic guide: Rough grind—120 to 220 grit for one to 1 1/2 days; fine grind—400 to 600 grit for two to three days; prepolish—levigated alumina for one to two days; mirror polish—tin oxide for two to three days.

Don't use too much water; it will
(Please turn to page 118)

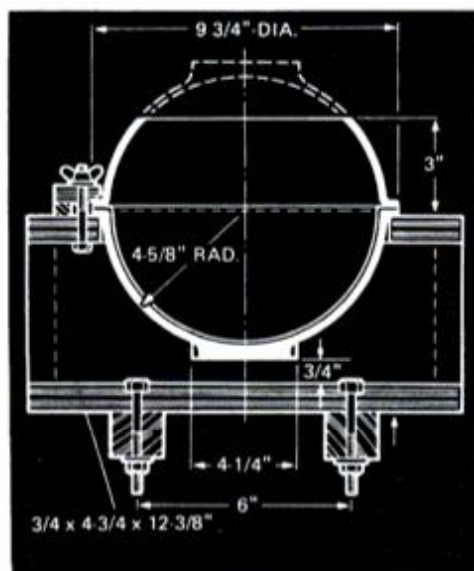
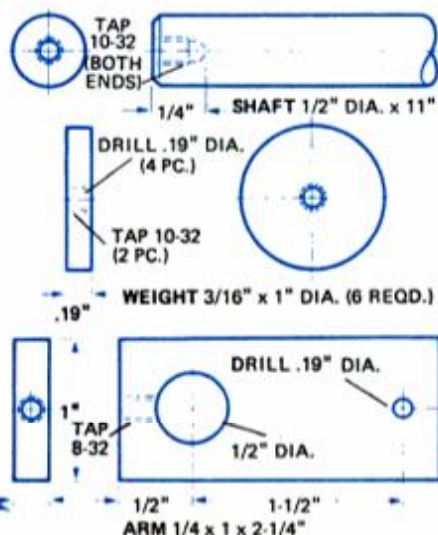
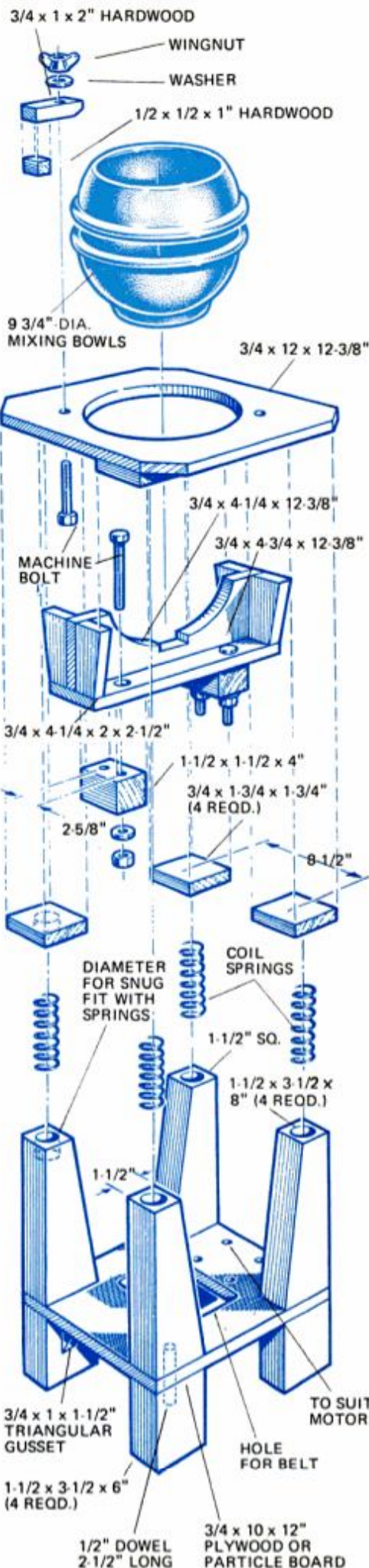

Perfect circles every time

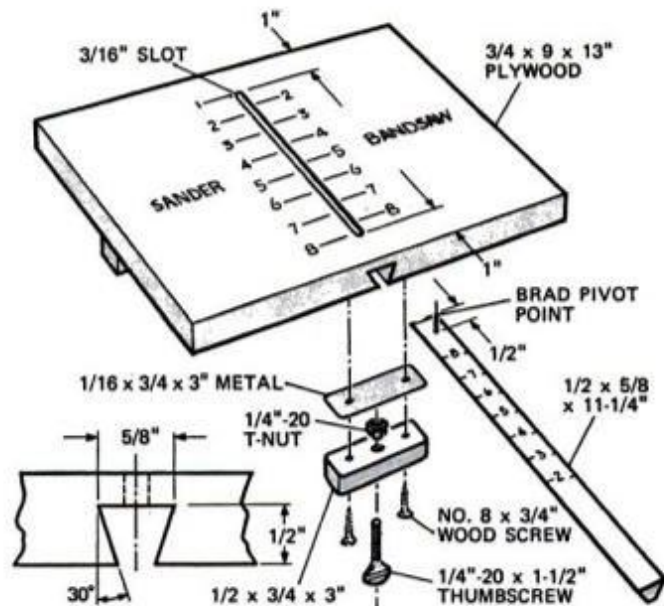

If you have need to cut a number of wood discs accurately and quickly, it will pay you to make this workshop fixture which will handle discs up to 16 in. in diameter. It's designed for use first on the bandsaw and then on the disc sander—first to saw the disc, then to sand it to the exact size. In each case the fixture is positioned by the miter-gauge table groove.

In use, you set a brad point for the

desired radius, lock it and impale the work on the point. Then you place the fixture in the saw-table groove, move it inward until the work touches the blade, clamp it in position with a C-clamp, turn on the saw and slowly rotate the blank. If a number of discs of the same size are to be cut, leave the pivot point undisturbed. If different sizes are needed, simply reset the pivot point for each change of size.

The setup is repeated in switching from bandsaw to sander, except that the brad point is set to the sander calibrations on the fixture. The disc is replaced on the brad, the sander turned on and the fixture moved inward in the groove until the wood disc contacts the spinning abrasive. Here, as before, you clamp the fixture and rotate the disc slowly to produce a perfect circle.—Paul D. Fiebich

Motor-reversing switch you can make

You can make a simple motor-reversing switch from a double-pole, double-throw knife switch which will operate most single-phase reversible motors up to 1 hp. Two extra contacts are added to one side of the switch. All are mounted on a plastic base (discard the porcelain one) cut to fit a standard utility box.

Make a safety cover of 1/8-in. plastic by cutting a half-circle wood

block the width of the utility box. Then heat a 2-in.-wide strip of plastic over an electric hotplate until it softens. Bend it over the wood form and hold until it cools. Add plastic sides to the curved piece so they lap box, cement with plastic solvent and trim flush. Cut a slot to accommodate the switch handle and attach cover to sides of box with sheet-metal screws. —William Waggoner

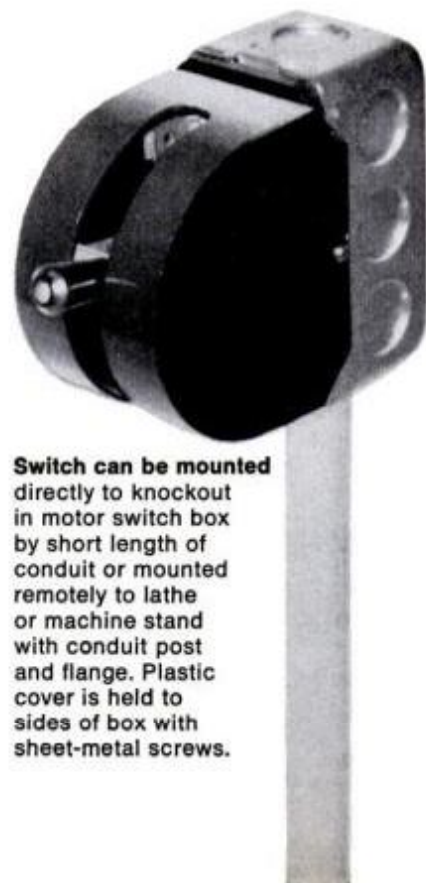

Switch can be mounted directly to knockout in motor switch box by short length of conduit or mounted remotely to lathe or machine stand with conduit post and flange. Plastic cover is held to sides of box with sheet-metal screws.

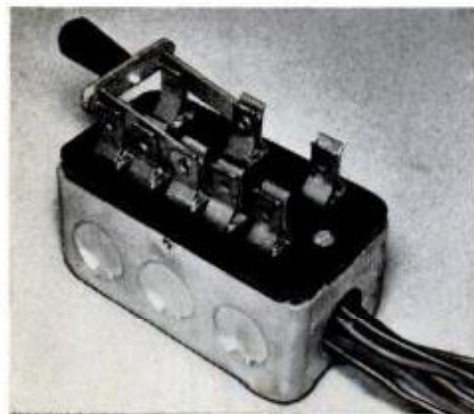

Switch's porcelain base is replaced with plastic one cut to the same size as box.

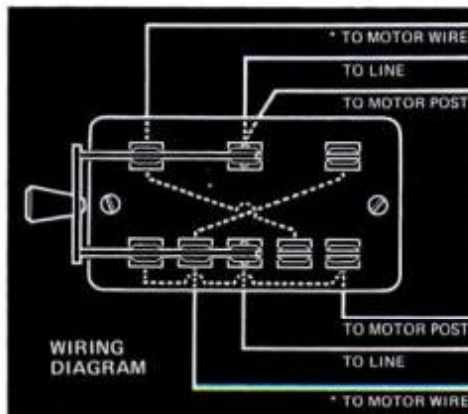

Follow diagram in wiring the switch to line cord and motor. Note two extra contacts.

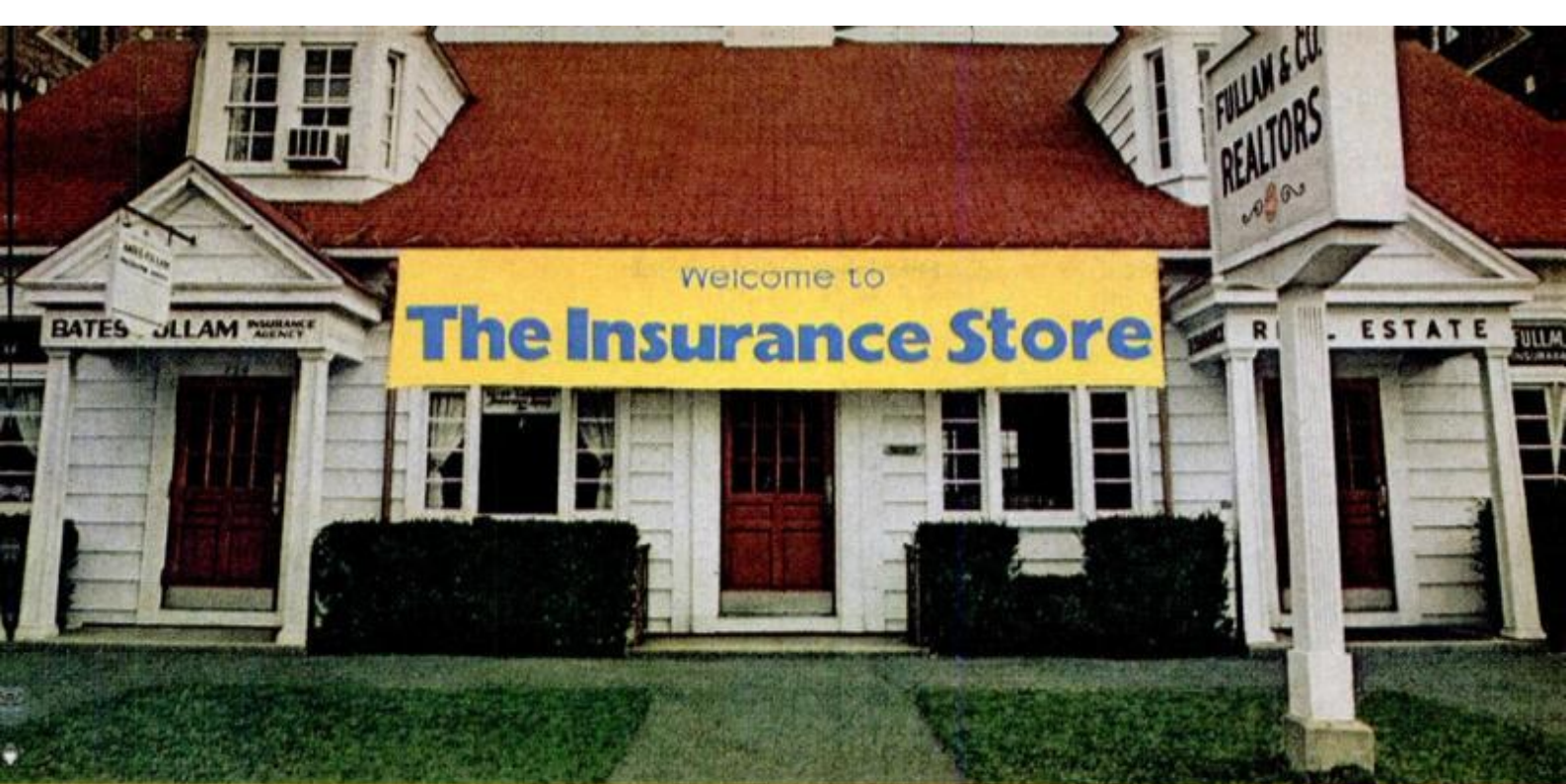

Why it pays to shop at The Insurance Store.

Today, buying insurance is like buying a new house or a car.

It pays to shop and compare.

Because insurance companies don't all charge the same rates.

And insurance policies don't all provide the same coverage.

But by shopping—you can both save money and get the best protection.

Introducing One-stop Insurance Shopping.

Now there's a new easy way to do all your insurance shopping.

Simply visit The Insurance Store.

With one stop, you can find any and every kind of insurance you need.

You save time. Save money on low prices. And get the right coverage.

Special Departments for Special Needs.

At The Insurance Store, insurance is our main business. Not just a sideline.

Boat Dept.

Auto Dept.

Life Dept.

Commercial Dept.

So the entire store is filled with insurance.

In fact, many Insurance Stores have even set up special departments for all the different kinds of insurance they sell. Including homeowners, automobile, marine, health, life, theft, liability, bond, aviation, and business insurance.

Within each department, you'll find a wide variety of insurance policies and prices.

So when you shop at The Insurance Store, you can always select. You don't have to merely settle.

Your Choice of Leading Brands—including Continental Insurance.

At The Insurance Store, you'll also find a wide variety of insurance companies.

Some specialize in low price.

Others, in broader coverage.

But we at Continental offer a combination of both.

For example, consider our unique PCP Plan, the all-in-one plan.

It lets you combine separate policies on your home, your car, and yourself all into one neat little package that actually gives you more insurance coverage for your insurance dollar.

Save with Low Prices and Exact Coverage.

You don't have to know a lot about insurance at The Insurance Store. Because the trained professionals there do.

They can tell you if you have the right policy. Or not.

If you have too much coverage. Or too little.

And, quite often, by recommending the exact policy and coverage you need—they can save you money in the process.

24-hour Service.

At The Insurance Store, we service

what we sell.

Let's say you buy a Continental Insurance automobile policy.

You automatically get 24-hour toll-free Dial-A-Claim Service.

It's backed by over 1600 claims adjusters located throughout the U.S. and Canada.

So anytime, anywhere you need help, help is always nearby.

What's Best for You.

Every Insurance Store is owned and operated by an independent insurance agent.

Unlike agents who represent Allstate or State Farm only, independent agents are beholden to no one insurance company. Including Continental.

And so if the company with which they place your insurance doesn't do what's best for you, they're free to switch their insurance to another company which will.

That gives them tremendous leverage to use on your behalf. And use it they do.

Over 16,000 Locations to Serve You.

For the name and address of the agent who operates The Insurance Store nearest you, just see the Yellow Pages under Continental Insurance.

Need insurance? Shop and save at The Insurance Store.

Continental Insurance
featured at
The Insurance Store



craft could be kept together. His design not only does this, but it also lets you store frequently used tools for ready access in upper drawers of the swing-out drawer box. Lighting and electrical outlets are integral.

The bench couldn't have met the requirements we set if it weren't fairly large, so you should plan ahead in construction—if a tight corner or stairway is a possible obstacle, do the final assembly in the room where you'll use the bench. Accurate cutting is vital. If you have (or have access to) radial-arm and table saws, this will go quickly; if you are limited to portable tools, it will take longer, but you can still do a good job. Essentials

use a smooth-cutting blade and face the back of the panel up. Follow with rabbets along the inside back of both side members, using a router or a dado head on a table saw. Dados for shelves can be cut with a radial-arm saw, router or portable saw. They cannot be cut accurately or safely with a table saw.

Facing strips are applied to cross members, and flexible wood trim to exposed edges, before main assembly is done. Overhang from the trim, which is available in 1-in. by 8-ft. rolls, is removed with a block plane or sharp knife.

If joints are made well, you can assemble the cabinet with 2-in. fin-

panel to just under exact inside dimensions of the cabinet, then mark as in the photo. Curved cuts on doors can be made with a bandsaw or sabre saw. Install door hinges, using the method illustrated for alignment. It's all right if doors touch at the center; later you can trim them for 1/8-in. clearance.

To make finger slots, cut out waste between 7/8-in. holes with a fine blade in a sabre saw (cut from the back), using a tacknailed guide strip.

Since the thickness of the laminate and hinge sections are the same—1/16 in.—the drop-leaf hinge need not be set into the wood. Attach it to the fixed cabinet surface first, setting

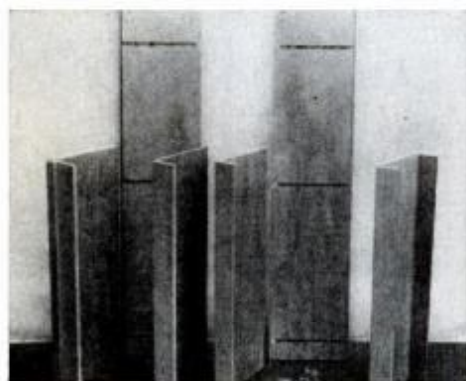

1. Major components ready for assembly—blind dados are made easily by gluing softwood inserts into the voids.

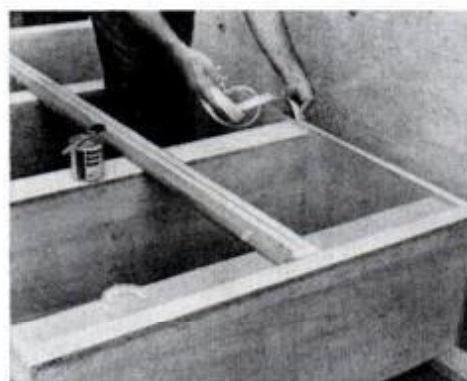

3. Surface long front edges carefully. If wood trim strip veers off, cut it short, butt-join a new piece and continue on.

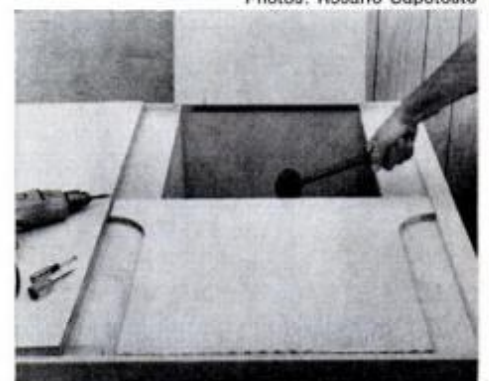

5. With hinge attached, lay door in place and tap with mallet. Screwheads will make indentations showing the correct location.

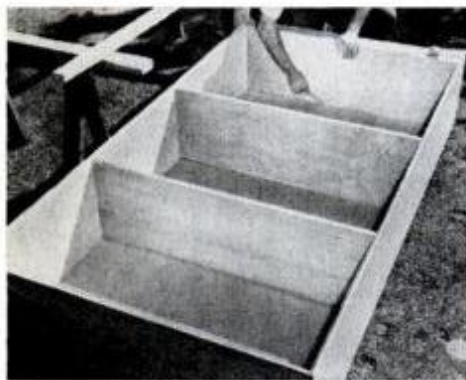

2. Panel for doors, drop leaf is accurately marked for cutting when inserted into front of the frame, back surface down.

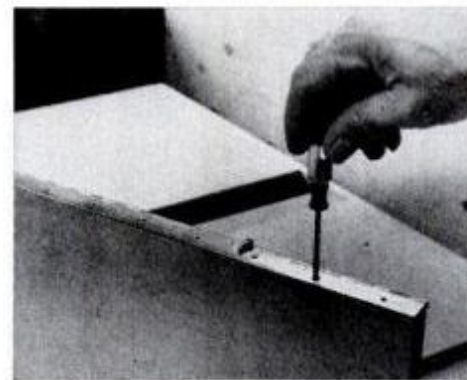

4. For perfect hinge alignment, attach a doubled-up hinge to the door and turn in roundhead screws near each end to hold it.

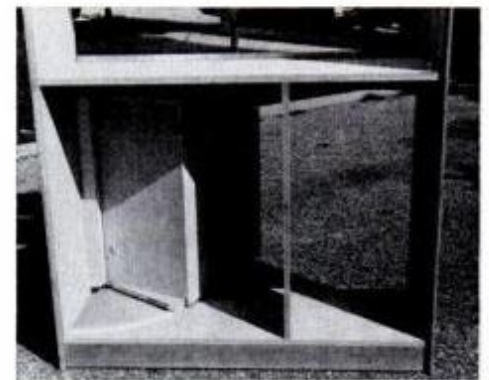

6. Rear view shows how bottom extension helps support weight of drawer box. Glide rides smoothly on track cut from laminate.

are a circular saw, sabre saw, router and drill—and a really straight strip of wood to guide the saw and router.

Wood chosen for our prototype was lumber-core birch. You could economize by using ordinary fir plywood and a painted finish, but select panels carefully if you do.

■ **Begin the project** by cutting the side panels; use a portable saw, since 4x8-ft. panels on a table saw are extremely awkward. Tack-nail a straightedged wood strip for a guide (allowing for the offset of the base),

ishing nails and glue; otherwise, screws will be necessary, with counter-bored holes and wood plugs. Test fit before applying glue; recheck squareness during assembly. When glue has set, cut the 1/2-in.-plywood back to fit rabbets and attach it temporarily with 1 1/2-in. wood screws into cross members. It will be glued in later, with nails around the perimeter.

■ **Doors and drop leaf** are cut from one panel in their relative positions for best grain appearance. Cut the

the pivot axis in from the edge so the panel will close flush with the cabinet front. Make a stiff paper or cardboard pattern for the inner piece of laminate, cutting it about 1/16 in. undersize so it won't have to be forced against the walls. Allow a rear overhang of about 1/4 in. to trim later. Use wrapping-paper slip sheets to help position the laminate before bonding it into place. Apply 1-in. strips of laminate to the drop leaf's shorter edges, then its longer ones,

(Please turn to page 108)

look what this special coupon brings to you

Helps You BUILD ... RESTORE ... REFINISH anything of wood! Easier!

Start Now getting more fun out of woodworking. Let this newest, biggest product-finder Catalog *make every workshop project a crowning success!*

In Constantine's picture-packed Catalog you'll find instantly *whatever you need* for easier, better woodworking. You'll save time and money shopping from the world's largest mail-order source for imported and domestic wood. Endless variety.

See page after page of finest CABINET-MAKING woods, many in full color. Kiln-dried. First quality. Thicknesses from 1/4 to several inches.

Select from world's finest — walnut, rosewood, teak, purpleheart, lacewood, ebony, zebra, satinwood, lignum vitae, cocobola, cherry, avodire, mahogany, maple, many more. Solid wood. Inlays. Plywood. Veneers.

Discover amazing values for woodworkers.

WOOD FINISHES. Match anything!

FURNITURE HARDWARE. Period. Modern. Cabinet pulls, latches, hinges, leaf supports, hi-fi slides. Miniature hardware too!

UPHOLSTERY. Caning, rush-seating, etc.

SIMPLIFIED VENEERING. Discover Constantine's easy method of veneering without clamps! Quickly cover beat-up tables, chests, cabinets with beautiful veneer.

PICTURE KITS. All-wood, pre-cut parts. Ready for easy assembly. Ideal table-top hobby. Success assured.

TRAY MOLDING. Ready to use around wood pictures or richly grained plywood panels. Molded fingerrip. Grooved. Needs no handles. Beautiful.

SIMPLIFIED SHELVES. Revolutionary brackets with hanger installed. Hang forever on one screw or toggle in any wall. Terrific!

NEWEST MATERIALS. LATEST TOOLS. Hundreds of most-needed products. Time-savers. Labor-savers. Many found nowhere else.

Plus WOOD CARVING tools, patterns, instructions. **Plus BOOKS** and **PROJECT PLANS** on every subject.

Big, new Catalog offers large selection of marquetry picture kits including famous "America" series. Available nowhere else.

ACT NOW. Don't lose a day of workshop fun. Benefit from unsurpassed values in new Catalog. Enjoy beautiful **WOOD SAMPLES**.

Mail Coupon for Special Offer

Accept this offer to own a fascinating set of 2 x 4 specimens of world's most glamorous veneers. *Compare!* Then instantly identify finest woods wherever you go. Send only \$1. *Dollar refunded on first order.* Mail Special Coupon TODAY!

CONSTANTINE
2051 Eastchester Rd., Bronx, N.Y. 10461
Serving Craftsmen Since 1812

20 WOOD SAMPLES

Finest woods from around the world! Purpleheart. Lacewood. Mahogany. Rosewood. Satinwood. Zebra wood. Walnut. Teak, etc. Rich colors, fascinating grains, exotic aromas. Compare 20 most-wanted woods. *Learn to identify!*

20 wood samples from around the world

Plus World Famous
CONSTANTINE'S woodworker CATALOG

Discover Veneer Magic!



Creative Veneer Craft

ONLY \$1.95
Postpaid

Here's the fascinating book that reveals everything you need to know about the easy art of creating decorative veneer cutouts! It's the perfect supplement to Constantine's giant 96-page Catalog/Yearbook!

Your complete how-to guide!
Techniques, patterns, ideas.

CONSTANTINE 2051 Eastchester Rd.
Bronx, N.Y. 10461

- Enclosed \$1 for Wood Samples & Woodworkers' Catalog. (Dollar refunded on first order.)
 Also enclosed \$1.95 for Creative Veneer Craft, the how-to book. Catalog only 50¢

TEAR OUT!

MAIL NOW!

Name.....
Address.....
City..... State..... Zip.....

96 PICTURE-PACKED GIANT PAGES

CONSTANTINE'S
WOOD
Catalog/Yearbook 1976 ★★ ★



Great Book
United States of America

Veneer
reproduction
see page 46



Celestron® Multipurpose Telescopes

On Display at Museums and Planetariums Throughout the Country

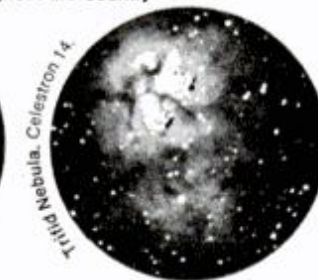

The Choice. Three reasons why experienced telescope enthusiasts and leading colleges, universities and science centers the world over repeatedly select Celestron telescopes:

The Celestron 5. A tabletop observatory for exploring the Moon, planets, scores of open star clusters and gossamer nebulae at up to 300X. For casual observing or tele-photography, rest the instrument on any flat surface, swing up the tube and focus. Close in on the whiskers of a squirrel at the near focus of 20 ft. or the face of a friend at half a mile. The 3½-lb. tube demounts for hand-held shots at 25X. (Size swung down: 7" x 8" x 16", Wt.: 12 lbs., Base price, including electric star tracker and automatic star locator, \$750)

The Celestron 8. Eight full inches of aperture make this



FREE
COLOR
CATALOG

portable observatory in a suitcase the amateur's favorite for studying the surface features of Mars, the subdivided rings of Saturn, the ever-changing belt structure of Jupiter, the intricate filamentary detail of deep-sky nebulae, the central regions of globular clusters at up to 500X. Also the ultimate terrestrial telescope or telephoto! (Size swung down: 9" x 12" x 22", Wt.: 23 lbs., \$895)

The Celestron 14. The appeal of this prestigious, fully electric dome instrument is enhanced by a unique design that also makes it the world's largest one-man-portable. Demount and load it into your compact car in five minutes! Within range of the Celestron 14, at up to 850X, are the delicate contrast levels of the diffuse and planetary nebulae, the spirals of remote galaxies, and the quasars. (Size swung down: 18" x 22" x 44", Wt.: 108 lbs., \$3,750)

Celestron Pacific 2835 Columbia • Box 3578-PM • Torrance, CA 90503
World's Leading Manufacturer of Compact-Portable Telescopes

New Tool Works Wonders With Wire!

WIREFORMER

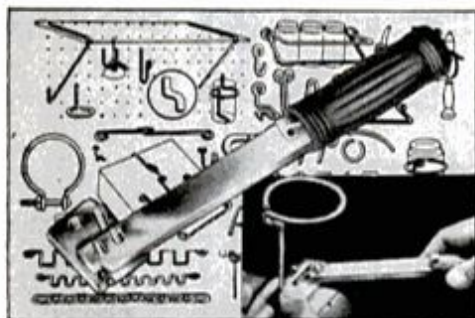

IT BENDS! IT CUTS! IT STRAIGHTENS!

WIREFORMER is a simple, precision made, vise-held tool of innumerable uses. Make your own peg board hooks, clamps, handles, braces, brackets, etc.—any shape you want. Forms an eye of 3-16" inside diameter (just right for any nail, screw, or bolt up to that size). Even uses coat hanger wire. No pliers needed. **WIREFORMER** does the work with the pressure of one finger. Straightens the wire if you make a mistake. Cuts the wire just where you want it. Forms any angle, arc or circle. Bends both right and left. Tool is case hardened, plated, with a plastic handle. Fits in your pocket. Complete instructions, illustrated brochure showing many things to make.

SOLD ONLY BY MAIL. MONEY BACK GUARANTEE. Five dollar bills will get you one, or send check or money order for just **\$4.98**

We pay postage and handling charges.

VINKMULDER TOOL CO. Dept. PM-16
2223 Estelle Dr., S.E. Grand Rapids, Mich. 49506

Fast Track to a Cool Job!

★ TRAIN AT HOME TO BE A Motorcycle Mechanic



If you like to ride a cycle for fun... learn how to fix it for profit! Can you imagine a better way to earn your living? And to make it even better, the pay is great—whether you choose to work in a cycle shop for someone else or decide to start your own cycle repair business. Now, thanks to North American, there's a fast, easy way to get the training you need... at home in your spare time. No need to quit school or your job. Experts show you step-by-step everything from minor tune-ups to major overhauls.

CYCLES ARE BIG BUSINESS ... AND SO IS FIXING THEM!

There are more than 3 million cycles registered in the U.S. today. Plus an estimated 3 million more dirt bikes. But, there are fewer than 10,000 motorcycle mechanics available to repair them. (Imagine only one mechanic for every 600 motorcycles!) No wonder career opportunities are so great... and getting better every day. The door is open to you now. Rush coupon for free color brochure and full information.

INCLUDED TO START YOU FAST! SPECIAL CYCLE TOOLS & TEST INSTRUMENTS

Professional tools plus your North American "know-how" turn you into a skilled mechanic. We teach you how to use wrenches, sockets, impact screwdrivers, timing lights, electrical test instruments, compression gauges, vacuum gauges, degree wheels, soldering irons, ignition wrench sets, dial indicators and much, much more! We even include a set of special cycle tools and instruments to get you started fast! Find out all about it now. Send for **FREE CAREER INFORMATION.** No cost. No obligation... now or ever! Rush coupon today.



Careers by Home Study
NORTH AMERICAN SCHOOL OF MOTORCYCLE REPAIR
4500 Campus Drive, Dept. PROCS Newport Beach, CA 92663
Rush free color brochure and full information on how I can become an expert motorcycle mechanic for only a few dollars a month.

NAME _____ AGE _____
ADDRESS _____
CITY _____ STATE _____ ZIP _____

MINI WORKSHOP (NO. 1)

(Continued from page 106)

and trim flush. Laminate the work surface only after the hinge position is certain.

■ **The swinging drawer box** is assembled with butt joints, except for the rear, which is rabbeted for a 3/8-in. plywood back—attach it only after drawer runners are installed. The metal glide and laminate track should be in place before you locate the hinge.

■ **Installation of the lamp and outlet wiring** is easier if done before the back panel is installed permanently, although it must be in place when outlet strips are added. The Plug-mold strip is sold in 6-ft. lengths; cut one length down to obtain two 24-in. pieces.

Connect all wires together in a surface-mount box located on the bottom of the shelf above the work area. Pass the power cord through a hole in the back panel. A perforated-hard-board tool board can be mounted between the outlet strips, with stand-out cleats for clearance.

■ **To finish the prototype**, a coat of white Firzite was applied to the fir plywood back, then the entire inside was painted white. Exterior wood was given a wash coat of Constantine's sanding sealer which had been diluted 1:1 with lacquer thinner and applied with a cloth.

After light sanding, Beverlee's Provincial stain was applied with a cloth, one section at a time, and wiped with a clean cloth. This was followed by two coats of Constantine's Wood-Glo satin finish, with light sanding with 220-grit paper between coats.

Floor must be level

Three important things should be noted: First, the cabinet may tend to rack or twist if placed on an uneven floor. Check it with a level at the installation point, and shim if necessary, before final trimming of the doors.

Second, expect some degree of warping of the drop leaf, since it is a freestanding panel laminated on one side without the customary backing sheet. Visually, the warp is not serious, and in our prototype two heavy-duty magnetic catches eliminate it when the leaf is up in the closed position.

Third, the unit must be secured to the wall because it will tend to tip forward when all hinged parts are in the open, full-forward position. Two screw eyes at the top rear can be used to receive washered screws, or screws can be driven into studs through the back panel in the upper compartment. ★★

FREE

The world's largest catalog
of electronic kits.



- Automotive Accessories & Tune-Up Equipment • Garage Door Openers • Intercoms • Fishing, Marine & Aircraft Accessories
- Two-Way Telephone Amplifiers • Digital Stopwatch • Amateur Radio Gear • Color TV's • Hi-Fi Components — over 400 kits in all!

Every Heathkit product comes with a fully-illustrated, step-by-step assembly manual that tells you everything you need to know to make kitbuilding fun and easy. Thousands of people have discovered the satisfaction — and savings — of handcrafting a fine piece of electronic equipment. You can build it better ...let us show you how.

Send for a free copy of the Heathkit Catalog today!

Heath Company, Dept. 17-13
Benton Harbor, Michigan 49022

HEATH		Schlumberger	
NAME _____		Send to: Heath Company, Dept. 17-13 Benton Harbor, Michigan 49022 Yes, please rush my FREE Heathkit Catalog!	
ADDRESS _____			
CITY CL-582	STATE	ZIP	

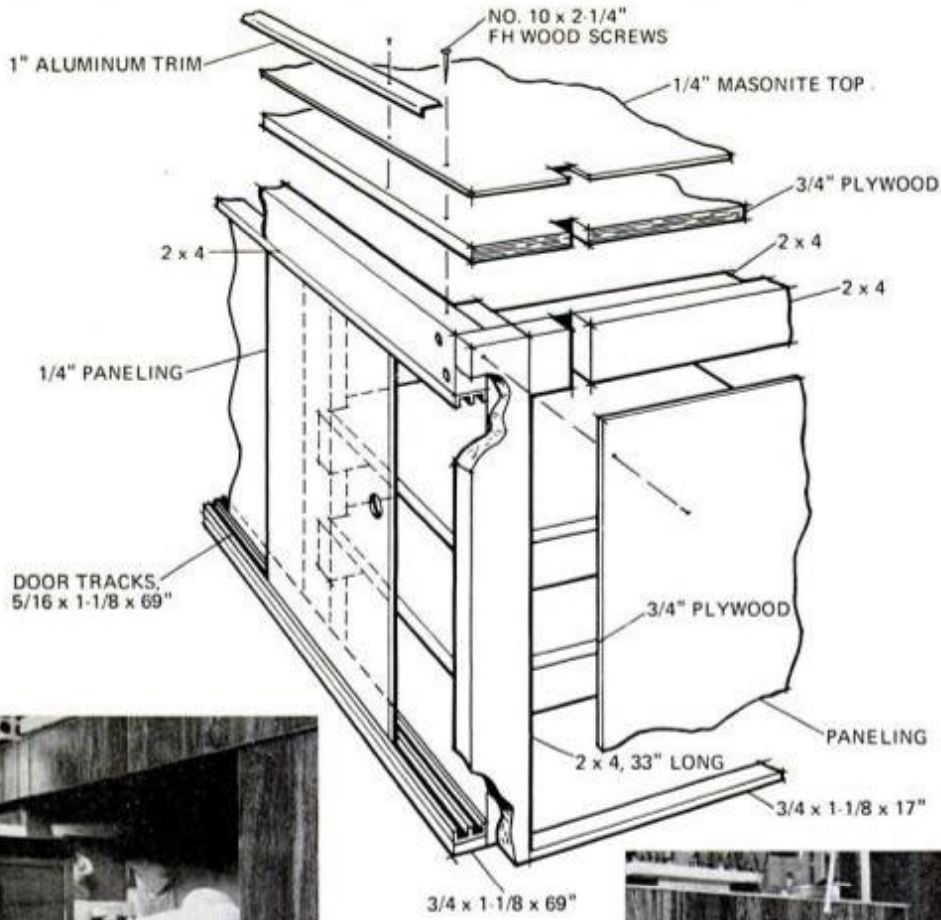

Under-bench area offers plenty of storage space for Shop-Vac and full set of attachments (left), model-building supplies (right). Sliding doors are 1/4-in. paneling running in commercial door tracks.

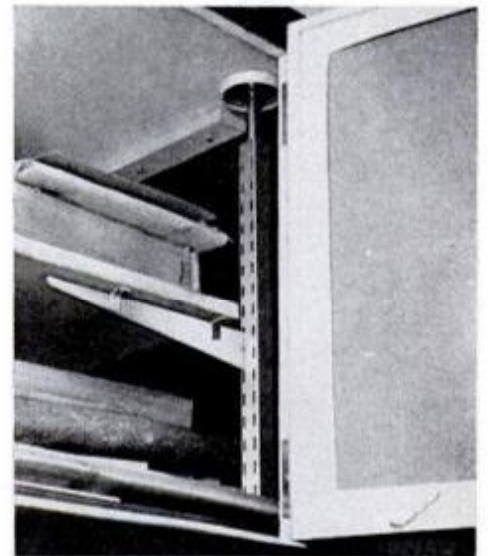
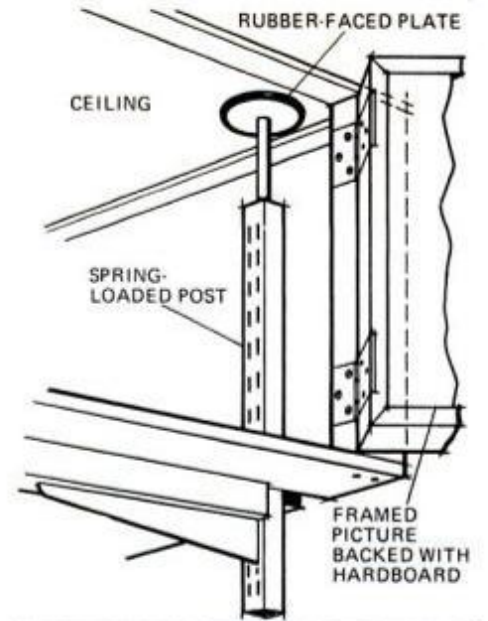

Poles anchor structure firmly to ceiling, so that no wall attachment is needed.

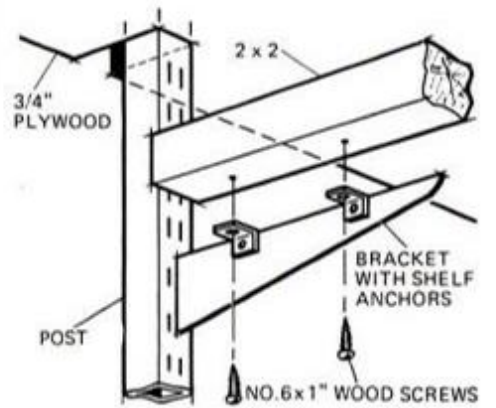
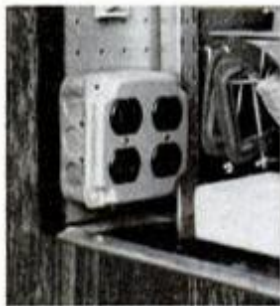

More storage above working area. Drawing shows attachment of beams to poles.

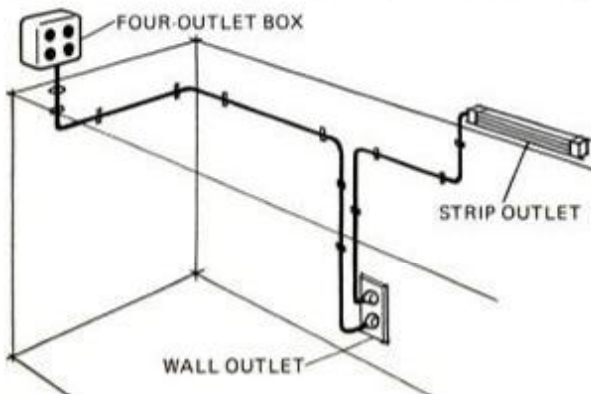

Wiring setup uses existing wall outlet behind bench to provide accessible power for tools through four-outlet, surface-mount box and continuous-outlet strip at other end of bench.

WEATHER DEMONS IN THE SKY
 (Continued from page 52)

is in a better position to judge wind shear effect—pilots or ground controllers? Why wasn't runway closed after Capt. Bliss's warning? A \$4.6 billion damagesuit has been filed—the largest ever as the result of a plane crash. Ironically, as recently as the destructiveness of wind was hardly recognized. More attention was paid its twin brother—turbulence (CAT).

CAT is wind shear or high altitudes in clear skies. It doesn't have ample to crash because sky in which sudden downward who remain suffer injuries CAT and inversely, studied for October, 1977 forum on approach and no standard tion stat ar in terms of definition performance, its effect air traffic controller is warn pilots of trolleings several winntement appears

A rash of wind mts struck with Ozark Air Lines an ILS (instru approach into tional Air-orm with low the heavy and ort and recommend-ort ed.

Paul G. Malone, the subject engineer, the action system was Flight 66 crash. Successful in measuring and severity of wind claims, but indicates needed before the Administration de-

lion Administration de- system has merit. adopted, every runway at art in the country would ve the system installed to many millions of dollars. This would mean an invest- when, is where the wind shear stands. Nothing offers avia-ore of a challenge.

hen Schultz—Orangeville, Penna. of walnut in the rough, and after planing gured I saved enough money to pay for the Planer. It really does a good job. *—Springfield, Ohio

dfather clocks and many other work and I couldn't do my job —Flat Rock, Illinois

known authority—the Belsaw as the most useful shop tool any would own. We use one every day in the Workbench ...couldn't get along without it." Jay Hedden, Editor Workbench Magazine

NOW! Your home workshop can pay off

BIG...

This one power-fed tool saws, planes & molds in one fast operation.



ONLY THE Belsaw WILL ... RIP Power-feed Rip Saw

MOLD Power-feed Molder

PLANE Power-feed Planer

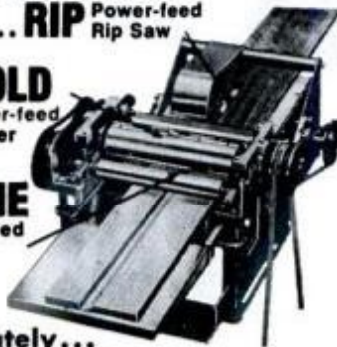

separately... or All in One Operation... — a real money-maker for you!

YOUR OWN Part time BUSINESS or full time — right at home

Men and women everywhere are using this low-cost powerfeed machine to start and build their own new businesses...and YOU can do the same. Supply lumber yards, contractors and carpenters in your area with door and window trim ...base shoe...bed mold...cove and quarter round...ALL of their trim. You can sell picture frame to lumber yards, paint stores, department stores... and direct to users.

Read what these Belsaw owners say! "I've been a planer man 44 years and now retired. The saw has earned me \$60,000 in eleven years with the only expense being \$7.50. For the initial cost, it's the best investment I ever made." Robert Sawyer—Roseburg, Oregon

"The machine pays for itself making money out of scrap... a very well built machine and I confess it is more than expected for the price. It does everything you need." Ken Schultz—Orangeville, Penna.

"I bought a planer of walnut in the rough, and after planing figured I saved enough money to pay for the Planer. It really does a good job." *—Springfield, Ohio

"My father clocks and many other work and I couldn't do my job... I bought one." —Flat Rock, Illinois

"I'm a known authority—the Belsaw as the most useful shop tool any man could own. We use one every day in the Workbench Magazine...couldn't get along without it." Jay Hedden, Editor Workbench Magazine

Only complete workshop tool of its kind in the world turns rough lumber into finished stock.

The BELSAW Planer/Molder/Saw is a versatile piece of machinery. It turns out profitable precision molding, trim, flooring, furniture...in all popular patterns. Rips, planes, molds separately...or all at once. Used by individual home craftsman, cabinet and picture framing shops, lumber yards, contractors and carpenters.

No previous experience necessary

Never before has there been a three-way, heavy-duty woodworker that does so many jobs for so little cost. Saws to width, planes to desired thickness, and molds to any choice of patterns. Cuts any molding pattern you desire. Provides trouble-free performance. And is so simple to operate even beginners can use it!

Let Belsaw prove YOU can do it, too!

Try it in YOUR Shop...on our **30-DAY FREE TRIAL**

No Obligation and No Salesman Will Call.

RUSH COUPON TODAY! BELSAW POWER TOOLS CO. 906J Field Bldg. Kansas City, Mo. 64111



BELSAW POWER TOOLS
 906J Field Bldg., Kansas City, Mo. 64111

Please send me complete facts about **PLANE—MOLDER—SAW** and details about 30-day trial offer. I understand there is no obligation and that no salesman will call.

Name _____
 Address _____
 City _____
 State _____ Zip _____

ALLISON 'OPTO-ELECTRIC' The BEST...the ULTIMATE of ALL Ignition Systems!



(We challenge ANYONE to dispute this Fact)

Never wears out or needs any Maintenance!



gives you Maximum Power with continuous PEAK PERFORMANCE

...while reducing Maintenance and Operating Costs!

★ The Allison OPTO-ELECTRIC System eliminates the Points and Condenser, replacing them with an OPTO-ELECTRONIC TRIGGER, using a Light-Emitting Diode and Photo transistor. The System operates on a beam of Light. As there are NO moving parts in rubbing contact, "Friction-wear" is completely eliminated...Timing adjustments are PERMANENT.

● Gives 40-Times more Timing accuracy than ANY system using "Mechanical" Breaker-Points! UNLIMITED RPM! "Electronically-Controlled" DWELL automatically supplies HIGHEST Performance at both Low and High speeds. Spark strength does not fall off at high RPM. POSITIVE SPARK helps eliminate "Misfire" for faster acceleration and improved Engine Performance. Sparkplugs LAST 3 to 10-Times LONGER.

● Easier Starting under any condition! Smoother running... (NO TIMING FLUCTUATION as with Magnetic Impulse Units). All SOLID-STATE Components. UNAFFECTED By Temperature, Moisture, or Vibration! Only Highest grade materials used... Guarantees you Solid, Dependable Performance!

● PERFECT TIMING INCREASES Engine Efficiency and Gas Mileage. SAVES Precious Fuel! Allison gives you MAXIMUM Engine Efficiency 100% of the Time... and that's the name of the game for the BEST in GAS MILEAGE AND ECONOMY.

★ Perfect Timing and Dwell never change.

● Pays for itself! Eliminates ignition Tune-Ups forever! "INFINITE LIFE"...Once installed...Never needs replacing!



★ PROVEN RELIABILITY!
Each Unit Tested to 15,000 RPM.

● Road and Race Proven.
(Opto-Electric Systems won at INDY Two years in a row!)

★ "EASIEST-TO-INSTALL" UNIT ON THE MARKET.
(Not necessary to dismantle Distributor as with other systems).

★ If you want the BEST, and SAVE! This is IT!

ORDER with CONFIDENCE... SATISFACTION GUARANTEED

10-YEAR FACTORY WARRANTY!
(Free Repair or Replacement).

● Send Check or M/O (Calif. Res. add Tax.) State Make, Year, Engine Size. (4, 6, or 8-Cylinder).

★ (So New...it's Sold ONLY FROM FACTORY DIRECT).

● You may use your MASTER CHARGE or BANKAMERICARD. Send us (1) Your Number, (2) Interbank No., (3) Exp. Date.

M/C or B/A Card Holders, ORDER by TOLL FREE PHONE: (800) 423-6525, Ext. 2 (When in Continental U. S. A.) And YOUR ORDER will be SHIPPED IMMEDIATELY.

★ Before buying any other Type ignition system... Send Postcard for our FREE BROCHURE.

★ If you have already installed a C-D ignition system, Modernize and Increase its Efficiency... CONVERT YOUR "C-D" UNIT TO BREAKERLESS! Opto-Electric "TRIGGER UNIT"...Only \$34.95

● Our BEST Salesmen are the users of our ALLISON System!



America's Oldest and Largest Mfg. of Opto-Electronic Ignition Systems.

ALLISON
AUTOMOTIVE COMPANY

1267-X, East EDNA PL., COVINA, CAL. 91722

WEATHER DEMONS IN THE SKY (Continued from page 111)

dent investigation report declares.

On Dec. 17, 1973, an Iberian Airlines DC-10 on an ILS approach dipped below its glide slope, struck the approach-light piers 500 feet short of runway 33L at Logan International Airport in Boston and skidded to a stop 3000 feet beyond the runway threshold. There, 167 people evacuated a craft virtually split in two. The increased rate of descent was "induced by an encounter with a low altitude wind shear at a critical point in the landing approach," the NTSB concluded.

The next accident known to have been caused by wind shear was that of the ill-fated Flight 66, and several weeks after that, on Aug. 7, 1975, wind shear brought down a plane that had just taken off in Denver. The Continental Air Lines 727 had raised its gear when suddenly it fell back to earth on its belly from an altitude of about 200 feet. The fuselage split in two places and one passenger sustained serious injuries.

The unofficial explanation is that the plane lost power in one engine, and the reduced thrust could not overcome a severe wind shear.

Comes and goes

Wind shear is elusive—overcoming its dangers will be one of the most baffling problems the airlines have ever faced. It can exist one minute, disappear the next and reappear two minutes later.

This was vividly demonstrated when Flight 66 died. Between the time Capt. Nickerson struggled to bring his L-1011 back into the sky and the time Flight 66 didn't make it, several other aircraft landed without encountering any wind shear.

You can't close airports when wind shear is likely to be present—it's around as often as not. Closing airports indiscriminately would literally shut down commercial aviation.

The only tangible scheme seems to be developing equipment that warns of the presence of wind shear before an aircraft begins its approach—before control passes from the pilot to the gods who watch descents.

One piece of equipment that looks promising, oddly enough, was developed to measure another serious turbulent condition called wake vortex.

Wake vortex turbulence is generated by large jet aircraft, especially jumbo jets, operating at low speeds during approaches and departures. Invisible eddies created behind the jets resemble tornadoes in form and severity—especially violent to following aircraft coming in for a landing.

Wake turbulence normally creates

severe disturbances in the runway area for a minute or two after an aircraft passes—more than five minutes in a calm and stable atmosphere.

From 1964 to 1972, 112 accidents in which 44 fatalities occurred were blamed on wake vortex turbulence. One such crash occurred on July 15, 1969, at Kennedy International Airport in New York. A Boeing 707 took off from runway 31L. About two minutes later, New York Airways Flight 905 was cleared for landing on this runway. As the aircraft came to within 50 to 100 feet of the ground, its left wing suddenly lowered violently, the entire plane turned sharply and crashed.

The violence of the tornado-like wake vortex that destroyed the aircraft and killed three of its occupants was demonstrated by the fact that the plane came to rest 160° from its original direction of landing.

Detecting turbulence

To prevent wake vortex turbulence accidents, increased separation between aircraft taking off and landing has been imposed. This varies from three to seven minutes, depending on atmospheric conditions.

Increased spacings, however, have caused air-traffic delays. In an effort to overcome them, equipment to detect and track vortices has been developed that's been undergoing tests for over a year.

The setup I saw was in position at the threshold to runway 31R at Kennedy. Developed by Avco Corp., it consists of a series of wind-speed measuring devices called anemometers and an acoustic-pulse sensing system which tracks vortices up to about 2000 feet.

An operator monitoring the computer readout can communicate with the control tower, advising of the severity of vortices and recommending shorter or longer landing times.

According to Paul G. Malone, Avco's on-site project engineer, the wake vortex detection system was modified after the Flight 66 crash.

"We've been successful in measuring the presence and severity of wind shear," Malone claims, but indicates more tests will be needed before the Federal Aviation Administration decides if the system has merit.

If it is adopted, every runway at every airport in the country would have to have the system installed to make aviation as wind-shearproof as possible. This would mean an investment of many millions of dollars.

This, then, is where the wind shear problem stands. Nothing offers aviation more of a challenge. ★ ★ ★



**The '75
NASCAR Champion
won more races**

**than the '74
NASCAR Champion.**

In 1974, Richard Petty won ten Winston Cup races. And his fifth NASCAR Grand National Championship.

In '75, with more than a month remaining in the NASCAR season, Richard already had twelve races under his belt. And his sixth Grand National crown. Giving the king of stock car racing an unprecedented 176 career victories.

Most all of Richard's racing milestones were won in Dodge and Plymouth race cars. Sparked by Champion plugs. Which is about as great a recommendation as you'll ever get.

So when you need spark plugs, just remember this: Richard Petty chooses Champion. Shouldn't you?

Send for two
Champion
Racing Decals.
Enclose 30¢ in coin for
postage and handling.
CHAMPION
DECAL OFFER,
P.O. BOX 2343,
REIDSVILLE,
NORTH CAROLINA
27322



Fill 'er up with Champions.



IMPORTS AND MOTORSPORTS

More mpg for Mazda



Mazda hasn't just been spinning its rotors. It has raised mpg of the '76 models 40 percent over last year's EPA certification figures, and has just introduced a new, top-of-the-line model EPA-rated at 29 mpg highway.

The last two years have seen the need for increased fuel economy from internal-combustion auto engines.



The challenge has been greatest for rotary-engine advocates—apparently too great for GM: Unable to boost mpg, it dropped plans for rotary models and is sitting on an investment of millions.

The new Mazda Cosmo, shown above, uses the Mazda two-rotor powerplant (110 hp at 6000 rpm) that has been made more fuel-efficient by a number of modifications. Among them are improved apex seals, leaner mixtures from a new carburetor, more precise timing and scavenging, less back pressure and an added heat exchanger. What it adds up to is good economy with the same old great performance (see RX-4 test and *PM Owners Report*, page 96, July '74). The \$6000 Cosmo wouldn't be a Mazda without its whacky styling elements, but, still, it's an interesting car.

Toyota keeps on truckin'

Among the changes and additions in the '76 Toyota lineup is this long-bed version of the SR-5 Sport Truck. The 87.8-inch cargo body is on a wheel-

base of 110 inches. Toyota now has four pickup models: the basic half-ton and the Sport Truck, both in short and long-bed versions. The short beds are 72 inches long and have 12.2-gallon fuel tanks, while the long beds have a fuel capacity of 16.1 gallons. Pickup prices start at \$3578.



Bikecentennial!

It's heartening to see that assimilation of Harley-Davidson motorcycles into the respectable conglomerate of AMF Inc. has taken no meanness out of the machines. They still flaunt their nonconformity, and the 1976 models carry it to new heights. If Paul Revere could have gotten his hands on a bike for his midnight ride, surely it would have been a metallic black Liberty Edition FX/FXE-1200. You can almost feel that steely-eyed eagle's talons cutting into your leathers. The Liberty Edition graphics (below) are just what's needed for a bikers' bicentennial. The mural-like decal is applied over a metallic black paint finish in which aluminum chips are suspended in clear acrylic.

Paint isn't the only new H-D story.



Two lightweight bikes are added to the street-machine line. The SS-175 and SS-125 (above) are two-stroke singles with oil injection and five-speed transmissions. The SS machines have a lot of nice features, but unique to the 125 is an automatic spring-loaded chain tensioner.

Shaft drive for Yamaha



Not too long ago, BMW and Moto Guzzi were the only motorcycles with the very desirable feature of shaft drive. Smooth and maintenance-free, shaft drive is catching on. Honda introduced it on the Gold Wing last year, and now Yamaha has it on its new XS 750C.

The four-stroke, three-cylinder bike is an eye-catcher for other reasons, too: The cast aluminum wheels of six-spoke design replace the standard spoke type, and the front and rear brakes are hydraulically operated disc brakes. The XS 750C also features automatically canceling turn signals and a positive crankcase ventilation (PCV) system.

More and more people are moving up to large displacement bikes like the XS 750C and the Harley heavyweights. Their performance and touring comfort are the reasons, but they are heavier bikes than most people are used to. And they are unique in other ways. In a feature next month we'll be discussing what to consider before you move up to a big bike. ★★★

RUST AND CORROSION
A PROBLEM? Reach For

LIQUID WRENCH®

REGULAR NO. 1

The super-penetrating rust solvent that loosens rusted nuts, bolts, parts in seconds!



LIQUID WRENCH®

NEW! NO. 2

Quickly cleans and lubricates... stops squeaks, protects metal, dries wet engines!



RADIATOR SPECIALTY CO.
CHARLOTTE, N. C. 28237



For close-ups, Sedic cameras take two accessories: Copy stand (above, left) shoots at 10 cm (4 inches); stand doubles as focus and framing check in other close-up uses (above, right). Close-up attachment (top right) has focus chain, shoots at 20 inches.

TURN POCKET CAMERAS INTO PHOTO SYSTEMS *(Continued from page 75)*

and a 1.5X telephoto (equivalent to a 75-mm).

What the angles mean

The pictures on page 75, shot at about the same distance, should give you a fair idea of what those angles mean.

After testing all of these except the Sedic telephoto, I was reasonably happy with the way each of them performed optically. Their convenience, however, varied.

The Computar set was convenient to mount: Both lenses screwed easily into a mounting frame that you can leave on the camera. But figuring out just what each lens sees is a problem. For the wide-angle, you have to overlook the bright frame in the finder and think of the entire finder area. That isn't too difficult—but it isn't too accurate, either: The lens actually takes in quite a bit more than that. For the Computar telephoto, you have to mentally restrict your image to an area whose limits can be derived from the lines of the finder, a process just about as difficult as it sounds.

The Computar set requires re-focusing, too: to shoot a subject 10 feet away, you set the focus scale at 15 feet when using the wide-angle, and about 3 feet when shooting with a telephoto, according to a scale on the bracket.

Built in telephoto easiest

Kodak's Tele-Instamatic 608 is the easiest of all: With the telephoto built in, there's nothing to carry, mount or lose; the lever that switches

in the telephoto lens simultaneously switches in a viewfinder mask to show the new field of view.

Sedic accessory lenses are quite easy to use, too: Each screws right into the lens mount, and each comes with a bulky but clear viewfinder.

The Sedic's threaded lens mount takes more than just accessory lenses: Sedic also makes a close-up lens and a copy/close-up lens and stand (see photographs above), and you can also fit filters. For \$10, the close-up lens brings the Sedic's minimum focus distance down to 50 cm—about 20 inches; a dangling chain helps you set the distance accurately, and a prism attached to the lens corrects the viewfinder for parallax. The other attachment takes you down to 10 cm (4 inches) with a frame attached that shows you exactly what's in view and in focus. It also doubles as a copy stand for shooting down onto small objects.

Not all Sedic accessories fit the front element, either: For rapid sequence shooting, you can fit the more expensive Sedic models with a compact, spring-wound motor drive, the first in 110-film photography (and, at \$30, the world's least expensive motor drive).

For 110 cameras whose lenses aren't threaded like the Sedic's, Hoya makes a \$4/slip-on skylight filter to reduce the blue-tint in distant scenery. And Andrew Jacobsen, 5618 East Edgemont, Scottsdale, Ariz. 85257, makes a \$25 custom adapter that holds Series VIII filters in front of both your camera's lens and its electric eye (if any). ★★★

EASY COLOR PRINTS FROM SLIDES

Continued from page 79

enough to minimize the problem of keeping solutions within the recommended temperature limits.

Filtration's easy, too

Finding what filters give you the right color balance is the hardest part of color printing, but Ciba makes that easy, too. Each package of papers is stamped with basic filter recommendations for use with Kodachrome slides (though the data sheet and Cibachrome's \$5 instruction book don't tell you that). Once you've adjusted that filter pack to match your tastes and your equipment, you can easily calculate the changes you'll need to print from Ektachrome, Agfachrome, GAF or Fujichrome slides (the book tells you how; data sheet gets you figure it out indirectly).

When you switch to a new batch of paper, you just modify your standard filter packs by the difference between the filter recommendations for the two batches. If the second batch calls for 10 units more magenta, just add 10M to all previous filter packs.

What you'll need—and want

If you want to do your Cibachromes as cheaply as possible, all you'll need is a pack of 20 sheets of Cibachrome 8x10 paper for \$25 (or 10 11x14 sheets for \$24.25), a \$15 chemical kit (enough for either pack of paper), three trays and a set of filters for your enlarger's filter drawer (\$27.50 from Ciba, though available from other sources, too). But you'll be well advised to buy a drum (Ciba's is \$17.50, but other drums will do), so you can process your prints with the light on, instead of spending nine minutes in the dark.

As you can see from the photo on page 79, I added a few extras to this basic setup: A Chromega motorized agitator base (\$70) and a \$23 Chromega drum (because it fits the agitator better than the Ciba drum does), an \$80 Brantronics Temp-Set bath to keep my chemicals at precisely 75°, and a Chromega color head for my enlarger (\$233 with stabilized power supply) so I could just dial in my filter changes instead of having to shuffle filters physically.

Two other additions in the picture are so cheap it would be folly to skimp on them. Falcon's Air-Evac bottles extend the life of the expensive color chemicals by collapsing like accordions to expel air and bring the bottle cap right down to the level of the chemicals. And Unicolor's Jingle Bells timer (\$17 from Spiratone) ingeniously signals when each step of processing should end, too. ★ ★ ★

RICHARD PETTY says:

"Want to really learn how to repair cars? Check out NRI home training"



You get all this equipment and more with the NRI Master Automotive Technician's Course... including NRI's exclusive Achievement Kit, and 70 profusely illustrated "bite-size" lesson texts.

"NRI provides the most up-to-date complete courses

in Auto Mechanics I've ever seen. I know the importance of a good mechanic, and the opportunities out there for trained men. That's why I'm glad to see home training like the two NRI courses. It's a lot of training for a very few bucks.

Save Gas... Save on Repair Bills. NRI's Tune-Up Course will teach any homeowner all he needs to know, quickly, with hands-on experience. The course includes 8 important service items, including a Dwell Tachometer, Volt Amp Tester, and Tune-Up Tool Kit.

Become a Professional Mechanic. NRI's Master Automotive Technician Course gives you the essential training and diagnostic equipment to be a real pro. You get 10 pieces of auto service equipment, including a Dwell Tachometer, AC Power Timing Light, Volt-Amp Tester, Ignition Analyzer Scope and a complete set of tools.

Train with the Leaders—NRI & McGraw-Hill. No other school has NRI's experience in home training, or McGraw-Hill's background in continuing education. Mail the coupon and check what they have to offer." NRI AUTOMOTIVE DIVISION, 3939 Wisconsin Ave., Washington, D.C. 20016

**RUSH FOR FREE CATALOG
NO SALESMAN WILL CALL.**



NRI SCHOOLS
McGraw-Hill Continuing Education Center
3939 Wisconsin Avenue,
Washington, D.C. 20016

946-016

Check below for your free Automotive Catalog. Or select one of the other courses instead.

AUTOMOTIVE MECHANICS COURSES

TV/Audio, Communications, and Computer Electronics Courses

Air Conditioning, Refrigeration, and Heating Courses

Name

Age

(Please Print)

Address

City

State

Zip

APPROVED FOR CAREER STUDY UNDER GI BILL.
Check for details.

ACCREDITED MEMBER NATIONAL HOME STUDY COUNCIL

The no-compromise vacation. The only place you cut corners is on the cost.

We'd like to help you spend less money for your vacation this year. Without getting less vacation for your money.

So we've put together what's probably the most helpful vacation planning guide in America. It's full of facts about things you can do here. And you'll be surprised how many of them are free.

Even the Trip Kit is free. Just send us the coupon.

And find out how far your vacation dollar can take you.



Name _____ Address _____
City _____ State _____ Zip _____

Free South Carolina Trip Kit

Mail to South Carolina Division of Tourism, Room 206, Box 78, Columbia, South Carolina 29202.

the original
"wedge-type" screwdriver

QUICK- WEDGE

SCREW-HOLDING
SCREWDRIVER

Does all the job!
**HOLDS,
STARTS,
DRIVES,
AND SETS**
the screw
normal tightness!

GET A SET TODAY!
At your dealer's
or write

**KEDMAN
COMPANY**
Box 267
Salt Lake City,
Utah 84110

17
SIZES

©1975 by
Kedman Company



DO-IT-YOURSELF
SOLID WALNUT
GRANDFATHER

CASE KITS FROM UNDER \$100

- All critical parts pre-assembled
- All miters pre-cut
- All screwholes pre-drilled
- Solid 1" and 3/4" American Black Walnut

**FREE
COLOR
BROCHURE**

OTHER CROWN PRODUCTS

Assemble and finish your own heirloom quality mantel and wall clocks. Send 50¢ for our color catalog of case kits, dials, movements, tables, shelves and many other kits.

Crown of Fairhope

P.O. Drawer G-145
759 Nichols Avenue
Fairhope, Alabama 36532

AMERICA'S FINEST MANTEL CLOCKS AT FACTORY PRICES.

SPEEDY GEM POLISHER

(Continued from page 103)

only splash out. Always start with full load of rocks to get proper action. The rocks should circulate, rising to the top of the center of the bowl, traveling to the edge and then going under again. The pattern of the motion can be varied by changing the angular relationship of the weight arms, while the speed of rock motion can be varied by adding or removing weights. Although the polisher is not very noisy, it can be made quieter by covering the bowl with an old bath towel doubled up. ★ ★

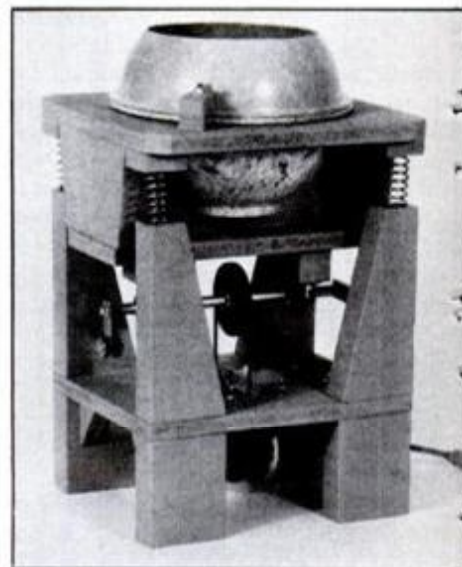

Complete polisher with bowl in place (the second hold-down clamp is hidden)

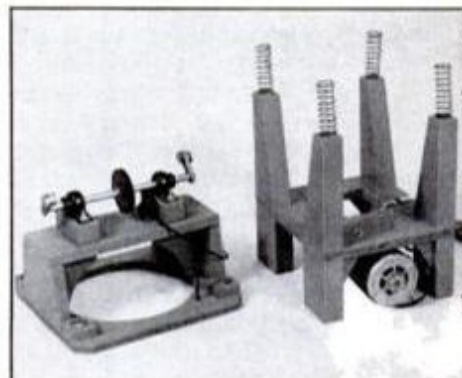

Major assemblies, platform inverted to show pillow blocks, shaft, arms, pulley.

HARDWARE REQUIRED

- 2 10-32 x 1" RH machine screws
- 2 1/4 x 2 1/2" machine bolts
- 4 1/4 x 3" machine bolts with nuts
- 4 1/4 x 1 1/2" machine bolts with nuts
- 2 1/4" wingnuts
- 2 pillow blocks, Fafnir PB 1/2
- 2 3/16" or 1/4" V-belt pulleys; 3" dia., 1/2" bore
- 3/16" or 1/4" V-belt, 22" long or to suit
- 1/4-hp split-phase motor, 1725 rpm
- 2 8-32 x 1/4" setscrews
- 2 10-32 x 1/4" setscrews
- 4 coil springs, approx. 1 1/8" O.D. x 4" long; 10 coils, .090" dia. wire.

Turn Extra Time Into **Extra Income!** Earn \$5 TO \$8 an Hour

Be your own boss
in a money-making
business of your own.

No
Experience
Needed

Sharp-All lets you Sharpen Saws

garden and shop tools
for home and industry

Start Earning FAST—No Experience Necessary.

With SHARP-ALL it's easy to start your own business. No selling is involved, no inventory. People bring in their work... you take in year round CASH Profits and keep 90¢ out of every dollar you earn. Work sparetime or fulltime right at home in your garage, basement or tool shed. Work the hours you want—FREE Book tells how to start your own business even while working at your regular job.

Big PROFITS In Sharpening.

Every home and business has saws and tools that need periodic sharpening. There's plenty of business waiting for the man who can sharpen saws, planer knives, jointer blades, wood chisels, scissors, pinking shears, snips, lawnmowers, axes and other garden, shop and home tools. SHARP-ALL does ALL these jobs and more... quickly, and at a big profit. You will be sharpening headquarters for carpenters, builders, lumberyards, factories, home workshops and hobbyists... hundreds of jobs right in your own neighborhood.

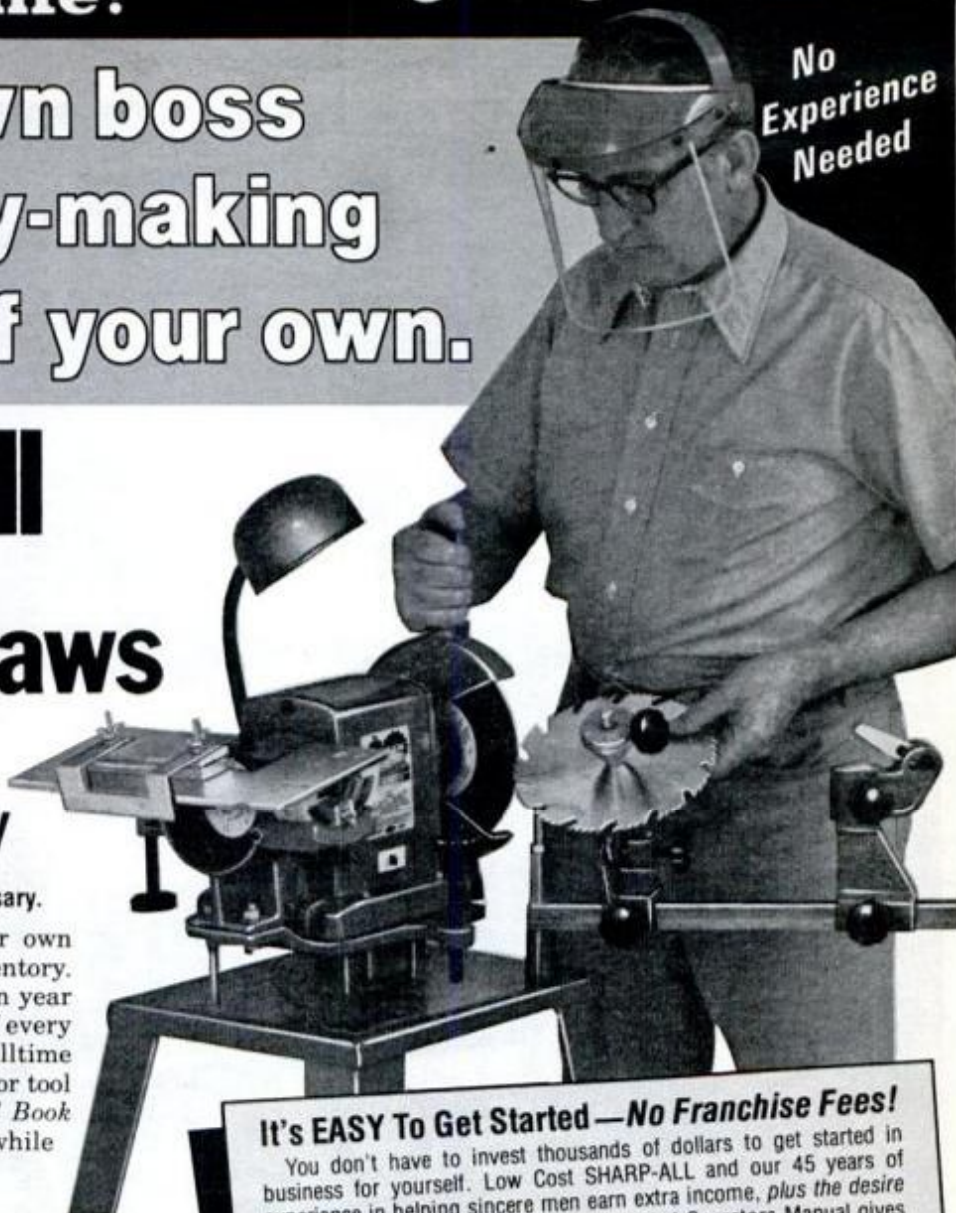

It's EASY To Get Started—No Franchise Fees!

You don't have to invest thousands of dollars to get started in business for yourself. Low Cost SHARP-ALL and our 45 years of experience in helping sincere men earn extra income, plus the desire to get ahead is all you need. Fully illustrated Operators Manual gives clear, step-by-step instructions, shows exactly how to sharpen each tool, where to get business, what to charge, how to get free advertising... all the "tricks of the trade". And, SHARP-ALL does the kind of precision job that brings customers back time after time.

Send for FREE Book "Lifetime Security." Do It Today!

There is NO OBLIGATION and
NO SALESMAN Will Call!

ACT NOW!
Coupon
Brings
Full Details!

SEND FOR FREE FACTS TODAY!

You risk nothing by accepting this offer to see how easily you can turn your spare time into Big CASH Profits with your own Complete Sharpening Shop. Send coupon or mail postcard for full details on our exclusive

30-Day FREE Trial Offer!

FREE Booklet gives full details—

Our Free Book tells how to start a profitable, lifetime home sharpening business, how we help you grow, how we'll finance you.

Send for
your copy
today. No
obligation.

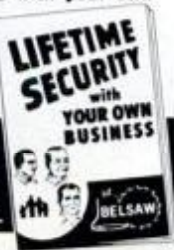

No Obligation . . . No Salesman



BELSAW SHARP-ALL CO.
716J Field Bldg.
Kansas City, MO 64111



RUSH
COUPON
TODAY!



Please send my FREE copy of your book "Lifetime Security" and full details on your 30-Day Free Trial Offer!



Name _____



Address _____



City _____ State _____ Zip _____

BELSAW SHARP-ALL Co., 716J Field Bldg., K.C., MO 64111

Demand for electronics technicians will continue to grow year after year, according to responsible projections, not only in broadcast control (shown here), but in hospitals...industry...offices...schools. Electronics is the field for tomorrow.



16 WAYS TO MOVE AHEAD IN

Choose the one that's right for you, now. The one that can make your future more rewarding, more secure, more enjoyable. These steps to your better tomorrow are available from Electronics Technical Institute...the finest in electronics home study courses and programs!

"Building" is a key word at Electronics Technical Institute. Whether your goal is to get into TV Repair and Service, get your FCC license, move into computers, advance in your present job through learning solid-state technology, or become an electronics draftsman, you build a solid future where the action has to come.

You build that future on a foundation of learning that is useful...practical...step-by-step...hands-on.

You build it from the beginning by a special, simplified, building-block teaching system called *Autotext* (exclusive with Electronics Technical Institute) that makes learning fun. You keep building, combining hands-mind-equipment in the most practical way, so you can "talk shop" or present an idea effectively, and you *can also do the job!* You've learned by doing, and you gain all the confidence that comes with it.

You build with the concerned personal help of a licensed instructor who knows the subject and wants to know you. You build with the reputation of the school that began as the Marconi Institute back in 1909.

In many phases of building your technical know-how, you use specially developed Project Kits that move in a logical sequence, hands-on, from the first step through completion of basic units. There is no surer way to build solid electronics knowledge and your own confidence in what you can do.

Choose your future...here, and now!

Fundamental Electronics

Get a solid foundation for entering the fast-moving world of electronics where today is great, and tomorrow will be greater. Learn it the simple, easy, step-by-step, programmed way called *Autotext*, exclusive with ETI!

Electronics Drafting

Learn a vitally needed specialty that translates new tech-

ELECTRONICS

nological concepts and developments to the practical drawing board. Become a specialist-in-demand, through ETI's training. Learn it at home...get your future moving now!

Color TV Servicing

There's a real future waiting for the established color television technician. You become that technician through this program that takes you step-by-step to *theoretical and practical* mastery of color TV. Get your tomorrow started today!

Master TV/Radio Servicing

Here is true "master" preparation for a career that can take you as far as you want to go into radio and television servicing, both black and white, and color. The helpful, practical ETI way can be your way to more money, security, success!

Communications

ETI's communications program opens up a whole range of career development possibilities in electronics. Solid-state receivers, solid-state audio equipment, communications equipment, CATV, as well as preparation for FCC-licensed positions in commercial broadcasting and mobile communications. You can find a real future here!



Industrial Electronics

You open great career opportunities through this program, as instrumentation technician, electronic equipment maintenance technician, electronic calculating machine technician and audio technician. It also prepares you to move into and up in communications, automation and industrial electronics!



Digital Technology

Join the digital revolution which is radically altering our lives today and tomorrow. Get solidly trained in the new digital specialties that can lead to a real future as a digital control technician, electronic calculating machine technician, field representative, manufacturer's representative.

Electronics Technology

Learn electronics across the board! You'll be ready for real career advancement with training that can lead to technical positions in communication, automation and industrial electronics, and can also help you in sales positions, management and administration.

Computers

ETI offers training opportunities in Computer Technology and Computer Programming. Learn at home, and get ready to enter a field where incredible developments are sure to continue. It's practical, useful—the step-by-step ETI way!

Advanced Electronics

Want greater challenges and career advancement? This course is for you. It can be valuable preparation not only for a technical career, but also for the fields of sales, management and administration. Make your move now!

Digital Electronics—Advanced

Here's a special course for those already in the field of digital electronics, ready to move into more advanced areas. This is how to move up in sales, management and administration. Here's your tomorrow!

Black and White TV Servicing—Advanced

This can be your own "advance" source to black-and-white TV competence from A to Z. You'll construct a receiver yourself, if you wish. A key to life-time success!

Industrial Instrumentation—Advanced

Move up in the world...the wonderful electronics world! This course opens up a whole range of careers in the industrial field, as instrumentation technician, laboratory technician, process control technician or electronic calculating machine technician. Get ready...and go!

Color TV Servicing—Advanced

Here is the "graduate" course in color TV for those who already know television fundamentals. You'll learn color TV from top to bottom, build your own set if you choose. A great way to build your future!



Solid-State Electronics—Advanced

Applications of transistors are increasing all the time and the

transistor may be a breakthrough comparable in importance to the development of nuclear energy. Solid-state can mean your solid career development, too, through ETI!

FCC License Preparation

Here is real down-to-earth practical preparation to take your 3rd, 2nd, or 1st class Federal Communication Commission Radio-telephone License examinations. Get yourself ready now for any of the FCC-licensed positions involving broadcasting, mobile communications, microwave communications links, marine communications equipment or in many other positions in solid-state, communications, CATV. Get ready for tomorrow...today!

And it's simple to check it all out right now, with no obligation—and no salesman will call. All it takes to get the colorful new 48-page ETI Career Book is a card or coupon. If you like electronics, you'll enjoy reading about it. You owe it to yourself to get the facts.

The Career Book itself may be worth real money to you, as you make plans for your future and consider the many opportunities open to you through 16 different courses and



programs in electronics. To build a future in electronics, the first step is to send for your free ETI Career Book today!

Electronics Technical Institute

Division of Technical Home Study Schools

Electronics Technical Institute, Dept. 2-110-016
Little Falls, New Jersey 07424

Send me the Electronics Technical Institute Career Book.

Tell me how I can get ahead in Electronics through ETI. I've checked the fields of special interest to me.

- | | | | |
|---|---|------------------------------------|---|
| <input type="checkbox"/> TV/Audio Servicing | <input type="checkbox"/> Communications | <input type="checkbox"/> Computers | <input type="checkbox"/> Business and Engineering |
| Black and White | FCC License | Digital Electronics | Electronics Fundamentals |
| Color | Aircraft | Computer Technology | Electronics Drafting |
| Solid-State | Marine | Computer Programming | Industrial Electronics |
| CATV | Mobile Two-Way | | Advanced Electronics |
| Closed Circuit | Microwave | | Industrial Instrumentation |
| Video Recorders | | | Electronics Technology |
| Radio | | | Medical Electronics |
| Hi-Fi Stereo | | | |

Check here for Veterans information.

Name _____ (please print)
Address _____
City _____ State _____ Zip _____

BUILD YOUR OWN CAMPER! **SAVE UP TO 50%**



SEND 25¢ FOR DETAILS

5th Wheel Plans.....	\$12.95
Cover basic frame, electric, plumbing, (general construction)	
Camper Plans.....	5.95
Pickup Cover.....	3.95
Travel Trailer.....	4.95
Econoline Type Van.....	4.95
Pass. Bus or Delivery Van.....	4.95

EQUIPMENT CATALOG

Send \$1.00 postage, handling (Refundable)

VIKING CAMPER SUPPLY INC.
 99-8P Greenwood Ave.
 Minneapolis, Minn. 55403
 Please send _____ for which I enclose \$ _____
 NAME _____
 ADDRESS _____
 CITY _____ STATE _____ ZIP _____



Send for **New 1976**

WOOD and woodshop supplies CATALOG

New MINI-DOLLHOUSE FURNITURE KITS—NEW MINI-LATHE
 Fine domestic and imported Hardwoods... dimensions, blocks, plywoods. Everything for your shop... hand and power tools, upholstery and lamp supplies, cabinet hardware, clock and inlay picture kits, much more - in stock. For catalog send 50¢ for handling, postage to:

CRAFTSMAN WOOD SERVICE Dept. A-16, 2729 South Mary Street Chicago, Illinois 60608

THE MODEL RAILROADING HANDBOOK.

The only book with the best proven modeling techniques for all aspects of the hobby. 227 pages, eight in color, with over 220 illustrations. \$7.95 soft cover, \$15.00 hardback postpaid in U.S.A. from The Company Co., Dept. B, Box 1633, Manhattan Beach, CA 90266.



"SAVE YOUR HEART"

with a **STAIR-GLIDE®** stairway lift

RENTAL-PURCHASE Program Available

Your STAIR-GLIDE® installs easily and in less than 2 hours. No marring walls or stairway. No special wiring required. Shipped directly from factory within 4 days. STAIR-GLIDE®... the nation's largest selling stairway lift! UL LISTED! USED BY THOUSANDS: CARDIAC PATIENTS, ARTHRITIS, SENIOR CITIZENS, RESTRICTED PHYSICAL ACTIVITIES, POST OPERATIVES... and household convenience. (outdoor models available) WRITE FOR FREE BROCHURE AND NAME OF DEALER NEAREST YOU.

AMERICAN STAIR-GLIDE® CORP.
 4001 East 138th, Dept. POP-16
 Grandview, Missouri 64030

FOR DEEP-WATER JOBS, CALL A SMALL SUB (Continued from page 55)

waves flipped the momentarily slack towline around the hatch lock on the sub's rear buoyancy sphere. The hatch cover was pulled off, and more than a ton of water poured into the sphere. The increased weight snapped the towline as *Pisces III* plunged into the depths. At 1575 feet, she hit bottom.

Seventy-six hours later, with the air supply almost exhausted, the sub and its two crewmen were rescued. The operation involved two other manned submersibles, including Vicker's *Pisces II*; an unmanned, surface-controlled recovery vehicle, *CURV III*, made available by the U.S. Navy, and two support ships.

The rescue dramatically demonstrated the submersible's value in deep-water work. *Pisces II* and *CURV III* were sent down to the disabled sub, carrying toggles—devices with two arms that open and close like an umbrella. Using manipulator arms, the rescue vehicles inserted two toggles through the open hatch of *Pisces III*'s flooded compartment. Then the toggles' arms were snapped open and locked in position. Lines from the toggles to a support ship were used to winch *Pisces III* to the surface.

Big in North Sea

Though this dramatic occurrence isn't typical of day-to-day operations, it shows the potential dangers facing the commercial subs as they work in rough ocean waters.

The accelerated search for oil and gas deposits in offshore waters has created a big demand for submersibles, especially in the North Sea,

where 14 subs are operating now, with another six under construction for duty there. Subs are also being used in offshore-oil work in the Mediterranean, Caribbean and the Gulf of Mexico.

This increased need has meant brisk business for the two major builders of these subs: Perry Oceanographics, Inc., Riviera Beach, Fla., and International Hydrodynamics Co., Ltd. (HYCO), Vancouver, B.C., maker of the *Pisces* subs.

The world's largest fleet of commercial submersibles is operated by Vickers Oceanics, a British company that has nine subs and five support ships. On this side of the Atlantic the leaders are International Underwater Contractors, Inc., City Island, N.Y. (three subs) and HYCO of Canada.

The subs carry out various assignments in the oil fields. They make seabed surveys for new pipelines and siting of underwater structures; inspect and maintain rig structures, pipelines and wellheads; locate and recover lost equipment; make videotape and photo records of inspections.

Some subs are equipped with manipulators, mechanical arms that can be fitted with a variety of tools for such tasks as gripping, cutting, sawing, drilling and pumping. They can be switched under water.

A big advantage of the sub over the human diver is that the vessel can go a lot deeper. At present, the maximum working depth for a diver is about 1000 feet. Some subs, on the other hand, have a depth limit of better than 6000 feet.

Bruce C. Gilman, executive vice-

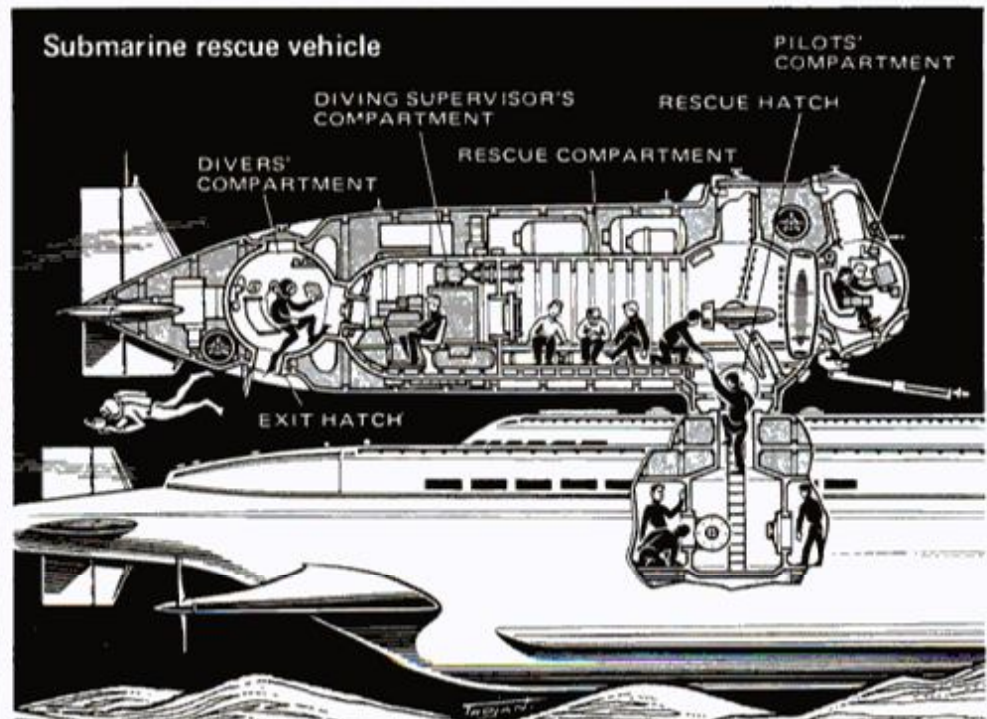

president of Perry Oceanographics, points out that at any depth the manned submersible has obvious advantages: "It can perform heavier tasks and deliver greater loads than can the diver. It can work in stronger currents and for longer periods. It can carry to a work site 70-mm cameras, video equipment, lights and water-sampling gear, which, if divers were used, would at least require many dives."

However, there are jobs at levels down to around 1000 feet that call for a diver's greater dexterity and ability to work in confined spaces. To fill this need, subs such as Vickers' VOL LI have lock-in, lock-out systems that enable divers to exit from and re-enter a pressure sphere separate from the compartment containing the operating crew. While the pressure of the divers' sphere equals that of their working depth, the pilots' sphere is at a pressure approximating that at surface level, providing them and any passenger-observer with a "shirt sleeve" environment.

No need for speed

When compared with even a small atomic submarine displacing about 3000 tons, the commercial sub of 10 or 15-ton displacement is a real mid-get. The typical submersible has underwater speeds of 3 to 5 knots. Higher speeds are not needed and would waste energy. Power for propulsion and operating onboard equipment comes from batteries, usually the lead-acid type. Oxygen is fed into compartments at controlled rates, and carbon dioxide is removed from the atmosphere by scrubbers.

Dive duration for many subs ranges from about 5 to 10 hours. In the event of an accident, emergency life-support systems can sustain a crew for several days.

Despite the success of current submersibles, there is room for improvement. There's a need for increased power—and fuel cells and nuclear energy are mentioned as possible sources. The launch and recovery of subs in rough seas could be made surer and safer. A possible solution developed by a Swedish company utilizes a 1600-ton submarine-support vessel as the mother ship for a 50-ton submersible, which is launched and recovered in calm, below-surface depths. The drawing on page 124 shows the military version of this system, in which the submersible is used as a rescue vehicle.

The need for commercial subs should even increase, experts say, as the search for oil and gas sources expands into deeper waters and as the mining of minerals from the ocean floor becomes established. ★ ★ ★

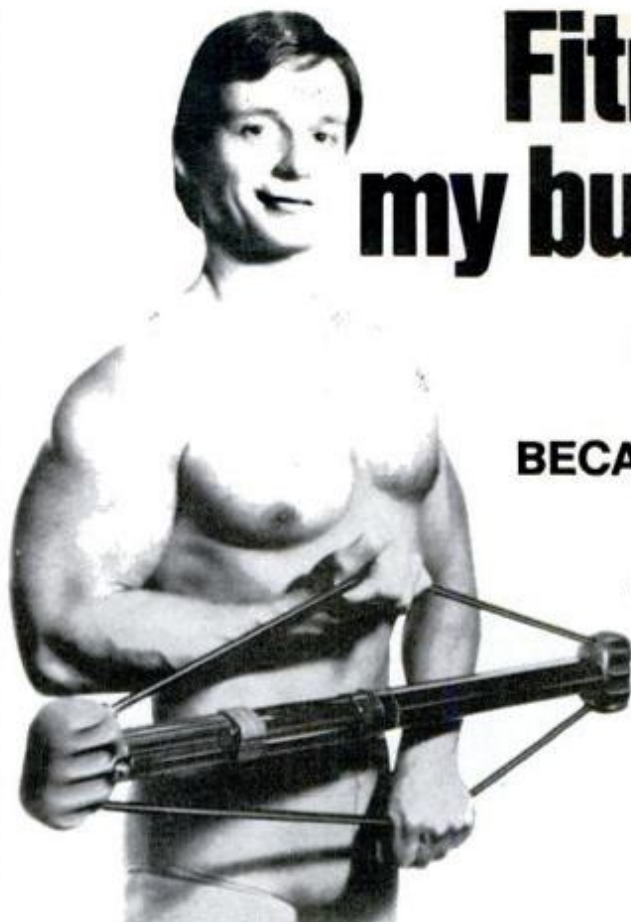

Fitness is my business

**I RECOMMEND
BULLWORKER
BECAUSE IT'S FAST,
IT'S EASY
AND IT REALLY
WORKS!**

Aside from keeping many of the stars you see in the movies and on television in top shape, Mike Fretault, at 40, is still one of the most sought-after stunt men in the business.

Most men know they're not getting enough exercise to keep their bodies in shape.

Twenty years as a fitness coach has taught me one important fact: most men will not stick with a training program long enough for it to them any good, unless the training is fast, easy and shows results right away.

Bullworker gets a top score on all three counts:

—it's fast: each exercise takes only 7 seconds and the complete workout can be done in about five minutes

—it's easy: any man between 15 and 65 in good general health can perform the full program without getting tired

—you see your results right from the very first day on the built-in Powermeter gauge. After two to three weeks of regular training, most men can expect to measure an extra inch or two of muscle on their shoulders,

chest and biceps—and an inch or two less flab around the middle.

And that's just the start: there are specialized exercises for building-up or trimming-down any part of your body you want to. What's more since Bullworker training is progressive, you perform better each time. Yet the training always seems easy since with every workout your strength increases by about 1%—that's an increase of up to 50% in just three months, and I've seen many men go on to double and even triple their strength. For my money, Bullworker is the most advanced home trainer on the market. I use it and recommend it to any man who wants to get back in top shape fast.

For free details about Bullworker Fitness Training, recommended by fitness experts, champion athletes and nearly two million enthusiastic users the world around, mail coupon for FREE BOOKLET today. No obligation, no salesman will visit.

BULLWORKER SERVICE, 201 Lincoln Blvd., P.O. Box 20, Middlesex, N.J. 08846

239

FREE BOOKLET



24 pages of action photos in full color show you how to build a powerful body in just five minutes a day

BULLWORKER SERVICE, Dept. BW2117
201 Lincoln Blvd., P.O. Box 20, Middlesex, N.J. 08846

Please send me my FREE full color brochure about BULLWORKER 2 without obligation. No salesman will visit.

Name _____ Age _____
please print

Street _____ Apt. No. _____

City _____

State _____ Zip _____

Canada: Home delivery duty paid. Ask for FREE booklet.

HERE COME THE DIESELS

(Continued from page 61)

diesels can take away a very strong enthusiasm for them among many people, or detract from the very clear advantages of this long-lived type of automotive powerplant. There's no ignition system to go wrong, and there isn't even a carburetor to fiddle with since diesels use a fuel-injection system. Easy maintenance is a bonus to the owner on top of the excellent fuel efficiency.

Let's take a look now at what's available in diesel cars and what's coming down the road.

General Motors diesels

Sources at Oldsmobile presently admit they've been developing a diesel V8 based on the 350-c.i.d. Olds block. Plans call for selling it to Chevrolet (by Olds Div.) to drop into 1977 Chevy vans, pickups and some passenger cars. Whether the Olds diesel V8 will then appear in Oldsmobiles is moot.

An Olds insider told us recently the decision to experiment with the division's V8 was due to that engine's very strong bottom end. The 350's bearings and crank can take the added strains of high compression

with little (if any) modification.

General Motors, too, is toying with at least one other diesel-powered car—the Vega. This subcompact, shown to the press, carries a 2100-cc, 60-bhp German Opel diesel engine instead of the regular ohc Four.

Volkswagen diesel

Also experimental but a natural for production quite soon is the Volkswagen diesel. Two VW Rabbits with diesel powerplants based on the standard VW gasoline four-cylinder engine have been tested by the EPA. The diesel got 51 mpg on the highway and 40 mpg in the city. Possibly—this is *really* speculating—since AMC is buying VW (Audi) engines you'll see a VW diesel in something like the AMC Pacer or Gremlin before 1980.

We found out what it's like to drive the 1.5-liter, 50-hp diesel Rabbit from a New Jersey Dasher owner. He told us how he was invited to drive the experimental diesel-powered Rabbit at the Volkswagen of America offices in Englewood Cliffs, N.J. The marketing department there is doing a study on customer reaction to diesels. The Dasher owner, who displayed a good knowledge of cars, was impressed. The diesel ran up to

60 mph in about 18 seconds, emitted practically no smoke after a short warmup and retained the Rabbit's handling (after suspension modifications to handle the greater weight of the engine).

Driving was a bit noisy, however, but not bad considering no special sound-deadening had been added—as it would be if the car goes into production. And, yes, he would willingly pay \$200 more for a diesel, answering a question from the marketing people about the diesel versus the gasoline Rabbit.

New International diesel

International Harvester now makes diesel engines available in its Scout II, Traveler wagon and Terra pickups. After testing and comparing several diesels, I-H settled on the Nissan CN6-35 unit, an in-line Six of 198 c.i.d. Nissan builds Datsun cars and trucks in Japan. This engine develops 92 bhp at 4000 rpm with a compression ratio of 22:1. The powerplant itself weighs 662 pounds.

Fuel mileage for the Nissan diesel is said to be 50 to 60 percent above that of gasoline engines in the same vehicles. Prices of diesel-engined Scouts, Travelers and Terras are quite a bit more than their gasoline

You can buy three products to do three jobs... or buy just **ONE** to do all three!



Demoisturize. Lubricate. Free rusted parts. Permatex has a product that does all three jobs from one can: "DLF". It Dries metal surfaces, Lubricates parts, Frees connections. One can, three jobs.

That's efficiency, economy, performance. DLF. Push button maintenance from Permatex.

PERMATEX COMPANY, INC.
P.O. Box 1350, West Palm Beach, Florida 33402
Telephone (305) 686-0880 Telex 513-417



counterparts—\$2200 more, in fact.

Peugeot diesel

Peugeot began offering diesels in Europe in the early '60s, but didn't bring them into this country until 1974. The latest Model 504 Peugeot diesel car has a four-cylinder push-rod engine delivering 65 bhp at 4500 rpm. Torque is fairly weak (88 ft.-lb. at 2500 rpm), so no automatic transmission is available.

We drove a Peugeot 504 diesel and found it pleasant and amazingly quiet for a diesel—but lazy. Driving it takes patience. Cold-morning starting does, too—it demands switching on a glow-plug with the ignition key before spinning the engine. Most automotive diesels have similar systems. You usually wait less than a minute for the glow-plug to heat, though. A dashboard light comes on to tell you when the engine's ready to crank. Once the engine is warm, the car starts without waiting for the glow-plug.

Mercedes diesel

Mercedes surprised many Americans with a five-cylinder, in-line automotive diesel for 1975. Actually, odd-cylinder diesels are fairly common. John Deere, Detroit Diesel

(GM), Ford, Deutz, Onan and Hercules all make three-cylinder diesels; some are two-strokes.

Mercedes sells two series of passenger-car diesels: the four-cylinder 240D and five-cylinder 300D. Internally, they're practically alike. The 300D simply has one more cylinder and one extra main bearing.

Externally, these cars are again very similar—same wheelbase, overall length and interior dimensions. The 300D comes with an automatic transmission as standard; in the 240D it's optional.

The 240D puts out 62 bhp at 4000 rpm; the 300D develops 77. Compression ratio on both engines is 21:1.

In normal driving, the five-cylinder 300D feels almost—but not quite—like a six-cylinder gasoline engine. It's noticeably smoother than the four-cylinder 240D, which in itself isn't annoyingly rough or noisy. You know you're driving a diesel, though, and again, there's the typical diesel laziness, especially in the 240D.

We're sure to see more automotive diesels in the near future. Within a few years, many corner filling stations likely will be adding one more pump. The day of the passenger-car diesel is definitely dawning. ★★★

PM OWNERS REPORT—MERCEDES

(Continued from page 64)

everything on the car works, and that's saying quite a lot nowadays."

A Florida administrator: "The Mercedes is put together in fine detail instead of the assembly-line theory."

"American workers can't duplicate Mercedes quality because we no longer give a damn," states the Michigan cattleman.

All in all, then, owners of diesel-engined Mercedes appear well pleased and satisfied. We'll let some random, noncategorizable comments serve to ring down the curtain.

A lady in Washington, D.C.: "I like everything about the car. It handles well and, being small, is much easier to park than our big Oldsmobile. Furthermore, it doesn't create air pollution and is much cheaper to operate."

The president of an Indiana ad agency: "I'm essentially a salesman and need a car that will travel 300,000 miles with great economy and comfort. This 240D is better than any other car I've ever owned. Diesels are obviously the engines of the future—they make gasoline engines obsolete." ★★★

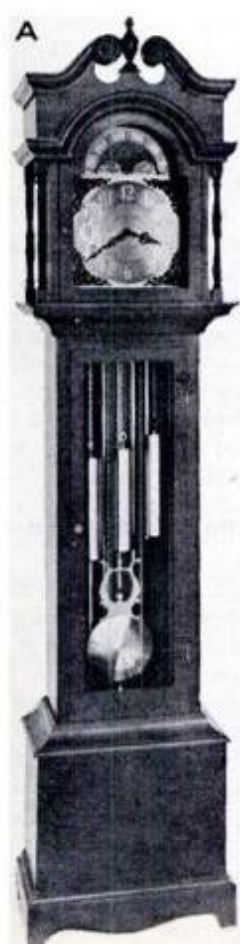

BUILD THESE BEAUTIFUL CLOCKS

BUY AT FACTORY PRICES AND SAVE \$200 OR MORE!

Kits for you to cut and assemble in solid Cherry, Walnut and Honduras Mahogany. No plywood or plastic.

Handsome Moving Moon and "Tempus Fugit" Dials are gracefully styled in solid brass. German-made weight-powered movements play the beautiful Westminster, St. Michael and Whittington Chimes.

Send just \$1.00 for plans and instructions to build your choice of (A) Grandfather, (B) & (C) Grandmother, (D) Steeple plus information-packed catalog of movements, dials, parts and kits to build these and 14 other fine clocks. All 4 plans — \$3.50.

CATALOG ALONE — 25¢

MONEY BACK GUARANTEE
ON ALL ITEMS

MASON & SULLIVAN CO.
OSTERVILLE, CAPE COD, MASS. 02655

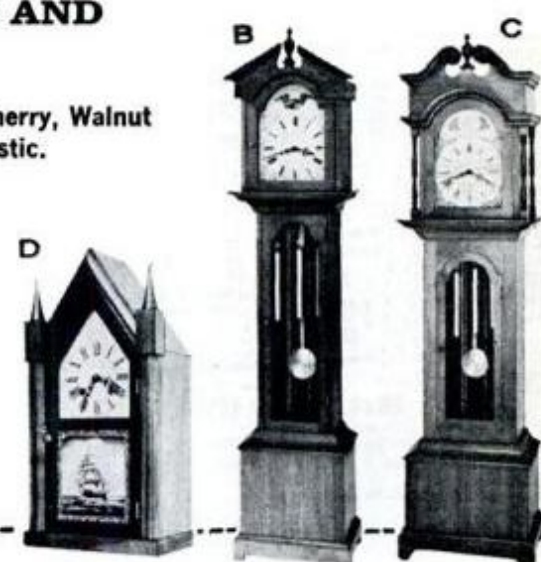

MASON & SULLIVAN COMPANY
Dept. PMH, Osterville, Mass. 02655

Please Rush the following plans:
CLOCK A B C D @ \$1.00 each
Send all 4 plans @ \$3.50
Send catalog only @ 25¢

Name _____
Street _____
City _____ State _____ Zip _____



YOUR PHOTO WAREHOUSE!
SAVE UP TO 60% ON ALL ITEMS
OPEN SUNDAYS 10-4

PHONE ORDERS (212) 233-9191

NEW BAYONET MOUNT
HONEYWELL ASAHI PENTAX K2
FULLY AUTOMATIC

with f/8 Lens | with f/4 Lens | with f/2 Lens

\$349 **\$389** **\$455**

K-2 BODY ONLY \$289.00
ORIGINAL CASE 24.00
ADAPTER for Screw-In Lenses 7.50

KONICA AUTOREFLEX T3

FULLY AUTOMATIC with f/7 Lens

\$269 with Case
\$305 with Case
\$355 with Case

ACCESSORIES:
BODY ONLY \$209.00
BLACK BODY Add 14.95
Light Image FOCUSING Add 7.00
HOT SHOTS 5.95

MIRANDA DX3 SLR CAMERA
with f/8 Lens

\$258
CASE \$14.00

OLYMPUS OM SYSTEM 1MD
with f/8 \$245
with f/4 \$279
ORIG. CASE \$14.95

Celtic Lenses
28mm 12.8 WIDE-ANGLE \$72

Rollei 35S
Multi-Coated Lens

\$129

KONICA Auto S3
with f/8 Lens

\$127 with CASE
AUTO-UP \$29.00
CASE \$16.95

Minolta SR-T 202.
with f/7 **\$235**
with f/4 **\$259**
with f/2 **\$299**

SUNPAK Auto 511
Thyristor Electronic Flash System

\$79.95
Battery Pack for 511 **\$34**

KODAK XL 360
Movie Camera
incl. Batteries & Film

\$169.95 List \$257

KODAK CAROUSEL 840H Projector
\$149.95

GOSSNER METER LUNA-PRO **\$75**

ENLARGER SPECIALS!

BOGEN 22A SPECIAL ENLARGER... 35mm & 2 1/4" with 50 & 75mm Lenses **\$78**

BESELER 23C II ENLARGER... 35mm & 2 1/4" with 2 Lenses **195**

OMEGA PROLAB B66 ENLARGER... 35mm & 2 1/4" with 2 Lenses **185**

WE CARRY A FULL LINE OF CIBACHROME PAPER AND CHEMICALS IN STOCK AT LOW PRICES!

B&H COUPON

FREE ROLL OF COLOR FILM WITH EVERY ORDER
SPECIFY FILM SIZE

EXPIRES MARCH 1, 1978

SONY TRINITRON COLOR TV
KV1214 **\$305**

12" screen diagonally
100% solid state
One button Auto-Tuning
Color & Hear

FILM BARGAINS!

ALL FILM INCLUDES MANUFACTURERS' FILM PROCESSING

KODACHROME 64 or 25	135-36 exp.	\$4.75
FUJICHROME R100	135-36 exp.	3.59
KODAK HI-SPD EKTACHROME	135-36 exp.	5.89
VPS VERI-COLOR	135-36 exp.	12.49
AGFACHROME 64	135-36 exp.	3.89

\$1.50 Only for Shipping Film
Minimum: 10 Rolls

WE CARRY A FULL LINE OF CIBACHROME PAPER AND CHEMICALS IN STOCK AT LOW PRICES!

MAIL & PHONE ORDERS ACCEPTED. NY residents add sales tax. MASTER CHARGE users give Card No., Bank No. & Expiration Date. Add \$3.00 shipping on all items under 5-lbs. Prices subject to change without notice. Not responsible for typographic errors.

OPEN MON.-THUR: 9-6:30/FRI.: 9-2
CLOSED SAT./OPEN SUNDAY: 10-4

FOTO & ELECTRONICS CORP.
DEPT. P, 17 WARREN ST. N.Y., N.Y. 10007
[Between 5th & Church, 1 Blk. from City Hall]

PHONE ORDERS: PHONE (212) 233-9191
ASK FOR PAUL

SNARLED AND BROKEN CASSETTE TAPES

(Continued from page 95)

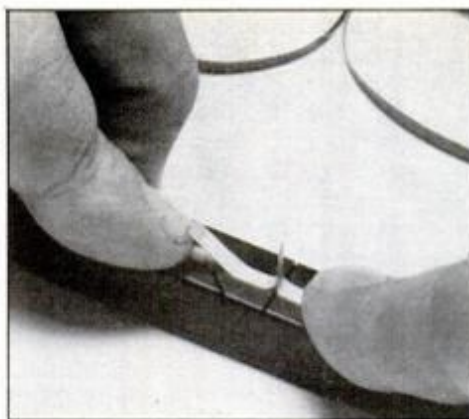

Splicing tabs to make repairs are easier to apply than splicing the damaged tape on rolls. Splicing tabs need less trimming, pick up less finger oils.

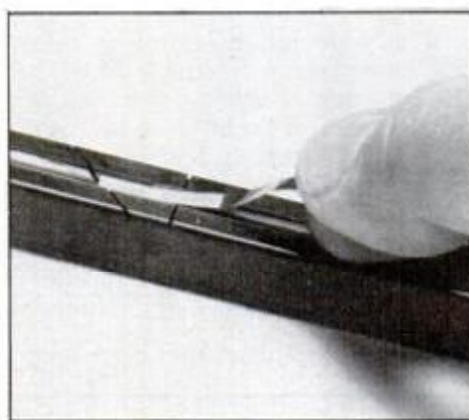

Splicing block holds tape in precision channel while you cut and trim with your razor blade. With this type of splicing block it's easy to flick out tape.

around the cassette's internal hubs. But the cure is usually simple: Hold the cassette three or four feet above a hard surface (such as a desktop or an uncarpeted floor), and drop the cassette so that it lands flat. Do this several times, including at least once on each side. It won't damage the cassette, and will frequently cure the jam-up.

If it doesn't, you'll have to open the cassette. If it's held together with screws (usually five small Phillips-head ones), you're in luck. Place the cassette flat and screw-side up on a table with plenty of clear working space. Carefully remove the screws, the top shell and the plastic slip-sheet inside. If your luck still holds, and the tape hasn't broken or stretched, you can simply smooth it out and wind it back in place. Check to make sure the tape can then move freely and in its correct path from one hub to the other, then reassemble.

Welded cassettes

There seems to be no good way to

open welded cassettes; the best way found is to stand the cassette up on its broad edge (the one through which the tape shows), rest a screwdriver on the seam in one corner between the tab pushout and the rear edge), hammer the screwdriver until the seam opens, then force the screwdriver down the edge to break the rest of the seam. Repeat this on the other side and, if need be, along the back seam. Then lay the cassette flat and gently pull the shells apart so that the parts all stay in place on the lower shell.

Tool No 1: the spare-parts kit

If you've just had to blast open a welded cassette, or if parts of a cassette are broken or missing, and the problem is due to such carelessness as using fixed plastic guides instead of tiny rollers to guide the tape, you'll need a spare-parts kit like the Maloney Audio Accessory kit shown, or the similar ones sold by Robins and Certron.

These kits are actually spare-parts kits with everything but tape. There are two shells, plastic hubs, the slip-sheets which prevent friction and static electricity from building up inside the cassette, tiny teflon rollers and stainless-steel pins to hold them in place, pressure pad assemblies, and metal shields, plus, usually, a cassette splicer to splice tape.

As needed, you can replace missing or defective parts from one of the kits, or lift the entire tape pack out of the old shell to fit into a new one. If that's the case, then wind the tape carefully around the rollers inside the plastic tape guides and in front of the pressure pad behind the tape window at the cassette's edge. This isn't as easy as it sounds—cassette tapes are thin and wispy, and it helps if you hold your breath to prevent the tape from being blown away as it can be done.

Tool No. 2: the 3M repair kit

If the only problem is a broken tape, you don't have to open the cassette up—not since 3M brought out its handy Cassette Editing and Repair Kit. The kit includes plastic repair wands with sticky ends which you can fish down into the cassette shell to pick up the tape—usually after several tries—bring it out for splicing (more often than you'd like to admit). Once the repair is complete, you fit one end of the kit's repair wand into one of the tape hubs to wind the slack tape you've pulled out and splice.

Tool No 3: the splicing block

Splicing any tape requires a device to cut broken tape ends neatly and to hold those ends in alignment while the splicing tape is applied and trimmed. There are lots of splicers around for cassette tape (regular-tape splicers can't be used—cassette tape's too narrow), some with two arms that hold the tape while a third arm comes down to trim the tape ends or the splicing tape, others are simple blocks with channels that hold the tape while you cut and trim with razor blades. Most professional tape editors use blocks like the Editall, and I found it the easiest to use of the three splicers shown on page 95. The Editall's weight keeps it steady (you can also screw it down), its slot is deeply undercut to hold the tape securely, its aluminum construction keeps razor blades from widening the cutting slits and its splicing tape tabs are very easy to apply.

The 3M kit's splicing block, molded into the kit case, held the tape as securely, but didn't sit as steadily or resist cutting like the Editall. Its splicing tabs were almost as easy to use. The small splicing block that came with the Maloney kit was adequate, but nothing more; the splices with it appeared to be Editabs.

Splicing

When splicing, always be sure the tape's shiniest side is up, and that neither end is twisted. Then overlap the ends by half an inch or so, make a diagonal cut with a razor blade (or your cutter's built-in splicer, if it has one), remove the loose ends, butt the clean-cut ends together, and attach the tape. Trim away any bits of splicing tape which overlap the edges of the tape; overhead-arm splicers do this for you, but with blocks, you have to run your razor blade along the undercut lip of the tape-holding slot to do it. ★★★

INVISIBLE REVOLUTION INSIDE YOUR PHONE

(continued from page 94)

netic data bits, form a data bank to which CC refers 180,000 times per second for instruction on what to do with the calls it senses.

Smart? Actually CC is, like all computers, an idiot that can do only one thing at a time. But since it does them at electronic speeds, CC processes calls hundreds of times as fast as older switching systems.

ESS isn't everything

ESS isn't the only new development to improve your phone service. For example, some phone offices are now using microfilm and minicomputers

for high-speed directory assistance.

Instead of having operators leaf through stacks of telephone books, directory pages are recorded on microfilm, 1440 directory pages to a strip, with up to 60 strips—15 million listings—controlled by one mini-computer. To locate a particular listing, the DAS/M information operator presses a key corresponding to a particular directory, then the first four letters of the last name. The computer locates the page and flashes it onto a TV-type screen. And systems already exist to have computers "print" directories on microfilm to enable quick updating of new subscribers and number changes.

Bell Laboratories is constantly



Lighted pushbuttons using solid-state Light-Emitting Diodes (LEDs) instead of incandescent bulbs will use less power and burn out less often. Several phone companies are now using them.

dreaming up new ideas—like Picture-phones—that someday may be available to everyone. Solid-state amplifiers are now being built into handsets used by rural customers to boost the volume of telephone conversations that have gone through long, rural lines. The Bell System is already using a new round storage battery, good for 30 years' service, and one whose principles may someday be applied to automotive use.

Finally, a touch of the awesome future is provided in the design of pocket-size cordless telephones: women might wear them around the neck, and men could have one in a billfold format. Even interconnection between phones and telephone exchanges may involve fiber optics—hair-thin glass fibers carrying light instead of electricity. Impossible to believe? Some still say that about ESS. ★★★

Another quality product from Gold Mark!

GoldMark™

Speed Control.



Now control the speed of your car automatically with the push of a button. Safe. And it saves on gas!

Now you can reduce miles and miles of highway fatigue to pleasure driving—with speed control. Automatic control takes over for you—and maintains a constant speed. Helps avoid speeding tickets. Saves on gas. And it's safe to use. Brake pedal automatically releases control. Special feature allows you to resume set speed with a flick of a switch! Fits most cars with automatic transmission.

Do-It-Yourself Kit contains everything you need to install. Complete, illustrated instructions for installing with standard tools.

GoldMark 

Look for Gold Mark quality products in the automotive department of your favorite store.

Материал, защищенный авторским правом

Clean spark plugs can save you 1 to 2 gallons of gas per tankful

TURBO-BLAST

Amazing New Spark Plug Cleaner

SAVE GAS... AND GET UP TO 50,000 MILES ON YOUR SPARK PLUGS

- ★ Rugged 12,000-RPM motor—plugs into any household outlet
- ★ No compressed air or batteries
- ★ Comes with glass bead abrasive to clean 250 plugs. Additional beads available.

Cleans any plug in seconds!



JAYCRAFT CORP., DEPT. PM-1
760 North Marshall Ave., El Cajon, CA. 92020

Name _____
Address _____
City _____
State _____ Zip _____

\$19.95 plus \$1.55 shipping & handling. California residents add state sales tax.

SATISFACTION GUARANTEED or return within 30 days for refund

WHAT'S HE DOING!

Making a Concrete Flower Pot! . . . and **SO CAN YOU!**

Make and sell your own Ornamental Concrete items. Rush **\$3.00** for Book about Aluminum Molds with prices and production trade secrets direct from world's largest mold manufacturer. Over 350 designs to select from.

Send **\$3.00** CONCRETE MACHINERY COMPANY
Today To → P. O. BOX A99 - HICKORY, N. C. 28601



- FOR • KITCHEN
• WORKSHOP • BOAT
• TRAILER • CAMP
• GARAGE MAGNETIC



Solve your HANG-UPS

Magnabar Mark XII. Lifetime guarantee, convenient, practical, versatile, trouble-free. Fashioned in 12" hardwood, singly boxed. Mounts quickly on any surface. Excellent gift. Model SS-12: **\$5.95** p.p. each. Send check or M.O. Complete Catalog on request.

Phelon Magnagrip Company, Inc.
Dept. A103 East Longmeadow, Mass. 01028

SEEDS FOR THOUGHT

First the editors of Popular Mechanics assembled every bit of data a man needs to know to make his lawn, garden or house plant display the envy of his neighborhood . . . THIS YEAR!

Then they condensed and programmed these essentials and added twenty fact-packed charts and tables along with scores of show-how drawings.

Then they printed this vital material on heavy, plastic coated stock (so it would be washable) and spiral bound and hole punched it so it could lay flat on a table, set up as an easel on his potting bench or hang on a wall.



Order your copy today!

Popular Mechanics Complete Gardening Guide

Box 1014, Dept. C5,
Radio City, N.Y. 10019

Please rush _____ copy(ies) Popular Mechanics Complete Gardening Guide. I am enclosing my check or M.O. for \$4.49 postpaid.

Name _____
Address _____
City _____ State _____ Zip _____
Make checks payable to Popular Mechanics

HM Specialties

No "cuss words" around this beauty.



Installation of Rockwell's Single Control faucets is quick and easy. There are no special, costly tools needed. Just a pair of wrenches makes the most hesitant handyman the hero of his household. Our do-it-yourself instructions are right on the box. There's even a pamphlet inside for extra help if needed.

When it is installed, our single control faucet reflects your own good taste. And they're available for kitchen, lav, and bath.

Building Components Division, Rockwell International.

Rockwell International

Материал, защищенный авторским правом

BE A



E. SIMMONS-EL
(Bronx, N.Y.)
"While training I earned \$400 and now make between \$25 and \$30 more a week part-time. The Locksmithing Institute is the greatest! Instructors were superb!"



JOSE F. COLLAZO
(El Paso, Tex.)
"Believe locksmithing to be an interesting and profitable occupation . . . I earned \$1,000 while training and I now earn approximately \$300 a month in my spare time!"



FRANK R. BISHOP
(Holt, Mich.)
"I really enjoyed the Locksmithing course. Lessons, materials and instructors were excellent. I'm telling my friends about the course, as it is well worth the tuition."

LOCKSMITH

TRAIN AT HOME—EARN WHILE YOU LEARN

Add to YOUR INCOME—even double it with easy spare-time earnings. Cash in on the nationwide shortage that demands hundreds more trained locksmiths. Quickly step into a big pay opportunity, full- or part-time job or start a high-profit shop of your own! Even earn as you learn.

EARN EXTRA MONEY RIGHT AWAY!

You can quickly qualify as a skilled locksmith. Age, education, even minor physical handicaps don't matter in this ever-growing trade. So easy to learn—it's easy, it's fun, it's just like a fascinating new hobby!

Study at home as little as one hour a week. All special professional tools, supplies, including files, tweezers, cylinders, door handles, assemblies, gauges, pins, springs, extractors, picks, wrenches, and different kinds of locks and keys—even key machine—supplied to you! Gain practical experience by doing real jobs

on car locks, house locks, padlocks, safe locks, etc. Just follow well-illustrated lessons under the guidance of experts.

For a future as your own boss or in a high-pay job, get all the facts, complete details. Write today for FREE Illustrated Book, FREE Sample Lesson Pages give exciting facts. (No cost, no obligation, and no salesman will call.)

Our School, (Established 1948) is licensed by the State of N.J. and an Accredited Member of the National Home Study Council. Also approved for Veterans Training, under the new G.I. bill.



LOCKSMITHING INSTITUTE

Div. Technical Home Study Schools
Dept. 1110-016, Little Falls, N.J. 07424

THIS KEY MACHINE



PLUS 306

pieces of equipment
LOCKS, PICKS & TOOLS
supplied for use with course



SEND TODAY FOR FREE BOOKLET

LOCKSMITHING INSTITUTE
Division Technical Home Study Schools
Dept. 1110-016, Little Falls, New Jersey 07424

Please send without obligation the FREE illustrated booklet, "Your Opportunities in Locksmithing." I understand no salesman will call.

NAME _____

ADDRESS _____

CITY _____ STATE _____ ZIP _____

Check here if eligible for Veteran's Benefits

Your
Opportunities
in
Locksmithing



Driving the Renault 5

by Bill Hartford
and Michael Lamm

There are already a million Renault 5s on the road—in Europe. Here, they go on sale next month. In Europe, the 5 has proven itself and is highly acclaimed. Here, the 5 is an underdog in a field of small, economical sedans priced from \$3000 to \$4500. The Renault 5 is joining the Chevy Chevette, VW Rabbit, Honda Civic and still more high-mpg models from Japan.

It may be that the 5 has the edge on all these competitors for one very big reason: its big-car ride. Drivers used to big Detroit sedans are bound to be impressed by the 5. It's only 141.5 inches long, but its wheelbase is a full 95 inches. Actually, it's 94.6 inches on the right side and 95.8 inches on the left—because rear wheels are independently suspended with transverse torsion bars. Since they're transverse they must be offset one ahead of the other.

The 1300-cc in-line Four is up front, driving the front wheels. It's not transverse like the Rabbit or Civic, though. It runs the long way, yet behind the transaxle for better weight distribution. The engine actually sticks back into the passenger compartment a bit, but Renault designers cleverly disguised this fact with what looks like an upright console. The console houses the optional radio which also stands upright.

Sound insulation is so good you hardly hear the engine, and all around it's a rather quiet car. The unitized body sits on a stamped plat-

(Please turn to page 136)



Renault 5GTL feels like much bigger car.

Part of big-car ride is a result of the tremendous wheelbase for car of its length, as evident above. At right is indication of high degree of body roll which can prove annoying. The front-wheel-drive French import is fitted with steel-belted radials.



RENAULT 5 SPECIFICATIONS

Vehicle type: front-engined, front-wheel-drive, 3-door, 4-passenger hatchback

Price: 5TL—\$3250 (est.) p.o.e. East Coast
5GTL—\$3500.

East Coast availability, Feb. '76;
West Coast, Apr. '76.

ENGINE

Type: In-line Four, ohv, water-cooled, cast-iron block, aluminum head, wet and removable sleeves, longitudinally mounted behind drivetrain

Bore and stroke: 2.9 x 3.0 in. (73 x 77 mm)

Displacement: 78.66 cu. in. (1289 cc)

Compression ratio: 8.5:1

Max. bhp @ rpm (SAE net): 58 @ 6000

Max. torque @ rpm (SAE net): 70 @ 3500

Carburetion: Weber 2-bbl.

DRIVETRAIN

Transmission: 4-speed transaxle, all synchro

Ratios: 1st, 3.667:1 3rd, 1.456:1

2nd, 2.235:1 4th, 1.026:1

Reverse, 3.545:1

Clutch: Single dry plate, woven asbestos lining, 7.125-in. diameter

Final drive ratio: 3.625:1

DIMENSIONS (inches)

Wheelbase: 95.8 (L), 94.6 (R)

Overall length: 141.5

Overall width: 60.0

Overall height: 55.0

Track, front and rear: 50.7/49.0

Turning circle diameter (between curbs): 32 ft.

Curb weight: 1819 lbs.

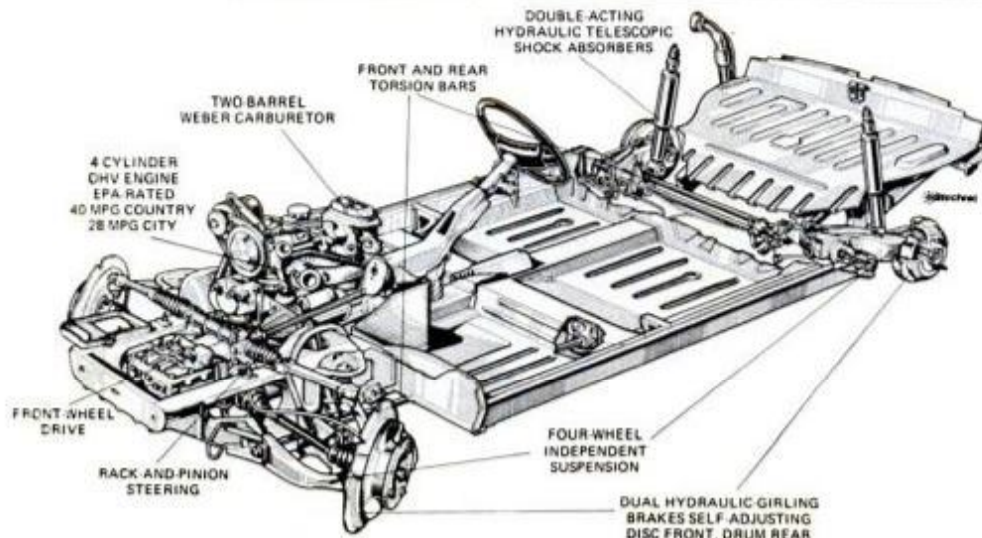

Fold-back, canvas sunroof is also a lunroof. Rear wiper is standard on 5GTL.



Get in on the PROFITS in SMALL ENGINE service and repair Start your own money

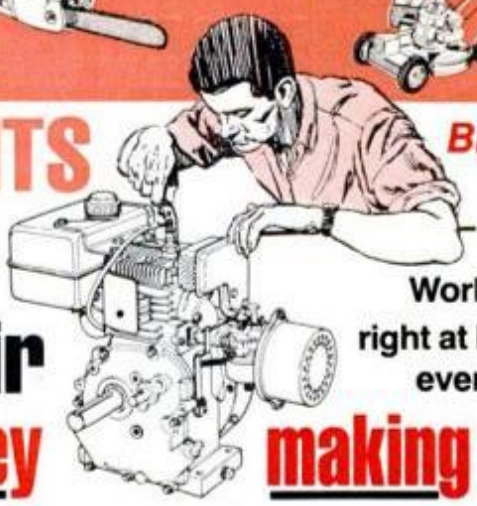

BEAT INFLATION!
Cash in on the huge demand for small engine repair.

Work part time, full time right at home - we help you every step of the way.

making business!

In just a short time, you can be ready to join one of the fastest growing industries in America...an industry where qualified men are making from \$10.00 to \$15.00 per hour...and that's just for labor. Parts, engines and accessories add even more to the profits.



Because the small engine industry has grown so quickly, an acute shortage of qualified Small Engine Professionals exists throughout the country. In fact, it's not unusual for a good small engine man to be three to four weeks behind in the summer and at least a week behind in the winter. When you see how many small engines are in use today, it's easy to understand why qualified men command such high prices—as much as \$17.50 for a simple tune-up that takes less than an hour!

46-million small engines are in service today!

That's right—there are over forty-six million 2-cycle and 4-cycle small engines in service across the U.S.A. That's the official count from the Engine Service Assn., and new engines are being built at a rate of one-million per month! With fully accredited and approved Belsaw training, you can soon have the skill and knowledge to make top money servicing these engines. Homeowners and businessmen will seek you out and pay you well to service and repair their lawnmowers, tillers, edgers, power rakes, garden tractors, chain saws, mini-bikes, go-carts, snowmobiles, generators, snowblowers, paint sprayers... the list is almost endless.



No experience necessary.

You don't have to be a 'born mechanic' or need prior experience. If you can read, you can master this profitable trade right at home, in your sparetime, without missing a single paycheck. Lessons are fully illustrated—so clear you can't go wrong.

You receive trade secrets and business plans

We guide you every step of the way, including tested and proven instructions on how to get business, what to charge, how to get free advertising, where to get supplies wholesale...all the "tricks of the trade"...all the inside facts you need to assure success right from the start.

Increased Income

"I've had about 8 years experience repairing small engines... but repairs were only minor... until I started the Belsaw Course."



Walter H. Strick Campbell, California

With our famous 'learn-by-doing' training method, you get practical 'hands-on' experience with specialized tools and equipment that you'll receive with your training *plus* a brand-new 3 HP engine—all yours to keep!

SEND FOR FREE FACTS!

You risk nothing by accepting this offer to find out how Belsaw training can give you the skills you need to increase your income in a high-profit, recession-proof business of your own.

Just fill in and mail coupon below (or send postcard) to receive full information and details by return mail. **DO IT TODAY!**



BELSAW INSTITUTE OF SMALL ENGINE REPAIR
516J Field Bldg., Kansas City, MO. 64111

There is NO OBLIGATION and NO SALESMAN Will Call—ever!



You get all this Professional equipment with your course—and it's Yours to KEEP!

Send TODAY for this fact-filled **FREE BOOKLET!**



Tells how you quickly train to be your own boss in a profitable Sparetime or Fulltime business of your own **PLUS** complete details on our **10-Day NO RISK Trial Offer!**

BELSAW INSTITUTE, 516J FIELD BUILDING KANSAS CITY, MISSOURI 64111

YES, please send me the FREE booklet that gives full details about starting my own business in Small Engine Repair. I understand there is no obligation and that no salesman will call.

Name _____
Address _____
City _____
State _____ Zip _____

Kiss your boss good-bye and say hello to your own money-maker.

FACT: Sales of auto repair parts are up a big 20% over last year. That's because people are holding onto their cars and maintaining them.

FACT: Through ABC Mobile Systems, you can start a business with just \$7,000 that capitalizes on this huge market.

FACT: You're protected by our six-month, buy-back guarantee. ABC has over 165 successful franchise units nationwide — we're sure our program works. Fully-equipped, radio-dispatched ABC vans go out and supply service stations and garages with everything they need to do brake or muffler work. Last year, our franchises accounted for \$16 million in retail brake work alone!

FACT: You don't have to know a thing about cars. Our classroom/on-the-job training guides you every step of the way.

OPPORTUNITY: Brake repair is a \$600 million industry. Muffler repair is \$800 million. You operate a low-overhead, service business in your own protected territory. Customers call you. And there's no need to work nights, Sundays or holidays.

So decide: should your boss profit from your hard work or should you? Then get all the facts about this exciting, always-in-demand business. Call today!

CASH REQUIREMENT: \$7,000

ABC MOBILE SYSTEMS

Call collect or write:
RON NORRIS
ABC Mobile Systems Dept. 301
1902 Potrero Ave.
So. El Monte, Calif. 91733
(213) 579-7260

DRIVING THE RENAULT 5

(Continued from page 134)

form chassis, with independent torsion-bar suspension all around. Front is by unequal-length control arms; rear by trailing arms. The front torsion bars are longitudinal and, as mentioned, the rears are transverse, all helping to maximize interior space by running no leaves, axles or coils up under the body.

Steering comes by rack and pinion, feels precise and quick. Gearshifting is precise, too, despite the tricky linkage required to go forward around the engine. Front disc brakes are standard.

The rear seatback folds flat, and with the rear hatch you've got the equivalent of a small station wagon. Even with the seat back up, there's a big square cave hidden beneath the fold-up parcel shelf.

The 5 comes in two levels of luxury: the plain Jane 5GTL and the plainer Jane TL (if you know a non-sexist equivalent for "plain Jane," let us know.) Both share the same mechanicals, the difference coming in carpeting, vinyl appointments, garnish and a rear-window wiper/washer standard on the GTL.

Options include a sunroof, various radios, airconditioning, roof and ski racks, custom wheels, trailer hitch and so on.

The Americanization of the front and rear ends with smart-looking soft bumpers is well done. And, by

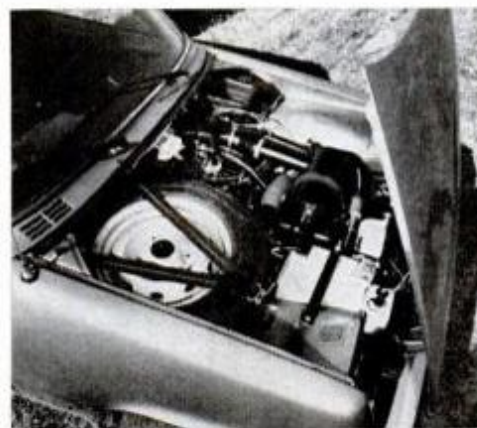

In-line, four-cylinder engine of 1300-cc displacement is well hidden by spare tire.

the way, don't think the front end is a copy of the AMC Pacer. If anything, the Pacer is a copy of the 5, since the 5 was introduced in Europe in 1972.

We had the opportunity to drive the first 5s to arrive in the United States and here are our reactions to the car.

Lamm: If you look beyond the appearance and take a test drive, you'll discover that the Renault 5 rides like



Interior of 5GTL is plain, but shows thoughtful use of carpeting and vinyl.



Hatchback up and rear seat folded opens up 31.5 cubic feet of cargo space.

no other minicar. The R5 on pavement feels like a duck landing on Lake Chelan. It's that smooth—and amazingly silent.

The R5 handles and maneuvers fine, but leans a lot. It's got the cornering poise of a 1949 Nash. Yet the R5 goes where you point it, and front-wheel drive lets you whip through sharp, fast benders in complete control. Standard Michelin radials help, both on cornering and braking.

Acceleration comes as another surprise. For a car that can squeeze 40 miles from a gallon of gas, this one moves out. It's willing and strong. Long grades don't leave it puffing. And for fast passing on two-lane highways, you plug in third, nudge the gas, and around you go. The R5 has that rare combination of zip plus sip.

Workmanship impressed me, as did seating up front. Front buckets recline in the GTL, which helps you find a comfortable position. The rear seat, though, feels a trifle tight for adults.

It's a pleasant, well-thought-out, well-built car that might put Renault back among the important importers.

Hartford: Put a flaky, 1950s canvas sunroof over a big, yawning hole in the roof, and put it in a little car

(Please turn to page 137)

DRIVING THE RENAULT 5

(Continued from page 136)

that's so modern in every other way and what do you have? A Renault 5, of course. The front-wheel-drive 5 is big in economy, ride, performance, roominess... but it's biggest in... personality. For me that's the clincher. The Chevette may be cheaper, the Civic more chic, the Rabbit a model of lean, Teutonic efficiency, but only the sunroofed 5 would give me what I'd want in a small, economy sedan: some fun getting where I'm going. I'll go out of my way, or pay extra, because *how* I get somewhere counts. With the 5, the inconvenience would be that the Renault dealer nearest me is some miles away. It would be the same for most people because of the still-small dealer network.

I put enough miles—and fast miles they were—through the hilly roads, and on freeway stretches, in Northern California to have complete con-



Styling of Renault 5 is obviously French, as evident, for example, in treatment of the taillights and vent slots positioned at the rear corners of the car.

fidence in the car—in its handling, stability and braking. That's a more significant statement when you know my two kids were in the car with me on those roads. The car maintained a tenacious hold on the road through lots of fast S-turns despite the annoyingly high degree of body roll.

Amusingly, the most terrifying (for the kids) part of a dirt-road ride near Muir Woods was turning the car around on a road hardly wider than the length of the car. On one side the road dropped off into a deep valley and they thought that that's where we'd all wind up. Needless to say, an 11.8-foot-long car is incredibly maneuverable.

I don't particularly like the cheap treatment of the dash, and I don't find the instrument layout aesthetically pleasing, but I do like being able to get into a comfortable driving position because of the neat seats and good relationship of all the controls. I don't like the spare tire mounted in the engine compartment, but, ah, that sunroof! The biggest, bloomin' sunroof in the business—and happily, there's a solid car under it. ★★

LIVE IN THE WORLD OF TOMORROW... TODAY!

And our FREE 164 PAGE CATALOG is packed with exciting and unusual values in hobby, electronic and science items — plus 4,500 finds for fun, study or profit... for every member of the family.

A BETTER LIFE STARTS HERE

4 1/4" ASTRONOMICAL TELESCOPE

See moon craters, rings of Saturn, double stars. New equatorial mount, F 10, 1 1/4 wave mirror (Pyrex), gives theoretical limit of resolution. Rack & pinion focusing. Aluminum tube, BK mirror, 1 1/2" F.L., 12X Kellner achromatic eyepiece and Barlow lens to double & triple power up to 33X. Free Star Chart plus 2 Books. Stock No. 85-105H (Shipping Wt. 42 lbs.) \$159.50 FOR 4 1/4" WITH CLOCK DRIVE \$281.87H \$286.50 FOR 6" REFLECTOR TELESCOPE (4RX to 360X) \$85.187H \$249.50 FOR 6" WITH CLOCK DRIVE \$285.066H \$285.00 FOR 3" DELUXE REFLECTOR (30 to 90X) \$80.162H \$ 89.95 Ppd. STANDARD 3" REFLECTOR \$85.240H \$ 59.95 Ppd.



SUPER POWER FOR ANY RADIO

New antenna assist turns a tiny transistor into a tuner, has pulled in stations up to 1000+ miles away! Just set beside radio (no wires, clips, grounding, and tune-tune Select-A-Tenna's dial to same frequency—"gangbusters"! Great for clearing weak signals in radio-depressed areas, off-road islands, crowded frequency stations. Solid state—uses no electricity, bats, tubes. Stock No. 72-095H \$15.95 Ppd. ULTRA SELECT-A-TENNA No. 72-147H (OVER 1000 MI.) \$22.95 Ppd.



NASA-CHOSEN FOR APOLLO/SOYUZ

157 mi. out in space, the Astronauts used this super 20X60 binocular (modified) to view Earth! Our biggest, most powerful for distance. Eye-off objects come in big, clear & sharp to the edge through the 60mm objective lenses. 125-ft. field of view at 1000 yds. Relative brightness, 9.0. Fully coated optical, 20X spot-disk eye-lenses. Coated BK-7 Porro-prism. Extra long All-American style with fold-down rubber eyepiece. Includes case & strap. Stock No. 1556H (01x81 1/2") 47.5 oz.) \$99.95 Ppd.



WORLD'S SMALLEST CALCULATOR

Small but mighty! 8-digit, 4-function electronic calculator does everything big ones do—except has automatic "C" key... for only \$19.95. Take it anywhere. Fits in your pocket—2 1/2 size of cigarette pack, 3 1/2 oz. dynamic features: floating decimal, constant key, lead zero depression, mode! Includes plug-in rechargeable Ni-Cad battery pack, 2 x 3 1/2 x 9 x 1 1/2" with plenty of room for most fingers. Another Edmund first with advanced technology. Stock No. 1945H \$19.95 Ppd.



MAIL COUPON FOR GIANT FREE CATALOG!

164 PAGES • MORE THAN 4500 UNUSUAL BARGAINS

Completely new Catalog. Packed with huge selection of binoculars, microscopes, binoculars, magnets, magnifiers, prisms, photo components, ecology and Urevis Lighting items, parts, kits, accessories — many hard-to-get surplus bargains, 100's of charts, illustrations. For hobbyists, experimenters, schools, industry.

EDMUND SCIENTIFIC CO.
300 Edcorp Building, Barrington, N.J. 08007

Please rush Free Giant Catalog "N"

Name _____
Address _____
City _____ State _____ Zip _____

FREE BICENTENNIAL LIGHT SHOW

IN BARRINGTON, N.J. ONLY 10 MINUTES AWAY AT EDMUND FACTORY STORE



AMAZING KRESKIN'S ESP MACHINE

See first article Dec. Popular Mechanics "The Amazing ESP Machine" Which light stays on when you push the button—Triangle, Arrow, Dots or Heart? If you've got ESP you or your subject will guess right, significantly. Solid state ESP Tester has guaranteed random circuit for accuracy—you can't beat the machine by memorizing! Run classic ESP, precognition, probability, telepathy experiments. Portable. Res. 4 AA batts. No. 72-090N (6 1/4 x 3 1/4 x 2 1/4") \$29.95 Ppd. EXTRA PADS TO RECORD 250 EXPERIMENTS Stock No. 72-092N \$3.50 Ppd.



FUEL MISER RECLAIMS HEAT

Save your 40% wasted heat to warm a basement, garage or rec room at no extra cost! Instead of going "up the chimney" it takes where you want it. Remove part of furnace exhaust pipe, slip Heat Exchanger in. At 123" fan automatic, forces clean air through unit which heats to over 200°F., can be ducted to 20 ft. from unit. 110v AC. Inst. No. 19-194H (5" DIA.) Ship. 17 lb. \$106.00 FOR No. 19-195H (6" DIA.) " " \$106.00 FOR No. 19-198H (7" DIA.) " " \$106.00 FOR



"FISH WITH A MAGNET"

Go treasure hunting on the bottom! Fascinating fun & sometimes profitable! Tie a line to our 5 lb. Magnet—drop it overboard in bay, river, lake or ocean. Troll it along bottom—your "treasured" haul can be outboard motors, anchors, other metal valuables, 5 lb. Magnet is war surplus—Alnico V Type—Gent, cost twice our price. Lifts over 150 lbs. on land—much greater weights under water. Stock No. 72-103H (5 lbs.) \$17.50 Ppd. GIANT ELECTROMAGNET LIFTS 500 lbs. Stock No. 71-936H \$11.50 Ppd.



PRO ELECTRONIC SOUND-CATCHER

Parabolic mike with 8 1/2" transparent reflecting shield & 2 I.C.'s in amplifier magnifies signals 100X that of omni-direction mikes. Catch sounds never before heard! Highest signal to noise ratio poss. Earphones, tape recorder output, tripod socket; req. two 9v trans, batt. (not incl.). No. 1649H (5 1/2 LB.) \$299.00 Ppd. LOW COST MODEL: NO EARPHONES, ELECTR. CIRC. No. 1665H \$149.00 Ppd. LOWER SENSITIVITY ECON. MOD. W/O ELECTR. No. 80-242H \$89.50 Ppd.



AUTHENTIC SCALED WINDMILLS

Real-thing replicas show wind direction, wheel silently revolves on ball bearings. Give your grounds unique rural charm! Great centerpiece for planter, flowers. Use to hold yard light, house number, sign or as mailbox. For school, a fun "cooney erisks" science project—does everything but pump water, heavy gauge steel, durable outdoor finish; aluminum color w/ red trim. 17" DESK MODEL... No. 71-923H... \$11.95 Ppd. 4 1/2" FEET—14 LB... No. 71-924H... \$34.95 Ppd. 8 FEET—46 LB... No. 85-229H... \$49.95 FOR

COMPLETE AND MAIL WITH CHECK, M. O. OR CHARGE NO.

EDMUND SCIENTIFIC COMPANY
300 Edcorp Building, Barrington, N.J. 08007

How Many	Stock No.	Description	Price Each	Total

SEND FREE 164-PAGE CATALOG "N" Add Handling Chg. \$1.00. Orders Under \$5.00, 50¢. Orders Over \$5.00 I enclose check money order for TOTAL \$ _____

Charge my BankAmericard Charge my MasterCard Interbank No. _____

My Card No. is _____ Signature _____

Card Expiration Date _____ NAME _____

30-DAY MONEY-BACK GUARANTEE. You must be satisfied or return any purchase in 30 days for full refund. *\$15.00 minimum

CITY _____ STATE _____ ZIP _____



Our whole family helped assemble this wonderful Schober Organ... and now we all play it!

Talk about real family fun! We all worked together, for a few hours almost every day. Almost too soon, our Schober Organ was finished. Our keen-eyed daughter sorted resistors. Mom soldered transistor sockets, although she'd never soldered anything before. And it did our hearts good to see the care with which our son—he's only 12—installed the transistors. Me? I was the quality control inspector—they let me do the final wiring.

Our completed Schober Organ compares favorably with a "ready-made" one costing twice as much! (The five models range from \$650 to \$2850.)

Just send the coupon for the fascinating Schober color catalog (or enclose \$1 for a 12-inch LP record that lets you hear as well as see Schober quality).

The *Schober Organ Corp.*, Dept. PM-28
43 West 61st Street, New York, N.Y. 10023

- Please send me Schober Organ Catalog.
 Enclosed please find \$1.00 for 12-inch L.P. record of Schober Organ music.

NAME _____

ADDRESS _____

CITY _____ STATE _____ ZIP _____

FREE COLOR CATALOG



Build Your Own Grandfather Clock starting under

\$200

(Including West German Movement)

- Do-It-Yourself Case Kits, parts pre-cut
- Solid 3/4" Black Walnut, Cherry, Mahogany, Oak
- Movements and dials
- Finished Clocks
- Direct Factory prices



Write for free color catalog

EMPEROR CLOCK COMPANY

Dept. 448 Fairhope, Ala 36532

WORLD'S LARGEST MANUFACTURER OF GRANDFATHER CLOCKS

Visit our Factory



Gardener's blower

Instead of raking up leaves and grass clippings, many professional gardeners use gasoline-powered blowers to corral such debris. These units are rather expensive, so I made an electric one using the motor and fan from a used canister vacuum cleaner. Patches were soldered over the case's mounting bolt holes to prevent leakage, and a hole was drilled in the rim for the handle that had been on the frame. The switch was mounted on the case with two bolts, their heads inside to avoid interfering with the fan. After slipping the hose over the nipple projecting from the case, I made a snug fit with two angle brackets attached with sheet-metal screws; these were the only parts added to the cleaner.—*Ernest C. Bangert*

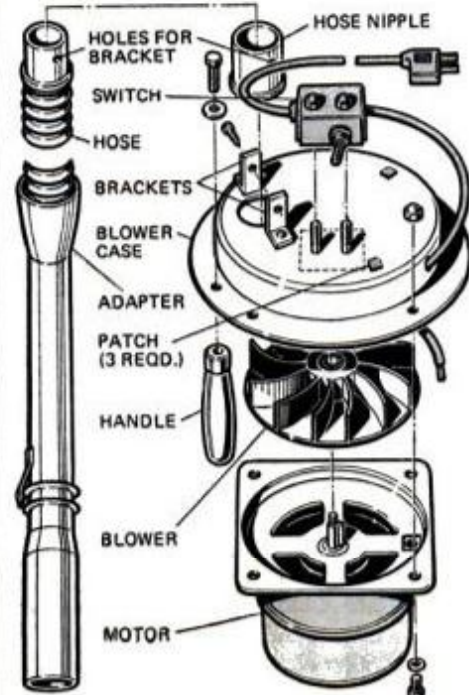

GET RID OF ULCERS FOR GOOD

AND ENJOY BETTER HEALTH

Medically-proven formula has helped thousands get rid of ulcers & digestive problems. You'll feel better & sleep better. Write today for FREE information. **Palafax-Knight Labs, Dept. CB-1**
2311 Veteran, Los Angeles, CA 90064

BASEMENT TOILET



Flushes up to existing sewer or septic tank by powerful, self-contained pump operated by normal water pressure. No digging up floors. Clog resistant, easily installed. Make basement into game room, den, apartment with private bath. Financing available. Write for free literature. *Dealer inquiries invited.*
SANDERS, Dept. J-25, Box 92102, Houston, Tx 77206.



LEARN SMALL ENGINE REPAIR

at home in spare time-quickly!

Good Business-Great Hobby!

10c BRINGS BOOK, FULL FACTS

MODERN SCHOOLS

4225 N. BROWN AVE. DEPT. PM SCOTTSDALE, AZ 85251

EARN WHILE YOU LEARN

Be an **Aircraft Mechanic**... in 17 months!

SPARTAN School of Aeronautics Dept. PROCS, International Airport, Tulsa, OK 74151

Name _____ Age _____

Address _____

City _____ State _____ Zip _____

Check here if eligible for GI Bill benefits. Approved for VETERANS

FREE BOOK YOUR FUTURE IN AVIATION

LEARN **UPHOLSTERY** AT HOME! SPARE OR FULL TIME... MEN & WOMEN ALL AGES!

Send for free book on learning to reupholster chairs, footstools, all furniture for BIG MONEY in spare or full time. No experience needed. We show you how - provide EVERYTHING needed to start: (1) Home training covering all phases. (2) All tools and 6 big furniture kits. (3) Free supplies, frames and materials to build \$300 worth of furniture, covers to keep or sell. Write TODAY for big free upholstery career book. No salesman will call. Veteran Approved. **MODERN UPHOLSTERY INSTITUTE**, 1205 W. Barkley, Box AAFM, Orange, CA 92666

Learn CUSTOM PICTURE FRAMING

For Fun Or Profit!

Let Professionals show you the trade secrets of custom portrait and picture framing. It's a fascinating, satisfying craft—yet a framer's skills are worth \$8 to \$10 an hour or more!

Start a clean, quiet business you can easily manage from home in part time — we'll show you how, help you every step. Write for complete details — no obligation and no salesman will call.

SEND FOR DETAILS!

CREATIVE FRAMECRAFTERS, 1205 W. Barkley, Dept. AFM, Orange, CA 92666

IF YOU CAN SING, WHISTLE, OR HUM A TUNE... you can play the Musical Saw. No notes to read, no musical knowledge required. If you are 10 or 70, you play or no pay. Musical Saw, soft hammer, bow, resin and lessons mailed on 5 days' trial. Write today for details and free copy of "Sawing News of the World," picturing successful saw musicians. **MUSSEHL & WESTPHAL**, 107 Fort St., Fort Atkinson, Wisconsin, 53538.

GUARANTEED 10 YEARS!

9 INCH LOCK BLADE

NEW—original design—first time offered. Opens instantly. Automatically locks into position. To close simply press button in handle. Has unusual sure-grip finger grooves - fits hand snugly — won't slip. Safety finger guard. Jet black handle richly trimmed with **Heavy Chrome**. Ideal for hunting, fishing and all around use.



\$2.75

Mirror polished imported stainless steel blade is tough and sharp. Use for target throwing, 5" open, 5" closed. Has that good feel of Fine quality. If Broken Within 10 Years We Will Replace At No Charge. Use 30 days at our risk. Money Back if not pleased. Send \$2.75 plus 25¢ shipping. **Order Now!** United Knife Co., Dept. LBB-9609, 9043 So. Western, Chicago, Ill. 60620. Mail order only.



**"For an amateur,
he's a whiz.
How'd he get
so good?"**

Whatever practical skills you've been wanting to develop, Audel has comprehensive, step-by-step Guides to help you. They show you all the professional tricks of the trades

in clearly diagrammed and illustrated "how-to" steps. They can save for you, over and over. Here are four of Audel's many fields . . .

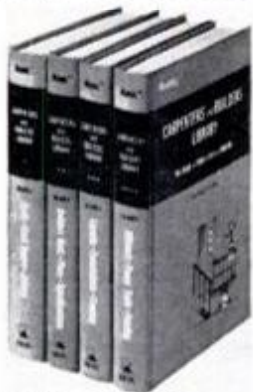

CARPENTERS AND BUILDERS LIBRARY

1490 pages of the latest information on modern construction in four volumes. They cover every phase of carpentry from foundations to finishing with easy-to-grasp, step-by-step instructions . . . all illustrated with thousands of diagrams, charts and photos. No. 23169 — 4 Volumes — \$21.25

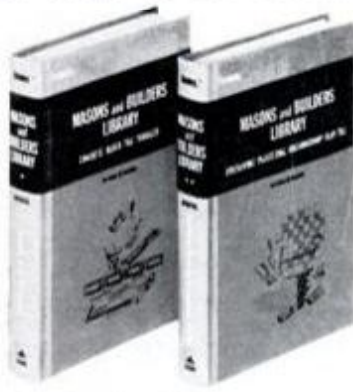

MASONS AND BUILDERS LIBRARY

Two illustrated volumes on the science of masonry and bricklaying. Packed with how-to information and directions, rules, processes, definitions, formulas, diagrams, tables, estimating. A complete and authentic trade reference library. 752 pages. No. 23185 — 2 Volumes — \$12.95



PLUMBERS AND PIPEFITTERS LIBRARY

A valuable 3-volume guide to the principles, methods and short cuts of modern plumbing. Tools, fittings, fixtures, installation, drainage, welding and much more are all covered in these fully illustrated, easy to understand volumes. No. 23155 — 3 Volumes — \$15.50



MACHINISTS LIBRARY

Three books covering the entire field—1216 profusely illustrated pages on practical fundamentals of basic machine shop operations, setup and operation of spot machines, down-to-earth data on toolmaking procedures, layouts, jigs and fixtures, etc. . . . equally valuable for beginners and experienced men alike. No. 23174—3 Volumes—\$19.50

**SATISFACTION
GUARANTEED
OR YOUR MONEY
BACK!**

If you are not completely satisfied with the books, you may return them within 10 days for a full refund.

153

 Theodore Audel & Co.
4300 West 62nd Street
Indianapolis, Indiana 46206

SEND NO MONEY—15-day FREE EXAMINATION

Theodore Audel & Co.—Self Improvement Publishers since 1879
4300 West 62nd Street, Indianapolis, Indiana 46206

cc13

Yes . . . please rush me the book(s) checked at right for my 15-day free trial. If not completely satisfied—I may return them and owe nothing. Otherwise, I will pay the modest amount on the invoice accompanying my book(s), including shipping and handling, and keep them for my "how-to" library.

Save shipping and handling costs. Full payment enclosed. (Plus sales tax, if any.)

- 23169
- 23185
- 23155
- 23174

Name _____
Address _____
City _____ State _____ Zip _____

Every book here was custom-written* for

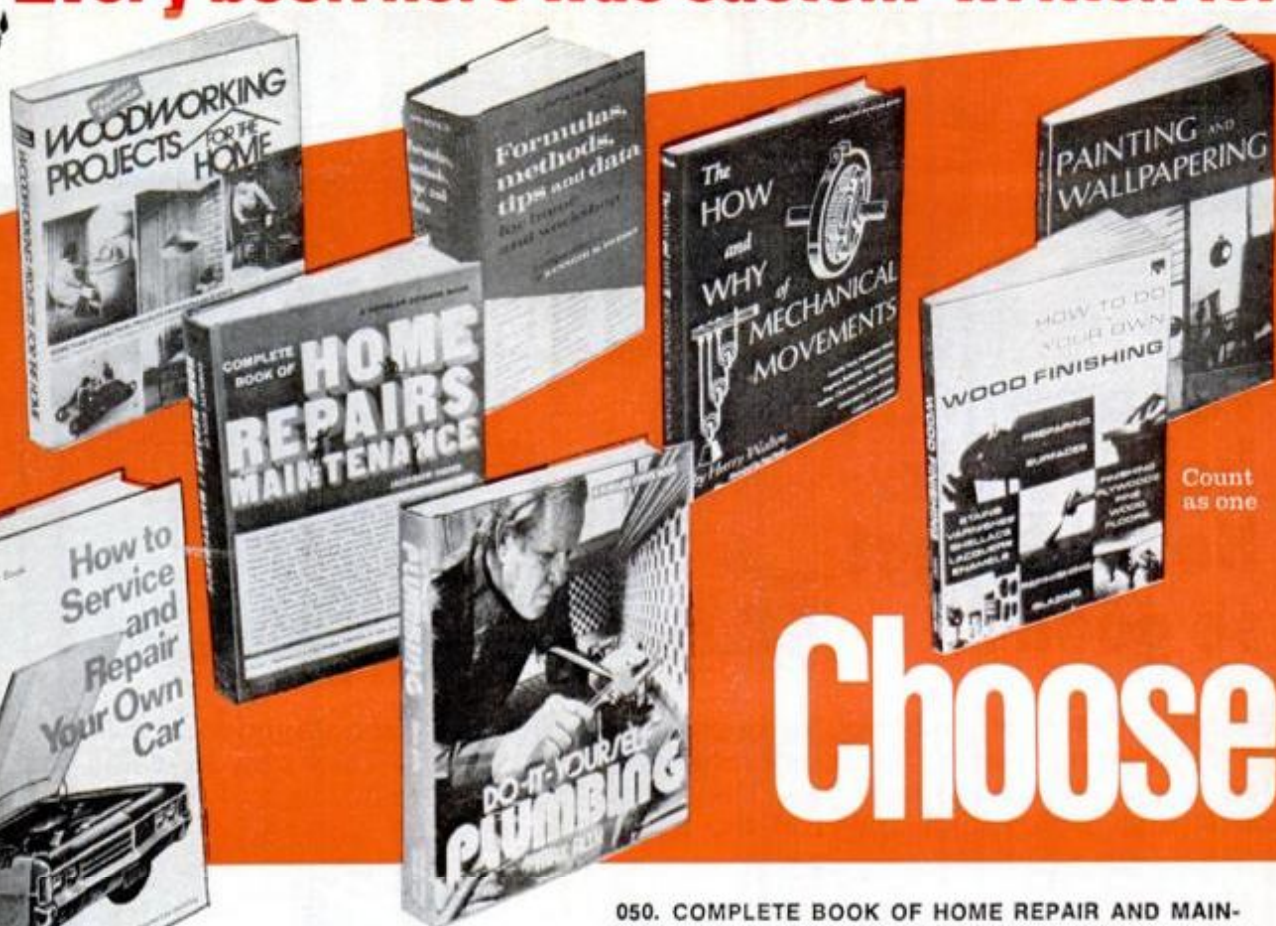

Choose

Popular Science
books show you how to
SAVE by doing it yourself.

075. HOW IT WORKS ILLUSTRATED by Rudolph F. Graf and George J. Whalen. Detailed technical drawings and easy-to-understand explanations on a wide variety of tools, appliances, machines and gadgets. Retail \$10.95.

085. COMPLETE GUIDE TO HOME APPLIANCE REPAIR by Evan Powell. How to repair dozens of large and small appliances including toasters, fry pans, sewing machines, skillets, refrigerators, more. Over 500 how-to pictures. Retail \$11.95.

101. WOODWORKING PROJECTS FOR THE HOME (from Popular Science magazine). Construction plans for more than 100 projects—tables, desks, chairs, storage units, much more. Retail \$10.00.

097. DO-IT-YOURSELF PLUMBING by Max Alth. How to do every plumbing job step by step, from fixing a leaky faucet to installing all the plumbing in a new house. 471 show-how illustrations. Retail \$11.95.

057. DO-IT-YOURSELF HOME PROTECTION by Ralph Treves. How to plan, choose, buy or build and install all home and car security systems, simple to complex. Retail \$7.95.

042. FORMULAS, METHODS, TIPS AND DATA FOR HOME AND WORKSHOP by Kenneth Swezey. Thousands of methods, calculations, tables for every home or workshop job. Retail \$10.95.

050. COMPLETE BOOK OF HOME REPAIR AND MAINTENANCE by Jackson Hand. How to make home repairs expertly, modernize as you repair. Retail \$9.95.

036. THE HOW AND WHY OF MECHANICAL MOVEMENTS by Harry Walton with brilliant explanatory drawings by Ray Ploch. How six basic mechanical elements power every machine ever invented. Retail \$10.00.

038. ELECTRONICS FOR EVERYBODY by Ronald Benrey. Do-it-yourself electronics. How to build kits or your own projects. Retail \$7.95.

044. COMPLETE BOOK OF HOME WORKSHOPS by David X. Manners. Everything about how to design, plan and build an efficient home shop for every purpose. Retail \$9.95.

084. DE CRISTOFORO'S COMPLETE BOOK OF POWER TOOLS. From 1/4" drill to lathe—how to use all your power tools more effectively. Over 1500 how-to illustrations. Retail \$11.95.

056. HOW TO SERVICE AND REPAIR YOUR OWN CAR by Richard Day. How to prevent car troubles, pinpoint trouble, fix it. Illustrated how-to on dozens of servicing and repair jobs. Retail \$10.95.

1055. 2-BOOK HOME DECORATING PACKAGE includes two paperback books: How To Do Your Own Painting & Wallpapering and How To Do Your Own Wood Finishing. Many how-to pictures. Retail \$7.00.

1056. 2-BOOK BUILDING PACKAGE includes two paperback books: How To Work With Concrete & Masonry and Home & Workshop Guide To Sharpening. Many how-to pictures. Retail \$7.00.

053. HOW YOUR CAR WORKS by Sam Julty with brilliant explanatory drawings by Ray Ploch. How all the systems of your car work—engine, fuel system, exhaust system, drive line, brakes, more. Retail \$11.95.

POPULAR SCIENCE BOOK CLUB

P.O. Box 2006, Latham, N.Y. 12111

POPULAR SCIENCE BOOK CLUB members



any 3 for \$1
(regularly up to \$35.85)

Count as one

when you join the Popular Science Book Club

And then keep saving 25% to 60% on books covering a wide range of subjects . . . home improvement and repair, house-building, cars and car repair, home workshop, appliance repair, electronics, how things work, home protection, mathematics, masonry and carpentry, modern technology, science, space and more.

* The Popular Science Book Club regularly offers custom-written books to its members. These are specially commissioned books written by the leading authors in the popular science field on all the subjects of greatest interest to members. Men like Ralph Treves, R. J. DeCristoforo, Richard Day and many more.

These books are offered at discount exclusively to Popular Science Book Club members. Nobody else can get these books at the discounts available to Club members. And, in addition to these Popular Science original books, you're offered the best books on popular science subjects from all other publishers. These books are available at the same 25% to 60% discounts.

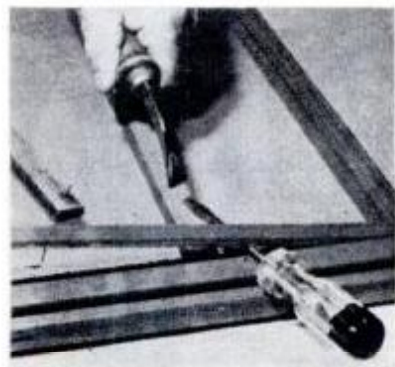

Repairing screens.

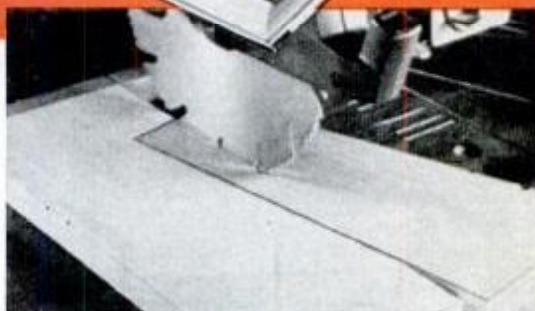

Simple homemade jig permits cutting tapered pieces on the radial arm saw.

HOW POPULAR SCIENCE BOOK CLUB WORKS

- You get any 3 of these books (up to \$35.85 worth of books) for only \$1 plus postage and handling when you join Popular Science Book Club.
- About every four weeks, you receive a bulletin describing the coming selection and alternate books also available. If you want the selection only, do nothing. It will be shipped to you automatically. If you don't want the book, or want alternate books, or no books, just indicate your wishes on the form that comes with the bulletin and return it by the date shown.
- Your only obligation is to buy two Club selections in the next year.
- You save 25% to 60% on every book, yet virtually all PSBC books are identical to publishers' editions. Same binding, paper, jacket—same everything except price.
- You may return any book within 10 days after examining it if you're dissatisfied with it for any reason.

Mail the attached card or write to the address at left



FREE BLUEPRINTS and TRIAL LESSON
—for your greater success in Building

Beginners, craftsmen, even foremen and superintendents, have sent for these free blueprints and trial lesson in Plan Reading as a means of trying out Chicago Tech's home-study Builders training. Learn how you can master Plan Reading—Estimating—and the practical details of all types of construction in your spare time at home. Mail coupon below today—see how you, too can prepare for a better job—higher income, or start your own contracting business.

CHICAGO TECHNICAL COLLEGE/School for Builders
2000 S. Michigan Ave., Chicago, Ill. 60616

CHICAGO TECHNICAL COLLEGE Veterans Dept. PM-16, 2000 S. Michigan Ave., Chicago, Ill. 60616 Here

Please mail me a Free Trial Lesson, Blueprints and Builders Catalog. I understand there is no obligation—no salesman will call.

NAME _____ AGE _____
ADDRESS _____
CITY _____ STATE _____ ZIP _____

A ROLLTOP DESK YOU CAN BUILD

(Continued from page 82)

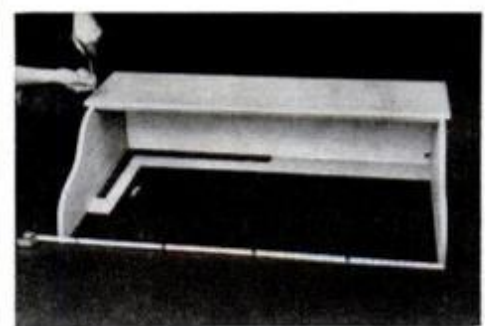

After parts are test-fitted, screws are driven in counterbored holes and capped.



Pencil trays are made by passing stock at 75° angle across 10-in. blade.

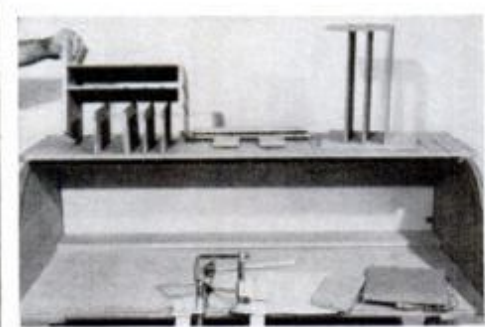

Preassemble right and left section of cubbyhole unit first, then glue rest.



Beveled slats for tambour lid are ripped with sharp blade at 10° angle.

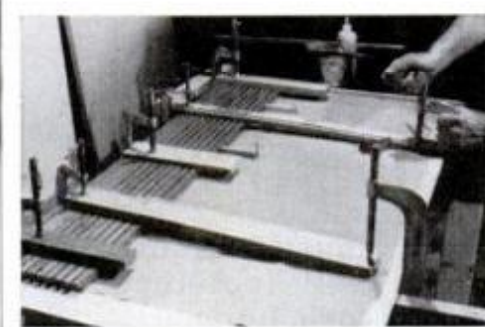

Slats are glued to cloth back 8 to 10 at a time, apply glue to cloth only.

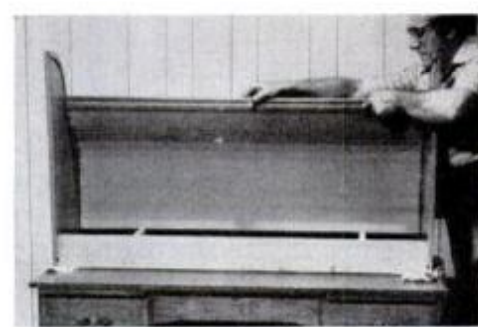

Slat ends are waxed, then inserted into track. Complete by screwing top to base.

COUNTERFEIT GUNS
Authentic machined metal replicas of famous firearms disassemble like originals.

Precision machined metal models look, feel, weigh, disassemble like real guns—Over 28 hand finished parts. Perfectly legal — CANNOT be fired. Great for decorating den, office, rec. room. Send for free color brochure of 28 models of famous historical to modern military firearms. **\$29.95**

REPLICA MODELS Inc.
Dept. PM-1, 610 Franklin St., Alexandria, Virginia 22314
Send \$300. Add \$1.25 postage per model.
Enclosed \$ _____

NAME _____
ADDRESS _____
CITY _____ STATE _____ ZIP _____
 PLEASE SEND FREE FULL COLOR CATALOG.

BIG PROFIT HOME BUSINESS

Make Real Money at Home in Spare Time. No Previous Experience Needed

LEARN GUN REPAIR!

BECOME AN EXPERT! KNOW—
• Gun Repair, Customizing, Accurizing • Moders & Black Powder Ballistics
• Reloading, Custom-Ammo Making • Stock Carving Design, Checking, "GUN-PRO" Book FREE!
• Firearms Importing Plus Much, Much More FIRST & ONLY COURSE OF ITS KIND!

Your love of guns and shooting can lead to an exciting career opportunity! Let leading Arms Experts train you in the many proven ways to make \$\$\$ with guns! Booming firearms sales create big demand for skilled craftsmen, qualified sales advisory personnel. Fed. Gun Laws permit licensed trainees to sell arms, ammo without inventory. Order for others on cost-plus basis. Save up to 50% and more on fine guns, accessories, gunsmith supplies! Start your own business; or prepare now for a high-pay "Gun-Pro" Career with manufacturers, importers, gun shops, sports stores. We show you the way! 120

North American School of Firearms, Dept. PM-16
Careers by Home Study • 4500 Campus Dr., Newport Beach, CA 92663
Rush me your free "Gun-Pro" Career Kit—no salesman will call.

NAME _____ AGE _____
ADDRESS _____
CITY _____ STATE _____ ZIP _____

sharp chisel; use damp cloth to remove traces that remain (finish won't take over glue).

9. Glue edge strip to each bottom back frame to form groove for the back panel.

10. Use brads and glue to install pedestal back panels. Add solid cherry strips to raw plywood edges at back.

11. Cut pedestal base pieces to rough overall size, then miter corners carefully for perfect fit.

12. Attach long trim pieces to sides of pedestal first. If you prefer to avoid mitered corners, use butt joints at the corners and lap the side members with the fronts.

13. Cut front and rear base pieces to size, miter or butt the ends, and glue in place.

14. Nails driven from rear with only the points protruding will keep the base pieces in place during clamping—a very important step.

15. Fit the back apron "Q" so it sets in 1/4 in. closer to the front

than is indicated in the full-size plans. This is to allow clearance for direct drilling of lagscrew pilot holes from within the pedestal. This is an easier and more effective way to secure (rather than to use blind dowels as shown in plan). Use 1/4 x 1 1/2-in. hex-head lags and drive with socket wrench.

16. Screw and glue center frame supports into place.

17. Install center frame and drill holes for screws (instead of dowels) from within the base. Countersink the heads.

18. Use smooth-cutting blade to cut desktop panel. Add 1/4 x 3/4-in. solid-wood strips to ends first, then front and rear strips to conceal plywood edges.

19. If sufficient number of long clamps are not available to clamp the strips, you can do a good job with masking tape. Apply plenty of strips to insure good contact.

20. Important note when using

(Please turn to page 146)

Need More Income? Be Your Own Boss

Earn \$5 TO \$8 an Hour

In Profitable Sparetime Business of Your Own

Sharpening SAWS

with Professional Accuracy

The need for precision sharp saws and tools by industry, contractors as well as handymen, is creating exceptional opportunities for the man who wants to have a business of his own. You don't have to quit your present job because you can run this service in your sparetime, on weekends, or in the evenings.

Foley Sharpening Equipment Lets You
Sharpen Variety of Saw Blades

Here's what others say

"... Started in sparetime. Last year with fully equipped sharpening shop did over \$30,000 in business."

F.B. New York

"An accident almost crippled me for life but thanks to Foley equipment and the training I received at your school I now have a profitable business which proves 'You can't keep a good man down'."

J.H. North Dakota

"The Foley Filer handles all my needs. For what customers were demanding of me I thought I'd need extra machines and equipment. Not so, the Foley Filer takes care of everything I need."

H.F. Pennsylvania

"Your equipment is built to last. It'll outlive me (and outwork me)!"

C.W. Iowa

"I'm a 'retired farmer' at 68 but my Foley equipment keeps me busier than ever—and it's profitable too!"

L.J. Minnesota

"I started a small sharpening operation in my garage. I now have 2 other branches and several people working for me. My gross income is in the five figure bracket."

L.G. Chicago

"Who says a woman can't succeed in supposedly a man's business. I did and today I'm doing business with many industries. I just finished sharpening 55 ten food band saws."

A.A. Wisconsin

"Looking for a snow plow, I stopped in at a rental outlet. Browsing around, I noticed a power chain saw and it dawned on me that rental shops could mean extra profits for my sharpening business. Now I have extra business all of the time from rental outlets."

M.S. Vermont

"The Quality of Foley equipment has guaranteed me repeat business because I can turn out quality jobs every time. You might say, I've built my reputation on Foley's."

C.D. Colorado

You can sharpen combination (rip and crosscut) circular saws, band saws, hand saws, crosscut circular saws as well as Carbide-tipped saw blades—and do a perfect job every time without experience or special training. The precision Foley sharpening equipment does it for you automatically! Set up in basement or garage, work your own hours in your own way and earn big sparetime profits.

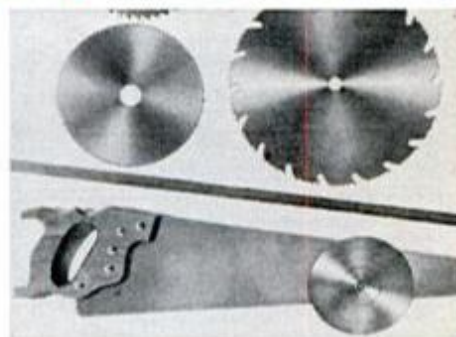

EVERY COMMUNITY NEEDS THIS SERVICE. Regardless of the size of the city or small town, this service is needed. And we'll show you how to get started.

Dick and Jo Ann Koester after being in business less than a year wrote: "We have acquired another Foley Saw Filer and for the past two months we have been in full-time operation. As we live in a small town of 150 population in a farm area we have had to pick up business fast and already sharpen an average of 15 to 20 saws a day. Business for the future looks even better as good machine filing is our best advertising."

Foley
will
Finance You

We Finance You! Foley will help you get started with minimum investment. No franchise fee. Write for complete information. No obligation.

Foley

FOLEY MANUFACTURING CO., 116-6 Foley Bldg.
Minneapolis, Minnesota 55418

Send for more information on this money-making business.

Name _____

Address _____

City _____ State _____ Zip Code _____

inventors

...Manufacturers Need
New Products

If you have an idea for a new product, or a way to make an old product better, contact us, "the idea people." We'll develop your idea, introduce it to industry, negotiate for cash sale or licensing.

Send for our FREE "Invention Kit." It has a special "Invention Record Form," an important brochure, "Your Invention - Its Development, Protection & Marketing," and a Directory of 500 Corporations Seeking New Products. You'll learn how ideas become a reality!



RAYMOND LEE ORGANIZATION
230 Park Ave. No., New York, N.Y. 10017

I'd like to find out how to take action on my idea. Send Free "Invention Kit No. A-12"

Name _____ Please Print
Address _____
City _____ State _____ Zip _____

SAN FRANCISCO LOS ANGELES TORONTO VANCOUVER DENVER CHICAGO



Print Your Own

Cards, Stationery, Advertising, labels, tickets, announcements, QSL cards, greeting, sympathy, prayer cards, etc. Save money. Print for others, good profit. Have home print shop. Pays for itself in a short time. Sold direct from factory. Easy rules sent. We supply everything. Send 25c for catalog. **KELSEY PRESSES** Meriden, Conn. 06450

MAIL THIS Kelsey Presses Dept. 76-BA
COUPON TODAY Meriden, Conn. 06450

I enclose 25c send big catalog and free samples.

Name _____
Address _____
City _____ State _____ Zip _____

Be a VETERINARY ASSISTANT

...Lab Aide, Zookeeper, Pet Shop/Kennel Owner
MEN- WOMEN! Train at Home in Spare Time...
Send for Career Kit—ALL FREE!

Name _____ Age _____
Address _____
City _____ State _____ Zip _____
North American School of Animal Sciences, Dept. PA003
Careers by Home Study
4500 Campus Dr., Newport Beach, CA 92663 2944



Save time, money, and aggravation.
Be your own all-around Fix-it, Revamp-it,
Restore-it Expert with—

THE COMPLETE BOOK OF HOME REMODELING

by Robert Scharff, known for over 25 years as "Mr. Fix, the Home Repairman!"

496 pp., 400 illus., \$14.95

"COMPLETE" the title says, and "complete" the coverage is—everything you need to know about home remodeling from start to finish. How to finance remodeling. Whether and how to hire a contractor or architect. What and what not to tackle yourself. And from there on, Scharff takes you through the whole gamut of specific systems and specific projects—all fully illustrated. Modernizing electrical, plumbing, and heating systems. Renovating kitchens and bathrooms. Converting basements, attics, even garages, to useful living areas. Adding extensions, patios, and decks. You name it—Scharff tells you how to do it right. Economically, easily, attractively, and painlessly!

At your bookstore or from:
McGraw-Hill Book Company Dept. 25
1221 Avenue of the Americas, New York, N.Y. 10020



Repair any watch

... LEARN AT HOME

Unique Sweeney System develops your watch repair skills step by step at home in spare time. No previous experience needed. Low tuition. Free sample lesson and full information.

CHICAGO SCHOOL OF WATCHMAKING
Dept. 116, Fox River Grove, Ill. 60021

DRILL YOUR OWN WATERWELL

With this low-priced outfit you can drill your own water well at a cost of about 12¢ per foot! Also, this unit can be operated horizontally to drill free-flowing springs in hill-sides. A big, fact-filled package and 24-page book "How To Drill Your Own Water Well" is just \$1.00 PPD. (Refundable) "WRITE TODAY"

DEEPROCK MFG. CO.
703 Lafayette Pkwy., Dept. PM 16, Opelika, Ala. 36801

A ROLLTOP DESK YOU CAN BUILD

(Continued from page 144)

tape to apply the vertical strips to the front edges of the pedestals: Elsewhere the strips are cut a bit oversize so they overhang and later are planed flush. But here the strips must be fitted flush at the start along the inner sides of the pedestals because they would be difficult to trim flush. In this case, it is advisable to use round toothpick standoffs to keep the tape away from the glue line. Otherwise, a gummy residue will result that's hard to remove. See sketch, page 82.

21. When using masking tape, it is important to get a good-quality brand such as Scotch.

22. To drill holes for screws in desktop, set the top onto pedestals, then draw pencil lines on bottom of the top panel to outline the location of the pedestals.

23. Drill a 3/32-in. pilot hole for each screw location. Do this from the back face using the pencil outline as a guide. Since the panel cannot be handled on the drill press, all drilling must be done by hand. Therefore a drilling jig is a must for accuracy. See sketch, page 83.

24. When preliminary pilot holes have been drilled through the top, position the top onto the pedestals and drill through the top to transfer the pilot holes into the top edges of the pedestals.

25. Use a spur bit (which has a brad point) to counterbore 3/8-in. holes 1/8 in. deep into the top for matching wood plugs. This bit is recommended because it will do a clean job. Use the drilling jig for controlling depth and to assure perpendicularity.

26. Now proceed to drill the larger screw clearance holes into the top. Note that if the larger screw clearance holes were bored first, the spur bit would wobble around and tear up the work.

Steps for assembling

27. Glue and screw center frame and apron between pedestals. Apply glue to top edges and to the top and secure with screws. Be sure piece is level on floor or table.

28. Cut plugs from solid stock with a plug cutter—orient the grain direction and glue into place. Go easy with the glue.

29. Drawer fronts. Set the saw arbor to 8° bevel and slice ends first, then the sides; otherwise, chipping may occur. Pieces can be held firmly against rip fence by hand for this operation.

30. Rolltop. Plans call for 9/16-in.-wide groove in the ends for the tambour top. The contoured groove is best cut with a router using a straight bit.

MATERIALS LIST

PEDESTAL BASE

- | Pcs. | Size (letter key to drawings), description |
|------|--|
| 1 | 3/4 x 29 1/2 x 51 1/2" (A) Top* |
| 2 | 1/4 x 3/4 x 52" (B) Top edge strips, long |
| 2 | 1/4 x 3/4 x 30" (C) Top edge strips, short |
| 4 | 3/4 x 28 x 29 1/4" (D) Pedestal sides* |
| 8 | 1/4 x 3/4 x 29 1/4" (E) Pedestal facing strips |
| 4 | 3/4 x 3 3/8 x 13 1/4" (F) Bottom rails front and back* |
| 4 | 3/4 x 2 1/4 x 13 3/4" (G) Bottom frames front and back |
| 4 | 3/4 x 2 1/4 x 24 3/8" (H) Bottom frames, sides* |
| 2 | 1/4 x 9 3/4 x 24 1/2" (I) Dust panels*** |
| 6 | 3/4 x 2 1/4 x 13 3/4" (J) Upper frames, fronts |
| 6 | 3/4 x 2 1/4 x 13 3/4" (K) Upper frames, backs* |
| 12 | 3/4 x 2 1/4 x 24" (L) Upper frames, sides* |
| 4 | 1/4 x 9 3/4 x 24" (M) Dust panels*** |
| 4 | 1/2 x 4 x 29 1/2" (N) Pedestal base, long |
| 4 | 1/2 x 4 x 15 3/4" (O) Pedestal base, short |
| 2 | 1/4 x 13 3/4 x 25 1/2" (P) Pedestal backs*** |
| 1 | 3/4 x 5 1/2 x 21" (Q) Back apron |
| 2 | 3/4 x 2 1/4 x 21" (R) Center frame, front and back* |
| 2 | 3/4 x 2 1/4 x 22 1/2" (S) Center frame, sides* |
| 1 | 1/4 x 17 x 22 1/2" (T) Dust panel*** |
| 2 | 3/4 x 3/4 x 25 3/4" (U) Center frame supports* |
| 2 | 3/4 x 12 1/4 x 26 1/4" (V) Drawboards** |
| 4 | 1/4 x 3/4 x 26 1/4" (W) Drawboard edge strips |
| 2 | 3/4 x 3/4 x 13 1/4" (X) Drawboard nosings |
| 1 | 3/4 x 4 7/16 x 20 7/8" (Y) Center drawer, front |
| 1 | 1/2 x 2 7/16 x 20 3/4" (Z) Center drawer, back* |
| 2 | 1/2 x 3 3/16 x 23 1/2" (AA) Center drawer, sides* |
| 1 | 1/4 x 20 3/8 x 23 3/8" (BB) Center drawer, bottom*** |
| 8 | 3/4 x 5 1/2 x 13 3/4" (CC) Drawer fronts |
| 2 | 1/2 x 1 1/4 x 13 3/4" (DD) File-drawer front joiners |
| 4 | 1/2 x 4 7/16 x 12 3/8" (EE) Drawer backs* |
| 8 | 1/2 x 5 3/16 x 23 3/4" (FF) Drawer sides* |
| 2 | 1/2 x 10 3/8 x 12 3/8" (GG) File drawer, backs* |
| 4 | 1/2 x 11 3/16 x 23 3/4" (HH) File drawer, sides* |
| 6 | 1/4 x 12 3/8 x 23 3/8" (II) Drawer bottoms*** |
| 2 | 3/4 x 2 x 9" (JJ) Drawer board stops* |
| 8 | Drawer pulls, Amerock No. 152 |

PEDESTAL BASE

- | Pcs. | Size (letter key to drawings), description |
|--------------------|--|
| 1 | Lock, Corbin No. K02066 |
| Tambour top | |
| 1 | 3/4 x 13 1/4 x 52" Top |
| 1 | 3/4 x 1 1/8 x 49" Top back rail* |
| 1 | 1/2 x 3/4 x 49" Top front strip |
| 1 | 3/4 x 4 1/8 x 49" Bottom rail* |
| 2 | 3/4 x 13 1/4 x 28 1/2" Ends** |
| 1 | 1/4 x 13 1/4 x 49 3/4" Back*** |
| 1 | 3/4 x 2 x 49 3/4" Bottom slat (K) |
| 27 | 3/4 x 3/4 x 49 3/4" Tambour strips |
| 1 | 1/4 x 3/4 x 48 3/4" Canvas cover strip |

Interior of tambour top

- | | |
|---|--|
| 1 | 1/2 x 8 1/2 x 48 7/8" |
| 4 | 1/2 x 8 1/2 x 10 3/8" (A) Panels |
| 2 | 1/4 x 3 1/16 x 8 1/2" (B) Bottoms |
| 1 | 1/4 x 8 1/2 x 10 1/2" (C) Scrolled divider |
| 5 | 1/4 x 8 1/2 x 12 1/2" (D) Panels |
| 2 | 1/4 x 8 1/2 x 14 1/4" (E) Panels |
| 2 | 1/4 x 2 3/4 x 8 1/2" (F) Partitions |
| 1 | 1/2 x 4 3/8 x 8 1/2" (G) Partition |
| 3 | 1/4 x 4 3/8 x 8 1/2" (H) Scrolled dividers |
| 2 | 1/2 x 7 3/8 x 8 1/2" (J) Partitions |
| 2 | 3/4 x 2 3/8 x 8 1/2" Pencil troughs |
| 1 | 1/4 x 11 x 48 7/8" Back*** |
| 3 | 1/2 x 2 7/16 x 4 7/16" Drawer fronts |
| 3 | 1/4 x 2 7/16 x 4 7/16" Drawer backs |
| 6 | 1/4 x 2 7/16 x 8 7/16" Drawer sides |
| 3 | 1/4 x 4 7/16 x 8 7/16" Drawer bottoms |
| 2 | 1/2 x 2 7/16 x 12 1/2" Drawer fronts |
| 2 | 1/4 x 1 1 3/16 x 11 7/8" Drawer backs |
| 4 | 1/4 x 2 7/16 x 8 7/16" Drawer sides |
| 2 | 1/4 x 1 1/8 x 8 7/16" Drawer bottoms |
| 7 | 1/4 x 1/2 x 1" Drawer stops |
| 7 | Amerock knobs No. 850 |
| 1 | 21 x 48 3/4" Medium-weight canvas |

* Poplar wood
** Veneer plywood (cherry)
*** Plywood (gum)

31. After gluing up solid stock to get 13 $\frac{1}{8}$ -in. width, bandsaw the contours, then prepare to cut the grooves.

32. A router bit which will cut a 9/16-in.-wide groove in one pass is nonexistent (so far as I know); therefore, a $\frac{1}{4}$ -in. bit is used—a common size.

33. A "twin" or two-part template cut from standard tempered hardboard (Masonite) is used to cut the grooves. The radii vary between the two parts of the template so great care must be exercised to make the templates.

34. Templates. Draw the pattern full size onto paper, including the dotted base lines. Rubber-cement the drawings onto hardboard and bandsaw them carefully. Note that the difference between both forms is 5/16 in. and parallel. Tape both forms together with base lines lined up and with smaller form centered side to side over larger form; drill a couple registration pilot holes for nails through both sections.

35. Center one of the templates onto the end panel with the base line even with the bottom edge of the stock. Drive in a pair of snug-fitting brads to hold in alignment. Clamp to work table and make the first pass with the router. Take off only a little at a time to avoid burning the tool and wood.

36. When depth is reached, remove the first template and install the other using the same nail pilot holes to assure exact lineup which is important.

37. The two cuts made with the router will result in two $\frac{1}{4}$ -in. grooves with a space of 1/16 in. from outside to outside; thus a narrow strip of waste will remain in the center of the groove. This is cleaned out by making a freehand pass with the router.

38. Use a carbide-tip tool for cutting the tambour grooves and make each pass about $\frac{1}{8}$ in. or even less until $\frac{3}{8}$ -in. depth is reached.

39. After the grooves are cut and the inner faces of the end panels sanded, the top and back are assembled. Counterbored screws are used to make glue contact of top to sides. Plug the holes.

40. Cubbyhole unit. Make the required dado cuts, then assemble the left and right sections (as shown in photo on page 144). This will simplify assembly considerably. If an attempt is made to put it all together in one operation, proper clamping would be impossible. Half-inch lumber for this is not usually

stocked so you'll have to have it surface-planed at a lumberyard.

41. Prestain and finish the face of the back panel, then put it aside and proceed to stain the compartments. The job is tough because your hands won't fit in some of the compartments. Work from both sides (thus the reason for leaving off the back). See finishing steps later.

42. Tambour lid. Cut some boards to the required length for the slats, then run a dado cutter over the ends to form the notch.

43. Use a smooth-cutting blade to cut the strips. Set the arbor for a 10° tilt, then run each piece through twice to obtain the required bevel on both sides. Use two push sticks for safety and accuracy.

44. Sand and apply the finish to each piece before assembly. Don't get stain on the bottom surface; otherwise glue will not adhere properly. Use a flat board for a work surface. Lay sheets of kitchen wax paper down to prevent accidental sticking to table. Tape the canvas to the table to keep it flat, then brush a coat of glue on canvas (not the wood). Work about 8 to 10 slats at a time. Most wood warps when cut into thin sections so it is practically impossible to control all the slats in one step. Use sufficient number of clamps to get ample pressure throughout. The use of a thin guide strip nailed to the table at one end will insure accurate alignment.

45. When tambour is dry, wax the ends, then insert into the grooves. Wax in the grooves will help. Screw the unit to the desktop.

46. Finishing. Presand all components before assembly, then finish-sand by hand before applying finish. Use tack cloth to remove all sanding dust.

47. Apply a coat of American Lacquer thinned one to one with thinners to seal the wood and to permit better stain spread. Don't brush this on; use a pad of cheesecloth instead. Sand lightly after 10 minutes with fine paper (6 0); wipe with tack cloth.

48. Mix 1 part Sapolin Antique Walnut No. 300 and 1 part Sapolin Concord Cherry No. 305 stain. Apply with brush or cloth. Wipe off excess within 10 minutes.

49. When stain has dried (24 hours), apply a coat of Satinlac Low Gloss (or Constantine's Wood Glo). Sand first coat with 6/0 paper, then apply a second, final coat. Now stand back and admire your heirloom. ★★★

Are You Worth \$25,000.00 a Year?
Do You Want to be Your Own Boss?

Warner's newest shop is a unique breakthrough in the Engraving Field. It is not—and we repeat NOT—direct selling. It is a business that knows no season... yet it is a business that will never be taken over by the giant corporations. In fact, they will want you as a supplier! Now, Warner makes it possible for you, the independent businessman, to cash in on this once-in-a-lifetime opportunity... ON THE GROUND FLOOR. Full particulars FREE. Write today.

Warner Electric Co., Dept. E-2-FA
1512 Jarvis Ave., Chicago, Ill. 60626

FREE OUTFIT STARTS YOU IN
BIG MONEY SHOE BUSINESS!



Run your own profitable "shoe store" business from home in spare or full time. We give you—FREE—complete Starting Outfit that makes you \$217.00 EXTRA each month for just 2 easy orders a day. You feature 350 fast-selling dress, sport, work shoe styles for men and women. Air-cushion shoes, many other special features! Sizes 4 $\frac{1}{2}$ to 16—widths AA-EEEE. Draw on 300,000 pair stock. Earn prizes, bonuses, shoes for yourself—even a new car or color TV! Rush postcard for your FREE Starting Outfit today... Now!

MASON SHOE, Dept. G-526 CHIPPewa FALLS, WIS. 54729



Take In Up To
\$750 Per Week!
CUSTOMIZE
AUTO/VAN INTERIORS

UPHOLSTER ANY VEHICLE—START WITH YOUR OWN CAR OR VAN! A business so big, growing so fast, you need an appointment in most auto trim shops! Send for FREE MASTER PLAN, ILLUSTRATED BOOKLET on learning auto upholstery and interior customizing in your spare hours. No experience needed. VET APPROVED. AUTO UPHOLSTERY INSTITUTE, 1205 W. Berkeley, Dept. AAFM Orange, CA 92668

Scamp BUILD YOUR OWN TRAVEL TRAILER



- Hunting
- Fishing
- Camping
- Sleeps 4
- Guaranteed

For the first time - a fiberglass Do-it-Yourself Kit! No welding. Scamp kit includes all parts you need and fully-illustrated step-by-step assembly manual. Scamp can be completed in 60 hours with minimum tools. Also available ready to hitch-up-and-go.

Scamp

Write: SCAMP, DEPT. PM-1, Backus, Mn 56435
Rush full-color brochure. \$2.00 enclosed.
Name _____ Age _____
Address _____
City _____ State _____ Zip _____
Phone: Bus _____ Home _____

NEW DESIGN—FITS ALL PEGBOARDS!
World's best storage system. Every home, factory, and business needs it. Pegboard mounted cup and unbreakable jar. Keeps small shop supplies visible and clean. Hooty Dandy Cans and Jars: 10 for \$4.25, 30 for \$12.50, 72 for \$22.50. Postage Paid, no COD's. Send check or M.O. Dealer Inquiries Invited.
WICKLIFFE IND. INC.
29353 LUXONA
P.O. Box 286 PM16
Wickliffe, Ohio 44092

LEARN
MEAT CUTTING
Train quickly in 8 short weeks at Toledo for a bright future with security in the vital meat business. Big pay, full-time jobs—HAVE A PROFITABLE MARKET OF YOUR OWN! Time payment plan available. Diploma given. Job help. Thousands of successful graduates. OUR 53RD YEAR! Send NOW for a big new illustrated FREE catalog. No obligation. G.I. approved. NATIONAL SCHOOL OF MEAT CUTTING, No. 71-02-0197T, Dept. 50-C, 33 N. Superior, Toledo, Ohio 43604.

POWER HACKSAW
\$39.95 WORKS BEAUTIFULLY
Easy to assemble kit of cast iron parts. Use your own 1/4 hp. motor. 1/2" drill press needed for finishing work. Moves approx. 120 strokes/min. Send \$39.95. Catalog describing this and 51 other kits, only 50c. Write: Struck Corp., Dept. PM16H, Cedarburg, Wis. 53012

The Money Man

A STORY THAT NEEDS TO BE TOLD

BY JOHN VINCENT—AS TOLD TO RUTH L. McCARTY

I started out in business in October, 1974. Surprised? Well, don't be. I made every mistake in the book. I fell for every deal that even "smacked" of making quick money.

Needless to say, I paid my dues. I paid high.

I know what I'm going to say to you now will sound astounding. Some of you will even call me a liar. But, in the last few months I have discovered the true method to making money. Like many of you, I did not know this method was sitting right under my nose.

It took an outsider — my sixty year old father — to take note of what I was doing wrong. He set me straight. I was too involved to see. Probably a lot like you.

Now, a day does not go by when I do not receive stacks of money; it's piled on my desk from all over the country. I didn't start out with a fortune either.

My father told me to "copy" success. What did he mean? It is a lot like what Rockefeller said — "When you see someone making money hand over fist, do what he does."

I want to share my methods with you for two reasons. First, by letting you in on it, I become richer. Second, the base of my success is enriching other people and showing them how to get rich too. I want you to "copy" my success.

Now, don't get me wrong. I'm not going to send you a lot of get rich quick schemes or literature that will end up in the trash. I don't believe in doing business that way.

For the small price of \$3.00 I am going to send you three, well-written, complete instruction courses:

Item 1 — MAKE \$1000 IN THE NEXT 30 DAYS — GUARANTEED

Item 2 — HOW ELSE I MAKE MONEY

Item 3 — I MAKE \$167 IN 5 HOURS — HERE'S HOW

All starting materials are included FREE. You don't have to buy anything else from me.

I honestly do not want your money if what I send you does not help you. To prove this, I offer you my Iron Clad 100% MONEY BACK GUARANTEE. If you are not completely satisfied, and you do not make \$1000 or more after trying Item 1 for 30 days, I will refund your \$3.00 by return mail in 24 hours.

This may be the opportunity you have waited for. Don't let \$3.00 stand in your way.

100% MONEY BACK GUARANTEE

INSIDER CAPITAL Dept. 1101
Box 252 - 45 N. Main Street
Hatfield, Pa. 19440

O.K. John. Your offer sounds incredible, but what have I got to lose. Here's my \$3.00 for your complete package. Don't forget, if I am not completely satisfied and I do not make \$1000 or more after trying Item 1 for 30 days, you will give me a complete refund of my \$3.00. My order is on that basis only.

NAME _____

ADDRESS _____

CITY _____ STATE _____ ZIP _____

Includes Complete Starting Material

Satisfaction Guaranteed

Orders for Cash or Money Order processed in 24 hours. Allow 30 days if you send a check.

Copyright 1975. All Rights Reserved.

All orders shipped book rate. Add 50¢ for first class.

HINTS

FROM READERS

Bolt caps

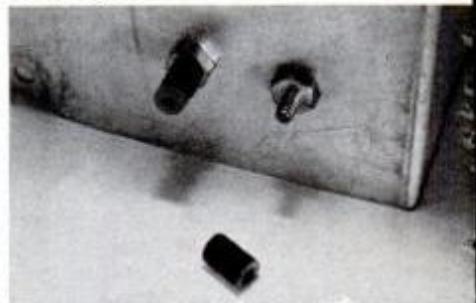

A protruding bolt end can be hazardous, but can easily be capped with a piece of rubber or plastic tubing with an inside diameter that assures a tight fit. Length should be slightly greater than that of bolt's projection. —Burt Web, Skokie, Ill.

Chain saw case

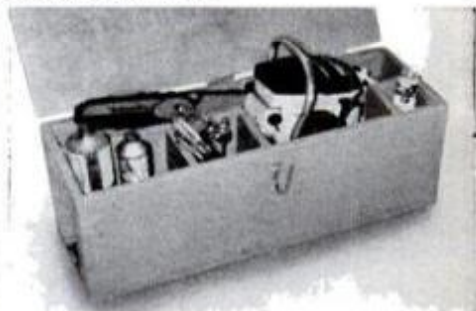

Whether you use your chain saw a little or a lot, it will last longer if you keep it clean and protected in a storage box made from scrap lumber. Spare parts and tools won't be left behind if they're stored in compartments alongside the blade. —Tom McCanna, Woodstock, N.Y.

Hammer as anvil



For hammer-shaping a sheet-metal part over a rounded surface, a ball-peen hammer clamped in a machinist's vise acts as anvil. Note padding to prevent marring of hammer poll. —Walter E. Burton, Akron, Ohio

Start your own money making business!

**Make up to \$12⁵⁰ an hour—
even while learning!**

*Train FAST
at home!*

*Get into this booming high-profit business that's
Easy to learn—Easy to do—Easy on You!*

Never before have money-making opportunities been so great for qualified Locksmiths. Now lucrative regular lock and key business has multiplied a thousandfold as millions seek more protection against zooming crime. Yet there's only one Locksmith for every 17,000 people!

Start Collecting CASH PROFITS Right Away

You're "in business" ready to earn up to \$12.50 an hour a few days after you begin Belsaw's shortcut training. Take advantage of today's unprecedented opportunities in Locksmithing for year-round EXTRA INCOME in-spacetime—or fulltime in a high-profit business of your own. Hundreds we've trained have done it. So can YOU! All tools plus professional Key Machine given you with course. These plus practice materials and equipment, plus simple, illustrated lessons, plus expert supervision, plus business-building guidance will enable you to KEEP THE MONEY COMING IN! Ideal for retirement—good jobs too.

SEND FOR EXCITING FACTS—No Obligation

Discover what's in Locksmithing for you—how Belsaw's Master-Locksmith-approved training can give you the skill you can depend on to EARN MORE—ENJOY LIFE MORE.

No Extra Cost! Included With Your Locksmith Training



BURGLAR ALARM AND SECURITY SYSTEMS training. Covers all phases of Burglar, Hold-Up and Fire Alarm servicing and installation. This valuable and timely instruction includes all special tools and supplies. ONLY Belsaw offers such extensive training in this rapidly expanding field as a part of your Locksmith training.

ADVANCED Locksmithing! How to change combinations, install and service Safe, Vault and Bank Safe-Deposit Box locks. You learn-by-doing on the locks that we supply. You'll find it fascinating and highly profitable work.

**Be
Your
Own
Boss!**



BE A LOCKSMITH!



"I began earning right after starting... made \$1,200 while I was still learning."

HARVEY COLE, Charlevoix, MI 49720

PRO KEY MACHINE YOURS TO KEEP!

This Pro Key Machine can alone add up to \$200 a month to your income... and it won't cost you a penny extra with your training.

Find out all about it!

Just fill in and mail coupon below (or send postcard) to receive full information and details by return mail. **DO IT TODAY!**



APPROVED Under GI Bill FOR VETERANS

ALL SPECIAL TOOLS AND EQUIPMENT INCLUDED!



10-DAY NO RISK TRIAL!
Send for details!
RUSH COUPON!

BELSAW INSTITUTE
106J Field Bldg., Kansas City, Mo. 64111

Hundreds of Belsaw trained men have succeeded in this fascinating and highly profitable field...

"I opened my own business, spare time, seven months after I enrolled and made a profit of \$329 for the first week."
B. A. Deberry Littleton, Colorado



"No more hard, nasty work for me. Now I have my own business and with hardly any effort I average around \$50 a day. Thanks for my new start in life."
Sam Walker Prichard, Alabama



There is NO OBLIGATION and NO SALESMAN Will Call—ever!

RUSH COUPON TODAY FOR THIS FACT-FILLED

FREE BOOKLET!

Tells how you quickly train to be your own boss in a profitable Sparetime or Fulltime business of your own PLUS complete details on our **10-Day NO RISK Trial Offer!**



Send for your copy today!

BELSAW INSTITUTE, 106J FIELD BUILDING KANSAS CITY, MISSOURI 64111

YES, please send me the FREE booklet that gives full details about starting my own business in Locksmithing. I understand there is no obligation and that no salesman will call.

Name _____
Address _____
City _____
State _____ Zip _____

... YOU Can Do It Too!

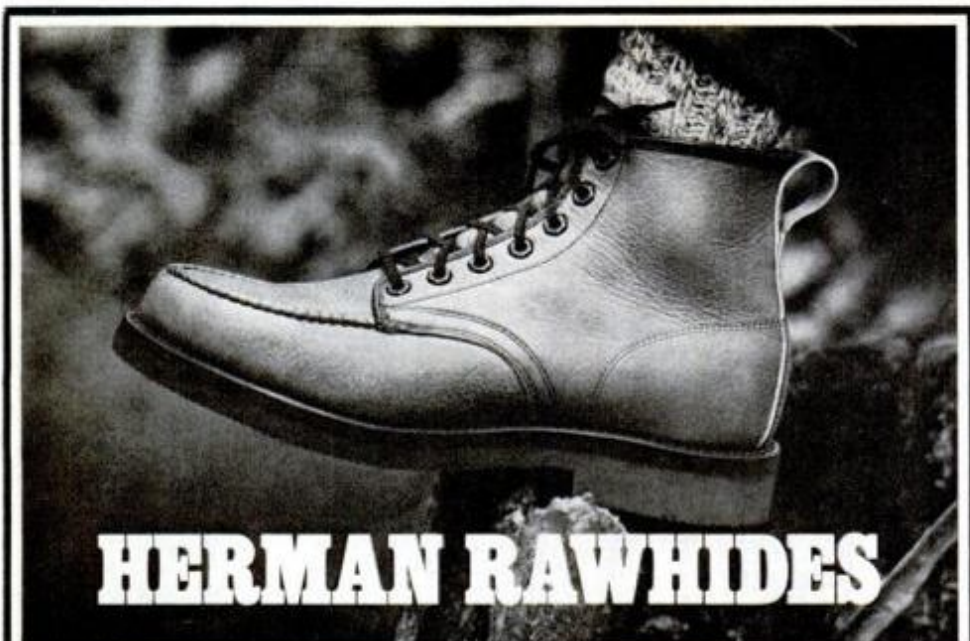

HERMAN RAWHIDES

Herman Rawhides take naturally to the outdoors. From the first day you own them, the supple, full grain rawhide uppers conform to your feet. The oil-resistant Neoprene soles and heels provide long wear and sure footing. On just about any surface. And fit? Herman Rawhides come in over 90 sizes: 9A to 14 EEE.

Cushion insoles are covered in full grain leather for even greater comfort. And Rawhides come in three styles: 8" boot (Style #7130); 6" shoe (Style #7630); and, oxford (Style #7430). Looking for real quality in outdoor shoes? Look up a pair of Hermans.



FREE CATALOG



J. M. HERMAN SHOE COMPANY, DEPT. 34, MILLIS, MASS. 02054
I'd like to try a pair of Herman Rawhides. Send me your catalog and the name of my nearest Herman Dealer.

Name _____
Address _____
City _____ State _____ Zip _____

PM-RH-1

IF YOU WANT MONEY BUT DISLIKE SELLING

Write for our full or part time action plan and make money at your own pace. No investors wanted — just ambitious people. Send \$3.00 for sample materials necessary for you to get started! (Refundable with first order — satisfaction guaranteed by Co.)

Dept. 233 (Check or M.O. please)
E.C.C. Box 7635, Waco, TX 76710

USE THE HAMMER WITH THE SOFT TOUCH



Stop battering your tools, marring your work. Four tough, rubber-like faces—round, dome, wedge and flat shapes—screw into aluminum-alloy hammer head. Great tool for the workshop, sheet-metal work, hammering out fender dents. A honey for the money. Only \$7.95 post-paid. Order yours today.

THE WAY-MAR COMPANY

P. O. Box 164
Hartsdale, N. Y. 10530

HOW TO BECOME A LOCKSMITH



COMPLETE BOOK OF INSTRUCTIONS
How To Fit Keys, Change Combinations, Master Key Locks, Keys By Number, Tools To Use, etc. Detailed illustrations. Satisfaction guaranteed. Get started! Order today.

Only \$5 ppd.

A.G. Ancele, P.O. Box 69234, Los Angeles, Ca. 90069

\$10 to \$20 in an hr!

INVISIBLE VINYL REPAIR

Big, fast earnings with amazing VIP Invisible Vinyl Repair. Big profits, big demand — car shops, homes, bars, motels, buses, etc. Easy, quick.

FREE details by mail. No salesman will call.
VIP, 2021 Montrose, Dept. 184, Chicago 60618

MAN-SIZE TRACTOR

Works faster, saves you time



Whiz through tough jobs with this big, powerful tractor. Mow 3 acres an hour: plow, till, bulldoze, remove snow fast with 21 big attachments. 14 H.P. More work-power with all-gear drive (no fluid power loss), automotive clutch, transmission and differential. Free catalog, prices.

ECONOMY TRACTOR
1005 K-1 Anoka Avenue
Waukegan, Wis. 53186

HINTS

FROM READERS

Handy soldering sponge



The tip of a soldering gun or iron should be kept clean and bright, and I've found that it's convenient to clean it with a small pad of steel wool held in a spring-type paper clip. The clip can be mounted permanently on the workbench with a screw.

—Ken Patterson, Regina, Sask.

Vise substitutes

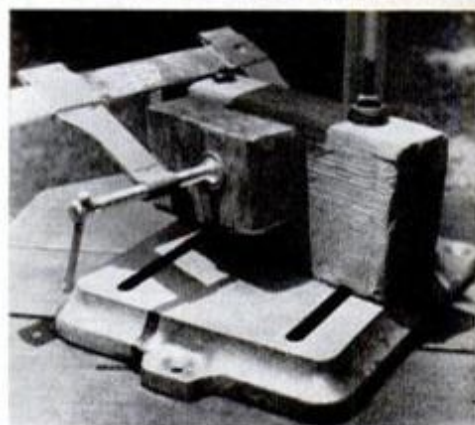
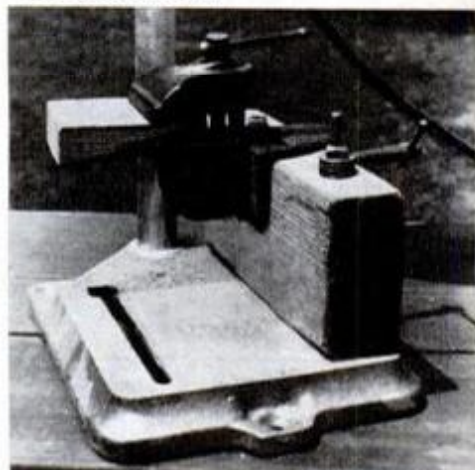

The drill-press vises I've seen on the market are either too expensive or lacking in jaw capacity and tilts. I've had good success with substitutes that use a scrap of 2x4 bolted to the drill-press table as an anchor. Large workpieces are held to it with bar clamps, smaller ones are held in a clamp-on vise.—Gary Cosand, San Bernardino, Calif.

STRIKING IT RICH

(Continued from page 85)

for "perforation." A perforating gun is lowered and a charge set off that pierces the well casing with many fine holes at the ideal depth—in the Mitchell well, between 1006 and 1016 feet. Hopefully, through these tiny holes oil will flow into the well.

Not that simple

But there's still more to come before a well is a well. The next step is called fracturing—"fracing" for short—done by pumping acid into the formation to eat out passages through which oil can flow to the well or by forcing in a sand-water slurry under high pressure. The latter method, called "hydraulic fracing," was used on the Mitchell well. Sand is driven into cracks in the oil-bearing formation and remains to hold them open as the water seeps away.

A "pay" formation is rock—limestone, sandstone or dolomites—that holds oil like a sponge. When passages are cut into it, radiating in all directions from the well, the oil flow is greatly increased. In the Mitchell well, about 10,000 pounds of sand and 300 barrels of water were used in the fracing process.

Doug had now poured \$2675 down

the hole in the cementing, perfing and fracing operations, and the job still wasn't done. Connecting the pump required inserting tubing into the well casing, a section at a time, then slipping rods down the tubing. The pump was screwed onto the last section of tubing at the top of the well.

It was mid-April and the day had finally come for the crucial test. Linda went off to school scarcely able to keep her mind on her teaching. Doug nervously started the pump, knowing he had everything they owned down a hole that might yield nothing more than saltwater.

A gusher at last

There were a few tense moments. "All of a sudden," says Doug, "the pipe running from the pump to the storage tank started vibrating and broke the baling wire that held it down. This was due to gas pressure." Soon oil, water and gas were all being blasted up the well by the pressure below rather than the pump. The well was "flowing" by itself—with an unexpected violence. Doug had to chain down the pipe to keep it from blowing out of the tank.

During the first three days, the Linda K, as Doug decided to name it, produced a phenomenal 100 barrels of crude a day. Later it tapered off to

76 barrels and finally settled down to a steady eight. That's still exceptional—a well considered good in that part of the country produces five or six barrels a day.

The Mitchells could hardly believe their success, yet they refused to break into wild celebration. They knew that any minute the bubble could burst—a piece of equipment could break or the well run dry. Still, they had started something good and their willingness to stick it out through hardship was paying off. Doug immediately moved the old Star spudder to a new site and, together with Linda and son Jim, is working on the Linda K No. 2.

Many small producers needed

The *Tulsa Daily World* saw in the Mitchells' success new incentive for small independent producers, 10,000 of whom have left the industry in the last 18 years. Said the *World*: "Repeated thousands of times across the nation, Mitchell's tactics could result in badly needed oil production for conversion to gasoline and other petroleum products."

If there's a lesson learned here, it's that all oil producers aren't big or rich. Some are just plain hard-working do-it-yourselfers who know how to get a tough job done. ★★

MAKE MONEY

Train at Home in Spare Time
WE FURNISH EVERYTHING
YOU NEED TO LEARN THIS
NEW CAREER... Even Show
You How and Where to Buy Equip-
ment & Supplies at Low Prices!



CUSTOMIZING

CARS, VANS, CYCLES, BUGGIES

INSIDE & OUT!

YOU LEARN INSIDE CUSTOMIZING, TOO!

Only the Customizing Center puts it all together for you — teaches you the complete "ins and outs" of van and car customizing. The same course teaches you with step-by-step lessons how to do paneling, upholstery, carpeting, drapes, built-ins, everything! Work with wood, vinyl, cloth and other materials. Learn how to mix or match colors. Includes basic information on installing high-back swivel and reclining seats, as well as beds, bunks, tables, etc.



YOU DON'T NEED ANY SPECIAL ART TALENT

We show you how to do everything so easy you can't miss... Fading, fogging, flames, scallops, lace, cobwebbing and other special effects. Included with your course is a wild assortment of patterns, decals and ideas that turn you into an expert with just a little practice. Not only do you learn how to use the air brush, but we show you secrets of pin-stripping, gold-leafing, custom lettering, decals, taping, masking, preparation — everything you need to know and want to learn about custom paint jobs.

START YOUR OWN SHOP — FULL OR PART TIME

We won't waste your time telling you how big the market is — or how much money you can make. You already know — or you wouldn't be reading this!

What we want you to know is how fast and easy we can train you to do this kind of work in your own garage or back yard — without charging you an arm and a leg for learning. Just spend an hour or two a day following our step-by-step instructions... and only weeks after you start you'll be handling an air gun and striping brush like you were born with them in your hands.

Get Ready for the Kind of Career that Pays You to Do What You Enjoy Doing Anyway!

Careers Through Home Study
CUSTOMIZING CENTER Dept. PBOC5
4401 Birch St., Newport Beach, CA 92663

Rush me free information and full color brochure. I understand it is absolutely free and without obligation; and no salesman will call.

Name _____ Age _____

Address _____

City _____ State _____ Zip _____

SAVE BY CUSTOMIZING YOUR OWN VAN OR CAR

... Start Earning Good Money Doing Vans for Others in Spare Time... Even Before You Finish Your Course!

How To Put On The Add-Ons!

Make more money selling and installing portholes, flares, custom windows, sun- and moon-roofs, air scoops, side pipes, spoilers and racks. We show you how... help you get set up for dealer discounts to save you money on your own jobs, or make more money on the jobs you do for others.

CUSTOMIZING CENTER Dept. PBOC5

4401 Birch Street, Newport Beach, California 92663

This Full Color Customizing Brochure Shows You How Easy It Is... How Fast You Can Start! Write for It Today... It's FREE!

Save on ACCORDIONS



40 MODELS — FAMOUS MAKES
Buy direct from importer. Big selection famous makes for students, teachers, professionals. Standard or Electronic. Save — eliminate middle man profit! No risk 5 Day Home Trial. Low down payment. Easy terms. We take anything of value in trade. Satisfaction Assured! Mail coupon.

FREE Catalogs and Price List

ACCORDION CORP. OF AMERICA — Dept. R-16
5535 Belmont Avenue, Chicago, Illinois 60641
Send FREE CATALOGS and Prices. Also send information on:
 Hohner 'button' Accordions Cordova Accordion Amps

Name _____
Address _____
City _____ State _____ Zip _____
 Check if you have a Trade-in!

DO-IT-YOURSELF TRACK POWER



MINI-DOZER for landscaping, gardening, mowing, 7 to 16 hp. Over 30 attachments. Unique, popular, easily assembled Kit. Factory direct savings. Odd job and resale opportunities are great. Send now, to:

STRUCK KIT, Dept. PM16, Cedarburg, Wis. 53012
 Catalog showing dozer kit construction & uses — 50¢
 Complete Plans for fabricating dozer tractor from local materials — \$6 (refunded on any purchase).
Name _____
Address _____
City, State, Zip _____

learn ACCOUNTING at home
1000s high pay "big name" jobs open to men, women in Accounting, Bookkeeping, Tax Return. Send for FREE "ACCOUNTING CAREER KIT." Approved for Veterans.
INCLUDED WITH COURSE
NAME _____ AGE _____
ADDRESS _____
FREE CITY _____ STATE _____ ZIP _____
BOOK NORTH AMERICAN SCHOOL OF ACCOUNTING, PROCS
4500 Campus Dr., Newport Beach, CA, 92663

USE ZIP CODE
A BUSINESS OF YOUR OWN
REPAIR HYDRAULIC JACKS
Earn while you learn at home. Millions of jacks in gas stations, trucking firms, etc. need servicing. We show you HOW. Start spare time in your basement or garage. Big opportunity for mechanics.
Write for folder No. PM-1 and free bonus offer
HYDRAULIC JACK REPAIR MANUAL CO., INC.
G. P. O. BOX 3 • STATEN ISLAND, N. Y. 10314

An Atlas Body—In 7 Days
my method of DYNAMIC-TENSION starts giving you results that you can feel and your friends will notice. Big, useful muscles. Gain pounds in weight where needed. Lose "pot belly." Send me your name and address for my 32-page book—FREE.
CHARLES ATLAS, 49 West 23rd St., New York, N. Y. 10010 Dept. NF

PRESCRIPTION EYEGLASSES BY MAIL
direct from manufacturer
Your own doctor's prescription will be filled, or your present lenses duplicated. The latest fashions. All types of lenses available. Accuracy and perfect fit absolutely guaranteed.
SEND FOR FREE FAMILY CATALOG. TODAY!
Est. 1959
PRISM OPTICAL INC.
Dept. M-35 135 West 41st St., N. Y., N. Y. 10036

HINTS

FROM READERS

Carving with impact



A lightweight air-impact hammer can replace the usual mallet to drive a woodcarver's chisel. At 3000 blows per minute, cutting is extremely smooth. Hammer works on as low pressure as 35 pounds per square inch from tank-type compressor. Right-angle guide brazed to chisel gives good control.—*Morton E. Milliken, Huachuca City, Ariz.*

Glue spreader

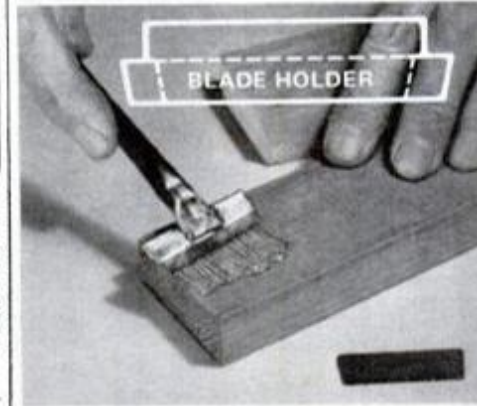

A spreader made from a 1½-in. length of worn hacksaw blade distributes paste-type glue in fine ridges over the joint area, also works with thinner adhesives. Holder (shaped as shown) and handle (5/16-in.-dia. x 6 in.) are soldered tin-can stock. Grinding blade section to a keystone shape lets holder grip it firmly. *Caution:* Don't try to break hacksaw blade—sharp fragments will fly when it snaps. Cutting and shaping can be done on a grinder.—*Walter E. Burton, Akron, Ohio*

NEED MONEY?

CHECK THESE SURE MONEY MAKERS

1. WORK AN HOUR A DAY

Make \$100 a month at home by mail. Complete, simple instructions, \$1.00. \$500 profit in three months or triple your money back. Rush \$1.00 today.

2. RECEIVE \$1000 CASH

in advance for addressing and mailing 4000 envelopes. After that, receive a stream of orders in your mail box that bring you many additional dollars in commissions. Set-up, \$2.00. Order TODAY and receive 3 MORE eye-opening Money-making Plans selling elsewhere for \$2.00.

3. GREATEST SALES

Letter ever written and how to mail it to only those who are interested so that HALF you mail it to send you back money. Complete set-up—\$2.00.

4. IF YOU HAVE

a rubber stamp with your name and address on it—we'll put you to work making up to \$6.25 each time you stamp it 100 times. Starting supplies—\$1.00.

5. AMAZING RETURNS!!

Instead of usual 1 or 2% returns—new clean 5½ x 8½ commission circulars bring back FIFTY orders for each 100 mailed per instructions. Camera ready copy, plus 50% return method—\$1.00.

6. I MADE \$700 IN 2 DAYS

I'll send you the Plan and a copy of the check for \$2.00. This for real. Guaranteed!

7. DREAM DEAL

Run our ads over your name. Be flooded with \$1 bills. Keep all the money. Orders filled FREE. Copy of ads and sample of \$1 item they sell—all for \$1.00.

- 50 Sources of Free Comm. Circulars \$1.00
- 50 Sources of Free Advertising \$1.00
- 50 Sources, Penny-a-Word Advertising \$1.00
- 100 Professional Mailers \$1.00
- How to prepare "Camera-Ready" Copy for Offset Printing \$1.00
- 100 Exchange Mailers \$1.00

8. TEMPORARY SPECIAL

All SIX Money-makers rushed to YOU for \$2.00.

9. 157 MONEY MAKERS

63 Camera-ready ads and circulars to run over your name, paying you 50% and 100% commission (up to \$10 per order). PLUS 94 Publications to run them in FREE for mailing or for 1c a word. PLUS How To Make \$1000 Yearly From Each Ad You Promote. Everything—\$2.00.

10. MAKE \$1000

Next month. Guaranteed Method! All starting materials included. 100% Money-Back Guarantee if you do not make \$1000 after trying for 30 days. Act now! Send \$3.00 for this one.

FREE GIFT

SUCCESSFUL LIVING GUARANTEED

My new Folio "How I Make Money In Mail Order." Guaranteed method—a \$1.00 value sent FREE with any order.

Circle Money Makers ordered. Remittance: \$ _____
1 2 3 4 5 6 7 8 9 10 All

First time customer special! All Money Makers—\$15.00 worth for \$8.95. Send \$8.95 for all or order individually from: INSIDER CAPITAL, Dept. 1101, Box 252, 45 N. Main Street, Hatfield, Pa. 19440

NAME _____
STREET _____
CITY _____ STATE _____ ZIP _____

(The well proven plan for Men And Women who'd like more out of life than just a job.)

IF YOU LIKE TO BUM AROUND, I'LL SHOW YOU HOW TO MAKE A LOT OF MONEY AT IT.

I did! I started out poor as a church mouse, dropped out of high school, and have never punched a time clock in my life.

And yet, at age 37 I had enough money to retire in style: in a \$100,000 home on the fabulous island of Bermuda, where I enjoy year 'round tennis and golf and deep-sea fishing from my own yacht.

Now a lot of nice people are going to hate my guts for telling you this—including many ministers, school principals, Boy Scout leaders, and old fashioned conservative tycoons who made it the hard way. But my dear mother taught me to always tell the truth, and that's the way it's going to be. I got where I am today not by practicing the Puritan Work Ethic, but by avoiding it. In short, I actually bummed my way into the big money.

The fact is: the only difference between me and most other lazy drifters is that I developed a certain "Game Plan" that can make anyone who'll listen an awful lot of money. It's also a great way for the woman who wants to make money at home. With my Book (either with or without any travelling) she can do it without even taking the curlers out of her hair.

I'll give you your money back plus bank interest if you don't agree my book's the greatest!

I'll bet you never heard of a guarantee that good before because you've never heard of a book that comes close to this. I guarantee that within thirty days after you've received it, you'll agree that you're able to do every one of the following amazing things I'm about to promise you. (Or you simply return my Book and I'll not only refund your money in full, but I'll actually pay you the same interest as if you'd kept it in the bank all that time! No questions asked.) I can afford to make this offer because I know just how good my Book is. I've lived it and made a bundle. (But frankly, by offering it to you, I expect to make enough to retire a second time.)

Now sit tight. Because you won't believe this. Here's what I'm prepared to promise and back up with interest:

\$\$ Say you feel like being a ski bum. Simply move to a city with slopes nearby. Or a beach bum, maybe. Just go somewhere that has one. (Or if you really like

it where you are, there's probably no need to move.) My Plan works in any city in the U.S. or Canada with 100,000 people or more. I guarantee you: You can get a great job the same weekday you arrive!! And it doesn't matter in the least who you are. Young or old, male or female, an eight foot giant or a three foot dwarf.

\$\$ I guarantee: In this particular job you can make up to \$30 an hour to start. And much more as you get the hang of it.

\$\$ I guarantee you won't need a college education for this job. Not even a high school diploma. Or any special training whatsoever.

\$\$ I guarantee you won't need to take any kind of examination or physical. You won't need to show any past work records, not even a social security card.

\$\$ I guarantee you'll never be fired!

\$\$ I guarantee you'll never again have to face unemployment.

\$\$ I guarantee you'll be making your money sitting down with almost no physical effort. And believe me, I guarantee it's perfectly legal!

\$\$ I guarantee you can dress any way you like. Never have to wear a jacket or tie again.

\$\$ I guarantee you can report for work anytime you feel like it. Come in at noon. Or work from your home.

\$\$ I guarantee you can stay on the job as long as you want. You can quit any time you like. Not worry about any kind of reference.

\$\$ Then move on to another city if you

like, and I guarantee: You can do the very same things all over again. It's simply a matter of where you want to be at the time.

\$\$ Finally, if you land in a city you'd like to stay in for awhile... I'll even show you exactly how—step by step—you can in a short time wind up owning the same kind of business you've been working for. Which, with a little more effort than you've been used to putting in can easily bring you up to \$75,000 a year. (And this is a cash business.) Maybe a lot more. And possibly a real fortune.

I did all this. And in just three years made enough money to retire to the heavenly climate of Bermuda; where, as I said before, I bum around all day: golfing, fishing, or anything else I feel like.

If you'd like to get down here—or to wherever your favorite spot in the world is—long before arthritis spoils your golf or tennis swing, I'd suggest you read My Book (If you're gonna bum around, you might as well do it in style).

Sincerely,



Allan R. Holleschau

Allan R. Holleschau
Bermuda

(WHEW! I'm glad this is finally over. It's the most work I've done in years!)

CALL THIS TOLL FREE NUMBER (24 Hrs. A DAY): 800-257-0300

(New Jersey residents call: 800-462-2000)

OR SAVE C.O.D. CHARGES AND MAIL THIS COUPON TODAY:

THE INSIDERS' MAIL BOX DEPT. H-02-PM
41 East 57th St., 29th Floor Tower Suite New York, New York 10022

Please rush me my copy of Allen Holleschau's book. I understand that if I'm not really wild about it, I can return it within 30 days for a full refund (no questions asked). Plus you'll send me full bank interest on the money I send you (just as if I'd kept it in the bank for a month). I can't lose. I can only make money!

Enclosed is \$7.95 (plus .55¢ for postage and handling). Send cash, check or money order. Payable to The Insiders' Mail Box, Inc.

NAME _____

ADDRESS _____

CITY _____

STATE _____

ZIP _____

New York State residents please add applicable sales tax.

© Copyright 1975 The Kimball-Nastri Group Ltd.

own **THE BEST** tools
 YOU ARE PROBABLY A BETTER CRAFTSMAN
 THAN YOUR PRESENT TOOLS LET YOU BE.

WHY NOT ENJOY OWNING
 AND USING THE BEST?



Five styles of unique Danish cabinetmaker's workbenches. One even folds for storage. Professional quality European chisels, mallet tools, gouges and carving tools. Swedish turning tools, Arkansas stones, slips and files, English tenon saws, wood-bodied Danish planes, and much more. If you are already good, owning and using our tools can make you even better.

That's what Leichtung, Inc., is all about.
outdo YOUR BEST work

LEICHTUNG, INC.
 5187 PM Mayfield Rd. Cleveland, Ohio 44124
 Name _____
 Address _____
 City _____ State _____ Zip _____

SEND FOR **FREE**
 BRAND NEW FULL-COLOR CATALOG

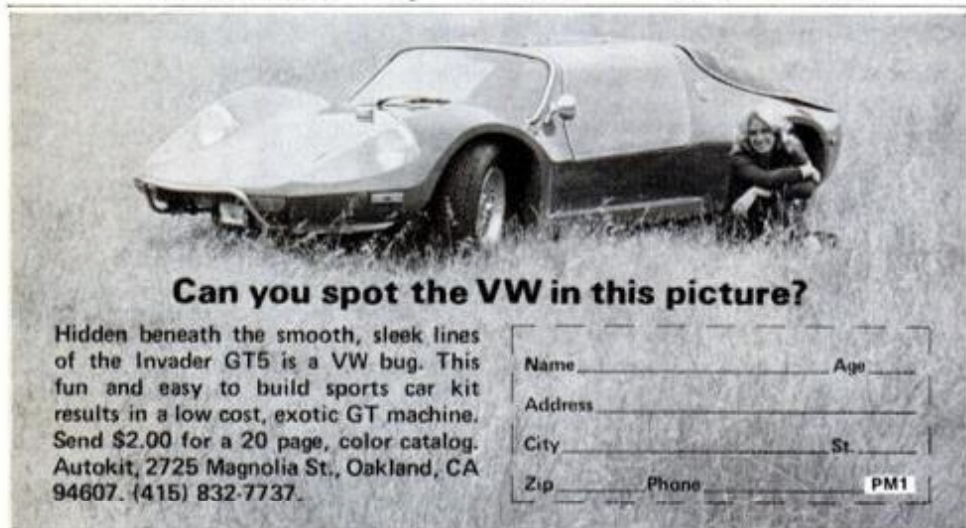

Can you spot the VW in this picture?

Hidden beneath the smooth, sleek lines of the Invader GT5 is a VW bug. This fun and easy to build sports car kit results in a low cost, exotic GT machine. Send \$2.00 for a 20 page, color catalog. Autokit, 2725 Magnolia St., Oakland, CA 94607. (415) 832-7737.

Name _____ Age _____
 Address _____
 City _____ St. _____
 Zip _____ Phone _____ PM1 _____

USE Zip Code When Answering Mail

Accept no substitutes

Original Spackle.[®]
 Smoothest off the knife. Smoothest on the wall. Dries fast and hard to a smooth, white paintable finish. No unpleasant odor. The painter's favorite.



In the familiar orange & blue package wherever paint is sold

the **muralo** company, inc.
 Bayonne 07002 / Chicago / Los Angeles

NEW Soundcart lets you hear it through your home & car 8-track



CB/TV/Telephone Outdoor Movies
 Cassette & Reel Recorders

New Soundcart transmits any electronic sound source through your car or home stereo speakers. Simply insert cartridge in tape deck and hook up to sound source. No more fuzzy, scratchy reception. Ideal for CB. Actually permits two-way telephone conversation thru your stereo speakers. Great for family or conference calls. Jac hook up for CB, TV & Recorders is \$9.95. Clasp hookup for phone and movie speakers is \$14.95. Send check or money order with your address to:

the **SOUND*ART**

4412 S.E. 29th
 Oklahoma City, Ok 73115

Moneyback Guarantee

NEXT MONTH IN PM . . .

- *How to avoid the accident you'd never forget*
- *12-page spring preview of pleasure boating*
- *One-of-a-kind home bar*
- *10 handsome homebuilts you can make and fly*
- *23 master's woodworking tips*
- *Use your one-car garage—and still get the car in*

SUBSCRIPTION SERVICE: Mail all subscription orders, changes of address (with your latest label), and Postmaster notices of undeliverable copies to Popular Mechanics, P.O. Box 646, New York, N.Y. 10019. All other correspondence relating to your subscription: James Gable, Customer Service Department, Popular Mechanics, P.O. Box 1567, New York, N.Y. 10019. Please enclose your latest mailing label for quickest service when writing about your subscription.

Popular Mechanics

250 West 55th St., New York, N.Y. 10019
 WPM6A1

YES! Please enter my subscription to POPULAR MECHANICS for:

- 1 year \$7.00 New
 2 years \$13.00 Renewal

Payment of \$ _____ is enclosed.

Bill Me _____
 initial here

Name _____ (please print)

Address _____

City _____ State _____ Zip _____

On new subscriptions, first copy will arrive in about 8 weeks.

(Above prices apply in U.S. & Possessions only. Canada add \$3 per year. All other countries add \$5 per year.)

CHANGING ADDRESS?

If you're planning to move, please let us know at least six weeks before changing your address. Attach current address label and fill in your name and your new address. This will serve to insure prompt service on your subscription.

Send old label with your name and new address to:
 POPULAR MECHANICS, Subscription Dept.
 Box No. 646, New York, N.Y. 10019

NAME _____ (Please print)

NEW ADDRESS _____

CITY _____ STATE _____ ZIP CODE _____

says Cliff Hicks,
Editor of the
Popular Mechanics
Do-It-Yourself
Encyclopedia:

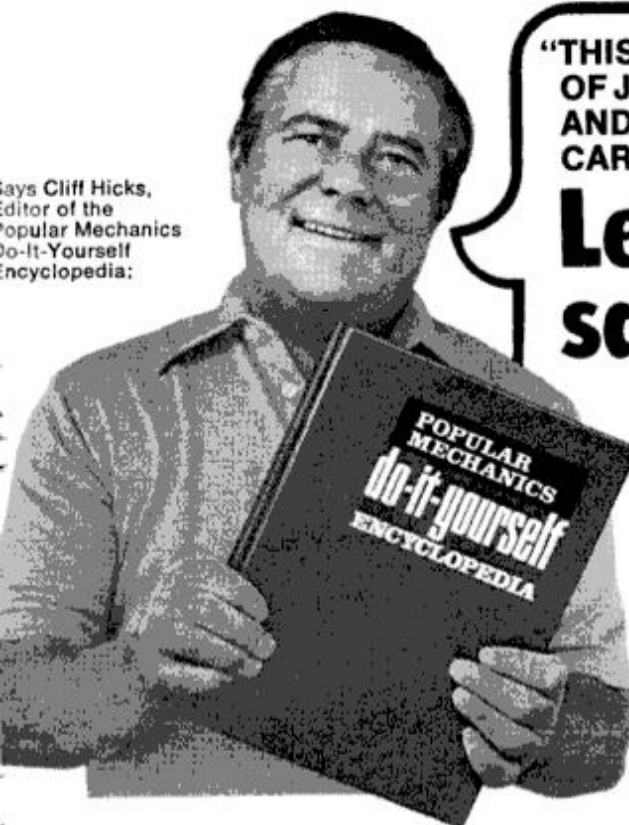

"THIS SET OF BOOKS CAN HELP YOU DO HUNDREDS OF JOBS AND PROJECTS WITH YOUR HANDS — AND SAVE A BUNDLE OF MONEY ON HOME AND CAR REPAIRS AND IMPROVEMENTS.

Let me send you a sample volume FREE

with a cancel-anytime subscription to the set"

- 196 pages
- 8 1/4" x 11"
- Over 600 how-to-do-it illustrations
- Stain-and-scuff resistant washable binding
- Opens flat for workbench use
- Big, easy-to-read type.

Sixteen 8 1/4" x 11" Volumes — 3,136 pages — Over 10,000 "show-how" illustrations

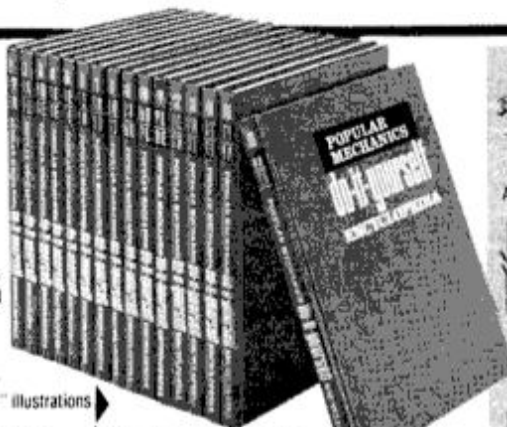

**VOLUME I—
A \$4.95 VALUE—
YOURS FREE**

A few of the subjects covered by more than 6,000 index entries — projects, plans and ideas for better living.

- APPLIANCES — Money-saving fix-it instructions
 - ATTICS — Get more use from available space
 - BASEMENTS — Waterproofing, finishing tips, etc.
 - BATHROOMS — Remodeling ideas
 - BEDROOMS — Built-ins, other spacesavers
 - BOATS — Plans for exciting boat designs
 - CAR REPAIR — A wealth of "show-how" illustrations
 - CONCRETE — The ABCs of good concrete
 - ELECTRIC WIRING — Basics of home wiring
 - GARAGES — Step-by-step plans for garage with patio
 - GARDENING — Gardening tips; how to build equipment
 - HOME MAINTENANCE — Tested how-to features
 - KITCHENS — Space and time savers
 - LANDSCAPING — Walls, patios, site planning
 - LAWNS — Seed, fertilizer, weed and disease control
 - LUMBER — Basic data every craftsman should have
 - MOVIES — Add a soundtrack; also, make titles
 - PHOTOGRAPHY — Picture-taking, darkroom techniques
 - POWER TOOLS — Ways to get more out of your workshop
 - PLUMBING — Understanding your home system
 - RECORD CHANGERS — Trouble-shooting
 - REFINISHING — How to get results you want
 - ROOFS — Important things you should know
 - SHELTERS — Protection for boats, mowers, etc.
 - STAIRS — Secrets of expert stair construction
 - SWIMMING POOLS — How to build with concrete blocks or fiberglass
 - TOYS — Powered toys, action toys, dollhouses
 - USED CARS — How to recondition
 - WOODWORKING — Use methods the experts use
- ...AND EVER SO MUCH MORE!



Why this invitation from Cliff Hicks? To introduce you to a remarkable set of books for the home handyman, craftsman, hobbyist and sportsman — the POPULAR MECHANICS DO-IT-YOURSELF ENCYCLOPEDIA.

The Do-It-Yourself Encyclopedia is a profusely illustrated, 16-volume reference library chock-full of step-by-step "how to do it" ideas, plans, projects and shopping tips to save you money. And Volume I of the set is yours absolutely free with this offer.

We will send you this Free volume — and future volumes for Free Trial — so you can see for yourself, without risk, just how valuable and useful the Do-It-Yourself Encyclopedia can be.

Your Free Volume I alone gives you a wealth of valuable information to help you repair auto bodies... antique furniture... squeeze a bedroom into a "tight" attic space... buy and troubleshoot home appliances... make musical instruments... make unusual models... fix a leaky basement... and more. And Volume I is just the beginning. You can readily imagine the benefits of having the entire Encyclopedia.

Save hundreds of dollars on repairs and home improvements

Stop throwing away hard-earned cash unnecessarily on electricians, painters, plumbers, who charge \$10... \$12... even \$14 an hour.

You can use this 16-volume Encyclopedia to lay a slate entryway... build a desk... construct a barbecue... make a runabout boat... build a whole new garage — for a fraction of what you'd spend to have others do these jobs for you. And that's only the beginning!

Easy-to-follow instructions bring you a wealth of exciting hobby and craft ideas.

Whether you're handy with tools or not so handy, this set is for you. Step-by-step, clearly illustrated instructions show you how to make furniture, toys, games; solve plumbing problems; do wiring, auto and appliance repair. You'll not only save labor costs — you'll learn how to get good buys in materials and appliances... learn what to look for in buying a house... learn of tests you should make in the store before you buy an air-conditioner... binoculars... a rotary mower... a used camera.

You'll get expert guidance in skills that can help you earn spare-time income... become a

better home gardener... build a duck blind... remodel with drywall... add a patio... construct dormers... much, much more. It's like having hundreds of professional craftsmen at your elbow advising you.

Turn to any of the 16 volumes in this remarkable 3,136-page Encyclopedia, and you'll discover new ways for you and your family to get more fun out of life... to live better for less money... to know the deep sense of accomplishment and self-reliance that come from being able to do it yourselves.

Want to solve common car ailments? Install a burglar alarm? Build a fun kind of boat? Build a band grinder or band sander? You can discover how to do all this — and much more — in your FREE Volume I alone.

Send for your Free first volume now. Thumb through it, try out a plan or project, use it at your workbench. Imagine 16 such magnificent volumes side by side, offering you money-saving tips... labor-saving information... time-saving advice... plus annual supplements that keep your know-how on new tools, materials and home improvement techniques up to date.

Decide — only after you have seen your Free Volume I — whether you wish to continue receiving additional volumes of the set as described on the order form. Each volume is sent on approval — there's no obligation to buy any at all. Keep only those you want to keep — cancel whenever you wish. Whatever you decide, Volume I is yours to keep Free. Don't delay — send for your Free Volume I today.

POPULAR MECHANICS BOOKS, Box 2315, F.D.R. Station, New York, N.Y. 10022

This certificate entitles you to a free gift — Vol. 1 of the 16-vol. Popular Mechanics Do-It-Yourself Encyclopedia, with no obligation to buy anything ever.

As a subscriber in good standing, you'll enjoy free examination of the additional volumes as you receive them. In about 6 weeks we'll send you Vol. 2, and 4 weeks later Vol. 3. After that, at approximately monthly intervals, we'll send you shipments of Vols. 4-6, 7-9, and 10-16. This way you'll be able to complete the set in 6 months. Also, you'll receive annual supplementary volumes as they are published on free 14-day approval with no purchase obligation. You may cancel at any time or return any volume within 14 days for full credit and no more will be sent. Take as many volumes as you like — or none at all. For each volume you keep, you'll be billed just \$4.95 plus postage and handling. But you need never pay for more than 1 volume per month no matter how many you have received.

Name _____ (PLEASE PRINT)

Address _____

City _____

State _____ Zip _____

Signature _____

This certificate subject to acceptance by the publisher.

N545

NEW RUBBER STAMP BUSINESS PAYS BEGINNERS UP TO \$16⁵⁰ AN HR.

**START AT HOME
IN SPARE TIME**
with Table Top Machine!

We Help Finance You...
at less than bank rates!

The multi-million dollar Rubber Stamp business—once controlled by a few big companies—is now being taken over by small operators—one in each community throughout the United States. Men and Women who have this inexpensive machine can turn out huge quantities of Rubber Stamps with special wording that buyers once were forced to buy from big cities. Material costing only 27¢ makes a stamp that sells for \$2.75. The machine that does the work is simple and easy to operate and it turns out as many as six Rubber Stamps at a time, each with different wording such as names, addresses, notices, stock numbers, prices and other "copy" needed by offices, factories and individuals. Working full capacity, it can earn as much as \$33.00 an hour for the operator! Now you can get into the big-pay business yourself, with your own home as headquarters. You don't need experience. We supply everything, including complete instructions and eight ways to get business coming in fast. We even help finance your start! Start making up to \$16.50 an hour from the very beginning. Cash in on the profitable Rubber Stamp business in your community right away. We'll mail full particulars FREE and no salesman will call. Be first in your locality. Rush coupon today or send your name and address on postcard to:

RUBBER STAMP DIV., Dept. R-2-FA
1512 Jarvis, Dept. R-2-FA Chicago, Illinois 60626

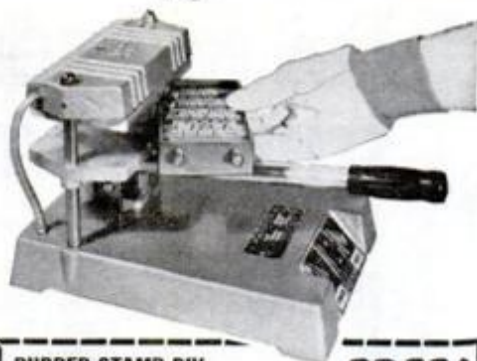

RUBBER STAMP DIV.
1512 Jarvis Ave., Dept. R-2-FA
Chicago, Illinois 60626

FREE!

Please rush full particulars about your financing plan and the little machine that can get me started in the profitable Rubber Stamp business at home in spare time. Everything you send me is FREE and no salesman will call.

Name.....

Address.....

City..... State..... Zip Code.....

REAL SWITCHBLADE... COMB!
5 INCHES LONG



ORDER NOW
WHILE THEY'RE STILL LEGAL

This is a REAL SWITCHBLADE. The blade is a COMB!!! Terrific GIFT item. Novel and Practical. Protects comb in pocket. Fine tooth comb is GREAT for sideburns and Mustache too! Satisfaction is Guaranteed. Complete with Lock. Only \$4.50 + 25¢ Postage. TWO for 9.00 postpaid. S&W KNIFE CO. BOX 35246 P.M. CHICAGO, IL. 60635

FIND BURIED TREASURE

Powerful electronic detector finds buried gold, silver coins, etc. Write or call for free catalog. Dealer inquiries invited.



Financing Available
Phone day - night (713) 682-2728
RELCO, Dept. DD 62

BOX 10839, HOUSTON, TEX. 77018

NEW 8 HP SUPER BRONC

THE BIG BIKE FOR
ALL SEASONS

Model
VT-8 Kit
Price—

\$299.95



Model VT-812
with knob tires

**HEALD'S
"SUPER BRONC"**

Model VT-8 has a new 8 HP 306 cc Tecumseh engine. Torque Converter drive, big air cushion tires, front and rear shocks, large padded seat, chrome fenders, #40 chain and chain tightener. Optional features include 21" x 12" wide, knob tires both front and rear, electric start, lights, aux. 5 qt. gas tank, front ski and quiet spark arrester muffler. Super Bronc comes in money saving easy-to-build semi-kit form. Kit price Model VT-8—\$299.95. Ideal for farm or recreational use.

FOR MORE INFORMATION WRITE:
HEALD INC., Dept. PM-1, P.O. Box 1148,
Benton Harbor, Michigan 49022

FREE CATALOG

Wife Beater!

Your faithful wife-navigator may be right most of the time — an Airguide auto compass is right all of the time. Versatile adhesive mount. Self illuminated. Adjustable compensators. At retail auto stores. Write for Catalog 76A.



Airguide
2210 Wabensia Chicago 60647

BUYING 'RECYCLED' CAR PARTS
(Continued from page 72)

because newer cars cost the wrecking yard more.

Generally speaking, too, yards that specialize charge more than the that don't. For instance, a dismantler who stocks only imported cars higher than one who carries both domestics and imports. Likewise, yards that specialize in trucks, obsolete parts, orphan makes or single makes of cars.

That's because a specialized yard bids higher to assure itself of a full well-rounded stock; also, in some instances, to corner the local market. By patronizing the specialized dismantler, though, you'll probably save time searching, and you often come out ahead financially by sidestepping the hot line. So I'm not saying you ought to avoid yards that specialize.

What about haggling? Should you haggle over price once you see the part? It can't hurt, but it usually doesn't do much good. Some of the more progressive yards don't. Play it by ear.

Warranties

Nearly all dismantlers give a warranty of some sort. Some will post signs stating time limits and conditions. The most common warranty runs 30 days on parts, but excludes any labor you expend.

Even if there's no sign or written warranty, many wrecking yards will replace any defective parts you've bought from them. Such unwritten warranties have no set time limit.

To prove you're not returning your own worn-out part, wrecking yards almost always die-stamp larger assemblies like heads, blocks and transmissions. Smaller items like master cylinders are marked with yellow paint.

What about roaming out back?

When you get to the wrecking yard, you should not expect to be allowed out back, fun as that might be. Most dismantlers have strict rules against "roamers" or "tourists" for two reasons: 1. Their insurance doesn't cover nonemployees; 2. roamers tend to help themselves to small parts, so pilferage becomes a problem. "It's not that we mind people stealing little things like gas caps and rotors," explains one yard owner, "but if we sell an engine, say, and the rotor is missing, it means we have to rummage around for a new one. The time we waste searching might cost us the sale."

Despite tight no-roam policies, the yard owner knows you, either a

Out Fuel Bills

NEW Electrically-powered "Hearth-Aid"
increases heat output of your fireplace by 500%

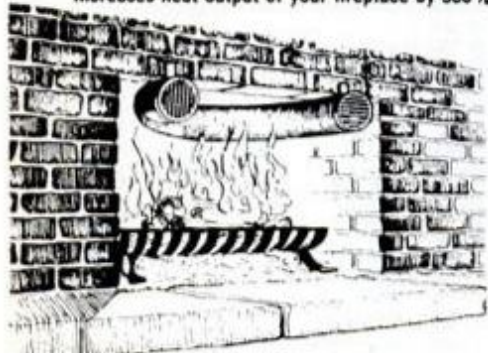

- ★ Adjustable. Fits all fireplaces.
- ★ Easy to install. No tools required.
- ★ Thermostatically controlled. Works automatically.
- ★ Produces over 20,000 BTU's of heat. Uses less than 20 watts of electricity.
- ★ Hi-Temp stainless steel construction.

The heat of a fire is sensed by a thermostat which activates a fan. The fan pulls cool air from the room through the tube where it is heated to over 400 degrees and forced back into the room at the rate of 200 cubic feet per minute, easily heating any size living area. **\$59.95**

Guarantee: 30 day satisfaction or money back.
1 year defect, workmanship.
For Free Pamphlet Write:

THERMALITE CORP.

Dept. PM1 P.O. Box 69, Hanover, Mass. 02339

friend or as a regular customer, he might sometimes take a chance on you. And a few yards actually encourage customers to roam and familiarize themselves with the merchandise. These, however, are rare.

In terms of money, you might save up to 15 percent on the price of the part if you remove it yourself, because otherwise the wrecker's man would have to do it.

Where a dismantler gets cars

Most cars in wrecking yards are insurance salvage—so-called "totals." After a wrecked car is declared a total loss (the cost of repairs equals or even exceeds the wholesale value of the car), the insurance company pays off the owner and in turn becomes the wrecked car's new owner. The insurer then puts the car up for bid. Wrecking yards are the most frequent bidders on such cars.

The average dismantler figures he needs to at least double his money on any car he buys. A yard that's doing good business in late-model cars will rotate its inventory 2½ times a year on popular makes (Fords, Chevys, VWs and the like) and twice a year on the so-called "heavies" (Cads and Lincolns, for example).

About 35 percent of the cars in wrecking yards are sold to dismantlers by private owners, especially in cases where something major is wrong with the car: a transmission out, terminal body cancer and so forth. In California, where the highway patrol cites polluters, cars that can't pass smog tests usually end up at the wrecker's.

Many types of buyers

Despite what you'd think, only about half of all wrecking-yard parts are sold to private car owners. Ironically, insurance companies buy back (indirectly) a considerable portion of the parts they previously sold to dismantlers. When you bash in a door, for example, and your insurance company (or someone else's) agrees to pay for repairs, the adjuster often specifies that the body shop use LKQ parts—of Like Kind and quality. Which means *used*. After all, your bashed door was used.

The component rebuilding industry also buys lots of parts from wrecking yards. So do new and used-car dealers, repair garages, service stations, trucking companies and taxicab owners. And why not? Components from wrecked cars, if they're usable, come assembled as built-up

(Please turn to page 158)

HENRY MORGAN SAYS: "Even if you don't know which end of a screwdriver you hold, you can learn to make money fixing appliances."



If you've seen this well-aged comic on television, you know I'm not in the business of fixing appliances. So what am I doing in an ad for an appliance repair course? It's simple: I got tired of laying out a sockfull of money every time something went wrong around the house. Then I came across an NRI ad and I thought, "Why not? I've spent a fortune on repairs . . . if I'm too stupid to fix a toaster, this is the way to find out."

So I took the course and now I can fix my own appliances and I can even make money out of it if I want to. As a matter of fact, there's enough money in fixing these things, I'm tempted to quit show business and go straight.

Think I'm kidding about the money? Just check out the receipts on your last repair bills. And then ask anybody if they know a good reliable repairman. You'll find they're scarcer than doctors who make house calls. If there ever was a field crying for good men, this is it. Opportunity is knocking louder than my car's engine, and it could be knocking for you.

If you've ever toyed with the idea of making it on your own, with your own repair business . . . NRI has a low-cost, home study plan that really makes sense. You can hang in there with your present job while you're learning, and you'll find NRI's course is quick, easy, and cheap.

Let's say you have trouble just plugging in your electric shaver. You'd better start with the basics . . . and the NRI course starts right there. First they tell you what electricity is, and you can't get any more basic than that. They take you by the hand, step by step, as fast or as slow as you want to go. If you get an attack of the stupids, there's always an NRI expert waiting to give you a hand. They do everything but turn the pages for you.

Like I say, I took the course and it turned out to be even better than they

said it would be. Sure they pay me for writing this ad, but it ain't much, believe me. I could make more in a month by fixing things for the neighbors . . . and I'm not kidding. It's just that I believe in seeing guys make it on their own. If you follow the simple texts and the big pictures, you can be a technician in no time. They even send you a professional appliance tester with the course.

You don't have to stop with toasters and irons. They'll even show you how to repair air conditioners, refrigeration units, commercial appliances, power tools, and small gas engines. That's where the big money is.

Take Henry's advice and send in the coupon. It's nice to find out you've got some hidden talents. And you'll save a bundle . . . or make it . . . or both.

Henry Morgan

Henry Morgan

APPROVED FOR CAREER TRAINING UNDER G.I. BILL
Check GI line in coupon for information.



600-016

Send For This Free Full-Color Book and See What NRI Can Do For You



NRI SCHOOLS
McGraw-Hill Continuing Education Center
3939 Wisconsin Avenue,
Washington, D.C. 20016

Send me your free book on Professional Appliance Servicing.
I understand there is no obligation, and no salesman will call.

Name _____ Age _____
(Please Print)

Address _____

City _____ State _____ Zip _____

Accredited Member National Home Study Council Check for facts on GI Bill

FREE catalog

over 2000

unique tools,
handy kits,
precision
instruments,
technical
supplies.



Over 23 years of service to the world's finest craftsmen and technicians.

National Camera
2000 West Union Ave. Dept. EAB
Englewood, Colorado, 80110

Send a FREE copy of the NC Flasher

name _____
address _____
city _____
state _____ zip _____

National Camera
2000 West Union Ave. Dept. EAB
Englewood, Colorado, 80110

A PRESTIGE CAREER WITH A GREAT FUTURE! BE A JEWELER.



Now you can learn quickly and easily at home how to buy, sell, grade and appraise **DIAMONDS & COLORED STONES, GEM IDENTIFICATION.**

Top opportunities with retail stores, suppliers, jewelry manufacturers. College unnecessary. GIA training gives you vital gem knowledge you need to become a professional jeweler. Enjoy a good income, recognition, and respect.

More than 25,000 jewelers have taken GIA training. Nonprofit Educational Headquarters of the Jewelry Industry.

Accredited Member National Home Study Council. **WRITE TODAY for complete information on our unique training programs. No obligation.**

APPROVED FOR VETERANS

GIA Gemological Institute of America
11940 San Vicente Boulevard, Dept. PM-16
Los Angeles, CA 90049

SPARE TIME INCOME? SELL KNAPP SHOES!

Sell famous Knapp Cushion Comfort Shoes full time or part time to supplement your income. Enjoy the financial success and security you've always dreamed about. Millions of repeat customers. Earn higher commissions plus bonuses. No investment. Free selling and training kit to get you started. America's No. 1 company in the direct selling shoe industry. Write 1 Margolis, 612 Knapp Centre, Brockton, Mass. 02401.



The more for the money shoe.

BUYING 'RECYCLED' CAR PARTS

(Continued from page 157)

units (you buy an entire engine, for instance, instead of a short block and the prices are definitely right).

You have to realize that the dismantling business is much more complicated today than it was even 20 years ago. Used to be, if you needed an axle for a 1947 Mercury, the wrecking-yard owner knew that an Ford or Mercury axle from 193 through 1948 would work. Today, though it's not that simple.

With eight different nameplates under the Chevrolet umbrella and seven of Ford parentage, you—the customer—have to be pretty specific when you ask for a part. You can simply say, "I need a heater blower for my 1971 Chevy," because the counterman won't know whether it's for a Vega, Nova, Camaro, Chevelle, Monte Carlo, Chevrolet, Corvette or Blazer. You'll have to give him year, make, model, engine size and option (blowers are different with different airconditioners).

Interchange manuals may help

It's true, though, that parts still interchange between certain makes and models. Two books no auto wrecker can be without are the Hollander Interchange Manual and the Mitchell Domestic Interchange Service Manual. These are published yearly and tell which parts interchange with which others, not just among makes but also between years.

When you phone a dismantler, and if he says he doesn't have the part you need, sometimes suggesting a quick search through an interchange manual can turn it up in another make or model of car.

Bring old part as a sample

When you arrive at the wrecking yard to pick up a part, be sure to bring along your old part as a sample. I mentioned this earlier, and it's very important. If it's that Torino decklid you need, show the parts man your old one. There might be differences in model trim or emblems. Likewise, if you need an axle, bring in your broken one. With so many variations among cars and suppliers, it's just good insurance.

You're ready now to shop for used parts with some confidence. Dismantlers have come to the point of meriting your confidence. Most are good, solid, reputable businesses; most of the people in the business are interested in cars and have tremendous car knowledge; often they'll help you with specific questions or problems; and their prices make shopping there very worthwhile. ★★

Magic Mail Plan—Make up to \$12 an Hour!



Get **ORDERS** and **CASH** from your mailman — do work in **SPARE TIME** at Home—or expand into **FULL TIME** business.

Send coupon for Free facts about the newest and most fascinating of all home operated businesses. For the first time a simplified machine brings the fabulous profits of Plastic Sealing and Plastic Laminating within the reach of the small operator. Anyone can learn to operate the machine with a few minutes practice—then with our Magic Mail Plan can get mail orders pouring in daily with cash

Get into **PLASTIC LAMINATING** at home

in every envelope. **No canvassing—no selling.** We supply the circulars you mail to bring back cash orders. *We even help finance you.* Don't wait. Rush your name. We'll send you **FREE** and postpaid, pictures, prices, details, and all the facts you need to start. Mail coupon or send name on postcard. **No charge.** **WARNER ELECTRIC CO., Dept. L2FA** 1512 Jarvis Ave.—Chicago, Ill. 60626

THIS MAN is taking out of the machine a Plastic Sealing Job—ordered by mail—only 11¢ in material cost brings back \$2.58 in cash by mail. Capacity of machine: \$40.00 profit per hour of operation.

Thousands of Beautiful Art Creations
JEWELRY • CIGARETTE BOXES • TRAYS
CANDLESTICKS • COASTERS • LAMP BASES
BOOK ENDS...ALL IN SPARKLING COLORED PLASTIC



WARNER ELECTRIC CO., Dept. L-2-FA
1512 Jarvis Ave., Chicago, Ill. 60626

At no cost to me, please rush complete details postage prepaid, I am under no obligation.

Name _____
Address _____
City _____ State _____ Zip Code _____
Less-than-bank-rate Credit Plan



GARAGE DOOR OPERATOR RADIO CONTROLLED From \$99.95!

• **RADIO CONTROLLED** from car transmitter or wall switch • **SAFETY** night and day, year round • **SECURITY** door locks tight when closed • **CONVENIENCE** in-car control any weather • **LIGHTING** garage lights automatically • **VERSATILE** fits all lifting type wood, metal or fiberglass doors, sectional and 1-piece • **EASY** homeowner installation in 2 to 3 hours • **SAVE** up to 50% direct factory purchase and PP or UPS home delivery

• **GUARANTEED** one year • **FREE** brochure
HELPMATE EQUIPMENT CO., Box 217 P.M. Baroda, Mich. 49101 (616-422-2311)

MOTOR's easy "2-step" repair method helps you FIX ALMOST ANY PART OF ALMOST ANY CAR...FAST

So clear, you'll breeze through tune-ups, engine overhauls, air conditioning, brake jobs—practically any repair on cars listed.

You just can't make mistakes with the "2-step" method in the new 1976 MOTOR AUTO REPAIR MANUAL. First the special "Trouble Shooter" section helps pinpoint in a flash the cause of trouble. Next, over 3,000 "How-To-Fix-It" close-up pictures (and plain-talk directions) show how to lick repair problems—fast and right! Even green beginner mechanics find the MANUAL so clear and easy to follow, they speed through jobs almost as fast as experienced pros!

Auto Repairman's "Bible"

Every job, from installing distributor points to front end jobs, is covered in minute detail for 2,300 U.S. car models, 1969-1976. More than 1,400 oversize pages of the giant MANUAL contain 55,000 specifications, thousands of illustrations, diagrams and charts — the "meat" of 300 official shop manuals.

You get service data on Transmissions, Steering, Brakes, Universals, Alternators, Fuel Pumps, Ignition Systems, much more! It's no wonder this illustrated MOTOR MANUAL is called the auto repairman's indispensable "Bible." It's no wonder that 7,500,000 copies have been purchased by repairmen, service station operators, the U.S. Armed Forces, schools and students all over the world. Here is the help every beginner or "pro" needs to fix almost any part of any car right the very first time. And save time, work, money!

Learn all about the 1976 cars and in addition see if Detroit's new specs and procedures affect your older car. Auto makers continually update and improve past model adjustment specs on older cars as new road test data comes in. That's why you'll need this new 1976 MOTOR MANUAL to get the best performance out of your car — even if you already own an earlier edition.

NEW
FOR
1976

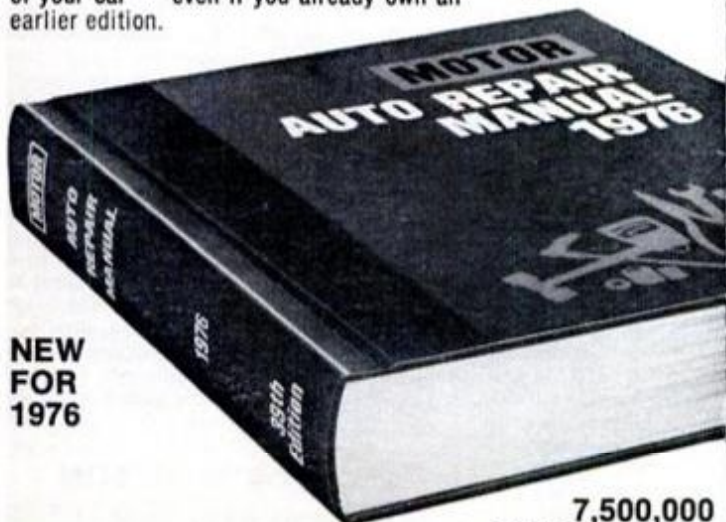

7,500,000
COPIES SOLD

Motor Books, Publisher's Office, 250 West 55th Street, New York, N.Y. 10016

1. Spot trouble fast



2. Fix it fast

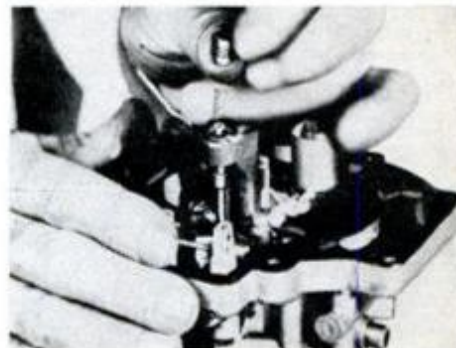

1976 edition covers all these makes

Bobcat	AMC Pacer	Volare
Toronado	Buick Special	Pinto
Mustang	Barracuda	Maverick
Mustang II	American	Vega
Chevette	Falcon	Nova
Pontiac	Oldsmobile F-85	Gremlin
Thunderbird	Ford Fairlane	Sunbird
Buick	Tempest	Century
Imperial	Corvette	Cutlass
Cadillac	Valiant	Monte Carlo
Lincoln	Mercury	Matador
Dart	Cougar	Skylark
Continental	Camaro	LeMans
Mercury	Front-drive	Skyhawk
Ford	Cadillac	Starfire
Chevette	Javelin	Monza
Chevrolet	Montego	Monarch
Chrysler	Torino	Granada
Plymouth	Mark IV	Cordoba
Dodge	AMX	Grand AM
Oldsmobile	Hornet	Astre
Comet	Challenger	Charger
Seville	Aspen	

Same Free 10-Day Offer on MOTOR's Auto Engines & Electrical Systems

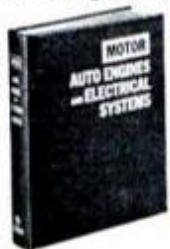

1,300 big pictures, over 700 pages. Clear how-to text explains how parts work, principles involved, design, construction, maintenance, etc. Covers all parts of engines and electrical system. High performance hints. For FREE trial, check box in coupon.

FREE WITH YOUR ORDER

MOTOR's Hi-Performance Tuning Guide, a \$2.95 value.



This 64-page Guide tells you all you need to know about getting the most performance out of any car. Covers carburetion, ignition systems, compression ratios, camshafts, exhaust systems, gear ratios, suspension systems and much more. Yours to keep free even if you're not completely satisfied with the Motor Manuals — it's our way of saying "thanks."

Send no money

The MANUAL costs \$13.95, but we'll send it to you for 10 days FREE trial, so you can see for yourself how it makes auto repairs go quick and easy. Use it for 10 days. If it doesn't give you complete satisfaction, return it and owe nothing. Mail the coupon today.

Order the New 1976 Edition now and try it FREE for 10 days

Mail to: MOTOR Books, Shipping Service
P.O. Box 2316, F.D.R. Sta., New York, N.Y. 10022

N-209

Please send the Manuals checked below for ten days free examination:

- MOTOR Auto Repair Manual, \$13.95
 MOTOR's Auto Engines & Electrical Systems, \$12.95

If I am not 100% satisfied, I will return the Manual(s) and owe nothing. Or I will keep the Manual(s) and pay the total price in three monthly installments, plus handling charge. I may keep the Tuning Guide free whatever I decide.

NOTE: The MOTOR Auto Repair Manual is also available in a DeLuxe edition with heavy duty fine grain bindings, thumb indexing and gilt edging. Check here if you'd prefer this version at \$18.95.

I want to save shipping charges.

I am enclosing payment for \$_____ in full. MOTOR will absorb handling charges. (Same return privileges, refund guaranteed.)

Print Name _____

Address _____

City _____ State _____ Zip _____

Signature _____ Tel. No. _____

All orders subject to acceptance by the publisher.
Offer available only in the Continental United States.
Allow 3-4 weeks for delivery.



I'd like to give this to my fellow men... while I am still able to help!

I was young once, as you may be—today I am older. Not too old to enjoy the fruits of my work, but older in the sense of being wiser. And once I was poor, desperately poor. Today almost any man can stretch his income to make ends meet. Today, there are few who hunger for bread and shelter. But in my youth I knew the pinch of poverty; the emptiness of hunger; the cold stare of the creditor who would not take excuses for money. Today, all that is past. And behind my city house, my

summer home, my Cadillacs, my winter-long vacations and my sense of independence—behind all the wealth of cash and deep inner satisfaction that I enjoy—there is one simple secret. It is this secret that I would like to impart to you. If you are satisfied with a humdrum life of service to another master, turn this page now—read no more. If you are interested in a fuller life, free from bosses, free from worries, free from fears, read further. This message may be meant for you.

By Victor B. Mason

I am printing my message in a magazine. It may come to the attention of thousands of eyes. But of all those thousands, only a few will have the vision to understand. Many may read; but of a thousand only you may have the intuition, the sensitivity, to understand that what I am writing may be intended for you—may be the tide that shapes your destiny, which, taken at the crest, carries you to levels of independence beyond the dreams of avarice.

Don't misunderstand me. There is no mysticism in this. I am not speaking of occult things, of innumerable laws of nature that will sweep you to success without effort on your part. That sort of talk is *rubbish!* And anyone who tries to tell you that you can *think* your way to riches without effort is a false friend. I am too much of a realist for that. And I hope you are.

I hope you are the kind of man—if you have read this far—who knows that anything worthwhile has to be *earned!* I hope you have learned that there is no reward without effort. If you have learned this, then you may be ready to take the next step in the development of your karma—you may be ready to learn and use the secret I have to impart.

I Have All The Money I Need

In my own life I have gone beyond the need of money. I have it. I have gone beyond the need of gain. I have two businesses that pay me an income well above any amount I have need for. And, in addition, I have the satisfaction—the deep satisfaction—of knowing that I have put more than three hundred other men in businesses of their own. Since I have no need for money, the greatest satisfaction I get from life is sharing my secret of personal independence with others—seeing them achieve the same heights of happiness that have come into my own life.

Please don't misunderstand this statement. I am not a philanthropist. I believe that charity is something that no proud man will accept. I have never seen a man who was worth his salt who would accept something for nothing. I have never met a highly successful man whom the world respected who did not sacrifice something to

gain his position. And, unless you are willing to make at least half the effort, I'm not interested in giving you a "leg up" to the achievement of your goal. Frankly, I'm going to charge you something for the secret I give you. Not a lot—but enough to make me believe that you are a little above the fellows who merely "wish" for success and are not willing to sacrifice something to get it.

A Fascinating and Peculiar Business

I have a business that is peculiar—one of my businesses. The unusual thing about it is that it is needed in every little community throughout this country. But it is a business that will never be invaded by the "big fellows." It has to be handled on a local basis. No giant octopus can ever gobble up the whole thing. No big combine is ever going to destroy it. It is essentially a "one man" business that can be operated without outside help. It is a business that is good summer and winter. It is a business that is growing each year. And, it is a business that can be started on an investment so small that it is within the reach of anyone who has a television set. But it has nothing to do with television.

This business has another peculiarity. It can be started at home in spare time. No risk to present job. No risk to present income. And no need to let anyone else know you are "on your own." It can be run as a spare time business for extra money. Or, as it grows to the point where it is paying more than your present salary, it can be expanded into a full time business—overnight. It can give you a sense of personal independence that will free you forever from the fear of lay-off, loss of job, depressions, or economic reverses.

Are You Mechanically Inclined?

While the operation of this business is partly automatic, it won't run itself. If you are to use it as a stepping stone to independence, you must be able to work with your hands, use such tools as hammer and screw driver, and enjoy getting into a pair of blue jeans and rolling up your sleeves. But two hours a day of manual work will keep your "factory" running 24 hours turning out a product that has a steady and

ready sale in every community. A half dollar spent for raw materials can bring you six dollars in cash—six times a day.

In this message I'm not going to try to tell you the entire story. There is not enough space on this page. And, I am not going to ask you to spend a penny now to learn the secret. I'll send you all the information, free. If you are interested in becoming independent, in becoming your own boss, in knowing the sweet fruits of success as I know them, send me your name. That's all. Just your name. I won't ask you for a penny. I'll send you all the information about one of the most fascinating businesses you can imagine. With these facts, you will make your own investigation. You will check up on conditions in your neighborhood. You will weigh and analyze the whole proposition. Then, and then only, if you decide to take the next step, I'll allow you to invest \$15.00. And even then, if you decide that your fifteen dollars has been badly invested I'll return it to you. Don't hesitate to send your name. I have no salesmen. I will merely write you a long letter and send you complete facts about the business I have found to be so successful. After that, you make the decisions.

Does Happiness Hang on Your Decision?

Don't put this off. It may be a coincidence that you are reading these words right now. Or, it may be a matter that is more deeply connected with your destiny than either of us can say. There is only one thing certain: If you have read this far you are interested in the kind of independence I enjoy. And if that is true, then you must take the next step. No coupon on this advertisement. If you don't think enough of your future happiness and prosperity to write your name on a postcard and mail it to me, forget the whole thing. But if you think there is a destiny that shapes men's lives, send your name now. What I send you may convince you of the truth of this proverb. And what I send you will not cost a penny, now or at any other time.

VICTOR B. MASON
1512 Jarvis Ave., Suite M-2-FA
CHICAGO, ILLINOIS 60626

Plenty of Jobs, Good Money in Drafting — according to U.S. Government Forecasts and Surveys of Private Industry



**INCLUDED!
WITH COURSE**

**THESE
3 BIG
DRAFTING
KITS***

U.S. Dept. of Labor reports future for draftsmen "favorable" . . . predicts rise in demand for qualified draftsmen. The Grantindustrial Company (Bruning Co.) reveals 94% of firms recently surveyed anticipate current demand for entry-level technicians will continue at least 5 more years. Salaries for draftsmen climbed 25% during last 3 years, according to 1974 survey of 6,000 draftsmen, by American Institute for Design & Drafting. Same survey reveals 78% believe there is shortage of good draftsmen.

YOU NEED NO DRAWING SKILL . . . NO TECHNICAL ABILITY
We supply necessary equipment plus easy-to-master, step-by-step instructions. Our staff of professional draftsmen guides you all the way. Even students not eligible to train elsewhere, because they lack high school diploma, have completed our course successfully.



**... when you train at home with us for a
GOOD PAY JOB IN DRAFTING**

MAKES \$\$\$ WHILE LEARNING!
"Imagine, I haven't even received my diploma yet, and I am already earning extra money!"
R. C. Nolan, Conn.



72% SALARY INCREASE!
"The Course helped in my promotion to senior estimator, with a 72% salary increase!"
Ollie Cook, Ft. Worth, Tex.

RUSH COUPON FOR FREE KIT...

Mail coupon today for FREE "DRAFTING CAREER KIT." 16-page book, "Your Future in Drafting" — jam-packed with revealing facts on your opportunities to enjoy good pay and job security in drafting . . . plus, valuable 5-way Drafting Instrument. Everything sent FREE and WITHOUT OBLIGATION. No salesman will call.

GI and VA Benefits!

North American School of Drafting, Dept. P80C5
4500 Campus Dr., Newport Beach, CA 92663
Rush "DRAFTING CAREER KIT" — ALL FREE!
No salesman will call.

Name _____ Age _____
Address _____
City _____ State _____ Zip _____



* Precision Drawing Instrument Set, Professional Drafting Board Outfit & Fingertip Tilting Drafting Table are included with your complete North American Course in Drafting.

**BEEN DISSATISFIED IN THE PAST?
HERE'S A PRESENT FROM THE FUTURE.**



This is our Criterion 2005 Heil Air-Motion Transformer Speaker System.

Incredible purity, astonishing clarity and definition are achieved through the use of the Heil Air-Motion Transformer Tweeter. Tastefully encased in a simple, uncluttered column, the 2005's "corona field" Heil Air-Motion Transformer reveals every important characteristic that the ear has been longing to hear. The 2005 offers outstanding dispersion to the highest frequencies, essentially flat response to beyond 22,000 Hz and complete freedom from fatigue producing distortion. The 2005 has a continuously variable control allowing infinite high frequency adjustment to balance with the acoustics of any room. Advanced engineering, outstanding performance and uncluttered styling. You'll find them all in the 2005. And you'll find the 2005 in any of our coast-to-coast electronic shopping centers and associated stores.

199.95

ELECTRONICALLY SPEAKING,
WHO KNOWS BETTER THAN

Lafayette
RADIO ELECTRONICS & SHOPPING CENTERS

SAVE Up to 90% on GOVT. SURPLUS

SEND FOR CATALOG



Our 31st year! Fantastic SURPLUS GUIDE with 100's of illustrations & 1000's of bargains in hydraulics, electrical, marine, auto, hardware items — and more. A must for hobbyists, sportsmen, machinists, inventors, etc. Send 50¢ to cover postage & handling. For extra quick delivery send \$1. Must include zip.

AIRBORNE SALES CO. Dept. PM76
8501 Steller Dr., P.O. Box 2727, Culver City, Ca. 90230

Name _____
Address _____
City _____ State _____ Zip _____

At Last a New Amazingly Simple GAS TURBINE JET ENGINE

Build from easy to follow plans. Length 15". Dia. 8 1/2". Wt. 15 lbs. Fuel: Gasoline/Kero.

"Screaming Demon" develops 20 H.P. Ideal project for serious-minded hobbyists, students; scientific and industrial arts classes. Make on 9" metal cutting lathe with milling attachment. For use on small racing boats, midget cars, etc. Full size assembly drawings with critical dimensions, bill of materials and photos. Price \$5.00. No C.O.D.

1510 26th St., Box 1398
SAVOY SCIENTIFIC, SANTA MONICA, CALIF. 90406



MEN-WOMEN MAIL ORDER HOME IMPORT BUSINESS

Start your own Home Business Now. I'll send you a free sample import to prove you can make big money in your own spare/full time business. No investment in stock. World's most famous importer will guide you. Clip this ad, good for free sample and big Free Report — tells all! Offer limited to adults. Mail this ad today.

THE MELLINGER CO., 6100 Variel Av. Dept. C2251, Woodland Hills, CA 91364

FREE SAMPLE IMPORT

Official Popular Mechanics PATCH

Collectors item! Quality woven emblem. Red white & blue! 85¢ plus 15¢ handling. Check or M.O. to PM PATCH, Box 1014, 15, Radio City, NY 10019

EXTRA MONEY '30 to '50 A DAY

Operate a community sharpening service with an investment of \$150. Work from your basement or garage. Our manual guides you in professional methods of grinding, of business promotion and in pricing your work.

- Hand Saws • Circular Saws • Knives • Chain Saws
- Scissors • Pinking Shears • Clipper Blades
- Planer and Dado Blades • Mower Blades

John Rodock says: "Thanks for shipping Model 331. It has paid for itself many times since I purchased it. Please send latest price list on grinding wheels."

154-A Oliver St. North Tonawanda, N.Y. 14120

TREYCO START NOW...WRITE TODAY



BOAT KITS BUILD YOUR OWN BOAT & SAVE \$\$\$

FRAME KITS, PLANS, FULL SIZE PATTERNS especially for amateurs. Send \$1 for 128 pg. catalog. Over 150 designs, includes FREE "Boatbuilding Supplies" brochure.

GLEN-L MARINE 9152 Dept T Rosecrans Bellflower, CA 90706

SURVEYING PAYS BIG

U. S. Dept. of Labor reports "openings for 26,000 Surveyors in next 10 years. Easy home-study plan guides you. Send for FREE "Surveying CAREER KIT." APPROVED FOR VETERANS.

Name _____ Age _____
Address _____
City _____ State _____ Zip _____

NORTH AMERICAN SCHOOL OF SURVEYING
4500 Campus Dr., Dept. 9-003 University Plaza, Newport Beach, CA 92663

ALL 3 FREE

Router adapter for drill stand

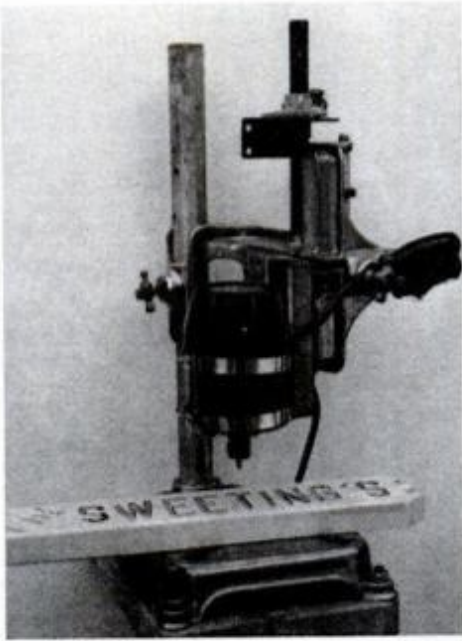

For some jobs, it's much more convenient to move the work than the router, and mounting it on your portable drill's drill-press stand gives excellent control. This adapter is easy to make if you weld—or have it done for a few dollars.

Weld the pipe to the channel back first, making sure it's square. Notch channel legs 3/4 and 2 in. up from bottom and 1/8 in. deep for clamps. Bend steel plate to router-body contour, then weld it to channel, leaving notches clear. Cut rubber to fit router body and fasten router in place with hose clamps. If router hits channel legs, remove excess from legs with grinder. Clamp pipe in drill stand and assembly is ready to use.

—Robert Jonick

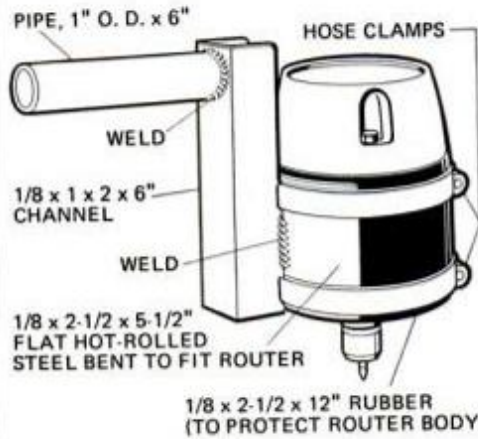

- MATERIALS NEEDED**
- 1/8 x 1 x 2 x 6" channel
 - 1" o.d. x 6" pipe
 - 1/8 x 2 1/2 x 5 1/2" hot-rolled steel plate
 - 1/8 x 2 1/2 x 12" rubber
 - 2 stainless-steel hose clamps, 4" or 5" i.d.

BARGAIN HUNTER

"Handiest tool you can have in your shop" — Popular Mechanics



Portable, lightweight 1" belt grinder-sander polishes, grinds, sands. Use 1/4 hp motor. 2", 4", 6" sanders and hacksaw also available.

\$50.20 with guard.
Write for free brochure or send order.

Arco Mfg. Inc.
1501 Clark Street
Racine, Wis. 53403

Be A Specialist Repair Air Compressors

New Manual Gets You Started. Well Illustrated. Parts Directory. \$3.95 Postpaid

Air-Power, P.O. Box 1411, Hickory, N.C. 28601

KARATE KUNG-FU

The Greatest Self-Defense System Known to Man! Learn-at-Home Course reveals hundreds of deadly self-defense secrets which will enable you to protect yourself from any attacker! Easy to learn! FOR FREE COLORFUL BROCHURE AND BOOKLET, Send 25¢ to UNIVERSAL, Dept. Z, Box 39303 Detroit, MI 48239

Learn Magic at Home with The Mark Wilson Course in Magic



Millions have enjoyed Mark Wilson perform Magic on Television and in person. Now, Mark has a home-study course in Magic which carefully explains more than 300 tricks in over 450 pages of step-by-step instructions. Over 2,500 illustrations reveal how to make these tricks baffling and entertaining to your audience.

Discover how easy it is to enter the Wonderful World of Magic: Send \$1 for your PREVIEW LESSON of tricks from Mark's course, plus information on the complete course.

© 1976 MWCIM Beverly Hills, CA

Mark Wilson Course in Magic
P.O. Box 440—AD
North Hollywood, CA 91603

I enclose \$1. Send PREVIEW LESSON, and information on complete course.

Name (Please print) _____ Age _____
Street _____
City _____ State _____ Zip _____

The Bargain Hunter

SPIRAL STAIR KIT

DO IT YOURSELF



Adjusts for floor-to-floor heights of 8'1 1/2" to 9'6".

4 ft. Diameter

\$355 FOB

3'6", 4'6", 5', 5'6", 6' diameters available at comparable savings.

the IRON SHOP
Dept. PM-1, 400 Reed Road
Broomall, Pa. 19008
Call or write for Free Brochure.
(215) 544-7100



GARAGE AND WORKSHOP HEATER

A must for the weekend mechanic, hobbyist, or handyman. Big 30,000 BTU output will warm the average two-car garage. Uses low-cost kerosene or fuel oil at the rate of only 1/4 gallon per hour. Operates nearly 10 hours on one filling. High capacity blower circulates clean hot air. Built-in solid-state safety control. Lightweight and portable. No installation or assembly required. Dimensions L 30" W 11" H 14". Weight 28 lbs.

\$99.95 Add \$2.00 for shipping and handling. Send check, money order to HandyMaster, P. O. Box 157, Dayton, Ohio 45401

SPC 215

THE ORIGINAL IMPORTED SWITCH-BLADE COMB



9" overall length
5 1/4" closed

• FUN
• PRACTICAL
• GUARANTEED

Spring action comb snaps into place at push of button. Locks shut to avoid opening in pocket. Perfect for conversation piece and practical use.

Send \$4.75 plus 25c postage and handling to: Money back if not completely satisfied.

EXECUTEK
777 South Central Expressway
Richardson, Texas 75080

FIX CLOCKS & WATCHES

FOR FUN & PROFIT! Fascinating new Handbook by master craftsman H.G. Harris gives you the kind of knowledge skilled watchmakers learn.

OVER 200 ILLUSTRATIONS show how to install hands, dials, crystals, mainsprings, stems . . . rehouse old movements in modern cases . . . speedily cure many troubles by demagnetizing or cleaning, etc. **INSTRUCTIONS COVER** every popular watch and clock, chimes, grandfather's, cuckoo, everyday alarm and electric clocks. Handbook tells you where to buy parts . . . where to send "overflow" work for repairs at wholesale prices. **FRIENDS GLADLY PAY \$5 to \$50 for restoring cherished timepieces.** Try the **HANDBOOK OF WATCH AND CLOCK REPAIRS.** Rush only \$5.95 plus 50c handling, on 10-day money-back guarantee.

EMERSON BOOKS, INC.
Dept. 737B Buchanan, New York 10511

FREE! ^{New} FUN-FILLED CATALOG 1600 UNUSUAL ITEMS

Funmakers·Hobbies·Sports·Star Trek Items Jewelry·Emblems·Patches·Psychedelia Science·Electronics·Photo·Imports Practical Jokes·Magic·Gifts

PLAYBOY MAGAZINE says: "Johnson-Smith opened to me a world of fantastic wonders . . . fabulous."
NBC-TV TODAY program: "Thanks for 'vanishing money.' We used it on show on Income Tax Day."
LIFE reprinted excerpts from catalog.
HARVARD CRIMSON: "JS book supplied humor for decades."
The Most Unusual Catalog in the World
MAD, NEW YORKER, CORONET, COLLIER'S, TIDE, etc., have written stories about this interesting catalog. Some quotes: "Magic wish book - fabulous treasure trove of novelty goods." "Only concern of its kind in America." Ranks with Disneyland, carnivals and the world's fair in popularity over the years - over 10,000,000 customers since 1914 who range from Shirley Temple to the King of Nepal and Johnny Carson. (Johnny Carson often reminisces about Johnson-Smith with his guests.)

Which Things Listed Below Would YOU Like?

NEW 1976 EDITION

No Other Catalog Like It Anywhere!



Year Out - Mail Today

FREE CATALOG!

Johnson Smith Co., Dept. C101
Mt. Clemens, Mich. 48043

Send 10¢ For Mailing (Please Print)

Name _____
Address _____
City & State _____
Zip _____ Apt. _____

Answers to Your Questions about this Free Catalog

Why is it Free? Read it for fun and entertainment, but it pays us to send it to you Free because most people find things they want and order them. **Is there any obligation?** Absolutely none!
Are there things to interest me? Yes! We think you'll find plenty to amuse and amaze you. Every item guaranteed. No other catalog like it. Send 10¢ for mailing cost.

Johnson Smith Co., Dept. C101, Mt. Clemens, Michigan 48043

PRECISION TOOL HANDLE FOR INJECTOR RAZOR BLADES



\$2.25 plus 30c post.

RAZOSHARP®
U.S. Pat. 3,608,105

IDEAL POCKET KNIFE—EXCELLENT OFFICE AND HOUSEHOLD UTILITY TOOL—Only holder to use standard injector type razor blades. Only holder allowing for varying blade length exposure and for complete blade sheathing and protection. Only razor blade holder to give precision tool feel.

ALWAYS RAZOR SHARP—When blade dulls—pop in new blade. Re-use injector type razor blades.

SHAVE and SAVE. Inexpensive injector razor blades always available. Excellent for cutting clippings, cardboard trimming. Ideal for opening packages, cartons, boxes, blister and shrink packs. Use for carving, whittling, sharpening, erasing, etc. Shave blade to suit use. Nothing to break or wear out.

UNCONDITIONALLY GUARANTEED
Extra uncut injector blades are \$4.50 per 100. Cut injector blades are \$8.00 per 100 blades.

RAZOSHARP Dept. A-1
421 Stockholm St., Bklyn., N.Y. 11237

"KLIC-A-LITE" GAS IGNITER



• No cord • No batteries
• Works in wind or rain
• One-year guarantee

A fast, safe, easy way to light soldering and welding torches, grills, camper stoves — all butane, propane and natural gas devices and appliances. 5" long barrel reaches into limited access area . . . keeps hands away from flame. \$7.95 plus 50¢ for postage and handling. (In California, add 6% sales tax.)

Send check or money order to
ROW, Inc., P.O. Box 839, Cupertino, Calif. 95014

MAKE TIFFANY-TYPE LAMPS

Revolutionary new method. Cartoon design printed on molded form, matching paper patterns, instructions. Many old designs. At most stained glass dealers. Information:

H. L. WORDEN, Granger, WA 98932

22" 20" 19 1/2"

FIX LAWN MOWERS



FOR FUN & PROFIT! Fascinating new Handbook by F. Peterson gives you the knowledge skilled mechanics learn.

OVER 125 ILLUSTRATIONS show how to trouble shoot, repair carburetors, engines, balance and sharpen blades, etc. Exploded drawings are extensively used.

INSTRUCTIONS COVER reel, rotary and rider mowers, preventive and routine maintenance, how to identify brand names, where to obtain replacement parts. How to buy and use a lawn mower. Friends gladly pay \$10 to \$50 to fix their lawn mowers. Try the HANDBOOK OF LAWN MOWER REPAIR.

Rush only \$7.95 plus 50¢ handling on 10-day money-back guarantee.

EMERSON BOOKS, INC. Dept. 736B
Reynolds Lane, Buchanan, New York 10511

WAREHOUSE DISCOUNTS ON NATIONALLY ADVERTISED

- C.B. RADIOS
- MONITOR SCANNERS FIRE POLICE IN FACTORY SEALED CARTONS

BUSINESS - RECREATION - PERSONAL SATISFACTION GUARANTEED

WRITE FOR QUOTE
ELECTRONICS WAREHOUSE, INC.
6234 LITTLE RIVER TURNPIKE (DEPT. 4)
ALEXANDRIA, VA. 22312
OR PHONE: (703) 256-1300

AUTOMATIC SAW SET

Set saw teeth automatically—400 per minute without effort. Perfect hammer and anvil action sets teeth uniformly—no tooth breakage.



FOR HAND SAWS AND BAND SAWS
Write for details
BURR MANUFACTURING CO.
8931 Venice Blvd.
Los Angeles, Calif. 90034

BUILD YOUR OWN POWER TOOLS

METAL PARTS KITS AT LOW FACTORY DISCOUNT PRICES FOR: **SAVE \$50 TO \$500**

• 12-IN. BAND SAW
• 18-IN. BAND SAW
• 6-IN. BELT SANDER
• SPINDLE SHAPER

PLANS Full Size Patterns **\$2.00 EACH** DEDUCTIBLE

• 10-IN. TILT/ARBOR SAW
• COMB. DRILL PRESS-LATHE **\$23.99 TO \$89.99**

Step-by-step plans, photos show how. No machining or welding. 68,000 in use. 5-Year Guarantee. Send \$2 for Plans, or 25¢ for Catalog.

GILLIOM MFG. CO.: Dept. PM-1, St. Charles, Mo. 63301

Learn LANDSCAPING

TRAIN AT HOME for exciting hobby or career. Start your own spare or full time Contracting business, work in Garden/Nursery field, or landscape your own property—we show you how. FREE BOOK-LET describes opportunities. No salesman.

LIFETIME CAREER SCHOOLS

Dept. A-945

2251 Barry Ave.,
Los Angeles, CA 90064



MAKE \$25 to 100 PER HOUR

BADGE-A-MINIT, a complete badge making system lets you make permanent metal pin back badges for fun or profit.

Badge parts cost pennies, you sell slogan buttons for up to 75¢ each, photo buttons for up to \$2.50 ea. Get FREE illustrated money making

Money Back Guarantee

plans by return mail, or send \$34.95 plus \$1.75 for shipping to RPM Assoc. Ltd., Box 618, Dept. PM-16, LaSalle, Ill. 61301

There are

Big Profits

in radiator repairs . . . and a BARBEE equipped shop will make them for you.

Radiator repair is big business. Cash in now on this rapidly growing field.

Barbee offers a complete training course and expert counseling on financing.

INVEST AS LITTLE AS \$1800 TO \$3000



A Down Payment gets you started immediately. Use the coupon for free catalog.

THE BARBEE CO.
BOX 323-PM, LOUISVILLE, KY. 40201

Please send catalog and complete information on the Barbee Plan.

Name _____
Address _____
City _____ State _____ Zip _____

EX-76 CAPACITIVE DISCHARGE IGNITION SYSTEM by A.R.M.

INCREASE YOUR GAS MILEAGE UP TO 20%

- Extend plug and point life
- Virtually eliminate tune-ups
- Improve performance • Featuring:
 - Solid State Reliability surpassing conventional CD systems
 - 1 year guarantee
- WATER RESISTANT COATING to eliminate moisture and guarantee performance in wet environments.



EX-76 Kit Form - \$30.00, with By-Pass Switch - \$40.00
EX-76 Assembled - \$35.00, with By-Pass Switch - \$45.00

Details Upon Request. Pa. residents add sales tax.

Dealer inquiries invited.

A.R.M. ELECTRONICS
Box 785 - Pittston, Pa. 18640

PUMP DRAINS pools, cellars, laundry tubs IRRIGATES - CIRCULATES - SPRAYS

Heavy duty ball bearing pump. All metal, rust-proof Type XB. Stainless shaft. Use 1/4 HP or larger. 1 HP 1,200 GPH 60" high or 3,000 GPH 25" well. 5,200 GPH max. 1 1/4" in; 1" out. Belt or direct drive. \$17.95 Type P won't rust or clog. Bronze bearing. To 2,400 GPH. 1" in; 3/4" out. \$11.95 p/pd cash with order. Money back Guarantee.

LABAWCO, 80 Hwy 206, Belle Mead, N.J. 08502

UNIMAT - able

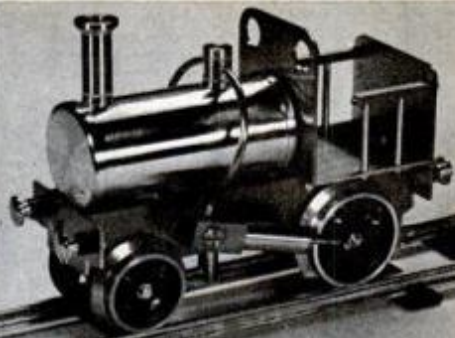

and cute as the

dickens

You can build this

"O" GAUGE LIVE STEAMER

to operate on

027 TRACK

with a UNIMAT or any larger lathe.

KIT AVAILABLE

ALL THE DRAWINGS AND STEP-BY-STEP INSTRUCTIONS BEGIN IN THE FEBRUARY 1976 ISSUE OF

LIVE STEAM

magazine

Box 286-E, Cadillac, MI 49601

SUBSCRIBE NOW

\$ 9.00 per year U.S.A.
\$10.00 per year (U.S. Funds)
in other countries

MOTOR OIL TESTER



Do you really know when to CHANGE YOUR OIL?

OIL THAT LOOKS CLEAN COULD BE DESTROYING YOUR ENGINE - OIL THAT LOOKS DIRTY MAY BE GOOD FOR THOUSANDS OF ADDITIONAL MILES

Don't just check your oil level, test it at the same time. The MOTOR OIL TESTER* will indicate the condition of crankcase oil in minutes using a drop of oil from the dipstick. Test for ACID, CONTAMINATION, DISPERSANCY & VISCOSITY. Evaluate OIL ADDITIVES. Test SYNTHETICS. The MOTOR OIL TESTER is the single most important preventative maintenance tool you can own. It will pay for itself even if it saves just one oil/filter change. It may even save your engine. FREE BROCHURE, BANKAMERICARD & MASTERCARD OK.

OIL RESEARCH ASSOCIATES **\$6.95** + 50¢ Post. & Handling
Cat. No. 404 00% Tax.
ATLANTIC RICHFIELD PLAZA STA. BOX 710224, L.A. CA 90071

YOU CAN TRANSFORM YOUR VW INTO A UNIQUE-PICK UP



VW ECONOMY WITH PICK-UP VERSATILITY



HOME INSTALLATION

One weekend using hand tools. • No torch cutting or welding. • No mechanical changes required. • Detailed instructions. • Precise body cutting templates. • Factory quality components. • Kit includes all needed hardware.

The FLATBACK



DEPT. PM 312 EAST 17TH
KANSAS CITY, MO. 64108

SEND

\$1 for color brochure & information
\$5 for installation instructions & templates



★ "SURE-BITE"
FISH SCENT!

● A few drops on your Bait, Lure, or Fly...sends Fish into a feeding FRENZY! Fish can't resist this Tantalizing-Aroma that says "FOOD"! ...a whiff, and they fight to get to your Lure! Acclaimed by Fishermen, and Tested under All conditions, in Lakes, Ponds, Rivers,
★ **GUARANTEED TO ATTRACT FISH!**
● **SPECIAL...only \$1.49 Each.**



● **HANDY "ROD-HOLDER"**
Ideal for CAMPER, BOAT or DEN.
Handsome and Practical Rack
● Holds and Protects 4 RODS.
Use Vertical or Horizontal on any Wall. Mounting Screws included.
★ **SPECIAL...\$2.49 PAIR**



★ Virgil Ward's...
"FISHIN-SOAP"

● Will not only Wash away Human Scent...
...But will also deposit a "FISH SCENT" on Bait and Lures that "FISH CAN'T RESIST"! It's Great!
● Wash hands in the Lake or Stream you are Fishing, and the Soap will milk into the water...Attracting Fish by "Scent"! Can also be used for Chumming! It will help put those BIG Fish on your Stringer.
● **SPECIAL...2 for only 99¢**

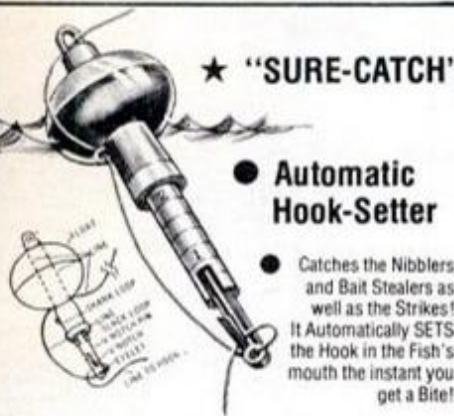

★ "SURE-CATCH"

● **Automatic Hook-Setter**

● Catches the Nibblers and Bait Stealers as well as the Strikes!
It Automatically SETS the Hook in the Fish's mouth the instant you get a Bite!
● You don't lose the Big Ones. Automatic "Trigger" sets hook! "Built-in-Scale" Weighs fish while still on the Hook. GREAT for Surface or Bottom Fishing! Can be used with or without Float for bottom Fishing. Simple instructions included.
● **SPECIAL...only \$1.99**

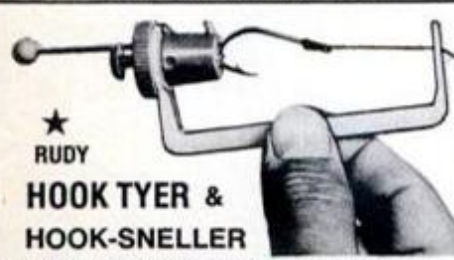

★ **RUDY HOOK TYER & HOOK-SNELLER**

Makes Tying ANY Hook a BREEZE! Just slip the Line in, Twist the Knob, Pull it Back...a Neat Uniform KNOT!
Professional Knots that STAY TIED. Ties CLINCH knots, BARREL Knots, DROP-LOOPS, End-Loops, Tapered Leaders, Also SPLICES Line! A Handy Tool for Every Fishing Need.
● **Only...\$1.49**

Sports LIQUIDATORS 8942-36 LANKERSHIM, SUN VALLEY, CAL. 91352
SPECIAL "GET ACQUAINTED" OFFER:
★ **25** Famous, Popular and Proven LURES \$6.95 All Different... for only **\$6.95**

The LURES in this "SET" were chosen by Expert Fishermen, as the Most widely used, PROVEN Fish-Catching Lures in use today!
Ideal to replenish any Fisherman's supply for Any and All Fishing Trips!
A Great "ALL AROUND" LURE SET...for Lake, River, Stream or Pond!
(Value over \$20.00).



IT'S LIKE ORDERING 5 LURES... AND GETTING
20 LURES FREE
OF EXTRA CHARGE!

TWELVE 'Famous' SPINNERS

● TWELVE 'Famous' SPOONS



● Lake and Stream Tested Favorites! A large purchase enables us to offer this Well Known Assortment of Lures (\$7.00 Value)
12 For only... \$2.95
● 3-Sets (36 Spinners) \$7.95



● Latest Assortment of Shapes, Weights and Actions! A COMPLETE SET to meet every fresh-water Fishing need. (\$6.00 Value).
12 For only... \$2.49
● 3-Sets (36 Spoons) \$5.95

TRIPLE 'XXX' MONOFILAMENT SUPER-FINE QUALITY LINE!

SPECIAL JUMBO BULK-SPOOLS



● New FRESH-STOCK Newest GOLD color.
* The BEST!
● XTRA SOFT! will not stiffen in any weather!
● XTRA STRONG! small diameter, low stretch!
● XTRA INVISIBLE! Gets more Strikes!

TEST	APPROX. YDS.	VALUE
4 lb.	2700	\$41.85
6 lb.	2200	\$40.75
8 lb.	1500	\$29.00
10 lb.	1250	\$26.40
12 lb.	1000	\$25.00
15 lb.	750	\$19.50
20 lb.	600	\$18.00
25 lb.	570	\$16.25
30 lb.	400	\$14.40
40 lb.	250	\$11.75
50 lb.	225	\$11.00

● X'TRA SPECIAL!

● Buy 2-Spools at Discount Price of \$5.45
Receive a \$2.00 LINE WINDER

● Special Discount ALL LB.-TEST: SAME PRICE
only \$2.95 each.



* SATISFACTION GUARANTEED...or Full Refund.

#0110 * SPECIAL... 25 Different 'Lure-Set'... only \$6.95

#0221 12-DIFF. SPINNERSonly \$2.95 ● #1001 Triple XXX BULK SPOOLonly \$2.95 LB. Test: _____

#0223 3-Sets (36) SPINNERSonly \$7.95 ● #1002 2-SPOOLS & LINE WINDER.....only \$5.45 LB. Test: _____

#0331 12-DIFF. SPOONS.....only \$2.49 ● #1610 "Sure-Bite" FISH SCENT ...only \$1.49

#0333 3-Sets (36) SPOONSonly \$5.95 ● #1290 Handy ROD-HOLDERonly \$2.49

#5280 "FISHIN-SOAP" 2 Bars only \$.99 ● #1850 RUDY HOOK-TYERonly \$1.49

#1300 HOOK-SETTERonly \$1.99

● Add 50¢ for Postage and handling. ● Send FREE DISCOUNT CATALOG

● MASTER CHARGE NAME _____

● BANKAMERICARD ADDRESS _____

Please List Interbank No. CITY _____ STATE _____ ZIP _____

Acct. No. ● Please send check Cash or... Money Order

Expiration date. (Because of the amazingly low price, we cannot accept C.O.D.'s)

Sports LIQUIDATORS
8942-36 LANKERSHIM, SUN VALLEY, CAL. 91352

Tiller Users!



If the tiller you've been using has its revolving blades in **FRONT** and **NO** power to the wheels (see 'TORTURE!' above), you won't ever be happy with it again once you try the **TROY-BILT™ Roto Tiller-Power Composter** which has its revolving blades in the **REAR** and **POWER DRIVEN WHEELS** — and is **SO EASY** to use you guide it with just **ONE HAND!** (see 'JOY!' above). You do **NOT** have to walk behind it, leaving footprints! It does **NOT** shake you half to death! It leaves **NO wheelmarks!** There's **NO** unbearable tangling! The **TROY-BILT®** is now in its 15th great year. **SO**, if you want tilling to be a **JOY** instead of **TORTURE** from now on, please mail the coupon below or a postcard right now for the whole story of this wonderfully different and better design in tillers! **OFF-SEASON SAVINGS** now in effect for a limited time.

TROY-BILT® Roto Tiller-Power Composters
102nd St. & 9th Ave., Troy, N.Y. 12180

TROY-BILT® Roto Tiller-Power Composters
Dept. 60191
102nd St. & 9th Ave., Troy, N.Y. 12180

Please send the whole wonderful story of **TROY-BILT® Roto Tillers** including prices and **OFF-SEASON SAVINGS** now in effect for a limited time.

Mr. _____ (Please Print Clearly)
Mrs. _____
Miss _____

Address _____
City _____ State _____ Zip _____

Full-Size FURNITURE PLAN Roll-Top DESK

Like the one Abe Lincoln used. Authentic double-pedestal desk, 30" x 52" x 30". Roll top unit adds 14" to height. Both single and double curve end panel drawings included. You'll love making it. You'll love using it. A woodworker's delight! Complete plan #140 (roll top unit) and #139 (desk) . . . both only \$12.00 . . . Each \$6.00



CATALOG \$1
Over 150 different, full-size professional plans. \$1.00—refunded with first order.

FURNITURE DESIGNS, Dept. PD-14
1425 Sherman Ave., Evanston, Ill. 60201



WOODEN TOY CLASSICS
Build this 1894 Renault and five other classics—Stanley Steamer, Ford Quadricycle, Wilton, Thomas and Mercer Harolabour from detailed wood-working plans. Cars measure 6 to 12 inches long. Free catalog with order.
\$2.00 ppd.
(Cat. includes 12¢ sale tax)
Catalog of more than 50 wooden toy plans, kits, toy-making supplies, and ideas.

LOVE-BUILT Toys & Crafts, 3517 Camby Rd.
P.O. Box 769, Dept. PB-1, Antioch, California 94509



OLD FASHION BRANDING IRON
YOUR CHOICE UP TO FIVE 3/8" COPPER LETTERS OR NUMBERS
ADDITIONAL LETTERS OR PUNCTUATIONS \$1.50 EACH
\$5.00 Plus 50¢ handling

I. MILLER ENTERPRISES
BOX 772-M
MANCHESTER MO. 63011

SILVO (BRAND NAME) TOOL CATALOG
Thousands of Exciting Tool Values! Stanley, Skil, Millers Falls, Wellsway, Dremel, Disston, Helios, Speedy Sprayers, Plumb, Kennedy, Huot, Rockwell, Channellock, Crescent, Vise-Grip, Ridgid, Unimat, Audel Books, Nicholson, General, Indestro, Xacto, Wiss, Pony Clamps, Wen, and many other Nationally Advertised brands of Tools & Supplies. We ship Coast to Coast at prices hard to beat. Send \$1.00 for our big 168 page tool catalog today.

SILVO HARDWARE CO.
107 Walnut St., Dept. PM-1, Phila., Pa. 19106

NEW HOT ITEMS

OVER 250 ITEMS

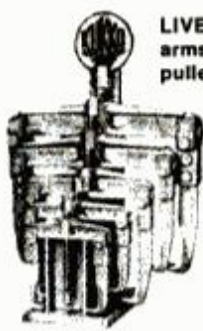

LIVE CENTER, adjustable arms, all types and sizes of pullers for all uses.

6 ton, 10 ton & 15 ton Hydraulic ram can be used with any make pullers.

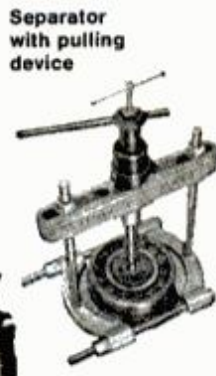

Separator with pulling device



Auto Maintenance

Industrial, Aviation, Mines, Railroad

Send for complete catalog & further information on pullers & meters

DISTRIBUTORS WANTED

KUKKO PULLER Corp. OF AMERICA

21 California Avenue
Paterson, N.J. 07503

Phone 201-274-7761-2

BUILD YOUR OWN CAMPER • TRAILER • 5th WHEEL • COVER • VAN

It's easy! Component kits, plans, & full size patterns especially for amateurs. You SAVE \$\$\$! Dozens of models, include pictorial instructions. Send \$1 (refundable) for RV KITS, PLANS, & EQUIPMENT catalog.



GLEN-L RVs 9152P Rosecrant Bellflower CA 90706

LUCKY SPLITTER ENDS WOOD SPLITTING DRUDGERY

New low cost **COMPACT MODEL** . . . for farmers, camps, cottagers. 10 ton ram, 2 cycles per min., splits logs 25" x 18". Carried in car trunk, placed up right or hung for storage. For with gas and oil details write:
PIQUA ENGINEERING, INC., Dept. P. Box 605 Piqua, O. 45356

5 SHOT MAUSER RIFLE GEWEHR 88

Shoots regular 8 mm. ammo!
regular \$49.50 Special \$32.50

Manufactured over 100 years ago in Germany to most exacting specifications, these true antique army rifles are in **GOOD CONDITION!** No license required. While they last, only \$32.50. Add \$5.00 for special selection. Original sling, \$2.50. Bayonet, \$7.50. (Add \$3.00 postage, 6% tax in California.)

MAUSER, Dept. PM-1
4535 Huntington Dr. So. Los Angeles 90032
(Please include statement you are 21 or over & there are no local restrictions against purchase)



Universal Router/Shaper Table—Ideal for shaping and jointing small materials that are normally difficult to handle. Build picture frames, plaques, or easily add a decorative touch to moldings. Features miter gauge for safe cutting at any angle. Accepts most router Skil, B&D, Stanley or Rockwell
— Add \$2.50 for shipping — Reg. \$16.95
71025-537 P—7 lbs. Special—\$10.98

NEW! CONVERT TV TO 6 FT. WIDE SCREEN! 
Easy Do-it-Yourself Kit
Project a giant 5'x6' picture onto wall or screen. B&W/Color. Kit contains detailed plans, inst., and Precision Lens System. Only \$15.95 ppd., or write for free illustrated details.
The Macrocoma Co., Dept. CA
Washington Crossing, PA 18977
Guaranteed to Work!

MAKE ANY LENGTH JACK POST
in a hurry
1' to 20' high. Furnish your own 1"—1/2" or 2" pipe or most any size wood post.
Satisfaction Guaranteed
BASTECO 7.95 POSTPAID
Send M.O. or check PAT. 3,027,140
BOX 142, BADEN, PA. 15005

CHEAP FUEL FOR HOME, CAR AND BUSINESS
Professional blueprints and manual show how to plan, construct, operate and maintain your own fuel generating plant using garbage, wastepaper and animal manure or field waste as feedstock. \$10.00 postpaid.
ALTERNATE ENERGY SYSTEMS,
P.O. Box 796, Kapaa, Hawaii 96746

SAVE ELECTRIC POWER!
Save up to 80% electrical power with this unique, inexpensive, portable, permanent and legal method applicable for shops, homes, factories, businesses, farms, sites. 100% Refund Guaranteed if not scientifically sound or if it employs gimmicks.
Information \$1.00
CONSUMERTRONICS CO.
P.O. Box 1399 Alamogordo, N.M. 88310

PLANS AND INSTRUCTIONS FOR
Go Kart \$2.00
Mini Bike \$2.00
Mini Car \$3.00
Pedal Boat \$4.00
12" Sail Boat \$4.00
Snowmobile Sleigh \$3.00
Mini Jeep \$3.00
Mini Vehicles Plans Dept. of Chaos, N.Y. 12021

THROTTLE-SPEED CONTROL \$18.95 P. PD.
A quality manual speed control at the lowest price. You can enjoy luxury driving and benefit from a terrible 15% saving on gas. Safe, system will not operate if electrical system or headlights burnout. Just a touch of the illuminated button stops it. A touch of the brake pedal releases it. 15 min. installation time, out of the way in engine-like firewall. Guaranteed. Fits all 12V cars and trucks. Send to:
PERFORMANCE
Box 129, 422 Sanford Rd., Westport, Mass. 02790

AMAZING ELECTRONIC PRODUCTS
Lasers super powered, burning, cutting, rifle, pistol, pocket-size in dark-shotgun directional mike—ultra-meters—giant Tesla-Stunwand-TV disrupter—energy producing, surveillance, detection, electrifying, 20 m cal, ultrasonic, cb, aero, auto aid mech devices, hundreds more—ALL NEW PLUS INFO UNITED PARTS SERVICE.
CATALOG \$1. INFORMATION unlimited
BOX 626 LORD JEFFERY ST. AMHERST, N. H. 03031

PORTABLE STEAM CLEANER
Steam in 60 seconds
CLEAN:
Engines, Air Filters, Lawn mowers, 3 year guarantee on fire box, coils. Uses liquid soap, propane fired. Weight 120 lbs. Auxiliary pump required on low water pressure.
WEDCO MFG. INC., Dept. M-6,
Scott Lane-Box D, Jackson, Wyo. 83001

MILITARY STUFF
1000s of things, **FLIGHT JACKETS, BOOTS, MEDALS, CHUTES, WINGS & RINGS, SURPLUS STUFF** — SEND 50c (\$1 for Air Mail) for big 65-page catalog to: **KEN NOLAN**, HQ 1, 16901 MILLIKEN, POB C-19555, IRVINE, CA 92713 714/556-8262.



ZZP! Seal Walls, Stops Leaks!

Now, seal seeping basements the way professional waterproofers do! ZZP! also makes swimming pools, boats, shower stalls watertight! ZZP! combines two epoxy pastes. Just mix quantity needed, brush on. Cures overnight. Withstands water pressure of 2 tons per sq. ft. Remainder keeps indefinitely. Instructions. Money-back guar. 1/2 gal. kit (max. coverage 7.25 sq. ft.) \$13.95 or 2 kits for \$24.95, plus \$1.25 shipping. Free literature. (Dealer inquiries welcomed!)

Construction Chemical Corp.

DEPT. M-3, R. D. 2, MONROE, CT. 06468

"LISTEN IN" TO POLICE-FIRE RADIO CALLS IN YOUR CAR!

WORKS with ANY CAR—Portable or HOME RADIO! Just PLUGS in—No wiring—3 minute hook-up. Switches instantly from regular radio to ALL POLICE-FIRE-EMERGENCY-TAXI—STATE-GOV'T 2 way radio, central Works Everywhere—Anytime! Dual Band 30-49 & 150-175 MHz. SEND ONLY \$2.00 (cash C.K.M.O. and pay postage \$17.99 C.O.D.) post- age or send \$19.00 for PPA Del in USA. COMPLETE with Antenna and Plug in to use with ANY Home or Portable Radio! Full Instructions—1 year Service Warranty—10 DAY MONEY BACK TRIAL—SOLD ONLY direct from Factory—WESTERN RADIO DEPT. BPM-1, KEARNEY, NEBR. 68647



USE ZIP CODE WHEN ANSWERING ADS

PUBLIC SALE—\$249.95

Manufacturer to you still in crates fully assembled.

Big powerful 7 H.P. Briggs & Stratton engine.

Compare at \$449.95
1500 will be sold immediately at this low price.



Full delivered price to nearest freight office.

Send money order, or send for free picture brochure while they last.

M&M Mfg Sales 405/631/3669
929 S.W. 29th Okla City, Okla 73109

FREE VENEERING MANUAL/CATALOG

"VENEERING MADE EASY"

Learn how to create beautifully veneered furniture, bend exotic veneers simply, instantly. Catalog shows simplified contact cement method that you learn fast. 90 varieties world's rarest veneers, pre-joined veneers, checkerboards, broad choice wood band & art inlays. Illustrated in full color — at reasonable prices. Send for free catalog now!

MORGAN, Dept. P01K28 Box 18169, Lou., Ky. 40218

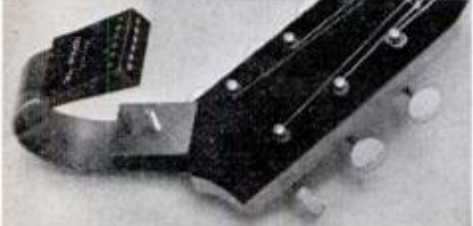

Tune your Guitar

Like a professional! This new invention is ideal for every guitarist—beginner or accomplished musician. Six precision-tuned reeds make exact tuning, a snap. Just clamp this gadget onto your guitar, then adjust the strings. When the right pitch is reached, the corresponding reed vibrates. Just as simple as that! Ideal for bands or combos. Tunes all instruments to exactly same pitch. Only \$6.95 plus \$5 shipping and handling. Money back guarantee. ED SALE Studio 834-B, Avon By the Sea, N.J. 07717

Unadorned power tools ... they do the same job as tools costing up to 5 times as much.

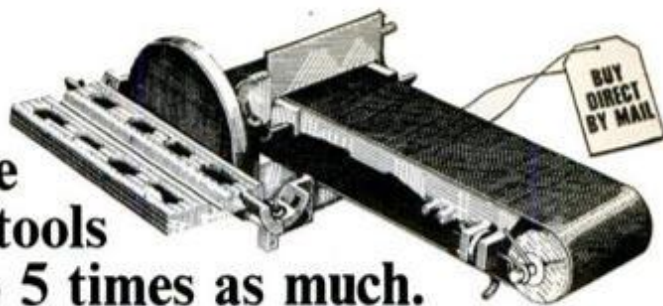

NOTE: Take advantage of these same low prices at our Royersford factory showroom at 4th and Spring Sts. (9 to 4:30 weekdays, 9 to 12 Sat.).

We skipped the chrome to save you money... but we did not skip anything on performance. Actually, we skipped more than just chrome, we cut out every costly frill that wasn't absolutely needed.

Our tools are not exactly flashy. We are the first to admit it. But in articles covering test results on AMT tools, written by leading publications such as Popular Science, our tools have been praised over and over again. In spite of their low prices, our tools are full scale and offer full performance and precision.



HERE'S HOW WE DO IT... First, we don't claim our tools should sell for five times the price! Just that our tools do the same job... with the same accuracy, ease and speed... and will last at least as long. AMT tools cost less to make and are sold direct. They are bona fide quality power tools used by serious amateurs and professionals alike and if sold in retail stores would be much higher in price. We use no magic, let's be specific: SIMPLICITY... AMT tools are soundly engineered to eliminate every frill and gimmick—to minimize material and production costs. Machined parts are used only where they're needed. Unadorned cast iron and aluminum save you a fortune.

DIRECT-FROM-FACTORY SAVINGS... You save a bundle, yet we offer a double guarantee backed by a 45-year-old company with millions of satisfied customers... and hundreds of orders pour in daily. LARGE VOLUME... Our own foundry and large mass production facilities plus large buying power all work to keep costs down.

STANDARD PARTS... Our designs use standard hardware items wherever possible. By avoiding custom-made parts we pass on tremendous savings to you.

If you are looking for power tools that perform like units costing many times our low prices, order today and you'll be one step closer to many hours of woodworking satisfaction.

Bill Morley

JOINTER-PLANER... 4" x 22". Cast iron and steel, precision ground adjustable tables. For planing, joints, bevels. Cuts to 1/4" depth. Fence adjustable 0° to 50°. Steel Knives, dual guards. Use any motor. Precision ball bearing industrial model, \$10.00 add'l. Wt. 19 lbs., f.o.b. factory. \$3780



TWO GUARANTEES

10-DAY MONEY BACK GUARANTEE
Try any of these power tools and compare it with any similar machine at any price. If not satisfied, return it for prompt, no questions asked refund. We pay the return shipping charges.

10-YR. FULL SERVICE GUARANTEE
Any part or parts of these AMT power tools (except motor which carries a one year guarantee) which become inoperative for any reason within ten years after purchase date will be repaired or replaced by the factory with no cost to the purchaser other than postage.

AMERICAN MACHINE & TOOL CO.
4th & Spring St., Royersford, Pa. 19468

Brand new electric motor developing full 1 h.p. 17 lbs. (Purchased separately, \$29.85). With any AMT machine here. \$24.90

POWER SAW 8" tilt arbor saw... cross-cuts, rips, mitres, cuts, compound angles, dados, coves, moldings. Completely assembled with ground cast iron table, safety guard, splitter, mitre gauge. Less blade, motor. Rip fence for easier work alignment. \$4.50 add'l. Ball bearing model. \$9.50 add'l. Takes 1/2 h.p. motor or larger, standard blades, attachments. Wt. 22 lbs., f.o.b. factory. \$2995



FREE OFFER, cabinet base plans, with one piece of 3/4" plywood, convert your \$29.95 saw into a floor model with a huge 27" x 24" top. Takes cabinet rip fence. \$5.50 add'l.

BELT SANDER A precision unit. It changes from horizontal to vertical in seconds. Heavy, sander includes 4" x 36" sanding belt. Uses 1/2 h.p. or larger motor. V-pulley drive and multi-purpose drive spindle. Disc sander accessory, \$12.50 add'l. Mitre gauge, \$1.95 add'l. 18 lbs., f.o.b. factory. \$2800



3' WOOD LATHE... 6" swing. Same precision and speed as \$40 units. Sturdy cast iron with tubular steel bed. Lever action tail stock, two-speed pulley, fits any motor. Set of 3 high speed turning chisels, \$6.95 add'l. 4" face plate, \$2.50 add'l. 15 lbs., f.o.b. factory \$1980



4' WOOD LATHE... 12" swing. Industrial size, does same job as \$75 units. Tubular steel bed rails, screw action tail stock, 3-speed pulley. Use any motor. 3 high speed turning chisels, \$6.95 add'l. 4" face plate, \$2.50 add'l. 30 lbs. f.o.b. factory. \$3910



DELUXE BALL BEARING 4' WOOD LATHE... 12" swing, similar to 4' model with heavy duty, double shielded, lubricated-for-life ball bearings. 3 high speed turning chisels, \$6.95 add'l. 4" face plate, \$2.50 add'l. 30 lbs., f.o.b. factory. \$4910

WOOD SHAPER KIT Makes beads, coves, and-groove joints, etc. Accurate cuts at high speeds. Sealed greased-for-life ball bearings. Less wood. Takes 1/4 h.p. motor or larger, standard cutters. Optional hold down assembly, \$3.95 add'l. 9 lbs., f.o.b. factory \$2595



BUY DIRECT... USE THIS HANDY ORDER COUPON NOW

AMERICAN MACHINE & TOOL CO., Dept. PM16, Royersford, Pa. 19468
Please send me the units checked. Payment in full enclosed \$_____ or \$5 deposit each item enclosed, balance C.O.D. I must be fully satisfied or will return unit within 10 days for full refund. No questions asked.

8" Power Saw at \$29.95
 Standard Rip Fence at \$4.50
 Long Cabinet Rip Fence at \$5.50
 Ball Bearing Spindle at \$9.50
 Belt Sander at \$28.00
 Disc Sander Attachment at \$12.50
 Mitre Gauge for Sander at \$1.95
 Jointer Planer at \$37.80
 Ball Bearing Spindle at \$10.00

G.E. Motor \$24.90 (with other item) \$29.85 (purchased separately)
 Wood Shaper Kit at \$25.95
 Opt. Hold Down Assembly at \$3.95
 6" Swing 3' Lathe at \$19.80
 12" Swing 4' Lathe at \$39.10
 Deluxe Ball Bearing 4' Lathe at \$49.10
 Face Plate \$2.50 } any Lathe
 Turning Chisels \$6.95 } above

NAME _____
 ADDRESS _____
 CITY _____ STATE _____ ZIP _____

CLOCK BUILDER'S HEADQUARTERS - USA

Largest selection of kits, movements, hardware

New: 1976 Bicentennial Grandfather Clock Kit
Inspired by original American design of Benj. Chandler, ca. 1776. A clock your grandchildren will be proud of—built by you of the finest materials. Described in 100 page clock catalog.

Grandfather, grandmother, wall, shelf, school, bracket and novelty clock kits!

Choose from 35 different clock kits featuring the finest cabinet work of solid American hardwoods plus the highest grade movements and hardware. Buy plans for as little as 80¢ or complete wood kits plus your choice of movements, dials and hardware. There are clocks to fit all budgets yet our insistence on top quality gives you the most value.



"AMAZINGLY COMPLETE" 100 PAGE CLOCK BOOK

Don't order your clock kit until you see the most in-depth clock builders catalog. A fascinating display of 35 clock kits, 30 clock plans, 114 movements, 150 dials, plus brass hardware, hands, hardwood moldings & trim. The hard to find and the unusual are included for both the novice and the experienced horologist.

Send 50¢ for Craft Clock Catalog

OVER 35 YEARS EXPERIENCE

CRAFT PRODUCTS COMPANY

Dept. 1, Elmhurst, Illinois 60126



PLAY GUITAR IN 7 DAYS OR MONEY BACK

In this Special Introductory offer you get all this: **TOP GUITARIST ED NALP'S** famous 6-disc Secret System worth \$4.00 which shows you how to play a beautiful song the first day and any song by ear or note in seven days! Contains 52 photos, 87 finger placing charts, etc., plus 110 popular and western songs, (words and music); \$1.00 Chord Finder of all the chords used in popular music; a \$1.00 Guitarrist Book of Knowledge; and the extra special \$1.00 value NEW wallet size Tuning Device for tuning any guitar by ear.

Total Value \$9.00—Now **\$3.98** SEND NO MONEY!

Just send your name and address. On delivery pay postpaid \$3.98 plus C.O.D. postage. Or send \$3.98 plus 50¢ shipping and handling charges with order to save C.O.D. costs. (Sorry, no C.O.D. outside Continental U.S.A.—remit with order.) Money Back Guarantee.

ED SALE Studio 134-G, Avon By the Sea, N.J. 07717

25 LIVE SEAHORSES 2.98

Kit has two mated pairs of freshly caught sea horses, including **ONE PREGNANT MALE**, who will give birth to as many as 25 babies. Marine salt, food and instructions included plus a live marine snail. **ABOVE KIT WITH CUSTOM AQUARIUM, SEA HORSE TREE, SEASHELLS, CORAL AND SILICA SAND \$5.98**
LARGE DELUXE AQUARIUM AND ALL ABOVE ACCESSORIES WITH 5 MATED PAIRS OF SEA HORSES (2 PREGNANT MALES—OVER 50 SEA HORSES) \$10.95
All kits sent post. Via Air Mail Live Delivery Guaranteed
Sea Horses, Inc. Dept. PM 174, Box 342096, Coral Gables, Fl. 33134

SAVE UP TO 85% GOV'T SURPLUS and NEW EQUIP'T

DIAL TELEPHONES
\$7.99

BATTERY OPERATED Motor Powered Wheel
\$9.98

Hand Radio
\$7.89

ALL ITEMS THIS AD F.O.B. LINCOLN, NEBRASKA
1980's of Bargains in Gov't, Surplus, Estate Inventories, Factory Directories, New Brand Name Equipment + Hardware + Watches + Tools + Plans + Maps + Surveys + Landscapes + Blueprints + Toys + Air Compressors + Gear Motors + Many Others.
SURPLUS CENTER PM-016 Lincoln, Nebraska Zip Code 68501

"LISTEN IN" TO CITIZENS BAND RADIO IN YOUR CAR!

Works with ANY CAR RADIO and antenna! Just plug in—1 minute hookup! Get all 23 CB channels—crystal controlled! Instant switch from CB to regular radio! Hear location of ALL STATE, COUNTY, LOCAL TRAFFIC, RADAR CONTROL, and ALL "smokies" NEVER GET CALLED SPEERING AGAIN! For Everyone-Everywhere—send \$19.99 for PPD del in USA. **SEND ONLY \$2.00** and pay postman \$17.00 C.O.D. note or send \$19.99 for PPD del in USA. **1-YEAR SERVICE GUARANTEE—10 DAY MONEY BACK TRIAL—COMPLETE READY TO PLUG IN AND LISTEN! Order TODAY—NOW!**
WESTERN RADIO, Dept. CPM-1, Kearney, Neb. 68847

LOCKSMITHING & Key Making

PRACTICAL UP-TO-DATE COURSE — ONLY \$9.95
Teaches you how to pick locks, de-code, make master keys, repair, install, service, etc. New self-instruction lessons for every handyman, homeowner, carpenter, mechanic, service station operator, fix-it shop, hardware dealer, gunsmith, 53 easy, illustrated lessons. Full price only \$9.95 postpaid. Satisfaction or refund guaranteed. Mail order today!
Nelson-Hall Inc., Dept. AS-2
325 W. Jackson Blvd., Chicago 60606

SECRET LOANS!

Borrow by mail in absolute privacy. Up to \$3000 from reputable company—founded 1897. No interviews. No co-signers. No mortgages. For full details write:

Dial Finance, Dept. 3591
340 S W. 8th St., Des Moines, Iowa 50309

X-Ray Glasses Apparently see thru skin, cloth, etc. Amazing optical illusion. 3762. Glasses . . . \$1.00	Super Power Magnets Lift 100 lbs. solid steel. Do stunts, treasure hunts. 4005. Lifts 50# . . . \$1.95 4055. Lifts 100# . . . \$3.95	Star Trek Set Plastic model kit. Phaser, Tricorder, Communicator. 6" exact replicas. 7662. Star Trek Set \$2.95
Pen Radio Self-powered, solid state radio hidden in fine pen case. Wear in pocket with earphone. 7052. Radio \$2.59	Hand Timer Import bargain. Good timer for non-pro events. start-stop button. Sweep hand. 2020. Timer . . . 98¢	Handcuffs Police style. Heavy duty steel. Lock & keys. Chrome plated. Regulation size. 9043. Cuffs \$3.95 9048. Case \$3.95
Sound Switch Surplus bargain. Sound activated. Use voice, whistle, clap to turn on lights, bells, alarms. Completely wired. 2 for \$3.00 6561. Switch . . . \$1.95	Pocket Telescope 8 power telescope is size of fountain pen. 6724. Scope . . . \$1.59	Calculator 99¢ Bargain Add subtract, multiply, divide. FAST! ACCURATE! Metal. Lightweight. Pocket size. Up to 9,999,999. 2376. 99¢
Air Car Battery model. 11" beauty rizes, floats in any direction. U-control 7606. Air Car . . . \$4.49	Slot Machine Bank Vegas replica. Real payoff. About 6". 4682. Slot Bank. \$4.95	Calculator 99¢ Bargain Add subtract, multiply, divide. FAST! ACCURATE! Metal. Lightweight. Pocket size. Up to 9,999,999. 2376. 99¢

Small Engines Service Manual



Tells and Shows You How to Fix Small Gas Engines on — **LAWN MOWERS, Garden Tractors and Tillers, and Power Equipment.**
Repair your own gas engines. Make Money repairing for others. New 11th edition gives complete information on repairing small gas engines under 15 cu. in. Only universal repair manual of its kind. New and updated. Information on all major manufacturers' engines. Authoritative section on engine fundamentals. Trouble shooting and servicing of ignition and carburetors. 328 pages with down-to-earth information. Nearly 900 illustrations with hundreds of clear exploded drawings. Easy enough for beginners to understand. Satisfaction Guaranteed or Money Back.

TECHNICAL PUBLICATIONS Div., Dept. PM-176
1014 Wyandotte, Kansas City, Mo. 64105

BURIED TREASURE

Locate from a LONG DISTANCE! with Ultra-Sensitive **DIRECTIONAL** Locator SEND FOR FREE INFORMATIVE BROCHURE
RESEARCH PRODUCTS
BOX 13441-AM TAMPA, FLORIDA 33611

METRICS ARE COMING!

U.S. TO METRIC SLIDE CHART
\$1.49
TERLAND METRIC DIST.
P.O. BOX 208 • Round Lake, Ill. 60073

IMPORTED LOCK BLADE KNIFE

ONLY \$275 each
9" Overall Length
5" When Closed
• Opens instantly
• Sharp and Tough
• Stainless Steel Blade
Flips open instantly and locks automatically to prevent accidental closing. Razor sharp tough stainless steel blade for reliable use and hard, long service. Money back in 5 days if not satisfied. Send \$2.75 plus 25¢ to cover postage and handling.
(Free Knife Catalog With Order)
WESTBURY SALES CO.
P.O. BOX 434, WESTBURY, N.Y. 11590
259 Post Ave. DEPT. L-1-PM

Heat-catcher™ CUTS HEATING COSTS

Transforms fireplace into efficient heater. Highly recommended by users from Coast to Coast for cabins, homes, lodges. 7 models. Patented. Write for Free Literature
LASSY TOOLS INC. PLAINVILLE
EST. 1939 CONN. 06062

Model 70-D **NEW** **DIAL CALIPER**
5 1/2" RANGE
ONLY \$9.95
+\$1.00 POSTAGE
3 for \$26.00



Measures inside, outside, depth & step readings. Dial graduated in .001" unbreakable, rust proof, patented construction. SEND FOR OUR METRIC model 80M available. - \$1.00. FREE WITH ORDER. CATALOG

SCHLESINGER'S FOR TOOLS, LTD.
1261 UTICA AVE., BROOKLYN, N.Y. 11203

NO GASOLINE!
Run your car, truck, tractor, boat or generator on wood scraps, coal, charcoal... without any poisonous material! Proven in hundreds of thousands of vehicles during World War II! Guaranteed.



FREE DETAILS Write **JEROME AMES**
16503 STOUT Dept. PM
DETROIT, MICH. 48219

U.S. SURPLUS HIGH SPEED ROTARY FILES Hardened Steel. For filing, drilling, milling, carving, routing any metal or wood. Cutting edges from 1/4" to 1", shanks all 1/4". Brand new, in air-tight G.I. packs. Export order add \$1.

32-Tool Set, G.I. cost \$265.00, now... \$18.00
14-Tool Set, G.I. cost \$109.00, now... \$12.00
Save Even More, Both Sets now... \$25.00
Two \$25 Sets (Limited Time)... \$40.00
100% Guaranteed. We pay the postage.



U.S. SURPLUS CENTER, Dept. 503
715 Camden, San Antonio, Texas 78215
Texas Orders add 5% tax

FREE FREE



FREE! POWERFUL MUSCLES FAST!
Fantastic New Discoveries in the science of bodybuilding. Add inches of powerful muscles to arms, chest, shoulders and legs. Secrets on trimming the waist with ultra-modern methods—fast! Results Guaranteed! Send for free brochure!

Universal Bodybuilding Box 485 Dept. M
Dearborn, Michigan 48121

ORIGINAL W.W.II HELMET **ONLY \$19.95**
PLUS \$2.00 POSTAGE & HANDLING



OVER 10,000 ITEMS IN STOCK COLLECTORS! OVER 10,000 ITEMS IN STOCK
Helmets, Uniforms, Bayonets etc. **FREE CATALOG**
UNIQUE IMPORTS, INC. Dept. PM1
610 Franklin St., Alexandria, VA 22314

DISCOUNT SALE \$9.95



AIR PISTOL \$7.95
IMPROVED MODEL. Built to last a Lifetime. Shoots both pellets and darts. This fine, well made .177 cal. German air pistol is just the ticket for target or varmints. Accurate. No CO2 cartridges to replace, either. Once in a lifetime bargain. Order several, Only \$7.95
Secret Helter, \$2.95 ppd. - 600 Deluxe Pellets, \$2.40 ppd.
20 Deluxe .177 cal. Steel Darts, \$2.00 ppd.
AIR PISTOL, Dept. PM-1
4535 Huntington Dr. So., Los Angeles, Calif. 90032

110 VOLT A.C. GENERATORS
60 cycles, 3000 watts. Wt. 27 pounds. 5"x10" Fanbelt driven from car or pickup. Operates T.V. All power tools. Over 13,000 in service. This is our 26th year. Guaranteed 6 months. \$115.50 Postpaid while sunny lasts. Our 1200-watt generator needs no battery. Special price—\$105.00 Postpaid
Virden Perma-Bilt, P.O. Box 7160 PM,
2821 Ma-s. Amarillo, Texas 79109



YOU CAN PROFIT from the growing demand for on-location cleaning.

You offer a service everybody needs... work part time or full time... own your own equipment... keep all you earn... start with just a small investment... and we help you every step of the way!

As a Von Schrader Associate, you have a complete plan for success. And right at the time when a fine opportunity couldn't be more welcome!

The way to independence

Have a profitable business of your own. Instead of working all your life for someone else and staying tied down, you can control your income. Make it grow bigger month by month, year by year. And you can start without leaving your present job! What would you think of a business that offers something everyone needs? Well, that's what Von Schrader does offer. As a Von Schrader Associate, you have all of these advantages:

- Demand for the service is repetitive and fast growing.
- No overhead—work out of your home.
- Set your own hours; hire help as needed.
- Everything you earn will be yours (no fees, dues or royalties).
- No special skills, education or experience needed.
- You receive free training and counsel.
- Your investment is unbelievably small.

Excellent income

These days, homes, businesses and public places everywhere have wall-to-wall carpeting. And walls and ceilings. All can be cleaned on-location beautifully and profitably with Von Schrader Detergers.

It's true! Unlimited opportunity is waiting for you as a Von Schrader Associate. How much you earn depends almost entirely upon the time and effort you put into it.

Your own boss!

Von Schrader Associates aren't dealers, licensees, franchisers, contractors or lessees. They pay no dues, fees or royalties. They work full or part time, as they wish, with their own Deterger(s).

We back you 100%

We help you reach your full potential. We show you how to get customers and provide advertising materials and literature with each Deterger. Our counsel is yours at no cost—now, later, always.

Remarkably small investment

Start your on-location cleaning service for much less than you imagined. Our complete, free booklet shows you how

you can take advantage of an opportunity you can't duplicate anywhere else. Anyone can get professional results with proven, high-quality Von Schrader Detergers. Simple in design, they're easy to operate, give quick results. Each Deterger includes all necessary accessories and a supply of cleaning materials. Many Associates start with one Deterger and then, as business grows, get all three.

Success speaks for itself!

If you were to meet a few of our Associates, you'd see their enthusiasm. Hear them tell of their success and personal satisfaction. You'd learn how many have expanded into a complete on-location cleaning service. And how they've become financially independent.

Find out how you can do the same. Take that important first step right now. Mail the coupon today. You've nothing to lose and everything to gain.

Take that first step! Mail coupon for free booklet with all the facts!
Read about the big demand for on-location cleaning, see why Von Schrader Detergers are the finest of their kind, how easy they are to operate. Learn how other men have become financially independent, how we help you every step of the way.
Extra! Special Recorded Message included with booklet! Listen as Francis Von Schrader talks to you personally about your growing future using Von Schrader Detergers.

VON SCHRADER company
40 years of helping people earn good money
1016 Place, Racine, Wisconsin 53403

Please send free complete information on Von Schrader Detergers. (No salesman is to call)

Name _____
Street _____
City _____
State _____ Zip _____

TURN YOUR CAR RADIO INTO A C.B. RECEIVER WITH A BEAR BUSTER CONVERTER



Model CBM-19S (23S)
\$44.95



Model CBM-19D (23)
\$34.95

In only three minutes for most cars, you can pick up all the excitement and valuable information of a C.B. radio! Bear Buster C.B. converters use AM car radio dial for tuning, car cigarette lighter for power. They monitor all 23 C.B. channels including state police. Provide a spot switch for immediate location of channel 19, the ones the truckers use. The new Bear Buster Model CBM-19S (23S) offers greater sensitivity, and has squelch control for eliminating interference. The Model CBM-19D (23) monitors all 23 channels but has no squelch control. Model CBM-19S (23S) is \$44.95; CBM-19D (23) is \$34.95. Please add \$.75 for handling and shipping. Ohio residents add 4% sales tax. Send check or money order. Satisfaction guaranteed.

ECD ELECTRONIC CIRCUITS & DESIGN CO., INC.
170 E. Market St. • Alliance, Ohio 44601

CLASSIFIED ADVERTISEMENTS

Rate: \$2.90 per word payable in advance each insertion. Bold face capitalized words—75¢ per word additional (First word set in Bold Face at no extra charge, Zip Code Free). Minimum insertion ten words. To be inserted under proper classification, copy must be in our office by the 10th of the second month preceding date of issue. The next available issue to place an advertisement in America's No. 1 Classified Section is March. The closing date is January 10th. Send remittance payable and order to Popular Mechanics, ATT.: H.E. Kappel, Class. Adv., Mgr., 224 West 57th Street, New York, New York 10019. As a consumer service and in cooperation with our mail-order advertisers who use post office box addresses for their convenience in handling your order, Popular Mechanics maintains a register of such mail-order advertisers containing their complete name and street address, which is available to you upon request.

When answering advertisements please use the zip code number

AUTOMOBILES

FABULOUS SAVINGS When buying, trading, financing autos. Valuable informative facts. \$2.00 Guaranteed. Frank, Box 13133P, Orlando, Florida 32809.

SAVE Gas Remove Smog Devices. Details \$4.00. Ross, Box 607, Titusville, Florida 32780.

"50 MPG Carburetors—Do they Exist? Free Details." Madison, Box 206-S, Berea, Kentucky 40403.

33% OFF Delta CDI Radar "Snoper", QI Lights, Gauges, Tools. Free catalog. Time Machines, 29M Falmouth St., Brooklyn, N.Y. 11235.

SANDBLASTERS, Easy removal of rust, paint, scale. \$129.50 up. Pressure-fed work on low air supply. Catalog-25¢. Tip Sandblast Manufacturers, 1330 Market, Youngstown, Ohio 44507.

SAVE Gas, Oil, Plugs. Details Free. Motaloy, 2532 Superior, Chicago, Ill. 60612.

EXPAND THE VOLUME OF YOUR GASOLINE. Better performance and mileage with **GASXPANDER.** Uses wasted engine heat. No maintenance. \$34.95 (yr&mk) model, engine. **GAS-X-CEL,** Star Rt., Glens Falls, New York 12801.

TORQUE GAUGES, For high performance driving or fuel economy. Details \$1.00. D.S., Box 98943, Des Moines, Washington 98188.

SAVE GAS. Give your car more pep, power and gas economy for less than \$5.00. **FREE** details. Ariel, P.O. Box 3803, Bayamon, P.R. 00620.

QUICK OIL CHANGE. One permanent installation. Connects directly to drain plug on pan. **FREE** literature. Sea Haven, Box 1201, Glendora, California 91740.

BUY CARS BELOW WHOLESALE. Dealer cost revealed. Complete instructions Latest consumer report. Information Free. Write Son-Roe, Dept. P176, 620 Rosalie, Phila., Pa. 19120.

MOTALOY Ring-Valve Replating Job—\$6.00 Money-Back Guarantee! Free brochure! Arrow Products, Box 3741, Broken Arrow, Okla. 74012.

GAS Savings, remove smog devices. Details \$4.00. Nor-Cal, Box 214932, Sacramento, Ca. 95821.

CUT Your Gas Bill by 30%! Send \$1.00, make and year of car, For Details, A.C. Enterprises, P.O. Box 241, Milton, Delaware 19968.

EASY Do-It-Yourself Tune-up guide, \$4.00. to: L. Green, 628 S. 5, Pocatello, Idaho 83201.

MIDGET CARS

YOUR AD IN POPULAR MECHANICS WILL BE SEEN By More than 5,000 active buyers for your products and services. It costs only \$2.90 per word. And, if you wish to run all or part of your ad in bold capital letters—you can do so for as little as 75¢ per word additional. Act now! Send your Classified ad to: **POPULAR MECHANICS, CLASSIFIED DEPARTMENT, 224 WEST 57TH STREET, NEW YORK, N. Y. 10019.**

PEDAL CAR KIT, Sensational New Fun Car You Pedal! Open Frame Speedster Type. The Ideal Sport, Work, Exercise Vehicle. Easy To Build! Details \$1.00. Pedal Engine Corp., Box 1648, Largo, Florida 33540.

AUTO SUPPLIES & EQUIPMENT

HYDRAULIC Jack repair kits parts and supplies. Catalog 50¢ (in coin). Hydraulic Jack Packing & Tool Co., Inc., General P.O. Box 3, Staten Island, N.Y. 10314.

"ALTERNATOR/Generator Rebuilding Book." Information: Hedelund Engineering, POB 5777, Las Vegas, NV. 89102.

REVOLUTIONARY Auto Air Conditioner You can build for About \$50. **SAVE GAS.** **FREE** Detailed Information. Spage Age Research Co., Dept. PM1, Box 770, Columbus, Indiana 47201.

PARTS: Army jeep and truck parts. Spare Parts & Equipment Co., P.O. Box 751, Lexington, Kentucky 40502.

UNIQUE Iglit Continuously Monitors Ignition Performance. Q-ARC, Box 47876, Los Angeles, Calif. 90047.

DISK BRAKE PACKER pack bearings without removal of wheels rotors calipers brakes lines. Trem Products, 78 Page Rd., Bedford, Mass. 01730.

AUTOMOTIVE Tools & Equipment, Nationally Advertised Brands at Discounted prices for Mechanics. Send Self-addressed Envelope for current specials. Associated Distributors, 401 Augusta St., Cincinnati, OH 45202.

HOTTEST Gas Saver on the market. Should **INCREASE MILEAGE** 15 percent. Free details. Free Energy Specialists Company, Dept. PM1, Route 1, Box 312-B, Conway, So. Carolina 29526.

VX-6 Treatment Ends Battery Failure—Summer And Winter. Dramatic Results. Five Year Guarantee. \$3.98—VX-6. 2061P Oak, Quincy, Illinois 62301.

VW STARTER Sticking? 6V Booster solenoid switch, wires, instructions. \$5.50. Niles Prod., Div. 2, Box 237, Moriarty, N.M. 87035.

CAR OWNERS, solve many future car problems. Trouble Shooting Chart, included free. Emergency Clothes Saver, send \$1.00. Charts, P.O. Box DC, Monterey Park, California 91754.

MOTALOY Ring Valve Job while you drive. \$6.75 Postpaid—Two \$12.50. Guaranteed. Andris, Dept. 263A, Box 34237, San Francisco, California 94134.

SAVE Money! Do it yourself and end expensive Auto Repairs. Book shows how! Send \$1.95. Carand Associates, 4 Pine Way, Long Valley, N.J. 07853.

WHEEL BALANCERS \$14.95 up. Free catalog. Jacobsen Manufacturing, Box 68143, Seattle, 98188.

IGNITIONS, High Energy Systems. Brochure. Labronics, 3635M Hillside, Ypsilanti, MI 48197.

MOTORCYCLES, BICYCLES, MOTORSCOOTERS, & SUPPLIES

GO-KARTS, Mini-Bike, 4 Wheel Bike Car. **AND** Ele-Bike. **PLUS** Learn to Weld instructions. **ALL** For \$2.00. E.J. Sales, Box PM 3084, Centerline, Mich. 48015.

ELECTRIC Bicycle and Tricycle Plans!!! \$2.00 (Refundable). Fast! Fun! Easy To Build! E.B. Enterprises, P.O. Box 444, Reseda, Calif. 91335.

AMERICAN Indian Motorcycle Parts. 119 East Huntington, Monrovia, California 91016. 213-447-4078.

ILLUSTRATED Catalog, 25¢. Parts and Accessories. Custom and Stock. For Most Makes and Models. Motorcycle Supply, Box 159M, Fairbury, Illinois 61739.

HONDA, \$25.00. Other Bargains. Send \$1.00 (Refundable). Motorscooter, P443, Bend, Oregon 97701.

MOTORIZE BICYCLES—PLANS!!!! Electric, \$2.00 ... Gasoline, \$2.00 ... Both, \$3.00 ... Guaranteed ... Britt, 956 Springdale, Atlanta, Ga. 30306.

BICYCLE Parts and accessories, wholesale prices. Write: Bicycles, 4093 Wm. Penn Highway, Murrysville, PA 15668.

MOTORCYCLE, Mini-Bike, Go-Kart, Supplies. Discount Catalog 25¢. Lorenzo, Danville, Illinois 61832.

MINI BIKE PLANS and INSTRUCTIONS, Bolt together, \$2.00. L. F. D. Dist. Co., Box 316A, Dante, Va. 24237.

AVIATION

AIRBOAT Propellers, Engines, Hubs, Mounts, Supplies. Corvair, V-W Conversions. Removable Airdrives. Catalog \$1.00. Banks-Maxwell, Box 3301E, Ft. Worth, Texas 76105.

ULTRA-LIGHT HANG GLIDERS From world's largest manufacturer. Unsurpassed quality & safety. Rogallo plans—\$5.00. Kits, Complete gliders. Free Rogallo & Icarus information. Free-Flight, 12424 Gladstone, Sylmar, California 91342.

BUILD—ONE-MAN JET HELICOPTER. Easy inexpensive. Detailed Plans, Drawings—\$6.00. Helicraft, Box 7153, Baltimore, Maryland 21218.

HANG GLIDING Handbook, 200 Pages, \$5.95 postpaid. Poynter, Box 4232-S, Santa Barbara, CA. 93103.

AIRBOAT Propellers, 2-blade, 3-blade, 4-blade. Multi-blade hovercraft fans. Test Propellers. Industrial Wood Fans. Catalog \$1.00. Arrowprop, Box 19225M, Oklahoma City, Oklahoma 73119.

HOVERCRAFT

AERO-CAR Amazing Hovercraft built easily with ordinary tools. Lawnmower engine power. Carries one man plus. Hovers, flies forward, backward. Sideways over and/snow/water. Complete construction plans and brochure. \$5.95. Aero-Projects, Box 5118PM, Clinton, New Jersey 08809.

HOVERCRAFT Plans All Sizes Tested Designs Catalog \$1.00. Universal Hovercraft, Box 281, Cordova, IL. 61242.

BOATS & TRAILERS

BOAT KITS, HULL KITS, FRAME KITS, PLANS & PATTERNS. World's Largest catalog, over 300 modern designs for the amateur in fiberglass, plywood, strip planking, steel, aluminum, cement, from 7 to 70 feet. **SAIL-Prms,** Day Sailers, Motor Sailers, Ocean Racers, Trimarans, Catamarans, **POWER-Cruisers,** Trawlers, Run-a-bouts, Fishing Boats, Kayaks, Inboard & Outboard Hydroplanes, Tunnel Boats. Also complete boat-building materials, sails, fiberglass, plywood, etc. Send \$1.00 for catalog or \$2.00 for catalog plus boat-building guide to Clark Craft, 16-P, Aqua Lane, Tonawanda, New York 14150.

FIBERGLASS BUILDER'S MATERIALS. Lowest factory prices in cloth, mat, roving, resin, epoxy, foam, bronze, nails, plywood, mahogany. Send \$1.00 for literature or \$2.00 for literature plus booklet on mold making and "How to" fiberglass. **CLARK CRAFT,** 16-P1 Aqua Lane, Tonawanda, New York 14150.

BOAT PLANS, FRAME KITS, FULL SIZE PATTERNS! Easy, proven methods especially for amateurs include step-by-step pictorial instructions. Huge 128-page catalog shows-Sailboats-Powerboats-Inboards-Outboards - Jets - Houseboats - Cruisers - Hydroplanes - Trawlers - Catamarans - Ski Boats - Tunnel Hulls - 8' to 49'. New "One-Off" Fiberglass Designs! Also fastenings, fiberglass, rigging, hardware, sails, spars, boat trailer plans, "how-to" books. Send \$1.00 for catalog plus Free "Boatbuilding Supplies" brochure. Glen L Marine, 9152 Dept. MP, Rosecrans, Bellflower, Calif. 90706.

CANOES! Kayaks! Factory Direct quality kits, from \$30.00. Many different models. Canvas, hulls. Strongest construction materials. Free literature. Sportscraft, Box 636-P, Allentown, New Jersey 08501.

FIBERGLASS Canoes, Kayaks, and Duckboats. Many exciting models. Easily assembled kits. \$49.95 up. Free Literature. Riverside Canoes, Box 5595-AA, Riverside, Calif. 92507.

NEW 1975 Outboards . . . Top Brands . . . GHP \$375 . . . 15 \$549 . . . 40 \$718 . . . 50 electric \$1030 . . . 70 electric \$1230 . . . All sizes. Evinrude-Scott-McCulloch-Parts. Handling \$1.00 Electra Marine, 610 Merrick Road, Lynbrook, New York 11563.

CANOE, Kayak Kits—Wood Canvas, Molded Fiberglass—Free Catalog. Trailcraft, Inc., Box 60686, Concordia, Kansas 66901.

FIBERGLASS Cloth and resin. World's finest cloth and non-run resin, at direct mill prices. Complete line of plastics, silicon bronze and brass screws, save 60%. No sales tax. Boat Plans. Catalog 25¢. Stiles Boat Supply, Box 11P, Linden Avenue, Mantua Heights, N.J. 08051.

BOAT KITS. Factory Molded Fiberglass. Assemble yourself, save half factory built cost. Sailboats: 16'—\$797; 21'—\$1399; 26'—\$2295; Power Cruisers: 22'—\$1598; 24'—\$2365. Easy Terms. Free Catalog. Luger, Dept. BC-76, 3800 West Highway 13, Burnsville, Minnesota 55337.

FREE catalog, Kayaks, Canoes, Sailboats, Pirogues, Fishing boats, Duckboats, Plans, Patterns, 41 models. Outdoor Sports, Box 1213-P, Tuscaloosa, Ala. 35401.

BUILD DRY ELECTRIC SUBMARINE, 2-man, information \$5.00. J. Brown, 3236 S. Franklin, Springfield, Missouri 65807.

CAMPERS AND TRAILER KITS—PLANS

CAMPER/TRAILER KITS, Plans, Full Size Patterns especially for amateurs. Save! Build your own RV! Dozens of models for domestic and import vehicles. New gas-saving models, pickup covers, fifth wheelers. Van Conversion plans \$5.00 Pictorial instructions assure professional results. Send \$1.00 (refundable) for illustrated details Plus RV Kits/Equipment catalog. Glen L RV's, 9152 PM Rosecrans, Bellflower, Calif. 90706.

MODULAR Tent Trailer Plans. Illustrated Brochure 25¢. KNH Products, Box 494, Waukesha, Wisconsin 53186.

MANUFACTURER Releases plans for simple do-it-yourself type construction of RV's. For complete line of Kits and Plans send \$2.00 to: **GO-LITE Campers, Inc.,** 23rd & Somers, Fremont, Nebraska 68025.

MARINE EQUIPMENT AND SERVICES

MARINE Engines, conversions, parts, equipment. Catalog Free! Stokes Marine Industries, Coldwater, Michigan 49036.

CONVERT Auto engines to marine. 68 Page Catalog, 50¢. Lehman Manufacturing Company, 800 Elizabeth Avenue, Linden 4, New Jersey 07036.

ATHLETIC AND BODY BUILDING COURSES

INCREASE Height! 2-6". 35¢ Guaranteed. Taller—YE, 232 Front, Napoleon, Ohio 43545.

ARMS, 18+ INCHES IN 90 DAYS Or Refund! Revolutionary Arms Specialization, \$3.00—Complete! (Karate—Free Information) Phenominics, Box 281D, Gresham, Oregon 97030.

DYNAMIC MUSCLES FAST! Guaranteed! Goliath Enterprises, Box 933F, Wheeling, Illinois 60090.

HUGE MUSCLES FAST! 35¢. Guaranteed. MUSCLES - ZV, 232 Front, Napoleon, Ohio 43545.

SPORTING GOODS AND EQUIPMENT

ARCHERY Lowest Discount Prices. All top brands. Orders shipped same day received. Money-back guarantee. World's Largest Supplier. Free catalog. Anderson Archery Corporation, Grand Ledge, Michigan 48837.

SCOTT'S handwarmer and bodywarmer. Get 140-150° out of each. Just add water. So order now. Bodywarmer \$9.95, Handwarmer \$4.95 ppd. Rodney Chicoline Sales, Box 49, Elk Point, So. Dak. 57025.

FANTASTIC THROWING KNIFE—Unusual, balanced, UNBELIEVABLE—IT WORKS! Steel, 10" long, instructions. Send \$5.00. Kung-Fu, Box 163, Cumberland, R.I. 02864.

HUGE Sportsman's Catalog low direct factory prices, fishing, hunting, archery, reloading, camping. Send \$1.00 Refundable. Herbers Inc., Dept. CPM, Waseca, Minn. 56093.

CAMPING EQUIPMENT & TENTS

POPULAR MECHANICS SAFETY PONCHO, Heavy-Duty Poncho of 100% Virgin Vinyl, imprinted with POPULAR MECHANICS Trademark and with its own Handy Carry Pack! Twenty-Four Self-Sticking Scotchlite Reflectors Included. (They Reflect the Headlights of Cars for Night Safety). Incredible for Camping, Cycling—Any Outdoor Activity! Only \$4.95 ppd. PM Poncho, Dept. HE, Box 1014, Radio City, N.Y. 10019.

TRAVEL AND RESORTS

VISITING BRITAIN? Save \$100's. Hundreds of Comfortable Low Cost Bed and Breakfast Addresses. \$5.00 Airmail \$9.00. Rogers, Flat 5, High St., Uttorex Staffs, England.

FISHING, TACKLE, LURES

FREE Catalog: Reels, Rods, Lures, Fishing Accessories, Lure Parts, Camping and Backpacking. Lowest Prices. Cabela's, Inc. Dept. S176, Sidney, Nebr. 69162.

EARTHWORMS, LIVE BAIT

GREY Nightcrawlers make money raising or Retailing Fishbait—Free Details—Fain's Wholesale Bait—Edison, Ga. 31746.

EARN Money Raising Fishworms For us! Exciting details free! Oakhaven-56, Cedar Hill, Texas 75104.

FREE Literature. Profitable Business Raising Fishworms, Crickets. We Teach you how to Raise and Sell. Write today. Carter Fishworms, Plains, Georgia 31780.

HYBRID Redworms, 5000-\$15.00; 20,000-\$30.00, postpaid with Raising Instructions. Brazos Worm Farm, Box 4185, Waco, TX 76705.

RAISE Grey Hula' Redworm Soilless Method. Three Oaks, Dresden, Tenn. 38225.

HUNTING, GUNS, DECOYS

PELLET GUNS And accessories. Sensible, enjoyable shooting anywhere. Finest adult models; satisfaction guaranteed. Free catalog. Write: Air Rifle Headquarters, Grantsville, WV 26147.

POULTRY & GAME BIRDS

QUAILS, Incubators, cages, supplies catalog. Marsh, 14216 Brookhurst, Garden Grove, Calif. 92643.

ORDER NOW! Commercial Lots—Pheasant, Quail, Chukar, Turkey, Mallard. "Restocking Manual" \$3.95. Northwest Farms, Box 3003PM, Portland, Oregon 97208.

RABBITS, CHINCHILLAS, FUR BEARING ANIMALS

PUT High Protein Meat on your table—Raise rabbits successfully. 68 page illustrated booklet tells how. 50¢ includes handling and mailing. American Rabbit Assn., 36 Arba Bldg., Bloomington, Illinois 61701.

RAISE Chinchillas. Guaranteed income. Illustrated catalog \$3.00. Refundable. DeShon Chinchilla, Route 2H, Roanoke, Indiana 46783.

AMAZING PROFITS!! \$10,000 Yearly Raising Rabbits for Wool and Breeding. Send \$1.00 for Details. American Angora, Malta 12, Montana 59538.

\$500-\$1000 MONTH Plan raising rabbits for us. Details 25¢. White's Rabbitry-PM, Hudson, Ohio 44236.

FANCY ORNAMENTAL POULTRY

BLUE-EGG ARAUCANAS, YOKOHAMAS, REDCAPS, Dominiques. Over 67 varieties Baby Chicks. Beautiful 24-page full color catalog. Send 25¢. Murray McMurray Hatchery, M165, Webster City, Iowa 50595.

PETS—BIRDS, CATS, HAMSTERS, ETC.

SKUNKS, Raccoons, Pets. Catalogue 50¢. Trails End Zoo, St. Stephen, S.C. 29479.

HORSES, LIVESTOCK

"HOW TO TRAIN HORSES"—FREE Book tells how to break, train, make money with horses. Beery School, 1101, Pleasant Hill, Ohio 45359.

ELECTRICAL SUPPLIES

ELECTRIC MOTOR SUPPLIES! Equipment Plans! Modequip, Box 7266, Kansas City, Missouri 64113.

ELECTRONICS

SURPLUS, Kits, Telecommunications, \$0.50, E-S Lab, Box 738C, College Park, MD 20740.

DISCOUNTED CB RADIOS, ACCESSORIES, All Popular Brands, ESCO CB Mart, Box 1167P, St. Joseph, Mo. 64502.

BATTERIES, GENERATORS

BATTERY Reconditioning Kit, includes molds, material, instructions. Apex Engineering, 3100 Ramona, Atascadero, California 93422.

ENGINES, MOTORS, MAGNETS

REWIND Car Generator for 110 VAC. Power Plant Plans \$2.00. Schmauss, 1228 East Cass, Tampa 33602.

RUN Three Phase Motors on Single Phase! Three Methods! New Illustrated Manual. \$3.00 Guaranteed! Lindsay, Box 12-1, Bradley, IL 60915.

WINDING Lesson, A.C.-D.C. Armatures, \$3.50. Data Company, 512 Kensington, Kansas City, Mo. 64124.

MACHINERY, TOOLS, & SUPPLIES

WOOD Shaper \$25.00—Lathe \$20.00—Table Saw \$30.00. Catalog \$1.00. Rego, 49H Downing, Fall River, Mass. 02723.

STAINLESS Screws stop rust! #6-32x1/2" \$2.10/50. Catalog 35¢. Gartmann Associates, Box 1005D, Delran, NJ 08075.

4" METAL Cutting Lathe \$54.50. Taig, Dept. D, 15048 Proctor, Industry, Calif. 91746.

MILLING Cutters, lathe milling attachments. Catalog \$1.00. Potter, Box 73, Cedar Rapids, Iowa. 52406.

BANDSAW BLADES. Any Size. Free catalog. Parker, R4, BX735, Sonoma, Cal. 95370.

SMALL FOUNDRY furnaces. Supplies. Free literature. Pyramid Products, 3736 South 7th Avenue, Phoenix, Arizona 85041.

PLANS, Tube bender, Press, Break, info., P. O. Box 56, Campo, Calif., 92006.

1400 CATALOGS Listed and Described! Sources for EVERYTHING Imaginable! Rush \$2.00. MASTERLOG, Box 24413-V, Oakland, California 94623.

"WISE-MATE"—The slickest, space-savingest way to independently mount your vise (or some other equipment) to a solid wall, post, or column. Complete with fastening devices—\$29.95 plus \$2.50 shipping charge. Free literature. Susy-Lu Enterprises, 12 Rambo Drive, New Castle, Delaware 19720.

ACCURATE, LOW COST, VERTICAL MILL, PLANS ONLY \$3.00 POSTPAID, MCKINSTRY, BOX 6344-J, SANTA ANA, CA. 92703.

UNIMAT Lathes—Maximats—Metals—Micrometers—Catalog \$1.00. Campbell, 1424 Barclay, Springfield, Ohio 45505.

CARBIDE ENGRAVING PEN. Writes on anything. Never needs sharpening. \$2.59. Rex Castellaw—Mail Order, 14141 Brenan, Santa Ana, Calif. 92705.

STAINLESS STEEL Nuts, bolts, screws. Hard to find sizes sold in small lots. Price sheets. Fastening Products, Box 151, Cheltenham, Pa. 19012.

HIGH SPEED Drill Set, 10 Pieces—1/16 to 1/4. Plastic Case \$5.00 Postpaid. Guaranteed. Karl Enterprises, 1716 Vanderbilt Road, Kalamazoo, Michigan 49002.

500 SOURCES Tools, Supplies, Books, \$2.00. Craftsman's Source Index, 4216 V, Telegraph, Oakland, California 94609.

BUFFING & POLISHING

BUFFING AND POLISHING COMPOUND KIT Contains assortment of 4 bars plus buffing and polishing instructions. Send \$4.00. Satisfaction or Money Back. Schaffner's, Dept. PM176, Pittsburgh, Pa. 15202.

WELDING, SOLDERING, PLATING

ELECTROPLATING Equipment, Portable Platers, Supplies, and "Know-How." Build your own tanks for nickel, chrome, etc. Easy-to-install PVC liners. Rectifier components—all sizes. Schematics, parts lists, formulas, operating instructions for all-plating. Guaranteed to save you 25%-75%. Some good used units for sale. Free Details. Platers Service Company, 1511-PM Esperanza, Los Angeles, California 90023.

WELDERS. Convert To Heliarc. High Frequency Unit 0-225AMP. Plans \$4.00. Convert To DC Plans \$3.00. Information Supply Co., Box 166, College Park, MD. 20740.

GOVERNMENT SURPLUS

1976 SURPLUS Army, Navy Store, 56 Page Illustrated catalog. Send \$1.00. Ruvel, 3037 North Clark, Dept. 1-J, Chicago, Illinois 60614.

JEeps \$52.50!—CARs \$31.50! 100,000 items!—YOUR AREA! \$2.00 MONEY BACK GUARANTEE!!! GISP-M-1, Box 99494, San Francisco, CA 94109.

FREE! Nationwide Surplus Data List. WRITE TODAY! NATIONWIDE AUCTIONEERS, Box 872PM, Anoka, Minnesota 55303.

"U.S. GOVERNMENT SURPLUS DIRECTORY." How, Where to buy 100,000 items (including Jeeps) . . . low as 2¢ on dollar! Most complete information available . . . \$2.00. SURPLUS DISPOSAL, Box 6586-AA, WASHINGTON, D.C. 20009.

GOVERNMENT SURPLUS, How and Where to buy in your area. Send \$2.00. SURPLUS, 30177PM HEADQUARTERS BUILDING, Washington, D.C. 20014.

JEeps!!! PICKUPS!!! 100,000 items direct from government. Your area. Latest information & surplus categories: \$2.00 MONEYBACK GUARANTEE. Order manual #156, from "Dependable Products", Box 113, Vista, California. 92083.

GOVERNMENT LANDS FROM \$7.50 ACRE! Vacating, Farming, Investment! Exclusive "Government Land Buyer's Guide" . . . plus "Land Opportunity Review" listing lands throughout U.S. Send \$2.00. Surplus Lands, Box 6588-AA, Washington, D.C. 20009.

HELMETS, Bayonets, Replica Guns, Catalog \$1.00. Tyco Camping, Box 302, Vienna, Virginia 22180.

NO Middleman. Used & Surplus equipment available directly from Government. \$2.00. Surplus Procedure Manual, 24413-CNTRL-Oakland-Main, California 94623.

JEeps, TRUCKS, Typically from \$52.40 . . . Automobiles, Boats, Motorcycles, Airplanes, Typewriters, Tools, Clothing, Sports, Camping, Photographic, Electronics Equipment . . . 200,000 Bid Bargains Nationwide Direct From Government . . . Low as 2¢ on Dollar! Surplus Catalog and Sales Directory \$1.00 (refundable first order). National Surplus Center, 204 Eastcass-PPM, Joliet, Illinois 60432.

HOBBIES AND COLLECTIONS

NAZI Souvenirs! Illustrated catalog \$5.00 bill (refundable). Disco, Box 331-P, Cedarburg, WI 53012.

COLLECT WORLD BANKNOTES. Fascinating, Colorful, Inexpensive. Five Different Plus Bargain List, \$1.00. Craddock World Currency, Box 38145, Houston, Texas 77088.

FLORIDA Shells 1/2" to 2" Specimens 25 for 6.95 postpaid. Aultz, PO Box 5021, Fort Lauderdale, Fla. 33310.

COLLECT Military Medals. List 50¢. Vernon, Box 387PM, Baldwin, N.Y. 11510.

AUTOGRAPHS—Letters, Documents of Famous People, Bought and Sold. Monthly Catalogues Issued. Neale Lanigan, Box 133, Fairview Village, Pa. 19409.

COLLECTING Political Items? List 50¢. Campaign Americana, Box 275PM, Merrick, NY 11566.

DOLLHOUSE MINIATURES Illustrated catalog \$1.50. Hobby Craft Miniatures, 118 West Main, Marshalltown, Iowa 50158.

DECALS, EMBLEMS, PATCHES

CUSTOM Designed Embroidered Emblems, Decals. Inexpensive. Free Catalog, details. Southern Emblem, Box 8PMB, Toast, North Carolina 27049.

EMBLEMS, Quality Patches, Beautifully Embroidered. Made to Order from your Design. Low Cost, Fast Service. Free Catalog with Design Guide. Donalyn Creations, Box 247PM, Cliffside Park, N.J. 07010.

FREE Catalog—Iron-on heat transfers. Beautiful Multi-Colors. Sample \$1.00. Specialty Wholesaler, Princeton, Iowa 52768.

STAMP COLLECTING

YOURS FREE! 55 Valuable Red China old and new postage stamps previously banned to Americans by the U.S. Gov't. At last you can legally own them—you may never have another chance as supplies are strictly limited so act fast! This spectacular and genuine offer given to introduce Kenmore's sensational world-wide Stamps-On-Approval Service for FREE examination. Buy \$2.00 or more and get valuable bonuses or buy nothing—return selections—cancel service anytime. In either case the 55 Red China stamps are yours to keep FREE. Send 10¢ for mailing to: Kenmore, Milford CR-289, New Hampshire 03055.

FREE! \$10.00 Giant Stamp Collection of 300 all different colorful valuable postage stamps from Africa—Europe—Asia—British Empire—Worth \$10.00—\$12.00 at catalogue prices. Also money-saving Booklet. All yours as a Get-Acquainted Gift. Adults only. Other fine stamps enclosed for your inspection. Frasek Co., Inc., PM-1, White Plains, New York 10601.

(Continued on next page)

STAMP COLLECTING

(Continued from preceding page)

50¢ BRINGS You 100 pictorials plus worldwide approvals. Capt. Shaw's Stamps, Box 277, Ocean Park, Maine 04063.

GRAB BAG Of over 100 unsorted stamps. Contains new issues, Asia, South Seas, Africa, etc. All for only 10¢. Littleton Stamps, Dept. EX-1, Littleton, N.H. 03561.

SPECIALS US commemoratives 211 different \$1.00. 32¢-\$3.00, 40¢-\$5.00, 50¢-\$10.00, 60¢-\$20.00, 65¢-\$35.00, airmails 36¢-\$1.00 61¢-\$5.00, no approvals. Regency Stamps, Box 8854, Pittsburgh, PA 15221.

SEND Only 10¢ for nice collection of U.S. Stamps including \$5.00 issue and scarce mint Sipek Souvenir Sheet. Attractive price lists of other beautiful stamps and collectors supplies also included **MYSTIC STAMPS**, Dept. SS-1, Camden, New York 13316.

50 SPORTS PICTORIALS 25¢ with approvals. Arbour, 3727 Downey Dale, Randallstown, Maryland 21133.

FREE! U.S. \$1.00 Stamp—Older issues, Commemoratives, Airmails, Virgin Islands, others. Catalog Value over \$5.00. U.S. Bargain Price List—All Free—Send 10¢ for mailing. Empire Stamp, Toronto, Canada M4W 2M2.

FREE! BIG BARGAIN CATALOG—NEW EDITION Listing thousands of bargains including U.S. & B.N.A. stamps, packets, albums, accessories and supplies. Also, fine stamps from our approval service which you may return without purchases and cancel service at any time. Jamestown Stamp, Dept. E16PM, Jamestown, N.Y. 14701.

SURPRISE COLLECTION! Exotic Mint British Colonials absolutely free with approvals. **VIKING**, Great Neck, NY 11021.

CANADA: Olympics, mint, only 25, approvals. Rheume, 91 Valois, Vimont, Que. Canada H7M 1A9.

50 DIFFERENT Pre-1945 United States. Including Commemoratives. Only 25¢ with profit-sharing approvals. 25 United States Airmails, 75¢. Universal, Box 6D, Kenosha, Wisconsin 53141.

BREATHTAKING Beautiful, 50 different mint Monaco pictorials—commemoratives only \$1.50 with mint complete set approvals. Pagoda, Box 132P, Sidney, Ohio 45365.

50 MINT British Empire \$1.00. B. Malover, Box 841, Southfield, Mich. 48076.

COLORFUL WORLDWIDE COLLECTION—Only 10¢ with approvals. Castle, Box 14330PM, West Allis, Wisconsin 53214.

FREE. U.N. Mint Set. Approvals. Hildebrand, Box 5645, Redwood City, California 94063.

OVER \$65.00 Catalog Value worldwide mint stamps for \$10.00. Largo, 1501 Broadway 2907B, New York, New York 10036.

FREE Mammoth Collection, Scott's, Master Global Albums, When You Buy Approvals. Bargain Stamps, Box 5345, Santa Ana, Ca. 92704.

U.S. 100 Different 10¢ with approvals. Bonus Stamps, Box 385, Midlothian, Virginia 23113.

WOW! 110 ALL DIFFERENT GERMANY 10¢. Commemoratives, Airmails, High Values, Big Catalog, bargain lists. Also, fine stamps from our approval service, which you may return without purchases and cancel service at any time. Jamestown Stamp, Dept. A16PM, Jamestown, N.Y. 14701.

BECOME A Stamp Dealer. \$1.00 brings 30 set stock. Resale value \$3.00. Stamps, Box 27, Fremont, Michigan 49412.

U.S. COMMEMORATIVES. 50 DIFFERENT 25¢. Approvals included. **LLOYD'S**, Box 5001, Monroe, Louisiana 71201.

10 ISRAEL Stamps Free to approval applicants. W-B Stamps, Wilkes-Barre, Pa. 18703.

FREE! 25 Worldwide to Approval Applicants. Weller, 34447-28 Yucaipa, Yucaipa, Calif. 92399.

FREE Catalog Available Now—U.S. Stamps, Box 4582, Overland Park, Kansas 66204.

100 TURKISH 10¢. Approvals. Box 212, Dept. P.M., New Hampton, N.Y. 10958.

FREE Duplicate Exchange - 2¢ Approvals. Belden, Box 4175, Dearborn, Michigan 48126.

TWO NUDE Sets Plus 100 Others 35¢. Approvals. Coleman, 411M Hawthorne, Smithville, Mo. 64089.

U.S. 6 DIFFERENT Commemorative plate blocks \$1.00! 30 different mint U.S. commemoratives \$1.00! 9 different mint U.N. sets \$1.00! Approvals. Gordon Davison, Hillsboro, New Hampshire 03244.

100 DIFFERENT British Empire 10¢. Approvals. Gibson, Box 34, Lansdowne, Pa. 19050.

65 DIFFERENT NUDES \$2.00. 80 Diff. \$3.00. No Approvals. Kemp, 9952 Tamarack, Pacoima, California 91331.

20 HISTORICAL U.S. Commemoratives 20¢. U.S. Approvals accompany. **PINTO STAMP CO.**, Box 111, Park Ridge, Ill. 60068.

50 YEARS Old, fifteen different United States, over fifty years old—25¢ with approvals. Jaxon, Box 145-P, Brooklyn, New York 11230.

SINGLE STAMPS 2¢ and up. Mounted in books. **TRUST STAMP COMPANY**, P.O. Box 100-P, Jamaica, New York 11435.

FREE Surprise collection sent with approvals. Gould, 1784 Union, San Francisco 94123.

FENNY! Approvals! Regardless catalogue! Kloster, 4164 52nd St., San Diego, Calif. 92105.

BUILD Large U.S. Collection Economically. Sherman, Box 15355G, Philadelphia, Pa. 19111.

500 DIFFERENT Stamps, \$1.50. Smith, 508-A Brooks. College Station, Texas 77840.

100 OLD United States between 1861 and 1939. \$1.00. Ed Roush, 423 Shepard, Mansfield, Ohio 44907.

U.S. BARGAIN, 50 Different 25¢, with beautiful worldwide, approvals. Stamp Center, Kennebunk, Maine 04043.

TEN Different Nudes: 20¢. Approvals. Stamp Farm, 2M86, Oxford, Wis. 53952.

100 DIFFERENT United States Commemorative, 50¢ with Discount Price List. Shelton, Box 547C, North Miami, Fla. 33161.

SCARCE Guinea UN Airmails \$2.25, catalog 25¢. Approvals. Stamphaus, Box 533, Salisbury, Mass. 01950.

U.S. MINT Specials! Flag Set complete \$1.50. 1¢, 2¢, 3¢ Famous Americans (21 different) \$1.50. Free List. Brooks, 2601 Avenue "U", Brooklyn, N.Y. 11229.

VIETNAM 25 Different 10¢ approval. Sam Chazen, Box 95, Ozone Park, N.Y. 11417.

110 DIFFERENT U.S. Commemoratives. \$1.00. Stamps, 7607 Larchview Drive, Dallas, Texas 75240.

OLDER U.S. ON APPROVAL. SURPRISINGLY GOOD SELECTIONS FOR ADULT COLLECTORS. RIVERTOWN, BOX 188P, LOWELL, MICHIGAN 49331.

WORLDWIDE New Issues—Free Weekly illustrated Lists. Brooks, 2601N Avenue "U", Brooklyn, N.Y. 11229.

WORLDWIDE Commemoratives. 25 Different 25¢. Approvals. Wilson, Box 116, Dollard des Ormeaux, Quebec, H9G-2H5 Canada.

50 DIFFERENT Old U.S. Revenue Stamps \$1.00. Winchester Stamps, Box 3592, Mansfield, Ohio 44907.

"WHOLESALE" U.S.—Foreign Pricelist and catalog Free! Everything Guaranteed. Schneider, Box 1240, Grand Rapids, Michigan 49501. "We accept Master Charge."

BETTER GRADE U.S., Canadian Stamps for advanced collectors. Borgen, Box 645, Seiad Valley, Calif. 96086.

225 DIFFERENT Worldwide: 25¢. Approvals. Tibbets, 8675 Meadow, Downey, California 90242.

FREE New used Congo animal set. Approvals included. Alpaughco, Box 225, Highbridge, N.J. 08829.

DOLLAR Brings 100 worldwide collection and assortment U.S. pictorials plus approvals. Satisfaction or instant refund. Cookstamps, 66 Belmont Road, Dept. C., Rochester, New York 14612.

FREE Worldwide packet. Penny approvals. Froehlich, Box 412A, Morton Grove, Illinois 60053.

50 DIFFERENT Argentina-10¢. Approvals. Gobestamps, Box 690, Saco, Maine 04072.

FREE Stamp Catalog: 3,000 different packets by countries, topics. Ullery, 1016 Meridian, Mishawaka, Indiana 46544.

SOUVENIR Sheet, 10¢, approvals accompany. L & L Stamps, Box 34344, Houston, Tx. 77034.

FREE U.S. mint error. Approvals. Chapmans, Box 487E, Galesburg, Michigan 49053.

FREE First Day Cover, Approvals, Gall, Box 96, Coopersburg, PA. 18036.

EXCHANGE. Send 100-200 different foreign with 35¢. Receive different. Patterson, Lancaster, New York 14086.

NEW, 100 spectacular worldwide stamps, value \$3.00—10¢. Colorful, discount approvals. Stampman, Box D64M RD 1, Chester, NJ 07930.

CANADA: Ten Late Commemoratives 10¢, Canadian Approvals, Harley Boardman, Little Valley, New York 14755.

50 DIFFERENT U.S. Stamps. Includes 1943 flag stamp of occupied nations. Only 35¢. Approvals included. Willett Co., Box 338-C, Yorktown Heights, N.Y. 10598.

MINT U.S. Airmails C34-6 \$1.35; C42-4 \$1.25; C53-6 \$1.00; C25-30 \$5.00; Philatelic Fiddler, Box 28522, San Antonio, Texas 78228.

U.S. 100 Different Unused and Used 75¢. 500—\$3.00, 1,000—\$5.00. Superioex, Avon Lake, Ohio 44012.

"MARS CONQUEST"—15¢ with Space approvals. Potomac Stamps, Washington, D.C. 20015.

"INVERTED ERROR"—Hammarskjold 15¢ with approvals. Belmont Stamps, Washington, D.C. 20015.

STORY Of ISRAEL in STAMPS \$1.00 Janet Ellen, Box 14215, Tahoe, Ca. 95702.

FREE! Beautiful Surprise nudes—Approvals included. Summit, 1146A-49th, Brooklyn 11219.

500 DIFFERENT \$1.00. Approvals. North Main, Box A6P, Thornville, Ohio 43076.

50% DISCOUNTS! Worldwide approvals. Premium. Gains, Box 788, Mattoon, Ill. 61938.

APPROVAL BUYERS Tremendous Savings General Foreign. Commemoratives and Pictorials 2, 3, 4 cents each, also Better Grade Sets and Singles we pay postage. P & S Terry, Linda Lane, Milton, New Jersey 07438.

207 DIFFERENT Triangles, Topicals, etc. Value \$7.00. Only 25¢. Approvals. Free catalog and coupon worth \$1.00. Jayto Stamps, Port Huron, Michigan 48060.

FREE "Cosmos-Space," with packet collections. Sunset Approvals, 33 Majorca Drive, Rancho Mirage, California 92270.

500 DIFFERENT Stamps \$1.50. Sun Post Express, Box 4531, Clearwater, Fla. 33518.

200 DIFFERENT U.S. includes many high values. \$2.00. Bernco, Box 8572, Canton, Ohio 44711.

100 WORLDWIDE—10¢. Approvals. Seaside, 6545-P1 Camino Venturoso, Goleta, Calif. 93017.

94 WORLDWIDE STAMPS—10¢. Colorful pictorials and commemoratives. Other stamps on approval. George Council Associates, Box 22, Landing, New Jersey 07850.

GOOD Stamps at 3¢ each in world packet of 250. Moose stamp free. Sunshine Stamps, Star Route, Damariscotta, Maine 04543.

U.S. CANADA Price List, 140 pages, 700 Illustrations. Stamp identifications—50¢. Thom, Box 17021, Minneapolis, MN 55417.

FREE, Huge bargain bulletins. Or try 121 different, U.S. \$1.00, 100 different Nudes, \$2.50; 500 different U.S. plus \$21.00 value in foreign \$8.50; 1000 different German, \$9.35. No Approvals. M & J Associates, 2831 Emerald Dr., Walnut Creek, Calif. 94596.

GIGANTIC Wholesale discounts. Lists, \$1.50 retail stamps your choice, 25¢. Blue Chips, Box 34203, Washington, D.C. 20034.

LOOK: 300 Worldwide Stamps, 25¢ with Approvals. Scenic Stamps, Box 1973G, Vancouver, Wash. 98663.

ZOOLOGICAL "Wildlife Animals"—East Germany's latest Gigantic Bicolored Commemoratives—Free! Approvals plus 101 Bonus Sets. William Deems, 226 Race, Ravenswood, West Virginia 26164.

U.S. POSTAL SERVICE BICENTENNIAL—4 Different stamps on 4 beautiful, historic First Day covers addressed to any name your choice. 60¢ Each or \$2.00 the set. K. M. Walsh, Box 308L, Tuckahoe, N.Y. 10707.

PICTORIAL Set Free To Approval Applicants Stating Wants. Casto, Box 927, Largo, Florida 35540.

HOW To make money collecting stamps, where to buy, sell. \$1.50. Brown's, 4667AC, East Main, Columbus, Ohio 43213.

FREE Bicentennial Packet with 3¢ Approvals. Frank, Box 368 Spencer, Iowa 51301.

FIRST DAY COVERS Three Different U.S. with cachet send \$1.00. Approvals, Crescenta Stamps, Box 405, Verdugo City, California 91046.

U.N. MINT 25 Different \$1.00. Philpot, Box 111, New Berlin, Wis. 53151.

BRASS Rods, Flats, Sheet. Price list 25¢. Box 55, Forest Park, Ill. 60130.

COLLECT Stamps for profit! **COLLECT** coins for profit! Complete guide booklets. How to start, where to sell. Each \$1.50. Mac's Gift Products, 421 8th St., Union City, N.J. 07087.

COINS, TOKENS, CURRENCY

GRAB BAG Of coins from 25 countries. Only \$1.00. Money back if not delighted. Littleton Coins, Dept. DX-1, Littleton, N.H. 03561.

SILVER DOLLARS Uncirculated. 1880-81—1883-84-85 \$10.00 Ea. Catalogue 50¢. Shultz, Box 746, Salt Lake City, Utah 84110.

UNCIRCULATED Foreign Coins. Make Jewelry, Decorations. Collections. Twenty Different \$1.00. Carson, Box 5404, Lawton, Oklahoma 73501.

THREE Buffalo Nickels and price list \$1.00. **PARK** Coin, 4400 Excelsior Blvd., Mpls, Mn. 55416.

COINS At Discount Prices! Free Brochure. Gene Carlton, Chandler, Okla. 74834.

FREE: Lists of Thousands of Stamps and Coins. No Approvals. Bryson, 612M White, Toledo, Ohio 43605.

FIVE Different U.S. Mint Error Coins \$2.00. Coin Lists Free. Sayers, 1000 Unaka, Johnson City, Tennessee 37601.

BARGAIN Coin List. 25¢ (Refundable). Economy, Box 92, Buzzard's Bay, Massachusetts 02532.

10 DIFFERENT Barber Dimes, \$8.95. Free Coin Catalog. Village Coin Shop, Dept. P, Plaistow, N.H. 03865.

TWO UNCIRCULATED LINCOLNS 1969S, 1970S and **CATALOGUE 10¢** **MAC'S DICKSON, BOX 197, SAN RAMON, CA 94583.**

GOLD Peso. BU, 1865 Mexican Maximilian, Only \$4.95. Coins, Ltd., Box 143-M, Canton, NC 28716.

COLLECT WORLD BANKNOTES. Fascinating, colorful, inexpensive. Five Different Plus Bargain List. \$1.00. Craddock Currency, Box 38145, Houston, Texas 77088.

EXOTIC Laos Coin Free, Approvals, Catalog. Send 10¢ Postage. Lexington Coin Galleries, Dept. MP1, Box 447, Lexington, Mass. 02173.

BRILLIANT Proof Sets + 1957, 1959, 1960. Each \$6.65; 1961, 1962, 1963, 1964, 1968-S, 1969-S, 1971-S, 1972-S Each \$5.15; 1958, 1970-S, 1973-S Each \$10.85; 1974-S \$10.45. All Sixteen Sets Super-Bargain Lists 30¢. Bebee's Incorp. Omaha, Nebraska 68111.

(Continued on next page)

ANTIQUES, RELICS, INDIAN GOODS AND CURIOS

INDIAN Relic list, Arrowheads \$4.00. doz. Folsom, \$5.00 each. C. Secrist, Deerfield, Missouri 64741.

SELLING 10,000 Indian Relics, Arrowheads, Knives, Spearheads, Scrapers, Etc. List Free. Lear's, Glenwood, Ark. 71943.

TELEPHONES, Parts, Advertiques, Largest Variety. Large Catalogue. 65¢. Phonoco, Box 277, Melrose, Wisc. 54642.

MODELS—CARS, SHIPS, TRAINS, PLANES, ETC.

SHIP MODEL Kits, Plans, Fittings from our own Workshop. Big Illustrated Catalog: \$1.00. Bluejacket Shipcrafters, 145-V Water Street South, Norwalk, Conn. 06854.

MODEL Airplanes—Big 220 Page Catalog \$1.50. Sig Company, Montezuma, Iowa 50171.

LIVE Steam powered backyard railroads! All sizes. Complete "bolt-together kits," and rough castings. Excellent drawings. 100 page catalog \$2.00. Little Engines, Lomita, California 90717.

SHIP And Airplane model kits catalog 25¢. Scientific, Inc., 340 Snyder, Berkeley Heights, N.J. 07922

"SHIP And Yacht model fittings: Pine construction hull kits; blueprints. Send \$1.00 for illustrated catalog. A.J. Fisher, Inc., 1002 Etowah Avenue, Royal Oak, Michigan 48067.

SHIP Model Kits, fittings, plans, books, tools, engines, motors. Free—new 1976 illustrated catalog. James Bliss & Co., Dept. SM, Route 128, Dedham, Mass. 02026.

RADIO Control Models—Big Discount Catalog \$2.00. Modelers Supply, Box 7185, Montgomery, Alabama 36107.

GAMES, TOYS, PUZZLES, NOVELTIES

ARMCHAIR FOOTBALL! Exciting gridiron action! Unique card game—solitaire or partners. American-Canadian rules. Complete instructions \$2.00. Select Services, Dept. PMD, 53 Aspendale, Scarborough, Ontario M1P 4J7.

MAGIC TRICKS, JOKES, VENTRILOQUISM

MAGIC! New 1976 Catalog, 35¢. Mystify. Entertain. Best tricks for amateurs and professionals. One of country's oldest dealers. Jeffries Magicland, Box 274-A, Dallas, Texas 75221.

PROFESSIONAL MAGIC! Direct From Factory To You. Giant Catalog—\$1.00. Refundable With First Order. Hank Lee's Magic Factory, 24 Lincoln Street, Dept. PM 3, Boston, Massachusetts 02111.

WOW! Magic, jokes. Largest selection. Amaze, mystify friends. Super Giant Catalog 25¢. Abracadabra-MP, Rahway, New Jersey 07065.

FABULOUS MAGICS New 1975 Catalog 50¢. Our Specialty Orders Shipped Same Day. No Substitutes. Fabulous Magic, 3319 East Charleston, Las Vegas, Nevada 89104.

VENTRILOQUISM! Information free. **EXCITING FULL COLOR DUMMY CATALOG**—25¢. Maher, Box 420PM, Littleton, Colorado 80120.

TWO! Different Magic Catalogs 25¢. Miami Magic, 9734 Bird Road, Miami 33165.

COMPLETELY Illustrated catalog, 84 pages, 25¢. Manhattan Magic, Box 334-M, N.Y.C. 10011.

WORLD'S Finest professional magic tricks. Joker's Novelties. Giant illustrated catalog 25¢. Top Hat, Evanston, Illinois 60204.

GENII! The International Conjurers' Magazine. P.O. Box 36068M, Los Angeles, Calif. 90036. Monthly Since 1936. Sample \$1.00. 1 year \$10.00. Not sold on newsstands. None free.

FREE! World's leading novelty catalog. 1600 Fun-makers, Jokes, Tricks, Science, Sports, Hobbies, Jewelry, Psychedelia. Johnson-Smith, C-4, Mt. Clemens, Mich. 48043.

BE A Magician! Two booklets explaining 156 tricks plus large professional catalog. \$1.00. Magic, Inc., 5082 Lincoln, Chicago, Illinois 60625.

FREE 1975 Magic Catalog plus gift certificate! Imperial, Box 623-P, Worcester, Massachusetts 01601.

COMEDIANS. Be one. Best Jokes book plus catalog. \$1.00. Johnson Jokes, Box 14381, Raleigh, N.C. 27610.

GET ON OUR MAILING LIST. Tricks, Jokes, Complete Shows. Send 30¢. Gimmick Magic, Box 693, Lynnfield, Mass. 01940.

BICENTENNIAL Magic Catalog, 25¢. Conjurers Craft, Box 65-M, New Hyde Park, N.Y. 11040.

FIRST Time offered, Magic catalogue. Just off press. \$1.00 refundable w/first order. Magic Workshop, P.O. Box 314, Rocky Hill, Ct. 06067.

BOOKS & PUBLICATIONS

PUBLISH your book! Join our successful authors: publicity, advertising, promotion, beautiful books. All subjects invited. Send for free manuscript report and detailed booklet. Carlton Press, Dept. PMA, 84 Fifth Avenue, New York 10011.

"SURVIVAL/MILITARY" Books, Manuals Catalog 50¢. Survival Freeze Dried Storage Foods By The Case. List 50¢. Hale Supply (K-50), McDonald, Ohio 44437.

WILLS: How to make and How to break them. \$1.00 to: ESSCO, Box 273B-2, Lake Katrine, New York 12449.

FREE Catalog! Books—All Subjects. Franklin, R.D.3, Box 305K-P, Somerset, N.J. 08873.

NATIONAL Geographic Magazines, 1888-1971, any issue. Buxbaum, Box 465-PM, Wilmington, Delaware 19899.

FREE Book. Prophet Elijah Coming Before Christ. Megiddo Mission, Dept. 63, 481 Thurston Road, Rochester, N.Y. 14619.

CLOCK And watch repairing books, tools, materials. Free catalog. North American, Box 77ANA, Fox River Grove, Illinois 60021.

SOLID STATE & HOBBY CIRCUITS MANUAL \$1.95 postpaid to your door. The new manual offers over 400 pages of circuits for the hobbyist, engineer, experimenter and do-it-yourself kit builder. **HURRY!**—Supply limited. Free catalog. Frazer & Associates, 1888 Century Park East Suite 10, Century City, Calif. 90067.

BOOK BARGAIN! Catalogs 20¢ refundable: Acropolis, P-Box 7, West Berlin, NJ 08091.

"SELECTED" SELF-IMPROVEMENT BOOKS! Free Illustrated Catalog! Low Prices. Sunrise Enterprises, Dept. PM12, Box 1064, Arcadia, Calif. 91006.

"BRAINPOWER" \$1.00 to: Hooks & Co., P.O. Box B, Lebanon, Ill. 62254.

RARE Bookfinder. Send Wants. **Ventreuren**, 1950 Post, #108PM, San Francisco, Calif. 94115.

ENERGY NEWSLETTER. FREE DETAILS. E. Williams, 5 Buckman, Winchester, MA 01890.

FREE! New Illustrated Catalog. 290 Exciting Self-Improvement Books. Jayessco, 31B11, 689A East 46 Street, Brooklyn, N.Y. 11203.

FREE Catalog Low Cost Books. Joe Neal, 3951 Northwest 191 Street, Opa-Locka, Florida 33055.

"UNUSUAL" Books! Catalogue Free! International Imports, Box 7798PM, Atlanta, Georgia 30309.

PLAYS, SONGS, MANUSCRIPTS

SONGS, SONGPOEMS Wanted for Radio Show. Hollywood Music Productions, 6425-PM Hollywood Boulevard, Hollywood, California 90028.

AUTHORS! Want your book published? Learn how—we publish, advertise, promote, distribute. Many successes. free booklet PM. Vantage, 516 W. 34th, New York City 10001.

SONGWRITERS LOOKING for CO-WRITERS on 50-50 basis. HAS songs recorded by BRENDA LEE, EDDY ARNOLD, and others. SEND lyrics to: NASHVILLE CO-WRITER PLAN, BOX 1152, NASHVILLE, TENNESSEE 37202.

SONGPOEMS! SONGS! Urgently Needed, 50-50 Agreement. Betty's Music Makers, 10355B Paradise Blvd. Treasure Island, Florida 33706.

BUSINESS SERVICES

ASIA Directory. World Products Information. Both for \$1.00. World Trade Inquiries, Box 6224, Spokane, Wa. 99207.

OIL & MINING NEWSLETTER. Exclusive inside sources—properties, financing. Sample \$1.00. World Resources, Box 283-P, Birmingham, Michigan 48012.

ZERO CASH BUSINESSES! COSIGNERS! 100% FINANCING! BGS International, 210 Fifth Avenue, New York, New York 10010.

BUSINESS OPPORTUNITIES

IMPORT-Export opportunity, profitable world-wide, mail order business from home, without capital or travel abroad. We ship plan for no risk examination. Experience unnecessary. Free report. Mellinger, Dept. C2701, Woodland Hills, California 91364.

250/THOUSAND Immediately. Free Supplies, Rush Stamped, Addressed Envelope; Ms. Wells, 1518 Woodside Ave., Baldwin, N.Y. 11510.

MAKE \$7.50 to \$15.00 hourly building portable custom cases in your home. Huge demand. Get orders by mail. We supply materials, instructions—everything. Free details. Custom Case, 6075 De Soto, Dept. 20-37, Woodland Hills, Ca 91365.

PROPRIETORSHIP-Partnership-Corporation Which is right for your new business and how to go about forming it. \$5.00. ISSCO, Box 4009, Irving, Texas 75061.

MAILORDER—Establish own business. Everything supplied—catalogs, ads, mailing lists. Merchandise dropshipped. Gif-Guide, 5818 Venice, Dept. 464, Los Angeles 90019.

\$200.00 WEEKLY Possible mailing circulars. Send Stamped Addressed Envelope. Mearian, 3565P, Albatross, San Diego 92103.

365 FAST, Easy ways to make money! Free! Rush name, address, zip. Perry 13263-F Ventura Blvd., Studio City, Calif. 91604.

\$3,000+ MONTHLY Possible at home. Start immediately. Details 25¢. Jannis, 17686 Bland, Detroit, Michigan 48234.

PHOTOSTAMP Agents Wanted. Make big money from home mailorder. Hundreds doing it! Free samples & details: Postermatic, Dept. C-7, East Providence, R.I. 02914.

HOW To start and succeed in your own mailorder business. Get the facts! Complete free details. Robins Company, Box 1121-C, Arcadia, CA 91006.

BECOME Tax consultant. Our students earn \$1,000-\$3,000 every tax season preparing returns evenings. State approved. National Tax School, Monsey 2AG, New York 10952.

OWN Your own wholesale business. **FANTASTIC PROFITS**, on 1000 different items. Free Details. John Colson, 178 Longview Drive, W. Webster, New York 14580.

EARN Money Raising Fishworms for us. Write Oakhaven-38, Cedar Hill, Texas 75104.

ABANDONED INDUSTRIAL SILVER—Yours for taking! \$24,000 yearly possible. Free information: Silverman B-13, Box 548, Woodville, Texas 75799.

LET Me show you how you can have your own Rubber Stamp business Free! Write: Roberts, Room RC-2-FC, 1512 Jarvis, Chicago, Ill. 60626.

PIANO Tuning Learned Quickly at Home! Musical knowledge unnecessary. Free information. Empire School. Box 450327, Miami, Florida 33145.

ADDRESSERS-MAILERS-HOMEWORKERS NEEDED! 50 firms listed. Information: Rush 25¢, Stamped, Addressed Envelope, South Plains Enterprises, Box 1086, Lubbock, Texas 79408.

BARGAIN MAILORDER LIBRARY. Professional secrets revealed, free details (Moneyback Guarantee), Suski, pmaa, 4318 Palmetto Avenue, Philadelphia, Pa. 19124.

MAILORDER—Nationally known **MILLIONAIRE** will teach you personally. Write for informative book, gift catalog, and complete details. **EVERYTHING FREE!** No Obligation. Mail Order Associates, Dept. 21, Montvale, NJ 07645.

EARN At Home! Rush 25¢ and SASE for offer. Details. J. Rohm, 65 N. Tenth St., Lemoyne, Pa. 17043.

COLLECT Names earn \$300 per thousand. **50 FREE** Dealerships available. Send 25¢ and stamped addressed envelope. Rick Dorrell, 5400 West 103rd Place, Overland Park, Kansas 66207.

\$250-\$500/THOUSAND. STUFFING ENVELOPES. COMPLETE ASSISTANCE. Rush stamped addressed envelope, Mailer Enterprises, Box 7538, Ft. Lauderdale, Florida 33304.

PROFITABLE Lifetime Business Opportunity. Free Information. Business Research & Development Co., Box C1002, Skokie, Ill. 60076.

MAKE BIG MONEY With our fantastic methods. Free Details. Ace Enterprises, Box 1025-PM, Williston, N. Dak. 58801.

YOUR Own Steady Repeat Business, Mail Color Brochure of Plastic Nameplates, Holders to Banks, Offices. Details \$2.00. Plastico, 1025 Green Valley, Waukesha, Wisconsin 53186.

\$300-\$700 MONTHLY. Raise Rabbits, Laboratory Animals for us. We supply Equipment, Breeders, Instructions. Details 25¢. MP11 Rabbits Of Michigan, Countyline Road, Pentwater, Michigan 49449.

MILLIONAIRE'S SECRET FORMULAS Free details. Learn how Millionaires make money fast. Write: Hall, 6111 Gulf Freeway, Box 26553, Houston, Texas 77207.

BECOME Our Mail Order dealer with \$35 investment. Details: Burnes, Box 499, Glen Ellyn, Illinois 60137.

MAILORDER SUCCESS. Tested procedures, instructions. West Bay, Route 1, Box 159-B1M, White Stone, Virginia 22578.

IMPORT-MAILORDER OPPORTUNITY. One year risk free trial basis. Earn \$15,000+ Annually or owe nothing. Details, Northeast Imports, Box 121M, Fremont, NH 03044.

\$500 MONTHLY Clipping items from your newspaper. Experience unnecessary. Free details. Send stamped envelope. Bill Derry Enterprises, P.O.B. 238, Kew Gardens, N.Y. 11415.

\$25.00 DAILY Possible! Addressing-stuffing envelopes. Typing/longhand. Details—Rush stamped envelope. Elite, Box 715-A, Lynbrook, N.Y. 11563.

\$100,000 YEARLY Possible! Your Own Business. Free information. CDC/10-016A, POB 11066, Tucson, Arizona 85734.

\$100 WEEKLY Possible! Clipping newspaper items. Stuff/address envelopes. Information—send stamped envelope. Income Opportunities, Box 721-A, Lynbrook, N.Y. 11563.

\$200—300+ DAILY. No gimmicks. Money back if not satisfied. Details \$2.00. Ideas International, PO Box 665 PM, Riverdale, Md. 20840.

HOME Business. Make Plastic Signs. Big Profits. Universal, Lenora, Kansas 67455.

PIANO Tuning quickly learned with home study course. Diploma granted. American Tuning School, 17050 Telfer Dr., Morgan Hill, Calif. 95037.

NEW Copyrighted Home Business Addressing Envelopes. Fantastic Profits. Send Self Addressed Stamped Envelope. Mantor House, Dept 8PM, Minoa, N.Y. 13116.

(Continued on next page)

BUSINESS OPPORTUNITIES

(Continued from preceding page)

ESTABLISH Successful Mailorder Business. Immediate, Continuous Income! Mears, C5363 Essex, Alexandria, Virginia 22311.

BECOME Our Mail Order Distributor with \$150 investment. Free Brochure. Audit Controls, 40 Brookside Ave., Fair Lawn, New Jersey 07410.

TAKE Catalog Orders. We drop-ship 1001 best-selling specialty products. Lowest below-wholesale prices. Immediate delivery. Spectacular home business opportunity. Free Book. SMC, 6061 De Soto Ave., Dept. 20-37, Woodland Hills, CA 91365.

\$200.00 SPARE Time earnings with your Tablesaw. Write: Workshop Five, 3800 Harney, Vancouver, Washington 98660.

VENDING Machines. No selling. Routes earn amazing profits. Big catalog Free. Parkway Machine Corporation, 1930PMB Greenspring Drive, Timonium, Maryland 21093.

\$1.00 LISTS You year sent to 1000 Importers, Jobbers, Mailers, our mailing year. Dixie, King, North Carolina 27021.

BECOME "Mortgage Broker." Lucrative! Capital Sources. Box 640099, Uleta, Florida 33164.

FREE COLLECTION AGENCY Details! \$1000.00 Monthly Possible. Master-PM, Dawsonville, Georgia 30534.

HOW TO RAISE \$100.00 to \$1,000,000.00! Write: Capital-PM, Dawsonville, Georgia 30534.

I MADE \$40,000.00 Year by Mailorder! Helped others make money! Free Proof! Torrey, Box 3189Y, Ypsilanti, Michigan 48197.

MAIL Baby Catalogs to New Mothers for Big Profits! Details 25¢. Volz-PM, Ypsilanti, Michigan 48197.

NEW, Compact fire extinguisher. Fantastic profits. Exclusive territories. Norwich Chemical, Norwich, Connecticut 06397.

RECEIVE Mail Galore! National Listing. \$1.00. Sullins, 1313-M, Brunswick, GA 31520.

\$200 WEEKLY! Make, Sell Bricks! Free information! Xcfto Bricks, 5715 N. Mozart, Chicago, Ill. 60659.

FREE WEALTH BOOK: "2100 Unique Ways to Make Money!" Worlds Biggest Collection of Home Businesses! Success-M, 26903 West Eight Mile, Detroit, Michigan 48240.

WORLD'S Largest Supply. 25% to 40% under wholesale. Closeouts. HONG KONG Clothes, Automobiles, Electronics. Free Details. International Buyers, Box 16386MM, Portland, Oregon. 97233.

REPAIR Hydraulic Jacks—Details Free. Write: Hydraulic Parts Supply, Box 4157, Brownsville, Texas 78520.

YOUR Own Mailorder Catalog Business. No Merchandise Investment, Details Free. A.M. Sales, 31-14 94 St., East Elmhurst, NY 11369.

FREE MAILORDER Report! Plan Guarantees Beginners \$50.00 per order - to \$750 Weekly! Professionals, Box 21093-E, Seattle, WA. 98111.

EARN \$60.00 Daily manufacturing Concrete Fence Posts. Practically no investment. Send stamped-addressed envelope. American, Excelsior Springs, Mo. 64024.

\$178.00 WEEKLY. Work one hour daily. Guaranteed, FAS, Box 13703-J, San Antonio, Texas, 78213.

MAILORDER Millionaire helps beginners make \$500 weekly. Free report reveals secret plan! Executive (IA), 333 North Michigan, Chicago 60601.

\$70 TO \$200 WEEKLY—Home, Spare Time Simplified Mail Bookkeeping. Immediate Income. Easy. Auditax, Box 34741A, Los Angeles, Calif. 90034.

\$400.00 MONTHLY Raising giant fishworms. Soilless method. Charlie Morgan, Bushnell, Florida 33513.

MAILORDER DEALERS. Merchandise Dropshipped, Free Catalog. Details. Dunes, 310 1A Southeast Parkway, Richmond, Indiana 47374.

MAKE \$92.00 FROM Square Foot Plywood (Jigsaw or Bandsaw necessary). (Proof), details 25¢. (Refundable). Woodart, Bridgewater, Mass. 02324.

CALIFORNIA MANUFACTURER NEEDS MAN to assemble our product and be local agent, experience unnecessary. May start while presently employed. Five-figure income for responsible applicant. S.K.R.M. Manufacturers, 911 N. Lagoon Ave., Wilmington, Ca. 90744.

PROFITS FROM CLASSIFIED ADVERTISING! Booklet shows you how to start your own business with Classified Advertising. Only \$1.00 (Refundable with first order.) H. E. KAPPEL, POPULAR MECHANICS, DEPT. P, 224 WEST 57TH STREET, NEW YORK, N. Y. 10019.

BLOCK Machines, Posts, Mold Catalog \$3.00 refundable. Carlayne, Route One, Box 95, Rapid City, South Dakota 57701.

VINYL'S WHERE THE MONEY IS! Invisibly repair, refinish, recolor furniture, luggage, car tops. Quick, easy. Two small \$20.00 jobs a day earn you \$1,000 a month. Homes, cars, offices, restaurants, unlimited customers. Start earning after a day's practice. Sensational details Free. VIP, 2007 Montrose, Chicago 60618.

NEW! Import-Export Opportunities Newsletter. Details free! International Marketing Services, Box "C", Barstow, Ca. 92311.

"INTERNATIONAL NEW PRODUCTS NEWS" Exciting new 8-page illustrated newsletter, 90 new products each issue. Write today: Usimco, Box 432, Bellflower, Calif. 90706.

SELL Books by mail. Complete dealer set-up—25¢. Midwest, Box 44R2-PM, Shawano, Wisconsin 54166.

\$500.00 POTENTIAL Addressing Envelopes. Setup \$2.00. Bumphus, Box 9306A, Wash., D.C. 20005.

\$500 WEEKLY At Home—New "Guaranteed Daily Income" plans—Free Report, Box 90133PM, Atlanta, Georgia 30344.

FANTASTIC Profits! Super mailorder business! \$42.45 possible each order. Free details. J&S Sales, A1, 1488 Trentwood, Wyoming, Mich. 49509.

\$250-\$500/THOUSAND, STUFFING ENVELOPES, COMPLETE ASSISTANCE. Send Stamped addressed envelope, Cedar Enterprises, Box 46, Nashua, Iowa 50658.

\$250-\$500/THOUSAND, STUFFING ENVELOPES, complete assistance, rush stamped addressed envelope, Triple H Enterprises, P.O. Box 123, Fishersville, Va. 22939.

\$165.00 WEEKLY Working one hour a day, guaranteed, stamped envelope brings brochure, Horizon Enterprise, 8050 South Main, Houston, TX 77025.

FREE SECRET BOOK "2042 Unique, proven enterprises". Fabulous "Little Knowns" Work home! Haylins, Carlsbad, Calif. 92008.

SELL Information by Mail! 2,400% Profit!!! Exciting Details Free! Sax, Dept. C-2901, Milan, Ohio 44846.

MAILORDER Beginners—Get All information to succeed! Adams (6D1), 12128 West 70th, Arvada, Colorado 80004.

"STARTING Your Own Business?" Step by Step instructions. Money-back Guarantee, \$3.95. Haendiges, 1313 Railroad, Bellingham, Washington 98225.

AMAZING Mail-order profits selling books and information! Free details. Valsaco, Box 268L, Eckert, Colorado 81418.

HIGH PROFIT BUSINESSES. 35¢ Guaranteed. MONEY-ZH, 232 Front, Napoleon, Ohio 43545.

CARPETLAYERS Earn \$1,500 monthly. Easy home training. Big demand. Write Carpet Crafts, 2675 1/2 Daily Drive, Camarillo, California 93010.

\$2,000 + Monthly! Selling information; Mailorder highest profits! Free proof: Expansions, Box 746, Rouses Point, N.Y. 12979.

MAILORDER IMPORT DIRECTORY of Foreign Bargains. Large, Completely Detailed listing of Overseas Suppliers! Send \$1.00 today! Value House, Box 363HX, New York 10011.

MAILORDER PROFESSIONAL Reveals Secret plan to high profit home business. Request free report today! Value House, Box 363FX, New York 10011.

100% PROFIT Bronzing Baby Shoes. FREE LITERATURE. NBC-PM, Gower, Missouri 64454.

MAIL Baby Catalogs to New Mothers. Big Profits! Details 25¢. Stovers, Box 23592-PM, Tampa, Florida 33623.

SECRETS! Mail Order Success. Internationally famous expert reveals how to make home business fortunes. Beginners: Get free report "Make Money By Mail." Discloses free advertising, profitable products. Mailco, Dept. CC701, Woodland Hills, California 91364.

\$128.00 IN Sales from \$12.00 material. Details, \$1.00 (refundable). Webber Enterprises, Box 241, Sun Prairie, WI 53590.

INSTALL burglar alarms without previous experience or costly equipment. Big profit. Free details. Nasco, Dept. C2701, Woodland Hills, California 91364.

FABULOUS Ground floor business opportunity. Amazing new method never before offered. Profitable wealth builder. Complete details and sample offer \$2.00 postpaid. Apcco, Dept.-6, Box 17703, San Antonio, Texas 78217.

BOOMING CATFISH FARMING. U.S. SPONSORED AND FINANCED. Proof of thrills-riches. 1974 national sales \$100 million. U.S. certified instructions. Airmailed details 50¢. Scientific Catfish Farming, Box 1089, St. Petersburg, Florida 33731.

500 COMPANIES Offer "work-at-home" Opportunities! Complete Directory \$2.00. National, 4216-R Telegraph, Oakland, Calif. 94609.

AMAZING PROFITS! Mail Baby Catalogs to New Mothers! Details 25¢. Addington's, Box 522AA, Belleville, Michigan 48111.

\$250-\$500 THOUSAND, STUFFING ENVELOPES, COMPLETE ASSISTANCE. Rush Stamped Addressed Envelope, Shee, Box 152-P1, Rego Park, N.Y. 11374.

RECEIVE BIG MAIL! Years listing. \$1.00. Stone's, 845 Fairway Drive, Miami Beach, Florida 33141.

\$250 THOUSAND, Stuffing Envelopes, Rush stamped, addressed, envelope. Richgo, Box 368, Reading, Mass. 01867.

SELL BOOKS BY MAIL—Hundreds titles. 400% profit. PROGRESSIVE, Box 23606DA, San Jose, CA 95153.

GOLD PANNING RUSH. PRESIDENT FORD SIGNED New gold laws. Thrills-riches. Map shows 20 gold producing states plus U.S. instructions \$5.00. National Laboratories, Box 1089, St. Petersburg, Florida 33731.

FREE Catalog! Learn Mailorder, Books, Magazines, New Products, Mailing Lists, Wholesale-Dropship Directories. National Mailers Exchange, Box 1355-PM, Sioux Falls, South Dakota 57101.

\$200+ WEEKLY. Sell Books by Mail. Free Details. Barclay Company—45PA, Halesite, New York 11743.

\$231.00 EXTRA Weekly Playing Mail Order "Money Game"! Details—Business, 2205-J Robinhood, Albany, Georgia 31707.

YOU Can profit two to three times your cost on 1001 quality items. Experience unnecessary. Send \$2.00 for tremendous catalog. Refundable on first order. Great Western Gifts, 1300 Sagebrush, #419, Euless, Texas 76039.

SELL SENSATIONAL LOW-COST BURGLAR ALARM. Lightning seller. Exceptional margin. Samples for trial. Northwest Electric, Ave. 203, Mitchell, S.D. 57301.

MAKE \$5000 Per Month from your own Home. Information free. Dreckmann, PM176, 945 Main, New Rochelle, New York 10801.

FASTEST Seller—Profits \$9.00 on every \$10.00. Free details, Hunt Enterprises, 244 Franklin St., Morrisville, Pa. 19067.

BIG Money-making Plaque. Details 50¢. Carver, PM, Route 1, Dawsonville, Ga. 30534.

EARN \$80.00 Daily Manufacturing Concrete Bricks-Tiles-Wooden Molds. Send Stamp, Hilmar, Route One, Box 347-DH, Valrico, Florida 33594.

PORTABLE Sandblaster \$29.95. Distributor wanted. Free brochure. Inka, Box 66573-A, Houston, Texas 77006.

\$10 DAILY Writing short articles at home. Begin immediately! Copyrighted report reveals how and where. Send \$1.50. E & D, 3816 Emerald Drive, Dept. PM-1, Ames, Iowa 50010.

WATCH REPAIRING. For cash income or hobby. Free sample home study lesson. Chicago School of Watchmaking, YAA, Fox River Grove, Illinois 60021.

ADDRESSERS, MAILERS NEEDED. 50 Firms Listed. Offer Details; Rush 25¢ Stamped, Addressed Envelope. AMD, Box 5437 Akron, Ohio 44313.

BECOME A Coin Dealer! \$10,000 Annually Possible! Write: International, Box 35122MA, Tulsa 74135.

RECEIVE \$50.00 For Every 100 Free Samples You Give Away. Information 25¢. Craig, 5444 Anton, Olympia, Wash. 98501.

100 WEEKLY Possible Stuffing-Mailing Circulars For Mailorder Firms I represent. Send Self-Addressed Stamped Envelope: Magnolia, Dept. TM, 1408 West Laster Avenue, Anaheim, CA 92802.

\$250-\$500/THOUSAND, STUFFING ENVELOPES, COMPLETE ASSISTANCE. Send stamped addressed envelope; LORDE ENTERPRISES, Box 4726 PM Panorama City, California 91412.

\$250-\$500/THOUSAND, STUFFING ENVELOPES Complete Assistance, Rush Stamped Addressed Envelope. King Publishing, Box 345, Wilkes-Barre, Penna. 18703.

SELL TO COLLECTORS By mail. 500% mark-up possible. Pleasant, profitable, low capital. Successful businessman tells how. JGS, Inc., Dept. A-55, P.O. Box 525, Merrifield, Virginia 22116.

\$500 MONTHLY. Immediate income. Stuff envelopes at home. Information, send self-addressed stamped envelope. Cottage, Box 25053-BAA, Los Angeles, CA. 90025.

\$128.00 IN SALES From \$12.00 material. New. Different. Everything Furnished. Rush 25¢ and a stamp for details. Herm's, 202 Pickrelltown, W. Liberty, OH 43357.

MAILORDER PROFITS Can make you rich! Free details. Strategic, Box 3374C, Evansville, IN 47732.

\$700 A WEEK WITH ONLY ONE HOUR OF WORK PER DAY. (plans 1 and 2). \$8,000 IN 30 DAYS WITH A \$1.00 INVESTMENT. (plan 3). \$6.98 for plans 1 and 2. \$3.98 for plan 3, or \$9.98 for all three plans. A MONEY BACK GUARANTEE INCLUDED. Send to J. G. Enterprises, 210 5th Avenue, New York, New York 10010.

FABULOUS Mailorder Opportunity!! 300% Profit Possible! Sample, Complete Details. Write: Radco, Box 101, Depew, N.Y. 14043.

DISCOUNT Auto supplies. Many items. Disco, Box 897, Aurora, Ill. 60507.

STREAMLINED Home-Study Mailorder Course! Guaranteed. \$2.00. Reliable, 8800 South Harlem #2127B, Oak Lawn, Ill. 60455.

MAKE Money as an inventor. Booklet reveals how to turn your ideas into profitable inventions. Only \$1.50. SAKO-E, Box 545 Dearborn, Mich. 48121.

TIRED OF GIMMICKS? We guarantee \$1,000 minimum per month with our plans. Free proof. Details 25¢. National Business Research, Box 8619-PM1, Jackson, Mississippi 39204.

COMPLETE Mailorder Jewelry Business. Free Details. Imperial, 621 Tucson, Lexington, Ky. 40503.

TRIPLE Your Present Salary in 30 days. Guaranteed! Free report reveals secret plan! Amex, 216 Jackson, 612-PM, Chicago 60606.

SAVE THOUSANDS! Have an expert analysis of your proposed business. Send for 20 page questionnaire today, return promptly for expert analysis. Total cost \$15.00 sent with initial request. Woodland Investments, Box 146M, Cheshire, CT 06410. Connecticut Residents Add 7%.

CAUTION. Get the FACTS before starting a mailorder business. Plus FREE mailorder Directory. \$1.00. Thrifty, RR#3, Clay, Ky. 42404.

(Continued on next page)

BUSINESS OPPORTUNITIES

(Continued from preceding page)

MAKE 250% Profit. Giftware, Novelties, Jewelry, Toys, Houseware, 1000 others. Giant Wholesale Catalog \$2.00. Refundable. Colonial Import, Box 405A, Boston, Mass. 02199.

STUFF ENVELOPES \$500/Thousand Immediately. Free Supplies. Rush Stamped, Addressed Envelope. RS-Industries, P.O. Box 2128PM, Santa Clara, Calif. 95051.

GET Started in mailorder without inventory. U.S. drop ship suppliers directory, \$3.00. Hamernick, 71 Strawberry Hill Avenue, Stamford, Conn. 06902.

\$250-\$500/Thousand Stuffing Envelopes Complete Assistance. Rush Stamped Addressed Envelope, Jim's Forwarding Service, 7013 Donald Avenue, Tampa, Florida 33614.

\$500.00 WEEK Your Own business at home. But not for everyone. Find out if you have what it takes. Free new report, "Success Now". Secrets from people who have become millionaires in mailorder. Clipper Industries, Box 10361M, Kansas City, Missouri 64111.

\$250-\$500/THOUSAND STUFFING ENVELOPES. COMPLETE ASSISTANCE. Rush Stamped Addressed Envelope. Kawaii-B1, Box 882, El Cerrito, California 94530.

NEED MONEY? "999 Successful Little-Known Businesses." Information: Business, Drawer 568-A, Anaheim, California 92805.

BREAKTHROUGH On hollow concrete wall construction forms. Get in on ground floor. Send \$2.00 for information. Box 1103, Fruita, Colorado 81521.

BARGAINS! Buy Wholesale and Below! Name Brands. Appliances . . . Furniture . . . Sports Equipment . . . Televisions . . . Cameras . . . Watches . . . Jewelry . . . Thousands More. Huge Discounts to \$1,000.00 on New Automobiles. All Makes. Free Details. Worldwide Bargainhunters, Box 730-AA, Holland, Michigan 49423.

CONTROL \$1,000,000 IN REAL ESTATE! Net \$2,000 monthly. No selling. No Capital to start. Unique leverage opportunity. Free Brochure. Kashbuilder, Box 1132-14R, Indianapolis, Indiana 46225

MAKE \$2,000.00 MONTHLY. Spare time. Unique proven enterprise. No selling. No capital to start. Free brochure. Kashbuilder, Box 1132-14R, Indianapolis, Indiana 46225.

\$500/THOUSAND POSSIBLE, STUFFING ENVELOPES, INFORMATION/SUPPLIES, STAMPED, ADDRESSED, ENVELOPE, AGENT, BOX 139-51, CLAYTON, INDIANA 46118.

MAKE Durable building plastic easily. Waterproof, fireproof, economical. Bays Laboratory, Cedaredge, Colo. 81413.

MAILORDER Course! Home Study 24 Easy Lessons, Start Easy Way. Free Details. Advanced Trading, 98-15 Horace Harding, Dept.-1, Flushing, N.Y. 11368.

SELL IMPORTED PRODUCTS. For high profit, no capital investment needed. Send one dollar handling charge for catalog/details: BURTON ENTERPRISES, BOX 5538, Fredericksburg, Virginia 22401.

FREE! Mailorder Know-how. All here. JK, Box 1443P, Ann Arbor, Michigan 48106.

MAIL ORDER COURSE COMPLETE Only \$2.00. Andree's Enrg., P.O. Box 217, Val D'or, Quebec, Canada J9P-4P3.

MAILORDER Dealers Wanted. Earn outstanding profits using tested promotions! Executive type business. Rutward-PG, Georgetown, CT 06829.

CUSTOM FRAMING-PICTURES, PORTRAITS-MAKES \$\$\$! New easy-to-learn method . . . everything you need to know and do to start making money quickly in this pleasant, profitable, fast-growing field. Details FREE. CREATIVE FRAMERS, 1205 W. Barkley, Dept. APM2, Box 16, Orange, Ca. 92666.

BUILD \$3,000.00 Foam Plastic Home One Week. Sell for \$50,000.00. Cost 80% less to Heat, Cool. Patent Pending. Drawings, details \$5.00 Refundable. Ark (X), Box 16046, Kansas City, Missouri 64112.

\$200.00 DAILY In Your Mailbox! Opportunity To Follow Mailorder Experts. Free Details, Associates, Box 136-A, Holland, Mich. 49423.

RECOVER SILVER From scrap! Businesses supply you scrap free. Simple, profitable home business. PreMet, Box 425-R, Willow Grove, Pa. 19090.

BUSINESS Loans. \$5,000 To \$10,000,000 Available. Free Loan Package. John Saisi, and Associates, 391 Gregg Ln., Buffalo Grove, Ill. 60090.

EARN BIG PROFITS. Every business a prospect. We drop-ship 1001 best selling products. Huge catalog \$2.00—refundable. TCA International, Dept. PM, 200 Silver Street, W. Babylon, N.Y. 11704.

MONEYMAKING OPPORTUNITIES

\$500.00 MONTHLY . . . Mailing our sales circulars . . . everything supplied. Details: Enterprise, Box 1296-BW, Newport News, Virginia 23601.

AMAZING Income for you with camera informative booklet \$1.50. Jeri Bowman, 16222 N. 34 Place, Phoenix, AZ 85032.

MAKE MONEY On Government Surplus. Report tells How and Where to Buy. Directory of Surplus Offices. Sale Terms. Mail Order Items. Booklet \$1.50. Heffer Enterprises, 131 West University Drive, Mesa, Arizona 85201.

CARVE Your own signs with patented GUIDE-ALL Router attachment \$25.00. Templates \$16.00 up. Free brochure. Rustic Shop, 7431 Artesia St., Buena Park, Calif. 90621.

UNLIMITED EARNINGS With Fantastic Money-making methods. Write: Ace, Box 1025, Williston, N. Dak. 58801.

MAKE Colorful concrete mushrooms for pennies. No molds to buy. Manual \$3.00. Matt, 1834 North 21, Sheboygan, Wisconsin 53081.

EXTRA MONEY! SELL "PERSONALIZED" SOCIAL SECURITY PLATES! FREE SALES KIT! KERN, 246PJ RICHMOND, N. MASSAPEQUA, NEW YORK 11758.

\$250-\$500/THOUSAND. Stuffing Envelopes. Complete Assistance. Send Stamped Addressed Envelope, J & B Distributors, 12712 Turquoise NE, Albuquerque, N.M. 87123.

\$250-\$500 THOUSAND STUFFING ENVELOPES COMPLETE ASSISTANCE. Rush Stamped Addressed Envelope. Opportunities SWS, Box 975-A1, Canyon, Tex. 79015.

HOMEWORKERS! Receive \$100 weekly income, mailing six envelopes daily. Setup \$2.00. GEMX, B21244A, Indianapolis 46221.

EXCITING! PROFITABLE! Make money helping others! \$3.00. DataCo, Box 2343-A, Scottsdale, AZ 85252.

MAKE EXTRA MONEY. New booklet reveals unusual method. Make up to \$50,000.00 in cash. Act now! Send \$1.00. Booklet #M056T. Keroselle, Dept. PM1, 116 Linden Ave., Verona, N.J. 07044.

SENSATIONAL Profit Plan. Free information. Business Research & Development Co., Box 1002, Skokie, Ill. 60076.

\$1,000 MONTHLY! Stuffing Envelopes and Clipping Newspapers: Send Stamped Addressed Envelope . . . McGuire, Box 144, Tacoma, Wash. 98412.

MAKE MONEY WITH YOUR IDEAS—Turn your ideas into cash. Booklet shows how anyone can do it. Send just \$1.50 to: Logan Enterprises, Dept. 1PM, 11 Utne Court, Lincoln Park, New Jersey 07035.

SPARE TIME CASH. Sell famous Hanover Shoes. Samples, sales kit free. No experience needed. No age limit. Big commissions. Hanover Shoe, Dept. 1531, Hanover, Pa. 17331.

CLIP NEWSPAPER ARTICLES. Get \$1.00 to \$5.00 Each. Details 25¢ and Stamped Address Envelope. MARBRK, 6103 East Admiral Blvd., Drawer 15740, Tulsa, Okla. 74115.

HOW To Make Money writing short paragraphs. Information Free. Barrett, Dept. C-27-K, 6216 N. Clark, Chicago 60660.

NEW Copyrighted Home Business Addressing Envelopes. Fantastic Profits. Send Self Addressed Stamped Envelope. Mantor House, Dept 8PM, Minoa, N.Y. 13116.

FREE—Easy Ways to make money selling exciting new products—Full—spare time. Send name, age for 5 months free subscription. Salesman's Opportunity Magazine, 1460 Hancock Center, Dept. 471, Chicago 60611.

VENDING Machines. No selling. Routes earn amazing profits. Big catalogue Free. Parkway Machine Corporation, 1930PM Greenspring Drive, Timonium, Maryland 21093.

MAKE Statuettes, novelties, imitation marble. Sell to stores or start gift shop. Free details. Marbleizing, 41 Waverton, St. Louis, Mo. 63124.

\$175.00 WEEKLY Correcting Pupils' Lessons! Samples, \$1.00! Castle's, 507-LP Fifth, NYC 10017.

LEARN The secrets of repairing junk batteries. "Fabulous Profits" at home. Apex Engineering, 3100 Ramona, Atascadero, California 93422.

GET World's Biggest Wholesale Import Catalog. Write: World, Medina, Washington 98039.

FREE WEALTH BOOK: "2100 Unique Ways To Make Money!" World's Biggest Collection of Home Businesses! Success-M, 26903 West Eight Mile, Detroit, Michigan 48240.

\$1,000 MONTHLY! Stuffing Envelopes and Clipping Newspapers: Send Stamped Addressed Envelope . . . JOY, Box 936-C, Hyattsville, Maryland 20783.

\$200.00 PROFIT. Sheet 1/4" plywood. Details 50¢. Novelties, 610 So. 24th, Elwood, Indiana 46036.

\$8,000 MONTHLY SPARE TIME! No Selling! Start Now! —Free Proof!—Owco, Box 665-A, Inglewood, Ca. 90307.

GET RICH With secret law that smashes debts and brings you \$500 to \$2 million cash. Free Report! Credit (6A1), 333 North Michigan, Chicago 60601.

EARN Big money as Manufacturers' Representative—Details. Keith Kittrell, 808 Broadway, Kansas City, Missouri 64105.

PROFITS FROM CLASSIFIED ADVERTISING! Booklet shows you how to start your own business with Classified Advertising. Only \$1.00 (Refundable with first order.) H. E. KAPPEL, POPULAR MECHANICS, DEPT. P, 224 WEST 57TH STREET, NEW YORK, N. Y. 10019.

VINYL'S Where The Money Is! Invisibly repair, re-finish, recolor furniture, luggage, car tops. Quick, easy. Two small \$20.00 jobs a day earn you \$1,000 a month. Homes, cars, offices, restaurants, unlimited customers. Start earning after a day's practice. Sensational details Free. VIP, 2062 Montrose, Chicago 60618.

STUFF Envelopes, \$25.00 hundred. Free supplies. Send stamped envelope. Isco, 3835M 42nd, San Diego, CA 92105.

\$350 DAILY in your mailbox—Free Report reveals fortune building secrets—Research, Box 90133PM, Atlanta, Georgia 30344.

LUCKY Charms can make you rich. Rush \$1.00. Treasure Chest, 9321 Capeview Avenue, Norfolk, Virginia 23503.

LOOK! Anyone, make money anywhere. \$1.00 brings particularls plus valuable gift. W. Smith, Box 1878, Cincinnati, Ohio 45201.

FREE SECRET BOOK "2042 Unique, proven enterprises". Fabulous "Little Knowns" Work home! Haylings, Carlsbad, Calif. 92008.

\$6,000.00-\$12,000.00 Raising Rabbits. 400,000 Books Sold. Free Details. Vidikapa, Box 1543-A9, Tampa, Fla. 33601.

MAKE MONEY in spare time. Ideas, methods, precautions. Ten points of information for \$1.00. FRANKLIN GIFTS, N1748 Smith, Dept. P16, Spokane, Wash. 99207.

SAVE—Send \$2.00 for ANALYSIS DETAILING COSTS AND POTENTIAL of most ventures advertised in these columns. Opportunity consultants, 16568 Palm Ave., Anderson, CA. 96007.

WANT MORE MONEY, BETTER JOB? Start technical career . . . the easy way! Free revealing details. Counseling, Box 1162-MP3, Tustin, California 92680.

MAILORDER SECRETS REVEALED! Unlimited Profit Opportunity. No capital required. Request free report. Value House, Box 363BX, New York 10011.

STUFF Envelopes ** 100 Unlimited Earning Opportunities! Information: Stamped Addressed Envelope. Services, 271RTM1, Owego, New York 13827.

GO Wild with delight! Dynamic new report reveals, "How To Build An Instant Fortune!" Proven secret-first time told! Guaranteed. No effort, expense, risk! Details free. Nubrenetics, Box 2201PM1, Ft. Myers, Fla. 33902.

\$250-\$500/THOUSAND, STUFFING ENVELOPES, COMPLETE ASSISTANCE. Rush Stamped Addressed Envelope. Lim, Box 4337, Waco, Texas 76705.

GAIN free \$2,500 Yearly. Stamp. Vuko, 2350 W47A, Denver, CO 80211.

\$200 WEEKLY OFFICIATING SPORTS—Community-High School-College. \$2.00. Sports Enterprises, Box 284, Camdenton, Mo. 65020.

NEW! Home Business Report. Many ideas for EXTRA INCOME. Satisfaction Guaranteed. Contact: Communiqué, Route 3, Box 279, Dept. PM, Gaston, OR 97119.

\$250/THOUSAND, STUFFING ENVELOPES IMMEDIATELY, FREE SUPPLIES, RUSH STAMPED, ADDRESSED ENVELOPE, V.A.B. 31B REGENTS AVE., MAPLE SHADE, NEW JERSEY 08052.

BIG Mail, Three Months plus FREE GIFT \$1.00 Bill. Kilbride, Drawer E-33, Hawthorne, Cal. 90250.

ASSEMBLE Your own MAIL ORDER LIBRARY! Catalogs. 10¢. Cazin, 526 Maple, Redwood City, CA 94063.

SELL SENSATIONAL LOW-COST BURGLAR ALARM. Exceptional margin. Samples for trial. Northwest Electric, Ave. 203, Mitchell, S.D. 57301.

HOW To Earn At Home Addressing Envelopes. Rush Stamped/Addressed Envelope. Taut, Box 90697E2, Atlanta, Georgia 30344.

START PROFITABLE Business at home! Free details. J.P. Hall, 7305 Bay Street, St. Petersburg Beach, FL 33706.

FABULOUS Opportunity! Earn money at home, stuffing, mailing in pre-addressed, stamped envelopes, furnished free. "PM", Box 7282, Akron, Ohio 44306.

SELL TO COLLECTORS By mail. 500¢ mark-up possible. Pleasant, profitable, low capital. Successful businessman tells how. JGS, Inc., Dept. A-65, P.O. Box 525, Merrifield, Virginia 22116.

JUNK CAR BONANZA—Discovered High Income for Individuals. No Investment. Thousands monthly. Complete independence working part-time. Send \$2.00 for Manual. Start making Big Money at once. Wildserve, Dept. H, 5050 Poplar, Suite 1717, Memphis, Tenn. 38157.

\$250/\$500/THOUSAND! Stuff envelopes . . . Ready-addressed, stamped. Supplies at cost! Rush stamped, addressed envelope! HOMEWORKERS' AGENCY, Box 2616-B1, Stuart, Fla. 33494.

AT HOME \$1000 A MONTH Stuffing Envelopes. Free Supplies. Rush stamped addressed envelope. Home Work, 29 Western Ave., Morristown, N.J. 07960.

MAKE Extra money. New booklet shows you how to make money in your spare time—without working. \$1.50. O.R.H. Enterprises, 1540 Broadway, Suite 303, New York, New York 10036.

HOMEWORKERS, No Nonsense, we mean business. \$300 Weekly mailing envelopes. Rush 25¢, stamped addressed envelope to Innovations, Box 1037, Langley Park, Maryland 20787.

\$750.00/THOUSAND STUFFING ENVELOPES Details, 25¢ and Self Addressed Stamped Envelope. Edwin Enterprises, Box 427C, Garden City, Mich. 48135.

WE BUY NEWSPAPER CLIPPINGS of Wedding Announcements for \$1.00 each. Instructions. \$1.00. Clippings, Box 741 PM, Gatesville, Texas 76528.

EARN Extra money, spare time selling send for sample, details \$3.25. Box 1631, Lafayette, IN 47902.

500 ITEMS FREE. Booklet tells how and where. \$1.00 postage and handling. David Conner interests, Box 27052, Houston, TX 77027.

RETIRED Or working? Earn \$32,000.00 per year. Guaranteed Results. Complete information. Send \$5.00 to: L. T. Enterprises, Box 443, Cape Charles, VA 23310.

(Continued on next page)

MONEYMAKING OPPORTUNITIES

(Continued from preceding page)

EXTRA MONEY—USING YOUR HOUSEHOLD TRASH. Instructions \$1.00 Guaranteed. JP, 2856-G Noid Rd., Midland, MI 48640.

FREE! List of Amazing Money-making Booklets. Government Surplus, Import-Export, Real Estate, Inventions. Act Now! Deejayce's, 532-P Nursery, Metairie, LA 70005.

\$250-\$500/THOUSAND, STUFFING ENVELOPES, COMPLETE ASSISTANCE. Rush Stamped Addressed Envelope, EZ-WAY, Box 381, Bandy, Virginia 24602.

\$250-\$750/THOUSAND, STUFFING ENVELOPES, COMPLETE ASSISTANCE. Send Stamped Addressed Envelope, Tri-Mac, Dept. T-152, Box 34255, Indianapolis, Indiana 46234.

\$250-\$500/THOUSAND STUFFING ENVELOPES, COMPLETE ASSISTANCE. Rush Stamped Addressed Envelope, GaCo, Box 9161-A1, Ogden, Utah 84401.

MONEY Clipping Newspaper Items! \$2.00-\$10.00 each! Free details! WESCO, PO Box 891A7, Michigan City, IN 46360.

WATER! WATER! WATER! Earn \$150-\$350 daily, determining drilling sites for water wells. Patented instrument. Details \$1.00. Accurate, Rt. 376, Poughkeepsie, N.Y. 12603.

COLLECT STAMPS for profit! How to start. Where to sell. Complete guide. \$1.50. Husseys, 611 F Brittany Place, Fayetteville, N.C. 28304.

MAKE MONEY writing short articles at home. Begin immediately! Copyrighted report reveals how. Send \$1.50. Husseys, 611 F Brittany Place, Fayetteville, N.C. 28304.

SELL YOUR PHOTOS—Report tells how and where. Color Slide Markets. \$1.50. Husseys, 611 F Brittany Place, Fayetteville, N.C. 28304.

NEW! Easy! I made over \$200. from one redwood 2x4 stud, so can you. Details only one dollar. Paul M. Cannon, Box 4610 S.E., Hwy. 20, Conyers, Ga. 30207.

IF YOU HAVE AN IDEA FOR A NEW PRODUCT . . . or a way to make an old product better, send for our **FREE INVENTORS KIT NO. A-85.** It gives important information on Protecting, Developing, Marketing your invention/idea for Cash/Royalty Sales, Raymond Lee Organization, 230 Park Avenue, New York City 10017.

MAKE MONEY playing poker! Expert reveals inside secrets. Send \$1.50. Husseys, 611 F Brittany Place, Fayetteville, N.C. 28304.

MAKE EXTRA MONEY in your spare time—without working. New booklet shows how. Send \$1.50. Husseys, 611 F Brittany Place, Fayetteville, N.C. 28304.

NEVER Won Anything? Anyone can win Sweepstakes contests! Free details. Services, Box 644-PCA, Des Moines, Iowa 50303.

START Immediately—Receive 100 letters a day, each containing \$1.00. Details, Rush \$1.00, Reichow, Box 37, Big-Flats, New York 14814.

MAKE \$50,000 Yearly. Become A Financial Consultant. Free Information—J.L.S. Consultants, 391 Gregg Lane, Buffalo Grove, Illinois 60090.

MAIL Letters featuring real merchandise. Get \$12.00 orders in every mail, \$8.00 profit. Details 25c. Molesworth, The Dalles, Oregon 97058.

\$10.00 DAILY Writing short articles at Home. Revealing reports. Send \$1.00. Wilson, 233 Foster, Albany, Ind. 47320.

\$500/THOUSAND POSSIBLE, STUFFING ENVELOPES, INFORMATION/SUPPLIES, STAMPED, ADDRESSED, ENVELOPE, Aaron, Box 466-0501, Monrovia, Indiana 46157.

YOU CAN EARN \$1000 WEEK PART TIME From your home during 200th birthday celebration of USA. Start now anywhere in US. Not a Franchise. Send \$10.00 and start making big money now. Marion Dorrah, 1960 74th Ave., Phila., Pa. 19138.

MAKE \$1.00 A Word with good Penmanship. Free Details. Raymond Thomas, Rt. 3, Box 49-B, Atlanta, Texas 75551.

REAL ESTATE INVESTMENT COURSE! Complete investment plans to make a million dollars through buying and operating real estate. Send only \$14.95 to: Claude Sausbury, 114 Harmony Dr., Rochester, N.Y. 14626.

EARN Big Money showing our new 1975-76 Catalog. Over 1,000 items. Appliances, stereos, power tools, jewelry, etc. Low wholesale prices; many name brands. For catalog, send \$2.00 (Refundable with first order) to: TJS Distributors, 110 2nd Avenue, Pelham, New York 10803.

MAKE Money with your Ideas, TIPS on how to protect them, TIPS on where to sell them, send \$1.50. A. Bonay House, 18 Wilson Lane, Huntington, Ct. 06484.

ENGRAVING, Trophies, Profit Crafts \$20. Hour or more. Free Catalogue. Skill-Craft, P.O. Box 132010-PM, Columbus, Ohio 43213.

PROFITABLE OCCUPATIONS

LAMINATING Home business in spare time. Material costing 42¢ returns \$3.20! No selling. Let your Mailman be your banker. Write for full particulars free. Warner, Room LC-2-FC, 1512 Jarvis, Chicago, IL 60626.

SEX Food MONEY. Psychologists Agree Society Relishes These "Big Three". Concerning MONEY. Earn \$100.00 NIGHTLY Playing Records. Complete Details. Photos Dos, Dont's Descriptions Etc. Send \$5.00. "Dynamic Uno", P.O. Box 8116, Corpus Christi, Texas 78412.

SHARPEN—Scissors, Pinkers, Light, compact equipment. Supplies. Blackhawk's, Sheldahl, Iowa 50243.

FREE Catalogs. Repair air conditioning refrigeration. Tools, supplies, full instructions. Doolin, 2016 Canton, Dallas, Texas 75201.

FT. SMITH Auction School, Ft. Smith, Ark. 72901. Resident & Home study. Veteran approved.

\$100.00/DAY POSSIBLE!!!! Buy Scrap Gold . . . Easy . . . Complete manual, \$4.00 Satisfaction Guaranteed . . . Brown, 956 Springdale, Atlanta, Ga. 30306.

PLASTERCRAFT!!!! Profitable home business. Molds available. Details: Lynnette, 6251C Mentor Park, Mentor, Ohio 44060.

BAKE New greaseless doughnuts in kitchen. Sell stores. Free recipes. Michael Ray, Waseca, Minn. 56093.

\$15 HOUR Fascinating Home Business or Hobby, Manufacturing item used in every home. Details 35¢ Refundable; Randall, 831 Bertrand, Prescott, Ariz. 86301.

"CANDLEMAKING" Profitable Spare or Full Time Business. Easy To Learn with Step-By-Step Handbook Course. \$3.00. Guaranteed. Riollano Enterprises, 2108 Davidson Ave., Bronx, New York 10453.

SALESMEN—DISTRIBUTORS

HERTEL exclusive reference Bible! Big profits! Startling 3-dimension cover! Demonstrator, supplies furnished. Top commissions plus extra bonus earnings! Free outfit. International Book, Dept. PM, Box 118, Wichita, Kansas 67201.

RED Hot! Chinese Embroideries 100% Handmade. Sample, information \$5.00. Tinsum, 4330 West Church, Fresno, CA 93706.

SELL CALENDARS, SPECIALTIES Repeat Business-Free Details - Fleming, 6535 Cottage Grove, Chicago 60637.

AUTOMATIC Fishhooks. Profitable Samples, \$2.00 (refundable). Aron, 61-PM, Mastic Beach, New York 11951.

100% PROFIT! Volume repeat orders! Amazing six in one lubricant. Write: Distributorship, 1240PM Alandaie, Albany, Oregon 97321.

SELL Fotofoam Printers, Businesses, Clubs, Hobbyists. Inventec, Box 128-G, Endicott, N.Y. 13760.

AGENTS WANTED

PROFITABLE Business! No investment! Take orders for America's finest shoes from friends, neighbors! Profitable. Easy. No experience needed. Selling outfit free. Mason Shoes, K-183, Chippewa Falls, WI 54729.

MAKE MONEY IN SPARE TIME. As a subscription sales representative for leading national magazines, you can earn generous commissions while learning the art of selling. Instructions and supplies will be sent to you free. Send this ad with your name and address to: **POPULAR MECHANICS**, Room 1107L, 250 W. 55th St., New York, N.Y. 10019.

SPARE TIME CASH. Sell famous Hanover Shoes. Samples, sales kit free. No experience needed. No age limit. Big commissions. Hanover Shoe, Dept. 1533, Hanover, Pa. 17331.

PRINTING Advertising Salesmen—Excellent money-making sideline selling Decalomania Name Plates, small quantities. Advertising Specialties, sign letters. Free Samples. Raico XL, Boston, Mass. 02119.

YOUR Own business. Used Suits \$1.50; Overcoats 65¢; Mackinaws 35¢; Shoes 12½¢; Ladies' Coats 30¢; Dresses 15¢. Enormous profits. Catalog Free. Nathan Portnoy Associates, 2109-AA Roosevelt Road, Chicago, Illinois 60608.

50% PROFIT Sell Engraved Metal Social Security Plates. Bicentennial-Zodiac. Free Sales Kit. Spray, Box 23-PM1, Rockford, Illinois 61105.

EMPLOYMENT INFORMATION

SHIPBOARD JOBS. World's Best Employment. \$25,000. A Year. No Experience Necessary. **FREE** 1975 Wage Scale, Details and List of 460 Steamship Owners. Commander, Box 278-A, Belle Mead, N.J. 08502.

OVERSEAS JOBS—WORLDWIDE! ALL OCCUPATIONS! To \$4100/Month! \$2.00. Global-C, Box 99494, San Francisco, CA 94109.

AUSTRALIA NEEDS WORKERS! Transportation, Settling-in Allowances! Details, \$1.00. Guaranteed. Bilmor, 8225X-6 Encino, Northridge, CA 91324.

AUSTRALIA Employment full information \$1.00. Roberts Enterprises, Box 25773, Okla. City, Okla. 73106.

WORK in Beautiful Australia! Complete details: Salaries, Schools, Texas, Rent, Immigration requirement forms, plus Giant Employers list. Send \$2.00. Jobs, P. O. Box 6047, Concord, California 94520.

AUSTRALIA NEEDS YOU!! JOBS, JOBS, . . . ALL SKILLS NEEDED. Government paid passage. Complete Factbook contains: Wages, Farming, Recreation, Rents, Taxes. Plus Giant Employers List. Guaranteed, \$1.00. Leman Enterprises, Box 228-B, Santa Maria, Calif. 93454.

SOLDIERS OF FORTUNE. Middle East. \$1100-\$2000 Monthly! Information/Forms \$3.00. Captain Miller, Box 91395-A, International Airport, Los Angeles, California, 90009.

EMPLOYMENT!! U.S.!! Foreign! Skilled, unskilled, equal opportunity, all fields, directory, application, resume instructions—\$3.00. National Information, Dept. 1-1, 422 Washington Building, Washington, D.C. 20005.

BOOMING MIDDLE EAST JOBS!!! \$800-\$5000 Monthly! All Occupations! Free Transportation! Directory/Forms \$2.00. Worldwide. Box 948-A, Long Beach, California 90801.

RADIO BROADCASTING! How to get into it. Free literature. Kegw, Box 5516-AB, Walnut Creek, CA 94596.

PROVEN JOB FINDING SYSTEM. New Book! Totally different system! It works! Details: Market Associates CA, Box 40529, Indianapolis, Indiana 46240.

EXCITING OVERSEAS JOBS! Over 100 Countries . . . Now Hiring! All Occupations. \$800-\$5000 Monthly. Latest Printouts \$2.00. Jobworld, 6311-A Yucca, Los Angeles, California 90028.

AUSTRALIA Needs You!!! Jobs, Jobs!!! Free Transportation! Housing, Farming, Recreation, Information. Giant Employers List!!! Guaranteed \$1.00. Vanguard, Box 2243-F, St. Louis, Missouri 63109.

MIDEAST Jobs, many other worldwide openings listed in latest issue of Foreign Employment Newsletter. Free information. Foreign, Box 188-XY, San Jose, California 95103.

TEXAS Certain Areas Booming. Free DETAILS REPORTS, Box 38618, GF-1, Houston, Texas 77088.

HELP WANTED

INVESTMENT Casting Mold Makers and Tool & Die Makers wanted. Mail resume: Roy Heath, Southern Tool & Machine Co., Box 2248, Anniston, Ala. 36201.

AN OHIO OIL Co. Offers PLENTY of MONEY plus cash bonuses, fringe benefits to mature individual in your area. Regardless of experience, airmail W. G. Read, Pres., American Lubricants Co., Box 696, Dayton, Ohio 45401.

OVERSEAS EMPLOYMENT . . . Europe, Australia, South America, Asia! All Occupations! \$700 - \$4,000 monthly! Employment International, Box 29217-AA, Indianapolis, Indiana 46229.

REAL ESTATE & FARMS

NEW! FREE CATALOG! Exciting Spring edition of country property! Over 5,400 New properties described, pictured—Land, Farms, Homes, Businesses—Recreation, Retirement; Selected Best throughout the U.S.! 76 Years' service—670 Offices, 42 states Coast to Coast. Mailed Free from the World's Largest! Strout Realty, Inc. 7-MX S. Dearborn, Chicago, Ill. 60603.

CANADIAN LAND FROM \$35.00 AN ACRE. Choice properties across Canada. Low monthly payments. Ideal for cottages, hunting, fishing, investment. Free catalogue. Canadian Estates Land, 286 Lawrence Avenue West, Toronto, Canada, M5M 3A8.

WYOMING RANCH LAND. 10 Acres \$30.00 down \$30.00 month. Owner-Mike Gauthier, 9550 Gallatin, Downey, Calif. 90240.

GOVERNMENT LANDS from \$8.50 ACRE! INVESTMENT, RECREATION, FARMING. \$2.00. Land-C, Box 99494, San Francisco, CA 94109.

55 ACRE, Canadian Border—hundreds campsites, islands, farmlands, directly from tax authorities. (Non-profit). Lists, photographs mailed. Register, Room 10, 110 Church Street, Toronto 1, Ont. Canada

\$3.50 ACRE! USA and Canada. Lists, photographs mailed. Government Lands, 421-PM Center, Lewiston, New York 14092.

"CANADIAN Country Acres and Lots." Our 60th year. Free catalogue. Tax Sale Service, Room 301-PM, 85 Bloor Street, East, Toronto, Ontario M4W 1B5.

CENTRAL Ontario—Choice 640 acre Sportsmen's paradises still available—\$20.00 plus \$6.50 taxes yearly. Maps, pictures, \$2.00 (Refundable). Information Bureau, Norval 4, Ontario, Canada.

NEW . . . BIG . . . SPRING '76 CATALOG . . . Free! Over 2,600 top values coast to coast! UNITED FARM AGENCY, 612-PM West 47th, Kansas City, Mo. 64112.

GOVERNMENT LANDS From \$7.50 Acre! Vacation'g, Farming, Investment! Exclusive "Government Land Buyer's Guide" . . . plus "Land Opportunity Review" listing lands throughout U.S. Send \$2.00. Surplus Lands, Box 19107-AX, Washington, DC 20036.

FREE CATALOG! Photos! Farms, Business, Retirement! All types, Sizes, Prices! SAFE-BUY Real Estate Agency, Inc., Box 589-PM, Little Rock, AR 72203.

GARDENING & LAWN CARE

GROW VEGETABLES LARGER, faster. Flowers too. Guaranteed new method. Instructions \$2.00. Greenhouses, Dept. A, Box 153, Kingstree, S.C. 29556.

HYDROTROPIC Greenhouses \$49.00 Distributors invited. Hydrotropics, 1538 E. Chestnut, Santa Ana, Calif. 92701.

PM'S BESTSELLING "COMPLETE GARDEN GUIDE" For the Man Who Needs All The Basics . . . Fast! Superbly Organized in Famous "Master Guide" Format. Dozens of Tables, Charts and Illustrations. Literally Crammed with Timely Bonus Specialties like Vegetables, Fruits, Nuts and Herbs, Garden Pools, Storage Structures, Planting Dates. Only \$4.49 ppd. PM Complete Garden Guide, Dept. HE, Box 1014, Radio City, N.Y. 10019.

FLOWERS, PLANTS, & NURSERY SUPPLIES

LEARN Landscaping and the growing of plants. Start a profitable business part or full time. Free information without obligation. Lifetime Career Schools, Dept. A-5, 2251 Barry Avenue, Los Angeles, California 90064.

GINSENG Bringing \$35.00 Pound. Have seeds, roots. Information: K. Collins, Viola, Ia. 52350. РУССКИЕ ПРАВОМ

(Continued on next page)

CONSTRUCTION PLANS, BLUEPRINTS

HOW I Heat My Home Using The Sun And Window Fans. Plans \$10.00. Stiber, 1991 Winterville Road, Athens, Georgia 30601.

75 HOME PLANS including year-round VACATION homes! Cost cutting booklet FREE... \$2.25. Guaranteed. Better Homes, Box 649S, Forest Hills, N.Y. 11375.

SAUNA Instructions—How to Build Room. Save hundreds of dollars. \$3.95 Postpaid. Included—\$50.00 Coupon Toward The Purchase Of Sauna Heater. Manuales, Box 4479, Minneapolis, MN 55321.

LOG CABINS AND "A" FRAMES

BUILD Log Cabins, Rustic furniture, Fireplaces! Complete manual \$3.00... "A" Frame plans, \$2.00. Guaranteed... Beels, 956 Springdale, Atlanta, Georgia 30306.

"A" FRAME CABIN. 1184 square feet: \$1950. material. Purchase locally. Complete plans, instruction manual & material list: \$5.00. Moneyback guarantee. Plan #4906, "Dependable Products", Box 113, Vista, California 92083.

NATURAL STONE HOUSE. Gather Rocks Free, Build In One Summer! Need Pickup, Hand Tools—No experience! Guaranteed "HOUSE OF STONE" manual, \$3.00. Stonehouse 175, Sweet, Idaho 83670.

LOG CABIN plans & detailed instructions: \$3.50. Moneyback guarantee. "Solley", Box 597, San Marcos, California 92069.

HOME CRAFTSMAN

WOOD—Domestic and Imported Hardwoods! 3500 items! Clock, musical instrument kits. Tools... discount prices! Hard-to-find hardware. 144 page catalog, 50¢. Craftsman, Dept. AX-16, 2729 Mary, Chicago, Illinois 60608.

101 PATTERNS, Gifts, Novelties, Shelves, Action Windmills, plus "Make Money Jig Sawing". \$3.00. Mastercraft, JSM, P.O. Box 631, Park Ridge, Illinois 60068.

CHARM From the past, build old fashion wooden water pump, great decoration item in the lawn. Plans \$2.00. Marcel Houle, 267 Denison, Granby, Quebec, Canada. J2G 4E3.

STAINLESS Steel screws, small quantities, free brochure; Elwick, Dept. 219, 230 Woods Lane, Somerdale, N.J. 08083.

1600 SOURCE LISTING FOR ANYTHING YOU WANT!!! \$2.00. Keyfile-C, Box 99494, San Francisco, CA 94109.

HOW TO Make kitchen cabinets and furniture. New illustrated manual shows you the latest step by step methods. Guaranteed. Write: Flint Woodworking, 1027 Mansfield City Road, Storrs, Ct. 06268.

CATALOG FULL SIZE FURNITURE PLANS—\$1.00 Refunded with first order. Traditional Early American, over 150! Furniture Designs, 1425 Sherman, Dept. CP-76, Evanston, Illinois 60201.

CABINETMAKING MADE EASY And "How to Make Formica Counter Tops." Two excellent guides let you build kitchen cabinets and counter tops like professionals. Extraordinary guides bring master craftsmen's shortcut methods. Satisfaction guaranteed. Write: Japs, 126-P Seventh North, Hopkins, Minn. 55343.

PICTURE Framing—Profitable full or spare-time business. Easy to learn with handbook-course "Guide To Picture Framing Profits." \$2.00 Guaranteed. Free framing-supplies catalog included. Japs, 126-PM Seventh North, Hopkins, Minnesota 55343.

FREE ENERGY! Sources of Supplies, plans, windmills, solar, methane, etc. Send \$2.00. PER-O, 15 Riverside, Saginaw, MI 48602.

PM'S GREAT, NEW MASTER HOME CARE GUIDE. The Latest and Greatest in The Popular Mechanics Master Guide Series. Lays Out All You Need To Know About Home Repairs, From Basement Waterproofing to Roof Repair. 24 Laminated, Wipe-Clean Sheets on 12 Stand-Up, Hang-Up Boards. 150 Charts and Illustrations. Properly Used, It Can Save Thousands of Dollars. \$4.49 ppd. PM Master Home Care Guide, Dept. HE, Box 1014, Radio City, N.Y. 10019.

PLANTERS—(Hanging/Floor). Architect Designed, Easy To Make For Fun And Profit. 10 Plans \$2.00. Planters, Box 367, Waterford, Michigan 48095.

SIMPLE Tool for handymen, carpenters, painters, really works—wish we'd discovered sooner—you make information \$1.25. Boyers, Addison, NY 14801.

WOODWORKING HANDBOOK, 900 Illustrations, 739 pages. The most complete and up to date book for the woodworker. Only \$8.95 postpaid. Hidalgo Supply Co. Dept. 7, Box 35339, Houston, Texas 77035.

12 GROSS Small Machine Screws, Nuts, Mixed \$6.95. 9 Pounds Mixed Wood Screws etc. \$12.75. Reg. \$26.95. Nuts, Bolts, Screws, Washers, Catalog. 75¢. Nutty Co., 1576SMS, Fairfield, Conn. 06430.

WOODEN BATHROOM ACCESSORIES. Plans—\$1.00. O'Hagan, Box 84, Rough and Ruddy, Calif. 95975.

500 SOURCES Tools, Supplies, Books, \$2.00. Craftsman's Source Index; 4216 W. Telegraph, Oakland, California 94609.

TABLES Low-cost designs for every need. Hand tools sufficient. Plans \$2.00. SKILLMAN, 101 Valley View, Coquille, Oregon 97423.

PLANTERS—(Hanging/Floor), Architect Designed, Easy To Make For Fun And Profit. 10 Plans \$2.00. Planters, Box 367, Waterford, Michigan 48095.

"UNLIMITED" Spare time earning. Light weight Pet Cages. Some built 30 to 40 per month. Sell to pet shops. Retail \$10.95 to \$14.95 year round. Complete specifications & plans 3-sizes. Only \$25.00. Check or money order. Durable Pet Cages, Box 12623, Capitol Station, Austin, Texas 78711.

DO-IT-YOURSELF

SOLAR Collectors, 68 cents per square foot—not \$6.00. Superior performance too. Information \$2.00. Chalett, Box 8106, Rochester, New York 14617.

APPLIANCE PARTS. Save Money by Repairing Your Own Major Appliances. Repair Parts And Service Literature Available for Most Popular Brands. Call 215-744-8383 or Write: Appliance Parts Distributors, 1210 East Venango Street, Philadelphia, Pa. 19134. Specify Make, Model, And Serial Numbers.

1400 CATALOGS Listed and Described Sources for EVERYTHING Imaginable! Rush \$2.00. MASTERLOG, Box 24413-Y, Oakland, California 94623.

ELECTROPLATING. Complete amateur's textbook All metals Electroplate metallic/nonmetallic items \$7.00. Details free. Tropic, Box 95-P3, Palm Bay, Fla. 32905.

IF YOU Have the dough to buy a \$200.00 workbench, buy it. If not, send \$1.00 for our poor-man's workbench plan and build your own for less than \$30.00. Full instructions and material list. Way-Mar, 58 Underhill Road, Scarsdale, N.Y. 10583.

PM'S FAMOUS MASTER SHOP GUIDE. One of The Most Important Tools You'll Ever Own! Lays Out Everything You Need To Know About Nails, Screws, Bolts, Drills, Adhesives, Ladders, Masonry, Plumbing and Electrical Work. 24 Stand-Up, Hang-Up, Wipe-Clean Laminated Pages. 56 Charts plus a Built-In Ruler, Protractor and Compass. Solid Value at \$4.49 ppd. PM Master Shop Guide, Dept. HE, Box 1014, Radio City, N.Y. 10019.

ENERGY Saving Plans. Water Wheels, Windmills, Electric Cars, Home Power Plants, Free info., plans list. Goodman Associates, 4 Berryville Pike, Summit Point, WV 25446.

ENERGY CRISIS? SOLAR/WIND ENERGY'S FREE!! Details, Manufacturers, \$2.00. Guaranteed. Bilmor, 8225M-5 Encino, Northridge, CA 91324.

DESIGN And build your own T.V. Antenna. Complete instruction book, \$3.00. E.H.P. Engineering, 7011-180th SW, Edmonds, Wa. 98020.

LEARN More, Earn More, How-To-Books On Everything. Send Stamp. Box A, Paramus, N.J. 07652.

REFINISH Furniture yourself. 8-Page pamphlet written by experienced refinisher. Send \$1.00 to: D. J. Austin, RR2, Wapello, Iowa 52653.

ELECTRIC SHOE DEMUCKER, Make for less than fifteen dollars. Details-material Sources. Send \$2.00. Walsch, P.O. Box 87, Greenbank, Wa. 98253.

SIMULATE BRICK Or Stone Walls, Fireplaces, Planters for pennies—instructions and tool \$3.00. RR7, Box 506, Ocala, Fla. 32670.

WINDTURBINES, Several Kinds, 12v-110v, \$5.00. Solar Heating, Power, Cooling, \$3.00. Power Mower Tree Limb Shredder, \$2.00. Automobile Battery Power, \$2.00. All illustrated instructions Guaranteed. Energycraft, 2350 W47P, Denver, Colorado 80211.

PORCELAIN Chip restoration! Saves bathtubs, sinks! Fast, easy. Complete do-it-yourself kit. Revolutionary. Never sold in stores. New space-age compound. Ten amazing glass-smooth, rock-hard permanent repairs. Only \$9.23 postpaid. Permafill, Box 25383, Houston, Tx 77005.

WINDTURBINE 12V-110. Engineered blueprints \$10.00. Sketch, information \$1.00. Lights, heat, Cool. Box 566, Half Moon Bay, Ca. 94019.

REPAIR YOUR COLOR TV. Anyone can. New Easy Method Information Free. Research Publications, Box 235P, Brea, Calif. 92621.

SAVE Home fuel oil. 50% possible. Easy, inexpensive. Complete details \$3.00. C. Gottenmoller, PO Box 818, Newark, DE 19711.

TELEPHONES UNLIMITED, Equipment, Supplies, Catalog 50¢. Box 1654B, Costa Mesa, California 92626.

SOLAR Energy Handbook, 3rd Edition, \$9.00. Ficoop, 2901S Wentworth, Milwaukee, WI. 53207. Satisfaction Guaranteed.

"HOW TO Fix Drips And Other Plumbing Problems." Written By Master Plumber. Satisfaction Guaranteed. Get Your Copy Now! \$2.00. Donald Gear, Box 444, Elkins WV 26241.

FIREPLACE—Modern. Heat Recovery system. Adaptable To All. Fireplaces unlike Any Now Available. 60,000 BTU output. Professional Prints, \$3.00. B & H Designers, Box 732, Post Falls, Idaho 83854.

ULTIMATE WATERBED PLANS Build For Profit Or Pleasure. Built-In Television, Stereo, Bar, Aquarium, Lightshow. Complete Plans—\$4.00. Creative Image, 936 New Haven Ave., Melbourne, Fla. 32901.

SAVE UP TO 75% HOME HEATING Up to 50% Cooling Cost. Now Amazing New Plan. Free information. Watus Enterprise, 3451-PM1 Colonville, Clare, Michigan 48617.

REPRODUCTION MOLDS

MOLDS For Ornamental Concrete. Our Catalog Contains Over 700 rubber and fiberglass molds. Catalog \$2.00. Plycrete Mold Co., Elk Rapids, Mich. 49629.

ARTS & CRAFTS

LEATHERCRAFT Catalog. Tools, Leather, Dyes, Dressings, Saddle Stamps, Buckles, much more. Send 25¢ to MacPherson Bros., P.O. Box 395, San Francisco, Calif. 94109.

GLASS BLOWING Kits and Supplies—Literature Upon Request—Willis Glass, P.O. Box 3460, Anaheim, California 92803.

MAKE Figurines, plaques, lawn ornaments. Molds, plastercraft kits, liquid rubber. Sample and catalogue 25¢. Wooley Company, Box 29-B, Peoria, Illinois 61601.

"GETTING Started in Stained Glass" 25¢. Whittemore, Box 2065Y, Hanover, Mass. 02339.

WHOLESALE Handicrafts Supply Directory \$3.00. RPH, 924 Winter Street, Stamford, Conn. 06905.

BINOCULARS, TELESCOPES, MICROSCOPES, MAGNIFIERS

FREE Binocular, Rifle scope catalog. Discount sale. Save 50%. Free gift with order. Write: United Binoculars, BN-9808, 9043 So. Western, Chicago 60620.

HUGE Discounts!! Bushnell, B&L binoculars/scopes. Free catalog & price list. Write: Marigold, Box 5038-C3, South San Francisco, CA 94080.

WHAT To Look For in binoculars. Write: Tele-optics, 5514 Lawrence, Chicago, Ill. 60630.

CAMERAS AND EQUIPMENT

FREE! FREE! BARGAIN BOOK. Central Camera Co., Dept. 311, 230 S. Washburn, Chicago, Ill. 60604.

PHOTO FINISHING

LOOK!—Special Money Saving Offer: Kodacolor Rolls developed with Jumbo Prints \$1.60. B&W 49¢. Big Discounts on supplies. Enclose Advertisement. Wisconsin Film, Dept. E, LaCrosse, Wisconsin 54601.

COLOR SLIDES

GAF Color Slides. All countries. Catalog 25¢. Worldwide, 7427-M Washburn, Minneapolis, Minn. 55423.

FREE 35MM Color Slide Encyclopedia. Same slides used in TV, national magazines. 126-pages individual listings. Write Wolfe Worldwide Films, Dept. 14-16, Los Angeles, Ca. 90025.

MOTION PICTURES & SOUND EQUIPMENT

UNUSUAL Movie supplies. Free circular. Esor, 47th Holly, Kansas City, Missouri 64112.

SUPER 8MM, 16mm, 8mm silent and sound film classics. Free catalog. NILES, 1141PM Mishawaka, South Bend, Ind. 46615.

SUPER 8, 8mm, 16mm, 35mm, 8&W and Color Film. Supplies, Processing Equipment. Send 25¢ for 84-page catalog refundable with order. Superior, 448 N. Wells, Chicago 60610.

175-FT. 8MM. CLASSIC SAMPLER . . . ONLY \$1.99. Highlights from heyday of the silents! Chaplin, Laurel & Hardy, Fairbanks, Keystone Kops, Gish, Pickford, Chaney, the first Indianapolis 500 and more. Order today . . . specify standard or super-8. Free catalog: 8MM & 16MM (silent & SOUND) movies & 35MM, 2" x 2" color slides. Blackhawk Films, 8018 Eastin-Phelan Bldg., Davenport, Iowa 52808.

CASTLE Home Movies Catalog—G & G Films, Box 321, Syosset, N. Y. 11791.

8MM—SUPER 8—16MM MOVIES! Biggest Selection! Lowest Prices! Free Catalog! Cinema Eight, Box PM, Chester, Connecticut 06412.

RADIO, TELEVISION & HAM EQUIPMENT

HEAR POLICE/FIRE Dispatchers! Catalog shows Directories of "Confidential" channels, Receivers. Send postage stamp! Communications, Box 56-PM, Commack, NY 11725.

CANADIAN Catalogs—Giant Savings, Surplus, Clearouts, Bankruptcy Stocks, Factory Deals. Rush \$1.00. Etco-PM, Box 741, Montreal "A".

36¢ RADIO & TV Tubes. Free catalog. Cornell, 4213-17 University, San Diego, California 92105.

GOVERNMENT Surplus receivers, transmitters, sniperscopes, parts. Catalog 25¢. Meshna, Nahant, Mass. 01908.

FREE Educational Electronics catalog. Progressive EduKits, Department 752B, Hewlett, New York 11557.

HIFI, TAPES, & RECORDS

FREE CATALOG. Collectors Records. Discs. Box 7216, Louisville, Ky. 40207.

9,500 OLD Radio Shows! Catalogue \$1.00. Box 9032-Z, Wyoming, Michigan 49509.

FREE Catalog—Electronic Kits—Amplifiers—Pre-amplifiers—Psychedic Strokes—SCA Adaptors—Color Organs—Digital Instruments—Guitar Amplifiers. FREE Subscriptions. SWTPC, Box PM32040, San Antonio, Texas 78284.

OLDIES 45 RPM Original Hits—Catalog 50¢. C&S Record Sales, Box 197, Wampsville, New York 13161.

(Continued on next page)

HIFI, TAPES, & RECORDS

(Continued from preceding page)

GOLDEN Age Radio. Complete taped Shows. Box 25215-M, Portland, Oregon 97225.

RECORD-TAPES! Discounts to 73%; all labels; no purchase obligations; newsletter; discount dividend certificates; 100% guarantees. Free details. Discount Music Club, 650 Main St., Dept. 1-16, New Rochelle, New York 10801.

CASSETTE LIBRARY. Motivational, educational, training, nostalgic. Sales. Rentals. Catalog \$1.00 refundable. Drawer 2871-P, Springfield, Mass. 01101.

FREE! Soundtrack Auction list. Whalon, 2321 P Hill, Redondo Beach, California 90278.

CLASSICAL CASSETTES! FREE CATALOG. Better quality. 50% less cost than records! CCC, Box 506PM, Saddle River, N.J. 07458.

RECORDS. Rare Originals. Send List. Oldies But Goodies, Box 3356, Pontiac, Michigan 48059.

RADIO Programs. Giant catalog listing thousands \$1.00 (refundable). Ayers, Newton Junction, N.H. 03859.

RADIO MEMORIES. Reels, Cassettes, 8-track. Box 714, Nekoma, N.D. 58355.

MUSIC INSTRUCTIONS & INSTRUMENTS

ACCORDIONS—Famous makes. 40 models. 5 Day Home Trial. Easy terms. Trades. Free Catalogs! Money saving Importer-to-you Price List. Write: Accordion Corporation, Dept. R, 5535 Belmont, Chicago 60641.

GUITARISTS' 72 PAGE CATALOG. Save up to 40% on guitars, amplifiers, sound reinforcement systems, accessories, books. **MUSICIAN'S SUPPLY, Inc.**, Dept. T, Box 1440, El Cajon, Ca. 92020.

OUTSTANDING Tone On Wooden Instruments. Instruction \$5.00. Marc Anthony, P.O. Box 1205, Crescent City, CA 95531.

EASY To play and make, quality dulcimers, banjos, thumb pianos, hammered dulcimers; instruments and kits. HERE, INC. #P, 410 Cedar Avenue, Minneapolis, Minnesota 55404.

ACCORDION Top Brands. Cordovox, Buy direct. Tremendous discounts. Trades accepted. Free brochure PM. Accordion-O-Rama, 874 Broadway, N.Y.C. 10003.

30% TO 50% DISCOUNT! Any Model: Guitar, Amp, Drum, Banjo, Dobro! Free Catalog! Warehouse P65, Box 11449, Fort Worth, Texas 76109.

WHOLESALE! Professional Guitars, PA Systems, Aitec Speakers, 240W RMS Amplifiers. Free Catalog. Carvin, Escondido, Calif. 92027.

POEMS Wanted for songs. Nashville Music Productions, Box 40001-P, Nashville, Tennessee 37204.

PLAYER PIANOS; PUMP ORGANS—books; repair manuals. Catalog \$1.00, refundable first order. Vestal Press, Box 97, Vestal 11, NY 13850.

LEARN Banjo. 5-String Bluegrass. No music. Makes learning easy. Free details. Blaylock, Box 25-M, Marietta, Georgia 30060.

UP TO 60% Discount Name Brand Instruments. Catalog. Freeport Music, 455F, Route 110, Melville, N.Y. 11746.

ACCORDIONS Manufacturing, 6846-P North, Chicago 60635. Concertinas - Chromatics - Heligons - Hohners - New - Used - Repairing - Wholesale Catalogs Free.

POEMS Songs wanted. Recording. Publishing guaranteed. Royalties. Radio-TV release. Broadway Music, Box 7438-PM, Sarasota, Fla. 33578.

ELECTRIFY Player Pianos, Pump Organs Quickly, inexpensively with Lee Silent Suction Units. Write: Lee Music, 525F Venezia Avenue, Venice, California 90291.

GUITAR, Banjo, Violin, Mandolin Making Materials, Accessories, Books. Catalog 25¢. Guitar Center, Box 15444, Tulsa, Oklahoma 74115.

NATIONAL sale, 10% off to makers and repairers of all string instruments. Wood, parts, accessories & thousands of items listed in new 64-page catalog. Write today for your copy and price list. Enclose 25¢ to cover postage & handling. International Violin Co., Dept. G—4026 W. Belvedere Ave., Baltimore, Md. 21215.

GUITAR Players Cloth—Cleans, Polishes, Protects. Steel Strings, Chrome & Wood. Only \$1.25. Parkrow, P. O. Box 55P, Woodbridge, Va. 22194.

KITS! Build dulcimers, guitars, harps, banjos, mandolins. From \$2.95. Finished instruments from \$23.95. Free catalog. 8665 West 13th-PM, Denver, Colorado 80215.

MUSICIANS! 990 Unique Ways To Make Money Playing Music. Kerns, 7249-P Fairbrook, Baltimore, Md. 21207.

STRINGS! ALL KINDS! Accessories, Parts, Catalog 25¢. Stringing, M1, Box 5444, Lindenhill, Flushing, New York 11354.

EDUCATION & INSTRUCTIONS

WELDING TRAINING. Basic and Advanced Training for Major Processes—Arc, Gas, Pipe, TIG, MIG, Plasma. Hobart, a nonprofit school, is accredited member NATTS. Approved Ohio 70-12-0064 HT. Write for school bulletin and course schedule. **HOBART SCHOOL OF WELDING TECHNOLOGY,** Box 76, Troy, OH 45373.

HIGH SCHOOL AT HOME in spare time. If you left school without finishing, write today for free brochure about our home study method, diploma, and accreditation. American School, Dept. X145, Drexel at 58th, Chicago 60637.

LEARN Flower Arranging and Floristry. Start business or hobby. Free information on home study course. Lifetime Career Schools, Dept. B-521, 2251 Barry Avenue, Los Angeles, California 90064.

BOOKKEEPING OR ACCOUNTING! Your own business or work for others. Easy home-study plan prepares you quickly. Veteran-Approved. Free "Accounting Career Kit." Write: Accounting School, Dept. PBCC5, Newport, California 92663.

AUCTIONEERING: Mendenhall School of Auctioneering. High Point, N.C. 27263. Free Information.

EARN WHILE YOU LEARN at home in your spare time. Modern Outdoor Equipment Repair School. Send for brochure, full facts. Dept. PM, 4225 N. Brown Ave., Scottsdale, Ariz. 85251.

LEARN CARTOONING At home. Free brochure. Bureau of Cartooning. Box 7069PM, Colorado Springs. Colorado 80933.

DETECTIVE Profession. Easy home study; free tie-tack or lapel pin, certificate, future. Professional Investigators, Box 41345. Dept. CP, Los Angeles, Calif. 90041.

CUSTOMIZE VANS, Trucks, cars. Learn big profit home business in spare time. Materials, tools included. Exteriors, interiors—painting, upholstery, special fittings. **FREE Career Plan.** Customizing Center, Dept. PBCC5, Newport, California 92663.

EXTENSION And Post-Graduate Awards in Philosophy, Art, Science, Botanic Medicine, Homeopathy, Radionics and others. 30 subjects. Curricular free (airmail \$1.00 refundable). Registrar, Sussex College of Technology, Highfield, Daneshill Sussex, England.

INSTANT MEMORY. . . . New way to remember. No memorization. Release "photographic" memory. Forget nothing! Liberates extraordinary knowledge talents, ESP. Immediate results! Free information. Institute of Advanced Thinking, Box 606-PM, Pacific Palisades, California 90272.

USED Courses! Books Catalog 10¢. (Courses Bought). Lee Mountain, Pisgah, Alabama 35765.

USED HOME STUDY COURSES BOUGHT, SOLD AND EXCHANGED. DEMONTMOLLIN, 318 MAJORCA, CORAL GABLES, FLORIDA 33134.

LEARN Asleep or awake! Records, tapes, equipment! Free catalog! Drawer PM-400, Ruidoso, New Mexico 88345.

BARTENDING-Bar Management Course. Free information. Universal Academy. Box 8180-AB, Universal City, California 91608.

ACCOUNTING CAREER. Many make \$1,200 monthly. You start, only 20 lessons, \$5.00 each. Pay as you learn and earn. State approved. Certificate. Start by Mailing \$5.00 for first lesson. Jenkins, Box 571, Taft, California. 93268.

RADIESTHESIA, Radionics, Dowsing. E.S.P. Courses and Equipment. Illustrated Catalog \$1.00 (refundable) Established 27 years. Dept PM/R Bruce Copen. Highfield, Daneshill, Sussex, England RH17 7EX.

AUCTIONEERING, Resident or home Study Course. Free Catalog, Nashville Auction School, 1921 West End, Nashville, Tennessee 37203.

AUTOSUGGESTION. Sleep-learning headquarters! Tapes, records, books, Gigantic catalog free. Research Association, Box 24PM, Olympia, Washington 98501.

DETECTIVE—Training Course. American Detective Institute, Box 418-A, Fairfield, Alabama 35064.

OWN Collection agency. "Little Gold Mine!" Franklin Credit, Roanoke, Virginia 24004.

PIANO Tuning quickly learned with home study course. Diploma granted. American Tuning School, 17050 Telfer Dr., Morgan Hill, California 95037.

LEARN Auctioneering. Term soon. Free Catalog. Reisch World Wide College of Auctioneering, Inc., Box 949, Mason City, Iowa 50401.

EARN ELECTRONICS DEGREE by correspondence. Free brochure. Grantham, 2004 Stoner, Los Angeles, California 90025.

LEARN Sewing Machine Repairing. Men, Women. Lucrative profits. Profession with bright future. Gresslin Correspondence School, Box 927, Spencer, Iowa 51301.

DETECTIVE Course. Free Information. Universal Detectives, Box 8180-F, Universal City, California 91608.

PIANO Technology—Electronic organ servicing, learned easily at home. G.I. Approved. Free booklet. Niles Bryant School, Dept. P, 3631 Stockton, Sacramento, California 95820.

UPHOLSTERY Decorating. Free Booklet. Learn at home. Upholstery Decorating School. Dept. 5310-016, Little Falls, N.J. 07424.

FREE Book tells how you can learn camera repair and service. Home study or classroom. Write today! National Camera, Dept. EAD, Englewood, Colorado 80110.

UNLOCK your Future. Become professional Locksmith by spare time homestudy. \$13.00 in an hour possible. All tools, equipment included. Facts Free. Send name. Locksmithing Institute (homestudy), Dept.

LOVE THE OUTDOORS? Interested in living, working in parks, recreation areas? See if you can qualify, training at home. Important, respected, rewarding field. Details Free by mail. National School (homestudy), Dept. 09-310-016, Little Falls, N.J. 07424.

LEARN Engine and Outdrive Principles of Operation thru Home Study. Write for School Catalog. Coastal Marine Institute, Drawer L, Daytona Beach, Florida 32018.

USED Courses! Books! List 15¢. Smith's, 124 Marlborough, Salem, Massachusetts 01970.

HOW to operate **PROJECTION EQUIPMENT** in schools, business, churches. **EASY,** new, instruction method. Send \$4.10 for **PROJECTIONIST PRIMER.** Ball State Bookstore, Muncie, Indiana 47306.

RADIO BROADCASTING! How to get into it. Free literature. Kfuz, Box 5516-Ab Walnut Creek, CA 94596.

RELIGIOUS VOCATION? Write: Church of Holy Light Inc., P.O. Box 4478, Pittsburgh, Pa. 15205.

LEARN Sewing Machine Repairing, Profitable Trade Free Details. Dykes, 187 FR, Rochelle, Ga. 31079.

WATCH REPAIRING. Complete home training. Diploma awarded. Free sample lesson. Chicago School of Watchmaking, YA, Fox River Grove, Illinois 60021.

START Your Own Correspondence School, Pioneer Schools, 550 B, S. Citrus, Covina, CA 91723.

LOCKSMITHING, LEARN EASY. This honorable craft, earn \$25.00 hr. possible your business. Course in book form. Many exploded views and pictures explaining all. Simple to understand. Compiled by Master Locksmith, 29 years experience.—(Guaranteed). Only \$7.95 pre-paid. Lee-Stan Publishers, 111 Powell Creek Cir., N. Ft. Myers, Fla. 33903.

VALUABLE Information! Get rich! \$1.00. 1000 Center, Bay City, MI 48706.

ELECTRONICS—Learn fast, easy, inexpensively. Job placement assistance. Write: National Homestudy, Box 2723D, South Bend, Indiana 46680.

LEARN To fix typewriters and office machines. 30 million typewriters need skilled repairmen. Earn as you learn at home in spare time. Facts free. Send name. Typewriter Repair School (homestudy), Dept. 3310-016, Little Falls, N.J. 07424.

ARCHITECTURAL ENGINEERING

NEW! Home study, **STRUCTURAL DESIGN COURSES** from Basics to High Level, to take **STATE LICENSING PROFESSIONAL EXAM.** or work for **ARCHITECTURAL ENGINEERING OFFICES; 8501 Pasadena Blvd., Pembroke Pines, Florida 33024.**

FOR INVENTORS

PROTECT Mfg/Market your invention. Super 64p. guidebook \$2.95. CPCO, 907 Nottingham Rd., Newark, Del. 19711.

IF YOU'RE SERIOUS—You should get "The Facts." 5534 Caminito Roberto, San Diego, California 92111. Free information, S.A.S.E.

INVENTIONS Wanted immediately for promoting on cash or royalty. Patented, un-patented. Free booklet outlines royalty rates, requirements. Write Kessler Corp., C-51-FT, Fremont, Ohio 43420.

SELL Your Ideas, Inventions direct. **INVENTORS MARKETPLACE, NEWSLETTER** Tells what where. 3 months trial \$5.00. Satisfaction Guaranteed. Box 198A, 3 George, Lake Grove, N.Y. 11755.

FREE PAMPHLET: "Tips on Marketing Your Invention." Write United States Inventors Service Company, Dept. P, 1435 G Street NW, Washington, DC 20005.

U.S. PATENT Office Searches, 234 Broadway, Room 3615, New York 10007. Free invention certificates.

INVENTORS: Your ideas and inventions (patented/unpatented) expertly searched, developed for commercial appeal and cash/royalty sales to manufacturers by professional invention Developer with excellent record of experience. B. S. Industrial Engineering; United States Patent Office former Patent Examiner. United States Government former Patent Advisor. Second decade reliable service! Member: United States Council International Chamber Commerce. Free "Invention Record" and "Recommended Protection Procedure." Airmailed! Write: Raymond Lee, Invention Developer, 230P-Park Ave., New York, New York 10017.

NEEDING Assistance? INVENTION DEVELOPMENT FOUNDATION, 155 Kent Street, Ottawa, Canada K1P 5P3.

INVENTORS—United States Patent Office Searches. Patent Development Engineering and Marketing of your inventions, ideas with manufacturer contacts. Send for **FREE INVENTION CERTIFICATES** and invention information. Serving inventors since 1948. George Spector, **LICENSING PROFESSIONAL ENGINEER—**Patent Engineer. Former **UNITED STATES PATENT OFFICE EXAMINER—** 3615 Woolworth Building, New York 10007.

CHECK All your inventions 1,834 ways for possible improvements! Booklet; \$3.00. Tech Enterprises, 8889 Ravenna, Twinsburg, Ohio 44087.

INVENTORS: Only 5 of 100 Succeed. Will you? Find out. **DETAILS FREE. AMERICAN TECHNOLOGY EXCHANGE,** Suite 1202-EDP, 1006 Grand, Kansas City, Mo. 64106.

INVENTORS! A successful design engineer and inventor with over thirty years of aerospace experience would like to share his expertise with idea people who need help in any phase of product development and/or promotion. Without obligation write: Invention Services, Inc., Box 206, Richmond Beach, Washington 98020.

FOR INVENTORS

(Continued from preceding page)

INVENTORS! Mechanical Engineering Problems Solved. Ideas Developed. Bear Notch Co., Box 24, Corinth, Vt. 05039.

GEARS, Motors, Metals, Tools, etc. 1000 Sources for Inventors Supplies! \$2.00. Inventor's Index, 4216-1, Telegraph, Oakland, California 94609.

PROFESSIONAL INVENTING SERVICES. Free Folder! Tech Associates, 24 Cotton Avenue, Braintree, Mass. 02184.

PATENT SEARCHERS Includes maximum speed, full Airmail report, copies of closest patents. Quality searches expertly administered with complete secrecy guaranteed. Ask for Free Invention Protection Form and "Patent Information." Write: **WASHINGTON PATENT OFFICE SEARCH BUREAU,** 734 15th St., N.W., Suite 709, Benjamin Franklin Substation, P.O. Box 7167-B, Washington, D.C. 20044.

PACKAGE YOUR INVENTION YOURSELF. Kit includes step-by-step package development chart, detailed instructions for low-cost packaging at home, selected easily adaptable patterns. \$3.98 ppd. The Art Department, Box 307, Spring Valley, Ca. 92077.

SEARCHES With patent abstracts \$12.00. "Filing Your Own Applications" \$14.90. "Selling Invention" \$5.90. Professional Engineer, Box 8001 JFK, P.O., Boston, Massachusetts 02114.

INVENTIONS WANTED

INVENTIONS—IDEAS WANTED. Developed, Marketed by leading professional organization for Cash/Royalty sales. **FREE EXAMINATION and CONFIDENTIAL REPORT** of the Commercial Features of Your Patented/Unpatented Invention. **FREE COPY** "How to Safeguard and Market Your Invention to Industry." Write **LAWRENCE PESKA ASSOCIATES,** Dept. C, 500 Fifth Ave., N.Y.C. 10036 or call our Toll Free Number 800-223-6655. New York State residents call (212) 354-9696. Branch offices throughout the United States and Canada.

INVENTIONS Needed immediately for manufacturers. For additional information write Kessler Corporation, C-51-1W, Fremont, Ohio 43420.

HONGKONG Factory needs several new products every month to satisfy their overseas buyers. Particularly interested household items, toys, games, gadgets. Please send sketches or detailed explanation for evaluation and cash/royalty purchase. If you have an article/accessory cannot produce domestically because of quantity, price or labour, please try us. Hongkong Plastic & Metal Products Company, P.O. Box 9627, Kwun Tong, Hongkong.

INVENTOR'S PARADISE—Combination Shows, Catalog Listing. **FREE DETAILS** To All Inquiries. Deadline Next Shows Soon. Paul Paulsen Jr., 401 So. Columbia, Frankfort, Ind. 46041.

INVENTORS! Protect your ideas! Free "Recommended Procedures." Washington Inventors Service, 422F Washington Building, District of Columbia 20005.

INVENTIONS MARKETED Cash, Royalties **FREE INVENTION PROTECTION CERTIFICATES.** George Spector Manufacturers Representative, Woolworth Building, New York, N.Y. 10007.

INVENTORS! Either we will sell or license your invention before you do, or we will pay you a cash bonus. **GILBERT ADAMS ORGANIZATION,** 80-B Wall St., Dept. 36A, New York, New York 10005.

FREE! DIRECTORY OF 500 CORPORATIONS SEEKING NEW PRODUCTS! For important information on Protecting, Developing, Marketing your invention ideas for Cash/Royalty Sales, write for **FREE INVENTORS KIT NO. A-84.** Raymond Lee Organization, 230 Park Avenue, New York City 10017.

MANUFACTURING

"INVENTORS Ideas developed." Research. Models. Manufacturing. Sales. Free Brochure. Since 1942. William Parker, Box 6305, Orlando, Fla. 32803.

BUY IT WHOLESALE

LIQUIDATORS Report—Mfg. closeouts Monthly Bulletin \$3.00. F. Mummert, 2149 Knoxville, Peoria 61603.

SHOPKEEPERS: Fun products. Free wholesale catalog. Name shop. Empire-PMD, 1916 Fifth, Sacramento, California 95814.

400,000 BARGAINS Below Wholesale: Many Free! Liquidations . . . Closeouts . . . Job Lots . . . Single Samples. Free Details. Bargainhunters Opportunities, Box 730-A, Holland, Michigan 49423.

HEARING Aids, batteries, Wholesale. Catalog 25¢. Fiston, Box 1444, New Preston, Conn. 06777.

WORLD'S Largest wholesale supply. 7853 American, Foreign Wholesalers. Rockbottom prices. Hongkong Clothes. Automobiles. Japan electronics. Free details. International Buyers, Box 16386M, Portland, Oreg. 97233.

SAVE Money! Buy Direct. 50% off hundreds of European & Asian Manufacturers. Name brand cameras, HiFi etc. Complete Directory \$2.00. Import Expo, 4216-P Telegraph, Oakland, California 94609.

EXPORT—IMPORT

MIRACLE Light—No Batteries. Matches. Lasts for hours. Camping, Fishing, Driving Cars. \$1.95 + 50¢. Kilbourne Enterprises, P.M. 101, Genoa, N.Y. 13071.

HONG KONG'S Best product catalogue. Airmailed \$2.00. Specialty, PM16 Box K, 3086, HongKong.

WORLDWIDE Trading Opportunities Weekly Report. Airmail \$3.00. Array Services, 104, Lorong "L", Republic of Singapore 15.

FOR THE HOME

DAMP BASEMENT? Book shows you how to fix it. GEPE, \$3.00 postpaid, Box 662, Elyria, Ohio 44035.

HOMEMADE Thermostat controlling device reduces heating costs, instructions \$2.00. Brigance, 7218 Garland Av., Washington, D.C. 20012.

SAVE \$1000! You can on home interest charges. Details, R.G.A.P.M., 3710 Melrose, Wooster, Ohio 44691.

IF YOU ARE REALLY SERIOUS ABOUT SAVING MONEY ON YOUR FUEL BILL GUARANTEED, and want to know how. Send \$2.00 to: **SAVINGS (3C),** 516 N. 13th Street, Lafayette, Indiana 47901.

OF INTEREST TO ALL

TREMENDOUS SAVINGS. Book Teaches Economical Food Buying. Send \$3.00. Bankross, Box 4146-AA, North Hollywood, California 91607.

AMAZING New Discoveries Mean Good Fortune For You. Now!—Easily. Free Details—Send No Money! Crest, Box 738, Newark, Delaware 19711.

CRIMEFIGHTERS! Detectives-Police Catalog \$1.00. Don-Q, Box 548-PMO, Seattle, Washington 98111.

\$800 MONTHLY Possible addressing—stuffing envelopes (longhand-typing) your home. Experience unnecessary. Details, send stamped addressed envelope. American, Excelsior Springs, Mo. 64024.

L'A'S V'E'G'A'S! FUN CAPITAL Of The World! Where The Action's At! Complete Guide, \$1.98. Guaranteed. Bilmor, 8225L-3 Encino, Northridge, CA 91324.

MIRALITE SHAVING CREME. 5 Year supply for \$3.00 postage paid. No dangerous spray cans. Add water to miralite and shave. Leaves skin soft and smooth. Send check or money order to: **MIRALITE-JRS., P.O. BOX 228, SKOKIE, ILL. 60076.**

LOSING HAIR? BALDING? DANDRUFF? Doctor's authentic, copyrighted booklet with proprietary offerings \$1.00. Dr. Shiffer Laboratories, Box 398PM, Punta Gorda, Florida 33950.

YOUR LIFE! HOW LONG?? Statistical odds of Reaching any age. \$2.00. McNiece, 4 Hemingway, Melville, New York 11746.

TRACE YOUR FAMILY TREE; Beautiful six-generation Family Pedigree Chart; Parchment suitable for framing; Fascinating hobby! Chart, worksheet, instructions, all \$3.00. Famsearch, 1832 Irvine, Tustin, California 92680.

NEW!! SECURITY TELEPHONE NUMBERS!! Get the most from your government! Help stop illegal practices! Use direct lines to White House, F.B.I., Civil Rights etc. Listed on back of beautiful, plastic, wallet size card. American Flag on front. Carry with you, keep at home. **FREE** listing of additional numbers. This card can save your life or someone you love. Money back guarantee! Act Now! Send \$5.00. **AMERICAN'S ALERT,** 1697 Broadway, Dept. PM-1, N.Y.C. 10019.

METRIC CONVERTER . . . All USA measurements in equivalent metric units . . . \$5.00 . . . Allen Foley House, 44 New Hartford St., 11A, New York Mills, NY 13417.

OF INTEREST TO WOMEN

\$300.00 WEEKLY Possible Stuffing Envelopes. Free Supplies. Send Stamped Envelope. United, 3838 1/2 Van Dyke, San Diego, CA 92105.

\$500 MONTHLY Possible clipping items from your newspaper. Experience unnecessary. Details, send stamped addressed envelope, American, Excelsior Springs, Mo. 64024.

CONTESTS Be a winner. Corporate Secretary shares private secrets. \$1.00. Security Lane, Box 12130, Seattle, Washington 98112.

WANT a new car, color TV, new clothes? Learn hundreds of ways to make money. 5 month subscription **FREE.** Write: Salesman's Opportunity Magazine, Dept. 570, 1460 Hancock Center, Chicago 60611.

GIFT SHOPPING

FREE Gift Catalog, Many Items Reduced, Bicentennial Items. Country Side Gifts, R. R. 3, Dept. 12, St. Francis, KS 67756.

FREE catalog of distinctive gifts. Chestnut Hill, 179 Main St., Dallas, Pa. 18612.

FREE GIFT CATALOG, BEAUTIFULLY ILLUSTRATED. DISTINCTIVE, INEXPENSIVE Gifts. Priefler, 367 Auburn Way, Suite 2, San Jose, Calif. 95129.

GIFTIME Catalog \$1.00 Refundable. Newest Items Made. Hanrahan Products, 7846-20th Ave., Kenosha, Wis. 53140.

FREE CATALOG GIFTS, JEWELRY and the **UNUSUAL.** Kendrick's, 106-PM South High Street, Antlers, OK. 74523.

LIFETIME Guarantee, Key Ring. Manufacturer guarantees lifetime replacement whenever **FLX-O-LOC** Key Ring breaks. \$2.00. West Bay, Route 1, Box 159-B1M, White Stone, Virginia 22578.

10 FAMOUS French Perfumes—Luxuriously Gift Packaged. \$6.75 Postpaid—Two \$12.50. Andris, Box 34287, San Francisco, California 94134.

FREE CATALOG. JOHN'S GIFTS dpm, 650 Webik, Clawson, Michigan 48017.

GENTLEMAN OF PLEASURE Unlimited Gifts \$2.00. Catalog, 303 West 42nd St., N.Y.C. 10036.

DISTINCTIVE GIFTS for the entire family. **FREE CATALOG. PRATT'S PLACE,** 2827 Kalmia Lee Court, #101, Dept. A, Falls Church, Va. 22042.

FREE Gift Catalog. Write Wesley Wickham, R384-2 Stewart Street, Zanesville, Ohio 43701.

CLOCKS, WATCHES, OLD GOLD, JEWELRY

HIGHEST CASH for Gold, Jewelry, Gold Teeth, Rings, Diamonds, Watches, Silver, Platinum. Mail Articles Today. Free gift with information. Chicago Gold & Precious Metals, 6 E. Monroe, Dept. 558, Chicago 60603.

CLOCK Movements—Battery, Electric, Chime, Grandfather—Tools; plus Fifty Ideas Making Decorator Clocks. Details \$1.00. Clock Repair Center, Dept. 201, P.O. Box 65, Carle Place, N.Y. 11514.

WATCH and Clock repairing books, tools, materials. Free catalogs. North American, Box 77-AN, Fox River Grove, Illinois 60021.

WANTED—Gold, silver, platinum (any form). Coins. Information Free. Wilmot's, 345D South Glassell, Orange, CA 92666.

HIGHEST CASH IMMEDIATELY for Old Gold, Silver, Platinum, Jewelry, Gold Teeth, Watches, Diamonds, Spectacles. Free information. Rose Industries, 29-A East Madison, Chicago 60602.

SEND Scrap Gold etc. Returned unless satisfied with instant cash. Confidential. 8350A. Kester, Panorama City, California 91402.

WEARING APPAREL

RUGGED DENIM CARPENTER'S APRON. POPULAR MECHANICS Shop Apron! Constructed of 100% Burlington Industrial-Weight Cotton with 3 Full-Depth Nail Pockets. Bright Yellow PM Imprint and Wrap-Around 21" Length. It's a Tough Utility Item for the Dedicated Do-It-Yourselfer! \$2.95 post paid. PM Apron, Dept HE, Box 1014, Radio City, N.Y. 10019.

BI-CENTENNIAL T-SHIRTS—Eagle, 1776-1976 Encircled by 13 Stars! Red and Blue on White. Age 5 thru adult. \$5.00 each. Island Enterprises, Amanda Park, Wash. 98526.

HEARING AIDS

HUGE SAVINGS. Eliminate dealer mark-ups. Free Trial. Batteries Wholesale. Terms arranged. Lloyds-PMC, Rockford, Ill. 61104.

HEARING Aids, Batteries, Discount Prices. Free Trial. Write: Rhodes, Brookport, Illinois 62910.

FREE HEARING AID CATALOG—Save 1/2—by mail! Write: "MONEYSAVERS", 9530PM1 Langdon, Sepulveda, CAL 91343.

TOBACCO

HANDCARVED Meerchaum Pipes Wholesale Catalog. Nichols, Box 3144, Enid, Oklahoma 73701.

BRIAR, MEERSCHAUM. Pipe making materials. Pimop, Box 59211, Chicago, Illinois 60659.

MEERSCHAUM Pipes—Free Catalog. Conner Imports, Box 9574-PM01, San Jose, Calif. 95157.

SAVINGS: Meerchaum Pipes And More, Plus Accessories. Free Information. Unikemp; 1310 Glendale Drive; Champaign, Illinois 61820.

CALCULATORS

INGENIOUS Pocket mechanical calculator. Adds, subtracts, multiplies, to seven digits. Send \$2.00 to: Calculator, 605 Engel Avenue, Park Ridge, IL 60068.

SCIENCE & CHEMISTRY

DISCOUNTED! Laboratory Chemicals, Glassware-Apparatus. Catalog-50¢. Deluxe Scientific, 507 Huron, Manitowoc, Wisconsin 54220.

CATALOGUE Of Very interesting Chemical Products. Formulas, Books, Experiments, Supplies, Surprising Extras. \$1.00. Kenrus-C, Box 205, Staten Island, New York 10306.

FORMULAS, PLANS, ETC.

500 PRODUCT FORMULAS. Easily prepared. Rush \$5.00 Distributor. R7B68, Milton, Florida 32570.

ANY Formula \$6.00. Catalog—Manufacturing Treatise \$1.00. Belfort, Box 568, Chicago 60690.

PLASTICS

CASTOLITE pours like water, hardens like glass without heat. Crystal clear, colors. Embed flowers, seashells, mementos, anything. Make fine gifts. Reproduce your designs with flexible molds any shape, size. Profitable. Illustrated Manual Catalog \$1.00. **CASTOLITE,** Dept. 76A-PM, Woodstock, Ill. 60098.

TREASURE FINDERS

FIND Lost Treasure, Coins, Gold, all metals. 12 models from \$59.95. **COMPASS METAL DETECTORS,** Dept. 705, 3700 24th Avenue, Forest Grove, Oregon 97116.

TIRED OF DIGGING UP TRASH? The All New "Coin-Shooter" Rejects Bottle Caps, Tin Foil, Nails and Shallow Trash. Detects Gold, Silver Coins and Jewelry. Free Literature. **B-TEX ELECTRONICS,** Box 451-U, Garland, Texas 75040.

FREE Treasure Detective Claws! Department PB6M, 11 Coventry, Englishtown, NJ 07726.

(Continued on next page)

TREASURE FINDERS

(Continued from preceding page)

POWERFUL Metrotech locator detect gold, silver, coins, relics. Moneyback guarantee, terms. Free information. Underground Explorations, Dept. A, Box 793, Menlo Park, California 94025.

FIND Buried treasure with patented metal detectors that distinguish metallic trash from treasure, have push button and automatic tuning, ground pickup eliminate feature, great range, etc. Free catalogue. Gardiner Electronics, Dept. 9, 4729 N. 7th Avenue, Phoenix, Arizona 85013.

TREASURE FINDER Locates buried gold, silver, coins, treasures. 6 powerful models. Instant financing available. Write or call for free catalog. Phone (713) 682-2728 day or night. Dealer inquiries invited. Relco, Dept. AA21, Box 10839, Houston, Texas 77018.

BURIED TREASURE—Locate up to Quarter Mile away with Ultra-Sensitive Directional Locator. Send for free, informative pamphlet. Research Products, Box 13441-AMC, Tampa, Florida 33611.

FREE FACT-FILLED Catalog! World's largest selection! Metal detectors starting at \$79.50. Two year guarantee! Three factories, U.S.-Canada, 1,200 dealers—Service Centers nationwide. Finest instruments at any price! Budget terms. Dealer inquiries invited. Write: White's Electronics, Inc., Dept. PA60, 1011 Pleasant Valley Road, Sweet Home, Oregon 97386.

GOLD

FIND OLD, Old Mines, Treasures, Pan Nuggets, Assay Gold Ore, Amazing Guide Reveals How. **DETAILS FREE.** Dave Hunt, Roosevelt, Utah 84066.

GOLD How To Find and Extract It. Maps, Diagrams. Complete only \$2.00. Monolith, Dept. B, P.O. Box 1397, Rockville, Maryland 20850.

PRECIOUS STONES & MINERALS

GET Free catalog no serious rockhound, gem cutter, jewelry maker, hobbyist or craftsman can be without. Full of bargains, exclusive items, low prices from largest suppliers and authorities in the field. Free new catalog just off the press, yours for the asking. Write: Grieger's, Dept. C-12, 900 South Arroyo Pkwy., Pasadena, California 91105.

500 POLISHED Gemstones \$5.00. Tumblecraft, 5401 James North, Minneapolis, Minn. 55430.

PLASTIC Casting Supplies, Molds, Jewelry Mountings, Cut Stones. Wholesale Catalog 25¢. Eloxite, 806R 10th St., Wheatland, Wyo. 82201.

GOLD 10 Small nuggets panned from Oregon Streams \$1.00. Robert Brandt, Sweethome, OR 97386.

CARTOONING, COMMERCIAL ARTS,

SIGN Painting—Easy method. Free Catalogue. Kaufmann Company, Centertown, Missouri 65023.

LEARN Sign painting at home. Free Talent test. Ben Kerns, Box 812-PM, Greenville, S.C. 29601.

MODERN Cartooning taught by mail. Write for free brochure. Cartoonorama—Box 263-PMM Branford, Conn. 06405.

COMPACT 35 lesson Cartoon Course and Cartoonist's Magazine. \$3.00. Hartman, Box 30367, Lincoln, Nebr. 68503.

FAST Commercial Art Course. Free Details. Box 1204-PM1, Youngstown, Ohio 44501.

ADVERTISING AGENCIES, ADV. SERVICES, MAILING LISTS

ADVERTISING Ratebook leading newspapers, magazines. \$1.00. Chicago Advertising Agency, 28-E Jackson, Chicago 60604.

MAILING List. Most all Kinds, \$10.00 per M, 500 Circulars mailed \$7.00. Dixmailers, King, NC 27021.

MAILORDER ADVERTISERS!! CLASSIFIED ADVERTISING CAN BE MOST PROFITABLE AND REWARDING. PROBLEM IS TO KNOW WHAT TO DO, WHAT NOT TO DO. COLUMBIA CAN HELP YOU WITH YOUR MAILORDER PROGRAM. OVER 20 YEARS CLASSIFIED ADVERTISING EXPERIENCE, KNOWLEDGE OF BEST PULLING PUBLICATIONS, EXPERT COPY SERVICE IS ALL YOURS AT NO INCREASE OVER PUBLISHER'S STANDARD RATES. CHANCES ARE YOU WILL SAVE MONEY. WRITE TODAY FOR FREE DETAILS PLUS YOUR FREE COPY OF "MAILORDER ADVERTISER'S RATE GUIDE". COLUMBIA ADVERTISING AGENCY, BOX 1285AB, RICHMOND, INDIANA 47374.

RUBBER STAMPS

ADDRESS Rubber stamp, \$1.95. Wendell's, Box 2284, Everett, Wash. 98203.

FREE catalog—Rubber Stamps—Signature Stamps—Business Cards. Youngers Stamp Shop, Princeton, Iowa 52768.

QUALITY Stamps 3 Lines \$2.50 Business Cards Catalog. Stamps, 1737 W. Coolidge, Phoenix, AZ. 85015.

CUSTOM Made Stamps. Free Catalog. ALLEGHENY, Box 14C, East McKeesport, PA 15035.

FREE Literature, Self Inking Stamps, RME Stamps, 132 Farmcrest, Rush, New York 14543.

3-LINE Stamps, \$1.99. 1 Day Service. Free Catalog. R & J, Drawer G, Bridge City, Tex. 77611.

FOTOFAM Printers Make Rubber Stamps Obsolete. Inventec, Box 128-B, Endicott, N.Y. 13760.

QUALITY RUBBER STAMPS 3 Lines \$2.50. Cloverleaf, Box 49, Selbyville, Del. 19975.

OFFICE SUPPLIES

MAILORDER RECORDS Help get increased business! Complete 32 Page Record Book shows your inquiries, orders, advertising, expense, etc. Only \$1.00. H. E. KAPPEL, POPULAR MECHANICS, DEPT. R, 224 WEST 57TH STREET, NEW YORK, N.Y. 10019.

PRINTING PRESSES, RUBBER STAMP OUTFITS

PRINTING TYPE—also Cuts, Ornaments. List and \$2.00 Rebate for \$1.00. Superior, Box 487, Lee's Summit, Mo. 64063.

PRINTING MACHINES. Offset, Mimeograph, Typewriters, Composing, Machines, Dixgraph, King, North Carolina 27021

PRINT YOUR OWN—Printing Presses, type, supplies direct from factory. Send 25¢ for catalog and samples to: Kelsey Co., DM, Meriden, Conn. 06450.

PRINTING Presses, type, Supplies Lists, 10¢. Turnbaugh Service, Mechanicsburg, Pennsylvania 17055

RUBBER Stamp Supplies; Starting Outfits. Catalog \$1.00 Refundable. Martin, 1432 Major, Jefferson City, Mo. 65101.

SPECIAL 20% Discount on New Custom Size Type Fonts. Stamp Presses, Supplies. Barco Type Mfg., 237 S. Evergreen, Bensenville, Ill. 60106.

TYPE FONTS, Hand Printing Presses, Supplies. 120 pages. \$1.00 deductible first order. Acme Type, 732 Federal, Chicago 60605.

SAME Day Shipment. Rubber stamps and supplies. Free wholesale price list. Star Stamp Supply, 732 Federal, Chicago 60605.

SIMPLE-X RUBBER STAMP PRESSES, Hydraulic operated electrically heated. Sizes 5" x 8", 8" x 12", 10" x 15". Starting outfits. Order for presses, supplies shipped day received. Send \$2.00 for Catalog and Brochure. Custom Manufacturers, Box 211-PM, Springfield, Mo. 65806.

PRINTING AND SUPPLIES

QUICK Cash Printing Catalog Write. Victor, Drawer 707P, Sharon, Pennsylvania 16146.

1000 EMBOSSED Business Cards \$6.25 Postpaid. Agents Wanted. Elco, 181-A, Sylvania, Ohio 43560.

FREE Literature, Business Cards, Letterheads, Labels, Rubber Stamps. Geer's, 111 North Drive, Ottawa, Ohio 45875.

FREE Literature: Rubber Stamps, Books, Business Cards, Printing, Labels. Jordan's, 552 West O'Connor, Lima, Ohio 45801.

QUICK Copy Offset Printing. Free introductory Offer, Nationwide Printing, 614 North Main, Bloomington, Illinois 61701.

WEB PRINTING—Long runs of booklets, brochures, etc. Free catalog. Carta Press, Box 261-D, New Canaan, Connecticut 06840.

PRINT It Yourself for Pennies. FOTOFAM Electronic stencil printers \$4.95 up. Samples, details free. Inventec, Box 128-B, Endicott, N.Y. 13760.

SAVE 45% Printing: 100—\$3.50; 1,000—\$6.95; 1,000 Envelopes \$11.95; 500 Business Cards \$5.00; 2,000 Booklets \$87.00; 300 Letterheads Envelopes \$13.00. Free Price List. "Avoid 27 Mistakes When Buying Printing". Speedy Offset Printers, 23739 Aurora, Bedford, Ohio 44146.

WHOLESALE Office Supplies, Equipment, Printing. Agents wanted. Atlantic, Box 1678-B, Florence, S.C. 29501.

DO YOUR Own Typesetting with transfer lettering. Free Samples/catalog. Seavue, 212-26P, 48th, Bayside, N.Y. 11364.

GUMMED LABELS

1,000 BEAUTIFUL Gold Stripe Labels \$1.00. Marie's, 609 Elm, San Angelo, Texas 76901.

1000 GUMMED Address Labels \$1.00. Wait's, Box 960A, South Bend, Indiana 46624.

1,000 GUMMED ADDRESS LABELS \$1.00. FREE LITERATURE, 225 Self-Stick Labels \$3.25. Acme, 1238 Voskamp, Pittsburgh, Pennsylvania 15212.

1,000 DELUXE, Gold Stripe, 2 Color, Gummed Labels \$1.25. Craig, 5444 Anton, Olympia, Wash. 98501.

REMAILING SERVICE

HONOLULU HAWAII 25¢ Each, \$3.00 monthly. Post Cards available. P.O. Box 1301, Honolulu, HI. 96807.

ATLANTA—Receiving, Forwarding, Individuals, Business!! Free Details. Liberator, 3404 Hill Drive, Duluth, Georgia 30164.

MOTOR CITY Remailing Service—all services available. INFORMATION, write: M.C.R.S., Box 890, Dearborn, Michigan 48121.

UNLISTED ADDRESS. Discreet and confidential. Re-mail 25¢ single. Mail Forwarding Service, 8050 S. Main, Houston, Texas 77025.

MIAMI 25¢. Letters remailed from 130 foreign cities. 300 U.S. cities. Marie, Box 1266, Miami, Florida 33134.

CONFIDENTIAL New York Mail Address \$5.00 Month. Telephone service \$5.00 Remails 25¢. Call Director, 1540 Broadway, Suite 303, New York 10036 212-221-1246.

YOUR Mail Received-Forwarded. Hedgpath, 324-M South First, Alhambra, Calif. 91802.

ATLANTA—Prompt, Confidential remail, 25¢, PMA, Box 77208, Atlanta, Georgia 30309.

CADILLAC REMAIL SERVICE Remails 25¢. Confidential, Dependable from Beautiful Northwest. P.O. Box 15711, Seattle, Washington 98115.

REMAILING DIRECTORY \$2.00. International Remail-Forwarding Association, P.O. Box 1744-M, Miami, Florida 33134.

CALIFORNIA: First Month FREE! Guaranteed. Mail Bag, Drawer 568-D, Anaheim 92805.

YOUR Mail Received, Forwarded, Westcoast, 1323 Euclid Avenue, M-1-6, Bellingham, Wash. 97225.

REMAILING 25¢, 5/\$1.00. See, 1557 E. 43rd St., Cleveland, Ohio 44103.

REPAIRS & SERVICING

COMPLETE Hydraulic Jack Repairing Manual \$3.00. Ironclad Moneyback Guarantee. Bayerco, 938-MR Betty Avenue, Neenah, Wisconsin 54956.

SPECIAL SERVICES

INFORMATION On anything. Ferguson Research Specialists. 60-15 Woodside, Woodside, New York 11377.

PROFITS FROM CLASSIFIED ADVERTISING! Booklet shows you how to start your own business with Classified Advertising. Only \$1.00 (Refundable with first order.) H. E. KAPPEL, POPULAR MECHANICS, DEPT. P, 224 WEST 57TH STREET, NEW YORK, N.Y. 10019.

BETTER HEALTH

HEALTH PROBLEMS? Free Factual magazine—Natural Living, Health, Organic Gardening. Provoker Press, St. Catharines, 402, Ontario L2R 7C9.

AMAZING How to Live Longer booklet \$1.00. Satisfaction Guaranteed. Reeves, 2261 Fairfield Ave., Fairfield, Ca. 94533.

"NU-LIFE" STOP SMOKING—kit. Thousands satisfied —MONEYBACK guarantee—Free details. Safeguards health. DAMCO, Box 6243, San Bernardino, Ca. 92412.

LOANS BY MAIL

BORROW by Mail! Up to \$3,000.00. Convenient terms. State Licensed. Postal Finance, Dept. 17-01, 6018 Maple Ave., Omaha, Nebraska 68104.

PERSONAL

BLACKJACK PLAYERS! Computer Proven Strategy. Guaranteed. Systems, Box 53485N, Houston 77052.

TELEPHONE MONITOR! Record conversations automatically! PM1, Box 192, Griffith, IN 46319.

DON'T DIE Without a Will! Prepare your own will. Details 25¢ Jones, Box 41301PM11, Sacramento, CA 95841.

INVESTIGATORS, Latest electronic aids. Clifton, 11500 N.W. 7th Avenue, Miami, Florida 33168.

STOP Electronic Eavesdropping! Security Catalog, \$1.00. McCord Electronics, Box 276-PM, Sylvania, Ohio 43560.

DIFFERENT! Your name & Social Security No. Beautifully Hand Lettered. Lifetime Plastic Card, \$3.00. Reid, Box 682, Henderson, N.C. 27536.

BECOME An ordained minister. Free ministerial credentials legalize your right to the title "Reverend." Write Church of Gospel Ministry, 486-P Skyhill Court, Chula Vista, Calif. 92010.

PSORIASIS SUFFERERS: DISCOURAGED! Write for Free important information that is helping thousands. Pixacol, Box 29277-PM, Parma, Ohio 44129.

BIBLE Questions answered. Stamped envelope. Bylon, 17167 Bentler, Detroit, Michigan 48219.

RECORD Telephone Conversation automatically. Leave Recorder Unattended. Robert's, Box 49-PM1, Parkridge, Illinois 60068.

ESCAPE From debts and bill collectors! Have AAA-1 credit everywhere. Free report reveals secret plan! Credit 4A1, 333 North Michigan, Chicago 60601.

LONG Term Financing. \$250,000 Up. T&F Sales, 4044 11 St., Milwaukee, Wis. 53209.

ELIMINATE DEBTS! DETAILS 35¢ Guaranteed. DEBTS-ZT, 232 Front, Napoleon, Ohio 43545.

\$15.00/HOUR PLAYING ROULETTE. FANTASTIC REVOLUTIONARY SYSTEM MAKES IT IMPOSSIBLE TO LOSE!!! GUARANTEED \$3.00—TRON, 2139 Westminister Dr., Wilmington, Del. 19810.

LITTLE KNOWN LAW! STOP JUDGMENTS—GARNISH- EES—HARASSMENT FROM CREDITORS—COMPLETE INFORMATION—ONLY \$2.00 (GUARANTEED!) TREND, 2A1—BOX 4479, WINTER PARK, FLORIDA 32793.

VETERANS! Collect \$1,000's little-known cash benefits and services! Amazing new Report shows how! \$2.00. Veterans Handbook, Box 19107-AA, Washington, DC 20036.

FREE Grants for craftspeople, artists, photographers. Up to \$15,000. Complete details. Send \$2.00 to WinWren-PM, P.O. Box 10914, Eugene, OR 97401.

FINANCE YOUR DREAMS With Government and Foundation Grants. Free details. **YOU PM1**, 6311 Yucca, Hollywood, California 90028.

HANDWRITING ANALYZED! Learn more about yourself and friends. Accurate, informative, entertaining. Send handwriting sample and \$2.00 per sample. Handwriting Analysis, Box 653, Noth Little Rock, Arkansas 72115.

(Continued on next page)

PERSONAL

(Continued from preceding page)

BIORHYTHM Computer Charts! One year \$10.00 give birthdate. **BIORHYTHMICS**, Box 13297, Phila., Pa. 19101.

SOCIAL SECURITY PLATES

GOLDEN Metal Social Security Plate with case only \$1.89. Robert Pattay, 9 Crest Ave., Dracut, Mass. 01826.

GOLD Metal Social Security Plate \$1.75 with Black Case And Identification Card. Send Name and Number to: George Anthony, PM, 626 Clinton Street, Brooklyn, New York 11231. Money Order Only.

WANTED MISCELLANEOUS

BASEBALL CARDS Wanted. Top prices paid for all pre-1965 cards. Rob Lifson, P.O. Box C, Jenkintown, Pa. 19046.

MERCURY Gold, Silver, Platinum: Ores assayed. Wholesale Terminal, Norwood, Mass. 02062.

WINEMAKING & OTHER RECIPES

WINEMAKERS Free illustrated Supply catalog of yeast, equipment. Continental, Box 68016-PM Indianapolis, Ind. 46268.

WINEMAKERS—Free Catalog. Fast Service. Large Selection! Kraus, Box 451L, Nevada, Missouri 64772.

WINEMAKING. Yogurt, Cheesemaking. Free catalog. Arbolyn, Box 663, West Columbia, S.C. 29169.

WINEMAKER'S Supply Catalog—Free. Bacchanalia, 273 Riverside Ave., Westport, Conn. 06880.

WINEMAKERS. Free illustrated catalog of yeasts, equipment. Semplex, Box 12276R, Minneapolis, Minn. 55412.

WINEMAKERS Free Informative Catalog. Yeast Equipment, Ingredients, **DANENBERGER'S**, Box 276-M, New Berlin, Ill. 62670.

WINE—Make wine in 30 days at home. Simple Recipe & Instruction, \$2.00. Emmitt Co., Box 272, Babylon, N.Y. 11702.

AMAZINGLY DELICIOUS!! Wine/Champagne Recipes using kitchen equipment. No specialties needed. Moneyback Guarantee. \$1.00. Leman Enterprises, Box 228A, Santa Maria, Calif. 93454.

FREE!! . . . FREE!! . . . AMAZINGLY DELICIOUS!!! DARK GERMAN BEER RECIPE, with Purchase of our famous home Wine/Champagne recipe booklet. Moneyback Guarantee. . . . \$3.00. Leman Enterprises, Box 228-D, Santa Maria, Ca. 93454.

VARIETAL Grape Vines. Zinfandel, Grenache, Cabernet Sauvignon, many others. Also Hops seed, plants. Write: Ogren's, 970 3rd Avenue, L.A., Calif. 90019.

MAKE DELICIOUS LIQUEURS At Home! Save money! Have fun! Revealing recipe free. Gourmet, 5133-P6 North Fairhill, Philadelphia, Pa. 19120.

CHAMPAGNE . . . Wine!!! Recipes, Guaranteed pennies a bottle!! \$3.00. Advanced Trading, 98-15 Horace Harding, Dept.-2, Flushing, N.Y. 11368.

MISCELLANEOUS

PSYCHOLOGY Stops Burglars with Electronic Burglar Alarm Stickers. Vinyl. Use indoors or out. 12 for \$2.00. Infram Company, Dept. 1A51, 1808 York Drive, Columbia, SC 29204.

COUNTERFEIT Coins? Better Yet! 3" Super coins. Exact Metal Replicas. Fine Detail. Catalogs, Sample —\$1.25. Grayling Gemcraft, Box 613PA, Grayling, Michigan 49738.

FOR Your Bicentennial collection, profile of Kennedy in silver on 3"x5" plaque \$5.00. Box 4378, Toledo, Ohio 43609.

WILLS!! . . . 4-will forms \$2.00 . . . W. D. Sales, 116-A, Fraternity Dr., Lafayette, LA 70501.

CATALOGS! Receive many! Catalog Directory, \$2.00. Box 33098, Washington, D.C. 20028.

HEARING Aid batteries wholesale. Free list. Habs, Box 51, York, Penna. 17405.

BOOKS On antiques and their prices. Free circular!! P. Warman Publishers. Uniontown, Penna. 15401.

ORNAMENTAL Iron designs. Book of 1600 beautiful, practical designs for railings, columns, etc. Free literature. Cunningham, 3881 South 3200 West, Box 20005, Salt Lake City, Utah 84120.

IDENTIFICATION CARDS. Send stamped self-addressed envelope for samples. **NIPCOM**, 727 North Main, Las Vegas, Nevada 89101.

WIN! Casino Games! Free Details! Xcito Games, 5715 N. Mozart, Chicago, Illinois 60659.

PRESCRIPTION EYEGLASSES. Free Catalog. A-Z Optical Company, Box 175, Dept. R26, Bay Station, Brooklyn, New York 11235.

NEW Credit, credit cards and loans! Guaranteed. Unitary-375V, Mary Esther, Florida 32569.

CURIOUS about the new Winner's Circle Handicapper for thoroughbreds? Write: Handicapper, 181 Box 1745, Evergreen, CO 80439.

MAGNETS. All types. Specials-20 d sc, or 10 bar, or 2 stick or 8 assorted magnets, \$1.00. Magnets, Box 192-A, Randallstown, Maryland 21133.

BEAT BLACKJACK!! New Powerful method guarantees winning. Free Information. Sheridan, 7730-M1 Fair Avenue, Sun Valley, California 91352.

DON'T DIE without a will! Blank Will Form protects your family. Only \$2.00—Guaranteed! Order today!! Craig, 5444 Anton, Olympia, Wash. 98501.

I.Q. SELF Test \$2.00 Guaranteed. Herald 2M5, 103 Rocklake, Longwood, Fla. 32750.

HOT GIFT Water-activated hand warmers \$4.99 . . . body warmers . . . \$8.99, guaranteed! Finley Enterp ises, Dept. 1PM1, 738 Elmer, Southbend, Indiana 46628.

BURGLAR ALARMS & HOME PROTECTION

BURGLAR—Fire Alarm, Supplies and Information. Free Catalog. Protecto Alarm Sales, Box 357, Birch Run, Michigan 48415.

IDENTIFY Valuables with diamond-tipped pen. Writes on any surface. \$3.00. Cook, Box 6A, Garland, Texas 75040.

FREE Catalog. Burglar—Fire Alarm Equipment. Vancor Security Systems, Box 438-T, Boston Mass. 02144.

PROTECT Your Home and Family! Combination Fire/Burglar Alarm. Sensitive, Dependable. Easy Installation! Only \$9.95—Guaranteed! D&G Products, (1A1) Box 869, Soldotna, Alaska 99669.

DIALING Unit automatically calls police. \$29.95. Free literature. S&S Systems, 5619-D St. John, Kansas City, Mo. 64123.

PROTECT Valuables! Engraving tool writes on any surface. \$2.98. Ellis, 400 Boundary, Yorktown, Va. 23692.

BELOW Wholesale prices. Pricing, information 50c. Ellin, 161 Bonad, Chestnut Hill, Mass. 02167.

PROTECT YOURSELF—Against Fire and Intruders!!! Alarm triggers at 135°F and upon forceful entry. Easy installation!! Batteries included. Guaranteed!! Only \$8.95. Order now!! Quality Products, Box 11780, Dept. A1, Aspen, Colorado, 81611.

NOW Available! Wholesale, Professional, Burglar-Fire Alarm Equipment for the Do-It-Yourselfer. Catalog 25c. Emel Electronics, PM1, Box 509, Flushing, N.Y. 11365.

SMOKE DETECTOR, LOW-COST EASY INSTALLATION. Wozniak, Box 9041, Madison, WI 53715.

MAGNETIC Padlock. Unpickable! Great for garages, tool sheds, barns, tackle and tool boxes. \$7.95 bicycle size \$8.75. Easy Shopper, 5240 Walsh, Dept. MP101, St. Louis, Mo. 63109.



THIS LABEL SAYS MORE

Popular Mechanics is far and away the acknowledged authority in the ever-expanding field of do-it-yourself activity. Our readers know the Popular Mechanics tradition of total involvement with leisure equipment, workshop accessories, tools, home and car care supplies—in virtually every area in which do-it-yourself products play a vital part. That's why, when you, the PM reader, see this Product Feature Mark on any product, anywhere, you know that product is a solid member of the growing family of products featured within the advertising pages of Popular Mechanics—a magazine devoted to serving the dedicated do-it-yourselfer for over 73 years.

LOOKING FOR IDEAS ON HUNTING, FISHING, CAMPING, BUILDING, TOOLS, ETC.? CHECK THESE LISTINGS, THEN USE THE COUPON BELOW.

WORTH WRITING FOR

453. Auto Tests & Tune-up Procedures . . .

Are made easy with the step-by-step guidance and graphic illustrations in this 34-page booklet from Montgomery Ward. It also includes an index to common car troubles and their probable causes. Normally \$1, but FREE to PM readers.

454. New 1976 Bushnell Catalog

This 40-page, fully illustrated catalog is packed with high quality optics including binoculars, riflescopes, telescopes, camera lenses, sunglasses, and more. Plus tips on selecting the right equipment for your purposes. Free.

455. Chain Saw Guide

This definitive 25-page booklet from Sabre gives all the tips and techniques you'll need to keep your chain saw working at peak performance plus a variety of interesting projects to build. Free

456. Easy Styling With Tiles . . .

Is offered by EasySet modular ceramic tiles for swift, simple, do-it-yourself decorating. A free 8-page booklet from American Olean gives details, colors, and instructions.

457. Angling For A Better Rod?

Here's an 8-page brochure from Fenwick, "How To Build Your Own Fishing Rod", providing step-by-step instructions that will let you create your hand-crafted custom rod. Only 25¢.

458. Get A Head Start On Spring Gardening!

Find the right Wheel Horse tractor for your gardening needs in this free, 36-page, color catalog. These sturdy, dependable lawn and garden tractors also accept many accessories—including snow removal attachments for winter use.

459. Electronic Organ Kits

Combine the pride of craftsmanship and the joy of music! Schober Organ Co. offers a package of information on their electronic organ kits and optional accessories that includes 24-page catalog in full color, demonstration record, price list, Organ News, and more. Free.

460. Woodworking Versatility . . .

with DeWalt Powershop radial arm saws. These rugged saws give precise, accurate performance for all types of cuts and DeWalt accessories let you handle any woodworking task. Free 12-page brochure.

461. Selling Your Invention

If you've been wondering about how to start marketing your invention, here's a detailed 16-page booklet that can help answer your questions. It's free from Kessler Sales Corporation.

463. Pella Window & Door Ideas

Full-color, 16-page booklet on how windows fit into contemporary and traditional architecture. Energy-conserving double-glazing systems, low-maintenance exterior, easy-washing features and other benefits illustrated. Patio and wood folding doors are covered. Free.

464. Protect Your Tools!

Here are sixteen full color pages of tool boxes, chests, and roller cabinets to safeguard your valuable tools. They're all made of high quality steel for maximum protection and there's sure to be one to fit your needs. Only 25¢ from Kennedy Mfg. Co.

465. A Custom Touch . . .

For your car's interior. Envair Corp.'s handsome floor mats are custom tailored for all imports and domestics. These rugged mats are made of sturdy natural coco fibre with moisture-absorbing capacity to help deter body rust. Free full color brochure.

466. Garage Door Openers

ElectroLift offers free data sheets on their dependable "install-it-yourself" openers. They feature: solid state controls, vacation security switch, automatic safety reverse, and more. UL Listed, full FCC compliance.

467. Is Canoeing For You?

Here are two free booklets from Grumman Boats. The "Learn To Canoe Directory" is a guide to places nationwide offering canoeing training; while the "Grumman Book Rack For Canoeists" lists books of special interest to canoeists and would-be canoeists.

468. Learn To Weld

A 320-page book, "New Lessons In Arc Welding", covers techniques, electrode characteristics, and related subjects. Practice material and exercises are suggested for each lesson. \$2.00 from the Lincoln Electric Co.

470. Wood Staining Guide

Here's how to use stains to enhance the natural beauty of wood. This 16-page pamphlet from Samuel Cabot treats interior, exterior, and furniture staining and gives tips for getting the best results. Only 25¢.

471. Heirloom Quality Floor Clocks

You'll take lasting pride and satisfaction in the meticulously crafted clocks you can assemble from Viking Clock Co.'s quality kits. Or order your clock fully assembled. Free full color brochure.

472. Have A Better Looking Car!

This 12-page booklet from Krylon is teeming with tips to keep your car looking and running great. It includes body maintenance, under the hood maintenance, and sophisticated—but easy—spray painting techniques. Only 25¢.

473. Looking For Unusual Tools?

National Camera offers their new Winter 1976 NC Flasher catalog. It's 80 fully illustrated pages of tools and technical supplies and lists over 2,000 items—including many unique tools not available from other sources. Free.

474. For A Beautiful New Surface . . .

that's easy to care for, try Nevamar plastic laminate from Exxon. Free 12-page illustrated flyer gives detailed step-by-step instructions that make application a cinch.

Popular Mechanics 176
Box 1718, Sandusky, Ohio 44870

This Coupon Expires March 31, 1976

Please see that I receive the items checked below. I have enclosed 35¢ for the overall service charge, plus remittance for any priced items.

<input type="checkbox"/> 453	<input type="checkbox"/> 456	<input type="checkbox"/> 459	<input type="checkbox"/> 463	<input type="checkbox"/> 466	<input type="checkbox"/> 470 (25¢)	<input type="checkbox"/> 473
<input type="checkbox"/> 454	<input type="checkbox"/> 457 (25¢)	<input type="checkbox"/> 460	<input type="checkbox"/> 464 (25¢)	<input type="checkbox"/> 467	<input type="checkbox"/> 471	<input type="checkbox"/> 474
<input type="checkbox"/> 455	<input type="checkbox"/> 458	<input type="checkbox"/> 461	<input type="checkbox"/> 465	<input type="checkbox"/> 468 (\$2.00)	<input type="checkbox"/> 472 (25¢)	

Total items requested _____ Total money enclosed (including 35¢ service charge) _____

Name (Please Print) _____

Address _____

Town _____ State _____ Zip Code _____

(Please send cash, check or money order made out to POPULAR MECHANICS. No stamps, please.)

Note: Popular Mechanics processes your requests for the above information and forwards these inquiries to the organization making the offer. Each company mails the material directly. Please allow 4-6 weeks for delivery.

You can forget about Delco's new Freedom Battery.

A revolutionary new battery designed to take care of itself for as long as you're likely to own your car.

It's the maintenance-free, worry-free, power-full Delco Freedom Battery from AC-Delco. Once it's installed you can virtually ignore it. That's why we named it "Freedom."

Features include sealed construction so you never have to add water, and Delco - Remy - pioneered changes in cell material and design to promote continuing reliable power.

The results are dramatic, even when compared to our

An advanced new technology for starting cars.



best conventional battery: superior ability to hold a charge, resistance to damage from overcharging, superior ability to withstand today's



No need to water it. You shouldn't have to clean it or check it. Shut the hood on battery worries.

higher under-the-hood temperatures and virtually no servicing required for the entire life of the battery.

Important new technology has made the Delco Freedom Battery a better way to start your mornings for a long time to come. And Freedom is just one more good reason to go with the names you know, AC-Delco.

Go with the names you know.

AC-DELCO DIVISION OF GENERAL MOTORS CORPORATION

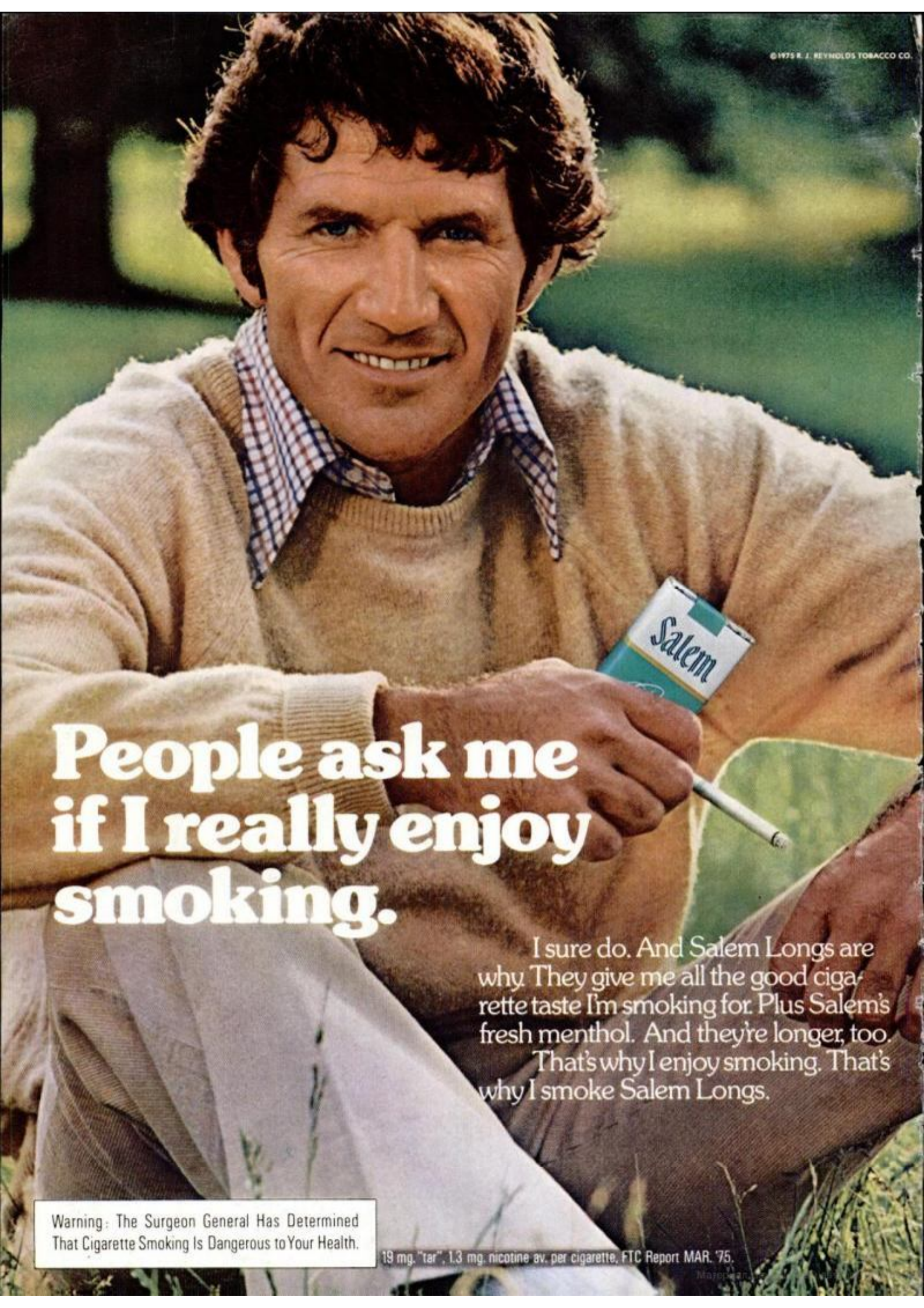

Материал, защищенный авторским правом

A man with dark, curly hair and a slight smile is shown from the chest up. He is wearing a light-colored, textured sweater over a blue and white checkered collared shirt. He is holding a pack of Salem cigarettes in his left hand and a lit cigarette in his right hand. The background is a soft-focus green field.

**People ask me
if I really enjoy
smoking.**

I sure do. And Salem Longs are why. They give me all the good cigarette taste I'm smoking for. Plus Salem's fresh menthol. And they're longer, too. That's why I enjoy smoking. That's why I smoke Salem Longs.

Warning: The Surgeon General Has Determined That Cigarette Smoking Is Dangerous to Your Health.

19 mg. "tar", 1.3 mg. nicotine av. per cigarette, FTC Report MAR. '75.

More than 100 years of experience.