

JULY 1975 75 CENTS

Popular Mechanics



**Amazing
synthetic
motor oil:
No more
oil changes?**

**A master
craftsman's
15 most ingenious
workshop ideas**

**8 neighborly
fences—
easy to
build**

**RUST: Your car's
worst enemy**

**ATTIC FANS:
Lowest-cost
way to cool
your home**

**World's biggest
car crash:
How it
happened**

AIRLINE PILOT'S REPORT

**NEW WARNING
HEADS OFF
AIR DISASTERS**

The National Champion asks for Pennzoil.

Whether it's a championship you're after, or simply superb performance, you can always depend on Pennzoil quality. The kind that comes from over 85 years in the business. And today, that quality is found in a whole family of Pennzoil products. For your car, truck, motorcycle, boat, snowmobile. In fact, Pennzoil makes a lubricant for almost any kind of engine. So remember Pennzoil. For quality performance.

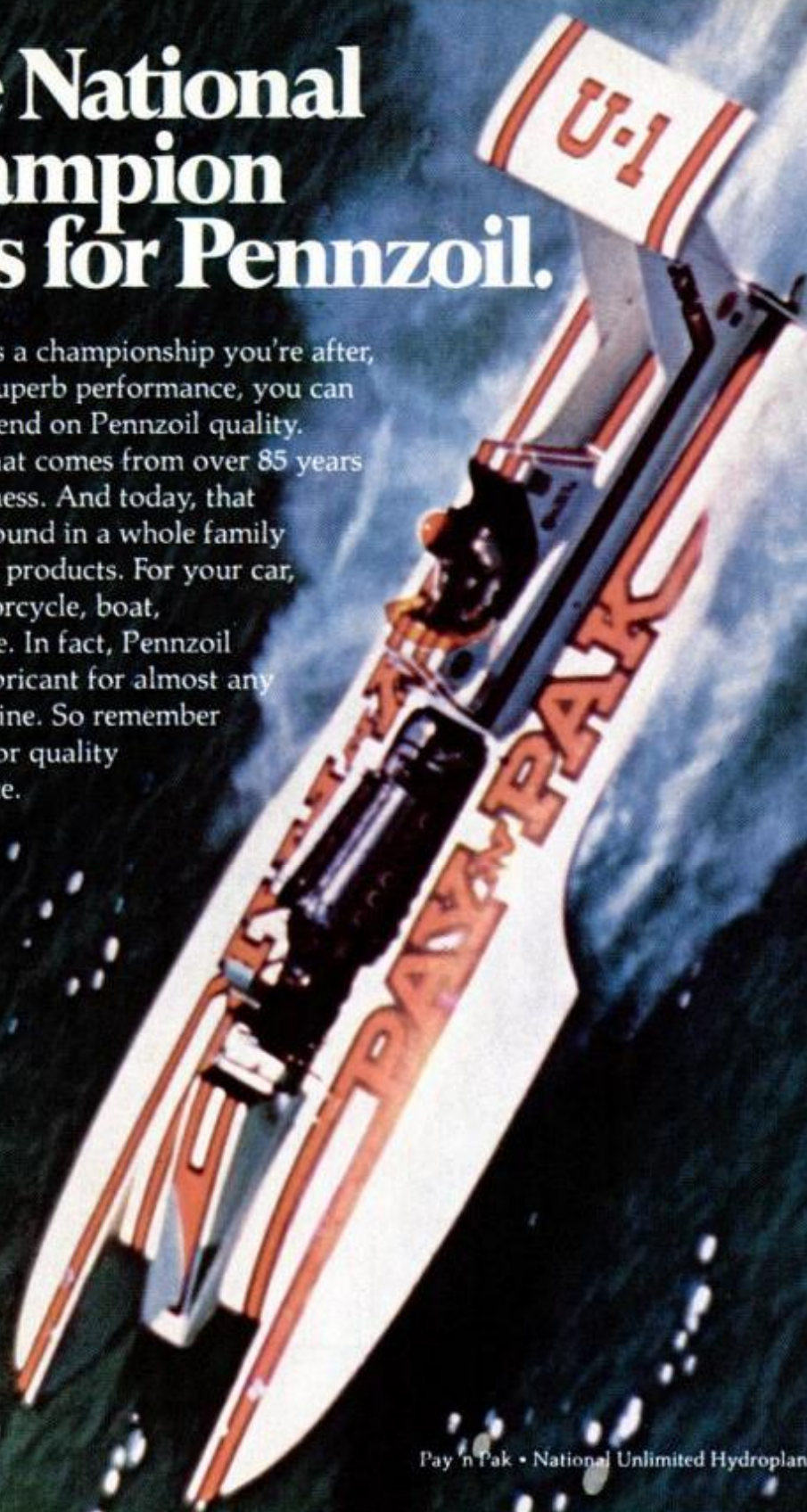

Pay n Pak • National Unlimited Hydroplane Champion • Owner—Dave Heerensperger

Whatever you drive, wherever you go, Pennzoil is worth asking for.



Motoroil, transmission and outboard oil

**FOR ABOUT
500,000 YEARS
MAN HAS TRIED TO BE
MASTER OF THE WATER.
NOW HE HAS THE
UPPER HAND.**



**BLACK MAX
IS COMING
FROM MERCURY**



BC
A BRUNSWICK COMP

Материал, защищенный авторским правом.

Not many get the chance to own a classic. Even fewer get the chance to build one.



Alfa Romeo Spider
Gran Sport Turismo, 1932
(1,954 parts - \$150)

Alfa Romeo 8C
300 Monza, 1931-34
(1,452 parts - \$125)

Rolls Royce Phantom II
Drop Head Sedan Coupe, 1932
(2,199 parts - \$200)

Fiat 130 HP
Grand Prix de France 1907
(823 parts - \$100)

**Introducing four classic car
model kits by Pocher d'Italia.
What makes them expensive are
their authentic components.
What makes one of them unique is
about a hundred hours of your kind of concentration.**

If you are already where you always
knew you were going—or if you're
still heading there—you know nothing
good ever comes easy. Or cheap.

That's why we think you may be
one of those people who will readily
recognize that these imported car
model kits are more than what they
seem to be.

They are more than just the opportunity
to build a model that is quite
possibly the most elegant in the world.

They are the most expensive of
their kind.

The most exacting of their kind.

And, like everything else that
doesn't come easy, they are the most
satisfying experience in the world.



Pocher d'Italia kits have long been recognized throughout the world as the Tiffany of their type.

Parts are made of chrome and brass and stainless steel and copper. High impact plastic. Genuine rubber.

And unlike other models,

these car models function. For example, in the Rolls Royce, the steering works.

The brake pedal operates on the four wheels and the hand brake operates on separate rear wheel brakeshoes.

The suspensions, of lined steel, are perfectly efficient. The headlights turn on from the dashboard. The crankshaft with connecting rods, pistons and gudgeon pins all operate when you turn the crank. At the same time, by means of V belt and gears, the fan, generator and magneto also operate.

The windows roll up and down. The doors open and close. So does the drop head hood, the bonnet and luggage compartment.

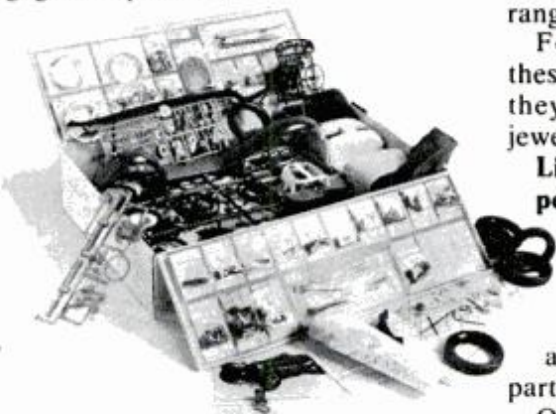

Each car model has its unique characteristics, and each is a marvel of engineering in miniature.

There are only four models you can build. But they are models of cars so classic they have become a part of history and a part of dreams.

Classic cars that are a part of time we will never see again.

The Fiat 130 HP Grand Prix de France 1907 (823 parts—\$100).

The 1931-34 Alfa Romeo 8C-2300 Monza (1,452 parts—\$125).

The 1932 Alfa Romeo Spider (1,954 parts—\$150).

The 1932 Rolls Royce Phantom II Drop Head Sedan Coupe (2,199 parts—\$200).

Pocher d'Italia models come as close to the real thing as any small scale reproduction possibly can.

They are in perfect 1/8 scale and were developed from the original blueprints and prototypes from factory archives.

Don't be misled. There is absolutely no comparison between Pocher d'Italia car model kits and the kits you knew as a youth. Or the ones your kids worked on.

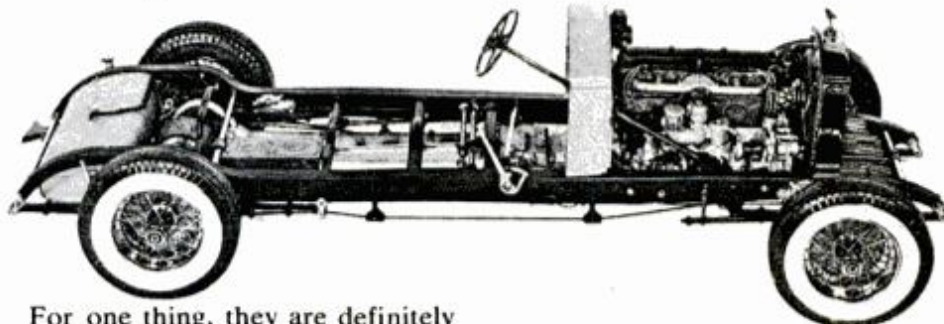

For one thing, they are definitely not picayune. Completed models range from 18½" to 26½" in length.

For another, models made from these kits are so frighteningly precise, they are like some strange, exotic jewel.

Like jewels, they are neither inexpensive nor effortless to attain.

The least expensive kit is \$100.

The most expensive is \$200.

Depending on the kit you choose, you'll be working with anywhere from 823 parts to 2,199 parts.

Obviously, this is something you won't complete in a weekend or two. Or without the utmost in concentration and care.

It is nothing for the fumble-fingered, nor the easily discouraged. It is, however, something quite marvelous for

anyone who finds new pleasures in losing himself completely in a project.

There's a possibility this may not turn out to be as difficult for you as we're making it sound. After all, each part is numbered and there's a booklet of complete instructions that leads you along, step-by-step.

An absolute minimum of mess.

You don't have to bother with dinky brushes or messy paints. Unless you want to change the color.

You don't need machining or special tools. There's hardly any gluing.

These car models are built almost like the real thing: with nuts, bolts and screws.

You can pay for a Pocher d'Italia kit by check, money order, American Express, Diners Club, Carte Blanche, BankAmericard, or Master Charge.

10 Day Inspection Period.

You can have 10 days to examine your kit and the instructions (without breaking open the see-through plastic bags or starting to work on it). After you've completely examined it, you can return it for full credit if you wish. If you keep it longer than 10 days or start to work on it, it's yours.

As you can see, you're not taking any chances at all. But the coupon below may be your only chance to get one of these collector's-item kits.

Choose your favorite, fill it out and send it in. We kind of envy you. You have a lot of interesting evenings and weekends ahead of you.

DELUXE CLASSICS, DEPT. PM
5900 WILSHIRE BLVD., SUITE 2760
LOS ANGELES, CALIFORNIA 90036

Please send me the _____ for _____
(name of car model kit) (price)

Enclosed is my personal check; money order.

Charge to my account number _____ Exp. _____

American Express BankAmericard Carte Blanche

Master Charge Diners Club

Signature (Please write) _____

I understand I may return the kit for full credit within 10 days if I have not opened the see-through plastic bags or started work on it. If I hold the kit longer than 10 days or begin work on it, that is proof I wish to keep it.

ADD \$30 FOR AIR FREIGHT OUTSIDE U.S. AND CANADA

Name _____

Address _____

City _____ State/Zip _____

AUTOMOBILES AND BIKES

- 16 Imports and Motorsports
- 30 Detroit Listening Post
- 32 The bike you sail like a boat
- 55 World's biggest highway crash
- 70 All about oil: What you should know before your next oil change
- 82 How to retrofit an electronic ignition kit
- 92 PM Owners Report: BMW
- 95 Rust: Your car's worst enemy

BOATING, OUTDOORS

- 50 Pop-up tent camper you can build
- 61 New speed for scuba
- 68 How to get home without gas
- 72 You'll fish faster in this speedy new tunnel
- 84 Tackle to take around the world

HOME AND YARD

- 62 Eight easy-to-build fence designs
- 77 10 steps to a sparkling swimming pool
- 100 A cooler house starts with a cooler attic
- 120 Quick coverup
- 132 'Pour' yourself a patio with plastic molds

ELECTRONICS, RADIO, TV

- 48 A good turntable kit that's easy to build
- 60 Now: LP records for your TV set
- 82 How to retrofit an electronic ignition kit

SCIENCE AND ENGINEERING

- 65 It's a real Rube Goldberg!
- 70 All about oil: What you should know before your next oil change

PHOTOGRAPHY

- 15 Photo hints
- 58 Infrared photography: Different—and easy

SHOP AND CRAFTS

- 78 Look what you can do with your portable drill
- 102 It's a great year for wine racks
- 106 15 great shop ideas from a master workshopper
- 136 When the chips are down, it's beautiful

AVIATION

- 74 New 'pull up' howler makes your flight safer

EVERY MONTH

- 8 Letters
- 10 All Outdoors
- 18 Appliance Clinic
- 22 Car Clinic
- 38 Homeowner's Clinic
- 40 Science Worldwide
- 42 The Bicycle Shop
- 86 It's New Now!

ON THE COVER

New warning heads off air disasters, as told by a pilot for one of the nation's leading airlines. *Illustration: Ed Valigursky*

AS A SERVICE TO READERS, *Popular Mechanics* publishes newsworthy products, techniques and scientific and technological developments. Due to possible variance in the quality and condition of materials and workmanship, *Popular Mechanics* cannot assume responsibility for proper application of techniques or proper and safe functioning of manufactured products or reader-built projects resulting from plans published in this magazine.

Popular Mechanics®

JULY 1975 • Vol. 144 No. 1

INTERNATIONAL EDITIONS: Australia, Caribbean, Mexico, Southern Hemisphere

SPECIAL FEATURES:

All about oil. Here's what you should know about oil—including the new synthetics. You may never need to change oil again. Page 70.

Rust: Your car's worst enemy. Autobody corrosion costs have skyrocketed to nearly \$7.5 billion a year. Here's what is being done about it. Page 95.

World's biggest highway crash. Despite pileup of some 300 vehicles in dense fog, freeway was cleared in hours and no one was killed. Page 55.

Tackle to take around the world. Carry-on, fit-together gear that will land almost any lunger anywhere now can fit under your airliner seat. Page 84.

A cooler house starts with a cooler attic. Prevent heat buildup with exhaust fans and vents and watch your airconditioning costs come down. Page 100.

15 great shop ideas from a master workshopper. Ingenious use of a power-equipped bench to keep portable tools ready at arm's length. Page 106.



Page 68



Page 77



Page 100



Page 60

SUBSCRIPTION SERVICE: Mail all subscription orders, changes of address with your latest label, to Popular Mechanics, P.O. Box 646, New York, N.Y. 10019. All other correspondence relating to your subscription: James Gable, Customer Service Department, Popular Mechanics, P.O. Box 1567, New York, N.Y. 10019.

POPULAR MECHANICS IS PUBLISHED MONTHLY by the Hearst Corporation, 224 West 57th Street, New York, N.Y. 10019, U.S.A. Single copy for the United States and Canada, 75 cents. Subscription prices: United States and Possessions, \$7.00 for one year; \$13.00 for two years; \$18.00 for three years. Canada, add \$3.00 for each year. All other countries, add \$5.00 for each year. Second-class postage paid at New York, N.Y., and at additional mailing offices. Authorized as second-class mail by the Post Office Department, Ottawa, and for payment of postage in cash. Registered as second-class matter at the Post Office at Mexico D.F., Mexico, June 20, 1950. © 1975 by The Hearst Corporation. All rights reserved. Printed in U.S.A.

POSTMASTER: Please send Forms 3579 to Popular Mechanics, P.O. Box 646, New York, N.Y. 10019.

PALL MALL GOLD 100's

Longer filter, longer tobacco, milder taste.

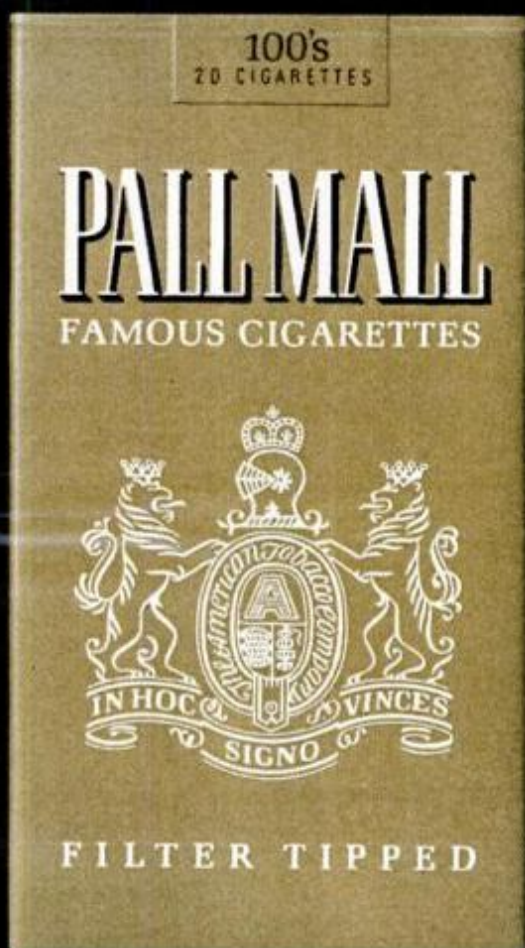

PALL MALL GOLD 100'S



ORDINARY FILTER KING

Longer...yet milder

Warning: The Surgeon General Has Determined
That Cigarette Smoking Is Dangerous to Your Health.

This One



P54F-C5Z-873X

20 mg. "tar", 1.4 mg. nicotine av. per cigarette. FTC Report Apr. '75.

JOHN A. LINKLETTER
Editor
SHELDON M. GALLAGER
Executive Editor
DANIEL C. FALES
Managing Editor
WAYNE C. LECKEY
Home and Shop Editor
ALVIN KIETZ
Art Director

BILL HARTFORD
Automotive
JOHN F. PEARSON
Science and Engineering
WM. T. McKEOWN
Boating and Outdoors
IVAN BERGER
Electronics and Photography
HARRY WICKS
Home Workshop
STEPHEN WALTON
Assistant, Home and Shop
MICHAEL LAMM
West Coast
ROBERT LUND
Detroit Automotive
GARRY WINTER
Copy Chief
RICHARD H. FUNK
Production
ALFREDO VEGA
Assistant, Production
DAVID KOMITAU
Assistant Art Director
IRA HERRICK
Assistant Art Director
DON L. MANNES
Assistant Art Director
ED MENTKEN
Assistant Art Director
CLIFFORD B. HICKS
Special Publications
LUDWIG ARONS
Special Projects
SOPHIE GRONOWICZ
Director, Bureau of Information
EVERETT JOHNSON
Cabinetmaker

DANIEL J. COLEMAN
Director of Advertising

ADVERTISING OFFICES: New York: 224 W. 57th St., 262-4282; Chicago: 520 N. Michigan Ave., 527-2400; Detroit: General Motors Bldg., TRinity 5-8711; Cleveland: 20310 Chagrin Blvd., Shaker Heights, Ohio, 283-7768; Los Angeles: 601 N. Vermont Ave., 666-6263.

JOHN A. REGINA
Advertising Production Manager

Published by The Hearst Corporation

JOHN R. MILLER
President
RANDOLPH A. HEARST
Chairman
RICHARD E. DEEMS
President, Magazines Division
JOSEPH F. KERN
Publisher

POPULAR MECHANICS IS PUBLISHED MONTHLY by the Hearst Corporation, 224 West 57th Street, New York, N.Y. 10019, U.S.A., John R. Miller, President; Randolph A. Hearst, Chairman; Harrison A. Mitnick, Treasurer; Harvey L. Lipton, Vice President and Secretary, Hearst Magazines Division; Richard E. Deems, President; Gilbert C. Maurer, Executive Vice President, Operations; Raymond J. Peterson, Executive Vice President, Advertising; William S. Campbell, Vice President and General Manager; John F. D'Avolio, Vice President and Resident Controller; Albert A. Rachol, Vice President and Director of Circulation; Joseph F. Kern, Vice President for Popular Mechanics.

ADDRESS ALL EDITORIAL COMMUNICATIONS to 224 West 57th St., New York, N.Y. 10019. For additional sources of information on the articles and products in this issue, write to the Bureau of Information, Popular Mechanics, for free "Where-to-Find-It" List.

40% More Cutting Power... Perfectly Aligned Cutters, ALWAYS

40% MORE CUTTING POWER

The joint rivet in a cutting plier is a fulcrum. The closer it is to the cutting edges, the greater your leverage and the greater your cutting power with less effort. In Channellock's WIREMASTER, the joint rivet is here,

PERFECT CUTTER ALIGNMENT

Unique enclosed joint design holds cutting edges in factory-perfect alignment for the long life of the plier. No way for the jaws to get out of line . . . ever.



Send For Our Free Catalog

CHANNELLOCK

No. 349 Wiremaster Hi-Leverage Plier.

CHANNELLOCK, INC., • Meadville, Pa. 16335

GET INTO THE STEAM OF THINGS

This steam engine kit is an ideal project for these cold winter evenings. It machines on a very small lathe such as the Unimat or the Sears/Atlas 6" and will prove that you are a better machinist than you think. Or, it makes a great project for school shop. The kit has all the parts you'll need, including complete drawings and instructions. It's a lot for \$6.95, postpaid.

Want to READ about Steam? MODEL STATIONARY & MARINE STEAM ENGINES, \$7—MODEL BOILERS & BOILERMAKING, \$7—EXPERIMENTAL FLASH STEAM (The hottest steam going.), \$11.

This is only 1 of 40 steam engine kits in our catalog—\$1 or FREE with order from this ad.



CALDWELL INDUSTRIES
BOX 170 LULING,
TEXAS 78648



Two ways to prevent lake, river or sea sickness.



It's no fun to have your boat's engine quit running miles from the marina. And it's a jolt when you see the repair bill these days.

But if you use a top quality outboard oil, you stand a great chance of avoiding engine ailments, and the repair bills that follow.

No marina can offer finer quality than these Quaker State Outboard Oils. Our BIA-certified 2-cycle oil for high-performance Service TC-W, or Quaker State Duplex HD.

That's because Quaker State Outboard Oils are made by specialists who have made quality a tradition.

They're blended and fortified to minimize spark plug fouling and port plugging; prevent ring-sticking and piston-scuffing; and prevent corrosion of engine interiors.

That kind of quality means great value for you. So use Quaker State in your boat's engine. For its continued good health.

Quaker State your outboard to keep it running young.

FROM READERS

Cities in the sky

The idea of *Cities in the Sky* (page 94, May '75) within the next 20 years seems premature. We will certainly need space for cities and there is still plenty on and in Earth: at the poles and in artificial caves in the Earth. This is far more feasible and inexpensive.

ANTHONY H. KLOTZ
BABYLON, N.Y.

I am an 18-year-old who is very captivated by the space effort, so much, in fact, that I have decided to make it my life's goal to be in space. Your article succeeded in reinstating that indescribable feeling in me.

GEOFFREY S. KING
FRANKENMUTH, MICH.

Space exploration, development and even colonization—antitechnologists to the contrary—stand to offer us some exciting possibilities.

But the supposed benefits of the proposed colonies were badly overstated. Most out of place was the statement that "it will take pressure off our current population explosion." Recognition that we have a population problem is commendable, but space colonies will never solve it. Ignoring the real problem of the rest of the world, America's population is growing by some 2.4 million people a year (including illegal aliens). At six colonies a year, it would take only a few years to fill up all the Lagrangian points.

ERNEST STILTNER
BOULDER, COLO.

Car Clinic and Fred save money

My husband reads every word you print and has for years. Fred and *Car Clinic* have saved us a great deal of money on repairs, etc.

MRS. FRED SIGRIST
OAK FOREST, ILL.

Are supertankers a superproblem?

The Supertanker: A Quarter Mile of Seagoing Oil (page 71, May '75) was certainly not up to your normal standards. Although Noël Mostert is a compelling writer, he has done a disservice to readers in his often misleading, inaccurate portrayal of Very Large Crude Carriers (VLCCs). The author's prejudice clearly

shows when he refers to the operation of VLCCs as "a bewildering, complex and even sinister new experience." In fact, tankers over the years have progressively gotten larger and a VLCC merely extends the ongoing evolution of tankers. The growth of tanker cargo-carrying capacity since World War II actually has been less than the growth of commercial aircraft from the DC-3 to the 747. I wonder if Mr. Mostert would refer to the operation of a 747 in the same way as he refers to the operation of a supertanker? The mere size of a carrier is no basis for its condemnation.

The navigation of VLCCs is not "virtually a new skill." Ship-handling or maneuvering is not fundamentally different on VLCCs than on smaller vessels. All ships have somewhat different handling characteristics. However, learning these characteristics presents no formidable problems, and an experienced mariner has no difficulty in shifting from one ship to another.

There is no basis for the statement that VLCCs "at five years are at the halfway point of their write-off lives" and that holding such a ship together beyond the five-year point may be difficult. International marine classification societies assure that vessels are designed, constructed and maintained to the highest standards. Far from being a threat to the oceans of the world, it is much safer to use VLCCs than to have many more smaller tankers crowding the ocean routes and ports and harbors of the world.

T.S. WYMAN, MANAGER
MARITIME RELATIONS
CHEVRON SHIPPING CO.
SAN FRANCISCO, CALIF.

Your condensation of *Supership* left out three important things: 1) The horrible prospects of an accident to a liquid gas carrier. These ships carry liquefied natural gas in giant "Thermos bottles" at minus 265° F. An accident, penetrating the tank (there are five at least), would result in the surrounding ocean being frozen up, a cloud of gas four or five miles square, the crew undoubtedly dead from the gas—and what happens when the gas finds the flame in the boiler? 2) The fact that many

of these giant vessels have only one licensed man on board. 3) There is no place anywhere around the United States and only one place in Canada where any ship as deep as these can come in for service.

One pipeline should come down the Alaska Highway to California, the other via Winnipeg to Chicago; then we do not need tankers.

G. ROSEKILLY
NAVAL ARCHITECT
SAN MATEO, CALIF.

You have continued the silliness of confusing "write-off life" with structural life. The write-off life is simply the period in which the owner is paying off the mortgage. Once he is beyond that period, he starts coining money, as the mortgage cost can be substantial. He, in fact, has more money for maintenance.

Structural life is another matter. Ships are designed for 10⁷ loading cycles. That's 1 billion cycles, which occur about every 6 to 7 seconds. This corresponds to each swell crossed, and is about 200 years. Statistically, it's expected that a very large percentage would survive that long, without the effect of other agencies.

Chief amongst these other agencies is corrosion. With modern coatings, this problem is diminished to the point where most coated vessels show virtually no corrosion.

These vessels are carefully inspected continuously. The crew has a vested interest in inspecting the vessel, as the oceans are very cold all year round. As a naval architect, I have inspected suspect vessels on a continuous basis, until we found the root cause of serious problems.

J.A. LORENZEN
ENGLISHTOWN, N.J.

\$1 problem solver

In the May *Appliance Clinic* (page 61) L.J. Ratcliff wrote of a problem with a Hotpoint electric range. I had this problem with the wire burning off every two weeks or so, until I solved my problem with a \$1 right-angle Phillips screwdriver. This is the only way I could get in there to tighten the screw enough to make good contact so it doesn't burn the wire off.

WILLIAM SCHULTE
EAU CLAIRE, WIS.

Is the famous Firestone Transport truck tire still selling at car tire prices?



In times like these especially, it's a question light truck owners are asking all the time.

And the answer's still yes.

Even though Transport[®] is a real truck tire, you can buy it, with a 6-ply rating, for a price comparable to what you'd pay for an original equipment passenger car tire.

And the Transport is built for truck use especially. With Shock-Fortified nylon body plies and the heavy construction you need to handle road hazards. With reinforced beads and sidewalls, and a tread made from a specially compounded Sup-R-Tuf long mileage rubber.

So if you've got to put on truck tires but you're put off by truck tire prices, remember Firestone Transport. Still close to car tire prices, only at your Firestone Dealer or Store.



Firestone Transport

ALL OUTDOORS

WITH BILL McKEOWN



We've examined a lot of neat little new items for sportsmen recently. Here are some that look good, or ones we have successfully tested.

On the water

Traditionally, there is more boating action this month than any other, and National Safe Boating Week, June 29 to July 5, always includes the busy Independence Day weekend. Latest Coast Guard accident statistics show 308 fewer boating fatalities last year in spite of half a million more boats afloat. But any aid to safety is important, and a clear non-skid surface coating called Stopslip, available in a spray can from dealers handling MDR products, should provide a safe step in the right direction on ladders, walkways and wet decks.

Racing boats are going faster—we can well remember the sensation as the speedometer passes 100 mph in a hydro racing outboard. Now Record Marine Equipment, Taren Point, Australia, has developed a life-jacket with built-in deceleration parachute for speeds from 90 to 200 mph. It will sell for under \$300, and reportedly can be repacked after each time you are thrown from your boat at those speeds. We haven't tested it yet, and somehow we hope we never have to.

The Hi-Performance Products division of Mercury outboards has developed a neat new steering unit for high-speed boats that relocates the steering cables below the driver's feet. Now you can break away out of the cockpit in a flip or crash without steering controls tangled around your legs.

From Sears catalogs and stores is a portable running light set for about \$22 that can fit out any boat from the smallest up to 26 feet for night navigation. Wiring is included for boats to 14 feet, bow and stern lights hinge out of the way for cartopping, and the kit's switch box can turn on both lights, just the white stern light as an anchor light, or a small courtesy light aimed down into the cockpit from the switch box for night fishing. The lights run off the motor's 12-volt battery and are detachable to keep them from being stolen.

To make theft of your complete boat more difficult, a \$50 anti-theft

and antivandalism kit has been introduced by Aqualarm, Inc., of Gardena, Calif. Magnetic sensors can be placed around the boat to trigger a loud alarm bell and, hopefully, scare away intruders.

Under water

A fishing reel with a real memory for where the big fish are is the claim for the new Rangefinder spincasting reel from St. Croix Fishing Gear, 9909 South Shore Drive, Minneapolis. A "Memory-Lok" makes possible repeat casts of the same distance to the same honey hole, or just the right depth or trolling level to clear the bottom snags. It's available with 90 yards of 8 or 10-pound mono from tackle stores or for \$9.95 from St. Croix.

Brightening the scene so an angler can see where his line is leading, Berkley & Co. has announced a new high visibility Trilene Tensimatic line with built-in optical brighteners that are easy to follow during casting but are reported to become almost invisible under water. Test strengths in a range from four to 60 pounds are available.

Fly-rod fishermen can join the tournament trail for some of the B.A.S.S. contests. Information is available from the Bass Anglers Sportsman Society, Box 3044, Montgomery, Ala. 36109. Scientific Anglers now produce a different System rod and reel for each of eight different weights of Hi-D fly lines. And Phillipson 3M now offers again Tonkin bamboo Peerless fly rods at peerless prices of up to \$250 each for these custom-made collectors' items.

For an unobstructed underwater scuba view, a Diviator Safety Pressure Mask is reported to keep the face plate fog-free, allow eye glasses, have low enough regulator noise for microphone use, and provide a leak-free seal for fully bearded divers. It's from Under Sea Associates, Melbourne, Fla.

Travel

Among new ways to see more and spend less are tent-camp trips without a tent, and guided tours without a guide. Along major interstate highways, KOA Campgrounds are introducing a tenting plan that provides a rental tent all set up and

ready with four cots for \$7. You'll need your own sleeping bags and food, but it should be an easy way to save without buying any equipment, a good method to test the sport for a night, and a handy substitute when all the nearby motels are full. Of course, if you have your own tent, you can save about 50 percent more by just renting campsite space.

Many national parks, and some West Coast cities and seashores as well, can be toured with a recorded cassette giving details and sound effects as you drive along. Some are available right at the park entrances. More information is available from Auto Tape Tours, Box 385, Scarsdale, N.Y. 10583.

Off-road and on

By 1980, one out of every five light trucks sold will have four-wheel drive, according to a recent estimate by Robert Loomis of Chrysler trucks. He predicted yearly sales of 675,000 4WDs by then. The current trend is toward full time four-wheel drive systems, and the Chrysler/Dodge transfer case is used by most other manufacturers as well.

A new convertible top with roof as well as side windows in the vinyl fabric is made for Universal Jeeps by Husky Products, Longmont, Colo. Called the Husky Surveyor Top, the tinted plastic gives an overhead view of mountain scenery. Models for other 4WDs have been announced as well.

Vega Wheelcamper, in Syracuse, Ind. is introducing two new Astro-lounge model travel trailers. Each of the 24 and 26-footers has a roof raised by one foot at the rear to provide added headroom for a "bunkhouse" with three berths. Ideal for a large family or group trailering, these Wheelcampers have all other standard features.

Shooting

For snakes, plinking, pests and skeet practice, the new CCI Mini-Mag .22 long rifle Shotshells turn your .22 rifle or handgun into a shotgun or survival gun. The new little shells come in plastic pocket-packs and are only about \$1.50 for 20 rounds. They're made by the CCI Sporting Equipment Div. of Omark Industries. ★★★

15 and 9.9 hp compacts. More of everything but size.

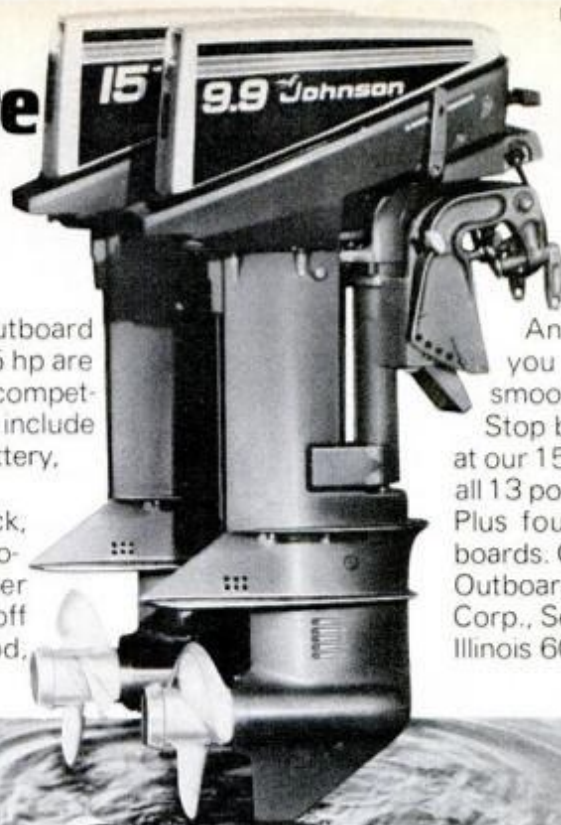

Nobody gives fishermen more in an outboard they can carry. Yet, our 9.9 hp and 15 hp are more compact than any comparable competitive motor. And electric starts, which include a 5 amp alternator to charge the battery, are sized the same as our manuals.

All have FireFlash ignition for quick, easy starts, long spark plug life. A programmed tilt-lock for shallow water running. Co-pilot steering for hands-off trolling. A sound-sealed powerhood,

mid-section Watershield silencing and thru-propeller-hub exhaust to keep you running quiet.

And our 1975 compacts give you still more of what you need for fishing. A new longer tiller handle puts twist-grip throttle and steering closer to you. Manual models can be started in gear at low trolling speeds.

And a new, heavier flywheel gives you easier starting, smoother idling, smoother trolling.

Stop by your Johnson dealer for a look at our 15 and 9.9 hp compacts. Look over all 13 power choices... 2 through 135 hp. Plus four new high-thrust electric outboards. Or write for free catalog. Johnson Outboards, Div. Outboard Marine Corp., Sea-Horse Dr., Waukegan, Illinois 60085, Dept. PM-75.



Performance-engineered by the world leader **Johnson** *First in Dependability*
OUTBOARDS

RICHARD PETTY says:

"Want to really learn how to repair cars? Check out NRI home training"

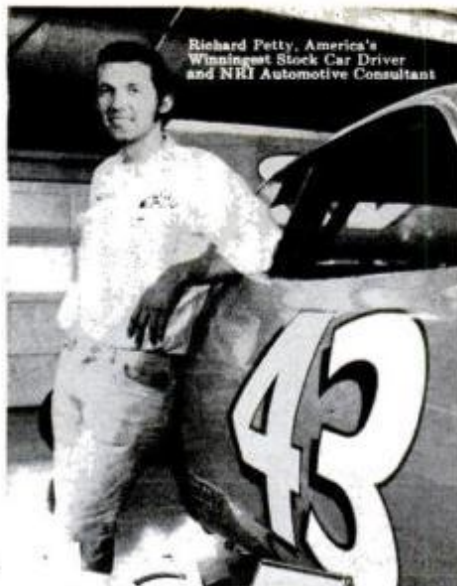

Richard Petty, America's Winningest Stock Car Driver and NRI Automotive Consultant



You get all this equipment and more with the NRI Master Automotive Technician's Course... including NRI's exclusive Achievement Kit, and 70 profusely illustrated "bite-size" lesson texts.

"NRI provides the most up-to-date complete courses in Auto Mechanics I've ever seen. I know the importance of a good mechanic, and the opportunities out there for trained men. That's why I'm glad to see home training like the two NRI courses. It's a lot of training for a very few bucks.

Save Gas... Save on Repair Bills. NRI's Tune-Up Course will teach any homeowner all he needs to know, quickly, with hands-on experience. The course includes 8 important service items, including a Dwell Tachometer, Volt Amp Tester, and Tune-Up Tool Kit.

Become a Professional Mechanic. NRI's Master Automatic Technician Course gives you the essential training and diagnostic equipment to be a real pro. You get 10 pieces of auto service equipment, including a Dwell Tachometer, AC Power Timing Light, Volt-Amp Tester, Ignition-Analyzer Scope and a complete set of tools.

Train with the Leaders—NRI & McGraw-Hill. No other school has NRI's experience in home training, or McGraw-Hill's background in continuing education. Mail the coupon and check what they have to offer." NRI AUTOMOTIVE DIVISION, 3939 Wisconsin Ave., Washington, D.C. 20016

**RUSH FOR FREE CATALOG
NO SALESMAN WILL CALL.**



NRI SCHOOLS
McGraw-Hill Continuing Education Center
3939 Wisconsin Avenue,
Washington, D.C. 20016

946-075

Check below for your free Automotive Catalog. Or select one of the other courses instead.

- AUTOMOTIVE MECHANICS COURSES** TV/Audio, Communications, and Computer Electronics Courses Air Conditioning, Refrigeration, and Heating Courses

Name _____ Age _____
(Please Print)

Address _____

City _____ State _____ Zip _____

APPROVED FOR CAREER STUDY UNDER GI BILL.
Check for details. ACCREDITED MEMBER NATIONAL HOME STUDY COUNCIL

New 1981 Home Training in
Automotive Servicing



NEXT MONTH IN PM . . .

- *Staying alive in a small car*
- *Exclusive Owners Report on the AMC Pacer*
- *How to preserve all outdoor surfaces of your home*
- *Try wind-powered radio-control models for fun and competition*
- *Ultrasound: Most fascinating new medical diagnostic tool*
- *How today's skillful offshore divers learn their job*

SUBSCRIPTION SERVICE: Mail all subscription orders, changes of address (with your latest label), and Postmaster notices of undeliverable copies to Popular Mechanics, P.O. Box 646, New York, N.Y. 10019. All other correspondence relating to your subscription: James Gable, Customer Service Department, Popular Mechanics, P.O. Box 1567, New York, N.Y. 10019. Please enclose your latest mailing label for quickest service when writing about your subscription.

Popular Mechanics

250 West 55th St., New York, N.Y. 10019
WPM5G1

YES! Please enter my subscription to POPULAR MECHANICS for:

- 1 year \$7.00 New
 2 years \$13.00 Renewal

Payment of \$ _____ is enclosed.

Bill Me _____
initial here

Name _____ (please print)

Address _____

City _____ State _____ Zip _____

On new subscriptions, first copy will arrive in about 8 weeks.

(Above prices apply in U.S. & Possessions only. Canada add \$3 per year. All other countries add \$5 per year.)

CHANGING ADDRESS?

If you're planning to move, please let us know at least six weeks before changing your address. Attach current address label and fill in your name and your new address. This will serve to insure prompt service on your subscription.

Send old label with your name and new address to:
POPULAR MECHANICS, Subscription Dept.
Box No. 646, New York, N.Y. 10019

NAME _____ (Please print)

NEW ADDRESS _____

CITY _____ STATE _____ ZIP CODE _____

DRAMATICALLY CUT HOME CARE COSTS!

Homeowners can do the work of "\$15-hr. journeymen" with the help of this new, systematic Master Guide.

From the editors of Popular Mechanics—

NEW! If you liked Master Shop Guide then its companion, Master Home Care Guide, is a must. You'll agree that it's the most concise and authoritative package of PM do-it-yourself home maintenance know-how ever! And only now available in this brand-new format.

EASY TO USE! Hang-it-up. Stand-it-up. You'll be delighted and amazed at the clarity of design. More than 150 charts and illustrations are sparklingly reproduced in crisp color tones on 24 plastic laminated pages (12 boards), then hole drilled and steel wire bound.

COVERS EVERYTHING! from water-proofing a basement to repairing a roof. Properly used, it will save you **hundreds** if not **thousands** of dollars by showing you the right way . . . the only way you'll know the jobs been done properly at the lowest cost . . . by doing it yourself!



PRE-INFLATION PRICE only
\$4.49 complete set of 12
8 1/2 x 11 boards!
postpaid

PARTIAL LIST OF CONTENTS

- PATCHING WALL CRACKS
- PAINTING A ROOM
- HANGING WALLPAPER
- HANGING DRAPERY
- INSTALLING TRAVERSE RODS
- HANGING DOORS
- INSTALLING LOCKSETS
- FIXING STICKING DOORS
- SILENCING SQUEAKY FLOORS
- REPAIRING FURNITURE SCRATCHES
- REMOVING ALL STAINS
- UNCLOGGING DRAINS
- STOPPING LEAKS
- CUTTING FUEL BILLS
- WEATHERSTRIPPING
- INSULATING
- ELECTRICAL EMERGENCIES
- WATERPROOFING A BASEMENT
- REPAIRING STORMS & SCREENS
- REPAIRING A ROOF
- MAINTAINING GUTTERS
- MAINTAINING DOWNSPOUTS
- EXTERIOR PAINTING
- WHAT PAINT TO USE

GOLD!

Yes, Master Home Care Guide is literally worth its weight in gold. It will be your most dependable helper for many years to come. Don't wait. Do yourself a favor and order one today!

At Last! The home maintenance companion to Master Shop Guide!

- Handy hang-up, stand-up format!
- 24 washable surfaces!
- 12 plastic boards laminated to last for years!
- 150 charts and illustrations!
- Great for "the man of the house"!

**MAIL
THIS
RUSH
ORDER**

Popular
Mechanics,
Dept G-5

Box 1014 Radio City,
New York, N.Y. 10019

Rush me _____ set(s) of the new
Master Home Care Guide. I enclose check
or money order for \$4.49 postpaid.

Name _____

Address _____

City _____ State _____ Zip _____

One of today's most practical handguns was designed over a hundred years ago.

During an ocean voyage in 1830, young Sam Colt whittled a wooden model of his first firearm. It was a single-barreled handgun with a revolving cylinder.

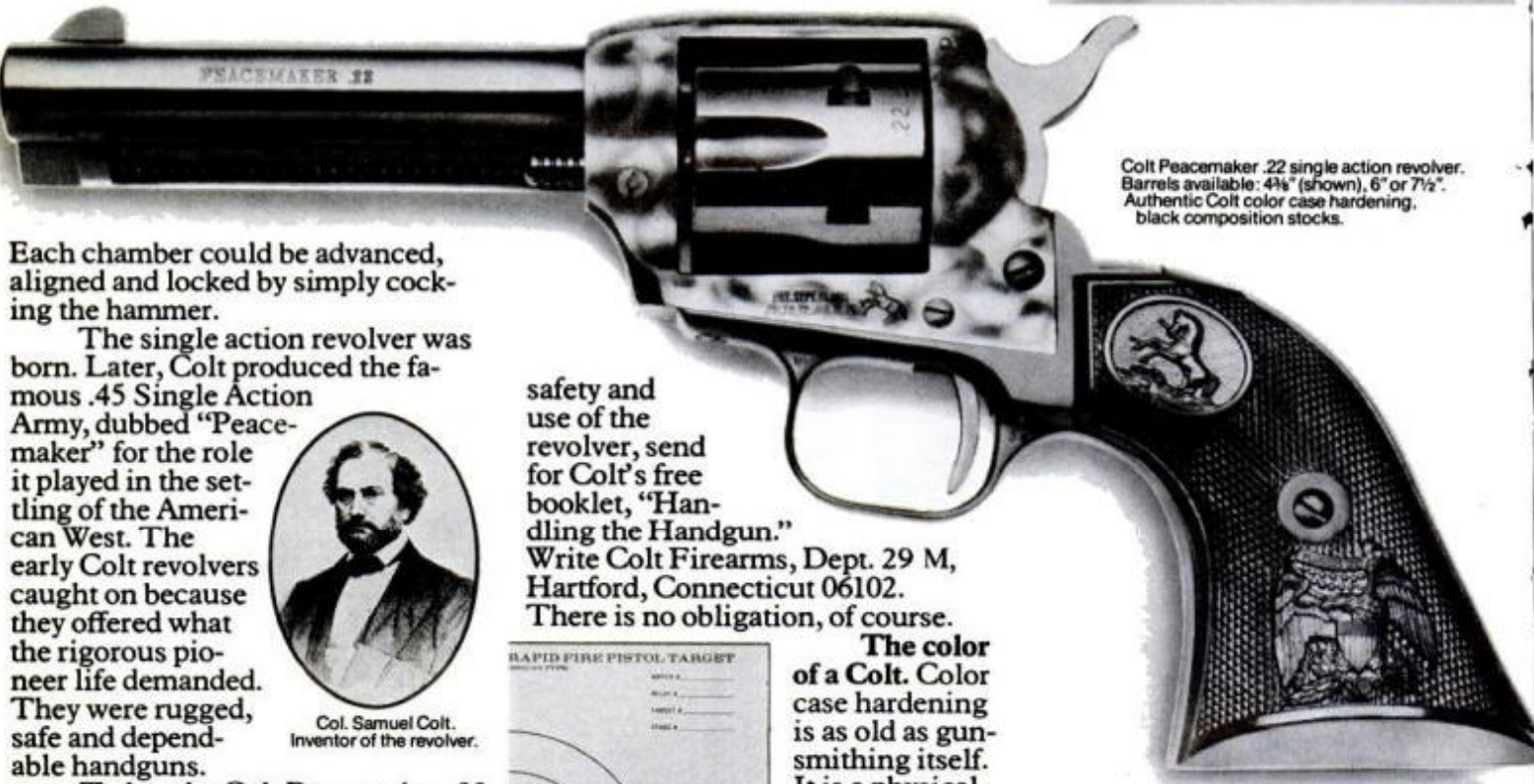

Colt Peacemaker .22 single action revolver. Barrels available: 4 1/2" (shown), 6" or 7 1/2". Authentic Colt color case hardening, black composition stocks.

Each chamber could be advanced, aligned and locked by simply cocking the hammer.

The single action revolver was born. Later, Colt produced the famous .45 Single Action Army, dubbed "Peacemaker" for the role it played in the settling of the American West. The early Colt revolvers caught on because they offered what the rigorous pioneer life demanded. They were rugged, safe and dependable handguns.

Today, the Colt Peacemaker .22 and New Frontier .22 incorporate the same Colt single action mechanism and design. And people buy them for the same reasons.

Built to take it. Fashioned from the strongest steel, the original Peacemaker had very few working parts. It was easy

to use and easy to clean. Its stocks were not wood—they were made of a tough, black composition material to resist warping and chipping.

The present Colt single action .22 revolvers are made the same way. Which makes them not only authentic, but practical.

A safe gun. The old Colt Peacemaker had three hammer positions: one for firing, one for loading and cleaning, and one for safety. All

present-day copies of that famous gun do not have all three positions. All Colt single action revolvers do.

Incidentally, Colt considers none of the three hammer positions a carrying safety. In the field carry your single action revolver with only five rounds loaded and the hammer down on the empty chamber. Never ask if a gun is loaded; look for yourself with the gun pointed in a safe direction and your finger off the trigger. Always handle every firearm as if it were loaded.

For additional facts on the

safety and use of the revolver, send for Colt's free booklet, "Handling the Handgun."

Write Colt Firearms, Dept. 29 M, Hartford, Connecticut 06102.

There is no obligation, of course.

The color of a Colt. Color case hardening is as old as gunsmithing itself. It is a physical process involving extreme heat that causes the steel frame of a revolver to take on a multi-colored, marbled appearance. Its purpose is not only cosmetic; color case hardening also helps protect the steel from rust.

Handling the Handgun

A Guide to Safe Shooting

Straight talk from the first name in handguns.

At Colt, this procedure is a subtle combination of art and science that has remained unchanged for more than a century. You can pay less for a color case hardened revolver made by another company. But the color won't be as brilliant nor as authentic. Because the name won't be Colt.

The practical side. The Peacemaker .22 and the New Frontier .22 are genuine counterparts of the original Colt Single Action Army "Peacemaker." But authenticity is not reason enough to buy one.

Buy one because its mechanism is function fired and its accuracy is laser tested before it ever leaves the factory. Or simply because as a .22, it uses less expensive ammunition

Colt New Frontier .22 features an adjustable rear sight and ramp front sight for improved accuracy.

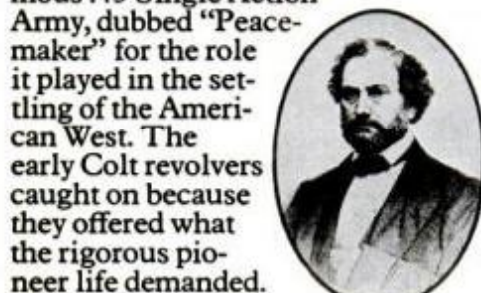

Col. Samuel Colt, inventor of the revolver.

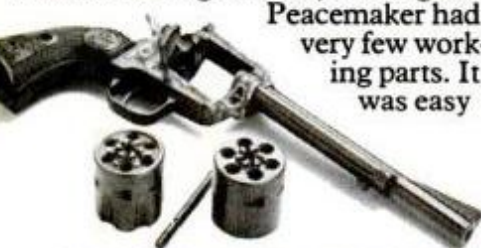

Both the Peacemaker .22 and New Frontier .22 are available with an interchangeable .22 Magnum cylinder.

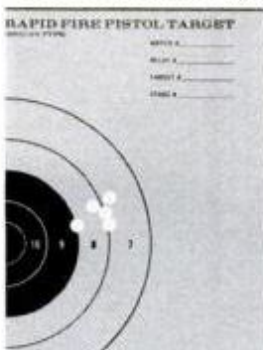

and is a good way to get into shooting. Buy one because it is a safe, rugged, dependable handgun. Buy one because it's a Colt.



COLT - an American heritage

PHOTO HINTS

FROM READERS



Loss-less lens cap ties on

A few inches of nylon shoelace, leather or other material can prevent lost lens caps. Just rivet one end to your cap, then form a loop to tie the other end around your neckstrap. Ends of nylon laces should be melted after cutting, so they won't unravel. When riveting plastic lens caps, make sure that you rivet against a hard object under the cap, so you won't break the plastic.—*Roger Adams, Los Angeles*

Joined film cans make grip with storage

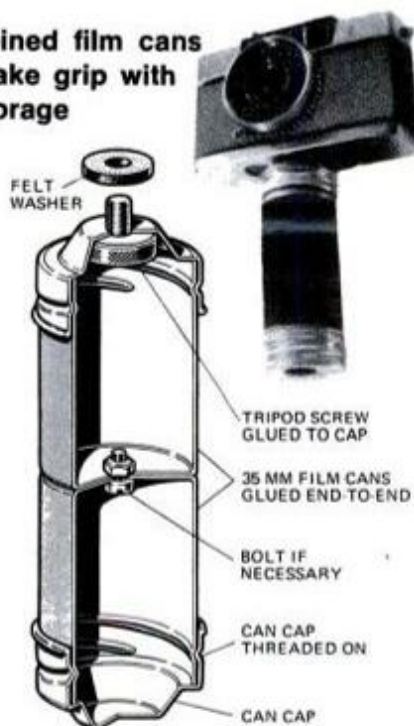

Bolting or epoxy-gluing two 35-mm film cans end to end can turn them into a good hand grip for a small 35-mm camera. A short, $\frac{1}{4}$ -20 screw glued into a hole in one of the end caps holds the camera, and each can can still store a roll of film. The grip may be covered with leather or other material, if desired.—*Harry Radsinsky, Charlotte, N.C.*

What Yashica means to the pet photographer:

Everybody loves pets. Their antics add special warmth to humdrum days. Yashica's Electro 35 GSN can help you capture your pets' glowing moments. It's an automatic camera, very simple to use. A computer brain controls the shutter. You just focus and shoot. The result — quality photographs that'll bring a smile to your face for years to come. And the Electro 35 GSN is budget priced. At your Yashica Dealer.



YASHICA
We do things differently.

YASHICA Inc., 50-17 Queens Boulevard, Woodside, New York 11377



IMPORTS AND MOTORSPORTS

The legend of LeMans

The excitement of motor racing is something the French know well. The annual Twenty-Four Hours of LeMans is to the French what Indy is to us: an integral part of the culture and the year's motorsports spectacular. That's why there's a LeMans circuit in the French section of The Old Country at Williamsburg, Va.

Last April, when this latest Busch Gardens theme park opened for preview looks, only the world's best "pilots" were hot-shoeing around the circuit—all drivers who competed at LeMans. That's Zora Arkus-Duntov,

designer of the Corvette, on the pole below. Behind him are Rene Dreyfus, champion of France in 1938, and Luigi Chinetti, whose name is synonymous with Ferrari in the United States. Also on hand were Phil Hill, only American to hold the World Driving Championship, Carroll Shelby, of Cobra fame and Pete DePaolo, winner of the 1925 Indy 500. It was a grand day to talk motorsports and to relax and enjoy being "in Europe." The Old Country is a carefully thought-out family entertainment park and there really is something for everybody. In fact, if you sport that paradoxical bumper sticker, "Fight smog, ride horses," you can skip LeMans and visit the Clydesdales at their stables—that is if they're not on duty pulling the Anheuser-Busch beer wagon. The big one, Chief, weighs in at 2200 pounds. That's one big horsepower! For more information, write Busch Gardens, Box 77, Williamsburg, Va. 23185.



Bits for the old block

Answering questions like: "Yeah, but where do you get parts?" used to take as much time out of the lives of imported car owners as getting the parts themselves. Parts supply still is a problem for owners of real exotic import-car models. Even this new Sears 1975 Imported Car Replacement Parts and Accessories catalog won't help the Maserati owner. But it'll be a real help to the rest of us who own cars built and imported in greater numbers. It's free at the nearest Sears store.

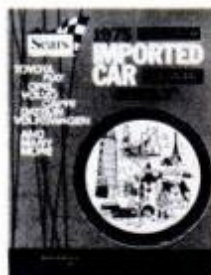

Rub-a-dub-dub

There's a new amphibian on the scene called the Polywog. The three-wheeled vehicle is powered by an 8-hp Briggs and Stratton engine that drives the rear wheels in a conventional manner on land. In the water, however, the rear wheels are canted to the hubs and locked into the "wobble" mode. Then, when the rear axle is driven, the wheels wobble producing a sculling action that propels the



Volkswagen leaves the rear engine further behind

VW's new van, just introduced in Europe, has its water-cooled engine up front. What the powerplant will be

if and when the new box comes here remains to be seen. Maybe diesel. Other VW news: The Rabbit is involved in two test programs. In Germany a fleet is being fueled with methanol in an experimental study; and here, VW of America and the National Highway Safety Administration are doing a year's study of VW's unique passive restraint system.



craft through the water. The designers estimate that it could be produced for about \$2500. For more information, write: Ty Jurras Agency, Motion Industries Marketing, 521 North La Cienega Blvd., Los Angeles, Calif. 90048. ★★★

Winston's box makes a difference.

The box fits in my jeans or jacket and doesn't get crushed. That makes a difference.

Winston's taste makes a real difference, too. No cigarette gives me more taste. For me, Winston is for real.

Warning: The Surgeon General Has Determined That Cigarette Smoking Is Dangerous to Your Health.

20 mg. "tar", 1.3 mg. nicotine av. per cigarette. FTC Report OCT. '74.

APPLIANCE CLINIC

BY PAUL MANN



By any other name . . .

I am very upset. Soon after purchasing several major appliances bearing the Westinghouse name, I read that Westinghouse was going out of the appliance business. Where does this leave me and all the other people who own units made by this company? What do we do for service and such?—Mrs. Edna Roche, Winston-Salem, N.C.

You can relax. The major-appliance part of Westinghouse's business has been purchased by White Consolidated Industries, Inc., one of the largest appliance companies in the country. You're probably familiar with its Kelvinator and Gibson brand names. As part of the agreement, White will continue to use the Westinghouse name on the Westinghouse line. This means that your Westinghouse dealer will still be able to supply Westinghouse appliances and service for any problem needing a Westinghouse-trained technician.

Percolator that won't

We have an electric coffee percolator. When we plug it in, it starts okay, but it shuts off before coffee brews. What's wrong?—S. R. Smith, Eureka, Calif.

A faulty thermostat. The thermostat, located in the base of the appliance with other electric components, is supposed to reach the point of "opening" when the coffee is hot. It is then supposed to keep closing when the coffee cools and opening when it returns to its proper, predetermined temperature. If your coffee is not percolating, the thermostat probably is not closing. If the thermostat failed to open, percolating would take place and go on without stopping.

The thermostat should be replaceable. Remove the base of the percolator, find and remove the thermostat, and replace it with one exactly the same. Test the appliance afterward to make sure it has not been grounded—it could be dangerous if it has. Connect a test light to a metal section of the percolator and to a grounded object such as a water pipe. Then plug the percolator into a wall outlet. If the test light glows, the appliance is grounded, and will not be safe to use until the short has been traced and fixed.

Elderly mower

I'm having trouble with the rewind starter of my Briggs & Stratton lawn mower (Model 6BHS). The part of the clutch that is free-running on the engine shaft frequently hits against the shaft while the engine is running, making a terrible noise and, I suppose, doing damage. Graphite and other lubricants were no help. What do you suggest?—George A. Knoblock, St. Louis.

Your machine is about 20 years old, and I think its problem is old age—specifically, wear between starter and clutch-assembly parts. This is creating a flip-flop action that leads to shaft encounters. If I'm right, there are two ways to solve the trouble and maybe let you get another decade or two of use from the mower:

First, replace the clutch and starter housing. You won't be able to get identical parts, but you can get a new assembly for about \$20.

Second, if you don't want to spend that much, you can convert your mower to manual-start by discarding the starter and clutch assembly, then buy a rope pulley cup and 3½-ft. length of nylon rope. This will cost you about \$2.

Tooth of the matter

Try this one for size: Our Lady Kenmore automatic under-the-counter dishwasher starts up okay and goes through the first wash with no trouble. But the second wash is hit-or-miss. Sometimes it will kick into second wash at once and proceed normally, but other times it won't restart on its own. Care to take a crack at it?—Jasper L. Savage, St. Louis.

Why not—but it is a tough one. I think the trouble may lie with the positive escapement of the timer. Essentially, the escapement is the geared mechanism that works in conjunction with the timer motor to rotate the cams that trip the switches to begin and end the dishwasher's several operations. I wouldn't be stretching my imagination to suggest that the escapement may have a worn gear tooth, which would sometimes be in position to halt the cycle.

To test my diagnosis, remove the timer from the dishwasher, hook it

up to a 110-v. line and watch the motor—there is a little peephole in the housing. Let the timer run its course a few times. If during any one cycle the timer motor stops and doesn't start again, the problem is probably a bum tooth. The solution is replacement of the timer.

Radio remedies

There is a positive way for George F. Wather to get rid of the noise in his radio when the thermostat switch of his electric range is operating (Appliance Clinic, page 66, Feb. '75). The reason his set picks up this noise is that the automatic gain control (AGC), which all radios have, is too high. The AGC automatically goes high when the last stage is not receiving a strong signal. This can be caused by such things as faulty alignment of the set or a defective component, but more than likely Mr. Wather is probably trying to pick up a very weak or distant station with an inadequate antenna. There are several things he can do if he is reasonably certain that his set is good:

1. Install an outdoor antenna which will be away from the range and provide a stronger signal.

2. Use a ground wire to the set, but not to the chassis—only to the terminals marked Antenna (ANT) or Ground (GRD).

3. Install a filter capacitor across the power line entering the set. A capacitor rated at .05 mfd. should suffice.

4. Install a filter capacitor across each of the switches and contacts of the range. Here again, .05 mfd. should do.

5. The ultimate in filtering would be to install RF chokes in each line to the radio and also to each line of the stove.—J. L. Buckwalter, Visalia, Calif.

And if nothing else works, he can shut off the radio and hum. Thanks for the suggestions, though. ★★

If you have a question about any appliance, send it to Appliance Clinic, Popular Mechanics, 224 West 57th St., New York, N. Y. 10019. Sorry, but letters cannot be answered individually. Problems of wide interest will be discussed in this column.

"It's my money. And I never forget it."

Jerry Sherman. Longshoreman



When do you use BankAmericard?

"Not all the time, but, you never know...anything can happen. Once, when I was in the army...coming back across the country...my old car was so loaded down that the shocks went out. I mean...it was flat! I was in this little town...and I had to come up with extra money to cover it. So I used BankAmericard. It saved me!"

Do you ever use your card when there's not an emergency?

"Sure. Let's say I find a pair of shoes on sale and I'm between pay checks. I get the shoes with BankAmericard, and then, when the bill comes, I can take care of it."

What about the cost of the card?

"It didn't cost me anything to get it.* It works the same as a store card. Only I can use it where I want to!"

What happens if you lose it?

"Nothing, if I contact the bank before somebody uses it. Even if somebody's already run up a bill of...say \$600 on it, the most I'm liable for is \$50... if that."

How do you feel about having BankAmericard?

"I'm careful with it. I don't use it all the time. But there've been times when if I hadn't had the card, I'd have really been out of luck. It's a good thing to have."

BankAmericard.
You never have to use it when you don't want to. But sometimes just having it makes all the difference.



*In most states, there is no fee for obtaining a BankAmericard® bank card.

*Service Marks Owned and Licensed by BankAmerica Service Corp.

©National BankAmericard Incorporated 1975

You only ride like a Pacer if you're wide like a Pacer.

The Pacer is wider than any other small car.

It's this extraordinary width that gives you such incredible stability. It also gives you much more.

For example, the width combined with rack-and-pinion steering gives you the sort of handling and agility found in sports cars.

And the Pacer's width combined with a unique isolated suspension system gives you a smooth and steady ride around tricky curves as well as over bumps.

And speaking of a smooth ride, the Pacer's width also means you get an unusual amount of room so you can ride around in comfort.

(The Pacer comes with AMC's proven 6-cylinder engine and a 22-gallon gas tank. Which means, in addition to everything already mentioned, you also get outstanding performance, excellent economy and long-distance driving range.)

When you ride in the Pacer you'll know what it's like to have width going for you.



AMC  **PACER**
The first wide small car.

And with the Pacer you get the wide coverage.

THE AMC BUYER PROTECTION PLAN.™

THE FOLLOWING PARTS AND SERVICES ARE COVERED
AGAINST FACTORY DEFECTS OR FAILURE DUE TO WEAR
FOR 12 MONTHS OR 12,000 MILES.**

PARTS FIXED OR REPLACED FREE

	AMC	GM	FORD	CHRYSLER
Engine/Drive train	YES	YES	YES	YES
Spark plugs	YES	NO	NO	NO
Shock absorbers	YES	NO	NO	YES
Brake linings	YES	NO	NO	YES
Clutch linings	YES	NO	NO	YES
Wiper blades	YES	NO	NO	NO
All light bulbs	YES	NO	NO	NO
Hoses & Belts	YES	YES	NO	NO

SERVICES PROVIDED FREE

Wheel alignment	YES	NO	NO	NO
Wheel balancing	YES	NO	NO	NO
Align headlights	YES	NO	NO	NO
Adjust carburetor	YES	NO	NO	NO
Adjust distributor	YES	NO	NO	NO
Adjust brakes	YES	NO	NO	NO
Adjust clutch	YES	NO	NO	NO
Adjust transmission bands	YES	NO	NO	NO
Adjust & tighten belts	YES	NO	NO	NO
Tighten nuts & bolts	YES	NO	NO	NO
Free loaner car	YES	NO	NO	YES
Trip Interruption Protection	YES	NO	NO	NO

™Buyer Protection Plan is a Trade Mark of American Motors Corporation.

**Chrysler coverage is 12 months, unlimited mileage.

AMC will fix or replace free every part (except tires) for 12 months or 12,000 miles, whether the part is defective or just plain wears out under normal use and service.

And when we say every part, we mean every single part. Even all those annoying little things that occasionally wear out. Like spark plugs, wiper blades, yes, even light bulbs.

AMC also has a plan to provide a free loaner car should guaranteed repairs take overnight. And a special Trip Interruption Plan that pays up to \$150 for food and lodging if guaranteed repairs have to take place more than 100 miles from home.

To cover a car with a plan as wide as ours, you have to have a car as good as the Pacer.

\$3,299*

*Manufacturers suggested retail price not including state and local taxes, destination charges. Wheel covers, white side wall tires, other options, extra.



We back them better because we build them better.



BY MORT SCHULTZ

CAR CLINIC

Chattering Caddy blades

I was elated to read in the Feb. 1975 issue of Car Clinic that Cadillac had apparently remedied the problem of chattering windshield wipers by issuing a modification kit (part No. 968-8242). But lo and behold, when I showed my dealer your writeup he told me the part number is for some sort of screen, and there is no cure for the problem. Is he right and are you wrong?—R. H. Miehling, San Rafael, Calif.

Yes and no. He's right and wrong—and I'm right.

The part number I gave is not for a modification kit, but for one part needed to make the repair. There are other parts. Exactly, here is what is needed to stop the windshield wiper blades of 1971 through 1973-model Cadillacs from chattering:

1. One shroud top vent screen (part No. 968-8242).
2. One or two Trico wiper-blade inserts (part No. 966-4094).
3. One or two Anco wiper-blade inserts (part No. 966-4091).

To do the job, remove the shroud top vent screen presently on the car and replace it with the new one. Replace the wiper-blade insert or inserts that chatter. Check the park position of both wiper blades to make sure the arms park as low as possible on the parking ramp at the rear edge of the shroud top vent screen. If necessary, adjust the wiper blade's parking position.

Luckless Lark

My 1975 Buick Skylark has been a disappointment. Oil accumulates in the air cleaner. My dealer tells me this is normal, and that the problem will dissipate when the oil rings seat. But I have used three quarts of oil in the first 1500 miles. Is he leveling with me?—M. Spivak, Beechurst, N. Y.

He might be. I think you should drive the car another 2000 miles; then you will have a clearer indication of oil consumption. Oil in the air cleaner could be a plasticizer oil (actually, polyvinyl chloride) applied to production air cleaner elements.

However, if the oil consumption doesn't get better, and oil in the air cleaner is motor oil, then several

things should be done to clear up the trouble:

1. Make sure the PCV valve is inserted tightly in its grommet.
2. See that there are no air leaks into the crankcase from the intake manifold end seals.
3. Tear the engine down and install new rings. They're unlikely to seat themselves, if they haven't after 3500 miles.

Ah, the dawn arrives

Why does my 1971 Ford Galaxie 500 with 351-cu.-in. engine and 37,600 miles need a new starter every 12,000 miles? I'm on my fourth one now.—Tony Onorato, Natick, Mass.

Probably because the flywheel is bad and is chewing up the starter drive. By now it should be dawning on someone that it isn't the starter.

Big squirt

Magic—that's what it is. With windshield wipers of my 1972 Pontiac Catalina station wagon turned on, the windshield washers start squirting and keep squirting unless one of two things happens: (1) I turn off the wipers; (2) the reservoir runs out of fluid. What now, Houdini?—Kirk Fletcher, Hudson, Wis.

My crystal ball tells me the problem lies in one of five areas, listed here in order of probability:

1. There's a grounded wire from the ratchet relay to the switch. Locate and fix it.
2. The wiper switch is bad. Test the switch, and replace it if it's shot.
3. A ratchet-wheel tooth has broken off. Replace the ratchet wheel.
4. The ratchet-wheel dog is broken or isn't contacting the ratchet-wheel tooth. Replace dog if it's busted, or try to make a repair if it isn't.
5. The lockout tang is broken or bent on the piston actuating plate. Replace the piston actuating plate.

Bottoms up

My 1974 Vega GT bottoms out repeatedly on slight bumps. The dealer says it's normal, but I don't think so. Do you?—Wayne Sherman, Flushing, N. Y.

I've driven a car like yours, and it

didn't bottom. Maybe yours is different. I don't know, but trying to fix the problem by modifying the vehicle with spring spacers and heavy-duty shocks will cost you a bundle. So before you go this route, if that's your intention, I think you ought to ask your dealer to get a factory field representative to check the vehicle. Let him decide if it's normal, and if it isn't what repairs must be done. I can't even guess; your information is so scanty. Does the car bottom in front? Rear? With load on? Or what?

Wandering mirror (continued)

Although I can't argue with your advice concerning the inside rearview mirror on Richard Doheny's '74 Matador that kept falling off (Jan. '75 Car Clinic), I would like to tell you

(Please turn to page 28)

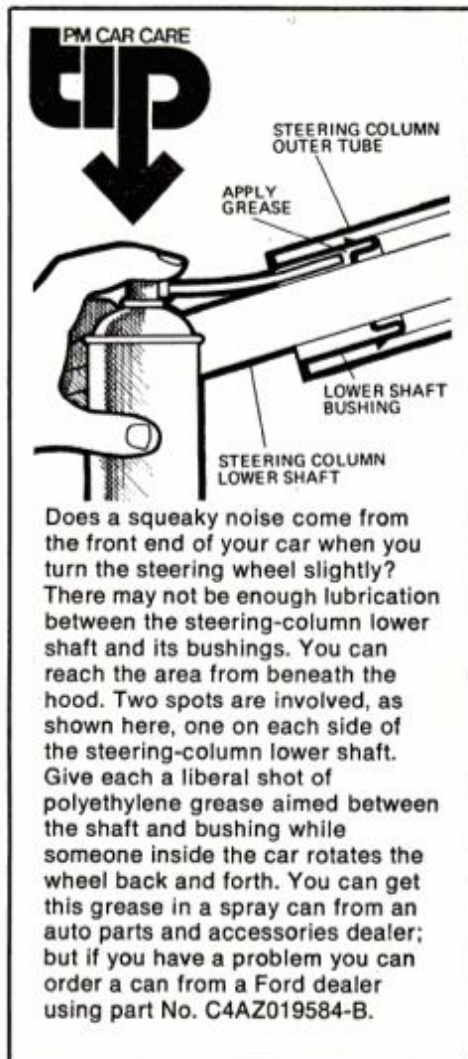

“Why Viceroy? Because I’d never
smoke a boring cigarette.”

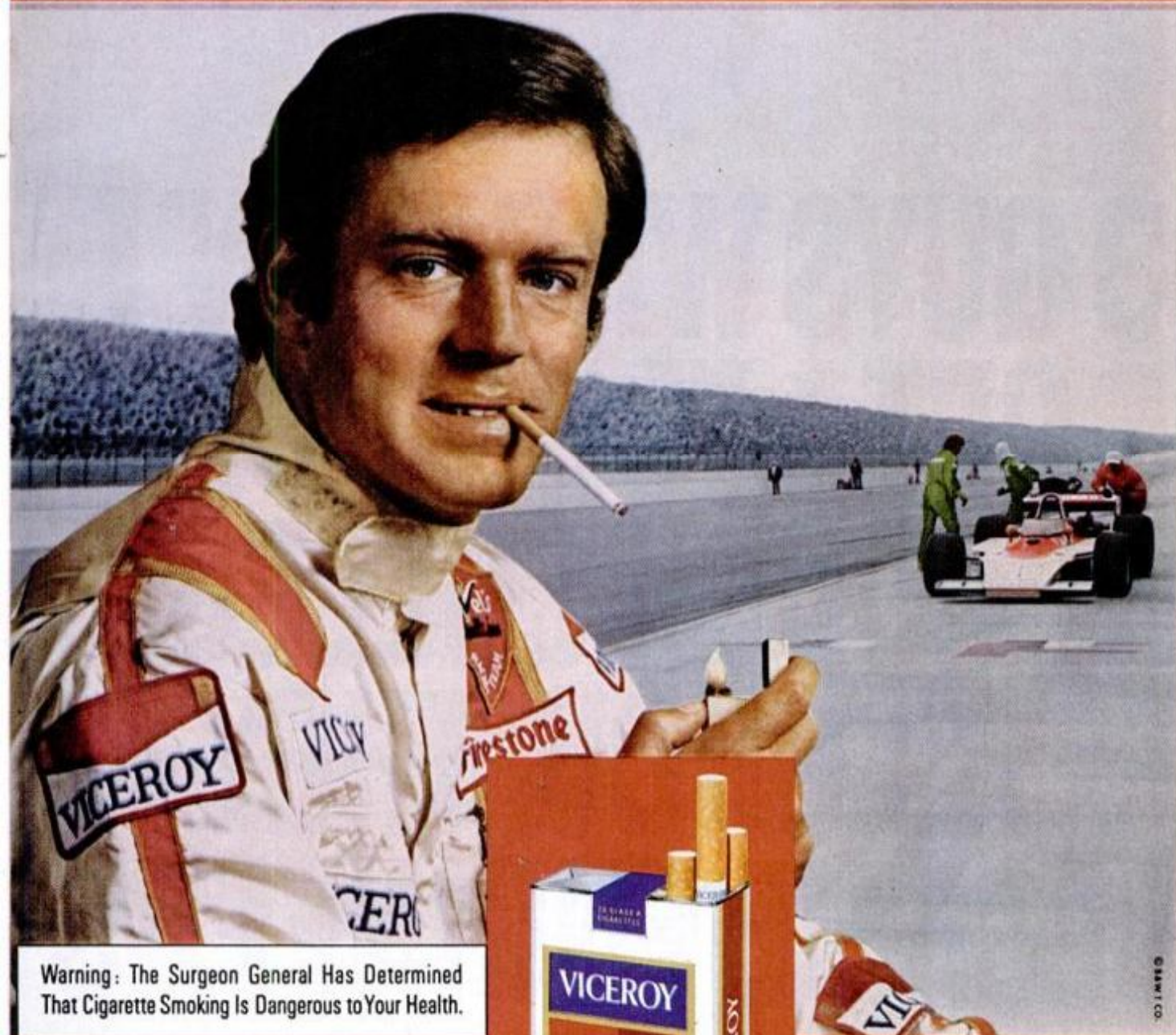

Warning: The Surgeon General Has Determined
That Cigarette Smoking Is Dangerous to Your Health.

16 mg. "tar," 1.0 mg. nicotine,
av. per cigarette, FTC Report Apr. '75



Enjoy Viceroy flavor—now in a bold new pack.

Viceroy. Where excitement is now a taste.

© 1975 L. CO.

**3 GUYS WHO DIDN'T
GET A FREE RIDE
THROUGH COLLEGE
TELL HOW THEY
BECAME ENGINEERS.**



BILL JOHNSON

"Get into college? After high school in Rutland, Vermont, I was glad to get into a machine shop not far away. Started as a lathe operator at 75 cents an hour. But thanks to ICS I've gone far. Studied Mechanical Engineering nights, at home. Never did take to classrooms or missed paydays. Won't say it was easy, but with the instructors' help I took it one step at a time. Today I'm Development Engineer with a paper converting plant near the Canadian border. Hunting's great. Salary's jumped 600 per cent since I started my ICS course. There's 40 men under me, future looks fine. Do I recommend ICS to my men? Yes I do."



GARY BURNASH

"Too bad, but the college I went to didn't hand out degrees in hot rodding. So after my first year my Dad and I had one of those long talks. The upshot was, it was time to get serious. So I got married, started to learn automotive tool making at Sheler Corporation outside Detroit, and signed on with ICS. They taught me everything. Print reading. Materials. Hydraulics. Even how to use a slide rule. When the boss found out, he gave me design work to take home. Pretty soon, I could talk to the big car companies in their own language. I'm making triple my starting salary now, but here's the best part—I'm a half owner in the business. If I want another raise, the man I ask is me."



JACK TERRY

"I grew up near the Okefenokee Swamp and what that means is, you don't expect life to be a gravy train with biscuit wheels. I went to work real early with the Florida Department of Transportation as a beginner draftsman. I heard the fellows tell of ICS so I sent for the information. Before long, I got to be a First-Level Highway Engineer at twice the pay. It took five promotions but the ICS training was a real help to pass each promotion exam."

ICS

International Correspondence Schools
Scranton, Pa. 18515

© 1975 Intext, Inc.

You, too, can become an engineer without going to college. At home, in about an hour a day, ICS can train you from scratch for one of the many secure, well-paying engineering jobs opening each year. To find out more about these opportunities and how ICS training works, mail card for career guidance booklet and free demonstration lesson. ICS is approved for veterans training. (If card is missing, write to: ICS, Scranton, Pennsylvania 18515.)

(Continued from page 22)

what I did when I faced the same problem. My method, self-imposed, did away with the need for getting the dealer involved.

The product I used to attach my fallen mirror back on the windshield, called E.Pox.E 5, is manufactured by the Woodhill Chemical Co. of Cleveland and is available in hardware and home equipment supply stores. The following procedure was observed:

1. Using the outline left by the mirror plate on the windshield, I masked the area with masking tape, leaving about 1/2-inch extra space on each side.

2. With a razor blade in a holder, I cleaned the masked-off windshield area thoroughly. I then cleaned the plate on the mirror arm by scraping it meticulously with a pocket knife. This was followed by light sanding of the arm with a piece of fine sandpaper to assure a flat surface.

3. The mirror arm and the wind-

shield area were then wiped with a clean dry rag.

4. I mixed equal, but small amounts of E.Pox.E 5 resin and hardener (the product is a two-part adhesive). Mixing was thorough until the adhesive turned to a milky appearance.

5. The adhesive was applied to the mirror plate only. It was not applied in a glob, but spread out thinly and smoothly. I left about 1/16 inch uncovered area around the border of the arm to allow for expansion of the adhesive and to avoid squishing it from around the edges, which would have resulted in unnecessary cleanup.

6. The mirror plate was pressed firmly against the windshield and held there one minute. I then taped the mirror to the windshield. This precaution was taken to keep the mirror from slipping until the mirror plate took maximum hold. The mirror was permitted to remain this way overnight. In the morning, I stripped away the tape, and did a little dab of cleaning here and there. The mirror has stayed where it's supposed to stay since then.—John Tek (address unknown).

Dear John: Thanks for a great suggestion that many of our readers, faced with the same trouble, can use once their vehicles are out of warranty.

Pitted points

My 1973 Ford Courier burns points every 2500 to 3000 miles. They are adjusted correctly, but pit very rapidly. What's the problem?—Scott Davis, North Hollywood, Calif.

I assume you replace the condenser with the points. If so, then you have an overcharging condition (high-voltage output) or a bad ballast resistor. A high charging rate means the voltage regulator is defective. To find out, connect a tachometer and voltmeter. Start the engine and let it run at 1800 rpm. The voltmeter should read 14-15 volts. If more, replace the regulator.

The ballast resistor is found on the side of the battery holder. Hook a voltmeter to it and turn on the ignition switch. You should get a reading of 4.5 to 6.6 volts. If not, replace the resistor.

Let's not drop it

We have a 1964 Dodge Polara with a light bulb that's burned out in the radio dial. Soon after we bought the car we had a Chrysler Airtemp air-conditioner installed under-the-dash directly beneath the radio. Is there any way of changing the bulb without dropping the airconditioner?—

Larry Fitzpatrick, Leawood, Kans.

Yes. Remove the radio through the glove-box opening in the instrument panel. Here's how:

1. Disconnect battery ground cable.
2. Remove control knobs from the radio.

3. Disconnect radio feed wire (the black one) from the fuse block.

4. Remove glove-box shell.

5. Disconnect antenna and speaker leads.

6. Remove mounting screw attaching radio to the instrument panel's lower reinforcement. This may mean slight loosening of the airconditioner mount if it's the only way you can get to the screw.

7. Loosen top screw on the radio bracket and remove the bracket.

8. Remove two nuts attaching radio to instrument panel, and remove radio through glove-box opening.

The replacement bulb can be either No. 1802 or 1893.

SERVICE TIPS

■ Some Ford Granadas and Mercury Monarchs may squeak in the rear. The squeak is probably coming from the rear-spring shackle bushings. Under your warranty, the dealer should remove the rear-spring bushings and replace them if they are worn. Whether new or to-be-used-again, the bushings should be given a bath in a product called Ru-Glide (Ford part No. C8AZ-19583-A). Your dealer's authorization to do this is given in article 1030, service bulletin 85 (3/7/75).

■ Do you own a '75 Chevy Camaro that's giving you a driveline shudder or vibration between 25 and 40 mph? The trouble may be caused by improperly formed rear springs which tip the rear-axle pinion nose down too far. The cars involved were assembled at the Norwood plant and have vehicle identification numbers (VIN) of 5N531538 through 5N547948. You'll find the VIN by looking through the windshield on the driver's side. Bring the car back to your dealer. Under service bulletin 75-T-8 (3/3/75), he is supposed to inspect the situation, and if the trouble can't be corrected by other means, he is to replace the springs.

■ Check your '75 Chrysler Corp. car (all except Valiants and Darts) to see if it has a battery heat shield. If it doesn't, your battery is going to start overheating. Some cars were accidentally shipped without the shield. If yours was, ask your dealer to apply the provisions of service bulletin 08-06-75 (1/14/75). ★★★

GOT A PROBLEM WITH YOUR CAR?

Just ask Mort about it. Send your question to the Car Clinic, Popular Mechanics, 224 West 57th St., New York, N.Y. 10019. While letters cannot be answered individually, problems that are of general interest will be published in the column.

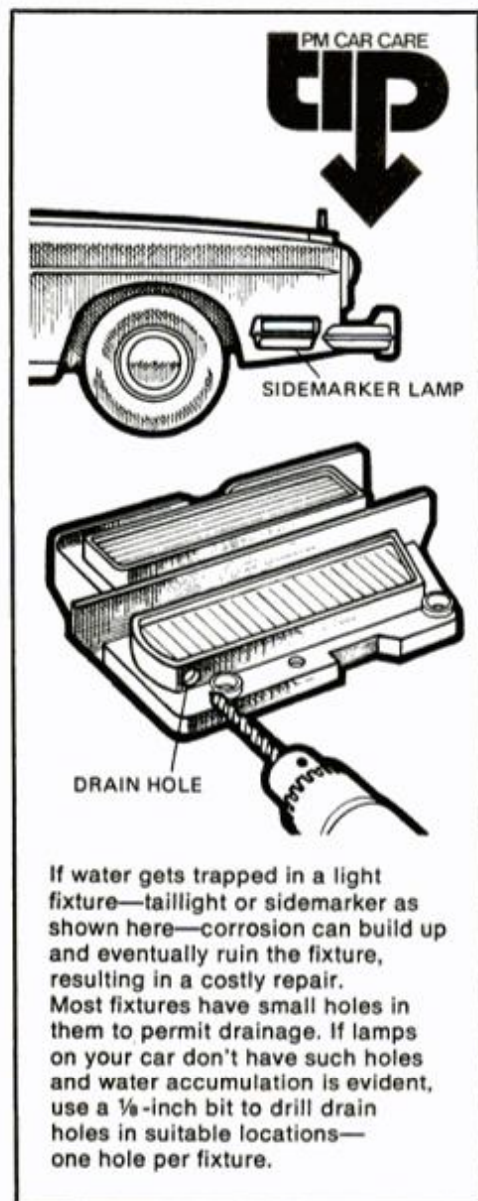

If water gets trapped in a light fixture—taillight or sidemarker as shown here—corrosion can build up and eventually ruin the fixture, resulting in a costly repair. Most fixtures have small holes in them to permit drainage. If lamps on your car don't have such holes and water accumulation is evident, use a 1/8-inch bit to drill drain holes in suitable locations—one hole per fixture.



(A) Dodge Dart Sport... the right size with the right kind of economy!



(B) Ramcharger... featuring full-time four-wheel drive!



(C) Dodge Coronet Brougham... a little bit smaller - a little bit sportier!



(D) Charger Special Edition... a whole new car!

Enter the Union Carbide Tune-Up Sweepstakes! Win the Dodge of your choice.

UNION CARBIDE offers you a chance to win one - or all four - of these 1975 Dodges. Or one of 100 Automatic Radio® car stereo tape players with AM radio. Or one of 1,000 car compasses. \$34,552 worth of prizes.

The Tune-Up Sweepstakes is sponsored by UNION CARBIDE Tune-Up Products, formulated to help prolong the life of your engine.

Tune-Up Products help you overcome many of the most common engine problems - the kind that can so often waste gas and oil and can lead to costly repair bills.

Use UNION CARBIDE Tune-Up Products for quicker, surer start-ups and a smoother, cleaner-

running engine. Mail in the entry form on this page today and put yourself in the running for these valuable prizes.



OFFICIAL RULES

1. Check off on an official entry blank, or write on a plain 3" x 5" piece of paper, the letter and name of the Grand Prize car you want to win.

2. Hand-print or type your name, address and zip code on your entry. Each entry must be accompanied by the AS number (generally printed on the upper or lower right corner of the back of the container) from a UNION CARBIDE Tune-Up Product, or the words "UNION CARBIDE Tune-Up Products" and the name of a UNION CARBIDE Tune-Up Product printed on a 3" x 5" piece of paper.

3. Enter as often as you wish (you may win 1 to 4 Grand Prize cars), but only one Grand Prize car may be designated on each entry, and each entry must be mailed separately to UNION CARBIDE Tune-Up Sweepstakes, P.O. Box 2310, Westbury, N.Y. 11591. Entries must be postmarked by August 31, 1975 and received by September 8, 1975.

4. IMPORTANT: You must write the letter of the Grand Prize car you want to win on the outside, lower left-hand corner of the envelope.

5. Four Grand Prizes are: (A) 1975 DODGE DART SPORT, 2-door coupe, color-keyed carpeting, heater-defroster, bumper guards, canopy vinyl roof, whitewall tires. (B) 1975 DODGE RAMCHARGER, Full-time 4-wheel drive system. Consists of 5 settings. Color-keyed interior. Fresh-Air heater-defroster, power front disc brakes. Includes removable steel top, 5-passenger seating, front bumper guards. (C) 1975 DODGE CORONET BROUGHAM, 2-door. Front bucket seats with fold-

ing center armrest. Color-keyed shag carpeting. Bumper guards, heater-defroster, whitewall tires, wire wheel covers, canopy vinyl roof. (D) 1975 DODGE CHARGER SPECIAL EDITION. Power front disc brakes, color-keyed carpeting, electronic digital clock, heater-defroster. Power steering, front bucket seats with armrest. TorqueLite automatic transmission, wire wheel covers. 100 First Prizes are AUTOMATIC RADIO® 8-track Stereo Tape Players with AM radio, Model No. MIR-1212. 1000 "Thank You" Prizes are North Star Compasses. Total value of all 1104 prizes is \$34,552.

6. The four Grand Prize winners will be selected in random drawings from among those eligible entries designating each Grand Prize. The balance of prizes will be awarded in random drawings from all other entries received. National Judging Institute, Inc., will conduct the drawings and their decisions are final. All prizes will be awarded and winners notified by mail. Odds of winning will be determined by the number of entries received. Liability for taxes is the responsibility of the winners. Prizes are non-transferable and not redeemable for cash. Winners may be asked to execute an affidavit of eligibility and release. For a list of major winners, send a stamped, self-addressed envelope to: UNION CARBIDE Tune-Up Sweepstakes Winners List, P.O. Box 2082, Westbury, N.Y. 11591.

7. Sweepstakes open to all U.S. residents, except employees and their families of UNION CARBIDE, its advertising and judging agencies. Void in Idaho, Missouri, Georgia and wherever prohibited, taxed or restricted by law.

Union Carbide Tune-Up Sweepstakes Official Entry Form

How to enter: Print name and address plus *AS* number from any UNION CARBIDE Tune-Up Product (usually on upper or lower right corner of back of container). Or on a 3" x 5" piece of paper, print "UNION CARBIDE Tune-Up Products" together with name of a Tune-Up Product (see rules at left). Mail to: UNION CARBIDE Tune-Up Sweepstakes, P.O. Box 2310, Westbury, N.Y. 11591.

Name _____

Address _____

City _____ State _____ Zip _____ (required)

Tune-Up Product: _____ A S# _____

Preferred Grand Prize Car: Letter _____ Name _____

UNION CARBIDE is a registered trade mark of Union Carbide Corporation.

ENTER AS OFTEN AS YOU LIKE. NO PURCHASE REQUIRED.

DETROIT LISTENING POST



BY ROBERT LUND

GM thinning big-car lines

Managers of GM's car divisions are now trying to make a case for which cars they will keep in 1977. "It's like asking a kid to thin out his collection of comic books," according to a company source. "He wants to keep all of them." But GM has decided some of the big cars will have to go after next year. GM isn't dropping any nameplates. It will still have five lines of cars. But there will be a cleanout of models. It's a tough decision. The divisions had to build a strong case with the higher-up to put the cars in production in the first place. Now they are being asked to decide which of their "children" will get the ax.

Chevy mini up for grabs

Speaking of cars as children, GM is in for some family trouble with its new small car, the mini Chevrolet. Whenever Chevy gets a new product, Pontiac comes along a year or so later and asks permission to put out a higher-priced version. If Pontiac gets a turn, Buick and Olds want one.

Even though it has yet to formally confirm it, GM will have a new mini this year—although it's a sure thing. Chevrolet is already saying that if and when such a car appears, Chevy wants it on an exclusive basis. No sharing with other divisions. But Chevy always takes this stance with a new car and, in the end, the other divisions always get a piece of the action. There's no reason to think the outcome will be different this time. There's already a report that Olds has outmaneuvered Pontiac for first crack at a follow-up edition.

Chrysler revives compact—again

Chrysler says its on-again, off-again small car is back on again—for the third time. It now calls the car an "all-new" domestic subcompact it will produce sometime in the indefinite future. Unless there's another change of plans, the car will not be all-new. It will be an Americanized remake of the French Simca. There will be two versions, Dodge and Plymouth, with choice of four or six-cylinder engine. Both versions will have front-wheel drive.

When? Chrysler used to be able to launch a new car from scratch to on-sale in two years. But Chrysler is running a much leaner ship these days. As a guess, the car could be ready as a late entry for the 1978 model year.

Breakthrough on radar brake

Several years ago there was talk of putting radar brakes on cars. That is, a radar unit that could anticipate an accident situation before it happened and then automatically activate the brakes to avoid the accident. The idea hasn't caught on for two reasons. One is price. The hardware costs something like \$500—too rich for most people. The other has to do with the equipment lacking discrimination. Early units could not distinguish between a dandelion and a Mack truck. If a leaf dropped in front of the radar scanner, the brakes went on.

GM has now developed a binaural (dual) radar system that can identify and evaluate the "degree of hazard" of an obstacle and automatically initiate the correct car reaction. Now if a way can be found to bring the price down. . . .

Ford shrinking Mark IV

Maybe it's coincidence, maybe not. The wheelbase of Cadillac's new "small" car, Seville, is 114.3 inches. Ford is working up a counterpunch car, a scaled-down Mark IV, and it will have a wheelbase of 114 inches.

Ford is also doing a feasibility study on a car to compete against GM's new mini. Ford says it is a long way from a build/no-build decision, but the odds favor a yes vote. Assuming the decision goes that way, the car could be out by 1977.

GM forming 'lean team'

GM is putting together a team of its top people in engineering and manufacturing to examine every available material for taking weight out of cars. GM knows how to reduce weight. That's no problem. What it wants to know is the cost of switching to aluminum and plastics versus steel for hoods, deck lids, fenders; and how cars made with alternate materials will hold up in the hands of custom-

ers. An aluminum or plastic roof may sound great, but if it likes the car price several hundred dollars or could lead to a durability problem, GM will stay with steel. That's what the study group will find out.

In a related move, GM will work up front-wheel-drive versions of all its cars as a test—it has no immediate plans to go fwd on all cars, but wants to explore some weight-saving advantages.

Spare tire to be retired

The spare tire is on the way out, but not immediately. Tire companies and automakers are talking about a long-wearing radial with a self-sealing capability if it is punctured. The tire isn't ready yet, at least not a marketable version.

Detroit has wanted to get rid of the spare for a long time. To cut costs, make more room in the trunk and now, to save weight. Several tires offered in the late '50s and early '60s were supposed to do away with the spare, but they didn't work out and the auto companies wisely kept the spare. The only drawback Detroit sees to the self-sealing radial is psychological. Car owners enjoy the security of knowing they have a back-up tire in the trunk; it will take time to get used to driving without one.

Radials give rough ride

For the first time in something like 15 or 16 years, I will not buy a new car this year. Can't afford it. I had the old car fixed up, including a new set of radial tires. This is my first experience with radials on my own car, although I've driven a lot of loaners and test cars with radials. I don't notice any difference with the tires at low speeds, but there's a vast difference at moderate and high speeds—from 55 up to 70 mph. The ride is rough and noisy. Not surprisingly, because the car wasn't designed for radials.

I'm not unhappy with the tires. Most of my driving is in the city and I seldom get up to 50. But if you do much high-speed driving and can't stand noise and vibration, I'd recommend against putting radials on an old car if the suspension isn't tuned for the tires. ★★

Mild. But not Meek.

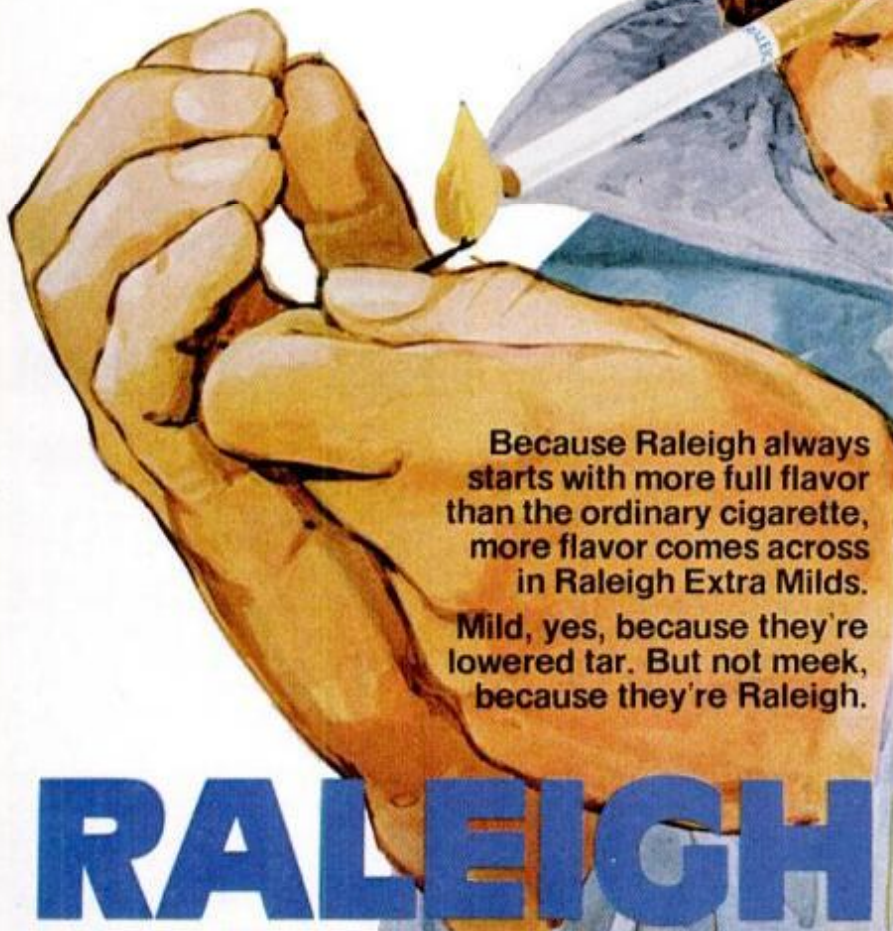

Because Raleigh always starts with more full flavor than the ordinary cigarette, more flavor comes across in Raleigh Extra Milds. Mild, yes, because they're lowered tar. But not meek, because they're Raleigh.



Get this Hawkeye Pocket Instamatic Camera by Kodak. Easy drop-in cartridge loading. Yours for free B&W coupons, the valuable extra on every pack of Raleigh Extra Milds. To see over 1,000 gifts, write for your free Gift Catalog, Box 12, Louisville, Ky. 40201

RALEIGH EXTRA MILD

Warning: The Surgeon General Has Determined That Cigarette Smoking Is Dangerous to Your Health.

Extra Milds, 14 mg. "tar," 0.9 mg. nicotine; Filter Kings, 16 mg. "tar," 1.0 mg. nicotine; Longs, 17 mg. "tar," 1.2 mg. nicotine, av. per cigarette, FTC Report Apr. '75

RISLONE ...

Good for Your Car,
a Bargain for You

RISLONE is best for you because you get twice as much product as in the 'little cans' for just a dime or two more. It also replaces a quart of crankcase oil. That's a bargain!

Better yet is RISLONE performance . . . known for over 40 years. RISLONE preserves engine performance by keeping rings, valves, guides and oil passages clean. RISLONE dissolves and disperses harmful deposits. That's the RISLONE difference. It's the economical product that really works for your engine, not your oil. You'll find your engine runs better and quieter in minutes with RISLONE. And the RISLONE performance treatment lasts because clean engines start easier, run cooler, pollute less, go farther on every gallon of gas.

Test drive RISLONE today. Get it at your nearest auto merchandise store.



RISLONE National Championship Racing Jacket . . . \$9.95 prepaid. Quality polyester & cotton wash/wear. RISLONE yellow with black & red emblems & stripes. S, M, L, XL. Send check or money order to: RISLONE Racing Jacket, The Shaler Company, Waupun, Wisconsin 53963

THE SHALER CO.

Waupun, Wisconsin 53863

In Canada: Warren Packaging Co. Ltd., Scarborough, Ontario

PM TEST REPORT

The bike you sail like a boat

by Bill Kilpatrick

Putting a sail on a bicycle may seem a bit like trying to mix oil and water, but a Connecticut engineer has gone ahead and done it anyway. He's George W. Patterson of New Canaan, and he calls his strange hybrid an AerOcycle. While he makes no claims for it as a serious means of transportation, he does promise that, once a rider gets the hang of it, zapping along at 30 to 40 mph can be great fun.

And it is—once you get the hang of it, like the man says. The AerOcycle is not just an ordinary bike with a sail stuck on it. It's designed especially for sailing only. It has no pedals and no coaster brake—only fixed footrests and a single hand-brake. You hold the sail boom with one hand and steer with the other—an exercise in coordination and dexterity that is a feat in itself.

The trick in mastering the AerOcycle is to remember that it's neither a boat nor a normal bike. Somehow, the conventional rules of sailing and cycling don't quite apply when you combine the two functions. Strange things happen, and you have to be prepared to learn new techniques and unlearn old habits.

For example, nautically minded types will instinctively lean to windward to offset the tendency to heel over to leeward. On a bike, this, of course, makes it virtually impossible to steer and is strictly contrary to good cycling practice that requires a rider to lean *with* the machine when making a turn.



Attempting to slow down when you're caught in a stiff breeze is an adventure. In a boat, you simply let out the sail, spill the wind, and the craft immediately reduces speed and rights itself automatically. But you can't let out the sail on the AerOcycle when you're holding onto the boom—the sail can swing only as far as your arm can reach. Flailing away at the footrests—your first impulse—accomplishes absolutely nothing since there's no foot brake. Even

(Please turn to page 34)



Beefed-up bike frame has unusual twin-tube construction with X-bracing for greatest strength. Note fixed, pedal-less footrests and forward-curving handlebars for safety in case of falls. At far left, PM reporter Bill Kilpatrick proves even a novice can sail AerOcycle, at least in a mild breeze. Fast, tricky maneuvers were a bit hairy, author reports.

Limited Time Offer!

Buy any
**Motorcraft
Oil Filter...**



And get your
choice of
**Motorcraft PCV Valve
or
Autolite Lawn Mower
Spark Plug**



FREE!

(Retail value up to \$3.00)

Summertime is tune-up time! For cars and lawn mowers. A great way to help tune-up your cars is to install a quality Motorcraft Oil Filter. Then just mail in the filter box top that shows the part number and get your choice of a Motorcraft PCV Valve or Autolite lawn mower spark plug—free! Ask for Motorcraft Oil Filters where you have your car serviced or wherever quality automotive parts are sold. This is a limited time offer—so hurry!

Motorcraft 



Mail this coupon with box top that shows part number from any Motorcraft Oil Filter to:

MOTORCRAFT REDEMPTION HEADQUARTERS, P. O. Box 5386, Milw. Jct. Sta., Detroit, Mich. 48211 PM

Check one box below and fill in information required.

Motorcraft PCV Valve
Present Brand & Part Number

Autolite Lawn
Mower Spark Plug
Present Spark Plug Brand

NAME _____

STREET NUMBER _____

CITY _____ STATE _____ ZIP _____

(or)
Car Make

Car

& Part No.

Engine Size

(cu. in. displacement)

LIMIT ONE PER CUSTOMER.

Offer expires Aug. 31, 1975 and good to retail customers only. Please allow three to four weeks for delivery.

SAKRETE®

Make something out of it!

Consider the man-hours you invest in your projects. Consider that SAKRETE Cement Mixes meet or exceed the standards of the American Society for Testing and Materials. Now guarantee your projects' lasting values by using ready-to-use SAKRETE Concrete, Sand or Mortar Mixes.



FREE . . . at your neighborhood SAKRETE dealer, our step-by-step instruction booklet featuring (20) select projects. Or, send 25¢ to cover handling to SAKRETE, P.O. Box 1071E, Cincinnati, Ohio 45201.

Insist on SAKRETE Concrete and Mortar Mixes
The brand the pros use.

SAKRETE is a registered trademark of SAKRETE, INC. © 1974

Accept no substitutes

Original Spackle®. Smoothest off the knife. Smoothest on the wall. Dries fast and hard to a smooth, white paintable finish. No unpleasant odor. The painter's favorite.



In the familiar orange & blue package wherever paint is sold

the **muralo** company, inc.
Bayonne 07002 / Chicago / Los Angeles

LAWN & GARDEN TRACTOR YOU BUILD SAVE \$150



A neat lawn and fresh, nutritious, home-grown vegetables are yours with less work with Yard Bronc. Tractor features 8 or 10 H.P. engine; 4-speed trans-axle; geared, auto-type steering; turf-saver tires; high back, foam seat, 1/2" thick steel frame and more. **Costs up to \$150 less** than store models because you assemble Yard Bronc. 22" x 34" chart steps you through in 10 hours, using common tools. Attachments include 36" mower deck, dozer blade, roller, dump cart, cultivator, disc, snow thrower, 6 others. **8 H.P. Yard Bronc Kit (TR-8-N) — \$499.95**
10 H.P. Yard Bronc Kit (electric start) — \$599.95
For free brochure, send ad to: Heald, Inc. Dept. PM-7
P.O. Box 1148, Benton Harbor, MI 49022

LOOKING FOR THAT POT OF GOLD?

Start Your Own Business at Home

Making Bird Baths, Flower Pots, Deer, Benches, Tables, Statuary, Flamingos, Mushrooms, Etc., Etc.

Send \$3.00 today for our book "TURN CONCRETE INTO GOLD"

TELLS TRADE SECRETS, and HOW TO DO IT. Send Today

CONCRETE MACHINERY CO., INC.
P.O. BOX 99A • HICKORY, N.C. 28601



BIKE YOU SAIL LIKE A BOAT

(Continued from page 32)

panic braking with the handbrake has little effect if a strong blow is determined to drag you along with it, like it or not. At this point, the AerOcycle tends to have a mind of its own.

For me, accustomed to horses, this was further complicated by the fact that the bike adamantly refused to heed repeated cries of "Whoa, you blankety-blank, whoa!"

When you get into trouble, you have three choices, none of them ideal. You can let go of the sail completely, try to make a quick turn into the wind or, as a last resort, take the coward's way and bail out. Releasing the sail isn't too practical since, once you've let go, the boom swings out of reach and isn't easy to recover. Turning isn't as simple as it may sound, especially if you're operating in a confined space or are heeling over at a precarious angle. Abandoning ship, while easy to do and harmless, doesn't seem consistent with a captain's heroic determination to stay with his vessel. So you hang on and pray.

Actually—kidding aside—I found the AerOcycle reasonably docile and manageable after 20 minutes of practice. Then riding it becomes an exciting and enjoyable experience. As proof of its capabilities, Patterson's 18-year-old son, Tod, has no difficulty performing graceful figure eights in an unbelievably small space and has been clocked at up to 45 mph. To watch his effortless achievements is a spectacular sight.

The 36-pound sailbike requires a steady breeze of at least 6 mph for proper operation, and higher winds are preferable for top performance. One interesting design feature is its forward-curving, hooked-shaped handlebars. These provide a firm, nonslip handhold and also eliminate the danger of pointed ends should a rider fall. Patterson plans an initial "back yard" production run of 50 units that will sell for about \$225 each. If sales are good, the AerOcycle will go into mass production, which should bring the price down considerably. Further information about the bike can be obtained from Patterson Engineering Co., 134 Valley Rd., New Canaan, Conn. 06840.

Is a sailing bike an odd sight? Well, not to all. Once, while demonstrating the AerOcycle in New York City traffic, Tod was approached by police in a patrol car who gave him a brief look, then passed on by without batting an eye. "I guess New York cops are immune to anything," says Patterson. ★★★

Where do the Pros get their training?

Almost half of successful TV servicemen have home study training and among them, it's NRI 2 to 1! A national survey*, performed by an Independent research organization, also showed that the pros named NRI most often as a recommended school and as the first choice by far among those who had taken home study courses from *any* school.

Why? Perhaps NRI's 60-year record with over a million students...the solid training and value built into every NRI course...and the designed-for-learning equipment originated by NRI are part of the answer. But send for your free NRI catalog and decide for yourself.

Training Geared for Success

NRI training is practical training... know-how aimed at giving you a real shot at a better job or a business of your own. You learn at home at your convenience with "bite-size" lessons that ease learning. Kits designed to give you practical bench experience also become professional instruments you'll use in your work.

Includes 25" Diagonal Color TV

As a part of NRI's Master Course in TV/Audio servicing, you build a big-screen solid state color TV with every modern feature for great reception. As you build it, you perform important experiments that demonstrate the action of the circuitry. And it comes



complete with console cabinet, an optional extra with other schools. Instruments include a 3½ digit precision digital multimeter, triggered sweep 5" oscilloscope, and integrated circuit TV pattern generator; all designed for training. There are courses costing far more that don't give as much.

Free Catalog . . . No Salesman Will Call

Choose from five different courses in TV/Audio servicing, depending upon your needs and budget. Or you can learn Computer Technology with a real programmable digital computer. Communications... Aircraft or Marine Electronics... Mobile Radio, and more. Send the postage-paid card for our free catalog showing details on all



NRI electronics courses. There's no obligation and you can see for yourself why the pros select NRI two to one! If card is missing, write to:

**Summary of survey results upon request.*



NRI SCHOOLS
McGraw-Hill Continuing Education Center
3939 Wisconsin Avenue,
Washington, D.C. 20016



HOMEOWNERS' CLINIC

Insulation for A/C

I intend to install central air conditioning this season. There are 3-in. batts in the ceiling, and I'm told by my airconditioning service people I need at least 7 in. of insulation. I've thought this excessive—Are they correct?—J. Heston, Tulsa, Okla.

I would agree with the suggestion, simply on the ground that most older homes tend to be under-insulated. Ceiling insulation should be R-19 to R-22. These R-ratings (thermal resistance) take the insulating value of structural materials into account; an insulation dealer in your area should be able to determine your needs. Check attic ventilation, too—see page 100.

Noisy steam heat

My home is steam-heated and during the heating season I'm bothered with noises in the system—a popping, cracking sound that banishes sleep. This I must correct before another heating season. What's the remedy?—Frederick Mason, Albany, N.Y.

A common cause is a defect that creates a vacuum somewhere in the system, usually in a line that slopes downward toward a radiator. Have your service company check to be sure pipes are correctly installed at the boiler. Then check lines to radiators yourself with a level to detect any that slope toward the radiator (they're supposed to slope away from it). You can then raise the radiator on wood blocks to achieve the correct slant.

Stretching bar clamps

My sofa has a wood front rail, the ends of which are loose in the leg joints; I suppose the glue has failed. I have two 36-in. bar clamps and my problem is how to use them to draw the joints tight.—E. Carlos, Chicago.

If the sofa is a standard size, the clamps will have to span 6 ft. I once solved a similar problem by boring two holes in a short length of $\frac{3}{4}$ -in. plywood, enlarging these to take the sliding jaws of the clamps. With these jaws hooked in the holes, you and a helper could place the clamps so the screw-actuated jaw will engage the legs, then tighten. You could draw the clamps tight enough to close the opened joints on fresh glue. Bore

tiny holes in inconspicuous places at each joint and force glue into joints with a glue injector. Wipe off excess glue before it dries or it may discolor the finish. Pad clamp jaws so they don't mar the legs.

Right damper length

I plan to build my own fireplace and I have gotten "yes-and-no" answers to my question of the proper length of the damper. Is the correct installation across the full width? If not, what part of the full width?—Thomas Fell, Nashville, Tenn.

In natural fireplaces of conventional size it's common to install full-width dampers. The damper should be the full width of the smoke opening—the distance measured at the back, often called the "fireback." A damper of shorter length may tend to create turbulence in the updraft, causing the fireplace to smoke—incurably in some instances. I'm assuming your fireplace is to be built into a wall and not the projecting or two-way types. These require a different damper assembly.

Paint peeling from concrete

Poured-concrete foundation walls of my 10-year-old home were originally painted above ground. Last year I repainted them with latex. This has peeled off in large sheets from ground level to top of the concrete, leaving the original paint. Can you tell me why, and advise what I should do?—John Rutherford, Washington, D.C.

The original coat must have been an oil-based exterior paint. Latex-based paints do not always bond solidly to the smooth oil-paint surface. If the original coating is still in relatively good condition, adhering solidly to the concrete, I suggest that you scrape off all loose material with a wire brush, wash and rinse the surface, let it dry thoroughly and apply an oil-based masonry paint. If you want to use latex instead, prepare the surface by removing as much loose material as possible with the wire brush, then applying a surface conditioner such as Glidden's Y-40 Spred Spar Varnish mixed with naphtha or mineral spirits (follow directions appearing on the can) before painting.

Sandblasting is an (expensive) alternative.

Mitered joints move

In my three-year-old home the door and windows trim (casing) is mitered at the upper corners. These joints open during the heating season and close in the summer. I'm going to paint the trim. Is there a way to stop this opening and closing?—Milton Greer, Aiken, S.C.

A permanent remedy is doubly difficult as this is caused by slight shrinkage and expansion of the trim wood, and perhaps of the frames. You might pry off one trim member, coat the joining miter surfaces with white glue or epoxy adhesive and then re-nail the member, without nails in the miters, as these could crack the casing next heating season. Any ordinary crack filler would probably be squeezed out and form a bead or ridge at the joints. Trim pieces must be removed with care to prevent damage, and the glued joints sanded after nailing and refinished to match.

Stubborn screens

Screens in my combination windows either stick or raise and lower with great difficulty. How can I make them easier to operate?—Mrs. Jack Thomas, Kansas City, Mo.

There is a silicone lubricant you can get in aerosol containers from your paint or hardware dealer that generally eases these parts and makes them slide with little effort—provided the channels have not been kinked, bent or otherwise damaged. It's a good idea to clean the channels first with a mild soapy solution, using a brush to remove the dirt and grime that collect in them in time. Then spray each channel and slide the screens up and down several times to distribute the lubricant uniformly. ★★★

Do you have a home maintenance or repair problem? Send it to Homeowners Clinic, Popular Mechanics, 224 West 57th St., New York, N.Y. 10019. Letters cannot be answered individually, but problems of wide interest will be discussed in this column. For more home repair and maintenance help, get PM's Home Care Guide, \$4.49 postpaid. Send orders to PM, Dept. HG5, Box 1014, New York, N.Y. 10019.

You've taken your
last rough puff, once
you come up to
the smooth taste
of extra coolness.
Come up to KOOL.



SUPER LONGS

KINGS

Warning: The Surgeon General Has Determined
That Cigarette Smoking Is Dangerous to Your Health.



13 mg. tar,
0.8 mg. nicotine

Now, lowered tar KOOL Milds

SCIENCE WORLDWIDE



NASA tests new airfoil

The most unusual thing about the twin-engined Piper Seneca shown above is its wing or airfoil. Though it's 27 percent smaller than the plane's original wing, the advanced technology airfoil is expected to demonstrate improved economy and safety in tests under way at the NASA Langley Research Center, Hampton, Va.

Called a supercritical airfoil, the wing was first developed for high-speed jet transports. It's said to improve an aircraft's lift and reduce drag. The supercritical wing has a flat upper surface and an unusual curvature to the lower surface—just the opposite of the conventional wing. It's hoped that continuing research will establish that the experimental wing will prove to be suitable for use by the general aviation industry.

Rash of minibike mishaps

Young adolescents are now sustaining injuries from minibike and motorcycle accidents in epidemic proportions, according to a report in a recent issue of the *Journal of the American Medical Assn.* There are some 10,000 accidents each summer, says the report, involving operators of minibikes or other unlicensed motor vehicles, and these are accidents requiring attention in an emergency room. At least 1000 of the patients will suffer severe handicapping complications that will cause a lifelong disability.

The two authors of the report base their findings on a study of accident

cases treated at the Alfred I. DuPont Institute, Wilmington, Del., over a three-year period. One of their major conclusions: "Adequate clothing combined with the proper use of the vehicle, such as is taught in driver training courses, could have prevented most of the minor injuries."

Cement with the bends

New types of building materials seem to come on the market in a steady stream. One of the newest—in fact, it's still under development—is a flexible cement and fiberglass combination. That is not a piece of sheet metal the man is bending—it's cement. The developer—PPG Industries of Pittsburgh—claims the stuff is a high-strength material with good fire resistance and will sell at a relatively low price.



Drop in energy use in '74

Energy use in the United States fell 2.2 percent in 1974 after rising steadily for more than two decades, according to preliminary Bureau of Mines figures recently released by Secretary of the Interior Rogers C.B. Morton. Demand for heat, light and power required energy equivalent to 73,121 trillion British thermal units (B.T.U.) in 1974, compared to 74,743 trillion B.T.U. in 1973. Morton said five factors accounted for most of the decrease: "The Arab oil embargo, higher prices, the economic slowdown, successful conservation efforts and a relatively mild winter." Biggest drop was in transportation. Jet fuel use was down 5.9 percent; gasoline, 2.1 percent.



Now: a motorized walker

The upright mobility required in many jobs can now be provided to paraplegics by a motorized walker developed by a subsidiary of the Whittaker Corp., Los Angeles. Powered by a 12-volt storage battery, it has a single drive wheel—the left front wheel—that acts as a pivot point. Steering is controlled by a tiller with thumb-operated switch. Optimum mobility is provided by a 38-inch turning radius and top speed of 1.6 mph on flat, hard surfaces. Support points at feet, knees, lower back and waist virtually lock the occupant into place, but with enough freedom for him to bend forward at the waist. ★ ★ ★

Remodeling with GAF doesn't have to have you climbing the walls or going through the roof.

HOMEOWNER'S GUIDE TO SUCCESSFUL REMODELING WITH TIPS ON ROOFING & SIDING

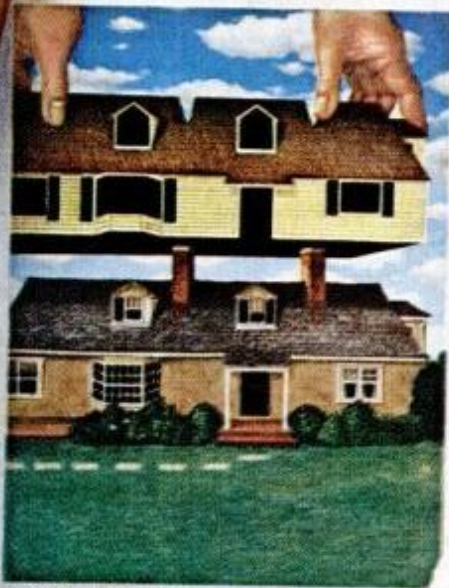

by A. M. Watkins,
author of The Complete
Book of Home Remodeling,
Improvement, and Repair.

CONTENTS:
Remodel or move?
How to increase the value of yr
Twelve fundamental tips
What makes a good plan?
How to finance
Adding living space
Conserving energy



Please rush me your free booklet
of objective remodeling informa-
tion, compiled by a well-known
authority.



NAME _____

ADDRESS _____

CITY _____

STATE _____ ZIP _____

Send literature on GAF roofing
 on GAF siding

GAF CORPORATION, GAF Building Products,
140 West 51 Street, New York, New York 10020

'OPTO-ELECTRIC'

The BEST...the ULTIMATE
of ALL Ignition Systems!



● (We challenge ANYONE to dispute this Fact.)

Never wears out or needs any Maintenance!



● gives you Maximum Power with continuous PEAK PERFORMANCE

...while reducing Maintenance and Operating Costs!



★ The Allison OPTO-ELECTRIC System eliminates the Points and Condenser, replacing them with an OPTO-ELECTRONIC TRIGGER, using a Light-Emitting Diode and Photo transistor. The System operates on a beam of Light. As there are NO moving parts in rubbing contact, "Friction-wear" is completely eliminated...Timing adjustments are PERMANENT.

● Gives 40-Times more Timing accuracy than ANY system using "Mechanical" Breaker-Points! UNLIMITED RPM! "Electronically-Controlled" DWELL automatically supplies HIGHEST Performance at both Low and High speeds. Spark strength does not fall off at high RPM. POSITIVE SPARK helps eliminate "Misfire" for faster acceleration and improved Engine Performance. Sparkplugs LAST 3 to 10-Times LONGER.

● Easier Starting under any condition! Smoother running... (NO TIMING FLUCTUATION as with Magnetic Impulse Units). All SOLID-STATE Components. UNAFFECTED By Temperature, Moisture, or Vibration! Only Highest grade materials used... Guarantees you Solid, Dependable Performance!

● PERFECT TIMING INCREASES Engine Efficiency and Gas Mileage. SAVES Precious Fuel! Allison gives you MAXIMUM Engine Efficiency 100% of the Time... and that's the name of the game for the BEST in GAS MILEAGE AND ECONOMY.

★ Perfect Timing and Dwell never change.

● Pays for itself! Eliminates ignition Tune-Ups forever! "INFINITE LIFE"...Once installed...Never needs replacing!



★ PROVEN RELIABILITY!
Each Unit Tested to 15,000 RPM.

● Road and Race Proven.
(Opto-Electric Systems won at INDY Two years in a row!)

★ "EASIEST-TO-INSTALL" UNIT ON THE MARKET.
(Not necessary to dismantle Distributor as with other systems).

★ If you want the BEST, and SAVE! This is IT!

ORDER with CONFIDENCE...
SATISFACTION GUARANTEED
...or Full Refund.

Only \$49.95
COMPLETE.

that's EVERYTHING!
including
Postage & Insurance.

10-YEAR FACTORY WARRANTY!
(Free Repair or Replacement).

● Send Check or M/O (Calif. Res. add Tax).
State Make, Year, Engine Size. (4, 6, or 8-Cylinder).

★ (So New...it's Sold ONLY FROM FACTORY DIRECT).

● You may use your MASTER CHARGE or BANKAMERICARD.
Send us (1) Your Number, (2) Interbank No., (3) Exp. Date.

M/C or B/A Card Holders, ORDER by TOLL FREE PHONE:
(800) 423-6525, Ext. 2 (When in Continental U. S. A.)
And YOUR ORDER will be SHIPPED IMMEDIATELY.

★ Before buying any other Type ignition system...

Send Postcard for our FREE BROCHURE.

★ If you have already installed a C-D ignition system,
Modernize and Increase its Efficiency...
CONVERT YOUR "C-D" UNIT TO BREAKERLESS!
Opto-Electric "TRIGGER UNIT"...Only \$34.95

● Our BEST Salesmen are the users of our ALLISON System!



America's Oldest and Largest Mfg. of
Opto-Electronic Ignition Systems.

ALLISON
AUTOMOTIVE COMPANY

1267-X, East EDNA PL., COVINA, CAL. 91722

ON-THE-ROAD REPAIRS BY EUGENE A. SLOANE



THE BICYCLE SHOP

If you are not prepared, breakdowns can delay or ruin a bike trip. You should know what tools to take and how to make at least the more common emergency repairs. Then you can be rolling again in minutes.

Tools you'll need—1. Hub wrenches (13 and 14-mm or 15 and 16-mm to fit hub-cone nuts). 2. Tire-patch kit (and tire irons for wired-on tires). 3. Small screwdriver. 4. Small adjustable wrench. 5. Brake third hand (holds brakes for adjustment). 6. Metric Allen wrenches (6, 7 and 8-mm). 7. Spoke nipple wrench. 8. Freewheel remover (to fit your freewheel) and wrench to fit it. 9. Bottom-bracket toolset (for your bottom bracket).

Parts to take—1. Four extra spokes with nipples (to fit rims). 2. Rear derailleur cable (can be cut to fit front derailleur). 3. Rear brake cable (can be cut to fit front brake). 4. Four chain links (your make of chain). 5. Two brake pads in holders. 6. Pressure can of Spray-Lube or Chain-Lube for chain and freewheel. 7. Small tube of hub grease (Phil Wood or Lubri-plate).

Broken spoke

To replace a spoke on the freewheel side of the rear wheel, you will have to remove the freewheel. Skip this step for front wheel and left side of rear wheel.

Step 1: Remove wheel. Remove quick-release skewer for axle locknut. Insert freewheel remover in freewheel, lock it in place with skewer or axle nut. Break freewheel loose with wrench. Remove skewer or nut and remove freewheel.

Step 2: Remove tire over spoke nipple. Remove top and bottom parts of broken spoke. Replace with new spoke. Run down nipple with screwdriver until snug. Replace tire (use fresh rim cement with tubular tire). Install spokes to spoke head (part that goes in last at hub) on flat side of hole. On some hubs, spoke holes are countersunk to relieve stress: Spoke head must always go on side opposite countersink. Replace tire on rim; inflate tire.

Step 3: Retune wheel. You'll likely need to tighten the replaced spoke first; rim will move toward side where nipple you tighten is located. Use chain stays or fork blades as truing guide. Be sure rim is accurately centered in dropouts.

Broken chain

Chains break because of wear or because rivets are pushed in too far or not enough. Derailleur chains have no master link, so you need a rivet remover. I like the one made by S.V.Tool Co., Inc. of Newton, Kans.

(your bike shop should have it); with it you can't push the rivet back too far. If chain breaks, remove old link and replace with spare of same make. If you're near a gas station, clean chain in kerosene while off the bike and spray with lube. Oil chain every day on the road to flush out sand and grime and re-lube links. With a three-speed or coaster brake bike, you can take off chain by removing master link. Always carry a spare.

Broken derailleur cable—**Step 1:** Unscrew cable-holding nut with a wrench or screwdriver and pull cable out through spaghetti tubing. Pull remaining part of cable out through shift lever.

Step 2: Lightly grease new cable, insert free end into shift lever, then into tubing, then into derailleur cable-lock bolt. Shift chain onto smallest rear sprocket. Pull cable taut; tighten cable locknut.

Step 3: Readjust derailleur travel. Stop bolts limit horizontal derailleur travel to prevent chain override and jamming in high and low gears.

Broken brake cable—**Step 1:** Use the third hand tool to hold brake closed. Loosen brake-cable locknut; pull through broken cable. Hold brake lever down; remove other end of cable. Insert free end of new cable, lightly greased, up through brake lever, spaghetti tubing and brake-cable locknut.

Step 2: With brakes squeezed so shoe pads are firm against rim, pull cable as taut as possible and tighten locknut. Release brakes, squeeze down hard on lever to stretch cable and take up resulting slack either by loosening locknut and pulling excess through or adjusting take-up barrel. Shoes should be about 1/8 in. from each side of rim, through 360° of rim rotation. When replacing brake pad, be sure closed end of pad holder faces forward, or pad will slide out the first time brake is applied. If brake squeals, toe shoe in slightly by bending brake arms, or check for particles embedded in shoe.

Freewheel problems

Dirt between freewheel pawls and ratchet can prevent bike from moving when pedals are turned. The remedy: remove the freewheel and dunk it vigorously in kerosene. Oil heavier than SAE No. 5 can also make trouble here; use very light oil or spray lubricant to regrease the freewheel.

Carriers

Metal carriers over rear wheels often work loose. A loaded carrier can slip, jam the rear brakes or fall off. Check bolts daily. ★★

31 mpg



Datsun Li'l Hustler. Catch of the year.

Here's one fish story you can believe. In Federal EPA tests our Li'l Hustler got 31 m.p.g. on the highway.* Better than any other pickup, large or small.

Our Li'l Hustler has other winning features. A strong 2000cc overhead cam engine, for instance. Power assisted brakes, slick handling torsion bar front suspension with a stabilizer bar get the job done with minimum maintenance.

There's a choice of bed sizes, too. Both standard and long bed versions haul up to 1400 lbs. of passengers and cargo. Interior comfort includes a contoured seat, package tray and glove box; flow-through fresh air and a powerful heater/defroster. Air conditioning and a 3-speed automatic transmission are optional.

No hooks, either. Just a tough, economical machine backed by 15 years' small truck experience. Land one at your nearby Datsun dealer.

Datsun Saves

America's #1 Selling
Small Pickup

*28 m.p.g. in California.

Bell & Howell Schools invites you to **BREAK INTO 4-C**

Pick up new professional skills in this exciting field as you build Bell & Howell's new quadrasonic audio center. It's the very first learn-at-home program of its kind!



You've probably heard a lot about 4-channel sound by now. It's the most talked about and impressive technical advancement in sound in years. Separately recorded channels literally wrap a room in sound for a totally new listening experience.

And the excitement doesn't stop there. Thanks to Bell & Howell Schools' brand new learning program, now you can explore quad sound for yourself—from the inside out—and master the technology behind this important advancement right in your own home!

It's your opportunity to break away from the everyday routine and learn new occupational skills that could lead you in exciting new directions. Mail the attached card, postage free, to get the facts today!

Take hold of opportunity with both hands now!

The world around you is changing every day. Forging ahead. The man who keeps pace is the man who continues to learn and grow. He's in the mainstream of life. Interested in what's going on. And he's much more interesting, too.

Bell & Howell Schools' new 4-channel audio program was designed to help you learn and grow. To put you in the mainstream of audio electronics technology. Where you can delve into fascinating electronics principles. Solve challenging problems and get actual hands-on, build-it-yourself experience.

And where you can acquire a sense of satisfaction and accomplishment you may not currently be getting.

Completely different from the typical kind of school you grew up with.

Learning all about quad sound with Bell & Howell Schools is a lot more interesting and convenient than "school" used to be. First of all, we know you can't afford to quit your job. So we set up a program that lets you work at home in your spare time.

There are no classes to attend. No dry lectures to sit through. Everything comes to you in the mail. Lesson by lesson. Exciting package after package. And you work at a flexible pace in the relaxed atmosphere of your workshop—or wherever your favorite spot may be.

Sure, books are important. But they're only the beginning.

With this fascinating learn-at-home program, you do a lot more than just read about electronics. You'll conduct dozens of experiments . . . build your own laboratory equipment for testing out electronics principles . . . and also as part of this program you put together a 4-channel amplifier and FM/FM stereo tuner as you delve into advanced audio technology.



We try to make learning so interesting you look forward to receiving each new lesson. And enthusiastically dive into each new project we send you.

We'll start you off on the right foot.

You may be thinking, "I don't have any training in electronics . . . I might be getting in over my head."

Well, you can stop worrying about that. You don't need previous experience. You'll begin with the basics and acquire a thorough understanding of the fundamentals before moving on.

And remember, it's not just reading. With your very first lesson you get our LAB STARTER KIT, consisting of a simple voltmeter and electronics "breadboard" you can experiment with right away.

Of course, if you're already into electronics, you might be thinking, "I already know the basics . . . I want to get into the advanced stuff right away!"

For you there's an advanced standing program that lets you skip the beginning lessons.

Next you build the exclusive Electro-Lab® electronics training system.

Once you've mastered the basics, we'll send you everything you need to put together these three important testing instruments:

The design console. You use it to set up and examine various kinds of circuits. It's completely modular . . . no soldering!

The digital multimeter. Use it to measure voltage, current and resistance. Displays data accurately in big, clear numbers—just like on a digital clock.

The solid-state "triggered-sweep" oscilloscope. Use it to analyze modern,

HANNEL AUDIO!



state-of-the-art integrated circuits. Triggered-sweep feature locks in signals for easier observation.

These three superb testing instruments are the basis of your own home electronics laboratory. You'll use them throughout the program as you move into more advanced electronics principles and work into audio technology.

Bell & Howell's high performance 4-channel audio center you actually build and experiment with yourself!

You need practical experience with high caliber equipment to develop professional skills and understand the ins and outs of today's audio technology.

So we came up with a system that Bell & Howell is proud to have its name on:

First, there's the sophisticated outstanding 4-channel amplifier with SQ full-logic decoding and front to back separation.
As you build and experi-

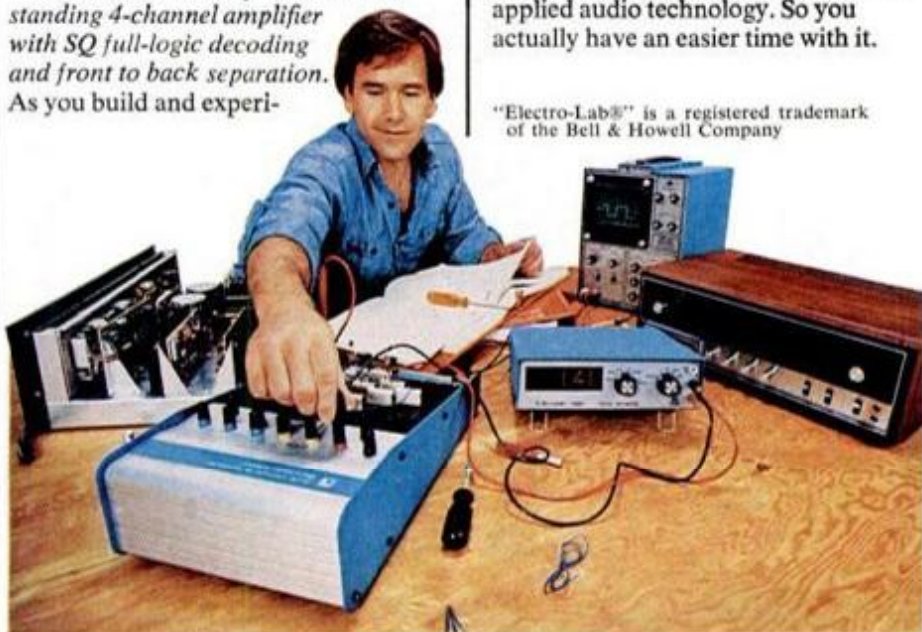

ment with this remarkable piece of equipment, you'll learn about matrix 4-channel and discrete—including CD-4 when processed through an external demodulator.

And with it you'll have the advanced circuitry you need to get into signal tracing low level circuits . . . troubleshooting high power amplifier stages . . . and checking the operation of tone control circuits.

Next, the advanced FM-FM stereo tuner. As you build this superb stereo tuner, you'll come to fully understand how the advanced, "state-of-the-art" features lead to such high performance specs.* You'll learn about all solid-state construction, FET front end for superior sensitivity, crystal IF filters for wide bandwidth and the superior multiplex circuit that produces such excellent stereo separation.

A wealth of knowledge in digestible chunks.

O.K.! So now you might be thinking, "It sounds really interesting . . . but kind of complicated." And you're right. But that is why we use the "hands on" teaching approach.

We've taken all the material and broken it down into short, simple-to-grasp lessons, so you can master one thing at a time before moving on. And we take you through it step by step. From the basics to advanced theory to applied audio technology. So you actually have an easier time with it.

"Electro-Lab®" is a registered trademark of the Bell & Howell Company

Special learning opportunities give you extra help and attention.

In case you do run into a problem or two, we're ready to give you more help and personal attention than you'd expect from most learn-at-home programs.

For example, many home study schools ask you to mail in your questions. Bell & Howell Schools gives you a toll-free number to call for answers you need right away.

Few home study schools offer personal contact with instructors. Bell & Howell Schools organizes "help sessions" in 50 major cities at various times during the year—where you can discuss problems with fellow students and instructors in person.

And when you're done, you'll know a lot more than just 4-channel sound!

You'll have covered the complete spectrum of electronics principles, leading to a full understanding of audio technology.

And while no school can promise you a job or income opportunity, you will have occupational skills necessary to become a full-service technician. With the ability to work on the entire range of audio equipment. Such as tape recorders, cassette players, FM antennas and commercial sound systems. You'll know audio technology from the inside out. And you'll be proud of it.

Plus you will have the basic skills that apply to the entire electronics field, including television technology and repair.

For more details, mail card today!

Here's your chance to break out of the mold. And break into 4-channel audio with Bell & Howell Schools. Why not look into it today. Mail the attached postage-paid card now.

Taken for vocational purposes, this program is approved by the state approval agency for Veterans' Benefits.

Wood cabinets available at extra cost.

35 watts per channel—Min. RMS into 8 ohms at less than 0.25% total harmonic distortion from 20-20,000 Hz, all channels fully driven.

If card has been removed, write:

An Electronics Home Study School
DeVRY INSTITUTE OF TECHNOLOGY

766R1

BELL & HOWELL SCHOOLS
4141 Belmont, Chicago, Illinois 60641

A good turntable kit that's easy to build

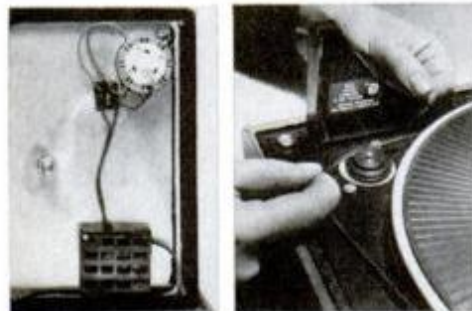

Rubber bumper on switch (top) gives table a needed starting boost when you switch it on. Simple construction under baseboard (left) shows why assembly takes only one hour. The moving belt (right) changes speeds from 33 to 45.



The Connoisseur BD-1 turntable kit is either very cheap or moderately priced, according to how much of it you buy: The kit itself is only \$59.95, but the arm is \$44.95, while the base (with top plate drilled to accommodate both arm and turntable) and the dust-cover are another \$11.95 each. So a complete BD-1 could cost as much as \$128.80, plus shipping and duty from its dealers in Canada.

As soon as you unpack it, you know you have an easy job ahead. Even counting the time it took me to make, find and unmake an error, total construction time was just

about an hour, plus another 15 minutes to install and align the tone arm on the pre-drilled base. The instructions could be clearer, but they'll do.

Starting the turntable sometimes required a manual spin, though a clever button on the switch is supposed to do that automatically. But once running, performance was good, with no audible wow, flutter or rumble. The base could use some damping to reduce floor-shake and acoustic feedback problems, though. The kit is now available from ETCO, 464 McGill, Montreal, Que.

—Ivan Berger

You can buy three products to do three jobs... or buy just **ONE** to do all three!

Demoisturize. Lubricate. Free rusted parts. Permatex has a product that does all three jobs from one can: "DLF". It Dries metal surfaces, Lubricates parts, Frees connections. One can, three jobs.

That's efficiency, economy, performance. DLF. Push button maintenance from Permatex.



PERMATEX COMPANY, INC.
P.O. Box 1350, West Palm Beach, Florida 33402
Telephone (305) 686-0880 Telex 513-417





Volkswagen was right. Ugly is only skin deep

For years, Volkswagen has run great ads telling how the real beauty of their product lies on the inside.

We couldn't agree more.

Which is why we designed our sexy Bradley body to fit perfectly onto a VW chassis.

That way, you wind up with a car that looks for all the world like a \$10,000 GT. But inside, you still get the famous economy and durability of a VW.

And because our fiberglass body is lighter, the finished product

performs better than a stock VW. With top speed increased to 100 mph, and mileage to 35 mpg.

Now, you won't get all this without doing some work. It'll take five or six weekends. But we provide every single part you need and you can do the job with ordinary tools. And you'll find the result well worth your time.

It's the perfect marriage.

The inner beauty of a Volkswagen.

And the outer beauty of a Bradley.

BRADLEY GT

BRADLEY / Automotive Div. of Thor Corp.
7669 Washington Ave. S.
Edina, Minn. 55435 Dept. PM-7

- Send me your brochure for \$1.00.
 Send an assembly manual for \$7.00.

Name _____ Age _____

Address _____

City _____

State _____ Zip _____

Business Phone (_____) _____

Home Phone (_____) _____

Excellent financing available.

Pop-up tent camper you can build



If you own a compact pickup such as this Datsun and are looking for a way to turn it into a nifty home on wheels for fishing trips or weekends at the lake, this self-contained pop-up tent camper could be it.

It sleeps two in a comfortable over-the-cab-and-hood bunk, provides standing headroom "downstairs," has a stove and ice chest, storage cabinets for food, clothes and water and a portable water-flush toilet.

It's literally a snap to open and close. To "pitch" this tent camper, you unsnap the vinyl cover, swing up the canopy, slide out a bed tray at the front and snap on the sidewalls—all in a matter of minutes. When collapsed for traveling, the camper is only 12 in. above the cab to add very little road drag.

Thin-wall conduit is used to make the canopy framework which is removed along with the built-ins for off-season storing. The remaining framework provides a handy, permanent cartop carrier for hauling pipe, lumber and the like. For plans and where to order see below. ★★★

HOW TO ORDER PM PLANS

To order plans and instructions for building the pop-up tent camper, send \$9.95 (check or money order) to Tent Camper, Popular Mechanics Plans Library, Box 1014, Radio City, New York, N.Y. 10019. Please allow two to three weeks for delivery.



Low camper profile cuts drag when traveling, adds greater gas mileage. Vinyl cover buttons down all around to hold canopy framework in place.



Bed tray slides out over hood to provide upper bunk for two. Canopy framework pivots at rear and rests when closed on permanent side rails.



Phantom view shows the sleeping quarters with zipper windows. Cabinets on each side of center aisle are below window level to preserve visibility when traveling.

PROBLEM



SOLUTION

A dirty carburetor is a pretty sticky problem. But there is a solution: STP Carburetor Spray Cleaner.

Very simply, here's how it works. A spray can with a handy nozzle helps you get into the tight spots, the throttle plate, choke, linkage and PCV valve.

The spray itself

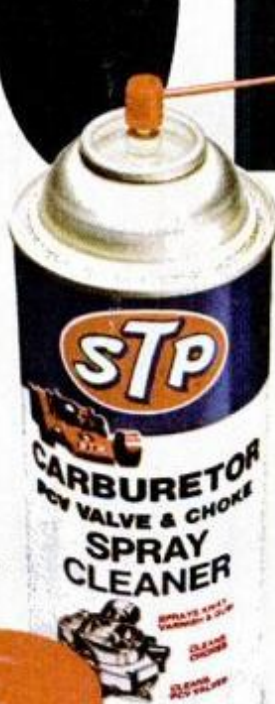

has two powerful cleaning agents that blast away sludge, varnish and gum. Those filthy deposits your car is better off without. And STP Spray Cleaner has a surface detergent to keep those deposits from building up again.

Try STP Carburetor Spray Cleaner. See how beautiful a carburetor can be.

Come to where the flavor is.

Marlboro Country.



Marlboro Red or Longhorn 100's —
you get a lot to like.

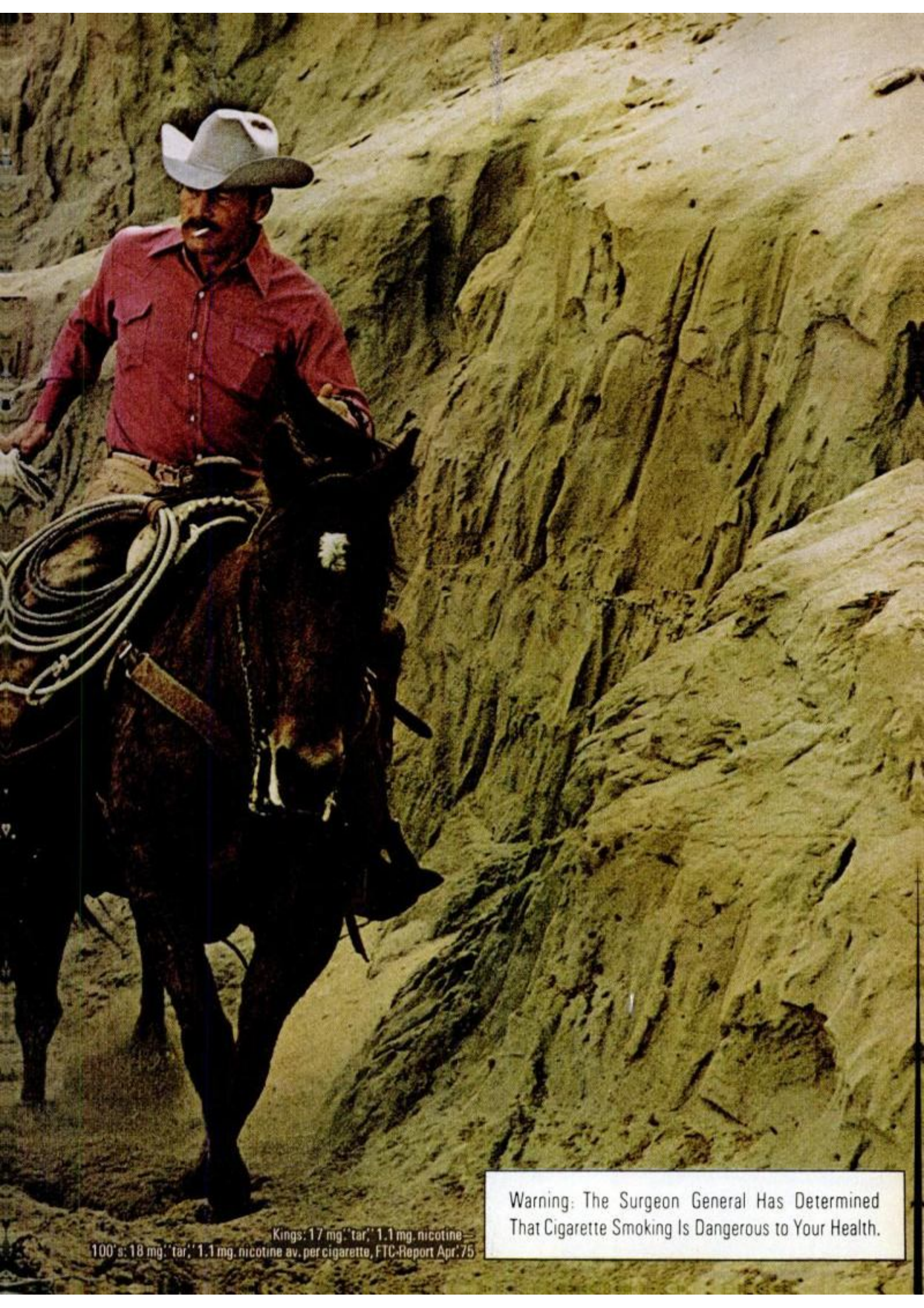

Kings: 17 mg. "tar," 1.1 mg. nicotine
100's: 18 mg. "tar," 1.1 mg. nicotine av. per cigarette, FTC-Report Apr. '75

Warning: The Surgeon General Has Determined
That Cigarette Smoking Is Dangerous to Your Health.



Living the life of Lee.

You see Lee on the job everywhere. Chetopa Twill work pants and shirts in a tough blend of polyester and cotton, Lee-Prest®. Ditto for those western twill Boot-Cut® flares the young man is wearing. His famous blue chambray work shirt is 100% cotton. The Lee Company, Work & Western Wear Division, P.O. Box 440, Shawnee Mission, Kansas 66201.

Lee
WORK CLOTHES

A company of  corporation

История и традиции в авторском стиле



World's biggest highway crash

by Michael Lamm WEST COAST EDITOR

The accident reports read like the script for a big Hollywood disaster movie. It's in the same vein as *Earthquake*, *Towering Inferno* and *Airport '75*—only this time it's on wheels.

The California Highway Patrol still refers to it as The Big One. Like a movie, it has its cast of thousands. It also has an action-packed—though confused—plot. Let's set the scene for this real-life extravaganza.

Location: A four-mile stretch of California Highway 91, also known as the Riverside Freeway, in and near the town of Corona—four lanes westbound and four eastbound. **Date and time:** The last day of February, 1975; action begins promptly at quarter to eight in the morning and continues in both directions for at least an hour and a half. **Cast:** Some 300 cars and trucks, perhaps 1000 persons in all, including members of

the CHP (California Highway Patrol), several local fire districts, all available ambulances and every tow truck within a 30-mile radius. **Props:** Heavy fog—"... like somebody flipped a Navy blanket over my windshield," as one of the participants puts it.

Apparently because of the unusually dense, suddenly-looming fog, vehicles in the westbound lanes abruptly start to slow down, triggering the beginning of the most massive highway pile-up in history. State Traffic Officer Dave Rogalia, summing up subsequent investigations, reports: "... the chain reaction started, and consequently we ended up with The

Big One, westbound. Then people in the eastbound lanes slowed, thus setting up the chain reaction for the eastbound accidents."

What happened during those terrible, agonizing moments—moments that were to stretch into more than an hour—as car after car and truck after truck slammed helplessly into each other? To piece together the story, I interviewed dozens of motorists who were actually involved in the crash, as well as police, fire and other officials.

The tale must be told in segments for that's how the catastrophe occurred—not in one single pile-up but in a series of separate collisions



The hulks of cars and trucks lined the sides of the freeway for miles and lay under a coating of snowlike, fire-retardant spray.

strung out over incredible space and time.

In asking each motorist to recount his own personal experience, I also put forward a key question: Knowing what you know now, having gone through what you went through, what would you do *differently* the next time you find yourself in a similar situation?

One of the first collisions involved two big trucks, one hauling rocks and the other carrying sand. The rock truck, a 1967 International, was driven by Charles Williams of Stanton, Calif. Williams told officers that he was traveling westbound in the right-hand lane when a small foreign car got onto the freeway in front of him from the Serfas Club access ramp. The fog was mild at that point, but very soon they both entered a heavy fog bank. Visibility was suddenly near zero.



Firemen at the scene of the accident which covered a four-mile stretch of the Riverside Freeway near Corona, Calif.

At this point, the small foreign car hit its brakes and almost stopped, whereupon Williams did the same. As Williams began to accelerate again, a 1963 Peterbilt towing a pair of sand-filled doubles plowed into the back of his International. The Peterbilt was driven by John V. Dillard of Mira Loma, Calif.

Dillard told me, "If I had it to do over again . . . if I ever get into a fog like that . . . I'm going to park it."

Alongside Dillard, in the second lane from the right, came a 1968 Olds Toronado driven by a woman on her way to the orthodontist. She asked me not to identify her. She told me, though, that this was the first time she'd ever driven in fog. The police report states that she stopped on the freeway next to Dillard and asked him if he was okay. Dillard told her, "Don't stop! Keep moving!" But it was too late. A 1973 Pinto driven by Leonard L. Larssen of Anaheim screeched to a halt just behind the Toronado. The latter, meanwhile, untouched, drove away before officers arrived.

Next came a 1974 Ford van, driven by Arthur Deltran Aviles of nearby Home Gardens, who rear-ended the Pinto. Aviles, in turn, was plowed into by the 1973 Monte Carlo of Jerry Wilson. All this went on right beside the two trucks.

When I talked to the woman who had driven the '68 Toronado, she told me she'd do nothing differently the

next time. I tried to lead her: Would she keep moving? Pull over in the fog? Park in the right lane ahead of the trucks? Each time she said no; she'd behave exactly the same way again if the accident happened tomorrow. I believe she thought I was a lawyer or was connected with an insurance company.

Arthur Deltran Aviles, 1974 Ford van driver and a college student, had this to tell me. "Well, I know that even as I was sitting there after I'd hit the Pinto, I was thinking to myself that I could have swerved left to the third lane. I could then have continued on and slowed down and stopped. I knew there wasn't anybody to the left of me for the next couple of seconds, because as I was entering the fog I looked in the outside rear-view mirror. Something had forewarned me that there was something up ahead. So that was one of the alternatives I had at the time, but I didn't do that."

Aviles struck his head on the steering wheel on the first impact. He was bleeding from the forehead when he got rear-ended himself. At that point, he slammed backward in his seat so hard that the seat broke away, and something struck the back of his head.

Somehow he made the right shoulder of the freeway, and while lying there, he remembers, "You could hear cars slamming together, screeching their brakes, and then pretty soon

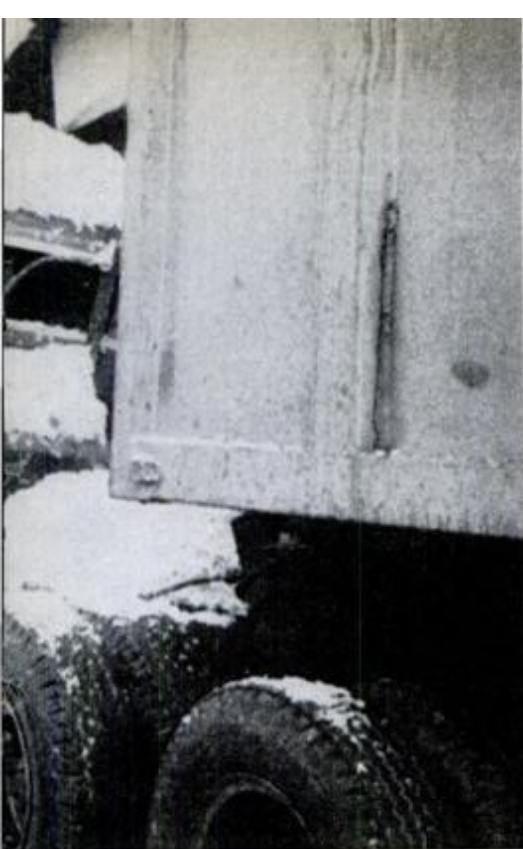

hill helped to hold the thick fog in place.

Also, commuter traffic is always heavy at that time of morning, both east and westbound, mostly between the city of Riverside just east of Corona and Orange County to the southwest.

Finally, there's heavy truck traffic early each weekday morning. Many of the trucks haul sand and gravel from the big pits at Colton, Riverside, Oro Grande, Victorville, and the Kaiser plant.

From an early eastbound segment of the accident, here's Robert Bruce Schroeder, aged 50, a plumber from Huntington Beach, Calif., whose green 1973 Datsun pickup got bounced around by two big semis and finally came to rest wedged between the duals of one of them.

"As a man with eight kids," Mr. Schroeder told me, "I do a lot of thinking, and yes, I know what I'd do differently next time. I was going between 30 and 40 when I hit. I'd go a lot slower. I might also have steered out of it.

"I was in the right-hand lane, and there was a truck stopped ahead of me. I saw him just before I hit him. I was in the process of turning to his right. I was going to steer through it. I remember getting on my brakes, but I didn't lose control, that much I know.

"Just as I got on my brakes, I was hit in the back by another truck. He went clear on into my back window with his radiator. I turned around for a quick look, and all I could see was radiator grille. He took me at a right angle. I know I could have driven right. I might have hit somebody standing on the shoulder possibly, I don't know, but anyway my front left hit the right rear of the standing truck, and then that just peeled off my motor. Then the rear

truck took me on up the mountain—actually, I was carrying him like a fifth wheel.

"He went up on the bank, and when he did that, that shoved me back in between the front duals of the next truck. I was pinned into my pickup, and then they came along with one of those pipes and cut the door open. I wasn't injured. I walked away from that thing. I hurt my right leg and rump a bit, though. But, man, I was lucky. All I could hear was crash, crash, bang, crash, up that canyon all the way."

In another part of the wreck, westbound this time, Carl W. Marsch, a 32-year-old longshoreman from Redondo Beach, was headed for work in his VW camper. He became No. 16 in a 19-car link of the chain. Marsch told me:

"Oh, yes, I have a definite idea about what I'd do differently. I'd pull over immediately, as far away from the freeway as I could get to the right, and stop and get out of my car and walk down the embankment over by the fence and wait there until the fog cleared.

"What happened—I broke my leg in five places, and I was trapped in my car for one and a half hours. I was conscious the whole time. I was going downhill, westbound, on the Riverside Freeway. It was clear when I started, though there were two small signs up that said FOG. It didn't look foggy to me, so I kept going. When it started getting a little foggy, I slowed down to about 20. All of a sudden the visibility got to be about five or six feet.

"Now I didn't dare slow down any further, because I was afraid of somebody behind me. You know people aren't used to driving that slow on the freeway. Suddenly, about 10 feet in front of me in the fog was this line of cars parked there. I hit

(Please turn to page 133)

you could hear them just running into each other with no braking at all. That's when it got a little spooky. You just didn't know when another semi was going to come along and clean out this whole act. But fortunately, it didn't happen."

This initial part of the accident was tame compared to what followed. At this point, I should mention several more contributing factors.

First, the 28th of February came five days after the nation went on Daylight Saving Time. Which means it was as dark at 8:00 that morning as it had been at 7:00 o'clock the week before. And the sun was just coming up.

Second, it's often foggy along this stretch of freeway, but a principal reason for the extreme density near Corona was a runoff basin below nearby Prado Dam.

In addition, the Riverside Freeway wends its way through something of a canyon at this point, boxed in by a low hill to the east. That

The clean-up began soon after hundreds of cars and trucks came to their abrupt stops. Amazingly, no one was killed. By early afternoon the site bore but little evidence of the massive accident that had taken place.



Infrared photography: Different—and easy

by Parry C. Yob Photos by the author

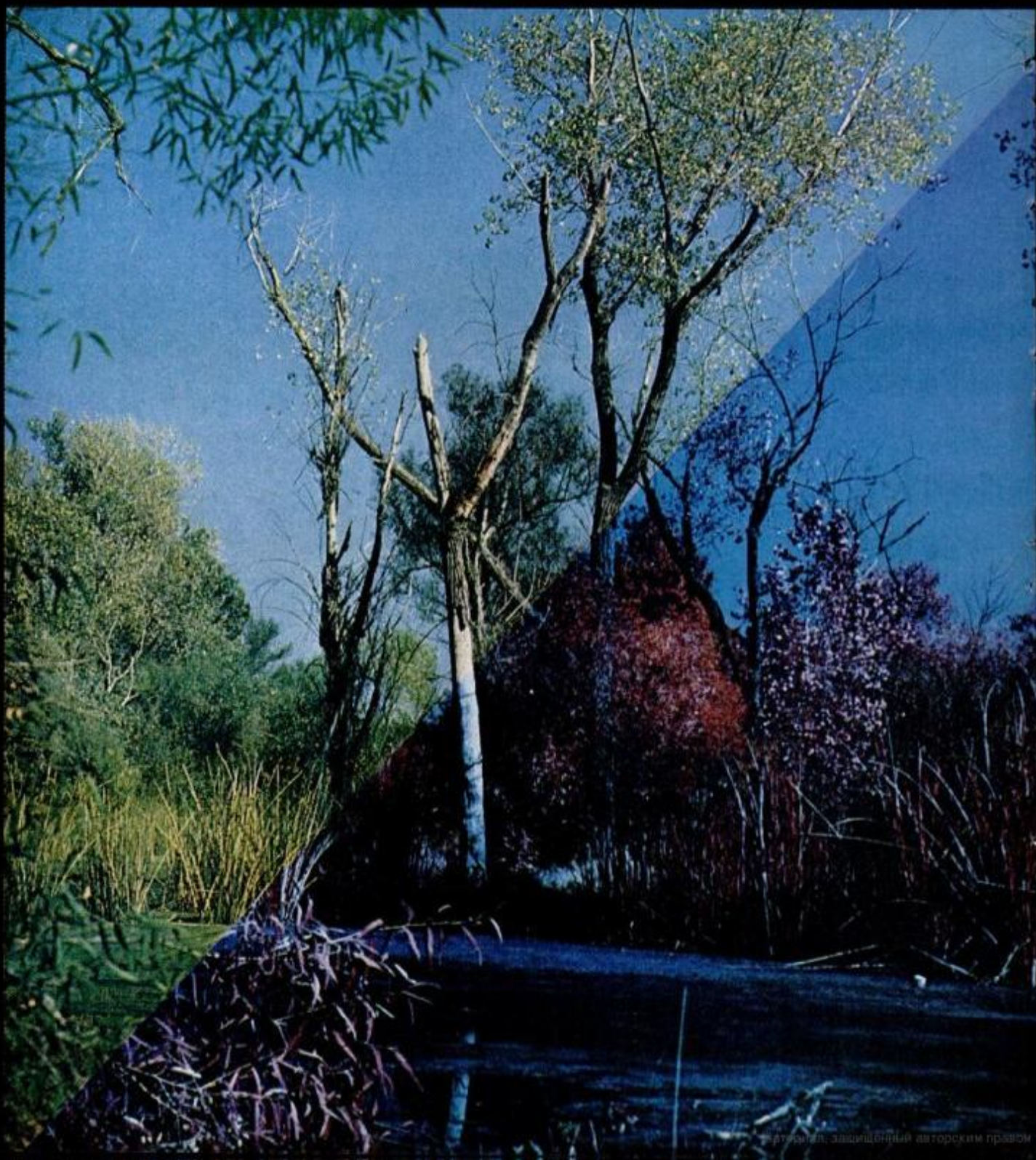



If your landscapes look so peaceful they put you to sleep, or if your outdoor subjects merge into their backgrounds, it's time to try infrared photography. The results have an air of mystery—but there should be no mystery about how to get them.

Since you can't see how much infrared your subject reflects, and since meters differ in their sensitivity to infrared, you'd expect exposure to be a problem. If anything, it's easier than with normal film.

For one thing, you'll need almost the same exposures for sunny-day shots from April to November—the only months you're likely to find foliage enough to give your shots dramatic impact. For distant outdoor scenes, where there's lots of atmosphere to reflect and scatter infrared, try 1/125 at f/11 for Kodak High Speed Infrared black-and-white film and the recommended No. 25 red filter; for nearby subjects, try 1/30 at f/11. And for Kodak Ektachrome Infrared color, try the same shutter speeds at f/16.

Focusing is easy, too—though infrared rays don't focus in the same plane as visible light. Most adjustable-camera lenses today have infrared focusing marks (a red "F" or dot) for black-and-white film; to use these, you focus normally, then read the distance setting and refocus till that setting is opposite the red mark. With single-lens reflex cameras, results will be close enough if you focus with a No. 25 red filter on (though you'll have trouble doing that except on the brightest days). For color, when visible light predominates, you need no correction.

Even with the sharpest focus, not everything will be sharp. Tree leaves, for instance, will often be a little fuzzy, but tree trunks and bare limbs will be sharp. That's because the leaves reflect so much infrared they leave a "halo" on the film, just as areas overexposed by normal visible light would do.

Infrared film is sensitive to visible light, as well as infrared. So, to keep

the visible light from swamping the infrared image, you need a filter: No. 25 red (or the darker 29, 70, 87, 88A or 88C) for black-and-white infrared film, and the No. 12 yellow (or 8, 15 or 22) for infrared color. Naturally, the filters will affect the visible-light image, too, but results are *not* the same as when shooting standard films with the same filters. In our barn scene above, for instance, a red filter would have darkened the foliage as well as having lightened the barn. But in infrared, the effect is completely different.

It's a bit too different when you're shooting people. Under infrared, flesh looks translucent, and blood vessels can stand out visibly (doctors use infrared as a diagnostic tool for that reason). So, though people may come out as ethereal-looking as our sample, they often look like ghostly waxworks.

Infrared landscapes are most spec-

Infrared black-and-white shot (above) turns foliage white and sky almost black for unearthly, moonlit look. Compare normal black-and-white, color shots (left).

tacular in the fall (before the wind blows the leaves away) and in summer. But a special precaution is required in summer: Infrared film should be kept as cool as possible, and processed as soon as possible after shooting. That's because warm objects emit infrared—and while an object would have to be at least 200° F. for you to photograph it by its infrared emissions, even a day or two at 80° or 90° can cause image deteriorations such as color shifts or fog.

If this should happen, don't give up: Even poor-looking, fogged infrared negatives can sometimes produce good prints, especially on a harder grade of paper. The results will be well worth the trouble. ★★★



People look strangely pale and translucent in infrared shots; note the pale lips, low contrast, change in hair color and eye shadow in the infrared photo (above, left).

Infrared color (left) darkens blue skies and turns foliage from green to magenta.

Now: LP records for your TV set

by Ivan Berger
ELECTRONICS EDITOR

Take a record from its jacket, drop it on a turntable, push a button—and instead of music, out comes a TV picture, visible on your existing set. That's the vision a host of major (and some minor) companies are offering for the end of next year.

Europeans can already buy video disc systems from TED (formerly Teldec), a Telefunken-Decca joint venture. Costing \$650 per machine and \$4.30 to \$11 per disc, the TED recordings will play for only 10 minutes.

At a disc speed of 1800 rpm, video's high frequencies make ripples in the groove too tiny for a needle to follow: TED's "stylus" rides, sledlike, over several such ripples at a time, squashing them down, then sensing



MCA/Philips discs are tracked optically by light reflected from laser, allow speed-up, slow-down, freeze-frame and reverse.

the pressure change as each ripple slips out behind the passing stylus. Proponents of other video disc systems claim that this can cause wear: TED itself claims 1000 plays per record.

The U.S. industry is waiting to see what the big guns—RCA and Philips—introduce for sale in late 1976. Each has a system claimed to play a 12-inch, \$10 disc for at least

30 minutes per side. But there are few other similarities between them.

RCA's system involves physical tracking of a groove—but not of the modulations that carry its signal. These are sensed electrically as a metal layer rises and falls beneath the stylus's level path along the groove (a phonograph needle, by contrast, rises, falls and moves from side to side with the groove modulations). RCA claims this reduces wear to the point that a disc will last thousands of plays (more often than you'll want to play one), and a stylus will be good for at least 200 hours and up to 300 hours before you have to spend \$10 on its easy-to-install replacement.

The other system, developed first independently, then cooperatively by Philips of the Netherlands and MCA Discovision of the United States (and compatible with discs made by Zenith), is far more sophisticated technically, which might make it harder to manufacture and service economically.

Where the RCA system scans the disc physically, guided by the grooves, the MCA/Philips disc is scanned by light from a laser which is guided by feedback from the optical pickup that senses not only the signal but when the laser beam is leaving the signal path. The disc, turning at 1800 rpm (to RCA's 450) reflects the laser beam back to an optical sensor that reads the signal-carrying modulations.

Since there are no physical groove walls to be jumped, the optical system also allows a single groove to be repeated, holding a single frame for closer study, and for frame-by-frame, or slow-motion viewing of the picture, either forward or backward.

The Philips system will probably be available first from Magnavox dealers—North American Philips has just bought a controlling interest in Magnavox. Players will cost about \$500, while discs will be about \$2 to \$10 each.

MCA already has a reservoir of more than 11,000 films available for disc use. The lasers will cost more to replace than RCA's capacitive-sensor

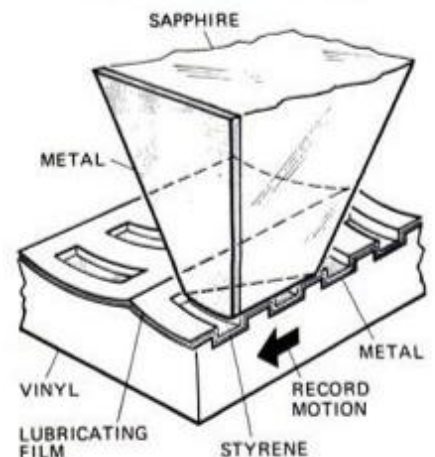

RCA disc has grooves tracked physically by stylus gliding over groove modulations (phonograph needles bob in and out to follow them), sensing varying distance of metal coating from plane of stylus motion.

styli, but will last "thousands of playing hours."

A smaller U.S. firm, i/o Metrics, is also working on an optical system, using a light bulb shining through a transparent disc. It hopes the players will cost about \$300 each, and one-hour color discs will sell for about the price of phonograph records. But no production plans have been announced so far. ★★

New speed for scuba



Hitched to an air tank, new Scuba-Drive provides 3-mph push which diver controls with switch in right hand, buoyancy compensator valve in left. At right, instructor Bruce Uekert shows diver Jane Edwards how to attach the 32-pound unit.



A piggy-backpack with electric power will be pushing scuba divers up to three mph underwater this summer. The new accessory is being introduced by the Kalamazoo Products Div. of the Shakespeare Co.

Recommended for experienced divers, the Scuba-Drive fits over the diver's air tank for an hour of constant running, at depths to 200 feet, before recharging of its two gel-cel batteries is necessary. Spare batteries are available for quick interchange. Thrust comes from the well-tested Shakespeare trolling motor, and speed is controlled by a hand-held switch with spring-clip bracelet so it can be dropped to leave hands free. Price is about \$500.

An underwater tow of three mph is also provided by the Submobile, \$450 from the same maker. Both units recharge overnight, help a diver cover more depth and distance while conserving air and energy.

—Bill McKeown



Push or pull power are options given by Scuba-Drive and surface or underwater hand-held Submobile.

Cypress Gardens photos by Jerry Imber

Eight easy-to-build fence designs

Good fences do indeed make good neighbors. Careful planning and fence-building know-how will get you off to the right start.

The most important step in planning a fence is deciding what you want it to do. For example, a fence can admit sunlight and allow air to circulate or it can block them out. It can furnish varying degrees of privacy.

A fence can protect your garden from neighborhood wildlife and child-life, or it can keep your youngsters and pets in so you know where they are. You can use a fence as a space divider, to define an outdoor living area or to screen a service yard. A fence can be a handsome backdrop for plantings.

The hardest part of building a fence is setting the posts. You'll do best to rent a posthole digger if you have a lot of holes to dig. The best way to align the holes and posts so

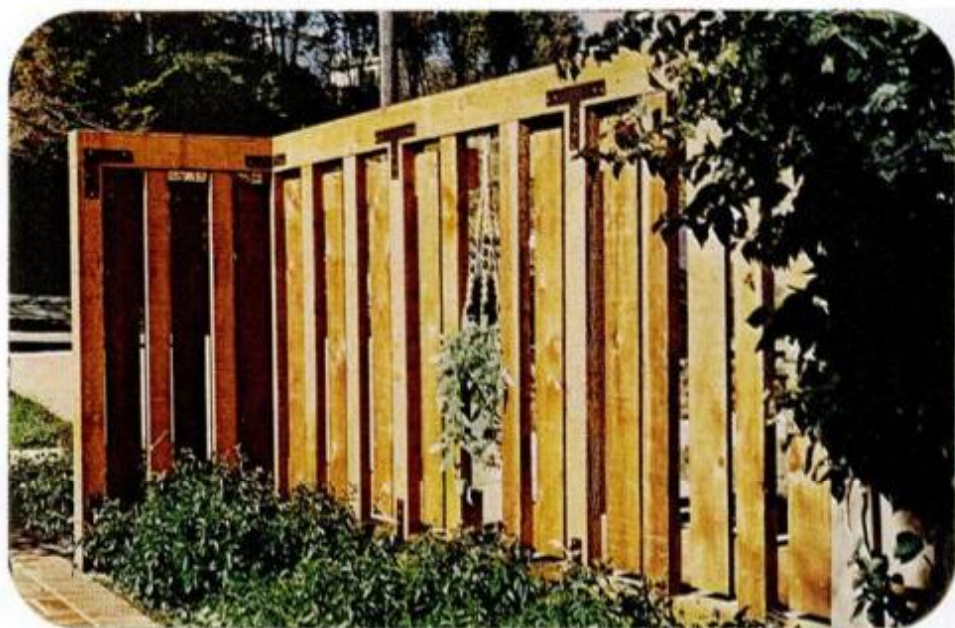

Photos: California Redwood Assn.



How to set fenceposts

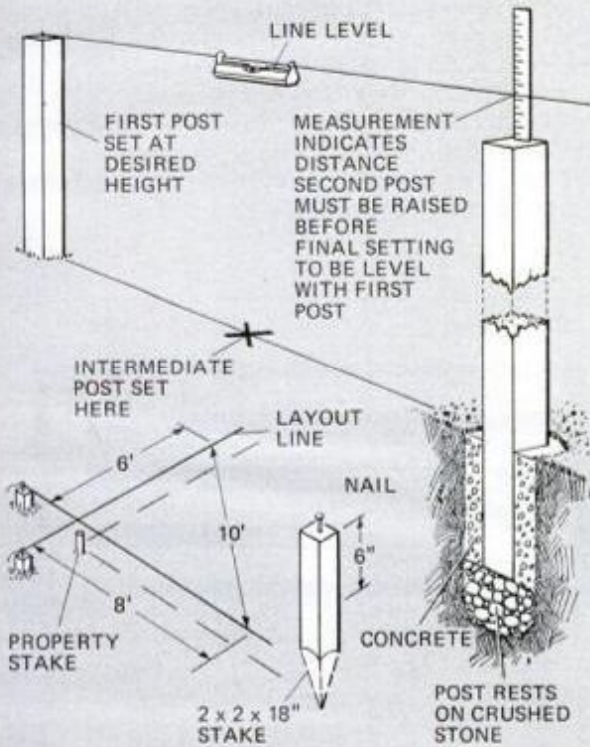
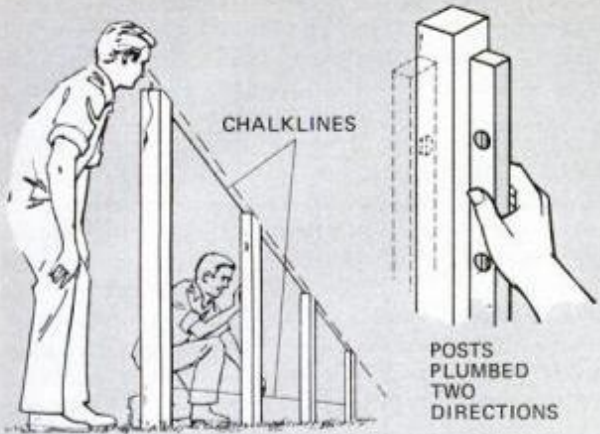

To obtain a square fence corner at your property line use 6, 8 and 10-ft. measurements as shown. Keep in mind that many zoning laws require fences to be set back a certain distance from property lines. After boundary markers for your fence have been accurately established, stretch a masonry (chalk) line taut between nails in tops of the marker stakes. Spot the locations of the posts on the ground along the line 8 ft. apart. Dig the holes for the two end posts first, a minimum of 30 in. deep for a low open fence, 36 to 42 in. deep for a high, heavy fence. If it's a long fence, dig the hole for the second post no more than 50 ft. from the first. Set one end post to establish the fence height, plumb both planes and attach a line to the top of the post. Stretch the line to the opposite end post, hang the line level on it, and, with a helper, raise or lower the far post until the line level reads level. Set the post accordingly by digging the hole deeper or filling, then set it permanently in concrete. The post should rest on crushed stone so water will drain freely and not promote decay.

High fences

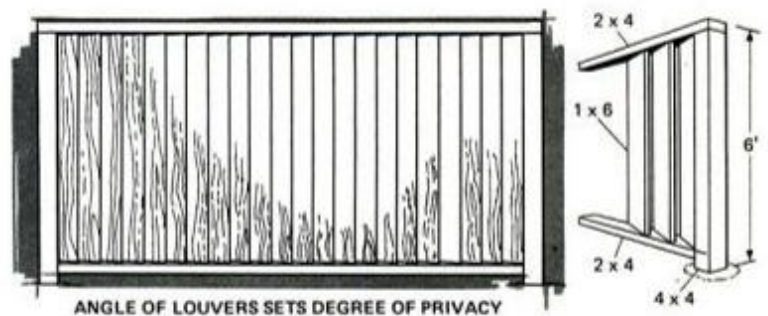
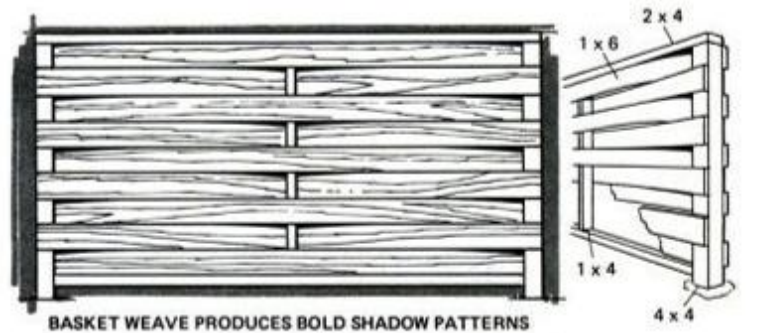
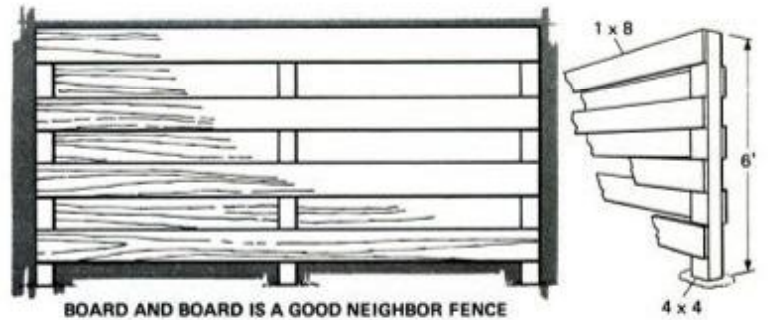
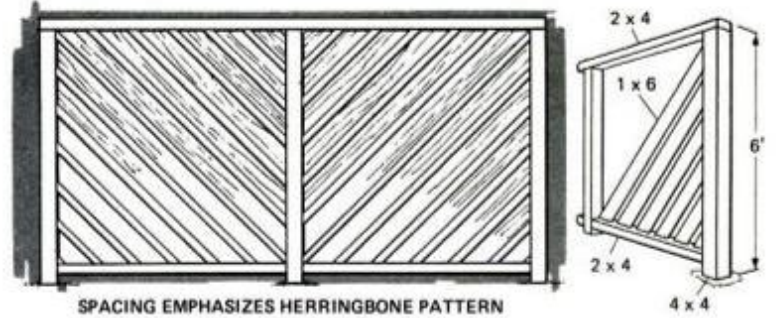
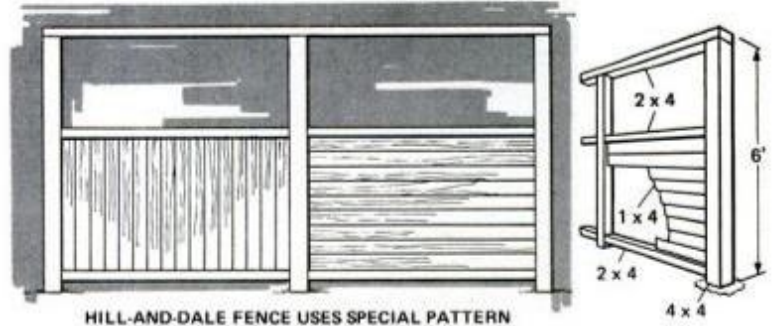

Art: Roy Grinnell

POST AND RAIL JOINTS

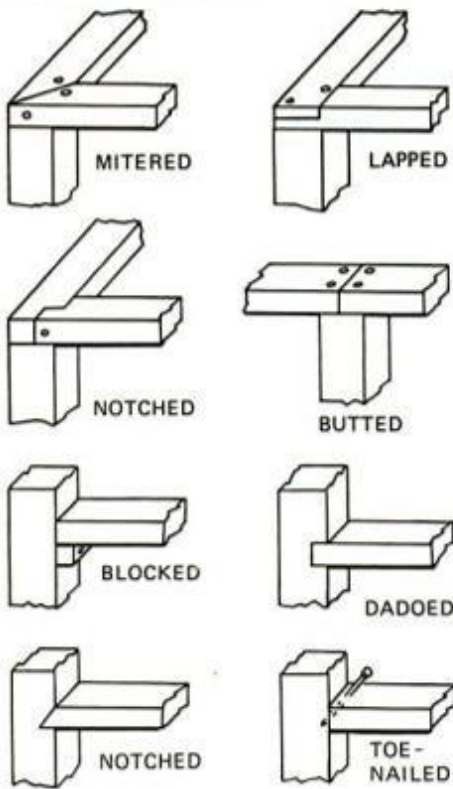

your fence will be straight is to dig and set the end posts first. Then stretch a string between them at ground line and mark the holes 8 ft. apart with stakes. Four-by-four posts are usually adequate for fences up to six feet high; higher fences, or fences in areas with strong winds, may require larger posts.

The most durable fences are made of redwood, which requires the least maintenance. Lumberyards sell several grades of redwood in two categories: the all-heartwood grades and those that may contain sapwood. All-heart redwood should always be used for posts and other members of a fence that will come in contact with the ground; it contains natural extractives that protect the wood from termites and decay. The more economical sapwood grades are okay for other fence members above ground.

Drawings at the left show different ways the top and bottom rails can be joined to the posts. Toenailed butt joints are the simplest, but also weakest. The top rails should be mi-

tered or lapped at the corner posts. It is important that you use aluminum-alloy, stainless-steel or hot-dipped galvanized nails in your redwood fence. Common nails won't hold as well and will rust and stain wood. Redwood fence boards come in 3, 4, 6, 8, 10 and 12-in. widths and various thicknesses. Both nominal and dressed sizes are given in the chart at the right. A 2x4, for example, measures approximately 2x4 in. rough. After surfacing, the same 2x4 measures 1 5/8 x 3 1/2 in. Other than for appearance, there is no need to stain or paint a redwood fence to protect the wood. Exposure to sun and rain will not harm it but will change its color. After a few months, the wood will develop dark streaks, but these will disappear in time and the wood ultimately will weather-bleach to a pleasing driftwood gray. However, a clear water-repellent finish is highly recommended. Easy to apply, it stabilizes wood color, retards weathering and reduces moisture effects. ★★★

Low fences

Most likely you will have height limitations for your fence along property lines, as local building codes impose restrictions. The three low fences shown here are of minimum height and often built to meet local requirements. All are "good neighbor" fences since they are good looking from either side.

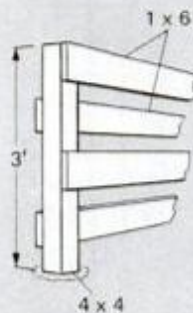

HORIZONTAL BOARD ON BOARD IS INFORMAL

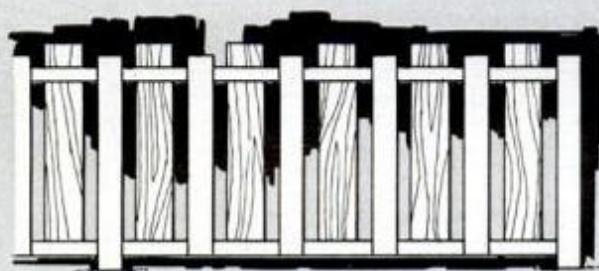

ALTERNATE WIDTHS ON ALTERNATE SIDES

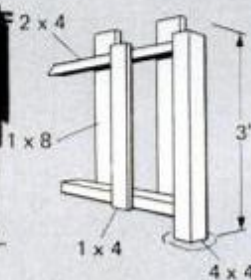

California Redwood Assn. recommends the application of a water repellent on redwood fences. This is best done before starting your fence; coat all surfaces, edges and ends. Water repellent retards natural weathering, reduces the effects of moisture, protects wood from dirt and grime and serves as a finish itself.

Most fences are built of 4x4 posts, 2x4 stringers and 1-in. boards (usually 8 or 10 in. wide). Redwood makes the best fence, unseasoned grade shrinks less and is more stable than other softwoods. Your lumber dealer will help you select the grade of redwood best suited for the fence you plan to build.

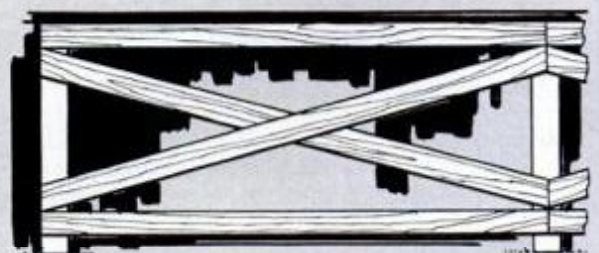
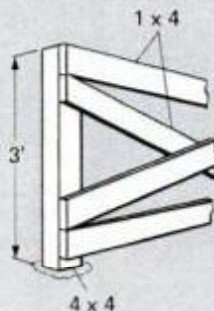

POST AND RAIL SUITS RANCH-STYLE HOMES

KILN-DRIED FINISH LUMBER

THICKNESSES

Nominal	1/2	3/4	1	1 1/4	1 1/2	2
Dressed	7/16	11/16	3/4	1 1/16	1 1/16	1 5/8

WIDTHS

Nominal	3	4	6	8	10	12
Dressed	2 1/2	3 1/2	5 1/2	7 1/4	9 1/4	11 1/4

UNSEASONED BOARDS, STRIPS, DIMENSION

THICKNESSES

Nominal	3/4	1	1 1/4	1 1/2	2	3	4	6
Dressed	11/16	2 3/32*	1 1/16	1 1/16	1 5/8	2 1/16	3 1/16	5 5/8

WIDTHS

Rough (nominal)	3	4	6	8	10	12
Dressed grade	2 1/16	3 1/16	5 5/8	7 1/2	9 1/2	11 1/2

Take good care of your redwood lumber between the time it is delivered and actually put to use. Store it under cover and off the ground. Store it where the wood will not be walked on, dented or otherwise marred, and store it flat. Lumber that is not stored on a flat surface may warp and retain a permanent bow which will show up in your finished fence.

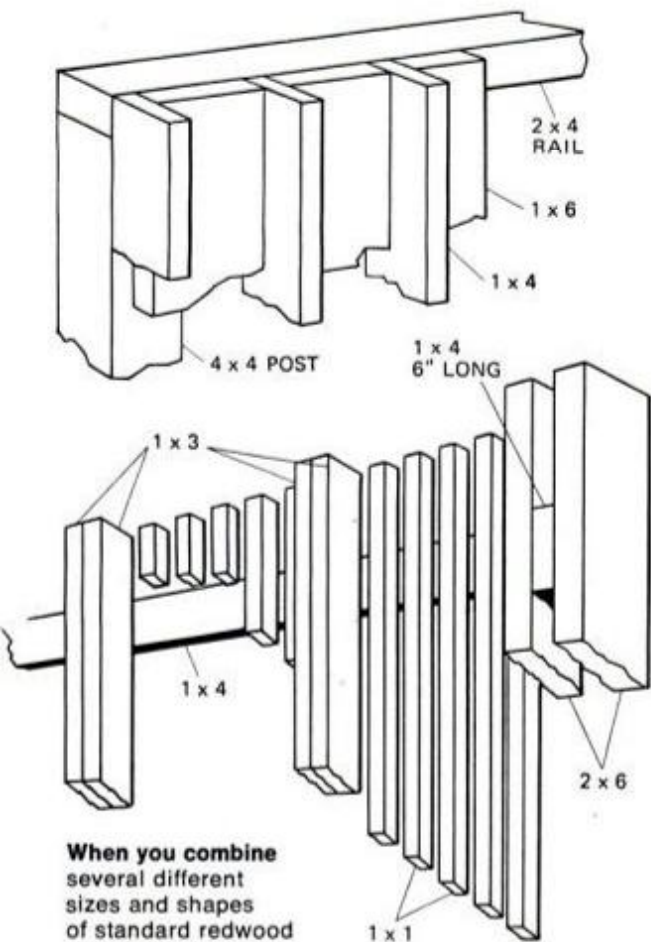

When you combine several different sizes and shapes of standard redwood lumber, as shown in these two examples, there is no end to the attractive fences you can design and build.



Deck wind screen with built-in benches and shrubbery niches provides solid-wall privacy for outdoor dining and leisure activities.

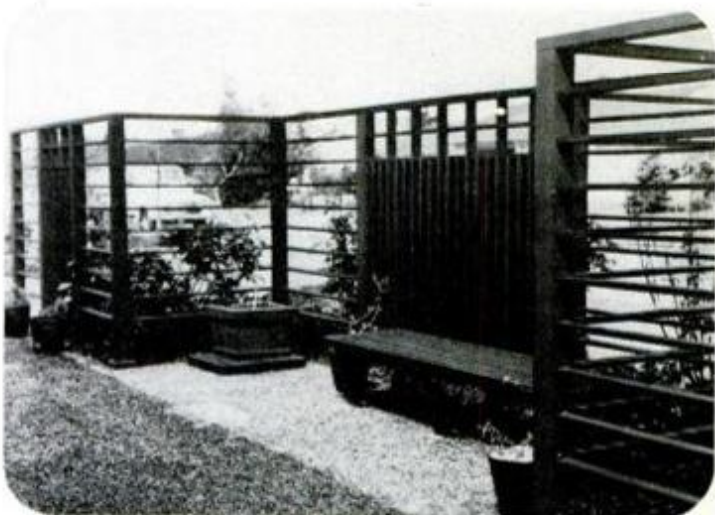

Open screen design effectively separates spaces without visually walling them off.

Baffle-like design breaks up strong wind currents, still lets air circulate freely.



It's a real Rube Goldberg!

The fantastic inventions that gave rise to a new term in our language also provided America with a lot of laughs.



Still creative at 80, Rube Goldberg gave up work as a cartoonist and turned to sculpture, completing some 300 pieces, including the head of Nikita Khrushchev. The cigar was a fixture with him.

The energy crisis might never have happened if we, as a nation, had simply closed our ears to the siren songs of the Fords and Edisons, and paid more attention to the work of Prof. Lucifer Gorgonzola Butts. In support of that view and in hopes of generating renewed interest in the energy-saving principles espoused by the professor, four examples of his highly original thinking are shown on these pages.

You will note that the systems shown do not rely for power on fossil fuels or electricity. (The auto doesn't count.) Instead, there's an ingenious use of gravity, bird power, goat power, monkey power, insect power and pancake power. Except for the gun, none of the elements has an adverse environmental effect. Contrast these clean and quiet systems, if you will, with the noise and fumes we're subjected to by Mr. Ford's brainchild.

Another good reason for publishing these inventions at this time is that July 4 is the anniversary of the birth

of Rube Goldberg, without whose dedicated efforts the work of Professor Butts would never have come to light. Rube died in 1970 at the age of 87, ending a creative career that had spanned 66 years. After publishing some 50,000 cartoons in addition to writing books, articles and short stories, Rube, at the age of 80, became a sculptor. He was, as his biographer Peter C. Marzio has so aptly described him, "a torrent of creativity, a wellspring of laughter."

He is best remembered for his fantastic inventions—a point made in the many newspaper eulogies that appeared after his death. "Indeed, his fantastically complicated devices to achieve ludicrously simple ends are today more profound commentaries on our times than they were when his mischievous mind first conceived them several generations ago," commented a Chicago *Sun-Times* editorial. "The contraptions Rube Goldberg invented in his younger years were the progenitors of the

© Rube Goldberg, permission granted by King Features Syndicate 1975

The Inventions of Professor Lucifer G. Butts, A.K.

By RUBE GOLDBERG

PROFESSOR BUTTS MAKES A PARACHUTE JUMP, FORGETS TO PULL THE STRING AND WAKES UP THREE WEEKS LATER WITH AN AUTOMATIC DEVICE FOR KEEPING SCREEN DOORS CLOSED. HOUSEFLIES (A) SEEING OPEN DOOR, FLY ON PORCH. SPIDER (B) DESCENDS TO CATCH THEM AND FRIGHTENS POTATO-BUG (C) WHICH JUMPS FROM HAMMER (D) ALLOWING IT TO DROP ON PANCAKE TURNER (E) WHICH TOSSES PANCAKE INTO PAN (F). WEIGHT OF PANCAKE CAUSES PAN TO TILT AND PULL CORD WHICH STARTS MECHANICAL SOLDIER (H) WALKING. SOLDIER WALKS TO EDGE OF TABLE AND CATCHES HIS HEAD IN NOOSE (I) THEREBY HANGING HIMSELF. WEIGHT IN NOOSE CAUSES STRING TO PULL LEVER AND PUSH SHOE AGAINST BOWLING BALL (J), THROWING IT INTO HANDS OF CIRCUS MONKEY (K) WHO IS EXPERT BOWLER. MONKEY THROWS BALL AT BOWLING PINS PAINTED ON SCREEN DOOR THEREBY CLOSING IT WITH A BANG. THE MONKEY IS LIABLE TO GET SORE WHEN HE DISCOVERS THAT THE BOWLING PINS ARE PHONEY SO IT IS A GOOD IDEA TO TAKE HIM TO A REAL BOWLING ALLEY ONCE IN A WHILE JUST TO KEEP HIS GOOD WILL.

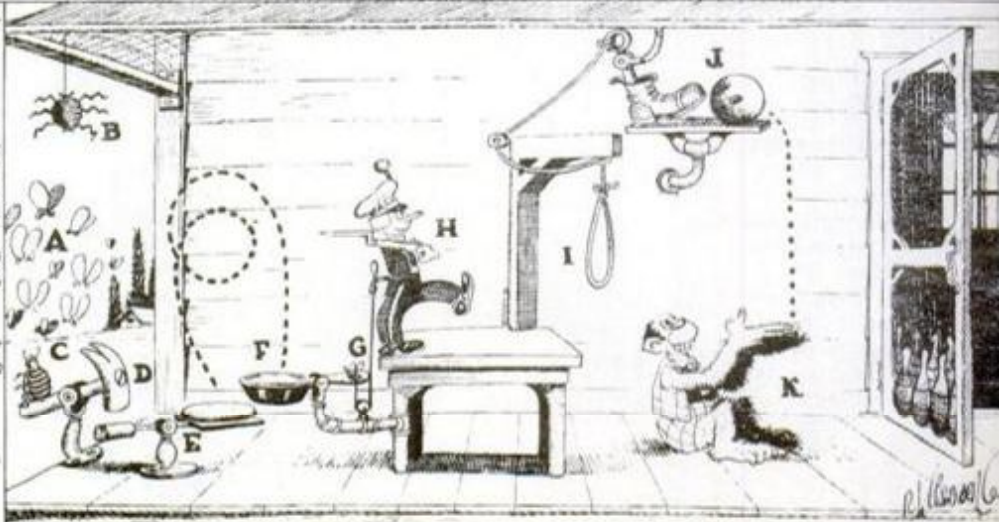

PROFESSOR BUTTS STEALS A RIDE ON TOP OF A TRAIN, FORGETS TO DUCK AT THE ENTRANCE OF A TUNNEL, AND BLURTS OUT AN IDEA TO INSURE SAFETY AT RAILROAD CROSSINGS. AS COMMUTER (A) HEARS TRAIN WHISTLE HE THINKS HE IS LATE AND RUNS ACROSS FIELD TO MAKE SHORT-CUT, SCARING OUT JACK-RABBIT (B) WHO ATTRACTS ATTENTION OF GIFFIK HOUND (C). HOUND JUMPS, PULLING STRING (D) WHICH RAISES END OF BOARD (E) AND PUSHES HANDLE OF SQUIRT GUN (F) WHICH WETS BACK OF DUCK (G). AS WATER ROLLS OFF DUCK'S BACK IT RUNS DOWN TROUGH (H) ON TO SPONGE (I). AS SPONGE BECOMES HEAVY, EXTRA WEIGHT PULLS HOOK (J) CAUSING IT TO RELEASE SPRING (K) CAUSING BASEBALL BAT (L) TO HIT BASEBALL (M) INTO CATCHER'S GLOVE (N) AND PUSH BOX OF TACKS (O) FROM SHELF. AS TACKS SPILL ON ROAD THEY PUNCTURE TIRES AND FORCE DUMB DRIVER TO STOP EVEN THOUGH HE WANTS TO BEAT SPEEDING TRAIN AT CROSSING. THE TIRE EXPENSE IS QUITE AN ITEM BUT TIRE BILLS ARE GENERALLY SMALLER THAN UNDERTAKERS' BILLS.

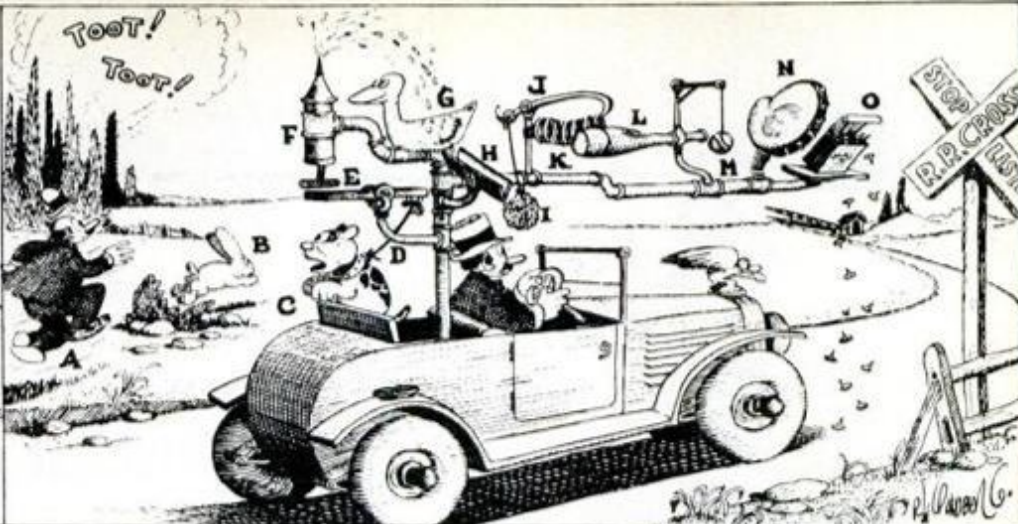

MAN IN RESTAURANT MISTAKES PROFESSOR BUTTS FOR A HERRING, SPRINKLES PEPPER ON HIM AND HE SNEEZES UP AN IDEA FOR SENDING A LATE-STAYER HOME. AT 1 A.M. DOOR OF CUCKOO CLOCK (A) OPENS CAUSING STRING (B) TO TRIGGER OF GUN (C) AND SHOOT CUCKOO (D) WHICH FALLS ON BOARD (E). WEIGHT OF CUCKOO THROWS KNIFE (F) AGAINST SAND BAG (G) CUTTING HOLE (H) IN BAG ALLOWING SAND (I) TO RUN DOWN ON SCALE (J). CORD (K) CLOSES SHEARS (L) WHICH CUT STRING (M) ALLOWING MASK (N) TO DESCEND OVER VICTIM'S HEAD (O). LODGE GOAT (P) THINKING THAT LATE-STAYER IS BEING INITIATED BUTTS HIM OUT INTO THE STREET. DON'T WORRY ABOUT HIS HAT AND COAT AS HE WILL NOT NEED THEM IN THE HOSPITAL.

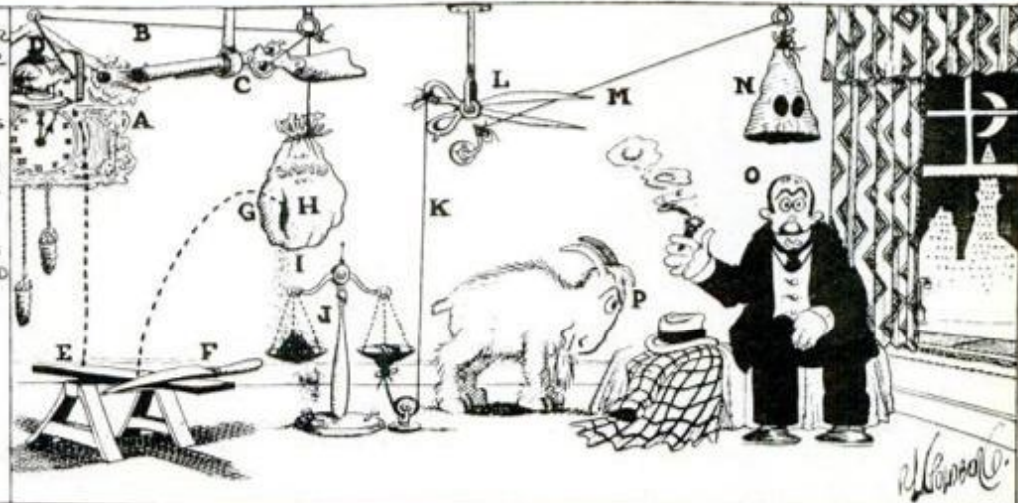

PROFESSOR BUTTS GETS CAUGHT IN A REVOLVING DOOR AND BECOMES DIZZY ENOUGH TO DOPE OUT AN IDEA TO KEEP YOU FROM FORGETTING TO MAIL YOUR WIFE'S LETTER. AS YOU WALK PAST COBBLER SHOP, HOOK (A) STRIKES SUSPENDED BOOT (B) CAUSING IT TO KICK FOOTBALL (C) THROUGH GOAL POSTS (D). FOOTBALL DROPS INTO BASKET (E) AND STRING (F) TILTS SPRINKLING CAN (G) CAUSING WATER TO SOAK COAT TAILS (H). AS COAT SHRINKS CORD (I) OPENS DOOR (J) OF CAGE ALLOWING BIRD (K) TO WALK ON PERCH (L) AND GRAB WORM (M) WHICH IS ATTACHED TO STRING (N). THIS PULLS DOWN WINDOW SHADE (O) ON WHICH IS WRITTEN: "YOU SAA, MAIL THAT LETTER." A SIMPLE WAY TO AVOID ALL THIS TROUBLE IS TO MARRY A WIFE WHO CAN'T WRITE.

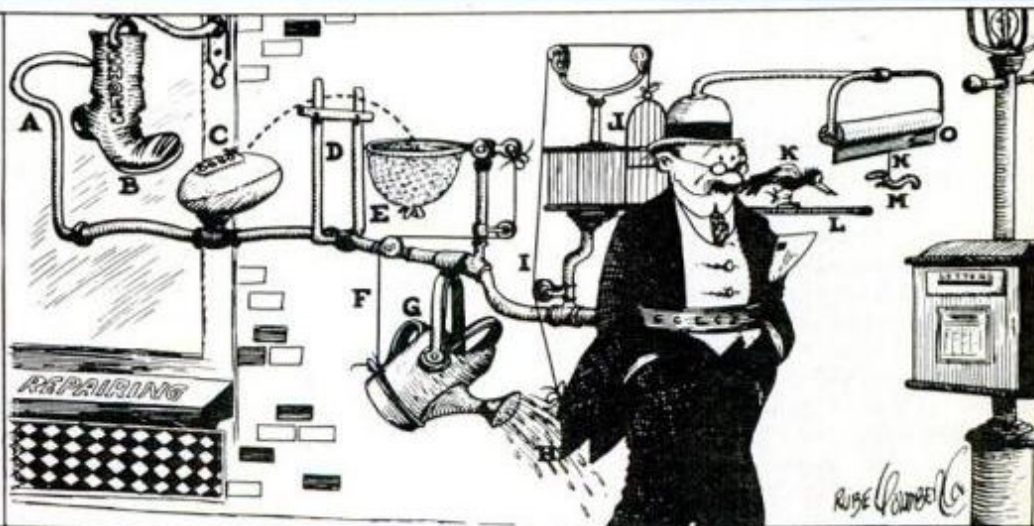

complex mechanical creatures which are now engaged in the amazingly simple occupation of picking up stones on the face of the moon," a reference to the Surveyor moon-lander.

Rube's contrivances had such impact that they ultimately added a new term to our language. A "Rube Goldberg," according to *The Random House Dictionary of the English Language*, is a device "having a fantastically complicated, improvised appearance"; it is also apt to be "deviously complex and impractical." Something

can also be descriptively identified as "Goldbergian" or "Rube Goldbergian".

In one of his books, Rube observed: "As we move forward along the gadget-strewn path of mechanization we become more and more aware of its general theme, DO IT THE HARD WAY. The more trivial the product, the more complicated the machine."

But Rube Goldberg was more than a social critic. He was also a vital human being and a very funny man, as the cartoons reproduced here show.—John F. Pearson

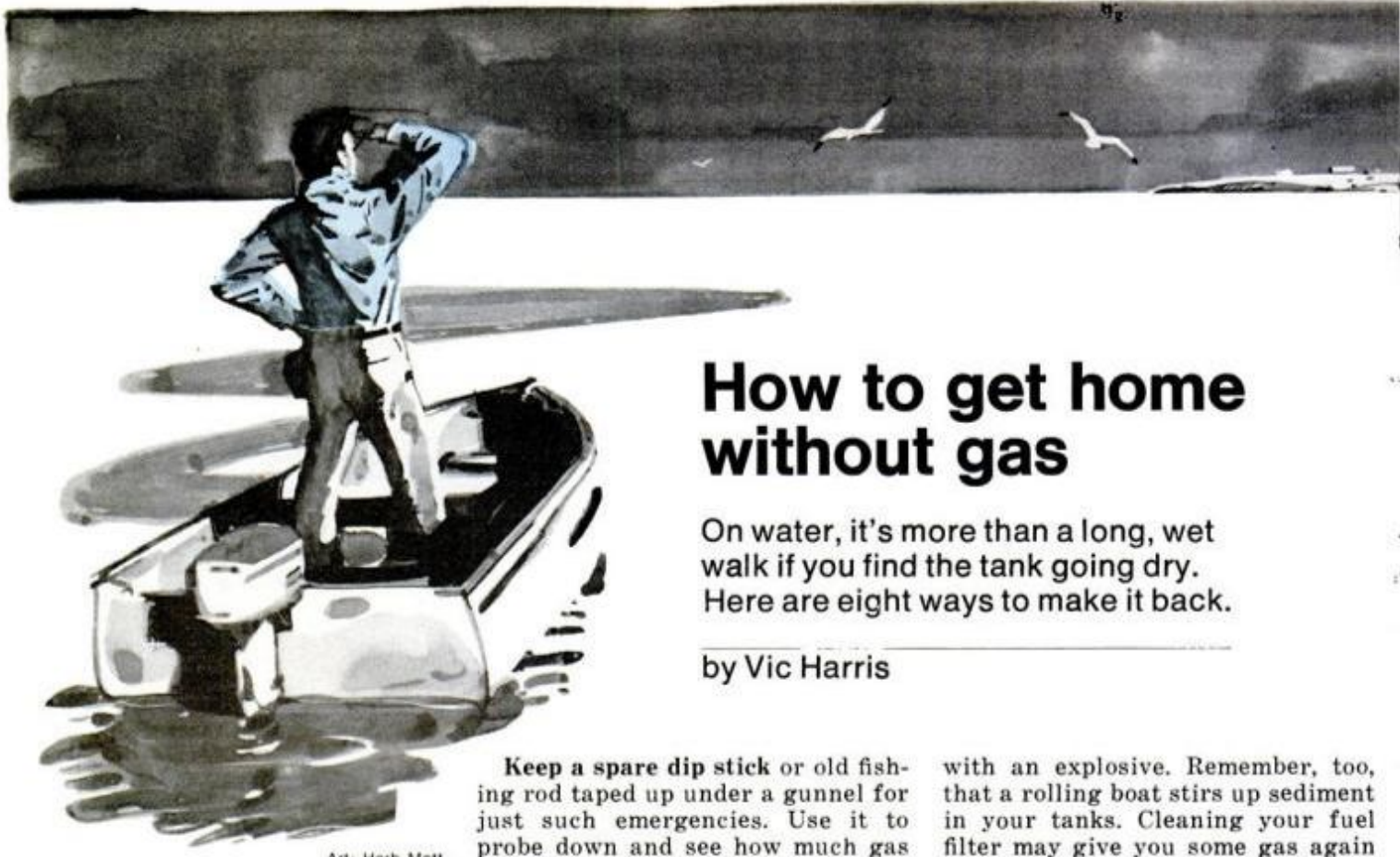

Art: Herb Mott

How to get home without gas

On water, it's more than a long, wet walk if you find the tank going dry. Here are eight ways to make it back.

by Vic Harris

It can happen to anyone. You are well offshore when your motor coughs, and the land is only a line along the horizon. You remember the fuel gauge has been none too accurate, and the kids didn't chip in and gas up after water skiing. Now the motor sputters again as the boat rolls and there is no doubt—you are about to run out of fuel, it's late afternoon and there are no other boats in sight.

Like many boatmen you haven't really planned what to do in a case like this. Most of us figure we'd drift a while until we could flag someone down for a tow, perhaps, or a loan of a couple gallons to get home. No more bother than a little embarrassment—if a boat comes by. But many skippers today have no gas to spare, even if you have some kind of siphon along. Right now is the time to figure what *you'd* do, and what you'd need to have along if your boat's gas tank threatens to run dry these days of shorter fuel supply.

First, that moment you start to sweat out your gas supply, slow down. Really slow. So slow no trace of wave is pushed out from your bow or rolls out from your stern. No energy should be used up moving extra water out of the way. It will be a long trip home at less than trolling speed, but it takes minimum fuel.

Keep a spare dip stick or old fishing rod taped up under a gunnel for just such emergencies. Use it to probe down and see how much gas is really left. And in your tool kit keep a long-tube siphon. This isn't just for borrowing gas. Your gas line's pickup may not quite reach the bottom of the tank. Siphon the extra out of the corners of a fixed tank, or pour it out of a portable outboard tank into a container, and you may get enough out of a "dry" tank to dribble into your carburetor for power to idle you home. Remember, of course, that you're working

Waving for help requires two hands for attracting attention of passing boats.



with an explosive. Remember, too, that a rolling boat stirs up sediment in your tanks. Cleaning your fuel filter may give you some gas again if there's still fuel in the tank and the filter is just clogged.

Waving for help is fine—if it works. One-hand signaling will probably just get you a friendly wave back from a passing boat. Instead, stand (if it's safe to) and swing both arms up and down at your sides. Holding a bright towel may help. Shouting usually doesn't, but continually sounding your horn might attract attention. Mirrors, smoke and dye markers, flares, flashing lights, firing a gun (if legal) can sometimes do the trick. Now is the time to be sure you have such equipment along. With two-way VHF marine band radio, you can call for help from the Coast Guard in many areas. Citizens Band is not C. G.-monitored, but try it anyway if you have one; someone may be listening.

The Coast Guard has a good booklet, *A Pocket Guide for Visual Distress Signals, CG-152*.

Kedging is a traditional method that does work very well today if the water is not too deep. During the centuries of sail (and no motors), a ship's longboat would row out ahead with the anchor and then drop it. Deckhands would then winch the ship forward as they hauled it back in. Today you do this singlehanded, but it works almost as well.

Stand up, face forward in your boat, and with a coil of nylon anchor line in one hand, swing your light "lunch

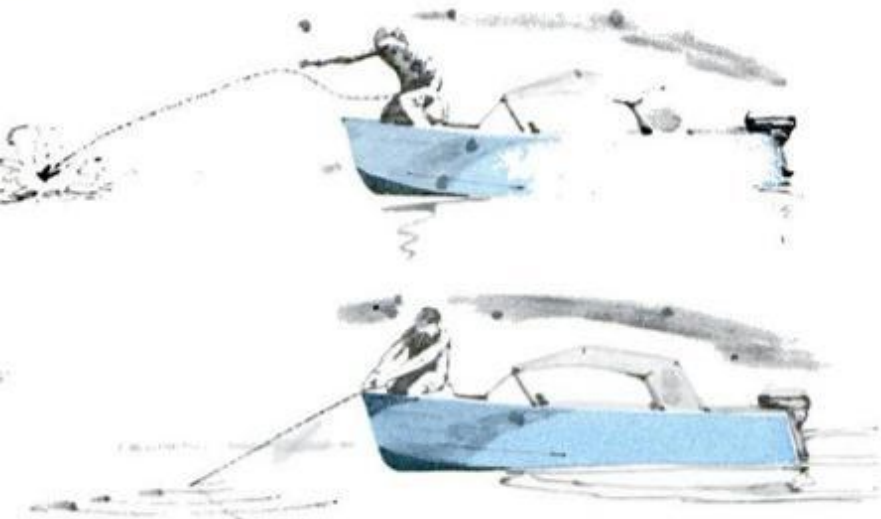

Kedging is a traditional way of tossing a small anchor forward and then hauling your boat to it. The system is just as successful, and exhausting, today.

hook" anchor forward as far as you can in an underhand toss. Once it sinks and bites in, haul your boat forward, raise the anchor, and coast along until your momentum stops. Don't overexert. You're going to need to do it a lot of times to get to shore, but if your anchor line is at least a little longer than the depth of the water, you can ease your way in. Kedging isn't fast, but it works.

Even calm lakes often have some current running that can eventually drift you in toward shore. If there is no wind, drop a crumpled piece of paper overboard and see which way it moves. If you can see landmarks ashore, line up sights on them and try to determine if the

water is carrying you in the direction you want to go.

A sea anchor—that cloth cone that keeps a disabled boat pointing



Sculling is a skill requiring practice, but is less likely to cause a heart attack.

into storm winds—can also help you drift along. Few small boats carry one any more, but a bailing bucket on a long line can work like one. In a river or tidal area where a current is drifting you rapidly, a powerboat's rudder is usually of little help when you try to steer. Using a paddle will sometimes push you in the right direction in a small boat. Have an anchor ready to toss out

(Please turn to page 134)

Sailing a powerboat requires something to catch wind. Not speedy, but it works.



Ways to call for help

When you run out of gas or have any other emergency afloat in which you require assistance, you will need to use sight or sound signals. Sound does not usually travel far enough to reach boatmen or people ashore out of sight over the horizon. Try whistles or fog horn blasts to attract attention of nearby craft that are visible. With a marine radio/telephone your "Mayday" call is limited by the range of your VHF set, usually about 20 miles.

Wave arms up and down at your sides during daylight hours while holding bright objects. Wave a flag or sheet of orange cloth. The Canadian Surface-to-Air Signal, a rectangle of fluorescent orange with a black ball on it, is recognized in both the United States and Canada.

On a sunny day, a mirror can reflect a beam of up to 8-million candlepower and can be seen 40 miles.

Fire is dangerous aboard any boat, but a smoke bomb is very effective if another boat or airplane is in sight. In dire emergency, a smudge fire of oily rags can be burned in a metal pail or tackle box.

Dye marker will turn water around you a bright greenish color for about half an hour and can be spotted by a plane 10 miles away. Use it once you see or hear a plane.

Surface-to-air signals

I REQUIRE DOCTOR —SERIOUS INJURIES	II REQUIRE MEDICAL SUPPLIES	X UNABLE TO PROCEED
N NO-NEGATIVE	Y YES— AFFIRMATIVE	JL NOT UNDERSTOOD
K INDICATE DIRECTION TO PROCEED	↑ AM PROCEEDING IN THIS DIRECTION	△ PROBABLY SAFE TO LAND HERE
F REQUIRE FOOD AND WATER	LL ALL WELL	□ REQUIRE COMPASS AND MAP

Small craft of wood or plastic are hard to spot in rough sea conditions. Folding metal and foil radar reflectors help search craft. Even metal pans hoisted in the rigging are an aid.

Helicopters can help locate your position, stand by until surface help arrives, and sometimes evacuate injured crew members. Because of their noise, however, you probably cannot communicate with them without a radio, and you can seriously endanger a copter by securing its hoist line to your boat (a normal reaction) while loading an injured passenger aboard a helicopter's litter. Instructions for working with a rescue helicopter are found in each issue of the United States Coast Pilot volumes.

Before setting out, it is always wise to let friends know where you're headed. Even more important, once you have called for help, notify those who are looking for you once you are safely home again.

New synthetic oils are now in the crankcase competition. Here's what you should know before your next oil change.

What oil for your crankcase? The selection is staggering. We found everything from "no-name" recycled oils for under 40 cents a quart to unheard-of "synthetics," with incredible mileage claims, for almost \$5 a quart!

Once you've got the stuff in your engine, no one seems to agree on how long it should stay there between changes. And after you do change oil, it's almost impossible to get rid of the stuff in a way that isn't bad for the environment. With all this in mind, PM decided to take a closer look at this whole business of motor oil, where it comes from, and where it goes.

What is motor oil?

Conventional petroleum-based motor oil is one of the many products of crude oil refining. At the refinery, the crude is distilled in tall "fractionating towers" or stills. Gas vapors and gasoline come out near the top, kerosene farther down, heavier heating and diesel oil near the middle, and lubricating oils even farther down. Various residues, including asphalt, are removed from the bottom of the tower.

The lubricating oil is separated into various weights, then processed chemically with "additives" so it can stand up to today's hot, corrosive engine environments. Common additives include:

- *Detergent-dispersants* to remove and suspend harmful sludge and varnish deposits until they can be removed by draining the oil.
- *Viscosity index improvers* to reduce the rate of oil thickening with changing engine temperatures.
- *Pour point depressants* which allow the oil to flow freely at low temperatures, minimizing wear when a cold engine is first started.
- *Antiwear additives* to strengthen the lubricating film so it can stand up to the extreme pressures found in modern engines.
- *Corrosion inhibitors* to counteract the acids and moisture that build up during engine operation and would otherwise rust and pit engine parts.
- *Oxidation inhibitors* to help prevent the formation of acid, sludge, and varnish in the first place.
- *Foam inhibitors* to break up the bubbles formed when oil is churned up. This is important because oil lubricates, air doesn't! (That's why

All about oil

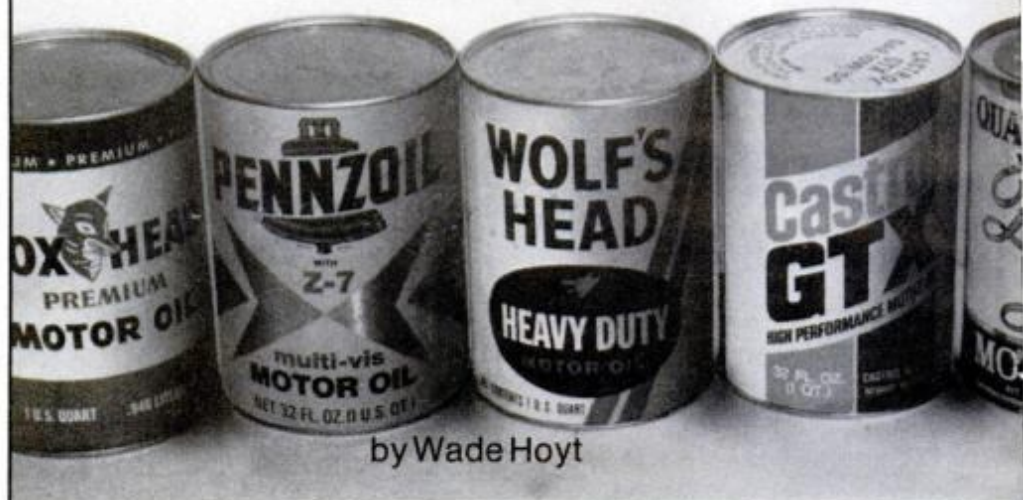

by Wade Hoyt

you should never overfill the crankcase; too high an oil level lets the crankshaft splash through the oil, causing excessive foaming.)

Although the oil itself never "wears out," many of its additives do get used up in their fight against harmful chemicals and conditions inside the engine. Changing the oil physically removes contaminants that are being held in suspension, and the new oil (hopefully) brings with it a fresh supply of additives.

We say "hopefully" because some bargain oils are short on additives. Fortunately, the American Petroleum Institute (API) rates oils on their ability to stand up to thousands of miles of modern driving. This is determined by a series of "sequence tests" run in the laboratory. For example, in the Ford sequence, tests are made for sludge and varnish formation during simulated stop-and-go driving. The Oldsmobile test measures rust and acid accumulation under the same conditions. The Olds test measures the ability of an oil to resist thickening as well as sludge and varnish formation under high-temperature conditions.

An oil passing all three of these tests can carry the API SE rating, meaning that it meets carmakers' warranty conditions for late-model cars. Although there are API ratings down to SA, we could not find any

oil for sale that wasn't either rated SE, or else had no rating at all (making it a very risky proposition indeed!). Oil rated SD meets warranty requirements for 1968-70 cars; SC meets 1964-67 requirements.

Usually, an SE oil can will also bear a statement such as:

"Meets car manufacturers test requirements."

"Passes ASTM sequence tests."

"Sequence tested."

"Meets (or exceeds, or surpasses) car manufacturers' service (or warranty) requirements."

Some marginal oils have to be tested several times before one sample squeaks through these tough sequence tests. To be on the safe side, owners of post-1970 cars should look for the phrase "Exceeds..." or "Surpasses...requirements" on the oil they use.

The Society of Automotive Engineers (SAE) sets the well-known oil viscosity (or "weight" or "grade") ratings. Oils are rated from 5 to 50. Straight 5-weight oil is the lightest and is recommended only for subzero temperatures, and not for sustained speeds over 60 mph. High performance (or just plain old) engines with "loose" clearances and/or high compression ratios often call for 40-weight oil. Trailer towing at high altitudes may require 50-weight oil. The SAE rating is not a



measure of an oil's quality; only of its viscosity.

Better oils meet several of these classifications and are called "multi-grade" or "multiweight" oil. The most popular is 10W-30 with a viscosity range from 10 to 30. The "W" stands for "winter," and denotes an oil suitable for use both above and below 32° F. Today's true "premium" oils, rated at 10W-40 or 10W-50, are suitable for all uses the year around.

Service life

Once you've decided which weight and API rating is right for your car, you can shop around for a brand that meets your requirements at the lowest possible price. But you still must face the problem of when to change it. Carmakers are now recommending intervals of 6000 to 8000 miles. (Porsche recommends 15,000 miles, but then its system has 11.2 quarts to dissipate heat and absorb contaminants!) All these manufacturers' recommendations are for the ideal driving conditions of long, high-speed trips. The small print in most owner's manuals tells you to change the oil twice as often under "severe service" conditions such as frequent short trips in which the engine barely warms up, trailer towing, stop-and-go driving, or very dusty off-road operation.

In a cold engine, sludge and varnish are more easily formed. Water, formed as steam in the combustion process, condenses on cylinder walls and turns to acid when exposed to other combustion by-products. Piston-ring blowby also contaminates the oil.

Carmakers try to cover themselves on oil changes by specifying a time limit as well as mileage; for example, 6000 miles or four months, whichever comes first. They also recommend changing the filter with every other oil change. That will leave a quart of dirty oil in the system on alternate changes, which is nothing to worry about. The fresh oil contains enough additives to last the recommended distance. Still, you might remove the oil filter, empty it of dirty oil and replace it. Naturally, oil filter manufacturers recommend that you change filters each time, and oil manufacturers (through the API) recommend that you change oil every 3000 miles or three months. You should follow the recommendations in your car's owner's manual, but keep those time limits and severe service cautions in mind!

Re-refined oil

Back in the good old days, when oil was sold in bottles instead of cans, there was a thriving business in "reclaimed" oil (the word "recycled" had not yet been invented). Today it's called re-refined oil, a pretty accurate description of how it's made:

Crankcase drainings are run through a fractioning still to remove impurities, then through a sulfuric acid treatment to precipitate out old additives, which are removed by forcing the oil through clay filters. At this point it can be sold as heating oil. It can be made suitable for automotive use by adding a modern additive "package" and blending it with "virgin" oils.

Nearly one-third of the lubricating oil used in West Germany today is re-refined, which helps to solve two problems there—the shortage of virgin oil and the disposal of used oil. Short-sighted legislation in the United States has crippled re-refining here.

Ten years ago, there were over 160 companies reclaiming oil for automotive use in America. Today there are less than 30, despite growing concern over the environment and over the squandering of a limited natural resource.

Under the urging of the powerful oil lobby, Congress passed some complicated shuffling of the excise tax laws in 1965 which removed the 6-cents-a-gallon tax on virgin oil sold to farmers and other "off-road" us-

ers, while the 3-cents-a-gallon tax remained on re-refined oil and blends. An IRS ruling makes the re-refiner pay the 6-cents-per-gallon tax on the virgin oil he buys for blending! This seriously cut into the price advantage of reclaimed oil.

In the same year, the Federal Trade Commission ruled that re-refined oil must bear the onerous label: "Previously used oil." To the average buyer, that sounds pretty suspicious. In fact, it sounds like a description of untreated crankcase drainings! As a result, retail sales of reclaimed oil hit rock bottom, and the industry has been "decimated,"

(Please turn to page 116)

How to get rid of oil you don't want

Now that you've figured out when to change oil, you still must decide what to do with the old stuff. This can be difficult; almost anything you do with crankcase drainings will eventually be hazardous to your health.

Dumping it down the drain will clog up your local sewage treatment plant and it will eventually find its way into someone's drinking water, too. The National Oceanic and Atmospheric Administration feels that the messy "tar" deposits washed up onto our beaches are really crankcase oil, dumped into storm sewers, then hardened by deep ocean temperatures.

Dumping it out behind the back fence is no good either, because it will certainly work its way down into the water table. Only one part-per-million of waste oil is enough to make drinking water repulsive in taste, says the EPA.

Pouring it, untreated, into your oil burner tank is out as well, because burning the oil releases potentially hazardous metallic particles into the air over your very own home.

The EPA estimates that 370-million gallons of waste oil are dumped every year, but it has yet to come up with specific recommendations for how the home mechanic can dispose of drained crankcase oil. Until it does, we have a recommendation that may be far from perfect, but beats sticking it down the drain.

If you cannot give the oil to someone who will forward it to a refining plant we figure that one big pile of sludge is better than many little piles. Pour your used oil into jugs or other nonleaking containers and put them out with the garbage. Under federal law, your local incinerator or dump is supposed to be doing something to prevent air pollution from the substances they burn or toxic leaching from the garbage they bury. When the EPA has a better idea, we'll let you know.—W. H.

Can a slow-speed sport use a high-speed hull? A lot of fishermen today think so, and so does at least one boatbuilder. Now if the bass aren't biting along one shore, MonArk's new McFast can crank up and plane you across the lake in a hurry. Fishing boats used to be heavy skiffs that could hardly row out of their own way—but no longer do you need to use a clunker to catch a lunker.

Viewed head-on, this new-look bass boat has twin sponsons separated by a mid-section airfoil that is characteristic of many of the hottest hydroplanes. The center slot, if properly designed, acts somewhat like a wing to lift the hull. Wetted area and water friction are reduced, and more speed is possible. Unlike a conventional catamaran with twin displacement pontoon hulls for added stability and carrying capacity, the successful tunnel hull skims over the water but without losing steering



Cranked into tight turn by MonArk president Zach McClendon, new hull throws roostertail but corners neatly.

You'll fish faster in this speedy new tunnel

MonArk's McFast 7 bass boat has a high-performance hull that can hustle.

by Bill McKeown BOATING EDITOR

control or going airborne.

Fortunately, this new one is successful and well engineered. Our tests revealed no tendencies for the hull to scoop air and try to kite, or to break free on turns and start to trip or spin out while cornering. Trimmed out on plane, the boat came up with no ugly tricks or stunts like trying to flip a helmsman into the water. An angler can concentrate on his sport instead of his safety.

But why this interest in speedy boats for the slow-speed activity of fishing? Several good reasons. Tournaments have helped push up bass-boat performance. Usually, after a day or so of scouting for likely fishing spots, the main event begins with a whistle or flare to send the contestants out to their predetermined spots. When one location doesn't pay off, they race out to another. In the past some entries have been dangerously overpowered. Most tournament rules now restrict horsepower to the

limit approved for each hull. This latest MonArk speedster is rated for 120 hp.

Getting to a lunker hole first is one satisfaction, and having a rig that's fast enough to get out to distant spots if you have only an afternoon free is another pleasure. But there is also the feeling of driving a hot and well-tuned rig. The average sports-car owner makes a lot more trips to the grocery store than turns around a racetrack, but he thoroughly enjoys a high-performance machine, and the same is true of a fast boat.

Not that this MonArk looks like a racing machine. At dockside or at anchor and viewed from a distance, the 16-foot, 9-inch hull with 77 $\frac{3}{4}$ -inch beam, interior depth of 21 inches and transom height of 20, looks much like a conventional bass boat, though the glistening metal-flake deck tends to give away the fact that she's something special. Inside the



Photos: Jack Penland

730-pound hull a maximum weight capacity of 1269 pounds can be carried, of which 819 pounds can be in passenger weight. Price of about \$3226 for a standard hull (\$3426 for metal flake finish) is not extra high for a quality fiberglass hull with added strength and flotation from foam sandwiched and sealed between the hull, deck and cockpit lining. Live wells, storage compartments, center console, lights, wiring and seats are all standard.

As I idled out to open water with sportsman Zach McClendon, president of MonArk, the hull handled like any conventional bass boat. Then the fun came as I added throttle. With the high pitch with which the engine was propped, she didn't want to come up on plane until the right tilt angle was tuned in with the instrument panel tilt switch toggle. Then the bow came down and she accelerated with the hint of the rush I remembered from Mollanari racing tunnels that

Weaving a wake like a snake, McKeown tests for any tendency to trip, finds hull performance stable and responsive.



Trailer-mounted outside Arkansas plant, new hull features from stepped-sponson bottom to metal-flake top finish are checked by McClendon and PM's McKeown.



Tunnel bottom slot is pointed out by racing driver-designer Mel Mut, creator of new MonArk tunnel hull.

Speedometer flickers at 50 as McKeown pushes 115-hp Johnson wide open with McClendon as copilot.

can top 100 with outboard power. Once on plane and cranked into tight turns, the speedster showed no tendency to break the prop loose to cause cavitation. She slowed but did not fall off plane during sharp cornering. On straightaways, the speedometer flickered over 50 with two aboard, and would undoubtedly have gone higher with a driver only. Adjusting motor height, switching props to tune for recommended peak rpm and fine adjustment of trim will all be refinements that each owner will experiment with for himself with this boat. And with it he will find the pleasures of the fine tuning of details that add up to high performance. McFast 7 is a boat that will reward a tinkerer with extra fractions of mph increments, but can do it without getting him in trouble.

The basic setup refinements have already been done by Melvin Mut, the noted racing-driver designer who was commissioned by MonArk to

create this boat. Because a fisherman may need to thread his way through stump-filled shallows where the big bass often are, Mel Mut showed me where he had introduced a step in his sponsons so the hull would have added maneuverability at high speeds. More than a talent for circling a racing oval was necessary for this type of craft. Cutting close to my photo boat, I found I might throw up a roostertail of spray, but could cut away without a skid or feeling the hull might want to swap ends. Though tested only with a high-spirited Johnson 115, the hull could undoubtedly handle more but, better still, will surely give lively performance as well with considerably fewer horses hitched to her transom.

MonArk, named because it is in MONTICELLO, ARKANSAS, claims to be the world's most diversified boat-builder, with recreational jon boats, semi-vees, canoes, pontoon cruisers, runabouts, custom houseboats, and

sport fishing boats, plus commercial fireboats, crewboats, patrol boats, tenders, pushboats, landing craft and many others I saw under construction in aluminum, fiberglass and steel. But the new McFast 7 is in a class by herself. With the performance capabilities an owner can tune into the rig, he may forget to care if the fish are biting or not. ★★

MONARK McFAST 7 BASS BOAT

Built by MonArk Boat Co.,
Box 210, Monticello, Ark. 71655

- Length overall: 16 feet 9 inches
- Beam: 77¾ inches
- Depth (interior): 21 inches
- Transom height: 20 inches
- Weight: 730 pounds
- Maximum recommended hp: 120
- Maximum capacity: 1269 pounds
- Maximum passenger capacity: 819 pounds
- Speed (max. hp: 50 to 60+ mph)
- Price: \$3,426 (metal-flake finish)

New 'pull up' howler makes your flight safer

by Robert Ford

Last December, TWA Flight 514 bucked its way through heavy rains and uncomfortable chop toward Dulles International Airport. Dulles, a pilot's delight with its long runways and uncluttered approaches, sprawls in historic country west of Washington. On a clear day, passengers and crew can spot Leesburg or Manassas in Virginia. Off to the west, they can see the beautiful Blue Ridge Mountains. But on this blustery Sunday morning, the 92 persons aboard the Boeing 727 saw nothing but gray cloud.

Flight 514 had been scheduled into National, Washington's old field on the Potomac, but conditions there—strong crosswinds and a slick runway—were not to the captain's liking. Along with several other inbound, he requested clearance to Dulles, which has a runway more closely aligned with easterly winds. The 727 was assigned an altitude and vectored westward, then "handed off" to Dulles controllers to work into their own traffic flow. This is routine procedure. The "new" controller provides headings and altitudes to a point from which a crew can complete an arrival on its own. Flight 514 reached such a point and was cleared for the Runway 12 approach.

Four minutes later it slammed into one of those beautiful mountains just west of Dulles.

The tragedy attracted unusual attention. Not only did it happen right in the federal government's back yard, but it came at a time when the Federal Aviation Administration and its system of air traffic control were under fire. The Air Line Pilots Assn., whose roster lists most of the pilots crewing scheduled airliners, and industry groups have long complained of sluggish FAA response to operational problems. A recent study by FAA's own investigators was also critical of current policies and suggested major changes in the agency's makeup and ways of doing business. Predictably, the hearing held to probe the TWA accident quickly became embroiled in the controversy surrounding air traffic control.

The crash came at the end of a year that had already seen eight airline accidents, all involving fatalities. The fact is, the fatality rate per hour aloft has gone up every year since 1971. True, only tiny changes are involved—0.138 deaths per 100,000 flying hours in 1973, 0.149 in 1974—but no such trend is to be tolerated in this game. There's no escaping the truth: American air travel is not quite as safe as it used to be.

Though the cause of the Flight 514 accident is yet to be determined, it seems to fit into a pattern that has worried airmen for years. I refer to the type of accident that occurs while a trained crew is in full control of an airworthy aircraft—the controlled-flight-into-terrain (CFIT) accident, as it is termed. A crash, in other words, which apparently cannot be attributed to crew incapacitation, mechanical failure, weather or other such factors. Whether the TWA crash was a CFIT accident remains to be seen, but it did rekindle interest in the problem.

A number of recent airline accidents seem to fit the pattern: a 707 settling into the sea right after take-off, a 1011 down in a Florida swamp, another 707 undershooting at a Pa-

cific island, a DC-9 undershoot in North Carolina, a DC-8 crashing into an Alaskan mountain—all, so far as could be learned, flying normally until impact. In some cases, no hint to the crew of trouble; in others, realization only in the final seconds.

It's not a new problem. The CFIT accident goes back to the first days of weather flying. Nor is it confined to airline flying, though an airliner is more apt to become involved simply because it flies more often in bad weather than other aircraft, civil or military. "Bad weather" in this context means clouds, precipitation or darkness, all of which reduce visibility. Pilots rarely fly into hills they can see or land short on clear days.

It is devilishly easy to become a CFIT accident statistic. An example: You are departing in a 707 at max gross weight with ceiling reported at 200 feet. Most of the concrete is used in getting airborne. Then with nose raised 15° and gear retracting, you flash across the fence and into a white void.

The whole world becomes you and a lapful of gauges that say you are hanging there at 200 mph, not climbing, not settling, and you fly as carefully as if replacing the mainspring of a watch. It's a long half minute

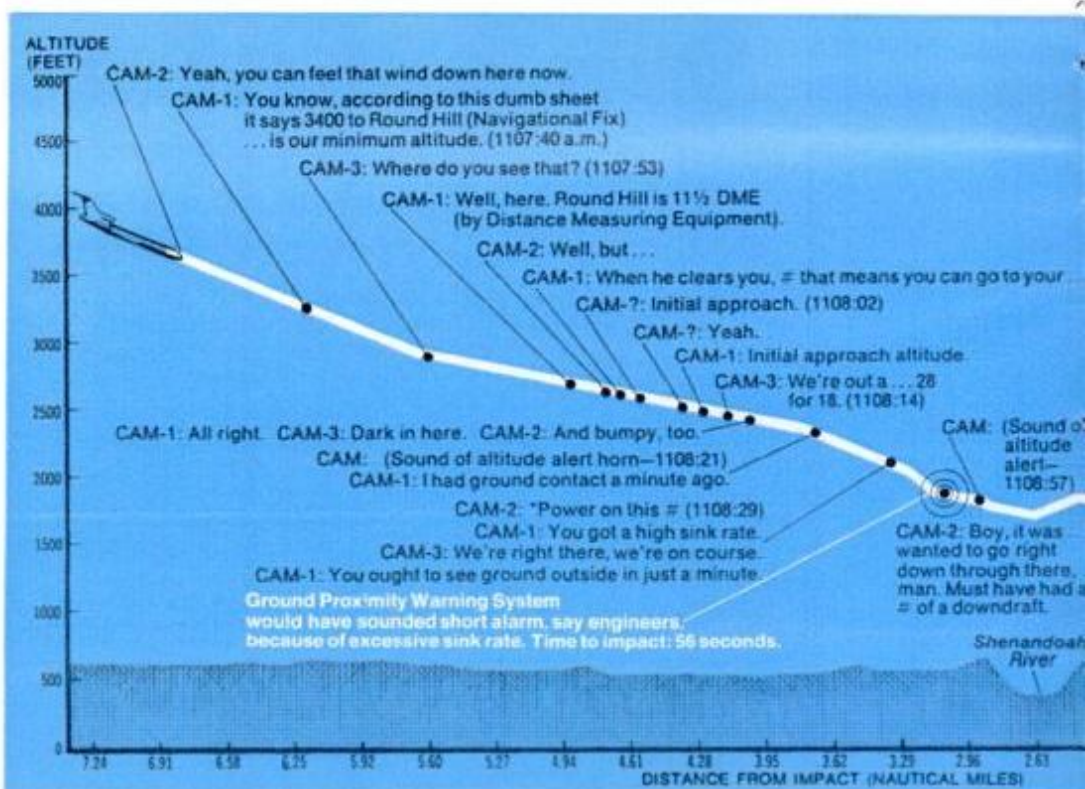

The author is a captain with one of the nation's leading airlines.

until the old girl takes hold and starts up, and it's a very bad time to have the crew's attention drawn away from the primary task—keeping the plane in the air. More than one crew is thought to have become so absorbed in solving a cockpit problem that no one noticed that the altimeters were slowly unwinding.

Or you're making a tight ILS (instrument landing system) approach through snow. You stay on the gauges, your copilot monitoring the approach with his own set and glancing ahead for sight of the ground. Five hundred feet—nothing; 400—nothing; 300—still nothing. Then comes decision height, signaled by a streak of light down there, repeatedly racing through the mist.

"Runway lights," says your copilot. You look up, see the faint white bulbs and resist the natural inclination to dive at the runway's end. You maintain the sink rate, plant the wheels without any try at a grease job and get busy with brakes and full reverse, trying to steer straight through clouds of loose snow thrown forward by reversed thrust.

A minor miscalculation, an attempt to fly instruments and visual at the same time—it's all too easy to land short or settle in during a go-around, and without ever being aware anything is amiss.

Another situation: You are letting down into Seattle, Denver or Los Angeles (anywhere with hills and/or TV towers nearby), flying vectors, turning and descending as the controller lines you up for approach. Because of heavy traffic, the controller "turns you loose" 20 miles

out to continue your approach. Now, what is the minimum safe altitude from there to the final approach fix? Can you go lower in this area? Your charts may not provide black-and-white answers. The rule for such a situation is ambiguous. And, as the FAA is quick to point out after an accident, you, as captain, are the final authority in all matters affecting the safety of your flight.

Evidence given at the Flight 514 hearing provides a chilling picture of disagreement and confusion as to how certain traffic situations should be handled, which minimum altitudes apply in certain instances and whether pilot or controller is responsible for obstruction clearance in terminal areas. The printed information supplied a pilot may differ significantly from that used by his controller.

Airmen and groundmen disagree as to interpretation of rules and procedures, even among themselves. Pilots have long assumed, for instance, that when a controller says, "I have you in radar contact," that means he will provide advisory service. Not at all, said an FAA expert at the hearing. This only means that a flight can receive radar service, not that it will.

"Horrible!" snapped an ALPA witness. "This will shock a lot of pilots," said another. And it will. It shocked this pilot.

Meanwhile, two new electronic devices offer great promise. One is an on-board altitude warning system, the other a warning feature for existing radar displays used by air traffic controllers. The latter draws data from air traffic computers and alerts

a controller when an aircraft under his charge has entered a potentially dangerous altitude/terrain situation. Here's how it works: An airplane is "painted" on a radar screen as a small dot, or blip, which inches along with each sweep of the antenna. Alongside it appears the plane's identification, speed and altitude.

With the new feature installed, "Z WARN" will start flashing above the call sign of a blip flying lower than the programmed minimum level for its area. An aircraft approaching Denver from the east is quite safe at 10,000 feet, for example, but if it continues on that heading, without climbing, it is headed for disaster, the Rockies rising to 14,000 feet and more just 35 miles west. Such a flight path-altitude combination sets off the warning and the controller advises the pilot concerned that a change of heading is in order. Additionally, altitudes during final approach are monitored, a high-pitched tone sounds and "G ALT" (glide altitude) flashes if a blip dips too far below the safe sloping path between radio fix and runway. Again, controller immediately advises pilot. Modification of terminal radar sets will begin this year, with more than 60 busy fields slated for installation.

Contrary to popular impression, an airline crew flies its own plane from lift-off to touchdown. Decisions regarding fuel loads, routes and altitudes to be flown, weather and field conditions at terminals and all other aspects of flight are made in the cockpit and radioed to ground—not the other way around.

An airliner requests and is given

CAM: COCKPIT AREA MICROPHONE
 CAM-1: VOICE IDENTIFIED AS CAPTAIN'S
 CAM-2: VOICE IDENTIFIED AS FIRST OFFICER'S
 CAM-3: VOICE IDENTIFIED AS FLIGHT ENGINEER'S
 CAM-7: UNIDENTIFIED VOICE
 *UNINTELLIGIBLE WORD(S) = DELETED WORD

CAM-1: Get some power on. (1109:20)
 CAM: (Radio altimeter warning horn sounds, then stops)

GPWS, triggered by too-rapid terrain closure, would have sounded continuing alarm, giving crew 20 seconds in which to pull up and avoid impact.

CAM: (Sound of impact—1109:22)

CAM: (Radio altimeter warning horn sounds, then stops—1109:14)

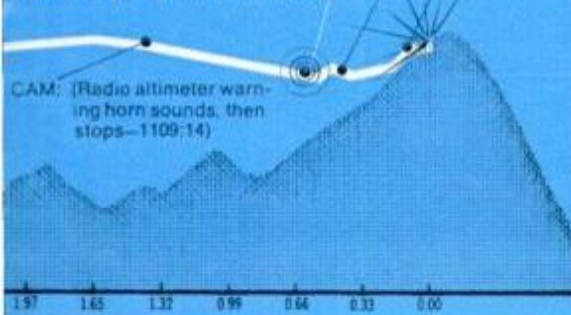

Cockpit conversations prior to crash of flight 514 (below), taped by on-board device, and other data were made available by National Transportation Safety Board. Information relating to the functioning of GPWS system came from other sources.



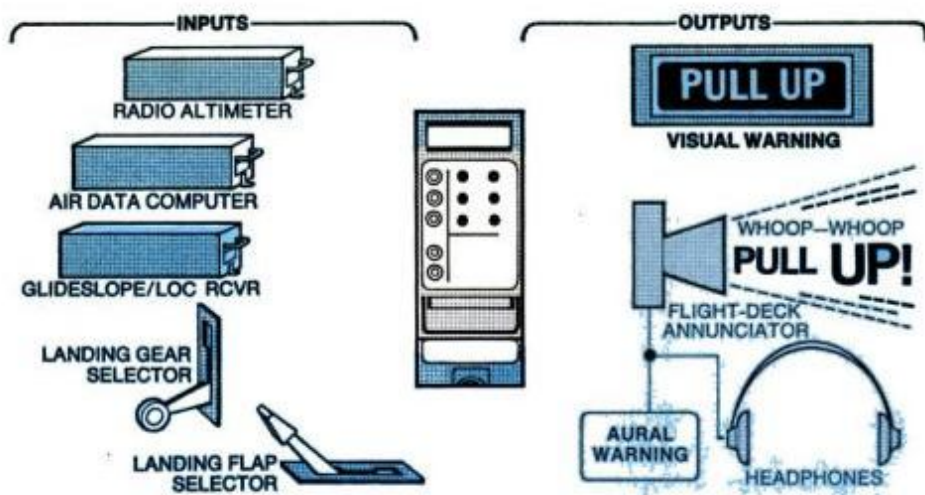

GPWS system is automatic. Small computer "decides" when plane is on unsafe heading.

a "clearance" to operate along Jet Airway 30 between Minneapolis and Chicago at 37,000 feet, say, and it must adhere to the flight plan unless an amendment is received.

Again, a crew is bound to comply with the vectors and altitudes issued to it, but it can and will refuse compliance if safety is questioned. Surface radar is adjusted to "see" planes, not weather, and a controller may request a heading which, unknown to him, requires flying into a storm, in which case he will be advised and a new heading suggested. The flexibility of FAA controllers when a line squall rolls through, particularly in such congested terminal areas as Chicago and New York, is a marvelous thing to witness. My cap is off to them.

The airline pilot has traditionally made his own instrument letdown and decision about landing when minimum legal altitude is reached. So, though he will welcome the new feature available to his controller, he'd rather get altitude warnings firsthand from on-board equipment.

This he will soon be able to do with the Ground Proximity Warning System (GPWS) developed by Sundstrand Data Control, Inc., of Redmond, Wash. Eight years ago, Sund-

strand's engineers began a detailed analysis of CFIT accidents recorded in the previous 20 years. Their aim was to design a unit that would warn the pilot whose flight path would, if unchecked, lead to a CFIT situation.

Several foreign airlines, their future 747 fleets in mind, showed special interest in the project. Flight testing began three years later and in 1970 an SAS DC-9 was equipped with GPWS for further evaluation.

In 1972 McDonnell Douglas made tests with a DC-10 and Boeing with a 737. Boeing decided last year to make Sundstrand's GPWS standard on its new jetliners. The system warns of five dangerous flight situations:

- **Descent after takeoff.** Should an aircraft lose altitude after takeoff, a whooping sound alternating with the spoken words, "Pull up, pull up," is heard on cockpit headsets and speakers. A red light on the instrument panel flashes the warning: "PULL UP." The altitude loss required to trigger the warning varies from any loss at 100 feet above the ground to 80 feet at 700 feet of altitude. The same protection is provided during go-around after a missed approach when gear or flaps retract out of landing positions.

- **Excessive terrain closure.** The warnings are set off when the aircraft flies toward an area of rising terrain, being activated by rapidly diminishing altitude readings as fed through a computer.

- **Excessive sink rate.** The alarms are sounded and flashed by abnormally high rates of descent below 2450 feet above the surface.

- **Inadvertent proximity to the ground.** In this mode GPWS acts as a back-up for the usual landing gear and flap position warning devices. It goes off below 500 feet if gear is not down and locked, below 250 feet if flaps are not in landing position. Secondary protection is afforded should sink rate exceed 1450

feet per minute below 500 feet, 760 fpm below 250 feet.

- **"Duck under"** during ILS approach. Tuning in an ILS frequency arms this mode. A voice repeating, "Glideslope," is heard and an amber light marked "Glideslope" flashes if the plane descends unsafely below the normal glidepath, the sloping radio signal leading to the runway. This warning may be cancelled by pressing the appropriate warning lamp, an option allowing a pilot to deliberately "duck under" when the runway is in full view and use its full length if poor braking action is reported.

The only other cancelable warning is that issued when flaps are not full down below 250 feet. A hydraulic failure would dictate a flaps-up arrival, and there are other circumstances which call for landing with less than full flaps.

With these two exceptions, GPWS warnings can be stopped only by taking corrective action to remove the aircraft from its potentially dangerous path of flight. A crew does not turn GPWS on, nor can it deactivate the system or even lower the volume of the aural alarms.

During normal flight there is no indication of its presence (the system is deactivated above 2450 feet radio altitude), an important feature in that routine cockpit sights and sounds are "tuned out" over a period of time. (A tape I made of cockpit sounds and conversation during a heavy takeoff from a runway of marginal length creates an effect on playback that is entirely different from the real thing. The main noises heard are the hum of the electric trim and the wind roaring past outside, two items I am totally unaware of during actual operation.) GPWS starts howling only when safety is threatened.

The new visual alert for radar controllers and Sundstrand's GPWS cannot in themselves prevent any accident, and neither is coupled in any way to an aircraft's flight control system. Each tells a crew that—whatever the reason—it is following a flight path that will lead to disaster if unchecked. Ample time for corrective action is allowed.

Soon after the TWA crash, the FAA issued a mandatory rule requiring GPWS aboard all turbine-powered planes operated by airlines, commuter carriers and air travel clubs. Pan Am had already signed up. Braniff International was the first to sign following the FAA order.

The hardware itself bears a surprisingly modest price tag as airiner equipment goes. Braniff figures about \$1 million to outfit its 87 planes, or a unit cost of about \$6900 with insta-

(Please turn to page 122)



Flasher—back-up for taped-voice warning—is indicated by pilot of corporate jet.

10 steps to a sparkling swimming pool

Thanks to efficient filtration systems that remove debris, and thanks to dry chlorine pool sanitizers that kill harmful bacteria and control algae growth, care of a swimming pool today can be simple. But it does require an efficient pool-maintenance routine if family and friends are to enjoy clean, healthy, sparkling water throughout the pool season. Here are 10 things to do to keep your pool—be it in-ground or above-ground—clean.



1. Determine your pool's capacity. Though pool water may appear clean and clear, if neglected, it can quickly become a breeding place for microscopic bacteria and tiny plant life called algae. Bacteria, viruses and algae cannot multiply in pool water properly treated with an inorganic chlorine sanitizer. Before you can start the chemical treatment of your pool water, you must determine the pool's capacity in gallons to give correct dosages. If the capacity is not noted by the manufacturer or builder, the following quick guide can be used:

If pool is rectangular or square, multiply length x width x average depth (feet) x 7.5 = total gallons (7.5 represents the number of gallons in a cubic foot of water).

If circular, multiply diameter x diameter x average depth x 5.9 = total gallons.

If oval-shape, multiply long diameter x short diameter x average depth x 5.9 = total gallons. (The last two methods are simplified shortcuts to figuring pool volume in non-square shapes; thus you multiply by

(Please turn to page 124)



Basic test kit (far left) is a must, measures pH of water and total chlorine level. Solutions change color at different pH levels.



Shock treating (left), with product like Olin's Sock It, is quick way to restore chlorine residual to proper level.



Dry chlorine in tablet form (far left) is used in floating chlorinator, released at regular intervals. Saves having to add sanitizer dose daily.



Pulsating chlorine feeder (left) uses pellets, runs up to month without refill depending on pool size. It reduces need for periodic superchlorination.

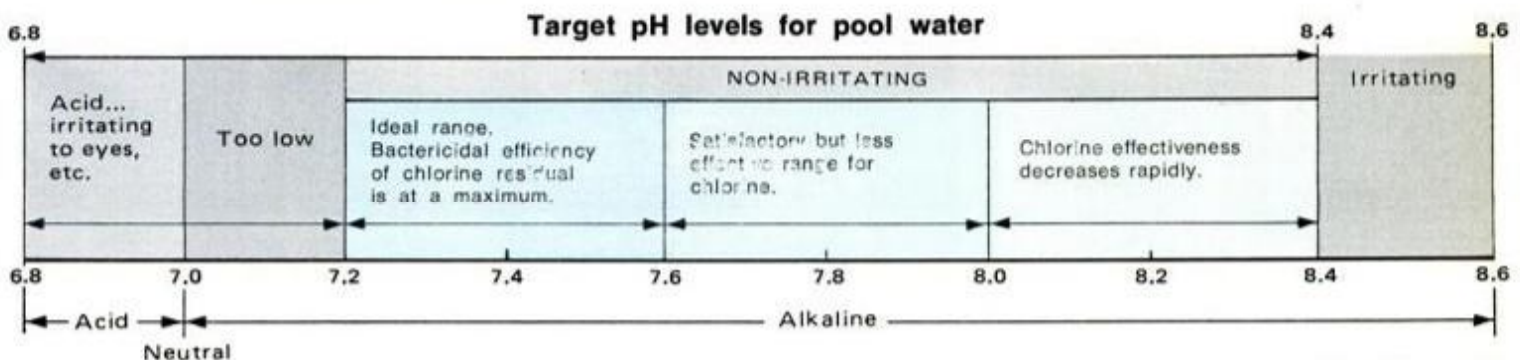



Look what you can do with

Accessories for drilling

With all the accessories of today, there aren't many jobs a drill can't do.

Drill, buff, polish, sand, scrape, cut, mix, grind—you name a shop job and it's a pretty safe bet there's an accessory around that will let you handle the task with your drill. In fact, when you consider all the jobs—besides boring holes—you can do with a drill, it becomes apparent why the portable drill is the most-purchased power tool.

Freeing both hands

With many accessories, you must have both hands free to handle the work while the tool does its job. Several makers offer horizontal drill stands for bench-mounting; these sell for about \$4 and are a must if you want to get more use from your drill. Vertical drill stands, on the other hand, are intended to convert a port-

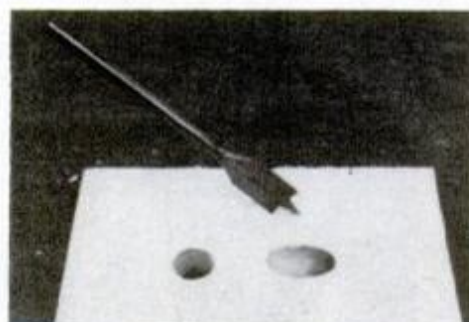

Spade (power) bit is perfect for drilling straight or angled holes in most woods.

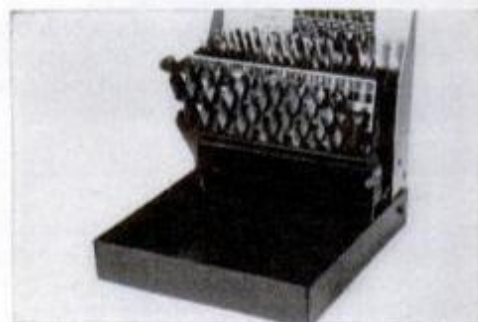

Bit case from Sears holds 29 bits, lists all sizes and their decimal equivalents.

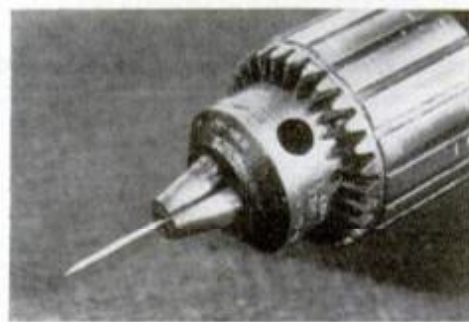

Stunt for drilling extra-small holes: Chuck a brad after nipping off its head.

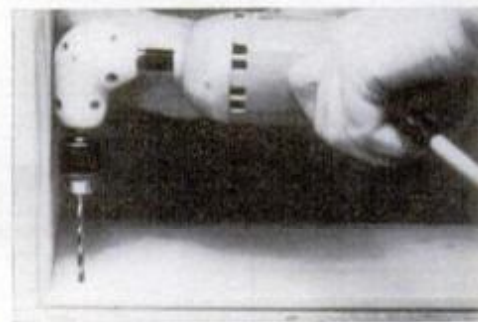

Right-angle attachment gets you close to a corner, can also be used for polishing.

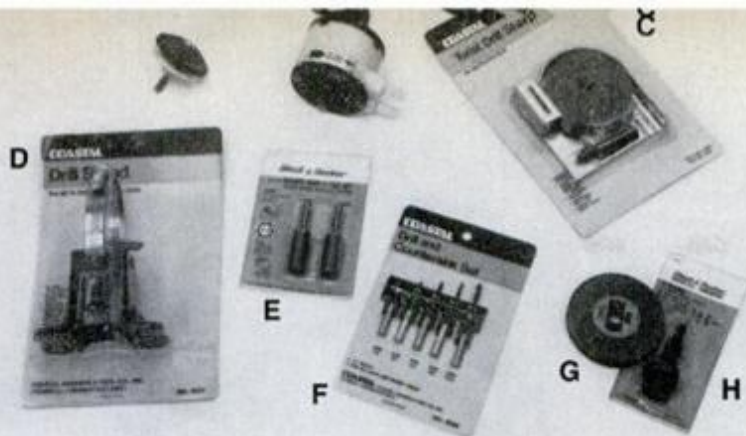

Increase drill versatility with: A, mower blade sharpener; B, water pump; C, low-cost drill sharpener; D, bench stand; E, rotary rasp-file; F, bits with built-in countersinks; G, grinding wheel, and H, an arbor for use with certain types of accessories.

Double-insulated ¼-in. drill kit comes with three bits, rubber backing pad, polishing pad, arbor, lamb's-wool bonnet, carrying case. By Black & Decker, \$15.



Accessories in Rockwell's blister package include ½, ¾ and 1-in. spade bits; ¼-in. masonry bit and Phillips-head and slotted screwdrivers.



Carbon and high-speed twist bits can be sharpened with this tool. It accepts 11 sizes.

your portable drill

by Harry Wicks

WORKSHOP EDITOR

Photos: Abe Dulberg and the author

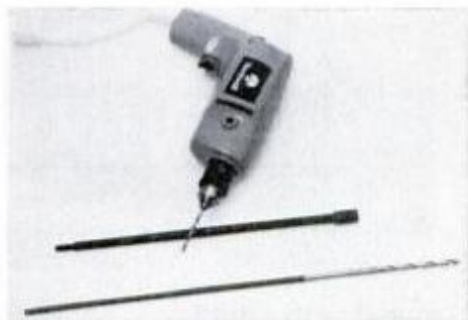

For deep drilling: electrician's 18-in. bit (foreground) and 12-in. bit extension.

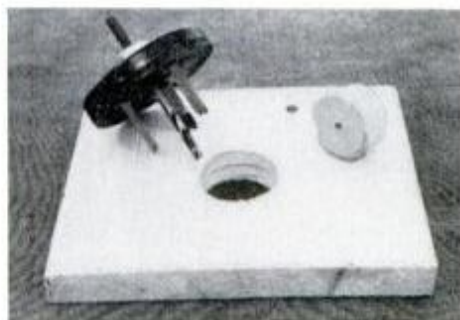

Adjustable hole saw cuts many sizes. Use with slow speed and moderate pressure.

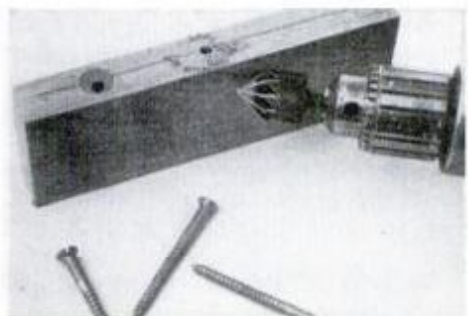

Countersink can be used in wood, plastics and composition materials. Shank is ¼ in.

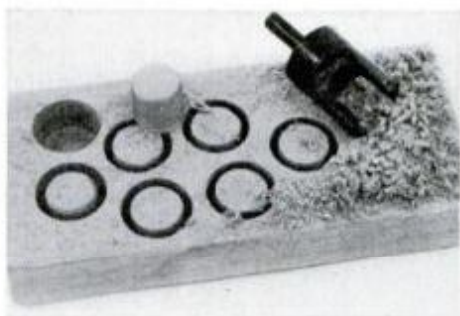

Dowel-plug cutter is best used in drill having a maximum speed of 3000 rpm.

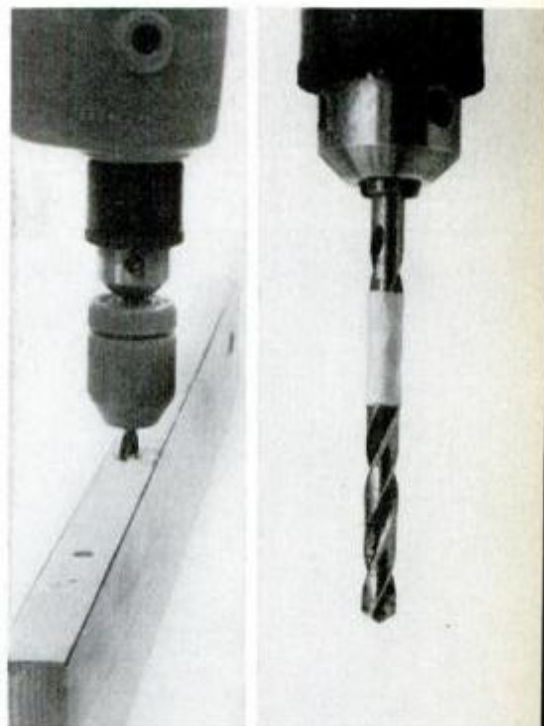

Commercial drill stop limits bit travel; masking tape (right) is homemade dodge.

For shaping, carving and cutting

Rotary rasps come in variety of shapes and sizes and should be used at high speeds. They're for carving, shaping and milling operations in soft materials, plastics, as well as in wood.

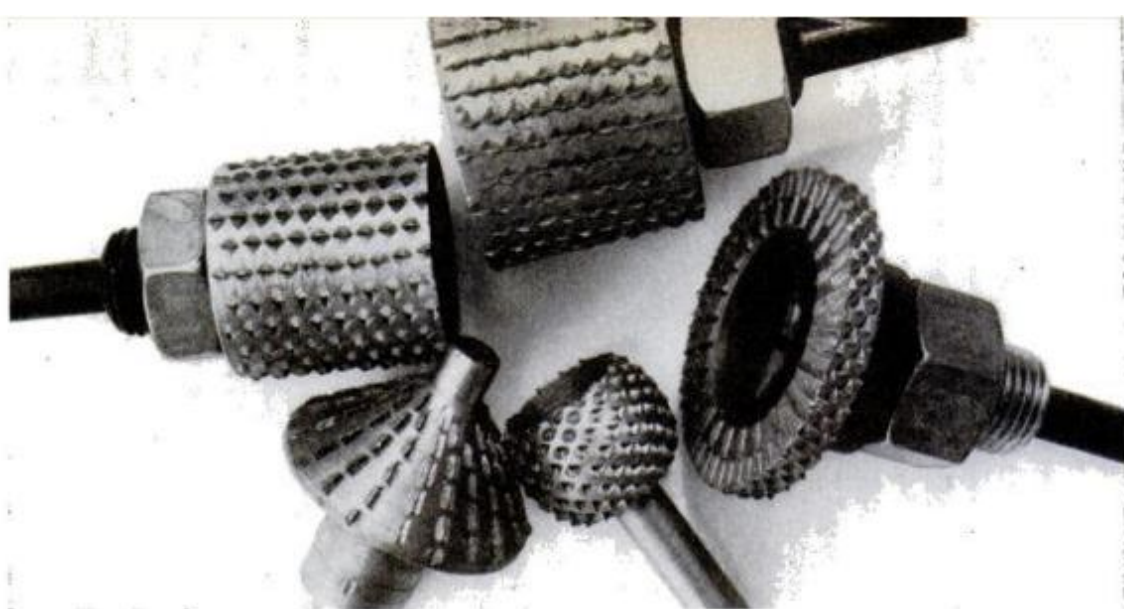

*Surform drum from Stanley has a sharp cutting edge located at each hole.



Surform quickly, neatly, removes stock; drill must be steadied with two hands.



Drum sanders do great job smoothing curves, come in various diameters.



Flexible shaft is perfect for forming, sanding, polishing. Cost: about \$13.

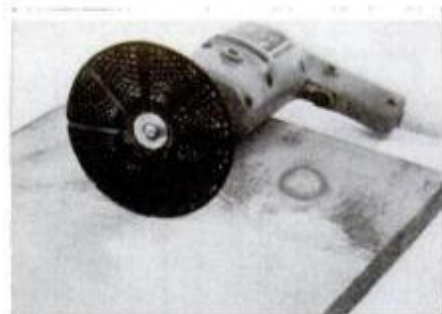

Metal sanding disc is okay for first-stage smoothing of rough, flat surface.

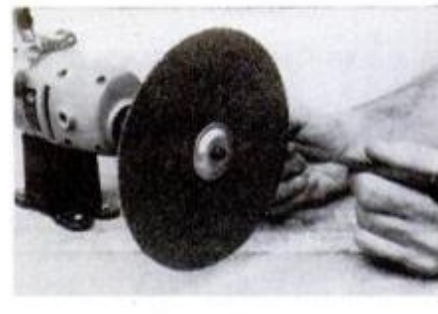

Zippidi-Do disc cuts through many materials including metal file shown.

Products featured in this article

- Spade bits, lamb's wool bonnet, screwdriver drill: Rockwell Manufacturing Co., 3171 Directors Row, Memphis, Tenn. 38131.
- Drill-bit case, electrician's 18-in. bit, bit extension, sander drum, masonry bits: Sears, Sears Tower, Chicago, Ill. 60684.
- Right-angle drill attachment, mower sharpener, low-cost drill sharpener, horizontal drill stand, drill and countersink bits, dial saw, countersink, rotary rasps and files, Zippidi-Do blade, disc rasp, cup brush, screwdriver attachment, stones, paint mixer: Coastal Abrasive & Tool Co., Inc., Trumbull, Conn. 06611.
- Water pump: North & Judd Mfg. Co., New Britain, Conn. 06050.
- Rotary rasps (pair), arbor, drill kit, flexible shaft, horizontal drill stand, vertical drill stand: Black & Decker Mfg. Co., Towson, Md. 21204.
- Plug cutter, Surform drum tool: The Stanley Works, 195 Lake St., New Britain, Conn. 06050.
- Sheet acrylics bit: Henry L. Hanson Co., Inc., Worcester, Mass. 01608.
- Drill stop, grinding wheel: Made by several manufacturers.

able drill into an accurate and reliable drill press. You can have this convenience for \$20 or so.

Accessories for drilling

Besides the high-speed twist bits that you probably got with your drill when you bought it, you ought to treat yourself to a full set of power (spade) bits. The larger-diameter ones come with step-down 1/4-in. shanks. Thus you can drill up to 1 3/8-in. holes with a 1/4-in. drill. For 1 1/2-in.-diameter and larger holes, you will have to use a hole saw. There are two types—nonadjustable and adjustable. A typical adjustable one is shown on page 79. The adjustable type gives a flexibility of hole sizes, but beware that it does not bore holes

as neatly as the single-size, rigid-type hole saws do.

Shaping with a drill

Several manufacturers now offer various accessories for shaping and milling with a drill. Of all drill accessories available, I think these are the least desirable. Remember that most wood shaping is best done at high speeds—30,000 rpm with a router, for example. In a drill, you will probably work with a speed somewhere around 2000 rpm. You pay for the difference in quality of work.

Tools labeled rotary rasps and files work best when used in a drill mounted in a vertical drill stand. Before using any rasp, make certain you

read the manufacturer's instructions carefully concerning speed and use.

Smoothing operations

For fast, easy stock removal on rough work, you can't beat Stanley's Surform drum for curved surfaces or a metal disc rasp for flat workpieces. These tools come with many cutting edges spaced about their work surfaces; thus it's best to stop periodically and clear the tool to keep it from clogging.

To sand various woods and metals, your best bet is to fit a rubber backing pad on an arbor and mount sandpaper discs of suitable grit. This type sanding is undesirable when finish and grain will show because of swirl marks, but it's perfect for fast stock removal and for preliminary sanding of metal.

Though not shown, a good sanding device is the Sand-O-Flex Wheel manufactured by Merit Abrasive Co. This

Other accessories

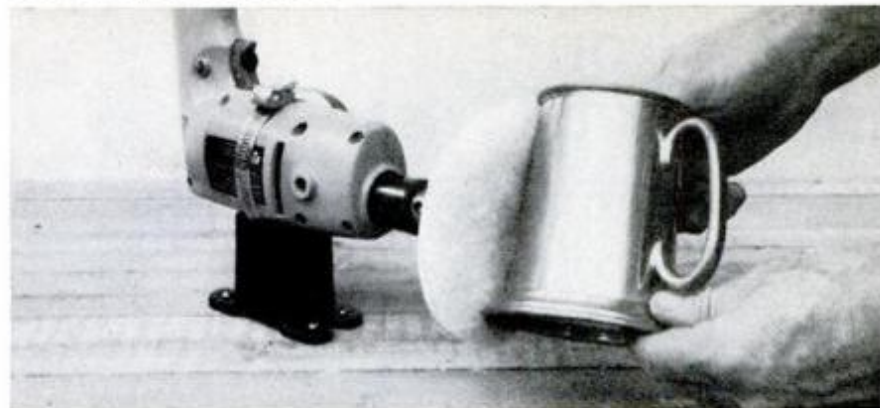

With drill mounted in horizontal drill stand, both hands are freed to hold work. Here, a pewter mug is polished with a lamb's-wool bonnet.



Variable-speed drill becomes screwdriver when fitted with driver bits.

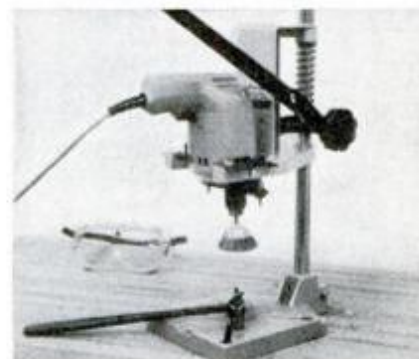

In vertical stand, drill is a drill press. Here, cup brush is chucked.

For those tough drilling chores

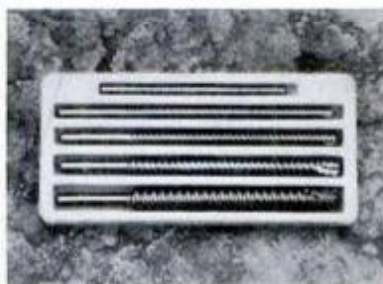

Bits for masonry, nonferrous metals have tungsten-carbide tips.



For superior holding power, drill hole in mortar joint, not brick.

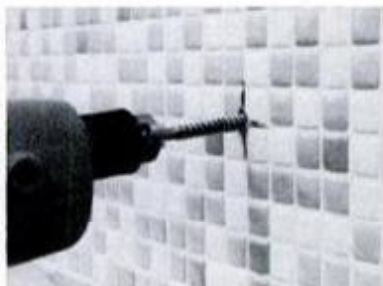

To drill ceramic tile, use slow speed; cool the bit with water.



Screwdriver attachment (from Coastal) lets single-speed drill drive screws.

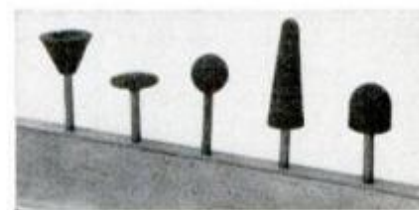

Assortment of shaped stones lets you handle most grinding, finishing jobs.



Specially shaped bit is used to bore chip-free holes in sheet acrylics.

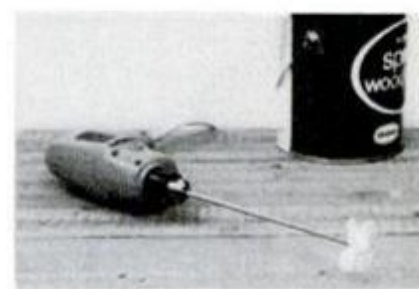

Fast, complete mixing of all paint is assured with powered homogenizer.

is a wheel fitted with short strips of sandpaper. As the wheel revolves, the flapping strips quickly smooth round or odd-shaped workpieces.

To make your drill a screwdriver, consider buying an attachment like that one shown above. But if you own a variable-speed reversible drill, you can make it a screwdriver by simply buying the driver bits. ★★★

Safety hints for accessory use

Always wear goggles when using drill and any accessory.

Always disconnect from power before changing bits or accessory in drill.

Use accessory only for the purpose for which it's designed.

Use accessory only at speeds suggested by accessory manufacturer.

How to retrofit an electronic ignition kit

by Michael Lamm
WEST COAST EDITOR



All Detroit cars now have breakerless electronic ignition systems. Advantages of electronic ignition (EI) include: no points to burn or adjust, no condenser, much greater plug life and almost no need for retiming your ignition. Once an EI is set, it's set for a good, long while, which means your ignition stays in tune a lot longer.

They're standard on new cars, yes, but did you know you can now get kits to convert older cars to breakerless EI systems? Most auto parts stores carry kits from more than a dozen manufacturers. Prices range



1 Remove distributor cap and wires and hoses which makes access easier.



The electronic ignition kit components the author installed on his '67 Camaro are shown below in box and above relative to the distributor.



from \$45 to \$70, and the novice can install such a kit in roughly 1½ hours. Once you've installed one, installation time for the next kit drops to about 20 minutes.

I recently put a Borg-Warner kit into my 1967 Camaro V8. It's really a simple job: The only tools I needed were a screwdriver and an awl.

Borg-Warner makes six basic kits to fit all AMC and Ford and GM V8s vintage 1957-74, all AMC and Ford and GM in-line Sixes of 1968-74, all Chrysler Corp. cars and trucks 1962-72, all Checkers 1965-74, and

most Delco-equipped Internationals from 1959 through 1974.

Instructions for the B-W unit come on the back of the kit, and there's an additional booklet inside that gives even more step-by-step details. No need to go through them all here, but basically here's what you do:

You take out your old points and condenser, replace the points with an electric-eye-like "trigger light," slip a "light chopper" under your stock rotor, and mount a separate "control box" somewhere in the engine compartment that's cool. After that

it's just a matter of plugging in a wiring harness (supplied) and attaching like-colored wires. Nothing to it.

You needn't take out your distributor, and there's only one part I found tricky. That was removing of the rubber plug at the bottom of the distributor. The B-W instructions didn't explain that this plug—

through which the former stock coil lead entered—has to be pushed *up* into the distributor and then forced out through a gap in the breaker plate. My awl helped here.

It helps, too, before starting the installation to remove the air cleaner plus some smog plumbing to make the distributor more accessible. I also disconnected the four sparkplug

wires on the right-hand bank of my engine.

For an explanation on how electronic ignition systems work and how to service them, see page 108, April '75. Fortunately, I found that my EI installation did not need to be retimed at all. But I think it was mostly just plain luck that it was right on. ★★★



2 Remove distributor rotor; set aside until ready to install light chopper.

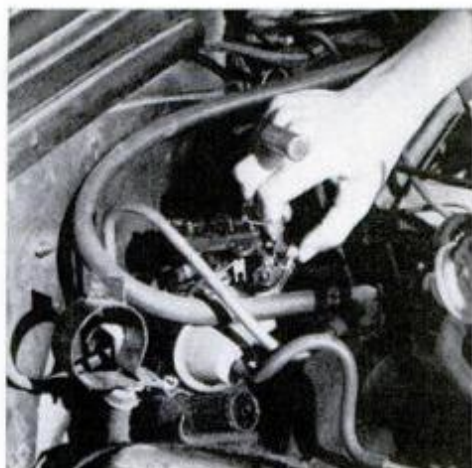

3 Remove distributor points and condenser; they're no longer needed.



4 Place the trigger light on the distributor plate ready to secure.

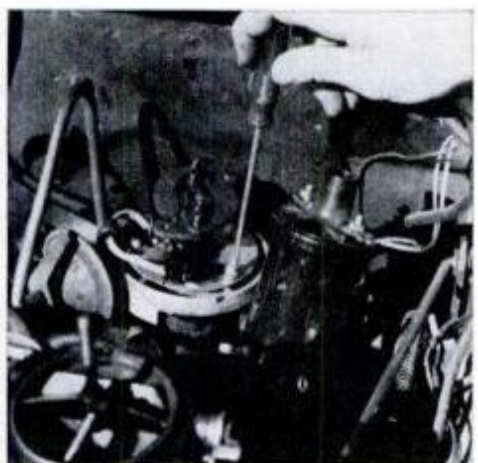

5 Secure trigger light to the plate using screws that held the points.

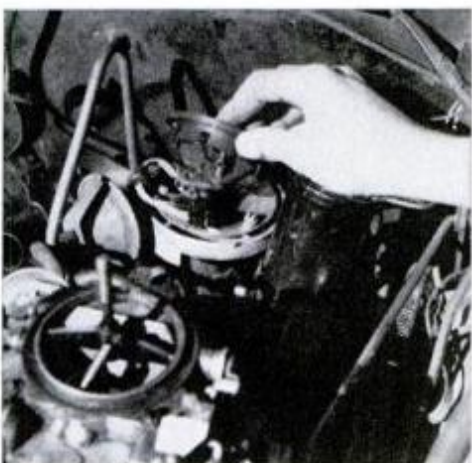

6 The light chopper from the kit is slipped over the centrifugal advance.



7 Bolt light chopper under stock rotor using screws from the kit.



8 Mount control box on inner fender or firewall using sheet-metal screws.



9 Plug wiring harness into control box and attach other ends as instructed.

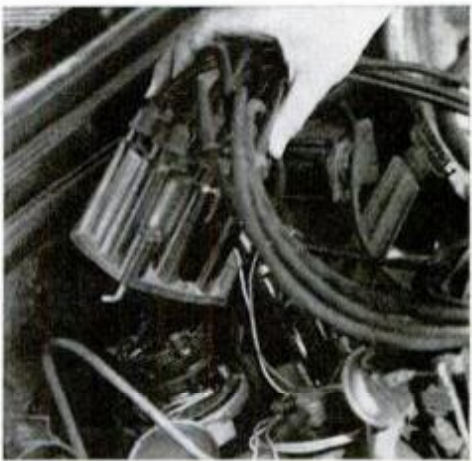

10 Replace distributor cap and plug wires; finish by checking timing.

Tackle to take around the world

by E. L. (Buck) Rogers

Gear that should land almost any lunger anywhere now can fit under your airliner seat.

Today there is no excuse to pass a likely fishing hole without a rod along. There's new gear available that's almost compact enough to hide inside a lunch box.

The legends say that the first travel rod was invented by an ancient Irish priest who liked to slip down to the river, pole in hand. When folks frowned on that sort of thing, the good priest used a little ingenuity and built a multipiece rod with sections short enough to be hidden underneath his robe. Thereafter, the holy man was seen spending considerable time meditating down by the river, and everyone was happy.

Since then, the fishing tackle industry has had problems improving on this situation. Anglers still trot around the world lugging oversize tackle boxes and long rod containers that roll off luggage conveyors and are sometimes lost or swiped during transport. Tackle boxes that survive travel in a baggage compartment can arrive with their contents in a jumbled mess that may take hours to put back in order.

Last summer, for instance, when I went fishing in Alaska with three friends, my gear consisted of two suitcases and one carry-on bag. My companions each had a tackle box, two or three rod containers, and assorted bags containing clothing and other accessories. In all, they had 18 baggage checks and paid \$76.45 for overweight luggage. When we ar-

For angling action on the go, the new compact equipment stows neatly into an airline bag.





En route to the Amazon, author Buck Rogers shows Braniff stewardesses high-flying display of carry-on fit-together gear.

rived in Dillingham after several plane changes, three rod cases and one tackle box were missing. I figured we were lucky. My friends figured I was smart when I opened a suitcase containing eight rods and enough reels, lures and accessories for all of us.

My basic travel tackle kit includes a bag big enough for all gear. Into this goes all rods needed, reel assortment, lures suitable for the fish and conditions to be encountered, clothing, and a lot of accessories. Result: A neat compact package that will

make long air trips safely and surely, and contains everything needed.

Tackle bags

The best I have found is a standard hard-sided suitcase. Sizes I use range from the 20-inch one-suitcase model to the largest three suitcase, and I make my selection after laying out all gear I intend to take. These bags are inexpensive to buy and provide good protection for your gear.

Another bag is required when you reach your destination because a suitcase isn't the handiest thing to tote across a gravel bar or stow in a dugout canoe. I take a pair of bags along with me—one packed with lures and the other full of spare fish-



Multisection break-down rods pack safely when taped together, stowed in suitcase.

ing equipment, clothing needed for the day and other accessories. Your tackle container must fold flat, should be waterproof, easy to carry, and have an opening large enough to pack and unpack with ease. I've tried every type imaginable, but finally settled for an airline flight bag. For best results, select the large-size quality model most airlines now sell. It is well constructed of water-repellent nylon, and has good zippers and a shoulder strap. Get a pair.



Fitted case sets are offered by some companies. This triple-duty rod from Berkley handles flies, spinning, casting.

Rods

The greatest single contribution to travel tackle is the recent development of quality rods which disassemble and fit a suitcase. They eliminate the need for separate rod containers—long the bane of the traveling fisherman—and come in multisection pack rods or telescopic models. Over a dozen makers now offer a variety of portables that break down into neat bundles of 20 inches or less. Use care in selecting your travel rod. Some are light sticks designed for the back packer and may not stand travel abuse.

Theoretically, each time you insert a ferrule in a rod you impair its action and strength. But don't let anyone tell you that good five and six-piece rods don't exist. Travel rods I've used for years have taken more punishment than an average rod gets in a lifetime, yet I'll put the action of these sticks up against any other

(Please turn to page 112)

Hard-sided, two-suitcase can carry clothes, rods, spinning and bait-casting reels, lures in plastic cases, extra line in assorted strengths, suntan and insect lotions, first-aid and snakebite kits, foul-weather gear, camera and tackle repair accessories.



IT'S NEW NOW

Home bar sink: Complete drink-mixing center

This colorful bar sink is designed especially for party fun. It has a mini cutting board on one side and three garnish cups on the other for cherries, olives, lemon slices. In light, easy-to-install, self-rimming acrylic, the 15 by 25-inch sink comes in red, yellow and black. Kohler Co., Kohler, Wis. 53044.



Kit-built greenhouse goes up in a day

Do-it-yourself greenhouse comes in kit form, needs no foundation, can be put up in a day. All parts are pre-cut and fit together with just one tool supplied. The aluminum-and-glass structure features sliding door and adjustable roof vent. Three sizes are available: 6 by 8 feet, \$489; 8 by 8 feet, \$589; 8 by 12 feet, \$789. Kits will be sold through nurseries and garden centers. Baco Leisure Products, Inc., 19 East 47th St., New York, N.Y. 10017.

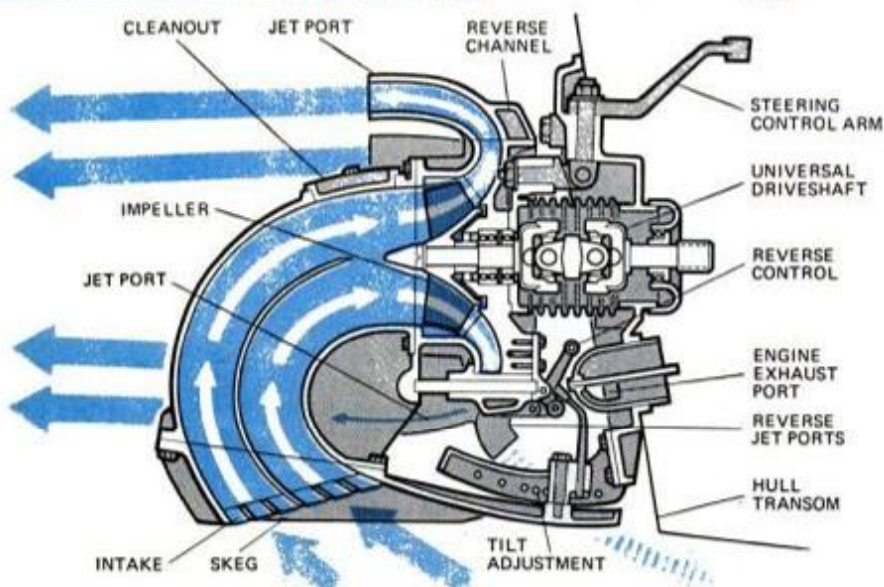

New boat power: Half jet, half outdrive

If the boat drive shown here looks strange, it's because it's the first of its kind—a brand-new concept in propulsion systems said to combine the best advantages of both water jets and stern drives. Like conventional jets, there's no prop to endanger swimmers or foul in shallow waters. Unlike other jets, however, the entire unit mounts outside the transom and swivels like a stern drive for steering, instead of using a fixed jet with a deflector plate. Result is claimed to be much more responsive steering control, especially at low speeds where regular jets tend to be sluggish. A cluster of seven separate jet nozzles replaces the usual single port, increasing power, reducing water-flow resistance and providing a shorter, smoother wake for water skiers. Rodler Development Co., 965 Willow St., San Jose, Calif. 95125.

THE LATEST PRODUCTS AND DEVELOPMENTS



Knitted statue is no yarn

The latest cultural craze in Europe is something called "soft art"—sculpture fashioned from materials other than clay, stone and steel. So what turned up at a recent London exhibition but this knitted figure of a woman knitting a figure of a baby. The piece is the work of French artist Abel Ogier who believes that only yarn can appropriately express the soft, tender mother-child theme. But will Mom ever finish Junior?



Flintless cigaret lighters

These butane pocket lighters have no flints to wear down and require replacement. Their fuel is ignited by a permanent piezoelectric crystal that emits a tiny spark when struck by a spring-loaded release. Trimly styled lighters also feature a sliding cover and adjustable flame. From \$28 to \$35 in black and chrome finishes. Braun North America, 55 Cambridge Pkwy., Cambridge, Mass. 02142.

It may be small, but it's got two engines!

If this isn't the smallest airplane in the world, it's certainly the smallest twin-engine craft. Less than 9 feet long with a wingspan of about 16 feet, it's powered by two nose-mounted power-saw engines, giving it a speed of 125 mph. French aircraft engineer Michel Colomban built it.



Do-it-yourself jigsaw puzzle

For jigsaw-puzzle fanciers who like to make their own it's no longer necessary to create a picture first, then laboriously cut it into pieces. A British company has come up with a blank board pre-cut into puzzle parts. All you do is draw or paint on the desired design. Advanced buffs can even try putting together the plain pieces without a picture—a real challenge. Hammoco Designs, Ltd., Ullenhall, Solihull, England.



Bike transmission shifts for you

The face in the spokes above is calling attention to a new automatic bicycle transmission, said to be the first of its kind. Called the Crosby-Matic, the device replaces the hub of the rear wheel and provides an infinitely variable range of speeds depending on load, automatically downshifting on upgrades. It's designed to fit most standard multispeed bikes and is expected to be in bike shops soon. Crosby Industries, Inc., Provo, Utah, is the maker.

NOW



Double-decker washer-dryer saves space

This compact two-in-one laundry center by Frigidaire combines a washer and dryer in a slim vertical unit only 2 feet wide by 5½ feet tall. Stacking the dryer above the washer has the added advantage of putting the dryer at a convenient working height for easy loading and unloading without stooping.

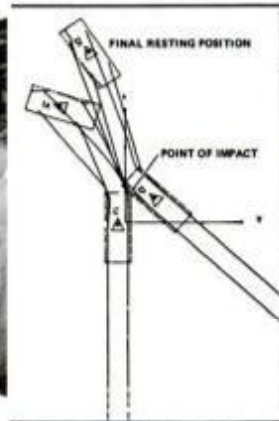

Mobile accident-detection lab solves car crashes

Police can now reconstruct traffic accidents scientifically in minutes, eliminating lengthy examinations that often cause extended highway delays. Vital crash clues, such as skid marks, vehicle direction and type of impact damage, are recorded electronically and fed into a mini computer on board a special accident-investigation van. This information is radioed to a central computer that determines the crash cause and flashes a visual display of the accident scene on a TV-like screen (right, above). Photocopies are made of the display for permanent record and the highway cleared. Calspan Corp., Buffalo, N.Y., developed system.

Home foot scale for proper-fitting shoes

Many people who buy shoes by mail or at discount centers don't have access to foot-measuring scales used in shoe stores. This inexpensive plastic version is designed for home use, especially for checking children's constantly changing foot sizes. \$2.95 ppd, Family Foot Fitter, Box 546, Palos Heights, Ill. 60463.



'Invisible' lifebelt looks like real belt

It doesn't look like a life preserver—until you need it. Resembling a decorative sport belt (right, above), it contains a folded, inflatable plastic life ring concealed in the lining. Squeezing a trigger instantly inflates the ring from a CO₂ cartridge and pops it out of the belt. In bright international yellow, the ring will support 300 pounds for 72 hours. Designed to give freedom of movement yet provide emergency aid, the belt is \$26.95 from The Mail Boat, Inc., 2190 S.E. 17th St., Fort Lauderdale, Fla. 33316.

Controllable hang glider—you fly it like a plane

Conventional hang gliders have no controls and are maneuvered merely by shifting body weight. This advanced design sports a tail with movable rudder and elevator operated just like a real airplane with a single control stick (right, below). Results are said to be much improved maneuverability and safety. Glide ratio is also superior—10 to 1 compared to usual 4 to 1. Called Eagle, kit form could sell for about \$1000. An information package is \$3.50 from Man-Flight Systems, Inc., Box 872, Worcester, Mass. 01613.

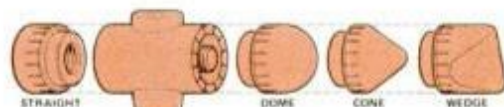

Soft-face hammer set

Great for car-body repair, metal forming and general shop use, this safe mallet-type hammer is complete with hardwood ash handle and four interchangeable, screw-on faces. The 1 1/8-inch-diameter rubber-like faces absorb impact, are nonmarring, will not mushroom head of tool (such as chisel) being hammered. \$6.95 ppd., Way-Mar Co., Box 164, Hartsdale, N.Y. 10530.

Pipe dream—or nightmare?

Who says drainpipe is just for plumbing? This artistic piece of "drainpipe sculpture" was cobbled up by the British firm of Allied Iron Founders to publicize the flexibility of its new line of PVC plastic pipe and fittings. The imaginative creation is currently touring Britain as part of a mobile industrial exhibit.



Snowless bobsled ride

You don't need snow to enjoy the thrills of a bobsled ride. This simulated bobsled run, a sort of super roller coaster, is a feature attraction at newly opened Busch Gardens in Williamsburg, Va., an entertainment park developed by Anheuser-Busch. The 2800-foot-long spiraling ride subjects passengers to some of the same G-forces as a jet fighter. Track, here under construction, is made up of steel beams and tubular steel supports.

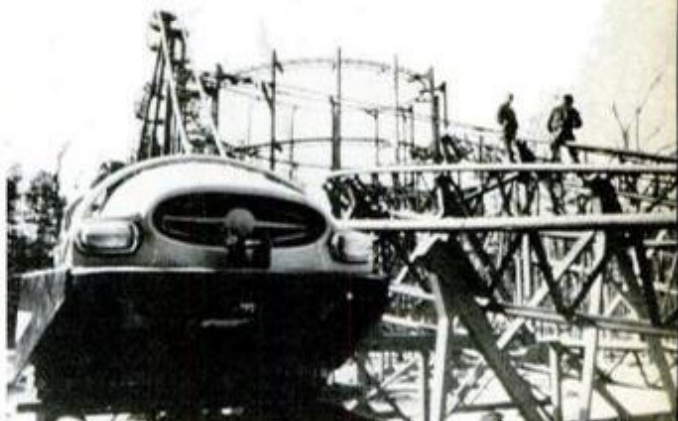

Digital direction finder

Somehow, you use your boat's direction finder only when it's dark and rough out and you're scrambling just to hold on. That's when you'll appreciate the digital station-frequency display on this new Heathkit RDF. It tells you when you've found the station even if it's momentarily silent—or tells what station you've found. A sense antenna also reduces 180° ambiguity. The kit costs \$240.



Car-tape player with 'punch'

Clarion's latest tape players have a loudness compensation circuit (called "punch sound" by the manufacturer) that boosts high and low frequencies when you turn down the sound (ears lose low and high-frequency sensitivity at low volume). This model, the 888, is rated at 7 watts per channel at a high 10-percent distortion level; figure 4 or 5 watts at more listenable distortion levels. Write Clarion Corp., 5500 Rosecrans Ave., Lawndale, Calif. 90260.

NOW



Temporary radiator protection

If you can't replace your car's coolant as often as ideal (every two years), you can gain temporary radiator protection with Anti-Freeze/Coolant Saver. It replenishes worn-out corrosion inhibitors, extending coolant life. \$1.75 from American Grease Stick, Box 729, Muskegon, Mich. 49443.



First electric plane

World's first electric-powered manned aircraft makes its initial test flight, at lower left, remaining aloft for nine minutes. A powered glider that has been converted to electric propulsion, the MB-E1 is equipped with a 13-hp motor that drives a pusher prop by V-belt (upper left). Maximum flight time for the plane is 20 minutes per battery charge. Designer and builder is Fred Militky, Kirchheim/Teck, Germany. More powerful versions are to come.



Wicker-like weatherproof furniture

Stylish patio furniture with the weather resistance of a modern boat hull is made of fiberglass-reinforced plastic, has open-weave look but won't rot, mildew, chip or scratch; can be painted as desired. Tables and chairs with cushions in a variety of colors are available. Chair shown is about \$52. Geostrand Products, Inc., 4236 South 36th Pl., Phoenix, Ariz. 85040.



Undercover for walls

Imperial Wall Cover provides a smooth surface over problem walls to which decorative wall coverings are to be applied. It's recommended for use over concrete, masonry, grooved paneling, old plaster because it bridges mortar joints, minor cracks and recesses. Retail price is about \$8.95 for a 2x18-foot roll. Imperial Wallcoverings, 23645 Mercantile Rd., Cleveland, Ohio 44122.



Emergency fan-belt kit

For temporary replacement of broken auto fan belts or as a permanent drive belt for appliances and tools, this kit provides a 42-inch length of polyurethane tube to ride in V-grooved pulleys, plus snap-in connector and cutter. \$4.95 postpaid from Stock Sales Co., Box 606, Mineola, N.Y. 11501.

Handiest autoflash yet

Braun's new 17BC is so tiny (just 3½ inches high), so light (3 ounces) and so well balanced you hardly know it's on your camera. It gives automatically controlled exposures from 3½ to 10 feet at f/5.6 on ASA 80 film, recycles in 9 to 12 seconds, gets up to 200 flashes per pair of AA batteries. Costs \$35.



Rolling lab keeps tabs on the sun

To check on the feasibility of solar heating in various localities, this giant mobile solar collector lab is on a two-year national tour that will take it to all parts of the country. The rolling rig saves the cost of setting up many fixed solar stations, is a joint project of the National Science Foundation and Honeywell, Inc.

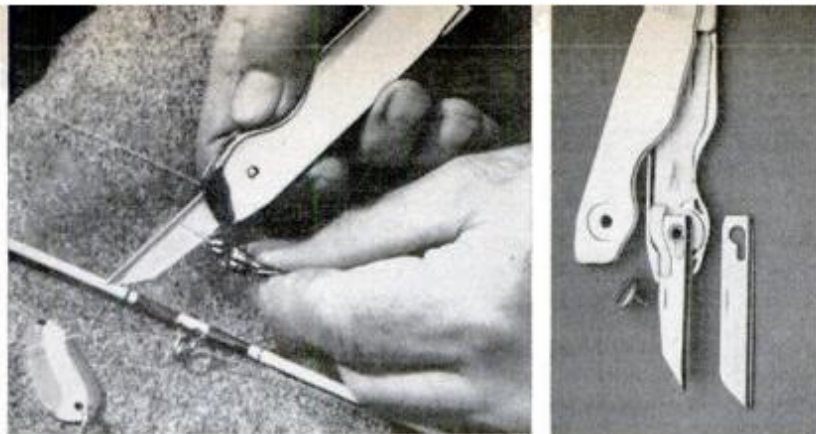

Replaceable-blade pocketknife

Described as combining the advantages of a traditional pocketknife with those of a utility knife, Stanley's pocketknife for light to medium-duty cutting jobs has a safety lock that holds the blade firmly while in use; pulling on the lock releases the blade to fold back into the handle. Blades—both utility and sheepfoot styles are available—are rust-proof stainless steel, can be changed quickly. Handle has room for holding a spare blade. Suggested list price is \$2.75. The Stanley Works, 195 Lake St., New Britain, Conn. 06050.



Home pocket-billiard game has a jackpot

A family pool game with a Las Vegas touch, Payout Pool rewards skillful shooting with a jackpot of tokens. Ante up, set the movable center pocket, align the bumper triangle for each shot and shoot. Sink a ball and the table pays. With nine numbered balls, cue stick, it's about \$20. Mattel Toys, 5150 Rosecrans Ave., Hawthorne, Calif. 90250.

A lifeline you throw like a hand grenade

Resembling the old German "potato masher" hand grenade, this emergency rescue aid can be tossed 75 feet or more to a swimmer in distress. Coiled inside is a 132-foot-long nylon lifeline. Called the BELL, it's made by Balcan Engineering, Ltd., 41 Witham Rd., Woodall Spa, England.



New turntable has super-bearing

This new Fons turntable, from Scotland, has a bearing so smooth that you can spin it by hand and find it still spinning minutes later. Price is \$269 without the arm, \$319 with the arm shown. Belt-driven, it runs at 33, 45 or 78 rpm speeds, all individually adjustable, with an electronic speed control.

Will the real legs please stand up?

Owners of the "What This Country Needs" restaurant in San Francisco think that table legs should be something more than mere supports so they ordered these shapely hand-carved replacements. Male diners may find them appealing; the gals too appealing.





What makes such a little known line of cars so revered by owners?

A nationwide survey based on 2,339,000 owner-driven miles

by Michael Lamm WEST COAST EDITOR

Bayerische Motorenwerke (BMW) presently imports three different series of cars: the Vega-sized 2002, the Granada-sized BMW 3.0, and the new-for-1975 series 530i that you see pictured here.

Fully 85.4 percent of our respondents own the four-cylinder 2002 series (1974 and '75 models), so our summary chart below is heavily weighted with 2002 data. And since the 530i was just starting to enter this country when we mailed our questionnaires, we unfortunately have no replies from 530i owners.

BMW prices begin at \$6037 for the basic 2002 two-door and go to \$14,204 for the 1975 3.0Si with automatic (West Coast p.o.e. figures). What induces a person to pay that sort of money for cars no bigger than Vegas and Granadas? To let the owners explain, here are typical responses:

The fuel-injected 2002tii, which develops a full 125 bhp, is a true sport sedan.

Handling far outdistanced other specific likes, and almost every BMW owner praised roadholding.

Writes an Upland, Calif., salesman and 1974 2002 owner, aged 20: "I've had my eye on BMWs ever since I was a sophomore in high school. That's given me a lot of time to check them out. At 7000 miles, I've had no troubles at all with my 2002. If I ever do, I'll repair them myself. Workmanship is the best. When you drive it, you know you have something under you—not like an American car. Ride is comfortable, and long trips pass quickly because of the extra comfort. I especially like the car's **handling** and overall performance—plus the classical look and the 26 to 32 mpg. This one should last me many years, and if I had to trade, it would be on a Bavaria 3.0."

Another salesman, 28, from Evanston, Ill.: "This is our second 2002. Our first, a 1970, never had a thing go wrong in the three years

Summary of 1974-75 BMW Owners Reports*

Total miles driven	2,339,580	Economy	41.4	Workmanship opinion:		What type of trouble?	
Average miles per gallon		Performance	40.5	Good to excellent	88.8%	Brakes	16.8%
Local driving	20.5	Comfort	31.5	Average to poor	11.2	Carburetor	15.5
Long trips	25.8	Styling	21.5	Comfort opinion:		Electrical system	11.8
Series		Workmanship	20.9	Good to excellent	73.9%	Transmission	9.9
BMW 2002	75.2%	Visibility	17.4	Average to poor	26.1	Automatic choke	9.3
BMW 2002tii	13.2	Specific dislikes:		Number of vehicles owned:		Did you repair it yourself?	
BMW Bavaria 3.0	6.7	Expensive service	16.2%	BMW only	42.9%	No	97.5%
BMW 3.0S	2.8	Ventilation system	11.8	Two cars	42.6	Yes	2.5
BMW 3.0CS	2.1	High initial price	10.2	Three cars	9.8	Dealer repairs satisfactory?	
Why did you choose the BMW?		Wind noise	8.3	Four or more cars	4.6	No	68.8%
Performance	29.8%	Poor gas mileage	7.0	Other cars owned:		Yes	31.2
Economy	25.8	What changes would you like?		Volkswagen	14.1%	Age distribution of owners:	
Handling	21.4	Better vent system	16.4%	BMW	12.5	15-29 years	48.4%
Reliability	20.8	Lower price	11.7	Chevrolet	12.5	30-49 years	34.0
Styling	14.6	Revised seat belts	9.3	Mercedes-Benz	9.8	50 and over	16.7
Workmanship	14.3	Different styling	6.4	Ford	8.2	Would you buy another BMW next	
Quality	13.7	Dealer service opinion:		Had any mechanical trouble?		time?	
Specific likes:		Good to excellent	52.0%	No	50.5%	Yes	90.9%
Handling	70.7%	Average to poor	48.0	Yes	49.5	No	9.1

*Percentages might not equal 100% due to rounding or insufficient data.

BMW 530i DRIVING IMPRESSIONS



The BMW 530i, marvelous as it is, has a few minor flaws. They're not glaring, but I'd like to get them out of the way before I launch into sustained praise.

First, the muffler is too loud, and the eight-bladed fan also makes a lot of noise above 40 mph. They're out of character in a car as refined as this.

Second, I dislike the 530i's four-spoke steering wheel. Its rim is slippery, its spokes ungrippable and the four little horn buttons need too much searching, especially if you have to honk during a turn.

And that's it. That's all I found wrong with what otherwise has to be one of the most thoroughly thought-out, best built, most complete, comfortable and precise-handling cars I've ever driven. It's one of the very few \$10,000 cars I consider worth the price.

There's nothing gimmicky about the car. The instruments don't look like they're off a jukebox. Front seats don't make you feel guilty because your bumps and their bolsters don't conform. Yet the seats are infinitely adjustable for height, rake and tilt. Along with the telescoping steering column, there's really no excuse for not finding one, two or more comfortable driving positions. And there's plenty of legroom and headroom front and rear. Visibility in all directions is excellent, thanks to thin pillars and tall windows.

Handling—the BMW 530i handles better than most sports cars. Its quick, responsive steering gives any driver total authority. This is power-assisted steering, with much less "power feel" than in American cars; if you didn't know it had power you'd think it was just light manual steering. As for the slippery steering-wheel rim, I understand that BMW is making a foam-rubber encased wheel

BMW 530i STANDARD EQUIPMENT AND FEATURES

Four-wheel, independent coil-spring suspension.
Four-wheel power d'sc brakes.
Steel-belted radial tires.
Four-speed, all-synchro transmission.
Electronic fuel-injection.
Overhead-cam, hemi-head, six-cylinder engine.
Infinitely adjustable front seats.
Adjustable steering column.
Quartz crystal clock.
Heated rear window.
Toolkit in deck lid.
Separate heater adjustments for feet and head.

Rechargeable pocket lamp with socket in glovebox.
Rebuildable shock absorbers.
ZF power-assisted steering.
Welded, unitized body with front and rear crush zones.

OPTIONAL EQUIPMENT

Three-speed automatic transmission.
Airconditioning.
Electric windows.
Sunroof.
Leather upholstery.
Limited-slip differential.

available optionally. It really ought to be standard.

Acceleration is brisk under full throttle. Factory literature lists 0-60 mph in nine seconds flat. I'd say that's a *little* optimistic, as is the factory's 124-mph top-speed figure. But the 530i has more than enough performance for any squeaky situation.

The body feels extremely tight and solid,

with no suspension whumps over rail crossings or potholes. Except for the engine, the car is very quiet. The body structure incorporates crush zones front and rear, and these have been extensively tested—they really do crush.

All in all, the 530i impressed me mightily, not just as a delightful car to drive but as a \$10,000 car worth owning.—M.L.



Toolkit is built in trunk lid. Instruments and controls are rationally positioned.

SPECIFICATIONS—BMW 530i FOUR-DOOR

Dimensions: Wheelbase: 103.8 in.
Overall length: 189.9 in.
Overall width: 67.2 in.
Overall height: 55.9 in.
Curb weight: 3300 lbs.
Engine: Sohc in-line Six, crossflow hemi head, 7 main bearings, electronic fuel injection.

Displacement: 182.0 cu. in.
Bhp @ rpm: 176 @ 5000.
Torque @ rpm: 251 @ 4500.
Miscellaneous
Brakes: Four-wheel discs, 10.7-in. rotors. Body/chassis: Welded steel, unitized, crush sections front and rear.

and 33,000 miles we owned it. The only costs were for brake linings and tune-ups. When we got ready to trade, we drove Saabs, Volvos and Peugeots on loan, and then bought the 2002. Of the four, BMW is the only car that hasn't compromised **quality** because of present economic pressure. If someone offered us a 450SEL Mercedes in equal trade, we wouldn't take it. It's that kind of car."

A Dallas aerospace engineer, 33, owner of a 3.0 Bavaria: "I like a car that handles well. I like to shift my own gears. The Bavaria handles as well or better than many sports cars. Workmanship is outstanding. Reliability, too. I've had no problems at all. Previously I owned a BMW 2002, which went 67,000 miles with only a radiator rebuild and a transmission overhaul (bad synchronizers).

Nearly 90 percent of our owners rated quality and workmanship good to excellent—a remarkable figure.

Excellent visibility is one of the first things you notice when you sit in the driver's seat.

My BMW dealer is no better, no worse than others, but I feel his charges for routine maintenance are too high."

Here's the owner of a 2002tii—21, a California university student: "I bought it because I believe it's the greatest car in the world. My father owned a 1971 2002 and put 80,000 troublefree miles on it before he sold it. Here's what I especially like about the tii: 1. visibility, 2. comfort and room (I'm 6-2 and it's a great four-passenger ski car), 3. handling and cornering, 4. quickness on pick-up, 5. brakes, 6. smooth gearbox, 7. controls—dials, 8. trunk space, 9. sunroof, 10. looks. I'd prefer the console smaller to give more legroom, and an 18-gallon gas tank instead of 13.5."

From Tennessee, a recording musician and

Bavaria owner, 37: "I bought it because it was touted to be the finest, most-advanced six-cylinder car in the world, according to *Road & Track*. The trans went out at 12,000 miles and had to be replaced. Brakes needed relining at 8000. The trunk wouldn't unlock. Even so, I'd rate workmanship as excellent. Maneuverability, too, and it's quiet on the road, with beautiful styling. But the gear changes (automatic) are still too rough, the stereo is nowhere near comparable to Cadillac or Audi, steering is too heavy despite being 'power assisted' and gas mileage at 15 to 20 mpg is inadequate."

A Michigan dental specialist, 26: "I wanted a sports car but needed a family car, thus the 2002. I couldn't believe the roadholding, handling, acceleration, solid construction and

Brake gripes centered on squeakiness. BMW 530i and 3.0Si use four-wheel discs; 2002 has rear drums.

By "entertaining," he means he likes cars he doesn't get bored driving.

check tire pressure. I wanted a quality car that would give me a minimum of problems. I got it, and it's fun to drive!"

An executive in a New Jersey motor vehicle bureau, 38: "In spite of the ridiculous price, the 2002tii offers good performance, good mileage, and besides, I commute 105 miles a day and need an **entertaining** car. When I bought the BMW, I already owned one sporty car (Porsche 911) and one transportation car (Chevelle wagon). But I needed something to commute which would give 100,000 trouble-free miles plus economy. I'm also critical of handling and performance, since I often compete in autocrosses in my Porsche. I would have preferred an American car at a lower price, but guess what? There aren't any. No U.S. car gives comparable mileage with the



Fuel-injected, three-liter Six, at left, powers the new 530i four-door sedan. The popular 2002 model is shown at right.

silence. I feel very safe and secure in this car. I know everything is there that's needed for quick passing, stopping, and swerving. It digs into curves and has great snow traction. Instrumentation is easy to read, and about all I can find wrong is that seat belts are hard to put on once the door is shut—I have to twist my body and grab the belt off its hook."

A San Antonio architect, 37, and 2002 owner: "I really like my car—proudest possession I have. I recommend it highly. Only sorry Detroit didn't make it. My gripes are minor: Dealer made no deals—sticker price was it, with low trade allowance. Expensive airconditioning doesn't reach back seat, which has too little legroom. Front seats, too, tend to cramp. But BMW makes an excellent engine, uses very good workmanship, beautiful paint and great performance with 22 to 26 mpg economy."

A 42-year-old California dentist, owner of a 3.0CS sport coupe: "Unbelievable handling, comfort, speed, quality, workmanship, and gas mileage. We were Cadillac owners before. This car makes a Cadillac look like an Erector Set. The 3.0CS is, in my opinion, the best motorcar on the U.S. market today."

A New York teacher, 25, 2002 owner: "No mechanical problems in 11,000 miles. Dealer is excellent on routine service, gives me an appointment and I'm taken immediately (no pun). Three mechanics attack my car, even

Many owners mentioned this; said solidarity made them feel well protected despite BMW's compactness.

How's this for service? And the car with 415,000 miles needed less work than most 100,000-milers.

BMW owners are constantly comparing their cars to Caddies, Lincolns and Mercedes.

handling, performance and quality. Maybe I could modify a Pinto or Vega to handle and go almost as well, but it would ride like a truck, break often and cost more."

The owner of a Michigan armored-car service, 42, whose company owns 35 BMWs and who owned 100 or more since 1969. He says:

"We currently have some half-dozen 1971 BMW 1600s and 2002s with around 350,000 miles. In 1969, we put a 1600 sedan into service and ran it 415,000 miles with only two valve grinds. The pan was never off the engine, and this car had its original clutch! I presently drive a 1974 2002 with 100,000 miles on the clock—have replaced the alternator, plugs, points, distributor cap, belts, and filters—that's it! It runs as well now as cars with 6000 miles; you can't tell the difference. Prices are high, but the product is excellent. You ask what I can find wrong with the 2002, so I'll tell you—the window cranks are weak and sometimes break. The chrome trim comes loose, so we screw it back on and have no more problems. BMW should also stick with Michelins. It keeps trying other tires, but we have problems with the others.

"I'll tell you, though, that if the whole world had to go to one make of car, it would have to be BMW. Dollar for dollar, it has no competition." ★★★

RUST

YOUR CAR'S WORST ENEMY

by Michael Lamm WEST COAST EDITOR

In 1968, rusted-out cars cost motorists an estimated \$5 billion. In everyday terms, the average tab came to \$100 per car that year.

Today, with nearly twice as much road salt being used, and taking inflation plus the higher price of cars into account, it's safe to call auto-body corrosion a \$7.5-billion-a-year blight. At \$7.5 billion, it puts the average cost to each of us who drives a car at \$150 a year. In localities where cars rust quickly, the cost is higher; in low-rust areas, of course, it's lower.

If \$7.5 billion seems a mind-boggling figure, keep in mind that the cost of muffler replacement alone ran to \$675 million in 1973. And the \$7.5 billion represents only the dollar cost of the rusted-out cars themselves. It doesn't cover the toll in accidents caused by leaky mufflers, punched-through floorboards, burst steel brake lines, ruptured spring towers and general structural collapse. It also doesn't take into account the medical expenses, time off the job and the deaths caused by auto-body corrosion. Because, acknowledge it or not, car cancer does kill people, just as surely as any other kind.

No one seems to care

I go back to Detroit about once a year, and it always amazes me to see so many Swiss-cheesed hulks running around. It strikes me as ironic that here in the city that produces all those shiny new ones, people put up with the cost, the danger and the ugliness of rust buckets as their own private transportation.

Detroit's clunkers aren't old cars by any means. If anything they're middle-aged. By age five, many cars

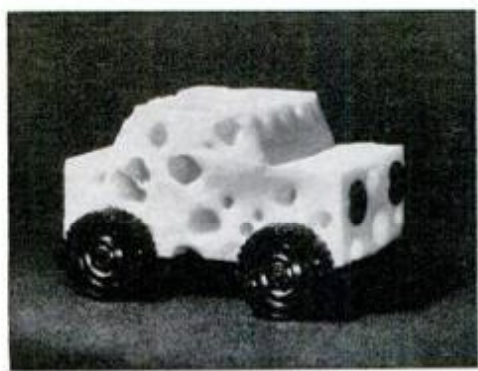

Photo: Jose Conte

in Detroit show spots and panels that are completely rusted through. James B. Garvie, superintendent of Detroit's Vehicle Management Div., told me, ". . . in an area such as Detroit, where salt is used on the streets every winter, you would be lucky to have a car go much longer than four years, possibly even three, without rust starting to show."

In 1951, the average lifespan of an American automobile was 13.5 years. Today, the average lifespan hovers between nine and ten years. Why?

One member of the auto establishment told me flatly: "Detroit has a vested interest in rust. The more cars rust, the more new ones get sold." He asked not to be identified.

What gets me about the auto-body corrosion calamity isn't the \$7.5-billion-a-year cost, although that bothers me, too. It's the meekly accepting attitude of the American public. Why isn't anyone hollering? Why isn't the Department of Transportation all fired up? Or the Department of Health, Education and Welfare, since this is a health problem? Or the Office of Consumer Affairs, since it's costing consumers all that money? But no one's saying a word. And it

shouldn't even be the bureaucrats—it ought to be the motorists themselves who yell, "Stop! I've had enough of trading cars every three years. I'm not going to put up with rust any more!"

Naturally it's not that simple, because it's usually not the person who bought the car new who has to put up with the rust. He sold it at age three; the actual problem of corrosion falls to subsequent owners. It's the little guy who inherits the rust, and poor people have neither the time, money, nor political clout to protest.

Why all this rust?

Thirty-five years ago, cars used not to rust, or rusted very little at least. It's interesting to trace how corrosion turned from a relatively minor problem into a very major one.

You know the old saw, "They don't make 'em like they used to," right? Well, it's a fact. In many ways, of course, cars are better today, but the old Model A Ford (1928-31) used sheet metal 0.048-inch thick in its fenders. Model A's body gauge was 0.040 inch. One reason you still see so many Model As around is that their fenders and body were built, and the fenders in particular had relatively smooth under surfaces—no pockets or crevices to catch and hold road splash.

From the mid-1930s through the 1950s, sheet metal for automobile bodies was a pretty consistent 0.037 to 0.040 inch. Recently, though, and especially in small economy cars like the Pinto, Vega and many imports, sheet-metal thickness has dropped to 0.032 inch. In some imports like the Toyota it's as thin as 0.029 inch. So we're down from 0.048 on the Model

A fender to nearly half that in several imports. And 0.029 inch is just over three times the thickness of a common soup can.

Now you say, "Well, steels are better today—technology is better." I'm afraid not. Today's steels are about the same, and the new technology of rust prevention, such as it is, simply tries to compensate for the loss of metal thickness and fights an uphill battle against air and road pollution.

Consider these added factors speeding auto-body corrosion:

1. Cars with separate frames can stand up under body rust better than cars with unitized bodies. That's because the frame members are thicker—heftier—than sheet metal, so while doors and fenders might look like lace curtains, the frame is still holding the car together.

In cars with unitized bodies, though, there's no separate frame. Unit bodies rely on box sections and gusseting for rigidity. The actual sheet metal used in some of these boxes and gussets, however, is much the same gauge as the outer skins. So since the boxes tend to trap moisture and salt, they're given to rusting just as quickly (more quickly in some instances) as door bottoms, fenders and quarter panels. In other words, unitized bodies can and sometimes do simply collapse from corrosion. *Most U.S. and imported small cars—subcompacts, compacts and ponycars—use unitized body construction. They're unitized, inexpensive, and*

supposed to be economical, so their engineers trim weight and cost by specifying thin-gauge sheet metal.

2. The two main causes of rusting—road salt and air pollutants—have increased tremendously in recent years. Municipalities and highway districts were using nine times as much road salt in 1971 as they had been in 1955—and 18 times as much as in 1947.

Salt companies currently sell nearly 10 million tons of road salt every year—and I mean they go out and aggressively sell it. It's been shown that the amount of salt bought by some of the big eastern cities has nothing to do with snowfall; also that the times when salt is spread on roads has nothing to do with snowfall intervals. Cities and state agencies are simply buying salt and dumping it on roadways all winter long. It's "good business." I'm not saying that salting roads is all bad—it's not. Salting is necessary in some areas. But it's overdone. There's no need to use so much.

Why, you ask, doesn't someone invent a salt that doesn't cause corrosion? Chemists have tried, believe me, and the car companies would like nothing better. So-called "inhibited" salts have been formulated. They're expensive, and none has been shown to do much good.

Salt, in any case, accounts for only about half of all auto-body corrosion. The other half is caused by atmospheric pollutants like sulfur dioxide. This is conceded to be one of the most corrosive pollutants around and it's one of the lovely things cars with catalytic converters spew out. But other airborne corrosives also contribute: acids, metallic powders, even dust. A Swedish study concluded that heavy industrial environments make bare steel rust eight times more quickly than rural environments.

What causes rust?

A very complex thing, rusting happens in two major ways. There's so-called "galvanic" corrosion and "concentration cell" corrosion. Both work electrolytically.

Galvanic corrosion needs two dissimilar metals plus an electrolyte—a fluid that conducts electricity. Suppose you have two sheets of steel held together by copper rivets. Salt spray (the electrolyte) makes a cathode of the copper and an anode of the steel. You get a reduction/oxidation reaction flow through the salt-spray solution. Pretty soon the steel around the copper is eaten away.

What about the door of a car, where there's only one type of metal—sheet metal? Can that also rust by galvanic action? Indeed it can. The

sheet steel used in car bodies contains two major constituents: pearlite and ferrite. These are crystals—the pearlite is black, the ferrite, white and carbon-free. There's enough difference between the electro-motive potential of the two to cause galvanic action. Thus an all-steel car body can rust all by itself, with no help from a dissimilar metal. All it needs is an electrolyte—a little impure water on its bare surface.

Concentration cell corrosion accounts for even more rusting than pure galvanic action. Here's how it works. Suppose you have a poultice of mud and road salt packed in under the unpainted surface of a fender. As galvanic corrosion takes place, free oxygen is consumed at the metal's surface. Pretty soon there's a much lower concentration of oxygen at the rust patch than there is in the atmosphere. This difference in oxygen concentration again sets off an electrolytic action, because in the absence of oxygen, metal can go into solution as cations, leaving behind two negatively charged electrons. These two free electrons move to the atmosphere, making iron hydroxide, which goes to iron oxide (rust) and water.

Note, though, that salt alone can't cause rusting. *Dry* salt plastered against a metal surface won't do a thing. In fact, trucks hauling dry salt inside huge salt mines don't show the slightest trace of rust. Trucks that haul away hot cinders from big coke ovens don't rust either, because the heat dries off any moisture that might become an electrolyte.

It's only the unprotected, *bare* metal that's vulnerable. Rusting usually eats its way from the inside of a car body toward the outside. Paint protects the exterior until it's scratched or nicked. Some late-model cars do tend to lose paint because of radical tuck-under, which lets the tires fling up stones that chip the finish. In those cases, rusting often moves inward as well as outward at the same time, and a panel can perforate (rust through) much more quickly.

What's being done about rust?

Talking to corrosion engineers at the Big Four auto companies, I got the impression they were mostly frustrated. They were trying to do a good job, but the cost controllers kept slapping them down. I feel that in all but one company, the corrosion engineer amounts almost to a figurehead.

That's not to say they're not doing anything. It's just that they're not doing enough. The only car made in Detroit today that goes beyond the current normal standard of rust pro-

SALT USAGE IN THE U.S.

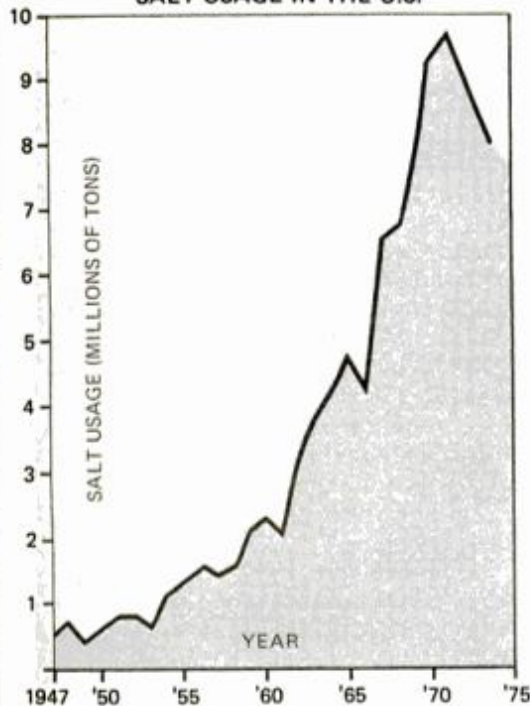

The purchase of salt by municipalities has been rising steadily. Salt melts ice on roads to minimize skidding accidents, but heavy use contributes to car-rusting and has a negative environmental impact.

tection is the new Cadillac Seville. It's too early to tell for sure, but the Seville appears to have about twice the rust resistance of most Detroit products. That might make it 10 years away from perforation in harsh environments instead of the usual five.

The corrosion engineer's arsenal of antirust weapons sounds impressive—such things as zinc-rich primers, galvanized steel, Zincrometal, spray-on plastisol vinyls, spray-in oily waxes, electroclips, plus Mortex insulation and Permagum dumdum. Indirectly, plastic grilles, molded polyurethane bumper pans and fender extensions and fiberglass pieces help combat rust.

Yet no carmaker is overly generous with any of these. In fact, they're about as stingy as they can be. So in

a way, they're paying lip service when they tell you about their anti-corrosion systems. They use them, but only where there's no choice.

I'll illustrate the point by citing the Vega's example. The Vega has gotten a terrible reputation as a ruster. From its inception, its front fenders would perforate within two years in harsh cities. Why? Because the sheet metal was thin (0.032 inch) and minimally protected. Didn't Chevrolet engineers know that Vega front fenders would rust out? They say no. Finally in mid-1974, three and a half years after the Vega's introduction, Chevy decided to add plastic inner liners inside the rear fenders. At the same time, the Vega wagon's rear-door outer panel became Zincrometal, and so did its quarter panels and wheelhouses.

Not wanting to risk another ruster with the Monza and its stablemates, Chevrolet and Fisher Body specified fender inner liners and Zincrometal inner fenders from the beginning.

And lest you think the Vega was unique, a few years ago Pintos also had two-year perforation problems with their front fenders. Same thing happened. The Pinto, too, got plastic fender liners after a few years of production.

Rust protection always has to be a compromise. All the automakers can do is slow down the corrosion process. They can never stop it altogether. And rust protection is a relatively new science, so many processes are still imperfect. Each contains built-in faults and restrictions.

Undercoating used to be a big thing. More recently, however, it's been shown to dry out, get brittle, stiffen, lose adhesion. When that happens, it creates pockets of moisture and salt on a car's underbody.

Zinc-rich primers (ZRP) came along around 1958, and are still widely used. They're relatively cheap and have the great advantage of weldability—you can weld through them. But ZRP used on the inner skins of doors, say, tends to flake off in some cases and erode sacrificially in others. Within about five years, either way, they're gone. Bye-bye rust protection.

Zincrometal is one of the new names around car companies these days. It's a one-side-coated steel. The coating is baked on in two stages. Zincrometal's coated surface is designed to face inward in, say, a door or quarter panel. (Zincrometal was developed by a company named Diamond Shamrock. It is now made under license by U.S. Steel, Armco and Inland Steel and is supplied to anyone who wants it.)

Zincrometal is moderately expensive, weldable, and has only one major drawback. It scratches fairly easily. Scratched or nicked, it rusts. So it needs careful handling on the line. Zincrometal can also be stamped, but complicated dies tend to abrade it.

Two-sided galvanized steel came into common use with the 1960 Falcon. The Falcon's rocker panels were galvanized. Ford soon found that although the Falcon's fenders, doors and other panels rusted as quickly as ever, its rockers looked new after five years on the road, and they showed very little rust even after eight. Today, the average Ford product contains 170 pounds of galvanized steel. GM uses roughly 100 pounds per car; Chrysler and AMC approximately 72 pounds.

But why, you ask, isn't galvanized used even more widely? Three rea-

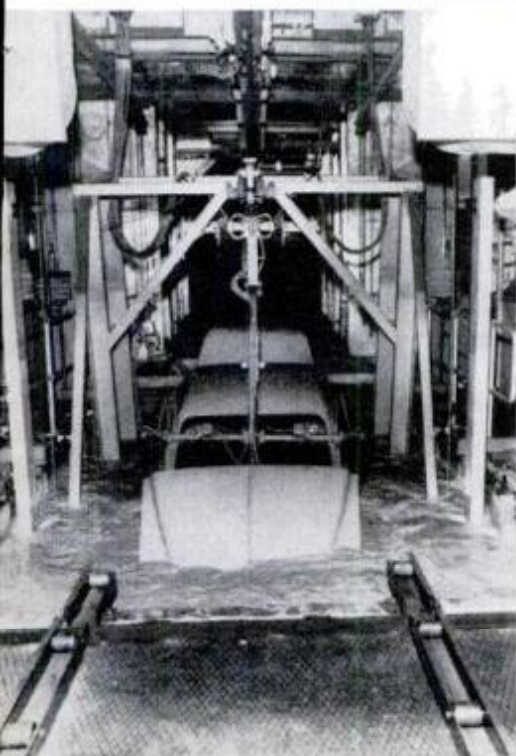
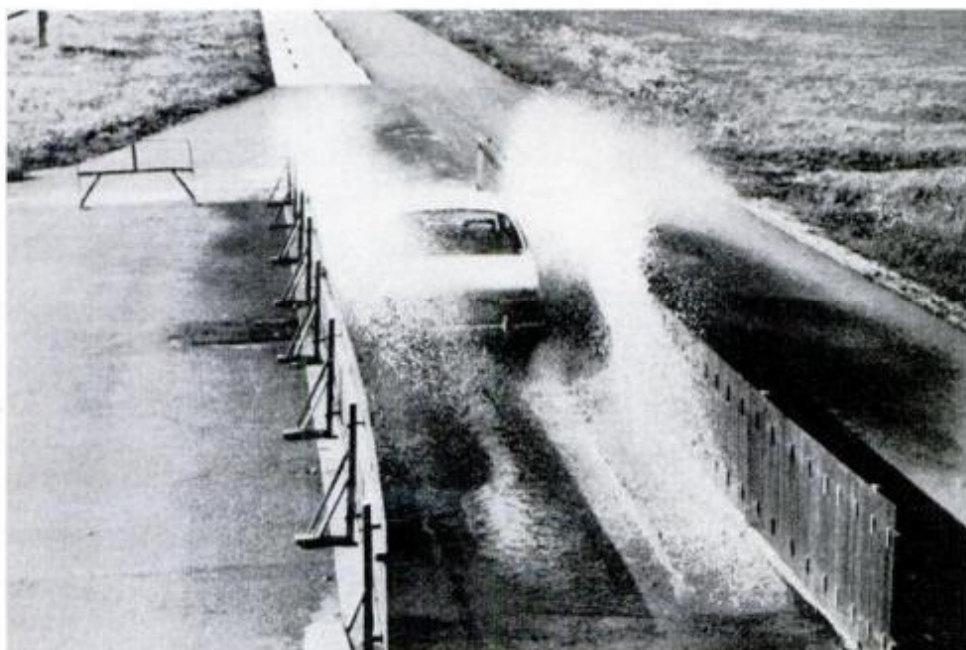

Automakers in Sweden are especially conscientious about designing corrosion resistance into their cars. Here are procedures used by Saab. Bodies are dipped in a corrosion primer bath as shown at left. Above is shown the application of an oil-based rust preventive and, at top, a Saab 99 is going through a drench check for water seepage.

PREFERRED DESIGNS FOR PREVENTION OF CORROSION AS RECOMMENDED BY THE SOCIETY OF AUTOMOTIVE ENGINEERS

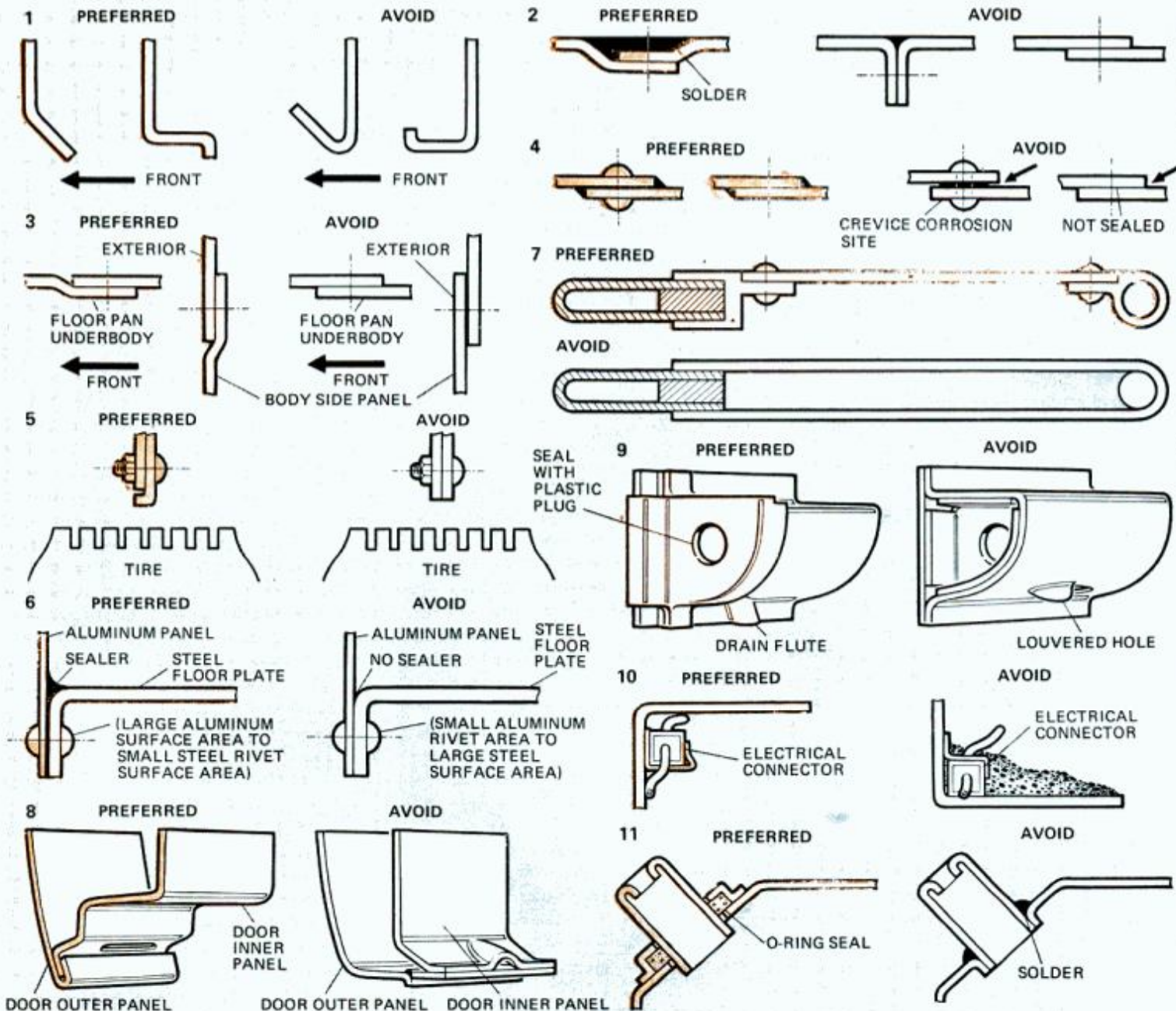

Art: Peter Trojan

Where to check for rust on your car

Most of today's cars use steel brake lines. Since bare steel would rust through in a few years in road-salt areas, these lines are coated with a thin coat of brazed copper and terne. But where such a brake line is scraped bare or nicked by a flying stone, the copper coating exposes the steel. What happens then: Salt spray acts as an electrolyte between the copper and steel, which actually speeds corrosion.

The SAE Journal, published by the Society of Automotive Engineers, reported in January 1966 that in salt-spray degradation of copper-brazed steel tubes, "pressure-retaining ability [is] reduced to practically nothing after 30 days' exposure." In other words, within a month the rusted-out brake lines can burst during normal stopping. They usually don't, but it's possible. More to the point, a survey of fleet operators in road-salt areas said that 40 percent of their cars' brake lines showed some measure of rust damage after only two years' service.

In Sweden, every car on the road is inspected once a year for safety defects. The government-owned company doing the in-

specting reports that many cars over five years old have rusting problem. Among 1969 models, for example, the British Ford Cortina showed the worst rusting and Peugeots came in second.

A common, very dangerous rust zone in small unit-bodied cars happens to be the tops of McPherson-strut spring towers. Mud and road salt pack into these areas and soon they rust through. Result: The entire front end of the car collapses.

Volkswagen Beetles have long had a corrosion problem around the battery box under the rear seat. Holes in the rear floor could let in carbon monoxide from the exhaust. Carbon monoxide entering the passenger compartment can affect any car. Mufflers and exhaust tubing rust through in a couple of years under the best of conditions. Add floorboard rust, speeded by sound-deadening mats that trap and hold moisture under carpeting and you have a lethal combination. The floor soon perforates.

Tailgates on station wagons used to rust quickly, often at bottom edges after leaves and water entered at the window. Leaves

clogged the drain holes, the tailgate soon rusted through and exhaust fumes were then sucked in. However, this is less of a problem now because some cars are using galvanized metal, but tailgates do still rust in some makes and models. The same is true of trunk floors in many regular coupes and sedans.

A few early Mustangs had problems with gas tanks rusting through because of a corrosive adhesive used under the trunk mat. These were "drop-in" tanks where the upper surface doubled as the trunk floor. A number of other Ford products used "drop-in" gas tanks, but the factory says these weren't affected by rust.

Less common than rusted-out doors but still known are collapsed A-arms and suspension components, broken steering linkage and carbon monoxide entry through the cowl or firewall when these are perforated.

Then, too, there are spare-tire wells that spare tires drop through, shock-absorber mounts that break off and motor mounts that can suddenly let go when rust really eats through the metal.

sons: It's relatively expensive, can't be formed into complicated shapes, and its "spangles" show through paint. Galvanized spangles are those starbursts you've noticed on rain gutters and trash cans. In out-of-sight places like rocker panels, the painted-over spangles aren't too noticeable, but higher up on a car body they are. All unitized cars now use galvanized rockers, and some use galvanized steel in hidden areas like cross members, spring towers, cowl plenums and engine attachment points, where looks don't matter.

Ford and the Budd Co. are beginning to use spray-on plastisol vinyls along body seams and in rust-prone areas under hoods, deck lids and so forth. This is a vinyl polymer with good adhesion, offering good protection. Fiat goes even farther with vinyl sprays and does up the whole undersides of rockers and valance panels so they totally resist water. So far, though, GM, Chrysler and AMC aren't sold on vinyls. One engineer told me there's reason to suspect that somehow hydrochloric acid forms around the vinyl spray patch. If that's so, it could cause more corrosion than the vinyl prevents.

Another anticorrosion weapon is an oily wax, sometimes called Nox-Rust, that all carmakers now use. It's sprayed into door hollows, quarter panels and hidden recesses with a long wand, much like the guns used by Ziebart and other aftermarket corrosion fighters. This wax varies in color from oxblood to aluminum. It does a good job, but creates two problems: It clogs drain holes in door bottoms and similar places, and a sloppy operator tends to miss spots. Quality control has to be watched.

Why don't the automakers give

their cars a Ziebart-like treatment right at the factory? Several reasons, say body engineers. First, there's a housekeeping problem—the sprayed-in goo drips and oozes out of pores for about 24 hours, leaving the plant a mess. Second, a car can't go through the paint ovens after treatment, because the asphalt-based material would melt. That's what the factories say, but they don't tell you both problems can be solved. The fact is, they don't want to asphalt-inject inner surfaces. Cars destined for low-rust areas don't need it. So, the factories leave it to local dealers in high-rust areas to spray in anti-corrosives as the market demands.

What's the car cancer cure?

What, then, is the overall answer to the car cancer problem? Is it hopeless? Do we simply give up and recognize that cars will rust in harsh environments? Or do we fight?

We fight, of course. I mentioned the Cadillac Seville as going beyond the norm in corrosion protection. The Seville, though, should be the norm, not the exception.

Fisher Body corrosion engineer Ted Lasko emphasizes that primers, sealers and coatings have to be used as systems. "For example, take the Seville door. We have Zincrometal on the door panel there. But that's not the only thing that's protecting the inside of that door. We have a triple system—the Zincrometal, electrophoretic paint on top of that, plus a third coating of wax material sprayed into the bottom cavity of the assembled door, where 99 percent of the corrosion takes place."

Most American cars fall between the extremes represented by the Seville on the one hand and the early

Vegas and Pintos on the other. Detroit has the technology—the Seville proves that. But Detroit feels it doesn't have the responsibility to prevent rusting: it says, "Well, a lot of cars live in areas where rust isn't a problem."

They figure, too, and rightly so, that the public accepts cars that rust, so why bother? It's true, of course, that there's never been a public outcry—even sotto voce—against rusty cars.

The shame of all this is that good anticorrosion engineering isn't all that tough. An engineer who cares can stave off rust in a very inexpensive way—by simply following the good practices put forth in an SAE (Society of Automotive Engineers) report called *Prevention of Corrosion of Metals*.

This SAE report details, among other things, choices of metals for specific applications. It tells how to lap joints so they're watertight and self-drying. It suggests ways to protect welds and flanges, how to make drains that don't clog, how to avoid or seal box sections and dozens of similar trade tricks. It's amazing to see how often these tricks are ignored, even if they'd cost nothing or almost nothing to implement.

The second way to sidestep rust happens to be more expensive, but it's necessary all the same. Corrosion engineers simply have to specify more rust-preventive metals, primers and sprays. They cost, but in the long run they're worth it.

The situation will improve only when the public demands it. Only when you and I gripe out loud—to the carmakers, to dealers, to lawmakers, and to insurance companies—will anything change. ★ ★ ★

ANTICORROSION TREATMENT OF THE 1975 CADILLAC SEVILLE

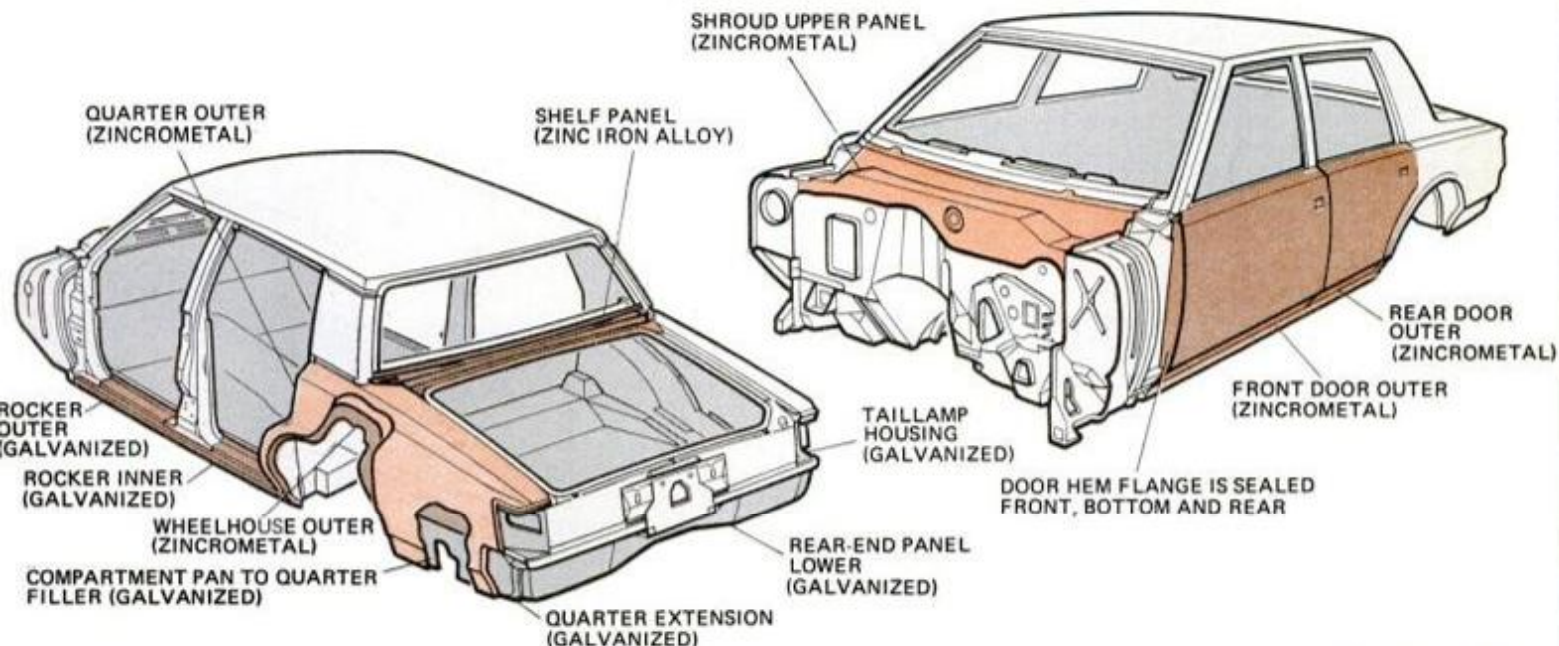

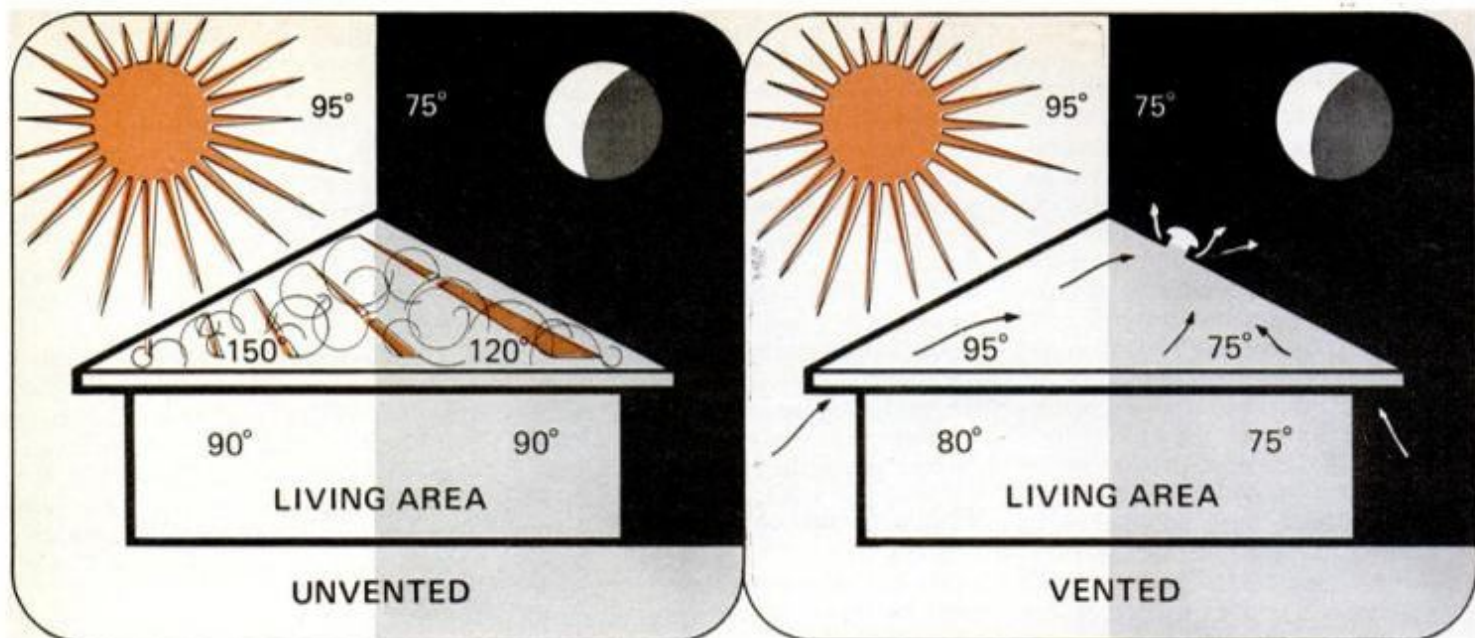

A cooler house starts with a cooler attic

Cool off your hot attic first, then your house and see what you save on airconditioning bills.

by Wayne C. Leckey HOME AND SHOP EDITOR

You've heard of a speed trap; what about a heat trap? Chances are, you have one under your roof.

Step into your attic on a sweltering day. You won't stay long: It's like entering an oven. When superheated air is trapped in the attic of your home, the temperature is often as much as 60° F. higher than outside. When daytime temperatures reach 95°, it can be as much as 150° in the attic. When the sun goes down, the outside temperature may drop 10° or more. Inside, however, the house continues to stay miserably hot because your attic "oven" is still at work. It takes about eight hours for the attic air to cool down to match the night air.

The solution, of course, is not to let the heat build up but to replace it throughout the day with fresh, cooler air from the outside. When attic temperature is kept low, heat can't radiate to rooms below. Consequently, it takes less cooling to keep your home comfortable on hot days and nights and, in turn, costs less to cool it since your airconditioning system runs less. Even without airconditioning, you'll feel the difference.

To lower attic temperature sig-

nificantly it takes more than the small gravity-type vents normally found in roof or gable. On hot days, such stationary ventilators cannot by gravity alone remove heat fast enough to prevent temperature build-up. It takes an automatic exhaust fan—power or wind-driven.

Fans that are automatic and have built-in thermostats start by themselves at a preset temperature. When attic temperature reaches 90°, for example, the fan is set to turn on and run throughout the heat of the day, pulling cooler air in and forcing hot air out. The fan runs until the temperature is below 90°, then shuts off automatically.

Flushing excess heat from your attic is accomplished best when there is an adequate number of air intakes along the eaves. With the fan located at the highest point in the attic and the intake vents at the lowest, uniform air flow is assured. Screenbacked vents (8 x 16 in.) are easy to install in the roof's soffit as shown at right, but where the roof has no overhang, gable louvers must provide air intake. Ideally, through-the-wall intakes would also be installed in the gables at the attic floor line.

Your home will have a lot to do

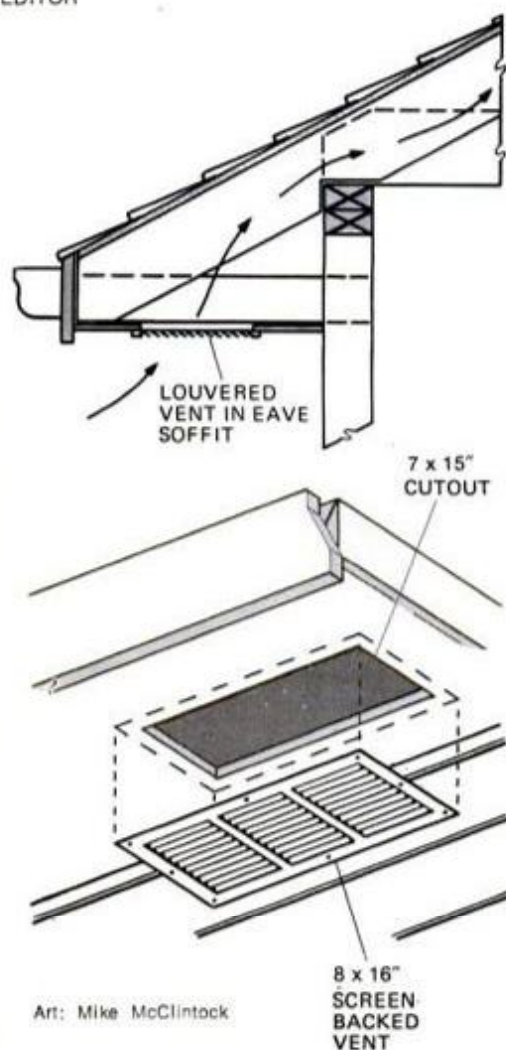

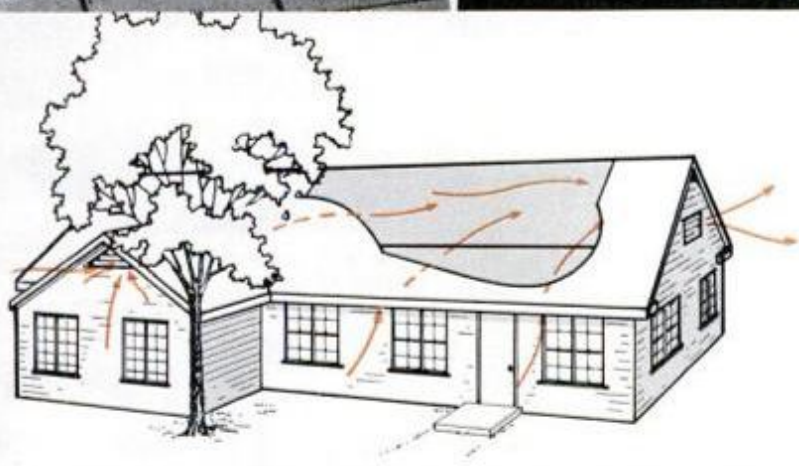

Wind-driven turbine ventilator by Triangle (above, left) turns with slightest breeze; escaping attic heat turns it when there is no breeze. One unit is required for each 1000 sq. ft. of attic area.

Automatic 16-in. Hunter fan (above, center) is designed to mount in gable opening to pull air through entire attic. It gives a complete air change every five minutes for 8500-cu.-ft. attic.

Vent-A-Matic power vent (above, right) is a low-profile ventilator designed for roof mounting, has 14-in. fan, turns on, shuts off automatically. Works best when intakes are around the eaves.

with the type of exhaust fan you install. If it has a conventional-pitch roof, you have a choice of installing a fan that mounts flush in a gable or one that mounts on the roof. If it has a hip roof, and no gables, the fan will have to be one that's designed to mount in the roof.

Three basic types of fans are shown in the photos above. Two are electric and thermostatically controlled. The turbine fan, at left, is nonelectric and is powered by the wind. Its spinning dome draws out the heat, and while somewhat less efficient than power models when there is no wind, it continues to draw out heat since the escaping heat itself causes it to turn. Its big advantage, of course, is that it costs nothing to operate. As with other rooftop ventilators, a turbine works best when the air intakes are located along the eaves.

Roof-mounted fans are easy to install by simply cutting a hole in the shingles and roof. Wide flashing fits up under the shingles to make the installation leakproof. ★★★

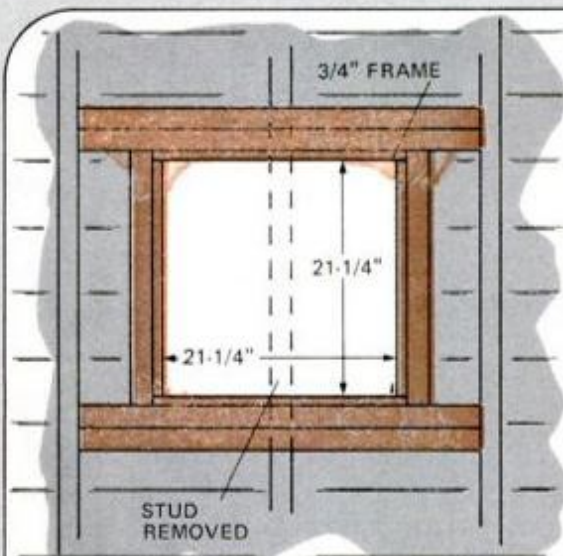

OPENING (REAR VIEW)

Installing a power ventilating fan in gable end of house requires cutting a suitable-size opening for it, framing with short 2x4 studs and headers and lining with a frame of 3/4-in. stock and 1 1/2-in. casing. Exterior covering is carefully cut back to fit snugly against the casing of frame, then caulked. Dimensions given here are for a 16-in. Hunter fan (Model 22082) which has louvers that seal opening when fan is off. Bead of caulking is also applied to flange of ventilator when fastening to casing with screws. Fan pulls air through louvers in opposite gable to flush heat from one end to other.

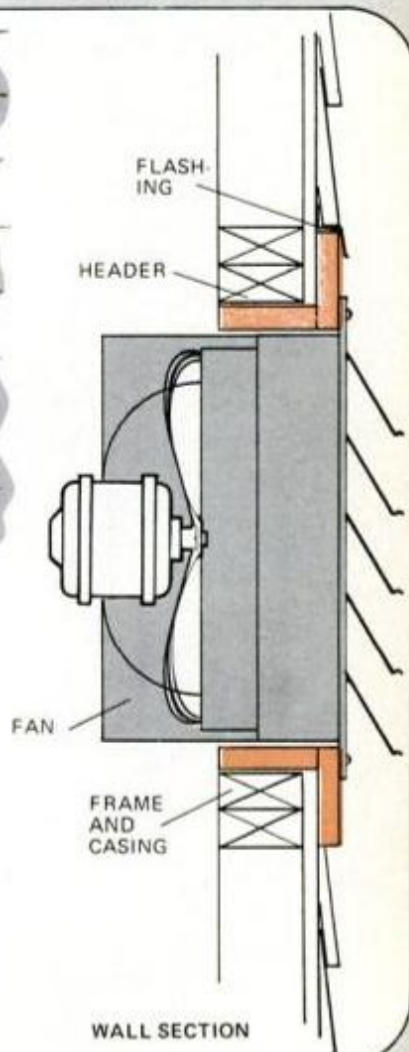

WALL SECTION

It's a great year for wine racks

Here are three you can make. The two tabletop designs hold six bottles each; the wall rack holds five.

by Rosario Capotosto

Having a modest selection of wines at hand in one of these handsome racks makes it easy to be a gracious host.

The charming wall rack, detailed below and shown at right, cradles five bottles. It can hold 10 or more if you lengthen the side members.

You can make it of any hardwood. We used cherry. The best way to cut the cradle side members is to do the holes first. If you have a drill press, use a 1½-in. spade bit and 3⅜-in. adjustable fly cutter; be sure to clamp work securely to the drill-press table. Do not bore the holes with a portable electric drill. Unfortunately

circle cutters for portable drills aren't large enough for use here. If you have no drill press, try careful hand-cutting with a jigsaw or sabre saw. This applies to racks shown on following pages.

After making the holes, it's easy to cut out the waste by sawing a line tangent to the holes. Sand both surfaces smooth before shaping the edges with a router. Use a sharp ⅜-in. corner-rounding pilot cutter; a dull one will tend to chip the wood at the ends of the bottle-holding slots. Finish-sand all parts before you start assembly.

A pair of ⅜-in. dowels are used

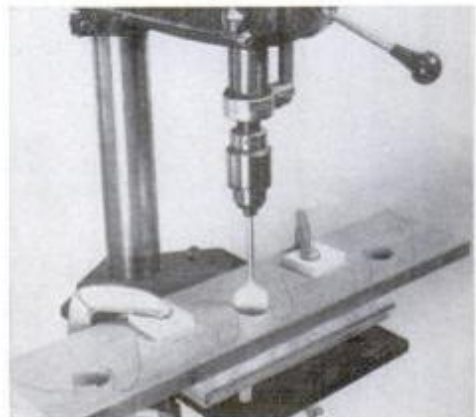

Use a sharp drill bit and a backup scrap board to obtain a clean-cut hole.



Clamp work securely and keep fingers out of way when using adjustable fly cutter.

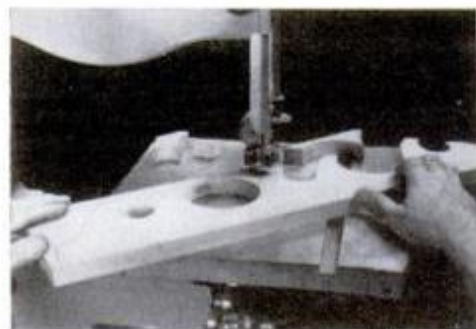

Drop out waste by making a pair of cuts tangent to each hole to create a slot.



Use corner-rounding bit to shape outer edges. Cutter must be extra sharp.

Wall-hung rack

Rack holds five bottles, can be made taller to take more.

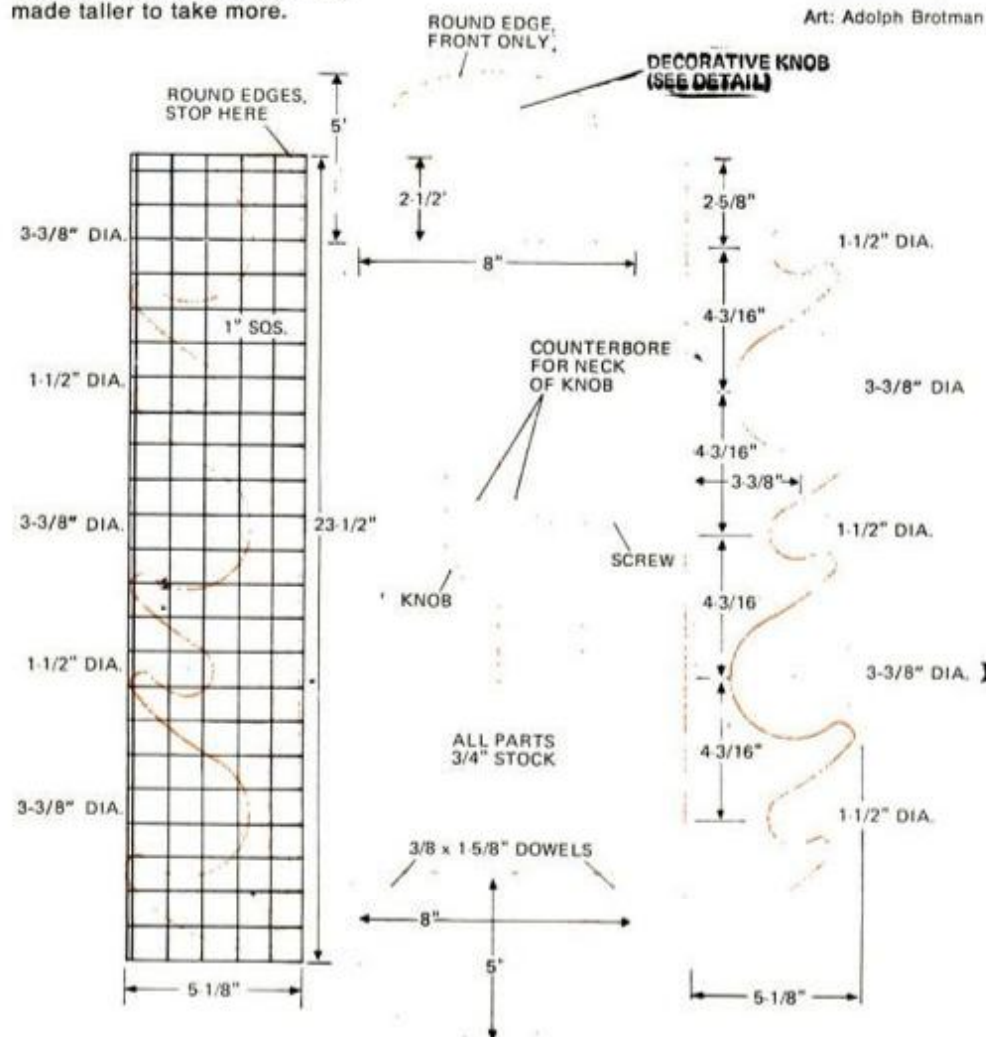



Colorful and extra simple to make, this attractive countertop rack (above) is half finished before you begin for it's made from prefinished wall paneling.

Wall-mounted rack at left cradles bottles with their labels in full view so you'll have no trouble selecting the wine you want at a glance. Rack is made of hardwood.

Plexiglas beauty below has look of lustrous glass. At home in the most formal setting, it keeps a sampling of your prize vintages at hand for any occasion.

Styling: Gabe Herrick Color photos: Frank Lusk

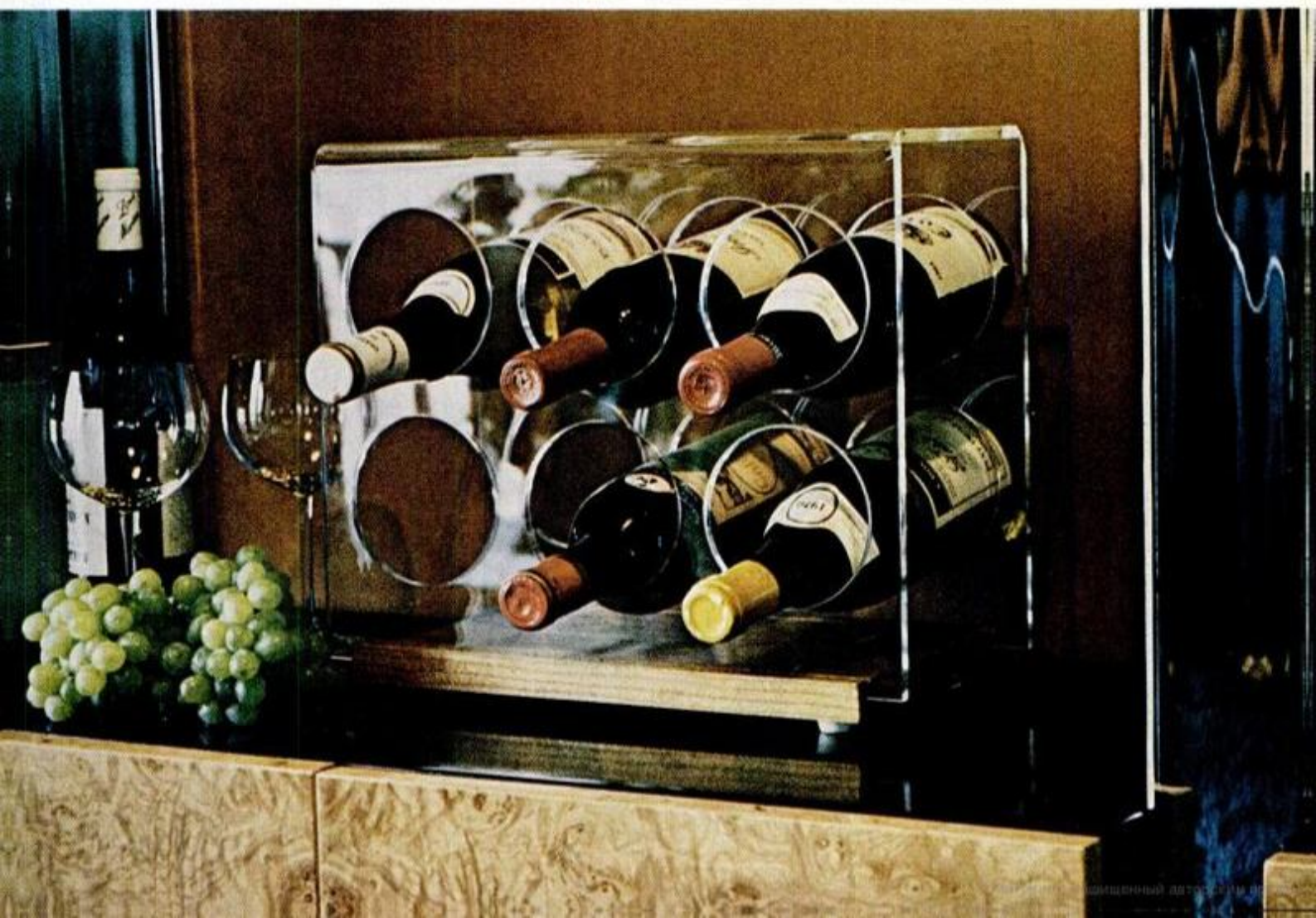

to join each side to the top and bottom back pieces. Drill holes in the sides first, then insert a pair of dowel centers to transfer and mark the holes accurately in edges of back members. Glue and clamp sides to backs and scrape off any squeezed-out glue before it dries.

The best and safest way to hang the rack is on a screw driven into a wall stud; use an expansion anchor or toggle bolt when you must hang it from a hollow wall. I used a decorative cabinet knob in a coun-

Wine storage tips

Strong light, especially sunlight, can be harmful to wine. It is not necessary to store wine under "darkroom" conditions, but all wine should be protected from light as much as possible. Wines should rest quietly; constant vibration can damage their flavor, so avoid storage near washers, dryers, dishwashers, refrigerators and other appliances with vibrating motors. A quiet corner in a basement, garage, closet or kitchen cabinet is preferred.

Wide and frequent fluctuations in temperature are also to be avoided. Wines may be stored safely for years in a fairly stable temperature ranging from 50° to 70° F. Temperatures are cooler at floor level and on interior walls or closets, rather than at exterior walls subject to sunlight and daily temperature changes. Position wine racks away from water heaters, stoves and heat ducts.

Wine bottles should rest on their sides, keeping the corks moist. Dry corks allow air to enter the bottle and spoil contents. Exceptions are newer bottles sealed with plastic corks or metal screw caps that can be safely stored upright.

terbored hole to conceal the hanging screw. Apply a coat of sanding sealer to the rack, then two coats of self-rubbing clear finish. Sand with No. 600 paper between coats, but leave the final coat unsanded.

Plexiglas rack. This sparkling see-through wine rack is made by heat-forming a sheet of 1/4-in. acrylic plastic into a U shape. Start with a piece 13 7/8 x 28-in. Mark centers for the holes, following the drawing, and punch them lightly with an awl. Drill 3 5/8-in. holes with an adjustable fly cutter mounted in a drill press. *Never try to use this tool in your portable drill.*

Clamp the workpiece firmly to the press table and run drill about 800 rpm. If your cutter is sharp and clean-cutting, the edges of the holes will come out fairly smooth. If your cutter is not sharp, they will be rough.

After the holes are bored, clamp the sheet in a bench vise. Scrape all exposed edges with the back of a squarely ground hacksaw blade to remove tool marks. Follow with sanding, starting with No. 400 wet-or-dry abrasive paper, then No. 600, wrapped around a small roll of short-nap carpeting or similar material. Sand

Plexiglas wine rack

Crystal-clear rack with the look of glass holds six bottles, rests on wood base.

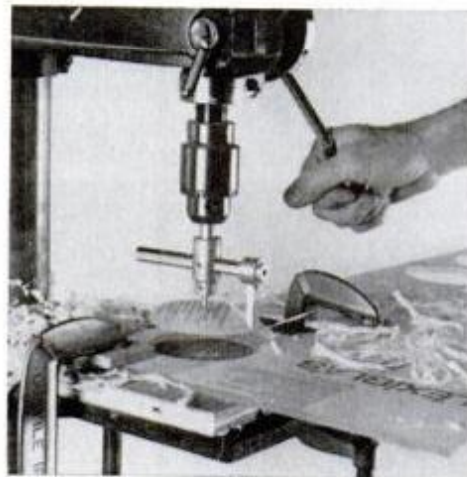
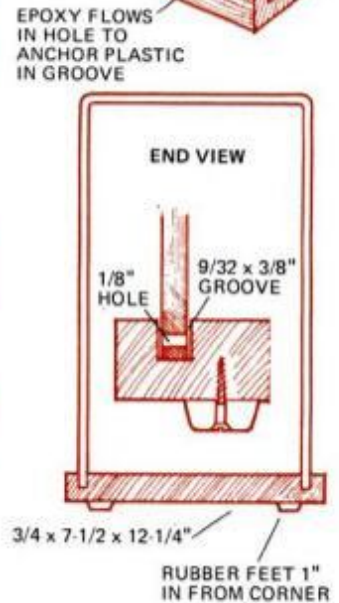
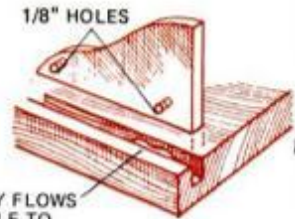
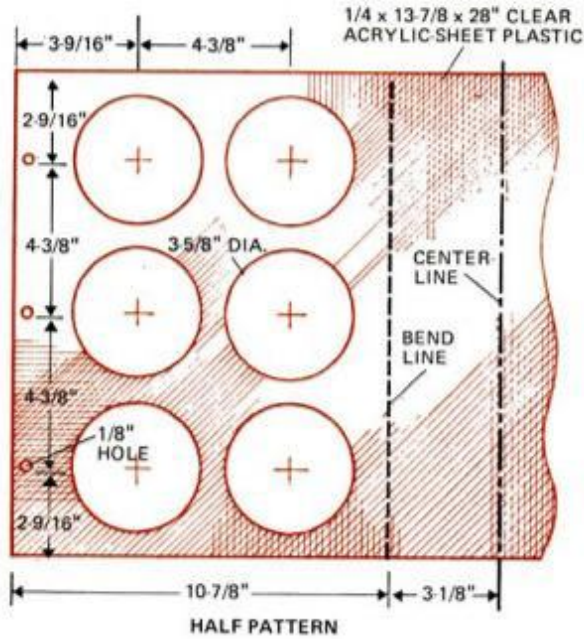

Use fly cutter in drill press to bore holes. Clamp work; run drill about 700/800 rpm.

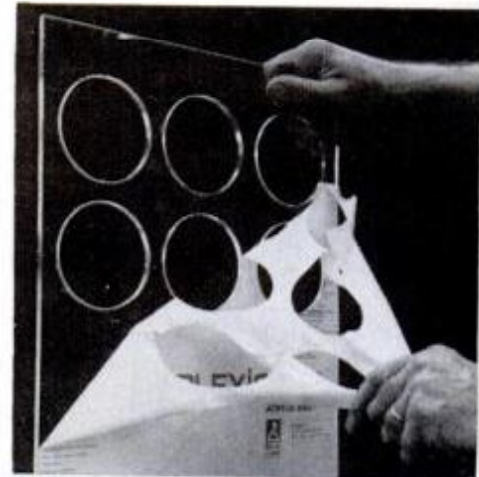

Peel off protective paper, then rinse plastic with soapy water to remove compound.

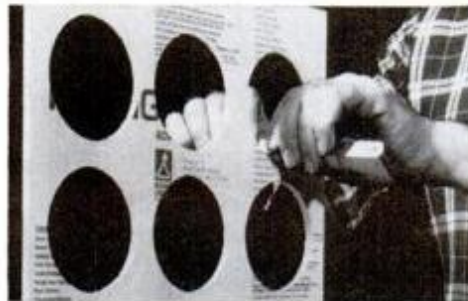

Scrape plastic edges with square-ground edge of hacksaw blade, pulling it to you.

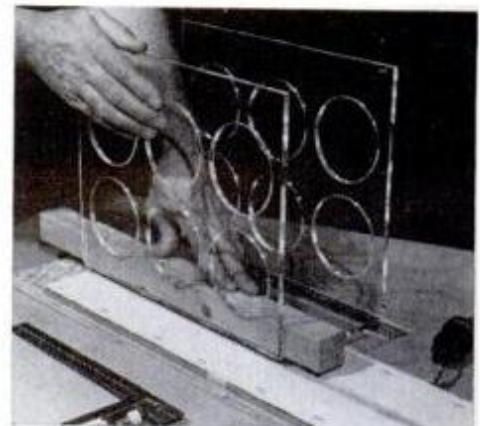

Lay plastic on strip heater; let soften 15 minutes. Wood block insures proper bend.



To polish edges, buff with polishing compound, cloth buffing wheel; press lightly.

until you get a satin edge and then ease all sharp corners.

For a high polish, you'll need polishing compound and a small buffing wheel chucked in a portable drill. Charge the wheel with compound and buff at high speed, but with medium pressure. It won't take much effort to obtain a high gloss. After polishing, peel off the protective masking paper and use a grease pencil to mark the bending lines. Now place the plastic on a strip heater and leave it there for about 15 minutes. When the heat has sufficiently softened the sheet, place a block of wood (with the corner rounded slightly) on the line. Use a square to be sure the block is held at a right angle to the edge of the plastic. Hold the block firmly; then slowly bend the sheet. Once the bend is started properly, you can remove the block and continue the bend a bit beyond a right angle to compensate for spring-back. Remove the work from the heater and hold it (a minute or two) until the plastic cools. Repeat this procedure for the second bend.

If you don't have a strip heater, you can make one with a special heating element (tape) sold at most plastic supply shops. The instructions are included with the unit.

For the base of the rack, cut two grooves a shade over 1/4-in. wide and 3/8-in. deep in a piece of hardwood, sand and apply the finish of your choice. The base shown is cherry, finished with Red Devil's dark-walnut oil stain.

Finally, drill three 1/8-in. holes along bottom edges of the plastic, wash the piece with soap and luke-

warm water, rinse and dry. Mix a bit of quick-drying epoxy and drop three small blobs into each groove so they coincide with the holes in the plastic. The epoxy will flow into the holes and anchor the piece in place.

Marlite rack. A couple scraps of prefinished Marlite wall paneling are used to make this good-looking rack. If you don't happen to have a scrap or two, you can order a single 16x96-in. panel from your lumber dealer; it will give you enough material for four racks, which make great gifts. The material is 1/4-in. tempered hardboard with a durable baked-on plastic surface. Many colors, plus wood grains and textured surfaces, are available.

Mark the centers for the 12 holes and use a fly cutter on the drill press with the work securely clamped. After cutting, sand all edges with No. 220 aluminum-oxide paper, followed with No. 400 and 600-grit, wet-or-dry paper (used dry).

Edges of tempered hardboard can be given an attractive, satin-smooth, dark-brown finish by burnishing. For the outside edges, use a cloth charged with auto-polishing compound and work it as though you were shining your shoes. Rub briskly until a good shine is obtained; follow by a hard rub with a dry cloth. To burnish the hole edges, use a buffing wheel in a portable drill. If you want a deeper color, apply a coat of clear finish to the edges.

Four 5/8 x 6-in. dowels are used to assemble the unit. Drill screw pilot holes into the ends of the dowels and clearance holes in the hardboard.

Use a very small amount of five-minute epoxy in the dowel ends and drive in screws.

If decorative screws are not available for the front of the rack, you might try this: Use a diagonal cutter to snip off the nails from the heads of four ornamental upholstery nails. Then back out the screws after the epoxy has set. Put a drop of epoxy into each of the cupped nailheads and insert screws. After the epoxy has hardened, replace the screws by turning them in by hand. A bit of soap on the threads will help. ★★

For a booklet containing some 17 other wine racks you can make from redwood, along with more tips on the proper way to store wine, send 50 cents to Louisiana-Pacific, 1300 S.W. Fifth Ave., Portland, Ore. 97201.

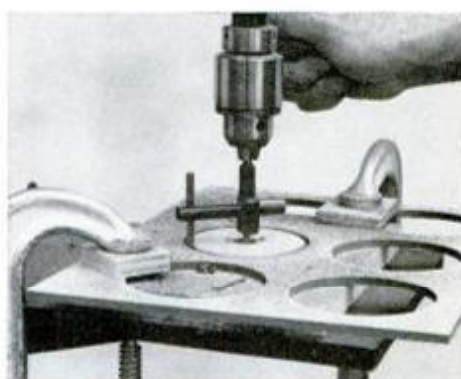

Bore holes with fly cutter, clamp work, use medium speed; don't force feed—go easy.

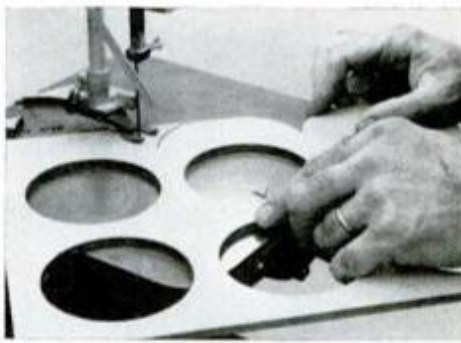

Jigsaw the outer cuts with a fine-tooth blade, saw hardboard with good side up.



Burnish the edges shoe-shine fashion with soft cloth and auto-polishing compound.

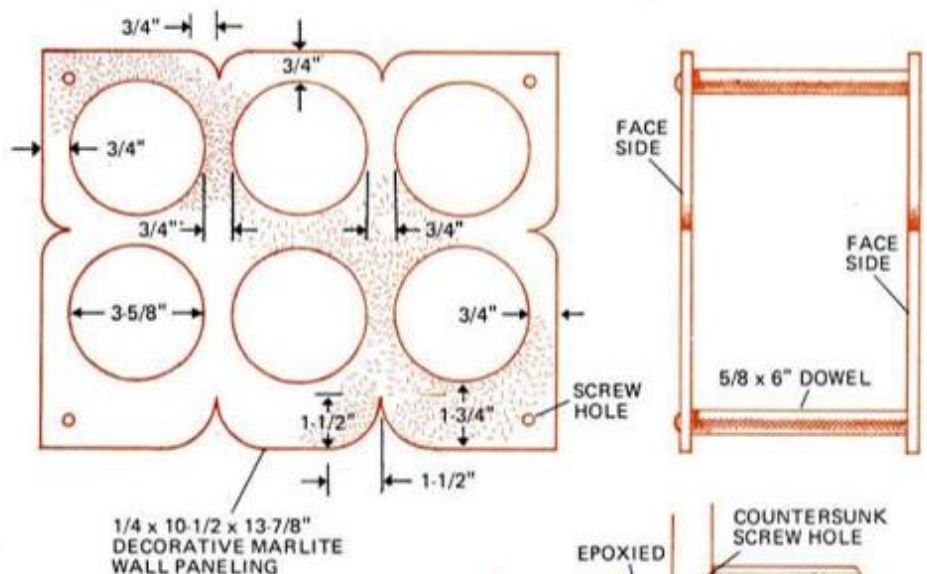

Marlite wine rack

Quick and pretty, it's made of colorful wall paneling.

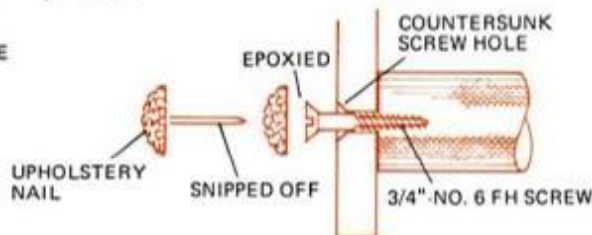

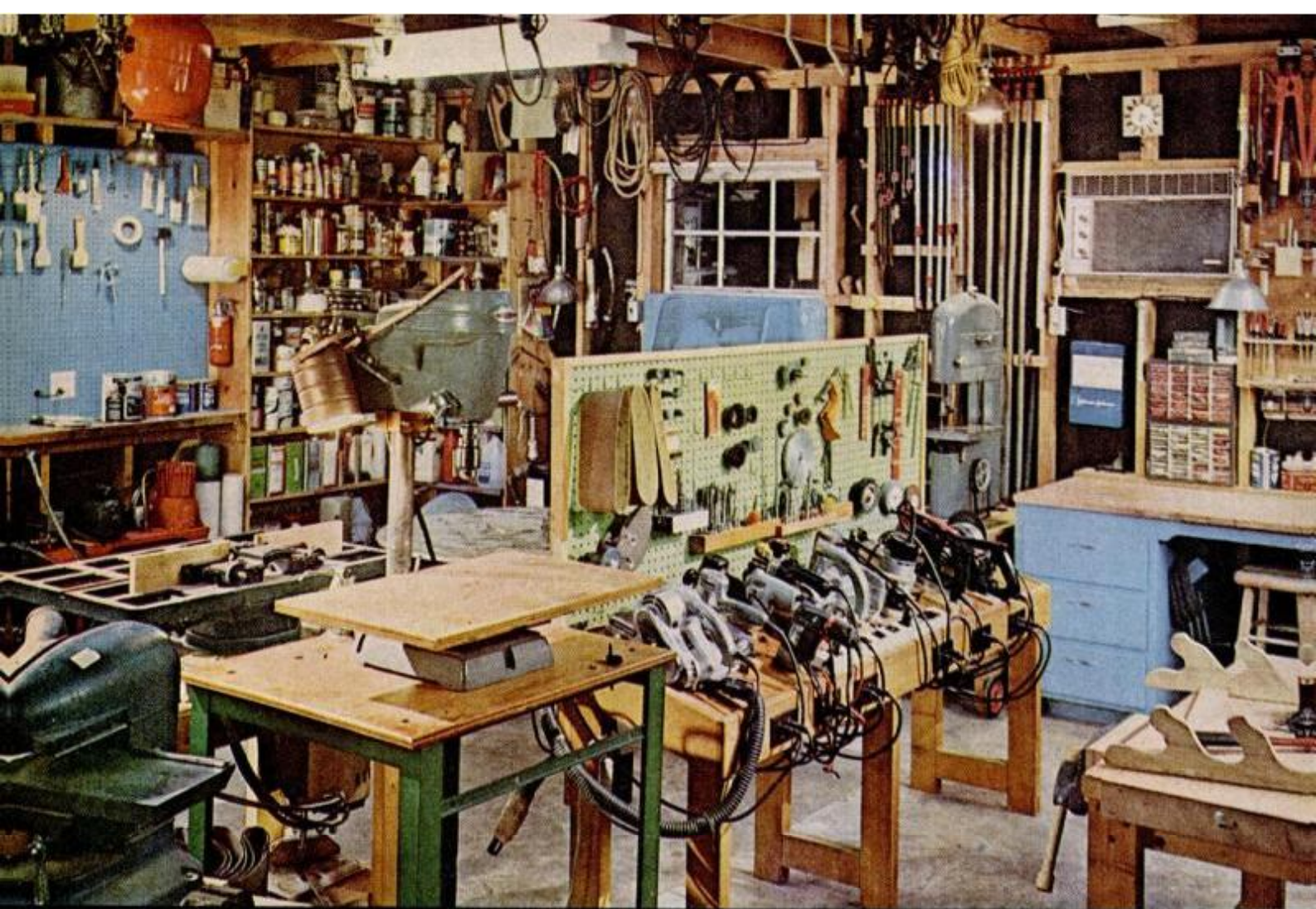



15 GREAT SHOP IDEAS FROM A MASTER WORKSHOPPER

Rugged and functional custom-built bench (top photo, left) for portable power tools is the heart of Russ Cross's fine workshop. PM's workshop editor drew plans so readers who would like to can duplicate the bench. The spray-painting setup in lower photo has small table for little workpieces, large surface for big work. When latter is used, small table is lifted off. Both tables can be rotated a full 360° to reach all sides of work.

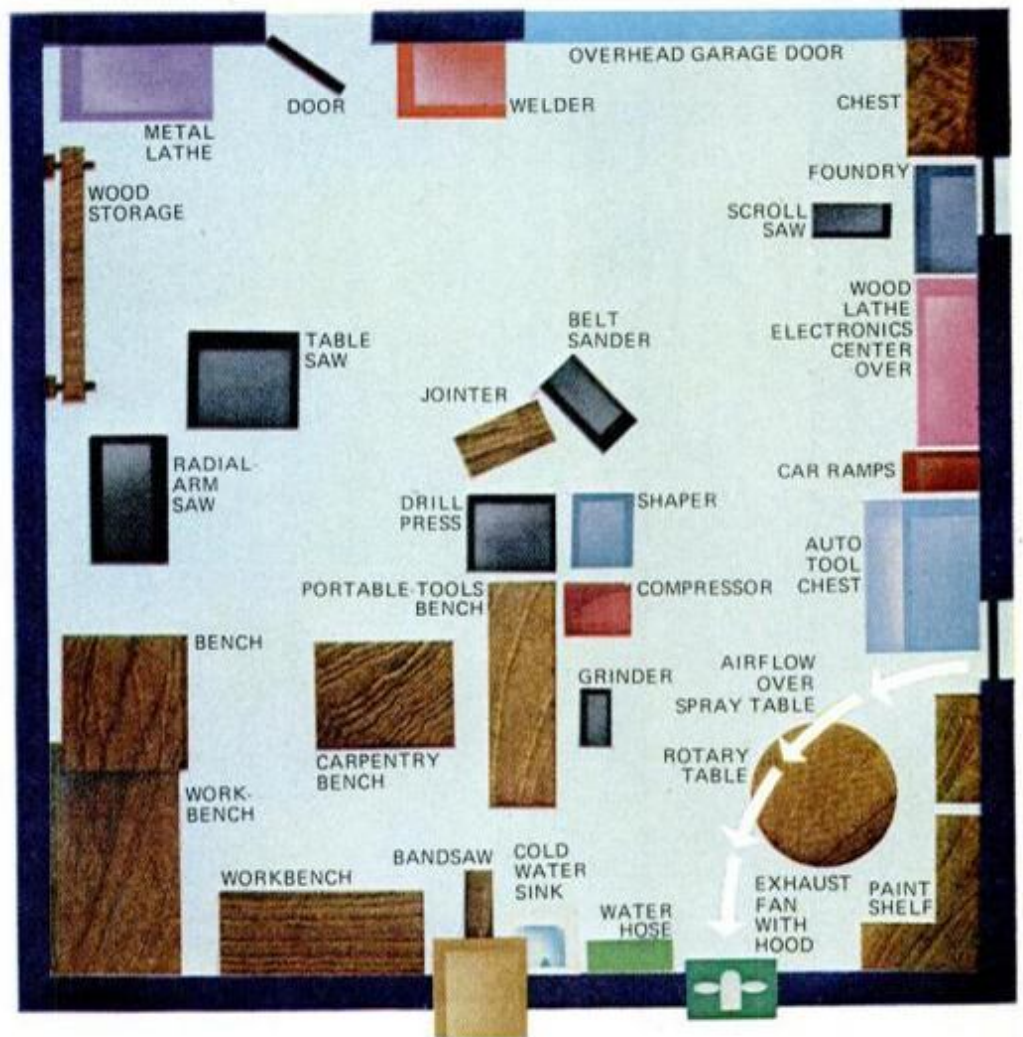

The shop is detached from the house. About half the area is for woodworking; the rest for automotive and other interests.

by Harry Wicks WORKSHOP EDITOR

Photos: Bill Hedrich, Hedrich-Blessing

15 SHOP IDEAS

Russ Cross has a spacious shop in a fairly new building behind his home in Mobile, Ala. My first impression on entering was that its owner has a reverence for tools and a solid knowledge of their use. Several days of practically living in this shop verified this appraisal. Originally from New Jersey,

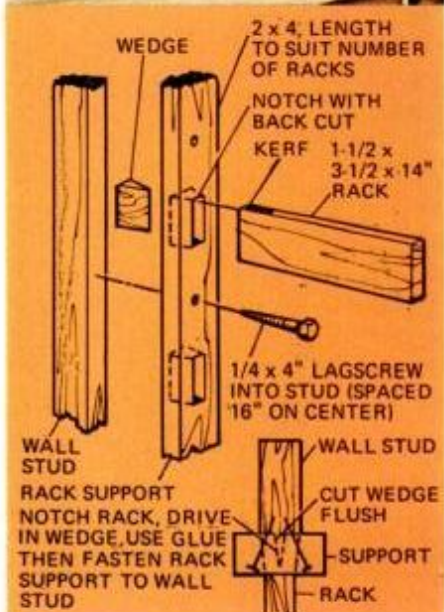
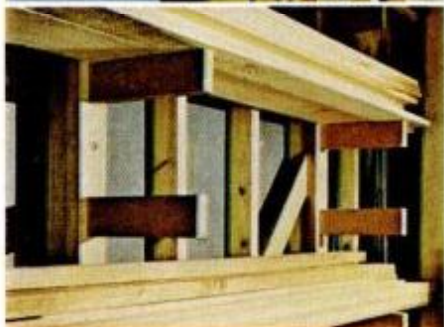
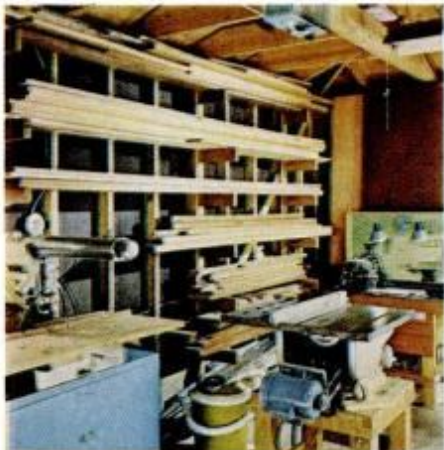

1 Lumber storage system is simple and sturdy. Each 2x4 rack is kerfed at its back end, held in notch with glued wedge. Lagscrews through rack support into studs hold rack in place. Nails into rack at an angle are optional.

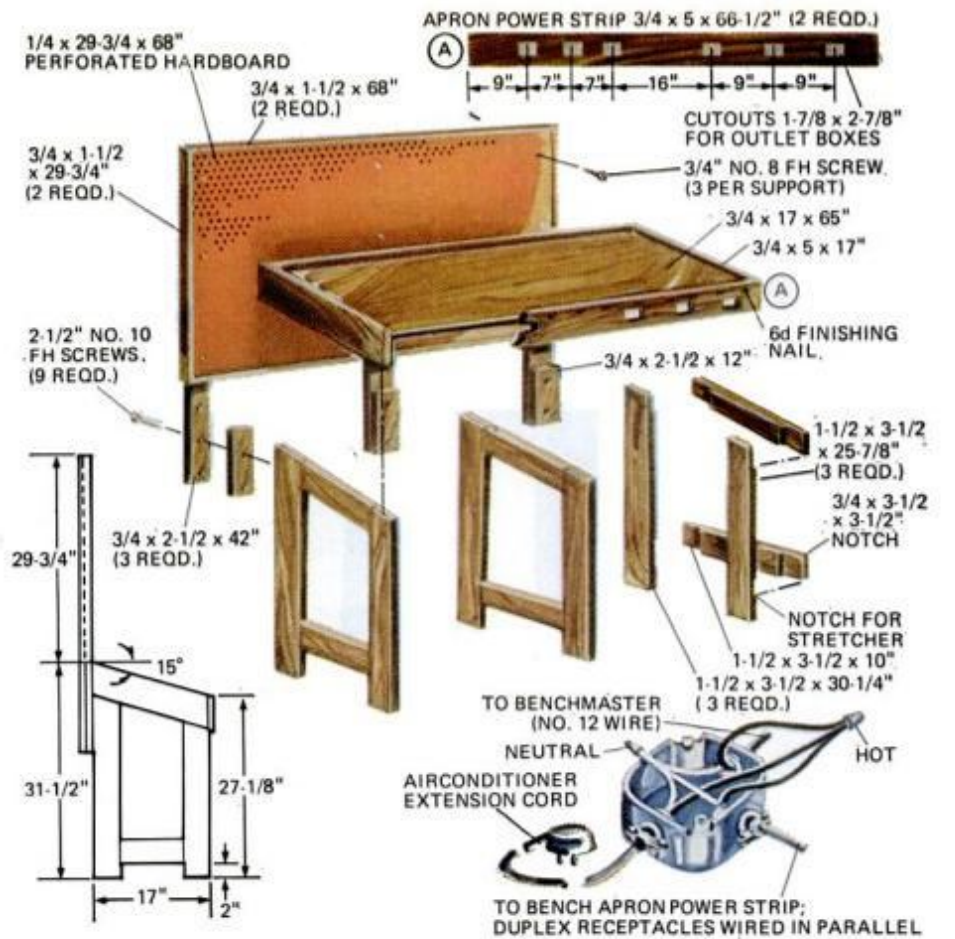

2 Custom bench—sized to suit the owner's collection of portable power tools—is equipped with a power strip that eliminates tangle of extension cords underfoot. Power gets to bench panel via 15-amp airconditioner extension cord. Portable-tool accessories are conveniently hung on perforated board.

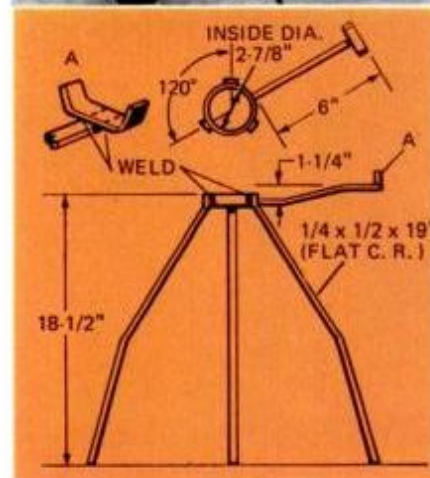
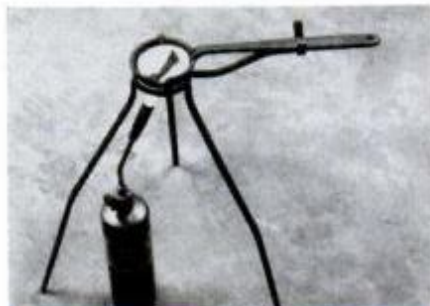

3 For melting lead held in plumber's ladle, Cross created this tripod (an exercise in his early brazing days). Setup is used outdoors *only* on concrete drive—there is no danger of fire should torch tip over.

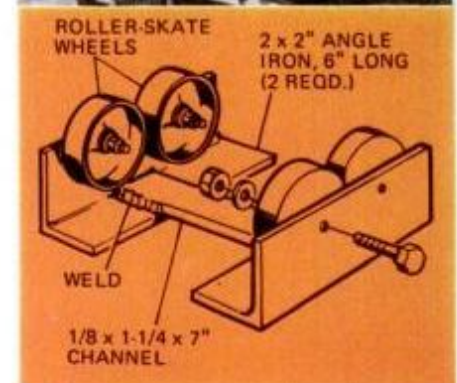

4 Welding round object is easier when it's held in pipe support made of roller-skate wheels. Tack pipes together, complete with top-welding by turning pipes. Exhaust fan overhead carries out toxic fumes.

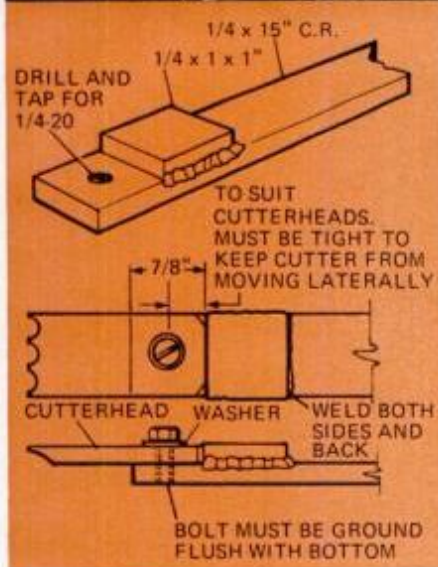
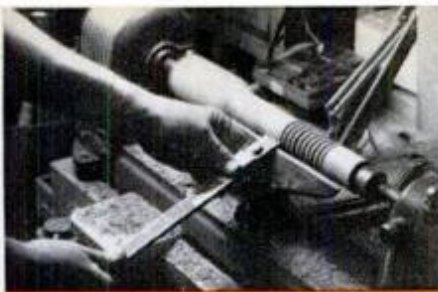

5 Custom-made lathe chisel extends mileage from molding-head cutter set. Idea works best with slow speed and a scraping action.

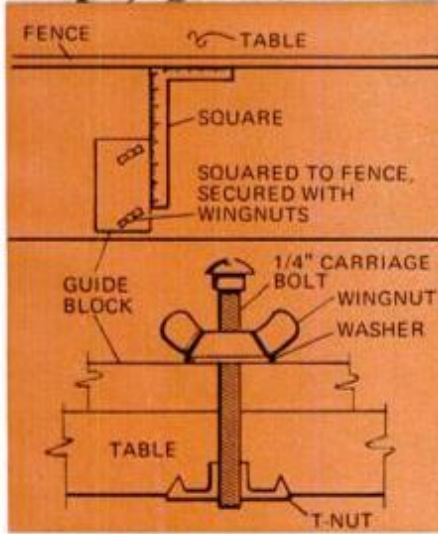

6 Radial-saw mitering is easier, more accurate with this setup. Helper fence is squared with conventional fence, held with wingnuts. Piece is cut using standard fence; mating board mitered with helper fence.

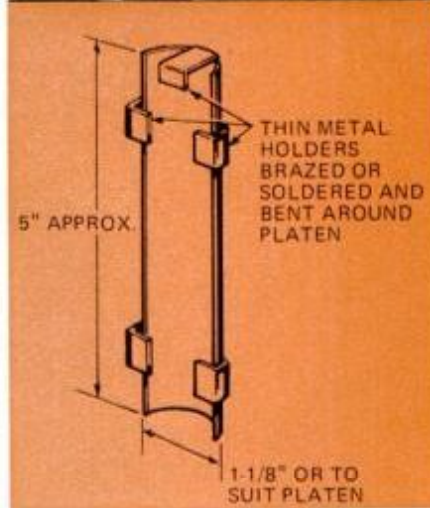
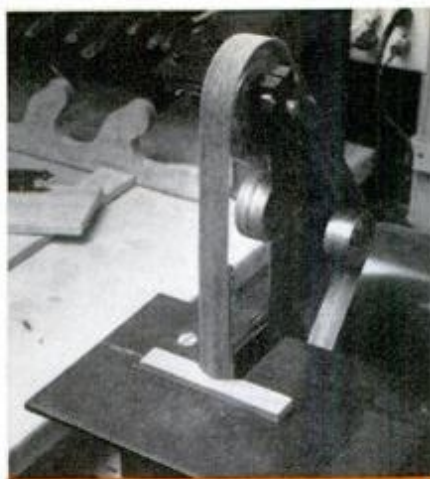

7 Sander-grinder is even more useful with this add-on device. It simply slips over platen and floats behind sander belt. Idea facilitates sanding concave curves in scrolls.

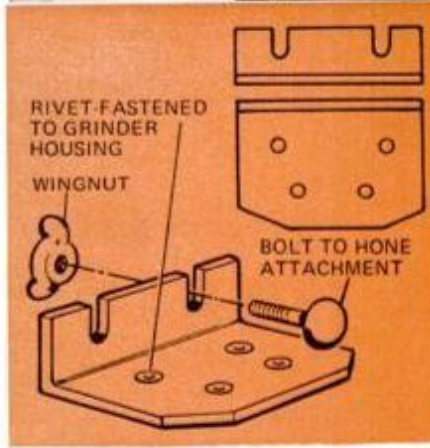
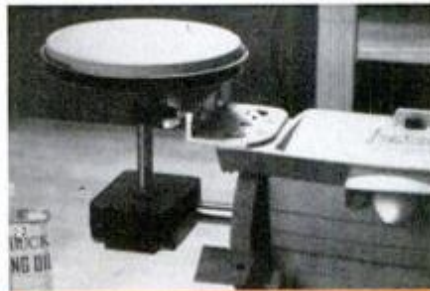

8 Store-bought hone-attachment for large grinder can be mounted on small grinder. Brass rod below is brazed to grinder-wheel nut; attachment's driveshaft is held in rod with cotter pin through bored hole.

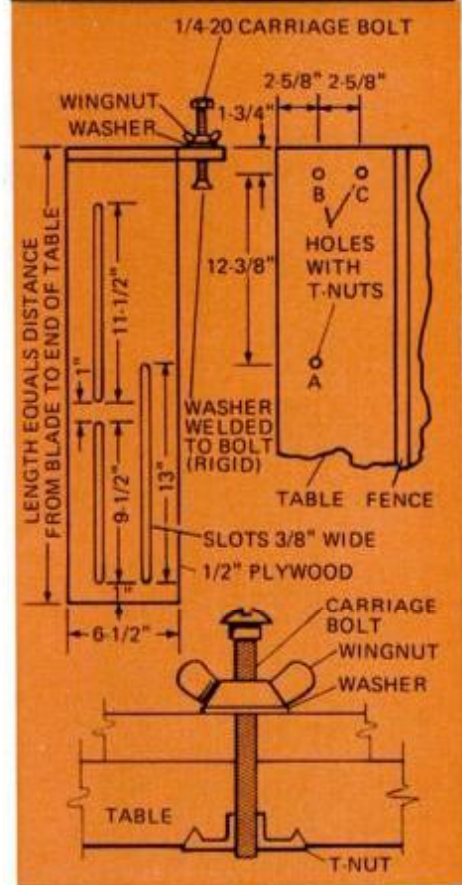
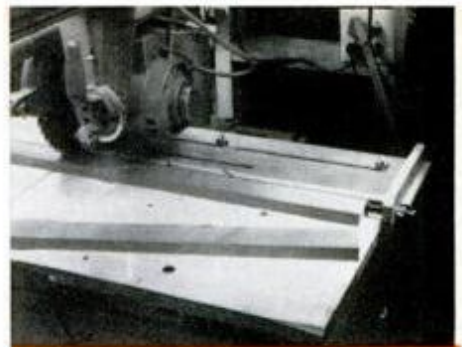

9 Radial-saw repetitive-cut jig lets sawdust fall to floor when lumber is pushed along fence. Two bolts are used in holes A and B for short pieces and in B and C for long pieces. All three holes are fitted with Teenuts.

Cross relocated in Mobile "for keeps" about 19 years ago. A 1950 graduate of Newark College of Engineering, he holds a B.S. degree in mechanical engineering.

Today, he is vice-president and sales engineer of a firm engaged in the sales and service of industrial automatic process controls and instrumentation.

As can be seen in the photos, Cross brings his professional thinking into his workshop—the room abounds with ingenious innovations.

I was particularly impressed with the power-equipped bench he designed for his portable power tools. Like many workshopers, Cross does much of his woodworking with portable tools. Unlike most, he

(Please turn to page 111)

They satisfied then. They satisfy now.



New Chesterfield Filters.

For 60 years Chesterfield has enjoyed a reputation for making great straight cigarettes. Today, we also have a filter cigarette. With a rich new filter blend as full flavored as all our tobacco experience could make it.

Try new Chesterfield filters.

They Satisfy

Warning: The Surgeon General Has Determined That Cigarette Smoking Is Dangerous to Your Health.

Filter King: 18 mg. "tar," 1.2mg. nicotine;
101's: 19 mg. "tar," 1.4 mg. nicotine Av. per cigarette by FTC Method

Материал защищен авторскими правами

15 GREAT SHOP IDEAS

(Continued from page 109)

figured out a way to keep them organized and within arm's reach whenever he's working. Readers can duplicate the setup from the plan on page 108. It can, of course, be customized to suit the number and type of tools you own.

Besides the 15 great shop ideas we zeroed in on, Cross's layout has many other features that elevate his workshop a notch or so above the average one.

He's also resourceful. For example, he found that an ideal source of free mahogany stock was the local Yamaha motorbike dealer. He said, "When I learned that these cycles were shipped in from the Far East in mahogany crates, I

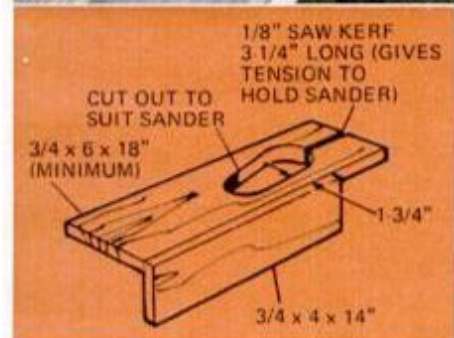

10 Belt-sander holder—so simple it prompts "why didn't I think of it" reaction—frees hands to hold workpiece. Fixture holds sander housing with just a pressure fit; kerf allows hole to open and accept sander.

quickly volunteered to help the dealer keep his yard free of this 'debris.' All that the stuff requires is a quick pass through a planer and it's ready for use."

Security gets top priority

Because of the considerable investment in his shop, Cross has given a great deal of attention to safeguarding it. He has many fire extinguishers spotted around the room for all classes of fires. Additionally, he keeps a length of garden hose close by the cold-water sink.

Outside lights are located all around the place. These can be controlled from either house or

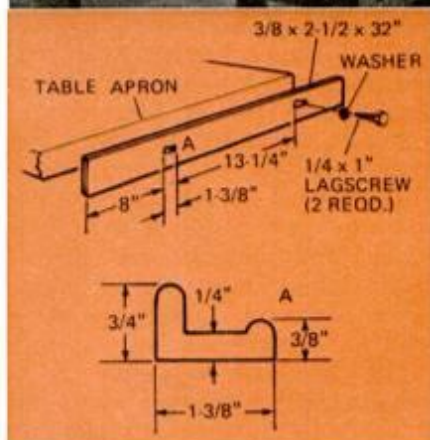

11 Sander stop prevents work from being flung off bench by belt sander. Of 3/8-in. stock, it pivots on lag screws in bench edge. Position is determined by which legs of cutouts "A" the lag screws are in.



12 Wall-mounted cabinet over wood lathe houses Cross's electronics workshop. Space-saving idea is his use of wood lathe as bench to support worktable/front of cabinet when it's in down position.

shop. The shop windows are barred and locked and the doors are double-locked. The warning system he has installed will remain a secret, "but," he advised, "it makes one helluva racket when it does go off."

For insurance purposes, all Cross's possessions are recorded on 8-mm movie film. "Much simpler than shooting snapshots," he says, "and it costs less and takes up less storage space." He cranked a 50-ft. reel of film through his film editor. On it was everything he has in his workshop. For example, a drawer yanked open and

(Please turn to page 122)



13 By moving jigsaw and belt sander, auto can be brought into shop for inclement-weather work session; auto tools and car ramps are nearby. Young neighborhood friends often use this area of shop.



14 Like many well-equipped shops, this one has a low carpenter's table in center of room. Power tools are within reach; owner is surrounded by benches having vises and hand tools for detail work.



15 Security tip. For complete property inventory, record all belongings on 8-mm movie film. Run film through film editor at times to be sure record is up to date. System costs less than shooting snaps.

What about your shop? Is it a candidate for PM's great shop series? Send a brief description and snapshots to Harry Wicks, Workshop Editor, Popular Mechanics, 224 West 57th St., New York, NY 10019. If PM's editors agree, we'll visit your shop to learn more about it. Snapshots can't be returned unless you enclose an addressed, stamped envelope.

one or two-piece rods I have tried. I prefer solid glass ferrules to metal. The newer fiberglass joints have more flex, which is important to action when five or six of them are involved.

Telescopic rods, around a number of years ago, seemed to fade from the fishing scene and now are growing popular again. Some low-cost makes even seem to have fair action, but select carefully. Several I have tested and can recommend without question for action and durability are manufactured by Lew Childre. Expect to see more telescopes on the market.

Quality is a key consideration for travel rods. Break a cheapie near home and you can replace it, but when one fails in the Amazon jungle or on a remote Canadian lake, you're in trouble. Accidents can happen anywhere, but the odds are reduced with good equipment, and the extra cost is a good investment.

Be particular about action, as well. Today's "wet noodle" sticks, designed to cast light lures to small fish and make casting easier for beginners, are not versatile enough for take-along use. More backbone is required to handle different-size lures so buy your travel rod with stiffer-than-normal action. I also prefer the longer conventional handles to the new pistol grips. My travel rods have tangled with bass, pike, tiger fish, snook and musky, for example; when you have a big tarpon on, a handle you can grip with two hands is a real advantage.

Among top manufacturers offering pack or telescopic rods are Berkley, Childre, Daiwa, Eagle Claw, Fenwick, Garcia, Gladding, Heddon, Johnson, Kodiak, Martin, Orvis, Sears, Shakespeare, St. Croix, Trimarc, and Zebco. Several of these also offer multipurpose kits. Berkley has a first-class eight-piece kit that makes up into a casting, spinning and fly rod in a choice of actions, plus three reels and extra line. Add a few lures and you have an outfit. Eagle Claw offers six-piece and eight-piece combinations, as does St. Croix and Martin. These firms, plus Orvis, Heddon, Fenwick and Gladding also offer combination spinning and fly-fishing outfits.

Reels

Picking reels-to-go creates no problem if you select quality and take one or more spares in each category. To prevent travel damage, pack them in sneakers or clothes, away from the bottom or sides of a suitcase. On arrival, go over each reel to tighten

nuts and screws that might have vibrated loose during a flight. Make this a habit.

Lures

Taking the right ones is extremely important and, because extra weight should be avoided, knowing what to leave home is also important. I separate my lures by size, type of action and species of fish each attracts; then stow them in durable plastic boxes. For instance, I have four containers packed with spinning lures. This includes small spoons, spinners and a variety of others that I know attract trout and cast well with light spinning equipment. With these four I can go any place in the world and catch this species of fish.

Flies are also separated by type and size. Big streamers come along in a special box when I plan some saltwater fishing. Bass bugs and wet and dry trout flies also rate separate containers.

Larger casting and spinning lures require the real decisions, and are separated into boxes of spoons, surface lures, shallow running specials, soft worms and grubbies, jigs, little heavyweight jigs, and underwater wobblers, divers and bottom scratchers. Additional categories include jerk baits, spinner baits, buzz baits, trolling rigs, saltwater feathers, special lures for tarpon, and others. Various sized transparent plastic boxes would be best for lures but, to date, I haven't found any that can take travel abuse. Meantime, the opaque nonbrittle polypropylene boxes get me by.

Fishing accessories

Every fisherman's travel kit should also contain such spares as extra line, wire leaders, sinkers, snap swivels, pliers, pocket scale, reel oil and repair items like extra guides, thread, tape, a coil of light wire, glue. Big fish break lines, and plenty on hand will give you a second chance.

Other gear

Some extras can be almost as essential as tackle. Cameras, film, suntan lotion and insect repellent are among them. Don't forget a knife, flashlight, compass, first-aid kit, and a waterproof container of matches. When headed for the northwoods, I take extra insect repellent and perhaps a head net; for jungles, a survival kit, water purification tablets, snakebite kit. These emergency items are packed in a soft container, tossed in my suitcase, and may or may not come along on daily excursions in the field.

Select your clothing after you determine what the weather will be like at your destination. Most people take more than they need. A fisherman should have two pairs of sneakers and trousers, several pairs of socks, three long-sleeved shirts, a broad-brimmed hat, underwear, swimming trunks, shorts, a jacket (plus warm outer gear for a cold climate), rain gear, rubber pullovers such as Totes, and a pair of bandannas (primarily for neck protection from the sun). Of course, you will need other clothes for travel and social activities.

Packing

With the equipment mentioned, all I do is throw the right items in a suitcase the night before departure. A special expedition may require additional planning.

For example, on a recent trip to fish for dorado in Paraguay, I took a load of spoons and every big Rapala and Rebel I owned, plus some saltwater spoons and feathers for this big rough fish to be on the safe side. I left behind all soft lures, standard bass baits, small trout lures. I took four casting rods, two heavy-duty spinning rigs, three spinning reels in two sizes and four Ambassador casting reels. One was a larger-model 10,000 for a heavy trolling rod. Four 1/4-pound spools of line, tropical clothing, and complete accessory kits completed my gear for this trip. All fitted a two-suitcase bag and traveled as easily as my other suitcase of clothing.

A western trout trip would be even less complicated: two fly and two spinning rods, reels to match, several boxes of flies and lures, waders, a normal amount of medium-weight clothing and minimum accessories. This might be packed in a small one-suitcase, or included in a larger suitcase with my other clothing.

Travel tips

When heading for a far-off place, check seasons carefully from a climate, and fishing standpoint. We know one man who went to Chile in August to catch big trout and discovered he should have brought ice skates. Ask about air "excursion" fares which may save you even more than "economy." Resorts with IATA-approved fishing tours can usually be recommended.

And finally, vow never again to set out with your hands full of rod cases and assorted awkward boxes of tackle. Assemble a kit like those outlined here, and look forward to simplified travel to good fishing. ★★

The Great American Dream Machine

*You've always wanted to own a helicopter,
but you never could . . . UNTIL NOW!*

For the price of a two-seat sports car you can have a two-seat helicopter parked in your garage. The Scorpion Too is everyman's helicopter. It can carry a salt block, a camera, a tool box, a piston drill, or a passenger where you need it, when you need it. RotorWay's Scorpion has a history of proven performance and versatility. *It's not just a dream . . . it's a dream come true.*



You've always wondered what makes a helicopter tick.



Learn about the Scorpion by sending in for Phase I of our get acquainted program. We know that the purchase of a Scorpion requires careful consideration, and that's why this \$6 package has been specially prepared. It will spare you the time and inconvenience of researching on your own.

You will receive essential information on how to judge the validity of the Scorpion and gain valuable insight into rotorcraft operation and usage. In addition to becoming an armchair helicopter expert you will really enjoy the enclosed 33-1/3 sound track recording of a Scorpion Too as its pilot explores old ghost towns and gold mines on a flight through the Mohave Desert.

SEND \$6 NOW . . .

*. . . for our illustrated
information package!*

ROTORWAY, INC.
Dept. B7/14805 S. Interstate 10
Tempe, Arizona 85281

Name

Address

City St. Zip

 **RotorWay**
INCORPORATED

A man without a Scout®

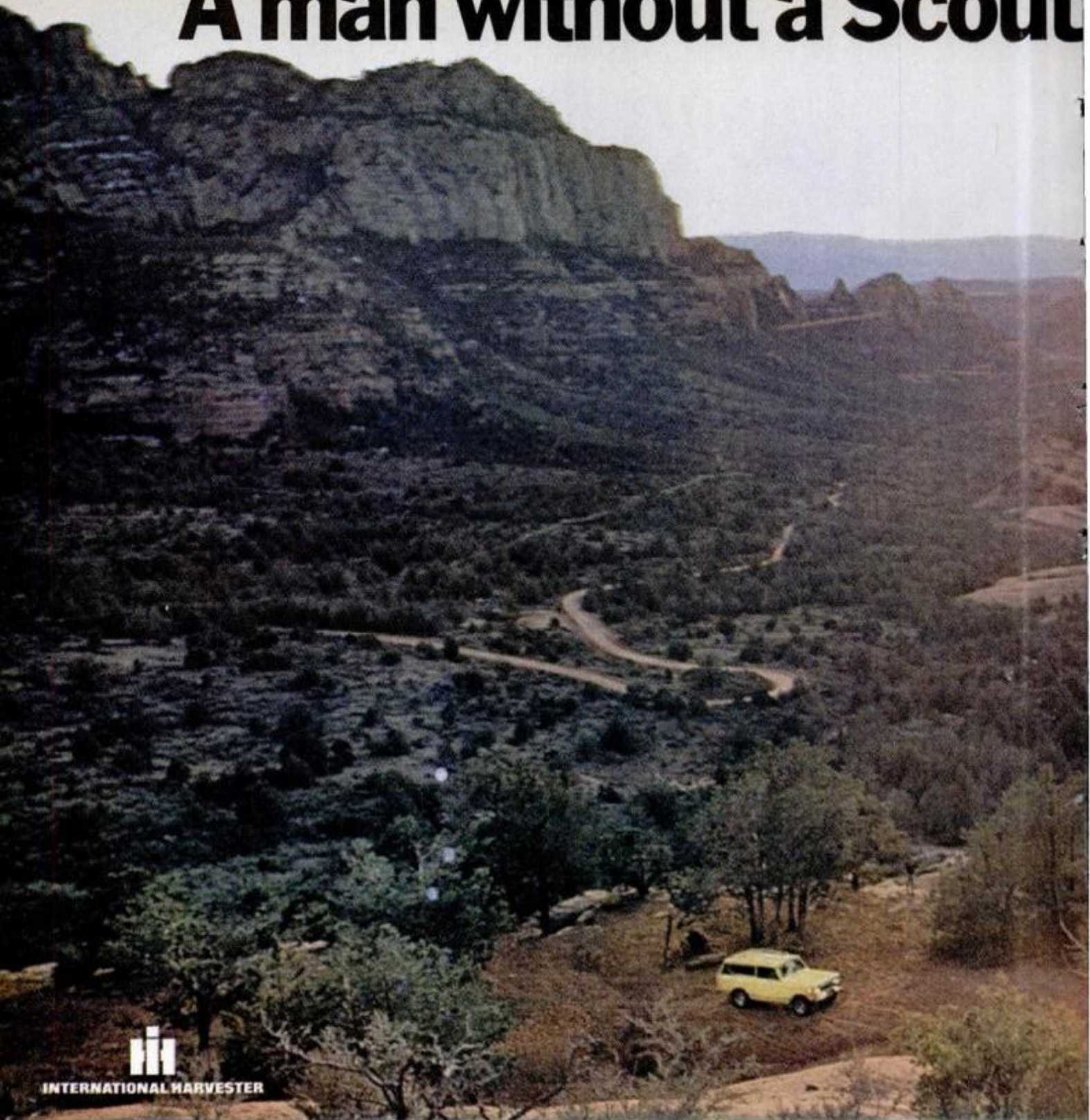

INTERNATIONAL HARVESTER

There's a lot of elbowroom left in America. But frankly, to enjoy it you've got to have a lot more going for you than a fancy name and 4-wheel drive.

You've got to have the most versatile full-size 4x4 ever built, bar none. More 4x4 than you could ever get for your money before. Scout.

You see, a Scout's rugged. Steel from the ground up. Optional steel-belted radials,

standard steel box frame, even a steel top.

It's stable. Sure footed where it counts. One hundred inches of wheelbase, with heavy-duty leaf springs all around and an antisway bar up front.

More maneuverable. Terrific in really tight spots. Smaller on the outside, with a short 33.8-foot turning diameter to boot.

And more roomy. On the inside where you need more room. So 5 giants can ride in comfort.

Mag wheels, quartz lights, bumper guards and black rear trim are dealer-installed accessories.

is a man without a country.



And with the folding rear seat, there's space for a whopping 82 cubic feet of cargo.

We could go on, of course.

About the standard power front disc brakes. The wide choice of truck-tough engines, from a gas-saving slant-4 to a powerhouse 345-cubic-inch V-8. Or the selective 4-wheel

drive, the only one that lets you switch over with a knob mounted right on the dash.

But then, if you love your country, you already get the picture.



Scout
The more a 4x4 can do,
the more it's worth.

ALL ABOUT OIL

(Continued from page 71)

according to Duane Ekedahl, executive director of the 26-member Association of Petroleum Re-Refiners.

You can still find re-refined oil in some areas, but it takes a lot of searching. As with any other oil, you should look for the SAE weight your engine requires, and an API "SE" rating on reclaimed oil.

Service-station owners, who used to be paid 1 to 2 cents a gallon for their old oil, now have to pay to have it hauled away. Naturally, there is a big temptation to just dump the stuff down the drain. This is doubly wasteful, because the potential uses for crankcase oil are many: Besides supplementing asphalt, heating oil and motor-oil stocks, Calspan Corp. has developed a process for extracting millions of dollars worth of commercially valuable lead from re-refinery wastes, and the French are extracting propane gas during a process said to yield a higher quality re-refined motor oil than the usual acid and clay filtering method.

Rep. Charles Vanik (D.-Ohio), a member of the House Ways and Means Committee and a longtime critic of the big oil companies, has

been leading an uphill fight against the various laws and rulings that have held back re-refining in the United States.

Synthetic oils

If there is a "glamor" product in the motor-oil business, it's certainly the new crop of synthetics. These new oils, or more properly "lubricating fluids," are a product of the chemical industry rather than the

Synthetic lubricants can hold up to five times more impurities than mineral oils do before they start to precipitate out.

petroleum industry (although there is considerable overlap between them).

The first widespread use of synthetic motor oil was made by the Germans during World War II. Their chemical lubricants helped to relieve the wartime shortage of natural oil, and didn't turn to molasses in the bitter temperatures of the Russian Front. Turboprop and jet aircraft have used only synthetic lubricants since their commercial introduction

during the 1950s. If you own a late-model car, chances are that its windshield wiper, heater and air conditioner motors, speedometer cable, starter, alternator and instruments are lubed for life with synthetics.

There are three basic classes of synthetics, but they all have several features in common: high lubricity, wide temperature range and a service life so long that your pleated paper oil filter will wear out before they do! They're also quite expensive, averaging \$4 to \$5 a quart! Most of them are still derived from petroleum or petrochemicals.

One reason that synthetics last so long is that they can hold more impurities in suspension than petroleum oils can. Motor oil acts as your engine's garbage pail. Its additives hold impurities in suspension so they don't clog up the oil filter. The filter should only have to screen out metallic wear particles. Synthetic lubricants can hold up to five times more impurities than mineral oils do before they start to precipitate out.

The three types of synthetic motor oils are:

■ *Esters*, which come in two varieties—diesters and polyolesters—are made from organic acids and petroleum-derived alcohols. Esters are the

Today's L&M... Proud tradition. Proud heritage. Proud taste.

The proud smoke.

Filter King, 18 mg. "tar", 1.2 mg. nicotine av. per cigarette, by FTC Method.

most popular of the synthetic motor oils now available. They have a film strength two to three times as high as mineral oils of the same viscosity. They resist the formation of sludge and gum, and will remove previously formed varnish and sludge deposits in an engine. For this reason, if you switch to an ester-based oil in an older engine, you should change the filter at about half the normal interval the first time. Most important, esters will last four to five times as long as petroleum oils between changes. They can be mixed with conventional motor oils in an emergency, although this will dilute their unique properties.

On the minus side, diesters attack the neoprene material sometimes used to make engine oil seals. Silicone, Teflon and nylon seals are not affected by it.

■ *Man-made hydrocarbons*, synthesized from petroleum-based chemicals. They have a very wide temperature/viscosity range, accept all common additives, and are compatible with today's petroleum oils and engine seals.

Mobile sells a synthetic hydrocarbon oil called Delvac SHC in Europe and Japan. It's available in 5W-40 and 10W-50 weights, and can run at

much higher temperatures and for longer distances than petroleum oils. In the lab, SHC has come through double-length sequence tests with flying colors, although one source says that Mobil "won't buck the car manufacturers by saying that you can run it for 24,000 miles or anything like that." This is a sore point that we will go into later.

■ *Polyglycols*, made from petroleum-derived alcohols and olefin oxides.

Synthetics will pour freely in Arctic temperatures so low that gasoline won't vaporize! Yet they withstand abnormally high temperatures.

Like the others, polyglycols will pour at lower temperatures, protect at higher temperatures, and go longer between changes than mineral oils. But they cannot be mixed with most other oils, so if you run low far from home, you'd better have a spare quart or two in the trunk.

Union Carbide introduced a polyglycol motor oil under the Prestone name in the '50s, but it was ahead of its time, and it cost \$1 a quart at

a time when premium mineral oils cost 35 cents!

How do they perform?

Amazing is the only word for synthetics. They will pour freely in Arctic temperatures so low that gasoline won't vaporize! Yet they withstand abnormally high temperatures.

An Opel running in the Monte Carlo Rally with Mobil SHC sprang a leak in its oil cooler. When the cooler was bypassed, mechanics figured the engine wouldn't make it through the Alps. The car not only finished, but a post-race teardown revealed no abnormal wear. Mobil claims that SHC is safe at up to 450° F. Ordinary oils literally turn to jelly between 300° F. and 350° F.

In today's smog-controlled engines used in stop-and-go traffic, such temperatures may not be abnormal after all. The Houston police force has been testing EON's E-11 ester synthetic in its cars. After 20,000 miles without an oil change, one engine was torn down and found to have no appreciable wear. The oil filter had collected no foreign material, but had to be replaced before the paper disintegrated. The test cars went 50,000 miles without an oil change, and

(Please turn to page 119)

© LIGGETT & MYERS INCORPORATED, 1975

RICH, MELLOW, DISTINCTIVELY SMOOTH

T & M

FILTER KINGS

A CIGAR

Warning: The Surgeon General Has Determined That Cigarette Smoking Is Dangerous to Your Health.

CAN AUTOMOTIVE ADDITIVES KEEP YOUR CAR RUNNING LIKE NEW?

Perhaps you just can't get yourself to believe that an additive in the fuel system can possibly solve what seems to be a mechanical problem: getting an engine to start easier, idle smoother or stall less.

The next time you're in an automotive department, stop in front of that big rack of additives. Remind yourself that every year, car owners buy over 500 million dollars worth of these various chemicals. Maybe they know something you don't.

Here at GUMOUT, we produce an additive that cleans the inside of a carburetor. Every carburetor needs cleaning because the gasoline passing through gradually builds up deposits of gum and varnish. This prevents the carburetor from feeding the proper mixture of fuel and air into the engine. As a result, the car becomes hard to start, idles roughly, loses pep and pick-up and stalls easily. Carburetor gum also increases the emission of dangerous fumes, and wastes gasoline. Newer cars are even more prone to these problems because of the anti-pollution devices which are now part of the fuel system.

If you are experiencing any of these problems, we suggest you put aside your skepticism toward automotive chemicals long enough to add a can of GUMOUT carburetor cleaner to your gas tank. See for yourself how much difference a clean carburetor can make!

GUMOUT will clean your carburetor on the inside while you drive, removing gum and varnish deposits from all the jets and passages. Try GUMOUT and see for yourself how much better your car performs. Easier starting; smoother idling, more lively acceleration, improved gas mileage, and a decrease in dangerous exhaust fumes.

GUMOUT is also available in a Jet-Spray can that's used by professional mechanics for quick cleaning of carburetor linkage, automatic chokes, and PCV valves.

Get GUMOUT wherever automotive products are sold.

GUMOUT Cleveland, Ohio 44104



ALL ABOUT OIL

(Continued from page 117)

oil temperatures as high as 550° F. were reportedly observed! For motorists who don't run their cars for more than 50,000 miles before trading them in, this kind of performance could virtually mean the end of oil changes.

All of Houston's 1500 police cars are now using E-11, which meets API "SE" specs for gasoline engines. EON now has two more synthetics, called D-15 and D-20, which meet the tough CC and CD diesel requirements.

On the minus side

There are some drawbacks to the use of synthetic oils. One is the common paper oil filter, which must generally be replaced before the oil. "We used to recommend a 24,000-mile filter change," says Bob Chabin of Darmex Industries, "but some of the filters people can buy will fall apart long before that. Now we recommend 15,000 miles." Other makers suggest filter changes at 10,000 miles.

A more obvious drawback is the price. Even with the long change intervals, it could take two or more years before the average driver began to save money on a synthetic.

For example, 10 quarts of mineral oil at 70 cents each plus a \$3 filter will see the driver of a late-model car through the average year's driving—12,000 miles—for \$10. Five quarts of a \$5 synthetic plus the same \$3 filter add up to \$28. It may last for two or three years of average driving, but about once a year you've got to replace the filter, and the quart of oil that you throw away with it—at \$8 a time. So you won't save much, if anything, on the oil. Gas savings of 5 to 10 percent are claimed with some synthetics due to reduced friction.

For a taxi or police fleet, synthetics make economic sense because they reduce downtime and labor charges for oil changes by 75 percent, as well as the volume of crankcase drainings to be disposed of. The engines in taxis and police cars may also need the protection from very high temperatures that synthetics provide. But not many average-use engines do. That's why several synthetic brands are sold only in bulk to fleets.

A further complication for new-car owners is the fact that carmakers don't yet recognize the longer change capabilities of synthetics when it comes to keeping your warranty in force. This is regrettable but understandable. After all, the service manager at your local dealer can't easily

analyze what's in your crankcase. If you haven't changed it in 12,000 miles, he will assume that you've voided your warranty.

Harry Reid of Hatco Chemicals, the manufacturer of diester lubricants sold by several other companies, describes new-car warranties this way: "The carmakers say, 'Change oil every so many miles, using a mineral oil that's barely adequate, and you will have protected your engine.' What they don't say is that there are higher-quality oils available that can protect the engine for much longer periods."

He also concedes that test standards such as the API sequence tests for petroleum oil are badly needed for synthetics. "When you pay the kind of money you must for a synthetic, you want a quality product with demonstrated performance," says Reid.

A subcommittee of the American Society for Testing and Materials, headed by Hugh Mullinger of Chrysler Engineering, is presently working on a grading system for synthetics.

Test cars went 50,000 miles without an oil change, and oil temperatures as high as 550° F. were reportedly observed.

There are a number of fly-by-night firms making inflated mileage claims for synthetics, or passing off diluted synthetic and mineral oil blends as 100-percent synthetics. Others try to sell an automotive lubricant with claims about its performance in diesel trucks. Some of these trucks have 250,000-mile warranties, so comparisons with auto engines are pretty meaningless.

Questions of price and quality may be resolved when some of the "brand name" oil companies get into the synthetic market. Mobil engineers are enthusiastic about their Delvac SHC. Now it's up to the marketing people to give the final okay for U.S. sales and set a price for it.

Castrol sells an ester synthetic for two-stroke snowmobile and motorcycle engines. It has tested a four-stroke synthetic extensively, but price remains a stumbling block. Says Castrol's marketing vice-president Tom Nasca: "There's no way a consumer can get a truly good buy on a four-cycle synthetic at this time. Most companies would have to charge between \$4 to \$5 per quart for an adequate synthetic, and that still wouldn't be up to the standards of Castrol and most other companies." ★ ★ ★

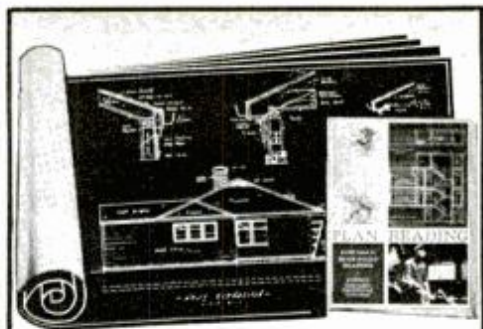

FREE BLUEPRINTS and TRIAL LESSON

—for your greater success in Building

Beginners, craftsmen, even foremen and superintendents, have sent for these free blueprints and trial lesson in Plan Reading as a means of trying out Chicago Tech's home-study Builders training. Learn how you can master Plan Reading—Estimating—and the practical details of all types of construction in your spare time at home. Mail coupon below today—see how you, too can prepare for a better job—higher income, or start your own contracting business.

CHICAGO TECHNICAL COLLEGE/School for Builders
2000 S. Michigan Avenue, Chicago, Ill. 60616

CHICAGO TECHNICAL COLLEGE Dept. PM-75, 2000 S. Michigan Ave., Chicago, Ill. 60616

Veterans Check Here

Please mail me a Free Trial Lesson, Blueprints and Builders Catalog. I understand there is no obligation—no salesman will call.

NAME _____ AGE _____
ADDRESS _____
CITY _____ STATE _____ ZIP _____

Who else WANTS to be a LOCKSMITH?

Train FAST at Home. It's EASY Making Up to \$10 an Hour—even while learning!

If you enjoy fixing things, you're a "natural" to make hundreds of EXTRA DOLLARS a year in the fascinating business of Locksmithing. Rising crime has increased demand for service a thousandfold. Yet there's only one Locksmith for every 17,000 people! COLLECT CASH PROFITS ALMOST AT ONCE! You're "in business" ready to make \$5 to \$10 an hour a few days after you begin Belsaw's shortcut training. Easy, illustrated lessons complete with ALL practice equipment PLUS KEY MACHINE YOURS TO KEEP enable you to get your share of this always-profitable business. Hundreds we've trained are doing it. So can YOU.

Mail coupon for FREE facts—No Salesman Will Call



Accredited Member Nat'l Home Study Council. Approved for Vets.

BELSAW INSTITUTE
106K Field Bldg.,
Kansas City, Mo. 64111

BELSAW INSTITUTE
106K Field Bldg., Kansas City, Mo. 64111
Name _____
Address _____
City _____ State _____ Zip _____
 Check here if eligible Veteran

SIMONIZ

HEAVY DUTY AUTOMOTIVE MOTORCYCLE WORKSHOP CAMPER POWER TOOL BICYCLE MOTOR BOAT SNOWMOBILE

or just about any- thing else you have 'round the house

CLEANER DEGREASER



Available in 28 oz. spray gun container and 64 oz. refill wherever you buy auto parts and accessories.

© MNP TETEXE CHEMICALS COMPANY, DIVISION OF MORTON-NORWICH PRODUCTS, INC., GREENVILLE, S.C. 29602

HOME IMPROVEMENT

Quick coverup



Before



After

Laundry appliances are hidden in a closet that looks like a window.

An attractive way to conceal storage areas is to hide them behind blinds. Made to order, slatted blinds can be hung easily from walls, ceilings, or in door frames because they are made of lightweight aluminum. The blinds shown, Riviera by Levolor, suit any decor and come in more than 100 decorator colors, including solids, patterns, wood grains and metallic finishes to match appliances. One or more blinds can be ceiling-hung to screen the utility area. The blinds are raised for access to hidden appliances and lowered when work is completed. If two or more blinds are used, individual sections can be raised or lowered as necessary. For an illustrated, 40-page booklet, *Window Magic*, send 50 cents to Levolor Lorentzen, Inc., Dept. PM, 720 Monroe St., Hoboken, N.J. 07030. ★ ★ ★

Scamp BUILD YOUR OWN TRAVEL TRAILER



- Hunting
- Fishing
- Camping
- Sleeps 4
- Guaranteed

For the first time - a Do-it-Yourself Kit! No welding. Scamp kit includes all parts you need and fully-illustrated step-by-step assembly manual. Scamp can be completed in 40 hours with minimum tools. Also available ready to hitch-up-and-go.

Write: SCAMP, DEPT. PM7, Backus, Mn. 56435
Rush me Brochure/Info. \$1.00 Enclosed
Name _____ Age _____
Address _____
City _____ State _____ Zip _____
Phone: Bus. _____ Home _____

LEARN PROFESSIONAL UPHOLSTERY AT HOME! SPARE OR FULL TIME...

MEN & WOMEN ALL AGES! Send for free book on learning to reupholster chairs, divans, footstools, all furniture for **BIG MONEY** in spare or full time. No experience needed, no age or educational limits. We show you how and provide **EVERYTHING** needed to start: (1) Home training covering all phases. (2) all tools and 6 big furniture kits for practice. (3) free supplies, frames and materials to build \$300 worth of furniture, yours to keep or sell. Write for big free upholstery career book. No obligation, no salesman will call. Veteran Approved. **MODERN UPHOLSTERY INSTITUTE**, 1205 W. Barkley, Box 16, 3PM, Orange, CA 92669

FIND BURIED TREASURE!

DETECTS COINS, RINGS, GOLD, SILVER Dealers Wanted

Send for FREE Catalog
White's electronics, inc.
Dept. PA5G
1011 Pleasant Valley Rd Phone
Sweet Home, Oregon 97386 (503) 367-2138

Print Your Own

Cards, Stationery, Advertising, labels, tickets, announcements, QSL cards, greeting, sympathy, prayer cards, etc. Save money. **Print for others, good profit.** Have home print shop. Pays for itself in a short time. Sold direct from factory. Easy rules sent. We supply everything. Send 25c for catalog. **KELSEY PRESSES** 75-8T Meriden, Conn. 06450

UPHOLSTERY/DECORATING made easy!

EARN AS YOU LEARN AT HOME

Send for free book about fascinating profession for men, women, all ages. Simple home study includes materials, frames, tools to make new furniture, redo old, keep or sell for profit. Easy to learn for handy folks. Professional accredited Diploma. Approved Vet. Training. No salesmen. **Upholstery & Decorating School, Div. Technical Home Study Schools, Dept. 5110-075, Little Falls, N. J. 07424.**

WE'VE GOT A DEAL YOU CAN'T REFUSE!!

Make 200% profit selling the world's best storage system. Every home, factory, and business needs this peg-board mounted cap and unbreakable jar. Send \$3.00 check or M.O. to receive a ten unit demonstration kit of our Handy Dandy Storage System, our complete sales program, and our lowest direct factory prices.

WICKLIFFE INDUSTRIES
P.O. Box 886, #875
Wickliffe, Ohio 44092

WEIGHT LIFTING EQUIPMENT

Complete catalog of over 90 items used by strong men, body builders and athletes to develop strength and muscles.

Send 35c today for your copy
WEIGHT LIFTING EQUIPMENT
P.O. Box 662 Holyoke, Ma. 01040

HYDRAULIC JACK REPAIRS

Earn While You Learn In Your Spare Time

Trained and qualified mechanics needed NOW to service inoperative hydraulic jacks. BIG opportunity for ambitious men. We show you HOW - in your basement or garage to earn spare time cash in an expanding industry. Don't wait, ACT NOW! Get the facts.

Write for folder No PM-7, and free bonus offer.

Hydraulic Jack Repair Manual Co., Inc.
P.O. BOX 34 STATEN ISLAND, N.Y. 10314

MUZZLE LOADER KITS



By CVA

- Complete instructions
- Rifled Barrel
- Fully Shaped & 90% Inletted

Well known, Connecticut Valley Arms Philadelphia Derringer Kit. Complete with all parts needed to make a handsome, fully shootable replica. Features .45 cal. octagonal barrel and authentic style percussion lock. Only \$21.95 postpaid.

Ruger Old Army Revolver .44cal, list \$125.00 SALE \$112.50. Lyman Enfield Muskatone .58cal, list \$225.00 SALE \$179.95. T/C Hawken Perc. Rifle .45 or .50cal, list \$205.00 SALE \$174.50. Bank Americard & Master Charge accepted.

FREE SPORTSMAN'S CATALOG Buy Direct & Save

Send for FREE Muzzleloading, Hunting, Fishing and camping catalog. All nationally advertised brands at lowest possible prices. Page after page of bargains. Write Today!

CHARTER OAK DISTRIBUTORS, INC.
Dept. PMM75 50 Walnut St., Middletown, Ct. 06475

FIX LAWN MOWERS FOR FUN & PROFIT



Fascinating new Handbook by F. Peterson gives you the knowledge skilled mechanics learn.

OVER 125 ILLUSTRATIONS show how to trouble shoot, repair carburetors, engines, balance and sharpen blades, etc. Exploded drawings are extensively used.

INSTRUCTIONS COVER reel, rotary and rider mowers, preventive and routine maintenance, how to identify brand names, where to obtain replacement parts. How to buy and use a lawn mower. Friends gladly pay \$10 to \$50 to fix their lawnmowers. Try the HANDBOOK OF LAWN MOWER REPAIR. Rush only \$7.95 plus \$3c handling on 10-day money-back guarantee.

EMERSON BOOKS, INC. Dept. 328B
Buchanan, New York 10611

PRESCRIPTION EYEGLASSES BY MAIL



direct from manufacturer

Your own doctor's prescription will be filled, or your present lenses duplicated. The latest fashions. All types of lenses available. Accuracy and perfect fit absolutely guaranteed.

SEND FOR FREE FAMILY CATALOG. TODAY!

Est. 1959

PRISM OPTICAL INC.

Dept. M-32 135 West 41st St., N. Y., N. Y. 10036

FIND BURIED TREASURE

Powerful electronic detector finds buried gold, silver coins, etc. Write or call for free catalog. Dealer inquiries invited.



Financing Available

Phone day - night (713) 682-2728

RELCO, Dept. DD 62

BOX 10839, HOUSTON, TEX. 77018



BUILD THESE BEAUTIFUL CLOCKS



NOW AT BIG SAVINGS!

Send just \$1 for plans & instructions to build choice of: (A) Grandfather, (B) Steeple, (C) grandmother—plus information-packed catalog of movements, dials, parts & kits to build these & 16 other fine clocks. All 3 plans—\$2.50. Catalog alone—25¢.

MASON & SULLIVAN COMPANY
Dept. PM Osterville, Mass. 02655

LIVE IN THE WORLD OF TOMORROW... TODAY!

And our FREE 180 PAGE CATALOG is packed with exciting and unusual values in hobby, electronic and science items — plus 4,500 finds for fun, study or profit... for every member of the family.

A BETTER LIFE STARTS HERE

OWN A WORKING DUTCH WINDMILL

Easily build a charming 1/5 scale replica of the real thing with our detailed plans, blueprints, list of materials needed and explicit instructions. 8' size can generate 1000w (12v current) of free electricity from the wind! 2', 4' & 8' sizes stand 3'6", 7' & 14' high, respectively. Get kudos from your neighbors for the beauty & practicality. If you're the least bit handy you can do it for \$250-\$350 (incl. complete material cost). Go Dutch!

Stock No. 9130H \$15.95 Ppd.



SUPER POWER FOR ANY AM RADIO

New antenna assist turns a tiny transistor into a tiger, has pulled in stations 1000 miles away! Just set it beside your radio (no wires, clips, grounding) and fine-tune Select-A-Tenna's dial to same frequency—"Gangbusters"! Terrific for sportsmen, vacationers. Great for clearing weak signals in radio depressed areas, off-coast islands, stations in crowded frequencies. Solid state—uses no electricity, bats, tubes. Works almost forever.

Stock No. 72,095H \$15.95 Ppd.



BIG 6 x 6" OPAQUE PROJECTOR!

Great buy! New light-weight compact enlarges any picture or print matter up to 6x6" for big projection 30 to 144" away. True color reproduction! Feat.: optically polished glass lenses, heat-resist. plate glass mirror, cut-free slide tray, heavy duty motor, large fan. Reqs two 200w household bulbs (not incl.). Steel body, 8" cord. 13x13x28 3/4".

Stock No. 80,217H (9 LB.) \$79.95 Ppd.

DELUXE 5x8" OPAQUE PROJECTOR No. 71,272H (SUPER SHARP!) \$139.95 Ppd.



BUILD A SOLAR HOME AND SAVE!

Beat the energy crisis—build a modern 10 room solar heated & air conditioned home designed by famous ecological architect Malcolm R. Wells! Its 11-yr.-proven "Thomson Solaris System" can cut conventional heating costs as much as 2/3! Your builder can modify or use as-is the complete blueprints included with "Solar House Plans III" by Edmund, Honan, Thomson & Wells. Estimated \$40,000 building cost. 48 pg. book shows all pros & cons. 11x17". No. 9469H (8 1/2" X 11" PAPER) \$24.95 Ppd.



FREE BICENTENNIAL LIGHT SHOW
EDMUND SCIENTIFIC COMPANY
EDMUND FACTORY STORE

AM RADIO FITS IN/ON YOUR EAR!

Wear it inconspicuously everywhere, listen as you work (lawn, yard, office), watch (game, bench) or wait. Instant music, news, sports. No gimmick—4/10 cc. technological wonder w/ integrated circuit, 11 transistors, patented ferrite antenna/tuner/volume dial. Works best outdoors. Uses hearing aid batt. (incl)—up to 100 hrs. playing. New batt. to slip in, avail. at drug stores (about 50¢). No lengthy wires, bulky cases, or power needed!

Stock No. 42,275H \$14.95 Ppd.

FEEL SAFER—USE A DOOR VIEWER

See (without being seen) who's at your door or in your yard, on your walk. Super view wide-field door Peepscope is 'an essential safety device for homes, apartments'. Camera buffs can use 175* Peepscope to make a pseudo fish-eye lens w/ almost the same extreme wide angle effect of a \$400 one! Its 3-element ground-glass lens gives biggest, clearest, brightest view we've seen, even with night lighting. Installs in seconds in 1 1/4" hole in doors from 1 1/4 to 2" thick.

Stock No. 42,169H \$6.95 Ppd.

"FISH WITH A MAGNET"

Go treasure hunting on the bottom! Fascinating fun & sometimes profitable! Tie a line to our 5 lb. Magnet—drop it overboard in bay, river, lake or ocean. Troll it along bottom—your "treasured" haul can be outboard motors, anchors, other metal valuables. 5 lb. Magnet is war surplus—Alnico V Type—Govt. cost twice our price. Lifts over 150 lbs. on land—much greater weights under water.

Stock No. 72,103H (5 lbs.) \$17.50 Ppd.

GIANT ELECTROMAGNET LIFTS 500 lbs. Stock No. 71,936H \$34.50 Ppd.

AUTHENTIC SCALED WINDMILLS

Real-thing replicas show wind direction, wheel silently revolves on ball bearings, give your grounds unique rural charm! Great centerpiece for planter, flowers. Use to hold yard signs, house number, sign or as mailbox. For school, a fine "energy crisis" science project—does everything but pump water. Heavy gauge steel, durable outdoor finish; aluminum color w/ red trim.

(12" DESK MOD.) No. 71,923H \$11.95 Ppd.

(4 1/2" - 14 LB.) No. 71,924H \$34.95 Ppd.

(8" - 46 LB.) No. 85,229H \$49.95 FOB

PRO ELECTRONIC SOUND-CATCHER

Parabolic mike w/ 183" reflecting shield & 2 LC's in amplifier magnifies signals 100X that of omnidirectional mikes. Catch a songbird 1/2 mile off; Q1V's hidden strategy; sounds never before heard. Super directivity gives highest signal to noise ratio poss. Safe; auto, cuts off ear-damaging noises. Earphones, tapes recorder output, tripod socket. Reel, two 9v trans. batt. (not incl.).

No. 1649H (2 1/2" LB.) \$299.00 Ppd.

BIG EAR "TOY" MODEL #R0,176H \$32.25 Ppd.

MAIL COUPON FOR GIANT FREE CATALOG!

180 PAGES + MORE THAN 4500 UNUSUAL BARGAINS

Completely new Catalog. Packed with huge selection of telescopes, microscopes, binoculars, magnets, magnifiers, prisms, photo components, etiology and Unique Lighting items, parts, kits, accessories — many hard-to-get surplus bargains. 100's of charts, illustrations. For hobbyists, experimenters, schools, industry.

EDMUND SCIENTIFIC CO.
300 Edcorp Building, Barrington, N. J. 08007
Please rush Free Giant Catalog "H"

Name _____
Address _____
City _____ State _____ Zip _____

COMPLETE AND MAIL WITH CHECK, M. O. OR CHARGE NO.

EDMUND SCIENTIFIC COMPANY
300 Edcorp Building, Barrington, N. J. 08007

How Many	Stock No.	Description	Price Each	Total

SEND FREE 180 PAGE CATALOG "H" Add Handling Chg. \$1.00. Orders Under \$5.00. 50¢. Orders Over \$5.00

Charge my BankAmericard * I enclose check money order for TOTAL \$ _____

Charge my Master Charge * Interbank No. _____

My Card No. is _____

Signature _____

Card Expiration Date _____ NAME _____

30-DAY MONEY-BACK GUARANTEE. ADDRESS _____
You must be satisfied or return any purchase in 30 days for full refund. *\$15.00 minimum

CITY _____ STATE _____ ZIP _____

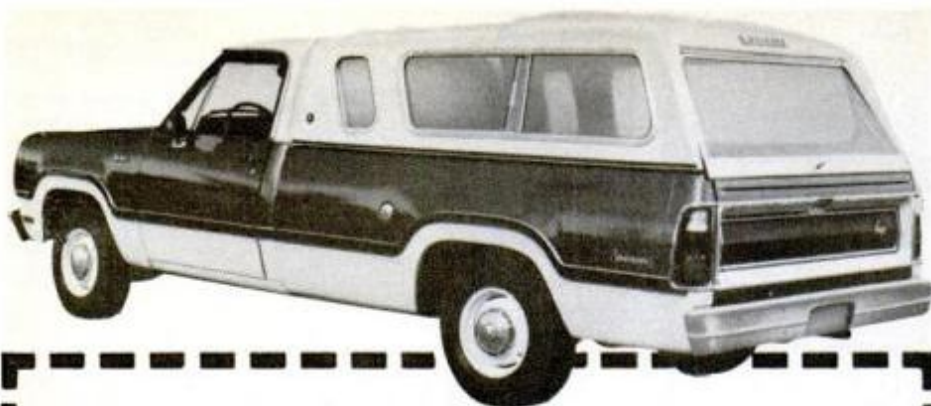

WINNEBAGO KAPS

Free folder shows you why we're number 1 in pickup covers.

Get the full story and pictures of Winnebago's full line of Thermo-Panel®, fiberglass, rotocast and aluminum KAPS, plus names of your nearest distributor.

NAME _____

ADDRESS _____ PHONE _____

CITY _____ STATE _____ ZIP _____

I do do not presently own a pickup truck. Make _____

Mail to Winnebago Industries, P.O. Box 152,
Forest City, Iowa 50436.

De 50

WINNEBAGO

SUPER CAULK™ Guaranteed for 20 Years

- Macco Acrylic Super Caulk will not lose adhesion, crack, bleed, stain or discolor
- Adheres to all common building materials
- May be painted within 30 minutes with oil base or latex paints
- Resists dirt pickup
- Easy to apply
- Hands and tools clean up quickly with soap and water
- For use inside or outside the home



Guarantee: Macco Adhesives guarantees that if Macco Acrylic Super Caulk is used as directed and fails within 20 years after application, Macco will replace an equal amount of material at no cost after inspection, and upon submission of proof of purchase to Macco. This guarantee applies to residential use only.

MACCO ACRYLIC SUPER CAULK.
IT'S CALLED SUPER FOR A REASON.

SCM MACCO ADHESIVES
SCM CORPORATION, WICKLIFFE, OHIO 44092

WHY OIL COOLERS?

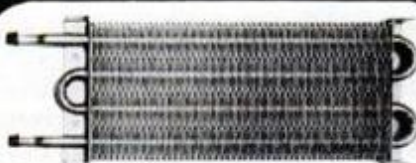

Because you have a major investment to protect. Because reduced maintenance costs are paramount to the thinking driver. Because better mileage is an end result of a more efficient engine.

Thermo-Chem external oil coolers, designed on the "full-flow" principle, allow the engine to maintain proper oil temperatures. Therefore your automobile or recreational vehicle can run cooler, smoother, longer, with less maintenance and greater reliability.

You need a Thermo-Chem Oil Cooler, especially if you drive a late model vehicle with its anti-pollution equipment, air conditioning, high-pressure cooling system, and cramped engine compartment which restricts air flow. It is important to know that an already overburdened engine cannot respond to your demands for extra performance without pushing oil temperatures to excessive levels.

THERMO-CHEM COOLS HI-PERFORMANCE ENGINES & AUTOMATIC TRANSMISSIONS. AN ABSOLUTE MUST FOR HEAVY-DUTY AND TOWING VEHICLES.

SEE YOUR LOCAL DEALER ABOUT THERMO-CHEM
OR SEND \$1.00 FOR CATALOG.

t-c THERMO-CHEM CORP.

10516 East Pine (Box 15457)
Tulsa, Oklahoma 74116 (918) 836-8841

15 GREAT SHOP IDEAS

(Continued from page 111)

exposed to just five or six frames is adequately recorded.

Currently, Cross is heavily into automotive repair. He enjoys auto mechanics and that's why his shop is built with an overhead garage door. Generally, he works on family cars outside, but in bad weather, he moves tools aside and pulls the car in.

Asked why he pursues do-it-yourself activities with such a seeming passion, Russ replied that "mostly, it's because I get fed up with the workmanship quality of many of today's so-called professionals.

"To give you an example," he continued, "I recently called in an outfit to install roof ventilators on my house. Would you believe that the 'pro' who showed up to cut some holes in my roof had just a hammer and screwdriver in one hand and a ladder in the other." At this point, Cross says he told the contractor to forget it, that he'd install the vents himself.

"The funny part about doing-it-yourself, or being a home handyman or whatever," Russ added, "is that besides saving money, you usually get a better job, gain a few new tools and—no matter how it turns out—you are always a little smarter than when you started. It's really the best way to go." ★★★

MAKING YOUR FLIGHT SAFER

(Continued from page 76)

lation at \$4600. Compare this with \$174.75 for a single DC-8 "Fasten Seat Belts" sign, \$20,701 for one of a 747's two windshields and \$22,738 for a 727's flight director system (two required per ship). Sundstrand will offer a more compact and less expensive model to small-aircraft owners.

As an airline pilot, I welcome these two new altitude warning systems, though I anticipate considerable grumbling from some of my colleagues, a few of whom privately say it is not the confusing charts, controllers or air traffic system that cause a CFIT accident, but the pilot himself. He and he alone bears final responsibility for missing all obstructions. He should not need "bells, horns, whistles and a tilt light" to tell him he's low.

I see their point but do not quite share this degree of self-confidence. We may be trained professionals with years of experience, but we remain human and capable of error. If the ship I'm commanding (or riding aboard) flies too low—for whatever reason—I want to hear that taped voice and see that tilt light. ★★★

Cash in on these days of fear...

BE A LOCKSMITH!

The demand for skilled locksmiths has never been higher...the pay has never been better and the way to learn has never been easier.

WITH OUR TRAINING YOU CAN SUCCEED . . . HERE'S PROOF:



Peter H. Rood, Torrance, Calif.
 "School and instructor were excellent. Really gave me incentive to get much deeper into the security end of it . . . earned \$1500 spare time while enrolled."

James D. Soule, West Chester, Pa.
 "Excellent course—very thorough and no short cuts! Am semi-retired. My wife and I are moving to Florida to open a combination gift and locksmith shop."



Keith Hamill, Toronto, Can.
 "Have seen other locksmith courses but none of them compared to yours. Now have a successful mobile service of my own and earn \$2000-\$3000 per month."

George James Luzzi, Norwood, N.J.
 "Earned \$1000 while training. Method of instruction, personalization . . . and overall thoroughness are wonderful. My instructor was encouraging and informative."



Edward H. McInroy, Honesdale, Pa.
 "First got interested in locksmithing as it is necessary for my job and there are so few locksmiths in the area. Enjoyed study as well as practical training."

Alexander Curto, Brooklyn, N.Y.
 "Found the course clear and concise . . . the 'learn by doing' quality brought a feeling of pride and accomplishment. Faculty was helpful, encouraging."



★ **Newspaper headlines tell the story.**

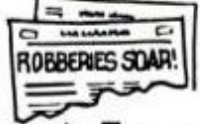

Pick up a paper any day. Burglary, housebreaking, vandalized homes—no wonder America is locked up tighter than ever before. And there are more homes, more stores and factories, more hotels, more cars, and more people. And that means more keys and locks.

★ **Earn as much as \$10 an hour—or more.**



Today a trained locksmith can just about write his own ticket. Earn as much as he wants to work. Earn in his spare time, in a business of his own, or in a highly-paid position with someone else. Earn in almost any part of the country he wishes to live.

★ **Learn at home—earn as you learn.**



Let Locksmithing Institute show you absolutely free how you can qualify for this exciting, action field. Mail the coupon below. It will bring you full details about the fast, easy course that trains you by "doing" for this highly-paid profession. See how you can learn at home, in your spare time, even while you hold down your present job. See how the key-making machine and complete set of tools included with the course can put you in business earning money right while you are learning.

★ **The fast way to success . . . independence.**



From the start you get practical experience doing real jobs on car locks, home locks, padlocks, and safes. Within six months you can be on the road to complete independence—no more low wages, layoffs. Don't you owe it to yourself to get the facts today? Use coupon below for free information. No salesman will call. You and you alone can make your decision based on the straight-forward facts you will receive.

LOCKSMITHING INSTITUTE

Dept. 1110-075
 Division of Technical Home Study Schools
 Little Falls, New Jersey 07424

LICENSED BY STATE OF NEW JERSEY. ACCREDITED MEMBER NATIONAL HOME STUDY COUNCIL. STATE APPROVED DIPLOMA. APPROVED FOR VETERANS TRAINING.

306 Pieces of Equipment

The locks, picks and tools you'll use in your course and in your future profession.



Plus This Professional Key Machine . . .

For quick money-making now and for years to come.



All Included With Your Locksmithing Institute Course



Special Instruction in Electronic Burglar Alarm Security Systems at no extra cost if you act now.



FREE BOOKLET

LOCKSMITHING INSTITUTE

Technical Home Study Schools
 Little Falls, New Jersey 07424

YES, rush me your free "Opportunities in Locksmithing", plus full details on money-making opportunities, key machine and tools, sample lesson pages, tuition and easy payment plans.

NO OBLIGATION . . . NO SALESMAN WILL EVER CALL

Name _____

Address _____

City _____

State _____ Zip _____

Check here for information on Veteran Benefits.

Dept. 1110-075

GUNK®**ENGINE CLEANER**

ENGINE-BRITE, America's No. 1 engine cleaner. Spray it on, hose it off. Powerful, self-emulsifying degreaser.

**TAR & BUG REMOVER**

Especially formulated to dissolve tar spots and loosen bug deposits on autos, cycles, etc.

BRAKE AND ELECTRIC PARTS CLEANER

Degreases and flushes away oil residues and grime from brakes, oil lines and intricate mechanisms. No flash point.

**GARAGE FLOOR AND MOWER CLEANER**

A superior grade cleaner for removing grease and grime from concrete surfaces. Sprinkle on wet surface, scrub, soak, rinse.

"Cleaning Problems End with GUNK Solutions."

GUNK LABORATORIES, INC.
5829 W. 66th St., Chicago, Ill. 60638
DEMPSEY & STANLEY, INC. Forest Park, Ill. 60130
RADIATOR SPECIALTY CO. Charlotte, N. C. 28237

an "adjusted" gallon figure of 5.9 instead of 7.5.)

2. *Maintain the proper pH level.* If your pool contains more than 1000 gallons of water, it's essential that you test the pH level of your water at least once a week. Chlorine effectiveness is closely related to the pH level of the water. The pH scale (it runs from zero to 14) is a measure of the acidity-alkalinity level of water.

Water having a pH level between zero and seven is acidic; water having a pH level between seven and 14 is alkaline. The ideal pH range for pool water is between 7.2 and 7.6—a point where the water is slightly alkaline. Below a pH level of 7.2, chlorine is consumed too rapidly. Above a pH level of 7.6, the chlorine effectiveness is reduced.

To get the pH level between 7.2 and 7.6 you should buy a reliable pool-test kit available at any pool-supply store. The test kit uses a phenol red indicator solution that changes color at different pH levels. It also should have an OTD (orthotoluidine solution) test involving color changes for chlorine residual.

Test kits are also available for measuring total alkalinity, calcium hardness and the cyanuric acid level of pool water. When purchasing a test kit, look for one with quality color standards that will not fade, and for calibrations that give you more than just a high-low reading. A good test kit will last for years, but be sure to buy fresh solutions every year. Old test solutions can give misleading results.

Chemicals that raise or lower the pH level of pool water are available at pool-supply dealers. To raise the pH, use soda ash; to lower pH, use sodium bisulfate or muriatic acid. Olin Chemicals' PH-Plus and PH-Minus are typical products available at your dealer.

3. *Maintain an effective chlorine level.* Once you've adjusted the pH of your pool water, you must maintain the proper amount of available chlorine residual at all times. This will provide enough chlorine to:

1. Control immediately any bacteria and algae already contaminating the water (initial chlorine demand).

2. Establish a chlorine residual (free available chlorine) that will fight any other contaminants entering the pool.

To satisfy the initial chlorine demand and establish a free available

chlorine residual, you must treat your pool water with daily dosages of the correct amounts of chlorine sanitizer. At times, additional dosages will be required to overcome special problems such as heavy use of the pool, long periods of rain, or winds bringing in debris and pollen.

Use your pool test kit to check the level of available chlorine in the water. This should be done every day. This chlorine residual should be kept at between 0.6 and 1.0 parts per million (ppm) for unstabilized pools, and between 1.0 and 1.5 ppm for stabilized pools (these terms are explained in the following step). Burning eyes and skin irritations among swimmers are usually caused by chloramines—nitrogen compounds that thrive in pool water that has too low a free available chlorine level. (This is contrary to popular belief that eye-smarting results from over-chlorination.)

Most pool owners use a form of inorganic dry chlorine called calcium hypochlorite. It comes in granular form for pouring, or in tablet form for use in pool floaters or pool skimmers. Be sure to follow the instructions of the manufacturer to insure correct dosages and a proper sanitizing routine. Most efficient brands of dry chlorine have either a 65 or 70-percent available chlorine content.

4. *Stabilized water could be for you.* Since the sun's ultraviolet energy tends to dissipate available chlorine in pool water, pool owners who live in areas experiencing long periods of sunshine and heat may find that the chlorine residual in their pool water is being consumed quickly.

This problem can be overcome by stabilizing pool water with a chemical called cyanuric acid. Cyanuric acid protects the chlorine residual in pool water, yet it is nontoxic, does not affect the disinfection process and does not decompose. A pool stabilizer should be purchased as a separate product. Directions on the package should be followed for the correct dosage.

5. *Watch out for chlorine lock.* If you decide to stabilize your pool water, even though you may have followed the manufacturer's directions to the letter, an excessive amount of cyanuric acid in the water can reduce the effectiveness of your chlorine sanitizer.

This condition of over-stabilization or "chlorine lock", where the germ-killing power of the chlorine is neu-

tralized, occurs when the level of cyanuric acid reaches 100 to 150 parts per million. The normal level of stabilizer is 25 to 50 ppm. The chlorine residual should be 1.0 ppm for stabilizer levels of 25 to 60 ppm, and 1.5 ppm for stabilizer levels of 61 to 100 ppm.

To remedy this condition, use a test kit that checks levels of cyanuric acid. If the level is too high, remove enough water from the pool so that the 25 to 50 ppm stabilizer level is achieved when the pool is refilled.

6. *Quick cures for warm-weather problems.* If your chlorine residual drops below recommended levels for any length of time, bacteria, unsightly algae patches and bad tastes and odors are certain to appear. Two powerful weapons that can be used to combat these problems are superchlorination and shock treatment.

Superchlorination is an extra heavy dose of chlorine—roughly 1 oz. of dry chlorine (65 or 70-percent available chlorine) added to 1000 gallons of water. Shock treatment is a dosage that is twice as powerful—1 oz. of dry chlorine (65 or 70-percent available chlorine) added to 500 gallons of water. Note that some manufacturers may differ on exact dosages.

You should superchlorinate when a pool is opened for the season, when a pool is refilled, after a long period of sunny and hot weather, after heavy use, after severe rain or windstorms, or whenever unpleasant tastes and odors are present in pool water. A shock treatment should be used if algae patches appear on pool walls or submerged fixtures, or if the water gives off an objectionable odor.

If either treatment is used during daytime hours, the regular dose of chlorine sanitizer should be added in the evening. Be sure to check the chlorine residual with a test kit before using the pool. If the residual level is too high (above 2 ppm), let the pool stand unused until morning or until the residual drops to a safe level. Remember, the solution to most serious pool problems is superchlorination or shock treatment.

7. *Keep your filter clean.* The two most commonly used filters are sand filters and diatomaceous-earth filters. Pool water is recirculated through the filter under pressure created by a pump. Increased pressure is usually an indication of ineffective filtration.

A pressure buildup across the fil-

(Please turn to page 130)

If You Like To Work With Your Hands... You Can Start Your Own Business



Sparetime or Fulltime

Turn your sparetime into extra dollars this proven practical way in the profitable saw maintenance business. Every community needs this service. You do it all automatically with Foley Saw maintenance equipment.

We Help You Get Started

Foley shows you how to make money in this multi-million dollar industry. You quickly learn how to sharpen valuable saws and other tools. Excellent profits. No special skills needed.

Minimum Investment Needed

Start this profitable business with very little money in your basement or garage. No franchise fees. Foley will help finance you. You can start earning cash as soon as your Foley equipment arrives. Send coupon for more information by mail.



FOLEY MANUFACTURING CO.
716-5 Foley Bldg., Minneapolis, Minn. 55418

Rush information to me. I understand there's no obligation.

Name _____
Address _____
City _____ State _____ Zip _____

A WHOLE NEW WAY OF SHARPENING!

Amazing CERAMIC Sharpening Rod ends dull knives...

restores razor-sharpness gently, without wearing down the blades!

Entirely different, more effective than any sharpening tool you've ever used... at about one-third the cost of a good sharpening steel! Exclusive ceramic surface gives knives super-sharp edge in just a few strokes without harmful grinding or wearing away of blades. Ideal for sharpening any knife, scissors or cutting tool you own! Measures 13 1/4" long, with solid ash handle and hanging thong.

Sharpens your knives effortlessly in seconds... adds years to their lives!

ONLY \$3.95 postpaid



30-Day Money-Back Guarantee!

DISCOVERY HOUSE, INC. Dept. RP7
25 Sylvan Rd., South, Westport, Conn. 06880

Please rush _____ MAC Sharpening Rod(s) at just \$3.95 each*, shipping and handling included. If not completely satisfied, I will return Rod(s) within 30 days for full and prompt refund. Also send FREE Discovery House Catalog of unique items from around the world. Check or M.O. for \$_____ enclosed.

Print Name _____
Address _____
City _____ State _____ Zip _____

*Conn. Residents Add 7% Sales Tax.

TURBOBLAST

Get Up To 50,000 Miles On Your Spark Plugs

- Cleans all types of plugs in seconds
- Requires no compressed air



- Supply of glass bead abrasive for cleaning 250 plugs. Additional beads available
- Rugged, long life without maintenance
- Powered by rugged 12,000 RPM 120V motor

NEW



JAYCRAFT CORP. DEPT. PM-7
760 North Marshall Ave., El Cajon, Calif. 92020

Name _____
Address _____
City _____ State _____ Zip _____

\$19.95 Plus \$1.55 for shipping and handling
SATISFACTION GUARANTEED or your money refunded in 30 days
California Residents Add State Sales Tax

The better the training the better you'll

Send for one of these **FREE** illustrated

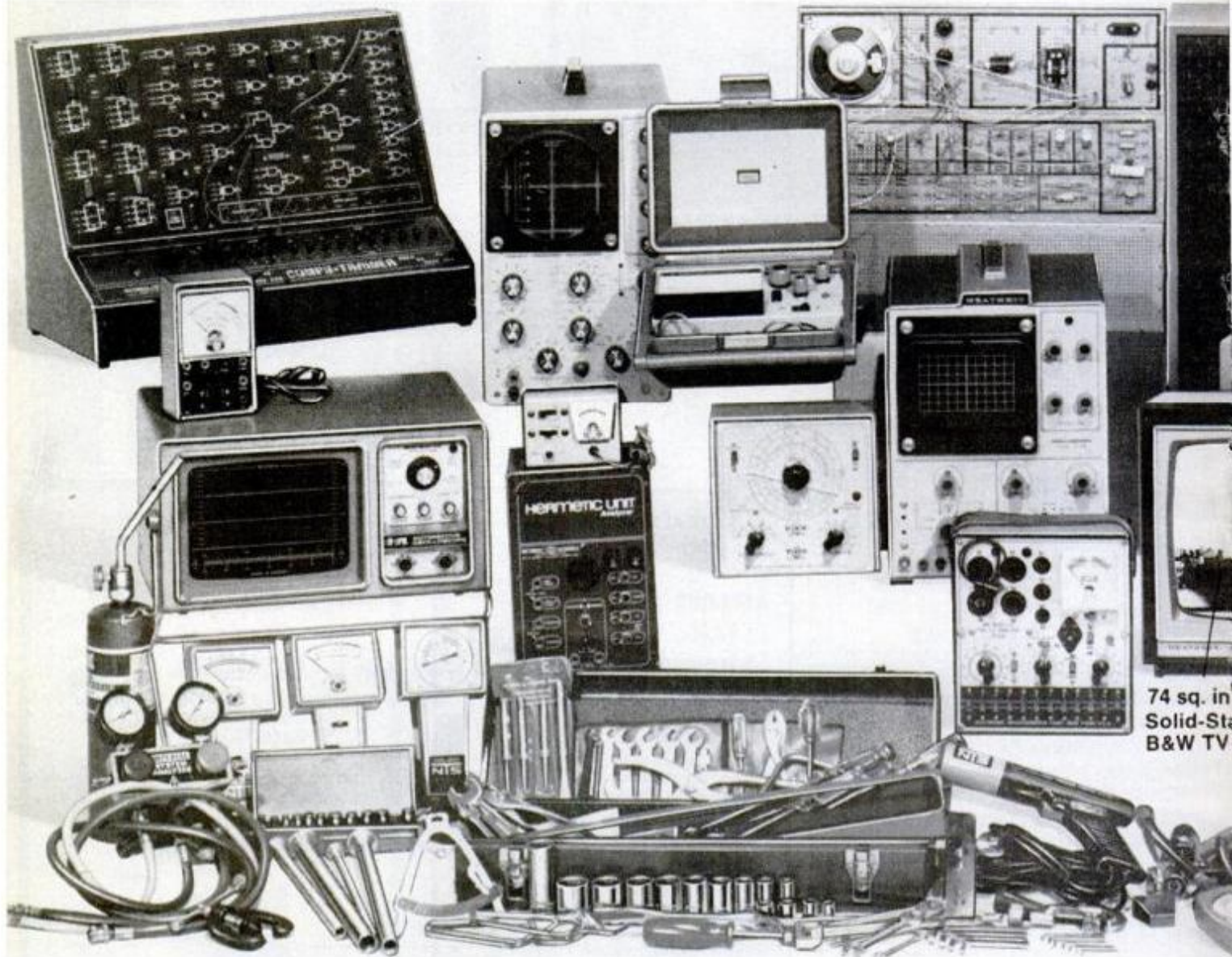

74 sq. in.
Solid-State
B&W TV

Build and keep some of the finest technical equipment made when you train with an NTS Project-Method home study course. And it's usually the same type of equipment you'll meet in the field and use on the job. It will help you acquire first-hand experience and skill — help prepare you better for a variety of exciting technical careers:

ELECTRONICS DIVISION: Courses include professional equipment like 5" solid-state oscilloscope, transistor and tube-tester, vector monitor scope, 74 sq. in. B&W TV, and solid-state stereo AM-FM multiplex receiver, speakers. Color TV courses feature advanced NTS/HEATH DIGITAL GR-2000 Color TV with silent varactor diode tuning; digital read-out channel selection (with optional digital clock), big 315 sq. in. screen.

MECHANICS DIVISION: Learn engine diagnostics, motor overhaul, transmissions, automotive maintenance. Courses include 9 in. solid-state automotive oscilloscope, testers, tools, mechanic's steel tool box, & more.

AIR CONDITIONING, REFRIGERATION/HEATING DIVISION: Learn servicing of commercial, industrial and residential heating and cooling equipment. Courses include hermetic unit analyzer, leak detector, charging testing-purging manifold set, tools and more.

HOME APPLIANCES DIVISION: Courses cover repair and maintenance of washers, dryers, ranges, smaller appliances. Equipment includes NTS Circuit-Trainer and professional multimeter.

and the equipment be equipped.

Career Guides:

COMPARE OUR
KITS AND LESSONS.
COMPARE OUR
TUITION.



NTS/HEATH
GR2000
Digital
Solid-State
Color TV
315 sq. in.
Picture

12:01:36

(Simulated TV Reception)

LOWER TUITION FOR YOU: We employ no salesmen, pay no commissions. You receive all home-study information by mail only. Make your own decision, your own comparisons. Send card today or write for illustrated catalog in field of your choice, all details.

NO OBLIGATION. NO SALESMAN WILL CALL.

APPROVED FOR VETERAN TRAINING
Get facts on new 2-year extension.

NATIONAL TECHNICAL SCHOOLS

TECHNICAL-TRADE TRAINING SINCE 1905
Resident and Home-Study Schools
4000 So. Figueroa St., Los Angeles, Calif. 90037

NATIONAL TECHNICAL SCHOOLS

4000 South Figueroa St., Los Angeles, Calif. 90037

Dept. 201-075

Please send FREE Color Catalog and Sample Lesson.
NO OBLIGATION. NO SALESMAN WILL CALL.

- Electronics Division
- Mechanics Division
- Air Conditioning/Refrigeration/Heating Division
- Home Appliances Division

NAME _____ AGE _____

ADDRESS _____

CITY _____ STATE _____

Please fill in Zip Code for fast service _____

- Check if interested in G.I. Bill information.
- Check if interested ONLY in classroom training in Los Angeles.

SEND FOR THIS CATALOG

100's of illustrations & 1000's of bargains in hydraulics, electrical, marine, automotive, hardware items... and more! A must for hobbyists, sportsmen, machinists, inventors, just about everybody! Airborne's 30th

Anniversary Surplus Guide is our best ever! Send 50c to cover postage & handling. In a hurry? Send \$1 for airmail. Must include zip.

AIRBORNE SALES CO.
8501 Steller Dr. Dept. PM75
P.O. Box 2727
Culver City, Ca. 90230

Satisfying customers since 1945.

SAVE UP TO 90% ON GOVT. SURPLUS

inventors

...Manufacturers Need New Products

If you have an idea for a new product, or a way to make an old product better, contact us, "the idea people." We'll develop your idea, introduce it to industry, negotiate for cash sale or licensing.

Send for our FREE "Invention Kit." It has a special "Invention Record Form," an important brochure, "Your Invention - Its Development, Protection & Marketing," and a Directory of 500 Corporations Seeking New Products. You'll learn how ideas become a reality!

RAYMOND LEE ORGANIZATION
230 Park Ave. No., New York, N.Y. 10017
I'd like to find out how to take action on my idea. Send Free "Invention Kit No. A-12"

Name _____ Please Print
Address _____
City _____ State _____ Zip _____
SAN FRANCISCO LOS ANGELES TORONTO VANCOUVER DENVER CHICAGO

DRAFTING PAYS BIG!

U.S. Labor Dept. says "42% more Draftsmen needed in next 10 years." Easy home-study plan guides you. Send for FREE "Drafting Career Kit."

APPROVED FOR VETERANS.

NAME _____ AGE _____
ADDRESS _____
CITY _____ STATE _____ ZIP _____
NORTH AMERICAN SCHOOL OF DRAFTING, Dept. PM005
4500 Campus Dr., Newport Beach, Calif. 92653

5-IN-1 MINIATURE MACHINE SHOP

"No bigger than a typewriter, this precision tool will outperform machines many times its size!"



still \$199.50 fob. Tenally, NJ

Versatile, accurate, easy to use. Lets model makers, hobbyists, gun buffs, students, machine all small parts from metal, wood, plastic. Easy to set-up unit features all-angle headstock, ball bearing 11-speed spindle, steel upright post. Lathe swings 3" x 7" centers. Drill press cap, 5/8". Price includes 1/10 hp motor, parts, plus 44-p metal machining handbook that 'shows you how'. Send \$2 for your copy, or request free brochure.

EDELSTAAL, Dept. BG5, Tenally, N. J. 07670

Let Belsaw prove YOU can Earn Up To \$800 an Hour

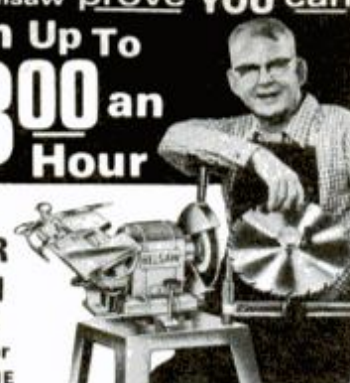

In YOUR OWN SPARE TIME or FULLTIME

SHARPENING BUSINESS!

On our 30-DAY FREE TRIAL OFFER

You risk nothing by accepting this offer to see how easily you can turn your spare time into big Cash Profits with your own Complete Sharpening Shop. No selling... no previous experience needed. Our famous Sharp-All and show-how instruction set you up to make \$200, \$500, \$700 a month CASH sharpening Saws, Knives, Scissors, Lawnmowers, Shop and Garden Tools... all cutting edges.

Send for all the facts! Our Free Book tells how to start a profitable, lifetime home sharpening business, how we help you grow, how we'll finance you.

Send for FREE details, mail coupon below or contact 310-44

BELSAW SHARP-ALL CO., 716K Field Bldg. Kansas City, Mo. 64111

No Obligation... No Salesman Will Call

YES, BELSAW, 716K Field Bldg., Kansas City, Mo. 64111, please send me the FREE BOOK that gives full details.

Name _____ Please Print
Address _____
City/State _____ Zip _____

WINDMILLS

Send \$1.00 (refundable) for our catalog which contains information on pumping windmills, towers, wind generators, hand & windmill pumps, repair parts, prices and more.

Our "Baker" windmills have been harvesting the wind for nearly 100 years.

O'BROCK WINDMILL SALES
Box PM 1
North Benton, Ohio 44449

GEM-CRAFT KIT

Complete Cabochon Diamond Compound Sanding/Polishing Kit to Fit your 1/4" Drill \$19.95 ppd.



Everything you need for sanding and polishing gemstones as the professionals do. Includes 2 sanding discs, 4 polishing discs, w pads, 6 syringes of diamond compound, extender fluid, compound roller, glue, sandpaper, shaft adapter and shank to fit 1/4" drill with instructions. Send check, M.O. or charge no.

RAN-CO Lapidary Products
19015 Parthenia St. — Northridge, CA 91324

GARAGE DOOR OPERATOR... \$99.95!



• RADIO CONTROLLED from car transmitter or wall switch • SAFETY night and day year 'round • SECURITY door locks tight when closed • CONVENIENCE in car control any weather • LIGHTING garage lights automatically • VERSATILE fits all lifting type wood, metal or fiberglass doors sectional and 1-piece • EASY HOME INSTALLATION in just 2-3 hours • SAVE up to 50% direct factory purchase and PP or UPS home delivery • GUARANTEED one year • FREE brochure

HELPMATE Equipment Co., Box 51PM Baroda, MI 49101

SWIMMING POOL

(Continued from page 125)

ter occurs when the filter is clogged with sediment and dirt from the pool. Best cure is to backwash it (reverse the flow of water) according to the manufacturer's instructions.

8. Use vacuuming equipment. Swimming-pool vacuum cleaners operate on the same principle as ordinary home vacuum cleaners except that water is drawn through the machine instead of air. Sediment and dirt drawn from the pool floor and sides are carried through the cleaner's piping for removal through the filter. If there is a large amount of sediment, the water should be discharged to waste instead. Try to vacuum your pool at least once a week. A brush fitted to the head of the cleaner will loosen particles that adhere to the bottom.

9. Don't forget the skimmer. Practically all pools have an automatic surface skimmer built directly into the pool or attached to the filtering system to remove leaves, bugs and other floating objects from the water. During filtration, surface water is drawn through the skimmer and into the filter, carrying off dust, oil film and other inert matter before it can settle to the pool floor. A basket strains off coarse material such as leaves or twigs.

Pool owners also should purchase a hand leaf skimmer for heavy-duty cleaning. This is nothing more than a plastic screen or net attached to a long pole. Keep one handy at pool-side and use it whenever there is an accumulation of leaves and other large floating matter.

10. Handle dry chlorine with care. Never mix calcium hypochlorite with anything but water. It should not be mixed or contaminated with any foreign substances, including household products, soap or paint products, solvents, acids, pool chemicals, vinegar, garbage, beverages, oils, pine oil or dirty rags. Always keep burning material such as a lighted cigarette away from any container of dry chlorine.

Store your chlorine sanitizer in a cool, dry place and keep it in its original container. Replace the cover and don't store it in any other container. Never reuse an empty container. Instead, wash it thoroughly and then discard it.

Always use a dry, clean cup to measure out doses of any dry, granular chlorine. Any contamination of foreign matter in the cup may cause fire. ★★★

IT'S LIKE GETTING EVERY FIFTH TANKFUL OF GAS FREE!

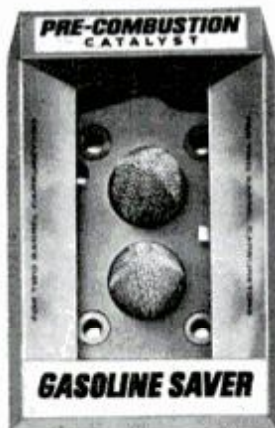

Install an MBI Catalyst and a unique engineering principle goes to work for you . . . it actually **ELECTRO-CHARGES** your gas so you can get up to **22% more mileage** from every gallon when installed as instructed.

You should know two facts from the start. One, the MBI Pre-combustion Catalyst is not a mechanical gimmick or gadget. It is a scientific device based on an exclusive design protected by a U.S. Patent.

Secondly, you should know its remarkable mileage economy has been proved by exhaustive, independent tests. Leaded gasoline is required. And normally, full economy is realized only after a break-in period of 1000 to 1500 miles following installation. Effectiveness reports from Scott Laboratory, national magazines, fleet and municipal users are available.

HOW THE CATALYST WORKS

What makes the MBI Catalyst so effective is its unique electro-chemical charging action.

You install the device between the carburetor and the intake manifold. It is a specially molded gasket incorporating two separate cone-shaped screens — one of cadmium fitting within another of nickel, with air space between.

As gasoline is injected, the dual screens give each drop a positive electrical charge, drawing it instantly to the negatively charged walls of the manifold.

On contact, manifold heat completely vaporizes the fuel so it enters all cylinders much more evenly than before.

HOW YOU BENEFIT

You get a totally clean burn. There are no rich or lean cylinders. Carbon build-up is prevented. Your gasoline burns with maximum efficiency. Hesitation, pre-ignition and dieseling are usually eliminated.

Your engine operates with smooth, even power all the time. So efficiently in fact that if your car now requires high octane gas, you can probably switch to regular leaded gasoline without knocking or pinging.*

Regular or premium, you can get up to 22% better mileage when the MBI Catalyst is properly installed, according to simple instructions in the package. That's like getting every fifth tankful **FREE**. Mail the coupon and start saving.

YES, I'D LIKE TO GET EVERY FIFTH TANKFUL FREE.

Send me prepaid the proper model MBI Catalyst for my car.

Name _____
Address _____
City _____ State _____ Zip _____
Car make _____ Model _____ Year _____

Engine size (cu. inches)	Carburetor make & number of barrels	
1-Barrel Models		\$23.15
2-Barrel Models		\$23.95
4-Barrel Models		\$24.75

Mail with check or money order to:

MBI Mo-Bile Industries, Inc.

244 NORTH RANDOLPHVILLE RD.
PISCATAWAY, N.J. 08854

*Note: The MBI Catalyst is not yet available for 1975 cars, which require unleaded gas.

BASEMENT TOILET

Flushes up to existing sewer or septic tank by powerful, self-contained pump operated by normal water pressure. No digging up floors. Clog resistant, easily installed. Make basement into game room, den, apartment with private bath. Financing available. Write for free literature. Dealer inquiries invited. SANDERS, Dept. J-25, Box 92102, Houston, Tx 77206.



Make Rubber Stamps for BIG PAY



Need more money? Earn \$60-\$70 a week, spare time, at home making rubber stamps for offices, factories, individuals. Hundreds of uses. Hundreds of prospects—everywhere. Right in your own community. Turn out special stamps for names, addresses, notices, prices, etc. in minutes with table-top machine. We furnish everything and help finance you, at less than bank rates. Write for free facts. No salesman will call.

Rubber Stamp Div., 1512 Jarvis, Dept. R-2-EM, Chicago 60626

Train for an OUTDOOR CAREER PARK RANGER

FREE BOOK tells how to train at home, in spare time for rewarding, responsible careers outdoors! Ecology/Conservation/Leisure Time explosion has created enormous shortage in trained men! Write! No salesman will call.

NATIONAL SCHOOL, Dept. 9110-075
Div. Technical Home Study Schools
Little Falls, N.J. 07424



FREE HUNTING KNIFE

When you send for our new catalog of knives, from all the world. Just send \$1.00 to cover postage and handling to:

MUNCIE KNIFE CO. P.O. Box 905, Muncie, Indiana 47305.
Include this ad for knife.

Repair any watch



... LEARN AT HOME

Unique Sweeney System develops your watch repair skills step by step at home in spare time. No previous experience needed. Low tuition. Free sample lesson and full information.

CHICAGO SCHOOL OF WATCHMAKING
Dept. 175, Fox River Grove, Ill. 60021

SECRET LOANS!

Borrow by mail in absolute privacy. Up to \$3000 from reputable company—founded 1897. No interviews. No co-signers. No mortgages. For full details write:

Dial Finance, Dept. 3382
340 S.W. 8th St., Des Moines, Iowa 50309

COUNTERFEIT GUNS

Authentic machined metal replicas of famous firearms disassemble like originals.

Precision machined metal models look, feel, weigh, disassemble like real guns—Over 20 hand finished parts. Perfectly legal —CANNOT be fired. Great for decorating den, office, rec. room. Send for free color brochure of 28 models of famous historical to modern military firearms. \$29.95



REPLICA MODELS Inc.
Dept. PM-7, 610 Franklin St., Alexandria, Virginia 22314
Send \$300 Add \$1.25 postage per model.
Enclosed \$ _____

NAME _____
ADDRESS _____
CITY _____ STATE _____ ZIP _____
 PLEASE SEND FREE FULL COLOR CATALOG.

HOW TO BECOME A LOCKSMITH

COMPLETE BOOK OF INSTRUCTIONS How To Fit Keys, Change Combinations, Master Key Locks, Keys By Number, Tools To Use, etc. Detailed illustrations. Satisfaction guaranteed. Get started! Order today. Only \$5 ppd.

A.K. Ancele, P.O. Box 69234, Los Angeles, Ca. 90069

PUMP DRAINS pools, cellars, laundry tubs IRRIGATES — CIRCULATES — SPRAYS

Heavy duty ball bearing pump. All metal, rust-proof Type XB. Stainless shaft. Use 1/4 HP or larger. 1 HP 1,200 GPH 60" high or 3,000 GPH 25" well. 5,200 GPH max. 1 1/4" in; 1" out. Belt or direct drive. \$17.95

Type P won't rust or clog. Bronze bearing. To 2,400 GPH. 1" in; 3/4" out. \$11.95
Ppd cash with order. Money Back Guarantee.

LABAWCO, Box 40, Belle Mead, N.J. 08502

AAMCO® And You Can Make It!

The world's largest transmission chain is still growing strong after eleven years. Over 500 of our franchises located from coast to coast. New openings in some markets mean you too might qualify. For further information write:

AAMCO Transmissions, Dept. 720
408 E. Fourth St., Bridgeport, Pa. 19405

LEARN SURVEYING AT HOME

U.S. Bureau of Labor Statistics predicts shortage of 50,000 civil engineering technicians (surveyors, etc.) by 1975. Send for FREE "SURVEYING CAREER KIT."
NAME _____ AGE _____
ADDRESS _____
CITY _____ STATE _____ ZIP _____
NORTH AMERICAN SCHOOL OF SURVEYING & MAPPING
4500 Campus Drive • Dept. 906 • University Plaza, Newport, Calif. 92660





engrave money (legally)

One dollar makes ten. Make profits up to ten times your cost—full or part time—right in your own home.

Engrave much needed nameplates, directories, signs, trophies, badges in plastic, metal and wood on the time-tested New Hermes Engravograph.

Simple to operate. It's tracer-guided. Engraving is a permanent business — not a fad — with small investment of less than \$450; money back guarantee. Trained representatives at your service.

Write for free illustrated catalog 10.

**new
hermes
engravograph**

20 Cooper Square, New York, N.Y. 10003
World's largest engraving machine manufacturer.

**5000 KILLED
300,000 INJURED
EVERY YEAR BY FIRE
PROTECT YOUR
LOVED ONES**

SEND TODAY FOR FREE
FIRE ALARM CATALOG

SAFETY ENTERPRISES
BOX 22021-P
MEMPHIS TENN. 38122

DO IT YOURSELF! **MAKE MONEY CUSTOMIZING VANS, CARS, CYCLES!**

See \$5555 doing your own work... make \$5555 customizing for others... spare time or full.

WE SHOW YOU HOW ... at Home, in Your Spare Time!

You don't need special talent — just tools and professional guidance. And, that's what you get. Tools you need, plus easy, step-by-step instructions.

LEARN CUSTOMIZING INSIDE AND OUT! Discover how to create wild scenic effects with air brush and decals. Install outside "add-ons" like portholes, scoops etc. Do interior upholstery, carpeting, make built-ins, etc. No obligation, no salesman will call. Get This **FREE Book!** Careers by Home Study. Write today!

Make Big Money CUSTOMIZING VANS, CARS, CYCLES. **CUSTOMIZING CENTER, Dept. PB065 4401 Birch St., Newport Beach, CA 92663**

'Pour' yourself a patio with plastic molds

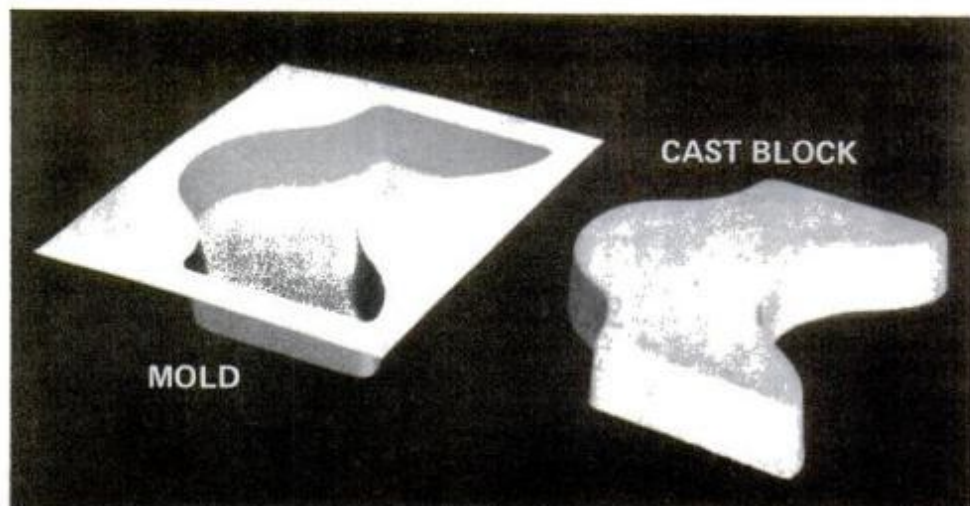

MOLD

CAST BLOCK

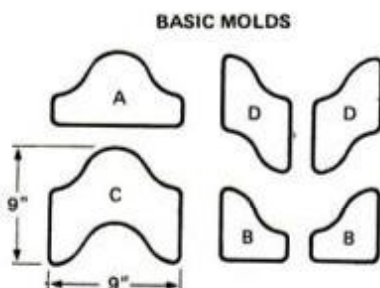

BASIC MOLDS

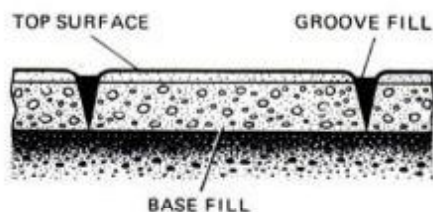

BASE FILL

Typical set of molds includes two of (A), two of (B), six of (C) and two of (D). To cast colored stones, the first 3/4-in. layer in mold is colored cement-and-sand mix. Mold shapes shown above produce interlocking pattern at right.

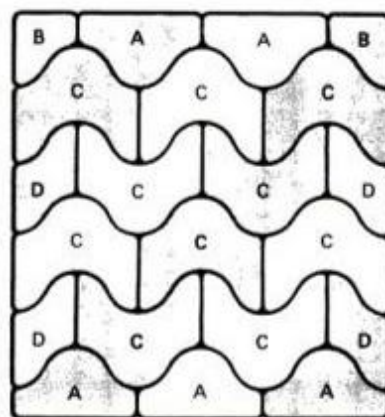

Plastic molds in various shapes and sizes provide a new way for the do-it-yourselfer to "pour" a patio or walk. It's done by filling the molds with concrete until you have enough paving blocks for the size of patio or walk you want. Then you lay them on a level bed of sand in an interlocking pattern and "caulk" the joints with cement, or leave open. You'll have fun doing it and end up with a one-of-a-kind patio that's a showpiece.

The reusable, one-piece flexible molds are first coated with motor oil, then filled with concrete containing fine and coarse aggregate. You let it harden in the molds, invert to lift out and let cure as you continue to cast and stockpile the molded shapes. With a sufficient number of molds, you can

fill 50 or so an hour, equivalent to 30 sq. ft. of area. Available in four different patterns, a set of 12 molds is priced at \$11.50 postpaid from Form-lite Products, 2 Hughes Ave., Rye, N. Y. 10580. ★★★



This attractive pattern is called Serpentine; each row interlocks with the other.

van square on. All I had time to do was put my foot on the brake, and the whole front end of my bus collapsed. It just collapsed. And the steering wheel broke off and broke my ribs. I'm lucky not to have been burned. People were smoking outside my bus."

A little later, also westbound but independent of Carl Marsch's segment, another series of rear-enders started piling up. A GMC tanker had topped in the right-hand lane, and I was hit by an International double bumper, which in turn was slammed into by a 1970 Chevrolet. Then came a 1973 Chevy and a 1969 Ford, all within a matter of seconds.

The '69 Ford caught fire when it was hit from behind by a 1962 Autocar diesel, and altogether there were about 20 cars involved in this pile-up. The driver of the Ford that burned asked not to be identified, so I'll call him Smith. When I asked him what he'd do differently another time, Smith told me:

"I'd do exactly what I did to save my own life. As far as avoiding the accident, I couldn't have. I was on a panic stop, skidding. The street surface was damp. I smacked into the Chevy but couldn't get out before the truck hit me from behind. It was a matter of five or six seconds. I was unable to turn off my ignition, I looked in the rear-view mirror, and when I saw the truck barreling up, I lay down on the front seat. The truck hit, and glass showered down on me. The car was burning as I climbed out. The gas tank had ruptured. I crawled out on the shoulder."

I asked Smith why he'd had the foresight to lie down on his front seat. "It was a conditioned reflex," he replied. "I've always thought about what I'd do in a situation like that. So since it saved my life, I couldn't do anything differently."

The semi that hit the back of Smith's Ford was a 1962 Autocar and truck piloted by Henry Gunn of Fontana, Calif.

"I'd stopped in town and asked another trucker how the fog was up ahead, and he said clear. But when I came to the fog, it was like somebody had drawn the shades. You couldn't see anything."

"I was doing 10 to 15 mph, but by the time I saw this red taillight, I'd already hit the Ford. I just ran up on it. It burst into flames, and since the Ford had already hit a Chevy that was resting up against another Chevy ahead, the Chevy in front of the Ford went up over the Ford. The Chevy came across my

radiator back to my windshield, and then it spun around to my left off on the driver's side and set back down on its wheels. My hood came off, and it was wedged between the corner of her [the Chevy's] windshield and my door.

"So I kicked my door open and went out across this woman's hood. She was getting out, and she started to faint. About that time this other truck hit the back of mine. So I grabbed her and tried to run to safety with her. We got out by the fence when I looked back at the car that was burning, and oh, it was smashed down flat. I was trying to look inside when a fellow walks up behind me and catches me on the shoulder and says, 'That's my car.' I said, 'Is there anybody else in it?' and he said no. They had some more fires up behind us."

Over in the eastbound lanes again,

"I stopped in town and asked another trucker how the fog was up ahead, and he said clear. But when I came to the fog, it was like somebody had drawn the shades. You couldn't see anything."

a 1975 Luv pickup driven by Richard Lynn Martin, a 25-year-old construction worker from Huntington Beach, went into the back of a 1967 Freightliner that had already landed as No. 6 in a chain of eight vehicles. Martin told me:

"I was going about 45 to 50 mph when I hit him. It 'did a number on' my truck. I wanted to slow down as fast as possible. I think the next time I'd just pull off into the center of the freeway—the median center divider—and just stop. The fog was so thick near Serfas Club Drive that I could stick my hand out the window and not see the fingers."

Another and much different answer to my question came from William W. Scherrer, driver of a 1970 Ford semi. "All of a sudden it was like somebody closed the door in front of you. I was in the far right lane—the truck lane—but there was no time to do anything except apply the brakes and hang on. I rear-ended the Marshburn truck, and a tanker just missed me. I couldn't have done anything differently, but there are things companies could do to make things safer. Like for instance, on our diesel engines, they have what

they call a 'Jake brake'—a Jacobs brake. It seems to me that if it were a law to have a Jake brake, a man would have a better chance of stopping that much quicker."

A Jacobs brake is applied to a diesel engine to make it a compressor when decelerating. A dashboard switch puts the Jake brake either on automatic, manual or off. Scherrer feels that while he probably still have hit the Marshburn truck, a Jake brake would have slowed him down sooner.

Trucker Monrad Byron Lindbergh felt that flares ought to be mandatory, because he and some other victims spent several minutes finding some. "I think amber four-way flasher lenses might be a good idea, too," he added.

Another victim suggested setting up big wind machines in the canyon to clear out the fog. One trucker said automatic signs like those now in use in Northern California—the powerful electric signs that light up when a sensor reads the dense fog—would help.

But most people said they'd simply pull off the freeway, stop and wait for the fog to lift.

The CHP estimates that 300 cars and trucks became entangled along this four-mile stretch. The total might never be known, though. One CHP report says, "Primary concern of officers at the scene was caring for the injured and clearing the roadway. Many involved parties were handed blank accident reports at the scene and advised to complete same and file with CHP at a later date. CHP was unable to get complete diagram of scene due to vehicles being moved to avoid more accidents."

Many victims simply exchanged insurance information and, if their cars still ran, drove away. Many more never bothered to fill out or return the CHP accident-report blanks. Only 135 filed actual statements.

By some miracle, no one was killed. The worst injury was a broken back. There were many lacerations and broken limbs, and a good number of CHP reports were taken at local hospitals.

By 11:00 a.m., the inner lanes, both eastbound and westbound, were clear enough so traffic could pass, and by that time the fog had lifted enough to make driving safe. By 1:00 o'clock that afternoon, all of the crippled cars and trucks had been taken away, and most of the debris had been cleared.

The Big One was over. ★ ★ ★

Henry Morgan says:

"If I can learn to fix my own appliances... you can too!"

"I have 10 thumbs . . . five on each hand. So fixing appliances hasn't been one of my strong points. But I saw an ad that said they could teach me all I need to know . . . at home, in my spare time. I sent for the NRI catalog on their course in Servicing Electrical Appliances . . . and it looked like a pretty good deal. Now that I'm into the course, I can tell you this: it's the only thing I've ever sent away for that was even better than they said it was!

Now I can thumb my nose at the repairman. I really can do it myself. Not just the toaster or mixer,



but the big stuff, too . . . like the washer, oven, even the lawn mower engine.

They give you everything you need. Bite-size lessons you can handle, with an experienced instructor ready if you need help. You even build the professional appliance tester that the pros use for trouble shooting and repairs.

The course is short, it doesn't cost very much, and you'll soon find yourself picking up spare time money doing repairs for other people. They even show you how to set up your own business, if you've a mind to.

Find out for yourself. Send for the free catalog. If I can do it, so can you."

Henry Morgan

RUSH COUPON FOR FREE CATALOG.
No Salesman will call



Please send me your free catalog "Servicing Electrical Appliances". 600-075

Name _____ Age _____
(Please Print)

Street _____

City _____

State _____ Zip _____

Approved for Career Training under GI Bill—check for information.



NRI SCHOOLS
McGraw-Hill Continuing
Education Center
3939 Wisconsin Avenue,
Washington, D.C. 20016

Accredited Member National Home Study Council

GET HOME WITHOUT GAS

(Continued from page 69)

if it looks as if you'll be swept around a bend, or are drifting or being blown in the wrong direction.

A powerboat becomes a not-very-manageable sailboat the instant the engine stops and a breeze is blowing. If it can push you home, raise a canvas top, floorboards, a blanket on paddles—anything that will catch the wind. Use paddles, oars or boards over the side, as well, to help you steer; your outboard skeg or inboard rudder needs propeller wash to be effective.

And don't be surprised if a rescue helicopter hovers right over you if you are quite near shore. The pilot knows his down draft blast can blow you toward land. But again, if you are alone offshore and the wind is moving you out, anchor and wait for a wind shift.

Your anchor doesn't reach the bottom? Lower it anyway. Its drag will slow your drift speed, and should catch the bottom before you get blown into shoals and trouble. Lower your anchor at night in deep water for the same reason. Rig an anchor light as high as possible if you will be napping while you drift.

Paddles or oars are required a-board small powerboats in some states just for no-power emergencies. But the modern outboard or inboard is no rowboat, and you can sometimes end up with a heart attack if you try to paddle it to shore. In shallows, a long push-pole is better. Experiment, but if a paddle doesn't seem to help, use it as a makeshift rudder as you drift instead. Old-timers used a long oar for sculling, and workboat hands in the Bahamas and down through the Caribbean still do. If you have mastered this tricky art, and have a transom notch to hold the oar, you'll be in luck.

Getting a tow back to port is more difficult than it might seem. Although traditions of the sea require you to render assistance to a vessel in distress, there was a time when experienced boatmen were reluctant to offer a tow. A towline might break or tow bitt pull out and the rescuer find himself blamed (or sued) for damages or injuries.

Now a "Good Samaritan" ruling protects a boat coming to your aid. But you must still have a good strong towline and bitt or cleat to secure it to, and stand and keep passengers clear of the line in case it should snap. Remember that you must steer your boat to help the towing craft, and signal if you are being towed too fast—a frequent

mistake. A sailboat, particularly, should be towed at a very moderate speed; the mast usually makes a good sound post to secure the tow-line to.

Care must be taken not to over-run or ram the boat ahead when it slows down. A wise boatman has a sharp knife handy to cut the tow-line in an emergency, while hoping that this dangerous maneuver will never be necessary since a cut or broken line under strain can lash around when it first parts. Sailboats with wire rigging often carry bolt or wire cutters to clear away the damage when a mast breaks.

When towing a boat with an inexperienced helmsman aboard, or none at all, there can be times when wind and wave conditions will make the boat wander and yaw from side to side. One answer is to rig a bridle with lines to each side of the boat in tow. Forming a V back from the transom of the tow boat, these will help the disabled craft track in a straight line astern.

A little worthwhile practice with a friend can teach you a lot about towing and, like a man-overboard rehearsal, is excellent training on a quiet afternoon. It takes little time to run through the proper routines for handling emergencies you hope you'll never meet.

Don't be surprised if a rescue helicopter hovers right over you if you are quite near shore. The pilot knows his downdraft blast can blow you toward land.

Finally, there are alternatives to your main gas engine. Don't overlook the new little electric trolling motors as a standby if you have a battery aboard. The passage home may be a long, slow one, but these small underwater fans can ease along a sizable craft. A tiny gas outboard, fueled in an emergency with barbecue lighter fluid or lantern fuel, can also push a big hull inshore to a more protected anchorage until help comes along. Even small sailboats and outboards often mount a transom bracket for an even smaller emergency outboard motor that they carry as a spare. And big powerboats frequently rig a way for their generator engine to drive the propeller shaft if the engine goes out.

Running out of gas afloat is unpleasant, and usually due to exceptional carelessness. But it does not have to be a "peril of the sea" if you have planned what to do. ★ ★ ★

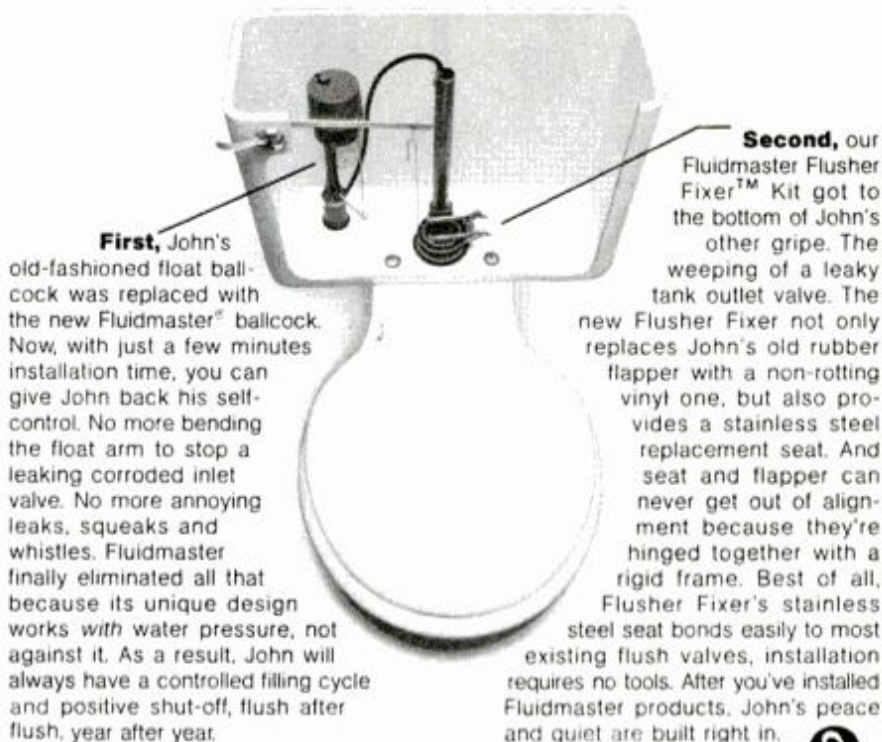

FLUIDMASTER, INC.
1800 Via Burton, Anaheim, CA 92805

Before Fluidmaster, John was a pain in the ear.

POWER ACTION ACCURACY



NOW—FOR THE FIRST TIME "A NEW INNOVATION IN GOLF"

A tested and proven golf aid to eliminate the most common errors of golf, slicing, hooking, swaying, hitting from the top and hitting behind the ball.

All professional golfers advocate keeping the weight on the inside of the right foot on the backswing and pushing off the right foot on the downswing, giving your game greater power and accuracy.

This stated by the pro's to be the one difference in your game and theirs, but literally impossible before POW—ACC to concentrate on and achieve.

POW—ACC keeps the right knee flexed, forcing your weight to the inside of the right foot on the backswing, enabling you to push off the right foot on the downswing.

POW—ACC forces you to be more powerful and accurate golfer.

Three aluminum, sturdily constructed magnetic discs that attach and remove easily in seconds from spikes of outer right golf shoe.

Order now—only \$5.95 plus 30c handling and postage.

Send check or money order to
A. M. CORTESE
P.O. Box 229—Dept. 6PM
Northfield, Ohio 44067 (Pat. Pending)



INTRODUCTION TO REFRIGERATION

a technical home study course covering fundamental principals and practical applications of domestic and commercial refrigeration. The course includes instruction with 16 personally graded correspondence lessons. The cost, including text book, is \$70.27. We have offered courses since 1891 and have many to choose from.

UNIVERSITY OF WISCONSIN-EXTENSION

Departments of Engineering, Mathematics & Applied Sciences

432 North Lake St. Madison, Wis. 53706

Please send me complete details on your REFRIGERATION course

NAME _____
STREET _____
CITY _____ STATE _____ ZIP _____

When the chips are down, it's beautiful

Plain window glass takes on a decorative sculptured look when it's glue-chipped.

by John P. Reid



Post lanterns, lampshades and skylights are a few of the many decorative uses for glue-chipped glass. Glass is cut to desired shape before chipping.

Once a secret process, now a neglected art, glue-chipping glass is both fun and fascinating. The decorative sculptured patterns you create on the glass surface are never alike; you never know what you'll get. Patterns may resemble ferns, feathers, sunbursts, fish scales, flames or clouds.

The basic process is simple. A film of old-fashioned animal glue sticks to etched glass with a bond stronger than the glass itself. The glue shrinks as it dries and sets up stresses. Triggered by a temperature shock, the glue shatters and tears thousands of tiny chips from the glass in random patterns.

Animal glue is sold as ground

glue in paint and hardware stores and as glue size in art-supply stores. You will also need 80-grit silicon carbide or Alundum abrasive powder from lapidary supply houses or hobby shops catering to amateur telescope makers.

For each 40 square inches of glass, sprinkle a tablespoon of glue over two and a half tablespoons of cold water in a kitchen measuring cup. Set aside to swell.

Pieces of glass are etched in pairs. Sprinkle water and abrasive powder on one piece and place the other on top. Rub the two pieces together, changing position and adding fresh abrasive, until both are uniformly etched on one side. Wash with clear

water and dry. Do not touch the etched surface.

Next, set the measuring cup of glue in the top of a double boiler containing water in both halves. Heat slowly and stir until the glue just dissolves. Now pour glue over the carefully leveled glass until it flows to the edges. Let cool and dry. Slow drying will give you the best results.

The chipping action may begin spontaneously when the glue is dry so wear safety goggles from this step on. But a temperature shock is usually needed to start things. Arrange a way to warm the glass in an enclosure to about 105°F. by the heat of a light bulb. After an hour at this temperature, chill the glass by setting it outdoors in winter or in an iced picnic cooler in summer. In a minute or two the chipping action will start. It may take a second heating-cooling cycle to finish the piece.

This is the basic process for glue-chipping glass for lanterns, lampshades, skylights, bathroom windows, tabletops or whatever. Every piece will not be a success so make extras and choose the most interesting. But each new piece will be a surprise. That is half the fun.

Every 19th century manufacturer of glue-chipped glass had his own methods. Here are some variations you might like to try after you have mastered the basic process.

- Wash newly chipped glass in trisodium phosphate, rinse, dry and chip a second time. This produces double-chipped glass, a better diffuser of light but less interesting.

- When glue is gelled but not yet dry, harden it by dipping for several minutes in 37 percent formaldehyde diluted 30:1. This makes large chips and wide, sweeping patterns.

- Add substances to the glue that will crystallize but have no chemical effect. Photo hypo crystals were used in one secret process. ★ ★ ★



1. Etch glass surfaces by rubbing the two pieces together after sprinkling their surfaces with abrasive and water.



2. Pour melted animal glue over etched glass. The glue should not be overheated and the glass must be level.



3. As glue dries it shrinks and "shatters" and tears off tiny chips of glass, leaving sculptured-looking surface.

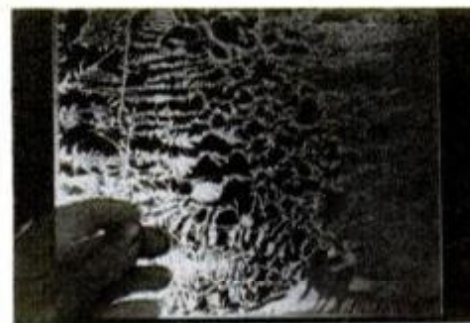

4. Although flakes are actually torn from the glass, the resulting surface details are rarely sharp and thus safe.

THE IDEAL JOB?

Many INVESTIGATOR-ADJUSTERS feel they have it. Interesting, challenging work, freedom, car expenses. Without obligation, find out if you can qualify by training at home. No salesman will call. UNIVERSAL SCHOOL (homestudy) Dept. 8110-075 Little Falls, NJ 07424.

Start your own part or full time

MONEY-MAKING BUSINESS

Every home and building offers you potential income. Clean wall-to-wall carpeting, upholstery and walls on customers' premises with Von Schrader professional cleaning equipment. Work part time or full time. No fees, no contracts to sign. You own your equipment. Proven reliable and profitable for thousands of users. Enjoy a steady, growing business with Von Schrader Detergers—and we'll help you every step of the way. Write today for full information.

VON SCHRADER CO., 1076 Pl., Racine, Wis. 53403



Only \$4.98
NO MORE
DIM
FLASHLIGHTS

Finally! A powerful 50 watt 12 volt that lets you see what you're doing. Just clip it to your battery and instant brightness all around your car. Hooks to almost anything to free both hands. Built strong to last long. ORDER NOW AND GET 2 FREE BULBS. 15 FOOT CABLE LIGHT \$4.98. 2 FOR \$9. 25 FOOT CABLE LIGHT \$5.49. 2 FOR \$10.

ADD \$1.25 FOR POSTAGE AND HANDLING. WICKS CO., 51 BUCHANAN PL., BRONX, N.Y. 10453

**USE ZIP CODES
WHEN ANSWERING
ADS**



GRANDFATHER CLOCK

Made of 3/4 inch Solid Walnut. Completely assembled and finished. Movements, carries 1 year warranty, 8 day weight driven, by skilled German Craftsmen. Strikes Westminster Chimes, 4 on 1/4 hour, 8 on 1/2, 12 on 3/4, and 16 on hour. Height 76 inches, Width 17 1/2 inches, Depth 10 1/2 inches. Free Brochure. Regular price \$399.95, Sales Price \$359.95. Offer good for 90 days. Satisfaction Guaranteed.

Georgetown Grandfather

Clocks

P. O. Box 325

Georgetown, Georgia 31754

"SAVE YOUR HEART" with a STAIR-GLIDE®



stairway elevator RENTAL PURCHASE Program Available

Installs easily. No marring walls. Shipped from factory in 4 days. STAIR - GLIDE®... #1 selling stairway elevator!

WRITE FOR FREE BROCHURE AND NAME OF DEALER NEAREST YOU.

AMERICAN STAIR-GLIDE® CORP
4001 E. 138th, Dept. PD775
Grandview, Mo. 64030

BUILD YOUR OWN CAMPER!

SAVE UP TO 50%



SEND 25¢ FOR DETAILS



5th Wheel Plans	\$12.95
Cover basic frame, electric, plumbing, (general construction)	
Camper Plans	5.95
Pickup Cover	3.95
Travel Trailer	4.95
Econoline Type Van	4.95
Pass. Bus or Delivery Van	4.95

EQUIPMENT CATALOG

Send \$1.00 postage, handling (Refundable)

VIKING CAMPER SUPPLY INC.

99-8P Glenwood Ave.
Minneapolis, Minn. 55403
Please send _____ for which I enclose \$ _____
NAME _____
ADDRESS _____
CITY _____
STATE _____ ZIP _____



LEARN MEAT CUTTING

Train quickly in 8 short weeks at Toledo for a bright future with security in the vital meat business. Big pay, full-time jobs—HAVE A PROFITABLE MARKET OF YOUR OWN! Time payment plan available. Diploma given. Job help. Thousands of successful graduates. OUR 52¢ YEAR! Send NOW for big new illustrated FREE catalog. No obligation. G.I. approved. NATIONAL SCHOOL OF MEAT CUTTING No. 01977 Dept. 50-W, Toledo, Ohio 43604

At Last a New Amazingly Simple

GAS TURBINE JET ENGINE



Build from easy to follow plans. Length 15", Dia. 8 1/2", Wt. 15 lbs. Fuel: Gasoline or Kero.

"Screaming Demon" develops 20 H.P. Ideal project for serious-minded hobbyists, students, scientific and industrial arts classes. Make on 5" metal cutting lathe with milling attachment. For use on small racing boats, model cars, etc. Full size assembly drawings with critical dimensions, bill of materials and photos. Price \$5.00. No C.O.D. SAVOY SCIENTIFIC, BOX 1398, SANTA MONICA, CALIF. 90406



THIS LABEL SAYS MORE

Popular Mechanics is far and away the acknowledged authority in the ever-expanding field of do-it-yourself activity. Our readers know the Popular Mechanics tradition of total involvement with leisure equipment, workshop accessories, tools, home and car care supplies—in virtually every area in which do-it-yourself products play a vital part. That's why, when you, the PM reader, see this Product Feature Mark on any product, anywhere, you know that product is a solid member of the growing family of products featured within the advertising pages of Popular Mechanics—a magazine devoted to serving the dedicated do-it-yourselfer for over 73 years.

The Bargain Hunter

LIMITED TIME SALE

SAVE MONEY.
DO-IT-YOURSELF
KIT.

Baroness Curio Cabinet

5'8"H x 12"D x 27"W
Model 12F completed
13 1/2" front and sides

\$99⁵⁰
Regularly \$119.50

Compare finished model at \$395.00

- Solid one-inch Honduras Mahogany
- All mortises and tenons pre-cut.
- All hardware, drawings and easy to follow illustrated instructions included.
- Each piece may be ordered separately. (Glass, mirror and light fixture not included).



Personal checks accepted



Finished models and partially assembled kits available. Write for free color brochure.

Baroness Curio Cabinet Co.

Dept. 4 • P.O. Box 9122
156 Noel Avenue • Mobile, Al. 36609
Visit our plant in historic Mobile.

EXTRA MONEY

'30 to '50
A DAY

Operate a community sharpening service with an investment of \$150. Work from your basement or garage. Our manual guides you in professional methods of grinding, of business promotion and in pricing your work.

- Hand Saws • Circular Saws • Knives • Chain Saws
- Scissors • Pinking Shears • Clipper Blades
- Planer and Dado Blades • Mower Blades

John Rodock says: "Thanks for shipping Model 331. It has paid for itself many times since I purchased it. Please send latest price list on grinding wheels."

TREYCO P.O. Box 216-A
North Tonawanda, N.Y. 14120

START NOW...WRITE TODAY



BUY GOV'T SURPLUS SAVE TO 85%

FISH/WORM SHOOKER

4713 W WALL
Cast Iron
Over \$11.00
\$7.95

• ITEM #475 - Harvest worms without digging. One or two pounds of worms. Fold worm comb and lift out. 110-VAC. Creates powerful electrical field in ground of water. Ideal for experiments.

DIAL TELEPHONES

4713 W WALL
4713 W WALL
\$7.89

• Ideal for use as extension phones, private phone systems, etc. Work on any commercial system. Reconditioned, work like new. Choice of wall mounting or desk. (4713) 1 up (4713) 2 up

POCKET 20,000 OHM/VOLT 14-RANGE MULTIMETER

4713 W WALL
\$13.95

• ITEM #423-101 - Precision tester. Has ground 2-terminal movement. Range: AC DC volts, 0.5-25-125-1000 DC Ohm 2-50, 2-210 ohm Resistance 2-500-5 meg 20-amp center scale. Includes manual 20 to plus 22. With test leads 41" x 31" x 1"



1000's Of Bargains In Gov't Surplus. Excess Inventory, Factory Clearance, New Small Home Appliances • Radios • Watches • Power Plants • Pumps • Surveying • Telephones • Electronics • Tools • Air Compressors • Gear Motors • Many Others.

SURPLUS CENTER PM-075 Lincoln, Nebraska Zip Code 68501



PORTABLE STEAM CLEANER

Steam in 60 seconds
CLEAN:
Engines, Air Filters, Lawn mowers. 3 year guarantee on fire box, coils. Uses liquid soap, propane fired. Weight 120 lbs. Auxiliary pump required on low water pressure.
WEDCO MFG. INC., Dept. M-6,
Box D, Jackson, Wyo. 83001

IMPORTED LOCK BLADE KNIFE

ONLY \$275 each

9" Overall Length
5" When Closed

- Opens instantly
- Sharp and Tough
- Stainless Steel Blade



Flips open instantly and locks automatically to prevent accidental closing. Razor sharp tough stainless steel blade for reliable use and hard, long service. Money back in 5 days if not satisfied. Send \$2.75 plus 25¢ to cover postage and handling.

WESTBURY SALES CO.

P.O. BOX 434, WESTBURY, N.Y. 11590
DEPT. L-7-PM

GRANDFATHER CLOCKS

SAVE 50%

BUILD YOUR OWN FROM OUR SEMI-ASSEMBLED CASE KITS

We are the ONLY producer of COMPLETELY HANDCRAFTED semi-assembled clock kits! Major assemblies carefully fitted and joined by experienced cabinetmakers. (No power tools required.)

- Highest quality imported German movements
- Tubular or rod chimes
- Moving moon dials
- Kits for wall & mantel clocks available
- Templates & case plans

Send 50¢ for complete catalog

H. DeCOVNIK & SON,
194 Market Plaza
P.O. Box 68, Dept. M-75
Alamo, Calif. 94507



DUNE-BUG

Complete plans & specs on how to build or buy - disc, prices on parts, kits, engines, & raw material.



Send \$2 for DUNE-BUG pkg. to:
Box 987M7, Azusa, Ca. 91702,
Ph (213) 334-0334

DISCOUNT SALE \$9.95

AIR PISTOL \$7.95

(WITH FREE CAN OF PELLETS) PFD
IMPROVED MODEL. Built to last a lifetime. Shoots both pellets and darts. This fine, well made .177 cal. German air pistol is just the ticket for target or varmints. Accurate. No CO2 cartridges to replace, either. Once in a lifetime bargain. Order several. Only \$7.95
Secret Leather Holster, \$2.95 ppd. • 400 Deluxe Pellets, \$2.48 ppd.
20 Deluxe .177 cal. Steel Darts, \$2.00 ppd.
AIR PISTOL, Dept. PM-7
4535 Huntington Dr. So., Los Angeles, Calif. 90032



FREE!

HIT ALBUM by Your Favorite Top Star

12" Stereo LP, Cartridge, or Cassette
Worth up to \$7.98 at Regular Music Service prices
Choose from 140 hit albums by stars like John Denver, Elvis, Charley Pride, Charlie Rich, Three Dog Night, Carpenters, Fiedler/Boston Pops, etc. Send for FREE Selection Certificate and album list. Nothing to buy - no obligation. Enclose \$1.25 now for postage & handling. RCA Music Service, Dept. 6PV, P.O. Box RCA 1, Indianapolis, Ind. 46291.
Pay only postage & handling

A YEAR'S INCOME IN 6 WEEKS

BLACKJACK PLAYERS
Use my unbeatable, quickly-learned system to earn over \$50.00 on HOUR in any casino. Play relaxed. No cards or charts to memorize, and IT WORKS!
• 30-DAY FREE HOME TRIAL •
You must be satisfied 100%. No obligation. Get a deck of cards and try it. You'll be amazed.
FREE DETAILS VIA AIRMAIL
MEL GRANT, Dept. 278
324 So. First Street Alhambra, CA 91802

MAKE \$25 to 100 PER HOUR

BADGE-A-MINIT, a complete badge making system lets you make permanent metal pin back badges for fun or profit.
Badge parts cost pennies, you sell slogan buttons for up to 75¢ each, photo buttons for up to \$2.50 ea. Get FREE illustrated money making plans by return mail, or send \$34.95 plus \$1.75 for shipping to RPM Assoc. Ltd., Box 618, Dept PM-75, LaSalle, Ill. 61301



THROTTLE-SPEED CONTROL \$18.95 P. PD.

A quality manual speed control at the lowest price. You can enjoy luxury driving and benefit from a terrific 15% saving on gas. Safe, system will not operate if electrical system or headlights burnout. Just a touch of the illuminated switch turns it on. A touch of the brake pedal releases it. 45 min. installation time, out of the way on engine-side firewall. Guaranteed. Fits all 12V. cars and trucks. Send to **PERFORMANCE**
Box 129 Westport, Mass. 02790

110 VOLT A.C. GENERATORS

60 cycles, 3000 watts. Wt. 27 pounds, 5"x10" Fanbelt driven from car or pickup. Operates T.V. All power tools. Over 13,000 in service. This is our 25th year. Guaranteed 6 months. \$115.50 Postpaid while supply lasts. Our X1200-watt generator needs no battery. Special price—\$95.00 Postpaid.
Viriden Perma-Bilt, P.O. Box 7160 PM,
2821 Mays, Amarillo, Texas 79109

ClassMansShip

from Elite Enterprises
690 E. 1st Street Dept. PM775
Lakewood, Colorado 80521

Laser 917

The ultimate in a GT sports car kit. Take a VW chasis, combine it with your choice of power - VW, Porsche or Cobra, turn on the LASER 917 kit of steel chassis and steel axles in the most unusually designed street sports car of the times.
Fit to Sport! See Paul FREE* to place your order.
Name _____
Address _____
City _____ State _____ Zip _____
* Enclosed a \$2.00 for your catalog
* Enclosed a \$10.00 for catalog and assembly manual (Refundable on purchase of kit)
* This information included with \$10.00 catalog and manual

FREE WINDPOWER HEAT

cuts fuel bills, beats shortages. New, enlarged encyclopedic windmill/generator report deals not in theories, plans or experiments, but gives sources, capacities, specifications, instructions and actual costs of equipment you can buy today.
Only \$2.98. Also Henry Clews' authoritative Electric Power from the Wind: \$2. Both for \$4.49. And famous Dwyer precision portable wind speed indicator: \$6.95. All three \$9.98. Shipped postpaid promptly on MONEY BACK GUARANTEE.
ENERGY UNLIMITED, Dept. 507
219 Thorndike St., Palmer, Mass. 01069



NEW **FUEL ATOMIZER GASKET**
 —More than pays for itself in gas savings.
 —Easier starting under all conditions.
 —More complete burning of fuel.
 —Smoother running engine.
 —Faster acceleration—Less pollution.
 —Less spark plug fouling.
 —Less wear and tear for starter.

Send (cash, ck., mo.) 30 Day Money Back Guar. (No C.O.D.)
 Specify: MAKE, MODEL, ENG. SIZE

EKONO COMPANY—PM7
 4594 Bedford Avenue
 Brooklyn, New York 11235

1 BARREL \$ 8.95
 2 BARREL \$ 9.95
 4 BARREL \$10.95

Tax where applicable

ROUTER BITS
 HIGH SPEED STEEL, CARBIDE TIPPED, SOLID CARBIDE, FORMICA TRIMMERS, PILOTED; ETC.
 Professional quality tools at lowest cost through mail order. What others call special, we have in stock. Send \$2.5 for catalog and price list to:

TECHNICUT TOOL SUPPLY
 P.O. Box 233, Newbury, Ohio 44065

"OUR FOUNDRYETTE" BLAST FURNACE
 SINCE 1935
 Hobbyists, Schools, Inventors, etc. Make your own castings of any metal from cast iron, down to lead and zinc. Available in sizes from 1 1/2 to 285 lbs. RED BRASS. Complete units furnished with all sizes. Send 25¢ for circular.

KANSAS CITY SPECIALTIES CO., INC.
 Dept. P-7, P.O. Box 193, Middleton, Wisconsin 53562

AMAZING NEW ELECTRIC ARC WELDER \$14.99!
 Twice as big—better—more power welds, brazes, solders, cuts all metal! Use any 110 volt house plug! In Multitask, Build-repair, most anything for cars—factory—home. Complete ready to use with kit of steel, bronze, carbon welding rods—Bix-eye shield—automatic arc torch, welding instructions—no experience needed!

Send ONLY \$2.00 (cash, ck., mo.) and pay postman \$12.99 plus COD postage or send \$14.99 for PP Del in USA. Lifetime burnout guarantee—10 day money back free trial! Now, save and make money. Order yours today! Midway Welder Dept. KPM-7, Kearney, Nebr. 68847

PLANS AND INSTRUCTIONS FOR

Go Kart	\$2.00
Mini Bike	\$2.00
Mini Car	\$3.00
Pedal Boat	\$4.00
12" Sail Boat	\$4.00
Snowmobile Sleigh	\$3.00
Mini Jeep	\$3.00

Mini Vehicles Plans Dept.-C
 Chazy, N.Y. 12021

You Don't Have to BE BALD!
 Is there a simple, inexpensive, easy way to stop hair loss and promote new hair? THE ANSWER IS YES! Here in one concise book are all the needed facts—the truth that will not only save you money, but will help SAVE YOUR HAIR. Guaranteed! SEND ONLY \$2.95 (plus 35¢ postage & handling) to:

INSPIRATIONAL BOOKS
 2300 Benrus Blvd., Dept. P San Antonio, Texas 78228

SAVE ELECTRIC POWER!
 Save up to 80% electrical power with this unique, inexpensive, portable, permanent and legal method applicable for shops, homes, factories, businesses, farms, sites. 100% Refund Guaranteed if not scientifically sound or if it employs gimmicks.

Information \$1.00

CONSUMERTRONICS CO.
 P.O. Box 1399 Alamogordo, N.M. 88310

110 VOLT "PLUG-IN" YOUR TRUCK OR CAR!
 Mounts Under Dash or Hood in 10 Minutes—Has Off-On Sw., Voltage Ind., Lights Up To 4000 Watts—110 Volt DC Power from car Alternator. Home Carpenter - Farm - Builders - Tools - Lights - Heaters - Drills - Saws, Starters, Car, Quik Chargers - Welds - Brazes, Solders.

Send ONLY \$2.00 (cash, ck., mo.) and pay postman \$12.99 plus COD postage, or send \$14.99 for PP Del. in USA. Complete Ready To Use With Speed Control—Full Instructions. One Year Service Warranty—10 Day Money Back Trial—Ideal for pickups—All Cars—Campers—Hush order.

WESTERN ELECTRONICS, Dept. PM-7, Kearney, Nebr. 68847

DRILL YOUR OWN WATER WELL

With this low-priced outfit you can drill your own water well at a cost of about 12¢ per foot! Also, this unit can be operated horizontally to drill free-flowing springs in hillsides. A big, fact-filled package and 24-page book "How To Drill Your Own Water Well" is just \$1.00 PPD. (Refundable) "WRITE TODAY!"

DEEPROCK MFG. CO.
 1001 Lafayette Pkwy., Opelika, Ala. 36801

FIX LAWN MOWERS
 FOR FUN & PROFIT! Fascinating new Handbook by F. Peterson gives you the knowledge skilled mechanics learn. OVER 125 ILLUSTRATIONS show how to trouble shoot, repair carburetors, engines, balance and sharpen blades, etc. Exploded drawings are extensively used.

INSTRUCTIONS COVER reel, rotary and rider mowers, preventive and routine maintenance, how to identify brand names, how to obtain replacement parts. How to buy and use a lawn mower. Friends gladly pay \$10 to \$50 to fix their lawn mowers. Try the HANDBOOK OF LAWN MOWER REPAIR. Rush only \$6.95 plus 50¢ handling on 10-day money-back guarantee.

EMERSON BOOKS, INC.
 Dept. 329B Buchanan, New York 10511

HAPPINESS PLANTS



(Cordyline Terminalis Kunth)

FLOWN DIRECTLY FROM HAWAII

This century-old Hawaiian Happiness Plant only has to be placed in water and it will begin to send out shoots which will develop into exotic foliage. After a period of development you can enjoy its satin green leaves, flowers & fragrance. The plant can grow up to 6 to 10 ft. in height. A lilac scented flower will appear from its center and small berries will appear that change from yellow to red.

2 Happiness Plants \$2.00 + .50 post. & handl.

Gary Evan Hawaii Nursery
 175 Fifth Avenue, Dept. MH7
 New York, New York 10010

JEEP OWNERS PICK UP OWNERS FISHERMEN HUNTERS

FREE 116 page CATALOG

Flotation Tires & Wheels
 Unique Camping & Equipment
 Set of 4 Tires & Super Wide Cepek Wheels only \$199.95

ARMSTRONG Tires

SEND TODAY INCLUDE ZIP CODE! FOREIGN CANADIAN & AIRMAIL REQUESTS \$1

Dick CEPEK 3201 CALIFORNIA AVE. Dept. 221 SOUTH GATE, CA 90280
 COPYRIGHT 1975 DICK CEPEK, INC.

Specials from Silvo
 (BRAND NAME) TOOL CATALOG



No. 9216 (old 315K) Rockwell 7 1/4" Heavy Duty Builders' Saw Kit—Contains: No. 215 (old 315) H.D. Builders Saw plus Rip Guide and Carrying Case. Specs: Speed 5800 RPM, 11.5 Amps, Cuts 2 1/2" at 90° and 1 1/2" at 45°. External gear lubrication. 100% ball bearing construction. Wrap around base. Auxiliary front blade shield. Depth and angle adjustment scales. Kickproof clutch. Light weight aluminum alloy housing. Blade included. UL Listed. Add \$4.00 for shipping weight of 24 lbs. Reg. \$101.95

9216-R7 P-24 lbs. Special—\$76.50

No. 215 (old 315) Rockwell 7 1/4" H.D. Builders Saw—See description above. Net weight of saw is 12 1/2 lbs., add \$3.00 for shipping weight of 16 lbs. Reg. \$89.95

215-R7 P-16 lbs. Special—\$68.50

No. 74 Millers Falls Mitre Box—World famous for quality, one piece cast iron bed and back for strength, Oilite bearing, saw guides, Graduated arc and index plate, travels freely from 45° to 90° right or left and locks at any angle (automatic locks at 0°, 9°, 22 1/2°, 30° and 90° right or left). Complete with 28" x 5" saw. Capacity 10 1/2" at 90°, 7 1/4" at 45° add \$6.00 for shipping weight of 37 lbs. Reg. \$157.45

74-M18 P-37 lbs. Special—\$99.98

10 Millers Falls

No. 300 — Millers Falls Hack Saw — Deep Throat Frame. Extra capacity 4 3/4" depth of cut for professionals. Blade tension lever for positive guide tensioning, adjustable for 10" and 12" blades. Four blade positions—ideal for left, right, vertical and flush cutting. Molded handle with hand guard. Blade included. Add \$1.00 for shipping. Reg. \$14.69

300-M18 P—2 lbs. Special—\$9.75



STANLEY

Stanley (set of 5) Nail Sets — 1/2 to 3/2" tip sizes—Square Head, Round Knurled Shank — Alloy steel hardened and tempered. Tips are cupped and chamfered. Square head prevents rolling. Tips are polished. Reg. \$5.47

1 1/4 Set-519 set of 5 \$3.95

Stanley Bench Planes — Made of finest iron castings—machined true—adjustable cutter—hardwood handles and knobs.

3-519 P—4 lbs. add \$1.10 — 1 3/4" Cut x 8" long—Reg. \$21.15 \$15.49

4-519 P—4 lbs. add \$1.10 — 2" Cut x 9" long—Reg. \$21.15 \$14.80

5-519 P—5 lbs. add \$1.25 — 2" Cut x 14" long—Reg. \$24.25 \$16.89

6-519 P—8 lbs. add \$1.60 — 2 3/4" Cut x 18" long—Reg. \$44.45 \$27.50

7-519 P—9 lbs. add \$1.75 — 2 3/4" Cut x 22" long—Reg. \$56.45 \$34.85

No. 15210 Stanley Mini Hack—10" long with blade—Uses regular hack saw blades or broken ones. Durable all steel frame. Does everything a big hack saw will do and more.

15210-519 Reg. \$2.69 \$1.90

SILVO (BRAND NAME) TOOL CATALOG

Thousands of Exciting Tool Values! Stanley, Skil, Millers Falls, Wellsaw, Dremel, Disston, Helios, Speedy Sprayers, Plumb, Kennedy, Huot, Rockwell, Channellock, Crescent, Vise-Grip, Ridgid, Unimat, Audel Books, Nicholson, General, Indestro, Xacto, Wiss, Pony Clamps, Wen, and many other Nationally Advertised brands of Tools & Supplies. We ship Coast to Coast at prices hard to beat. Send \$1.00 for our big 196 page tool catalog today.

Special extra discounts of 5% to 20% on quantity purchases on above special priced items and other items listed in our 196 page Silvo Tool Catalog.

SILVO HARDWARE CO.
 107 Walnut St., Dept. PM75, Phila., Pa. 19106

LOW COST Homes and Sheds



POLE BUILDING CONSTRUCTION

This one-of-a-kind book will save you money, labor, time and materials in building a small home, barn, or other structure. Involves limited grading, no excavation, flexibility in site, good wind resistance, few materials. Do it yourself with this clearly written book, illustrated with more than 60 special plans and drawings. 115 pp., oversized paperback, \$4.50 postpaid. Ask for **POLE BUILDING CONSTRUCTION**. Send to: **GARDEN WAY PUBLISHING CO.** Dept. 50197, Charlotte, Vermont 05445

MILITARY STUFF

5000 Products—All New! Mini-Medals, Patches, Flares, Insignia, Fatigues, Rings, Boots—50 Pages! Send 50¢ (refundable). Send \$1 for "AIR MAIL." **KEN NOLAN**, Foxhole 105, Irvine, Calif. 92705.

BURIED TREASURE

Locate from a LONG DISTANCE! with Ultra-Sensitive **DIRECTIONAL** Locator SEND FOR FREE INFORMATIVE BROCHURE

RESEARCH PRODUCTS
BOX 13441-AM TAMPA, FLORIDA 33611

RV KITS!

BUILD YOUR OWN & SAVE \$\$\$
CAMPER, COVERS, VANS, TRAVEL TRAILERS AND 5th WHEELERS
Plans & Full Size Patterns
WRITE FOR FREE CATALOG
GLEN L RVs
9152P Rosecrans, Bellflower, Ca 90706

"LISTEN IN" TO POLICE-FIRE RADIO CALLS IN YOUR CAR!

WORKS with ANY CAR—Portable or HOME RADIO! Just PLUGS in—No wiring—3 minute hookup! Switches instantly from regular radio to ALL POLICE-FIRE-EMERGENCY-TAXI-STATE-GOV'T 2 way radio calls! Works Everywhere—Anytime! Dual Band 36-48 & 150-175 MHz.
SEND ONLY \$2.00 (cash Ck M.O.) and pay postage \$12.00 (CD) post- age or send \$14.99 for PPD Del. in USA. COMPLETE with Antenna and Plug in to use with ANY Home or Portable Radio! Full instructions—1 year Service Warranty—10 DAY MONEY BACK TRIAL—SOLD ONLY Direct from Factory—
WESTERN RADIO DEPT. BPM-7 KEARNEY, NEBR. 68847

ORIGINAL W.W.II HELMET

(NOT A REPLICA) **\$19.95** PLUS \$2.00 POSTAGE & HANDLING

OVER 1000 ITEMS IN STOCK COLLECTORS! THE BEST BUY WE SELL!

Helmets, Uniforms, Bayonets etc. FREE CATALOG
UNIQUE IMPORTS, INC. Dept. PM1
610 Franklin St., Alexandria, VA 22314

• **BOBBE: "KUNG-FU MEDITATION"**—\$1.95.
• **"IRON PALM IN 100 DAYS"**—\$6.98. • **"SECRETS OF CHINESE KARATE"**—\$6.95. Many more.

• **MUNCHAKUS (KUNG-FU STICKS)**: Strongest construction, octagon, 14"—\$4.95. FREE Local shipping.

• **KUNG-FU TRAINING DISKS**: Attached FREE Training Lessons reveal secret self-training step-by-step. 19 special alloy disks—\$3.00.

• **KUNG-FU UNIFORM**: Hand made, Knot buttons, Freedom of movement.

Information FREE. Send money order to **MR. YANG, C&S Co., 2402E St. Charles Pl., Cinnaminson, NJ 08077**

INSTANT 110 VOLTAGE POWER ANYWHERE

for cars, campers, trucks, boats w/alternator runs all power tools, lites, heaters. NOT a junction box, but a rugged plastic case. Up to 5000 watts, 2 outlets, safety fuse, voltage lite, U.L. Approved. Install easily in minutes. Great for farmers, sportsmen & emergencies. Guaranteed for the life of your vehicle. ONLY 15.95 postpaid cash, check, M.O. Bank- American or Master Charge w/Exp. date.

KAL SALES, Dept. PM1 3375 Park Ave., Wantagh, N.Y. 11793

KARATE

JUDO-SAVATE
JIU-JITSU

THE GREATEST SELF-DEFENSE SYSTEM KNOWN TO MAN!

Learn-At-Home-Course reveals hundreds of deadly self-defense secrets, which will enable you to protect yourself from any attacker! Easy to learn! FREE COLORFUL BROCHURE REVEALS SELF-DEFENSE TECHNIQUES.

Send to: **UNIVERSAL, Dept. M**
BOX 39303 DETROIT, MICHIGAN 48239

NO GASOLINE!

Run your car, truck, tractor, boat or generators on wood scraps, coal, charcoal... almost any carbonaceous material! Proven in hundreds of thousands of vehicles during World War II! Guaranteed!

JEROME AMES
P.O. BOX 52, Dept. PM
DETROIT, MICH 48223

FREE DETAILS Write

SEEDS FOR THOUGHT

First the editors of Popular Mechanics assembled every bit of data a man needs to know to make his lawn, garden or house plant display the envy of his neighborhood... THIS YEAR!

Then they condensed and programmed these essentials and added twenty fact-packed charts and tables along with scores of show-how drawings. Then they printed this vital material on heavy, plastic coated stock (so it would be washable) and spiral bound and hole punched it so it could lay flat on a table, set up as an easel on his potting bench or hang on a wall.

Order your copy today!

Popular Mechanics Complete Gardening Guide
Box 1014, Dept. G-5,
Radio City, N.Y. 10019

Please rush _____ copy(ies) Popular Mechanics Complete Gardening Guide. I am enclosing my check or M.O. for \$4.49 postpaid.

Name _____
Address _____
City _____ State _____ Zip _____

Make checks payable to Popular Mechanics

HM Specialties
Материал, защищенный авторским правом

FREE FREE

FREE! POWERFUL MUSCLES FAST!

Fantastic New Discoveries in the science of bodybuilding. Add inches of powerful muscles to arms, chest, shoulders and legs. Secrets on trimming the waist with ultra-modern methods—fast! Results Guaranteed! Send for free brochure!

Universal Bodybuilding Box 485 Dept. M
Dearborn, Michigan 48121

VALUABLE COUPON

a self teaching BELT & WALLET MINI-COURSE.

The Belt & Wallet Mini-Course includes everything you need to make the projects as shown.

Regular \$9.95*
\$6.95 ONLY
with coupon

Save \$3.00 OFF

tandy
LEATHER COMPANY

(Please print)

*Prices subject to change without notice.

GOOD ONLY AT TANDY LEATHER COMPANY COUPON CONDITIONS

Mail or take this coupon to Tandy Leather Co., locations in most cities nationwide. When ordering by mail be sure to enclose local tax plus 95¢ for shipping. Limit one coupon per person. Not redeemable for cash and may not be used toward tax or postage. Coupon must be presented at time of purchase. Cannot be used in combination with any other Tandy offers.

WPMM Name _____
Address _____
City _____ State _____ Zip _____

OR you may order this offer direct from Tandy Leather Co., Dept. WPMM, 1001 Foch St., Fort Worth, Texas 76107. Send FREE Catalog

EXPIRES JAN. 31, 1976

CLASSIFIED ADVERTISEMENTS

Rate: \$2.65 per word payable in advance each insertion. Bold face capitalized words—75¢ per word additional (First word set in Bold Face at no extra charge, Zip Code Free). Minimum insertion ten words. To be inserted under proper classification, copy must be in our office by the 10th of the second month preceding date of issue. The next available issue to place an advertisement in America's No. 1 Classified Section is September. The closing date is July 10th. Send remittance and order to H. E. Kappel, Popular Mechanics, 224 West 57th Street, New York, New York 10019

Please make remittance payable to Popular Mechanics. . . . When answering advertisements please use the zip code number

AUTOMOBILES

SAVE Gas-Remove Smog Devices. Details \$3.00, Ross, Box 5607, Titusville, Florida 32780.

SANDBLASTERS, \$32.50—\$749.50. Free Catalog—Truman, 1330 Market, Youngstown, Ohio 44507.

"50 MPG Carburetors—Do they Exist? Free Details." Madison, Box 206-5, Berea, Kentucky 40403.

V-8 Runs on 4. Proven Simplified Method. Details \$3.00. Kinney, 2335 N. Milford, Highland, Mich. 48031.

PEDAL CAR. Revolutionary New Design. Fast, Light, Fun To Drive. Easily Built From Kit or Plans. Complete Brochure \$2.00. (Refundable). Pedal Engineering, Box 1648, Largo, Florida 33540.

33% OFF Delta CDI. Radar "Snooper", QI Lights, Gauges, Tools. Free catalog. Time Machines, 29M Falmouth St., Brooklyn, N.Y. 11235.

SAVE GAS PLUS MORE POWER With vapor injector. Free information, Box 53A, Colbert, Wash. 99005.

TOTAL RUSTPROOFING FOR YOUR CAR. Rust can be stopped indefinitely no special materials, tools or know-how required. Instructions \$3.50. Lloyd Schumann, RD4, Geneva, Ohio 44041.

REPAIR & RECHARGE AUTO AIR-CONDITIONERS Illustrated Instructions, ppd. \$5.50 - Ward, 101 Wilson, Hightstown, N.J. 08520.

MANUALS For Every American and Imported Car. Free Catalog, Carbooks, 181 Glen Ave., Sea Cliff, New York 11579.

SAVE GAS!! Increase mileage with the PIII! Auto Club and laboratory tested. Free details or send \$6.95 to Gas Saver, Box 914, Jamesville, NY 13078.

ADD PROPANE—BUTANE To Your Engine. Keep Gasoline For Reserve! FREE DETAILS. LPGas Automotive, Box 2253, Eugene, Oregon 97402.

HOT-POLAR: CRAZY Electronic Switching—12-volt D.C.—BATTERY AND GROUND Probe Test Light. Solid-State. \$12.95. DETAILS: Big Bear Electronics, 133 Skyline Drive, White Bear Lake, Minn. 55110.

AUTO SUPPLIES & EQUIPMENT

DISK BRAKE PACKER pack bearings without removal of wheels rotors calipers brakes lines. Trem Products, 7A Page Rd., Bedford, Mass. 01730.

"ALTERNATOR/Generator Rebuilding Book." Information: Hedlund Engineering, POB 5777, Las Vegas, NV. 89102.

REVOLUTIONARY Auto Air Conditioner You can build For About \$50. **SAVE GAS.** FREE Detailed Information. Space Age Research Co., Dept. PM7, Box 770, Columbus, Indiana 47201.

PARTS: Army jeep and truck parts. Spare Parts & Equipment Co., P.O. Box 751, Lexington, Kentucky 40502.

UNIQUE Ignit Continuously Monitors Ignition Performance. Q-Arc, Box 47876, Los Angeles, Calif. 90047.

SUN-ROOFS. Plexiglas. \$89.95 (Introductory Special non-electric normally \$129.95) Kit \$59.95, electric available, easily installed. Many models, literature. Write Sun-Air Sky-Roofs, Box 8A, Breese, Ill. 62230.

BURN Gasoline, Kerosene, Diesel, Alcohol. Increase Performance, Reduce Emissions. Kits \$5.00 up. Franchise's available. Power Genie, Box 872, Lancaster, Pa. 17604.

THEFT Proof Your Ignition. For All Conventional Systems. Hot-Wiring, Keys Useless! \$4.95. RB Products, Box 216, Forest Park, Illinois 60130.

RADAR Snooper, Auto Accessory Literature. Fletcher . . . 906M Lindale, Richardson, Texas 75080.

CHEVROLET Owners Original Equipment Name Brands 283-307-327-350 Hydraulic Lifters \$32.00 Set. Complete Engine Gasket Set \$14.00. Rod And Main Bearing Set Standard Size \$34.00. Chrome Piston Rings \$25.00. Timing Chain And Cam Gear \$15.00. Also 1/2 Inch Drive Air Impact Wrench \$55.00. Air Chisel \$19.95. Send Money Order Plus \$1.00 For Postage To: G & G Sales, P.O. Box 462, Rice Lake, Wisc. 54868. Add 4% Wisc. Sales Tax.

HYDRAULIC Jack repair kits parts and supplies. Catalog 50¢ (in coin). Hydraulic Jack Packing & Tool Co., Inc., General P.O. Box 3, Staten Island, N.Y. 10314.

STOP AUTO THEFT! Vehicles Cannot Be Started by "Hot Wiring", Master Keys, etc. Easily Installed. \$3.98 Money Back Guarantee! Give Vehicle Model. Neutronics, 11541 Strand, Dallas, Texas 75218.

MOTORCYCLES, BICYCLES, MOTORSCOOTERS, & SUPPLIES

PEPPY Electric Bicycle. Plans . . . \$3.96. Zeemco, 3621 North Wilton, Chicago, Illinois 60657.

MOTORCYCLES. Go-Karts. Tires, Accessories. Discount Catalog 25¢. Lorenzo, Danville, Illinois 61832.

AMERICAN INDIAN MOTORCYCLE COMPANY. WORLDS LARGEST Supply of Parts for AMERICAN INDIANS, 213-447-4078, 119 East Huntington Drive—Monrovia, California 91016.

HONDA, \$25.00. Other Bargains. Send \$1.00 (Refundable). Motorscooter, P443, Bend, Oregon 97701.

MOTORIZED BICYCLES—PLANS!!!! Electric, \$2.00 . . . Gasoline, \$2.00 . . . Both, \$3.00 . . . Guaranteed . . . Britt, 956 Springdale, Atlanta, Ga. 30306.

REPAIR BICYCLES For Fun and Profit. Send \$3.00 to Plaza Bike Shop, 1523 Woodside Rd., Redwood City, Ca. 94061.

WATER CUSHION for motorcycles. Ride farther with more comfort. \$24.95. JML Products, Box 3708-A, Dept. PM, Milwaukee, Wis. 53217. 1-414-352-8848.

BIKE RADIO with HEADLIGHT & HORN. 3 units in 1. Fits on handlebar—remove easily. \$18.95. S & W Enterprises, 1647 Arriba, Monterey Park, Calif. 91754.

TIRES NEEDED For 6 Wheel drive Amphi-Cat. Mariner, P.O. Box 89, Yarmouth, Maine 04096.

ILLUSTRATED Catalog, 25¢. Parts and Accessories. Custom and Stock. For Most Makes and Models. Motorcycle Supply, Box 159M, Fairbury, Illinois 61739.

GO-KARTS, Mini-Bike, 4 Wheel Bike Car, AND Ele-Bike. PLUS Learn to Weld Instructions. ALL For \$2.00. E.J. Sales, Box PM 3084, Centerline, Mich. 48015.

CAFE RACER Special Equipment From The Leader—Racer 1. Dynamite New 1975 Catalog. Send \$1.00. DCW1, 304 Agostino, San Gabriel, Cal. 91776.

SPACE, ROCKETS, ASTRONAUTS

ROCKET Building Publications. Catalog 50¢. Refundable. Rockets, Box 7274, Long Beach, Ca. 90807.

SECRET FORMULA Rocket fuel, plus plan for trial rocket \$1.00. "Kilco", Box 12, Leamington, Ontario, Canada N8H 3W1.

MOON PHOTO'S Other Space Souvenirs World's Largest Catalog. Free. Astroland Products, Box 234, Merritt Island, Florida 32952.

AVIATION

ALL About Ballooning. Handbook \$3.95. Aerostation, Box 141, Long Sault, Ontario, Canada K0C 1P0.

HANG GLIDING handbook . . . Completely Illustrated . . . Free Details!! Flight, 1819 W. Main, Dept. M6, Houston, Texas 77006.

AIRBOAT Propellers, Engines, Hubs, Mounts, Supplies. Corvair. V-W Conversions. Removable Airdrives. Catalog \$1.00. Banks-Maxwell, Box 3301E, Ft. Worth, Texas 76105.

ULTRA-LIGHT HANG GLIDERS From world's largest manufacturer. Unsurpassed quality & safety. Rogallo plans—\$5.00. Kits, Complete gliders. Free Rogallo & Icarus information. Free-Flight, 12424 Gladstone, Sylmar, California 91342.

BUILD—ONE-MAN JET HELICOPTER. Easy inexpensive. Detailed plans, drawings—\$5.00. Helicraft, Box 7153, Baltimore, Maryland 21218.

JET Engine Plans, Catalog, Builders Newsletter \$1.00. Doyle, Box 310, Montclair, New Jersey 07042.

HOVERCRAFT

AERO-CAR Amazing Hovercraft built easily with ordinary tools. Lawnmower engine power. Carries one man plus. Hovers, flies forward, backward, Sideways over land/snow/water. Complete construction plans and brochure. \$5.95. Aero-Projects, Box 5118PM, Clinton, New Jersey 08809.

HOVERCRAFT Plans All Sizes Tested Designs Catalog \$1.00. Universal Hovercraft, 1204 Third, Cordova, IL. 61242.

POWER BREEZE—World's most popular ACV. Plenty of photos and complete plans \$5.00. Box 4304, Panorama City, California 91402.

BOATS AND TRAILERS

BOAT KITS, HULL KITS, FRAME KITS, PLANS & PATTERNS. World's Largest catalog, over 300 modern designs for the amateur in fiberglass, plywood, strip planking, steel, aluminum, cement, from 7 to 70 feet. **SAIL**-Prams, Day Sailers, Motor Sailers, Ocean Racers Trimarans, Catamarans. **POWER**-Cruisers, Trawlers, Run-a-bouts, Fishing Boats, Kayaks, Inboard & Outboard Hydroplanes, Tunnel Boats. Also complete boat-building materials, sails, fiberglass, plywood, etc. Send \$1.00 for catalog or \$2.00 for catalog plus boat-building guide to Clark Craft, 16-P, Aqua Lane, Tonawanda, New York 14150.

FIBERGLASS BUILDER'S MATERIALS. Lowest factory prices in cloth, mat, roving, resin, epoxy, foam, bronze nails, plywood, mahogany. Send \$1.00 for literature or \$2.00 for literature plus booklet on mold making and "How to" fiberglass. **CLARK CRAFT,** 16-P1 Aqua Lane, Tonawanda, New York 14150.

FREE Catalog, Kayaks, Canoes, Plans, Kits, 36 models. Outdoor Sports, Box 1213-P, Tuscaloosa, Ala. 35401.

NEW 1974 Outboards Top Brands . . . 6 H.P. \$365 . . . 15 \$530 . . . 40 \$685 . . . 50 Electric \$998 . . . 70 Electric \$1200. All Sizes. Evinrude-Scott-McCulloch-Parts. Handling \$1.00. Electra Marine, 610 Merrick Road, Lynbrook, N.Y. 11563.

BOAT BAILER: Automatic: "DRAIN CHECK". Fits popular transom drain tubes. \$6.95 At your dealers; or, add \$1.50 P.P., Handling. Write: De PERSIA, Grand Haven, Michigan 49417.

BOAT Kits. Molded Fiberglass. Save money-assemble yourself. Factory molded sections bond into one-piece craft. 20 models-14' to 32' Cruisers, Runabouts, Sailboats, Accessories, motors, trailers, Easy terms, Free catalog. Luger, Dept. BC-75, 3800 West Highway 13, Burnsville, Minnesota, 55337.

BOAT PLANS, FRAME KITS, FULL SIZE PATTERNS Especially for amateurs. Easy, proven methods, step-by-step pictorial instructions. All boat types 8' to 49'. Sail - Power - Inboards - Outboards - Jets - Houseboats - Cruisers - Hydroplanes - Trawlers - Catamarans - Ski Boats - Tunnel Hulls. Also fastenings, fiberglass, rigging, hardware, sails, spars, boat trailer plans. "How-to" Books. Send \$1.00 for HUGE NEW 120-page catalog plus FREE "Boatbuilding Supplies" brochure. Glen L, 9152P Rosecrans, Bellflower, CA 90706.

CANOES! Kayaks! Factory Direct quality kits, from \$30.00. Many different models. Canvas, hulls. Strongest construction materials. Free literature. Sportscraft, Box 636-P, Allentown, New Jersey 08501.

FIBERGLASS Cloth and resin. World's finest cloth and non-run resin, at direct mill prices. Complete line of plastics, silicon bronze and brass screws, save 60%. No sales tax. Boat Plans. Catalog 25¢. Stiles Boat Supply, Box 11P, Linden Ave., Mantua Heights, N.J. 08051.

FIBERGLASS Canoes, Kayaks, and Duckboats. Many exciting models. Easily assembled kits. \$49.95 up. Free literature. Riverside Canoes, Box 5595P, Riverside, Calif. 92507.

FISHING/SURFING/SAILING/POWER DORIES. BROCHURE. PHOTOS: 40 PLANS \$1.00 AIR MAIL \$2.00. TEXAS DORY BOAT PLANS, BOX 720, GALVESTON, TEXAS 77550.

FIBERGLASS Cloth, Matt, Polyester and Epoxy Resins. Wholesale Catalog and Boat Molding Book \$1.00 (Refundable). Seifert's, Box 1206-M, Green Bay, Wis. 54302.

HYDROPLANE PLANS—Hedlund Racing Boats, top designs for Stock Outboard competition. Send self addressed, stamped envelope for brochure. Hedlund Marine Sports, 515B Green Bay, Wilmette, Illinois 60091.

TUG-BUG, New-Unsinkable-simple-safe. Swimmers and divers tow and safety marker float. Battery powered electric motor with 12 lb. thrust. Weighs 16 lb. without battery, fits in car trunks or back seats. \$95.00 FOB without battery. Commercial Pallet-Pak, Co., 123 Truxton Ave., Ft. Walton Beach, Fla. 32548.

SAILMAKING. Step by Step \$3.00. Bowen, 64 Huddleston, Scarborough, Ontario M1L 4L2.

CAMPERS AND TRAILER KITS—PLANS

RECREATION VEHICLE KITS, plans, and full size patterns. Build your own camper, pickup cover, van conversion, fifth wheel, travel or camping trailer and **SAVE!** Dozens of models for domestic and import vehicles. Prepaid freight special. **HUGE** illustrated catalog includes RV equipment. Send \$1.00 (refundable). Glen L, 9152P Rosecrans, Bellflower, CA 90706.

MARINE EQUIPMENT AND SERVICES

MARINE Engines, conversions, parts, equipment. Catalog Free! Stokes Marine Industries. Coldwater, Michigan 49036.

CONVERT Auto engines to marine. 68 Page Catalog, 50¢. Lehman Manufacturing Company, 800 Elizabeth Avenue, Linden 4, New Jersey 07036.

ATHLETIC AND BODY BUILDING COURSES

KUNG-FU! Learn from Disciple of Bruce Lee (Kato). Details 25¢. Galaxy Enterprises AAG, Box 2176, Northlake, Illinois 60164.

WEIGHT Exercising Equipment, send 25¢ to cover postage for illustrated catalog. Exercising Equipment, P.O. Box 662, Holyoke, Mass. 01040.

DYNAMIC MUSCLES! FAST! No Gimmicks. Free Illustrated Brochure. Inquire: Goliath Enterprises, Box 933f-PM, Wheeling, Illinois 60090.

MUSCLE!!! New Illustrated Bodybuilding Catalogue —25¢. 18483 Brady, Redford, Michigan 48240.

ARMS, 18+ INCHES IN 90 DAYS Or Refund!! Revolutionary Arms Specialization. \$3.00—Complete!! (Karate—Free Information) Phenoministics, Box 2810, Gresham, Oregon 97030.

SPORTING GOODS AND EQUIPMENT

"HANDMADE EARLY AMERICAN WALKING STICKS Polished Walnut Finished Wood With Polished Brass Head. A Friend On Your "WALK FOR HEALTH" \$8.95 Postpaid. Mary McMahon, 789 Wiggins Ferry, Creve Coeur, Missouri 63141."

ARCHERY Lowest Discount Prices. All top brands. Orders shipped same day received. Money-back guarantee. World's Largest Supplier. Free catalog. Anderson Archery Corporation, Grand Ledge, Michigan 48837.

FREE CATALOG. Fishing Tackle, Archery, Hunting and Camping Equipment. Lowest Prices. Cabela's Inc., Dept. S757, Sidney, Nebraska 69162.

HUGE Sportmans Catalog low direct factory prices, fishing, hunting, archery, reloading, camping. Send \$1.00 Refundable. Heters Inc., Dept. CPM, Waseca, Minn. 56093.

TRAMPOLINES — Kits 6' x 12' \$129.00 literature; Trampkits, 10560 Eagle Dr., Jonesboro, Ga. 30236.

PERMANENT MATCH Lighter, Unbelievable, strikes like match, \$1.00 Postpaid. W. Bole, Dept. 17, R1, Box 277, Vicksburg, Michigan, 49097.

POPULAR MECHANICS SAFETY PONCHO. Heavy-duty Poncho of 100% Virgin Vinyl, imported with **POPULAR MECHANICS** Trademark and with its own Handy Carry Pack! Twenty-Four Self-Sticking Scotchlite Reflectors Included. (They Reflect the Headlights of Cars for Night Safety). Incredible for Camping, Cycling—Any Outdoor Activity! Only \$4.95 p.p. PM Poncho, Dept HE, Box 1014, Radio City, N.Y. 10019.

CAMPING EQUIPMENT & TENTS

POCKET Purifier, Cups of Drinking Water Instantly, Lifetime Guarantee! Free Brochure. Herrco, 67 So. Farnham, Dept. 6C, Galesburg, Illinois 61401.

FISHING, TACKLE, LURES

NOT JUST ANOTHER FISH STORY! The amazing LURA Fishstick can help you put fishsticks on your table. Powerfully scented paste for luring fish comes in a retractable lipstick-style cartridge. Rub the paste on your lure. Will not wash off in either fresh or salt-water. The 3½ inch long cartridge sells for only \$3.95 each, 2 for \$5.95 p.p. Money back guarantee. Want to catch fish? **ORDER TODAY!!** Falconer House, Dept. F4, Box 88240, Indianapolis, Ind. 46208.

FANTASTIC Price on Berkley Dew Flex monofilament. ¼ pound spool just \$1.00 plus .25¢ postage & handling. =4, 6, 8, 10, 12, 15, 20, 25, 30, 40 lb. test. Send for **FREE** Hunting, Fishing, Camping Catalog. All nationally advertised brands at lowest prices. Charter Oak Distributors, Inc., Dept. PMC75, 50 Walnut St., Middletown, Ct. 06457.

WHY Pay More? Krafty Fish Caller Only \$8.75!! Creative, 737 Orchid, Plantation, FL 33317.

FINNEY FERRET—World's only guidable lure. Performance guaranteed. Details free. VanHorn, P.O.B. 452, Crystal Lake, Illinois 60014.

EARTHWORMS, LIVE BAIT

EARN Money raising fishworms for us! Exciting details free! Oakhaven—56, Cedar Hill, Texas 75104.

FREE Literature. Profitable Business Raising Fishworms, Crickets. We Teach you how to Raise and Sell. Write today. Carter Fishworms, Plains, Georgia 31780.

HUNTING, GUNS, DECOYS

PELLET GUNS and accessories. Sensible, enjoyable shooting anywhere. Finest adult models; satisfaction guaranteed. Free catalog. Write Air Rifle Headquarters, Grantsville, WV 26147.

POULTRY & GAME BIRDS

QUAILS, Incubators, cages, supplies catalog. Marsh, 14216 Brookhurst, Garden Grove, Calif. 92643.

HAWKS, FALCONS

INTRODUCTION To Hawking, an Illustrated Guide to Falconry. \$5.00. "Hawking," P.O. Box 580, Davis, California, 95616.

RABBITS, CHINCHILLAS, FUR BEARING ANIMALS

\$300-\$700 MONTHLY. Raise Rabbits, Laboratory Animals for us. We supply Equipment, Breeders, Instructions. Details 25¢. MP11 Rabbits Of Michigan, Countyline Road, Pentwater, Michigan 49449.

RAISE Chinchillas. Guaranteed income. Illustrated catalog \$3.00. Refundable. DeShon Chinchilla, Route 2H, Roanoke, Indiana 46783.

\$500-\$1000 MONTH Plan raising rabbits for us. Free details. White's Rabbitry-PM, Hudson, Ohio 44236.

AMAZING PROFITS!! \$10,000 Yearly Raising Rabbits for Wool and Breeding. Send \$1.00 for Details. American Angora, Malta 12, Montana 59538.

RAISE Rabbits successfully by knowing facts. 25 cents for 64 page illustrated book describing 25 breeds, housing, breeding, feeding, markets and marketing. American Rabbit Association, 36 Arba Building, Bloomington, Illinois 61701.

PETS—BIRDS, CATS, HAMSTERS, ETC.

PETS, Reptiles, raccoons, skunks, squirrels. Catalogue 25¢. Trails End Zoo, St. Stephens, S.C. 29479.

SPECIAL Numerous exotic pets—land Hermit crabs. Can live out of water. \$4.95 pair. Shipped airmail Prepaid. Guaranteed live delivery. OCEANS OF LIFE, 1747 N.E. 45 St., FT. LAUDERDALE, FLORIDA 33334.

HORSES, LIVESTOCK

"HOW TO TRAIN HORSES—FREE Book tells how to break, train, make money with horses. Beery School, 1107, Pleasant Hill, Ohio 45359.

ELECTRICAL SUPPLIES

ELECTRIC MOTOR SUPPLIES! Equipment Plans! Modequip, Box 7266, Kansas City, Missouri 64113.

ELECTRONICS

FREE! Bargain Catalog—I.C.'s, LED's, readouts, fiber optics, calculator parts & kits, semiconductors, parts. Poly Paks, Box 942PM, Lynnfield, Mass. 01940.

BATTERIES, GENERATORS

BATTERY Reconditioning Kit, includes molds, material, instructions. Apex Engineering, 3100 Ramona, Atascadero, California 93422.

ENGINES, MOTORS, MAGNETS

MOTORS, shaded-pole gear, 110-V., 7 RPM, ideal for slow-moving displays, \$16.50 postpaid. Way-Mar, P.O. Box 164, Hartsdale, New York 10530.

WINDING Data. 275 motors, \$1.25. Data Company, 512 Kensington, Kansas City, Mo. 64124.

REWIND Car Generator for 110 VAC. Power Plant Plans \$2.00. Schmauss, 1228 East Cass, Tampa 33602.

RUN Three Phase Motors on Single Phase! Three Methods! New Illustrated Manual. \$3.00 Guaranteed! Lindsay, Box 12-C, Bradley, IL 60915.

TOOLS FOR SALE

DREMEL, Atlas, Maximat, Unimat, Toolkraft, X-acto, Foremost, etc. Priced For Your Pocket. Catalog \$1.00 Refundable. Visit our Showroom. Tools Unlimited Inc. PM, 2106 Union Boulevard, Bayshore, New York 11706.

MACHINERY, TOOLS, & SUPPLIES

4" METAL Cutting Lathe \$54.50. Taig, Dept. D, 15048 Proctor, Industry, Calif. 91746.

500 SOURCES Tools, Supplies, Books. \$2.00 Craftsman's National Resource Directory, 4216-V Telegraph, Oakland, Cal. 94609.

UNIMAT Lathes-Maximats-Metals-Micrometers. Catalogue \$1.00. Campbell, 1424 Barclay, Springfield, Ohio 45505.

SMALL FOUNDRY furnaces. Supplies. Free literature. Pyramid Products, 3736 South 7th Avenue, Phoenix, Arizona 85041.

1000 CATALOGS Listed and Described! Sources for EVERYTHING Imaginable! Rush \$2.00. MASTERLOB, Box 24413-VS, Oakland, California 94623.

MILLING Cutters, lathe milling attachments. Catalog \$1.00; Potter, Box 73, Cedar Rapids, Iowa. 52406.

12 GROSS Small Machine Screws Mixed-\$6.95 Nuts, Bolts, Screws, Washers, Assortments, Catalog 60¢, Nutty Co., 1576SMS, Fairfield, Conn. 06430.

BANDSAW BLADES. Any Size. Free catalog. Parker, R4, BX735, Sonora, Cal. 95370.

POWER TOOLS—Coast to Coast at prices hard to BEAT. Rockwell, Skil, Milwaukee, Stanley, Miller Falls, & many other top quality lines. Send \$1.00 for catalog today. Also qualify for our special of the month sales for one year. Doro Sales, Inc., 926 Little East Neck Rd., West Babylon, L.I., 11704, Dept. 1.

PLANS, Tube bender, Press, Break. Info., P.O. Box 56, Campo, Calif., 92006.

ABRASIVE BELTS BELOW WHOLESALE on 100 belts or more. Tell us length, width, grit required. SCHAFFNER'S, PM775 SCHAFFNER CENTER, PITTSBURGH, PA. 15202.

BUFFING & POLISHING

ABRASIVE Belts, abrasive flapwheels, buffing compound, buffing wheels. Wholesale catalog and how to use. \$2.00 Refundable first order. Schaffners, PM7 Schaffner Company, Pittsburgh, Pa. 15202.

WELDING, SOLDERING, PLATING

ELECTROPLATING Equipment, Portable Platers, Supplies, and "Know-How." Build your own tanks for nickel, chrome, etc. Easy-to-install PVC liners. Rectifier components—all sizes. Schematics, parts lists, formulas, operating instructions for all-plating. Guaranteed to save you 25%-75%. Some good used units for sale. Free Details. Platers Service Company, 1511-PM Esperanza, Los Angeles, California 90023.

GOLD PLATING. Household Equipment—Sample \$2.00. Bowen, 64 Huddlestone, Scarborough, Ontario M1L 4L2.

GOVERNMENT SURPLUS

FREE! Nationwide Surplus Data List. **WRITE TODAY!** NATIONWIDE AUCTIONEERS, Box 872PM, Anoka, Minnesota 55303.

"U.S. GOVERNMENT SURPLUS DIRECTORY." How, Where to buy 100,000 items (including Jeeps) . . . low as 2¢ on dollar! Most complete information available . . . \$2.00. **SURPLUS DISPOSAL**, Box 6586-AG, WASHINGTON, D.C. 20009.

GOVERNMENT SURPLUS, How and Where to buy in your area. Send \$2.00. **SURPLUS**, 30177PM HEADQUARTERS BUILDING, Washington, D.C. 20014.

1975 SURPLUS Army, Navy Store, 56 Page Illustrated catalog. Send \$1.00. Ruvel, 3037 North Clark, Dept. 7-J, Chicago, Illinois 60614.

JEEPS \$52.40. Airplanes \$75.01. Typewriters \$6.70. Boats \$7.50. Typical Bargains Available Nationwide. Sales Directory And Surplus Catalog \$1.00 (Refundable). Midwest Surplus, Box 401-PM, Dayton, Ohio 45401.

JEEPS!!! PICKUPS!!! 100,000 items direct from government. Your area. Latest information & surplus categories: \$2.00 **MONEYBACK GUARANTEE.** Order manual =150, from "Dependable Products", Box 113, Vista, California. 92083.

JEEPS From—\$52.50; Typewriters from—\$4.15; Cars from—\$31.50. Walkie-talkies, motorcycles, airplanes, boats. Typical "As Is" bid bargains from Uncle Sam. Tremendous variety. Exciting free list. Write Enterprises, Box 402-X114, Jamaica, New York 11430.

HOW TO MAKE MONEY ON GOVT. SURPLUS Send \$1.00 to: Compo House, Dept S, 20 Clark's Hill Ave, Stamford, CT 06902.

GOVERNMENT LANDS FROM \$7.50 ACRE! Vacating, Farming, Investment! Exclusive "Government Land Buyer's Guide" . . . plus "Land Opportunity Review" listing lands throughout U.S. Send \$2.00. Surplus Lands, Box 6588-AG, Washington, D.C. 20009.

GOVERNMENT Surplus Bonanza—Information! P.O. Box 502E, Pasadena, Texas 77501.

GOVERNMENT SURPLUS JEEPS! 100,000 other items. Order 1975 **DEPENDABLE** nationwide "How-Where" directory manual =867 . . . \$2.00 **REFUNDABLE** **DIRECT DISPOSAL**, Box 806-Z, Union, New Jersey 07083.

MAKE Money: Government Surplus—Complete information \$1.50. G&S Sales, Dept 7PM, 506 Augusta, O'Fallon, Ill. 62269.

HOBBIES AND COLLECTIONS

CLOCKMAKERS Supplies, parts, hardware. Complete pendulum escapements. Catalog \$1.00. Swisscraft, 974 Balmorel, Detroit, Mich. 48203.

COLLECT Military Medals. List 50¢. Vernon, Box 387PM, Baldwin, N.Y. 11510.

AUTOGRAPHS—Letters, Documents of Famous People, Bought and Sold. Monthly Catalogues issued. Neale Lanigan, Box 133, Fairview Village, Pa. 19409.

COLLECTORS! Original WWII German Helmets, \$21.95. Other military collectibles, Free Catalog. Unique Imports, Dept. PM, 610 Franklin Street, Alexandria, VA 22314.

SEA Shell Starter Collection. \$4.95. Allace, Box 628, Montreal, Canada, H3C 2T8.

"COLLECTORS SERIES" Airplanes, Automobiles, Railroad Prints Ready For Framing. Send \$1.00 For Catalog of These Beautiful Lithographs. "Collectors Series" PM, 161 W. Harrison, Chicago, Illinois 60605.

FREE Bargain list for Butterflies, Beetles, Seashells, Minerals, Collectors Wonderland, Dept. 15, Box 1170, New York 10008.

"APACHE"—Authentic Fine Stone Arrowhead Collections. 25-\$5.50, 100-\$15.00. Tribal Hall-S, Apache Junction, Arizona 85220.

DECALS, EMBLEMS, PATCHES

CUSTOM Designed Embroidered Emblems, Decals. Inexpensive. Free Catalog, details. Southern Emblem, Box 8PMB, Toast, North Carolina 27049.

DECALS—Wildlife—Dogs—Horses. Send—10¢ for Free Folders. PM, Tyler, 1301 Methuen Street, Dracut, Mass. 01826.

EMBLEMS, Patches, Beautifully Embroidered. Made To Order From Your Design. Low Cost, Fast Service. Free Catalog With Design Guide. Donalyn Creations, Box 247PM, Cliffside Park, N.J. 07010.

RUGGED DENIM CARPENTER'S APRON. **POPULAR MECHANICS** Shop Apron! Constructed of 100% Burlington Industrial-Weight Cotton with 3 Full-Depth Nail Pockets. Bright Yellow PM Imprint and Wrap-Around 21" Length. It's a Tough Utility Item for the Dedicated Do-It-Yourselfer! \$2.95 post paid. PM Apron, Dept HE, Box 1014, Radio City, N.Y. 10019.

STAMP COLLECTING

YOURS FREE! 40 RED CHINA Postage Stamps banned to American collectors for a generation by U.S. Gov't. Now at last you can legally own them; and these stamps are so worth having that experienced and beginning collectors alike want them—so act fast, because supplies are strictly limited! You also get 110 other stamps from Britain's Lost Empire plus illustrated Album to keep as a Bonus should you buy \$2.00 from our Approval Selection. Or return Album and 110 stamps with selection and buy nothing. Cancel service anytime. But Red China stamps are yours to keep! Send 10¢ for mailing while supplies last. Kenmore, Milford RC-154, New Hampshire 03055.

WOW! 110 ALL DIFFERENT GERMANY 10¢. Commemoratives, Airmails, High Values, B.G. Catalog, bargain lists. Also, fine stamps from our approval service, which you may return without purchases and cancel service at any time. Jamestown Stamp, Dept. A75PM, Jamestown, N.Y. 14701.

NOW 50 IRAQ 10¢ with Approvals. Box 307, Goshen, N.Y. 10924.

TRIANGLES! 25¢ with unusual approvals. Tradewinds, Box 489, Fern Park, Fla. 32730.

FIRST DAY COVERS Three Different U.S. Commemoratives With Beautiful Cachet \$1.00, Approvals. Crescenta Stamps, Box 405, Verdugo City, California 91046.

FREE! BIG BARGAIN CATALOG—NEW EDITION Listing thousands of bargains including U.S. & B.N.A. stamps, packets, albums, accessories and supplies. Also, fine stamps from our approval service which you may return without purchases and cancel service at any time. Jamestown Stamp, Dept. E75PM, Jamestown, N.Y. 14701.

1500 FOREIGN \$2.00; 5000 \$4.00. 1000 pre-1939 USA, contains dues, revenues, commemoratives, presidential, older issues, high values, etc. \$4.00; 4000 \$12.00. 300 pre-1941 USA commemoratives \$2.00; 700 \$4.00. No approvals. Meyers, 5321 Fleming, Richmond, California 94804.

FREE Mint British Colonials from Antigua, St. Christopher, Nevis, Sarawak, Turks, Caicos, Tristan Caymans, St. Vincent. Free with approvals. Viking, Great Neck, NY 11021.

FREE! 25 Worldwide to Approval Applicants. Weller, 34447-28 Yucaipa, Yucaipa, Calif. 92399.

100 DIFFERENT British Empire 10¢. Approvals. Gibson, Box 34, Lansdowne, Pa. 19050.

10 QUATAR Stamps Free—Approvals, W-B Stamps, Wilkes-Barre, Pa. 18703 Dept. PM

FREE Mint U.N. with approvals. Stamps Unlimited, Box 2295, Kalamazoo, Michigan 49003.

PHILATELIC property remainder clearance! \$40.00 worth of fine high value stamps, plus 1000 different miscellaneous unpriced postage stamps. All for only \$10.00. Order Now! Shipped first class registered. Money back guaranteed. Eric's Stamps, Box 1444-B, Kitchener, Ontario, Canada.

COLORFUL Miniature set of 8 only 10¢. Approvals. Gorliz, Box 76457 PM, Atlanta, Georgia 30328.

ANIMAL KINGDOM! Fifty Different—25¢. Pictorial Approvals Included. Edmund Molzan, Drawer 2276, Alameda, Calif. 94501.

65 DIFFERENT NUDES \$2.00, 80 Diff. \$3.00. No Approvals. Kemp, 9952 Tamarack, Pacoima, California 91331.

JAPANESE COMMEMORATIVES—pictorials. Mint complete sets cataloging over \$10.00 only \$2.00 with accompanying mint approvals. Satisfaction guaranteed. Pagoda, Box 132P, Sidney, Ohio 45365.

FOREIGN Approvals! Gigantic values! 3¢ each. ABC, Dept. 3301-A, Box 6000, San Francisco 94101.

FRANCE #1100—\$4.95 each. Israel—1974 Jerusalem Exhibition—3-S/\$4.00 Set. Limited Quantity. Want Lists Solicited Europe 1964 to date. Mint only. Franklin, P.O. Box 467-PM7, Jamaica, New York 11434. Money Order Only.

20 HISTORICAL U.S. Commemoratives 20¢. U.S. Approvals accompany. PINTO STAMP CO., Box 111, Park Ridge, Ill. 60068.

50 YEARS Old, fifteen different United States, over fifty years old—25¢ with approvals. Jaxon, Box 145-P, Brooklyn, New York 11230.

SINGLE STAMPS 2¢ and up. Mounted in books. TRUST STAMP COMPANY, P.O. Box 100-P, Jamaica, New York 11435.

FREE Surprise collection sent with approvals. Gould, 1784 Union, San Francisco 94123.

PENNY! Approvals! Regardless catalogue! Kloster, 4164 52nd St., San Diego, Calif. 92105.

BUILD Large U.S. Collection Economically. Sherman, Box 15355G, Philadelphia, Pa. 19111.

MYSTERY Packet. \$9.00 Catalog Value. Only 35¢. Stamps, Box 27, Fremont, Michigan 49412.

500 DIFFERENT Stamps, \$1.50. Smith, 508-A Brooks. College Station, Texas 77840.

100 OLD United States between 1861 and 1939. \$1.00. Ed Roush, 423 Shepard, Mansfield, Ohio 44907.

U.S. BARGAIN, 50 Different 25¢, with beautiful worldwide, approvals. Stamp Center, Kennebunk, Maine 04043.

RUSSIAN Space Collection 50¢, including Russian Approvals. Snedco, Waldwick, New Jersey 07463.

TEN Different Nudes: 20¢. Approvals. Stamp Farm, 2M80, Oxford, Wis. 53952.

100 DIFFERENT United States Commemorative, 50¢ with Discount Price List. Shelton, Box 547C, North Miami, Fla. 33161.

BETTER GRADE U.S., Canadian Stamps for advanced collectors. Borgen, Box 645, Seiad Valley, Calif. 96086.

SCARCE Guinea UN Airmails \$2.25, catalog 25¢. Approvals. Stampnaus, Box 533, Salisbury, Mass. 01951.

U.S. MINT Specials! Flag Set complete \$1.50. 1c. 2¢. 3¢ Famous Americans (21 different) \$1.50. Free List. Brooks, 2601 Avenue "U", Brooklyn, N.Y. 11279

"INVERTED Error!" Dag Hammarskjold, 10¢ with approvals. Belmont Stamps, Washington, D.C. 20015.

VIETNAM 25 Different 10¢ approval. Sam Chazen, Box 95, Ozone Park, N.Y. 11417.

110 DIFFERENT U.S. Commemoratives. \$1.00. Stamps, 7607 Larchview Drive, Dallas, Texas 75240.

50 DIFFERENT U.S. Stamps. Includes 1943 flag stamp of occupied nations. Only 35¢. Approvals included. Willett Co., Box 338-C, Yorktown Heights, N.Y. 10598.

EISENHOWER, TRUMAN or LYNDON B. JOHNSON Memorial Stamp on lovely, official, First Day Cover addressed any name of your choice. 60¢ each—all 3 for \$1.50. K. M. WALSH, Box 308AA, TUCKAHOE, N.Y. 10707.

PICTORIALS Collection! Fifty Different, 10¢, Approvals. Ross, Box 564-M, Yonkers, New York 10702.

WORLDWIDE 500 Different \$1.00. Nickel Approvals Accompany. Fies, Box A-6P, Thornville, Ohio 43076.

EXOTIC Sets, 100 Beautiful Stamps \$1.00! Approvals. Leonal, 2422 Ivy, McAllen, Texas 78501.

OLDER U.S. ON APPROVAL. SURPRISINGLY GOOD SELECTIONS FOR ADULT COLLECTORS. RIVERTOWN, BOX 188P, LOWELL, MICHIGAN 49331.

FREE Mint Philippines with Approvals. Chapmans, Box 487-P, Galesburg, Michigan 49053.

WORLDWIDE New Issues—Free Weekly Illustrated Lists. Brooks, 2601N Avenue "U", Brooklyn, N.Y. 11229.

WORLDWIDE Collection over 150 interesting stamps 10¢. Approvals Accompany. Casto, Box 927, Largo, Florida 33540.

LOOK: 300 Worldwide Stamps, 25¢ with Approvals. Scenic Stamps, Box 1973G, Vancouver, Wash. 98663.

STEEL STAMPS. Multicolored Paintings printed on USS steel foil. Mint set from Bhutan, 25¢. Topical Approvals. LeBlanc, Box 110P6, Glen Cove, New York 11542.

225 DIFFERENT Worldwide: 25¢. Approvals. Tibbets, 8675 Meadow, Downey, California 90242.

FREE New used Congo animal set. Approvals included. Alpaughco, Box 225, Highbridge, N.J. 08829.

GUARANTEED: Our selected stamp investments will increase in value or we will buy them back within five years. For Details Send \$1.00 (refundable). Fleming, Box 11225C, San Francisco, Calif. 94101.

OLYMPIC GOLD COIN STAMPS, 25¢. Beautiful mint set, embossed coin-shaped stamps from Sanda Island. Topical approvals. LeBlanc, Box 110-P10, Glen Cove, New York 11542.

ELUSIVE Mint 6.7 bulk rate Coil plus Bargain Lists only 10¢. Watson Stamps, P.O. Box 79, Tioga, Louisiana 71477.

WORLDWIDE Commemoratives. 25 Different 25¢. Approvals. Wilson, Box 116, Dollard des Ormeaux, Quebec, H9G-2H5 Canada.

FREE Lists! Discount prices. U.S. Plates, Singles. Scotco, Box 470855-PM6, Miami, Fla. 33147.

CANADIAN PROSPECTORS—Here's that **NORTHERN GOLD.** 200 different Canadian just \$3.84. RUSH your order. AINJILL'S, P.O. Box 746, Dearborn, Michigan 48121.

UNITED STATES, Japan, Foreign Approvals! Chariot, 12935 Duntun, Whittier, Calif. 90602.

50 SPORT PICTORIALS 25¢ with approvals. Arbour, 3727 Downey Dale, Randallstown, Maryland 21133.

CONQUEST Of Mars. Yemen's Latest Collection. 10¢ With Space Approvals. Potomac Stamps, Washington, D.C. 20015.

SEND Only 10¢ for nice collection of U.S. Stamps including \$5.00 issue and scarce mint Sipez Souvenir Sheet. Attractive price lists of other beautiful stamps and collectors supplies also included. MYSTIC STAMPS, Dept. SS-1, Camden, New York 13316.

GRAB BAG Of over 100 Unassorted stamps. Contains new issues, Asia, South Seas, Africa, etc. All for only 10¢. Littleton Stamps, Dept. EX-1, Littleton, N. H. 03561.

LIQUIDATING Collections, Lots, Accumulation. Bargain Lists Free. Alatalo, Maynard, Mass. 01754.

BEAUTIFUL 4 Sets—25¢. Approvals. Mohawk-A, Box 4002, Schenectady, N.Y. 12304.

50 DIFFERENT Old U.S. Revenue Stamps \$1.00. Winchester Stamps, Box 3592, Mansfield, Ohio 44907.

"WHOLESALE" U.S.—Foreign Pricelist and catalog Free! Everything Guaranteed. Schneider, Box 1240, Grand Rapids, Michigan 49501. "We accept Master Charge."

BARGAIN Approvals! Leader, 1052 Howie Avenue, Coquitlam, British Columbia, Canada V3J 1T6.

COINS, TOKENS, CURRENCY

4 BUFFALOS \$1.20—Or List 25¢. Rongo, 1265-81 Street, Brooklyn, New York, 11228.

BICENTENNIAL COLONIAL BANKNOTES Each dated 1776. Authentic replicas of original money. 7 different. They look and feel 200 years old. Ideal for framing. Send \$2.00 to Educational Enterprises, Box 4296, East Providence, Rhode Island, 02914.

\$\$\$\$ FROM Coin Collection! How to start Where To Sell. List Of Valuable Coins! Send \$1.00. Gift House, Dept. 7-M, 130 Corbin Ave., Jersey City, New Jersey 07306.

10 DIFFERENT Buffalo Nickels, \$4.00. Free Coin Catalog. Village Coin Shop, Dept. P, Plaistow, N.H. 03865.

COINS At Discount Prices! Free Brochure. Gene Carlton, Chandler, Okla. 74834.

SILVER DOLLARS Uncirculated. 1880-81—1883-84-85 \$10.00 Ea. Catalogue 50¢. Shultz, Salt Lake City, Utah 84110.

UNCIRCULATED Silver Dollar \$8.95. \$2 Bill \$3.95. Oz. Silver Bar \$6.95. Catalog 25¢. Coin Pocket, 342 S Central, Lawrence, N.Y. 11559.

FREE: Lists of Thousands of Stamps and Coins. No Approvals. Bryson, 612M White, Toledo, Ohio 43605.

1939 UNCIRCULATED Liberty Dimes, \$2.00. Michael Nelson, Rt. 1 Galaway, Cottage Grove, Wisconsin 53527.

INDIANHEAD And Lincoln Cents 1883-1949 33 Different \$2.99. Catalog 25¢. Edel's, Carlyle, Illinois 62231.

22 OLD Indian and Wheat cents, \$1.99. Coins, Ltd., Box 143-M, Canton, N.C. 28716.

COIN COLLECTORS! Clean, Polish, Protect coins like never before. Our products **GUARANTEED** to rejuvenate and protect coins from fading, rust, tarnish, corrosion. Perform **BETTER THAN ALL** comparable products. Non-abrasive, ideal for valuable coins, medals, etc. **METAL CLEANER**, for brass, copper, steel, aluminum coinage: \$4.49 ppd. **SILVER CLEANER**, for silver coinage: \$3.99. (Each polishes approx. 750 coins!) Robert Izzo, 1100 Ocean Avenue, Brooklyn, New York 11230.

NUMISMATIC SPECTACULAR! \$2.95 each! Large, two, three cent piece, shield nickel, ancient Rome. Matching free dollar value coin! Universal, Box 3223-P, Orange, California 92665.

INDIAN Cents 11 Different—\$7.95 23 Different—\$16.95 "S" Mint Lincolns before 1955 100 \$5.95, 500-\$25.00. Coins, 20929 Ventura, Woodland Hills, Ca. 91364.

INDIANS AND BUFFALOS FREE Buffalo Nickel with Indian Head Penny (over 65 years old) for \$1.00. Our catalog too. Superior Coin Co., Room 1112-A, 100 Fifth Ave., New York, NY 10011.

GRAB BAG Of coins from 25 countries. Only \$1.00. Money back if not delighted. Littleton Coins, Dept. DX-1, Littleton, N. H. 03561.

ANTIQUES, RELICS, INDIAN GOODS AND CURIOS

ANTIQUE Telephone. Illus. Catalog 30¢. Telephone Company, Turtle Lake, Wis. 54889.

INDIAN Relic list. Arrowheads \$4.00. doz. Folsom, \$5.00 each. C. Secrist, Deerfield, Missouri 64741.

SELLING 10,000 Indian Relics. Arrowheads, Knives, Spearheads, Scrapers, Etc. List Free. Lear's, Glenwood, Ark. 71943.

CIVIL WAR MINIEBALLS—Guaranteed Authentic With Battle Description, Suitable For Framing, Send \$3.00: Civil War Relics, Box 158, Duluth, Ga. 30136.

GENUINE antique, science engravings. Framed. \$8.00 each. Klein Galleries, 139 E. Arch, Mansfield, Ohio 44903.

MODELS—CARS, SHIPS, TRAINS, PLANES, ETC.

"VETEMOBILE" Mobile, 6 colors. 6 body styles, '53-'75. Free swinging 'Vettes, each over 5" long. Ready to hang. \$4.50. Unassembled, \$3.75. Includes postage. Philmobile Company, Dept. P.M., P.O. Box 6686, Providence, R.I. 02940.

SHIP MODEL Kits, Plans, Fittings from our own Workshop. Big Illustrated Catalog: 75¢. Bluejacket Shipcrafters, 145-V Water Street South, Norwalk, Conn. 06854.

NEWEST, GREATEST FLYING HOBBY—ROCKETS! Zoom from Realistic Electric Launch Systems to 2,500 Feet on Safe, Thrifty, Solid-Propellant Power. Gentle Parachute Recovery For Over-and-Over-Again Flights. Tracking, Experiments, Real Miniaturized Still and Movie Cameras. Build your Own Exciting, Low-Cost Space-Age Adventure—Starting With a Big, New Full-Color Catalog of Over 80 Models (Including Ready-to-Fly). Send 25¢ to **ESTES INDUSTRIES**, Dept. 7L, Penrose, Colorado 81240.

SHIP Model Kits, fittings, plans, books, tools, engines, motors. Illustrated catalog 75¢. Mass. residents add 3% tax. James Bliss & Co., Dept. SM, Route 128, Dedham, Mass. 02026.

MODEL Airplanes—Big 220 Page Catalog \$1.50. Sig Company, Montezuma, Iowa 50171.

LIVE Steam powered backyard railroads! All sizes. Complete "bolt-together kits," and rough castings. Excellent drawings. 100 page catalog \$2.00. Little Engines, Lomita, California 90717.

SHIP And Airplane model kits catalog 25¢. Scientific, Inc., 340 Snyder, Berkeley Heights, N.J. 07922

"SHIP And Yacht model fittings: Pine construction hull kits; blueprints. Send \$1.00 for illustrated catalog. A.J. Fisher, Inc., 1002 Etowah Avenue, Royal Oak, Michigan 48067."

GAMES, TOYS, PUZZLES, NOVELTIES

BINGO Games Complete—\$6.00 Up. Sylvian's, 71 Circuit, Warwick, R.I. 02889.

LIKE a fast-playing, simple but challenging game for two? Get **LAST**; send \$2.00 to: Ebel Enterprises, 309 W. Chapel Hill St., Durham, N.C. 27701.

MINIATURE Charms-Trinkets-Toys. TREASURE CHEST, 9321 Capeview Avenue, Norfolk, Virginia 23503.

NEW—GREAT GRID GAMES, CONTAINS 66 GAMES AND 20 HOURS ENTERTAINMENT. ORDER ONE VOLUME PER PLAYER \$1.42 EACH. W. L. THOMAS & ASSOCIATES, BOX 714, RICHLAND, WASHINGTON 99352.

MAGIC TRICKS, JOKES, VENTRILOQUISM

MAGICIANS' Close-up Catalog. 25¢. Conjurers Craft, Box 65-M, New Hyde Park, N.Y. 11040.

FREE Trick And Two Magic Catalogs Send 75¢. Kafers Magic, Bordentown, N.J. 08505.

PROFESSIONAL MAGIC! Direct From Factory To You. Giant 1975 Catalog - \$1.00. Refundable With First Order. Hank Lee's Magic Factory, 35 Hillside Avenue, Medford, Massachusetts, 02155.

MAGIC! Amaze. Mystify. Entertain! Large Catalog 25¢. Hundreds of Best Tricks for Stage, Pocket, Parlor. Jeffries Magicland, Dept. 11, Dallas, Texas 75201.

FABULOUS MAGICS New 1975 Catalog 50¢. Our Specialty Orders Shipped Same Day. No Substitutes. Fabulous Magic, 3319 East Charleston, Las Vegas, Nevada 89104.

VENTRILOQUISM! Information free. EXCITING FULL COLOR DUMMY CATALOG—25¢. Maher, Box 420PM, Littleton, Colorado 80120.

TWO! Different Magic Catalogs 25¢. Miami Magic, 9734 Bird Road, Miami 33165.

COMPLETELY Illustrated catalog. 84 pages, 25¢. Manhattan Magic, Box 334-M, N.Y.C. 10011.

WORLD'S Finest professional magic tricks. Joker's Novelties. Giant illustrated catalog 25¢. Top Hat, Evanston, Illinois 60204.

WOW! Magic, jokes. Largest selection. Amaze, mystify friends. Super Giant Catalog 25¢. Abracadabra-MP, Rahway, New Jersey 07065.

GENIE, The International Conjurers' Magazine. P.O. Box 36068M, Los Angeles, Calif. 90036. Monthly Since 1936. Sample \$1.00. 1 year \$10.00. Not sold on newsstands. None free.

FREE! World's leading novelty catalog. 1600 Fun-makers, Jokes, Tricks, Science, Sports, Hobbies, Jewelry, Psychedelia. Johnson-Smith, C-4, Mt. Clemens, Mich. 48043.

BE A Magician! Two booklets explaining 156 tricks plus large professional catalog. \$1.00. Magic, Inc., 5082 Lincoln, Chicago, Illinois 60625.

FREE 1975 Magic Catalog plus gift certificate! Imperial, Box 623-P, Worcester, Massachusetts 01601.

BE A MAGICIAN! Mystify. Amaze. Giant Magicians Catalog, 75¢ plus FREE trick. Universal Magic, 256 South Robertson-MP, Beverly Hills, California 90211.

FREE \$5.00 Vanishing Card Trick With Secret How To Select Chosen Card With YOUR FEET. Only \$2.00. "Magic Unusual", P.O. Box 112, Boise, Idaho 83701.

BOOKS, CATALOGS, NEWSPAPERS

"BRAINPOWER" \$1.00 to: Hooks, Sr., P.O. Box B, Lebanon, Ill. 62254.

ATHEIST Book Bargains. Free Catalog. Truth Seeker, Box 2832, San Diego, Cal. 92112.

FREE list. 290 Books. Health, Love, Success, Happiness, Occult, Wealth, Hobbies, and more. C. Ruderer, 98-25 Horace Harding, Rego Park, New York 11368.

SAVE MONEY! RECEIVE OVER 300 MAJOR MONTHLY MAGAZINES ABSOLUTELY FREE! Amazing details only \$2.00. Troy Enterprises, Department M-PM, 1876 South Broad Street, Trenton, New Jersey 08610.

NATIONAL Geographic Magazines, 1888-1971, any issue. Buxbaum, Box 465-PM, Wilmington, Delaware 19899.

FREE Book. Prophet Elijah Coming Before Christ. Megiddo Mission, Dept. 63, 481 Thurston Road, Rochester, N.Y. 14619.

BACK ISSUE MAGAZINES, 200 Titles 1890-1974. Everybody's, 317 West Sixth Street, Los Angeles, California 90014.

CLOCK And watch repairing books, tools, materials. Free catalog. North American, Box 77AGA, Fox River Grove, Illinois 60021.

BOOKS, how to, self improvement, 40/\$3.00 List 25¢. Gunning, Box 457PM, Rd #8, York Pa. 17403

PUBLISH Your Book! Join our successful authors: publicity, advertising, promotion, beautiful books. All subjects invited. Send for Free manuscript report and detailed booklet. Carlton Press, Dept. PMS, 84 Fifth Avenue, New York 10011.

TELESCOPE MAKING FOR BEGINNERS by Roy Worvill —\$5.95. Orbiting Book Service, Box 13, New York, New York 10038.

SELF-Improvement, autosuggestion, health books. Write: Drawer 589, Appalachia, Virginia 24216.

HOW To Make Money in Real Estate. An Outstanding Book! \$2.25 ppd. House of Sassoon, Dept. X, 6070 Pickford Street, Los Angeles, California 90035.

"SELL YOUR HOUSE YOURSELF. SAVE THOUSANDS!" Complete Guidebook, 160 pages, \$5.95 postpaid. Raygor Publications, 1552-A Arona, St. Paul, Minnesota 55108.

COSTA RICA. New Book, Everything You Need To Know About Costa Rica. Send \$3.95. El Sol, P.O. Box 910, St. Petersburg, Fla. 33731.

FREE Details—amazingly, inexpensive books. ATC, Box 9353-P, El Paso, Texas 79984.

LOW COST BOOKS, Manuals, Directories, Free Information, Books, Box 60538, Nashville, Tennessee 37206.

PLAYS, SONGS, MANUSCRIPTS

COUNTRY-WESTERN Songs-Poems needed for publishing-recording. Ballads, rock, gospel, etc. Our artists need new song material. Outstanding Offer. Monthly Awards. Country-Western Recording. Box 523 (PM), Quincy, Mass. 02169. Talent Co.

SONGWRITERS, Want help placing songs? Write for Free details: Publications, Box 328-PM, Nashville, Tennessee 37202.

SONGS-POEMS Wanted for publishing-recording at our expense. Authors of accepted songs pay \$8.75 for one hand-cut record. Monthly awards. Fabulous \$1,000.00 Offer. Talent, 17 (PM) Longwood Road, Quincy, Mass. 02169.

SONGWRITERS LOOKING for CO-WRITERS on 50-50 basis. HAS songs recorded by BRENDA LEE, EDDY ARNOLD, and others. SEND lyrics to: NASHVILLE CO-WRITER PLAN, BOX 1152, NASHVILLE, TENNESSEE 37202.

WANT Your book published? Learn how—we publish, advertise, promote, distribute. Many successes. Free booklet PM. Vantage, 516 W. 34th Street, New York City.

SONGS, SONGPOEMS Wanted for Radio Show. Hollywood Music Productions, 6425-PM Hollywood Boulevard, Hollywood, California 90028.

BUSINESS SERVICES

MAILING LISTS For Small and Large Businesses. Current & Complete. Free Catalog. D.M. Inc., Waseca, Minn. 56093.

PROFITS FROM CLASSIFIED ADVERTISING! Booklet shows you how to start your own business with Classified Advertising. Only \$1.00 (Refundable with first order.) H. E. KAPPEL, POPULAR MECHANICS, DEPT. P, 224 WEST 57TH STREET, NEW YORK, N.Y. 10019.

BUSINESS OPPORTUNITIES

IMPORT-EXPORT Opportunity, profitable World-Wide, Mail Order Business From Home, Without Capital or Travel Abroad. We Ship Plan for No Risk Examination. Experience Unnecessary. Free Report. Mellinger, Dept. A2707, Woodland Hills, California 91364.

A FORTUNE IN JUNK! LEARN UPHOLSTERY AT HOME . . . TURN CAST-OFFS INTO CHAIRS, SOFAS WORTH \$100'S. NO EXPERIENCE NEEDED. WE SHOW YOU HOW . . . EVEN SUPPLY ALL TOOLS AND PRACTICAL FURNITURE KITS! VETERAN APPROVED. BOOKLET MAILED FREE. MODERN UPHOLSTERY INSTITUTE, 1205 W. BARKLEY, DEPT.-3PM3, BOX 16, ORANGE, CALIF. 92666.

CUSTOM PICTURE FRAMING—A Satisfying, Profitable Craft! Learn at home—no experience needed, we supply everything. Booklet mailed Free. Creative Framecrafters, 1205 W. Barkley, Box 16, Dept. 3PM, Orange, California 92666.

"BUILD Your Own Mailorder Business." Get Helpful Facts . . . FAST!! Landmark, 4513 Robbins, Orlando, Florida 32808.

SECRETS! Mail Order Success. Internationally famous expert reveals how to make home-business fortunes. Beginners: Get free report "Make Money By Mail." Discloses free advertising, profitable products. Maico, Dept. AC707, Woodland Hills, California 91364.

SUB-WHOLESALEERS Needed Immediately, No Experience—\$1.00—Refundable. B&B, R6B302, Chatsworth, GA. 30705.

DELUXE Selling Outfit—35,000 Office Supplies. Refundable deposit required. Oseco, 3505-PM Elston, Chicago 60618.

\$700.00 MONTHLY. Spare Time. Completely Guaranteed. Details: Key Distributors, Box 5175, Williford, Ohio 44094.

EARN FINDER'S FEES. \$10,000! More! Write: Business Digest-2F, Farmington, New Mexico 87401.

EARN EXTRA Money at Home in The Mail Order Business. Experience not Essential. Details Free. The Henry Banks Co., Box 457, Graham, Texas 76046.

\$250/THOUSAND, Stuffing envelopes, free supplies, rush stamped addressed envelope. Jadco, Box 23099-P6, San Jose, Calif. 95153.

STUFF env. \$25.00/100 immediate earnings. Send addressed, stamped env. E. M. Cottrell, Box 510, Bell, Ca. 90201.

ABANDONED INDUSTRIAL SILVER—yours for taking! \$24,000 yearly possible. Free information: Silverman B-13, Box 548, Woodville, Texas 75979.

200% TO 300% Profit, Gifts, Novelties. Jumbo Catalog \$1.50 Refundable. Cunningham, 223 5th Avenue, Brookings, S. Dakota 57006.

\$300-\$700 MONTHLY. Raise Rabbits, Laboratory Animals for us. We supply Equipment, Breeders, Instructions. Details 25¢. MP11 Rabbits Of Michigan, Countyline Road, Pentwater, Michigan 49449.

\$250-\$500/THOUSAND, STUFFING ENVELOPES, FREE SUPPLIES, Rush Stamped Addressed Envelope, "Mitch", Box 551PM1A, Havelock, N.C. 28532.

250/THOUSAND, STUFFING ENVELOPES. FREE SUPPLIES. Rush Stamped, Addressed Envelope. Beach, Box 3505, Lancaster, Ca. 93534.

STUFF Envelopes Spare Time \$30.00 per Hundred. Immediate Earnings. Beginners instructions \$1.00. Refundable. JB, Box 225, Inver Grove Heights, MN. 55075.

\$12.50 HOUR With Vacuum Cleaner Repair-Rebuilding Business! Proof—Baron, Box 863AB7, Portales, New Mexico 88130.

FREE CATALOG, DETAILS. Lucrative costume jewelry distributorships. No investment. SHOWCASE, 24831A Spadra, Mission Viejo, California 92675.

\$250/THOUSAND, Stuffing Envelopes, Free Supplies, Send 25¢ and Stamped Addressed Envelope: 3-K Enterprises, Box 19858, Milwaukee, WI 53219.

\$250/THOUSAND, Stuffing Envelopes, free supplies, send stamped addressed envelope: Phillips, Box 733, Idaho Falls, Idaho 83401.

EARN Thousands as a distributor salesman of our high quality products. Details—rush stamped addressed envelope: Florida Mechandising, Inc., Box 1656, Pompano Beach, Florida 33061.

FREE DETAILS. Extra income by mail. Learn how. Stephen, Box 115C, West Chicago, Illinois 60185.

UNLIMITED earnings possible . . . addressing, mailing commission Circulars! Details, send stamped self-addressed envelope. Ark, Box 3373F, Amarillo, Texas 79106.

ACT Now! Buy Wholesale. Gifts, Toys, Novelties. \$1.50 Brings plans and catalog. Larsons, Box 342AP, Fourth and Hicks, Florida, Florida 33857.

AMAZING PROFITS!! Mail Baby Catalogs to New Mothers! Exciting Details 25¢. Addington's, Box 522AG, Belleville, Michigan 48111.

\$100.00 DAILY. \$11.00 brings detail package airmail. Bousfield 30B7, Box 1511, Redding, Calif. 96001.

SELL Ordinary Sand \$5.00 pound. Plan, \$4.95. Details, 25¢ SANDCO-PM, Ceres, California 95307.

\$250/THOUSAND, STUFFING ENVELOPES, SUPPLIES FREE, Send Stamped Addressed Envelope, Jen Enterprise, Box 703M, Brookings, S.D. 57006.

VENDING Machines. No selling. Routes earn amazing profits. Big catalogue Free. Parkway Machine Corporation, 1930PMB Greenspring Drive, Timonium, Maryland 21093.

"SELL Books By Mail. Complete Dealer Setup 25¢. Packerland Publishing, Box 3193J7, Green Bay, Wis. 54303.

YOUR OWN Successful mailorder business!! Learn how before investing. Free Details. Northeast Associates, Box 191-MG, Coventry, Connecticut 06238.

MAILORDER SUCCESS Can Be Yours!! Sell Proven, Profitable "How-To" Books. Complete Instructions, Sample Catalog 25¢. BC Robinson, 3001 South Michigan, Chicago, Illinois 60616.

PIANO Tuning Learned Quickly at Home! Musical knowledge unnecessary. Free information. Empire School, Box 450327, Miami, 33145.

CALIFORNIA MANUFACTURER NEEDS MAN to assemble our product and be local agent, experience unnecessary. May start while presently employed. Five-figure income for responsible applicant. S.K.R.M. Manufacturers, 911 N. Lagoon Ave., Wilmington, Ca. 90744.

SELL Books by Mail. Complete Dealer Set-Up 25¢. Ultis Distributors. Box 34672-PM, Los Angeles, California 90034.

FREE!! "Turn \$10 Into Fortune!" Hotline, Box 3155-P. Springfield, Missouri 65804

EARN Money raising fishworms for us! Write: Oakhaven-38, Cedar Hill, Texas 75104.

\$400.00 MONTHLY Raising giant fishworms. Soilless method. Charlie Morgan, Bushnell, Florida 33513.

MAKE \$92.00 FROM Square Foot Plywood (Jigsaw or Bandsaw necessary). (Proof), details 25¢. (Refundable). Woodart, Bridgewater, Mass. 02324.

FREE 100-Page Catalog waiting to bring you Big spare-time cash commissions. Sell Advertising Book Matches. Every business a prospect . . . complete selling instructions furnished. Steady, repeat business. Dept. MX775, Superior Match Company, 7530 South Greenwood Avenue, Chicago, Illinois 60619.

MAKE \$7.50 to \$15.00 hourly building portable custom cases in your home. Huge demand. Get orders by mail. We supply materials, instructions—everything. Free details. Customcase, 6075 De Soto, Dept. C-20-31, Woodland Hills, California 91365.

PORTABLE Sandblaster \$29.95. Distributor wanted. Free Brochure. Inka, Box 66573-A, Houston, Texas 77006.

\$1.00 LISTS You year sent to 1000 Importers, Jobbers, Mailers, our mailing year. Dixie, King, North Carolina 27021.

\$100.00 DAY. Manufacturing Concrete Blocks, Posts, Semi-Automatic Block Machines. Mold Equipment Catalog, over sixty items, \$3.00 refundable. Carlayne, Route One, Box 95, Rapid City, South Dakota 57701.

SELL Books by mail. Complete dealer set-up—25¢. Midwest Mail Sales, Box 44R2-PM, Shawano, Wisconsin 54166.

PIANO Tuning Quickly learned with home study course. Diploma granted. American Tuning School, 17050 Teller Dr., Morgan Hill, Calif. 95037.

\$200.00 DAILY In Your Mailbox! Opportunity To Follow Mailorder Experts. Free Details. Associates, Box 136-A, Holland, Mich. 49423.

BECOME "Mortgage Broker." Lucrative! Capital Sources. Box 640099, Uleta, Florida 33164.

FREE COLLECTION AGENCY Details!! \$1000.00 Monthly Possible. Master-PM, Dawsonville, Georgia 30534.

HOW TO RAISE \$100.00 to \$1,000,000.00!! Write: Capital-PM, Dawsonville, Georgia 30534.

I MADE \$40,000.00 Year by Mailorder! Helped others make money! Free Proof! Torrey, Box 318YY, Ypsilanti, Michigan 48197.

MAIL Baby Catalogs to New Mothers for Big Profits! Details 25¢. Volz-PM, Ypsilanti, Michigan 48197.

NEW, Compact fire extinguisher. Fantastic profits. Exclusive territories. Norwich Chemical, Norwich, Connecticut 06397.

RECEIVE Mail Galore! National Listing. \$1.00. Sullins, 1313-M, Brunswick, GA 31520.

MAILORDER BEGINNERS LIBRARY, Learn Professional Secrets Inexpensively! Write: HOW, Box 4457-PM7, Downey, California 90241.

WATCH REPAIR. Learn this cash business at home. \$5 monthly. Free details. Chicago School of Watchmaking, YTA, Fox River Grove, Illinois 60021.

TAKE Catalog orders. We drop-ship 1001 best selling specialty products. Lowest below wholesale prices. Immediate Delivery Spectacular home business opportunity. Free Book. Specialty Merchandise, Dept. 20-31, Woodland Hills, California 91365.

\$200 WEEKLY! Make, Sell Bricks! Free information! Xcito Bricks, 5715 N. Mozart, Chicago, Ill. 60659.

HOW TO OPERATE a Profitable Bookkeeping Service For Small Businesses. R.I. Systems, Co. 1645-A Warwick Avenue, Warwick, R.I. 02889.

START Your Own Correspondence School • Pioneer Schools, 209 S. Citrus, Suite 7, Covina, Ca. 91723.

MAILORDER—Establish own business. Everything supplied—catalogs, ads, mailing lists. Merchandise dropshipped. Gift-Guide, 1137 Crenshaw, Dept. 445, Los Angeles 90019.

FREE WEALTH BOOK: "2100 Unique Ways To Make Money!" World's Biggest Collection of Home Businesses!! Success-M, 26903 West Eight Mile, Detroit, Michigan 48240.

EARN \$80.00 Daily Manufacturing Concrete Bricks-Tiles-Wooden Molds. Send Stamp, Hilmar, Route One, Box 347-DH, Valrico, Florida 33594.

\$15,000 + ANNUALLY. IMPORT MAILORDER OPPORTUNITY. One year risk free trial basis. Details: North-east Imports, Box 121M7, Fremont, NH 03044.

\$100,000 YEARLY Mailing Information! Free Proof! Albers, Box 17052, Minneapolis, Minnesota. 55417.

NOW: A LUCRATIVE NEW FIELD! Invest Dimes-Reap Dollars—Reach Millions. We Help. An Annual \$25,000 easy, Part Time. Write for Free Literature. Howell's NuDeal, 550 Redbud St., Waldron, Ark. 72958.

WORLD'S Largest Supply. 25% to 40% under wholesale. Closeouts. HONG KONG Clothes. Automobiles. Electronics. Free Details. International Buyers, Box 16386MM, Portland, Oregon. 97233.

ASSEMBLE BALL POINT PENS As Our Dealer. Excellent Part Time Income. \$1.00 Brings Details, Pens. Peggy Ann Pens, Attn. R. Cuppy, 2121 Madison, Charleston, Illinois 61920.

CONVERT Used Beer Can Tabs into Profitable business. Complete Method \$3.00—Tab, 15402 Corkhill, Maple Heights, Ohio 44137.

REPAIR Hydraulic Jacks—Details Free. Write: Hydraulic Parts Supply, Box 4157, Brownsville, Texas 78520.

YOUR Own Mailorder Catalog Business. No Merchandise Investment, Details Free. A.M. Sales, 31-14 94 St., East Elmhurst, NY 11369.

CLIP NEWSPAPER ITEMS. \$500.00 monthly Possible: Send 50¢ and Stamped, Addressed Envelope. News Clip, P.O. Box 402, 310 Franklin Street, Boston, Mass. 02110.

STUFF Envelopes. Earn \$500 per thousand. Free Supplies. Send stamped addressed envelope. Gozdanovic, 160 Banner Way, Pittsburgh, Pa. 15201.

\$40,000.00 YEAR in your own carpet and rug business. Start spare time from your home. No stock or capital needed. Write for carpet sample—Money-making facts and prices. Carpets, Dept. C248, Resaca, Ga. 30735.

STUFF Envelopes \$500.00/Thousand. Free Details. Send Stamped Addressed Envelope. Mantor House, Dept. 8PM9, Minola, N.Y. 13116.

NEW Mailorder publication. Tells everything! Details free: Adams, Room 6C7, 12128 W. 70th., Arvada, Colorado 80004.

BUILD BASKETWEAVE FENCE SECTIONS. BE YOUR OWN BOSS, WORK YOUR OWN HOURS, EARN \$100.00 A DAY. START YOUR OWN BUSINESS FOR UNDER \$100.00 TOTAL COST—GUARANTEED! INFORMATION \$1.00. BOMAR FENCING, BOX 312, FRASER, MICHIGAN 48026.

\$50,000.00 YEARLY!! EASILY By Mail! Instructions With Proof! Dollar Bill. Carter Company, 22 Laplaza Acres, Searcy, Ark. 72143.

"\$500/THOUSAND POSSIBLE STUFFING ENVELOPES, INFORMATION/SUPPLIES, STAMPED, ADDRESSED, ENVELOPE, Agent-57, Box 159, Clayton, Indiana 46118."

SELL World's Largest Selection Historical "antiqued" reproduction on parchment! 100-300% profit! Wholesale—Retail! Volume advertising, freedom documents—Bicentennial! Hundreds of ideas!! Catalogue, details, 10 samples \$1.00. Garen's, Box 28097-A, Columbus, Ohio 43228.

AMAZING BUSINESSES you can start at home. Free Details!!! UMC, PM-65B, 8228 Wynne, Reseda, Calif. 91335.

CLIP Newspaper items For \$2.00 to \$10.00 each. No investment. Free details. Cardinal Publishing, Box 5200-C38, Jacksonville, Florida 32207.

FREE MAILORDER Report! Plan Guarantees Beginners \$50.00 per order - to \$750 Weekly! Professionals, Box 21093-E, Seattle, WA. 98111.

ESTABLISH Highly Profitable Mailorder Business! No Inventory. Free Details. Parrish, Box 3-PM, Albert Lea, Minnesota 56007.

MAILORDER Professional Books Learn Facts, Secrets Free Details. PERRY'S, Box 17194, West Hartford, Conn. 06117.

EARN WHILE LEARNING. Small Engine Repair Business. Details \$2.00, Refundable. Wagner Enterprises, Rt. 1-PM, Plymouth, Wis. 53073.

\$60 DAILY. Manufacturing New Building Block (Easily!) Complete Instructions \$2.00. Guaranteed. "Miracle Brick-D", 42308 284th SE, Enumclaw, Washington 98022.

UNLIMITED Profits! Best Mailorder Opportunities! Free Details! JM17, 555 Roscoe, Chicago 60657.

REPAIR AIR COMPRESSORS. Full or spare time. Thousands need service and repair now. Very few trained in this field. New manual tells how. Theory, trouble-shooting, overhaul . . . Parts directory. \$3.00 Postpaid. Air-Power, Box 1411, Hickory, N.C. 28601.

U.S. GOVERNMENT FINANCES SMALL BUSINESSES. Quick action. Authentic instructions \$3.00. COUNSELOR, Box 1089, St. Petersburg, Florida 33731.

EARN \$60.00 Daily manufacturing Concrete Fence Posts. Practically no investment. Send stamped-addressed envelope. American, Excelsior Springs, Mo. 64024.

BOOMING CATFISH FARMING. U.S. SPONSORED. Financing. Proof of thrills-riches. Air-mailed details 50¢. Catfish Industries, Box 1089, St. Petersburg, Florida 33731.

RECEIVE \$100 daily. Send \$1.00 for plan and formulas to: Banks Enterprises, Box 337PM, Stanardsville, VA 22973.

\$250/THOUSAND, STUFFING ENVELOPES, FREE SUPPLIES, Send Stamped Addressed Envelope, DanManCo, Box 3012, Superior, Wisc. 54880.

\$250-\$500/ THOUSAND, STUFFING ENVELOPES, COMPLETE ASSISTANCE, Rush Stamped Addressed Envelope. FRM Enterprises, Box 472, Elwood, IN 46036.

ZODIAC Signs, New, Exciting Excellent Profits. Write: Cutter Graphics, 1600 Dewey Ave., Rochester, N.Y. 14615.

MAILORDER—ESSENTIAL Library of Instructional Books for Everyone Entering This Fantastic Field. \$1.00 for Introductory Book. G&D Sales, Box 144A, Belvidere, Illinois 61008.

BECOME Tax consultant. Our students earn \$1,000-\$3,000 every tax season preparing returns evenings. State approved. National Tax School, Monsey 2GF, New York 10952.

\$250/THOUSAND, STUFFING ENVELOPES, FREE SUPPLIES, Send Stamped Addressed Envelope, PLB, Box 47, Northfield, Ohio 44067.

START DEALERSHIP, Books. Investment, experience unnecessary. Wilson, Box 5516A, Walnut Creek, CA 94596.

HOW To Make Money, Wholesaler, \$5.00. Tonycotton, 5210 Palco Place, College Park, Maryland 20740.

PAWNBROKING SCHOOL: Learn by mail \$10.00. Pawnbroker Thayer, Bath, Maine 04530.

EXTRA income opportunities start the day you receive information \$4.00 full price. Phillips, 26 Sunset Terrace, Baldwinville, New York 13027.

\$250 THOUSAND ENVELOPES STUFFED. Free Supplies. Send 25¢ to: Celia Baker Co., 65 N. Joliet St., Joliet, Ill. 60431.

FREE Secret Book "2042 Unique, Proven Enterprises." (Flash! Now "4,044"!) Fabulous "Little Knowns." Work Home! Haylings, Carlsbad, Calif. 92008.

\$2000. MONTHLY Fabulous New Business. Rush 25¢ For Brochure. Staro Co., 33 Kelley St., Taunton, MA 02780.

EARN \$200.00 weekly. Fantastic (Instant Profits). Mailorder Plan. Send 25¢ for Confidential Details. Unicorn, PMM7, 7350 Nugget, Colorado Springs, Colo. 80911.

EARN Extra money mailing commission circulars. Free details. Luan Enterprises, Box 2771, South Bend, Ind. 46614.

HOMEWORKERS, Mailers Needed! 50 Firms Listed! Send 25¢ Stamped Addressed Envelope. Makowiec, 24644 Eton, Dearborn Heights, Mich 48125.

\$250-\$500/THOUSAND STUFFING ENVELOPES, COMPLETE ASSISTANCE RUSH Stamped Addressed Envelopes. Bigsky, Box 3884, Butte, MT. 59701.

ADDRESSERS—Mailers—Homeworkers Needed! 100 Firms Listed. Rush \$1.00, Stamped Addressed Envelope. Abbe S. Sull, 332 Sterling, Buffalo, New York 14216.

\$250/THOUSAND, STUFFING ENVELOPES, FREE SUPPLIES Rush Stamped Addressed Envelope, D-Enterprises, Box 736-B-7, St. Charles, MO. 63301.

\$250-\$500/THOUSAND STUFFING ENVELOPES, COMPLETE ASSISTANCE, Send Stamped Addressed Envelope, Henriksen, Box 6080-PM7, Mpls., Minn. 55406.

\$250-\$750/THOUSAND STUFFING ENVELOPES, COMPLETE ASSISTANCE, Send Stamped Addressed Envelope, Tri-Mac, Dept H109, Box 34255, Indpls., Ind. 46234.

HOMEWORKERS \$250/THOUSAND STUFFING ENVELOPES, free Supplies. Rush stamped, self-addressed envelope. Davco, Box 11011-P, Omaha, Neb. 68111.

HOME MONEYMEN. KEEPING Track of business deductions can be complex. **MISTAKES ARE COSTLY.** Quick and easy tax accounting kit **SAVES YOU** time and money. **PROVEN.** \$1.00. Accounts Dept., Box 6671, Santa Rosa, Ca. 95401.

WORK is what it takes to make money learn how to be mail order distributor send \$10.00 for complete instructions. BJ Enterprises, Box 97, Beaver Dams, NY 14812.

STENCIL Addresses On Curbs! Make \$35,000 Year! Details 25¢. Mitnik, Box 177, Midway City, California 92655.

COLLECT Names Earn \$300.00 Per Thousand Possible. Also, 50 FREE Dealerships Available. Send 25¢ And Stamped Addressed Envelope. G. Cattanch, 400 Griffin Ave., Pacifica, Calif. 94044.

\$100.00 PLUS Weekly, part time, at home. Free details. Send stamped self-addressed envelope. Consumers United, Dept. 37, 23 Royalston Lane, Center-each, N.Y. 11720.

\$100.00 WEEKLY Guaranteed addressing envelopes. Setup \$2.00. Bumphus, Box 9306-P, Washington, D.C. 20005.

MAILORDER Start own highly successful business! Free report. Contemporary, Box 1144H, Forest Park, GA. 30050.

MAILORDER professionals help beginners make \$1,000 in 30 days. Free proof! American Executives, 216 West Jackson, 612-7PM, Chicago 60606.

MONEYMAKERS! Jewelry, watches, gifts—BELOW Wholesale. **FREE** catalog. Olympic House, 34043A 51st. Ave. So., Auburn, Washington, 98002.

MAILORDER MAKES \$50,000.00 year! **START** home business in spare time. Make extra money. Literature free. Lyu, 1003 Wellington, Greenville, Michigan 48838.

HOMEWORKERS, Mailers needed. 50 firms listed! Send 25¢, stamped addressed envelope. P.F. Windisch, 1160 Bower Hill Road, 914B, Pittsburgh, Penna. 15243.

SUPPLY Electric Power To Entire Housing Development, Factory, Home! The Original Worlds Most Powerful Endless Belt, Train, Parachute, Oscillatory, Super-Turbine And Solar Air Tower Convection Current Motors You've Read About! Also Practical Inexpensive Solar Refrigeration, Air Conditioning, And Photo-Electric Power Perfected Now! Fusion Power Simplified. Patents Pending. Drawings, Details \$5.00 Each. All \$19.00 Refundable. "Ra", (G), Box 16046, Kansas City, Missouri 64112.

1000% PROFIT Bronzing Baby Shoes At Home. **FREE LITERATURE** NBCPM, Box 570472, Miami, Florida 33157.

PROFITABLE Dealerships available. Mail catalogs to new parents. Details. Burns, Box 499-B, Glen Eilyn, Ill. 60137.

BUILD \$3,000.00 Foam Plastic Home, One Week. Sell For \$50,000.00. Costs 66% Less To Heat, Cool. Patent Pending. Drawings, Details, \$5.00 Refundable. Ark(X), Box 16046, Kansas City, Missouri 64112.

NEW Mail order approach details: \$1.00. McQueary Enterprises, 1007 E. Orange Grove, Pasadena, CA. 91104 Dept. B.

ESTABLISH Successful Home Mailorder Business! Mears, C5363 Essex, Alexandria, Virginia 22311.

PERMANENT Magnet Self Powered Motor That Works! Patent Pending. Drawings, Details \$10.00 Refundable. "Miracle Science", Dept. 73, Box 16046, Kansas City, Missouri 64112.

\$500 MONTHLY! Stuffing Envelopes and Clipping Newspapers: Free Supplies, Rush stamped addressed envelope. J. M. Winter, 18 Carey St., Mahopac, New York 10541.

MAILORDER. \$500 Monthly Selling Information. Free Proof! Associates, Box 123-F, Wenonah, N.J. 08090.

\$500 Monthly homework!! 12 Ways! Rush \$1.00, stamped addressed envelope: Gonzales, Box 3723, Beaumont, Texas 77704.

SPARE-TIME SECOND-HAND BUSINESS. Complete instructions \$2.00. Drexler-P3, Box 26419, Phoenix, Az. 85068.

"USE 66% Less Electricity! How To Air Condition Cool And Heat Home With Microwave Oven! Simple. Patent Pending. Drawings, Details \$5.00. "Spaceman" (V.), Box 8170, Kansas City, Missouri 64112.

BOOKKEEPERS Earn \$10.00-\$20.00 hour. Operate Book keeping Service by mail. Universal Bookkeeping, Box 664-M, Springfield, Missouri 65801.

MAILORDER'S BEST SELLING BEGINNERS LIBRARY. Learn Professional Secrets and Make Money! Write: Barclay, Box 45PG, Halesite, N.Y. 11743.

MAKE Durable building plastic easily. Waterproof, fireproof, economical. Bays Laboratory, Cedaredge, Colo. 81413.

LEARN AUTO UPHOLSTERING & Vehicle Interior Customizing. Save **BIG MONEY, EARN BIG MONEY!** Start with your own car, learn at home, spare time, through A.U.I. proven home instruction course. Includes custom and standard cars, boats, campers, trailers, bucket and standard seats, tops, headliners, auto glass, carpeting, diamond tufting, tuck & roll—everything to make you a real auto trim expert in few short months! Tools & do-it-yourself kits included. Send for **FREE** facts and auto trim career booklet. **AUTO UPHOLSTERY INSTITUTE**, 1205 W. Barkley, Dept.-3PM, Box 16, Orange, Calif. 92666.

\$178.00 WEEKLY. Work one hour daily. Guaranteed, FAS, Box 13703-J, San Antonio, Texas, 78213.

MAILORDER Millionaire helps beginners make \$500 weekly. Free report reveals secret plan! Executive (1A8), 333 North Michigan, Chicago 60601.

BECOME Our Mail Order Distributor with \$150 Investment. Free Brochure. Audit Controls, 40 Brookside Ave., Fair Lawn, New Jersey 07410.

\$30,000 YEARLY. Unique home business. Free details. Messmore & Sons, 630 PM Baylor St., Pacific Palisades, CA. 90272.

EASY, PROFITABLE. Your own envelope stuffing business. Start immediately. Two complete home-worker plans, \$5.00. Guaranteed. **B.M.C.O.**, P.O. Box 88, Logan, Utah 84321.

SELL Music books by mail through classified ads. We dropship. Free 'starter kit'. Shinco, 5090C Dobrot, Central Point, Oregon 97501.

FREE Moneybook! "Millionaires Success Secrets." Amazing profit opportunities. B&M Distributors 233, Box 1116, San Francisco, 94101.

LIQUID PLASTIC ROOFS—Save Hundreds doing your own Roof—or Earn Unlimited Profits from Others. Revolutionary low Cost Method is Clean, Easy, Lightweight. Proven Superior in All Ways. No Experience Needed; Earn Immediately. Order Any Amount. Full Details: "PERMAPLASTIC", Box 1164, Meadow St., Allentown, PA. 18102.

T.V. THEFT ALARM This is what Hotels, Motels, and Homes have wanted for years. Big profits and Lifetime Commission. Send \$2.00 for details. Teledyne Security Systems, 73282 Hwy 111, Palm Desert, California 92260.

EARN \$10.00 PER HOUR With our Handwriting Analysis Machine. No knowledge of Handwriting Analysis necessary. No selling. Fascinating business you can start from home. Complete step-by-step details on how to start in large booklet, \$2.00. Comprise Instruments, Section 130, 1445 Fifth St., Santa Monica, CA 90401.

PROFITS FROM CLASSIFIED ADVERTISING! Booklet shows you how to start your own business with Classified Advertising. Only \$1.00 (Refundable with first order.) **H. E. KAPPEL, POPULAR MECHANICS, DEPT. P, 224 WEST 57TH STREET, NEW YORK, N.Y. 10019.**

\$70 TO \$200 WEEKLY—Home, Spare Time Simplified Mail Bookkeeping. Immediate Income. Easy. Auditax, Box 34741A, Los Angeles, Calif. 90034.

HOMEWORKERS! Receive \$100 weekly income, mailing six envelopes daily. Setup \$2.00. Gemco, 821244A, Indianapolis 46221.

MONEYMAKING OPPORTUNITIES

STUFF Envelopes \$500/thousand. **FREE** Supplies. Rush Stamped Addressed Envelope . . . Capital Enterprises, 2 Orion Ct., Baltimore, Md. 21237.

DOLLARS! INDEPENDENCE! STUFF ENVELOPES. \$25.00 HUNDRED. STAMPED, ADDRESSED ENVELOPE, BRINGS DETAILS. Palmer-L, P.O. Box 20028, El Cajon, Ca. 92021.

365 FAST, Easy ways to make money! Free! Rush name, address, zip. Perry, 13263 PM, Ventura Blvd., Studio City, Calif. 91604.

"SHIP MODELS-ASSEMBLED, Ready to display or sell. Sizes from 10" to 43" length. Wholesale prices. **FREE** colored catalog. **SHIP MODEL EMPORIUM, 8001—15th Ave. N.W., Seattle, 98117."**

\$500 MONTHLY Possible! Clipping newspaper items for publications. Details—Rush stamped envelope. Income, Box 7218, Lynbrook, N.Y. 11518.

MEN—Women; Earn Spare Cash Taking orders for Bicentennial, Zodiacs, Religious, Other Engraved Metal Social Security Cards. Free Sample, Kit. Lifetime Products, Box 25489-P, Raleigh, N.C. 27611.

\$250.00 THOUSAND, STUFFING ENVELOPES. FREE SUPPLIES, RUSH STAMPED Addressed Envelope. Glenco Mailers, Box 495C, Glenwood Springs, CO. 81601.

NEVER Before So Much for so little. Buy necessities below wholesale! Particulars Free. Write: Warner, Room CC-2-EK, 1512 Jarvis, Chicago, Ill. 60626.

STUFF ENVELOPES \$250/THOUSAND! FREE SUPPLIES! Rush Stamped Addressed Envelope. Jackson, 2150PM Prospect, Cleveland, Ohio 44115.

PHOTOBUTTON Machine \$250.00 (was \$500.00). Specialties, 1180 Deharo, San Francisco, Cal. 94107.

YOUR MAILBOX FULL OF \$1.00 DAILY. Plan plus 6 moneymaking ideas for \$1.00. B-F Enterprises, Box 5187, Lubbock, Texas 79417.

HORSEPLAYERS. Professor discovers startling new way to eliminate losers through computer study. Stafford, 5711-14th, Brooklyn, N.Y. 11219.

\$500 PROFIT FROM \$50 SALE. Million Dollar Success Plan. Confidential guide and samples for \$1.00. Bolger, Box 5591, San Diego, Calif. 92105.

ATTENTION! Wanted, persons interested in being contestants on various television game shows. For instructions send \$2.00. "DMS" P.O. Box 515, ANSONIA STATION, NEW YORK, NEW YORK 10023.

TIRED of gimmicks? Complete guide shows you how to get started and succeed in mail order. Send \$6.45 to Walter, P.O. Box 907-M, Tacoma, Washington 98401.

\$1,000 MONTHLY Mailing Letters. Guaranteed. Details, 25¢. SANDCO-PMG, Ceres, California 95307.

FREE OFFER! Make Big Money Selling Beautiful Jewelry. Send for **FREE** catalog and **FREE** starting outfit. Heritage—23, 103 Goodhue Building, Beaumont, TX 77701.

VENDING Machines. No selling. Routes earn amazing profits. Big catalogue Free. Parkway Machine Corporation. 1930PMM Greenspring Drive, Timonium, Maryland 21093.

FOOTBALL Fans - Earn Possible \$10.00 Per Fan. Details \$1.00. YAB Enterprises, Box 6264, New Orleans, La. 70114.

HOW To Make Money writing short paragraphs. Information free. Barrett, Dept. C-27-D, 6216 N. Clark, Chicago, 60660.

WORLD'S Leading Contest Magazine, 50¢. Prize-winner, 1315 Central, St. Petersburg, Fla. 33705.

CLIP Newspaper items, \$1.00-\$5.00 each. Details free. Walter, Box 1360-PA, Erie, Pa. 16512.

LEARN, EARN Mail Order from Home Spare Time. Been telling how since 1929. Facts, Stories, Sources, Thousand Offers, Complete Course in Mail Order. Sample Copy 50¢; Year \$12. Mail Trade Magazine, Box 1302, Springfield, IL 62705.

ADDRESSERS—Mailing-Homeworkers-Needed! 50 Firms Listed. Rush 25¢, Stamped, Addressed Envelope. Cannon Enterprises, Box 34057, Bethesda, Md. 20034.

MAKE Statuettes, novelties, imitation marble. Sell to stores or start gift shop. Free details. Marbleizing, 41 Waverton, St. Louis, Mo. 63124.

\$175.00 WEEKLY Correcting Pupils' Lessons! Samples, \$1.00! Castle's, 507-LP Fifth, NYC 10017.

LEARN The secrets of repairing junk batteries. "Fabulous Profits" at home. Apex Engineering, 3100 Ramona, Atascadero, California 93422.

FREE! LATEST DIRECTORY OF 500 CORPORATIONS SEEKING NEW PRODUCTS! If you have an idea for a new product—or a way to make an old product better, send for our **FREE INVENTORS KIT NO. A-85.** It gives vital information on developing and marketing your invention/idea for Cash/Royalty Sales to corporations nationwide. Raymond Lee Organization, 230 Park Avenue, New York, N.Y. 10017.

GET World's Biggest Wholesale Import Catalog. Write: World, Medina, Washington 98039.

WILL You actually (really & truly) address, stuff and mail 20 envelopes a day? Then don't let's mess around. Send \$5 and we'll show you how to make up to \$1,000 monthly and even much more. **GUARANTEED!** Contractual Arrangements. Habersham-Hall, Box 613-F, San Pedro, CA 90733.

\$60 PER Evening Addressing Envelopes. Homework Guaranteed. Free Details. Sterim, Box 23E, Sterling Heights, Mich. 48078.

FREE WEALTH BOOK: "2100 Unique Ways To Make Money!" World's Biggest Collection of Home Businesses!! Success-M, 26903 West Eight Mile, Detroit, Michigan 48240.

FREE Details! Win lifetime income from Dice, Roulette, Thoroughbred, Harness, Dog Racing. Guaranteed! Research, Box 551PM, Mineola, N.Y. 11501.

\$1,000 MONTHLY!! Stuffing Envelopes and Clipping Newspapers: Send Stamped Addressed Envelope . . . **JOY,** Box 936-C, Hyattsville, Maryland 20783.

WOODWORKERS—Earn \$10.00 per Hour Constructing Projects for Craft and Consignment Shops. Guaranteed instructions describe Projects and Selling Methods. \$3.00. Woodcraft Ideas, Box 193, New Middletown, Ohio 44442.

500/THOUSAND, Stuffing Envelopes, Stamped Addressed Envelope: Wiley, 1833-31 Shoshone Drive, Lafayette, Indiana 47905.

\$200.00 PROFIT. Sheet 1/4" plywood. Details 50¢. Novelties, 610 So. 24th, Elwood, Indiana 46036.

BIG Profits in Sporting Goods. Rice's, 107-A Thriftway Plaza, Ruskin, Fl. 33570.

SELL Sensational Low-Cost Burglar Alarm. Lightning Seller. Exceptional Margin. Samples for Trial. Northwest Electric., Ave. 995, Mitchell, S. Dak. 57301.

\$500/THOUSAND POSSIBLE STUFFING ENVELOPES, INFORMATION/SUPPLIES, STAMPED, ADDRESSED, ENVELOPE, Aaron-57, Box 466, Monrovia, Indiana 46157.

\$8,000 MONTHLY SPARE TIME! No Selling! Start Now! —Free Proof!!—Owco, Box 665, Inglewood, Ca. 90307.

STOP WISHING! This is it. Servicemen, vets, anyone. Make money at home, camp, anywhere. Nothing like it. Stamp, 25¢ brings loads particulars, info. Bill Smith, P.O. Box 1878, Cincinnati, Ohio 45201.

37 WAYS To Make Money When Your'e Out Of Work. Details Free. R&R Investment Co., Box 132, Southeast Ave., Tallmadge, Ohio. 44278.

THIS FANTASTIC MONEY FORMULA Made me an extra \$21,413.25 last year. It can do the same for you. Learn this vital secret. Send \$3.00 to: RLA, Inc., Box 579A, Dana Point, CA 92629.

EARN \$60.00 daily practical work making concrete fence posts at home. Part Time/Full Time. Free information. McLendon, Box 1255, Cedartown, Georgia 30125.

MAIL Order Beginners! Let us help. Mellinger Bros., P.O. Box 86, Belton, Mo. 64012.

ADDRESSERS Mailing Needed. Earn to \$150.00 weekly. Details 25¢ plus stamped addressed envelope. Daniel Wanser, P.O. Box 27, Bellmore, N.Y. 11710.

NOW, MAKE BIG MONEY selling America's most exciting jewelry—**AUTHENTIC, HAND-CRAFTED INDIAN JEWELRY.** Wear it. Show it to friends. Sells on sight. Buy at **WHOLESALE**, sell for **BIG PROFITS.** Complete, unique program. For free information, write: Southwest Market Research, Dept. D-7, P.O. Box 6589, Albuquerque, N.M. 87107.

BECOME Professional Driving Instructor. Own Business. \$400.00 weekly. Howard David, 1818 Everts, Phila., PA. 19152.

IDEAS for starting your own business—**FREE DETAILS** . . . Ideas, Dept. 8A, 4667 Schwegler Rd., Cass City, Mich. 48726.

\$128.00 In Sales from \$12.00 Material. New . . . different. Everything furnished. Write: Sales, Dept. 8A, 4667 Schwegler Rd., Cass City, Mich. 48726.

EASY, Pleasant, Profitable Home Work. Full . . . Spare Time. Write: Work, Dept. 8A, 4667 Schwegler Rd. Cass City, Mich. 48726.

FREE Secret Book "2042 Unique, Proven Enterprises." (Flash! Now "4,044"!): Fabulous "Little Knowns." Work Home! Haylings, Carlsbad, Calif. 92008.

GET RICH BY MAIL. Details \$1.00. Money back if not delighted. Rondac, P.O. Box 94, Staten Island, N.Y. 10306.

HOMEWORKERS—\$60.00 To \$100.00 Plus Weekly, Details, Send Stamp. H&K Inc. Box 8351-A, St. Louis, Missouri 63132.

\$100.00 WEEKLY Clipping Newspaper Articles! Details 25¢ and Stamped Envelope. Sunny, Box 579E, Plaistow, New Hampshire 03865.

\$39.60 DAILY. Immediate Proven Income. Easy Home-work. No Mailorder Gimmick! Free Details Self-addressed Stamped Envelope: Sbiamec, Box 4160, Los Angeles, CA. 90028.

MAKE MONEY PLAYING POKER. Expert Reveals inside Secrets. Learn how to become a constant Winner. Only \$1.00. Artistic Gifts, P.O. Box 65, Seymour, Conn. 06483.

\$500 WEEKLY—Guaranteed Easy, Immediate Spare-time Earnings At Home—Free Proof—Research, Box 90133PM, Atlanta, Georgia 30344.

STUFF Envelopes \$250/Thousand. Guaranteed. Free Details. Send Stamped, Addressed Envelope. NRG, Owego, New York 13827.

UNIQUE Moneymaking Homework. \$1.00 and stamped, self-addressed. —10 envelope for information. Kelly Ross, 3148 East Vanburen, Suite 129, Phoenix, Arizona 85008.

\$10.00 DAILY Writing short articles at home. Copyrighted report reveals how and where. Full information. \$1.00. Lanfair Enterprise, 31 Christen Ct., Lancaster, New York, 14086.

CREDIT Available to place your own ads (or new ads written for you)! Take months to repay costs advanced. For application, information, send \$3.00 deposit (applied to first payment or refundable). Joseph Mondy, 1800 Castle Ave., Cleveland, Ohio 44113.

MAKE \$5.00! 1000 Envelopes Stuffed!! To Start rush \$1.00. D. Dixon, 2652 Lamott Ave., Willow Grove, Pa. 19090.

EXCEPTIONAL PROFITS Installing professional-grade, Silent, Police-Calling, hold-up & burglary alarms. We show you how—Fast. Write: Garrison Protective, B-500, 42-55 Colden, Flushing, New York, 11351.

MAKE Money! Your Old Phonograph Records may be Valuable. Booklet and Information Reveals How—\$2.00. Songs and Records, Box 863PM, Burbank, CA. 91503.

GET RICH With secret law that smashes debts and brings you \$500 to \$2 million cash. Free Report! Credit (6A7), 333 North Michigan, Chicago 60601.

\$40 DAILY Possible tying fishing flies at home. Details 50¢. Flyco, Box 946-P, Albany, Oregon 97321.

FREE—Easy Ways to make money selling exciting new products—Full—spare time. Send name, age for 5 months free subscriptions. Salesman's Opportunity Magazine, 1460 Hancock Center, Dept. 339, Chicago 60611.

PROFITABLE OCCUPATIONS

ADVERTISING Business—You own it! \$400 first week or money back. Write: Action Ad Clock, Room AC-2-EK, 1512 Jarvis, Chicago, Ill. 60626.

FREE Catalogs. Repair air conditioning refrigeration. Tools, supplies, full instructions. Doolin, 2016 Canton, Dallas, Texas 75201.

FT. SMITH Auction School, Ft. Smith, Ark. 72901. Resident & Home study. Veteran approved.

\$100.00/DAY POSSIBLE!!!! Buy Scrap Gold . . . Easy . . . Complete manual, \$4.00 Satisfaction Guaranteed . . . Brown, 956 Springdale, Atlanta, Ga. 30306.

PLASTERCRAFT!!! Profitable home business. Molds available. Details: Lynnette, 6251C Mentor Park, Mentor, Ohio 44060.

YOUR OWN Security Guard Agency. Complete Manual, \$5.00. Marsec, Box 621, Santa Fe, N.M. 87501.

SALESMEN—DISTRIBUTORS

SELL CALENDERS, SPECIALTIES Repeat Business - Free Details - Fleming, 6535 Cottage Grove, Chicago 60637.

SELL Blue ribbon Hertel Bible! Startling cover; Full color 3-dimension Nativity. Top commission, liberal bonus. Sells itself! Liberal easy credit plan. No investment. Demonstrator furnished. Write for everything! International Book, Dept. PM, Box 118, Wichita, Kansas 67201.

FREE Sample. Full Size fabulous Victory Miracle Cloth. Hot \$1.00 seller; pays 80¢ profit. Startling demonstrator. Every surface sparkles like magic. Sample, details: Barry, Dept. A4187, 1312 Washington, St. Louis, Missouri 63103.

NEED EXTRA INCOME? Sell famous Knapp Cushion Comfort Shoes. Part-time, full-time. Over \$8 million in commissions last year. No investment. Free selling kit. Write I. Margolis, 612 Knapp Centre, Brockton, Mass. 02401.

AUTOMATIC Fishhooks. Profitable Samples, \$2.00 (refundable). Aron, 61-PM, Mastic Beach, New York 11951.

EXCELLENT Commissions, Terrific Bonuses, Showing Businessmen Pens, Calendars, Advertising Specialties, Etc., Dept. PM7, Imperial Ideals, Box 10093, Kansas City, Missouri 64111.

BECOME A Successful Manufacturers' Representative. Manufacturers' Agents' Newsletter Tells You Which Firms Are Looking For Representatives, the Firm's Product Line and Territories Available. For Information write: Manufacturers' Agents' Newsletter, Dept. 152A, 23573 Prospect Ave., Farmington, Michigan 48024.

CANADIANS Sell exclusive products, Details, OPTIMUM, Box 178, Brossard, Quebec, Canada.

KEYCASES By the card sell easily to small stores. High Profits. Sample and information 25¢. Pliant Plastics, Spring Lake, Mich., 49456.

EARN Big Commission Full or Part Time. Show America's largest line low Price Business Printing and Advertising Specialties Plus Calendars in season. No experience. No investment. No collections or Deliveries. On-the-spot commissions. Big Free Sales Kit Samples hundreds items used daily by businessmen. Merchandise bonuses for you. Build profitable repeat business. Start now. National Press, Dept. 5BB, North Chicago, Ill. 60064.

BIBLES WHOLESALE—Free Circulars, Details. Write Bible Publishers, Box P5065, San Antonio, Texas 78201.

EXTRA Income Childrenbooks! Free information. Johl, Box 600-B, Stanton, California 90680.

RUBBER Stamps to 50% discount. Same day shipment. Free catalog. Star Stamp, Department 5M, 732 Federal, Chicago, Illinois 60605.

AGENTS WANTED

EVERY Man a prospect. Refundable sales kit offer showing line belt buckles, tie clasps, money clips, cuff links, lapels, identification badges, individualized with customer's name and emblems. Cap badges for trucking, bus, taxi, police, firemen. Also postal, letter carriers and heavy construction emblems. Choice 5000 emblems. Hook-Fast, Box 1088-PM, Providence, R.I. 02901.

YOUR Own business. Used Suits \$1.50; Overcoats 65¢; Mackinaws 35¢; Shoes 12½¢; Ladies' Coats 30¢; Dresses 15¢. Enormous profits. Catalog Free. Nathan Portnoy Associates, 2109-AA Roosevelt Road, Chicago, Illinois 60608.

FABULOUS New Beauty Mask. Earn Fantastic Profits Part Time. Also Party Plan—Crew Manager Opportunities. Barnes, Box 759-H, Portsmouth, Va. 23705.

DEALERS Wanted! No Product Investment. Details 25¢. Giftworld, Box 567PM, Pontotac, MS. 38863.

MAKE MONEY IN SPARE TIME. As a subscription sales representative for leading national magazines, you can earn generous commissions while learning the art of selling. Instructions and supplies will be sent to you free. Send this ad with your name and address to: **POPULAR MECHANICS**, Room 1107L, 250 W. 55th St., New York, N.Y. 10019.

SELL Lifetime Metal Social Security Plates. Big Profit. Free Sales Kit. HOUSE OF PLATES, 2529 4th Street, Ceres, Calif. 95307.

NO Investment! Instant Income! Selling outfit free! Take orders for America's finest shoes from friends, neighbors. Easy. Profitable. No experience necessary. Mason Shoes, K-157, Chippewa Falls, WI 54729.

EMPLOYMENT INFORMATION

AUSTRALIA—NEW ZEALAND WANT YOU !!! 50,000 Jobs! Paid Transportation! Latest Information and Forms, \$1.00 Austco, Box 3623-E, Long Beach, California 90803.

OVERSEAS JOBS—Now Hiring, 103 Countries, All Occupations, High Pay, Free Transportation, Tax Benefits. Latest Computerized Reports—\$2.00. TRANSWORLD, International Airport, Box 90802-E, Los Angeles, California 90009.

OPPORTUNITY—Knocks! Australia calls! Gov. jobs available Skills needed. Employer's lists given. Housing and taxes. G. Oiter, Box 825A, Detroit, Mich. 48226 \$1.00.

JOBS, Jobs—Secret Information on How To Find a job during the recession—Send \$2.00 Refundable To: Wayne & Co., P.O. Box 37350, Jacksonville, Florida 32205.

AUSTRALIA—New Zealand Need Population Millions!!! Jobs Plentiful!! Unemployment Rare! All Skills Needed. Paid Transportation, Settling-in Allowance. Details, Employers List, \$1.00 Moneyback Guarantee. Bilmor Sales, 8225A4, Northridge, CA. 91324.

TEXAS Certain Areas Booming. Free DETAILS. REPORTS, Box 38618, DA3, Houston, Texas 77038.

AUSTRALIA WANTS YOU!!!! Free Transportation. Complete Details Employers List. Forms. Guaranteed. \$1.00. Tri-State Sales, Box 4249-A Evansville, In. 47711.

SOUTHERN AFRICA Land of Gold. Booming Economy. No unemployment. Paid Transportation. Complete Guide Airmailed \$2.00. Conway Employment, Box 127, Fish Hoek 7975, South Africa.

AUSTRALIA NEEDS YOU!!!! Thousands of jobs—FREE transportation. Forms, details, and GIANT EMPLOYERS LIST. \$1.00. Davco, Box 948A1G, New London, Conn. 06320.

"GOVERNMENT OFFICER" Over 18? Become official under oath. No examinations. Quick income. Guaranteed. Free information. Loopholes, 3251 Oaks Rd., Ellicott City, Md. 21043.

CALIFORNIA Jobs, hundreds listed daily. Send \$1.00 for current San Diego classified jobs available. American Distr. Co., P.O. Box 1471, El Cajon, California 92022.

FREE transportation! AUSTRALIA employment book. All skills needed. Latest information. \$1.00 guaranteed. Wayne & Co. Box 37350, Jacksonville, Fla. 32205.

DAILY Overseas Jobs!! Current Listings by the Publishers of Globescanner. Call (804) 644-0351. From 6 PM to 9 AM. For more information call during business hours. Trans-Global Overseas Network, 301 E. Franklin, Richmond, Va. 23219.

OVERSEAS Employment — Technicians. Electrical, mechanical, maintenance, instrumentation technicians. Five years experience in refinery, petrochemical, or oil and gas industries required. Rush resume to Dan Redwine, Scientific Placement, Inc., 2700 S. Post Oak Rd., Houston, Tx. 77027.

HELP WANTED

CALIFORNIA Jobs—Engineers, Machinists, Electronics. Weekly list companies hiring \$3.00. Dynamics, Box 1867, Covina, CA 91722.

OVERSEAS EMPLOYMENT . . . Europe, Australia, South America, Asia! All Occupations! \$700 - \$4,000 monthly! Employment International, Box 29217-AG, Indianapolis, Indiana 46229.

EARN At Home Addressing Mail. Details 25¢ and Stamped Envelope. Deeco-151, Box 9308, North Hollywood, Cal. 91609.

REAL ESTATE & FARMS

FREE 75th Anniversary SUMMER Catalog! Over 5000 rural properties described, pictured—Land, Farms, Homes, Businesses—Recreation, Retirement, Selected Best throughout the U.S.! Over 700 Offices, 41 states Coast-to-Coast. Mailed FREE from the World's Largest **STROUT REALTY, Inc. 7-MX S. Dearborn, Chicago, Ill. 60603.**

CANADIAN LAND FROM \$35.00 AN ACRE CHOICE. Properties available across Canada. Low monthly payments. Ideal for farming, cottages, hunting, fishing. Free Catalogue. Canadian Estate Land, Dept. PMC-7, 286 Lawrence Ave. West, Toronto, Ont., Canada M5M 1B3.

MAKE \$500-\$1500 MORE On The Sale Of Your House. Complete Details \$5.00 Money Back Guarantee. **CAN DO . . .**, 26 Crocker Avenue, Johnson City, New York 13790.

BIG . . . FREE . . . CATALOG! 256 pages! Over 2,600 top values in 40 states coast to coast! UNITED FARM AGENCY, 612-PM West 47th St., Kansas City, Mo. 64112.

\$5 ACRE, Canadian Border—hundreds campsites, islands, farmlands, directly from tax authorities. (Non-profit). Lists, photographs mailed. Register, Room 10, 110 Church Street, Toronto 1, Ont. Canada

\$3.50 ACRE! USA and Canada. Lists, photographs mailed. Government Lands, 220-PM Delaware, Buffalo, New York 14202.

"CANADIAN—Country Acres and Lots." Our 60th year. Free catalogue. Tax Sale Service, Room 301-PM, 85 Bloor Street, East, Toronto, Ontario M4W 1B5.

CENTRAL Ontario—Choice 640 acre Sportsmen's paradises still available—\$20.00 plus \$6.50 taxes yearly. Maps, pictures. \$2.00 (Refundable). Information Bureau, Norval 4, Ontario, Canada.

PROBATE LAND SALE: Los Angeles County, California. One acre sub-divided lots. CPA must liquidate. Small down, take over payments. Wall Street Properties, Box 24646, Los Angeles, California 90024.

CALIFORNIA Acreage. Excellent investment potential. \$20.00 down. \$20.00 monthly. Box 35291, Los Angeles 90035.

WYOMING RANCH LAND. 10 acres \$30 down, \$30 month. Owner—Mike Gauthier, 9418 Florence, Downey, Calif. 90240.

FARM & GARDEN EQUIPMENT

RIDINGS LAWNMOWERS Shipped from Factory bargain priced. Free Brochure. Tomco, Box 72, Oak Grove, Missouri 64075.

HYDROPONIC GREENHOUSE. Send for Details: Iott Engineering, 4660 73rd, LaMesa, Cal. 92041.

FLOWERS, PLANTS, & NURSERY SUPPLIES

LEARN Landscaping and the growing of plants. Start a profitable business part or full time. Free information without obligation. Lifetime Career Schools, Dept. A-833, 2251 Barry Avenue, Los Angeles, California 90064.

FREE Samples, literature from our plastic flower pot sale. Send \$1.00 (postage and handling). Floripot, Box 34, Bethel, MN. 55005.

CONSTRUCTION PLANS, BLUEPRINTS

HOUSE Plans, inexpensive, Send stamp to: Technical Drawing, Box 123, Provo, Utah 84601.

INFLATED BUILDING COST—Build it Yourself. Manufacture Your Own Building Material. Building Method and 5 Blueprints—Vacation—Hunting Cabin, Workshop, Storage Building, Garage, Leisure Room Addition—Package \$10.00. Dyco Building Systems, Box 2095, Kerrville, Texas 78028.

BIG MONEY IN BUILDING TRADES—Learn Blueprint Reading—Complete Course—\$10.00—C.H.I. Construction Company, 8237 Roxbury, Los Angeles, California 90069.

LOG CABINS AND "A" FRAMES

BUILD Log Cabins. Rustic furniture, Fireplaces!! Complete manual \$3.00 . . . "A" Frame plans, \$2.00 . . . Guaranteed. . . . Beels, 956 Springdale, Atlanta, Georgia 30306.

HOME CRAFTSMAN

"UNIQUE Outdoor Mixing Bin" Hand Mixes, Cement, Garden Compost's, etc. Copyrighted Instructions \$2.00. Voigt Designs, P.O. Box 3037, San Mateo, Calif. 94403 142 W. 41st Av.

SEND For Yard Plans, easy \$1.00. W. Griffin, 1806 Brimmer, Pueblo, Colo. 81005.

FURNITURE PLANS, Full Size, Completely detailed, Shop Ready, Period and Modern. Catalog 50¢ from PRO-AM PLANS, Dept. PMC 75, 612 Oriole Lane, Mt. Prospect, Ill. 60056.

101 PATTERNS of smart Gifts, Novelties, Shelves, Action Windmills plus "Make Money Jig Sawing". \$2.00. Mastercraft, 75M P.O. Box 631, Park Ridge, Ill. 60068.

WOOD—Domestic and Imported Hardwoods! 3500 items! Clock, musical instrument kits. Tools . . . discount prices! Hard-to-find hardware. 144 page catalog, 50¢. Craftsman, Dept. AX-75, 2729 Mary, Chicago, Illinois 60608.

CLOCK MOVEMENTS: Westminster Chime, Pendulums, Conventional, Dials, Accessories. Free Catalog. Klockit, Box 629, Lake Geneva, Wisconsin 53147.

HOW To Make Kitchen Cabinet's and Furniture. New Illustrated Manual shows you the latest and easiest step by step Methods. Guaranteed Satisfaction. Write: Flint Woodworking, 1027 Mansfield City Road, Storrs, CT. 06268.

CATALOG FULL SIZE FURNITURE PLANS—\$1.00 Refunded with first order. Traditional Early American, over 150! Furniture Designs, 1425 Sherman, Dept. CP-75, Evanston, Illinois 60201.

CABINETMAKING MADE EASY And "How to Make Formica Counter Tops." Two excellent guides let you build kitchen cabinets and counter tops like professionals. Extraordinary guides bring master craftsmen's shortcut methods. Satisfaction guaranteed. Write: Japs, 126-P Seventh North, Hopkins, Minn. 55343.

PICTURE Framing—Profitable full or spare-time business. Easy to learn with handbook-course "Guide To Picture Framing Profits." \$2.00 Guaranteed. Free framing-supplies catalog included. Japs, 126-PM Seventh North, Hopkins, Minnesota 55343.

PLANTERS—(Hanging/Floor), Architect Designed, Easy To Make For Fun And Profit. 10 Plans \$2.00. Planters, Box 367, Waterford, Michigan 48095.

BEGINNERS Can learn woodworking in 25 lesson projects. Free details. Old Craftsman, 16115 Burton Court, Livonia, Michigan 48154.

BEAUTIFUL JUG LAMP!! Easy . . . Inexpensive . . . Sell-800% Profit! Plans, \$1.00. Dickson's, Box 1135GN7, San Rafael, California 94902.

GIANT WOODCARVER'S VISE, \$12! Plans \$2.00. Les Co., 4210 Knowles, Kensington, MD. 20795.

COMPLETE CABINET PLANS! Designed for all kitchens and bathrooms. \$6.00. Creations II, Box 184, Danville, CA. 94526.

METRIC RULE Hard-to-find 3-meter steel pocket tape makes work easy with new, simple metric-system. \$3.00 postpaid, 2 for \$5.00. Metric Industries, Box 26, Lake Forest, Illinois, 60045.

BUILD Templates for efficient sawing-routing operations. Drawings—\$3.00 . . . J-R Tools, Box 666, Saugus, Calif. 91350.

FREE ENERGY! Sources of Supplies, plans, windmills, solar, methane, etc. Send \$2.00. PER-O, 15 Riverside, Saginaw, MI 48602.

BUILD A RECYCLED MARTIN HOUSE OF CANS Send \$1.25 Self Addressed Envelope For Plans. Litch Const., Langford, So. Dak. 57454.

DO-IT-YOURSELF

FREE Solar Energy Catalogue. Send stamp. Centerline, 401W South 36th Street, Phoenix, Arizona 85034.

SAVE! Install Central Air Conditioning Yourself. Send \$1.00 For "How-To" Plans, Box 3329, Longwood, Florida 32750.

SAVE! SAVE! SAVE! ON CENTRAL AIR CONDITIONING Install it yourself in your forced air furnace with a few simple hand tools and one of our complete kits. Eliminate sky-high installation costs, save hundreds of dollars. Write for free "how-to" brochure. McGraw-Edison Company, Air Comfort Division, 756E N. Clark St., Albion, Mich. 49224.

KAHLUA Recipe. \$1.00. No special equipment. Majors, Box 1580, Hawthorne, California 90250.

AMAZING Electronic Products Pocket Laser. See-in-the-Dark, Radio Scramblers, penlight Strobe, Bug Detectors, TV Disruptor, Many More, All New Catalog \$1. Information Unlimited, West St., Milford, New Hampshire 03055.

BURGLAR-FIRE Alarm Supplies and Information. Free Catalog. Protecto Alarm Sales, Box 357A, Birch Run, Michigan 48415.

1400 CATALOGS Listed and Described Sources for **EVERYTHING** Imaginable! Rush \$2.00. **MASTERLOG**, Box 24413-YS, Oakland, California 94623.

STOP LEAKS. Liquid plastic stops leaks on any surface. Excellent for roofs and basement walls. Protects and beautifies. Eight attractive colors. Easy to apply. For free information call or write. (312) 568-3111 U.S. Polycoat, Corp.—850 West 119th Street—Dept. 101 Chicago, Illinois 60643.

SOLAR Pool Heater. Inexpensive. Easy plans. \$2.00. Sunsound, 256 S. Robertson, Beverly Hills, Calif. 90211.

PLANS For Childrens combination toy box, chalk board and book case. Send \$2.00 to Plans, Box 88452, Tukwila, Wash. 98188.

400% PROFIT. Giant Blowup Pictures from your present darkroom. Easily built plans. \$3.00. Guaranteed! Sunsound, 256 S. Robertson, Beverly Hills, Calif. 90211.

PLASTIC Tit Tat Toe MACHINE you can build **BUT NOT BEAT.** Complete plans **PATTERNS**, \$1.98. Gieszl, Box 254, Silver Spring, Maryland 20907.

GET RID OF TERMITES. Don't Let them eat your Home. You use Simplified Professional Know-how that works. Send for Free Details. Monroe Termite Advisory Reports, 703 Almar, Santa Cruz, California 95060.

STOPS-HEAT, FADE, GLARE. Conserve Energy! Insulate Your Glass Windows And Doors. Apply Reflective Window Film To Existing Glass. Saves On Airconditioning And Heating Cost. No Adhesive Or Special Tools Needed. Turns Ordinary Glass Into One-Way Mirror. Used In Store-Office-Apartment-Resident-Car-Van-Boat. Complete Kit! 18" x 10"-\$19.95; 26" x 5"-\$11.95; 36" x 6"-\$19.95. Sample, Brochure Send 50¢—Central Florida Sun Control, Rt. 1, Box 70, Lake Placid, Florida 33852.

SWIMMING Pool Chemicals—Make Your own—Save 75%—Formula \$5.00. 383 Lincoln Dr., Cheshire, Conn. 06410.

NATURAL STONE HOUSE. Gather rocks free, build in one summer! Need pickup, hand tools, no experience! Guaranteed. "HOUSE OF STONE" Manual, \$3.00. Stonehouse 82, Sweet, Idaho 83570.

CHAMPAGNE & Winemaking . . . \$2.00. American Enterprises, Box 666-E, San Juan Capistrano, CA 92675.

FREEZER Convert refrigerator to upright freezer. Plans \$5.00—Kit \$30.00. Appliance, 781 Greenland, Cookeville, Tennessee 38501.

ENERGY Saving plans. Water wheels, windmills, electric cars, Home Power Plants, Free Info., Plans List. Goodman Associates, 4 Berryville Pike, Summit Point, West Virginia 25446.

SAVE MONEY, hot water, fuel, Reduce electric and water bills. Shower control installs in seconds. Rush \$1.79. Floyd Williams, Rt. 2, Box 957, Monroe, N.C. 28110.

ELECTRIC Motor troubleshooting repair guide and catalog for Air Conditioning: \$3.00. EMS, 1308 North 14th, Kingsville, Texas 78363.

INGENIOUS INDEXING Lathe Attachment. Any number divisions. Plans \$10.00 **STIRLING** Hot-Air Engine Model Plans \$5.00. Addressed Stamped Large Envelope. Iger, 166 Palm, San Francisco 94118.

ELECTROPLATING. Complete amateur's textbook All metals Electroplate metallic/nonmetallic items \$7.00. Details free. Tropic, Box 95P7, Palm Bay, Fla. 32905.

REPRODUCTION MOLDS

FIBERGLASS/Latex Molds for casting Ornamental Concrete and/or plaster. Catalog \$2.00. Freeman Industries, Joliet, Montana 59041.

ARTS & CRAFTS

LEATHERCRAFT Catalog. Tools, Leather, Dyes, Dressings, Saddle Stamps, Buckles, much more. Send \$2 to MacPherson Bros., P.O. Box 395, San Francisco, Calif. 94109.

GLASS BLOWING Kits and Supplies—Literature Upon Request—Willis Glass, P.O. Box 3460, Anaheim, California 92803.

MAKE Figurines, plaques, lawn ornaments. Molds, plastercraft kits, liquid rubber. Sample and catalogue 25¢. Wooley Company, Box 29-B, Peoria, Illinois 61601.

LARGEST HANDICRAFTS SUPPLY DIRECTORY \$3.00. R.P.H. Manufacturing Co., 924 Winter Street, Stamford, Conn. 06905.

BINOCULARS, TELESCOPES, MICROSCOPES, MAGNIFIERS

"**EVERYTHING** You always wanted to know about Binoculars." Write: Tele-Optics, 5514 Lawrence, Chicago, IL. 60630.

CAMERAS AND EQUIPMENT

FREE! FREE! BARGAIN BOOK. Central Camera Co., Dept. 371, 230 S. Wabash, Chicago, Ill. 60604.

BUILD Your Own Underwater Camera Case. Complete Plans, \$3.00. E.R.P., Box 98943, Des Moines, Washington 98188.

PHOTO FINISHING

LOOK!—Special Money Saving Offer! Kodacolor Rolls developed with Jumbo Size Prints \$1.60. B&W 49¢. Big Discounts on supplies. Enclose advertisement. Wisconsin Film Service, LaCrosse, Wisconsin 54601.

COLOR SLIDES

GAF Color Slides 12,500—All Countries Catalog 25¢. Worldwide, 7427-M Washburn, Minneapolis, Minn. 55423.

FREE 35MM Color Slide Encyclopedia. Same slides used in TV, national magazines. 126-pages individual listings. Write Wolfe Worldwide Films, Dept. 14-75, Los Angeles, Ca. 90025.

MOTION PICTURES & SOUND EQUIPMENT

175-FT. 8MM, CLASSIC SAMPLER . . . ONLY \$1.99. Highlights from heyday of the silents! Chaplin, Laurel & Hardy, Fairbanks, Keystone Kops, Gish, Pickford, Chaney, the first Indianapolis 500 and more. Order today . . . specify standard or super-8. Free catalog: 8MM & 16MM, movies & 35MM, 2" x 2" color slides. Blackhawk Films, 1678 Eastin-Phelan Bldg., Davenport, Iowa 52808.

UNUSAL Movie supplies. Free circular. Esor, 47th Holly, Kansas City, Missouri 64112.

8MM—SUPER 8—16MM MOVIES! Biggest Selection! Lowest Prices! Free Catalog! Cinema Eight, Box PM, Chester, Connecticut 06412.

SUPER 8MM, 16mm, 8mm silent and sound film classics. Free catalog. NILES, 1141PM Mishawaka, South Bend, Ind. 46615.

SUPER 8, 8mm, 16mm, 35mm, B&W and Color Film. Supplies, Processing Equipment. Send 25¢ for 84-page catalog refundable with order. Superior, 448 N. Wells, Chicago 60610.

16MM Films. Free List. Urbanski, PMCA, 8142 S. Kenneth, Chicago 60652.

RADIO, TELEVISION & HAM EQUIPMENT

FREE Educational Electronics catalog. EduKits Workshop, Department 746B, Hewlett, N.Y. 11557.

HEAR POLICE/FIRE Dispatchers! Catalog shows Directories of "Confidential" channels, Receivers. Send postage stamp! Communications, Box 56-PM, Commack, NY 11725.

RADIO Tubes, 1924 to 1974. Preller T.V., Augusta, Ark., 72006. (501) 347-2281.

CANADIAN Catalogs—Giant Savings, Surplus, Clear-outs, Bankruptcy Stocks, Factory Deals. Rush \$1.00. Etco-PM, Box 741, Montreal "A".

36¢ RADIO & TV Tubes. Free catalog. Cornell, 4213-17 University, San Diego, California 92105.

500 MILE Daytime B.C. Reception. Plans—Kits—Tuners. SASE. Superclieve, 2555 Sykes, Rogue River, OR. 97537.

UNDERSTAND POLICE RADIO CONVERSATIONS 10 Code and Meanings, \$3.00 per List. John McCorkel, 3440 Burr St., Gary, Ind. 46406.

GOVERNMENT Surplus receivers, transmitters, snooperscopes, parts. Catalog 25¢. Meshna, Nahant, Mass. 01908.

HIFI, TAPES, & RECORDS

FREE Catalog—Electronic Kits—Amplifiers—Pre-amplifiers—Psychedelic Strobes—SCA Adaptors—Color Organs—Digital Instruments—Guitar Amplifiers. **FREE** Subscriptions. SWTPC, Box PM32040, San Antonio, Texas 78284.

8-TRACK Fidelity Stereo Tapes. Any Top Rock, Oldies, Radio Shows, Humor, Party. \$3.50 you name it. List 50¢ (refundable). DiWan Company, Box 1302, Springfield, IL 62705.

OLDIES 45 RPM Original Hits—Catalog 50¢. C&S Record Sales, Box 197, Wampsville, New York 13161.

FREE RECORD ALBUMS AVAILABLE For Postage and Handling. Details \$1.00: Lend-an-Album, Box 25, West Bend, Wisconsin 53095.

"**RECORD COLLECTORS JOURNAL**", The Monthly Publication Reaching a World-Wide Audience of Collectors, Dealers, Beginners of 78's, 45's, LP's, Tapes. How to Evaluate, Sell, Buy, Locate Profitably. Submit Questions, Want/Sell List for Information. RCJ, Box 1200-P, Covina, California 91722.

OLD Radio Programs. Thousands Available! Huge Catalog \$1.00! Radio Vault. Box 9032-Z, Wyoming, Michigan 49509.

RECORDING Tape Closeout "Reel" Bargains. Mitchell, Box 132PM, Flushing, NY 11367.

COMPLETE Stock of 9-TRACK tapes prerecorded and blank Stereo equipment and accessories available. Discount prices. Free catalog. Victory Tape Sales, 2646 N.E. 189th Terrace, N. Miami Beach, Fla. 33160.

FREE Catalogue. 2500 Rare Collectors Records. Collectors Records, Box 7216, Louisville, Ky. 40207.

RADIO Programs. Sound Tapes Of Past, Box 3402M, Seminole, Florida 33542.

MUSIC INSTRUCTIONS & INSTRUMENTS

WOODS, Parts for making, repairing violins, guitars, other string instruments. Complete kits. Free catalog. Dept. PX-International Violin Co. 4026 West Belvedere Ave., Baltimore, Md. 21215.

ACCORDIONS—Famous makes. 40 models. 5 Day Home Trial. Easy terms. Trades. Free Catalogs! Money saving Importer-to-You Price List. Write: Accordion Corporation, Dept. R, 5535 Belmont, Chicago 60641.

ACCORDION Top Brands. Cordovox, Buy direct. Tremendous discounts. Trades accepted. Free brochure PM. Accordion-O-Rama, 874 Broadway, N.Y.C. 10003.

30% TO 50% DISCOUNT! Any Model: Guitar, Amp, Drum, Banjo, Dobro! Free Catalog! Warehouse P59, Box 11449, Fort Worth, Texas 76109.

WHOLESALE. Musical Instruments—Accessories. Allied, 573 Route 17, Paramus, New Jersey 07652.

KITS! Build dulcimers, guitars, harps, banjos, mandolins. From \$2.95. Finished instruments from \$23.95. Free catalog. 8665 West 13th-PM, Denver, Colorado 80215.

SWISS Finest Music Boxes, Movements. Spielman, 55 West 42nd, New York, 10036.

STRINGS! Accessories, Parts, Discounts, **FREE** Catalog. Stringking, M7, Box 5444, Lindenhill, Flushing, N.Y. 11354.

EASY To Play And Make, Quality Dulcimers, Banjos, Thumb Pianos; Instruments And Kits. Can Be Profitable Hobby. **HERE, Inc.** #P, 410 Cedar Avenue, Minneapolis, Minn. 55404.

WHOLESALE! Professional Guitars, PA Systems, Altec Speakers, 240W RMS Amplifiers. Free Catalog. Carvin, Escondido, Calif. 92027.

POEMS Wanted for songs. Nashville Music Productions, Box 40001-P, Nashville, Tennessee 37204.

PLAYER PIANOS; PUMP ORGANS—books; repair manuals. Catalog \$1.00, refundable first order. Vestal Press, Box 97, Vestal 11, NY 13850.

LEARN to Play Piano—Guitar—Accordion My Way. Write: Hall's, Box 181PM, Lynwood, California 90262.

LEARN Banjo. 5-String Bluegrass. No music. Makes learning easy. Free details. Blaylock, Box 25-M, Marietta, Georgia 30060.

UP TO 60% Discount Name Brand Instruments. Catalog. Freepost Music, 455F. Route 110, Melville, N.Y. 11746.

ACCORDIONS Manufacturing, 6846-P North, Chicago 60635. Concertinas - Chromatics - Heligons - Hohners - New - Used - Repairing - Wholesale Catalogs Free.

POEMS Songs wanted. Recording. Publishing guaranteed. Royalties. Radio-TV release. Broadway Music, Box 11647-PM, Sarasota, Fla. 33578.

PLAY GUITAR IN 7 DAYS. COMPLETE KIT. Send \$3.49 to: Compo House, Dept G, 20 Clark's Hill Ave, Stamford, CT 06902.

SONGWRITERS. Present your songs to publishers like professionals. Also who, where, how. Informative booklet. \$3.00. Sunsound, 256 S. Robertson, Beverly Hills, CA 90211.

13 MUSICAL instrument kits, solid walnut, spruce. Rembrand Company, RRR, Newton, Iowa 50208.

ELECTRIFY Player Pianos, Pump Organs Quickly, Inexpensively with Lee Silent Suction Units. Write: Lee Music. 525F Venezia Avenue, Venice, California 90291.

GUITAR, Banjo, Violin, Mandolin Making Materials, Accessories, Books. Catalog 25¢. Guitar Center, Box 15444, Tulsa, Oklahoma 74115.

EDUCATION & INSTRUCTIONS

WELDING TRAINING Basic and Advanced Training for Major Processes—Arc, Gas, Pipe, **TIG MIG,** Plasma. Hobart, a non-profit school, is accredited member **NATTS.** Approved Ohio 70-12-0064 HT. Write for school bulletin and course schedule. **HOBART SCHOOL OF WELDING TECHNOLOGY,** Box 75, Troy, Ohio 45373.

10—LESSONS—\$10.00. Economics Correspondence Course. Henry George School of Social Science, 1318 Beacon Street, Brookline, Mass. 02146.

EARN WHILE YOU LEARN At Home in Your Spare Time. Modern Outdoor Equipment Repair School (Coleman and others). Dept. PME, 4225 N. Brown Ave., Scottsdale, Arizona 85251.

WANTED "Unknown Definition of God" Amazing report reveals how to unlock Bible's tremendous creative force. Forge ahead. \$7.00. Lakewood Products, Dept. SCI, Box 29, Jamaica, New York 11435.

AMATEUR Radio. Complete correspondence Code and Theory license courses. Ron Reed Electronics Institute, 12217 Santa Monica Boulevard, Los Angeles, Calif. 90025.

SMALL ENGINE REPAIR—Earn And Learn At Home. (Briggs & Stratton and others). Modern Small Engine Repair School, Dept. PMR, 4225 N. Brown Ave., Scottsdale, Arizona 85251.

COMPLETE YOUR HIGH SCHOOL At Home In Spare Time. Texts Furnished. No Classes. Our Diploma Awarded. Our 7th Year. Free Brochure. American School, Dept. XB45, Drexel at 58th, Chicago 60637.

EARN WHILE YOU LEARN At Home In Your Spare Time. Send For Brochure, Full Facts. Modern Gun Repair School, Dept. PM, 4225 N. Brown Ave., Scottsdale, Arizona 85251.

LEARN ACCOUNTING! U.S. Labor Department reports "33,000 NEW Accountants, 78,000 NEW Bookkeepers needed EACH YEAR for next ten years". Easy home-study plan prepares you. Approved for Veterans. Send for FREE "Accounting Career Kit". North American School of Accounting, Dept. PBC55, Newport Beach, California 92663.

SMALL ENGINE REPAIR—Earn and learn at home. Modern Small Engine Repair School, Dept. P, 4225 N. Brown Ave., Scottsdale, Arizona 85251.

LEARN Asleep or awake! Records, tapes, equipment! Free catalog! Drawer PM-400, Ruidoso, New Mexico 88345.

BARTENDING—Bar Management Course. Free information. Universal Academy. Box 8180-AB, Universal City, California 91608.

COLLEGE Degrees at home. Choice of subjects. Easy tuition. Free inf. Elysion College, B. C. Box 909, San Ysidro, Cal. 92173.

ACCOUNTING CAREER. Many make \$1,200 monthly. You start, only 20 lessons, \$5.00 each. Pay as you learn and earn. State approved. Certificate. Start by Mailing \$5.00 for first lesson. Jenkins, Box 571, Taft, California, 93268.

RADIESTHESIA, Radionics, Dowsing, E.S.P. Courses and Equipment. Illustrated Catalog \$1.00 (refundable) Established 27 years. Dept PM/R Bruce Copen. Highfield, Danehill, Sussex, England RH17 7EX.

AUCTIONEERING, Resident or home Study Course. Free Catalog, Nashville Auction School, 1921 West End, Nashville, Tennessee 37203.

AUTOSUGGESTION. Sleep-learning headquarters! Tapes, records, books, Gigantic catalog free. Research Association, Box 24PM, Olympia, Washington 98501.

DETECTIVE—Training Course. American Detective Institute, Box 418-A, Fairfield, Alabama 35064.

RELIGIOUS VOCATION? Write: Church of Holy Light Inc., P.O. Box 4478, Pittsburgh, Pa. 15205.

USED Courses! Books! List 10¢. Smith's, 124 Marlborough, Salem, Massachusetts 01970.

OWN Collection agency. "Little Gold Mine!" Franklin Credit, Roanoke, Virginia 24004.

PIANO Tuning quickly learned with home study course. Diploma granted. American Tuning School, 17050 Telfer Dr., Morgan Hill, California 95037.

DETECTIVE Profession. Easy home study, free tie-tack or lapel pin, certificate, future. GI approved. Professional Investigators, Box 41345, Dept. CP, Los Angeles, Calif. 90041.

LEARN Auctioneering. Term soon. Free Catalog. Reich World Wide College of Auctioneering, Inc., Box 949, Mason City, Iowa 50401.

EARN ELECTRONICS DEGREE by correspondence. Free brochure. Grantham, 2004 Stoner, Los Angeles, California 90025.

LEARN Sewing Machine Repairing. Men, Women. Lucrative profits. Profession with bright future. Gresslin Correspondence School, Box 927, Spencer, Iowa 51301.

PROBLEMS? There's an Answer! Free Home Study by Mail in the Torah or Confraternity New Testament. Please state your Religion, Lamplight Studies, Box 88-D, Brooklyn, New York 11229.

EXTENSION And Post-Graduate Awards in Philosophy, Art, Sciences, Botanic Medicine, Homeopathy, Radiology and others. 30 subjects. Curricular free (airmail \$1.00 refundable). Registrar, Sussex College of Technology, Highfield, Danehill Sussex, England.

DETECTIVE Course. Free information. Universal Detectives, Box 8180-F, Universal City, California 91608.

PIANO Technology—Electronic organ servicing, learned easily at home. G.I. Approved. Free booklet. Niles Bryant School, Dept. P, 3631 Stockton, Sacramento, California 95820.

WATCH REPAIRING. 35 Lesson Home Study Course. Free sample. Diploma awarded. Chicago School of Watchmaking, Dept. YT, Fox River Grove, Illinois 60021.

FREE Lifetime Ordination. Become Chaplain Missionary. Bishop, Box 744, McKeesport, Pa. 15134.

PARAPSYCHOLOGY. Complete Study Course, Certificate. Free information. American Parapsychological Research Foundation, Box 5395-8B, Sherman Oaks, Calif. 91413.

PENMANSHIP Corrector. Improve Poor Penmanship Quickly. Details Free. Thurmon, Box 824, Stinnett, Texas 79083.

LEARN ELECTRONICS FAST! You can begin secure high paying career within weeks. Includes test equipment, kits, tools. Diploma awarded. Amazing low price! Details 10¢. National Homestudy, Dept. PM7, 21733 Carriage Drive, South Bend, Indiana 46614.

INSTANT MEMORY. . . . New way to remember. No memorization. Release "photographic" memory. Forget nothing! Liberates extraordinary knowledge talents, ESP. Immediate results! Free information. Institute of Advanced Thinking, Box 606-PM, Pacific Palisades, California 90272.

PRIVATE DETECTIVE Training manual. \$2.00. "Professional Secrets," 3034 Walnut, Lincoln, NE. 68503.

NOW! YOUR OWN BURGLAR/FIRE ALARM BUSINESS OR Alarm installation position through training at home. Great demand, rapidly expanding field. Full information by mail, no salesmen. Security Systems Management School (homestudy), Dept. 7310-075, Little Falls, N.J. 07424.

UNLOCK your future. Become professional Locksmith by spare time homestudy. \$13.00 in an hour possible. All tools, equipment included. Facts Free. Send name. Locksmithing Institute (homestudy), Dept. 1310-075, Little Falls, N.J. 07424.

LEARN To fix Typewriters and Office Machines. Many trained men needed. Make up to \$25.00 in one hour on overhaul. Learn at home in spare time. Facts Free. Send name. Typewriter Repair School (homestudy), Dept. 3310-075, Little Falls, N.J. 07424.

UPHOLSTERY Decorating. Free Booklet. Learn at home. Upholstery Decorating School, Dept. 5310-075, Little Falls, N.J. 07424.

FREE Book tells how you can learn camera repair and service. Home study or classroom. Write today! National Camera, Dept. EAD, Englewood, Colorado 80110.

DETECTIVE Training Method. Free information. International Investigators, Box 982P, Palm Springs, California 92262.

FOR INVENTORS

PATENT Application Financing. Free patent search plan. Global Patent Division, 139-G Lake Merced Hill South, San Francisco, California 94132.

INVENTORS—UNITED STATES PATENT OFFICE SEARCHES. PATENT DEVELOPMENT Engineering and MARKETING of your inventions, ideas with MANUFACTURER CONTACTS. Send for FREE INVENTION CERTIFICATES and Invention Information. Serving inventors since 1948. GEORGE SPECTOR, LICENSED PROFESSIONAL ENGINEER—PATENT ENGINEER. Former UNITED STATES PATENT OFFICE EXAMINER—3615 Woolworth Building, New York, New York 10007.

U.S. PATENT Office Searches, 234 Broadway, Room 3615, New York 10007. Free invention certificates.

INVENTORS: Your ideas and inventions (patented/unpatented) expertly searched, developed for commercial appeal and cash/royalty sales to manufacturers by professional Invention Developer with excellent record of experience. B. S. Industrial Engineering; United States Patent Office former Patent Examiner. United States Government former Patent Advisor. Second decade reliable service! Member: United States Council International Chamber Commerce. Free "Invention Record" and "Recommended Protection Procedure." Airmail! Write: Raymond Lee, Invention Developer, 230P-Park Ave., New York, New York 10017.

FREE PAMPHLET: "Tips on Safeguarding Your Invention." Write: United States Inventors Service Company, 501-P Thirteenth Street N.W., Washington, D.C. 20004.

AUCTION: We Buy Ideas. For information send \$3.00 to: George W. Smith, Box 8436, McConnell, AFB, Kansas 67221.

NEEDING Assistance? **INVENTION DEVELOPMENT FOUNDATION**, 155 Kent Street, Ottawa, Canada K1P 5P3.

ROYALTY Money Paid For Inventions. American Square Factory, Jamestown, N.C. 27282.

PATENT SEARCHERS Includes maximum speed, full Airmail report, copies of closest patents. Quality searches expertly administered with complete secrecy guaranteed. Ask for Free Invention Protection Form and "Patent Information". Write Dept. 707, WASHINGTON PATENT OFFICE SEARCH BUREAU, 734 15th St., N.W. Washington, D.C. 20005.

INVENTIONS Wanted immediately for promoting on cash or royalty. Patented, Un-Patented. Free booklet outlines royalty rates, requirements. Write Kessler Corporation, C-57-FI, Fremont, Ohio 43420.

SEARCHES—Abstracts nearest patents, \$18.00. Inventors Guide; Filing Your Own Patent Application, \$14.90. Research, Evaluations. Professional Engineer, Box 8001 JFK., PO. Boston, Massachusetts 02114.

FILE FOR YOUR OWN PATENT—Clear instructions for writing, drawing, invention selling plus legal forms, Bristol boards for drawings, sample patents, etc. All you need. Save hundreds of dollars. FREE leaflet or send \$10.00 now for complete kit. KRAG STORM CO., 323 East 17th Street, New York, New York 10003.

NEW Idea Show Coming! Spring-Fall Shows. All Inventions Welcome. Free Details. Applications, No Obligation. Write: Paul Paulsen, Jr., 401 So. Columbia St., Frankfort, Ind. 46041.

"INVENTION MARKETING MADE EASY". How the professionals do it, with step-by-step process and examples. Save hundreds of dollars. Book \$5.00. 735 State St., Suite 613, Santa Barbara, Cal. 93101.

INVENTORS: Only 5 of 100 succeed. Will you? Find out. DETAILS FREE. AMERICAN TECHNOLOGY EXCHANGE, Suite 1202-EDP, 1006 Grand, Kansas City, Mo. 64106.

MR. INVENTOR: AMERICA'S FOREMOST BROKERAGE FIRM offers a complete service for inventors. For an HONEST evaluation, FREE "Proof of Invention" PROTECTION forms and other important information WRITE: Charles S. Prince, Inc., Business Builders, 509-A 5th Avenue, NYC, 10017.

INVENTIONS WANTED

CASH—Royalties for patented, unpatented inventions. Global Marketing Service, 139-G Lake Merced Hill South, San Francisco, California 94132.

INVENTORS! Protect your ideas! Free "Recommended Procedures." Washington Inventors Service, 422F Washington Building, District of Columbia 20005.

FREE! LATEST DIRECTORY OF 500 CORPORATIONS SEEKING NEW PRODUCTS! If you have an idea for a new product—or a way to make an old product better, send for our FREE INVENTORS KIT NO. A-04. It gives vital information on developing and marketing your invention/idea for Cash/Royalty Sales to corporations nationwide. Raymond Lee Organization, 230 Park Avenue, New York, N.Y. 10017.

INVENTIONS MARKETED Cash, Royalties FREE INVENTION PROTECTION CERTIFICATES. George Spector Manufacturers Representative, Woolworth Building, New York, N.Y. 10007.

INVENTIONS IDEAS WANTED Developed, Marketed by leading professional organization for Cash/Royalty sales. FREE EXAMINATION and CONFIDENTIAL REPORT of the Commercial Features of Your Patented/Unpatented Invention. FREE COPY "How to Safeguard and Market your Invention to Industry" Write or Call: LAWRENCE PESKA ASSOCIATES, Dept. C, 500 Fifth Ave., N.Y.C. 10036, (212)354-9696, 150 S. Wacker Dr., Chicago, Ill. 60606, (312)346-1172, 1 Biscayne Tower, 2 So. Biscayne Blvd., Miami, Florida 33131. (305)358-1366, 44 Montgomery St., San Francisco, Calif. 94164 (415)956-1212, 1888 Century Park East, Los Angeles, Calif. 90067 (213)552-2020.

INVENTORS! FREE BOOKLET LISTING 1,000 CORPORATIONS Which may be interested in your invention. Many well-known manufacturers have engaged us to locate new products like yours. For Free INVENTORS KIT regarding the successful promotion of your invention or idea, contact: GILBERT ADAMS ORGANIZATION, Dept. 36G, 80 Wall Street, New York, N.Y. 10005.

HONGKONG Factory needs 10-15 new products every month to satisfy their overseas buyers. Particularly interested household items, toys, games, gadgets. Please send sketches or detailed explanation for evaluation and cash/royalty purchase. If you have an article/accessory cannot produce domestically because of quantity, price or labour; please try us. Hongkong Plastic & Metal Products Company, P.O. Box 9627, Kwun Tong, Hongkong.

INVENTIONS Needed immediately for manufacturers. For additional information write Kessler Corporation, C-57-IW, Fremont, Ohio 43420.

INVENTORS—Before cashing in, know what you have. Market research your invention. A stitch in time EARNS nine! Inexpensive. Free information. Deep Roots, 1000 Market, Lewisburg, Pa. 17837.

MANUFACTURING

INVENTORS Ideas Developed. Research, Models. Manufacturing. Sales. Free Brochure. Since 1942. William Parker, Box 6305, Orlando, Fla. 32803.

BUY IT WHOLESALE

PAPER MILL Seconds Generous Sample Paper \$3.00. Willoughby, P.O. Box 121, Watervliet, Michigan 49098.

400,000 BARGAINS Below Wholesale: Many Free! Liquidations . . . Closeouts . . . Job Lots . . . Single Samples. Free Details. Bargainhunters Opportunities, Box 730-A, Holland, Michigan 49423.

WORLD'S Largest wholesale supply. 7853 American, Foreign Wholesalers. Rockbottom prices. Hongkong Clothes, Automobiles, Japan electronics. Free details. International Buyers, Box 16386M, Portland, Oreg. 97233.

HEARING Aids, batteries, Wholesale. Catalog 25¢. Fiston, Box 1444, New Preston, Conn. 06777.

STOP Paying Retail Prices! Get Wholesale Catalogs Stacked 6 Feet High! What's New, 25 East Washington, Chicago, Illinois 60602.

WORK GLOVES Sold direct to the public. But at 1/2 the price you would pay in a store. All types gloves leather, cotton, rubbercoated. Send 50¢ for catalog. Sara Glove Company, P.O. Box 53, Southington, Conn. 06489.

STORE Owners, Salesmen, Flea Market Dealers. Our Giant 96 page wholesale merchandise catalogue. \$2.00. Hamernick, 71 Strawberry Hill Ave., Stamford, Conn. 06902.

ORIGINAL Inflatable Vinyl Beds. None Better. Advantages Of Waterbeds Without Weight. Twin Size \$39.95, King Size \$69.95. Send Payment Plus \$3.00 Shipping. "MYCLOUD" (TM), Dept. 69, Box 16046, Kansas City, Missouri 64112.

EXPORT—IMPORT

JAPAN: 1200 Products directory. Illustrated Manufacturers' names, addresses. \$5.00. Send cash. Yamagata Office, 814 Togin Bldg., Marunouchi, Tokyo.

ORIGINAL Oil Paintings \$96 Dozen, Color Brochure 25¢. McDaniel, 3632 Topax, Claymont, Delaware 19703.

THE FABULOUS IMPORT-EXPORT BUSINESS. Learn how to get started fast. Report reveals foreign suppliers. Ideal export items. Send \$1.00. WESTERN PUEBLO, 4672 Park Blvd., San Diego, Ca 92116.

ORIGINAL Oil Paintings 16"x20", \$40.80 Dozen. F.O.B., Mimanov, PM75, Box 169, Hainesport, N.J. 08036.

FOR PARENTS

NEW—Parents List 30/\$3.00. Lang, Box 189PM, Morningdale, Mass. 01530.

FOR THE HOME

DAMP BASEMENT? Book shows you how to fix it. GEPE, \$3.00 postpaid, Box 662, Elyria, Ohio 44035.

NON-SKID SAF-T-BAK RUG BACKING. Adds body. Lengthens rug life. Washable. Quart \$2.75; gallon \$8.25. Testworth Laboratories, Inc., 401 S. Main St., Columbia City, IN 46725.

OF INTEREST TO ALL

FREE LIST! Low Cost Books. Novelties Unlimited, 2730 Yonge #205B, Toronto, Canada M4N 2J1.

PARAPHERNALIA Catalog. Hundreds of items. Send 50¢ To: Poor Richards Head Supplies, P.O. Box 24521, Cleveland, Ohio 44124.

OVERWEIGHT! How to lose fast! Easy! Safe! **GUARANTEED!** Wall Chart included. Send \$3.00. Jerryco, P.O. Box 6173, Honolulu, HI. 96818.

\$100 WEEKLY POSSIBLE Stuffing-mailing circulars for mailorder firms I represent. Send stamped addressed envelope. John Martin, Dept. TM3; Box 23033; Minn., Mn. 55423.

CRIMEFIGHTERS! Detectives-Police Catalog \$1.00 Don-Q, Box 548-PMO, Seattle, Washington 98111.

HOMEWORKERS, Mailers needed! 50 firms listed! Send 25¢ stamped, addressed envelope. Shirley's Services, Box 7947, Kansas City, Mo. 64129.

"SURVIVAL" Long Storage Foods. Descriptive List 50¢. "Survival/Military"—Books/Manuals Catalog 50¢. Hale Supply (K-50), McDonald, Ohio 44437.

\$800 MONTHLY Possible addressing—stuffing envelopes (longhand-typing) your home. Experience unnecessary. Details, send stamped addressed envelope. American, Excelsior Springs, Mo. 64024.

"CONSUMER SURVIVAL KIT". CURRENT! INFORMATIVE! Details 25¢. Custom House PM, Patterson, New York 12563.

NEW and different colored Gift Catalog Free. Sensational—unusual gifts of every kind. Write Bradley, 589-P Ridgewood, Brooklyn, New York 11208.

NOW!!! "Make and Break Wills", 3 Will Forms . . . \$2.00. Less-Box 1198, Flushing, New York 11354.

ASTOUNDING — New — Know God Better. \$2.00. Williams, Box 908, Hurst, TX. 76053.

OF INTEREST TO WOMEN

WANT a new car, color TV, new clothes? Learn hundreds of ways to make money. 5 month subscription FREE. Write: Salesman's Opportunity Magazine, Dept. 469, 1460 Hancock Center, Chicago 60611.

\$500 MONTHLY Possible clipping items from your newspaper. Experience unnecessary. Details, send stamped addressed envelope, American, Excelsior Springs, Mo. 64024.

GIFT SHOPPING

JEWELRY catalog many beautiful items send .50¢ receive \$2.00 discount toward first order. D. Schodrof, Box 387-PM, Sheridan, IL. 60551.

GIFTIME Catalog \$1.00 Refundable. Newest Items Made. Hanrahan Products, 7846-20th Ave., Kenosha, Wis. 53140.

FANTASTIC Gift Catalog. Amazing Bonus. 50¢. Generopol, Box 961, Lomita, CA 90717.

FREE Shopping Gift Catalog. R. Jean, 63 Old Meadow Rd., Dracut, Mass. 01826.

CLOCKS, WATCHES, OLD GOLD, JEWELRY

HIGHEST CASH Immediately for Old Gold, Jewelry, Gold Teeth, Watches, Diamonds, Spectacles, Silver, Platinum. Free Information. Rose Industries, 29-A East Madison, Chicago 60602.

JEWELRY Sample \$10.00. AED, #303, 3100 S. Michigan, Chicago, Ill. 60616.

WATCH and Clock repairing books, tools, materials. Free catalogs. North American, Box 77-AG, Fox River Grove, Illinois 60021.

WANTED—Gold, silver, platinum (any form). Coins. Information Free. Wilmot's, 345 South Glassell, Orange, CA 92666.

BEAUTIFUL 31-day Pendulum Wall Clock. Rice's 107-B Thriftway Plaza, Ruskin, Fl. 33570.

PUKA SHELLS. Hawaii's Fashion Jewelry. Write: Kawika, Box 8196, Honolulu, Hawaii 96815.

HEARING AIDS

HUGE SAVINGS. Eliminate dealer mark-ups. Free Trial. Batteries Wholesale. Terms arranged. Lloyds-PMC, Rockford, Ill. 61104.

FREE HEARING AID CATALOG—Save by mail. Write: "MONEYSAVERS", 9530-PM-7, Langdon, Sepulveda, California 91343.

HEARING Aids, Batteries, Discount Prices. Free Trial. Write: Rhodes, Brookport, Illinois 62910.

HEARING Aids—Huge savings on tiny, all in the ear, eyeglass, behind the ear and body models. Free home trial. Low as \$10 monthly. Write for free catalog. Prestige, Dept. R-6, Box 10947, Houston, Texas 77018.

TOBACCO

HANDCARVED Meerchaum Pipes Wholesale Catalog. Nichols, Box 3144, Enid, Oklahoma 73701.

BRIAR, MEERSCHAUM. Pipe making materials. Pimpop, Box 59211, Chicago, Illinois 60659.

MEERSCHAUM Pipes—Free Catalog. Conner Imports, Box 9574-PM5, San Jose, Calif. 95157.

FREE Sample of our Best Selling tobacco. Bradley's, Dept. 1, 170 Cypress, Abilene, Texas 79601.

SCIENCE & CHEMISTRY

DISCOUNTED! Laboratory Chemicals, Glassware-Apparatus. Catalog-50¢. Deluxe Scientific, 507 Huron, Manitowoc, Wisconsin 54220.

KIRLIAN PHOTOGRAPHY KIT NOW ONLY \$24.95 postpaid, guaranteed!! Details—25¢. Order from: Kits, 580 Commonwealth, Boston 02215.

CATALOGUE Of Ver-ry Interesting Chemical Products. Formulas, Books, Experiments, Supplies, Surprising Extras. 75¢. Kenrus-C, Box 205, Staten Island, New York 10306.

FORMULAS, PLANS, ETC.

ANY Formula \$5.00. Catalog—Manufacturing Treatise \$1.00. Belfort, Box 568, Chicago 60690.

PLASTICS

INJECTION MOLDING—Small plastic parts made to your specification. Simple tooling averages \$50.00. Pliant Plastics, Spring Lake, Mich., 49456.

CASTOLITE Pours like water, hardens like glass without heat. Crystal clear, colors, Embed flowers, seashells, mementos, anything. Make fine gifts. Form flexible molds over patterns of any shape, size. Reproduce your own designs in plastics, candlewax, metal, plaster, cement. Profitable. Send \$1.00 for illustrated Manual Catalog. **CASTOLITE**, Dept. 75H/PM, Woodstock, IL. 60098.

TREASURE FINDERS

"METAL Detectors-Powerful, lightweight, inexpensive. Free brochure. Fortune Electronics, Dept. AC, 4410 Alameda, El Paso, Texas 79905."

GOLD! Where to pan it throughout U.S.! **FREE** DETAILS: Moran, 2R Van Buren, Scotia, N.Y. 12302.

TIRED OF DIGGING UP TRASH? The All New "Coin-Shooter" Rejects Bottle Caps, Tin Foil, Nails and Shallow Trash. Detects Gold, Silver Coins and Jewelry. Free Literature. **D-TEX ELECTRONICS**, Box 451-U, Garland, Texas 75040.

POWERFUL Metrotech locator detect gold, silver, coins, relics. Moneyback guarantee, terms. Free information. Underground Explorations, Dept. A, Box 793, Menlo Park, California 94025.

BURIED TREASURE—Locate up to Quarter Mile away with Ultra-Sensitive Directional Locator. Send for free, informative pamphlet. Research Products, Box 13441-AMC, Tampa, Florida 33611.

FREE FACT-FILLED Catalog! World's largest selection! Metal detectors starting at \$79.50. Two year guarantee! Three factories, U.S.-Canada. 1,200 dealers—Service Centers nationwide. Finest instruments at any price! Budget terms. Dealer inquiries invited. Write: White's Electronics, Inc., Dept. PASU, 1011 Pleasant Valley Road, Sweet Home, Oregon 97386.

FIND Buried treasure with patented metal detectors that distinguish Metallic trash from treasure, have push button and automatic tuning, ground pickup eliminate feature, great range, etc. Free catalogue. Gardiner Electronics, Dept. 9, 4729 N. 7th Avenue, Phoenix, Arizona 85013.

TREASURE FINDER Locates buried gold, silver, coins, treasures. 6 powerful models. Instant financing available. Write or call for free catalog. Phone (713) 682-2728 day or night. Dealer inquiries invited. Relco, Dept. AA21, Box 10839, Houston, Texas 77018.

GOLD

NOW! FIND GOLD, OLD MINES, BURIED TREASURES, PAN NUGGETS, AMAZING GUIDE REVEALS HOW. DETAILS FREE. Dave Hunt, Roosevelt, Utah 84066.

PRECIOUS STONES & MINERALS

GET Free catalog no serious rockhound, gem cutter, jewelry maker, hobbyist or craftsman can be without. Full of bargains, exclusive items, low prices from largest suppliers and authorities in the field. Free new catalog just off the press, yours for the asking. Write: Grieger's, Dept. C-12, 900 South Arroyo Pkwy., Pasadena, California 91105.

500 POLISHED Gemstones \$5.00. Tumblecraft, 5401 James North, Minneapolis, Minn. 55430.

PLASTIC Casting Supplies, Molds, Jewelry Mounts. Cut Stones. Wholesale Catalog 25¢. Eloxite, 8068 10th St., Wheatland, Wyo. 82201.

EARN MONEY, MAKE JEWELRY. Amazing motorized gem cutting machine with Diamond Blade, grinding, sanding, polishing wheels, Bonus African rock assortment; amethyst, garnet, transvaal jade, agates. \$109.90. Guaranteed 5 years. Order 6262900, Earth Treasures, Dept. P, Galesburg, IL. 61401. Other models from \$45.00. Free catalog available.

CARTOONING, COMMERCIAL ARTS,

LEARN Sign painting at home. Free Talent test. Ben Kerns, Box 812-PM, Greenville, S.C. 29601.

SIGN Painting—\$1000 per Month Part-Time. Free Catalogue. Kaufmann Supply, Centertown, Missouri 65023.

MODERN Cartooning taught by mail. Write for free brochure. Cartoonorama—Box 263-PMG, Branford, Conn. 06405.

COMPACT 23 lesson Cartoon Course and Cartoonist's Magazine, \$2.00. Hartman, Box 30367, Lincoln, Nebraska 68510.

FASCINATING Systems. Sign Painting-Cartooning. Straley, 1704 South Center, Springfield, Ohio 45506.

SIGNS Hand Routed Redwood 16 Letters \$4.00 Ppd. Sack, Shell Knob, Mo. 65747.

ADVERTISING AGENCIES, ADV. SERVICES, MAILING LISTS

ADVERTISING Ratebook leading newspapers, magazines. \$1.00. Chicago Advertising Agency, 28-E Jackson, Chicago 60604.

MAILING List, Most all Kinds, \$10.00 per M, 500 Circulars mailed \$7.00, Dixmailers, King, NC 27021.

RUBBER STAMPS

3-LINE Stamps, \$2.50 Signature Stamps, \$5.75 Postpaid. Ulrich, Box 568, Athens, Alabama 35611.

FREE catalog—Rubber Stamps—Signature Stamps—Business Cards. Youngers Stamp Shop, Princeton, Iowa 52768.

3-LINE Stamps, \$2.50. Signature Stamps, \$5.95. Tabco, Tomkins Cove, New York 10986.

CUSTOM Made Stamps. Free Catalog. **ALLEGHENY**, Box 14C, East McKeesport, PA 15035.

QUALITY Stamps 3 lines \$2.50 Business Cards Catalog. Stamps, 1737 W. Coolidge, Phoenix, AZ. 85015.

PERSONAL Printer—Name, Address. Complete Compact Kit. \$4.98 Postpaid. Accardo's, Box 29262, New Orleans, Louisiana 70189.

OFFICE SUPPLIES

MAILORDER RECORDS Help get increased business! Complete 32 Page Record Book shows your inquires, orders, advertising, expense, etc. Only \$1.00. **N. E. KAPPEL, POPULAR MECHANICS, DEPT. R, 224 WEST 57TH STREET, NEW YORK, N. Y. 10019.**

PRINTING PRESSES, RUBBER STAMP OUTFITS

SIMPLE-X RUBBER STAMP PRESSES, Hydraulic operated, electrically heated. Sizes 5" x 8", 8" x 12", 10" x 15". Starting outfits. Order for presses, supplies shipped day received. Send \$2.00 for Catalog and brochure. Custom Manufacturers, 2251-P N. Golden, Springfield, Mo. 65806.

PRINTING MACHINES. Offset, Mimeograph, Typewriters, Composing, Machines, Dixgraph, King, North Carolina 27021

NEW Catalog No. 13, 120 Pages, hand printing presses, type fonts, supplies. Send \$1.00 deductible first order. Acme Type, 732 Federal, Chicago, Illinois 60605.

SAME Day shipment on rubber stamp supplies. Revised wholesale price list No. 11 free. Star Stamp Supply, 732 Federal, Chicago, Ill. 60605.

PRINT YOUR OWN—Printing Presses, type, supplies direct from factory. Send 25¢ for catalog and samples to: Kelsey Co., DM, Meriden, Conn. 06450.

PRINTING Presses, type, Supplies Lists, 10¢. Turnbaugh Service, Mechanicsburg, Pennsylvania 17055.

RUBBER Stamp Supplies; Starting Outfits. Martin, 1432 Major, Jefferson City, Mo. 65101.

SPECIAL 20% Discount Introductory Offer on our New Custom Size Type Fonts. Buy Direct From Manufacturer—(No Middleman Profit) Type, Presses, Mounts. Barco Type Mfg., 237 S. Evergreen, Bensenville, Ill. 60106.

RUBBER STAMP MANUFACTURER SUPPLIES. PRESSES, STARTING OUTFITS. CATALOG \$2.00 REFUNDABLE. JACKSON'S SUPPLY, BOX 443A, FRANKLIN PARK, ILL. 60131.

PRINTING AND SUPPLIES

PRINTING Catalog—High Quality—Low Cost. Victor, 707-P, Sharon, Pennsylvania 16146.

1000 EMBOSSED Business Cards \$6.25 Postpaid. Agents Wanted. Elco, 181-A, Sylvania, Ohio 43560.

NOVELTY Business cards, Free sample. Empire-PM, 1916 Fifth, Sacramento, California 95814.

FREE Literature, Business Cards, Letterheads, Labels. Rubber Stamps. Geer's, 111 North Drive, Ottawa, Ohio 45875.

\$7.90 YOUR COPY Reverse of 1000, 8 1/2 x 11 Circulars, your copy black ink. Mailtrade, Box 1302, Springfield, IL 62705. Samples 20¢ stamps.

FREE Literature: Rubber Stamps, Books, Business Cards, Printing, Labels. Jordan's, 552 West O'Connor, Lima, Ohio 45801.

QUICK Copy Offset Printing. Free Introductory Offer. Nationwide Printing, 614 North Main, Bloomington, Illinois 61701.

100 BUSINESS CARDS \$2.00 postpaid—3 Lines. Gateway, Box 927, Hialeah, Fla. 33011.

PRINTING—Letterhead or envelopes. Johnson, 2925 Maiden Lane, Altadena, California 91001

GUMMED LABELS

1000 GUMMED Address Labels \$1.00. Walt's, Box 960A, South Bend, Indiana 46624.

1,000 GUMMED ADDRESS LABELS \$1.00. FREE LITERATURE, Acme, 1238 Voskamp, Pittsburgh, Pennsylvania 15212.

REMAILING SERVICE

NEW YORK, New Jersey, Remails, 25¢, Fahey, Box 159, Matawan, N.J. 07747.

LAS VEGAS Remails, 35¢/\$3.00 Monthly. Post Cards. B&B, Box 14516, Las Vegas, Nv. 89114.

ALAMO City daily remails. Letters only 25¢. Alamo Remail Service, 1723 Donaldson, San Antonio, Texas 78228.

CONFIDENTIAL Montreal Address. Receiving-Forwarding. Single remails 25¢. Business—Personal. Monthly rates. Postcards. Details. Quebec Dior Service, 6231 Louis-Hebert, Montreal, Canada H2G 2G6.

YOUR Mail Received, Forwarded. Details Free Westcoast, 1323 Euclid Avenue, M-75, Bellingham, Wash. 98225.

MIAMI 25¢. Letters remailed from 130 foreign cities. 300 U.S. cities. Marie, Box 1266, Miami, Florida 33134.

SECRET. Receiving—forwarding. Discreet and confidential. Remail 25¢ single. Mail Forwarding Service, 8050 S. Main, Houston, Texas 77025.

DEPENDABLE, Confidential, Free Information. Harding, 642 LaBrook Drive, Richmond, Virginia 23225.

CONFIDENTIAL New York Mail Address \$5.00 Month. Telephone service \$5.00 Remails 25¢. Call Director, 1540 Broadway, Suite 303, New York 10036 212-221-1246.

CONFIDENTIAL! Receiving-Forwarding. Free Brochure. Johl, Box 600-M, Stanton, Calif. 90680.

K.C. CONFIDENTIAL Remails 25¢. Forwarding. KCC, Box 412, Kansas City, Missouri 64141.

PHILADELPHIA, Bicentennial City, remails 25¢, 5/\$1.00. Mills, 36 Dewey, Cheltenham, Pa. 19012.

YOUR Mail Received-Forwarded. Hedgpath, 324-M South First, Alhambra, Calif. 91802.

NEW YORK Your Mail Received—Forwarded—25¢. Whalen, P.O. Box 1183, Woodhaven, New York 11421.

FREE NASA Viewcard. Space City Remails, Box 9296PM, Houston, Texas 77011.

REMAILING—confidential and dependable—from Freeport, Bahamas. 50¢ Each. Ted's, P.O. Box F-2638, Freeport, Grand Bahama Island.

SPECIAL SERVICES

1974 POPULAR MECHANICS INDEX & SHELL WRAPPER Actually Converts Your '74 PM Issues Into a Complete "Reference Library." Over 5,000 Entries from the Past Year Are Cross Referenced and Built into a Handsome and Sturdy Lacquer Board Shelf Wrapper. From "A Penthouse for a VW Beetle" to "16 Ways to Hide Plywood Edges." It's All at Your Finger Tips. \$2.69 post paid. PM Index-Wrapper, Dept. HE, Box 1014, Radio City, N.Y. 10014.

BETTER HEALTH

NATURE'S Answer Against Cancer, Heart Attack, Arthritis, Diabetes, Cataract. Free Information. Provoker Press, St. Catharines 202, Ontario. L2R 7C9

HEMORRHOIDS Cured. Information free. Young, Box 9542PM, Seattle, WA. 98109.

YOU CAN REDUCE Results Guaranteed. Free Details. Exlor, Box PM1865, Ft. Smith, Ark. 72901.

LOSE Weight Permanently! Easy Proven Technique. Copyrighted booklet. Guaranteed! \$2.00. Sunco, Box 915, Chatsworth, Calif. 91311.

STOP SMOKING! Guarantee Results. Send \$1.00. J & M Enterprises, Box 1364-B, Jackson, Miss. 39205.

SMOKERS!! QUIT NOW!! Live longer!! I can show you how. \$2.00 to: Iquit, Box 914, Jamesville, N.Y. 13078.

I LOST 100 LBS! You can too—No Gimmicks! No Pills! No Starvation diets! This amazing plan tells how—Send \$2.98—10 day money back guarantee (no-COD) Ideal Plan, Rt. 2, Box 49H, Dept 107, Latta, South Carolina 29565.

ASTHMA, RUPTURE—I ENDED BOTH. Free facts—say which. John Mortimer, Box 608, Victoria, B.C. Canada V8W 2P3.

PERSONAL

BUGGED???? New locator finds them fast. Write Clifton, Box 220-P, Miami, Florida 33168.

BECOME An ordained minister. Free ministerial credentials legalize your right to the title "Reverend." Write Church of Gospel Ministry, 486-P Skyhill Court, Chula Vista, Calif. 92010.

NEW Scientific Way to predict your future. Details . . . J. Martin, 5459 Coolbrook, Montreal, Quebec.

PSORIASIS SUFFERERS: DISCOURAGED? Write for Free important information that is helping thousands. Pixacol, Box 29277-PM, Parma, Ohio 44129.

NEED Money—Debts Too Big? Consolidate Bills. "Quick-Cash" Emergency Loans Available. Helped Thousands since 1936. Free Application, Interstate, 28 E. Jackson, Suite 1204-X3, Chicago 60604.

BIBLE Questions answered. Stamped envelope. Byron, 17167 Bentler, Detroit, Michigan 48219.

RECORD Telephone Conversation automatically. Leave Recorder Unattended. Robert's, Box 49-PM7, Parkridge, Illinois 60068.

DON'T DIE Without a will! Protect your family! Blank Will form only \$2 . . . guaranteed! Order today. Castleway, Box 29844, Dept. 1A7, Atlanta 30329.

ARE YOU STILL PAYING TAXES? Be President of your own tax-exempt Church or other non-profit Corporation. FINANCE YOUR DREAMS. Get Foundation grants. Free details. YOU-PM7, 6311 Yucca, Hollywood, California 90028.

TELEPHONE MONITOR! Records conversations privately, automatically, using portable recorder. Box 192PM, Griffith, IN 46319.

YOU Will not die without a will, for you will have a perfect will when you send \$2.00 for do-it-yourself blank will form. Dallas Reese Co., Murphy, N.C. 28906.

TATTOO? Remove: Slow, Sure Method! Mail \$3.00 To: Taurus Enterprises, Box 35237, Station 'E', Vancouver, British Columbia, Canada V6M4G4.

"HOW To Make a Complaint and Get Action"—\$3.00. Details on other How-to-books, 35¢ and SASE. Books, 614-A South Summer St., Holyoke, Ma. 01040.

ESCAPE From debts and bill collectors! Have AAA-1 credit everywhere. Free report reveals secret plan! Credit 4A7, 333 North Michigan, Chicago 60601.

MONEY SBA LOANS. Step by Step Program. Gets Results. Send \$5.00. El Sol, P.O. Box 910, St. Petersburg, Fla. 33731.

LOOK Younger, I Am Judged 10 Years Younger than I Am. Learn My Secrets, Three Vitamins I Take, Special Foods, How I Clean My Face And Hair, Much More. \$5.00. "Secrets" P.O. Box 711, Metairie, Louisiana 70004. Moneyback Guarantee.

UNEMPLOYMENT Insurance. Collect every nickel. Detailed Instructions. \$2.00. Clifton, Box 220W, Miami, Florida 33168.

SOCIAL SECURITY PLATES

GOLDEN ENGRAVED SOCIAL SECURITY Plate with case \$2.00. Cloverleaf, Box 49, Selbyville, Del. 19975.

WANTED MISCELLANEOUS

MERCURY Gold, Silver, Platinum: Ores assayed. Wholesale Terminal, Norwood, Mass. 02062.

USED HANDGUNS, Hi-Power Rifles, Pump, And Double Shotguns. Price, Description Please. Powers, Inc., Perry, Fla. 32347.

WINEMAKING & OTHER RECIPES

WINEMAKERS FREE ILLUSTRATED Supply catalog of yeast, equipment. Continental, Box 18223-PM, Indianapolis, Ind. 46218.

WINEMAKERS, 20 easy Wine, Beer Recipes. Only \$2.00. R.R. Enterprises, 6 Liana Street, Woburn, Mass. 01801.

HOW To Make Delicious Wines and Champagne, for pennies a bottle! No special equipment needed. Booklet reveals amazing home winemaking secrets! Money back guarantee. Send \$1.75 (check or money order) to: Brookside Publications, Box 494, Wayne, Pa. 19087.

HOT TAMALES—Easy-How-to Photos—\$2.00—Martinez, Box 621, Santa Fe, N.M. 87501.

WINEMAKING Made Easy. Simple Instructions Using Kitchen Utensils. Guaranteed—\$1.00. Stardan, 10775A, S.W. Hawthorne Lane, Portland, Oregon 97225.

WINEMAKING. Yogurt, Cheesemaking. Free catalog. Arbolyn, Box 663, West Columbia, S.C. 29169.

WINEMAKER'S Supply Catalog—Free. Bacchanalia, 273 Riverside Ave., Westport, Conn. 06880.

WINEMAKERS. Free illustrated catalog of yeasts, equipment. Semplex, Box 12276R. Minneapolis, Minn. 55412.

WINEMAKERS Free Informative Catalog, Yeast Equipment, ingredients, DANENBERGER'S, Box 276-M, New Berlin, Ill. 62670.

NEW! . . . FREE CATALOG . . . 30 VARIETIES FRUIT & GRAPE CONCENTRATES . . . 100 WINE & LIQUEUR FLAVORS. Complete line of Winemaking Supplies. Kraus, Box 451-L, Nevada, Missouri 64722.

WINEMAKING. . . Don't Let Your Fruit Spoil. Free Recipes. Central Kentucky Winemaking, 787 Limestone, Lexington, Kentucky 40508.

WINE—CHAMPAGNE—BEER!!! Guaranteed recipes. No special equipment. \$1.98. Davco, Box 948B1G, New London, Conn. 06320.

OLD GERMAN Wine Recipe, Complete Instruction \$2.95. Moore Enterprises, Drawer 35, Cherryville, Mo. 65446.

FREE Advice Anytime!!!—With "Homewinemakers"—"Easy Methods Recipes Book"—Satisfaction Guaranteed \$3.00. Jesse's Research, 240 Roberts Road, Plumboro, Pa. 15239.

GOURMET BEER Guaranteed Recipe. Send \$2.00. El Sol, P.O. Box 910, St. Petersburg, Fla. 33731.

MISCELLANEOUS

FREE ELECTRICITY—Government predicts rationing. Generate own. Save \$\$\$ Instructions \$3.00 (refundable). Katz 1280-FE Sawmill, Yonkers, N.Y. 10710.

PROFITABLE show betting thoroughbreds. Trots moneyback guarantee. Lucas, Box 7284M, Pittsburgh, Penna. 15213.

DON'T DIE Without a will!! Three will forms. Rush \$2.00! Sunshine, Dept. PM7, Box 2100, Boca Raton, Florida 33432.

ABUNDANT LIVING, Will help you to be happy. \$5.00. Sand's, Rm. 9, 410—6th and Fawcett, Tacoma, Wash. 98402.

IDENTIFICATION CARDS, Birth Certificates, Diplomas, Legal Forms. Samples 25¢. Publication, Box 26062T, Los Angeles, Calif. 90026.

DON'T die with a Will. Making it yourself protects your family immediately. Blank Will Form and Booklet \$2.00. Prentice, Dept. 3B7, 4311 Chetwin Terrace, Easton, Pa. 18042.

FLYGONE Kills Flies By Thousands, \$3.95 Postpaid. Universal, Lenora, Kansas 67645.

FREE Flexible magnetic strip with, 20 disc, or 10 bar, or 2 stick, or 8 assorted magnets, \$1.00. Any 5 sets, \$4.50. Magnets, Box 192-FA, Randallstown, Maryland 21133.

LEGAL Will Without A Lawyer! Four parchment will forms, Book "Making/Breaking Wills," \$2.00. Good-Stuff, 224 Centre, #D7, NYC 10013.

THOROUGHLY HANDICAPPER NEEDS BANKROLLING. I make no false promises or phony guarantees. Send contributions large or small to: W.F. Wiemers, 416 Chartres St., New Orleans, La. 70130.

PRINTERS OLD TYPE DRAWERS. Thousands of decorative uses. \$11.75. WOODEN TYPE, assorted letters, 6 for \$5.00. King, 240 West 40, NYC 10018.

4 WHEEL Drive, Build your ATV from readily available material (it works). Info Pak \$5.00—Plans \$20.00. Bulldog Engineering, 509 Industrial Ave., Boynton Beach, Fla. 33435.

BOOKS On antiques and their prices. Free circular!! P. Warman Publishers. Uniontown, Penna. 15401.

DON'T Die Without A Will! Protect Your Family. Quality Will Forms (2) Only \$2.00—Guaranteed. Order now! AJG, 12446 Otsego, Dept. 1C7, No. Hollywood, Calif. 91607.

ORNAMENTAL Iron designs, Book of 1600 beautiful, practical designs for railings, columns, etc. Free literature. Cunningham, 3881 South 3200 West, Box 20005, Salt Lake City, Utah 84120.

IDENTIFICATION CARDS. Send stamped self-addressed envelope for samples. NIPCOM, 727 North Main, Las Vegas, Nevada 89101.

WIN! Casino Games! Free Details! Xcito Games. 5715 N. Mozart, Chicago, Illinois 60659.

ROLL Your own Cigarettes with American Blend or Menthol Tobacco. Cigarette Makers and papers available. For free Tobacco sample write Green River Tobacco, Box 1313M, Owensboro, Ky. 42301.

PRESCRIPTION EYEGASSES. Free Catalog. A-Z Optical Company, Box 175, Dept. R26, Bay Station, Brooklyn, New York 11235.

HORSEPLAYERS—Free!!!! How Turfwin Won \$300 Weekly. Guaranteed! Turfwin, Box 581 PM7, Port Washington, N.Y. 11050.

WHAT'S YOUR I.Q.? Easy, self-scoring test reveals Amazing Facts about your mental personality. Send \$2.00 today. Guaranteed. Dulemba, Dept. A1, 1465 Hiawatha, Jackson, Michigan 49201.

HOW INTELLIGENT Are you? Self-scoring test reveals I.Q. in 45 minutes! Send \$2. today—Guaranteed! Motivational Publications Dept. 115C, Box 7147, London, Ont. Canada.

STILL BUILDING BOOK, 57 Drawings, 6 Models. All sizes from Stovetop to Mountaintop! 100 pages, \$3.75. DOCUMENTED, Box 1004, Fostoria, Ohio 44830.

DON'T Die without a will! Blank will forms protect your family. Only \$2.00—guaranteed! Order today!! Legal, AC7 Rt. 1, 14145 Hatfield Road, Rittman, Ohio 44270.

CHEAP Electrical Power! Amazing Invention! Details \$2.00. Technical Advances Co., 3465 Loma Vista, Flagstaff, Ariz. 86001.

TREASURE Hunting Tips; Detector Buying Hints, Both \$1.00. How To Win At Poker, \$2.00. Free Catalog Ghost Town, Treasure Hunting Books. Slocum Books, Box 655A, Simi, Calif. 93065.

BURGLAR ALARMS & HOME PROTECTION

BURGLAR-FIRE ALARM Supplies and Information. Free catalog. Protecto Alarm Sales, Box 357, Birch Run, Michigan 48415.

NOW Available! Wholesale. Professional, Burglar-Fire Alarm Equipment for the Do-It-Yourselfer. Catalog-25¢. Emel Electronics, Dept. PM7, Box 509, Flushing, NY 11365.

LOCKSMITHING Supplies—Buyers Guide \$1.00. Despubs, Box 22005H, Phoenix, Arizona 85028.

DOUBLE Duty Alert—Combination burglar/fire alarm. 24 hour protection!! Installs in seconds. \$8.95 - batteries included. Guaranteed!! Order Now!! Sunshine, Box 2100, Dept. PM7, Boca Raton, Florida 33432.

FREE Fire Alarm catalogue. Safety Enterprises, Box 22021-M, Memphis, Tenn. 38122.

PROTECTION!! Battery-operated alarm warns of fire or intruders. Installs in seconds. Batteries included. Guaranteed! Order now. Only \$8.95. Hillier Associates, Dept. A7, 384 Old Lancaster Road, Sudbury, Massachusetts 01776.

Question:

WHAT ARE PICTURE TOOLS?

Answer:

WORKSHOP TOOL MARKERS

POPULAR MECHANICS PICTURE-TOOLS are a great new idea to take the confusion out of *what goes where* on workshop tool panels.

The complete PM PICTURE-TOOL KIT consists of seven big sheets (9¾ x 11¾ in.) of a special heavyweight paper with a pressure-sensitive adhesive on the back. On each sheet are beautiful drawings of hand tools and portable power tools—all (74 in total) you're likely to have in your shop. Most are full size; the others, only slightly reduced.

Also enclosed in the kit is a blank sheet of the same special paper, printed in an overall color to match the tools. This sheet enables you to design your own drawings or silhouettes of any special tools you have.

Each of the PM PICTURE-TOOLS is carefully die-cut. You simply peel it off the backing paper and

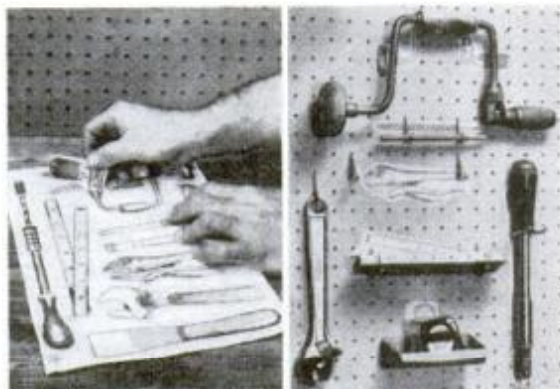

apply it to the proper spot on your panel. You can apply PICTURE-TOOLS to any painted or unpainted wood, plywood, hardboard and even perforated-hardboard surface.

Later if you want to move a few tools or rearrange the entire panel, you can peel off the

PM PICTURE-TOOLS and move them to new locations. They are reusable!

Once your PICTURE-TOOLS are in place, you'll know at a glance exactly where each tool in your shop belongs. You'll also know—again at a glance—what tools are missing.

Best of all, you'll be surprised how PM PICTURE-TOOLS will instantly and dramatically enhance the appearance of your shop!

Order your PM PICTURE-TOOL KIT today!
Only **\$4.49** postpaid

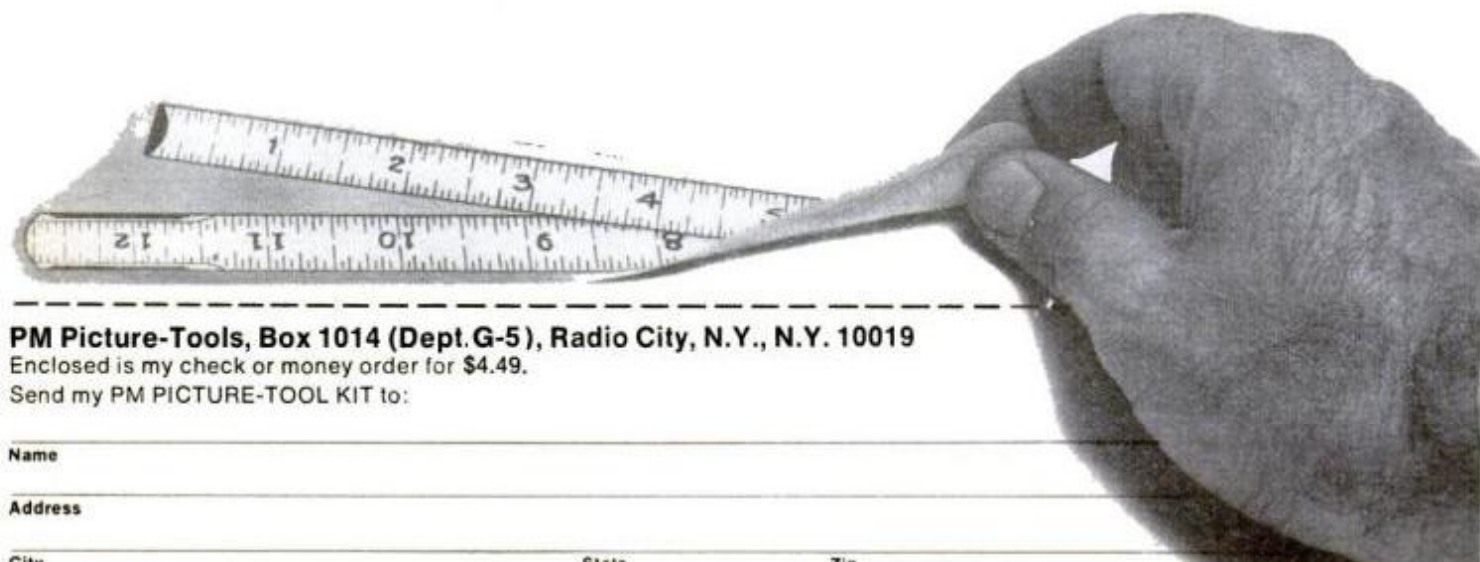

PM Picture-Tools, Box 1014 (Dept. G-5), Radio City, N.Y., N.Y. 10019

Enclosed is my check or money order for \$4.49.

Send my PM PICTURE-TOOL KIT to:

Name _____

Address _____

City
H.M. SPECIALTIES

State _____ Zip _____
(PLEASE MAKE CHECKS PAYABLE TO POPULAR MECHANICS)

152 POPULAR MECHANICS

AC-Delco offers a little less fooling around.



Simplify your tune-ups with Delco-Remy UNI-SET. It's a set of points and a factory-matched condenser in one unit. Just tighten two screws, and it's installed. There's no separate condenser screw to install. And because UNI-SET has special circuitry already built in to help control

radio interference, you can discard your distributor's old radio interference shield, if present.

Add AC Spark Plugs to your Delco-Remy UNI-SET and you have a matched team—built to work to-

gether. A tune-up with AC Spark Plugs and Delco-Remy UNI-SET can help improve your car's performance and gasoline economy.

So next time you need a tune-up, remember who gives you a little less fooling around for your money. Get Delco-Remy UNI-SET and AC Spark Plugs.



AC-Delco
Division of General Motors Corporation

Warning: The Surgeon General Has Determined
That Cigarette Smoking Is Dangerous to Your Health.



Start fresh with Belair.

Just the right touch of menthol.

Double-duty Cooler. This 2-gallon insulated Igloo Jug keeps refreshments cold, and is sturdy enough to sit on. Yours for free B&W coupons, the valuable extra on every pack of Belair. To see over 1000 gifts, write for your free Gift Catalog: Box 12, Louisville, Ky. 40201.



Kings, 16 mg. "tar," 1.1 mg. nicotine; Longs, 17 mg. "tar,"
1.2 mg. nicotine, av. per cigarette, FTC Report Oct. '74