

# Popular Mechanics



## MINI OFFICE IN A CHEST

organizes your paperwork —  
conceals it when closed.

One of three original desks  
you can build Starts page 73

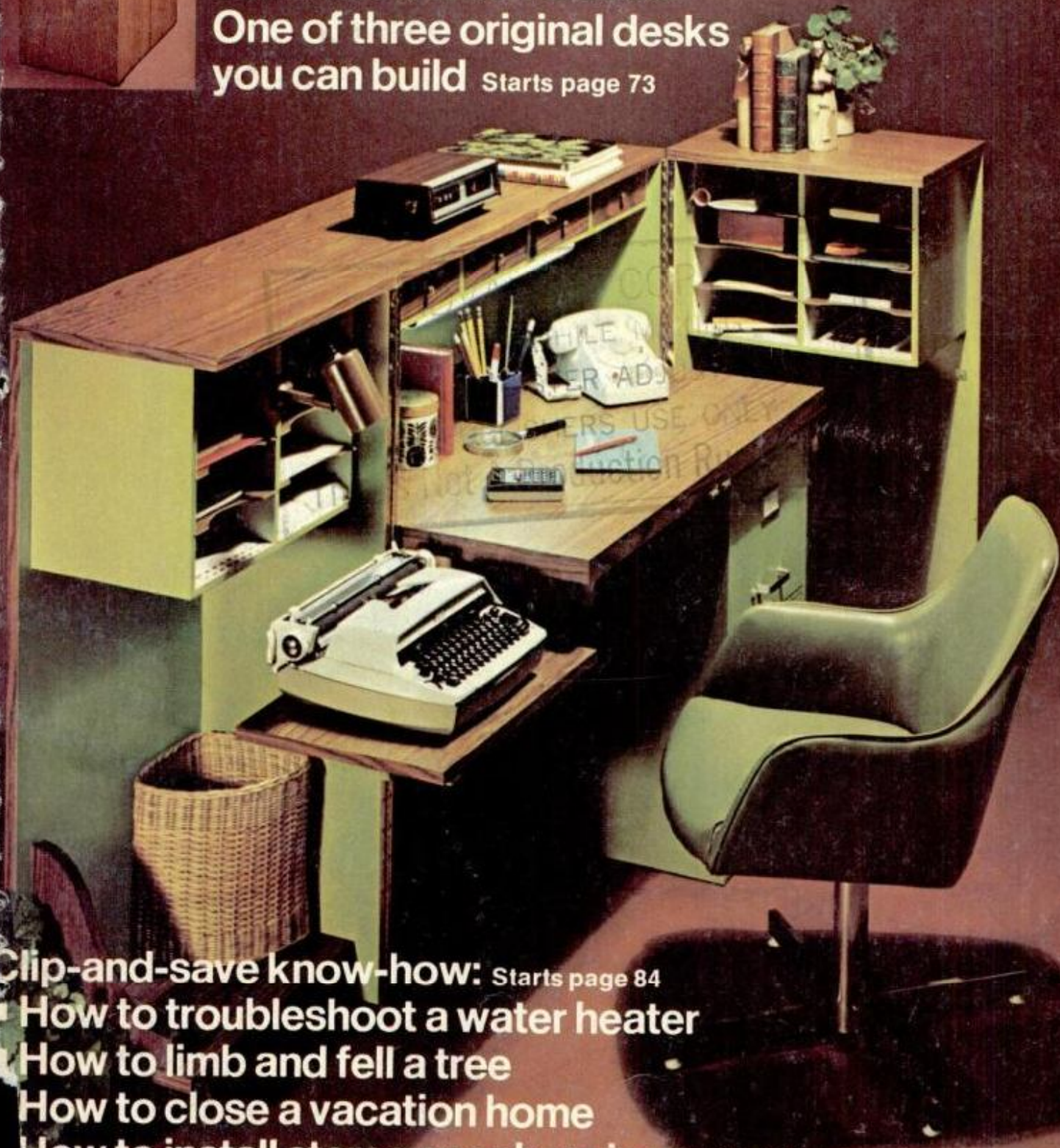

Clip-and-save know-how: Starts page 84

- How to troubleshoot a water heater
- How to limb and fell a tree
- How to close a vacation home
- How to install stereo speakers in your car





# Get a taste of what it's all about.

Get a taste of excitement. A taste that doesn't fade away with the first puff. Viceroy taste. Full flavor that comes on smooth from start to finish. It's what smoking's all about.

King Size  
and Long Size

## It's all there in Viceroy.

Warning: The Surgeon General Has Determined  
That Cigarette Smoking Is Dangerous to Your Health.

© BROWN & WILLIAMSON TOBACCO CORP.

King Size, 17 mg. "tar," 1.2 mg. nicotine; Long Size, 18 mg. "tar," 1.3 mg. nicotine av. per cigarette, FTC Report Feb. 73

Материал, защищенный авторским правом



# Most automatic rifles are as accurate as you are...for at least the first shot. But what about the second? And the third?

**Automatic rifle accuracy starts with your ability to recover from the first shot's recoil. Here's how the Remington Model 742 WOODSMaster helps...straight from the men who designed it.**

The real key to hunting accuracy with an automatic is its speed of operation. If the rifle ejects and chambers cartridges too quickly (which is often the case), most hunters have a hard time recovering from recoil and barrel whip. If the rifle operates too slowly, a hunter may lose the extra-shot advantage he bought the rifle for in the first place. Somewhere between "too fast" and "too slow" is an optimum. So the Remington designers set out to build a truly automatic rifle with an optimum rate of operation...a rate that would let a hunter make the most of the accuracy built into the rifle. The result of their efforts is the Remington Model 742.

The 742's rate of operation is engineered to help a hunter fire several shots quickly and maintain his sight plane from shot to shot, without changing position or grip. This rate is fast enough to maintain the automatic advantage...yet slow enough to give the hunter a big edge in his recovery from recoil. Which leads up to the second big reason why a rifle's operating speed is important: recoil reduction.

If the rifle mechanism operates too fast, a recoil reduction system really doesn't have a chance to be effective. And if the rate is too slow, it isn't needed because the hunter has plenty of time to recover...at the expense, perhaps, of additional shots. Essentially, the system in the Model 742 operates like most other automatic rifles. But here's where Remington designers used some engineering imagination.

The recoil force is more than required to operate the mechanism...and more than enough to give you a jolt. So by capturing the peak of the recoil force in what Remington designers call an "Inertia Sleeve", that peak recoil force is split. This means you receive a softened initial recoil push.

Now the real advantage is obvious. You're set for your next shot quicker with the 742 than with other types of rifles. And the more experience you have with the 742, the steadier you should become. That means greater control. And greater control means you have a better chance of keeping your sight picture from shot to shot.

Like every Remington rifle and shotgun, the 742 has certain features we think you'll want to know about. Like the "Teflon"-S\*\* coating we've added to interior moving parts. The result is longer wear, smoother operation and easier cleaning. And the artillery-type bolt locks up safe and strong. In fact, the action is so safe and strong that the 742 and its moving parts perform effortlessly despite bad weather. The artillery-type bolt locks up tight with multiple lugs. Three rings of solid steel completely enclose the cartridge head.

A rich blueing, "vibra-honed" parts with a mirror-like finish, Du Pont RK-W wood finish (just about the most rugged finish available) make the 742 owner a proud one.

The 742 comes in five great calibers: 6mm Rem., 280 Rem., 30-06, 308 Win., 243 Win. And you have your choice of an ADL or BDL "Custom Deluxe". The BDL, incidentally, is available in right- and left-hand cheekpiece models. There's an 18½" barrel carbine that's great for hunting in brush, too. All feature black fore-end caps, white line spacers, clip magazines and receivers that are drilled and tapped for scope mounts. Priced from \$184.95\*, the 742 offers a hunter tremendous dollar value. Finally, you ought to know that we test and prove the Model 742 with Remington ammunition. So, if you're after top performance, it makes sense to use Remington ammunition.

This report about the Model 742 WOODSMaster and all other "Remington Reports" are based on information straight from the men who design and engineer every Remington product. For even more details, send a postcard to: Remington Arms Company, Inc., Dept. 353, Bridgeport, Conn. 06602, for a copy of our free 1973 full-color Remington catalog.

**Great guns deserve great ammunition. We make both.**

This "Core-Lokt" bullet still had 62% of its original weight when recovered from a Kodiak bear.

Remington cartridges with "Core-Lokt" bullets have dropped more big game than any other cartridges. In any of 26 big-game calibers.



\*Prices shown are suggested minimum prices, subject to change without notice.  
\*\*Reg. U.S. Pat. Off. for Du Pont's non-stick finishes. "Remington", "Woodsmaster" and "Core-Lokt" are trademarks registered in the U.S. Pat. Off.

**Remington** 



# A plug for people who change their own

We figure you power buffs have lots of interests and lots of equipment to go with them. So NGK builds a plug for practically every internal combustion engine made.

Also, being mechanically hip, you appreciate quality and efficiency. So we build the most efficient, toughest plug we can. The kind you'd want to put in your own car, bike, outboard, buggy...whatever.

But all our plugs—and it takes the company computer to keep track of them—have one thing in common: a never-say-die "Heart of Copper".

Used in place of ordinary iron cores, this highly conductive copper core delivers maximum performance under all conditions.

It dissipates heat fast, cuts down plug damaging hot spots and piston-popping pre-ignition. A long-nosed insulator holds just the right amount of heat to reduce tip fouling. In hot engines or cold, under easy or hard use, NGK's fire on time, every time.

If you're a motorcycle owner, you probably know all about NGK performance. You sports car types do, too. But NGK's work just as great in utility and recreational vehicles. And they'll fire-up your hairy V-8 as quick as your one-lunger saw.

Take our tip. Screw in a set of "Heart of Copper" NGK's. They're a change for the better.

NGK, the long life, hi-performance plug.



NGK SPARK PLUGS (U.S.A.), INC., 12511 Beatrice St., Los Angeles, California 90026



# TOO MANY CHEFS CAN SPOIL YOUR OIL.

It seems as if everybody has something for you to add to your crankcase these days.

For some reason people think the more additives you put into your car's crankcase, the more you'll get out of your car. The fact is, it could work out just the opposite.

Some additives may thicken the oil to the point that it becomes harmful. Especially in cold weather when thickened oil can lead to increased engine wear.

Also, when the electrolyte fluid in your battery is cold, its output is lower. That, with hard cranking because of thickened oil, can cause hard starting, which puts a strain on your battery.

In addition additives don't remove contaminants. Only an oil change will remove contaminants.

The truth is you don't need supplemental additives. All they can do is cost money. If you want your engine to run well, don't add things to your crankcase. Put in a good quality motor oil to begin with, and change your oil according to the auto manufacturer's recommendations, and you'll be giving it all it needs. Because a good oil already has special additives in it. The same type that some people try to make you pay extra for.

No one makes motor oils better than Gulf. If you'd like to know more about them, stop in at any Gulf station, or write to: Gulf Consumer Information, Box 1519-H, Houston, Texas 77001. We'll be glad to tell you about our motor oils, and anything else you might want to know about our products or your car.

We think that if you learn all you want to know about your car and our products, we can keep you on the road. And us, too.

**GET TO KNOW GULF AND YOU'LL GET TO KNOW YOUR CAR.**



GULF OIL CORPORATION

This One



274Q-6HZ-EZHX



INTERNATIONAL EDITIONS  
Australia, Caribbean, Denmark,  
Mexico, Southern Hemisphere,  
Sweden

## AUTOMOBILES, DRIVING

- [26B](#) The X1/9: Fiat has a deal you can't refuse
- [36](#) Detroit Listening Post
- [57](#) Imports and Motorsports
- [66](#) Driver's Report: Cortez motor home
- [98](#) Detroit promises clean-air '75s . . . but ups the sticker another \$300
- [138](#) Grade crossings take a deadly toll
- [146](#) Saturday Mechanic: Fast fixes for a hesitation problem
- [154](#) Cartop carrier transports bikes for the whole family
- [166](#) How to fit a fairing and ride a racer!

## SHOP AND CRAFTS

- [26A](#) Hints from readers
- [73](#) Mini home offices: Three novel PM-styled desks
- [73](#) The Wall-Hugger: Folded it takes only a foot of floor space
- [76](#) The Swing-Wing: From king-size chest, it opens wide for business
- [80](#) The Split-Level: For the man who likes plenty of room
- [150](#) Make your own rotary cutters for offbeat jobs
- [153](#) Hints from readers
- [156](#) Multipurpose cutting board handles glass, cardboard, photo mats and roll paper
- [162](#) Roll-away workbench: lot of shop, small space
- [164](#) Hints from readers
- [170](#) Benchtop saw table converts portable to 'radial'

## HOME AND YARD

- [84](#) How to troubleshoot a water heater
- [90](#) How to fell, buck and limb a tree
- [94](#) How to close up your vacation home
- [106](#) Outdoor gear for indoor emergencies
- [130](#) Shredders, grinders, chippers
- [160](#) Playback tennis 'court' improves your backhand

## BOATING, OUTDOORS

- [106](#) Outdoor gear for indoor emergencies
- [109](#) Stirrups for your spear gun
- [134](#) How to select a modern scattergun
- [143](#) Fitting out for bass

## ELECTRONICS, RADIO TV

- [122](#) Car stereo speakers: How to install them
- [125](#) Car stereo speakers: How to pick them

## PHOTOGRAPHY

- [60](#) Photo hints
- [128](#) Pocket cameras become big business

## SCIENCE, INVENTIONS

- [96](#) 'Combat cops' fight crime like commandos

## AVIATION

- [102](#) Homebuilt aircraft: Modern biplane in classic style

## EVERY MONTH

- |   |                                     |
|---|-------------------------------------|
| <a href="#">8</a> Letters   | <a href="#">40</a> The Bicycle Shop |
| <a href="#">20</a> Car Clinic   | <a href="#">48</a> All Outdoors     |
| <a href="#">24</a> Homeowners' Clinic   | <a href="#">62</a> Appliance Clinic |
| <a href="#">30</a> Science Worldwide  |                                     |
| <a href="#">110</a> It's New NOW: Latest products and developments<br>(A 12-page roundup) |                                     |

Roll-away  
workbench . . . [162](#)

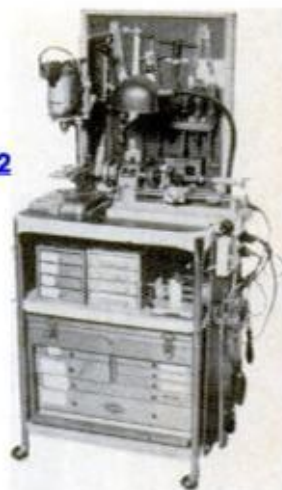

Multipurpose  
cutting board . . . [156](#)

Cartop  
bike  
carrier . . . [154](#)



Selecting  
a modern  
scattergun . . . [134](#)

Worth writing for: see page 26H

ON THE COVER: The Swing-Wing—mini office in a chest (inset)—one of three original desks for the home designed by PM editors and featured in this issue. Photos by George Ratkai

AS A SERVICE TO READERS, *Popular Mechanics* publishes newsworthy products, techniques and scientific and technological developments. Due to possible variance in the quality and condition of materials and workmanship, *Popular Mechanics* cannot assume responsibility for proper application of techniques or proper and safe functioning of manufactured products or reader-built projects resulting from plans published in this magazine.



# In your home you have this symbol by the dozen. Do you know what it really means?

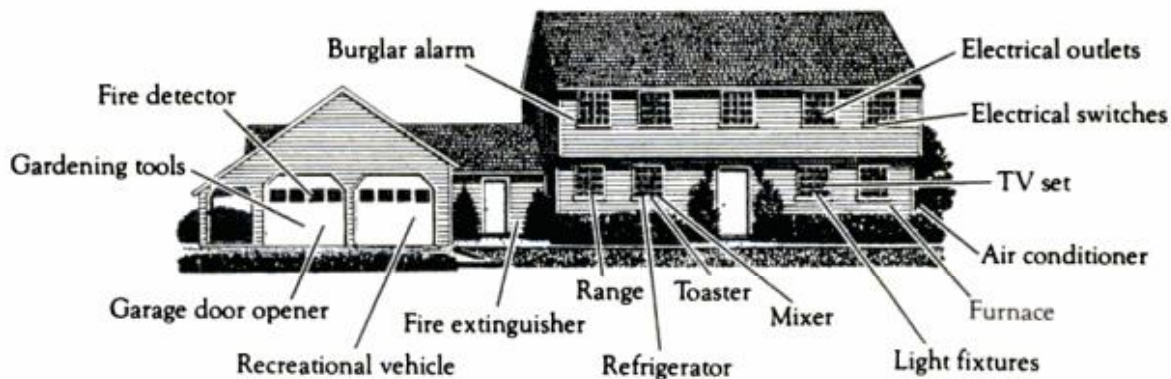

## Here's how a product earns the UL symbol.



**Submittal.** A manufacturer turns his product over to UL for evaluation. He wants UL to verify by examination and test that the design meets recognized safety requirements.



**Testing.** UL engineers put the product through normal use tests, then tests far more rigorous. They want to determine it is adequately safeguarded against electric shock, fire and casualty hazards.

**Identification.** Only those products that meet UL's safety requirements earn the right to use the UL symbol. Look for it!

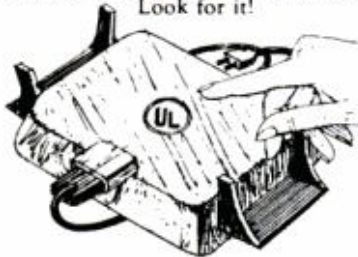

**Factory Follow-Up.** UL conducts unannounced in-plant inspections ranging from several times a year to daily. Factory production controls are audited right in the plant to make certain the UL symbol only goes on products that continue to meet the safety requirements.



**Do your part.** Use the product only for its intended purpose. Read the operating instructions. Heed the safety warnings. Safety is a team effort.

Underwriters  Laboratories, Inc.

Chicago and Northbrook, Ill.,

Melville, N.Y., Santa Clara, Calif., Tampa, Fla.



**Front end shimmy  
can start right here.**



**Right here is where  
Shimmy Stop stops it.**

**Introducing Shimmy Stop...a totally  
unique do-it-yourself way to  
restore worn ball joints without  
spending a lot of money!**

Worn ball joints can cost you a bundle... because they affect the way your tires wear, the way your car handles, the way the front end keeps its alignment. Until now, the only way to solve the problem was to replace the ball joints. That can cost up to one hundred dollars!

Now there's Shimmy Stop... a compound that restores worn ball joints (still within recommended tolerances) for a fraction of their replacement cost! Once you inject SHIMMY STOP into the ball joint, it cures to a self-lubricating solid that actually reduces the tolerance to zero!

Shimmy Stop is so easy to use... the job takes just about 30 minutes following simple, illustrated instructions. And it lasts for thousands and thousands of miles!

Look for the Shimmy Stop display and your free worn ball joint gauge at your favorite auto supply store.

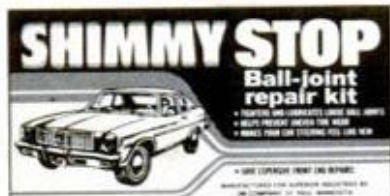

**SHIMMY STOP™**



**SUPERIOR INDUSTRIES  
INTERNATIONAL, INC.**  
DEPT. P9-14721 KESWICK STREET • VAN NUYS, CA 91405  
PHONE (213) 873-5181

## Popular Mechanics

**JIM LISTON**, Editor

**SHELDON M. GALLAGER**, Executive Editor

**JOHN A. LINKLETTER**, Managing Editor

**WAYNE C. LECKEY**, Home and Shop Editor

**ALVIN KIETZ**, Art Director

<b>BILL HARTFORD</b>	Automotive
<b>JOHN F. PEARSON</b>	Science and Engineering
<b>WM. T. McKEOWN</b>	Boating and Outdoors
<b>IVAN BERGER</b>	Electronics and Photography
<b>HARRY WICKS</b>	Home Workshop
<b>STEPHEN WALTON</b>	Assistant, Home and Shop
<b>MICHAEL LAMM</b>	West Coast
<b>ROBERT LUND</b>	Detroit Automotive
<b>GARRY WINTER</b>	Copy Chief
<b>RICHARD H. FUNK</b>	Production
<b>ALFREDO VEGA</b>	Assistant, Production
<b>DON EVANS</b>	Technical Art Director
<b>JOSEPH P. BEATON</b>	Assistant Art Director
<b>DAVID KOMITAU</b>	Assistant Art Director
<b>IRA HERRICK</b>	Assistant Art Director
<b>CLIFFORD B. HICKS</b>	Special Projects
<b>SOPHIE GRONOWICZ</b>	Director, Bureau of Information
<b>EVERETT JOHNSON</b>	Cabinetmaker

**DANIEL J. COLEMAN**, Director of Advertising

**ADVERTISING OFFICES:** New York: 224 West 57th St., 765-6850; Chicago: 520 N. Michigan Ave., 527-2400; Detroit: General Motors Bldg., TRinity 5-8711; Cleveland: 20310 Chagrin Blvd., Shaker Heights, 283-7788; Los Angeles: 601 North Vermont Ave., 666-6263.

**JOHN A. REGINA**, Advertising Production Manager

Published by The Hearst Corporation

**FRANK MASSI**  
President

**JOHN R. MILLER**  
Executive Vice President

**RICHARD E. DEEMS**  
President, Magazines Division

**JOSEPH F. KERN**  
Publisher

**ADDRESS ALL EDITORIAL COMMUNICATIONS TO:** 224 West 57th St., New York, N.Y. 10019. For additional sources of information on the articles and products in this issue, write to Bureau of Information, Popular Mechanics, for free "Where-to-Find-It" list.

**SUBSCRIPTION SERVICE:** Mail all subscription orders, changes of address, correspondence concerning subscriptions, and Postmaster notices of undeliverable copies to Popular Mechanics, Box 648, New York, N.Y. 10019. Please enclose your latest address label for quickest service when writing about your subscription.

**POPULAR MECHANICS IS PUBLISHED MONTHLY** by The Hearst Corporation, 224 West 57th Street, New York, N.Y. 10019, U.S.A., Frank Massi, President; John R. Miller, Executive Vice President; Harrison A. Mitnick, Treasurer; Harvey L. Lipton, Vice President and Secretary. Hearst Magazines Division: Richard E. Deems, President; Raymond J. Petersen, Executive Vice President; William S. Campbell, Vice President and General Manager; John F. D'Avolio, Vice President and Resident Controller; Albert A. Rachol, Vice President and Director of Circulation; Joseph F. Kern, Vice President for Popular Mechanics. Single copy in the United States and Canada, 60 cents. Subscription prices: United States and Possessions, \$5.97 for one year; \$10.97 for two years; \$14.97 for three years. Canada, add \$2.00 for each year. All other countries, add \$4.00 for each year. When changing address, give old address as well as the new, with zip code, and allow six weeks for change to become effective. Second-class postage paid at New York, N.Y., and at additional mailing offices. Authorized as second-class matter by the Post Office Department, Ottawa, and for payment of postage in cash. Registered as second-class matter at the Post Office at Mexico D.F., Mexico, June 20, 1950. © 1973 by The Hearst Corporation. All rights reserved. Printed in U.S.A.



# 6 Grow with the future in any one of big-money careers

Send postpaid coupon below for FREE booklet of your choice.



For over sixty years LaSalle has been helping ambitious men start new and profitable careers. We can help you too. LaSalle's practical home study program lets you learn at your own pace. Experienced instructors supervise your work by mail every step of the way. You receive individual assistance whenever you need it. Send for FREE booklet on the field you like best. Mail coupon below. No stamp needed. There is no obligation. LaSalle, 417 S. Dearborn St., Chicago, Illinois 60605.

## DIESEL Mechanics

Called one of the best non-college careers by U.S. Department of Labor. Big field where even newcomers earn good pay.

## AIR CONDITIONING & Refrigeration

Short supply of trained men to service and install commercial and home equipment. Wide-open field.

## DRAFTING

Enjoy good pay as a draftsman in construction, manufacturing, many other industries. No drawing skill required to learn.

## COMPUTER Programming

High-pay, prestige field. All it takes to start training is a high school education and a logical mind. Technical experience not needed.

## AUTOMOTIVE Mechanics

Uncrowded field with great opportunities to earn a high income. 150,000 more trained mechanics needed.

## ELECTRONICS Technician

Earn a big pay in TV and radio broadcasting, automation, industrial electronics. Training for FCC license available.



### MAIL THIS POSTAGE PAID ENVELOPE

Cut coupon along dotted lines, fill in your name and address ...fold, seal (tape, paste or staple) and mail. Dept. 93-077  
No stamp or envelope is necessary.

Please rush me, without obligation, the free booklet and full information on the field I have checked below:

- |   |   |
|---|---|
| <input type="checkbox"/> Diesel Mechanics     | <input type="checkbox"/> Air Conditioning and Refrigeration |
| <input type="checkbox"/> Drafting             | <input type="checkbox"/> Computer Programming               |
| <input type="checkbox"/> Automotive Mechanics | <input type="checkbox"/> Electronics Technician             |

Name.....Age.....  
(please print)

Street.....Apt. No.....

City.....

State.....Zip.....

13R

FOLD HERE ↓ (DO NOT CUT) SEAL AND MAIL TODAY - NO STAMP NEEDED.

FIRST CLASS  
PERMIT NO. 27  
CHICAGO, ILL.

BUSINESS REPLY MAIL

No postage stamp required if mailed in the United States

Postage will be paid by

**LA SALLE EXTENSION UNIVERSITY**  
*A Correspondence Institution*  
**417 S. DEARBORN STREET**  
**CHICAGO, ILLINOIS 60605**

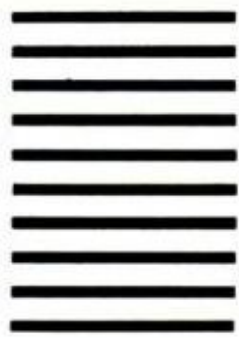

© 1973 LaSalle Extension University, A Correspondence Institution



# 'Until now installing a bathtub was a real problem.'

But now there's Versa-Bath. Borg-Warner's new 4-piece bath/shower cove, a remodeler's delight.

Versa-Bath is packaged in one easy-to-carry carton, will fit through any standard doorway, and assembles quicker than a blinkin' of an eye. Its rigid walls fasten right to the studs. No sub-walls. No tiling. No grouting.

Versa-Bath is easy to clean with just the wiping of a damp cloth, and will maintain its brilliant lustre over the years.

You'll find Versa-Bath at leading building supply stores nationally. To find your Borg-Warner dealer, dial 1-800-243-6000, free, any time, any day. (In Connecticut, 1-800-882-6500.) Or write: Borg-Warner, Plumbing Products Division, Mansfield, Ohio 44902.

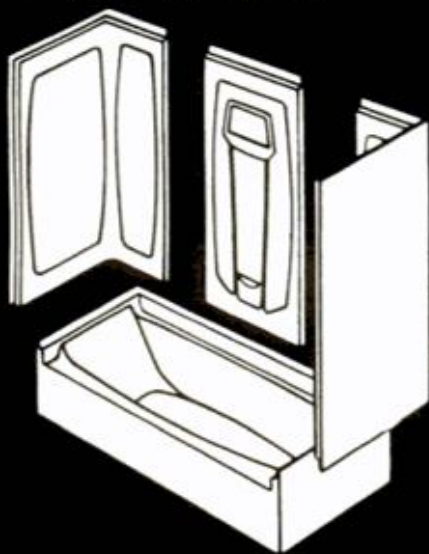

Borg-Warner Corporation  
Plumbing Products Division

**BORG WARNER**

## LETTERS

### TO THE EDITOR

#### He'll keep his '71

Congratulations on being one of the first publications to "tell it like it is" about the 1974 Mustang II (*Detroit Listening Post*, page 56, July *PM*). All the auto mags are now stating how great this revamped Pinto is going to be when it hits the dealers' carpeting this fall. Bunk. When I first saw photos of this thing Dearborn is calling a Mustang with the Mach I name on the back deck, all I could think was blasphemy!

I'm currently driving a 1971 Mustang 351 Ram-Air fastback. I consider it the best looking body shape of all the Mustangs since the 1965 model. On a recent round trip to Florida we averaged 18.5 mpg at speeds around 65 to 70 mph. The engine does not hesitate, stall, balk or give any troubles exhibited by the ill-performing '73 offerings. The *true* sporty, performance-able ponycars will probably increase in value in the future. I'm keeping mine.

GRANVILLE, MASS.

DAVID W. PULASKI

#### PM by cassette?

Prior to my recent blindness, I had always felt a good deal of my scientific and mechanical knowledge was attributed to the pleasant hours I had spent in reading *PM*. I would very much like to continue this input if I can, and, therefore, require your assistance. Could you possibly direct me to a source whereby this information would be available either on disc or cassette? If no organization for this purpose does exist, would it be possible that one of your readers is in a position to exchange this kind of information via cassette with me?

MASSAPEQUA PARK, N.Y. GEORGE I. BEHRENS

*We don't know of any group that records the contents of PM on discs or cassettes, but if there is one, we'll be glad to put you in touch with Mr. Behrens. There is a braille edition of each month's PM available through the Regional Library for the Blind. If any readers are interested in the braille*

*(Please turn to page 11)*





Send  
for one of  
these  
**FREE**  
**BOOKS**



NO SALESMAN WILL CALL

## 2 well-paid skills NRI can teach you at home...

Begin earning \$5 to \$7 an hour  
in your spare time as you learn  
a profitable new skill

### 1 NRI AUTOMOTIVE SERVICING

Learning to service automobiles can be easy, exciting, and quick... the NRI way. You can choose the Master Automotive Technician training or a shorter Automotive Tune-up and Electrical Systems course.

#### *Practical tools and equipment for car servicing*

With the Master Course, you get—at no extra cost—your own ignition analyzer scope, as well as a dwell-tachometer, timing light, complete set of tools, volt-amp tester and assorted gauges. The Tune-up and Electrical Systems home training plan has 8 important service items.

#### *Keep your present job while you learn*

NRI home training lets you stay on the job, while learning a skill that's in demand. With the tools and training you receive, you can start earning money in your spare time, almost from the start of the course.

### 2 NRI AIR CONDITIONING, REFRIGERATION and HEATING

Step into a high-paying career or part-time job in this swiftly-growing industry. The NRI Air Conditioning, Refrigeration and Heating courses were developed with technical assistance from the York Division of the Borg-Warner Corporation.

#### *Exclusive Training Units and Window Air Conditioner*

NRI training units include a Circuit Demonstrator for learning basic electricity; a Control Simulator for learning electric controls; and with the Master Course, a 5,000 BTU window air conditioner for troubleshooting and your own use. Graduates are also offered a week's residence training at York Institute as an optional extra at no additional cost.

**APPROVED UNDER GI BILL**—If you have served since January 31, 1955, or are in service now, check GI line in the coupon.

#### SEND FOR ONE FREE NRI CATALOG



#### NRI HOME TRAINING

3939 Wisconsin Avenue, N.W., Washington, D.C. 20016

Please send me the free catalog I have checked below. I understand there is no obligation. No salesman will call.

I am interested in: CHECK ONLY ONE

AUTOMOTIVE SERVICING  
946-093

AIR CONDITIONING, REFRIGERATION-  
AND HEATING 513-093

Name \_\_\_\_\_ Age \_\_\_\_\_  
(Please Print)

Address \_\_\_\_\_

City \_\_\_\_\_ State \_\_\_\_\_ Zip \_\_\_\_\_

Send me facts on GI Bill

ACCREDITED MEMBER NATIONAL HOME STUDY COUNCIL





We said part **2001** may  
make gaskets obsolete.

Here's how.

We call Part 2001 Permatex Gel Gasket. There's nothing like it.

Gel Gasket goes on instantly and sets up in minutes. Squeeze it out . . . assemble the parts . . . drive away. You've made a gasket.

Gel Gasket comes off instantly . . . like peeling bananas.

How good is it? Gel Gasket doesn't relax, creep or absorb . . . and it mates to surfaces like skin.

Economical? A tube is enough for four engines.

Practical? It's an inventory in your tool box . . . not on your walls.

With Permatex Gel Gasket you save time, money, labor, space . . . and the job of ordering or finding the right gasket.

Will it make most gaskets obsolete? Get a tube. Do it!

PERMATEX COMPANY, INC.,  
P.O. Box 1350, West Palm Beach, Florida 33402.  
Telephone 305/686-0880. Telex 513-417.



**Permatex**  
our name is our bond



## LETTERS

(Continued from page 8)

edition, information may be obtained either through the Regional Library or directly from Mr. Martin Droege, Clovernook Printing House, 7000 Hamilton Ave., Cincinnati, Ohio 45231.

### Simpler fly cutter

Since I don't have the milling capacity required by *Fly-Cutter Holder You Can Make for Your Lathe* (page 172, July PM)—and I'm sure most people don't—I thought you might be interested in a fly cutter that's easier for the average guy to make. It can be almost any size that is required, based

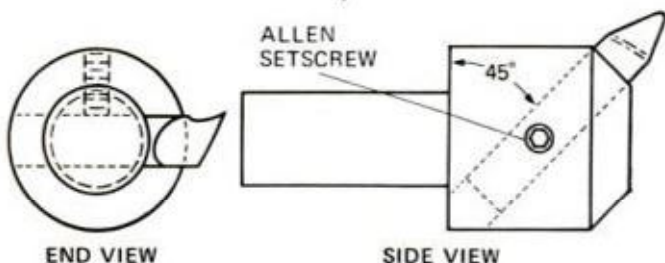

on available material. For cutters, I use round stock and have used pieces of broken taps, drills and drill rod that I heat-treat with a propane torch. You can modify the shape of the cutter for other uses, such as boring or spot facing around a hole.

FLORISSANT, MO.

RICH BENOODT

### Right war, anyway

The tank in the foreground of the photo on page 111 of the June *It's New Now* is a Cromwell, a British tank, not the Sherman. The tank in the background is a model of a latter World War II version of the Sherman.

GRAND ISLAND, N.Y.

PETER GILMORE

### Not so new now

The Austrians are actually behind the United States in the method of stopping a runaway truck by turning it uphill (*It's New Now*, page 117, July PM). In Hawaii in 1967, I saw these turn-offs along the famed Pali Highway. One improvement in

(Please turn to page 12)

# HERMAN SURVIVORS®



We build Herman Survivors® to do two things well: Cover a lot of territory in great comfort. And stand up to the kind of punishment outdoorsmen give them. In any kind of weather. That's why we build the uppers of soft, durable burgundy full-grain glove leather, line them with Ensolite® for warm feet right down to  $-20^{\circ}$ , then line the whole upper and soft padded cushion insole with saddle tan full-grain cowhide for even greater comfort. After that we stitch the boot down to resilient, oil-resistant Neoprene® crepe soles and heels. These Hermans come in two styles: 8" insulated boot, #7192, and 6" insulated shoe, #7192-6. They're tough. And they're comfortable. Like all our boots. When you're looking for quality in an outdoor shoe, hunt up a pair of Hermans.



J. M. HERMAN SHOE COMPANY,  
DEPT. 34, MILLIS, MASS. 02054

That sounds like my kind of boot.  
Send me your catalog and the name  
of my nearest Herman dealer.

PM-BGL-3-9

NAME \_\_\_\_\_

ADDRESS \_\_\_\_\_

CITY \_\_\_\_\_

STATE \_\_\_\_\_

ZIP \_\_\_\_\_



## LETTERS

(Continued from page 11)

Hawaii: the use of gravel to make the truck "sink in" and stop much faster.

YELM, WASH.

CHARLES E. LISBON

I am in the Army Corps of Engineers, and we employed this method in the steep mountain passes of Vietnam. In fact, it has been in use for at least 15 years.

FORT BELVOIR, VA.

KENNETH DESAUTELS

### Film hazard: uranium ore

Regarding the letter, "Do Security Checks Ruin Film?" in your July *Letters to the Editor* (page 8): Put your film all in one place and tell the checker, then he will not run it through the X-ray machine. At least, they have been helpful to me that way.

Another thing I learned too late: Don't take your film around uranium ore. I stopped to look at a display table of specimens in a Colorado hotel. Not until six months later, in an article I chanced to read, did I get a clue as to what happened to my film. Even the Kodak developer couldn't figure it out

and sent me replacement film, thinking there was something faulty with the original batch.

CRAWFORDSVILLE, FLA.

EDNA KNOWLTON

### Wishes he had found Mort sooner

I recently picked up my first copy of *PM* and was surprised to find someone who can write about auto repairs in language that even I can understand. My only regret is that I was not introduced to the magazine and especially Mort Schultz's articles at an earlier date.

FLUSHING, N.Y.

LAWRENCE A. NADLER

### Pretty tight turn

In *Cars the Red Baron Would Love* (page 138, July *PM*) that Mercedes-Benz 450SE sounded pretty fantastic. Its turning radius is only 37.5 feet when the wheelbase is 112.8 feet.

NORWALK, CONN.

RICHARD S. ELECK

*You never saw a longer car, did you?*

(Please turn to page 14)



**Find out how you can shoot creative, professional-looking photos.**

**Get the facts on the Honeywell Pentax Spotmatic II.**

Pentax incorporates the world's best metering system, a unique flare-taming lens, classic design, and many other technological advancements into the world's best-selling 35mm SLR. You'll get crisp, clear, vibrantly colorful results even under the toughest shooting conditions. Write for FREE literature describing our better-than-ever 35mm SLR's. Honeywell Photographic, Dept. 116-238, P.O. Box 22083, Denver, Colorado 80222.

**Honeywell Pentax**



**WHATEVER YOUR PLANS,  
THEY PROBABLY DON'T INCLUDE  
TIRE TROUBLE.**



Photographed at Lion Country Safari, Florida.

Steel Radial 500—we think you'll say "They're the best tires I've ever owned". • A 40,000 mile radial (that's 3 or 4 years of average driving). • Two belts of brass plated, high tensile steel cord under the tread. • Better handling and steering than any conventional tire we have on the road today. • A computer designed quiet running tread. • And six ways to charge it at most Firestone Dealers and Stores.



**Let Firestone put the 40,000 mile Steel Radial 500  
between you and tire trouble.**

**Firestone**  
The people tire people



## LETTERS

(Continued from page 12)

(Even when you think of the wheelbase in inches, the turning radius is pretty good.)

### Right down the alley

For the maintenance men of the Mechanical Dept., County of Los Angeles, your article on *How to Troubleshoot Your Airconditioner* (page 72, July *PM*) was right down the alley—there's so much of that in county buildings.

VAN NUYS, CALIF.

M. R. HATTABAUGH

### Pontoon Fun Raft

It took approximately one year and \$650 to build my pontoon boat from your construction drawings (*Build This Pontoon Fun Raft*, page 138, March '70 *PM*). We are really enjoying it. I built it in my 20 by 20-



foot garage; I would not advise anyone doing so because of the limited space.

HOUSTON, TEX.

JACK A. WARD

### New autopilot

*New Autopilot Got Started With Ben Franklin's Kite* (page 122, July *PM*) is very well done. I think your text and article give a better description for the layman than I have been able to organize.

I consider it an honor to have the autopilot described in this way in such a popular magazine.

SILVER SPRING, MD.

MAYNARD L. HILL

### Coffee-Table Aquarium

While visiting friends, I saw a beautiful hexagon-shaped aquarium in one of their homes. The man who built it said he got the plans several years ago from *PM*. Would

you please try to find the plans for this so I can buy them.

CLEVELAND, OHIO

MRS. A. G. PALMER

We found them. You can order a photo copy of *PM's Coffee-Table Aquarium* (page 150, April '68) for \$1.45. Write to *Popular Mechanics*, Dept. CO, Box 1014, Radio City, N.Y. 10019, and ask for plan No. X19A.

### Candlestand Lamp

The *Candlestand Lamp* (page 168, Nov. '70 *PM*) was my first large lathe project, and it turned out very nicely. Instead of using two glued pieces to make the lower turning, I used four 3/4-inch boards. I'm very happy with it.

ENDICOTT, N.Y.



JOHN M. SCHMIDT

### Splendid Hydro Dynamic

Here's the *Hydro Dynamic* (page 144, March '63 *PM*) that I built from plans I bought from you. It is a splendid boat—very stable and fast. I have a 50-hp Johnson on



it. I am now building the P38. Keep up the good work; I love to build things.

AURORA, COLO.

LAURENCE MARGHEIM

### Yes, we have an index

Did you put out an index for 1972 as you did in 1971? Haven't seen anything on it and would like to order one. Don't stop putting one out; it is a lifesaver in finding articles when they're needed.

PORTLAND, ORE.

JIM ADAMS

Yes, we have a *PM Index and Shelf Wrapper* for 1971 and 1972. Order them from *Popular Mechanics*, Dept. IXL, Box 1014, Radio City, New York, N.Y. 10019. They are \$1.49 each. Be sure to state which year you want and include your full address. ★★



# HOLD IT



## POWERGUN 1000™ STAPLE GUN

Powerful enough to do any stapling job because it even drives into hardwoods (like Oak) better than other staple guns. Ceiling tile, paneling, upholstery, fencing, insulation, name it—the Powergun 1000 does it. Easily. Sold separately or as a kit. Swingline has a staple gun for your every need.

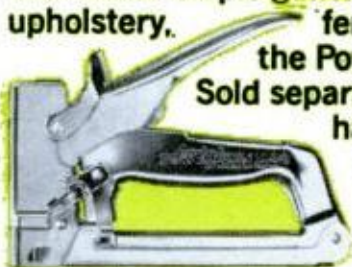

## RIVET-IT™ RIVETING PLIER

It fastens anything to anything professionally—the way the factory does and you've always wanted to! Repairs autos, boats, appliances, cycles, sleds, toys, gutters and spouts, pots, pans. Holds tight. Better than nuts, bolts, screws or solder. Rivets don't come loose. You fasten from one side. Perfect for can't-get-to places. Try it!



## THE LITTLE RED FIXER™

**ELECTRIC GLUE GUN** An easy-to-use all purpose household fixer that repairs in 60 seconds. It's small and fits any hand. Yet, its space-age adhesive makes it big enough to do almost any job. Securely binds combinations of wood, tile, leather, plastic, fabric, metal, masonry, vinyl, inflatable toys, pools, rainwear. Kit includes 29 FixStix. Buy one.



# Swingline®

Swingline, Inc., 32-00 Skillman Avenue Long Island City, New York 11101



**3 GUYS WHO DIDN'T  
GET A FREE RIDE  
THROUGH COLLEGE  
TELL HOW THEY  
BECAME ENGINEERS**





## BILL JOHNSON

"Get into college? After high school in Rutland, Vermont, I was glad to get into a machine shop not far away. Started as a lathe operator at 75 cents an hour. But thanks to ICS I've gone far. Studied Mechanical Engineering nights, at home. Never did take to classrooms or missed paydays. Won't say it was easy, but with the instructors' help I took it one step at a time. Today I'm Development Engineer with a paper converting plant near the Canadian border. Hunting's great. Salary's jumped 600 per cent since I started my ICS course. There's 40 men under me, future looks fine. Do I recommend ICS to my men? Yes I do."



## GARY BURNASH

"Too bad, but the college I went to didn't hand out degrees in hot rodding. So after my first year my Dad and I had one of those long talks. The upshot was, it was time to get serious. So I got married, started to learn automotive tool making at Sheler Corporation outside Detroit, and signed on with ICS. They taught me everything. Print reading. Materials. Hydraulics. Even how to use a slide rule. When the boss found out, he gave me design work to take home. Pretty soon, I could talk to the big car companies in their own language. I'm making triple my starting salary now, but here's the best part—I'm a half owner in the business. If I want another raise, the man I ask is me."



## JACK TERRY

"I grew up near the Okefenokee Swamp and what that means is, you don't expect life to be a gravy train with biscuit wheels. I went to work real early with the Florida Department of Transportation as a beginner draftsman. I heard the fellows tell of ICS so I sent for the information. Before long, I got to be a First-Level Highway Engineer at twice the pay. It took five promotions but the ICS training was a real help to pass each promotion exam."

### ICS

International Correspondence Schools  
Scranton, Pa. 18515

You, too, can become an engineer without going to college. At home, in about an hour a day, ICS can train you from scratch for one of the 45,000 secure, well-paying engineering jobs opening each year. To find out more about these opportunities and how ICS training works, mail card for career guidance booklets and free demonstration lesson. (ICS is approved for veterans training.)



## CAR CLINIC

BY MORT SCHULTZ

### Bellyache

*I own the perfect car—a 1972 Fiat 128. However, dealer service shops get a ridiculous price for changing the oil, so I thought I would do it myself. My problem is that no one will tell me what size wrench I need to remove the oil plug. Can you?—James Wiercinski, New York, N.Y.*

The size of the hex-head wrench you need is 12 mm, and you should be able to order one through a Fiat dealer using part No. 50113. Oil should be changed every 3000 miles and oil filter every 6000 miles. Replacing the oil filter requires removal of the belly pan on the right side, which is held by three bolts. The belly pan is a protective sheet-metal covering that runs the length of the underside of the car. A special oil-filter wrench (Fiat part No. 60312) is needed to remove and to install the filter. Fiat has published an excellent manual entitled *Fiat 128, US Version, Do It Yourself Troubleshooting and Repair Manual*. It sells for \$4 and goes under part No. 8009. You can order it from a Fiat dealer or from the service department of Fiat Roosevelt Motors, Inc., 532-540 Sylvan Ave., Englewood Cliffs, N.J. 07632.

### Pinged off

*My 1969 Chevrolet Impala with 350-cu.-in. engine and four-barrel carburetor has developed a severe ping after 34,000 miles. The ping only occurs when the engine has been driven more than five miles and is at maximum operating temperature. I use a high-octane gasoline, have taken several high-speed trips to purge the engine of impurities, have used upper lubricants, have poured various carbon-removing additives down the carburetor and have also tried a crankcase additive. The Chevrolet dealer has tried additives, tune-ups and valve adjustments with no improvement. I am told there is nothing else to do, but tear down the en-*

*gine and clean out all carbon. Is there a simpler solution?—Dr. J. Anthony Hockett, Overland Park, Kans.*

You've tried all the simple solutions; now it's time to clean out the carbon.

### Tailspin

*We have a 1969 Ford XL with power front disc brakes. When applying the brakes in slippery weather (snowy or icy), we think the front wheels are locking up, causing the car to slide before it comes to a stop. We don't get this sensation on dry pavement. Is there anything we can do?—Mrs. Robert David, Detroit.*

If rear brakes are not applying properly, it could produce a "grab" up front. I would have the rear brakes, which are drum brakes, inspected for sluggish wheel-cylinder action and worn linings.

### How's this grab you?

*I've found that many owners of Plymouths have been experiencing a brake-grab problem. I had the trouble with a 1969 Satellite station wagon and found that it was caused by dust accumulating on brake parts and collecting moisture. I had wheels removed and dust blown out thoroughly. The grabbing condition stopped, and I have had no further trouble although I made it a practice to have this done about once a year.—A. W. Anders, Tampa, Fla.*

Thanks for this information; it may benefit many drivers who are having the same problem.

### Interrupted symphony

*I share a problem with other Oldsmobile owners (mine is a Toronado) and perhaps*

*(Please turn to page 22)*



# MOONLIGHTING MADE EASY.

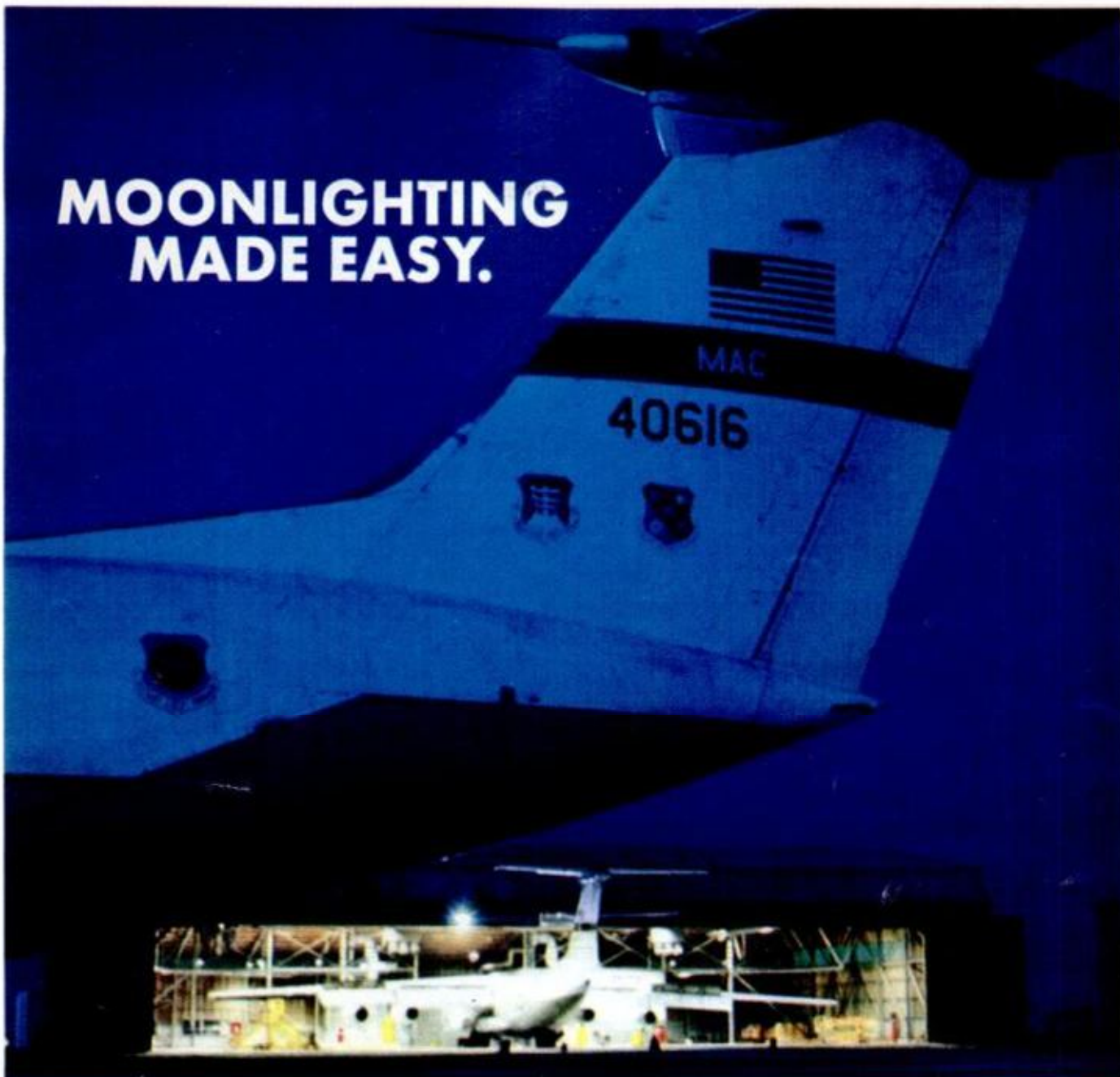

Ordinarily, moonlighting makes for a long, long day. And when the money is gone, there's often nothing to show for it.

So consider an alternative: The Air Force Reserve.

For one thing, the hours are better. We only ask you for one weekend a month. And the pay is good. Even when you're just starting with us, we'll pay you \$40.96 for that weekend. Considerably more when you're with us for two weeks in the summer. Also, the promotions and raises keep coming regularly.

But there's a lot to like besides the money. Some reservists like the chance they have to learn new skills. Or sharpen old ones. Some like the companionship. Others, the idea that there's a pension waiting that no one can take away from them. And the idea that you are helping both yourself and your country at the same time.

Think about it. Then fill in and mail the coupon, or pick up the phone and call 800-525-9984,

toll free (in Colorado, 800-332-9952). There'll be somebody on the job to give you the name and address of your nearest Air Force Reserve Unit. Check 'em out, because our kind of moonlighting is not only easier to take, but a lot more interesting.

Air Force Reserve 3-PM-93

Box A  
Randolph AFB, Texas 78148

Please send me more information. I understand there is no obligation.

Name \_\_\_\_\_ Sex  (M)  (F)  
(Please Print)

Address \_\_\_\_\_

City \_\_\_\_\_

State \_\_\_\_\_ Zip \_\_\_\_\_ Phone \_\_\_\_\_

Soc. Sec. # \_\_\_\_\_ Date of Birth \_\_\_\_\_

**AIR FORCE RESERVE.  
YOUR LOCAL AIR FORCE.**



## CAR CLINIC

*(Continued from page 20)*

*with other owners of GM cars. I get disturbing noises (clicks, buzzing) from the radio when I activate a switch or motor that operates on electricity. Is there a solution?—Harvey Kamp, Evansville, Ind.*

I assume your radio is AM/FM and the antenna is in the windshield. Allow me to quote from Delco Electronics which is responsible for this component:

"The location of the windshield antenna directly above the instrument panel makes it more susceptible to pops and buzzes caused by operation of many electrical devices. Other momentary noises from owner-actuated devices, such as turn signals, power windows or brake light switches, are considered normal on weaker stations . . . A new type of interference on weak FM stations can be encountered when wiper blades pass over the antenna. A swish may be heard."

There may be a mechanical cause for your problem, but if none is found then your situation would fit right in with the Delco statement. Mechanically, make sure suppressors are tightly in place and have them checked with an ohmmeter for resistance. Also see that the instrument wiring harness extending from one side of the dash to the other isn't resting on the antenna lead.

### More rapping about radios

*I read in your column recently that you helped a gentleman find a place to have the radio in his foreign-made car repaired. I'm in the same boat and need your help. The car is a 1972 VW Super Beetle. The radio is AM/FM, and has a defective IC chip. Who makes the VW radio and where can I get it fixed? It is marked "made in Japan."—Paul B. Glass, Iselin, N.J.*

Volkswagen does not equip cars with radios. They are installed by dealers who get them from various distributors that carry several different brands. If, for example, the name on your radio is Sapphire, the manufacturer would be Motorola. But this company is only one that has made

radios supplied to VW dealers. Others are Panasonic, Sony, Clarion. My advice is this: Check back with your dealer. He should know who supplied the radio, so don't let him tell you otherwise.

### Booster club

*As soon as cold weather strikes (0° or lower), I have to literally stand on the power brake pedal of my 1967 Mercury Caliente to get the car to stop until it has been driven two miles. Brake fluid has been drained and a high-quality fluid put in. What do you think?—Fred Witt, Beloit, Wis.*

I think your car is one of those 1967 Calientes, Comets and Cougars subject to recall for inspection and possible replacement of the brake booster unit (power brake). The trouble involves a rubber diaphragm that loses flexibility on cold days until the heat of warm-up allows it to become pliable. Although you don't say so, you probably aren't the original owner and therefore didn't receive notice of the recall. In any case, Ford has told me to tell you that a representative from their Milwaukee district office will be in touch and that if your car falls into the recall category, "arrangements will be made to have any necessary repairs made without charge."

## SERVICE TIPS

□ **Owners of 1973 Chrysler Corp. cars:** A stumble (noticeable lag) on acceleration with a 340 or 400 cu.-in. engine with four-barrel carburetor, or a 440-cu.-in. engine with TQ carburetor, may be caused by an undersize accelerating pump plunger cap. If an inspection of the fuel discharge from the accelerator pump discharge jets verifies this condition, a new plunger and check-valve seat (part No. 3780111) should be installed.

□ **Owners of 1973 Fords, Mercurys, Lincolns:** If the 8x32 3/8-in. self-tapping screw is missing from your 4300-4V carburetor, you are probably experiencing cold-start problems. This screw plugs off the choke heat vacuum passage, preventing the engine from loading up on a cold start. If the screw is missing, get one installed under the provisions of technical service bulletin 41, page 5. ★★★

**GOT A PROBLEM WITH YOUR CAR?** Ask Mort about it. Send your question to Car Clinic, Popular Mechanics, 224 West 57th St., New York, N.Y. 10019. Letters cannot be answered individually, but problems of general interest will be published in the column.



**POPULAR  
MECHANICS  
PRODUCT FEATURE**

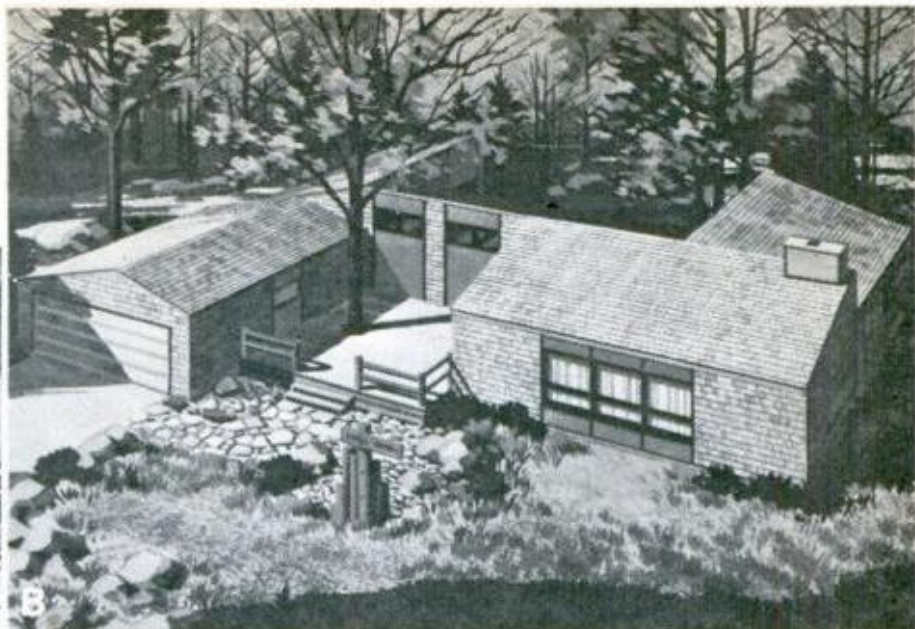

# Grow your own home.

Expandable weekender, featured in Popular Mechanics May issue, can be built in five stages. Starter unit structure (figure A) has living/sleeping space, with fully equipped kitchen/dining area, bath and laundry. Snug, and efficient, beginning structure has 448 sq. ft. Add living space as time and budget allows in four more modules until completed structure, with 1512 sq. ft., (figure B) presents a well designed living complex, planned

from the start for economy, livability, and appearance.

Order plan #875, for \$35 for 1 set, or \$50 for 4 sets of same plan, from Home Building Plan Service, or make your selection from the library of Second Home Plans described below. All designs show architectural renderings in full color, plus floor plans.



**1. BRAND NEW! RECREATION AND HOLIDAY HOMES.** Our 150 designs in full color, in an all new collection of contemporary, chalet, A-frame, split level, expandable, other designs. New structures designed for environmental compatibility, difficult sites. **\$2.50**

**3. GREAT IDEAS FOR SECOND HOMES.** 41 designs in a full color collection of innovative structural ideas. Included are clusters, modules, A-frames, round houses, chalets. Find your permanent home, or vacation design. **\$1.00**

**2. THE SECOND HOME.** 27 plans never offered before. Full color book showing homes designed for vacation, suitable for permanent residence. Select chalets, pole houses, geometric, octagonal, hillside; others. Incorporating the best in forward looking architectural design. **\$1.00**

**4. VACATION HOMES.** 15 plans for second homes, from moderately sized to larger living areas. All styles. Full color. **\$.50**

**EXCLUSIVE!**

**FOR THE  
A-FRAME  
ENTHUSIAST**

For fans of the A-frame, we have produced a book containing exclusively A-frame designs. Many appear in our other Vacation home plan books, others do not. If the A-frame's for you, you'll want this book, containing 50 plans. **\$1.00**

**HB HOME BUILDING PLAN SERVICE**

**PS** ATTN: RALPH RITTENOUR STUDIO 39H  
2235 N.E. SANDY BLVD., PORTLAND, OREGON 97232

Please rush me the HBPS PLANS BOOKS checked below.

Enclosed is my check or money order for \$ \_\_\_\_\_

- |  |   |
|--|---|
| <input type="checkbox"/> New Recreation & Holiday Homes ..... \$2.50 | <input type="checkbox"/> Vacation Homes ..... .50     |
| <input type="checkbox"/> The Second Home .... 1.00                   | <input type="checkbox"/> A-Frame Designs ..... 1.00   |
| <input type="checkbox"/> Great Ideas for Second Homes..... \$1.00    | <input type="checkbox"/> All five Above Books... 5.00 |

Name \_\_\_\_\_

Address \_\_\_\_\_

City \_\_\_\_\_ State \_\_\_\_\_ Zip \_\_\_\_\_

For fast Air Mail handling, add \$1.50 per complete package or 75¢ per book.



## HOMEOWNERS' CLINIC

BY W. CLYDE LAMMEY

### Chair restoration

*I have an old chair, not a genuine antique, in which the screws holding some parts have loosened and the heads are exposed, making the whole piece quite unsightly. Is there some way of concealing the heads of new screws I will have to use as replacements?—R. W. Hadley, Portsmouth, N.H.*

Use what are known as screwhead buttons. These are made of hardwood and they come with flat and half-round heads. They make a neat, acceptable finish.

To apply these hardwood buttons, you counterbore to recess the head of the screw to a depth of  $\frac{1}{8}$  to  $\frac{1}{4}$  in. The hole should have a diameter that will take the button with a light drive fit (the buttons are slightly tapered).

If you cannot obtain the buttons locally, write to Albert Constantine & Sons Inc., 2050 Eastchester Rd., Bronx, N.Y. 10461, or Craftsman Wood Service Co., 2727 South Mary St., Chicago, Ill. 60608.

### Latex over oil paint?

*My old house needs repainting. Original paint seems to be in fairly good condition, needing only to be wire-brushed and sanded here and there. But I've got a question: Can I use a newer latex paint over the old paint?—J. Hendrickson, Sioux City, Iowa.*

Latex paint can be used on a surface that has been painted previously with an oil-based paint if the surface is sound, clean and dry.

### Wind-damaged door

*My wood combination door was flipped open by the wind and split along the hinged side. New doors are expensive. Is it possible to repair it?—E. Corbell, Memphis.*

If the split or splintering is clean and can be tightly fitted back into place, a sound repair is possible. Spread waterproof

glue uniformly along the length of the split, then apply a few C-clamps to bring the split together tightly. Where the split extends to the bottom of the door, you will need to use bar clamps. You can reinforce the glued joint further with corrugated fasteners spaced 12 in. apart.

### Brass or plating?

*How do I tell for sure if metal is genuine brass or some other metal brass-plated?—Jay Holden, San Francisco.*

A magnet will show if a ferrous metal, such as steel, has been brass-plated. If the metal under the plating is steel, the magnet will be strongly attracted to it. But if the metal is all brass, which is a nonferrous metal, the magnet will not be attracted. However, there are other nonferrous metals that are sometimes plated with brass, and these pieces would not affect the magnet either.

### Painting fiberboard walls

*I have fiberboard walls—that's what I hear they are called—on a back porch. The paint appears to be that which was applied originally, but now the walls are in need of repainting. Should I use a latex or an oil paint?—Jim Winston, Topeka, Kans.*

From your description I suppose that these walls have been made with tongue-and-groove "planks," that were either pre-painted or factory painted. I would prefer to use a latex paint after applying a primer of the type intended for such paint. ★★★

*Do you have a home maintenance or repair problem? Send it to Homeowners' Clinic, Popular Mechanics, 224 West 57th St., New York, N.Y. 10019. While letters cannot be answered individually, problems of wide interest will be discussed in this column.*





## Spend a milder moment with Raleigh.

A special treatment softens the tobaccos  
for a milder taste.

Put it all together. Enjoy your hobby more with this 18-pc. Fleet All-Purpose Tool Kit: wrenches, pliers, screwdrivers. Yours for free B&W coupons, the valuable extra on every pack of Raleigh.

To see over 1000 gifts, write for your free Gift Catalog:  
Box 12, Louisville, Ky. 40201.



© BROWN & WILLIAMSON TOBACCO CORP.

Filter Kings, 16 mg. "tar," 1.2 mg. nicotine; Longs, 18 mg. "tar," 1.3 mg. nicotine, av. per cigarette, FTC Report February 73

Warning: The Surgeon General Has Determined  
That Cigarette Smoking Is Dangerous to Your Health.



# New industry-proven adhesive... SuperBonder™



## For all your bad breaks.

At last . . . a "miracle" adhesive that works!  
Loctite SuperBonder sets in seconds,  
without clamping, to  
bond china, glass,  
jewelry, toys, rain-  
wear, ceramics, etc.  
. . . just about any  
hard-to-fix item.



LOCTITE Corporation, Newington, Conn. 06111

Use it right out of the tube; no mixing. It forms  
a permanent, invisible bond. Sold with an  
unconditional 100%  
money-back guarantee.  
Available at your local  
Hardware Store or  
Hardware Dept. If you  
don't see it, ask for it.

TM Loctite Corp.

# Jock itch (or chafing, rash, itching, sweating) shouldn't be treated lightly.

If your groin, thighs, or  
buttocks suffer from redness,  
rash, chafing, soreness,  
excessive perspiration, or  
Jock Itch (Tinea cruris), then  
you need medicated Cruex®.

Cruex soothes itchy,  
inflamed skin. Absorbs  
perspiration. Helps cushion  
against further irritation. And  
medicated Cruex helps  
prevent fungous infections  
that can develop.

Cruex spray-on powder  
reaches hard-to-get-at



places so you avoid the sting  
and burn of rubbing or  
smearing on ointments,  
creams or powders.

Get fast relief with  
soothing, cooling Cruex.

## Cruex. Guaranteed to work or your money back.



# HINTS

## FROM READERS

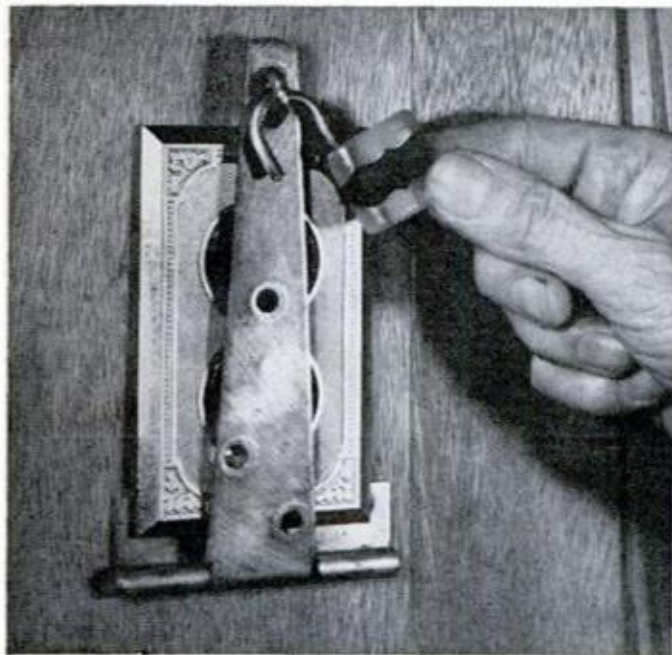

### Locking electric outlet

A workshop duplex receptacle can be locked for the safety of children or to prevent unauthorized use of tools by means of a T-hinge, screw eye and padlock or combination lock. It is necessary to cut a slot through the strap end of the hinge for the screw eye.—*Ken Patterson, Regina, Sask.*

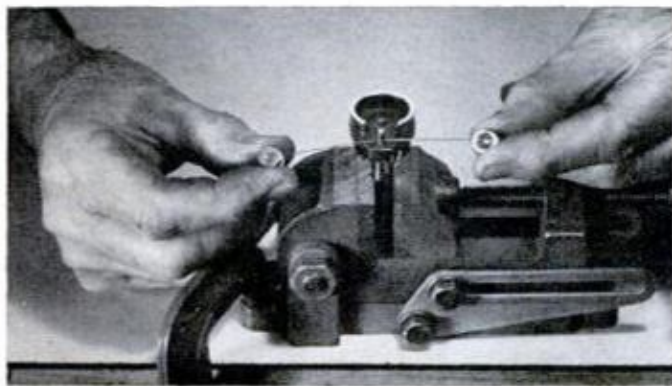

### Jeweler's saw without frame

A frameless jeweler's saw blade (or part of a broken one) can be useful in tight spots and for removing encrusted dirt from recesses. Make "handles" by placing each blade end between washers and clamping washers together with a short 6-32 bolt and nut.—*Walter E. Burton, Akron, Ohio*

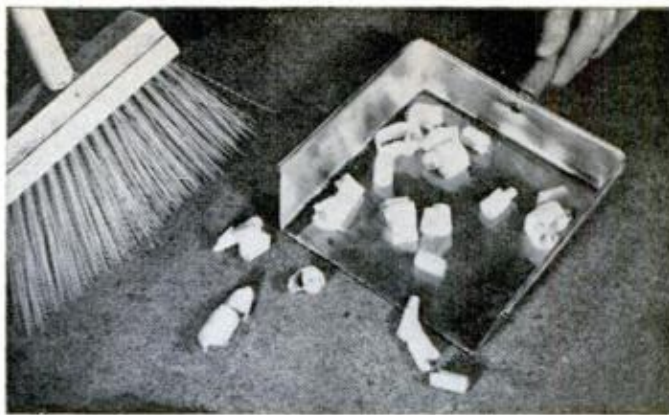

### Jumbo workshop dustpan

A large cake pan with one side cut away and a file handle screwed on makes a handy shop dustpan, can also catch lathe and drill-press chips.—*Allen Wilks, Matawan, N.J.*



### Test lamp from ballpoint pens

This test lamp uses ballpoint pen barrels (Bic) as probes. With cartridges removed, brass tips are wired in series to lamp socket and plug.—*Bill Morlock, Elma, N.Y.*

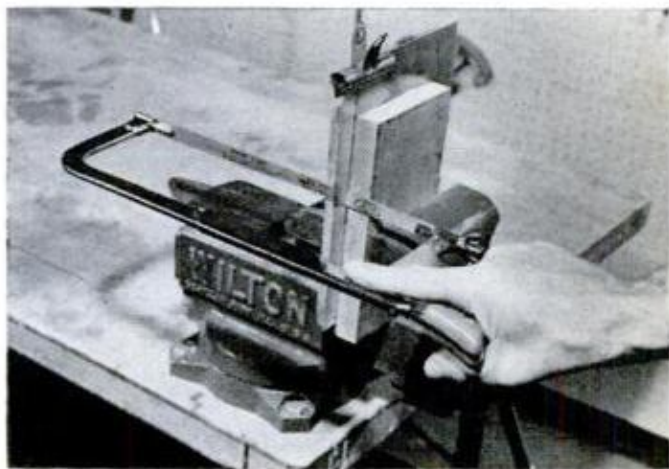

### Clip stops curling

To cut a narrow strip from thin sheet metal, hold stock between scrap blocks and use a spring clip after starting the cut to prevent curling.—*E. Dussault, Oak Park, Ill.*





# The X1/9: Fiat has a deal you can't refuse

By the end of this year Fiat will corner the market with a safe, speedy, futuristic sports car under \$3600

by Bill Hartford

AUTO EDITOR



PHOTOS BY THE AUTHOR

**Mid-engine X1/9** is a knockout from any angle. The front spoiler on the Bertone body is not so much for aerodynamic stability as it is for directing the airstream to the front radiator. Cutaway view shows the component placement. Spare tire is behind passenger seat. Steering is worm and roller; turning circle, 32 ft. 10 in. Wheelbase is 86.7 in.; length, 150.5 in.; width, 61.7 in.; height, 46 in., and weight, 1940 lbs. Gearbox is four-speed synchromesh with fourth a .959:1 overdrive ratio. Lift-off roof panel stows in front boot. Rollover bar and differentially deformable body contribute to passenger safety. Headlights pop up.

If you watch the auto market, you know that models of many European cars jumped \$1000 in less than a half-dozen years. And if you've looked longingly at a Porsche 914 recently and remember that it was \$3600 only a few years ago when you didn't buy, you know you blew it!

But you've got a second chance—a second chance to get a futuristic 1970s sports car at a 1960s price. We compare it to the 914 because these are the only two-seater, mid-engine, Targa-roofed designs available; and it compares favorably to the 914 in more ways than just the lower sticker.

The X1/9 is Fiat's replacement for the 850 Spider—a car that has enjoyed great success in this country as an excellent low-priced sports car. Its

*(Please turn to page 26D)*

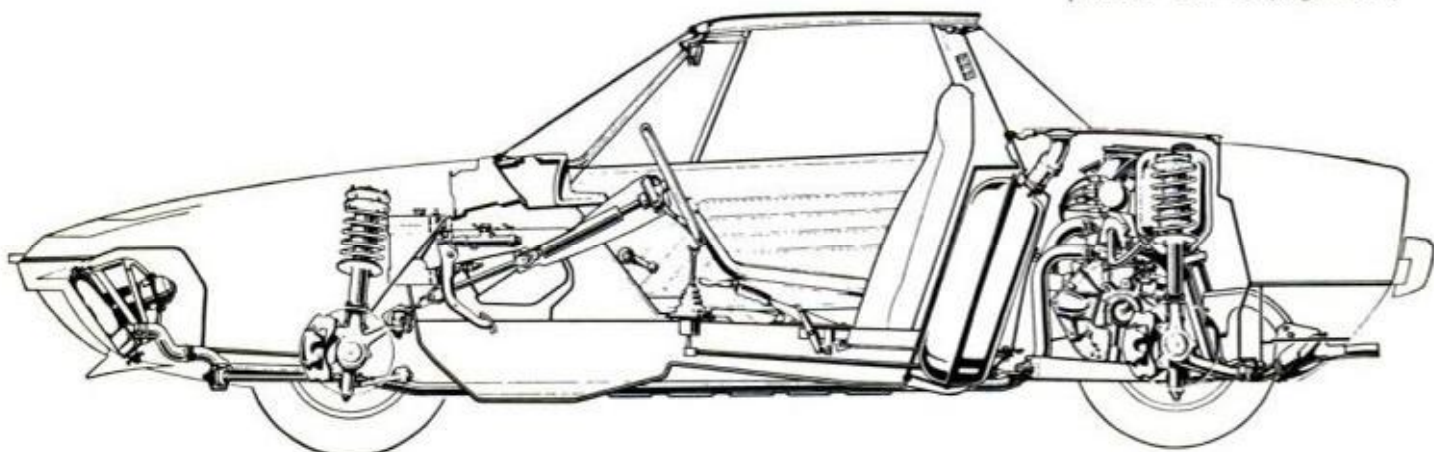



# No Miracles Today!

**Just a simple reminder  
to keep your engine properly tuned  
for improved gasoline mileage**

We have no magic formula to improve gasoline mileage, but we do know that a properly tuned engine can help. For example, one misfiring spark plug in a V-8 engine can reduce gasoline mileage as much as 12%.

A tune-up with new AC Fire-Ring Spark Plugs can help improve your gasoline mileage . . . and ACs will help give you quick starts and a smooth-running engine.

To help you with your next tune-up, we are making available a comprehensive booklet containing the manufacturer's tune-up specifications for all

American-made cars built since the early '60s. Spark plug type and gap, cam-dwell, timing and other important tune-up information . . . it's all here! And it's yours for only \$1.00.

Try a set of AC Fire-Ring Spark Plugs at your next tune-up. We believe they'll do a good job for you.



**AC SPARK PLUG DIVISION**

---

Send me a copy of the "AC Engine Tune-Up Specifications," plus an AC Fire-Ring Spark Plug decal. \$1.00 (cash, check or money order made out to AC Spark Plug Division) is enclosed to cover postage and handling (No C.O.D.s please).

Send to: TUAR CO.  
P.O. Box 354  
Flint, Michigan 48501

Name \_\_\_\_\_

Address \_\_\_\_\_

City \_\_\_\_\_ State \_\_\_\_\_ Zip \_\_\_\_\_ PM



## FIAT'S X1/9

(Continued from page 26B)

production stops as the X1/9's starts. The secret of the 850's success is often seen as its Bertone styling. But I've always found the car too cute, its lines too soft, almost effeminate for my taste. The X1/9 is something else. With its distinct aerodynamic wedge shape, the car has a forward thrust that is bold and assertive. There's no "best angle" to view it; every angle delights my sense of automobile design. But beauty is in the eye of the beholder and it's up to you to turn thumbs up or down on Bertone's latest from the pictures here (the cars will start arriving in showrooms soon).

The white car shown below is parked off

the road near Campofelice under a hot Sicilian sun: judiciously I stopped driving after going over my head and almost running off (and down!) one of the tight, wind-up turns on the tortuous, legendary Targa Florio circuit. A good time to take some pictures, I thought. My tripod kept the camera from shaking.

A more demanding route couldn't have been chosen by Fiat to show off its new car. The choice reflects the company's confidence in the X1/9. New-car press previews often wind up as destruction tests, with journalists flogging the cars unmercifully—to learn the car's capabilities, of course, but often with a child's devilish curiosity to see when it will break!

The car didn't break, or even overheat. I wouldn't have been surprised if it did after running at or above the 6800-rpm red line in the lower gears through the mountain roads, and all the way to them on the autostrada at the top speed of 105 mph.

The 1290-cc overhead-cam Four (same as in Fiat 128 models) is water-cooled, the radiator and thermostatically controlled electric fan being mounted in the nose of the car. Coolant tubes run down the center in the backbone tunnel. They are protected by the floorpan, integral with the stressed

(Please turn to page 26F)



Roll bar is discernible after the removable root section is lifted off. Fixed-glass backlight keeps back draft out of passenger compartment at speed. In U.S. market car may be regarded as underpowered by enthusiasts who expect to smoke off the line. Styling, economy, initial purchase price are all big pluses, but most outstanding characteristic is handling. It's a car for those who love to drive. And the harder you drive it the more it will reward your skills.





# Announcing

## Popular Mechanics Picture-Tools - the handiest shop-organizers ever designed

POPULAR MECHANICS PICTURE-TOOLS are a great new idea to take the confusion out of *what goes where* on workshop tool panels.

The complete PM PICTURE-TOOL KIT consists of seven big sheets (9¾ x 11¾ in.) of a special heavyweight paper with a pressure-sensitive adhesive on the back. On each sheet are beautiful drawings of hand tools and portable power tools—all (74 in total) you're likely to have in your shop. Most are full size; the others, only slightly reduced.

Also enclosed in the kit is a blank sheet of the same special paper, printed in an overall color to match the tools. This sheet enables you to design your own drawings or silhouettes of any special tools you have.

Each of the PM PICTURE-TOOLS is carefully die-cut. You simply peel it off the backing paper and apply it to the proper spot on your panel. You can apply PICTURE-TOOLS to any painted or unpainted wood, plywood, hardboard and even perforated-hardboard surface.

Later if you want to move a few tools or rearrange the entire panel, you can peel off

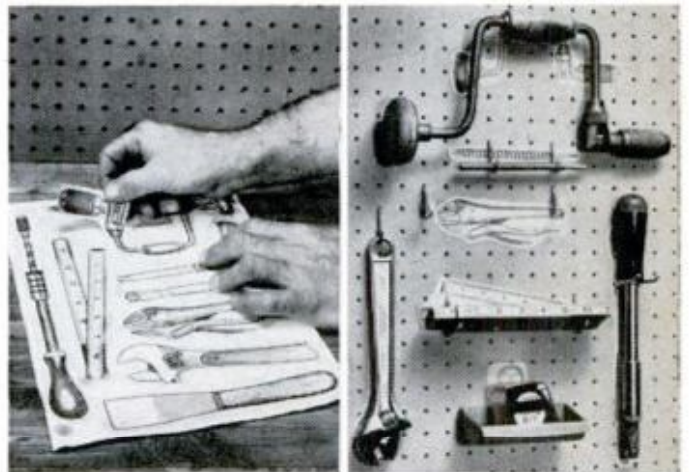

the PM PICTURE-TOOLS and move them to new locations. They are reusable!

Once your PICTURE-TOOLS are in place, you'll know at a glance exactly where each tool in your shop belongs. You'll also know—again at a glance—what tools are missing.

Best of all, you'll be surprised how PM PICTURE-TOOLS will instantly and dramatically enhance the appearance of your shop!

**Order your PM PICTURE-TOOL KIT today!**

Only

# \$3.95

Popular Mechanics, Box 1014 (Dept. PT), Radio City, N.Y., N.Y. 10019

Enclosed is my check or money order for \$3.95.

Send my PM PICTURE-TOOL KIT to:

Name \_\_\_\_\_

Address \_\_\_\_\_

City \_\_\_\_\_

State \_\_\_\_\_

Zip \_\_\_\_\_



# OLDER SEAL LIQUID WRENCH



Liquid Wrench is the super-penetrating rust-solvent that loosens rusted nuts, bolts, screws and parts—in seconds! Safe on all metals, use it on a bulldozer or even your watch!



Lan-Lin gets down deep—removes paint, grease, grime, ink!

Trans-Medic stops transmission troubles! You'll feel the difference!

RADIATOR SPECIALTY CO., CHARLOTTE, N. C. 28201

Look for

## GUNK®

when you want to clean anything!

... like engines, power mowers, concrete driveways, parts.

There's a

GUNK

product for almost any degreasing job in factory, shop or home.



Engine Brite Engine Cleaner. Spray it on... hose it off! "Dirt and grease wash away."



B.O.P. Small Parts Cleaner with dip basket ... soaks parts clean.



GP cleans oil, grease, dirt from garage floors, driveways, power mowers, machinery.

GUNK LABORATORIES, 5829 W. 55, CHICAGO, ILL. 60638  
Gunk Chicago Co. Radiator Specialty Co.  
River Forest, Ill. Charlotte, N. C.

## FIAT'S X1/9

(Continued from page 26D)

body structure—an effective arrangement.

The X1/9 engine, placed transversely just ahead of the rear wheels, is rated at 75-hp DIN in the European version we drove. Net figure for the U.S. version will be lower, but top speed performance should near 100 mph and through the gears it will compare to the 128SL coupe.

Access to the single-carbureted engine is through the slotted, flat-black hatch visible in the photos. Maintenance will be easy through the wide opening, much easier than 914 owners have it. The rear luggage compartment is not as large as the Porsche's but I vote for the easier serviceability. Fiat's layout switches stowage of the removable roof section to the front.

I personally prefer the more open-space feeling that the Porsche configuration offers, but that's no criticism of the 1/9's superb interior layout of instruments and



Wheels and tires are 4½Jx13 in. and 145HR-13 radials. Dual hydraulic circuits operate disc brakes on all four wheels. Suspension is four-wheel independent.

controls, excellent driving position and seats, and interior trim. Design of the small-diameter, padded, sports steering wheel is terrific. Fiber optics light the switches and ventilation is flow-through. You can spend hours at the wheel and then regret having to stop. Unless, you've almost gone over the edge driving the route of the Targa Florio. That's the danger of being too steeped in the romance of all those superdrivers who have challenged that circuit and won. The first to do it in an international Grand Prix was Felice Nazzaro in a FIAT in 1907 (Back then FIAT was an acronym for *Fabbrica Italiana Automobili Torino*). There's nothing to match the romance of road racing! My 1973 Popular Mechanics Grand Prix of Sicily is over. I won. I beat the road. The marque: FIAT... X1/9. ★★★





## THE GREAT AMERICAN SCOPE IS THE ALL STEEL SCOPE.



ALL NEW 4-POWER MODEL K4.

### NEW

All Steel for strongest, surest protection ever designed for a precision sighting instrument. Process-formed, one-piece steel tube.

### NEW

New distinct contours, beautifully machined quality. A fine match for the finest rifles. Unconditional guarantee on materials and workmanship.

### NEW

Extremely advanced, freeze-dried, vacuumized, dry nitrogen process. Super sealed, super fog-free. Even with turret caps off, eyepiece loosened. Guaranteed for life against fogging.

### NEW

New super-strong turret with adjustment capability that exceeds accuracy capability of finest rifles made.

### NEW

Uniquely knurled steel turret caps, Range Focus ring (on K8, K10, K12, V9, V9-W, V-12), and eyepiece lock rings for positive, sure grip.

## THE ALL STEEL SCOPE IS GREAT FOR TOUGH HUNTING.

Weaver: for 40 years, the Great American Scope. Now the only All Steel Scope. Steel because it gives much stronger protection to Weaver's superior lens system. Steel because it is far more compatible with glass than aluminum, plastic, or brass. Steel because its super quality assures total reliability, permits complete fogproofing.

### A WIDER VIEW FOR THE SHOOTERS WHO WANT IT.

Weaver's new Wider-View is an outstanding sighting instrument. It has every popular K and V Models feature. Plus a 25% wider picture. Plus a handsomely-styled and precision-machined eyepiece. Look at Wider-View in three fixed-power K-W Models, three variable-power V-W Models.



Now eight K Models and three new Wider-View K-W Models, four V Models and three new Wider-View V-W Models. See them at your dealers.

Or write for FREE catalog:  
W. R. Weaver Company, Dept. 91,  
El Paso, Texas 79915

**WEAVER**  **SCOPES**

ALL NEW, ALL STEEL, ALL AMERICAN  
AND ALL WEAVER.



# WORTH WRITING FOR

LOOKING FOR IDEAS AND INFORMATION ON HUNTING, FISHING, CAMPING, BUILDING, TOOLS, ETC.? CHECK THESE LISTINGS, THEN USE THE COUPON BELOW.

## 183. NUTONE BUILT-IN PRODUCTS GUIDE

Beautifully illustrated, full-color all new magazine has 76 pages of ideas and information on a wide variety of household systems—includes kitchen appliances, music systems, light systems, etc. From NuTone Div. of Scovill. \$1.00.

## 184. PUT YOUR SIGHTS ON THIS!

New, full-color catalog lists and describes in intricate detail the complete line of Browning Firearms and outdoor accessories. Over 100 pages of gear to choose from. Free.

## 185. CHILTON'S REPAIR & TUNE-UP GUIDES

Loaded with fresh, essential, practical information. The most complete series available covering most popular makes and models. Probably the most useful buy you'll ever make for your car. For complete information write for brochure. Free.

## 186. ELECTRONICS IDEA BOOK

Fascinating 126-page book contains literally hundreds of ideas that are bound to excite the imagination of everyone who's into electronics. From Etco Electronics. \$1.00.

## 187. BRAND NAME AUDIO COMPONENTS

52-page catalog listing thousands of Brand Name audio components priced at big savings from one of the largest and most reliable mail order houses in the country. From Dixie Hi-Fi. Free.

## 188. "THE RETURN OF THE LUGER"

Good brochure gives full facts

and data on .22 caliber Luger available from Stoeger Industries. Includes attractive holsters. Free.

## 189. CAR CARE TOOLS

Complete 64-page catalog features hundreds of tools to make working on your car easier and faster. Full specifications and prices. From K-D Tools. Free.

## 190. BLAST OFF!

With this model rocketry catalog from Estes Industries. Includes over 70 pages of items, including 26 new kits. They really fly, up to 2500 feet! 25¢.

## 191. TAKE THE GUESSWORK OUT OF FINE PHOTOGRAPHY

Complete 30 page full-color brochure gives listings of entire Honeywell Pentax line of fine cameras, lenses & accessories. Excellent data for any photo buff. Free.

## 192. PM'S COMPLETE GARDENING GUIDE

It's never too late to order your PM Gardening Guide. It's loaded with tips and information about landscaping, transplanting, pruning, lawn care, soil improvement, etc.—Everything you need to know to make your garden grow. \$3.95.

## 193. CHEMICAL CURES FOR YOUR CAR

Here's some excellent literature that gives full information on complete range of chemicals that can prolong the life of your engine. Included are additives, engine cleaners, lubricants, etc. From Kapro Corp. Free.

## 194. MAKE IT TOUGH FOR THIEVES.

Informative, new full-color book-

let from the world's largest padlock manufacturer pictures and describes 129 different security devices. Includes brochure on how to guard against burglars. From the Master Lock Co. 15¢.

## 195. AIR GUNS THAT SIZZLE

Full color brochure introduces entire array of air guns from pistols to rifles. Gives excellent information and specifications. From Crosman Arms. Free.

## 196. CAST AWAY INTO METAL CRAFTS

Fully detailed and illustrated craft manual teaches you how to cast your own metal rings, pendants, earrings, and other fine jewelry. It's easy and the results are beautiful. From California Crafts Supply. \$1.50.

## 197. "101 REASONS TO OWN A CHAIN SAW."

This imaginative booklet has trees full of projects from log chairs to tree houses that can be simplified by using a chain saw. Complete with plans and instructions for each. From McCulloch Corp. 25¢.

## 198. RACK-UP YOUR WINE

Fully-illustrated booklet contains more than a dozen easy-to-build redwood wine rack plans, complete with directions and material lists. Also included are design and construction ideas, finishing suggestions and tips for proper storage. From Louisiana-Pacific Corp. 50¢.

## 199. PUT YOUR FEET IN THEM

Catalog describes full line-up of quality outdoor shoes and boots. All of them are fit for work, fun and feet. From Jos. Herman Shoe Co. Free.

POPULAR MECHANICS 973  
BOX 1718, SANDUSKY, OHIO 44870

Please see that I receive the items checked below. I have enclosed 35¢ for the overall service charge, plus remittance for any priced items.

- |                                       |                                    |                                       |                                       |
|---------------------------------------|------------------------------------|---------------------------------------|---------------------------------------|
| <input type="checkbox"/> 183 (\$1.00) | <input type="checkbox"/> 187       | <input type="checkbox"/> 191          | <input type="checkbox"/> 195          |
| <input type="checkbox"/> 184          | <input type="checkbox"/> 188       | <input type="checkbox"/> 192 (\$3.95) | <input type="checkbox"/> 196 (\$1.50) |
| <input type="checkbox"/> 185          | <input type="checkbox"/> 189       | <input type="checkbox"/> 193          | <input type="checkbox"/> 197 (25¢)    |
| <input type="checkbox"/> 186 (\$1.00) | <input type="checkbox"/> 190 (25¢) | <input type="checkbox"/> 194 (15¢)    | <input type="checkbox"/> 198 (50¢)    |
|                                       |                                    |                                       | <input type="checkbox"/> 199          |

Total items requested \_\_\_\_\_ Total money enclosed \_\_\_\_\_

Name \_\_\_\_\_  
(Please Print)  
Address \_\_\_\_\_

Town \_\_\_\_\_ State \_\_\_\_\_ Zip Code \_\_\_\_\_  
(Please send cash, check or money order made out to POPULAR MECHANICS. No stamps, please.)

NOTE: POPULAR MECHANICS processes your requests for the above information and forwards these inquiries to the organization making the offer. Each company mails the material directly. Please allow 4-6 weeks for delivery. Unfortunately, we are unable to process requests outside of the U.S. and Canada.



Mail the Card Today!

# FREE

Find All Your Electronic Needs  
In One Complete Book



468  
PAGES

The World's Largest  
Consumer Electronics Catalog

Featuring Everything In Electronics for:

• HOME • INDUSTRY • LABORATORY

All From One Source—All From One Catalog!

- Stereo Hi-Fi • The Latest in 4-Channel Stereo
- CB Equipment • Ham Gear • Test Equipment
- Tools • PA & Intercom Systems • TV • Radios
- Musical Instruments • Cameras • Auto Accessories
- Tape Recorders • Tubes, Books, Parts
- and Much More!

Mail This Card Today for a Friend

### STORE LOCATIONS

NEW YORK	PENNSYLVANIA	GEORGIA
NEW JERSEY	MARYLAND	INDIANA
CONNECTICUT	OHIO	VIRGINIA
MASSACHUSETTS	ILLINOIS	MISSOURI
WISCONSIN	MINNESOTA	

LAFAYETTE RADIO ELECTRONICS  
P.O. Box 10  
Syosset, L.I., N.Y. 11791

Please Send the FREE CATALOG 740 15093

Name \_\_\_\_\_

Address \_\_\_\_\_

MAIL THIS  
CARD TODAY



# FREE!

LAFAYETTE  
CATALOG 740

15093

Name \_\_\_\_\_

Address \_\_\_\_\_

City \_\_\_\_\_

State \_\_\_\_\_

Zip \_\_\_\_\_

MAIL THIS  
CARD TODAY



# FREE!

LAFAYETTE  
CATALOG 740

15093

Name \_\_\_\_\_

Address \_\_\_\_\_

City \_\_\_\_\_

State \_\_\_\_\_

Zip \_\_\_\_\_



Mail This Card Today For Your

# FREE

1974 LAFAYETTE CATALOG 740

## 468 Pages



- Stereo Hi-Fi • CB Equipment • Test Equipment • Musical Instruments • Ham Gear • PA Systems • Cameras • Auto Accessories • Tools • Books • Parts • and Much More!

### SATISFACTION GUARANTEED OR MONEY REFUNDED

#### LAFAYETTE Leads The Way In 4 CHANNEL STEREO Components



LR-4000



Micro 23  
CB 2-Way Radio



Dyna-Com  
Walkie-Talkies

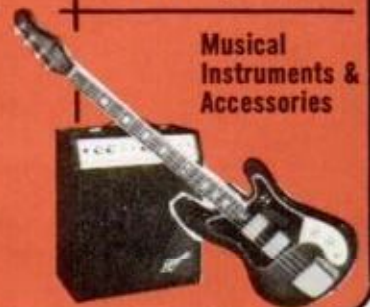

Musical  
Instruments &  
Accessories

#### Do A Friend A Favor . . .

Have a friend interested in hi-fi or electronics? Send us his name and address and we will send him his own personal copy of the 1974 LAFAYETTE Catalog 740.

**FREE** Mail the Card Today!

# LAFAYETTE

## RADIO ELECTRONICS

P.O. BOX 10  
SYOSSET, L.I., N.Y. 11791

PLACE  
STAMP  
HERE

# LAFAYETTE

## RADIO ELECTRONICS

P.O. BOX 10  
SYOSSET, L.I., N.Y. 11791

PLACE  
STAMP  
HERE



# New from PM

POPULAR MECHANICS PICTURE-TOOLS are a great new idea to take the confusion out of *what goes where* on workshop tool panels.

The complete PICTURE-TOOL KIT consists of seven big sheets (9¾ x 11¾ in.) of a special heavy-weight paper with a pressure-sensitive adhesive on the back. On each sheet are beautiful drawings of hand tools and portable power tools—all (74 in total) you're likely to have in your shop. Most are full size; the others are only slightly reduced.

Each of the PM PICTURE-TOOLS is carefully die-cut. You simply peel it off the backing paper and apply it to the proper spot on your panel. Once the PICTURE-TOOLS are in place, you'll know at a glance exactly where each tool in your shop belongs.

To order, send \$3.95 (check or money order) to: Popular Mechanics, Box 1014 (Dept. PT), Radio City, New York, N.Y. 10019 with your name and address.

POPULAR MECHANICS COMPLETE GARDENING GUIDE. First we assembled every bit of information you need to make your lawn and garden beautiful. We condensed *these* basics to *their* essentials. Then we added more than 20 fact-packed tables and charts, and scores of show-how drawings. Finally, we printed this vital material on heavy plastic-coated cards, and spiral-bound them together.

You'll be amazed at the vast amount of information packed into your COMPLETE GARDENING GUIDE. Planting dates and depths for all kinds of seeds and bulbs; when to prune what, and how; information on the 56 most popular shrubs, and the 21 best hedges; all about ground covers; how to lay flagstone, patio blocks, bricks; how to build decks—and much, much more.

To order, send \$3.95 (check or money order) to: Popular Mechanics, Box 1014 (Dept. GG), Radio City, New York, N.Y. 10019 with your name and address.

1973 INDEX AND SHELF WRAPPER. Do you want to find an article on 17 ways to thiefproof your car? How to build a colonial footstool? The latest bicycle touring gear? How to remodel your bath?

Your copies of PM are chock-full of such information. Sometimes, though, it can be frustrating to find the article you want.

The 1973 PM INDEX AND SHELF WRAPPER references and cross-references all of those thousands of items. You can find *any* article in seconds.

Reserve your copy now. We'll rush it to you when it's available in December. Send just \$1.49 to Popular Mechanics, Box 1014 (Dept. PMI), Radio City, New York, N.Y. 10019 with your name and address.

FOR PEACE OF MIND  
INSIST ON

## Master®

Security is vital to your peace of mind. That's why you should insist on Master when you have a security problem . . .



### Gun safety.

Prevent tragic accidents with patented Master Gun Lock. Covers trigger so gun can't fire. Fits most firearms. Only \$5.95



**Hard-to-protect property.** Lock it to an immovable object with *The Crimelfighter*. Vinyl-covered specially-hardened steel chains. With Master combination or laminated padlocks.



### Trailer theft.

Patented *No-Tow* trailer lock. Guards against towaway theft. Sizes to fit most trailer couplers. Only \$12.95

Insist on Master  
for your security needs.

**Master Lock Company**  
MILWAUKEE, WISCONSIN 53245



## SCIENCE WORLDWIDE

### Icebreaker saws through ice

A new type of icebreaker, equipped with ice-chomping circular saws, is under development for the U.S. Coast Guard. Three saws, mounted on runners projecting forward of the bow, cut slots in the ice. As the ship

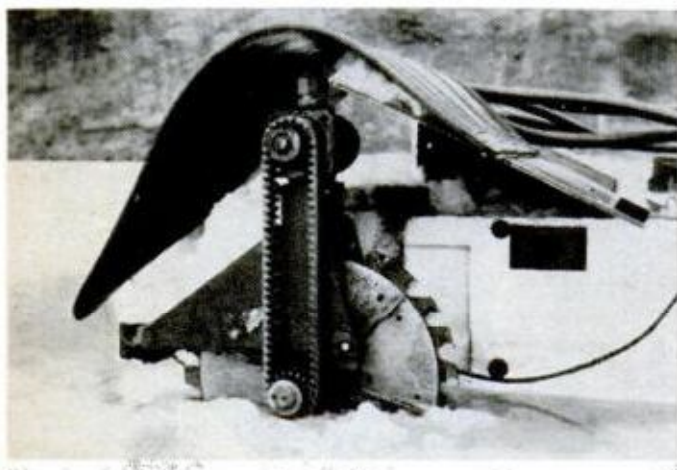

moves forward, pressure from the bow breaks off slabs that slide under the hull and are pushed to either side. Slabs come to rest under ice sheet, leaving a clear channel. Conventional icebreakers leave a channel clogged with broken ice, making passage difficult for following freighters. The concept has been tested with a one-sixth-scale model (shown) by ARCTEC, a Maryland lab specializing in cold-regions research. Results indicate a full-scale ship could clear a channel of ice two and a half feet thick at a speed of five knots. This would make it effective in assisting winter marine transportation in the upper reaches of the Mississippi and in the Great Lakes.

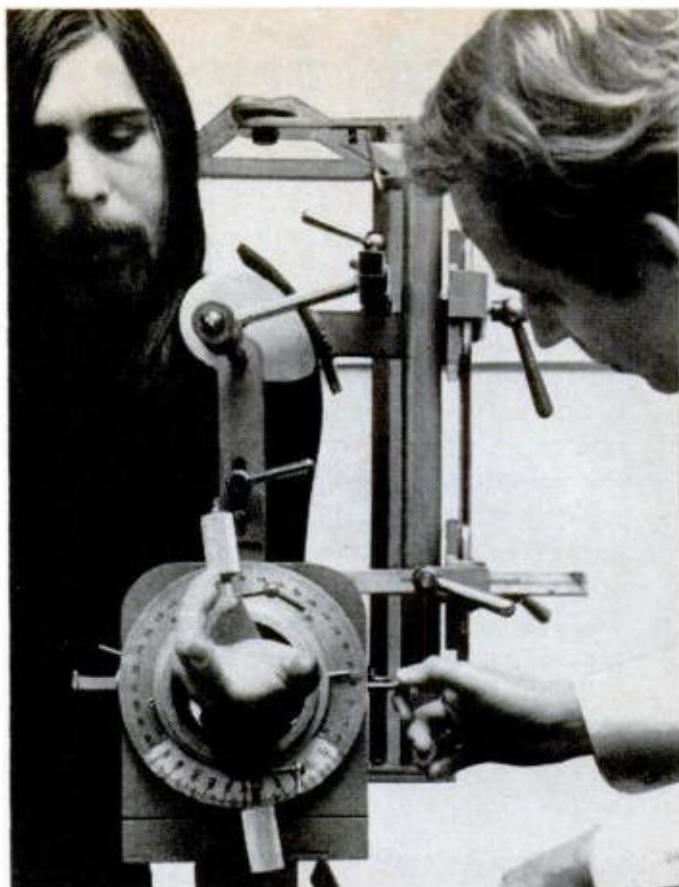

### Measuring a musician's potential

Some musicians find that they reach a point where their technical facility no longer improves. This is due primarily to physiological shortcomings, according to Dr. Christoph Wagner, a researcher at the Max Planck Institute, West Germany. An amateur musician himself, Dr. Wagner has devised several instruments for measuring factors such as flexibility in joints and arms, and extensibility of the hands. In photo, Dr. Wagner checks flexibility of subject's hand and forearm. The doctor believes that his tests show whether a musician has the potential to become a top performer—or whether he has limitations that no amount of training can overcome.

### Space communications by laser

A sun-powered laser that can provide the long life required for practical space communications systems is under development by the Air Force. It's part of a program aimed at determining the feasibility of satellite optical communications. By means of a series of lenses and mirrors, the device will collect and focus rays from the sun, stimulating material in the laser to produce

*(Please turn to page 32)*



# America's No.1 'holding' company.



No matter what Elmer's\* you use, you can be sure it's going to hold.

Elmer's Glue-All: for wood, leather, paper and cloth. Even Styrofoam\*\*:

Elmer's Epoxy: extra tough. For metals or bonds that need to be water-proof.

Elmer's Contact Cement: where you can't use clamps. Bonds instantly.

Elmer's. The glue that puts it all together. For good.



For Elmer's brand new handyman booklet containing ideas on how-to "make and fix" many things around the house, send 25¢ for postage and handling to Elmer's "Make-It & Fix-It" Booklet, Dept. MFM, Box 266, Medina, Ohio 44256.

\*Registered Trademark of Dow Chemical Co.

## An Open Letter To Readers of POPULAR MECHANICS Who Dream of Going Into The Mail Order Business— But Can't Get Started!

Mail order is a strange and wonderful way of doing business. It is fascinating to all kinds of people because you start a mail order business with a small investment as a part-time business or a long-term project. House Beautiful's "Window Shopping" is the busiest shopping street in mail order land. We're professionals in this fascinating business with its fabulous future. We have the experience and know-how to help produce the results you need to sell your products and insure success. For an excellent, down-to-earth primer on "How To Start A Successful Mail Order Business", send 25¢ (to cover postage) to

### HOUSE BEAUTIFUL—DEPT. P.M.

Room 969, 717 Fifth Avenue, New York, N.Y. 10022

Send booklet "How to Start a Mail Order Business" to:

NAME \_\_\_\_\_

ADDRESS \_\_\_\_\_

CITY \_\_\_\_\_ STATE \_\_\_\_\_ ZIP \_\_\_\_\_

## New Tool Works Wonders With Wire **WIREFORMER**

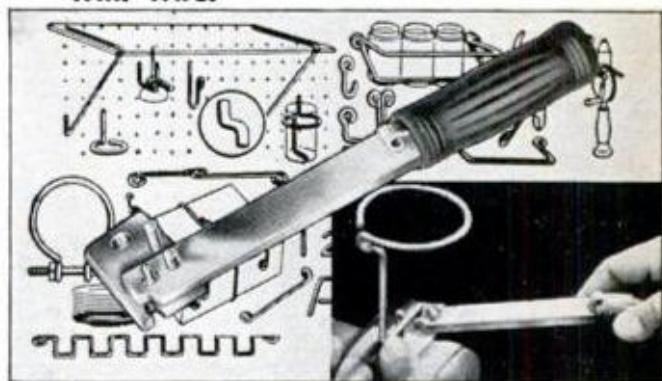

### IT BENDS! IT CUTS! IT STRAIGHTENS!

WIREFORMER is a simple, precision made, vise-held tool of innumerable uses. Make your own peg board hooks, clamps, handles, braces, brackets, etc.—any shape you want. Forms an eye of 3-16" inside diameter (just right for any nail, screw, or bolt up to that size). Even uses coat hanger wire. No pliers needed. WIREFORMER does the work with the pressure of one finger. Straightens the wire if you make a mistake. Cuts the wire just where you want it. Forms any angle, arc or circle. Bends both right and left. Tool is case hardened, plated, with a plastic handle. Fits in your pocket. Complete instructions, illustrated brochure showing many things to make.

SOLD ONLY BY MAIL. MONEY BACK GUARANTEE. Four dollar bills will get you one, or send check or money order for just **\$3.98** We pay postage and handling charges.

**VINKEMULDER TOOL CO. Dept. PM93**  
2223 Estelle Dr., S.E. Grand Rapids, Mich. 49506



LIVE IN THE WORLD OF TOMORROW . . . TODAY!

# UNUSUAL BARGAINS

NEW PRODUCTS • NEW MATERIALS • NEW IDEAS

## "FISH" WITH A MAGNET



Go treasure hunting on the bottom! Fascinating fun & sometimes profitable! Tie a line to our 5 1/2-lb. Magnet—drop it overboard in bay, river, lake or ocean. Troll it along bottom—your "treasure" haul can be outboard motors, anchors, other metal valuables. 5 1/2-lb. Magnet is war surplus—Ainco V Type—Gov't cost \$30. Lifts over 150 lbs. on land. Stock No. 70,571H . . . \$14.00 Ppd. Stock No. 60,215H 1 1/2 lbs. \$5.75 Ppd. Stock No. 70,570H 3 1/2 lbs. (lifts 40 lbs.) . . . \$8.75 Ppd.

## KNOW YOUR ALPHA FROM THETA!



For greater relaxation, concentration, listen to your Alpha-Theta brainwaves. Ultra-sensitive electrode headband slips on/off in seconds—eliminates need for messy creams, etc. Attach'd to amplifier, filters brainwaves, signals beep for ea. Alpha or Theta wave passed. Monitor button simulates Alpha sound; audio & visual (L.E.D.) feedback. Reliable, easy-to-use unit—comparable to costlier models. Completely safe. Comprehensive instruction booklet. No. 1635H (8x3x4"); 24 oz.) \$124.50 Ppd.

## LEARN POINTS OF ACUPUNCTURE



Ancient Chinese healing art made simple! Theory based on body's life energy flowing thru sub-skin meridians with vital points. Big 22 x 35" two-color chart vividly shows all the 14 meridians and their 500 to 800 points that acupuncturists must learn to pierce for healing and pain removal. Back, front & side views of body labeled with meridian descriptions; types of needles, complete bibliography. Heavy grey paper. Stock No. 82,054H \$2.95 Ppd. 10 OR MORE (SAME STOCK NO.) EA. \$2.25 Ppd.

## GIANT WEATHER BALLOONS

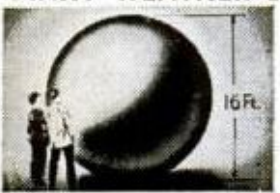

"Balls of fun" for kids, traffic stoppers for stores, terrific for amateur meteorologists. Create a neighborhood sensation. Great backyard fun. Exciting beach attraction. Amateur meteorologists use to measure cloud heights, wind speed and temp. Made of heavy-duty neoprene. Inflate with vacuum cleaner or auto air hose; or locally available helium for high rise.

Stock No. 60,568H (8' size) . \$2.50 Ppd. Stock No. 60,632H (16' size) \$8.75 Ppd.

## NEW! FORD TURBINE ENGINE KIT



Think Wankel's great? Build a 1/4 scale model of Ford's revolutionary, "better" answer for a clean-burning economy engine! Harnesses power prev. used in jets w/ ingenious engineering like exhaust regenerator, variable power turbine nozzle, electronic control system. Exact detail model shows actual working compressor, gears, turbine, regenerator, power output shaft; glowing combustion chamber. Balt. oper. (2 "AA" not incl). Instructions. Stock No. 71,851H . . . \$12.95 Ppd.

'Bright Ideas' in Unique Lighting Big, new 100-page handbook packed with facts, loaded with illustrations. All latest developments, applications, equipment. 8 1/2" x 11" looseleaf paper to fit 3 rings. Stock No. 9100 H . . . \$3.00 Ppd.



## MAIL COUPON FOR GIANT FREE CATALOG!

148 PAGES • MORE THAN 4,500 UNUSUAL BARGAINS!

Completely new 1974 Catalog. Packed with huge selection of telescopes, microscopes, binoculars, magnets, magnifiers, prisms, photo components. Ecology and unique lighting items, parts, kits, accessories—many hard-to-get surplus bargains. 100's of charts, illustrations. For hobbyists, experimenters, schools, industry.

**EDMUND SCIENTIFIC CO. 300 Edscorp Building, Barrington, N. J. 08007**  
Please rush Free Giant Catalog "H"

Name \_\_\_\_\_  
Address \_\_\_\_\_  
City \_\_\_\_\_ State \_\_\_\_\_ Zip \_\_\_\_\_

**EDMUND SCIENTIFIC CO.** MONEY BACK GUARANTEE  
**300 EDSCORP BLDG. BARRINGTON, NEW JERSEY 08007**  
ORDER BY STOCK NUMBER - ADD \$1 HANDLING CHARGE - SEND CHECK OR MONEY ORDER

## SCIENCE WORLDWIDE

(Continued from page 30)

light beams. These beams are capable of transmitting data, television, voice and other program material.

## Most distant quasar reported

A new quasar some 10 billion light years from Earth—more distant than any other known object—was recently reported by University of California astronomers. Quasar stands for "quasi-stellar radio source," a bright object that emits powerful radio waves and looks like a star.



## Tiny TV eye for industrial probes

A TV camera only one and a half inches in diameter has been developed by British engineers for probing pipelines, fuel tanks, aircraft frames and other structures. The structure being examined does not have to be dismantled. The camera can be attached to cables from 50 to 450 feet long and is said to produce remarkably sharp pictures.

## Vitamin E may be good for lungs

Urban dwellers choking on smog and auto exhaust may be able to safeguard their lungs with vitamin E. A Duke University researcher, working with rats, reports that a vitamin-E-rich diet may help neutralize the damaging effects on lungs of pollutants such as ozone and nitrogen oxide. ★ ★ ★



# New Rubber Stamp Business Pays Beginners <sup>UP</sup> <sub>TO</sub> \$16.50 an hr.

**START AT HOME IN SPARE TIME WITH  
THIS LITTLE TABLE TOP MACHINE . . .  
WE'LL EVEN HELP FINANCE YOU  
. . . at less than bank rates!**

The multi-million dollar Rubber Stamp Business—once controlled by a few big companies—is now being taken over by small home operators—one in each community throughout the U.S. Men and women who have this inexpensive machine can turn out huge quantities of Rubber Stamps with special wording that buyers once were forced to order from big cities. Material costing only 27c makes a stamp that sells for \$2.75. The machine that does the work is simple and easy to operate and it turns out as many as six Rubber Stamps at a time each with different wording such as names, addresses, notices, stock numbers, prices and other "copy" needed by offices, factories and individuals. Working full capacity, it can earn as much as \$33.00 an hour for the operator! Now you can get into the big-pay business yourself, with your own home as headquarters. You don't need any experience. We supply everything, including complete instructions and eight ways to get business coming in fast. Start making up to \$16.50 an hour from the very beginning. Cash in on the profitable Rubber Stamp business right away.



**WE HELP  
FINANCE YOUR  
START IN BUSINESS**

**TAKES  
ONLY 2  
SQUARE FEET  
OF SPACE**

- Read the complete and fascinating Rubber Stamp story in the big, over-100-page book. Learn how we even help finance your start. The book contains over 100 illustrations and photographs. And you can read it for a full thirty days without risking a penny!

*They tell it Like it is...*

• H. D. B. writes: "It all started from an initial \$11.00 deposit on your kit. From your spare-time home business to \$62,000.00 last year I consider excellent progress. And, I am still growing. I've never been successful until you came along . . ."

• . . . and, E. H. T. now has five dealers working for him in order to supply all the stamps that were ordered as a result of an advertisement. He says, "Success is assured when you manufacture a commodity that everybody needs. There is no better way to build a business than manufacturing your own product."

• "If I could not get another Warner Rubber Stamp Shop, you couldn't beg, borrow or steal the one I have now," writes D. R. N. of California. "I am even getting business away from competitors because I do good work and give a guarantee."

Have you neglected looking into an opportunity that gives you additional income while you are employed, and that will go on giving you additional income even after you're collecting Social Security? Now is the time.

**SEND THE COUPON TODAY!**

**NOW!** Read the *NEW Warner Success Plan* for 30 days—**ENTIRELY AT MY RISK!**

**Find out how YOU can build, step-by-step, to  
BIG PROFITS —and PERSONAL INDEPENDENCE.**

In this amazing Plan you will find exact and detailed instructions for starting a Home Business in spare time—without giving up your present job and without risking the loss of a single paycheck. The Warner Success Plan shows you—with photographs and drawings—just how to make Rubber Stamps just as good as those turned out by the big companies. It shows you how to get orders **without canvassing or house-to-house selling**. It shows you how to expand, how to get others to work for you and how to be **SURE** of at least twice the money you make on your present job for a life of personal independence.

**OVER 100  
FACT-FILLED  
PAGES . . .**

**MORE THAN 100  
ILLUSTRATIONS**



But don't make any decision now. Read the Plan first—entirely at my risk. Then—after you have made a careful investigation, after you have talked things over with your family—only then do you decide what you want to do.

The thing to do now is to get the full details which I'll send you **FREE**. No salesman will call to urge you to buy anything. Mail the coupon today—or just send a postcard—and I'll see that complete information goes out to you by return mail—**postpaid**.

**RUBBER STAMP DIVISION, Dept. R-2-CK\*  
1512 Jarvis Avenue, Chicago, Ill. 60626**

**SEND  
NO MONEY**

Rubber Stamp Division, Dept. R-2-CK  
1512 Jarvis Ave., Chicago, Ill. 60626

Please rush full particulars. Tell me about your less-than-bank-rate Credit Plan and about the little machine that can get me started in the profitable Rubber Stamp Business at home in my spare time. Everything you mail me is **FREE**. No salesman will call.

NAME \_\_\_\_\_

ADDRESS \_\_\_\_\_

CITY/STATE/ZIP \_\_\_\_\_



# When John Olin fired the iron fence in 1922, he knew

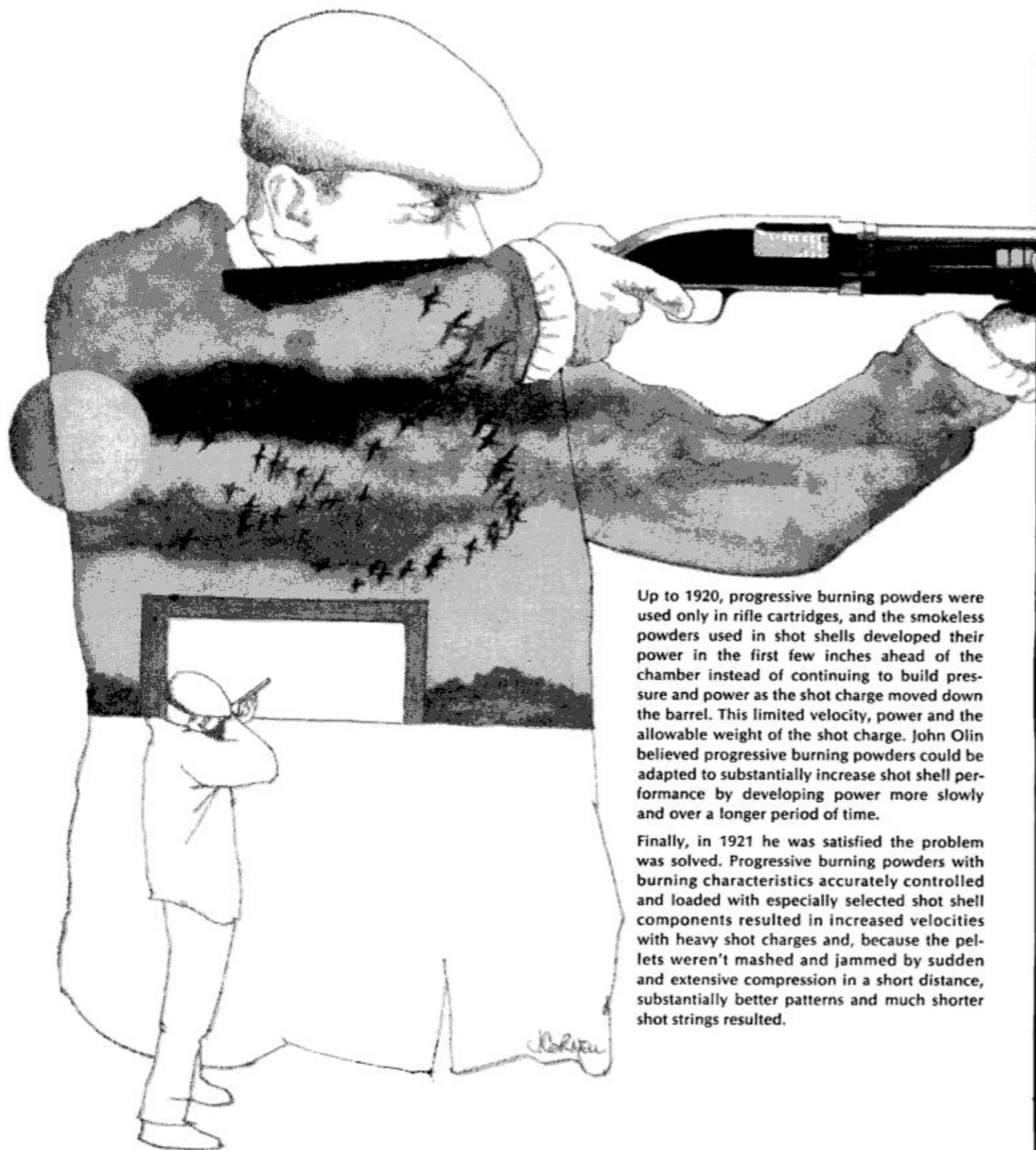

Up to 1920, progressive burning powders were used only in rifle cartridges, and the smokeless powders used in shot shells developed their power in the first few inches ahead of the chamber instead of continuing to build pressure and power as the shot charge moved down the barrel. This limited velocity, power and the allowable weight of the shot charge. John Olin believed progressive burning powders could be adapted to substantially increase shot shell performance by developing power more slowly and over a longer period of time.

Finally, in 1921 he was satisfied the problem was solved. Progressive burning powders with burning characteristics accurately controlled and loaded with especially selected shot shell components resulted in increased velocities with heavy shot charges and, because the pellets weren't mashed and jammed by sudden and extensive compression in a short distance, substantially better patterns and much shorter shot strings resulted.



# first Super-X against an he had something extra.



But John Olin couldn't resist. Even though all the tests checked out perfectly, he had to make a simple test of his own. He went behind the plant where a long corrugated iron fence stood and fired against it. First, he shot the accepted long range load of the day. Then the new load. The sound of the new load striking the fence told the story. It was the sound of power. All this was later confirmed by sophisticated technical equipment, including a Flightometer invented by F. W. Olin, John Olin's father and founder of the Western Cartridge Company.

Introduced in 1922, the new load was named Super-X for two reasons: first, the super excellence of the results and secondly, because no load information other than shot size was printed on box or shell. This mystery or "X" factor led to the Super-X name. Super-X gave more velocity with 25% more shot and supported in every way the field test results duck hunters along the Illinois river had enthused over.

Instantly successful, Super-X attracted a horde of imitators and detractors. Some even went so far as to put damaged shotguns in shop windows with signs indicating that Super-X had done the damage. The net result was that more and more shooters wanted "that powerful new long range load". The smear campaign backfired. Hunters knew a good thing when they saw it.

But 1922 is ancient history, and no product stays on top from nostalgia alone. Constant research and restless dissatisfaction that anything is ever



as good as it might be have led to more than fifty years of improvement in shot shell design and performance. They are far too numerous to list all, but a few of the Super-X highlights through the years deserve to be mentioned.

- |                                 |  |
|---------------------------------|--|
| FIRST copperized (Lubaloy) Shot | FIRST (and only) Ball Powder   |
| FIRST Molded Fiber Filler Wads  | FIRST 2 3/4" magnum  |
| FIRST 3" shell                  | FIRST protective (Mark 5) shot collar  |
| FIRST Rifled Slug Load          | FIRST magnum with powdered polyethylene in shot column (Super-X Double X) for up to 90% patterns |
| FIRST 1 3/8, 1 7/8 oz. 3" loads | FIRST compression-formed, one piece plastic case, eliminating base wads                          |
| FIRST over-powder cup wad       |  |
| FIRST overlay base wad          |  |
| FIRST high wet strength paper   |  |
| FIRST Sealed Gas Chamber        |  |

Today's Super-X is the culmination of 51 years of long range shot shell innovation and brings to wild fowlers all of the desirable features developed over that time. Super-X today comes with non-corrosive priming, Ball Powder for cool, clean burning, an over-powder cup wad to keep hot gas out of the shot column, cushion filler wads to soften ignition shock, and hard round shot protected against deformation against the barrel by the Mark 5 collar. All packed into a tough one-piece, compression-formed, plastic case that shrugs off weather. Look for Super-X in either



Western or Winchester brand — you've got history and performance on your side when you do.

WINCHESTER-*Western*, 275 Winchester Avenue, New Haven, Connecticut 06504

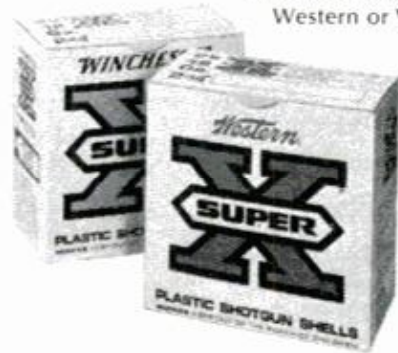

winchester  
the way you  
want it



---

## DETROIT LISTENING POST

---

### Junior Cadillac for '75

Cadillac's long-promised junior car will be out next year. Positively. No evasions, no contingencies. The crew assigned to the car is working around the clock, seven days a week. GM hasn't fixed a date for production, but Cadillac is under orders to get rolling no later than the beginning of the '75 model run, before that if possible. If Cadillac can make it, the car will be a half-year model, with the first showing of the first pilot job at the Chicago Auto Show in late February or early March. Cadillac has never had a half-yearer before, but GM wants its Mercedes fighter to be unleashed as soon as it's ready, and never mind waiting for new-model time.

---

### Half-pinter for AMC

American Motors is between the fat and the fire on talking or not talking about the ultimate mini it has coming a year from now. The company has put a tight security wrap on the car but would like to spike some of the rumors. One story making the rounds is that the car will be a glamorized golf cart. That's bunk, according to a debunker inside the company. Basis for the golf cart description is the fact the car will have a wheelbase just over 90 inches. The tiniest mini yet has also been confused with a modified Gremlin a Michigan company is developing to run on batteries. The only for-sure information on the car is that it will have a single seat, accommodate two people and measure 150 to 160 inches in overall length. But AMC insists it will be a real car, not a motorized grocery cart nor a chopped-down version of anything AMC has now.

---

### Scramble for GM Wankel

There's a hot argument waxing inside GM over which division or car should get second

crack—after Vega—at GM's Wankel engine. The hair-pulling is between Pontiac, Buick and Olds. Cadillac takes an indifferent position on the rotary, isn't particularly concerned one way or the other. GM's working up a list of possible applications for the engine—automotive and nonautomotive—and it could turn out that none of the car divisions will get second dibs on the Wankel. GM's developing a mini motor home, to be produced either by Chevrolet or Truck & Coach Div. As of right now, the division that produces the mini home is the favorite to get the Wankel after Vega.

The company apparently feels its rotary engine has been developed to a point where engineers who were working on it can be reassigned to other projects. For instance? Studying larger versions of the Honda stratified-charge engine, for one, and evaluating a car-size—as opposed to a truck-size—turbine for another.

---

### Chrysler pushing turbine

Chrysler has made, or believes it's about to make, an important breakthrough on the turbine. Question is in what area. Cost of producing the engine? Materials? Performance versus a conventional piston engine? Pollution control? Chrysler isn't talking, yet. The company may be holding off on this disclosure in order to use it as a zinger intended to counter GM's Wankel coming next year.

---

### New approach on lights

Some low-price cars may go to small (1.5 and 9-volt) batteries for lights other than headlights as a means of simplifying electrical wiring and reducing the drain on the car battery. Electrical engineers say mini throwaway batteries could be used to power lights in such areas as the engine compartment, trunk, glove box and dome lamp. In

*(Please turn to page 38)*





CARPET DETERGER



UPHOLSTERY DETERGER



WALL DETERGER

# PART TIME or FULL TIME

*have your own  
money-making  
business*

**You offer a service everybody needs . . . work part time or full time . . . own your equipment . . . keep all you earn . . . start with just a small investment . . . and we help you every step of the way!**

Have your own money-making business and make the kind of income you probably thought impossible. You can when you clean carpeting or upholstery or walls with Von Schrader professional cleaning equipment. Every home, every building, are potential customers. And every customer represents repeat business.

Moreover, we help you every step of the way . . . just as we have helped thousands of other Von Schrader Associates build money-making businesses for almost 40 years. Here are some comments. Carpet: "You people sure helped me and I'll never forget it. I'm averaging about \$18,000 a year."—*H. Kendall*. "During first 2 months made \$2500 net."—*R. Pilon*. Upholstery: "One day I did a \$135 job. Best week was \$500."—*C. Lambert*. "We passed over the

\$450 mark in five days."—*T. E. Baylor*. Wall: "I work just 2 or 3 days a week. Best month was \$1200."—*J. R. Johnson*.

There are three easy-to-operate Von Schrader Detergers. You need no special skills. Each offers a proven way to a growing income. (1) Von Schrader Carpet Deterger gives deep-level cleaning to carpeting. (2) Von Schrader Upholstery Deterger cleans fabrics and synthetics beautifully. (3) Von Schrader Wall Deterger cleans walls (and ceilings) five times faster than by hand.

You can start with just one Deterger. Then, as your business keeps growing, you may want to add the other two and thus offer a complete cleaning service.

There are no fees, royalties, or contracts. There's no franchise involved to shackle you with giving up part of your income. Instead, you own your equipment, keep all you earn. Cost of the equipment is so small you may find it hard to believe. What's more, we help you get started and continue to help afterwards. For complete information—without any obligation—send for the interesting free booklet.

## "Let me send you our free booklet that gives all the facts"

—Francis von Schrader, President

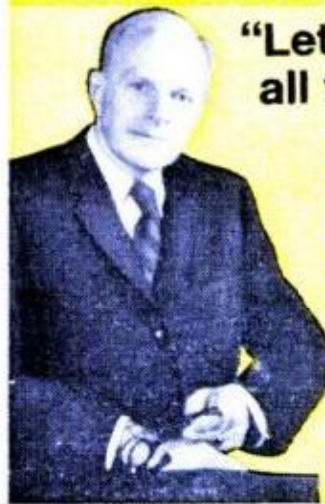

Read about the big demand for on-location cleaning, see why Von Schrader Detergers are the finest of their kind, how easy they are to operate. Learn how other men have become financially independent, how Von Schrader helps you every step of the way. Fill in the coupon and send for free booklet.

**Extra! Special Recorded Message included with booklet.** Listen as Francis von Schrader talks to you personally about your growing future with Von Schrader Detergers.

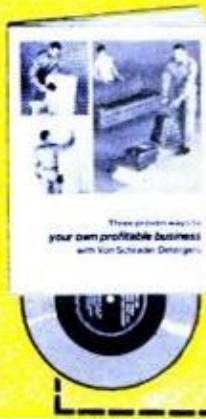

39 years of helping people earn good money

### VON SCHRADER company

1094 Place, Racine, Wisconsin 53403

Please send complete information on Von Schrader Detergers.

Name \_\_\_\_\_

Address \_\_\_\_\_

City \_\_\_\_\_

State \_\_\_\_\_ Zip \_\_\_\_\_



## DETROIT LISTENING POST

(Continued from page 36)

addition to conserving the car battery for other accessories, this approach would save on production costs and let car owners handle their own services.

### Too much mini?

Are automakers overdoing it in trying to miniaturize components? Supplier sources working on down-the-pike parts say some electronic items will be so mini-size it will be impossible for mechanics to adjust or repair them. Parts will have to be pitched out or returned to the factory for rebuilding and replaced with a new piece. This may be a boon for the parts companies, but it puts Detroit in sharp conflict with the conservation movement.

### Sleek Jeep

American Motors' ace stylist, Dick Teague, who manages to get a dollar's worth of new look for every quarter that he spends, has

been given a don't-spare-the-whipped-cream bankroll to high-style AMC's Jeep. Be a couple years before you'll see the results.

### Dummy lights overdone?

The government has ordered the auto companies to install a light-combined-with buzzer on the dashboard of all '75 cars to alert the car owner if the pollution control system fails or malfunctions. (But there's nothing in the law requiring the car owner to have the gear repaired if it conks out.) Detroit has no choice but to go along with the law. But carmakers aren't happy about adding a dummy light each time the government mandates a new piece of equipment.

Charlie Heinen, executive engineer for Chrysler, makes an interesting point on this. The more complicated the car, Heinen points out, the more chances there are for something to go wrong. And dummy lights can go wrong, just like anything else. So do you add a backup dummy light to tell you if the primary dummy light is working? Heinen and his counterparts at the other companies hope not. ★★★



# RAINCOAT IN A CAN

Even in wettest conditions, GE Ignition Protector keeps ignition wires, spark plugs, coil connections, distributor caps and battery terminals dry. Phfff! One spray does it. Waterproofs. Seals out dirt. Fights corrosion. Does it all. And since it's silicone, it lasts. So get it at auto counters. And get one sure start after another and another and another.

MEMBER  
**apaa**  
ASSOCIATION OF PROFESSIONAL AUTO ACCESSORIES

**GENERAL ELECTRIC**

Build **POPULAR MECHANICS'** little **CARRIAGE HOUSE!** Simply great! A back-yard building that isn't an eyesore. Styling blends in with most homes. It will take your mower, lawn furniture and tools—or the kids' overnight guests. Use it as your shop or home office. Overall outside dimensions 10-ft. 4 in. x 12-ft. 4 in. For one complete set of plans send \$3.95 to **POPULAR MECHANICS Dept. FA, Box 1014 Radio City, N.Y. 10019.** For two sets of plans (you may need one for your local building department) send \$5.49.





**"He took it up  
as a hobby.  
Audel  
made him  
an expert!"**

Whatever practical skills you've been wanting to develop, Audel has comprehensive, step-by-step Guides to help you. They show you all the professional tricks of the trades in clearly diagrammed

and illustrated "how-to" steps. They can save for you, over and over. Here are eight of Audel's many fields . . .

**(Practical 3rd Edition)  
AUDEL AUTO GUIDE**

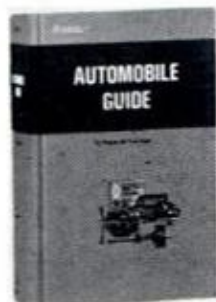

**800 pages  
Hundreds of  
illustrations**

**Fix almost any car FAST.  
Step-by-step Guide covers:**

Troubleshooting • Unique symptoms-and-Causes Charts • Spark Plugs • Batteries • Tune-up • Distributors • Ignition Testing • Starters & Generators • Lighting • Tire Servicing • Brakes • Power Brakes • Front Suspension • Steering Systems • Wheel Alignment • Chassis, Springs & Shocks • Fuel Pumps • Carburetors • Cooling Systems • Lubricating Systems • Pistons & Rings • Crankshafts and Connecting Rods • Camshafts • Valves • Clutches • Automatic & Manual Transmissions • Drive Shafts • Universal Joints  
No. 23192 \$8.95



**PLUMBERS AND  
PIPEFITTERS LIBRARY**

A valuable 3-volume guide to the principles, methods and shortcuts of modern plumbing. Tools, fittings, fixtures, installation, drainage, welding and much more are all covered in these fully illustrated, easy to understand volumes.

No. 23155 3 Volumes \$13.50



**CARPENTERS AND  
BUILDERS LIBRARY**

1490 pages of the latest information on modern construction in four volumes. They cover every phase of carpentry from foundations to finishing with easy-to-grasp, step-by-step instructions . . . all illustrated with thousands of diagrams, charts and photos.

No. 23169 4 Volumes \$18.50



**MASONS AND  
BUILDERS  
LIBRARY**

Two illustrated volumes on the science of masonry and bricklaying. Packed with how-to information and directions, rules, processes, definitions, formulas, diagrams, tables, estimating. A complete and authentic trade reference library. 752 pages.

No. 23185 2 Volumes \$11.25

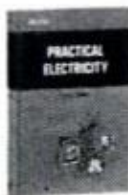

**PRACTICAL  
ELECTRICITY  
(2nd Edition)**

Presents the fundamentals of electricity in clear, concise terms.

Easily grasped explanations and over 1300 illustrations and diagrams, for electrical workers and apprentices.

No. 23160 \$5.95



**HOME  
APPLIANCE  
SERVICING**

Handy and practical "how-to" instructions for servicing, repairing, assembling, wiring and testing practically all home appliances.

No. 23016 \$6.95



**HOME REFRIGERA-  
TION & AIR  
CONDITIONING**

Practical information on operation, servicing and repairing of modern household refrigerators and air conditioners. Covers auto air conditioners, too.

No. 23133 \$6.95



**RADIO AND  
TV LIBRARY**

Two volumes covering all you need to know about radio and TV. The Books — **Radioman's Guide (3rd Edition)** and **Television Service Manual (3rd Edition)**—provide basic step-by-step guidance for the operation, trouble-shooting and repair of radio, black and white and color TV sets. The books may be bought in combination, or separately.

No. 23161 The 2-book Library \$11.50  
No. 23162 TV Service Manual \$5.95  
No. 23163 Radioman's Guide \$5.95

 <b>Theodore Audel &amp; Co., Division of HOWARD W. SAMS &amp; CO., INC.,</b> 4300 West 62nd Street, Indianapolis, Indiana 46268		<b>P093</b>
Please mail me for 10 days' FREE EXAMINATION the books I have checked at right. I agree to mail \$3 in 10 days for each book or set ordered and to further mail 1/2 of the purchase price 30 days later, with balance plus shipping costs to be mailed within another 30 days. I may return the books for refund if not completely satisfied.		
Save shipping costs. Check here <input type="checkbox"/> if you enclose full payment (plus sales tax, if any). We will pay postage charges. You have same return privilege. Canadian prices slightly higher.		
Name _____		<input type="checkbox"/> 23192 <input type="checkbox"/> 23155 <input type="checkbox"/> 23169 <input type="checkbox"/> 23185 <input type="checkbox"/> 23160 <input type="checkbox"/> 23016 <input type="checkbox"/> 23133 <input type="checkbox"/> 23161 <input type="checkbox"/> 23162 <input type="checkbox"/> 23163
Address _____		
City _____	State _____	
Zip _____		



## THE BICYCLE SHOP

BY EUGENE A. SLOANE

Newly introduced ultralight 'wired-on' tires offer all the advantages of tubular sew-ups without their repair problems. But installation is tricky. Here's how.

**T**ubular tires, the kind that are sewn up all the way around their inside circumference, offer so many advantages that experienced cyclists are willing to put up with the problems of repair. Now, however, there is a new "wired-on" tire that offers all the features of tubular tires without the problem of time-consuming flat fixing.

With its tube, the new tire weighs only 17 ounces (about 4 ounces more than the

tires, offer less rolling resistance and can be used with lighter rims, so they are easier to pedal. However, they're more prone to flats. The new lightweight wired-on clinchers are the same size as tubulars, so are much easier to pedal than ordinary clinchers. For enthusiasts who want the advantages of tubulars with the convenience of clinchers, the lightweights are the answer.

The new lightweights are made exactly like tubulars, with the addition of a wire bead—but since they are not shaped like a conventional tire, great care must be taken in installing them. If they aren't mounted on the rim exactly right, they will blow out at the 90-pound pressure you must inflate them to.

The new tires are called *Corsa Strada* and are distributed by Raleigh. They are handmade in Italy, and may be in short supply at this time. Remember: You *must* use a 27 x 1 $\frac{1}{8}$ -inch tube with them.

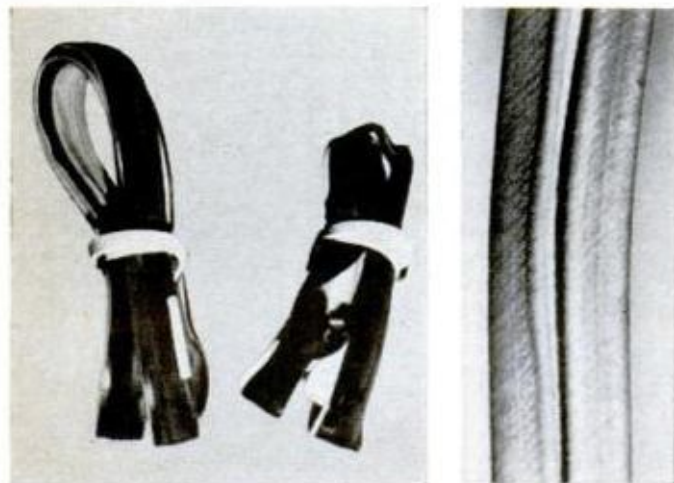

New *Corsa Strada* lightweight tire (left) is shown alongside a conventional tubular tire; both are folded for use as spare tires. The photo at right shows the wire (bead) on both sides of the new tire's opening.

kind of tubular tire you'd use for touring). By comparison, conventional "wired-on" tires with tubes weigh 24 ounces (about 41 percent more than the new superlight). On the other hand, the new tire costs upward of \$13 with tube while the conventional 27 x 1 $\frac{1}{4}$ -inch tire costs about \$8 with tube.

Tubular tires, which are 27 x 1 $\frac{1}{8}$  inches versus 27 x 1 $\frac{1}{4}$  inches for conventional

**Step 1:** If rim tape is not installed (to protect tube from spoke heads) install it. Make sure valve hole in tape is over the rim valve hole. If tape is already in place, be sure it is centered in rim well.

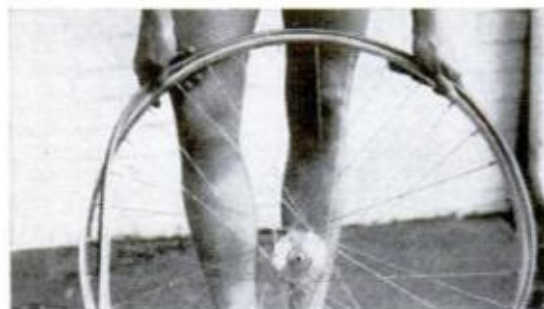

**Step 2:** Put one side of the tire over rim edge, so bead of tire is in place all around the rim. Make sure only *one* side of the tire is in place. The other side must be off the rim so the tube can be installed.

**Step 3:** Install the tube valve in rim-tape and rim-valve holes. You will probably have to lift rim tape up off the rim to get the rubber-covered valve of the tube through it. Then install the tube all the way around inside the tire, working from the opposite side of the tire you installed in Step 2. Note

*(Please turn to page 42)*



# CHANNELLOCK

Gives You More In Hand Tools Including

## WRAP AROUND BITE

(PLUS tongue-'n-groove muscle)

Another CHANNELLOCK first: curved jaws that wrap around and grab hold of round work plus CHANNELLOCK's exclusive machined, smooth working, undercut, never-slip adjustments. The "muscle" of a wrench, the easy handling of a plier in hard-to-reach spots . . . yours with CHANNELLOCK Curved Jaw tongue-'n-groove pliers.

GET THE WHOLE STORY. Our catalog is yours for the asking.



### MEET THE FAMILY



No. 410-9 1/2"



No. 415-10"  
Smoothjaw



No. 420-9 1/2"



No. 422-9 1/2"  
Curved Jaw



No. 424-4 1/2"



No. 426-6 1/2"



No. 430-10"



No. 440G-12"



No. 442-12"  
Curved Jaw



No. 460G-16"

TOOLS BY  
**CHAN NEL LOCK**

MEADVILLE, PA. 16335



## THE BICYCLE SHOP

(Continued from page 40)

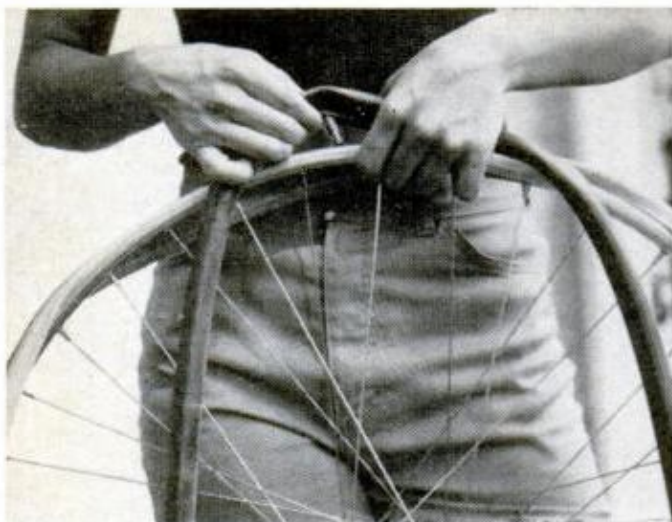

in the photo above that one edge of the tire is outside the rim; this is the proper position for inserting the tube in this step. You will note that there appear to be two inches extra of tube circumference; this is normal. As you insert the tube, spread the extra length around inside the tire.

**Step 4:** Before we go into this step, remember that you should not use any tire irons or other tools to install these superlight tires. If you do use tools, chances are excellent you will pinch the tube and cause a flat. In this step, starting at the side of the rim opposite the tube, push (with thumb and fingers) the tire onto the rim so the remaining tire bead falls in place inside the rim. As you work around the rim, make sure tube is well inside the tire so it can't get caught between tire bead and the upper part of the

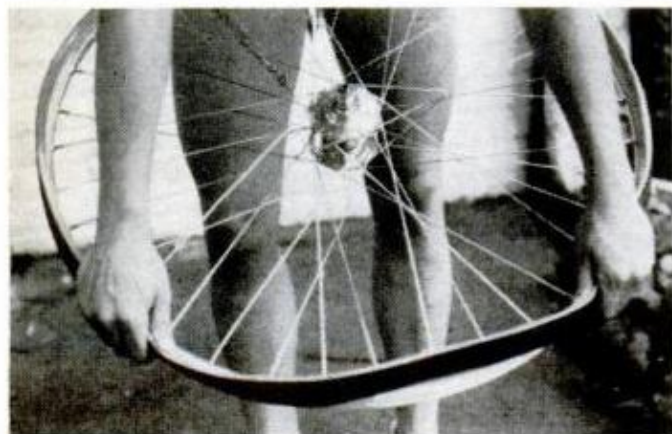

rim brake flat (which will keep tire from seating into rim and cause a blowout). To make it easy for the tube to spread about inside the tire as you inflate it, it's a good idea to spread some talcum powder inside the tire before you mount it on the rim.

**Step 5:** Inflate the tire to about five pounds, and (with fingers) make sure the tire bead is well seated inside the rolled inside section of the rim. (Contact between tire wire bead and rolled or formed section of the rim is what keeps the wired-on tire from coming off the rim.) Make sure the tire is also on evenly; the same amount of tire casing should show on both sides of the tire. Inflate to 20 pounds or so and check tire seating again. Repeat at 40



pounds. Once you are sure tire, especially at valve, is well seated and bead is holding it in rim, inflate to normal for this tire—90 pounds per square inch.

The new Corsa Strada wired-ons look so much like tubulars that you will have a lot of fun fooling your friends who won't believe you are not riding tubulars. And you won't have to carry two or three spare tubulars on trips; all you'll need will be, perhaps, one tire casing and one or two extra tubes and a patch kit. Weight is less than the complete tubulars you carried before.

If the Corsa Strada seems like too much trouble, a compromise between a heavy wired-on and the new tubular-type wired-on would be the Japanese light gumwall 27 x 1 $\frac{1}{8}$ -inch tire which weighs only 18 $\frac{1}{2}$  ounces and costs around \$9 with tube. These tires are a bit trickier to mount than conventional wired-ons, but easier to mount than the Corsa Strada. I prefer the Corsa Strada because they ride just like tubulars; in fact, they *are* tubulars except for the wire bead and non-sewn-up construction.

If this point hasn't been made clear, you should remember that the new Corsa Strada lightweights and the new Japanese lightweight wired-on tires fit on the *same* rims as your conventional 27 x 1 $\frac{1}{4}$ -inch wired-on tires. But both the lighter tires *must* be used *only* with the new 27 x 1 $\frac{1}{8}$ -inch tubes. (You can use a 27 x 1 $\frac{1}{4}$ -inch tube in an emergency, inflated to about 60 p.s.i., but when you feel the tire thumping, stop and let some air out to avoid a blowout.)

You can't use the new Corsa Strada or new Japanese wired-ons with tubular rims; and, of course, you can't use tubulars on wired-on tire rims except in dire emergency. Tubulars will stay on wired-on rims long enough to get home, but wired-ons won't stay on tubular rims because they have no bead-seating well.

(Please turn to page 44)





# 1933



# 1973

Loctite Lock n' Seal is a revolutionary liquid material that hardens in the *absence* of air. It fills the gap between threaded assemblies to make them vibration proof. Lock washered assemblies can vibrate loose. Assemblies treated with Lock n' Seal can't. Yet disassembly's just as effortless. Use it on auto engines, power mowers, cycles, outboard motors, bicycles . . . wherever a loose bolt or screw can cause problems. Ask for Lock n' Seal at your hardware or auto supply store.



Loctite Corporation — Newington, Connecticut 06111



The Slaymaker family name has stood for quality and dependability in padlocks since 1888. You could trust it on the first locks Sam Slaymaker made in 1888, and you can trust it on the padlocks we make now.

**Slaymaker Lock Company**  
Lancaster, Pa. 17604

# free! 1974 Olson CATALOG



**SAVE ON THE BEST AND NEWEST IN ELECTRONICS**

- Stereo / 4 - Channel Systems
- Tape Recorders
- Radios • Phonos • Kits
- Amateur/Shortwave Gear
- CB • Antennas • Police/ Fire Radios
- Calculators, Timepieces • Security Test Equip. • Parts, Tubes, Batteries, Wire, Hardware

**free! MAIL TODAY**

**Olson** Electronics Dept. JK  
260 S. Forge St., Akron, Ohio 44327

Send My FREE 1974 Olson Catalog

Name \_\_\_\_\_

Address \_\_\_\_\_

City \_\_\_\_\_ State \_\_\_\_\_

Zip



**ARROW**  
HEAVY DUTY T-50  
**STAPLE GUN**



**SHOOTS  
A STAPLE** T-50 \$14.95

**Wherever You'd Drive A Nail!  
FASTER . . . BETTER . . . CHEAPER!**



**1/4" STAPLE**  
for tacking window screening, shell papers, closet linings, window shades, draperies, etc.

**5/16" STAPLE**  
for tacking light upholstery, leatherettes, cornices, quilting for closets, wall decorations, etc.



**3/8" STAPLE**  
for fastening light insulation, roofing papers, electrical wires, weatherstripping, wire mesh, etc.



**1/2" STAPLE**  
for tacking underlayments for carpets, porch screening, felt stripping, canvas, fiberglass, etc.



**9/16" STAPLE**  
for tacking metal lathing, cornerite, wire fencing, roof coverings, insulation board, etc.



**CEILTILE**  
staple - especially made for safe, secure installation of ceiling tile.

**TRY IT-SEE FOR YOURSELF!**  
Available at **HARDWARE • LUMBER • BUILDING MATERIAL**  
**• STATIONERY • VARIETY** and Other Retail Outlets  
**ARROW FASTENER COMPANY, Inc.**  
**Saddle Brook, New Jersey 07663**

## THE BICYCLE SHOP

(Continued from page 42)



### Leg power or battery—take your choice

An electric bicycle that gives you the option of pedaling or purring along on battery power is one answer to the gasoline shortage. It's ideal for an older rider who needs some mechanical assistance. The new Solo Electric goes about 16 mph and travels 25 miles between charges from a 24-volt charger (available as an option). It fully charges overnight. The cycle is \$495 and the charger is \$45. The supplier is Solo Motors, Inc., Box 5030, 5100 Chestnut Ave., Newport News, Va. 23605.



### Even an electric drill won't flatten 'em

It will add about three extra pounds of weight per tire—but if you're tired of flats, you can fill your tires with TyrFil and they'll be impervious to punctures. We can't recommend the material for tourists (who wants to carry around six extra pounds?) but it would be fine for a child's bike or for an industrial bicycle. You need special tools to install the stuff, and a filled tire costs around \$10. The maker is Synair, 14191 Livingston St., Tustin, Calif. 92680.—E.A.S.



# Stick 'em up with Macco Liquid Nails®

a waterproof general-purpose construction adhesive for

paneling • pegboard shelves • molding • drywall ceramic tiles • veneer brick

Do it yourself easier and better with the complete line of Macco adhesives and sealants. At lumber stores, hardware stores, and home improvement centers.

Available in cartridges, quarts and gallons.

PM-39



**SCM MACCO® ADHESIVES**  
SCM CORPORATION, WICKLIFFE, OHIO 44092



## UPHOLSTERING AND DECORATING PAYS BIG MONEY

Make money even while you learn as you build attractive new furniture from kits supplied. These you can keep or sell to make money! We send you all tools and materials, fillings, fabrics, frames—show you step-by-step how to do custom upholstery—gain skill quickly. Many thousands of men and women now enjoy secure futures with Upholstering skills that bring TOP PROFITS, HIGH-PAY JOB OPPORTUNITIES, INDEPENDENCE—part-time or full-time!



### UPHOLSTERY & DECORATING SCHOOL

Div. Technical Home Study Schools

Little Falls, N.J. 07424

Dept. 5110-093

Rush me full information on success opportunities in upholstery. No obligation—no salesman is to call.

Name .....

Address .....

City ..... State & Zip .....

(Inquiries serviced only in U.S.A. and Canada)

Check here if eligible for Vet Benefits.

# ONLY \$2.00 WHEN YOU BUY A GE SUPER SWITCH™

ELECTRIC CONTROL

The first aid kit's by Johnson-Johnson. Perfect for your car, home, place of work! It's a \$3.95 value.

And the SUPER SWITCH control? It's GE's new mercury switch. Completely silent. With standard or lighted handles, for single or two-switch circuits. Easy to install.

And so durable. GE will mail you a free replacement if any SUPER SWITCH fails for any reason, in normal home use, within 50 years.

To get that \$3.95 J&J first aid kit for only \$2, send the front of one SUPER SWITCH package — and your \$2 check or money order (no stamps), payable to General Electric Super Switch — to GENERAL ELECTRIC, P.O. BOX 6333, CHICAGO, ILL. 60677.

Please allow 4-6 weeks for delivery. Offer ends June 30, 1974.



**GENERAL ELECTRIC**



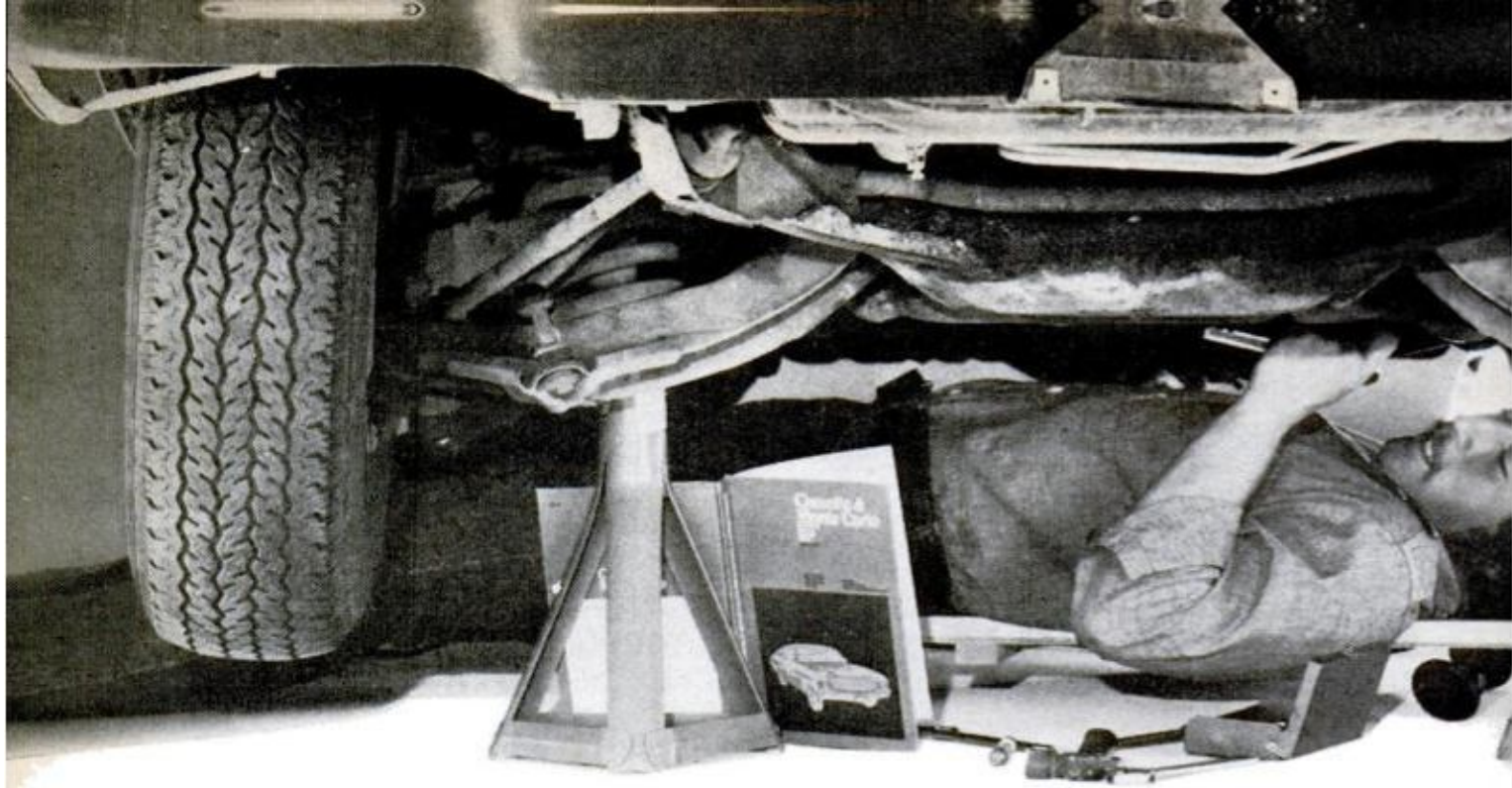

# Friends indeed... for cars in need.

## Chilton's Repair & Tune-up Guides for American and imported cars.

There are a lot of other manuals around—basically rehashes or outright copies of factory service manuals—padded with superfluous stuff you cannot use.

But Chilton Guides are no ordinary manuals. They're loaded with fresh, essential, practical information. To help you prevent trouble, with precisely detailed preventive-maintenance schedules. To keep your car in tune, with easy-to-follow diagnosis and adjustment instructions. To get you out of trouble, with comprehensive, accurate repair procedures.

Because the Chilton editors who write these Guides are also knowledgeable automotive people. They've been through it all, step by step. They've anticipated problems you might encounter. They have the know-how and experience to explain with language and illustrations you'll understand.

In short, Chilton's Repair & Tune-up Guides are your kind of books. Clear, concise, totally useful. For the few bucks they cost, probably the most useful buy you'll ever make for your car.

Keep the one for your car in your glove compartment. It will be handy to have, when you need help.

### Organized for fast help.

- Table of contents lists all major headings with page references.
- Each guide starts with complete information on exact identification of the car model, engine, etc. There's even a brief history of your car.
- Content arranged for maximum convenience. Chapters on General Information; Lubrication and Maintenance; Tune-up and Troubleshooting; Engine and Engine Rebuilding; Emission Controls and Fuel Systems; Chassis; Electrical System; Clutch and Transmission; Drive Train; Suspension and Steering; Brakes; Body.

- Chapters open with a basic description of the subject, so even the beginner gets a fundamental understanding before he starts.
- The appendix gives you a lot of helpful data—conversion tables, tap-drill-size chart, anti-freeze information.

### Bonus benefits.

- Complete coverage on all systems—everything you can reasonably expect to do yourself—you won't be led into hopeless projects.
- Special section shows you how to get maximum clean-running performance from emission controls.
- All necessary specifications.
- Troubleshooting is divided into two sections. *General Diagnosis* tells you how to locate the general problem area. *Specific Diagnosis* pinpoints the problem systematically.
- Informative illustrations—many photos, drawings, exploded views, diagrams, tables.
- Notes and cautions appear where necessary. They'll help you avoid possible pitfalls and problems.
- Helpful hints on how to get some jobs done without those hard-to-get factory tools specified in service manuals.

### High value, low price.

To work with all the material shown in just one Chilton Guide, you would have to wade through a half-dozen factory manuals and other references. They'd be worth well over \$20.00, if you could get them.

Yet, in durable hardcover, most of Chilton's Automotive Repair & Tune-up Guides sell from only \$5.95 to \$9.95, and some are available in paperback—from \$4.95 each.

### Ordering information. The most complete series available, covering most major makes and models.

Note: H-Hardcover; P-Paperback.

#### DOMESTIC CARS

- AMX & Javelin.** All models, 1968 to 1971. H-\$5.95 (5605).
- Barracuda & Challenger.** Barracuda, 1965 to 1972; Challenger 1970 to 1972. H-\$6.95 (5721). P-\$4.95 (5807).
- Camaro.** All models, 1967 to 1972. H-\$6.95 (5617). P-\$4.95 (5782)
- Chevelle, El Camino & Monte Carlo.** Chevelle and El Camino 1964 to 1972; Monte Carlo, 1970 to 1972. H-\$6.95 (5717). P-\$4.95 (5783).
- Chevy II & Nova.** Chevy II, 1962 to 1968; Nova, 1969 to 1972. H-\$6.95 (5718). P-\$4.95 (5784).





**Corvair.** All Corvair models and engines, including Greenbrier and 95 trucks, 1960 to 1969; Turbochargers and multiple carburetion setups. H-\$5.95 (5607).

**Corvette (1953-62).** Solid-rear-axle Corvettes, 1953 to 1962; 4-cylinder and V-8 engines; fuel injection; fiberglass body service. H-\$6.95 (5606).

**Corvette Stingray (1963-72).** The entire series. H-\$6.95 (5670).

**Dodge Charger.** All Dodge Chargers, plus Canadian models, 1967 to 1970. H-\$5.95 (5600).

**Dodge Dart & Demon.** Dart, 1965 to 1972; Demon, 1971 and 1972. H-\$6.95 (5720).

**Fairlane & Torino.** Fairlane, 1962 to 1970; Torino, 1968 to 1972; Mustang, 1967 to 1972. H-\$6.95 (5740). P-\$4.95 (5785).

**Gremlin & Hornet.** All Gremlins and Hornets, 1970 and 1971. H-\$5.95 (5615).

**Laverick.** All 1970 Mavericks. H-\$5.95 (5585).

**Mustang.** All models from 1965 to 1972. H-\$6.95 (5741). P-\$4.95 (5786).

**Oldsmobile.** Sedan, Runabout, Station Wagon, 1971 and 1972. H-\$6.95 (5715). P-\$4.95 (5787).

**Roadrunner, Satellite, Belvedere, GTX.** Road Runner and Satellite, 1968 to 1973; Belvedere, 1968 to 1970; GTX, 1968 to 1971. H-\$6.95 (5810). P-\$4.95 (5821).

**Tempest, GTO & Le Mans.** Tempest, 1968 to 1970; GTO and Le Mans, 1968 to 1973; T-37, 1971. Available 10/73. H-\$8.95 (5809). P-\$6.95 (5905).

**Valiant & Duster.** Valiant, 1963 to 1972; Duster, 1970 to 1972. H-\$6.95 (5719). P-\$4.95 (5788).

**Vega.** All models, 1971 and 1972. H-\$6.95 (5716). P-\$4.95 (5789).

#### IMPORTED CARS

**Audi.** Super 90, 100, 100LS, 100GL from 1970 to 1973. Available 1/73. H-\$8.95 (5864). P-\$7.95 (5902).

**Austin-Healey.** Models 100-6 (1957-1959), 3000 Mark I-II-III (1959-1967), Sprite Mark II-III-IV (1961-1969), Austin America (1968-1969). H-\$5.95 (5496).

**MW.** All 4-cylinder models, 1959 to 1970. H-\$6.95 (5576).

**Triumph.** 1600, 2000, 2600. from 1970 to 1972. H-\$6.95 (5814).

**Volvo.** From 1971 to 1973. Available 11/73. H-\$8.95 (5861). P-\$7.95 (5904).

**Nissan, 2nd ed.** The Nissan Patrol, 1500-1600-2000 sports cars, 10, 1200, Pickups, and 240Z, from 1961 to 1972. H-\$6.95 (5660). P-\$4.95 (5790).

**Volvo.** Models 1100, 1500, 1600, 600, 850, 850 Spider/Coupe, 24 Sedan, 124 Spider/Coupe, 1964 to 1970. H-\$5.95 (5556).

**Volvo.** Models XK 120, XK 140, XK 150 and 150S, 340, 420, 20G, and XKE from 1954 to 1969. H-\$5.95 (5464).

**MG, 2nd ed.** Midget, MGB, and MGB GT from 1961 to 1972; the IGC and MGC GT from 1968 to 1969; the 1100 from 1962 to 1967. H-\$6.95 (5661). P-\$4.95 (5791).

**Mazda.** Rotary Engine RX2, 1971 to 1973, and RX3, 1972 and 1973. Available 12/73. H-\$8.95 (5862). P-\$7.95 (5906).

**Mercedes-Benz 1.** 190c, 200, 190De, 200D, 230, 220b, 220Sb, 230S, 250S, 220SEb, 250SE, 230SL, 250SL, 220SEb/c, 250SE/c, 300SE/c, 300SEb, 300SEL, 220D/8, 220/8, 230/8, 250/8, 280S/8, 280SEL/8, 280SE/8, 280SL/8, 300SEL/8, and 300SEL/8 6.3, up to 1970; diesel engines also included. H-\$7.95 (5536).

**Mercedes-Benz 2.** 220D/8, 220/8, 230/8, 250/8, 250C, 280, 280C, 280S/8, 280SE/8, 280SEL/8, 280SL/8, 300SEL/8, 280SE 3.5, 300SEL 3.5, 280SE 4.5, 280SEL 4.5, 300SEL 4.5, 300SEL 6.3, 350SL, 450SL, and 450SLC, from 1968 to 1973. Available 12/73. H-\$9.95 (5867). P-\$8.95 (5907).

**Opel, 2nd ed.** Kadett, Rallye, and GT, 1964 to 1970; CIH 1.9 liter engines. H-\$4.95 (5634). P-\$4.95 (5792).

**Peugeot.** Models 403 and 404, 1960 to 1968. H-\$4.95 (5465).

**Porsche 1.** Models 356, 911, and 912, 1950 to 1968. H-\$5.95 (5337).

**Porsche 2.** 911, 912, 914, and 914/6 from 1969 to 1973. H-\$6.95 (5811). P-\$4.95 (5822).

**Renault, 2nd ed.** Dauphine, Caravelle, and Renault 8, 10, 12, and 16, 1964 to 1972. H-\$6.95 (5662). P-\$4.95 (5794).

**SAAB.** Models 95, 96, GT 750, Monte Carlo 850, and Sonett II, 1960 to 1970; V-4 and 2-stroke engines, competition tuning. H-\$7.95 (5541).

**Simca.** 1000, 1118, and 1204 models, 1963 to 1969. H-\$4.95 (5535).

**Sunbeam-Hillman.** Sunbeam Imp, Minx and Super Minx, Hillman Husky, Arrow, Rapier, Alpine, and Sunbeam Tiger 260, 1956 to 1969. H-\$5.95 (5497).

**Toyota 1.** Corona, Mark II, Corolla (including the 1200 engine), Crown, Land Cruiser (including 155 h.p. engine), and Stout pickup from 1965 to 1970; 1970 Hi Lux truck with 8RC engine. H-\$5.95 (5339). P-\$4.95 (5795).

**Toyota 2.** Carina, Celica, Corolla, Corona, Mark II, Crown, Hi-Lux, and Land Cruiser from 1970 to 1972. H-\$6.95 (5812). P-\$4.95 (5849).

**Triumph 1.** Models TR-4, TR-4A, TR-250, TR-6, GT6, Spitfire 4, and Spitfire Mark II and III, 1963 to 1970. H-\$5.95 (5557).

**Triumph 2.** GT6 Mark III from 1971 to 1973, Spitfire Mark IV from 1971 to 1972, Spitfire 1500 for 1973, TR-6 from 1969 to 1973. Available 1/74. H-\$8.95 (5863). P-\$7.95 (5910).

**Volkswagen 1.** All models, plus Types 1, 2, 3, and Super Beetle, 1949 to 1971; automatic stick shift; fuel injection service. H-\$4.95 (5624). P-\$4.95 (5796).

**Volkswagen 2.** Types 1, 2, 3, and 4 from 1970 to 1973. Available 12/73. H-\$8.95 (5865). P-\$6.95 (5911).

**Volvo 1.** PV444, PV544, P1800, 122S, 142, 144, 145, and 164, 1965 to 1970. H-\$4.95 (5635).

**Volvo 2.** 142S, 142E, 144S, 144E, 145S, 145E, 164, 164E, 1800E, and 1800 ES from 1970 to 1973. H-\$6.95 (5813). P-\$4.95 (5850).

## CHILTON BOOK COMPANY

Radnor, Pa. 19089

Complete and mail this coupon today!

TO: CHILTON BOOK COMPANY  
Dept. PM973, Radnor, Pa. 19089

Send me the books for the numbers I have written in the spaces below. (Please write in numbers that appear in parentheses after prices.) My check/money order for \$\_\_\_\_\_ is enclosed. All checks/money orders should be made payable to **Chilton Book Company**. Pa. residents add 6% sales tax.

Name \_\_\_\_\_

Address \_\_\_\_\_

City \_\_\_\_\_ State \_\_\_\_\_ Zip \_\_\_\_\_

Telephone \_\_\_\_\_



## ALL OUTDOORS

**National Hunting & Fishing Day**, Saturday, Sept. 22, should offer a particularly appropriate chance for outdoorsmen to tell our conservation story. Boatmen, campers, hikers, swimmers, fishermen, skiers, hunters, snowmobilers, recreational-vehicle owners are on record for many years as the leaders among those who work actively to improve our environment. Recent figures indicate hunters have been paying a large share of the tab: \$427 million has been collected for conservation since 1937 from the federal excise tax on sporting arms and ammunition. Game management and protection of nonhunted and endangered species are among supported activities. The new National Hunting & Fishing Day is a chance to show what the appeals of the outdoors are all about.

As the summer has shown, careful camping doesn't require a lot of gasoline or other energy in short supply. Recreational Vehicle Institute figures indicate the average outdoorsman doesn't travel more than about 300 miles from home, and the Family Camping Federation notes the vacationing family's car and completely self-contained rig uses only one-third of the energy consumed at home.

Our field tests of equipment continue to locate items particularly suitable and durable for outdoor use. Tried any of the new air rifles recently? If your last experience was with your first BB gun years ago, better take a look at some of the variable-power high accuracy models now available, like the latest from Daisy, Crosman, Sheridan Blue Streak, Benjamin, Sears and others. Weighted and balanced like conventional guns, they are recommended for beginners and advanced shooters alike.

Campers can now light up the dark with more than a candle or campfire. New fluorescents use much less current. For night fishing or even changing a tire, consider one of the improved headband flashlights.

Two of the most remarkable sports machines we have ever test-driven are Outboard Marine's new rotary outboard engine and Curtis Pitts's world championship Pitts aerobatic biplane which we checked out recently. Each will be given a full report in upcoming issues.

A code of ethics for outdoorsmen, prepared by Warren Page, president of the National Shooting Sports Foundation, was unanimously adopted by the American Outdoorsman Conference at a recent annual convention. The code is designed for hikers, skiers, hunters, fishermen, snowmobilers, boatmen, campers and all the others that make up the continent's nearly 100 million outdoorsmen.

For nearly 25 years, Page was shooting editor of *Field & Stream* magazine, and now 50 of his stories about hunting, outdoor adventure, game rifles and conservation have been brought together in a distinguished new volume, *One Man's Wilderness*, \$8.95 from Holt, Rinehart and Winston.

**Activities calendar:** Sept. 4-8, International Tuna Cup Match, Wedgeport, N.S.; 9, National Industrial Trap Championships, Middletown Sportsman Club, Middletown, Ohio; 14-16, North American Sail & Power Show, Cedar Point Marina, Sandusky, Ohio; 14-16, NRA Canadian American International Skeet and Clay Pigeon Championships, Malone Skeet and Trap Club, Malone, N.Y.; 19, Family Camping Federation symposium, *Camping and the Energy Issue—'74 and Beyond*, O'Hare Inn, Chicago, Ill.; 22, NATIONAL HUNTING & FISHING DAY, nationwide; 26-28, All American Bass Tournament, Watts Bar Lake, Tenn.; 27-30, Newport International Sailboat Show, Goat Island Marina, Newport, R.I.; 27-30, North Atlantic Boat Show, Yacht Haven West Marina, Stamford, Conn.; 29-30, International Benchrest Tournament and Hunter Rifle International Championship, Central Pennsylvania Rifle Club, Dauphin, Pa.

*(Please turn to page 50)*



# Tools can't fix everything. (That's why Mystik created Tool Box Tapes.)



**Sponge Tape.** Unbeatable for weatherstripping, cushioning or for replacing gaskets.



**Strapping Tape.** Fiberglass reinforced for extra strength.

**Duct Tape.** Great for sealing ducts, vents or air conditioners.



**Fabric Tape.** Heavy-duty for anything from window shades to tents.



**Carpet Tape.** Use it indoors or outdoors.



**Aluminum Tape.** Rust-proof and strong. For patching drain pipes, gutters, auto bumpers or other metal surfaces.

**Electrical Tape.** Great convenience and safety. U. L. Listed #988L.



Mystik Tapes, Borden Chemical, Division of Borden Inc., 50 West Broad Street, Columbus, Ohio 43215.



## SUBSCRIBER'S

### Change of Address Form

Please use this form to notify us at least six weeks before you move to your new address.

**1. Present address:** Attach address label from a recent issue, or print your name and address exactly as shown on the label.

NAME _____			
ADDRESS _____			
CITY _____	STATE _____	ZIP _____	

**2. Fill in new address:**

NAME _____			
NEW ADDRESS _____			
CITY _____	STATE _____	ZIP _____	

**3. Mail this form to:**

**POPULAR MECHANICS**  
Subscription Service Dept.  
Box No. 646  
New York, N.Y. 10019

## PAYS FOR ITSELF!



**Wheel Balancer**  
only \$13.98

Float-O-Matic pays for itself the second time you use it. Quickly levels on any solid surface. Easy to use. Durable, light weight. Accurate bubble-centering concept means no guesswork... you're an expert in minutes. Extends tire life and allows greater control at freeway speeds. **MORE ACCURATE!** The lug holes on your wheel are machined within closer tolerances than the center hole. Float-O-Matic uses these closer tolerances to insure more accurate balancing than the older cone-type units. Fits all cars and light trucks except those with closed center wheel hubs. Can be used on VW, Saab, Peugeot and other imports with large center holes by adding adapter. **KIT:** Contains 50 assorted weights and balancing tool... \$8.99. **ADAPTER:** Allows balancing of all imported car wheels with large center holes... \$4.49. Send check or Money Order... Satisfaction Guaranteed.

**AUREUS INDUSTRIES** DEPT. 11  
P.O. BOX 3 / MERCER ISLAND, WA 98040

Name _____
Address _____
City _____ State _____ Zip _____
Car(s)/yr _____

Balancer-\$13.98  Kit-\$8.99  Adapter-\$4.49  
Add \$1.00 for postage and handling.



## ALL OUTDOORS

(Continued from page 48)

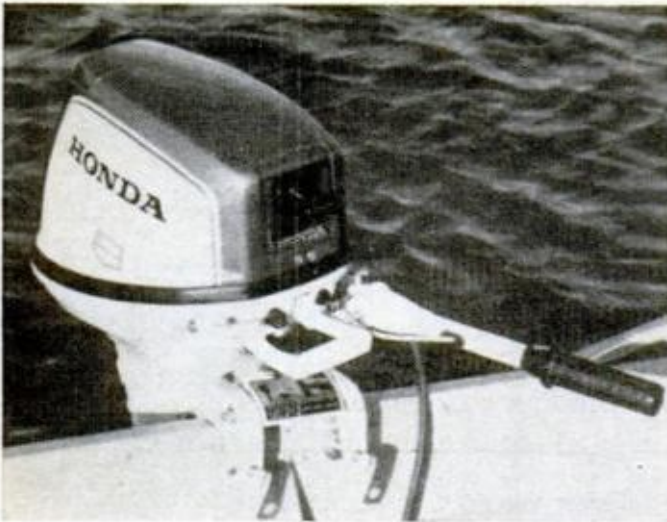

**New water power** from a motorcycle maker is Honda's four-stroke B-75 K1 outboard with 7.5 hp, overhead cam, and reportedly quiet operation using only  $\frac{3}{4}$  gal. per hour at full throttle. No fuel/oil mix needed.



**Keeping tools handy** should be easy with Tempo Tool Bag slipped through handle of 6-gal. portable tank to provide storage on each side. Made of gas and oil-resistant vinyl. \$4.50, Tempo Products, Cleveland.

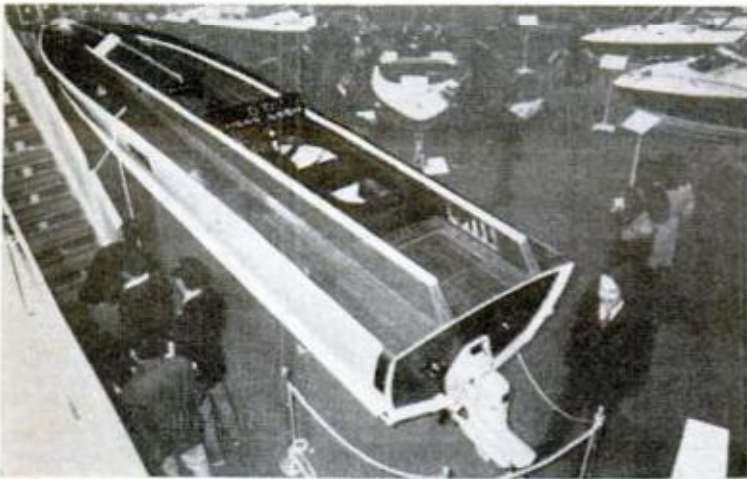

**Latest look in offshore racers**, seen at the Tokyo boat show, is long and lean. Yamaha X-100 is 33 ft. long with a 4.5-ft. chine beam and is powered with twin 351-cu.-in. Holman Moodys. The boat is by Annapolis, Md., designer John Gill.

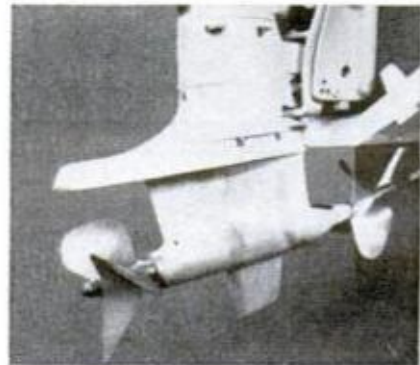

**Narrow Yamaha X-100** requires tandem engine placement, "Coaxial Drive" prop arrangement engineered by Gill. Minimal torque, high speed, easy motion in big seas are reported from tests.



**Bass boats are getting bigger.** Apollo, from Triple C Enterprises, Cabot, Ark., is 18-footer mounting Hardin Marine engine with water-jet power from 12YJ Jacuzzi Jet and reported thin-water speeds to 55 mph.



**Newest from Evinrude** are '74 Sport Line models: 50-hp Sizzler, Hustler 70 and Strangler 135. Custom red, white, blue styling is featured, plus stainless-steel props. Also new in line: 9.9 and 15-hp models.

(Please turn to page 52)





# EVERYBODY'S STEAMCLEANER

## HOT DOUBLE OFFER!

... and almost everyone is a prospect

- Air Conditioning
  - Animal Farms
  - Boats, Marinas
  - Building Cleaning
  - Business Machines
  - Cafes, Hotels
  - Cycle Shops
  - Dairies
  - Farms, Ranches
  - Fish Markets
  - Fur Farms
  - Garages
- Ice Plants
  - Industrial Plants
  - Lawn Mower
  - Meat Markets
  - Print Shops
  - Refrigeration
  - Saw Mills
  - Service Stations
  - Super Markets
  - Truckers
  - Veterinarians

TAKE THE FOOLISHNESS OUT OF STEAMCLEANING



PRODUCES  
HOT  
STEAM

**FAST!**

DEALER'S PRICE **\$189<sup>50</sup>**

## BIG MONEY 2 WAYS!

### 1. DEVELOP YOUR OWN SUKII DEALERSHIP—

Big Money Filling Demand All Over Your Territory

Earn a giant \$135.00 profit per sale. Dozens of different kinds of businesses . . . service stations, garages, factories, farmers, etc. . . . earn extra profits by saving time and work cleaning their property and equipment. Keeps customers happy, too.

### 2. BE A SUKII FRANCHISE DISTRIBUTOR—

Earn Biggest Profits, Realize Your Dreams

Openings available right now for top-flight men and organizations qualified to step into the booming SUKII picture. Unique moneymaking program with protected territory.

MAKE YOUR SUKII PROFIT CHOICE  
AND MAIL COUPON TODAY!

**SUKII**  
INTERNATIONAL

P.O. BOX 973  
JACKSON, WYOMING  
83001

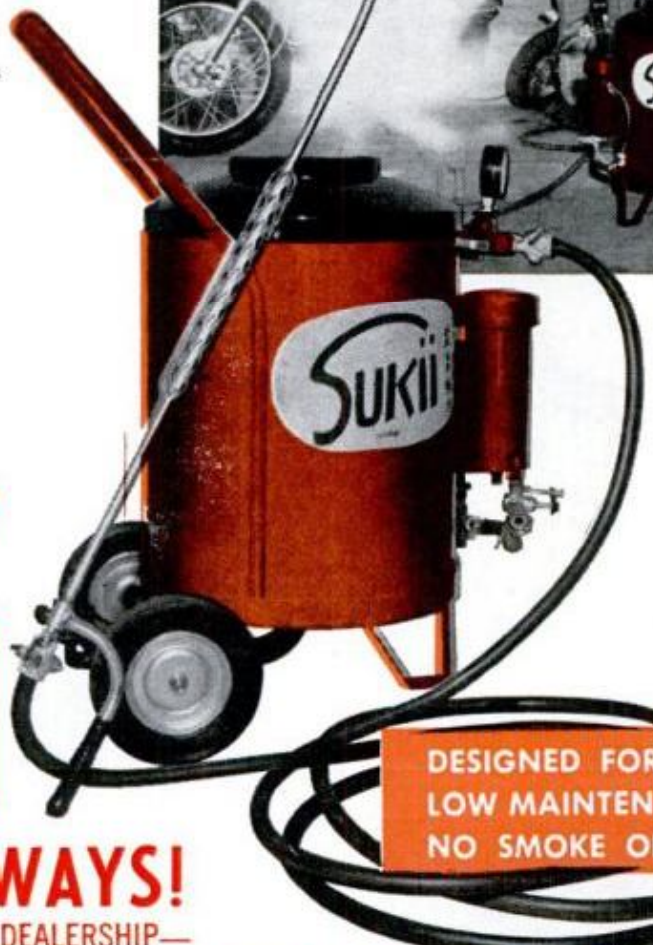

SUKII . . .

lightweight, quickfiring, long-lived, easy to operate, the choice of steam cleaners. L.P. gas fired and at a price users can live with.

DESIGNED FOR SIMPLICITY.  
LOW MAINTENANCE COST—  
NO SMOKE OR FUMES.

### CLEAN UP RIGHT HERE

Get All The Facts!

SUKII

Dept. PM-9

P.O. Box 973, Jackson, Wyo. 83001

Tel me how to clean up with new, re-designed SUKII instant steam cleaning machine!

- Here's check or m.o. for \$189.50—rush one demonstrator machine (\$325.00 retail value) and moneymaking details.
- Tell me how to get started as SUKII dealer.
- How do I qualify for that EXCLUSIVE FRANCHISE and PROTECTED TERRITORY as a SUKII distributor?

PHONE \_\_\_\_\_

NAME \_\_\_\_\_  
SHIPPING \_\_\_\_\_  
ADDRESS \_\_\_\_\_

(Please do NOT use P.O. Box No.)

CITY \_\_\_\_\_ STATE \_\_\_\_\_ ZIP \_\_\_\_\_



## ALL OUTDOORS

(Continued from page 50)

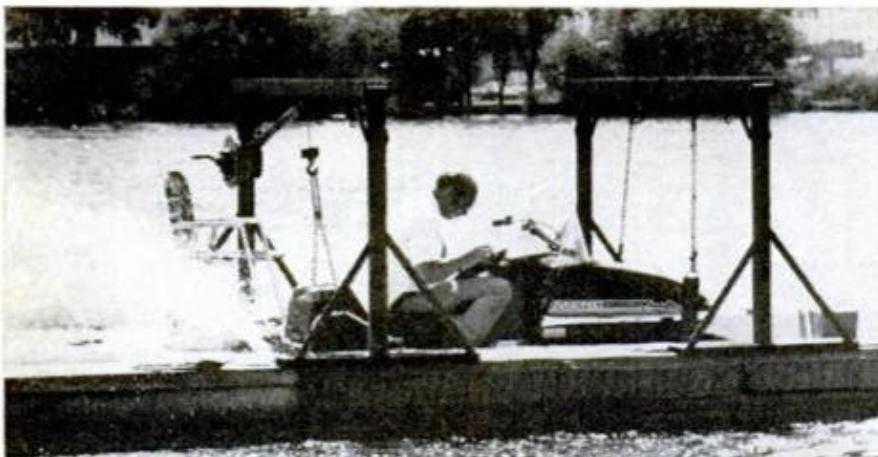

**Head start on snow season** begins afloat on Fox River, Oshkosh, Wis., at Mercury Marine test base where suspended snowmobiles throw wet rooster tail. Track turning in water has resistance to stop over-revving while cooling, lubricating. Three Trail Boss Mercs are offered for '74.



**Choke-Matic** claims double-barrel versatility for single-barrel pump or auto shotguns. After first shot choke closes. \$35. Triple-S Development Co.



**Blunderbuss fanciers** who have wondered where their next model was coming from can get this Queen Anne period flintlock muzzle loader by Navy Arms Co., 689 Bergen Blvd., Ridgfield, N.J. 07657, for \$100.



**Multipurpose cartop carrier**, the Hema Exclusive rack, telescopes to fit any size car, folds into trunk, adapts for luggage, skis, fishing rods, canoes. Model is \$40 from ICM Marine Products, North Vancouver, B.C.

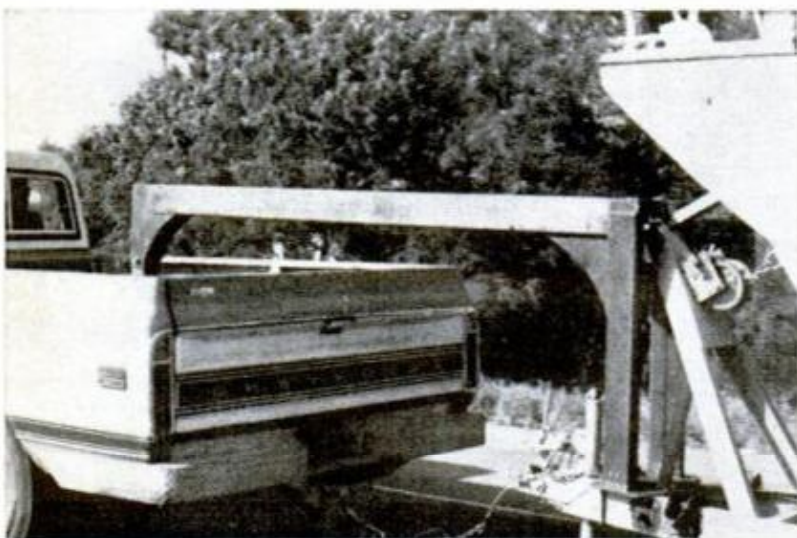

**Make your trailer into a fifth-wheeler** with new adapter kit from Land N' Sea Craft, San Jose, Calif. Designed for their Trail-A-Cruiser amphibious RV, fifth-wheel bracket unit can be bolted to almost any trailer tongue. \$485 with hitch included.



**Glass-to-glass "Taper Lok" ferrule** of new Daiwa 8300 Super Power two-piece rods can provide light continuous one-piece action, strength in wide selection of sizes.



## IMPORTS AND MOTORSPORTS

### How to run a rally

Running rallies is a tough test for tires. There's no better approach to research and development of family car tires than running them on a rally car—and that's exactly what **Pirelli** does with its tires. Among the



many rally-winning cars running on **Pirellis** is the Fiat 124S shown here. "Rally-developed" last year in international rallying are three new radial tires now available here: the Cinturatos CN54/70, CN36/70 and AS35.

The sport of rallying is a fascinating one and we like what **Pirelli** president Giorgio della Seta says about rallying and the young driver: "It's tempting for young drivers to show off their driving prowess through speed rather than skill . . . the rally can channel enthusiasm so the car will be treated as a *precision* instrument rather than an

new concept in tires recently announced by **Pirelli** involves design change where sidewalls operate under compression rather than under tension as with con-

ventional tire. Advantages include cool running, simpler construction, safety in event of blowout (wheel supported on rubber which won't come off rim).

### What she's burning is rubber



"Cha-cha" Muldowney's real name is Shirley. That should be the clue that this driver isn't one of the boys. She's the first woman racer to earn an NHRA AA fuel dragster competition license, and she knows how to use it! She turned a 6.61 E.T. at 211.0 mph recently. For relaxation she runs a Plymouth Satellite Sebring Funny Car on the NHRA circuit.

*(Please turn to page 58)*

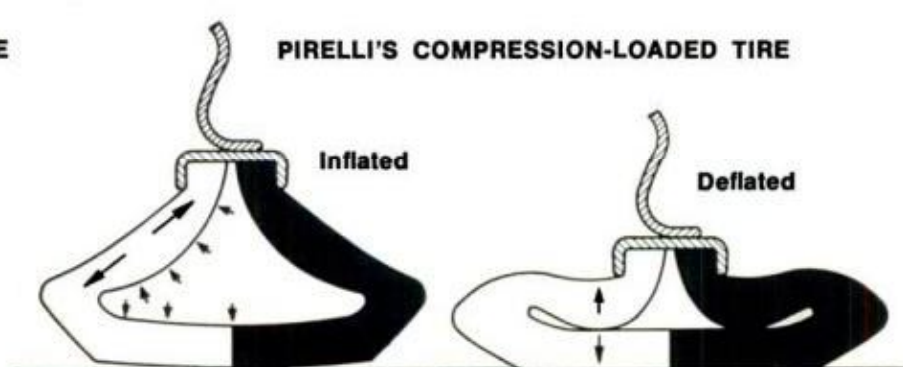
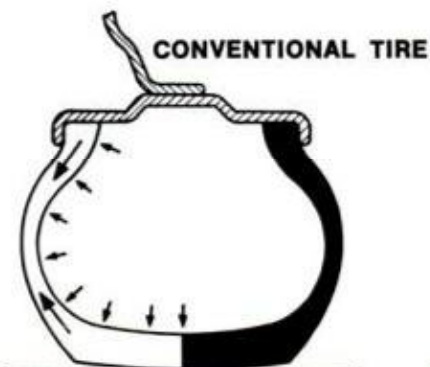



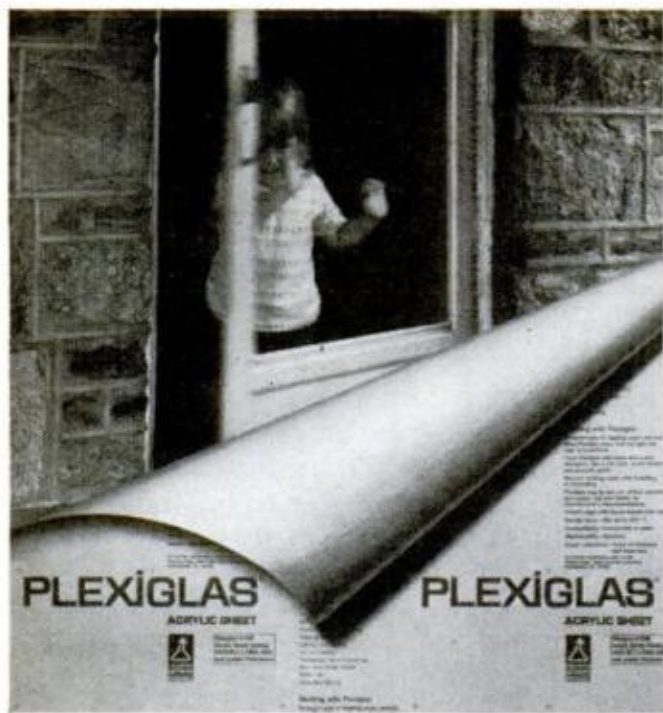

# WHEN YOU SAY PLEXIGLAS,<sup>®</sup> you're asking for the finest in safety glazing.

No other glazing material has the record for dependable, quality performance that Plexiglas brand acrylic sheet has. In storm doors, garage doors, tub and shower enclosures, anywhere you want protection against glass-breakage accidents in your home, Plexiglas can give you safety insurance.

Don't wait for a glass-related injury to discover how much Plexiglas safety insurance for your family is worth. Act today. Get your glass or hardware dealer to replace ordinary glass in hazardous areas with Plexiglas.

Plexiglas meets all state safety glazing law requirements. If you do not see the name Plexiglas on the masking paper, you are not getting Plexiglas brand acrylic sheet. Ask for it by name.

You can install Plexiglas yourself. To find out how easily, send for free installation instructions to: Rohm and Haas Company, Box 784 FG, Philadelphia, Pa. 19105.

**ROHM  
AND  
HAAS**   
PHILADELPHIA, PA. 19105

Plexiglas acrylic plastic is a combustible thermoplastic. Observe fire precautions appropriate for comparable forms of wood. For building uses, check code approvals. Impact resistance a factor of thickness. Avoid exposure to heat or aromatic solvents. Clean with soap and water. Avoid abrasives.

## IMPORTS AND MOTORSPORTS

(Continued from page 57)

### Something new for rough riders

Every motorcycle rider should know the value of protective gear—without learning the hard way. It's natural to find your limits by pushing a little farther each time. And you can be sure that the time will come when you're saddled up for dirt and riding the pegs that you'll lose it. It's nice when this doesn't result in a "handlebar smile." One way to protect against broken teeth is with this crossbrace tooth guard—a 1½-inch



foam blanket wrapped in naugahyde. Get it from Webco dealers for \$2.95 (Webco Inc., 218 Main St. Venice, Calif. 90293).

Speaking of rough riders, the world's best took Carlsbad, Calif., by storm at the Hang Ten United States Motocross Grand Prix, first such World Championship event to be held in this country. We missed it, but marked July 14, '74 for next season's Hang Ten. The turnout of fans and the TV ratings indicate that motocross is red-hot and growing—for spectators and participants. Top participant is Roger de Coster of Belgium riding a Suzuki. If he keeps his lead, he'll take the '73 Championship. He carries the big banner for Suzuki, but others are hanging ten for the team, too. Picture is of Rich Thorwaldson crossing finish to grab the 250-cc Motocross and overall title at Pro Pacific AMA Motocross in Northern California. ★★





# True Grit. When ordinary blades can't cut it.

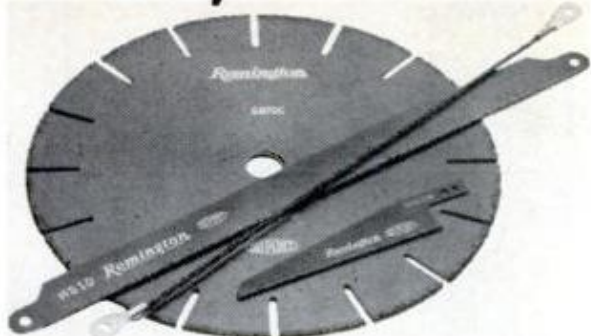

When ordinary blades can't do the job, Remington "Grit-Edge" blades take over. They take the tough out of tough jobs, saw through "unsawable" materials. How? Hundreds of tungsten carbide particles permanently bonded to the blades make them a match for materials that usually call for expensive diamond or solid tungsten carbide toothed blades. And if that isn't true grit, what is?

Remington "Grit-Edge" blades are available for Hack-saws, Saber Saws, Circular Saws, Bandsaws, and as a Rod Saw. The only thing ordinary about them is their low cost, which is a bargain considering their long life and the jobs they do.

For more information, see your hardware dealer or write: Grit-Edge Products, Dept. 365, Remington Arms Company, Inc., Bridgeport, Connecticut 06602.

**Remington** 



"Remington" is a trademark registered in the U. S. Patent Office.  
"Grit-Edge" is a trademark of the Remington Arms Company, Inc.

## RECOMMENDED CUTTING APPLICATIONS FOR "GRIT-EDGE" BLADES

Material	Rod Saw	Hack-saw	Saber Saw	Circ. Saw
Ceramic Tile	X	X	X	
Slate	X	X	X	
Marble	X	X	X	
Flagstone	X	X		
Brick	X	X		
Glass	X	X		
Fiberglass	X	X	X	X
Tempered Hardboard			X	X
Asbestos Cement	X	X	X	X
Composition Board			X	X
Synthetic Marble	X	X	X	X
Plywood			X	X
Plaster			X	X
Counter Top Material	X	X	X	X
Hardwood Flooring			X	X
Stranded Cable	X	X		
Spring Steel	X	X		
Hardened Chain	X	X		
Stainless Steel	X	X	X*	
Tailpipe Bolts	X	X		
Cast Iron	X	X		

\*requires coolant and variable speed machine.

# ZAP!

## SEALS CRACKS TO STOP WET BASEMENT PROBLEMS

Or Your Money Back

**ZAP!** Here is a new Epoxy Sealant that really works and at a fraction of the cost of a professional job.

**ZAP!** is easy to use. Simply mix the two epoxy liquids and apply with a paint brush. The ZAP! mix has a consistency like whipped cream, brushes on easily and does not run even on vertical surfaces. **ZAP!** provides a permanent seal even on damp surfaces and will withstand water pressures up to two tons per square foot. **ZAP!** is economical. Just mix the quantity you need — you only have to apply it over the problem areas. The rest will keep indefinitely. **ZAP!** is versatile. In addition to waterproofing basements, ZAP! patches boat leaks, seals shower stalls, fixes cracked tanks, patches swimming pools. AND, as an adhesive, ZAP! glues metals, wood or masonry in any combination for household repairs. Now you can bond new cement to old, fix furniture, lay bricks or tile, do hundreds of home repair jobs quickly, easily and professionally.

**Construction Chemical Corp.**  
Dept.F1,RD #2, Monroe, Conn. 06468

Please send me the complete ZAP kit with 1/2 gal. Epoxy Sealant, mixing stick and paint brush for \$13.98 postpaid. I understand I must be completely satisfied or my money will be refunded.

Enclosed is \$ \_\_\_\_\_

Name \_\_\_\_\_ (please PRINT)

Address \_\_\_\_\_

City \_\_\_\_\_

State \_\_\_\_\_ Zip \_\_\_\_\_

**SAVE MONEY! Order 2 complete kits for only \$24.95 . . . You save \$3.00**



# PHOTO HINTS

## FROM READERS

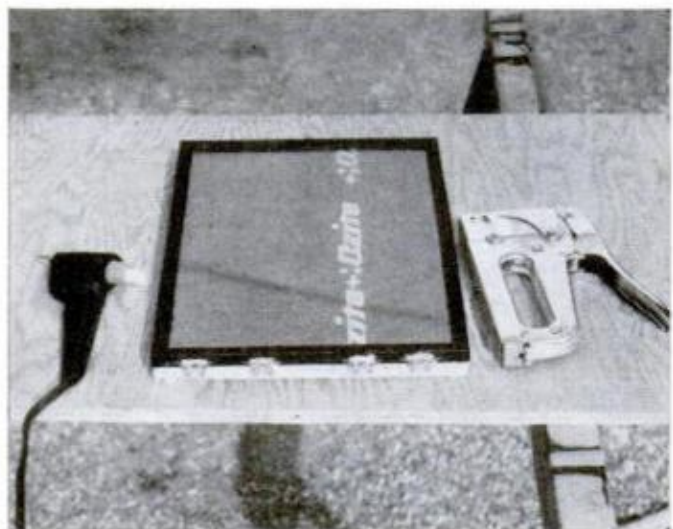

### Picture frame makes an inexpensive photo proofer

The quickest, easiest way to evaluate your shooting is by contact-printing a proof sheet for each roll you shoot. But commercial proofing easels cost \$10 or more, and the cheapest, simplest alternative—a sheet of plate glass—is likely to collect fingerprints, or slip out of your hands and shatter on the floor.

But you can build your own proofer for under \$3. Materials are just a 9x12 picture frame with glass, a piece of 1/2-inch plywood cut to the frame's outside dimensions, a 12-inch square of indoor-outdoor carpet, plus hinges and tack bumpers.

To start, remove the small nails or wires

which hold the glass in the frame and take out the glass. Then line the frame's inside rim with glue, replace the glass and weight it with a heavy book till dry.

While that's drying, paint the bottom and edges of the plywood (but not the top), and put a tack bumper on each corner of the bottom. When the paint dries, place the frame on the base and secure the hinges. Then glue the carpet square—face down and foam backing up—to the plywood base. Trim away the excess. A bulletin-board pushpin in the frame side opposite the hinge makes a good lifting handle.

—Kenn Oberrecht, Fairbanks, Alaska.



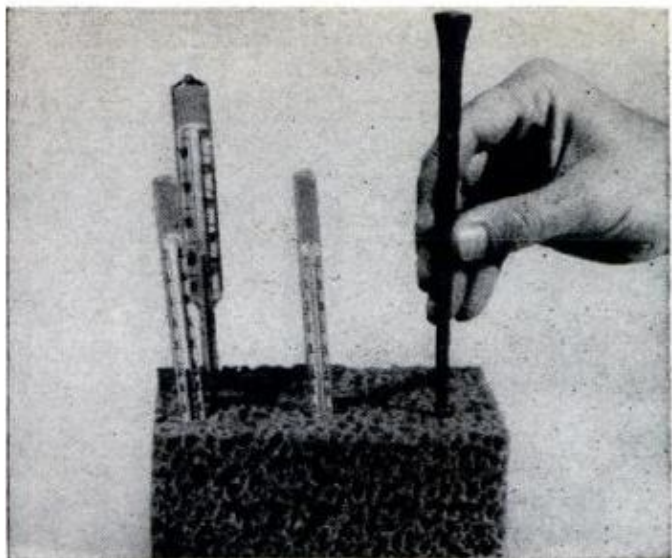

### Sponge holds darkroom thermometers

Need a safe, convenient place to hold your darkroom thermometers? Cut holes in a large plastic sponge, using a sharpened piece of quarter-inch copper tubing as a cutter. The holes in the low-cost "rack" will hold the thermometers and stirring rods conveniently—and you can still use the sponge for wiping up darkroom spills.

—Ken Patterson, Regina, Sask.

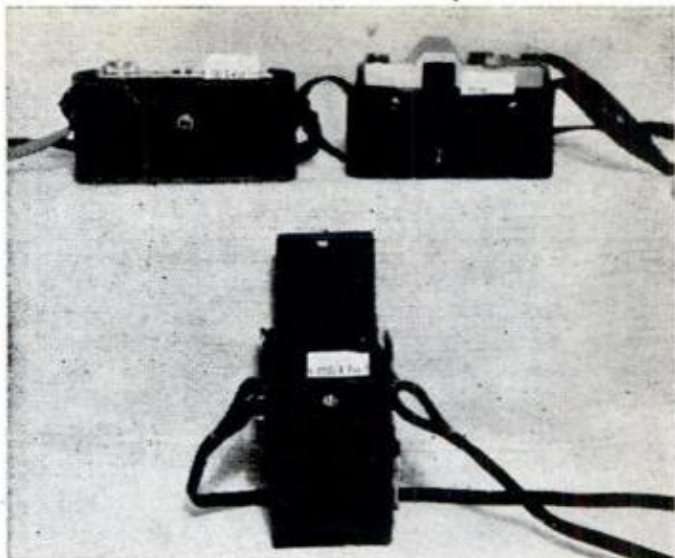

### Data sheet makes handy film reminder

You won't forget what's in your camera if you fold the film's data sheet and tuck it into your camera case with the film's name showing. What's more, that leaves the data sheet right there when you want it for checking exposure, filter factors or anything else you may suddenly want to know about before you push the button.

—V. P. Kisner, Harvey, Ill.



## Minolta helps you define the innocence of children.

You can enter a child's world with a camera that doesn't hold you back, a camera responsive enough to catch the fleeting moment.

From the moment you pick it up, you're comfortable with a Minolta SR-T. This is the 35mm reflex camera that lets you concentrate on mood and insight. The viewfinder gives you all the information needed for correct exposure and focusing. Because you never have to look away from the finder to adjust a Minolta SR-T, you're ready to catch the one photograph that could never be taken again.

Try a Minolta SR-T camera and rediscover childhood. For more information, see your photo dealer or write Minolta Corporation, 200 Park Avenue South, N.Y., N.Y. 10003. In Canada: Anglophoto Ltd., P.Q.

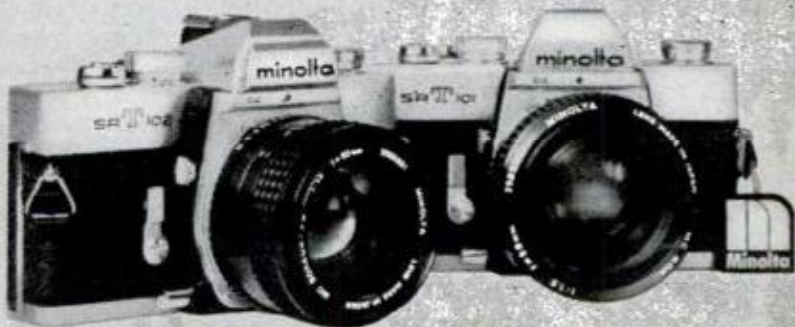

**Minolta SR-T 101/Minolta SR-T 102**



## APPLIANCE CLINIC

BY PAUL MANN

### Coy coil

*I have a 10-year-old Hamilton gas clothes dryer that has pooped out. The appliance switches on, and the drum revolves okay, but the burner doesn't go on. What's wrong?—Roy Granelli, Los Angeles.*

Sounds as though the igniter coil has gone bad. It has just one function: to light the gas pilot light, which in turn lights the main burner. If this coil has burned out, there will be no ignition.

Pull the wall plug, shut off the main gas valve, and remove the front or the top of the unit (depending on the model you own). The burner has to come out since the coil is attached to it. Disconnect the old coil and install a new one.

You'll be interested to learn that *PM* has planned a Clip-and-Save Know-How feature on troubleshooting clothes dryers. Watch for it in an upcoming issue.

### Unagitated agitator

*I have a Maytag automatic clothes washer (Model 142B), which is about 13 years old. It is kept in the basement where the temperature never goes below 60° F. During the wash cycle the agitator moves very, very slowly. I suspect that the grease in the drive gears has congealed, but an appliance man has told me that the machine is just too old to work properly and that I should buy a new one—from him, of course. What do you think?—Albert Dalton, Waterbury, Conn.*

The problem may be the drive belt's self-adjusting mechanism. The agitator is driven by a belt that is driven by the motor. The belt is adjusted by a spring-loaded mechanism—springs pull the motor back to tighten the belt as the agitator kicks in. The motor rides back on four nylon rollers, and experience has shown that these rollers are probably causing the problem. After years of use, one or more of the rollers can break, which means that the motor won't slide

back to the position required for full belt adjustment on agitation. You can check on this by removing the front panel from the machine, revealing the motor. Lift the motor up and down on its mount. If there is sloppiness, rollers should be replaced.

Considering the washer's age, this would be a good opportunity to replace springs as well. You can probably do the job yourself by taking the motor out of the machine and taking apart the slide assembly. Rollers can be ordered by using part No. 2-11952. Springs are part No. 2-2718. Total cost of parts is about \$2. They can be ordered from the Maytag Co., 2232 Route 22, Union, N.J. 07083.

One more thing: The belts in these machines must not be adjusted too tightly. To adjust the agitator belt, pull the motor back all the way against its slide and see to it that there is  $\frac{3}{8}$ -in. play at the belt's midpoint.

### Attack from the rear

*Our Frigidaire refrigerator-freezer developed a loud whine from the small fan motor that circulates air from the freezer compartment to the refrigerator section. An authorized serviceman replaced the motor for \$38.20—\$17 for the part and the rest for labor. The high cost of labor results from the fact that the motor is located behind the freezer compartment, requiring much dismantling so you can reach it. Could I cut an access door in the rear of the appliance that would permit easy removal of the motor should it fail again?—John J. Steinke, Lakeland, Fla.*

Your proposed access hole wouldn't do you a bit of good, since the motor mounts from the front. You still would not be able to remove the motor from the rear if it failed again. Besides, motor failure such as this isn't a common problem, as motors are

*(Please turn to page 64)*



# LEARN THE PROFESSIONAL METHOD OF APPLIANCE REPAIR

*For extra income, a job skill  
in demand, a business of your  
own—or to save money on  
your own appliance repairs.*

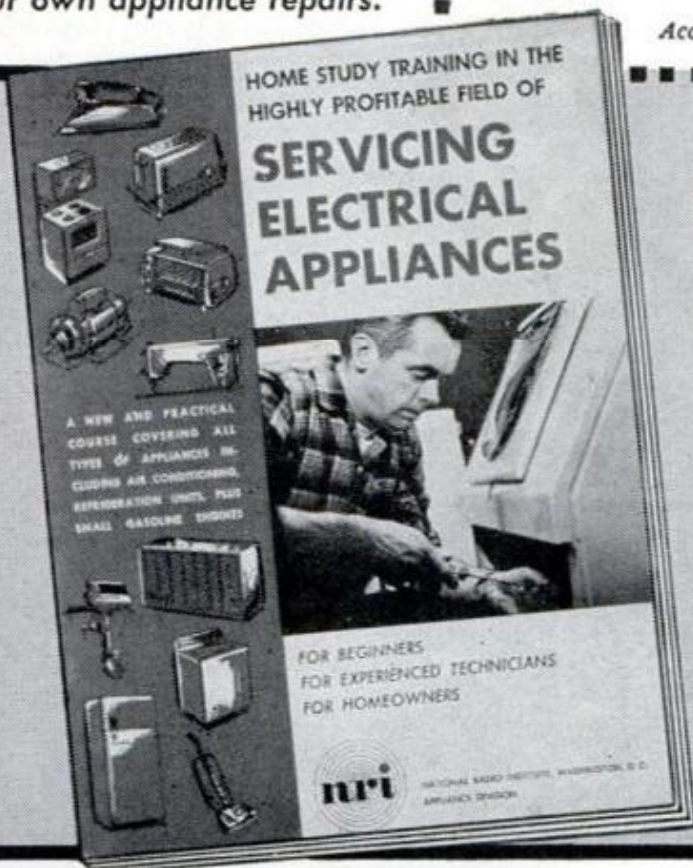

## SEND FOR FREE CATALOG

Appliance Division, National Radio Institute  
Washington, D.C. 20016

600-083

Send me your illustrated free book that tells about opportunities in Servicing Electrical Appliances, and gives details of NRI's simplified training plan. I understand there is no obligation, no salesman will call.

Name \_\_\_\_\_ Age \_\_\_\_\_

Address \_\_\_\_\_

City \_\_\_\_\_ State \_\_\_\_\_ Zip \_\_\_\_\_ Code \_\_\_\_\_

Check here for facts on New GI Bill.

Accredited Member National Home Study Council

MAIL COUPON ABOVE  
FOR THIS  
**FREE**  
**NRI**  
**CATALOG**

AVAILABLE UNDER NEW GI BILL  
If you served since January 31, 1955,  
or are in service now, check GI line  
in coupon above.

## A new, short, easy course trains you at home

Now you can prepare quickly to do professional appliance servicing at home in your spare time.

You are ready to start servicing appliances after only a few lessons. The entire course can be finished in a matter of months.

This is the fastest way to a new job or skill or extra income or a business of your own. Wherever you live or want to live, you'll find a demand for top-notch appliance servicemen.

There are probably thousands of broken appliances right in your neighborhood. These can mean cash profits for you starting soon. Use your spare time

to make \$5 to \$7 an hour fixing appliances for friends and neighbors.

Low-cost training plans cover —

- Small and large home appliances
- Farm and commercial equipment
- Portable electric tools
- Small gasoline engines

— there is even special training to prepare you for air conditioning and refrigeration.

Special NRI appliance testing equipment is included in your course at no extra cost. Mail coupon for your FREE NRI Catalog. No salesman will call.



NATIONAL RADIO INSTITUTE • APPLIANCE DIVISION  
Washington, D. C. 20016



## APPLIANCE CLINIC

*(Continued from page 62)*

equipped with highly reliable double bearings. I'd pass this experience off as a fluke.

### Slow mix

*My General Electric mixer doesn't work properly. In LOW position, it makes noise but won't revolve. In MEDIUM, it makes noise and revolves as if it were binding. What do you think is wrong?—Paul Dembry, Grosse Pointe, Mich.*

I think you have a gear problem. Gears probably aren't meshing properly, perhaps because of stripped teeth. A GE small-appliance center in my area quotes a carry-in charge of \$5.90 to replace them. If you want to tackle the job yourself, cost will be about \$1.55 for each of two gears.

Disassemble the appliance to reveal the gears, seated beneath the bottom plate, and inspect for damage. After new gears are in place, lubricate them with gear lubricant or petroleum jelly.

### Switch off

*Here's an odd one for you, Paul, concerning a Westinghouse food waste disposer. It will work for a bit after it is first started, and then cut off. If I wait a few minutes and push the reset button, the unit then operates properly for the remainder of the cycle. What's wrong?—Richard T. Carey, New Carrollton, N.C.*

It's easier to say what isn't wrong. What isn't wrong is the motor and the wiring—or you wouldn't be able to restart the disposer and make it work for its entire cycle by pushing the reset. A weak reset switch is a likely possibility. The surge of current when the unit is started may be causing a weakened bimetal to flex and cut off the motor. A new switch will cost between \$11 and \$15, depending on which disposer model you have. ★★★

*If you have a question about any appliance, send it to Appliance Clinic, Popular Mechanics, 224 West 57th St., New York, N.Y. 10019. Sorry, but letters cannot be answered individually. Problems of wide interest will be answered in this column.*

### ITT Credit Reserve can give you the security of knowing \$3,000 is available to you within 24 hours.

ITT Credit Reserve is a personal financial service funded and established by International Telephone and Telegraph Corporation for those 25 and over with family incomes of at least \$8,000.

Membership provides you and your family with a \$3,000 line of credit, all or any part of which may be drawn upon in less than 24 hours.

A payment schedule and full information on interest rates are available upon inquiry.

Your inquiry about ITT Credit Reserve will be treated in complete confidence.

## ITT CREDIT RESERVE

a service of International Telephone and Telegraph Corporation



Please send information on ITT Credit Reserve. No obligation, of course.

NAME \_\_\_\_\_ AGE \_\_\_\_\_

ADDRESS \_\_\_\_\_

CITY \_\_\_\_\_ STATE \_\_\_\_\_ ZIP \_\_\_\_\_

Mail to: F. Robert Stark, Service Director, 2080 First Security Building, Salt Lake City, Utah 84111  
or phone toll-free 800-453-9100 (24 hours a day — 7 days a week)



Every home a super receiver

# ELECTRONIC MIRACLE TURNS YOUR HOUSE WIRING INTO A JUMBO TV ANTENNA

- uses no current
- plugs in to any outlet
- no special tools or additional material required
- no more rabbit ears . . . ugly outside antennas

Utilizes all the wiring in your home  
... every room a reception area

Do you know that you have one of the greatest TV antennas ever constructed? It's better than any set of rabbit ears, more efficient than complicated external antennas. It's your house. Yes, the wiring in your home constitutes a giant antenna that acts as a super receiver for TV, FM, all kinds of difficult reception.

And the secret to using all this reception potential is an amazing little plug-in attachment that utilizes the receptivity of your house wiring without using a single bit of electrical power. Yes, you simply attach the adapter easily & quickly to your set . . . plug it in to any wall outlet and immediately your entire electrical system is working for you. No ugly looking rabbit ears, no difficult, dangerous to maintain external antennas, and reception so sharp and clear it will amaze you even in the more difficult areas. Order one for every set in your house, no interference from simultaneously operating sets. Only \$1.99. Full instructions included.

**JAY NORRIS** CORP.

25 W. Merrick Rd., Dept. ME-45 Freeport, N.Y. 11520  
Serving Satisfied Customers for over 25 Years

HUNDREDS  
OF THOUSANDS  
IN USE!



only  
**\$1.99**

**BUY WITH CONFIDENCE —  
MONEY BACK GUARANTEED**

Jay Norris Corp., 25 W. Merrick Rd., Dept. ME-45  
Freeport, N.Y. 11520

Please rush \_\_\_\_\_ Indoor TV Antenna(s)  
@ only \$1.99 plus 50¢ shipping and handling, under  
your money back guarantee.

SAVE! Order TWO Antennas for only \$3.50 plus  
50¢ shipping and handling.

SAVE MORE! Order SIX Antennas for only \$8.99  
plus \$1.00 shipping and handling.

Check or money order enclosed for total \$ \_\_\_\_\_

\_\_\_\_\_ (N.Y. residents add sales tax.)

Name (print) \_\_\_\_\_

Address \_\_\_\_\_

City \_\_\_\_\_

State \_\_\_\_\_ Zip \_\_\_\_\_

©1973, Jay Norris Corp.





There's lots of visibility for driver through all that glass. The luggage pod (on top at rear) is an option.

**I**t drives better than a car," wrote one owner, a New York manufacturer. That might seem an overly enthusiastic reaction to herding around an 8500-pound Cortez Touring Home that's 21 feet 4 inches long. But in my own test driving, I found the Cortez is also more fun to drive than a car—I got more kick out of driving than I had in years.

Each owner I queried had something good to say about the way the front-wheel-drive Cortez handles. A good part of their joy comes from its 455-cu.-in. Olds Toronado engine; there's always a nimble response to the accelerator, even on a hill. Another factor is the ride; a four-wheel independent suspension system carries you along in a remarkably luxurious fashion. The power steering, combined with power brakes that stop the vehicle with no nonsense, gives a driver the feeling of complete control. And it's quiet. The driver and front-seat passenger can converse normally while traveling at highway speeds.

Little wonder owners like to drive it!

Because of its front-wheel drive, the Cortez doesn't have the usual drivetrain running its full length. Consequently, it has a low profile for a motor home; the roofline is only eight feet above the road—and you

*(Please turn to page 66B)*

## Driver's report: Cortez motor home

PM driver proves what owners say: This 21-foot, front-wheel-drive vehicle handles like a car.

---

by John Linkletter  
MANAGING EDITOR





# CAMERA HUT

## Announces

The Sensational, Incredible, "Exclusive"  
**CAMERA HUT PHOTO BUYERS CLUB**  
 Enroll now and receive these fantastic membership privileges.

### \$ SAVINGS ON ALL PHOTO EQUIPMENT

By joining this exclusive club, Camera Hut insures you of 100% complete satisfaction - plus all that you ever dreamed of when owning the special equipment you guard and enjoy. As a member you will be able to 'Buy Right', any photo item you lay your eyes on. **HOW? We guarantee it!** After searching & finding the photo item of your choice, send us any current local or nationally advertised ad & deduct **5% OFF!** - That's correct, you search & find, deduct 5% off the advertised price and we do the rest. As a member you enjoy 'Buying Right'.

### LIFETIME PHOTO EQUIPMENT INSURANCE

The item you decide to purchase now, will hold for as long as you own it, a lifetime guarantee against breakage or defect in manufacture. Yes, even if you break it, drop it or smash it, Camera Hut will have it repaired at 'NO CHARGE'. This is your lifetime insurance that you enjoy as a Camera Hut Photo Buyers Club member.

### TRADE-IN INSURANCE GUARANTEE

If you ever decide to upgrade your equipment or just decide to trade, your bargaining days of losing are over. Camera Hut guarantees for the first 5 Years, 1/2 of what you paid, to be applied towards your next purchase. That's right! We will allow you - 50%, anytime within 5 years, of whatever you paid - whenever you decide to trade. You don't lose! You're a winner, when you're a member of the club.

**SPECIAL INTRODUCTORY OFFER TO NEW MEMBERS** **4** ROLLS FRESH KODAK CX 135-20 FILM WITH PROCESSING (NOT RELOADS)

SEND COUPON NOW OR JOIN AND CHARGE IT

### PHOTO GUIDANCE

Did you ever talk to a 'Camera Salesman' and ask a question and get double talk for an answer? Not at the club. If you have any questions or problems, no matter how technical, just write to us, our expert camera men will answer you by return mail. All we do is assist you in making the right decision when using your equipment. As a member of the club, you will be a better informed 'Photo Genius'.

### EXCLUSIVE MEMBERSHIP PRIVILEGES

As a member of the club, you get first crack at all brand new photo releases by our periodic mailer. Yes, as new equipment is introduced by manufacturers, we will send you, by return mail, photos & descriptions of each item, even before they are nationally advertised. In addition to our 'new stuff', you get to take first crack at our huge inventory of 'Brand Used Creampuff Specials' before we even get to advertise them. Yes, you're practically on the inside - 'on the ground floor' - so to speak. Becoming a member of the club is an investment with great returns. We're sure you'll agree once you enroll.

### SPECIAL INTRODUCTORY OFFER!

As if what you were getting wasn't enough - if you enroll NOW! - you will receive a \$30.00 PLUS value of: 4 rolls of fresh KODAK CX 135-20 film with processing - in addition to your regular club membership card.



CHARGE BankAmericard or Mastercharge

# CASH IN ON OUR GIANT BONANZAS



**FTB**  
**QL**  
 w/Case  
**1.8 Auto FD**  
**\$199.50**

Canon FTB w/1.4 Auto FD & Case **229.50**  
 Canon FTB w/1.2 Auto FD & Case **319.50**  
 Canon FTB Body ..... **159.95**  
 Canon F1 Body ..... **294.50**  
 Canon TLB w/1.8 Auto & Case .. **169.95**

### AMERICA'S #1 CHOICE BRAND NEW 27 PIECE SLR OUTFIT - JUST SELECT YOUR FAVORITE SLR CAMERA LISTED BELOW, AND RECEIVE:

- Your favorite SLR camera (Listed Below)
- Camera Eveready case
- 50 52.55 or 58mm
- Automatic Lens (Listed Below)
- Electronic Flash
- Polygraph lens
- Film holder
- Cable release
- Deluxe SLR gadget bag
- Prepaid processing mailer
- Tele converter
- Case for tele converter
- Lens cleaning tissue
- Lens brush
- K 135 - 20 Film
- Album refills
- Deluxe photo album
- Screw in filter
- Wrist strap
- Camera clean set
- Camera Hut unconditional 3 year warranty
- Lens hood
- Photo Book (5.90 value)
- Choice of fully automatic or fully automatic 35 3.5 wide angle
- Neck Strap
- Skyline filter for normal tele or W/A lens
- Case for tele or W/A lens

### ALL SLR PRICES LISTED INCLUDE ALL ABOVE ITEMS

MINOLTA SRT-100 55/1.9 Auto MC Rokkor	267.50
MINOLTA SRT-101 55/1.7 Auto MC Rokkor	315.00
MINOLTA SRT-101 58/1.4 Auto MC Rokkor	342.00
MINOLTA SRT-101 58/1.2 Auto MC Rokkor	385.00
MINOLTA SRT-102 50/1.7 Auto MC Rokkor	389.00
MINOLTA SRT-102 50/1.4 Auto MC Rokkor	414.00
HONEYWELL Spotmatic 55/1.8 Super Takumar	289.50
HONEYWELL Spotmatic 50/1.4 Super Takumar	315.00
CANON FT QL 50/1.8 Auto Canon	239.50
CANON FT QL 50/1.8 Auto Canon	269.50
CANON FTBGL 50/1.8 Auto Canon	314.50
CANON F1 50/1.8 Auto Canon	449.50
PETRI FT II 55/1.8 Auto Petri	219.50
PETRI FT EE 55/1.8 Auto Petri	235.00
MIRANDA Sensomat RE 50/1.8 Auto Miranda	239.50
MIRANDA Sensomat RE 50/1.4 Auto Miranda	269.50
MIRANDA Sensorex II 50/1.8 Auto Miranda	309.50
MIRANDA Sensorex II 50/1.4 Auto Miranda	339.50
MIRANDA Sensorex EE 50/1.8 Auto Miranda	339.50
MIRANDA Sensorex EE 50/1.4 Auto Miranda	369.50
NIKON Photomic FTN 50/2 Auto Nikkor	429.50
NIKORMAT FTN 50/2 Auto Nikkor	319.50
NIKORMAT FTN 50/1.4 Auto Nikkor	349.50
MAMIYA/SEKOR 500 DTL 50/2 Auto Mamiya	229.50
MAMIYA/SEKOR 1000 DTL 55/1.8 Auto Mamiya	259.50
MAMIYA/SEKOR 1000 DTL 55/1.4 Auto Mamiya	289.50
MAMIYA/SEKOR XTL 55/1.8 Auto Mamiya	359.50
KONICA Auto Reflex A II 52/1.8 Auto Hex	289.50
KONICA Auto Reflex TII 52/1.8 Auto Hex	329.50
KONICA Auto Reflex TII 52/1.4 Auto Hex	359.50
YASHICA TL Super 50/1.7 Auto Yashinon	239.50
YASHICA TL Electro X 50/1.7 Auto Yashinon	259.50
EXAKTA 1000 RTL 50/1.8 Auto Oreston	259.50
RICOH Singlex TLS 55/1.7 Auto Rikenon	215.00
RICOH Singlex 401 55/1.4 Auto Rikenon	279.50
FUJICA ST 701 50/1.8 Auto Fujinon	239.50
FUJICA ST 701 50/1.4 Auto Fujinon	269.50
FUJICA ST 801 50/1.8 Auto Fujinon EBC	314.50
FUJICA ST 801 50/1.4 Auto Fujinon EBC	344.50

CAMERA HUT LTD.  
 Moorestown Mall, Rt. 38 & Lenola Rd., Moorestown, N. J. 08057

PM 9/73

Yes, please enroll me at once in the Camera Hut Photo Buyers Club. I am enclosing \$25.00 introductory membership fee, which I understand will allow me to enjoy all privileges you stated in your ad. Thereafter, you may bill me \$5.00 per year to

maintain club membership, sending me an additional roll of Kodak CX 135-20 film with processing each time I renew. I understand that I am not obligated to purchase anything at any time. I may discontinue membership at my discretion.

NAME \_\_\_\_\_

ADDRESS \_\_\_\_\_

CITY \_\_\_\_\_ STATE \_\_\_\_\_ ZIP \_\_\_\_\_

I want to join and buy now:

Items selected \_\_\_\_\_

Ad enclosed \_\_\_\_\_

Please charge: MC  BA

All items subject to increase due to fluctuating U.S. \$ import tax & availability.

Price \_\_\_\_\_

5% less \_\_\_\_\_

Member price \_\_\_\_\_

Add appropriate sales tax \_\_\_\_\_

Total \_\_\_\_\_

CAMERA HUT LTD. PM 9/73

Moorestown Mall, Rt. 38 & Lenola Rd., Moorestown, N. J. 08057

Include remittance with order. (Sorry - No C.O.D.'s)  
 MINIMUM ORDER \$1.00 - SEND \$1.00 FOR SPECIAL RUSH MAILING (Orders over \$25.00 - add \$3.00 for Shipping)  
 RUSH ORDERS - Mail Certified Check or Money Order

Please forward \_\_\_\_\_

NAME \_\_\_\_\_

ADDRESS \_\_\_\_\_

CITY \_\_\_\_\_ STATE \_\_\_\_\_ ZIP \_\_\_\_\_

Please charge: MC  BA

All items subject to increase due to fluctuating U.S. \$ import tax & availability.

Price \_\_\_\_\_

Add appropriate sales tax \_\_\_\_\_

Total \_\_\_\_\_



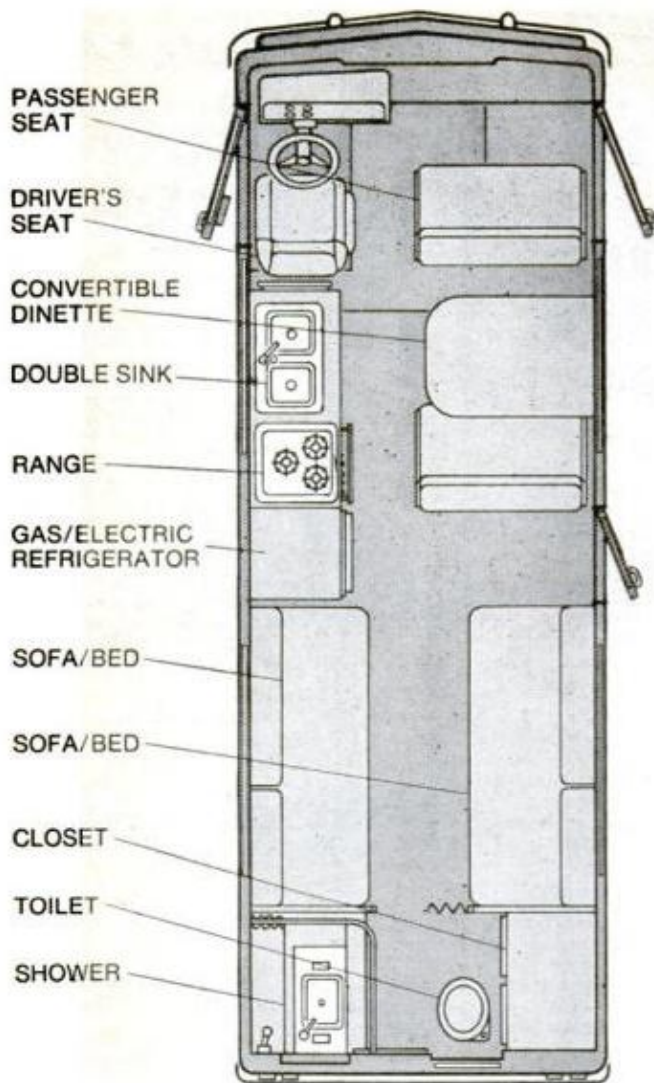

really don't need the doorstep to mount through the side door. The low-to-the ground construction has one other payoff: You don't have that top-heavy feeling you find in some motor homes.

On the other hand, there is a hump over the front-drive setup that's a bit of an obstacle when you climb to either of the front seats from the rear. (With two-door access to the front seats, however, you don't have to make that climb very often.)

The Cortez has a fairly standard interior layout. It sleeps four, two on single sofa/beds at the rear and two on the convertible dinette. Of course, it has the amenities you'd expect: three-burner stove with oven, sink, seven-gallon water heater, six-foot 12-volt/110-volt electric refrigerator, shower, 38.5-gallon holding tank, wood paneling, wool carpeting, 38.5-gallon water tank with demand pump and a 22,000-B.T.U. ducted forced-air heater. Then there are such nice touches as, for example, 11 individually controlled lights and five dome overheads, plus five electrical outlets.

Other luxuries that come as standard equipment are a 36,000-B.T.U. automotive airconditioner, six-way power seat, cruise control, Thermo-san waste-disposal system, trailer hitch and water purifier.

One of the niftiest features for the driver

(Please turn to page 66D)

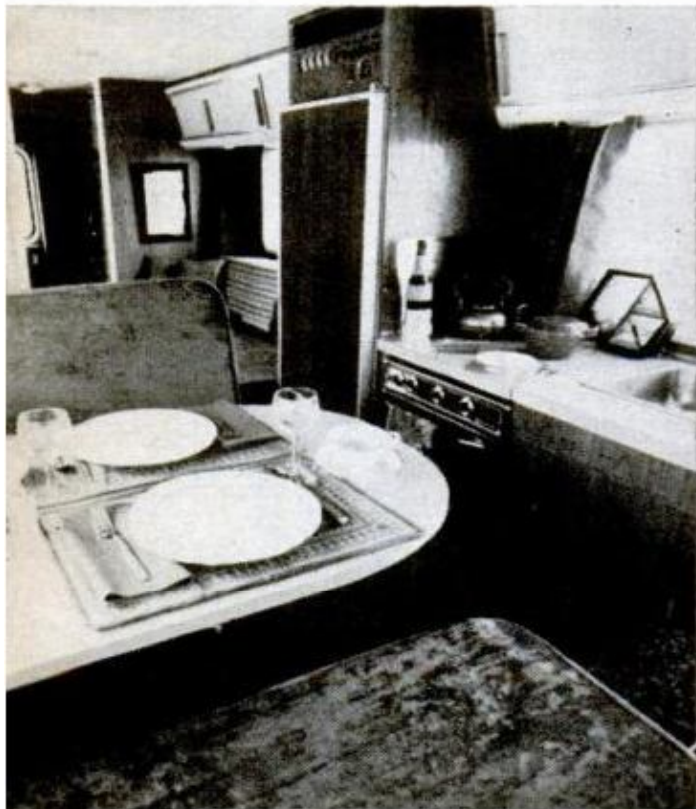

**Passenger seat**, which faces forward while you travel, flips over to become dinette seat (in foreground of left-hand photo). Above: Driver's six-way power seat faces tilting steering wheel and the well-arranged instrument and control-knob display of dashboard.



# "How I rewired my taillights with a plastic straw and Dow Corning Bathtub Caulk"



We knew our silicone rubber bathtub caulk was good for a lot more things than bathtubs, and when we heard how Larry Oswald of Sewickley, Pa., used it, our opinion was confirmed.

"When my taillights started getting dimmer and dimmer, I took them apart and found that the sockets, wires, everything, were all corroded.

"So I cleaned everything up, bought two new sockets, and decided this time that they weren't going to corrode.

"I had a tube of Dow Corning® Bathtub Caulk lying around the house, so I figured why not, and caulked up the sockets.

"Then I figured that if it'd work on the sockets, it'd work on the splices.

I cut two small pieces off a plastic drinking straw, slid one over each set of wires to keep them from getting stuck together, tied the wires together, and then pumped them full of caulk.

"It's been six months now, and my taillights are still brighter than ever."

Next time you're faced with a plumbing leak, broken gasket, or

almost any fix-it job around the house, get the Dow Corning Silicone Bathtub Caulk out of the bathroom and put it to work.

You'll find it in white and pastel decorator colors in the hardware or paint department of your favorite store. Look for Dow Corning Silicone Sealer in clear, black, or aluminum in tubes and cartridges, too.

Dow Corning Corporation, Dept. D-3102, Midland, Michigan 48640.

## DOW CORNING

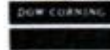

## miniWINCH

Pulls In Excess Of 1 Ton - Weighs Only 12 Pounds

\* Simple to operate \* Attaches to any popular chain saw

Powerful help for  
Homeowners —  
Sportsmen —  
Contractors —  
Snowmobiles —  
Campers —  
Boatowners —  
Builders —  
Farmers —  
Rescue Units



BUY IT FROM YOUR LOCAL  
CHAIN SAW DEALER OR DISTRIBUTOR

TRIWAY MANUFACTURING, INC. \*  
P.O. BOX 37 MARYSVILLE, WASHINGTON 98270

## COMPACT, EASY TO HANDLE

Smith's CAVALIER™

Welding and Cutting Outfit

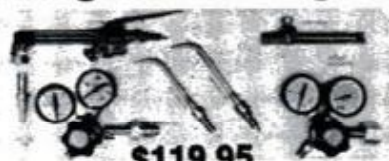

\$119.95

Perfect for anyone who requires light weight and yet capabilities of welding up to 1/2" steel and a cutting range up to 1 1/2" steel. Tips provided in outfit weld to 3/16" and cut 3/4". Included is 12 1/2', 3/16" hose. \$119.95 Postage Prepaid (N.J. residents add 5%). Send check or money order to D. E. Farrell, P.O. Box 81, Elizabeth, N.J. 07201. 30 day money back guarantee.

# All New

Includes  
**FREE**  
Ohms  
Calculator

72 pages  
of products,  
projects, tips,  
formulas,  
tables, etc.  
from your  
local  
**CALECTRO**  
Electronics  
Distributor!

Includes  
20" x 30"  
Wall Chart

**GC ELECTRONICS**  
DIVISION OF HYDROMETALS, INC.  
ROCKFORD, ILLINOIS 61101 U.S.A.



# Sharpen All These For Cash Income

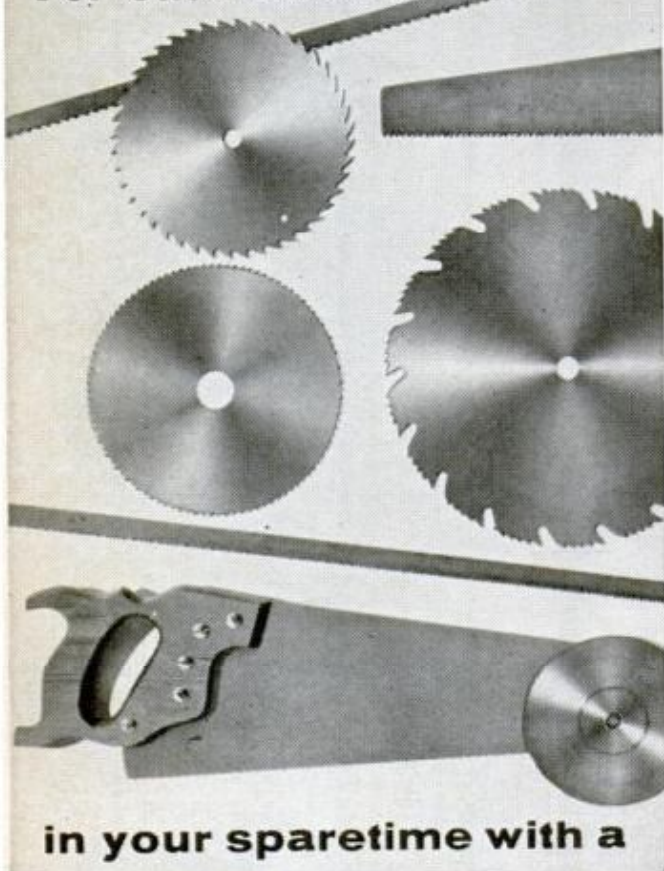

in your sparetime with a

## Foley Saw Filer

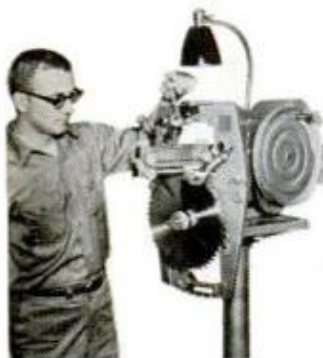

You can sharpen combination (rip and crosscut) circular saws, hand saws, band saws, crosscut circular saws—and do a perfect job every time without experience or special training. The precision Foley Filer does it for you *automatically!* A complete repair shop in one machine! Set up in basement or garage, work your own hours in your own way and earn big sparetime profits.

### Earn \$3 to \$6 Extra An Hour

You can make up to \$3 or \$6 an hour—\$20 to \$30 a week in your spare time as a starter. "My spare time saw filing business has made me \$952 these first ten months," says R. T. Chapman.

**FREE BOOKLET** shows you how to get into this CASH business.

**FOLEY MFG. CO.**  
916-3 Foley Bldg., Minneapolis, Minn. 55418  
Send me free book "MONEY MAKING FACTS"  
and Time Payment Plan.

Name \_\_\_\_\_

Address \_\_\_\_\_

City \_\_\_\_\_ State \_\_\_\_\_ Zip Code \_\_\_\_\_



## CORTEZ MOTOR HOME

(Continued from page 66B)

is the lighted label just above each knob on the dashboard. If, between trips, you tend to forget which switch is which, the label locates it again for you at a glance. After I picked up the test motor home at Kevah Konner agency in Pine Brook, N.J., I set out in an unfamiliar vehicle on a crowded, strange highway in the evening during a rainstorm. Unable to spare more than a half second glance away from the road, I found myself blessing the guy who put those lighted labels in place so I could instantly find the right knobs.

Among the options (which can run the Cortez base price of \$22,250 as high as \$25,000) are a generator (three choices available), a 13,000-B.T.U. roof-mounted airconditioner, a fiberglass rooftop luggage pod, stereo radio and a smoke and gas-fume detector.

The construction of the Cortez drew favorable mention from owners. The company describes it as "welded steel unitized construction." A New Jersey research engineer likes the resultant "solid feel," and an executive likes the "inherent safety."

I found that I got 7.9 miles per gallon. Owners, who had driven anywhere from 3500 to 8500 miles, reported they were getting 7 to 10.5 mpg.

Troubles are minor, contend the owners. One, a New Jersey executive who has previously owned a Cortez, said: As with a boat, "the shakedown cruise is a longer process than assembly-line inspection. With such a complex piece of equipment, you are bound to develop certain problems.

"On the whole, the Cortez has been very good. The overall quality in the most recent one, I would have to say, is somewhat marred by sloppy workmanship which was not apparent in the earlier version. The troubles which have developed, however, are mostly nit-picking, annoying problems which better workmanship would have overcome."

He concludes: "When I consider I am driving my family many thousands of miles in our motor home, I think it is very important to recognize that in a Cortez this is done with a great feeling of security, and in a very luxurious fashion."

Further information about options, color choices and the like is available from the maker, the Cortez Corp., 777 Stow St., Kent, Ohio 44240. ★★★



# Find the answers to 1001 workshop questions

## quickly, easily with the **POPULAR MECHANICS MASTER SHOP GUIDE**

24 hangup boards, coated with wipe-clean plastic keep vital how-to-do-it information always at your finger tips.



Here in an easy to use, last-forever format are the answers to everything you'll ever need to know about: nails, screws, bolts, wall-fasteners, drills, abrasives, lumber, hardwoods, moldings, plywood, hardboard, gypsum, adhesives, plumbing, electrical work, floor and wall tile, glass. Facts on remodeling measurements, gutters, concrete, garden chemicals. Plus—all on one board—a ruler, protractor, 45-degree triangle, and compass for accurate circles! You'll reach for the **MASTER SHOP GUIDE** for every job you tackle!

What nail should you use? How many pounds will a  $\frac{1}{4}$ -inch toggle bolt hold? How can you save money ordering lumber? What size quarter-rounds are available? How do you bleach close-grained hardwoods? What glue is best?

Repairs, too! Illustrations on plumbing, electrical, floor or wall tile, plastic laminates, glass, remodeling. All the basic dimensions you'll need!

By the editors of *Popular Mechanics*—order yours now—you'll use it the rest of your life!

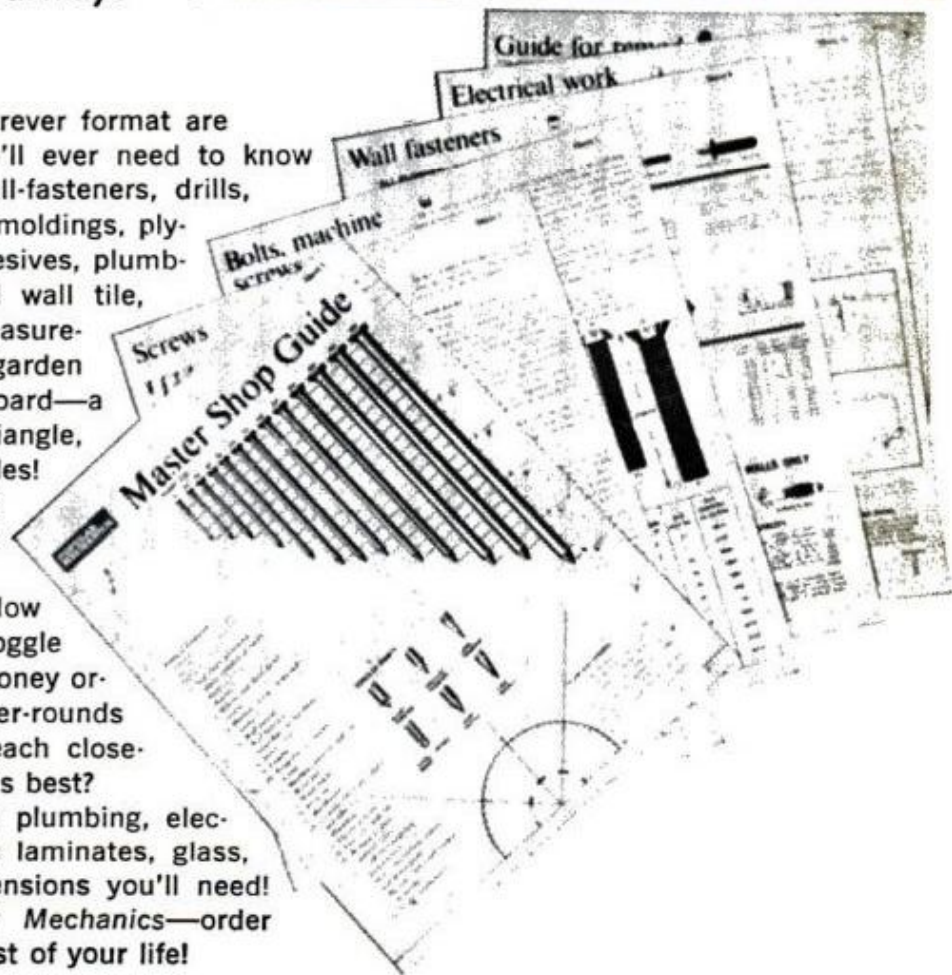

**Popular Mechanics, Dept. SG-9**  
Box 1014, Radio City,  
New York, N.Y. 10019

Rush me \_\_\_\_\_ sets of the  
**MASTER SHOP GUIDE.**

I enclose check or money order  
for \$3.95 for each set ordered.

NAME \_\_\_\_\_

ADDRESS \_\_\_\_\_

CITY \_\_\_\_\_ STATE \_\_\_\_\_ ZIP \_\_\_\_\_

SEPTEMBER 1973 66E

Материал, защищенный авторским правом



# OCTOBER PREVIEW

## OF POPULAR MECHANICS



NEW MUSTANG II

### '74 Cars: 20 pages of buying information

Another record year for car sales may be ahead, with waiting lists for certain gas-saving compacts. PM's 20-page car section will make you a smarter buyer.

### Half baths that fit small spaces

We show the floor plans, designs and new fixtures that make possible half baths that will fit in as little as 15 sq. ft. of floor space. Another bath will make your home more livable and add more to its value than the cost.



### North Sea oil

The North Sea doesn't yield its oil riches without a struggle. Here's how American divers and drillers meet the challenge.

### Stain removers

We've rounded up the best methods of removing stains from almost everything in the home.



### Bolt-on body for a VW

Want to update a Volkswagen with a new body styled years ahead? We show the latest, and list where you can get them.

## PLUS

How to waterproof a basement • How to keep gutters and leaders clear • How you pay for boredom on the assembly line • The cars PM auto editors drive • How to install TV antennas • PM editor tops 100 mph in rotary outboard • One man's collection of antique tools • How to repair a fiberglass fishing rod • All the new outboard motors.

**Buy it on your newsstand. Better yet, make sure you'll keep getting this kind of exciting fare. Send this coupon with your check to:**

**POPULAR MECHANICS**  
250 West 55th Street  
New York, New York 10019

Please enter my subscription for  1 yr. \$5.97 or  2 yrs. \$10.97

Name \_\_\_\_\_ (Please print)

Address \_\_\_\_\_

City \_\_\_\_\_ State \_\_\_\_\_ Zip \_\_\_\_\_

Payment of \$\_\_\_\_\_ is enclosed.  New  Renewal

On new subscriptions, first copy will arrive in about 8 weeks.

(Above prices apply in U.S. and Possessions only. Canada, add \$2 per year. All other countries, add \$4 per year.)

WPM311



# Jobs open up for Technicians with down-to-earth training!

Opportunities are everywhere and the pay is excellent in the technical service industries. But it takes the right training to get a man started: NTS Project-Method Home Training!

You learn by building the latest equipment and test instruments (which are included in your tuition). You're guided every step of the way by easy-to-read NTS Lessons.

When you graduate, you know service and repair from the bottom up, inside-out!

You have answers on the tip of your tongue. Know-how at your fingertips. You have the down-to-earth training experience employers are willing to pay good money for!

Find out. Send card today. No obligation. No salesman will call.



Solid-State Color TV  
315 Sq. In. picture

## ELECTRONICS DIVISION

NTS offers a wide-range of training with solid-state equipment (almost all of it commercially available). Build a solid-state 315 sq. in. Color TV; solid-state B&W TV; solid-state FM multiplex Receiver and Speakers; solid-state Oscilloscope; solid-state Compu-Trainer. Plus, Amateur Phone Transceiver, FET Volt-Ohmmeter, Electronic Tube Tester, Signal Generator, and more! Get valuable experience in the latest electronics technology. Read details in catalog.



## MECHANICS DIVISION

NTS includes professional tools and test equipment. Earn as you learn. Make money even before you graduate! Big 109 piece Socket Wrench and Tool Set — all American made! And a Performance Kit — Timing Light, Smog Valve Tester, Compression Tester, Remote Starter Switch, Dwell Tach, Alternator-Generator-Regulator Tester. Also, "Speed Shop" lessons and diesel training.

## APPROVED FOR VETERAN TRAINING

Accredited Member: National Association of Trade & Technical Schools; National Home Study Council.

## CLASSROOM TRAINING AT LOS ANGELES

Train in sunny Southern California. NTS occupies a city block with over a million dollars in training facilities. Check box.

**NATIONAL TECHNICAL SCHOOLS**

WORLD-WIDE TRAINING SINCE 1905

Resident & Home Study Schools

4000 So. Figueroa St., Los Angeles, CA. 90037



## AIR CONDITIONING/ REFRIGERATION & HEATING DIVISION

NTS provides you with the important tools of the trade! Courses include specially-designed Hermetic Unit Analyzer — a tester with multiple applications; Leak Detector-Soldering Kit — with hundreds of uses; Charging-Testing-Purging Manifold Set with dispensing and piercing valves. Plus, Socket, Wrench, Open-End Wrench, Tube Bender Sets, and more!



## HOME APPLIANCE DIVISION

Multiply your experience with appliance circuitry through the exclusive NTS Circuit Trainer. Eliminates the need to buy dozens of appliances for training purposes. The 4-in-1 Appliance Tester performs many troubleshooting tasks. It includes an Ohmmeter, Voltmeter, Ammeter, and Wattmeter; measures both AC and DC currents; it will be valuable to you during training and on the job!

## NATIONAL TECHNICAL SCHOOLS

WORLD-WIDE TRAINING SINCE 1905

Resident & Home Study Schools

4000 So. Figueroa St., Los Angeles, CA. 90037

Send for color Catalog and Sample Lesson — both FREE! Check below. No salesman will call. No obligation.

- Electronics Division       Mechanics Division  
 Air-Conditioning, Refrigeration, Heating Division       Home Appliance Division

NAME \_\_\_\_\_ AGE \_\_\_\_\_

ADDRESS \_\_\_\_\_

CITY \_\_\_\_\_ STATE \_\_\_\_\_ ZIP \_\_\_\_\_

- Check for Veteran Training under G.I. Bill  
 Check if interested in information on Classroom Training in Los Angeles

Dept. 201-093



# You were born smart.





# Make it pay off in the Navy.

Get advanced technical training in electronics or nuclear power.

If you're a high school graduate who can meet our qualifications, the Navy will offer you over \$17,000 worth of advanced technical training in our Advanced Electronics or Nuclear Power programs.

These are very special programs, and the academic schedule will be tough . . . calling for plenty of concentration and honest effort. It'll take more than a good mind to make it. You'll need a strong desire to learn and achieve. And a willingness to do your share of the house-keeping chores. But any man who learns to operate or

repair the Navy's sophisticated electronic systems or nuclear power plants, guarantees himself a firm foothold in the future, whether

he stays in the Navy or not.

For more details, talk to your local Navy Recruiter. Or mail the coupon below. Or call toll-free, anytime, 800-841-8000.

**Be someone special  
in the New Navy.**

TO: Captain Robert W. Watkins, USN  
Building 157, Fourth Floor  
Washington Navy Yard  
Washington, D.C. 20374

349

Please send more information on:

- Advanced Electronics Program  
 Nuclear Power Program  
 Other Navy career opportunities.

If you really don't want to wait, call 800-841-8000 toll-free (24 hours a day, seven days a week). In Georgia, call 800-342-5855. Call collect: In Alaska—272-9133, in Hawaii—533-1871.

Name \_\_\_\_\_ Age \_\_\_\_\_

Address \_\_\_\_\_

City \_\_\_\_\_ Phone \_\_\_\_\_

State \_\_\_\_\_ Zip \_\_\_\_\_

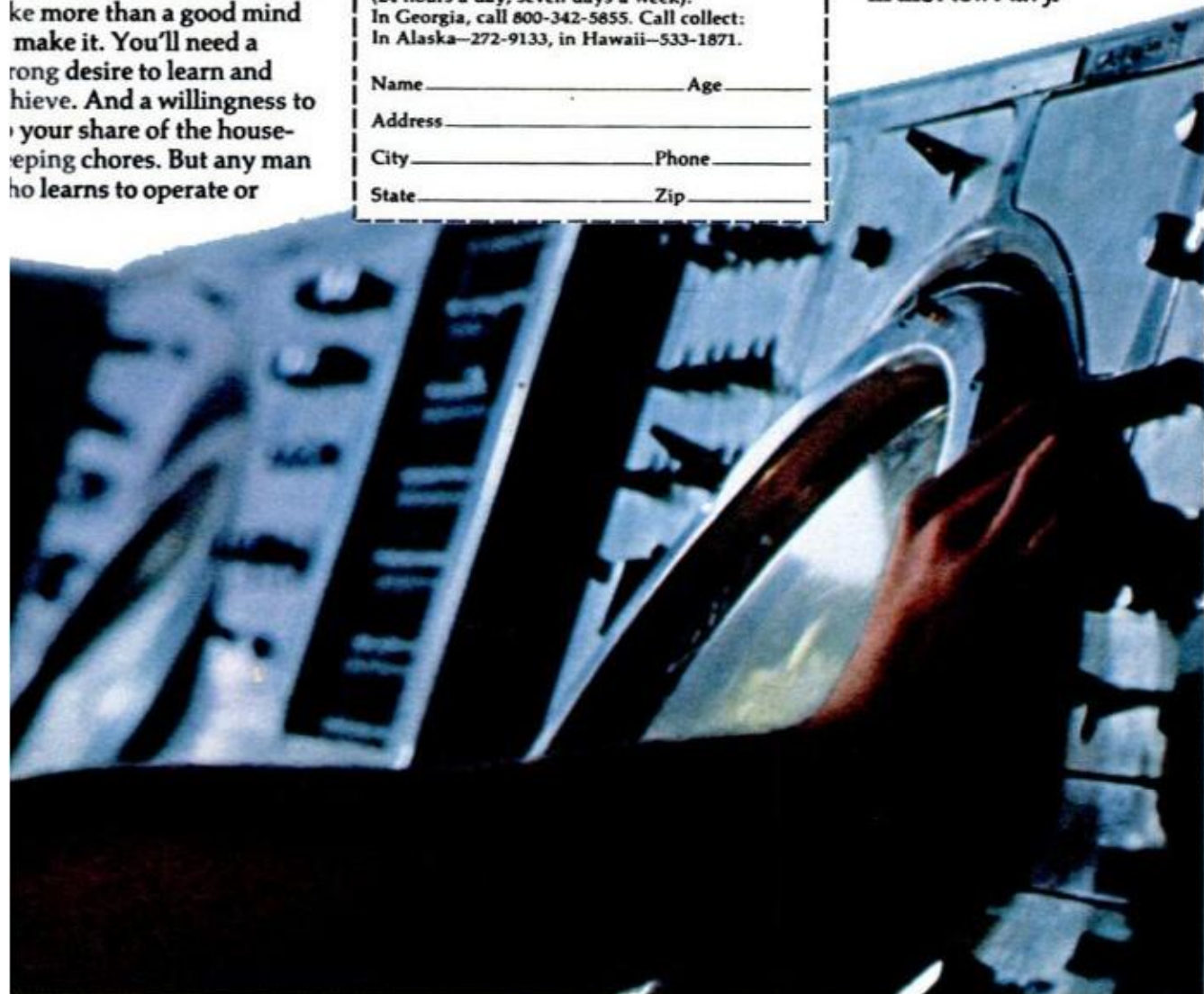



Photographed on Vancouver Island, British Columbia.



# Canada at its best.

Try the light, smooth whisky that's becoming America's favorite Canadian  
Imported Canadian Mist.

CANADIAN WHISKY—A BLEND, 80 OR 86.8 PROOF, BROWN-FORMAN DISTILLERS IMPORT COMPANY, N.Y., N.Y. © 1973



# A place to do your paperwork at home

Your choice of three novel, PM-designed desks that serve as mini offices.

## 1. THE WALL-HUGGER

**Folded, it takes only  
a foot of floor space.**

There are few families that don't need some little nook or corner for doing paperwork—a place for Dad to tackle the monthly bills and plan new projects, a kitchen organizer for Mom, a homework and hobby center for the kids. On these pages, PM presents three original ideas for home desks that are more than just desks. They range from simple to elegant, from small to spacious. Each offers a maximum of work and storage facilities in a minimum of space. Each is, in effect, a mini office in itself.

We call the three the "Wall-Hugger," the "Swing-Wing" and the "Split-Level." Each is designed to solve a particular problem or suit a special need. If you never thought you had space



PHOTOS BY ROBERT D. BORST

**Foldaway work center** hangs on adjustable wall brackets, is easily located at any desired height. In raised position (top), hinged desk provides roomy 36x39-in. surface—wide enough for two to work at together from opposite sides. When not in use, leg folds up and top swings down against wall, out of way (bottom).





Adding a bulletin board gives you place for messages, postcards, shopping lists. This one is made of cork squares, has space at left for clock and wall phone

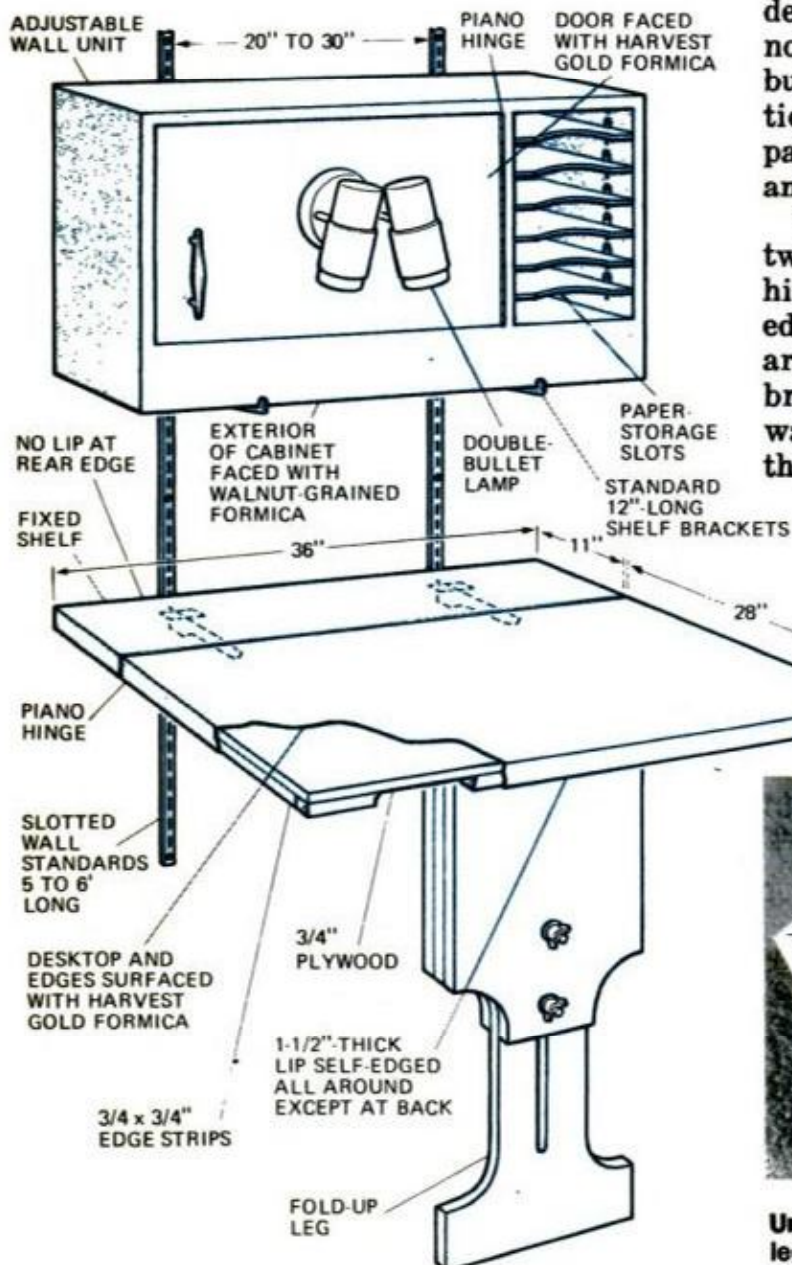

for such a unit, consider the possibilities shown here. Two of the three, the Wall-Hugger and Swing-Wing, take little floor space and fold away when not in use. The Wall-Hugger hangs on adjustable shelf brackets and features a drop-down desktop that stores neatly out of the way against the wall. The Swing-Wing sports two hinged extensions that open out to a 7-ft. width, revealing a desk, two-drawer file cabinet, retractable typewriter table and drawers for supplies. With the wings closed, it becomes a handsome, compact chest.

The Split-Level is a more elaborate classic design with rich, massive looks that would be the envy of many a company executive. It has a large main work surface at standard desk height, plus an L-shaped secretary return at a lower level for typing. While it requires more space than the other two units, it adds elegance as well as usefulness to a den or family room. All three designs are distinctive; they offer features not found in commercial units and can be built yourself for far less cost. Construction of the Wall-Hugger is shown on these pages. Details for building the Swing-Wing and Split-Level are in the next two articles.

The basic Wall-Hugger unit consists of two separate parts—a drop-down desk hinged to a wall shelf and a cabinet mounted above the desk. Both desk and cabinet are supported on ready-made metal shelf brackets of the type that hook into slotted wall standards. This makes it easy to adjust their height and enables them to be placed

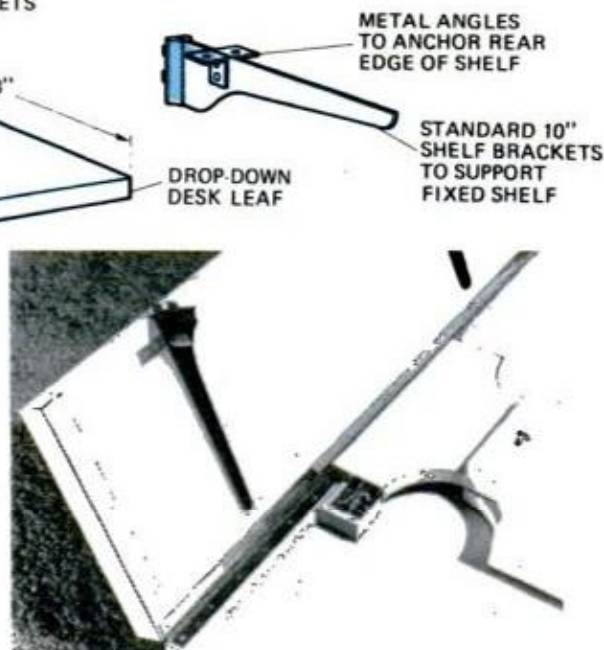

Underside view of desk shows how fold-up leg is locked closed by a small latch bolt.



virtually anywhere—in a kitchen as a menu-planning center, in a master bedroom as a hideaway home office or in a youngster's room for study and hobby activities.

In its raised position, the desk forms a spacious 36x39-in. work area—that's large enough for two persons to share from opposite sides. The cabinet above has open paper-storage slots at one end and space behind a door for a typewriter and other supplies. A double-bullet pinup lamp on the face of the door illuminates the desk, and a fluorescent fixture hidden in a recess under the cabinet provides additional down lighting to bath the wall dramatically below it.

The flexible wall-track system makes possible a number of variations on the basic arrangement. A bulletin board, as shown on the facing page, offers an attractive and useful accessory and can be attached to the wall standards with clips made from

*(Please turn to page 178)*

PETER TROJAN



Wall cabinet stores typewriter, other supplies (top photo). Lower photo shows recess in underside of cabinet for a fluorescent light controlled by main switch in outlet box.

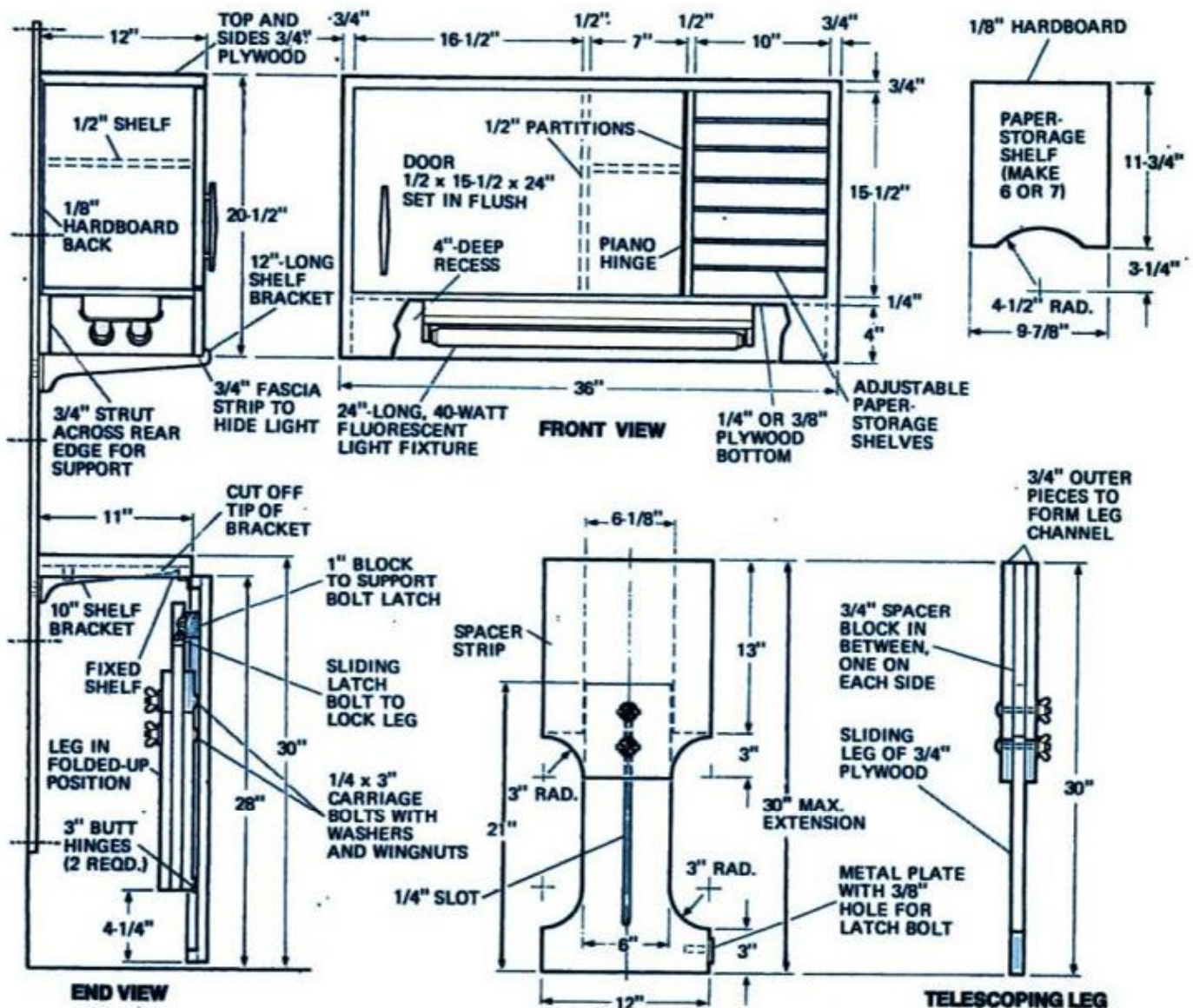



## 2. THE SWING-WING

# In-a-chest home office opens wide for business

Remember the old rolltop desk—how you could pull down the front and walk away without disturbing your work? You can do the same almost with this modern version which has wraparound wings that close like the twin doors on a refrigerator.

Posing as a king-size chest when closed, the desk features a swing-out shelf that provides a regulation-height typing stand. Two paper-storage compartments in the wings are within easy reach of your chair. A shallow under-the-desk drawer keeps pens, pencils, clips and the like extra



When wings are swung shut, office fits in a 29x43x48-in. chest. Swung open wide, wings provide spacious work center measuring a whopping 7½ ft.



Wings wrap around file cabinet on one side (see above), desk on other. Swing-ing typing-shelf parks under desk drawer when shelf is not used.





handy. Important papers can be stored safely and locked in a fireproof, steel filing cabinet. There's a shelf for a waste-basket and drawers galore for storing countless "office" supplies. A built-in fluorescent light provides glare-free illumination, and a mini spotlight makes typing a pleasure.

The unit is designed around a two-drawer, metal file cabinet and built largely from  $\frac{3}{4}$  in. plywood covered with handsome wood-grain plastic laminate.

File cabinets come in various sizes, but to obtain a regulation desk height of 30 in.

and a standard typing shelf of 26 in., you must select a cabinet that measures  $29\frac{1}{4}$  in. high. Width and depth are not so important; the cabinet shown measures 15 in. wide and  $27\frac{3}{4}$  in. deep.

The chest consists of three separate sections—a center section and two wings. The cutting schedule on page 182 shows how the 16 basic parts can be economically laid out on two 4x8-ft. sheets of  $\frac{3}{4}$ -in. plywood. Although it costs a bit more than common fir plywood, cabinet-grade, lumber-core plywood was used in the original. It is less

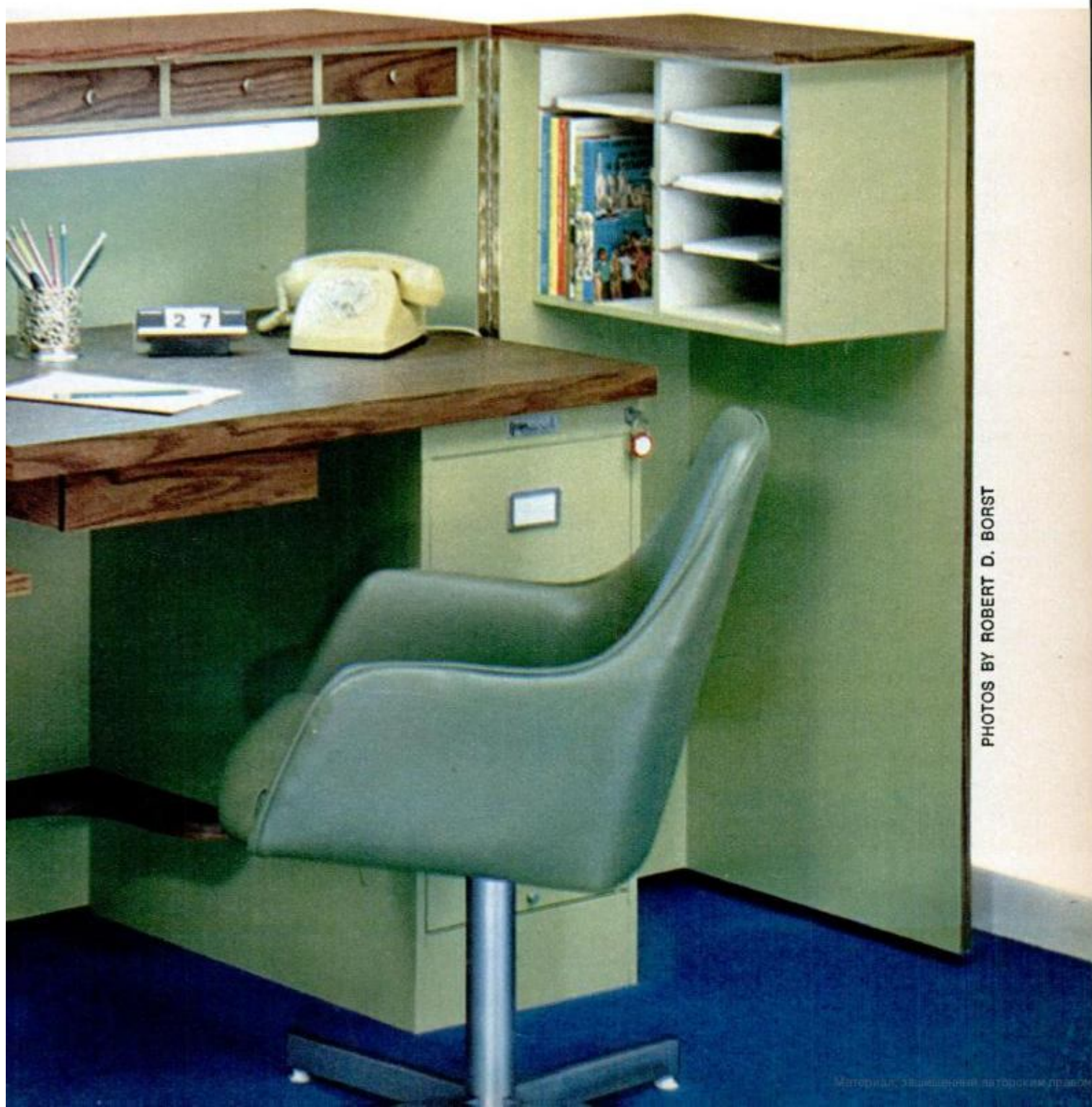

PHOTOS BY ROBERT D. BORST



## A lot of 'office' in less than 4 ft. of space

susceptible to warpage and has a smoother surface for painting.

Begin making the center section which includes parts E and F. Parts E are  $14\frac{5}{8}$  x  $47\frac{5}{8}$  in., part F is  $14\frac{5}{8}$  x 43 in. A  $\frac{3}{8}$  x  $\frac{3}{8}$ -in. rabbet is cut along the rear edges of all three parts, and a  $\frac{3}{8}$  x  $\frac{3}{4}$ -in. rabbet is cut across each end of part F. Glue and nail part F to parts E, then enclose the back with a  $\frac{3}{8}$ -in. plywood panel,  $42\frac{1}{4}$  x  $47\frac{5}{8}$  in. Glue two 2 x  $29\frac{1}{4}$ -in. strips of  $\frac{1}{8}$ -in. tempered hardboard vertically to the inside of part E (see top view, page 78) at points X, front and back. These will

bring the file cabinet flush with the right-hand side of the desktop and provide clearance for the right-hand wing.

Make the desktop and drawer next, as detailed on page 182. Remember that dimensions given accommodate a 15 x 28-in. file cabinet. Note that the top is  $\frac{3}{8}$  in. wider at the back than the front and that it's made double-thick except where it rests on top of the file cabinet. A  $\frac{3}{4}$  x 1 x 14-in. cleat is screwed to the inside of part E ( $29\frac{1}{4}$  in. high) to support the desktop along the left-hand edge. Holes are made in the

(Please turn to page 182)

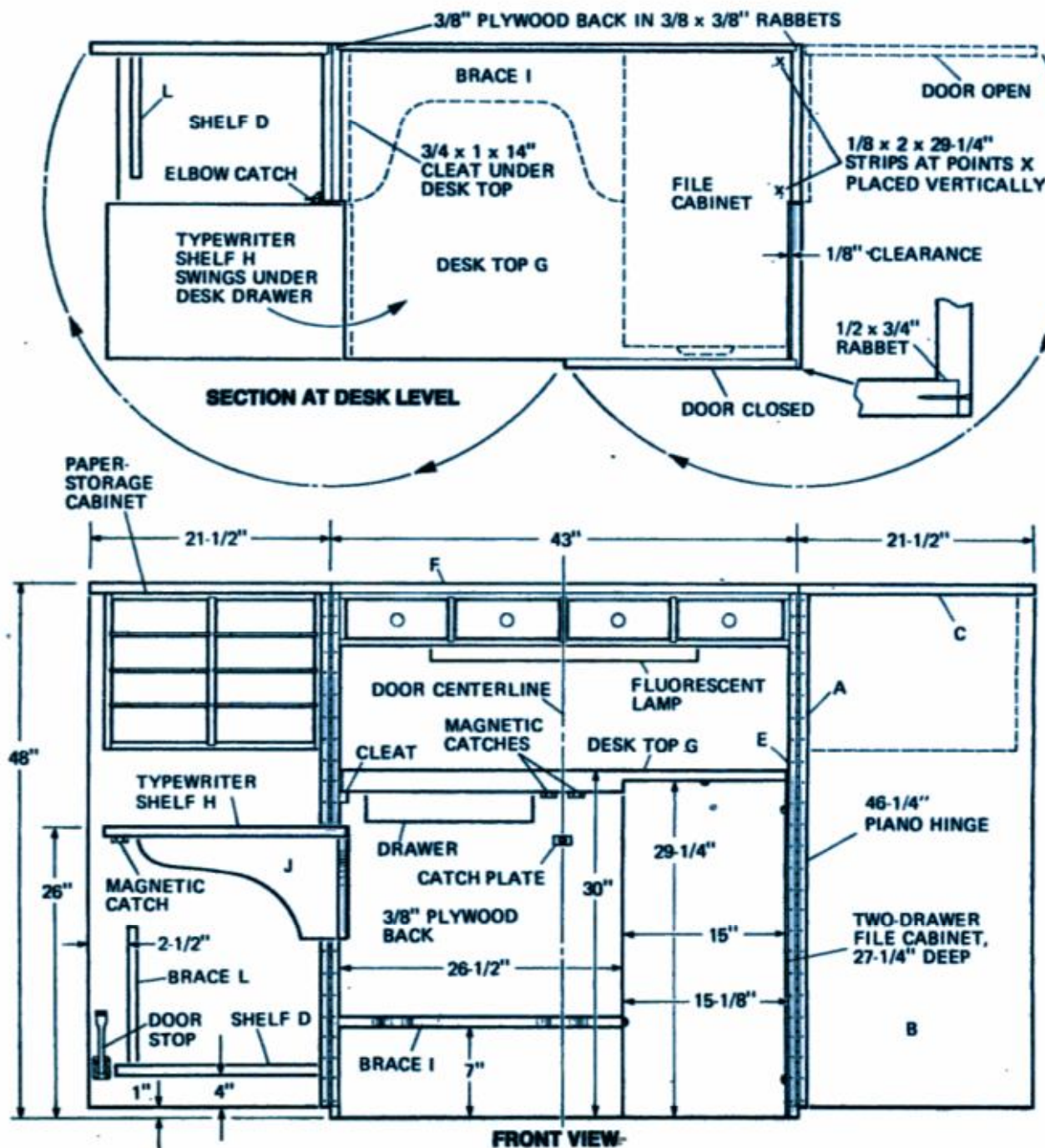



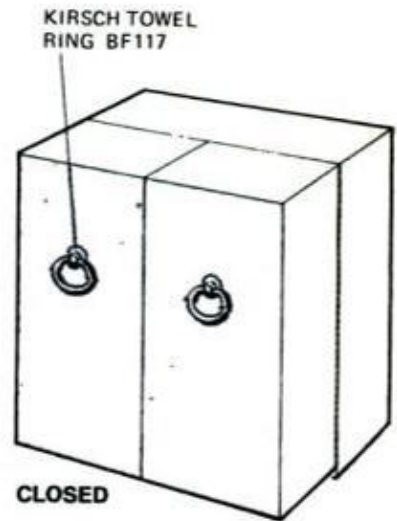
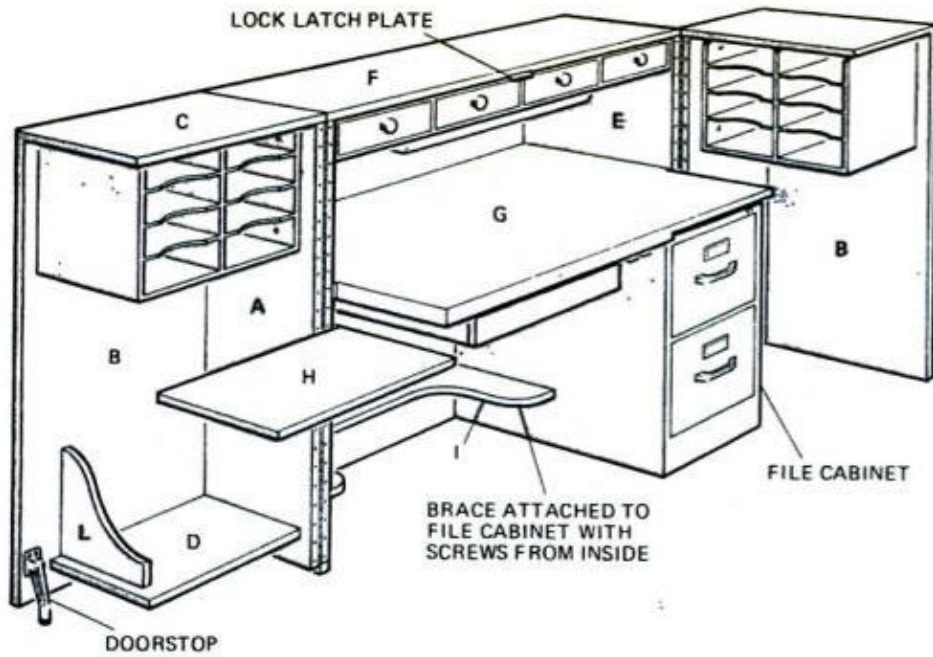

### FOUR-DRAWER COMPARTMENT

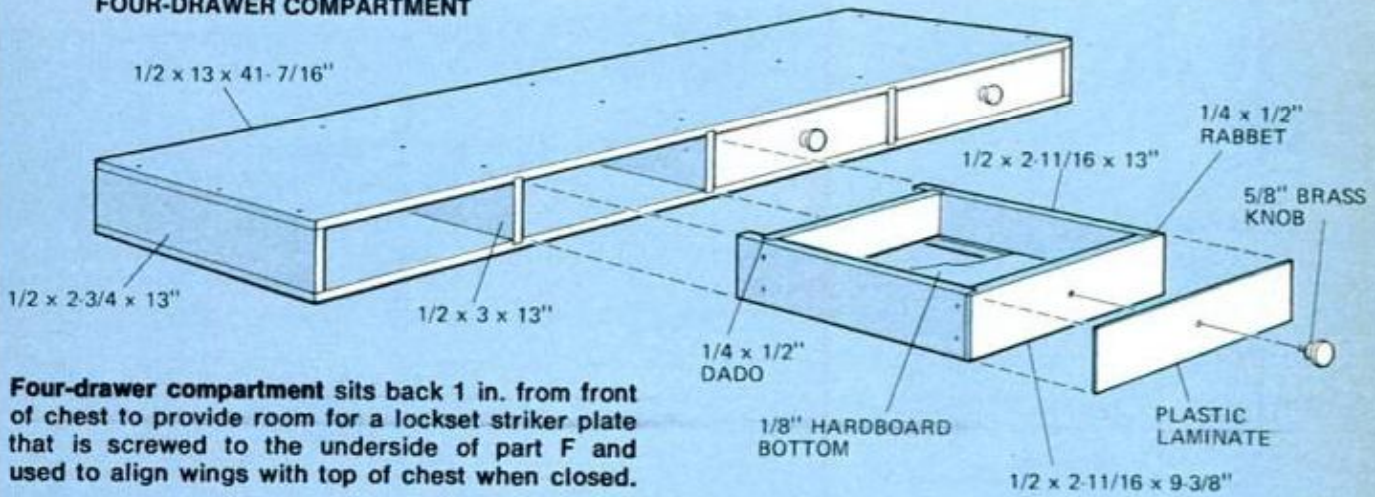

Four-drawer compartment sits back 1 in. from front of chest to provide room for a lockset striker plate that is screwed to the underside of part F and used to align wings with top of chest when closed.

### TYPEWRITER SHELF DETAILS

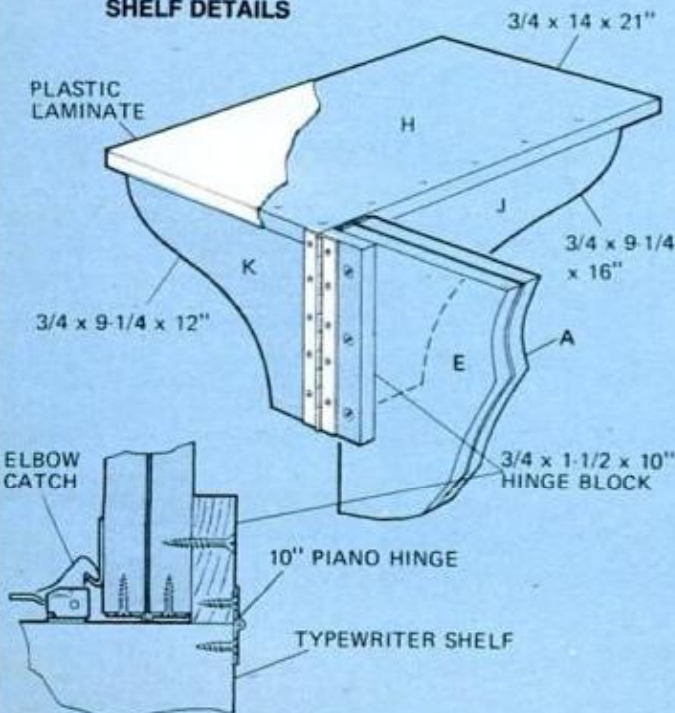

### PAPER-STORAGE COMPARTMENT

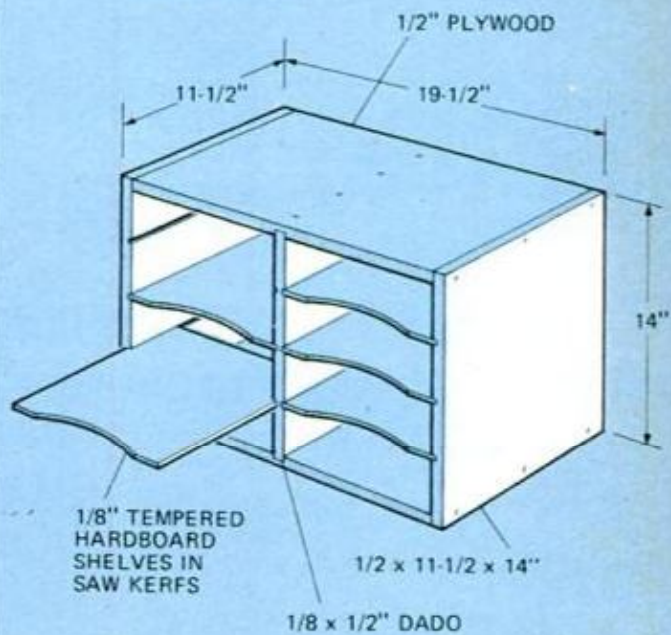



### 3. THE SPLIT-LEVEL

# A desk for the man who likes plenty of room

Here's a fun project intended to brighten the environment of a home office, whether you use it full time or just for extra work that you bring home from time to time. The clean and simple design is devoid of frills and gingerbread.

Because it is extra sturdy, with plywood doubled-up to obtain a 1½-in. thickness throughout, and entirely covered with plastic laminate, the desk is not "cheap." As shown on the facing page, it costs about \$325 to make, but similar-type units that





are offered commercially run \$600 and up.

You'll need six 4x8-ft. sheets of  $\frac{3}{4}$ -in. plywood plus four large sheets of Formica: two 4x8 ft., one 4x6 ft. and one 4x9 ft. Your local supplier may not stock them but can usually fill such an order in a week.

Be sure to lay out and mark all pieces of plywood for cutting; remember to allow ample waste for the saw-blade kerf. When laying out the Formica allow at least  $\frac{1}{8}$ -in. extra overall to provide an overhang when the laminate is applied to the plywood. If

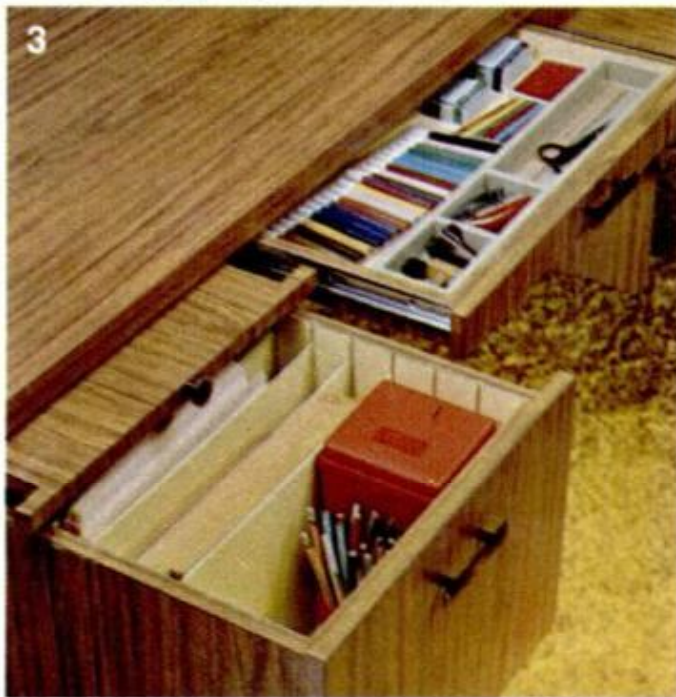

**1. Two-level desk** lets you spread out work without mess, features secretary return with top at right height from floor (26 in.) for typing.

**2. Drawer in secretary return** has hardboard slides that serve as paper-supply trays and compartment for pencil sharpener, office supplies.

**3. Deep drawer and pencil drawer** hold large supply of office materials. Extra kerfs cut in drawer sides let you shift dividers as need arises.

**4. As handsome from rear as from front,** desk has clean, contemporary styling to go with almost any decor. Formica surfaces minimize maintenance.

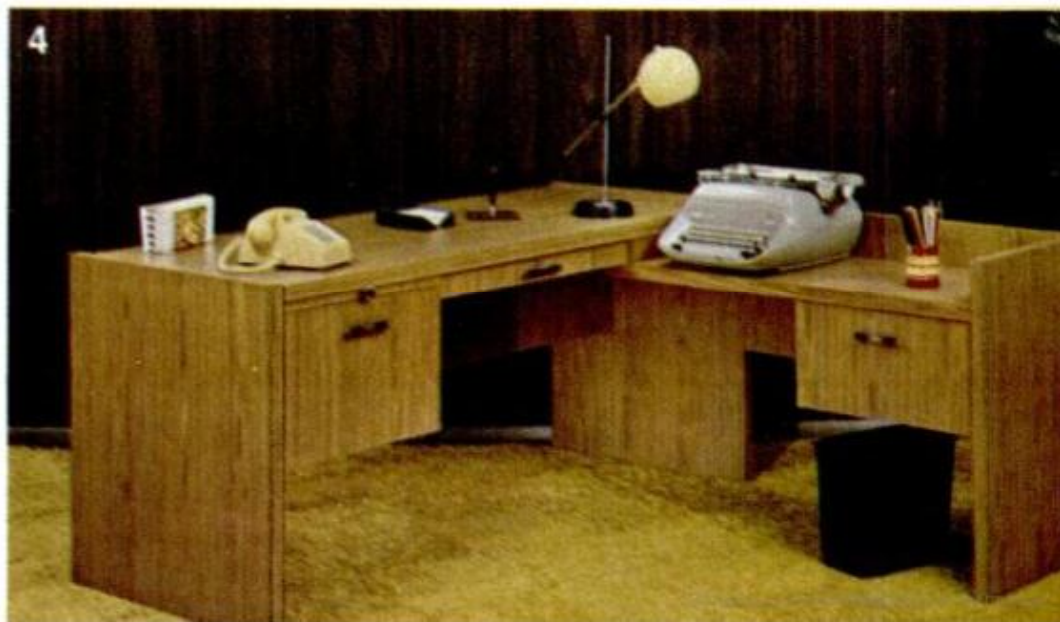



## Build the desk now—add the secretary return later

the laminate is to be cut on a table saw using a carbide blade, lay out the pieces to be cut on the good side. If you'll use a sabre saw that's equipped with a fine-tooth hacksaw blade, lay out the pieces on the back side and provide good support to prevent any chipped edges (from saw chatter and flopping laminate).

With all pieces cut and marked for identification, assemble the desk and return without glue to check for fit. If you're working alone, lay the setup on its back so you will have no trouble supporting the weight while you position and fasten the wells for the two deep drawers.

Next, the two units can be uprighted for temporarily joining the return to the desk. A simple method here is to use a handscrew

(clamp) on the end leg of the desk at desired height. The apron, or back, on the secretary return can be rested on this clamp while you make final measurements and fit the filler blocks and stop under the desk top. When you are satisfied with all fits, including the three drawers' sliding action, disassemble the piece.

Take time to think out the laminating steps and, in fact, consider jotting down the sequence so you won't run into trouble. (It may prevent a ruined piece of laminate.) Laminate all parts except those which must be left uncovered so that the desk and return can be permanently assembled.

To assemble the desk, again work with it lying on its back. Fasten the ends to the

(Please turn to page 176)

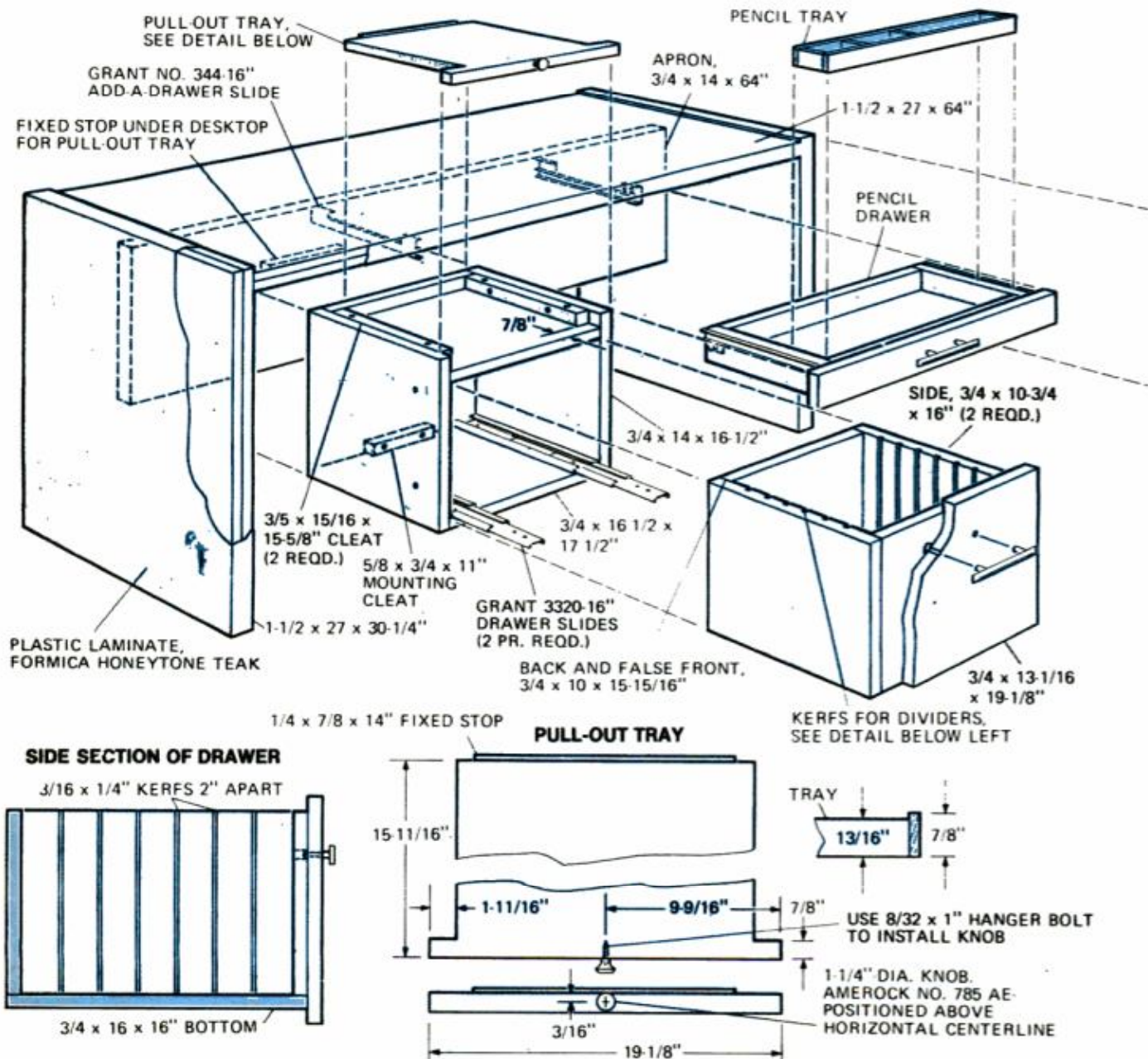



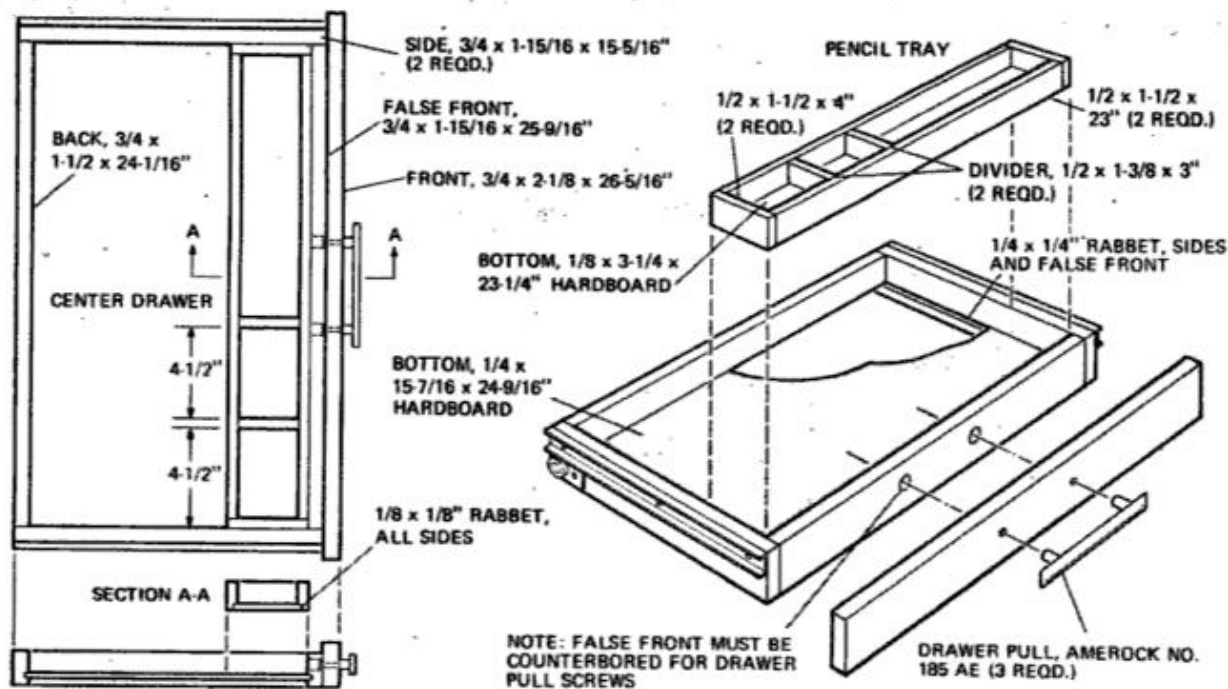

**Exploded view showing split-level desk assembly**

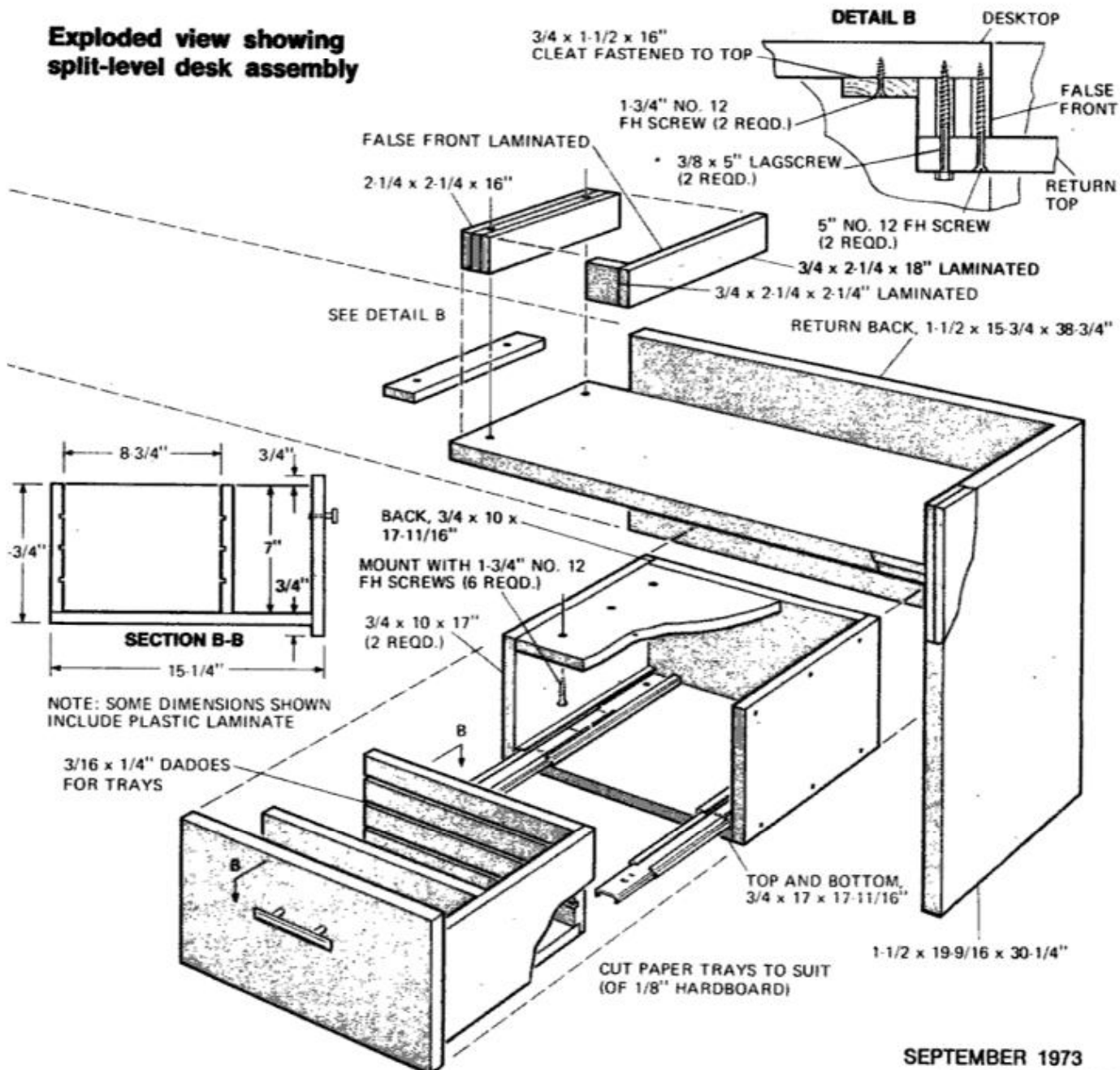



Typical electric water heater

# How to

DATA BY ED FRANZESE

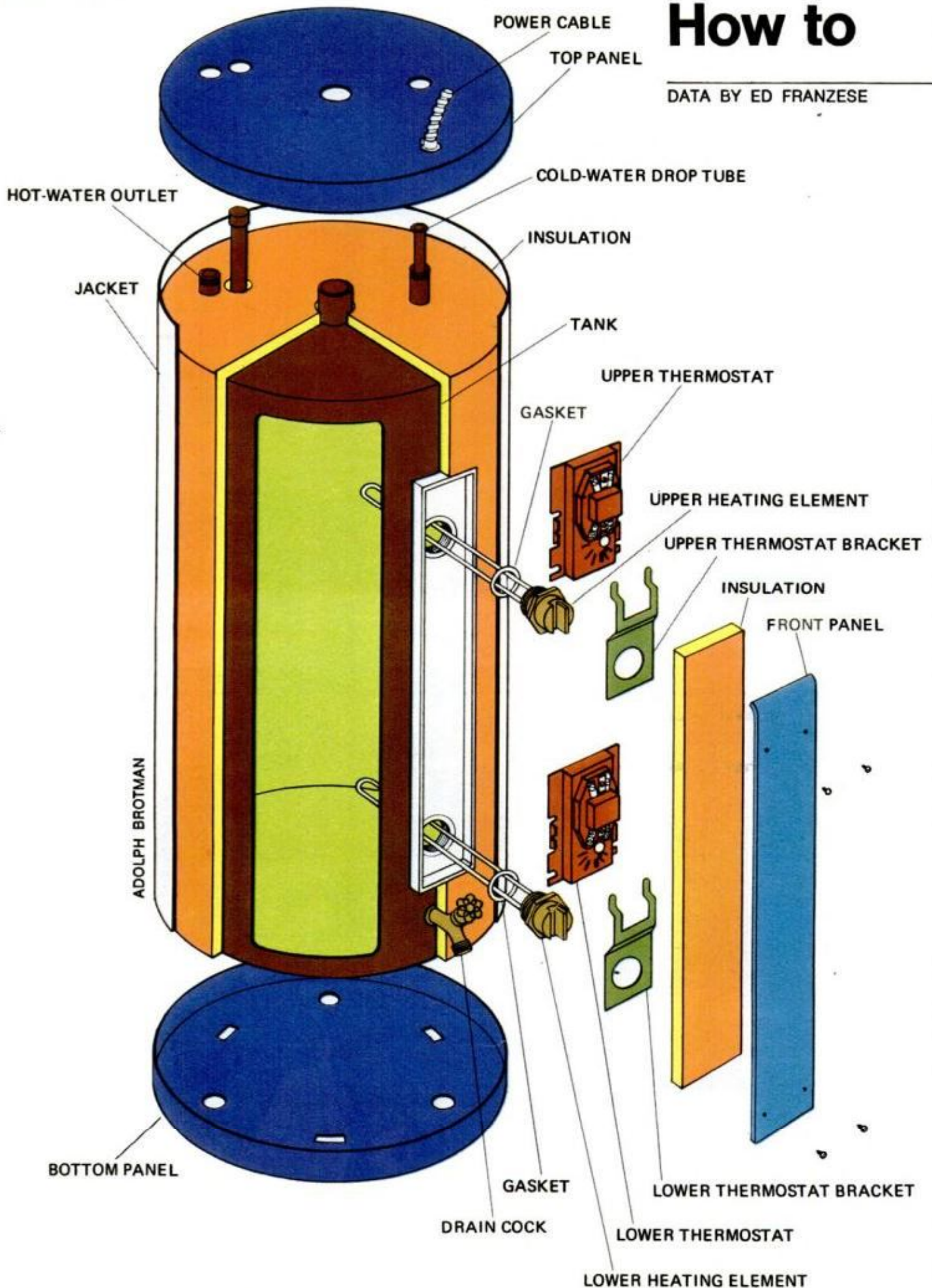



# Troubleshoot a water heater

If your water heater fails to perform satisfactorily, the fault may not lie within the heater at all. Leaking faucets or hot-water demands in excess of heater capacity may be the problem, or impure water may have damaged the heater and thus caused the trouble. The charts on the following pages will help you pinpoint and correct most common hot-water problems. The illustration at the left shows the major parts of a typical electric water heater and their locations. Other illustrations show components made by different manufacturers, and gas-heater details.

## Average monthly hot water requirements

FAMILY SIZE	CONSUMES PER MONTH
2	700 gallons
3	950 gallons
4	1200 gallons
5	1450 gallons
6	1700 gallons
7	1950 gallons

A water heater is basically a storage tank. Cold water enters through the top and goes to the bottom through a pipe called a drop or dip tube. The water is heated by either electric elements or a gas burner, rises to the top of the tank, and is discharged through the outlet pipe there. Thermostats are used to regulate the heat source in order to maintain a constant water temperature within the tank.

Hot-water requirements vary with different family sizes, locations, washing methods and the number of water-using appliances in the home. A tub bath generally requires 7 or 8 gal. of hot water, a quick shower 2 to 3 gal. A dishwasher will use 9 gal. for each load; washing dishes by hand will use from 2 to 7 gal. Figures in the chart at left are average. When replacing a faulty heater, estimate the tank size you need by dividing the number of gallons shown for the number of people in your family by 30. This gives your average daily hot-water requirement, which is also the

## Methods of heating water electrically

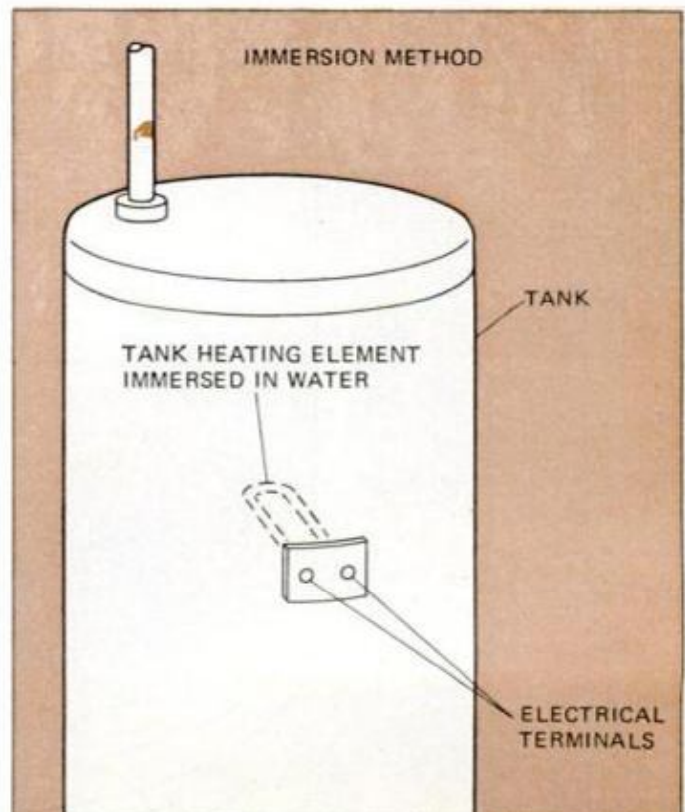
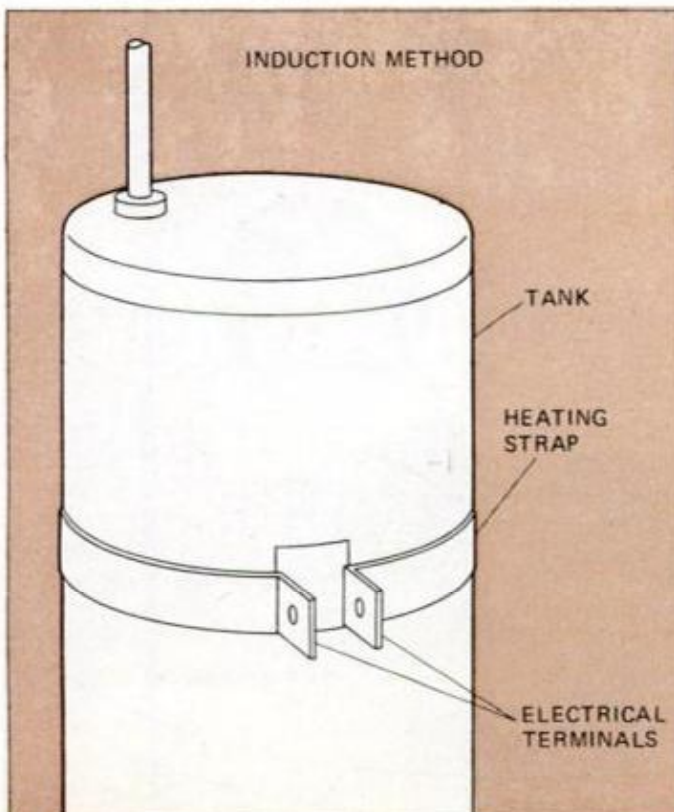



## No hot water

### IMMERSION HEATING ELEMENTS

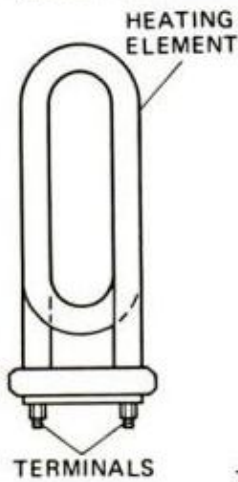
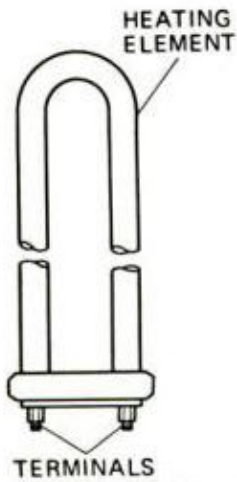
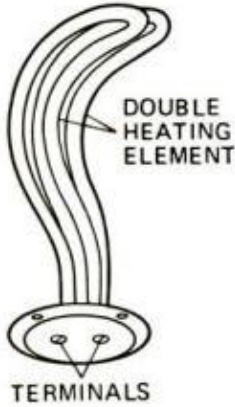

### POSSIBLE CAUSES

### WHAT TO TRY

1. Blown fuse.	Replace fuse. If new fuse blows, a short circuit exists in water heater. Disconnect power. Remove panel and make visual inspection of wiring. If wiring is good, call serviceman.
2. Heating element burned out.	Disconnect power. Place continuity tester across heating-element terminals. No reading indicates an open coil in element. Before replacing immersion-type element, close cold-water inlet valve and drain tank past element. Install new element. Refill tank, check for leaks and turn on power. On band heaters, loosen snap or bolt, slip band off tank and replace with new one. Retighten fasteners, replace insulation, turn on power.
3. Calcium buildup on heating element (immersion type).	Remove element. Use a vinegar-and-water solution to clean off all calcium deposits; then reinstall element.
4. Thermocouple defective (gas).	Clean pilot orifice. Turn thermostat valve to Pilot. Depress pilot button and light pilot. Hold button in for 30 to 40 seconds. If pilot fails to stay lit, replace thermocouple.
5. Thermostat defective (gas).	Turn thermostat valve to On position and temperature control to Hot position. Run hot water. If burner fails to light after two or three minutes, replace thermostat.

### Typical gas water-heater controls

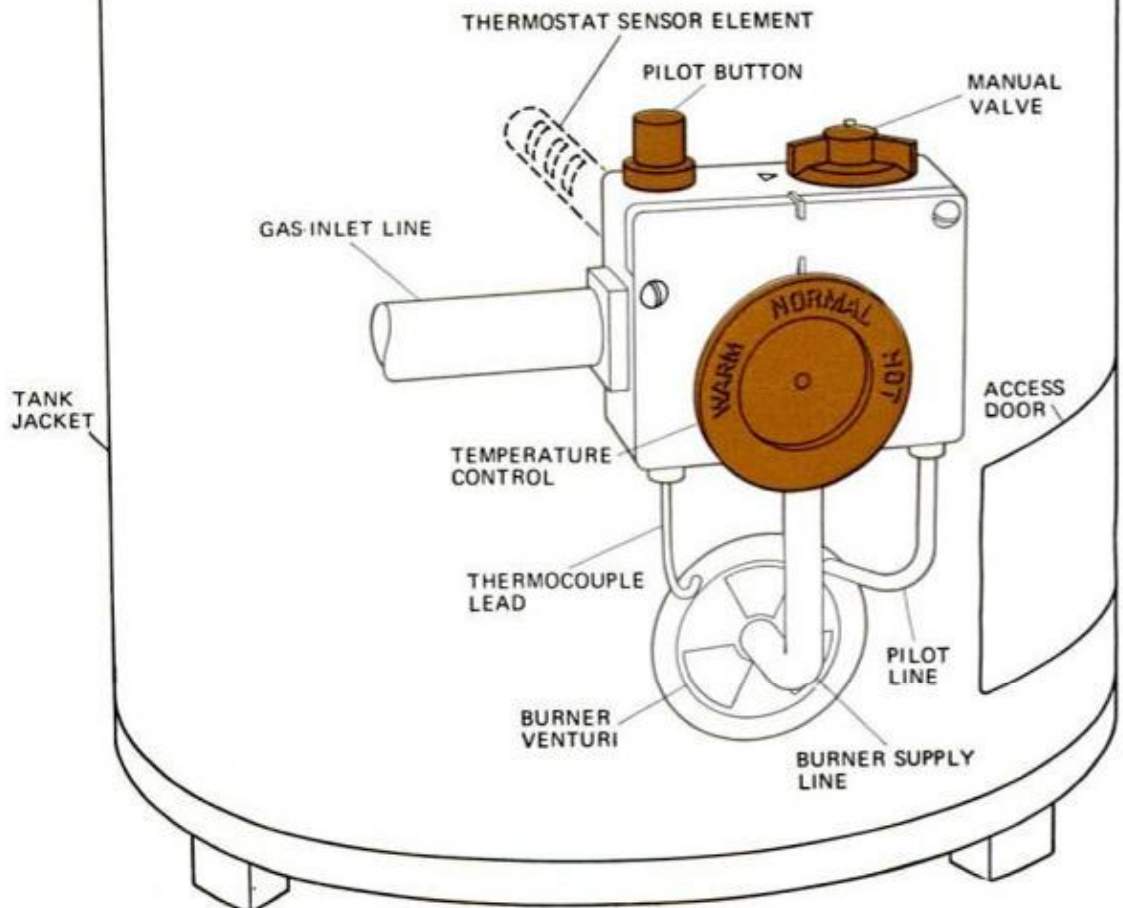



## Not enough hot water

POSSIBLE CAUSES	WHAT TO TRY
1. Thermostat setting too low.	Turn setting to Normal (140°-150° F.).
2. Lower heating element burned out (immersion type).	Turn off power. Check element with continuity tester. No reading indicates an open coil. Replace.
3. Undersized tank.	Check quantity of water used by family and appliances. See hot water requirements chart.

## Slow recovery between demands

POSSIBLE CAUSE	WHAT TO TRY
1. Top heating element burned out.	Turn off power. Check top heating element for continuity across terminals. If there is no reading, replace element.

## Steam in hot water

POSSIBLE CAUSES	WHAT TO TRY
1. Thermostat contacts burned (electric).	Look for shorted or burned terminals. Replace thermostat.
2. Thermostat set too high.	Lower setting to Normal (140°-150° F.).
3. Thermostat runaway (gas).	Check whether thermostat is cutting off main burner. If burner fails to go out when temperature control is turned to Low, replace thermostat.

tank size needed. To be on the safe side, allow a little extra capacity. For example, a family of five consumes 1450 gal. of hot water per month; 1450 divided by 30 is about 48 gal. A 50-gal. heater is indicated.

Recovery time is the time a water heater takes to replace hot water. A minimum recovery rate would be eight hours to heat a tankful of 50° F. water to 150° F. This would allow the heater to recover overnight, so a family could start the day with a new tankful of hot water. For practical reasons, most water heaters sold today have a much quicker recovery rate than eight hours.

Any hot water that goes to waste will, of course, leave less hot water available to use. A leaking faucet is one of the most common forms of water waste. A slow drip—about one drop per second—wastes about 200 gal. of water a month, 5 tankfuls in the case of a 40-gal. heater. A more serious leak, such as a smooth stream that runs about 3 in. before breaking up into droplets, wastes about 1000 gal. a month. Other factors in hot-water waste are the

amount of water standing in pipes and the number of running feet of pipe in the system; they should be taken into account when you plan any new water-heater installation.

There are two types of electric water heaters, induction and immersion. An induction heater has a heating element strapped around the outside of the tank and covered with insulation. Heat passes through the wall of the tank to the water. In an immersion heater, the heating elements (usually two) pass through the tank wall directly into the water, with flanges and gaskets to keep the tank watertight where the elements enter. Some common types of immersion elements are shown on page 86. The wattage rating of the elements and the size of the tank will determine the time required for water to reach the desired temperature (recovery time). A large tank, holding more water than a small one, will also naturally require more electricity to heat a tankful of water.

A typical two-element, electric water heater has a "load-limiting" circuit to keep

## THERMOSTATS

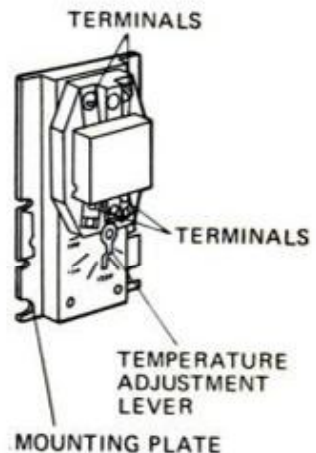
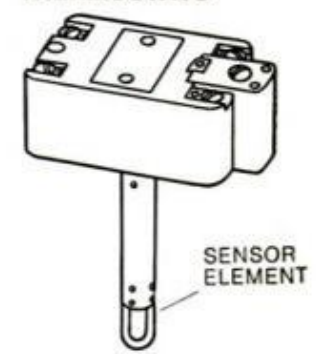



## High water-heating cost

POSSIBLE CAUSES	WHAT TO TRY
1. Leaking hot-water faucets.	Replace washers in all leaking faucets.
2. Thermostat setting too high.	Turn thermostat to Normal setting (140° to 150° F.).
3. Scale deposits appearing on heating elements.	Remove and clean elements. See "Not enough hot water," page 87.

## Water under heater

POSSIBLE CAUSES	WHAT TO TRY
1. Thermostat leaking.	Check flange and gasket around thermostat. Replace gasket if leaking.
2. Plumbing connections.	Check all sweated (soldered) connections in and around tank. If leaks are found, make any necessary repairs.
3. Condensation.	Check for moisture buildup in insulation if basement is cold or damp. Moisture resulting from condensation will not drip steadily as it would from a leak.
4. Leak (hole) in tank.	Use boiler plug for temporary repair if hole is accessible. Replace tank eventually.

## Water black or discolored at faucets

POSSIBLE CAUSE	WHAT TO TRY
1. Magnesium in water.	Magnesium rod in tank is probably corroded. Shut off power and water supply. Remove metal band or screws from top panel of water heater. Remove insulation and then remove head of magnesium rod with socket wrench. Replace with a new rod, using sealer or Permatex on threads. Reassemble, turn on water and power. Allow about 24 hours for the lines to clear.

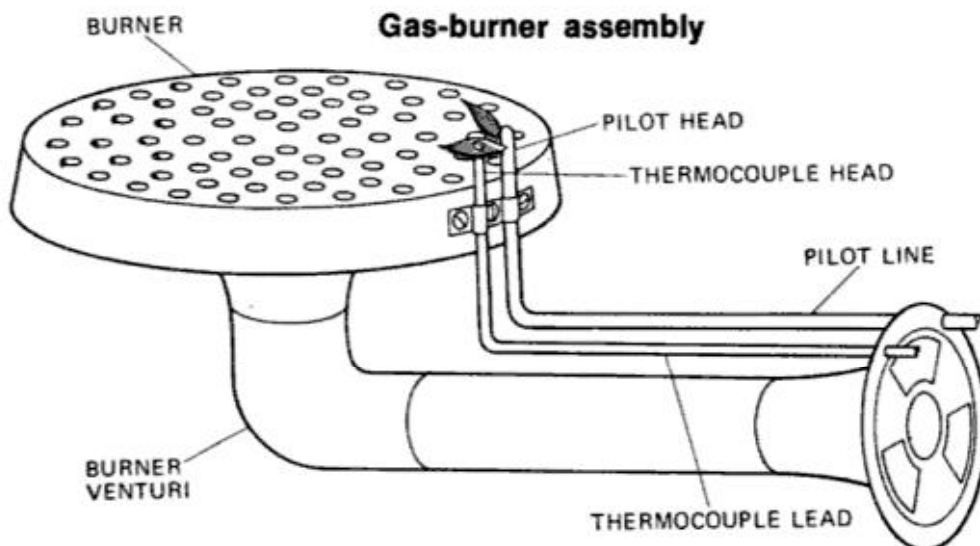



## Location of pressure-relief valve

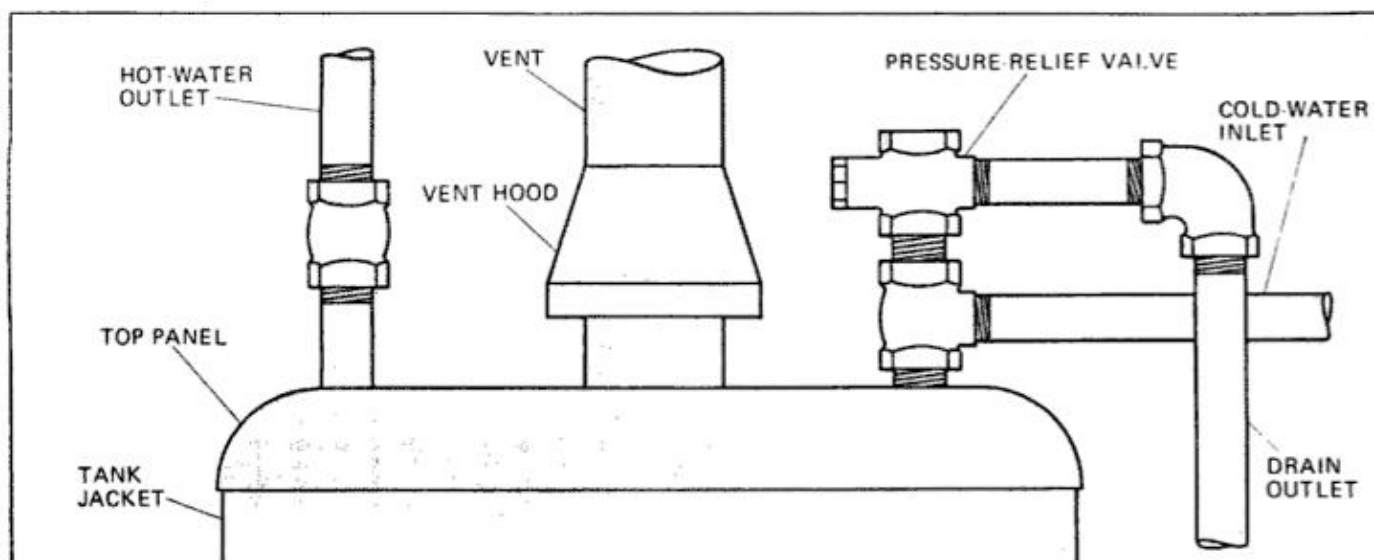

both elements from drawing current at the same time. It operates as follows: With a tankful of cold water, the upper (secondary) heating element is turned on by the upper thermostat. About 25 percent of the total volume of water in the tank is heated by this element. The lower (primary) element is turned on only when the upper thermostat has sensed that the water at the top of the tank has reached the desired temperature and is ready for use. The lower element now heats the remainder of the water in the tank. If some of the hot water is used, cold water entering the tank through the drop tube is heated by the lower element. When all the water in the tank has been heated, the lower element is turned off by its thermostat. In the load-limiting circuit, wiring is usually color-coded with a blue lead to the upper element, a yellow lead to the upper thermostat and then to the upper element's other terminal, a red lead to the upper thermostat and then to the lower element and a black lead to the lower thermostat and then to the lower element's other terminal.

Gas water heaters have a single immersion thermostat, located near the bottom of the heater, a burner and a thermocouple-governed pilot light. Heater controls are a temperature dial, a pilot reset button and a manual valve with OFF, PILOT and ON positions. A thermocouple screwed into the base of the thermostat is attached to the burner and enveloped by the pilot flame. Gas from the main line enters the thermostat at one side.

The gas water heater is lit as follows: The pilot button is depressed, the pilot light

is lit with a match or igniter, and the pilot button is held down for 30 to 45 seconds. The pilot flame striking the thermocouple head makes it generate a current that actuates a magnetic valve in the thermostat; this is a safety device that shuts off the supply of gas to the pilot light when it goes out. The pilot button is released and the manual valve is turned to the ON position. The burner is now lit by the pilot light.

If the burner does not light, turn the temperature dial to a higher setting, then return it to NORMAL. The thermostat maintains a constant water temperature by means of a bimetal or bellows regulating the supply of gas to the burner.

With both types of water heater, a pressure-relief valve is installed in the cold-water line just above the tank. This valve gives protection from pressure buildup in case of thermostat failure. Most of these valves are set 25 to 35 pounds per square inch above normal water pressure, to a maximum of 125 p.s.i. Valves may be spring-operated and resettable or replaceable lead plugs that melt at high temperature.

Normal hot-water temperature is 140-150° F. Most water heaters also have temperature settings for WARM, about 120° F., and HOT, about 160° F.

Because water often contains corrosive impurities, water-heater tanks are made of copper or glass. In addition, some heaters also have a magnesium-rod anode. Corrosive agents will attack the rod instead of the tank, but when the rod has become badly corroded, it will discolor hot water and must be replaced. ★★★



# How to fell, buck and limb a tree



## Study the tree first

The initial step is to closely examine the tree to determine which way it will fall. Although almost every tree leans in some direction, just how the tree will actually fall depends upon how you make the felling cuts. Even in relatively open country, the direction of the fall is important. There may be other trees in the area that you do not want damaged.

When working in close quarters, you are well advised to use a hefty guy rope tied near the top of the tree and a pulley. Have a helper put a strain on the rope to guide the falling tree. The pulley keeps him out of the path of fall.

Basically, there are three reasons why a homeowner has to take down a tree on his property: 1. Room is needed for an addition; 2. The tree has died and poses a safety threat with the first heavy windstorm that comes along, or 3. A dense cluster of trees requires some prudent thinning.

There are, of course, correct methods for felling, bucking and limbing trees that will make the job easier and—more important—safer. For example, when felling trees, one of the first rules to observe is to always *make gravity work for you*.

However, this often is not possible in crowded suburban areas. The tree is, just as likely, leaning toward your or a neighbor's house or garage. Here it is essential to cut the tree down in stages, using ropes to make certain that the tree limbs and trunk pieces will fall exactly where you want them to.

Felling a tree with a handsaw or ax is now a thing of the past. A gas or electric chain saw is the only way to go, but it must be used correctly. If you don't own a chain saw, it is well worth the few dollars it will cost to rent one.

*Planning pays off.* Before starting, take the time to study the wind's direction and velocity. These factors will have a direct bearing on how the tree will fall. *Don't ever attempt to bring down a tree in a heavy or gusty wind.*

Be sure you have a clear escape route. It should be at an angle of 45° in the opposite direction from the line of fall. Play it safe and clear away all potential obstacles along your escape route—tools, ropes and the like—before you start the felling operation.

Felling of large-diameter trees and trees in crowded suburban neighborhoods should never be attempted by an amateur. Unless you have full confidence that you can drop the tree where you want it, in the long run you'll save money and aggravation by calling in a professional to do these more difficult jobs.



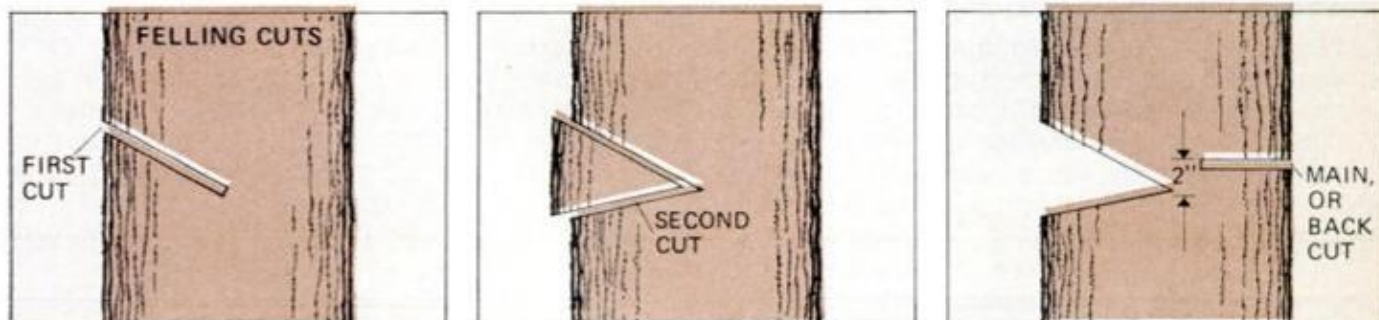

### Basic sawing techniques—notching and felling

Done properly, it takes three cuts to fell a tree: two passes to make the undercut (notch) and a back cut on the opposite side of the trunk. If you are a beginner, mark all three cuts waist high on the tree trunk with chalk. The notch should be cut in the sequence shown above to a depth of approximately one-third tree diameter, and perpendicular to the line of fall. After making the first two cuts, remove the wedge from the trunk.

Make the back cut at least 2 in. higher than the notch so as to leave a "hinge" of uncut wood to guide the tree over. *Do not cut through the notch.* Besides guiding the tree, the hinge will also prevent the tree from twisting as it falls. As the tree starts to fall, pull your saw free. Immediately turn off power and retreat quickly along your pre-planned escape route. From here on, gravity takes over.

### When to use a felling wedge

If you suspect the tree may not fall in the desired direction, or may tilt back causing the saw to bind, do not complete the back cut. Withdraw the saw and use wood, plastic or magnesium wedges to open the cut and tilt the tree in the desired direction of fall. *Caution: When using wedges, make certain the chain saw does not come into contact with wedge or the saw will kick back.* Felling wedges are available at most chain-saw dealers or you can cut your own of hardwood.

With the tree felled, you can now trim off the waist-high stump close to the ground, repeating the three-cut method mentioned above.

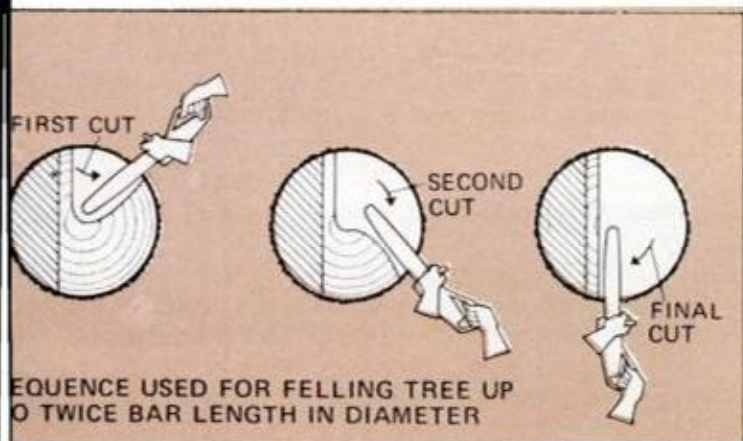
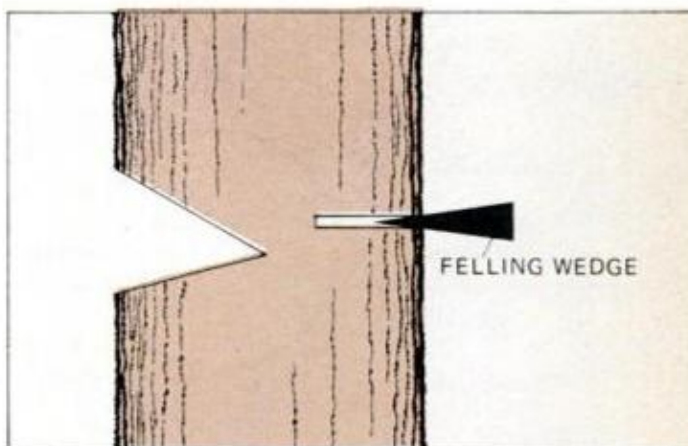

### Sawing sequence for large-diameter trunks

As a rule of thumb, large-diameter trees (up to twice the chain-saw-bar length in diameter) should be handled by a professional; cutting one down is not a job for a fledgling woodcutter. However, if you are confident of your tree-felling ability, and the tree is standing out in open terrain, you should always use felling wedges in the manner described above.

To fell a large tree, use a series of cuts as shown at left. Notice that the cuts are made so that the third and final cut leaves the hinge wood parallel to the notch cut. This is a must, so make the cuts with maximum care.



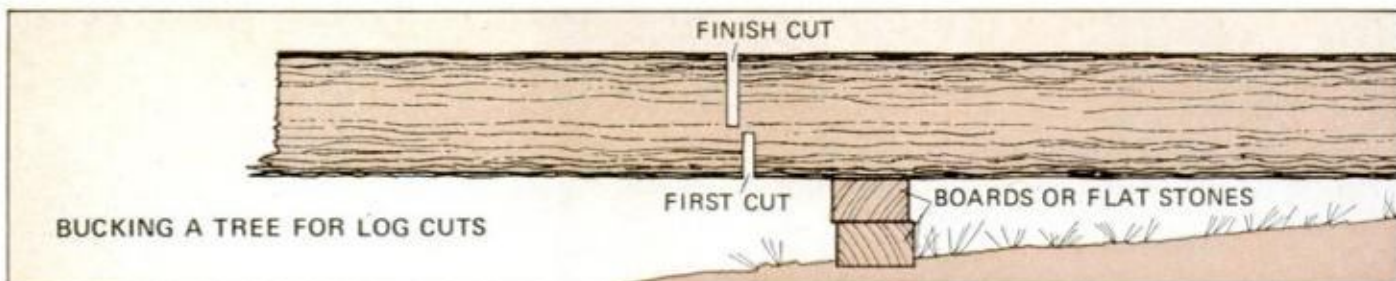

### Relieving stress is necessary to cut through logs

Once the tree is down, keep in mind that the wood is heavy and that it will bend and pinch the saw if improperly supported. (The trunk will weaken at the point where you make the cut unless the tree is lying on perfectly flat ground or supported as shown.) If you make the cut with the tree on the

ground, don't let the saw's chain dig into the earth; it is harmful for the saw, and you stand a good chance of being struck by flying debris. To cut the trunk, use the bucking and two-cut sequence shown. The first cut should be no deeper than one-third the trunk diameter.

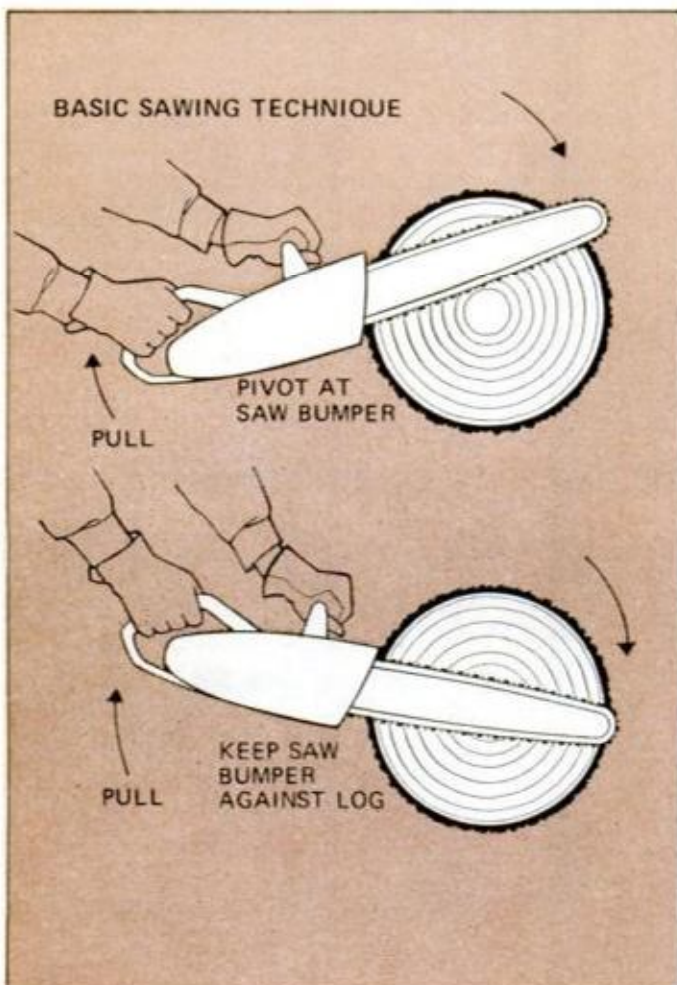

### Cutting up a small-diameter trunk

Most homeowners cut up a felled tree trunk for fireplace logs—usually about 24 in. long. When the trunk is of a diameter smaller than the saw's bar length, the cut can be made in one pass if the tree is supported properly as described above. If necessary, to avoid the cut closing on the bar, insert a wedge into the cut to hold it open and away from the bar. Start the cut with the saw's bumper snugged against the tree trunk and with the blade held at an angle. Holding the saw firmly, fully open the throttle and slowly lower the traveling chain into the wood. Keep the throttle full-open throughout the cut.

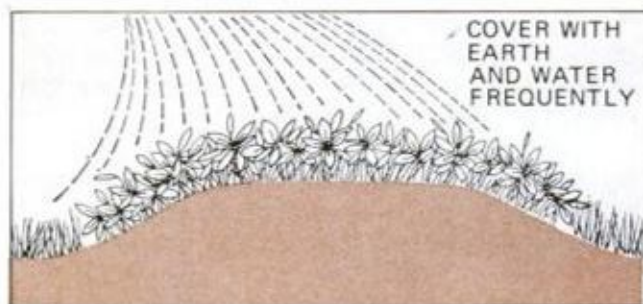
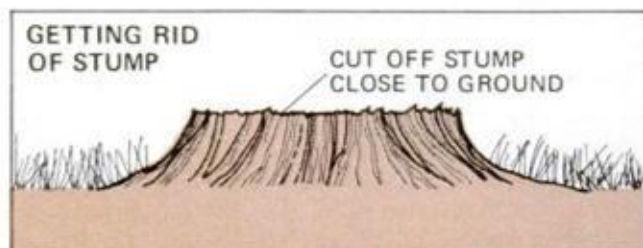

### Getting rid of the tree stump

The most popular method of getting rid of a tree stump is by burning. Present environmental conditions now make this not only undesirable but, in most areas, illegal. The alternatives?

1. Dig out by hand, cutting away sections of root as you go. If you must remove the stump immediately (to make way for a footing, for example), you are well advised to call in a professional nurseryman with his power equipment which will chip out a stump in a half hour or less.

2. The cheapest way to eliminate a stump is to simply bury it. Cut the stump off close to the ground and cover it with soil. To speed the rotting process, bore holes 6 in. deep before burying. For aesthetic reasons, cover the mound with ground-cover plantings. To speed the rotting process, water frequently.



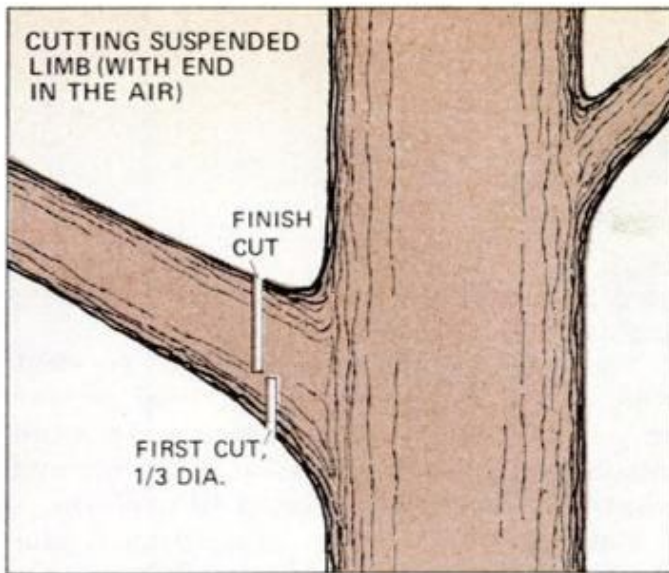

### Limbing a tree

There are two things to guard against when limbing a tree: First, the possibility that the cut branch will whip back in the direction of the woodcutter, and second, the impulse to work from an improperly positioned, thus unsafe, ladder.

To prevent the first, use the cutting sequence shown. To saw off a large limb supported only by the trunk, first cut one-third of the way through the limb on its underside. Make second cut through the limb from the top. Make certain you lash the ladder securely to the tree. Run a rope around the trunk a couple of times, then tie it securely to the top rung. Plant the ladder so that its feet are level and are placed a distance from the base of the tree that is equal to one-quarter of the vertical height.

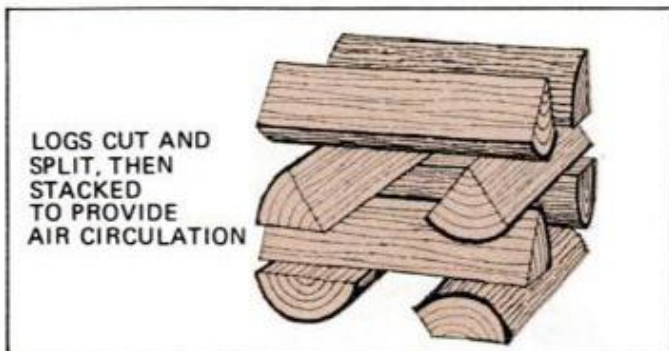

### Stacking fireplace logs

For use as firewood, the logs should be stacked and allowed to dry out before splitting. Splitting goes quickest if you use a steel splitting wedge and a sledge rather than an ax. And it's a lot safer.

A good method of storing firewood is shown above. Twelve or fourteen logs may be stored in this manner without danger of toppling over. If you are interested in knowing just how much fuel you have accumulated, one cord of wood equals 128 cu. ft. Assuming you've cut your logs into 24-in. lengths, it would take a pile 16 ft. long and 4 ft. high to equal this volume.

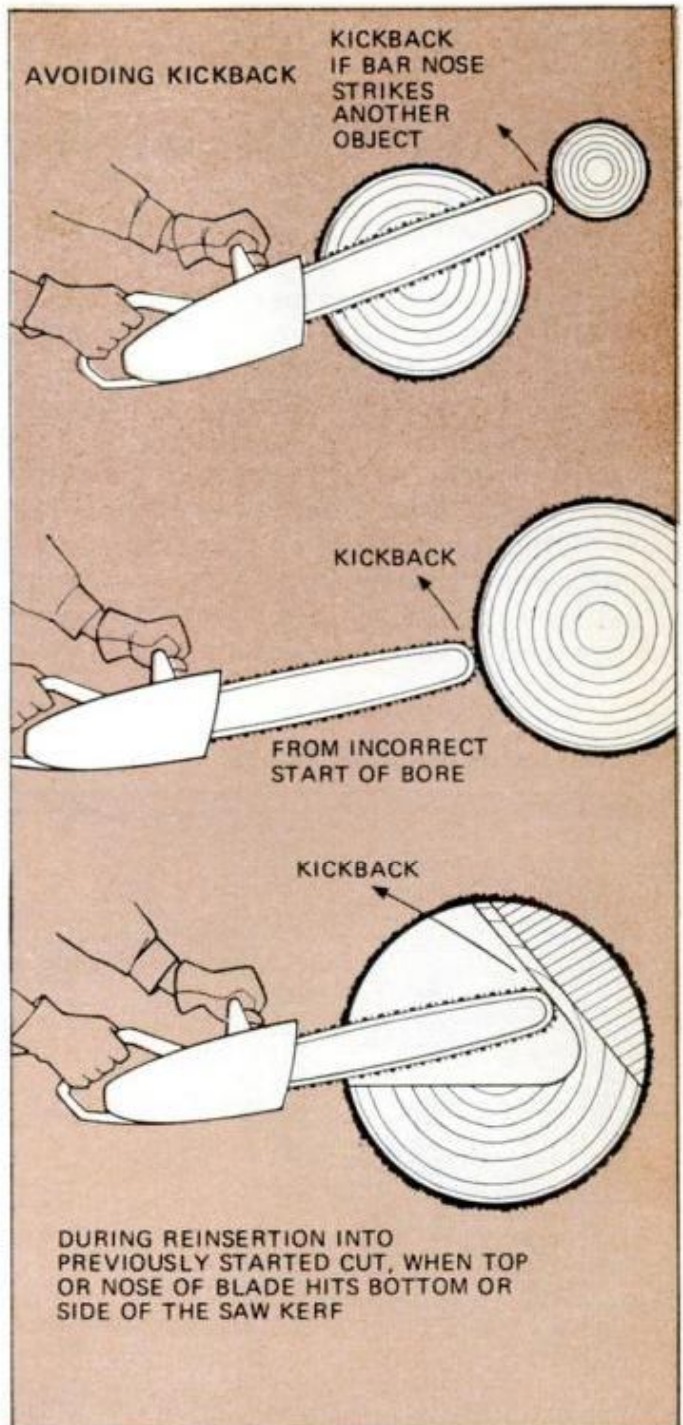

### Avoiding kickback

When cutting with the nose of the bar, take extra care to protect against chance of saw kickback. It will occur when any of the three conditions illustrated above exists.

Safety rules you should always observe:

1. Think the job out beforehand and stick to your plan.
2. Plan an escape route at 45° angle opposite the direction of tree fall.
3. Wear a hard hat if there is any chance of timber or branches falling from above.
4. Don't wear loose-fitting clothing. It could become caught in the chain saw or falling limbs. Always wear work gloves.
5. If your job collects a crowd, stop. Keep bystanders, especially children, clear of your cutting site and area of tree fall.
6. Work only with a sharp saw chain. ★★★



# How to close up your vacation home

DATA BY JOHN GAYNOR

With the end of summer fast approaching, now is the time to think about "battening down the hatches" at a vacation home which will be unattended during the winter months.

Many of the closing-down chores are things you've done year after year, and most of the items listed on these pages are simply common sense. But, if you make up a list and assign each member of your family specific tasks, the closing-down will

go a lot faster—without chance of missing any important items.

You can usually hire a local resident who, for a nominal fee, will keep an eye on your place during your absence. To avoid misunderstandings, agree upon his fee and what services he is expected to perform.

Finally, check your homeowner's insurance policy to see if any conditions must be met to assure your policy remains in full force during your absence.

## Grounds, dock and boat check

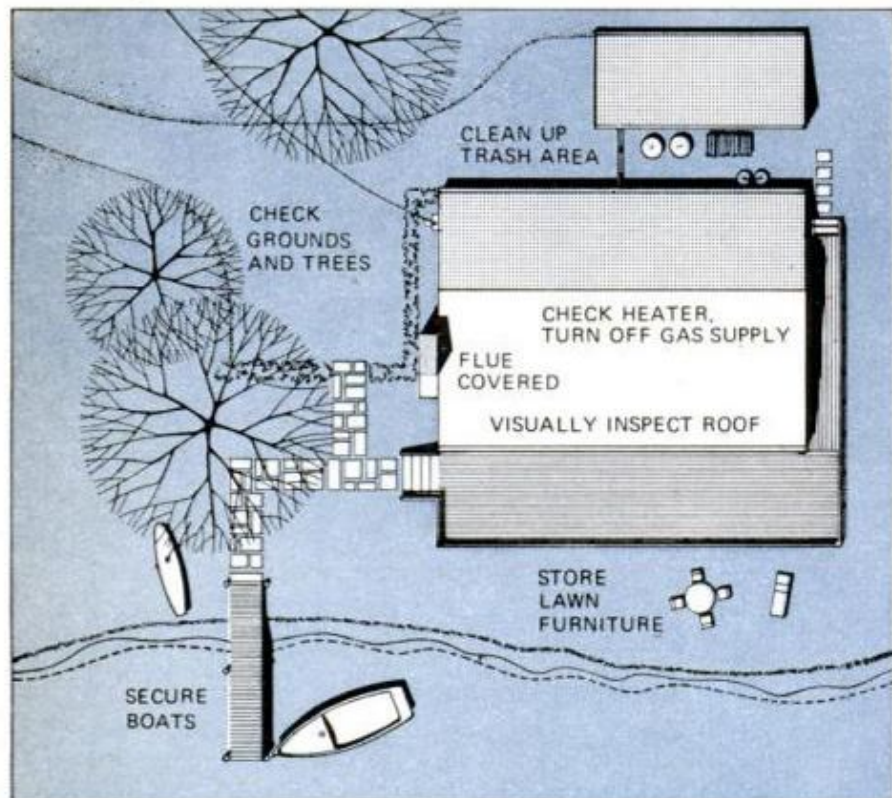

**Start with inspection** of house exterior and grounds. Look for, and remove, broken or dead tree limbs or trees which may be leaning dangerously toward your house. Your "check-list" tour should include the following:

1. Clean out gutters and leaders.
2. Repair any loose roof shingles.
3. Point up any loose chimney bricks.
4. Clear *all* accumulation from the crawl-space area.
5. See that garbage cans have properly fitting covers. Scrub the cans with disinfectant and soap and water. When dry, store them out of the weather. Throw out damaged and uncovered cans.
6. Keep out vermin by covering chimney flues with a galvanized sheet-metal cap, securely fastened. *Immediately, upon fastening flue cover, go inside and put a big sign on the fireplace to assure you uncover flues prior to use next season.*

If possible, your boat should be drydocked. This may be: 1) at the local marina, 2) at your year-round home after a trailer tow or 3) stored on your vacation-home property. Items 1 and 2 simplify your task considerably. If you elect to do your own storing, follow these simple guidelines: Pick an area near the house on the opposite side from prevailing winds. A small boat can be inverted and stored on sawhorses; just make certain it is lashed down securely with a stout cord. With boat stowed, check your dock, mooring lines and accessories for any loose gear which may be stored in and lashed to the boat. Larger boats can be stored on a trailer but provide maximum protection against weather damage and vandalism.

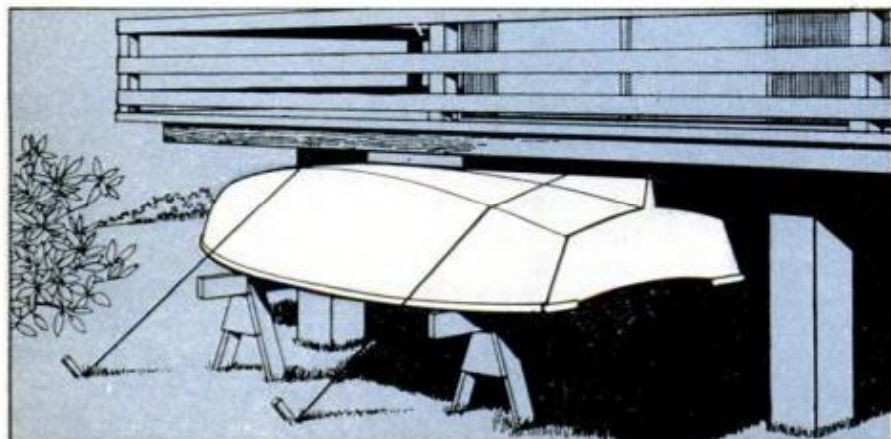



## There's work to be done inside too

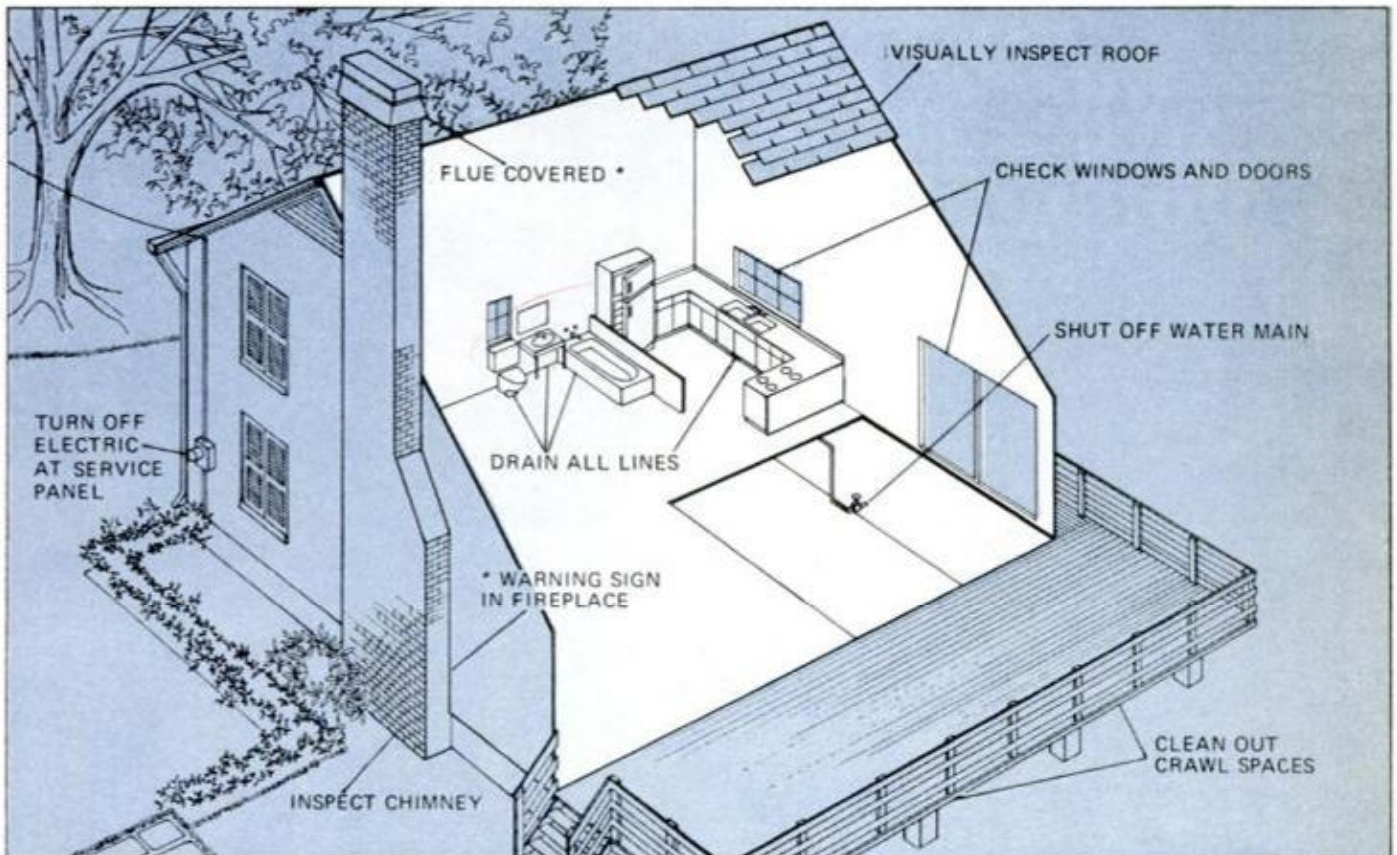

**Scatter a liberal number of mothballs** around the house, in each room. Mothballs will be easier to gather than flakes next spring. Also place mothballs between mattresses and springs. Since camphor evaporates when exposed to air, you may wish to have your "caretaker" replenish the supply every six weeks or so. *Do not set rodent traps.* Decomposition over the winter can cause an odor that will be difficult to eliminate. A strong camphor odor will deter most rodents from entering the house.

**Clean out all foodstuffs.** Food packed in cardboard containers (cereals, flour and the like) will attract rodents and other vermin. Foods packaged in cans and bottles may be subject to below-freezing temperatures and stand a good chance of exploding. At best, they will probably outlive their shelf lives if left behind. Your best bet is to remove all food from your vacation home before leaving. For economy, of course, bring home what you can. Add what you decide isn't worth packing to the pile of trash that is to be hauled to the dump.

Before locking the front door, make a final check to assure that all combustible materials—paints, solvents, cleaning fluids, matches and the like—are removed from the house. Turn the heater switch to off, shut off the gas supply at the main and pull the main electric fuse (or trip the breaker). Finally, check screens, windows and doors to make certain they are firmly secured.

**Shut off water-supply main and drain all water-supply lines.** Open valves on fixtures, drain fittings at their lowest points and leave valves open. A small amount of water may remain in the valves. To remove it, rig a section of hose to the pressure side (outlet) of your vacuum cleaner and blow out the fixtures. If your summer home is closed while the climate is still moderate, small amounts of water remaining in valves and lines left open will evaporate prior to freezing weather. Drain or siphon water from the toilet-bowl tank and remove the last bit with a sponge. Pour about a cup of permanent-type antifreeze in every trap. (Don't forget, the bathtub drain has a trap too.) Pour two cups of antifreeze in the toilet bowl. Water-pump and well-point systems vary depending upon the type installation. Here, it is best to have your plumber show you what to do the first-time around. Write down what he tells you for use next year. (You may have a foot-valve type point, a flexible submersible point, or other: "Breaking" the vacuum by needless loosening of fittings can shorten the life of the fitting.)

**Final points:** Make certain your washed-down refrigerator is propped open. Also, it is worth the few dollars more your caretaker will charge to have him clear the driveway after each snowfall. In the event that fire should break out while the house is closed, a clear access could spell the difference between minimal damage and total loss. ★★



# 'Combat cops' fight crime like commandos

by Frank Datnow

PHOTOS BY JAMES H. PICKERELL



Special combat-trained police (above) are organized into five-man teams. Each consists of a team leader equipped with a .223 AR-15 semiautomatic rifle, an observer packing an Armalite 180, a scout also with an Armalite, marksman carrying a .234 Remington with telescopic sight, rear guard or "back-up" man armed with a 12-gauge shotgun.

In simulated raid, paramilitary police take cover against a hidden sniper, looking more like infantrymen storming an enemy-held position than cops on city street. In actual "battle" conditions, men wear protective helmets just like field troops. Old movie sets like this one are often used for training exercises.



**E**quipped with high-powered rifles, flack vests, gas masks and other military-type field gear, a small band of men prepares to close in on a dangerous barricaded sniper. Except that their uniforms are of traditional police blue, they look more like combat troops than cops. Yet cops they are—a new breed of heavily armed, combat-trained crime fighters developed specifically to meet the rising tide of political terrorists, drug-crazed desperados and hardened killers now appearing on American streets.

The emergence of the so-called "urban guerrilla" has made such conventional police weapons as the billy club and .38 revolver as outmoded as bows and arrows against machine guns. As a result, law enforcement agencies all over the country are training special elite paramilitary police units to fight back-alley gunmen in the same way as an enemy in the jungle. One of the most highly rated of these is a branch of the Los Angeles Police Department known as Special Weapons and Tactics, or SWAT for short. SWAT headquarters is in a downtown Los Angeles "command post" from which its mobile units can be dispatched in minutes by radio to any part of the city as soon as an alarm call comes in indicating a crime situation that may be too serious or massive for local police to handle alone. This is when SWAT forces swing into instant action.

SWAT units are organized into five-man

teams, each with its own leader, usually of sergeant rank, equipped with a .223-cal. AR-15 semiautomatic rifle. His teammates consist of a "scout" equipped with an Armalite 180, a rifle of the same caliber as the AR-15 but with a folding stock, an "observer" also packing an Armalite 180, a "marksman" carrying a .234 Remington 700 with a high-power telescopic sight, and a "rear guard" toting a 12-gauge shotgun. They all carry sidearms as well. Like infantrymen, they wear flack vests, helmets, and web cartridge belts with canteens, ammo pouches, first-aid kits, tear-gas canisters, gas masks, signal lights and other gear.

Each team member has a specific job to do. The scout usually takes the "point," going in first to assess the situation before others are deployed. The marksman is the "long rifleman." From a rooftop or other distant vantage point, he can pick off a sniper hundreds of feet away—an impossible task for an ordinary policeman equipped only with his service revolver. The rear guard acts as a "back-up" man to protect the team against an attack from behind or to move in quickly if others need help. Last year alone, SWAT forces were called into action 46 times—on the average of nearly once a week to handle a major crime or potential riot. Their valor and effectiveness have proved the combat cop is America's new hope in the war on lawlessness. ★★ ★



Men in "ambushed" patrol car above learn how to fight their way out of such traps using their vehicle as cover for protection. Training program includes practice in handling all emergency situations that may arise. At left, team leader displays portable field case containing high-powered rifles, ammunition, tear-gas canisters, gas mask and other combat gear ready for use.



# Detroit promises clean-air '75s . . . but ups the sticker another \$300

by Robert Lund

The toughest jobs in Detroit today are held by four guys named Meyers, Heinen, Jensen and Starkman. They are the front-line generals leading Detroit's frantic search for hardware that must be developed if carmakers are to meet clean air standards the government has ordered for 1975-76.

The auto companies have more engineers and technicians working on the engine emissions problem than they've ever assembled for any single project in automotive history. If you count all the backup help—computer programmers, model builders, test drivers, clerks and all the rest—Detroit has a minimum of 25,000 people working full time on the cleanup.

How's it going? To find out, *PM* interviewed the executives in charge of antipollution activities at the four auto companies. Namely:

Gerald C. Meyers, Group Vice President-Product, American Motors Corp.

Charles M. Heinen, Executive Engineer-Materials Engineering, Chrysler Corp.

Donald A. Jensen, Director of Automotive Emissions, Ford Motor Co.

Ernest S. Starkman, Vice President in Charge of Environmental Activities, General Motors Corp.

In answering *PM's* questions, the auto executives did so on the basis of the best information available at the time they were interviewed. "But," the auto men cautioned, "if the government changes the rules or if there's a breakthrough in technology before you get in print, we'd change our answers to the questions."

Here are the questions and the industry's answers from Messrs. Meyers (AMC), Heinen (Chrysler), Jensen (Ford) and Starkman (GM):

*On the basis of what you know now, can you meet the emission standards for 1975?*

AMC: Yes.

Chrysler: We have every intention.

Ford: We don't know and won't know until final procedures for 1975 certification are established. We understand the procedures may not be finalized for several months.

GM: GM's been able to meet the emissions limits of the EPA interim standards with experimental systems operating under controlled conditions in our laboratories and proving grounds. But we don't know and won't know whether our vehicles with these systems comply with all requirements of the Clean Air Act for emissions at preproduc-

tion certification, off the production line, and after extended customer service until we have further development and field-testing experience, and until we know all test procedures that will be used by EPA to determine compliance.

*Can you meet the standards for 1976?*

AMC: No, we can't.

Chrysler: We've been saying we don't know how to meet them and we still don't.

Ford: We know of no way of meeting the '76 standards.

GM: The same factors apply here as for the 1975 interim limits. At this time, we don't know of any proven technology for





AMC's Meyers



Chrysler's Heinen



Ford's Jensen



GM's Starkman

meeting the stringent 1976 limits for oxides of nitrogen in mass production vehicles. We agree with EPA's indication to Congress that these limits are unnecessarily strict and should be eased, and we hope Congress will act accordingly. But as of now they are in the law, and we must continue our engineering to find a feasible way to meet them.

*Are you committed to use of catalytic converters to meet the 1975-76 standards? If so, what do you estimate the cost will be to car buyers?*

AMC: We'll use catalytic converters. The cost to car buyers will be \$300-plus.

Chrysler: We're committed to the oxidation catalyst where it's absolutely necessary. But we don't believe the oxidation catalyst is currently in a state of development where it should be installed on cars. As you know, Chrysler is challenging the standards and we don't feel the standards are immutable. They may be changed. They should be changed. What will the catalyst cost? The oxidation catalyst alone will run plus-\$150.

Ford: At this time, catalytic converters offer the only opportunity for approaching the 1975-76 standards across our full range of production. There's not enough time to tool up for other systems, even if they were available. We estimate a '75 car with catalysts will cost about \$300 more than a '73.

GM: We believe our catalytic systems are the best choice of available alternatives for reducing emissions on most full-size cars, and we expect they will be necessary to meet the interim 1975 limits for cars sold in California. The interim 1975 limits for the rest of the country are so stringent we may find it necessary to use them nationwide on a variety of our cars. But we don't yet know

how many or which models. We're continuing to make preparations for manufacture and installation of converters on 1975 models, including commitments to suppliers, and we're continuing development work on catalysts and system components.

We don't know at this point what the cost will be to the car buyer. It will depend on the specific emission-control equipment used on our various models and results of further development. We've said retail prices of cars equipped with systems we are now developing to meet all requirements of the law for 1975 and 1976 could be increased by \$275 over today's prices.

*What comes after the catalytic converter?*

AMC: We don't know what comes next.

Chrysler: Without knowing what the standards will be, we don't know. The logical thing would be to get away from a hang-on and try to do the job in the engine.

Ford: We'll continue our efforts to develop new internal-combustion engine designs and alternate power sources. But we have no way of knowing now what might turn out to be viable.

GM: What will prove feasible in future development, from emissions and all other considerations, we don't know at this time. Today, our catalytic systems are showing promising results, in terms of emission-conversion efficiency and catalyst durability, also in fuel economy and driveability. We believe the catalyst's ability to clean up

---

**As PM went to press, GM announced a breakthrough in design of a platinum and palladium-coated, ceramic-bead catalyst that promises to last the "life of the car."**

---



pollutants not consumed in the engine, and thus insure low emissions despite engine variables, will make it the most consistent performer in customer service of any choice available to us now.

*Are you looking at alternate technologies, something better and beyond the catalytic converter? If so, what?*

AMC: We're looking at everything and anything anyone suggests.

Chrysler: We've been looking at alternate technologies a long time. We had a Wankel program before any of the other companies. We looked at the Honda-type engine something like 12 years ago. We've even looked at steam and electric cars. But our big emphasis has been on the turbine. We discontinued that work almost completely because of the oxides of nitrogen standard. Now that's changed—or looks like it's changed—so we're going gung-ho on the turbine again.

Ford: We've been looking at alternate power sources for some time—the PROCO (programmed combustion) engine, the Stirling, the Wankel, the Rankine cycle engine, the gas turbine and battery-powered motors.

GM: We are working comprehensively on many alternate technologies and we have been for many years—including Stirling cycle, gas turbine, battery and hybrid-powered vehicles, and modifications of the present engine, such as use of stratified charge and the rotary engine.

*Honda, Daimler Benz and Toyo Kogyo say they have engines now that will meet the 1975 standards without catalytic converters.*

### **Detroit fiddles while Honda burns—clean**

To meet 1975 emissions standards, Honda modified its engine instead of hanging on expensive catalytic converters. The stratified charge engine, which Honda calls compound vortex controlled combustion (CVCC), is used in Honda Civic. Detroit has been aware of stratified charge for years, but questions its application to larger engines for heavier cars. In the Honda engine an ohc drives three valves: two intake and one exhaust. A rich fuel/air mixture enters a small precombustion chamber, and a lean mixture the conventional combustion chamber. On compression stroke the rich mixture is packed in the precombustion chamber. This more volatile charge is ignited and the flame front travels down exploding the lean mixture which couldn't be ignited by a sparkplug alone.

—B.H.

*Why not use one or more of these engines or approaches to solve the problem?*

AMC: There's no time left to develop these ideas to 1975 requirements.

Chrysler: If they've got the answers, more power to them. Unfortunately, none you mentioned could meet the 1976 standard as originally written. They couldn't meet the NO<sub>x</sub> standard. But forgetting that obstacle, even if we'd completed design work on one of those engines, there would be no possibility of putting it in across the board for another 5 to 10 years. If we changed engines, the turbine is by far the most attractive.

Ford: EPA looked at some of their reported tests and made a judgment they probably could meet 1975 requirements. But they haven't said they could meet the legal requirements for 1976. There's no way we could tool up to produce such systems for 1975, then scrap the engines for 1976. The machine-tool industry told EPA it would take 12 years to retool the domestic auto industry.

GM: These engines have shown capability of meeting emission limits in controlled tests of individual cars, but they still must be proven out in mass production and normal service experience. Even if this were already accomplished successfully, there's no longer sufficient lead time to produce them for a significant portion of our 1975 or 1976 models.

*How will you use the extra year you've been given to solve the emissions problem?*

AMC: We'll use it to meet the new requirements and look for alternatives.

Chrysler: We'll use it to try to develop

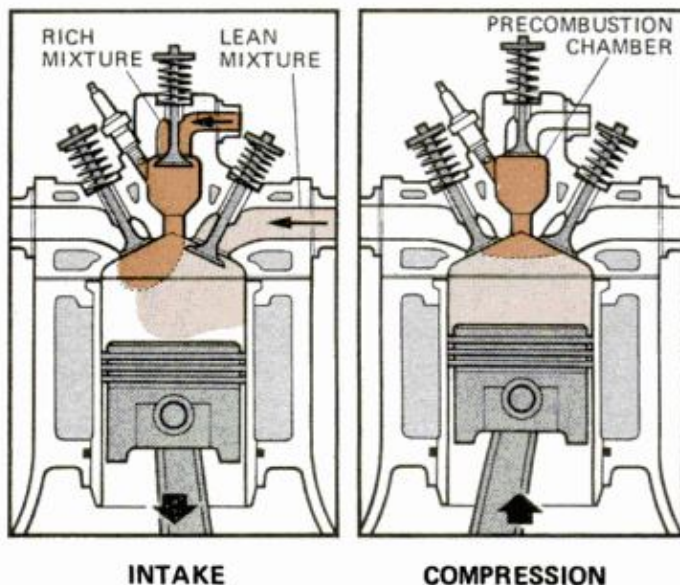



a catalyst that'll stand up better and to work on alternate engines. But don't discount the internal combustion engine. If they get realistic with the standards, we think the piston-type internal-combustion engine can meet the requirements. We can still do a lot with the present engine, including reactors, electronics, altitude compensators, new types of carburetion.

Ford: We need more time. But we'll use the year to continue our all-out efforts to improve and prove out catalyst technology and to develop new concepts in design of our internal combustion engines and to work on alternate power sources.

GM: Instead of the year's deferment of the 1975 standards which we'd requested, EPA established interim standards so stringent that they could well require the use of catalysts and other advanced control equipment on a wide variety of our 1975 cars nationally. To meet EPA requirements, we must begin certification tests for our 1975 cars later this year. As for 1976 cars, the very stringent standards have not yet been modified or deferred. So virtually no additional time for development and engineering has been given us by the EPA order.

*The National Academy of Sciences has criticized Detroit for concentrating on the least desirable system of controlling emissions. How do you respond to that?*

AMC: The Academy has perfect hindsight and ignores the time limitations imposed on the industry to meet 1975 requirements.

Chrysler: I'd burn out your tape recorder if I responded appropriately. The Academy

is blessed with 20-20 hindsight. We said a year ago the catalyst wasn't the way to go. But EPA said the only way a company could show a good-faith effort was to get ready to put on catalytic converters. We argued against catalysts more vociferously than any other company. We said the standards were incorrect and a third have proven incorrect. I think the remaining two-thirds will eventually be deemed incorrect. We've insisted all along that the logical way to go is to improve the internal combustion engine on a low-cost basis along lines we know how to develop and are working to develop.

Ford: We don't agree with the Academy. We submitted more than 1700 pages of technical data to EPA to support our position

#### NEXT MONTH:

**The '74 cars are here. Should you trade in? Hang on? Or cop out? PM auto editors in New York, Detroit and California report on how they are getting along with their cars.**

on the advisability of catalyst technology. The Academy has yet to produce one piece of data to support its position.

GM: Although the NAS concluded that technology is available to meet the original 1975 standards, it noted many qualifications and expressed concern over the timetable. It concurred with our position that, for some time, the only hope for meeting the requirements in 1975 has been to concentrate on developing catalytic converter systems for the conventional piston-type gasoline engine. ★★★

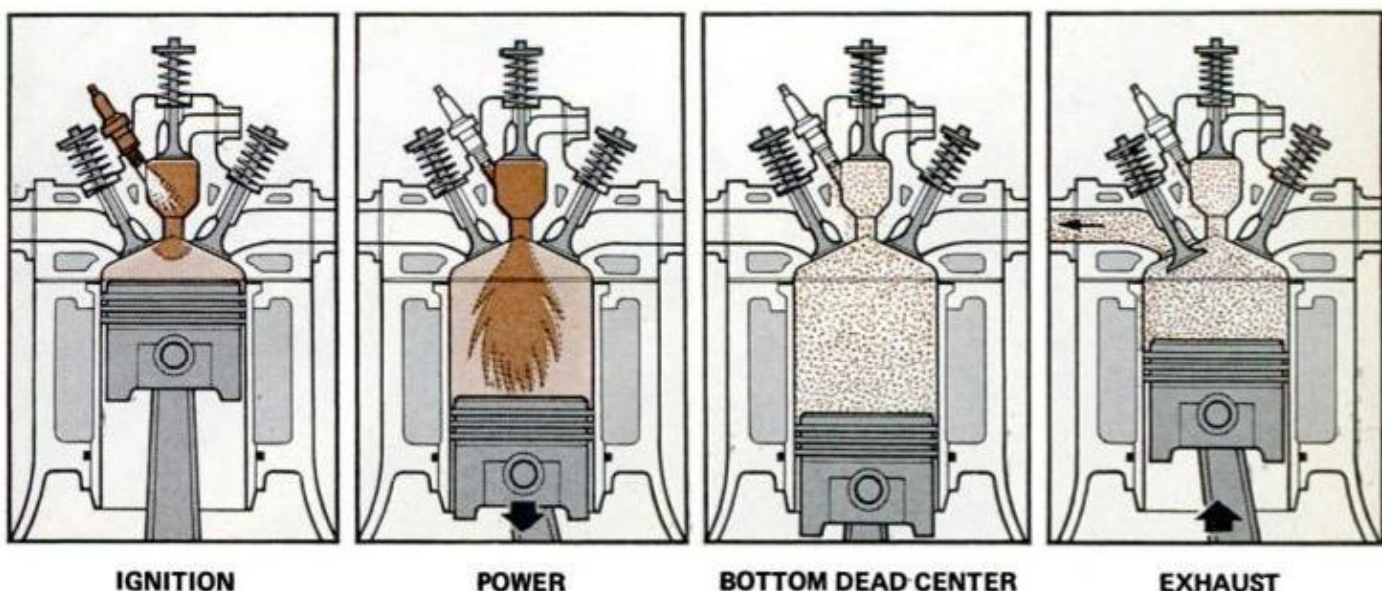



# Modern biplane in the classic style

by Sheldon M. Gallager  
and Howard Levy

PHOTOS BY HOWARD LEVY

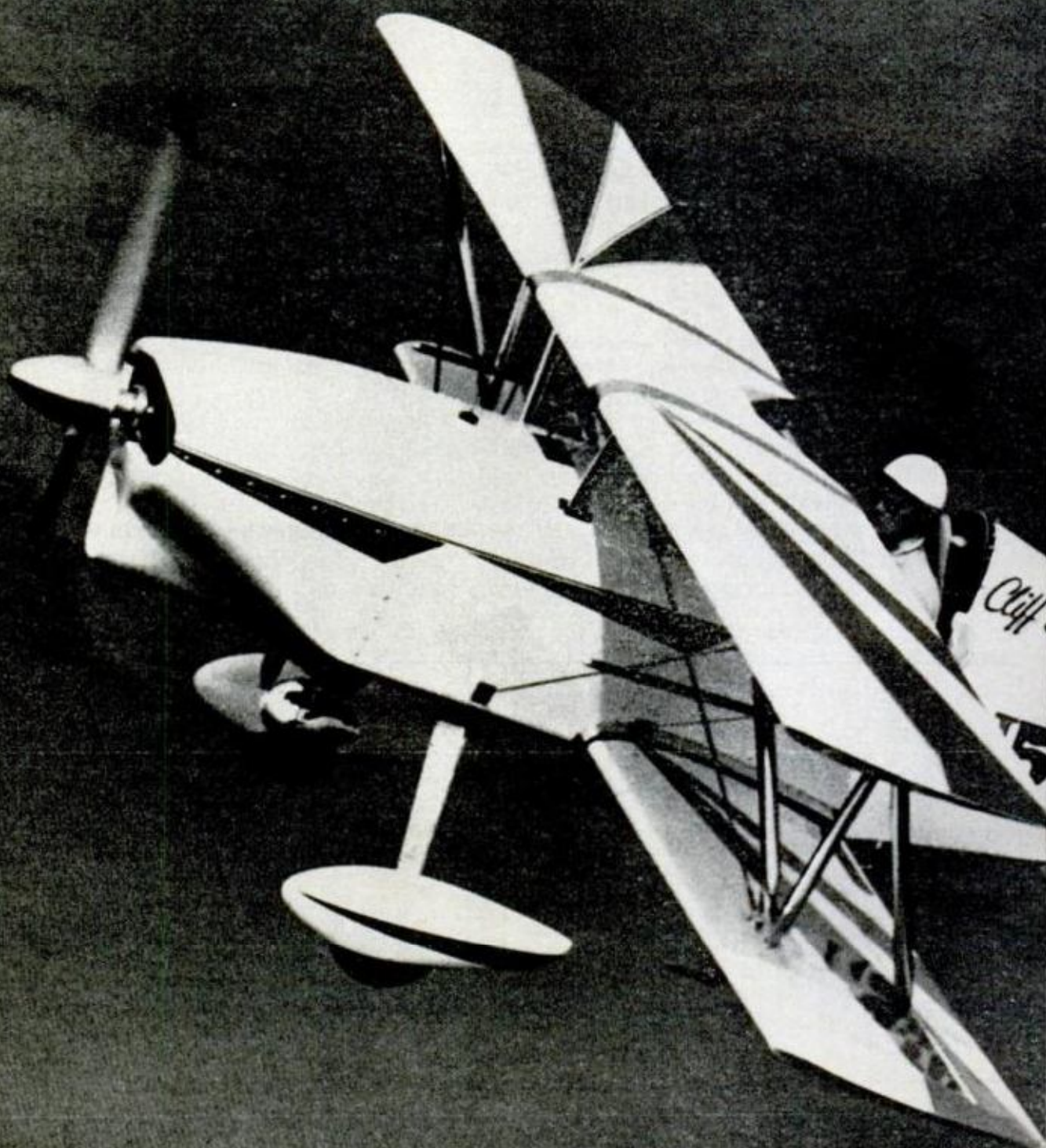



This little two-winger has all the nostalgia of early aircraft with present-day ruggedness, performance and flyability. More than 10,000 sets of plans are already out to build-it-yourselfers.



**Variations in basic design** show how minor modifications can make a big difference in craft's appearance. At top above is original EAA prototype, a straight-forward, no-frills biplane in classic style. Slicked-up versions below it and at left on the facing page sport streamlined struts, wheel pants, colorful markings and other touches that produce a classy, modern look. Note bubble canopy added by one builder (third photo from top). At bottom, nose is given completely different, vertically elongated shape merely by omitting side cowling around engine's cylinder heads.

It can look like a vintage World War I fighter or a sleek modern sport plane—it all depends on how you dress it up. The classic open-cockpit, single-seater biplane, designed especially for do-it-yourself construction, was officially commissioned by the Experimental Aircraft Assn. and developed by several of its members. The nostalgic little two-winger has proved so popular that more than 10,000 sets of plans have already been dispensed by the EAA.

For lack of a better name, the ship has been dubbed the EAA Biplane or "Bipe" for short. Its appearance and performance are more inspired than its name, however. What makes the Bipe so intriguing

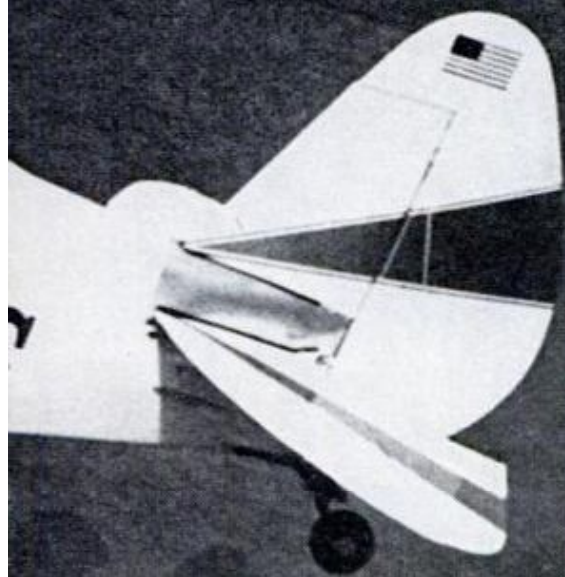



## Nostalgia of the old days in a ship you can build for the present

OVERALL LENGTH	17 FT.
WINGSPAN	20 FT.
EMPTY WEIGHT	640 LBS.
GROSS WEIGHT	1023 LBS.
MAX. SPEED	125 MPH
CRUISE SPEED	110 MPH
RANGE	200 MI.
RATE OF CLIMB	1000 FPM
MAX. POWER	150 HP
STANDARD POWER	85 HP

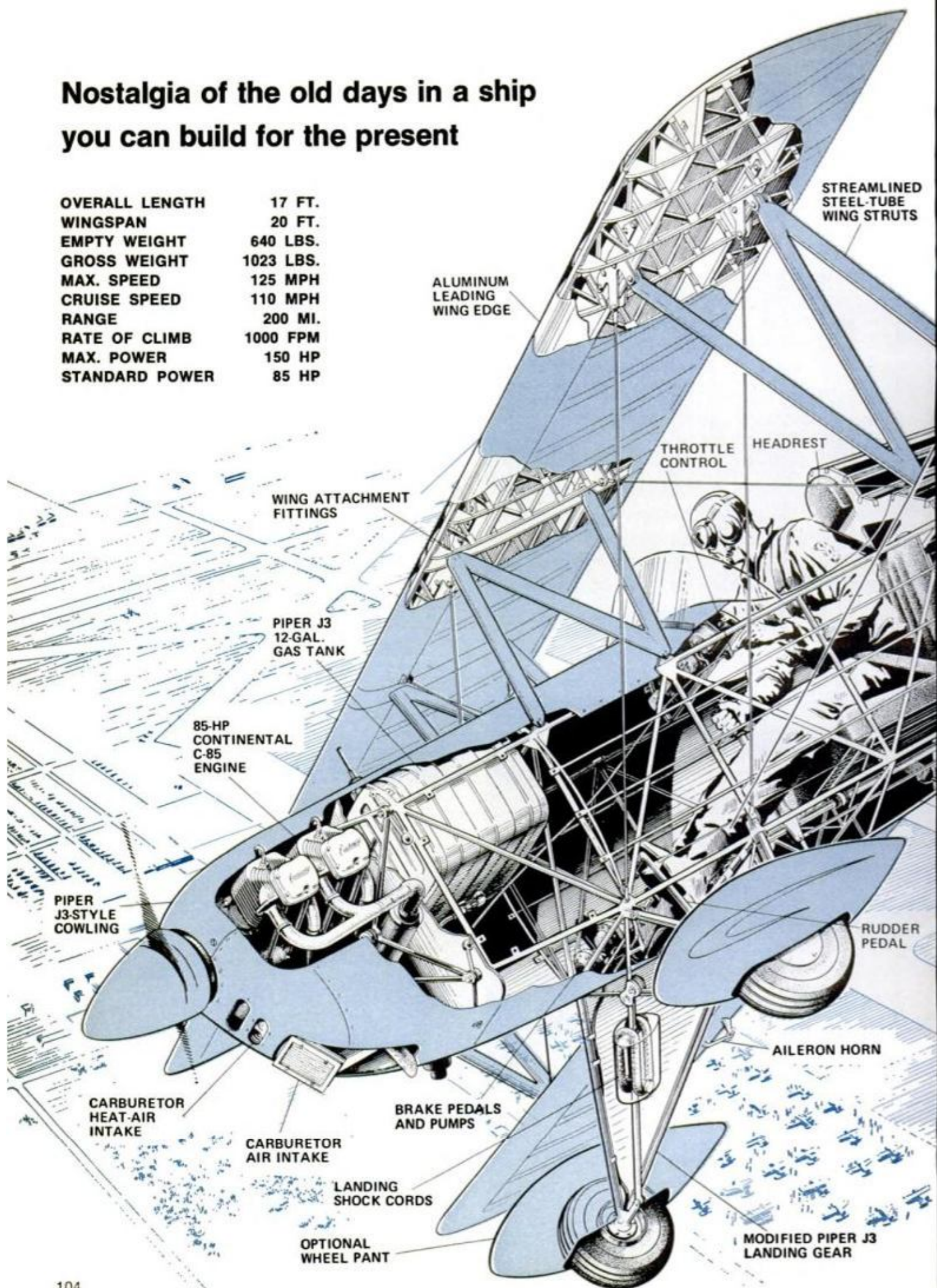



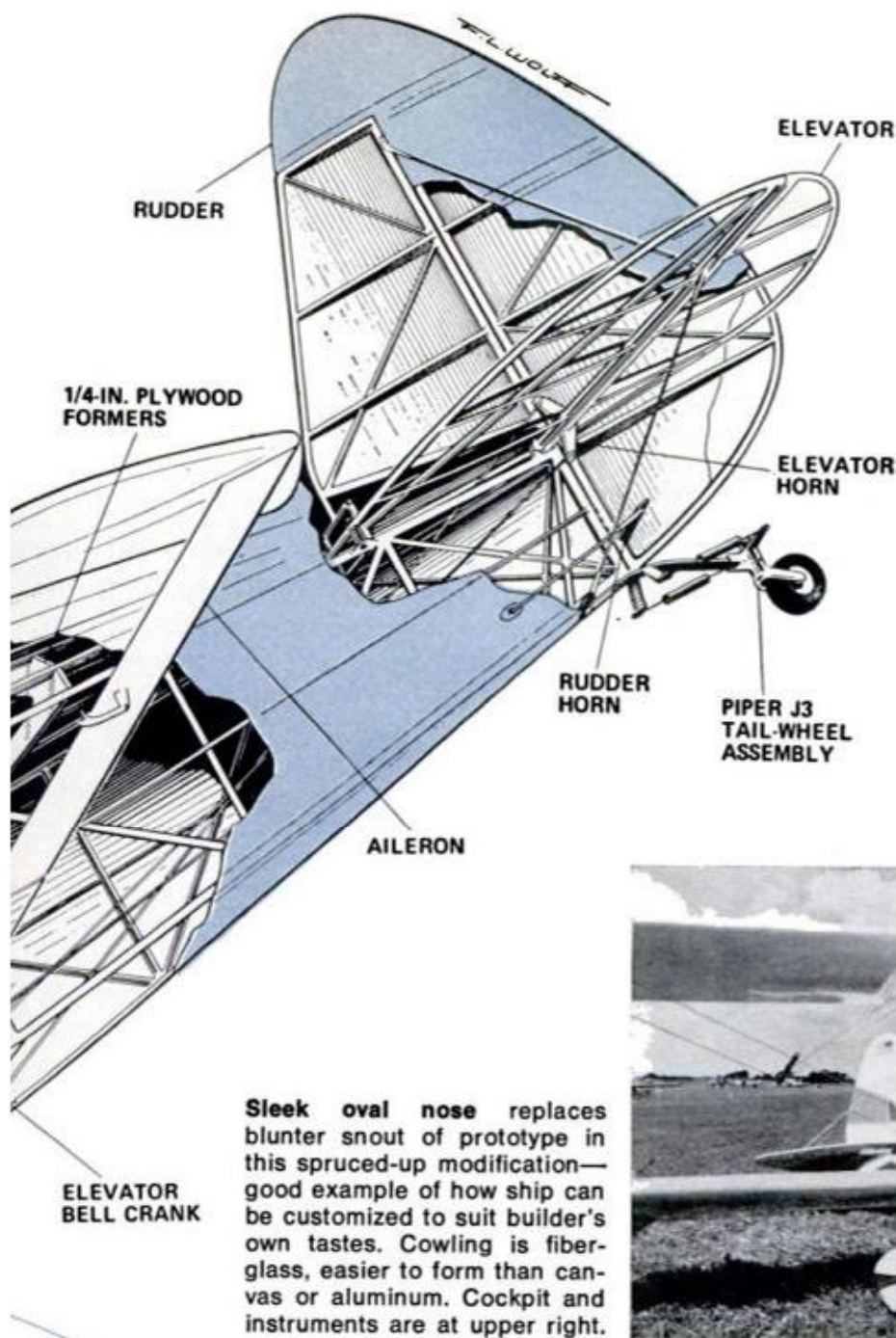

**Sleek oval nose** replaces blunter snout of prototype in this spruced-up modification—good example of how ship can be customized to suit builder's own tastes. Cowling is fiberglass, easier to form than canvas or aluminum. Cockpit and instruments are at upper right.

is its ease of construction and versatility. Although the prototype is powered by an 85-hp Continental engine, it's stressed to take powerplants up to 150 hp. It's also easily customized by adding streamlined struts, wheel pants, fancy nose cowlings and other personal touches. At least one builder made it into a tandem two-seater, and another enclosed the cockpit with a bubble canopy.

Construction is all wood in the wings and a combination of wood and steel tubing in the fuselage. The original Bipe is fabric-covered, but a number of builders have substituted aluminum for more permanence. For simplicity, only the

lower wing incorporates ailerons, and stock Piper J3 parts are used in the main landing gear, steerable tail wheel and gas tank. Overall length is 17 feet with a wingspan of 20.

On its 85-hp engine, the Bipe hits a top speed of 125 mph, cruises at 110, climbs 1000 feet a minute and has a range of 200 miles. Its official service ceiling is 11,500 feet, though some builders have pushed this to as much as 15,000 using heftier powerplants. Plans are \$27 for EAA members and \$37.50 for nonmembers. These are available from the Experimental Aircraft Assn., Box 229, Hales Corners, Wis. 53130. ★★★



# Outdoor gear for indoor emergencies

During disaster or dimout, many new items of camping equipment can do double duty if selected carefully.

by Lewis Perdue

Floods and disasters, fuel shortages, electrical brownouts and failures keep forcing millions of Americans to try to become as self-sufficient as their ancestors once were. Camping equipment intended for use for fun outdoors can be the answer for today's city and country dwellers when civilization gets jerked out from under our feet.

When recent heavy rains changed a placid river into a torrent that rose to within inches of their door, one family kept a written record of their plight. Their home was spared, although amphibious vehicles rescued neighbors from roofs of houses nearby. But the powerplant supplying electricity for the valley was under water so lights didn't light, the trash compactor wouldn't compact, the stove couldn't cook, dishwasher wouldn't wash, refrigerator no longer functioned and the freezer lost its battle against outside heat as melting ice cream oozed down the front. Their water pump wouldn't pump—but they couldn't use that water source anyway because a rising water table had overflowed their septic tank into the well. Their oil-burning furnace wouldn't heat because its control and circulating pump were electric. The family tried to boil water and cook in their fireplace but, like the ornamental fireplaces found in so many homes, it was ill-suited for utility. The charcoal barbecue grill was not much more help.

Fortunately the family had a camping stove that could serve for cooking food and boiling water plus a lantern to shed light on these essential chores. Both were fueled

with gasoline and they were able to siphon enough from their car to keep both going until electric power was restored. Looking back afterward, they realized how lucky they had been.

When faced with a long-term power interruption, the basic requirements for most families are heat to cook and warm the kitchen plus light during the night. Non-electric camping gear powered with propane or gasoline can fill these bills. If the emergency occurs during warm months, keeping room temperature up is less serious. But during blizzard or ice-storm power shortages of winter, heat conservation and fuel economy are vital.

When the heating system fails during cold weather, the entire family should limit itself to one or two rooms, and not try to heat the entire house. The kitchen is best choice as a family room, since it can be partly or completely warmed by heat given off while preparing food. The kitchen should also be used for living and sleeping, with screened-off areas to give privacy for anyone too modest for communal living. Good sleeping bags will save fuel by allowing room heat to be drastically lowered at night. Down-filled bags are best, but are expensive. A bag with at least three pounds of polyester fill usually runs a close second. Remember that some ventilation must be provided for fresh air, particularly if a combustion heater is being used.

A first question by campers and homeowners alike when shopping for campstoves, heaters and lanterns is: propane or gasoline?

Propane is more expensive, but is more convenient to use. When the demand is

**Portable generators** that provide such comfort around a campground can be life and money-savers when powering appliances.







**Campstove cookery** indoors will often prove a lot easier than preparing meals in a fireplace. Kitchen can be closed up into family room for warmth or even emergency sleeping.

greatest, however, the supply of the standard 14.1-ounce propane cylinders may dwindle. If you decide on propane, it could be worthwhile to keep on hand a refillable bulk tank. It will cost more initially but allows long-term savings.

During an emergency, an adequate supply of white gasoline can also run short if filling stations cannot meet demand or power fails for their electric pumps. Regular gas can be used with some makes; with others it should be avoided except in emergencies. Additives in the gasoline can eventually clog orifices and valves, and possibly cause danger of lead contamination. It is best to keep on hand a supply of the recommended fuel, particularly for use with catalytic heaters where impurities can ruin the unit.

An advantage claimed for some liquid-fueled models is that, though they have to be pumped periodically, they can be made to work better in cold weather. Several bottled-gas LP lanterns, for instance, become dimmer as the temperature drops, and stove burners lose efficiency. Brightness levels of some propane lanterns will drop 20 to 80 percent as temperatures go from 70° to 35°. Extra pumping of gasoline models can prevent this. Coleman units use a patented LP regulator to keep temperature changes from lowering efficiency.

A single-mantle lantern will produce about as much light as a 75-watt light bulb and will burn about two ounces of propane or three of gasoline per hour. A double-mantle lantern can produce about 20 percent more light and uses about three ounces

of propane or five ounces of gasoline an hour. A two-burner stove, using both burners, might need 11 ounces of gasoline per hour, while a similar propane stove should exhaust a 14.1-ounce cylinder in about 3½ hours.

Flame and catalytic heaters are available, with catalytic by far the safest in households with pets and small children. The flameless catalytic is less likely to start a fire or cause a burn. Propane-fueled catalytics are much more convenient than liquid-fueled models since no tall sooty flame is needed to prime LP heaters.

Some gasoline lanterns and stoves can burn LP gas when a converter is used. This may void the warranty, however, and like other emergency preparations should be experimented with in advance. Study instructions regarding ventilation, as well. Whether your appliances burn gasoline or propane, they use up oxygen, and their use indoors in a completely closed kitchen or bedroom could be dangerous.

Once you are prepared for emergency food, light and heat, give thought to the problems of a nonfunctioning water pump, defrosting freezer and refrigerator, and radios and TV with no power to give you reports of the disaster. When your home freezer stops running, keep it closed. Food will usually stay frozen for two days in a fully loaded freezer and at least a day in a half-loaded one. If it's winter and the temperature is not likely to rise above freezing outdoors, some of the food can be placed there before it starts to thaw, but be sure it is placed where it is protected



from animals, both domestic and wild. In some areas of the flood-ravaged Northeast last year, freezer trucks were available where people could store food from powerless home freezers. In other parts of the country, commercial frozen-food lockers have been borrowed or rented during similar emergencies. Local police or Red Cross units can sometimes advise if these are available, once the initial emergency has passed but power lines are still down.

Many campers own small hand-carried gasoline-powered generators. These small powerhouses often pack 1100 to 1500 watts of power into a 60 to 100-pound package. They can be stowed easily in a car trunk or back of a station wagon and can be carried by one or two men. These portables can bring convenience and comfort to a campsite with little effort and cost, but if selected for suitable use during a home emergency as well, they can switch from pinch-hitter role to that of star performer.

A typical 1100-watt plant, 19 by 17 by 16 inches, may cost \$150 and provide a great deal of camping satisfaction and emergency aid for the money. A typical freezer may use about 300 watts of power, a furnace fan 270, TV 300 and a radio 80. One burner of an electric stove can consume about 1250 watts, so you'd need either a bigger generator (1500 watts at about \$200 weighing 75 pounds), or a smaller hot plate. An electric frying pan would not be a good substitute; many use about 1200 watts.

Care must be taken not to overload your generator. Most motors will draw from it an extra amount of power (surge current) when they start and could overload the generator even though your constant operation load current is within the unit's limits. One rule of thumb is to hook up appliances which use power equal to no more than 75 percent of the generator's maximum operating capacity.

Most appliances have wattage requirements stamped or embossed on them. Some carry only current ratings, but these can be converted into watts since wattage equals current (amperes) times voltage (120 volts). Many generators can be run on either gasoline or natural gas and have designs that make conversion simple for the camper or homeowner.

Another source of emergency electrical power is your car's generator or alternator. A temporary 12-volt automotive extension trouble lamp can be plugged into a car's

## Generator wattage required

Add up items you use to determine approximate portable generator capacity you need.

APPLIANCE	AVERAGE POWER USED (WATTS)
Electric blanket	200
Broiler	1350
Coffeemaker	800-1100
Furnace fan	270
Oil burner	270
Water pump	340
Frying pan	1200
Hot plate	1250
Radio	80
Color television	325
Sump pump	400
Range (per element)	1250
Refrigerator/freezer	350-450
Freezer	300
Space heater	750-1500
Iron	900-1200
Water heater	1500
Light bulbs	Indicated on bulb

cigaret-lighter socket, and several companies sell converters that will supply enough current to power lights, radios and small appliances. These converter kits, however, will not run the induction motors found in refrigerators, freezers, pump and furnace motors and other large appliances. But auxiliary alternators from many of these same companies, designed for use in addition to your car's standard alternator, can power induction motors. Since a car engine is not primarily intended for producing electricity, however, it will be less efficient than a small portable auxiliary 1100-watt generator that's priced only about twice as much as the auto modifications or additions and is much less expensive to run.

Many other camping items, of course, can become very useful indoors, especially if resumption of electrical power is delayed over several days. Candles, flashlights, water-purification equipment, first-aid gear, warm clothing, foul-weather gear and extra camp bedding will be put to excellent use if additional disaster victims must move in temporarily with you. With luck, the situation will be cleared up quickly, but the camper who has chosen his outdoor gear with a thought for indoor use as well will never regret it. ★ ★ ★



# Stirrups for your spear gun

by Gene Cabot

**L**oading or reloading a spear gun should be done in the water, a chore which can be both difficult and painful with the butt pressed against your chest.

Letting leg action do the work is a big improvement that is easy with cross braces mounted as shown. Using soft do-it-yourself aluminum, cut and round upper and lower straps and bend to shape to fit gun shaft. Rivet or bolt the straps together with aluminum to prevent galvanic corrosion. Spray with zinc-chromate primer and paint with nonreflecting flat black. The stirrup also acts as a stabilizer when you aim the spear gun as you swim toward a target.



**Leg push** with flippers on the stirrups while you hold shock cord stretches elastic for easy cocking of gun in the water.

**Single or twin-rubber guns** are fitted with aluminum straps (below left) by bending to shape.

**Straps** (below center) can be partially shaped, then bent to final fit as bolts are tightened.

**Removal of stirrup strap** (below right), is simple when bolts are used instead of rivets.

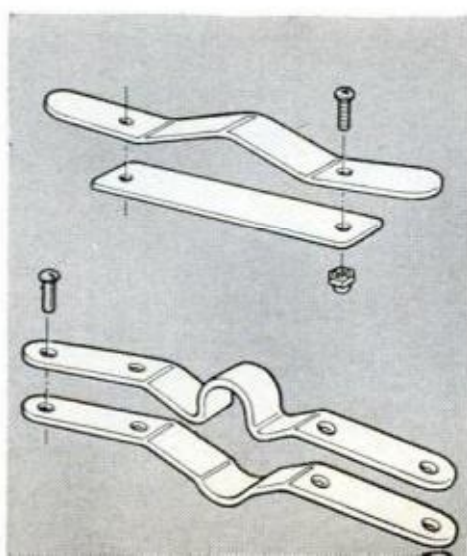



# IT'S NEW NOW

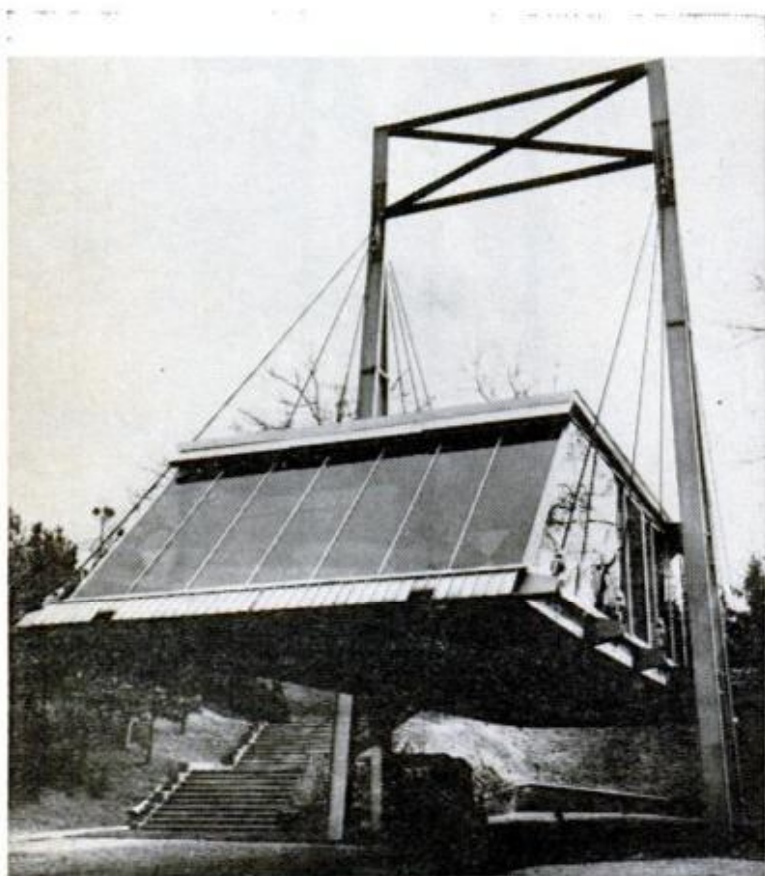

## 'Flying' house is full of suspense

One way to have a dry cellar and save on the cost of a foundation is to hang your house in space like this one. Designed by Italian architect Lorenza Papi of Florence, the unusual structure is suspended on cables from an A-frame support. Should you want a change of scenery, it's easily disassembled and moved to a new location.



## See-through carriage lets baby look out, mother look in

Infants get a better view of the world around them and their mothers a better view of them with this see-through baby carriage. The transparent canopy eliminates the dark, closed-in effect of conventional carriages, believed by some to be psychologically bad for newborns. It also makes it easier for Mom to keep tabs on baby. Patterson Edwards, Ltd., Lee High Rd., London S.E.

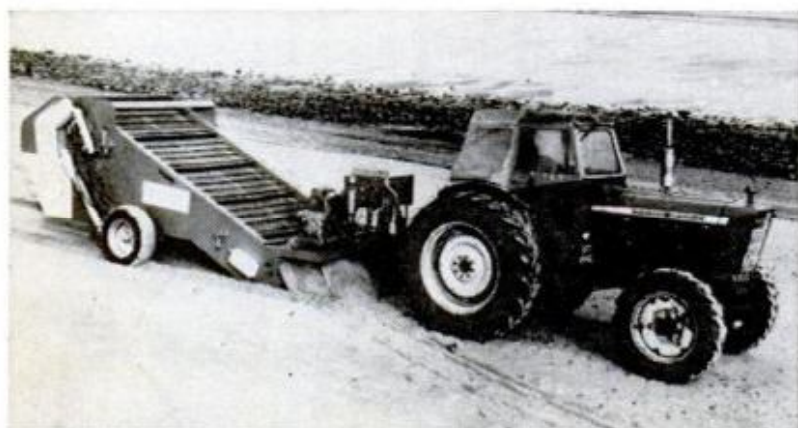

## Mechanical 'beachcomber' cleans English beaches

It looks something like a harvester, but the only crop it gathers is one of rusty beer cans, broken bottles and other debris left by summer beach-goers. Dubbed the "Beachcomber," the machine sifts the sand and scoops out trash 'on British shores. Holywell, Newcastle-upon-Tyne.





**New fast French hydrofoil**

Skimming along at speeds up to 106 mph, the 3.7-ton hydrofoil above is a "small" test prototype for much larger craft to come weighing 140 to 150 tons. It's powered by two airplane-type turbojet engines, each developing 1028 pounds of thrust. At low speeds (top), it planes on two sponson-like pontoon hulls. As speed increases, it climbs completely out of the water and rides on three foils (bottom). The high-speed craft is being developed by the French firm of Aerospatiale for fast coastal transportation.

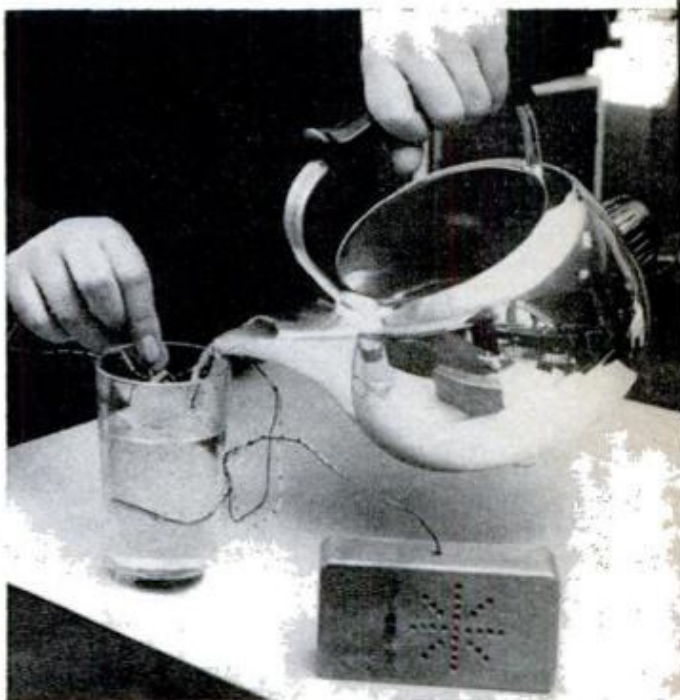

**Out of the minds of babes  
come real inventions**

Inventing starts at an early age in England. At the Walkden County Secondary School in Worsley, pupils are encouraged to come up with new technological developments as part of their science classes. The program has proved so successful that more than a dozen inventions have already been patented and sold to manufacturers by the children. That above automatically alerts the blind when a glass is filled to safe level.



**Truck trap catches brakeless  
runaways before they crash**

What looks like an ordinary median strip between highway lanes is actually a trap. Filled with soft gravel, it's designed to catch and stop runaway trucks whose brakes have failed on long downgrades. It's located at the bottom of a steep mountain road near Los Angeles, the site of many past accidents.



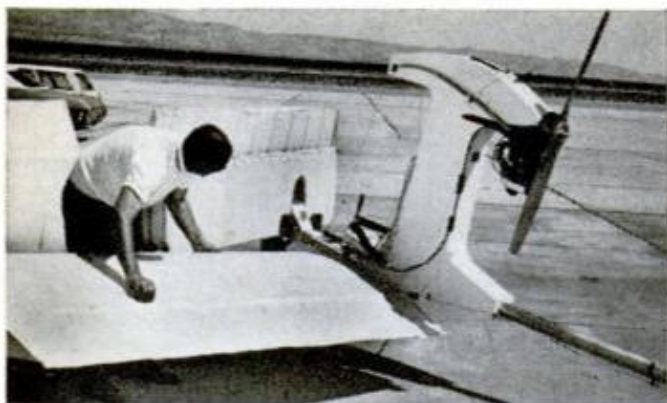

## World's lightest aircraft?

This build-it-yourself airplane weighs less than its pilot—only 120 pounds. Made of lightweight foamed-plastic panels with an aluminum-tube tail boom, it resembles an early Wright Brothers creation and, in fact, incorporates some of the same basic principles. In place of ailerons, it uses "wing warp" for roll control, just as the Wrights' did, and has "plug-in" wing spars borrowed from the World War I French Spad. Its pusher prop is powered by a 15-hp McCulloch kart engine, giving the ship a cruising speed of 50 mph. Though it's not officially established, designer Bob Hovey, an aerospace engineer, believes his flyweight is the world's lightest man-carrying, prop-powered aircraft. Plans are \$10 from R.W. Hovey, Box 1074, Saugus, Calif. 91350.



## Opaque marker for nonporous surfaces

Micro-Marker II writes in opaque lacquer on metal, glass, plastic, rubber—any nonporous surface—with a metal fiber tip. Available with fine or broad tip in 11 colors: red, blue, black, white, orange, yellow, green, brown, violet, gray and light blue. Markers are \$1.50 each postpaid from Easy-Mark, Inc., 39 Crosby St., Lowell, Mass. 01852.



## Fancy pliers in small sizes

Small but tough, these jeweler's pliers are nickel-plated, feature box joints—stronger than lap joints—and have vinyl-covered grips. Made of drop-forged tool steel, they are available with serrated jaws for firm grip or smooth jaws to avoid marring, in flat-nose, chain-nose, round-nose and looping styles; wire cutter matches pliers. Pliers are 5 to 6 in. long. For information, prices, write Brookstone Co., Peterborough, N.H. 03458.





### Soundless hovercraft for sneak attacks

Carrying a crew of two and four soldiers, this amphibious hovercraft is the British Army's latest mechanized weapon for raiding and reconnaissance operations. In use, the go-anywhere Cushioncraft CC7 has a beam of 15 feet, but collapsible side decks enable it to be narrowed to half this width for easy road transport. It's the first air-cushion vehicle to feature virtually noiseless operation, making it ideal for quiet sneak attacks.

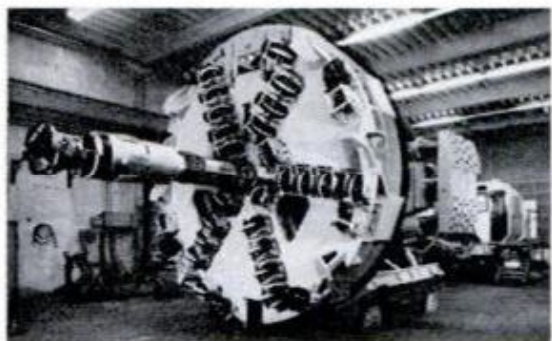

### 'Mechanical moles' dig tunnels like a knife through butter

The days of sandhogs hacking their way through tunnels with jackhammers and hand shovels are gone. Now giant tunnel boring machines (TBMs) chew subway-size holes through the earth at the rate of more than 100 feet a day—10 times faster than the rate considered good not long ago. Huge hydraulic jacks push the TBMs along as whirling cutters slice through rock and clay. Some TBMs like Ingersoll-Rand's (middle photo above) have pilot drills that probe ahead for dangerous gas pockets, a major tunneling hazard in the past.



### Flying Pinto sprouts wings

One of these days you may be able to drive your car to a nearby airport, put on a pair of wings, fly to a distant city, then park the wings and drive on into town. That's the idea behind the AVE Mizar flying car shown above undergoing FAA certification tests at Point Mugu, Calif. The hybrid consists of the wings, engine and airframe from a Cessna Skymaster mated to a modified Ford Pinto. The conversion from car to plane is said to take only two minutes and you're on your way. In flight, a pusher-type prop powers the "rent-a-wing" car.



# NOW



## Rotary engine enters yard-maintenance field

Follow the Wankel trend with a rotary-engined walk-behind lawnmower. Manufacturer, Arctic Enterprises, Inc., Thief River Falls, Minn. 56701, says its Grass Cat's 4-hp, German-made rotary Wankel plant cuts noise and vibration, while its increased torque range boosts cutting power. Mower's sticker price: \$159.95. Company is also considering the rotary engine for self-propelled mower and tractor applications.



## Decorative heater is cooler, safer

Hearthstone portable plug-in heater boasts efficient, economical radiant heating at safe, low temperatures, features thermostatic control with temperature adjustment. With decorative, baked-on harbor scene or ember-red surface, unit is \$69; with sailboat blueprint design, \$79. Sold in department stores. Infra-Red Circuits and Controls Corp., 215B Central Ave., Farmingdale, N.Y. 11735.



## Now skin prints are fingering criminals

Until now, fingerprints left on a crime victim's body have been difficult to detect because, unlike those on wood or metal surfaces, they are not visible to the eye or a conventional camera. Now two Scottish radiologists have developed a new technique in which the victim's skin is dusted with a metallic powder, then X-rayed. Metal particles adhering to skin show up as patterns duplicating attacker's prints. The method was devised by Daniel Graham and John Thompson working with Glasgow police.





**Take your choice—  
strobe or flashcube:  
Now you can switch-  
shoot with either**

Want to shoot strobe flash with a nonstrobe camera or flashcubes with a noncube camera? You can do either with these clever adapters, and both have their advantages. Strobe flash saves the cost of cubes, but offers a limited number of shots per charge. By switching over to cubes, you can keep right on shooting after a strobe has petered out. The adapter at far left fits a small strobe to X-type Instamatic cameras, snapping into the flashcube socket. The adapter at near left lets you use flashcubes with any camera having a shoe mount and strobe sync. Both sell for about \$10 each at photo shops and discount centers. Kalimar, Inc., 2644 Michigan Ave., St. Louis, Mo.



### From snowmobile to 'boat-mobile'

You don't have to wait until the snow flies to use your snowmobile with the conversion rig below. Just put on a pair of pontoons and you have a speedy little water craft capable of hitting up to 25 mph. The experimental rig, not yet on sale, is being developed by Massey-Ferguson, Des Moines, Iowa.



### Economy blowtorch

Ideal for wide variety of household chores, UL 100 blowtorch is said by maker to be the only UL-listed torch in its price range, features solid-brass burner, clog-proof filter. Suggested price is \$6.95. Bernz-O-matic Corp., Driving Park Ave., Rochester, N.Y. 14613.



### Handy headlight reminder

You can't forget to turn your car lights off when parking with this alarm to remind you. It buzzes whenever ignition is turned off with lights on. Only two simple connections to fuse-block clips are required. \$5.95 postpaid from Yorkhouse, Box 1006, La Habra, Calif. 90631.





## Sailboat with a split personality thinks it's two rowboats

This unusual come-apart sailboat knocks down into two-self-contained halves, each serving as a small rowboat (bottom photo, near left) when you're not sailing. The sections go together in 15 seconds to produce a hull about 15 feet long with a Marconi mainsail and Genoa jib (far left). Apart, the sections nest neatly together for compact storage and easy cartopping (top photo, near left). Boat is made by the Dutch firm of N. V. Jachtwerf in Volendam, Holland, sells abroad for about \$800.



## Wise solution for a problem stump

One way to handle a problem stump—turn it into a decorative lawn carving. That's what W. L. Husted of Cedar Rapids, Iowa, did. His wise old owl is the result of a few hours' work with chainsaw, truck, reflectors for eyes, hardboard for a hat.

## Fast help for cars in distress

Pull the handle on this emergency roadside call box, press any of four buttons—fire, police, ambulance or service—and help is on the way in seconds. Radio system by ADT, 155 Ave. of Americas, New York, N.Y.



## Ford flies car parts to get them to you faster

Called the "Midnight Special," a big DC-9 is readied for takeoff in the dark of night, its cargo automotive replacement parts. The plane leaves Detroit every evening in a new service to speed parts to Ford auto dealers all over the country.





**Would you believe a supersonic jet that can land on a dime?**

Cross a helicopter with a supersonic jet and you have this versatile new British-designed Harrier fighter soon to join the U.S. Marine Corps. Swiveling jets permit either vertical or forward flight. The droop-winged craft can climb 40,000 feet in less than 2½ minutes and hit speeds of Mach 1.25.

**Door viewer offers protection through wide, wide angle**

Unwelcome company will have no place to hide when you survey your doorstep with this \$5.95 viewer. Its optical glass (not plastic) lenses give a 190° field of view. Installed in doors up to 2½ in. thick by drilling one hole, viewer is available in brass or chrome. At hardware stores or from Loxem Manufacturing Corp., Box 47307, Dallas, Tex. 75247.

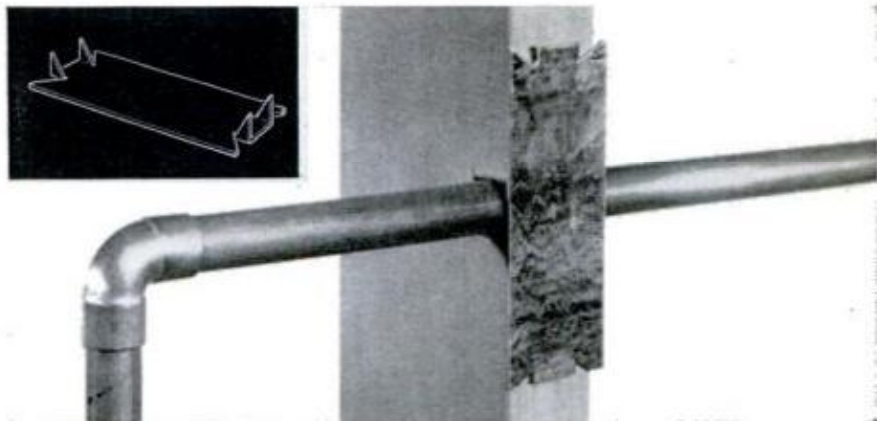
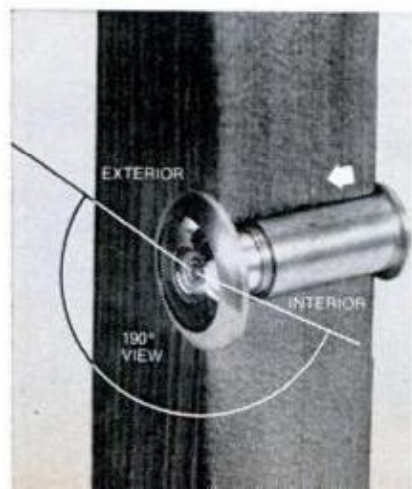

**Hammer-in strips protect pipes, cable**

"Idiot strips" protect pipes and electrical conduit running through wall studs from being accidentally punctured when you drill holes or drive nails into walls. The metal strips, about 10 cents each, are sold through building supply dealers. Modern Metals, Inc., 1311 Ashland St., Houston, Tex. 77008.

**Flashing lights to lull you to sleep**

The old four-poster goes modern with this overhead psychedelic light display. Designed by New York artist Earl Reiback, it produces ever-changing patterns of light and color, is said to induce sleep in insomnia sufferers. But the price may keep you awake: \$8500.







## Take a trip with a tour guide on tape

You don't need a guide along when you go on a driving tour with a "robot guide" on tape. Available for most U.S. national parks, the cassettes describe passing scenery, rent for \$5, including tape player, from travel and car-rental agencies. Comprehensive Communications, 565 Fifth Ave., New York, N.Y. 10017, developed the idea.



## Boat hook grows from short to long

Boat hooks are handy when you need a long reach, but are awkward to stow aboard small craft. Now a British firm has a telescoping version that collapses from 8 feet to only 3½ feet. Channel Marine, Ltd., 49 Harbour Parade Bus Station, Ramsgate, Kent, England, is the maker.

## World's smallest live-steamer

What is believed to be the world's smallest operating live-steam locomotive is shown at right—the product of 2000 hours of work by Arthur Sherwood, an engineering professor at the University of Sydney, Australia. Built on a scale of 1/240, it's less than 4½ inches long and actually runs on steam generated by a tiny butane burner. But it's big compared to Sherwood's electric models—they're on a 1/480 scale and are half the size!



## Pilotless jets for fighting robot wars

Air battles may soon be fought by planes without pilots. Slung under the wing of its "mother" ship, the pilotless jet below is readied for launching in Air Force tests at San Diego, Calif. After its release, the Ryan BGM-34A craft, armed with deadly accurate Maverick missiles, is guided remotely to its target by crewmen aboard the mother ship. The mini jet can execute all maneuvers of a conventional manned fighter with one big advantage—it doesn't have to worry about getting shot at.

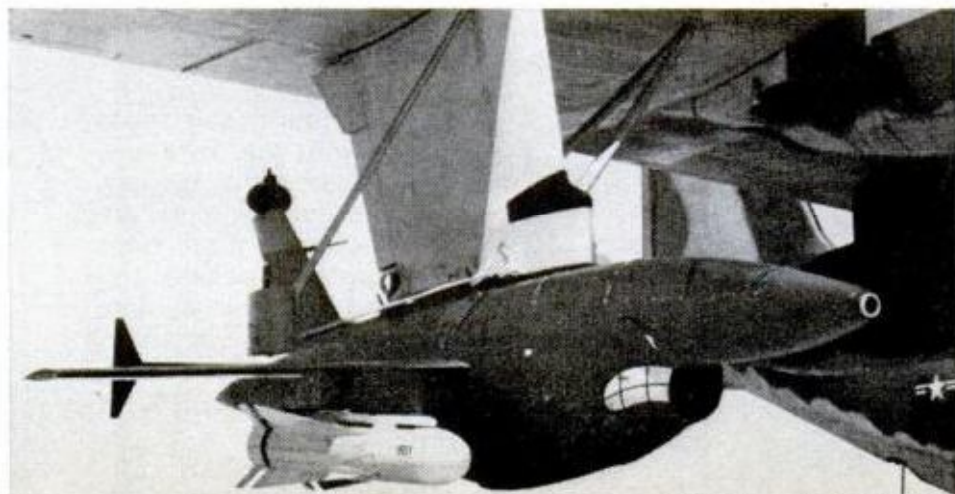





### Help with home wiring, plumbing

These large-scale sets of diagrams, prepared by professionals, take you step-by-step through all aspects of residential plumbing and wiring. Each set is \$5. From Home Building Plan Service, Dept. PM, 2235 N.E. Sandy Blvd., Portland, Ore. 97232.

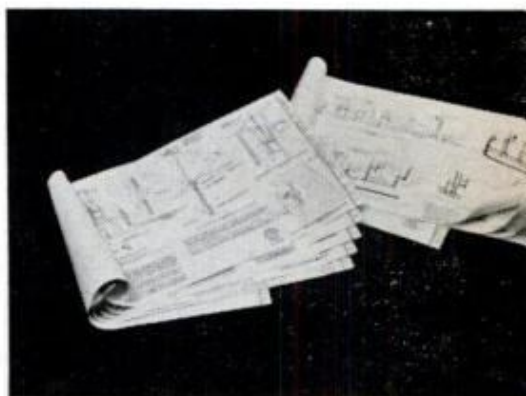

### String-by-number

String art, long used in schools, has now been packaged in kit form for fun at home. String wound around small nails tacked in boards produces striking three-dimensional "pictures" like the animals and sailboats above. Kits, for \$6 or \$12, include string, nails, patterns, boards, instructions from Atech Enterprises, Inc., 1326 New York Ave., Huntington Station, N.Y. 11746.



### Mechanical baby sitter: Modern substitute for Mom

Busy mothers might welcome this mechanical baby sitter developed by German designers Gunter and Iri Beltzig of Deimhausen. A sort of combination baby carriage and playpen, the futuristic device serves as both a bed for infants at nap time and a play area to keep them safely occupied when awake. Incorporated in the automated center is a motor-driven rocker, regulated bottle warmer, programmed snack dispenser, timed sun lamp, taped music for entertainment and a variety of toys to play with. Apparently the only thing missing is an automatic diaper-changer—the designers haven't figured that out yet.



### Well, they beat walking, traffic, fuel shortages

Powered by an old lawnmower engine, these motorized roller skates hit speeds up to 20 mph and get 145 miles to the gallon. They're the brainchild of 75-year-old Tommy Hancocks of Beaconsfield, England, who figures they're just the thing for beating both traffic jams and fuel shortages. Throttle and clutch are controlled by bending the knees, leaving the hands free.



# NOW

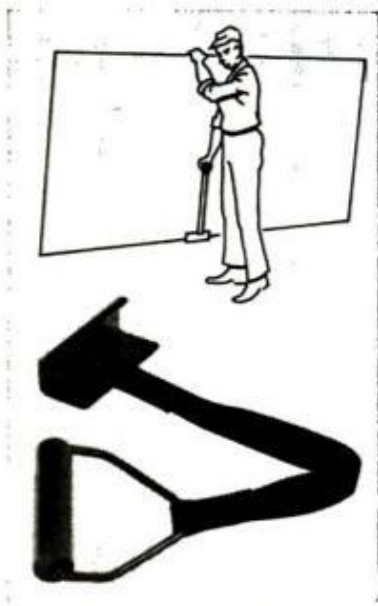

**Handy panel carrier**

Plywood toter makes awkward 4x8 panels easy to carry. Pocketable nylon-belt or all-steel model sells for \$4.95 at building supply and hardware stores, or from Metaltek, Inc., Box 30388, Raleigh, N.C. 27612.



**Electric trucks are back**

Remember those old electric trucks you used to see in some U.S. cities? They're back again—at least in Britain. Battery-powered garbage truck above is one of several being tried in Manchester, England, to provide quiet fume-free operation. Maker is Crompton Leyland Electricars.



**Picture-taking rocket**

Ever wish you could photograph the flight of a model rocket from the rocket itself? Sounds impossible, but now there's a battery-powered Super-8 movie camera to fit a toy rocket. Middle photo shows rocket's eye view of parking lot below, while lower photo shows chute deploying for recovery. Camera, about \$20, was developed by Estes Industries, Box 227, Penrose, Colo. 81240.



**Mini one-man diving bell**

Sealed inside a watertight capsule, an engineer is lowered over the side of a ship to inspect the underside of the hull. Developed by the Navy, the plastic-sided capsule provides greater visibility and comfort than are possible through use of divers.



**Special saw for laminates**

This double-edged saw for laminates, plywood, veneers and plastic pipe has extra teeth on the back of the curved tip for making internal starting cuts. The 12½-in.-long Swedish-steel blade has 14 points to the inch, can also be used in a miterbox. No. 314 Laminate Saw is \$4.45 at hardware and building-supply dealers. Sandvik Steel Inc., 1702 Nevins Rd., Fair Lawn, N.J. 17410, makes it.





### Big jumps on tiny trampolines

You need a sure eye and quick reflexes to hit the mark on these mini trampolines. Only 28 inches in diameter, they're designed to fit in spaces too small to permit conventional-size trampolines. They're also said to sharpen gymnastic skills due to the added coordination needed. Maker is Textil & Kunststoffverarbeitung, Box 93, D 5812 Herbede, Germany.



### New refrigerator requires less electricity

Consumption of 30 to 50 percent less electricity than competitive models is claimed for Philco-Ford's new frost-free refrigerator design. Liner molded from single piece of plastic allows more efficient use of insulation and heating elements, fewer parts, less chance of leaks. Unit is decorated to taste with changeable front panels.



### One-lunger in kit form

This 3.5-hp, one-cylinder air-cooled gasoline engine comes in a kit you can put together with simple hand tools, has a variety of applications. \$59.95 from Clinton Engines Corp., Maquoketa, Iowa 52060.

### Monster hauler rolls on 80 wheels

Looking like a giant mechanical centipede, this mammoth flatbed hauler rides on 20 sets of four-wheeled axles or a total of 80 tires. Made for carrying large industrial equipment, it's more than 70 feet long and 22 feet wide. It can tote loads up to 620 tons and itself weighs 920 tons. Top speed is a slow crawl—about 3 mph. Mitsubishi Heavy Industrial Co. of Japan is the carrier's maker.





# Car stereo speakers: How to install them

by Eugene Walters

**Y**ou don't have to have a pro install your car speakers to get a professional-looking job like the one above. But it pays to do it like the pros do.

First, decide where you want your speakers. Rear-deck speakers are often easiest to install, since many U.S. cars already have the necessary holes. But front mounts—in the doors or front kick panels—give you the best stereo effect in the front seat. And that's the seat most likely to be occupied.

Probably the hardest part of mounting speakers in a door is finding a spot where they won't interfere with structural members or the window mechanism and at the same time won't be placed where the seats will swallow up their sound. Pros (like the

ones at Wally's Tape City in New York, where the pictures on the facing page were taken) know these spots, but you'll have to find them. Loosen the door trim panel, and check out possible speaker sites as you raise and lower the window. Then measure carefully and cut your hole. Use a sabre saw or hacksaw, or drill a circular pattern of holes and saw from one hole to the next. But don't use a power drill or saw on carpet-covered doors—the carpet may tear or run.

To run the speaker wires, remove the inner kick-plate trim (just in front of the door) and drill holes opposite each other in the door edge and door pillar. Line the holes with grommets, so their edges won't cut the insulation. Run wire through the holes to the speakers, and solder them so

PHOTO BY THE AUTHOR

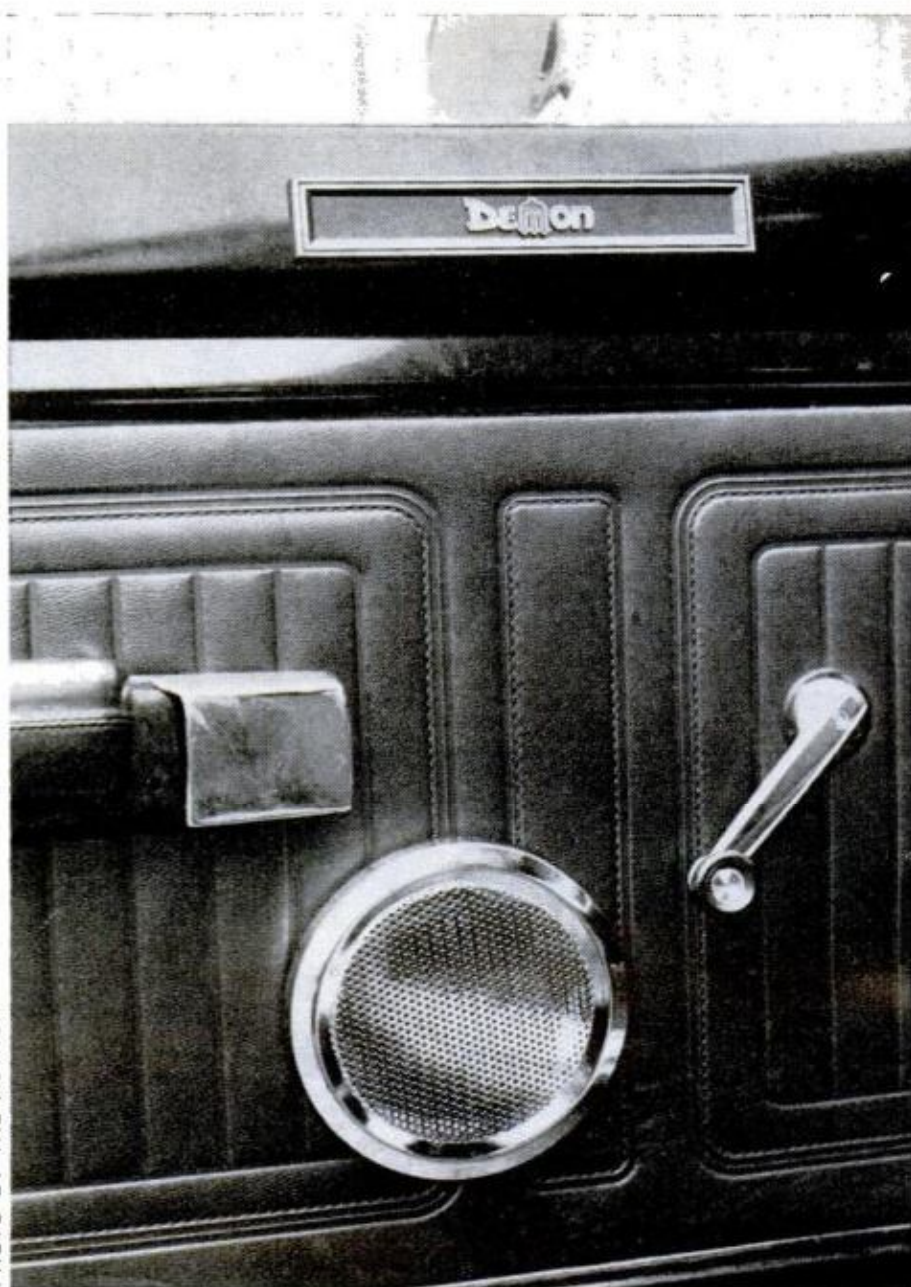



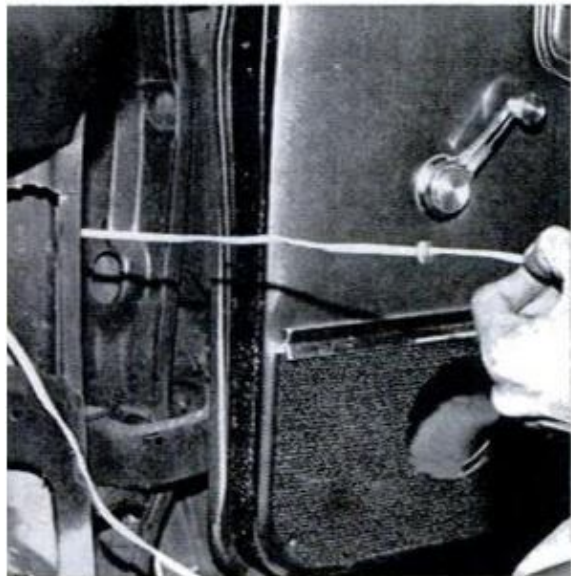
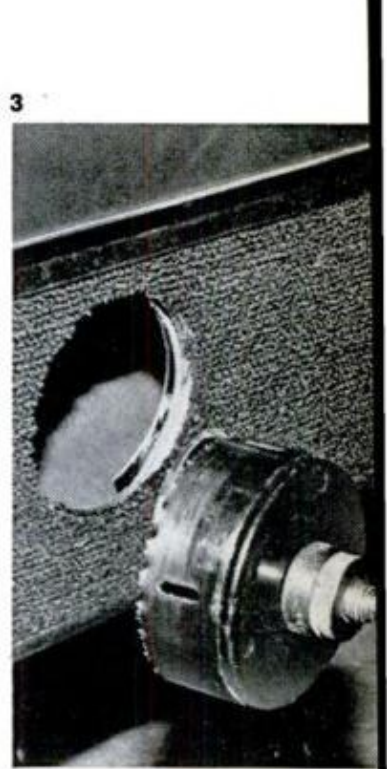
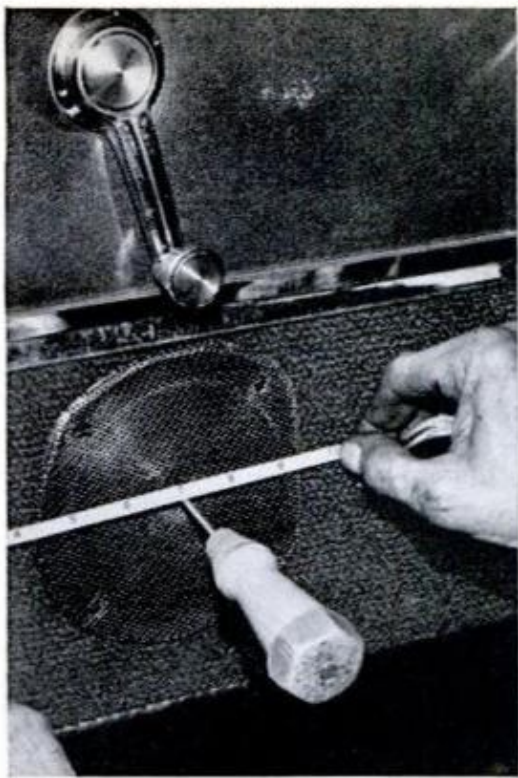

After opening inside door panel to find suitable speaker location, measure distance on panel (1), mark punch and drill mounting holes (2), and cut speaker hole (3). Remove car's inner kick-plate panel (4), drill kick panel and door edge, then thread wire (4 and 5); note grommets in holes. Run leads to speaker (6) and solder; be sure positive wire goes to same terminal of each speaker. Position speaker, align screw holes (7), mount speaker and grille (8). Use self-tapping screws if door is metal, speed nuts or washers and lockwashers if fiber. Grille here matches car interior, but chrome finish shown on facing page resists scuffs best.

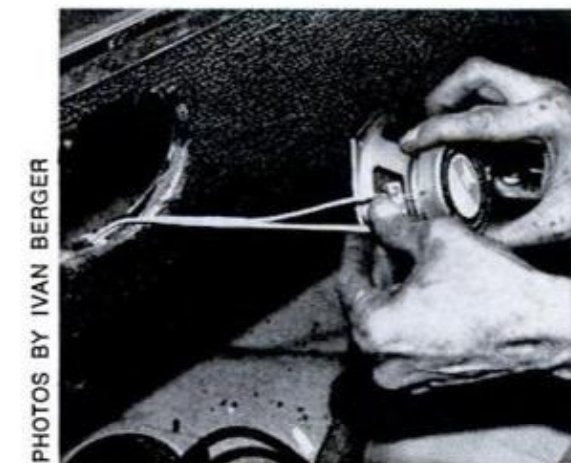

PHOTOS BY IVAN BERGER



## Rear-deck speakers are easy to install



**Rear-deck mounting** is simplified in many cars by holes precut for 6x9-in. speakers. If you have to cut your own hole, you can reduce the amount of hacksaw work needed (upper right) by drilling holes around the speaker periphery, then hacksawing between them. Slanting rear windows on most cars prevent use of sabre saws. Wiring inconspicuously is easier if you unscrew the door saddle (upper left), clear out pebbles or debris that could cut wires, then run wire under saddle. Grille cloth can keep holes in metal grille from focusing sun's burning rays on speaker. Cut to fit the speaker (right), then apply under the grille (lower right). Avoid plastic grilles on rear-deck speakers; they tend to warp or melt.

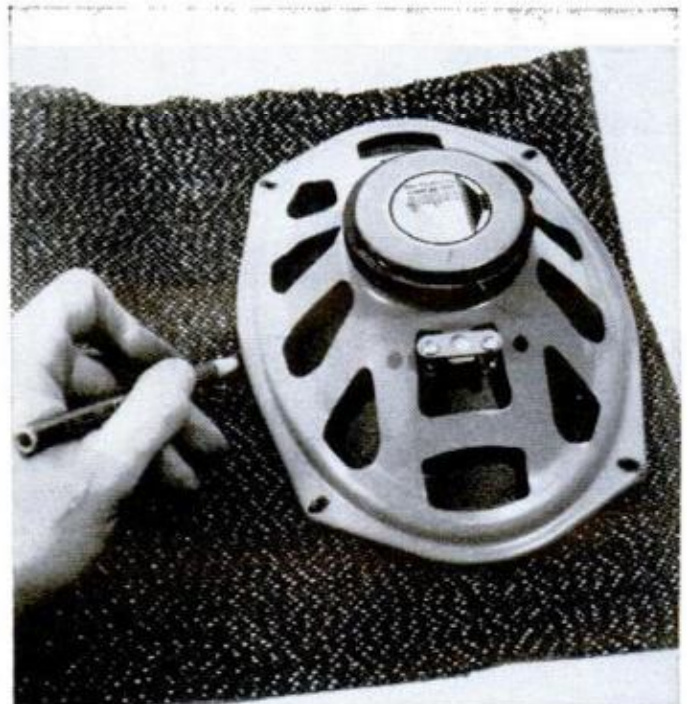

they can't vibrate loose. Make sure the "hot" leads from each channel of your tape deck go to the same terminal on each speaker, or you'll lose bass response.

For rear-seat speakers, snake the wires unobtrusively through the car by tucking them under the edge of the carpet or floor mats. Where the wires pass the doors, run them under the door saddle (first removing the saddle to clear away gravel or debris that might cut the wires).

To get the wires into the trunk, you must usually remove the rear seat cushion, which is easy. But getting it locked back in again is usually a two-man job. The holes that pass the wire into the trunk should also be grommeted to prevent chafing; it's not a bad idea to caulk the space around the wires, too, against the possibility of exhaust-fume leaks.

Wedge-type, surface-mounting speakers are easiest to mount on the rear shelf, requiring only screw holes for attachment and

*(Please turn to page 191)*

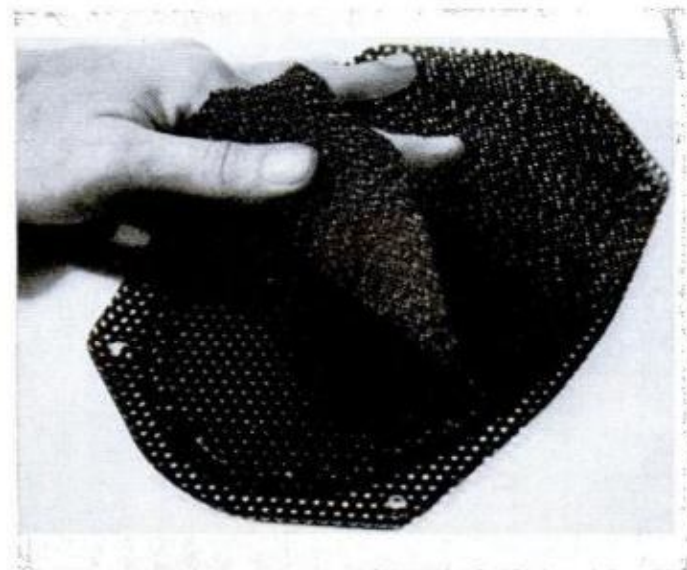

PHOTOS BY THE AUTHOR AND IVAN BERGER



# Car stereo speakers: How to pick them

Specifications don't  
tell the story—  
but your ears can.

by Ivan Berger  
ELECTRONICS EDITOR

PHOTOS BY PETER SCHNEIDER

Picking the right high-fidelity speakers for your home is hard. But picking speakers for your car stereo is even harder—at least, if you really want to get the best possible sound.

Specifications tell you little about how a speaker sounds, and you can seldom hear car speakers demonstrated—almost never in a car, where the sound differs from that in a showroom.

Still, there are some listening tests you can make, though not all of the tests you'd use in picking speakers for the car's good (but difficult) acoustical environment are the same ones you'd use in picking speakers for your home.

High frequencies, for instance, needn't extend as high for car speakers as they should for home hi-fi; the car's upholstery absorbs most of the upper frequencies, and highway noise will mask the rest. (Nonetheless, most of the speakers we checked had substantial, if irregular, response above 13,000 Hz.) Because of these high-frequency losses, car speakers should sound a little "brighter" than home speakers do. But avoid speakers that sound shrill, a sign of high-frequency peaking and distortion.

Since car speakers usually face your knees, your elbows, or the back of your head, good dispersion of what highs there are becomes even more important than at home—especially since the highs won't bounce as they do in normal rooms. A hissy, unrecorded section of a tape, or noise between FM stations, makes a good test: Check to see if the tone of the hiss changes much when you walk past the speaker. The more

Car speakers of many types are shown here with PM's test gear.





# Basic specifications of 19 car stereo speakers

SPEAKER	PRICE PER PAIR	NOMINAL CONE SIZE	IMPEDANCE (OHMS)	RELATIVE EFFICIENCY <sup>1</sup>	RATED FREQUENCY RESPONSE	MAGNET WEIGHT	GRILLE	POWER-HANDLING CAPACITY	REMARKS
Afs Kar Kriket	\$40	5"	8	-3 db.	65-17,000 Hz.	10 oz.	Cloth	10-w. RMS, 18-w. peak	In large wedge enclosure, choice of colors
Altec 405A	30	4"	8	-4 db.	60-15,000 Hz.	28 oz.	None	10 w.	
Dynamite Sound ST-112	17.50	5 1/4"	8	-5 db.	50-10,500 Hz.	12 oz.	Padded	10 w.	
GC Audiotex 30-3004	12	5"	8	-4 db.	NA	3 oz.	Chrome	5 w.	
GC Audiotex 30-3010	13	5"	8	-1 db.	NA	3 oz.	Aluminum	5 w.	In plastic mount for surface or under-dash mounting
Heath CRA-1000-2	20	5"	4	-4 db.	60-15,000 Hz.	9.8 oz.	Plastic	10 w.	With adapter plates for 6x9" openings
Heath CRA-1000-5	20	6x9"	4	+2 db.	40-15,000 Hz.	10 oz.	Metal	10 w.	
Jensen SK96RRFX	50	6x9"	8	0 db.	40-16,000 Hz.	20 oz.	Plastic	25 w.	
Jensen SK525FX	40	5 1/4"	8	-3 db.	55-13,000 Hz.	10 oz.	Padded	25 w.	
Philco-Ford	24.60	6x9"	3.2	-7 db.	NA	2 oz.	Metal	NA	Supplied with Philco-Ford car radios
Philco-Ford	24.60	5 1/4"	3.2	+1 1/2 db.	NA	3 oz.	Metal	NA	Supplied with Philco-Ford car radios
Pioneer TS-52	60	6" woofer, 2" tweeter	4	-2 1/2 db. (-4 db.) <sup>2</sup>	70-12,000 Hz.	6.8 oz. (woofer)	Plastic	8 w., 16-w. peak	Ultraverse mount, swiveling tweeter
Poly-Planar	20	6x10"	8	-4 db.	60-20,000 Hz.	NA	Plastic	NA	All-plastic, flat rectangular "cone"
Realistic 12-1845	20	5 1/4"	8	-1 1/2 db.	NA	8 oz.	Padded	5 w.	
Realistic 12-1846	20	5"	8	-4 db.	50-16,000 Hz.	32 oz.	Rubber	12 w.	
Toshiba TCS-10	30	5"	4	-1 db. (-2 db.) <sup>3</sup>	NA	NA	Plastic	5 w.	
Trusonic 50FR	30	5"	8	-3 db.	50-18,000 Hz.	32 oz.	Chrome	12 w.	
Wally's 5-inch	20	5"	8	-4 db.	NA	6 oz.	Metal	5 w., 16-w. max.	
Wally's 6x9	40	6x9"	8	-2 db.	NA	14 oz.	Metal	10 w.	

Notes: <sup>1</sup>See text. <sup>2</sup>Measured with speaker panel surface-mounted in simulated car trunk to improve base response. <sup>3</sup>Measured with enclosure mounted over 5" hole in simulated car trunk. NA-Not available.



even the sound, the better the dispersion.

Low-frequency response will probably be better in the car than in the showroom, since the car's interior is too small for standing waves to create bass peaks and dead spots, and too oddly shaped for resonances to overemphasize some frequencies. Most car speakers will deliver more bass when mounted in a door (and still more when mounted in the parcel shelf above a car trunk) than they can in the small boxes usually used for demonstration enclosures. And though "wedge" speakers designed for mounting on rear decks (or in station wagons) have built-in enclosures, their bass response can be increased by mounting open-bottom wedges over large holes leading to the trunk, or removing their speakers for surface mounting in a trunk shelf or door panel.

Make sure whatever bass you do hear is clean, not thumping muddily away like a juke box. A male announcer's voice on FM should sound natural on a good speaker, not as if he were speaking from the bottom of a barrel. Boomy, resonant bass may sound more spectacular than the real thing (especially on rock), but it muddies up the music, makes announcements and song lyrics (already difficult to hear on a noisy highway) unintelligible, and eventually gets very tiring to listen to.

It's especially important that car speakers sound clear at high sound levels, since

high volume is often needed to overcome road, wind and motor noise. If you can, compare speakers to see which can play loudest before they sound distorted to you—distortion is always tiring to hear, and you don't need extra sources of fatigue while driving. If possible, for this test drive the speakers with the same tape unit you're buying, or one with about the same power and impedance ratings—it matters little how clean your speakers sound if your tape player can't drive them without distorting.

Since car radios and tape units have only limited power, speaker efficiency is important. Typical in-store demonstrators let you switch from one speaker to another. The louder the speaker, the more efficient it is. But don't give this figure too much weight: of the 19 speakers we checked, seven were identical in efficiency, and 12 were within one db. of one another (three db. is about the smallest easily detectible difference).

Take manufacturers' frequency response ratings with a grain of salt. Sure, every speaker will deliver some sound at every frequency within its rated range, but the ratings don't say whether the lowest and highest rated frequencies are 3 db. or 23 db. softer than the mid-frequencies, or how even the sound may be between those limits. And take magnet weight as only the very roughest indication of how good a speaker is—manufacturers seem to be developing a horsepower race here. ★★★



**Test setup** (left) used for speaker efficiency and frequency response checks included imitation "car trunk" used as speaker enclosure and a battery of instruments. Pioneer (above) had aimable tweeter, bass reflex woofer, could be mounted permanently or for easy removal.



# Pocket cameras become big business

by Ivan Berger  
PHOTOGRAPHY EDITOR

**K**odak's Pocket Instamatics are catching hold even quicker than the original Instamatics did. Neither the first nor the smallest subminiature cameras, they are the first for which you can find film in any drugstore. And now a host of 110-size cameras and accessories from other companies are helping to swell the boom. Most of the new cameras are simple ones, but more sophisticated models are coming from Argus and Yashica, probably from Rollei and Minolta (already manufacturers of subminiature cameras) and possibly from Konica as well.

**Kodak still makes most 110 cameras, but not all of them. Clockwise from upper right: Kodak Pocket 30 with Prinz flash (on Kodak Pocket stand), Kodak Pocket 40 with Kalimar flash, Soligor 110 (with Magicube on side), GAF 220, Kodak 20 with Soligor flash, Kodak 60 on Capro stand. Center: new Kodak 10, shown with flash extender now included with all Kodak 110s, free to older Kodak 110 owners.**

"Redeye" flash reflections are a problem with flash mounted close to the lens, so Kodak now packs a Magicube extender with every Pocket Instamatic, and offers one free to older Pocket Instamatic owners; for other camera owners, the price is now reduced to \$1.50. Electronic flash units cut the cost per shot for heavy flash users, but, with the exception of the Kalimar, don't

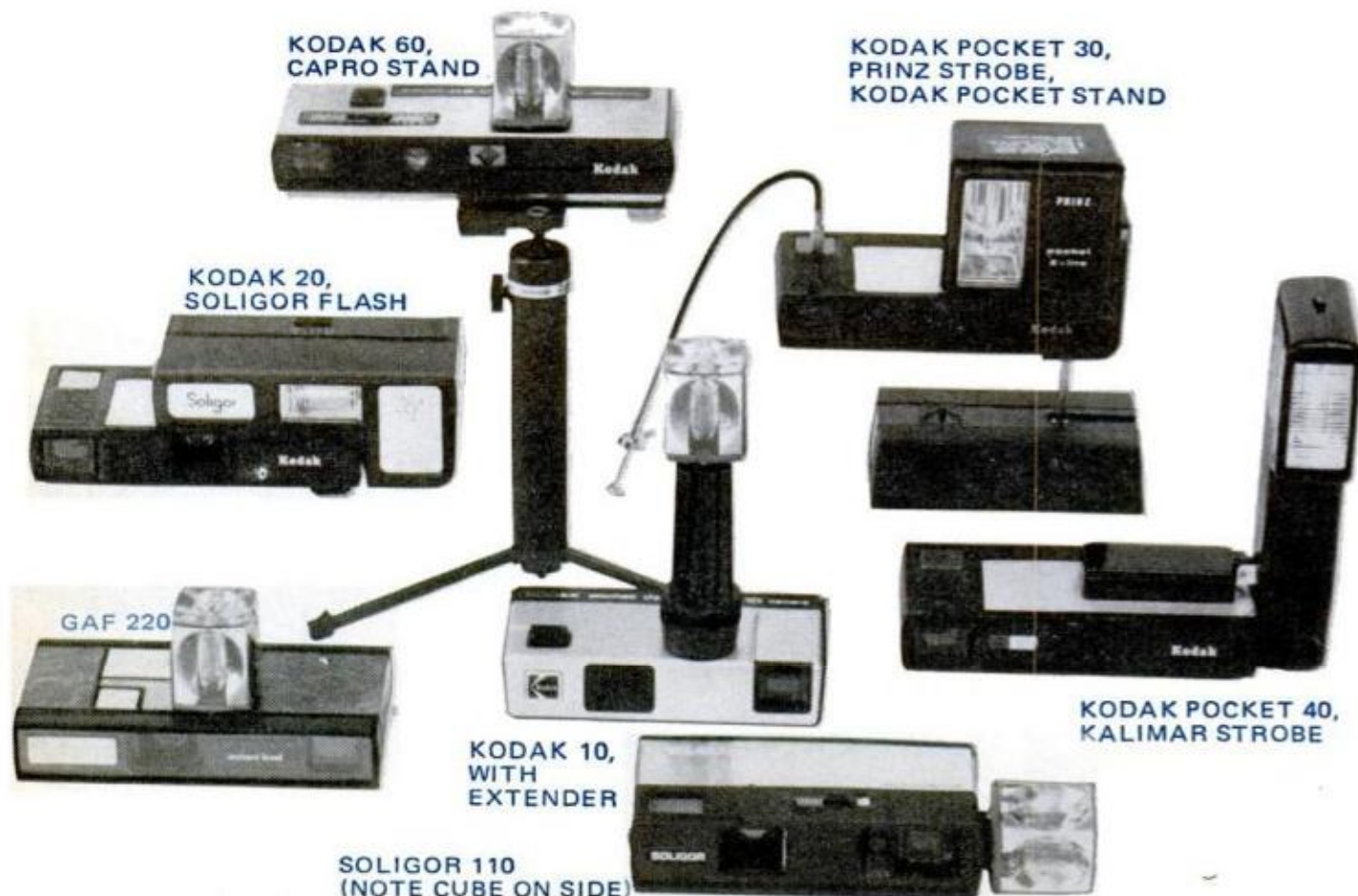





**Pocket Instamatic shots** are at their best as slides. At top left: Kodak's Pocket Carousel (center), next to standard Carousel tray for size comparison; D&L 33-mm lens in front of tray; in foreground, Capro viewer, Kodak and Hanimex 2x2 slide adapters, Berkey 2x2 mounts; right, Minolta 16 projector for 2x2 mounts, with slide previewer (circled). At left, Argus 2110 Pocket Slide Theater. Above: Bell & Howell Slide Cube projector with short-focus lens for 110 projection.



help with redevye. The built-in strobe on Keystone's new 110 Everflash doesn't either, but the side-mounted flashcube on the Soligor 110, two inches farther from the lens than top-mounted cubes, does.

Kodak's Pocket Carousel for 30x30-mm-mount 110 slides is being joined by an Argus table-viewer/projector combination, with some Hanimex projectors in the offing. Capro now has a pocket slide viewer that takes 110 slides still mounted on the "stick" as Kodak returns them. Other processors, and now Kodak, too, will also return 110 slides in standard 2x2-inch mounts for use in regular slide projector's lens.

Most useful of accessories I've tried is Kodak's new Pocket Instamatic Clip (like most electronic flashguns, it doesn't seem to fit non-Kodak 110 cameras too well). It's cheap, effective camera insurance. For better, if bulkier, protection, cases are now available in plastic or vinyl from Kodak, Casemakers, Service and others. ★★★

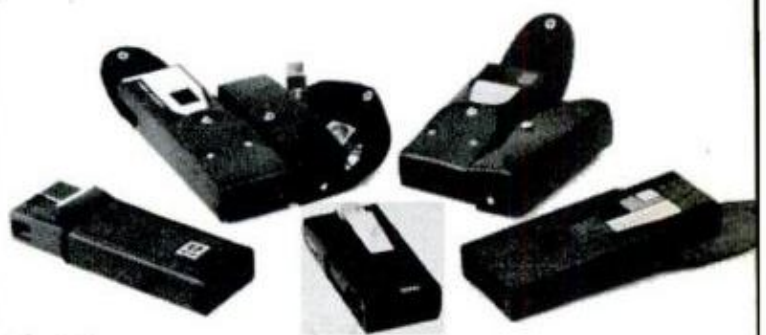

**Cases protect cameras;** clips keep them in your pocket (top). Case at left in upper shot and clip on camera at center are from Kodak. Others (including two-piece model with detachable film and Magicube case) are by Casemakers. Tanks and reels (lower photo) were here for 110 before cameras were, since 110 film is 16 mm wide. Shown from left to right are Honeywell, Nikon, Jobo and Kinderman.



# Shredders, grinders, chippers

They make mulch, compost and new soil.

by Gerald Kratsch

The grass clippings or leaves you discard this season can enrich your soil next year. You can put garden residue to good use—and eliminate a disposal problem at the same time—with one of the shredders, grinders or chippers now available. Some of them can reduce debris volume by a ratio of 15 to 1.

Fine shredding helps speed the decomposition of materials in a compost pile. Coarser chopping produces good mulches. With a chipper, branches can be turned into chips for use as ground cover. These machines are especially useful for the organic gardener.

Here and on the next three pages is a brief look at some units now on the market.



## Shredder-bagger: designed for light-duty work

This is the most common type of shredder, the simplest in design and the lowest in cost. It uses high-speed rotary blades that are similar to the cutter on a rotary mower. Blade velocity creates a discharge of air that propels the shredder material into a plastic or cloth bag, or blows it into a pile. (A variation on the basic design uses a hammer-type rotor that beats material into small

pieces.) The shredder-bagger processes newly fallen leaves (no decayed leaves, compost or other decayed material), twigs and branches that are up to approximately half an inch in diameter, as well as dried stalks and small vines. These units are powered by gasoline engines of 5 hp or under. Their prices are in the range of \$140 to \$195.





### Brush chipper: for heavy work

Most chippers have two revolving blades that turn at high speed and cut against a fixed blade. Except for differences in size and cost, they work just like larger machines used by professionals to process whole trees. Compact garden chippers are designed for branches as large as 2 inches, for heavy shrub trimmings and stems. They turn the material into very fine, compact particles. They are not designed to process compost, soil, manure, large quantities of leaves or grass clippings. Chippers are powered by gas engines that range from 4 to 10 hp and are priced from \$360 to \$660.



### Grinder: more versatile than rotary

The shredder-grinder uses a high-speed hammer-mill rotor—a series of "hammers" mounted on a shaft or drum—that grinds against a grid, reducing the material to a size that allows its passage through the holes of the grid. Since only a little air discharge is developed, the grinder cannot be used for power bagging. Processed material is discharged onto the ground or into a container. This machine does all the work of the rotary plus processing topsoil, clay, dried manure, branches slightly larger than half an inch in diameter. Grinders have engines of from 2 to 7 hp; prices range from \$180 to \$500.



### Kemp shredder: the inside story

In this shredder-bagger, the shredding drum (1) and the teeth or hammers (2) rotate in a clockwise direction. Material is forced at high speed against a baffle plate (3), where most of the shredding takes place. If material is not shredded sufficiently to allow it to fall through the screen (4), it is carried around again for more shredding action. Some additional shredding of soft material takes place against the surface of the screen, where hard material such as phosphate rock also is ground. The baffle (3) keeps material in contact with the specially hardened shredding teeth.





#### A 5-hp 'composter' from Allis-Chalmers

Powered by a Briggs & Stratton engine, this machine shreds and grinds leaves, clippings and heavier material such as twigs and small branches into fine particles ready for the compost pile. Three hammermill-type blades are fed from hopper; particles discharge from bottom gate.



#### Bolens 6-hp mulcher-bagger

Six reversible cutting knives chop leaves, grass clippings, sticks, vines, tree prunings, hedge trimmings and other garden wastes into mulch. A mulch helps control soil temperature; protects soil from sun in hot weather, and slows the cooling process when the mercury begins to drop.

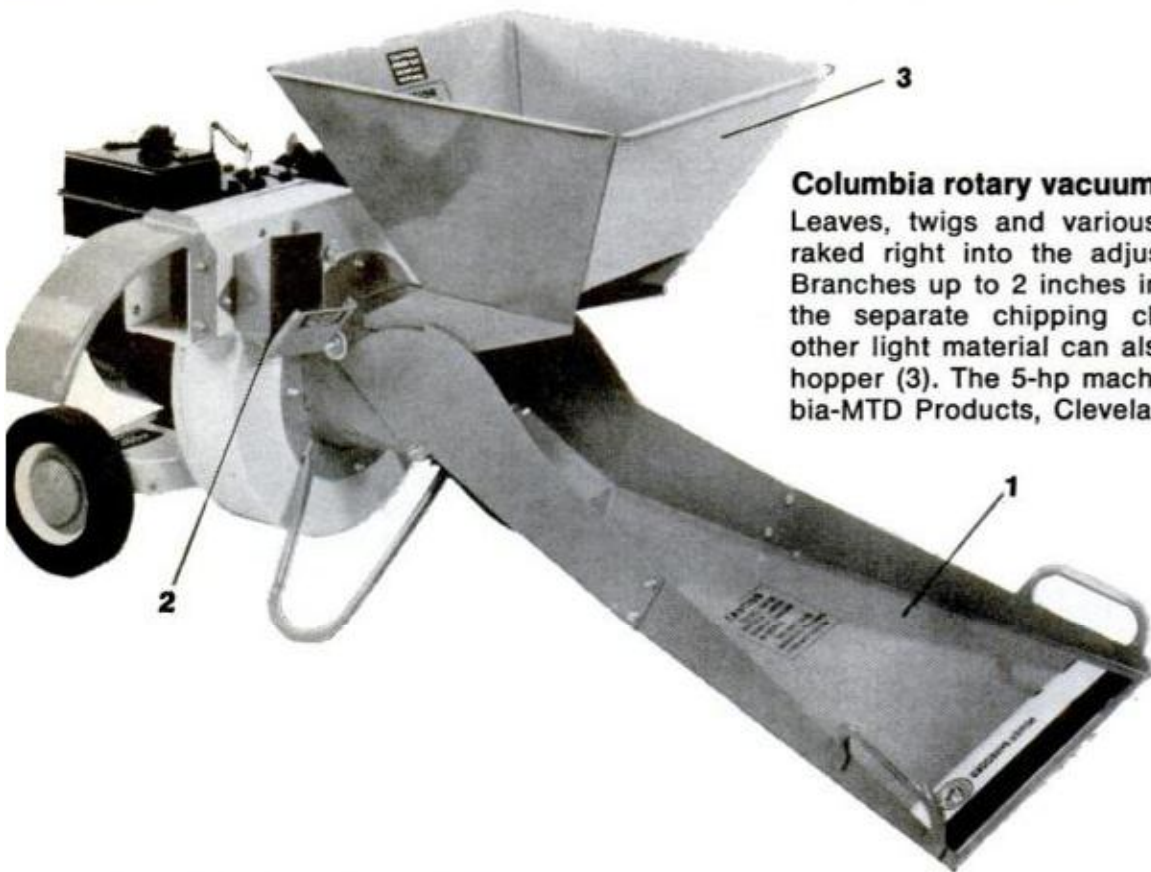

#### Columbia rotary vacuum shredder-bagger

Leaves, twigs and various other debris can be raked right into the adjustable drop chute (1). Branches up to 2 inches in diameter are fed into the separate chipping chute (2). Leaves and other light material can also be poured into wide hopper (3). The 5-hp machine is made by Columbia-MTD Products, Cleveland.





### Shredder attachment for Gilson tractor

Owners of "S" series tractors can add this front-mounted shredder, driven by the tractor's PTO (power take-off). There is a 15-inch clearance above the ground to permit direct discharge into container. The unit handles larger branches, root clumps and other coarse garden wastes.

### A shredder and chipper in one package

Another machine for making little ones out of big ones is Billy Goat Industries' Chippit. It has two hoppers—one for shredding leaves and vines, the other for chipping branches. Both can be fed at the same time. A 5-hp model processes 2-inch branches, and the 8-hp Chippit handles 3-inches. ★★★





# How to select a modern scattergun

Shot shooters can select from a fine new assortment for skeet, trap and game.

by Gary Gillespie

In a country once described as a "nation of riflemen," the shotgun has become America's most widely used and versatile hunting and target tool. True, the rifle remains king for certain types of long-range accuracy, particularly for big game. But in all-around use, the scattergun now ranks first across fields and forests, trap and skeet ranges. As proof of this popularity, there now exists a wide variety of shotgun models, actions, gauges and prices.

To anyone in the market for the latest in smoothbores, this presents a problem and an opportunity. It is difficult to choose from so many options, but there is also a better chance to find a shotgun particularly suited to your activities.

□ *Single shot* is usually the lowest priced action, except for expensive trapshooting models. With simple "break-open" design, it is a popular beginner's gun, particularly in "youth" versions with short stocks. Due



**Over and unders**, like new Browning Liege (above and at top), permit barrels with different chokes, open and tight, on same gun.

**Upland gunners** prefer a light, fast-handling model, often 20 gauge, for short-range work such as quail hunting in Southwest.





to its limiting one-shot feature, however, it is a poor long-term choice for serious hunting. Price range: \$30 to about \$55.

□ *Pump action* is a feature of America's basic "bread and butter" shotgun. Its rugged dependable action requires little maintenance. For varied types of shooting, look for models permitting interchangeable barrels with different chokes. These can give you, in effect, three shotguns for about 50 percent more than the cost of just one. Price range: \$100 to \$230.

□ *Semiautomatic* is usually called "automatic" or "autoloader." This gun reloads automatically each time you pull the trigger and fire. Automatics are more expensive than pump actions and require more frequent cleaning and maintenance. They are appropriate for all types of hunting and highly versatile when the barrels are interchangeable. They excel for the fast shooting encountered in skeet doubles and such

sports as quail and dove hunting. Gas-operated models are lighter in recoil—a worthwhile factor for both youngsters and ladies. Price range: \$145 to \$270.

□ *Bolt-action shotguns* are repeating models that use the familiar rifle-type action. Usually they lack the "feel" and swinging qualities of more common shotgun actions for serious hunting, but can be good, low-priced utility guns for occasional use on garden pests and the like. Price range: \$35 to \$70.

□ *Over-and-under double barrel* models have been growing in popularity recently but generally are the highest priced type of action. Two barrels, positioned one atop the other, permit two chokes on the same gun—open for the first shot and tighter for the second. The over and under is ideal for hunting upland birds such as grouse and pheasant. Price range: \$200 to \$1300.

□ *Side-by-side double barrel* has the two barrels positioned horizontally. Advantages



**Browning Liege**, with newly popular over-and-under barrels, is example of high-quality economy at \$473. It's available in 12 gauge only with all field chokes.

**Fully-equipped waterfowl hunter** can use 20 gauge over decoys; should pass shoot with 12 or 20 magnum.









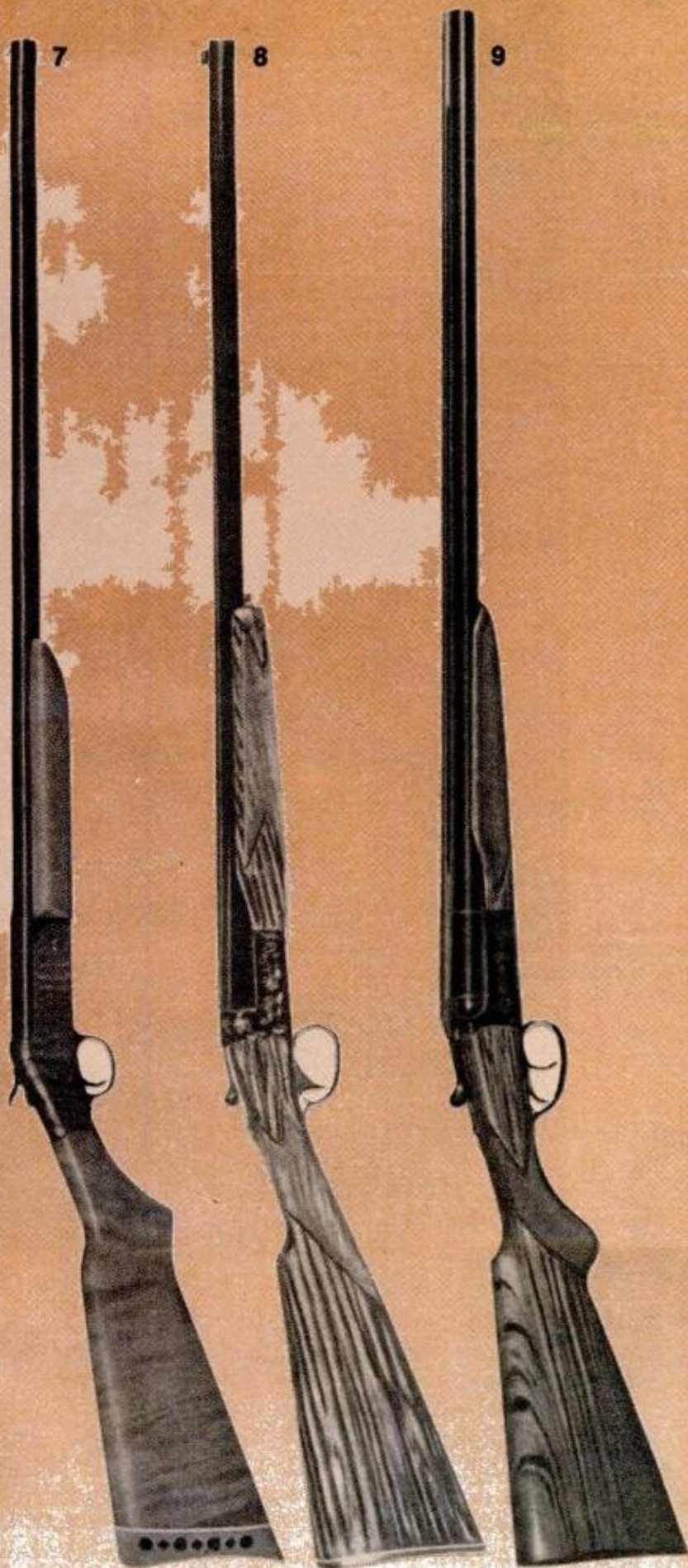

**Sears** extensive gun line, all tested by Ted Williams, includes this low-recoil auto. New over/under magnum 12 is priced under \$200.

are similar to those of over and unders, but these are often lighter and faster handling. For budget buys, look for two-trigger models without automatic ejectors. Price range: \$110 to \$325.

□ *Choke selection* determines the degree of narrowing or constriction at the muzzle or outer end of the barrel. Open chokes such as "skeet" or "improved cylinder" let pellet pattern spread quickly for close shots within 30 yards or less. These open chokes are best for game in close cover. Select intermediate or "modified" choke if your shooting is varied

*(Please turn to page 188)*

**1. Savage 333**, new over and under in 12 or 20 gauge, has ventilated rib, auto ejector, interchangeable barrels, \$274.

**2. Winchester** new single-shot, Model 37A, comes in 12, 16, 20, 28, 410 gauges; has shorter stock for 410, 20. From \$47.

**3. High Standard Supermatic** gas-operated autoloaders have 26, 27, 28 or 30-inch barrels; at \$160 up, 12 or 20 gauge.

**4. Mossberg Model 500** pump, \$107 up, is in 12, 16, 20 gauges. Pederson Custom Guns will feature fitting, import actions.

**5. Marlin 120 Magnum 12-gauge** pump has 3-inch or standard shells. \$230 trap 120 has Monte Carlo stock, 30-inch barrel.

**6. Remington's** new 3200 is modernized version of famous Model 32. O/U 12-gauge field, trap, skeet models, \$450 up.

**7. Harrington & Richards Model 158** is a single-shot gun that is available in 12, 16, 20 and 410 gauges. Price: \$41.95.

**8. Ithaca Gun's** new double-barrel Model 280 side-by-side in 12 and 20 gauge has traditional English-style stock, \$305.

**9. Beretta GR-2** from Garcia is a classic side-by-side double in 12 or magnum 20 gauge with double triggers; about \$300.



# Grade crossings take a deadly toll

Inadequate warning systems and driver negligence add up to 1400 deaths a year. Now new safety measures are under study.

by Jack Harrison Pollack

A tragedy at Congers, N.Y., provided the impetus for the development of the Solitron system, which uses radio waves to activate a warning device in a motor vehicle near crossing. Photo shows front section of school bus, sliced in half by freight train.

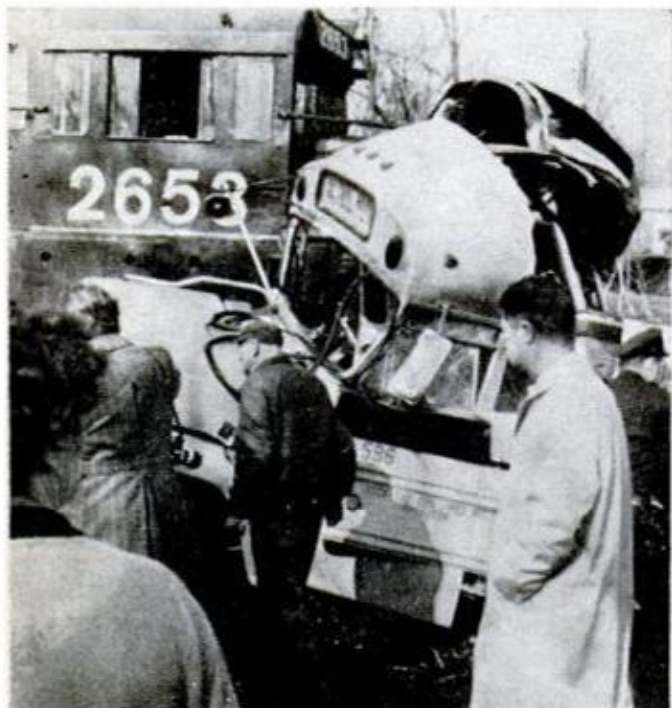

**T**RAIN HITS SCHOOL BUS . . . 5 KILLED IN GRADE-CROSSING WRECK . . . FAMILY WIPED OUT IN RAIL-HIGHWAY CRASH.

Headlines may vary, but the story is essentially the same: Each year approximately 1400 persons are killed and 1000 injured in 12,000 accidents at the more than 200,000 public grade crossings in the United States.

Four out of five of these crossings are protected only by passive devices such as the





ROY GRINNELL

familiar crossbuck (X) sign, according to the U.S. Department of Transportation. A study by the DOT found that 30,000 grade crossings warranted immediate improvement. Yet only about 1300 receive automatic protective devices each year.

Even at many "protected" crossings, lights flash and gates come down long before a train arrives—if, in fact, a train does.

Countless drivers cross tracks day after

day without seeing a train, tending to make them less cautious. In time, even warning devices become part of the familiar scenery. This helps to explain why two out of three victims die at grade crossings within 25 miles of home. Two-thirds of fatal accidents occur in daylight and clear weather, and most frequently during the peak traffic period between 4:00 and 6:00 p.m.

The old "stop, look and listen" advice to



## Primitive accidents in the space age

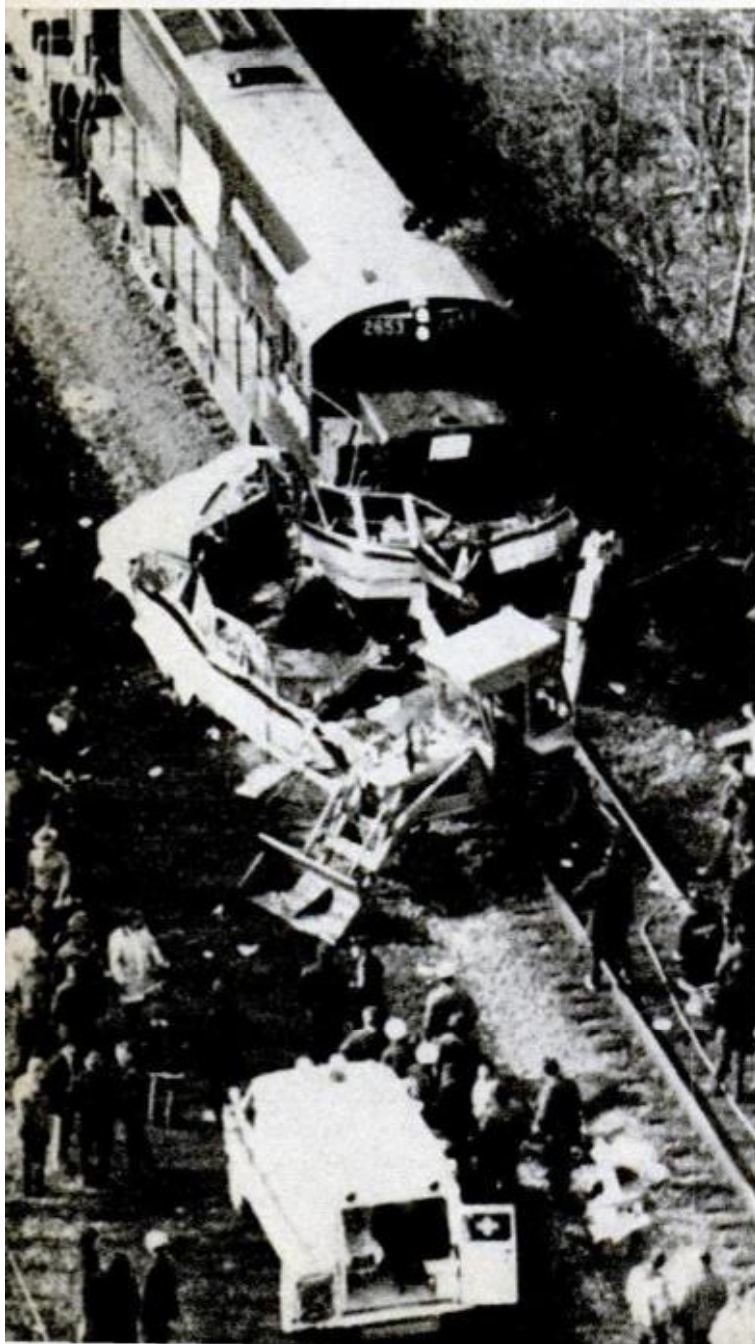

motorists is as antiquated as the sleepy 19th-century crossing watchman with his flag or swinging lantern. But it is still important. Though school (and public) buses are required to come to a full stop at most grade crossings, some drivers fail to do so.

That's what happened in March, 1972, at a grade crossing at Congers, a town about 25 miles northwest of New York City. Five high-school students were killed and 44 injured when their bus was hit by an 83-car freight train traveling at about 25 mph. The train ripped the bus in two—dragging one section for a quarter of a mile before coming to a stop. (A train may need as much as two miles to come to a stop.)

Witnesses said the driver failed to stop at the grade crossing and to open the bus door for a look down the tracks, as is required. The driver was ultimately convicted of negligent homicide.

The only protection at the Congers crossing was a warning sign. A railroad spokesman described the crossing as "private," meaning that the road is not a federal, state or town highway. Thus, there is no legal requirement that it have gates or flashing lights. After the accident, school buses were rerouted to another crossing equipped with automatic gates.

More than half of the nation's grade crossings are still "protected," as in the horse-and-buggy days, with the standard stationary crossbuck. It is utterly inadequate at the majority of crossings. The black-and-white sign is too often obscured by trees, shrubbery or billboards, located too close to the tracks or desperately in need of paint. At night you may not notice it at all, especially if it is not reflectorized. Is it any wonder, then, that almost two out of three grade-crossing accidents occur at crossings having only these signs?

New-type signs were recently installed at 204 public grade crossings along the 351-mile B&O Railroad mainline between Washington, D.C., and Parkersburg, W. Va. These signs say: "Look for Trains" and

**Five students died** and 44 were injured in the Congers crash. The 83-car freight pushed the forward section of bus a quarter of a mile before coming to a stop. Driver, convicted of negligent homicide, failed to stop at crossing.



"Railroad Signal Ahead." They are on 36-inch, diamond-shaped, reflectorized metal and painted in black on a yellow background.

The most effective device, introduced in 1936 and improved since, is the automatic short-arm gate working in conjunction with a flashing electric signal. When a train approaches, red lights flash. After three to five seconds, the gate, illuminated by a red light, descends, blocking the right half of the highway, but leaving the left clear so that a car can't be trapped. The gate rises only after the tracks are clear in both directions.

In the entire country, about 9000 grade crossings are equipped with these automatic gates and flashing lights, and some 33,000 with flashing lights alone. They are not cheap—the gate and lights cost over \$20,000 to install—but even in wealthy New York State, less than half of the grade crossings have automatic gates or warning lights. They are being installed at the rate of only 30 a year, which means it will take 80 years to complete the job!

Some time back, Webster City, Iowa, residents were outraged to learn that the town could spend \$2 million for an emergency power plant but not \$5000 for an automatic gate (the necessary wiring circuits are already there with the present signals). In Houston, people stood on a railroad track in protest of the lack of even a warning signal at a crossing where six had recently died.

A few communities are trying to reduce grade-crossing accidents with \$100 motorist fines and court appearances for violations at crossings. San Joaquin County, Calif., launched such an enforcement campaign several years ago after eight teenagers were killed at a crossing when their minibus became stalled. This county has six railroads and nearly 1000 grade crossings—probably more than in any comparable area in the world.

A "near miss" educational campaign is being sparked by the National Safety Council. Train crews on 12 railroads now record reckless motorist behavior which could result in a collision. Railway officials promptly report these violations to a driver's company or school district, or contact the offending motorist himself.

The ideal solution, of course, is to elimi-

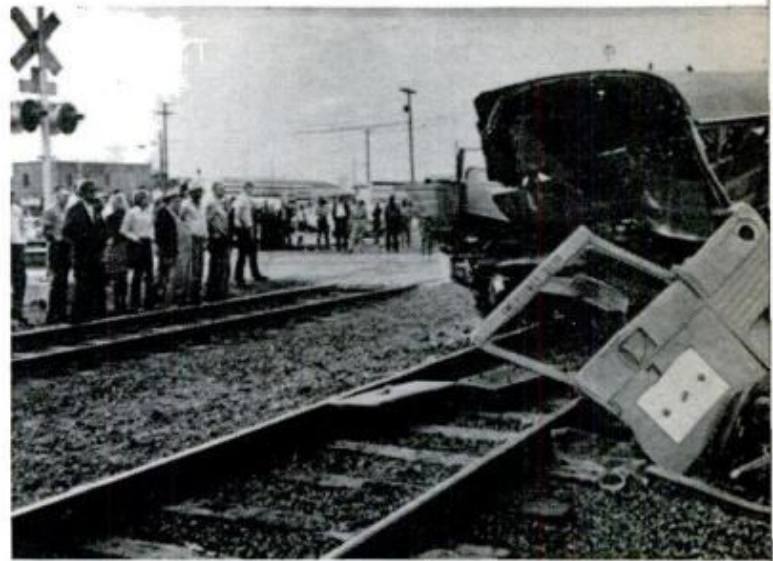

**Another tragedy** occurred early this year at Littlefield, Tex., when a Sante Fe freight plowed into a bus carrying 29 children. Seven were killed and 16 hospitalized as a result of the crash.

nate grade crossings by building overpasses and underpasses. But this is almost an impossible task. There is one public grade crossing (and perhaps one private) for every mile of the 220,000 miles of rail track in the United States. "Universal grade separation would cost about \$100 billion—four times the total investment of all our railroads combined," estimated John A. Volpe when he served as Secretary of Transportation.

The problem is complicated by the open-



## Research is a vital need

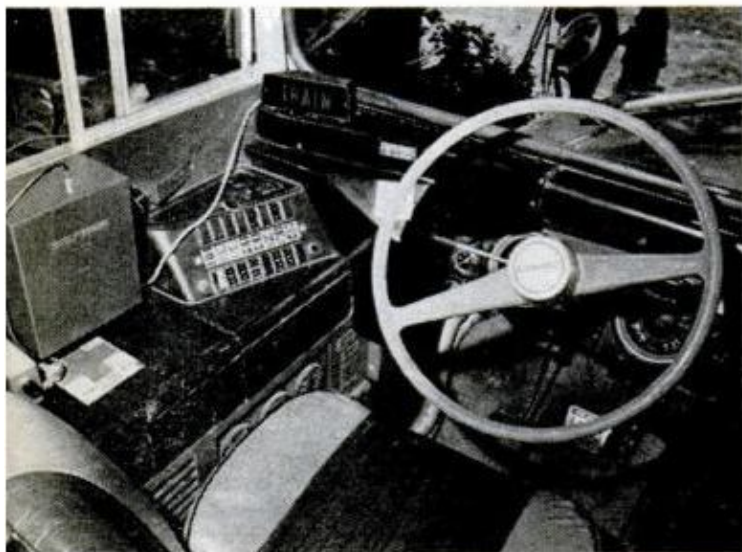

**Receiver in Solitron system** is in box at left. When it picks up signal, it triggers warning device.

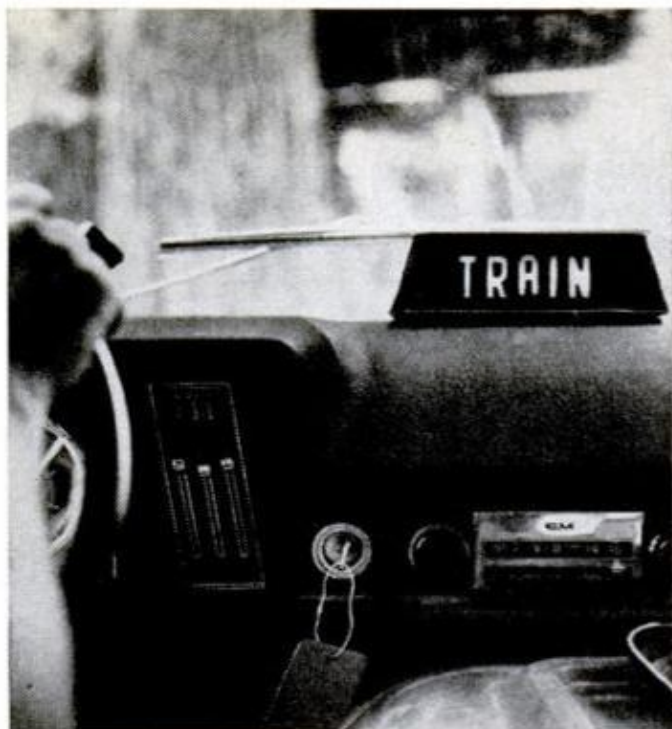

**Display box** produces series of "beeps" as well as visual warning to driver. System can't be turned off.

ing of several hundred new grade crossings each year. New roads, especially in expanding suburban areas, are still being built across railroad tracks. Result: Though the United States has been eliminating grade crossings since the turn of the century, today there are more than existed in 1900.

Grade-crossing improvement costs big money. Federal funds are available, but they are restricted to use on federal-aid highway systems, which limits this source to some 47,000 crossings. And even these must compete with all other highway improvements for available federal highway funds. In 1970, for example, only \$120 million out of more than \$5 billion in federal highway trust funds went into grade-crossing projects.

Some 16 states have launched their own grade-crossing protection and maintenance funds. Unfortunately, other states spend their motor vehicle and gasoline tax monies on everything from oyster propagation to mosquito control—but not on grade-crossing safety.

A basic attack on the whole problem has been started by the Federal Railroad Administration (FRA) and Federal Highway Administration (FHWA). It involves the making of an inventory and detailed description of every grade crossing in the nation. The study is now underway in five states; eventually it will include all 50. The information obtained will be keyed to accident

data and used to develop a system of grade-crossing priorities.

Another federal study is designed to assess driver understanding and reactions at various types of crossings.

New technical improvements are also in the works. A protection system under development for the Department of Transportation uses a continuous microwave signal (rather than track circuits) from a point up-track from the grade crossing. When a train passes a sensor, the microwave signal is turned off and the crossing devices—flashing lights or gates—are activated.

This system can operate in all kinds of weather. While it would give essentially the same message to the motorist, it would probably cost less to install and maintain than the present electric warning systems.

Another study, involving train visibility, is being conducted for the FRA by the National Bureau of Standards. This includes the development of on-train visual aids such as attention-arresting lighting and reflective devices and a study of the effectiveness of various paints and reflective materials.

An improved version of the common crossbuck is suggested by Dr. David M. Lipscomb, a scientist at the University of Tennessee. He would equip it with six equally spaced white lights that would begin to flash randomly at the approach of a

*(Please turn to page 190)*



# Fitting out for bass

It's top tackle that takes the tournament lunkers; here's what the experts use

by Gene Nichols



Fishermen who want to try different gear for getting bigger catches can match tourney winner Martin's bait-casting rig, bass-boat choice.

Roland Martin has already won over \$30,000 in B.A.S.S. events with catches like 12-lb. largemouth this spring from Rodman Reservoir, Fla.

Largemouth bass have become the most sought-after game fish in the country, and the bass boom has inspired a lot of new and specialized tackle and gear.

Professional fisherman Roland Martin has been called the world's best bass angler, and we asked him for an exclusive summary of his recommendations for PM readers. A former Army officer and schoolteacher with a B.S. degree in biological sciences, Martin was named Bass Angler of the Year by the Bass Angler Sportsman Society (B.A.S.S.) in 1971 and 1972. He has now won over \$30,000 on the tournament circuit to top Bill Dance and is presently leading in B.A.S.S. competition points for this year. Here are the equipment suggestions from the 32-year-old ace from Tulsa:

**Rods:** Bait-casting tackle is the choice of many tournament fishermen, with a very sensitive tip combined with plenty of backbone for turning big ones before they can hang you on brush piles and stumps. Spinning, spin casting and fly casting can also be effective for bass. Martin's \$50 3M-Phillipson Bass Slayer is the 5½ or 6-footer.

**Reels:** Among fine bait-casting reels now







available are the Penn Levelmatic, Garcia Ambassadeur, Shakespeare, Daiwa, Sears and Pflueger. Says Martin, "Drag, free spool mechanisms and braking systems are keys to quality." Narrow spools, for better line control, are easier for the beginner.

**Lines:** Choosing a quality brand is essential to prevent stories about "the one that got away." A bargain-basement line can break just when the pressure's on. Among today's popular reliable brands are DuPont's Stren, Cortland Line Micron, Bonnyl, Berkley, Shakespeare and Perlene. Martin rates proper softness for casting distance and accuracy, knotting strength and resistance to wear as all very important.

**Bass boats:** Today's fast fishing machines have come a long way since the old-time skiffs. Speed, stability, maneuverability, shallow draft and ability to handle rough

**Knife choice** for bass busters can range from the Garcia survival sheath knife shown at upper left to a number of folding models.

**Bait for bass** includes the varied collection of "New Reliables" from Garcia shown below, with worms, plugs, jigs and rattlers.





offshore water are requirements. Martin's own Ranger also features bait wells with aerators, fish box, steering console, cushioned seats and other refinements.

*Outboard motor:* Powerful but matched to hull, easily serviced, low profile, rugged prop, power trim are Martin preferences.

*Electric outboard:* A silent, light little mill with comfortable controls, low battery drain is the choice of bass busters. Martin uses a Sivertrol electric up front, a Johnson 135 on the transom.

*Fish locators:* Dedicated anglers swear by the new electronic structure and lunker spotters. A top model should suppress outboard motor and subsurface bubble interference, and be water and rough-usage resistant. Martin's is the new 660 Locator/Sounder, from Lowrance Electronics, that can be read down to 660 feet.

*Lures:* There are thousands on the market and the ardent bassman stocks a variety. Plastic worms, bugs and frogs are effective. Spinner baits are good at depth or on the surface where a buzzing Aggravator can anger a bass into striking. Jigs work well. Surface plugs were the first bait-casting artificials, and currently balsa surface lures like the Big O and Bagley Bait's Big-B are hot. Other favorites include Hula Poppers, Jitterbugs and Tom Cats, plus swimming lures like the Rappalla, Rebels and Mirro-Lures.

*Accessories:* Roland Martin recommends foul-weather gear, cap with bill, Polaroid sun glasses, underwater thermometer, hooks and sinkers, long-handled landing net, filet knife, CB radio, screwdriver, tackle box, jump suit, deck shoes, plus all your own preferences. ★★★

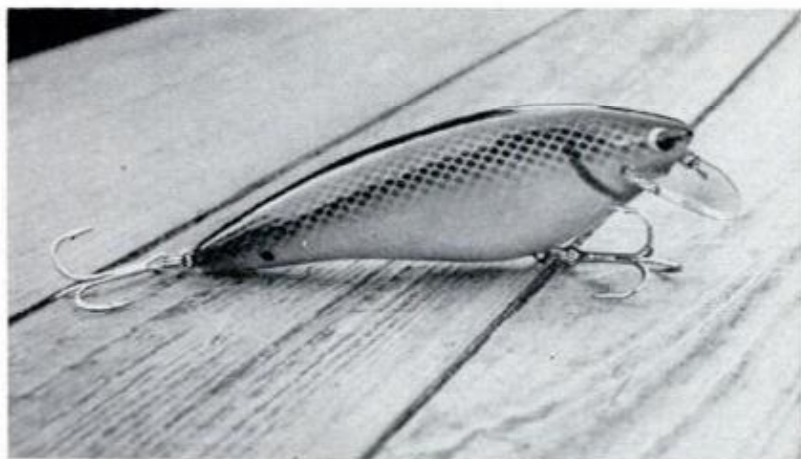

Tournament anglers nowadays favor a pregnant balsawood minnow. Bagley's is called the Big B.

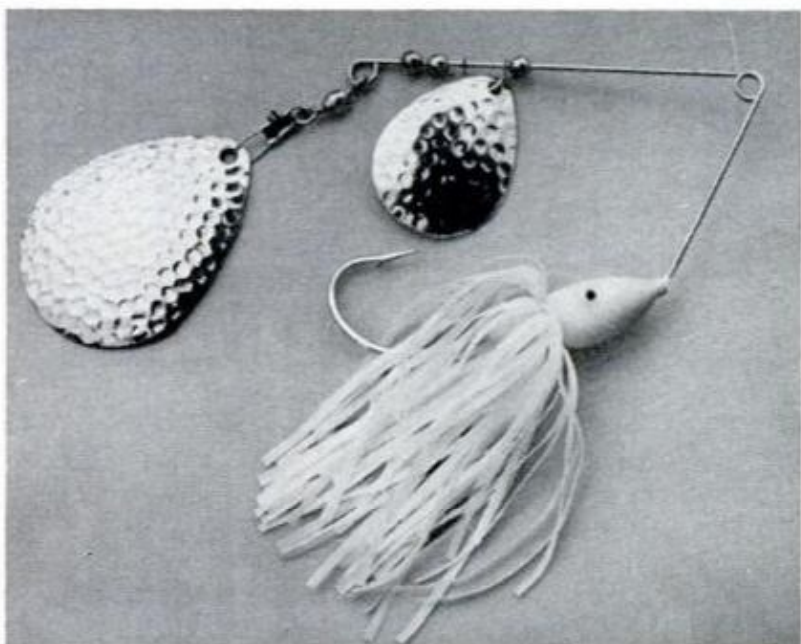

Switch Blade from Bagley's won 1972 National Bass Open. The lure can be ripped along the surface for a buzz effect or fished deep with a slow retrieve.



Multipurpose pliers should be able to crimp and cut; may also disgorge hooks, open cans and bottles, scale your catch.



# Fast fixes for a hesitation problem

by Mort Schultz

**Carburetor accelerating pump** provides sufficient fuel during quick acceleration. If it's not doing its job, hesitation will result.

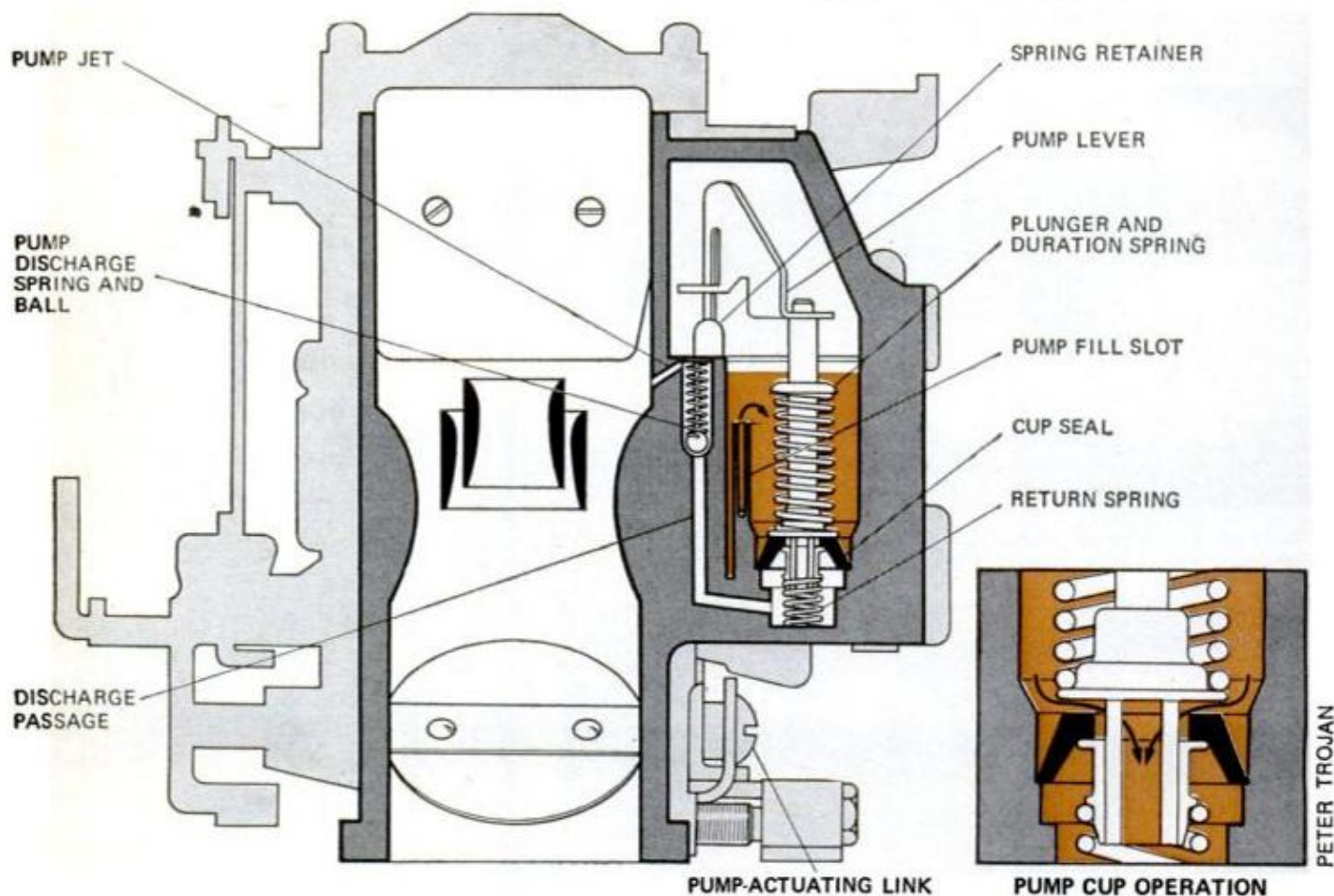

Some call it flat-spot acceleration. Others call it stumble. Whatever you call it, it's lag as you give an engine gas in a situation calling for quick response. The engine doesn't pick up promptly. It falters. Here's a troubleshooting sequence for tracking down a hesitation problem.

**Accelerating pump.** When you press down on the gas pedal to pick up speed rapidly, the amount of air flowing through the

carburetor is increased. Gasoline, being heavier than air, lags behind. Thus, the engine would momentarily be starved for gasoline were it not for the accelerating pump which shoots gas into the carburetor.

To check your accelerating pump or accelerating pump circuit, warm up the engine so the choke plate is open, turn the engine off and remove the carburetor air cleaner. Have someone step up and down on the gas



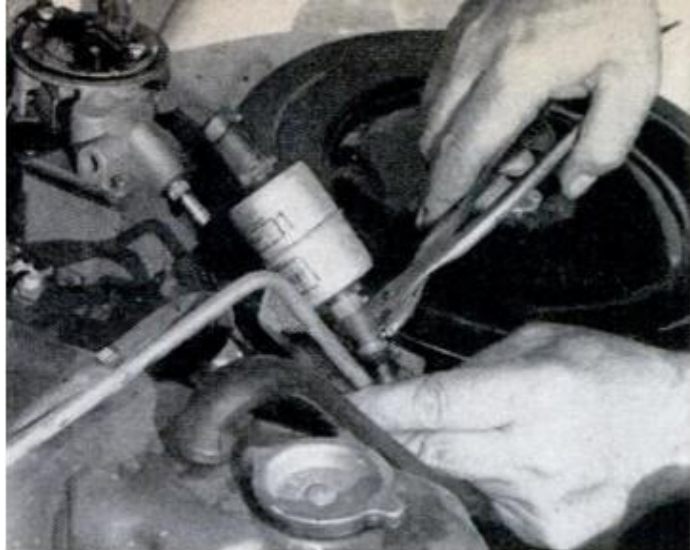

**In-line fuel filter** that's partially clogged will obstruct the smooth flow of fuel to the carburetor. To replace, remove clamps from both ends of the fuel lines at the filter and insert a new filter.



**Internal-type fuel filter** is found at inlet to the carburetor. When clogged, it, too, will restrict fuel flow and cause hesitation. When replacing, take care not to lose retaining spring; it can be reused.

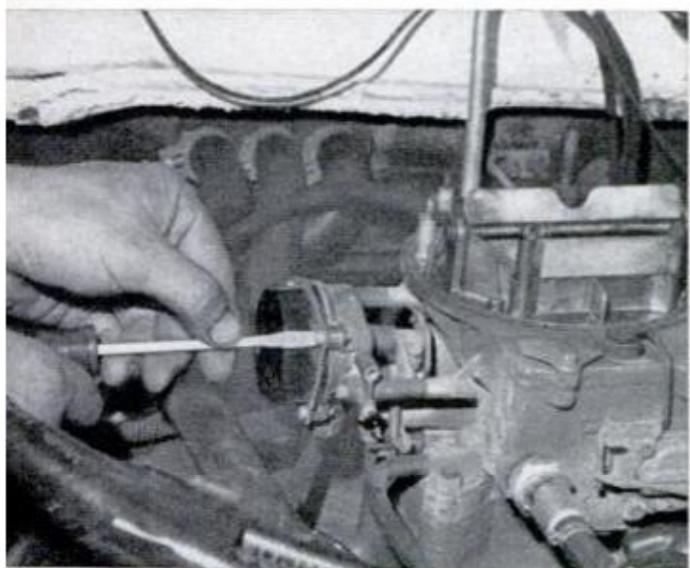

**Automatic choke**, if not adjusted properly, will cause hesitation while engine is cold. Choke controls on carburetor are adjusted by loosening retaining screws and rotating cover one notch at a time.

pedal quickly two or three times, or manipulate the accelerator yourself by actuating the throttle lever to simulate a rapid acceleration situation. A stream of gasoline should squirt into the carburetor each time the gas pedal is pressed.

As the throttle linkage moves (this is the linkage from the gas pedal to the throttle lever), examine it closely. Movement should be smooth—no hangups that could cause lagging acceleration. A dirty or bent linkage should be fixed.

If the squirt of gasoline shooting into the carburetor is weak (or there is no squirt), the accelerating pump is probably bad or the pump circuit is clogged. In either event, the carburetor should be disassembled for service. But first check another possibility—the fuel filter.

**Fuel filter.** How long has it been since you replaced the fuel filter? A partially clogged filter may cause engine lag on acceleration. Every car has a fuel filter—either in the fuel line between the fuel pump and carburetor or inside the fuel inlet at the carburetor. Replace the filter; it may be obstructing full fuel flow.

**Automatic choke.** Does hesitation occur only when the engine is cold? There's a good chance that (1) the automatic choke is misadjusted; (2) the vacuum break is out of whack; (3) the exhaust emission control system isn't working just right.

The automatic choke provides a richer fuel mixture for cold-engine starting and operation. If the choke isn't adjusted correctly or if it is sticking, engine performance will suffer until the engine warms up.

To check choke operation, remove the carburetor air cleaner and start the cold engine in the proper manner. Depress the accelerator pedal to the floor one time before turning the ignition switch. The choke plate should close over the throat of the carburetor. As the engine starts and idles, the plate should open partially, then wider and wider until it is fully open as normal operating temperature is reached.

If the choke sticks, clean dirt off the linkage and from around plate pivots. There are several different brands of good-quality choke cleaners available.

Rule out misadjustment of the choke as a cause of hesitation by readjusting the choke



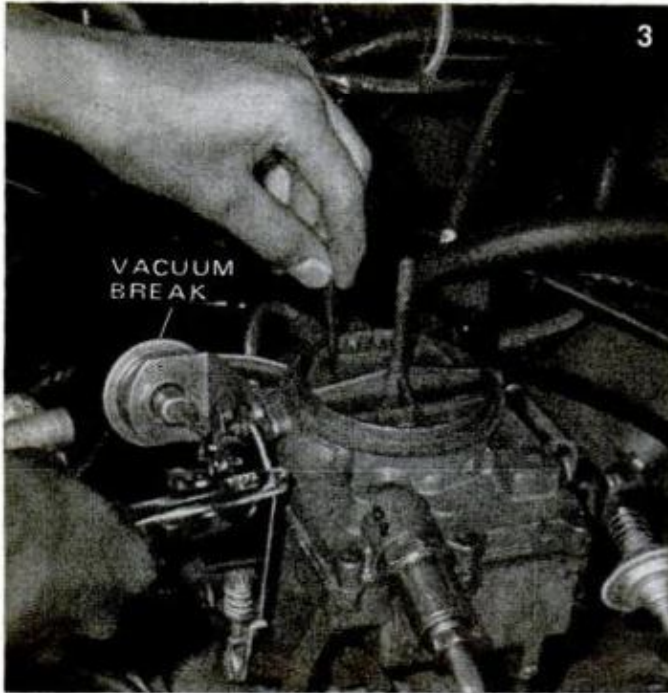
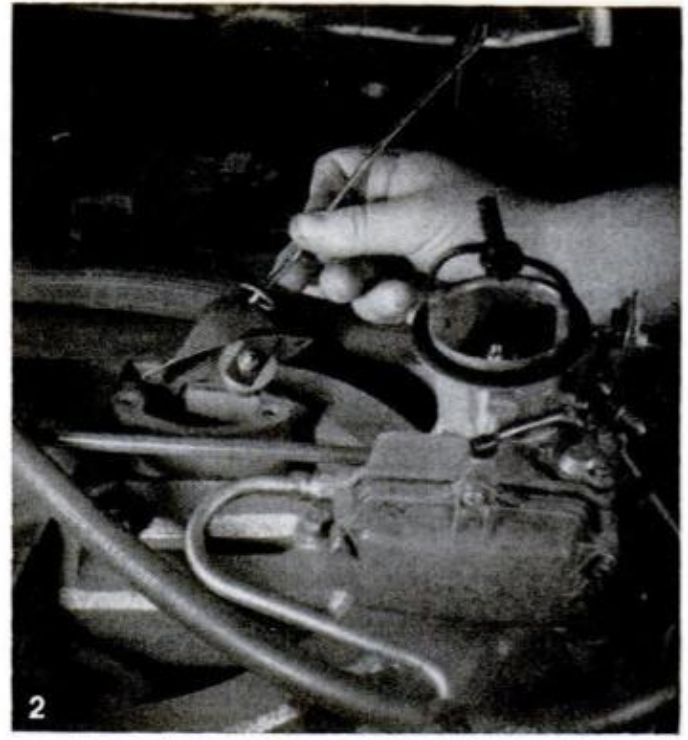
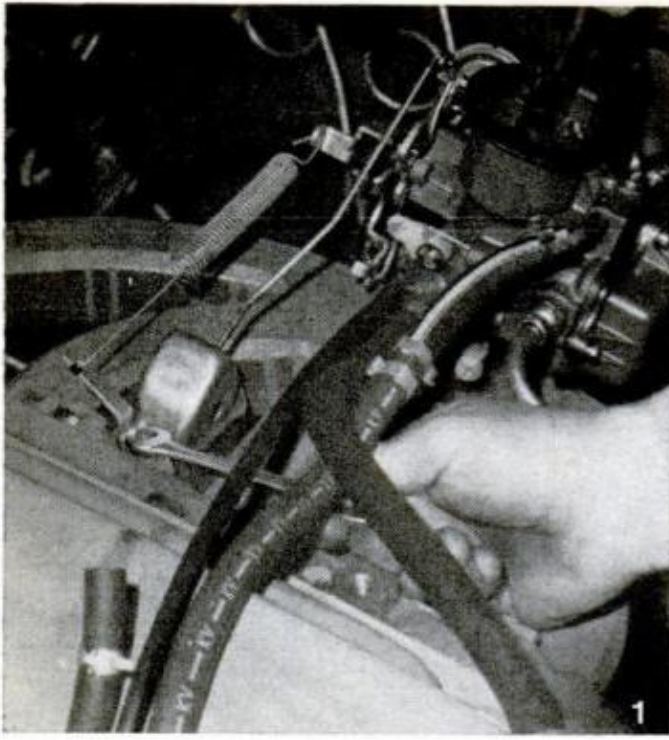

- 1 **Automatic choke**, if not located on the carburetor, will be found at the manifold. The well-type choke has a cover that is removed before adjusting.
- 2 **Well-type automatic choke** is adjusted after unbolting cover. Loosen thermostatic spring retaining nut and move control to rich side one notch.
- 3 **Vacuum break**, which prevents overchoking, is set by placing proper size gauge between choke plate and carb wall and bending choke rod (see text).

to provide a richer fuel mixture. This is trial-and-error, but worth the trial. There are two common types of automatic choke controls. One has a thermostatic spring in a round housing on the side of the carburetor.

The other choke control has a thermostatic spring inside the manifold, with a fairly long rod extending from the control to the choke plate. This is called a well-type automatic choke.

Resetting the choke control on the carburetor is done by having the choke plate wide open and loosening several retaining screws. Rotate the housing cover one notch

to the rich side as marked on the cover. Tighten the screws. Now, test engine pick-up with the engine cold. If the hesitation problem persists, move the choke control one more notch to the rich side. If results are still the same, give up. Your lag problem isn't caused by the choke. Move the control back to its original setting.

If your car has a well-type choke, check that the choke plate is open and unbolt the choke housing (it's a small domed metal cover) from the manifold. Lift out the choke control. Loosen the retaining nut, move the control one notch to the rich side, and proceed in the same way described for



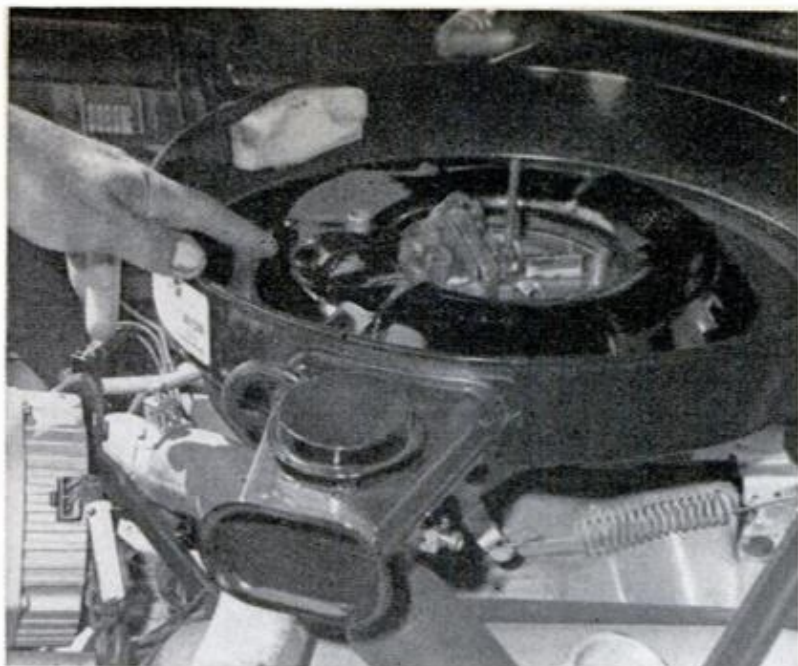

**Carburetor-air-cleaner housing** of late-model cars incorporates thermostatically controlled valve to supply preheated air to carb while engine is cold. Air is picked up at hot exhaust manifold and enters flange C on the snorkel tube via flexible hose. Butterfly A closes off snorkel tube and preheated air goes directly to carb. When engine is running at operating temperature, butterfly A opens, cover B closes off hot air from the manifold and outside air goes directly to the carb through the snorkel tube.

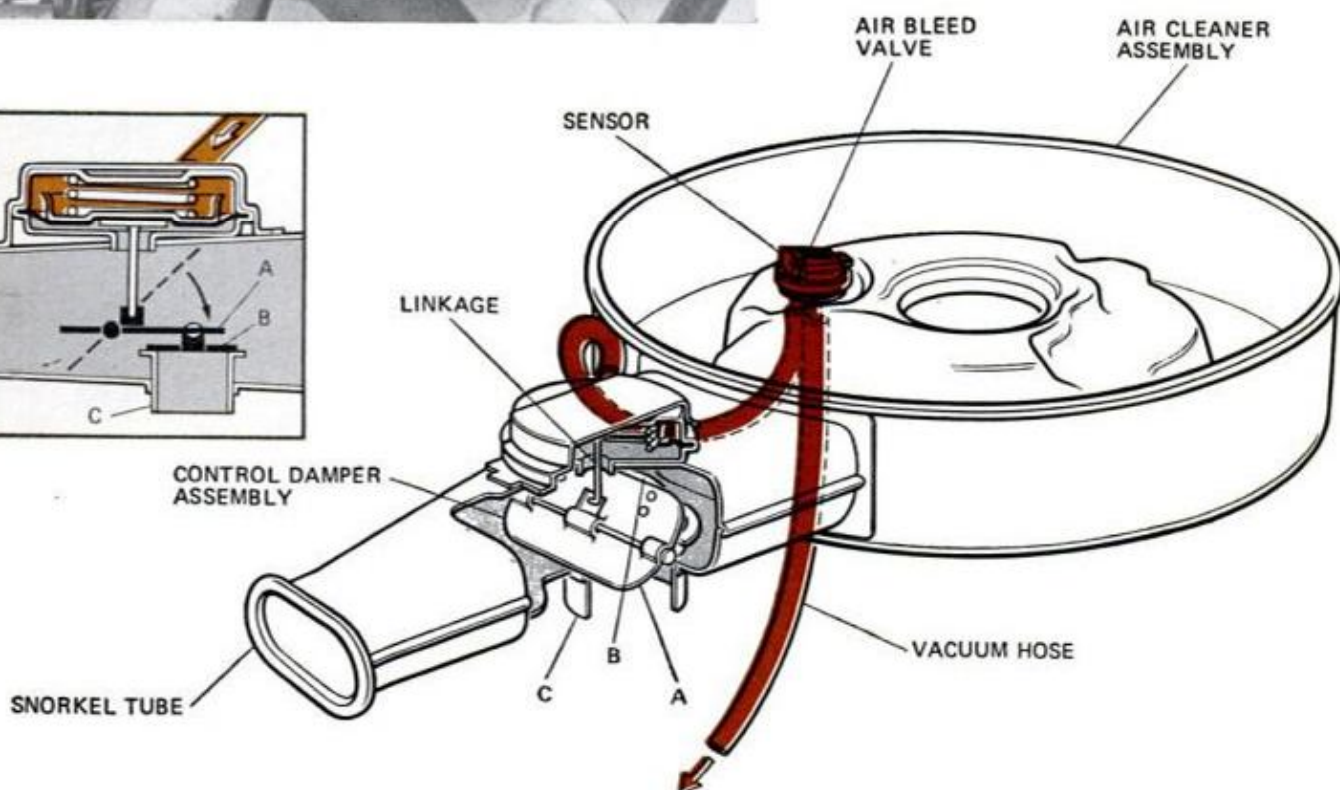
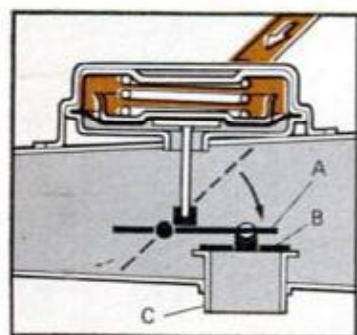

servicing the carburetor-mounted control.

**Vacuum break.** The purpose of a vacuum break is to prevent overchoking. In general, when a cold engine starts, manifold vacuum is transmitted through a channel to a vacuum-break diaphragm that opens the choke plate partially so the engine will run without loading up. If this part isn't adjusted correctly, hesitation is possible.

Don't confuse the vacuum break with the choke unloader. The purpose of the unloader is to allow leaning out of the fuel mixture should the engine flood as it's started. By depressing the accelerator pedal to the floor and keeping it there, you set the unloader

mechanism into motion to force the choke plate open part way, allowing extra air to lean out the fuel mixture.

Consult your service manual to determine how to adjust your vacuum break. Generally, adjustment is done by seating the diaphragm and placing a specified size gauge between the lower edge of the choke plate and wall of the carburetor. If the opening is too small or too wide, the vacuum-break rod, choke rod, or vacuum-break link is bent until the gauge is made to fit properly.

**Emission control.** If your car is a 1968 model or newer, it probably has a thermo-

*(Please turn to page 188)*



# Make your own rotary cutters for those offbeat jobs

by Walter E. Burton

PHOTOS BY THE AUTHOR

## BLANK CUTTERS



No matter how many small router bits or similar rotary cutters the home shop may boast, there are occasions when an offbeat type is needed but not available from normal sources. Often the shop owner can make the needed cutter. The photo shows a quintet of small cutters that were produced with typical lathe equipment.

Determining the precise size and shape of a cutter, as well as the form of the teeth, must be worked out. Often store-bought cutters can be used as guides, especially with respect to tooth shape. For cutting wood, a tooth preferably should have considerable rake and be formed by surface meeting at a rather sharp angle; for cutting brass there can be little or no rake.

**Making the blank.** All cutters shown above have  $\frac{1}{4}$ -in. shanks. The two-flute, router-type bit was made from  $\frac{1}{4}$ -in. drill rod, the others from  $\frac{1}{2}$ -in. drill rod turned

**Five special cutters** from blanks ready to be hardened. From left: "Saw" for cutting  $\frac{1}{8}$ -in.-deep grooves and producing matchstick strips for modelmaking; two-flute router for cutting 5-mm grooves; two-edge molding cutter; cutter with pilot tip (similar to Woodruff keyseat cutter) for  $\frac{3}{16}$ -in. groove  $\frac{1}{8}$  in. deep; double-head cutter for forming matching tongue.

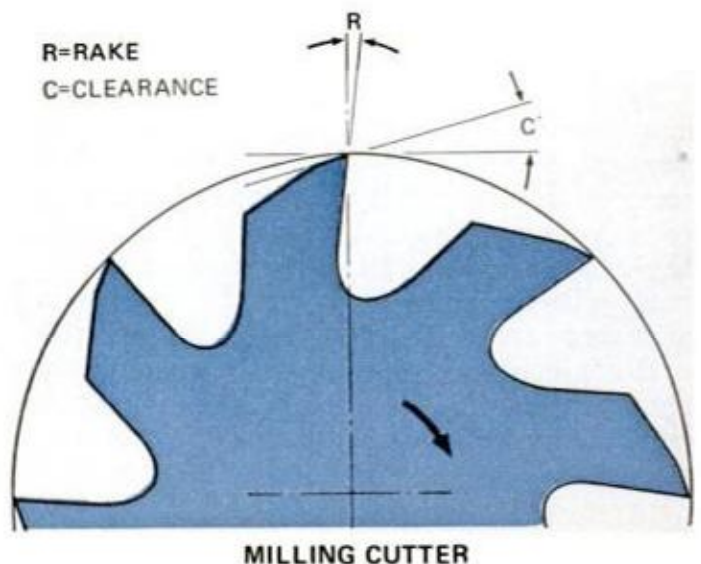



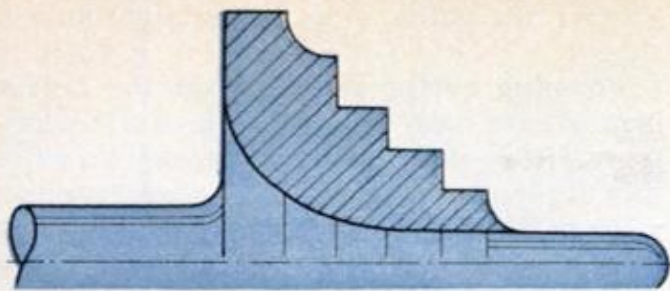

MOLDING CUTTER

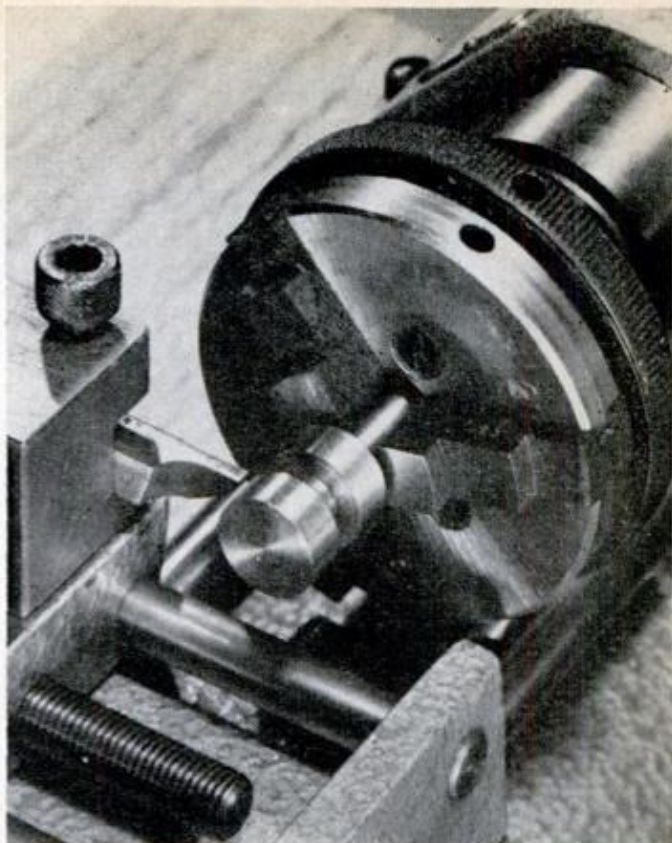

Two-headed, tongue-forming cutter (top photo) was blanked out with cutoff bit, then sides of heads were dished to reduce rubbing. Photo above shows how teeth of two-headed cutter were formed with file.

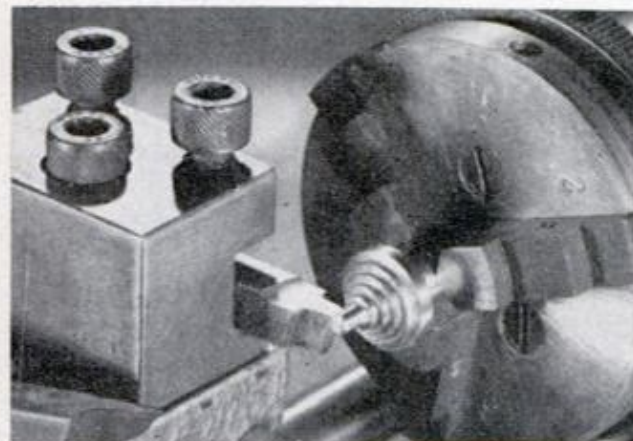

Round-nose cutter (top photo) forms cove grooves in special molding cutter. Square grooves were made with cutoff bit. Photo above shows end-cutting rotary file used to mill curved cutting notches.

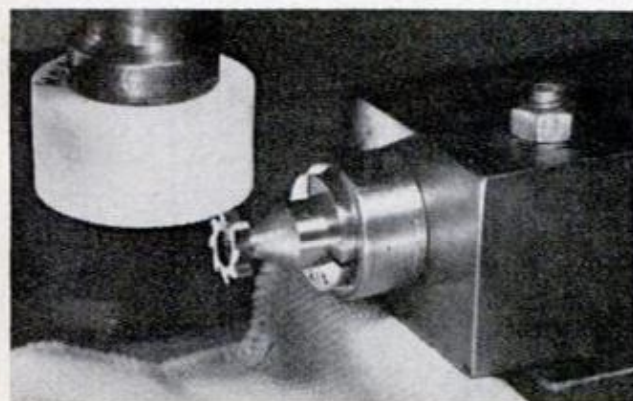
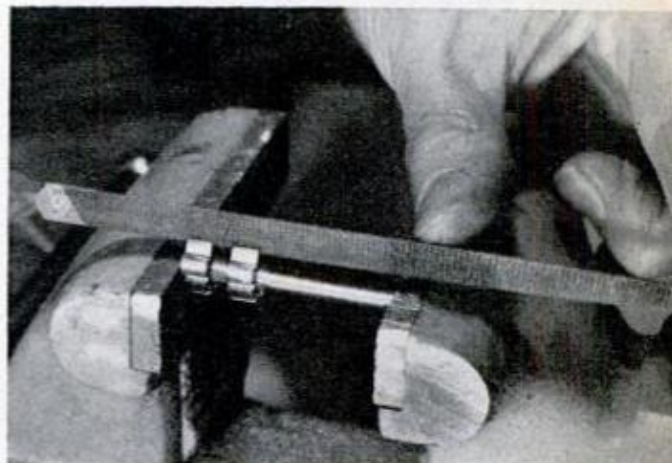
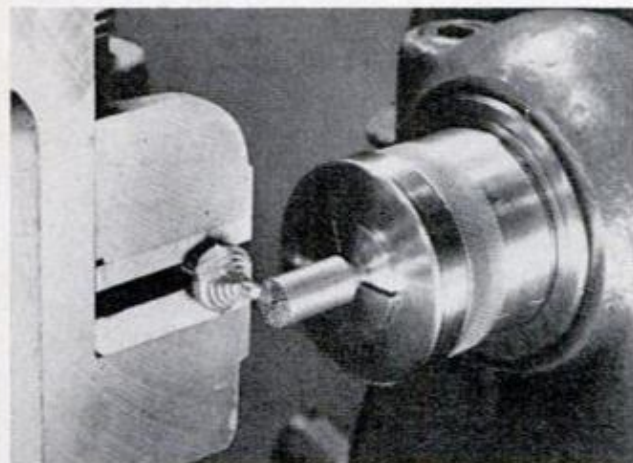

Unimat lathe, set up as a vertical grinder, touches up clearance on the teeth of factory-made cutter.

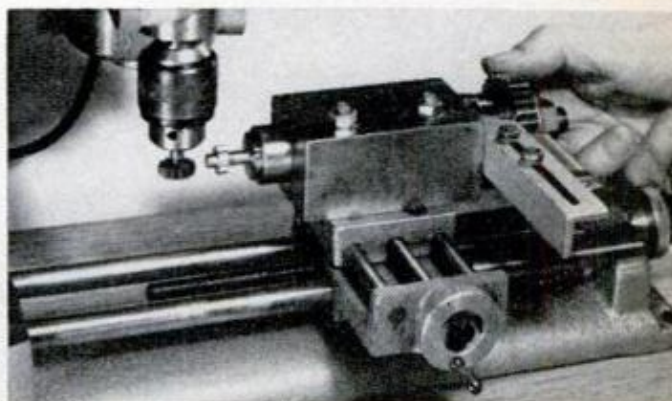

Woodruff keyseat cutter is used to rough-cut notches in 8-tooth cutter with aid of indexing attachment.



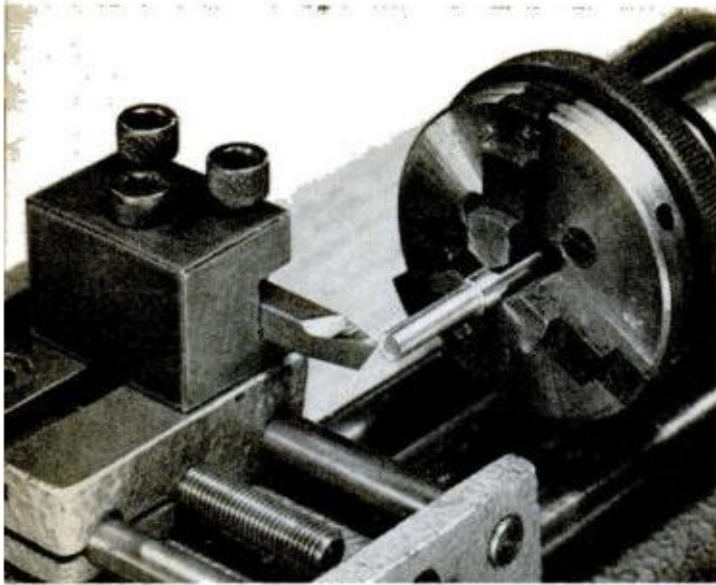

down. To form the cutter contours, I simply ground the lathe bits to the appropriate shape.

**Forming cutter edges.** After the cutter blanks have been turned to the desired contours, it is necessary to "notch" them to produce cutting edges. There are various ways to do this. For precise spacing of cutting edges around the circumference, some sort of indexing arrangement is handy. An indexing head, such as that supplied as a Unimat accessory, can be used. It normally includes a collet or chuck for gripping the cutter shank. Notched or perforated plates enable the cutter to be rotated a certain number of degrees (fraction of a circle) at a step.

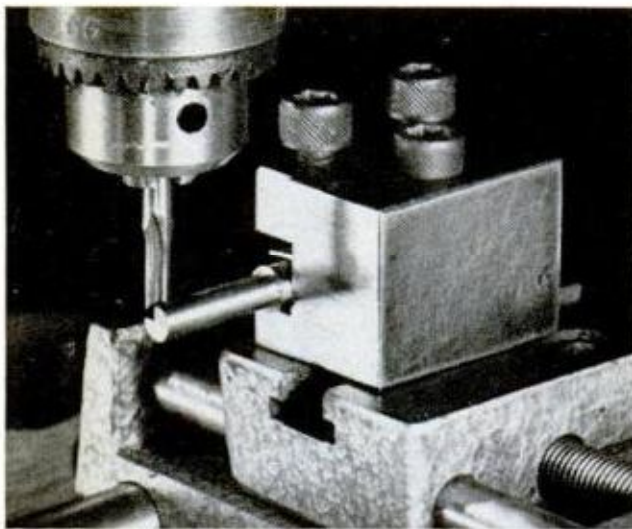

Two-flute router bit is being machined from 1/4-in. drill rod (top) with end turned to 5-mm. diameter. In lower photo, longitudinal flutes (right-angle grooves 180° apart) are formed with blank held in Unimat tool block. Filing relieves edges and end.

The shop-made indexing attachment shown at the bottom of page 151 uses standard lathe collets (from a 9-in. lathe) to grip the cutter shanks. It was described in *Indexing Attachment for Small Lathes* (page 223, Oct. '54 PM). It fits the Unimat perfectly, being fastened to the carriage T-slot with two 1/4-in.-20 carriage bolts extending through vertical holes in the body block.

It is possible, of course, to form cutting edges without using an indexing attachment. Most cutters will work even if the cutting edges are not precisely spaced.

Cutting edges can be formed by milling. Here the router bit is clamped in the Unimat toolholding block and the two longitudinal flutes cut with a bit of similar shape. The conical molding cutter was clamped in a milling vise on a 9-in. South Bend lathe, and an end-cutting rotary file, operating much like an end mill, was used to rough out the two cutting edges.

**The two-headed cutter,** which resembles two Woodruff keyseat cutters on the same shank, was rough-machined on a lathe with a parting-tool bit. The head was divided into eight reasonably equal parts and marked with a file. Hacksaw cuts were made to a depth of about 1/16 in., then files were

*(Please turn to page 190)*



TWO-FLUTE ROUTER BIT

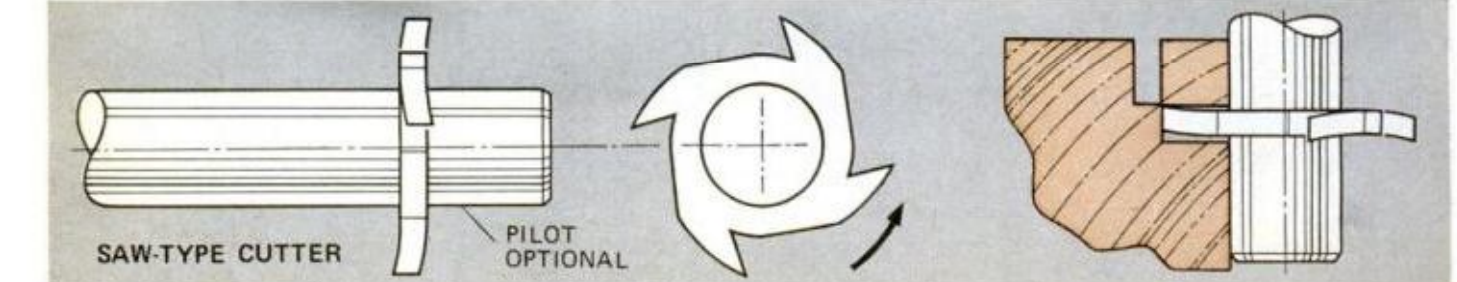

SAW-TYPE CUTTER

PILOT OPTIONAL



# HINTS

## FROM READERS

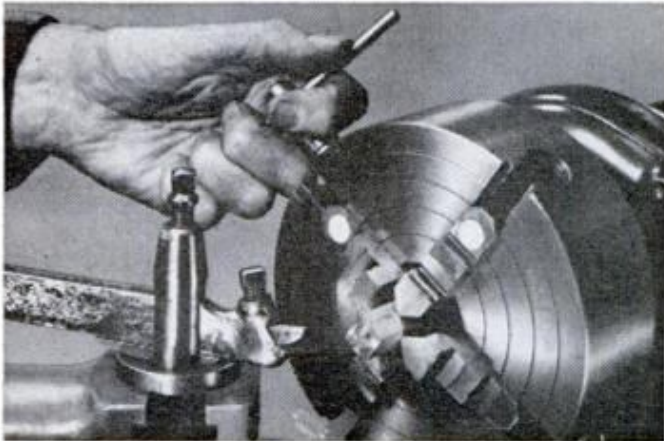

### Tagging chuck jaws

When machining several identical parts in an independent-jaw lathe chuck, you'll save adjustment time by loosening the same jaws each time a piece is removed. To do this, mark the jaws to be loosened in any convenient manner—with dots of adhesive tape, for example.

—Walter E. Burton, Akron, Ohio.

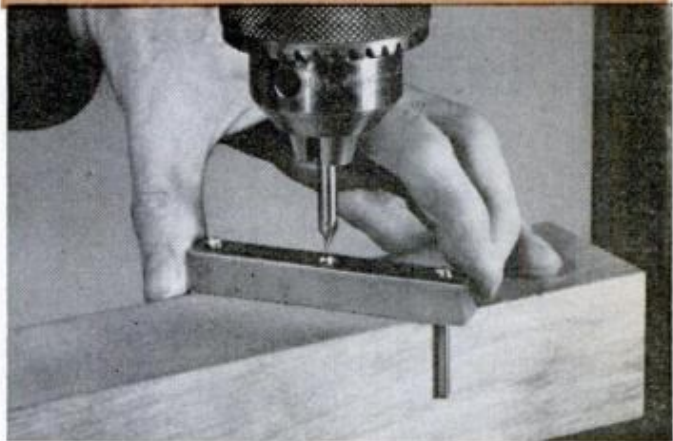
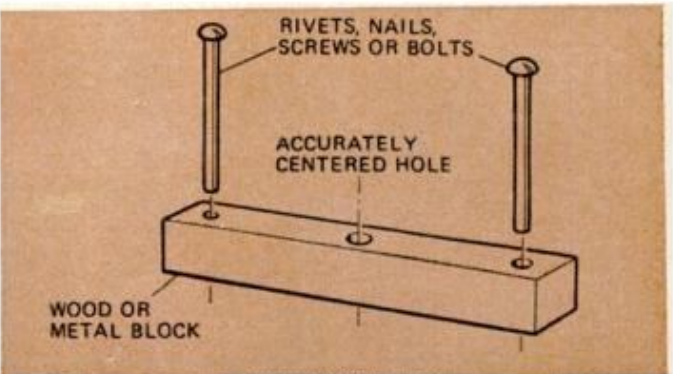

### Centering device

Made from any handy materials, this tool makes it easy to scribe centerlines and punch holes in pipe, boards or metal right on the button. The middle hole can be sized for a desired drill. Just be sure to center this hole accurately as its position will determine the device's accuracy.

—Phillip Dacus, Memphis.



### Inexpensive cleaning aid

A plastic golf-club tube can be used as an extension nozzle for a vacuum cleaner for getting under refrigerators and into other tight places. The flexible tube can be forced into openings too narrow for a rigid nozzle of the same size, and won't scratch furniture or appliances. Tube shown cost 10 cents.—Burt Web, Skokie, Ill.

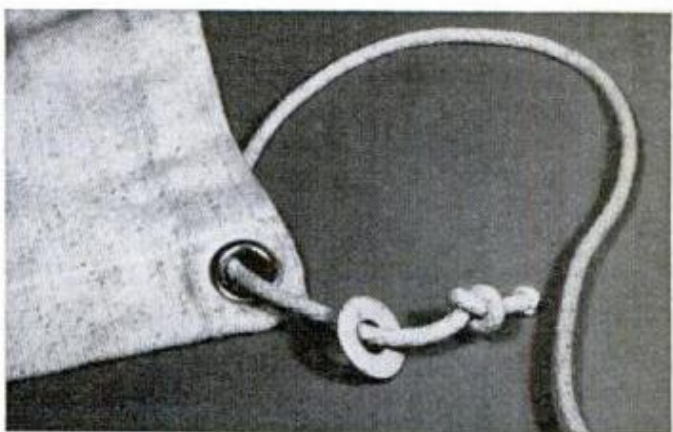

### Washer secures small knot

When a camper had to secure a tent flap by means of a grommet and rope, he found it difficult to tie a knot large enough to keep from pulling through the hole. With a flat washer from his car's toolbox slipped onto the rope behind the knot, rope and tent flap were held fast.

—Victor Lamoy, Saranac Lake, N.Y.



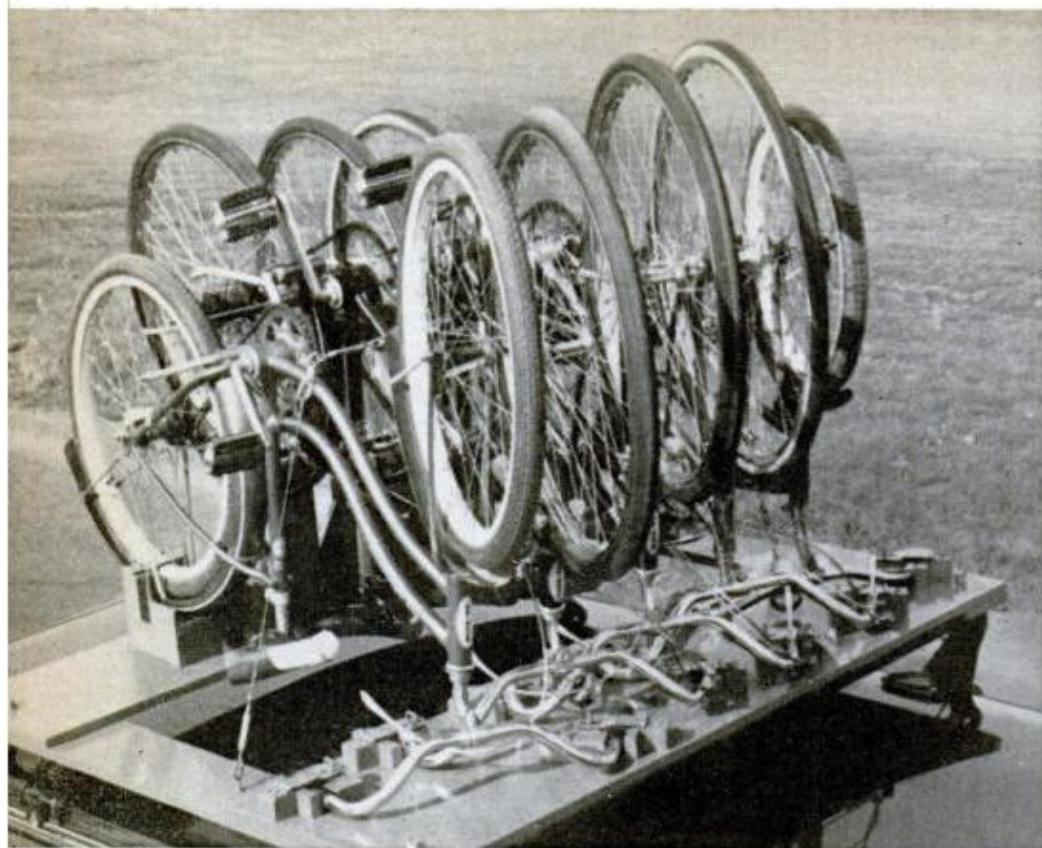

**Bicycles for two adults and three children are mounted without disassembly on carrier. Wire passing through eyebolts attached to bike frames gives extra security. Unit is fastened to luggage rack with wingnuts, can be installed by one person, comes apart for convenient storage.**

## Cartop carrier transports bikes for the whole family

by Homer G. Wolfe

Transporting the family's bicycles to a distant starting point can be a chore. It usually means either partially dismantling the bikes or fussing with a tangle of tie-down straps. With a carrier like this, you and the family will have more time for bike riding since loading and unloading can be done in no time at all.

The clamps, consisting of garage-door hasps and turnable spring-loaded eyes, hold each bike firmly by its handlebars and rear wheel. I made the plywood carrier in one weekend for about \$29; it is mounted on an inexpensive removable luggage rack.

Three clamps are used to hold each bike. To locate them, place the bikes upside down on the carrier in the desired positions.



Handgrip clamps are located and screwed down first. Then the height and location of each rear-wheel clamp is determined by blocking up the back fender until the bike seat is about even with the carrier platform. Distance from platform to fender minus  $\frac{3}{4}$  in. gives dimension A in drawing on opposite page. Dimension B is calculated by measuring distance from outside of bicycle fender to inside of wheel rim, then adding  $\frac{3}{8}$  in. allowance for compressed sponge rubber. Since all clamps are custom fitted to individual bikes, they should be fastened to the carrier with screws only—you may later replace a bike. Spacers shown in the drawing are not structural; they're designed to prevent wind noise. ★★★



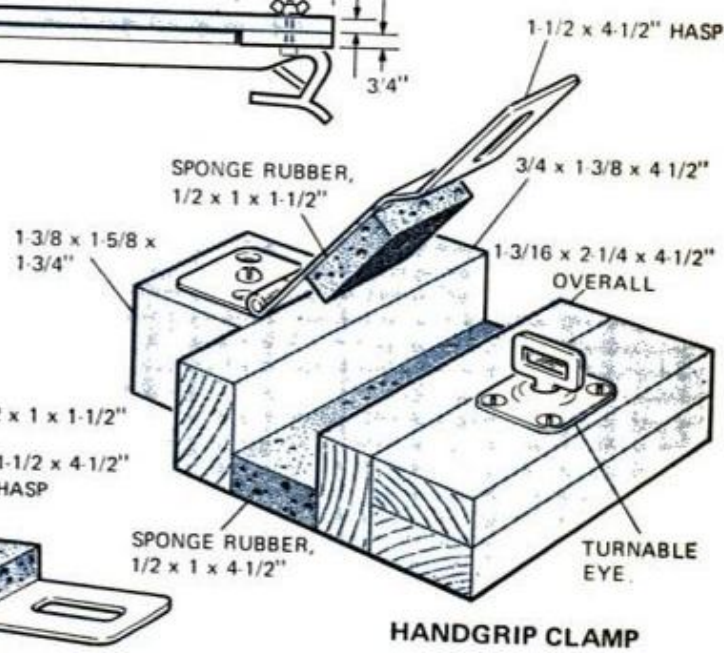
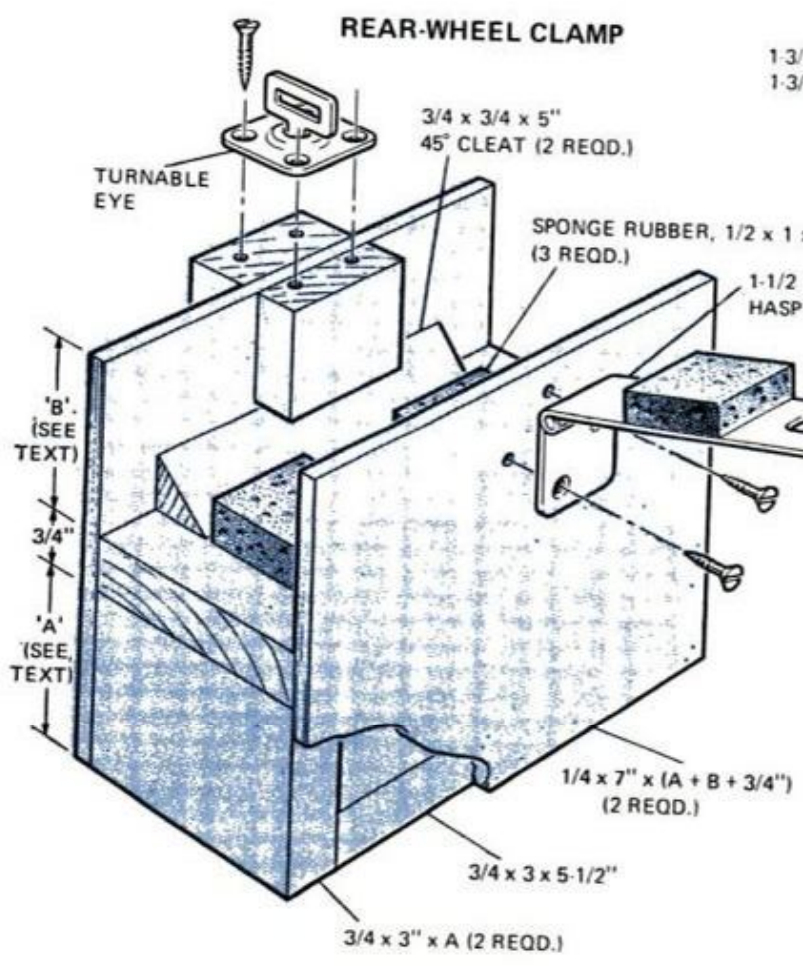
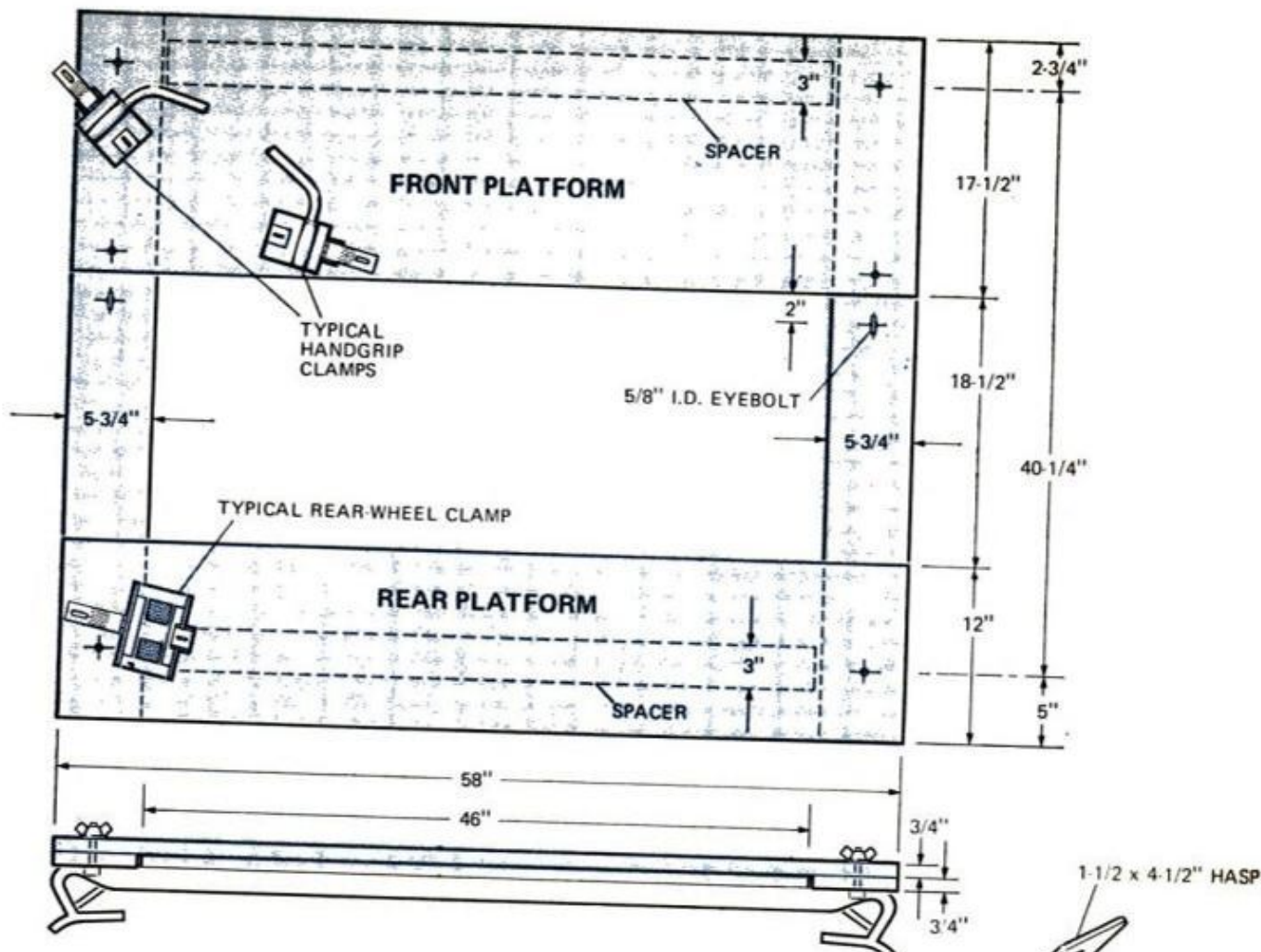

Clamp setup below is for flat handlebars, but turn-down type can also be fitted.

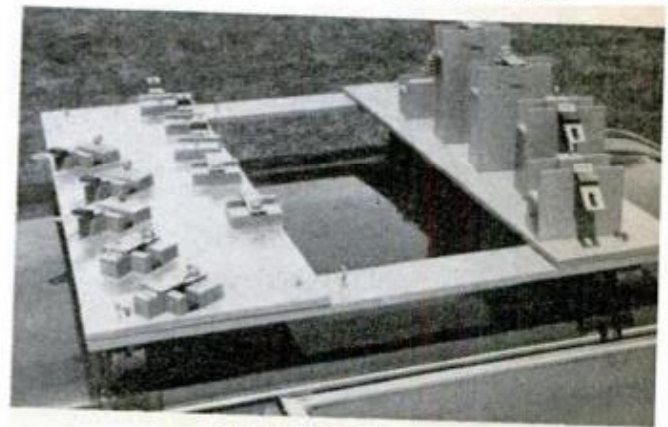





**Scoring picture and window glass square-**  
ly is easily done by aligning edge with  
grid lines in cutting board and drawing  
glass cutter along hinged nonslip straight-  
edge. Latter serves as pressure bar, too.



# Multipurpose cutting board handles glass, cardboard, photo mats and roll paper

by C. E. Banister

A good cutting board is a valuable tool for both shop and darkroom work. Besides giving you accurate results every time, one will keep other surfaces from being marred by routine cutting jobs.

This board can be scaled to any size that meets your needs. Rather than incorporating a knife, it allows you to use the cutting tool most appropriate for whatever job you're doing by running it along a solid metal straightedge. The adjustable stop facilitates repeated cuts. If you are left-handed, you'll find the board easy to work with, too. The cost of materials is under \$10.

Dimensions given in the drawing on page 158 are for a board about as large as you can work on comfortably. If you scale it down, the press bar should still be at least  $1\frac{3}{16}$  in. high and 2 in. wide, and of a good grade of hardwood. For the baseboard, I used fir plywood,  $\frac{3}{4}$  x  $27\frac{1}{2}$  x  $30\frac{1}{2}$  in., cut as shown. Note that the press bar and its extensions are 1 in. thick overall, while the anchor blocks are  $1\frac{3}{16}$  in. thick. This allows material up to  $\frac{1}{4}$  in. thick to be cut against the length of the fence. Thicker materials can be cut between the anchor blocks.

The 20-ga. sheet metal—I used galvanized—is 1 in. wide, rabbeted into the press bar so it is flush on the underside, and extends  $\frac{1}{16}$  in. beyond it. The metal is attached with contact cement; clamping is advisable

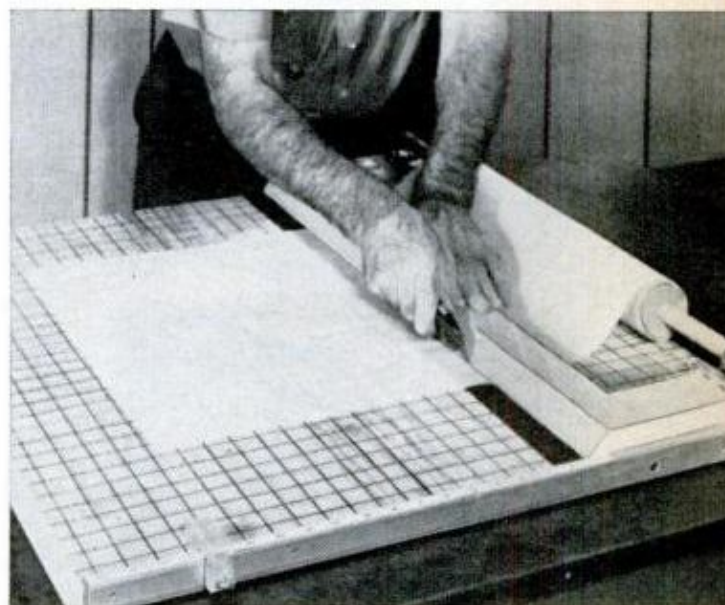
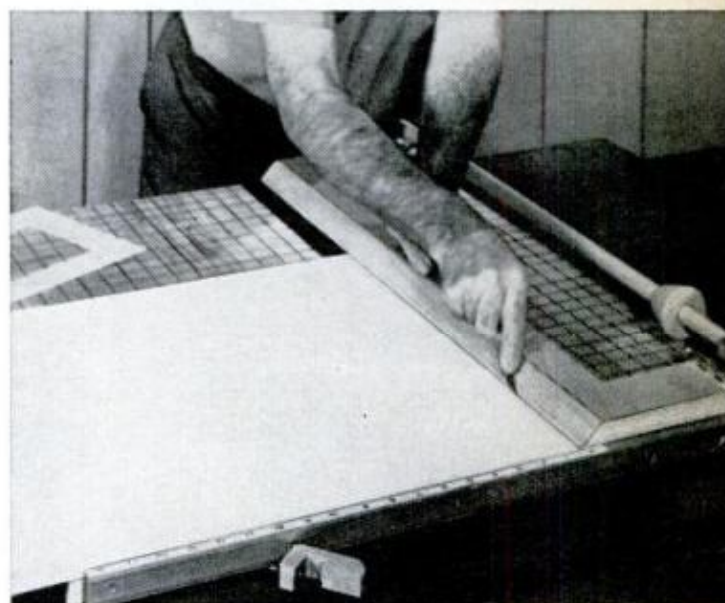
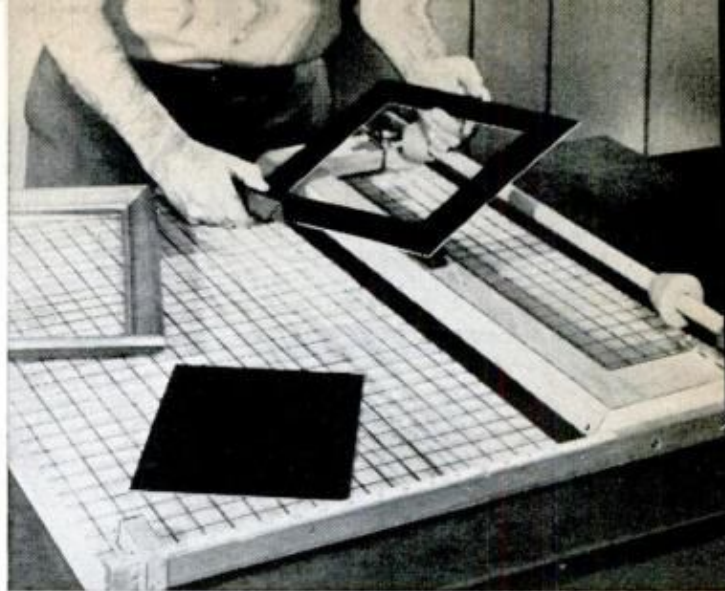

**Versatility of cutting board** is demonstrated by its handling of a wide variety of materials. At top, picture mats with beveled edges are readily and accurately made. Bevel of press bar makes cutting angle precise. Middle photo shows board with stop removed to permit cutting of extra-large sheet. Roll-paper holder, shown in use in bottom photo, allows cutting of roll materials up to 24 in. wide, including photographic paper (under recommended safelight).



# CONSTRUCTION DETAILS

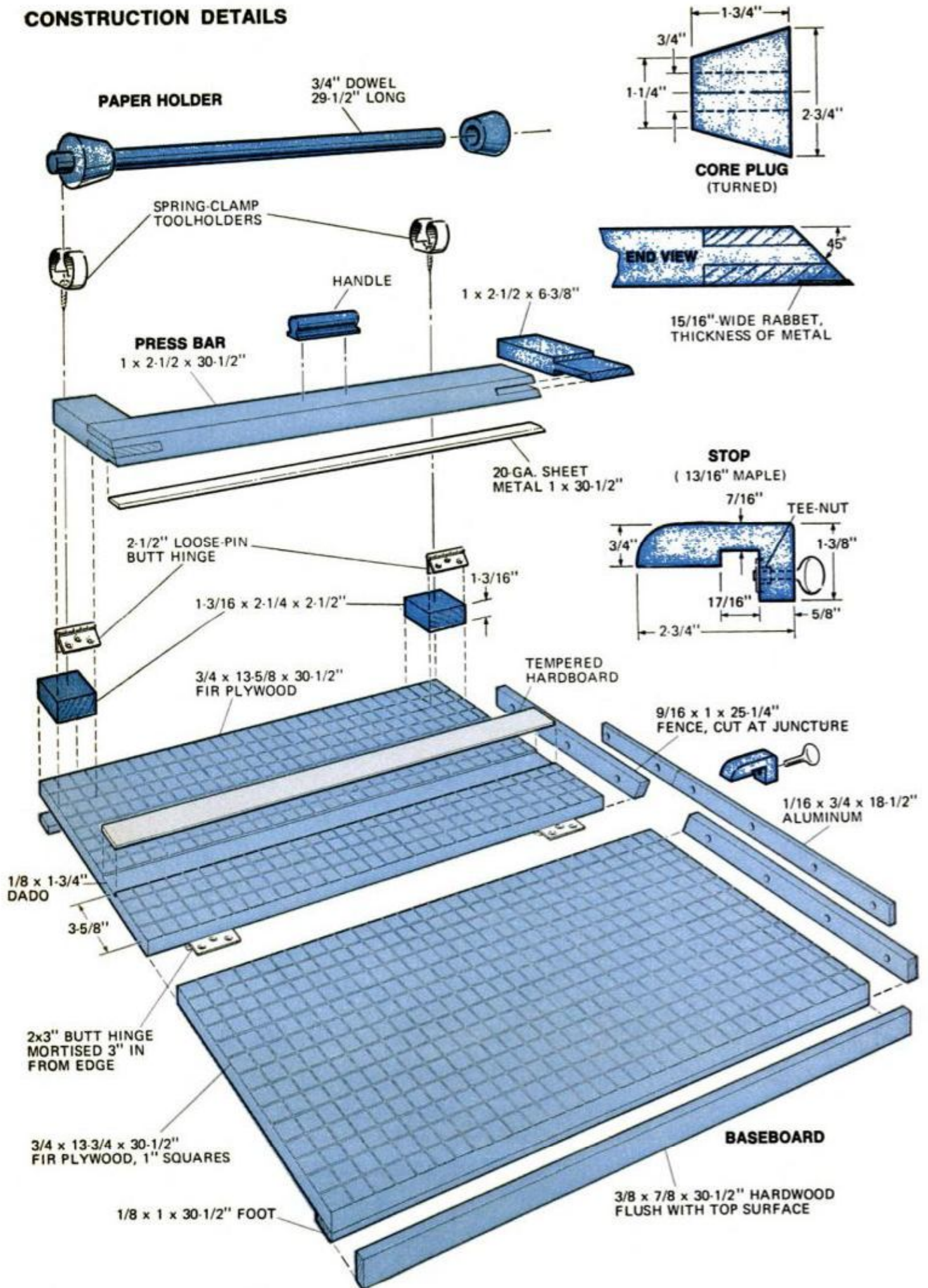



## Cutting surface is replaceable

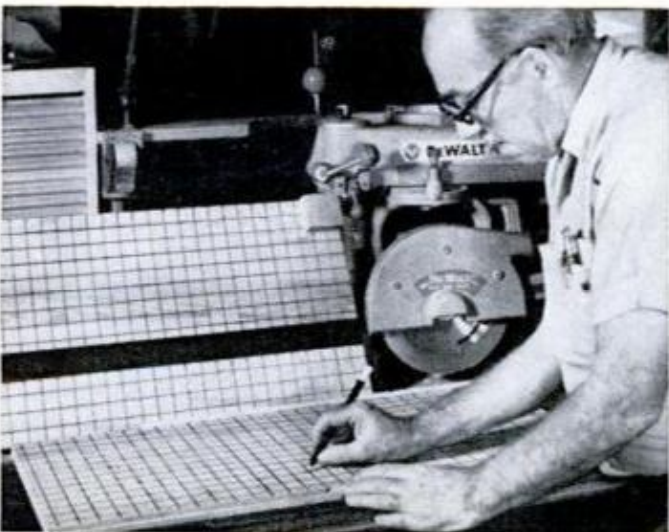
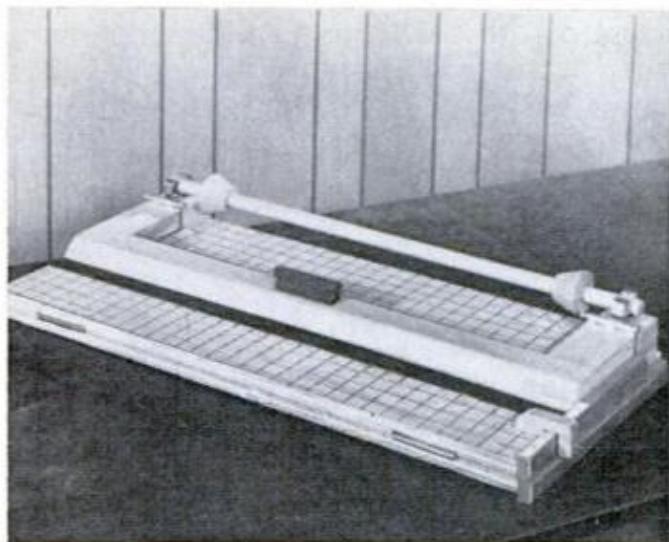

for this step, and be sure there's always adequate ventilation when you're working with contact cement. The 45° cut on the press bar is made after the straightedge has been cemented in place.

The anchor blocks, attached to the baseboard with screws and glue, must be positioned accurately, since they will determine the ultimate squareness of the board. Small errors can be compensated for by shimming the hinges connecting the blocks to the press bar.

The routed or plowed  $\frac{1}{8}$  x  $1\frac{3}{4}$ -in. dado in the baseboard is for the replaceable tempered hardboard cutting surface, which should be cut for a snug fit. There are actually four different cutting surfaces, as the hardboard can be turned end for end, then turned over and finally turned end for end again before replacement.

The fence is secured with  $1\frac{1}{2}$ -in. No. 10 screws, and the  $\frac{1}{16}$ -in. aluminum, on which the stop rides, is attached to it with No. 4 screws. A commercially available metal tape with a pressure-sensitive adhesive back was used for the scale; a yardstick ripped to the proper width would be a suitable alternative.

Core plugs for the paper holder are turned on the lathe using the screw center and bored for  $\frac{3}{4}$ -in. dowel before being cut off from waste stock.

It is advisable to clamp the assembled anchor blocks and press bar to the baseboard before laying out the 1-in. squares. Measurement should start from the metal straightedge on the press bar for the lines that will be parallel to it, and from the upper edge of the baseboard or fence for the others.

Stain and finish the completed cutting board as desired. I used a clear resin sealer and urethane varnish. ★★★

**Cutting board folds for storage** (top left), but can be built more simply when space is no problem. With the folding feature omitted, the  $\frac{1}{8}$ -in. feet, otherwise required by hinge thickness, are no longer needed. In middle photo, V-grooves are cut  $\frac{1}{32}$  in. deep with thin saw blade set at 45°; a single pass will complete each V-cut. A molding head with V-knives could also be used. At left, grooves are darkened with fine-point felt-tip marking pen before final finishing of the board. Paint or India ink could also be used.



# Playback tennis 'court' improves your backhand

Plywood sheet with folding wings lets you switch from basketball to tennis for back-yard practice.

by L. H. Nichols

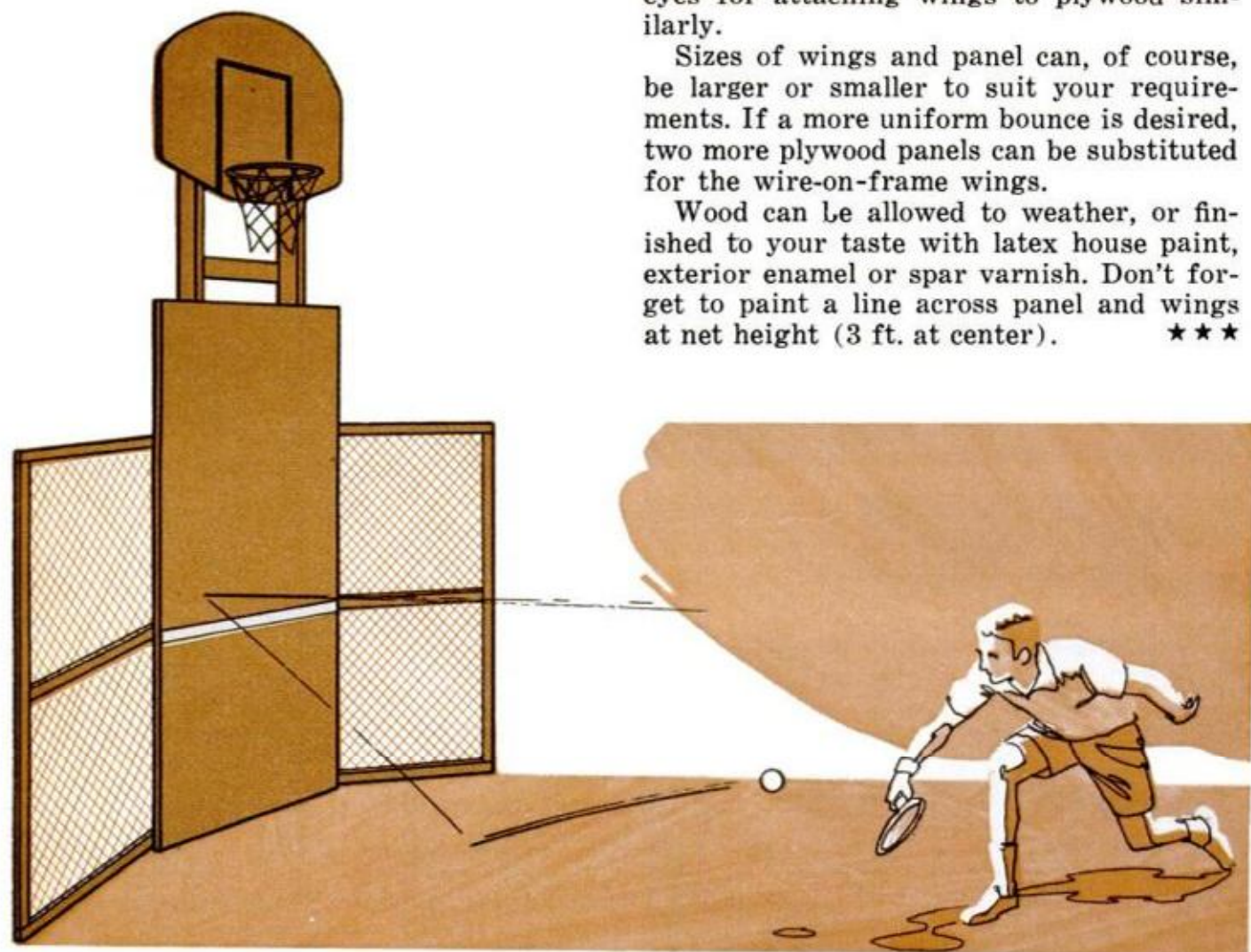

**B**asketball for the kids and tennis for you—or vice versa. This unit lets you practice both, combining a regulation-height basket and backboard with a removable tennis practice wall. You can switch from one to the other in minutes because the tennis wall is attached with screw hooks and eyes.

Uprights are 2x6s, spliced with 1/2-in.-dia. lagscrews, if necessary, to make the proper height. Diagonal cross members are also 2x6s and may be mortised into the uprights. A 2x4 crossbar and toggle bolts secure the unit to the overhang of house or garage. Basket and backboard, purchased as a unit, are attached to uprights with screws so that the basket rim is 10 ft. above the ground.

Wing frames of 1x2s are assembled with nails or corrugated fasteners; then galvanized netting is stretched across framework and stapled in place. Lattice strips may be used to conceal netting edges.

To install hooks and screw eyes, hold the plywood panel against the uprights to center it, and then mark locations of hooks and eyes for a tight fit. Locate hooks and eyes for attaching wings to plywood similarly.

Sizes of wings and panel can, of course, be larger or smaller to suit your requirements. If a more uniform bounce is desired, two more plywood panels can be substituted for the wire-on-frame wings.

Wood can be allowed to weather, or finished to your taste with latex house paint, exterior enamel or spar varnish. Don't forget to paint a line across panel and wings at net height (3 ft. at center). ★★★



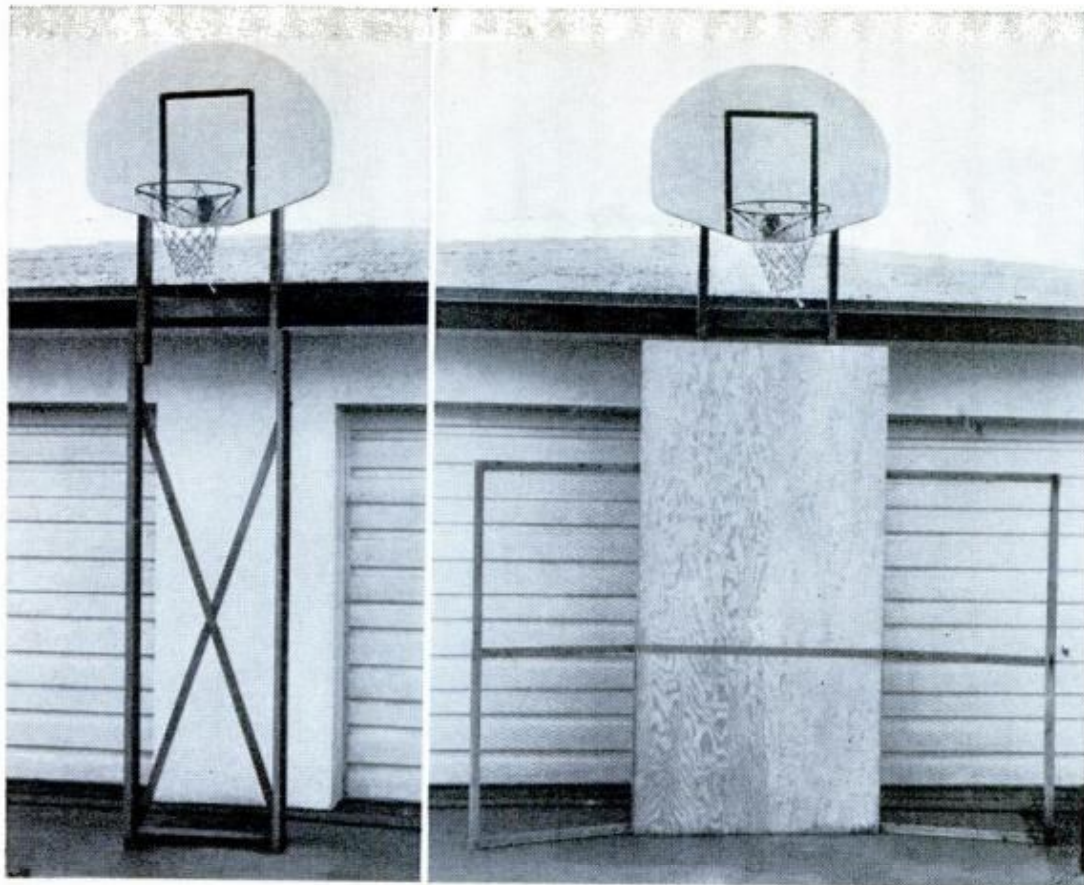

**Conversion** from one sport to another is nearly instantaneous. Tennis setup (near left) gives a lot of area to hit ball. For basketball practice (far left) the backboard uprights are unobstructed.

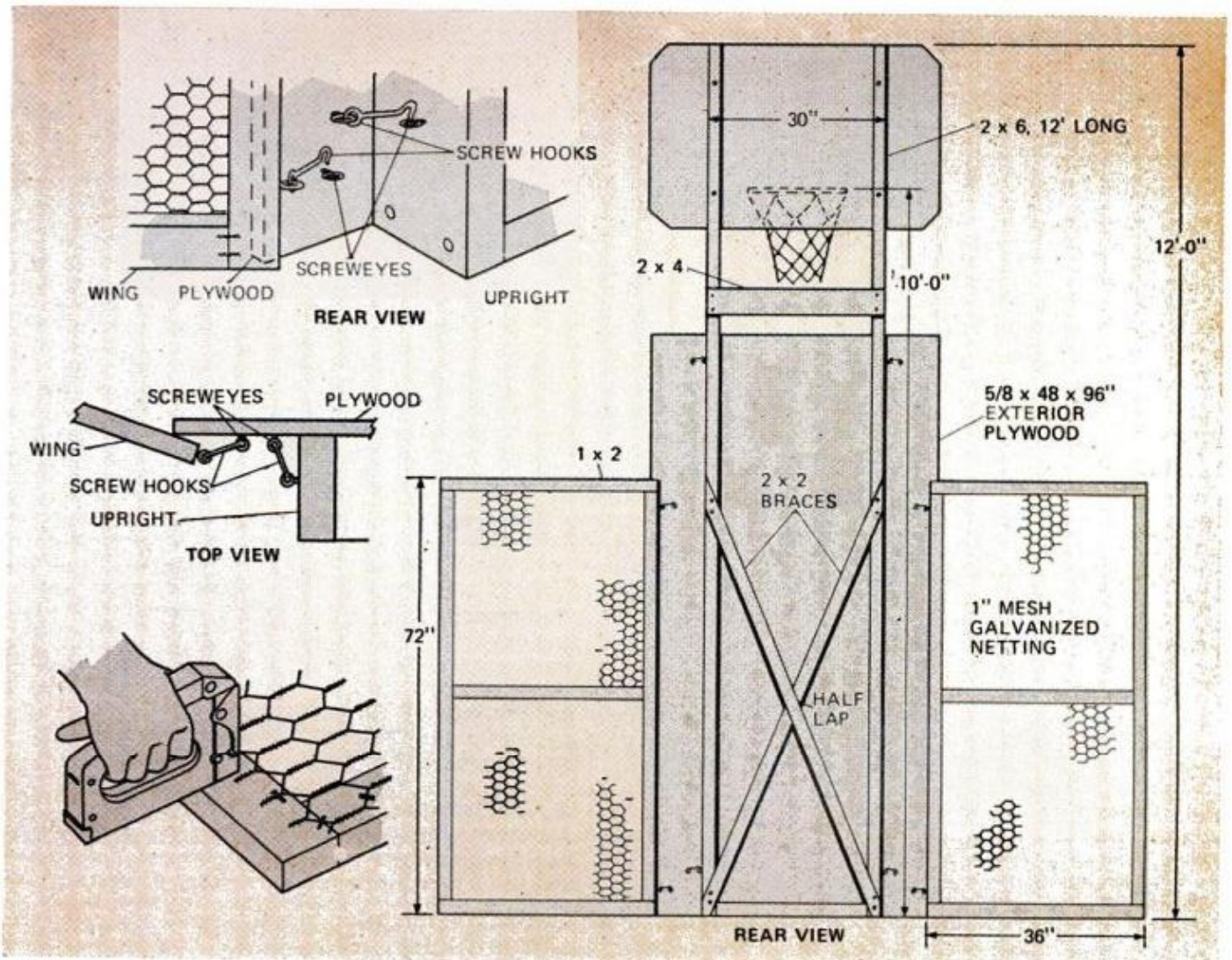



# Roll-away workbench packs a lot of shop in a small space

by Charles Green

For the hobbyist who has no permanent place for his activities, this rolling mini workbench is ideal. Built around a caster-mounted metal serving cart—the type sold at department stores—it is especially handy if your space is limited because it can be stored in a closet. It keeps everything together too; you simply stow your toolbox collection on the shelves and have three toolboards for tools too big for the boxes.

Dimensions given are for the bench shown in the photos; these can be varied to suit the cart you buy.

Use clear pine to construct the toolboard frame; the square cleat in front of it, fastened to the cart top, gives added rigidity. If greater rigidity is required, fasten a piece of 1/4-in. plywood to the underside of the top. Bolt two pieces of perforated hardboard to the sides of the cart for convenient tool-hanging space as well. Either end panel is also a logical spot for mounting a duplex convenience outlet. The gooseneck lamp allows you to aim the light where it's wanted; or you can mount a high-intensity lamp on the toolboard. Weight of the machinist's tool chest gives ample stability; if necessary, you can replace the cart's casters with heavy-duty ones. ★★★

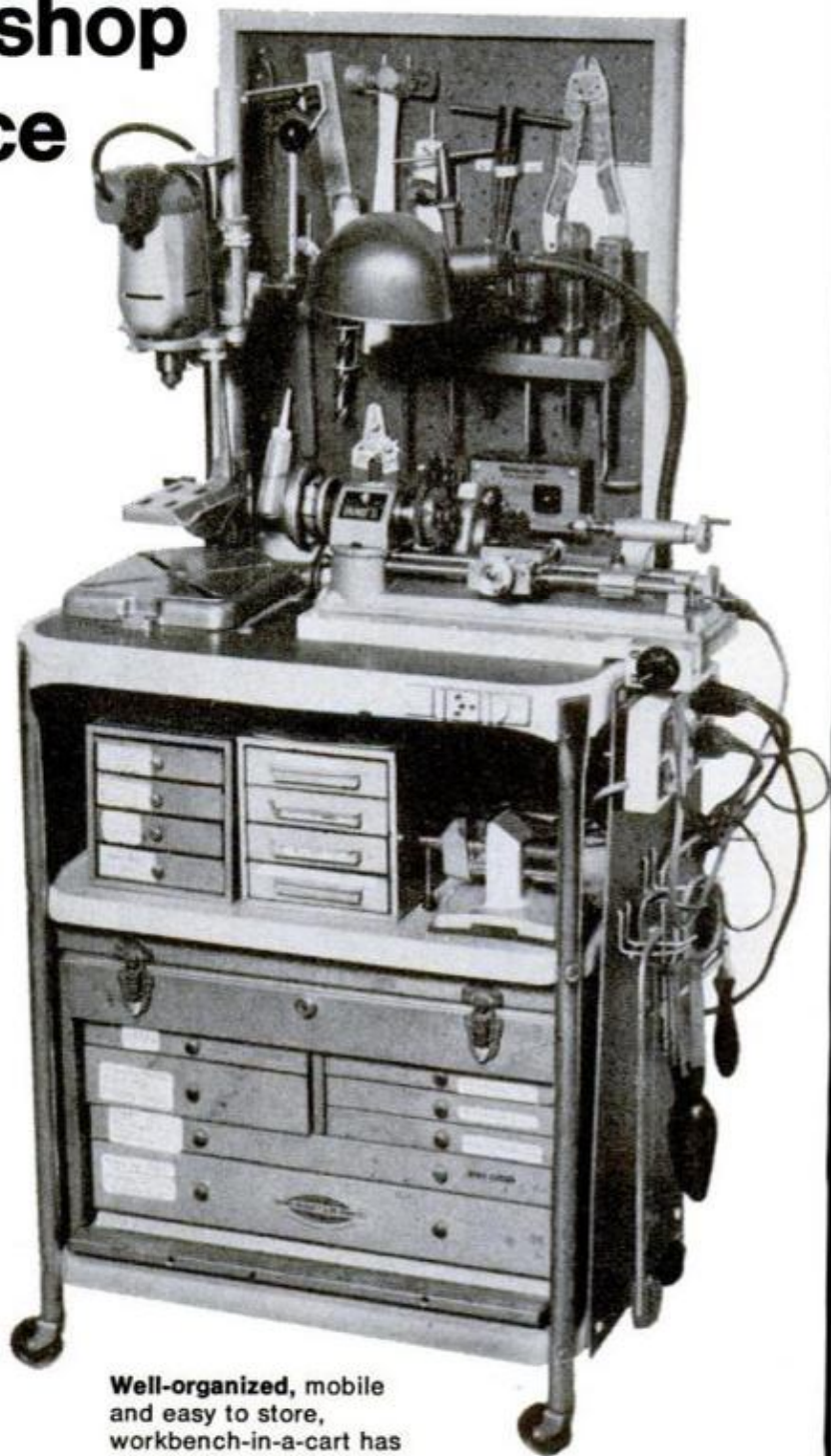

**Well-organized, mobile and easy to store, workbench-in-a-cart has plenty of room for tools and project parts. Bench consists of toolchest mounted in a \$12 metal serving cart (available at most department stores). Rest of materials—hardboard, wood, hardware—add just a few dollars to the cost.**



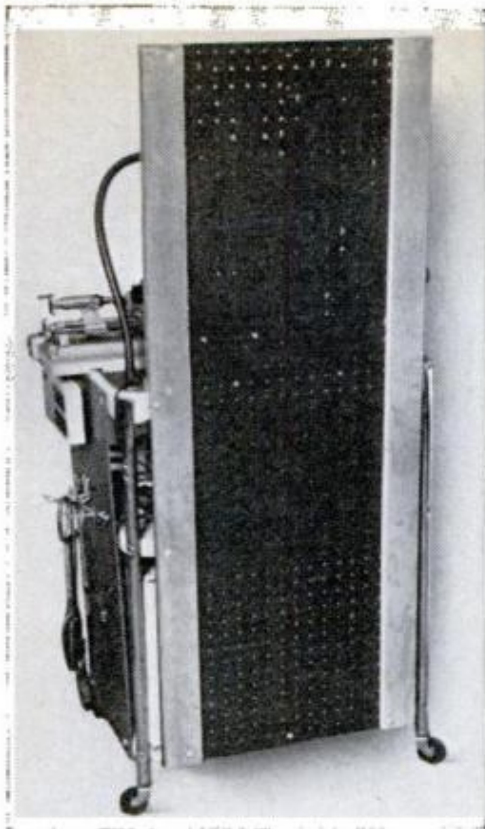

View from rear shows rolling bench's simple construction—hardboard panel and uprights bolted to cart frame.

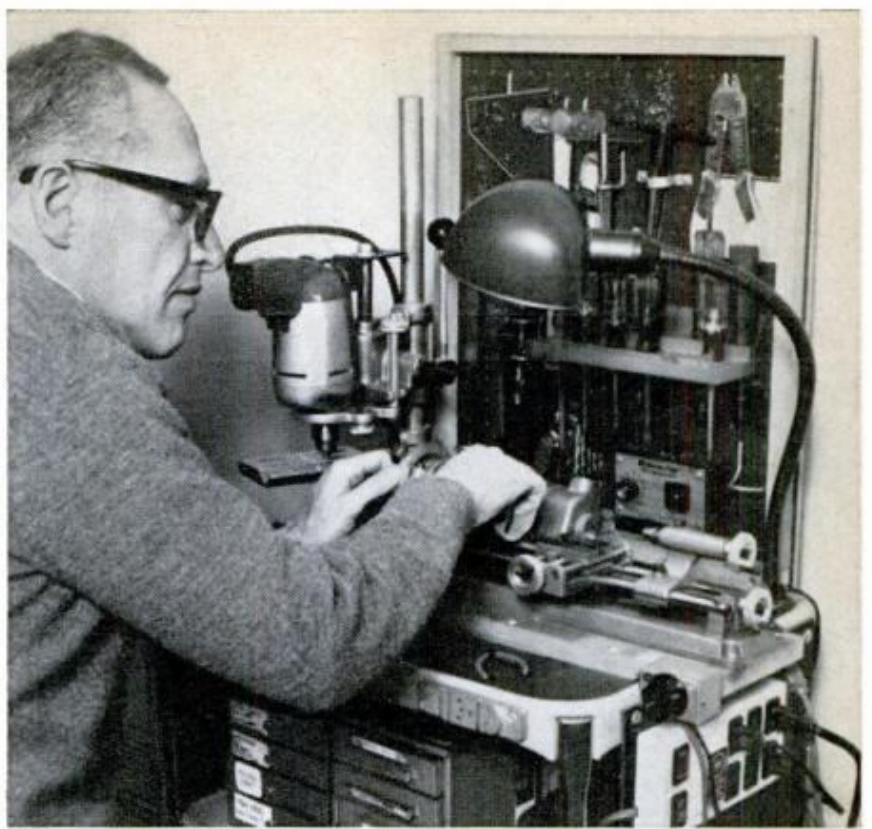

Benchtop height should be as close to 30 in. as possible for most comfortable sit-down working. Power outlets and controls are within easy reach. Standard hangers hold tools on hardboard panels.

### CONSTRUCTION DETAILS

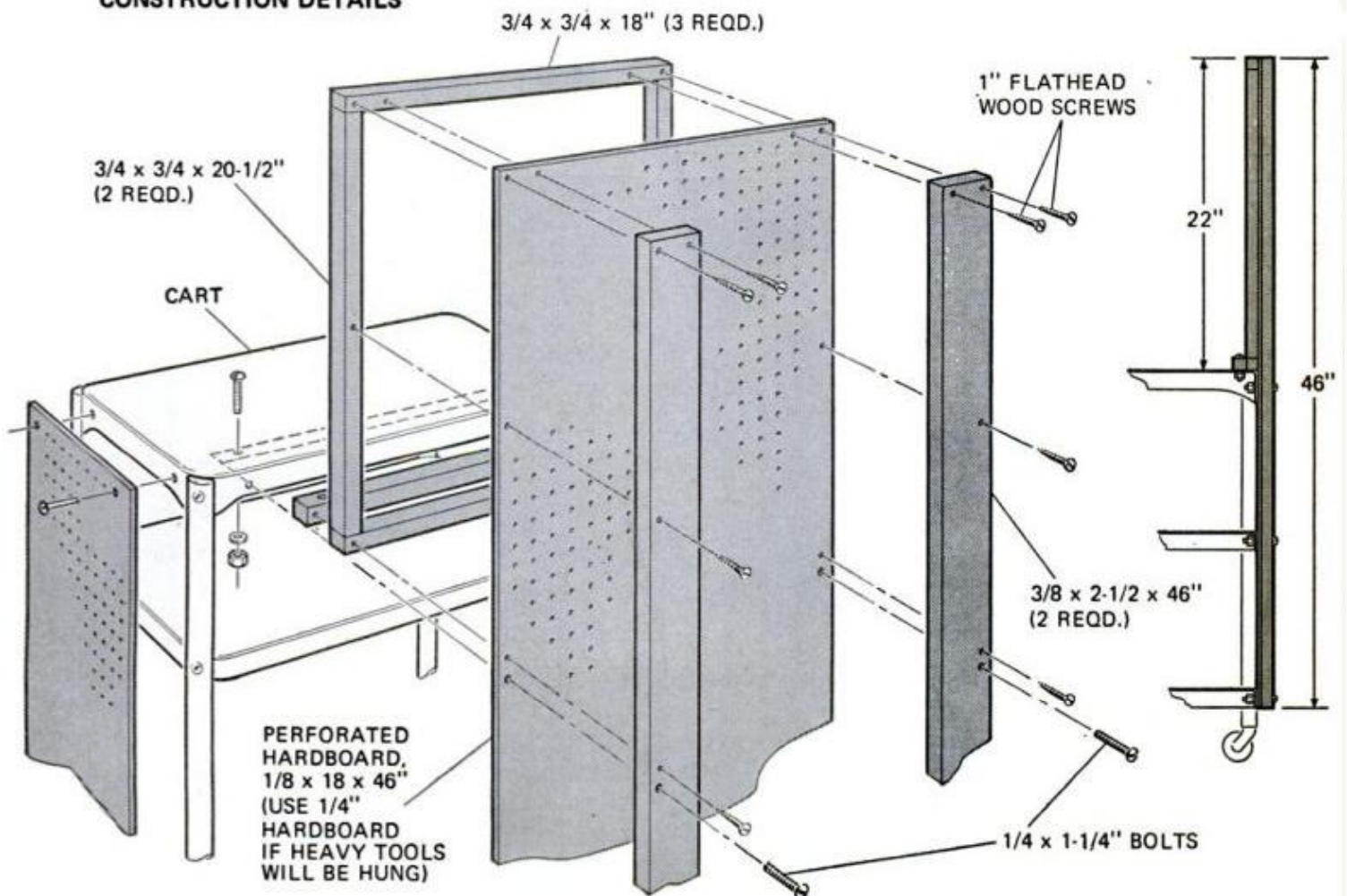



# HINTS

## FROM READERS

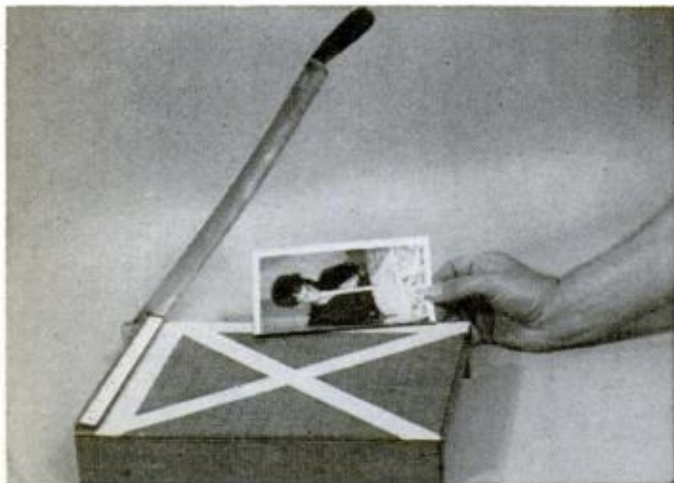

### Slip-proof paper cutter

To keep photos and other materials from slipping on the board of a paper cutter, try using masking tape to provide a nonslip surface. One strip of the tape is placed next to the cutting edge, another along the top adjacent to the guide and two more along the board's diagonals.

—Ken Patterson, Regina, Sask.

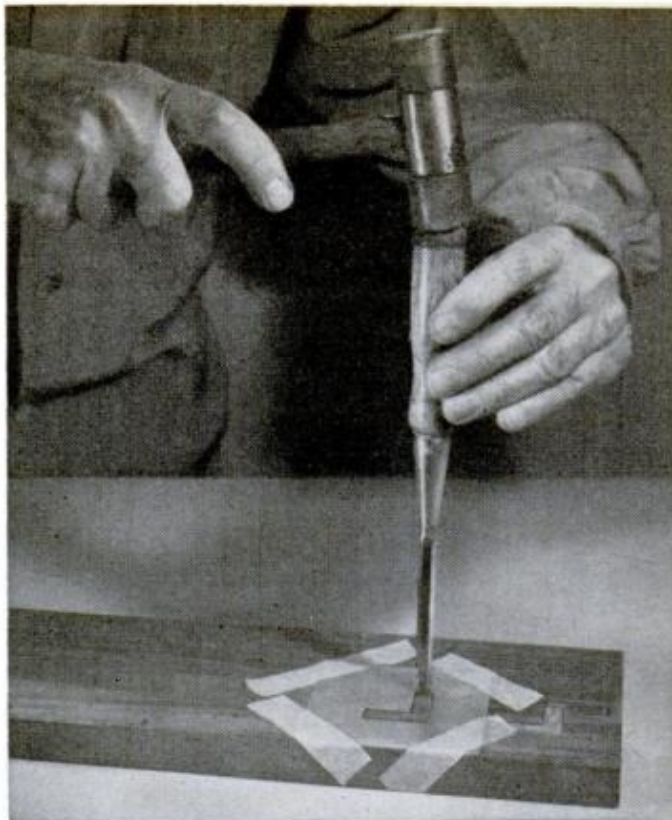

### Chisel template for mortising

An easy and accurate way to guide a chisel when it comes to cutting several same-size mortises is to use a sheet-metal template. It can be made with the chisel from a scrap of soft aluminum and attached to the workpiece with tape or clamps. Once mortise is started, template is removed.

—Walter E. Burton, Akron, Ohio.

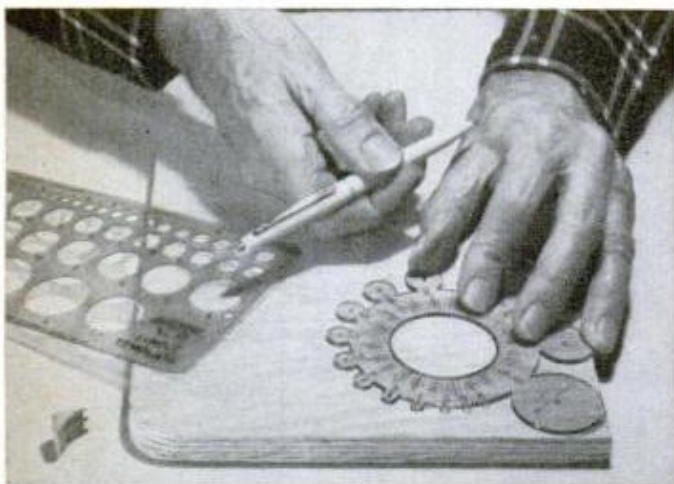

### Drafting tool rounds corners

Faster than a compass, a draftsman's circle template is a handy tool in the shop for quickly marking corners on work to be rounded. Two types of templates are shown. A French curve, marked with tape, is great for "freehand" contours that must be duplicated or drawn in a reversed position.

—E.B. Walters, Chicago.

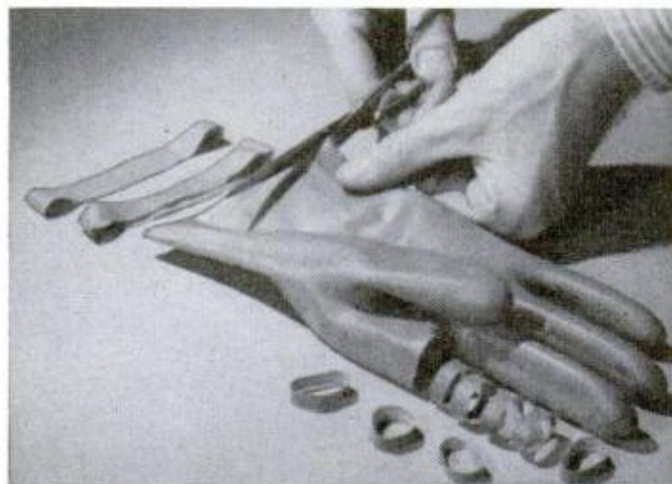

### Rubber bands from gloves

Next time you get a hole in a rubber glove, don't toss out the glove. It has considerable salvage value when used to make rubber bands of various sizes—small ones from the fingers, large ones from the wrist. Bands can be made as wide as desired for many uses around the home and shop.

—William Swallow, Brooklyn.



THE WORLD'S FASTEST, MOST SUCCESSFUL BODY SHAPER EVER!

# SLIM DOWN

**Our Guaranteed "5" Minute Body Shaper Does It ...**

**Without giving up the foods you love!**

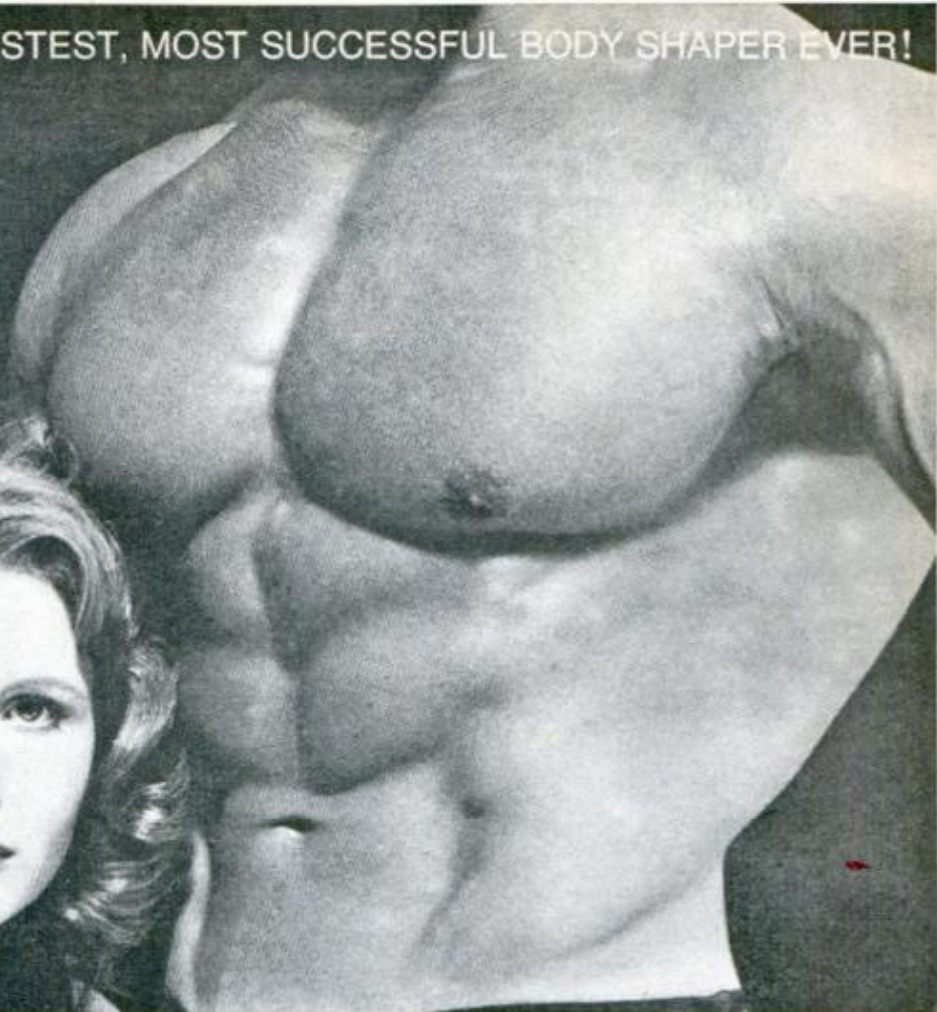

Joe Weider, fitness expert and trainer of champions since 1936 says:

**"Give me 5 minutes twice daily for only 7 days and you'll lose up to 3 inches from your waistline, up to 10 pounds of unwanted weight, and 'shape up' — or I will return every penny."**

**Let's face the facts why you're out of shape.**

You eat the wrong combination of foods, you do not get enough exercise to thoroughly work your muscular, metabolic and respiratory systems daily. Because of this, fat accumulates around your waistline, heart and other body organs, slowing you down, aging your body and destroying your vitality, virility and youth. There is only one way to firm up and shape up: that is through proper exercise and proper nutrition. Effortless exercisers, reducing pills, sauna shorts, weighted belts, dangerous and painful diets and other gimmicks designed to appeal to your laziness will not work and have been exposed by the medical profession as frauds, ineffective and in some cases dangerous. They can only reduce your pocketbook. Face up to it...If you want to slim down, firm and shape up, you must work off the inches, and there is no safer, faster and more enjoyable way to do it than with our patented, truly miraculous "5" Minute Body Shaper Plan.

**How does this ingenious "5" Minute Plan slim, firm and shape you up?**

Its miraculous slimming action is based on doing one simple "5" Minute Continuous Rhythm coordinated exercise! That's all you do! That's all your body needs to help make up for the lack of activity it doesn't get most of the day. The action is designed to supply your waistline and hipline (where fat accumulates quickest, giving your body a flabby, weak and distorted look) with the activity it needs to slim you and keep you slim. It also burns off excess fat FAST by speeding up your metabolism and respiratory system, using up stored calories, carbohydrates and fats and releasing excess water, thereby shaping and firming up your total body!

Patent Pending. © Copyright Joe Weider, 1973

It's safer than strenuous gym workouts, beats the time consumption and dangers of gym workouts...or any other vigorous sport.

The unit weighs about 16 ounces and fits any wallet-size case. You can carry it with you and use it — anytime — wherever there's floor space for your body. Even while watching television.

**What the experts say:**

Medical Doctors, Chiropractors, Osteopaths, Athletic Coaches...agree it's the most successful Waistline-Weight Reducer and Shaping Up Plan ever invented!

"Doctors have always known, exercise done while lying on the back virtually eliminates strains while slimming and reshaping the body. Yours is the finest Body Shaper Program on the market."

RICHARD TYLER, Chiropractor

"Beats jogging and working out in gyms — and much safer. I lost 4½ inches off my waist in 14 days."

JIM HANLEY, famous athletic coach

"Miraculous! Weighs less than a pound, is simple to use and beats working out in a gym with 30 different exercisers."

TOM MINOCHELLO, famous gym owner

"Based on sound physiological and medical knowledge, it burns fat and shapes the body without strain to the heart or other organs. I lost 32 lbs. of excess weight using it."

PIERRE GRAVEL, DC

## 5 MINUTE BODY SHAPER

We'll slim your body... while you watch the girls!

**What comes off in 14 days?**

Individual results vary, but during an average 14-day period you can expect to lose up to 4 inches from your waistline and up to 10 pounds from your present weight. It strengthens your heart and lungs, increases stamina and endurance, improves your digestive function and general health. It also shapes you up — from head to toes. For a "5" Minute Exerciser — it sure does a lot.



Weighs just 16 ounces. Small enough to fit into pouch shown.

**FREE TRIAL OFFER: Get it off last... and see measurable results in three days or every penny back!**

Proven results are already verified by the thousands. The guarantee is in writing. Now, can you think of a reason for not ordering your "5" Minute Total Body Shaper and start looking and feeling like a million...in just 3 days?

**DISCOVER A NEW JOY IN YOUR BODY GIVE IT SEX APPEAL! COMPLETE KIT ONLY \$9.95**

**JOE WEIDER, Dept. BR/1**  
**"5" Minute Body Shaper Plan**  
 21100 Erwin Street,  
 Woodland Hills, Ca. 91364  
 Dear Joe: Rush me your '5' Minute Body Shaper and Slimmers Course in plain wrapper, with your money back guarantee offer!  
**I ENCLOSE \$9.95 FOR THE ABOVE.**  
 CASH     CHECK     MONEY ORDER  
 Send \$1.00 extra for Air-Mail. (No COD's Accepted)  
 Calif. residents add 5% sales tax. (\$10.50)  
 Name .....  
 Address .....  
 City..... State.... Zip.....

IN CANADA: "5" Minute Body Shaper Plan, 2875 Bates Road, Montreal, Quebec



# How to fit a fairing and ride a racer!

by Wally Wyss



This Dunstall Norton is a Commando 750 given the slick treatment by special-equipment supplier and retired British road racer Paul Dunstall. At right: two extensively modified Suzuki X-6 Hustlers.

In Europe, the term "cafe racer" used to be a put-down. It referred to the motorcyclist who played at being an Isle of Man road racer, someone who owned a racy machine but merely parked it near his table at the local outdoor cafe. He still has the exhibitionism of the chopper builder, but the cafe racer really makes his bike more aerodynamic and often safer with his modifications.

The typical cafe racer's machine starts as a big road bike—350 cc or more. It's just a stock machine before the owner decides to go the racer route with bright colors and bullet fairing. The first step, usually, is to remove the stock handlebars and replace them with clip-ons. These are stubby little grips that demand a whole new style of riding. You have to hunch forward and lean more into turns. At low speeds, clip-ons







**Kawasaki 750** still has its stock frame, but almost everything else right down to the pistons of the ported engine and suspension has been given hop-up treatment.



**Honda 750** has an extra disc brake up front, a pair of Dunstall clip-ons, special tank and solo seat, Koni shocks and extractor exhausts. And, of course, a fairing—this one the full type.



The **disc brakes** and magnesium wheels are only two of the fascinating details on this BSA (poised on its stand at right).

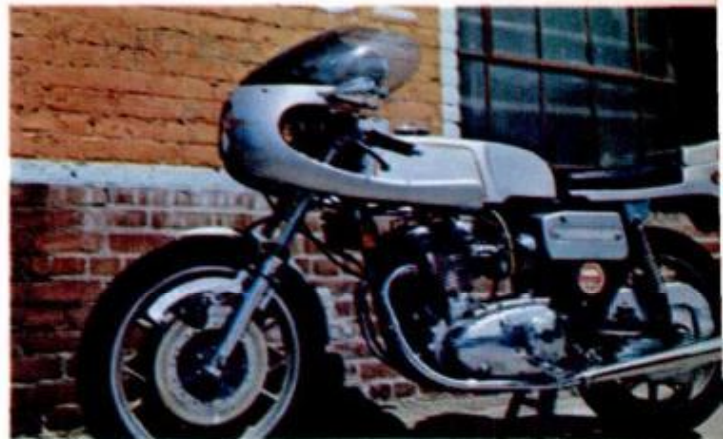

**BSA cafe racer** has a completely enclosed chain guard, stainless-steel bolts throughout and "engine-turned" brackets—a jewel of a machine.

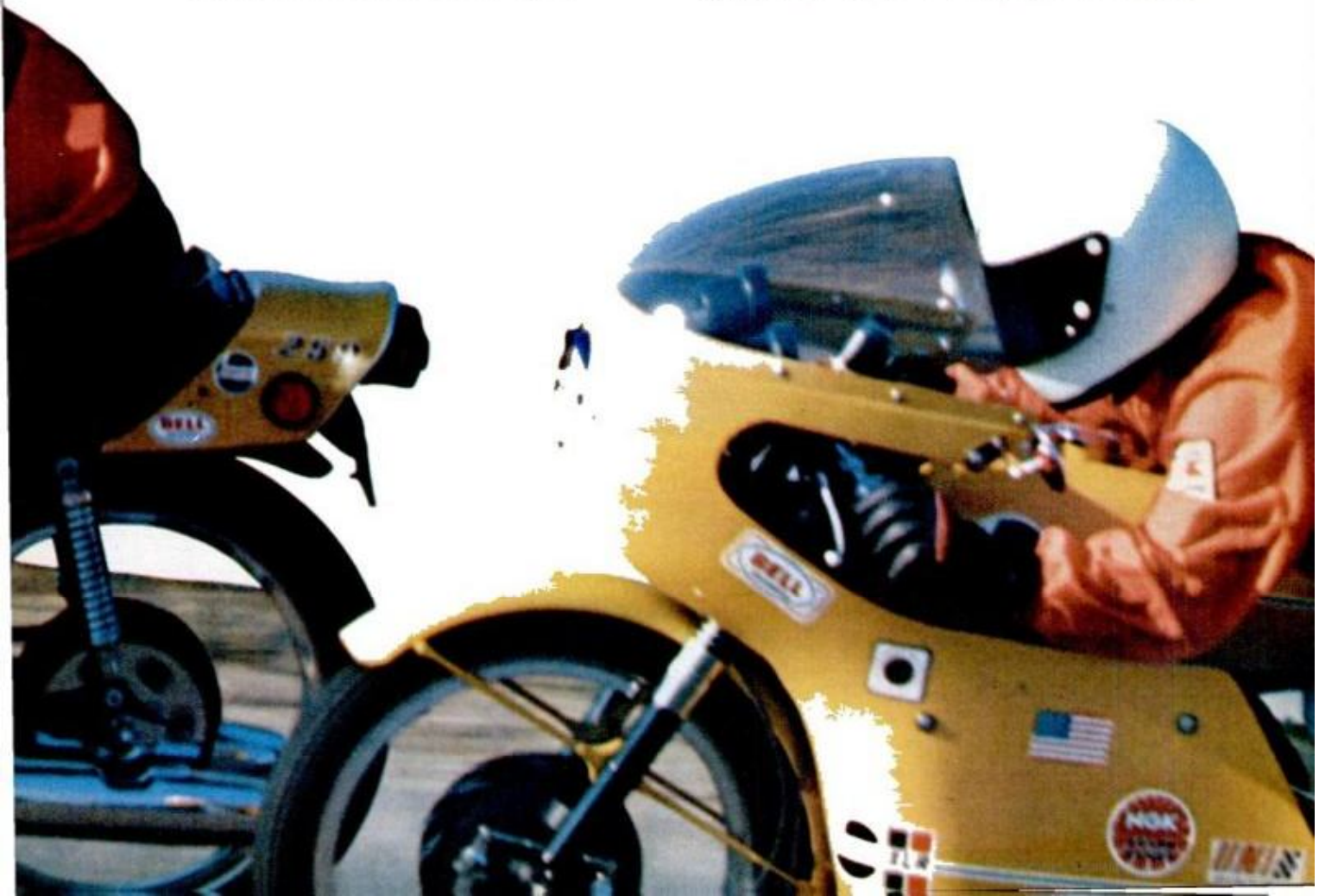





**1. Removing the headlight housing** is the first step in fitting this Honda 750 with specially designed half fairing with ready-made brackets. It will be reinstalled on the fairing.

**2. Remove the original-equipment fuel tank** for access to the frame of the motorcycle. You might have to flip the saddle up on its hinges in order to remove the tank.

**3. Determine the best location for front support bracket on the steering head.** Slide fairing on to check positioning before bolting it on. You could also choose to weld it.

**4. Drill the fairing for the front-support mounting bolts.** If you intend to mount speedometer, tach, oil and water-temp gauges on fairing dash, now is the time to do it.

**5. Position the horizontal bracket on the horizontal frame tubes and check that gas tank clears it before bolting in place.** Then drill the fairing for the mounting bolts.

**6. Slide fairing on and attach.** Reinstall gas tank, headlight and any other parts that were removed. Expect job to take about four hours—more if you must fabricate brackets.

are difficult to handle but not as unwieldy as the extended front forks of the typical chopper.

The next most frequent replacement is the seat. Most big bikes have a long padded seat suitable for two, but cafe racers, due to their semi-crouch riding position, need to move their fanny aft. Hence, no room for riders. Thus, the "solo" seat which usually sweeps up to offer support in back for the buttocks.

Fast growing in popularity are larger gas tanks—huge five and seven-gallon jobs that will take you a few hundred miles non-stop. Many of the new fiberglass tanks will bolt right onto a Honda and make it look as hairy as the ultimate factory cafe racer—the 1200-cc Mammoth Munch!

True to the original sarcastic definition

of a cafe racer (their bikes are called "cafe racers," too), only a few of the machines seen in the United States so far have real engine modifications. The most frequent engine mod, if any, is the addition of racing-style extractor exhausts which give more power through a careful modulation of back pressure. Motorcycle cams are also becoming a popular item, much as they were with cars in the '50s.

Some more sophisticated cafe racers boast suspension work and expensive modifications like replacement of the front drum brakes with a hydraulic disc brake or even dual hydraulic disc brakes.

Wire wheels, while traditional with motorcycles, are not universally loved by racers, many of whom have had spokes

*(Please turn to page 192)*



# Now you can refinish your car's damaged surface areas professionally

You already have the skill to refinish your car's damaged surface. All you need is a few minutes practice on a tin can. Send a self-addressed stamped envelope, and we'll send you brief illustrated uncomplicated instructions free.



With Dupli-Color® touch-up paint, you can be sure of professional results. Used by millions, Dupli-Color duplicates your car's original color exactly. Dries in minutes to a hard high-gloss finish. Beautiful! Professional!

In all popular domestic and foreign car colors wherever auto supplies are sold. Brush-in-cap bottles, Auto-Spray® cans. Get color code number or letter from body plate.

## DUPLI-COLOR. PRODUCTS

Dept. P, 1601 Nicholas Blvd., Elk Grove, Illinois 60007

Illustrated booklet shows tricks of the auto refinishing trade

		
Find body plate under hood or on front door jamb. Color code usually single letter or number. Get exact matching Dupli-Color.	Hold Dupli-Color spray can 8 to 10 inches from surface. Spray fast, smooth side-to-side strokes in one minute intervals.	For touching up a small nick or scratch. Cut small hole similar in size and shape to nick and spray Dupli-Color through it.

## I-N-V-E-N-T-O-R-S WE NEED INVENTIONS

Sell your invention for cash—need money for Patent?—Are technical problems holding you back? Universal Inventions has helped inventors all over the world—just like yourself—why not you? Inventions provide the magic spring-board to sudden riches. REMEMBER, we either sell your invention or pay you a cash bonus. Write for details. UNIVERSAL INVENTIONS, Dept. 13, Marion, Ohio 43302

**HEAVY DUTY WELDER**  
with special \$7.00 gift offer to Popular Mechanics Readers  
**10-DAY FREE TRIAL**  
**Lifetime Guarantee**  
Buy Factory Direct and Save **18.95** POST PAID  
Fits ordinary 110V outlet  
Not one • but 6 welding heats



Weld, braze, solder or cut most anything made of metal. No experience necessary. Follow simple instructions to make repairs on cars, trailers, farm and lawn equipment, bicycles, appliances, etc. Make campers, boats, furniture, hundreds of valuable items. **NOTHING ELSE TO BUY!** Comes complete with full face shield, pack of welding and brazing rods, heavy duty power cables, special electric torch attachment, ground clamp, flux, easy-to-follow illustrated instructions, rod holder, etc. Uses standard 1/8" rods to weld iron, steel, brass, bronze, aluminum, other metals. New improved HEAVY DUTY circuit gives more welding power. Gives 4 times the heat needed to melt toughest iron. Plus into ordinary 110V outlet. 6 WELDING HEATS for professional quality welding of "tough" to "light-weight" metals. 10 day MONEY BACK GUARANTEE. Lifetime parts and service guarantee. An excellent gift for any occasion. FREE! Mention you saw this ad in Popular Mechanics and receive a \$7.00 gift pack of welding rods free. For same-day C.O.D. shipment just call (713) 682-5681 or send only \$2.00 and pay postman \$16.95 plus small C.O.D. when delivered or charge to your BankAmericard or Master Charge card or for postpaid shipment send \$18.95 check or M.O. to WEL-DEX, Dept. W-203 Box 10776, Houston, Tex. 77018.

**WHITE'S METAL DETECTORS**

WHITE'S ELECTRONICS, INC. manufacture the World's Largest and Finest Line of Mineral and Metal Detectors. Ghosttowning, beachcombing, bottle hunting, coin hunting—all types of TREASURE HUNTING or PROSPECTING, amateur or professional. Detect conductive metals—Gold, Silver, Copper Nuggets—Coins—Rings—Jewelry, etc. Underwater or on the land. "There are no finer at any price" 25 production models to choose from—T.R. or B.F.D.

Priced from \$75.00 up  
—Always specify the Blue & Gold  
ASK FOR WHITE'S BY NAME  
—Free Literature—  
WHITE'S ELECTRONICS  
Rm. No. 512  
1011 Pleasant Valley Rd.  
Sweet Home, Oregon  
33794 Hazel Street  
Abbotsford, B.C. Canada  
Eli-Air Industrial Park  
Dexter Drive, East  
Evansville, Indiana 46514



**NO MONEY DOWN**  
*Start Profitable Business in Your Garage or Basement*



Start in sparetime; build a money-making full-time business in your garage or basement. We'll start you in business with No Money Down. Your earnings easily cover the low monthly payments. Sharpening saws is an important service in any neighborhood or small town—You can earn \$3 to \$6 an hour sharpening hand, band or circular saws.

**No Experience! No Selling**

The easy-to-operate Foley Saw Filer is automatic—it does the job for you. You can be doing business the day after you receive your machine. And with a saw filing business customers will come to you. No door to door selling! You are supplying a much needed service. If you'd like more information about this unique business opportunity, return coupon (no salesman will call) and we'll send you our fact-filled

**MONEY-MAKING BOOKLET FREE!**

Foley Manufacturing Co.  
943-3 Foley Bldg., Minneapolis, Minn. 55418  
Send for FREE book on Money-Making facts about the sharpening business.

NAME \_\_\_\_\_  
ADDRESS \_\_\_\_\_  
CITY \_\_\_\_\_ STATE \_\_\_\_\_ ZIP CODE \_\_\_\_\_

**LPI**

## BIG MONEY

- LIGHTNING TECHNOLOGY
- GET IN ON GROUND FLOOR
- BE YOUR OWN BOSS
- LEARN AT HOME

WRITE:  
Lightning Protection Institute School  
122 W. Washington Ave.  
Madison, Wis. 53703

No obligation.



# Benchtop saw table converts portable to 'radial'

Your portable power saw becomes a lot handier and safer with Safe-T-Track, a new benchtop saw table I've just tried. With it, a handyman can use his portable saw to crosscut, rip, miter, mortise, groove, bevel and dado with the precision of a radial-arm saw.

As with a radial saw, the work is held firmly in place and your hands are clear of the blade. To cut a board, you just push the saw forward between two parallel guide rails—it's that simple to make either a perfect 90° or 45° cut. Lock the saw in place, turn the crosscut guide at a right angle and you can rip boards of any length.

Designed for a table or bench, the saw table comes in two sizes. The \$49.95 Executive will crosscut up to 16 in., miter a 7-in board and rip a 12-in. board in half. The larger \$59.95 Professional will crosscut up to 20 in., miter a 7½-in. board and rip a 14-in. board in half. Prices do not include saw.

The guide table will accept any portable saw from 6½ to 10-in. dia. and requires only seconds to install and remove. Blade angle and depth of

by **Wayne C. Leckey**  
HOME AND SHOP EDITOR

PHOTOS BY ROBERT D. BORST

With work clamped in place and the saw self-guided, the do-it-yourselfer can make a perfect cut almost with his eyes shut.

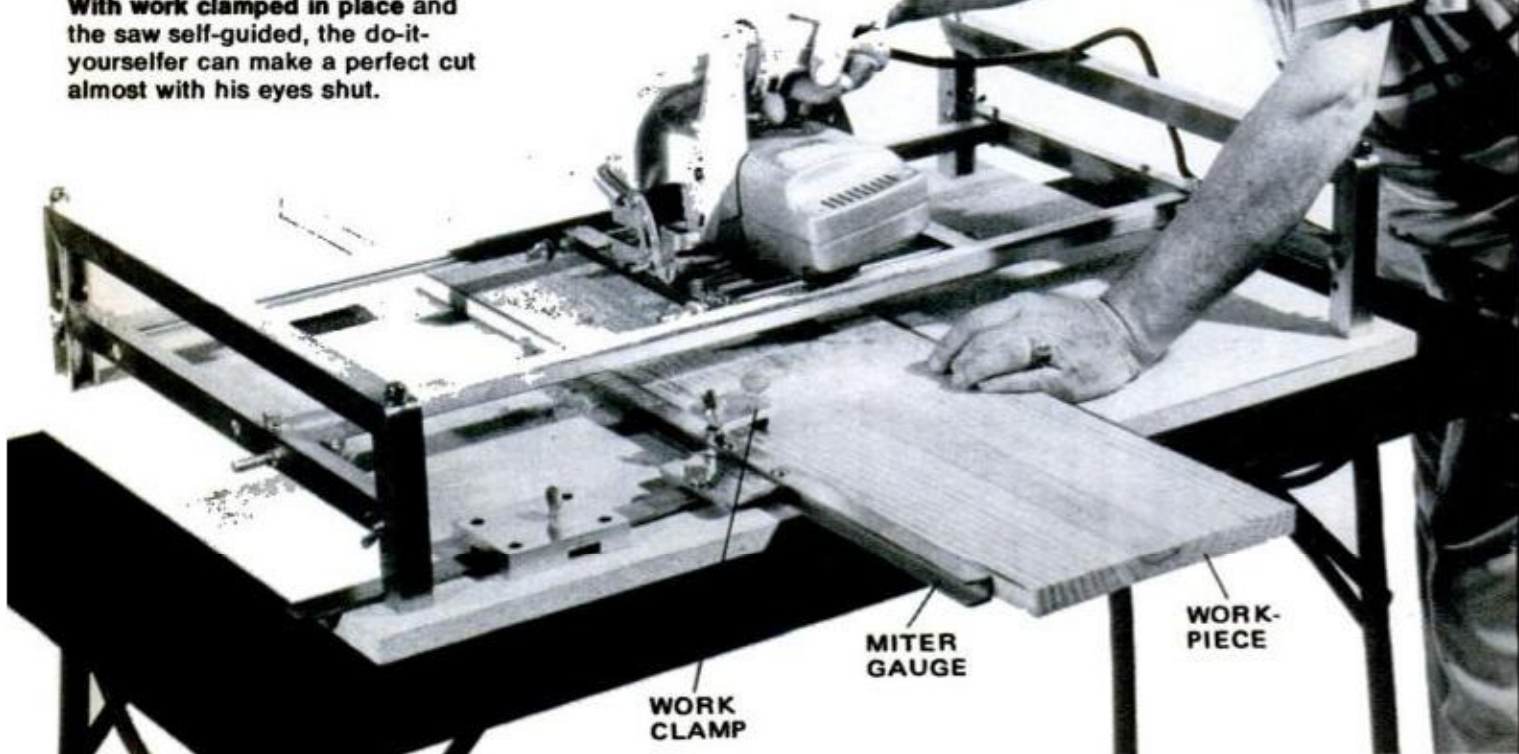



## OWNER-MANAGER WANTED

Nationally advertised business in your area builds your income with 7 quality, on-location services in homes, offices, motels, shops. We train, guide, help finance, back you. Start spare time, add profits to job salary. We equip men you hire. Each full-time serviceman adds several thousand dollars to your yearly profit. Just \$1195 cash puts you in a prestige business. Interesting lifetime career. Get facts by mail. Write TODAY before your area is taken.

DURACLEAN INTERNATIONAL, 3-169 Deerfield, Ill. 60015

## POWER HACKSAW \$29.95



### WORKS BEAUTIFULLY

Easy to assemble kit of cast iron parts. Use your own 1/4 hp. motor. Drill press needed for finishing work. Moves approx. 120 strokes per min. Send \$29.95. Satisfaction guaranteed. Catalog describing 51 kits, only 50¢. Write:

Struck Corp., Dept. PM93H, Cedarburg, Wis. 53012



## Print For Profit

Cards, Stationery, Envelopes, Advertising, labels, tickets, announcements, Q.S.L. cards, greeting, sympathy, prayer cards, tags, etc. Save money. Pays for itself in a short time.

### Own a Printing Business

We supply everything direct from factory only. Easily followed rules. Also raised printing like engraving. Have home shop. Add to income. Send 25¢ for catalogue. **KELSEY PRESSES 73-Z, Meriden, Conn. 06450**



## Repair any watch

### ... SWISS OR AMERICAN

Unique, modern Sweezy System starts you making repairs right away. Develops skill step by step at home in spare time. Diploma awarded. Free sample lesson. No obligation.

**CHICAGO SCHOOL OF WATCHMAKING**  
Dept. 193, Fox River Grove, Ill. 60021



## LEARN MEAT CUTTING

Train quickly in 8 short weeks at Toledo for a bright future with security in the vital meat business. Big pay, full-time jobs—**HAVE A PROFITABLE MARKET OF YOUR OWN!** Time payment plan available. Diploma given. Job help. Thousands of successful graduates. **OUR 50th YEAR!** Send NOW for big new illustrated FREE catalog. No obligation. G.I. approved. No. 0197T

**NATIONAL SCHOOL OF MEAT CUTTING**  
Dept. 50-A, Toledo, Ohio 43604

## PUMP DRAINS pools, cellars, laundry tubs IRRIGATES — CIRCULATES — SPRAYS

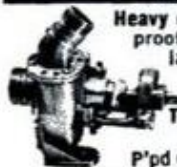

Heavy duty ball bearing pump. All metal, rust-proof Type XB. Stainless shaft. Use 1/4 HP or larger. 1 HP 1,200 GPH 60" high or 3,000 GPH 25" well. 5,200 GPH max. 1 1/4" in; 1" out. Belt or direct drive. \$14.95 Type P won't rust or clog. Bronze bearing. To 2,400 GPH. 1" in; 3/4" out. \$9.95 P'pd cash with order. Money back Guarantee.

**LABAWCO, Box 40, Belle Mead, N.J. 08502**

## FIND BURIED TREASURE

Powerful electronic detector finds buried gold, silver coins, etc. Write or call for free catalog. Dealer inquiries invited.



Financing Available 19.95  
Phone day - night (713) 682-2728 to  
**RELCO, Dept. D-3 198.50**  
BOX 10839, HOUSTON, TEX. 77018

SEPTEMBER 1973 171



## BUILD THESE BEAUTIFUL CLOCKS



NOW AT BIG SAVINGS!

Send just \$1 for plans & instructions to build choice of: (A) Grandfather, (B) Steeple, (C) Grandmother—plus information-packed catalog of movements, dials, parts & kits to build these & 16 other fine clocks. All 3 plans—\$2.50. Catalog alone—25¢.

**MASON & SULLIVAN**  
Dept. PM, Osterville, MA 02655  
IN CANADA: COLONIAL TIMES  
Box 2 Stn S Toronto, Ontario M5M466

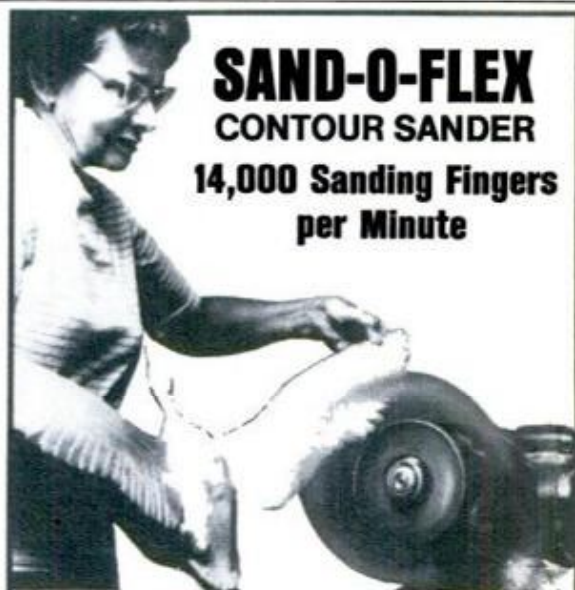

## SAND-O-FLEX CONTOUR SANDER

### 14,000 Sanding Fingers per Minute

Whether sanding carved birds, driftwood or refinishing furniture, you need Sand-O-Flex. Eliminate hand sanding on curved or flat surfaces. Ideal for boats, frames, moldings, carvings. Sand wood, plastic, ceramics, metal, fiberglass.



**MERIT ABRASIVE PRODUCTS, INC.**  
201 W. Manville, Compton, California 90224

### ORDER SANDER KIT BY MAIL \$19.95

\$24.65 value. 8 brush 6" wheel and 4 abrasive refill coils. Adapters fit 1/4" drill or bench motor. No. C.O.D.'s. Add \$2.00 for postage.

## Fast Track to a Cool Job!

Send for FREE CAREER KIT!



## Be a MOTORCYCLE MECHANIC...

★ Learn in spare time at home

Big demand for cycle mechanics opens exciting new opportunity for men who love motorcycles. No previous experience needed. No need to quit school or job. Experts train you step by step at home in spare time. Qualify for good-pay job or your own repair business. **RUSH COUPON FOR FREE "CAREER KIT"**

### SPECIAL CYCLE TOOLS & TEST INSTRUMENTS INCLUDED

Careers by Home Study  
**SPARTAN SCHOOL OF MOTORCYCLE REPAIR, Dept. 34179**  
4500 Campus Dr., Newport Beach, CA 92663  
RUSH FREE "CAREER KIT" without obligation.

NAME \_\_\_\_\_ AGE \_\_\_\_\_  
ADDRESS \_\_\_\_\_  
CITY \_\_\_\_\_ STATE \_\_\_\_\_ ZIP \_\_\_\_\_



## HOW TRACKS ARE ALIGNED

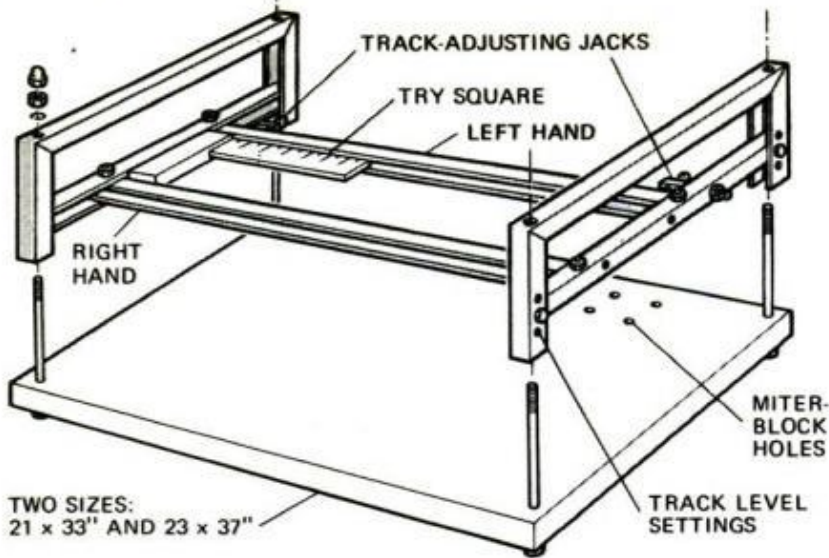

cut are set by adjustments on the saw. A saw carriage glides on stainless-steel bearings so you can use a hollow-ground (planer) blade without binding. With right blade, you can cut metal, plastic and stone.

If you have no portable saw, you can get the rig with heavy-duty 7½-in. Track Mate saw for \$34.95 more. Toolco Industries, 3021 Nebraska Ave., Santa Monica, Calif. 90404. ★★★

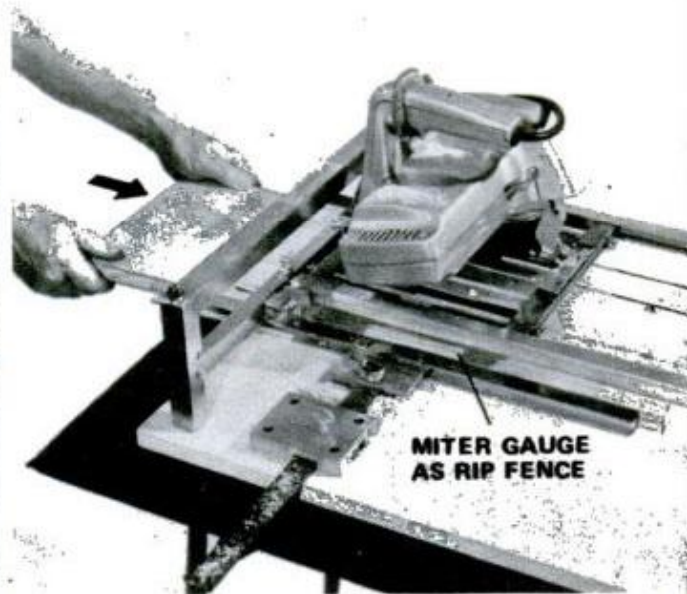
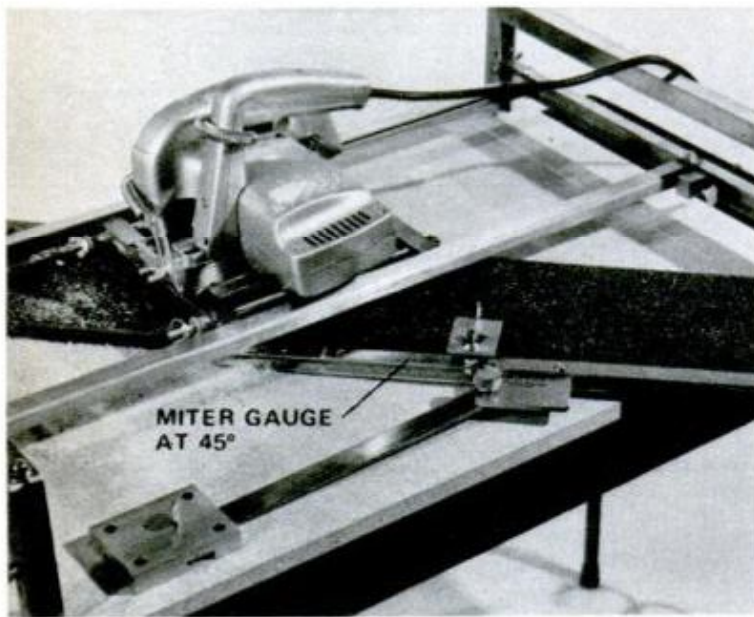

## TRIGGER-ENGAGING SPRING

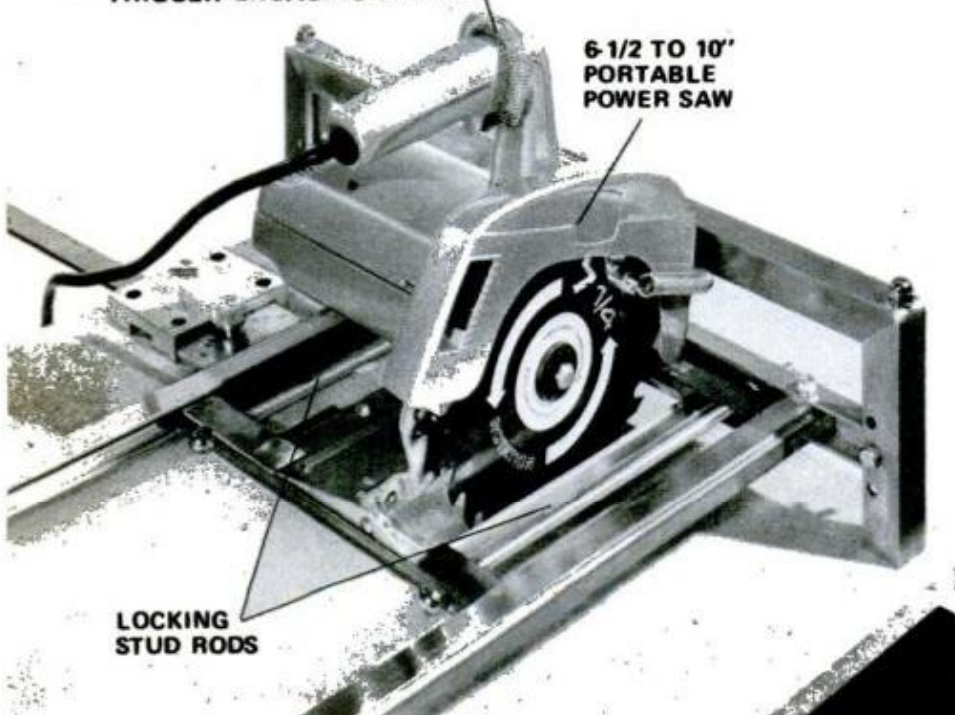

Miter gauge (above left) can be set to cut 22½°, 45° and 60° angles by backing out knurled knob from tapped hole. Hold-down thumbscrew keeps board from shifting; two-way clamp block permits the miter gauge to serve as a rip fence.

With saw locked in place at far end of table (above, right), you can rip a board by feeding it between end posts. Here the miter gauge is used as a rip fence to guide the board, and is adjustable for width of cut.

Carriage platform (left) is custom-fitted to suit your make and model saw. Saw can be removed in seconds when desired. Threaded stud rods allow carriage to be locked in place for ripping operations. Coil spring holds trigger in "on" position.



New square-cornered Sylvania picture tube

Handsome woodgrain cabinet, at no extra cost. (Offered only by NRI)

6-position detented UHF channel selector

Modular construction with plug-in circuit boards

Automatic color control

Automatic degaussing

Automatic tint control

100% solid state chassis

Automatic fine tuning



## NOW... learn color TV servicing while building this NEW 25" DIAGONAL SOLID STATE SET created by NRI for home training

NRI wanted more than a hobby kit TV . . . so we built one from the circuits up, specifically for teaching advanced electronics. You can only get this superb set from NRI . . . it's exclusive with NRI Color TV Servicing Course.

NRI was first to supply home study students with custom-designed training kits to give practical hands-on experience as you learn. Now NRI scores another first . . . with the exclusive 25" diagonal picture tube, solid chassis, color TV set designed-for-learning. You build it yourself with NRI's TV-Radio Servicing Course.



*Kit for kit, dollar for dollar, you get more for your money from NRI.*

The TV-Radio Servicing Course includes a wide-band service type oscilloscope and a color bar cross-hatch generator . . . along with

other valuable equipment you will use to perform experiments and make repairs on your own and other sets.



You'll soon find yourself earning \$5 to \$7 an hour, in your spare time . . . even before the course is completed.

Learning at home is easy . . . the simplified NRI way. Texts are "bite-size" and fully-illustrated, leading you step by step, stage by stage, to a thorough knowledge of electronics. You can introduce defects into circuits, perform experiments, and discover the how and why of circuitry and equipment operation.



*Train with the Leader—NRI.*

The same training innovations which have made NRI the leader in career training at home are now available to you. Mail the insert card for a free full-color catalog which spells out the NRI "discovery" method of learning. There's no obligation. **NO SALESMAN WILL CALL.**

**APPROVED UNDER NEW GI BILL.** If you have served since January 31, 1955, or are in service, check GI line on reply card.



**NRI TRAINING**  
3939 Wisconsin Avenue, N.W.  
Washington, D.C. 20016





## THE SPLIT-LEVEL DESK

(Continued from page 83)

top and the apron, and install the well for the drawer. Remember to install the pullout tray before fastening the well to the desk—because of those fixed stops. Fasten the drawer to the slides and upright the desk so the ends can be laminated.

Construct the secretary return using the same technique. One advantage of this unit is that *the return does not have to be built right away*—it is not an integral part of the setup, as can be seen in the drawings and photos. You can build either one or both units to suit your personal needs and budget. The desk is handsome whether the return is used or not. And you can always add it later.

Costs could be kept down somewhat by using laminate on the top only and staining or painting the rest of the desk. But if you choose this course, you will have to use a cabinet-grade, higher-cost plywood. In any event, the top, at the least, should be laminated to provide a durable, trouble-free surface that won't be marred easily by ball-point pens and pencils through paper.

The interior of the desk shown was finished by applying a sealer coat of shellac thinned 50 percent and following that with two coats of semigloss harvest gold latex enamel. The pencil tray is a quickie project in itself and is of great value for keeping small items from drifting to the rear of the shallow pencil drawer. ★★★

### Manufacturers of materials used

(Available locally, or write to the maker for nearest source.)

**Drawer pulls**—Amerock Corp., Dept. PM, Rockford, Ill. 61101. Knob No. 785 AE, pulls No. 185 AE.

**High-back chair**—Sears, Roebuck and Co., Model No. P3 KX 7778N, Tobacco. Order from your local store or through the catalog.

**Plastic laminate**—Formica Corp., Formica Building, Dept. PM, 120 East Fourth St., Cincinnati, Ohio 45202. No. 417 Honeytone teak, suede finish 64.

**Drawer slides**—Grant Hardware Co., Dept. PM, 141 High St., West Nyack, N. Y. 10994. No. 344-16-in. Add-A-Drawer slides for pencil drawer, and two pairs of No. 3320-16-in. slides for the deep drawers.

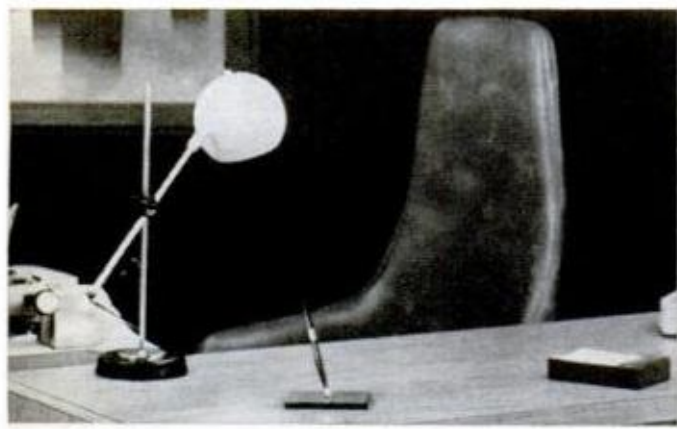

**Executive-type chair with extra-high back** enhances look of office setup—but any chair could be used.



**Doubled-up plywood panels** achieve thickness of 1½ in. To assemble the panels, use screws and glue.

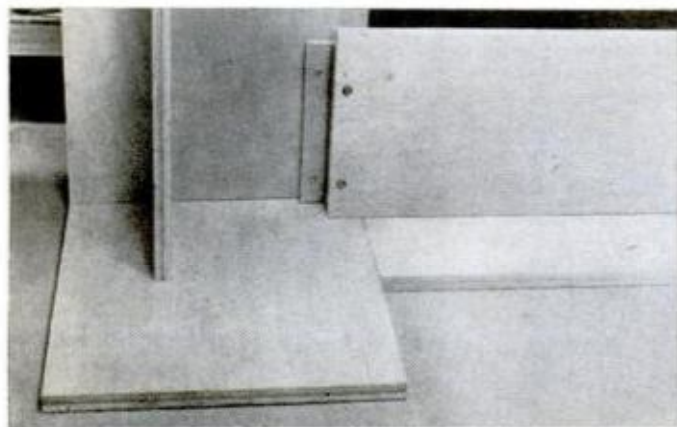

**Assemble units dry for test fit, then disassemble for lamination.** Underside of desk and return is shown.

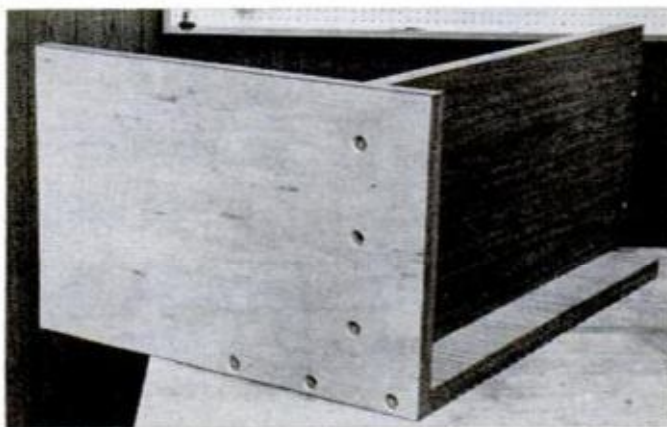

**Assemble sections with lagscrews** in counterbored holes after partial lamination; then laminate the ends.



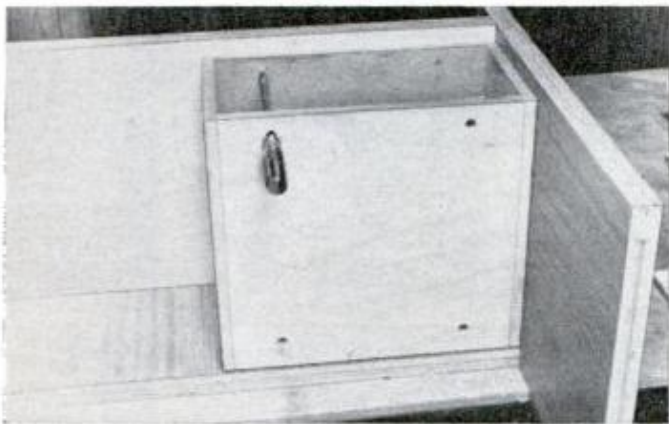
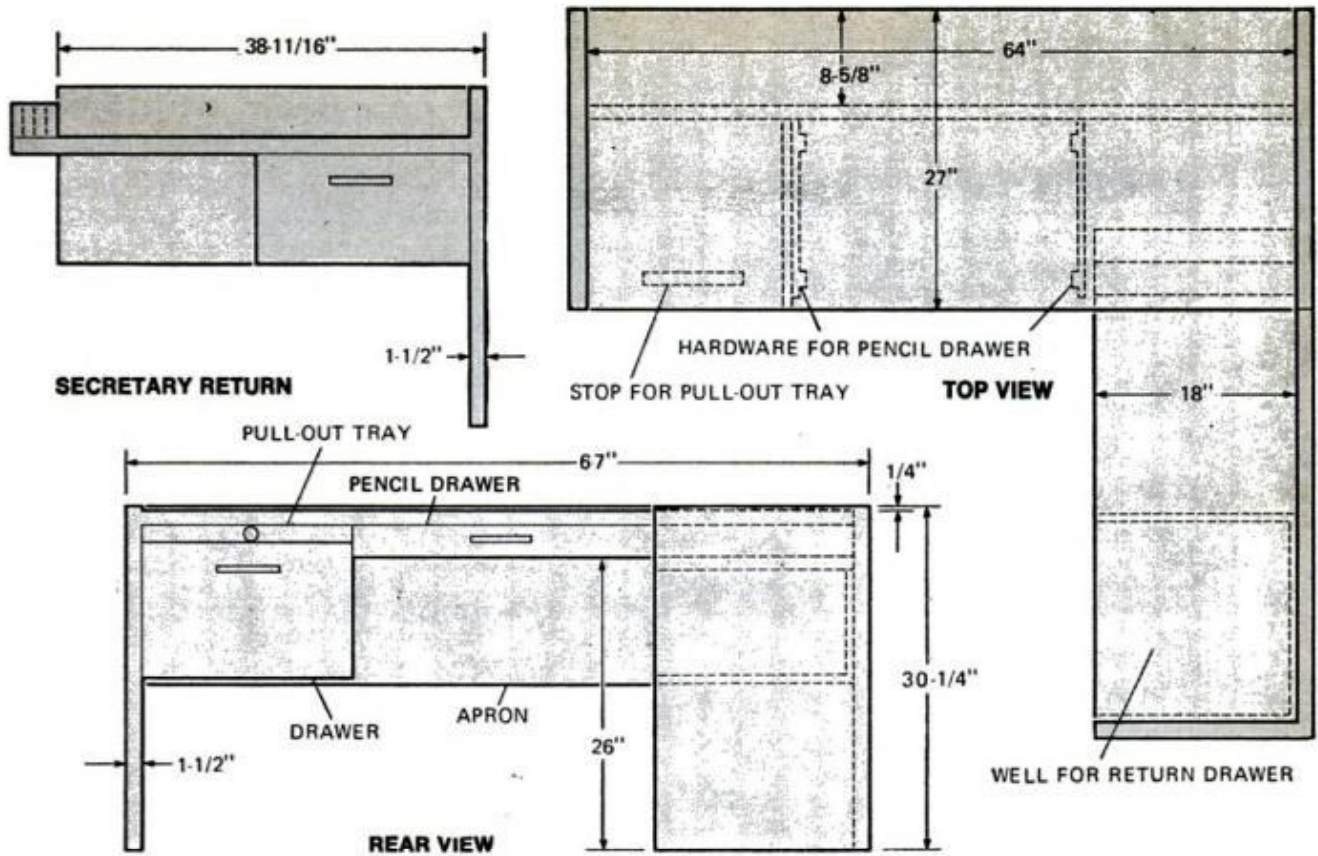

**Access holes** drilled in bottom of drawer compartments aid in mounting to underside of tops with screws.



**Sturdy drawer slides** easily support weight of fully extended drawer. Drawer is then fastened to slides.

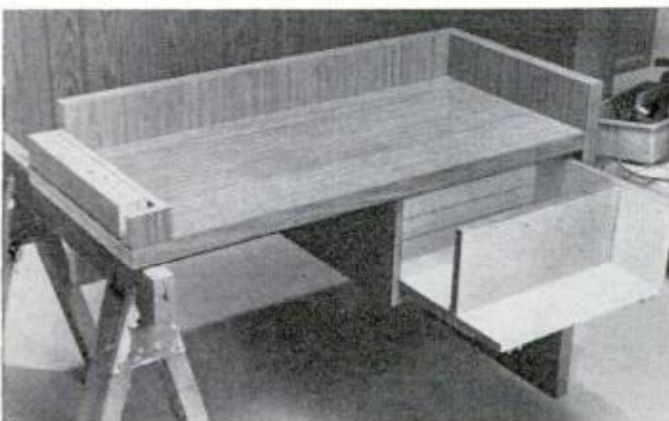

**Return with spacer block** is shown at left end. Drawer front has not yet been installed on the drawer.

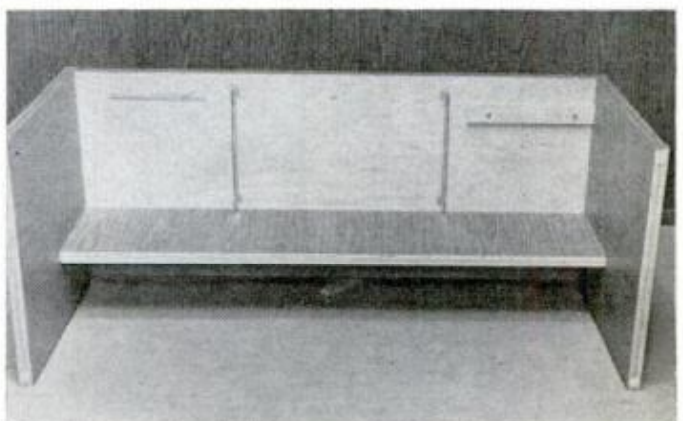

**Underside view of desktop** shows position of pencil drawer slides and stop blocks for tray and return.



## THE WALL-HUGGER DESK

(Continued from page 75)



For permanent setup, desk can be supported on standard two-drawer filing cabinet in place of folding leg.



Drawing board can be mounted on shelf brackets, as at right. Sketch below shows bulletin-board construction.

regular shelf supports. If you'd like more shelves in place of the bulletin board, these, too, can easily be added between the desk and cabinet, again using stock brackets. Other possibilities include magazine racks, pencil drawers, even a drawing board—all mounted by means of the same hook-in shelf brackets. Typical mounting arrangements for such accessories are shown below.

The main parts for both cabinet and desk can be cut from a single sheet of  $\frac{3}{4}$ -in. plywood. The rear portion of the desk is anchored to two 10-in. shelf brackets with metal angles. This holds it in place so it can't slip off as the folding portion is raised and lowered. Edge strips are fastened under the desk to give it the smart, modern appearance of a double-thick counter. The top and sides are then covered with a counter-

(Please turn to page 180)

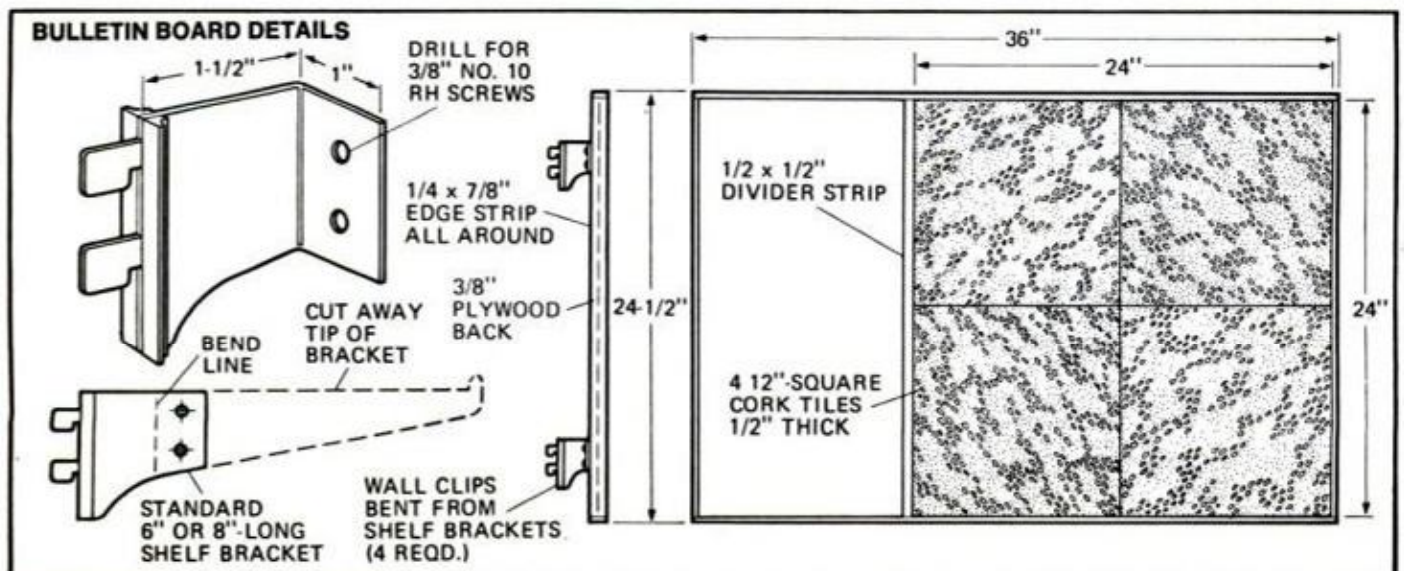
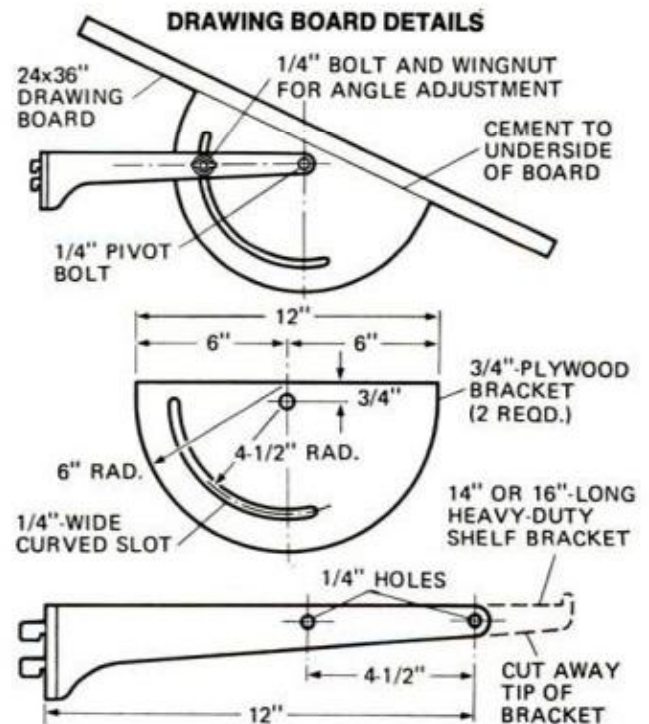



## BUILD YOUR OWN CAMPER!



SEND 25¢ FOR DETAILS

SAVE  
UP TO  
50%



### EQUIPMENT CATALOG

Send \$1.00 postage, handling.  
(Refundable)

VIKING CAMPER SUPPLY,  
INC.  
99-BP Glenwood Ave.  
Minneapolis, Minn. 55403

Please send \_\_\_\_\_ for  
which I enclose \$.....  
NAME.....  
ADDRESS.....  
CITY.....  
STATE.....ZIP.....

5th Wheel Plans ...\$9.95  
Cover basic frame,  
electric, plumbing,  
(general construction)  
Camper Plans ..... 4.95  
Pickup Cover ..... 2.95  
Travel Trailer ..... 3.95  
Econoline Type Van 3.95  
Pass. Bus or  
Delivery Van .... 3.95

## WHAT'S HE DOING!

Making a Concrete  
Flower Pot! ... and  
**SO CAN YOU!**

Make and sell your own  
Ornamental Concrete items.  
**Rush \$3.00 for Book**  
about Aluminum Molds  
with prices and production trade secrets  
direct from world's largest mold manufacturer.  
Over 350 designs to select from.



Send **\$3.00** CONCRETE MACHINERY COMPANY  
Today To ➔ P. O. BOX A99 - HICKORY, N. C. 28601

**EARN \$20.00  
PER HOUR**  
by Assembling



## MINI-DOZER

Build crawler tractor for  
yourself or resale. 7 hp. kit,  
\$498.95. 12 hp. kit, \$748.95. 20  
attachments — loader, blade, mower, snowblower, garden  
implements. Send \$1 for "tell-all" brochure or \$5  
for Build-It-Yourself Plans (\$ refunded on any purchase).  
Struck Corp., Dept. PM93, Cedarburg, Wis. 53012.

## A BUSINESS OF YOUR OWN REPAIR HYDRAULIC JACKS



Earn while you learn at home. Millions of jacks in gas and auto service  
stations, trucking firms, body shops, riggers, factories and farms need  
servicing ... most of which you can learn to repair. We show you  
HOW. Start spare time in your basement or garage. Big opportunity for  
mechanics. ACT NOW! Write for folder PM-9, and free bonus offer

**HYDRAULIC JACK REPAIR MANUAL CO., INC.**

G. P. O. BOX 3 • STATEN ISLAND, N. Y. 10314

**1¢ SALE**  
GUARANTEED  
10 YEARS



The knife for hunting,  
fishing and all around  
use. Mirror polished,  
imported stainless  
steel blade honed to a  
razor's edge. Rugged. Opens  
quickly, easily. Locks into  
position. Blade will not close  
when in use. Press button in handle  
to close. Safety finger guard. Sure-  
grip handle. Balanced for target throwing.

**IF BROKEN WITHIN 10 YEARS WE  
WILL REPLACE AT NO CHARGE!** Use 30  
days. Money back if not pleased. Special 1¢ sale.  
REG. PRICE \$2.50. Send \$2.51 & receive 2 knives. Add  
49¢ postage, handling. Remit TOTAL \$3.00 for 2 knives.  
ORDER NOW! Midwest Knife Co., 9043 S. Western Ave.,  
Dept. DDK-7608, Chicago, Ill. 60620. Est. 1936.

## AAMCO® And You Can Make It!

The world's largest transmission chain is still growing  
strong after nine years. Over 500 of our franchises located  
from coast to coast. New openings in some markets mean  
you too might qualify. For further information write:

**AAMCO Transmissions, Dept. 91**  
408 E. Fourth St., Bridgeport, Pa. 19405

## THE TALLEST HUMAN IN THE WORLD...AND HIS DAD!

**Robert Wadlow, at the age of  
22, reached the record height  
of 8 ft. 11.1 in. His father  
was the long time Mayor  
of Alton, Illinois.**

**The heaviest human on record  
weighed 1,069 lbs. and was  
buried in a box the size of  
a piano case.**

**The highest divorce  
settlement ever made  
was \$9,500,000.**

**The longest single un-  
broken apple peel on  
record is 1,568.5 in.  
The apple was 15 in.  
in diameter!**

**The greatest number  
of children pro-  
duced by a mother  
is an unbelievable 69.**

**The most expensive  
wine in the world cost  
about \$300 a glass.**

**Here it is—the only  
book of its kind—  
The Guinness Book  
of World Records—  
enlarged and up-  
dated! It contains  
over 3,000 all-time  
records, statistics,  
spectacular feats of  
man, nature, science,  
space, the arts, enter-  
tainment, the world of  
sports and little  
known fantastic  
phenomena.**

**The biggest!  
smallest!  
richest!  
highest!  
shortest!  
oldest!  
lightest!  
longest!  
fastest!  
slowest!  
greatest!**

**—The N.Y. Times  
Settle any argu-  
ment! Amaze  
your friends! You  
won't be able to  
put it down. This 637 page  
fantastic hard-covered  
volume is a must for any  
library. Nearly 10  
million copies sold.  
worldwide. Only \$5.95.**

\*\*\*\*\* MONEYBACK GUARANTEE \*\*\*\*\*  
**BOOK OF WORLD RECORDS, DEPT. G-268**  
1966 BROADWAY, NEW YORK, N.Y. 10023

Please rush me \_\_\_\_\_ Guinness Book of World  
Records at \$5.95 ea. (plus 60¢ post. and hand.)  
Enclosed is my check or money order for  
\$\_\_\_\_\_. If not completely satisfied, I'll re-  
turn the book within 15 days for a full refund!

name \_\_\_\_\_ please print

address \_\_\_\_\_

zip \_\_\_\_\_

**Make check/money order payable to  
Book of World Records.**

© 1973



## THE WALL-HUGGER DESK

(Continued from page 178)

top laminate such as Formica. We chose Harvest Gold, but any color can be used.

To collapse the drop leaf, the hinged leg is folded up underneath and held by a small latch bolt. The telescoping leg should slide smoothly but not be loose. If it binds, it may be necessary to add thin cardboard shims to the spacer blocks at the top. Adjust the fit so the leg just slides freely when the wingnuts are loosened. Tighten the nuts to lock it at the desired height.

The upper cabinet is 12 in. deep and rests on 12-in. shelf brackets. While most brackets are sturdy enough to support its weight, it's a good idea to screw the cabinet to the wall tracks to help carry the load and prevent any tendency for the cabinet to tip forward. With the cabinet positioned at the desired height, locate a pair of screws in the wall tracks behind it near the top, remove the screws and drill matching holes in the back of the cabinet. Then run the screws through the back and into the same holes in the wall tracks. If necessary, use longer screws than those supplied to assure a firm grip in the wall anchors.

The bullet lamp is fastened to the door with a short  $\frac{1}{8}$ -in. pipe nipple. The wire runs through the door and is stapled along

the back side to the hinge point, using insulated staples. Form a loop in the wire where it passes around the hinge to allow some slack. This permits the door to be opened and closed without the lamp cord interfering with its operation. (Note: While this method does not conform to accepted code practice for permanent house wiring, it is adequate in this case because the wall cabinet is not considered a permanent part of the house.) The fluorescent fixture is wired through a surface-mount duplex receptacle that provides a switch for controlling the light, plus an extra convenience outlet for plugging in an electric pencil sharpener, desk lamp or other appliance.

The cabinet is finished in walnut-toned Formica with Harvest Gold laminate on the door to match that on the desk. Not counting incidental hardware and scrap lumber, you can build the basic units for about \$60, including the Formica (half a 4x8 sheet each of the walnut and gold). The bullet lamp, a Sears Model 34 A 8702, is about \$15 and the two-tube, 24-in. fluorescent fixture about \$12. These bring the total cost to approximately \$87. If you wish to eliminate the Formica and go to a painted finish, you can save about \$35, but the laminate is well worth the expense as it hides joints, simplifies construction and adds a slick, marproof finish to the project. ★★★



Many variations are possible using adjustable shelf brackets in slotted wall standards. Shelf over desk (left, above) has a stock plastic Rubbermaid kitchen



drawer screwed underneath for storing pencils and other small office supplies. Magazine rack (right) rests on sloping brackets sold ready-made for this purpose.



Makes old windows work like new  
... without replacing the whole window!

CBW Side Ride™ Window Channels eliminate drafts,  
rattles and sticking.

Can be installed in less than 45 minutes.

Designed with a built-in activated parting bead, this unique device effectively takes the place of old worn out ropes and chains—or other systems that simply do not work.

Constructed of extra heavy aluminum and stainless-steel, they're rugged and easy to work with. Made to last a lifetime. Costs as little as \$4.60 per window. Fits all standard 1 3/4" sash.

For free instruction, and where to buy, write:

**Quaker City Manufacturing Company**  
701 CHESTER PIKE, SHARON HILL, PA. 19079



**MAKE \$200**

Installing a burglar-fire alarm system in a home, store, factory or office. No experience needed. Electric, wireless, ultrasonic types—where to get—how to install—what to charge. Program includes manual—wiring diagrams—trap charts—proven tips for getting sales. Complete, professional, authentic instruction kit only \$9.95 PPD. Guaranteed. Order now and get free job pricing guide.

**or more this weekend!**

ELLIS PUBLISHING COMPANY  
810 31st St., Union City, N.J. 07808

**Be a VETERINARY ASSISTANT**

... Lab Aide, Zookeeper, Pet Shop/Kennel Owner  
**MEN - WOMEN! Train at Home in Spare Time ...**  
**Send for Career Kit—ALL FREE!**

Name \_\_\_\_\_ Age \_\_\_\_\_  
Address \_\_\_\_\_  
City \_\_\_\_\_ State \_\_\_\_\_ Zip \_\_\_\_\_  
North American School of Animal Sciences, Dept. 34 179  
Careers by Home Study  
4500 Campus Dr., Newport Beach, CA 92663 234



**locksmithing and key making**

**PRACTICAL UP-TO-DATE COURSE—ONLY \$7.95**

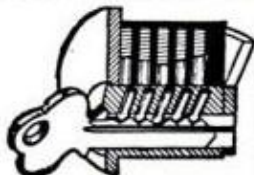

Teaches you how to pick locks, de-code, make master keys, repair, install, service, etc. New self-instruction lessons for every handyman, homeowner, carpenter, mechanic, service station operator, fix-it shop, hardware dealer, gunsmith. 53 easy illustrated lessons. Full price only \$7.95 postpaid. Satisfaction or refund guaranteed. Mail order today!

**NELSON-HALL CO., Dept. 6JX-2**  
325 W. Jackson Blvd., Chicago 60606

**USE ZIP CODE WHEN ANSWERING ADS**

**20 WOOD SAMPLES with woodworkers Catalog**

ENJOY woodworking more! Let Constantine's big picture-packed Catalog-Manual help you build new furniture—refinish, restore beat-up cabinets, chairs, chests, tables, etc. Find instantly whatever you need. Buy at money-saving prices from world's largest catalog source for imported and domestic woods. Cabinet lumber, carving blocks, veneers, plywood, pipe briar, inlays and more!

Newest Catalog features new tools, materials, shop devices. Fabulous all-purpose clear finish. Glue that needs no clamps. Inlay picture kits, 99¢. Needed products found nowhere else. Plus wood-working instructions, plans, patterns!

**Catalog & Wood Samples Only \$1**  
Dollar Fully Refunded on-First Order  
Accept this offer to own fascinating set of 20 2x4 specimens of world's glamorous veneers—Rosewood, Satinwood, Lacewood, Teak, etc! Compare! Then instantly identify finest woods wherever you go. Send only \$1 for Wood Samples and Woodworkers Catalog. Dollar refunded on first order.

**CONSTANTINE**

2051 Eastchester Rd., Bronx, N.Y. 10461

Enclosed \$1 for Wood Samples & Woodworkers Catalog. (\$1 refunded)



**2,000**  
**PRODUCTS FOR SHOP & HOME**  
Woods—Veneers—Finishes  
Furn. Hardware—Lamp Parts  
Cane—Upholstery—Tools  
Picture Molding—Clock Kits

**FREE WITH CATALOG**  
"101 PROJECT IDEAS"

**96 GIANT PAGES**

Catalog only 50¢



Name \_\_\_\_\_  
Address \_\_\_\_\_  
Zip \_\_\_\_\_

**FREE OUTFIT STARTS YOU IN BIG MONEY SHOE BUSINESS!**



Run your own profitable 'shoe store' business from home in spare or full time. We give you—FREE—complete Starting Outfit that makes you \$217.00 EXTRA each month for just 2 easy orders a day. You feature 350 fast-selling dress, sport, work shoe styles for men and women. Air-cushion shoes, many other special features! Sizes 4 1/2 to 16—widths AA-EEEE. Draw on 300,000 pair stock. Earn prizes, bonuses, shoes for yourself—even a new car or color TV! Rush postcard for your FREE Starting Outfit today . . . Now!

**MASON SHOE, Dept. F-780, CHIPPEWA FALLS, WIS. 54729**

**Magic Mail Plan—Make up to \$12 an Hour!**



Get **ORDERS** and **CASH** from your mailman—do work in **SPARE TIME** at home—or expand into **FULL TIME** business. Send coupon for Free facts about the newest and most fascinating of all home operated businesses. For the first time a simplified machine brings the fabulous profits of **Plastic Sealing** and **Plastic Laminating** within the reach of the small operator. Anyone can learn to operate the machine with a few minutes practice—then with our **Magic Mail Plan** can get mail orders pouring in daily with cash in every envelope. **No canvassing—no selling.** We even

**Get into PLASTIC LAMINATING at home**

**WE'LL HELP FINANCE YOU AT LESS THAN BANK RATES.** supply the circulars you mail to bring back cash and orders, financing help, too. Rush name. We'll send you **FREE** and postpaid, pictures, prices, details, finance plan, all the facts you need. Mail coupon or send name on postcard. No charge. **WARNER, 1512 Jarvis, Dept. L-2-CK, Chicago, Ill. 60626**

**THIS MAN . . .**  
... is taking out of the machine a Plastic Sealing Job—ordered by mail—only 1lb in material cost brings back \$2.58 in cash by mail. Capacity of machine: \$40.00 profit per hour of operation.

**Make Thousands of Beautiful Art Creations**

**COSTUME JEWELRY • CIGARETTE BOXES**  
**TRAYS • CANDLESTICKS • COASTERS**  
**LAMP BASES • BOOK ENDS...ALL IN SPARKLING COLORED PLASTIC**



**WARNER ELECTRIC CO., 1512 Jarvis Av. Dept. L-2-CK, Chicago, Ill. 60626**

At no cost to me, please rush full details and financing plan, postage prepaid. No obligation.

Name \_\_\_\_\_  
Address \_\_\_\_\_  
City \_\_\_\_\_ State \_\_\_\_\_ Zip Code \_\_\_\_\_



## IN-A-CHEST HOME OFFICE

(Continued from page 79)

bottom of the cleat for attaching the desktop with  $1\frac{1}{4}$ -in. No. 8 fh screws. Screw holes are also made across the plywood back and in the top of the metal file cabinet, although the desktop is not permanently installed at this time.

Except for being right and left-handed, with the left wing having a shelf at the bottom, both wings are made alike. Parts A measure  $14\frac{5}{8} \times 46\frac{5}{8}$  in. and have a  $\frac{1}{2} \times \frac{3}{4}$ -in. rabbet along the front edges to accept parts B, which measure  $21\text{-}3/16 \times 46\frac{5}{8}$  in. The latter are glued and nailed in the rabbets with finish nails and checked for squareness. Parts C measure  $14\frac{5}{8} \times 21\text{-}7/16$  in. and are rabbeted ( $\frac{3}{8} \times \frac{3}{4}$  in.) along two edges to fit over and flush with the top edges of parts A and B, then glued and nailed. Part D (the wing shelf) is secured with  $\frac{3}{4}$ -in.-square cleats glued and screwed to parts A and B. Screw holes for attaching shelf brace L are drilled through parts B and D for screws driven from the front and up from the bottom.

The actual length of part I is determined by the width of the file cabinet. In the original it measures  $14 \times 26\frac{3}{8}$  in. and is anchored in place by a cleat at one end and the file cabinet at the other. Two holes

(Please turn to page 186)

### CUTTING SCHEDULE

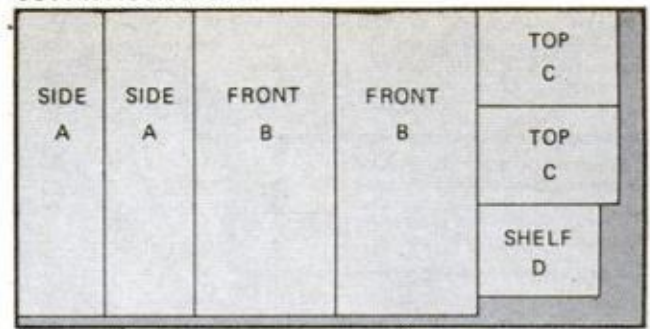

$3/4 \times 4 \times 8'$  LUMBER-CORE PLYWOOD

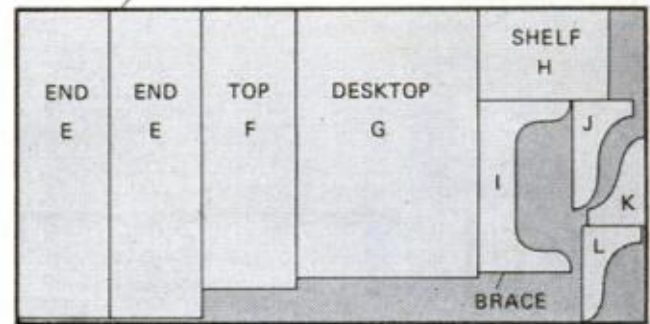

### ACTUAL CUTTING SIZES

- (A)  $\frac{3}{4} \times 14\frac{5}{8} \times 46\frac{5}{8}$  in.—Wing sides
- (B)  $\frac{3}{4} \times 21\text{-}3/16 \times 46\frac{5}{8}$  in.—Wing fronts
- (C)  $\frac{3}{4} \times 14\frac{5}{8} \times 21\text{-}7/16$  in.—Wing tops
- (D)  $\frac{3}{4} \times 12 \times 18\frac{1}{4}$  in.—Wing shelf
- (E)  $\frac{3}{4} \times 14\frac{5}{8} \times 47\frac{1}{2}$  in.—Chest ends
- (F)  $\frac{3}{4} \times 14\frac{5}{8} \times 43$  in.—Chest top
- (G)  $\frac{3}{4} \times 28 \times 40\frac{1}{2}$  in.—Desk top
- (H)  $\frac{3}{4} \times 14 \times 21$  in.—Typewriter shelf
- (I)  $\frac{3}{4} \times 14 \times 26\frac{3}{8}$  in.—Brace
- (J)  $\frac{3}{4} \times 9\frac{1}{4} \times 16$  in.—Typewriter-shelf brace
- (K)  $\frac{3}{4} \times 9\frac{1}{4} \times 12$  in.—Typewriter-shelf brace
- (L)  $\frac{3}{4} \times 9\frac{1}{4} \times 11$  in.—Wing-shelf brace

### UNDERSIDE OF DESKTOP

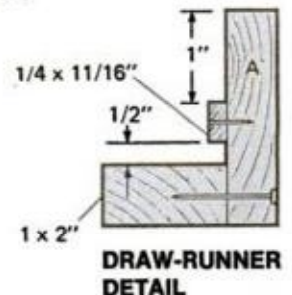
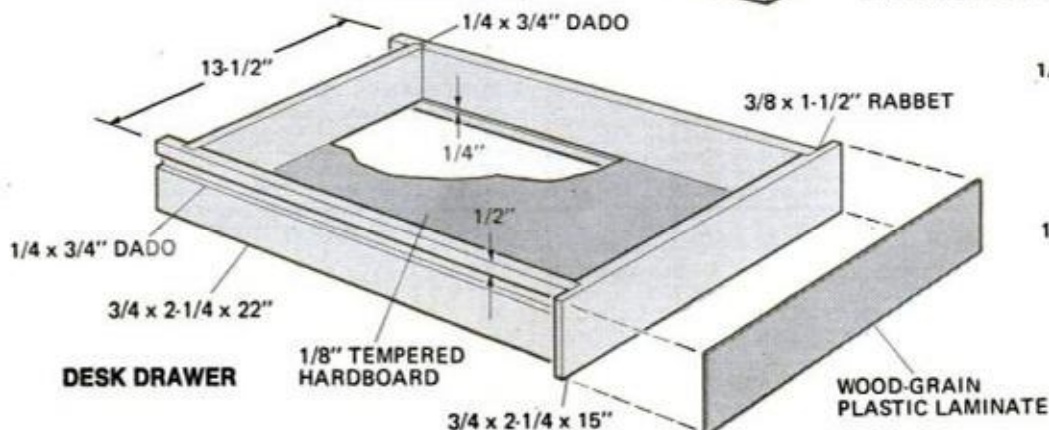
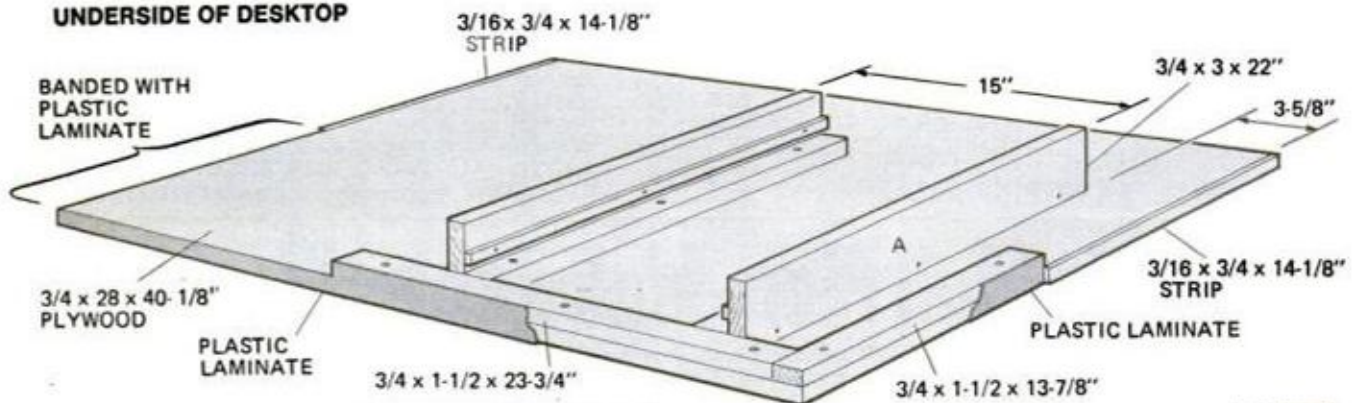



# Who'd have thought I'd make so much money without going to college?



I still have to pinch myself every time I see my paycheck — it seems too good to be true!

Especially when I remember how sorry everyone felt for me because I couldn't go on to college. "Without college, it's a losing battle!" they all said.

Well, the college boys left for school, and I found a job. I worked hard, too, but never made it big.

Then I happened to read an announcement like this... about the exciting job opportunities in Electronics.

I discovered that with proper training I could qualify for a job in many of the fields where the action is today... computers, medical science, pollution control, radio and TV broadcasting, to name just a few. I found out that once I had some experience, I could earn \$12,000 a year or more... the kind of money any college man would be proud of.

Most important — I realized how easy it would be for me to get this training. Right at home. In my spare time.

With a home-study course from Cleveland Institute of Electronics.

It looked like a terrific deal, so I enrolled with CIE... and did I learn fast! I'm happily employed in Electronics now, earning good money in a career that means something. It's all so unreal that every once in a while I have to pinch myself.

Without college, I never thought I could do it. But, thanks to CIE there are now some college guys who envy me!

This composite story is typical of hundreds told by CIE graduates who are now enjoying exciting new careers in Electronics.

## Send for 2 FREE BOOKS

So find out for yourself. Ask for CIE's 2 FREE BOOKS, "Succeed in Electronics" and "How to Get a Commercial FCC License." They describe the opportunities open to men with electronics training and show you how CIE courses can prepare you for a meaningful, rewarding career in the Science of the Seventies.

Both books are FREE... send for them today! For your convenience, we will try to have a representative call. Mail reply card or coupon to CIE... or write: Cleveland Institute of Electronics, Inc., 1776 E. 17th St., Cleveland, Ohio 44114.

## APPROVED UNDER NEW G.I. BILL

All CIE career courses are approved for educational benefits under the G.I. Bill. If you are a Veteran or in service now, check box for G.I. Bill information.

### CIE Grads Report Success



"My CIE course gave me the technology I needed to understand many of the electronics concepts I never dreamed I could learn. I'm already earning 30% to 40% more than I could have without my CIE training."

Joe Perry, Cambridge, Mass.



"When I started my CIE training, I worked on a tugboat. Then I landed a broadcast engineering job at a TV station. During my first year in broadcasting, I finished my CIE course and got two raises."

Richard Kihn, Anahuac, Texas

## CIE Cleveland Institute of Electronics, Inc.

1776 East 17th Street, Cleveland, Ohio 44114  
Accredited Member National Home Study Council

Please send me 2 FREE BOOKS describing opportunities in Electronics and how to prepare for them.

Name \_\_\_\_\_  
(Please print)

Address \_\_\_\_\_

City \_\_\_\_\_

State \_\_\_\_\_ Zip \_\_\_\_\_ Age \_\_\_\_\_

### Veterans and Servicemen:

Check here for G.I. Bill information.

PM-83



## GOVT. SURPLUS

and other bargains  
**SAVE to 90%**

Send for this catalog

The world-famous Airborne Catalog. Fully illustrated. Contains 1000's of bargains in hydraulics, electrical, marine, automotive & hardware items . . . and more! A must for mechanics, machinists, hobbyists, sportsmen, inventors, etc. Send 35¢ to cover postage & handling. In a hurry? Send \$1 for airmail delivery. Must include zip.

**AIRBORNE SALES CO.** Dept. PM73  
8501 Steller Dr., Box 2727, Culver City, Ca. 90230  
Satisfying world-wide customers since 1945



## NO MORE 'BLINDSPOT'!

with the SAF-T-TWO MIRROR

ADJUST FOR A CLEAR  
REAR VIEW HERE

SEE WHAT'S IN THE  
BLINDSPOT HERE

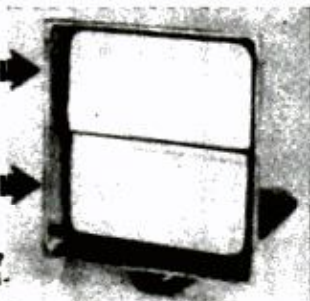

Had a close call lately?  
Drive regularly in multi-lane traffic?

Then you need SAF-T-TWO . . . the split-level, non-distorting mirror that gives both a clear rear view AND a clear, undistorted view of the blindspot! Universal mount - handsomely chromed - a beautiful addition to your motoring safety and pleasure . . .

To order, mail this coupon with check or money order to  
**SAF-T-PRODUCTS, 1099 N.W. Le Jeune Rd. Miami, Fla. 33126**

I am enclosing \$9.95 (drivers side)  \$17.50 (both sides)

MAIL TO

name \_\_\_\_\_  
address \_\_\_\_\_ city \_\_\_\_\_ state \_\_\_\_\_ zip \_\_\_\_\_  
I understand my mirror will be shipped prepaid within four weeks and comes with a money back guarantee if I am dissatisfied . . .

## NEW Chairs, Sofas, FURNITURE FROM OLD



• LEARN RE-UPHOLSTERY AT HOME . . . FOR FUN OR PROFIT!  
Turn cast-offs into \$100's. No experience needed. We show you how . . . get you started fast!

Send for  
**FREE BOOK**

Name \_\_\_\_\_ Age \_\_\_\_\_  
Address \_\_\_\_\_  
City \_\_\_\_\_ State \_\_\_\_\_ Zip \_\_\_\_\_

MODERN UPHOLSTERY INSTITUTE, Box 899-PM ORANGE, CA. 92669

## BASEMENT TOILET

Flushes up to existing sewer or septic tank by powerful, self-contained pump operated by normal water pressure. No digging up floors. Clog resistant, easily installed. Make basement into game room, den, apartment with private bath. Financing available. Write for free literature.

**DOSS, Dept. J-25, Box 10947, Houston, Tex. 77018**



## HOME-WORKSHOP ELECTRIC ARC WELDER \$9.99!



WELDS—BRAZES—SOLDERS—CUTS  
—ALL METALS! Plugs into ANY 110 volt socket. MAKE—REPAIR most anything for CAR—HOME—BUSINESS. Lifetime BURNOUT GUARANTEE 10 day money back trial (if retrnd). **HEAVY DUTY** Design. No experience needed—FREE WELDING LESSONS!

(cash, ck, M.O.) and pay postman \$7.99 COD  
SEND **\$2.00** postage or send \$9.99 plus \$2.00 for postage—packing in U.S.A. COMPLETE READY TO USE—Includes BIG pack steel, Brazing, Solder, Carbon "touch" rods & ELECTROFLAME ARC TORCH! OFFER LIMITED—Order TODAY!  
MIDWAY WELDER, Dept. EPM-9, Kearney, Nebr. 68647

## IN-A-CHEST HOME OFFICE

(Continued from page 182)

are drilled through the side of the cabinet for screws from the inside.

The 14 x 21-in. swing-away typewriter shelf consists of parts H, J and K, assembled as detailed on page 79. Parts J and K are glued and screwed along adjacent edges of part H. A 10-in. length of piano hinge is used to hinge the assembled shelf to a 3/4 x 2 x 10-in. wood block, which is later screwed and glued to the inside of part E, 26 in. up from the floor.

Now you are ready to cover the various parts and assemblies with plastic laminate. The original was covered with Formica's English oak, No. 343, finish No. 64. It will take approximately two and a half 4x8-ft. sheets.

If working with plastic laminate is a new experience for you, we refer you to *How to Work With Plastic Laminate* (page 154, March '70 PM) which explains how to cut, cement and trim the material. The most professional (and fastest) trimming job is done with a portable router, using special cutters, but it can be done with a special hand tool made by Arlyn Industries, 6921 Stride Ave, Burnbay 3, B.C., Canada.

Only part L is covered with laminate on both sides, others just on the edge and one side. In each case, the edges are banded first. A good place to start is on parts D and L since these, particularly part L, must be screwed in place before part B can be covered on the outside. In the case of the wings, the extra width that the 1/16-in. laminate adds has been accounted for in the overall sizes given for parts B and C. Inside surfaces not covered with laminate were painted olive green, as was the file cabinet. Here it's wise to paint the back panel of the center section before assembling the desk.

When all parts are covered with laminate, you can start putting the desk together. First lay the center section on its back and position the file cabinet against the 1/8-in. hardboard strips. Use two C-clamps to hold the cabinet in place and drill two screw holes through the sheet metal opposite each hardboard strip. Drill two more through the back of the file cabinet and the plywood back. Use 3/4-in. No. 8 rh wood screws into the hardboard strips, and 3/4-in. stovebolts through the plywood back.

Next install the desktop by turning screws up through the left-hand cleat, through



holes in the top of the file cabinet and holes in the plywood back. Add the typewriter shelf by screwing the block to which it is hinged to part E at a point 26 in. up from the floor. The shelf should clear the desk drawer by  $\frac{1}{4}$  in. Part I is added next and is held with screws inserted through its cleat, the side of the file cabinet and the

Wings are hinged last with  $46\frac{1}{4}$ -in.-long plywood back.

piano hinges. It's best to hold the wings in their open position by clamping them temporarily to the sides of the center section. Hinges are surface-mounted, with the barrel centered over the joint.

The striker plate from a lockset is used to align the two wings with the top of the center section when they are swung shut. Two magnetic catches, screwed to the underside of the desktop at the front, are used to hold the doors shut. A third magnetic catch is used to hold the typewriter shelf closed, while an elbow catch is used to lock the shelf in open position. The plate for the magnetic catch on the typewriter shelf is fastened to the plywood back with a short stovebolt. A pivoted doorstop is used to keep the left-hand door "locked" to the floor when the typing shelf is being used.

Twin paper-storage bins, and the four-drawer compartment, held in place by screws, are detailed on page 79. Large decorative towel rings are used for elegant wing pulls, and a regular 24-in. under-cabinet fluorescent fixture attaches to the underside of the drawer compartment. A roundhead screw in the center partition of the paper bins will act as a hook for a pinup lamp to spotlight the typing shelf. ★★

#### MANUFACTURER'S PRODUCTS

**Companion side chair**—Cat. No. C3KX7796N, olive green, Sears, Roebuck & Co.

**Portable electric typewriter**—Celebrity power 12, Cat. No. 3H5360N, Sears, Roebuck & Co.

**Plastic laminate**—English oak No. 343, No. 64 finish, Formica Corp., 120 East 4th St., Cincinnati, Ohio 45202.

**Pinup light**—Handymate PN-2, walnut, Swivelier Co., Inc. Nanuet, N.Y. 10954.

**Wing pulls**—Antique brass Chateau No. BF117 towel rings, Kirsch Co., Sturgis, Mich. 49091.

**Paint**—Velour semigloss alkyd enamel, olive green, Devco Paint Co., Inc., 2 Oxford Drive, Moonachie, N.J. 07074.

**File cabinet**—two-drawer, full-suspension with lock, 15 x 28 x  $29\frac{1}{4}$  in. Modern Steelcraft Co., 1101 Linwood St., Brooklyn, N.Y. 11208.

**Door holder**—5 in. dull bronze, No. J1235 DEZ, The Spartan Works Ltd., 27 Ludlow St., New York, N.Y.

While materials for this desk cost about \$265, you can build it for considerably less by painting the outside instead of covering it with plastic laminate, and by buying a used file cabinet instead of a new one. You could also save on the towel-ring handles and the lamps.



The real beauty of Lindal Cedar Homes:

# Floors that won't let you down.

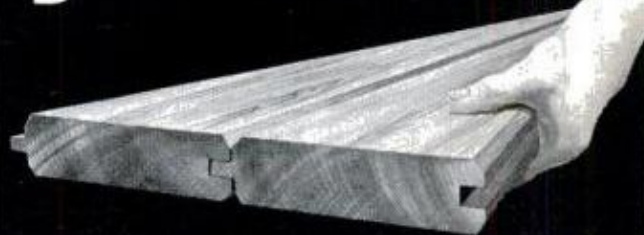

Step on it, drive a truck on it. Our *double-thick* (2x8), interlocking subflooring is extra-strong, extra-quiet. And roof decking is just as thick! See our naturally beautiful, uncommonly durable pre-cut homes—get 82 floor plans and prices—by sending \$1 for your 44-page Lindal Planbook.

**LINDAL CEDAR HOMES** PM39

10411 Empire Way S., Seattle, WA 98178  
Phone (206) 725-0900

Enclosed is \$1 for my Lindal Cedar Homes Planbook. (Add 50¢ for Air Mail)

Name \_\_\_\_\_

Address \_\_\_\_\_

City \_\_\_\_\_

State \_\_\_\_\_ Zip \_\_\_\_\_

Area Code \_\_\_\_\_ Phone \_\_\_\_\_

*Lindal homes are sold throughout the world.*



## FAST FIXES FOR HESITATION PROBLEM

(Continued from page 149)

static valve in the air cleaner snorkel that is controlled by a temperature sensor in the air cleaner. This valve permits control of carburetor air to allow leaner carburetor calibrations and thereby reduce emissions.

Check the operation of this valve by starting a cold engine. Look inside the snorkel. The valve should be closed. As the engine begins to warm up, the valve should open and be fully opened when the engine reaches normal operating temperature. If not, the entire system must be checked.

**Fuel system.** How's the rest of the fuel system? Other areas that can cause hesitation include a fuel pump which is failing, a carburetor float level that is set too low or carburetor passages that are plugged with dirt. Is it time for a complete carburetor overhaul? If yours hasn't had one in 30,000 miles or so, and hesitation is your problem, do the job.

Here are a few more things to check:

**Air leaks** into the fuel intake system will lean out the fuel mixture and can result in hesitation, as well as rough idle.

If you have a vacuum gauge, hook it up and let your engine idle after it has warmed up. The engine should be set to idle at the manufacturer's recommended rpm. If the vacuum-gauge needle holds steady at an extremely low reading (much less than the 19 to 21 inches that is considered normal), an air leak probably exists at the carburetor or intake manifold. If you don't have a vacuum gauge, just tighten all carburetor and manifold bolts.

**Distributor vacuum advance unit.** Check for damaged vacuum advance by removing the distributor cap, pulling the vacuum line off the vacuum inlet of the vacuum chamber, moving the distributor plate against its rotation and holding a wet finger tightly over the vacuum inlet. The distributor plate should remain in position. If it snaps back, the diaphragm in the vacuum chamber is probably leaking. Replace the vacuum advance unit.

**Ignition timing.** Flat-spot acceleration will result if timing isn't adjusted to manufacturer's specification. Check timing with a stroboscopic timing light.

**Other possibilities.** Less likely, but possible, causes of hesitation are incorrect distributor point gap and dwell, sparkplug gap and condition, and ignition coil output. Check 'em out. ★★★

## SELECTING A MODERN SCATTERGUN

(Continued from page 137)

with ranges between 25 and 40 yards. "Full" chokes throw the tightest long-range patterns best for 35 to 50-yard shots when hunting large wary game such as wild turkeys or pass shooting at ducks and geese.

□ *Gauge designation* tells relative diameter of the barrel. Largest capacity gauges have smallest numbers.

**10-gauge:** Uncommon today. Found only in a few double-barrel shotguns.

**12-gauge:** The most popular gauge. Appropriate for all target shooting and hunting; best choice for the one-shotgun man who hunts a variety of game.

**16-gauge:** Declining in use, superseded by heavier loads in some 20-gauge shells.

**20-gauge:** Good choice for upland game where faster, lighter handling helps. Adequate for ducks over decoys; not for pass shooting. Lighter recoil aids beginners, ladies.

**28 gauge:** Fast handling with no noticeable recoil, but light shot charge restricts it to experienced gunners hunting small upland birds at short range.

**410 gauge:** Light shot charge is more likely to cripple than down game. Best reserved for target use or pests of barn-pigeon category. Don't choose 410 for beginners; it's a difficult tool, for experts only.

□ *Magnum* shotguns in 12 and 20 gauges will take larger shells that open to 3 inches after firing, rather than the standard length of 2¾ inches. Heavier shot charges give greater range.

□ *Rifled slugs* fit any shotgun, are slightly more accurate in skeet or improved cylinders. Slug barrels with rifle sights are available.

□ *Selection* should be based on good feel and fit of gun, recommendations of friends, considerable shopping and catalog study. A good dealer can order specific models. Young beginners might start with a 20-gauge pump with shortened stock. For waterfowling, pick 12 or 12 magnum pump or autoloader. Same gun with interchangeable barrels or adjustable choke, or 20-gauge magnum, is a good all-around choice. For short-range upland game, a 20-gauge is suitable, while long range requires 12-gauge or 20-gauge magnum.

*And the best buy?* An American 12-gauge pump action with interchangeable barrels or adjustable choke probably offers the most for the money. ★★★





- OPENS & CLOSES
- ILLUMINATES
- SECURELY LOCKS



... ANY GARAGE WITH UPWARD ACTING DOORS

- Wood, Metal, Fiberglass
- Sectional or one piece
- Up to 20 feet wide

**THOUSANDS IN USE!**  
Shipped PP or UPS



**GARAGE DOOR OPERATOR RADIO CONTROLLED \$99<sup>95</sup>!**

- SAFETY night and day year 'round
- SECURITY door positively locked when closed
- CONVENIENCE in-car control of door
- EASY INSTALLATION in two hours
- SAVE up to 50% direct factory purchase
- GUARANTEED one year

Free Brochure HELPMATE Equipment Co., Box 51 PM-9 Baroda, Mich. 49101

**ORIGINAL SELF-STICKING**

**Magic-mounts®**  
FOR ALL YOUR HANG-UPS

- |                |               |                   |
|----------------|---------------|-------------------|
| <b>29¢</b>     | <b>39¢</b>    | <b>49¢</b>        |
| STRIP HANGERS  | UTILITY HOOKS | WALL HOOKS        |
| CLIP-HANGERS   | WALL HOOKS    | MINI-HOOKS        |
| KEY RACKS      | WALL HOOKS    | CUP HOOKS         |
| WALL HANGERS   | WALL HOOKS    | ALL-PURPOSE HOOKS |
| PROTECTOR PADS | WALL HOOKS    |                   |



MILLER STUDIO, INC., NEW PHILADELPHIA, OHIO 44663

**BELSAW PLANER • MOLDER • SAW**



**30-DAY FREE Trial!**

Now you can use this ONE power-feed shop to turn rough lumber into moldings, trim, flooring, furniture...ALL popular patterns. RIP...PLANE...MOLD—separately or all at once with a single motor. Free 30-Day Trial. Low Cost—only \$35 down.  
Send Postcard Today—No Salesman Will Call.  
BELSAW POWER TOOLS 904S Field Bldg., Kansas City, Mo. 64111

**LEARN UPHOLSTERY AT HOME!**

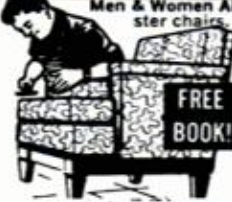

Men & Women All Ages! Send for free book on learning to reupholster chairs, divans, footstools, all furniture for BIG MONEY in spare or full time. No experience needed, no age or educational limits. We show you how and provide EVERYTHING needed to start: (1) Home training covering all phases, (2) all tools and 6 big furniture kits for practice, (3) free supplies, frames & materials to build \$300 worth of furniture, yours to keep or sell. Write TODAY for big free upholstery career book. No obligation, no salesman will call. Veteran Approved. Modern Upholstery Institute Box 899-PM2, Orange, Calif. 92669.

**"LISTEN IN" TO POLICE-FIRE RADIO CALLS IN YOUR CAR!**

WORKS with ANY CAR—Portable or HOME RADIO! Just PLUGS in—No wiring—3 minute hookup! Switch instantly from regular to ALL POLICE-FIRE-EMERGENCY-COMMERCIAL-TAXICAB-STATE-CITY-GOV'T 2 way Radio calls in YOUR AREA. DUAL-HI-LOW BANDS TUNES 36-49 & 150-175 MHS. USE Everywhere—anytime—always works.  
SEND ONLY \$2.00 (cash, Ck., M.O.) and pay postman \$9.99 plus COD pstg or send \$11.99 for ppd Del in USA. COMPLETE, ready to use with instructions. One Year service Warranty—10 DAY MONEY BACK TRIAL (if rtd). Sold Only—DIRECT FROM FACTORY at this Low Price!  
WESTERN RADIO BPM-9 KEARNEY, NEBR. 68847



**5-in-1 MINIATURE MACHINE SHOP**

**UNIMAT**

VERSATILE UNIMAT converts from precision lathe to vertical mill, drill press, grinder or polisher Easy to use Make all small precision parts—for models, guns, cameras, inventions \$199.50, ready-to-use Send for free details (Available in Canada.)

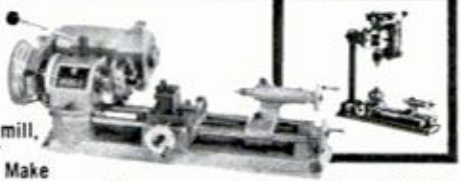

AMERICAN EDELSTAAL, INC DEPT B13, 1 ATWOOD AVE., TENAFLY, N J 07670

**LEARN DRAFTING AT HOME**

U.S. Labor Dept. says "42% more Draftsmen needed next 10 years." Send for FREE "DRAFTING CAREER KIT."

NAME \_\_\_\_\_ AGE \_\_\_\_\_

ADDRESS \_\_\_\_\_

CITY \_\_\_\_\_ STATE \_\_\_\_\_ ZIP \_\_\_\_\_

NORTH AMERICAN SCHOOL OF DRAFTING, Dept. 34179  
Accredited National Home Study Council 4500 Campus Drive, Newport, California 92660

**RONSON Multi-Fill**

fuels most butane lighters

From 49¢

The clean quality butane that won't clog.



**GERSTNER CHESTS** are for the FEW TRUE Craftsmen

GERSTNER TOOL CHESTS Dept. I-3 20 Cincinnati Street Dayton, Ohio 45407

Send 25¢ for Catalog



**5 DAY HOME TRIAL DISCOUNT BREAKTHROUGH ON ACCORDIONS**

SAVE 1/2 OFF retail prices of comparable accordions. Buy direct from world's largest dealer. Over 40 models for Student, Teacher, Professional. Electronic, Standard & Button Models—Amplifiers too! All Big Names. Try before you buy. Free accessories. E-Z Terms. Trades. Lifetime Performance Policy. FREE Color Catalogs/Discount price list. Rush coupon.

FREE Color Catalog

Discount Prices

42 Models

Accordion Corp. of America—Dept. R-93 5535 W. Belmont Ave., Chicago, Ill. 60641

Send FREE accordion catalogs and discount prices. Include special information checked:

Accordion Amplifiers  Button Accordions

Name \_\_\_\_\_

Address \_\_\_\_\_

City \_\_\_\_\_ State \_\_\_\_\_ Zip \_\_\_\_\_



## GRADE CROSSINGS TAKE DEADLY TOLL

*(Continued from page 142)*

train. "The random pattern is to prevent the light from being ignored," he explains. "Random signals are more disturbing than periodic or rhythmic ones. The motorist should be disturbed and alerted."

One positive result of the Congers, N.Y., tragedy is a new warning system developed by Solitron Devices, Inc., an electronics firm located but a few miles from the scene of the crash. The system is composed of two units—a small radio receiver installed in a school bus or other motor vehicle, and a transmitter in the locomotive. The transmitter sends out a signal for a predetermined distance (a radius less than 20 city blocks is adequate). The signal, picked up by the receiver, triggers the warning system.

The driver is alerted by a series of attention-getting beeps and by the word TRAIN, in large red letters, flashing on and off on a dashboard unit. The driver can't turn the unit off, and the beeping and flashing continue until the train has passed out of the area.

The unit in the motor vehicle is expected to cost less than \$100, while the train's transmitter system will run under \$300, according to Benjamin Friedman, Solitron's president.

"We were all deeply affected by the accident," explains Friedman. "Some of our

employees' children were on that bus. We set out to utilize our technological expertise to develop a means of preventing this kind of carnage in the future."

The FRA and the National Traffic Highway Safety Administration recently began a project to determine the feasibility of various train-to-motor-vehicle types of warning systems.

Former Secretary of Transportation Volpe sums up the grade-crossing problem in blunt words: "All of us have the same reaction when we hear of an accident between a motor vehicle and a train. Why in this period of advanced technology must such primitive accidents occur? I have asked myself that question many times and, frankly, I am not satisfied with the answers. There is no excuse for these kinds of accidents. They must not be allowed to continue." ★★★

## ROTARY CUTTERS FOR OFFBEAT JOBS

*(Continued from page 152)*

used to shape the teeth. (Unhardened drill rod is easily sawed and filed.)

The little "saw" cutter has four teeth, two being filed like the teeth on a crosscut saw, one set slightly toward the shank and the other toward the tip to provide clearance. The other two teeth were filed like those on a rip saw, and similarly set. Teeth were positioned by first marking saw slots 90° apart.

**Tooth shape.** After a cutter has been turned and the teeth approximately formed, it is necessary to provide relief by removing metal behind each cutting edge. At the same time, it generally is desirable to remove metal from in front of each edge, so the edge will strike the work with more of a shearing action. If suitable milling cutters (or grinding wheels) are available, these operations can be performed at the time the blank is notched. Otherwise, the tooth can be shaped by careful filing and smoothed with abrasive stones, or by grinding. If you intend to finish-grind the cutter after hardening, sufficient metal should be left during other forming operations.

After a cutter has been shaped, except for final touch-up with a grinder, it is hardened and tempered. For ordinary high-carbon drill rod, hardening can be done by heating to a cherry red, quenching in cold water, polishing a "test" area, reheating until the polished spot turns a light yellow (straw) color and cooling in water. ★★★

**KEEP YOUR COPIES  
OF PM . . . and watch for  
the inexpensive Annual  
Index that will be avail-  
able in January.**

The Index will enable you to locate any article which appeared in 1973 or find information on any particular subject in just a few seconds.

**The Annual Index makes  
your copies of Popular Me-  
chanics more valuable!**



## INSTALLING CAR STEREO SPEAKERS

(Continued from page 124)

a grommited hole for the wire. If the wedge has an open bottom, cutting a larger hole under the speaker will give you better bass response, by letting the trunk act as a resonator.

But wedge speakers can obscure rear vision, and their plastic cases can warp in sunlight. So flush-mount speakers are usually preferred (and many wedges' grilles and speakers can be disassembled and flush-mounted, if you prefer).

Most American cars now have 6x9-inch speaker ovals cut in the metal frame under the rear shelf, often with the deck's fiber covering perforated to form a grille. If your car lacks these perforations, you'll have to cut the fiber. A sharp knife does the cleanest job, but the speaker grille should cover ragged saw-cut edges. If the metal is not pre-cut, you'll need a hacksaw or sabre saw. Window overhangs make sabre saws impossible to use from above the shelf on many cars, but if so, you can get in the trunk and cut upward from there. Speaker attachment holes can be poked through the fiber with an icpick; if you have to drill the metal your-

## Try the rust fixer

from **DAP**



**DERUSTO® Enamelized Spray Paint.** Prevents rust, stops rust. Has rust preventive primer built into every color. Beautifies, protects new and rusted metal surfaces with push-button ease. In 23 colors plus clear.

### America's First Name in Home Fix-up



DAP Inc., Dayton, Ohio 45401  
Subsidiary of *Plough, Inc.*

## Try the joint fixer

from **DAP**



DAP Latex Caulk guns easily to fill cracks, joints and gaps in siding, around windows and doors. Takes paint after only two hours. Stops leaks. Won't stain, blush or bleed through paint.

### America's First Name in Home Fix-up



DAP Inc., Dayton, Ohio 45401  
Subsidiary of *Plough, Inc.*

self, drill from inside the trunk until the metal is holed, then finish with the icpick. Bolting the speakers in place is easiest if you have a helper in the trunk to hold the speaker nuts and lockwashers as you tighten the screws from above.

Rear-deck speaker grilles should be dark to avoid annoying reflections and preferably not be plastic, which can warp. But metal grilles' small holes (or those in some deck perforations) can focus the sun's rays like pinhole lenses, sometimes damaging speakers. Here's where an ounce of prevention (or an ounce of grille cloth) is worth lots of cure. Before attaching a metal grille, cover its underside with speaker grille cloth. Cut the cloth to fit the grille and tack it in place with beads of cement around the grille edge.

If you're wiring stereo speakers in both the front and rear of the car, use identical speakers mounted at identical heights for best sound balance. Add-on front-rear stereo balance controls may cause distortion in some installations, but they're cheap, so try them if you like. Four-channel tape decks (and some stereo ones) have built-in connections and balance controls for four speakers. ★★★



## HOW TO FIT A FAIRING AND RIDE A RACER!

*(Continued from page 168)*

snap. The racers came up with expensive one-piece, cast-alloy mags to replace wire wheels and, predictably, the bucks-up racer sports the same.

The most sensational modification is the addition of a fairing. These can be divided into roughly three classes—the full fairing, which extends from a clear wind-screen right down under the engine; a bullet-shaped half fairing, or the more traditional Harley or BMW-style shield-type half fairing; the latter disdained by cafe racers who consider that style the province of “full dresser” riders.

In most states where rear-view mirrors are required on road bikes, the fairings must be rigged with mirrors, and there are as many solutions as there are fairings. One cafe racer we tried had sports-car-style mirrors that looked good, but they were mounted so low on the fairing that we skinned our knuckles on them everytime we turned a corner.

The dividing line between the purely cosmetic “cafe racer” and the truly functional machine comes in the decision of the builder to move the braking and shift linkage pedals further aft where the pilot's feet will be. You can still ride a bike with clip-ons with the foot-brake pedal and shift lever in the stock position, but you lose reaction time in moving your foot forward to activate the controls. It's a lot of work to move these controls back but that's the only way you can make a cafe racer really functional.

The American trend toward cafe racers caught most of the world's bikemakers by surprise and, at this writing, only Triumph has anything that approaches a cafe racer—a new model called the Hurricane that has a seat-molded-into-the-gas-tank one-piece unit designed by American fairing designer Craig Vetter. Moto-Guzzi, the big Italian firm just bought by Alessandro De-Tomaso, is said to be introducing a factory cafe racer and the Japanese will not be far behind.

But now's the fun stage, as it is with any emerging recreational trend. Making a cafe racer out of a “Kwacker” (Kawasaki) when no bolt-on parts exist is a lot more challenging to do-it-yourself bikers than buying a Dunstall Norton cafe racer ready-made.

Although many cafe racer parts are

foreign-made, the American motorcycle accessory manufacturers are getting hip fast and soon domestic choices of fairings, solo seats, clip-ons, extractor exhausts and the like will outnumber the foreign offerings. Following is a list of some of the suppliers of cafe-racer hardware:

Avon Fairings, Box 327, Athena, Ore. 97813.  
Chariot Cycle Ltd., 303 Selkirk Ave., Winnipeg, Man.  
Commanche Products, Rt. 2, Box 136, Clearview Rd.,  
Cottontown, Tenn. 37048.  
Dick Pearce Garage, 729 South Central, Los Angeles,  
Calif. 90021.  
Harry Hunt, 23 San Bruno Ave., Brisbane, Calif. 90045.  
Hooker Headers, 1032-TF West Brooks St., Ontario,  
Calif. 91762.  
Kerker Raving Products, Box 4152, Glendale, Calif.  
91202.  
Kintab, 128 West Chestnut, Monrovia, Calif. 91016.  
Kook's Custom Headers, 401 Suffolk Ave., Brentwood,  
N.Y. 11717.  
Monotrack Engineering, 959A West 17th St., Costa  
Mesa, Calif. 92627.  
Paul Dunstall, Well Hall Rd., London SE9, England.

### U.S. Dunstall dealers:

Boston Cycles, 124 Brighton Ave., Boston, Mass.  
02134.  
Competition Cycle Center of the South, 1421 North  
Dania, Fla. 33004.  
Firth Motorcycles, 1857-9 Danforth Ave., Toronto,  
Ont.  
Moto Sports, 1988 Pearl Rd., Brunswick, Ohio 44212.  
Motor Cycles Unlimited, 5768 Paradise Drive, Corte  
Madera, Calif. 94925.  
Sport Centre, 6027 Whittier Blvd., Los Angeles, Calif.  
90022.  
Super Motorcycle Center, 8508 Hampton Blvd., Nor-  
folk, Va.  
YBM Sales Inc., 572 West Lancaster Ave., Bryn  
Mawr, Pa. 19010.  
Paul Kinch Co., 5 Cardiff Rd., Luton, Bedfordshire,  
England.  
Sonicweld, 14547 Arminta, Unit J, Van Nuys, Calif.  
91402.  
The Fibreglas Works, 3921 Portola Dr., Santa Cruz,  
Calif. 95060.  
Trabaca Products, 837 West 18th St., Costa Mesa,  
Calif. 92627.  
Trackmaster Frames, 14646 Blythe No. 28, Van Nuys,  
Calif. 91402.  
Vetter Fairings, Box 216, Urbana, Ill. 61801.  
Webco Inc., Box 429, Venice, Calif. 90291.  
Weber Cams, 310 South Center, Santa Ana, Calif.  
92703.  
Wheelsmith Engineering, 3635 West McFadden, Santa  
Ana, Calif. 92704.  
Yoshimura Racing, 2190 Shasta Way, Simi Valley, Cal-  
if. 93065. ★ ★ ★



## Announcing — The Popular Mechanics Index and Shelf Wrapper

Here's a great idea that will multiply the value of your back issues of PM. Reserve your copy now!

Want to find an article on 17 ways to thiefproof your car? How to build a colonial footstool? The latest bicycle touring gear? How to remodel your bath, or how to take the high cost out of hi-fi?

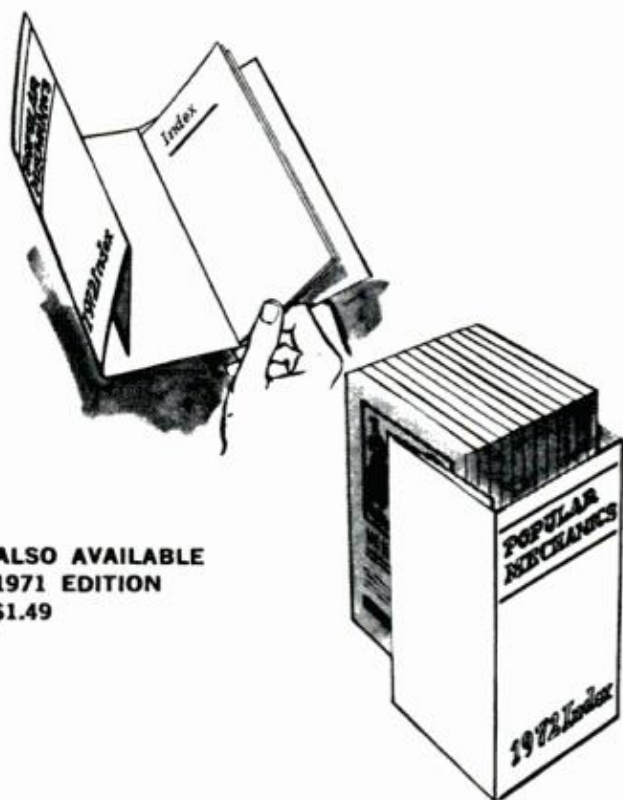

ALSO AVAILABLE  
1971 EDITION  
\$1.49



Your copies of *PM* are chock-full of such information. *PM* publishes literally thousands of ideas and items each year. Sometimes, though, it can be frustrating to find an exact article that you recall appeared several months ago.

The new *PM Index and Shelf Wrapper* solves that problem. Each of those thousands of items which appears in *PM* throughout the year is not only referenced, but thoroughly cross-referenced as well. You can find *any* article you want in seconds! Or you can find *all* the articles on broad categories such as auto repair, electrical wiring, plumbing, photography and other subjects at a glance!

Best of all, the *Index* is bound into a handsome wrapper made of heavy board. The wrapper precisely encloses the 12 issues which are cross-referenced in the *Index*, and makes a beautiful and useful addition to your bookshelves.

Reserve now your copy of the *1973 Index and Shelf Wrapper* listing and cross-listing all *PM* articles published throughout 1973.

The entire handsome package—*Index and Shelf Wrapper*—is yours for only \$1.49. Write for your copy today!

Popular Mechanics, Dept. PM-71-72  
Box 1014, Radio City,  
New York, N.Y. 10019  
Rush me, just as soon as it  
becomes available, a copy of the  
*PM Index and Shelf Wrapper*.  
I enclose check or money order  
for \$1.49.

NAME \_\_\_\_\_  
ADDRESS \_\_\_\_\_  
CITY \_\_\_\_\_ STATE \_\_\_\_\_ ZIP \_\_\_\_\_



# The bargain hunter

**PLASTIC CUTTER**  
CUT SHEET PLASTIC,  
MICA, TILE,  
EASILY



**AMAZING  
NEW  
TOOL**

Save hundreds  
of dollars remodeling  
kitchen cabinets, ceilings,  
floors, etc. with this new cutter

**ORDER NOW AND  
INSTRUCTIONS ON CUTTING  
WILL BE INCLUDED**

Satis. Guar. No C.O.D.s  
Add 50¢ Handl. & Post.  
Dealership inq. invited Only

**\$4.98**

**TOLCO** 930 N.W. 27th AVE  
MIAMI, FL.

**STOP LEAKING  
faucets forever**



90% of faucet leaks are due to bad seats. Obtaining the correct seats with washers and installing them is very difficult. There are over 100 different sizes and thread combinations available. **THIS UNIVERSAL KIT FITS ALL MAKES AND SIZES OF CONVENTIONAL FAUCETS.** Only ordinary household tools are needed for installation. The surgical stainless steel seats were originally developed for highly alkaline water systems (where brass seats lasted less than a year) and are unconditionally guaranteed to never wear out, corrode, or need replacing. Special washer design compensates for worn moving valve stem parts and gives a smooth soft action. Also ends the frustration of hot water shutdown due to expanding rubber washers.

"Every word you said is true about your product," J.D. Chicago, IL.  
"Yesterday I repaired two leaky faucets with no problems and complete success." T.H.H., Jr. So. Yarmouth, MA.  
"I have been using your Universal Faucet Repair Kit, and am amazed at the restoration of old faucets." H.W., Seattle, WA.  
"Will be happy to recommend your product to . . . friends and acquaintances." N.D.A., Montpelier, VT

**KIT INCLUDES:** 8 seats with washers (Do the whole house and garden), installation tool, EASY illustrated instructions, \$6.95 + 50¢ shipping and handling. Used in thousands of U.S. homes and businesses. No-time limit money back guarantee.

**VULCAN MFG. CO.**  
Box 33, Dept. PM 9-2  
Grand Valley, Colo. 81635



**FREE!!! POWERFUL MUSCLES FAST!**  
Fantastic New Discoveries in the science of bodybuilding. Now, in the privacy of your bedroom, our method will add inches of powerful muscles to arms, chest, shoulders & legs. Learn secrets on trimming the waist with ultra-modern methods—fast! Results Guaranteed! Send for free brochure, Universal Bodybuilding, Box 485-MI, Dearborn, Mich. 48121.

**Easy to Build PLANS  
AND INSTRUCTIONS for**

Go Kart	.....	\$2.00
Mini Bike	.....	\$2.00
Three Wheeler	.....	\$2.00
Three Wheeler A.T.V.	.....	\$5.00
Mini Car	.....	\$3.00
Pedal Boat	.....	\$4.00
12' Sail Boat	.....	\$4.00
Sail Board	.....	\$2.00
Pontoon Boat	.....	\$1.00
8' Hydroplane	.....	\$2.00
Two People Mini Jeep	.....	\$3.00
Snowmobile Sleigh	.....	\$3.00

**MINI VEHICLES PLANS**  
"DEPT. C"—P.O. Box 92  
Chazy, N.Y. 12921

**GRANDFATHER CLOCKS  
SAVE 50%  
BUILD YOUR OWN  
FROM OUR  
SEMI-ASSEMBLED  
CASE KITS**



We are the **ONLY** producer of **COMPLETELY HAND-CRAFTED** semi-assembled clock kits! Major assemblies carefully fitted and joined by experienced cabinet-makers. (No power tools required.)

- Highest quality imported German movements
- Tubular or rod chimes
- Moving moon dials
- Kits for wall & mantel clocks available
- Templates & case plans

Send 50¢ for complete catalog

**H. DeCOVNICK & SON,**  
P.O. Box 68, Dept. M93  
Alamo, Calif. 94507

**OLD-FASHIONED  
ROLL-TOP DESK**  
FULL-SIZE PROFESSIONAL PLANS



At last! Plans for authentic Roll Top Desk. Easy to use. #139 Double Pedestal Desk, 30" x 52" x 30" high. #140 Roll Top Unit adds 14" to hgt. Both single and double curve end panels on drawing. EACH plan \$5 or \$10 for both. Mailed 1st Class p.p.d. **SATISFACTION GUARANTEED!**

**FREE WITH ORDER**—Catalog of 150 full-size plans, Early Amer., Medit., Spanish, Modern, English furniture. **CATALOG ONLY—\$1.00, refundable.**

**FURNITURE DESIGNS Dept. PD-93**  
1425 Sherman—Evanston, Illinois 60201

**SILVO  
(BRAND NAME)  
TOOL  
CATALOG**



**Thousands  
of exciting  
tool values!**

Stanley, Skil, Thor, Wen, Disston, Wiss, Wellsaw, Dremel, Plumb, Hook, Kennedy, Channellock, Rockwell, Helois, Vise-Grip, Crescent, Rigid, Pony Clamps, Unimat, Freedom and many other Nationally Advertised brands of Tools & Supplies. We ship Coast to Coast at prices Hard to Beat. Send \$1.00 for our big 152 page tool catalog today.

**Silvo Hardware Co., PM-73**  
107 Walnut St., Philadelphia, Pa. 19106

**WATER  
WATER  
WATER  
WATER  
WATER**

"HOW TO DRILL YOUR  
OWN WATER WELL"

**\$1.00 p.p.d.**  
SATISFACTION  
GUARANTEED

**DEEPROCK CO.**  
OPELIKA, ALA. 368601

**195 FREE WHOLESALE CATALOGS!**



Buy below wholesale! 5 ways. 76 countries. Biggest import bargains! Profitable mail-order business from home—without capital or experience. 315 drop-shippers. Your own business catalog imprint. Automobile discounts. **Send no money—Request "Free Digest"**

**VAULT INTERNATIONAL**  
Box 7284 W1  
Lexington, Ky. 40502



**Bartlett Flying Saucer** ultra-light hovercraft powered by ordinary lawn mower engine—easy to build—fun to fly—complete plans, kit brochure, photos and supply sources \$3.00. All orders returned via airmail. Write:

**HERB BARTLETT**  
Box 3339-M, Scottsdale, Arizona 85257

**SEND NO MONEY! EASY TERMS!  
GUARANTEED PERFECT FACET  
STONE at Mail Order Prices!**



Dazzling full-cut solitaire boldly blazes on onyx black richness. Massive gold ring sculptured in genuine 18 karat HGE fineness.

**WRITTEN LIFETIME GUARANTY \$150**  
**LUXURY DRANTOP JEWELRY TOTE**  
**FREE WITH TRIAL ORDER**

Rush my **BLACK BEAUTY** size . . . INSTANT CREDIT  
 Her **BLACK BEAUTY** (not shown) . . . O.K.

Name . . . . .  
Address . . . . .

**Wonda Gems** 108-RYDER STATION  
BROOKLYN, N.Y. 11234

**IMPORTED  
LOCK BLADE  
KNIFE**



**ONLY \$275 each**

Locks into position to prevent accidental closing. Razor sharp tough stainless steel blade for reliable use and hard, long service. Money back in 5 days if not satisfied. Send \$2.75 plus 25¢ to cover postage and handling.

**WESTBURY SALES CO.**  
P.O. Box 434, Westbury, N.Y. 11590  
Dept. L-10-PM



**FIX LAWN MOWERS**  
**FOR FUN & PROFIT!** Fascinating new Handbook by F. Peterson gives you the knowledge skilled mechanics learn. **OVER 125 ILLUSTRATIONS** show how to trouble shoot, repair carburetors, engines, balance and sharpen blades, etc. Exploded drawings are extensively used.

**INSTRUCTIONS COVER** reel, rotary and rider mowers, preventive and routine maintenance, how to identify brand names, where to obtain replacement parts. How to buy and use a lawn mower. Friends gladly pay \$10 to \$50 to fix their lawn mowers. Try the **HANDBOOK OF LAWN MOWER REPAIR**. Rush only \$6.95 plus 50¢ handling on 10-day money-back guarantee. **EMERSON BOOKS, INC., Dept 947X, Buchanan, New York 10511**



**110 Volt A.C. GENERATORS**  
 60 cycles. Fanbelt driven from car or gas engine. Operates T.V., refrigerators, radios, all power tools, projectors, P.A. systems and fluorescent lights. Over 12,000 in service. Guaranteed six months. 1500-watt \$85.00 postpaid. 3000-watt \$105.50 postpaid. Special X-1000 watt self-excited generator \$85.00 postpaid.

**TOOL POWER™ patent pending**  
 115 volts D.C. 5000-watts. 50 amps from your car's alternator. **Guaranteed 20 years.** Install in ten minutes. Operates all power tools, electric motors up to 2 h.p. Arc welding, fast battery charging. Any like device by any name is an infringement of our patent pending. All copiers are notified. Be safe, buy from the inventor and developer. \$25.00 postpaid. Attractive dealer plan.

**VIRDEN PERMA-BILT CO.,**  
 P.O. Box 7160PM  
 2821 Mays, Amarillo, Texas 79109

**BUILD YOUR OWN**  
 Cabover Campers • Covers  
 16' & 20' Travel Trailers  
 • PLANS •  
 PATTERNS • KITS  
 ★ FREE CATALOG ★  
**GLEN L** Recreational Vehicles



9152P Rosecrans, Bellflower, Calif. 90706

**PRECISION TOOL HANDLE FOR INJECTOR RAZOR BLADES**



**\$2.25**

**RAZOSHARP®**  
 U.S. Pat. 3,608,195

**IDEAL POCKET KNIFE—EXCELLENT OFFICE AND HOUSEHOLD UTILITY TOOL**—Only holder to use standard injector type razor blades. Only holder allowing for varying blade length exposure. Only holder allowing blade to be completely sheathed and protected. Only razor blade holder to give precision tool feel.

**ALWAYS RAZOR SHARP**—When blade dulls—pop in new blade. Re-use injector type razor blades. **SHAVE and SAVE.** Inexpensive injector type razor blades always available. To expose new sharp edge—reverse blade or clip dull edge. Excellent for cutting clippings, cardboard, trimming. Ideal for opening packages, cartons, boxes. Use for carving, whittling, sharpening, erasing, etc. Shape blade to suit use—snip edge, grind or break with pliers. Nothing to break or wear out.

**RAZOSHARP®** Dept. A-9  
 421 Stockholm St., Bklyn., N.Y. 11237



**SAVE HUNDREDS OF DOLLARS**  
 Build this extraordinary authentic "Western Frontier Style" storage building. A little bit of the old west in your backyard. Many uses as a workshop, tools, garden equipment, playhouse, etc. Mounted on skids for portability. 10 ft. wide, 11 ft. long, 9½ ft. high. No expensive tools needed. Simple step by step plans. Send \$2.75 for plans and material list.

**HAMMOND BARN** Dept. PM7,  
 Box 39027, Indianapolis, Indiana 46239

**Free Gasket Tips**



Latest tips on overcoming engine sealing problems; avoiding intake manifold drain slot trouble, newest one-torque head gaskets and many more!

For your **FREE GASKET TIPS**, write:  
**FEL-PRO INCORPORATED**  
 Dept. 73 PM-9  
 7450 N. McCormick Blvd.  
 Skokie, Illinois 60076



**HEARING AIDS**  
**UP TO 50% OFF** COMPARABLE AIDS ★

**BUY DIRECT • 20 DAYS FREE TRIAL** Body Aids \$49.95 up. Tiny All-in-the-Ear; Behind-the-Ear; Eye Glass Aids. No salesman will call. Write **LLOYDS**  
 ★ Dept. PM, 905 9th St., Rockford, Ill. 61108 ★

# How to get rich

**START YOUR OWN BUSINESS RIGHT FROM YOUR HOME — AND MAKE A FORTUNE IN MAIL ORDER!**



**Mail Order Beginners Get Cash by Mail!**

Have you ever thought of operating a little mail order business of your own? Something you could start on a shoestring right from home in your spare time. It's a fabulous business!

Bob Carter of Newark, N.J. ran his first small mail order ad in House Beautiful magazine—offering an auto clothes rack. Business Week reported that his ad brought in \$5,000 in orders. By the end of his first year in Mail Order, he had grossed over \$100,000!

Another beginner—a lawyer from the midwest, sold a mail order item to fishermen. Specialty Salesman magazine reveals, "he made \$70,000 the first three months!"

There is no other business where you can make a fortune so fast. Come up with a "hot" new item...and **WHAM!**

It strikes like a bolt of lightning! Millions of people read your ad and suddenly, you are swamped with cash orders from all over the country...

**MORE MONEY** in 60 days than you could earn in a lifetime!

Like the Vermont dealer who ran one ad in Sports Afield magazine. His ad pulled 22,000 orders—over **A HALF MILLION DOLLARS IN CASH!**

Yes, Mail Order is the fastest-growing, most profitable business in America! And now with the population explosion...the huge teenage market...and more people moving to the suburbs—we are on the verge of the **BIGGEST BOOM** in Mail Order history!

## Free

If you are sincerely interested in starting a lucrative business of your own **ACT NOW!** We can help you get rich in Mail Order just as we've helped others. Mail the coupon or send a postcard. We'll send you a free book, catalog, ads and complete facts about our offer. No salesman will call. No obligation. You don't need previous experience but you must be over 21. Write to:

**Mail Order Associates, Inc., Dept. 432**  
**Montvale, New Jersey 07645**

**Mail Order Associates, Inc., Dept. 432**  
**Montvale, New Jersey 07645**

Please rush full details immediately.

Name \_\_\_\_\_

Address \_\_\_\_\_

City \_\_\_\_\_

State \_\_\_\_\_ Zip \_\_\_\_\_



## SMALL ENGINES SERVICE MANUAL



New 10th Edition  
595

Send Check or Money order with order and we send postpd.

Tells and Shows You How to Fix Small Gas Engines on LAWN MOWERS, Garden Tractors and Tillers and Power Equipment. Repair your own gas engines. *Make Money repairing for others.* New 10th edition gives complete information on repairing small gas engines under 15 cu. in. *Only universal repair book of its kind.* Information on all major manufacturers' engines. Authoritative section on gas engine fundamentals. Trouble shooting and servicing of ignition and carburetor equipment. Illustrated with hundreds of clear and concise exploded drawings. Over 300 pages with practical down-to-earth information for mechanics and easy for a beginner to follow. *Satisfaction Guaranteed or Money Back.*

Technical Publication Div., Dept. PM-973  
1014 Wyandotte/ Kansas City, Mo. 64105



### ALARM STICKER DECALS Scare Away Would-be Thieves and Molesters.

Protect your Home, Car, Office, Boat, Cycle or any personal possession you don't want stolen or tampered with.

These 3 color **inside/outside** professional decals will supply you with the added protection needed to make would-be thieves go elsewhere!

**Futronic Security System decals are exactly the same as those sold with expensive alarm systems** (and until now most people had to buy the complete alarm system to get the decals). Now you can enjoy this added protection for pennies!

For your decals write Dept. C.P.O. Box 333, Main Station, Yonkers, N.Y. 10702

Send for 1 decal 39¢; 3 decals \$1.00; 7 decals \$2.00; 10 or more, 26¢ ea. (Include your zip.)

**Futronic Security Systems**  
a division of M.J.F. Futronic Systems, Inc.

### DETROIT APPROVED PICKUP TANKS



Original equipment type poly, now available in auxiliary tanks for pickups. Increase gas capacity 40 gals. Far superior to metal, complete hidden, no body work necessary. Easy 1 hour installation—Truck discounts pay for tanks in a short time. Two tanks, brass valve, hose, complete. Meets Federal Regulations.

**PICKUP EQUIPMENT CO. LTD.**  
Dept. PM-973, P.O. Box 7635  
WACO, TEXAS 76710  
CALL TOLL FREE 800-433-2386

## KARATE

JUDO • SAVATE • JIU-JITSU

The Greatest Self-Defense System Known to Man! FREE Brochure reveals Self-Defense Techniques.

Send to: Universal, Dept. M Box 39303, Detroit, Mich. 48239 **FREE**

### Want to make some easy money?

Let us show you how to begin AT ONCE...full or spare time. Many report \$10 to \$50 PROFIT FIRST HOUR! Nothing to buy...no salesman will call. EVERYTHING NEEDED SENT FREE including BEAUTIFUL SAMPLE!



Write: Russell Products Co.  
DEPT. K25. COLUMBIA, TENN. 38401

DIGITAL: THEORY, DESIGN, CONSTRUCTION

## LOGIC NEWSLETTER

SAMPLE COPY \$1.00  
LOGIC NEWSLETTER  
POB 252  
WALDWICK, N.J. 07463

### LICKITY SPLITTER

ENDS WOOD SPLITTING DRUDGERY

New low cost COMPACT MODEL... for farmers, camps, cottagers. 10 ton ram, 2 cycles per min., splits logs 25" x 18". Carried in car trunk, placed up right or hung for storage. For details write:

PIQUA ENGINEERING, INC., Dept. P, Box 605 Piqua, O. 45356

### BEAT THE DICE TABLES

Double-Your-Money-Back Guarantee  
Play in all Legalized Casinos

Place only 5 bets. All numbers are in your favor... including 7... 2, 3, 4, 5, 6, 7, 8, 9, 10, 11, 12...

**You win every roll!**

Send \$1 for Details. M. C. CORBIN CO. Dept. MGPM9  
P.O. Box 869, Radio City Sta., N.Y. 10019

### learn ACCOUNTING at home

1000s high pay "Big Income" jobs open to men, women in Accounting, Bookkeeping, Tax Return. Send for FREE "ACCOUNTING CAREER KIT." Approved for Veterans.

INCLUDED WITH COURSE



NAME \_\_\_\_\_ AGE \_\_\_\_\_  
ADDRESS \_\_\_\_\_  
CITY \_\_\_\_\_ STATE \_\_\_\_\_ ZIP \_\_\_\_\_

**FREE BOOK!** NORTH AMERICAN SCHOOL OF ACCOUNTING, Dept. 34179  
Accredited Member, National Home Study Council • 4500 Campus Dr., Newport Beach, CA. 92663

## WANTED

If you're a mover looking for that once-in-a-lifetime profit opportunity in an exploding growth industry, write for free INFORMATION KIT about one of the major breakthroughs in security systems since the beginning of crime. Flashguard answers an urgent, unfilled need and presents perhaps the most exciting business opportunity in any industry today. No experience. Start part-time. FLASHGUARD, INC. Dept. 3, 927 Penn Ave., Pittsburgh, Pa. 15222.

## BASEMENT TOILET FLUSHES UP



TO OVERHEAD SEWER OR SEPTIC TANK. NO DIGGING UP FLOORS. INSTALLS EASY. Write McPHERSON, INC., BOX 15133, TAMPA, FLORIDA 33614

USE ZIP CODES WHEN ANSWERING ADS

## Muzzle Loading KITS

Complete with all parts needed to make a handsome, fully shootable Muzzle Loading Pistol. .44 cal. precision rifled, octagonal barrel, front and rear sights. Stock fully contoured and Semi-inletted. All holes drilled and tapped. Illustrated instructions. Available in Percussion and Flintlock Models. Model KA702 (pictured) \$19.95 + \$1 Shipping.

Complete Kentucky Rifle Kits available from only \$57.45 (Percussion) and \$61.45 (Flintlock) plus postage.

**CONNECTICUT VALLEY ARMS, INC.**  
Dept. PM  
Higginum, Conn. 06441  
Enclosed is a self-addressed, stamped envelope. Please send FREE Brochure on CVA Muzzle Loading Kits.

Name \_\_\_\_\_  
Address \_\_\_\_\_  
City \_\_\_\_\_ State \_\_\_\_\_ Zip \_\_\_\_\_

**CVA** CONNECTICUT VALLEY ARMS, INC.



# CLASSIFIED ADVERTISEMENTS

Rate: \$2.20 per word payable in advance each insertion. Capitalized words—75¢ per word additional. Minimum insertion ten words. To be inserted under the proper classification, copy must be in our office by the 10th of the second month preceding date of issue. The next available issue to place an advertisement in America's No. 1 Classified Section is November. The closing date is September 10th. Send remittance and order to H. E. Kappel, Popular Mechanics, 224 West 57th Street, New York, New York 10019. Please make remittance payable to Popular Mechanics.

POPULAR MECHANICS

WHEN ANSWERING ADVERTISEMENTS PLEASE USE THE ZIP CODE NUMBER

## AUTOMOBILES

**CAPACITIVE DISCHARGE IGNITIONS, DISCOUNTED.** Rodgers, Son (PM), Box 3583, Anaheim, Calif. 92803.

**TUNE UP.** Do Your Own. Save Money. Do It Right. Fully Explained \$3.95. GM, Box 1237, Garland, Texas 75040.

**AUTOMOBILE SIXTY SECOND TIRE FIX.** No Tools—No Jack-Dealers Invited. Sample, And Details, ppd. \$3.98—Warne, 6922 Congress, Detroit 48207.

**WANTED To Buy:** Old Automotive Literature, 1900-1955. David Ficken, Box 11, Babylon, New York 11702.

**MAN POWERED,** Hydraulically Boosted, Fun Passenger Car. Stylish, Pollution Free, Inexpensive. Fantastic Commercial Potential. Detailed Blueprints \$5.00. Voyce Engineering, Box 4367, London, Ontario, Canada.

**1974 AUTO Wholesale Prices \$2.00.** Petros Products, 5404A South Mozart, Chicago, Illinois 60632.

**BE ALARMED! AVOID PARKING TICKETS!** Multi-use precision-pocket-timeralarm: Times 5 Minutes to 1 Hour. Keychain Attached! Send \$6.00 Postpaid. ALDERMAN, Dept. AG973, 511 37th Avenue, East Bradenton, Florida 33505.

## MIDGET CARS

**KARTS and MINI-BIKE Parts Catalog** Only \$1.00. ARE, P.O. Box 159, Lindenhurst, N.Y. 11757.

**YOUR AD IN POPULAR MECHANICS WILL BE SEEN** By More than 5,000,000 active buyers for your products and services. It costs only \$2.20 per word. And, if you wish to run all or part of your ad in bold capital letters—you can do so for as little as 75¢ per word additional. Act now! Send your Classified ad to: **POPULAR MECHANICS, CLASSIFIED DEPARTMENT, 224 WEST 57TH STREET, NEW YORK, N. Y. 10019.**

## AUTO SUPPLIES AND EQUIPMENT

**STOP Thieves' With Auto Guard Electronic Protection.** \$6.95 Guaranteed. Williams, 189, 4401 Germantown Ave., Philadelphia, 19140.

**HYDRAULIC Jack repair kits parts and supplies.** Catalog 50¢ (in coin). Hydraulic Jack Packing & Tool Co. Inc., General P.O. Box 3, Staten Island, N.Y. 10314.

**THIEVES CAN'T Drive your car when this easily installed system is used.** Plans \$1.00-kit \$3.50. Farleys, Box 285, King of Prussia, Pa. 19406.

**EXCLUSIVE Foreign Car Auto Dismantling.** Import Auto Supply, 101 North Manchester, Anaheim, California 92802. (714) 776-9900.

**AIRMASTER Gas Saver Fits All Cars.** \$14.95. Airmaster, Lenora, Kansas 67645.

**ALTERNATOR/Generator Rebuilder's Course;** includes Tooling & Test Equipment. Write: Hedelund Engineering, P.O. Box 2127, Sepulveda, California 91343.

**PARTS:** Army jeep and truck parts. Spare Parts & Equipment Co., P.O. Box 751, Lexington, Kentucky 40502.

**RING-Valve Job while driving.** \$6.50 postpaid. (Two-\$12.00). . . . Established 1951. . . . Results Guaranteed!! Motaloy, Grantham, Penna. 17027.

**AIR PURIFIER FOR YOUR CAR OZO AUTO.** Destroy Pollution, Destroy Odors, Smoke, Exhaust Fumes in your Car. Transistorized One Year Warranty. Send Check or Money Order for Only \$37.50 Each PPD. Pure Air Products—P. O. Box #218, Basking Ridge, New Jersey 07920, Dealer Inquiries Invited.

**NEW! Automatic Oil Changer! Save Money! Fast—Easy—Moneyback Guarantee!** Only \$19.95. Lindo, Box 691 No. Hollywood, Calif. 91603.

**"FREE INFORMATION" Aire Puffed Plastic Seat Covers.** For All Cars. Alpine Sales, 5213-C Alpine St., Fayetteville, N. Car. 28301.

**SAVE \$\$\$\$\$ MOTALOY Ring-Valve Job \$5.95. AIRMAILED!! With FREE GIFT!! Guaranteed!! Free Information.** Flewellings! Box 21-PM9, Tustin, California 92680.

**GUARD YOUR CAR! Auto Guard Foils Car Thieves!** Easy to install. Only \$7.95—Guaranteed! Order Now!! HARCO, Box 1296, Desk 1PM9, Jacksonville, North Carolina 28540.

**KISS Your points and condenser goodbye!** MOBELEC breakerless C.D. ignition. Performance Associates, 1512 Bexley, Austintown, Ohio 44515.

**SIMPLE Instructions:** Convert Auto Generator to Powerful 12 Volt Motor—\$1.00. DanRan, Box D, Reno, Nevada. 89506.

**QWIK—CHANGE** Changes the Oil Through Car's Dipstick! Eliminates oil messes! Complete instructions included. \$6.95 Guaranteed! Thomas Sales, 453 Cummings, Virginia Beach, Va. 23452.

**RING—VALVE JOB WHILE DRIVING! 1973—MOTALOY'S 20TH ANNIVERSARY!!** (It works and works.) Results guaranteed! \$5.95 Airmail postpaid Two—\$11.00! Motaloy Division CH, RR8, Box 604, Fayetteville, North Carolina 28304.

**FANTASTIC—Car Polish.** High Shine, send \$3.00 for pint. Richard, 110 Mohawk Drive, East Hartford, Conn. 06108.

**MOTALOY RING VALVE Job While You Drive!!!** Guaranteed \$6.00 . . . Two \$11.00. Andris, Box 34237, San Francisco, California 94134.

**SCRUB-EEZE™;** New from Orient. **CLEANS ANYTHING!** Guaranteed for 1 YEAR! Never use sponges again. Dirt & grease shakes off. Gentle to all painted surfaces. **IDEAL** for Campers, Cars, Boats, etc. **GIANT** 10 inch size: **SEND \$1.50 each—2 for \$2.75 PPD.** To: **JADE PRODUCTS,** Dept. PM9, P.O. Box 288, Oakdale, N.Y. 11769.

**NO-WELD TOWBAR—E-Z Plans—\$3.00.** HUSKY Enterprises, P.O. Box 13404, Spokane, Washington 99213.

**SAVE \$\$\$\$ MOTALOY Ring-Valve job.** While driving!! Just drop into gas tank. \$5.95. **NO MORE BATTERY TROUBLE!** For life of your car!! Just pour VX-6 into battery! \$2.95. **REPAIR MUFFLER—tailpipe yourself!!** \$2.95. **AIRMAILED—Free information—Guaranteed.** Flewellings, Box 21-PM74, Tustin, Calif. 92680.

**AMAZING:** This Fantastic, new, long-handle "DRY CLEANER"! Remarkable Silicone treated car mop. A Great Buy. Fast and Easy to use. Satisfaction Guaranteed. Send \$2.98 plus 50¢ postage: Butler's House of Gifts, 1163 Sutter Ave., (10¢) Brooklyn, New York 11208.

## SNOWMOBILES

**KID'S SNOWMOBILE** Under \$75: 3 1/2 H.P.; Plans \$5.95; Albar, PM9, RR Box 386, Yarmouth, Maine, 04096.

## AUTO TRAILERS

**FIFTH Wheel Trailer, Pickup Camper, Cover, Trailers, Build Yourself.** Save! Complete plans—Fifth Wheel \$9.95; Camper \$4.95; Trailer \$3.95; Cover \$2.95. Conversions—Econoline type Van \$3.95; Passenger bus or delivery Van \$3.95; Equipment Catalog \$1.00 (refundable). Details 25¢. Our 13th year. Viking Camper Supply, 99-F Glenwood, Minneapolis, Minn. 55403.

## MOTORCYCLES, BICYCLES, MOTORSCOOTERS AND SUPPLIES

**MAKE Your Bicycle Electric.** Plans \$2.95. Kielian, 130 Drake, South San Francisco, Calif. 94080.

**HONDA,** \$25. Other Bargains. Send \$1.00. (Refundable). Motorscooter, P443, Bend, Oregon 97701.

**BOLT-ON TORQUE CONVERTER** Makes out-dated, out-classed, mini-bikes competitive, mean machines. More Low end muscle—more high end hustle. Fits B&S, Tecumseh, most engines. 35 minute installations. \$34.95 ppd. No C.O.D. Information + decal 25¢. **MAX-TORQUE, Inc.,** 7300 Monticello, Skokie, Illinois 60076.

**ILLUSTRATED catalog,** 25¢. Parts And Accessories. Custom And Stock. For Most Makes and Models. Motorcycle Supply, Box 159M, Fairbury, Illinois 61739.

(Continued on next page)



## MOTORCYCLES, BICYCLES, MOTORSCOOTERS AND SUPPLIES

(Continued from preceding page)

**GO-KART—MINI-BIKE** Plans. Easy to follow. **SAVE MONEY.** Build your own. Go-Kart plan \$2.00. Mini-Bike plan \$2.00. Both plans \$3.00. **GUARANTEED.** RWM Sales, P.O. Box 660A3, Belleville, Illinois 62222.

**FANTASTIC ZEEMO ELECTRIC BICYCLE** Plans-Complete, Illustrated, \$3.95. **ZEEMO**, 2239 N. Lincoln, Chicago, Illinois 60614.

**GO-KARTS** Factory Direct Low As \$19.95. Send 35¢ for Catalog. Schmieder Motors, RD #1, Doylestown, Penna. 18901.

**MINI-BIKES, ATV'S.** Wheels, Engines. Wholesale Catalog 25¢. Lorenzo, Danville, Illinois 61832.

**BICYCLE TRAILER** With suspension Plans \$1.00. Wesley Dann, 944 So. Westmoreland, Los Angeles, Calif. 90005.

**BICYCLES**—Quality 3, 5, 10, 15 speeds Specialty Components, Tools, Clothes, Shoes, Etc. Send \$2.00. **WARES** Catalog, Department P.M., 2656 N. 76th, Milwaukee, Wisconsin 53213 (Since 1939)

**BIKE AND MINI-BIKE GOGGLES.** All Purpose, Well Padded, \$1.00 P.P. Phillips-Wilson, P.O. Box 3125 Augusta, Ga 30904.

**KIDS** Look E-Z-Build **GO-KART** or **MINI-BIKE** plans & instructions \$1.00 E. J. Sales, Box APM 3084, Centerline, Mich. 48015.

**BICYCLE PARTS CATALOG.** Gold mine for hard to get foreign and domestic parts, tools and accessories. Send \$2.00 for this big 8½ x 11 inch 160 page catalog. Refundable if not completely satisfied. Wheel Goods, Dept. J, 2737 Hennepin, Minneapolis, Minnesota 55408.

## SPACE, ROCKETS AND ASTRONAUTS

**ANTIGRAVITY DEVICE.** Brochure rushed free. AGD, Box 3062 PM, Bartlesville, Oklahoma 74003.

**ANTIGRAVITY** Spacedrive Plans! Scientific Experiments Reveal New Force. \$3.00. Carter, Box 831, Avalon, Calif. 90704.

**MILLION DOLLAR MODEL ROCKET SALE.** Countdown for savings. Kits, Motors and Supplies. Everything ½ Price. Send 25¢ For Complete Catalog and Decal Packet. AVI, 9PM, Mineral Point, Wisc. 53565.



## AVIATION

**BUILD**—One-Man jet helicopter. Easy inexpensive. Detailed plans, drawings—\$5.00. Helicraft, Box 7153, Baltimore, Maryland 21218.

**ALL** About Ballooning. Handbook \$3.00. Aerostation, Box 141. Long-Sault, Ontario, Canada. KOC IPO

**BE A** Government licensed aviation mechanic. Practical training. Free Information. Aero Mechanics School, Dept. PM, Municipal Airport, Kansas City, Missouri 64116.

**HANG GLIDING.** Self-Soar, Skysurf: Free Information Kit. Service To Students, Instructors, Business. All Top Plans Available: Books Too. Sample **LOW & SLOW** Magazine, \$1.00. Send To: **SELF-SOAR** Association, Box 1860, Santa Monica, California 90406.

**HANG GLIDERS.** Proven Rogallo Design. Plans—\$5.00, Kits, Accessories, Complete Kites. Compare Quality And Price Before You Buy. Free-Flight Systems, 10730 Whiteoak, Granada Hills, California 91344.

**AIRBOATS,** 8 to 90 HP. Portable Air-drives, Airboat Kits, Twin Engine Hovercraft Plans, \$10.00. Small Hovercraft Plans, \$5.00. Airboat Plans, \$5.00. Propellers, Engines, Supplies, Catalog \$2.00. Arrowcraft-PM, Pearland, Texas 77581.

**JET** Strap-On Helicopter Plans \$2.00. Information 50¢. Compco, Inc., Box 1267, Redwood City, California 94064.

**AIRBOAT** Propellers, Engines, Hubs, Mounts, Supplies, Corvair, V-W Conversions. Removeable Airdrives. Catalog \$1.00. Banks-Maxwell, Box 3301E, Ft. Worth, Texas 76105.

**HANG GLIDERS.** Rogallo and Monoplane Set, \$10.00. Catalogue, 50¢. Eipper-Formance, Inc., 741-M East 223rd St., Carson, California 90745.

## HOVERCRAFT

**MX55 HOVERCRAFT**—Illustrated Plans 75¢. National Aviation, Dept. 35, Dublin, New Hampshire 03444.

**INSTALL** Kart, Lawnmower, Snowmobile Power On This Hovercraft, Plans, Instructions, \$6.00. Airboat Plans Instructions, \$5.00. Design Book For Homebuilders, \$5.00. Palmer Aerosystems, P. O. Box 1891M9, Coral Gables, Florida 33134.

**AERO-CAR.** Amazing Hovercraft built easily with ordinary tools. Lawnmower engine power. Carries one man plus. Hovers, flies forward, backward, Sideways over land/snow/water. Complete construction plans and brochure. \$5.95. Aero-Projects, Box 5118PM, Clinton, New Jersey 08809.

**HOVERLOG '73**—Most Complete Hovercraft Catalog Available. JLO Engines, Multi-Wing Fans, Plans, Kits, "Hoverbugs". Complete Catalog \$2.00. Venture, Dept. 502, Box 5273, Akron, Ohio 44313.



## BOATS AND TRAILERS

**FREE** 112-page Camping, Marine Color Catalog. Laacke & Joys, 1439 N. Water, Milwaukee, Wisconsin 53202.

**CANOE KITS**—Wood Canvas, Molded Fiberglass—Free Catalog. Trailcraft, Inc. Box 60686, Concordia, Kansas 66901.

**FIBERGLASS BUILDERS MATERIALS** Low-cost factory prices in cloth, matt, roving, resin, epoxy, foam, nails, fittings. Send \$1.00 for literature (refundable) or \$2.00 for literature plus booklet on Mold-making and "How to Fiberglass". Clark Craft, 16-P1 Aqua Lane, Tonawanda, N.Y. 14150.

**FIBERGLASS** Canoes, Kayaks, and Duckboats. Many exciting models. Easily assembled kits. \$44.95 up. Free Literature. Riverside Canoes, Box 5595P, Riverside, Calif. 92507.

**FIBERGLASS** Cloth, matt, polyester and epoxy resins. Wholesale catalog 25¢. Boat Molding book 30¢. Seifert's, Box 1206-M, Green Bay, Wis. 54305.

**BOAT KITS-PLANS AND PATTERNS-FRAME KITS,** World's largest catalog. Over 300 top designs from 7-77' in plywood, ferro cement and fiberglass. Sailboats include: Windmill, Snipe, Motor Sillers, Trimarans, Catamarans. Powerboats include: Cruisers, Houseboats, Deep V's, Fishin'ski, Runabouts, Hydroplanes, Canoes, Kayaks, inboards, outboards. Send \$1.00 for large catalog or \$2.00 for catalog plus "Boat Builders Guide". Clark Craft, 16-P Aqua Lane, Tonawanda, N. Y. 14150.

**BOAT PLANS, FULL-SIZE PATTERNS, FRAME KITS** With step by step written and pictorial instructions especially for amateurs. Easy to build. Send \$1.00 for **HUGE 100 PAGE** Illustrated Catalog. Over 125 modern designs from 8 to 49'. Includes Sail, Jets, Inboards, Outboards, Cruisers, Houseboats, Hot Boats. Catamarans. Hydros. Also available—"Boat Building With Plywood" Hard cover—219 pages \$7.50. GLEN L. 9152 MP Rosecrans, Bellflower, Calif. 90706.

**FIBERGLASS** Cloth and resin. World's finest cloth and non-run resin, at direct mill prices Flotation foam. Complete line of plastics, silicon bronze and brass screws, save 60%. No sales tax. Boat Plans. Catalog 25¢. Freight prepaid. Stiles Boat Supply, Box 11P, Linden Ave., Mantua Heights, N.J. 08051.

**REPAIR,** Waterproof with bulk epoxy adhesive. Free Brochure. Construction Chemicals, Box 257, Monroe, Conn. 06468.

**CANOE!** Kayaks! Factory-direct quality kits, from \$25.00. Many different models. Canvas hulls. Strongest construction materials. Free literature. Sportscraft, Box 636-P, Allentown, New Jersey 08501.

**FREE** Catalogue—plans, patterns: Canoes, sailing canoes, kayaks, 14-17' trailable cruising sailboats. Quicksilver, 255A Shamrock Blvd., Venice, Florida 33595.

**KAYAKS,** Canoes, Plans, Kits, Finished Craft, Books. Free Catalog. Outdoor Sports, Box 1213P, Tuscaloosa, Ala. 35401.

**BOAT** Kits. Molded Fiberglass. Save money-assemble yourself. Factory molded sections bond into one-piece craft. 20 models-14' to 32' Cruisers, Runabouts, Sailboats, Accessories, Motors, Trailers. Easy terms. Free catalog. Luger, Dept. BC-73, 3800 West Highway 13, Burnsville, Minnesota, 55377.

**NEW 1973** Outboards . . . Top Brands 6 H.P. \$288 . . . 18 \$418 . . . 40 \$565 . . . 50 \$728 . . . 65 Electric \$958 . . . 85 Electric \$1,098 . . . ALL SIZES . . . Scott-McClulloch Parts . . . Handling 50¢ . . . Electra Marine, 610 Merrick Rd., Lynbrook, New York 11563.

**SAILMAKING** Step By Step \$5.00. Bowen, 40 Lillooet, Richmondhill, Ontario.

**FIBERGLASSING?** Complete Instructions! "Craftmans Fiberglass Manual." Only \$2.00. Postpaid! Edryn Corporation, Box 537-PE, Cocoa Beach, Florida 32931.

**FIBERGLASS** Cloth, mat, resin. Flotation foam. Complete supplies. Catalog 25¢. Kick-Shaw, Inc., 3511 Hixson Pike, Chattanooga, Tenn. 37415.

**300 DESIGNS,** Patterns, some Kits. Plywood, Fiberglass, ferro-cement to 60 Feet. Books. Large Catalogs: Powerboat \$1.00, Sailboat 50¢. Large Selection Boat, House Trailers, Campers, Summer Camps, Workshop, Garage Plans Circulars. Marinecraft, Box 161-M, Brighton, Massachusetts 02135.

**SCRUB-EEZE™:** New from Orient: **CLEANS ANYTHING!** Guaranteed for 1 YEAR! Never use sponges again. Dirt & grease shakes off. Gentle to all painted surfaces. **IDEAL** for Campers, Cars, Boats, etc. **GIANT** 10 inch size: **SEND** \$1.50 each—2 for \$2.75 PPD. To: **JADE PRODUCTS,** Dept. PM9, P.O. Box 288, Oakdale, N.Y. 11769.

## CAMPERS AND TRAILERS— KITS—PLANS—

**CABOVER** Campers & Pick-Up Covers for Compact & Standard Trucks, 16 & 20 Trailers. Build and Save. Large scale plans and full-size patterns with written & pictorial instructions. Complete accessory and aluminum covering kits. Free literature. Glen L. 9152MP Rosecrans, Bellflower, California 90706.

**PERFECT** Backcountry reception with your Radio, Campers, Trailers, Motorhomes, free details. Signal Booster, 18196 Camino Diablo, Yuma, Arizona 85364.

**SPORTSVAN CAMPER CONVERSION PLANS** Dodge, Ford, Chevrolet! Thirty-two Jumbo Size Pictures show you how to build Kitchens; Storage Units; Adult, Youth, Child Beds; Drapery; Screens; Four large, easy to read Instruction Sheets! Plans by retired Camper Manufacturer (\$3.50). Shepard Campsters, Route 1—Box 81, Oklawaha, Florida 32679.

**CAMPER EQUIPMENT:** Discounted prices, complete selection parts, equipment, accessories. \$1.00, refundable. 200+ page catalog. **ALLWEATHER SUPPLIERS,** Dept. PM, 832 Seward, Evanston, Illinois 60202.

## MARINE EQUIPMENT AND SERVICES

**MARINE** Engines, conversions, parts, equipment. Catalog Free! Stokes Marine Industries, Coldwater, Michigan 49036.

**CONVERT** Auto engines to marine. 68 Page Catalog, 50¢. Lehman Manufacturing Company, 800 Elizabeth Avenue, Linden 4, New Jersey 07036.



## MARINE EQUIPMENT AND SERVICES

(Continued from preceding page)

**FREE** Brochure Conversion Kits, Propellers, gears V-Drives 1/0 Drives Gas, Diesel, Starmarine, 1931 Embarcadero, Oakland, Calif. 94606.

**MARINE** Supplies, Ignition Parts, Free literature. Michael's, 991 Broadway, Bayonne, New Jersey 07002.

## ATHLETIC AND BODY BUILDING COURSES

**POWERFUL** Muscles fast! Free brochure. Universal Bodybuilding, Box 4327-C, Dearborn, Michigan 48126.

**KUNGFU**, Illustrated instructions. \$2.00 complete. RSH, 5834 Manton, Chicago, Illinois 60646.

**KUNG-FU** Secret # Manual-\$2.00-Green Dragon Fighting Society, 4350 N. Cicero, Chicago, Illinois 60641.

**"GIANT Arms."** Dr. Young, Revolutionary discovery. Inquire. Gaucho, Box 1769-A7, Chicago 60690.

**STRENGTH BUILDING FAST ISOMETRICS!** Illustrated Instructions. No apparatus needed. Complete \$2.00. Mitchco, P.O. Box 2604, Dept. C973, Mobile, Ala. 36601.

**ARMS**, 18-20 Inch in 90 Days or Complete Refund!! Miraculous Revelation! \$3.00. Phenoministics, Box 281, Gresham, Oregon 97030.

**KUNGFU** Manual on Poison-Hand, Death-Touch \$2.29. Manual on Fighting Like Cobra, Tiger, Dragon, Leopard, Snake-\$6.25. Green Dragon KungFu Fighting Society, 4350 N. Cicero, Chicago, Illinois 60641.

**SHORT STATURED?** Growth, Height Increase Facts, Medical Details. Adults, Youngsters. 25¢ to: Physical Culture, Box 1548-PM9, Pompano Beach, Florida 33060.

**"GIANT Arms"**. American Indian Hand Wrestling Kit!!!! Junior—\$7.98, Adult—\$12.98. Moneyback Guarantee. Modern Enterprises, Dept. A9, Santa Anna, Texas 76878.

**MASCULINE** Voice Building Course, \$1.98 Album, Man Makers, Box 11567, Chicago, 60611

## SPORTING GOODS AND EQUIPMENT

**FREE** Catalog low direct factory prices, fishing, Hunting, Archery, reloading Camping supplies. Send today. Herters Inc., Dept. CPM, Waseca, Minn. 56093.

**FREE WHOLESALE CATALOG.** Lure parts, Molds, Rod Blanks, Reels, Archery, Metal Detectors, Rare Hardwoods, FinnySports (ME), Toledo, Ohio 43614.

**ARCHERY** Lowest Discount Prices. All top brands. Orders shipped same day received, Money-back guarantee. World's Largest Supplier. Free catalog. Anderson Archery Corporation, Grand Ledge, Michigan 48837.

**FREE CATALOG.** Fishing Tackle, Archery Hunting and Camping Equipment. Lowest Prices. Cabela's, Inc., Dept. S-21, Sidney, Nebraska 69162.

## AQUARIUM SUPPLIES

**AQUARIUMS.** Filters, Fishfoods, Air-pumps, World-champion Guppies. 448-page Fishbook, \$3.95. Catalog 25¢. Fishmart, Ortonville, Mich. 48462.



## FISHING, TACKLE, LURES

**MOLDS**—For casting your own fishing sinkers. Free illustrated booklet. Reading Instrument Co., Box P-78, Reading, Pa. 19603.

**FISHERMAN'S DREAM BOOK**—FREE, 170 page catalog just loaded with Hard-To-Find Fishing Tackle Specialties and Do-It-Yourself Goodies. Our 29th year. **NETCRAFT** Inc., Box 5510, Dept. PM-12, Toledo, Ohio 43613.

## EARTHWORMS, LIVE BAIT

**EARN** Money raising fishworms for us! Exciting details free! Oakhaven—56, Cedar Hill, Texas 75104.

**FREE** Literature. Profitable Business Raising Fishworms, Crickets. We Teach you how to Raise and Sell. Write today. Carter Fishworms, Plains, Georgia 31780.

**BIG** Profits Raising Worms Soilless Method, Three Oaks, Dresden, Tennessee 38225.

## HUNTING, GUNS, DECOYS

**PELLET GUNS** For Fun or Serious Target Shooting Anywhere. Giant Selection. Finest Models. Satisfaction Guaranteed. New 100 Page Catalog Free (\$1 Value). Write: ARH, Dept. 15, Grantsville, West Virginia 26147.

**DUCK** Hunting Stamps Wanted. Write For Latest Buying List To: Stamps Information Associates, 675 Massachusetts Avenue, Cambridge, Massachusetts 02139.

**DUCK** And Goose Decoys. Buy Direct And Save. Send For Free Catalogue To: Decoys, Rt. 11, Box 229B, Houston, Texas, 77050.

## DOGS AND KENNELS

**BULLDOGS** A.K.C. English U.K.C. American PIT Bullterriers O.L. Hill, RT2, Box 276 San Angelo, Tex. 76901—915-653-0315

## POULTRY AND GAME BIRDS

**QUAILS**, Incubators, cages, supplies catalog. Marsh, 14216 Brookhurst, Garden Grove, Calif. 92643.

**GAMEBIRDS:** Started and Adult, Pheasant, Quail, Chukar, Mallards, Turkeys: Game and Ornamental. Catalogue, 35¢. Northwest Farms, Inc., Box 3003-PM, Portland, Oregon 97208.

## RABBITS—CHINCHILLAS—FUR BEARING ANIMALS

**\$500-\$1000 MONTH** Plan raising rabbits for us. Free details. White's Rabbitry-PM, Hudson, Ohio 44236.

**RAISE** Rabbits Successfully by knowing Facts. 48 Page Illustrated Book describing 25 Breeds, Housing, Breeding, Feeding, Markets, Marketing, etc. 25 cents. American Rabbit Association. 36 Arba Building, Bloomington, Illinois 61701.

**EARN** \$10,000 Yearly Raising Angora Wool and Breeding Stock. Details 25¢ coin. American Angora, Malta 12, Montana 59538.

**TOPLESS INCOME RAISING** Mutation chinchillas. 25¢: bulletin \$1.00. Chinchilla, 11PM9, Port Richey, Florida 33568.

**RAISE** Chinchillas. Guaranteed Income. Catalog \$1.00. DeShon Chinchilla, Route 2H, Roanoke, Indiana 46783. Missouri Agent, Rudolph Eggemann, 9615H Tocan Court, Affton, Missouri 63123.

## PETS—BIRDS, CATS, HAMSTERS, ETC.

**PETS**, Reptiles, raccoons, skunks, squirrels. Catalogue 25¢. Trails End Zoo, St. Stephens, S.C. 29479.

## HORSES, LIVESTOCK

**"HOW TO TRAIN HORSES"**—FREE Book tells how to break, train, make money with horses. Beery School, 1108, Pleasant Hill, Ohio 45359.

## CAMPING EQUIPMENT AND TENTS

**FREE** Outdoorsman's Catalog. Features Outdoor clothing, boots, tents, packs, hunting, fishing, hiking equipment, government surplus etc. Satisfaction Guaranteed. Write for free copy today. P & S Sales, Dept P-9, Box 45095, Tulsa, Okla. 74145.

## TRAVEL AND RESORTS

**IF YOU** Drive an Auto, Then You should belong to Highways Mutual Aid Society. Only \$5 for Details or \$10 for Full One-Year Membership. No other Costs. It's Great. Lifeways, Box 589, Battle Creek, Michigan 49016.

## ELECTRICAL SUPPLIES

**LAMP** Parts. Catalog, prices, wiring instructions. 50¢. Refunded first order. Gyro, 5218P N.W. 35 Ave., Miami 42, Florida 33142.

**TRANSMISSION** Of Electrical Energy through the Atmosphere. Large amount of H.P. possible anywhere. Find out how. No Gimmick. Send \$2.—To: Tesla Research, 887 West, 20th Ave., Vancouver 9, B.C., Canada.

## BATTERIES, GENERATORS

**BATTERY** Reconditioning Kit, includes molds, material, instructions. Battery Shop, Box 820, La Quinta, California 92253.

## ENGINES, MOTORS, MAGNETS

**WINDING** Data, 275 motors, \$1.25. Data Company, 512 Kensington, Kansas City, Mo. 64124.

**STEAM** Engine Kits, Catalog-Handbook \$1.00. Reliable Industries, New Baltimore, Mich. 48047.

**MOTOR REWINDING SUPPLIES!** Equipment plans! Modequip, Box 7266, Kansas City, Mo. 64113.

**REWIND** Car Generator for 110 VAC. Power Plant Plans \$2.00. Schmauss, 1228 East Cass, Tampa 33602.

## MACHINERY, TOOLS AND SUPPLIES

**SMALL** Foundry furnaces. Supplies. Free literature. Pyramid Products, 3736 South 7th Avenue, Phoenix, Arizona 85041.

**MAXIMAT**, Unimat Lathes. Metals, Micrometers. Catalogue 50¢. Industrial \$2.00. Campbell (PM), 1424 Barclay, Springfield, Ohio 45505.

**4" METAL** Cutting Lathe Kit \$29.50. Completely assembled machining unit \$89.50. Taig Mfg., Dept. T, 15048 Proctor, Industry, Calif. 91746.

**1400 CATALOGS** Listed and Described! Sources for EVERYTHING imaginable! Rush \$2.00. **MASTERLOG**, Box 24413-(VI), Oakland, California 94623.

**END** Mills. Lathe Milling Attachments: Information. Potter, Box 73, Cedar Rapids, Iowa 52406.

**NUTS**, Bolts, Screws, Washers, Threaded Rod, Assortments, Catalog 25¢. Nutty Co., Box 1576 SMS, Fairfield, Conn. 06430.

**FINEST** Tools—Catalog 50¢—Woodcarvers Supply, 3112 West 28th, Minneapolis, Minnesota 55416.

**SEND** For Complete Catalog of Maintenance Free Stainless Steel Nuts, Bolts, Washers, Etc. \$1.25. Summit Fasteners, Box 183A, Lansdale, Pa. 19446.

**SEND** 10¢ Postage For Free Drill, And Surplus Tool Lists. Save Up To 90%. Salme, 15 Briarcliff Lane, Holden, Mass. 01520.

(Continued on next page)



## WELDING, SOLDERING, PLATING

**LEARN COMPLETE PLATING BUSINESS.** Metals, Plastics, Baby-Shoes, Make Your Own Equipment Fiberglass Tanks Over 30 Years Experience. \$5.00 Will Start You In Business. NU-Lite Platers Research, Inc., 72-32 Calamus Ave., Woodside, N.Y. 11377.

**SUPER-ROD.** Metallurgical Breakthrough. Weld Aluminum, Brass, Copper, Pot Metal with Propane Torch. 12" rod \$2.00. K & B Supply, 4014 N. 7th Street, Suite 2A, Phoenix, Arizona 85014.

**PLATING Equipment, Portable Platers, Supplies, and "Know-How".** Build your own tanks for nickel, chrome, etc. Easy-to-install PVC liners. Rectifier components—all sizes. Schematics, parts, lists, formulas, operating instructions for all plating. \$10.00 post-paid. Guaranteed to save you 25%-75% or immediate refund. Some good used units for sale. Platers Service Company, 1511-A Esperanza, Los Angeles, California 90023.

## GOVERNMENT SURPLUS

**100,000 BARGAINS** From Uncle Sam—Directory of How To Order \$1.00. A. Naals, Box 3021, Noroton, Connecticut 06820.

**AMAZING Bargains!! Official Guide Tells How? Where? Money-Back Guarantee!** \$2.00. Connell, 1804 Savannah, Charleston, S.C. 29407.

**42,000,000 ACRES** Valuable Government Land still available. Some for \$2.00 per Acre. Buy, Lease, or Homestead FREE. For 1973 report, send \$1.00. Government Land, Box 789PM2, York, Penna. 17405.

**SURPLUS BARGAINS**—War, government, Industrial surplus at savings to 80%! Clothes, boots, cots, tents—bargains for farm, home, outdoors. **SEND FOR FREE CATALOG**—must give zip code. **SURPLUS STORE**, Sioux Falls, S.D. 57102.

**GOVERNMENT Surplus. NATIONWIDE Complete Brochure \$1.00.** Hilco Auctioneers, Anoka, Minnesota 55303.

**JEeps!!! PICKUPS!!!** 100,000 Items direct from government. Your area. Latest information & surplus categories: \$2.00 **MONEYBACK GUARANTEE.** Order manual #128, from "Dependable Products". Box 113, Vista, California, 92083.

**NO CATCHES.** Buy any surplus direct from U.S. gov't. All information \$2.00. Bridgeworth, P.O. Box 2292-C, Vancouver, Washington 98661.

**1973 SURPLUS Army, Navy store, 52 Page illustrated catalog.** Send 50¢. Ruvel, 3037 North Clark, Dept. 9-J, Chicago, Illinois 60614.

**JEeps \$52.40.** Airplanes \$75.01. Typewriters \$6.70. Boats \$7.50. Direct from Government. Directory and Surplus Catalog \$1.00 (Refundable). Midwest Surplus, Box 401-PM, Dayton, Ohio 45401.

**GOVERNMENT SURPLUS.** How and Where to buy in your area. Send \$2.00. **SURPLUS INFORMATION, 30177PM HEADQUARTERS BUILDING,** Washington, D. C. 20014.

**"U.S. GOVERNMENT SURPLUS Directory."** How, Where to buy 100,000 items (including Jeeps) . . . low as 2¢ on dollar! Most complete information available . . . \$1.00. **SURPLUS DISPOSAL, Box 6586-AI, WASHINGTON, D.C. 20009.**

**JEeps From—\$52.50.** Typewriters from \$4.15; Cars from \$31.50. Walkie-talkies, motorcycles, airplanes, boats. Typical "As Is" hid bargains from Uncle Sam. Tremendous variety. Exciting free list. Write: Enterprises, Box 402-X92, Jamaica, New York 11430.

**MAKE MONEY** On Government Surplus. How and Where to Buy. Directory of Surplus Offices. Sales. Terms. Mail Order Items. Send \$1.00. Alexander Mail Order Services, 4375 Knollton Road, Indianapolis, Indiana 46208.

**JEep And Gov't. Surplus Buying Manual \$1.00.** Gov't. Surplus Bargain Catalogue \$1.00. Gov't. Surplus Land Buying Manual \$1.00. All three only \$2.00. Surplus Information, Box 52PM, Thomasville, Penna. 17364.

## HOBBIES AND COLLECTIONS

**COLLECT Military Medals, list 25¢.** Vernon, Box 387PM, Baldwin, N.Y. 11510.

**NAZI War Souvenirs Free illustrated catalog.** Delta, Box 361PS, Lafayette, Calif. 94549.

**NAZI Medals, Photos, and Jewelry.** Also War Mementos from Other Countries. Catalog and War Poster, 25¢. Hutchinson House, Box 6411, Chicago, Illinois 60680.

**50 GORGEOUS Jungle Butterflies \$2.90.** 20 Exotic Seashells \$1.25. Collectors Wonderland, Box 1170, New York 10008.

**LIONEL Trains Discount Prices** Send \$1.00 For 1973 Catalog (Refundable). Railroad, Box 691, Dept PM, Endicott, New York 13760.

**FASCINATING HOBBY** For fun or Profit! Carve Life Sized birds From Chunk Balsa. New Manual Tells How To Carve, Paint, Mount. Start With Robin. Patterns included. \$3.00 Satisfaction Guaranteed. J. L. Davies, 751A Fredrick, Sun Prairie, Wisc. 53590.

## DECALS, EMBLEMS, PATCHES

**CUSTOM Designed Embroidered Emblems, Decals, Inexpensive.** Free Catalog, details. Southern Emblem, Box 8PMB, Toast, North Carolina 27049.



## STAMP COLLECTING

**88 COUNTRIES—ONLY 10¢!** Worth \$5.00 at catalog prices!! Incredible collection of genuine postage stamps from 88 different countries—from Afghanistan to Zambia, North to South Pole! British, French, Portuguese, Spanish Colonies. Old 19th Century, New Issues, Moon and Outer Space stamps, etc. All for only 10¢! Also, other exciting stamps to examine free. Buy any or none, return balance, cancel service anytime. Plus Wonderful Free Catalog! H. E. HARRIS, Dept. SS-63, Boston, Mass. 02117.

**YOURS FREE! 40 RED CHINA** Postage Stamps banned to American collectors for a generation by U.S. Gov't. Now at last you can legally own them; and these stamps are so worth having that experienced and beginning collectors alike want them—so act fast, because supplies are strictly limited! You also get 110 other stamps from Britain's Lost Empire plus illustrated Album to keep as a Bonus should you buy \$1 from our Approval Selection. Or return Album and 110 stamps with selection and buy nothing. Cancel service anytime. But Red China stamps are yours to keep! Send 10¢ for mailing while supplies last. Kenmore, Milford RC-430, New Hampshire 03055.

**INDONESIA—50 Different 10¢ Catalogues \$2.75.** Approvals. Hijop, Box 505, Norristown, PA 19404.

**DUCK Hunting Stamps Wanted** Write For Latest Buying List To: Stamps Information Associates, 675 Massachusetts Avenue, Cambridge, Massachusetts 02139.

**3¢ PLATE Block 25¢** with comprehensive U.S. stamp and Supply catalog. Schultheis, Box 2151C, New Hyde Park, New York 11040.

**RARE Stamp Free!** Also new packet Aden to Urundi, with Kennedy, Triangles, Space, Sports, Ships, Dogs, Cats, Reptiles, plus others. All free. Send 10¢ for mailing. Empire Stamp Co., Dept. 1, Toronto, Canada.

**SURPRISE Collection!** Exotic mint British Colonials, absolutely free with approvals. Viking, Great Neck, N.Y. 10021.

**FREE! Big Bargain Catalog—New Edition** listing thousands of bargains including U.S. & B.N.A. stamps, packets, albums, accessories and supplies. Also, fine stamps from our approval service which you may return without purchases and cancel service at any time. Jamestown Stamp, Dept. E93PM, Jamestown, N.Y. 14701.

**200 WORLDWIDE Stamps 10¢.** Approvals. White, 6808-E Chrysanthemum, Indianapolis, Indiana 46224.

**SENSATIONAL WORLD MIXTURE "ELITA"; BIG THREE POUND PARCEL CONTAINS ABOUT 7000 STAMPS, THOUSANDS OF PICTORIALS, YOURS FOR JUST \$25.00 DELIVERED, DUTY FREE (HALF POUND SAMPLE \$5.00) LIST FREE WITH 200 STAMP OFFERS. B. SCHULZE STAMPS LTD., 139A ESTELLINE, VICTORIA, B.C., CANADA.**

**AIRMAILS 100 Different 60¢ w/inexpensive Approvals.** Finch, Box 4103, Hacienda Heights, California 91745.

**ISRAEL Pictorials, commems galore.** 25 different, only 10¢ with low price U.S. and Foreign approvals. KAYCO, P.O. Box 437, Flushing, N.Y. 11367 Dept. M.

**WOW! 110 All Different Germany 10¢.** Commemoratives, Airmails, High Values, Big Catalog, bargain lists. Also, fine stamps from our approval service, which you may return without purchases and cancel service at any time. Jamestown Stamp, Dept. A93PM, Jamestown, N.Y. 14701.

**CANADA, 25 Different Commemoratives, 25¢.** Approvals. Wilson, Box 116, Dollard des Ormeaux, Quebec, Canada.

**VALUABLE Stamp Packet Only 10¢** With Approvals. Marquardt, Box 4503, Milwaukee, Wisconsin 53207.

**AMAZING Value—Enormous Worldwide Collection!** Hundreds of Colorful Stamps—Airmails, Commemoratives, Strange Countries, Nature's Wonders. Catalog over \$10.00, only 10¢. Approvals, Buy Any or None. Cancel Anytime. Daniel Healy, Box 1164PM9, Arlington Heights, Illinois 60006.

**FABULOUS Collection!** 107 different stamps from all seven continents. Get Q.E.-II Silver Wedding (bound to be a classic), giant Mongol horseman, many other new, old issues from Asia, Africa, Europe, North, South America, Australia, Antarctica. Also stamp selections to examine. Buy any or none, return balance. Cancel service anytime. Send 10¢ now. Williams Co., PM87, St. Stephen, N.B., Canada.

**200 WORLDWIDE 25¢** To Approval Applicants. Polze, Box 5215, Milwaukee, Wisconsin 53204.

**KAZAM! 25¢, 50 Mid-Eastern, Approvals. ALLADIN, Box 602, Jefferson City, Tenn. 37760.**

**SINGLE STAMPS 2¢ and up.** Mounted in books. TRUST STAMP COMPANY, P. O. Box 100-P, Jamaica, New York 11435.

**LOOK! 100 Beautiful Romania Pict. 25¢** Approvals. Scenic Stamps, Box 1973-B, Vancouver, Wash. 98663.

**22 TRIANGLE Stamps Only 10¢.** Get This Timeless Treasure Of Gorgeous, Colorful, Triangle Shaped Postage Stamps. Approvals included. Send Today! Stamps, Box 1444-B, Kitchener, Ontario, Canada.

**100 DIFFERENT United States Stamps, 25¢** With U.S., Foreign Approvals. ShelRon, Box 547C, North Miami, Fla. 33161.

**50 DIFFERENT Old U.S. Revenue stamps \$1.00.** Winchester Stamps, Box 3592, Mansfield, Ohio 44907.

**OLDER U.S. stamps, covers, on approval** to adults only. Surprisingly good. ENGLE, Box 208P, Lowell, Michigan 49331.

**TEN Different Nudes; 20¢.** Approvals. Stamp Farm, 2M58, Oxford, Wis. 53952.

**50 DIFF. U.S. COMMEMORATIVES 25¢.** Fine U.S. Approvals Accompany. Craig Stamps, Box 425-N, Bellmore, N.Y. 11710.

(Continued on next page)



## STAMP COLLECTING

(Continued from preceding page)

**FOREIGN Approvals! Gigantic values!** 3¢ each. ABC, Dept. 3301-A, Box 6000, San Francisco 94101.

**"AFRICA" 25 Beauties, 15¢.** Approvals, Gorliz, Box 28765 PM, Memphis, Tennessee 38128.

**U.S. MINT Specials!** Flag set, complete \$1.00. 1¢, 2¢, 3¢ famous Americans (21 different) \$1.00. Free list. Brooks, 2601 Avenue "U," Brooklyn, N.Y. 11229.

**PENNY!** Approvals! Regardless catalogue! Kloster, 4164 52nd St., San Diego, Calif. 92105.

**FREE Surprise collection sent with approvals.** Gould, 1784 Union, San Francisco 94123.

**ABSOLUTELY Free United States Mint Souvenir Sheet** When Requesting United States Approvals. K&B, Box 70, Brooklyn, N.Y. 11223.

**500 DIFFERENT Stamps, \$1.25.** Smith, 508-A Brooks, College Station, Texas 77840.

**100 DIFFERENT British Empire 10¢.** Approvals. Gibson, Box 34, Lansdowne, Pa. 19050.

**"INVERTED Error" Dag Hammarskjold, 10¢ with approvals.** Belmont Stamps, Washington, D. C. 20015.

**100 OLD United States between 1861 and 1935, \$1.00.** Ed Roush, 423 Shepard, Mansfield, Ohio 44907.

**225 STAMPS For only 10¢!** Airmails. Pictorials: stamps from strange countries cataloging up to 25¢ each! Plus unusual stamps to examine. Buy any or none return balance, cancel service anytime. Mystic Stamp Co., Camden 80, New York 13316.

**FREE! 10 African Beauties! 30 Others!** Approvals. Cambridge, Box 2311, Heath, Ohio 43055.

**20 HISTORICAL U.S. Commemoratives 10¢.** Bargain U.S. Approvals. PINTO, Box 111, Park Ridge, Illinois 60068.

**80 DIFFERENT U.S. Stamps.** Includes 1943 flag stamp of occupied nations. Only 25¢. Approvals included. Willett Co., Box 338-M, Yorktown Heights, N.Y. 10598.

**50 YEARS Old, fifteen different United States, over fifty years old—10¢ with approvals.** Jaxon, Box 145-P, Brooklyn, New York 11230.

**QUALITY AND LOW PRICE. EXCELLENT** For advanced or beginner. Mounted approvals 2¢ up, all countries in Scott's Order. Preview Stamps, P.O. Box 20667, San Diego, California 92120.

**U.S. BARGAIN, 50 Different 10¢,** with beautiful worldwide, approvals. Stamp Center, Kennebunk, Maine 04043.

**210 DIFFERENT U.S. Commemoratives \$1.00.** Stamps, 7607 Larchview, Dallas, Texas 75240.

**HITLER, 100 Germany 10¢!** Approvals. White Rock Stamps, 13125 24th M Avenue, Surry, B. C., Canada.

**RUSSIAN Space Collection 25¢,** including Russian Approvals. Snedco, Waldwick, New Jersey 07463.

**FREE WORLDWIDE Commemoratives, Pictorials Beautiful Stamps, Approvals.** Closson, P.O. Box 663, Madison, North Carolina 27025.

**LIECHTENSTEIN #356-\$19.00; France #1100-\$4.00; UN 29-30-\$15.00; NH. CWO.** Submit Lists Western Europe Only. All NH. Franklin, Box 467L, Jamaica, 11434.

**FREE "Space", with packet approvals.** Sunset Stamps, Box 69473, Los Angeles, California 90069.

**60 DIFFERENT United States (30 Commemoratives) 25¢.** Seidenberg, Salem 169, Oregon 97308.

**1500 FOREIGN \$2.00; 5000 \$4.00; 9000 \$6.00.** 1000 pre-1939 USA, contains dues, revenues commemoratives, presidentials, high values, older issues, etc. \$3.00; 5000 \$12.00. 300 pre-1940 USA commemoratives \$2.00; 700 \$4.00. No approvals. Meyers, 5321 Fleming, Richmond, Calif 94804.

**500 DIFFERENT World Wide 50¢!** Approvals. Gordon Davison, Hillsboro, New Hampshire 03244.

**STOCK Reduction Sale.** Send \$1 for \$2 Value; \$2 for \$5 Value. Gallery, Box 35291, Los Angeles 90035.

**GET Scarce Kennedy memorial, Red China, Vietnam stamps plus new countries, topicals, commemoratives, many more!** Valuable collection of 100 different stamps from the world over. Colorful new and old issues—wild animals, famous people, far places, others! Also stamp selections to examine. Buy any or none, return balance. Cancel service anytime. Rush 10¢ today. Garcelon Co., 8PMA, Calais, Maine 04619

**LYNDON B. JOHNSON Memorial stamp on lovely First Day Cover** addressed any name of your choice. 50¢ from: K.M. WALSH, Box 308-G, TUCKAHOE, N.Y. 10707.

**FREE Pictorials with Approvals.** Chapman Stamps, Box 487-P, Galesburg, Michigan 49053.

**255 DIFFERENT Worldwide; 15¢.** Approvals. Tibbets, 8675 Meadow, Downey, California 90242.

**50 DIFFERENT British Commonwealth Foreign Many Pictorials, Commemoratives, 10¢ Approvals Included.** City Stamp Co., Box 216, Station W., Toronto, Canada M6M-4Z2.

**BRITISH COMMONWEALTH Mint Pictorials. Ten Different 10¢ With Bargain Approvals.** Charles Locks, 5607 La Mirada, Los Angeles, California 90038.

**231 WORLDWIDE Stamps 10¢!** Approvals. Holland, 1227A Sixth, Redlands, California 92373.

**FREE Canadian. Approvals. Stamps Unlimited, Box 2338, Kalamazoo, Michigan 49003.**

**MAGNIFICENT! Butterfly Stamps. 50 Different \$1.00.** Approvals and Personalized Collection Program. Northeast Stamp, 1 Laurel Hill Lane, Milford, New Hampshire 03055.

**FREE! Illustrated Bargain List Plus Surprise Gift.** Eckert, Box 205, Clifton, New Jersey 07015.

**FREE Surprise Gift Sent With Approvals.** Boudreau, Box 275, St. Lambert, Quebec, Canada.

**FREE, Mint Worldwide Packet. Approvals.** Hildebrand, Box 5645, Redwood City, California 94063.

**GRAB BAG of over 100 unassorted stamps.** Contains new issues, Asia, South Seas, Africa, etc., plus copy of most wonderful Catalog of Stamp Offers in America. All for only 10¢. Littleton Stamps, Dept. BB-1, Littleton, N.H. 03561.

**SAN MARINO'S Latest 1973 Bicolored Gigantic Fruits, "Apples, Grapes, Strawberries"—Free!** Approvals plus 101 Bonus Sets. William Deems, 226X Race, Ravenswood, West Virginia 26164.

**FREE BARGAIN LISTS! U.S. Mint Singles-Plate Blocks.** Scotco, Box 855-PMM, Miami, Fla. 33147.

**UNITED STATES COMMEMS 300 Different \$3.00; 400 Different \$6.00; 500 Different \$10.00; 600 Different \$30.00.** Norman Sparhawk, 94 Pitman, Providence, Rhode Island 02906.

**107 EXCITING British Colonies. 25¢.** Approvals. Castle, Box 15-PM93, Flushing, New York 11352.

**FREE British Mints. Approvals Accompany.** Chapmans, Box 487-B, Galesburg, Michigan 49053.

**PICK AND Choose from Thousands of Stamps 3¢ Each.** Continental, Box 9384M, No. Hollywood, Calif. 91609.

**50 BIG Beauties 10¢ with approvals.** Irvines, 1726 East Earl Drive, Phoenix, Ariz. 85016.

**FASCINATING Pick-And-Choose Packet Approvals.** Bargain Hunter's Delight, as much is taken from old collections. Rivertown, Box 188P, Lowell, Michigan 49331.

**FREE Duplicate Exchange. 2¢ Approvals.** Belden, Box 4175, Dearborn, Michigan 48126.

**SPECIAL Offer! 100 Unusual Stamps 10¢ with Request for Approvals and Bargain List.** Continental, Box 9384P, No. Hollywood, Calif. 91609.

**THOUSANDS Of Stamps 3¢ each.** Pan Pacific Stamp Co., P.O. Box 9413, No. Hollywood, Calif. 91609.

**40 DIFFERENT U.S. COMMEMORATIVES 20¢ With U.S. and Canadian Approvals.** Mary C. Armstrong, Box 409, Kennett Square, Pennsylvania 19348.

**FREE Twelve New Africa, Rwanda etc., Approvals included.** Alpaughco, Highbridge, NJ 08829.

**VIETNAM 25 Different 10¢ approval.** Sam Chazen, Box 95, Ozone Park, N.Y. 11417.

**FAT BUNDLE Of Fall Fun, only \$3.00 postpaid.** Contains World-Wide Mint, used sets, Singles, Packets. No Approvals. Yukon, Dept. AB, Box 385, Teaneck, N.J. 07666.

**"WHOLESALE" U.S.—Foreign Pricelist and catalog Free!** Everything Guaranteed. Schneider, Box 1240, Grand Rapids, Michigan 49501.

**FREE World Collection. Over 100 stamps.** Approvals. Global, Box 792, Livermore, Cal. 94550.

**BUY Stamps & Coins Wholesale.** Learn Secrets, How & Where. Detailed booklet \$2.00. Lee Ltd., 331 W. Pender, Vancouver, Canada.

## COINS, TOKENS, CURRENCY

**FIFTEEN Different Indian Cents \$6.98; Crisp New \$2.00 Bill \$7.49.** Super-Bargain Lists 50¢. Bebee's, Incorp., Omaha, Nebraska 68111.

**\$1000.00 BANKNOTE 25¢ with comprehensive U.S. coin and Supply catalog.** Schultheis, Box 2151C, New Hyde Park, New York 11040.

**1909 VDB's! Rare Lincoln Cents, \$3.95.** 3 for \$10.00. Coins West, 21 Central, Campbell 1, CA 95008.

**COINS At Discount Prices! Free Brochure.** Gene Carlton, Chandler, Okla. 74834.

**FREE: Lists of Thousands of Stamps and Coins. No Approvals.** Bryson, 612M White, Toledo, Ohio 43605.

**22 "S" LINCOLNS Including 1955S, \$1.75. 24 1909-1939, \$1.75. 10 "S" Jeffersons, \$1.75.** All different. All three \$5.00. HARRIS, Box 2308P, Santa Cruz, California 95060.

**EXACT Replica Colorado-California \$2.00 each.** HOF, 1418 Montague, Washington, D.C. 20011.

**SEND Only \$1.00 for Coin Collecting Outfit.** Contains 25 new coins from 25 countries, PLUS magnifier, wooden nickel, "HOW TO COLLECT COINS" booklet, special coin envelopes, foreign banknote and big catalog of coins, paper money, collectors supplies. Littleton Coins, Dept. GH-1, Littleton, New Hampshire 03561.

**50 DIFFERENT Foreign Coins, \$3.00.** Hoffman, Box 98-M, Clarence, New York 14031.

**5 DIFFERENT Liberty Nickels, \$1.75.** Free Catalog, Village Coin Shop, Dept. P, Plaistow, New Hampshire 03865.

(Continued on next page)



## COINS, TOKENS, CURRENCY

(Continued from preceding page)

**LINCOLNS:** 30 Different 1910-40 \$3.00. 35 Different Uncirculated \$3.00. Both \$5.00. Nayko, Box 233, Kennedy Airport, New York 11430.

**LINCOLN WHEAT PENNY'S.** Hoard from the Old Southwest. Many "S" Mints. 500 for \$19.95 Postpaid. Robert Astrich, P.O. Box 1217, Bellaire, Texas 77401.

**CANADIAN Silver Dollars** 1968-73. Ten, only \$15.00. Benny Lee Ltd., 331 West Pender Street, Vancouver, Canada.

**IMPORT Foreign Coins for Fun and Profit.** Eliminate middlemen. Addresses in 127 Countries. Instructions \$2.00. Intercol, Box 1122, Menlo Park, California 94025.

**GOLD COINS** Of the World. Beautiful Low Prices. Plus thousands of United States Coins. Free price list. Please send long, airmail envelope, Self-addressed, stamped. Silver Center, Box 22171-M, San Francisco, California 94122.

**USA SILVER Dollars** Nice Condition 10 Different Dates Only \$39.95 post paid. El Paso Coin Co., P.O. Box Q, El Paso, Texas 79952.

**GOLD—(1865)** Mexican Maximilliano Peso. Bu \$2.95. Northwoods, Bigfork, Minn. 56628.

**COIN Catalogue** 50¢. Raibl Enterprises, 2355 Scenic Highway, Pensacola, Florida 32503.

**MEXICO** Revolutionary "Pancho Villa" 10 and 5 Centavos Copper Coins Dated 1915 Nice Condition only \$2.95 each. Delivered Postpaid. El Paso Coin Co., P.O. Box Q, El Paso, Texas 79952.

**SILVER DOLLARS** Uncirculated, 1880-81—1883-84-85 \$8.00 Ea. Catalogue 50¢. Shultz, Salt Lake City, Utah 84110.

**BARGAIN Coin List.** 10¢. Economy Sales, Box 92, Buzzard's Bay, Massachusetts, 02532.

**MEXICO:** Silver Dollars Dated 1957 To 1967 In Nice Condition. Ten For \$3.95 Delivered Postpaid. El Paso Coin Co. Inc., Suite 108, El Paso National Bank Bldg., El Paso, Texas 79952.

**MEXICAN COIN CATALOG**—Order one of the most complete listings of Modern Mexican Coins Available—Many priced close to Silver Bullion price—FREE—Send Name and Address to: Alpha Coin Co., Box 31099, El Paso, Texas 79931.

## ANTIQUES, RELICS, INDIAN GOODS & CURIOS

**FREE!!** Lists Antiques, Indian Relics, 10 Arrowheads \$4.00. Hyde's, Box 2304, Santa Fe, New Mexico 87501.

**INDIAN** Relic list, Arrowheads \$4.00, doz. Folsom. \$5.00 each. C. Secrist, Deerfield, Missouri 64741.

**APACHE ARROWHEAD COLLECTIONS**—Perfect. 25—\$5.00, 100—\$15.00. GERONIMO, PMD1239, Apache Junction, Arizona 85220.

**SELLING** 10,000 Indian Relics. Arrowheads, Knives, Spearheads, Scrapers, Etc. List Free. Lear's, Glenwood, Ark. 71943.

**AUTHENTIC WESTERN ARROWHEADS**—Perfect, 25-\$5.00, 100-\$15.00. **BROKEN ARROW**, PMD1208, Scottsdale, Arizona 85252.

## EVERYBODY LIKES DIXIE GUN WORKS.

**TONS** Of antique gun parts and supplies. All reproduction muzzle loading guns. Send \$2.00 for enlarged illustrated catalog No. 121. Dixie Gun Works, Union City 12, Tennessee.

**10 BEAUTIFUL** Arrowheads \$2.00. Guajardo's, 8713 Shaver, El Paso, Texas 79925.

## MODELS—CARS, SHIPS, TRAINS, PLANES ETC.

**SHIP MODEL Kits, Plans, Fittings** from our own Workshop. Big Illustrated Catalog: 50¢. Bluejacket Shipcrafters, 145-V Water Street, South Norwalk, Conn. 06854.

**SHIP And Airplane Model Kits Catalog** 25¢. Scientific, Inc., 340 Synder, Berkeley Heights, N.J. 07922.

**SHIP Model Kits, fittings, plans, books, tools, engines, motors.** Big illustrated catalog 50¢. Mass. residents add 3% tax. James Bliss & Co., Dept. SM, Route 128, Dedham, Mass. 02026.

**MODEL Airplanes**—Big 220 Page Catalog \$1.00. Sig Company, Montezuma, Iowa 50171.

**SHIP And yacht model fittings:** Pine construction hull kits; blueprints. Send 75¢ for illustrated catalog. A. J. Fisher, Inc., 1002 Etowah Avenue, Royal Oak, Michigan 48067.

**LIVE Steam powered backyard railroads!** All sizes. Complete "bolt-together kits," and rough castings. Excellent drawings. 100 page catalog \$1.00. Little Engines, Lomita, California 90717.

**NEWEST, GREATEST FLYING HOBBY—ROCKETS!** Zoom from realistic electric launch systems to 2,500 feet on safe, thrifty, solid-propellant power. Gentle parachute recovery for over-and-over-again flights. Tracking, experiments, real miniaturized still and movie cameras. Build your own exciting, low-cost space-age adventure—starting with a big, new full-color catalog of over 80 models, (including ready to fly). Send 25¢ to: **ESTES INDUSTRIES**, Dept. 7N, Penrose, Colorado 81240.

**12" BRASS Cannon Kits.** Spec. 25¢. Cannon, 758-24th Ave. No., So. St. Paul, Minnesota 55075.

**SCALE Model Cannons, Ships, Tanks, Airplanes, Autos, Trains and Accessories.** New Catalog \$1.50. Frontier Models, 1583 West Washington Blvd., Los Angeles, Calif. 90007.

**LIVE Steamers.** A Man's Hobby. Big Engines Scaled to Model Sizes. Stationary, Marine, Boilers, Gauges, Pumps, Fittings. Catalog \$1.00. H.P.K., "R", Centuck 34, Yonkers, New York 10710.

## GAMES, TOYS, PUZZLES, NOVELTIES

**PUZZLENUTS—GAMES and PUZZLES** Magazine \$9.00/yr. Sample Issue \$1.00. Box 1176F, Palo Alto, Cal. 94302.

**KITES!** Quality Action Styles! Brochure 10¢. Hutchinson, PM9, 83 Tremont, Barre, Vermont 05641.

**MINIATURE CHARMS** Make Fascinating Party Favors. Fantastic Assortment of 25 \$1.00. **TREASURE CHEST**, 9321 PM9 Cape View Avenue, Norfolk, Virginia 23503.

**MIDGET** vegetable pellet gun, ammunition right from your refrigerator \$1.00. Guyco, Box 26414, Tucson Arizona 85726.

**SEND ME ONE DOLLAR,** and I'll send you the Toughest, Meanest, Rottonest Jigsaw Puzzle you've ever tried to put Together. Armbruster, Box 1176, Palo Alto, California 94302. **GUARANTEED!**

## CANON TRICKS, JOKES, VENTRILOQUISM

**HOUDINI'S** Greatest Magic! You can do them all!! Giant illustrated catalog 25¢. House Of 1000 Mysteries, P.O. Box 2026P, Pompano Beach, Florida 33061.

**LEARN VENTRILOQUISM! GUARANTEED.** Dummies, Courses. Catalog 25¢. Ventriloquism, 3746 West 63rd Street, Chicago, Illinois 60629.

**CATALOG 10¢.** 1,500,399 Tricks, Jokes, Novelties, Elbee, 7408P, San Antonio, Texas 78207.

**VENTRILOQUISM!** Learn at home. Guaranteed. Information FREE! Dummy Catalog 25¢ Maher, Box 9037PM, Denver, Colorado 80209.

**FREE!** World's leading novelty catalog. 1600 Funmakers, Jokes, Tricks, Science, Sports, Hobbies, Jewelry, Psychedelia. Johnson-Smith, C-10, Mt. Clemens, Mich. 48043.

**COMPLETELY** illustrated catalog. 84 pages. 25¢. Manhattan Magic, Box 334-M, N.Y.C. 10011.

**MAGIC MAGAZINE.** Tricks, News, Dealers Offerings. Monthly Since 1936. 2 sample Copies \$1.00. Genii, P.O. Box 36068M, Los Angeles, California 90036.

**WORLD'S** Finest professional magic tricks. Joker's Novelties. Giant illustrated catalog 10¢. Top Hat, Evanston, Illinois.

**FABULOUS MAGICS** New 1973 catalogue 25¢. Our specialty orders shipped same day no substitutes. Fabulous Magic, 3319 East Charleston, Las Vegas, Nevada 89104.

**BE A Magician!** Two booklets explaining 156 tricks plus large professional catalog. \$1.00. Magic, Inc., 5082 Lincoln, Chicago, Illinois 60625.

**MAGIC!** Amaze, Mystify, Entertain! Hundreds Of Newest Tricks For Pocket, Parlor, Stage. Complete Catalog Only 25¢. Jeffries Magicland, Dept. 11, Dallas, Texas 75201.

**TWO!** Different Magic Catalogs. 25¢. Miami Magic, Box 1047, Miami 33133.

**JOKES, Gags, Puzzles, Novelties, Magic Tricks.** Latest Catalog. 25¢ Postage And Handling. Fun Shop, Box 5067, Mission Hills, California 91345.

**FREE Trick and Magic Catalogue** 35¢. Magic House, 531-A 78th St., Brooklyn, N.Y. 11236.

**CATALOG 10¢.** Magic, Tricks, Novelties. Plus Free Trick. Sun Magic, Oakhill, Williston, Vermont 05495.

**WOW!** Largest Selection—newest, best tricks, jokes. Giant 150 page catalog 25¢. Abracadabra-MP, Colonia, New Jersey 07067.

## BOOKS, CATALOGS, NEWSPAPERS

**LAKE WORTH** Monster—Amazing Tales of Sightings of this World Famous Humanoid. Author Autographed \$2.25 Postpaid. Box 12713, Fort Worth, Texas 76116.

**FREE VENTRILOQUIST NEWSPAPER!** Fascinating, Informative, Profitable! No obligation. Maher, Box 9037PB, Denver, Colorado 80209.

**AUTO REPAIR BOOK**—End Expensive Repairs. Do Job Yourself. Send \$1.95. A&L Sales, (PM-9), 1027 Samford, Auburn, Ala. 36830.

**LIKE** Free Catalogs? Diane P. Anderson, 260 Crittenden Blvd., Rochester, N.Y. 14642.

**SAVE 70%!** Hundreds-Exciting Unusual Books! Giant Catalog. 25¢. Variety, 7-B3, Wilste, Hillsdale, N.J. 07642.

**WIRETAPPING EXPOSE**—Your Privacy Invaded—Details \$1.00. Refundable. Don-Q, Box 548, Dept. PMO, Seattle, Wa. 98111.

**THE VINEYARD**—Tough Talking Orthodox Christian Journal. \$3.00, 1745 No. Cicero, Chicago, Ill. 60639.

**BOOK SALE!** For the entire family 20¢ to 50¢. Free brochure. Winchester Enterprises, 2807PM Hargrave Street, Philadelphia, Penna. 19136.

**FREE** Book locating. Send wants. Bazaar Book Search, Box 496, Chico, California 95926.

**LATEST** Military Manuals/Books Catalog 25¢. Hillcrest Publications (K-18), McDonald, Ohio 44437.

**FREE BOOK.** Prophet Elijah Coming Before Christ. Megiddo Mission, Dept. 63, 481 Thurston Road, Rochester, N.Y. 14619.

(Continued on next page)

Материал, защищенный авторским правом



## BOOKS, CATALOGS, NEWSPAPERS

(Continued from preceding page)

**NATIONAL Geographic Magazines, 1888-1971, any issue.** Buxbaum, Box 465-PM, Wilmington, Delaware 19899.

**LOGIC NEWSLETTER, Learn Theory, Design, Symbolic Logic, BOOLEAN ALGEBRA, Sample Copy \$1.00. LOGIC NEWSLETTER, P.O.B. 252, Waldwick, New Jersey 07463.**

**FREE! 306 Magazines Monthly.** 81 Subjects. Kel-Bridge House, Dept. 2093, 5130 Broerman Ave., Cincinnati, Ohio 45217.

**HOW TO GET Success, Wealth, Happiness, Health. How To Solve Personal Problems.** Free List. Carnation House, 365-A Carnation Street, Chattanooga, Tennessee 37419.

**PUBLISH Your Book!** Join our successful authors: All subjects invited. Send for free appraisal and detailed booklet. Carlton Press, Dept. PMU, 84 Fifth Avenue, New York 10011.

**NATURE'S Answer Against Cancer, Heart Attack, Arthritis, Diabetes, Cataract.** Free Information. Provoker Press, St. Catharines 202, Ontario.

**FREE! 276 Magazines monthly—67 subjects!** Complete directory \$1.00 . . . Satisfaction Guaranteed. Aleph-B, Box 5877-PM2, Stanford, California 94305.

**COMPLETE HOLY SCRIPTURES, Jewish \$4.00.** Tenach, 27 Fig Tree, Dunnellon, Fla. 32630.

**BOOKS—MANUALS, Money-making, Self-Improvement—Free Details.** Ralpc, Box 8184M9, St. Paul, Minnesota 55113.

**RENOVATION And Maintenance. Ideas for the Old House.** Published Monthly. \$1.00 for Sample Copy. **THE OLD-HOUSE JOURNAL**, Dept. 1, 199 Berkeley Place, Brooklyn, N.Y. 11217.

**BOOKS.** On any Subject free information. Byrne Sales, 5445 W. 64, Dept P 11, Chicago, Ill. 60638.

## PLAYS, SONGS, MANUSCRIPTS

**SONGPOEMS, SONGS! Urgently Needed.** Possible Recording/Publishing. 50-50 Agreement. Betty's Music Makers, 222B 150th Avenue, Madeira Beach, Florida 33708.

**PUBLISHING Contract Guaranteed** on selected songs and poems. Free evaluation. Hollywood Songwriters', 6253 Hollywood, 117-PM, Hollywood, California 90028.

**RECORDS Made.** Publishing Contract Guaranteed On Accepted Songs, Poems. Send: Talent Searchers Of Hollywood, 6311-X Yucca, Hollywood, Calif. 90028.

**SONGS, POEMS WANTED!** For publishing, recording at our expense! **TALENT**, 17-PM, Longwood Road, Quincy, Mass. 02169.

**POEMS, Songs Wanted For Immediate Recording—Publishing. Free Evaluations.** Three Rivers Music Center, 258B—107th Avenue, Treasure Island, Florida 33706.

**SONGS, Poems Needed.** New Songs Recorded. Publishing Guaranteed. Musically Yours, Box 606PM, Laurel, Florida 33545.

**SONGWRITERS! POETS!** We need new song material for immediate publishing, recording consideration! Accepted songs recorded, published at our expense! **GRAND RECORDING**, 1354-PM Hancock Street, Quincy, Mass. 02169.

**SONGS SONGPOEMS Wanted For Radio Show.** Hollywood Music Productions, 6425-PM, Hollywood Boulevard, Hollywood, California 90028.

## BUSINESS SERVICES

**PROFITS FROM CLASSIFIED ADVERTISING!** Booklet shows you how to start your own business with Classified Advertising. Only \$1.00 (Refundable with first order.) **H. E. KAPPEL, POPULAR MECHANICS, DEPT. P, 224 WEST 57 STREET, NEW YORK, N.Y. 10019.**

## BUSINESS OPPORTUNITIES

**FREE Literature—Start Your Own Mail Order Business At Home.** The Tomlyn Co., Box 614 (C-9), Clifton, N.J. 07012.

**DISTRIBUTE Nationally Published Abbreviated Bible.** Others Sell, you Profit Big. Unique Details, Sample Volume \$5.00. \$200/Week Easy Part Time. Potomac, 4629 Willowbend, Houston, 77035.

**LIBERATE YOURSELF.** Become Our Distributor Making Highest Profits On 1001 Products. We Drop-Ship Novelties, Gifts, Toys. \$2.00 Brings 150 Page Catalog (Refundable With First Order). **ALLEN WHOLESALE COMPANY**, 12135 Mitchell Avenue 220-PM, Mar Vista, California 90066.

**AMAZINGLY Profitable! Sell Books By Mail From Own Catalog.** Details, \$1.00 (Refundable). Sabacy Products, Box 15206G, Lakewood, Colorado 80215.

**OPERATE Charm And Modeling Business By Mail.** Royce, 14603 Dorchester, GM-93, Dolton, Illinois 60419.

**328 FAST, Easy ways to make money!** Free! Rush name, address, zip. Perry, 13263-E Ventura Blvd. Studio City, Calif. 91604.

**SECRETS! Mail Order Success.** Internationally famous expert reveals how to make home business fortunes. Beginners! Get free report "Make Money By Mail." Discloses free advertising profitable products. Mailco, Dept. GC709, Woodland Hills, California 91364.

**INSTALL Burglar alarms without previous experience or costly equipment.** Big profit. Free details. Nasco, Dept. G2709, Woodland Hills, California 91364.

**HOW And Where To Get Capital.** Get \$500 to \$2 million. Free information. Counselor-17, Kerrville, Texas 78028.

**BIG Business in Vinyl Repair.** Sensational process repairs, refinishes, recolors vinyl, leather, naugahyde furniture, car tops. One 20 minute job puts \$20 in your pocket. Make \$600 a month spare time. Homes, restaurants, offices, cars, unlimited customers. Easy to learn and do. Details Free. VIP, 2007 Montrose, Chicago, 60618.

**FREE Millionaire Book "990 Successful, Little One-Man Businesses. Work home!"** SBI-7, Kerrville, Texas 78028.

**PREPARE Tax Returns—Policeman Albert Myers made \$2000 his very first season.** Train at home. VA Approved. National Tax School, Monsey, 2SD, N.Y. 10952.

**NEW! Profitable Mail Order Business!** Free Details! Xcito Businesses. 5715 N. Mozart, Chicago, Illinois 60659.

**FANTASTIC MONEY-MAKING INFORMATION** Send 25¢ To: Horizon Sales Company, Dept. 2Y9, 236 Belleville Turnpike, Kearny, N.J. 07032.

**50-400% PROFIT!! Sell Tested, Proven, Legitimate, Money-making Publications by mail.** Complete Details 25¢. **PAIT**, 140T South B, Tustin, California 92680.

**DAYDREAMING? STOP!** Opportunity Catalog Offers Books That Can Make You Rich! 25¢. **HAMLET HOUSE**, 3A9 6247 2nd NW, Seattle 98107.

**\$700 MONTHLY.** Immediate income. Stuff envelopes at home. Information, send self-addressed stamped envelope. Cottage, Box 25053-CAI, Los Angeles, Cal. 90025.

**HOW Mail Order Fortunes are Made.** Free Details. Curtis, Box 817C, Wellsboro, Pa. 16901.

**BIG Profits selling Nameplates, Custom Engraving—Free Details.** R.P.H. Manufacturing, 249-C Winter, Stamford, Conn. 06905.

**START A Profitable Business At Home.** My Booklet Explains, Tells How. Only \$1.00. Ellis Keller, 820-M Calvert St., York, Pa. 17403.

**SANDBLASTERS \$32.50-\$749.50.** Free Catalog. Truman, 1330 Market, Youngstown, Ohio 44507.

**\$2000, MONTHLY Selling Information By Mail; Free Details:** Clark, Box 80521-M, Atlanta, Georgia 30341.

**CLAIM ABANDONED SILVER—\$20,000 Secret Revealed! Free Information:** Silverman 4A-13, Box 548, Woodville, Texas 75799.

**MONTHLY \$1500—From your home, easily!!** Write: E. Enterprises (P9), 1019 Hillside, Valdosta, Ga. 31601.

**AMAZINGLY INFORMATIVE NEWSLETTER** Reveals Best Business and Investment Opportunities. Free Details, Quality Products, 32 Maine Avenue, Carteret, New Jersey 07008.

**GUARANTEED. \$1.00 For Each Envelope You Stuff.** Details \$2.00. Fuller, 228 Lemmon, Sumter, South Carolina 29150.

**MAILORDER FAILURES Outnumber Successes! Why? Your Future DEMANDS Reply to: PATHFINDERS—Suite 205-A-25 Van-Reipen Avenue, Jersey City, New Jersey 07306. Information Rushed FREE.**

**START Your Own Correspondence School.** United Career Schools, 5820P Imperial Hwy, South Gate, Calif. 90280.

**I MADE \$2,000.00 Monthly by Mailorder . . . Evenings Only! You Can Too—Free Proof!** Asbury, Box 161-D, Madison, Ohio 44057.

**HERBALISM! The Home Gold Mine! FREE LESSON, SEEDS!** Herbalism Institute-B, Box 968, Glendora, California 91740.

**BIG PROFITS!! SELL ENGRAVED, METAL, SOCIAL SECURITY PLATES, FREE SALES KIT!** MYERS, 928-PM CRESCENTHILL, NASHVILLE, TENNESSEE 37206.

**MAILORDER Dealers Wanted.** Earn outstanding profits using tested promotions! Rutward-PD, Georgetown, Conn. 06829.

**PIANO Tuning Learned Quickly at Home!** Tremendous field! Musical knowledge unnecessary. GI Approved. Information Free. Empire School, Box 327, Miami, 33145.

**WORLD'S Largest supply, Merchandise 25% to 40% under wholesale.** Bankrupts. Closeouts 10¢ on dollar. Imports. Hong Kong clothes. Automobile discounts. Free details. International Buyers, Box 16386 MM, Portland, Oregon 97233.

**SELL Books by mail. Complete dealer set-up—25¢.** Midwest Mail Sales, Box 44R2-PM, Shawano, Wisconsin 54166.

**MAKE A Years Income in 8 weeks** Camping. No selling. Capital or Land necessary. Write: Edrus, Route 5, Box 5733, Gig Harbor, Washington 98335.

**BECOME "Mortgage Broker."** Lucrative! Capital Sources, Box 99-A, Uleta, Florida 33164.

**MAKE Magnetic signs, Machineless method.** Profits enormous. Write: R1B49APM, Bardstown, Ky. 40004.

**ADVERTISING BUSINESS—YOU Own it.** \$400 First Week or Money Back. Electric Neon Action Ad Clock, 229 W. Illinois, Chicago 60610.

**HOLLYWOOD CEMENTCRAFT:** Offers Highly Profitable Home Business. Experience Unnecessary. Unlimited Unique Pottery Designs Easily Made Without Moulds. Bird-baths, Fountains, Wishing-Well, Waterfalls, etc. Chemical Coloring Formulas. Marble-glazing. FREE Illustrated Brochure. **CONCRETE FACTS**, 602 Athens Street, Altadena, California 91001.

**COPUBLISH "Mail Sale Advertiser,"** leading mailorder paper. Copy and details 25¢: U.S.A. only. Vanroy Shirk, Lebanon, Pa. 17042.

**VENDING Machine big catalog. Rake,** 523 A Spring Garden, Philadelphia, Pa. 19123.

(Continued on next page)



## BUSINESS OPPORTUNITIES

(Continued from preceding page)

**FREE Catalogs.** Repair air conditioning refrigeration. Tools, supplies, full instructions. Doolin, 2016 Canton, Dallas, Texas 75201.

**SELL** Books by mail. 400% profit. Royal, Box 450-X, Cleveland, Ohio 44127.

**\$70 TO \$200 WEEKLY**—Home, Spare Time Simplified Mail Bookkeeping. Immediate Income. Easy. Auditax, Box 34741A, Los Angeles, Calif. 90034.

**VENDING** Machines. No selling. Routes earn amazing profits. Big catalogue Free. Parkway Corporation, 715PBM Ensor Street, Baltimore, Maryland 21202.

**\$60.00 DAY.** Manufacturing Concrete Posts. Blocks. Mold Equipment Catalog \$1.00 refundable. Carlyne, Route One, Box 95, Rapid City, South Dakota 57701.

**MAILORDER** Records help get increased business! Complete 32 page Record Book shows your inquiries, orders, advertising, expense, etc. Only \$1.00. H. E. KAPPEL, POPULAR MECHANICS, DEPT. R, 224 WEST 57TH STREET, NEW YORK, NEW YORK 10019.

**REPAIR** Hydraulic Jacks—Details Free. Write: Hydraulic Parts Supply, Box 295, Port Isabel, Texas 78578.

**EARN** \$60.00 Daily manufacturing Concrete Fence Posts. Practically no investment. Send stamped-addressed envelope. American, Excelsior Springs, Mo. 64024.

**\$50.00 PLUS 50% COMMISSION** Stuffing 200 already stamped, addressed envelopes, our circulars. Information 25¢ with stamped, self-addressed envelope. Brewster-PB, Clearwater, Florida 33517.

**\$400.00 MONTHLY** Raising giant fishworms. Soilless method. Charlie Morgan, Bushnell, Florida 33513.

**EARN** Money raising fishworms for us! Write: Oakhaven-38, Cedar Hill, Texas 75104.

**WATCHMAKING** Makes every day a payday. Learn this cash business at home. Free details, Chicago School of Watchmaking, YWA, Fox River Grove, Illinois 60021.

**\$1.00 LISTS** You year sent to 1000 Importers, Jobbers, Mailers, our mailing year. Dixieme, King, North Carolina 27021.

**\$200.00 SPARE** Time earnings with your Tablesaw. Write: Workshop Five, 3800 Harney, Vancouver, Washington 98660.

**STUFF** Envelopes. \$25 Hundred. Immediate Earnings! Beginner's Kit, \$1.00 (refundable). Lewcard, P392M, Brea, Calif. 92621.

**\$200 WEEKLY!** Make, Sell Bricks! Free Information! Xcito Bricks, 5715 N. Mozart, Chicago, Ill. 60659.

**MAIL** Baby Catalogs Imprinted with your address to New Mothers for Big Profits! Details 25¢. Volz PM, Ypsilanti, Michigan 48197.

**I MADE \$40,000.00** Year by Mailorder! Helped others make money! Start with \$15.00—Free Proof. Torrey, Box 318-Y, Ypsilanti, Michigan 48197.

**SELL** New Sensational Car Thief Signal. Lightning Seller. Samples for trial. Northwest Electric, Ave. 180, Mitchell, S. Dak. 57301.

**BECOME** Our Mail Order Distributor with \$150 investment. Free Brochure. Audit Controls, 40 Brookside Ave., Fair Lawn, New Jersey 07410.

**PORTABLE** Sandblaster \$29.95. Distributor wanted. Free brochure. INKA, Box 66573—A. Houston, Texas 77006.

**MAILORDER** Millionaire helps beginners make \$500 weekly. Free report reveals secret plan! Executive (IA9), 333 North Michigan, Chicago 60601.

**MAILORDER** Catalogs. Your Name Imprinted. Merchandise Drop-Shipped. Details 25¢. AM Sales, 31-14-94, East Elmhurst, N.Y. 11369.

**FREE SECRET BOOK** "2042 Unique, Proven Enterprises." Tiny businesses but huge profits! How Little Fellows beat inflation. Work home! Haylings-T21, Carlsbad, California 92008.

**BOOKKEEPERS** Operate Profitable Bookkeeping Service. Earn \$10.00-\$20.00 hour. Details free. Universal Bookkeeping, Box 664-M, Springfield, Missouri 65801.

**SECRETS** of getting rich with other people's money. \$5000+ possible in one day. Free details. JPA, Dept. 305, Box 101, Park Ridge, N. J. 07656.

**GROUND** Floor opportunity in an Engraving business of your own—spare time or full time. One piece of raw material costing \$4.50 will produce products worth \$180.00! Free particulars! Write: Warner, Room EC-2-CK, 1512 Jarvis, Chicago, Illinois 60626.

**\$1000 PER MONTH** Possible. From Your Own Home. Write: Charles A Enterprises, R-1, Box 1022, Bend, Oregon 97701.

**\$200.00 DAILY** In Your Mailbox! Opportunity To Follow Mailorder Experts. Free Details. Associates, Box 136-A, Holland, Mich. 49423.

**RECEIVE** Mail Galore! Your name on our national mailing lists, \$1.00. Sullins, Box 1313, Brunswick, Georgia 31520.

**STUFF** Envelopes. \$28.00 Hundred. Immediate Earnings. Beginners Kit, \$1.00 (Refundable). John Keen, P.O. Box 9995, San Diego, Calif. 92109.

**100% PROFIT** Bronzing Baby Shoes At Home. Free Literature. NBC-PM, Gower, Missouri 64454.

**\$25.00 HUNDRED** Addressing possible year 'round. Special information 25¢ with self-addressed stamped envelope. Cove-B, 627 Franklin, Clearwater, Florida 33517.

**\$1000 MONTHLY** from your own home. Write: Jordan, Box 884, Dept. PM9, Visalia, Calif. 93277.

**DO SIMPLE ADDRESSING**—Mailing. Receive \$12.95 orders. Keep \$8.00 profit. Details Free! Quality, Box 9-P, East Rockaway, N.Y. 11518.

**MEN**—Women! Fill out income tax forms at home in own business. We show you how. Simple, easy to learn. \$700 per month earnings possible. Details mailed free. No salesmen. Hurry. Federated Tax Home Training School, 2065 Montrose, Chicago 60618

**CAMPERS.** Earn income while camping. No capital, Land or Selling required. Welba, Box 366, Anaheim, California 92805.

**MAILERS** Wanted!! Free Information. A. Allen, 2418 Lori, Santa Ana, California 92706.

**MAKE** \$7.50 to \$15.00 hourly building portable custom cases in your home. Huge demand. Get orders by mail. We supply materials, instructions—everything. Free details. Customcase, 6075 De Soto, Dept. C-P9, Woodland Hills, California 91364.

**TAKE** Catalog orders. We drop-ship 1001 best selling specialty products. Lowest below wholesale prices. Immediate Delivery. Spectacular home business opportunity. Free Book. Specialty Merchandise, Dept. S-P-9, Woodland Hills, California 91364.

**\$13,250.00** IN three months. Get Free Proof. Paco, Box 37157, San Antonio, Texas 78237.

**HOW TO MAKE MONEY ADDRESSING, MAILING LETTERS.** OFFER DETAILS 10¢. Lindbloom, 3636 West Peterson, Chicago 60659.

**900% PROFIT** Possible in magnetic signs. Get in on this fast growing, money making industry. We sell plans for building sign machines, supplies and custom signs. Dealers wanted. Magna, Box 1033M2, St. Charles, Mo. 63301.

**\$2000.00 MONTHLY** Selling Information By Mail. Ropchan, Box 5341P, Sherman Oaks, Calif. 91413

**CALIFORNIA MANUFACTURER NEEDS** Man to assemble our product and be local agent, experience unnecessary. May start while presently employed. Five-figure income for responsible applicant. S.K.R.M. Manufacturers, 2347 West 238 Street, Torrance, California 90501.

**MAILORDER BEGINNERS LIBRARY.** Learn Professional Secrets Inexpensively! Write: HOW, Box 4457PM9, Downey, California 90241.

**YOUR OWN MAIL ORDER BUSINESS! 4 MILLION NEW PROSPECTS ANNUALLY! 25¢ BRINGS VALUABLE DETAILS.** EVANS ENTERPRISES DEPT. 23PM, 77 MAY STREET, IRVINGTON, NEW JERSEY 07111.

**FOR SALE AUTO PARTS STORES.** For locations and information write: G. A. Millinger, 2754 Quincannon Lane, Houston, Texas. 77043

**EARN** More than many professional men! \$1000. Month Mail Order Collection Agency. Continental, Box 2023-A, Des Moines, Iowa 50310.

**ESTABLISH** Profitable Home-Operated Mailorder Business!! Minimum Investment. Everything Available to Insure Immediate Success. Rush 25¢ Today for Complete Package. Learn How you Can Cash in on this Great Moneymaking Opportunity. Carpenter, Box 6308A, Long Beach, California 90806.

**MAKE** 2 To 3 Times your cost on hundreds of products. Gift Items, Novelties, 1001 other. \$2.00 Brings Giant Catalog, Refundable on First Order. Redmond's, 10391 Samoa Dr., Huntington Beach, Calif. 92646.

**PLAN** Ahead "1974's Greatest Mailorder Opportunities." Absolutely free. Neil H. Tasker, Shamokin, Pennsylvania 17872.

**FANTASTIC PROFIT POTENTIAL!!** Establish Your Own Successful Mailorder Business Featuring Popular Books. Everything tested. Proven, Available. Rush 25¢ for full Details, Sample. Nationwide, Box 4367FD, Columbia, S. C. 29240.

**INDEPENDENCE. FINANCIAL SUCCESS.** Learn profitmaking secrets of home operated mail order business. Small amount of capital needed. No experience necessary. Our guidance can make you rich. Free report. Tipton, Dept PM9, Box 19507, Oklahoma City, Oklahoma 73119.

**\$92.00 FROM** Square Foot Plywood (with Jigsaw or Bandsaw); 25¢ Rushes Revealing Details. Woderz, Bridgewater, Mass. 02324.

**WORLD'S EASIEST** Mailorder Business. Free Details. Arteric, 770 E. Griffith, Fresno, California 93704.

**"MAILORDER** Course! Home Study". 24 Easy Lessons. \$2.00. "Bill" Lambertson, 132 Tamiami Station, Dept. PM93, Miami, Florida. 33144.

**\$300 WEEKENDS AT OUTDOOR FLEA MARKETS NO SELLING. INSTRUCTIONS** \$1.00. Abel Products, 1115 W. Farnum, Royal Oak, Michigan 48067.

**VACUUM** signmaker. Element. Instructions \$10.00. Homecraft, 2350 W47th, Denver, Colorado 80211.

**INVEST** \$2.00. Start Business Right. Learn Methods, Hidden Problems. Simple. Blunt Pamphlet by Old Pro. Box 13213, Pittsburgh, Pennsylvania 15243.

**MAILORDER** How to Start. Details 25¢. Joe Holmes, 509 Loch Aish Rd., Ambler Penna. 19002.

**SPECTACULAR** Profits! Specialty Wholesale Merchandise. Catalog, Price List, \$1.00 Refundable (First Order). Woodlake House, 23201-B Oxnard St., Woodland Hills, Calif. 91364.

(Continued on next page)



## BUSINESS OPPORTUNITIES

(Continued from preceding page)

**\$500 WEEKLY**, Selling Business Information by Mail. Cox, Box 1405-A, Grants Pass, Oregon 97526.

**\$500 PER MONTH!** Complete Home Business. Ready to go. No-Time-Limit Guarantee! Rush \$2.00. COLUMBIA, Box 24413-MI, Oakland, California 94623.

**PROFIT \$3.50 Per Sale.** Selling Personalized Products! Details Free. SKYCO, Box 1232A, Rockville, Maryland 20850.

**UNLIMITED PROFITS FROM YOUR OWN ONE-MAN ELECTRONIC FACTORY.** Capital unnecessary, sales handled by professionals. Revealing literature free. BARTOPMA, Box 248 Walnut Creek, California 94596.

**\$150 WEEKLY** Possible Addressing, Stuffing Envelopes. Information Send 25¢ Stamped, Addressed Envelope To: D & M Advertising, Box 4347-M, Colorado Springs, Colorado 80930.

**FREE "Money In The Mail"**, Milan, Box 32284, Decatur, Georgia 30032.

**RAISE** Capital Without Collateral or Credit. Unique Plan Assures Success. Enterprises, Box 247-M, Columbus, Georgia 31902.

**GINSENG** Seeds, For Planting. \$5,000 Possible Growing 1/4 Acre. For Information, Price List. Write; Ginseng, McDonald, Tennessee 37353.

**DETAILED** Information on how I Started a Small Business in My Spare Time. Nothing Held Back. The Business is Profitable and Growing. All facts. Well Worth the Price of \$10.00. Lifeways, Box 589, Battle Creek, Michigan 49016.

**PROFIT** Potential \$6.04 to \$604.00. Details 25¢. WIS, Box 188-PM, Birnamwood, Wisconsin 54414.

**PIANO** Tuning Made Easy. Manual and all necessary Tools, only \$22.50. Ten-day Money-Back Guarantee. Details Free. Stamm Industries, 297 Richard, Oregon, Illinois 61061.

**\$250.00 PER** Thousand stuffing envelopes! Unconditional Money-Back guarantee! Complete Starters Kit \$1.00. HOMEWORKERS, Box 24413-NI, Oakland, Cal. 94623.

**YOUR** Imagination Can Make You Rich Selling Information by Mail! MOAA, Box 21091-A, Philadelphia, Pennsylvania 19154.

**MAKE \$40 daily!** Manufacture, Sell Patio Tiles! Free Details! Hilmar, Rt. 1, Box 347D H, Valrico, Fla. 33594.

**FREE** Sample Import! Proves money you can make in own Home Import Business. 200% Profit. Clip ad for Free Sample, Free Book. Mellinger, Dept. G2709, Woodland Hills, Ca. 91364.

**WRITING** Services . . . Mailorder . . . Dealers Only. Goutell, 175 Fifth Avenue, NYC 10010.

**EARN** Thousands at home. How to sell books by mail. Free details. Wisdom House, Box 1106P, Largo, Florida 33540.

**GUARANTEED HIGH-PROFIT** Advertising Specialties. Send stamped return envelope. Baughan, Postbox 1426-AAP, Plainfield, New Jersey 07061.

**OUTSIDERS CONNECTION!!** We're offering your first time opportunity of earning exceptional profits in your sparetime distributing our uniquely revealing business newsletter. Everything supplied. Free details. Our Times, 520-C Fifth Avenue, New York, 10036.

**RAISE** Rabbits, other Laboratory animals for us. We supply equipment, breeders and instructions. Details 25¢. Rabbits of Michigan, MP-11 Countyline Road, Pentwater, Michigan 49449.

**SECRETS** For Simplified **SUCCESSFUL** Mail Order and Importing. Guaranteed. **FREE** Bulletin. Holladay House, Box 86638A, North Vancouver, B.C., Canada.

**WILL YOU RETIRE IN POVERTY?** Don't. Success Can Be Yours In Mail Order. Details Free. Offer Limited. House Of Distinction, Box 607, Iowa City, Iowa 52240.

**SELL** Books Mailorder!! Highly Profitable! Details. Derbes, Box 2667, New Orleans 70176.

**EXTRA \$1200** Possible. Exciting; Career Later. Free Evaluation. Saylor, Box 622, Irving, Texas 75060.

**FREE** Details! Business By Mail Handbook. Creative, Box 460, Lomita, California 90717.

**FREE**—Million Dollar Mail Order Secret. Raney—18 Oneida, Centereach, New York 11720.

**MAILORDER** Secrets! Expert Explains. Free Details. Diamond, Box 223PM9, Pottsboro, Texas 75076.

**300% PROFIT** Possible—sell books by mail. Details. 25¢. Naggo, Box 11478PMB, Chicago, Illinois 60611.

**THINKING** of Starting a Business? Read this detailed report, "How to Start and Form a Business". Only \$2 postpaid. Business Research Services, 4047 Old York Rd., Philadelphia, PA 19140.

**BIG** Profits . . . As Research Expert!! Instructions \$3.00. ANCO, Box 3311, Dept. PM, Ft. Pierce, Florida 33450.

**\$48,000.00 YEARLY** Possible. Some No Investment. For Detail Send 25¢ To Cover Postage, Handling. Looksee, Box 3483, San Antonio, Texas 78211.

**FREE** Catalog Bargain Books. Make Money. Stagecoach Sales, 250P Circle Drive, Ruidoso Downs, New Mexico 88346.

**WORLD'S GREATEST BARGAINS.** U.S., Foreign Wholesalers. Buy Direct . . . Start Your Own Sparetime Business. Free Details. Yorkshire, Box 401-D, Molalla, Oregon 97038.

**AUTO TRIM, CUSTOMIZING** . . . Learn these high paying skills at home in spare time! Free Booklet. Auto Institute, Box 64-WPM, Orange, Calif. 92669.

**WE NEED GINSENG GROWERS!** \$3,000-\$30,000 annually! We Buy Your Crop. Send \$2 for seed sample and information. Glass's Ginseng Exchange, Box 336, Rochdale Station, Jamaica, N.Y. 11434.

**STEADY** Home income addressing mailing, newspaper clippings, 30 firms. Profitable Plans \$1.00. GMI, Box 441-2, Somerset, Ky. 42501.

**HOW TO RAISE** \$100.00 to \$1,000,000.00!! Write: Capital-PM, Dawsonville, Georgia 30534.

**SELL** Books By Mail. Dealership Information 25¢. House of Better Books, 33 Stonycliff Road, Centerville, Mass. 02632.

**FANTASTIC PROFITS!** Your Own Home Business. Fulker, 422 Northeast Knott, Portland, Oregon 97212.

**\$\$\$ FINANCIAL INDEPENDENCE.** Be Successful Businessman. No Tricks. Send Stamp. Box 25079, West Los Angeles, Calif. 90025.

**FREE COLLECTION AGENCY** Details!! \$1000.00 Monthly Possible. Master-PM, Dawsonville, Georgia 30534.

**MONEYMAKING OPPORTUNITY** Booklets. Send for free brochure. Dept. PM. ARE, Box 159, Lindenhurst, New York 11757.

**NO** Credit Check—No Rejects We finance all sales. \$1.00 Brings you full information. \$500.00 weekly income. \$249.95 Package—Black History. Bear, Box 13585, Sta. K, Atlanta, Ga. 30324.

**AMAZING!** Mail Order business "KNOW-HOW" 2-hour Course \$2.00. **FREE** details. Fortune World, Box 4012, Foster City, California 94404.

**\$5,000.00 WEEKLY** Possible. Simply Change Refrigerators, Air Conditioners to Use 1/3 less Electricity. Details \$40.00. Refundable. Spaceman, Box 16046, Kansas City, Missouri 64112.

## MONEYMAKING OPPORTUNITIES

**OVER \$16.50** an hour. Spare time at home! Rubber Stamp industry needs small manufacturers. We furnish all equipment and know-how! Particulars free! Write: Roberts, Room RC-2-CK, 1512 Jarvis, Chicago, Ill. 60626.

**MAKE MONEY** With Your Camera. Booklet \$1.00. RAINIER, 453 Algonquin, Hampton, Virginia 23661.

**LEARN** Sign Painting—\$1000 Monthly, Part-Time. Free Catalogue. Kaufmann Company, Centertown, Missouri 65023.

**BUY BELOW WHOLESALE.** Make Big Profits. Gift Items, Carded Merchandise. Free Catalog. Little Town Products, 39 Cottage, Morrisville, Vermont 05661.

**\$500 MONTHLY** Possible clipping newspaper items—at home, spare time. Details free. Clippings, Box 5877—PM2A, Stanford, California 94305.

**CATALOG** Publisher Wants Mailorder Dealers. Particulars, 25¢. Mears-PM, 5363 Essex, Alexandria, Virginia 22311.

**MAKE \$1.00 PER SALE** Selling engraved metal Social Security plates. **FREE SALES KIT.** Engravaplates, Box 10460-199, Jacksonville, Florida 32207.

**DRAMATIC** 10-Second Demonstration pays 400% profit! Sensational Victory Miracle Cloth polishes metal, wood to a sparkle, even removes rust. Really something to see! Hottest door-to-door, mail order, fund-raising item in years. Rush name, address for **FREE SAMPLE**, really "Impressive" discounts. BARRY PRODUCTS, Dept. 240, 1312 Washington, St. Louis, Mo. 63103.

**SKETCH** Photos (Homeworker's Goldmine!) Details. Gem, 365-D Longhill, Shelton, Conn. 06484.

**BEAUTIFUL** Sparkling, Gemsai Trees Use Real Gemstones! \$8.00 Kits, Retailers For \$20.00 Completed. Enjoy With Pride This Easy Profitable Work At Home. Details And Mounted Gem \$2.00. Gemkraft, 10276 Tams Drive, Baton Rouge, Louisiana 70815.

**INTERESTING** Magazine. Something For Everyone! Three Issues 50¢. Micci, Box 938-PM, Las Vegas, Nevada 89101.

**MAKE \$2,000 PER MONTH FROM YOUR OWN HOME.** Send for **FREE** Details To: Eagle's Enterprises, Box 1981, Oklahoma City, Oklahoma 73101.

**CLIP** Newspaper items. \$1.00-\$5.00 each. Details free. Walter, Box 1360-PA, Erie, Pa. 16512.

**RETIRE ANYTIME** In Luxury! Easy, Legitimate! Details. Premier Enterprises, Box 10597-AJ, Pittsburgh 15235.

**\$100.00 EXTRA WEEKLY EASY! SPARE TIME! DETAILS, BEAUTIFUL SAMPLE FREE.** RUSSELL PRODUCTS, DEPT. P41, COLUMBIA, TENNESSEE 38401.

**CASH** In on your Hobby. **PHOTO** report tells how, where. **COLOR** slide Markets. Send \$1.00 To: TOBEY'S, 419 University Blvd, East, Suite A2 648, Silver Spring, Md. 20901.

**GROW GINSENG** For Profit. Write for Free Growing Information. Pulvermacher's Produce, Dept. C, Richland Center, Wis. 53581.

(Continued on next page)



## MONEYMAKING OPPORTUNITIES

(Continued from preceding page)

**MAKE** Statuettes, novelties, imitation marble. Sell to stores or start gift shop. Free details. Marbleizing, 41 Waverton, St. Louis, Mo. 63124.

**HOW** To Make Money Writing Short Paragraphs. Information Free on "Home Studies in Writing". Barrett, Dept. C-27-A, 6216 N. Clark, Chicago 60660.

**\$2.40 HOURLY** Making simple wood novelties. Free details! Gene's, 55 Boxwood, Falmouth, Mass. 02540.

**WORLD'S** Leading contest magazine, 25¢. Year, \$4.00. Prizewinner, 1315 Central, St. Petersburg, Fla. 33705.

**HOW TO GET RICH!!** Free "Money-making Brochure"! Success International, Box 2447-C, Livonia, Mich. 48151.

**VENDING** Machines. No selling. Routes earn amazing profits. Big catalogue Free. Parkway Corporation, 715PMM, Ensor Street, Baltimore, Maryland 21202.

**FREE**—Easy Ways to make money selling exciting new products—Full—spare time. Send name, age, for 5 months free subscription. Salesman's Opportunity Magazine, 1460 Hancock Center, Dept. 17-JM, Chicago 60611.

**PENNY STOCKS** Have Profit Potential. Free Information. Analyst-P.M., Box 214, Redondo Beach, California 90277.

**\$40 DAILY** Possible tying fishing flies at home. Details 25¢. Flyco, Box 481PM, Albany, Oregon 97321.

**EARN MONEY**, learn mailorder, spare-time, at home, reading leading (since 1929) trade magazine, product sources, stories, tips. Sample 50¢, year \$5. Mail Trade, Box 1302, Springfield, Illinois 62705.

**ADDRESSERS**—50 Companies want Addressers. Send self-addressed envelope. Cal Enterprises, Box 4516-X, Compton, Calif. 90224.

**SWEESTAKES** Contests. How to win. Write for free information. General Contests, 1609-18 East 5th., Duluth, Minnesota 55812.

**FREE SECRET BOOK** "2042 Unique, Proven Enterprises." Largest successful collection! Fabulous "Little Knowns." Work home! Haylings-T20, Carlsbad, Calif. 92008.

**\$200.00 FROM** Sheet 1/4" plywood (scrap). Details 25¢. Novelties, 610 So. 24th, Elwood, Indiana 46036.

**LEARN** The secrets of repairing junk batteries. "Fabulous Profits" at home. Battery Shop, Box 820, La Quinta, California 92253.

**GET** World's Biggest Wholesale Import Catalog. Write: World, Medina, Washington 98039.

**START** Small, **HIGHLY PROFITABLE ELECTRONIC PRODUCTION IN YOUR BASEMENT.** Investment, knowledge unnecessary. Postcard brings facts. Barta-PMM, Box 248, Walnut Creek, California 94597.

**BIG** Money In "Hot Dogs". Build A Street Vendor's Pushcart. Easy Plans \$3.00. Thomas, 100 Bellvue, Chicago 60611.

**ADDRESSERS** And Mailers Needed! Free Details! Splendid Opportunity! Delta, Box 24-P, Chalmette, Louisiana 70043.

**SCIENTIFIC** Messages: Big Earnings uncrowded profession. Learn spare time at home. Diploma awarded. Free catalog. Write: Anderson School, Dept. L-1C, Princeton, Illinois 61356.

**\$15 HOURLY!** Learn Methods and Shortcuts of Repairing Fiberglass on Cars and Boats. Only \$3—Guaranteed! Order today! Penwal Products, 1865C Lilac Lane, Dept. 1P9, Aurora, Ill. 60506.

**\$125.00 WEEKLY** Home Addressing Clipping News Items From Your Newspaper. Information. Send \$1.00. Stamped Self-Addressed Envelope. Southwest Sales-35C, Box 1257, Las Vegas, Nevada 89101.

**NEVER WON ANYTHING?** Anyone Can Win Sweepstakes Contests! Free Details. Services, Box 644-PCJ, Des Moines, Iowa 50303.

**DEMONSTRATORS** Needed. Car Electricity Adapter Provides 110V, 2500W Electricity From Car Alternator. Sells Itself. RLH Enterprises, Box 8908, Shreveport, Louisiana 71108.

**SPARE** Time Cash. Sell Famous Hanover Shoes. Actual Samples and sales kit Free. No experience needed. No age limit. Lowest prices for highest quality makes selling easy. Every man a prospect. Big daily commissions. For full details, write: Hanover Shoes, 1040 Carlisle, Hanover, Pa. 17331.

**WANT** To get rich buying penny mining stocks? Send \$2.95 for copy "Secrets of Stock Promoters." A.N.A. Distributors, 301-2515 Burrard, Vancouver 9, B.C., Canada

**MAKE MONEY IN SPARE TIME.** Earn generous commissions as a subscription representative for leading magazines. For free details, send this ad with your name and address to: **POPULAR MECHANICS**. Room 1107S 250 W. 55th St., New York, N.Y. 10019.

**START** Profitable Home Business Clipping Newspaper Items. Details Free. Benton House, Dept. 193, 1024 Benton, Fort Worth, Texas 76112.

**MAKE** Money arranging fund raising affairs. Free booklet tells how. Barts, 46 Chestnut Street, East Orange, New Jersey 07018.

**EARN** Up to \$1500.00 in just 30 days! Write: Miller, Box 291-B, Munising, Michigan 49862.

**EARN** \$100 Weekly Addressing For Firms. Details free. Pat Richardson, Box 4097, Yuma, Arizona 85364.

**400% PROFIT** From Square Foot 1/4" Plastic. Details Free. Jo-Mar-Ko, P.O.B. 34893, Detroit, Mich. 48234.

**MAILORDER**, Home Business Ideas! Information Free! ABC Enterprises, Box 1824-P, Columbus, Georgia 31902.

**EARN MONEY**, Part Time or Full time. No Investment; no Obligation! Try us! Details 25¢. Ayton, PM9, 5506 16th Avenue, Brooklyn, New York 11204.

**YOUR** Idea and \$5.55 could make you Rich. "Ideas, Inventions and Patents" tells you in plain language how to develop your idea and make money. Send \$4.95 plus 60¢ handling To: Pioneer Press, Dept. PMR, P.O. Box 76025, Atlanta, Georgia 30328.

**\$250.00 PER** Thousand stuffing envelopes! Unconditional Money-Back guarantee! Complete Starters Kit \$1.00. **HOMEWORKERS**, Box 24413-MI, Oakland, Cal. 94623.

**\$400 MONTHLY.** Four hours weekly. Easy work. Free proven method. Experience unnecessary. Tikal International, 5a. Avenida "B" 3-03 (Z-9) Guatemala, Central America.

**START** your own Mailorder business. Teach yourself. Inexpensive. Details free. Mundus, P.O. Box 69-D, Selden, N.Y. 11784.

**MAKE MONEY** on Government Surplus. How and Where to Buy. Directory of Surplus Offices. Sales Terms. Mail Order Items. Send \$1.00. Dahler Enterprises, 3233 Minnehaha Ave., Dept. 102, Minneapolis, Minn. 55406.

**ADDRESSERS** And Mailers Needed. Immediately Earning! Details 10¢. Lily, Box 4967-P9, NYC 10017.

**200% PROFIT** Selling Rings. Triple Money in 30 Days or Money Back. Free Details, Anka, P.O. Box 8036-PM, Cranston, Rhode Island 02920.

**"STREAMLINE** Home—Study Mail Order Course." \$2.75. Cazin, 526 Maple, Redwood City, California 94063.

**MILLIONAIRES**, Reveal Their Successes! Write: Rizin, 1533 Ash, Detroit, Mich. 48208. P.M.

**SELL** Your Photos. Report tells How, Where. Color Slide Markets. Only \$1.00. Andy's Gift Shop, 113 Flintrock, Del Rio, Texas 78840.

**FREE**—Million Dollar Mail Order Secret. Raney—18 Oneida, Centereach, New York 11720.

**OPEN** The Door To Mailorder Knowledge. Write: Naggo, Box 11478PMM, Chicago, Illinois 60611.

**HOMEWORKERS EARN \$150.00 WEEKLY ADDRESSING OUR SALESLETTER. IT'S SO EASY, SO PROFITABLE AND NO EXPERIENCE NECESSARY. DETAILS 25¢. GLOBE ENTERPRISE, BOX 2323-C, NEWARK, NEW JERSEY 07114.**

**NEED** Cash? We pay cash for Newsclippings & Boxtops. Free details. Troy Company, Dept. 411PM, Bayonne, New Jersey 07002.

**GIANT** Below Wholesale Gift Catalog. Send \$2.00. Refunded on First Order, Guaranteed. J & M SPECIALTY PRODUCTS CO., 1916 Artesia Blvd., Redondo Beach, Calif. 90278.

**IT'S EASY TO SELL KNAPP SHOES.** Earn Extra Money Immediately During your own Part-Time Hours. Very High Commissions. Everyone is a Prospect. Free Selling and Training Kit. Lowell Harris, Dept. PM-9, Knapp Centre, Brockton, Massachusetts 02401.

**6,000 TO 12,000 YEARLY** Raising Rabbits. Book tells all. 400,000 sold. \$1.00 or free details. Vidikapa, Box 1543 PM9, Tampa, Florida 33601.

**FORTUNES IN LAND! AMAZING PROFITS!** Lots, acreage few dollars. Your community, any state on **SIGNALS!** Free information. Land Signals DPLM-1, Box 25, Marshall, Texas 75670.

**MONEYMAKING OPPORTUNITY** Booklets. Send for free brochure. Dept. PM, ARE, Box 159, Lindenhurst, New York 11757.

### PROFITABLE OCCUPATIONS

**BAKE** New greaseless doughnuts in kitchen. Sell Stores. Free Recipes. Michael Ray, Waseca, Minn. 56093.

**FT. SMITH** Auction School, Ft. Smith, Ark. 72901. Resident & Home study. Veteran approved.

**BECOME** A Mortgage Broker. Highly respected, interesting, lucrative prestige business. For complete information write: United, Box 6284-F, Marietta, Georgia 30060.

**LEARN GUN REPAIR GUNSMITHING** in spare time. Book, details 10¢. Modern Gun Repair School, Dept. 2209, 4225 N. Brown, Scottsdale, Arizona 85251.

**PLASTERCRAFT!!!** Profitable home business. Molds available. Details: Lynnette, 6251C Mentor Park, Mentor, Ohio 44060.

**SHARPEN**—Scissors, Pinkers. Light, compact equipment. Supplies. Blackhawk's, Sheldahl, Iowa 50243.

### SALESMEN-DISTRIBUTORS

**BIGGEST** earnings ever! Show famous Hertel fully referenced Bible on proved plan. Startling 3-dimension cover. Easy credit plan. No investment. Demonstrator furnished. Write: International Book, Dept. PM, Box 118, Wichita, Kansas 67201.

(Continued on next page)



## SALESMEN—DISTRIBUTORS

(Continued from preceding page)

**\$100.00 EXTRA** A week easy! Spare time! Double Air Cushion shoes, Men's, women's line. Dress, work, play. Highest commissions. Shoes for yourself. Outfit Free. Bronson, Dept. H-93, Minneapolis, Minnesota 55408.

**HOUSEHOLD PRODUCTS ROUTE. EARN \$25** or more daily. Also Party Plan opportunities for men, women full, part time. McNess, Freeport (2693) Illinois 61032.

**PUBLICATIONS** for local wholesale distribution, higher profits. Details, sample, \$1 refundable. Publisher, 404 West Jefferson, Springfield, Illinois 62702.

**NEW, Compact fire extinguisher.** Fantastic profits. Exclusive territories. Norwich Chemical, Norwich, Connecticut 06397.

**AUTOMATIC Fishhooks.** Free details. Samples, \$2.00. Aron, 61PM, Mastic Beach, New York 11951.

**SELL Advertising Ball Pens, Calendars, Ad-Specialties—Build Own Repeat Business—Free Details—Fleming, Dept. A, 6535 Cottage Grove, Chicago 60637.**

**DISTRIBUTE Specialty Merchandise.** Buy Below Wholesale. Details Free. Ecu Wholesale, Box 215-AA, Ecu, Mississippi 38841.

**EARN Big Commission Full or Part Time.** Show America's largest line Low Priced Business Printing and Advertising Specialties Plus Calendars in season. No experience. No investment. No collections or Deliveries. On-the-spot commissions. Big Free Sales Kit Samples hundreds items used daily by businessmen. Merchandise bonuses for you. Build profitable repeat business. Start now. National Press, Dept. 73-B, North Chicago, Ill. 60064.

**MAJOR 43 Year Old Greeting Card Publisher—now seeking full or part-time salesmen to contact retail stores.** No experience necessary. Easy sales. Huge commission rate. Write today. Moderne Card Company, Dept. PM-9, 3855 North Lincoln Avenue, Chicago, Illinois 60613.

**TAKE Orders for Signs, Nameplates.** High Earnings! Cencraft, 7548-W Kilgarry, Pico Rivera, Calif. 90660.

## AGENTS WANTED

**EVERY Man a prospect.** Refundable sales kit offer showing line belt buckles, tie clasps, money clips, cuff links, lapels, identification badges, individualized with customer's name and emblems. Cap badges for trucking, bus, taxi, police, firemen, also postal, letter carriers and heavy construction emblems. Choice 5000 emblems. Hook-Fast, Box 1088-PM Providence, R.I. 02901.

**WANT To Make Up To \$100 A Week** spare time, and earn shoes for yourself for life, too? No investment. Rush card for free details. Mason Shoes, K-952, Chippewa Falls, Wisconsin 54729.

**ESTABLISH Your own business.** Low prices on used clothing, shoes, household goods. Unlimited profits. Free catalog. Northwestern Distributors, 2129-31 North Western Avenue, Chicago, Illinois 60647.

**PRINTING, Advertising Salesmen—Excellent moneymaking sideline selling Decalomania Name Plates, small quantities.** Advertising Specialties, sign letters. Free Samples. Ralco XL, Boston, Mass. 02119.

**YOUR Own business.** Used Suits \$1.50; Overcoats 65¢; Mackinaws 35¢; Shoes 12½¢; Ladies' Coats 30¢; Dresses 15¢. Enormous profits. Catalog Free. Nathan Portnoy Associates, 2109-AA Roosevelt Road, Chicago, Illinois 60608.

**\$75 DAILY** showing car owners how to end Waxing-Polishing Forever. Samples, details Free. International, 34 E. 12th Street, New York, N.Y. 10003, Dept. PMD4.

**BIG PROFITS** Selling Car Electricity Adapter. Powers electrical appliances from alternator equipped vehicles. Sample \$12.50. Free details. Power Products Co., 20 Jerusalem Avenue, Hicksville, New York 11801.

**UNLIMITED! Prospects! Income!** Good automotive products. Details, Jem, 6116-PMS3 Orinoco, Indianapolis, Indiana. 46227.

## EMPLOYMENT INFORMATION

**AUSTRALIA** Most Comprehensive Information, From Americans Now Living In Australia, \$2.00 For Brochure, Ausco Inquiry, Box 29, Burra 5417, South, Australia.

**OVERSEAS JOBS—Now Hiring, 103 Countries, All Occupations, High Pay, Free Transportation, Tax Benefits, Latest Computerized Reports—\$2.00. TRANSWORLD, International Airport, Box 90802-E, Los Angeles, California 90009.**

**AUSTRALIA—NEW ZEALAND WANT YOU !!!** 50,000 Jobs! Paid Transportation! Latest Information and Forms, \$1.00. Austco, Box 3623-E, Long Beach, California 90803.

**JOB Information Guides, 50 States, Canada! \$1.00 Per State Wanted.** Nationwide. Box 165, Homewood, Illinois 60430.

## HELP WANTED

**OVERSEAS Jobs—Europe, South America, Australia, Far East, etc.** 2000 openings all trades. Construction, Office, Engineering Sales, etc. \$700 to \$3,000 month. Expenses paid. Free Information. Write: Overseas Jobs, International Airport, Box 536-M, Miami, Florida 33148.

**OVERSEAS EMPLOYMENT** . . . Australia, Europe, South America, Asia! All Occupations! \$700-\$3,000 monthly! Write: Employment International, Box 29217-AI, Indianapolis, Indiana 46229.

## REAL ESTATE AND FARMS

**FREE CATALOG!** Giant Fall-Holidays edition of country property! Over 5,200 New properties described, pictured—Land, Farms, Homes, Businesses—Recreation, Retirement. Selected Best thruout the U.S.! 73 Years' service—670 Offices, 41 states Coast to Coast. Mailed FREE from the World's Largest! **STROUT REALTY, Inc.,** 60-MX E 42nd St, NY, NY 10017; 7-MX Dearborn, Chicago, Ill. 60603; 150-MX N. Santa Anita, Arcadia, Ca 91006.

**CANADIAN LAND FROM \$19.00 AN ACRE CHOICE.** Properties available across Canada. Low monthly payments. Ideal for farming, cottages, hunting, fishing. Free Catalogue, Canadian Estate Land, Dept. PMC 9, 286 Lawrence Ave. West, Toronto 20, Ont., Canada.

**42,000,000 ACRES** Valuable Government Land still available. Some for \$2.00 per Acre. Buy, Lease or Homestead Free. For 1973 report, send \$1.00. Government Land, Box 8PM3, Thomasville, Penna. 17364.

**IDEAL 5-ACRE RANCH.** Lake Conchas, New Mexico. \$3,975. No Down. No Interest. \$29/mo. Vacation Paradise. Good Investment. Free Brochure, Ranchos, Box 2006AX, Alameda, California 94501.

**CASH IN ON THE REAL ESTATE BOOM! FOR KNOW-HOW INFORMATION WRITE: BOX 100, 359 EAST 6th AVENUE, ROSELLE, N.J. 07203.**

**FORTUNES IN LAND! ROAD TO RICHES!** Buy CHEAP. On SIGNALS! Your Community Or Any State. Free Information. Land Signals, DPLM-1, Box 325, Scottsville, Texas 75688.

**CENTRAL Ontario—Choice 640 acre Sportsmen's paradises still available—\$20.00 plus \$6.50 taxes yearly.** Maps, pictures. \$2.00 (Refundable). Information Bureau, Norval 4, Ontario, Canada.

**FREE Catalog! PHOTOS!** Coast to coast farms, business, retirement. All types, sizes & prices. **SAFE-BUY Real Estate,** Box 589-PM, Little Rock, Ark. 72203.

**\$1 ACRE—Canadian border—hundreds campsites, islands, farmlands, directly from tax authorities.** (Non-profit). Lists, photographs mailed. Register, Room 10, 110 Church Street, Toronto 1, Canada.

**BOILING Spring Lakes—America's Greatest Real Estate Value, 1/3 acre vacation or retirement homesites only \$900 cash price.** Ten-year terms available. Money-back inspection guarantee. Carolina coast, multi-million dollar, 14,000 Acre development. 50 fresh water lakes, private ocean beach, golf course, motel, and country club. Free literature. Dept. 1-M, Boiling Spring Lakes, North Carolina 28461. (Registered under Federal Land Sales act but not offered to residents of states requiring separate registration.)

**CANADIAN Vacation lands: Full price \$385.00.** 40 acres. \$10 month. Suitable cottage sites, hunting, fishing, investment. Free information. Land Corporation, 3768-C Bathurst, Downsview, Ontario, Canada.

**\$1.00 ACRE! USA and Canada.** Lists, photographs mailed. Government Lands, 220 Delaware Ave., Buffalo, New York 14202.

**GOVERNMENT LANDS FROM \$7.50 ACRE!** Vacationing, Farming, Investment! Exclusive "GOVERNMENT LAND BUYER'S GUIDE" . . . plus "LAND OPPORTUNITY REVIEW" listing lands throughout U. S. Send \$1.00. Surplus Lands, Box 6588-AI, Washington, D. C. 20009.

**SURPLUS Forest, Mountain, Desert, Waterfront Land.** Neglected Estates, Farms, Groves, Cabins. Throughout United States, Canada, Mexico. Low prices. Easy terms. Free list. Box 6272, Dept 46, Santa Ana, California 92706.

**CANADIAN Land.** Full Price \$285.00. \$10.00 Down, \$10.00 Month. Ideal Vacation, Hunting, Fishing. Free Information, Vacation Acres, 7771A, Bernard, LaSalle 660, Canada.

**AVOID MAJOR MISTAKE.** Expert reveals "How to Avoid Ten Biggest Home-Buying Traps." Now Low-Cost Paperback. Only \$2.95 plus 35¢ Handling. Money-Back Guarantee. All About Houses, PM, Piermont, N.Y. 10968.

**FREE . . . NEW . . . Big . . . Fall Catalog.** Hundreds of top real estate values coast to coast. **UNITED FARM AGENCY,** 612-PM West 47th St., Kansas City, Missouri 64112.

**BUYING PROPERTY?** Brokers Little Secret. Mortgage Calculator. Know monthly payments in advance. Interest rate: 7% to 11%—Satisfaction Guaranteed. \$2.00. Thomas Co., Rates Division. 171-08 Hillside, Jamaica, N.Y. 11432.



## FLOWERS, PLANTS & NURSERY SUPPLIES

**LEARN Landscaping and the growing of plants.** Start a profitable business part or full time. Free information without obligation. Lifetime Career Schools, Dept. A-366, 255 Barry Avenue, Los Angeles, California 90064.

**GINSENG BRINGING \$30 Pound.** Have seeds, roots. Goldenseal. Full information. K. Collins, Viola, Iowa 52350.

**LEARN Flower Arranging.** Start business or Hobby. Free information on home study course. Lifetime Career Schools, Dept. 8771, 2251 Barry Avenue, Los Angeles, California 90064.

(Continued on next page)



## FLOWERS, PLANTS & NURSERY SUPPLIES

(Continued from preceding page)

**POPULAR MECHANICS COMPLETE GARDENING GUIDE.** Information on how to make your lawn and garden beautiful. Tables and charts, and scores of show-how drawings. Planting dates and depths for all kinds of seeds and bulbs; when to prune and what, and how; information on the 56 most popular shrubs, and the 21 best hedges; how to lay flagstone, patio blocks, bricks—and much, much more. Printed on heavy plastic-coated cards, and spiral bound together. To order send \$3.95 to: Popular Mechanics, Box 1014, Dept. GGH, Radio City, New York, N.Y. 10019 with your name and address.

## BUILDING AID BOOKS

**HANDYMEN, Builders.** Measure levels and grade differences on 150' building site, garden, patio, septic system in minutes with  $1/16$ " accuracy. Build this simple, accurate level in one evening for under \$4.00. Replaces expensive optic level on average job, yet only one person required. Detailed plans, instructions sent airmail, duty-free for only \$1.00. Rodlen Builders, Haliburton, Ontario, Canada.

## CONSTRUCTION PLANS, BLUEPRINTS

**HOUSE EXPANSION PLANS** And detail instruction book provide anything from an extra room to 1000 s/f addition. Build what you need at big do-it-yourself saving. Book with 1 set working blueprints \$14.50! With 4 sets (required by contractors) \$20.00. Money-Saver Projects, Box 303-44B, Chappaqua, New York 10514. Information available.

## LOG CABINS & HOMES

**BUILD Log Cabins, rustic furniture, fireplaces!!!** Complete manual, \$3.00 . . . "A" Frame plans, \$2.00 . . . Guaranteed. . . . Beels, 956 Springdale, Atlanta, Georgia 30306.

**"A" FRAME CABIN.** \$500. Material. Purchase locally. Completely illustrated instruction manual & material list: \$2.00. Moneyback Guaranteed. Order plan #1923, from "Dependable Products", Box 113, Vista, California 92083.

## HOME CRAFTSMEN

**SKIL-CRAFTS** Current 200 plus page catalog with world's largest finest selection of Hobbycraft, leathercraft, artist supplies. Send \$1.00 for postage and handling; refunded on first \$5.00 minimum catalog order. Skil-Crafts, Box 105-P, Joplin, Mo. 64801.

**UNFINISHED** Picture Frame Molding, Direct From Mill. Details 25¢. Durapau Molding, Drawer 670, Lake Arthur, Louisiana 70549.

**101 PATTERNS** Of Smart Gifts, Novelties, Shelves, Action Windmills, Plus "Make Money Jig Sawing". \$2.00. Mastercraft, 95M 7041 Olcott, Chicago 60631.

**PORTABLE** Bar; 4' x 4' x 16". Finished Top 4' x 3" x 20". Complete Instructions \$1.75. Workmans, Day Rd., Mansfield, Ohio 44903.

**POPULAR MECHANICS MASTER SHOP GUIDE.** Greatest product offered to a man with a workshop. All information printed on heavy boards, punched and ready to hang above his workbench. Covers wall fasteners, nails, screws, bolts, twist drills, abrasives, lumber, moulding patterns, plywood grades, hardboard, dry-wall plumbing supplies, electrical supplies. Plus information on score of other subjects. Send \$3.95 to: **POPULAR MECHANICS**, Dept. HE, 224 West 57th Street, New York, New York 10019.

**CABINETMAKING MADE EASY** And "How to Make Formica Counter Tops." Two excellent guides let you build kitchen cabinets and counter tops like professionals. Extraordinary guides bring master craftsmen's shortcut methods. Satisfaction guaranteed. Write: Japs, 126-P Seventh North, Hopkins, Minn. 55343.

**CATALOG FULL SIZE FURNITURE PLANS** —\$1.00 Refunded with first order. Traditional. Early American, over 150! Furniture Designs, 1425 Sherman, Dept. CP-93, Evanston, Illinois 60201.

**ORNAMENTAL IRON WORK.** Beautiful scrolls with inexpensive professional bender. Modular segments. Details Free. Fuschlin, Box 472, Woodland, California 95695.

**WORKBENCH** And tool panel anyone can build. Complete with material list. \$1.00. Way-Mar, 58 Underhill Road, Scarsdale, New York 10583.

**WOODWORKING** Catalog and Manual 50¢. Plus free "101 Project Ideas." World's most beautiful veneers, lumber, plywood! Wood finishing, upholstery supplies, Cane, Lamp Parts, Furniture hardware, Animal whittling blocks, 2,000 workshop products. Constantine, 2051-C Eastchester Road, Bronx 10461.

**PICTURE Framing**—Profitable full or spare-time business. Easy to learn with handbook-course "Guide To Picture Framing Profits." \$1.50 Guaranteed. Free framing-supplies catalog included. Japs, 126-PM Seventh North, Hopkins, Minnesota 55343.

**BIRD HOUSES** For Fun and Profits. 20 Projects And Plans. \$1.00. Infoco-P9, Box 34260, Washington, D.C. 20034.

**DOWELL-ALL,** Jig for Making Frames for Kitchen Cabinets, Screens Etc., Lets you Drill 2 Precise  $1/4$ " Holes in Both Pcs. of Stock, \$6.95. Cal Johnson, 2285 Huether, Muskegon, Mich. 49445.

**STAINED GLASS** Professional photographic instructions by British craftsmen. Details 25¢. Old World Crafts, P.O. Box 7, Falmouth, Cornwall, England. TR11 2DY.

## DO-IT-YOURSELF

**CONVERT TV** to 6-ft wide screen! B&W/Color. Do-it-Yourself—easy! Kit, instructions, lens, \$12.95 ppd. Free illustrated details. Macrocoma, PM-9, Washington Crossing, Penna. 18977.

**ROLL-TOP** Trestle desk. Assemble yourself. Kit includes Hardware. \$49.95 PPD. Details! Andy's Woodshed, Dept. PM, 630 North Grant, Stockton, Cal. 95202.

**STEAM** Engines, Flash And Watertube Boilers, Burners, Steam Lawnmower. Pictures, Descriptions, Drawings 2 Dollars. We can supply Castings To Make The Old Popcornpopper Steam Engine. Travis Tool Co., Sidney, Iowa 51652.

**BURGLAR-FIRE** Alarm Supplies and Information. Free Catalog. Protecto Alarm Sales, Box 357A, Birch Run, Michigan 48415.

**CONVERT MOWER** Engines into air compressors. Write: Showalter, Box 409, Abilene, Kansas 67410.

**REPAIR MINIBIKES, LAWNMOWERS, BICYCLES,** Sewing Machines, Auto Engines, Mazda/Wankel, Motorcycles, Magic, boats. Over 100 How-To-Books. Free Brochure. Mastercharge accepted. Sincere, Box 10422, Phoenix, Arizona, 85064.

**BEAT INFLATION!** Make Artificial Facebricks—Under 10¢ Sq. Foot. Any Color, Style. Details: Wagner, 1349 Ayrault Road, (A9-B9), Fairport, N.Y. 14450.

**ARTIFICIAL** Fireplace Cabinet for T.V., Stereo, Bar Built of Wood Material. List Instructions Plans \$4.00. MMP Fireplaces, Box 1069, San Fernando, California 91341.

**MAKE YOUR OWN INDIAN SOFTSOLE MOCCASINS.** Professionally Graded Patterns and Instructions. Send \$1.00 with Shoe Size. Moccasins, 17 F RichMar Road, Owings Mills, Maryland 21117.

**WATERPROOF,** Repair, build with bulk epoxy adhesive. Free Literature. Construction Chemicals, Box 257, Monroe, Conn. 06468.

**NEW:** One Drop Holds 2,000 Pounds. Industrially Developed Adhesive. Bonds Anything to Anything in Seconds, Dries Clear, No Mixing. Each 130 Drop Tube \$1.98 PPD. Guaranteed. Mimic, Box 68, Albertson, New York 11507.

**1400 CATALOGS** Listed and Described Sources for EVERYTHING Imaginable! Rush \$2.00. MASTERLOG, Box 24413-YI, Oakland, California 94623.

**24" SHEET** Metal Brake \$59.00 F.O.B. Omaha. Maple Village Shops, 9628 Sahler, Omaha, Nebr. 68134.

**CENTRAL** Air Conditioning Simplified Humidifiers, Ductwork, Electronic Filters, easy, quick. Our planning guide shows you everything. \$1.00. Air-Ways, 32 Washington Avenue, Port Jefferson Station, New York 11776.

**BARN** With Loft 8'x12'! Detailed Plans with Material List. Only \$2.50—Guaranteed! Order Today!! JaBar Enterprises, Dept. 3C9, 1448 West Strasburg, West Chester, Penna. 19380.

**SPINNING WHEEL KIT!** Early American full-size, working replica. Actually spins! Has 18" assembled wheel and all parts of sanded solid maple. Easy instructions. Free color brochure, prices. Haltec Corporation, Dept. H, 32123 Winona Road, Winona, Ohio 44493.

**GRANDFATHER CLOCK KITS**—Name Brand, Westminster Chime. Write: 4600 36th S.E., Grand Rapids, Michigan 49508.

**MAKE** The Engine you now have in your car working with Water. It will Cost you Less than \$30.00 to make it. Send \$10.00 for Information and Drawings Showing you How To Do It. Write: George Eliades, 271 Concord Avenue, Toronto 4, Canada.

## ARTS AND CRAFTS

**"GETTING** Started in Stained Glass" 25¢. Whittemore, Box 2065Y, Hanover, Mass. 02339.

**FREE LITERATURE** For sculptors showing how to make molds, cast plastics. Adhesive Products Corporation, 1660 Boone Avenue, Bronx, N.Y. 10460.

**FREE:** New handicraft catalog. Supreme Handicrafts, Box 395-PM, Sioux Falls, South Dakota 57101.

**LEARN** Arts & Crafts at home. Excellent full or part time business opportunities, or hobby. Free booklets. Lifetime Career Schools, Dept. E-805, 2251 Barry Avenue, Los Angeles, California 90064.

**MAKE** Figurines, plaques, lawn ornaments. Molds, plastercraft kits, liquid rubber. Sample and catalogue 10¢. Woolley Company, Box 29-B, Peoria, Illinois 61601.

**LEARN** Flexible Mold Making and Casting in Plaster and Imitation Marble. Complete Instructions \$10.00. Rapid Marbleizing, 41 Waverton, St. Louis, Missouri 63124.

**LIQUID LATEX** Paratol 706-G compound for making rubber mold. Toughest, finest quality. Instructions. Money-back guarantee. Postpaid \$3.75 quart, \$10 gallon. TESTWORTH, 139 Commercial, Addison, Ill. 60101.

## BINOCULARS, TELESCOPES, MICROSCOPES, MAGNIFIERS

**POCKET** Tele-Microscope 1.98. Free Catalogue. Modern M Inc., Box 795-PM, Independence, Mo. 64052.

(Continued on next page)

Материал защищен авторским правом



## BINOCULARS, TELESCOPES, MICROSCOPES, MAGNIFIERS

(Continued from preceding page)

**TELESCOPE** (Reflectors) complete kits. Other accessories, request free literature. Criterion Manufacturing, Dept. PM 44, Hartford, Connecticut 06101.

**FREE** Binocular, Riflescope catalog. Discount sale. Save 50%. Free gift with order. Write: United Binoculars, BN-7108, 9043 So. Western, Chicago 60620.



## CAMERAS AND EQUIPMENT

**FREE! FREE! BARGAIN BOOK** Central Camera Co., Dept. 391, 230 S. Wabash, Chicago, Ill. 60604.

**USED** Photographic Equip. Nationwide Monthly "Shopper" Free Sample. Shutterbug Ads, Box 730-P, Titusville, Fla. 32780.

**PHOTOGRAPHY** for pleasure or profit. Learn at home. Practical basic training. Long established school. Free booklet. American School of Photography, 555 E. Lange, Dept. 820-04, Mundelein, Illinois 60060. A home study school.

**OIL** Coloring Photographs—A fascinating hobby or profitable sideline for those with artistic talent. Learn at home. Easy simplified method. Free booklet. National Photo Coloring School, 555 E. Lange, Dept. 820-01, Mundelein, Illinois 60060. A home study school.

## PHOTOS AND PHOTO SUPPLIES

**CASH** For PHOTOS! All Subjects! Latest Comprehensive Want List & Manual \$3.25. Satisfaction Guaranteed! Research, Box 213, New York, N.Y. 10016.

## PHOTO FINISHING

**CAMERA FANS!** Expert photofinishing by one of Country's largest labs at lowest prices. Fast service and free "Foto-Fan" Stamps you quickly redeem for valuable Photo Supplies. 8MM Kodachrome \$1.29; 8 Exp. Kodachrome \$1.79; 35MM Kodachrome 20 Slides \$1.39; 8 Exp. Black White 69¢. Satisfaction guaranteed. Send exposed film or request free mailers, complete Price List and Gift Catalog. Direct Mail Photo, Box 8352-PM, Pittsburgh, Pa. 15218.

## COLOR SLIDES

**35MM COLOR** Slides. 10,671 individually sold. Described, Encyclopedia catalog 10¢. Wolfe Worldwide, Dept. 14-93, Los Angeles, Calif. 90025.

**ADD** interesting Shapes to slides! Not necessary to re-mount. Samples, details 25¢ coin. Heindl, 192 St. Paul St., Rochester, N.Y. 14604.

## MOTION PICTURES AND SOUND EQUIPMENT

**CLASSIC 8MM. MOVIES . . . 35MM. 2"x2" Color Slides. . . largest selection anywhere!** Silent classics, comedy, history, sport, news, documentaries, features, others! 16MM films also Free catalog. Blackhawk Films, 690 Eastin-Phelan Bldg., Davenport, Iowa 52808.

**UNUSUAL** Movie supplies. Free circular. Esor, 47th Holly, Kansas City, Missouri 64112.

**FREE!** 64-Page catalog. 8-16MM film supplies, processing equipment. Superior, 448 N. Wells, Chicago 60610.

**8MM—SUPER 8—16MM MOVIES!** Biggest Selection! Lowest Prices! Free Catalog! Cinema Eight, Box PM, Chester Connecticut 06412.

**FREE** Catalog—8mm-16mm—Top Manufacturers—G & G Film Library, Box 321, Syosset, New York 11791.

**16MM, 8MM** Sound and Silent Classic Films. Free Catalog. Niles, 1019-PM So. Michigan, South Bend, Indiana 46618.

## RADIO, TELEVISION AND HAM EQUIPMENT

**PSYCHEDELIC** Freaks—Any T.V. Becomes A Brilliant Light-Display. Constant Intriguing Motion, Endless Shapes, Patterns, Designs. You'll Groove On It For Hours. Made In Minutes With Household Materials. No Tools Required. Complete Instructions \$1.00 Postpaid. Northern States Press, 902 Badger Rd., Madison, Wisconsin 53713.

**SAVE** Money on parts and Transmitting—receiving tubes, Foreign—domestic. Send 25¢ for giant catalog. Refunded first order. United Radio Company, 56-PM Ferry Street, Newark, N.J. 07105.

**36¢ RADIO & TV** Tubes. Free catalog. Cornell, 4213-17 University, San Diego, California 92105.

**GOVERNMENT** Surplus receivers, transmitters, snooperscopes, parts. Catalog 25¢. Meshna, Nahant, Mass. 01908.

**GIANT** Canadian Electronics Surplus Catalog. \$1.00. Etco PM, Box 741, Montreal.

**RESISTOR** Color Coder 50¢. Norvex Co., 3920 Larkin St., Norfolk, Va. 23513.

**ELECTRONIC TV ANTENNA.** Fantastic miniature antenna plugs into wall outlet . . . turns home's wiring system into huge TV antenna! Every channel sharp, clear. Attaches in seconds. Improves FM radio reception. Guaranteed. \$1.95 postpaid. Russell House, PM-9, Box 97, Fanwood, New Jersey 07203.

## HIFI TAPES, RECORDS AND ELECTRONICS

**OLD** Radio Programs. Stamp For Special Flyer. Stop, Box 3402M, Seminole, Fla. 33542.

**FREE** Catalogues, 2000 hard to find unusual records. Rose's Records, Box 7216, Louisville, Ky. 40207.

**OLDIES** 45 RPM Original Hits—Catalog 50¢. C&S Record Sales, Box 197, Wampsville, New York 13161.

**FREE** Catalog—Electronic Kits—Amplifiers—Preamplifiers—Psychedelic Strobes—SCA Adaptors—Color Organs—Digital Instruments—Guitar Amplifiers. **FREE** Subscriptions. SWTPC, Box PM32040, San Antonio, Texas 78284.

**8-Track** Tapes • Catalog free. C. Bolton, 1114 9th Ave., So. Sioux City, Nebraska. 68776.

**OLD** Radio Programs. All Your Favorites. Lowest Prices, Prompt Service. Catalogue 25¢. Nostalgic Radio, Box 29, Peoria, Ill. 61601.

**SUSPENSE—Fibber—Benny; Others.** Cassette \$4.00/Hour. Free Catalog. Radio-Heyday, 8162 West Balmoral, Chicago, Illinois 60656.

**FREE CATALOG.**—Tremendous electronic bargains. American, Box 4188E, Mountain View, California, 94040



## MUSIC AND MUSICAL INSTRUMENTS

**ACCORDIONS** And Amplifiers! New—Used. Cordovox, Excelsior—Top Makes! Save to 50%. Direct factory dealer. Terms. Trades accepted. 5 day home trial. Free catalog—Discount prices. Write: Accordions Unlimited, Dept. R, 3147 North Luna, Chicago 60641.

**FREE CATALOG—30% DISCOUNT.** Best Names In Musical Instruments. Dial For Music, 7 Crescent Drive, Spring Valley, N.Y. 10977.

**LEARN** To read music in one evening. Free brochure. Jordan, 27495 Road 176, Dept. PM-9, Exeter, Calif. 93221.

**EASY** To Play And Make. Quality Dulcimers, Banjos, Thumb Pianos; Instruments And Kits. Can Be Profitable Hobby. **HERE, Inc.,** #P. 410 Cedar Avenue, Minneapolis, Minn. 55404.

**ELECTRIFY** Player Pianos, Pump Organs Quickly, Inexpensively with Lee Silent Suction Units. Write: Lee Music, 525F Venezia Avenue, Venice, California 90291.

**30% TO 50% DISCOUNT!** Any Model: Guitar, Amp, Drum, Banjo, Dobro! Free Catalog! Warehouse P37, Box 16399, Fort Worth, Texas 76133.

**PLAYER** Piano Rebuilding—get details from: Vestal Press, Vestal 11, N.Y. 13850.

**POEMS** Wanted for songs. Nashville Music Productions, Box 40001-P, Nashville, Tennessee 37204.

**VIOLIN** And Guitar makers—send for latest Free Catalogue of woods & accessories. International Violin, PM1, 414 East Baltimore St., Baltimore, Md. 21202.

**WHOLESALE!** Professional Guitars, PA Systems, Altec Speakers, 240W RMS Amplifiers. Free Catalog. Carvin, Escondido, Calif. 92027.

**WHOLESALE.** Musical Instruments—Accessories. Allied, 573 Route 17, Paramus, New Jersey 07652.

**RECONDITIONED** Accordions for sale—Save \$\$\$, Top Brands. Write for free descriptive folder. A-1 Rebuildit Accordions, 31 E. 18th St., N.Y.C. 10003.

**ACCORDION** Top brands. Buy direct. Tremendous discounts. Trades accepted. Free brochure PM. Accordion-O-Rama, 874 Broadway, N.Y.C. 10003.

**GUITAR,** Banjo, Violin, Mandolin Making Materials, Accessories, Books. Catalog 25¢. Guitar Center, Box 15444, Tulsa, Oklahoma 74115.

**NEW GUITAR MAKING BOOK & NEW TOOLS.** Overholtzer, 618 Orient, Chico, Cal. 95926.

**LEARN** Banjo. 5-String Bluegrass. No music. Makes learning easy. Free details. Blaylock, Box 25-M, Marietta, Georgia 30060.

**ACCORDION** Manufacturing 6846-P North Avenue, Chicago, Illinois, 60635. Concertinas, Chromatics, Heligons, Hohners, Guitars, Drums, New, Used, Tuning, Repairing. Wholesale Catalogs Free.

**POEMS,** Songs wanted. Recording. Publishing guaranteed. Royalties. Radio-TV release. Broadway Music, Box 11647-PM, Sarasota, Fla. 33578.

**KITS!** Build dulcimers, guitars, balalaikas, thumb pianos, harps. From \$2.95. Finished dulcimers from \$19.95. 8665 West 13th Avenue, PM, Denver, Colorado 80215.

**30% DISCOUNT** Name Brand Musical Instruments. Free Catalog. Freeport Music, 455F Route 110, Melville, N.Y. 11746.

**30% + DISCOUNT.** Name Brand Musical Instruments. Free Catalog. Continental Music, P. O. Box 3001, Dept. D, Garden City, New York 11530.

**SWISS** Music Boxes, Movements. Highest Quality. Spielman, 55 West 42nd, New York 10036.

## EDUCATION AND INSTRUCTION

**NOW!** Be A **CREDIT-COLLECTION SPECIALIST**—Jobs Waiting For Novice—Advancement For Experienced Collectors—J. Scalo—1250 Camino Real—#306, Millbrae, California 94030.

**ADVERTISING** Interest you? Professional Course. Write: Advertising Assistance-S, 655 Teresita, San Francisco 94127.

(Continued on next page)



## EDUCATION AND INSTRUCTIONS

(Continued from preceding page)

**SURVEYING PAYS BIG!!!** United States Department of Labor reports "Openings for 26,000 Surveyors in next ten years." Easy home-study plan guides you. Send for Free "Surveying Career Kit." North American School of Surveying, AZ, Newport Beach, California 92663.

**WELDING TRAINING** Basic and advanced training for major welding processes—Arc, Gas, Pipe, TIG, MIG, plasma. Hobart, a non-profit school, is accredited by NATTS. Approved Ohio 70-12-0064 HT. Write for school bulletin and course schedule. **HOBART SCHOOL OF WELDING TECHNOLOGY**, Box 73, Troy, Ohio 45373.

**FINGERPRINTING**—Investigation. Exciting, secure career. Learn at home. Free book. State age. Institute of Applied Science, 1920 Sunnyside, Dept. 169, Chicago, Illinois 60640.

**VENTRILQUISM**—Profitable Hobby or Career! **FREE** newspaper and Home Course Scholarship. Maher, Box 9037PI, Denver, Colorado 80209.

**ACUPUNCTURE BOOKS And SUPPLIES CATALOG!** Wong, Box 219W, Toronto, Canada M6M 4Z2.

**LIVE, WORK, EARN OUTDOORS!** Be a Park Ranger. Train in spare time at home. Important, rewarding, respected work. Good pay now. Great future. Trained men in demand. Details Free. National School, Dept. 4-30, 2019 20th St., NW, Washington, D.C. 20036.

**DRAFTING**—Blueprint Reading (Mechanical, Electronic, Architectural). Home Courses \$25.00. Send \$2.00 first lesson. Prior Inc., 23-09 169th Street, Whitestone, New York 11357.

**WATER FACTS!** Easy to Read Fact Sheet for Each Chemical Element Commonly Found in Water, and Harmful Level. Free List of Titles. **TERIDEN**, Dept. A, 1104 Vine, Paso Robles, Calif. 93446.

**MOTORCYCLE MECHANIC.** Train at home in Spare Time. Make good Money in motorcycle shop or Start Own Business. Motorcycle Tools, test instruments included. **FREE** "Career Kit!" Dept. AZ, Spartan School/Motorcycle Repair, 4500 Campus Drive, Newport Beach, CA. 92663.

**VETERINARY ASSISTANT**—Train at home for exciting animal care career. Send for **FREE** "Career Kit". North American Home-Study School of Animal Sciences, AZ, Newport Beach, California 92663.

**NONRESIDENT DEGREES! HONORARY DEGREES!** Nationwide Faculty. Catalog: \$3. United States University Of America, Box 4552-PM, Washington, D.C. 20017.

**MISSOURI** Auction School. Veteran Approved. Free catalog. 1600-03 Genesee, Kansas City, Missouri 64102.

**EXTENSION** And Post-Graduate Awards in Philosophy, Art, Sciences, Botanic Medicine, Homeopathy, Radionics and others. 30 subjects. Curricular free (airmail \$1.00 refundable). Registrar, Sussex College of Technology, Highfield, DaneHill, Sussex, England.

**LEARN** Sewing Machine Repairing. Men, Women. Lucrative profits. Profession with bright future. Gresslin Correspondence School, Box 927, Spencer, Iowa 51301.

**LEARN** Auctioneering. Term soon. Free catalog. Reisch Auction College, Box 850, Mason City, Iowa 50401.

**ORDINATIONS**, Lifetime! Church chartered 1887! Write! 708 Bragg, Monroe, North Carolina 28110.

**RELIGIOUS VOCATION?** Write: Church Of Holy Light Inc., P.O. Box 4478, Pittsburgh, Pa. 15205.

**USED Courses! Books Catalog 10¢.** (Courses Bought). Lee Mountain, Pisgah, Alabama 35765.

**AUTOSUGGESTION.** Sleep-learning headquarters! Tapes, records, books, Gigantic catalog free. Research Association, Box 24PM, Olympia, Washington 98551.

**OWN** Collection agency. "Little Gold Mine!" Franklin Credit, Roanoke, Virginia 24004.

**AUCTIONEERING.** Resident or home Study Course. Free Catalog. Nashville Auction School, 1921 West End, Nashville Tennessee 37203.

**PERFECT** Husband-Wife Business. Learn Upholstery at home. Make \$10 in an hour. Buy—repair—sell for even bigger profits. Kits, tools, included. Free Booklet. Upholstery & Decorating School, (home-study), Dept. 5310-093, Little Falls, New Jersey 07424.

**DETECTIVE** Profession, Easy home study; free tie-tack or lapel pin, certificate, future. GI approved. Professional Investigators, Box 41345, Dept. CP, Los Angeles Calif. 90041.

**DETECTIVE** Course. Free Information. Universal Detectives, Box 8180-F, Universal City, California 91608.

**LEARN** To Fix Typewriters. Desperate shortage trained men. Hundreds needed. Make up to \$25 in one hour. Learn at home in spare time. Industry Approved course. Facts Free. Send name. Typewriter Repair School, (homestudy), Dept. 3310-093, Little Falls, New Jersey 07424.

**PIANO** Tuning quickly learned with home study course. Diploma granted. American Tuning School, 17050 Telfer Dr., Morgan Hill, California 95037.

**DETECTIVE** And Fingerprinting Courses. Write: Detectives, Box 185-P, Fairfield, Alabama 35064.

**SHORTCUTS** To Success! Highly Effective, Profitable Short Courses. (75 Choices). Study At Home. Diploma Awarded. Our 27th Year. Free Literature. CIEE-25, Box 10634, Jackson, Miss. 39209.

**WATCH REPAIRING.** Learn at home in spare time. Diploma awarded. Free sample lesson. Chicago School of Watchmaking, Dept. YW, Fox River Grove, Illinois 60021.

**UNLOCK** Your Future. Become professional Locksmith by spare time home-study. Make up to \$6 per hour. All tools, equipment inc. Facts free. Send name. Locksmithing Inst. (Homestudy), Dept. 1310-093, Little Falls, New Jersey 07424.

**SERVE** God's Ministry. Free. Ordination. Bible Institute, Box 744, McKeesport, Pa. 15134.

**LEARN** Asleep or awake! Records, tapes, equipment! Free catalog! Drawer PM-400, Ruidoso, New Mexico 88345.

**GET A** British Degree. Divinity. Philosophy, Radionics. 35 Courses. Prospectus free. Brantridge, Forest School, Highfield, Dane Hill, Sussex, England.

**NOW!** Your Own Burglar/Fire Alarm Business. Train at home. Expanding field. Course includes professional tools Plus equipment, supplies for first job. Information by mail. Security Systems Management School (homestudy), Dept. 7310-093, Little Falls, N. J. 07424.

**USED Courses! Books! List 10¢.** Smith's, 124 Marlborough, Salem, Massachusetts 01970.

**BRICKLAYING** Information, send 8-cents. The Pretlo Services, P.O. Box 114, Durham, N.C. 27702.

**COMPLETE YOUR HIGH SCHOOL** at home in spare time. Texts furnished. No classes. Diploma. Our 76th year. Free Brochure. American School, Dept. X645, Drexel at 58th, Chicago 60637.

**FREE** Book tells how you can learn camera repair and service. Home study or classroom. Write today! National Camera, Dept. EAD, Englewood, Colorado 80110.

**LEARN ACCOUNTING!** U.S. Labor Department reports "33,000 NEW Accountants, 78,000 NEW Bookkeepers needed EACH YEAR for next ten years". Easy home-study plan prepares you. Approved for Veterans. Send for **FREE** "Accounting Career Kit". North American School of Accounting, AZ, Newport Beach, California 92663.

**EARN HIGH SCHOOL** Equivalency Diploma from your State. Business, College Accepted. 5 Week Home Study Program Guarantees you Pass GED. Simplified, Fun, Budget-Priced. Brochure Mailed Free. Bright Futures Corporation, Box 514PMA, Jackson Heights, New York 11372.

**JACK** Hudson made \$20,000 working just 6 months in Accident Investigation. Train at home in spare time. No college. No selling. Free placement service for jobs that furnish car and expenses. Huge, growing field. Men needed urgently. Details Free. Universal Schools, Dept. 1-21, 1129 20th St. NW, Washington, D.C. 20036.

**GRAPHOANALYSIS**—Learn scientific handwriting analysis for profit, pleasure. Free sample lesson, catalog, reveals plan. Write: IGAS Inc., 325 Jackson, Dept. JX-2, Chicago 60606.

**LEGAL INVESTIGATION** Pays big! Work with trial lawyers. Fascinating, big-pay career. Learn at home, spare time. No college. No experience. Details Free. Universal Schools, Dept. 3-21, 1129 20th St. NW, Washington, D.C. 20036.

**TRAVEL AGENT** Book Prepares for Position as Travel Agent. Shows how to Write Airline Tickets, Read Tariffs, Construct Domestic, International Fares. \$8.95. Researcher Books, POB 70662-P, Seattle, Washington 98107.

**LEARN** Skiing!!! Record Demonstrates! \$5.98. Quality, Box 94-PM9, Baldwin, N.Y. 11510.

**AUTOMATIC** Multiplication Technique. Refundable \$2.00 Instructions, your Number logic computes problems quickly. Example 17x19. **NO MEMORIZATION.** Mental Math. P.O. Box 365, Danvers, Illinois 61732.

**BECOME** Notary. Free particulars. Smidts, 405 Richardt Avenue, Evansville, Indiana 47711.

### FOR INVENTORS

**IDEA**-Invention—Then What! Rankin-File, Box 566M, Willoughby, Ohio 44094.

**INVENTIONS** Needed immediately for manufacturers. For additional information write: Kessler Corporation, C-59FI, Fremont, Ohio 43420.

**U.S. PATENT** Office Searches, 234 Broadway, Room 3615, New York 10007. Free invention certificates.

**INVENTORS**—United States Patent Office Searches, Patent Development Engineering, marketing of inventions—ideas by Licensed Professional Engineer—Patent Engineer and United States Patent Office Former Examiner. Inventions developed for patenting and marketing. We are contacted by many manufacturers seeking to purchase appropriate new products invented by our clients. Send for Free invention Certificate and Invention Information. Serving Inventors since 1948. George Spector, Licensed Professional Engineer—Patent Engineer—3615 Woolworth Bldg., New York, N.Y. 10007.

(Continued on next page)



## FOR INVENTORS

(Continued from preceding page)

**PATENT** Application Financing. Free patent search plan. Global Patent Division, 2420 77th, Oakland, Calif. 94605.

**PATENT** Searches including maximum speed, full airmail report and closest patent copies. Quality searches expertly administered with complete secrecy guaranteed. Free Invention Protection Form and "Patent Information." Write: Dept. 15, Washington Patent Office Search Bureau, Benjamin Franklin Substation, P.O. Box 7167, Washington, D.C. 20044.

**PROSECUTE** Your Own Patent Application. All Material Necessary—Write: Inventors Service, Box 3574, Washington, D.C. 20007.

**FREE PAMPHLET:** "Tips on Safeguarding Your Invention." Write: United States Inventors Service Company, 501-P Thirteenth Street N.W., Washington, D.C. 20004.

**INVENTORS:** Your ideas and inventions (patented: unpatented) expertly searched, developed for commercial appeal and cash/royalty sales to manufacturers by professional Invention Developer with excellent record of experience. B. S. Industrial Engineering; United States Patent Office former Patent Examiner, United States Government former Patent Advisor. Second decade reliable service! Member: United States Council International Chamber Commerce. Free "Invention Record" and "Recommended Protection Procedure." Airmailed! Write: Raymond Lee, Invention Developer, 230P-Park Ave., New York, New York 10017.

**PATENT SEARCHES** \$35 For simple search. Report mailed day after search is made. Lusk-Evans Limited, 1120 Connecticut Avenue, N. W. Suite 940, Washington, D.C. 20036.

**PATENTS** Do It Yourself. Step by Step Detailed. E. Hall, 468 Goodspeed, Virginia Beach, Virginia 23451.

**PUBLICATIONS** About Inventing, Patents, Marketing, Licensing. Write: Synthesis, Box 157, Manhattan, California 90268.

**YOU WILL INVENT** A Moneymaking Product within 4 Weeks or don't pay a cent! Free Details. KM Publications, Box 3727-N, Anaheim, CA. 92803.

**MR. INVENTOR:** Inventions needed by Manufacturers. Development Assistance & Patent Searches. Patent Application Finance Plan if required. Write: Charles S. Prince, Invention Consultant, 509-E 5th Avenue, New York City 10017.

**IDEAS, INVENTIONS AND PATENTS.** An Easy to Read Book That Tells You How to Get a Patent in Plain Language. Complete Information, Including Sample Patent. Send \$4.95 and 60¢ Postage and Handling To: Pioneer Press, Dept. PM9, P.O. Box 76025, Atlanta, Georgia 30328.

**NEEDING** Assistance? **INVENTION DEVELOPMENT FOUNDATION**, 155 Kent Street, Ottawa, Canada K1P 5P3.

## INVENTIONS WANTED

**INVENTORS**—If you have an invention (patented or unpatented), write for free brochure outlining manufacturers' requirements, royalty rates. Kessler Invention, C-591W, Fremont, Ohio

**ROYALTIES—PRESTIGE! INVENTION ACTION** Marketing Your Ideas. Write Today for **FREE INFORMATION.** THOMAS ENTERPRISES, 310P, West Seventh, Los Angeles, CA 90057.

**INVENTORS!** Protect your ideas! Free "Recommended Procedures." Washington Inventors Service, 422F Washington Building, District of Columbia 20005.

**FREE** "Directory of 500 Corporations Seeking new Products." For information regarding developments, sale, licensing of your patented/unpatented inventions. Write: Raymond Lee Organization, 230-N Park Avenue, New York, New York 10017.

**CASH-Royalties** for patented, unpatented inventions. Global Marketing Service, 2420-G 77th, Oakland, California 94605.

**WE EITHER** sell your invention or pay cash bonus. Write for details. Universal Inventions, 28-E, Marion, Ohio.

**INVENTORS!** Don't sell or license your Invention until you receive our offer. Eagle Development Company, Dept. H, 83 Wall Street, New York City 10005.

**NEW PRODUCTS—INVENTIONS—IDEAS** Researched/Developed/Marketed by Professional Organization for Cash/Royalty Sales. **FREE EXAMINATION** and **CONFIDENTIAL REPORT** of the Commercial Features of your Patented/Unpatented Invention. **FREE COPY** "How to Safeguard and Market Inventions to Industry." Write: **LAWRENCE PESKA ASSOCIATES**, 500-C Fifth Avenue, New York City 10036.

**INVENTORS!** Either we will sell your invention before you or anyone else does, or we will pay you a cash bonus. Get Free Invention Evaluation and information write: Gilbert Adams Organization, Invention Brokerage, Dept 15, 81 Wall St, New York, NY 10005.

**INVENTORS**—Tired of Deals, Schemes, and Unreasonable fees to sell your Invention? Stop wasting time and money. Our large factory facilities in **HONG KONG** will purchase good commercial ideas and inventions for **CASH** and **ROYALTIES** under licensing agreement to manufacture for our customer accounts in U.S.A., U.K., and Europe. Write: RS (North America) & Co., Box 149MX, Tustin, California 92680.

**I-N-V-E-N-T-O-R-S!!! ONE OF THE WORLD'S LARGEST** New Product Companies can Develop, Finance and Place your Idea or Invention, Patented or Unpatented, to the attention of our national manufacturer clients who seek new products. Cash sale or royalties possible. Write for Free Literature. **\*\*NORTH AMERICAN\*\*** 2775 W. Algonquin Rd., Rolling Meadows, Ill. 60008, or Phone Mr. Stone Collect, 312-394-1100.

## BUYING AND SELLING

**A FOGGED** Windshield is Dangerous. Keep your Windshield Fog Free Even in the Worst Weather with **NO FOG CLOTH**. One Application Lasts All Day. Guaranteed. Only \$1.19 PPD. CJW Enterprises, Box 361, Bronx, N.Y. 10468.

## BUY IT WHOLESALE

**FREE!** Wholesale Dropship Catalog. Send 25¢ Postage, Handling. Idea, 629 Lyall, West Covina, California 91790.

**WORLD'S** Largest wholesale sources. U.S., foreign factory suppliers will dropship for you. 200 free catalogs. Get free samples. Your business imprint catalog. Free details. International Buyers, Box 16386-M, Portland, Oregon 97233.

**MEXICO IMPORTS**—Handbags, Wallets, Dealers Cost. Free brochure. Lumbley, Dept. P, Post Office Box 5535, San Diego, California 92105.

**HEARING** Aids, batteries, Wholesale. Catalog 25¢. Fiston, Box 1444, New Preston, Conn. 06777.

**165 FREE** Wholesale Catalogs! Mailorder Dropshippers. Your Business Imprint. Automobile Discounts. Free "Digest." Vault International, Box 7284W, Lexington, Kentucky 40502.

**FREE** Catalog Gifts, Specialties, Toys, Below Wholesale. Andrew. 5275 DeLongpre, Hollywood, California 90027.

## EXPORT-IMPORT

**JAPAN:** 1200 Products directory. Illustrated Manufacturers' names, addresses. \$5.00. Send cash. Yamagata Office, 814 Togin Bldg., Marunouchi, Tokyo.

**ORIGINAL** Oil Paintings \$96.00 Dozen. McDaniel, 3632 Topax, Claymont, Delaware 19703.

## FOR THE HOME

**WARNING** Stickers! Deters burglars!—Warns your property protected by alarm system. Place on doors-windows! 5-11, 12-52! Guaranteed! Hillside House, Dept. W9, 1019 Hillside, Valdosta, Ga. 31601.

**POACHED** Egg Skimmer. Serves Vegetables! Meatballs! Berries! Guaranteed! \$3.50. Box 666-A9, South Orange, New Jersey 07079.

## OF INTEREST TO WOMEN

**SPAKETIME** Income. Experience Unnecessary. Write Orders Complete Line Hosiery Men, Women and Panty Hose, Guaranteed to one Year! Money-making Outfit \$1.00. Specialty House, Dept. PM, 1669 Johnson Road N.E., Atlanta, Georgia 30060.

**HOW** To make money clipping newspaper items. \$2.00—\$10.00 each... Details free. Clippings, Box 5877—PM2C, Stanford, California 94305.

**WANT** A new car, color TV, new clothes? Learn hundreds of ways to make money. 5 month subscription **FREE**. Write: Salesman's Opportunity Magazine, Dept. 17-JO, 1460 Hancock Center, Chicago 60611.

**\$6.00 DOZEN** Paid lacing baby boots! Cowboy, Warsaw 9, Indiana 46580.

**\$500 MONTHLY** Possible addressing—stuffing envelopes (longhand—typing) at home. \$500 monthly Clipping news items from your newspaper. Information: Send stamped self-addressed envelope. American, Excelsior Springs, Missouri 64024.

**NEW** magazine, foods, decorating, household tips, family living. Sample 25¢. Homemaking Magazine, 404 West Jefferson, Springfield, Illinois 62702.

**EARN UP TO \$150.00 WEEKLY**... Home addressing for us. Details 25¢. Smith's, Box 2469-PM, Newark, New Jersey 07114.

**DO SIMPLE** Addressing—Mailing. Receive \$12.95 Orders. Keep \$8.00 Profit. Details Free! Quality, Box 9—PW, East Rockaway, N. Y. 11518.

**HOW TO MAKE MONEY ADDRESSING, MAILING LETTERS. OFFER DETAILS 10¢.** Lindbloom, Dept PM, 3636 Peterson, Chicago 60659.

**EARN \$100 Weekly** Addressing Form Firms. Details free. P. Richardson, Box 4097, Yuma, Arizona 85364.

**FREE!** List Of Low Cost Books... Home, Business, Mail Order, Craft, Personal Problems, Self Improvement, Astrology, Numerology. J & M Enterprises, 1403 Auburn, PMS, Longview, Texas 75601.

(Continued on next page)



## OF INTEREST TO WOMEN

(Continued from preceding page)

**BECOME A Professional Writer!** Magazines will Pay Big Money for Filler—Simple Sentences and Paragraphs, Ten Lessons Teaches How. \$5.95. Buy Wright's, Dept. 222, Dunnigan, California 95937.

**BINGO Winners Method.** Only \$2.00. Bingo, Box 65, Lebanon, Pa. 17042.

## GIFT SHOPPING

**CATALOG.** Best Mail Order Specialties and Gifts. Buy Below Wholesale. Send 25¢ (Refundable). Specialty House, Dept. PM, 1669 Johnson Rd., N.E., Atlanta, Georgia 30306.

**DISTINCTIVE Gifts. MAKE Xmas. Shopping EASY. HUNDREDS** of Unique Gifts. **FREE** Catalog. P-B Enterprises, Dept. 1, 170-172 E. King St., Lancaster, Penna. 17602.

**SAVE GAS.** Shop by Mail. **FREE** Gift Catalog. **RAINIER**, 453 Algonquin, Hampton, Virginia 23661.

**NEW!** Beautiful! Gift Catalog. Bonus Gift. Avoid Christmas Rush! Send \$1.00. (Refundable First Order). Gulf Coast Enterprises, Box 875 PM, Lynn Haven, Florida 32444.

**LSP**, 836 Flatbush Avenue, Brooklyn, New York 11236. (968-7638) S. Reing-Teitelbaum Catalog.

**FREE** Catalog Unusual Gifts for all Occasions. Robert and Lee Co., 314 South Gay Ave., Panama City, Fla. 32401.

**FREE GIFT CATALOG.** Interesting and unusual items. Rainbow Products, 410 S. 31st Street, Philadelphia, Pa. 19146.

**FABULOUS** Space Pen—designed for Apollo Astronauts—Exquisitely gift packed in beautiful sparkling cylinder, a truly unique gift for someone special. AG7—Desk set. \$5.00—25¢ post. Four Winds Enterprises, 87 Alpine Drive, Cohocton, New York 14826.

**FREE** Distinctive Gift Catalog. Hanson House, 163 Meadowbrook Farm, North Chili, New York 14514.

**OVER 100** Distinguished Gifts Mail Ordered. Satisfaction Guaranteed. Write: **NORESH**, 105-24 64Rd., Forest-Hills, New York 11375.

## WATCHES, OLD GOLD, JEWELRY

**HIGHEST CASH** For Gold, Jewelry, Gold Teeth, Rings, Diamonds, Watches, Silver, Platinum. Mail Articles Today: Free gift with information. Chicago Gold & Precious Metals, 6 E. Monroe, Dept. 158, Chicago 60603.

**WATCH** And Clock repairing books. Free list. North American, Box 77-AJ, Fox River Grove, Illinois 60021.

**CASH** Immediately for Old Gold, Jewelry, Gold Teeth, Watches, Diamonds, Spectacles, Silver, Platinum, Mercury. Free information. Rose Industries, 29-A East Madison, Chicago 60602.

**CLOCK.** Watch Repairing Tools, Supplies. Catalog. \$1.25. G/M, 1521-A West Magnolia, Burbank, California 91506.

## HEARING AIDS

**HUGE SAVINGS.** Eliminate dealer mark-ups. Free Trial. Batteries Wholesale. Terms arranged. Lloyds-PMC, Rockford, Ill. 61108.

**HEARING** Aids, Batteries, Discount Prices. Write: Rhodes, Box 518 PM, Paducah, Ky. 42001.

**WHOLESALE** Discounters! Famous Aids! Batteries! Repairs! AidMart, Drawer Z-2, St. Petersburg, Florida 33731.

**HEARING** Aids—Huge savings on tiny, all in the ear, eyeglass, behind the ear and body models. Free home trial. Low as \$10 monthly. Write for free catalog. Prestige, Dept. R-6, Box 10947, Houston, Texas 77018.

**FREE**—Hearing Aid Catalog. Save HALF! Write: "MONEYSAVERS", 9530-PMH Langdon, Sepulveda, California 91343.



## SCIENCE AND CHEMISTRY

**AMAZING!** Scientific Catalog—Apparatus—Glassware—Chemicals. Catalog—50¢. Hagenow Laboratories, Manitowoc, Wisconsin 54220.

**CHEMISTRY** And Biology Catalog 35¢. Boulevard Laboratories, Suite 302, 3114 E. 83rd St., Chicago, Ill. 60617.

**CATALOGUE** Of those very hard-to-find chemical products, things that go boom, multi-stage rockets, 500 How-To books, 10,000 formulas of every conceivable mixture in science and industry. 50¢. Kenrus-C, Box 158M, Staten Island, New York 10309.

**DISCOUNT!** Laboratory Chemicals, Glassware-Apparatus. Catalogue—50¢. Deluxe Scientific, Manitowoc, Wisconsin 54220.

**COMPLETE** Catalog, 35¢. Bargain List. Laboratory Sales, Box 161-A, Brighton, Mass. 02135.

**+ - × ÷ CALCULATOR OWNERS:** Compute **SQUARE ROOTS**, Trigonometric Functions, Logarithms, Exponentials, and More! Quickly, Accurately, Easily! Manual \$2.00. Send Today—Unconditional Moneyback Guarantee! Mailmann Optics and Electronics, Electronics Division, 836 South 113, West Allis, Wisconsin 53214.

## FORMULAS, PLANS, ETC.

**ANY** Formula \$5.00. Catalog—Manufacturing Treatise 25¢. Belfort, 192 N. Clark, Chicago 60601.

**FIFTY** Favorite Formulas for \$1.00. Q&A Distributors, R7, B68, Milton, Florida 32570.

## PLASTICS

**CASTOLITE** Pours like water, hardens like glass without heat. Crystal clear, colors. Embed natural flowers, seashells, mementos, anything. Make fine gifts. Form flexible molds over any pattern, size. Reproduce your own designs in plastics, candlewax, metal, plaster, cement. Profitable. Illustrated Manual and Catalog Only \$1.00. **CASTOLITE**, Dept. 73K/PM, Woodstock, Ill. 60098.

**LARGEST** Handicrafts and Candlecrafts Catalogue \$1.00. (Refundable). R.P.H. Manufacturing-24-M-9, Winter, Stamford, Connecticut 06905.

## TREASURE FINDERS

**FREE** Catalog. Metal Locators, Detector, Room 966-U, 102 W. Arrellaga, Santa Barbara, Ca. 93101.

**SEARCH** Treasure Finders. Locate gold, silver, coins, relics. Operate underwater. Money back guarantee. Free information. Search Electronics, Box 8396-A, St. Petersburg, Florida 33738.

**TREASURE** Finder locates buried gold, silver, coins, treasures. 6 powerful models. \$19.95 up. Instant financing available. Write or call for free catalog. Phone (713)-682-2728 day or night. Dealer inquiries invited. Relco, Dept. A-40, Box 10839, Houston, Texas 77018.

**FREE 156** Page Detector Catalog. General Electronic Detection Co., Box 67, Bellflower, California 90706.

**FIND** Buried treasure with revolutionary patented, analytical metal detector. Features push button and automatic tuning, negligible ground pickup, greatest range. Free catalogue. Gardiner Electronics, Dept. 9, 4729 N. 7th Avenue, Phoenix, Arizona 85013.

**POWERFUL** Metrotech locator detect gold, silver, coins, relics. Moneyback guarantee, terms. Free information. Underground Explorations, Dept. A, Box 793, Menlo Park, California 94025.

**GOLDAK** Treasure locators—Pleasure and profit in a hobby you'll enjoy. Find coins, relics, gold, silver. Charge on Bank-Americard. **GOLDAK**, Dept. PM, 1101-A Air Way, Glendale, California 91201.

**TREASURE** Locators. Most complete line. Free information. **TESOROS**, Apartado 7-905, Mexico 7, Mexico.

**TIED UP DIGGING UP TRASH?** The All New "Coinshooter" Rejects, Bottle Caps, Tin Foil, Nails and Shallow Trash. Detects Gold, Silver Coins and Jewelry. Free Literature. **D-TEX ELECTRONICS**, Box 451-U, Garland, Texas 75040.

**FREE FACT-FILLED CATALOG.** World's largest line of metal detectors. Models as low as \$49.50 and up. Two year Guarantee. Three factory locations, U.S. and Canada, plus over 1,000 dealers and 35 Service Centers from coast to coast. No finer instruments made at any price. Budget terms. Write: **WHITE'S ELECTRONICS, INC.**, RM #381 1011 PLEASANT VALLEY ROAD, SWEET HOME, OREGON 97386.

**FISHER DETECTORS.** You deserve the best. Free literature. FRL, Dept. PM-9, P.O. Box 490, Belmont, California 94002.

## PRECIOUS STONES & MINERALS

**500 POLISHED** Gemstones \$5.00. Tumblercraft, 5401 James North, Minneapolis, Minn. 55430.

**GET** Free catalog no serious rockhound, gem cutter, jewelry maker, hobbyist or craftsman can be without. Full of bargains, exclusive items, low prices from largest suppliers and authorities in the field. Free new catalog just off the press, yours for the asking. Write: Grieger's, Dept. C-12, 900 South Arroyo Pkwy., Pasadena, California 91105.

**ROCKHOUNDS!!** Receive Interesting, Valuable Specimens Monthly. Free Information. Minerals, Box 487M3, Yucaipa, California 92399.

**GOLDPANS** Nugget trap inserts. Also use Dry. \$8.00 postpaid, or write for particulars. Supra Goldpans, P.O. Box 30, Clarkston, Wash. 99403.

**PLACER** Gold Samples \$5.00, refundable. Variety Bookshop, Box 140, Lewiston, Idaho 83501.

**CONCENTRATES.** Titanium, Pound One Dollar Plus Postage. Platinum Group, Ounce Ten Dollars. Prospector, 527 S.E. Morrison, Portland 97214.

## CARTOONING, COMMERCIAL ARTS, SHOWCARD & SIGN PAINTING

**SIGN** Painting—\$1000 per Month Part-Time. Free Catalogue. Kaufmann Supply, Centertown, Missouri 65023.

**COMPACT** 23 lesson Cartoon Course and Cartoonist's Magazine. \$2.00. Hartman, Box 30367, Lincoln, Nebraska 68510.

**MODERN** Cartooning taught by Write for free brochure. Cartooners, Box 263-1M, Branford, Conn. 06405.

**CARTOON** For Money!! Big Free Success, Box 885-C, Dearborn, Michigan 48121.

**LEARN** Sign painting at home. Free literature. Ben Kerns, Box 812, Greenville, S.C. 29601.

(Continued on next page)

Material, энциклопедия



## CARTOONING, COMMERCIAL ARTS, SHOWCARD AND SIGN PAINTING

(Continued from preceding page)

**FASCINATING** Systems. Sign Painting-Cartooning. Straley, 1704 South Center, Springfield, Ohio 45506.

**HOW TO MAKE MONEY WITH SIMPLE CARTOONS**—Informative book sent FREE tells way to big income. Cartoonists Exchange, 99, Pleasant Hill, Ohio 45359.

**LEARN** Cartooning at Home. Approved for Veterans. Free Bulletin. Cartooning, Box 70690, Colorado Springs, Colorado 80933.

## ADVERTISING AGENCIES, ADV. SERVICES, MAILING LISTS

**ADVERTISING** Ratebook leading newspapers, magazines, 25¢. Chicago Advertising Agency, 28-E Jackson, Chicago 60604.

**MAILING** List, Most all Kinds, \$9.00 1000 Gummed, Circulars mailed \$5.00 1000. Dixmailers, King, North Carolina 27021.

## RUBBER STAMPS

**FREE** Catalog, Pocket Stamp \$1.25, Self Inking Stamps, Seals, Rush Stamps, 132-P-Farmcrest, Rush, New York 14543.

**FREE** Catalog—Rubber Stamps, Business Cards, Labels, Printing, Youngers Stamp Shop, Princeton, Iowa 52768.

**POCKET** Stamp \$1.00. Dealer's Wanted! Day's, 97 Stark Avenue, Dover, New Hampshire 03820.

**RICH** Cherry Finish Handle Address Stamp \$1.95. A-Z Stamps, 216 Edanfield, Azusa, Calif. 91702.

**FREE** Stamp Catalog. 45 Type Styles. Fast Service, low prices. Jackson's, Box 443A, Franklin Park, Ill. 60131.

## OFFICE SUPPLIES

**MAILORDER RECORDS** Help get increased business! Complete 32 Page Record Book shows your inquiries, orders, advertising, expense, etc. Only \$1.00. H. E. KAPPEL, POPULAR MECHANICS, DEPT. R, 224 WEST 57TH STREET, NEW YORK, N. Y. 10019.

## PRINTING PRESSES, RUBBER STAMP OUTFITS

**SIMPLE-X RUBBER STAMP PRESSES.** Hydraulic operated, electrically heated. Sizes 5"X8", 8"X12", 10"X15". Starting outfits. Orders for presses, supplies shipped day received. Free catalog low supply prices. Send \$1.00 for postage and handling (refundable on first order). Custom Manufacturers, 406-P East Elm, Springfield, Missouri 65801.

**PRINTING** Presses, type, supplies. Lists, 10¢. Turnbaugh Service, Mechanicsburg, Pennsylvania 17055.

**NEW** Catalog No. 13, 120 Pages, hand printing presses, type fonts, supplies. Send \$1.00 deductible first order. Acme Type, 732 Federal, Chicago, Illinois 60605.

**PRINTING** MACHINES. Offset, Mimeograph, Typewriters, Composing, Machines. Dixgraph, King, North Carolina 27021.

**SAME** Day shipment on rubber stamp supplies. Revised wholesale price list No. 9 free. Star Stamp Supply, 732 Federal, Chicago, Ill. 60605.

**MIMEOGRAPHS.** Duplicators Prints. Several Colors Without Extra Drums. Rollers. Write: AM Sales, 31-14 94, E. Elmhurst, NY 11369.

**MAKE** Your own self-molding Rubber Stamps and Printing-Cuts. Plexirubber, Argyle A, Wisconsin.

**RUBBER** Stamp outfits, supplies. Kiewiet, 2025 Barney Road, Kalamazoo, Michigan 49007.

**PRINT YOUR OWN**—Printing Presses, type, supplies direct from factory. Send 25¢ for catalog and samples to: Kelsey Co., DM, Meriden, Conn. 06450.

**LOW** Priced Rubber Stamp Manufacturing Supplies, Starting Outfits. Martin, 1432 Major, Jefferson City, Missouri 65101.

Rubber Stamp manufacturers supplies. Presses, starting outfits. Best prices, service. Catalog. Jackson Supply, Box 443A, Franklin Park, Ill. 60131.

## PRINTING AND SUPPLIES

**DISTINCTIVE** Letterheads, Cards, Signs, McDonald, 545 North Oakland, Pasadena, Calif. 91101.

**BUSINESS CARDS** Raised Letters \$5.65 Thousand. Like Engraved. Free Samples. Kavanagh, Box 1222, Brooklyn, N.Y. 11202.

**FREE** Offset Catalog. Fast-Economical, Seaview, 212-26P 48th, Bayside, NY 11364.

**FREE** Literature: Business Cards, Rubber Stamps, Address Labels Printing Big Selection. Jordan's, 552 West O'Connor, Lima, Ohio 45801.

**QUALITY** Printing. Novelty and Imported Items. Catalog 25¢. John G. Robeson, Box 2316, Hyattsville, Maryland 20784.

**PRINTING** Supermarket Short Run Specials. 1000-\$4.75, 5000-\$22; 1000 Envelopes \$8. Shipping 9 hours. Get Free Printing Specials Price List "Do You Make These 18 Mistakes When You Buy Printing." Speedy Offset Printers, 23877 Aurora, Bedford, Ohio 44146.

**1000 EMBOSSED** Business Cards \$5.25 Postpaid. Agents Wanted. Elco, 181-A, Sylvania, Ohio 43560.

**QUICK** Copy Offset Printing. Free Introductory Offer. Nationwide Printing, 73 E. University, Champaign, Ill. 61820.

**DISTINCTIVE** Embossed Letterheads, Envelopes, Cards inexpensive. Postpaid. Universal, 226-T Myrtle, Scotch Plains, New Jersey 07076.

**BUSINESS** Cards and Stationery—State your Occupation—we'll send appropriate samples. A.E. Lutz Co., P.O. Box 156, Dewitt, New York 13214.

**FREE** Literature, Business Cards, Letterheads, Labels, Rubber Stamps. Geer's, 111 North Drive, Ottawa, Ohio 45875.

**FREE** Information About Personalized Business Printing. Longwood Press, Fort Johnson, N.Y. 12070.

**BUSINESSMEN, MOONLIGHTERS, HOBBYISTS.** All you need to get the ball rolling are **BUSINESS CARDS.** Get the highest **QUALITY, best SERVICE,** live the part, be recognized. \$7.95 per thousand. Eastern Graphics, Dept. S, Box 211, Rowayton, Conn. 06856.

**QUALITY PRINTING; SAMPLES—LIST 10¢ SELCO PRODUCTS, DEPT. 38, DANVERS, MASSACHUSETTS 01923.**

## MULTIGRAPH, MIMEOGRAPH

**PROFITS FROM CLASSIFIED ADVERTISING!** Booklet shows you how to start your own business with Classified Advertising. Only \$1.00 (Refundable with first order.) H. E. KAPPEL, POPULAR MECHANICS, DEPT. P, 224 WEST 57TH STREET, NEW YORK, N. Y. 10019.

## GUMMED LABELS

**1000 GUMMED** Address Labels \$1.00. Wait's, Box 960A, South Bend, Indiana 46624.

**1,000 GUMMED ADDRESS LABELS \$1.00 FREE CATALOG, Acme, 1238 Voskamp, Pittsburgh, Pennsylvania 15212.**

**"SURPRISE!** 1,000 For 69¢ Guaranteed. TALLAMART, Box 3361PM, Tallahassee, Florida 32303."

## REMAILING SERVICE

**CONFIDENTIAL** — Receiving-Forwarding. Details Free—Remails 25¢. Hillegas, Box 169-P, Hainesport, New Jersey 08036.

**UTMOST** Care is given Handling Business and Personal Mail. We are one of the Best in this Field. Dunn Mail System of New York, 1758 First Avenue, New York, New York 10028.

**REMAILS** Receiving, Forwarding \$3.00 Monthly. Remail 25¢ Each. Bates, 31 Lamar Place, Yonkers, New York 10710.

**KING CRAB CAPITAL OF THE WORLD** 35¢. Remails. Receiving, Forwarding, Re-addressing. Postcards and Souvenirs. Monthly Rates. Oceanside, Box 1455, Kodiak, Alaska 99615.

**NEW YORK CONFIDENTIAL** Remails 25¢; \$2.75 Monthly. Details Free. Ross, Box 706-M, North Bellmore, N.Y. 11710.

**SECRET.** Receiving—forwarding. Discreet and confidential. Remail 25¢ single. Mail Forwarding Service, 8050 S. Main, Houston, Texas 77025.

**MIAMI** Remails 25¢—Monthly rates. Remails—view cards from 80 Foreign cities. Marle, Box 1266, Coral Gables, Florida 33134.

**YOUR** Mail Received—Forwarded. Hedgpeh, 324-M South First, Alhambra, Calif. 91802.

**CONFIDENTIAL** New York Mail Address \$3.00 Month. Telephone Service \$5.00. Re-mails 25¢. Details Free. Birnhan, 152 West 42. New York 10036.

**REMAILS**—Forwarding, 25¢—\$3.00 Monthly. Hill, P.O. Box 2408, Denver, Colorado 80201.

**FREE:** First Month's Receiving-Forwarding Service. Wright, D-2112, Asheville, North Carolina 28802.

**WASHINGTON, D.C. POSTMARK.** Singles 25¢, Monthly \$3.00. Morgan, Box 31099, Washington, D.C. 20031.

**CANADA** Remailing-Forwarding 35¢ Each or Monthly. Emkay, Box 5815 A, Toronto, Ontario M5J 1A2.

**REMAILS** Great Smoky Mountains Area, 35¢. Box 10440—A, Knoxville, Tennessee 37919.

**FIRST MONTH FREE.** World Mail Bag, Drawer 568B, ANAHEIM, CALIFORNIA 92805.

## REPAIRS AND SERVICING

**PROFITS FROM CLASSIFIED ADVERTISING!** Booklet shows you how to start your own business with Classified Advertising. Only \$1.00 (Refundable with first order.) H. E. KAPPEL, POPULAR MECHANICS, DEPT. P, 224 WEST 57TH STREET, NEW YORK, N. Y. 10019.

## SPECIAL SERVICES

**INFORMATION** On Anything. Universal Information, Box 9131, Shreveport, La. 71109.

**POPULAR MECHANICS INDEX AND SHELF WRAPPER** 1971 and 1972 editions now available. You will be able to find any article that appeared in P. M. covering those years in seconds. These annual indexes will make your copies of P. M. even more valuable! Each \$1.49. Send checks to: Popular Mechanics, Dept. HE, Box 1014, Radio City, New York, New York 10019.

**GHOSTWRITING** — Internationally-Published Professional Confidentially-Researches, Ghostwrites. Academic Specialist. Queen, 19 Northumberland, Mount Holly, New Jersey 08060.

**INFORMATION** On anything. Ferguson Research Specialists, 72-25 Woodside, Woodside, New York 11377.

(Continued on next page)



## TOBACCO

**PIPE SMOKING PLEASURE**, only as satisfying as the tobacco you put in it. Write for factory-fresh samples. Green River Tobacco, Box 991, Owensboro, Ky. 42301.

**BRIAR PIPES**. Discount Prices. Write: Maxima, Box 26-D1, Vails Gate, New York 12584.

**ELECTRIC** Cigarette machine makes them better—easier. Free details. Mahair, 415 Morris Bridge Road, Zephyrhills, Fla. 33599.

## BETTER HEALTH

**20,000,000 PEOPLE** Have hypertension, blood pressure problems. Do you? Do-it-yourself testing, evaluation, equipment. Free details. Vital Signs Company, 4531A Morris Road, Jacksonville, Florida 32225.

**SLUGGISH? TIRED?** Chinese Super-tonic \$9.95. Health, Box 65976, Vancouver, Canada.

## PERSONAL

**HEIRLOOM** Raspberry Wine Recipe. Excite! Send \$2.00 To: Verda's, P.O. Box 1605, Tarpon Springs, Fla. 33589.

**INGROWN** Toenail. Pain Stopped. Proven Method. Instructions \$2.00. John Teegardin, 1739 Pine Street, Santa Monica, Calif. 90405.

**LOSE** Weight—Stop Smoking. Proven Methods. Only \$1.00 Each. Postpaid. Colo Enterprises, Drawer H, Brooklyn, New York 11223. Gravesend Station.

**BORROW** By Mail! Up to \$1500.00. Convenient terms. State Licensed. Postal Finance, Dept. 17-N, 6018 Military Ave., Omaha, Nebraska 68104.

**SECRET** Plan Wipes Out All Debts. \$500 to \$25,000 in as little as 90 minutes. Clear credit. Free details. Counselor-7, Kerrville, Texas 78028.

**27 WAYS** To Improve Your I.Q.. Plus Self Scoring I.Q. Test. Guaranteed—Send \$3.25 Today To: Calco, Dept. G, Box 1437, Alameda, California 94501.

**THE STRANGEST SECRET**. LP Record by Earl Nightingale. The Secret of Success in any Area of Life and Work. Over a Million Sold. \$9.95. New York Residents Add Tax. Kindustry, 165 Tremper Avenue, Kingston, New York 12401.

**FREE** Gospel Literature foretelling second coming of Christ. Scheall, Box 263-PM, Duluth, Minn. 55801.

**INSTANT DEBT RELIEF** Without borrowing. Without Bankruptcy. Have excellent credit in 45 days. Free!!! Wealth Building, Box B9, 1996 Hoyt Street, Lakewood, Colorado 80215.

**HIGHER INCOME**, Security And Power. 256 Page Book "Thinking Big" Reveals Secrets That Make Men Rich! Send \$2.00. MAN Trading Co., North Shore, Derry, N.H. 03038.

**NEED** Money-Debts Too Big? Consolidate Bills. Free Emergency Loans. Write: Interstate, 28 E. Jackson, Suite 1204-X3, Chicago 60604.

**LOSING HAIR? BALDING? DANDRUFF?** Free copyrighted booklet, Dr. Shiffer Laboratories, Dept. 536, Box 398, Punta Gorda, Florida, 33950.

**PSORIASIS** Sufferers: Discouraged? Write for Free important information that is helping thousands! Pixacol, Box 38-PM, Avon Lake, Ohio 44012.

**BIBLE** Questions answered. Stamped envelope. Bylon, 17167 Bentler, Detroit, Michigan 48219.

**INVESTIGATORS**. Latest electronic Aids. Free Literature. Clifton, 11500-P NW 7th Ave., Miami, Florida 33168.

**RECORD** Telephone Conversation automatically. Leaver Recorder Unattended. Robert's, Box 49PM9, Parkridge, Illinois, 60068.

**RECEIVE** Phony State Chartered University Degrees immediately. Box 11516. Tucson, Arizona 85706.

**CASH LOANS** by mail! Up to \$2,500 on signature alone. No collateral! Secret! Union Finance Company, 3608 No. 16th St., Dept. PM, Phoenix, Ariz. 85011.

**SEE THRU WALLS!** New Secret Two-Way Super Spy Device, instructions included. Guaranteed only \$2. World-9C20, 3047 University, San Diego, Cal. 92104.

**TELL** Fortunes accurately—Immediately! ESP Aids, Box 21-PM, Olympia, Washington, 98501.

**TATTOO** Removing—Chemical Do-it-Yourself Method—Free Details: Atlanta, 907P Beachpoint, Pickering, Ontario, L1W 2A4

**"RULE** Others With Thoughts." (Telepathy). Write: Clarion, Box 1769-A7, Chicago 60690.

**STOP SMOKING NOW!** Free details. Mark, Box 3982, Lewiston, Michigan 49756.

**CREDIT** Cards . . . loans . . . no credit investigation!!! Guaranteed Free report. Continental-23, Nicerville, Florida 32578.

**SECRET LOANS BY MAIL**. Borrow \$100 to \$3000 for any good reason in absolute privacy. No interviews, no endorsers, no co-signers. Fast service. Write: Dial Finance Co., Dept. 3516, 418 Seventh Street, Des Moines, Iowa 50309.

**JOIN** International Order Dirty Old Men Card-Certificate \$1.00. Caboose, Camillus, N.Y. 13031.

**HOW** To Attract Good Luck! Specific steps you can take! \$2.00. RYA, 5391 Balboa, San Diego, California 92117.

**MAKE** Your Will! 4 Forms, Instruction Manual \$1. Guaranteed! Sawyer's, Department PM9, Box 8484, Emeryville, California 94662.

**YOUR QUESTIONS FULLY ANSWERED** . . . Regardless of your problem. Any Subject. Any Business. Reasonable Fees. Prompt, Reliable Details Guaranteed. Write Today. Bermal, Box 291PM, Mt. Vernon, New York 10551.

**IDENTIFICATION CARDS**. Photo Laminated Certificates. Diplomas. Send Stamped Self-Addressed Envelope. For Samples. DOWNES, P.O. Box 10148, Cheyenne, Wyoming 82001.

**HAVE A CONFIDENTIAL CHICAGO ADDRESS**, Business, Personal. MCOC-60, 216 Jackson, Chicago 60606.

**DELUXE WILL KIT!** 64 Page Book Explains How!! 4 Forms. Guaranteed!! Send \$2.00. Laurie's Favors, Desk B9, 312 Lakeshore, Lindenhurst, Illinois 60046.

**STOP SNORING**. Easy method fully explained. \$3.95. Snoring, 14241 Mango, Del Mar, California 92014.

**"MAKE Your Own Will"** . . . SIX Forms. Information Booklet, \$2.00. **GUARANTEED!!!** Plato, Box 207-P9, Saint-Davids, Pennsylvania, 19087.

**BECOME** Ordained Minister. Free Information. Church, Box 324, Daytona Beach, Florida 32015.

## WANTED-MISCELLANEOUS

**MERCURY**. Gold, Silver, Platinum; Ores assayed. Wholesale Terminal, Norwood, Mass. 02062.

**WANTED**—Antique Bicycles. Any Related Items. Berry, 2101 Coal S.E., Albuquerque, New Mexico 87106.

**JAPANESE** Swords Wanted. Don Beck, 1828 Ida, Ft. Wayne, Indiana 46808—219-437-1801.

## WINEMAKING & OTHER RECIPES

**FREE** Winemakers Comply Catalog. Winecraft, Abington, Pa. 19001.

**CONCENTRATE** Catalog. 60 Varieties. Vendramino Wine Co., Dept. A, 13273 Michigan Ave., Dearborn, Mich. 48126.

**WINEMAKERS** FREE Supply Catalog. Excellent Selection of Fruit & Grape Concentrates. Kraus, Box 451-L, Nevada, Missouri 64772.

**WINEMAKERS**. Free illustrated catalog of yeasts, equipment. Semplex, Box 12276R, Minneapolis, Minn. 55412.

**WINEMAKER'S** Supply Catalog—Free. Bacchanalia, 273 Riverside Ave., Westport, Conn. 06880.

**HOMEWINE MAKING SEND** For FREE Informative CATALOG OF RECIPES, EQUIPMENT, and INGREDIENTS. Brewer's Yeast Dry Malt, Crystal Malt, Bottle Caps, Barrels, Chemicals, Concentrates. Over 250 Items. Winemaking Is A Fascinating Hobby. Write To: Danenberger's, Box 276-M, New Berlin, Ill. 62670.

**WINEMAKER'S!** Free Illustrated Catalogue of Quality Products. Brant's Wine Rack, Box 3256-M, Orange, California 92665.

**WINE CELLAR**—New low cost interlocking units in traditional design, unlimited capacity. Start with 7 bottle rack \$4.98, postpaid. Free picture brochure. Winemaker's Catalog. ADDARACK, Box 30230M, Cincinnati, Ohio 45230.

**WINEMAKERS**. Tremendous selection. Fast service. Free catalog. Winecraft, Columbia Mall, Columbia, Maryland 21043.

**WINECRAFT**—469 Items—Free Catalog. P.O. Box 11186, Phoenix, Arizona 85061.

**LARGEST** Stock supplies and equipment. We have the know-how. Write for catalog, advice, consultation . . . also wholesale. (231-6414) Jim Dandy Wine Supplies—now at 8454 Beechmont, Cincinnati, Ohio 45230.

**WINEMAKERS:** Free Catalog. Fast Service. Arbolyn, Box 663, West Columbia, South Carolina 29169.

## MISCELLANEOUS

**"4-IN-1"** POSTAGE Scale, Needed in Every Home & Office. It's a Combination Letter Scale, Ruler, Magnifier and Letter Opener. Only \$1.25 Postpaid. Willcara, Starrucca, Pa. 18462.

**BLANK WILL FORM**. \$2.00 Guaranteed! Order Today! J. G. Enterprises, Box 314, Moncure, N.C. 27559.

**CUT** Cigarette costs in half with our custom-blended tobacco and rollers: filter or plain. Free sample: Green River Tobacco, Box 954, Owensboro, Ky. 42301.

**RECROOM LAMPS** EXCITING. Gogo girls in motion many more barlites in color. For free brochure and pricelist send self address large stamp envelope to: Magic Motion Lamps, 2617 E. Birchwood Ave., Cudahy, Wisc. 53110.

**BOOKS** On antiques and their prices. Free circular!! P. Warman Publishers, Uniontown, Penna. 15401.

**SUFFERING** From Arthritis? Try Ginseng: Information Free. Write: Ginseng, Asheville 53, North Carolina.

**PRE-PACKAGED** Toys complete with free self-selling display rack. Free Details. Toys, 1916 Fifth, Sacramento, California 95814.

**HOW INTELLIGENT ARE YOU?** Self Scoring Test Reveals I.Q. In 45 Minutes! Send \$2 Today—Guaranteed!!! H&M, Box 67184 PM-1-9, Century City, Calif. 90067.

**SLEEPATRON**. New sleep. Gardiner Electric, North 7th Avenue, Minneapolis, Minn. 55412.

**IDENTIFICATION** self-addressed envelope.



## MISCELLANEOUS

(Continued from preceding page)

**HOW INTELLIGENT** Are You? Self-scoring test reveals I.Q. in 45 minutes! Send \$2 today—guaranteed!! Mann, 3545 Lincolnshire Woods, Dept. 9A1, Toledo 43606.

**1400 CATALOGS** Listed and Described! Sources for **EVERYTHING** imaginable! Rush \$2.00. **MASTERLOG**, Box 24413-(UI), Oakland, California 94623.

**CREDIT Cards** . . . loans . . . no credit investigation!!! Guaranteed Free report. Continental-24, Nicerville, Florida 32578.

**HEARING Aid** batteries wholesale. Free list. Habs, Box 51, York, Penna. 17405.

**DON'T Die** Without a Will. Protect your Family. Blank Forms Only \$2 Guaranteed. Order Today. House of Virgo, Box 493, PM9, Lodi, New Jersey 07644.

**ORNAMENTAL Iron** designs. Book of 1600 beautiful, practical designs for railings, columns, etc. Free literature. Cunningham, 3881 South 3200 West, Box 19005, Salt Lake City, Utah 84119.

**DIGITAL Watch** Is the Newest Concept in Watches, not just a new Face on Standard Movement. Swiss made for Quality and Accuracy. Mainspring Guaranteed for Life. Gold Finished Case, Black Face, Black Suede Band. Exact Hour and Minute indicated by Large Numerals. Women's Identical, But Smaller. \$24.95. Merkler, Dept. 2PM9, Defiance, Missouri 63341.

**ASTROFOIL**, For Sun, Shelter, Safety. Developed for NASA, Waterproof, Windproof, 84" X 66" 3 ounces. Tanning Aid, Emergency Blanket for Prevention of Injury Shock. 100's of uses for Motorists, Skiers, Snowmobilers, Campers. \$2.95 Plus .50 postage and Handling. **IMPEX Associates**, 1329 Griffin Ave., Mahtomedi, Minn. 55115.

**SUPERPOWER TV Antenna!** "Utilize House Wiring . . . Sharp Picture, any Outlet". Instructions. Now only \$1.00. Guaranteed Performance! Cyra, P119, 23616 Archibald, Carson, California 90745.

**MUSTACHE N BEARD Grooming Set** Is for Any Man who wears a Mustache or Beard. Look Sharp—Set Includes Shears, Shaper, Brush, Comb, Mini Razor, Mustache Wax and Style Guide. Satisfaction Guaranteed. Send \$14.95. Merkler, Dept. 1PM9, Box 156, Defiance, Missouri 63341.

**GLOBAL Time Indicator Wheel.** Tells time around the world. Excellent for businessmen, travel. 3 wheels \$1.00. Send self-addressed envelope. SUN, 135 W. 25 St. N.Y.C. 10001.

**U.S. \$1000 Bills!!** Obsolete Exact Replicas 5/\$4.00. National, Box 81652-XI, San Diego, California 92138.

**DON'T DIE** Without a Will! Self-Explanatory Blank Will Forms \$2.00 Guaranteed. Clayton Sales, (42B9), 314 S. Patterson Park Ave., Baltimore, Maryland 21231.

**DON'T PAY INCOME TAX.** Legally. No Matter what your Income. Rich men's methods adapted for anyone's use. Free Details. Trauhhaus-44, Box 3004, Duluth, Minnesota 55803.

**MAGNETS** All types. Specials—20 disc magnets, or 2 stick magnets, or 10 small bar magnets, or 8 assorted magnets. \$1.00. Maryland Magnetic Company, Box 192-A, Randallstown, Maryland 21133.

**DON'T DIE** Without a Will! Blank Will Form protects your Family. Only \$2—Guaranteed! Order Today!! Mile, Box 1533, Decatur, Georgia 30031.

**BECOME Ordained Minister.** Free Information. Church, Box 324, Daytona Beach, Florida 32015.

**100% ALL-TOBACCO Cigars** Direct From Factory (Free Catalog) Write: S&S, Box 35178-C, Chicago, Ill. 60635.

## BURGLAR ALARMS & HOME PROTECTION

**DOORMAT ALARM.** Know Instantly When Anyone Enters Your Premises. Free Literature. Ayton, P.M., 5506 16th Avenue, Brooklyn, N.Y. 11204.

**LOCKSMITHING Supplies—Buyers Guide** \$1.00. Despubs, Box 22005H, Phoenix, Arizona 85028.

**FREE Catalog** on Burglar-fire Alarm Equipment. Protecto Alarm Sales, Box 357-D, Birch Run, Michigan 48415.

**BURGLAR & FIRE ALARM SUPPLIES AND SYSTEMS.** Send \$1.00 for catalog. J & J Alarm Systems, 51 Pythian Ave., Torrington, Conn. 06790.

**BURGLAR—Fire Alarm Equipment.** FREE 62 Page Catalog (limited time, regularly \$1.00). **K-TRONICS INDUSTRIES**, Box 391-M, Fairfield, Conn. 06430.

**NEW!** Puts out home fires automatically. Asleep, away from home. Protected territories. President, Box 1834, Sumter, S.Car 29150.

**BURGLAR—PROOF YOUR HOUSE!!** Treasury, Intelligence Expert's Modernized "Home Security Manual" Demonstrates Economical Do-It-Yourself Savings!! Guaranteed. FREE Information. Sullivan House, Department 27-S, 2402 South 222nd, Seattle 98188.

**DAY AND NIGHT PROTECTION AUTO BURGLAR ALARM.** Sounds Loud Warning, Prevents Theft. Easy Installation on Any Car. Fits 6 or 12 Volts—\$4.98 PostPaid. **MARDI GRAS IMPORTS**, 9604 Jefferson Hwy., New Orleans, La. 70123.

# A Brand New Edition of the Famous PM CATALOG of Plans and Publications



**Popular Mechanics** 25¢

## Plans Publications Projects

Listed inside are the famous PM publications: the **Motor Shop Guide**, containing all the basic shop information you've ever wanted to know; the **Garaging Guide**, jammed with how-to for green thumbs; a series of great auto tune-up booklets, plans for everything from a beautiful tool storage structure to a 20-foot travel trailer! Also, we offer a special service—photocopies of a thousand and more great PM articles of the past.

FOR ORDERING INSTRUCTIONS see page 51 and 52.



**MAIL THIS COUPON** 

Here it is—the great **NEW** edition of the **PM Catalog!** Want to build a garage, sidewalk car for the kids, run-about, sailboat, even an airplane or house? You'll find all these great plans listed here, along with a thousand and one other fascinating projects; also the finest of how-to books and shop guides. You know they're great if they're from **Popular Mechanics**. Send 25¢ for your **PM Catalog** today!

**Popular Mechanics, Box 1014, CO-9**  
Radio City, N.Y. 10019.

I am enclosing 25¢ in coin (no stamps please) for my copy of the **Popular Mechanics Catalog**.

Name \_\_\_\_\_  
Address \_\_\_\_\_  
City \_\_\_\_\_ State \_\_\_\_\_ Zip \_\_\_\_\_



# Unadorned power tools.

4' Wood Lathe  
at \$29.95

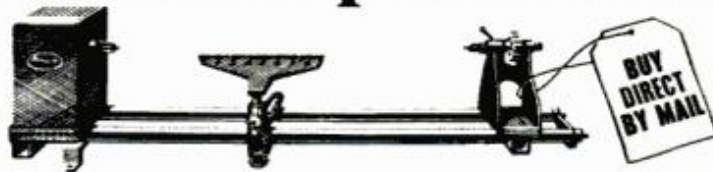

## They do the same job as tools costing up to 5 times as much.

We skipped the chrome to save you money... but we did not skip anything on performance. Actually, we skipped more than just chrome, we cut out every costly frill that wasn't absolutely needed.

The lathe shown above isn't exactly flashy. We admit it. But in a recent article, Popular Science used it to demonstrate wood lathe technique and said: "You won't go wrong with this economical introduction to wood turning." It is typical of our tools which in spite of low prices, are full scale and offer full performance and precision.

**HERE'S HOW WE DO IT . . .** First, we don't claim our tools should sell for five times the price! Just that our tools do the same job . . . with the same accuracy, ease and speed . . . and will last at least as long. AMT tools cost less to make and are sold direct. They are bona fide quality power tools used by serious amateurs and professionals alike and if sold in retail stores would be much higher in price. We use no magic, let's be specific: **SIMPLICITY . . .** AMT tools are soundly engineered to eliminate every frill and gimmick—to minimize material and production costs. Machined parts are used only where they're needed. Unadorned cast iron and aluminum save you a fortune.

**DIRECT-FROM-FACTORY SAVINGS . . .** You save a bundle, yet, we offer a double guarantee backed by a 38-year-old company with millions of satisfied customers . . . and hundreds of orders pour in daily.

**LARGE VOLUME . . .** Our own foundry and large mass production facilities plus large buying power all work to keep costs down.

**STANDARD PARTS . . .** Our designs use standard hardware items wherever possible. By avoiding custom-made parts we pass on tremendous savings to you.

If you are looking for power tools that perform like units costing many times our low prices, order today and you'll be one step closer to many hours of woodworking satisfaction.

*Bill Monty*

### POWER SAW 8" tilt arbor saw . . . crosscuts, rips,

mitres, cuts compound angles, dados, coves, moldings. Completely assembled with ground cast iron table, safety guard, splitter, mitre gauge. Less blade, motor. Rip fence for easier work alignment, \$3.50 add'l. Ball bearing model, \$5.00 add'l. Takes 1/3 h.p. motor or larger, standard blades, attachments. Wt. 26 lbs., f.o.b. factory



**\$19.95**



**FREE OFFER, cabinet base plans, . . .** with one piece of 3/4" plywood, convert your \$19.95 saw into a floor model with a huge 27" x 24" top. Takes cabinet rip fence, \$4.50 add'l.

### TWO GUARANTEES

**10-DAY MONEY BACK GUARANTEE**  
Try any of these power tools and compare it with any similar machine at any price. If not satisfied, return it for prompt, no questions asked refund. We pay the return shipping charges.

**10-YR. FULL SERVICE GUARANTEE**  
Any part or parts of these AMT power tools (except motor which carries a one year guarantee) which become inoperative for any reason within ten years after purchase date will be repaired or replaced by the factory with no cost to the purchaser other than postage.

**AMERICAN MACHINE & TOOL CO.**  
4th & Spring St., Royersford, Pa. 19468

**Brand new electric motor** developing full 1 h.p. 17 lbs. (Purchased separately, \$24.85). With any AMT machine here. **\$19.90**

**BUY DIRECT**  
... USE THIS HANDY  
ORDER COUPON  
NOW

**AMERICAN MACHINE & TOOL CO., Dept. PM-93, Royersford, Pa. 19468**

Please send me the units checked. Payment in full enclosed \$\_\_\_\_\_ or \$3 deposit each item enclosed, balance C.O.D. I must be fully satisfied or will return unit within 10 days for full refund. No questions asked.

- |   |  |
|---|--|
| <input type="checkbox"/> 8" Power Saw at \$19.95  | <input type="checkbox"/> Jointer Planer at \$29.95             |
| <input type="checkbox"/> Standard Rip Fence at \$3.50   | <input type="checkbox"/> Ball Bearing Spindle at \$10.00       |
| <input type="checkbox"/> Long Cabinet Rip Fence at \$4.50   | <input type="checkbox"/> Wood Shaper Kit at \$19.95            |
| <input type="checkbox"/> Ball Bearing Spindle at \$5.00   | <input type="checkbox"/> Opt. Hold Down Assembly at \$2.75     |
| <input type="checkbox"/> Belt Sander at \$19.95   | <input type="checkbox"/> 6" Swing 3' Lathe at \$14.95          |
| <input type="checkbox"/> Disc Sander Attachment at \$7.95   | <input type="checkbox"/> 12" Swing 4' Lathe at \$29.95         |
| <input type="checkbox"/> Mitre Gauge for Sander at \$1.95   | <input type="checkbox"/> Face Plate \$2.50 (either Lathe)      |
| <input type="checkbox"/> Drill Press at \$39.95   | <input type="checkbox"/> Turning Chisels \$5.95 (either Lathe) |
| G.E. Motor <input type="checkbox"/> \$19.90 (with other item) <input type="checkbox"/> \$24.85 (purchased separately) |  |

NAME \_\_\_\_\_

ADDRESS \_\_\_\_\_

CITY \_\_\_\_\_

STATE \_\_\_\_\_

ZIP \_\_\_\_\_

### 3' WOOD LATHE . . . 6" swing.

Same precision and speed as \$40 units. Sturdy cast iron with tubular steel bed. Lever action tail stock, two-speed pulley, fits any motor. Set of 3 high speed turning chisels, \$5.95 add'l. 4" face plate, \$2.50 add'l. 15 lbs., f.o.b. factory



**\$14.95**

### 4' WOOD LATHE . . . 12" swing.

Industrial size, does the same job as \$75 units. Tubular steel bed rails, screw action tail stock, three-speed pulley. Use any motor. 3 high speed turning chisels, \$5.95 add'l. 4" face plate, \$2.50 add'l. 30 lbs., f.o.b. factory



**\$29.95**

### JOINTER-PLANER 4 1/8" x 22".

Cast iron and steel, precision ground adjustable tables. For planing, joints, bevels. Rabbets to 3/8" depth. Fence adjustable 0° to 50°. Steel knives, dual guards. Use any motor. Precision ball bearing industrial model, \$10.00 add'l. Wt. 19 lbs., f.o.b. factory



**\$29.95**

### BELT SANDER A precision unit.

It changes from horizontal to vertical in seconds. Heavy, sander includes 4" x 36" sanding belt. Uses 1/3 h.p. or larger motor. V-pulley drive and multi-purpose drive spindle.



Disc sander accessory, \$7.95 add'l. Mitre gauge, \$1.95 add'l. 15 lbs., f.o.b. factory

**\$19.95**

### DRILL PRESS

Precision 32" radial unit has standard features and many extras. Depth of throat up to 16". Head tilts and table stays level. Drills to center of a 32" circle. All cast iron and steel. Takes standard motor. 32 lbs., f.o.b. factory.



**\$39.95**

### WOOD SHAPER KIT Makes beads, coves, moldings, tongue-and-groove joints, etc. Accurate cuts at high speeds. Sealed greased-for-life ball bearings. Less wood. Takes 1/4 h.p. motor or larger, standard cutters.



Optional hold down assembly, \$2.75 add'l. 15 lbs., f.o.b. factory

**\$19.95**



## THE CLUB CAB. America's Number 1 idea in pickups this year.

Dodge makes pickup history by giving you 34 cubic feet of extra storage space inside for the things you don't want to leave outside. Available in Dodge's Camper Special option with a wide choice of trim.



## DODGE SPORTSMAN. America's Number 1 selling compact wagon.

Hi-ho, space lovers.

Sportsman gives you a choice of seating arrangements for from five to fifteen people, front disc brakes, a zippy optional 360-cu.-in. V8, and just about any luxury option you can get on a car, from air conditioning to AM/FM radio. You can take it with you in a Sportsman.



# Turn to Dodge for leadership in Recreational Vehicles.

FOR LEADERSHIP IN R.V.S...





# Can you spot the Camel Filters smoker?



© 1973 R. J. Reynolds Tobacco Co.

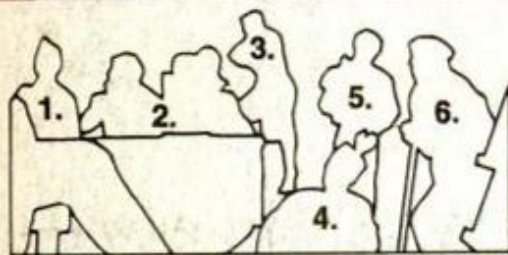

Even at the firemen's parade, everyone seems to have a gimmick—almost everyone. Pick the one who doesn't. **1.** Sorry. Meet "Clean Ed" Mealmangel, discount diner owner. Gimmick: Leaves his thumb print in mashed potatoes. Smokes ABL's "Any Brand Left" in the ash trays. **2.** No. And no. Tex'n'Tilly, icky-poo radio-TV personalities. Gimmick: If it moves, interview it. They once even used a stethoscope to talk to a mole. **3.** Jerry Jibroni. Spends so much time setting up, he never sees parade. Smokes cigarettes so super-long he almost needs binoculars to light them. **4.** He's Tom Thump. His bass drum really is a gimmick: Can't stand the noise, but he likes to wear it. Puts cotton in his ears and in his cigarette filters. **5.** Right. He enjoys the passing parade, without any gimmicks. That's why he smokes Camel Filters. They're good tasting, easy and honest. His kind of cigarette. **6.** He's "Sweeps" Streate. Hopes mounted police won't parade. But they always do.

**Camel Filters.**  
**They're not for everybody**  
 (but they could be for you).

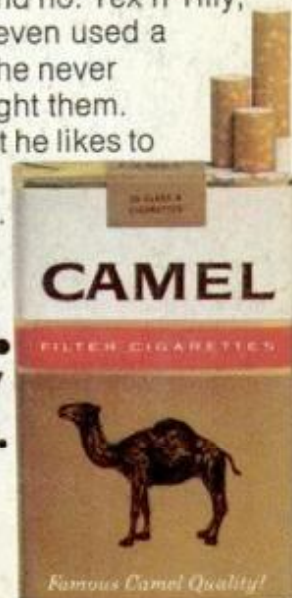

Warning: The Surgeon General Has Determined That Cigarette Smoking Is Dangerous to Your Health.

20 mg. "tar", 1.3 mg. nicotine av. per cigarette, FTC Report FEB. '73.