

# Popular Mechanics

JUNE 1973  
60 CENTS

## BEST BIKES YOU CAN BUY

Chosen and rated  
by bicycle expert  
Eugene Sloane

Page 98

How to get  
started in soaring

Page 71

Inside the new  
Zankel  
outboard

Page 141

M's perfect  
fishing boat

Page 134

Clip-and-save  
know-how:

- How to  
fix a doorbell
- How to work  
with ladders
- How to paint  
your house

Car stereos you  
build from kits

Page 156





## Spend a milder moment with Raleigh.

A special treatment softens the tobaccos for a milder taste.

Put it all together. Enjoy your hobby more with this 18-pc. Fleet All-Purpose Tool Kit: wrenches, pliers, screwdrivers. Yours for free B&W coupons, the valuable extra on every pack of Raleigh.

To see over 1000 gifts, write for your free Gift Catalog: Box 12, Louisville, Ky. 40201.



© BROWN & WILLIAMSON TOBACCO CORP.

Filter Kings, 17 mg. "tar," 1.3 mg. nicotine; Longs, 19 mg. "tar," 1.5 mg. nicotine, av. per cigarette, FTC Report August '72

Warning: The Surgeon General Has Determined That Cigarette Smoking Is Dangerous to Your Health.

Материал, защищенный авторским правом



## STEVE PETRASEK PROVES IT AGAIN...WITH THE FIRESTONE WIDE OVAL TIRE SYSTEM.

Nobody puts tires to a tougher test than Firestone tire engineer Steve Petrasek. Every November with two buddies, he drives the strange looking caravan above from Akron into the wilds of Montana in 31 hours. He *really* lays it on those tires — hour after hour of turnpike pounding at the legal limit, with stops only for fuel and a change of drivers. And that Jeep in tow is really loaded, putting even more of a demand on those tires. Then when Steve gets near where he's going, off he heads down the backroads where those tires have to do some clawing to keep a foothold.

With a hunting trip like that facing him every year, you might wonder what tires Steve uses, since he can take his choice of any we have. Steve sticks with The System. And if you're looking for something to improve the way that camper of yours handles on and off the road, we'd better tell you what The System is:

**On the front** you put Firestone's Transport 500 Wide Oval™ tires. They're the



steering part of The System, and that wide, wide tread is designed to give you a stable-as-a-table feeling and a whole lot of mileage.

**On the rear** go Firestone's Traction All Season Wide Oval™ truck tires. They're the drive part of The System, and those computer designed treads will let you run along at turnpike speeds, then pull off the road into almost any kind of mud, sand, or snow and keep on going.

See your Firestone Dealer about The System. Or write to Steve c/o Firestone, Akron, Ohio 44317 for more information.

**The Wide Oval Tire System  
for Campers.**

# Firestone

This One



N3LC-NH2-ZTHC

JUNE 1973

1

# Three reasons to buy Jeep® Trucks in '73

1. Jeep Guts

2. Jeep Quadra-Trac™



3. This \$200.00 Cargo Cap at no extra cost



CAP HAS 45" JALOUSIE WINDOWS AND SCREENS. LOCKABLE LIFTGATE WITH SAFETY GLASS

**When you consider all the rugged,** standard features of the 1973 Jeep Truck such as... double side wall box construction • easy-open tailgate • high-strength frame • multi-leaf springs at all 4 wheels... you'll know why Jeep guts mean miles of dependable service.

**Now Quadra-Trac**...the new automatic full time 4-wheel drive system...is available on '73 Jeep Trucks. Quadra-Trac... makes hauling easier on or off the road...and eliminates the need for shift levers and front locking hubs.

**And talk about value**...we have made this handsome cargo cap, worth more than \$200.00, available to our dealers at no extra cost...so now they can offer it to you at no extra charge when you

buy a Jeep J-4500 or J-4600 Truck equipped with these popular options: The Townside Pickup Box • Custom Cab • 360V-8 Engine • power steering and brakes • dual low profile mirrors • custom wheel covers • AM radio and two-tone paint with wood-grain trim.

**Whatever the job you've got in mind,** Jeep Truck has the guts to handle it...because it's a genuine Jeep. This year make your '73 truck a '73 Jeep.

 **Jeep**  
**Toughest 4-letter word on wheels.**

Buckle up for safety . Drive your Jeep vehicle with care and keep America the Beautiful.

# Winchester and Western extra-power 22s have all the flat-shooting, power-packed, high-velocity performance you'd expect from any ammunition marked Super-X.

Each offers the utmost you can get from a 22 Short, Long, or Long Rifle, in the original brand of long-range power that's never been topped.

**Super-X . . . the name that means "extra power" now in both Winchester and Western brands.** For years hunters who require the most powerful ammunition have relied on Super-X to bring down big game, or high flying waterfowl. This same kind of reliable Super-X extra power goes into our high velocity Super-X 22s too, to give you a cartridge that hits with impressive power for a rim fire . . . perfect for small game, pests or varmint hunting.

**1. Exacting bullet weight and contour.** To ensure all the long-range, wind-bucking accuracy you need, to go along with extra power, Super-X bullets are made to exacting standards of weight and contour, so they'll hit where you're holding for elusive rabbits or wary squirrels. Bullets are available in Short, Long, Long Rifle, Lubaloy or Kopperklad coated for better performance. Hollow points, too, in Short and Long Rifle.

**2. Precision-formed brass case.** There's only one brass good enough for Super-X ammunition . . . the brass we make ourselves in our own brass mill. It's a special cartridge brass that's drawn and shaped to perfection. You get the same kind of precision in a Super-X 22 case that goes into our largest center fire ammunition.

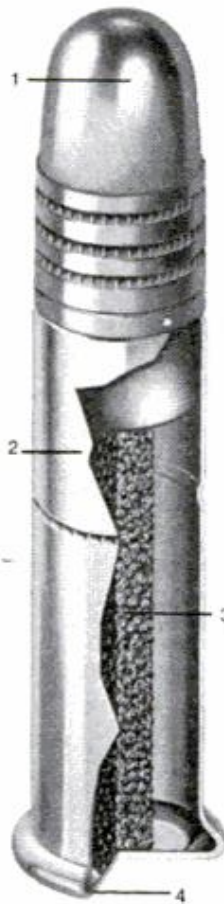

**3. Clean, progressive-burning Ball Powder.** A superior smokeless propellant, Ball Powder is the result of an exclusive Olin manufacturing process, and has been proven by sportsmen around the world for more than 30 years. Ball Powder provides highly uniform ballistics that are especially important for 22 accuracy . . . and gives clean-burning, controlled ignition for progressive burning and fast barrel times. Each Super-X Short, Long, or Long Rifle bullet is powered by a custom-formulated load of Ball Powder, that's custom-measured for optimum velocity, accuracy, and performance.

**4. Non-corrosive priming.** Consistency is the name of the game in compounding the priming that's carefully spun into the rim of every Super-X 22 rim fire cartridge. Consistency means exactly the same primer ignition impulse every time you pull the trigger on Super-X . . . and that spells tight groups at all 22 rim fire ranges. Consistency also means non-corrosive performance you can count on in any weather, for hunting, plinking, or target shooting. Super-X is available now in both Western and Winchester brands. New plastic, all-weather 100-pack also available.

**WINCHESTER-Western** 275 Winchester Avenue, New Haven, Connecticut 06504.



 winchester  
the way you  
want it

Ask for the new  
High Strength Plastic 100 pack

## AUTOMOBILES, DRIVING

- [32 Detroit Listening Post](#)
- [44 Imports and Motorsports](#)
- [83 Trail-bike carrier—sturdy and inexpensive](#)
- [94 PM Owners Report: Plymouth Satellite](#)
- [130 PM Owners Report: Buick Electra](#)
- [155 New stereo match mates for your car](#)
- [164 Saturday Mechanic: Putting ping in its place](#)

## BOATING, OUTDOORS

- [58B Form-fit fillet knife](#)
- [98 Eugene Sloane picks the best bikes for your family](#)
- [134 PM's ideal fishing machine](#)
- [138 What preserver must you pick?](#)
- [141 Inside that rotary-powered outboard](#)

## HOME AND YARD

- [74 Spruce up your patio with indoor-outdoor carpet](#)
- [76 Outdoor furniture easy to build as stacking blocks](#)
- [79 Swimming pool filter you can make](#)
- [80 Weatherproof shelter for your portable grill](#)
- [84 How to test and repair doorbell systems](#)
- [88 How to paint the outside of your home](#)
- [92 How to work with ladders](#)
- [104 How to work magic with moldings](#)
- [142 Bolens QT-16: Big but quiet](#)
- [150 The house that has its furnace in the sky](#)

## SHOP AND CRAFTS

- [66 'Dead-man' switch for your drill press](#)
- [158 How to drill angled holes accurately](#)
- [162 Hints from readers](#)
- [170 Hints from readers](#)

## PHOTOGRAPHY

- [58 Photo hints](#)
- [144 Ultra-versatile electric eye: Miranda's new EE Auto Sensorex](#)
- [147 World's most versatile tele lens](#)

## ELECTRONICS, RADIO, TV

- [155 New stereo match mates for your car](#)
- [180 New motorcycle alarm](#)
- [196 Electronic 'cops' help catch crooks](#)

## SCIENCE, INVENTIONS

- [122 When the next big flood hits . . .](#)
- [150 The house that has its furnace in the sky](#)
- [196 Electronic 'cops' help catch crooks](#)

## AVIATION

- [71 Put yourself in the sailplane pilot's seat](#)
- [127 Breezy little homebuilt: A beginner's dream plane](#)

## EVERY MONTH

- [8 Letters](#)
- [20 Car Clinic](#)
- [30 Homeowners' Clinic](#)
- [40 Science Worldwide](#)
- [48 Appliance Clinic](#)
- [52 All Outdoors](#)
- [61 The Bicycle Shop](#)
- [110 It's New NOW: Latest products and developments \(A 12-page roundup\)](#)

# Popular Mechanics

JUNE 1973 • VOL. 139 No. 6

### INTERNATIONAL EDITIONS

Australia, Caribbean, Denmark, Mexico, Southern Hemisphere, Sweden



[Beginner's dream plane . . . 127](#)



[Sturdy trail-bike carrier . . . . . 83](#)



[Drilling at an angle . . . . 158](#)

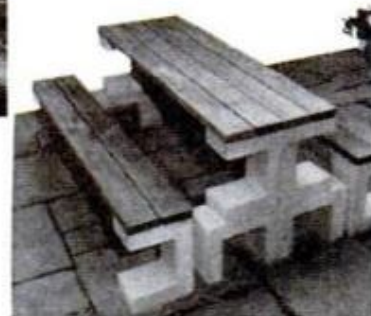

[Easy-to-build outdoor furniture . . 76](#)

### COVER PHOTO:

The Schwinn Deluxe Touring Paramount P10-9, a 10-speed model of the Paramount shown on page 99 in the article, *Eugene Sloane Picks the Best Bikes for Your Family*.

AS A SERVICE TO READERS, *Popular Mechanics* publishes newsworthy products, techniques and scientific and technological developments. Due to possible variance in the quality and condition of materials and workmanship, *Popular Mechanics* cannot assume responsibility for proper application of techniques or proper and safe functioning of manufactured products or reader-built projects resulting from plans published in this magazine.

# HOLD IT



## POWERGUN 1000™ STAPLE GUN

Powerful enough to do any stapling job because it even drives into hardwoods (like Oak) better than other staple guns. Ceiling tile, paneling, upholstery, fencing, insulation, name it — the Powergun 1000 does it. Easily. Sold separately or as a kit. Swingline has a staple gun for your every need.

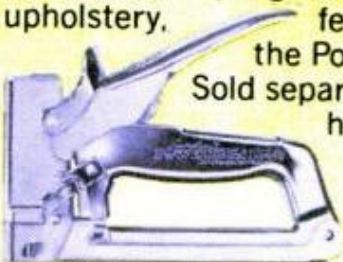

## RIVET-IT™ RIVETING PLIER

It fastens anything to anything professionally — the way the factory does and you've always wanted to! Repairs autos, boats, appliances, cycles, sleds, toys, gutters and spouts, pots, pans. Holds tight. Better than nuts, bolts, screws or solder. Rivets don't come loose. You fasten from one side. Perfect for can't-get-to places. Try it!



## THE LITTLE RED FIXER™

**ELECTRIC GLUE GUN** An easy-to-use all purpose household fixer that repairs in 60 seconds. It's small and fits any hand. Yet, its space-age adhesive makes it big enough to do almost any job. Securely binds combinations of wood, tile, leather, plastic, fabric, metal, masonry, vinyl, inflatable toys, pools, rainwear. Kit includes 29 FixStix. Buy one.



# Swingline®

Swingline, Inc., 32-00 Skillman Avenue Long Island City, New York 11101

# MEET ARIENS 7 MEMBER ENVIRONMENTAL TRAC-TEAM

7 HP  
power  
source

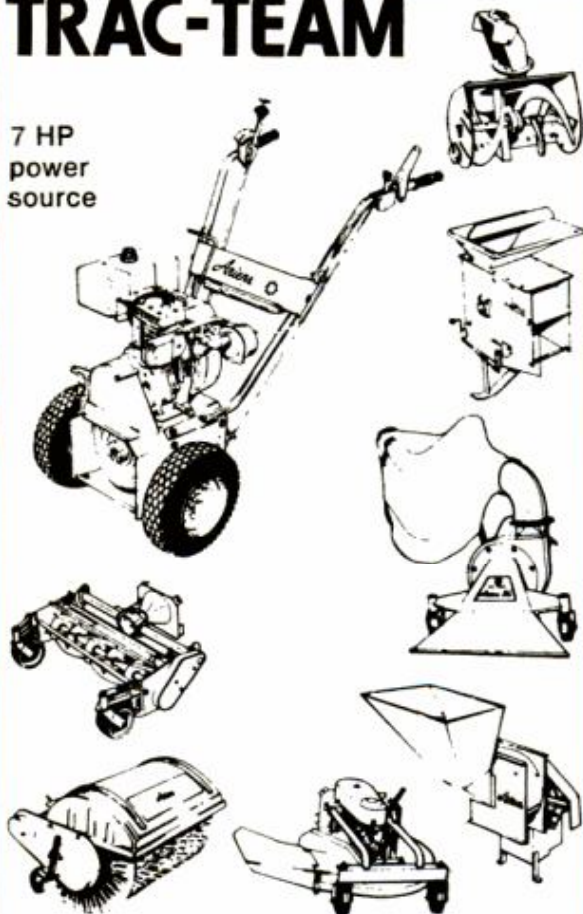

The Ariens Environmental Trac-Team is a single 5 HP or 7 HP power source to which attachments can be added. Seven attachments, namely, a 26" Rotary Mower, 30" Reel Mower, 24" Sno-Thru, 30" Lawn Vacuum, 36" Brush-Sweeper, Shredder-Bagger and a Shredder-Grinder can be added to the 7 HP tractor. A 30" Reel Mower, 20" Sno-Thru and a Shredder-Bagger can be added to the 5 HP tractor.

The Ariens, Four-Season, Environmental Trac-Team offers the ecology minded person an opportunity to start building a year 'round GARD-N-YARD® working team. Write for complete line catalog today.

Ariens Company, 806 West Ryan  
Brillion, Wisconsin, 54110  
Phone 1 (414) 756-2141



A CUT ABOVE THE REST!

# Ariens

## Popular Mechanics

**JIM LISTON**, Editor

**SHELDON M. GALLAGER**, Executive Editor

**JOHN A. LINKLETTER**, Managing Editor

**WAYNE C. LECKEY**, Home and Shop Editor

**ALVIN KIETZ**, Art Director

<b>BILL HARTFORD</b>	Automotive
<b>JOHN F. PEARSON</b>	Science and Engineering
<b>WM. T. McKEOWN</b>	Boating and Outdoors
<b>IVAN BERGER</b>	Electronics and Photography
<b>HARRY WICKS</b>	Home Workshop
<b>STEPHEN WALTON</b>	Assistant, Home and Shop
<b>MICHAEL LAMM</b>	West Coast
<b>ROBERT LUND</b>	Detroit Automotive
<b>GARRY WINTER</b>	Copy Chief
<b>RICHARD H. FUNK</b>	Production
<b>ALFREDO VEGA</b>	Assistant, Production
<b>DON EVANS</b>	Technical Art Director
<b>JOSEPH P. BEATON</b>	Assistant Art Director
<b>DAVID KOMITAU</b>	Assistant Art Director
<b>IRA HERRICK</b>	Assistant Art Director
<b>CLIFFORD B. HICKS</b>	Special Projects
<b>SOPHIE GRONOWICZ</b>	Director, Bureau of Information
<b>EVERETT JOHNSON</b>	Cabinetmaker

**DANIEL J. COLEMAN**, Director of Advertising

**ADVERTISING OFFICES:** New York: 224 West 57th St., 765-6850; Chicago: 520 N. Michigan Ave., 527-2400; Detroit: General Motors Bldg., Trinity 5-8711; Cleveland: 20310 Chagrin Blvd., Shaker Heights, 283-7788; Los Angeles: 601 North Vermont Ave., 606-0263.

**JOHN A. REGINA**, Advertising Production Manager

Published by The Hearst Corporation

**FRANK MASSI**  
President

**JOHN R. MILLER**  
Executive Vice President

**RICHARD E. DEEMS**  
President, Magazines Division

**JOSEPH F. KERN**  
Publisher

**ADDRESS ALL EDITORIAL COMMUNICATIONS TO:** 224 West 57th St., New York, N.Y. 10019. For additional sources of information on the articles and products in this issue, write to Bureau of Information, Popular Mechanics, for free "Where-to-Find-It" list.

**SUBSCRIPTION SERVICE:** Mail all subscription orders, changes of address, correspondence concerning subscriptions, and Postmaster notices of undeliverable copies to Popular Mechanics, Box 646, New York, N.Y. 10019. Please enclose your latest address label for quickest service when writing about your subscription.

**POPULAR MECHANICS IS PUBLISHED MONTHLY** by The Hearst Corporation, 57th St. at 8th Ave., New York, N.Y. 10019, U.S.A., Frank Massi, President; John R. Miller, Executive Vice President; Harrison A. Mitnick, Treasurer; Harvey L. Lipton, Secretary; Richard E. Deems, President of Magazines; Raymond J. Peterson, Executive Vice President of Magazines; William S. Campbell, Vice President and General Manager of Magazines; John F. D'Avolio, Vice President and Resident Controller of Magazines; Albert A. Rachol, Vice President and Director of Circulation; Joseph F. Kern, Vice President for Popular Mechanics. Single copy in the United States and Canada, 60 cents. Subscription prices: United States and Possessions, \$5.97 for one year; \$10.97 for two years; \$14.97 for three years. Canada, add \$2.00 for each year. All other countries, add \$4.00 for each year. When changing address, give old address as well as the new, with postal-zone number, if any, and allow six weeks for change to become effective. Second-class postage paid at New York, N.Y., and at additional mailing offices. Authorized as second-class mail by the Post Office Department, Ottawa, and for payment of postage in cash. Registered as second-class matter at the Post Office at Mexico D.F., Mexico, June 20, 1950. © 1973 by The Hearst Corporation. All rights reserved. Printed in U.S.A.



# Kiss that "nothing" job good-bye forever!

We'll show you how to be a "somebody" in the high-paid world of **ELECTRONICS**

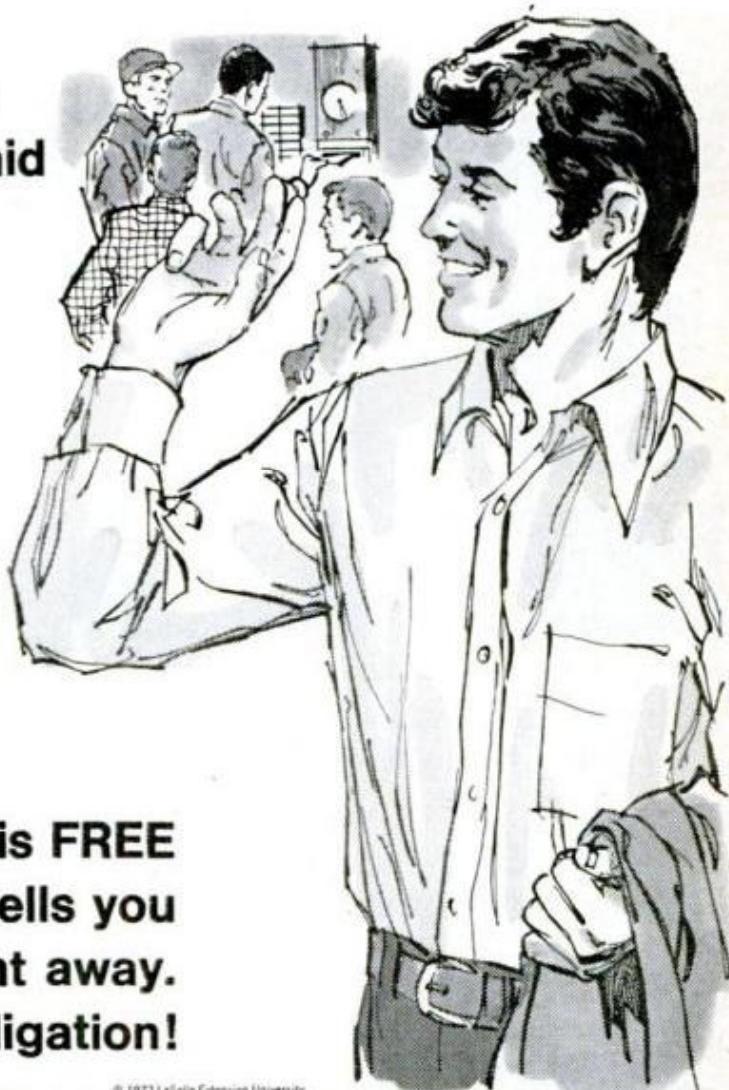
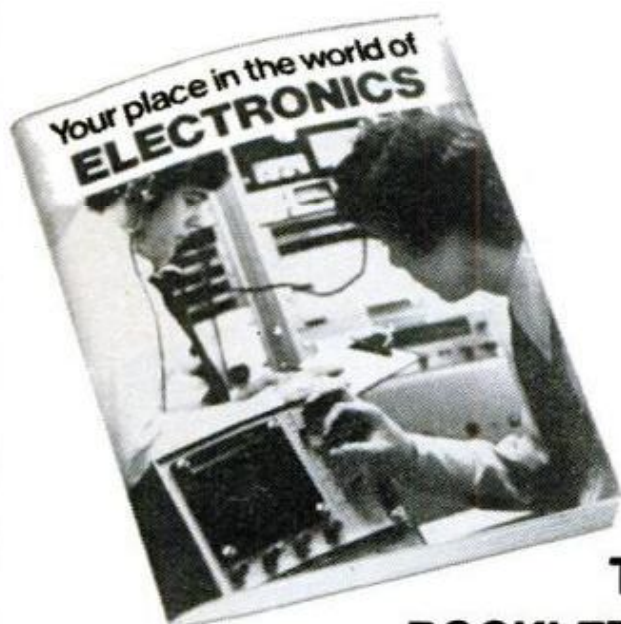

This **FREE BOOKLET** tells you how to get started right away. **No obligation!**

Why stay in a job without a future when there are so many opportunities in the big, exciting world of electronics? That's where the action is today. And you can get into it, too!

Thousands of technicians are needed NOW in TV and radio broadcasting. And in the fascinating new areas of Electronic Crime Detection . . . Electronic Factory Automation . . . Electronic Traffic Control. And many other "world of tomorrow" fields.

LaSalle will train you at home, in your spare time, to start a fascinating, high-pay career in electronics. No previous experience or college

is necessary. Experienced LaSalle instructors teach you basic principles, then lead you step-by-step to practical applications. You even build your own electronics equipment. *Emphasis is on the most modern techniques.* And, if you choose the communication field, LaSalle will prepare you to pass the exam for the FCC license.

Get with it today! Send for free sample lesson and valuable career booklets now. No obligation. LaSalle, 417 S. Dearborn Street, Chicago, Illinois 60605.



## ALL 3 FREE!

FREE sample lesson. FREE illustrated booklet, "Your Place in the World of Electronics", and FREE guide on "How to Obtain Your Commercial FCC License."

© 1973 LaSalle Extension University

## MAIL FOR FREE BOOKLETS

### LA SALLE EXTENSION UNIVERSITY

*A Correspondence Institution*

417 S. Dearborn Street, Dept. 90-071, Chicago, Illinois 60605

YES, I want, free of cost or obligation, your sample lesson and also your two illustrated booklets, "Your Place in the World of Electronics" and "How to Obtain Your Commercial FCC License." I am especially interested in: (check one)

- |  |  |
|--|--|
| <input type="checkbox"/> Communication Electronics   | <input type="checkbox"/> Automation Electronics  |
| <input type="checkbox"/> Instrumentation Electronics | <input type="checkbox"/> First Class FCC License |

Mr. \_\_\_\_\_ Age \_\_\_\_\_  
Mrs. \_\_\_\_\_  
Miss \_\_\_\_\_ (Circle title and please print)

Address \_\_\_\_\_ Apt. No. \_\_\_\_\_

City \_\_\_\_\_ State \_\_\_\_\_ Zip \_\_\_\_\_

04B

# HANDY LITTLE DEVILS FOR NASTY LITTLE JOBS.

Patching . . . caulking . . . whatever the job, top-quality Red Devil tools and chemicals make it easy!

For patching holes and cracks, use a quality spackling compound like Red Devil ready-mixed Patch Paste® — and a Red Devil Putty Knife.

Red Devil Putty Knives are so ruggedly built, you'll never need to replace one unless you lose it!



To seal cracks around tubs, sinks and showers, apply a bead of Red Devil Tub & Tile Caulk from its handy tube. Perfect for resetting loose tiles, too!

It's easy . . .  
with the Devil!

## Red Devil

Red Devil Inc.  
Union, N.J. 07083



## Bore 35 standard holes with just one tool

### New IRWIN Expansive Bit

lets you dial your size

Just turn the dial and you're set to go with this new Irwin Expansive bit. No hunting for the size you need. Fits all hand bit braces. Clean, fast, accurate boring action from  $\frac{1}{8}$ " to 3"—35 standard hole sizes in all!

And what a really fine precision tool to own. It's drop-forged from special bit steel, heat treated full length, machined for accuracy and sharpness, highly polished, too. Two cutters supplied with each bit. Model No. 21 with  $\frac{5}{8}$ " to 1 $\frac{3}{4}$ " boring range also available. Ideal for home handyman, professional woodworker, or farm. See your independent hardware or building supply dealer soon.



No. 22  
Micro  
Dial  
only  
\$6.30

$\frac{1}{8}$ " to 3"  
boring  
range

## IRWIN

every bit as good  
as the name

at Wilmington, Ohio 45177, since 1885

## LETTERS

### TO THE EDITOR

#### Not pollution free

*The First Pollution-Free All-Electric Bus* (page 97, March PM) is not pollution free. No means for producing electric energy is pollution free. We might as well admit we are not able to mine, harvest, manufacture without creating pollution. The thing is to determine what pollution we must accept, then try to eliminate the rest.

SALEM, ORE.

SID BARTLETT

#### Carriage House is just great

The Carriage House built from your plans (*A Back-Yard Storage Building That Isn't an Eyesore*, page 55, March '72 PM) is just great for storing lawn equipment. Our son has lots of fun with friends in the upper bunkhouse, used for storing lawn furniture in winter. Cost was about \$1500, including patio, vinyl siding, heavier frame.



BRIGANTINE, N.J.

JIM KAUFFMAN

Other readers who would like to build this storage building can order Carriage House plans from Popular Mechanics, Dept. CHL, Box 1014, Radio City, N.Y. 10019. Send \$3.95 for one set or \$5.49 for two.

#### Osprey plans and landing gear

While the concept of the Osprey (*Flyweight Flying Boat You Can Build Yourself*, page 78, April PM) is the brainchild of Mr. Pereira, the engineering design was done by me. The concept, design and engineering of the folding wings was mine alone.

Since the right to sell plans is shared equally by Mr. Pereira and me and since only he was listed as a source of Osprey plans, I believe in fairness to me and as a service to readers, you should make known

(Please turn to page 10)



# How to handle your car when you're loaded.

There are times when even the best suspension system can't cope with your car's rear-end sag.

When you tow a recreational vehicle. Or a horse trailer. Or a boat. Or a snow-mobile. Or any off-road vehicle.

When you overload the rear end of your car, or wagon, or pick-up-truck—with people, luggage, tools, samples or equipment.

The sensational new Scovill Load-Tamer works with your air shocks to keep your car on the level. No more sag. No more drag. You accelerate better, corner better, steer better. Your headlights aim properly. Your tires wear better. In short, you get a safe, reliable, comfortable ride.

Scovill Load-Tamer adjusts your air shocks to compensate for any load in the rear. You just set a dial, conveniently located on the instrument panel, and your air shocks

automatically adjust to any load condition. You can inflate or deflate them, from 20 PSI to 150 PSI, in two to three minutes, even while you're driving.

Scovill Load-Tamer automatically shuts off when the desired pressure is reached and your car is riding level. It automatically restores lost pressure, protecting you against minor system leaks or bleed-off peaks. It works with any air shocks: Delco Pleasur-Lift, Gabriel Hi-Jacker, Columbus Levelizer, Monroe Max-Air and Ride-Leveler, Goerlich Thruway Air Adjustable, Air Shox, CureRide, Weight-Lifter. Any air shocks!

Ask for the Scovill Load-Tamer wherever air shocks are sold or serviced. (For the name of a place near you, write to the address below.)

Suggested retail \$59.95, plus installation. Small investment to let you handle your car safely when you're loaded.

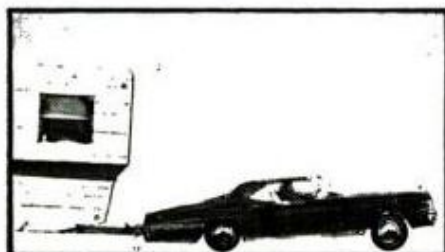

To prevent rear-end sagging and dragging,

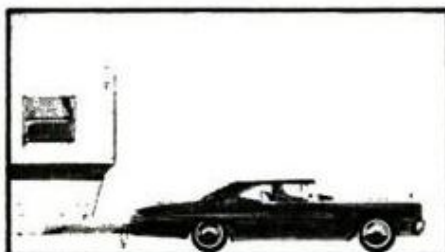

Scovill Load Tamer keeps your car on the level.

## Scovill load-tamer

Auto Load Leveling System.  
It lets you control your air shocks.



Scovill Manufacturing Company, Automotive Products, Scovill Square, Waterbury, Conn. 06720  
Load-Tamer is a trade mark of the Auto Load Leveling System made only by Scovill Manufacturing Company

## LETTERS

(Continued from page 8)

that plans are available from me (Jet Plans, 1800 Carmelo Drive, Carmichael, Calif. 95608). In addition, a tricycle landing gear has been designed and engineered (but not tested). Plans for this gear are an additional \$4 when purchased with Osprey plans (total: \$69) or \$25 separately. CARMICHAEL, CALIF. J. EUT TILESTON

### First step in remodeling: Build a pool table

Thanks for the plans for the low-cost, well engineered pool table (*\$300 Pool Table for \$107*, page 63, Jan. *PM*).

We added a ball return, made from short lengths of 3-in. plastic sewer pipe glued together. We also added two supporting braces from the table bottom to the stand's



cross member to stop endwise movement. We painted the legs and sides, eliminating the cost of plastic laminate, but even at that the cost was a hair under \$120.

We also remodeled the basement to make room for it.

NEW PLYMOUTH, IDAHO DARRELL HOLBROOK

### Electronic calculators

Please expand upon *Electronic Calculators: How to Choose the Right One* (page 86, Feb. *PM*) with a comparison table of, say, 40 or 50 models. Also discuss more sophisticated models you can program for finding algebraic unknowns or trig functions.

DES MOINES, IOWA RICHARD E. LEONARD

*We originally planned a table for the article, but got bogged down in the hundreds of models available. Even 40 to 50 models would take too much space to cover properly—and by the time the article appeared, many of those models would have been replaced by newer ones (the calculator market is very volatile). As to more sophisticated calculators, a report on one is coming.*

### Quicker rewinder

After seeing *Cassette-Tape Rewinder* (page 144, Jan. *PM*), I decided to write about my idea. An ordinary Bic ballpoint pen with a hexagonal barrel may be used to wind a



cassette tape cartridge forward or backward. Since there isn't any slippage, the pen may be quickly spun with your fingers. NILES, ILL. DANIEL R. WEAVER

### Lightweight brakes for Teenie Two

Your readers might be interested in a lightweight hydraulic brake system developed for the *Teenie Two* (page 94, May '71 *PM*). It could as well be applied to other small aircraft or other wheeled vehicles.

I have arranged to obtain copies of full-scale drawings and close-up photos at \$8.25 per set. My address is 6705 Grosvenor Pl., Indianapolis, Ind. 46220.

The unit has the same effect as a disc brake in its action. The total system weight is 3.3 pounds, and it can easily be produced on a lathe. Parts, except for steel pistons, are aluminum. O-rings do the sealing, and 1/8-in. thinwalled brass tubing is used for the plumbing and standard fittings. The "discs" are 5-in. steel V pulleys with centers removed and fastened with spacers to the wheels.

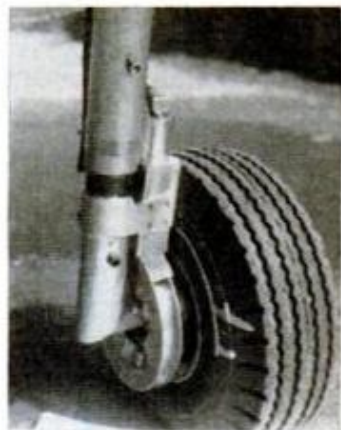

INDIANAPOLIS, IND.

LEON LINN

### Bicycle enthusiast

Your series on bicycle repairs is really valuable and helpful. I am a bicycle enthusiast who likes to do his own repairs, and it saves

(Please turn to page 12)

# True Grit. When ordinary blades can't cut it.

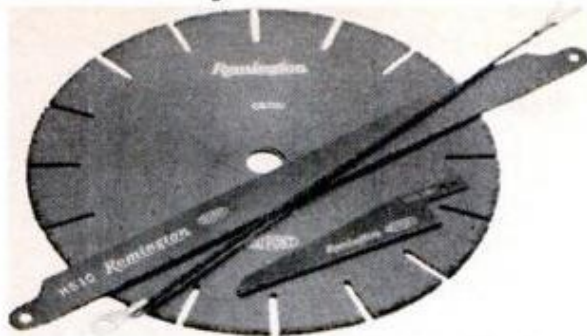

**GRIT  
EDGE**

When ordinary blades can't do the job, Remington "Grit-Edge" blades take over. They take the tough out of tough jobs, saw through "unsawable" materials. How? Hundreds of tungsten carbide particles permanently bonded to the blades make them a match for materials that usually call for expensive diamond or solid tungsten carbide toothed blades. And if that isn't true grit, what is?

Remington "Grit-Edge" blades are available for Hack-saws, Saber Saws, Circular Saws, Bandsaws, and as a Rod Saw. The only thing ordinary about them is their low cost, which is a bargain considering their long life and the jobs they do.

For more information, see your hardware dealer or write: Grit-Edge Products, Dept. 197, Remington Arms Company, Inc., Bridgeport, Connecticut 06602.

**Remington** 

"Remington" is a trademark registered in the U. S. Patent Office.  
"Grit-Edge" is a trademark of the Remington Arms Company, Inc.

## RECOMMENDED CUTTING APPLICATIONS FOR "GRIT-EDGE" BLADES

Material	Rod Saw	Hack-saw	Saber Saw	Circ. Saw
Ceramic Tile	X	X	X	
Slate	X	X	X	
Marble	X	X	X	
Flagstone	X	X		
Brick	X	X		
Glass	X	X		
Fiberglass	X	X	X	X
Tempered Hardboard			X	X
Asbestos Cement	X	X	X	X
Composition Board			X	X
Synthetic Marble	X	X	X	X
Plywood			X	X
Plaster			X	X
Counter Top Material	X	X	X	X
Hardwood Flooring			X	X
Stranded Cable	X	X		
Spring Steel	X	X		
Hardened Chain	X	X		
Stainless Steel	X	X	X*	
Tailpipe Bolts	X	X		
Cast Iron	X	X		

\*requires coolant and variable speed machine.



are you headed for a time-clock number?

...or a BIG PAY place in

# AIR CONDITIONING

40,000 new servicemen needed  
...you can be one of them

Air conditioning, refrigeration and heating is one of America's fastest growing fields. Service and installation technicians are in desperate demand.

And you can join this force of men making big money right now by becoming a skilled technician with our help.

Top men are making 2 and 3 times more than unskilled workmen. Yet we can teach you these skills so quickly you'll be earning money long before you've finished learning.

### AMERICA'S FOREMOST COURSE AT A MATCHLESS LOW PRICE

Learning at home is hailed by educators as being far superior to classroom work with all its mass production and distractions.

In our fine, professional 100-lesson textbook course you will receive the clearest instructions in unmistakable simple language. Plus self-projects, self exams and graded exams.

Directed by Roy Anderson whose experience with home study and Army-Air Force training goes back to 1935, we

have prepared material that will turn out top-notch graduates. And we do it at a cost so much lower than any comparable course that you simply will not believe it possible.

One way we do it is by not loading our students with costly equipment and tools—most of which you probably already have, or can buy locally for less than some schools charge you!

The Liberty School is a fine, professional and very intimate institution of learning-at-home, supervised in every tiny detail by Mr. Anderson.

We can't begin to tell you all of the advantages in this small space—but we'll give you all the details if you send in your name and address. Remember, we have NO salesmen, so no one will bother you. In the privacy of your room you can study the description of our lessons and make up your own mind without any pressure whatsoever.

A big pay future is waiting for you—grab it now.

**LIBERTY SCHOOL Dept. J-6**  
1111 W. Park, Libertyville, Illinois 60048

Be Your Own BOSS course includes directions on How to Own  
YOUR OWN Business!



Roy Anderson  
LIBERTY SCHOOL, Dept. J-6  
1111 W. Park  
Libertyville, Illinois 60048

**SEND ME YOUR NAME AND ADDRESS**  
—I'll rush you FREE details by mail.

Dear Mr. Anderson: Please send me description of your course on AIR CONDITIONING, REFRIGERATION AND HEATING. I understand this places me under NO obligation and that NO salesman will call.

Name \_\_\_\_\_ Age \_\_\_\_\_  
Address \_\_\_\_\_  
City \_\_\_\_\_ State \_\_\_\_\_ Zip \_\_\_\_\_

# Power Steering and Tilt-Wheel Steering: Getting to campsite can be a darn sight easier.



This comfort-and-convenience package can help make your camping trips easier and more enjoyable.

**Power Steering.** Order it on your Chevrolet or GMC camper and you'll find steering effort is reduced, handling is improved. Great for wheeling into tight parking places or traveling rough back roads.

**Tilt-Wheel Steering.** Order it and you can move the steering wheel up, out of the way, for easy entry and exit. Then you can adjust the wheel to your most comfortable driving position. And keep changing wheel positions *while you drive* ... without pulling off the road. Great idea to help reduce fatigue on long trips.

Visit your Chevrolet or GMC Truck dealer and tell him you want a demonstration of Power Steering and Tilt-Wheel Steering.  
Saginaw Steering Gear Division,  
General Motors Corporation

**SAGINAW** POWER STEERING  
TILT-WHEEL STEERING



## LETTERS

(Continued from page 10)

me a lot of money. Also, doing my own repairs gives me a sense of accomplishment. I find most repairs aren't very hard with proper directions (such as yours); they are just time-consuming.

How long has your *Bicycle Shop* been running, and how long do you plan to continue printing it?

OAKLAND, CALIF.

RANDALL MCKIBBEN

*Eugene Sloane's Bicycle Shop started in our March '72 issue (page 76) and will continue as long as people ride and repair bicycles.*

### Not from an assembly line

Regarding the comment that the "American Mercedes" . . . came off the assembly line in Long Island City" (*Imports and Motor-sports*, page 52, Feb. PM), let me say they were *not* produced on an assembly line.

One of my teachers in school helped assemble them, and he told us about them. The parts would not fit, so they had to remake many of them. There must be one or two living on Long Island whose fathers worked on them.

NORTH WEBSTER, IND.

HAROLD A. LEACH

### The price is not right

In describing our Drain King (*Super Duper Drain Declogger*, page 95, April PM), you gave the wrong price. The correct



price is \$4.95 ppd. Readers can order it from G.T. Water Products, Inc., Box 44156, Van Nuys, Calif. 91412.

VAN NUYS, CALIF.

G.T. WATER PRODUCTS

### How to get those 90° corners

As a beginner in woodworking, I find it very fascinating. However, I've had a problem with plywood. Recently, I purchased a 4x8 sheet and found that the corners are

(Please turn to page 14)

# When you want the very best stereo without paying the highest price

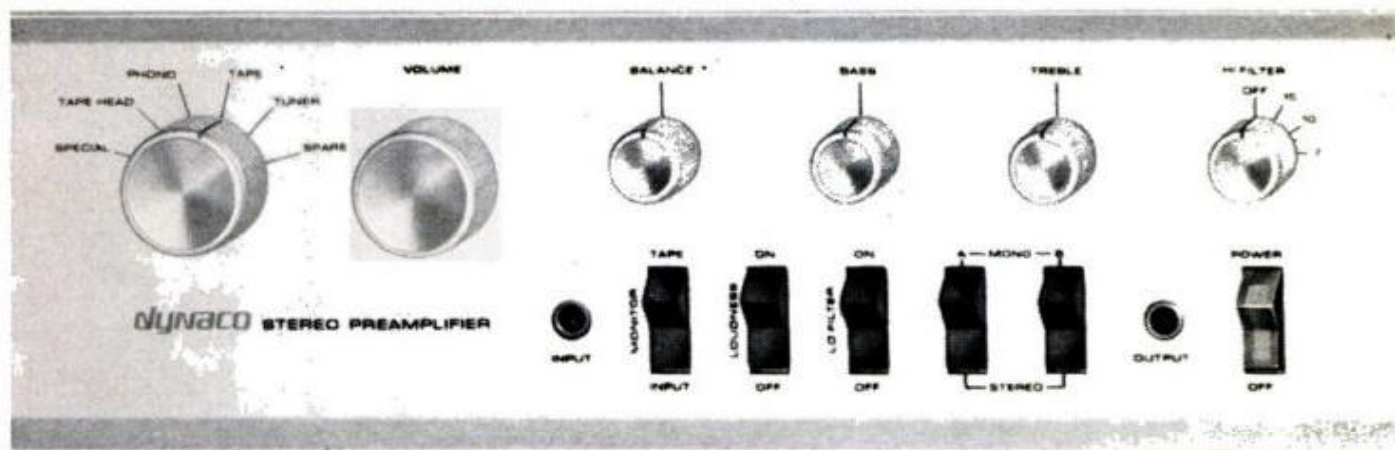

PAT-4 Preamplifier

## BUILD A DYNAKIT

The experts agree that Dynakits deliver pure performance that match the most costly components. A few evenings of your time brings you substantial savings with unparalleled listening satisfaction. It's easy, fun and educational. Advanced engineering, with functional simplicity which is a hallmark of Dynaco's designs, add a special satisfaction for you who appreciate excellence.

It's much easier to build a Dynakit. Thoroughly proven circuits, supplied preassembled and tested on fiberglass etched circuit boards, leave only the mechanical assembly and interconnection to you. Detailed step-by-step instructions with easy-to-follow pictorial diagrams clearly show every connection. In high fidelity stereo or 4-channel sound there is no match for Dynakit value.



A-25  
Loudspeakers



SCA-80Q  
Amplifier



AF-6  
AM-FM Tuner

Gentlemen:

PM

Please send new 1973 full color catalog.

Name \_\_\_\_\_

Address \_\_\_\_\_

City \_\_\_\_\_ State \_\_\_\_\_ Zip \_\_\_\_\_

***DYNACO INC.*** Division Tyco  
3060 Jefferson St., Phila., Pa. 19121  
Also available in Canada  
from Dynaco of Canada, Ltd.

# LIQUID WRENCH



Liquid Wrench is the super-penetrating rust-solvent that loosens rusted nuts, bolts, screws and parts—in seconds! Safe on all metals, use it on a bulldozer or even your watch!



Lan-Lin gets down deep—removes paint, grease, grime, ink!

Trans-Medic stops transmission troubles! You'll feel the difference!

RADIATOR SPECIALTY CO., CHARLOTTE, N. C. 28201

Look for

## GUNK

when you want to clean anything!

... like engines, power mowers, concrete driveways, parts.

There's a **GUNK**

product for almost any degreasing job in factory, shop or home.



Engine Brite Engine Cleaner. Spray it on... hose it off! "Dirt and grease wash away."



B.O.P. Small Parts Cleaner with dip basket... soaks parts clean.



GP cleans oil, grease, dirt from garage floors, driveways, power mowers, machinery.

GUNK LABORATORIES, 5829 W. 56, CHICAGO, ILL. 60638  
Gunk Chicago Co. Radiator Specialty Co.  
River Forest, Ill. Charlotte, N. C.

## LETTERS

(Continued from page 12)

not 90°. How can I be sure of getting 90° corners all around?

MISHAWAKA, IND.

DAVID C. CERRI

If you have a large table saw, you can use it to square the end of a 4x8 by first tacking a guide strip to the underside of the panel to ride the edge of the saw table. However, because a 4x8 weighs a "ton" and is unwieldy for one person to handle, it's easier to true up with a sabre saw or portable circular saw. As before, you should clamp or tack a guide strip to the top of the panel, square with the edge, and guide the saw along the strip.

### Compressed-air buses?

To fight pollution in towns, why not use compressed-air-propelled public transportation? Compressed air is currently used in propelling torpedoes and mine locomotives, and I think it could be used for urban transportation as well.

Buses could be equipped with bottles of sufficient capacity to cover the range from terminal to terminal. The bottles could be refilled in one or two minutes from a large bottle charged by an electric compressor.

TURIN, ITALY

GEORGE M. CHINAGLIA

### Dinner plate is a no-no

Once in a while, I see hints printed that suggest using a metal-foil TV dinner plate to hold small articles when you're working on a project. This suggestion is a no-no around electric and electronic equipment; it's a shock hazard and might also cause damage to your equipment.

HAMMONTON, N.J.

H. B. DILKS

### Stripper won't bevel, too

I would like to know what kind of wire stripper will strip wire and leave the insulation beveled as shown in the "right way" (*How to Cut, Splice and Connect Wires*, page 138, March *PM*). It's possible with a large wire, but you show a No. 12 or No. 14.

GRANADA HILLS, CALIF.

H. G. THOMSEN

There is no such tool. Beveling must be done with a knife after stripping—and it can be done only on large wire. ★ ★ ★



# Your son could get a lot more than enjoyment from a Daisy B-B Gun.



A Daisy is a gun, not a toy. And they are made for boys who are ready to treat them like guns.

If you have a son who wants a Daisy, there are two questions we'd like you to ask yourself.

First, is he ready for it?

Second, what will you and your son get out of it?

You're the only person who can answer the first question. But we'd like to answer the second one.

With your help, your son can get a lot out of a Daisy.

He can start with one of our lighter models. Then move up to a larger model that resembles a big-game gun or western carbine.

Later he may want to move up to a pump-up air rifle, or CO<sub>2</sub> Gun.

A Daisy is the best way in the world for a boy to learn the lessons of marksmanship and proper gun handling. Lessons that also teach patience, responsibility and respect.

You'll get something out of it, too: the pleasure of watching your son learn and grow with his Daisy.

Think about it.

If your son is ready for a Daisy, we'll have a Daisy ready for him.

**Daisy**  
SINCE 1886

**The B-B Gun every boy dreams about.**

Division Victor Comptometer Corporation, Rogers, Arkansas 72756

## OF POPULAR MECHANICS



### Storage building can double as playhouse

We offer plans for three back-yard storage buildings to relieve your garage of clutter. Double doors let you store your mower, lawn furniture, bulky items. The kids—and neighbors—will love these attractive "houses."



### 150-mph karting: Your chance to be a racer

Karting has come a long way from lawnmower-engine days. It's now a high-speed sport that still lets the low-budget guy compete. Here's how you can do it.



### How to get more outdoor living space

Decks can provide valuable outdoor living areas on steep lots—or transform shaded back-yard areas that can't support a lawn properly. We offer all the basics you need for construction.

### How to troubleshoot an air conditioner



What you learn from this article (by an expert) may save you money and the trouble of lugging your unit to the shop. You'll want to clip and save it as a valuable reference.

### Hutch-table you can build

The top of this Early American table flips back to reveal a "hutch" beneath. With the top raised, it takes little space against a wall. Complete plans.



A leg-powered machine for easy swimming. • Homebuilt aircraft: two-seater with dual controls • Four electronic kits for your car • New line of boat ropes • Owners reports on Chevy El Camino and Ford Ranchero • New aircraft autopilot • PM tests J.P. Penney's newest circular saw • How to replace disc brake pads • Commemorative guns.

**Buy it on your newsstand. Better yet, make sure you'll keep getting this kind of exciting fare. Send this coupon with your check to:**

**POPULAR MECHANICS**  
250 West 55th Street  
New York, New York 10019

Please enter my subscription for  1 yr. \$5.97 or  2 yrs. \$10.97

Name \_\_\_\_\_ (Please print)

Address \_\_\_\_\_

City \_\_\_\_\_ State \_\_\_\_\_ Zip \_\_\_\_\_

Payment of \$ \_\_\_\_\_ is enclosed.  New  Renewal

On new subscriptions, first copy will arrive in about 8 weeks.

(Above prices apply in U.S. and Possessions only. Canada, add \$2 per year. All other countries, add \$4 per year.)

WPM3F1

# Grande Canadian.

From the last North American frontier.

From the pride  
of a rugged land, from  
rich Canadian grains,  
from glacier-pure water,  
comes Grande Canadian.

**Made smooth  
from selected  
Canadian Whiskies.**



EIGHTY PROOF ©GRANDE CANADIAN IMPORTS CO., NEW YORK, N. Y.

# Find the answers to 1001 workshop questions

## quickly, easily with the POPULAR MECHANICS MASTER SHOP GUIDE

24 hangup boards, coated with wipe-clean plastic keep vital how-to-do-it information always at your finger tips.

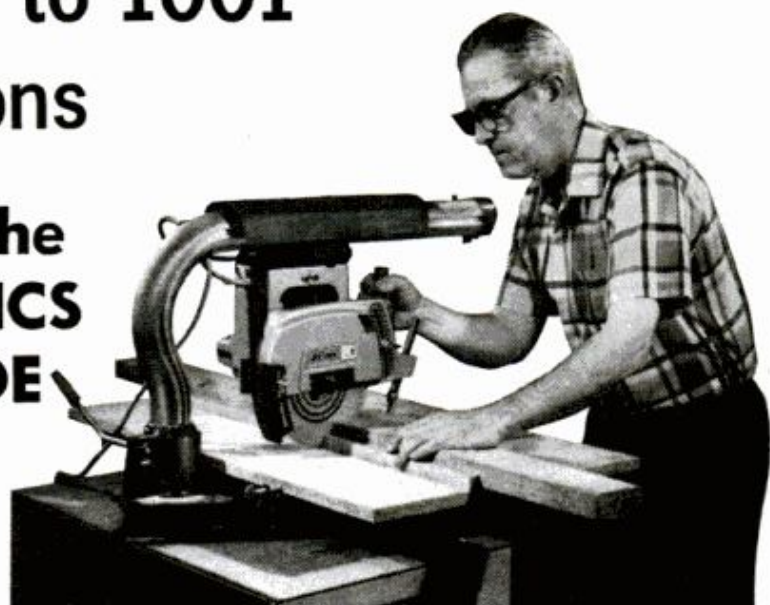

Here in an easy to use, last-forever format are the answers to everything you'll ever need to know about: nails, screws, bolts, wall-fasteners, drills, abrasives, lumber, hardwoods, moldings, plywood, hardboard, gypsum, adhesives, plumbing, electrical work, floor and wall tile, glass. Facts on remodeling measurements, gutters, concrete, garden chemicals. Plus—all on one board—a ruler, protractor, 45-degree triangle, and compass for accurate circles! You'll reach for the MASTER SHOP GUIDE for every job you tackle!

What nail should you use? How many pounds will a 1/4-inch toggle bolt hold? How can you save money ordering lumber? What size quarter-rounds are available? How do you bleach close-grained hardwoods? What glue is best?

Repairs, too! Illustrations on plumbing, electrical, floor or wall tile, plastic laminates, glass, remodeling. All the basic dimensions you'll need!

By the editors of *Popular Mechanics*—order yours now—you'll use it the rest of your life!

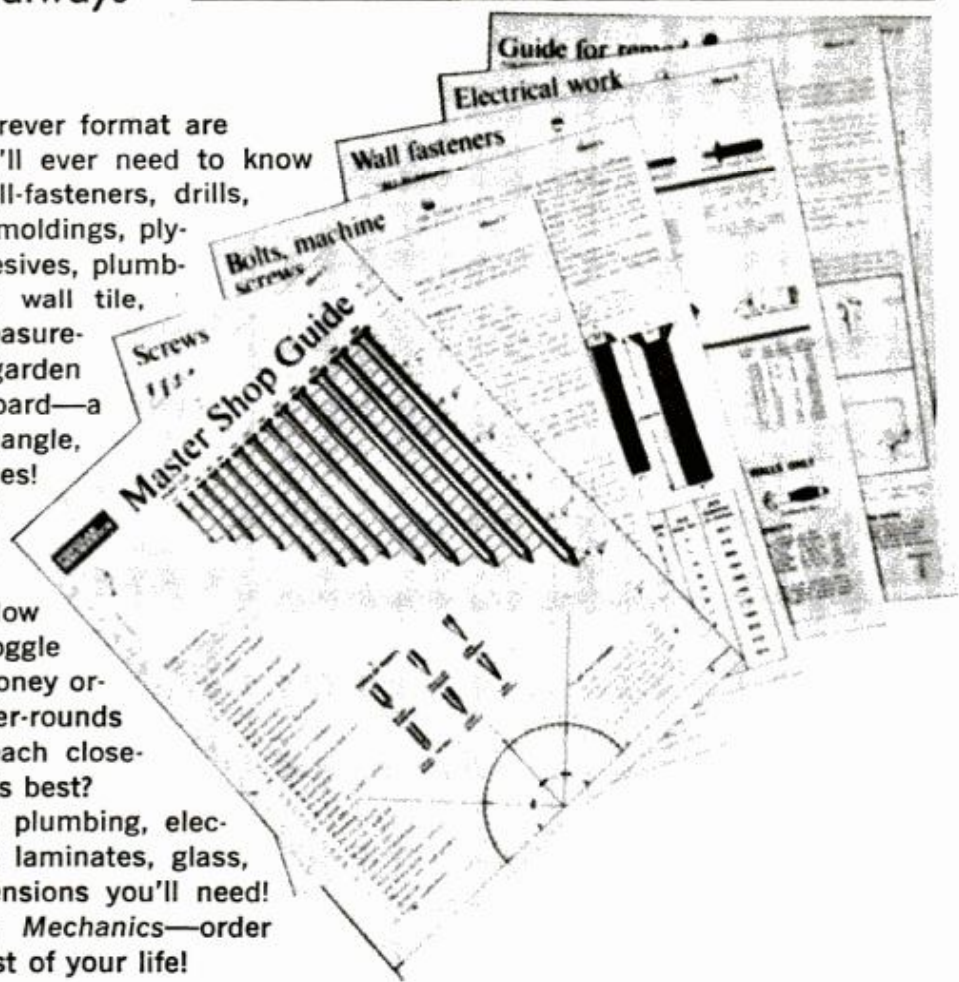

Popular Mechanics  
P.O. Box 1014 Dept. SG  
Radio City, New York 10019

Rush me \_\_\_\_\_ sets of the  
MASTER SHOP GUIDE.

I enclose check or money order  
for \$3.95 for each set ordered.

NAME \_\_\_\_\_

ADDRESS \_\_\_\_\_

CITY \_\_\_\_\_ STATE \_\_\_\_\_ ZIP \_\_\_\_\_

If you've ever said...

# "There must be a better way to earn a living..."

one of our free Career Guidance Booklets may provide the opportunity you've been looking for.

It happens to all of us, sooner or later. No matter what kind of job we have.

One day, it suddenly strikes home that—like it or not—we're going to have to work for a living, the rest of our lives. And most of us are horrified at the thought of forever being locked into the jobs we now hold.

"Surely," we tell ourselves, "there must be a way to earn enough extra dollars each month to balance the family budget. Surely, there must be a way to get the kind of position where you don't have to worry about job security. Surely, there must be a way to get a job that offers greater opportunity for advancement, and more job satisfaction."

"Surely," in other words, "there must be a better way to earn a living!"

If you, too, have been thinking these thoughts lately, you'll find one of our free Career Guidance Booklets very helpful at this time. We invite you to send for one.

Your free booklet will describe the opportunities for higher income and greater job security you might



expect in one of the career fields listed on the attached card or coupon below. It will also explain why ICS can prepare you for this new career field . . . right in your own home . . . in your spare time . . . *regardless of your education or past experience.*

In addition, you will receive a free "Demonstration Lesson" that lets you see why preparing for a rewarding career—the ICS way—may be a lot easier than you think.

Please bear in mind, as you fill in the attached postpaid card or the coupon below, that ICS has a long and distinguished record of success as a career training organization. In fact, more than 8,500,000 men and women have turned to ICS for career training, since 1891.

ICS has provided training programs for various divisions and branches of companies like Ford; U.S. Steel; Chrysler; Mobil; DuPont; etc.

ICS Career Training is approved for Veterans and Servicemen under the new G.I. Bill, and is Accredited by the Accrediting Commission of the National Home Study Council.

In short, ICS training methods are valued and respected not only by ICS graduates . . . but also by leaders in Business, Industry, Government, and Education.

Now it's your turn to discover how ICS training can start you in a rewarding new profession. Just fill in the attached postpaid card or coupon below, and mail it today for your free Career Guidance Booklet and free "Demonstration Lesson."

(If card is missing, please fill in the coupon below and mail it to: ICS, Scranton, Pennsylvania 18515.)

Keep this certificate when you mail the coupon for your free Career Guidance Booklet and "Demonstration Lesson"

This certificate symbolizes the long and distinguished record of success that ICS has enjoyed as a Career Training Institute. It is your assurance that ICS stands ready to serve you, just as it is serving individuals, business and industry of the world.



**ICS** International Correspondence Schools  
Scranton, Pennsylvania 18515

RA739X

Please send me a free Career Guidance Booklet, and a free "Demonstration Lesson" for the field I have checked. I understand I am under no obligation.

- |  |  |  |  |
|--|--|--|--|
| <input type="checkbox"/> Accounting                                      | <input type="checkbox"/> Communications/<br>Broadcasting/Elec-<br>tronics Specialist | <input type="checkbox"/> FCC Licensing                       | <input type="checkbox"/> Restaurant/Club<br>Management   |
| <input type="checkbox"/> Air Conditioning/<br>Refrigeration &<br>Heating | <input type="checkbox"/> Drafting  | <input type="checkbox"/> Hotel/Motel<br>Management           | <input type="checkbox"/> TV Repair and<br>Servicing  |
| <input type="checkbox"/> Airline/Travel                                  | <input type="checkbox"/> Electrician   | <input type="checkbox"/> Income Tax<br>Specialist            | <input type="checkbox"/> High School<br>Division (For<br>students who want<br>to earn a High<br>School Diploma.) |
| <input type="checkbox"/> Automotive<br>Mechanics                         | <input type="checkbox"/> Electronics<br>Technician                                   | <input type="checkbox"/> Interior Decorat-<br>ing and Design |  |
| <input type="checkbox"/> Business<br>Management                          | <input type="checkbox"/> Engineering   | <input type="checkbox"/> Production<br>Management            |  |
| <input type="checkbox"/> CATV/MATV<br>Electronics<br>Specialist          | <input type="checkbox"/> Check here for special information if age 16, or under.     |  |  |
| <input type="checkbox"/> Computer<br>Programming                         |  |  |  |
| <input type="checkbox"/> Computer<br>Servicing                           |  |  |  |

Name \_\_\_\_\_ Age \_\_\_\_\_

Address \_\_\_\_\_ Apt. no. \_\_\_\_\_

City \_\_\_\_\_ State \_\_\_\_\_ Zip \_\_\_\_\_

Approved for Veterans' Training. Eligible Institution under the Guaranteed Student Loan Program. Accredited Member National Home Study Council. Canadian residents use coupon address for service from ICS Canadian, Ltd. In Hawaii: 931 University Ave., Honolulu, Hawaii 96814

## CAR CLINIC

BY MORT SCHULTZ

### Red-hot transmission

*The transmission in my Mercury Montego station wagon heats up so bad that it smells as if the bands are burning. Transmission fluid turns a dark brown. The unit has been disassembled by a local Ford agency, but nothing seems wrong. Please help.—P. B. Hoyt, North Bennington, Vt.*

Are you carrying or pulling a heavy load? If you are, then I would consider adding an auxiliary transmission oil cooler. A local radiator shop can help. If load is normal and you don't pull a trailer, then maybe there is a restriction in the onboard transmission oil cooler. This cooler, which is located in the bottom tank of the radiator, assists in cooling transmission fluid. I would have a radiator specialist drop the bottom tank of the radiator and check for clogging.

If the cooler is fouled, replace it. You will not have to buy a new radiator—just a new cooler.

### In a fog

*The windshield of my 1970 Toyota Corolla fogs from body heat alone in cold weather. If I turn on the heater-defroster, the back windshield fogs, which is dangerous. Leaving windows closed or cracked makes no difference. Ten thousand blessings if you can help.—Mrs. Arlette Miller, Decatur, Ill.*

I can't tell if you are using the heater in the right way, but if you aren't you'll stay in a fog. The two important settings are RECIRCULATE and FRESH. RECIRCULATE provides rapid heat by circulating and heating air already in the car. FRESH draws in air from the outside. If you keep the setting on RECIRCULATE, all you'll be doing is pushing moist air around, and that will fog the windows.

The proper way to use this control is to set it on RECIRCULATE to get rapid heat, but as soon as the rear window starts fogging, switch over to FRESH. Set the control

to give highest heat to get maximum defogging.

### Rattling around

*Unless I hold the shift stick by hand, it rattles in second and third gears. The car is a 1969 Karmann Ghia. The VW dealer installed a grease fitting and filled something with grease. It didn't help. Any ideas?—M.D. Edwards, Memphis, Tenn.*

He filled the shift coupling, which may be worn. The grease treatment, if effective at all, is only temporary. The shift coupling should be replaced.

Another reason for the rattling noise may be worn or out-of-round nylon bushings along the shift tube. This, too, is fixed by replacement.

### Inclined to trouble

*If the parking brake of my 1972 Ford Gran Torino station wagon isn't applied hard before I move the shift lever from DRIVE to PARK, it takes a Herculean effort to shift out of PARK.*

*One time my wife parked on a gradual incline and shifted to PARK before applying the parking brake. I had to have the car towed to my dealer and repairs made. The dealer says that he has received no instructions from the factory on how to correct this. Is he right?—Roger T. Patterson, Bristol, N.H.*

That he is. Parking a car with automatic transmission takes care. Obviously you are parking on some sort of incline. If you don't set the brake first, the car will roll back a few inches, which will put the full weight of the vehicle on the parking pawl, making it tough to shift.

When parking, you should apply the foot brake firmly, set the parking brake firmly

*(Please turn to page 22)*

©1971 R. J. Reynolds Tobacco Company, Winston-Salem, N.C.



**Today, a man needs a good reason to walk a mile.**

**Start walking.**

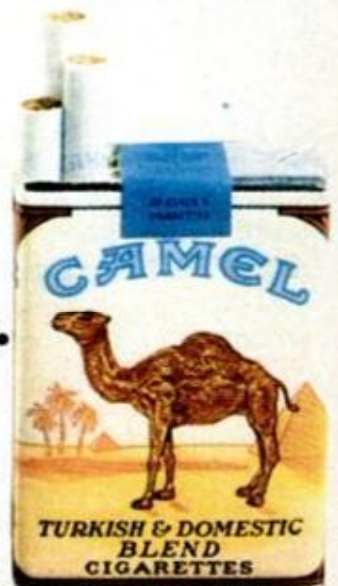

Warning: The Surgeon General Has Determined That Cigarette Smoking Is Dangerous to Your Health.

25 mg. "tar," 1.6 mg. nicotine av. per cigarette, FTC Report FEB. '73.

Материал, защищенный авторским правом

## CAR CLINIC

(Continued from page 20)

and then, with both brakes applied, shift from DRIVE to PARK.

### High Idle

I own a 1970 Chevrolet Monte Carlo. It has a 400-cu.-in. 265-hp engine with a two-barrel carburetor and four-speed transmission. When the engine is cold, it idles at about 2200 rpm, which is much too fast. There is no fast-idle adjustment on the carburetor, and the dealer tells me that I'm stuck with it unless I install a manual choke. How about it?—Chris J. Prange, Waupun, Wis.

Your dealer is mistaken in telling you that there is no way of making a fast-idle adjustment on this carburetor. If he consults page 6M-25 of the Chevrolet overhaul manual he'll see that rpm can be decreased by backing out the idle-speed screw that controls the fast-idle cam. However, the specified fast-idle speed for this engine is 2200 to 2400 rpm!

### Blackout

My problem with a 1968 Oldsmobile 98 is electrical. The voltage regulator clicks with a vibration sound that can be heard inside the car. If the lights are on, they will go dim as to be almost out when I slow down and stop. On acceleration, they come back to full brightness. The battery has been tested, the voltage regulator replaced and the alternator checked. What now?—Hugh Lewis, Coshocton, Ohio.

Look first for a loose drive belt and see to it that carburetor idle is set to specification. Then check to see if the regulator is grounded properly by wrapping one end of a ground wire around one of its mounting screws and attaching the other end to a clean ground on the engine. If the regulator is in good condition and grounded properly, this trouble shouldn't exist unless there's something wrong inside the alternator.

### Roaring Beetle

For those who may find themselves in a predicament similar to mine of hearing a strange, exhaust-type roar coming from their VW, may I suggest they check the air-cooling fan for the engine? They may find that the label affixed to the fan shroud which shows the valve clearance has lost its adhesiveness and has fallen over the louvers. This creates a loud roar while the engine is running at speeds other than idle. I hope this personal experience may save someone worry and costly repairs, either from a crooked mechanic who wants to make something out of nothing or from the engine overheating because of a reduction in air flow.—David L. Sullivan, Kansas City, Mo.

Good tip on how to keep a Beetle from driving you buggy. Thanks, Dave.

## SERVICE TIPS

● According to the Rubber Manufacturers Assn., a two to four-pound increase in the tire inflation cold pressure recommended by vehicle manufacturers for normal service will result in "more mileage and a better wear pattern for belted-bias and radial tires." However, you should not exceed the maximum cold inflation pressure (load) which is molded on the sidewall of each tire. This is 32 pounds per square inch (p.s.i.) for load range B tires. This maximum is increased to 36 p.s.i. for load range C tires and to 40 p.s.i. for load range D tires.

● If you're experiencing erratic transmission operation with a 1973 Chrysler Corp. car, there's a chance that the automatic transmission control-rod return spring has broken or become stretched. This spring is supposed to pull the transmission control rod forward when the throttle closes. Ask your dealer to replace the spring (part No. 2946637) and check the adjustment of the transmission control linkage.

● Are you getting a rattle from the fuel tank of your 1971 or 1972 Oldsmobile, that's especially audible when the tank is half full? It's possible that the tank is vibrating against the body. If so, you can get rid of the noise by inserting an insulation pad (part No. 400109) between the fuel tank and body panel. ★★★

**GOT A PROBLEM WITH YOUR CAR? Ask Mort about it. Send your question to Car Clinic, Popular Mechanics, 224 West 57th St., New York, N.Y. 10019. Letters cannot be answered individually, but problems of general interest will be published in the column.**





## When you get away from it all, are there some things you don't want to get away from?

For some people, getting away from everyday pressures and stresses means going off into the woods with a pack on their backs.

But most of us want to take a little more.

At Starcraft, we build into our mini motor homes everything you want to take with you when you get away from it all.

We call it Starcraftsmanship. It's the standard of excellence that makes a Starcraft mini motor home a luxurious home in the woods for your vacation and weekends. And a great second car you can use weekdays in town.

You can see Starcraftsmanship reflected in dozens of ways.

In living space to relax.

In a kitchen as complete as the one you left behind. With a 3-burner range, oven, hood, sink, big refrigerator and 35" working-height counters.

In a bathroom complete with a molded fiberglass shower, flush toilet, sink, medicine cabinet, and light.

In big beds made of thick foam cushions.

In the large wardrobe and storage cabinets.



You get two different floor plans to choose from.

And three different chassis: Ford, Chevrolet, or Dodge. Each with deluxe adjustable driver and passenger seats.

You can choose from a red or green motif with color coordinated draperies,

stain-proof cushion upholstery, accent paneling and wall-to-wall floor covering.

Starcraftsmanship keeps going on after you buy, too. In great warranties. And high resale values.

See the Starcraft mini motor homes at your Starcraft dealer. Or write to Starcraft, Dept. G39-6, Goshen, Indiana 46526, for further information.

The time you spend in a Starcraft mini motor home will be the time of your life.

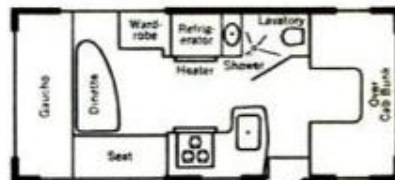

Front door model.

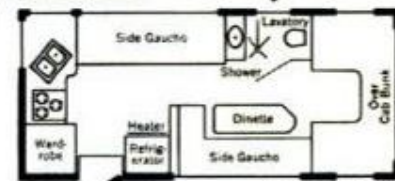

Rear door model.



Starcraft. The more you live with it, the more you appreciate it.

# Turn to Dodge. For leadership

*In motor home chassis . . . pickups for camping use . . . compact wagons . . . even cars with complete factory-engineered trailer-towing equipment, Dodge has put more firsts on the road than anyone else.*



*Large or small, when it comes to motor home chassis, Dodge outsells them all.*



*The big Dodge offers a trailer-towing package that's completely factory-engineered from radiator to hitch platform.*

*4 out of 5 motor homes are all Dodge underneath.*

*Dodge is Number 1 when it comes to taking care of you while you travel. Over 200 Dodge R.V. Service Centers are now in operation, and more are on the way.*



*Dodge builds the chassis for more mini-motor homes than any other manufacturer.*



**Extra care in engineering makes a difference in Dodge...depend on it**

# in recreational vehicles.

*Dodge makes a full range of pickups for outdoor use.*



*Dart Sport. A complete traveler with options such as a fold-down rear seat and a trailer-towing package so you can pull up to 2500 pounds. Dodge brings you new ideas about visiting the outdoors economically.*

*Dodge introduces the Club Cab with 34 cubic feet of extra storage space inside. We've got to be Number 1 in Club Cabs because we're the only ones who make them.*



*When it comes to American-made compact wagons, Dodge Sportsman is the Number 1 seller.*



  
**CHRYSLER**  
MOTORS CORPORATION

**Turn to Dodge for leadership in Recreational Vehicles.**

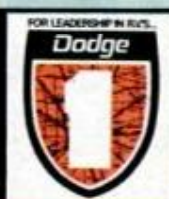

# IF YOU CAN USE ANY OF THESE TOOLS...

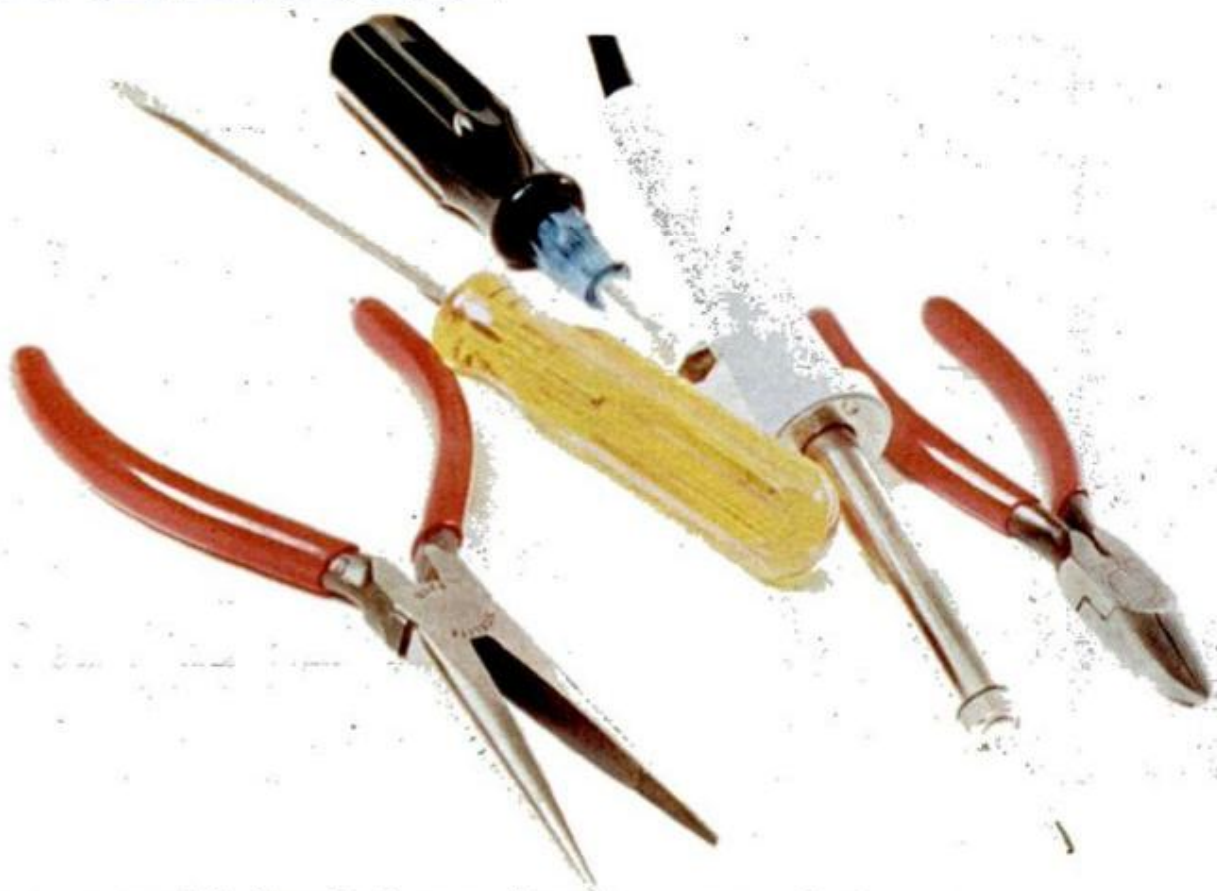

**...you could build a whole new future...**

**and build  
yourself  
a Bell & Howell  
solid state  
color TV while  
you're at it!**



If you're already handy with a set of tools, here's a way to pick up a pretty thorough knowledge of electronics: build yourself a solid state color TV as part of a complete learn-at-home program from Bell & Howell Schools.

This important project gives you valuable "hands on" experience with solid state circuitry—the kind of *practical* experience you'll need to build a successful career. It's a vital part of your total electronics education.

Once you've completed your program, you could be ready to build a new career—or start a business of your own—in home entertainment electronics.

#### Fix stereo systems . . . FM-AM radios . . . phonographs . . . tape recorders

With your new skills, you can build and service stereo-hi-fi systems—including FM-AM radios . . . phonographs . . . open reel tape recorders and cassette or cartridge player/recorders. You could even build yourself a complete "home entertainment communications center"—complete with the new gadgetry of cartridge television when it comes out. The skills you build up by following this brand-new program are more than enough to service almost any type of home entertainment electronic device.

#### A complete at-home learning program in home entertainment electronics

Don't confuse this program with an ordinary hobby kit. It's much more than that. It's a complete at-home learning program prepared by skilled instructors at Bell & Howell Schools.

It doesn't matter if you've never had any training in electronics before. Nobody's going to start throwing "diodes" and "capacitors" at you right off. You start with the basics. You take it one step at a time. You walk before you run. And you'll be amazed at how quickly you start to feel comfortable with things that seemed complicated at the beginning.

#### Attend special "help sessions" if you like

In case you should run into a sticky problem or two—one that you can't handle on your own—come in and see us. We've scheduled help sessions every few Saturdays at the Bell & Howell Schools and in many other cities throughout the U.S. and Canada. Drop by. Meet an expert instructor in person. Talk over any rough spots with him—and with other students. You'll enjoy the chance to "talk shop."

#### Master the most up-to-date solid state circuitry

Solid state is here to stay. Not just color TV but almost every type of electronic device will eventually move farther and farther in the direction of *total* solid state circuitry. Get to know the most advanced "trouble-shooting" techniques for these sophisticated circuits. You'll find an almost irresistible demand for your skills.

#### Why you should know electronics

No matter where you look, the amazing

technology of electronics is becoming a bigger and bigger part of the picture. More and more automotive parts and diagnostic instruments are electronic. Many large manufacturing plants use sophisticated electronic systems—controlled by a few skilled electronics technicians. The increasing use of two-way radio . . . the huge promise of cable television . . . the astonishing growth of electronic data processing all open doors to exciting new career opportunities for the man with thorough training in electronics. In fact, the day may come when the man who does *not* have electronic skills will be severely handicapped in many industries.

#### Why you should get your training from Bell & Howell Schools

Skilled instructors at Bell & Howell Schools—carefully selected for their knowledge, experience and teaching ability—plan each program with the utmost care and attention. Each year, they spend about \$200,000.00 improving programs and materials and keeping them in step with new developments in electronics. Thousands of people have used their Bell & Howell Schools training as the foundation for new careers and businesses of their own in electronics.

#### You build and keep the exclusive Bell & Howell Schools Electro-Lab®—a complete laboratory-in-the-home

To make sure you get practical experience with instruments used daily by professionals, you build and keep a Design Console, an Oscilloscope and a Transistorized Meter (see details at right). These are the three instruments you'll work with constantly—both during your program and thereafter.

#### CONSIDER THESE ADVANTAGES:

**Help Sessions** We've scheduled "help sessions" every few Saturdays at the Bell & Howell Schools and in many other cities throughout the U.S. and Canada. Top instructors give you expert guidance and you meet other students, too.

**Resident Study** After you complete your program, you can transfer to any of the resident schools for more advanced study, if you wish.

**Lifetime National Placement Assistance** When you complete your course, we help you locate a position in the field of Electronics that fits your background and interests. This unique service is available at any time after you graduate.

**Veterans' Benefits** We are approved by the state approval agency for Veterans' Benefits. Check the box for details.

**Student Financial Aid** We are an eligible institution under the Federally Insured Student Loan Program. Check the box for details.

## Detach postage-paid reply card and mail today for free information



25-inch picture (measured diagonally)

■ **Bell & Howell Solid State Color TV.** Ultra-rectangular tube . . . 25-inch picture measured diagonally . . . full 315 sq. inch viewing area. Solid state modular circuitry . . . 4 advanced IC's . . . 100 transistors . . . 72 diodes . . . individual plug-in circuit boards. Special UHF/VHF tuning features . . . built-in self-service components.

■ **Design Console** Use this to rapidly "breadboard" circuits without soldering. Equipped with built-in power supply . . . test light . . . speaker . . . patented plug-in modular connectors.

■ **Oscilloscope** Portable 5-inch wide-band oscilloscope offers bright, sharp screen images . . . calibrated for peak-to-peak voltage and time measurements . . . 3-way jacks for leads, plugs, wires.

■ **Transistorized Meter** Combines most desired features of vacuum-tube voltmeter and quality multimeter. Registers current, voltage and resistance measurements on a large, easily-read dial. Features sensitive, 4-inch, jewel-bearing d'Arsonval meter movement.

### For Free Information, Mail Card Today!

If card has been removed, write:

An Electronics Home Study School  
DEURY INSTITUTE OF TECHNOLOGY

ONE OF THE  
**BELL & HOWELL SCHOOLS**  
4141 Belmont, Chicago, Illinois 60641

348R

## HOMEOWNERS' CLINIC

BY W. CLYDE LAMMEY

### Flocked picture frame

*Lately I've seen an attractive picture frame decorated in what the dealer called "flock" or "flocking." He tried to explain, but I still don't understand what it's all about. Can you fill me in?—Mrs. John Drummond, Kansas City, Kans.*

The procedure is quite simple, although this treatment of picture framing is relatively new. You buy a flocking kit, available from dealers in art supplies, decide where you want flocking on the frame, coat this area with adhesive and immediately spray on the flock fibers. Both the adhesive and the flocking fibers can be obtained in a wide variety of colors; the kit includes the adhesive, a selection of fibers and the sprayer or gun.

### The best shade tree

*What would you suggest as the best shade tree to plant to provide maximum shade?—Ralf Cozzens, Indianapolis.*

I'd plant sugar maple. It's a slow-growing hardwood to be sure, but if well cared for, it develops a spreading, symmetrical top and its autumn leaf coloring, in my opinion, is unrivaled. Make sure that you select a well developed, balled specimen and remember to ask your nurseryman for tips on planting it.

### Veneer patching

*I have a secretary desk with veneered lid and drawer fronts. Pieces of the veneer have broken away at a corner of the lid and one drawer front. Can these be replaced? How?—Dee Bolt, Lima, Ohio*

It takes time, patience and a matching veneer. First you scrape away all the old glue from areas where the new veneer is to be laid. Then, with a sharp knife or chisel, square the edge of the existing veneer with

a slight bevel, taking care that the cut edge (line) is straight.

Select new veneer having a grain to match that of the old veneer as closely as possible; bevel-cut it and test fit. When you're satisfied with the fit, glue new veneer in place and hold it there with clamps or weights until the glue is dry. Sand flush, then stain the new veneer to match the old, using painter's or artist's colors. Apply the stain with a fingertip or cheesecloth and rub it out until the colors blend or are slightly darker than the color of the old finish. Allow this to dry thoroughly (48 to 72 hours) and follow by spraying with a clear finish (of the type available in aerosol containers).

### Moss grows in lawn

*I have a healthy growth of moss in my lawn, especially on the north side of the house, where the area is shaded part of the day. Doesn't this indicate the soil is depleted? How do I get rid of the moss? What do I do afterward?—Neil Besser, Dubuque, Iowa.*

A carpet of moss doesn't always indicate poor soil—rather, it means poor growing conditions for the turf. Usually you can lift the moss with a rake, spread additional soil to replace that removed, then rake in a complete fertilizer and reseed the area with a shady-grass mixture. Cover the seeding with straw to keep the soil in place. Add more fertilizer during the growing season to promote a vigorous growth of grass. Keep the area mowed but never shorter than 1½ in., and remove all clippings after each mowing. Give the area another seeding in the fall. ★★

*Do you have a home maintenance or repair problem? Send it to Homeowners' Clinic, Popular Mechanics, 224 West 57th St., New York, N.Y. 10019. While letters cannot be answered individually, problems of wide interest will be discussed in this column.*



## Come where it's cool

Only Kool can deliver the taste of extra coolness. And only Kool can deliver this offer. A "KOOLHOUSE"! It's a ten-sided canopied pavilion 11' 2" in diameter, 7' 6" in height. Easy to put together, great for parties or for just a little shade in your own backyard. Ordinarily \$199.00, the "Koolhouse" is yours for only \$129.00 and one end flap from any carton of Kools. Enjoy your "Koolhouse" all summer. And enjoy Kools all year round.

18 mg. "tar," 1.5 mg. nicotine av. per cigarette, FTC Report Aug. 72.

© 1973, BROWN & WILLIAMSON TOBACCO CORP.

### KOOLHOUSE OFFER!

Price includes delivery of a complete "Koolhouse"...folding walls and door (with aluminum frames and fiberglass screening), heavy-duty vinyl roof cover and instruction booklet.

Allow 6-8 weeks delivery. Offer good until 12/31/73 (or while supply lasts) and is limited to the U.S.A. You must be 21 or over.

Make certified check or money order payable to KOOLHOUSE offer. Mail to Box 3000KH, Louisville, Kentucky 40201.

Please send me \_\_\_\_\_ KOOLHOUSE(S). For each one I enclose \$129.00 and one end flap from any carton of Kools.

- Certified Check
- \*  BankAmericard
- Money Order
- \*  Master Charge



\*Card # \_\_\_\_\_ Expires \_\_\_\_\_  
 Phone \_\_\_\_\_  
 Name \_\_\_\_\_  
 Address \_\_\_\_\_  
 City \_\_\_\_\_ State \_\_\_\_\_ Zip \_\_\_\_\_

No P.O. Boxes, please

Warning: The Surgeon General Has Determined That Cigarette Smoking Is Dangerous to Your Health.

## DETROIT LISTENING POST

---

### Service by computer

There's been a lot of talk about installing computers in service shops, like the Volkswagen idea, so mechanics can hook into sensors on the car, take a reading of what the problem is and then fix it. That's still quite a way down the pike for domestic cars. But GM's got an experiment going right now that would accomplish the same thing.

A couple of years ago, Pontiac dealers were equipped with teletypes so they could talk back and forth with the factory to find out about orders, when cars would be shipped, to order parts, and so on. GM figured that by feeding certain information into a computer, the teletype service could be used by mechanics to find out what's wrong with a car. Not everything. It's not that far advanced. But GM's working on a service-by-computer program covering the charging system, automatic temperature control, cruise control and ride vibration—but only for Pontiac cars. The mechanic can get on the teletype and "discuss" the problem with the computer, which comes back with a typed statement explaining the problem and how to correct it. GM says if the experiment is a success, it will extend the idea to other parts of the car and other makes of cars.

---

### Telescoping fenders

There are some experimental cars hidden behind the high fences at Detroit proving grounds with front fenders that telescope back into recesses in the front doors on impact. The fenders are independent of the grille and retract automatically when the bumper collides with an object exceeding the capability of the bumper to absorb the blow.

This approach, combined with energy-absorbing bumpers and grilles that fold in on impact, would leave only the hood vul-

nerable to damage in a "soft" collision. But even the hood could be protected by reducing the length of it and sloping the nose forward.

---

### Back to the basic bumper

Is it really necessary to use complicated, costly telescoping devices on bumpers to achieve the impact-absorbing capability ordered by the government? American Motors says not and promises to prove the point on two of its '74 cars—probably Ambassador and Matador, which will get free-standing bumpers. This indicates some kind of strut arrangement with an open space between the bumper and the body.

AMC says the reason the industry didn't go this route in the first place is because the companies were concerned about the cosmetics of going from pretty, do-nothing bumpers to utilitarian bumpers. They had to have a bumper that'd meet the government standard and, secondary consideration, conceal the gap between the bumper bar and the car.

The cosmetic consideration complicated things, with the result that bumpers have become unnecessarily elaborate and expensive.

AMC also predicts that as soon as the rest of the guys get used to the idea that there's nothing wrong with a little open area showing between the bumper and the car, all of the car makers will move to simple, stick-out bumpers. They'll cost less than present-day bumpers to install, less to fix when you have an accident.

---

### Repositioning gas tanks

Car builders feel they've just about run out the string trying to find a material to make a puncture-proof gas tank. Engineers are

*(Please turn to page 34)*



# Caprice bends over backward to put you at ease.



Caprice Sport Sedan in front of the San Francisco Opera House.

Comfort and luxury are inseparably tied together in Caprice.

Like the available reclining passenger seat, shown above, that independently adjusts up and back. Sink back into this sumptuous seat and watch the world go by.

Then picture yourself behind the wheel. You're



sitting on molded full-foam seats.

Stretch your legs out. Way out. You've got a good yard or so.

Look around. Handsome woodlike vinyl accents, rich feeling knit cloth or pattern cloth fabrics, assist grips on the front doors.

1973 Caprice. You might not want to look any higher.

**Chevrolet. Building a better way to see the U.S.A.**

**Chevrolet**

Take a second to buckle up. It could save a lifetime.





## engrave money (legally)

One dollar makes ten. Make profits up to ten times your cost—full or part time—right in your own home.

Engrave much needed nameplates, directories, signs, trophies, badges in plastic, metal and wood on the time-tested New Hermes Engravograph.

Simple to operate. It's tracer-guided.

Engraving is a permanent business — not a fad — with small investment of less than \$400; money back guarantee. Trained representatives at your service.

Write for free illustrated catalog 10.

**new  
hermes  
engravograph®**

World's largest engraving machine manufacturer.  
20 Cooper Square, New York, N.Y. 10003

**A**

**B**

**C**

**BUILD THESE BEAUTIFUL CLOCKS**

**NOW AT BIG SAVINGS!**

Send just \$1 for plans & instructions to build choice of: (A) Grandfather, (B) Steeple, (C) Grandmother—plus information-packed catalog of movements, dials, parts & kits to build these & 16 other fine clocks. All 3 plans—\$2.50. Catalog alone—25¢.

**MASON & SULLIVAN COMPANY**  
Dept. PM, Osterville, Mass. 02655

## DETROIT LISTENING POST

(Continued from page 32)

now looking at the idea of relocating the tank in a more sheltered area where it's less likely to be exposed to the risk of rupturing. Detroit thinks Mercedes has the right idea in its new 450, which has the tank positioned over the rear axle.

### Electronic everything?

Electronics have never really caught on in carmaking, although there have been a few foot-in-the-door developments occurring in recent years. The electronic ignition system, electronic voltage regulator and digital clock, for example. All are credited to Chrysler Corp. But that's not much of a list when you consider the dozens of areas on automobiles where electronics could be used.

A lot of good ideas that haven't made it have originated outside Detroit, with the electronics industry. They didn't succeed because the electronics industry hasn't shown much savvy in the way it pitches its products at carmakers.

The devices, whatever they might be, are offered as hang-ons, instead of being integrated and related to the rest of the vehicle. Then, whenever Detroit shows any interest and asks for prices, the electronic companies will quote in small lots, just the way they do when they sell to a manufacturer of aircraft.

When Detroit talks prices, it's by the carload, in tens of thousands.

But you're going to see a lot of electronic applications on cars the next few years. The supplier companies are learning the ropes of selling to Detroit and the auto companies have set up departments to work with suppliers in developing new products—stuff like computer-controlled brakes, lights, dashboard gauges, fuel/fluid controls, and hardware that'll regulate the distance between cars, tune the engine while you're driving and make adjustments in steering depending on pavement conditions and crosswinds.

The latest piece of electronics in the works is an electronic air/fuel control—not to be confused with electronic fuel injection. Chrysler discloses that it's working on an electronic air/fuel mixer and may have the item on a few '75s. ★★★

# We'll pay you \$45.64 to go to meetings.

There's more money today in the Army Reserve. As a private with over four months service, you'll earn \$45.64 a weekend. And your pay goes up as you go up.

In the Reserve things are happening faster these days. It's easier to get in — the waiting lists have vanished. It's easier to get promoted — the men who served in World War II are retiring.

It's always paid to go to meetings in the Army Reserve. Now it pays more.



Army Reserve Opportunities PM 6-73  
P.O. Box 6834  
Philadelphia, Pa. 19132

Tell me more about how the  
Army Reserve pays.

Name \_\_\_\_\_

Address \_\_\_\_\_

City \_\_\_\_\_

State \_\_\_\_\_ Zip \_\_\_\_\_

Phone \_\_\_\_\_ Age \_\_\_\_\_

**The Army Reserve.  
It pays to go to meetings.**



**Give old John something  
to shut him up.**

Leaks. Squeaks. Whistles.

Chances are, your toilet is trying to tell you it has a serious problem. Simple, but serious. An out-dated, corroded ball cock that leaks.

There are different ways to deal with toilet noise. Pretend to ignore it. Have some sleepless nights. Fuss and cuss a lot (not recommended where children are present).

Or, stop toilet noise once and for all. With Fluidmaster.

Fluidmaster eliminates the old-fashioned tank float and arm. And, because Fluidmaster operates hydraulically, it works with water pressure, for fast, positive shut-off.

Write today for full details.

And give John the silent treatment.

Manufacturer of the  
Model 100, 200 and 400.



**FLUIDMASTER, INC.**  
1800 Via Burton  
Anaheim, Calif. 92805

## JOCK ITCH ISN'T SOMETHING TO BE TREATED LIGHTLY.



Jock Itch is a fungous infection. It can become serious. It can keep coming back even though you try all manner of "remedies," from baby powder to petroleum jelly.

But you can get fast relief with Cruex®, the spray-on medicated powder specifically made to fight Jock Itch.

Cruex soothes itchy, inflamed skin. Cushions against further irritation. And absorbs perspiration



(an important factor in the growth of Jock Itch fungi—tinea cruris). Its medication directly attacks susceptible fungi. And because you spray Cruex on, you can reach into hard-to-get-at places and avoid the sting or burn of rubbing, dabbing, or smearing. So fight Jock Itch seriously (and help keep it from recurring) with cooling, soothing Cruex. Guaranteed to work or your money back.

**CRUEX, THE MEDICATED SPRAY SPECIALLY FORMULATED TO FIGHT JOCK ITCH.**

©1972 Pharmcraft Division Pennwalt Corporation

36

POPULAR MECHANICS

PHARM  
& PHARMACRAFT

# THIS CAN BE YOUR "BIG BREAK"

if you're a man who's ever said...

**"I'm sick and tired of my Job!"**



Be sure to send for your 2 FREE books today. For your convenience, we will try to have a representative call. If coupon has been removed, write to Cleveland Institute of Electronics, Inc., 1776 East 17th Street, Cleveland, Ohio 44114.

**FILL IN COUPON AND MAIL TODAY**

**CIE** Cleveland Institute of Electronics, Inc.  
1776 East 17th Street, Cleveland, Ohio 44114  
Accredited Member National Home Study Council

Please send me your two FREE books:

1. Your school catalog, "Succeed in Electronics."
2. Your book on "How To Get A Commercial FCC License."

Name \_\_\_\_\_ Age \_\_\_\_\_

(please print)

Address \_\_\_\_\_

City \_\_\_\_\_ State \_\_\_\_\_ Zip \_\_\_\_\_

**APPROVED FOR TRAINING UNDER G. I. BILL**

**Veterans & Servicemen:** Check here for G. I. Bill information **PM-80**

## SCIENCE WORLDWIDE

### At last: a preventive for common cold

Interferon, a protein taken from human white-blood cells that have been infected by viruses, can stop the common cold. In a recent test carried out in England, the substance was administered to 16 volunteers who later were exposed to a cold virus. None became infected. But 13 out of 16 other subjects, who had not been given interferon, developed cold infections. Discovered in 1957, interferon is secreted by white-blood cells to interfere with—or prevent—the viral infection of other cells. But it will be years before the substance becomes generally available, according to the team of British and American medical researchers who are testing it. Complex production problems must be solved first.

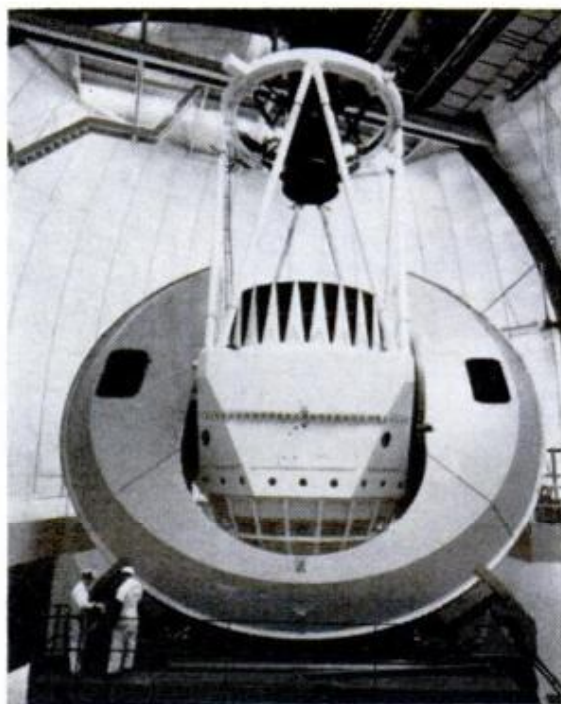

### World's newest big eye on space

A 158-inch reflecting telescope, the nation's latest instrument for studying outer space, has been unveiled at the Kitt Peak National Observatory in Arizona. When placed in full operation next October, the scope will enable astronomers to observe quasars and pulsars as well as radio and X-ray sources. The \$10-million instrument is housed in a circular building 105 feet in diameter and 185 feet high. Advanced design gives it a wider field of view than any other existing reflecting telescope, including the world's largest, the 200-inch Hale telescope at Mount Palomar in California.



### Machine helps paraplegic tots to walk

Body braces attached to swiveling metal feet give youngsters with paralyzed limbs the ability to walk. By rocking his shoulders from side to side, the child activates the spring-loaded metal feet, causing them to move forward, a step at a time. The device was developed by two Britons.

### Miniature flowmeter goes under skin

A microminiaturized electronic device that can be implanted under the skin to monitor blood flow and heart action following surgery has been developed by engineers and surgeons working together at Stanford University. Powered by a self-contained battery, the tiny instrument can be switched on and

*(Please turn to page 42)*

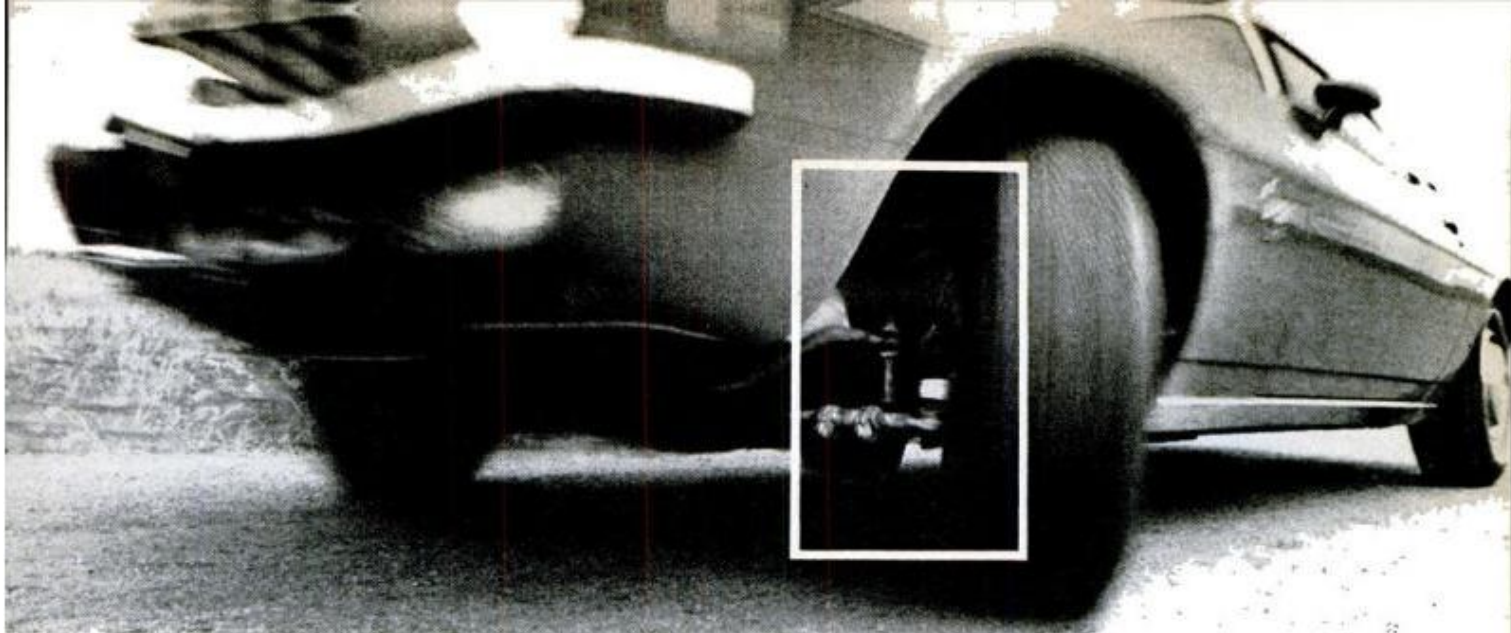

## No matter how well your car handles, it's going to get worse!

**Introducing SHIMMY STOP . . . the do-it-yourself compound that keeps ball joints from causing uneven tire wear, sloppy handling and dangerous loss of front-end precision!**

NO MATTER HOW WELL YOU MAINTAIN YOUR CAR, the ball joints on the front-end wear mile after mile, and get looser until tires wear unevenly, the steering wheel starts to shimmy, and the front-end won't hold an alignment.

REPLACING BALL JOINTS IS COSTLY, often costing up to \$100.00. But until now, that was the only way to solve the problem.

NOW THERE'S SHIMMY STOP . . . a compound that restores worn ball joints still within manufacturers replacement tolerances . . . without the cost of ball-joint replacement!

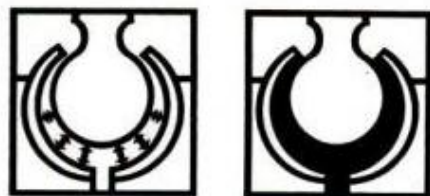

Here's how SHIMMY STOP works . . . how it actually reduces ball joint tolerances to zero:

1. SHIMMY STOP is mixed in its cartridge and injected into the ball joint via the existing grease fitting.
2. Inside the ball joint, SHIMMY STOP fills the worn area between ball and socket . . . reducing the tolerance to zero . . .

3. . . . once the ball joint is sealed with the plug provided, the compound cures to a tough, self-lubricating solid.

SHIMMY STOP COMPOUND comes in a cartridge that acts just like a grease gun. The handle, nozzles, plugs, instructions and specifications are included. And there's a special sticker to note the mileage when SHIMMY STOP is installed.



SHIMMY STOP has been tested for years in private and fleet cars . . . and performance proved by a private automotive testing agency for more than 1,250,000 miles.

THIS FREE BALL JOINT GAUGE shows how badly worn the ball joints are and if you should use SHIMMY STOP or replace the ball joints.



WHAT HAPPENS WHEN YOU USE SHIMMY STOP? Front-end alignment holds longer . . . tires wear more evenly, steering becomes safer, more precise . . . a new car feeling comes back to your car.



SHIMMY STOP . . . developed, tested and proven by 3M Company research . . . and distributed by Superior Industries. Write for your free ball joint gauge now. And, ask about SHIMMY STOP at your favorite auto supply store.

# SHIMMY STOP

**Popular Mechanics**  
PRODUCT FEATURE



**SUPERIOR INDUSTRIES**  
14721 Keswick Street  
Van Nuys, California 91405

LIVE IN THE WORLD OF TOMORROW... TODAY!

# UNUSUAL BARGAINS

NEW PRODUCTS • NEW MATERIALS • NEW IDEAS

## ACTUAL WORKING SOLAR HOME PLANS SEE FEATURE ARTICLE IN THIS ISSUE!



Learn all about the most fascinating possible home of the future. It can be your "now" answer to today's energy crisis in housing. Expert Dr. Harry E. Thomason tells advantages, problems, savings, and more in this important 20-page fact-filled booklet. Also includes 8-page oversize insert of basic, actual solar home plans, a valuable guideline to you and your architect in fitting space requirements, design ideas, and local area building codes.

No. 9440H (Solar House Plans) \$10.00 Ppd.

## "FISH" WITH A MAGNET



Go treasure hunting on the bottom! Fascinating fun & sometimes profitable! Tie a line to our 5 1/2-lb. Magnet—drop it overboard in bay, river, lake or ocean. Trawl it along bottom—your "treasure" haul can be outboard motors, anchors, other metal valuables. 5 1/2-lb. Magnet is war surplus—Alnico V Type—Gov't cost \$50. Lifts over 150 lbs. on land.

Stock No. 70.571H ..... \$14.00 Ppd.

Stock No. 60.215H ..... 1 1/2 lbs. .... \$ 5.75 Ppd.  
Stock No. 70.570H ..... 3 1/2 lbs. (lifts 40 lbs.) ..... \$ 8.75 Ppd.  
Stock No. 85.152H ..... 15 1/4 lbs. (lifts 350 lbs.) ..... \$33.60 FOB

## GIANT WEATHER BALLOONS



"Balls of fun" for kids, traffic stoppers for stores, terrific for amateur meteorologists. Create a neighborhood sensation. Great backyard fun. Exciting beach attraction. Amateur meteorologists use to measure cloud heights, wind speed and temp. Made of heavy-duty neoprene. Inflate with vacuum cleaner or auto air hose; or locally available helium for high rise.

Stock No. 60.568H (8' size) . \$2.50 Ppd.

Stock No. 60.632H (16' size) \$8.75 Ppd.

## AMAZING NEW WANKEL ENGINE KIT!



Thrill to the fun of building your own see-through motorized model of revolutionary pistonless type engine... only engine expert\* think economically modifiable to meet new pollution standards. Replaces piston, cylinder, crank assemblies with rotating discs (sections removed for firing chambers). Smaller than conventional; fewer parts, greater reliability, same speed w/less horsepower. Feat: flashing plugs, rubber fan belt, stick-shift on-off switch. Req. 2-1.5V batt. (not incl.).

(4 1/2" X 5" X 9") ..... \$6.75 Ppd.

No. 73.424H ..... \$15.25 Ppd.  
510-Page Wankel Engine Book  
Stock No. 9.439H

## AMERICAN MADE OPAQUE PROJECTOR



Projects illustrations up to 3" x 3 1/2" —enlarges them to 35" x 30" if screen is 6 1/2 ft. from projector, larger pictures if screen is farther away. No film or negatives needed. Primarily intended for children. Projects charts, diagrams, color or black-and-white in darkened room. 115 v. A.C. . . . 6 ft. cord and plug included. Size 12" x 8" x 4 1/2" wide. Weight 1 lb. 2 ozs. Plastic case.

Stock No. 70.199H ..... \$8.75 Ppd.

'Bright Ideas' in Unique Lighting Big, new 100-page handbook packed with facts, loaded with illustrations. All latest developments, applications, equipment. 8 1/2" x 11" looseleaf paper to fit 3 rings. Stock No. 9100 H ..... \$3.00 Ppd.



## MAIL COUPON FOR GIANT FREE CATALOG!

164 PAGES • MORE THAN  
4,000 UNUSUAL BARGAINS!

Completely new 1973 Catalog. Packed with huge selection of telescopes, microscopes, binoculars, magnets, magnifiers, prisms, photo components. Feology and unique lighting items, parts, kits, accessories—many hard-to-get surplus bargains, 100's of charts, illustrations. For hobbyists, experimenters, schools, industry.

**EDMUND SCIENTIFIC CO. 300 Edscorp  
Building, Barrington, N. J. 08007**  
Please rush Free Giant Catalog "H"

Name \_\_\_\_\_  
Address \_\_\_\_\_  
City \_\_\_\_\_ State \_\_\_\_\_ Zip \_\_\_\_\_

**EDMUND SCIENTIFIC CO.** MONEY BACK GUARANTEE  
**300 EDSCORP BLDG.**  
**BARRINGTON, NEW JERSEY 08007**

ORDER BY STOCK NUMBER • ADD \$1 HANDLING CHARGE • SEND CHECK OR MONEY ORDER

## SCIENCE WORLDWIDE

(Continued from page 40)

off by radio. It relays information on blood flow and heart rate by radio telemetry, much like satellites and space probes.

## A telephone with built-in memory

A phone that automatically dials a call to anywhere in the country at the touch of a single button has been developed by Bell Laboratories. Slightly larger than a standard desk phone, it is the first telephone with a solid-state memory and is capable of dialing any of 32 prerecorded numbers. It will be available in some states in 1974.



## Marshland transplanted at Swiss airport

In building a new runway at the Kloten-Zurich Airport, engineers maintained the natural beauty of the area by carefully transplanting the marshy turf that had to be removed. Scooped up in large patches, the turf was moved over 200 yards to a new site. This ambitious undertaking is an ecological first, say the Swiss.

## Map of planet Mars now available

First detailed map of the entire surface of Mars has been completed by the U.S. Geological Survey and the Jet Propulsion Laboratory, Pasadena. It's based on thousands of photos returned by the Mariner 9 spacecraft during its 1971-72 mission. Scaled 1 inch to about 400 miles, it is 36 by 39 inches. You can order it for 75 cents from the U.S. Geological Survey Distribution Section, 1200 South Eads St., Arlington, Va. 22202. ★★



# Want a job doing what comes naturally? Take this test.



Think you're a "natural" technician? Then you should be a lot better than average at spotting the differences between

similar objects. For example, which part, A, B, C, D, or E has a visible defect?

Answer: D

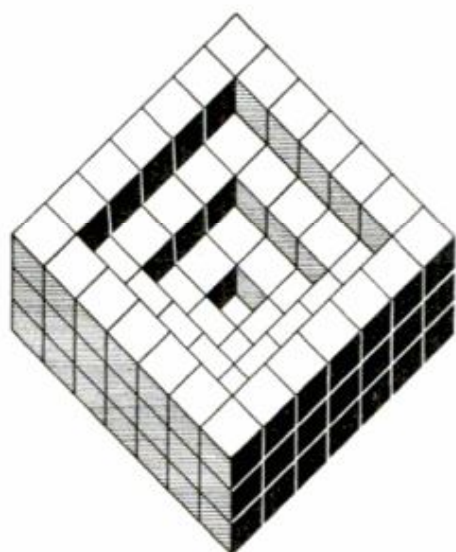

Here's a tougher one. Give us the right total of cubes in this figure. You'll be proving to yourself you have the kind of clear head and mechanical aptitude that really count for something in the Air Force.

Answer: 112



Good imagination and deductive powers? They'll help you fly through the Air Force's many types of advanced technical training. Think - which ones

of cubes A, B, C, or D could be the same cube as the one on the left, only turned?

Answer: A, B, C, D

Illustration Courtesy of Ar. Publishing Co., Inc.

Got them right? Then you might rack up high scores on the Air Force Aptitude Test. And that could do you a lot of good. Now, by qualifying you for outstanding technical training in one of over 100 Air Force jobs, from aircraft mechanic to medical specialist. And later, when you offer prospective employers a reusable skill.

Think it over. Mail in the coupon, or call 800-447-4700, toll free (in Illinois call 800-322-4400) for the nearest Air Force representative, and get the details. If you have natural mechanical talents, the Air Force will see to it those talents get

trained. Neither you nor the Air Force can afford to let them go to waste.

Air Force Opportunities	1PM63
Box A	
Randolph AFB, Texas 78148	
Name _____	
Address _____ (Please Print)	
City _____	
State _____ Zip _____ High School _____	
Soc. Sec. # _____ Age _____	

**Find yourself in the Air Force.**

## IMPORTS AND MOTORSPORTS

### Symphony in speed

It was all music for Kawasaki as its new Z-1 lapped Daytona for 24 hours shattering a bundle of World and American speed and endurance records. Four riders took turns in the wind section: Crouched low behind the special racing handlebars on the production machine, they set an average speed of 109.641 mph. (That topped the previous mark of 90.511 mph set by Suzuki in 1968.) Later on a slightly modified Z-1, Yvon Du-



Hamel posted the American one-lap record of 160.288 mph. In setting the new world and American records, the 903-cc bike covered 2631.402 miles. The American Motorcycle Assn. (AMA) and Federation International Motorcyclist (FIM) logged all the times and speeds for other manufacturers to see—and shoot for. Who'll try next?

### Shaped for speed

When a car weighs less than 2000 pounds and is capable of speeds of 200 mph, it's got to have the right aerodynamics—just to stay on the ground! The Lamborghini Countach, just shown at the Geneva Auto Show, has gone into production after two years of development and if it meets all the performance specs it was meant to meet, it'll be the fastest production car in the world. We mentioned this V12, mid-engine



machine last year before the photo above became available. (See *In The World's Most Exciting Cars . . . The Engine's Breathing Down Your Neck!* page 112, Oct. '72 PM.)

### Driving at speed

Road racing is a skill best learned under the watchful eyes of professional instructors—like those at Fred Opert's Racing School, now at Pocono Raceway where Fred is also starting police driver training and planning a '74 high-school Formula Vee interscholastic league. For more information write him at Pocono International Raceway, Box 500, Mount Pocono, Pa.

### The hot setup

There's a whole industry built up around the desire to hop up the VW Beetle, and a lot of time and effort is spent fitting goodies to the Bug. Now VW will do it for you. For \$250 over the price of the Super Beetle, or \$2669, you can drive right out of the showroom in a Sports Bug. It's a nice package for the money: The black chrome trim



and wider sports wheels are obvious in the photo and the wheels (5-1/2 J 15) are fitted with 170/70x15 radial tires. Inside are two special, European rally-type front bucket seats and small-diameter, padded steering wheel. Color them yellow and metallic blue. Speaking of Beetles, if you're confused about telling this year's from last year's, and back to the 1949 model, see the '73 edition of *What Year Is It?* Write Volkswagen of America, Englewood Cliffs, N.J. 07632, or get it from a dealer.

### Safety by the numbers

We like Fiat's comprehensive approach to the safety car problem. It has worked up a trio of Experimental Safety Vehicles (ESVs) in various weight classes—1500,



2000 and 2500 pounds. Above is the ESV 2000, which is based on the Fiat 128 model. Not so bad looking for an ESV, is it?

### Safety by the dollars

It's now quite certain that the National Highway Traffic Safety Administration will impose the ignition interlock standard. That means you cannot start your car until you buckle up, and it'll take about \$50 worth of electronics to do the trick. How unfair to drivers who use belts all the time!

What does seem fair are recent British court rulings where accident victims received less insurance compensation for injuries received because they were not wearing belts. The courts viewed the nonwearing of belts as "contributory negligence."

Why not write your local radio station, newspaper and police department about highway accident reports? Ever wonder if victims were wearing belts? Ask them to include this information. We bet it will lead to greater use of safety belts. And you will have prevented more injuries and deaths than you'll ever know. ★★★

## LEARN TO BE A SKILLED LOCKSMITH



Change combination of pin tumbler cylinder  
**EARN \$1.50 in 15 MIN.**

**TYPICAL JOBS EARN YOU \$271 PART TIME (in only 53 hours!)**

Owner loses key: pick car trunk—  
**EARN \$5.50 in 10 or 20 MIN.**



Install new knob door lock—**EARN \$15.00 in 30 MIN.**

After-hour emergency opening—**EARN \$2.50 to \$5.50 in 20 MIN.**

### Hundreds have succeeded like these Belsaw Graduates:

**R. W. Davis, St. Louis, Mo.:** "I am doing a wonderful business thanks to your course in locksmithing. Last Saturday I took in \$110.00."

**Pierson Crook, Los Angeles, Calif.:** "I am making \$200 a month extra income with the Belsaw Locksmith Course. I would recommend your course to anyone."

Big demand for skilled Locksmiths! Earn big money spare time in your own home. Be your own boss. No layoffs. Steady year 'round income. Age and schooling are no handicap.

**BELSAW INSTITUTE** training...approved by master locksmiths...helps you start faster with easy picture lessons guided by your own mail instructor.

Get thorough job training on all types of locks. We supply tools, equipment and business help: how to start, how to charge, how to get jobs, how to earn while you learn and build a lifetime cash-profit business. Accredited Member National Home Study Council. Approved by State Board of Education. Approved for Veterans.



**This key machine is yours to keep!**

### MAIL COUPON—NO SALESMAN WILL CALL

**BELSAW INSTITUTE, 104H Field Bldg.  
Kansas City, Mo. 64111**

Send **FREE** book, "Keys To Your Future!"



Name \_\_\_\_\_

Address \_\_\_\_\_

City \_\_\_\_\_ State \_\_\_\_\_ Zip \_\_\_\_\_



# Friends indeed ...for cars in need.

## Chilton's Repair & Tune-up Guides for American and imported cars.

There are a lot of other manuals around—basically refreshes or outright copies of factory service manuals—padded with superfluous stuff you cannot use.

But Chilton Guides are no ordinary manuals. They're loaded with fresh, essential, practical information. To help you prevent trouble, with precisely detailed preventive-maintenance schedules. To keep your car in tune, with easy-to-follow diagnosis and adjustment instructions. To get you out of trouble, with comprehensive, accurate repair procedures.

Because the Chilton editors who write these Guides are also knowledgeable automotive people. They've been through it all, step by step. They've anticipated problems you might encounter. They have the know-how and experience to explain with language and illustrations you'll understand.

In short, Chilton's Repair & Tune-up Guides are your kind of books. Clear, concise, totally useful. For the few bucks they cost, probably the most useful buy you'll ever make for your car.

Keep the one for your car in your glove compartment. It will be handy to have, when you need help.

**The most complete series available, covering most popular makes and models.**

• AMX • Austin-Healey • BMW • Barracuda • Belvedere • Camaro • Capri • Challenger • Chevelle • Chevy II • Corvair • Corvette • Corvette Stingray • Dart • Datsun • Demon • Charger • Duster • Fairlane • Fiat • Gremlin • Hornet • Jaguar • Javelin • MG • Maverick • Mercedes-Benz • Monte Carlo • Mustang • Nova • Opel • Peugeot • Pinto • Porsche • Renault • Road Runner • SAAB • Satellite • Simca • Sunbeam Hillman • Torino • Toyota • Triumph • Vega • Valiant • V W • Volvo. And more Guides are on the way.

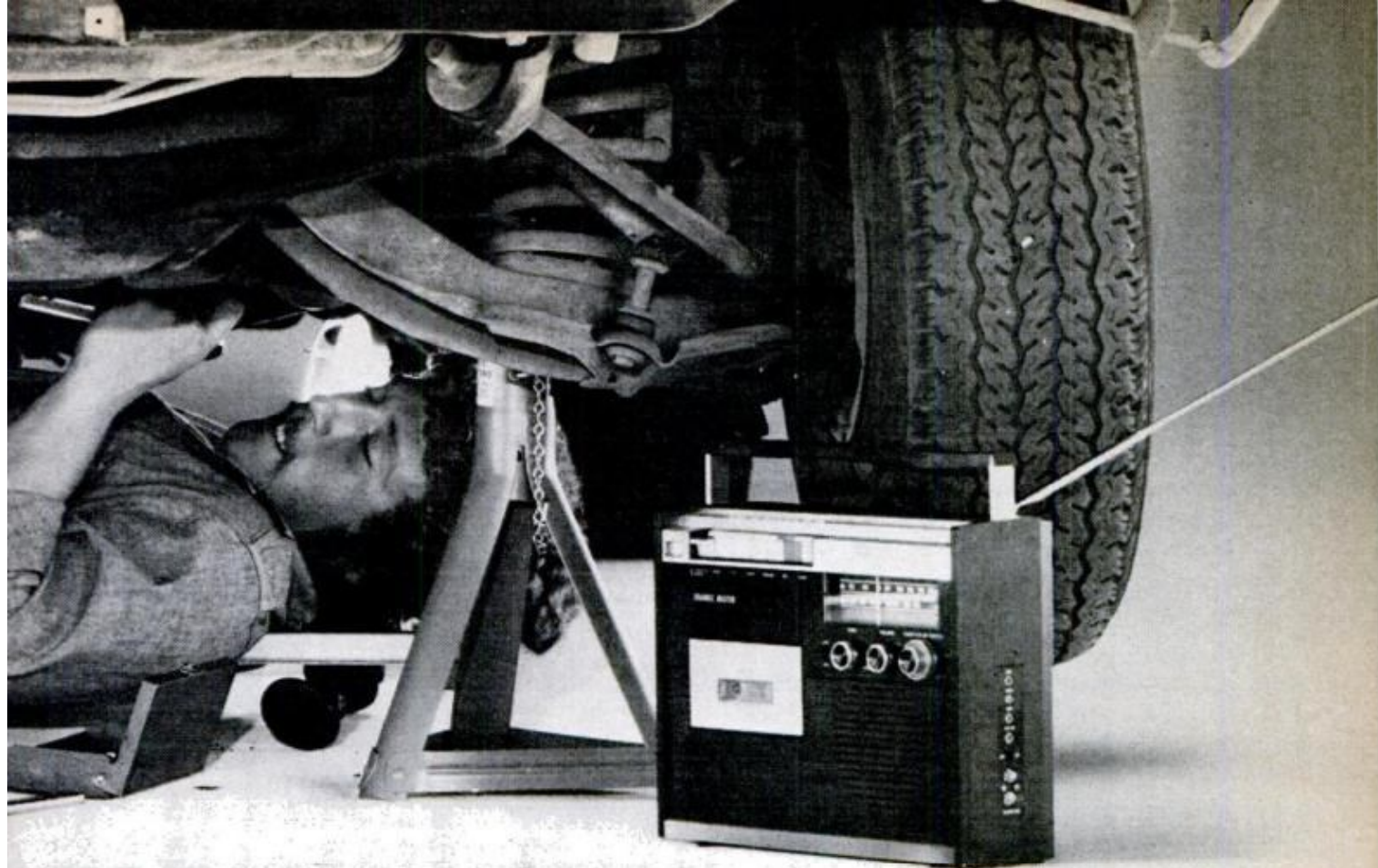

### Organized for fast help.

- Table of contents lists all major headings with page references.
- Each guide starts with complete information on exact identification of the car model, engine, etc. There's even a brief history of your car.
- Content arranged for maximum convenience. Chapters on General Information; Lubrication and Maintenance; Tune-up and Troubleshooting; Engine and Engine Rebuilding; Emission Controls and Fuel Systems; Chassis; Electrical System; Clutch and Transmission; Drive Train; Suspension and Steering; Brakes; Body.
- Chapters open with a basic description of the subject, so even the beginner gets a fundamental understanding before he starts.
- The appendix gives you a lot of helpful data—conversion tables, tap-drill-size chart, anti-freeze information.

### Bonus benefits.

- Complete coverage on all systems—everything you can reasonably expect to do yourself—you won't be led into hopeless projects.
- Special section shows you how to get maximum clean-running performance from emission controls.
- All necessary specifications.
- Troubleshooting is divided into two sections. *General Diagnosis* tells you how to locate the general problem area. *Specific Diagnosis* pinpoints the problem systematically.
- Informative illustrations—many photos, drawings, exploded views, diagrams, tables.
- Notes and cautions appear where necessary. They'll help you avoid possible pitfalls and problems.
- Helpful hints on how to get some jobs done without

those hard-to-get factory tools specified in service manuals.

### High value, low price.

To work with all the material shown in just one Chilton Guide, you would have to wade through a half-dozen factory manuals and other references. They'd be worth well over \$20.00, if you could get them.

Yet, in durable hardcover, most of Chilton's Automotive Repair & Tune-up Guides sell from only \$5.95 to \$7.95, and some are available in paperback—just \$4.95 each.

## CHILTON BOOK COMPANY

Radnor, Pa. 19089

### Fill in and mail this coupon!

TO: CHILTON BOOK COMPANY  
Dept. PM673  
Radnor, Pa. 19089

- Send your free brochure describing Chilton's Automotive Repair & Tune-up Guides.
- Send me the Chilton's Automotive Repair & Tune-up Guide for \_\_\_\_\_

make                      model                      year

I prefer  hardcover  paperback (please check one).  
It is my understanding that I will be billed later.

- Send your free brochure describing Chilton's Auto Repair Manual (CARM).
- Send your free brochure on Chilton's Guides for Recreational vehicles.

Name \_\_\_\_\_

Address \_\_\_\_\_

City \_\_\_\_\_ State \_\_\_\_\_ Zip \_\_\_\_\_

Telephone \_\_\_\_\_

## APPLIANCE CLINIC

BY PAUL MANN

### Icicles instead of cubes

*I have a Coldspot frostless refrigerator-freezer with an automatic icemaker. The icemaker makes trouble by overflowing with water when it fills up. Why?—M. C. Weatherby, Pedricktown, N.J.*

Try these possible causes:

First, you may have a hard-water condition in your area, and minerals may have built up in the molds, causing the level to change. If so, you'll see the minerals' whitish deposits. Clean out the molds.

Second, a sliver of foreign matter may have wedged itself beneath the water inlet valve and is keeping the valve open long enough for water to overflow. Take the solenoid off the valve and make sure the unit is clean.

If all else fails, you can reduce the water level. This will make smaller ice cubes, but stopping the overflow is more important. Take off the icemaker cover and remove the motor assembly plate. There you will find a water switch, operated by a cam. Move the switch away from the cam just a bit. This will reduce the amount of water being delivered.

### Phew, what's burning!

*Recently we had a water leak in the back of our Frigidaire multicycle washing machine. In order to locate the leak, which turned out to be a bad hose, I laid the machine on its front. When I righted the unit, I found a large oil slick on the floor. My wife has since been complaining of a burning odor when she washes clothes. What's wrong?—H. Rappoport, North Palm Beach, Fla.*

The laying of the machine on its front may or may not be coincidental with the fact that the problem has occurred at this time. The only oil you will find in a washing machine is in the transmission. The malfunction may be causing the motor to bind, thus making it overheat, which would account for the odor. It's possible that, by

laying the machine on its front, you aggravated an already deteriorating situation. It could also have caused components to shift, throwing a load onto the motor via the belt. In any event, if the machine is operated in this condition much longer, chance of the motor burning out becomes likely. I would have the transmission inspected immediately and repaired if necessary. Also check for an allied malfunction—the drive belt in particular.

### Battery airconditioner

*Does anyone make a room airconditioner that operates on batteries?—Mrs. H. M. Spencer, Avon Park, Fla.*

Not that I know of.

### Kooky gasket

*I have a General Electric dishwasher (model SD 300Y1) that I bought in 1964. I recently installed a new motor, but can't get the gasket between the motor and the bottom of the tub to stay in place. It pops out of round. The gasket has sealed and doesn't leak, but so little of it is in place that it scares me. I've tried all sorts of gasket sealers, including contact cement. What now?—Alan S. Doctor, Fresno, Calif.*

The first thing I'd do is get rid of the gasket. It may have become distorted, but even if it hasn't, using those "gasket sealers," especially contact cement, is not advisable. Most have a tendency to dry out a gasket.

With a new, correct gasket for this unit, you should have no problem if you follow these instructions: Notice that the motor housing fits against a flange in the bottom of the tub and is held by a double U-shaped clamp that's attached with two bolts. The gasket goes between the flange and motor housing. As you tighten up on the bolts,

*(Please turn to page 50)*

Yes, longer yet milder

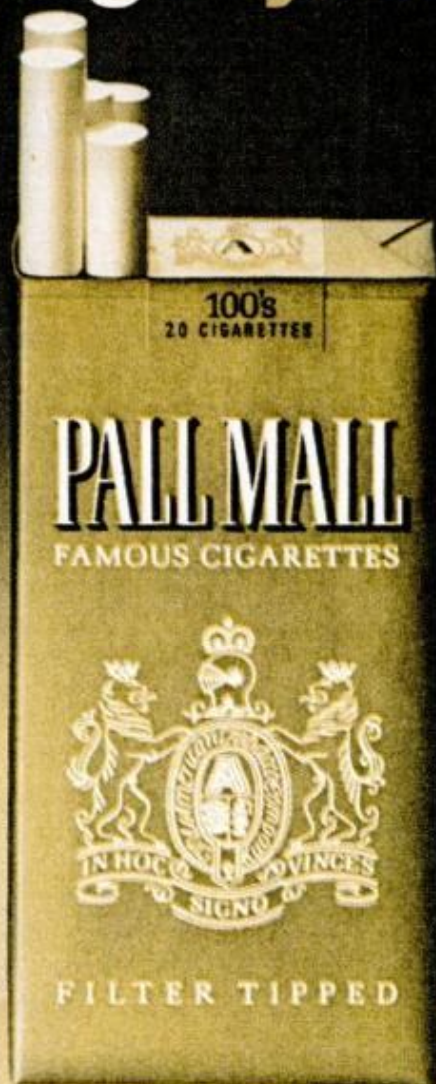

**PALL MALL**  
**GOLD 100's**

Longer length, milder taste

Warning: The Surgeon General Has Determined  
That Cigarette Smoking Is Dangerous to Your Health.

20 mg. "tar" 1.4 mg. nicotine av. per cigarette, FTC Report FEB. '73.

## ANTI-POLLUTION AUTO ENGINES NEED SPECIAL VALVE PROTECTION

**RISLONE**  
**GIVES**  
**IT...**



*Test Drive it!*



**FREE** Get some hints from a REAL engine expert, Smokey Yunick. Send large, self-addressed, stamped envelope and we will send 32-page booklet.

## THE SHALER CO.

Waupun, Wisconsin 53963  
In Canada: Canadian Shaler Products Co., Toronto 9, Ontario

**HEAVY DUTY WELDER**  
with special \$7.00 gift offer to Popular Mechanics Readers  
**10-DAY FREE TRIAL**  
**Lifetime Guarantee**  
Buy Factory Direct and Save **18<sup>95</sup>** POST PAID  
Fits ordinary 110V outlet  
Not one - but 6 welding heats

Weld, braze, solder or cut most anything made of metal. No experience necessary. Follow simple instructions to make repairs on cars, trailers, farm and lawn equipment, bicycles, appliances, etc. Make campers, boats, furniture, hundreds of valuable items. **NOTHING ELSE TO BUY!** Comes complete with full face shield, pack of welding and brazing rods, heavy duty power cables, special electric torch attachment, ground clamp, flux, easy-to-follow illustrated instructions, rod holder, etc. Uses standard 1/8" rods to weld iron, steel, brass, bronze, aluminum, other metals. New improved HEAVY DUTY circuit gives more welding power. Gives 4 times the heat needed to melt toughest iron. Plugs into ordinary 110V outlet. **6 WELDING HEATS** for professional quality welding of "tough" to "light-weight" metals. 10 day MONEY BACK GUARANTEE. Lifetime parts and service guarantee. An excellent gift for any occasion. **FREE!** Mention you saw this ad in Popular Mechanics and receive a \$7.00 gift pack of welding rods free. For same-day C.O.D. shipment just call (713) 682-5681 or send only \$2.00 and pay postman \$16.95 plus small C.O.D. when delivered or charge to your BankAmericard or Master Charge card or for postpaid shipment send \$18.95 check or M.O. to WEL-DEX, Dept. W-203, Box 10776, Houston, Tex. 77018.

## APPLIANCE CLINIC

(Continued from page 48)

the gasket compresses and will stay in place. That's all there is to it. There is no need to use any kind of "sealer."

### Gas attack

*We have a three-year-old Ward's Signature gas dryer. Sometimes the clothes smell like gas after they have been dried. Can you tell me why?—Tom McFarland, Anoka, Mo.*

I seriously doubt if it's gas that you are smelling. Of course, anything is possible. For example, it is possible that the pilot light is going out and its gas shut-off is being delayed because of a slow safety switch. But when this happens, clothes usually won't dry thoroughly. It is also possible that some gas is escaping during the last five minutes of the cycle when the gas supply should be completely off to allow the clothes to cool and "fluff." If this were happening, though, chances are you would smell gas around the dryer and not only on the clothes.

This leads me to the conclusion that the odor is being caused by something other than gas. Maybe a chemical reaction, which is apparent only after drying, is taking place between the soap you are using in the washing machine and the clothes. As a start, I would change my brand of washday soap or detergent.

### Inharmonious humidifier

*I own a West Bend automatic humidifier that occasionally makes an annoying squeaking noise as the wheel rotates. The wheel drive pulley and idler are clean and rotate normally, so what do you think is causing this?—Ralph Puller, Franklin Park, Ill.*

Sounds to me as if the wheel is coming into contact with the three plastic wear pads on the inside back panel of the unit. If this is causing the noise, spread a layer of petroleum jelly on each pad. ★★★

*If you have a question about any appliance, send it to Appliance Clinic, Popular Mechanics, 224 West 57th St., New York, N.Y. 10019. Sorry, but letters cannot be answered individually. Problems of wide interest will be answered in this column.*



**OLYMPIC GOLD MEDAL WINNER —**  
**develops amazing new Iso-kinetic device and says —**

NOW... YOU CAN ACTUALLY

# DIAL A POWERFUL BODY IN MINUTES A DAY!

Through the science  
 of Iso-kinetics

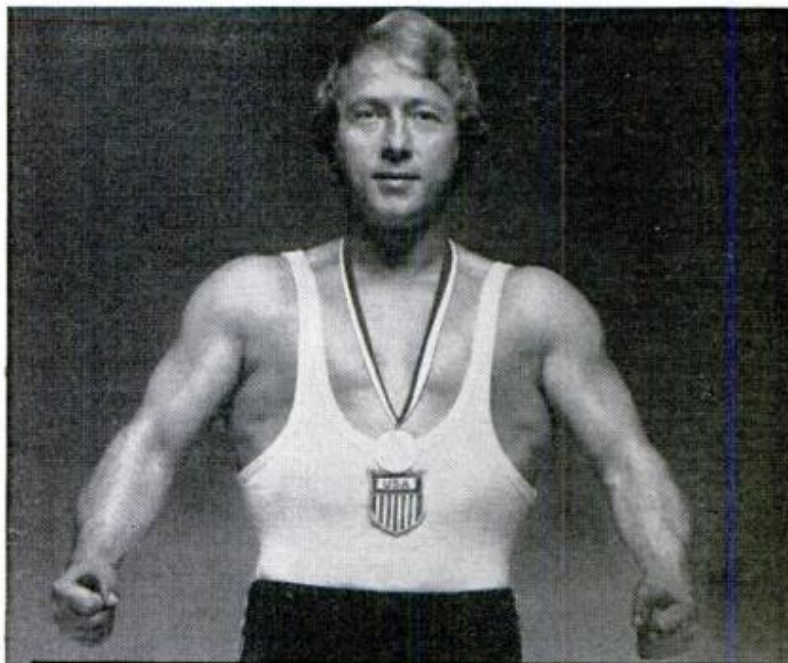

EXPERIENCE NEW POWER  
 THROUGH THE ISO-KINETIC METHOD

—Without weights!—Without springs!—Without exhausting work and exercise through the science of Iso-kinetics—a break-through in body training!

In only a few minutes of enjoyable exercise you can:—Burn off fat and flab and replace it with beautiful, hard lean muscle!—Trim that embarrassing (and unhealthy) midline bulge and replace it with a flat, hard attractive waist!—Build power-packed muscle into your arms, shoulders, back and legs!—Give yourself the beautiful, muscular, trim (and healthy) looking body that nature intended for you.

**HOW? You'll be astonished how easy it is. Through Iso-kinetics.**

**Meet Ike Berger—THE INVENTOR OF THE EXER-DIAL!**

- Olympic gold medal winner (U.S. Weightlifting Team, 1956).
- World Weightlifting champion (three times)
- Pan American Games champion (twice)
- National Champion (twelve times)
- Undeclared in competition against the Soviet Union (six tours behind the Iron Curtain)
- First man in the world to press double body weight
- Held 23 world records (his Olympic record of 336 pounds at 130 pound body weight made him the strongest man in the world, pound for pound and stood unbroken for NINE YEARS)
- Received athletic awards from a U.S. President, the Premier of Russia, the Shah of Iran

## THE STORY OF THE EXER-DIAL

For many years, Mr. Berger sought the ideal method to build power and strength. Dissatisfied with available devices he finally developed the amazing EXER-DIAL that operates without weights, springs and without the risk of any harm to the user. No weights to drop, no springs to snap back causing injury. And best of all, the EXER-DIAL allows you to advance to ever-greater strength levels as you grow more muscular and stronger by simply DIALING THEM! That's right. A

twist of the dial and you advance to a higher strength level.

More than that, the EXER-DIAL allows you to "target in" on each individual muscle group of your body so you can concentrate your power building where you need it most, thru Iso-kinetics.

## HOW? SIMPLE

Again, the "secret of the dial" allows you to "split" the pressure so that by another twist of the dial you can actually reverse power thereby giving you a fabulous "pulling" effect as well as a "pushing" effect—AT DIFFERENT STRENGTH LEVELS AS YOU DIAL THEM.



## AWARDED A U.S. PATENT

Never has there been anything like this! In recognition of this fact, the Federal government has awarded Mr. Berger a U.S. Patent.

## DOCTOR'S APPROVAL

When shown to a New York Physician, he found it "suitable for the follow-

ing kinds of training: . . . Training for endurance . . . Training for muscular power . . . Training for resilience . . . Training for muscular performance . . . Training for increased muscular endurance capacity . . . And especially suited for athletes to develop strength and stamina, and motivated individual fitness program." (THE DOCTOR'S LETTER IS ON FILE WITH US.)

## AGE IS NO BARRIER

No matter what your age, no matter what your physical shape, EXER-DIAL MUST HELP YOU. There is nothing to lose. Simply send in the coupon below for a FREE booklet showing you the amazing muscle-building facts discovered by Ike Berger.

© 1973 Body Pride Enterprises, Inc.

**TURN MIDDLE-AGE BULGE, FLAB INTO ROCK HARD MUSCLE**

Body Pride Enterprises, Inc., Dept. EX-1  
 509 Fifth Avenue,  
 New York, N.Y. 10017

Yes, send me my FREE full color brochure showing how I can develop rock hard muscles in just a few minutes a day. I understand there is no obligation on my part. (Please enclose 25¢ for postage and handling.)

Name \_\_\_\_\_

Address \_\_\_\_\_

City \_\_\_\_\_

State \_\_\_\_\_ Zip \_\_\_\_\_

## ALL OUTDOORS

From now at least until National Hunting & Fishing Day on Saturday, Sept. 22, sportsmen will be trying out new equipment afield. Here are selections we have tested, examined, or feel deserve special attention—everything from a Dodge motor-home chassis that promises better ride (Chevy has a new one too) to a meter that locates a fish's favorite oxygen level. Looks like a lot of inventive scientists are outdoorsmen as well.



Fishermen who stalk stripers and tarpon in the dark recommend the new rechargeable Koehler 5200 Safety Cap Light. A 12-hour charge gives 12 hours illumination. It's \$82 f.o.b. from Koehler, Marlborough, Mass.



Thermos calls it the new Cup-Caddy Deluxe Picnic Jug. It comes in one and two-gallon faucet-jug models and hides six seven-ounce plastic cups inside flip-lid top. Drinks inside are insulated to keep hot or cold.



Lowrance, the Fish Lo-K-Tor D/F maker, has added a new Fish-N-Float Marker Kit. Six colorful markers with weights and nylon line are in the \$10 set. Drop one to mark a fishing hole, or gear lost overboard.



BernzOmatic's little Table Cooker stove looks neat enough for dining table or patio use, turns up for fondues or down for warming, and doubles for camp cooking as well. The compact two-pound unit is \$11.97.



More power and fewer bumps are claimed for the new RM motor-home chassis from Dodge Trucks. A 440-cu.-in. engine, nonflat-spotting polyester tires, softer springs, front disc brakes, tilt steering are featured.

*(Please turn to page 54)*



# DATSUN SAVES

## About a gallon of gasoline a day.

With the demand for fuel rising faster than the supply, here's one way to help ease our energy crisis. According to the latest U.S. Bureau of Highways figures, the national average for gas mileage is about 13.5 miles per gallon. The new Datsun 1200 gets around 30 miles per gallon or over *twice* the national average. The average car in the U.S. is driven just over 10,000 miles a year, so you can save about a gallon of gas every day by driving a 1200. With gasoline prices going up, it's a considerable savings of another important resource: your money. Drive a Datsun... then decide.



**DATSUN**  
From Nissan with Pride

## ALL OUTDOORS

(Continued from page 52)



**Remington's Model 1100** commemorative 12-gauge shotgun will fittingly recognize completion this year of Ducks Unlimited's 1100th wildlife habitat project. A DU medallion and numbers will mark limited series.

**Sentry Oxygen Monitor**, an electronic device for anglers to measure parts-per-million of oxygen in water, is now available. Taking up where fish depth finders and water temperature meters stop, the hand-held meter reads 5 to 13 p.p.m. when probe reaches best fishing level. About \$175. Bass-Ox, Austin, Tex. 78723.



**First aid in a wallet pack** is the advantage of tiny new pocket-sized kit. Plastic pages enclose adhesive bandages, antiseptic, aspirin, knuckle bandage, gauze pad and first-aid booklet. One of smallest kits around, it should be handy addition for any pack, tackle box or hunting jacket. Pocket pack is \$1.49. Other Cutter Lab outdoor aids include insect repellents, snake-bite kit.



**Fishermen** who think they can make a better bass bait have a head start with the **Worm-Maker Kit** from Super Sport, Box 696M, Bishop, Calif. 93514, for \$14.95. It makes worms, frogs, crawlers in any color, scent.



**Ultimate in adjustments** seems to be offered in the new **Anschutz 1413 Super Match 54** from Savage Arms. An Olympic winner, it has variable-angle hook butt plate, even adjustable cheek-piece. About \$450 plus sights.



**A lightweight nylon mountain tent** that sleeps four is \$120 from Sears stores or catalog. Only 15 lbs. with frame fitting inside tent under outer fly, it can be moved after it's pitched. Two-man model, \$89.



**Frontier 4x scope** from Redfield has scratch-resistant anodized tube, coated optics and fogfree O-ring seals of top-line models at \$53. Buyer's guide is free from Redfield, Dept. PM, 5800 E. Jewell Ave., Denver, Colo. (Please turn to page 56)

A MIRACLE ADHESIVE SO STRONG

MIRACLE ADHESIVE

# ONE DROP HOLDS 2 TONS!

- Set In Seconds!
- No Mixing. No Clamping, No Mess!
- Bonds rubber, plastic, metal, ceramic, glass, porcelain!
- Replaces nails, screws, bolts!
- 132 Bonds to the Tube!
- One Square Inch Will Stand 5,000 lbs. pull!

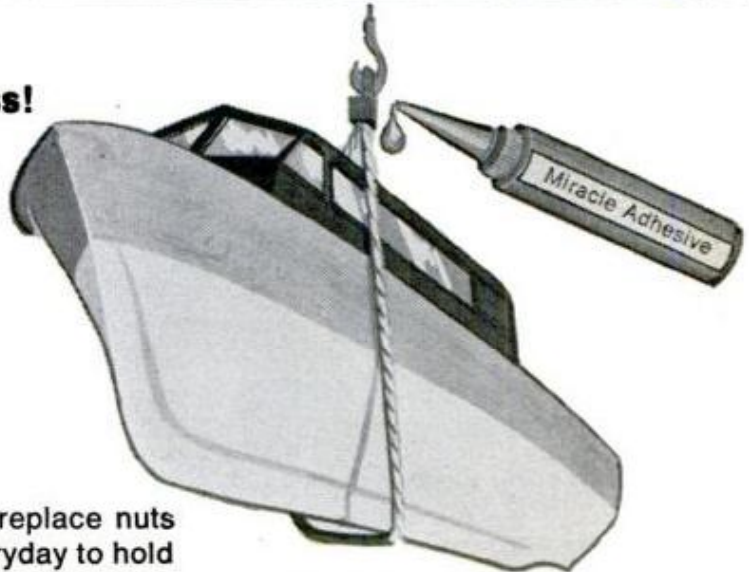

New Miracle Adhesive was developed to replace nuts and bolts in American industry. It is used everyday to hold parts of planes, cars, tractors, derricks *together!* Now you can use it to hold almost everything and anything!

Imagine just one drop of Miracle Adhesive holds with up to 2 tons of tensile strength holding power. Not an ordinary epoxy, it can be used instantly without compounding—NO WAITING . . . NO CLAMPING or TIEING . . . NO MESSY MIXING! Dries to an invisible bond in seconds.

#### Proven In Industry—Use It 1,000 Ways In Your Home

Your Miracle Adhesive applicator tube dispenses clear, colorless formula drop by drop. Use it everywhere. It's non-toxic. Resists chemicals, weather, moisture . . . indefinitely. The repair will be many times stronger than the original piece.

#### Now In Handy Drop-by-Drop Applicator For Home Use!

Now for the first time Miracle Adhesive is available for home use in a Single-Drop Tube Dispenser. (132 bonds) for only \$2.50. It is ideal for use in your home or shop. You'll find it useful in 1,000 ways. It must bond *anything* stronger, tighter, neater instantly or your money refunded immediately.

**JAY NORRIS** CORP.

25 W. Merrick Rd., Dept. ME-44,  
Freeport, N.Y. 11520

Serving Satisfied Customers for over 25 Years

#### LOOK WHAT YOU CAN REPAIR INSTANTLY:

- Repair a bike.
- Permanently seal garden hose.
- Join cracked floor tiles.
- Repair broken dentures.
- Fix pots, pans, mixers, appliances.
- Make broken china and porcelain new again.
- Mend furniture.
- Watertight cracked rubber boots.
- Repair broken panes of glass.
- Splice film, audio tapes.
- Bond a broken golf club, baseball bat.

#### BUY WITH CONFIDENCE

#### 30-DAY MONEY-BACK GUARANTEE

Jay Norris Corp., 25 W. Merrick Rd.  
Dept. 00-00, Freeport, N.Y. 11520

Please rush me \_\_\_\_\_ dispenser(s)  
Miracle Adhesive @ \$2.50 each plus 50c shipping and handling.

SAVE! Order TWO for only \$4.50 plus 50c shipping and handling.

SAVE MORE! Order 6 for \$11.50 plus \$1.00 shipping & handling.

Enclosed is  check or  money order for \$\_\_\_\_\_. (N.Y. residents add sales tax.)

PRINT NAME \_\_\_\_\_

ADDRESS \_\_\_\_\_

CITY \_\_\_\_\_

STATE \_\_\_\_\_ ZIP \_\_\_\_\_

© Jay Norris Corp. 1973

## ALL OUTDOORS

(Continued from page 54)

A new take-down bow is the Ben Pearson Silencer with what they call "hyper-kinetic" limb design. The 58-in. bow is said to have lateral stability for torque-free shooting. Simple take-apart feature makes packing and travel easier for archer. Grip is fitted for hunter or target shooter's hand in Marblewood. Priced under \$100 by Ben Pearson Archery, Dept. PM, Box 270, Tulsa, Okla. 74101.



Slugs can be fired from shotgun with amazing accuracy using a \$5 Slug Site. Metal sight is attached with adhesive, easily removed, and no tapping is needed. Slug Site, 3835 University, Des Moines, Iowa 50311.

For portable shower or supply for drinking and wash water, the Aqua-Jet from Denmark fills up with three gallons from a water faucet and then maintains pressure until almost empty. Rubber reservoir does not need to be elevated for unit to squirt many feet. Unit is \$19.95 from Inter-Commerce, Box 152, Somerville, N.J. 08876, or sporting goods and camping outlets.

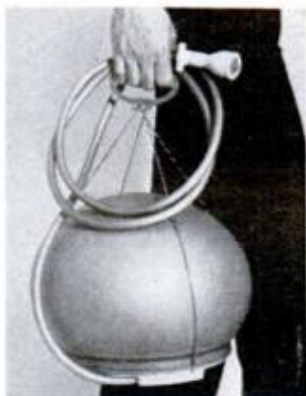

New size, shape and strength for auxiliary fuel tank for small boats is provided in seamless nylon. The 6 $\frac{3}{4}$ -gal. tank is rotationally cast by Goodyear Tire & Rubber for Rupco Industries, Cleveland, Ohio 44131.

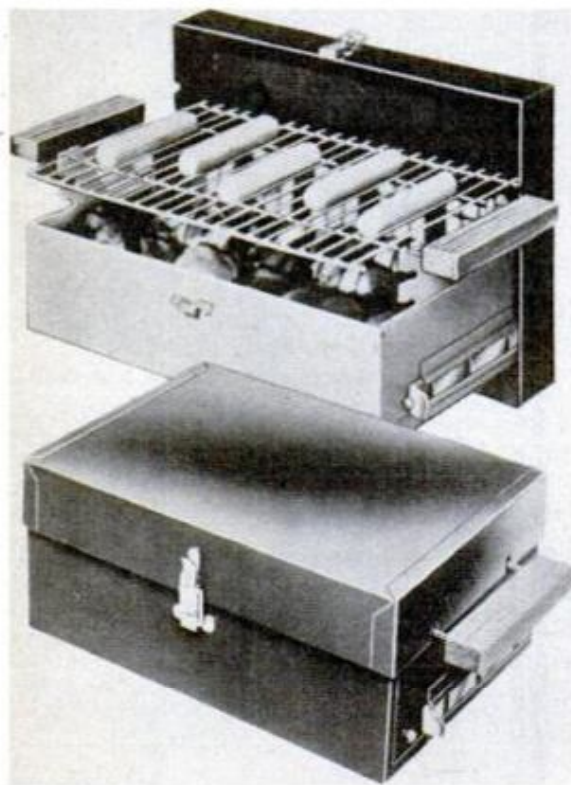

Grill-in-a-Box, a 14-pound camp stove can do triple duty and handle the sooty job of carrying charcoal by toting it inside. Serving tray, grill or smoker, it is \$19.95 from Hempco, 7020 Plainfield Rd., Cincinnati, Ohio.

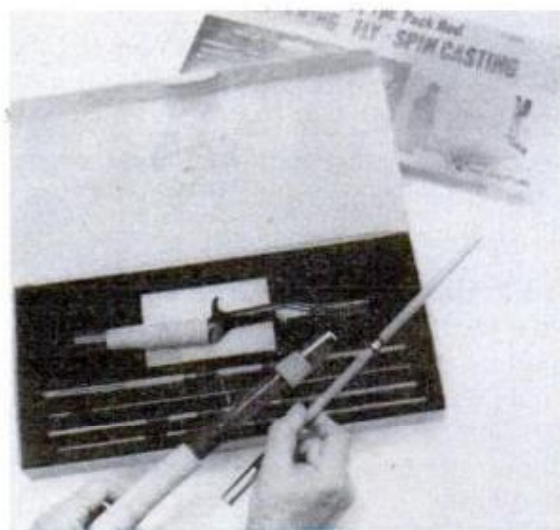

Neat new little deluxe pack rod from Sears has one handle for spin casting and a second which can take an open spinning reel or reverse for fly fishing. The three-way \$17.99 set easily fits backpack or briefcase.

# Tools can't fix everything. (That's why Mystik created Tool Box Tapes.)



**Sponge Tape.** Unbeatable for weather-stripping, cushioning or for replacing gaskets.



**Strapping Tape.** Fiberglass reinforced for extra strength.

**Duct Tape.** Great for sealing ducts, vents or air conditioners.



**Fabric Tape.** Heavy-duty for anything from window shades to tents.



**Carpet Tape.** Use it indoors or outdoors.



**Aluminum Tape.** Rust-proof and strong. For patching drain pipes, gutters, auto bumpers or other metal surfaces.



**Electrical Tape.** Great convenience and safety. U. L. Listed #988L.

Mystik Tapes, Borden Chemical, Division of Borden Inc, 50 West Broad Street, Columbus, Ohio 43215.



# The Electronic Ignition that turns on Tom McCahill.

When Tom McCahill tested Gaylord's CompuSpark™ Capacitive Discharge Ignition, he said it flat out; "For my money, CompuSpark's a steal. Under 50 bucks: No moving parts. Fully electronic. Solid-state. And CD, too! "It's built like a brick out-house. They tried to wear one out and stopped at 270,000 miles when the car fell apart.

"What's in it for you? It virtually does away with point wear. Ends plug fouling hassles and puts plug wear way down the road. Often cuts your gas consumption by 20% and makes your engine run clean.

"The reasons for all this are as obvious as warts on a snake. A 60,000 volt spark is a helluva lot hotter than a stock ignition. CompuSpark — 'The Ignition System with a Brain™' actually computes spark characteristics to engine RPM. You get the right spark at the right time and the right place. Darned things run great in Alaska or the tropics. Why not? All silicon, y' know. And the anti-theft lock really works!

"Another thing: CompuSpark is guaranteed one month longer than a Rolls-Royce: 37 months free repair or replacement. 30 day money back guarantee, too!

"Think of it this way: One skipped tune-up and CompuSpark has paid for itself. Two and you're money ahead. Plenty more where that came from — you're in clover, right? You bet.

"Order your CompuSpark now. It turned me on. I'm sure it'll turn you on, too!"



Installs in 15 minutes.

(c) 1973 CD Systems Division  
Gaylord Electronics Inc. Dept. 20JN.  
2314 Fourth St. Berkeley, Calif. 94710  
415/849-0300

Rush me:  CompuSpark ready to install. \$49.95  
 Kit \$39.95  
 CompuSpark brochure, free.

Car Year & Make \_\_\_\_\_

Name \_\_\_\_\_

Address \_\_\_\_\_

City, State, Zip \_\_\_\_\_

Enclosed: \$ \_\_\_\_\_ Ship ppd \_\_\_\_\_ Ship C. O. D. \_\_\_\_\_

Charge to my:  
 Master Charge  BankAmericard  American Express  
For Credit Card orders supply all card information.  
California residents, please include sales tax.

# PHOTO HINTS

## FROM READERS



**Slip-in easel** can be made to fit any size paper, is easy to load in the dark or under safelights. Black paint keeps reflections from fogging paper, also reminds you to focus on a blank paper sheet, not on the easel, for more accurate focusing. Detail (bottom) shows how molding holds down paper edge.

### Paper slips into inexpensive 16x20 easel

Easels for 16x20 enlargements are rather expensive—especially if you don't make such big enlargements very often. So I made my own for less than \$4, and in approximately two hours' time. It's just a piece of half-inch plywood that is cut two inches wider and two inches longer than the paper size it's designed for. (If you cut your paper to custom sizes—for full-negative prints from 35 mm, for instance—you can build the easel to fit them, too.) Cut three strips of No. A-749 metal edging (available from most of the better hardware stores) to fit three of the paper's sides, and mount them, flat-side down, on the plywood base with  $\frac{3}{8}$ -in. x No. 4 sheet-metal screws. This will leave a small groove between the wood base and the metal edging that's intended for the paper to slide into. Paint easel flat black to prevent flare in printing.—*Roger Adams, Los Angeles.*







### Use your enlarging easel as a ready-made copy frame

An enlarging easel and a copy frame have the same basic purpose: to hold a piece of paper flat. So if you have an easel, you have a ready-made copy frame, too. To get the even lighting that copying requires, you can use soft daylight—wait for an overcast day, or prop your easel up in the shade

of a building where it gets even skylight, not direct sun. The easel borders needn't appear in your final print. Normally, I move in closer with my camera to crop out the easel border, and crop out whatever is left of it when I make my enlargements.—*Don Anderson, Sunnyvale, Calif.*



## Minolta helps you enjoy lunch with friends.

It takes a quick eye and a responsive camera to see the pictures that are everywhere.

If you have the insight, a Minolta SR-T could be the camera. This is a 35mm reflex you'll be comfortable with from the moment you pick it up. It lets you concentrate on the picture, because the viewfinder shows all the information needed for correct exposure and focusing. You never have to look away from the finder to adjust a Minolta SR-T, so you're ready to catch the one photograph that could never be taken again.

Next time you come across some friends, be ready with a Minolta SR-T. For more information, see your photo dealer or write Minolta Corp., 200 Park Ave. So., N.Y., N.Y. 10003. In Canada: Anglophoto Ltd., P.Q.

**Minolta SR-T 101/Minolta SR-T 102**



# Form-fit fillet knife

by Monte Burch



**M**aking your own custom-fitted fillet knife is easier than it looks. In fact, you might end up making several for friends. The knife can be as plain or fancy as you like, with the handle carved, checkered or just left to show the grain patterns of some special wood. The handle shown here is bigger than that of most factory-made knives, and provides a good grip for working when the knife becomes wet and slippery. A leather thong run through a hole in the handle and slipped over your wrist will keep you from dropping it should you clean your catch over the water or use it as a boat knife.

The blade metal is the key to a good fillet knife. You'll want a thin blade that is flexible so it will bend slightly to cut in close to skin and backbones, and it should be easy to resharpen. Best materials are discarded keyhole or "wall-saw" blades.

1

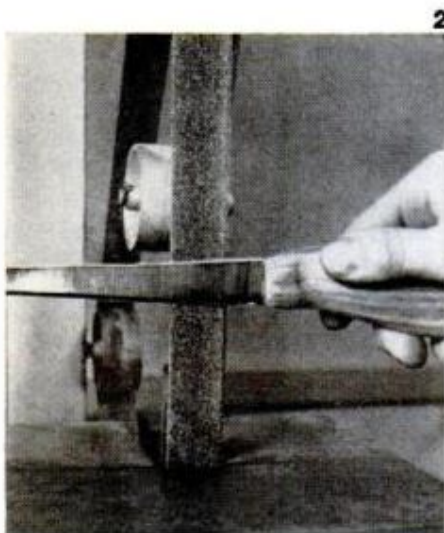

2

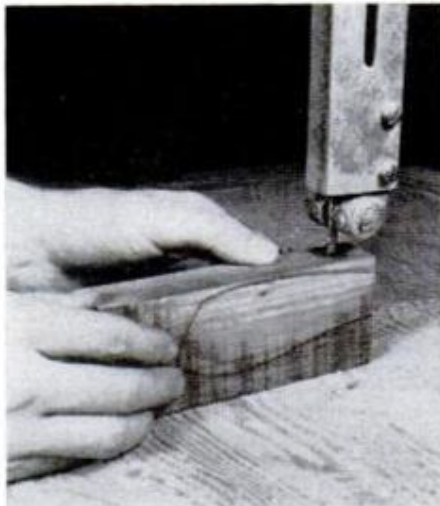

3

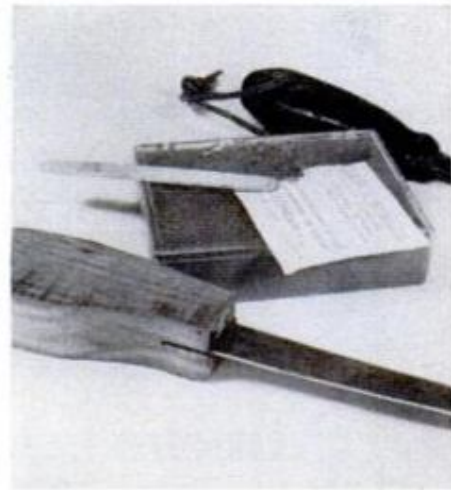

4

**Handsome knife and sheath**, shown above in photo 1, can be designed for individual owner. Blade is shaped from keyhole saw blade (2) and is flexible enough for easy trimming around bones and along skin. Handle, large enough for secure grip, is roughed out of hard, water-resistant wood (3). Amaranth, rosewood or zebrawood are recommended. Cut slot for blade with bandsaw or hand backsaw for tight fit. Trim and shape handle with files, rasps or carving chisels, round with progressively finer sandpaper. Epoxy in the blade (4).

Even an old handsaw will work, but it is thinner and more prone to break. Keyhole blades are the best thickness; when ground they offer correct flexibility and are easy to sharpen if of good high-carbon steel.

To shape the blade, enlarge the squared pattern and trace it on the saw blade. Heavy

*(Please turn to page 56F)*

# HOW MUCH COULD YOU BORROW?

**FIND OUT NOW!**

## HOW YOU SCORE YOURSELF

Just fill out the simple, self-scoring credit chart at right. Your score will tell you the amount of the personal loan (or line of credit) for which you may apply—up to \$3000.

## A CREDIT SERVICE OF ITT

Direct Credit Service, an ITT Financial Service Company, takes the doubt and uncertainty out of applying for a loan—and offers the modern conveniences and privacy of direct mail service.

Add up your score—then please write, or for extra fast action, telephone toll free:

**800-826-6959** (24 hrs. a day—7 days a week)

Miles E. Gibbons  
Suite 250  
100 Barstow Commons  
Eau Claire, Wis. 54701

If your score is:	17	18,19	20,21	Over 21
We invite you to apply for:	up to \$1,000	up to \$1,500	up to \$2,000	up to \$3,000

Enter the correct number in the point-score box at right, then add up your total score.

AGE					POINT SCORE
21-25	26-30	31-40	41-50	51-64	
1	2	3	3	3	
TOTAL INCOME (in thousands)					
Under 8	8-10	10-12	12-15	Over 15	
1	3	4	6	8	
YEARS WITH PRESENT EMPLOYER					
Under 1	1-3	3-6	6-12	Over 12	
1	2	3	4	5	
DEPENDENTS (including self)					
1	2	3	4	Over 4	
3	4	3	2	1	
YEARS AT PRESENT ADDRESS					
Under 2	2-4	4-7	7-10	Over 10	
1	2	3	4	4	
PERSONAL DEBT IN THOUSANDS (exclude mortgage)					
Over 5	4-5	2½-4	1½-2½	Under 1½	
0	1	2	4	6	
<b>TOTAL</b>					

An ITT  
financial service  
company

# direct credit

**DIRECT CREDIT SERVICE LTD.**

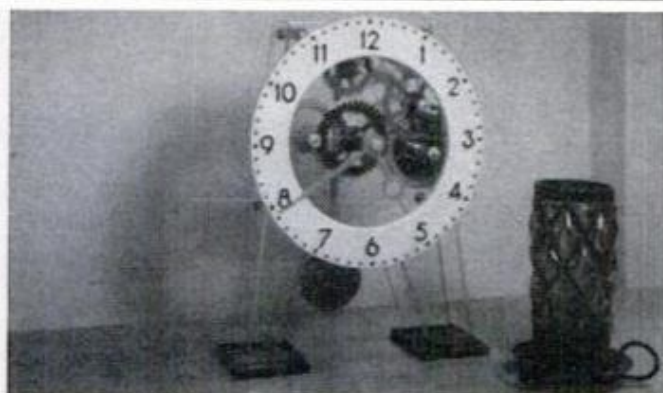

## BUILD CLOCKS THAT REALLY WORK

Above—Our exclusive **COLOR CLOCK** with clear plastic frames to let you see what makes it tick, as featured in April issue of Popular Mechanics. W. German movement with adjustable pendulum for accurate timekeeping. \$9.00 postpaid.

At Left—An accurate reproduction of a 13th century wooden clock that was popular in the days of Columbus. \$5.50 Postpaid.

FREE with any order from this ad, The 1973 **CRAFTSMANSHIP CATALOG** with more clocks, and steam engines, tools and books you've never seen before.

**CALDWELL INDUSTRIES**  
Box 170 Luling, Texas 78648

## NO MONEY DOWN

*Start Profitable Business in Your Garage or Basement*



Start in sparetime; build a money-making full-time business in your garage or basement. We'll start you in business with No Money Down. Your earnings easily cover the low monthly payments. Sharpening saws is an important service in any neighborhood or small town—You can earn \$3 to \$6 an hour sharpening hand, band or circular saws.

## No Experience! No Selling

The easy-to-operate Foley Saw Filer is automatic—it does the job for you. You can be doing business the day after you receive your machine. And with a saw filing business customers will come to you. No door to door selling! You are supplying a much needed service. If you'd like more information about this unique business opportunity, return coupon (no salesman will call) and we'll send you our fact-filled

## MONEY-MAKING BOOKLET FREE!

**Foley Manufacturing Co.**  
616-3 Foley Bldg., Minneapolis, Minn. 55418  
Send for FREE book on Money-Making facts about the sharpening business.

NAME \_\_\_\_\_  
ADDRESS \_\_\_\_\_  
CITY \_\_\_\_\_ STATE \_\_\_\_\_ ZIP CODE \_\_\_\_\_



## FORM-FIT FILLET KNIFE

(Continued from page 56D)

the outline with a crayon. The handle end of the blade can be untrimmed for about two inches where it fits into the handle.

Though the blade can be filed into shape with a new single-cut mill-bastard file, a grindstone makes the job easier. Work slowly and keep the blade cool by dipping in water; if it gets too hot or turns color it will be ruined. Shape the blade now but do not taper the edge to sharpen it.

For the handle, choose a good hard, oily, moisture-resistant wood like amaranth,

**Handle can be shaped** to size of fisherman's hand (5), and after final smooth sanding, it can be finished with rub-on or spray-on gunstock finish for final waterproof sealing treatment. Spar varnish is also suitable. Sheath leather is trimmed from tooling stock (6), allowing extra space for rivets. Punch top and bottom holes and close rivets (7) with hammer. Proceed with only one hole and rivet at a time while you are closing the sheath to prevent puckering and insure proper lineup. Smooth the edge with a belt-slicker-tool finish.

rosewood or zebrawood. Fit the blade into a tight slot cut in the handle. Cut the handle to shape with a bandsaw or coping saw. Smear a good two-part epoxy cement on the blade and force it into the handle. Let set for at least 12 hours.

Using files, rasps or carving chisels, cut the handle to shape and finish with fine sandpaper. Grind or file down the blade to rough-sharpen it to a 5° to 10° taper angle. Next hone on a good stone fastened to your benchtop, stroking with moderate pressure. Put masking tape on blade and finish handle with a waterproof coating like Tru-Oil Gun Stock Finish. Spray is easiest to apply.

For a custom sheath, buy a piece of scrap belly tooling leather from a crafts shop. Fold over knife and mark to shape, leaving room for rivets. Then cut, rivet, smooth the edge; leave natural color or dye. Follow by leather finish and polish. ★★

5



6

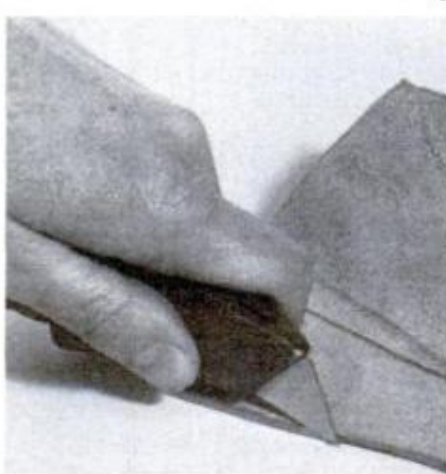

7

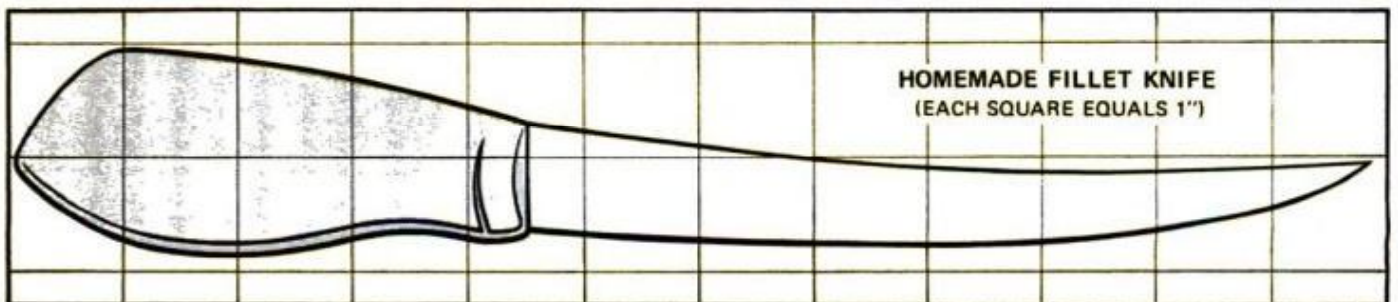
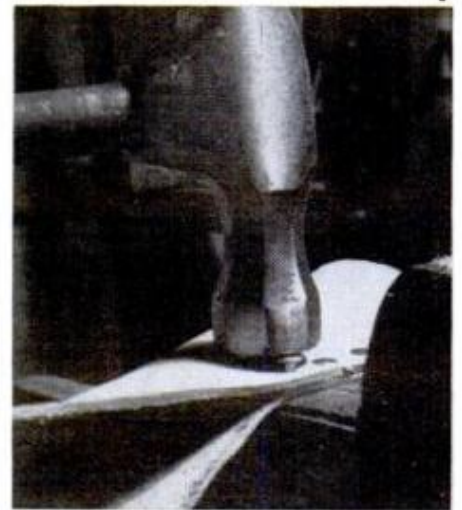



## When the going gets hot and heavy, you need Sunoco Special

Ever haul hundreds of pounds of gear and people? Or pull a boat or trailer? Or burn up the miles on an Interstate?

Then you need Sunoco Special 10W-40 motor oil.

It's formulated to give you extra protection against thickening or breaking down under heavy-load, high speed driving conditions...summer, winter, all-year long. And Sunoco Special meets or

exceeds the warranty standards of all car manufacturers.

Sunoco Special does all the work of a 10W, 20, 30 and 40 motor oil, so it's four oils in one... four oils that can protect your engine under any conditions, any time of year.

Next time you change oil, change to Sunoco Special.



**Sunoco Special. The long mileage motor oil.**

# Here it is! Popular Mechanics COMPLETE GARDENING GUIDE

All the basic information on home gardening at your fingertips!



## Partial list of contents:

Landscaping

Garden surfaces

Gardening in your  
climate

How to improve  
your soil

Starting seeds

Trees

All kinds of  
transplanting

Shrubs

All about pruning

Flowers

Lawn care

Vegetables

Garden pools

Fruits, nuts  
and herbs

Container gardening

Outdoor play areas

Storage structures

FIRST WE assembled every bit of information you need to know to make your lawn and garden the most beautiful in your neighborhood. We condensed *these* basics to *their* essentials. Then we added more than 20 fact-packed tables and charts, and scores of show-how drawings. Finally, we printed this vital material on heavy plastic-coated cards, and spiral-bound them together.

*You'll be amazed at the vast amount of information packed into your COMPLETE GARDENING GUIDE!* Planting dates and depths for all kinds of seeds and bulbs; when to prune what, and how; information on the 56 most popular shrubs, and the 21 best hedges; all about ground covers; the shapes and heights of the 52 most popular tree species; how to select evergreens; how to lay flagstone, patio blocks, bricks; how to build decks; all about air-layering, whip-grafting and other ways of starting plants; how and when to transplant almost anything; all about lawn renovation; and much, much more. *You can have all this basic gardening know-how at your fingertips!*

*No gardener can be a complete gardener without the COMPLETE GARDENING GUIDE! Order your copy today!*

**POPULAR MECHANICS, Box 1014 (Dept. GG) Radio City, New York 10019**

Enclosed is my check for \$3.95.

Send my PM GARDENING GUIDE to:

Name \_\_\_\_\_

Address \_\_\_\_\_

City \_\_\_\_\_ State \_\_\_\_\_ Zip \_\_\_\_\_

Ken Waller writes to tell us that...

CASE #136  
(in a continuing series)

# "I lost 3 inches off my waistline, 6 pounds...and shaped up - in 5 days!"

"I did it with one 5-minute exercise, twice daily, lying on my back—WITHOUT DIETING!"



The first body shaper so effective—  
results have been notarized!

Before I started on the "5-Minute Body Shaper" Plan I weighed in at 220 on November 1st. On that date my waist measured 36 inches. On November 5th, just five days later, I weighed 214 and my waist measured 33 inches. I'd

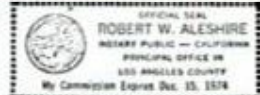

lost 6 pounds and 3 inches from my waist in just five days with no special dieting or exercise. Just the "5-Minute Body Shaper" Plan. KEN WALLER

Nov. 1st.  
Weight 220  
Waist 36"

"I'm usually in good shape, being a physical fitness buff, but when I moved from St. Louis to Los Angeles, I neglected my eating and fitness habits. I gained weight and softened up. I had no time to go to the gym, so I tried the '5-Minute Body Shaper' Plan. I was amazed at how fast I firmed, trimmed, tightened up my waist and got rid of extra body fat. It sure beats jogging and gym workouts for people who have little time to shape up! Thanks for your well thought out plan! Good luck with it!"

Nov. 5th  
Weight 214 (lost 6 lbs.)  
Waist 33" (lost 3 inches)

## HERE'S WHAT THE EXPERTS SAY:

"Doctors have always known, exercise done while lying on the back, virtually eliminates strain while slimming and reshaping the body. Yours is the finest Body Shaper Program on the market." RICHARD TYLER, Chiropractor

"Beats jogging and working out in gyms—and much safer. I lost 4½ inches off my waist in 14 days."

JIM HANLEY, famous athletic coach

"Based on sound physiological and medical knowledge, it burns fat and shapes the body without strain to the heart or other organs. I lost 32 lbs. of excess weight using it."

PIERRE GRAVEL, President,

Canadian Council of Chiropractic Research

## WHAT IS THIS INGENIOUS PLAN?

The Weider "5-Minute Body Shaper" plan is based on doing ONE CONTINUOUS RHYTHMIC CO-ORDINATED EXERCISE. That's all you do! This one 5-minute exercise is designed to attack the Waistline and Hipline (where fat accumulates quickest, giving your body a flabby, weak and distorted look)—as well as burn off excess body fat fast by speeding up your metabolism, burning stored calories and releasing excess water—while re-shaping your bustline, hipline, firming up your legs and arms—YOUR TOTAL FIGURE!

It's safer than strenuous gym workouts, beats the time consumption and dangers of gym workouts....or any other vigorous sport.

The unit weighs about 8 ounces and fits any wallet-size case. You can carry it and use it wherever there's floor space—anytime. Even while watching television.

## WHAT COMES OFF IN 14 DAYS?

Individual results vary, but during an average 14-day period, you can expect to lose up to 4 inches from your waistline and up to 10 pounds from your present weight. It strengthens your heart and lungs, increases stamina and endurance, improves your digestive function and general health. It also shapes you up—from head to toes. For a "5-Minute Exerciser—it sure does a lot."

Patent Pending. © Copyright Joe Weider, 1973

## ✦ EXPOSING EFFORTLESS EXERCISERS

Reader's Digest (September, 1971), New York Times and Good Housekeeping, among others, exposed sauna wraps, inflated belts, weighted belts and effortless exercisers as frauds. Scientific researchers, medical and fitness experts all agree...there is only one way to firm, shape and trim up your body... you must work the inches off!

## NO GIMMICKS, NO CATCHES MONEY BACK GUARANTEE OFFER

Because this isn't a "gimmick" plan—and you have been fooled in the past by "effortless exercisers"—I make you this UNCONDITIONAL GUARANTEE.

"GET IT OFF FAST"—and see measurable and firming results in 3 days or return the exerciser for a full 100% refund!

Proven results are already verified. The guarantee is in writing. Now you can think of a reason not ordering your "5-Minute Total Body Shaper"?

## '5' Minute BODY SHAPER The Body Shaper that Works

## FREE TRIAL OFFER!

Weight just 16 ounces! See your exciting new body begin to take shape in 3 days or return lightweight Body Shaper (small enough to fit into pouch shown) for a full 100% refund!

DISCOVER A NEW JOY  
IN YOUR BODY —  
GIVE IT SEX APPEAL  
COMPLETE KIT ONLY  
\$995

JOE WEIDER, DEPT. PM-6  
21100 Erwin Street, Woodland Hills, California 91364

Dear Joe: Rush me your 5 Minute Total Body Shaper and Slimmer Course in plain wrapper, with your money back guarantee offer!

I Enclose \$9.95 For The Above.  Cash  Check  Money Order  
\$1.00 extra for Air Mail. (No COD's Accepted). Calif. residents add 5% sales tax (10.50)

Name \_\_\_\_\_  
Address \_\_\_\_\_  
City \_\_\_\_\_ State \_\_\_\_\_ Zip \_\_\_\_\_

IN CANADA: "5" Minute Body Shaper Plan, 2875 Bates Road, Montreal, Quebec





## **A beautiful way to end paint failure.**

Paint puts a film over wood.  
With time, it can crack,  
peel or blister.

When you stain with  
Olympic, the finish goes  
into the wood. Lets it  
breathe.

Never cracks, peels or  
blisters—brings out wood's  
texture instead of  
smothering it.

If your home is painted,  
you may still be able to  
refinish with Olympic Solid  
Color Stain. They're so rich  
in pigment, you can stain  
light over dark.



For your dealer's name call 800-243-6000, toll-free.

In Connecticut dial 1-800-882-6500. For a free color folder, write:  
1148 NW Leary Way, Seattle, Wa. 98107.

Olympic Stain. A division of COMERCO, INC. 

© 1987 Olympic Stain, a division of Comerco, Inc. All rights reserved.



## THE BICYCLE SHOP

BY EUGENE A. SLOANE

**T**ake any group of 20 to 30 cycle tourists pedaling happily through the countryside. Chances are that one of the bicycles is about to suffer a breakdown because its owner did not make a routine pretrip check.

Busted spokes, chains and cables are commonplace on a trip, but need not occur if you know how to prevent them. Worse yet, it's possible to develop dangerous high-speed wobble on a fast downhill run that can lead to a serious accident, if your bike is not in good shape. Or brakes can fail or carriers fall off. At best, mechanical failure wastes time on the road; at worst, it can cause an accident to you and fellow cyclists.

Check your bicycle before a trip as carefully as you plan the trip itself. Here's what you should do:

**1. Wheels.** They must be straight so caliper brakes can grab evenly on both sides of the rim. Check by spinning the wheel, with thumbs on the brake shoe. True by tightening spoke on side **away** from wheel untruthness. If the wheel is too far to the right, tighten a left spoke, and vice versa. Untrue wheels also contribute to dangerous wheel wobble on fast downhill runs. (See [How to True a Wheel, page 40, April PM.](#))



**2. Tires.** You don't want a blowout—especially riding fast downhill. Check tread and sidewalls for gouges, cracks. Discard tires with bad cuts. Remove embedded foreign materials, like glass or metal, from tread. Dress tubular-tire cuts with gum rubber. Remove clincher tires and check inside of casing for cuts. Remove tubular tires, take off old tire cement with paint remover, replace with fresh cement. Use two coats on rim, one on tire. Don't get paint remover on tires!

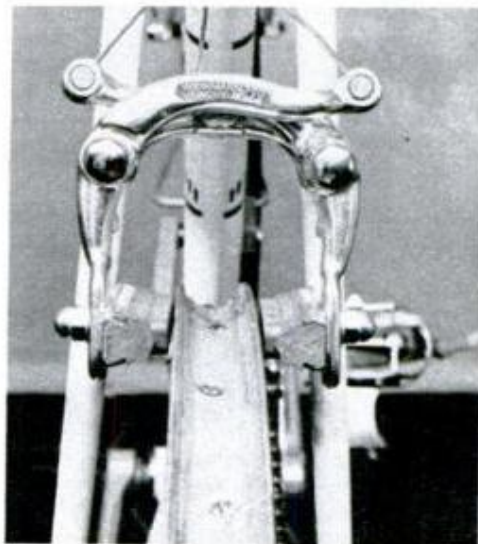

**3. Brakes.** Make sure both brake shoes grab rims evenly. Take up cable slack if handlebar brake levers have to be depressed more than 1½ inches (see [Brake Adjustment, page 76, March '72 PM.](#)) Replace any brake shoes that have become hardened with age; remove foreign materials from shoes. Replace worn or frayed cables. Adjust so brake shoes are about ⅛ inch from rim and are parallel to rim surface when depressed.

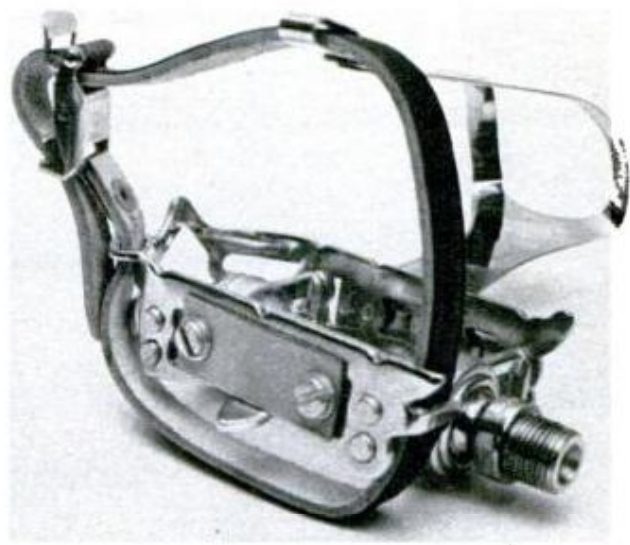

**4. Pedals.** To keep your feet from slipping off pedals, equip pedals with toe clips and straps. If you have rubber-body pedals, replace with all-metal rattrap type to which you can fit toe clips. Spin pedals to check for grit and sideplay; relubricate if necessary. (See [Pedal Maintenance, page 34, July '72 PM.](#))

*(Please turn to page 62)*

## THE BICYCLE SHOP

(Continued from page 61)

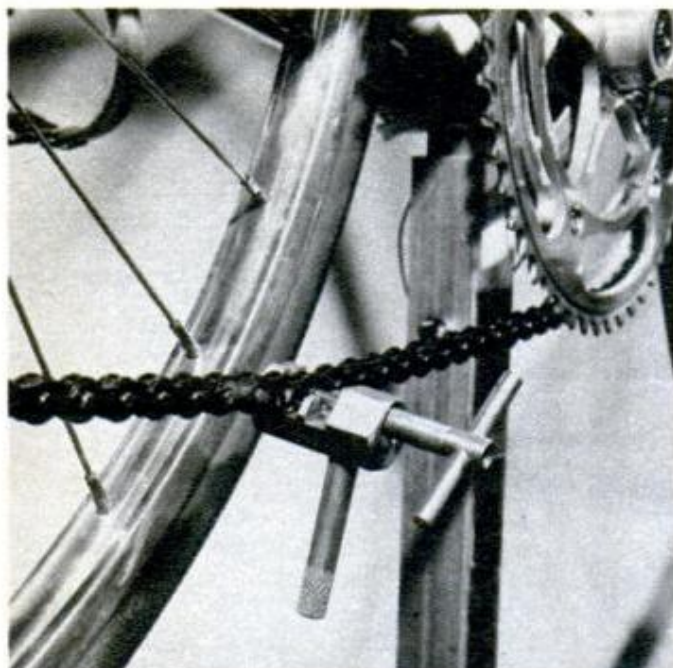

**5. Chain.** Remove chain with rivet-removing tool. Check for wear by pulling links lengthwise and from side to side. Excess wear is indicated if a link can be pushed forward and back in line with chain. Replace worn chain. Agitate chain in kerosene, wipe clean, spray with Chainlube and replace it on your bike. (See Chain Care, page 31, April '72 PM.)

**6. Headset.** Hold handlebars firmly, push back and forward sharply to check for looseness in steering head. Lift front wheel, rotate bars; they should turn freely. If you feel any roughness, stiffness, grittiness or looseness, disassemble, clean and reassemble. (See Headset Adjustment, page 38, Sept. '72 PM.)

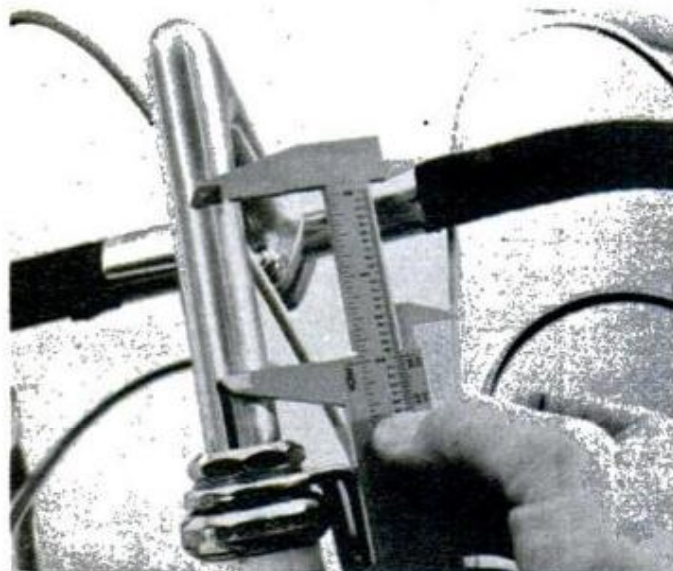

**7. Handlebars.** Make sure at least 2 inches of stem, above stem split skirt end, is inside the headset—so handlebars won't snap off as you strain uphill.

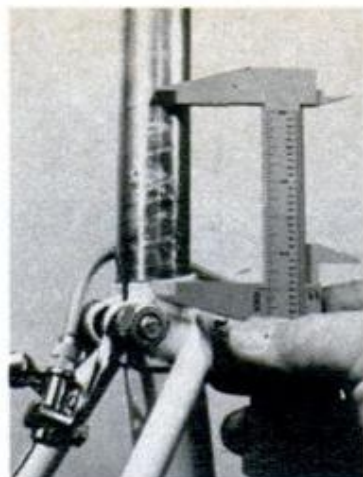

**8. Seat.** If it's leather, clean with saddle soap, then treat with neat's-foot oil to soften and weatherproof it. Make sure at least 2½ to 3 inches of seat post is inside the seat tube.

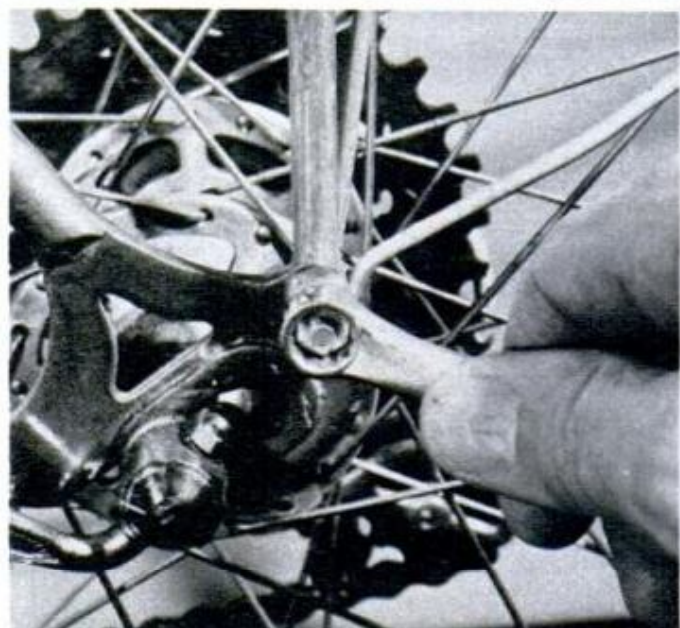

**9. Carrier.** If you have a metal carrier attached over the rear wheel, check bolt tightness at seat stays and fender eyes on dropouts. If you've had trouble with carrier slipping when loaded, wedge a block of wood between the carrier and seat stay bridge.

(Please turn to page 64)

# Suburban. A truck for wagon people.



Series 10 Chevrolet Suburban Estate. Looks like a wagon. Rides easy like a wagon. Underneath it's a tough truck.



Series 20 moves up to 14,000 lbs. of people, luggage, trailer and Suburban. 454 V8 available. Front stabilizer bar available for improved stability. Power front disc brakes standard. Seats available for up to nine.



Wagon-type tailgate available with a window that retracts manually. Electrically if you order it. Exposes 144 cu. ft. of load space.



Cheyenne Super luxury available. 6 1/2" foam seats. Nylon-blend carpet. Acoustical headliner. Full-gauge instrumentation.



New folding second seat standard on Series 20; available, Series 10. Cushion folds forward. Backrest folds down.

Please enclose 50¢ in coin (to cover mailing and handling) for each copy of Chevrolet's Recreational Vehicle Buyer's Guide ordered.

Name \_\_\_\_\_

Address \_\_\_\_\_

City \_\_\_\_\_

State \_\_\_\_\_

ZIP \_\_\_\_\_

Mail to: Recreational Vehicle Buyer's Guide

P. O. Box 7271 Detroit, Michigan 48202 PM 258

1973 Chevrolet Recreational Vehicle Buyer's Guide. 84 pages, most in full color. A beginner's guide to Chevrolet trailering vehicles, pickup campers and motor homes. An expert's handbook of specifications and recommendations.

**Chevrolet** Building a better way to see the U.S.A.

**MY SPARE TIME HOBBY  
MAKES ME  
\$500 an hour  
CASH PROFIT**

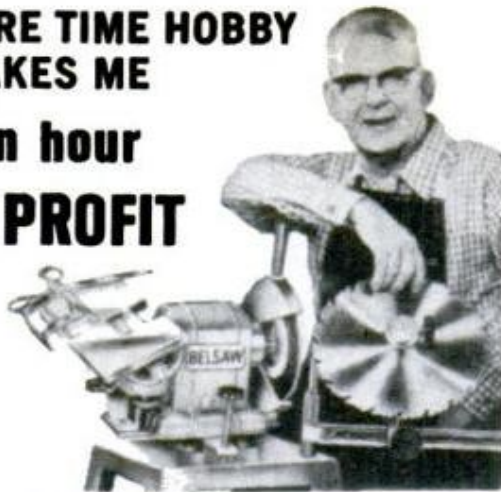

**START YOUR OWN SPARE TIME BUSINESS**  
You can turn your spare time into Big Cash Profits with your own **COMPLETE SHARPENING SHOP**... Grind saws, knives, scissors, skates, lawn mower blades... all cutting edges. Your Own Cash Business with no inventory... right at home... no experience needed. **FREE BOOK** tells how you can start your own spare time business while you are still working at your regular job. Low Cost—time payments.

Just Mail Coupon—No Salesman Will Call

**FREE  
BOOK**

**BELSAW SHARP-ALL CO.**, 714H Field Bldg., Kansas City, Mo. 64111  
Send Free Book, "LIFETIME SECURITY." No obligation.

Name \_\_\_\_\_  
Address \_\_\_\_\_  
City \_\_\_\_\_ State \_\_\_\_\_ Zip \_\_\_\_\_



**Dirtex®  
POWDER  
Cleaner**

General purpose, quick dissolving powder cleaner for use on every washable surface. Available where paint is sold.

**SAVOGRAN**   
Norwood, MA. 02062

**THE BICYCLE SHOP**

(Continued from page 62)

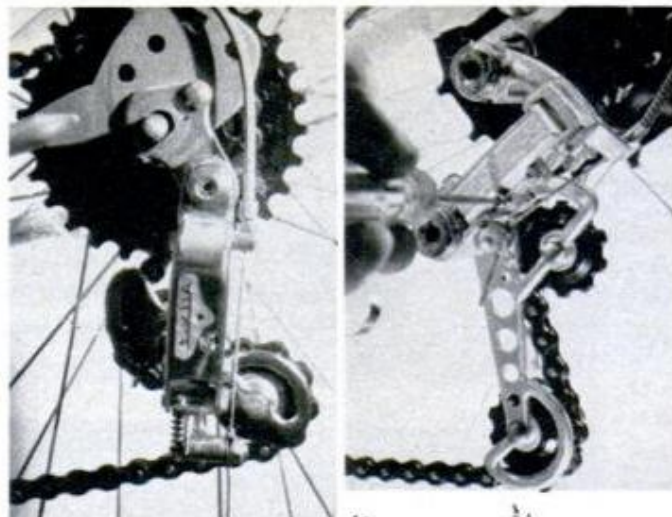

**10. Derailleurs.** They should be cleaned with kerosene; use a small paintbrush so you don't have to remove them. Don't get kerosene on tires or brake shoes. Hang bike from ceiling, go through all gears to make sure derailleur is properly adjusted. If chain goes off high or low gears, readjust derailleur. (See Derailleur Adjustment, page 31, Oct. '72 PM.)



**11. Bottom bracket.** Remove chain from chainwheel. Spin chainwheel, listen for sounds of grit in bearings. Chainwheel should spin freely. Grab both cranks, twist left to right to check for sideplay; there should be none. Readjust movable cup as necessary. If grit is in bearings, disassemble, clean, regrease, reassemble. (See Care of Bottom Brackets, page 67, May '72 PM.)

You might also read through the sections on maintenance, touring and camping in my book, *The Complete Book of Bicycling*, 342 pages, Trident Press. Happy cycling! ★★★

**Having trouble with your bike? Ask Gene about it. He uses every third or fourth Bicycle Shop column to answer reader mail. Send your letter to Bicycle Shop, Popular Mechanics, 224 West 57th St., New York N.Y. 10019.**

# MOONLIGHTING MADE EASY.

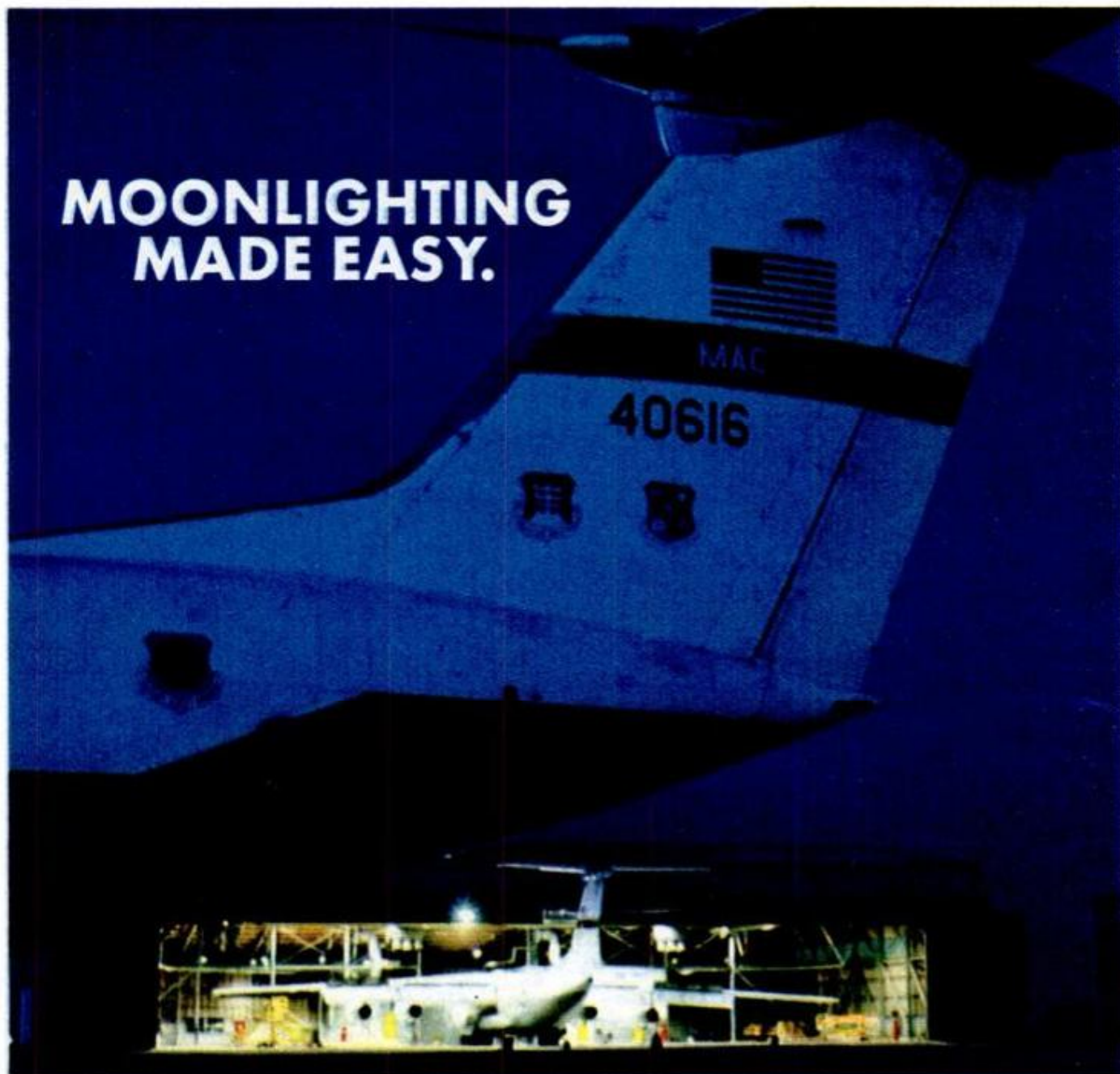

Ordinarily, moonlighting makes for a long, long day. And when the money is gone, there's often nothing to show for it.

So consider an alternative: The Air Force Reserve.

For one thing, the hours are better. We only ask you for one weekend a month. And the pay is good. Even when you're just starting with us, we'll pay you \$40.96 for that weekend. Considerably more when you're with us for two weeks in the summer. Also, the promotions and raises keep coming regularly.

But there's a lot to like besides the money. Some reservists like the chance they have to learn new skills. Or sharpen old ones. Some like the companionship. Others, the idea that there's a pension waiting that no one can take away from them. And the idea that you are helping both yourself and your country at the same time.

Think about it. Then fill in and mail the coupon, or pick up the phone and call 800-525-9984,

toll free (in Colorado, 800-332-9952). There'll be somebody on the job to give you the name and address of your nearest Air Force Reserve Unit. Check 'em out, because our kind of moonlighting is not only easier to take, but a lot more interesting.

Air Force Reserve Box A Randolph AFB, Texas 78148	3-PM-63
Please send me more information. I understand there is no obligation.	
Name _____ Sex <input type="checkbox"/> (M) <input type="checkbox"/> (F)	
(Please Print)	
Address _____	
City _____	
State _____ Zip _____ Phone _____	
Soc. Sec. # _____ Date of Birth _____	
<b>AIR FORCE RESERVE. YOUR LOCAL AIR FORCE.</b>	

# 'Dead-man' switch for your drill press

A drill-press key accidentally left in the chuck presents a real hazard if your drill press is turned on. But with this safety switch it can't happen because the motor can't be turned on by its own switch until the chuck key is inserted in a second switch.

The heart of this "dead-man" control is a microswitch attached to a  $1\frac{1}{2} \times 1\frac{3}{4} \times 2$ -in. hardwood block that's mounted inside a standard outlet box. When the handle of the chuck key is inserted in a hole in the cover plate, it depresses the normally-open microswitch button and closes the switch.

The wood block is attached to the blank cover first, then a  $\frac{1}{4}$ -in. hole is drilled through the center of both. The block is removed and an L-shape notch is made in it to accommodate the microswitch. The wiring diagram shows how the switch is wired into the existing motor cord. Standard box connectors are used to attach the cut ends of the cord to the box.

—Robert K. Wallace

PHOTOS BY ROBERT D. BORST

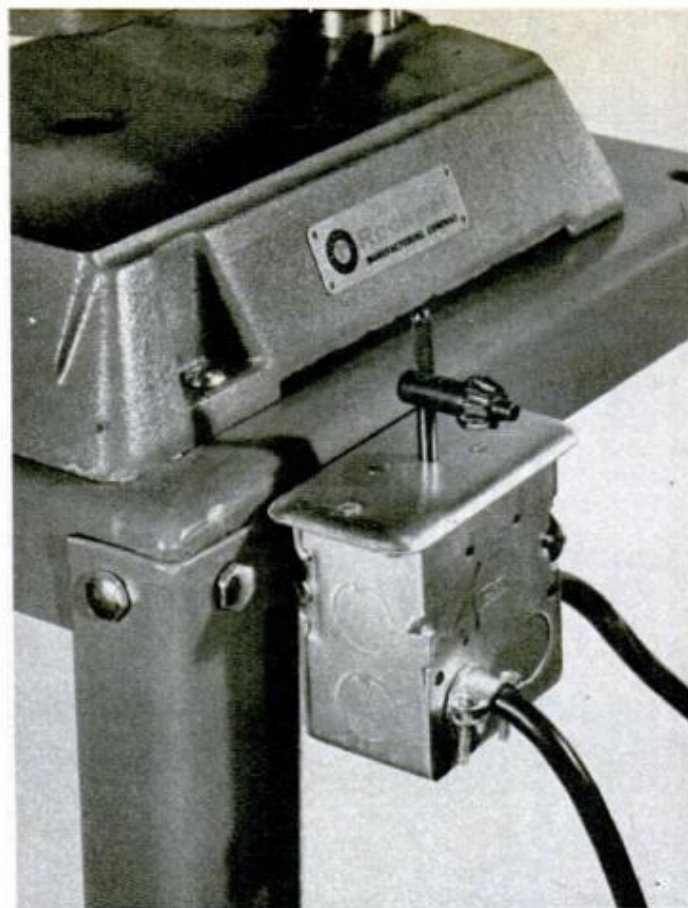
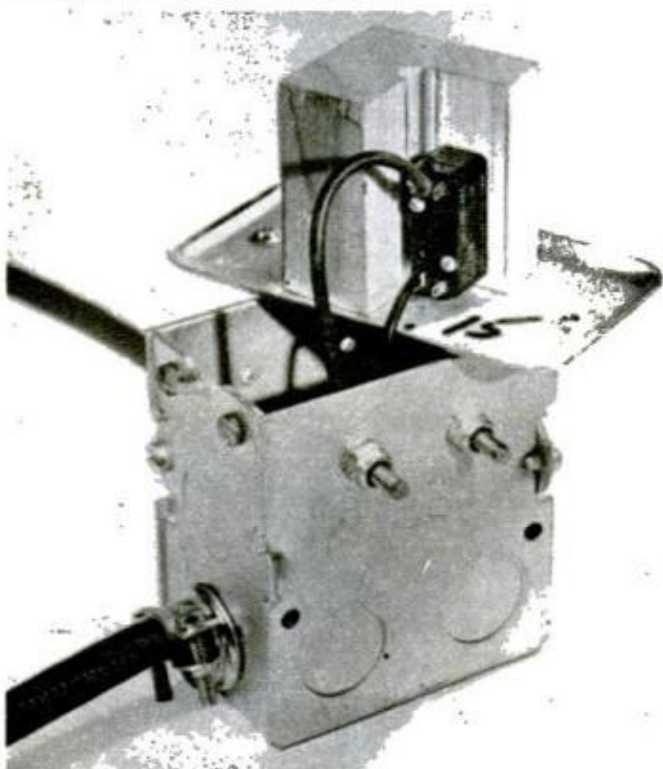

Only when chuck key is in place in safety switch will drill press run. With motor switch turned "off," safety switch makes good place to store and keep track of elusive key. Switch box bolts to drill-press stand.

Chuck-key handle depresses button on microswitch to close circuit. Microswitch is wired into "hot" side (black wire) of motor cord. Both motor and safety switches must be "on" before drill press will operate. Key is required to work switch, can't be left in chuck.

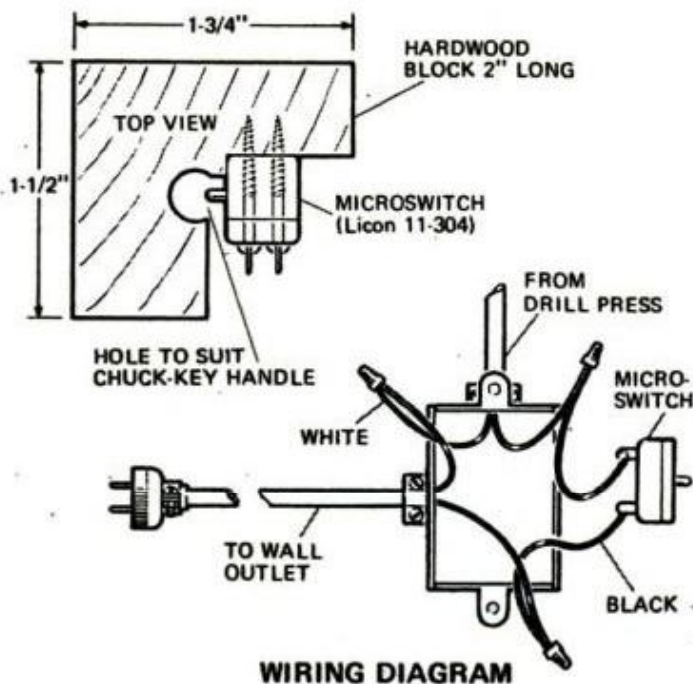



# Opel: Number one seller in Germany.

## Opel Manta Luxus: \$3,058.50 in America.

The Opel outsold every other car in Germany in 1972. The plush Manta Luxus is one of the reasons why. For the above price you get all the standard features listed on the price sticker below. Give up a little plush and Manta is \$2,849.50. Or go sporty with Manta Rallye — \$3,046.50. All prices are Manufacturer's Suggested Retail Prices, including dealer new vehicle preparation

charges. Optional equipment, State and local taxes and transportation charges are additional.

Manta. The personal-size sport coupe proven in more than 2 billion miles of actual driving. Manta. With rack and pinion steering. A 1.9 liter engine. Disc brakes up front. A grand-touring ride. Manta. Luxurious. Economical. Comfortable. Really ready for America.

 <b>BUICK MOTOR DIVISION</b> GENERAL MOTORS CORPORATION <b>MANUFACTURER'S SUGGESTED RETAIL PRICE</b>	
Buick Motor Division, Inc. (Buick Division) 2000 BROADWAY, NEW YORK, N.Y. 10008 Buick Division, Opel Division 2000 BROADWAY, NEW YORK, N.Y. 10008	
<b>MODEL:</b> MANTA LUXUS <b>TYPE:</b> COUPE <b>PRICE:</b> \$3,058.50	<b>STANDARD EQUIPMENT:</b> 1.9 LITER ENGINE DESIGNED FOR NO-LEAD, LOW-LEAD FUEL, WITH HYDRA-LIC VALVE LIFTERS AND AUTOMATIC CHOKE • POWER BRAKES WITH FRONT DISC, BELT TIGHTENERS • CARPETED TRUNK COMPARTMENT, PAPERBACK SHIELD AND FLOOR • CUSTOM CLOTH TRIM WITH VINYL EDGING, AND COLOR COORDINATED INTERIOR • RINGED REAR QUARTER WINDOWS • RUBBER BUMPER GUARDS AND STEPS • ELECTRIC CLOCKS • RALLYE TYPE WHEELS AND STEERING WHEEL • ADJUSTABLE FRONT SEAT BACKS
<b>EXTRAS:</b> (See dealer for details)	<b>MSRP:</b> \$3,058.50

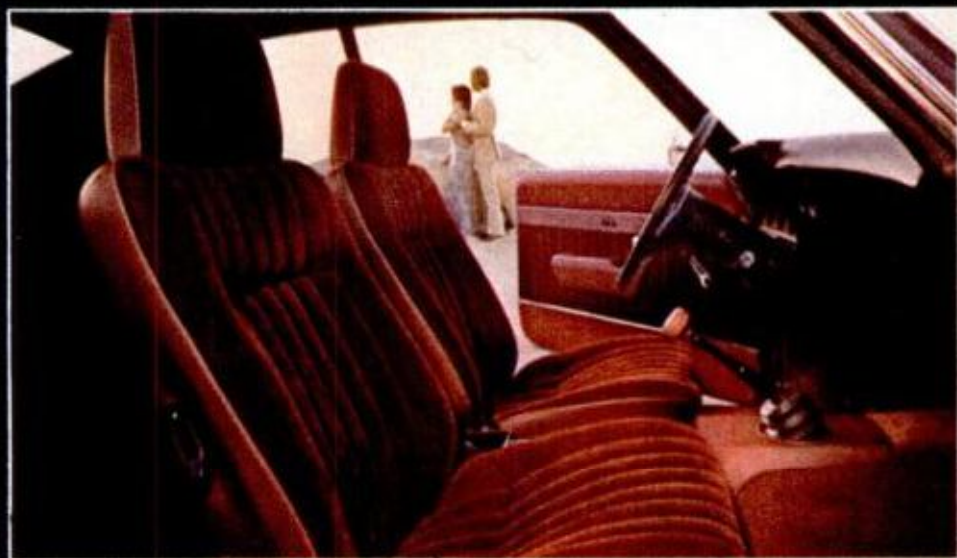

**German precision imported by General Motors.**  
**Sold and serviced by 2200 Buick dealers.**

# Come to Marlboro Country.

100's: 18 mg. "tar," 1.3 mg. nicotine—  
100's: 19 mg. "tar," 1.5 mg. nicotine av. per cigarette, FTC Report Aug. '72

Warning: The Surgeon General Has Determined  
That Cigarette Smoking Is Dangerous to Your Health.





Marlboro Red  
or Longhorn 100's—  
you get a lot to like.



# “I'd like to talk to the guys who think they can't install wall paneling. And the wives who wish they would.”

Wally Bruner, host of the do-it-yourself TV show “Wally's Workshop,” has advice for homeowners:

“Some men think the job of installing paneling's too hard for them. Yet these same guys will repaint or repaper a room or a wall time after time.

“Well, paneling's a lot easier than you think. If you can measure and saw, you can panel. And working with 4' x 8' panels, the job goes fast.

“Once your paneling's up — no more repainting or papering, ever. And you've got a happy wife, because nothing beats paneling for handsomeness and easy upkeep.

“Also, if there's anything special you need to know — on planning or installation, for instance — you can just ask The Paneling People, your nearest U.S. Plywood dealer.”

For a listing of U.S. Plywood/Weldwood dealers check the Yellow Pages under 'Plywood.' Discover for yourself why the company that makes fine U.S. Plywood products, and the dealers who carry them, deserve to be called

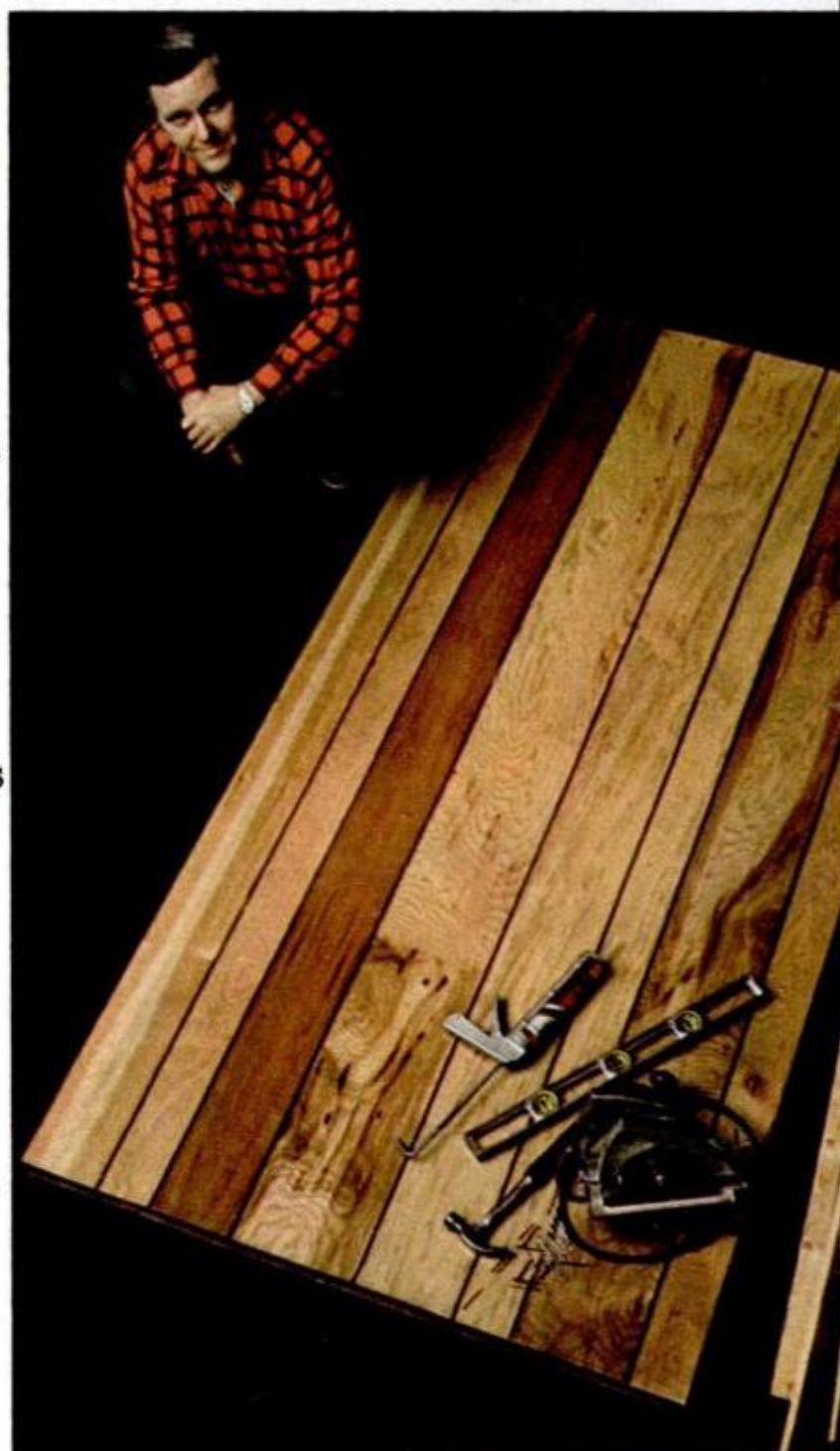

## The Paneling People.



# Put yourself in the sailplane pilot's seat

Flying sailplanes is no longer a rich man's sport. You can join a club and share equipment and expenses with other thermal-seeking adventurers.

by Harvey Shaman

PHOTOS BY THE AUTHOR



The altimeter read 3000 feet. I reached for the red knob in the center of the instrument panel. A smooth, hard pull ended in a loud *thwang* as the towline was released. I pulled up in a climbing turn to the right, and the towplane dived to the left. I was on my own at last—my first solo flight in a sailplane.

The green pellet in the slender glass tube of the variometer on the instrument panel moved upward, indicating I had flown into rising air. I swept into a tight turn and the altimeter began winding up—3200, 3400, 3800 feet. Five minutes after releasing from the towplane, I flew out of the top of the thermal, 5000 feet above the ground. In that moment of exhilaration I felt as though I had conquered the air—as unfettered as a smooth-sailing bird.

Sailplane flying is not a sport reserved for a select few. The Soaring Society of America, a national organization, reports a membership of 11,713 in some 215 soaring clubs scattered throughout the country.

Sailplane flying is a lot simpler than fly-

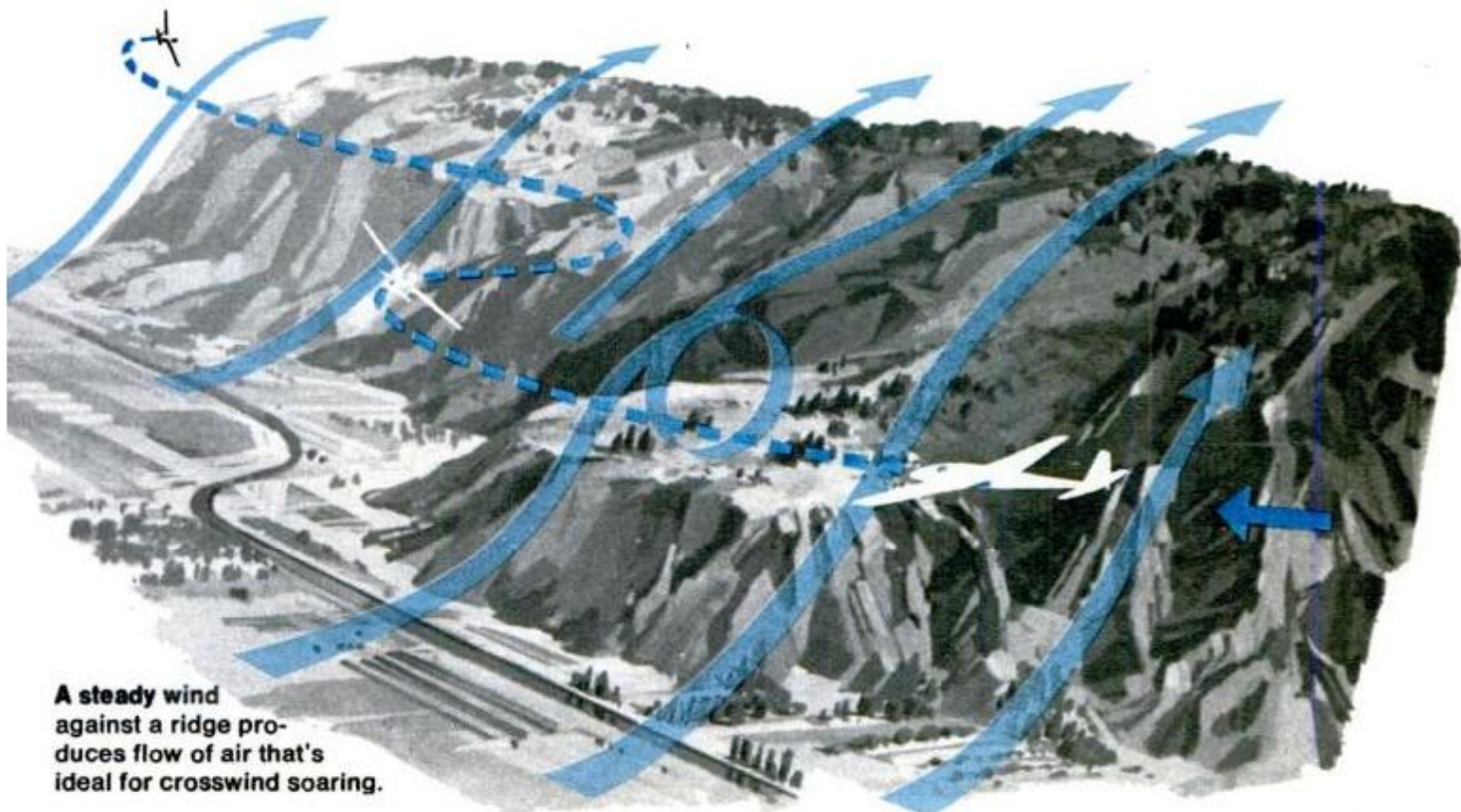

A steady wind against a ridge produces flow of air that's ideal for crosswind soaring.



**Learning to fly on tow** (top photo) can be one of the trickier aspects of sailplane flying. Beginner must learn how to avoid towplane's prop wash.

**At a prearranged altitude**, the sailplane pilot releases the towline and starts to look for rising air. The towplane dives out of the flight path.

**Pilots usually try to keep within sight of the airport.** Flying too far can lead to unplanned landing in pasture. Plane then must be safeguarded.



ing a powered plane. There is no engine to bother with and no complex navigational or radio equipment. Generally, you fly within sight of the airport from which you take off. Only after you become very experienced do you think about cross-country flights.

Basically, all airplanes are alike, whether you fly a fiberglass or aluminum sailplane, a powered lightplane or a supersonic jet. A plane flies because the wing moving through the air creates lift. As long as the airplane moves forward fast enough to create lift, it will stay in the air. The jet

*(Please turn to page 174)*

**'I felt as though I had conquered the air'**

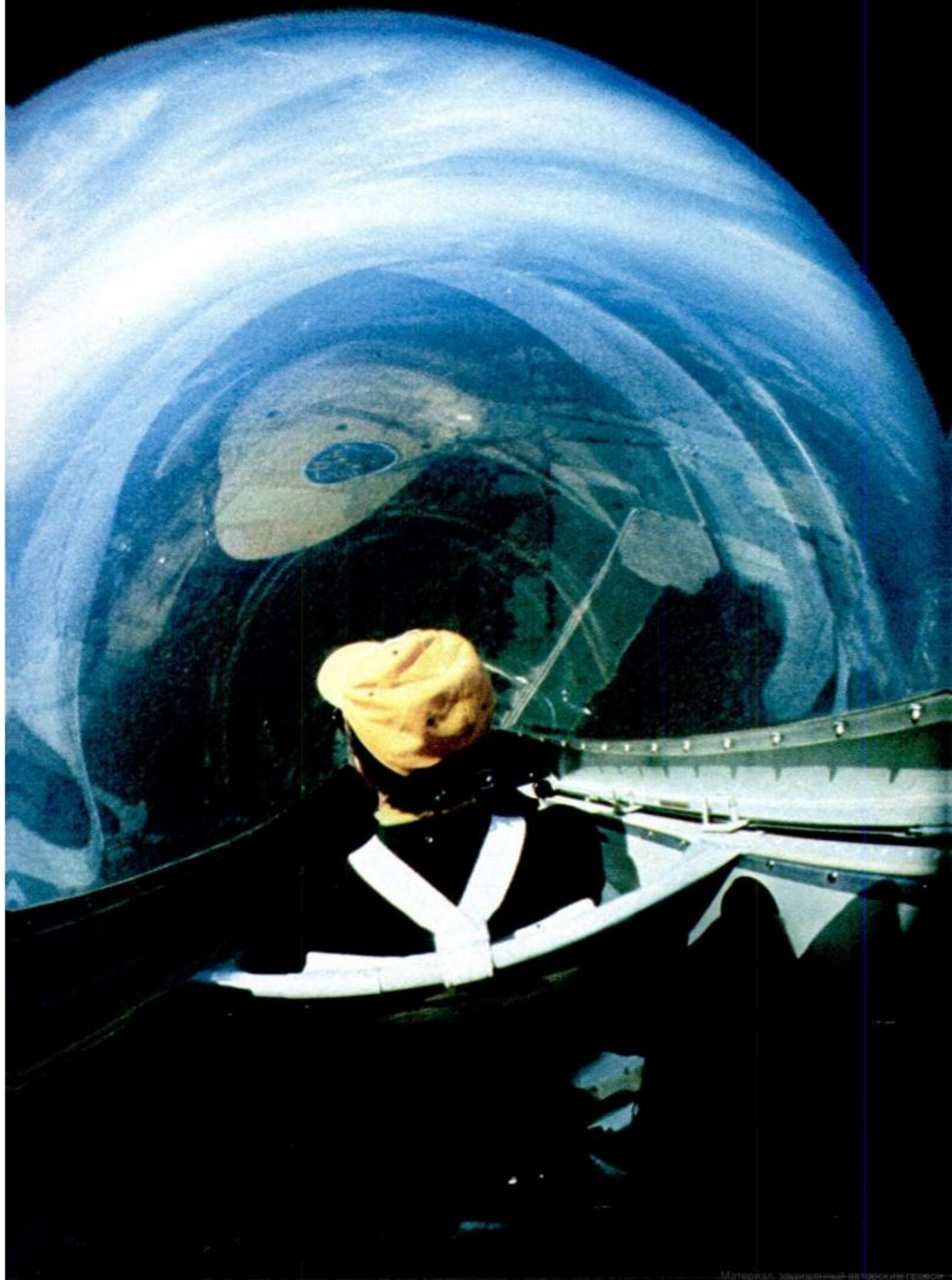



# Spruce up your patio with indoor-outdoor carpeting

by Harry Wicks  
WORKSHOP EDITOR

If you want to change the look of your yard and still have it finished this summer so you can enjoy it, consider making the change by using carpeting designed specifically for outdoor use.

Manufactured by Ozite Corp., 1755 Butterfield Rd., Libertyville, Ill. 60048, the carpeting is available in solid colors and striped, multicolored patterns, as well as in a realistic-looking grasslike texture called Lawnscape, shown above in baseball-star Mickey Mantle's yard.

By covering your outdoor "floor," you can make a patio or deck as charming as any room inside your home. The carpeting is easy to work with, and you can save on installation because you can do it yourself. You can cut the material with scissors.

This striking striped carpeting, called





Sunnyside Up, comes in 6-foot widths and in three color combinations. It sells for \$5.95 a square yard.

Sunnyside Up can be laid over any existing wood deck, concrete patio or other rigid surface. Adjoining strips can simply be butted together without stitching. If necessary, double-sided carpet tape can be used to keep edges from curling.

Lawnscape, the synthetic grasslike material, comes in 6 and 12-foot widths for \$6.95 a square yard. It should be laid over an asphalt or concrete base.

Any of the carpeting can be installed permanently with special adhesives supplied by the manufacturer. ★★★



1. **Famous Yankee star** Mickey Mantle chose Lawnscape for poolside patio covering. Mickey uses the patio to keep his putting eye sharp.
2. **Carpeting here** runs from family room out onto patio. Result: Continuity of decorating theme indoors and out.
3. **Sunken concrete patio** was updated by adding bright colors. Use of bold stripes makes patio appear larger.
4. **Gaily colored stripe pattern** called Sunnyside Up is available in warm and cool colors to suit your preference.
5. **Carpeting can be cut** with ordinary scissors, does not require any stitching where adjacent pieces meet.

# Outdoor furniture easy to build as stacking blocks

by Gary Gerber, IDSA

This summer you'll enjoy your back-yard patio even more if you add this handsome, contemporary furniture to the scene. Easy to construct, these sturdy pieces have low-cost chimney blocks for legs; a lot of high-priced lumber is eliminated from the project. Blocks used for the bench and seats cost about 90 cents apiece. They were purchased at a local mason's supply outlet.

For each bench, you'll need 2x6x48-in. redwood boards and a pair of chimney blocks. After drilling a  $\frac{3}{4}$ -in. hole  $\frac{1}{2}$ -in. deep, in each end of the wood (about  $3\frac{1}{4}$  in. in from the end) drill pilot holes for No. 12 woodscrews. Next, using masonry bits, drill each chimney block for the anchors. Drill the block deep enough to insert

plastic or metal masonry anchors. To make bits last longer, drill holes in blocks using several bits. Start with a small-diameter bit and work your way up to the finish size to suit the anchor.

After pushing in anchors, attach seat boards to chimney blocks using No. 12 fh screws. Finally, to conceal the screwheads, apply waterproof glue to a  $\frac{1}{2}$ -in. lengths of  $\frac{3}{4}$ -in. dowel and tap in dowels. To make the table, place two benches back-to-back atop two pairs of chimney blocks as shown

**Picnic table** and matching benches (below) can be put together quickly using a minimum of tools because the wood is simply fastened to freestanding blocks. Only 2x6 redwood and chimney blocks are needed.

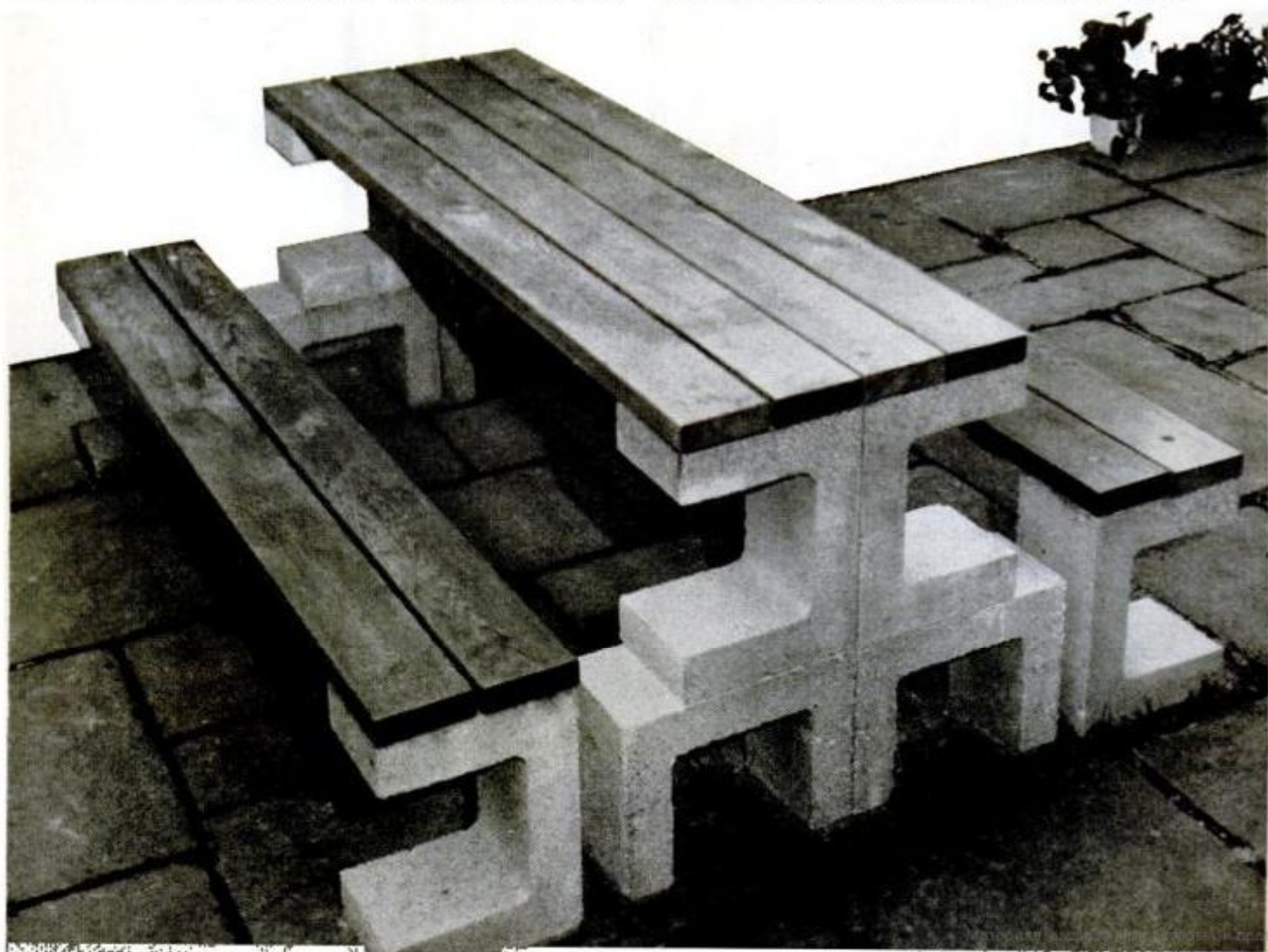



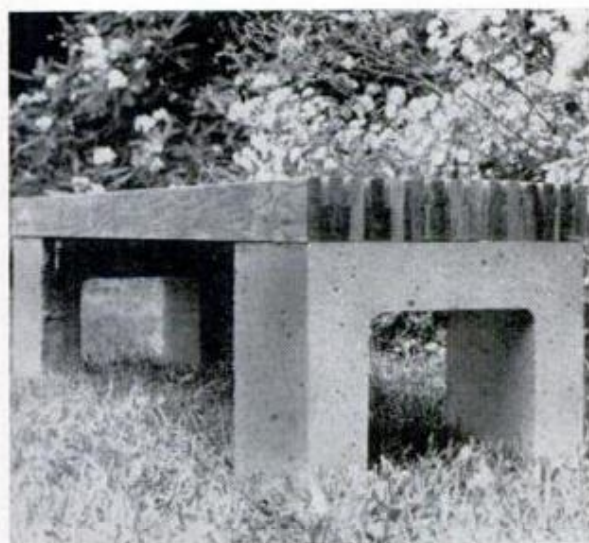
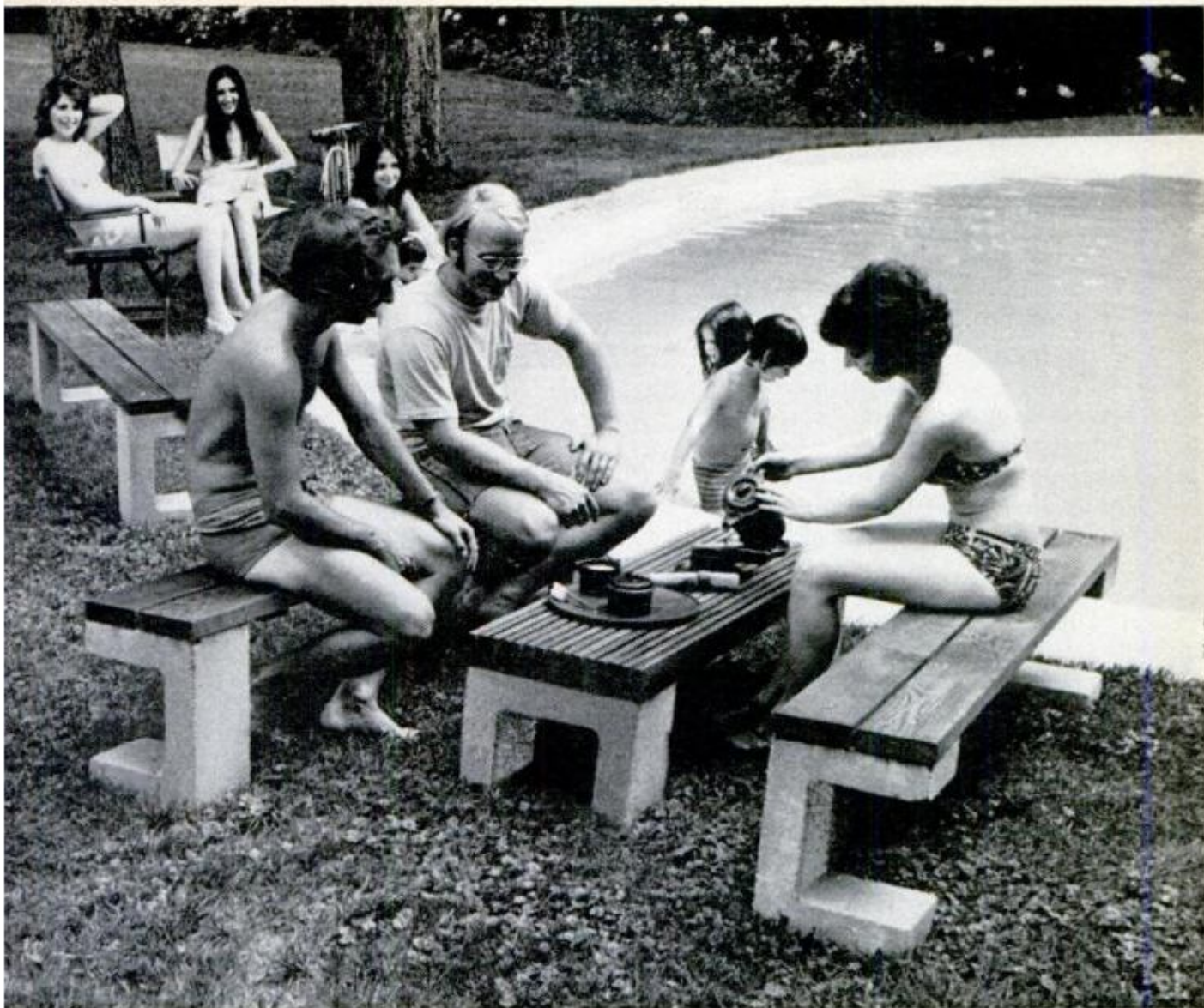

**Slatted coffee table** is a slight variation of the furniture shown on facing page. The  $\frac{3}{4}$ -in. redwood stock is separated by spacers, and the seat assembly is fastened to the blocks as detailed in the drawing at the right.

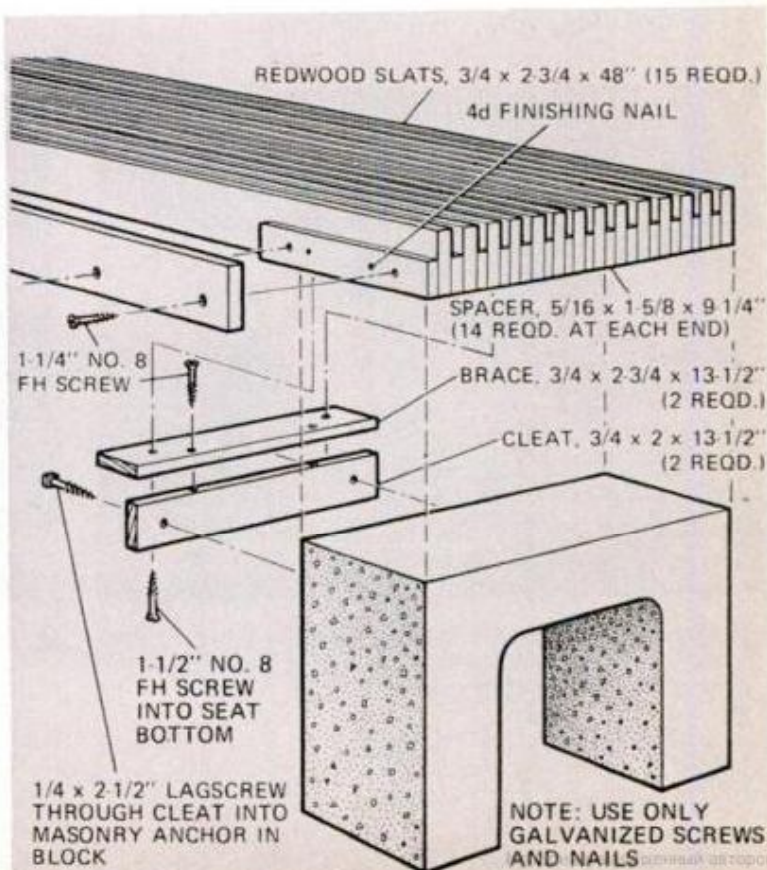

## Fastening wood to chimney block

in the photo on page 76. I've found the table is sturdy enough without tying the two benches together, and you retain the flexibility of being able to take apart the table to create two benches.

To build the coffee table with slatted top, use 14 spacers at each end of the table to

separate the 15 redwood boards. Fasten the spacers to each board with 4d finishing nails, and tie them all together with an L-shaped brace on the bottom which, in turn, is fastened to each chimney block.

For eye-appeal, give the blocks one coat of pastel-shade masonry paint. ★★★

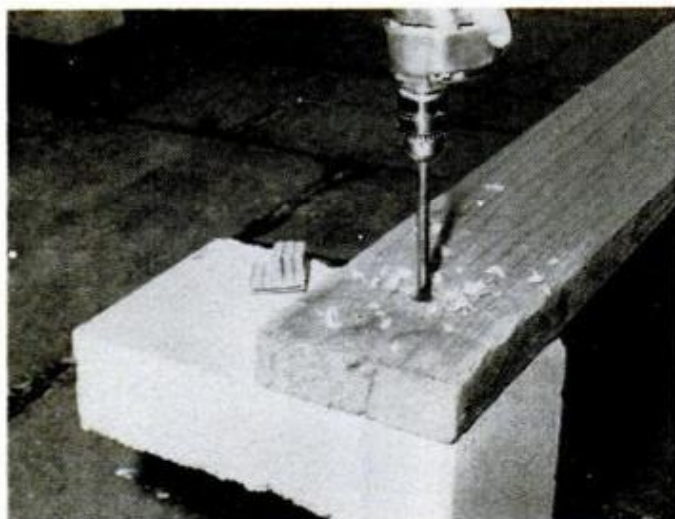

**1** Bench seat boards are cut to length, positioned on blocks and  $\frac{3}{4}$ -in. holes are drilled through. Tip of bit marks spot where you will drill block.

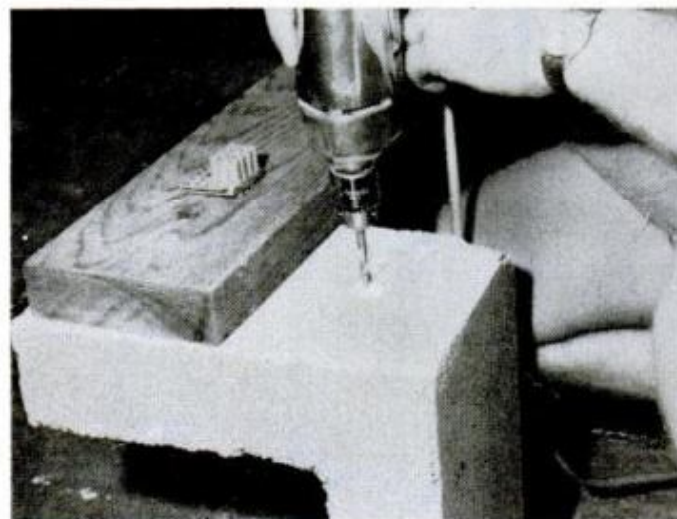

**2** Holes in masonry should be bored in stages to make bits last longer. Start with a small bit and work your way up to the desired diameter.

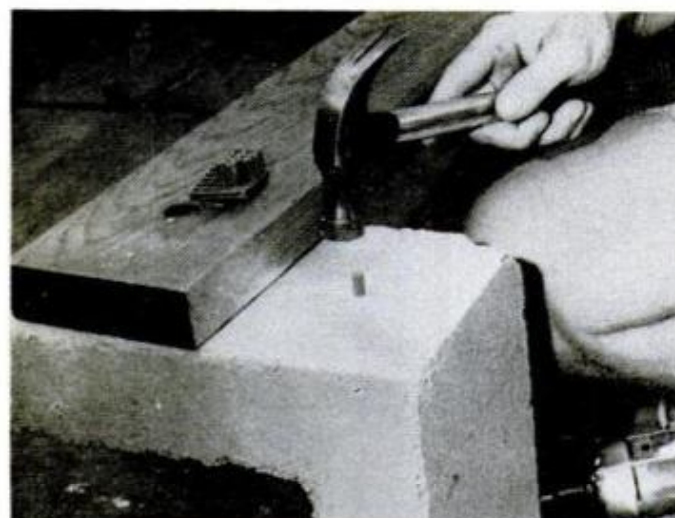

**3** Masonry anchors are then tapped into the predrilled holes. Author used one at each end: Two per board at each end would be even better.

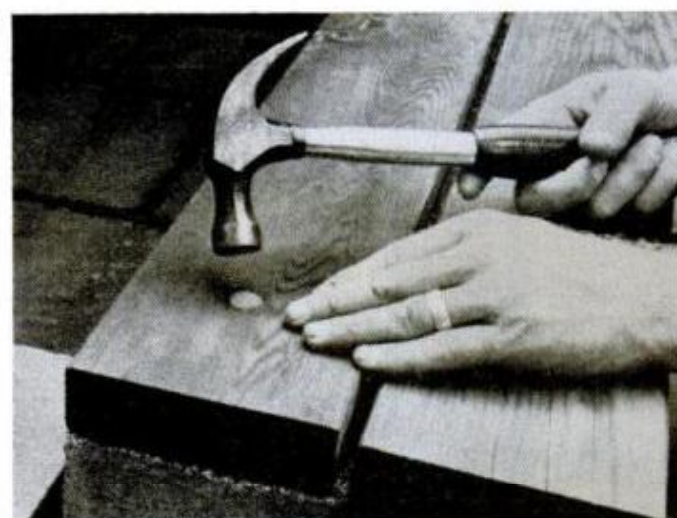

**4** Flathead screw is turned home in counterbored hole;  $\frac{3}{4}$ -in.-dia. dowel plug hides screwhead. Use waterproof glue to assure dowel staying put in hole.

# Swimming pool filter you can make

by James M. Miller

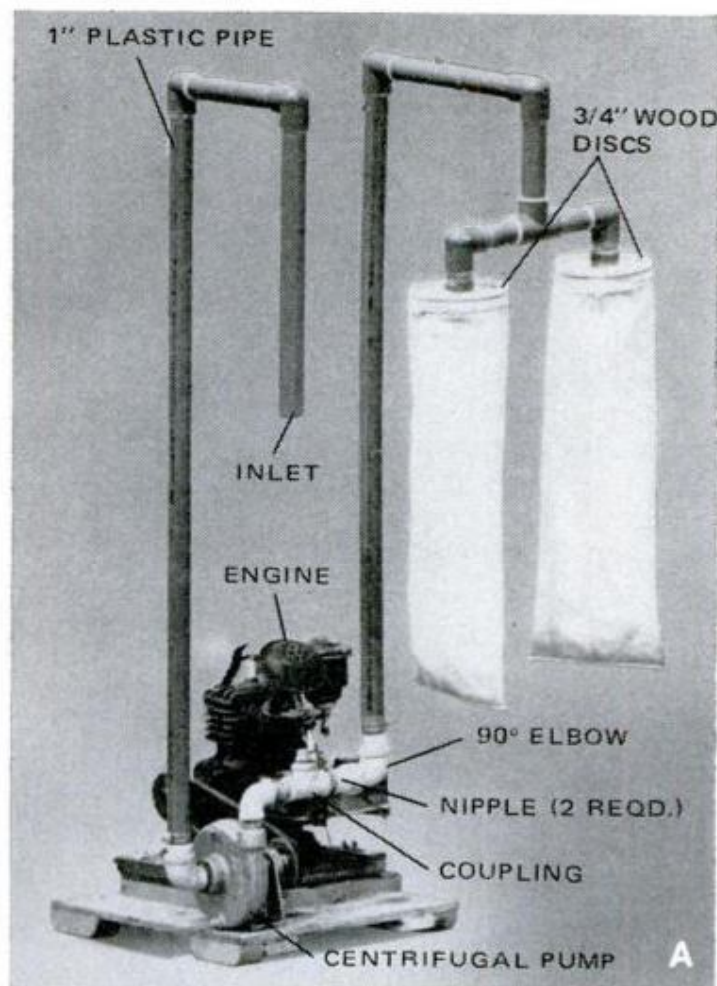

I rigged a filter for my 15-ft. above-ground pool from an old lawn-mower engine, a 30-gpm centrifugal pump from Sears, some 1-in. plastic pipe and two canvas bags, as shown in photo A.

To use the filter, you first prime the pump by running a garden hose in the intake pipe. Next you place diatomaceous earth in a bucket and mix with water until you have a thick slurry. (Use  $\frac{1}{2}$  lb. of earth for each filter bag.) Submerge the bucket in the pool under the intake pipe (photo D), and with the pump running, suck the slurry into the canvas bags. The earth, coating sides of the bags, does the filtering. It takes about six hours a day to filter my pool. ★★★

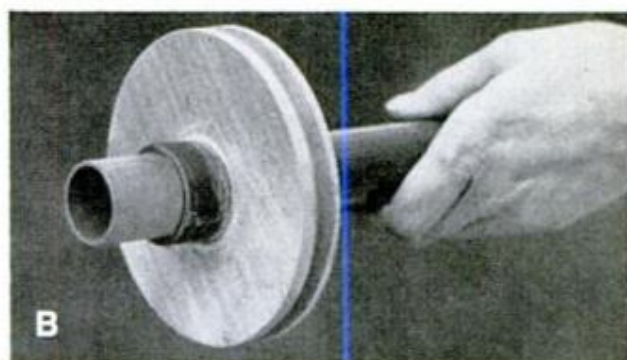

The wood discs that hold the filter bags (photo B), are cut from  $\frac{3}{4}$ -in solid wood, grooved around the edge for drawstrings, waterproofed with three coats of marine paint and cemented to the plastic pipe with epoxy. Use two bags for 15-ft. pool, three for 18-ft. Intake pipe should extend at least 8 in. in water to prevent pump cavitation (diagram C) and permit swimming while filter runs. Each supply pipe should be about 20 in. long. If near outlet, electric motor can be used to drive pump; I used a gas engine because pool was too far from house.

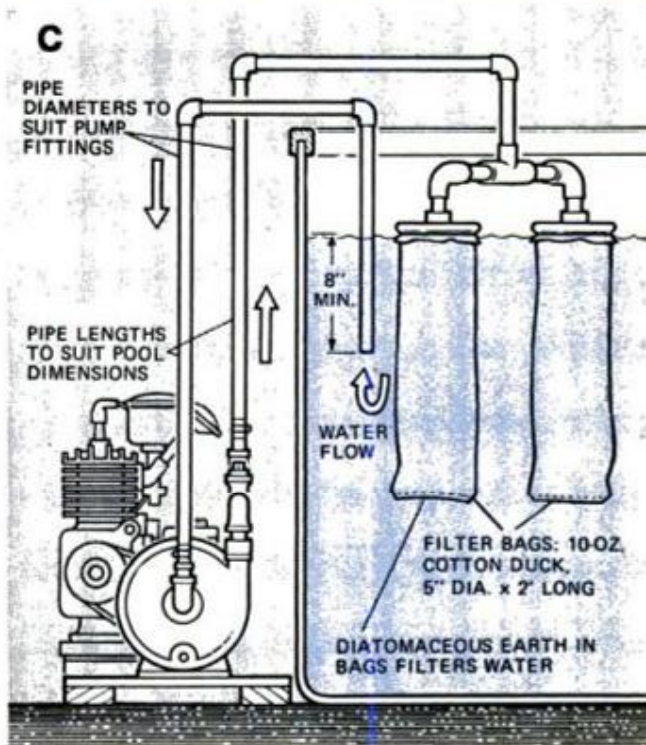

# Weatherproof shelter for your portable grill

Outdoor cooking can be more work than pleasure if it requires having to round up the necessary gear each time—from the kitchen and a cluttered garage or basement.

With a weatherproof shelter for your grill, supplies and utensils, cookouts will be a lot less trouble. This shelter, designed by architect George Whittier, A.I.A., for Western Wood Products Assn. and PM readers, has a slide-out workshelf and room enough to keep everything handy. Materials should cost less than \$200.

Before building, choose the unit's location carefully, making sure drainage is good. Since the structure may be considered a permanent addition to your property, check local codes to determine whether a building permit will be required. You may wish to attach the unit to your house or to a fence or privacy screen. If so, change the dimensions to suit; if it will butt against the house, it must be properly flashed to prevent leaks.

Begin construction by setting a floor of patio blocks in concrete, with anchor bolts

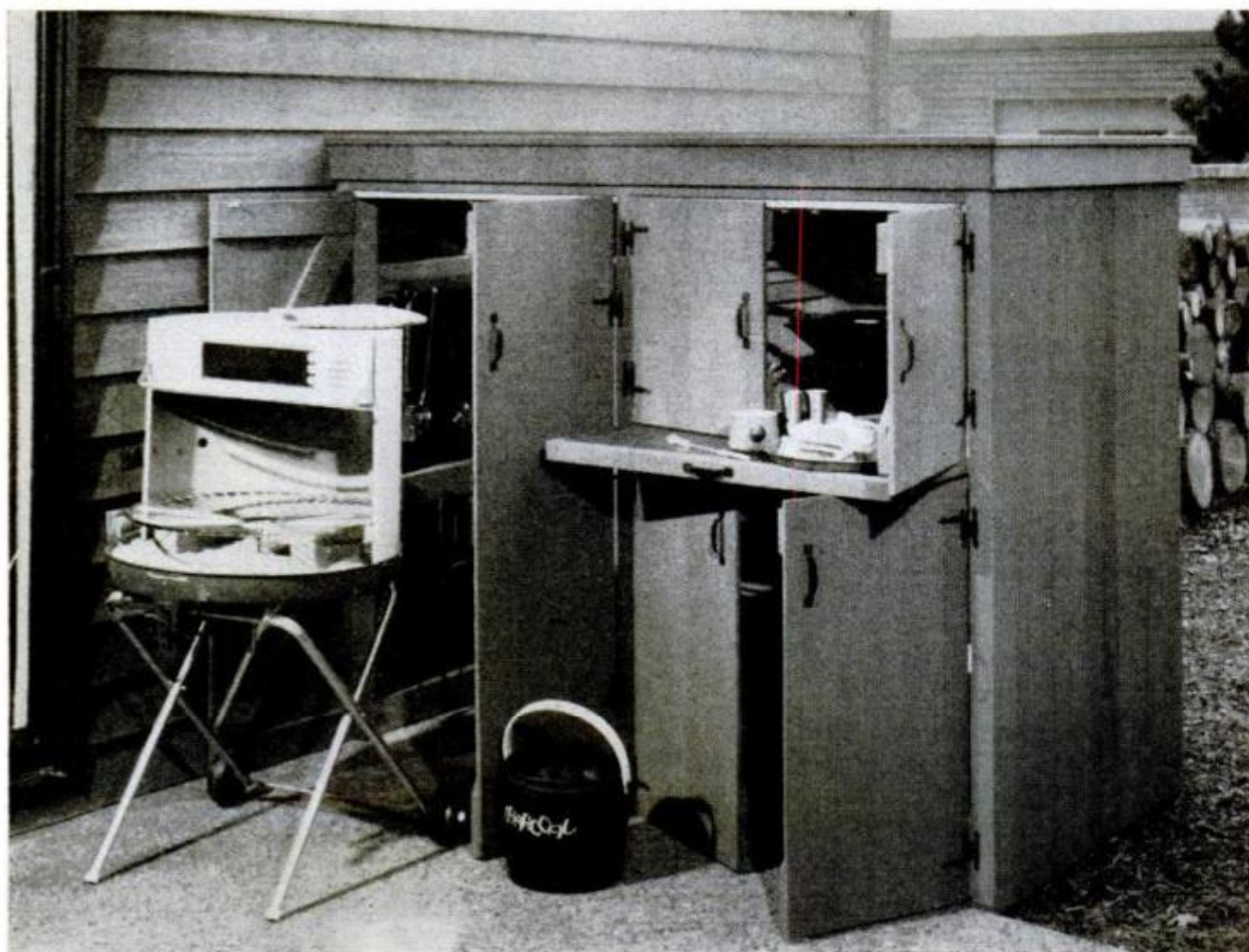

protruding through holes drilled in four of the blocks. (This slab should rest on footings.) Framing is with 2x4s. Start the framing with one middle section and two end sections. Since the middle and one end are identical, one frame can serve as a pattern for the other. Horizontal members tie the sections together into a boxlike frame.

Both roof and slide-out shelf are made from Weyerhaeuser Co.'s Panel No. 15, a 1/4-in. aluminum-clad plywood product available at lumberyards. Above the slide-out shelf is a wider storage shelf, which may be easier to install if sawed in half and re-joined in place. Fixed shelves are notched to fit framing. When shelves have been installed, the roof can be added and trimmed with 1x3s. Then 1/2 x 3 1/2-in. tongue-and-groove western cedar siding is applied vertically and blind-nailed to the 2x4 cross members for a weathertight wall. Doors are made of the same siding, blind-nailed to 1x4 diagonal bracing using a jig of cleats nailed to your workbench or a sheet of plywood.



**Shelter keeps** outdoor cooking equipment, supplies together. Shelf provides easy-to-clean work surface.

Use 10d common nails to spike the 2x4s together and 8d common nails to toenail them. Siding and 3/4-in. lumber require 6d finishing nails. The roof is attached to the rafters with neoprene washer roofing nails 12 in. apart, then caulked. Friction catches hold the doors closed.

The structure can be stained or painted

TECHNICAL ART BY PETER TROJAN

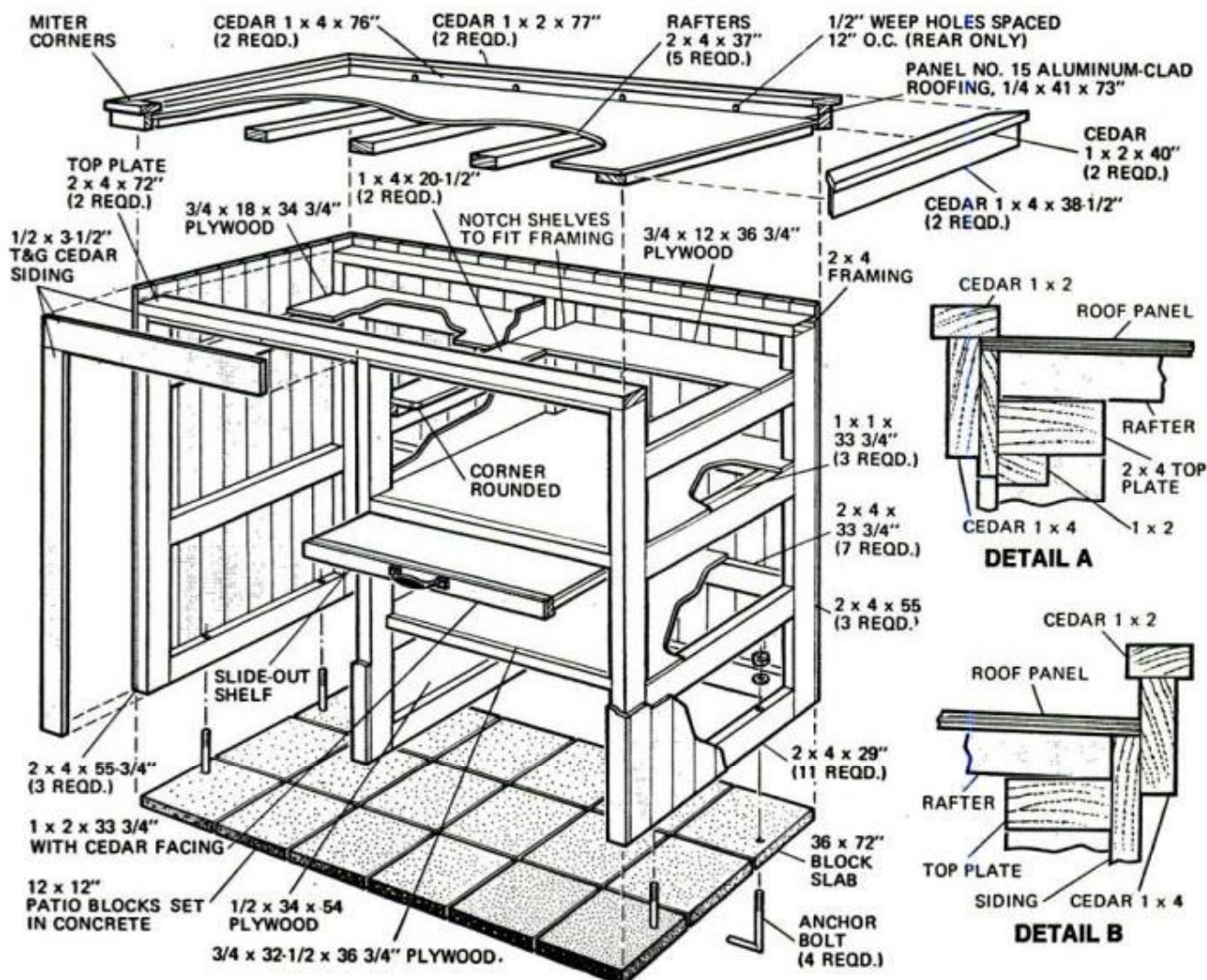

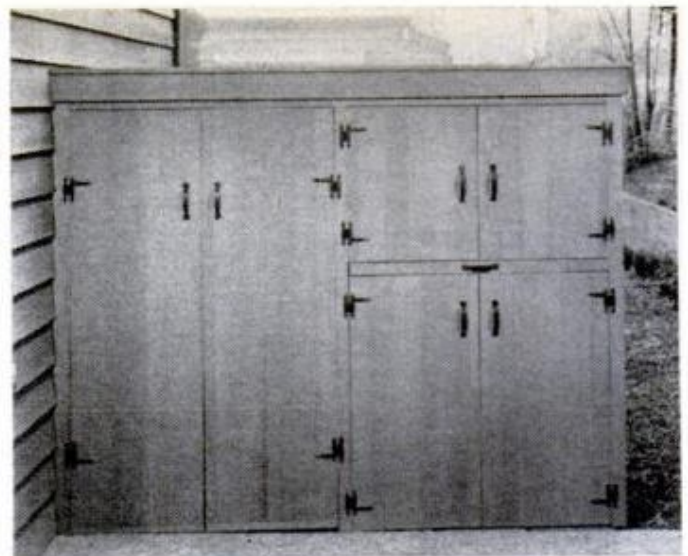
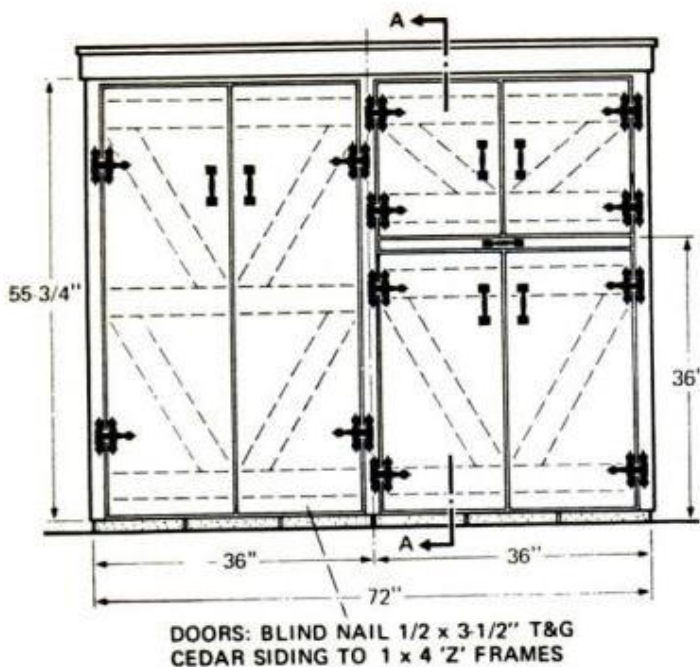

**Closed shelter gives** weathertight protection of contents. Roof slopes 3/4 in. to the back, drains through weep holes in rear fascia. Notched corners allow close attachment to the house.

after doors are hung; use saw-textured siding with stain. Wood siding other than cedar may be used, and other styles of siding are also possible. For best appearance, use the same material for both walls and fascia. Since the unit shown butts against house siding, its corner pieces were notched to fit.

The shelter is designed so that it can be readily adapted to other uses, such as for storage of garden tools or outdoor sports equipment. Poolside use is another possibility. The unit could also include a weather-

proof electrical outlet, allowing temporary installation of a portable refrigerator in the lower cabinet for entertaining.

The prototype shown was built for the Western Wood Products Assn., which offers detailed construction plans, and a materials list, for 25 cents. Write Dept. P-9P, Yeon Building, Portland, Ore. 97204. ★★★

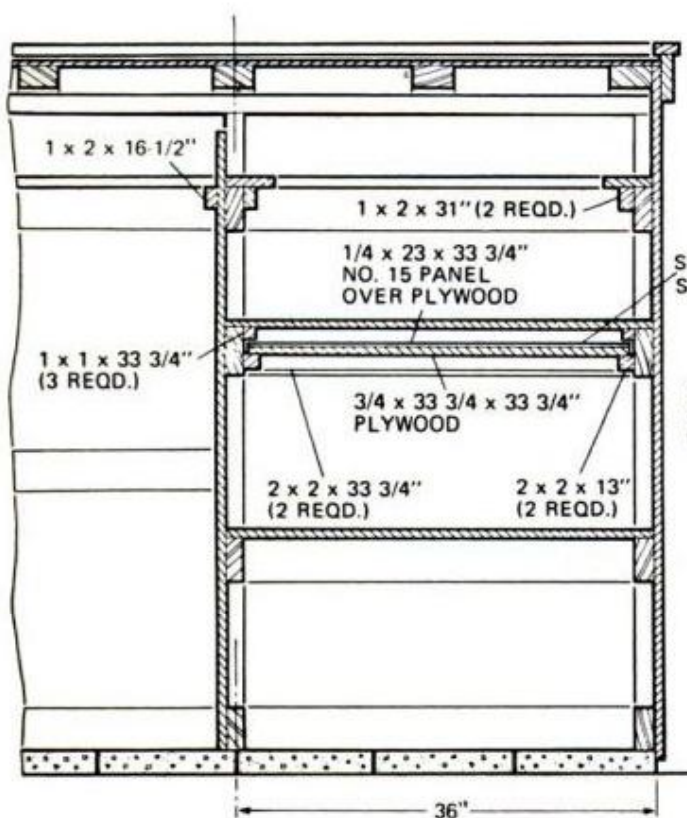

FRONT VIEW, SECTION B-B

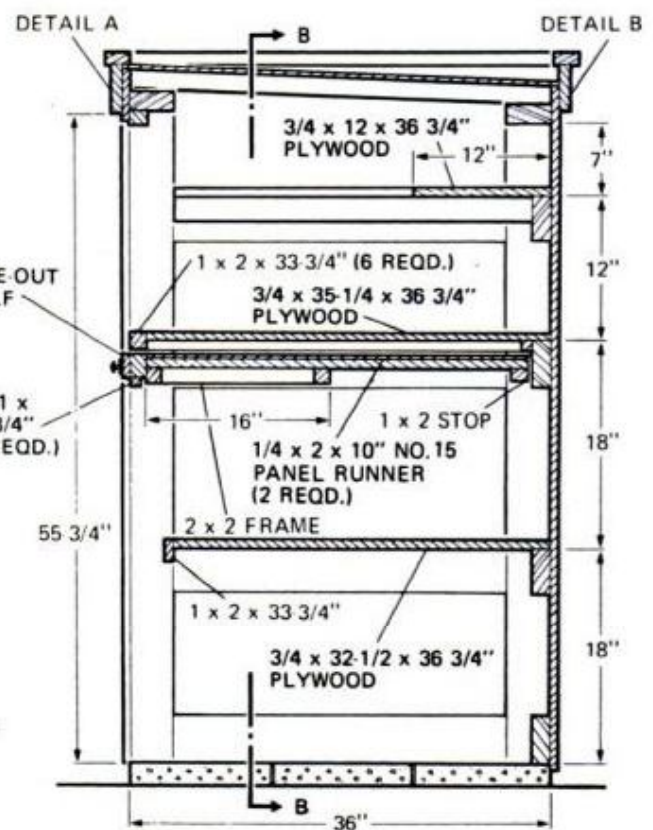

SIDE VIEW, SECTION A-A

# Trail-bike carrier— sturdy and inexpensive

If you have a trail bike that weighs more than 300 pounds, you can't use bumper-mounted brackets to carry it.

This sturdy, removable carrier will safely handle any bike your car's suspension can, and should cost no more than about \$10 for materials. If you don't do the welding yourself, measure and cut the parts in advance

and take them to a local welding shop. It shouldn't cost more than an additional \$10. (Check for gas leaks before welding.)

Dimensions will vary, of course, to suit your car and bike. You'll also find the carrier strong enough to incorporate a trailer hitch (where permitted by law).

—Dwayne L. Harlan

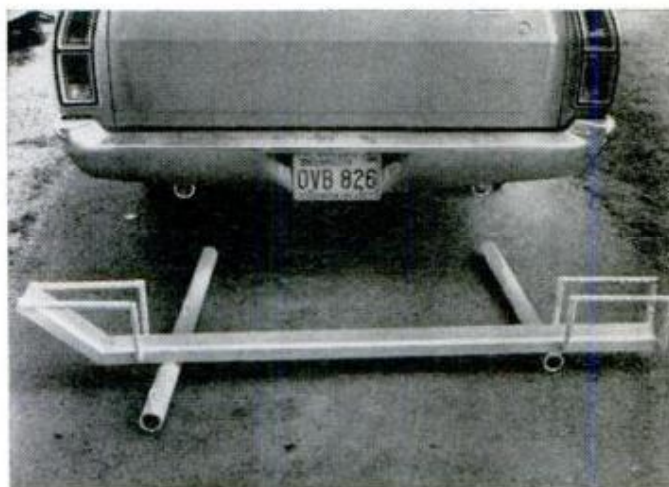

Carrier holds 315-lb. trail bike—too heavy for bumper-mounted types—slides into mounts welded or bolted to underframe of car, leaves bumper unmarred.

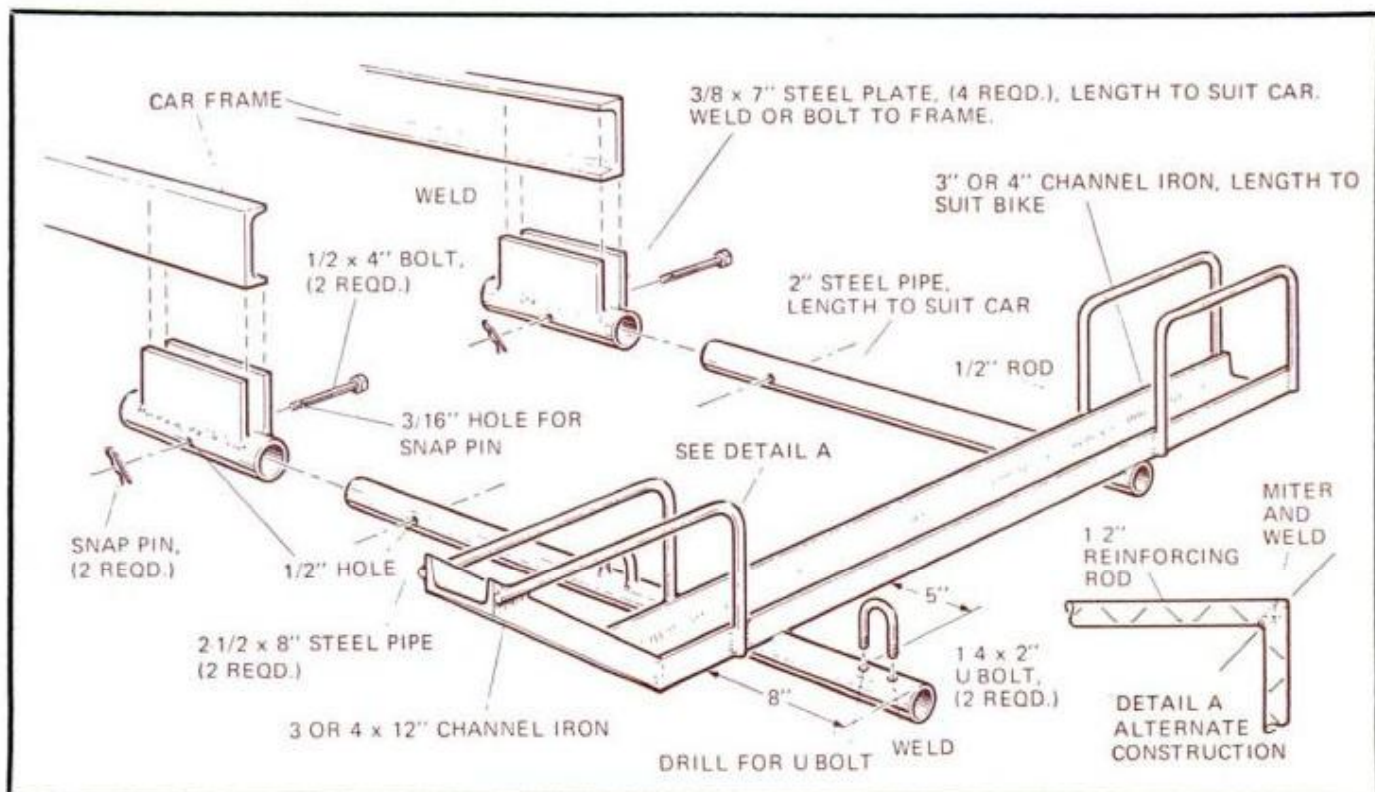

# How to test and repair doorbell systems

DATA BY ED FRANZESE



Though a doorbell setup is one of the easiest-to-understand mechanical systems in a typical home, a malfunctioning system is often neglected because the average home handyman thinks the service job is beyond his skills. The fact is—with a little common sense—a do-it-yourselfer can determine and correct a faulty system a lot quicker than he might suspect. But you do need an understanding of the basics of a doorbell system and some rather common “tools.” The information you need you’ll find on these pages. The “tools” consist of common household articles like lighter fluid, cotton swabs and fine-grit sandpaper, plus a pocket continuity tester.

You should be aware that there is a dif-

ference between a line tester (for 110-v. branch-circuit testing) and a continuity tester. Both testers light up to show whether the part (or system) is working—but a continuity tester is for low amperage only. And it must be used with electric current off. (Both types are shown in the photo on page 86.) Continuity testers range in price from about \$2 to \$5 at hardware and electrical-supply stores.

The photo below shows the three doorbell components: door button, transformer and chime box. The step-down transformer lowers the household current from 115 v. to a doorbell working voltage of approximately 16 v.—enough to produce a strong magnetic field in the chime box terminal block when

PHOTOGRAPHY BY ROBERT D. BORST

WIRES TO 115-V.

TRANSFORMER

BELL-WIRE  
TERMINAL SCREWS

DOORBELL BUTTON

CHIME BOX AND COVER



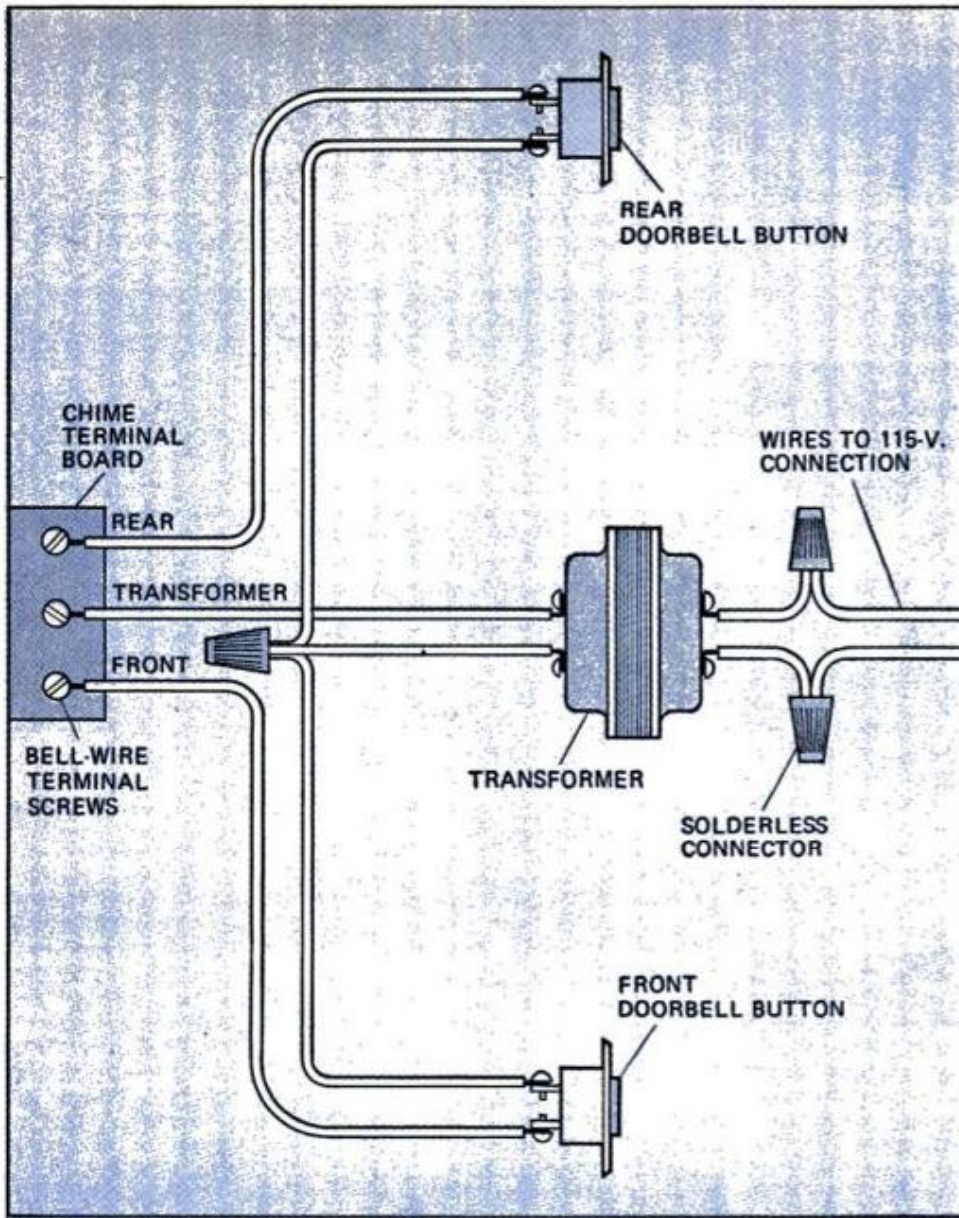

**Buzzers** and doorbells require low-voltage electricity through a transformer hookup. The transformer reduces the 120-v. current to voltage desired. In system at left, front and back-door-chime hookup is accomplished by connecting wires as shown. Caution: Make certain that power is off when wiring the transformer to a 110-v. source.

ADOLPH BROTMAN

**Basic components** of doorbell/chime system are easier to understand than most homeowners suspect. The system appearing on the facing page is made by Nutone (model LA-18 with a teakwood chime-box cover).

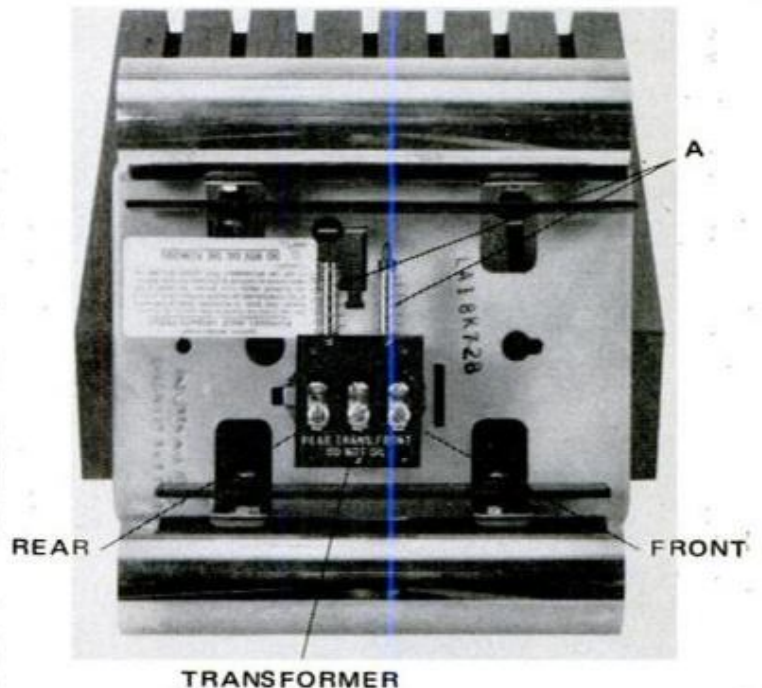

**Three screws** on chime-box terminal screw are easily accessible for making connections. The vertical plungers marked A, directly above the terminal screw board, should **never be oiled**.

## How to test components

the circuit is completed by the doorbell button. A chime box is designed for various tones: chimes, buzzing or ringing, depending on the model.

When the doorbell button is pressed, a circuit is completed at the chime-box terminal board. For example, if the front doorbell button is pressed, there will exist a voltage of 16 v. across the terminals marked *Trans.* and *Front*. This voltage creates a magnetic field in this terminal box which pulls a striker rod through its internal hole, causing it to hit one of the sound bars and produce the sound (something like a "ding"). When the button is released, the circuit is broken, the magnetic field at the terminal board collapses and the spring tension on the striker rod snaps the rod to the other sound bar producing a "dong" sound.

Testing sequence for the system doesn't matter: Most often, however, the problem will be in either the chime box or doorbell button. Remove the cover from the chime box and disconnect the three wires on the terminal board. Remove the two screws holding the electromagnet to the box and carefully lift out the terminal box, striker rods and springs. With a paper clip or nail file, pick the spring off of the striker rod, being extra careful not to stretch or deform it. Using cotton swabs soaked with lighter fluid, thoroughly clean the striker rods and striker-rod holes in the terminal block until they begin to shine. Reassemble springs on striker rods.

A very quick test can now be made of the chime-box terminal board to determine if the windings in each striker-rod hole are intact. Place the tester clip on the terminal marked *Trans.* and the continuity tester probe on either *Front* or *Rear* terminal. If the windings are good, the tester will light. Check both front and rear terminals in

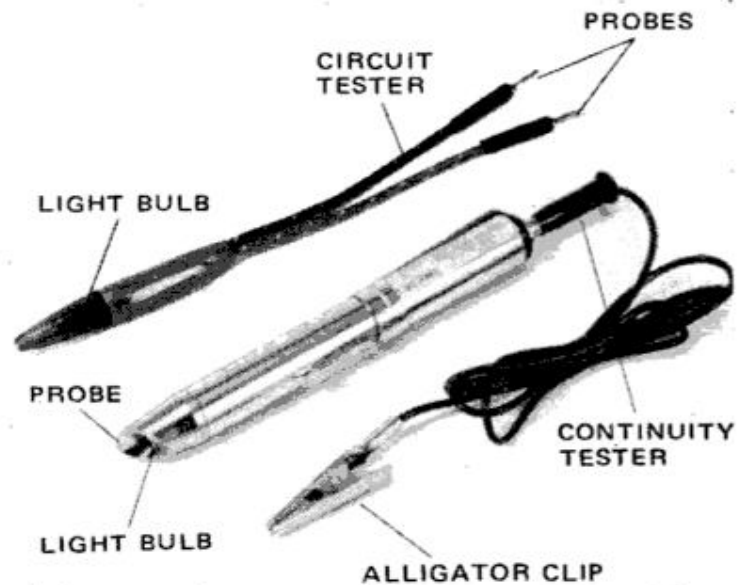

Two testers you should have in your toolbox are circuit and continuity testers. Power **must be off** before using latter.

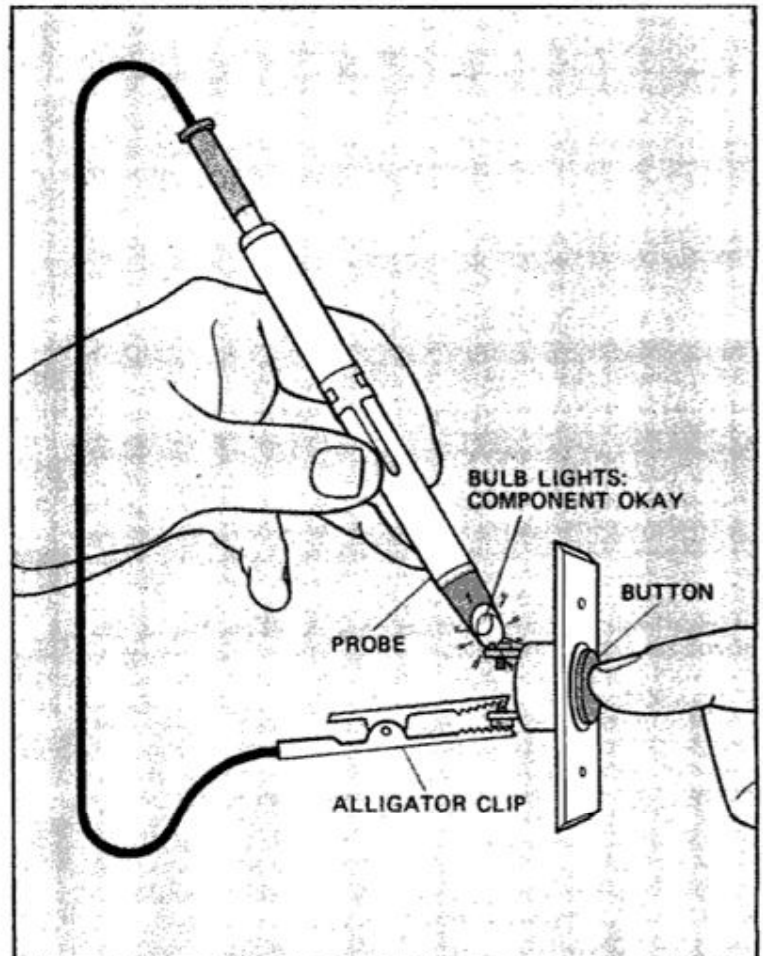

Doorbell button is checked by placing alligator clip on one screw, body of continuity tester on second. If tester lights when doorbell is depressed, the doorbell component is okay.

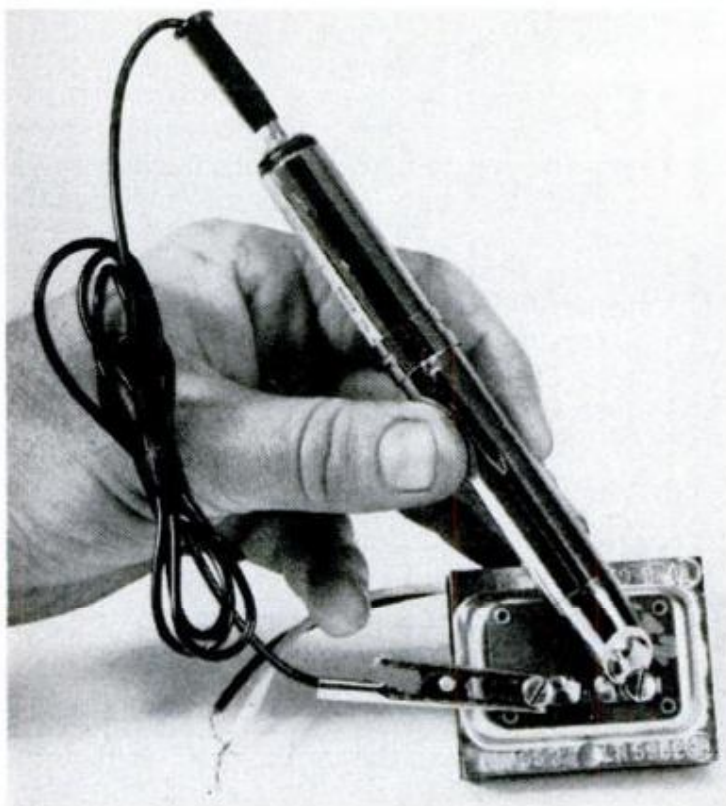

**Transformer** is checked for continuity by placing alligator clip on one screw, tester probe on the second.

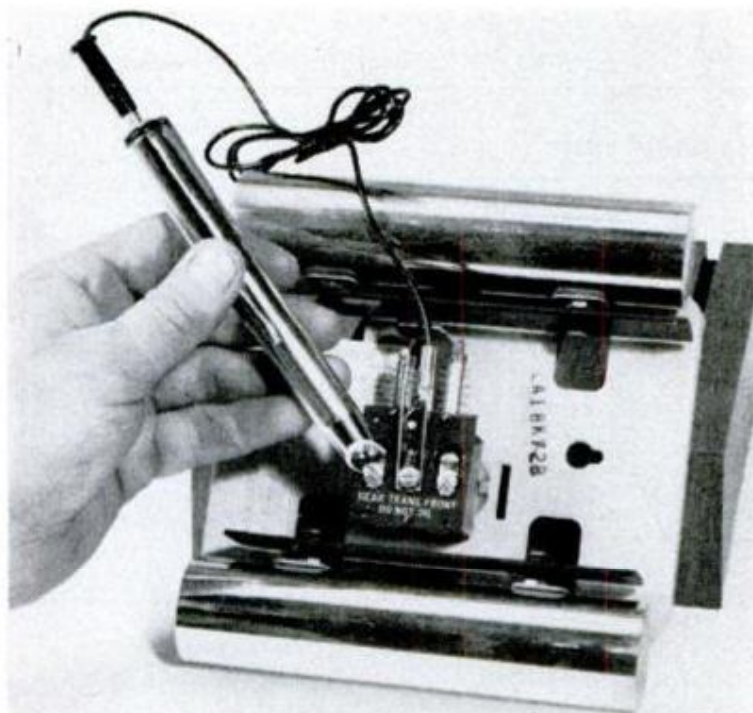

**To check chime box**, alligator clip is placed on center (transformer) screw, front and rear-door terminals are then tested.

this manner. If the tester does not light, the fault is in the chime-box terminal block and it should be replaced. While the cover is off, it's a good idea to clean up the sound bars with lighter fluid.

To test the doorbell button, remove the two wires connected to the button. Place the continuity tester probe on one screw terminal and the clip on the other. Press the button to close the circuit. If the button is good, the tester will light. A spring(s)-loaded button (the type shown in the photos) cannot be repaired and must be replaced. A copper-strip button (usually rectangular in shape) *can* be repaired. To do it, first disassemble the button. Then, clean the copper contacts with fine sandpaper; also clean the copper in the terminal block of the button. Reassemble and test again. If it still doesn't work, replace it.

Before installing any new or repaired button, clean the bell wire (coming from the hole in the wall) of any rust or scale.

The last component to check is the transformer. *Caution: At your house service panel, first turn off the power to the transformer.* Next, place the continuity tester probe on one terminal screw and the clip on the other. If the transformer is good, the tester will light. A transformer that tests bad *must be replaced.*

The drawing on page 85 shows the complete wiring diagram of a two-bell system. If rewiring is necessary, use this as a guide. Chances are, any doorbell system you buy will include installation instructions and schematics. You are well advised to take the time to read through the material to assure you completely understand it. Although some chime-box mechanisms may differ slightly from the model shown, the test procedures and the repairs will remain the same. ★★

# How to paint the outside of your home

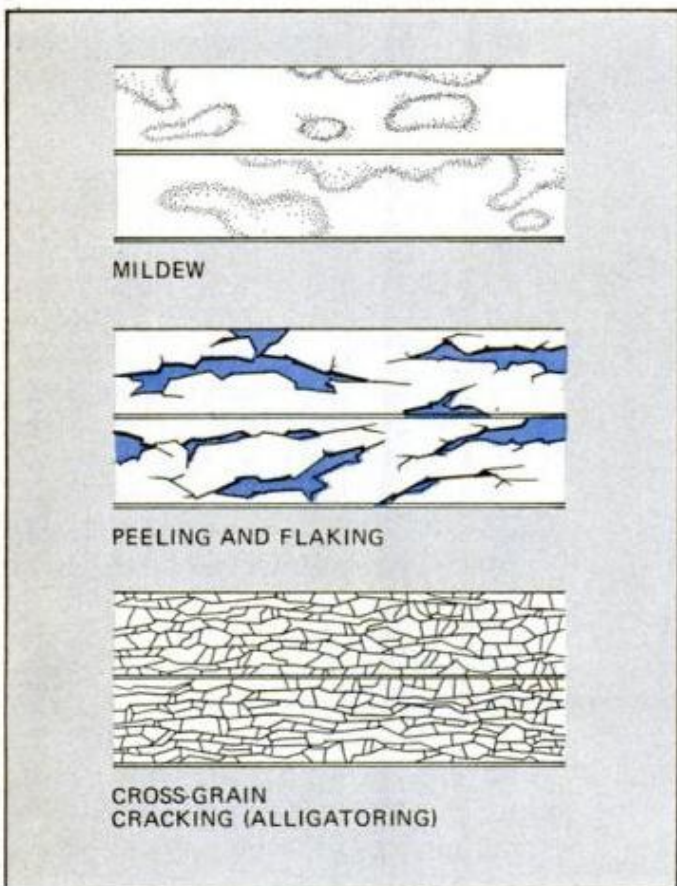

**D**oes your house need painting this year—or next year? The know-how necessary for you to make that decision is an important element in a home maintenance program.

Your first step is to make a careful examination of the paint surface. If your inspection reveals that now is the time to paint, there are several factors that you must take into consideration before starting the job.

- Consider climate, weather conditions and the kind and quality of paint to use.
- Determine how much surface preparation you will need and what you will have to do to correct localized breakdowns of the various surfaces (see drawings at left).

Moisture is the major culprit in house-paint failure. No matter what quality of paint you use, the paint will still break down if moisture problems exist. (See *Get a Peelproof Paint Job*, page 152, Oct. '72 PM). Poor quality or improperly applied paint will also fail. For other paint facts you should know, read on.

## How to choose the right paintbrush

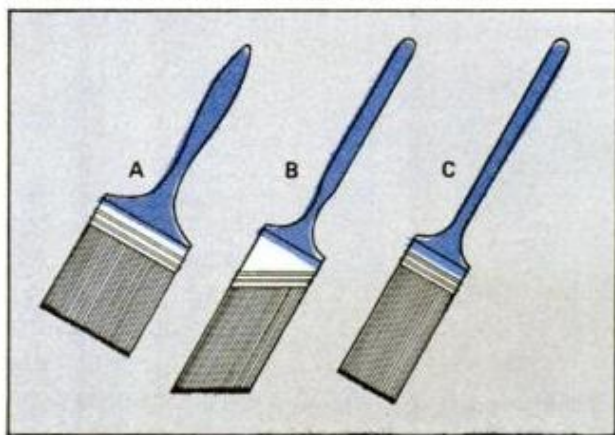

### Types of brushes

Three brushes you should have are: A) large brush, 3 to 6 in. wide; B) sash brush, available in widths from 1 to 3 in.; C) flat or oval brush from 1 to 3 in. wide. Bristles should be nylon if you use water-base paint.

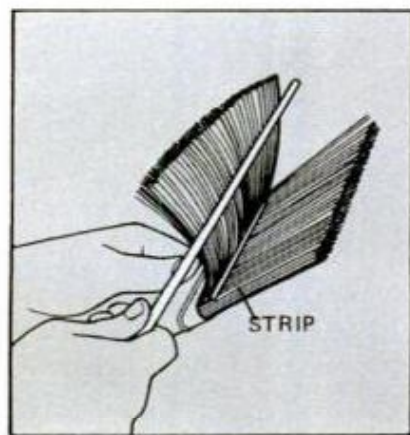

### Note 'strip'

Check brush for strip (gap) in heel by separating bristle layers with stick. Strip indicates quality brush, better bristle shape, greater paint capacity.

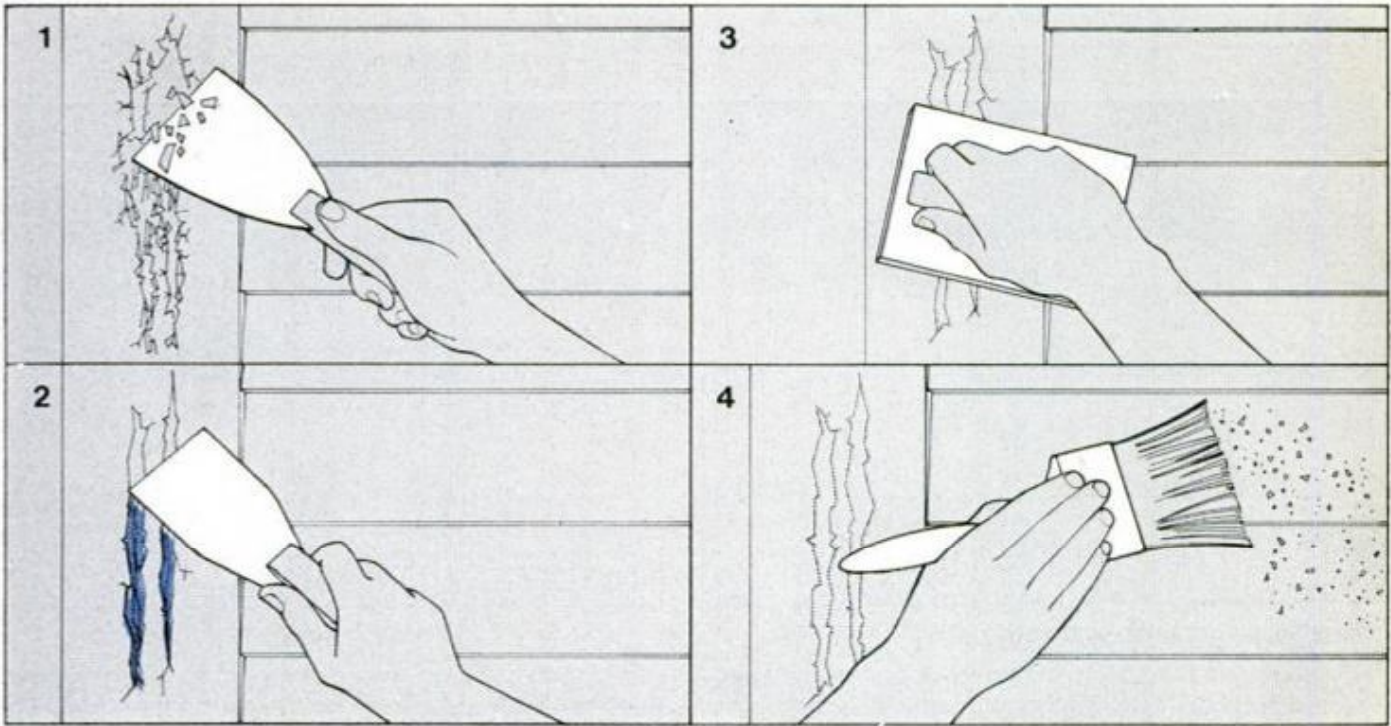
**Surface preparation**

**1** Use a rigid scraper to remove all loose and flaking paint. If you own a portable drill, a coarse-grit sanding disc does this step quickly.

**2** Fill all cracks and surface imperfections with crack filler compatible with your paint. Filler must be dry before paint is applied.

**3** Sand area thoroughly so bared wood blends into surrounding painted area. Job can be done by hand, but it's easier with a power sander.

**4** Finally, dust off surface and wash with warm water and mild detergent to remove grime and dirt. Rinse with garden hose, allow to dry.

**Test for bounce**

Brush bristles against back of your hand; a good brush feels springy. Pass brush gently along any surface to see whether bristles fan out excessively.

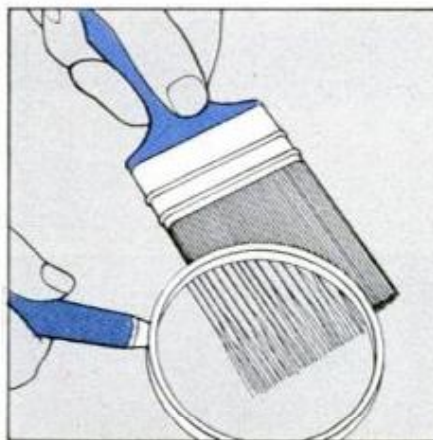
**Look for 'flags'**

A good brush has bristles that are "flagged"—splits at bristle ends. The more flags the better; they help hold paint and spread it smoothly.

**Inspect the setting**

In well-made brushes, bristles are solidly set in rubber—and so marked. "Vulcanized in rubber" stamped on brushes means fewer bristles will fall out.

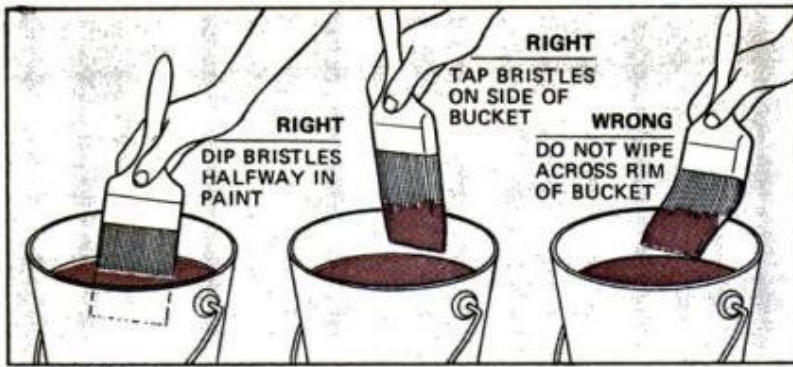

### How to dip a brush

Thickness and smoothness of paint are controlled by amount carried by your brush. To use brush properly, dip bristles halfway into paint (far left); deeper dipping will cause excessive paint accumulation in heel of brush. To remove excess, tap brush lightly against side of can. Never wipe bristles against can rim (near left).

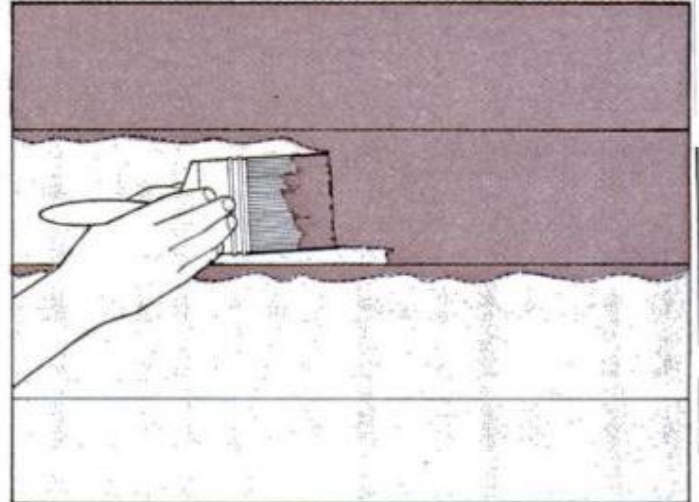
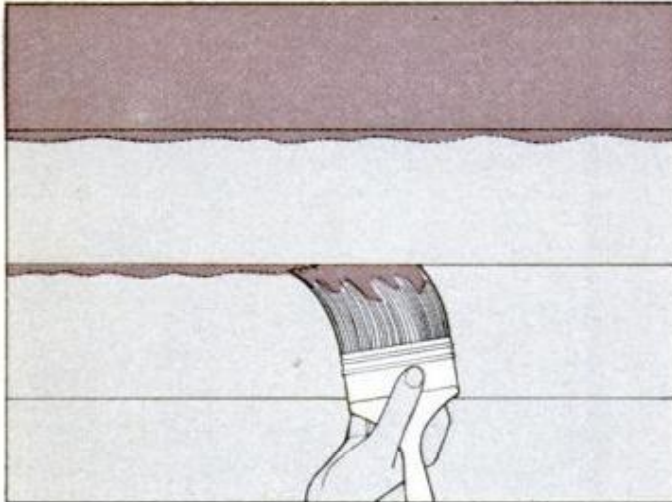

### How to paint with a brush

When painting beveled siding (clapboard) or shingles, apply paint to butt edge for a 3 or 4-ft. run first. Then you can apply paint to weather face, or

wide part of siding, using technique shown below. Painting butt edge second would mar already-painted weather face with bristle marks.



### Brush technique

Correct way to apply paint to siding is shown in three steps above. First, dab generous blobs of paint along clapboard, then use long, leveling

strokes to spread paint smoothly (middle). To achieve uniform, good-looking finish, apply finish brush strokes holding brush at slight angle.

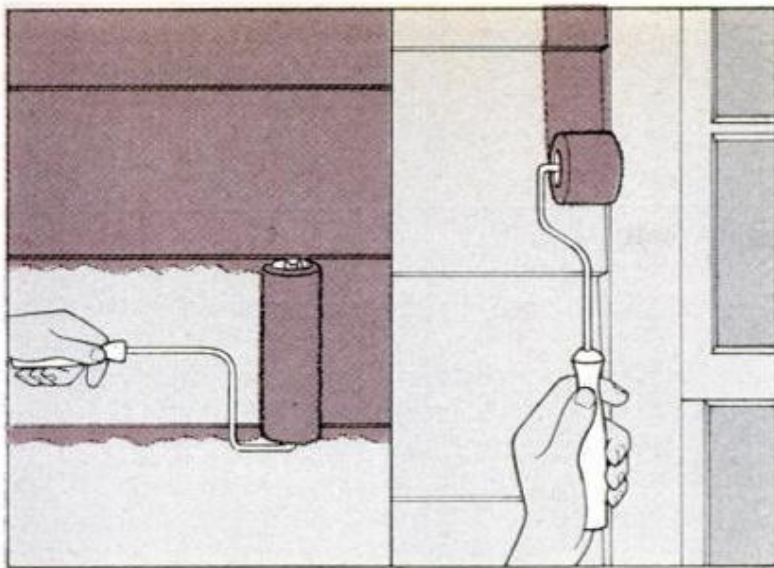

### Roller technique

Paint rollers can be used with latex house paints and, in general, are easier and faster than brushes. To paint siding face of 7 to 8-in. width, use 7-in. roller. For weather faces over 8 in., use 9-in. roller. Apply spots of paint and work roller from unpainted area into area previously painted. Use an edging roller similar to that shown in the sketch for painting hard-to-get-at areas such as those around edges, windows and door frames. Be sure that the roller nap is compatible with the paint.

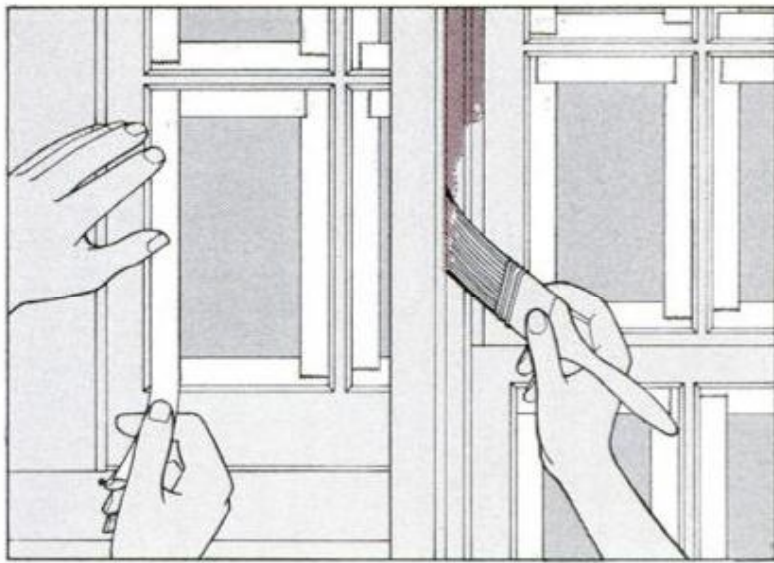

### Painting double-hung windows and trim

Since neatness counts (sloppy cutting-in means lots of cleanup later) when painting window trim, muntins and bars, it's wise to use masking tape around the edges of glass. But remember to remove the tape before the paint dries. Correct procedure for painting windows is to lower upper sash, raise inside sash and paint exposed checkrail. Next, paint crossbars and muntins. Do areas that can be comfortably reached first; paint the balance when sashes are back in normal position. Paint casing and sill last. If you are using an alkyd paint, leave the windows slightly open until the paint is completely dry.

### Computing paint needs

There are three basic elements to keep in mind when computing the amount of paint you'll need:

- The size of the area to be coated.
- The number of coats you'll apply.
- The condition of the surface.

To determine quantity, multiply length of the house (L) by the height at the eave or soffit (H) in feet. This gives the area in square feet of one side. Repeat this step for all sides. To determine area of gable end, multiply width (W) by height (G) and divide by 2. Do this step for each gable. After you have totaled up all areas such as walls, dormers, gables and overhangs (keeping colors separate), deduct the areas of any large windows and doors (or brick veneers). Since most paint will cover about 400 sq. ft. per gallon (check the can label for claimed coverage), divide the total net area by 400 for gallons required per coat of paint.

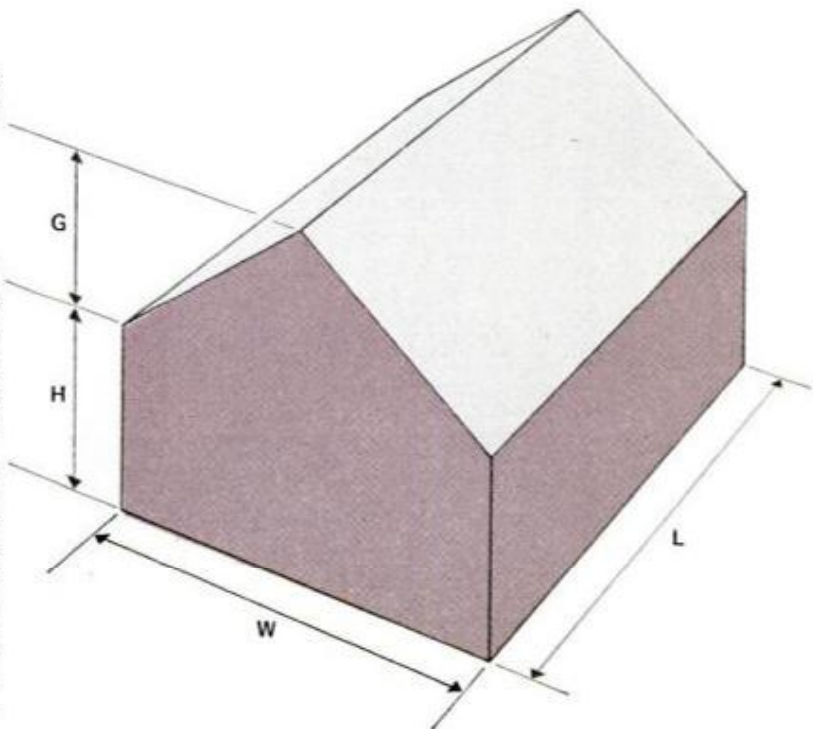

# How to work with ladders

Professional ladder-users will tell you, "If you don't know how to use a ladder wisely, you should stay on the ground." That advice is correct. Ladder accidents can be broken down into three groups:

- A ladder that should have been replaced is used.

- The wrong kind of ladder for the job is used.

- A safe ladder is used improperly.

On these pages, you'll find all the know-how you need to avoid these common errors. And, for extra safety, *always* inspect a ladder before each use.

## Typical household ladders

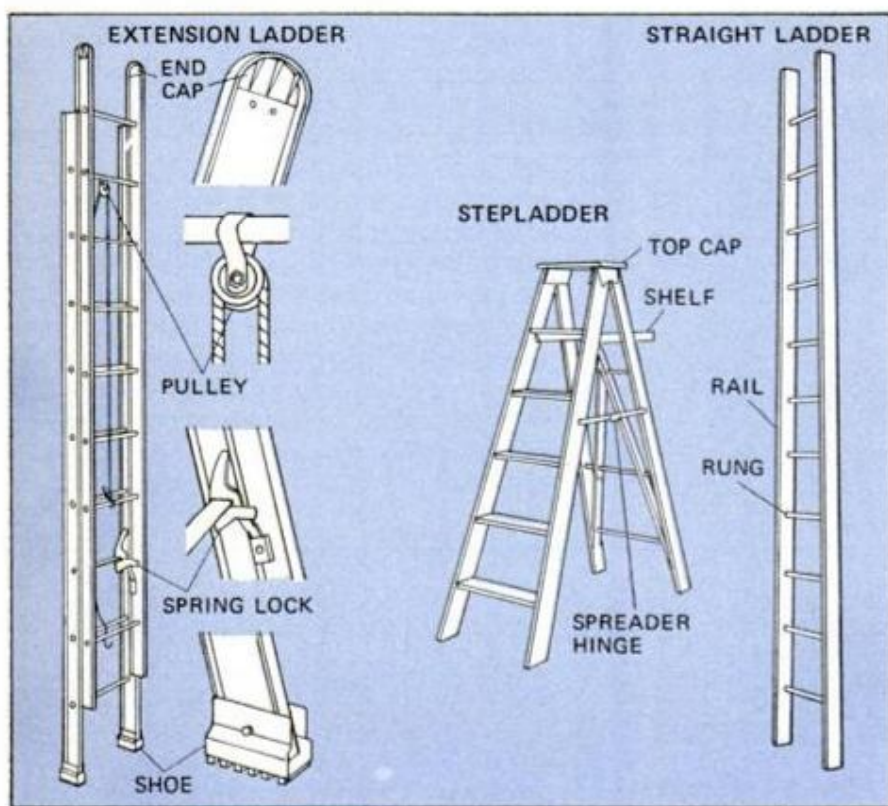

Typical household stepladders come in 4, 5, 6 and 7-ft. heights. Taller ladders available are used mostly by pros. Costs range from about \$11 to \$21 for wood, with aluminum ladders slightly higher. Single ladder is adequate if you own a ranch home, but for higher altitudes you'll need an extension ladder. These are available in wood, aluminum and (most costly) magnesium.

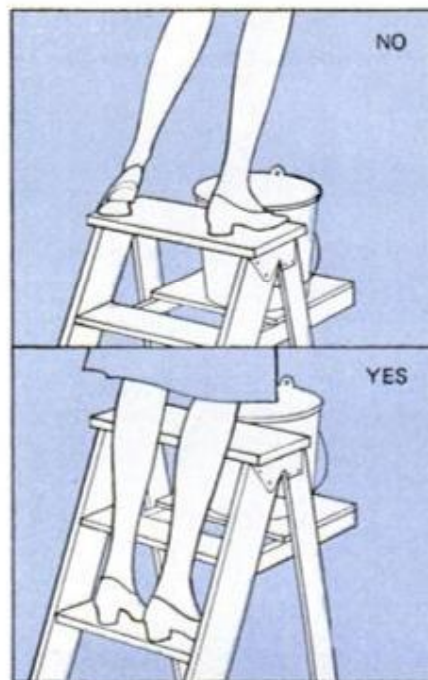

## Stepladder safety

Never stand on top cap (step) or tool shelf. If your shins rest against a tread, you have better balance and are working safely. Other tips: Always be sure that spreader hinges are fully locked, and, if you're working indoors on a dropcloth, smooth out the wrinkles before placing ladder.

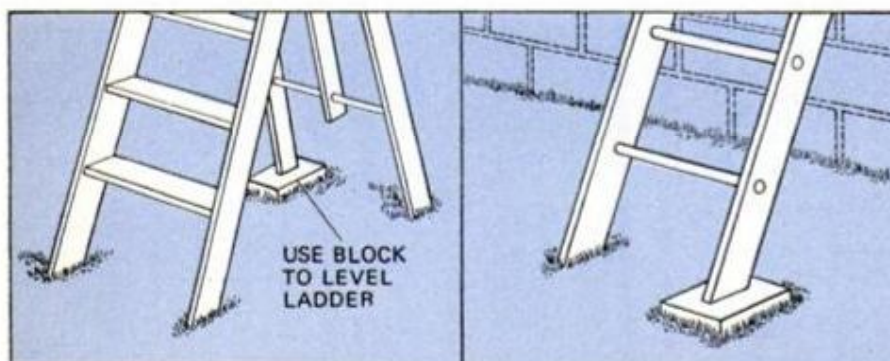

## Be sure ladders are level

Always "try" ladder on its first or second rung with a slight jump or bounce before climbing. This lets you know if the ladder is squarely planted or ground is too soggy. If either condition exists, use a board or 3/4-in. plywood under one or both legs.



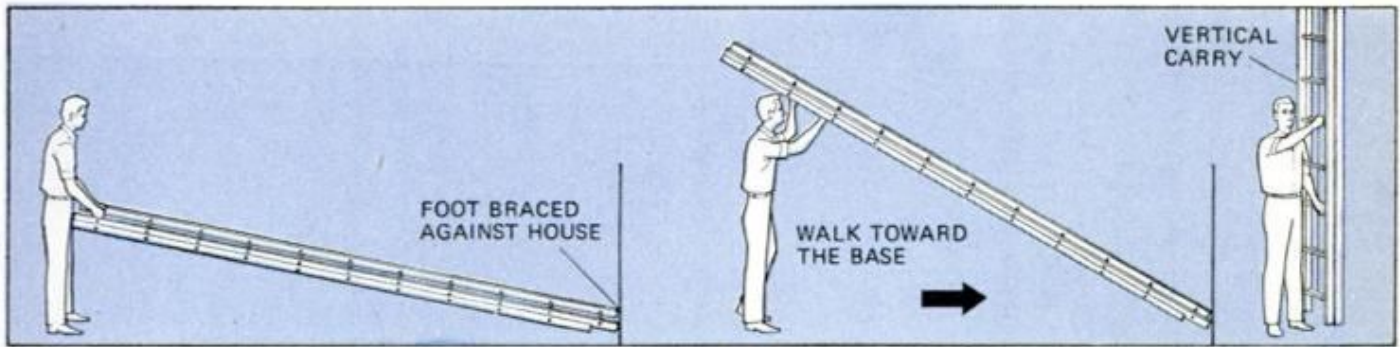

### Carrying and erecting an extension ladder

To raise ladder, brace its foot against base of the house. Standing at opposite end, slowly walk toward base, transferring your hands from rung to rung as you go. (To lower ladder, reverse procedure.)

To move ladder a short distance, carry it vertically after lowering top portion to maintain better control. If you're using an aluminum ladder, watch out for overhead power lines.

### Positioning and climbing a ladder

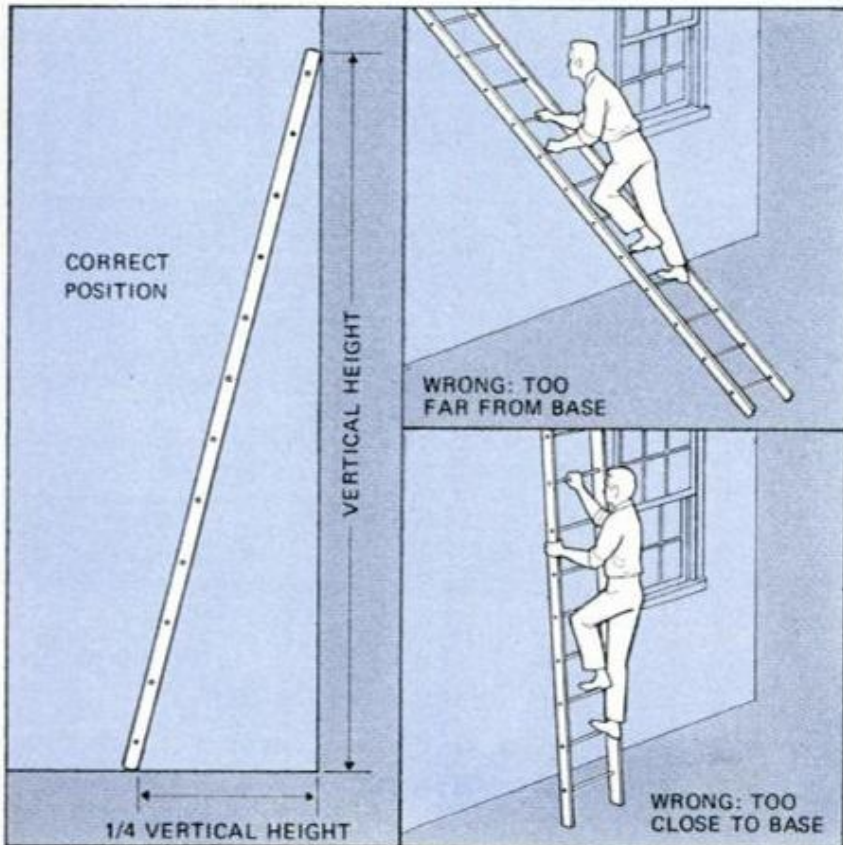

An extension ladder must be placed the correct distance from the wall it rests against. If the foot is too far out (sketch, top right), the base will slide away as you move your weight up the rungs; if too close, the ladder may tip backward or slide laterally on the wall. Overlap on an extension ladder is important, too; figure at least 3 ft. overlap for a 36-footer, 4 ft. for ladders up to 48 ft. and 5 ft. for longies up to 60 ft.

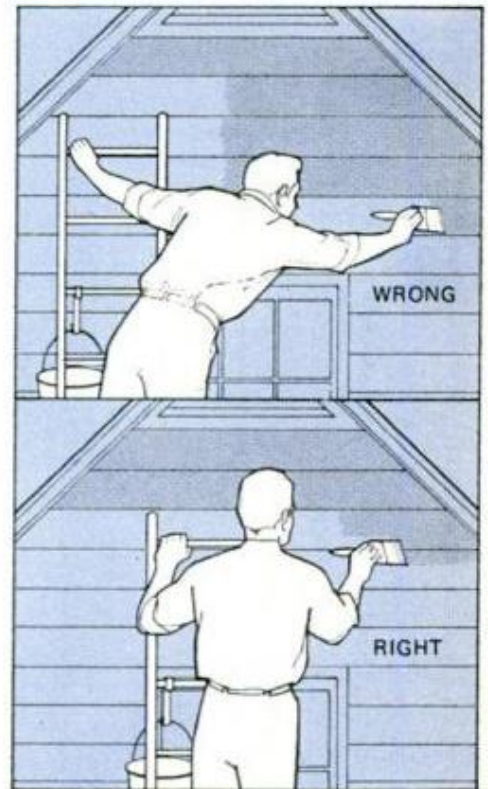

### Don't overreach

Wrong way to work is shown in top drawing; this is uncomfortable and unsafe because user's weight is unevenly distributed, causing overload at one point. Right way to work is shown directly above. Set ladder where object to be painted (or worked) can be reached handily. Don't ever lean out far to one side of the ladder.

# Looks aren't everything;



**Satellite coupes** have been considered as restyled for 1973, but sedans and wagons retain earlier lines. Most buyers listed appearance as the main reason for buying. Bumpers use rubber knockers front and rear, which leaves design more integrated than other makes. Front window vents are one "improvement" the owners would like to see.



PHOTOS BY THE AUTHOR

A nationwide survey based on 860,000 owner-driven miles.

by Michael Lamm

**S**tyling still sells. It's the No. 1 reason for Satellite purchases. More people bought this Plymouth intermediate on the basis of looks than for any other reason.

Any regrets? Most owners had none—a healthy 24.3 percent said specifically that there was nothing about the car they

didn't like. And when asked what changes they'd like to see, 19.3 percent said, "Leave it alone!" All in all, that's a rare endorsement for any car.

The Satellite's best-liked feature, next to styling, is the way it handles. "It handles well with the torsion-bar suspension," writes a Massachusetts retiree, "and has plenty of speed and power for sustained turnpike driving." A Texas printer: "Great stability on the highway, and good maneu-

# it needs gas, too!



**Torsion-bar** suspension system offers good stability and little body roll in hard cornering. Owners appreciate the Satellite's fine handling and standard disc brakes. They like the dash gauges, but some say that plastic parts squeak. Seat-belt guides in front bench are good if you're careful not to sit on them! Large rear pillars in coupes make backing tricky. Many drivers of coupes and wagons say they can't tell where rear bumper ends. Otherwise the Satellite owners voiced few objections.

verability." "Easy handling in traffic and easy to park," notes an Ohio clerk. "I like its ease of going from low to high speeds . . . and its high-speed handling," says a Washington clergyman.

However, a very small percentage (5.2 percent) was dissatisfied with the ride. Complaints were split equally between people who felt the ride was too hard and those who thought it too soft. Different shock absorbers and handling packages might ac-

count for the extremes. The majority, though, felt their Satellites had a smooth, quiet ride, and praise in that department far outweighed complaints.

Plymouth puts its intermediates on two different wheelbases, as does Ford and General Motors. Four-door Satellites, including wagons, use the 117-inch wheelbase; two-doors, the 115-inch span. Six-cylinder engines are standard in all but the Sebring Plus, Regent and Road Runner, yet only

## Generally good workmanship; brickbats for dealer service

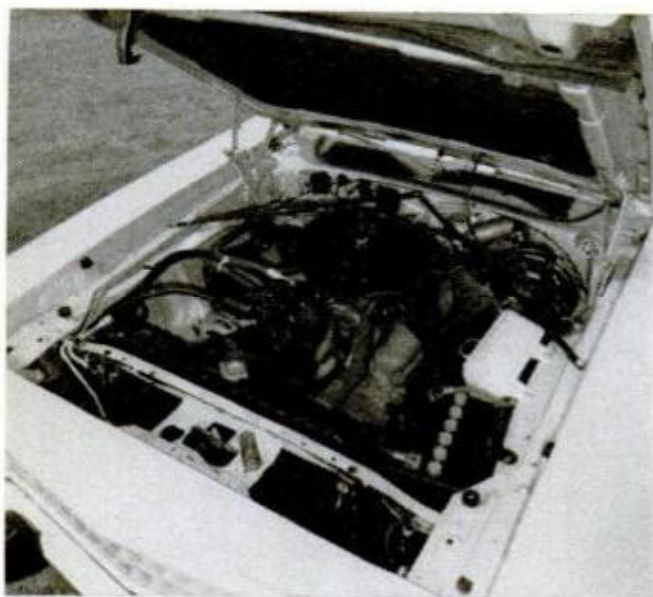

It's the right size, not too big nor too small, say owners, who also like ride.

318 V8 was the pick of 82.5 percent of owners, runs with reasonable economy.

Centered spare tire takes up a lot of trunk space, but few owners complained.



2.1 percent in our survey chose the Six. Not enough purchasers bought the Road Runner to tabulate. The 318-c.i.d. V8 proved the most popular by far (82.5 percent.)

As with most new cars, owners voiced a persistent plea for better gas mileage. The chorus came from a smaller percentage than usual (9.1), and a fair number even thought the Satellite was giving them *good* gas mileage. The 318 V8's average of 12-16 mpg leaves the Satellite looking good alongside some other cars we've evaluated lately.

No one gave brakes a bad mark. All Satellites have standard front discs, and these apparently give good stopping without much squealing. A few people suggested making radial tires standard, and it looks like they will be in a year or two.

Another nagging complaint centered on rear visibility. Satellite coupes have large blind spots, which make backing up a guess-and-by-golly situation. But that's one price you pay for sporty looks.

Satellite wagons have an automatic tailgate lock that can't let kids and dogs accidentally spill themselves out on the road. Wagon owners had various things to say:

"Anyone who has ridden in the second and third seats has praised the wagon's comfort and smooth ride."—Ohio trucker. "I like the wagon's appearance, and the tail-

## Summary of 1973 Plymouth Satellite Owners Reports\*

Total miles driven .....860,725

### Body styles:

Two-door hardtop .....51.7%  
Four-door sedan .....22.5  
Station wagon .....13.7  
Two-door coupe .....12.1

### Series:

Sebring Plus .....29.3%  
Sebring .....28.0  
Satellite Custom .....24.3  
Satellite .....14.6  
Satellite Regent .....3.8

### Engines:

225-cu.-in. Six .....2.1%  
318-cu.-in. V8 .....82.5  
340-cu.-in. V8 .....3.0  
400-cu.-in. V8 .....12.0  
440-cu.-in. V8 .....0.4

### Average mpg by engines:

318-cu.-in. V8: Local driving 12.7  
Long trips .....15.7  
400-cu.-in. V8: Local driving 11.1  
Long trips .....13.1

### Transmissions:

Automatic .....96.6%  
Three-speed manual .....2.1  
Four-speed manual .....1.3

### Why the Satellite?

Styling .....40.7%

Past experience .....24.2  
Size .....18.2  
Price .....15.3  
Economy .....6.8

### Specific likes:

Handling .....46.5%  
Styling .....43.8  
Ride .....27.9  
Comfort .....25.2  
Economy .....14.2  
Performance .....12.4

### Specific dislikes:

Poor gas mileage .....18.7%  
Rattles .....8.7  
Poor workmanship .....8.7  
Wind noise .....6.5  
Harsh ride .....5.2

### What changes would you like?

Better workmanship .....9.1%  
Better gas mileage .....9.1  
Better rear vision .....6.8  
Install vent windows .....6.3

### Had any mechanical trouble?

No .....53.7%  
Yes .....46.3

### What type of trouble?

Carburetor .....13.4%  
Cold starts .....9.8  
Electrical .....8.9  
Wipers/washer .....8.0

### Did you repair it yourself?

No .....98.2%  
Yes .....1.8

### Dealer repairs satisfactory?

Yes .....61.9%  
No .....38.1

### Dealer service opinion:

Good to excellent .....45.7%  
Average to poor .....54.3

### Workmanship opinion:

Good to excellent .....58.8%  
Average to poor .....41.2

### Is the Satellite your only car?

Yes .....51.4%  
No .....48.6

### Other cars owned:

Plymouth .....22.9%  
Chevrolet .....16.9  
Dodge .....11.0  
Chrysler .....9.3  
Ford .....9.3

### Age distribution of owners:

15-29 years .....34.3%  
30-49 years .....30.1  
50-plus .....35.5

### Would you buy another Satellite?

Yes .....75.3%  
No .....24.7

\*Percentages might not equal 100% due to rounding or insufficient data.

gate is designed for short women, who can operate it easily."—Ohio accountant. "Only wagon in its price range that lets you open rear door with the window up."—Florida executive. "The wagon makes a good road car, cruises well at high speed, brakes are good, but there's too much road noise."—New York salesman. "The rear glass dirties up fast—new body lines were supposed to stop this, but they don't."—New Jersey engineer. "Lots of room inside for hauling, excellent for camping, but gets poor gas mileage and does not hold road well above 50 mph."—Michigan traffic officer. "Heavy rains get into rear of wagon. Lack of roof gutter means you can't open tailgate without soaking the interior."—New Jersey chemist.

What do owners think of the Satellite's workmanship? Only 8.7 percent cited poor workmanship as a specific dislike, and 58.8 percent rated it good to excellent. Complaints (where there were complaints) centered on thin paint, rattles, squeaks, and panel misalignments.

Things aren't so rosy in the dealer service department, though. Fully 54.3 percent rated service average to poor. Here are some typical comments: "Long delays and waits for parts." "I asked dealer to check out power-steering leaks, but he didn't do any-

thing, and now I have to take it back again." "Car hard to start on cold mornings, engine races and no dealer satisfaction as yet." "Once the car gets sold, the dealer doesn't know you." "Engine timing had to be reset because of poor make-ready. While car was in shop, dealer smashed a fender, then did a very poor repair job. Car had only 400 miles on it."

What changes would Satellite owners suggest? Here's a random bit of kibitzing: "I hate those seat-belt receptacles on the front seat. My wife drives with the seat forward, and when I move it back, it jams the belt." "Adjustable seatbacks." "Spare tire more out of the way." "Put metal frames around windows so they seal right." "Vents on side windows." "Less plastic in grille and dashboard." "When you order custom wheels, I think the set should include all five instead of just four." "Air vents up front by your feet, like they used to have."

Quite a number of people mentioned the Satellite's electronic ignition system, mostly as an auxiliary reason for buying the car. An ex-truck driver said he'd heard the electronic ignition was trouble-free, as was the proven 318 engine. It sounded to him like a reliable combination. A Colorado housewife decided, "Less maintenance because of electronic ignition." ★ ★ ★

# Eugene Sloane picks the best bikes for your family

PM's bicycle columnist picks 19 bicycles that are best buys for riders age 3 and up. If you're ready for a new bicycle, here's what to look for.

by Eugene A. Sloane

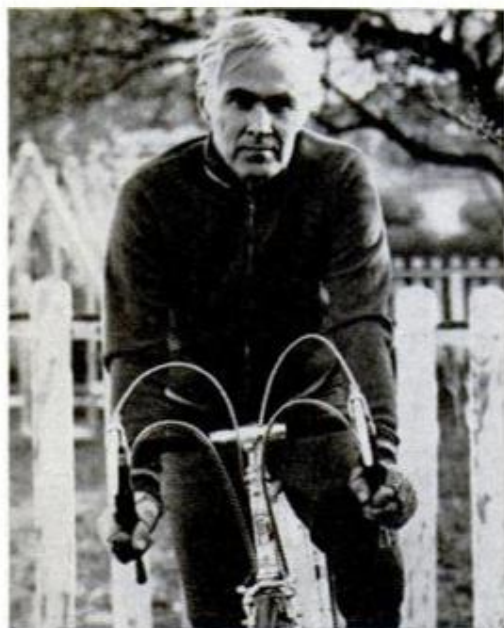

**Best-known** of America's bicycle writers, Eugene A. Sloane does PM's column, *The Bicycle Shop*, and is author of *The Complete Book of Bicycling* (Trident Press, New York). He personally tested hundreds of bicycles for this article. An active bicyclist, he has just completed a two-month tour across the United States.

The bicycle boom in America reached a fantastic new high in 1972, and 1973 promises to be another record-breaker. There were more bikes sold in 1972 (around 13.5 million) than passenger cars, and more sold than in any previous year in the bicycle's 67-year history.

As a result, bicycle manufacturers from all over the world have literally deluged the American market this year with models of every type, description and price. Many of these bicycles represent very good value, but some are of quite dubious quality for the price. So when *Popular Mechanics* asked me to look over the bicycle field and select from the literally hundreds of makes on the market from every European country, even including Russia and Czechoslovakia, and from Taiwan, Japan, Korea, Hong Kong,

NISHIKI SEMI-PRO COMPETITION



FUJI ROAD RACER S10-S





PEUGEOT PX 10



DBS  
LA MIGLIORE  
PROFESSIONALE  
531-DB

Adult-bike choices (\$250 and up) are these three slick models that weigh in at 21 to 25 pounds.



SCHWINN DELUXE PARAMOUNT P15-9



RALEIGH GRAND PRIX DL115



JEUNET 620

Four bicycles make up the selection in \$100 to \$249 adult category. Ranging from the low end to the high end of that price limit, they're fine bikes that will last a lifetime with reasonable care.



DBS SPESIAL 113-3U

## Sloane's choices are available countrywide

India, Mexico and South American countries, they gave me quite a task. Or so it seemed.

Actually, I was able to rule out many of the bicycles right away on the basis of very limited distribution in the United States; good as the bikes may be, they're ineligible for my selection if you have to go 500 miles to buy one. So the bicycles I *have* selected should be available, at least in the larger cities, in each state. If you can't find the bicycle you want, I've listed the name and address of the bicycle manufacturer or importer to whom you can write for the name of the dealer nearest you.

Prices and manufacturers' specifications are as accurate as possible at the time this issue went to press. However, due to fluctuations in the value of the dollar abroad, prices may rise—in some cases as much as 10 to 20 percent above those quoted here. It's advisable to check prices with several dealers.

### Bicycles for ages 3 to 5

Bikes for 3 to 5-year-olds are generally considered to be in the toy category. As a result, it is relatively difficult to find a sturdy bike for this age group: one that is safe to ride and well enough made to be handed down from one child to the other. *Any* bicycle should have brakes; kiddie bikes are no exception. Riding a bicycle with no brakes, a child can hit an inclined driveway or a hill and be unable to stop.

The ideal children's bicycle should have coaster brakes (*not* caliper brakes with brake levers on handlebars where the child can't reach them). The bike should be convertible; that is, have a removable top bar so it can be made into a boy's or girl's bike simply by adding or removing the top bar.

In my opinion, considering the rough treatment 3 to 5-year-olds give bikes, solid or semipneumatic tires are a plus, since they are immune to flats. Finally, the bicycle should have pedal and rear reflectors for



The choices for adult bicycles in the under-\$100 class include one 10-speed (the Crystal 220) and two three-speeds. Bikes in this price range are generally heavier than the higher priced models.



RALEIGH SPORTS DL22



CRYSTAL 220



SCHWINN VARSITY SPORT 144



HISHIKI OLYMPIC



RALEIGH RECORD 24 DL129

Three 10-speed models make up Sloane's choices in bicycles for youngsters aged 10 to 12. Frames are small enough for that group.

## Best bikes for children

twilight visibility (I hope your youngster isn't riding around at night).

I don't think training wheels are any great advantage; in fact, I've found them to prolong dependence long after the child should have learned to balance by himself. A few minutes a day on the parent's part, holding the child up and teaching him to lean away from the direction he's about to fall, should bring him sufficient pedal proficiency to keep himself upright. My selections:

● *Schwinn Pixie Model J42-6 (\$38.95)*: This is first choice because it is typically Schwinn-built of heavy-gauge steel, with sturdy frame members that will stand a lot of kicking around. Tires are semipneumatic on 16-inch wheels. The bicycle has a rear coaster brake which, like all such brakes, stops the bicycle when the pedal is depressed backward. The top bar is removable, so it can be converted to a boy's bike by installing the bar or to a girl's by removing it. Handlebars are sensibly designed for easy steering (not high-rise), and the saddle is conventional spring design rather than the banana type that invites accidents by making it easy for two to ride. The Pixie has a one-piece chainwheel and crankset that is simple to service. It also has chromed fenders,



SCHWINN BREEZE K64-6

chain guard and reflectors on pedals and on rear fender. The 16-inch wheels each have 24 spokes. Color choices are "Flamboyant Red" and "Kool Lemon." The Pixie weighs 32 pounds.

● *Columbia Cricket Model 9161 (\$49.95)*: It's difficult to select a well-designed bike for small children; most have dangerous high-rise handlebars and banana saddle that contribute to accidents. The Cricket has flat handlebars, conventional spring saddle, 16-inch wheels, tube tires and removable training wheels. Cranks are one-piece steel. The bike has coaster brake and reflectors. This model is not convertible; it comes as a boy's or girl's bike. (Girls are riding boy's bikes

[\(Please turn to page 188\)](#)



HUFFY DREAM CYCLE H-100

Though the 3 to 5-year-olds' bikes have training wheels, Sloane suggests such aids be given up early so a tot isn't dependent on them.

COLUMBIA CRICKET 9161





RALEIGH MOUNTIE DL80-L

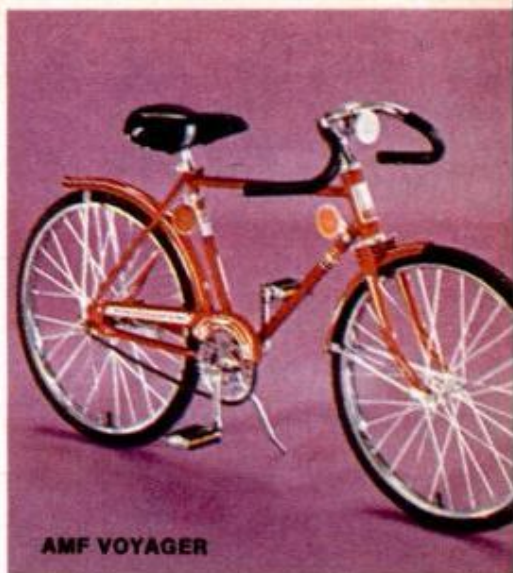

AMF VOYAGER

**Youngsters** in the 6 to 9 age group need bicycles with 20-inch wheels. Hand caliper brakes are not desirable because children this age do not have the reach or strength to operate handlebar-mounted levers safely. The bikes shown are solid, easy for children to steer accurately.



SCHWINN PIXIE J42-6

# How to work magic with moldings

Inexpensive and readily available at your local lumberyard, standard moldings will let you work wonders with your walls.

by Harry Wicks  
WORKSHOP EDITOR

The next time you plan to redecorate a room, pause a bit before deciding that a coat of paint or wallpaper is all you need do to get the look you want. With a little planning, you will be pleasantly surprised at how dramatic a change of room appearance can be achieved by simply adding wood moldings to the walls. Placing moldings on a flat wall surface is an inexpensive way to create a luxurious look.

Wood moldings are available in a large variety of styles and sizes at most lumberyards. The rooms shown are good examples of what you can accomplish through thoughtful use of moldings. And when you have the know-how for working with this shaped stock, you'll be able to duplicate

WESTERN WOOD MOULDING AND MILLWORK PRODUCERS PHOTOS

PREFINISHED PLYCAP MOLDING TO MATCH 1/4" PLYWOOD PANELING

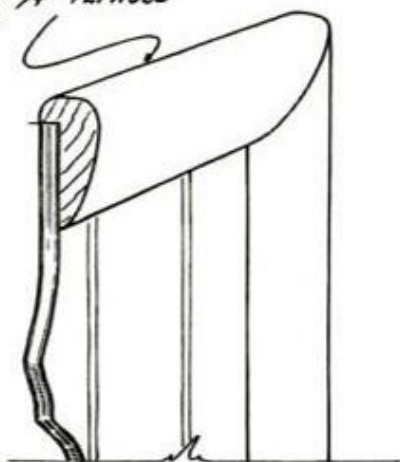

PREFINISHED PLYWOOD

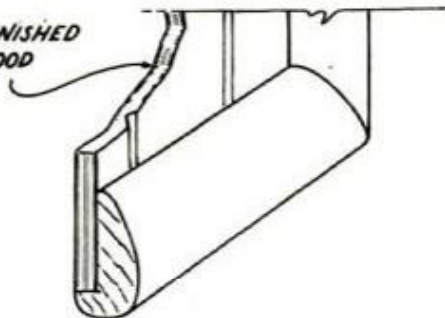

Framed plywood panels have a look of luxury, yet cost less than a fully paneled wall. The plywood is glued to wall, then surrounded with prefinished plicap moldings.



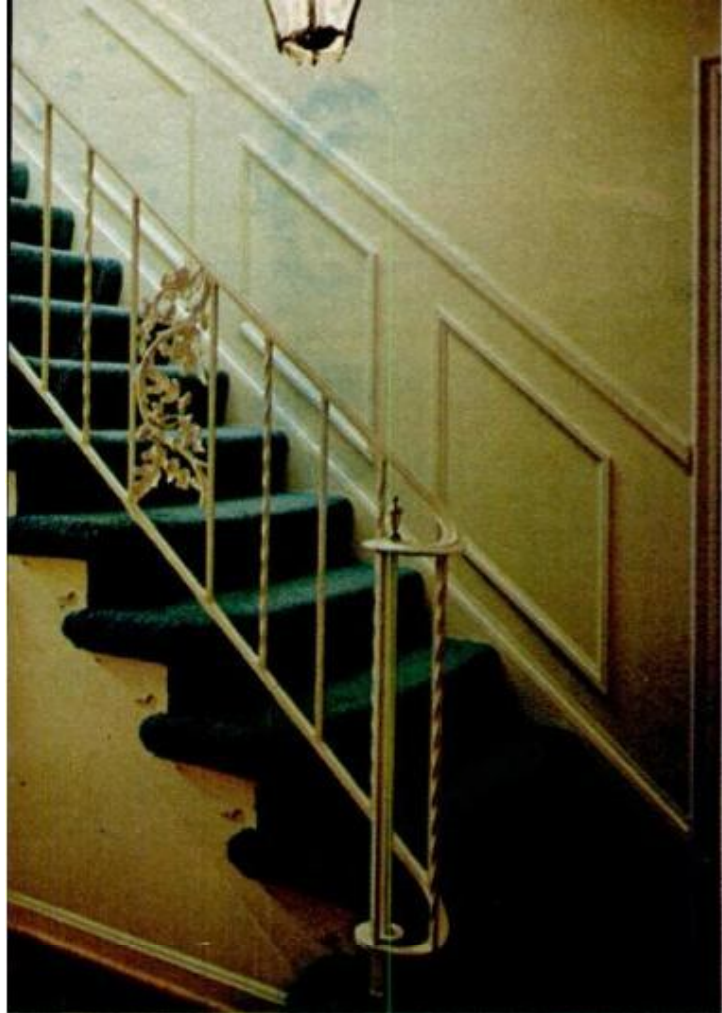

**1 Paneled wainscoting** helps to reduce a feeling of height and emptiness of stair wall. Section drawings of moldings used in the rooms on this page are on the following pages (Figs. 1-4). Know-how for working with the moldings begins on page 108.

**2 Wallpaper or fabric** can be used in conjunction with moldings to create a new room mood. Here, wallpaper is pasted on an inexpensive C-D plywood, which is then trimmed with selected moldings. Each framed panel is suspended from two picture hooks.



**3 You can dress up** an inexpensive flush door with wood moldings. Two versions—hung in same opening—show how the moldings can change the look.



**4 Moldings on an exterior door** should be attached with waterproof glue and finishing nails. Miter joints were used on all corner joints shown here.

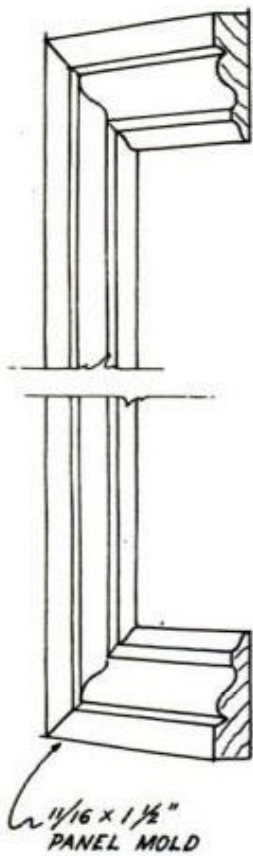

Molding details can be effectively used to set the period of design. To duplicate the room above, panels must be sized proportionately to suit the wall.

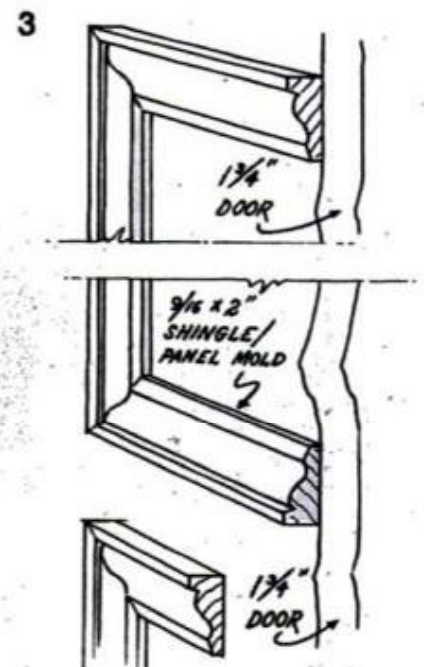
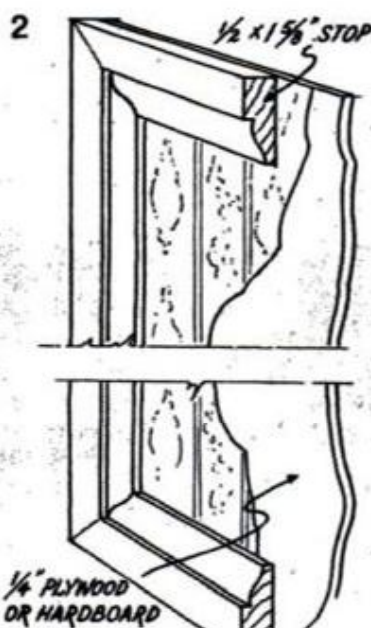
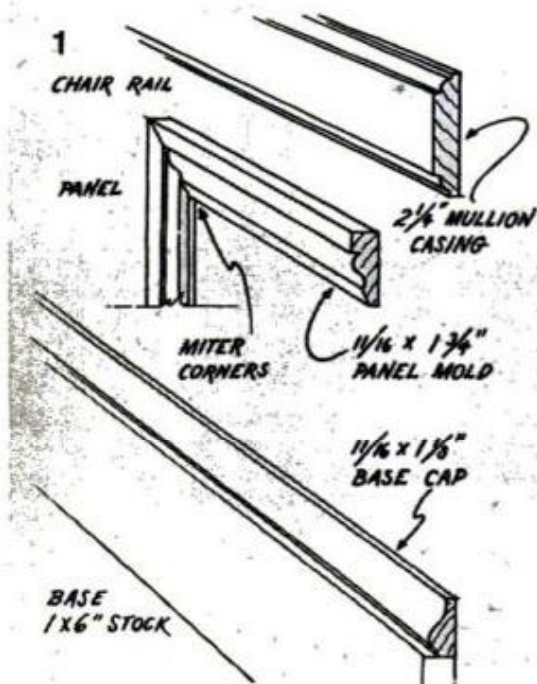



Fresh, crisp look is achieved by painting moldings to contrast with walls. Chair rail not only looks good, but acts to protect walls from chair bumps.

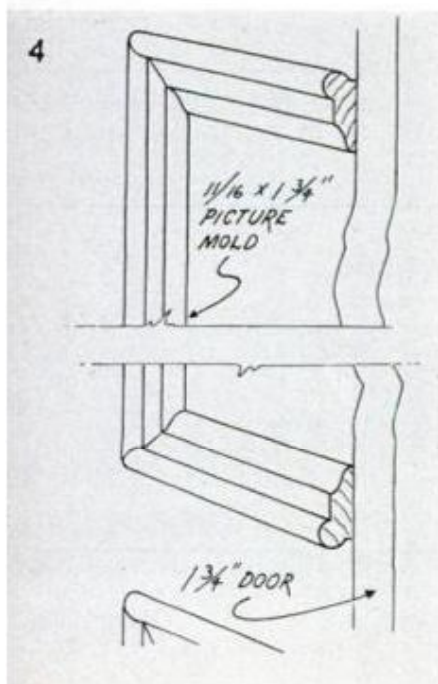
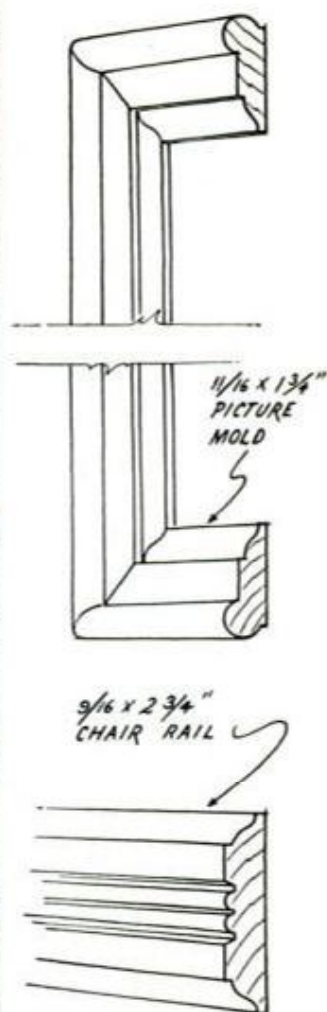

these examples more easily than you might suspect. The key to successful use of moldings lies in careful planning.

Your first step should be a trip to your local lumberyard to learn which moldings it keeps in stock (usually, small samples are displayed on a board). Armed with this information, take the time to draw a scale floor plan and wall elevations of the room to be treated. To lay out a room such as the one above, the elevation drawing should indicate the chair rail at desired height (36 to 42 in.). Work out panel design and sizes so the wall will be symmetrical with panels balanced in height and width, and so the spaces between panels will be equal.

The examples shown in photos and section drawings on these pages can be duplicated or can serve as a springboard for your own creative designs. For more information on designing and decorating with wood moldings, write to Western Wood Moulding and Millwork Producers, Dept. PM, Box 25278, Portland, Ore. 97225. Or check out the free literature rack at your local lumberyard. For working with molding know-how, turn the page.

# Work magic with moldings

Make no mistake about it, your molding job will look only as good as the craftsmanship you put into it. How joints fit and nails are placed accurately reveal just how much effort was applied. The first rule is never to guess at miter cuts—always use a miterbox. Also, get in the habit of using sharp saws only. A dull saw—no matter how great your patience and effort—is almost certain to produce unsightly, amateurish-looking joints. Always place the piece of molding in the miterbox as it is to be installed on the wall. (It is important to remember this rule or you will waste a lot of molding by making miter cuts in the wrong plane.)

Because they tend to open, inside joints should always be coped as shown below. Here, after cutting miter at desired point, use a coping saw held at a 45° angle, a *must on all convex moldings*, to create a back-cut. Follow the miter-cut profile to cut out this wedge and you'll have a perfect joint. A coped joint—like all molding joints—should be installed with glue as well as nails. ★★★

## How to miter and cope moldings

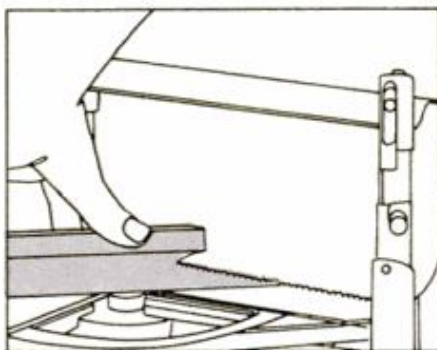

**Set miterbox saw** at 45° to make miter cuts. Always hold molding securely while doing the cutting.

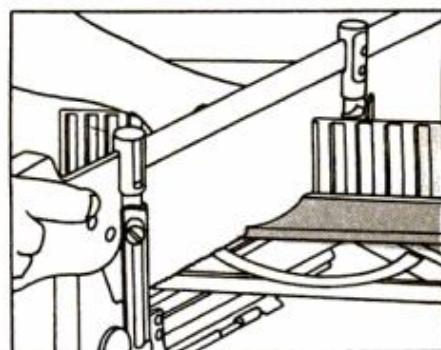

**To cope a joint**, first make the miter cut to the exact length desired as shown above.

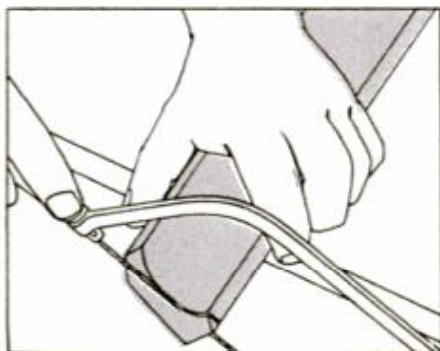

**Next, with coping saw** held at 45° angle, follow miter line (profile) to cut out wedge-shape piece.

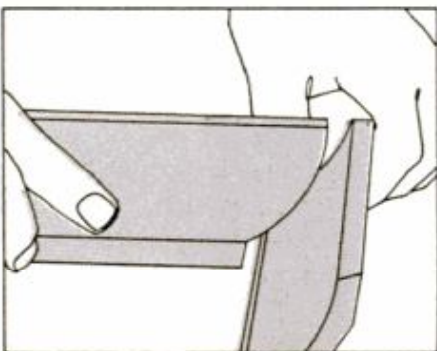

**Test-fit** the coped molding against piece of molding it will butt. In sequence shown, it's cove mold.

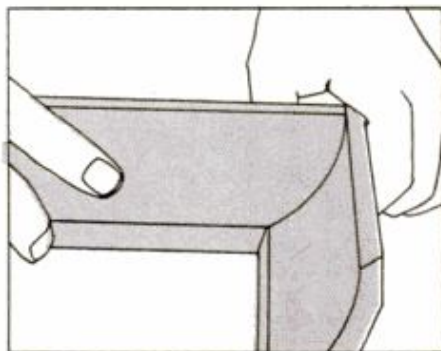

**If necessary**, use block plane and sandpaper to assure tight-fitting joint. Glue and nail to fasten.



## How to do blind nailing

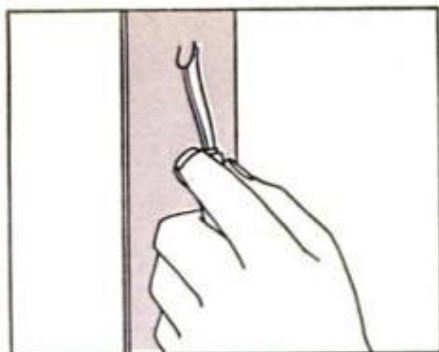

Carefully gouge up a small sliver of wood that's wide enough to conceal the finishing-nail head.

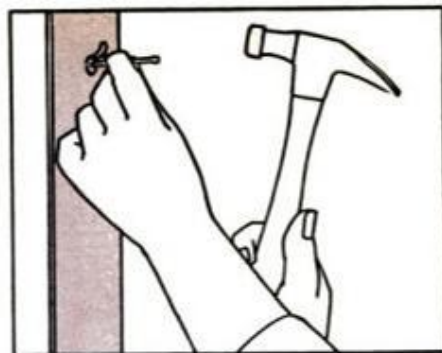

Carefully swing sliver out of way, then drive in the nail. Next step is to set the nailhead.

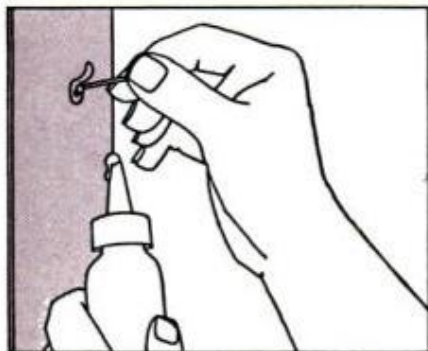

Apply white glue to the sliver and push it into place. Immediately wipe off any glue ooze-out.

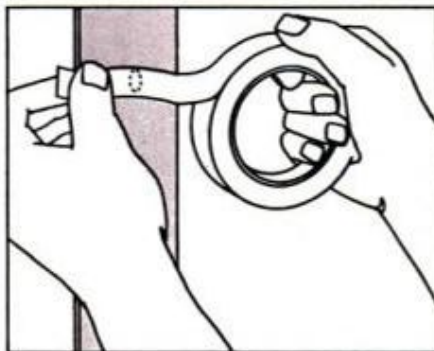

Press on a piece of masking tape to hold the sliver in place until the glue is completely dry.

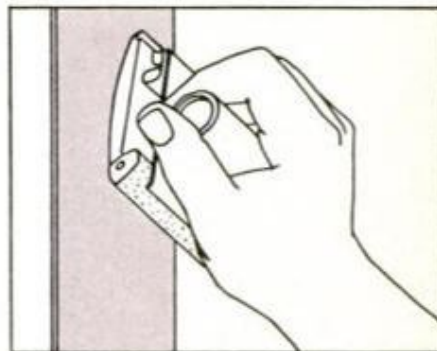

After glue is dry, remove masking tape and touch up the blind spot with a fine-grit sandpaper.

## Where moldings meet at right angle

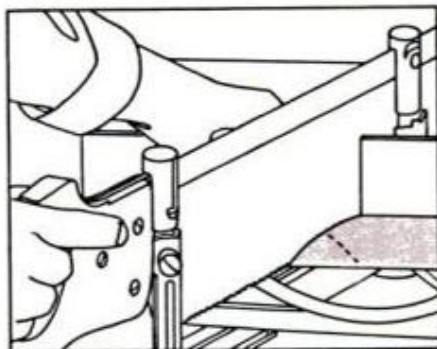

Two 45° cuts are made to create point with length equal to half-width of the molding.

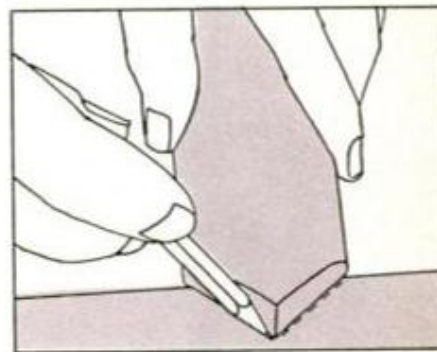

Use this piece as the pattern for laying out the cuts to be made on the piece it will join.

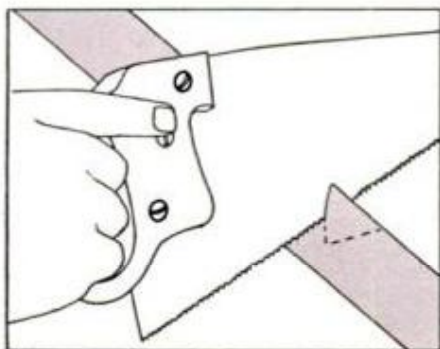

Following the lines, use a fine-tooth, crosscut saw to make the cutout on the mating molding.

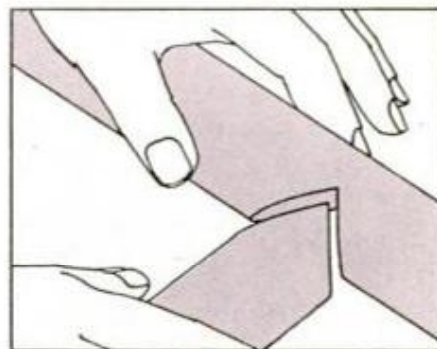

Check joint for fit. If you made the cuts carefully, joint should be practically invisible.

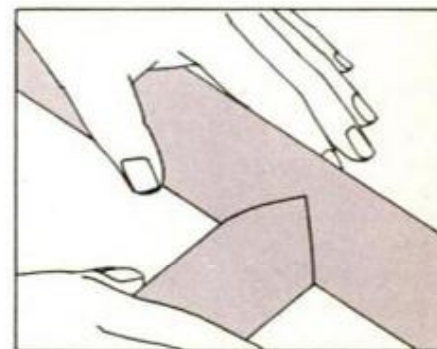

When satisfied with the joint, use glue and toenail several brads through one mold into other.

IT'S NEW

# NOW

**Go-anywhere ATV swims in water, paddles through mud and swamps, climbs rocky slopes and—oh, yes—even rides smoothly on highways**

What may be the ultimate in all-terrain vehicles is this trick-wheeled TerraStar "swimming car" developed by Lockheed and under test by the U.S. Army. Each wheel assembly has three fat-tired rollers arranged in a spider-like cluster. On paved roads or smooth ground, only the lower wheels turn. But in water, sand or soupy muck, the entire clusters rotate, propelling the vehicle like paddle wheels. Steering is by "skid-turning"—braking wheels on one side while speeding up the others, the way a tank turns.

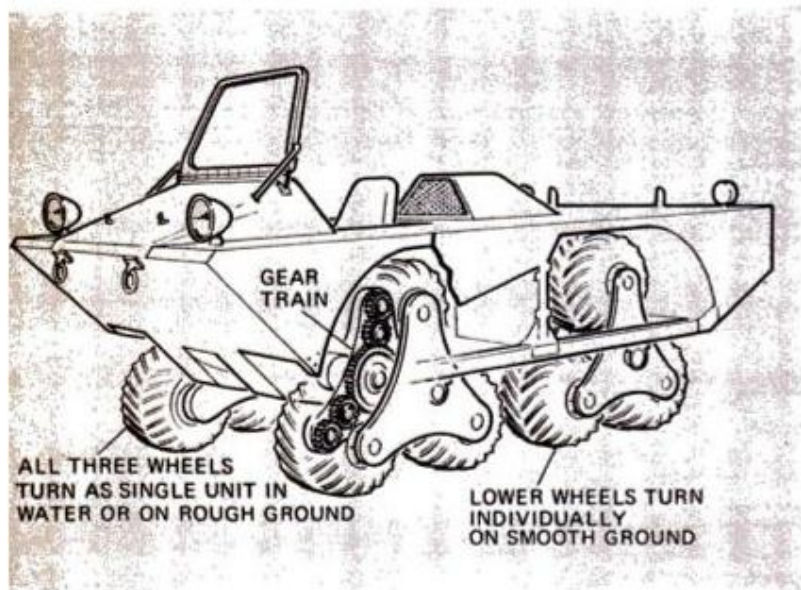
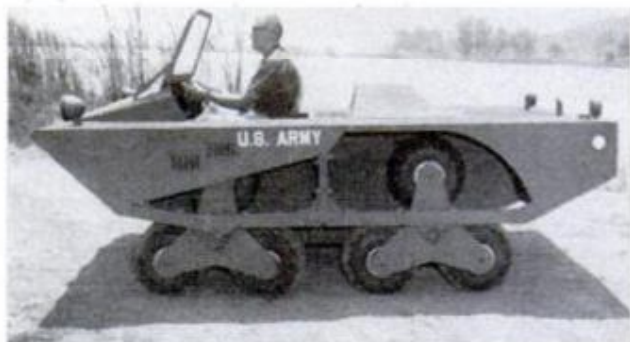

## Homebuilt sub

It took him 10 years, but he finally did it—built his own submarine. The pride of Frenchman Bernard Pierson, the two-man, 10-ton mini sub is 42 feet long and about 10 feet in diameter. It's powered by twin diesel engines, plus two electric motors for operating diving and ballast controls. How far down it will go isn't known for sure—he's still experimenting.



---

## THE LATEST PRODUCTS AND DEVELOPMENTS

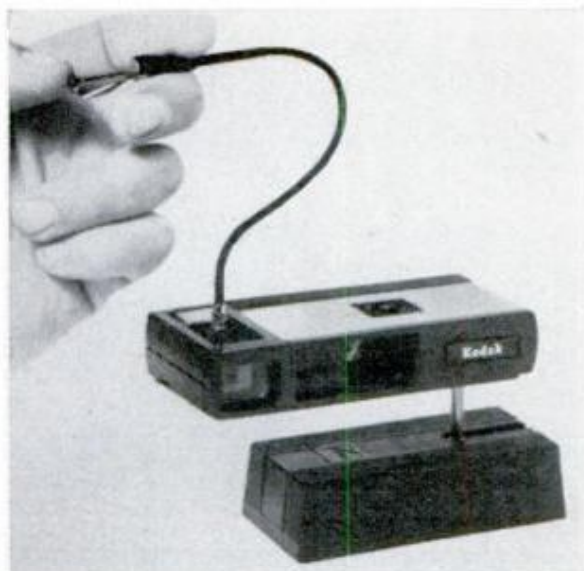

**Pocket stand for pocket cameras**

This pocket-sized stand is made by Kodak for its new Pocket Instamatic and other small X-series cameras. Offering firm support for long exposures, it holds camera at any angle, stores a cable release. \$4.95.



**Reflective lounge pad speeds sun tanning**

You may not look like this tempting beauty, but you'll tan faster and more evenly with the reflective pad she's using. Pad fits standard deck chairs, folds for carrying, has nonreflective flip side. \$26.45 postpaid, Tan-A-Matic, 16681 Barberry, Southgate, Mich 48195.

---

Can you guess—is this a real tank? Turn the page to find out



# NOW

**Surprise! They're not real tanks at all—just tiny models authentic enough to look real**

What looks like a giant Sherman tank crashing through the woods on the preceding page is actually about 18 inches long—one of 30 precisely detailed, radio-controlled replicas operated by a club of modelbuilders called the Bromley Tank Corps near Kent, England. Each Sunday, the group stages mock battles with pellet-firing guns, smoke bombs and miniature explosions for realistic effects. Models, below, are 1/9th-scale reproductions of World War II tanks.

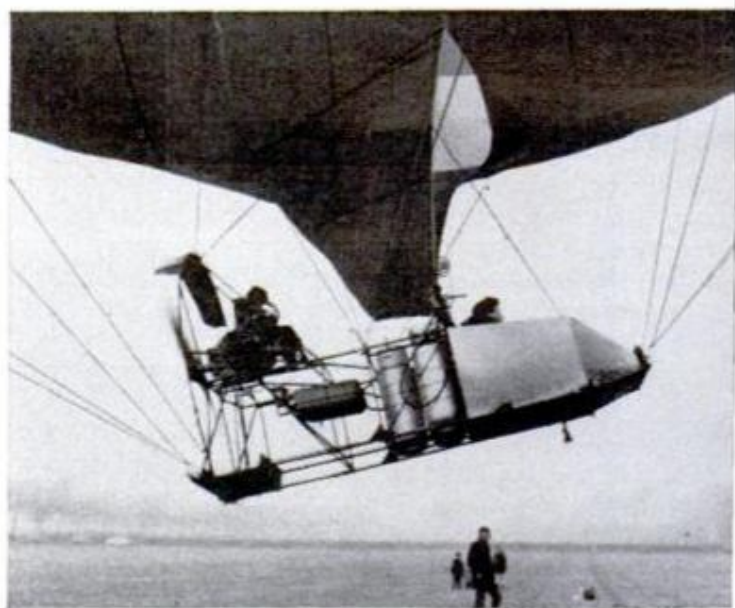
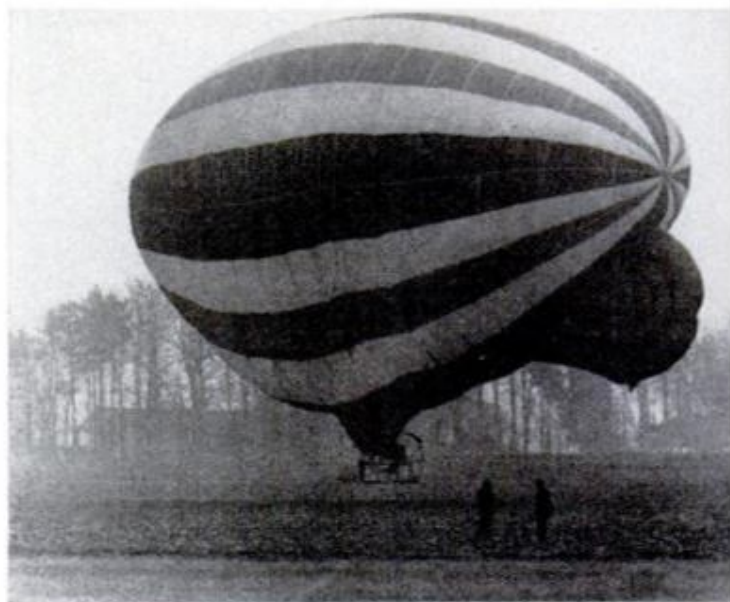
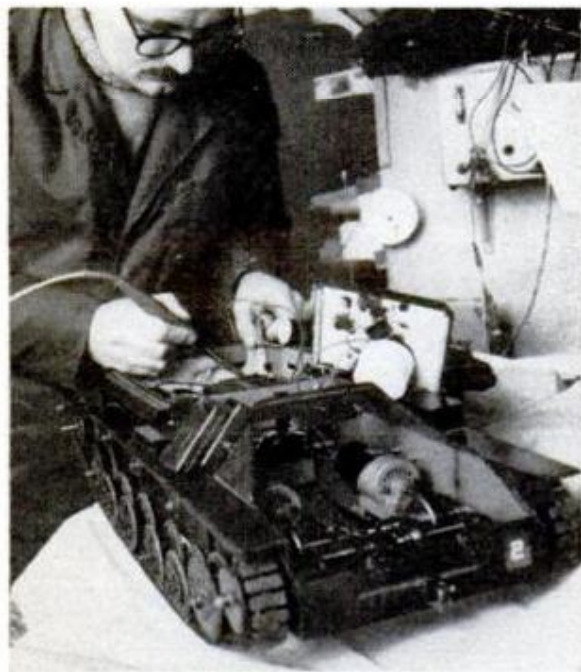

**Half balloon, half dirigible, it's a propeller-powered bag of hot air—but it flies just like an airship**

Add an engine to a hot-air balloon and you get the odd-looking half-breed above, designed to combine advantages of balloon and dirigible without their disadvantages. Hot-air balloons need no expensive helium for support, but can only drift with the wind. In this modified version, a VW-powered prop mounted on a gondola propels the craft at up to 30 mph. Propane burners heat air for support. Don Cameron and Ted Hall of Newbury, England, conceived the hybrid.

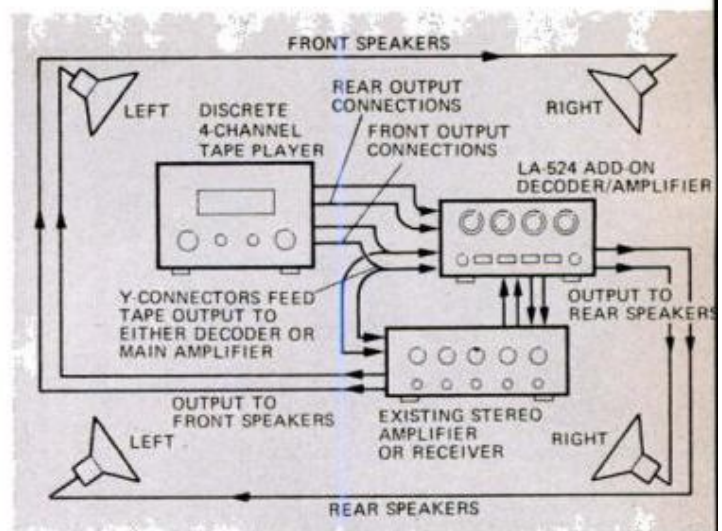

### Low-cost add-on SQ decoder/amplifier

You can add virtually any 4-channel sound to a stereo amplifier having tape-monitor facilities with this low-cost SQ decoder. Lafayette LA-524 includes two extra channels of amplification for rear speakers and an SQ matrix for decoding SQ records. Dual hookup using Y-connectors (see diagram) simultaneously feeds a 4-channel tape player to both decoder and your main amplifier for discrete 4-channel sound from 4-channel tapes or derived 4-channel from 2-channel tapes. Price is \$82.95.

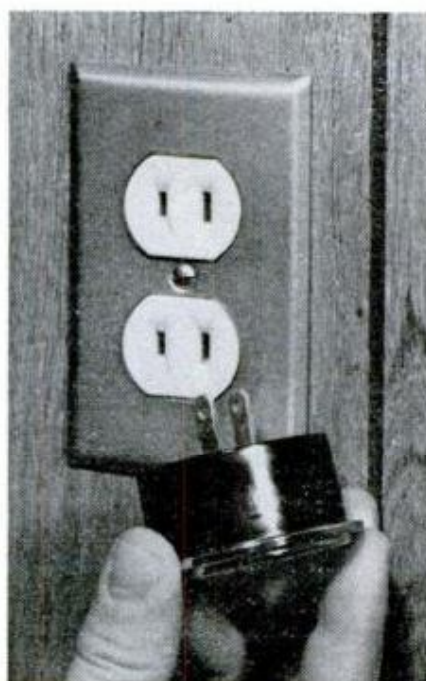
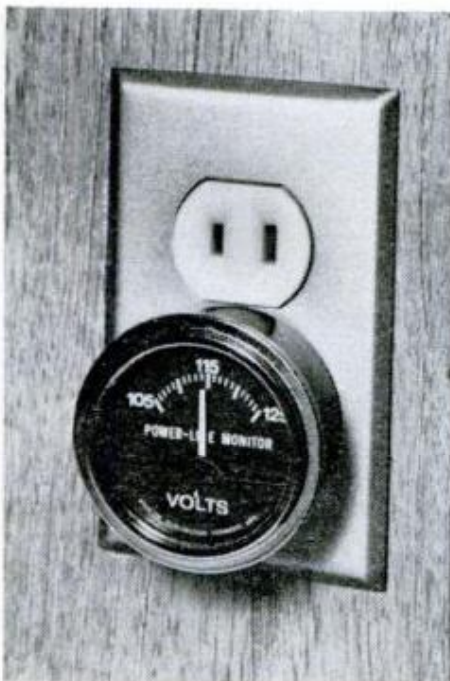
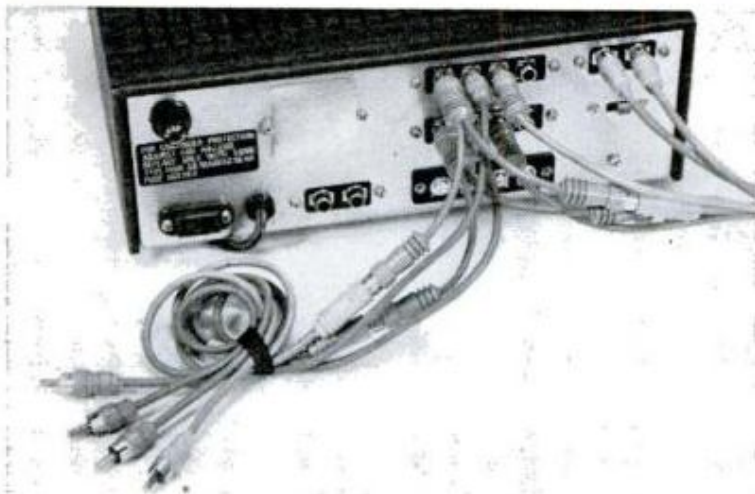

### Notice dimming lights, shrinking TV pictures? This plug-in voltmeter tells you at a glance if your power is dropping

In these days of frequent brown-outs and power cutbacks, this plug-in voltage monitor is a handy way to keep tabs on power in your home. It fits any standard wall outlet and reads from 105 to 125 volts. It warns you when incoming power falls below safe levels for operating household appliances and can also detect overloaded circuits. \$12.96 from Pro-con, 36 South St., Burlington, Vt.

# NOW



## Handy cord hid-ers take the tangle out of those messy appliance wires

Eliminating appliance-cord clutter is easy with these two handy cord hid-ers, designed to fit right over standard wall outlets. One in upper photos consists of a plastic flange held in place by the outlet's cover plate. You just wrap excess cord length around the flange and tuck the wires into a bottom slot for a neat, jumble-free appearance. Lower model is a boxlike enclosure that not only stores extra wire, but also conceals plugs and outlets. A base plate is fastened on first and the cords wrapped around molded-in clips. Slipping on a plastic cover then hides the whole works. Flange type is about 50 cents, box type about \$1. CalComp Consumer Products, 2537 Via Palma, Anaheim, Calif. 92801, is the manufacturer of both.

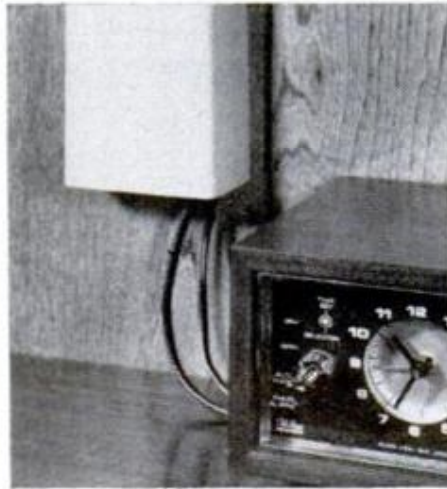

## Light, go-anywhere cordless trimmer for shrubs and bushes frees you from having to trail a long power cable from the house

Weighing just a little more than 3 pounds, this light-weight, cordless hedge trimmer made by Disston gives you 35 to 45 minutes' cutting time on an overnight charge. Its double-edged alloy-steel blades, 13 inches long, are treated with a nonstick coating for easier cutting. The trimmer also features convenient pushbutton operation with a safety switch lock to prevent accidental starting. The price of \$39.98 includes both batteries and a plug-in recharging unit (top photo). Disston Div., H. K. Porter Co., Porter Building, Pittsburgh, Pa. 15219.



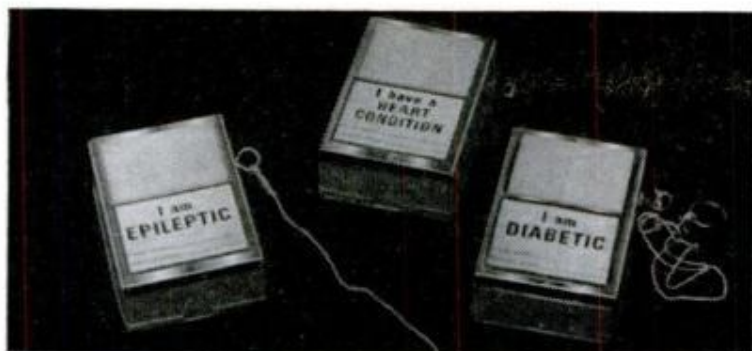

### Emergency alarm summons aid for the ill

Persons subject to sudden diabetic, epileptic or heart seizures can call for help with one of these tiny battery-powered pocket alarms. If an attack strikes, they pull a string, setting off a high-pitched screech. Alarm gives patient's condition, name and address, sells for \$5 from Stanley Hagler, 55 East 9th St., New York, N.Y.



### Truck needs no roads—it rolls its own wherever it goes

Laying down its own flexible roadbed as it rolls along, this go-anywhere truck was designed by British Royal Engineers for the quick installation of emergency roadways for use by military vehicles in wilderness terrain.



### Kodak adds new movie features

Kodak's latest addition to its line of "binocular"-shaped XL-type Super-8 movie cameras is this Supermatic 24. An advanced version, it features remote control, zoom and provision for filters over both lens and light-meter eye. \$189.50.



### 'Instant' camera has own flash

First instant-picture camera to come out since Polaroid in 1949 is this Keystone. It uses standard Polaroid film, but is said to be first to have built-in electronic flash. A clever focus-coupled diaphragm automatically stops down for correct flash exposure at any distance. \$79.95, Berkey Photo, 842 Broadway, New York, N.Y.

# NOW



## Kit-built quad decoder now comes with built-in SQ

Heathkit's 4-channel decoder now comes in a new model incorporating SQ circuitry for playing latest SQ-encoded records. The inexpensive adapter is designed for use with two stereo amplifiers (one must have tape-monitor facilities for connection). It decodes other matrix systems besides SQ, offers derived 4-channel sound from 2-channel sources. AD-2022 kit priced at \$39.95 is manufactured by the Heath Co., Benton Harbor, Mich. 49022.

**If it flashes red,  
watch out: Speed minder  
warns you if you  
exceed the legal limit**

You won't get a speeding ticket if you heed the clever little warning device shown at right. You set its dial to the maximum allowable speed and a red light flashes on if you unconsciously drive faster. The electronic control clocks your ignition system's pulses and automatically lights if the number exceeds the preset limit. It works on four, six or eight-cylinder cars, has a self-sticking dashboard mount and needs but three electrical connections. \$6.95 postpaid from Reese Instrument, Ltd., Patrick St., Limerick, Ireland.





**New scuba vest  
can be inflated  
three ways—slow,  
fast and faster**

This versatile new scuba vest can be inflated three ways for precise control of buoyancy under water. For slow filling, you breathe orally into a large flex hose (far left, opposite page). For faster inflation, air can be fed in directly from a mouthpiece on the regulator's second stage (lower middle photo). In an emergency, pulling a cord (near left) triggers a CO<sub>2</sub> cartridge, inflating the vest instantly. An asymmetrical shape with inflator hose at highest point in collar prevents trapped air, permits full deflation. Model 1988, \$70. Heathways, Box 45055, Los Angeles, Calif. 90045.

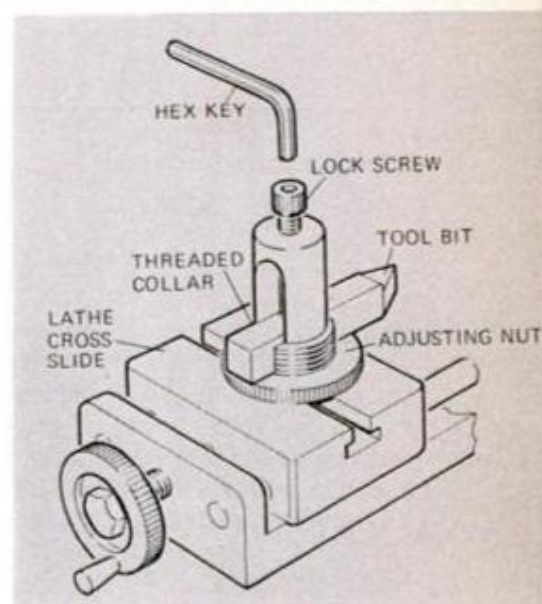

**Adjustable  
toolpost for  
Unimat lathe**

Unimat lathe enthusiasts can now buy an adjustable toolpost that mounts on the lathe's cross slide, accepts 1/4-in.-square tool bits and rotates through 360°. Adjusting nut governs height; lock screw secures the bit. Made of hardened stainless steel, the accessory is \$8.95 from Unimat dealers or post-paid from Glengineering, 239-43 66th Ave., Douglaston, N.Y. 11362.

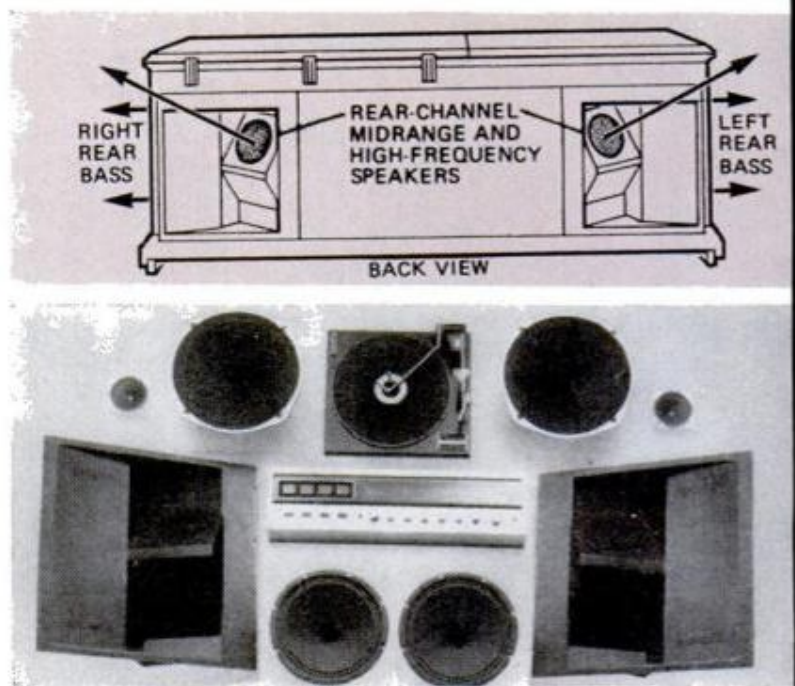
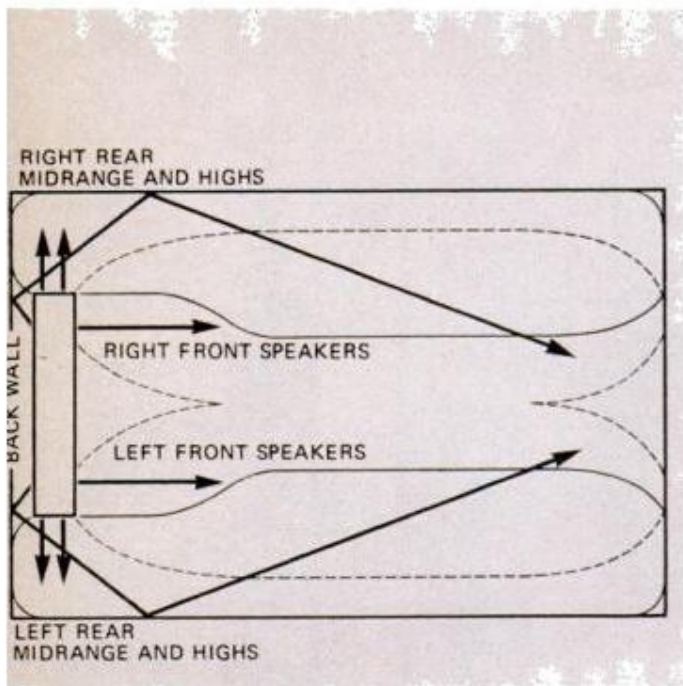

## Rigid-frame hacksaw ends blade twist

Fully extended to take a 12-in. blade, Estwing's tubular-frame hacksaw remains extra rigid to stop blade twist and wobble and insure accurate blade alignment. Saw has comfortable checkered grip, no bolts or rivets to loosen, long blade life. Tube inserts in handle more than 2½ in. with longest blade to provide strong-braced support. Both 10 and 12-in. sizes sell for \$4.30.

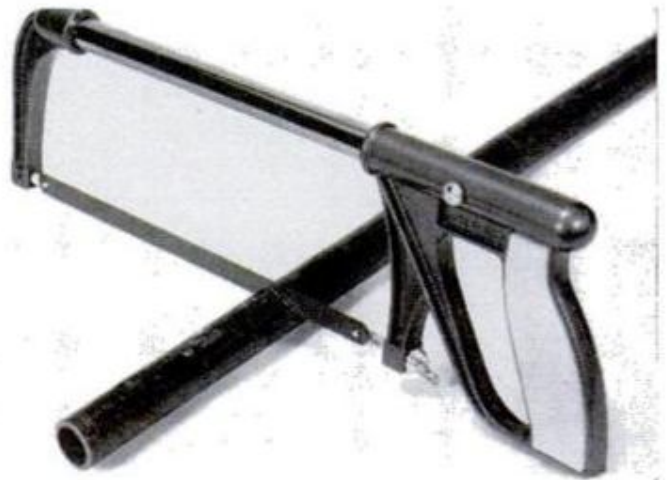

## New high-flying hobby: First gas-powered model helicopter

This "Mini-Chopper" is said to be the first gasoline-powered, free-flight model helicopter to perform successfully. Powered by an .020 Cox engine, it climbs 700 feet a minute up to altitude of more than 1000 feet. When out of fuel, it autogyros gently back to earth. \$24.50, Trid-N-Tru Toys, Inc., 1135 East Truslow Ave., Fullerton, Calif. 92631.



**Four channels, one box—  
Motorola does it with  
mirrors, sort of**

Lurking within this innocent-looking, Mediterranean-style Motorola console is a complete four-channel sound system. The two front-channel speaker systems are aimed directly into the room, as in an ordinary stereo set (diagram, far left). But rear channels take a more complex path: Rear-channel bass signals spill from side-mounted, 10-inch woofers (paired short arrows on diagram), while angled rear tweeters (see back view, top center) bounce rear-channel, middle and high frequencies off wall behind the cabinet, reflecting them like a mirror toward the back of the room.

**One-man roll-on boat loader  
makes cartopping a breeze**

Getting a boat on or off a cartop carrier is an easy one-man job with this self-loader. A sloping rail attaches to the car, and a roller mounts on the boat's bow. You just "wheelbarrow" the boat up the rail and onto the roof racks. \$59.95, Tempo Products Co., 6200 Cochran Rd., Cleveland, Ohio 44139.

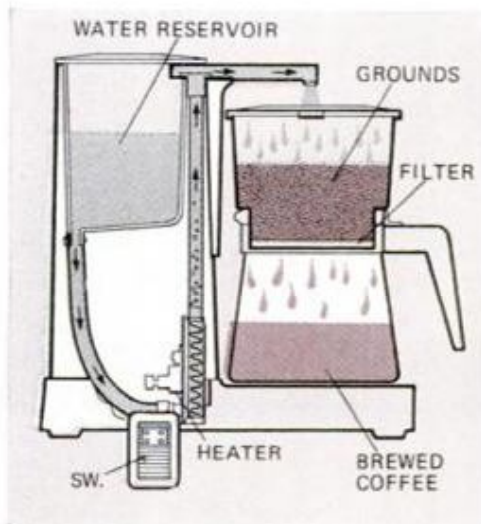

**Coffeemaker brews it  
fresh in 90 seconds**

Add cold water and ground coffee, press a button, and West Bend's Quik Drip coffee machine does the rest—automatically. It heats water to just the right temperature, then drips it through grounds only *once* to capture best coffee flavor, not bitter oils. Makes two to eight cups, one each 90 seconds. \$29.99.

# NOW

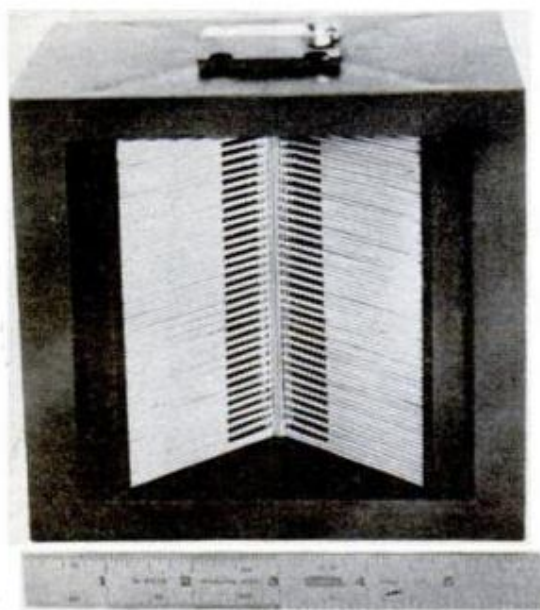

## New hi-fi speakers have no cones

These coneless speakers don't push air back and forth like a piston, as in conventional types. They translate electromagnetic signals into sound waves through microscopic movements of tiny plastic "levers." Results are said to be low mass, lack of inertial sluggishness, flat response to 25,000 cycles, virtually unmeasurable distortion. Two models, 28 and 42 inches high, available soon. ESS Inc., 9613 Oates Dr., Sacramento, Calif. 95827.

## Husky chain-door lock opens with key

The Brute is the toughest chain-door lock ever, maker claims, and protects your home even when you're out—but you can reach in far enough to unlock it with a key when you return. Price is \$14.95. From Ideal Security Hardware Corp., 215 East Ninth St., St. Paul, Minn. 55101.

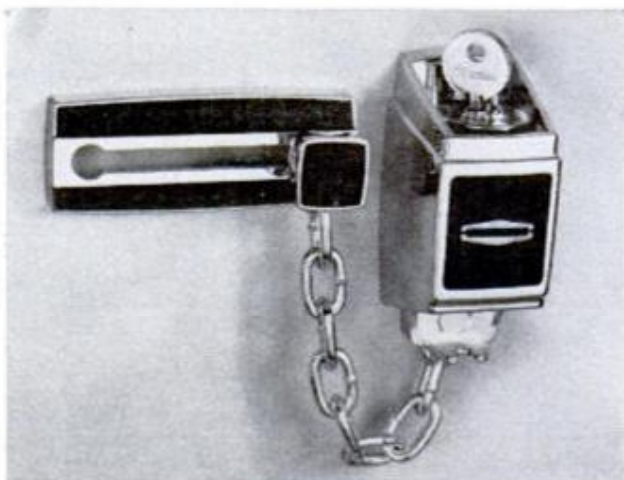

## Kit speeds finicky paint job

Designed to make fast work of painting window sash and trim, Trim 'n Sash Kit includes two pad painters with micro-adjustable guides and metering paint tray. Price is \$3.20. Red Devil, Inc., 2400 Vauxhall Rd., Union, N.J. 07083.



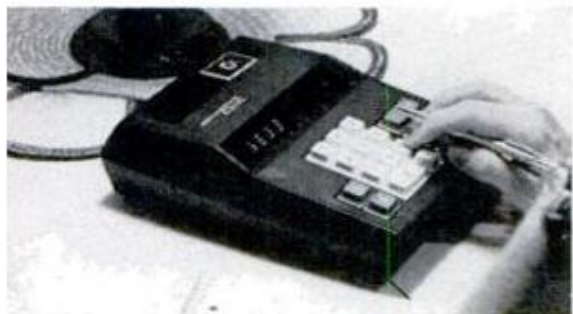

### Mini calculators do new tricks

Mini calculators are getting more versatile every day. One at top above is said to be first hand-held size to provide a printed readout on paper, giving you a permanent record of computations. Price is \$325 from Iain Jones International, 6428 N.E. Expressway, Norcross, Ga. Pocket model at center, made especially for business use, figures interest rates, percentages, discounts, bond yields and other financial functions. It's \$395 from Hewlett Packard, 10900 Wolfe Rd., Cupertino, Calif. Desktop calculator at bottom is inexpensive version for home or office use, sells for \$99.50 from Edmund Scientific, 700 Edscorp Bldg., Barrington, N.J.



### 'Instant' photo album needs no messy pasting

Easy-to-arrange photo album requires no cement, corner tabs or other means to hold pictures in place. You just peel back a clear-plastic sheet, lay out photos as desired, then replace plastic to keep prints clean and flat. Albums of various sizes are about \$10; refills, \$5.50. Holson Co., 111 Danbury Rd., Wilton, Conn. 06897.



### Skid prevention for rugs

You can anchor rugs and carpets securely with Carpet-Grippers, reusable self-sticking squares. Package of 12 is \$1.25, plus 25 cents for postage and handling from Carpet Products Co., Box S, Central Square, N.Y. 13036.

# When the next big flood hits...

A year ago, Hurricane Agnes dumped 25.5 cubic miles of water on the eastern United States, causing a record disaster. Lessons were learned, but will they help next time?

by Robert Dymont

A spring flood brought disaster to Elmira, N.Y., in 1946. The Chemung River, which slices through the city, raged over its banks and flooded adjacent streets, inundating cars and battering buildings.

At the flood's peak, 115,000 cu. ft. of water per second surged down the Chemung. The disaster was termed a "100 year" flood—the odds were that a flood of that magnitude would occur only once in a century. This was some consolation to Elmirans.

The city of 40,000 lies in southcentral New York, just above the Pennsylvania line. Its location puts it right in the path of water runoff from upstate mountains. Corning, a few miles west, has the same problem. It is located at the confluence of the Tioga and Cohocton rivers. They form the Chemung, which runs southeast through Elmira and ultimately empties into the Susquehanna. The Susquehanna winds through Pennsylvania and Maryland to the sea.

Elmira's river site has helped its development as an industrial city. Today, its plants manufacture electronics equipment, textiles, tools, fire engines and auto parts. Sometimes called the "Gliding Capital of America," it's the home of the famous Schweizer sailplanes and the site of an annual national soaring meet.

Through the years systems of dikes and reservoirs were built to protect Corning and Elmira. By 1972, Elmira's system consisted of 58,400 feet of earth levees and 10,400 feet of concrete walls. These 22-foot-high barriers were designed to protect the city against any flood up to one of 100-year magnitude.

But the system was not designed to con-



Elmira's north-side flood wall was a huge spillway at 9:00 a.m., June 23. The rush of water was part of the worst flood in the state's history.

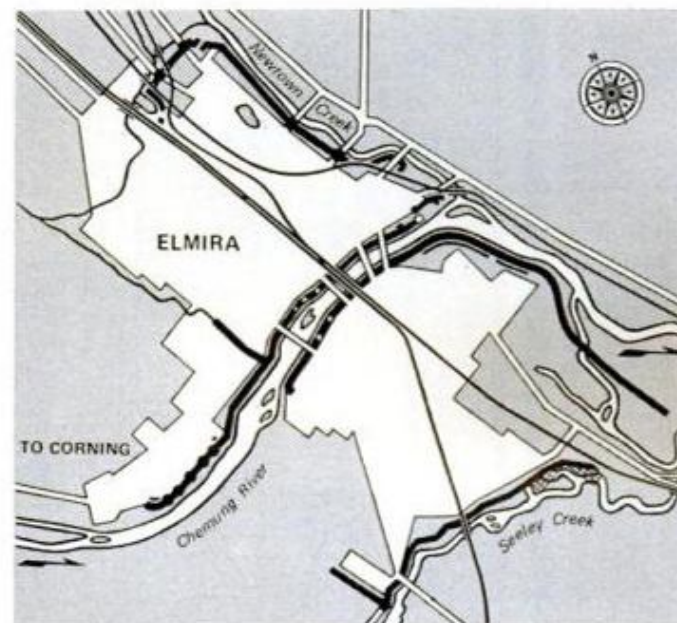

No stranger to floods, Elmira has a system of 58,400 feet of earth levees and 10,400 feet of concrete walls (as indicated by heavy lines).



**The Chemung River** ran wild, pushing houses from foundations, tossing cars like so many toys. It turned streets into muddy river bottom.



**Rescue boat patrols** Elmira's East Church Street. Under city's Emergency Flood Plan, fire department directed boat rescue operations.

ILLUSTRATIONS BY PETER TROJAN

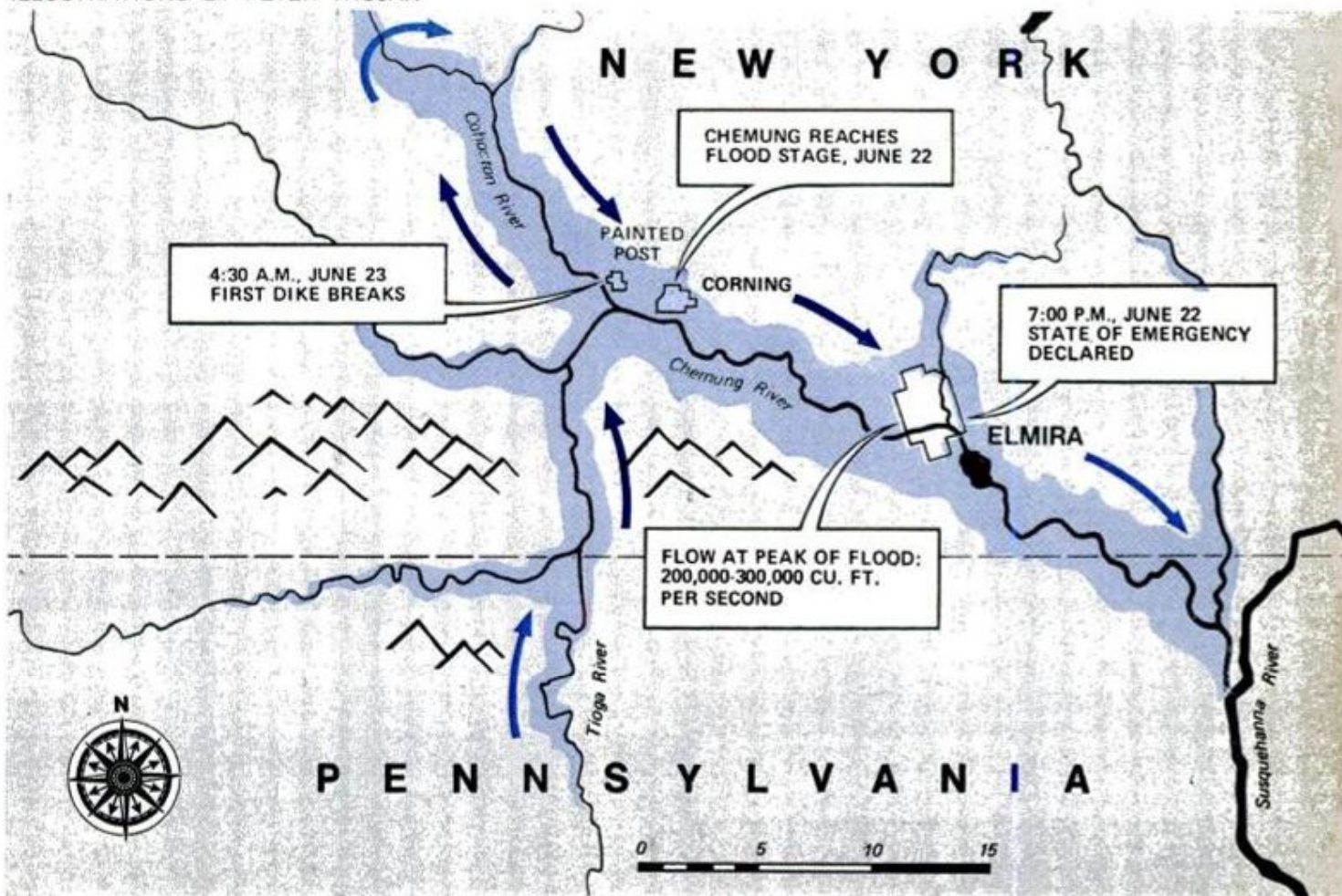

## Nuclear gauge reads mountain snowpack

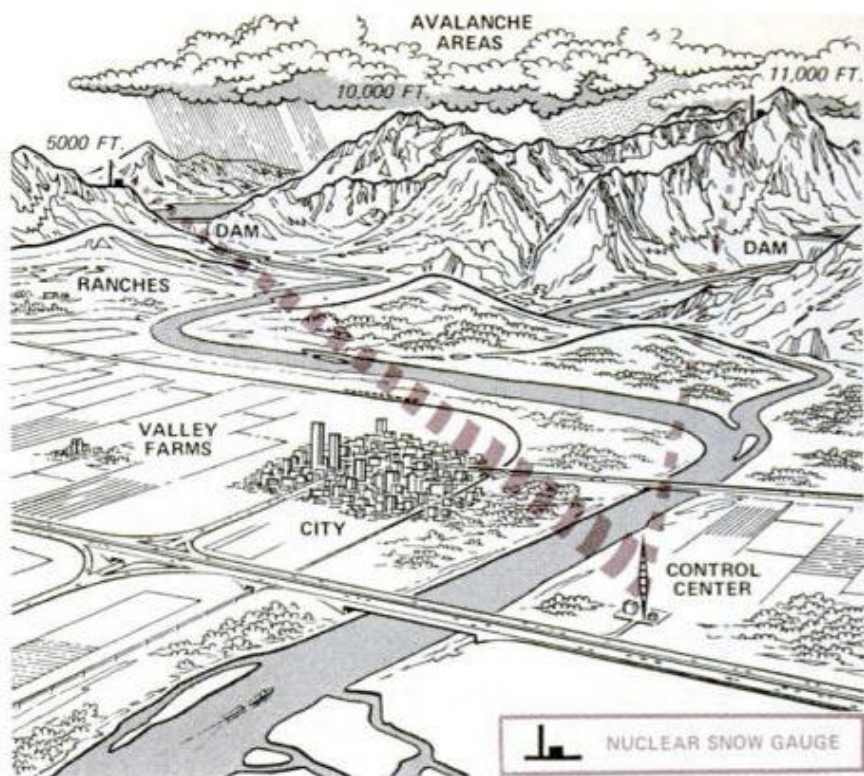

Seated in a Berkeley, Calif., laboratory, U.S. Forest Service researchers can now accurately predict flood, avalanche and water-runoff conditions in the Central Sierras. This is made possible by a remotely operated, nuclear snow gauge. The gauge reads a profile of the snowpack and the data is telemetered to a control center. From there the information travels by commercial phone line to the lab. The system is operated by a small computer.

Key unit in the gauge is the density sensor (shown being installed in photo). It consists of two long metal tubes set in the ground 26 inches apart. They extend to a height greater than the maximum anticipated snow accumulation. A radioactive source—cesium 137—is suspended in one tube, a sodium iodide crystal detector in the other. The cesium emits gamma photons that travel through the snow to the detector

unit. The number of gammas recorded is relative to the snow's density.

Both the cesium and detector units travel up the tubes. A lift mechanism moves them at a rate of 12 inches per minute, and readings are taken every half inch.

The nuclear gauge provides an amazing variety of data: total snow depth; density; total water content; water content increase or decrease; amount of snow fallen since last measurement; melt rate between measurements; water the snowpack can hold before it starts to discharge. This information is of keen interest to Forest Service scientists and other "flood watchers."

The first remote nuclear gauge was tested in 1971. It worked so well that other units were installed at Red Mountain near Silverton, Colo., Mount Baldy at Sun Valley, Idaho, and Mount Hood in Oregon.

—Edwards Hay

tain the deluge created by Hurricane Agnes. Last June, Agnes swept north and was apparently headed out to sea when she stalled over northern Pennsylvania and southern New York. Between June 20 and June 24, the tropical storm dumped an estimated 25.5 cubic miles of water—one fourth the volume of Lake Erie—on the eastern United States. The Corning-Elmira area recorded over eight inches of rain.

By 7:00 p.m., Thursday, June 23, a gauge at Elmira's Lake Street Bridge showed that the Chemung was 17 feet above normal. Mayor Richard C. Loll and City Manager Joseph E. Sartori declared a state of emergency and directed Albert J. DeRenzo, acting public works director, to put the Emergency Flood Plan into effect.

West of Elmira, the Cohocton River had risen 30 feet when—at 4:30 a.m., Friday—





The power of the raging water was great enough to flip this two-story house. Thousands were left homeless.

a dike broke at Painted Post, a village near Corning. Soon four other dikes were breached. A wall of water poured south through Corning and Elmira.

Elmira's levees and dikes were breached at eight points before they were engulfed by a rush of water that eventually covered a good part of the city. At the height of the flood, the flow at Elmira was estimated at between 200,000 and 300,000 cu. ft. per second—about twice the volume of water experienced in 1946.

The torrent tumbled houses from foundations, carried away cars like so many toys, tore loose great slabs of concrete sidewalk. One of the city's bridges was completely washed out, others were damaged. Factories, stores, banks, offices and homes were awash in a sea of mud.

This was no 100-year flood—more like a 1000-year flood, according to some observers. From New York to Virginia the deluge took a record toll: 118 lives lost and \$3.5 billion in property damage.

Both Corning and Elmira sustained heavy damage. A total of 18 lives were lost in the Corning area—but not a single person perished in Elmira. This accomplishment was attributed to the city's Emergency Flood Plan, which had been updated as recently as May, 1972. Under it, some 15,000 people were evacuated, most having

moved to safe ground 12 hours before the dikes were breached.

Public Works Director DeRenzo had direct responsibility for implementing the plan. Functioning under him were various officials and organizations—police chief, fire chief, superintendent of buildings; members of the school board and the local civil defense organization; representatives from the telephone, gas and electric companies.

An operations center was set up in the city manager's office at city hall. A second command post, after city hall became



Huge slabs of sidewalk were torn loose and floated down streets. After flood, city looked like war zone.



**West wing** of Jones Memorial Hospital at Wellsville, west of Elmira, toppled into the river at the height of the flood. After the deluge came massive clean-up operations, and restoration of power and sanitation facilities. A new Elmira could emerge from the disaster—in the event a \$72-million renewal project is realized. For this, federal funds will be needed.

flooded, was available at Elmira College.

A master list of phone numbers was used to call officials, clerks and other aides to city hall. They arrived within an hour after the emergency had been announced.

The fire department was responsible for small-craft rescue and relief operations. The police controlled traffic and the movement of people away from flooded areas.

By radio, the public was kept informed about dangerous areas, clear evacuation routes and the location of shelters.

At the city hall operations center, DeRenzo, the fire chief and police chief kept on top of the situation by telephone and radio, ham and citizens-band operators playing important roles. The three men maintained contact with federal and state agencies and with officials of other cities.

"Some of the on-scene reports received from upriver municipalities proved more reliable than state and federal information," says DeRenzo.

This is but a brief summary of a complex operation involving an entire community. The plan achieved its primary goal: the safe evacuation of all flood victims. As Elmira's city fathers will tell you, though property can't be saved from the ravages of a flood of such magnitude, lives can.

Elmira learned the importance of good

communications during the emergency. As a result, officials are making a list of all amateur radio operators in the city and the surrounding area. In the future, they will be assigned to posts at hospitals, police stations, fire stations and other key points.

Authorities are also compiling a master list of all boat owners and are making up ID cards for officials, doctors, nurses and other key people. This will permit them freedom of movement during curfew hours.

After the water had receded in Elmira, city, state and federal agencies took the first steps in a massive cleanup effort. Mud and debris were bulldozed from streets, dikes shored up, bridges repaired. Power was restored and the sanitation system repaired. While water purification units were being set up, drinking water and food were trucked in.

Shelter was another problem. Trailers and mobile homes were set up in parks or driven into driveways of wrecked homes so that the owner had a place to live while he worked on his house.

Slowly, Elmira pulled themselves out of the mud and started to rebuild. Optometrist Arthur Wellington voiced a typical sentiment when he was seen leaving his Water St. office carrying an adding ma-

*(Please turn to page 178)*



## Breezy little homebuilt: A beginner's dream plane

The ultimate in simplicity, this snappy VW-powered single-seater by Pazmany has already won two awards for outstanding design and low-cost construction. You can buy plans for it.

by Sheldon M. Gallager and Howard Levy

When Ladislao Pazmany brought his latest homebuilt to the Experimental Aviation Assn.'s annual "fly-in" at Oshkosh, Wis., last fall, he had to truck it in. It was so new the paint was still wet and it couldn't be flown. Almost before the paint had dried, the trim little single-seater won two awards;

PHOTOS BY HOWARD LEVY

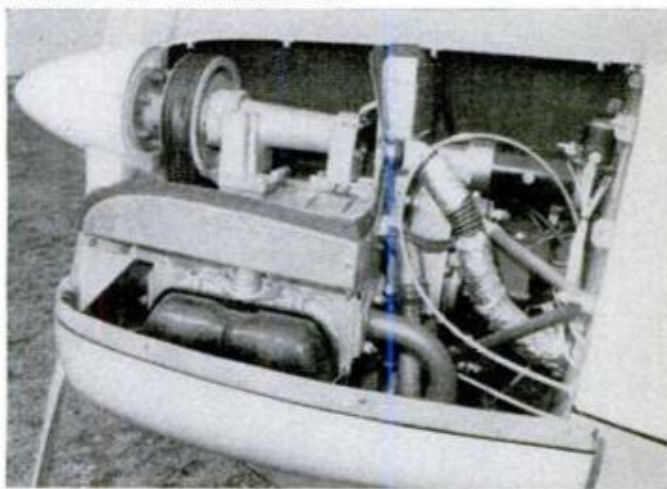

Mini powerplant, shown with cowling removed, is 54-hp VW engine turning prop through a simple V-belt drive.



Side-hinged canopy swings up for access to cockpit, is fully removable.



**Top-mounted** horizontal stabilizer, forming T-tail arrangement, is easier to construct than conventional tail, also gives good stability and control in flight.

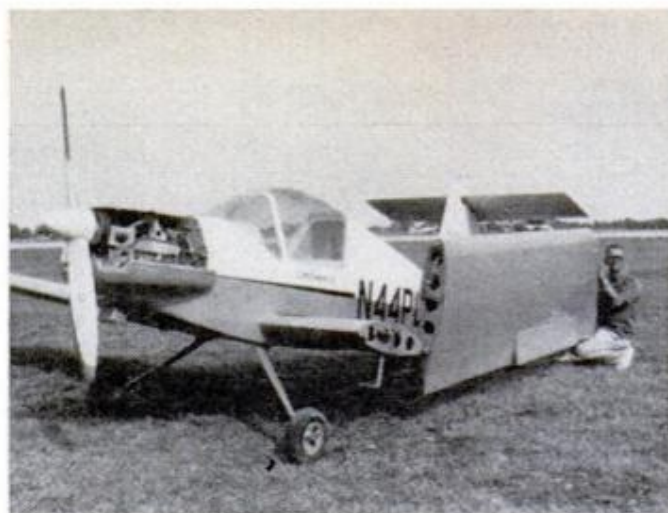

**Rear-folding wings** make ship compact for storing and towing. Note simplified landing gear—just two spring-steel struts. Wheel fairings can be added or omitted.

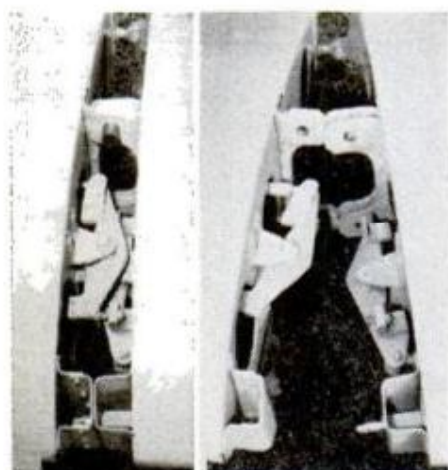
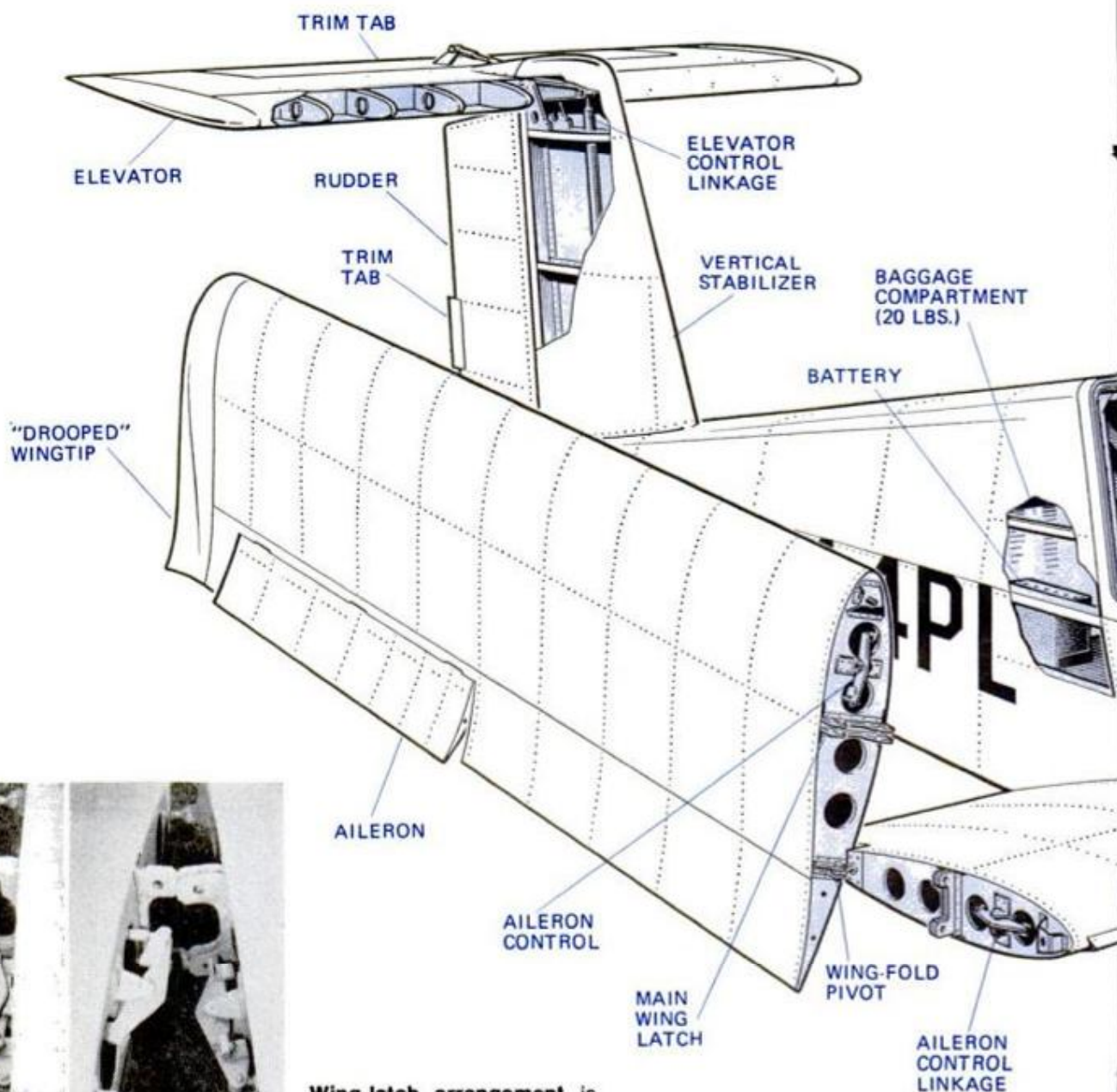

**Wing-latch arrangement** is shown at left. Wing swings on pivot fitting at rear. Snap-in strips cover slot.



Cockpit is roomy, clean, uncomplicated. Only barest number of most necessary flight instruments are used in order to keep cost and complexity to a minimum.

OVERALL LENGTH . . . . .	16 FT. 2 IN.
WINGSPAN . . . . .	26 FT. 8 IN.
EMPTY WEIGHT . . . . .	578 LBS.
GROSS WEIGHT . . . . .	850 LBS.
ENGINE . . . . .	54-HP, 1600-CC VW
TOP SPEED . . . . .	110 MPH
CRUISING SPEED . . . . .	100 MPH
STRESS LIMIT . . . . .	± 6G

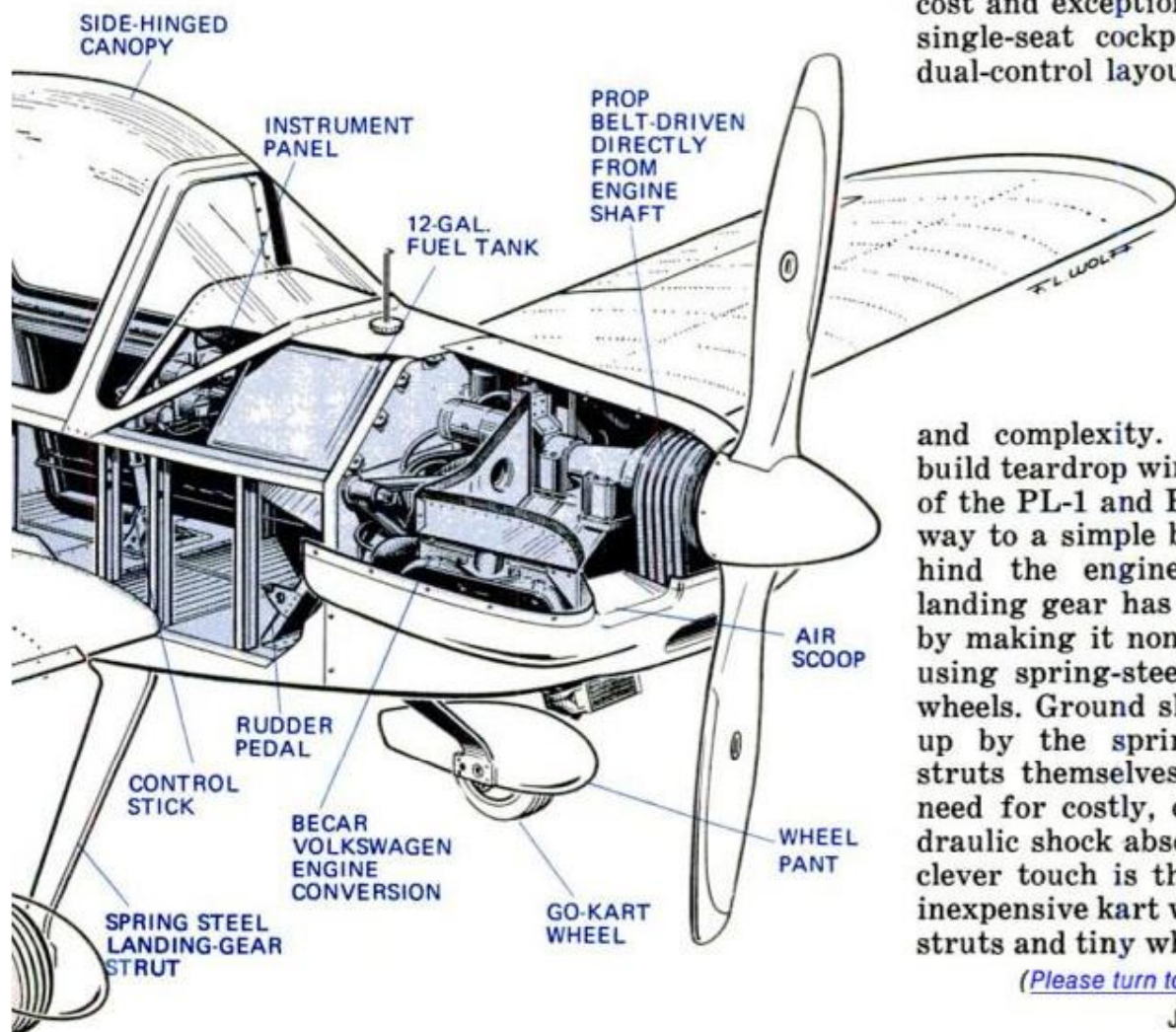

for "Outstanding New Design" and "Outstanding Contribution to Low-Cost Flying."

This instant winner, shown here, is the Pazmany PL-4A—actually the fourth in a series of homebuilts that has brought "Paz" international acclaim for his simple yet solid aeronautical concepts. The first, a two-place, dual-control version, the PL-1, proved so successful it was adopted by the National Chinese Air Force on Formosa for use as a primary trainer (see *The Homebuilt Plane That's Going Commercial*, page 92, July '72 PM). A second version, the PL-2, is now being tested by the South Korean Air Force for military use and by a Japanese manufacturer planning to put it into production for civilian use.

The new PL-4A is a no-frills modification designed especially for beginning builders and fliers. Though lacking some power and refinements of earlier models, it features easy construction, low cost and exceptional flyability. A single-seat cockpit replaces the dual-control layout to save space

and complexity. The tricky-to-build teardrop wingtip fuel tanks of the PL-1 and PL-2 have given way to a simple boxlike tank behind the engine firewall. The landing gear has been simplified by making it nonretractable and using spring-steel struts on the wheels. Ground shocks are taken up by the springiness of the struts themselves, eliminating a need for costly, complicated hydraulic shock absorbers. Another clever touch is the use of small, inexpensive kart wheels. The slim struts and tiny wheels offer mini-

(Please turn to page 186)

# Only 11.3 (smooth, comfortable) miles from every gallon

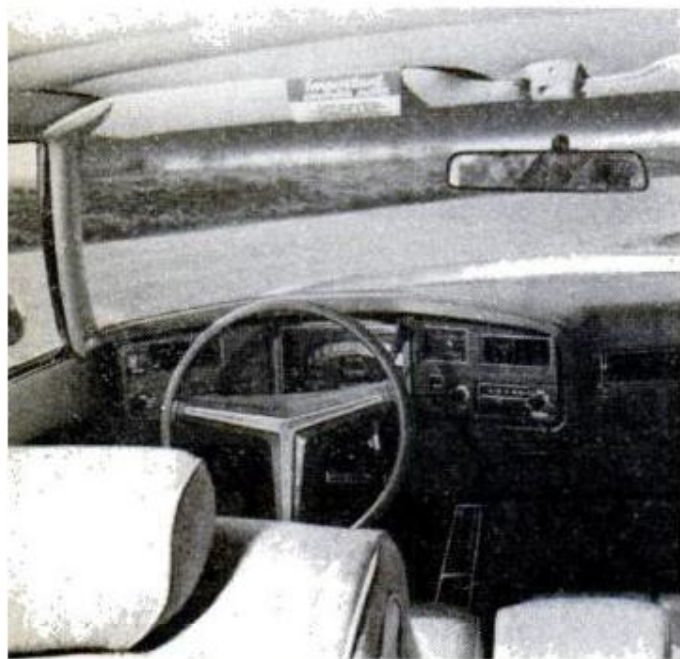

**Electra shares** its basic body with Cadillac. Several owners compared their Buicks with Cads, saying they felt they were getting as much car for less money. Smooth, quiet ride, easy control were points that owners praised. Wide front seats adjust six ways for individual comfort, cost \$205 extra. Electra owners aren't interested in flashy performance, but many mentioned

heady acceleration (455-c.i.d. V8 comes standard along with Turbo Hydra-Matic and most power accessories). Limited trim package can be ordered for any Electra at \$277 extra, includes acoustical insulation, special seats, emblems, lights. Flow-through ventilation system uses a blower that comes on automatically each time the ignition switch is turned on.

A nationwide survey  
based on 1,000,000  
owner-driven miles

PHOTOS BY THE AUTHOR

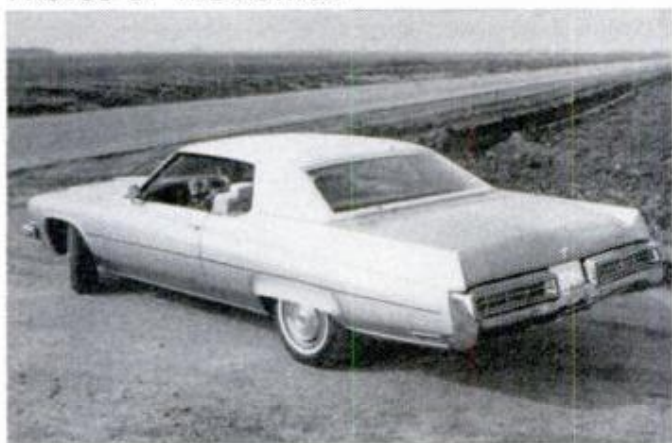

**Despite soft springing** and easy ride, big Electra responds well to quick maneuvers, doesn't wobble or lean on hard turns. Standard front discs aid stopping, and radial tires are optional along with special, no-cost suspension changes (when ordered from factory). Controls for power windows, seat, external mirror are at driver's left.

---

by Michael Lamm

**B**uicks become a way of life to some families. Sons buy Buicks because their dads bought them, and their dads bought them because *their* dads bought them.

So it's not surprising that almost half the Electra owners we surveyed were repeat customers. "Have owned four Le Sabres." "This is my 14th Buick." "My fourth Buick—I haven't been satisfied with anything else." "Always been a Buick booster." "This is my sixth Buick. Each one has been better than the last one." These are comments taken at random from the first 14 questionnaires that were on the top of our pile.

Electras appeal mostly to older, more affluent buyers. Nearly 56 percent of our respondents are over 50. Many are professional people, white-collar, with a good percentage of retirees. They don't care too much about flashy performance, but put a lot of stock in comfort, luxury, convenience, a smooth ride and silence. The Electra provides these in abundance. A New Jersey florist comments, "My brother has owned Cadillacs for quite a few years, while I'm a Buick man. In the opinion of friends who ride in both, Buick is the better riding."

Judging from the number of times the name "Cadillac" crept into the responses, many Buick owners seem to be frustrated Cadillac aspirants. A New York social worker says, "I bought my Electra for the pleasure of a Cadillac without the high price. I personally think it's much more comfortable than the Cadillac, plus it's a few thousand dollars cheaper." A retired Indianan: "I believe it has everything a Cadillac has except the prestige and that extra \$1600 on the price tag."

A quarter of all Electra owners had no complaints whatsoever about their cars—

## 'I have never had a bad Buick . . .'



another quarter, however, thought their Electras ought to get better gas mileage. Average of owners' local and long-trip driving is 11.3 mpg. Reactions ranged from surprise to rage, and in many cases owners blamed their smog systems. "Am disappointed in gas mileage—8 to 10 mpg. Understand it is due to emission controls," writes a Los Angeles real estate man. Actually, according to a recent Environmental Protection Agency report, the fuel penalty caused by pollution controls is only 7 percent. The rest is attributable to power options, airconditioning, automatic transmissions and the weight of big cars.

A New York foreman: "I'm sure not happy with the gas mileage. I was getting 15-16 mpg from my other two Electras." Smog devices also take the blame for sluggishness, stalling, hard starts in cold weather, rough idle and dieseling. These problems aren't limited to Buicks—owners of nearly all 1973 makes voice similar complaints. There's no doubt that carburetor adjustment is more critical and harder to make, that the 1973 engines are more complicated and temperamental than earlier models. There's also no doubt that mechanics blame some of their own deficiencies on "smog paraphernalia." It's much easier to shrug and sigh, "Well, it's the smog stuff" than to take time to tune out a rough idle or hard start.

What changes would Buick owners rec-

ommend? "Doors are very heavy and difficult to open on sloping streets," writes a Maryland surgeon; "if not careful, door tends to fall back and bump knee or worse. A firmer intermediate stop is needed." A Virginia bank employee: "Would like radial tires as standard equipment." "Change the styling," says a Delaware ophthalmologist, ". . . can't it look more like a Continental?"

An Alabama CPA: "Design seat belts so they fasten easier." A New Jersey funeral director: "Add front vent wings so that damn fan wouldn't have to be blowing all the time." A Utah civil servant: "Better gas mileage and better use of horsepower." Plenty of amens on that last one.

Most complaints actually tended to be minor, and most owners didn't even have any. Bearing that in mind, here are some of the more common. "Too short a warranty period—should be two years and 24,000 miles." "Craftsmanship poor for a \$6000 car. There's apparently a lack of pride or poor training among factory and dealer mechanics." "Can't see fenders." "Too big to fit into my garage." "Sides of body curve inward at bottom, which lets gravel from tires chip paint and makes car hard to keep clean." "Wind noises from windows that don't seal properly." "Dealer service takes too long—nine days to repair a steering box."

But the majority drowns out these complaints with plaudits. "It's a pleasure driv-



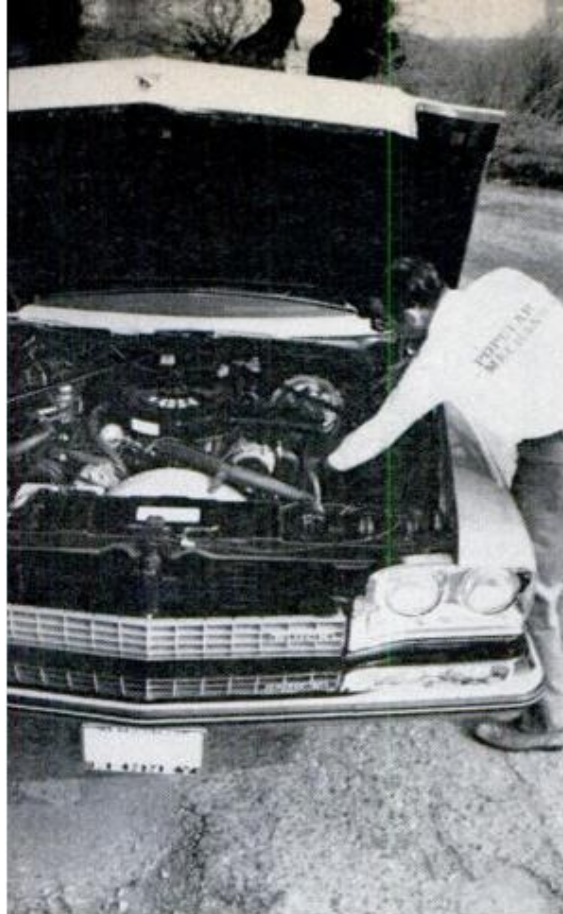

A single piece of fiberglass-reinforced, molded plastic serves as combination fan shroud, windshield wiper reservoir, and radiator overflow tank for closed cooling system. Exhaust-gas recirculator speeds warmups, cuts smog. Optional engine package with twin exhausts gives 250 bhp net, while the standard V8 puts out 225.

Electra's spare rests so far forward that you have to climb into trunk to retrieve it. Luggage compartment is fully carpeted. Electric trunk release (optional) has button in glovebox. Ample rear overhang makes the Electra harder to parallel park than most, but driver can see all four fenders, so he needn't park by ear.

ing my Buick—handles with ease at turnpike speeds and takes the bumps right out of the road." "I have never had a bad Buick in my 30 years of ownership." "It's one of the prettiest cars on the road today—really *the* prettiest." "I feel good driving it!" "Good resale value—I trade every two years

and pay about \$1000 difference on a new Buick." "Troublefree and dependable." "Lots of room and luxury inside." "Roominess, spacious trunk, good visibility." "Remarkably fine quality of workmanship to my absolute amazement, both on this and my previous 1972 Buick." ★★★

## Summary of 1973 Buick Electra Owners Reports\*

Total miles driven . . . . .1,041,244

### Body styles:

Four-door sedan . . . . .73.3%  
Two-door hardtop . . . . .26.7

### Miles per gallon:

Local driving . . . . .9.7  
Long trips . . . . .12.8

### Why did you buy an Electra?

Past experience . . . . .45.9%  
Styling . . . . .14.2  
Comfort . . . . .11.0  
Size . . . . .11.0  
Ride . . . . .9.6

### Specific likes:

Ride . . . . .50.0%  
Handling . . . . .47.6  
Comfort . . . . .45.1  
Styling . . . . .35.9  
Performance . . . . .17.0  
Roadability . . . . .10.7

### Specific dislikes:

Poor gas mileage . . . . .25.1%  
Poor workmanship . . . . .10.2  
Rattles . . . . .7.9  
Cold starts . . . . .6.0  
Wind noise . . . . .5.1

### What changes would you like?

Better gas mileage . . . . .15.3%  
Better workmanship . . . . .8.5  
Changed styling . . . . .6.3  
Remove smog devices . . . . .5.7  
Change ashtray location . . . . .5.1

### Had any mechanical trouble?

No . . . . .65.2%  
Yes . . . . .34.8

### What type of trouble?

Electrical . . . . .39.0%  
Windshield wipers . . . . .9.1  
Carburetor . . . . .9.1

### Did you repair it yourself?

No . . . . .97.4%  
Yes . . . . .2.6

### Dealer repairs satisfactory?

Yes . . . . .76.8%  
No . . . . .23.2

### Dealer service opinion:

Good to excellent . . . . .36.4%  
Average to poor . . . . .63.6

### Workmanship opinion:

Good to excellent . . . . .66.3%  
Average to poor . . . . .33.7

### Is the Electra your only car?

Yes . . . . .38.2%  
No . . . . .61.8

### Other cars owned:

Buick . . . . .26.2%  
Chevrolet . . . . .21.2  
Ford . . . . .12.8  
Pontiac . . . . .9.3  
Volkswagen . . . . .6.3

### Age distribution of owners:

15-29 years . . . . .4.5%  
30-49 years . . . . .39.6  
50-plus . . . . .55.9

Percentages might not equal 100% due to rounding or insufficient data.

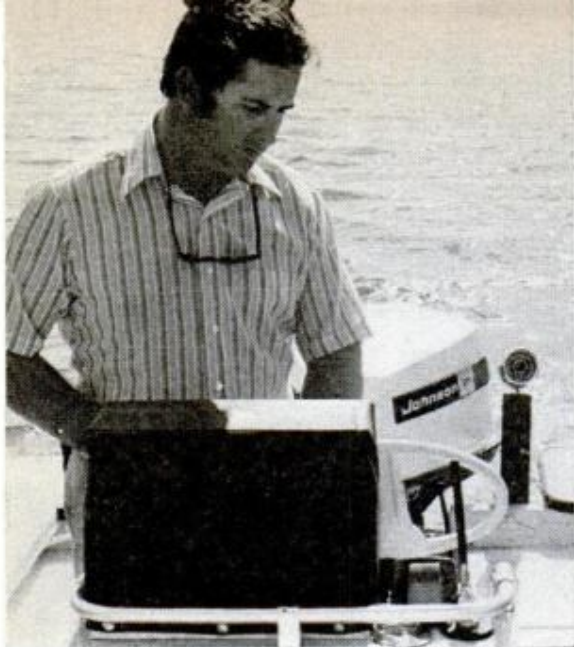

# PM's ideal fishing machine

by Robert D. Stearns

**Noted fishing and boating authority** Bob Stearns is also a marine biologist, Miami University researcher and lieutenant commander, USNR. Here he predicts the offshore fish chaser of the future. If and when a boat is produced that meets PM's specifications, we will feature it.



- |  |  |
|--|--|
| <input type="checkbox"/> Trimmable V-hull          | <input type="checkbox"/> Transom lift-out ladder   |
| <input type="checkbox"/> No-snag gunwales          | <input type="checkbox"/> Fish-finder console       |
| <input type="checkbox"/> High-low headlights       | <input type="checkbox"/> Remote control transducer |
| <input type="checkbox"/> Inner flotation ring      | <input type="checkbox"/> Console toilet            |
| <input type="checkbox"/> Recessed cockpit lighting | <input type="checkbox"/> Retractable windshield    |
| <input type="checkbox"/> Cockpit drain channel     | <input type="checkbox"/> Multiple power options    |

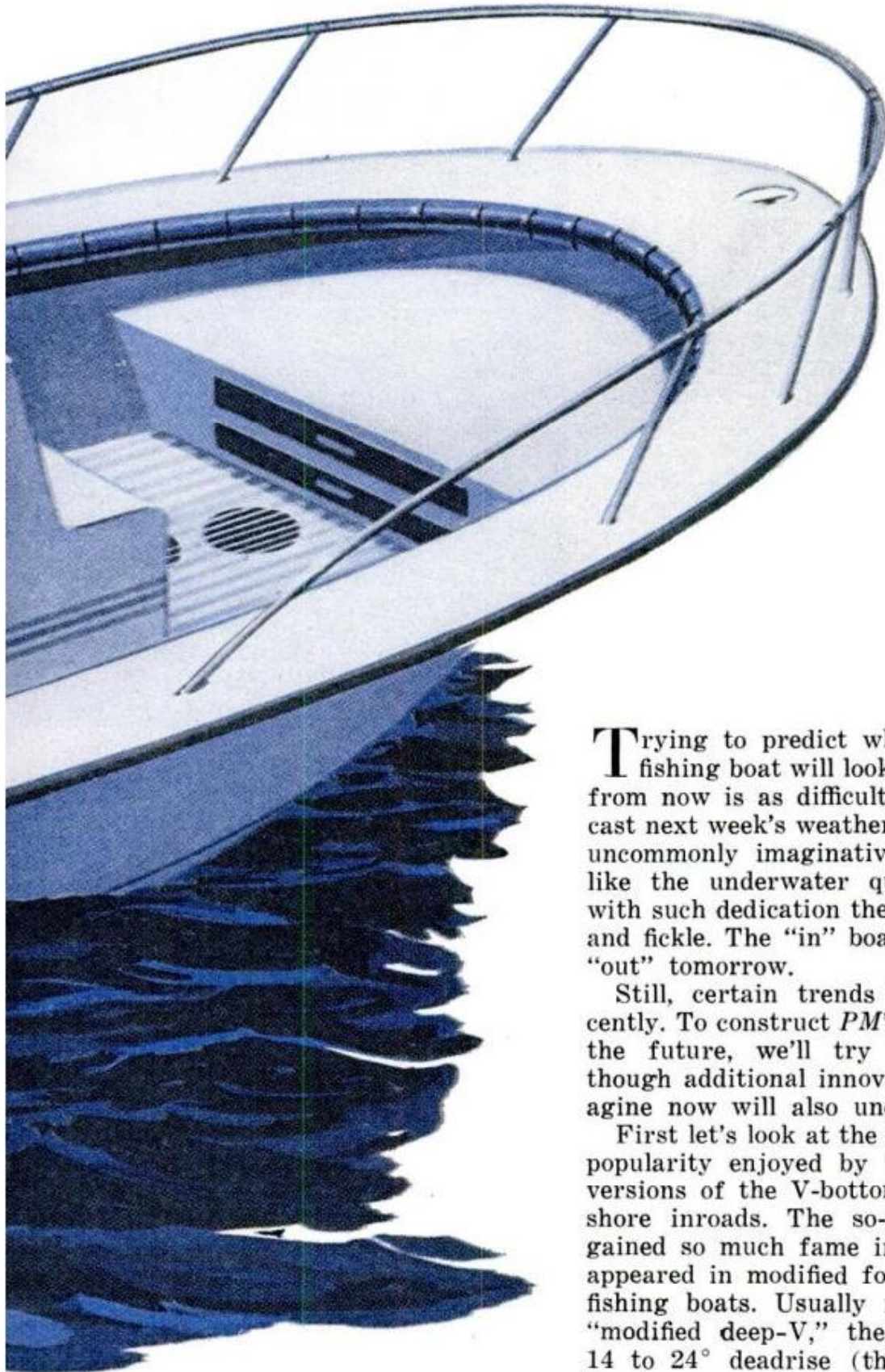

Trying to predict what your big-water fishing boat will look like a couple years from now is as difficult as trying to forecast next week's weather. Fishermen are an uncommonly imaginative breed, but much like the underwater quarry they pursue with such dedication they are unpredictable and fickle. The "in" boat of today is often "out" tomorrow.

Still, certain trends have surfaced recently. To construct *PM's* fishing dream for the future, we'll try to project ahead, though additional innovations we can't imagine now will also undoubtedly arrive.

First let's look at the hull. In spite of the popularity enjoyed by trihulls, the newer versions of the V-bottoms are making off-shore inroads. The so-called deep-V that gained so much fame in ocean racing has appeared in modified form in many newer fishing boats. Usually referred to as the "modified deep-V," these hulls feature a 14 to 24° deadrise (the angle between a line drawn straight across the transom from

chine to chine and another line between one of the chines and the keel). The reason is simple: Fishermen are becoming more exploratory, and exploring means covering vast watery distances. A hull that is rough riding and wet takes all the fun out of such expeditions, and the deep-Vs definitely rate tops in riding comfort. Even now it is not uncommon for south Florida anglers to cover 200 or more miles of ocean in small open boats in a day's fishing.

Most likely our hull of the future that will head out on deep water will continue the deep-V trend with numerous modifications. Deadrise will probably be 20 to 28°, a slight increase over today's most popular models. "Steps," those horizontal longitudinal strakes that provide lift, will be computer-designed to best width and angle for top performance over a much wider variety of sea conditions. Speed is essential for great distance, and a boat forced to slow down by a little chop won't fill our bill.

Trim tabs have gained popularity recently, especially with deep-V enthusiasts. In the future there should also be adjustable remotely controlled trimming surfaces at various points along the steps, allowing a fisherman to vary riding characteristics to suit an even larger range of sea conditions. You might want to increase forward lift in a following sea to prevent the bow from burying, or to decrease lift in that area to reduce pounding in a head sea.

Molded-in-place transom wells are getting more attention. They can be kept dry for storage or flooded with circulating seawater for carrying live bait. One nice thing about transom wells: They increase the effective length of the boat while adding very little weight, so a 22-footer with two-foot wells will perform like a 24-footer, improving the ride in choppy water.

Our future transom wells should have two more features: remotely controlled trim tabs molded into the bottom of the wells and retractable boarding ladders, one on each well, for boarding ease and safety.

Gunwales will be flat and wide, 10 to 12 inches, with nonslip surfaces. There will be no protrusions, and all cleats will be recessed so there is nothing to trip over, nothing to snag a fishing line. Inboard edges will be padded for added comfort when you're leaning against them while underway or fighting a fish. A gunwale gate in the topsides would make boating a big one easier.

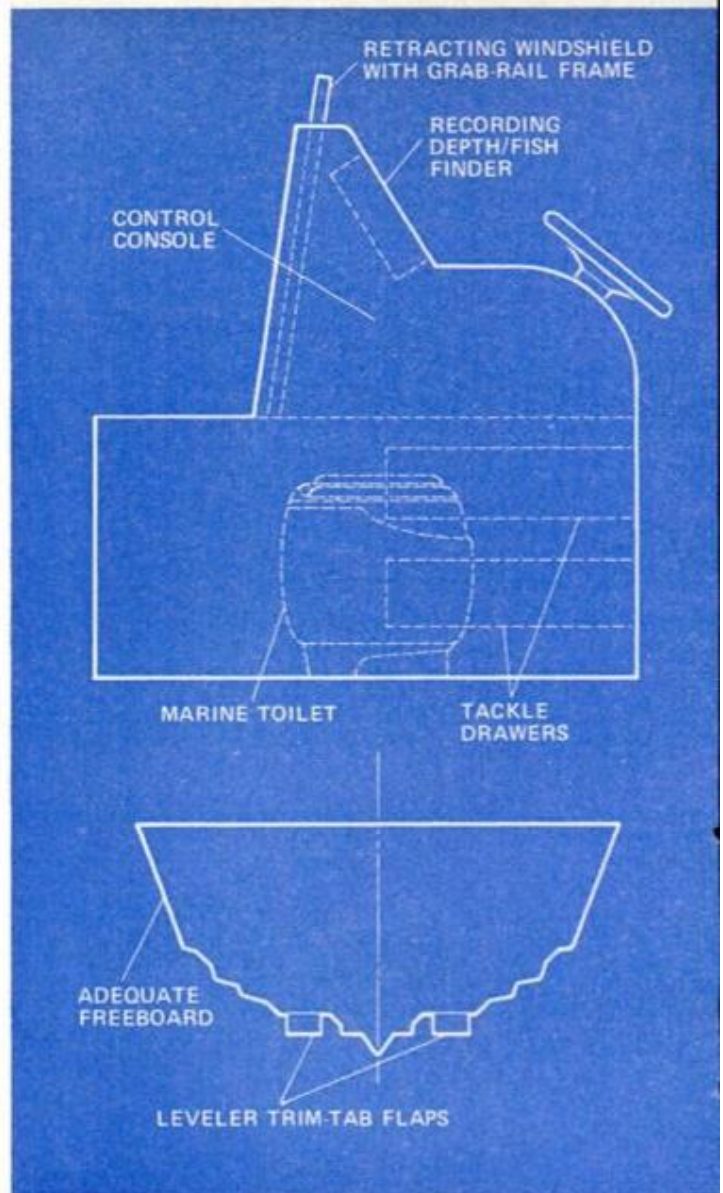

Under the gunwale, around the entire circumference of the boat, there might be an air-bag flotation collar that automatically inflates if the boat becomes filled with water or capsizes.

Large-capacity and locking fishing-rod racks will store a dozen rods securely under each gunwale. For night fishing, soft indirect lighting under the gunwales would spill no light overboard or into the helmsman's eyes. More boats will have high-low headlights for night running, docking and reading clear water.

Many innovations will be developed for the bilges (between the cockpit sole and the keel). Water-and-gasolineproof closed-cell polyfoam can strengthen the outer thirds of the bilges. The center section over the keel will be open, or have a ballast tank installed for flooding when seas are rough or causing a roll during drift fishing in a beam sea. Large, stainless-steel scupper grills

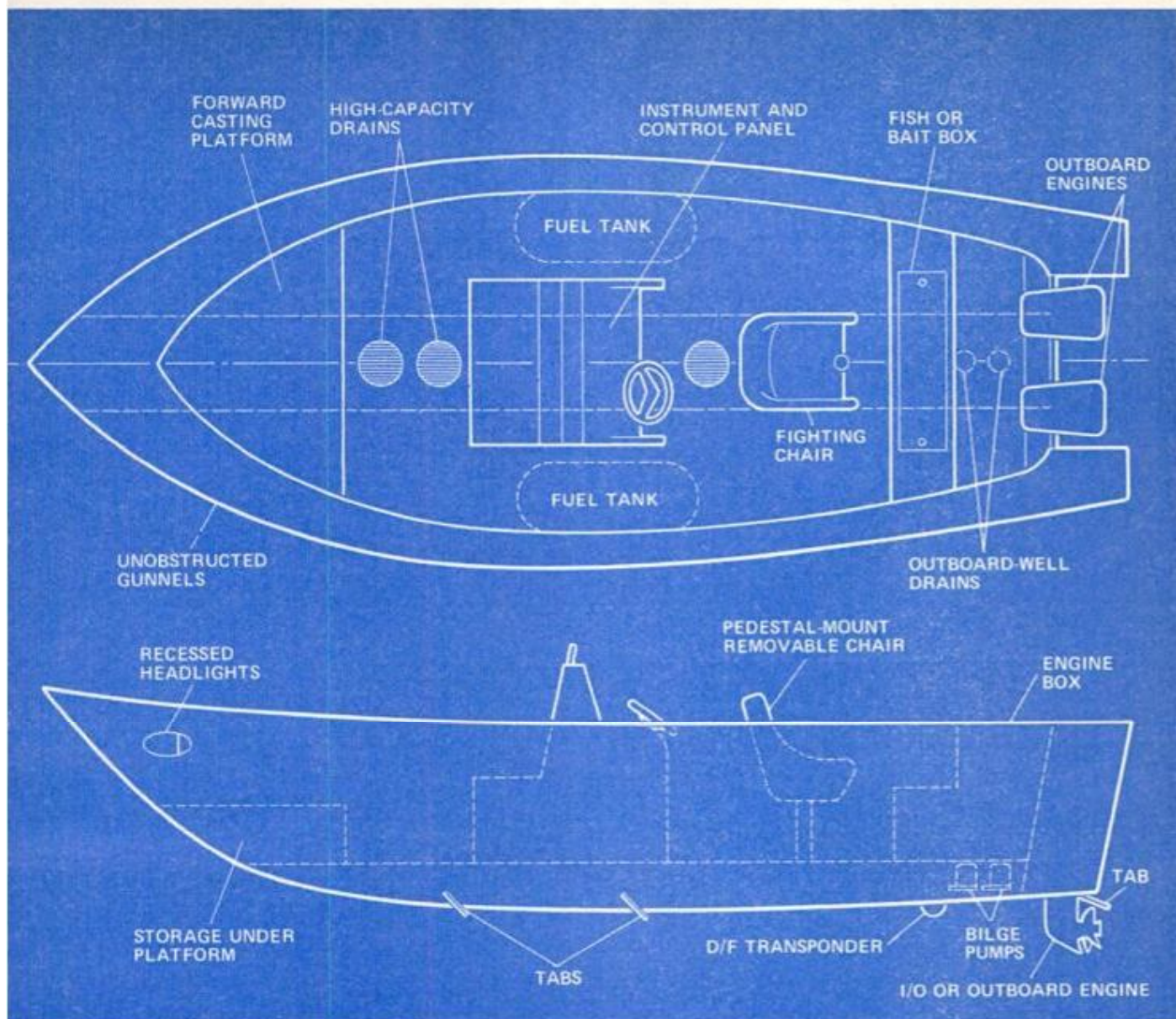

could drain cockpit water through this center tunnel. Two 1000-gallon-per-hour automatic bilge pumps would remove the dangerous water that can create unstable ballast above the waterline in a self-bailing boat.

The center console, well aft for comfort, could feature a built-in recording fish/depth finder connected to a remotely controlled transducer that aims down or in any direction. Short and long-range radio telephones inside the console would have telescoping antennas. The sprayshield of tough plastic, framed with an aluminum grab rail, would retract into the console. Inside, removable drawers for tackle will have their own lids for moving about. For family fishing, an enclosed marine toilet can be installed. Complete canvas curtains will enclose the cockpit for cruising or shower protection. Within the console, a secret compartment could house a burglar alarm.

Inside one of numerous lockers will be a refrigerator for ice and food. The deep gunwale-to-gunwale fishbox will be topped with a snap-on cushion. Overall boat length will be 20 to 25 feet, with a beam of 8 feet, for easy trailering.

Future power should offer many options. Conventional outboard, I/O stern drive, in-board or rotary-combustion engines may be chosen to drive remotely controlled variable-pitch propellers or water jets. Turbine jet power may be harnessed to props or provide thrust of air or water. Fishermen will still need a great variety of trolling-to-top speeds plus high maneuverability and control. Tunnel enclosure of propeller blades and tilt options should help protect lower units when a fish heads for thin water. Oversize fuel tanks will use latest techniques in safe, fire-retardant installations. And it's a safe bet most fishermen will still prefer two engines rather than one. ★★★

# What preserver

## If you owned a boat like this . . .



Wellcraft 24-ft. Nova: I, II or III.



Scatcraft also has PFD for skier.



MonArk 14 needs I, II, III or IV.



Starcraft 15 uses Types I to IV.



Sylvan 28 has I, II or III plus IV.



Duo Sprite, like all sailboats and craft without power, now needs PFDs.

If you own a boat, or even plan to rent or ride in one. You need to check the new federal regulations. The recent Boating Safety law now makes it necessary for every boat to carry approved life preservers for every passenger. Though the law applies only to federal waterways (and that includes most of the boating waters in the country), nearly all states are also passing similar statutes to cover any ponds that have been left out. It makes sense. A little rowboat on a river can turn over more easily sometimes than a large power craft out on open seas. Now the rules specify preserver types for every kind of boat. This year it may be more difficult to drown.

Approved life preservers are called personal flotation devices (PFDs) by the Coast Guard. They are divided into five categories—according to the amount of buoyancy and performance you can expect from them. Which PFDs you must use depends on the length and type of your boat.

**Type I** personal flotation device is designed to turn an unconscious person from face downward in the water to vertical or slightly backward position. As it must have more than a 20-lb. buoyancy, it is the type for rough water, but it is not very comfortable to wear.

**Type II** provides the unconscious person with the same

### Old Preservers = New Types

160.002, 160.003,	
160.004, 160.005 . . . . .	Type I
160.009 ring buoy . . . . .	Type IV
160.047 vest . . . . .	Type II
160.048, 160.049	
cushions . . . . .	Type IV
160.050 ring buoy . . . . .	Type IV
160.053 work vest . . . . .	Type V
160.055 preserver . . . . .	Type I
160.060 vest . . . . .	Type II
160.064 special devices—	

Devices worn may equal Type II or Type III. Type III is marked "may not turn unconscious wearer." Grasped device equals IV.

# must you pick?

... you'd buy



New laws require a PFD whenever you're in any boat . . . and sometimes when you're not!

by George Daniels

**Type I**—These personal-flotation devices may be bulky to wear but are designed to turn an unconscious person face upward in the water. The 20 pounds of buoyancy will float wearer in vertical or in slightly backward position. This is the PFD recommended for extended rough-water use offshore.



**Type II**—Less buoyancy (15½ lbs.) but more freedom of action are found in these PFD designs. Wearer is turned face up if unconscious; models with collar help hold head up. Racing jackets, like those by Gentex at left may have leg straps to prevent ride-up, give driver added protection.



**Type III**—Suitable for more sheltered waters where man overboard may be picked up quickly, these PFDs are for conscious wearers, sailors, even ski jumpers with model above. Stearns makes models at left. Sears, others have similar PFDs.

position change, but may have as little as 15½-lb. buoyancy, permitting a more comfortable design suited to average boating conditions.

**Type III**, with at least 15½-lb. buoyancy, is designed to keep a conscious person in a vertical or slightly backward position. As less position-turning is necessary, this one can be designed for still less bulk and more freedom of action. You can wear it for boating activities likely to result in frequent dunkings, as in windy weather while sailboarding.

**Type IV**, with at least 16½-lb. buoyancy, is designed to be thrown to a person in the water and to be grasped, not worn. Buoyant cushions and ring life buoys are both in this class.

**Type V** is the special purpose PFD category for specific and restricted uses. The only preserver of this type now approved is a "work vest" used around merchant ships. Other Type V PFDs may come later.

You can continue to use your present Coast Guard-approved life preservers, as long as they are serviceable, if they are the type permitted for your boat. Check our Old-New chart on page 138 to compare preserver numbers with type classes. All PFDs must be immediately accessible and of the proper size for the wearer. Small youngsters will need child-sized PFDs.

*Boats under 16 feet long*, including canoes and kayaks, must carry at least one PFD of Type I, II, III or IV for each person aboard. You can choose any regular type or its equivalent under the old number system.

*Boats over 16 feet* must carry a Type I, II or III (not IV) for each person aboard, except for canoes or kayaks where a Type IV is permitted for each person.

*All boats*, however, must carry at least one Type IV for man overboard emergencies. If this is a permitted type for your boat

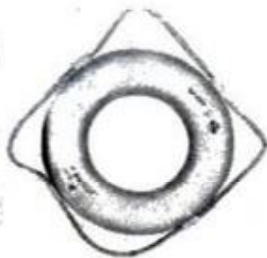

**Type IV**—Intended for throwing to a man overboard, these preservers can count as the required PFDs aboard craft under 16 feet in length. Larger boats must carry at least one Type IV ring or cushion.

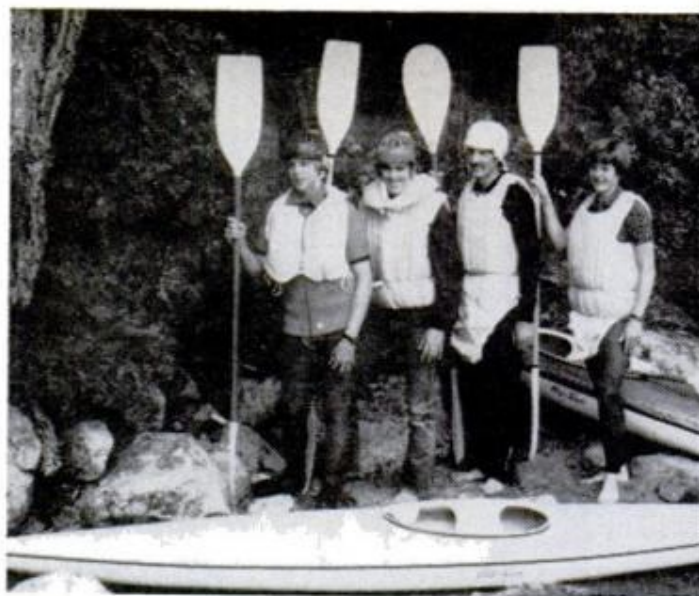

**Special-purpose PFDs** are permitted for white-water events in canoes and kayaks. Extralight air-cell vests like Flotherchoc models above from Old Town Canoes use sealed polyvinyl sacs for the flotation.

and you carry one for each person aboard, that's all you need. If your boat is over 16 feet and is required to carry one of the other types for each person, the Type IV must be carried as an extra. The only time you would not be required to carry a Type IV is when you're out alone and have one of the other required PFDs, or if all aboard are wearing such PFDs. The easy answer: Carry an approved buoyant cushion along.

An exception is made for white-water canoes and kayaks enclosed by a deck and spray skirt. Since some regular PFDs might be difficult to wear while paddling, you're permitted to wear a vest-type life preserver that contains permanently inflated air sacs. The sacs must be made of not less than 12-mil polyvinyl chloride film. If you weigh more than 90 pounds, the rules require at least 150 sacs and 13-lb. buoyancy. If you're under 90, it's 120 sacs or more and 8½-lb. buoyancy. Canoe and sport suppliers carry these special vests.

If your boat is less than 16 feet, you can get by with Type IV buoyant cushions, but they are difficult to wear in the water and now is a good time to get approved vests or jackets while keeping the cushions as extras.

So long as you carry the required type and number of PFDs for all aboard—even for water skiers being towed behind—passengers may wear any other flotation devices, approved or otherwise, or none at all. And if you fall overboard, just yell for a Type IV. ★★★



# Inside that rotary-powered outboard

Rumors put it at 300 hp—  
world's most powerful kicker

Under the cowls of the new rotary combustion Wankel-type motors from Outboard Marine Corp. are stacked some mighty potent mills. Four complete combustion chambers—each with individual carburetor, condenser, sparkplug and rotor—drive one central crankshaft. Output is estimated at 300 hp with a peak of 8000 rpm. That makes these the most powerful outboards ever built.

No engines will be for sale, however, until at least 1975, according to OMC's Marine V-P, Charles Strang. His engineering ace, Si Metcalf, will only admit to a displacement of two liters (about 122 cu. in.) and two-thirds more horsepower than current top high-performance machines. Extensive racing and testing are already under way. Evinrude and Johnson factory drivers report outstanding acceleration torque plus power for safer nose-down trimming. ★★

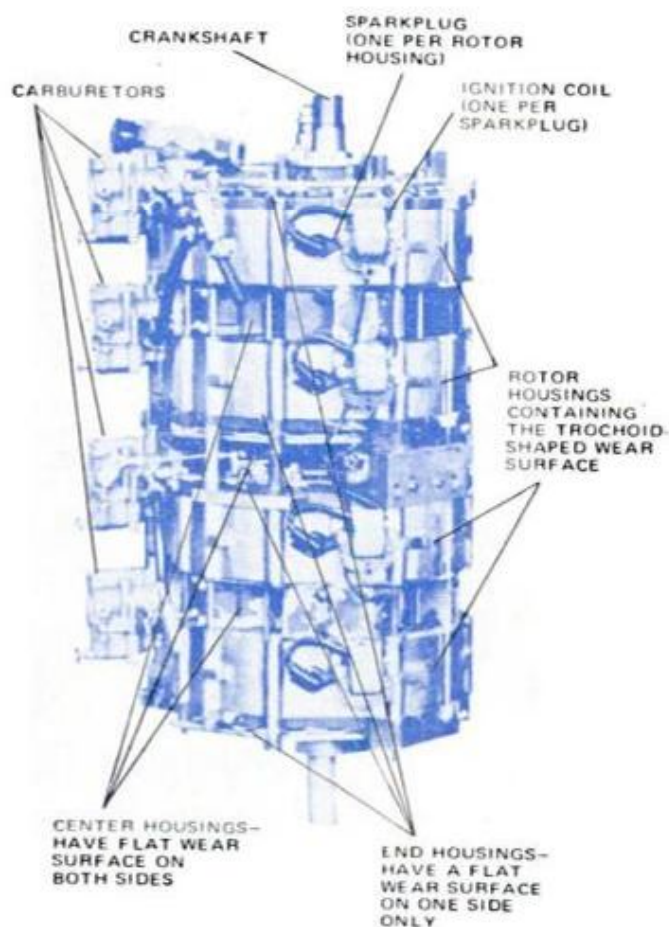

Taking the wraps off, ace unlimited driver Bill Muncey shows top half of Evinrude's new rotary high-performance mill. Johnson is testing a similar engine.

Torque to spare puts the R-C rig out in front of conventional tunnel-hull racer. Factory team drivers say trimming flighty airborne hulls is now easier, safer.



# Bolens QT-16: big but quiet

Power equipment is the source of much unwanted noise. Here's how Bolens soft-pedals its 16-hp tractor

by Gerald Kratsch

When you start the engine, you know the Bolens QT-16 is a different breed of cat. It doesn't roar. For a garden tractor that boasts 16 hp, it's pretty quiet.

The QT-16 was developed in response to the public's growing awareness of noise as a pollutant. In some localities—Chicago, for one—permissible noise levels for outdoor power equipment are being spelled out.

In field tests, Bolens' new tractor reportedly produces 69 decibels at a distance of 50 feet. In similar tests, other comparable tractors were said to record from 74 to 87 decibels. The decibel is a common unit used in measuring the intensity of sound at its source. A big rocket blasting off, for example, produces 180 decibels in its immediate vicinity, and a household vacuum cleaner generates from 60 to 70 decibels.

Bolens engineers produced a "quiet" air-cooled, gas-engine tractor by including these features in their design:

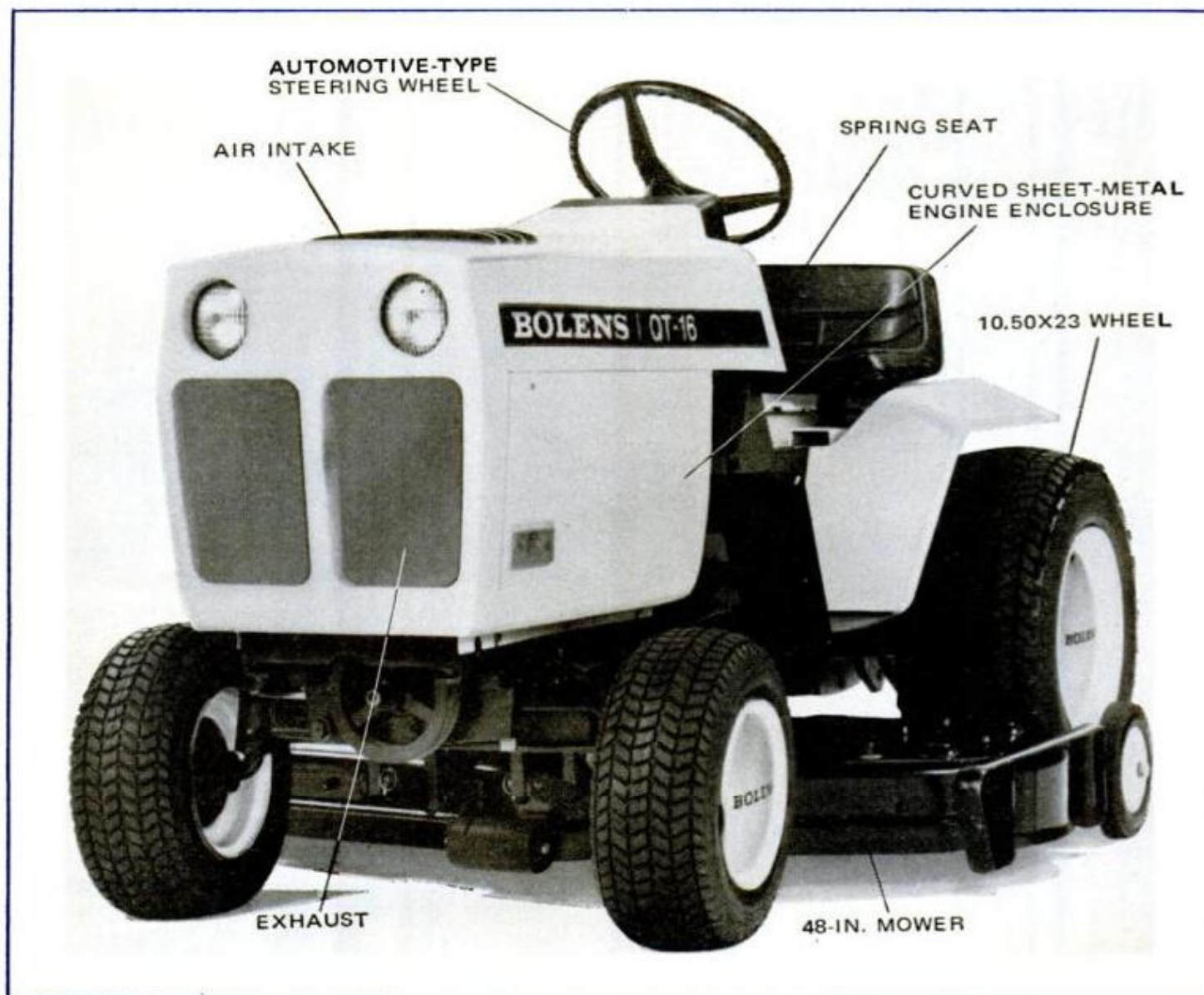



**The QT-16** has an in-line drive train and a hydrostatic transmission controlled by a foot pedal. It comes equipped with a 48-inch center-mount mower and has a list price of \$2195.



**Biggest tractor** in the Bolens line is this 18-hp machine. It is 12½ inches longer and 12 inches wider than the QT-16, but it costs more and has no special noise-muffling design.

- An Onan four-cycle, two-cylinder engine that's different from earlier Onan powerplants. Forces from its horizontally opposed pistons tend to cancel each other, permitting the engine to run more smoothly. It's made of die-cast aluminum and has steel cylinder liners. Air intake is through an exterior rotating screen, and carburetor air is channeled through a baffled rubber duct, into a sealed air-cleaner box.
- Rubber mounts isolate and cradle the engine, reducing transmitted vibration.

- A large muffler is enclosed under the hood.
- Curved sheet-metal surfaces enclose the engine on all sides. (Flat sheet metal tends to act like a drum in transmitting noise.)
- Noise-damping material is used on interior walls of the hood.
- Engine exhaust is directed towards the front, away from the operator.
- Slower power-takeoff speeds (for attachments) reduce vibration.

The result of these improvements: a garden tractor easier on the ears. ★ ★ ★

# Ultra-versatile electric eye: Miranda's new EE Auto Sensorex

by Ivan Berger  
PHOTOGRAPHY EDITOR

**Most popular** Auto Sensorex equipment includes waist-level finder (shown on camera, open), standard eye-level prism finder, and 28-mm, 135-mm and 35-mm f/2.8 EE lenses. More EE lenses are coming, and a dozen non-EE wide-angle, tele, zoom and macro lenses from 17-mm ultra-wide to 200-mm (in addition to the longer, non-Miranda lenses) can be used with manual metering.

**E**lectric-eye exposure control isn't just for the beginner. Add it to an advanced camera, and you have an even more versatile tool than you began with.

Miranda's new EE Auto Sensorex is a good example. Even before the electric eye was added, the Sensorex was one of the most versatile 35-mm cameras around. Instead of the permanently mounted pentaprism finder of most 35-mm SLRs, it has removable finders; in seconds, you can replace its prism with a folding, waist-level finder for low-angle shots, or a critical-focusing finder (not shown) for technical photography. And since the Miranda body is shallower than the bodies of most other reflexes, there's room to mount adapters for Exakta/Topcon, Nikon and Pentax/Practica mount lenses, yet still have them focus to infinity. (Adapters are also available for lenses from Canon, Contax, Leica and Nikon rangefinder cameras, too, but because their bodies are slimmer than the Miranda's their lenses will not retract enough to be focused at infinity, and must be used for close-ups only.)

Not that the Miranda system really lacks

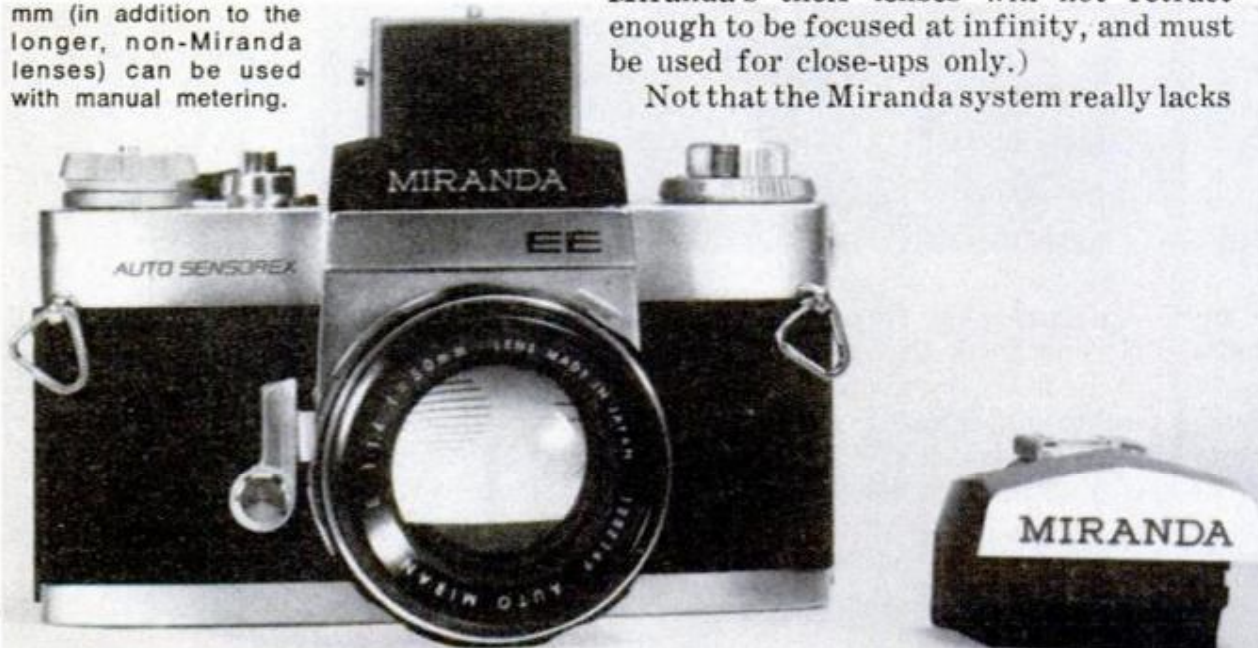

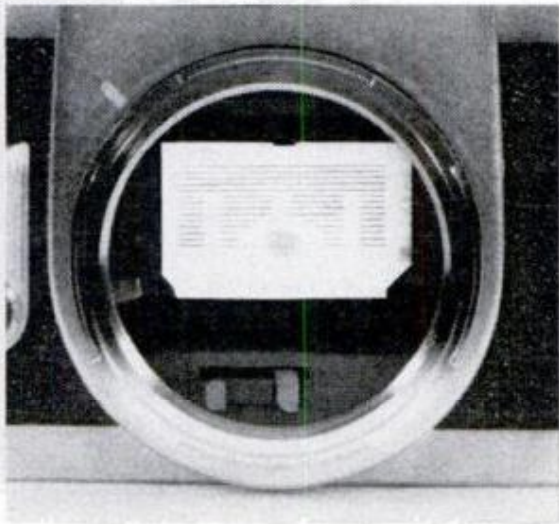

**Light-collecting slits** on mirror are for dual-pattern meter. On "spot" setting, meter reads light only from the 2 percent or so of the image area covered by the central circle; on "average" and manual settings, meter uses all slits (about  $\frac{1}{3}$  of image area). To keep sky light from affecting average readings, bottom of mirror (top of the upside-down image projected on the film) has no light-gathering slits.

PHOTOS BY ROBERT D. BORST

**Normal f-stop scale** plus EE setting gives choice of manual or automatic exposure control at all times. Lock button (arrow) keeps diaphragm from slipping out of EE position accidentally. Meter operates and scale is visible with waist-level finder shown, or with prism finder. Meter selection switch surrounds rewind crank.





Low-angle photos (above) are easy, using waist-level finder. Below: Meter indications as seen in viewfinder.

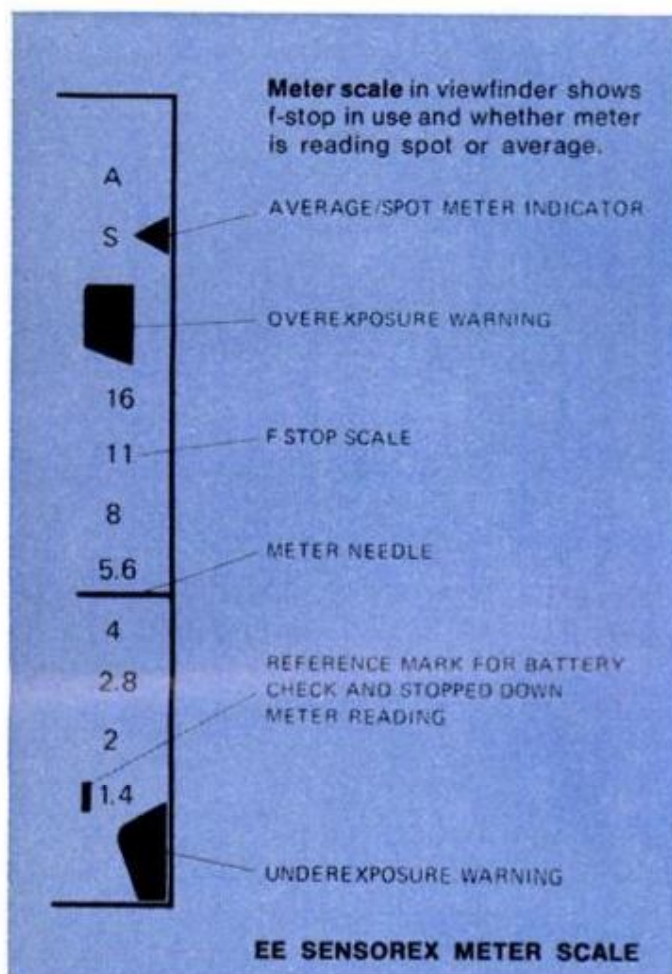

lenses of its own. There are now about a dozen lenses in the line, from 17-mm ultra-wide angle to 200-mm telephoto, a 90-230-mm telephoto zoom, plus a macro lens—and Miranda-mount lenses up to at least 800-mm are available from other manufacturers.

But for the EE Sensorex, Miranda had to bring out six of those lenses in new versions—with more revised lenses coming soon. The reason? Automatic control. Set one of the new lenses to EE, and the EE Sensorex will automatically adjust the f-stop for correct exposure, taking either a central spot or wide-area average meter reading, according to your setting of the meter switch. Making the lens close down at the moment of exposure to the aperture selected by the camera's meter (instead of the aperture selected by the photographer, as non-EE automatic lenses do) took some extra linkage in both camera and lens.

But the new system is compatible with the old: The new lenses work just like the old on Mirandas with nonautomatic metering, and old lenses work on the new camera, though you still have to set their f-stops. Whatever the lens, the EE Sensorex offers both spot and average readings (about 2 percent and a third of the picture area, respectively—exact coverage depends on the lens's focal length), not just the average reading of other Sensorexes. (Spot metering is only unavailable when you take manual readings with an EE lens.)

Once I got over the hangup of remembering to lock the lens into EE position and to switch the meter on, I got nice, uniform contact sheets without under or overexposed shots. Since meter coverage varies with the lens in use, it takes some practice till you're sure just what is and isn't metered (a problem with all meter-in-the-mirror cameras), but it's not too critical.

Aside from that, my only gripe was the finder screen—a little dimmer and harder focusing than some others I've used. Maybe I'm used to microprism focusing screens; but even so, Miranda's rangefinder screen (and almost everybody else's) should be diagonally split instead of horizontally—that way, horizontal objects would be as easy to focus on as vertical ones.

The Miranda Sensorex EE, with f/1.4, 50-mm lens, sells for less than \$400; the Sensorex II, with manual, average-reading meter, is about \$60 less. For information, write AIC, 168 Glen Cove Rd., Carle Place, N.Y. 11514. ★★

# World's most versatile tele lens

New Vivitar zooms from 70 to 210 mm—and focuses to 3 inches!

by Ivan Berger  
PHOTOGRAPHY EDITOR

PHOTOS BY ROBERT D. BORST AND IVAN BERGER

The ideal lens, I've always felt, would be a lightweight, compact, ultrasharp, f/1.4, 20-to-200-mm zoom that could focus all the way from infinity down to an inch or so. That's a tall order, and enough to make most lens designers shudder. But the designers of Vivitar's new Series 1 lenses have just come up with the closest approach to my dream lens yet: a sharp (I wouldn't quite say ultrasharp), reasonable-sized, 70 to 210-mm f/3.5 zoom telephoto that focuses down to about three inches. At that distance, it makes photos nearly half life-size on the negative (and considerably bigger than

**Control collar** on Vivitar 70-210-mm lens controls zoom and focus, provides balanced grip. Zoom, focus and f-stop settings are grouped closely together, are all visible from top of camera.

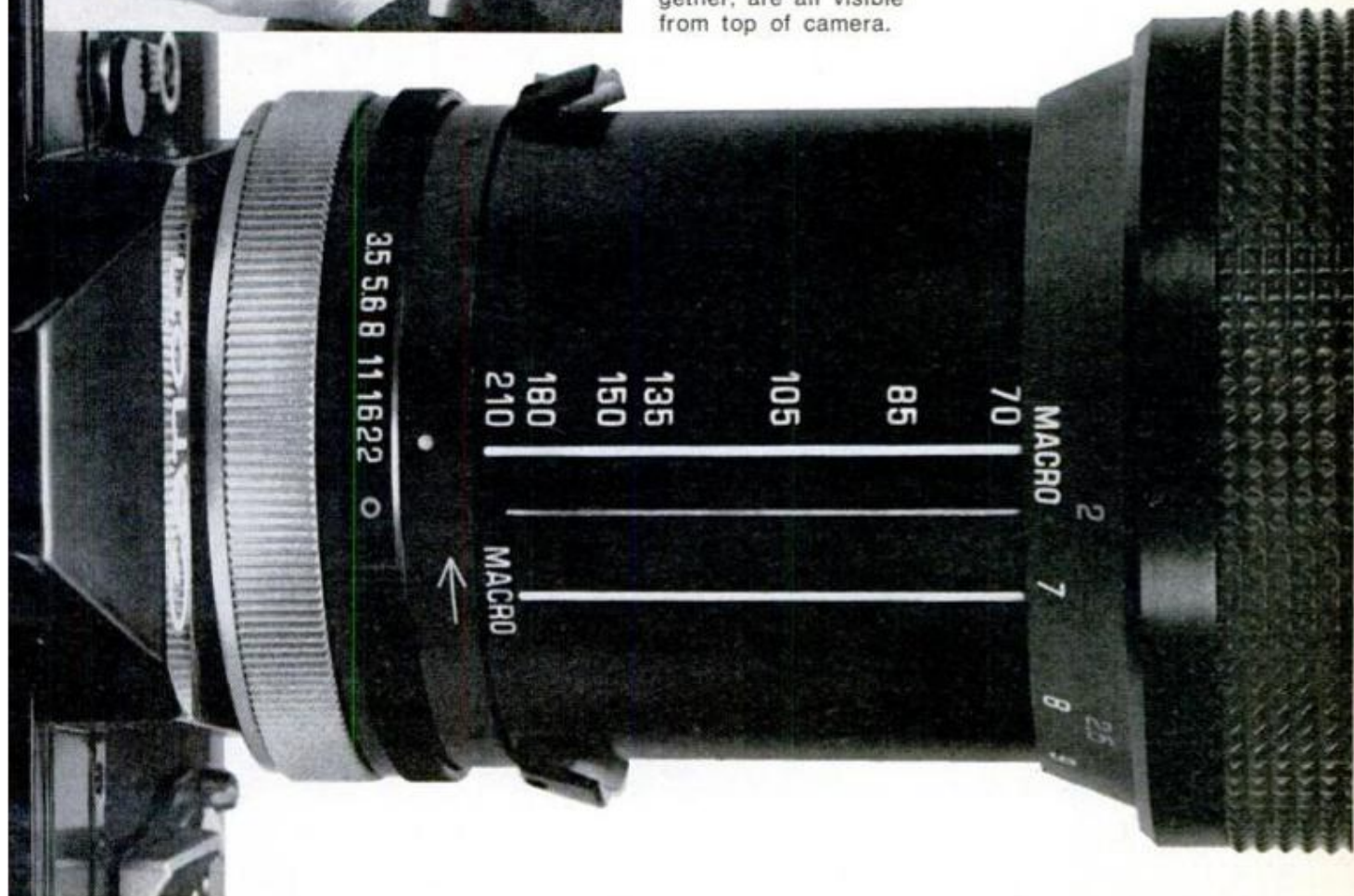



remote and power

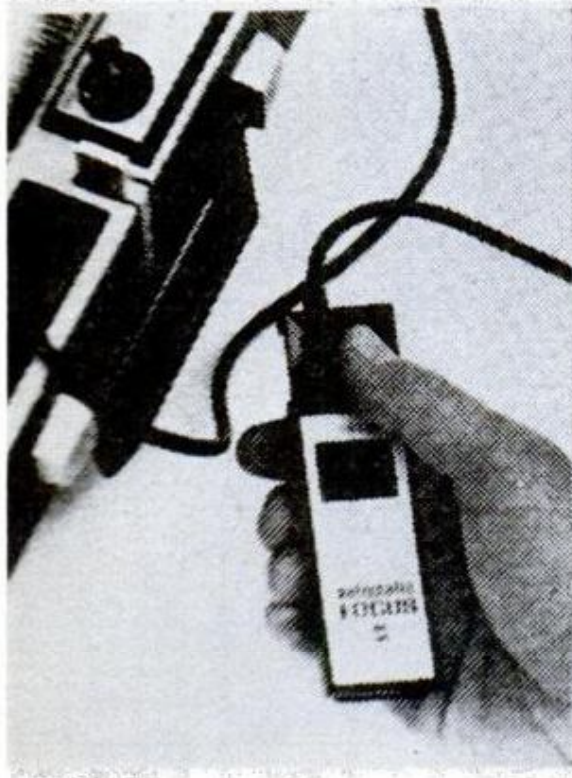

weight, balance and handle  
 handle should be part of  
 not part of its lid); if you  
 your projector on a high s  
 it above your head, too. S  
 takes to load a box of slid  
 and whether the slides will  
 there, with no danger of s  
 ple a cardboard slide, then  
 with your hands and run  
 projector, to see how jam-  
 If it does jam, see how e  
 can be cleared. And comp  
 projectors, side by side, pro  
 lar slides—see which is

**Ultraclose-up capability** of new Vivitar lets it shoot as close as 3 inches from its own front element (top). Close-up results (above) aren't as sharp at edges as

they are in normal-distance shooting (only true macro lenses have flat fields close up), but they're even sharper at the center than this engraving shows.



life when enlarged). And though I've been reluctant to use zooms before (I've found them awkward and unsharp), I took to this one like a duck to water.

For one thing, it's a very easy lens to use. Just twist the big, fat, easy-to-grip, vinyl-knurled sleeve for focusing and slide it back and forth to zoom—accomplishing both functions with a single control. The control moves in the logical directions, too: You slide back the ring to pull the image “closer” by zooming to a longer focal length, and focus clockwise from infinity down (the same direction as just about every camera I've used except the Nikon and the old Contax). The f-stop control is small and set well back, so there's no possible way that you can confuse it with the zoom/focus sleeve.

Weighing 31 ounces, and measuring  $6\frac{1}{8}$  inches long by  $3\frac{1}{6}$  inches in diameter, the Series 1 70-to-210-mm is about the size and weight of ordinary zooms, but it's well balanced and its control sleeve is just where your hand will best support the lens for tele shots. And having a sleeve full of focal lengths so handy, as any zoom-lens user can tell you, gives you a lot more flexibility in choosing viewpoints and camera angles, and in precisely cropping in the camera image (vital for good slides). I found the lens as sharp and contrasty as my conventional, nonzoom 135-mm tele at all distances from infinity down to its minimum normal focusing distance of about  $6\frac{1}{2}$  feet. At this distance (a bit closer than the average for zoom lenses in this focal length range), you can cover a field as big as 22 x 32 inches at 70 mm—enough to shoot a vertical head-to-leg shot of a medium-sized adult—or zoom in to cover a field of  $7\frac{1}{2}$  by 11 inches at 210 mm, which is just enough for a tight head shot.

But that's just the beginning of this new Vivitar's close-up capability. Pull the control sleeve back to its 210-mm setting, push a latch button on the left side of the lens barrel, twist two finger grips left to align the yellow “Macro” inscriptions on the barrel and sleeve, and things start happening inside the lens. You're still focused at  $6\frac{1}{2}$  feet, but now you're in macro range, ready to focus on any object down to  $11\frac{1}{2}$  inches away from the focal plane—which is as little as three inches from the front lens surface.

In macro range, you don't turn the con-

*(Please turn to page 184)*

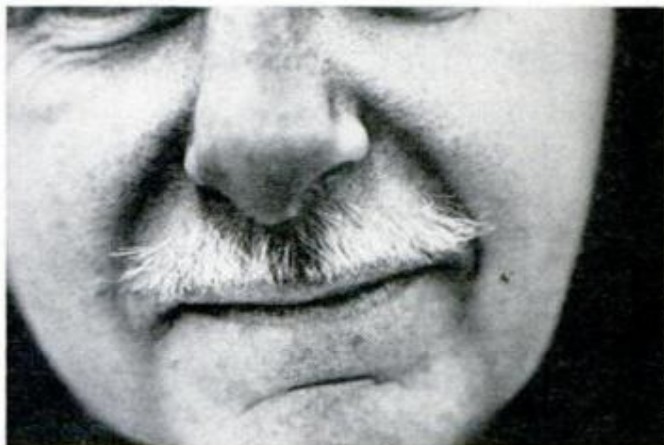

IVAN BERGER

In macro mode, fast-focusing capability helped keep moving kitten in sharp focus (top); good balance helped keep even hand-held 1/30 second shot (above) sharp. Closest normal-mode focus distance (6 feet,  $6\frac{1}{2}$  inches) covers field areas shown at 70 mm (below), 210 mm (bottom photo). Closer than that, use macro.



# The house that has its furnace in the sky

Solar-heated homes, costing almost nothing to operate, are at last nearing reality with this latest version so simple in design that you can even buy plans showing how to build one yourself.

by Omer Henry

Can you heat your house for nothing? Probably not quite yet, but you can come pretty close with the latest in a series of solar-heating systems designed to bring into reality man's long-sought dream to harness free energy from the sky. Known as the Solaris system, it's the culmination of years of research by Dr. Harry E. Thom-

ason, a graduate physicist, and his engineer son, Harry Jr. So promising is the newest version that the Federal Housing Administration has already approved the basic design for government-insured mortgage loans—a significant step for the traditionally cautious FHA—and a major equipment supplier, Edmund Scientific, is publishing a booklet of construction plans for use by architects, contractors and even do-it-yourselfers interested in building their own solar-heated homes.

It all started more than a decade ago when Thomason unveiled his first solar-heated home under somewhat less than ideal conditions. The gawky, odd-looking structure near Washington, D.C., vaguely resembled a greenhouse with large expanses of glass-faced roof panels extending all the way to the ground. The idea was to trap solar heat behind the glass, use its energy to heat water flowing down the roof, then use the resulting hot water to warm the house. It worked fine when the sun shone brightly—but the sun didn't always shine. On the important day of the test demonstration, news reporters and government officials looked on dubiously as Thomason nervously eyed the cloud-darkened sky and a steadily falling thermometer gauge. An unusually long string of sunless days had dropped the temperature of his hot-water supply to below 60° F.—hardly enough to heat a house to the required 70° to 72° F. Pessimists shook their heads and said the sys-

**Latest solar-heated design** has lost greenhouse look of earlier models, offers clean, contemporary styling with generous living space. Only "giveaway" is steeply pitched gable on which heat-trap panels are mounted. Low extension on the left covers solar-heated swimming pool with roof that doubles as sun deck and auxiliary reflector to increase heating capacity of traps.



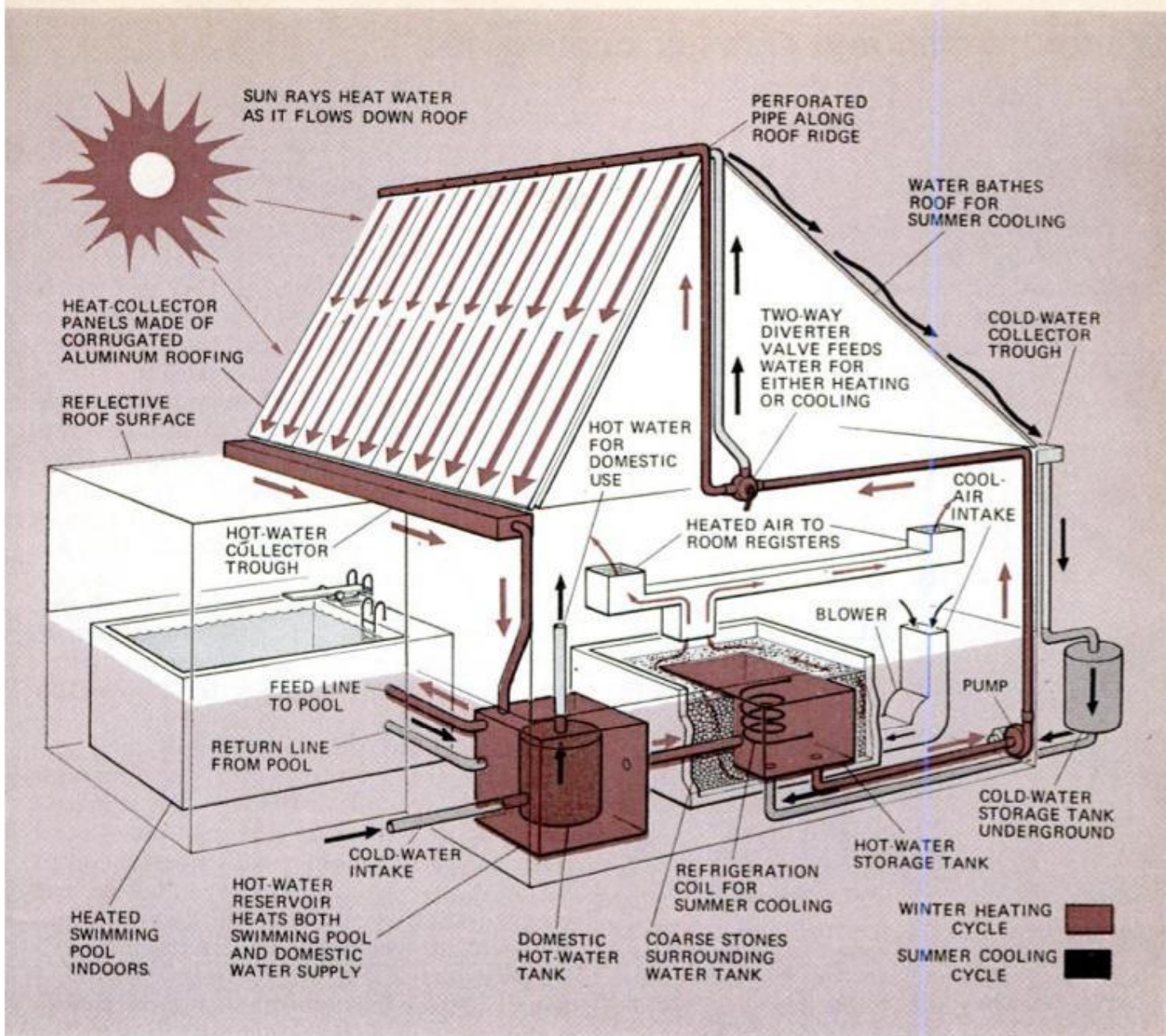

tem would never work. That was in 1959. Thomason can laugh about it now—but it wasn't funny then.

Today's house is a far cry from that early beginning. Gone is the glassy greenhouse look, replaced by smart, contemporary styling. The solar collector panels, instead of running to the ground, stop at the normal roof line and thus are much less conspicuous. Extending out from their lower edge is a shiny sun-deck roof that acts as a huge reflector, bouncing additional sun rays up to the solar panels above. Adding the reflector increases heating efficiency by as much as 30 percent, Thomason found. Other improvements, such as slowing the water flow to let it absorb more heat and installing better insulation to reduce heat loss, also helped. As a result, sun-heated water now runs off the roof at sizzling temperatures at times approaching the boiling point.

Gone, too, is the costly, cumbersome 1600-gallon steel drum Thomason originally used as a hot-water storage tank. In its place is a simple bin made of waterproofed concrete block. Surrounding the bin, located in the basement, is a bed of coarse stones. Water heated by the solar roof panels flows down into the bin where its heat energy

**Basic principle** of solar heating is shown above. Water pumped up to roof ridge cascades down southwest slope through heat-trap panels, at times reaching temperatures near boiling point. This hot water flows into storage tank under house where its heat is transferred to surrounding bed of coarse stones. Air blown through the stones picks up heat and pipes it through ducts to warm house. At same time, water also heats domestic hot-water supply and swimming pool. As stored water cools, it's pumped back up to roof for reheating, and cycle is repeated to keep water constantly hot. In summer, system is reversed. Water is cooled by refrigerating coil and pumped up to northeast side of roof. Here it bathes roof, helping to cool house, and is further cooled itself by evaporation. Air blown through the cold stones surrounding water tank is also piped through house to cool it.

## Winter heating and summer cooling, too

is transferred to the adjacent stones. Air forced through the stones by a blower picks up the heat and circulates it through the house in conventional warm-air heating ducts. As water in the bin cools, it's pumped back to the roof, reheated by the solar traps,

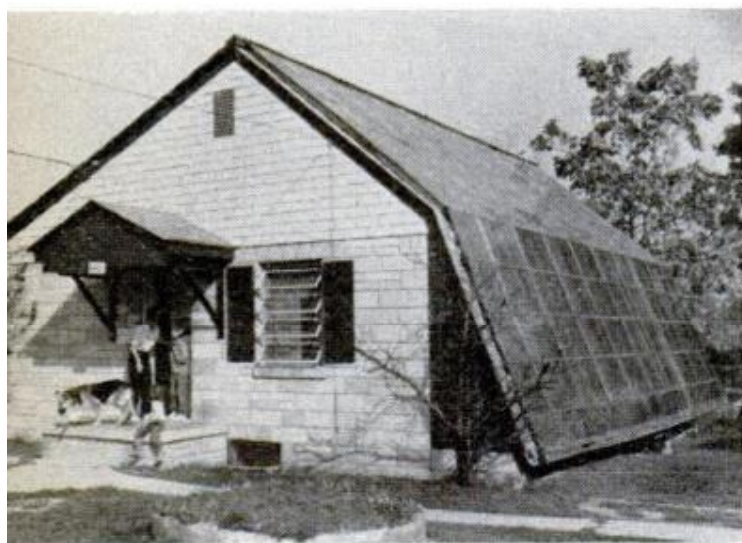

**First solar house** built by Dr. Thomason in 1959 is still in use today—14 years later. Though less efficient than newer models and suffering a bit from glass-sided "greenhouse" look, it proved method workable.

**How clever use** of roof reflector augments heating in winter is shown in diagram below. Reflector is angled so as to catch low sun rays in winter, but deflect them away from heat traps when sun is high in summer.

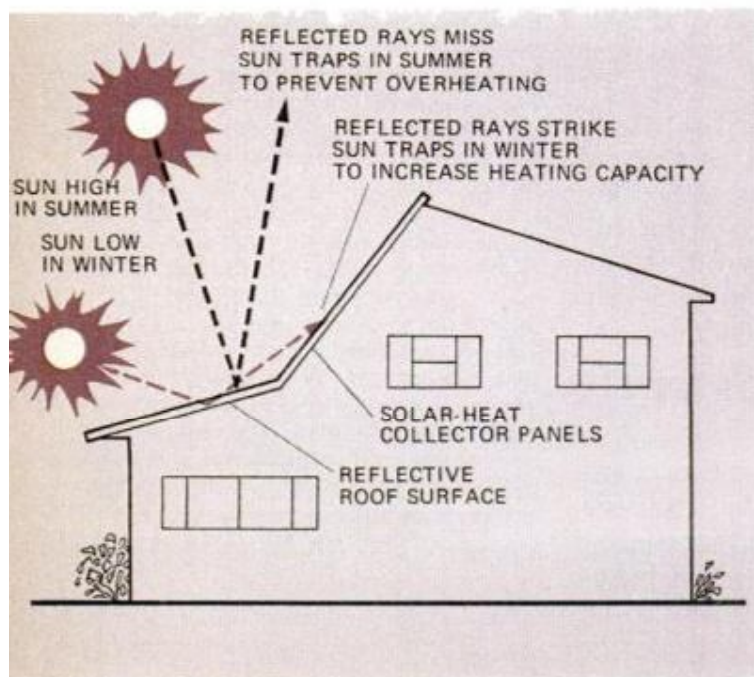

then returned to the bin hot again in a constantly repeating cycle.

Because water is one of the best heat-storing mediums known, it can keep a house warm not only throughout the night, but even over a fairly extended period of sunless days. In cloudy weather, the heat traps continue to operate, though at reduced output. The Solaris system also produces hot water for domestic use and, in Thomason's case, maintains an indoor swimming pool at a comfortable bathing temperature for year-round enjoyment.

Another system feature is that it can easily be "reversed" to provide a simple, inexpensive form of summer airconditioning. Incorporated into the water-storage bin is a refrigerating coil operated by a  $\frac{3}{4}$ -hp compressor. In summer, the coil cools the water and this, in turn, chills the surrounding stones. Air blown through the stones is cooled and circulated through the same ducts to cool the house. Moisture condenses out as it passes through the chilled stones, leaving cool, dry, dehumidified air without the need for a separate dehumidifier.

The water in the storage bin, instead of being pumped through the heat-trap panels, is sprayed out over the opposite side of the roof. As it bathes the roof, it helps to provide additional house cooling and is itself partially cooled by evaporation. Unlike conventional airconditioners that must run constantly through the heat of the day, the compressor in Thomason's system is turned on only at night when temperatures are lower and it can operate more efficiently. This is important considering that airconditioners constitute a major source of power consumption in summer. By operating only at off-peak hours, Thomason's system avoids this heavy drain that often results in brownouts and blackouts.

Depending on location and climate, the Solaris system can supply 60 to 90 percent of a home's heating needs—not perfect but surprisingly good. In northern areas, supplementary heat, usually a gas or oil burner, is required on extra-cold days or over long periods of sunless weather. Even at that, fuel costs are remarkably low. In Washington, D.C., Thomason has been able to run

his three-bedroom house on about \$7 worth of oil a year. Out in Coos Bay, Ore., where winters get really rough, one builder using the Solaris system is well pleased with the results. While neighbors complain about monthly heating bills of \$60 to \$70 for oil, his own have been averaging only \$7 to \$12. His highest bill was \$20 for February in 1969—the worst winter at Coos Bay in 50 years!

Installation costs for a typical Solaris system run around \$2000 to \$2500—about double that of a conventional heating plant. Does solar heating make sense if you're going to need an auxiliary furnace as well? The answer may be yes for several reasons: First, though initial costs are high, they're offset by substantial savings in operating expense, even where supplementary heat is required. Secondly, with predicted fuel shortages to come and steadily rising fuel costs, such a system may become almost a necessity to augment conventional heating and lessen the drain on critically depleted fuel supplies. Thirdly, you get central air-conditioning as a virtually free bonus.

Certainly the system makes most sense in moderate climates where little or no auxiliary heat may be needed. Recognizing this, the Thomasons have developed a simplified version, shown below, for warm, sunny southern climates. It requires no additional

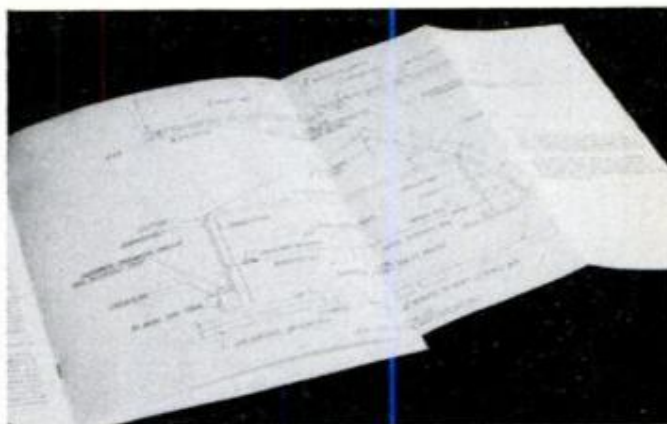

**Handy booklet of plans**, available from Edmund Scientific, explains basic solar-heating principle and includes many construction details on fold-out pages (top photo). Though not intended to serve as complete architect's blueprints, plans offer a helpful guide to any architect or builder. Booklet sells for \$10.

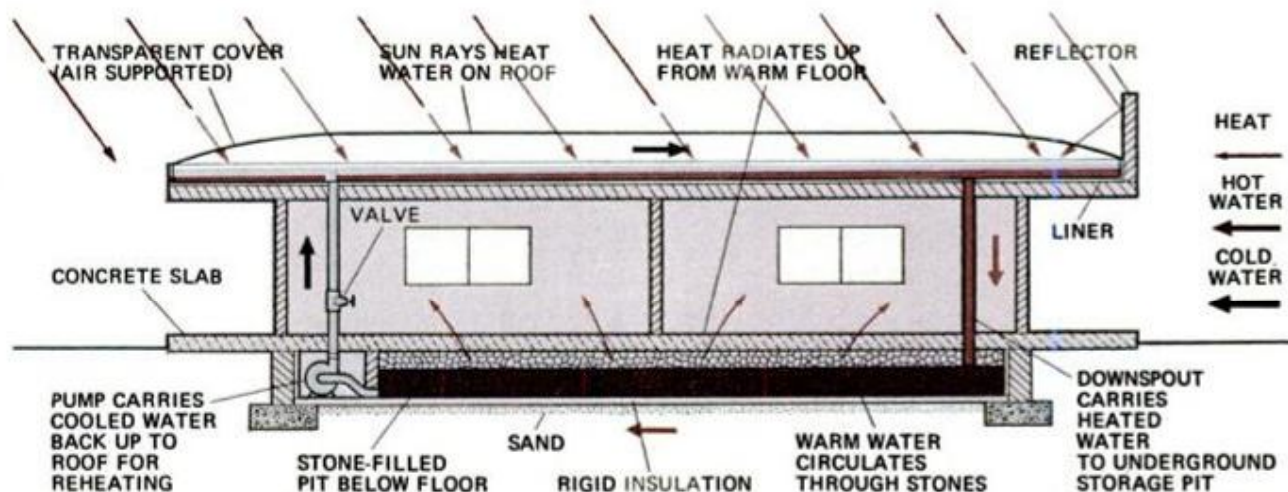
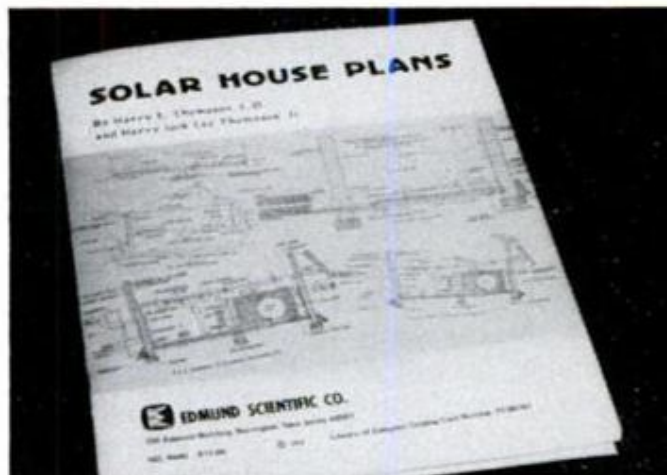

**Simplified system** for mild climates requires only solar-heated water reservoir on roof and storage pit un-

der floor. House is heated by warmth radiating up from the floor as pump circulates water to keep it hot.

## Cutaway of typical solar-heat-trap panel

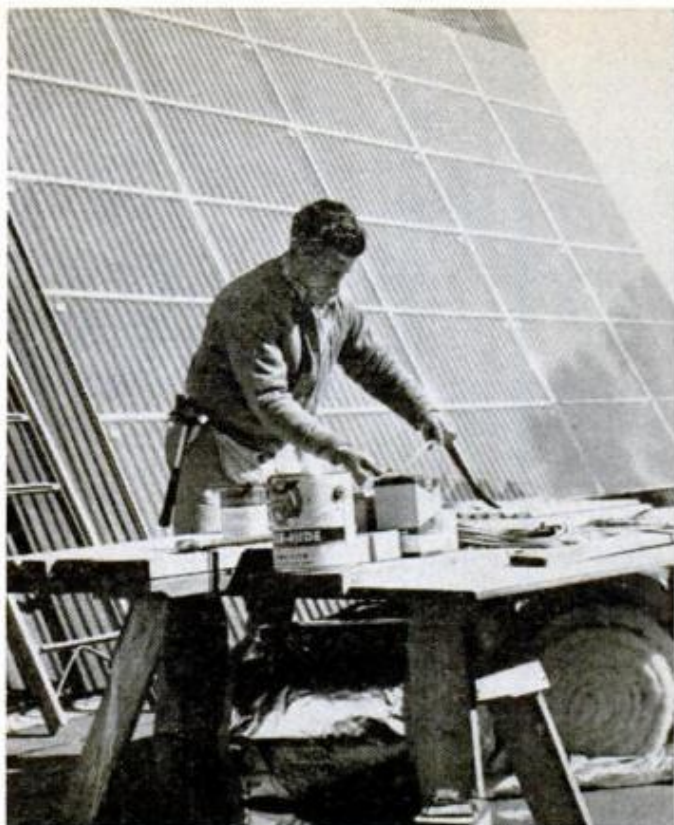
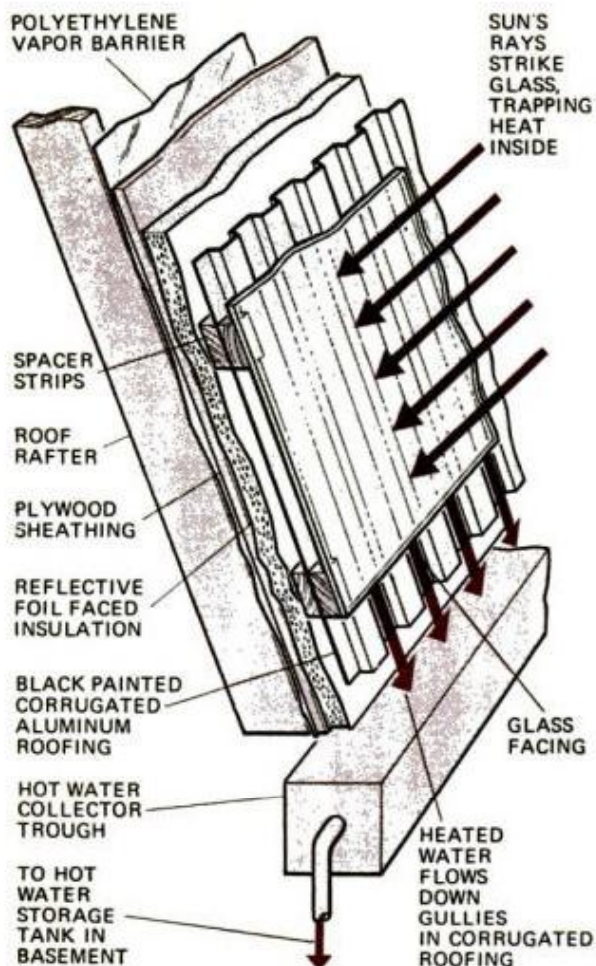

**Easy-to-make solar panels**, shown above and in diagram at left, are constructed of common, readily available building materials. Channels for water flow down roof are formed by standard corrugated aluminum roofing covered with panes of glass. Glass traps solar heat, warming water as it cascades down roofing channels. Heated water collects in trough along roof eave, then is fed to hot-water storage tank in home's basement.

heating at all and is less costly to install. Readers interested in knowing more about the Solaris system can obtain a booklet of plans and specifications for \$10 from Edmund Scientific Co., 101 East Gloucester Pike, Barrington, N. J. 08007. Standard building materials are employed through-

**Underground heat-storage "tank"** in basement is concrete-block bin surrounded by coarse stones and topped with black polyethylene—much simpler than costly special 1600-gallon steel tank used in early model.



out, even to the ingenious use of ordinary corrugated aluminum roofing to form the spillway for water running down the heat-trap roof panels. The system is so simple it can be installed in existing homes, though it is more readily adaptable to new construction. ★★★

**Small compressor** located outside house provides summer airconditioning merely by cooling water in storage tank and reversing heating cycle. Air is cooled by the water and circulated through house by a blower.

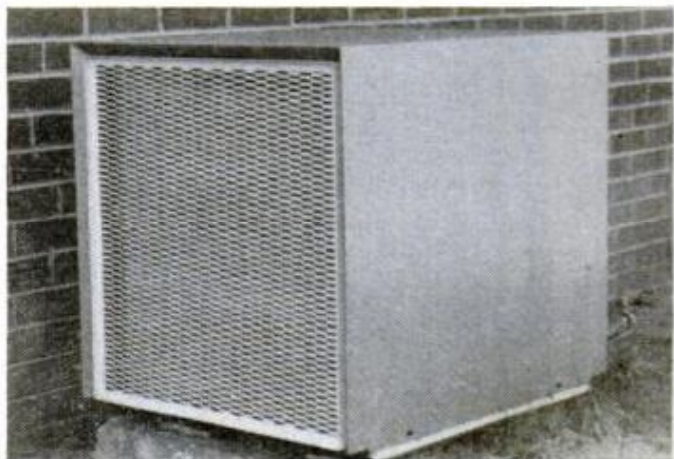

# New stereo match mates for your car

Heathkit's stack-mounting cassette tape deck and FM-stereo tuner make a slick pair of go-togethers for on-the-road hi-fi. You can build one or both.

by Sheldon M. Gallager

With all the accessory equipment available for cars these days, many dashboards look like Christmas trees hung with assorted gear dangling haphazardly down around your knees. Not so with this kit-built pair of stereo match mates designed especially by Heath for simple mounting and elegant appearance. The twins consist of an FM-stereo tuner and a stereo cassette player that also doubles as a monaural recorder. Both are identically sized and styled to go together as companion units.

A clever, versatile mounting system gives you a choice of several different installation arrangements. You can suspend the units side by side, stack them vertically or floor-mount them on the transmission hump—all with hardware supplied with the kits. The hump-mount arrangement, shown at right, above, makes for a particularly trim-looking installation and offers several advantages. It adds a swank "console look" to your car, puts the units in the center, equally accessible to driver or passenger, and eliminates the knee-knockers that often hang too far below the dash for safe and comfortable legroom. Even when dash-mounted, however, the units are so slim—only 2½ inches thick—that they take up little space.

Everything is designed for easy operation without your having to take your eyes

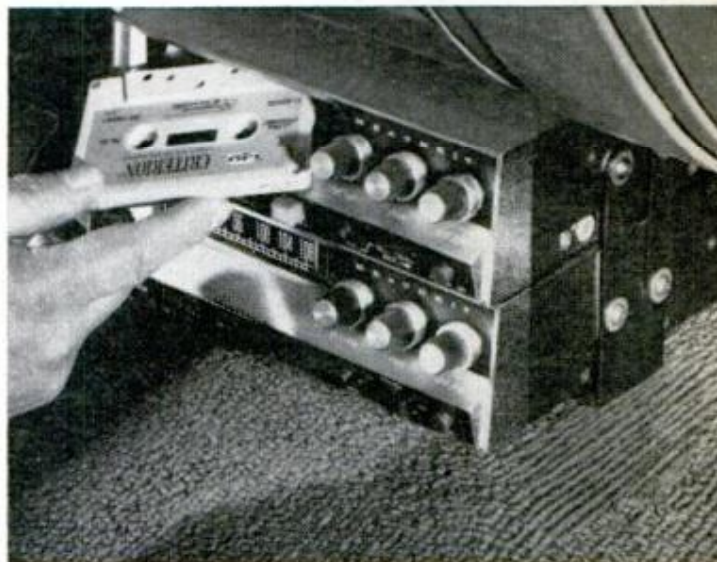

Stacked neatly under dash on transmission hump mount, Heathkit's twin cassette recorder and FM-stereo units are equally accessible to driver and passenger, do not block use of floor-type stick shift. Front-loading tape deck makes it easy to slip in cassettes without taking eyes off road.

PHOTOS BY ROBERT D. BORST

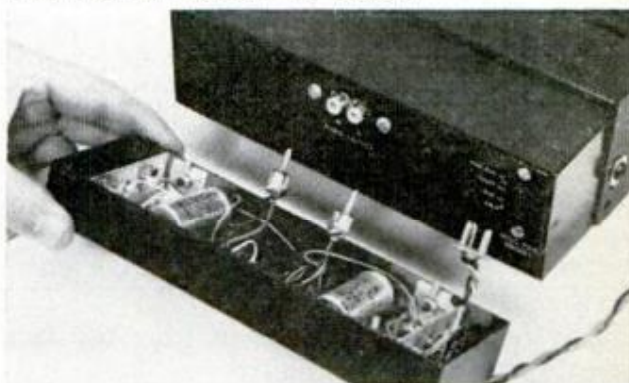

Tiny amplifier section plugs into rear of either tape or tuner unit and provides power for both, saving cost of having to buy two identical amps.

Similarly styled FM tuner (left) and cassette player (right) each have three knobs for volume, tone and balance adjustments. Three-way "joy stick" control on tape deck provides fast forward, rewind and eject. Mike for recording plugs into side of deck.



off the road. The tape player loads from the front. You just slip a cassette into a slot and the machine turns on automatically and starts playing. At the end of the tape, it shuts itself off and out pops the cassette. The added recording feature, not generally found on car players, enables you to make verbal notes as you drive along, such as to describe passing scenery, keep a record of route numbers, dictate business reminders and the like. A switch on the mike lets you turn the recorder on and off remotely without having to fumble for a control on the machine itself.

The tuning control on the FM receiver is a large round roller that can be conveniently thumb-operated by feel. A light blinks on when you're precisely tuned to an FM station to save your having to look at the dial, and a second light tells you when you've hit a stereo broadcast. Thus you can tune in stations quickly and accurately merely by watching the lights flash on out of the corner of your eye.

Another handy feature is that the tuner and tape deck both share the same basic power supply and amplifier, saving the cost of duplication. The power amplifier is actually built as a separate unit and plugs in-

**Rear view** of stacked units shows how tuner and tape deck are easily interconnected with plug-in cables so both operate from same power supply. Terminal strip at left side of lower unit provides connections for stereo speakers. Units are shown on pedestal-type hump mount for floor installation.

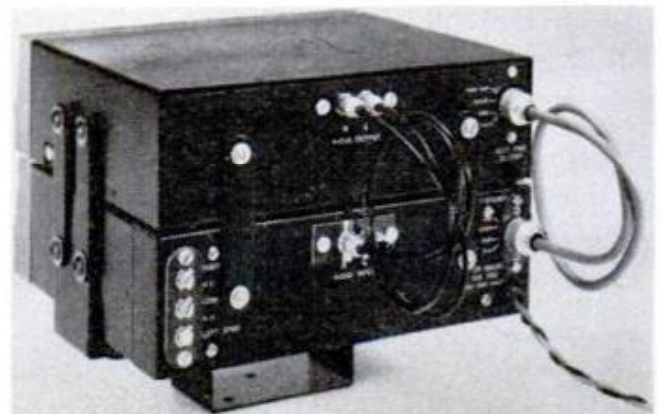



to the back of either the tape deck or tuner—whichever you decide to build first. Later, you can add the second component simply by running connecting cables from it to the power amplifier already installed on the first unit. The amplifier operates on any 12-volt d.c. source in a car, boat, camper or motor home. Dual antenna jacks on the FM tuner permit you to feed both it and your car's regular AM radio from the same antenna. Your car's antenna plugs into the FM tuner and a second cable, also provided, connects the tuner to your AM radio.

Construction is simplified by a preassembled tape-transport mechanism in the cassette player and a preassembled, pre-aligned tuning unit in the FM receiver. These come ready to install. There are only four small circuit boards to wire—one in the tuner, two in the tape deck and one in the power amplifier. You can complete the amplifier in an evening and the other two units over a weekend. Sound quality comes as close to living-room hi-fi as is possible in a car-sized package and is surprisingly rich, clean and full-bodied. Frequency response is from 3 to 15,000 cycles. Power output is  $3\frac{1}{2}$  watts per channel—seemingly a bit low by home standards, but in a car enough to blast you right out of your seat.

Prices for the kits are \$29.95 for the CRA-1000-1 power amplifier, \$64.95 for the CR-1000 tuner, and \$89.95 for the CT-1001 cassette deck. Two stereo speaker systems are also available, one containing two 5-inch round cones for door mounting and the other two 6 by 9-inch oval types for rear-deck installation, both \$19.95. The kits and speakers are available from Heath Co., Benton Harbor, Mich. 49022. ★★★

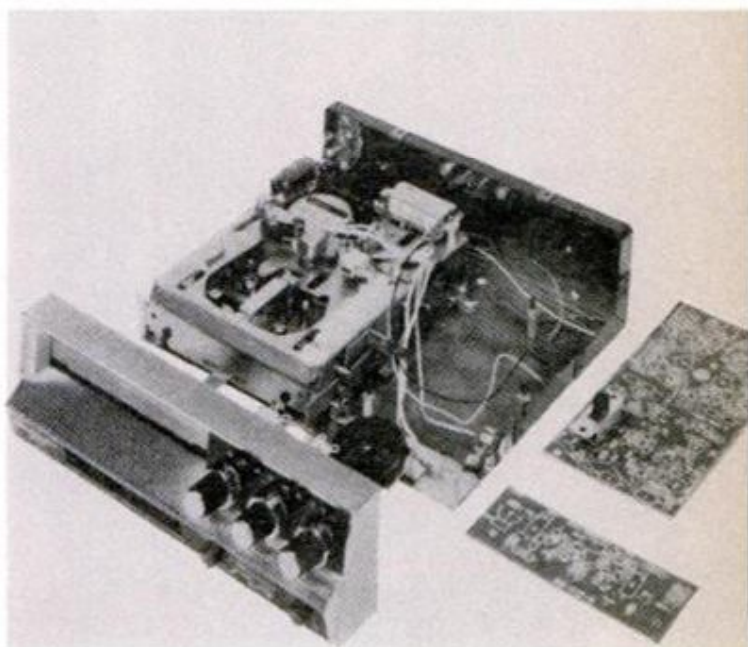
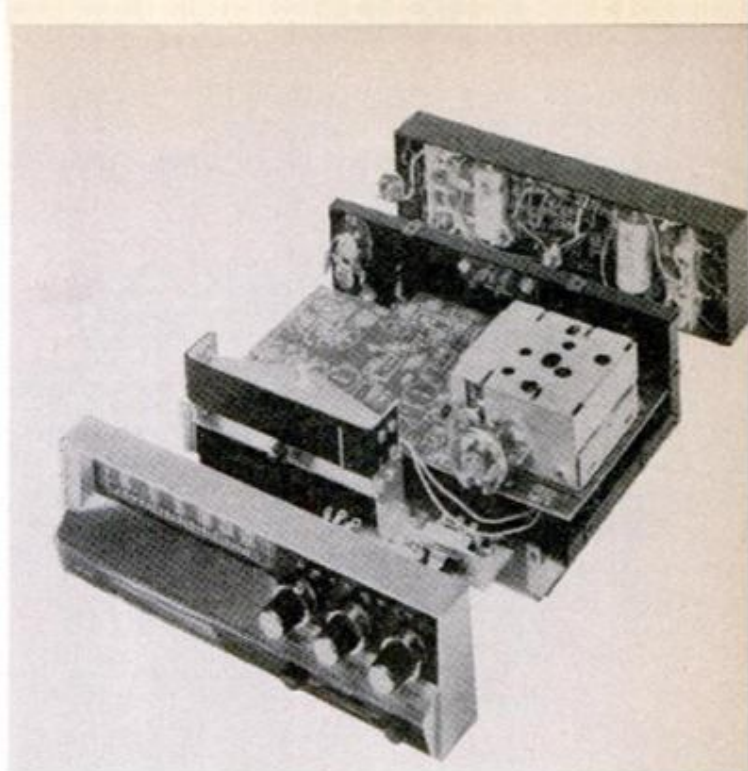

Basic elements in construction are illustrated above. Top photo shows FM receiver with preassembled tuning unit on circuit board and plug-in amplifier section at rear. Bottom photo shows cassette player with ready-made tape-transport mechanism at left and two circuit boards at right.

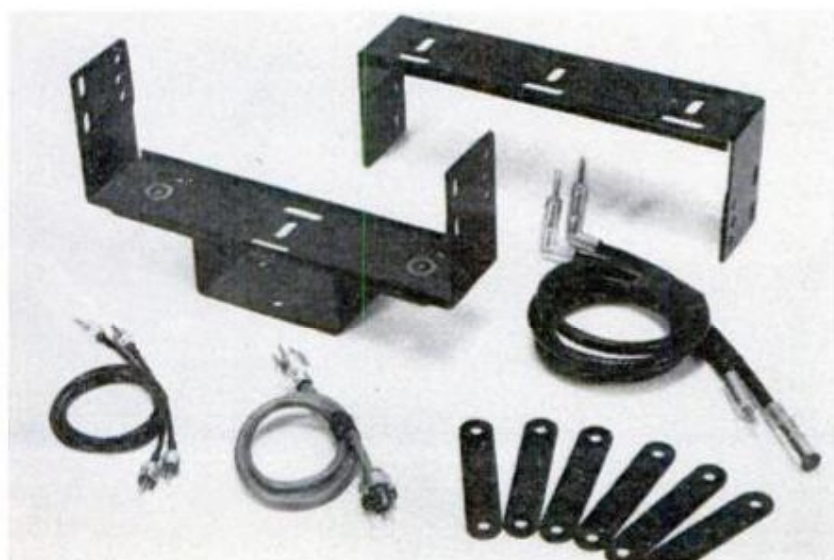

Assorted hardware provided with kits includes U-shaped hanger brackets for under-dash mounting, pedestal-type hump mount for floor installation, interconnecting audio, power and antenna cables, and six straps for joining stacked units.

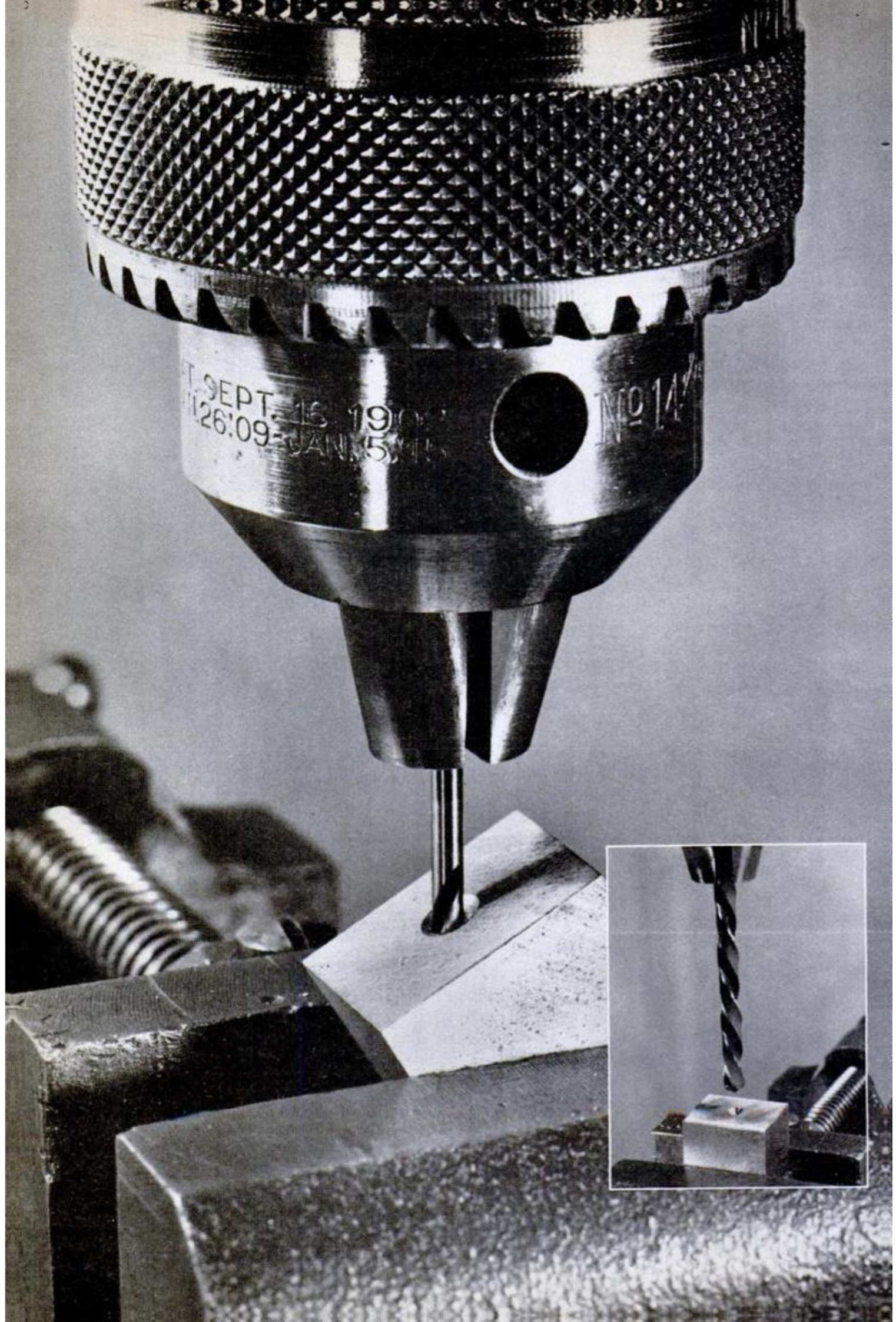

# How to drill angled holes accurately

The biggest problem is to stop drill-bit 'wander.' Here's how.

by Walter E. Burton

**Angle-drilling** (left) is easy when "crater" is first made with a large twist drill held perpendicular to workpiece (see inset photo). Punch mark in wall of depression serves as starter hole for lathe center-drill; twist drill finishes hole. Wires (below, right) show angles of holes drilled through metal bars and blocks by author. Boring bar, second from right, required drilling two angled holes.

TECHNICAL ART BY FRED L. WOLFF

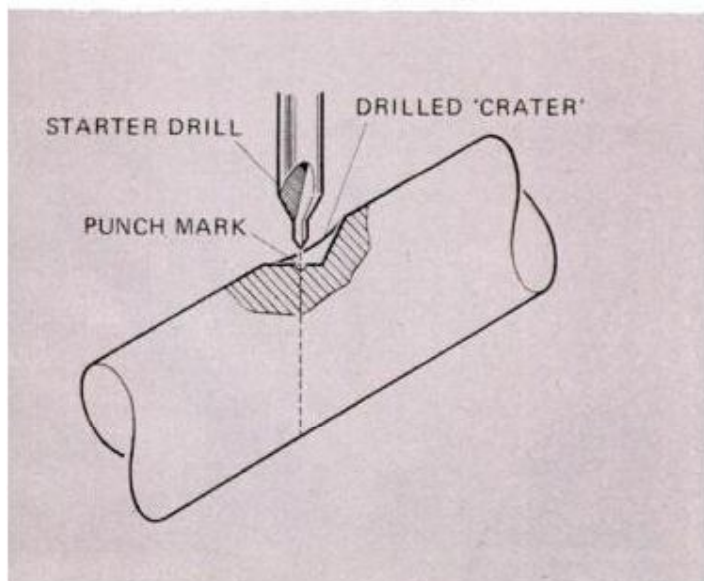

Drilling a hole at an angle can be a frustrating job, especially when you're drilling metal. Starting the hole is difficult because the drill bit tends to wander or grab. Finishing the hole is no cinch, either—breaking through can be ticklish, with jamming and bit breakage possible.

But there are tricks that can take some of the headaches out of angle drilling. First off, you must provide a surface perpendicular to the drill bit so it can start squarely.

The simplest way to do this is to start drilling with the bit at a right angle to the surface and then tilt either the workpiece or the drill until the desired angle is reached. The latter is done when you're using a portable drill in wood and other soft materials, but locating the hole at a precise point requires care. Another drill-starting trick is to make a center-punch mark at an angle, as shown in bottom, left photo on page 160.

When using a conical "crater" formed with a drill, start drilling as shown at the left. The width of the crater side (crater radius) should be nearly equal to the diameter of the hole to be drilled.

After making a punch mark at the desired location, begin drilling with a regular lathe center drill. Select a "stubby" one since a steeply angled surface may cause a twist drill to grab at the corners.

With the drilled-crater technique, it may be desirable to use initially a twist drill that is slightly smaller than the finished

PHOTOS BY THE AUTHOR



## Square starting is the secret

diameter of the hole. Best results with this method will be obtained when the hole is perpendicular or nearly perpendicular to the crater side.

The use of a machined groove for a starting land, shown below, right, is especially helpful when several holes are to be drilled at the same distance from the end of a rod and at the same angle to its axis. The groove can subsequently be removed by machining the bar to a smaller size, as was done with the one shown on page 159.

Although it is not practical to make too deep a hole with an end mill, it can be used to make a very neat starting recess, as shown on page 161.

If a number of identical workpieces are to be drilled, a jig can be made to speed the job of starting and drilling holes at the same angle.

The methods shown on these pages should produce accurate results if care is taken in locating the starting surface and in positioning the punch mark. Once started, drilling should go smoothly until the bit breaks through. The beginning of this moment can usually be felt and often heard. Feed slowly and carefully at this point, until the drill emerges completely and runs free. If bit jamming is a recurrent problem, clamp a piece of scrap material to the bottom of the workpiece for the drill to continue into,

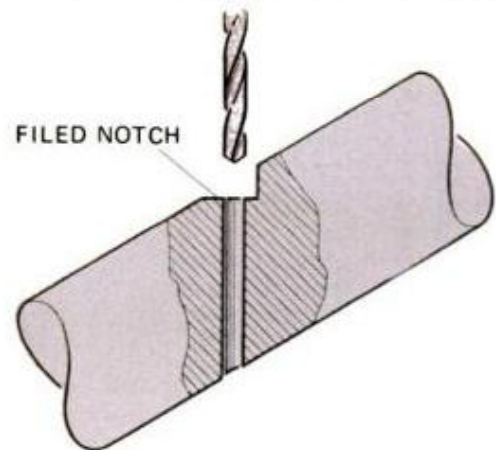
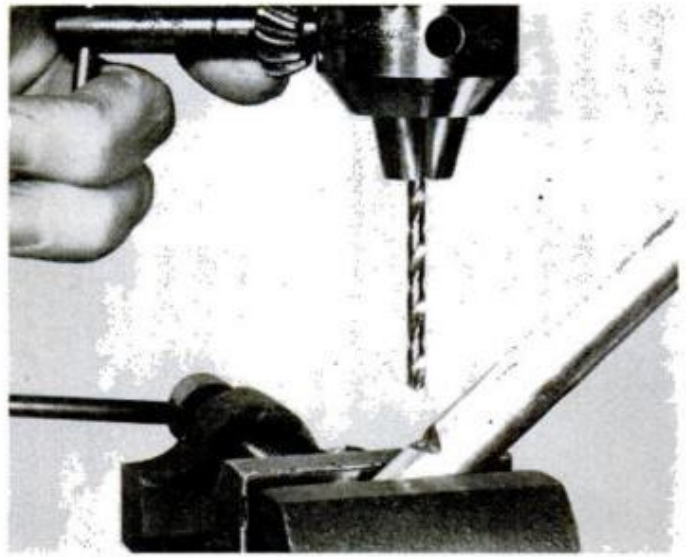

**When notch is filed** or sawed in bar with one side perpendicular to hole axis, it provides flat surface for drill. The technique works fine when finished appearance is unimportant. Punch mark and the use of lathe center-drill give the most accurate start.

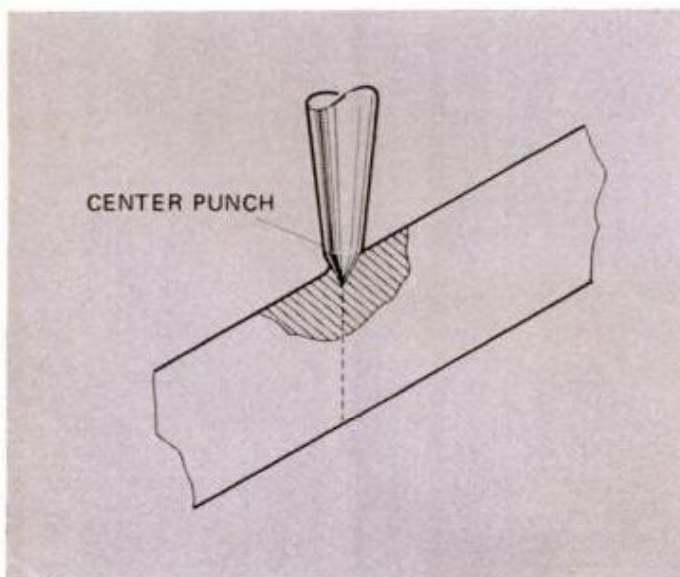

**Angled punch mark** helps start a drill when angle and hole size are both small. To keep the bit from drifting, the entire drill tip should contact the punch mark.



**Machined groove** is a variation of the notch method. Starting surface can be turned at any desired angle, but groove must be wide enough for drill clearance.

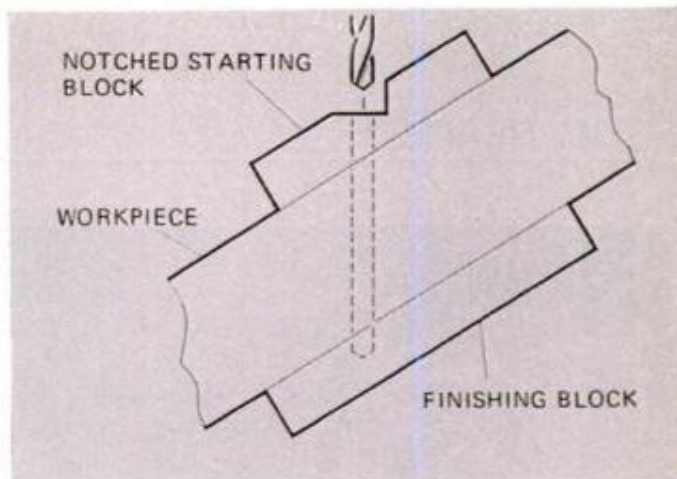
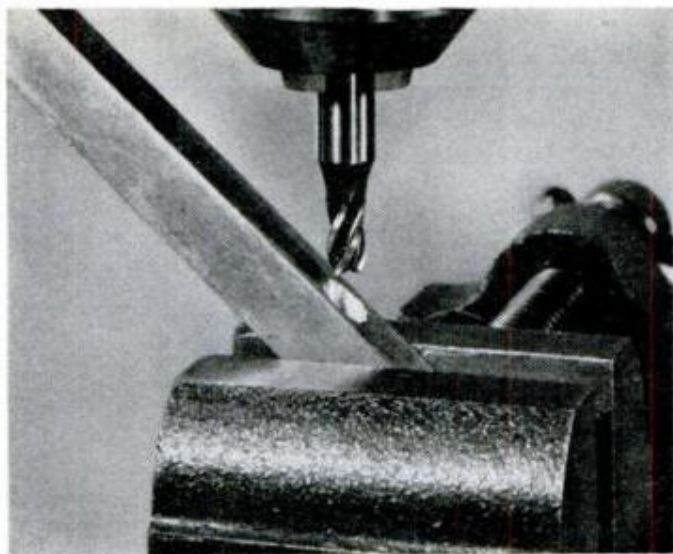

Starting block of scrap material, notched to angle desired, is clamped to workpiece; a finishing block clamped underneath assures clean drill breakthrough.

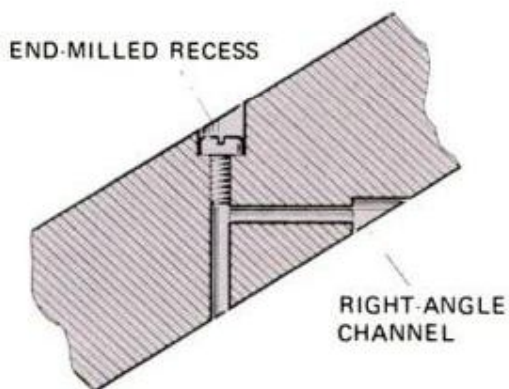

End-milling a recess is the neatest way to provide a starting surface for drill. When hole is to accommodate a pan-head screw, recess is milled slightly larger than diameter of head, which seats squarely against flat. Right-angled channel is typical use of method.

so that it will leave a clean-edged hole on the workpiece.

A scrap block can also be used to aid starting (top, right). When no finishing block is used, there are usually some irregular fragments (burrs) to trim away from the bottom of the hole.

Secure clamping of the workpiece is important in angled drilling, since bit pressure will tend to swing the workpiece downward. When using a progression of drills of several different sizes, start each drill carefully to prevent grabbing. Generous use of cutting oil is also helpful. And wearing a face shield or goggles for protection from flying chips is not just a good idea—it's a must. ★★★

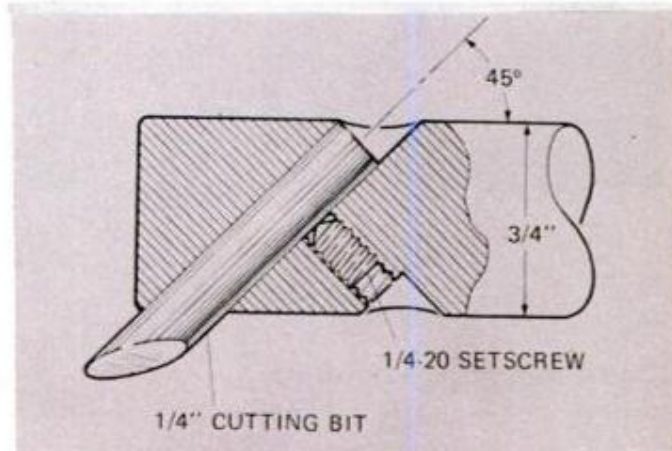

Boring bar for lathe is made using the end-mill technique. Grind cutting bit from high-speed steel, tap hole to receive 1/4-20 Allen setscrew for locking bit.

# HINTS

## FROM READERS

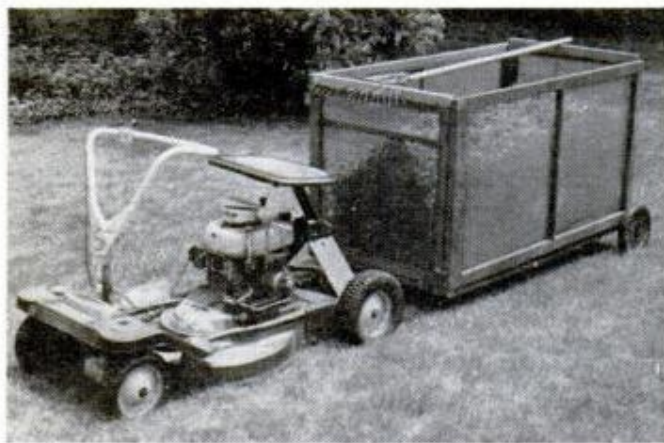

### Leaf cart from old screens

When I replaced my wood screens with aluminum combinations, I made this king-size, towable leaf cart from the old screens, placing lawnmower wheels at cart's end so it can be tilted. Axle is  $\frac{3}{4}$ -in. pipe. Bottom screen is reinforced with  $\frac{1}{2}$ -in. hardware mesh and one side unhooks for fast unloading.—*R. K. Pedersen, Plainfield, N. J.*

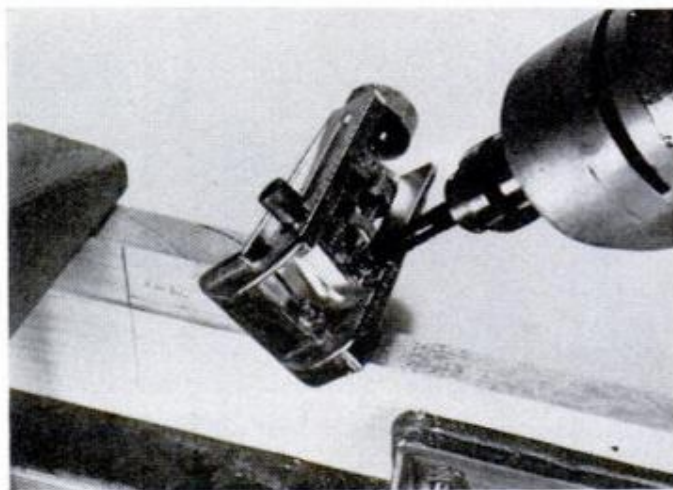
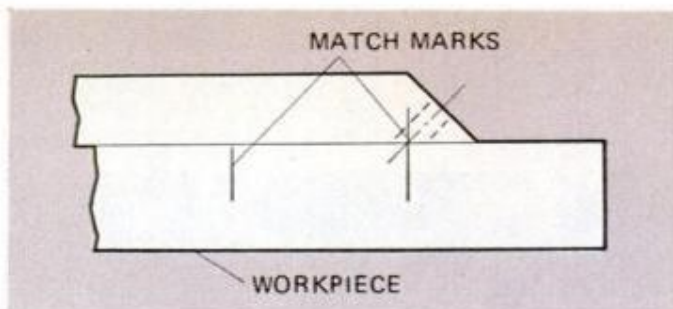

### Doweling-jig aid

Recently I had to drill a row of angled holes in a length of stock. To simplify the task, I cut the angle in a short block, then clamped the block in the doweling jig. Then I drilled the holes, moving the block and jig as a unit and using match marks to align the setup at hole locations.

—*S. C. Peterson, St. John's, Nfld.*

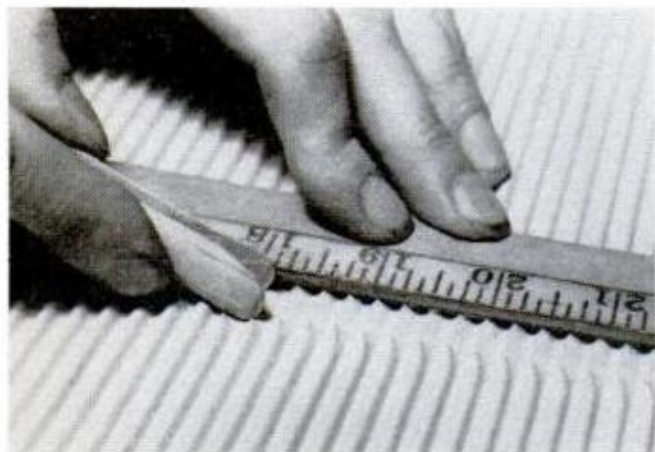

### Clothespin scores cardboard

When corrugated cardboard is used for wrapping, it must be scored to bend neatly. A knife is of no use for this purpose as it cuts the paper facing on cardboard, weakening it. I've found that an ordinary clothespin, drawn over the corrugated side, scores a neat double line that makes creasing easy.

—*William Swallow, Brooklyn.*

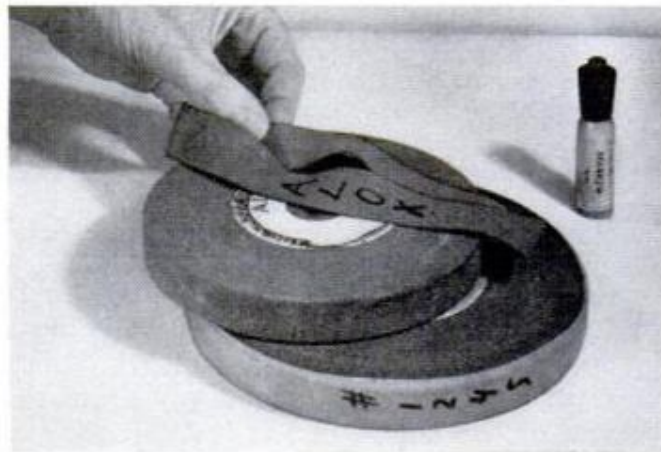

### Better grinding-wheel storage

A large rubber band (or a section cut from an old inner tube) will give good protection against chipping when storing a grinding wheel. Mark wheel data—grit type, size and wheel catalog number—on the band with a waterproof felt-tip pen for speedy identification of various wheels.

—*Walter E. Burton, Akron, Ohio.*

# WITH 794 BRANDS TO PICK FROM, WE FIGURE YOU NEED A LITTLE HELP.

**HOW WE CAN HELP.** With almost 800\* different companies putting their names on every kind of recreational vehicle imaginable, how do you make an intelligent buying decision?

We can give you some help here, by touching on a few important points to look for. But to help you dig in a lot further, we're offering "The Consumer's Guide to Recreational Vehicles"—a must-read before you buy anybody's RV.

For in-person help, you should visit an Open Road dealer. He's a knowledgeable fellow who doesn't have to talk you into any one type, because Open Road makes them all: motor homes, van motor homes, mini motor homes, campers, travel trailers. In 29 different models, priced \$1,395 to \$13,295.† He can also help your financing, with a plan that makes our finest motor home as easy to own as a station wagon.

**IT HELPS TO HAVE THE INCREDIBLE STRENGTH OF UNI-BOND.** You could pay thousands of dollars more for somebody else's motor home to get the kind of strength we build into the walls, roofs and floors of our Statesman series.

An aluminum exterior is first bonded to tough crossgrain plywood. Which is then bonded to a core network of solid wood framing studs and cellular foam. These in turn are bonded to the interior to a second layer of crossgrain plywood with a vinyl-clad natural wood veneer. The result of all this? An impact-resistant shield that keeps noise, heat and cold outside, where they belong.

\*Recreational Vehicle Institute "Facts and Trends" 1972.

†Mfgs. suggested retail prices, excluding tax, license, transp., dealer prep. and factory or dealer-installed options, if any.

© 1973 Open Road Industries



**WE HELP YOU FEEL LIKE YOU'RE IN A HOME.** Inside you'll feel good. Every Open Road has an interior to be proud of, whether you buy our least expensive camper or our best motor home.

For example, we finish our wood cabinet doors on the inside, just like the outside. We even put moldings on the edges (drawers, too) so they keep out dust and feel smooth to the touch. On most models, deep pile nylon carpeting is standard, wall-to-wall. Mattresses are thick, showers are inviting. Our upholstery fabrics are beautiful but tough and treated to ward off stains. Appliances are name brand, specially constructed to hold up under rugged RV use.

It also pays to look for the things you don't see, like how a manufacturer hangs his cabinets. Open Road anchors them into solid wood studs. Many others simply screw them into thin plywood panels, where they can work loose from the vibration of normal road travel.

In short, the days of roughing it are over. With Open Road you get the comforts of a good home, built to last.

**HELP IS WHERE YOU NEED IT.** There's a strong argument for buying a long-established brand name with hundreds of dealers all over America. (At trade-in time, see how much more our name is worth.) Our nationwide network provides help away from home, whether it's full service, parts or information on the best campgrounds.

PM - 1



## HELP.

Please rush 79-page "Consumer's Guide to Recreational Vehicles" (\$1.50 value)—along with your oversized full-color catalog giving details on all 29 Open Road models. I enclose \$1 to cover handling and shipping.

Please rush free rental information, under separate cover.

Name \_\_\_\_\_

Address \_\_\_\_\_

City \_\_\_\_\_ State \_\_\_\_\_ Zip \_\_\_\_\_

**HELP Headquarters**

P.O. Box 6121, Glendale, Calif. 91205

# OPEN ROAD

More great ways to get away.



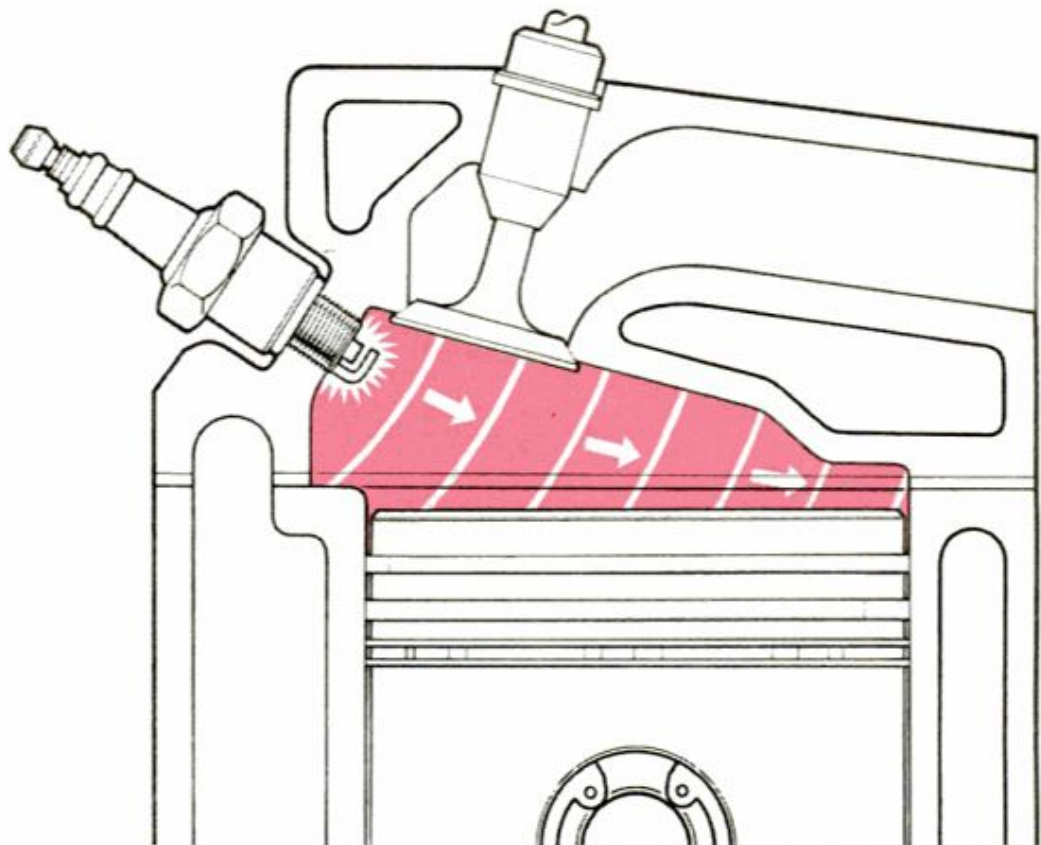

TECHNICAL ART BY PETER TROJAN

# Putting ping in its place

Combustion in an engine cylinder should be smooth as it progresses across the chamber. An interruption of this gradual burning results in noise called ping.

by Mort Schultz

**I**t's called ping, detonation or spark knock. Any of these names refers to an explosion of the fuel mixture part way through the normal combustion process. This explosion produces a sharp rise in pressure that shakes your cylinder head(s), causing it to vibrate which, in turn, creates a metallic ring.

Some detonation is normal, however. Buick, for one, puts it this way: "Light detonation may occur when operating a synchromesh car in high gear with full throttle between 14 and 22 mph, or when operating an automatic transmission car in DRIVE with full throttle at low speed even when ignition timing is correct and proper fuel is used.

"This light detonation is normal and no attempt should be made to eliminate it by retarding the ignition timing, which would reduce economy and overall performance."

But heavy detonation is something else. A hard knock while accelerating at full or nearly full throttle can lead to loss of power, increased fuel consumption and overheating.

If the shock waves are severe enough and are allowed to continue, they can fracture sparkplug insulators and damage pistons, connecting rods, bearings and crankshaft.

What causes detonation? Remember that ideal combustion is a gradual burning of the mixture so that combustion gases will have time to expand and maintain a steady pressure on the piston during most of the power stroke. In other words,



ideal combustion is a progressive burning of the mixture from sparkplug tip outward through the combustion chamber.

The boundary line between harmful detonation and no (or acceptable) detonation is slim. Combustion chamber design plays an important role in the maintenance of this balance.

In a typical engine, by the time the flame front has reached the valve area, burned gases have already built up a pressure of 400 to 600 pounds per square inch (p.s.i.). The remaining unburned fuel, therefore, is compressed to this pressure.

Since temperature increases with pressure, the remaining unburned fuel could explode if the chamber's design didn't keep temperature below the detonation point. The remaining unburned fuel is near or in contact with the comparatively cool cylinder head and piston head, which keep it from exploding.

This works fine providing other variables do not upset the delicate balance. Low-octane fuel will do it; so will overadvanced

ignition timing. Other causes of ping include the use of sparkplugs having an incorrect heat range, a manifold heat-control valve that becomes stuck in the "on" position, and a carbon buildup developing inside the engine.

With the possible exception of carbon, you can usually get rid of any problem that is causing engine ping by yourself. Start with gas and timing—they are the two main causes.

Are you using the grade of gas recommended by the manufacturer of your car? As you know, gasoline has an octane (antiknock) rating which represents its ability to resist detonation. The higher the octane rating the greater will be its resistance.

1. **Check dwell** (angle through which points are closed) by meter to coil side of distributor and ground.
2. **If not to maker's specifications**, adjust distributor contact points and check the reading again.
3. **Before adjusting ignition timing**, set carburetor idle speed to maker's specification using a tachometer.
4. **Overadvanced ignition timing** and low-octane gas are major causes of pinging. Set timing to spec.

1

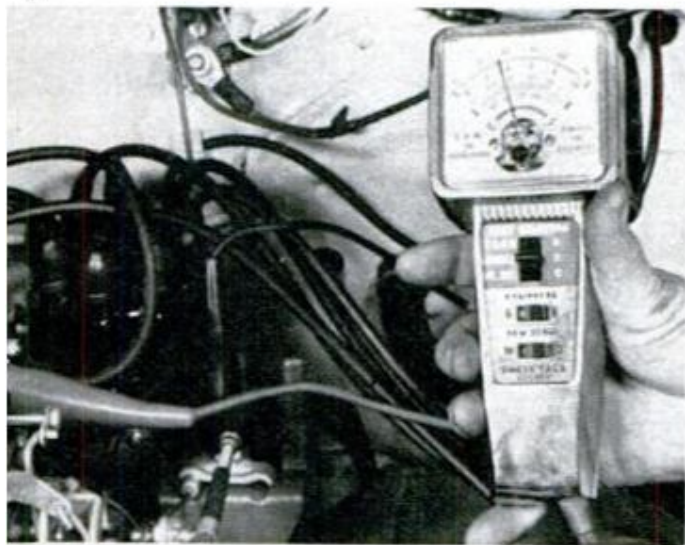

2

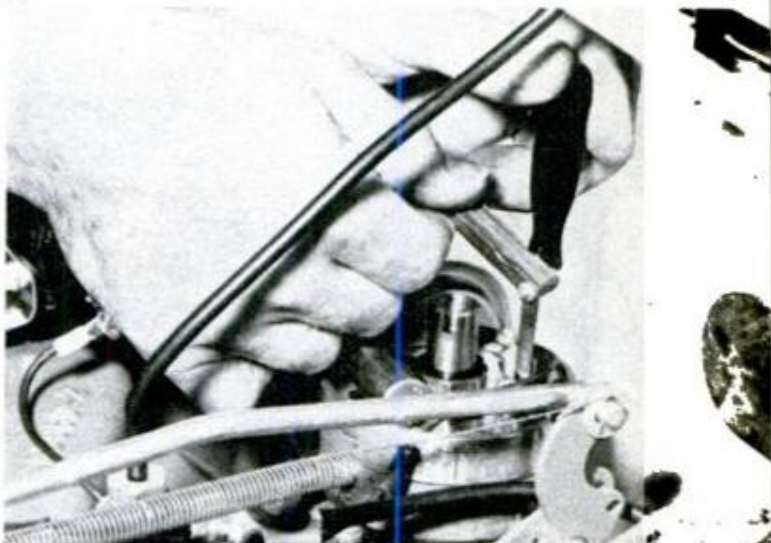

3



4

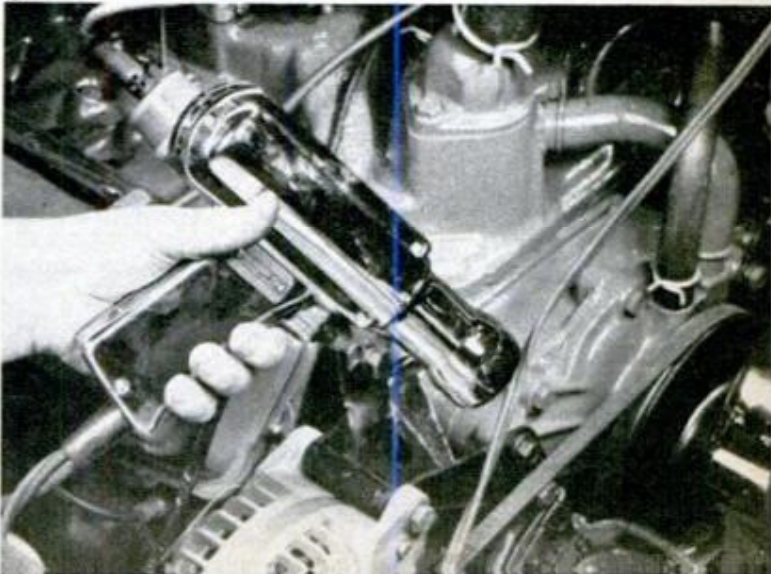

## Octane rating: What it is and how it's determined

Octane rating of a particular brand and grade of gas is determined by comparing its resistance to detonation with a blend of iso-octane, which is given an octane rating of 100, and n-heptane, which has an octane rating of 0 (no resistance to detonation). Therefore, if a gas has an octane rating of 96, it has the same resistance to detonation as a mixture of 96 percent iso-octane and 4 percent n-heptane.

If the fuel's resistance to detonation is too low for your particular engine, the fuel mixture will explode and power will be

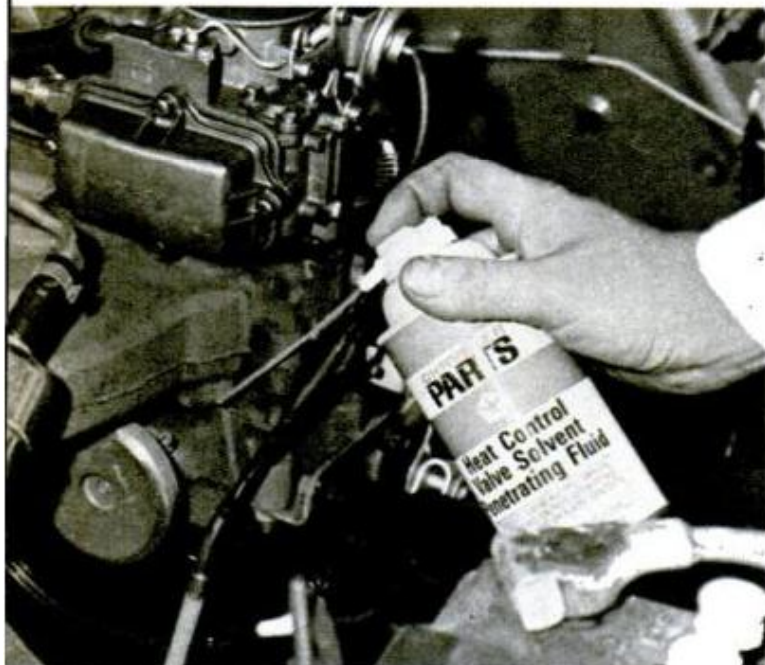

applied to the pistons with sharp, hammer-like blows. And that's "ping."

What to do? First make sure that you are using the grade of fuel called for by the manufacturer. If you are using the right grade, try switching brands. Octane ratings between fuel of the same grade but of different brands can differ.

If ping continues, you may decide to up the octane of the fuel you are using, and it may work. But this is only covering up the real reason for ping. If the recommended fuel is being used, the engine will not ping if other conditions which cause detonation don't exist.

By the same token, if fuel of a higher octane than that recommended is being used, the engine still may ping if another

problem exists. Octane is not a cure-all.

Turn next to ignition timing. If timing is too far advanced, causing spark to occur too early, sparkplugs can overheat and cause premature ignition of the fuel mixture. Technically, this is not detonation, but pre-ignition which is an explosion of the entire supply of fuel in the combustion chamber. However, the two conditions are closely allied and produce the same combination of troubles.

To obtain correct timing, find the specification for your engine. If the car is a late model, you will find this spec on a decal attached to a spot beneath the hood. If it isn't there, consult an owners manual or service manual.

Before timing the ignition, you should check distributor point dwell, which is the number of degrees that distributor points remain closed. Dwell has a direct bearing on timing.

Every manufacturer has a recommended method for timing his engines. Generally, though, the timing light is connected to the

*(Please turn to page 168)*

**If a stuck manifold control heat valve contributed to pinging, free it. Keep it free with solvent.**

**Switch to cooler sparkplug (marked by shorter insulator) if hot plug contributes to pinging condition.**

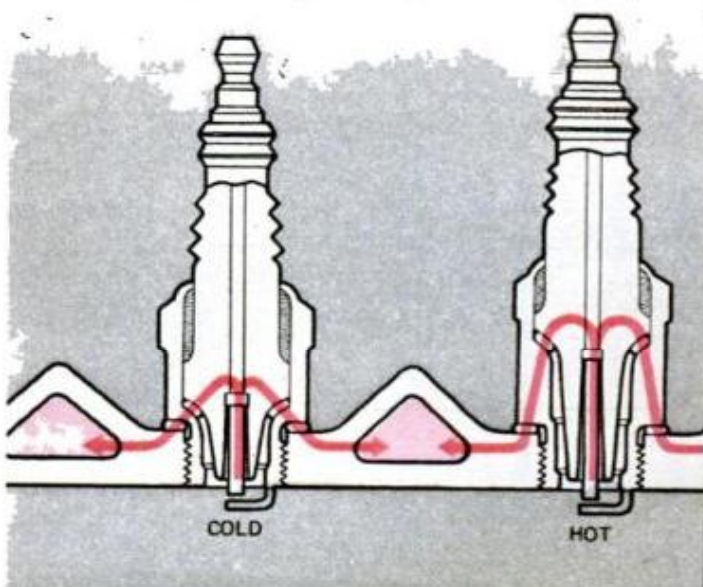

Get away from the crowd.  
Get the flavor you want in  
Old Gold Filters.

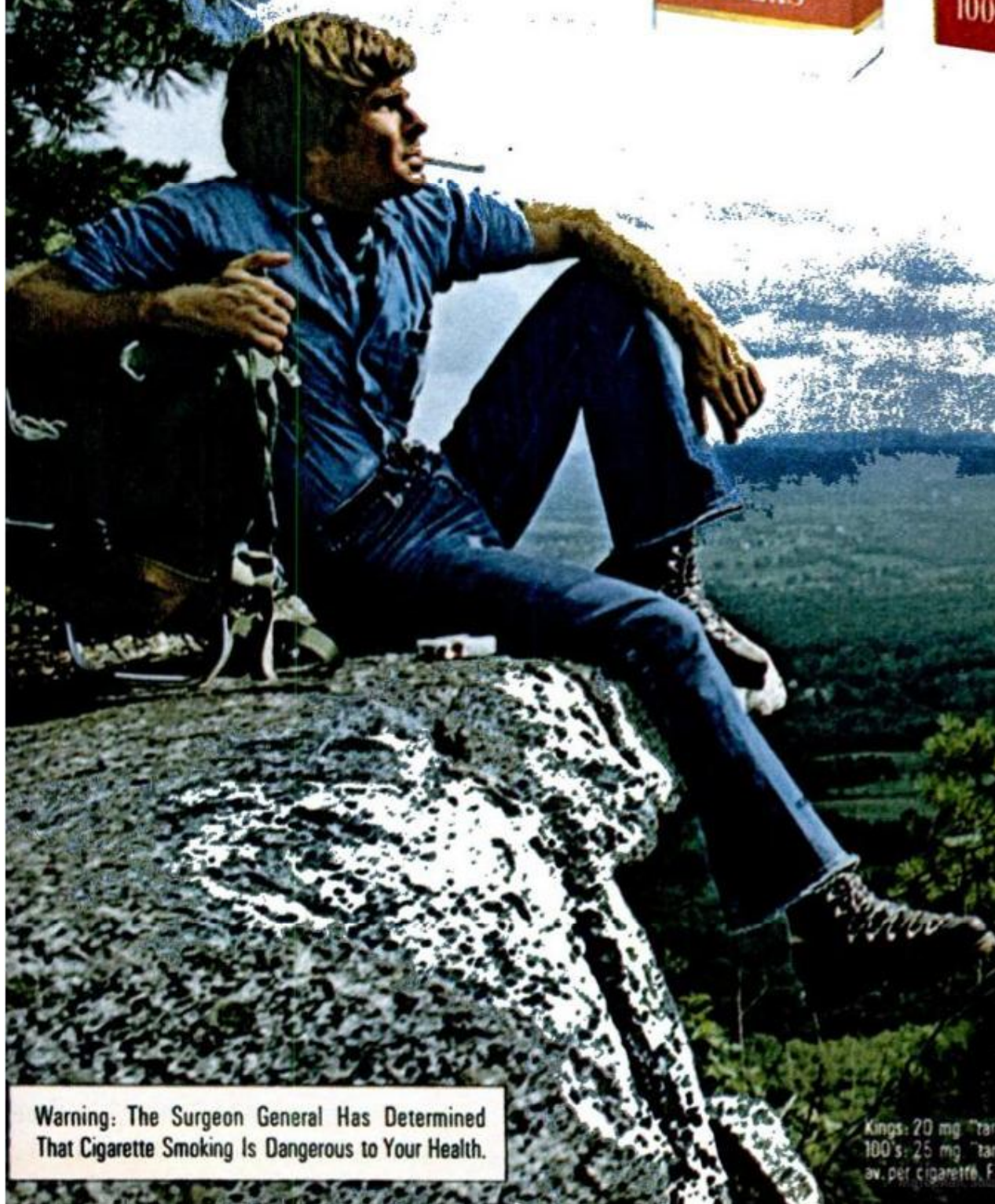

Warning: The Surgeon General Has Determined  
That Cigarette Smoking Is Dangerous to Your Health.

Kings: 20 mg "tar," 1.3 mg nicotine,  
100's: 25 mg "tar," 1.6 mg nicotine  
av. per cigarette. FTC Report Aug. '72.

## PUTTING PING IN ITS PLACE

*(Continued from page 166)*

No. 1 sparkplug and to the battery. If the manufacturer says to do so, disconnect the vacuum hose at the distributor vacuum advance and plug off the hose's opening, so that idle speed isn't affected.

If timing isn't correct, loosen the distributor and turn the distributor housing slowly until the specified mark is directly opposite the pointer. Tighten the distributor and recheck the timing to make sure it hasn't been altered. Reconnect the vacuum hose.

Suppose you don't have a timing light, dwell meter and tachometer—but you do have ping. You can try to determine if timing is causing the condition by first marking the position of the distributor so you can bring it back to the original position.

Drive the car and listen for the characteristics of the pinging condition. The best way is to accelerate from about 10 mph to about 25 mph with wide-open throttle.

To eliminate the pinging, which indicates that ignition timing is overadvanced, turn the distributor housing a few degrees in the direction of the rotor rotation. This retards the timing. Check by driving again.

Now, check the manifold heat-control valve. If it is stuck in the on position, it could be causing excessive engine heat which is permitting the fuel mixture to explode.

Make sure the engine is cold, and reach beneath the exhaust manifold where the heat-control valve counterweight is located.

Can you move it by hand? If not, apply a liberal dose of heat-valve lubricant to the shaft and try to free the valve by hand.

If the valve is stuck fast, tap the counterweight gently as you apply more and more solvent. At some point you may have to give it up as a lost cause and have the valve replaced.

Sparkplug heat range also affects combustion in the cylinder. The heat range of a sparkplug refers to its ability to transfer heat from the firing end up through the insulator, gasket and shell to the cylinder head and water jacket.

Each size of sparkplug is manufactured in heat ranges varying from cold to hot. Let's define these terms, because they frequently cause confusion.

A cold sparkplug transfers heat rapidly;

*(Please turn to page 195)*

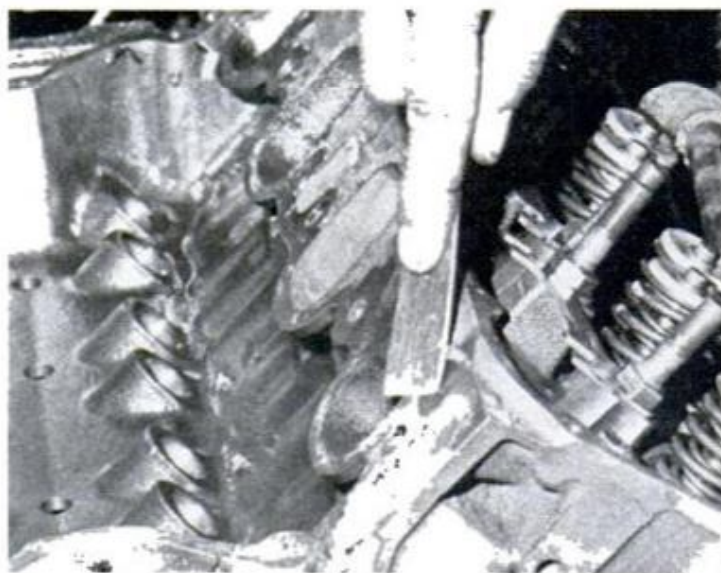

If engine is in perfect tune, then carbon buildup is cause of ping; you'll have to tear down and clean.

To determine if sparkplugs are too hot for engine, remove and check electrodes: hot plugs burn white.





When all the roads start to feel like railroad tracks, you know it's time for new shocks.

But maybe you don't know there's more than one type. That's where your Delco man comes in. He has three different types to offer, and he'll be happy to let you know which one is just right for you.

For example, if you spend a lot of time on the highway or especially rough

roads, Heavy Duty Delco Pleasurizers are designed to help make riding smooth and handling easy. For city driving, regular Delco Pleasurizers can ease you over the irregularities of city streets. Delco Pleasur-lifts give the same ride control under normal driving conditions and are easily air-adjustable to help your car haul boats, trailers or carry heavy loads.

When you know you need new shocks, you ought to know you have a choice. So let a Delco man tell you about Pleasurizers, Heavy Duty Pleasurizers and Pleasur-lift shock absorbers. After all, it's his business to know what's right for your car.

**THE MORE YOU KNOW,  
THE MORE YOU'LL WANT DELCO.**



**WHEN YOU NEED NEW SHOCKS,  
YOU OUGHT TO KNOW WHICH TYPE.**

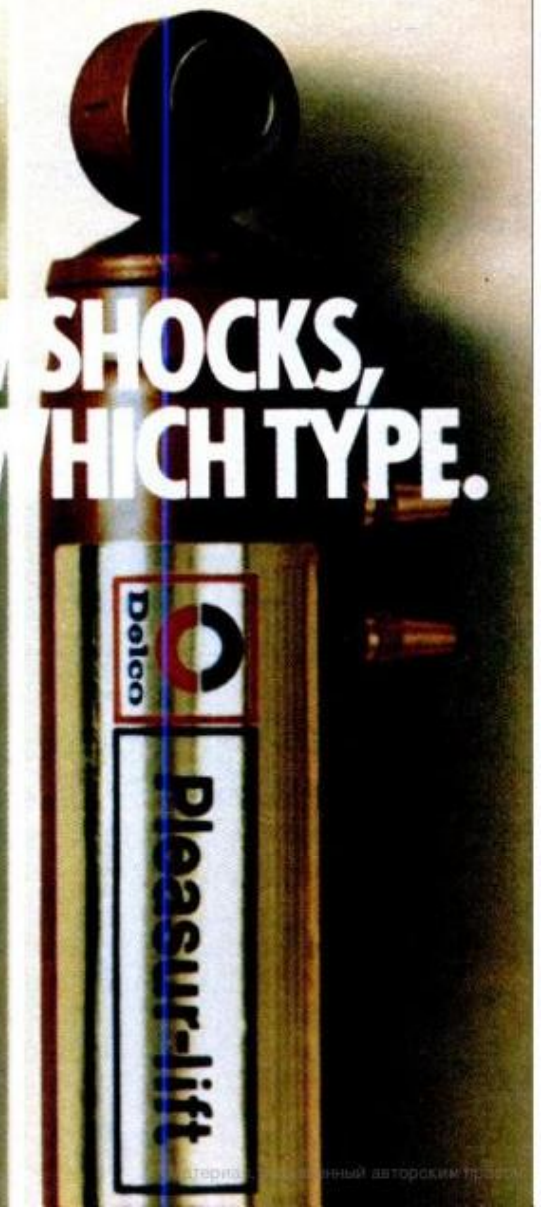
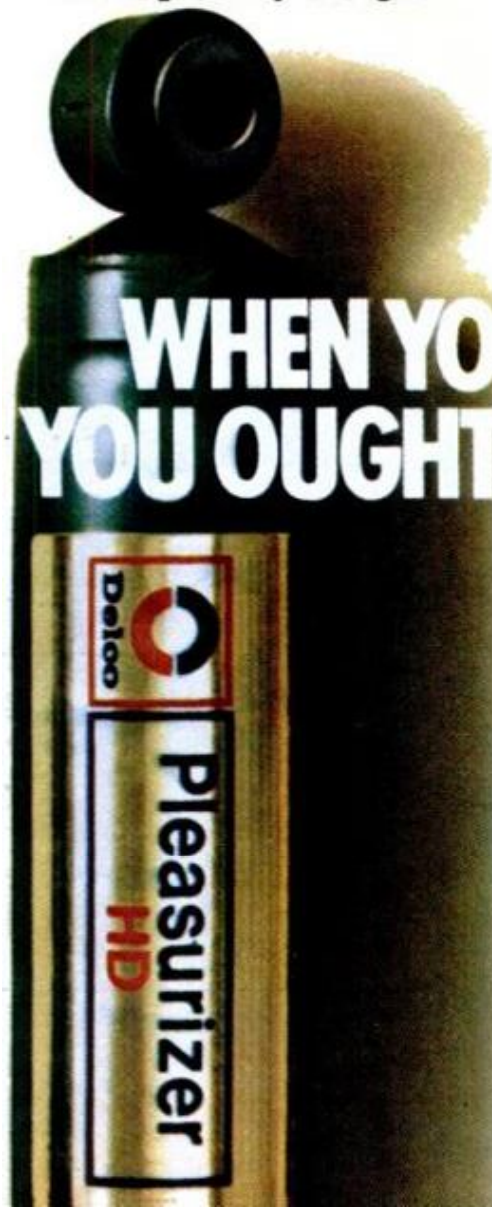

# HINTS

## FROM READERS



### Easier softening brushes

If you label brushes with their last previous use, it will tell you what solvent to use to soften the bristles if they have not been completely cleaned. Use a ballpoint pen on a strip of plastic-coated, cloth adhesive tape such as Mystik tape. Yellow is a highly visible tape color.

—Walter E. Burton, Akron, Ohio.

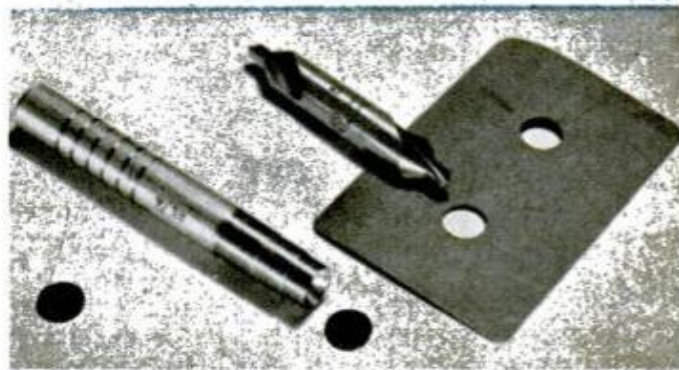
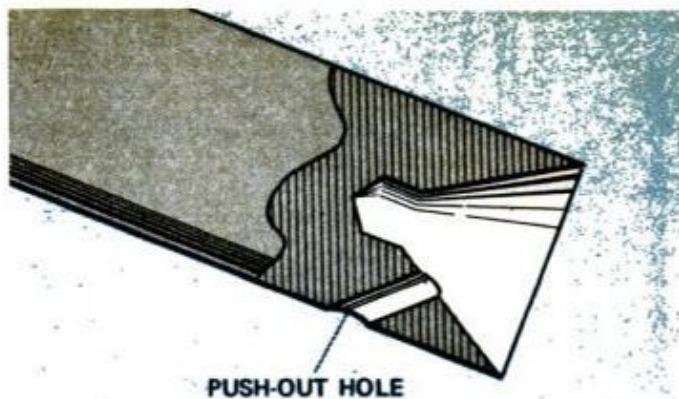

### Homemade gasket punch

When I needed a gasket punch, I turned a piece of shafting to the desired punch diameter, then center-drilled it until the drill's cutting edge reached the shaft's o.d., making a knife edge. The fairly sharp taper of the hole helps slugs fall out, but you may want to drill a push-out hole.

—John Mallak, Silver Lake, Minn.

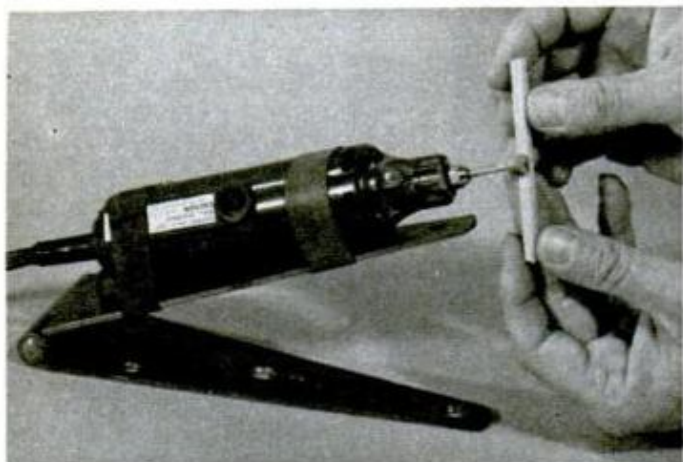

### Hinge makes grinder stand

A simple adjustable stand for a small hand grinder can be made by fastening the tool to a large strap hinge with heavy rubber bands. Choose a hinge with stiff action or peen the pin with a hammer until the hinge will hold at any position. The stand should also help with "three-handed" soldering jobs.—Ken Patterson, Regina, Sask.

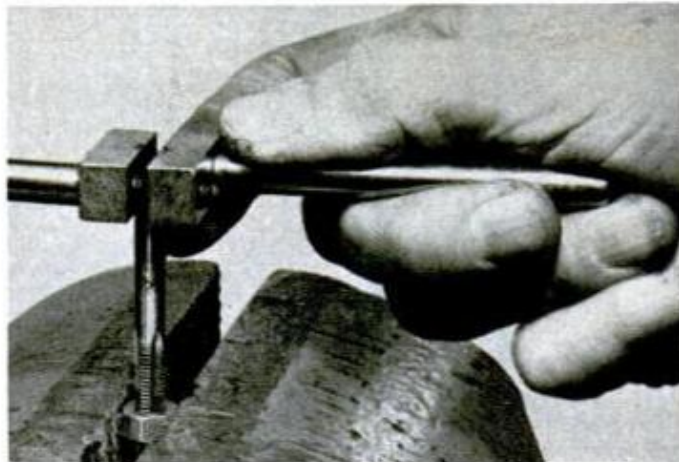

### Tap trick for tight nut

If a nut fits bolt threads too tightly, squeeze it in a vise while running a tap through it. This will enlarge the threaded hole more or less uniformly, often enough to assure a free-running fit. If the nut should be plated, it can be protected from vise marks with sheet-aluminum pads.

—W.B. May, Oak Park, Ill.

# You've got more going for you with NTS home training

Check it out. ✓ Professional equipment and Project Method instruction. That's what NTS training is all about!

✓ Lesson materials, equipment, instruments, tools — all carefully selected to make your course interesting and practical!

✓ Experiments, kit building, job projects, trouble-shooting. You train quickly, easily, and it stays with you.

✓ Special Personal Development Manuals — how to get a job — open a business of your own, and many more.

✓ Check the box on the coupon to show your choice in one of four great fields. Then mail for FREE color catalog, full details. No obligation. No salesman will call.



Solid-State  
315 sq. in.  
Heath  
Color TV

## NTS ELECTRONICS DIVISION

Equip yourself for better pay in Color TV & Radio Servicing, Computer Electronics, Automation/Industrial Electronics, or Electronic Communications. Build your own solid-state 315 sq. in. Heathkit color TV, solid-state B&W TV, 5-watt Transceiver, solid-state Compu-Trainer, solid-state Oscilloscope, solid-state Stereo and Speakers, and more!



## NTS MECHANICS DIVISION

Gear up for high-paying jobs. Service auto and diesel engines. Repair cars and trucks from bumper to bumper. You train with essential engine diagnostic instruments plus complete American-made socket wrench and tool set. Auto courses include "Speed Shop" lessons. With NTS training you can make money even before you graduate!

## APPROVED FOR VETERAN TRAINING

Accredited Member: National Association of Trade and Technical Schools, National Home Study Council

Send for FREE color catalog and sample lesson today!

## NATIONAL TECHNICAL SCHOOLS

World-Wide Training Since 1905  
Resident & Home Study Schools  
4000 So. Figueroa St., Los Angeles, Calif. 90037



## NTS AIR CONDITIONING, HEATING, REFRIGERATION DIVISION

Tool up for big opportunity. Men who can service heating and cooling systems (residential and commercial) are in demand. You train with pro equipment: Hermetic Analyzer, Leak Detector, Charging-Testing-Purging Manifold Set, and more! Make part-time money while becoming an NTS Master Technician. Then go after the job you've always wanted!



## NTS HOME APPLIANCE DIVISION

Be the man they pay to fix washers, dryers, sweepers, compactors, dishwashers. Multiply your experience with appliance circuitry through the exclusive NTS Circuit Trainer. Detect malfunctions with your NTS Appliance Tester. Make good money full- or part-time. Start your own home appliance repair shop.

## NATIONAL TECHNICAL SCHOOLS

World-Wide Training Since 1905  
Resident & Home Study Schools  
4000 So. Figueroa St., Los Angeles, Calif. 90037

CHECK ONE ONLY. Please rush FREE CATALOG and SAMPLE LESSON for course checked below. (No obligation. No salesman will call.)

- |  |  |
|--|--|
| <input type="checkbox"/> Electronics Division                              | <input type="checkbox"/> Mechanics Division      |
| <input type="checkbox"/> Air-Conditioning, Refrigeration, Heating Division | <input type="checkbox"/> Home Appliance Division |

NAME \_\_\_\_\_ AGE \_\_\_\_\_

ADDRESS \_\_\_\_\_

CITY \_\_\_\_\_ STATE \_\_\_\_\_ ZIP \_\_\_\_\_

Dept. 201-063

- Check here if interested in veteran training under new G.I. Bill.  
 Check if interested ONLY in classroom training at Los Angeles.

## IN THE SAILPLANE PILOT'S SEAT

(Continued from page 72)



**Golf cart** is used to jockey planes around airport. Some sailplanes have empty weight of but 600 pounds. Many are made of aluminum or fiberglass.

engine or propeller of a powered plane produces its forward motion. The sailplane pilot, on the other hand, keeps the nose of his ship pointed slightly downward so that it slides "downhill," somewhat like a sled.

A power plane that loses its engine becomes a glider and a skillful pilot can land it safely. Of course it won't have the efficiency of a sailplane, which may have a glide ratio of 45 to 1, meaning that at one mile above the ground it can fly 45 miles before touching down. Even a less sophisticated craft such as the Schweizer 2-33 two-place trainer has a glide ratio of 23 to 1.

When the sailplane is sliding back to the ground it is said to be gliding. When it moves up in a rising body of air, it is soaring. And soaring is the name of the game. The greater your skill in searching out rising air currents, the longer you will be able to stay up in the air.

Rising air is created in different ways. When the sun warms an area on the ground, heat is radiated to the surrounding air. At some point, the warmer air will begin to rise, creating a thermal. You can spot thermals by the small white puffy clouds that

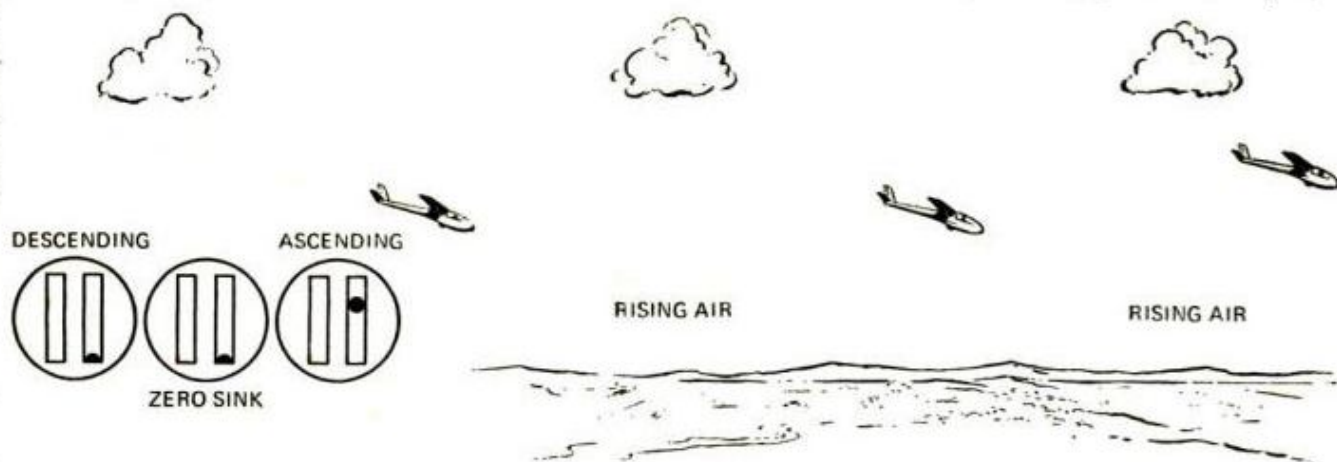

**Technique** in cross-country flying (above) is to find a thermal, gain altitude and head for the next area of rising air. When green pellet rises in the variometer tube, plane is in rising air. Red pellet signals sinking air.

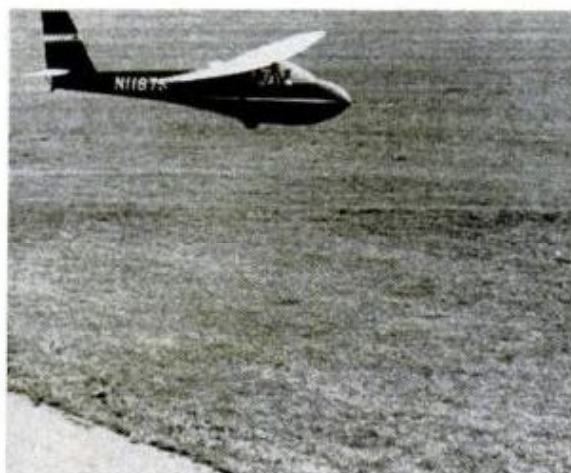



you see on bright sunny days. As the warm air rises it starts to cool. When it cools enough to condense the water vapor within it, clouds form.

Another way to find rising air is to ridge soar. When wind blows against the side of a hill it will blow up and over the hill. Get in this rush of air and you can soar back and forth across the face of the ridge for hours. Last year, I used this method to soar my plane for 5 hours and 40 minutes.

The jackpot of soaring is the mountain wave. Under certain atmospheric conditions a standing wave of air is formed downwind from a mountain. The air can rise thousands of feet a minute and if you get your sailplane into its lift you can go right up with it. The world altitude record for sailplanes of 46,267 feet was reached this way. The flight was made in a Schweizer 1-23 by Paul Bickle in 1962.

Sailplanes are strong enough to take practically any stresses that might be imposed by even the severest turbulence. Their basic structure is similar to that of other types of aircraft. Some are made of aluminum, some of wood, a few of steel tubing with a cloth covering. In recent years fiberglass planes have come on the market.

The largest American manufacturer—Schweizer Aircraft of Elmira, N.Y.—makes four different models. Three are all aluminum. The fourth, the 2-33 trainer, has an aluminum wing and a fuselage of steel tubing with a canvas covering. It has a wingspan of 51 feet, is almost 26 feet long and weighs over 1000 pounds with two persons aboard.

Depending on design, sailplanes have optimum gliding speeds of from 45 to 60 mph. But a high-performance, competition plane may hit 150 mph in its final glide.

Sailplanes have a single landing wheel



Relatively few instruments are needed for sailplane flying. Altimeter is at extreme left; variometer at extreme right. Tow release knob is in center of the panel.



Dive-brake control is located to pilot's left. Students are taught to test the control before getting into landing pattern. A "frozen" control is not unknown.

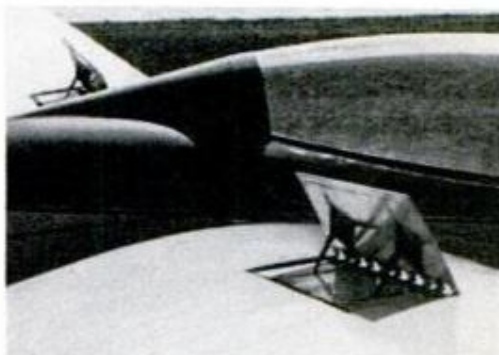

Extended, the dive brake allows plane to lose altitude without causing it to pick up speed. Dive brakes make landing easier, but plane can land without them.



Unlike powered planes, the sailplane speeds up in coming in for landing. This provides safety margin if there's a sudden gust. Brakes are used on final glides as the plane comes in at about 60 mph. The final touchdown should always be made into the wind. Plane shown in this landing sequence is a Schweizer trainer.

## Straightforward, simple flying

and spoilers or air brakes, which are similar to the flaps usually found on powered aircraft. Spoilers allow you to control your rate of descent with great accuracy.

The controls are similar to those of a conventional airplane. There is a stick to control the elevators and ailerons, and two foot pedals to operate the rudder.

Instrumentation is very simple. Basically, there is an airspeed indicator, an altimeter and a variometer to tell you if you are going up or down. Usually, there is also a ball-bank indicator, which tells you if you are slipping or skidding your turns. In addition, there may be a clock and a compass.

One misconception many people have is that soaring is dangerous. I've heard many

experienced power pilots say, "You couldn't get me into one of those things if you paid me!"

How wrong they are. Soaring is the most straightforward, simple type of flying. The ship is controlled in exactly the same way as a power plane, by stick and rudder. But the sailplane pilot must have a much greater understanding of the air mass in which he flies and must plan his flight with great care.

For the most part, a power pilot flies where he wants to go regardless of wind direction or how strong the wind is blowing. The sailplane pilot always must be aware of how the wind is affecting him and where he is in relation to the airport. It is very easy to drift so far from the field that you can't glide back and are forced to land in some farmer's back yard.

Power planes and sailplanes require different landing techniques. A power plane

*(please turn to page 178)*



1

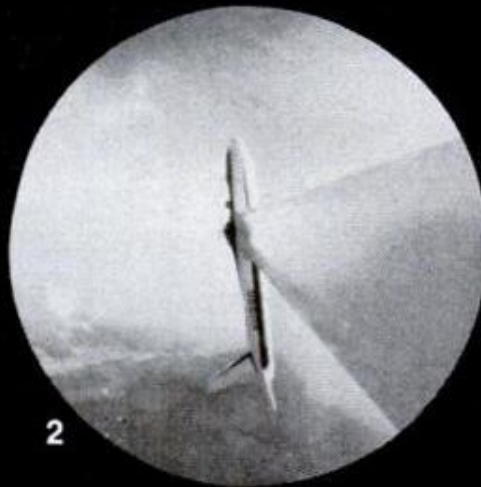

2



3

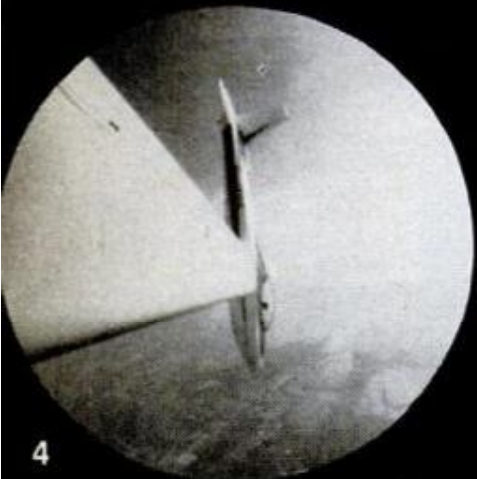

4



5

**Despite** their fragile look, sailplanes are heavily stressed and can do loops and other aerobatic maneuvers that are impossible for most powered light-planes. This loop was shot with a sequence camera fixed on the sailplane's wingtip. The author, riding as passenger, tripped the shutter by means of control cable taped to the wing. Fisheye lens was used.

# Now you can refinish your car's damaged surface areas professionally

You already have the skill to refinish your car's damaged surface. All you need is a few minutes practice on a tin can. Send a self-addressed stamped envelope, and we'll send you brief illustrated uncomplicated instructions free.

With Dupli-Color® touch-up paint, you can be sure of professional results. Used by millions, Dupli-Color duplicates your car's original color exactly. Dries in minutes to a hard high-gloss finish. Beautiful! Professional!

In all popular domestic and foreign car colors wherever auto supplies are sold. Brush-in-cap bottles, Auto-Spray® cans. Get color code number or letter from body plate.

## DUPLI-COLOR. PRODUCTS

Dept. P, 1601 Nicholas Blvd., Elk Grove, Illinois 60007

### Illustrated booklet shows tricks of the auto refinishing trade



Find body plate under hood or on front door jamb. Color code usually single letter or number. Get exact matching Dupli-Color.



Hold Dupli-Color spray can 8 to 10 inches from surface. Spray fast, smooth side-to-side strokes in one minute intervals.



For touching up a small nick or scratch. Cut small hole similar in size and shape to nick and spray Dupli-Color through it.

## 5-in-1 MINIATURE MACHINE SHOP

### UNIMAT

VERSATILE UNIMAT converts from precision lathe to vertical mill, drill press, grinder or polisher. Easy to use. Make all small precision parts—for models, guns, cameras, inventions \$169.50, ready-to-use. Send for free details (Available in Canada.)

AMERICAN EDELSTAAL, INC DEPT BF3, 1 ATWOOD AVE., TENAFLY, N J 07670



## MAN-SIZE TRACTOR

PRICED WITH THE COMPACTS!

Mows up to 60" swath!



Handles 48" and 60" mowers . . . bigger implements for gardening, dozing, removing snow. Here's why: Big 14 hp . . . extra size and traction . . . all-gear-drive with automotive clutch, transmission and differential. More for your money! Send for free catalog.

**ECONOMY TRACTOR**  
1005 K-6 Anoka Avenue  
Waukesha, Wisconsin 53186

## a new look

\*FREE full color illustration (see coupon)



**RotorWay**

## at the fabulous Scorpion Too

Have you heard about sport flying?  
Did you know that you can participate in your own personal helicopter

The Scorpion Too is RotorWay's answer to backyard flight.

Remember, the Scorpion is a true vertical take-off helicopter, it takes off straight up.

Send \$5 now for graphically illustrated color package containing:

- Fundamentals of rotorcraft flight
- Illustrated flight maneuvers
- How you learn to fly
- Scorpion development history
- Helicopter design theory
- Engineering definitions
- Power plant considerations
- Price information
- Performance specifications
- Unique features of the Scorpion Too
- Three-view dimensioned drawing
- Electrical and other options
- Exploded view of sub-assemblies
- Description of major component areas
- Information on how to proceed

Using a 140 h.p. engine, it cruises at 75 m.p.h. and can carry over 400 lbs. The most exciting news about the twin-seat Scorpion is its low cost, but then it's about time a helicopter became a recreational vehicle.

\*Enclose this coupon with your \$5 and you will receive free, along with your package, a 25"x38" full color reproduction of this beautiful scaled cut-away drawing (as shown above). Rotorway commissioned Dick Aleith, one of the West's leading illustrators, to create this work of art. It's truly a collector's item.

ROTORWAY, INC.  
Dept. O/14805 S. Interstate 10  
Tempe, Arizona 85281

Name \_\_\_\_\_  
Address \_\_\_\_\_  
City \_\_\_\_\_ State \_\_\_\_\_ Zip \_\_\_\_\_

## IN THE SAILPLANE PILOT'S SEAT

(Continued from page 176)

slows up in descent. The sailplane does just the opposite. In fact, it speeds up to allow for a greater safety margin in the event of a sudden wind gust or should the wind stop blowing. The rate of descent is controlled by extending the spoilers, which decrease the amount of lift of the wing. Still you can land a sailplane with such precision that you can come to a stop within a few feet of a given spot.

Soaring is basically a club sport because you need someone on the ground to hook you to the towplane or the winch, and to run the wingtip during takeoff. You also need assistance in retrieving the sailplane after a landing and to tow it back to your takeoff position.

I belong to the Long Island Soaring Assn. A \$400 initiation fee bought me a share of the equipment and I pay monthly dues of \$9 for operating expenses. Flying and instruction are free. My only additional outlay is a small fee to cover the costs of operating the towplane.

(Costs may be a bit lower in your area. I know of a club in the Midwest that charges a \$55 initiation fee, \$23 a year in dues and \$5 a month for operating expenses.)

We have five different sailplanes, ranging from basic trainers to high-performance ships. We also own two towplanes and two other power planes for those interested in power flying as well.

The club is set up so that maintenance and other duties are shared. Flight instruction for new members is handled by experienced members.

Another way to soar is to go to a commercial operator. He has sailplane equipment available for rental, as well as qualified instructors and the necessary personnel and equipment to conduct a sailplane operation. The big drawback is cost—about \$20 to \$25 an hour compared to the \$6 an hour that club flying usually averages—but then you do have the advantage of not having to wait your turn.

There is usually a soaring site within two hours of any major city in the United States. If you have trouble locating one, inquire at your local airport. Or get in touch with the Soaring Society of America, Box 66071-P, Los Angeles, Calif. 90066. This organization will send you a complete list of soaring clubs and schools in the United States. ★ ★ ★

## WHEN THE NEXT BIG FLOOD HITS . . .

(Continued from page 126)

chine, about the only piece of equipment deemed salvageable. "If I were 26, I'd start all over again," he said. "So I'm 52—and I'll start all over again."

He moved to another location on Water St., which is on the river's doorstep, but now he has a second-floor office.

Both Elmira and Corning have unveiled massive rebuilding plans. The \$72 million Elmira plan is believed to involve an area greater than any urban renewal project ever proposed. Corning's plan calls for an expenditure of \$30 million.

Much of the money would have to come from the federal government—and recent budget-cutting moves in Washington have many Elmiraans worried. But one way or another, they say they will rebuild.

Improved flood protection for Elmira and other cities in the area is under construction. The projects include dams on the Tioga and Cowanesque rivers in northern Pennsylvania. But these dams and other protective installations being built could not save cities and villages from storms like the one triggered by Agnes.

The Army Corps of Engineers, which has prime responsibility for such protection, never builds to cope with maximum flood conditions. It would be unfeasible, says the Corps, to provide adequate protection against rare, huge storms.

And just how good is our weather and flood warning system? A panel of experts—the National Advisory Committee on Oceans and Atmosphere—made a study of the effectiveness of the warning system in connection with Agnes. The committee's report stated, in part:

"Could . . . losses have been avoided or diminished through a more efficient performance of the warning services?"

"The answer is mixed. The system creaked but the people did well and some were outstanding. NACOA's judgment is that the performance of the National Oceanic and Atmospheric Administration, including its National Weather Service, was good. Taxed to the limits of its capacity, the system appears to have barely coped with the behavior of a most exceptional storm. What pulled it through were the people. But we do worry about next time. The national warning system is not geared—and could not be—to exceptional storms, like Agnes . . ."

★ ★ ★

Wickes pre-assembled  
**VACATION HOME**

PRICES START AT **\$4,500**

(DECK OPTIONAL)

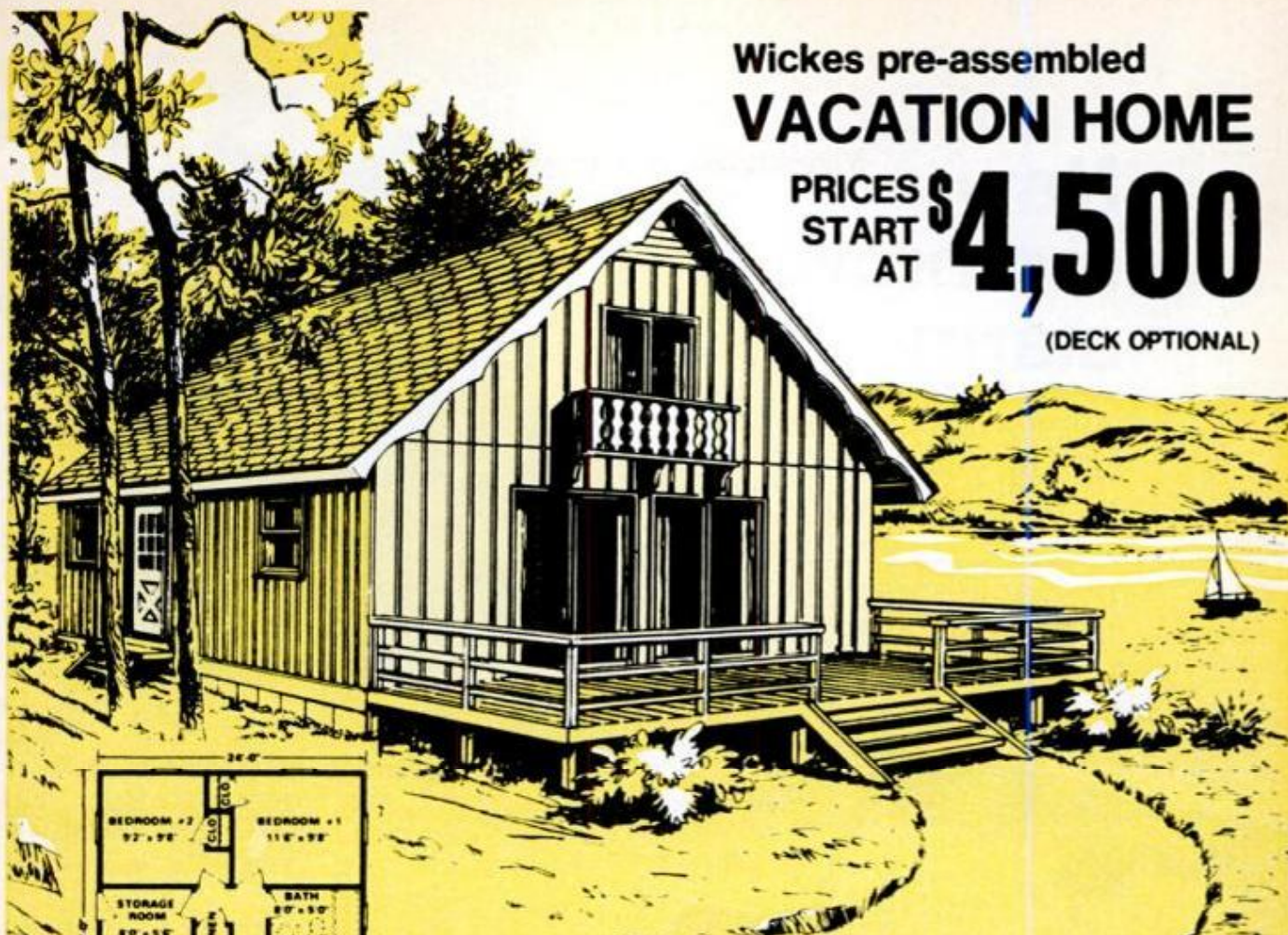

LAKE HAUS  
FIRST FLOOR PLAN

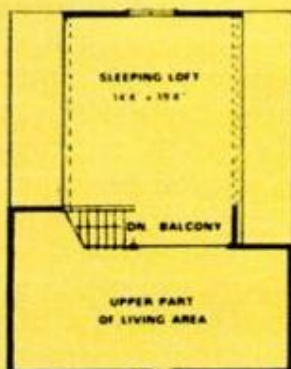

LAKE HAUS  
SECOND FLOOR PLAN

**Start making your dream a reality...**

Now, you can have the vacation home you've dreamed of . . . at a price you can afford. The average do-it-yourselfer can easily erect the basic shell, using many pre-assembled components. Cost of materials for the shell unit pictured (less deck) starts at \$4,500\*

It has two bedrooms and a large sleeping loft . . . plenty of room for the family. Other models are also available at equally affordable prices. Custom-tailored finishing packages (interior trim, plumbing, etc.) are available to complete your dream home.

\* Exclusive of taxes and delivery — slightly higher in Wisc.

Send \$1.00 for "Quick & Easy" Planning Guide.

105L6

Name \_\_\_\_\_

Address \_\_\_\_\_ Phone \_\_\_\_\_

City \_\_\_\_\_ State \_\_\_\_\_ Zip \_\_\_\_\_

I plan to build \_\_\_\_\_, at \_\_\_\_\_

(when)

(where)

THE WICKES CORP. / P.O. BOX 3244-L / SAGINAW, MICH 48605



**Wickes  
Lumber**

Available through over 100 Wickes Centers in: Ark, Conn, Del, Ga, Ind, Me, Md, Mass, Mich, NH, NJ, NY, Ohio, Okl, Pa, RI, SC, Tex, Va, Vt, Wisc, and adjoining areas.

# New motorcycle alarm

Almost as safe as taking your bike to bed with you

by Ivan Berger  
ELECTRONICS EDITOR

PHOTOS BY ROBERT D. BORST

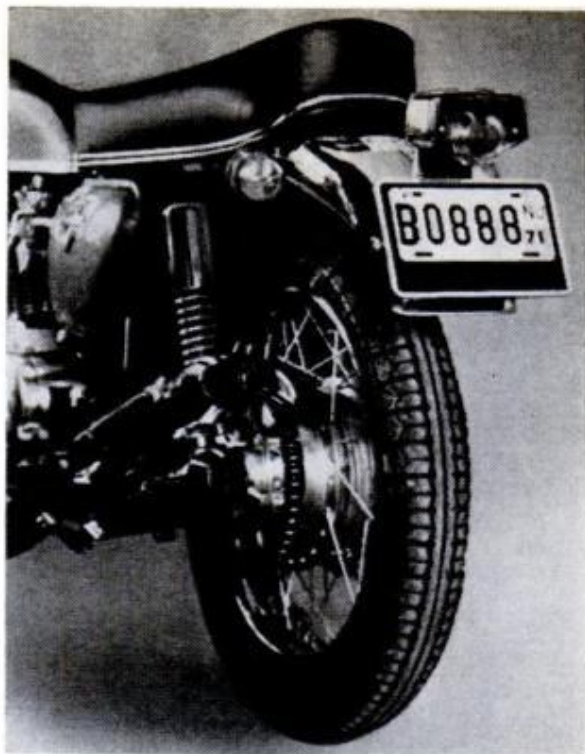

Open, Cycle-Gard II shows dual horns, mercury tilt switches.

Alarm broadcasts 500 ft. to pocket beeper.



Sleeping with your cycle is no way to protect it from theft. A motorcycle theft alarm can help you sleep a little easier—but what if you can't lock your bike within earshot of your bedroom?

Try Cycle-Gard II. It not only emits an ear-piercing, intermittent horn bleat (over 100 decibels) that can be heard about 300 feet away, but broadcasts to a small radio receiver, too. With the receiver clipped to your shirt pocket or belt or sitting in its recharger on your night table, you'll hear the alarm's warning up to about 1/10 mile away (the distance will be less where steel-framed city buildings get in the way).

The alarm mounts to a license-plate bracket (with a little drilling needed for some foreign bikes). Tilting or shaking the bike or trying to open the alarm sets it off; but if the bike stays upright and undisturbed, the alarm shuts off within a minute. Cycle-Gard II is \$89.95; Cycle-Gard I (without radio) is \$29.95. These units are made by Security Div., Alcotronics, Church Rd. and Roland Ave., Mount Laurel, N.J. 08057. ★★★

# 4 needed skills NRI can teach you at home

NRI courses can show you how to service  
TV-Radio, Repair Cars or Appliances or have a career in  
Air Conditioning, Refrigeration and Heating

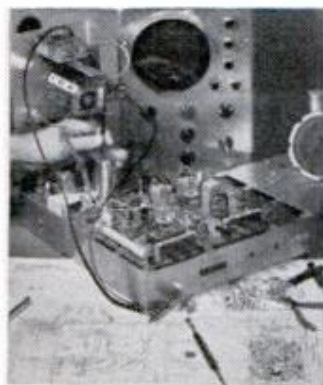

## TV-Radio Servicing

The NRI TV-Radio Servicing course includes your choice of black and white or 25" diagonal solid state color TV training equipment. NRI courses cover FCC license preparation, complete communications electronics, aircraft electronics, mobile communications, marine electronics, amateur radio, industrial and computer electronics.



## Automotive Repair

Take your choice of the Master Automotive Technician course or the shorter Automotive Tune-up and Electrical Systems course for the man seeking greater understanding of basic car repair. Both courses include professional equipment so that you get "hands-on" experience and the chance to earn spare-time money making repairs.



## Appliance Repair

NRI trains you to fix all kinds of electrical appliances, plus washers, refrigerators, house wiring, electric motors, even small gas engines. Bite-size texts fully illustrate each point. An appliance tester is included for fast troubleshooting, so you can begin earning money repairing appliances long before you finish the course.



## Air Conditioning, Refrigeration, and Heating

NRI can teach you to install, maintain and service the latest in cooling and heating equipment. The Course was created by NRI with technical assistance of the York Division, Borg-Warner Corp., and includes a window air conditioner for training and your own use. A real high-paying career.

## Hands-on training and bite-size texts

NRI was the first to supply home study students with custom-designed training kits to give practical hands-on experience as you learn. You get more value from the exclusive Achievement Kit sent the day you enroll, to "bite-size" texts and training equipment.

## Earn \$5 to \$7 an hour spare or full time

Tens of thousands of NRI graduates are proof it is practical to train at home in your spare time. Keep your present job while preparing for a better one and earn \$5 to \$7 an hour extra in your spare time.

## Train with the leader—NRI

The same training innovations which have made NRI the leader in career training at home are now available to you. Let NRI help you step up to better part-time or full-time earnings, a brighter future. Decide now to move ahead . . . the decision is yours to make. Mail the postage-free card today for a free full-color catalog in the field of your choice. No obligation. No salesman will call.

**APPROVED UNDER GI BILL**—If you have served since January 31, 1955, or are in the service now, check GI line on insert card.

SEND THE CARD TODAY FOR FREE CATALOG



**NRI TRAINING**

3939 Wisconsin Avenue  
Washington, D.C. 20016

## MOST VERSATILE TELE LENS

(Continued from page 149)

trol ring to focus—you slide it, as you do to zoom in normal operation. It's an easy switch to master, and it's the key to the lens's ability to get sharp pictures over a wide, wide range of distances.

The problem is, a lens's sharpness changes as you focus it. Lenses are designed for maximum sharpness at one distance (usually infinity, but closer for macro lenses). Focus them at any other distance, and their performance deteriorates. In Vivitar's new Series 1 lenses, steps have been taken to minimize this change, allowing closer sharp focusing. In the fixed-focal-length members of the Series, a single "corrector" element at the rear of the lens compensates for the change in aberration as the lens is focused. (The corrector also shortens the distance the lens must travel away from the film for close focusing, which leads to more reliable focusing mechanisms and helps keep the lenses—already compact at infinity—compact at close-focusing extensions, too.) This approach allows Vivitar's Series 1 135-mm  $f/2.3$  to focus to 3 feet from the film plane,

---

### **Vivitar doesn't call it a 'macro' but a 'macro-focusing' lens. It's an important distinction.**

---

and its 200-mm  $f/3$  to focus to 4 feet. The average 135-mm lens will focus only to 5.6 feet, and the average 200-mm will focus only to 9 feet.

But this approach, ingenious as it is, won't work with zoom lenses. No fixed correction can cope with changes in both focal length and focus. Most zooms keep things under control by shifting elements within the lens as you zoom, moving the front elements (not the whole lens, as in conventional, nonzoom optics) for focusing; so does this Vivitar. But in macro mode, three groups of elements inside the lens move as a unit to shift the lens's optical center further from the film plane as you slide the control collar away from you—just as the optical center of a bellows-mounted lens would move outward when you extended the bellows.

The front elements, which normally do the focusing, are left in their close-focus position for maximum sharpness (turning the focus control just degrades the image).

That's good human-engineering, too: Because the proper macro setting is already at minimum focusing distance, not infinity, there's no temptation to degrade the image by trying to focus just a little closer; and because, at the transition point, you're focused for the same distance in either normal or macro mode, the total effect is nearly that of smooth, continuous focusing from macro to infinity.

Vivitar is careful, nonetheless, not to call this a "macro" lens, but a "macro-focusing" one. It's an important distinction. Though the lens's focusing range extends into the true macro area, and its close-up resolution is respectably high, this is still, basically, a tele lens, designed for maximum sharpness when shooting distant objects. The macro-focus feature is just an extra convenience that increases the utility of the lens; it's still not as sharp close up as a lens that has been specifically corrected for macro use (though the Vivitar is probably a lot sharper than a macro lens would be at infinity).

A close look at the lower photo on page 148, and the second photo down on page 149, will show definite blurring at the edges—blurring that didn't occur on any of my tele shots. The blur is a little more pronounced with the mustache shot on page 149, both because it was shot wide open at  $f/3$  (the copy shot on page 148 was made at about  $f/16$ ) and because the subject curves away from the lens—the field on which the lens will focus sharply follows the curve of the front element (a good, true macro would have a flat field), making the Vivitar better for shooting a bee inside a flower than a fly on a tomato.

Nonetheless, it's a very useful close-up lens. For one thing, its good balance lets you shoot comfortably at even  $1/30$  second. For another, its fast operation helps you shoot small, moving objects like the wobbly young kitten on page 149.

The Vivitar Series 1 70-210-mm macro-focusing zoom sells for about \$369 (less case and lens hood); the 135-mm  $f/2.3$  will be about \$179.50 and the 200-mm  $f/3$  will be about \$209.50 (both with built-in, telescoping hoods). About 15 more Series 1 lenses are under development, including high-speed lenses, ultralong but ultracompact teles, and lots more zooms (including a wide-angle that Vivitar hopes will zoom from about 20 to 45 mm). For more information, write Ponder & Best, Inc., 1630 Stewart St., Santa Monica, Calif. 90406. ★★★



# What Do Many Doctors Use When They Suffer Pain Of Hemorrhoidal Tissues?

Exclusive Formula Gives Prompt, Temporary Relief In Many Cases from Such Pain. Also Helps Shrink Swelling of Such Tissues Due to Infection.

In a survey, doctors were asked what *they* use to relieve such painful symptoms. Many of the doctors reporting said that they either use Preparation H themselves or in their office practice.

Preparation H gives prompt, tem-

porary relief for hours in many cases from pain, itching in hemorrhoidal tissues. And it actually helps shrink painful swelling of such tissues when infected and inflamed. Just see if doctor-tested Preparation H® doesn't help *you*.

## NEW SUPER TRYKE

KIT PRICE \$369.95



YEAR ROUND FUN

HEALD'S NEW "SUPER TRYKE" Has full suspension front and rear, large 21" dia. x 12" wide ATV tires and 8 H.P. 306 cc. Tecumseh Engine. Torque Converter drives differential rear axle through #40 chain. Options include electric start, front ski, lights, roll bar, spark arrester muffler. Tryke comes in easy-to-build semi-kit form. Base kit price \$369.95. Ideal for farm or recreational use on snow, sand or trails.

FOR MORE INFORMATION WRITE  
HEALD INC., Dept. PM-6, P.O. Box 1148,  
Benton Harbor, Michigan 49022

**FREE CATALOG**

## BUILD, FLY YOUR OWN COPTER!

It's great sport to fly a Bensen Gyrocopter — lowest cost, too. Fly high or low, fast or slow. Adapts to floats. Pilot ages range from teens into 60's. Enjoy flying this easy way! Plans, parts and factory kits available. Get colorful info packet with photo, specs, 3-View Drawings. Send \$5 today!

BENSEN AIRCRAFT CORP., Dept. PM-63  
RDU Airport, Raleigh, N. C. 27602

NAME \_\_\_\_\_

ADDRESS \_\_\_\_\_



## GARAGE OPERATOR... \$89.95!

- RADIO CONTROLLED from car transmitter or wall switch
- SAFETY night and day year 'round
- SECURITY door locks tight when closed
- CONVENIENCE in car control any weather
- LIGHTING garage lights automatically
- VERSATILE fits all lifting type wood, metal or fiberglass doors sectional and 1-piece
- EASY HOME INSTALLATION in just 2-3 hours
- SAVE up to 50% direct factory purchase and PP or UPS home delivery
- GUARANTEED one year
- FREE brochure

HELMATE Equipment Co., Box 51PM, Baroda, MI 49101

## A FUN-FRAME PLAYHOUSE TO BUILD



A real fun playground for children with a swing set, sandbox, play table and a seesaw. An attractive addition to your backyard. Complete construction plans, detailed diagrams, and material lists. One set of plans \$3.95, two sets \$5.50 (you may need to file one set with your local building dept.). To order plans: Send your check or money order to: **IDEA ENTERPRISES, Dept. PM, G.P.O. Box 1720, Grand Central Station, New York, N.Y. 10017.**

All plans sent postpaid first class mail

## BUILD YOUR OWN GRANDFATHER CLOCK



Save over 50% by building your own grandfather clock. Stately, straight-sided "AMERICAN CLASSIC" with beveled plate glass sides. Narrow waist designs: "SPIRIT OF '76" with finely sculptured crown and brass-tipped pillars; or easy to build, always popular "SPIRIT OF THE CENTURY." Our kits are Red-i-Kut, semi-assembled, hand-crafted of solid 3/4" kiln-dried mahogany, cherry or walnut. Tubular bell or Westminster rod chimes. Moving moon dials painted by our own artists, and our own original Goddess Diana or Lady Florentine pendulums. Gorgeous solid bronze dials with raised numerals and corners. Send \$2.50 for all three plans, plus description of kits and movements, as folks have for more than fifty years.

**KUEMPEL CHIME CLOCK WORKS & STUDIO**  
Route 3, Box 240J, Excelsior, Minnesota 55331

# BRADLEY GT

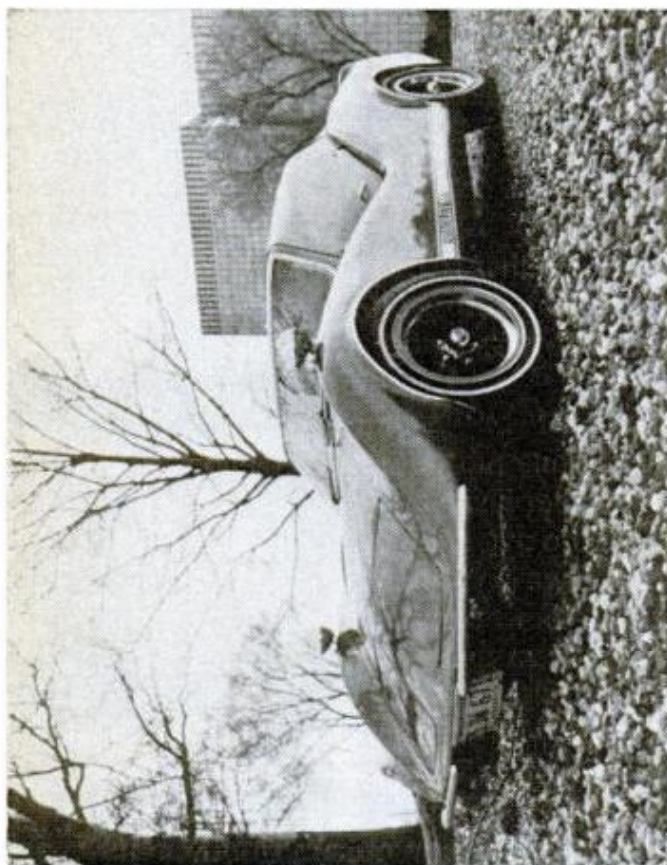

## ...VW IN DISGUISE! **BUILD YOUR OWN SPORTS CAR!**

... WITH THE exciting Bradley GT sports body kit - designed for easy, fast assembly on a stock VW chassis. No welding or special tools required. The dynamically designed body is prefinished in a choice of 50 brilliant colors. The Bradley GT resembles a VW only in respect to its economy and reliability. The stock VW engine gives surprising performance and handling because of the Bradley GT aerodynamic body design reduced weight and lower center of gravity. With a stock VW engine, the Bradley GT will cruise at 80 m.p.h. at 28 miles per gallon.

The comprehensive kits include all parts, hardware, nuts and bolts, and full assembly manual. The assembly manual includes over 150 photos and diagrams covering all phases of preparation and complete assembly.

Easily assembled on a stock VW chassis, the Bradley GT is fascinating and practical, blending beauty and function into a truly creative and exciting motoring experience.

FOR FULL INFORMATION, FULL-COLOR POSTER AND BROCHURE  
SEND \$2.00 TO

AMERICA'S LEADING KIT-CAR BUILDER

## BRADLEY AUTOMOTIVE

DEPT. PM6/7669, WASHINGTON AVE. SO., EDINA, MN. 55435/612-941-6727

ENCLOSED IS \$ \_\_\_\_\_ PLEASE RUSH \_\_\_\_\_

POSTER, BROCHURE AND COMPLETE INFO, (\$2.00)  ASSEMBLY MANUAL \$7.00

NAME \_\_\_\_\_

ADDRESS \_\_\_\_\_

CITY \_\_\_\_\_ STATE \_\_\_\_\_ ZIP \_\_\_\_\_

MY PHONE NUMBER \_\_\_\_\_

## BREEZY LITTLE HOMEBUILT

(Continued from page 129)

mum drag in flight to compensate for their nonretractability.

The all-metal ship is made of Monel assembled with "Pop" rivets—those handy fasteners that make blind riveting a snap. The main airframe is slab-sided with a minimum of curves and bends. A 54-hp VW engine drives the prop through an ingeniously simple V-belt and pulley arrangement providing a 2¼-to-1 reduction ratio. This gives a prop speed of 1780 rpm at an engine speed of 4000 rpm. While power is modest, it's enough to push the PL-4A along at a top speed of 110 mph and a cruising speed of 100. The earlier PL-2, with twice as many horses, cruises at about 136 mph—only a bit better. The PL-4A's improved efficiency on less power is the result of its lighter weight and smaller size. Overall length is 16 feet, 2 inches—about 3 feet shorter than the PL-2. Wingspan is 26 feet, 8 inches against 28 feet for the PL-2. Empty weight is 578 pounds, with a gross of 850. The PL-2 weighs in at about 900 pounds *empty*—there's the big difference.

Despite its simplicity, however, the PL-4A incorporates some sophisticated innovations not found in its predecessors. Its wings fold for easy storing and road-towing, whereas those on the PL-1 and PL-2 are fixed. Also, formed into the wingtips is a slight downward-curving gull-like "droop." This improves wingtip lift much the same as wing flaps increase lift on other aircraft. The result is prolonged lift at near-stall speeds. Since wings stall progressively from their outer tips inward, becoming less and less stable as their lift area narrows, the ability to keep the wingtips "flying" even after a plane reaches its normal stall point adds much to its stability, handling ease and safety at critical landing and take-off speeds. The PL-4-A can land at 55 mph in 500 feet and take off in the same distance.

While Paz doesn't claim acrobatic capabilities for his tiny newcomer, it's stressed at plus or minus 6G—far in excess of minimum stress requirements for commercial lightplanes and easily enough to withstand even the tortures inflicted on it by inexperienced pilots. Like all of Paz's home-grown creations, the PL-4A is a rugged and "forgiving" plane built to take abuse. Estimated cost is \$2000, including engine. Plans are \$50 from Pazmany Aircraft Corp., Box 10051, San Diego, Calif. 92110. ★★★



SEE FOR YOURSELF

# How to Fix Almost Any Part of Almost Any Car

QUICKLY, EASILY and RIGHT on the very first try



- Transmissions
- Starter Switches
- Carburetors
- Fuel Pumps
- Valves
- Ignition
- Engines
- Brakes
- Overdrives
- Axles

- Universals
- Steering Gears
- Dash Gauges
- Power Brakes
- Water Pumps
- Starters
- Front Ends
- Oil Pumps
- Rear Ends

USED BY  
U.S.  
ARMED  
FORCES

## THIS GIANT PICTURE BOOK SHOWS YOU STEP-BY-STEP HOW TO REPAIR PRACTICALLY EVERY CAR BUILT FROM 1967 THRU 1973

Whether You're a Beginner or an Expert Mechanic—This Manual Can Help You "Breeze Through" the Toughest Auto Repair Job

OVER 6,000,000  
COPIES SOLD!

DON'T waste time, money, energy by trying to guess how to fix a car! Do what the experts do. Whether it's a simple carburetor adjustment or a complete overhaul — simply look up the job in the index of MOTOR's New AUTO REPAIR MANUAL. Turn to page covering job. Follow clear illustrated, step-by-step instructions. See for yourself how easy it is!

No guesswork! MOTOR's MANUAL takes nothing for granted. Tells you where to start. What tools to use. Then it leads you easily and quickly through the entire operation!

**Over 3,000 Pictures! So Complete, So Simple, You CAN'T Go Wrong!**

MOTOR's MANUAL covers all major makes. 1967 thru 1973, including compacts. Over 1,000 giant pages. 3,000 "This-Is-How" pictures. "Quick-Check" charts. 55,000 essential specifications. Over 225,000 service and repair facts. Instructions and pictures are so crystal-clear you just can't go wrong!

### Meat of 300 Official Shop Manuals

Engineers from every automobile plant in America worked out these time-saving procedures for their own motor car line. Now this wealth of "Know-How" from 300 Official Shop Manuals has been "billed down" into crystal-clear terms in one handy indexed book! No wonder MANUAL is used by so many schools!

**SEND NO MONEY  
Try Book 10 Days FREE**

Mail coupon today and we'll send MANUAL to use FREE for 10 days. Test book in your own garage or shop. It's GUARANTEED to pay for itself in 10 days. If it doesn't, return it, and owe nothing. Rush coupon now. MOTOR BOOK DEPT., P.O. Box 2316, F.D.R. Sta., N.Y., N.Y. 10022. (SCHOOLS, BOOKSTORES: Write for discounts.)

**CLEAR UP 'MYSTERIES'.** "I always rely on MOTOR when I do a repair I am not familiar with."  
—E. Jones, Minnesota (Shop Owner)



**GREAT HELP FOR STUDENT.** "MOTOR pulled me out of some rough spots in high school, and now in the Armed Forces motor pool."  
—W. Bekemerer, Missouri (Apprentice)

MAIL COUPON FOR

**FREE  
10-DAY TRIAL**  
OF MOTOR'S AUTO REPAIR MANUAL

MOTOR BOOK DEPT. F116  
P.O. Box 2316, F.D.R. Sta., New York, N.Y. 10022

Please send me the Manuals checked below for ten days free examination:

- 11122 MOTOR's Auto Repair Manual, \$10.95
- 12526 MOTOR's Auto Engines & Electrical Systems, \$10.95

If I am not fully satisfied, I will return the shipment promptly and owe nothing. Or I will keep it and pay the total price in three monthly installments, plus a small shipping charge.

#### I WANT TO SAVE SHIPPING CHARGES

I am enclosing payment of \$..... in full and you will pay shipping charges. (Same return privileges, refund guaranteed.)

Print Name..... F116

Address.....

City & State..... Zip.....

Signature Please..... Age.....

Offer available only in the Continental United States and Canada. Prices slightly higher in Canada. Delivery will normally be 3-4 weeks in Eastern U.S. and slightly longer West of the Miss.

(H.M. Books)

### Same FREE 10-Day Offer on AUTO ENGINES & ELECTRICAL SYSTEMS

Over 700 pages. 1,300 pictures. Clear how-to text on principles, design, maintenance of all parts of engines & entire electrical system. For FREE trial, check coupon.



## BEST BIKES FOR YOUR FAMILY

*(Continued from page 102)*

these days, so perhaps convertibility isn't all that important.) Weight is 31 pounds. This is an extremely sturdy bike, so if you have a large family, I'd recommend it.

- *Huffy Dream Cycle H-100 (\$31.88)*: A convertible model, the H-100 has 16-inch semipneumatic tires, flat handlebars, spring saddle, removable fenders, training wheels, coaster brake. Not a toy-type kiddie bike.

### Bikes for ages 6 to 9

Boys 6 to 9 take a dim view of a convertible bicycle, since they prefer one essentially masculine in nature. For this age group, bicycles should have larger wheels, around 20 inches. Hand caliper brakes are definitely not desirable because children this age do not have the reach or the strength to work handlebar-mounted levers safely.

Preference of boys a few years ago for so-called "high-rise" handlebars and banana seats is, fortunately, diminishing. High-rise bars force the child to ride with elbows up at chin height, making accurate steering very difficult. Banana seats practically beg him to carry along a passenger, which adds to instability and distracts the boy who's steering. Children this age are notoriously unpredictable; they are likely to swerve in any direction at any time in any amount of traffic. It makes sense, therefore, to give the child a bicycle with conventional flat bars, spring saddle and diamond or cantilever frame, all of which make accurate steering as easy as possible. My selections:

- *Raleigh Mountie DL80 (boy's) and DL80L (girl's) (\$54.95)*: These are one-speed miniature models of the adult-size three-speed. They have 20-inch wheels, coaster brakes, and pedal and rear reflectors. Tires are 20x1 $\frac{1}{8}$ -inch pneumatic. The bike comes with chromed fenders and kickstand. Handlebars are flat type, seat is conventional spring and the boy's frame is diamond design. The girl's frame is standard U-shape, with double down tubes. A good-sized chain guard is standard. Both models have a 14-inch frame and weigh 26 pounds.

- *Schwinn Breeze Model K84-6 (girl's) and Speedster Model K34-6 (boy's) (\$53.95)*: Here's a one-speed, coaster-brake, tough little machine that can take anything three or more children in line can dish out. The boy's frame is a modified diamond shape;

the girl's, a conventional down-tube U-shape. Both are strongly welded of heavy-gauge seamed tubing. Each model has sensible, flat handlebars. The saddle is conventional spring design and it can be adjusted to fit the growing child. The fork is of forged steel, as is the chainwheel and bottom bracket assembly. Fenders and wheels are chrome-plated, tires are 20x1 $\frac{3}{8}$ -inch nylon cord which will take a lot of curb banging. Both models have a kickstand, reflectors on pedals and rear fenders and weigh 31 pounds.

- *AMF Voyager Models T-1201 (boy's) and T-1211 (girl's) (\$65)*: This bike has one-speed coaster brake, 20-inch wheels and comes in boy's and girl's frames. The boy's is a double-top-tube cantilever frame; the girl's, a double-down-tube U-frame. The boy's model has taped, downturn handlebars; the girl's model has flat bars. Both have spring saddles, 20 x 1 $\frac{3}{8}$ -inch tires, kickstand, pedal and rear reflectors, fenders and chain guard. These are simple, basic, unadorned and sturdy bikes that will take a lot of kicking around.

### Bikes for ages 10 to 12

A few years ago, children this age wanted nothing more in a bicycle than that it resemble a sports car or motorcycle as closely as possible. Bikemakers met this demand with expensive 20-inch wheel bicycles with "five on the bar" gearshift, high-rise "sissy bars," dragster smooth rear tires and smaller front wheels. Today's child knows a lot more about bicycles. He is, thankfully, asking for a bicycle that resembles the 10-speed "racer" with narrow seat and downturned handlebars ridden by his older brother. Accordingly, I have selected three very well made, 10-speed bicycles for these youngsters, with frames small enough for them to ride comfortably and safely. These machines are a smaller version of medium-quality adult 10-speeds, and on them the 10 to 12-year-old can accompany his parents on bicycle trips of 40 to 50 miles a day. My selections:

- *Raleigh Record 24 DL129 (\$94.95)*: This 24-inch, 10-speed version of the adult Raleigh Record is a new, scaled-down model ideal for boys 10 to 12. Made to Raleigh quality standards, with main tubes of 2030 steel, it has a frame size of 18 inches, three-piece steel-cottered cranks, rattrap pedals, front and rear side-pull caliper

*(Please turn to page 190)*

# Industry tested SuperBonder™ Adhesive.



New, Miracle SuperBonder adhesive, from Loctite, proved successful in many industry applications now available for home use. Repairs almost anything and everything... in seconds... without clamps. Bond vinyl car trim, repair vinyl upholstery, valuable ceramics, china, glassware, toys. Build models. Send check or money order for \$2.00 plus 50c for postage and handling for SuperBonder, from Loctite, the makers of Lock n' Seal.

SuperBonder Offer P2  
Box 1014  
Hartford, Connecticut 06101



Please send \_\_\_\_\_ tube(s) SuperBonder. \$2.00 per tube plus 50c per order enclosed for handling and postage. (Conn. residents add 7% State tax.) Allow minimum 14 days for delivery

NAME \_\_\_\_\_ AGE \_\_\_\_\_

ADDRESS \_\_\_\_\_

CITY \_\_\_\_\_ STATE \_\_\_\_\_ ZIP \_\_\_\_\_

**MONEY BACK GUARANTEE**

TM Loctite Corp.

## locksmithing and key making

**PRACTICAL UP-TO-DATE COURSE — ONLY \$7.95**

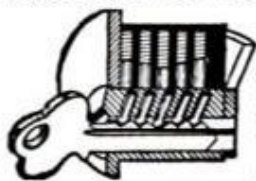

Teaches you how to pick locks, de-code, make master keys, repair, install, service, etc. New self-instruction lessons for every handyman, homeowner, carpenter, mechanic, service station operator, fix-it shop, hardware dealer, gunsmith. 53 easy illustrated lessons. Full price only \$7.95 postpaid. Satisfaction or refund guaranteed. Mail order today!

**NELSON-HALL CO., Dept. 6FX-2**  
325 W. Jackson Blvd., Chicago 60606

## I-N-V-E-N-T-O-R-S WE NEED INVENTIONS

Sell your invention for cash—need money for Patent?—Are technical problems holding you back? Universal Inventions has helped inventors all over the world—just like yourself—why not you? Inventions provide the magic spring-board to sudden riches. REMEMBER, we either sell your invention or pay you a cash bonus. Write for details, **UNIVERSAL INVENTIONS, Dept. 13, Marion, Ohio 43302**

**WHITE'S METAL DETECTORS**

WHITE'S ELECTRONICS, INC. manufacture the World's Largest and Finest Line of Mineral and Metal Detectors. Ghostwriting beachcombing bottle hunting coin hunting—all types of TREASURE HUNTING or PROSPECTING amateur or professional. Detect conductive metals—Gold, Silver, Copper Nuggets Coins Rings, Jewelry, etc. Underwater or on the land. "There are no finer at any price" 25 production model to choose from—T.R. or B.F.D.

Priced from **\$750 up**  
—Always specify the Blue & Gold Ask FOR WHITE'S BY NAME  
—Free Literature—  
**WHITE'S ELECTRONICS**  
Rm. P.O. 512  
1011 Pleasant Valley Hill,  
Sweet Home Oregon  
23784 Hazel Street  
Abbotsford, B.C. Canada  
Ex. Air Mail, Visa, P.M.  
Detroit Div. East  
Enlist Ind. 40514

## VENTURE CAPITAL—SMALL BUSINESS LOANS— BUSINESS OPPORTUNITIES

Every month NATIONAL INVESTMENT REPORTER lists 100's of venture capital sources and small business loan sources. All these sources are interested in loaning money to new and small businesses. If you need \$1,000 or \$10 million there is sure to be at least one source to fill your need. Every issue is also packed with little known business opportunities located from coast-to-coast. To get your business started order NATIONAL INVESTMENT REPORTER today. Sample \$2, 6 month subscription (6 issues) \$10.00, 12 month subscription (12 issues) \$18.00.

**NATIONAL INVESTMENT REPORTER**  
Dept. 111, Box 7212, Chicago, Illinois 60680

## START A BUSINESS in your neighborhood



Sharpen Hand or Power  
Saws with the

### FOLEY SAW FILER

Start your business in sparetime and make CASH PROFITS right away. No stock to carry, no selling involved, no experience needed —the Foley Saw Filer does every sharpening job **automatically!** Earn \$3 to \$6 an hour sparetime in your own garage or basement. Profit 90c on every dollar.

Best of all, every saw you sharpen, will be resharpened again and again—watch your repeat business grow! Add cash to your income now, while you build retirement security with the Foley Saw Filer.

**FREE BOOK** shows how you can make money as thousands of others have. Send coupon today. There's no obligation, and no salesman will call—so write today!



**Foley Manufacturing Co.**  
643-3 Foley Bldg., Minneapolis, Minn. 55418  
Send for FREE book on Money-Making facts about the sharpening business.

NAME \_\_\_\_\_  
ADDRESS \_\_\_\_\_  
CITY \_\_\_\_\_ STATE \_\_\_\_\_ ZIP CODE \_\_\_\_\_

# KARATE

JUDO-SAVATE  
JIU-JITSU

The Greatest Self-Defense System Known To Man! Learn-At-Home-Course reveals hundreds of deadly self-defense secrets, which will enable you to protect yourself from any attacker! Easy to learn! FREE COLORFUL BROCHURE REVEALS SELF-DEFENSE TECHNIQUES. **FREE**

Send to: **UNIVERSAL, Dept. M**  
BOX 39303 DETROIT, MICHIGAN 48239



## BEST BIKES FOR YOUR FAMILY

(Continued from page 188)

brakes, downturned handlebars. It weighs 29 pounds, has reflectorized pedals, narrow racing saddle. Tires are clincher type. Shift controls are located on the down tube, which is the safest location for youngsters. Frame is fully lugged, and bottom bracket assembly has micrometer adjustment of ball-bearing races for low friction operation.

● *Schwinn Varsity Sport 144* (\$104.95 without fenders, \$109.95 with fenders): Another 10-speed scaled to fit boys (or girls) 10 to 12. It has downturned racing handlebars, narrow racing saddle, side-pull caliper brakes. The gearshift lever is stem-mounted. The bike has one-piece steel cranks, weighs 36 pounds.

● *Nishiki Olympic* (\$109.95): This is an adult bicycle that comes in a 19-inch frame size that will fit the taller child in the upper range of the 10 to 12-year age group. Even though this model has 27-inch wheels, the smaller frame sizes can be ridden by these youngsters. (My 11-year-old rode a 21-inch frame with 27-inch wheels over 50 miles on a one-day trip.) The Olympic is a fairly low-cost bicycle that will stand up to juvenile treatment. Brakes are alloy center-pull, rims and hubs are aluminum alloy, as are handlebars and stem. The saddle is narrow, nylon-quilted; handlebars are the turned-down type, and it uses Shimano Eagle steel derailleurs. The Olympic, which weighs about 33 pounds, also comes in a girl's model.

### Adult bicycles (under \$100)

I have selected two three-speed bicycles and one 10-speed in the under-\$100 price category for adults. A three-speed bicycle, while considerably heavier than most 10-speeds, does have certain advantages for some uses. For example, if all you want is something for scooting around the college campus or for casual evening rides of a few miles, then a three-speed bicycle can be used. The three-speed can have a chain guard, fenders, metal wire carriers and lights. You can, of course, hang all this stuff on a 10-speed, but you'd be carrying a lot of extra steel that will make long trips a lot more work than they should be. Selections:

● *DBS Special Model 113-3U* (man's) and *263-3U* (woman's) (\$89.95): Made by Jonas Oglænd in Norway, this rugged all-welded lugless frame features a front in-

ternal expanding hub brake and coaster rear brake made for safe riding down steep Norwegian hills. Brakes are outstanding, and the front hub brake gives excellent stopping power even on rainy days. Another feature is a built-in wiring system, so generator wiring is not exposed but runs inside the frame. The rear light is fixed to the fender (generator and front light not provided). Tires are 26 x 1 $\frac{5}{8}$ -inch clinchers on alloy rims. It comes with kickstand, chromed rear luggage carrier with spring clamp and front light mount. The Special has flat handlebars, spring saddle, excellent multicoat enamel finish. Weight is 38 pounds. Frame size is 22 inches; this may seem a bit big for women, but remember the lady's model has no top tube, so the only consideration is whether you can reach the pedal at the bottom of the stroke from the lowest seat position.

● *Raleigh Sports DL22* (man's) and *DL22L* (lady's) (\$79.95): In both men's and women's frames, this old English "racer" standby is a tough three-speed with front and rear side-pull caliper brakes that will give you good service on short trips. An option, if you have short fingers and prefer a coaster brake, is a rear-coaster-brake, three-speed hub with front caliper side-pull brakes, available with the 19 $\frac{1}{2}$ -inch women's frame. Men's frame comes in 21 and 23-inch sizes, women's in 19 $\frac{1}{2}$  and 21. The bicycle has flat handlebars, spring saddle, rear bag, pump, rear and pedal reflectors, chain guard and front light mount on the stem. A new feature is the Raleigh self-adjusting brakes which automatically compensate for brake cable stretch and brake shoe wear. The Sports also has full fenders and three-piece steel cranks. It weighs 38 pounds.

● *Crystal Model 220* (\$99.50): A low-cost 10-speed with center-pull caliper brakes, 27 x 1 $\frac{1}{4}$ -inch clincher tires, seamed steel lugged frame, turned-down handlebars and narrow racing saddle. Frame sizes are 22 and 24 inches, which fit riders from 5 feet 9 inches up to 6 feet 1 inch. This bicycle weighs 34 pounds, which is reasonable for a 10-speed in this price range.

### Adult bicycles (\$101 to \$249)

Last summer you would have had trouble buying a medium-priced bicycle; today, with all the bikes being imported, you should have no trouble finding one. Here

[\(Please turn to page 192\)](#)

# Announcing

## Popular Mechanics Picture-Tools - the handiest shop-organizers ever designed

POPULAR MECHANICS PICTURE-TOOLS are a great new idea to take the confusion out of *what goes where* on workshop tool panels.

The complete PM PICTURE-TOOL KIT consists of seven big sheets (9¾ x 11¾ in.) of a special heavyweight paper with a pressure-sensitive adhesive on the back. On each sheet are beautiful drawings of hand tools and portable power tools—all (74 in total) you're likely to have in your shop. Most are full size; the others, only slightly reduced.

Also enclosed in the kit is a blank sheet of the same special paper, printed in an overall color to match the tools. This sheet enables you to design your own drawings or silhouettes of any special tools you have.

Each of the PM PICTURE-TOOLS is carefully die-cut. You simply peel it off the backing paper and apply it to the proper spot on your panel. You can apply PICTURE-TOOLS to any painted or unpainted wood, plywood, hardboard and even perforated-hardboard surface.

Later if you want to move a few tools or rearrange the entire panel, you can peel off

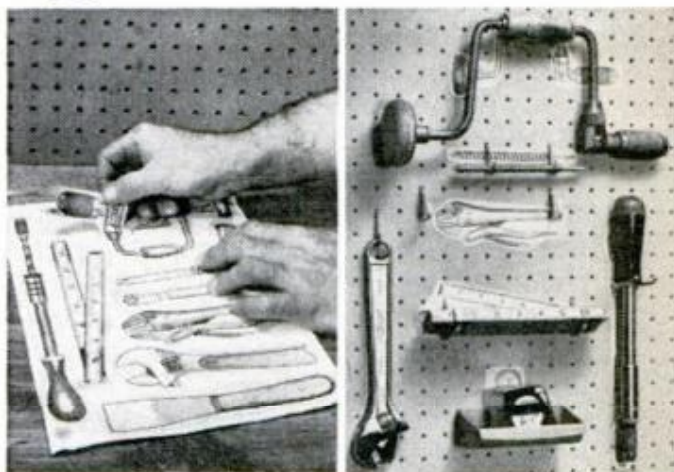

the PM PICTURE-TOOLS and move them to new locations. They are reusable!

Once your PICTURE-TOOLS are in place, you'll know at a glance exactly where each tool in your shop belongs. You'll also know—again at a glance—what tools are missing.

Best of all, you'll be surprised how PM PICTURE-TOOLS will instantly and dramatically enhance the appearance of your shop!

**Order your PM PICTURE-TOOL KIT today!**

Only  
**\$3.95**

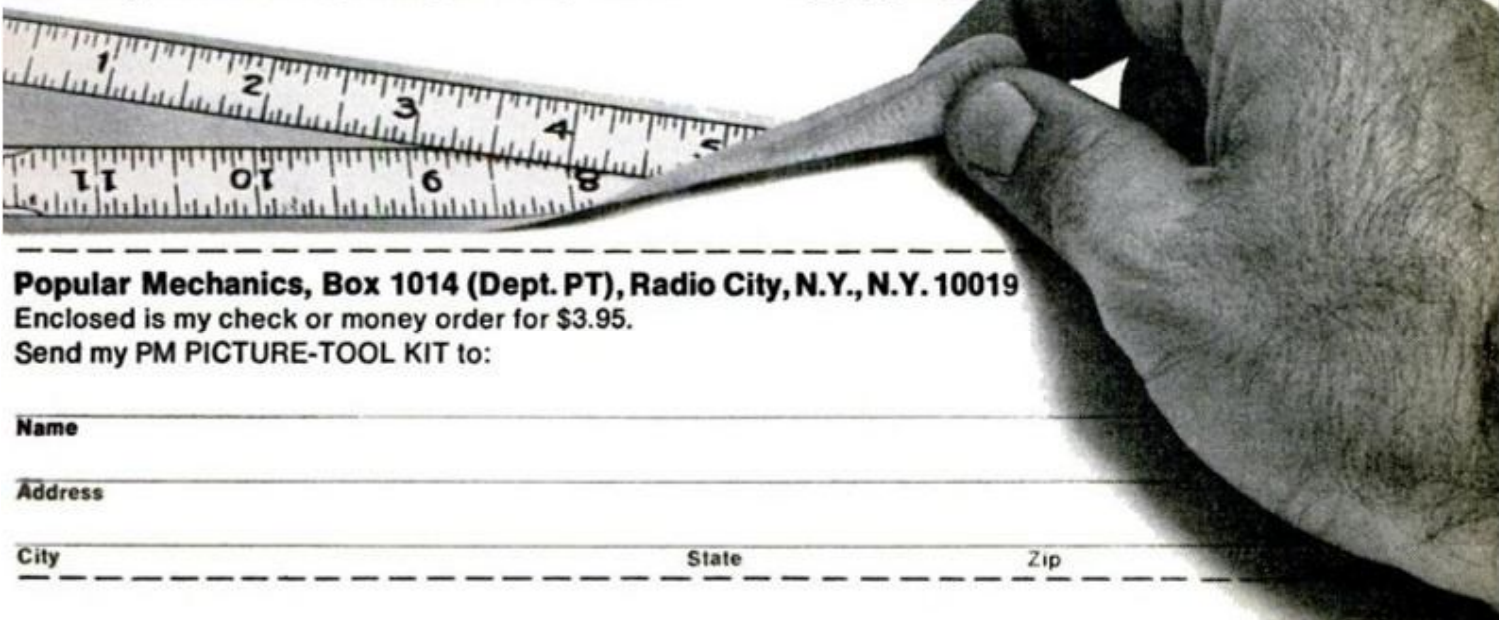

**Popular Mechanics, Box 1014 (Dept. PT), Radio City, N.Y., N.Y. 10019**

Enclosed is my check or money order for \$3.95.

Send my PM PICTURE-TOOL KIT to:

Name \_\_\_\_\_

Address \_\_\_\_\_

City \_\_\_\_\_

State \_\_\_\_\_

Zip \_\_\_\_\_

## BEST BIKES FOR YOUR FAMILY

*(Continued from page 190)*

are four selections in the low, medium and higher end of this price bracket. These machines are, of course, not the only models made that represent good value at the price, but they are tops among the ones that do. With reasonable care, they can last a lifetime. Selections:

● *Raleigh Grand Prix Model DL115 (man's) and DL115L (lady's) (\$120)*: If you're looking for a reasonably good 10-speed at a fairly low price, the Grand Prix is it. The frame is Raleigh 2030 seamed high-carbon steel, and it comes in sizes 21½, 23½ and 25½ inches for men and 21½ for women. The frame is fully lugged with cutaway-style lugs. The saddle is all leather with chrome frame; brakes are Weinmann 999 center-pull. The 10-speed gearshift levers are mounted on the down tube, the safest location. Derailleurs are Simplex Prestige front and rear. Gearing is medium range, with a rear freewheel gear cluster of 14 to 28 teeth and a steel dual chainwheel with 40 and 52 teeth. Pedals are steel rattrap without toe clips or straps. Tires are 27 x 1¼-inch clincher type. The top tube has brazed-on cable fittings. The downturned handlebars and stem are of aluminum alloy, as are rims and hubs. It weighs 30 to 31 pounds, depending on frame size.

● *Jeunet Model 620 (\$160)*: A good 10-speed bicycle, in rather limited distribution yet. It has a high-carbon steel, lugged frame, with chromed fork and stay tips. Its three-pin steel dual chainwheel with 46 and 52 teeth, with the 14 to 24-tooth rear freewheel gear cluster, makes this a rather narrow-range model that's fine for teenagers but not geared high enough for most people over 30. Ribs and hubs are aluminum alloy with tubular tires and quick release. Lyotard steel pedals have toe clips and straps. The saddle is molded vinyl, which is rather hard for most people. Handlebars and stem are aluminum alloy. Frame sizes are 21, 23, and 25 inches. The 620 comes with Simplex Prestige derailleurs and a pump mounted in brazed-on pump clips on the top tube. This is a handsome machine that weighs only 25 pounds. There's a lot of handwork in its striping and finishing.

● *Fuji Road Racer S10-S (\$169)*: The S10-S has a frame of steel alloy tubing, which, along with aluminum alloy components, accounts for its relatively low weight of 29 pounds for a bike in this price range.

Frame tubes and stays are brazed up rather than welded, making for a stronger frame. Cranks are aluminum alloy cotterless Sugino three pin. Gearing is medium range, with a 14, 17, 20, 24 and 28-tooth freewheel and a 40 and 48-tooth chainwheel. Rims and hubs (with quick release) are high flange, have 27 x 1¼-inch clincher tires. Its center-pull Dia-Compe brakes have quick release for easy wheel removal. The saddle is leather, handlebars and stem are aluminum alloy. Pedals are steel rattrap, without toe clips and straps. A pump is supplied.

● *Nishiki Semi-Pro Competition (\$209.95)*: This bike compares well with those costing \$50 more. It has double-buttressed chrome molybdenum frame with chrome rear stays, fully lugged. The high-tension-steel tubular fork has chrome tips. It's equipped with the better Sugino Mighty Compe five-pin dual chainwheel and cranks. Tires are 27 x 1¼-inch clinchers on aluminum alloy rims and hubs. Gearing is medium range. The derailleurs are Sun Tour VGT aluminum alloy. The men's model has aluminum alloy handlebars and stem, with gearshift levers located in the handlebar ends. It also has rattrap pedals with toe clips and straps. The seat is plastic with leather padding, and the brakes are Dia-Compe center-pull. Frame sizes are 19, 21, 23 and 25 inches. The women's model, which comes in 19 and 22-inch frame sizes, costs about \$25 less because it has flat handlebars with gearshift levers on the stem and rattrap pedals without toe clips or straps. Weight of the Semi-Pro is about 28 pounds.

### Adult bicycles (\$250 and above)

The biggest differences between bikes in this category and those in the \$100 to \$249 group are in quality of components, hand assembly and brazing of the frame, time-consuming hand finishing and striping and the "Rolls-Royce one-upmanship" that comes with owning the very best. Campagnolo and Shimano side-pull brakes are beautiful to look at, and Campagnolo Nuovo Record and Shimano Crane aluminum alloy derailleurs are likewise things of beauty and a joy forever. Campagnolo parts cost is high; you could buy a cheap 10-speed for under the \$100 you'd pay for one set of Campy brakes and derailleurs. Of the dozens of makes and models of over-\$250 bikes on the market, I have *not* selected the most expensive by any means. There's a

*(Please turn to page 194)*



# MOLDS

for making  
Ornamental Concrete  
Items...



Book about Aluminum  
Molds with prices and  
production trade secrets  
direct from world's largest  
mold manufacturer.

SEND  
\$3.00

CONCRETE MACHINERY COMPANY, INC.

P. O. BOX A99 - HICKORY, N. C. 28601



36-pc. Tool Set, G. I. cost \$265.00, now  
16-pc. Tool Set, G. I. cost \$109.00, now  
Save Even More, Both Sets, now

\$15.00  
\$ 9.00  
\$22.00

U. S. Surplus High Speed Rotary Files, Hard-  
ened Steel, use on any metal or wood for  
filing, drilling, milling, carving, routing—a  
thousand uses in every shop. Sets assorted in  
sizes from 1/4" shanks. All brand new in air-  
tight, G.I. packs. Order now!

U. S. SURPLUS CENTER  
C-1790 Nason Avenue  
COLUMBUS, OHIO 43207



Repair any watch

... SWISS OR AMERICAN

Unique, modern Sweazey System starts you making  
repairs right away. Develops skill step by step at  
home in spare time. Diploma awarded. Free  
sample lesson. No obligation.

CHICAGO SCHOOL OF WATCHMAKING  
Dept. 163, Fox River Grove, Ill. 60021

## SUBSCRIBER'S

### Change of Address Form

Please use this form to notify us at least six  
weeks before you move to your new address.

**1. Present address:** Attach address label from  
a recent issue, or print your name and address  
exactly as shown on the label.

NAME _____			
ADDRESS _____			
CITY _____	STATE _____	ZIP _____	

**2. Fill in new address:**

NAME _____			
NEW ADDRESS _____			
CITY _____	STATE _____	ZIP _____	

**3. Mail this form to:**

**POPULAR MECHANICS**

Subscription Service Dept.  
Box No. 646  
New York, N.Y. 10019

NO JOKE: The trouble with shooting

## BENJAMIN'S NEW SUPER SINGLE SHOT AIR RIFLE

is that owners could talk a donkey's hind  
leg off in telling about its power and ac-  
curacy—far and away the most potent in  
its class—and how it gives you the upper  
hand on target and small game hunting  
trips, time and again!

Despite Benjamin's enviable reputation, would you be-  
lieve some folks are under the impression that it can't  
be all that wonderful? To set things straight, once and  
for all, we present the impartial views of those that  
saw it from the business end:

Soupy Can: "Plinking tin  
cans is duck soup for  
Benjamin."

J. Rabbit: "Thanks to  
Benjamin, I'm in it  
up to my ears."

Paper Target: "Benjamin helps you improve  
your aim at home in off-season."

What more can we add other than to say  
see your sporting goods dealer now. There are  
many expertly crafted features in a Benjamin  
that set it apart for all uses—indoors or out.  
Choice of BB or 177 or 22. Reasonably priced.

**BENJAMIN AIR RIFLE COMPANY**

896 Marion St., St. Louis, Mo. 63104

You Can **DEPEND** on **BENJAMIN**

**FREE  
CATALOG**

Walnut Monte Carlo Stock  
and New Design Pump Handle,  
Thumb Safety Behind Breech.

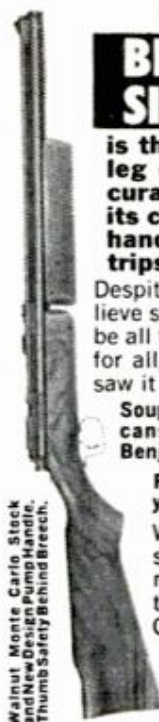

## Special-T

INTERNATIONAL NETWORK OF  
**VINYL REPAIR CENTERS**

Our Men Are Doing Jobs of  
**\$100, \$585, \$5,160, \$33,000, \$44,000**

... And They Are Making  
**\$20 to \$30 per hour**  
application time.

**YOU too can make that BIG MONEY**

... full time or part time, doing Vinyl Repair, Re-  
coloring, Conditioning for Offices, Restaurants, Hotels,  
Hospitals, Airlines, Business, Homes, Cars, Boats. Every-  
where you look there is Vinyl in need of repair—to bring  
you a **GOOD, STEADY, HIGH INCOME!**

**YOUR OWN BUSINESS**

3 Programs: \$198 — \$485 — \$1285

- You will get the best equipment and supplies in the  
business — 2 to 3 years ahead of competition.
- You will be thoroughly trained. Comprehensive manual  
— In-field instruction — 1 week factory training ap-  
proved by Calif. State Dept. of Education

**GET STARTED NOW!** This is still a new profession, but  
don't procrastinate! Age, sex, experience or education are  
not important. For full information send coupon today!

**GET FREE INFORMATION**

**SPECIALTY COATINGS & CHEMICALS, INC.**  
7314 Varna Ave., Dept. PMG, No. Hollywood, Calif. 91605

Name \_\_\_\_\_

Address \_\_\_\_\_

## BEST BIKES FOR YOUR FAMILY

(Continued from page 192)

\$1000 British Condor, for instance, with beautiful drilled-out chainwheels that look like Flemish lacework. The Eisentraut sells for \$650, the Masi for \$625, the Cinelli for \$575 and the Bob Jackson for \$550. But these are all very limited production machines, with each firm making around 600 a year. The models I have selected may not be immediately available either, but at least you can get a firm delivery date, and, if you want the best, they're worth waiting for. Selections:

● *Peugeot Model PX 10 (\$250)*: The reason the price of this 10-speed, all-double-butted 531 Reynolds-tubing-frame machine is so low is that almost all components are made in France, so you pay a minimum of duty and extra shipping costs. About the only part not made in France is the frame tubing, made in England. The PX 10 has 27 x 1 $\frac{1}{8}$ -inch tubular tires. Its French-made parts are: Simplex Prestige derailleurs, Stronglight aluminum-alloy double chainwheel, Mafac Racer center-pull brakes (very good stopping power) and Normandy aluminum-alloy hubs with quick release. The saddle is butt leather in a narrow racing design. Handlebars and stem are aluminum alloy. Gearing is medium range—okay for touring. This is a lightweight (only 21 pounds), high-performance machine representing top value for the money, in my opinion. You should have no trouble buying this model from any Peugeot dealer.

● *DBS La Migliore Professionale Model 531-DB (\$365)*: Another good-value 10-speed of highest quality, made by Jonas Oglænd in Norway. The handmade, brazed frame is of Reynolds 531 double-butted manganese-alloy steel with a yield strength of around 80,000 pounds per square inch. This model features top-grade Campagnolo components, including hubs, headset and pedals. The frame is fully lugged, with cutout Nervex lugs hand-stripped. Brakes are Weinmann 999 center-pull with quick release. The gearshift levers are Campagnolo and are located at the ends of the handlebars where they are far easier to reach than on the down tube. Handlebars and recessed stem are by Cinelli, elegantly engraved. The saddle is top-of-the-line Brooks Professional, of butt leather with copper rivets on an aluminum-alloy seat post. Tires are tubular, on aluminum-alloy rims. Frame size is limited to 23 inches,

which will fit most people 5 feet 10 inches to 6 feet 1 inch, depending on the variables of leg and torso length. I understand this bicycle will be available in a wider range of frame sizes later this year. Gearing is low-range, with a 47 and 52-tooth chainwheel and a 13, 15, 17, 20 and 22-tooth freewheel. Weight is 22 $\frac{1}{2}$  pounds.

● *Schwinn Deluxe Paramount P15-9 (\$452)*: A truly deluxe 15-speed lightweight bicycle specially designed by Schwinn engineers for the touring cyclist, this model has ultrawide-range gears that will take you up almost any hill, even loaded down with camping equipment. The frame is brazed up entirely by hand. All frame tubes, fork and stays are the top-quality manganese-alloy Reynolds 531 double-butted steel. The frame is joined in Nervex Professional cut lugs. Dropouts are Campagnolo forged. Frame sizes are available to suit almost any adult: 20, 21, 22, 23, 24, 25 or 26 inches. For about \$50 extra, you can even have a specially built frame just to fit your own body. An extra-wide gear range includes rear freewheel with 14, 16, 19, 25 and 31 teeth; the triple chainwheel has 36, 49 and 54 teeth. All components are Campagnolo, including derailleurs, hubs, headset, pedals and seat post. Brakes are Weinmann 999. The P15 comes with 27 x 1 $\frac{1}{4}$ -inch clincher tires as standard, with 27 x 1 $\frac{1}{8}$ -inch tubular tires optional at a slight extra cost. The saddle is Brooks Professional butt leather. Weight of the bike is about 25 pounds. Delivery may take up to six months, but if you want one of the best touring bikes on the market, the wait is worthwhile. Schwinn service is excellent. ★ ★ ★

### Manufacturers or importers

- AMF Wheel Goods Div., Box 344, Olney, Ill. 62450.
- Columbia Manufacturing Co., Inc., Westfield, Mass. 01085.
- Crystal Bicycles, Beacon Cycle and Supply Co., Inc., 1801 East Bolivar Ave., Milwaukee, Wis. 53207.
- DBS Oglænd, Intersport, Inc., Box 1241, Bellevue, Wash. 98009.
- Fuji Bicycles, Toshoku America, 551 Fifth Ave., New York, N.Y. 10017.
- Huffy, The Huffman Manufacturing Co., 7701 Byers Rd., Box 1204, Dayton, Ohio 45401.
- Jeunet Bicycles (see Crystal Bicycles, above).
- Nishiki Bicycles, West Coast Cycle Supply, 1241 East Watsoncenter Rd., Carson, Calif. 90744.
- Peugeot Bicycles, Franklin Imports, Inc., 2 Webster Pl., Ridgefield Park, N.J. 07660.
- Raleigh Industries of America, Inc., 1168 Commonwealth Ave., Boston, Mass. 02134.
- Schwinn Bicycle Co., 1856 North Kostner Ave., Chicago, Ill. 60639.

## PUTTING PING IN ITS PLACE

(Continued from page 168)

it is used to avoid overheating where combustion-chamber temperatures are relatively high. Cold sparkplugs have a shorter insulator tip so that heat is transferred rapidly. A hot sparkplug has a much lower rate of heat transfer and is used to avoid fouling where combustion chamber temperature is relatively low as it would be during periods of prolonged idling and continuous stop-go operation. The longer insulator forces heat to travel a longer distance. The tip, then, isn't quite cooled by the time the next combustion cycle occurs.

How do you know if overheated sparkplugs are causing preignition? Examine a few plugs. If they have a ghostly white color, they are too hot and you should substitute colder plugs. But when you switch from hotter to colder plugs, move but one heat range at a time.

The last great contributor to engine ping is carbon that has built up inside the engine. For one thing, carbon in a cylinder can become red hot, causing the fuel mixture to ignite before the sparkplug ignites

## Try the fastener fixer

from **DAP**



DAP Panel and Dry Wall Adhesive fastens wood and drywall panels to studding, old walls or furring strips easier than nailing method. Simplifies alignment and installation of paneling and wallboard.

### America's First Name in Home Fix-up



DAP Inc., Dayton, Ohio 45401  
Subsidiary of *Plough, Inc.*

## Try the 20-year fixer

from **DAP**



DAP BUTYL-FLEX® Caulk lasts up to 5 times longer than ordinary caulks. Ideal for tough sealing jobs including roof vents, metal flashings and seals between dissimilar materials.

### America's First Name in Home Fix-up



DAP Inc., Dayton, Ohio 45401  
Subsidiary of *Plough, Inc.*

it. This is preignition and it can really bust things up inside.

Carbon increases the compression ratio, too, which increases temperature. As we have pointed out, the higher the temperature of the fuel mixture the greater will be its tendency to detonate. Keep in mind that carbon is an excellent insulator which can reduce the effective cooling surface in the region of the last-to-burn portion of the fuel charge.

What to do about it? The best thing is to try to prevent carbon in the first place. One of the major reasons it forms is running an engine on a fuel mixture that is overly rich.

Another big factor is operating a car primarily in slow traffic. If you live in a city where this can't be helped, try to get the car on an open highway once a week for a long drive at good speed. Once carbon gets a toehold, you can try to get rid of it with carbon solvent, which is available at gasoline stations and auto-supply stores. If this doesn't work, then the valve train has to be removed and all of its parts cleaned, as well as all pistons, head surfaces and cylinder walls. ★ ★ ★

# Electronic 'cops' help catch crooks

by Sheldon M. Gallager



**Exact locations** of police cars show up on TV-like monitor screen in dispatcher's office, making it easy to send the nearest cars to a crime scene without having to call each one individually to find out where it is. In the German-developed Siemens system (upper left), moving dots indicate car positions on a miniature map. In background is enlarged wall map of same area. U.S. system, devised by GTE Sylvania, is similar except that duplicate map viewer is installed in each car (right, above) as well as in dispatcher's office (lower left). It also includes keyboard communication system that will permit messages to be transmitted by pushbutton code instead of by voice.

Calling "Car 54—where are you?" may be as much a thing of the past as the once-popular TV laugh show. Now police dispatchers don't have to call car 54—or any of their other cruisers—to find out where they are. The cars' exact locations automatically show up on a TV-like monitor screen at headquarters, enabling a dispatcher to rush the closest units to a crime or accident merely by watching the screen.

Such electronic patrol-car control is already being tried in several U. S. and foreign cities and is designed to speed the apprehension of criminals as well as aid

police in fire, rescue and other emergency operations. Two systems, one by Siemens in Germany and the other by GTE Sylvania in this country, are similar in use, but differ slightly in method. In the Siemens version, each patrol car transmits a continuous series of radio "beeps" coded to identify it from other cars. The signals are received almost simultaneously by four radio stations spaced apart around the city. Slight differences in reception times—varying only a few millionths of a second—indicate how far away the car is from each station and

*(Please turn to page 198)*

## MAKE UP TO \$12 AN HOUR AT HOME

Let Me Prove It To You FREE!

I'll show you how Plastic Laminating at home, spare time, can give you as much as \$12 each hour you operate. Table-top machine sets up anywhere. Easy. Fun. No experience needed. We furnish everything. We'll even help finance you. No house-to-house selling. Orders come by mail. Write for facts FREE. No salesman will call.



WARNER ELECTRIC, Dept. L-2-CF, 1512 Jarvis, Chicago, IL 60626

## LEARN UPHOLSTERY AT HOME!



Men & Women All Ages! Send for free book on learning to reupholster chairs, divans, footstools, all furniture for BIG MONEY in spare or full time. No experience needed, no age or educational limits. We show you how and provide EVERYTHING needed to start: (1) Home training covering all phases, (2) all tools and 6 big furniture kits for practice, (3) free supplies, frames & materials to build \$300 worth of furniture, yours to keep or sell. Write TODAY for big free upholstery career book. No obligation, no salesman will call. Veteran Approved. Modern Upholstery Institute Box 899-KJE, Orange, Calif. 92669.

## HOW TO GET RICH -- AT HOME!



There is no other business like mail order. Start on a shoestring in your spare time and make a fortune fast. It strikes like a bolt of lightning! Millions read your ad and suddenly you are swamped with cash orders from all over the country. MORE MONEY in 60 days than you could earn in a lifetime! Write for free book and complete details. Mail Order Associates, Inc. Dept. 383, Montvale, N.J. 07645

## FIND BURIED TREASURE

Powerful electronic detector finds buried gold, silver coins, etc. Write or call for free catalog. Dealer inquiries invited.



Financing Available 19.95  
Phone day - night (713) 682-2728 to  
**RELCO, Dept. D-3** 198.50  
BOX 10839, HOUSTON, TEX. 77018

## "LISTEN IN" TO POLICE-FIRE RADIO CALLS IN YOUR CAR!

WORKS with ANY CAR—Portable or HOME RADIO! Just PLUGS in—No wiring—3 minute hookup! Switch instantly from regular to ALL POLICE-FIRE-EMERGENCY-COMMERCIAL-TAXICAB-STATE-CITY-GOV'T 2 way Radio calls in YOUR AREA. DUAL-HI-LOW BANDS TUNES 36-49 & 150-175 MHS. USE Everywhere—anytime—always works. SEND ONLY \$2.00 (cash, Ck., M.O.) and pay postman \$9.99 plus COD P&H or send \$11.99 for ppd Del in USA. COMPLETE, ready to use with instructions. One Year service Warranty—10 DAY MONEY BACK TRIAL (if rtd). Sold Only—DIRECT FROM FACTORY at this Low Price! WESTERN RADIO BPM-6 KEARNEY, NEBR. 68847



## PUMP DRAINS pools, cellars, laundry tubs IRRIGATES — CIRCULATES — SPRAYS



Heavy duty ball bearing pump. All metal, rust-proof Type XB. stainless shaft. Use 1/4 HP or larger. 1 HP 1,200 GPH 60" high or 3,000 GPH 25' well. 5,200 GPH max. 1 1/4" in; 1" out. Belt or direct drive. \$14.95 Type P won't rust or clog. Bronze bearing. To 2,400 GPH. 1" in; 3/4" out. \$9.95 p'd cash with order. Money back Guarantee.

LABAWCO, Box 40, Belle Mead, N.J. 08502

## ACCORDIONS • Big Discounts

Buy Direct Importer-to-You



NEW ELECTRONIC MODELS SAVE 1/2 42 "New Sound" Electronic and Standard models, Amplifiers too! All Famous Makes. Try before you buy—5-Day Trial. Easy Terms, Trade-Ins. Free Accessories. Money Back Guarantee. Free Color Catalogs, Handy Selection Guide, Discount Prices. Write

Accordion Corporation of America 5535 W. Belmont, Dept. R-53, Chicago, Ill. 60641

## GOVT. SURPLUS

and other bargains  
SAVE to 90%



Send for this catalog

The world-famous Airborne Catalog. Fully illustrated. Contains 1000's of bargains in hydraulics, electrical, marine, automotive & hardware items ... and more! A must for mechanics, machinists, hobbyists, sportsmen, inventors, etc. Send 35¢ to cover postage & handling. In a hurry? Send \$1 for airmail delivery. Must include zip.

**AIRBORNE SALES CO.** Dept. PM73  
8501 Steller Dr., Box 2727, Culver City, Ca. 90230  
Satisfying world-wide customers since 1945



## PLANER • MOLDER • SAW

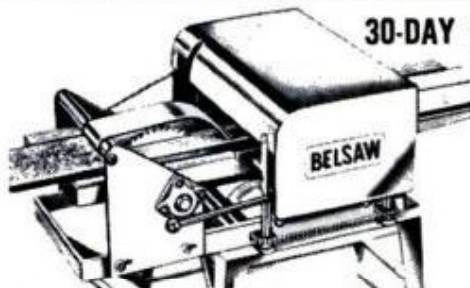

30-DAY FREE Trial!

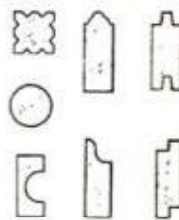

Now you can use this ONE power-feed shop to turn rough lumber into moldings, trim, flooring, furniture ... ALL popular patterns. RIP... PLANE... MOLD—separately or all at once with a single motor. Free 30-Day Trial. Low Cost—only \$35 down.

Send Postcard Today—No Salesman Will Call.  
BELSAW POWER TOOLS 904H Field Bldg., Kansas City, Mo. 64111

## TURBO-BLAST SPARK PLUG CLEANER

\$19.95  
ppd.

SAVE MONEY DON'T THROW AWAY GOOD SPARK PLUGS



GET UP TO 50,000 MILES ON YOUR SPARK PLUGS

Produces professional results without compressed air. Rugged 110V 12,000 RPM motor generates high speed jet of tiny glass beads to scour plugs clean in seconds. Includes supply of beads for 250 plugs. 30-day money back guarantee. \$19.95 ppd. Calif. Res. add \$1.00 Sales Tax.

Jaycraft Corp, 760 N. Marshall Ave, El Cajon, CA 92028.

## HOME FRUIT DRYER

With our plans and instructions, you can make your own fruit dryer using salvage parts and inexpensive materials. Only ordinary tools are required. Dried peaches, pears, and apples surpass any candy made for being purely delicious. This unit has a large capacity and will cost just a few dollars to build. Complete plans and instructions are just \$3.00.

## THRIFTWAY

P.O. Box 914, Provo, Utah 84601



**Pictures of wanted criminals, maps of crime locations, license-plate numbers and other important data can be sent directly to patrolling police with this mobile British facsimile system. Above, officers study photos and sketches of suspected criminals without even having to leave their car.**

## ELECTRONIC 'COPS'

*(Continued from page 196)*

pinpoint its location. The beeps show up as tiny moving dots on a TV map in the dispatcher's office—like blips on a radar screen. By watching the map, the dispatcher can tell which cars are nearest a trouble spot and direct them to close in immediately.

In the Sylvania system, each car has a dash-mounted miniature map viewer and typewriter-like keyboard. Patrolling officers report their positions periodically by pressing keys that transmit the appropriate map coordinates to a corresponding map screen at headquarters so the dispatcher can see at a glance where each car is. The system also permits urgent messages to be sent by pressing other keys. An officer in trouble and perhaps wounded, for instance, can summon additional police aid simply by tapping an emergency "help" button without taking the time to make a regular radio call. Since both systems are based on coded

**Material to be transmitted over mobile facsimile system is fed into electronic scanner at police headquarters where image is converted into radio signals. Signals are picked up by similar scanners in police cars and converted back into visual images rolling out on strips of paper (left).**



radio pulses rather than conventional voice transmission, criminals aren't tipped off by listening in on police conversations.

Another new crime-fighting aid is a mobile facsimile system developed by the British firm of Muirhead, Ltd. of Beckenham. With this, patrolling police can receive actual pictures of wanted criminals, maps of crime locations—even copies of fingerprints—right in their cars. The original picture is fed into an electronic scanner at headquarters and transmitted by radio to each patrol cruiser where a receiving scanner recreates the image on photosensitive paper. The system can also transmit written messages, license-plate numbers and other confidential information to avoid voice calls that might be overheard. So criminals, who usually count on being one jump ahead of police, may soon find electronic "cops" a jump ahead of them. ★★

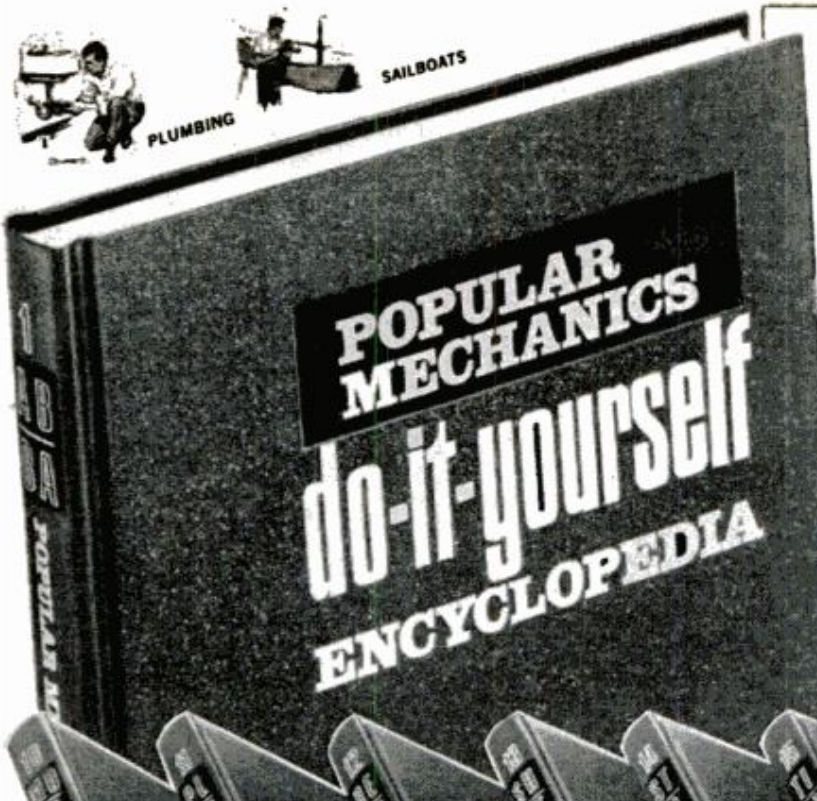

# FREE

## TO READERS OF POPULAR MECHANICS

Volume 1 of the All-New, Profusely Illustrated  
"Do-It-Yourself" Reference Library for Home  
Handyman, Craftsman, Hobbyist, Sportsman—  
Chock-Full of Step-by-Step "How-to-Do-It"  
Ideas, Plans, Projects and Shopping Tips  
to Save You Money...

**16 DELUXE VOLUMES**  
3,136 "How-To-Do-It" Pages  
OVER 10,000 "SHOW-ME-HOW" ILLUSTRATIONS  
"Instant Index" of More Than 6,000 Entries  
STAIN AND SCUFF RESISTANT, WASHABLE BINDINGS  
HUGE 8 1/2" x 11" VOLUMES

# FIX your appliances, car, house, SAVE on air conditioning, guns, home improvements, power tools and more

Now...we are proud to offer you the product of POPULAR MECHANICS' most ambitious publishing venture. And we are delighted to send you Volume 1 Free—and future volumes for Free Trial—so you can see for yourself, without risk or cost, just how valuable, useful to you and your family the New POPULAR MECHANICS DO-IT-YOURSELF ENCYCLOPEDIA can be.

Your Free Volume 1 gives you a wealth of valuable illustrated "how-to" information to help you solve common car ailments... add a bedroom... collect antique guns... use power tools... make musical instruments... build and use backyard barbecues... antique furniture... catch fish... anchor boats... make models and toys... build a boat... letter your own signs... repair auto bodies... buy and fix home appliances... load your own ammunition... fix a leaky basement... plus "Project-a-Plans" for animal cut-outs and lettering—and ever so much more!

Consider the thrill of owning a more modern, more beautiful home... a handsome boat... a smoother running car... a cabin in the woods or at the shore. Imagine your wife's joy with a more efficient kitchen...

a more luxurious porch or patio. Think of your children's pleasure with custom-built water-skis or a new mini-car. All these can be yours for the cost of materials alone when you have this exciting new DO-IT-YOURSELF ENCYCLOPEDIA.

### Save High Labor Charges — Up to \$12 an Hour

Best of all, you save such high costs of labor as electricians at \$4.79 an hour, painters at \$4.05 an hour, plumbers at \$4.31 an hour, TV repairs at rates up to \$12.00 an hour—even more.

You can actually use this Encyclopedia to save \$15.00-\$20.00 on a TV adjustment, \$75.00 on laying a slate walk, \$300.00 on enclosing a porch. You can build a professional-looking desk for just \$19.00 in materials, a big barbecue for just \$12.00, a sturdy cabin boat for only \$600.00, a whole new garage or porch for only \$500.00 to \$700.00—and this "know-how" is there when you want it!

Every imaginable subject of value to your "do-it-yourself" talents is covered. Whether you're a home handyman—or not very handy at all—there are illustrated, easy-to-follow, step-by-step instructions for all your home

maintenance problems: plumbing... wiring... painting... papering... decorating... and more. Money-saving, up-to-the-minute information and diagrams on appliance repair... TV adjustments... automobile repair... power tools, to mention a few.

### Every Page Offers an Exciting New Benefit for Your Home and Family

Turn to any of the 3,136 big pages in this fabulous Encyclopedia, and you'll discover new ways to have more fun out of life... to live better for less money. You'll find countless ideas and plans to increase leisure-time enjoyment for you and every member of your family—plus ideas for earning a substantial spare-time income.

**Your First Volume FREE—No Obligation**  
Accept your Free first volume now entirely at our expense. Thumb through it—select a plan or project—use it at your workbench. Try to imagine 16 such magnificent volumes side-by-side, offering you money-saving tips... labor-saving information... time-saving advice... plus a host of valuable home-improvement ideas.

Here are just a few of more than 6,000 specific entries in the "Instant Index" covering projects, plans and ideas for better living, greater savings for you and your family...

**APPLIANCES**—Complete money-saving fix-it instructions plus "Before You Buy" tips.

**BASEMENTS**—Waterproofing, finishing walls, ceiling, floor, adding laundry, workshop, darkroom, bar, music center, built-ins.

**BATHROOMS**—Money-saving remodeling ideas.

**BEDROOMS**—How to increase sleeping quarters, storage space.

**CEILINGS**—All about materials, installation.

**CONCRETE**—The ABC's of how to mix, use and cast.

**DOORS**—How to hang a door, choose hardware, decorate.

76 Picture-Filled  
Articles on BOATS

**ELECTRIC WIRING**—All the basics of home wiring.

**GARAGES**—Build carport or garage with step-by-step plans.

**GARDENING**—How to build equipment, control weeds, mulch, propagate shrubs.

**KITCHENS**—Step-saving layouts.

**LANDSCAPING**—Build retaining walls, patios; plant shrubs; fell trees.

**FIX YOUR CAR! 538**  
"show-how" photographs, drawings, diagrams on automobile care and repair.

**MOTORCYCLES**—Care and repair.

**MOVIES**—Add a soundtrack to home movies. Novel tiling techniques.

**PLUMBING**—How to do your own plumbing.

**POWER TOOLS**—How to use, repair all kinds. "Before You Buy" tips.

**REFINISHING**—How to get the professional-looking finish you want.

**ROOFS**—Everything you should know about roofs and roofing.

68 Detailed Articles on ELECTRONICS, RADIO, TELEVISION, HI-FI, TAPE, STEREO.

**SHELVES**—Decorative storage—permanent or adjustable.

**STAIRS**—Here are the secrets of expert stair construction.

**SWIMMING POOLS**—How to construct the pool to fit your budget.

**TOYS**—Make all kinds—wheel toys, pull-toys, powered toys, action-toys, dollhouses.

**USED CARS**—Recondition your old car and add dollars to its worth.

**WOODWORKING**—Use the methods the experts use.

**YARD IMPROVEMENTS**

...AND EVER SO MUCH MORE!

## Mail Now for Your FREE Volume 1!

**Popular Mechanics Books**  
Box 2315, F.D.R. Station, New York, N.Y. 10022

This certificate entitles you to a free gift—Vol. 1 of the 16-vol. Popular Mechanics Do-It-Yourself Encyclopedia, with no obligation to buy anything ever.

As a subscriber in good standing, you'll enjoy free examination of the additional volumes as you receive them. In about 6 weeks we'll send you Vol. 2, and 4 weeks later Vol. 3. After that, at approximately monthly intervals, we'll send you shipments of Vols. 4-6, 7-9, and 10-16. Also, you'll receive annual supplementary volumes as they are published on free 14-day approval with no purchase obligation. This way you'll be able to complete the set in 6 months, and keep it up-to-date. You may cancel at any time or return any volume within 14 days for full credit and no more will be sent. Take as many volumes as you like—or none at all. For each volume you keep, you'll be billed just \$3.49 plus postage and handling. But you need never pay for more than 1 volume per month no matter how many you have received. There is no charge for this extended payment service.

F016

Name \_\_\_\_\_  
Address \_\_\_\_\_  
City \_\_\_\_\_  
& State \_\_\_\_\_ Zip Code        
Signature \_\_\_\_\_

HM Books

POPULAR MECHANICS BOOKS Box 2315, F.D.R. Station, New York, N.Y. 10022

# The bargain hunter

## EMERGENCY AIR

**First Air Kit.** The portable air supply you keep in your car. Lightweight compressor plugs into your car cigarette lighter. Delivers up to 55 pounds air pressure automatically. Ideal for tire repairs, air mattresses, beach toys, footballs, etc. Only \$24.95 including shipping. Send check, money order, Bank Americard or Master Charge number to:

**THOMAS INDUSTRIES INC.**

Dept. P  
1419 Illinois Ave.  
Sheboygan,  
Wisconsin  
53082



**ONLY \$24.95 TRY FREE FOR 10 DAYS**  
If not completely satisfied, return for full refund.



### SAVE HUNDREDS OF DOLLARS

Imagine yourself the builder of this attractive ALL PURPOSE BARN 24' X 36' X 18' high with easy to follow plans. Appealing to the eye in suburban, farm, ranch, lake area. Many uses as 3 or 4 car garage, boats, campers, store, lodge. Plans call for concrete floor, ceiling joist, plywood loft flooring, suggested window and door location. Send \$5.00 for plans and material list. Additional plans with above order \$2.00 each. Hammond Barns Dept. PM-6, Box 39027, Indianapolis, Indiana 46239.

### LOW VOLTAGE CIRCUIT TESTER

CHECKS ALL 6 & 12 VOLT WIRING AND LIGHTING CIRCUITS WITH POWER ON

#### TESTS

Shorts in Wiring • Grounds in Field Coils  
Breaks in Wiring • Timing of Ignition  
Radio Circuits • Continuity of Field Coils  
Antenna • Ground Circuit of All Lamps  
Wire Connectors • Battery Cable Circuits  
Fuses • Stuck Points in Relay  
Bulbs • Adjustment of Switches  
Ground in Armatures • Circuit of All Lamps



(Actual size 7 3/8" long)

Send Check or Money Order, Satisfaction Guaranteed

\$2.50 Postpaid

**\$2.50**

**MEAD TOOL CO.**  
444 Espanola Way

Miami Beach, Fla. 33139

### SILVO

(BRAND NAME) TOOL CATALOG

Thousands of exciting tool values!



Stanley, Skil, Thor, Wen, Disston, Wiss, Welisaw, Dremel, Plumb, Huot, Kennedy, Channellock, Rockwell, Helois, Vice-Grip, Crescent, Rigid, Pony Clamps, Unimat, Foredom and many other Nationally Advertised brands of Tools & Supplies. We ship Coast to Coast at prices Hard to Beat. Send \$1.00 for our big 152 page tool catalog today.

Silvo Hardware Co., PM-73  
107 Walnut St., Philadelphia, Pa. 19106

### YOUR OWN RADIATOR BUSINESS

"\$70,000 LAST YEAR"

says D. Carter, Lemoyne, Pa.



Complete turn-key package: training school in radiator repair technology and business management plus special power-equipped auto radiator shop.

Don Carter writes: "Averaging \$30 an hour, expect to hit \$80,000 next year." Mail this coupon for complete story.

NAME \_\_\_\_\_  
ADDRESS \_\_\_\_\_  
CITY \_\_\_\_\_ STATE \_\_\_\_\_  
ZIP \_\_\_\_\_ PHONE \_\_\_\_\_

**INLAND MFG. CO. Dept. PM-6**  
1108 Jackson Street • Omaha, Nebr. 68102

Light, compact . . . one person can operate it . . . easily . . . quickly . . . accurately!

only **\$17.95** plus \$1.00 shipping



### SPLIT-IMAGE TRANSIT LEVEL & INCLINE FINDER

(NEW IMPROVED G-3 MODEL)

For surveying, carpentry, brick laying, cement work, landscaping, etc. Not a gadget . . . nor merely a leveling device but an amazing precision instrument that not only measures level but also shows amount of correction needed . . . measures incline to a fraction of an inch . . . up to 60 feet at a time. So accurate it can be used for most grading and construction work. Dual (inch/metric) calibration. Complete with rugged, protective carrying case/cover which also doubles as target, . . . 90 day warranty against material and workmanship. Send check or m.o. (no c.o.d.'s) to:

**HOWARD ALAN INDUSTRIES**  
METRIC DIVISION  
Dept. PM-6, P.O. Box 311, Northfield, Illinois 60093



### FREE!!! POWERFUL MUSCLES FAST!

Fantastic New Discoveries in the science of bodybuilding. Now, in the privacy of your bedroom, our method will add inches of powerful muscles to arms, chest, shoulders & legs. Learn secrets on trimming the waist with ultra-modern methods—fast! Results Guaranteed! Send for free brochure. Universal Bodybuilding, Box 485-MI, Dearborn, Mich. 48121.

### EXTRA MONEY

\$30 to \$50 A DAY



Operate a community sharpening service with an investment of \$150. Work from your basement or garage. Our manual guides you in professional methods of grinding, of business promotion and in pricing your work.

- Hand Saws • Circular Saws • Knives • Chain Saws
- Scissors • Pinking Shears • Clipper Blades
- Planer and Dado Blades • Mower Blades

John Rodock says: "Thanks for shipping Model 331. It has paid for itself many times since I purchased it. Please send latest price list on grinding wheels."

**TREYCO** P.O. Box 216-A  
North Tonawanda, N.Y. 14120  
**START NOW...WRITE TODAY**





**SPLIT-IMAGE TRANSIT.** This amazingly accurate instrument indicates level and measure incline to a fraction of an inch. Shows exactly how much correction is needed. Ideal for carpentry, masonry, contour plowing, surveying, etc. This new level and incline measure makes other methods obsolete. **Transit \$10.95 + \$1.25 pp.** Leatherette Case \$3.95. Send check or M.O. on 10 day money-back guarantee. **J. W. HOLST, INC.,** Dept. PM-6, 1005 E. Bay, East Tawas, Mich. 48730.

**DIGITAL: THEORY, DESIGN, CONSTRUCTION**

## LOGIC NEWSLETTER

**SAMPLE COPY \$1.00**  
LOGIC NEWSLETTER  
POB 252  
WALDWICK, N.J. 07463

**WATER WATER WATER WATER WATER WATER**

"HOW TO DRILL YOUR OWN WATER WELL"

**\$1.00 ppd**

SATISFACTION GUARANTEED

**DEEPROCK CO.**  
OPELIKA, ALA. 36801

## FACTORY CLOSEOUT!

**AIR PISTOL \$6.95 ppd.**  
FREE CAN OF PELLETS with Free can of pellets

Shoots both pellets and darts. This fine, well made .177 cal. German air pistol is just the ticket for target or Varmints. Accurate. No CO2 cartridges to replace, either. Once in a lifetime bargain. Order several. Supply limited. Only \$6.95 ppd.

(Secret leather holster, \$2.95 ppd.)  
600 Deluxe Pellets, \$2.40 ppd.  
20 Steel Darts, \$2.00 ppd.  
**AIR PISTOL, Dept. PM-6**  
4535 Huntington Dr. South  
Los Angeles, Calif. 90032



## FLY YOUR OWN 747 JUMBO JET



Two Ft. Long -22" wingspan  
**IT ACTUALLY FLIES!**

Scale models of BOEING 747 and the 19" L-1011 and DC-1C. They all soar and adapt to sling or CO-2 cartridge. Only \$4.00 each. All three for \$11.00. ALSO-CESSNA AEROBAT 150. 26" wingspan. Rubber band powered, adapts to .020 gas engine. \$6.00. All four-\$15.00. \$1.00 postage and handling for EACH plane. New York residents add sales tax.

**JOYCE'S TIMELY GIFTS,**  
Dept. 2PM, 1326 New York Ave.,  
Huntington Station, N.Y. 11746

## THE U.S.A. IS GOING METRIC!

Dial Conversions like you dial a telephone! You can't afford to be without the . . .

## DIAL-A-GON ANGLO-MET-CONVERTOR



**EASY TO USE . . . EASY TO READ . . .** convert English measures to metric on one side . . . metric measures to English on the other . . . in dry and liquid measures, miles/kilometers, inch/mm., feet/meters, yards/meters, fahrenheit/centigrade. 6" dia. Made of heavy, durable plastic. U.S. Pat. 3,544,768. Only \$5.98 ea. plus 50¢ shipping. Send check or m.o. (No c.o.d.'s) to:

**HOWARD ALAN INDUSTRIES, METRIC DIVISION**  
Dept. PM-6, P.O. Box 311, Northfield, Illinois 60093

## 1600 Novelties

**FREE!** New World Famous Catalog  
Hard-to-get Novelties, Jokes, Tricks, Hobbies, Sports, Science, Electronics, Funmakers, Psychodelia, Emblems, Posters, Magic, Games, Gifts, Models, Money Makers, Jewelry, Bargains, Gadgets, Books, Photo & Optical, Tools, Watches, etc. No letter necessary. Send name, address.  
Johnson Smith Dept. C106, Mt. Clemens, MI 48043

## BUILD YOUR OWN

Cabover Campers • Covers  
16' & 20' Travel Trailers  
• PLANS •  
PATTERNS • KITS  
★ FREE CATALOG ★  
**GLEN L** Recreational Vehicles



9152P Rosecrans, Bellflower, Calif. 90706



## MULTI-FAB IRON WORKER

- PUNCH
- SHEAR
- BEND

Work with metal as easily as wood. Punch up to 3/8" hole in 1/4" steel. Shear up to 1/8" x 2" steel. Bend 1/8" x 4" steel. Double the capabilities for aluminum. Fabricate professionally your own custom designed brackets, handles, stands, toys . . . all of those unobtainable or hard to find parts for your vehicles, machinery, appliances and implements. Combine metalworking with woodworking for an endless variety of projects and products. Multi-Fab is constructed of 1/2" steel, stands 11" high, is bench mounted and requires no power supply. Send check or money order for \$89.00 on 10-day money back guarantee or write for complete details to: **PRODUCT DIV., C-D CORP., 1315 E. 8 Mile Rd., Hazel Park, Mi. 48030.**

Easy to Build PLANS AND INSTRUCTIONS for

Go Kart	.....\$2.00
Mini Bike	.....\$2.00
Mini Car	.....\$3.00
Pedal Boat	.....\$4.00
Sail Boat	.....\$2.00
Snowmobile Sleigh	\$3.00

Mini Vehicles Plans  
Dept. C P.O. Box 92  
Chazy, N.Y. 12921



## now you can have MUSCLE

Yes! Now you can gain weight, muscle-up all over. No gimmicks or gadgets. Just a brand new scientific body-building principle that packs on pounds of healthy body weight, slims flabby waistlines and gives you a brand new appearance. Add powerful muscles to your arms, chest, shoulders and legs. Send 25¢ coin to cover postage and handling costs, for **FREE** easy-to-follow plan.

Please send your free brochure under plain cover

# FREE!

Name \_\_\_\_\_ (Please Print)  
Address \_\_\_\_\_  
City \_\_\_\_\_  
State \_\_\_\_\_ Zip \_\_\_\_\_

**HERCULES II Dept. 15830**

P.O. Box 78, Meadowvale, Ont. Canada



## Emergency Tow Rope

EMERGENCY TOW IS STRONGER THAN CHAIN! Tested strength 6500 lbs. (3 1/2 Ton.) It is MUCH EASIER TO HANDLE THAN CHAIN (Weighs only 13.4 lb.) It is HANDY TO STORE. It won't RUST, SCRATCH, OR RATTLE.



EMERGENCY TOW is perfect for the: TRAVELER, VACATIONER, SPORTSMAN, CAR OWNER, BOAT OWNER, HOME OWNER, FARMER, or ANYONE who needs a tow.

PAYS FOR ITSELF MANY TIMES OVER. SEND CHECK OR MONEY ORDER FOR \$6.00 POSTAGE PAID TO SAFETY SERVICE CO. P.O. BOX 26026 ALBUQUERQUE, N.M. 87125



## stop toilet tank sweating

Eliminate toilet tank sweating, soggy covers and wet, messy floors. Temperator mixes hot & cold to temper the water. Removes chill that causes tank to sweat. Thousands in use. Complete with instructions and list of components required.

- Solid Brass Temperator \$12.95 postage pd.
  - For summer camps and cottages, available with drain to empty water line, prevent winter freeze-ups. \$13.95 postage pd.
- OAKRIDGE IND.**  
P.O. Box 18475-A, Cleveland, OH 44118

## DETROIT APPROVED PICKUP TANKS



Original equipment type poly, now available in auxiliary tanks for pickups. Increase gas capacity 40 gals. Far superior to metal, complete hidden, no body work necessary. Easy 1 hour installation—Truck discounts pay for tanks in a short time. Two tanks, brass valve, hose, complete. Meets Federal Regulations.

PICKUP EQUIPMENT CO. LTD.

Dept. PM-673  
P.O. BOX 7635  
WACO, TEXAS 76710

## IMPORTED LOCK BLADE KNIFE

ONLY \$275 each

9" Overall Length  
5" When Closed

- Sharp and Tough
- Stainless Steel Blade



Locks into position to prevent accidental closing.

Razor sharp tough stainless steel blade for reliable use and hard, long service. Money back in 5 days if not satisfied. Send \$2.75 plus 25¢ to cover postage and handling.

**WESTBURY SALES CO.**  
P.O. Box 434, Westbury, N.Y. 11590  
Dept. L-253-PM

## Build Your Own Kit CANOE or KAYAK.

Quality Wood/Canvas Designs.

From \$25.00

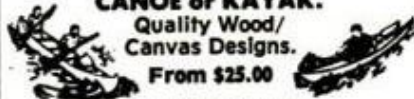

Free Literature!

**SPORTSCRAFT**

Box 636-PM Allentown, N.J. 08501

## DUNE-BUG BIKES OR KARTS



**\$1 PLANS PARTS OR COMP. UNITS**  
One dollar brings you complete info. on how and what to build or buy. Discount prices (automatic clutch, \$9.95). Parts, kits, engines, and raw materials, comp. drawings, pictures & specifications.



\$1 for DUNE-BUG bike or kart info, or \$3 for all to: Box 987-P6 Azusa, California 91702

## PORTABLE STEAM CLEANER

Steam in 60 seconds

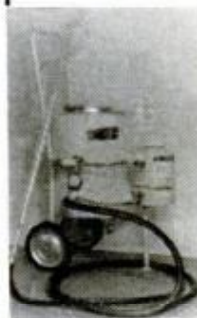

**CLEAN:** Engines—Air filters—lawn mowers—trucks—tractors

"Big enough to do the job, small enough to get there."

Fast, economical, ruggedly built. 3 year guarantee on coils & firebox. Propane fired. Weighs 120 lbs.

Auxiliary pump required on water pressures below 60 lbs. or on well systems.

**WEDCO MFG. INC., Dept. M-4,**  
Box D, Jackson, Wyo. 83001

## HEARING AIDS

UP TO **50% OFF** COMPARABLE AIDS ★

BUY DIRECT • 20 DAYS FREE TRIAL Body Aids \$39.95 up. Tiny All-in-the-Ear: Behind-the-Ear; Eye Glass Aids. No salesman will call. Write **LLOYDS** ★ Dept. PM. 905 9th St., Rockford, Ill. 61108 ★

## BUILD YOUR OWN CANOE



WOOD & CANVAS OR FACTORY MOLDED FIBERGLASS

MANY MODELS TO CHOOSE FROM \$19.50

FREE CATALOG  
**TRAILCRAFT, INC.**  
Box 60679, Concordia, Kansas 66901

**POPULAR MECHANICS PM-BEE!** Plan for a radio-controlled model that flies on CO<sub>2</sub>. Fuel is nonflammable and odorless. Sophisticated and simple to build! To obtain full-scale pattern from which you can trace off the parts directly, send \$3.49 to **POPULAR MECHANICS Dept. FA, Box 1014 Radio City, New York, N.Y. 10019.**

## 110 Volt A.C. GENERATORS

60 cycles. Fanbelt driven from car or gas engine. Operates T.V., refrigerators, radios, all power tools, projectors, P.A. systems and fluorescent lights. Over 12,000 in service. Guaranteed six months. 1500-watt \$65.00 postpaid. 3000-watt \$105.50 postpaid. Special X-1000 watt self-excited generator \$85.00 postpaid.

**TOOL POWER™ patent pending**

115 volts D.C. 5000-watts. 50 amps from your car's alternator. **Guaranteed 20 years.** Install in ten minutes. Operates all power tools, electric motors up to 2 h.p. Arc welding, fast battery charging. Any like device by any name is an infringement of our patent pending. All copiers are notified. Be safe, buy from the inventor and developer. \$25.00 postpaid. Attractive dealer plan.

**VIRDEN PERMA-BILT CO.,**  
P.O. Box 7160PM  
2821 Mays, Amarillo, Texas 79109

## NEW Small Engines Service Manual

10th Edition

Tells and Shows YOU How to Fix Small Gas Engines on Lawn Mowers, Garden Tractors, Power Equipment



400,000 copies of the previous editions have been sold to mechanics, beginners, schools and Do-it-Yourselfers. Edited by mechanics with easy-to-follow instructions on air cooled engines under 15 cubic inches.

This new 10th edition is completely revised and up-dated. Includes nearly every popular 2-cycle and 4-cycle engine. Complete information on repairing, maintenance and servicing of small gas engines. Hundreds of photos and exploded view drawings. **Step-by-step easy to follow instructions** for everything from minor tune-ups to major overhaul. Section on trouble shooting for beginners.

**\$5.95** Send Check or Money Order and we ship promptly postpd. **Satisfaction Guaranteed or your Money Back.**

**Order Today** Technical Publications Div., Dept. PM-673  
1014 Wyandotte, Kansas City, Missouri 64105

### BECOME AN ARTIST OVERNIGHT!

Fantastic new manual shows you how to produce life-size oil images of anyone in minutes or double your money back! ALL you need is oil or acrylic paint, brush, canvas. No expensive equipment needed. Amaze your friends. Make extra money part time. Uses no photos, gadgets, or painting by numbers. Even a child can do it. Complete method. \$3.98



JIFFY PORTRAIT, DEPT. P.M.6  
1315 Ronan Ave., Wilmington, Calif. 90744

### BEAT THE DICE TABLES

All Legalized Casinos

#### Double-Your-Money-Back GUARANTEE!

Place only 5 bets. All numbers are in your favor including 7... 2, 3, 4, 5, 6, 7, 8, 9, 10, 11, 12.

You win every roll!

Send \$1 For Details  
M.C. CORBIN CO. Dept. MGPM6  
Box 869 Radio City Sta. N.Y. 10019

### GARAGE DOOR OPENER \$10.00

One pull opens or closes balanced rollup doors. Send \$1.00 for installation instructions (refunded with order) to:

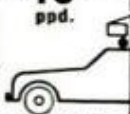

R M PRODUCTS PATENTED  
Box 36252  
Cincinnati, O. 45236



Bartlett Flying Saucer ultra-light hovercraft powered by ordinary lawn mower engine—easy to build—fun to fly—complete plans, kit brochure, photos and supply sources \$3.00. All orders returned via airmail. Write:

HERB BARTLETT  
Box 3339-M, Scottsdale, Arizona 85257

### THE AUTO ELECTRIC



110V D.C. electricity from a vehicle alternator  
• Light Bulbs  
• Power Tools  
• Battery Charging  
\$14.95  
with 150 V.D.C. meter Postage \$1.25  
Auto Air Equipment, Inc.  
P.O. Box 2885—Amarillo, Tex. 79105

## ANNOUNCING POPULAR MECHANICS INDEX AND SHELF WRAPPERS —1971 & 1972 eds.

A great idea that will multiply the value of your back issues of PM. The indexes are bound into handsome wrappers made of heavy board and encloses the 12 issues which are cross-referenced in the Index. Makes beautiful and useful additions to your bookshelves. Price \$1.49 ea. Send orders to Popular Mechanics (Dept. I), Box 1014 Radio City, New York, N.Y. 10019.

## USE ZIP CODE WHEN ANSWERING ADS

### HOME-WORKSHOP ELECTRIC ARC WELDER \$9.99!



WELDS—BRAZES—SOLDERS—CUTS—ALL METALS! Plugs into ANY 110 volt socket. MAKE—REPAIR most anything for CAR—HOME—BUSINESS. Lifetime BURNOUT GUARANTEE 10 day money back trial (if retnd). HEAVY DUTY Design. No experience needed—FREE WELDING LESSONS!

(cash, ck, M.O.) and pay postman \$7.99 COD postage or send \$9.99 plus \$2.00 for post-packing in U.S.A. COMPLETE READY TO USE—Includes BIG pack steel, Brazing, Solder, Carbon "touch" rods & ELECTROFLAME ARC TORCH! OFFER LIMITED—Order TODAY! MIDWAY WELDER, Dept. EPM-6, Kearney, Nebr. 68847

### MAKE MONEY!

### REPAIR HYDRAULIC JACKS



Earn while you learn at home. Millions of jacks in gas and auto service stations, trucking firms, body shops, riggers, factories and farms need servicing... most of which you can learn to repair. We show you NOW. Start spare time in your basement or garage. Big opportunity for mechanics. ACT NOW!

Write for Folder P.M.6, and Free Bonus Offer

Hydraulic Jack Repair Manual Co., Inc.

P.O. BOX 3 • STATEN ISLAND, N.Y. 10314

## BASEMENT TOILET FLUSHES UP



TO OVERHEAD SEWER OR SEPTIC TANK. NO DIGGING UP FLOORS. INSTALLS EASY. Write McPHERSON, INC., BOX 15133, TAMPA, FLORIDA 33614

Build POPULAR MECHANICS' little CARRIAGE HOUSE! Simply great! A back-yard building that isn't an eyesore. Styling blends in with most homes. It will take your mower, lawn furniture and tools—or the kids' overnight guests. Use it as your shop or home office. Overall outside dimensions 10-ft. 4 in. x 12-ft. 4 in. For one complete set of p'ans send \$3.95 to POPULAR MECHANICS Dept. FA, Box 1014 Radio City, N.Y. 10019. For two sets of plans (you may need one for your local building department) send \$5.49.



## Print For Profit

Cards, Stationery, Envelopes, Advertising, labels, tickets, announcements, Q.S.L. cards, greeting, sympathy, prayer cards, tags, etc. Save money. Pays for itself in a short time.

### Own a Printing Business

We supply everything direct from factory only. Easily followed rules. Also raised printing like engraving. Have home shop. Add to income. Send 25c for catalogue. KELSEY PRESSES 73-Q, Meriden, Conn. 06450



## LEARN MEAT CUTTING

Train quickly in 8 short weeks at Toledo for a bright future with security in the vital meat business. Big pay, full-time jobs—HAVE A PROFITABLE MARKET OF YOUR OWN! Time payment plan available. Diploma given. Job help. Thousands of successful graduates. OUR 50th YEAR! Send illustrated FREE catalog. No obligation. G.I. approved. No. 01977

NATIONAL SCHOOL OF MEAT CUTTING  
Dept. 50-X, Toledo, Ohio 43604



## MINI-BIKE PARTS

### Wholesale Prices

"Build your own" kits...Big savings...Repair parts...Welded frames & forks, enameled...Chains...Clutches...Brakes & throttle controls...Wheels...Tires...Bearings...Axles...Engines...etc. Send 50¢ for illustrations and lists...SAVE DOLLARS! BYCO, Dept. B, 7528 Oakwood St., Omaha, NE 68127

HEADQUARTERS FOR EVERY TYPE & SIZE AT REAL DOWN-TO-EARTH MONEY SAVING PRICES!

ALL FAMOUS BRANDS!

**TIRES!**

AUTO TRUCK SPORT CAR FARM TRAILER

TREMENDOUS SAVINGS! LET US PROVE IT TO YOU! ...WRITE US TODAY...

Send for your FREE catalog!

RELIABLE TIRE CO. 1111 Chestnut St. Camden, N.J. 08103

# CLASSIFIED ADVERTISEMENTS

Rate: \$2.20 per word payable in advance each insertion. Capitalized words—75¢ per word additional. Minimum insertion ten words. To be inserted under the proper classification, copy must be in our office by the 10th of the second month preceding date of issue. The next available issue to place an advertisement in America's No. 1 Classified Section is August. The closing date is June 10th. Send remittance and order to H. E. Kappel, Popular Mechanics, 224 West 57th Street, New York, New York 10019. Please make remittance payable to Popular Mechanics.

WHEN ANSWERING ADVERTISEMENTS PLEASE USE THE ZIP CODE NUMBER

## AUTOMOBILES

**WANTED To Buy:** Old Automotive Literature, 1900-1955. David Ficken, Box 11, Babylon, New York 11702.

**AUTOMOBILE SIXTY SECOND TIRE FIX. NO TOOLS—NO JACK-DEALERS INVITED. SAMPLE, DETAILS, PPD. \$3.98—WARNE, 6922 CONGRESS, DETROIT 48207.**

**CAPACITIVE DISCHARGE IGNITIONS. DISCOUNTED.** Rodgers, Son (PM), Box 3583, Anaheim, Calif. 92803.

**SAVE Money!** End Expensive Automobile Repairs. "Auto Repair Book" \$1.95. Meiner, 630 Granger, Hanover, Pennsylvania 17331.

**WORLD CARS 1973,** Italian Automobile Club, English Text. 440 pages, 9½ x 11". Specifications Data, 800 Models, 27 Countries. 1000 Illustrations. Postpaid, \$19.50. Santomasso, 1255 Boulevard, New Haven, Conn. 06511.

**SCR/CD IGNITION.** Increased Performance, Mileage. Fits most cars, negative ground. State make, displacement, model year. \$44.95. Texas residents add 5% sales tax. Magna Dwell, Box 2171, Abilene, Texas 79604.

**TUNE-UP SPECIFICATIONS.** New computerized listing fits in your shirt pocket. Covers 1964-73 American Cars. \$3.00 postpaid. Tune-Up Primer, Dept. D, Box 6005B, Orlando, Florida 32803.

**SUPERSCATES,** Racing, Gasoline Powered, Plans, Booklet, \$5.50, Free Picture, Nicholas, Box 10095, St. Petersburg, Florida 33733.

**TUNE-UPS.** Complete, simple, illustrated guide to tuning your own car. \$1.00. **INFOSERV,** 2951 Manor, Yorktown, N.Y. 10598.

## AUTO SUPPLIES AND EQUIPMENT

**PICKUP OWNERS:** Spare Tire Access Without Muscle Torture, Profanity! New Products! Guaranteed. Research, Box 13237P, Gainesville, Florida 32601.

**PARTS:** Army jeep and truck parts. Spare Parts & Equipment Co., P.O. Box 751, Lexington, Kentucky 40502.

**ALTERNATOR/Generator** Rebuilder's Course; includes Tooling & Test Equipment. Write: Hedlund Engineering, P.O. Box 2127, Sepulveda, California 91343.

**MOTALOY,** Ring-Valve Job While Driving. \$6.00. Literature. E&G Sales, Box 18384-P, Memphis, Tennessee 38118.

**RING-Valve Job** while driving. \$6.50 postpaid. (Two-\$12.00). . . . Established 1951. . . . Results Guaranteed!! Motaloy, Grantham, Penna. 17027.

**BUY AT WHOLESALE.** Send \$1.00 for Catalog. Specialty Products, Box 397, Butte, Montana 59701.

**"PATENTED"** Revolving Exterior Automobile Mirror. Novel, Safe, Stays Clear All Weather. \$16.00, Two \$30.00. Revmirror, Box 3335, Cape Town. R.S.A

**NEW! MAGIC—HOSE "Instant Gravity" SIPHON.** Foolproof Operation. Never Fails! **FREE** Particulars. **WARREN'S,** Dept. 16, 5245 Eastern, Las Vegas, Nevada 89119.

**TOWBAR** Plans, send \$3.00. Plans, Box 292, New Albany, Ohio 43054.

**POWER** Electric Appliances from Alternator equipped cars. Information Free. D. Godard, Box 229A, RR1, Washington, North Carolina 27889.

**FREE** Flashlite With **MOTALOY** Ring Valve Job \$6.00. Guaranteed. Flewellings', Box 21, PM6, Tustin, Calif. 92680.

**AUTON** Ignition, The **VELVET GATE,** Information, Autonics, Box 1581K, National City, California 92050.

**RADIATOR PROBLEMS?** Heating? Leaking? Rusting? Experienced Journeyman Thoroughly Explains Cooling System. Send \$2.00 to: Radiator Care, Box 547, Whittier, Calif. 90602.

**AUTO GUARD** Prevents Auto Theft. Protects Cars, Trucks. Easily Installed. Send \$6.95 To: Auto Guard, Box 44483-1A7, Los Angeles, Calif. 90044.

**TAILGATORS** You Pay! Send \$2.00 For Rear Bumper Sticker To: Giltner, Box 20705, Phoenix 85036.

**KITS** For Any Engine. Beat 1975 emissions, burn kerosene. Power Genie, Box 872, Lancaster, Penna. 17604.

**AMAZING MOTALOY** Ring-Valve job While driving. \$6.00 Guaranteed. Free information. James Bryant, 2133 Arcadia Place, Jacksonville, Florida 32207.

**CALCULATOR,** Trip Expenses, Arrival Times, Gas Mileage, Tax, Expense Accounts Recorded \$2.25 P.W. Photography, Box 562 Oak Ridge Station, Royal Oak, Michigan 48073.

**RING—VALVE JOB WHILE DRIVING! 1973—MOTALOY'S 20TH ANNIVERSARY!** (It works and works!) Results guaranteed! **\$5.95** Airmail ppd. Motaloy Division CH, RR8, Box 604, Fayetteville, North Carolina 28304.

**HANDLE HIGHWAY EMERGENCIES!** 14-Piece Safety Kit Includes Dry Chemical Fire Extinguisher, Tire Inflator-Sealer, "Help" Flag, 2 Fusee Flares, Moisturized Handwipes Reusable Storage Kit. Only \$12.95. Chardon Products, 10 Chardon Road, Medford, Massachusetts 02155.

**ED WAGNER FOREIGN AUTO SALVAGE INC.,** Dismantling 2000 Foreign Cars For Parts. Located On U. S. Route 19, RD #1, Harmony, Penna. 16037 (412) 368-8831.

**AMAZING** New Auto Electronic Strong Ignition Kit. Enjoy faster starts, more power and pep, hotter spark, 100% safe. Send only \$9.00. H & W Disc-Ad Inc., Box 43, LaCrescent, Minn. 55947.

**RECREATIONAL VEHICLE BUYER'S GUIDE.** 84-page guide, prepared by Chevrolet, full of facts, figures and full color illustrations. 50¢. Recreational Vehicle Buyer's Guide, Dept. C, P.O. Box 7271, Detroit, Michigan 48202.

## AUTO TRAILERS

**FIFTH** Wheel Trailer, Pickup Camper, Cover, Trailers, Build Yourself. Save! Complete plans—Fifth Wheel \$9.95; Camper \$4.95; Trailer \$3.95; Cover \$2.95. Conversions—Econoline type Van \$3.95; Passenger bus or delivery Van \$3.95; Equipment Catalog \$1.00 (refundable). Details 25¢. Our 13th year. Viking Camper Supply, 99-F Glenwood, Minneapolis, Minn. 55403.

## MOTORCYCLES, BICYCLES MOTORSCOOTERS AND SUPPLIES

**CUSTOMIZE** Your Motorcycles with Latest Luxury Sports Seats. Styled to Fit Every Model and Taste. Consterdine, 219 Austin, Sandusky, Michigan 48471.

**HONDA, \$25.** Other Bargains. Send \$1.00. (Refundable) Motorscooter, P443, Bend, Oregon 97701.

**BOLT-ON TORQUE CONVERTER** Makes out-dated, out-classed, mini-bikes competitive, mean machines. More Low end muscle—more high end hustle. Fits B&S, Tecumseh, most engines. 35 minute installations. \$34.95 ppd. No C.O.D. Information + decal 25¢. **MAX-TORQUE, Inc.,** 7300 Monticello, Skokie, Illinois 60076.

**BICYCLE PARTS CATALOG.** Gold mine for hard to get foreign and domestic parts, tools and accessories. Send \$2.00 for this big 8½ x 11 inch 160 page catalog. Refundable if not completely satisfied. Wheel Goods, Dept. J, 2737 Hennepin, Minneapolis, Minnesota 55408.

**ILLUSTRATED** Catalog 25¢. Parts And Accessories, Custom And Stock. For Most Makes And Models. Motorcycle Supply, Box 159M, Fairbury, Ill. 61739.

**MAKE** Your Bicycle Electric. Plans \$2.95. Kielian, 130 Drake, South San Francisco, Calif. 94080.

**BICYCLES—**Replacement Parts, Tools, Accessories, Repair Books, over 1,000 Items. 1973 Catalog. \$1.00 Refundable with \$5.00 Purchase, Action Accessories, Box 15, Liverpool, New York 13088.

**MOTORCYCLE.** ATV'S. Trailers. Supplies. Discount Catalogs 25¢. Lorenzo, Danville, Illinois 61832.

(Continued on next page)

## MOTORCYCLES, BICYCLES, MOTORSCOOTERS AND SUPPLIES

(Continued from preceding page)

**MOTORIZED** Your Bicycle With Mower Engine. Plans \$2.00. Motor's, Box 415, Baraboo, Wisconsin 53913.

## SPACE, ROCKETS AND ASTRONAUTS

**ANTIGRAVITY** Solved! Revolutionary Spacetravel Revealed. \$2.00. Antigravity, Box 831, Avalon, Calif. 90704.

**GROW** With The Fastest Growing Company In The Field Of **MODEL ROCKETRY**. Up To 40% Savings On Equipment, Kits And Motors. AVI, Mineral Point, Wisconsin 53565. Send 50¢ For Details And Issue Of **GALACTIC CHRONICLE**.



## AVIATION

**HANG** Gliders. Three different designs. Plans, kits ready-to-fly. Large catalogue, 25¢. Eipper-Formance, Inc., P.O. Box 246-M, Lomita, Calif. 90717.

**AIRBOAT** Engines, Propellers, Hubs, Mounts, Supplies, Corvair, VW Conversions. Removable airdrives, Propellers, Hubs for Snowmobile Engines. Catalog \$1.00. Banks-Maxwell, Box 3301E, Fort Worth, Texas 76105.

**BUILD**—One-Man jet helicopter. Easy inexpensive. Detailed plans, drawings—\$5.00. Helicopters, Box 7153, Baltimore, Maryland 21218.

**JET** Strap-On Helicopter Plans \$2.00. Information 20¢. Compco, Inc., Box 1267, Redwood City, California 94064.

**HUNDREDS** Aircraft Photos. Past, present. Illustrated catalogue 25¢. Astro Photographers, Box 243, Kennedy Airport, New York 11430.

**ALL** About Ballooning. Handbook \$3.00. Aerostation, Box 141, Long-Sault, Ontario, Canada. KOC 1PO

**HANG GLIDERS**. Proven Rogallo Design. Plans—\$5.00. Kits Accessories, Complete Kites. Compare Quality And Price Before You Buy. Free—Flight Systems, 10730 Whiteoak, Granada Hills, California 91344.

**BE** A Government licensed aviation mechanic. Practical training. Free Information. Aero Mechanics School, Dept. PM-1, Municipal Airport, Kansas City, Missouri 64116.

**HOW YOU CAN AFFORD AN AIRPLANE** if you can't afford one. \$3.50. A.R. Crowe, 1915 Arthur, Corvallis, Oregon 97330.

## HOVERCRAFT

**AERO-CAR**. Amazing Hovercraft built easily with ordinary tools. Lawnmower engine power. Carries one man plus. Hovers, flies forward, backward, sideways over land/snow/water. Complete construction plans and brochure. \$5.95. Aero-Projects, Box 5118PM, Clinton, New Jersey 08809.

**HOVERCRAFT** Plans. All sizes; Tested designs. Photos. Information: \$1.00. Universal Hovercraft, 2611 182nd Place, Redondo Beach, California 90278.

**INSTALL** Kart, Lawnmower, Snowmobile Power On This Hovercraft, Plans, Instructions, \$6.00. Airboat Plans Instructions, \$5.00. Design Book For Homebuilders, \$5.00. Palmer Aerosystems, P. O. Box 1891M6, Coral Gables, Florida 33134.

## INFLATABLE BOATS

**QUALITY** inflatables. Pyrawa canoes from \$34.95. Kaik dinghies from \$19.95. Lightweight. Compact. Portable. Packs in own carrying bag. Ideal for fishermen, backpackers river runners, outdoorsmen. Rugged, safe for whitewater rivers, ocean surf, rocky streams, lakes. Built to last! Free color brochure. Leisure Imports, Dept. PM6 St. James, N.Y. 11780.



## BOATS AND TRAILERS

**FIBERGLASS BUILDERS MATERIALS** Lowest factory prices in cloth, matt, roving, resin, epoxy, foam, nails, fittings. Send \$1.00 for literature (refundable) or \$2.00 for literature plus booklet on Mold-making and "How to Fiberglass". Clark Craft, 16-P1 Aqua Lane, Tonawanda, N.Y. 14150.

**BOAT KITS-PLANS AND PATTERNS-FRAME KITS**, World's largest catalog. Over 300 top designs from 7-77' in plywood, ferro cement and fiberglass. Sailboats include: Windmill, Snipe, Motor Sailors, Trimarans, Catamarans. Powerboats include: Cruisers, Houseboats, Deep V's, Fishin'ski, Runabouts, Hydroplanes, Canoes, Kayaks, Inboards, outboards. Send \$1.00 for large catalog or \$2.00 for catalog plus "Boat Builders Guide". Clark Craft, 16-P Aqua Lane, Tonawanda, N. Y. 14150.

**BOAT PLANS, FULL-SIZE PATTERNS, FRAME KITS** With step by step written and pictorial instructions especially for amateurs. Easy to build. Send \$1.00 for **HUGE 100 PAGE** Illustrated Catalog. Over 125 modern designs from 8 to 49'. Includes Sail, Jets, Inboards, Outboards, Cruisers, Houseboats, Hot Boats, Catamarans, Hydros. Also available—"Boat Building With Plywood" Hard cover—219 pages \$7.50. **GLEN L.** 9152 MP Rosecrans, Bellflower, Calif. 90706.

**FIBERGLASS** Canoes, Kayaks, and Duckboats. Many exciting models. Easily assembled kits. \$44.95 up. Free Literature. Riverside Canoes, Box 5595P, Riverside, Calif. 92507.

**FIBERGLASS** Cloth and resin. World's finest cloth and non-run resin, at direct mill prices Flotation foam. Complete line of plastics, silicon bronze and brass screws, save 60%. No sales tax. Boat Plans. Catalog 25¢. Freight prepaid. Stiles Boat Supply, Box 11P, Linden Ave., Mantua Heights, N.J. 08051.

**CANOE!** Kayaks! Factory-direct quality kits, from \$25.00. Many different models. Canvas hulls. Strongest construction materials. Free literature. Sportsraft, Box 636-P, Allentown, New Jersey 08501.

**LIGHTS** Of all kinds, electrical accessories, portable power, cook and tableware. Free catalog. Bass, Box 901PM, Marblehead, Mass. 01945.

**FREE** Catalogue—plans, patterns: Canoes, sailing canoes, kayaks, 14-17' trailable cruising sailboats. Quicksilver, 255A Shamrock Blvd., Venice, Florida 33595.

**NEW 1972** Outboards . . . Top brands . . . 6 H.P. \$278.00 . . . 18 \$404.00 . . . 40 \$548.00 . . . 50 \$698.00 . . . 65 Electric \$928.00 . . . All sizes . . . Scott-McCulloch Parts . . . Literature .50¢ . . . Electra Marine . . . 675 Merrick Rd. Lynbrook, N.Y. 11563.

**FIBERGLASS** Cloth, matt, polyester and epoxy resins. Wholesale catalog 25¢. Boat Molding book 30¢. Seifert's, Box 1206-M, Green Bay, Wis. 54305.

**CANOE KITS**—Wood Canvas, Molded Fiberglass—Free Catalog. Trailcraft, Inc., Box 60686, Concordia, Kansas 66901.

**KAYAKS**, Canoes, Plans, Kits, Finished Craft, Books. Free Catalog. Outdoor Sports, Box 1213P, Tuscaloosa, Ala. 35401.

**AUTOMATIC** Boat Bailers and Transom drain checks, \$6.95 ea. plus, \$1.50 Handling. De Persia, Grand Haven, Michigan 49417.

**CANOE** and Kayak Kits. Molded ABS. \$127 complete ready to trim and assemble. Sabot Canoes, Box 4004, Huntsville, Alabama 35802.

**FIBERGLASS** Cloth, mat, resin. Flotation foam. Complete supplies. Catalog 25¢. Kick-Shaw, Inc., 3511 Hixson Pike, Chattanooga, Tenn. 37415.

**BUILD YOUR OWN FIBERGLASS BOAT** New Revolutionary Foam Sandwich Construction. Plans for the Amateur include 50 Designs, 12 to 60', in Power and Sail. Book complete with Building Procedures/over 200 photos. Send \$7.50 to: Clark Craft, 16-123 Aqua Lane, Tonawanda, N.Y. 14150.

**PLANS, Patterns, Kits**. Catalogs: Powerboat \$1.00, sailboat, 50¢. Marinecraft, Box 161-M, Brighton, Mass. 02135.

**LUCANDER** Designs, Sail, Power, Brochure \$1.00. Box 3184, Brownsville, Texas 78520.

**BOAT** Kits. Molded Fiberglass. Save Money—Assemble Yourself. Factory Molded Sections Bond Into One-Piece Craft. 20 Models—14' to 32' Cruisers, Runabouts, Sailboats, Accessories, Motors, Trailers. Easy Terms Free Catalog. Luger, Dept. BC-73, 3800 West Highway 13, Burnsville, Minnesota 55337.

**CANOE, KAYAKS**—Complete molded, seamless, polyethylene Canoes and Kayaks from \$79.00. Free literature. County Plastics Corp., 100 Verdi Street, Farmingdale, New York 11735.

**BEST PRICES** ON KAYAKS, Rafts, Life Jackets, etc. Free Catalog: Northwest River Supplies, Box 3195 Moscow, Idaho 83843.

**RACE BOAT PLANS**. All classes inboard, outboard hydros, runabouts. Huge savings using easy to follow blueprints, instructions. 27th year! Brochure 50¢ refundable. Champion Boats, 5849 Hazelbrook, Lakewood, Calif. 90712.

## CAMPERS AND TRAILERS— KITS—PLANS—

**BUILD YOUR OWN VAN CAMPER**—Dodge, Ford, Chevrolet! Thirty-two large pictures show you how to build Kitchens; Storage Units; Adult, Youth, Childs Beds; Drapery; Screens! Easy to read directions! Plans by retired Camper Manufacturer for General Motors! (5.00). Shepard Campsters, Route 1, Box 81, Oklawaha, Florida 32679.

**CABOVER** Campers & Pick-Up Covers for Compact & Standard Trucks, 16 & 20 Trailers. Build and Save. Large scale plans and full-size patterns with written & pictorial instructions. Complete accessory and aluminum covering kits. Free literature. Glen L. 9152PM Rosecrans, Bellflower, California 90706.

**CAMPER EQUIPMENT:** Discounted prices, complete selection parts, equipment, accessories. \$1.00, refundable, 200+ page catalog. **ALLWEATHER SUPPLIERS**, Dept. PM, 832 Seward, Evanston, Illinois 60202.

**FREE CATALOG**—Recreational vehicle plans, kits, supplies, accessories. All your needs at low discount prices. Lucky Camper, Box 8657 A6, White Bear Lake, Minn. 55110.

## MARINE EQUIPMENT AND SERVICES

**MARINE** Engines, conversions, parts, equipment. Catalog Free! Stokes Marine Industries, Coldwater, Michigan 49036.

**CONVERT** Auto engines to marine. 68 Page Catalog. 50¢. Lehman Manufacturing Company, 800 Elizabeth Avenue, Linden 4, New Jersey 07036.

**FREE** Brochure Conversion Kits, Propellers, gears V-Drives 1/0 Drives Gas, Diesel. Starmarine, 1931 Embarcadero, Oakland, Calif. 94606.

**MARINE** Supplies, Ignition Parts. Free literature. Michael's, 991 Broadway, Bayonne, New Jersey 07002.

(Continued on next page)

## MARINE EQUIPMENT AND SERVICES

(Continued from preceding page)

**RECLINER** Boat Seat Kit. Easily Made. Neptune Mfg., 11615 Southeast Lexington, Portland, Oregon 97266.

**COMPETITION MARINE EQUIPMENT.** Over 300 items for complete auto conversions and installations in high performance SK and ski boats. Mail \$1.00 for new '73 catalog complete with photos, specifications and prices. Glenwood Marine, Dept. PM, 1627 W. El Segundo Blvd., Gardena, California 90249.

## ATHLETIC AND BODY BUILDING COURSES

**POWERFUL** Muscles fast! Free brochure! Universal Bodybuilding, Box 4327-C, Dearborn, Michigan 48126.

**TERRIFIC** Muscles And Perfect Body Proportion Without Special Apparatus or Exercisers. Free Proof. Hercules II, P.O. Box 78-PM-4, Meadowvale, Ont., Canada.

**BE Taller!** 2" to 4". Secret illusionary methods, devices, Height increasers, lifts. For Treatise, send \$1.00 to: Physical Culture, Box 1548-PM8, Pompano Beach, Fla. 33060.

**KUNGFU,** Illustrated instructions. \$2.00 complete. RSH, 5834 Manton, Chicago, Illinois 60646.

**UNDERWEIGHT!** It Affects Your Appearance and Self-Confidence. ASA Method Guarantees Real, Healthy Weight-Gain. Send \$5.50 To: ASAM, P.O. Box 368C, McDonald, Tenn. 37353.

**MASCULINE** Voice Builder 98¢. Man Makers, Box 11567, Chicago, Illinois 60611.

**"GIANT Arms."** Dr. Young. Revolutionary discovery. Inquire. Gaucho, Box 1769-A7, Chicago 60690.

**ISOMETRIC** Exerciser, Builds Muscles Fast! Complete Course And Plans \$3.00. Isobar, Box 1025, Covington, La. 70433.

## SPORTING GOODS AND EQUIPMENT

**SPORTSMEN** Unique Western Style Belt Buckles. Low Prices. Free Brochure, Larry Liebig, 8476 Remmet, Canoga Park, Cal. 91304.

**PLAY BETTER GOLF!** Three New Ideas. Free Information. Liberty House, Dept. PM6, 55 Orient Ave., Brooklyn N.Y. 11211.

**FREE** Catalog low direct factory prices, fishing, Hunting, Archery, reloading Camping supplies. Send today. Herters Inc., Dept. CPM, Waseca, Minn. 56093.

**FREE WHOLESALE CATALOG.** Lure parts, Molds, Rod Blanks, Reels, Archery, Metal Detectors, Rare Hardwoods, Finny sports (ME), Toledo, Ohio 43614.

**FREE 1973** Catalog! Guaranteed lowest prices! Rods, Reels, Lures, Accessories—Thousands of items. Cabela's, Inc., Dept. S-18, Sidney, Nebraska 69162.

**NEW!** Fold-Away Racks for Water Skis, Fishing Rods, Nets, Paddles. Vast Products, P.O. Box 6034, Bakersfield, Calif. 93306.

**GOLFERS!** Get Longer Drives . . . Better Putts! We'll Show You How. Information Free. Barrickman Sales, Dept. PM6, Route 1, Box T-34, Shelbyville, Kentucky 40065.

**NEW!** Swiss Type Army Knife! It's a Portable Tool Kit in one, 2 Knives, Can Opener, Scissors, Screwdriver, Bottle Opener, File, Cork Screw and Awl. Strong Durable Stainless Steel Blades. With Case. Money Back Guarantee. Send \$7.95. La Tain Enterprises, P.O. Box 87, Wallingford, Pa. 19086.

**GOLFERS!** Get longer drives better putts We'll show you how. Free Information! Lartridge, 2706-M Areba, Houston, Texas 77088.

208 POPULAR MECHANICS

**PLAY Better Golf.** Three New Ideas. Free Information. Norm's Golf Accessories, 33 Voorhes Street, Teaneck, New Jersey 07666.

**PLAY BETTER GOLF.** THREE New Ideas. FREE Information. HOB, 428 Duke Lane, Fort Collins, Colorado 80521.

**IMPROVE** Your Golf Game! Free Information On Three Proven Ways. Westley, Box 27 A, Western Springs, Ill. 60558.



## FISHING, TACKLE, LURES

**MOLDS**—For casting your own fishing sinkers. Free illustrated booklet. Reading Instrument Co., Box P-78, Reading, Pa. 19603.

**FISHERMAN'S DREAM BOOK**—FREE, 170 page catalog just loaded with Hard-To-Find Fishing Tackle Specialties and Do-It-Yourself Goodies. Our 29th year. **NETCRAFT** Inc., Box 5510, Dept. PM-12, Toledo, Ohio 43613.

**FISHERMEN!** 20 Of World's Most Famous Dry Flies. Leather-Like Snap Case Charts Each Fly On Inside Cover. Approx. 7" x 6" x 1". No. 630-PM63 \$5.98. Tex. Residents Add 5% Sales Tax. The Top Floor, 3883 Turtle Creek #2312, Dallas, Texas 75219 \*Hook Size #12.

**FISHERMEN** 20 Assorted Professional Fish Flies \$5.98. Rose Lee Co., 538 Linden Place, Orange, N.J. 07050.

**FISHERMAN'S TOOL** . . . Fifteen tools in one. Line and leader cutter, jackknife, cleans fish, removes hooks, hones hooks, opens bottles, cans and much more. Superior quality steel. A must for every sportsman. Send \$8.95 To: New World Products, Dept. 103, 107 N. Elm Creston, Iowa 50801.

**FISH FRYERS** Complete With Propane Cylinder, Regulator, Hose, Valve And Burner. \$35.95 Plus Tax. Murrice Associates, Inc., 311 Holiday Blvd., Pineville, Louisiana 71360.

## EARTHWORMS, LIVE BAIT

**ANNOUNCING!** Nature's Newest Cash Crop. . . Fishworms! Amazing Newsletter Free! Gloworm, PO1B6, 3910 Elfin, Louisville, Kentucky, 40207.

**EARN** Money raising fishworms for us! Exciting details free! Oakhaven—56, Cedar Hill, Texas 75104.

**FREE** Literature. Profitable Business Raising Fishworms, Crickets. We Teach you how to Raise and Sell. Write today. Carter Fishworms, Plains, Georgia 31780.

**HYBRID REDWORMS.** 5,000 - \$12.00; 20,000-\$24.00. Postpaid with raising instructions. Brazos Worm Farms, Route 4, Waco, Texas 76705.



## DOGS AND KENNELS

**SPANIELS** (American Water) Hunter's—Retrievers. Snapshots. Bovey's, Plainfield, Wisconsin 54966 (715-335-6984).

**SIBERIAN** Husky Puppies. Wonderful Working Dogs. Blaze Ridge Kennels, Box 250, North San Juan, Calif. 95960.

## POULTRY AND GAME BIRDS

**COLOR** Poultry Book \$2.50—"Everything—You Name It"! Official Bantam Book \$3.00; Pheasant Breeding \$5.95; Ducks, Geese, Swans of North America \$7.95. Stromberg's Pets Unlimited, Fort Dodge 25, Iowa 50501.

**QUAILS,** Incubators, cages, supplies catalog. Marsh, 14216 Brookhurst, Garden Grove, Calif. 92643.

**COLORED BROCHURE.** Rare chicks, ducklings, guineas, bantams, peafowl. Enclose \$1.00. Cline's, Excelsior Springs, Missouri 64077.

## RABBITS—CHINCHILLAS—FUR BEARING ANIMALS

**RAISE** Rabbits Successfully by knowing Facts. 48 Page Illustrated Book describing 25 Breeds, Housing, Breeding, Feeding, Markets, Marketing, etc. 25 cents. American Rabbit Association, 36 Arba Building, Bloomington, Ill. 61701.

**\$500-\$1000** MONTH Plan Raising Rabbits For Us. Free Details. White's Rabbitry, Mt. Vernon, Ohio 43050.

**MAKE** Big Money Raising Chinchillas, Cavies, Rabbits for us. Catalog 25¢. Keeney Brothers, New Freedom, Pa. 17349.

**EARN** \$10,000 Yearly Raising Angora Wool and Breeding Stock. Details 25¢ coin. American Angora, Malta 12, Montana 59538.

**TOPLESS INCOME RAISING** Mutation chinchillas. 25¢; bulletin \$1.00. Chinchilla, 11PM6, Port Richey, Florida 33568.

**RAISE** Chinchillas. Guaranteed income. Catalog \$1.00. DeShon Chinchilla, Route 2H, Roanoke, Indiana 46783.

**RAISE** Rabbits. Markets buying One to 1,000. Dependable. Details 25¢. National Rabbit Markets, Box 35855-M, Houston, Texas 77035.

## PETS—BIRDS, CATS, HAMSTERS, ETC.

**PETS,** Reptiles, raccoons, skunks, squirrels. Catalogue 25¢. Trails End Zoo, St. Stephens, S.C. 29479.

**950 PICTURE** Pet Hobby Supply Catalog 50¢. "Everything—You Name It"! Cage Making Equipment. Stromberg's Pets Unlimited, Fort Dodge 25, Iowa 50501.

**HUMMINGBIRD FLOWERLIKE** Feeders. Instructions. Packaged Two, Postpaid \$3.60. Sylvan Crafts, Creamery Road, Warren, Penna. 16365.

**LIVE** Seahorses, marine specimens, aquarium supplies. Illustrated catalog 35¢. Marine, Box 23158-G, Ft. Lauderdale, Florida 33307.

## HORSES, LIVESTOCK

**"HOW TO TRAIN HORSES"**—FREE Book tells how to break, train, make money with horses. Beery School, 1106, Pleasant Hill, Ohio 45359.

## CAMPING EQUIPMENT AND TENTS

**FREE** Jumbo 124-large camping catalog. Largest selection in the U.S.—I. Goldberg, Dept. PM, 902 Chestnut Street, Philadelphia, Pa. 19107.

**TUPI** Tents. Professional Sioux design. Painted with Poles. 25¢ for Literature. FAP, 806-P Cadillac, Wheaton, Ill. 60187.

**FREE** 112-page Camping, Marine Color Catalog. Laacke & Joys, 1439 N. Water, Milwaukee, Wisconsin 53202.

## TRAVEL AND RESORTS

**FREE** Brochures On Tourist Attractions. Regional Addresses Northeast, Southeast, Northwest, Southwest. \$1.50 ea. (4) \$5.00. Vacation Info., Box 263, Rochelle Park, N.J. 07662.

## ELECTRICAL SUPPLIES

**METERS**—Surplus, new, used, panel and portable. Send for list. Hanchett, Box 5577, Riverside, Calif. 92507.

(Continued on next page)

Материал, защищенный авторским правом

## ELECTRICAL SUPPLIES

(Continued from preceding page)

**AN ELECTRICAL OUTLET AS CLOSE AS** your Car, Truck, Tractor. . . 110 Volt Power from Car, Truck or Boat Alternator. Send \$2.00 for complete Brochure. Sullivan Petro Sales, P.O. Box 1365, Gadsden, Ala. 35902.

**BRIGHT To Dim G/E Lighting Control** Let's You Dial Amount Of Light You Want. Easily Connected, Guaranteed. \$5.95, Gentry's, Box 52427, Houston, Texas 77052.

**LIGHT DIMMER CONTROL KIT—600** Watt, Easy To Assemble, Install. \$3.95. Pacesetter, Dept. 63M, 7808 N. 13th Avenue, Phoenix, Arizona 85021.

**LAMP Parts, Catalog, prices, wiring** instructions. 50¢. Refunded first order. Gyro, 5218P N.W. 35 Ave., Miami 42, Florida 33142.

## BATTERIES, GENERATORS

**BATTERY Reconditioning Kit, includes** molds, material, instructions. Battery Shop, Box 820, La Quinta, California 92253.

**CORROSION KILLS** batteries. Spray on **KOROSION KILLER**, wipe off Corrosion. \$2.98 Guaranteed. Royalty PM27, 81 East State, Columbus, Ohio 43215.

## TOOLS FOR SALE

**215 PC. TOOL SET \$44.95 PLUS POST-** AGE. Write: Opportunity House, 1335 N. Orange Drive, Hollywood, California 90028.

## ENGINES, MOTORS, MAGNETS

**WINDING** Data, 275 motors, \$1.25. Data Company, 512 Kensington, Kansas City, Mo. 64124.

**STEAM** Engine Kits, Catalog-Handbook \$1.00. Reliable Industries, New Baltimore, Mich. 48047.

**MOTOR REWINDING SUPPLIES!** Equipment plans! Modequip, Box 7266, Kansas City, Mo. 64113.

**REWIND** Car Generator for 110 VAC. Power Plant Plans \$2.00. R. Schmauss, 1228 East Cass Street, Tampa, Florida 33602.

## MACHINERY, TOOLS AND SUPPLIES

**SMALL** Foundry furnaces. Supplies. Free literature. Pyramid Products, 3736 South 7th Avenue, Phoenix, Arizona 85041.

**METAL** Cutting Band Saws. Use Vertically Or Horizontally. Less Than \$100.00. Send Addressed Stamped Envelope For Full Details To: Saws, P.O. Box 295, Marcellus, Mich. 49067.

**MAXIMAT, Unimat** Lathes. Metals. Micrometers. Catalogue 50¢, Industrial \$2.00. Campbell (PM), 1424 Barclay, Springfield, Ohio 45505.

**4" METAL** Cutting Lathe Kit \$29.50. Completely assembled machining unit \$89.50. Taig Mfg., Dept. T, 15048 Proctor, Industry, Calif. 91746.

**SHOPSMITH IS BACK!** Send 25¢ for Catalog. Includes Accessories, Prices, Parts. Factory Authorized Sales and Service. Hobbymodels, 418 Fulton St., Peoria, Illinois 61602.

**1400 CATALOGS** Listed and Described! Sources for EVERYTHING Imaginable! Rush \$2.00. MASTERLOG, Box 24413-VF, Oakland, California 94623.

**ABRASIVE BELTS WHOLESALE.** Also Buffing and Polishing Compounds. Our 30th year. Save. Wholesale price list and how to use them. Mail \$2.00. Guaranteed. Buff And Polish Guide, PM-5, 910 S. Cypress, Pompano, Fla. 33060.

**50% DISCOUNT** All tools. Buy Direct. \$1.00 (Refundable) brings **BIG** Listing and valuable samples. Cash Industries, Box 4804-PM-6, Pittsburgh, Pennsylvania 15206.

**ROUTER** Bits, 1/4" Shank, High Speed Used; Excellent Condition. \$2.50 Dozen. Postpaid. Lillian's, Box 4777, North Hollywood, California 91607.

**SEND** For Complete Catalog of Maintenance Free Stainless Steel Nuts, Bolts, Washers, Etc. \$1.25. Summit Fasteners, Box 183, Lansdale Pa. 19446.

**FOUR-Fingered 'RETRIEVER'** Tool. Needle-sharp spring-steel feelers. Wide spread, strong, Curvable shaft. 18", \$2.25. 24" \$2.50. Pair \$3.50. Postage prepaid (Manufacturers Agents, 5,000 available). 5129 No. 6th Street, Phoenix, Ariz. 85012.

**NUTS, Bolts, Screws, Washers, Threaded** Rod, Assortments, Catalog 25¢. Nutty Co., Box 1576 SMS, Fairfield, Conn. 06430.

**4-IN-ONE** Screwdriver. New Unusual Top Quality Precision Made. Two (2) Double Reversible Slotted And Phillips Type Bits Snap Interchangeably. Amber "Tenite" Handle With Six Grooves Polished Smooth. Fits Hand Comfortably. Every Mechanic And Homeowner Needs One. Ten Day Refund Guarantee. Send \$3.98. **DORANTER** Economy Enterprises, P. O. Box 477, Rochester, New York 14602.

## WELDING, SOLDERING, PLATING

**PLATING** Equipment, Portable Platers, Supplies, and "Know-How". Build your own tanks for nickel, chrome, etc. Easy-to-install PVC liners. Rectifier components—all sizes. Schematics, parts lists, formulas, operating instructions for all plating. \$10.00 post-paid. Guaranteed to save you 25%-75% or immediate refund. Some good used units for sale. Platers Service Company, 1511-A Esperanza, Los Angeles, California 90023.

**WELDERS.** Convert To Heliarc. High Frequency Unit 0-225AMP. Plans \$4.00. Convert To DC Plans \$3.00. Information Supply Co., Box 166, College Park, MD. 20740.

## GOVERNMENT SURPLUS

**"U.S. GOVERNMENT SURPLUS** Directory." How, Where to buy 100,000 items (including Jeeps) . . . low as 2¢ on dollar! Most complete information available . . . \$1.00. **SURPLUS DISPOSAL**, Box 19107-AF, WASHINGTON, D.C. 20036.

**JEeps!!! PICKUPS!!** 100,000 Items direct from government. Your area. Latest information & surplus categories: \$2.00 **MONEYBACK GUARANTEE.** Order manual #125, from "Dependable Products". Box 113, Vista, California, 92083.

**NO CATCHES.** Buy any surplus direct from U.S. gov't. All information \$2.00. Bridgworth, P.O. Box 2292-C, Vancouver, Washington 98661.

**1973 SURPLUS** Army, Navy store, 52 Page illustrated catalog. Send 50¢. Ruvel, 3037 North Clark, Dept. 6-J, Chicago, Illinois 60614.

**JEeps!!! TRUCKS!! LAND!** 100,000 Amazing Bargains direct from Uncle Sam nationwide. How, where your area. Complete Sales Directory \$2.00. **MONEYBACK GUARANTEE.** Diversified Surplus, Box 27177-F, San Antonio, Texas 78227.

**JEeps** \$52.40. Airplanes \$75.01, Typewriters \$6.70. Boats \$7.50. Direct from Government. Directory and Surplus Catalog \$1.00 (Refundable). Midwest Surplus, Box 401-PM, Dayton, Ohio 45401.

**GOVERNMENT SURPLUS—TRUE FACTS ABOUT BUYING JEEPS, BOATS, ETC. YOUR OWN AREA. COMPLETE INFORMATION \$2.00. REFUNDABLE. WHITE, BOX 153, LEOLA, PENNSYLVANIA 17540.**

**GOVERNMENT SURPLUS, How and Where** to buy in your area. Send \$2.00. **SURPLUS INFORMATION**, 30177PM **HEADQUARTERS BUILDING**, Washington, D. C. 20014.

**GIANT 10 Ft. Surplus Weather Balloon.** \$2.98, Moneyback Guarantee. Tom Henry, 2332 Harrison Street, Oakland, California 94612.

**SURPLUS** Aircraft Equipment, motors, radios: catalogue 50¢; Kohler, Box 69606, Los Angeles 90069.

## HOBBIES AND COLLECTIONS

**NAZI** War Souvenirs! Illustrated Catalog \$3.00 Cash. Disco, Box 331-S, Cedarburg, Wisconsin (53012).

**COLLECT** Military Medals, list 25¢. Vernon, Box 387PM, Baldwin, N.Y. 11510.

**NAZI** War Souvenirs Free Illustrated catalog. Delta, Box 361PS, Lafayette, Calif. 94549.

**NAZI** Medals, Photos, and Jewelry. Also War Mementos from Other Countries. Catalog and War Poster, 25¢. Hutchinson House, Box 6411, Chicago, Illinois 60680.

**NAZI** Silver Coin, \$3.95. Five different metals \$6.95. Maco, Box 3402, Providence, R.I. 02909

**HOBBY** Trade Magazine for All Hobbyist—Collectors Sample 35¢. Box 134, Clifton, New Jersey 07011.

**BLACK GOLD** One of the Worlds Great Treasures, Have You Ever Seen It? Unrefined Petroleum Direct from its Underground Reservoir in Display Container. Send \$1.98. Kalyen Enterprises, 7298 Cloverdale Rd., Cymnet, Ohio 43413.

**MODEL RAILROAD BASCULE BRIDGES.** Catalog 25¢. Russell **MOBI-MODELS**, Box 301 Uleta, Miami, Florida 33164.

**BUY:** Old Trains, Mechanical Toys. H. Mueller, Box 645, Sheboygan Wisconsin 53081.

**THREE REVISED COLLECTORS GUIDES.** Coins, Stamp, Paper Money. 579 Pages \$2.98. Satisfaction Guaranteed. Bates, 31 Lamar Place, Yonkers, New York 10710.

**BOTTLE COLLECTING!!** Cleveland's "Bottle Pricing Guide" lists/prices 3,600 new/old bottles. 1250 pictured. 18 categories. \$5.95 postpaid. Cleveland, 320AHM Main, San Angelo, Texas 76901.

**50 GORGEOUS** Jungle Butterflies \$2.90. 20 Exotic Seashells \$1.25. Collectors Wonderland, Box 1170, New York 10008.

## DECALS, EMBLEMS, PATCHES

**CUSTOM** Designed Embroidered Emblems, Decals, Inexpensive. Free Catalog, details. Southern Emblem, Box 8PMB, Toast, North Carolina 27049.

**NASA ASTRONAUT** Patches. Complete Set (30), \$39.95. Skylab \$1.50. (Included Free) Banner Supplies, Box 125-P, Jamaica, N.Y. 11414.

**EMBLEMS** Embroidered to your own design. Leading manufacturer offers custom emblems in any quantity. Send sketch for firm quote or write for free Design-An-Emblem Guide and literature. A-B Emblem, Box 5695, Weaverville, North Carolina 28787.



## STAMP COLLECTING

**COMPREHENSIVE** Worldwide Price Lists 25¢ Refundable, Liberty Philatelic, Brewster, New York 10509.

**LOOK!** 100 Beautiful Romania Pict. 25¢ Approvals. Scenic Stamps, Box 1973-B, Vancouver, Wash. 98663.

**FREE** Perforation Gauge. Bargain Lists. No Approvals. Stamps, Box 27, Fremont, Michigan 49412.

(Continued on next page)

## STAMP COLLECTING

(Continued from preceding page)

**WOW!** 1000 Different Worldwide Stamps (\$35.00 Cat. Value) \$2.00 with profit sharing approvals. Universal, Box 6MA, Kenosha, Wisconsin 53141.

**SPECTACULAR** 154 Worldwide 10¢ Commemoratives, Mysterious Continents! Approvals. Holland, 1227 Sixth, Redlands, California 92373.

**FREE!** Big Bargain Catalog—New Edition listing thousands of bargains including U.S. & B.N.A. stamps, packets, albums, accessories and supplies. Also, fine stamps from our approval service which you may return without purchases and cancel service at any time. Jamestown Stamp, Dept. E63PM, Jamestown, New York 14701.

**FREE** Surprise Gift Sent With Approvals. Boudreau, Box 275, St. Lambert, Quebec, Canada.

**55 DIFFERENT** Including Triangles, Space, Others, 10¢ to approval applicants. L. Baird, PM-34, Box 8128, Portland, Oregon 97207.

**WOW!** 110 All Different Germany 10¢ Commemoratives, Airmails, High Values, Big Catalog, bargain lists. Also, fine stamps from our approval service, which you may return without purchases and cancel service at any time. Jamestown Stamp, Dept. A63PM, Jamestown, New York 14701.

**FREE** Mixture, Contains Many Commemoratives, Pictorials, British Colonies, Foreign Approvals. City Stamp Co., Box 216, Station "W", Toronto 15, Ont., Canada.

**22 TRIANGLE** Stamps Only 10¢. Get This Timeless Treasure Of Gorgeous, Colorful, Triangle Shaped Postage Stamps. Approvals Included. Send Today! Stamps, Box 1444-B, Kitchener, Ontario, Canada.

**200 WORLDWIDE** 50¢ To Approval Applicants. Polze, Box 5215, Milwaukee, Wisconsin 53204.

**50 DIFFERENT** Old U.S. Revenue stamps \$1.00. Winchester Stamps, Box 3592, Mansfield, Ohio 44907.

**OLDER U.S.** stamps, covers, on approval to adults only. Surprisingly good. ENGLE, Box 208P, Lowell, Michigan 49331.

**FREE** New used Congo animal set, Approvals included. Alpaughco, Highbridge, N.J. 08829.

**TEN** Different Nudes: 20¢. Approvals. Stamp Farm, 2M55, Oxford, Wis. 53952.

**50 DIFF. U.S. COMMEMORATIVES** 25¢. Fine U.S. Approvals Accompany. Craig Stamps, Box 425-N, Bellmore, N.Y. 11710.

**FOREIGN** Approvals! Gigantic values! 3¢ each. ABC, Dept. 3301-A, Box 6000, San Francisco 94101.

**3¢ PLATE** Block 25¢ with comprehensive U.S. stamp and Supply catalog. Schultheis, Box 2151C, New Hyde Park, New York 11040.

**"AFRICA"** 25 Beauties, 10¢. Approvals, Gortiz, Box 28765 PM, Memphis, Tennessee 38128.

**100 DIFFERENT** United States Stamps, 25¢ With U.S. Foreign Approvals. ShelRon, Box 547C, North Miami, Fla. 33161.

**U.S. MINT** Specials! Flag set, complete \$1.00. 1¢, 2¢, 3¢ famous Americans (21 different) \$1.00. Free list. Brooks, 2601 Avenue "U", Brooklyn, N.Y. 11229.

**PENNY!** Approvals! Regardless catalogue! Kloster, 4164 52nd St., San Diego, Calif. 92105.

**FREE** Surprise collection sent with approvals. Gould, 1784 Union, San Francisco 94123.

**PENNY** Stamps! 1000 Mounted in book at 1¢ each! Trust Stamp Company, P.O. Box 100-P, Jamaica, New York 11435.

**ABSOLUTELY** Free United States Mint Souvenir Sheet When Requesting United States Approvals. K&B, Box 70, Brooklyn, N.Y. 11223.

**500 DIFFERENT** Stamps, \$1.25. Smith, 508-A Brooks, College Station, Texas 77840.

**100 DIFFERENT** British Empire 15¢. Approvals. Gibson, Box 34, Lansdowne, Pa. 19050.

**"INVERTED Error"** Dag Hammarskjold, 10¢ with approvals. Belmont Stamps, Washington, D. C. 20015.

**100 OLD** United States between 1861 and 1935. \$1.00. Ed Roush, 423 Shepard, Mansfield, Ohio 44907.

**225 STAMPS** For only 10¢! Airmails. Pictorials: stamps from strange countries cataloging up to 25¢ each! Plus unusual stamps to examine. Buy any or none return balance, cancel service anytime. Mystic Stamp Co., Camden 80, New York 13316.

**FREE!** 10 African Beauties! 30 Others! Approvals. Cambridge, Box 2311, Heath, Ohio 43055.

**VALUABLE** Collection! Get scarce Red China, Pope John, Apollo 14, Antigua military costume, Iwo Jima memorial stamps, many more. 100 Different new and old issues from the world over—savage warriors, wild beasts, famous people, exotic scenes. Also stamp selections to examine. Buy any or none, return balance. Cancel service anytime. Rush 10¢ handling. Garcelon Stamp Co., OPMX, Calais, Maine 04619.

**1000 PRE-1939** USA, contains dues, revenues, commemoratives, presidentials, high values, older issues, etc. \$3.00; 5000 \$12.00. 300 pre-1940 USA commemoratives \$2.00; 700 \$4.00. 5000 foreign \$3.00; 9000 \$5.00. No approvals. Meyers, 5321 Fleming, Richmond, California 94804.

**20 HISTORICAL** U.S. Commemoratives 10¢. Bargain U.S. Approvals. PINTO, Box 111, Park Ridge, Illinois 60068.

**FREE** Beautifully Designed Space Selection. Approvals. House of Hoke, Sebring, Florida 33870.

**VIETNAM** 25 Different 10¢ approval. Sam Chazen, Box 95, Ozone Park, N.Y. 11417.

**80 DIFFERENT** U.S. Stamps. Includes 1943 flag stamp of occupied nations. Only 25¢. Approvals included. Willett Co., Box 338-M, Yorktown Heights, N.Y. 10598.

**50 YEARS** Old, fifteen different United States, over fifty years old—10¢ with approvals. Jaxon, Box 145-P, Brooklyn, New York 11230.

**QUALITY AND LOW PRICE. EXCELLENT** For advanced or beginner. Mounted approvals 2¢ up, all countries in Scott's Order. Preview Stamps, P.O. Box 20667, San Diego, California 92120.

**U.S. BARGAIN**, 50 Different 10¢, with beautiful worldwide, approvals. Stamp Center, Kennebunk, Maine 04043.

**210 DIFFERENT** U.S. Commemoratives \$1.00. Stamps, 7607 Larchview, Dallas, Texas 75240.

**HITLER**, 100 Germany 10¢! Approvals. White Rock Stamps, 13125 24th M Avenue, Surry, B. C., Canada.

**RUSSIAN** Space Collection 25¢, including Russian Approvals. Snedco, Waldwick, New Jersey 07463.

**"WHOLESALE"** U.S.—Foreign Pricelist and catalog Free! Everything Guaranteed. Schneider, Box 1240, Grand Rapids, Michigan 49501.

**FREE WORLDWIDE** Commemoratives, Pictorials Beautiful Stamps, Approvals. Closson, P.O. Box 663, Madison, North Carolina 27025.

**FREE \$1.50** Better Grade Worldwide Approvals. Stamps Unlimited, Box 2338, Kalamazoo, Mich. 49001.

**SENSATIONAL** Penny Approvals! Pictorials, Topicals, Etc.! Write Today! Schmidt, 634-M Station A, Richmond, Calif. 94808.

**2000 MISSION** Mixture \$1.00. 12,000 \$5.00. 1000 Large \$5.00. Stamps, Box 9, West Union, Iowa 52175.

**HARRY S. TRUMAN** Memorial stamp on lovely First Day Cover addressed any name your choice. 50¢ from: K. M. WALSH, Box 308D, Tuckahoe, New York 10707.

**FREE** "Space", with packet approvals. Sunset Stamps, Box 69473, Los Angeles, California 90069.

**PAINTINGS—25** Different 25¢. Northern, Box 565, Hull, Quebec, Canada.

**FREE** Older Korean Set. Approval Applicants. W—B Stamp Company, Wilkes-Barre, Penna. 18703.

**60 DIFFERENT** United States (30 Commemoratives) 25¢. Seidenberg, Salem 169, Oregon 97308.

**IRELAND** 50 Used \$2.00. George Ginovsky, Box 2370, Hyattsville, Maryland 20784.

**510 DIFFERENT** Worldwide Stamps \$1.00 With Approvals. Gormish, 211 Beach, Cambridge Springs, Pennsylvania 16403.

**FREE** First Day Cover; Approvals. Gail, 2545 Tilghman, Allentown, Pa. 18104.

**WORLDWIDE** 500 Different \$1.00. 1000 Different \$2.00. Hefen Sugar Grove, Ohio 43155.

**KENNEDY! OLYMPICS! SPACE!** Beautifully Multicolored Pictorials, 10¢ Accompanying Approvals! Stickler's Philatelymania, Readville, Massachusetts 02137.

**200 DIFFERENT** Worldwide Stamps 10¢. Approvals Included. White 6808-E Chrysanthemum, Indianapolis, Indiana 46224.

**60 ASIA** 10¢—With Approvals. Belke, 1824 Gates, Brooklyn, N.Y. 11227.

**STAMPS** Free! New Issues—New Countries—Triangles—Rockets—Olympics—Scouts—Birds—Flowers—Animals—Also Old Canadian and U.S. Stamps. Plus complete illustrated Canadian Stamp Catalog. Send 10¢ for mailing. Gray Stamp Co., Dept. A, Toronto, Canada.

**SEND** Only 5¢ for Worldwide Collection of over 50 different Singapore, Grenada, Chad, etc. Contains old and new Issues, sports, animals, etc. You will also receive interesting lists and a certificate worth 50¢ toward purchases. Goliath Co. Dept. TP-1, Bethlehem, New Hampshire 03574.

**SEND** Only 10¢ for nice collection of U.S. stamps including "\$5.00." Issue and scarce mint Sipex Souvenir Sheet. You will also receive the most wonderful catalog of stamp offers in America. Littleton Stamps, Dept. SS1, Littleton, New Hampshire 03561.

**U. S. Plate** blocks 7 different 3¢ commemoratives \$1.00! Approvals. Gordon Davison, Hillsboro, New Hamp. 03244.

**DYNAMITE!** 107 exciting British Colonials, 25¢. Approvals. Castle, Box 15-PM6, Flushing, New York 11352.

**UNUSUAL—SPECTACULAR—COLLECTION!** Catalogue—\$8.35. Worthwhile—Colorful—Dubai Sets Paintings—Space—Transportation—Tropical Fish—Others. Exceptional Introductory Approvals. 25¢. Richley, Box 2288, Littleton, Colorado. 80120.

**500 DIFFERENT** Worldwide Plus complete nudes set \$1.25. Free list. Rhea, Box 90406-P, Nashville, Tenn. 37209.

(Continued on next page)



## STAMP COLLECTING

(Continued from preceding page)

**3-D BHUTAN** Space set 50¢ with pictorial approvals. Robert Hedges, Route 3, Hagerstown, Maryland 21740.

**FREE**, Mint British Colonies Packet. Approvals. Hildebrand, Box 5645, Redwood City, California 94063.

**40 DIFFERENT U. S. COMMEMORATIVES** 20¢ With used U. S. Approvals. Mary C. Armstrong, Box 409, Kennett Square, Penn. 19348.

**SOMETHING** Different. Personalized worldwide approvals. Fine, 4350 Melrose, Montreal, Canada.

**KAZAM!** 25¢, 50 Mid-eastern. Approvals. ALLADIN, Box 602, Jefferson City, Tenn. 37760.

**\$3.00 VALUE**, Only \$.25 To: New Approval Applicants. Jenco, Box 242H, Wayne, N.J. 07470.

**307 DIFFERENT** Triangles, Sports, Topicals, Etc. Worth Near \$8.00. Only 25¢. Bargain Approvals. Free Catalog, \$1.00 Coupon. Jayto Stamps, East Syracuse, New York 13057.

**APOLLO "17 Flights"**, Romania's Latest Commemoratives—Free! Approvals Plus 101 Bonus Sets. William Deems, 226 Race, Ravenswood, West Virginia 26164.

**FREE** British Mints. Approvals Accompany. Chapmans, Box 487-B, Galesburg, Michigan 49053.

**FIRST DAY COVER** Mailing Service. Next Issue And Details FREE. Handling 25¢. Whelpley, 7530 Robin Rest, San Antonio, Texas 78209.

**LIQUIDATING** Tremendous Accumulation. Collections, Lots, Miscellaneous. Lists Free. Alatalo, Maynard, Mass. 01754.

**FREE BARGAIN LISTS!** U.S. Mint Single-Plate Blocks. Scotco, Box 855-PMJ, Miami, Fla. 33147.

**\$10 CATALOG** Value for \$1. Sam's, Box 710, Spencer, Iowa 51301.

**DREAMS COME TRUE.** 1001 British Empire Mixed off Paper Including Pictorials \$100 Plus 10¢ postage. Exchange Offers List Enclosed. Trading Post, P.O.B. 52, Alexandria, Virginia 22313

**255 DIFFERENT** Worldwide: 15¢. Approvals. Tibbets, 8675 Meadow, Downey, California 90242.

**LIECHTENSTEIN #356-\$19.00; France #1100-\$4.00; UN 29-30-\$15.00; NH, CWO.** Submit Lists Western Europe Only. All NH. Franklin, Box 467J, Jamaica, 11434.

## COINS, TOKENS, CURRENCY

**INDIANS, Lincolns!** Selling barrel of Indian and Lincoln Cents (1860's thru 1930s, all Mints) at \$9.95 per pound! Maximum 10 pounds. Silver's, 86 E. Campbell Ave., Campbell 1, Ca. 95008.

**1909 VDB's!** Rare Lincoln Cents. \$3.95. 3 for \$10.00. Coins West, 21 Central, Campbell 1, Ca. 95008.

**\$1000.00 BANKNOTE** 25¢ with comprehensive U.S. coin and Supply catalog. Schultheis, Box 2151C, New Hyde Park, New York 11040.

**SILVER DOLLARS** Uncirculated, 1880-81—1883-84-85 \$8.00 Ea. Catalogue 50¢. Shultz, Salt Lake City, Utah 84110.

**LINCOLNS 1909-1958** Every year including 1909VDB, 1922D. 50 different (Regularly \$12.60.) SPECIAL \$6.95. HARRIS, Box 2037P, Santa Cruz, California 95060.

**SPANISH** Treasure catalogue, Bargains on Coins, Gold, Treasure, Special Bit of eight \$1.00 with catalogue. Colonial House, 909 Travis, Houston, Texas 77002.

**100 INDIAN** And Lincoln Cents 1920's and older \$5.00, 100 early "S" Cents \$5.00. 100 Mixed Steel Cents \$5.00. 40 Buffalo Nickels \$5.00. Free Catalog. Wesley Rool, Box 9, West Union, Iowa 52175.

**BARGAIN** Coin List, 10¢. Economy Sales, Box 92, Buzzard's Bay, Massachusetts, 02532.

**\$\$\$ COLLECT, BUY, SELL COINS** For investment, profit. Instructions \$1.00. Satisfaction or Refund. F. A. Vickery Enterprises, 510 N. A Street, Dept. 6, Eloy, Arizona 85231.

**USA SILVER** Dollars Nice Condition 10 Different Dates Only \$39.95 post paid. El Paso Coin Co., P.O. Box Q, El Paso, Texas 79952.

**COINS** At Discount Prices! Free Brochure. Gene Carlton, Chandler, Okla. 74834.

**MEXICO:** Silver Dollars Dated 1957 To 1967 In Nice Condition. Ten For \$3.95 Delivered Postpaid. El Paso Coin Co. Inc., Suite 108, El Paso National Bank Bldg., El Paso, Texas 79952.

**GOLD—(1865)** Mexican Maximiliano Peso, Bu \$2.95. Northwoods, Bigfork, Minn. 56628.

**3 DIFFERENT** Barber Quarters, \$2.80. Free Catalog. Village Coin Shop, Dept. P. Plaistow, N.H. 03865.

**COMMEMORATIVES—**Brilliant Unc. + Oregon Trail \$37.89; Texas Centennial \$35.88; Carver \$7.48. 1972-S Proof Set \$6.68; Bargain Lists 18¢. Bebee's, Incorp., Omaha, Nebraska 68111.

**SEND** Only 5¢ for valuable booklet "How To Collect Coins" which is loaded with expert advice. You will also receive 5 different foreign coins and your copy of the most unusual and interesting collectors catalog available anywhere. Littleton Coins, Dept. VB-1, Littleton, New Hampshire 03561.

**COIN** Catalogue 50¢. Raibl Enterprises, 2355 Scenic Highway, Pensacola, Florida, 32503.

**UNITED STATES COINS!** All Types Mixed Grab-Bag Style. Values \$6.00-\$60.00. Send \$4.00. Coin Surprises, P.O. Box 532, Dearborn, Michigan 48121.

**EXACT** Replica Colorado \$20.00 Gold Piece \$2.00. HOF, 1418 Montague, Washington, D.C. 20011.

**GOLD COINS** Of the World. Beautiful Low Prices. Plus thousands of United States Coins. Free price list. Please send long, airmail envelope. Self-addressed, stamped. Silver Center, Box 22171-M, San Francisco, California 94122.

**MEXICO** Revolutionary "Pancho Villa" 10 and 5 Centavos Copper Coins Dated 1915 Nice Condition only \$2.95 each. Delivered Postpaid. El Paso Coin Co., P.O. Box Q, El Paso, Texas 79952.

**INDIAN** Head Cents 2 Different Dates 50 Cents. Spruceland Coins, Box 2114, Springfield, Mass. 01101.

**UNCIRCULATED 'S'** Lincolns, three different, 10¢. Bargain lists included. Farley Coins, Metamora, Illinois 61548.

**CALIFORNIA** Gold Pieces 50¢ Size 1853-1857. 5 Different \$1.95—25/\$6.95. U.S. Silver Dollar \$1.95. Allen's, 5674-G Beacon, Pittsburgh, Pa. 15217.

**FREE:** Lists of Thousands of Stamps and Coins. No Approvals. Bryson, 612M White, Toledo, Ohio 43605.

## ANTIQUES, RELICS, INDIAN GOODS & CURIOS

**FREE!!** Lists Antiques, Indian Relics, 10 Arrowheads \$4.00. Hyde's, Box 2304, Santa Fe, New Mexico 87501.

**PERFECT** Flint Knife, 4 Perfect Arrowheads, Hide Tanner, \$4.00. List Free. Lear's, Glenwood, Ark. 71943.

**INDIAN** Relic list, Arrowheads \$4.00, doz. Folsom, \$5.00 each. C. Secrist, Deerfield, Missouri 64741.

**APACHE ARROWHEAD COLLECTIONS—**Perfect, 25—\$5.00, 100—\$15.00. GERONIMO, PMD1239, Apache Junction, Arizona 85220.

**COLORFUL** Polished Gemstones (150) \$3.00. Indianmade Arrowheads (15) \$3.00. Larger (12) \$4.00. Ekbergs, 1404 South Glendale, Sioux Falls, South Dakota 57105.

**WEIRD, FUNNY OLD ADVERTISEMENTS**—Hilarious Big Book 120 Pages \$2.00 ppd.—Box 910-A, Aberdeen, South Dakota 57401.

**1,000 HISTORIC POSTERS** And Handbills. Most Under \$1.00. Send 25¢ For Catalog. Buck Hill, Dept. PM Johnsburg, N.Y. 12843.

## MODELS—CARS, SHIPS, TRAINS, PLANES ETC.

**NEWEST, GREATEST FLYING HOBBY—ROCKETS!** Zoom from realistic electric launch systems to 2,500 feet on safe, thrifty, solid-propellant power. Gentle parachute recovery for over-and-over-again flights. Tracking, experiments, real miniaturized still and movie cameras. Build your own exciting, low-cost space-age adventure—starting with a big, new full-color catalog of over 80 models, (including ready to fly). Send 25¢ to: **ESTES INDUSTRIES**, Dept. 7K, Penrose, Colorado 81240.

**SHIP MODEL** Kits, Plans, Fittings from our own Workshop. Big Illustrated Catalog: 50¢. Bluejacket Shipcrafters, 145-V Water Street, South Norwalk, Conn. 06854.

**SHIP** And Airplane Model Kits Catalog 25¢. Scientific, Inc., 340 Synder, Berkeley, Heights, N.J. 07922.

**SHIP** Models Kits, fittings, plans, books, tools, engines, motors. Big illustrated catalog 50¢. Mass. residents add 3% tax. James Bliss & Co., Dept. SM, Route 128, Dedham, Mass. 02026.

**MODEL** Airplanes—Big 220 Page Catalog \$1.00. Sig Company, Montezuma, Iowa 50171.

**SHIP** And yacht model fittings: Pine construction hull kits; blueprints. Send 75¢ for illustrated catalog. A. J. Fisher, Inc., 1002 Etowah Avenue, Royal Oak, Michigan 48067.

**MINIATURE** Screws, Size 1-72 X 3/16. Straight Slot Flathead Package. 200 For \$1.00 Postage Paid. 3 Packages For \$2.50. Write: A. H. Edelen, 2562 Calle Narcisco, 1000 Oaks, California 91360.

**LIVE** Steam powered backyard railroads! All sizes. Complete "bolt-together kits," and rough castings. Excellent drawings. 100 page catalog \$1.00. Little Engines, Lomita, California 90717.

**N SCALE** Trains by Mail, 60 page color catalog, \$1.00. Train Master, 6 Highland Ave., Albany, N. Y. 12205.

## GAMES, TOYS, PUZZLES, NOVELTIES

**KITES!** Quality Action Styles! Brochure 10¢. Hutchinson, PM6, 83 Tremont, Barre, Vermont 05641.

**PLAY POSTAL CHESS.** State Whether Beginner, Intermediate Or Advanced Player. Two Opponents \$2.00. Global Chess, Box 747, Delaware, Ohio 43015.

## MAGIC TRICKS, JOKES, VENTRILOQUISM

**HOUDINI'S** Greatest Magic! You can do them all!! Giant illustrated catalog 25¢. House Of 1000 Mysteris, P.O. Box 2026P, Pompano Beach, Florida 33061.

**CATALOG 10¢.** 1,500,399 tricks, jokes, novelties. Elbee, 7408P, San Antonio, Texas 78207.

**FREE!** World's leading novelty catalog. 1600 Funmakers, Jokes, Tricks, Science, Sports, Hobbies, Jewelry, Psychedelia. Johnson-Smith, C-10, Mt. Clemens, Mich. 48043.

**COMPLETELY** Illustrated catalog. 84 pages. 25¢. Manhattan Magic, Box 334-M, N.Y.C. 10011.

(Continued on next page)

## MAGIC TRICKS, JOKES, VENTRILOQUISM

(Continued from preceding page)

**MAGIC MAGAZINE.** Tricks, News, Dealers Offerings. Monthly Since 1936. 2 sample Copies \$1.00. Genii, P.O. Box 36068M, Los Angeles, California 90036.

**WORLD'S** Finest professional magic tricks. Joker's Novelties. Giant illustrated catalog 10¢. Top Hat, Evanston, Illinois.

**FABULOUS MAGICS** New 1973 catalogue 25¢. Our specialty orders shipped same day no substitutes. Fabulous Magic, 3319 East Charleston, Las Vegas, Nevada 89104.

**BE A Magician!** Two booklets explaining 156 tricks plus large professional catalog. \$1.00. Magic, Inc., 5082 Lincoln, Chicago, Illinois 60625.

**VENTRILOQUISM!** Learn at home! Guaranteed! Write! Information Free! Dummy Catalog 25¢. Maher, Box 9037P, Denver, Colorado 80209.

**VENTRILOQUISTS** Dummy Catalogue 25¢. Storyteller Studios, Box 633PM, Bellflower, California 90706.

**MAGIC!** Amaze, Mystify, Entertain! Hundreds Of Newest Tricks For Pocket, Parlor, Stage. Complete Catalog Only 25¢. Jeffries Magicland, Dept. 11, Dallas, Texas 75201.

**CATALOG** 10¢. Loaded with Magic, Tricks, Novelties. Sun Magic, Oakhill Williston, Vermont 05495.

**TWO!** Different Magic Catalogs. 25¢. Miami Magic, Box 1047, Miami 33133.

**WHOLESALE** Novelties, Games, Gags, Gimmicks Jokes. Catalog \$1.00. Universal Distributing, Box 411-6, Tomah, Wisconsin 54660.

## BOOKS, CATALOGS, NEWSPAPERS

**FREE** Brochure! on Self Improvement Books. Fits Most All Needs, Benefits Every One. Clark Enterprises, 10744 66th South, Seattle, Wash. 98178.

**ANTIQUE BUYER'S GUIDE,** Makes You an Authority, Wholesale, Retail Prices, Illustrations Send \$1.95. Becker's, 52 Eugene, Tonawanda, N.Y. 14150.

**WIRETAPPING** Expose Revolting National Scandal. Details \$1.00 Refundable . . . Don-Q, Box 548, Dept. PM, Seattle, Washington 98111.

**BEYOND 2000—**Boggling, Staggering, a book of the Future \$1.00. Schmieder, RD #1, Doylestown, Penna. 18901.

**FREE!** List Low cost Books. Success, Happiness, Wealth, Personal Problems. Reelfoot Shopper, 508 Fonville, Martin, Tenn. 38237.

**GREAT** Catalogs—Free! Diane P. Anderson, 260 Crittenden Blvd, Rochester, New York 14642.

**MECHANICAL COMPONENTS—**Over 37,000 Miniature Gears, Bearings, Drive Belts, Couplings, Etc.—448 page Catalog "A" \$1.00. Winfred M. Berg, Inc. Box B, East Rockaway, New York 11518.

**LATEST** Military Manuals/Books Catalog 25¢. Hillcrest Publications (K-18), McDonald, Ohio 44437.

**FREE BOOK.** Prophet Elijah Coming Before Christ. Megiddo Mission, Dept. 63, 481 Thurston Road, Rochester, N.Y. 14619.

**NATIONAL** Geographic Magazines, 1888-1971, any issue. Buxbaum, Box 465-PM, Wilmington, Delaware 19899.

**WORLD'S** Most Outspoken Publication. Natural Health, Healing, Organic Gardening. **FREE** Copv. Provoker Press, St. Catharines 102, Ontario.

**LOGIC NEWSLETTER.** Learn Theory, Design, Symbolic Logic. **BOOLEAN ALGEBRA,** Sample Copy \$1.00. **LOGIC NEWSLETTER,** P.O.B. 252, Waldwick, New Jersey 07463.

**FREE** Catalog. Rare Oriental Occult Supplies. Box 1562, Manila, Philippines.

**FREE CATALOG.** Self Improvement Books. 180 Titles. Lowest Prices. Mailer Enterprises, Bcx 1517, New York, N.Y. 10001.

**LADIES!** Free List Of Low Cost Books . . . Personal Problems, Self Improvement, Home Business, Astrology, Numerology, Craft, Mail Order. J & M Enterprises, 1403 Auburn, PM, Longview, Texas 75601.

**AMAZING** Book Offer, Money Health Security All Subjects. Free Catalog C1. Morgan Enterprises, 59-14 Xenia Street, Corona, New York 11373.

**FINER BOOKS** Hobby, Improvement, Money-Making. Free Details. RALPCO, 2445 North Dunlap, Dept. 2E3, St. Paul, Minnesota 55113.

**TREASURE GUIDE** \$1.00, Flag Display Etiquette 50¢. USP-CORP, Stuart, Florida, 33494.

**FREE** Illustrated Circular! Low Cost Book Sale. Think and Grow Rich, Psycho-Cybernetics, Solving Personal Problems, Dynamic Thinking, Dreams Revealed, Fortune Telling. House of Cooper, 4724 N. Van Ness, Fresno, Calif. 93704.

## PLAYS, SONGS, MANUSCRIPTS

**YOUR SONG** Recorded by "Top Ten" Producer. Maximus Music, 2376 Saybrook Road, Cleveland, Ohio 44118.

**SONGWRITERS! POETS!** We need new song material for immediate publishing, recording consideration! Accepted songs recorded, published at our expense! **GRAND RECORDING,** 1354-PM Hancock Street, Quincy, Mass. 02169.

**PUBLISHING** Contract Guaranteed on selected songs and poems. Free evaluation. Hollywood Songwriters', 6253 Hollywood, 117-PM, Hollywood, California 90028.

**RECORDS** Made. Publishing Contract Guaranteed On Accepted Songs, Poems. Send: Talent Searchers Of Hollywood, 6311-X Yucca, Hollywood, Calif. 90028.

**POEMS** Set to music. Songs recorded. Send poems, songs. Crown Music, 49-C West 32, New York 10001.

**POEMS** Needed. Free information. Successful Songs, RFD 3, Brookfield, Connecticut 06804.

**SONGPOEMS, SONGS!** Urgently Needed. Possible Recording/Publishing, 50-50 Agreement. Betty's Music Makers, 222B 150th Avenue, Madeira Beach, Florida 33708.

**SONGS, POEMS WANTED!** For publishing, recording at our expense! **TALENT,** 17-PM, Longwood Road, Quincy, Mass. 02169.

## BUSINESS SERVICES

**PROFITS FROM CLASSIFIED ADVERTISING!** Booklet shows you how to start your own business with Classified Advertising. Only \$1.00 (Refundable with first order.) **H. E. KAPPEL, POPULAR MECHANICS, DEPT. P, 224 WEST 57 STREET, NEW YORK, N.Y. 10019.**

**CORRESPOND** With Mail Order Professionals or Beginners in Your Area Who Wish to Correspond With YOU. Exchange Ideas, Develop New Businesses Together. 50 Contacts \$1.00. D. Jones, Box 2125, Spokane, Wash. 99210.

## BUSINESS OPPORTUNITIES

**START** Big-Pay Business at home in spare time. No experience needed to operate little tabletop machine for bronzing baby shoes. Make \$7.95 profit on every pair. Full particulars free! Send postcard to: Mason, Room MC-2-CF, 1512 Jarvis, Chicago, Illinois 60626.

**GINSENG** Seeds, For Planting. \$5.00 Possible Growing 1/4 Acre. For Information, Price List. Write: Ginseng, McDonald, Tennessee 37353.

**HERBALISM!** The Home Gold Mine! **FREE LESSON, SEEDS!** Herbalism Institute-B, 1339 Remuda, Glendora California 91740.

**REMOUNT** Unused automobile seats for sale or home use. Instructions \$1. C. Ljohn, 5118 S. Dorchester. Chicago, Ill. 60615.

**PROFITABLE MAILORDER YOURS!** Start Immediately. Everything Available. Sample Package, Confidential Details Free. Lewis, Box 683A, Colfax, Washington 99111.

**FREE** Booklet, "How To Sell By Mail." Write: Ransone, Box 1719, Richmond, Virginia 23214.

**EARN** Money at home! Details, 16¢ stamps. Spencer Associates (1PM6) Box 218 Smyrna, Ga. 30080.

**OWN ROUTE** Plastic Laminating Vendors. 400% Profit. Details, Sample, 25¢. Akron, 3720 E. 59th, Tulsa, Okla. 74135.

**SELL** Professional Oil Portraits From Photos! Ness-PM, Scarcliffe, Malverne, New York 11565.

**EARN TO \$50,000.00 YEAR. NEW EXPLODING MEDICAL CLAIM SERVICE FIELD. NO EXPERIENCE NECESSARY.** Information send \$2.00 to: Claims 3908 Lee Drive, Suite 106, Anniston, Alabama 36201.

**EARN AT HOME** Details 25 Cents Plus Stamped Self-Addressed Envelope. Clemmons House, Clemmons, N.C. 27012.

**MAILORDER** New Products Catalog \$1.00. Refundable. Antonacci Products, 3028 Brighton 8 Street, Brooklyn 11235.

**TRUTH ABOUT MAILORDER! REPORT \$2.00. GERALD STIDLEY, 831 CRANE 402B-6, DEKALB, ILLINOIS 60115.**

**ESTABLISHED** Business needing individuals to earn \$20,000 to \$60,000 per year distributing new product. Small investment required. Send \$1.00 for product information and sample. Kwik Meal, P.O. Box 481, Price, Utah 84501.

**FREE** Millionaire Book . . . "Get A Fortune in successful, Little business. Work home! SBI-7, Kerrville, Texas 78028.

**HOW AND WHERE TO GET CAPITAL.** Get \$500 to \$2 million. Free information. Ccounselor-17, Kerrville, Texas 78028.

**IMPORT-Export** Opportunity, profitable world-wide, mail order business from home, without capital or travel abroad. We ship plan for no risk examination. Experience unnecessary. Free Report. Mellinger, Dept. G2706, Woodland Hills, California 91364.

**SECRETS!** Mail Order Success. Internationally famous expert reveals how to make home business fortunes. Beginners: Get free report "Make Money By Mail." "Discloses free advertising profitable products. Mailco Dept. GC706, Woodland Hills, California 91364.

**INSTALL** Burglar alarms without previous experience or costly equipment. Big profit. Free details. Nasco, Dept. G2706, Woodland Hills, California 91364.

**BUILD** Your own business. You keep profits. Gifts, 4238 Birchwood Ave., Jacksonville, Fla. 32207.

**EXCITING** Home Mailorder Business! Follow The Experts With Proven Plan . . . Fantastic Opportunity. Free Details. Associates, Box 136-A, Holland, Mich. 49423.

**FREE—**Million Dollar Mail Order Secret. Rane—18 Oneida, Centereach, New York 11720.

**LAWS—REGULATIONS:** For Mailorder. Details—"Air-Mailed"—Free! TCR, Box 787PM, New York 11757.

**HUNDREDS** Unknown Businesses—Little Or No Investment. Box 2864-PM, Sepulveda, California 91343.

**MAILORDER FAILURES** Outnumber Successes! Why? Your Future **DEMANDS** Reply To **PATHFINDERS,** Suite 205-A, 25 Van-Reipen Avenue, Jersey City, New Jersey 07306! Happy information **FREE.**

(Continued on next page)

Material, защищенный авторским правом

## BUSINESS OPPORTUNITIES

(Continued from preceding page)

**BIG PROFITS!! SELL ENGRAVED, METAL, SOCIAL SECURITY PLATES. FREE SALES KIT! MYERS, 928-PM CRESCENTHILL, NASHVILLE, TENNESSEE 37206.**

**MAILORDER Dealers Wanted.** Earn outstanding profits using tested promotions! Ruward-PD, Georgetown, Conn. 06829.

**MAKE To Triple Times your Cost.** Hundreds of Products, Gifts, Novelties, Toys, many others, \$1.00 brings Giant Catalog, Refundable with First Order. **DONMAR, PM-1, 809 Ravenwood, Arlington, Texas 76013.**

**PIANO Tuning Learned Quickly at Home!** Tremendous field! Musical knowledge unnecessary. GI Approved. Information Free. Empire School, Box 327, Miami, 33145.

**400% PROFIT Possible!!** Sell Mailorder Books From Own Catalog. Everything Furnished. Free Details, Sample Catalog. Sullivan, Box 222E, Needham, Mass. 02192.

**MAILORDER INSTRUCTION PUBLICATIONS!!** Professional, Reliable, Profitable. Write: **HOW, Box 4457 PM6, Downey, California 90241.**

**EARN \$50.00 To \$100.00 Weekly** possible, home typing. Complete instructions, \$2.00. Jordan, 27495 Road 176, Dept. PM-6A, Exeter, Calif. 93221.

**I MADE \$3,000.00 Monthly** in Mailorder Evenings only. You can too! Free Proof—Bryant, 8601 Bowing Green, Austin, Texas 78758.

**WORLD'S Largest supply, Merchandise 25% to 40% under wholesale.** Bankrupts. Closeouts 10¢ on dollar. Imports. Hong Kong clothes. Automobile discounts. Free details. International Buyers, Box 16386 MM, Portland, Oregon 97233.

**SELL Books by mail.** Complete dealer set-up—25¢. Midwest Mail Sales, Box 44R2-PM, Shawano, Wisconsin 54166.

**1000% PROFIT Bronzing Baby Shoes.** Free Literature. NBC, Box C-4-PM, Coral Springs, Florida 33065.

**MAKE A Years Income in 8 weeks** Camping. No selling, Capital or Land necessary. Write: **Edru's, Route 5, Box 5733, Gig Harbor, Washington 98335.**

**BECOME "Mortgage Broker."** Lucrative! Capital Sources, Box 99-A, Uleta, Florida 33164.

**MAKE Magnetic signs, Machineless method.** Profits enormous. Write: **R1B49APM, Bardstown, Ky. 40004.**

**ADVERTISING BUSINESS—YOU Own it.** \$400 First Week or Money Back. Electric Neon Action Ad Clock, 229 W. Illinois, Chicago 60610.

**HOLLYWOOD CEMENTCRAFT:** Offers Highly Profitable Home Business. Experience Unnecessary. Unlimited Unique Pottery Designs Easily Made Without Moulds. Bird-baths, Fountains, Wishing-Well, Waterfalls, etc. Chemical Coloring Formulas. Marble-glazing. **FREE Illustrated Brochure. CONCRETE FACTS, 602 Athens Street, Altadena, California 91001.**

**COPUBLISH "Mail Sale Advertiser,"** leading mailorder paper. Copy and details 25¢. U.S.A. only. Vanroy Shirk, Lebanon, Pa. 17042.

**VENDING Machine big catalog.** Rake, 523 A Spring Garden, Philadelphia, Pa. 19123.

**DRAFTSMEN! Operate own DRAFTING SERVICE!** Full, Part Time; Experience unnecessary; Details: Roberts Drafting, 1741 Circle Road, Baltimore, Maryland 21204.

**FREE Catalogs.** Repair air conditioning refrigeration. Tools, supplies, full instructions. Doolin, 2016 Canton, Dallas, Texas 75201.

**ADDRESSERS And Mailers Needed.** Details 10¢. Lindbloom, 3636 West Peterson, Chicago 60659.

**\$25.00 HUNDRED** Addressing. Possible Year 'round. Complete instructions 25¢ for registration, postage. Cove, Box 1348-B, Clearwater, Florida 33517.

**\$70 TO \$200 WEEKLY—Home, Spare Time Simplified Mail Bookkeeping.** Immediate Income. Easy. Auditax, Box 34741A, Los Angeles, Calif. 90034.

**VENDING Machines.** No selling. Routes earn amazing profits. Big catalogue Free. Parkway Corporation, 715PBM Ensor Street, Baltimore, Maryland 21202.

**\$60.00 DAY.** Manufacturing Concrete Posts. Blocks. Mold Equipment Catalog \$1.00 refundable. Carlayne, Route One, Box 95, Rapid City, South Dakota 57701.

**SELL Books by mail.** 400% profit. Royal, Box 450-X, Cleveland, Ohio 44127.

**MAILORDER Records help get increased business!** Complete 32 page Record Book shows your inquiries, orders, advertising, expense, etc. Only \$1.00. **H. E. KAPPEL, POPULAR MECHANICS, DEPT. R, 224 WEST 57TH STREET, NEW YORK, NEW YORK 10019.**

**TAKE Catalog orders.** We drop-ship 1001 best selling specialty products. Guaranteed lowest below wholesale prices. Fantastic spare-full time home business. Free book show you how. **SMC, 6061 SPF, De Soto Avenue, Woodland Hills, California 91364.**

**REPAIR Hydraulic Jacks—Details Free.** Write: Hydraulic Parts Supply, Box 295, Port Isabel, Texas 78578.

**EARN \$60.00 Daily** manufacturing Concrete Fence Posts. Practically no investment. Send stamped-addressed envelope. American, Excelsior Springs, Mo. 64024.

**\$50.00 PLUS 50% COMMISSION** Stuffing 200 already stamped, addressed envelopes, our circulars. Information 25¢ with stamped, self-addressed envelope. Brewster-PB, Clearwater, Florida 33517.

**JOIN The professionals.** Profitable Gift Catalog Distributorship. Giffair, 1430-4 Wells, Milwaukee, Wisconsin 53233.

**PROFITABLE BUSINESS—Molding Rubber,** Hobby Supplies. Details 10¢. Chaney's, 5415 L San Jose Blvd., Jacksonville, Fla. 32207.

**\$400.00 MONTHLY** Raising giant fishworms. Soilless method. Charlie Morgan, Busnell, Florida 33513.

**EARN Money raising fishworms for us!** Write: Oakhaven-38, Cedar Hill, Texas 75104.

**SELL LIFETIME METAL SOCIAL SECURITY PLATES. BIG PROFITS! SAMPLE AND SALES KIT FREE. RUSSELL PRODUCTS, MAURY COUNTY SHOPPING CENTER, DEPARTMENT P41, COLUMBIA, TENNESSEE 38401.**

**FREE 1973 100-Page Catalog** waiting to bring you Big spare-time cash commissions. Sell Advertising Book Matches. Every business a prospect... complete selling instructions furnished. Steady, repeat business. Dept. MX-673, Superior Match Company, 7530 South Greenwood Avenue, Chicago, Illinois 60619.

**FREE Collection Agency Details.** \$1000.00 Monthly Possible. Master, Drawer 77009-PM, Atlanta, Georgia 30309.

**WATCHMAKING** Makes every day a payday. Learn this cash business at home. Free details, Chicago School of Watchmaking, YSA, Fox River Grove, Illinois 60021.

**\$1.00 LISTS** You year sent to 1000 Importers, Jobbers, Mailers, our mailing year. Dixiemi, King, North Carolina 27021.

**EARN Thousands at home.** How to sell books by mail. Free details. Wisdom House, Box 1106P, Largo, Florida 33540.

**HOW To Raise \$100.00 To \$1,000,000.00!!** Drawer 77009-A, Atlanta, Georgia 30309.

**\$200.00 SPARE Time earnings** with your Tablesaw. Write: Workshop Five, 3800 Harney, Vancouver, Washington 98660.

**YOUR OWN MAIL ORDER BUSINESS! 4 MILLION NEW PROSPECTS ANNUALLY! 25¢ BRINGS VALUABLE DETAILS. EVANS ENTERPRISES DEPT. 23PM, 77 MAY STREET, IRVINGTON, NEW JERSEY 07111.**

**DO SIMPLE ADDRESSING—Mailing.** Receive \$12.95 orders. Keep \$8.00 profit. Details Free! Quality, Box 9-P, East Rockaway, N.Y. 11518.

**STUFF Envelopes.** \$25 Hundred. Immediate Earnings! Beginner's Kit, \$1.00 (refundable). Lewcard, P392M, Brea, Calif. 92621.

**SELL Selected Gifts, Merchandise** With Your Own Catalog. Low Cost Start. Big Initial, Repeat Profits. Complete Details, Sample Catalog 25¢. Billou, Box 7321, 59-01 Junction Blvd., Elmhurst, New York 11368.

**\$200 WEEKLY! Make, Sell Bricks!** Free Information! Xcito Bricks, 5715 N. Mozart, Chicago, Ill. 60659.

**SELL BURGLAR ALARMS.** Set of Five Warning Stickers \$1.00. Lee Specialties, Box 32P, Dobbs Ferry, New York 10522.

**EARN More than many professional men!** \$1000. Month Mail Order Collection Agency. Continental, Box 2023-A, Des Moines, Iowa 50310.

**MAIL Baby Catalogs Imprinted** with your address to New Mothers for Big Profits! Details 25¢. Volz PM, Ypsilanti, Michigan 48197.

**I MADE \$40,000.00 Year** by Mailorder! Helped others make money! Start with \$15.00—Free Proof. Torrey, Box 318-Y, Ypsilanti, Michigan 48197.

**MAILERS Wanted!!** Free Information. A. Allen, 2418 Lori, Santa Ana, California 92706.

**SELL New Sensational Car Thief Signal.** Lightning Seller. Samples for trial. Northwest Electric, Ave. 177, Mitchell, S. Dak. 57301.

**DON'T Die without a will!** Blank will form protects your family. Only \$2.00. Instructions included. 100% guaranteed. Order today!! Barons, Box 1033Y2, St. Charles, Missouri 63301.

**900% PROFIT Possible** in magnetic signs! Plans for building your own machine. Free details. Barons, Box 1033T2, St. Charles, Missouri 63301.

**INTERNATIONALLY KNOWN MANUFACTURER 1972 SALES 357 MILLION DOLLARS OFFERS YOU A Chance To Be In Your Own Business High Profits—New mobile auto parts distribution—152 Now Operating Nationwide.** Valley Forge Products, Div. Avnet Inc., Dept. S, Box 96, Inwood, N.Y. 11696.

**START YOUR OWN MAILORDER BUSINESS! ACT TODAY!** Free Details. Hautala, Box 125, Williston Park, New York, 11596.

**I MADE \$3,000.00 Monthly** in Mailorder... Evenings Only! Professional Secrets Revealed—Free Proof! Asbury, Box 161-D, Madison, Ohio 44057.

**MAILORDER Book Publisher Wants Dealers.** Big Profits! Mears-PM, 5363 Essex, Alexandria, Virginia 22311.

**INSTANT Mail Order!! Tested! Proven!** Profitable! Confidential Details 25¢. Getco, Ridgefarm, Illinois 61870.

**BECOME Our Mail Order Distributor** with \$150 Investment. Free Brochure. Audit Controls, 40 Brookside Ave., Fair Lawn, New Jersey 07410.

**BIG Money in Mail Order! Professionals Guide You!** Beckwith School—B82, 515 Route 46, Fairfield, New Jersey 07006.

(Continued on next page)

## BUSINESS OPPORTUNITIES

(Continued from preceding page)

**MAILORDER BEGINNERS:** Several Proven Starter Programs. Free Details! Thomas, Box 125, Williston Park, New York 11596.

**NAMEPLATES,** Custom Engraving. Big Profits. Distributors, Dealers, Catalogue 50¢ (Refundable). R.P.H. Manufacturing, 249-B, Winter, Stamford, Conn. 06905.

**PROVEN** Mailorder success methods! Join the moneymaking professionals!—Free beginners offer:—EVB, BX262E, Parkchester, New York, 10462.

**FREE BOOK** "How to Make Money in Mailorder": Nationwide, Box 302-(5C6), Leominster, Mass. 01453.

**MAKE \$40 daily!** Manufacture, Sell Patio Tiles! Free Details! Hilmar, Rt. 1, Box 347D H, Valrico, Fla. 33594.

**MAKE** Gorgeous original candles for all holidays and special occasions. Learn expert Candle decorating, candlemaking, use of professional molds. Free details on home instruction method. Candle Institute, Dept. C-93, 1600 Cabrillo, Torrance, Calif. 90501.

**MAKE** huge profits selling your own name brand single ingredient odorless deodorant which kills all odors. For use in Hospitals, Homes, Farms, etc. Sample and Formula \$3.95 postpaid. Frantom, 59PM Sapphire, Dvale, Trinidad W.I.

**RECEIVE MAIL** Galore! Your name on our national mailing lists, 50¢. Sullins, Box 1313, Brunswick, Georgia 31520.

**MAILORDER** Millionaire helps beginners make \$500 weekly. Free report reveals secret plan! Executive (1A6), 333 North Michigan, Chicago 60601.

**MILLIONAIRE MONEY-SECRETS!** Remove Debts, Raise Money, AAA Credit, Lifetime Income. Free Advisors, Box 616, Beverly Hills, Calif. 90213.

**CALIFORNIA MANUFACTURER NEEDS** Man to assemble our product and be local agent, experience unnecessary. May start while presently employed. Five-figure income for responsible applicant. S.K.R.M. Manufacturers, 2347 West 238 Street, Torrance, California 90501.

**PORTABLE** Sandblaster \$29.95. Distributor wanted. Free brochure. INKA, Box 66573—A, Houston, Texas 77006.

**CREATIVE?** "Free Mailorder Mini Course" MOAA, Box 21091-C, Philadelphia, Penna. 19154.

**BIG MONEY** Using Classified Ads. Free Details. Abel Products Company, 1115 West Farnum, Royal Oak, Michigan 48067.

**\$2,000 MONTHLY** in Fabulous New Business. Free Details. Nielsen's, Box 15894-P, Salt Lake City, Utah 84115.

**CLAIM ABANDONED SILVER**—\$20,000 Secret Revealed! Free Information: Silverman 4A-13, Box 548, Woodville, Texas 75979.

**NEW!** "Secrets of Mailorder," \$2.00. Aslinger, 2332 Reynolds, Rossville, Georgia 30741.

**CONDUCT** Your Own Business at Home. No Inventory. Complete Details \$1.00. Refundable. Lowe, Folsom, Pa. 19033.

**"MONEY In The Mail"**. Beginners Master Plan. Free Details. Maupin, 2300 Maryland, Decatur, Georgia 30032.

**PART—FULL TIME, LITTLE-NO CAPITAL.** Furnish Everything—Show You. Details, Catalog \$1.00. (Refundable). Keim's, P.O. Box 3416, New Orleans, Louisiana 70177.

**PHOTO** Button Machines Cheap. Send 50¢ For Sample Button To: Coffman, 1973M Glenhaven, Abilene, Texas 79603.

**SELL** Books. Exceptional Profits. Complete Mailorder Setup. Details 25¢. Cameo Book Supply, 3410 North Angus, Fresno, California 93726.

**MAKE YOUR FORTUNE** in Mail Order. Our Guide Shows How To Start. Write: Horizon Sales Company, Dept. 2B1, 236 Belleville Turnpike, Kearny, N.J. 07032.

**PROFITABLE** Mailorder Business! Proven Step By Step Program—Free Details—National Mailorder Exchange, 249 Main Street, Dep't. 4B6, Farmingdale, N.Y. 11735.

**EARN \$500.00 WEEKLY** in Amazing, New Businesses. Free Details: Clark, Box 80521-M, Atlanta, Georgia 30341.

**"MAILORDER** Course! Home Study," 24 Easy Lessons, \$2.00. "Bill" Lambertson, 132 Tamiami Station, Dept. PM63, Miami, Florida 33144.

**PREPARE** Tax Returns—Policeman Albert Myers made \$2000 his very first season. Train at home. VA Approved. National Tax School, Monsey, 2ND, N.Y. 10952.

**BUILD** Custom Cases at home for profit. Get orders by mail. We supply materials, instruction—everything. Free home business details. Custom Case Supply Co., 6075 CPF, De Soto Avenue, Woodland Hills, California 91364.

**NEW** Upholstery method, easy, inexpensive. Upholster for yourself or start business. Free details. Mid-West Upholstery Institute, 3229-PM Grayrock, Springfield, Mo. 65804.

**MAILORDER** Laws, Know The Facts \$2.00. Guaranteed. Ideal Enterprises, Box 515-F, Woodbridge, New Jersey 07095.

**\$2,000.00 MONTHLY** in Amazing Home Business. Details FREE. Flanders Company, Box 3221, Bridgeport, Connecticut 06605.

**MAILORDER** Sell New Burglar Alarms. Samples. Antonacci Products, 3028 Brighton 8 Street, Brooklyn 11235.

**FREE** Specialty Gift Catalog! Reveals Exceptional Beginners High Profit Drop-Ship Home Business Programs. Unique Sales (A61), 1130-69 St., Brooklyn, N.Y. 11219.

**PHOTO** BUTTON MACHINE \$29.95 With supplies to make 25. 8D Enterprises, 230 Greenwood, Lepanto, Arkansas 72354.

**HIGH** Profit Potential from Home Engraving Business! Steady Earnings. Write: Trend Craftsmen, 4901N Perrine, Midland, Michigan 48640.

**BE YOUR** Own Boss. Every Advertiser in this Section is in Mailorder. Why not You? Report gives details. \$1.00. Haman House, Dept. PMF, 110 Haman, Barrington Ill. 60010.

**DON'T** Answer this ad! This could be too much! Free Details. Boylil, P.O. Box 2091, La Puente, Calif., 91746.

**MONTHLY** Closeout BULLETIN!! Jewelry, Gifts, Toys; Box 852, Albany, New York 12201.

**HOMEWORKERS!** Addressing, Mailing, Drop-Shipping explained. Free details (8¢). Deedee Enterprises, Morrisonville, New York 12962.

**MAKE OVER \$92.00** FROM Square Foot Plywood (with Jigsaw or Bandsaw); Amazing (proof): Explicit, revealing details 25¢. Wodertz, Bridgewater, Mass. 02324.

**RAISE CAPITAL** WITHOUT COLLATERAL or credit. Unique plan assures success. Enterprises, Box 247-M, Columbus, Georgia 31902.

**\$19 HOURLY** Profit—Own Business with one service man. Quickly learned. Easy to do. Operate from home. Little over \$1000 starts your own nationally advertised business while continuing present job. Investigate immediately before your territory is taken. Free booklet explains everything. Send today. Then decide. Duraclean, C3-166 Duraclean Bldg., Deerfield, Ill. 60015.

**BIG** Profits Sell Lifetime Social Security Plates, Sample. Goldthwaite, 220-PM, Lawrenceburg, Tennessee 38464.

**\$2,000 MONTHLY POSSIBLE** Home Based Business, it's a Winner. Free Information. E-B Enterprises, Suite 711, 2105 Benecia, Los Angeles, Calif. 90025.

**EASY** Profits Showing UNIQUE Advertising and Souvenir matches. Dept. PM, 7284 Fordham, Goleta, Cal. 93017.

**HOW** To Make \$5,000.00 a month. Secret carpet cleaning formula revealed. Professional results guaranteed! Clean your own carpets save hundreds of \$\$! Start your own business, make a fortune! Details \$1.00 Tower Carpets 6B, 1080 S. Cypress, La Habra, Cal. 90631.

**\$2000.00 MONTHLY** Selling Information By Mail. Ropchan, Box 5341P, Sherman Oaks, Calif. 91413.

**EXTRA** \$1200 month possible. Exciting; Career later. Saylor, Box 622, Irving, Texas 75060.

**MANUFACTURE** Pet-stain remover, deodorizer. Formula, gallon concentrate \$10.00. Feola, 9 Pearl Street, Somerville, Massachusetts 02145.

**SURPLUS** printing: "Art Of Making Money". About mail order, patents, manufacturing, etc. Excellent book for small businessman. \$1.25 while they last. Order direct: Salem Village Publishers, Box 225-P, Danvers, Mass. 01923.

**COMPLETE** \$24.95 Outfit Makes Social Security Plates! Details: Ideaco, Box 69828PS, Los Angeles 90069.

**FREE** List new unique books and folios. Unusual bargains. Wealth, Success, Happiness. Same address 25 years. Send postcard. B. David Fox, 551 Robeson Street, Reading, Penna. 19601.

**MAILORDER** Catalogs. Your Name Imprinted. Merchandise Drop-Shipped, Details 25¢. AM Sales, 31-14-94, East Elmhurst, N.Y. 11369.

**AUTO INTERIOR CUSTOMIZING AND UPHOLSTERING** are today's high demand skills—yet easily learned at home! Fabulous profit potential. Send for FREE Opportunity Kit, details. Approved for Vets. Auto Upholstery Institute, Box 64-SPM, Orange, CA. 92669.

**MAILING** And ADDRESSING At Home. Information 25 Cents. Easy Order Company, Box 7851, Jacksonville, Florida 32210.

**SELL** Books Mailorder!! Highly Profitable! Details. Derbes, Box 2667, New Orleans 70176.

**WE NEED GINSENG** GROWERS! \$3,000-\$30,000 Annually! We Buy Your Crop. Send \$2.00 For Seed Sample And Information. Glass's Ginseng Exchange, Box 336, Rochdale Station, Jamaica, N.Y. 11434.

**\$350.00 WEEKLY** !!! Printing T-Shirts, Bumper Stickers, Posters, Decals, Circuits. No Experience Required!! Unexpensive Materials!!! Easy To Follow Complete Equipment Plans, \$3.00 Money-Back Guaranteed!! Villalba-5PO, 2920 SW. 33rd. Court, Miami, Fla., 33133.

**MAKE** \$500.00 Weekly. Free Details. Raymax, Box 1818-M, Escondido, California 92025.

**\$300.00 OR MORE**, Mailorder? New Guides Show How! Rush \$1.00, Refundable. Arts, 615-C Melrose Avenue, Bronx, N.Y. 10455.

**REUPHOLSTERY**, Profitable Home Business. Illustrated Manual \$2.00. Guaranteed. Russell—P-673, 1566 So. Burkhardt, Evansville, Indiana 47715.

**WHOLESALE** Guide . . . 126,000 PRODUCTS. Firms Listed. \$3.00. Budco, 911, Los Altos, California 94022.

**GET RICH FAST!!!** Easy, Proven Way—Spare Time! Secret "How" Report—\$1.00 (Deductible). Centaur, Dept.-M, 82 Aldine Street, Rochester, New York 14619.

**FREE SECRET BOOK** "2042 Unique, Proven Enterprises." Tiny businesses but huge profits! How Little Fellows beat inflation. Work home! Haylings-T15, Carlsbad, California 92008.

**SELL** Gifts By Mail. Wholesale, Retail. Free Details. Send-Away-EH, Georgetown, Connecticut 06829.

(Continued on next page)

## BUSINESS OPPORTUNITIES

(Continued from preceding page)

**SELL** Information By Mail! 2,400% Gross Profit! Sax, Dept. C-2306, Milan, Ohio 44846.

**SECRETS** of Mailorder Pros revealed! \$4.95 postpaid. Trader Mike, Box 1305-P, Newark, New Jersey 07101.

**DISTRIBUTORS** Wanted. Greatly Needed Product. Very Profitable Setup. Superior, PM, 2421 South Fulton Place, Tulsa, Okla. 74114.

**SELL** New Costume Jewelry. Big Profits. Free Detail's. Greco, 615-A Melrose Avenue Bronx, N.Y. 10455.

**BOOKKEEPERS** Operate Profitable Book-keeping Service. Earn \$10.00-\$20.00 hour. Details free. Universal Bookkeeping, Box 664-M, Springfield, Missouri 65801.

**FREE "HOW TO" BROCHURE. BOOST** Your Sales. Profitable techniques revealed. Satisfaction **GUARANTEED**. Write: Baughan, Postbox 1426-BP, Plainfield, New Jersey 07061.

**HOW TO START A BUSINESS** And Succeed. Complete Details. Positive Results \$1.50. Lou Larkin, Inverness, Florida 32650.

**MAGNETIC** Signs. Build your own plastic forming unit. A-B-C Plans—Plus Instructions, \$12 Complete. Guaranteed Results. Academy, Box 506, Miami, Florida 33157.

**SECRETS** of getting rich with other people's money. \$5000+ possible in one day. Free details. JPA, Dept. 302, Box 101, Park Ridge, N. J. 07656

## MONEYMAKING OPPORTUNITIES

**EARN \$100 A Day.** Sell and Install Simple Home Basement Flood Protectors. Any Storm Creates Big Sales Everywhere. Miller, 114-D Bradwell, Barrington, Illinois 60010.

**HOMEWORKERS.** Earn 50¢ Each. Collecting Names. 10¢. Gemco, B-21244A, Indianapolis, 46221.

**"AUTOMATIC SUCCESS** Techniques" developed—proven! Details. Premier Enterprises, Box 10597-BF Pittsburgh 15235.

**1000% PROFIT** selling authentic Burglar Alarm Decals. Self-adhesive. Sell on sight. Details-3 Samples \$1.00. Kay-Son, Box 363-PM, Oneonta, New York 13820.

**INVITATION** To the PROFITABLE WORLD of MAILORDER. Details 25¢. Devine, Box 56069, Chicago 60656.

**MAKE** Yourself Richer than you ever Dreamed Possible! Details 10¢. Winter, 601 Pelham Parkway North, Bronx, New York 10467.

**RETIRE ANYTIME IN LUXURY!** Easy. Legitimate. Details. Premier Enterprises, Box 10597-AF Pittsburgh 15235.

**\$2.40 HOURLY** Making simple wood novelties. Free details! Gene's, 55 Boxwood, Falmouth, Mass. 02540.

**HOW** To Make Money Writing Short Paragraphs. Information Free on "Home Studies in Writing". Barrett, Dept. C-27-X, 6216 N. Clark, Chicago 60660.

**MAKE \$1.00 PER SALE** Selling engraved metal Social Security plates. **FREE SALES KIT.** Engraving plates, Box 10460-199, Jacksonville, Florida 32207.

**MAKE** Statuettes, novelties, imitation marble. Sell to stores or start gift shop. Free details. Marbleizing, 41 Waverton, St. Louis, Mo. 63124.

**WORLD'S** Leading contest magazine, 25¢. Year. \$4.00. Prizewinner, 1315 Central, St. Petersburg, Fla. 33705.

**HOW TO GET RICH!!** Free "Money-making Brochure"! Success International, Box 2447-C, Livonia, Mich. 48151.

**VENDING** Machines. No selling. Routes earn amazing profits. Big catalogue Free. Parkway Corporation, 715PMM Ensor Street, Baltimore, Maryland 21202.

**FREE**—Easy Ways to make money selling exciting new products—Full—spare time. Send name, age, for 5 months free subscription. Salesman's Opportunity Magazine, 1460 Hancock Center, Dept. 17-FM, Chicago 60611.

**PENNY STOCKS** Have Profit Potential. Free Information. Analyst-P.M., Box 214, Redondo Beach, California 90277.

**200% PROFIT** Selling Rings. Triple Money in 30 Days or Money Back. Free Details, Anka, P.O. Box 8036-PM, Cranston, Rhode Island 02920.

**\$40 DAILY** Possible tying fishing flies at home. Details 25¢. Flyco, Box 481PM, Albany, Oregon 97321.

**EARN MONEY,** learn mailorder, spare-time, at home, reading leading (since 1929) trade magazine, product sources, stories, tips. Sample 50¢, year \$5. Mail Trade, Box 1302, Springfield, Illinois 62705.

**ADDRESSERS**—50 Companies want Addressers. Send self-addressed envelope. Cal Enterprises, Box 4516-X, Compton, Calif. 90224.

**SWEEPSTAKES** Contests. How to win. Write for free information. General Contests, 1609-18 East 5th., Duluth, Minnesota 55812.

**FREE SECRET BOOK** "2042 Unique, Proven Enterprises." Largest successful collection! fabulous "Little Knowns." Work home! Haylings-T14, Carlsbad, Calif. 92008.

**\$200.00 FROM** Sheet 1/4" plywood (scrap). Details 25¢. Novelities, 610 So. 24th, Elwood, Indiana 46036.

**ENORMOUS** Mailorder Profits! Money Back Guarantee. Tested, Proven, No Experience Necessary. Rush \$1.00. Thompson Enterprises, 1120 Cherrylawn, Pontiac, Michigan 48055.

**LEARN** The secrets of repairing junk batteries. "Fabulous Profits" at home. Battery Shop, Box 820, La Quinta, California 92253.

**GET** World's Biggest Wholesale Import Catalog. Write: World, Medina, Washington 98039.

**NEWSPAPERS** Needed! We Pay Cash for certain Newspapers. Tory Company, MP, Bayonne, New Jersey 07002.

**START** Small, HIGHLY PROFITABLE ELECTRONIC PRODUCTION IN YOUR BASEMENT. Investment, knowledge unnecessary. Postcard brings facts. Barta-PMJ, Box 248, Walnut Creek, California 94597.

**HOMEWORKERS.** Earn Big Profits Stuffing and Mailing. Send Stamped, Self-Addressed Envelope for Further Information. Missler Enterprises, P.O. Box 69, Bellevue, Nebraska 68005.

**ADDRESSERS** and Mailers Needed! Free Details! Splendid Opportunity! Delta, Box 24-P, Chalmette, Louisiana 70043.

**SOLAR ENERGY USE IT.** Details \$1.00. Solar-Pak, P.O. Box 23585, Tampa, Florida 33622.

**STUFF**—Mail Envelopes. Big Profits!! **COMPLETE INSTRUCTIONS** \$1.00 (refundable). No Further Investment Necessary. Danzig, Postbox 142PM63-430E8-Brooklyn 11218.

**"1001 THINGS Free"**. Plus Discount Merchandise Catalog \$2.00, Refunded. Apollo, Box 232-P, Utica, Mich. 48087.

**"MONEYMAKING** Opportunities from Consumer Education Association. Free Information. Associates, 7833A Coles, Chicago, 60649.

**MONEY** Available to Help You Operate in Mailorder. For Information, Samples of Type Plans Acceptable. 100 Buyers Names and \$1 Trade Certificate, Send \$1.00 Postage and Handling. Mastercraft, 962 Eva Avenue, Akron, Ohio 44306.

**LEARN BOOKBINDING** At Home, Fascinating. Money Making Craft. Thoroughly Illustrated With Photographs And Drawings. Complete Course \$9.95. Details Free. PBC Bookbinding, 601 West Fifth Street, Bonham, Texas 75418.

**NEVER WON ANYTHING?** Anyone Can Win Sweepstakes Contests! Free details. Services, Box 644-PCF, Des Moines, Iowa 50303.

**TOP \$\$\$\$** For ADDRESSERS-Mailers-Homeworkers! Numerous outstanding opportunities! **SURPRISE BONUS!** Send 35¢. RON-R, Box 24433, Los Angeles, Calif. 90024.

**INCREASE** your income! Send now for informative booklet "How to Make Money Writing Fillers." \$1.00 plus 30 cents handling. **STATION FOUR,** 525 32nd Ave., San Francisco, Calif. 94121.

**MAKE MONEY IN SPARE TIME.** Earn generous commissions as a subscription representative for leading magazines. For free details, send this ad with your name and address to: **POPULAR MECHANICS,** Room 1107S 250 W. 55th St., New York, N.Y. 10019.

**ATTENTION**—\$40,000 Yearly From Your Backyard, Plans \$1.—Reti, 302 Princeton Ave., Jersey City, New Jersey 07305.

**MAILORDER** One man operation can earn \$5,000-\$10,000 yearly—No merchandise investment, company dropships, does all work. Free details. Sunnyside, 39-02-PM 47th Street, Long Island City, New York 11104.

**HOW** To Earn At Home Addressing Envelopes. Send Self Addressed Stamped Envelope To: R.H.M. Productions, 11 Willard Ave., Mt. Vernon, New York 10553.

**HOW** To Build Fortune in Real Estate. Guaranteed!!! Send \$2.98. Kibbie, Dept. 5L1, Box 2742, Jacksonville 32203.

**SELL** Your Photos. Big Demand. Booklet Tells How. Where, Laws, Etc. \$1.00. Princess Gifts & Novelties, Dept. A-2, 1313 Ritchie Road, Forestville, Maryland 20027.

**400% PROFIT** From Square Foot 1/4" Plastic. Details 35¢ plus stamp. J-Mar-Ko, P.O. Box 34893, Detroit, Mich. 48234.

**BIG** Money! Free Social Security Plate Assortment. Trumans, PM67 Pool, Biddeford, Maine 04005.

**EXECUTIVE MAILORDER FRANCHISES FREE!!** 400% Profit selling advanced money-making books. Sell self-selling baby necessities. Free Details. Trinity, 1712F Lee, Detroit, Michigan 48206.

**HOMEWORKERS!** "25-In-One" plan. \$700.00 Monthly guaranteed, per instructions. \$2.00. Details 8¢. Deedee Enterprises, Morrisonville, New York 12962.

**EXPERT** Secrets Amazing Home Mailorder Business. Free Details. Young, Marion, N. Car. 28752.

**MONEY MAKING** Ideas for Rubber Stamp Manufacturers!! A. Zwier, Box 788, Mokena, Ill. 60448.

**\$100.00 WEEKLY** Possible Home Addressing! \$125.00 Weekly Possible Clipping Items From Your Newspaper. Information: Send \$1.00 And Stamped Self-Addressed Envelope. Winder's, 328 Jackson Avenue, Elyria, Ohio 44035.

**CASH** For Trash! your attic may hold a fortune, 224 page antique guide. \$2.00. George, 2317 34th, Lubbock Texas 79411.

**FREE** List of Low Cost Money Making Books. E. G. Skavlán, 3706 Penn No., Minneapolis, Minn. 55412.

**EARN** At Home. Mailorder Business Details **FREE!** Rusin, 8035 South Kostner, Chicago 60652.

**SUCCESS** Book—"Profits in Mail Order". \$2.50. Cazin, 526 Maple, Redwood City, California 94063.

**MAILORDER** Sell Engraved Social Security Plates. Complete Dealer Set-up. AM Sales, 31-14-94, East Elmhurst, N.Y. 11369.

**LEARN** Where To Obtain **LOWEST PRICES** On All Merchandise. We Provide Unlimited Sources. Free Details. **MONEYMAKER,** Box 175, North Branford, Conn. 06473.

(Continued on next page)

## MONEYMAKING OPPORTUNITIES

(Continued from preceding page)

**HOMEWORKERS EARN \$150.00 WEEKLY ADDRESSING OUR SALES LETTERS. DETAILS 25¢. CUR-JON MAILERS, BOX 523-PM, MAPLEWOOD, N.J. 07040.**

**MAKE Money Writing Fillers. How To Booklet \$1.00. Del's Country Barn, V-4 Route 4, Lee's Summit, Missouri 64063.**

**COLLECT COINS big PROFIT! LISTS of Valuable COINS. Roll of 1926s BUFFALO Nickel Worth \$13,000.00. HOW to START, WHERE to SELL. Send \$1.00. Wilson Gifts, 4158 Barnes, Bronx, New York 10466.**

**MILLIONAIRE Now \$1.00 Letter Explains. Money Back Guaranteed. P.O. Box 9963, San Diego, California 92109.**

**STRIKE IT RICH. Flood Of Money-making Ideas By Direct Mail From Hundreds Of Major Opportunity Companies. \$3 To: Heil, Box 1372, Lancaster, Penna., 17604.**

**48% RETURN Last Year, Inflationproof Investment. Argau, Box 4, Boonton 07005.**

**"THINK Big"! Gain Financial Security, Power Now! 256 Pages Tells How. \$2.00. Hammond, Route 15, Box 179R, San Antonio, Texas 78228.**

**THERE'S Money In Land. 1 Year Subscription To Government Land's Digest \$3.00. Details 25¢. Bob Musial, Box 11907, Chicago, 60611.**

**ADDRESSERS Mailers Needed. Details 10¢. Borchardt, Dept. PF, Postbox 1022, Mineral Wells, Texas.**

**MONTHLY News Letter Reveals Best Finders Fee, Business Investment Situations. Free Details. Robinson Enterprises, Box 38, Augusta, Ga. 30901.**

**BIG Money In "Hot Dogs". Build A Street Vendor's Pushcart. Easy Plans \$3.00. Thomas, 100 Bellvue, Chicago 60611.**

**"PROFITABLE PLASTER CASTING"—Exciting New Book!!—Details! Exclusive, 827 Yout, Racine, Wisconsin 53402.**

**SKETCH Photos (Homeworker's Goldmine!) Steady Market. Details. Gem, 365-D Longhill, Shelton, Conn. 06484.**

**DOLLAR-Maker "Tips"—Goldmine of Information \$3.00—Aneva's—186, 4221 S. 6th—A39, Milwaukee 53221.**

**POSTCARD Addressers Needed Immediately—Application \$.25. Meren, 2233 Lukes Lane, Baltimore, Maryland 21207.**

**FREE INFORMATION \$50.00 \$100.00 per week selling gifts from Sales Kit. Sample item \$1.00. NEE-LON, Box 6497PM Philadelphia, Pa. 19145.**

**MONEY TROUBLES! Need Help! Helped Others. Free Proof! Offenhauser, Box 111, Canonsburg, Penna. 15317**

**HOMEWORKERS Guaranteed \$25.00 Stuffing 100 Envelopes. Send Stamped Self Addressed Envelope And 50¢. Mirage, Dept. 56B-CB-R4, Warrensburg, Missouri 64093**

**PROTEST High Taxes, Make Money Selling PLUCKED DUCKS Free Sample—Box F Dysart, Iowa 52224.**

### PROFITABLE OCCUPATIONS

**INSTANT Money! Plastics are the wave of the future. Big profits now! At home! Spare time! Materials costing 11¢ bring back \$2.58 profits immediately! Free information. Rush name on postcard to: Warner, Room LC-2-CF, 1512 Jarvis, Chicago, Illinois 60626.**

**HOW To Finance Your Own Business. Get \$500 to \$2 million. Free offer. Capital-25, Kerrville, Texas 78028.**

**POLICE/Fire/Aircraft Scanner Receivers and Crystals. Fast sales, big profits. M.C.S., P.O. Box 612-PM, East Moline, Illinois 61244.**

**FT. SMITH Auction School. Ft. Smith, Ark. 72901. Resident & Home study. Veteran approved.**

**BECOME A Mortgage Broker. Highly respected, interesting, lucrative prestige business. For complete information write: United, Box 6284-F, Marietta, Georgia 30060.**

**HOW And Where to Get Capital. Get \$500 to \$2 Million. Free information. Counselor-25, Kerrville, Texas 78028.**

**SHARPEN—Scissors, Pinkers. Light, compact equipment. Supplies. Blackhawk's Sheldahl, Iowa 50243.**

**YOU Can make extra MONEY easy! Same Day. FREE information. Box 3025, Spartanburg, S. Car. 29302.**

### SALESMEN-DISTRIBUTORS

**SELL KNAPP SHOES . . . HIGH CASH COMMISSIONS IMMEDIATELY Plus monthly cash bonuses, benefits. Part-time or full time. Your own hours, your own nationally-famous business. No investment. Free selling and training kit. Lowell Harris Dept. PM-24, Knapp Centre, Brockton, Mass. 02401.**

**WANTED Man contact service stations. Long Needed Invention. Huge Profits. Write Cyclo, 3816 Dahlia, Dept. 171, Denver, Colo. 80207.**

**HERTEL Exclusive reference Bible! Make biggest profits with world's best seller! Startling 3-dimension cover! Demonstrator, supplies furnished. Top commissions plus extra bonus earnings! Write International Book, Dept. PM, Box 118, Wichita, Kansas 67201.**

**\$100.00 EXTRA A week easy! Spare time! Double Air Cushion shoes. Men's, women's line. Dress, work play. Highest commissions. Shoes for yourself. Outfit Free. Bronson, Dept. H-63, Minneapolis, Minnesota 55408.**

**PUBLICATIONS for local wholesale distribution, higher profits. Details, sample. \$1 refundable. Publisher, 404 West Jefferson, Springfield, Illinois 62702.**

**SELL Advertising Ball Pens, Calendars, Ad-Specialties—Build Own Repeat Business—Free Details—Fleming, Dept. A, 6535 Cottage Grove, Chicago 60637.**

**\$50-\$100 EVERYDAY. Commission paid daily. Changeable Electrical signs for businessmen. Associated, 137-K North Western, Los Angeles, 90004.**

**UNIQUE New Product. Samples 50¢. Goodrich, Box 654, Poughkeepsie, New York 12602.**

**HOUSEHOLD PRODUCTS ROUTE. EARN \$25 or more daily. Also Party Plan opportunities for men, women full, part time. McNess, Freeport (2663) Illinois 61032.**

**NEW, Compact fire extinguisher. Fantastic profits. Exclusive territories. Norwich Chemical, Norwich, Connecticut 06397.**

**LOOKING FOR A BETTER FUTURE? Use your spare time to show our New Line of Specialty Advertising, Calendars and Executive Gifts to Business Firms in your area. Prompt, friendly cooperation with a low pressure, progressive firm, in our 64th year, rated AAA-1. No investment or collections. Weekly commissions and Liberal Bonus. Samples furnished. Can be developed into a full time business. Write to: John McNeer, Dept. PM-6, Newton Mfg. Co., Newton, Iowa 50208.**

**EARN Big money calling on business-professional men. Send us their delinquent accounts for collection. General Finance, Dept. PM-11, Columbia Bank Bldg., Kansas City, Missouri 64106.**

**NEW Self selling Product! H&F Lamb, 670 Fairway Drive, PM-6, Plantation, Florida 33314.**

**AUTOMATIC Fishhooks. Free details. Samples, \$2.00. Aron, 61PM, Mastic Beach, New York 11951.**

**MONEY Making Opportunity. New Oriental Discovery Based On Acupuncture. Inquire: Art Illiano Company, Dept. PM, 3101 N. Stone Avenue, Tucson, Arizona 85705.**

### AGENTS WANTED

**ESTABLISH Your own business. Low prices on used clothing, shoes, household goods. Unlimited profits. Free catalog. Northwestern Distributors, 2129 No. Western Avenue, Chicago, Illinois 60647.**

**PRINTING, Advertising Salesmen—Excellent money-making sideline selling Decalcomania Name Plates, small quantities. Advertising Specialties, sign letters. Free Samples. Raico XL, Boston, Mass. 02119.**

**WANT TO MAKE UP TO \$100 A WEEK Spare time, and get free shoes for life, too? No investment. Rush Card for free details. Mason Shoes, K-930, Chippewa Falls, Wisconsin 54729.**

**EVERY Man a prospect. Refundable sales kit offer showing line belt buckles, tie clasps, money clips, cuff links, lapels, identification badges, individualized with customer's name and emblems. Cap badges for trucking, bus, taxi, police, firemen, also postal letter carriers and heavy construction emblems. Choice 4000 emblems. Hook-Fast, Box 1088-PM, Providence, R.I., 02901.**

**ZODIAC Jewelry \$50.00 Day Easy. Send \$4.95—Sample Retail \$9.95. Brochures Free. GET, 536 Allapattah, Miami, Florida 33142.**

**YOUR Own business. Used Suits \$1.50; Overcoats 65¢; Mackinaws 35¢; Shoes 12½¢; Ladies' Coats 30¢; Dresses 15¢. Enormous profits. Catalog Free. Nathan Portnoy Associates, 2109-AA Roosevelt Road, Chicago, Illinois 60608.**

**AGENTS-UP TO 100% profit fast selling New "SOIL-BAN" liquid invisible glove. Everyone's a prospect. RUSH \$2.00 for sample order. Write for details. Kramer Chemical, 707 Henry, Room 206C, Ann Arbor, Michigan 48104.**

### EMPLOYMENT INFORMATION

**NORTH IDAHO Information Packet. Employment, Housing, Recreation Questions Answered. \$2.00. Brown—Route -1- Box 40-B, Coeur d'Alene, Idaho—83814.**

**CALIFORNIA! Get The Facts! Employment, Housing, Education, Cost-Of-Living, Life-Style, And More! \$2.00. Jav-Mar, Box 1527, Garden Grove, Calif. 92640.**

**SORENSEN Research Guarantees savings for the Overseas Minded. Other Services Sold Under This Classification Are Evaluated. \$2.00. 1804 Mountain, Pomona, California 91767.**

**AUSTRALIA Most Comprehensive Information, From Americans Now Living In Australia. \$2.00 For Brochure, Ausco Inquiry, Box 29, Burra 5417 South, Australia.**

**ORLANDO, Gateway To Disneyworld- Send \$1.95 For Employment-Business Opportunities. Orlandorama, 302 Robinhill Dr., Altamonte Springs, Fla. 32701.**

**OVERSEAS EMPLOYEES GUIDE Discusses Various Conditions in Employment Contracts and Necessary Preparations. \$4.00. Otto Blume, 795 North Woodlawn Drive 1000 Oaks, Calif. 91360.**

**AUSTRALIA!! AUSTRALIA!! FREE DETAILS!! Paid Transportation. Latest information on Jobs. Send age, occupation. Write: Associated, Box 17-B-139, Lafayette, California, 94549.**

**OVERSEAS JOBS—Now Hiring, 103 Countries. All Occupations, High Pay, Free Transportation, Tax Benefits. Latest Computerized Reports—\$2.00. TRANSWORLD, International Airport, Box 90802-E, Los Angeles, California 90009.**

**AUSTRALIA—NEW ZEALAND WANT YOU !!! 50,000 Jobs! Paid Transportation! Latest Information and Forms. \$1.00. Austco, Box 3623-E, Long Beach, California 90803.**

(Continued on next page)

## HELP WANTED

**OVERSEAS EMPLOYMENT** . . . Australia, Europe, South America, Asia! All Occupations! \$700-\$3,000 monthly! Write: Employment International, Box 29217-AF, Indianapolis, Indiana 46229.

**OVERSEAS Jobs**—Europe, South America, Australia, Far East, etc. 2000 openings all trades. Construction, Office, Engineering Sales, etc. \$700 to \$3,000 month. Expenses paid. Free Information. Write: Overseas Jobs, International Airport, Box 536-M, Miami, Florida 33148.

**BOOKKEEPERS**—Part Time—your area. Bernie Schroll, 334 Coleman Drive, Monroeville, Penna. 15146.

**EARN** At Home Addressing Mail. Details 25¢ and Stamped Envelope. Deeco-151, Box 9308, North Hollywood, Cal. 91609.

**FREE DETAILS!** . . . **AUSTRALIA** . . . Paid Transportation!! Jobs Galore!! Send age, occupation. Write: Associated, Box 17-BA-139, Lafayette, California 94549.

**WORLD-WIDE** . . . **U.S.A. JOBS GALORE!!!** All occupations. Enjoy: Asia, Europe, Africa, South America, Florida, California. \$700.00 to \$3,500.00 monthly. Paid Overtime. Travel Allowance. Free Details! Send age, occupation. Write: Global Employment, Box 706-B-139, 2 Orinda, California 94563.

## REAL ESTATE AND FARMS

**FREE CATALOG!** Giant SUMMER edition! Over 5,200 properties described, pictured—Land Farms, Homes, Businesses—Recreation, Retirement. Selected Best throughout the U.S.! 73 Years' service, over 660 Offices, 41 states Coast to Coast. Mailed FREE from the World's Largest! **STROUT REALTY, Inc.**, 60-MX E. 42nd St. NY, NY 10017; 7-MX S. Dearborn, Chicago Ill. 60603; 521-MX E. Green, Pasadena, Calif. 91101.

**GOVERNMENT LANDS FROM \$7.50 ACRE!** VACATIONING, FARMING, INVESTMENT! EXCLUSIVE "GOVERNMENT LAND BUYER'S GUIDE" . . . plus "Land Opportunity Review" listing lands throughout U.S. Send \$1.00. Surplus Lands, Box 19107-AF, Washington, D.C. 20036.

**\$1.00 ACRE!** USA and Canada. Lists, photographs mailed. Government Lands, 220 Delaware Ave., Buffalo, New York 14202.

**CENTRAL Ontario**—Choice 640 acre Sportsmen's paradises still available—\$20.00 plus \$6.50 taxes yearly. Maps, pictures. \$2.00 (Refundable). Information Bureau, Norval 4, Ontario, Canada.

**FREE Catalog!** **PHOTOS!** Coast to coast farms, business, retirement. All types, sizes & prices. **SAFE-BUY Real Estate**, Box 589-PM, Little Rock, Ark. 72203.

**IDEAL 5-ACRE RANCH.** Lake Conchas, New Mexico. \$3,475. No Down. No Interest. \$29/mo. Vacation Paradise. Money Maker. Free Brochure. Ranchos: Box 2003PS, Alameda, California 94501.

**\$1 ACRE**—Canadian border—hundreds campsites, islands, farmlands, directly from tax authorities. (Non-profit). Lists, photographs mailed. Register, Room 10, 110 Church Street, Toronto 1, Canada.

**BOILING Spring Lakes**—America's Greatest Real Estate Value. 1/3 acre vacation or retirement homesites only \$900 cash price. Ten-year terms available. Money-back inspection guarantee. Carolina coast, multi-million dollar, 14,000 Acre development. 50 fresh water lakes, private ocean beach, golf course, motel, and country club. Free literature, Dept. 1-J, Boiling Spring Lakes, North Carolina 28461. (Registered under Federal Land Sales act but not offered to residents of states requiring separate registration.)

**CANADIAN** Vacation lands: Full price \$385.00. 40 acres. \$10 month. Suitable cottage sites, hunting, fishing, investment. Free information. Land Corporation, 3768-C Bathurst, Downsview, Ontario, Canada.

**AMERICA'S** Finest Improved 2 1/2-5 Acre Value. Water, Roads, Utilities, Walking Distance to Hunting, Fishing, Golf. Brochure. Box 433, Blanchard, Idaho 83804.

**CANADIAN LAND FROM \$19.00 AN ACRE CHOICE** Properties available across Canada. Low monthly payments. Ideal for farming, cottages, hunting, fishing. Free Catalogue. Canadian Estate Land, Dept. PMC-6, 286 Lawrence Ave. West, Toronto 20, Ont., Canada.

**FREE** . . . 256-page **SUMMER** catalog. Hundreds of top real estate values coast to coast! **UNITED FARM AGENCY**, 612-PM West 47th St., Kansas City, Mo. 64112.

**BUY LAND** cheap your community or any state on signal. Information free. Land Signals, Box 325, Scottsville, Texas 75688.

**MICHIGAN 10 TO 160 ACRE TRACTS** Lake Superior-Marquette Area from \$99.00 Acre Cabins, Trailers, camping welcome. (Acreage anywhere in Michigan). **FREE PICTURES.** Any terms A-OK with **BLOCH BROTHERS.** Write: 3650 Dixie, Drayton Plains 16, Michigan 48020.

**FREE** Real Estate Catalog! Recreational, Retirement and Investment Properties, Farms, Ranches, Businesses. Central States. Banner Advertising, P. O. Box 3333 (19-A), Springfield, Missouri 65804.

## FARM AND GARDEN EQUIPMENT

**RIDING LAWMOWERS** Shipped from factory—New 7 Horsepower, \$189.00. Freight paid. Free brochure: Tomco, Box 72, Oak Grove, Mo. 64075.

**WATER LEVEL** Adapters Attach to your Garden Hose. \$6.95. Timber Ridge Construction, Evergreen, Colorado 80439.



## FLOWERS, PLANTS & NURSERY SUPPLIES

**LEARN** Flower Arranging and Floristry. Start full or part time business or hobby. Free information on home study course. Lifetime Career Schools, Dept. B-702, 2251 Barry Avenue, Los Angeles, California 90064.

**LEARN** Landscaping and the growing of plants. Start a profitable business part or full time. Free information without obligation. Lifetime Career Schools, Dept. A-363, 2251 Barry Avenue, Los Angeles, California 90064.

**GREENHOUSE**—10'x12' Fiberglass. Fast, easy construction! Plans \$3.00. Guaranteed! Southwest-A1, Box 275, Garland, Texas 75040.

## CONSTRUCTION PLANS, BLUEPRINTS

**CUSTOM ARCHITECTURAL DRAFTING** Information Free. Russ Davis, 721 Franklin Rd., S.W., Roanoke, Va. 24016.

**GREENHOUSE**—8' x 12'. Build yourself for less than \$50.00. 5 different plans—\$2.00. Werth's, Box 1902GE, Cedar Rapids, Iowa 52406.

**HOUSE EXPANSION PLANS** And detail instruction book provide anything from an extra room to 1000 s/f addition. Build what you need at big do-it-yourself saving. Book with 1 set working blueprints \$14.50! With 4 sets (required by contractors) \$20.00. Money-Saver Projects, Box 303-44B, Chappaqua, New York 10514. Information available.

## LOG CABINS & HOMES

**BUILD** Log Cabins, rustic furniture, fireplaces!!! Complete manual, \$3.00 . . . "A" frame plans, \$2.00 . . . **Guaranteed.** . . . Beels, 956 Springdale, Atlanta, Georgia 30306.

**"A" FRAME CABIN.** \$500. Material. Purchase locally. Completely illustrated instruction manual & material list: \$2.00. Moneyback Guarantee. Order plan #1920, from: "Dependable Products", Box 113, Vista, California 92083.

## VACATION HOME PLANS

**FACTORY BUILT.** All Fuel Chimney, low cost, safe, efficient, installs easily. Stoves, Barbeques, Fireplaces. Preston Distributing, Foot Whidden, Lowell, Mass. 01852.

## HOME CRAFTSMEN

**SKIL-CRAFTS** Current 200 plus page catalog with world's largest finest selection of Hobbycraft, leathercraft, artist supplies. Send \$1 for postage and handling; refunded on first \$5 minimum catalog order. Skil-Crafts, Box 105-P, Joplin, Mo. 64801.

**101 PATTERNS** of smart Gifts, Novelties, Shelves, Action Windmills, plus "Make Money Jig Sawing". \$2.00. Mastercraft, 65M, 7041 Olcott, Chicago 60631.

**BIRD HOUSES** For Fun and Profits. 20 Projects And Plans. \$1.00. Infoco-P6, Box 34260, Washington, D. C. 20034.

**PICTURE Framing**—Profitable full or spare-time business. Easy to learn with handbook-course "Guide To Picture Framing Profits." \$1.50 Guaranteed. Free framing-supplies catalog included. Japs, 126-PM Seventh North, Hopkins, Minnesota 55343.

**CABINETMAKING MADE EASY** And "How to Make Formica Counter Tops." Two excellent guides let you build kitchen cabinets and counter tops like professionals. Extraordinary guides bring master craftsmen's shortcut methods. Satisfaction guaranteed. Write: Japs, 126-P Seventh North, Hopkins, Minn. 55343.

**1400 CATALOGS** Listed and Described! Sources for **EVERYTHING** Imaginable! Rush \$2.00 **MASTERLOG**, Box 24413-(WF), Oakland, California 94623.

**POPULAR MECHANICS MASTER SHOP GUIDE.** Greatest product offered to a man with a workshop. All information printed on heavy boards, punched and ready to hang above his workbench. Covers wall fasteners, nails, screws, bolts, twist drills, abrasives, lumber, moulding patterns, plywood grades, hardboard, dry-wall plumbing supplies, electrical supplies. Plus information on score of other subjects. Send \$3.95 to: **POPULAR MECHANICS**, Dept. HE, 224 West 57th Street, New York, New York 10019.

**CATALOG FULL SIZE FURNITURE PLANS**—\$1.00 Refunded with first order. Traditional, Early American, over 150! Furniture Designs, 1425 Sherman, Dept. CP-63, Evanston, Illinois 60201.

**ORNAMENTAL IRON WORK.** Beautiful scrolls with inexpensive professional bender. Modular segments. Details Free. Fuschlin, Box 472, Woodland, California 95695.

**WORKBENCH** And tool panel anyone can build. Complete with material list. \$1.00. Way-Mar, 58 Underhill Road, Scarsdale, New York 10583.

**CLOCK** Kits, Imported Battery And Pendulum Movements. Dials. Catalog 25¢. Newport, Box 6848A, Burbank Calif. 91505.

**INFOCO** Books. Pocket Duck Identifier; Sundial Construction; National Park Camping; Beekeeping for Beginners; Prospecting Techniques; Twenty Birdhouse Plans. \$1.00 each. Infoco-C6, Box 34260, Washington, D.C. 20034.

**FENCES**—50 Different Designs. \$3.00. Sorlie, 1820 12th Avenue South, Great Falls, Montana 59405.

**20 PLANS**—Full Size—Early American Novel Items for Fun or Profit. Send \$2.50. Cerbone—Box 18099—Philadelphia, Penna. 19147.

## DO-IT-YOURSELF

**SPECIAL** For small Apartments. Convert bed room in to play room and back in seconds. Construction-two beds, shelves, closet. \$4.50. Stan Co., Box 145, Garfield, New Jersey 07026.

(Continued on next page)

## DO-IT-YOURSELF

(Continued from preceding page)

**PLANNING AN UNDERGROUND SPRINKLER SYSTEM? INSTALL YOUR OWN AND SAVE.** World famous do-it-yourself Rain Jet Sprinkler equipment. Millions already installed. Available nationally. For free How to Install pamphlet, write Rain Jet Corporation, Dept. SWZ, 301 So. Flower St., P.O. Box 627, Burbank, Calif. 91503.

**CENTRAL AIR CONDITIONING FOR AS LITTLE AS \$500\*** Install It Yourself in your forced air furnace with ordinary hand tools—save up to \$200 on installation costs. Free brochure illustrates step-by-step procedure. McGraw-Edison Co., 7290 N. Clark St., Albion, Michigan 49224.

\*Cost varies according to size and construction of home.

**BURGLAR-FIRE Alarm Supplies and Information.** Free Catalog. Protecto Alarm Sales, Box 357A, Birch Run, Michigan 48415.

**WALL-SIZED TV . . . Build a 72-INCH TV PROJECTOR** for under \$15.00. Free details: Macrocoma, Dept. PM-6, Washington Crossing, Pennsylvania 18977.

**CONVERT MOWER Engines** into air compressors. Write: Showalter, Box 409, Abilene, Kansas 67410.

**INSTALL Your Own Underground Sprinkler System.** Send \$3.00 for illustrated instructions. Sprinklers, Box 121, Dunedin, Fla. 33528.

**1400 CATALOGS** Listed and Described! Sources for **EVERYTHING** imaginable! Rush \$2.00. MASTERLOG, Box 24413-(YF), Oakland, California 94623.

**REPAIR MINIBIKES, LAWNMOWERS, BICYCLES, Sewing Machines, Auto Engines, Mazda/Wankel, Motorcycles, Magic, boats.** Over 100 How-To-Books. Free Brochure. Mastercharge accepted. Sincere, Box 10422, Phoenix, Arizona, 85064.

**UTILITY BARN 8'x12'!** Detailed plans with material list. \$2.50—Guaranteed! JaBar, Dept. 3C6, 1448 West Strasburg, West Chester, Penna. 19380.

**GARAGE DOOR OPENER PLANS** \$2.50. Complete Details, Parts List. M. Izzl, Box 267 Bethpage, New York 11714.

**LAY CONCRETE BLOCKS** Professionally. Aluminum Mortar Gauger Assures Exact Amount Everytime. No Waste. For 8" Block \$9.95. 12" Block \$11.95. Plus C.O.D. Postage. Write: Brandt Enterprises, Inc., P. O. Box 392, La Grange, Mo. 63448.

**POCKET Sundial.** Make your own. Complete plans \$1.00. Box 27605M, Los Angeles, Calif. 90027.

**BUILD** These Three Plywood Tools and use your Circular Saw as a Table or Radial Saw. Plans, Instructions \$1.00. Rod's, 2319 Sandalwood, Gautier, Miss. 39553.

**MELT IRON** in \$12 forge. Plans \$2. Metalcraft, Box 447, White Rock, South Carolina 29177.

**CARNIVAL Building Plans:** Rides, Games, Shows; 264 Page Catalog Refundable \$1: Brill, Box 875-A, Peoria, Illinois 61601.

**AMAZING New Drain Unclogger**—open clogged drains fast—no mess—no chemicals—safe—convenient. Dorisco, Box 5633, Buena Park, California 90622.

**STOP CATCHING COLDS!** Convert your Window Air Conditioner to Centralized Air Conditioning for about \$10.00. Send \$1.00 for Instruction Book. New Methods Engineering, Box 150, Girard, Ohio 44420.

**SAVE \$25.00 OR MORE!** Step-By-Step 44 Page Illustrated Book Makes Home Plumbing Repairs Easy. One Simple Repair Can Save \$15 To \$25. Postpaid, Send \$2.00. Gentony's, Box 52427, Houston, Texas 77052.

**MIRACLE FIXTAPE** Impregnated Thermo Curing Epoxy. Repairs Mufflers Water Pipes Fenders. Wrap Like Bandage. 42" \$2.00, 72" \$3.00. Lunden, 1106 Southeast Avenue, Dept. 1F1, Aledo, Ill. 61231.

**SAVE Water—Save Money.** Install Water Saver In Toilet. Easy Installation Instructions. Fully Guaranteed. Send \$2.00 To: Downeast Sales, Elm Street, Kennebunkport, Maine 04046.

## ARTS AND CRAFTS

**POTTERS Wheel kits \$40.** Send 10¢ for brochure. Lipton Wheels, 2986 Adeline St. Berkeley, Cal. 94703.

**"GETTING Started in Stained Glass"** 25¢. Whittemore, Box 2065Y, Hanover, Mass. 02339.

**MAKE Figurines, plaques, lawn ornaments.** Molds, plastercraft kits, liquid rubber. Sample and catalogue 10¢. Wooley Company, Box 29-B, Peoria, Illinois 61601.

**FREE LITERATURE** For sculptors showing how to make molds, cast plastics. Adhesive Products Corporation, 1660 Boone Avenue, Bronx, N.Y. 10460.

**LEARN Arts & Crafts at home.** Excellent full or part time business opportunities, or hobby. Free booklets. Lifetime Career Schools, Dept. E-802, 2251 Barry Avenue, Los Angeles, California 90064.

**FREE:** New handicraft catalog. Supreme Handicrafts, Box 395-PM, Sioux Falls, South Dakota 57101.

## BINOCULARS, TELESCOPES, MICROSCOPES, MAGNIFIERS

**TELESCOPES** (reflectors) complete kits. Other accessories, request free literature. Criterion Manufacturing, Dept. PM, 41 Hartford, Connecticut 06101.

**FREE Binocular, Rifle scope catalog.** Discount sale. Save 50%. Free gift with order. Write, United Binoculars, BN-6808, 9043 So. Western, Chicago 60620.

**HOLD Camera or Binoculars** safely secured to chest ready for instant use. No neck strain with patented Kuban Hitch. One size fits all. Quality made elastic straps, spring steel adapters, heavy-duty snaps. Ideal gift for fishermen, photographers, boaters, skiers, Snowmobilers, hikers. \$7.50 postpaid. Satisfaction guaranteed. Free literature. Write: Kuban Hitch, Dept. PM, 5280 N.E. Main Street, Minneapolis, Minn. 55421.

**600 POWER ACHROMATIC TELESCOPE.** Build From \$38 Kit. Free brochure. Astrocraft, Box 447, White Rock, South Carolina 29177.



## CAMERAS AND EQUIPMENT

**FREE! FREE! BARGAIN BOOK** Central Camera Co., Dept. 361, 230 S. Wabash, Chicago, Ill. 60604.

**USED Photographic Equip.** Nationwide Monthly "Shopper" Free Sample. Shutterbug Ads, Box 730-P, Titusville, Fla. 32780.

## PHOTO FINISHING

**CAMERA FANS!** Expert photofinishing by one of Country's largest labs at lowest prices. Fast service and free "Foto-Fan" Stamps you quickly redeem for valuable Photo Supplies. 8MM Kodachrome \$1.29; 8 Exp. Kodachrome \$1.79; 35MM Kodachrome 20 Slides \$1.39; 8 Exp. Black White 69¢. Satisfaction guaranteed. Send exposed film or request free mailers, complete Price List and Gift Catalog. Direct Mail Photo, Box 8352-PM, Pittsburgh, Pa. 15218.

## COLOR SLIDES

**35MM COLOR Slides.** 10,671 Individually sold. Described, Encyclopedia catalog 10¢. Wolfe Worldwide, Dept. 14-63, Los Angeles, Calif. 90025.

**ASTRONOMY — Space — Underwater Slides Catalog.** Roberts, Box 608B, Dana Point, California 92629.

## MOTION PICTURES AND SOUND EQUIPMENT

**8MM—SUPER 8—16MM MOVIES!** Biggest Selection! Lowest Prices! Free Catalog! Cinema Eight, Box PM, Chester Connecticut 06412.

**CLASSIC 8MM. MOVIES . . . 35MM. 2"x2" Color Slides.** . . . largest selection anywhere! Silent classics, comedy, history, sport, news, documentaries, features, others! 16MM films also Free catalog. Blackhawk Films, 690 Eastin-Phelan Bldg., Davenport, Iowa 52808.

**UNUSUAL Movie supplies.** Free circular. Esor, 47th Holly, Kansas City, Missouri 64112.

**FREE!** 64-Page catalog. 8-16MM film supplies, processing equipment. Superior, 448 N. Wells, Chicago 60610.

**FREE Catalog—8mm-16mm—Top Manufacturers—G & G Film Library,** Box 321, Syosset, New York 11791.

**16MM, 8MM Sound and Silent Classic Films.** Free Catalog. Niles, 1019-PM So. Michigan, South Bend, Indiana 46618.

## RADIO, TELEVISION AND HAM EQUIPMENT

**36¢ RADIO & TV Tubes.** Free catalog. Cornell, 4213-17 University, San Diego, California 92105.

**SAVE Money on parts and Transmitting—receiving tubes.** Foreign—domestic. Send 25¢ for giant catalog. Refunded first order. United Radio Company, 56-PM Ferry Street, Newark, N.J. 07105.

**GOVERNMENT Surplus receivers, transmitters, snooper scopes, parts.** Catalog. 25¢. Meshna, Nahant, Mass. 01908.

**T/V SCHEMATICS/SERVICING MANUALS.** Service Data. B/W, Color. Domestic, Foreign. Radio Repair. Free List. Santomasso, 1255 Boulevard, New Haven, Conn. 06511.

**LIGHTNING Protection fuse box.** television or stereo on cable \$7.95. television on antenna or CB radio \$12.95. Vonada Products, Lincoln, Kansas 67455.

## HIFI TAPES, RECORDS AND ELECTRONICS

**HIGH Fidelity's Test Reports.** Up-To-Date Buying Guide of Over 175 Audio Products. 240 pages of Performance Tests, Pictures, Analyses and Prices. Send \$1.95 To: High Fidelity Test Reports, 2160 Patterson St., Cincinnati, Ohio 45214.

**FREE Catalogues,** 2000 hard to find unusual records. Rose's Records, Box 7216, Louisville, Ky. 40207.

**FREE Catalog—Electronic Kits—Amplifiers—Preampifiers—Psychedelic Strokes—SCA Adaptors—Color Organs—Digital Instruments—Guitar Amplifiers.** FREE Subscriptions. SWTPC, Box PM32040, San Antonio, Texas 78284.

**OLDIES 45 RPM Original Hits—Catalog** 50¢. C&S Record Sales, Box 197, Wampsville, New York 13161.

**AMAZING INDOOR TV ANTENNA:** Cures Poor Reception. All Channels Clear. Plugs Into Wall Outlet. Guaranteed: \$1.98. Little Town Products, 3 Cottage, Morrisville, Vermont 05661.

**BUY 8 Track Stereo Tapes** at fantastic Prices. Top Artists. Free Catalog, over 500 Tapes, Soul, Pop, Jazz, Country, New Trend, 6621 141st. Pl., N.E.-PM, Redmond, Wash. 98052.

**FREE Catalogue,** Electronic Calculators. Calculators Unlimited, Box 338, Hyattsville, Maryland 20781.

**TAPE RECORDING COURSE:** Taught by Studio Engineers. Free information. NNA, Box 721G, Rye, N.Y. 10580.

**8-Track Tapes • Catalog free.** C. Bolton, 1114 9th Ave., So. Sioux City, Nebraska. 68776

(Continued on next page)

Материал, защищенный авторским правом



## HIFI, TAPES, RECORDS AND ELECTRONICS

(Continued from preceding page)

**OLD Radio On Tape.** Catalog \$1.00. (Refundable). Radio Vault, Box 9032-PM, Wyoming, Michigan 49509.



## MUSIC AND MUSICAL INSTRUMENTS

**ACCORDIONS** And Amplifiers! New—Used. Cordovox, Excelsior—Top Makes! Save to 50%. Direct factory dealer. Terms. Trades accepted. 5 day home trial. Free catalog—Discount prices. Write: Accordions Unlimited, Dept. R, 3147 North Luna, Chicago 60641.

**SWISS** Musical Boxes, Movements. Bell Music, P.O. Box 1, Bay Station, Brooklyn, N.Y. 11235.

**LEARN** To read music in one evening. Free brochure, Jordan, 27495 Road 176, Dept. PM-6, Exeter, Calif. 93221.

**FREE CATALOG—30% DISCOUNT.** Best Names In Musical Instruments, Dial For Music, 90 North Main Street, Spring Valley, N.Y. 10977.

**EASY** To Play And Make. Quality Dulcimers, Banjos, Thumb Pianos; Instruments And Kits. Can Be Profitable Hobby. **HERE, Inc., #P, 410 Cedar Avenue, Minneapolis, Minn. 55404.**

**ELECTRIFY** Player Pianos, Pump Organs Quickly, Inexpensively with Lee Silent Suction Units. Write: Lee Music, 525F Venezia Avenue, Venice, California 90291.

**30% TO 50% DISCOUNT!** Any Model: Guitar, Amp, Drum, Banjo, Dobro! Free Catalog! Warehouse P34, Box 16399, Fort Worth, Texas 76133.

**PLAYER** Piano Rebuilding—get details from: Vestal Press, Vestal 11, N.Y. 13850.

**POEMS** Wanted for songs. Nashville Music Productions, Box 40001-P, Nashville, Tennessee 37204.

**VIOLIN** And Guitar makers—send for latest Free Catalogue of woods & accessories. International Violin, PM1, 414 East Baltimore St., Baltimore, Md. 21202.

**WHOLESALE!** Professional Guitars, PA Systems, Altec Speakers, 240W RMS Amplifiers. Free Catalog. Carvin, Escondido, Calif. 92027.

**WHOLESALE.** Musical Instruments—Accessories. Allied, 573 Route 17, Paramus, New Jersey 07652.

**RECONDITIONED** Accordions for sale—Save \$\$\$, Top Brands, Write for free descriptive folder, A-1 Rebuildt Accordions, 31 E. 18th St., N.Y.C. 10003.

**ACCORDION** Top brands. Buy direct. Tremendous discounts. Trades accepted. Free brochure PM. Accordion-O-Rama, 874 Broadway, N.Y.C. 10003.

**GUITAR,** Banjo, Violin, Mandolin Making Materials, Accessories, Books. Catalog 25¢. Guitar Center, Box 15444, Tulsa, Oklahoma 74115.

**NEW GUITAR MAKING BOOK & NEW TOOLS.** Overholtzer, 618 Orient, Chico, Cal 95926.

**POEMS,** Songs wanted for hit recording, guaranteed Publishing, radio release. America's most popular new talent studio. Broadway Music Productions, 11647PM, Bee Ridge, Sarasota, Florida 33578.

**30% DISCOUNT** Name Brand Musical Instruments. Free Catalog. Freeport Music, 455F Route 110, Melville, N.Y. 11746.

**I'LL** Teach you to read Music in one evening. Free brochure, Richardson, M&J Building, Suite 10, McAllen, Texas 78501.

**30% + DISCOUNT.** Name Brand Musical Instruments. Free Catalog. Continental Music, P. O. Box 3001, Dept. D, Garden City, New York 11530.

**LEARN** Banjo. 5-String Bluegrass. No music. Makes learning easy. Free details. Blaylock, Box 25-M, Marietta, Georgia 30060.

**ACCORDION** Manufacturing 6846-P North Avenue, Chicago, Illinois, 60635. Concertinas, Chromatics, Heligons, Hohners, Guitars, Drums, New, Used, Tuning, Repairing. Wholesale Catalogs Free.

**SPINET ORGANISTS.** New Device Quickly Eliminates Faulty Pedaling Fast! Easy! Guaranteed. \$3.98 Postpaid. Improvement Enterprises, RD1, Evans City, Pa. 16033.

**PIANO** Tuning Revealed! Free Details. Keynote, Box 22005J, Phoenix, Arizona 85028.

**COUNTRY** Songs Needed. 50/50 Co-Write \$1.00 Each. Poem-Lyric Reviewed. Libra, Box 1460, Studio City, Dept. P.M., Cal. 91604.

## CONSERVATION TRAINING

**GAME WARDEN,** Government Hunter, Forestry, Park & Wildlife Service announce job openings regularly. Prepare at home for outdoor work, good pay, security. Approved for Veterans! FREE! "CONSERVATION CAREER KIT." North American School of Conservation, MPS, Newport, California 92663.

## EDUCATION AND INSTRUCTION

**YOU CAN BE A COURT REPORTER**—High earnings, professional career in action-packed Civil and Criminal Courts. Urgent need for men and women in all 50 states. No age restriction. No college required. Begin with "Official 1973 Court Reporter Guide" \$4.95 postpaid. Veterans' information included. Money back guarantee. Leadership Publications, P.O. Box 2572, Columbus, Georgia 31902.

**WELDING CAREER TRAINING**—Arc, Pipe, Gas, TIG, MIG, Plasma. Write for Free bulletin. Accredited NATTS. Approved Ohio No. 70-12-0064 HT. **HOBART SCHOOL OF WELDING TECHNOLOGY, BOX 73, TROY, OHIO 45373.**

**INVESTIGATION & Claim Adjusting** are exciting big-pay professions. Quick easy-to-learn home-study course prepares you for all-around investigation jobs. Diploma and job placement service upon completion. FREE Details. Professional Careers Institute, Dept. P-SPM 1085 N. Main Street, Orange, Calif. 92667.

**RADIO & TELEVISION TRAINING.** Fix Radios & TV's first week—New Dynamic method. Write: Radio Television Training, Box 279 P-63, Syracuse, New York 13206.

**DEGREE**—Granting Correspondence School Directory; Fabulous Government Publications Catalogue; Secret Societies Guide. Free Details. Aureap, Allenhurst, New Jersey 07711.

**LEARN AUDITING FROM WELL KNOWN C.P.A.** Total cost \$15.95, postpaid. Send on ten day approval. Ask for C102-3P. Do not order unless you have fair knowledge of bookkeeping. The Counting House Publishing Co., Thiensville Wisconsin, 53092.

**YOU CAN BE A COURT REPORTER**—High earnings, professional career in action-packed Civil and Criminal Courts. Urgent need for men and women in all 50 states. No age restriction. No college required. Begin with "Official 1973 Court Reporter Guide" \$4.95 postpaid. Veterans' information included. Money back guarantee. Leadership Publications, P.O. Box 2572, Columbus, Georgia 31902.

**DEGREES** Without residence requirements! Honorary degrees. Catalog: \$3.00. United States University Of America, Box 4552-PM, Washington, D.C. 20017.

**MISSOURI** Auction School. Veteran Approved. Free catalog. 1600-03 Genesee, Kansas City, Missouri 64102.

**COMPLETE YOUR HIGH SCHOOL** at home in spare time. Texts furnished. No classes. Diploma. Our 76th year. Free Brochure. American School, Dept. XA45, Drexel at 58th, Chicago 60637.

**EXTENSION** And Post-Graduate Awards in Philosophy, Art, Sciences, Botanic Medicine, Homeopathy, Radionics and others. 30 subjects. Curricular free (airmail \$1.00 refundable). Registrar, Sussex College of Technology, Highfield, DaneHill, Sussex, England.

**PIANO** Technology—Electronic organ servicing, learned easily at home. G. I. Approved. Free booklet. Niles Bryant School, Dept. P, 3631 Stockton, Sacramento, California 95820.

**LEARN** Sewing Machine Repairing. Men, Women. Lucrative profits. Profession with bright future. Gresslin Correspondence School, Box 927. Spencer, Iowa 51301.

**LEARN** Auctioneering. Term soon. Free catalog. Reich Auction College, Box 850, Mason City, Iowa 50401.

**ORDINATIONS,** Lifetime! Church chartered 1887! Write! 708 Bragg, Monroe, North Carolina 28110.

**RELIGIOUS VOCATION?** Write: Church Of Holy Light Inc., P.O. Box 4478, Pittsburgh, Pa. 15205.

**USED** Courses! Books Catalog 10¢. (Courses Bought). Lee Mountain, Pisgah, Alabama 35765.

**AUTOSUGGESTION.** Sleep-learning headquarters! Tapes, records, books, Gigantic catalog free. Research Association, Box 24PM, Olympia, Washington 90851.

**OWN** Collection agency. "Little Gold Mine!" Franklin Credit, Roanoke, Virginia 24004.

**AUCTIONEERING.** Resident or home Study Course. Free Catalog. Nashville Auction School, 1921 West End, Nashville Tennessee 37203.

**FREE** Book tells how you can learn camera repair and service. Home study or classroom. Write today! National Camera, Dept. EAD, Englewood, Colorado 80110.

**HIGHLY** Effective college-level home study programs in Electronics Engineering and Engineering Mathematics. (Our 27th Year). Free Literature. Cook's Institute, Dept. 10, Box 10634, Jackson, Miss. 39209.

**PERFECT** Husband-Wife Business. Learn Upholstery at home. Make \$10 in an hour. Buy-repair-sell for even bigger profits. Kits, tools, included. Free Booklet. Upholstery & Decorating School, (homestudy), Dept. 5310-063, Little Falls, New Jersey 07424.

**DETECTIVE** Profession, Easy home study; free tie-tack or lapel pin, certificate, future. GI approved. Professional Investigators, Box 41345, Dept. CP, Los Angeles Calif. 90041.

**DETECTIVE** Course. Free Information. Universal Detectives, Box 8180-F, Universal City, California 91608.

**LEARN** To Fix Typewriters. Desperate shortage trained men. Hundreds needed. Make up to \$25 in one hour. Learn at home in spare time. Industry Approved course. Facts Free. Send name. Typewriter Repair School, (homestudy), Dept. 3310-063, Little Falls, New Jersey 07424.

**PIANO** Tuning quickly learned with home study course. Diploma granted. American Tuning School, 17050 Telfer Dr., Morgan Hill, California 95037.

**USED** Courses! Books! List 10¢. Smith's, 124 Marlborough, Salem, Massachusetts 01970.

**DETECTIVE** And Fingerprinting Courses. Write. Detectives, Box 185-P, Fairfield, Alabama 35064.

**SHORTCUTS** To Success! Highly Effective, Profitable Short Courses. (75 Choices). Study At Home. Diploma Awarded. Our 27th Year. Free Literature. CIEE-25, Box 10634, Jackson, Miss. 39209.

**WATCH REPAIRING.** Learn at home in spare time. Diploma awarded. Free sample lesson. Chicago School of Watchmaking, Dept. YS, Fox River Grove, Illinois 60021.

**UNLOCK** Your Future. Become professional Locksmith by spare time homestudy. Make up to \$6 per hour. All tools, equipment inc. Facts free. Send name. Locksmithing Inst., (homestudy), Dept. 1310-063, Little Falls, New Jersey 07424.

(Continued on next page)

## EDUCATION AND INSTRUCTIONS

(Continued from preceding page)

**HIGH SCHOOL DIPLOMA** For Adults. Earn State Diploma. Accepted by Civil Service, business, colleges. Low cost. No tedious study. Money-back guarantee. Details: H-S Program, Suite 2505, 1221 Avenue of Americas, New York, N. Y. 10020.

**SERVE** God's Ministry. Free. Ordination. Bible Institute, Box 744, McKeesport, Pa. 15134.

**VETERINARY ASSISTANT**—Train at home for exciting animal care career. Send for **FREE** "Career Kit". North American Home-Study School of Animal Sciences, AZS, Newport Beach, California 92663.

**LEARN** Asleep or awake! Records, tapes, equipment! Free catalog! Drawer PM-400, Ruidoso, New Mexico 88345.

**COLLEGE** Degree At Home. Your Choice of Subjects incl. Law. Easy Tuition Plan. Williams College, 1310 State Street, Boise, Idaho 83702.

**MILLIONS** Of Sewing Machines/Vacuum Cleaners Need repair. Train now for this High-Paying trade. Three Clothbound books, over 600 pages of instructional text—hundreds illustrations. Free wholesale buyers guide parts/tools. \$26.85. Mastercharge accepted. Sincere, Box 10422, Phoenix, Arizona 85064.

**LIFETIME** Ordinations. Free Home Training. Word-Science-Faith Church, 6 Buswell, #7, Boston, Mass. 02215.

**GET A** British Degree. Divinity. Philosophy, Radionics. 35 Courses. Prospectus free. Brantridge, Forest School, Highfield, Dane Hill, Sussex, England.

**TELEPATHY** Course—by Research Scientist. Send and Receive Mental Pictures. Write: Dr. J. Burns, Box 11201-C, Honolulu, Hawaii 96814.

**LET** Copyright Laws Make You Rich With Very Small Investment. Amazing Course \$3.00. Resnick, P.O. Box 1151, North Miami Beach, Florida 33160.

**UNIVERSITY** Degree. University of Louisiana, P.O. Box-50 Franklin, La. 70538. Send \$1.00 for Research On Education and Curricular.

**RELAX** Equivalent of up to 2 hours sleep in 10 minutes. Instructions \$1. Bar Enterprises, 7120 Hayvenhurst Ave., Van Nuys, Calif. 91406.

**FREE** Accredited High School Diploma Information! (NO Examination) Washington High Academy, Drawer 247E, Mango, Florida 33550.

**ALPHA** Theta Feedback Instruments—\$25. Sensitive Circuit of \$70 Unit. Ultimate ease of use. Inner Space Electronics, Box 308PM, Berkeley, Cal. 94701.

**COLLEGE** Degree Programs Through Home Study. Catalogue \$1.00. B647, Morgantown, Kentucky 42261.

**MEN WOMAN BARBERS** Razor and Style Men's Hair Basics. \$12. Leo Pinch c/o Cornwallis Inn, Kentville, N. S., Canada.

**ANALYZE HANDWRITING** Mini-Course. 50¢. 3 for \$1.00. Box 4432, Madison, Wisc. 53711

**USED** Courses! Books! List 10¢. Smith's, 124 Marlborough, Salem, Massachusetts 01970.

**BEAUTIFUL ORDINATION CERTIFICATE.** Write Ministry of Service Church, Box 526, Seymour, Texas 76380.

**CUSTOM ARCHITECTURAL DRAFTING** Information 25¢, Venco, Box 128, Ashley, Ohio 43003.

### FOR INVENTORS

**INVENTIONS** Needed immediately for manufacturers. For additional information write Kessler Corporation, C-56F1, Fremont, Ohio 43420.

**WORTHWHILE** Inventions Marketed. Patented or Unpatented. Harvey Engineers, Cambridge, Maryland 21613.

**U.S. PATENT** Office Searches, 234 Broadway, Room 3615, New York 10007. Free invention certificates.

**SYNTHESIS MAGAZINE**—About Invention. Write: Box 157, Manhattan Beach, California 90266.

**INVENTORS**—United States Patent Office Searches, Patent Development Engineering, marketing of inventions—ideas by Licensed Professional Engineer—Patent Engineer and United States Patent Office Former Examiner. Inventions developed for patenting and marketing. We are contacted by many manufacturers seeking to purchase appropriate new products invented by our clients. Send for Free Invention Certificate and Invention Information. Serving Inventors since 1948. George Spector, Licensed Professional Engineer—Patent Engineer—3615 Woolworth Bldg., New York, N.Y. 10007.

**PATENT** Application Financing. Free patent search plan. Global Patent Division, 2420 77th, Oakland, Calif. 94605.

**PATENT** Searches including maximum speed, full airmail report and closest patent copies. Quality searches expertly administered with complete secrecy guaranteed. Free Invention Protection Form and "Patent Information." Write: Dept. 15, Washington Patent Office Search Bureau, Benjamin Franklin Substation, P.O. Box 7167, Washington, D.C. 20044.

**PROSECUTE** Your Own Patent Application. All Material Necessary—Write: Inventors Service, Box 3574, Washington, D.C. 20007.

**FREE PAMPHLET:** "Tips on Safeguarding Your Invention." Write: United States Inventors Service Company, 501-P Thirteenth Street N.W., Washington, D.C. 20004.

**INVENTORS:** Your ideas and inventions (patented: unpatented) expertly searched, developed for commercial appeal and cash/royalty sales to manufacturers by professional Invention Developer with excellent record of experience. B. S. Industrial Engineering; United States Patent Office former Patent Examiner. United States Government former Patent Advisor. Second decade reliable service! Member: United States Council International Chamber Commerce. Free "Invention Record" and "Recommended Protection Procedure." Airmailed! Write: Raymond Lee, Invention Developer, 230P-Park Ave., New York, New York 10017.

**INVENTORS! EITHER I WILL SELL YOUR INVENTION BEFORE YOU** or anyone else does, or I will pay you a cash bonus. Get Free Invention Evaluation and information: write Gilbert Adams, Invention Broker, Dept. 15, 81 Wall St., New York, NY 10005.

**IMMEDIATE** Cash, for patent applications. Free patent searches. Write for details. Universal Patents, 184-D, Marion, Ohio.

**ANALYTICAL SERVICES**—Do you have a problem or an idea that needs engineering or scientific analysis? Let me help you. I've had 35 years experience as technical consultant to aerospace industry and the U. S. Gov't. If I can't help you I probably know someone who can. Free cost estimates. R. H. Olds, 19901 Merribrook Drive, Saratoga, Calif. 95070.

**FREE** Details "How to Safeguard, Develop and Market Your Invention." Write: World Wide Inventor's Service Co., 501A Fifth Ave., New York 10017.

**EUROPE/ASIA MARKET** for inventions booming, but metric descriptions required. New calculator converts U.S. lengths, distances, area, weights, liquids with slide-rule accuracy. \$3.00 postpaid. Guaranteed. Fischer/Robinson, Dept. PM45N-306, Box 711, Worthington, Ohio 43085.

## INVENTIONS WANTED

**INVENTORS**—If you have an invention for sale, patented or unpatented, write for free brochure outlining manufacturers requirements, royalty rates. Kessler Corporation, C-561W, Fremont, Ohio 43420.

**INVENTORS!** Protect your ideas! Free "Recommended Procedures." Washington Inventors Service, 422F Washington Building, District of Columbia 20005.

**FREE** "Directory of 500 Corporations Seeking new Products." For information regarding developments, sale, licensing of your patented/unpatented inventions. Write: Raymond Lee Organization, 230-N Park Avenue, New York, New York 10017.

**CASH**—Royalties for patented, unpatented inventions. Global Marketing Service, 2420-G 77th, Oakland, California 94605.

**WE** Either sell your invention or pay cash bonus. Write for details. Universal Inventions, 28-E, Marion, Ohio.

**INVENTORS!** Don't sell or license your invention until you receive our offer. Eagle Development Company, Dept. H, 83 Wall Street, New York City 10005.

**NEW PRODUCTS—INVENTIONS—IDEAS** Developed/Marketed by Professional Organization. **FREE INFORMATION** "How To Market Inventions To Industry". **LAWRENCE PESKA ASSOCIATES**, 500-C Fifth Avenue, New York City 10036.

**MR. INVENTOR:** Inventions urgently needed by manufacturers. Ideas developed. Guaranteed Patent Searches \$10. Immediate Patent Application Financing Plan if required. Charles S. Prince, Invention Consultant, 353-A West 57th Street, New York City, 10019.

### BUY IT WHOLESALE

**HEARING** Aids, batteries, Wholesale, Catalog 25¢. Fiston, Box 1444, New Preston, Conn. 06777.

**165 FREE** Wholesale Catalogs! Mailorder Dropshippers. Your Business Imprint. Automobile Discounts. Free "Digest." Vault International, Box 7284W, Lexington, Kentucky 40502.

**WORLD'S** Largest wholesale dropship sources. U.S., foreign. Factory suppliers dropship direct to you or customers. Now! have your own catalog for pennies. Free details. International Buyers, Box 16386-M, Portland, Oregon 97233.

**MERCHANTISE** Savings to 70%. Catalog \$2.00. Tietje, Box 30161, New Orleans La. 70190.

**BARGAIN DIRECTORY** Lists Close out Drop Ship sources many bargains \$1.00. Winchester Enterprises, 2807PM Hargrave Street, Philadelphia, Penna. 19136.

**SELL** Merchandise to Others, Catalog \$1.00. Edco Distributing, Box 49, Buffalo, New York 14224.

**FREE** Catalog. Gifts, Specialties, Toys, Below Wholesale. George, 5275 DeLongpre, Hollywood, California 90027.

### EXPORT-IMPORT

**JAPAN:** 1200 Products directory. Illustrated Manufacturers' names, addresses. \$5.00. Send cash. Yamagata Office, 814 Togin Bldg., Marunouchi, Tokyo.

**DIRECT** From Scandinavia: Grandfather's clocks, wrist watches, Pencils, Telephones, Playing cards, colour films, colour magazines, color slides, Catalog \$2.00. Write to: Ado-Mail, Gothersgade 97, DK 1123, Copenhagen, Denmark.

**MAILORDER**, Importing fantastic Directory \$2.00. Hettick, Lockbox 1495, Bismarck, North Dakota, 58501.

**SEVEN-IN-ONE** Money Making Directories For Importing, Drop-Shipping, And Domestic Mail Order Business. Only \$3.00 Money Back Guarantee. **ERLY T PRODUCTS**, Dept. 186, 3306 Heritage Lane, Corpus Christi, Texas 78415.

(Continued on next page)

## EXPORT—IMPORT

(Continued from preceding page)

**REVOLUTIONARY** Quality Pen Writes in Darkness. Batteries-Bulb-Boxed \$3.95. House of RussCar, 3908 West Franklin, Richmond, Virginia 23221.

**IMPORTING MADE EASY!** Our Dropship and Import Guide explains import inner workings in easy to follow language, reveals how to import in small lots. Furnishes valuable sources plus tips on where to buy, what to sell for sky-high profits. Profit margin can run up to 1000%! Send \$3.00 now to: **E. LOKER**, 50 Berkley Rd., Galt, Ontario N1S 3G6.

## FOR THE HOME

**RID** Your home of roaches. Effectively, easily. 2 packages, roach tabs, with directions \$1.00 postpaid. Theodore Gordon, Box 1223, New Haven, Conn. 06505.

**CARPET** Stained? Fantastic spot cleaner removes every stubborn stain. Moneyback guarantee! \$3.95. Tower, Dept. 6A, 1080 S. Cypress, La Habra, Cal. 90631.

## DEODORANT—COSMETICS

**AMAZING** New Apricot Hand and Body Lotion. A Delectable, Moisturizing Skin Lotion with the Scent of Orchard-fresh Apricots. Details Free. Weber Enterprises, 5300 Elvira, PM673, Woodland Hills, Calif. 91364.

## OF INTEREST TO WOMEN

**\$25.00 DAILY** Possible addressing-stuffing envelopes. Typewriter-longhand, also Clipping News items at home. Information: Send stamped addressed envelope. Ame-38, Box 310, Le Mars, Iowa

**1000% PROFIT** Bronzing Baby Shoes. Free literature. NBC, Box C-4PM-13, Coral Springs, Florida 33065.

**WANT** A new car, color TV, new clothes? Learn hundreds of ways to make money. 5 month subscription **FREE**. Write: Salesman's Opportunity Magazine, Dept. 17-F0, 1460 Hancock Center, Chicago 60611.

**\$6.00 DOZEN** Paid lacing baby boots! Cowboy, Warsaw 9, Indiana 46580.

**\$500 MONTHLY** Possible addressing-stuffing envelopes (longhand—typing) at home. \$500 monthly Clipping news items from your newspaper. Information: Send stamped self-addressed envelope. American, Excelsior Springs, Missouri 64024.

**NEW** magazine, foods, decorating, household tips, family living. Sample 25¢. Homemaker Magazine, 404 West Jefferson, Springfield, Illinois 62702.

**EARN UP TO \$150.00 WEEKLY** . . . Home addressing for us. Details 25¢. Smith's, Box 2469-PM, Newark, New Jersey 07114.

**BIG** Profits from Dolls! Start your own hobby-business dressing, making, repairing and selling dolls. Free information. Lifetime Career Schools, Dept. D-247, 2251 Barry Avenue, Los Angeles, California 90064.

**ADDRESSERS** And Mailers Needed. Details 10¢. Lindbloom, Dept. POM, 3636 Peterson, Chicago 60659.

**BINGO** Early! How to select cards with lucky numbers. Guidebook \$2.00. Gift House, Box 5007-P, Ft. Lauderdale, Florida 33310.

**LEARN** Expert Cake Decorating, Catering, Candymaking. Free details on home instruction. Candy & Cake, Dept. BPO, 1600 Cabrillo, Torrance, Calif. 90501.

**\$700 MONTHLY**. Immediate Income. Stuff Envelopes at Home. Information, send Self-Addressed Stamped Envelope. Cottage, Box 25053-CBF, Los Angeles, California 90025.

**SAVE HUNDREDS FURNISHING HOME** Specific Instructions. Guaranteed. Harmony House Report. \$3.98. Box 143, Newport, Penna. 17074.

**EARN** Extra \$50-\$100 Weekly Addressing. Details Free. P. Richardson, Box 4097, Yuma Ariz. 85364.

**ROACHES?** Instructions. \$2.00. ECO Products, 638 Hamlin Ave., Orange, Calif. 92667.

## GIFT SHOPPING

**HUMOROUS** Gift. Lifetime Treasure, "Diploma" from "The School of Hard Knocks." \$1.00. Art-O-Graphics, Box 36532, Houston, Texas 77036.

**FREE NEW COLOR** Gift Catalog. Free Bonus. Grzybowski, Box 3575, Daly City, Ca. 94015.

**AMAZING CATALOG** Beautiful Gifts. Earn Extra Money. Send \$1.25 Refundable. MVTP, Dept. C11-6, 215 Friendship, Salem, Oregon 97302.

**FREE** Gift Catalog—Useful Thoughtful Gifts. If Interested in Chess Please Request Supplement. Send Postcard To: Robert Olsen Associate, 67 Remsen Street, Brooklyn, New York 11201.

**BEAUTIFUL** Lodge Rings, Low Prices. Free Brochure. Clayton's, 1415 Jefferson Heights, Pittsburgh, Pennsylvania 15235.

**FREE** Attractive and Outstanding Catalog of Many Items. Beat The Christmas Rush. American Mos. P.O. Box 96, Malverne, New York 11565.

**FREE** Gift Catalog—Distinctive Gifts By Mail. Jo-Mar Galleries, 20 Sutin Place, Spring Valley, New York 10977.

**FREE** Catalog. Cottrell's Sales Company, 6253 South Michigan Avenue, Chicago, Illinois 60637.

**CLOSEOUT** Expensive Music Boxes \$10.95 Postpaid. Thomas Blair, Box 2, Westpoint, Tenn. 38486.

**GIFT** Shopping Made Easy. **FREE** Catalog. E.G. Skavlan, 3706 Penn No., Minneapolis, Minn. 55412.

**WOW!** 100 Stamps made from your favorite picture. Only \$3.00. Unlimited uses. Ames Gifts, 1357 Noble, Bronx 10472

## WATCHES, OLD GOLD, JEWELRY

**HIGHEST CASH** For Gold, Jewelry, Gold Teeth, Rings, Diamonds, Watches, Silver, Platinum. Mail Articles Today. Free gift with information. Chicago Gold & Precious Metals, 6 E. Monroe, Dept. 1058, Chicago, 60603.

**WATCH** And Clock repairing books. Free list. North American, Box 77-AF, Fox River Grove, Illinois 60021.

**CASH** Immediately for Old Gold, Jewelry, Gold Teeth, Watches, Diamonds, Spectacles, Silver, Platinum, Mercury. Free information. Rose Industries, 29-A East Madison, Chicago 60602.

**CAMEOS**. Beautiful Black Figure Set on Ivory Background. Pendant and Chain \$10.00. Koleka of Hawaii, 2326 Ahakapu, Pearl City, Hawaii, 96782.

**DIGITAL** Watches! New Look in Time! Swiss Movement. Accurate! Large Numerals! Brushed Gold Finished Case! Only \$22.95—Guaranteed! Order Today! Kona, 530 Concord Place, (186), Anaheim, California 92805.

**CLOCK**, Watch Repairing Tools, Parts Catalogue. \$1.00. G.M., 1521-A West Magnolia, Burbank, California 91506.

## HEARING AIDS

**HUGE SAVINGS**. Eliminate dealer mark-ups. Free Trial. Batteries Wholesale. Terms arranged. Lloyds-PMC, Rockford, Ill. 61108.

**HEARING** Aids, Batteries, Discount Prices. Write: Rhodes, Box 518 PM, Paducah, Ky. 42001.

**WHOLESALE** Discounters! Famous Aids! Batteries! Repairs! AidMart, Drawer Z-2, St. Petersburg, Florida 33731.



## SCIENCE AND CHEMISTRY

**AMAZING!** Scientific Catalog—Apparatus—Glassware—Chemicals. Catalog—50¢. Hagenow Laboratories, Manitowoc, Wisconsin 54220.

**CHEMISTRY** And Biology Catalog 35¢. Boulevard Laboratories, Suite 302, 3114 E. 83rd St., Chicago, Ill. 60617.

**COMPLETE** Laboratory Catalog 35¢. Laboratory Sales, Box 161-A, Brighton, Mass. 02135.

**CATALOGUE** Of those ver-ry hard-to-find chemical products, things that go boom, multi-stage rockets, 500 How-To books, 10,000 formulas of every conceivable mixture in science and industry. 50¢. Kenrus-C, Box 158M, Staten Island, New York 10309.

**DISCOUNTED!** Laboratory Chemicals, Glassware-Apparatus. Catalogue—50¢. Deluxe Scientific, Manitowoc, Wisconsin 54220.

## FORMULAS, PLANS, ETC.

**ANY** Formula \$5.00. Catalog—Manufacturing Treatise 25¢. Belfort, 192 N. Clark, Chicago 60601.

**STOP LOOSING YOUR HAIR**. Rescu-It Actually Stops Baldness Retards Hair Fallout. 8 oz Bottle Gives 30 Treatments. Only \$6.95 Postage Paid. **MUST STOP HAIR FALLOUT OR YOUR MONEY REFUNDED. FEDERAL DRUG ADMINISTRATION APPROVED.** House Of Excellence, 20 Lakeview Avenue, Lake Ronkonkoma, New York 11779.

## PLASTICS

**LARGEST** Handicrafts Supply Catalogue \$1.00 (Refundable). R.P.H. Manufacturing, 24-M-6, Winter, Stamford, Connecticut 06905.

**CASTOLITE** Pours Like Water, Hardens like Glass without heat. Crystal clear, colors. Embed natural flowers, seashells, mementoes, anything. Make fine gifts. Form flexible molds over any pattern, size. Reproduce your designs in plastics candlewax, metal, plaster, cement. Profitable. Illustrated Manual and Catalog Only \$1.00. **CASTOLITE**, Dept. 73G/PM, Woodstock, Ill. 60098.

**HUGE PROFITS**—Manufacturing Lucite Items. Experience Unnecessary—Free Details—Hallman, Box 5621, Sherman Oaks, Calif. 91413.

## TREASURE FINDERS

**SEARCH** Treasure Finders. Locate gold, silver, coins, relics. Operate underwater. Money back guarantee. Free information. Search Electronics, Box 8396-A, St. Petersburg, Florida 33738.

**FIND** Buried Gold, Silver, Jewelry, Coins, Relics, Magnetic Mineral Deposits with Ray Jefferson's Low Cost, Transistorized Metal/Mineral Detectors. 3 Exciting Models, all with Fatigue Free Arm Rest. Fun and Profitable. Write for Free Color Catalog. Ray Jefferson, Dept. MDPM Main and Cotton Streets, Philadelphia, Penna. 19127.

**TREASURE** Finder locates buried gold, silver, coins, treasures. 6 powerful models. \$19.95 up. Instant financing available. Write or call for free catalog. Phone (713)-682-2728 day or night. Dealer inquiries invited. Relco, Dept. A-40, Box 10839, Houston, Texas 77018.

**FREE** 156 Page Detector Catalog. General Electronic Detection Co., Box 67, Bellflower, California 90706.

**FIND** Buried treasure with revolutionary patented, analytical metal detector. Features push button and automatic tuning, negligible ground pickup, greatest range. Free catalogue. Gardiner Electronics, Dept. 9, 4729 N. 7th Avenue, Phoenix, Arizona 85013.

(Continued on next page)

## TREASURE FINDERS

(Continued from preceding page)

**DISCOVER AMERICA'S FASTEST GROWING HOBBY.** White's Electronics, Inc., would like to send you—absolutely FREE, their 42 page, fact-filled catalog on Mineral and Metal Locating Equipment. Amateurs or Professionals select from the world's largest line of metal detectors priced as low as \$79.50, up. Detect Gold, Silver, Copper—Nuggets, Coins, Jewelry, etc. Budget terms available. For your convenience we have three major factory locations in the U.S. and Canada, as well as over 1,000 authorized dealers to serve you. See your local Yellow Pages under "Metal Locating Equipment", or write: White's Electronics, Inc. Room No. 381, 1011 Pleasant Valley Road, Sweet Home, Oregon 97386—Elk-Air Industrial Park, Dexter Drive, East Elkhart, Indiana 46514—or White's Electronics Ltd., 33784 Hazel Street, Abbotsford, British Columbia, Canada.

**POWERFUL** Metrotech locator detect gold, silver, coins, relics. Moneyback guarantee, terms. Free information. Underground Explorations, Dept. A, Box 793, Menlo Park, California 94025.

**TREASURE SEEKERS:** Authentic Colorful 17 X 22 inch frameable treasure site maps. California Pacific or Gulf Caribbean Atlantic area. Send \$7.00 for both, \$4.00 each. Kwin-Lin Co., N-93 Fairview Ave., Paramus, New Jersey. 07652

**GOLDAK** Treasure locators—Pleasure and profit in a hobby you'll enjoy. Find coins, relics, gold, silver. Charge on Bank-Americard. **GOLDAK**, Dept. PM, 1101-A Air Way, Glendale, California 91201.

**TREASURE** Locators. Most complete line. Free information. **TESOROS**. Apartado 7-905, Mexico 7, Mexico.

**OIL-MINING** Newsletter. Sample \$1.00. World Resources, Box 283-PM, Birmingham, Michigan 48012.

**TIRED OF DIGGING UP TRASH?** The All New "Coinshooter" Rejects, Bottle Caps, Tin Foil, Nails and Shallow Trash. Detects Gold, Silver Coins and Jewelry. Free Literature. **D-TEX ELECTRONICS**, Box 451-U, Garland, Texas.

## PRECIOUS STONES & MINERALS

**500 POLISHED** Gemstones \$5.00. Tumblecraft, 5401 James North, Minneapolis, Minn. 55430.

**GET** Free catalog no serious rockhound, gem cutter, jewelry maker, hobbyist or craftsman can be without. Full of bargains, exclusive items, low prices from largest suppliers and authorities in the field. Free new catalog just off the press, yours for the asking. Write: Grieger's, Dept. C-12, 900 South Arroyo Pkwy., Pasadena, California 91105.

**ROCKHOUNDS!** Four Square Inches Lizard Stone, \$1.00. List 25¢. Hillard, Box 442 Frankfort, Kentucky 40601.

**GOLD** 10 Small nuggets panned from Oregon Streams \$1.00. Robert Brandt, Sweethome, Oregon 97386.

## CARTOONING, COMMERCIAL ARTS, SHOWCARD & SIGN PAINTING

**COMPACT** 23 lesson Cartoon Course and Cartoonist's Magazine. \$2.00. Hartman, Box 30367, Lincoln, Nebraska 68510.

**MODERN** Cartooning taught by mail. Write for free brochure. Cartoonrama—Box 263-7L, Branford, Conn. 06405.

**CARTOON** For Money!! Big Free Book: Success, Box 885-C, Dearborn, Mich. 48121.

**LEARN** Sign painting at home. Free Talent test. Ben Kerns, Box 812-PM, Greenville, S.C. 29601.

**FASCINATING** Systems. Sign Painting-Cartooning. Straley, 1704 South Center, Springfield, Ohio 45506.

**HOW TO MAKE MONEY WITH SIMPLE CARTOONS**—Informative book sent FREE tells way to big income. Cartoonists' Exchange, 96, Pleasant Hill, Ohio 45359.

**SIGN** Painting—\$1000 per Month Part-Time. Free Catalogue. Kaufmann Supply, Centertown, Missouri 65023.

**LEARN** Cartooning at Home. Approved for Veterans. Free Bulletin. Cartooning, Box 70690, Colorado Springs, Colorado 80933.

## ADVERTISING AGENCIES, ADV. SERVICES, MAILING LISTS

**500 NEW** Customers. Only \$5.00. Names, Box 9, West Union, Iowa 52175.

**FRESH** Lists. Cash Buyers. Free Details. Box 392PM, Brea, California 92621.

**ADVERTISING** Ratebook leading newspapers, magazines, 25¢. Chicago Advertising Agency, 28-E Jackson, Chicago 60604.

**MAILING** List, Most all Kinds, \$9.00 1000 Gummed, Circulars mailed \$5.00 1000. Dixmailers, King, North Carolina 27021.

## RUBBER STAMPS

**DELUXE** Address Stamp \$2.00. Metal Pocket Stamp \$3.00. **FAST, DEPENDABLE SERVICE**. Gagne, Box 46612G, Bedford, Ohio 44146.

**ADDRESS** Stamp \$2.00, Signature \$3.00. Pricelist 15¢. Friesen-Walker, Box 81-M, Nicoma Park, Oklahoma 73066.

**QUALITY** Rubber Stamps—3 Lines \$1.50. Kel, B-236, Rockaway, New Jersey 07866.

**FREE** stamp catalog. 45 type styles. Fast Service, low prices. Jackson's, Box 443A, Franklin Park, Ill. 60131.

**CUSTOM** Made Rubber Stamps. Immediate Shipment. Willis, Box 291, Aberdeen, Maryland 21001.

**FREE** Catalog, Pocket Stamp \$1.25, Self Inking Stamps, Seals, Rush Stamps, 132-P-Farmcrest, Rush, New York 14543.

**DELUXE** Rubber Stamps. Three Lines—\$1.00. **ALCO**, 2190-B Lantern, Lafayette Hill, Penna. 19444.

**ADDRESS** Stamp \$1.43, Signature Stamp \$2.95. Catalog. Carol's, McLoud, Oklahoma 74851.

**FREE** Catalog—Rubber Stamps, Business Cards, Labels, Printing. Youngers Stamp Shop, Princeton, Iowa 52768.

## OFFICE SUPPLIES

**MAILORDER RECORDS** Help get increased business! Complete 32 Page Record Book shows your inquiries, orders, advertising, expense, etc. Only \$1.00. **H. E. KÄPPEL, POPULAR MECHANICS, DEPT. R, 224 WEST 57TH STREET, NEW YORK, N. Y. 10019.**

**CUSTOM**—Engraved Nameplates. Signs. Lowest prices! Cencraft, 7548-R Kilgarry, Pico Rivera, Calif. 90660.

**MIMEOGRAPH** Machines. "Half Priced." Everett Enterprises, 39 Brentwood Road, Tewksbury, Massachusetts, 01876.

## PRINTING PRESSES, RUBBER STAMP OUTFITS

**SIMPLE-X RUBBER STAMP PRESSES.** Hydraulic operated, electrically heated. Sizes 5"x8", 8"x12", 10"x15". Starting outfits, Orders for presses, supplies shipped day received. Free catalog low supply prices. Send \$1.00 for postage and handling (refundable on first order). Custom Manufacturers, 406-P East Elm, Springfield, Missouri 65801.

**PRESS 'N' PRINT** Mimeograph Machines. Brand New, Complete With Supplies. Only \$34.95. Details 25¢. Devine, Box 56069, Chicago 60656.

**RUBBER** Stamp outfits, supplies. Kiewiet, 2025 Barney Road, Kalamazoo, Michigan 49007.

**PRINTING** Presses, type, supplies, Lists, 10¢. Turnbaugh Service, Mechanicsburg, Pennsylvania 17055.

**NEW** Catalog No. 13, 120 Pages, hand printing presses, type fonts, supplies. Send \$1.00 deductible first order. Acme Type, 732 Federal, Chicago, Illinois 60605.

**PRINTING MACHINES.** Offset, Mimeograph, Typewriters, Composing, Machines. Dixgraph, King, North Carolina 27021.

**SAME** Day shipment on rubber stamp supplies. Revised wholesale price list No. 9 free. Star Stamp Supply, 732 Federal, Chicago, Ill. 60605.

**RUBBER** Stamp manufacturers supplies. Presses, starting outfits. Best prices, service. Catalog. Jackson Supply, Box 443A, Franklin Park, Ill. 60131.

**LOW** Priced Rubber Stamp Manufacturing Supplies, Starting Outfits. Martin, 1432 Major, Jefferson City, Missouri 65101.

**MAKE** your own self-molding Rubber Stamps and Printing-Cuts. Plexirubber, Argyle A, Wisconsin.

## PRINTING AND SUPPLIES

**PRINTING** by Mail Supermarket. 1000 Copies \$5.95. 5000 Copies \$22.50. 100 Copies \$2.50. 1000 Envelopes \$7.50. 200 Letterheads and Envelopes, both \$5.50. 1000 Letterheads and Envelopes both \$13. Business forms, 10 pads, 100 sheets each, \$5.99. 1000 Adv. Flyers, Free layout, typesetting, color paper \$25. 3000 with one photo \$39.50. Min. order \$7.50, plus \$1.50 per M shipping. We ship in 9 hrs. Enclose 2 originals with remittance. Full Money-back Guarantee. Get Free Book, "Do you make these 18 mistakes when you buy printing." Speedy Offset Printers, 23852 Aurora, Bedford, Ohio 44146.

**BUSINESS**—Personal Printing, Labels, Cards, Economical. Samples. Burnfin, Weaubleau, Mo. 65774.

**QUICK** Copy Offset Printing. Free Introductory Offer, Nationwide Printing, 73 E. University, Champaign, Ill. 61820.

**FREE** Literature, Business Cards, Letterheads, Rubber Stamps, Business Labels, Name and Address Labels, Lifetime Social Security Plates, Medical Plates, Identification Tags. Geer's, 111 North Drive, Ottawa, Ohio 45875.

**BUSINESS CARDS** Raised Letters \$5.65 Thousand. Like Engraved. Free Samples. Kavanagh, Box 1222, Brooklyn, N.Y. 11202.

**FREE** Offset Catalog. Fast-Economical. Seaview, 212-26P 48th, Bayside, NY 11364.

**FREE** Literature: Business Cards, Rubber Stamps, Address Labels Printing Big Selection. Jordan's, 552 West O'Connor, Lima, Ohio 45801.

**BUSINESS** Cards and Stationery—State your Occupation—we'll send appropriate samples. A.E. Lutz Co., P.O. Box 156, Dewitt, New York 13214.

**DISTINCTIVE** Embossed Letterheads, Envelopes, Cards, Inexpensive. Postpaid. Universal, 226-J Myrtle, Scotch Plains, New Jersey 07076.

**QUALITY** Printing. Novelty and Imported Items. Catalog 25¢. John G. Robeson, Box 2316, Hyattsville, Maryland 20784.

**BUSINESS CARDS**, Raised letters Ideal for Home and Business \$5.25 per thousand. Send layout to: Eastern Graphics, Box 211, Rowayton, Conn. 06853.

**BUSINESS** Cards, Two Color!! Embossed, 1000 \$5.95 P.P. American, Rte. #3, Floyd, Va. 24091.

**1000 EMBOSSED** Business Cards \$5.25 Postpaid. Agents Wanted. Elco, 181-A, Sylvania, Ohio 43560.

**COLOURED** Business Cards, Original Samples. Colourcards, 1747 Selby, Saint Paul, Minnesota 55104.

**BUSINESS** Cards—Write For Very Low Prices. Business Card Specialists, G.P.O. Box 384, Flushing, N.Y. 11352. Dept. #5

**ECONOMICAL PRINTING.** 1000 Cards \$4.75. **UNIVERSAL**, 11828 Wright, Lynwood, California 90262.

(Continued on next page)

## PRINTING AND SUPPLIES

(Continued from preceding page)

**FREE** Samples Quality Personalized Memos! Novelties Brochures. 25¢ mailing. Ellenbogen Enterprises, 450 Seventh Avenue, New York 10001.

**2000 QUALITY** Business Cards \$12.00 Postpaid (No Cuts Or Logos). Send Copy. Connolly's, 4157 Perry, Denver, Colorado 80212.

**GOLD** Embossed Business Cards! Catalog. Graphics, 106J High, Westerly, Rhode Island 02891.

**BUSINESS** Cards, Labels, Printing. Graff, 3942 Lockport Road, Sanborn, New York 14132.

## MULTIGRAPH, MIMOGRAPH

**PROFITS FROM CLASSIFIED ADVERTISING!** Booklet shows you how to start your own business with Classified Advertising. Only \$1.00 (Refundable with first order.) **H. E. KAPPEL, POPULAR MECHANICS, DEPT. P, 224 WEST 57TH STREET, NEW YORK, N. Y. 10019.**

## GUMMED LABELS

**1,000 GUMMED** Address Labels \$1.00 Walt's, Box 966A, South Bend, Indiana 46624.

**1,000 GUMMED ADDRESS LABELS \$1.00 FREE CATALOG,** Acme, 1238 Voskamp, Pittsburgh, Pennsylvania 15122.

**SMILING "Happy Face"** Labels. Child's Name, Address ZIP. 500 \$1.50. Catalog 10¢. Lindburg, Box 1132, Florissant, Missouri 63031.

**500 GOLD** Address Labels. Distinctive. Plastic boxed. \$2.00. Free Gift. Catalog included. Sunshine House, Box 318A, Scituate, Massachusetts 02066.

**1,000 GUMMED ADDRESS LABELS, BOXED \$1.00. FREE CATALOG.** BELMONT, 4711C Linden, Lincoln, Nebr. 68516.

## REMAILING SERVICE

**REMAINS** \$2.00 Monthly. Businesses Welcome. Solann, Box 'L', Willingboro, New Jersey 08046.

**DEPENDABLE** Mail Service. Forwarding Remailing. \$3.00 Monthly. Remails 25¢ Each. Keats, Box 10162, Louisville, Ky. 40210.

**CONFIDENTIAL** Remails 25¢ Each. Receiving Forwarding \$3.00 Monthly. RMH, Enterprises, Box 169, Hainesport, New Jersey 08036.

**SECRET.** Receiving—forwarding. Discreet and confidential. Remail 25¢ single. Mail Forwarding Service, 8050 S. Main, Houston, Texas 77025.

**RECEIVING** — Forwarding — Remailing. Monthly Rates. Nortex, Drawer 5370, Ft. Worth, Texas. 76108.

**MIAMI** Remails 25¢—Monthly rates. Remails—view cards from 80 Foreign cities. Marie, Box 1266, Coral Gables, Florida 33134.

**YOUR** Mail Received—Forwarded. Hedgpath, 324-M South First, Alhambra, Calif. 91802.

**CONFIDENTIAL** New York Mail Address \$3.00 Month. Telephone Service \$5.00. Re-mails 25¢. Details Free. Birnhan, 152 West 42, New York 10036.

**CONFIDENTIAL.** Receiving Forwarding. Monthly Rates. Davis, Box 5012A, Reno, Nevada 89503.

**REMAILING** And mailing list monitoring. Write: **SPECTRUM, P.O. Box 3574, Charleston, S.C. 29407.**

**REMAINS** 25¢. Schneider Enterprises, POB 9369, Midtown Plaza, Rochester, N.Y. 14604.

**LOS ANGELES** Remails 25¢ Each, 5/1. Confidential. Dittofax, 5815 Compass, Los Angeles 90045.

**YOUR** Mail Received-Forwarded. Hillegas, Box 169-P, Hainesport, New Jersey 08036.

**SAN FRANCISCO** \$3.00 Monthly. 25¢ Each. Lee, Fox Plaza Box 2904, San Francisco. 94102.

**CANADA** Remails 35¢ Including Postage. Confidential, Box 5815, Station A, Toronto, Ontario.

**YOUR** Mail Received here. Forwarded there. Wright, B-2112 Asheville, N.C. 28802.

**REMAILING OUTSIDE U.S.A.** diplomatic immunity and discreet service from Toronto or Montreal \$1.00, from Europe \$3.00. Box 370, Toronto, Ontario M8Y 1R2.

**YOUR** Mail received and forwarded 25¢. Monthly rates \$3.00. Write: Puget Sound Remailing Service, Box 9068 South Tacoma Station, Tacoma, Washington 98409.

**NIAGARA FALLS** Remails 25¢. Post Cards 6/\$1.00. New Market, Box 2015, Niagara Falls, N.Y. 14301.

**CONFIDENTIAL** Receiving. Forwarding. Prices on Request. Byrd, Box 1568, Asheville, N. Car. 28802.

**FREE — MONTH'S — CONFIDENTIAL** Receiving-Forwarding World, Drawer 568A, Anaheim, California 92802.

**REMAILING—Receiving—20¢** Single \$2.50 Monthly. Wentz, Box 2439P, Newark, New Jersey 07114.

**INDY** Personal-Prompt-Reliable .25¢ ea., \$2.50 Per Month. Crossroads, P.O. Box 40043P, Indianapolis, Ind. 46260.

**KANSAS CITY** Remails, 25¢ Monthly Rates. Bell, Box 17095, Kansas City, Missouri 64132

## REPAIRS AND SERVICING

**PROFITS FROM CLASSIFIED ADVERTISING!** Booklet shows you how to start your own business with Classified Advertising. Only \$1.00 (Refundable with first order.) **H. E. KAPPEL, POPULAR MECHANICS, DEPT. P, 224 WEST 57TH STREET, NEW YORK, N. Y. 10019.**

**CLOTHING** Repair. Burns, Rips—Any Material Including Knits—**REWOVEN LIKE NEW** Prices Quoted. Mail To: Stadler Weavers, 310 E. Wisconsin, Milwaukee, Wisc. 53202.

## SPECIAL SERVICES

**INFORMATION** On anything. Ferguson Research Specialists, 72-25 Woodside, Woodside, New York 11377.

**KEEP** Your copies of PM—and watch for the inexpensive Annual Index, available in January 1972. It will enable you to locate any article which appeared in 1971 or find information on any particular subject in just a few seconds. The Annual Index will make your copies of PM even more valuable! Price \$1.49. Send checks to: Popular Mechanics, Dept. HE, 224 W. 57th St., New York, N. Y. 10019.

## TOBACCO

**CUT** Cigarette costs in half with our custom-blended tobacco and rollers: filter or plain. Free sample: Green River Tobacco, Box 954, Owensboro, Ky. 42301.

**PIPE SMOKING PLEASURE,** only as satisfying as the tobacco you put in it. Write for factory-fresh samples. Green River Tobacco, Box 991 Owensboro, Ky. 42301.

**BRIAR** Blocks for Smoking Pipes. Pimco, Box 59211, Chicago, Illinois 60659.

## BETTER HEALTH

**ARTHRITIS**—Immense relief, low-cost highly effective remedy. Information free. Health Island, Box 325, Scottsville, Texas 75688.

**HEART FLUTTERS?—RENOWN DOCTOR'S** Breathing therapy brings instant help. You've got only one heart—please cuddle it. Complete booklet mailed immediately. Send \$2.00 Today. Health Spots, 141 Locust St., PM6, Holyoke, Mass. 01040.

**HEMORRHOIDS** Can Be Cured. Details Free. Young, P.O. Box 9542-A, Seattle, Wash. 98109.

**ARTHRITIS, Rheumatism And Gout Sufferers!** Ease Your Discomfort Through Proper Diet, Exercise And Mechanical Means. \$1.75 Brings The Arthritis Handbook, Written And Recommended By Doctors. Californians Add Sales Tax. Mari Mountgarden, Room 18-G, 320 Elwood Avenue, Oakland, California 94610.

## PERSONAL

**DON'T DIE WITHOUT A Will!** Four Blank Will Forms and Instruction Booklet. Only \$2.00. Jamann, P.O. Box 1905, Laurinburg, N.C. 28352.

**BE** An Ordained Minister for Christ! Write: PO Box 4437, Charlotte, N Car. 28204.

**WIPE** Out Debts. Get \$600 to \$25,000 relief. Easy Loans. Free details. Counselor-7, Kerrville, Texas 78028.

**HOW** To develop a Better Speaking Voice. Lead the Conversation-124 Page Book tells How. Only \$2.00. International Mail Order, P.O. Box 157, Waipahu, Hawaii 96797.

**BORROW** By Mail! Up to \$1500.00. Convenient terms. State Licensed. Postal Finance, Dept. 17-E, 6018 Military Ave., Omaha, Nebraska 68104.

**INSTANT DEBT RELIEF** Without borrowing. Without Bankruptcy. Have excellent credit in 45 days. Free!!! Wealth Building, Box B-6, 1996 Hoyt Street, Lakewood, Colorado 80215.

**LOSING HAIR? BALDING? DANDRUFF?** Free copyrighted booklet. Dr. Shiffer Laboratories, Dept. 536, Box 398, Punta Gorda, Florida, 33950.

**PSORIASIS** Sufferers: Discouraged? Write for Free important Information that is helping thousands! Pixacol, Box 38-PM, Avon Lake, Ohio 44012.

**BIBLE** Questions answered. Stamped envelope. Bylon. 17167 Bentler, Detroit, Michigan 48219.

**INVESTIGATORS.** Latest electronic Aids. Free Literature. Clifton, 11500-P NW 7th Ave., Miami, Florida 33168.

**TELL** Fortunes accurately—Immediately! ESP Aids, Box 21-PM, Olympia, Washington, 98507.

**"RULE** Others With Thoughts." (Telepathy). Write: Clarion, Box 1769-A7, Chicago 60690.

**TATTOO** Removing—Chemical Do-it-Yourself Method—Free Details: Atlanta, 907P Beachpoint, Pickering, Ontario. L1W 2A4

**EARN INTEREST ON YOUR BILLS!** Fatten your savings account! New book shows how. Free details. Bestway—A432, Box 344, Stone Mountain, Georgia 30083.

**NEED** Money—Debts Too Big? **Quick** Cash. Secret Emergency Loans. Free Consolidation Plan Application. Interstate, 28 E. Jackson, Suite 1204-X3, Chicago 60604.

**RECORD** Telephone Conversation automatically. Leaver Recorder Unattended. Robert's, Box 49PM6, Parkridge, Illinois, 60068.

**RECEIVE** Phony State Chartered University Degrees immediately. Box 11516. Tucson, Arizona 85706.

**SEE THRU WALLS!** New secret two-way super spy device lets you actually see thru walls. Guaranteed. Only \$2. World-6C20, 3047 University, San Diego, Cal. 92104.

**PSORIASIS**—At Last. Information Guaranteed to Help, or Eliminate. Wayne Research, Box 5753P, Detroit, Michigan 48239.

**HAIR** Problems Analyzed Professionally. Lock of Hair and \$2.00: Harvey's Hair, 991 Lexington Avenue, New York 10021.

**SECRET LOANS BY MAIL** Borrow \$100 to \$3000 for any good reason in absolute privacy. No interviews, no endorsers, no co-signers. Fast service. Write: Dial Finance Co., Dept. 3466, 405 S. 16th Street, Omaha, Nebraska 68102.

(Continued on next page)

## PERSONAL

(Continued from preceding page)

**GUIDE TO HAPPINESS** This Book Shows the Way To Better, Happier Days. \$2.25 Postpaid. Maurer Enterprise, 533 Greystone, Canon City, Colo. 81212.

**FREE**, 10,000 valuable items and services. List 25¢. Warren, Route 1, Box 521, Ruston, Louisiana 71270.

**BLANK Forms**. Will, Birth, High-School. Each \$2.00; set \$4.00. Guaranteed. Dee, 4013C Guadalupe, Austin, Texas 78751.

**PLAY CHESS BY MAIL** For an international list, send player status and \$2.00 to: Box 370, Toronto, Ontario M8Y 1R2.

**CASH LOANS** by mail! Up to \$2,500 on signature alone. No collateral! Secret! Union Finance Company, 3608 No. 16th St., Dept. PM, Phoenix, Ariz. 85011.

**DISTINCTIVE** Engraved golden metal social security card. \$2.00—Guaranteed—Free case—Sunshine, 2228 Saul, Jacksonville, Florida 32216.

**GINSENG**. Legendary body, mind rejuvenator. Sample and Catalog \$1.00. Herbal Holding, 5854, Cal. 91413.

**UNBREAKABLE COMBS**, Family Variety (12) Packet. Only \$1.00. "Airway", P.O. Box 1080, Cedar City, Utah 84720.

**UNIVERSITY** Degrees (Phony) Shipped Immediately. Authentic Seal. State-2U, Box 5373, Station-F, Ottawa, Canada.

**REACH** Your Subconscious Mind! Find New Power For Success! Dynamic Thinking #WB-113 Tells How. Send \$1.00. RYA, 5391 Balboa, San Diego, California 92117.

**PROTECT YOUR VALUABLES**. Records Make The Difference In Fire Or Theft Losses. Send For Complete Inventory Record Book With Tips And Instructions. \$2.00. Gentony's, Box 52427, Houston, Texas 77052.

**SMALL** Business Loans. Quick Cash application. Write Financial, 28 E. Jackson, Suite 1204-X14, Chicago 60604.

## WANTED-MISCELLANEOUS

**MERCURY**. Gold, Silver, Platinum; Ores assayed. Wholesale Terminal, Norwood, Mass. 02062.

## WINEMAKING & OTHER RECIPES

**WINES** Amazing simple way to make Wine using our recipes and standard kitchen equipment. Guaranteed delicious. Instruction book \$2.00. Expert, P.O. Box 189, Reading, Mass. 01867.

**WINEMAKERS**. Free illustrated catalog of yeasts, equipment, Semplex, Box 12276R, Minneapolis, Minn. 55412.

**WINEMAKERS** . . . Free Illustrated Supply Catalog of Yeast, Equipment, Recipes. Continental, Box 18223-PM, Indianapolis, Ind. 46218.

**WINEMAKERS** Yeast, Recipes & Catalog 25¢. Kraus, Box 451-L, Nevada, Missouri 64772.

**WINEMAKER'S** Supply Catalog—Free. Bacchanalia, 273 Riverside Ave., Westport, Conn. 06880.

**WINEMAKERS**: Free informative catalog, recipes. Arbolyn, Box 663, West Columbia, S.C. 29169.

**WINEMAKING** Kit—\$4.98 Free Catalog and Recipes. JIMDANDY, Box 30230M, Cincinnati, Ohio 45230.

**HOMEWINE MAKING SEND** For FREE Informative CATALOG OF RECIPES, EQUIPMENT, and INGREDIENTS. Brewer's Yeast Dry Malt, Crystal Malt, Bottle Caps, Barrels, Chemicals, Concentrates, Over 250 Items. Winemaking Is A Fascinating Hobby. Write To: Danenberger's, Box 276-M, New Berlin, Ill. 62670.

**WINEMAKER'S!** Free Illustrated Catalogue of Quality Products. Brant's Wine Rack, Box 3256-M, Orange, California 92665.

**WINE CELLAR**—New low cost interlocking units in traditional design, unlimited capacity. Start with 7 bottle rack \$4.98, postpaid. Free picture brochure, Wine-maker's Catalog. ADDARACK, Box 30230M, Cincinnati, Ohio 45230.

**WINEMAKERS**. Make Delicious Wines—Champagne. Illustrated Instructions \$2.00. Enielas, Box 15894, Salt Lake City, Utah 84115.

**WINEMAKERS**—Imported 5 gallon Barley Wine Kits complete with reusable equipment—\$6.95 + \$.50 post; Renaissance Vintners, Box 3476, Santa Monica, Cal. 90403.

**CHAMPAGNE AND WINE LOVERS**. Newest Booklet On How To Make Champagne And Wine In Home Easy Step By Step Method. Send \$3.95. F & M Associates, Box 2136, Ogden, Utah 84404.

**HOME** Winemaking is rewarding—Free catalog. The Wine Shop, 426 Penn Ave., West Reading, Pa. 19602.

## MISCELLANEOUS

**DON'T DIE** Without A Will! Blank Will form protects your family Only \$2.00. Guaranteed! Order Today. R. L. Richardson, 11600 Constitution-NE, Albuquerque, New Mexico 87112.

**AUTHENTIC COMMISSION** (15x20) Your name enrolled as Staff Captain on Sailing Ship **TYPHOON** plus Autographed copy "TYPHOON TRILOGY", thrilling account of voyages and refurbishment. Both for \$4.95 postpaid. Captain Harmon, Dock 8, Palm Bay, Florida 32905.

**TICKETS, CHANCE BOOKS** Printed to Order—Free Catalog—Force Printing Company, 10 E. Maple Avenue, Penns Grove, New Jersey 08069.

**RECEIVE** Mail Galore!!!!!! Your Name on our national mailing lists!!!! \$1.00. Mailing Associates, Dept. C-1, Box 1003, Lancaster, Penna. 17604.

**BOOKS** On antiques and their prices. Free circular!! P. Warman Publishers, Uniontown, Penna. 15401.

**SUFFERING** From Arthritis? Try Ginseng: Information Free. Write: Ginseng, Asheville 53, North Carolina.

**ORNAMENTAL** Iron designs. Book of 1600 beautiful, practical designs for railings, columns, etc. Free literature. Cunningham, 3881 South 3200 West, Salt Lake City, Utah 84119.

**PRE-PACKAGED** Toys complete with free self-selling display rack. Free Details. Toys, 1916 Fifth, Sacramento, California 95814.

**BIRTH** Certificates, Marriage Certificates. Diplomas! 2 blank forms \$1.00. Sample 10¢. Standard Forms, Box 482-M, Washington, D.C. 20044.

**SLEEPATRON**. New device for inducing sleep. Gardiner Electronics, Dept. C, 4729 North 7th Avenue, Phoenix, Arizona 85013.

**HEARING** Aid batteries wholesale. Free list. Habs, Box 51, York, Penna. 17405.

**HOME** Water Distillers. Portable Appliances. Purest Water, Pennies Per Gallon. Remove All Impurities, Bad Tastes. Free Details. United Vito—Way, Box 2216-PM, Everett, Washington 98203.

**DIGITAL** Watch. Newest look in time. Mens or Womens. One year written guarantee. Lifetime mainspring. Gold finished case. Exact hour and minute indicated by easily read numerals. \$19.95. Rojod Sales, Box 636, Santee, Calif. 92071 CB6.

**1400 CATALOGS** Listed and Described! Sources for EVERYTHING Imaginable! Rush \$2.00. MASTERLOG, Box 24413-(UF), Oakland, California 94623.

**CARRYING** Cases made to order. Salesman, Mechanic, etc. Free literature. Harp Enterprises, 2263 84th Street, Dept. AA63, Brooklyn, 11214.

**MAGNETIC** Signs—Low Prices. Free estimates and setup suggestions. Magna, Box 1033BX2, St. Charles, Mo. 63301.

**INSTANT** Replacement High School Diploma blanks. Fill in information. Get wise. Don't lose best jobs. \$2.00. Guaranteed. Birth Certificate blank free. Hurry. Order yours today. GMI, Box 441 (2-2), Somerset, Kentucky 42501

**IDENTIFICATION** cards, **ELECTRONIC** surveillance equipment, etc. Como-PM, Box 758, Palatine, Illinois 60067.

**RECEIVE** Two big illustrated catalogs of personalized gifts, novelties, and jokes! Just send 25¢ in stamps or coin. Cougar Q Sales, 5822 Brookside Drive, Cleveland, Ohio 44144.

**BEAUTIFUL** Lifetime Birth and Wedding Trophies. Free information. Byrne Sales, 5445 W. 64 Street, Chicago, Ill. 60638. Dept. P11.

**TELEPHONE PICK-UP** Suction Cup Attaches Phone. No Wiring. Miniature Plug. Guaranteed \$3.95 Postpaid. B-H Sales, Route 3, Searcy, Ark. 72143.

**PHOTOSTAMPS** Postage Stamp Size, Gummed Back. Your Photo Reproduced Perfectly. 100 Only \$2.00. Free Sample Details. PostBox Sales, Box 143, Braintree, Mass. 02184.

**WIN AT POKER**, Know What Wins. Learn The Odds To Winning Hands. Rush \$1.00. Mail Shopper, Box 112PM, Valley Stream, New York 11582.

**DIPLOMAS!!!** Certificates! For Sale. Catalogue 25¢. Filiforms, Box 1808-BP, Albany, New York 12201.

**PLAY CHESS BY MAIL!** Write: AlphaScan Incorporated, Dept. PM, Post Office Box 2198, Hartford, Conn. 06101.

**ORNAMENTAL** Windmills For Your Yard. Price List And Brochure 25¢ Refundable. MACKS, Box 500, Elburn, Ill. 60119.

**BARGAINS!** Powerful **BINOCULARS!** \$4.98. IQ Tests! Self-Scoring! \$2.00! Pocket Tamper Proof Checkwriter! \$5.95! Kenlee, 466 River Road, Bogota, N.J. 07603.

**SPORTS ANALYSIS** Baseball, Football, Horse Racing, Further Information \$1.00. Analysis, 26151 Lake Shore #1124, Cleveland, Ohio 44132.

**TV PICTURE TUBES** manufactory direct, easy installation. Write: Ehes Co., 405 E. Jefferson, Cheyenne, Wyo. 82001.

## BURGLAR ALARMS & HOME PROTECTION

**LOCKSMITHING** Supplies—Buyers Guide \$1.00. Despubs, Box 22005H, Phoenix, Arizona 85028.

**FREE** Catalog on Burglar-fire Alarm Equipment, Protecto Alarm Sales, Box 357-D, Birch Run, Michigan 48415.

**BURGLAR & FIRE ALARM SUPPLIES AND SYSTEMS**. Send \$1.00 for catalog. J & J Alarm Systems, 51 Pythian Ave., Torrington, Conn. 06790.

**BURGLAR & Fire Alarm Equipment**. Low Prices. Hundreds Of Items. 1973 Catalog. Over 60 Pages. Just \$1.00 (Refundable on first order). K-TRONICS INDUSTRIES, Box 391, Dept. PM, Fairfield, Conn. 06430.

**INSTALL**. Repair. Buy. Sell Alarms Profitably. New Book Explains. \$4.95. Harvey Electronics, Box 3846, Wilmington, Delaware 19807.

**"HOW TO INSTALL PROTECTIVE ALARM DEVICES"**—By Donald Brann . . . \$4.50 Reveals Professional Secrets . . . Over 150 Illustrations . . . FREE Catalog . . . Alarm Supply, 7294 C Glenview, Fort Worth, Texas 76118.

**QUALITY** Auto Burglar Alarm \$4.98. Slezak. Six Strathmore, Brookline, Mass. 02146.

'73 Ford pickups  
start the better  
ideas coming  
all over again!

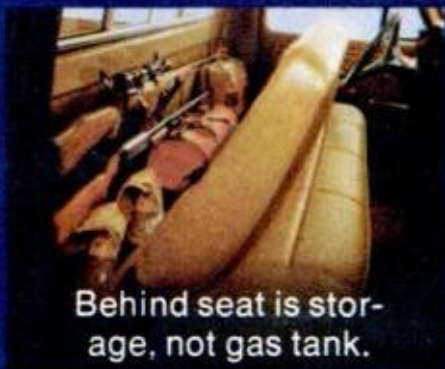

Behind seat is stor-  
age, not gas tank.



Ford box cover fits  
right, looks right.



Full-foam seat 5 in.  
deep is standard.



Optional "air" is all  
neatly built in.



Box sides are full  
depth double-wall.

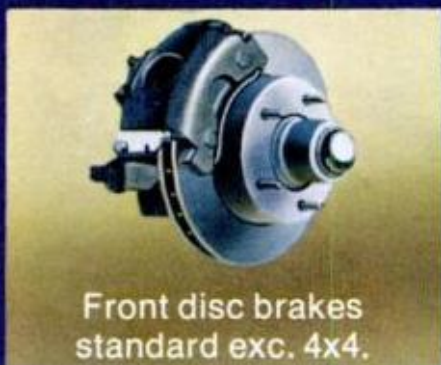

Front disc brakes  
standard exc. 4x4.



Roomiest Ford ever  
—quiet, comfortable.



Twin-I-Beam, start  
of Ford's great ride.



A better idea for safety:  
Buckle up.

FORD PICKUPS

FORD DIVISION 

Works like a truck / rides like a car.

# Salem refreshes naturally!



**Natural Menthol Blend**  
(means naturally fresh taste)



© 1973 R. J. REYNOLDS TOBACCO CO.

Warning: The Surgeon General Has Determined That Cigarette Smoking Is Dangerous to Your Health.

KING, SUPER KING: 20 mg. "tar", 1.4 mg. nicotine, av. per cigarette. FTC Report AUG. '72.

\* Не курить, если вы беременны или кормите грудью.