

# Popular Mechanics

In this issue—PM's best ever

## 40-PAGE HOME IDEAS GUIDE

full of the know-how you need to: Facelift your home

• Come up with a really different family room

• Make your own light fixtures • Install a prefab bath

• Get a new entry • Discover new products that

will give you ideas, ideas, ideas... Begins on page 137



## WHIRLYBIRDING:

A whole new idea in radio-controlled model flying

Page 69

## CLIP & SAVE KNOW-HOW:

- How to paint a room • How to install insulation
- How to add a garage-door opener
- How to put up ceiling beams • How to hang a door





## The motor that makes it here can make it anywhere.

This is Toledo Bend — 80 miles of bass woods and water on the Texas-Louisiana border.

With trees above water, jungle underneath, and stumps in-between—it's no place for weak-sister motors or tackle.

Evinrude's tough new bass boat motors take it in stride.

On the long runs, their high speed efficiency cuts miles and gallons down to size. Firepower electronic ignition keeps things smooth from top speed to trolling. Tough new motor mountings add strength where



For free catalog — write Evinrude Motors  
4292 N. 27th St., Milwaukee, Wis. 53216

you need it most. While balanced trim-tab steering and power shift keeps everything under finger-tip control.

Evinrude power covers the range of high-performance fishing. From the loop-charged 50 hp Lark shown here, to the high performance tournament class 135 hp V-4.

The tougher the going, the more Evinrude has going for you.

**EVINRUDE**   
DIVISION OF OUTBOARD MARINE CORP.  
*first in outboards*



**We dare to match  
shaves with a blade.**

**Any blade.**

The idea of the Norelco VIP™ Tripleheader is to give you a closer, more comfortable shave than any blade ever made.

That's why... we built the VIP, not with just one blade, but with 18 self-sharpening rotary blades, inside 3 super-thin floating heads that hug every curve of your face.

That's why... we built the VIP with adjustability—9 closeness-comfort settings so that you can now shave as close as you like.

In fact, the VIP can actually shave you *below skin level*. Comfortably.

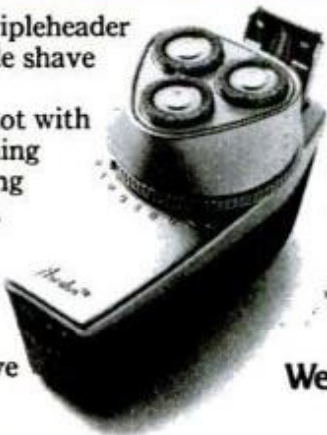

That's why... we built the VIP with a special pop-up trimmer, so you can keep your sideburns just the way you like them.

And that's why... the Norelco VIP Tripleheader dares to match shaves with a blade. Any blade.

*Available in cord or rechargeable models.*

**The Norelco VIP**  
We dare to match shaves with a blade.

© 1973 North American Philips Corporation, 100 East 42nd Street, New York, N.Y. 10017.

# The '73 Jeep Wagoneer. A beautiful way to act tough.



**Now it comes with more luxurious interiors...and more rugged components.**

Follow your whims, instead of a road map. Jeep 4-wheel drive will carry you into woods, through mud, over rocks, and deep into the back country, where your boat doesn't have to join a fleet.

The Jeep Wagoneer has always been big on power, big on ground clearance, big on comfort. But now this best-selling 4-wheel drive family wagon is better than ever. With new drive train components that are even more durable. Upgraded tires that have even more traction.

And interiors that are even more stylish. There's a fully-padded, new instrument panel. Newly-designed gauges. New door armrests, both front and rear. And it comes with just about every option, from air conditioning to snowplows. The Jeep Wagoneer will get you where you want to go—and do it in comfort. That's the beauty of it. *Buckle up for safety.*

**Toughest 4-letter word on wheels.**

**Jeep**

Buckle up for safety...drive your Jeep vehicle with care and keep America the Beautiful.

There are times when you just can't smoke. And that's when you should do what six million other Americans do.

Take a pinch of "smokeless tobacco." Place it between cheek and gum and let it rest there. You'll get full tobacco pleasure.

It's easy to see why cowboys are into "smokeless tobacco." And scientists and lab technicians are using it, too. And thousands of others who work with their hands. In places where smoking is out.

Even lawyers and judges are taking it into their courtrooms.

Students and teachers enjoy it in their classrooms.

Three great brands of "smokeless tobacco" are taking hold all over the country.

There's Copenhagen, which has the rich flavor of pure tobacco.

Skoal, laced with winter-green. And Happy Days Mint.

They all give you tobacco satisfaction without having to light up.



**Smokeless Tobacco.  
A pinch is all it takes.**

# There are times when a guy just can't smoke.

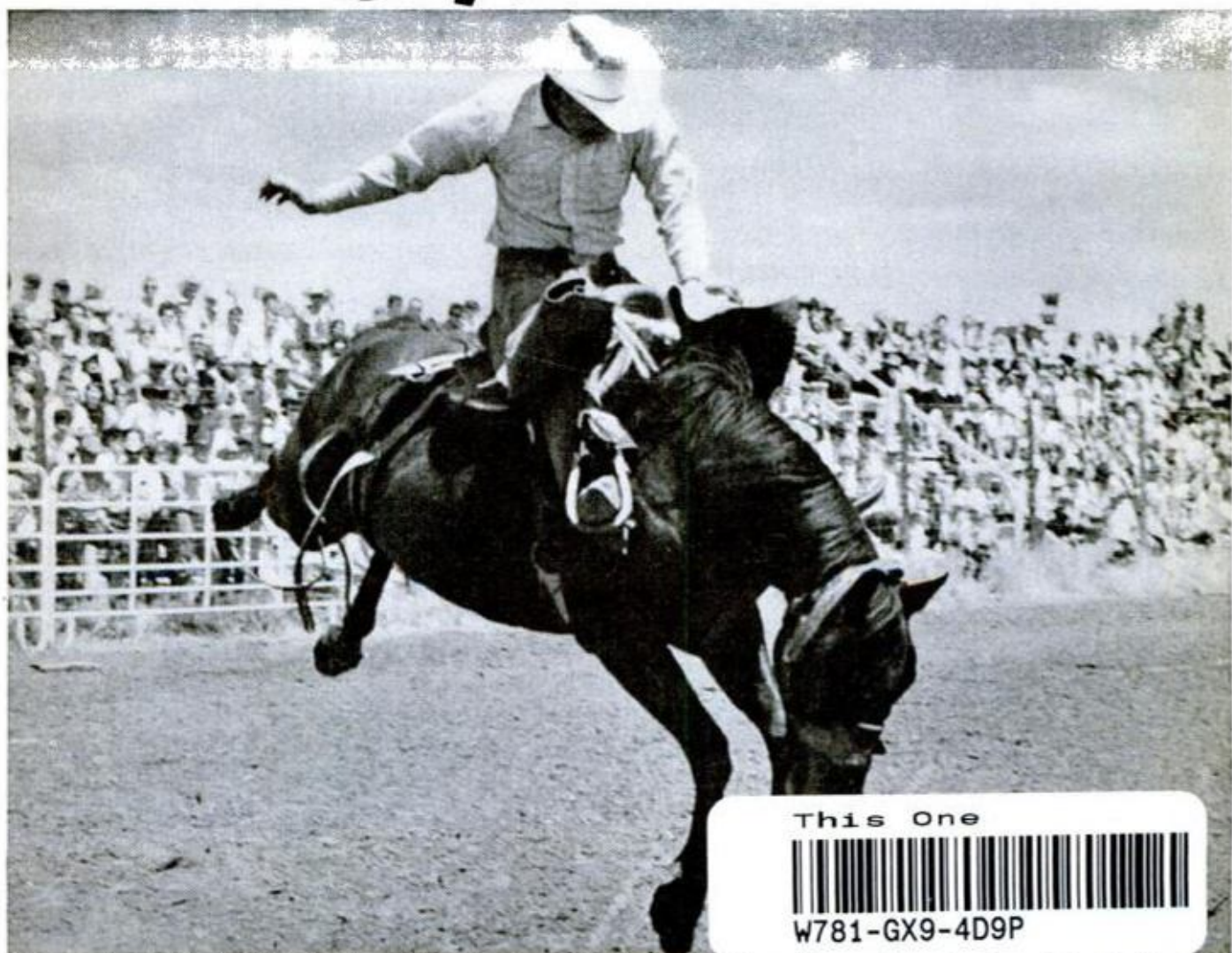

This One



W781-GX9-4D9P

For a free booklet that explains how to get the full enjoyment of "smokeless tobacco"— as well as a few free pinches that you can try for yourself— write to "Smokeless Tobacco," United States Tobacco Company, Dept. P-33, Greenwich, Connecticut 06830.

## HOW TO . . .

Pick a movie camera  
under \$100 . . . 106



Make a smart sofa  
from a flush door . . . 126



Make a handy stand  
for your sander . . . 128



Build a big trailer  
for your pickup . . . 102



## AUTOMOBILES, DRIVING

- [34 Detroit Listening Post](#)
- [62F Imports and Motorsports](#)
- [74 PM Owners Report: Oldsmobile Omega](#)
- [102 Big trailer for small trucks](#)
- [112 PM Owners Report: Full-size Fords](#)
- [116 Saturday Mechanic: Get a professional brake job at a do-it-yourself price](#)

## SHOP AND CRAFTS

- [120 Hints from readers](#)
- [122 Low-cost soil-conditioning tumbler you can make](#)
- [125 Hints from readers](#)
- [126 From flush door to sofa—in a weekend](#)
- [128 Mount your sander in this handy stand](#)
- [132 Colorful clock kit lets you see what makes it tick](#)
- [133 Hints from readers](#)
- [207 Plug-in lunch box](#)

## ELECTRONICS

- [69 What it takes to build and fly an RC model copter](#)
- [80 Recorders by the pocketful](#)

## EVERY MONTH

- [8 Letters](#)
- [22 Automobile Clinic](#)
- [30 All Outdoors](#)
- [40 The Bicycle Shop](#)
- [50 Appliance Clinic](#)
- [58 Science Worldwide](#)
- [66 Homeowners Clinic](#)
- [84 It's New NOW: The latest products and developments \(A 12-page roundup\)](#)

ON THE COVER: Whirlybirding—A whole new idea in RC model flying  
*Photo by Joe Fletcher*

**WORTH WRITING FOR: SEE PAGE 204**

AS A SERVICE TO READERS, Popular Mechanics publishes newsworthy products, techniques and scientific and technological developments. Because of possible variance in the quality and condition of materials and workmanship, Popular Mechanics cannot assume responsibility for proper application of techniques or proper and safe functioning of manufactured products or reader-built projects that result from plans published in this magazine.

## HOME IDEAS GUIDE

(A 40-page special starting on page 137)

- [141 Basement rec rooms with a family-room look](#)
- [144 Prefab baths: easy to install and clean](#)
- [146 Pretty, exciting wall coverings](#)
- [148 How to make a good entry](#)
- [160 Simple lights you can make to brighten your kitchen](#)
- [162 Facelifting—the cheapest way to get a 'new' house](#)
- [166 Wind-powered ventilators](#)
- [168 Trowel-on 'brick' looks like the real thing](#)
- [170 Low-cost garage-door opener anyone can install](#)
- [174 How to hang a door](#)
- [178 How to install insulation](#)
- [186 Right way to paint a room](#)
- [190 New compact heating/cooling system stands outdoors](#)
- [195 How to install plastic beams](#)
- [201 New products for the home](#)

## AVIATION

- [69 What it takes to build and fly an RC model copter](#)
- [78 Homebuilt aircraft: Flyweight flying boat](#)

## PHOTOGRAPHY

- [62D Photo hints](#)
- [106 Movie cameras: What do you get for under \\$100?](#)

## BOATING, OUTDOORS

- [96 Tow rig for snorkelers](#)
- [100 Underwater update](#)
- [102 Big trailer for small trucks](#)

**This car just  
ran 300 miles at  
Talladega  
without a gasket  
or a lockwasher...**



**What did it prove?  
At 163.098 mph, Lock-Nut works.**

Bobby Allison likes his cars to hold together. That's why there's Permatex Lock-Nut. Lock-Nut makes any threaded fastening absolutely vibration proof. Not maybe, like a lock washer, But absolutely, like nothing else. Yet, when it's time to disassemble, you can take it apart with normal tools.

Bobby knows what Lock-Nut can do. He built this race-legal 1968 Chevelle Late Model Sportsman. The 350-inch engine was assembled entirely with Permatex products. And it ran just fine, thank you. His NASCAR certified average for the three hundred miles, with normal pit stops, was 157.094.

Pretty good for the small block Chevy.

There's a lot more to this car than Lock-Nut. We'll be telling you and showing you as the car makes special appearances in your city.

In the meantime, remember this. If Lock-Nut works for Bobby Allison at racing speeds on the Talladega banking, imagine what it can do for you and yours on your friendly, neighborhood interstate, or even the road to the supermarket.

Want a free Permatex racing decal like Bobby's? Just send us a stamped self-addressed envelope. We'll take it from there.



PERMATEX COMPANY INC., P.O. Box 1350, West Palm Beach, Fla. 33402 305/686-0880

# MEET ARIENS 7 MEMBER ENVIRONMENTAL TRAC-TEAM

7 HP  
power  
source

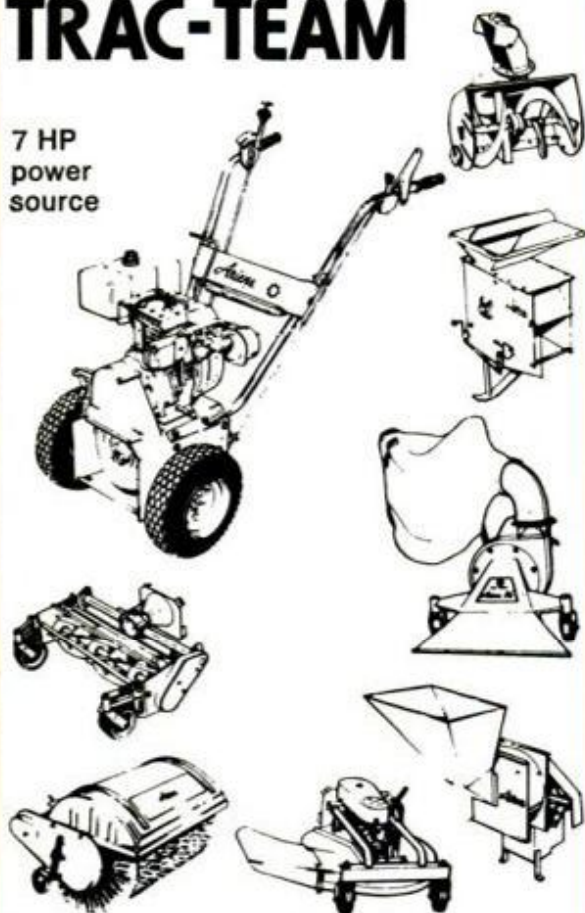

The Ariens Environmental Trac-Team is a single 5 HP or 7 HP power source to which attachments can be added. Seven attachments, namely, a 26" Rotary Mower, 30" Reel Mower, 24" Sno-Thro, 30" Lawn Vacuum, 36" Brush-Sweeper, Shredder-Bagger and a Shredder-Grinder can be added to the 7 HP tractor. A 30" Reel Mower, 20" Sno-Thro and a Shredder-Bagger can be added to the 5 HP tractor.

The Ariens, Four-Season, Environmental Trac-Team offers the ecology minded person an opportunity to start building a year 'round GARD-N-YARD® working team. Write for complete line catalog today.

Ariens Company, 806 West Ryan  
Brillion, Wisconsin, 54110  
Phone 1 (414) 756-2141



Applies to mowers only

A CUT ABOVE THE REST!

# Ariens

**JIM LISTON**

Editor

**SHELDON M. GALLAGER** **JOHN A. LINKLETTER**

Executive Editor      Managing Editor

**WAYNE C. LECKEY**

Home and Shop Editor

**ALVIN KIETZ**

Art Director

Published by The Hearst Corporation

**RICHARD E. BERLIN, PRESIDENT**

**RICHARD E. DEEMS**

President, Magazines Division

**JOSEPH F. KERN**

Publisher

**BILL HARTFORD** \_\_\_\_\_ Automotive  
**JOHN F. PEARSON** \_\_\_\_\_ Science and Engineering  
**WM. T. McKEOWN** \_\_\_\_\_ Boating and Outdoors  
**IVAN BERGER** \_\_\_\_\_ Electronics and Photography  
**HARRY WICKS** \_\_\_\_\_ Home Workshop  
**MICHAEL LAMM** \_\_\_\_\_ West Coast  
**ROBERT LUND** \_\_\_\_\_ Detroit Automotive  
**GARRY WINTER** \_\_\_\_\_ Copy Chief  
**RICHARD H. FUNK** \_\_\_\_\_ Production  
**ALFREDO VEGA** \_\_\_\_\_ Assistant Production  
**DON EVANS** \_\_\_\_\_ Technical Art Director  
**FRED A. LEERS** \_\_\_\_\_ Assistant Art Director  
**JOSEPH P. BEATON** \_\_\_\_\_ Assistant Art Director  
**DAVID KOMITAU** \_\_\_\_\_ Assistant Art Director  
**CLIFFORD B. HICKS** \_\_\_\_\_ Special Projects  
**SOPHIE GRONOWICZ** \_\_\_\_\_ Director, Bureau of Information  
**EVERETT JOHNSON** \_\_\_\_\_ Cabinetmaker

ADDRESS ALL EDITORIAL COMMUNICATIONS TO: 224 West 57th St., New York, N.Y. 10019. For additional sources of information on the articles and products in this issue, write to Bureau of Information, Popular Mechanics, for free "Where-to-Find-It" list.

**DANIEL J. COLEMAN**

Director of Advertising

ADVERTISING OFFICES: New York: 224 West 57th St., 765-6850; Chicago: 520 N. Michigan Ave., 527-2400; Detroit: General Motors Bldg., TRinity 5-8711; Cleveland: 20310 Chagrin Blvd., Shaker Heights, 283-7788; Los Angeles: 601 North Vermont Ave., 666-6263.

**JOHN A. REGINA** \_\_\_\_\_ Advertising Production Manager

SUBSCRIPTION SERVICE: Mail all subscription orders, changes of address, correspondence concerning subscriptions, and Postmaster notices of undeliverable copies to Popular Mechanics, Box 646, New York, N.Y. 10019. Please enclose your latest address label for quickest service when writing about your subscription.

POPULAR MECHANICS IS PUBLISHED MONTHLY by The Hearst Corporation, 57th St. at 8th Ave., New York, N.Y. 10019, U.S.A. Richard E. Berlin, President; Richard E. Deems, President of Magazines; John R. Miller, Executive V-Pres. of Magazines; Raymond J. Petersen, Senior V-Pres. of Magazines; William S. Campbell, V-Pres. of Magazines; Albert A. Rachoi, V-Pres. and Director of Circulation; Joseph F. Kern, V-Pres. for Popular Mechanics; Frank Massi, Executive V-Pres. and Treasurer; Harvey L. Lipton, Secy. Single copy in the United States and Canada, 50 cents. Subscription prices: United States and Possessions \$5.00 for one year; \$9.00 for two years; \$12.00 for three years. Canada, add \$2.00 for each year. All other countries, add \$4.00 for each year. When changing address, give old address as well as the new, with postal-zone number, if any, and allow six weeks for change to become effective. Second-class postage paid at New York, N.Y., and at additional mailing offices. Authorized as second-class mail by the Post Office Department, Ottawa, and for payment of postage in cash. Registered as second-class matter at the Post Office at Mexico D.F., Mexico, June 20, 1950. © 1973 by The Hearst Corporation. All rights reserved. Printed in U.S.A.

POPULAR MECHANICS



## DIESEL MECHANICS

Diesel Mechanics is called one of the ten best non-college careers by the U.S. Department of Labor. Trained and experienced men make upwards of \$10,000 a year for a forty-hour week. Even as an apprentice you'll be well paid and have every chance to move up into the big money! Get the training you need from LaSalle, in your spare time.



## AIR CONDITIONING and REFRIGERATION

Big futures in air conditioning—with plenty of chances to start a business of your own! Service and installation men are in urgent demand for homes, commercial buildings, apartment houses — in food markets, industrial plants, ships and planes! Newcomers are welcomed because of the fast growth of the field and short supply of trained men to handle all the work. Send for all the facts today!

## DRAFTING

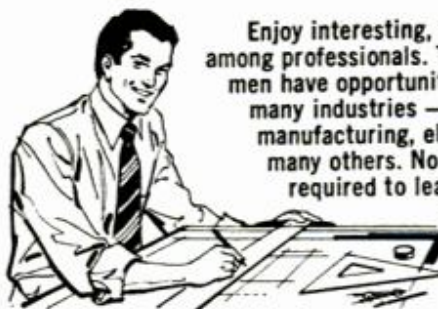

Enjoy interesting, well-paid work among professionals. Trained draftsmen have opportunities to grow in many industries — construction, manufacturing, electronics, and many others. No drawing skills required to learn. Full equipment supplied with lessons. Send for free booklet.

## COMPUTER PROGRAMMING

If it's a prestige job you want, prepare for a career in computer programming. All it takes to start training is a high school education and a logical mind. No technical background is required. Coupon brings you booklet that tells how to learn programming in your spare time at home. Free sample lesson also included.

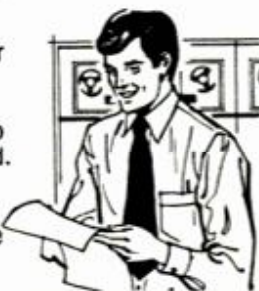

Grow with the future.  
Train at home for one of these

# big-money careers

Send coupon below for FREE booklet

For over sixty years LaSalle has been helping ambitious men start new and profitable careers. We can help you too. LaSalle's practical home study program lets you learn at your own pace. Experienced instructors supervise your work by mail every step of the way. You receive individual assistance whenever you need it. Send for FREE booklet on the field you like best. There is no obligation. LaSalle, 417 S. Dearborn St., Chicago, Illinois 60605.

## AUTOMOTIVE MECHANICS

The shortage of auto mechanics grows greater each year. 50,000 more are needed to service the ever-increasing number of cars and trucks on the road. Skilled mechanics earn over \$5.00 per hour (34 city survey). Even apprentices are well-paid. LaSalle trains you at home so you are prepared for a good start.



©1973 LaSalle Extension University.

LA SALLE EXTENSION UNIVERSITY  
A Correspondence Institution  
417 S. Dearborn Street, Dept. 88-059, Chicago, Illinois 60605

Please rush FREE booklet — without obligation — on the one field I have checked below:

- Diesel Mechanics  
 Air Conditioning  
 Drafting  
 Computer Programming  
 Automotive Mechanics

Print Name \_\_\_\_\_ Age \_\_\_\_\_

Address \_\_\_\_\_ Apt. No. \_\_\_\_\_

City \_\_\_\_\_

State \_\_\_\_\_ Zip \_\_\_\_\_

08R

# LIQUID WRENCH



Liquid Wrench is the super-penetrating rust-solvent that loosens rusted nuts, bolts, screws and parts—in seconds! Safe on all metals, use it on a bulldozer or even your watch!



Lan-Lin gets down deep—removes paint, grease, grime, ink!

Trans-Medic stops transmission troubles! You'll feel the difference!

RADIATOR SPECIALTY CO., CHARLOTTE, N. C. 28201

Look for

## GUNK®

when you want to clean anything!

... like engines, power mowers, concrete driveways, parts.

There's a

GUNK

product for almost any degreasing job in factory, shop or home.



Engine Brite Engine Cleaner. Spray it on... hose it off! "Dirt and grease wash away."



B.O.P. Small Parts Cleaner with dip basket... soaks parts clean.



GP cleans oil, grease, dirt from garage floors, driveways, power mowers, machinery.

GUNK LABORATORIES, 5829 W. 56, CHICAGO, ILL. 60638  
Gunk Chicago Co. Radiator Specialty Co.  
River Forest, Ill. Charlotte, N. C.

# LETTERS

TO THE EDITOR

## Good frames for good art

Your article, *Good Art at a Price You Can Afford* (page 73, Feb. PM) is a great job, more detailed than any we have seen before on the subject.

NEW YORK

HILDEGARDE POPPER

I'll be taking PM home with me tonight and will have fun reading your article after supper—even though I can see already the sparks which Harry Wicks' story and Robert Borst's photos will kindle in the lovely eyes of Mrs. H.

CHICAGO

DAN HOLMAN

Your article on picture frames gave me a whole new bunch of ideas.

GREENVILLE, N.H.

LAURENCE M. JOHNSON

I've never been happy with the frames I've gotten from professional framers so I'm planning to try my hand at framing, following your very clear instructions.

NEW YORK

RUTH GALANOPLOS

Your magazine the past two years has exceeded all my expectations and certainly your Great Workshop series and the story on making frames are out of this world.

WILMINGTON, MASS.

C. F. CAHIFF

Yup, our Home Workshop Editor did a great job—built all those picture frames in his shop, set up the photos, wrote the story and instructions. The only thing he didn't do was paint the pictures.

## Aerosols and animals

*Don't Take Chances With Aerosols!* (page 83, Feb. PM) is interesting, but why give publicity to vivisection? By mentioning vivisection, you, I assume, are supporting it. If so, I would ask you to think whether it seems possible that God ever intended that animals be tortured in order that we might be cured of disease.

STREAMWOOD, ILL. MRS. RONALD E. HOLMES

## Not Kawasaki's first four-stroke

*Imports and Motorsports* (page 24, Jan.

*(Please turn to page 10)*

POPULAR MECHANICS



CARPET DETERGER



UPHOLSTERY DETERGER



WALL DETERGER

# 3 proven ways to your own money-making business

**You offer a service everybody needs . . . work full time or part time . . . own your equipment . . . keep all you earn . . . start with just a small investment . . . and we help you every step of the way!**

Have your own money-making business and make the kind of income you probably thought impossible. You can when you clean carpeting or upholstery or walls with Von Schrader professional cleaning equipment. Every home, every building, are potential customers. And every customer represents repeat business.

Moreover, we help you every step of the way . . . just as we have helped thousands of other Von Schrader Associates build money-making businesses for almost 40 years.

There are three easy-to-operate Von Schrader Detergers. Each offers a proven way to a growing income. (1) *Von Schrader Carpet Deterger* gives deep-level cleaning to carpeting. (2) *Von Schrader Upholstery Deterger* cleans fabrics and synthetics beautifully (3) *Von Schrader Wall Deterger* cleans walls (and ceilings) five times faster than by hand.

You can start with just one Deterger. Then, as your business keeps growing, you may want to add the other two and thus offer a complete cleaning service.

There are no fees, royalties, or contracts. You own your equipment, the finest of its kind. And your investment is so small you may find it hard to believe. For complete information—without any obligation—send for the free booklet described below.



**“Let me send you our free booklet that gives all the facts”**

—Francis von Schrader, President

Read about the big demand for on-location cleaning, see why Von Schrader Detergers are the finest of their kind, how easy they are to operate. Learn how other men have become financially independent, how Von Schrader helps you every step of the way. Fill in the coupon and send for free booklet.

**Extra! Special Recorded Message included with booklet.** Listen as Francis von Schrader talks to you personally about your growing future with Von Schrader Detergers.



**VON SCHRADER company**

1043 Place, Racine, Wisconsin 53403

Please send complete information on Von Schrader Detergers.

Name \_\_\_\_\_

Address \_\_\_\_\_

City \_\_\_\_\_

State \_\_\_\_\_ Zip \_\_\_\_\_

# RIDGID

## Tubing Cutters give "pro" results!

### Quick-Acting Tubing Cutters

Open and close instantly. The most advanced tubing cutters made for thin and heavy wall copper, brass, and aluminum tubing, aluminum pipe and thin wall conduit. Wheels available for cutting plastic.

No. 131 — ¼" thru 1½" O.D.

No. 132 — ¼" thru 2½" O.D.

No. 133 — ½" thru 3½" O.D.

No. 134 — 1½" thru 4½" O.D.



### Midget Tubing Cutters

No. 103

1<sup>5</sup>/<sub>16</sub>" turning radius

No. 104

1<sup>11</sup>/<sub>16</sub>" turning radius

For extra-close-quarters cutting of hard and soft copper, aluminum, brass and plastic tubing. Dual rollers opposite hardened cutter wheel center tubing for smooth, fast, accurate cuts.

### 3 Tools in 1!

No. 10 — 1/8" thru 1" O.D.

No. 15 — 3/16" thru 1 1/8" O.D.

Quickly, smoothly cut copper, brass and aluminum tubing — also thin-wall conduit.

Have handy, fold-in reamer with gas cylinder wrench key cut into blade. For larger capacities (5/8" through 4 1/8" O.D.) see Nos. 20, 30 or 40. Cutters for plastic also available.



Free Catalog: Covers the complete line of famous RIDGID Pre-tested Work Saver Tools. Write Dept. PM-2, The Ridge Tool Company, Elyria, Ohio 44035, U.S.A.

# RIDGID®

Ridge Tool Subsidiary  
Emerson Electric Co.  
EMERSON

## LETTERS

(Continued from page 8)

PM) has one small error. On page 26, concerning the Kawasaki Z-1 900, you say: "You're right, the 900 stands for displacement of Kawasaki's first four stroke—903 cubic centimeters to be exact."

In the mid-1960s, Kawasaki manufactured (and sold in the United States) a four-stroke, twin-cylinder motorcycle of 624 cubic centimeters, designated the W1 and W2SS (depending upon carburetion).

Except for that error, I found the column most interesting and informative.

SALT LAKE CITY

ROBERT O. LINDSAY

*That earlier four-stroke was, indeed, sold in the United States from 1966 (when Kawasaki started bringing bikes here) until 1968. It is still sold, and is popular, in other parts of the world.*

Hooray for Bill Hartford's new column, *Imports and Motorsports*. As owner of a Valiant (Canada), a VW bus (Brazil) and a Yamaha motorcycle (Japan), I appreciate the emphasis on imports. PM is tops anyhow; now this makes it complete.

BIXBY, OKLA.

R. C. DAVIS

### This lamp is 'perfect'



Here is a photo of my husband's modified version of your lamp (*Build a Spanish-Style Lamp the Easy Way*, page 166, Oct. '71 PM).

He made it to match our semiformal living room (in Mediterranean style).

I hadn't been able to find a "store lamp" for less than \$100 that I liked.

This is perfect. Thanks!

HUNTSVILLE, ALA. MRS. PAUL MAKOWSKI

### 'Old farmer's way' to start a fire

In an otherwise good article on fireplaces, the instructions for getting a draft started violate a very fundamental safety rule (*How to Have a Smokeless Fireplace*, page 76, Jan. PM). The rule is never, never stuff paper in the chimney and light it! Burning paper has a habit of floating

(Please turn to page 12)

POPULAR MECHANICS

Материал, защищенный авторскими правами

# SIX REASONS WHY YOU SHOULD PUT FIRESTONE STEEL RADIAL 500 TIRES ON YOUR CAR VERY SOON.

- 1 They will put steel between you and tire trouble.** Two strong belts of brass plated high tensile steel cord are under the tread to stand up to chuckholes, curbs and roadjunk.
- 2 They are guaranteed for 40,000 miles.** When you think most people drive about 12,000 miles a year, imagine how long these tires should last.
- 3 They will give you better handling, more precise steering than any conventional tire we've ever made.** The steel belts stabilize the tread, help hold it to the road to deliver better handling and better cornering.
- 4 They are the quiet radials.** Compare the radials — you'll find Firestone has a computer designed, logarithmic tread pattern specially designed for quiet running and quiet cornering.
- 5 Firestone gives you 7 days to test the ride.** If you're looking for a smooth-riding radial, read our offer below.
- 6 We'll help you out when it comes to paying for them.** Your Firestone Revolving Charge, Master Charge, BankAmericard, Carte Blanche, Diners Club and American Express Card are good at most Firestone Dealers and stores.

#### OUR 40,000 MILE GUARANTEE

The Steel Radial 500 by Firestone is guaranteed to give you 40,000 miles of treadwear in normal passenger use on the same car. If it doesn't take your guarantee to any Firestone Store or participating Dealer. He'll replace the tire with a new one and give you credit for the mileage not received based on the then current adjustment price (approximate national average selling price) plus Federal Excise Tax. A small service charge may be added.

#### OUR 7 DAY TEST RIDE

Trade in your old tires on a set of Firestone Steel Radial 500's at any Firestone Store or participating Dealer. Drive on them for seven days. If you don't like the way they handle—or ride—return them within seven days and they'll put your old tires on again and refund your money. In full.

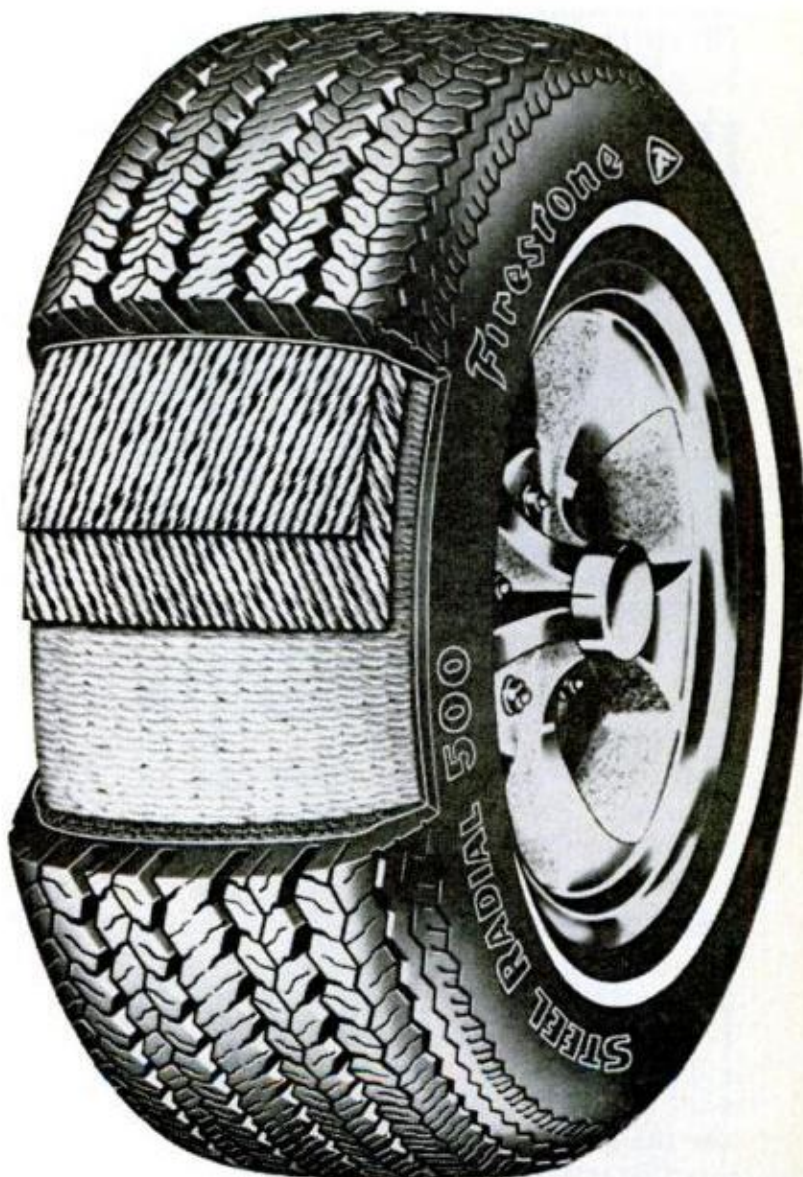

## Firestone

The people tire people

## LETTERS

(Continued from page 10)

out of the chimney and setting the roof on fire. The proper way, as any old farmer will tell you, is to twist the paper into a candle, light one end and *hold* it just under the throat.

SYRACUSE, N.Y.

LIONEL NAUM

### Solid oak gossip bench

Many enjoyable hours were spent working on this gossip bench which now has a prominent spot in our living room (*Build This Early American Gossip Bench*, page 152, March '71 PM). The bench is



made of solid oak and the last coat of finish was hand-rubbed with pumice stone and rottenstone to give it an extra smooth finish. Keep coming with these beautiful plans for Early American furniture!

PELLA, IOWA

DALE VAN DONSELAAR

### Behind the eight ball

Regarding the color photograph illustrating *\$300 Pool Table for \$107* (page 63, Jan. PM), what game are the gentleman and lady playing? If the gentleman makes what appears to be the eight ball, he will lose the game.

LONG BEACH, CALIF.

RAY KOMPSI

*And the lady will win. That's why we all agree he's a gentleman, whether he knows how to shoot pool or not. (Matter of fact, he's the man who built the pool table for us and wrote the article.)*

### Aeroprinting

We received the January issue of *PM* and its story on Aeroprint (*Color Prints*

*From a Spray Can*, page 156) with delight as well as surprise. But there were some errors. The color kit retails for \$29.95, not \$24.95. You state that capacity per kit is 57 8x10 prints, but the figure is 40 (the exact amount will vary from user to user). And last, total processing time is 36 minutes including four five-minute washes, not 36 minutes plus wash.

You also mention the cost of an Aeroprint may approach the cost of custom printing. This is not so. Commercial labs charge \$12 and up for an 8x10 print, while Aeroprint costs only about \$1.

AEROPRINT PRODUCTS USA JERRY FRANK  
EMERSON, N.J. EXECUTIVE V-P

*The capacity of 57 8x10 prints was calculated from Aeroprint literature. But the price comparison we gave was not for custom-lab prints, but for "commercial" prints—the drugstore kind. Aeroprint's main advantage, as we said, is that it lets you try such custom operations as special cropping, dodging and burning in, at drugstore prices.*

### Lamp stand—a challenge

The octagon lamp table (*A Beauty—and So Simple to Make*, page 154, Aug. '72 PM) seemed very challenging, so I tried it and it



was. I added a bottom, a 2-inch base molding and two doors with magnetic latches. I love the variety of projects you offer in *PM*.

INGLEWOOD, CALIF.

ELMER HOHBOCH

### How do you get the slip out?

I hope one of your readers can help me solve a problem. I do ceramics but find it difficult to handle large molds as I get older. I wonder if anyone has come up

*(Please turn to page 14)*

POPULAR MECHANICS

# 3 COMPLETE FISHING OUTFITS

NATIONALLY ADVERTISED 1973 MODELS  
2 LOADED TACKLE BOXES • 66 DEADLY LURES

# 411 Pcs.

**FREE!** If you order NOW!  
2 LEAKPROOF FLOATING  
TACKLE BOXES

3 EXPERTLY BALANCED RODS AND REELS

SMOOTH  
POWERFUL

ARGOSY DIRECT DRIVE  
TROLLING  
REEL

6 ft. 2 section  
BAMBOO ROD

EVERYTHING YOU NEED TO GO  
FISHING AT ONCE

28 pc.  
POPPING  
LURE SET

POWER ACTION  
BLACK MAGIC  
FIBRE-GLASS RODS

STRONGER THAN  
STEEL  
OR BAMBOO

MARK IV  
LEVELWIND  
CASTING  
REEL

SENSATIONAL VALUE !

# \$12<sup>95</sup>

5 pc. DROPLINE  
FISHING OUTFIT

DIP NET

NEW! SUPER "88"  
AUTOMATIC  
DUAL DRAG  
SPINCAST  
REEL

PUSH BUTTON  
CASTING  
ANTI REVERSE  
NO BACKLASH

STAR DRAG  
Found only  
on best reels

EACH ROD  
BALANCED TO PERFECTION

4 FAMOUS  
TROUT FLIES

NEW

50 NATURAL BAIT LURES  
SURE SHOT ACTION WITH SHRIMP  
MINNOWS, GRASSHOPPERS, MAYFLIES  
BUMBLEBEES, CRICKETS, LEECHES

FIELD TESTED LURES  
Proven the Deadliest Dozen Yet

CRAFTY LURES  
SELECTED FROM  
WORLD'S MOST POPULAR  
ALL TIME FAVORITES

**NEWEST! EASIEST WAY TO CATCH FISH!**

SELECTED FOR YOU BY EXPERTS. This choice fish-getting tackle used by thousands throughout the United States and Canada. Each item carefully chosen—everything you need for all types of fishing. Deadly lures that are all time favorites. A veteran angler or an occasional fisherman can be proud of this precision-built kit. You can go fishing at once. Compare! You may not find a bargain like this anywhere.

**LOOK! YOU GET EVERYTHING SHOWN.** Super "88" Spincast Reel • Comet X3C Bait Cast Reel • Argosy Direct Drive Trolling Reel • 5 ft. 2 pc. Fiber Glass Spin Cast Rod • 4 ft. Fiber Glass Bait Cast Rod • 3 1/2 ft. Fiber Glass Trolling Rod • 6 ft. 2 section Bamboo Pole and 25 ft. Bank Line • 66 proven Deadly Lures • 5 pc. Furnished Line • 2 Floating Tackle Boxes with removable trays • Fish Knife and Sheath • 28 pc. Popping Lure Kit • Dip Net, Stringer, Split Shot, Clincher Sinkers, Snap Swivels, Assorted Hooks, Snelled Hooks, 3 Plastic Floats, 6—3 way Swivels, 6 Snaps, 12—36" Leader Strands (8# Test), and complete instructions. 411 pieces in all.

**NIRESK DISCOUNT SALES, INC. CHICAGO 60606**

**MONEY BACK GUARANTEE!**

**NIRESK DISCOUNT SALES, Inc. DEPT. F3-103  
CHICAGO, ILLINOIS 60606**

**ORDER TODAY!** If you're not 100% pleased we'll refund your full purchase price promptly.  
**YOU KEEP 2 FREE TACKLE BOXES REGARDLESS!**

Please rush \_\_\_\_\_ 411 pcs. 3 Complete Fishing Sets

NAME \_\_\_\_\_

ADDRESS \_\_\_\_\_

CITY \_\_\_\_\_ STATE \_\_\_\_\_ ZIP \_\_\_\_\_

I enclose \$12.95 plus \$1.00 for postage & handling.

Ship C.O.D. I will pay C.O.D. charges & postage.

Ill. Residents please add 5% sales tax

To Canada: \$14.95 including Postage & Duty

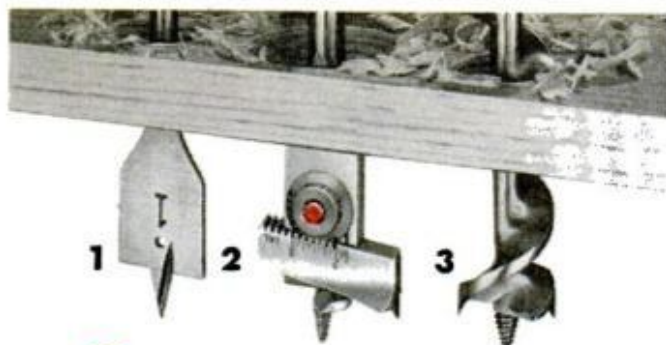

## 3 easy ways to bore holes faster

**1. Irwin Speedbor "88"** for all electric drills. Bores faster in any wood at any angle. 17 sizes,  $\frac{1}{4}$ " to  $1\frac{1}{2}$ ". Only \$.98 to \$1.70, depending on size. Also buy in sets.

**2. Irwin No. 22 Micro-Dial** expansive bit. Fits all hand braces. Just dial your size. Bores 35 standard holes,  $\frac{7}{8}$ " to 3". Only \$6.30. No. 21 small size bores 19 standard holes,  $\frac{3}{8}$ " to  $1\frac{3}{4}$ ". Only \$5.60.

**3. Irwin 62T Solid Center** hand brace type. Only 16 turns to bore 1" holes through 1" wood. Double-cutter boring action. Sizes  $\frac{1}{4}$ " to  $1\frac{1}{2}$ ".  $\frac{1}{4}$ " size only \$1.75.

**EVERY IRWIN BIT** made of high analysis tool steel, heat tempered, machine-sharpened and highly polished, too. Buy from your independent hardware, building supply or lumber dealer.

**Straight-Line Chalk Line Reel Box**  
only \$1.50 for 50 ft. size

New and improved Irwin self-chalking design. Durable aluminum alloy box. Practically damage-proof. Fits pocket or hand. 50 ft. and 100 ft. sizes.

**IRWIN** every bit as good  
as the name  
at Wilmington, Ohio 45177, since 1885



# the 3,000 lb. LIGHTWEIGHT

The Slaymaker Lock'n Cable Kit will give you the year-round protection, durability, and lightweight convenience you need.

**The CABLE:**

- 3,000 lbs. of break strength.
- six feet of tough, galvanized aircraft steel.
- vinyl coated.
- flexible, easy to carry—lock and cable weigh only 1 lb.

**The LOCK:**

- laminated steel body, case-hardened steel shackle.
- rust and corrosion-proof solid brass cylinder.
- special pin-tumbler mechanism that retains key until lock is securely closed.

# Slaymaker

LOCK COMPANY

Lancaster, Pennsylvania 17604

## LETTERS

(Continued from page 12)

with some sort of pump for taking the slip (which weighs 15 to 18 pounds per gallon) out of molds. A commercial pump costs \$300, but such expense is out of the question.

JACKSONVILLE, FLA. MARGARET FRUMERIE

*Has any do-it-yourselfer solved the problem? We'll pass your ideas to Mrs. Frumerie.*

## \$50 lightbox for \$56.26

I just got through making *A Lightbox for Under \$50* (page 112, Dec. PM) except that mine cost \$56.26. I would like to know how your contributor constructed his for less than \$50.

ROSAMOND, CALIF. HAROLD M. CHASE

*We don't know, other than that maybe things are cheaper over in Pomona where he lives.*

## Turn off the fan if the light's off

In your very informative *Slide Projectors Get Smarter All the Time* (page 140, Feb. PM), I couldn't help noticing that you suggest cooling the lamp with the projector fan after turning off the lamp—to lengthen the lamp's life. All of us here at J.C. Penney used to do it until I came across a paragraph on "Lamp Life" in Kodak Publication S-53. Kodak seems to feel that the fan *shouldn't* be used to cool the lamp after it's turned off.

J.C. PENNEY Co.  
NEW YORK

JOEL MAXWELL  
PHOTO SUPERVISOR

*You're right. Kodak says: "The fan should normally not be operated after the projector lamp has been turned off, because the rapid flow of relatively cool air tends to set up stresses in the lamp, condensers and the heat-absorbing glass by cooling their surfaces rapidly."*

*So why is there a FAN-ONLY position on the switch? Kodak says it's for cooling burned-out projector lamps for quicker replacement.*

*It also allows use of a "programmer" (which fades in an image from one projector while fading out the image from another.)*

★★★



# THE MONEY YOU WASTE ON OCTANE.

One of the most expensive ingredients in your gasoline is the octane. That's why it's such a shame to see people throw their money away on octane they don't need.

Every automobile has a certain octane requirement to run properly. Above that level, you're just throwing your octane away...and your money, too.

It's true, that back in the 50's and 60's, car engines were being built to run on fuels with higher and higher octane levels. But beginning with the 1971 models, manufacturers have dropped compression ratios. Which means you need less octane for your engine.

Most of today's engines are designed to run on 91 octane fuel. Even your big expensive car engines. And that's where Gulftane® Low-Lead gasoline comes in. It's a 91 octane fuel you can use in almost every '73 car, most '72's, many '71's, and millions of older cars. If you aren't sure about yours, check your owner's manual.

Just fill up your tank with Gulftane Low-Lead. If your engine makes a knocking sound, check the timing. The mechanism may need an adjustment.

If that doesn't work, step up in octane by trying Good\*Gulf. If it still knocks, then go to No-Nox.\* But try Gulftane Low-Lead first.

Other gasoline companies have low-lead gasoline, but *ours* costs less than our regular. And if you're going to start saving money, you might as well save all you can.

So stop throwing your money away and stop at a Gulf station for some Gulftane.

If you'd like to know more about Gulftane Low-Lead gasoline, ask at any Gulf station or write: Gulf Consumer Information, Box 1519-H Houston, Texas 77001. We'll be glad to tell you about it, and we'll try to answer any other questions you might have about your car.

You see, at Gulf, we'd like you to learn all you want to know about your car. And our products. That way we can keep you on the road. And us, too.

GET TO KNOW GULF AND YOU'LL GET TO KNOW YOUR CAR.



GULF OIL CORPORATION



# Jack Terry knows exactly where he's going. Thanks to ICS.

(A TRUE STORY)

At age 27, Jack Terry doesn't have it made yet.

But he knows where he's going. And he's on his way.

Jack jumped from beginner draftsman to Highway Engineer, first level.

At almost twice the pay.

"That took five promotions," Jack told us. "But my ICS training was a real help in passing each promotion examination.

"I really like my work and I know there are other promotions I can get. Because people just seem to need more roads. And there aren't that many good highway engineers around."

## **The right combination for success**

Jack has the right combination for success. He's in a growing field. And he has good training for it. You could, too.

Especially if you're interested in one of the fast-growing careers where ICS concentrates its training. Like accounting. Engineering. Auto repair. Electrician. Air conditioning, etc. (Check your choice on attached card.)

## **Ideal way to learn**

As an ICS student, you study at home,

on your own schedule. You waste no time traveling to and from class. And you never have to miss a paycheck.

But you're never alone. Skilled instructors are always ready to help you.

If you ever have any doubts or problems or just want to talk to your instructor, you can even call ICS from anywhere, at any hour. Toll-free.

## **ICS training works**

ICS has trained 8,500,000 people in the past 80 years.

Some of the top American corporations (including Ford, U.S. Steel, Mobil, Alcoa, Pan Am, GE, Motorola and RCA) use ICS courses in their own training programs. Government agencies and unions have also approved ICS training.

## **Free demonstration lesson**

If you want your job to give you more, (more money, more day-to-day satisfaction, and more future) send for our career guide booklets and free demonstration lesson.

Remember, it's your life. You might as well make the most of it.

## **ICS**

*We'll show you a better way to earn a living.*

*A man can take a lot of pride in a highway he's designed. Jack Terry of Lake City, Fla. knows that feeling. (Photo: Yale Joel)*

# NEVER AGAIN WILL EMPEROR BE



Model 120  
Black Walnut  
74" x 16 $\frac{3}{4}$ " x 10"

## EMPEROR GRANDFATHER CLOCK

### DO-IT-YOURSELF CASE KIT

MODEL 120 SOLID  $\frac{3}{4}$  INCH GENUINE BLACK WALNUT

## SALE PRICED

Regular \$129.50

# 89<sup>50</sup>

Finished  
Model 120 shown

Because of short supply,  
BLACK WALNUT PRICES HAVE GONE SKY HIGH!

**THIS OFFER WILL NEVER BE REPEATED!**

All pieces pre-cut and pre-sanded. Breakfront swan neck and finial, waist and dial doors, dial frame and sculptured base-front pre-assembled. Complete hardware and assembly instructions furnished. Each piece may be re-ordered separately.

#### QUALITY AT BARGAIN PRICES!

Black Walnut is the hardwood that has been selected by generations of craftsmen for the rich beauty of its grain and hue. This Emperor Grandfather Clock case is solid Black Walnut, so the clock you assemble will be worthy of becoming an heirloom. Yet, this special sale price is well below the cost of buying the lumber yourself and starting from scratch.

This offer will exhaust our present stock of Black Walnut bought before the price rise.

Fine craftsmanship gives Emperor Clocks a warm, rich beauty. Clock movements imported from West Germany insure lasting dependability.

#### 3 WAYS TO BUY

Do-It-Yourself Kit without movement; assembled, unfinished case without movement and completely finished clock with movement installed.

#### SAVE HUNDREDS OF DOLLARS

Buy a Do-It-Yourself Kit and movement from Emperor. Your cost \$169.00. Then compare your finished clock with other solid black walnut clocks retailing up to \$700.

**SEND FOR FREE COLOR BROCHURE**

#### MONEY-BACK GUARANTEE

If not completely satisfied, return collect in the original shipping carton within 30 days for a complete refund. No questions, no excuses.

**ORDER NOW! OFFER GOOD THROUGH JUNE 30, 1973**

# ABLE TO OFFER THIS BARGAIN!



100-M Movement  
with Tempus Fugit  
Dial  
ONLY \$79.50

## EMPEROR MOVEMENT FOR MODEL 120

### WEIGHT DRIVEN - EIGHT DAY - WESTMINSTER CHIMES

The Emperor Grandfather clock movement 100-M is manufactured by West German clocksmiths, who have been producing the world's finest clock movements for three generations. The solid brass dial is surrounded by embossed overlays. The face has a high, permanent polish and serpentine hands. In the arch above the dial is a shaped aluminum world with the words "Tempus Fugit" (Time Flies) inscribed in black enamel. Or, if you prefer, a moving moon dial with lunar calendar.

The completely weight-driven movement strikes the famous Westminster chimes on musically-tuned rods: four notes on the quarter-hour, eight on the half-hour, twelve on the three-quarter hour and sixteen on the hour. The hour is struck on additional tuned rods. All plates in the movement are solid brass, and all pinions are hardened steel . . . No plastic parts.

**Immediate Delivery - 1 Year Unconditional Guarantee**

#### SHOWROOMS

Fairhope, Alabama, Emperor Industrial Park (Factory)  
Pensacola, Florida, 8 miles East, U.S. 98  
Cape Girardeau, Missouri, 2125 Williams Street (Off I-55)  
New Orleans, Louisiana, 723 Royal Street (French Quarter)



100-M Movement  
with Moving Moon  
Dial  
ONLY \$94.50

**ORDER DIRECT WITH THIS FORM!**  
**OFFER GOOD THROUGH JUNE 30, 1973**

**THIS OFFER WILL NEVER BE REPEATED**

**KITS AND MOVEMENTS SHIPPED AT ONCE — F.O.B. FAIRHOPE, ALA.**  
**WORLD'S LARGEST MANUFACTURER OF GRANDFATHER CLOCKS**

TO: EMPEROR CLOCK COMPANY  
Emperor Industrial Park, Dept. 39, Fairhope, Alabama 36532

Please Check:  
New Customer   
Previous Customer

| QUANTITY | DESCRIPTION  | WEIGHT | REG. PRICE | SALE     | EXTENSION |
|----------|--|--------|------------|----------|-----------|
|          | Model 120-K Do-it-Yourself Case Kit, w/o movement                                      | 53     | \$129.50   | \$ 89.50 |           |
|          | Model 120-A completely finished clock with Tempus Fugit dial, Westminster chimes       | 95     | 369.50     | 299.50   |           |
|          | with moving moon dial, Westminster chimes  | 95     | 384.50     | 314.50   |           |
|          | Model 100-M movement complete with Tempus Fugit dial, Westminster Chimes for Model 120 | 32     | 79.50      |          |           |
|          | Model 100-M movement complete with moving moon dial, Westminster chimes for Model 120  | 32     | 94.50      |          |           |
|          | Detailed blueprint plans for Model 120   |        | 1.50       |          |           |

We accept personal checks.

TOTAL \$ \_\_\_\_\_

ENCLOSED: ( ) CHECK \$ \_\_\_\_\_

Alabama residents only, \$ \_\_\_\_\_  
add 4% sales tax

( ) MONEY ORDER \$ \_\_\_\_\_

CHARGE TO MY: ( ) MASTER CHARGE ( ) BANKAMERICARD

GRAND TOTAL \$ \_\_\_\_\_

Card number \_\_\_\_\_

Expiration date \_\_\_\_\_

NAME \_\_\_\_\_

ADDRESS \_\_\_\_\_

CITY \_\_\_\_\_ STATE \_\_\_\_\_ ZIP \_\_\_\_\_



Please send FREE color brochure on complete Emperor line

**VISIT OUR FACTORY SHOWROOMS MON.-FRI., 8 A.M. TO 5 P.M., EMPEROR INDUSTRIAL PARK, FAIRHOPE, ALA.**

# SOLUTIONS FOR MECHANICAL HEADACHES

# AUTOMOBILE CLINIC

BY MORT SCHULTZ

## Tight cap

*I have a problem with the oil filler cap of my 1971 Chevrolet Impala's 400-cu.-in. engine. The cap has been so stiff to get back on after adding oil that it has cracked and broken. Several pieces have dropped into the rocker-arm cavity. I would like to know if they can cause damage, and also if there is a different type of cap I can use that's easier to install.—K.E. Hart, San Jose, Calif.*

The pieces of cap that have fallen into the rocker arm cavity shouldn't cause damage unless they are 1/2-inch or more in diameter. Large pieces may plug one or both of the oil drain-back holes in the cylinder head, which could lead to spark-plug fouling and a leak at the valve cover gasket.

To get the pieces out, simply remove the valve cover. Otherwise, oil filler cap material is relatively soft and will cause no problem. Eventually the pieces will make their way to the oil sump and be drained from the engine when oil is changed.

There is no different type of cap you can use. However, if you find that a new cap is just as stiff as the old one, try spreading some lubricant, such as petroleum jelly, around the lip. This should allow the cap to slip into place easily.

## Mixing drinks

*If necessary, in an emergency, is it okay to mix two different brands of permanent ethylene glycol antifreeze, such as Zerex and Prestone, or will some incompatible-chemical reaction damage the cooling system?—Ken Greenberg, Chicago.*

Yes—it is okay; no—there will be no damaging chemical reaction.

## Removing sap

*Our driveway is under a poplar tree, and the sap has dripped on my car's finish. Is there a way of removing it?—Dom Paratore, Exeter, N.H.*

It's tough, especially if the sap has been allowed to harden over a period of time.

The ideal thing is to wash the car as soon as possible after tree sap falls on the finish. If the sap has time to take hold, it will work its way into the finish, much as egg would if splattered on the car.

You can try a couple of things. A finish conditioner sold by new-car dealers may help. But if the sap proves stubborn, dampen a rag with gasoline and "spot" the affected areas. Have someone follow behind and immediately wash the area with a household detergent solution. Flush with lots of water.

## Rear tire wear

*I've noticed a tire-wear condition I call "step-off" on the two rear tires only. The car is a 1970 Hornet with 232-cu.-in. engine. The outer ribs of the treads are wearing away faster than the rest. Why is this happening?—Andrew Duchay, Chicago.*

There are three primary causes of erratic tire wear in the rear. First, of course, is improper tire inflation. Then there is the chance that the rear wheels are out of balance. This, though, would cause the type of wear normally described as flat-spotting. Finally, erratic tire wear will result if the axle is bent, throwing rear-wheel alignment out of whack. Normally a vibration would be felt if this were the case.

## Fanning the fires

*While I was driving through South Carolina in August, the radiator and engine of my 1971 Oldsmobile overheated and literally blew apart. The mechanic who worked on the vehicle stated that the cause of the accident was that the fan clutch broke, causing the engine to overheat. It was further determined that the temperature-sending unit was defective. Since the red temperature warning light did not go on, I did not realize that the engine was overheating. What I would like to know is how an Oldsmobile owner can check the temperature-sending unit and*

*(Please turn to page 24)*

# Salem refreshes naturally!

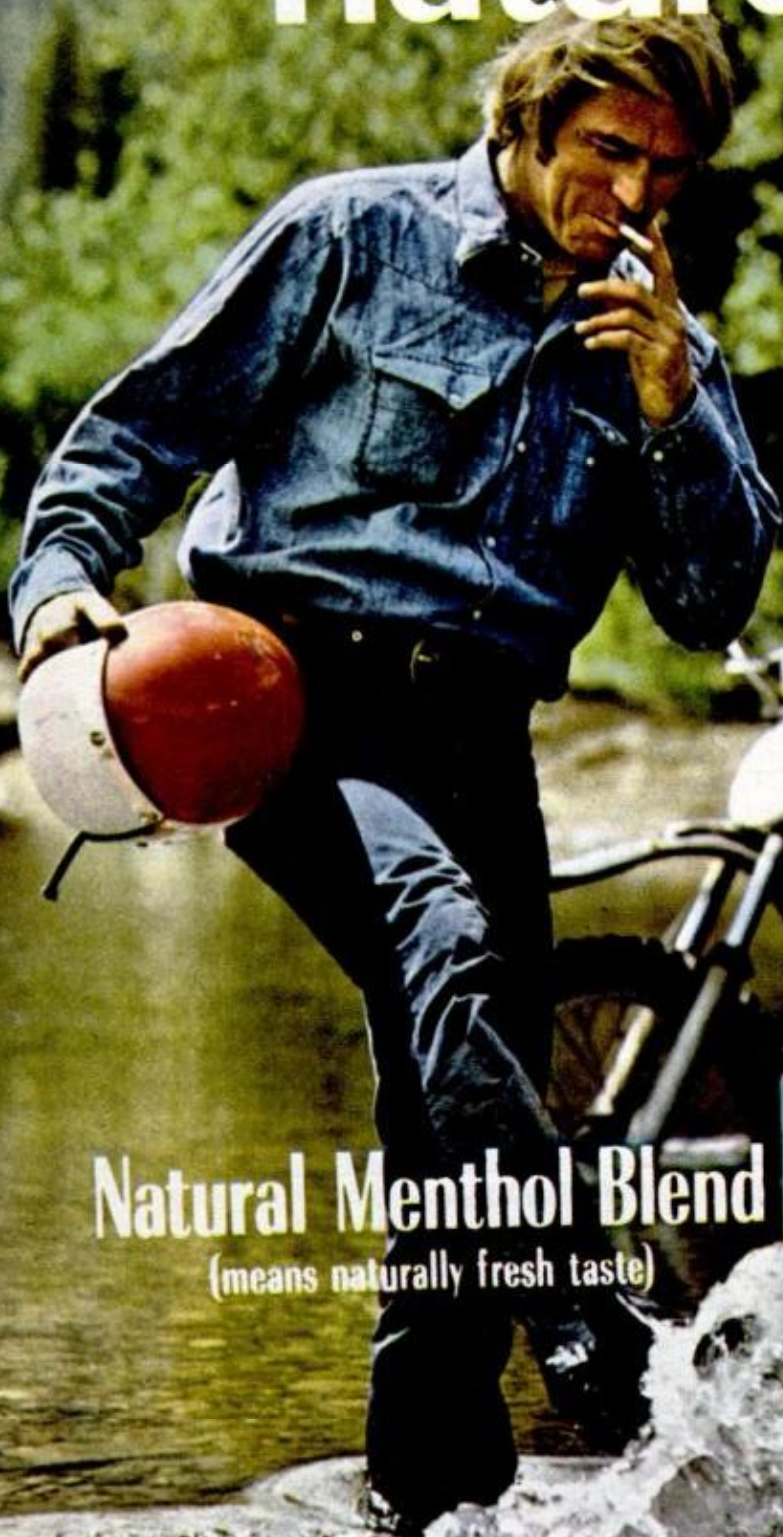

**Natural Menthol Blend**  
(means naturally fresh taste)



© 1972 R. J. REYNOLDS TOBACCO CO.

Warning: The Surgeon General Has Determined That Cigarette Smoking Is Dangerous to Your Health.

KING, SUPER KING: 20 mg. "tar", 1.4 mg. nicotine, av. per cigarette, FTC Report AUG. '72.

## AUTOMOBILE CLINIC

(Continued from page 22)

*fan clutch prior to a trip?—Col. Paul R. Kaufmann, Fort Meade, Md.*

The temperature-sending unit is part of the temperature indicator-light circuit. A shorted sending unit would cause the warning light to remain on constantly although the engine doesn't overheat. Most times the problem doesn't happen this way, but rather with a warning light that doesn't go on.

To check the warning light, turn the ignition key to START. The light should glow and continue to glow as you crank the engine. It should go out when the engine starts. If the light doesn't light in this way, the bulb has burned out, the fuse has gone bad, or there is an open circuit.

The fan clutch engages when it senses that air temperature has reached about 180° F. The most accurate way of checking its operation is to have a mechanic insert a special dial-type thermometer between the fan blades and radiator, and observe at what temperature the clutch engages. You know that the clutch has engaged when you notice a sharp increase in the fan noise.

You can find out if the fan clutch is operating by running a cold engine at slightly above fast idle (2000 rpm) for a minute or two. Stop the engine and turn the fan by hand. It should turn freely.

### Ruining contact points

*I have a 1972 Chrysler with a 400-cu.-in. engine. The car has only 10,000 miles and already I've had to replace the distributor contact points. What's wrong?—David Speth, Orchard Lake, Mich.*

You don't say whether the points were burned or pitted excessively. If burned, check for a high primary voltage condition resulting from an improperly adjusted or inoperative voltage regulator, or a faulty ballast resistor. A defective condenser or high resistance in the condenser circuit will cause points to burn, too, as will improper adjustment of the contacts themselves.

Finally, if a clogged engine breather is allowing crankcase pressure to force oil or vapors into the distributor, contacts can burn. Burning may also result if lubricant gets on points—lubricant that was placed in excess on the distributor cam.

If points were pitted excessively (a certain amount of pitting results from normal operation), make sure that condenser capacity, contact-spring tension and contact gap are to specification.

## Service Tips

● **Poor fuel economy** with a 1971 or 1972 Dodge car or truck having a 360 or 400-cu.-in. engine and Holley 2210 two-barrel carburetor may be caused by a sticking, sealed-bowl vent valve in the carburetor. If the valve is not closing, the engine will burn more gas. The problem can be solved and gas mileage improved by disassembling and cleaning the parts of the vent assembly in denatured alcohol, and by adjusting the clearance of the valve to allow insertion of a 0.015-inch gauge between the vent valve plunger stem and operating rod. The procedure is detailed in service bulletin 14-12-72D (9-27-72).

● **Two precautions** are needed to minimize the possibility of the tape of an 8-track radio/tape player from wrapping itself around the capstan. First, remove the tape cartridge before the unit is turned off. Secondly, clean the pickup head and capstan shaft every 100 hours of operation. Use isopropyl alcohol (rubbing alcohol) and a long cotton swab. It's not necessary to remove the unit from the car.

● **What's a worn ball joint?** This question should be resolved once and for all with the introduction of ball joints with wear indicator in new cars. On General Motors models, for instance, the lower joint uses a protrusion of a 1/2-inch-diameter nipple into which the grease fitting is threaded. The nipple projects 0.050 inch beyond the surface cover of the ball joint. As the joint wears, more room is left for the nipple to recess itself into the joint. To inspect units for wear, wipe the grease fitting and nipple free of dirt, and attach a grease gun as if you were going to lubricate the joint. If the grease gun forces the nipple flush with or recesses it beyond the surface of the cover, the ball joint is worn and should be replaced promptly. ★★★

---

**GOT A PROBLEM WITH YOUR CAR?** Ask Mort about it. Send your question to Auto Clinic, Popular Mechanics, 224 West 57th St., New York, N.Y. 10019. Letters cannot be answered individually, but problems of general interest will be published in the column.

---



# "The styling coup of '73"

When we introduced the Hornet Hatchback this fall, Car & Driver Magazine called it "The styling coup of '73."

And along with sportscar styling, you get room to travel in; 23 cubic feet of cargo space with the back seat folded down.

Now we've added something else. An optional Levi's interior. The look of jeans,

copper buttons, orange stitching...even a Levi's tab.

So if you want the style, the performance, the room, the Levi's interior and the American Motors Buyer Protection Plan, get a Hornet Hatchback at your AMC dealer, where he'll give you a good deal and a good deal more.



Buckle up for safety.

## AMERICAN MOTORS BUYER PROTECTION PLAN

1. A simple, strong guarantee, just 101 words!

When you buy a new 1973 car from an American Motors dealer, American Motors Corporation guarantees to you that, except for tires, it will pay for the repair or replacement of any part it supplies that is defective in material or workmanship. This guarantee is good for 12 months from the date the car is first used or 12,000 miles, whichever comes first. All we require is that the car be properly maintained and cared for under normal use and service in the fifty United States or Canada, and that guaranteed repairs or replacement be made by an American Motors dealer.

2. A free loaner car from almost every one of our dealers if guaranteed repairs take overnight.

3. Special Trip Interruption Protection.

4. And a toll free hot line to AMC Headquarters.

## AMC Hornet

We back them better because we build them better.



# I'd like to give this to my fellow men... while I am still able to help!

I was young once, as you may be—today I am older. Not too old to enjoy the fruits of my work, but older in the sense of being wiser. And once I was poor, desperately poor. Today almost any man can stretch his income to make ends meet. Today, there are few who hunger for bread and shelter. But in my youth I knew the pinch of poverty; the emptiness of hunger; the cold stare of the creditor who would not take excuses for money. Today, all that is past. And behind my city house, my

summer home, my Cadillacs, my winter-long vacations and my sense of independence—behind all the wealth of cash and deep inner satisfaction that I enjoy—there is one simple secret. It is this secret that I would like to impart to you. If you are satisfied with a humdrum life of service to another master, turn this page now—read no more. If you are interested in a fuller life, free from bosses, free from worries, free from fears, read further. This message may be meant for you.

By Victor B. Mason

I am printing my message in a magazine. It may come to the attention of thousands of eyes. But of all those thousands, only a few will have the vision to understand. Many may read; but of a thousand only you may have the intuition, the sensitivity, to understand that what I am writing may be intended for you—may be the tide that shapes your destiny, which, taken at the crest, carries you to levels of independence beyond the dreams of avarice.

Don't misunderstand me. There is no mysticism in this. I am not speaking of occult things, of innumerable laws of nature that will sweep you to success without effort on your part. That sort of talk is *rubbish!* And anyone who tries to tell you that you can *think* your way to riches without effort is a false friend. I am too much of a realist for that. And I hope you are.

I hope you are the kind of man—if you have read this far—who knows that anything worthwhile has to be *earned!* I hope you have learned that there is no reward without effort. If you have learned this, then you may be ready to take the next step in the development of your karma—you may be ready to learn and use the secret I have to impart.

## I Have All The Money I Need

In my own life I have gone beyond the need of money. I have it. I have gone beyond the need of gain. I have two businesses that pay me an income well above any amount I have need for. And, in addition, I have the satisfaction—the deep satisfaction—of knowing that I have put more than three hundred other men in businesses of their own. Since I have no need for money, the greatest satisfaction I get from life is sharing my secret of personal independence with others—seeing them achieve the same heights of happiness that have come into my own life.

Please don't misunderstand this statement. I am not a philanthropist. I believe that charity is something that no proud man will accept. I have never seen a man who was worth his salt who would accept something for nothing. I have never met a highly successful man whom the world respected who did not sacrifice something to

gain his position. And, unless you are willing to make at least half the effort, I'm not interested in giving you a "leg up" to the achievement of your goal. Frankly, I'm going to charge you something for the secret I give you. Not a lot—but enough to make me believe that you are a little above the fellows who merely "wish" for success and are not willing to sacrifice something to get it.

## A Fascinating and Peculiar Business

I have a business that is peculiar—one of my businesses. The unusual thing about it is that it is needed in every little community throughout this country. But it is a business that will never be invaded by the "big fellows." It has to be handled on a local basis. No giant octopus can ever gobble up the whole thing. No big combine is ever going to destroy it. It is essentially a "one man" business that can be operated without outside help. It is a business that is good summer and winter. It is a business that is growing each year. And, it is a business that can be started on an investment so small that it is within the reach of anyone who has a television set. But it has nothing to do with television.

This business has another peculiarity. It can be started at home in spare time. No risk to present job. No risk to present income. And no need to let anyone else know you are "on your own." It can be run as a spare time business for extra money. Or, as it grows to the point where it is paying more than your present salary, it can be expanded into a full time business—overnight. It can give you a sense of personal independence that will free you forever from the fear of lay-off, loss of job, depressions, or economic reverses.

## Are You Mechanically Inclined?

While the operation of this business is partly automatic, it won't run itself. If you are to use it as a stepping stone to independence, you must be able to work with your hands, use such tools as hammer and screw driver, and enjoy getting into a pair of blue jeans and rolling up your sleeves. But two hours a day of manual work will keep your "factory" running 24 hours turning out a product that has a steady and

ready sale in every community. A half dollar spent for raw materials can bring you six dollars in cash—six times a day.

In this message I'm not going to try to tell you the entire story. There is not enough space on this page. And, I am not going to ask you to spend a penny now to learn the secret. I'll send you all the information, free. If you are interested in becoming independent, in becoming your own boss, in knowing the sweet fruits of success as I know them, send me your name. That's all. Just your name. I won't ask you for a penny. I'll send you all the information about one of the most fascinating businesses you can imagine. With these facts, you will make your own investigation. You will check up on conditions in your neighborhood. You will weigh and analyze the whole proposition. Then, and then only, if you decide to take the next step, I'll allow you to invest \$15.00. And even then, if you decide that your fifteen dollars has been badly invested I'll return it to you. Don't hesitate to send your name. I have no salesmen. I will merely write you a long letter and send you complete facts about the business I have found to be so successful. After that, you make the decisions.

## Does Happiness Hang on Your Decision?

Don't put this off. It may be a coincidence that you are reading these words right now. Or, it may be a matter that is more deeply connected with your destiny than either of us can say. There is only one thing certain: If you have read this far you are interested in the kind of independence I enjoy. And if that is true, then you must take the next step. No coupon on this advertisement. If you don't think enough of your future happiness and prosperity to write your name on a postcard and mail it to me, forget the whole thing. But if you think there is a destiny that shapes men's lives, send your name now. What I send you may convince you of the truth of this proverb. And what I send you will not cost a penny, now or at any other time.

**VICTOR B. MASON**  
1512 Jarvis Ave., Suite M-2-CD  
CHICAGO, ILLINOIS 60626

# You can't get a good job without experience. We'll give you both.

There are lots of jobs in the want ads. Unfortunately, almost all the really good ones ask for experienced help.

So you ask yourself, how can I get experience if no one will ever hire me? One answer lies in today's Army.

You'll start at \$307.20 per month (before deductions). No experience necessary.

In fact, we'll give you that experience. Along with the training you need to perform your choice of over 300 jobs. Jobs you can turn into a career. In the Army, or out.

For more information see an Army Representative, or write Army Opportunities, P.O. Box 5510J, Philadelphia, PA 19143.

**Today's Army  
wants to join you.**

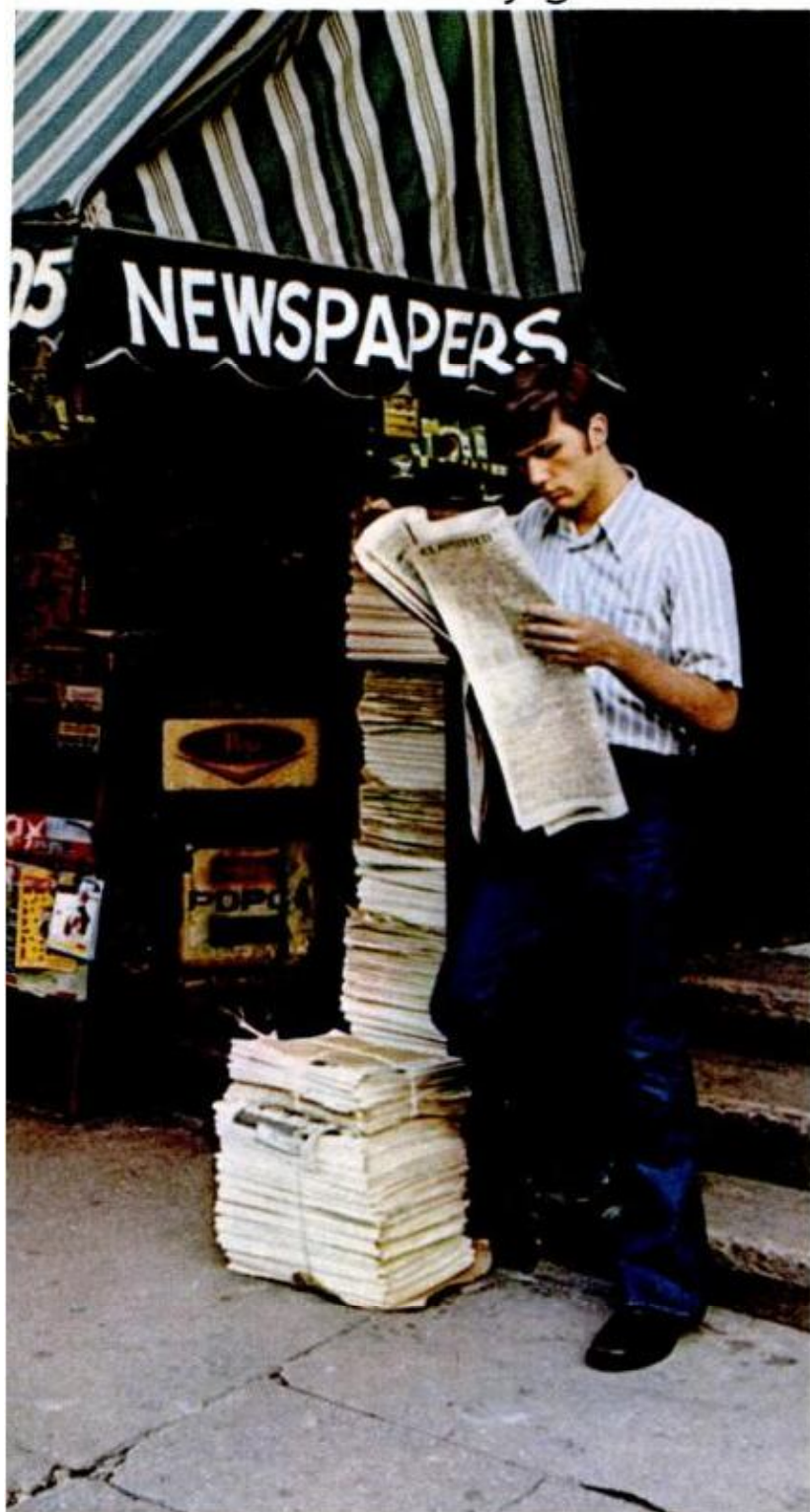

# ALL By BILL McKEOWN OUTDOORS

**PLANNING AHEAD** for the coming season, campers and outdoorsmen should start by sending 75 cents to the Superintendent of Documents, U.S. Government Printing Office, Washington D.C. 20402, along with a note asking for the book *National Parks & Landmarks No. 2405-0287*. This handy paperback in a size that can fit in a backpack describes natural, historical, recreational and cultural areas plus national capital parks that are administered by the National Park Service, as well as a number that are not. Hundreds of "sites declared eligible for registration as national historic, natural and environmental education landmarks" but not administered by the National Park Service are also listed. The book is a bargain directory of places to see.

For outdoorsmen and others, the low-cost publications of the Government Printing Office can be as welcome as an income tax refund which, in fact, they are. Interested in a specific national park, camping or boating in general? Write to the Superintendent of Documents about your special interests; by return mail you're likely to get a check list of half-a-dozen or more pamphlets covering the subject. Individual parks are also a source for booklets covering their history and points of interest.

**EVERYONE TALKS** about the environment but it is encouraging to hear when something is done about it. In Utah, the Division of Wildlife Resources reports two men are serving 90-day jail terms for shooting a golden eagle. The men claimed they did not recognize the bird so they shot it for coyote bait.

**KEEPING COMFORTABLE** outdoors with the right clothing is getting a big boost from the recent introduction of a number of light but durable items. Gladding's Aqua-Float Coat is a jacket suitable for boating, fishing or snowmobiling but is said to have enough buoyant foam lining to keep the wearer afloat in case of a dunking. Several similar life-preserver windbreakers have recently come on the market from other sources as well, and while most are not Coast Guard approved as legal "personal flotation devices," any one of them might save a life.

John Deere dealers, the source of much outdoor equipment, have borrowed from the astronauts a metallic Therm-O-Liner to reflect body heat for wearers of their new jackets.

Clothes to match your boat were bound to come, just as they have for snowmobilers. Appropriately enough, Arctic Cat's companion company, Silverline Boats, now has sets of child-size and adult windbreakers, warm-up and flotation jackets and full storm suits color matched to Silverline runabouts and cruisers. Or to look the same as your Johnson Stinger outboard, you can get a Fish-N-Boat Johnson jump suit at the same time that you buy your motor.

Outboard Marine, parent company of Johnson and Evinrude outboards, has added Bo'suns boating shoes to its extensive accessory line. The white pebble-grain Duratex vinyl uppers can be easily cleaned with soap and water; squeegee soles can grip slippery decks. We have tested them and can recommend them. OMC parts and accessories have also been expanded to include useful items such as propeller guard kits that provide a protective shield around the prop, electronic corrosion protectors, combination bilge pump blowers, dash instruments, power tilt and trim, self-contained marine heads, freshwater systems for OMC stern drives, and stainless-steel Teflon propellers—so popular they're made for Evinrudes, Johnsons and their competition as well.

Hardly attractive to wear, but worthwhile just the same, are earmuff protectors like those used by jet-aircraft mechanics. More and more shooters are starting to bring them to the range as part of their regular equipment. Recently we tested some red, white and blue Whisper-Pak muffs that are about \$10 from Ithaca Gun dealers. It was discouraging to find how much they can improve a score—no one likes to believe he still flinches occasionally—but we find the muffs really work, and are equally useful, of course, to prevent ear damage that might lead to deafness.

**RECREATIONAL VEHICLE** owners often seem to have trouble tracking down all the accessories they like to load aboard. One new source is a 200-page *Camper's Catalog* that covers a good assortment of the tons of gear available. It's offered by many RV dealers, and to find the closest, check with Camper's Pride, Box 965M, Elkhart, Ind. 46514. Next time you're looking for a power converter or a heater replacement, roll-up awning or new LP-gas tank you can write them instead of me.

**WHAT THE FISHING BOAT** of the future is going to look like will be previewed shortly in a

*(Please turn to page 32)*

'73 Ford pickups  
start the better  
ideas coming  
all over again!



Behind seat is storage,  
not gas tank.



Ford box cover fits  
right, looks right.



Full-foam seat 5 in.  
deep is standard.



Optional "air" is all  
neatly built in.



Box sides are full  
depth double-wall.



Front disc brakes  
standard exc. 4x4.

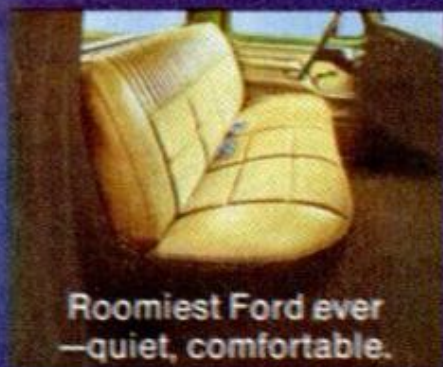

Roomiest Ford ever  
—quiet, comfortable.



Twin-I-Beam, start  
of Ford's great ride.



A better idea for safety:  
Buckle up.

FORD PICKUPS

FORD DIVISION



Works like a truck/rides like a car.

## ALL OUTDOORS

*(Continued from page 30)*

forthcoming issue. Now in preparation are drawings of PM's predictions for the ideal fishing rig.

**GUN FANS** have a number of new selections available, including several collectors' items that are almost too good to shoot. This year is the 150th anniversary of the venerable Texas Rangers. In their honor Winchester-Western Div. of Olin has issued a limited edition of 5000 commemorative Model 94 lever-action 30-30 rifles patterned after the famed old Winchester 1894 frontier model. A special-edition set of 150 will be offered through the Texas Ranger Assn. at \$1000 each, with the remainder sold by Texas dealers at \$135 per firearm.

Smith & Wesson's Texas Ranger commemorative will be a .357 revolver of the type used by the Rangers. Mounted in a presentation box with a bowie knife, the handsome set is priced at \$250.

Updating of a popular modern classic has been performed by Sturm, Ruger on its Single-Six revolver. Now the Ruger Super Single-Six, it has been refined to carry all six chambers fully loaded since a transfer bar is necessary to deliver hammer stroke to the firing pin, and the bar only rises into position when the trigger is pulled completely back. This new single-action six-shooter is strong enough to be "fanned," although the practice is not recommended. The revolver is expected to sell at about \$88 supplied with two cylinders—one for standard .22 loadings plus a magnum cylinder for powerful .22WMR cartridges—and 5½ or 6½-inch barrels.

From Remington comes announcement of its new Model 3200 American-made over and under 12-gauge shotgun. Similar to the Model 32, introduced in 1932 and produced for 10 years, this latest model has been radically upgraded. Air space between barrels keeps heat in one from distorting the other's aim. Stronger metals are used throughout. Field, skeet and trap grades will be available, starting at \$450.

Ithaca Gun's new one is the Deerslayer Model 51. Equipped to shoot rifle slugs, it is reported to be the first gas-operated semiautomatic of its type on the market. While a scope can be easily mounted for usual deer ranges, an owner can switch to regular shot-shells for birds and small game. Price for the shotgun will be about \$205.

**BOAT BUILDING BUFFS** have been showing new interest in catamaran sailboats, according to our mail, and to answer a lot of them at once here are two sources: Taft Marine, Dept. PM, 6512 Shingle Creek Parkway, Minneapolis, Minn. 55430, offers an all-glass

16-footer in kit form. Price is under \$900 and a trailer that fits it is also available. For starters-from-scratch, plans are \$5 for El Gato, No. B1233, a sailing cat, and \$5 for Pop-Cat, an outboard powered runabout. Both can be ordered from Popular Mechanics, Dept. CO, Box 1014, Radio City, New York, N.Y. 10019.

**SOME PEOPLE** don't like the sour taste of lemon, no one likes to own a "lemon," but everyone likes the smell of lemons, according to Johnson Wax researchers. They've come out with a lemon-scented spray called Glade Sunny Lemon that is claimed to be effective in masking the fish and bilge smells that can build up in a boat. If the stuff could also detour the seasickness that boat smells can help bring on, Johnson should have a nautical winner.

**OUTDOOR-TYPE READERS** are continually coming up with more uses for plastic bags and monofilament fishing line. Backpackers, of course, can bag almost everything to keep moisture out, and even a small camera can shoot right through protective plastic on a rainy day if the material across the lens is held tight and unwrinkled with a rubber band. A bag secured over a gun muzzle or around a prize fishing reel can keep the weather out until the last moment.

Mono line is regularly recommended for emergency thread to sew up a pack or tent rip or double as emergency guy lines or shoe laces. The Newton Line Co., one of the mono fishing line manufacturers, also notes that you can use it for emergency snares (breaking strengths go up from 2 to about 200 pounds) and as a repair medium for leaky rubber waders by heating and dripping it into the hole. Stow spare mono in your emergency kit along with a Swiss army knife, those plastic bags, matches and strapping tape and you'll find yourself inventing your own quick cures for ailing equipment in the field.

**RECENT PAMPHLETS** that are good, free and of special interest to outdoorsmen include one on care of fiberglass boats that is offered by Owens-Corning Fiberglas, Industrial Materials Div., Fiberglas Tower, Toledo, Ohio 43659, or boat dealers. *Fire Retardancy and Fiberglass Boats* comes from Hooker Chemical Corp., 1515 Summer St., Stamford, Conn. 06905. Any Sears, Roebuck store should now have in stock the new *Boating & Fishing* equipment catalog for summer, 1973. And Laacke & Joys, 1432 North Water St., Milwaukee, Wis. 53202, has recently enlarged their camping and marine mail order catalog and tell me they'll send it free to PM readers. ★ ★ ★

# DELCO PAIR-PAK. BECAUSE THEY'RE RIGHT FOR EACH OTHER, THEY'RE RIGHT FOR YOUR CAR.



Delco's made it easier for you to get the exact tune-up parts you need. Instead of asking for a set of points, and a condenser to go with them, ask for Delco's new Pair-Pak. You'll get a set of matched points and condenser in one convenient package.

Because the Pair-Pak points and condenser are

designed to work together, you get a good, clean break in the current that helps keep the points working cleaner, longer. And that means your engine works efficiently that much longer. Good for your engine, good for your pocketbook.

Next time you get involved in a tune-up, pick up a Delco Pair-Pak for your car. And you'll know you've got the right parts.



**THE MORE YOU KNOW,  
THE MORE YOU'LL WANT DELCO.**

DETROIT

# LISTENING POST

BY ROBERT LUND

**THE MINI-MINI CAR** may be here a lot faster than anybody figured. GM's working on two ultrasmall cars right now. That indicates the minimum mini's a lot closer than "the late 1970s" estimate GM puts out when asked, "When?"

GM wants to get a feel of what the market might be for a pinch-of-salt-size car before putting up the chips to produce it. So the current strategy calls for GM to join with a Japanese company and foot part of the bill for a new mini, which will be produced in Japan and imported into the United States for sale by GM dealers. After two years, GM will have a fair feel of the market and then decide whether to put a domestic version of the vehicle in production.

Both cars are being worked up now. The Japanese job could be ready in 18 months, as a '75 model or as a mid-year entry early in calendar 1975. There's a development program on the American follow-up car, but GM isn't pushing the project because it expects to pick up pointers on what to put on or leave off the home-grown version as a result its experience with the Japanese trailblazer.

**CHRYSLER'S GOT ONE TOO.** Chrysler's on-again, off-again small car is reportedly on again. Big C's taking a different tack this time. Instead of sizing and pricing the car to sell against

*Pinto, Vega and Gremlin, Chrysler will leapfrog the subcompact field and bring out a bantam-size car. Smaller than the current crop of pony-cars but not necessarily smaller than what the rival minis may be trimmed down to by 1975-76. How small? Say about 150 inches overall. But that's just a guess.*

**THE NEW LITTLE CARS** are more significant than they seem on the surface. They signal a new dimensioning of all cars. Smaller everything, from Cadillac and Lincoln on down.

Detroit's been saying for years it wants to reduce the number of models, cut out the proliferation, duplication and overlapping. So why complicate things by bringing out a new breed of automobile, the ultimate mini? Why add if the goal is to subtract? Will Detroit kill off something else to make room for the new shavetails? That's the idea, sort of. The mini-minis won't actually kill off current cars. But they'll be the successor automobiles to today's small cars, just as the medium-size cars will move down a notch to become subcompacts and the standard-size cars will shrink to medium size by today's definition. Everybody take one step back. That's the chain reaction the new shorties will set off when they appear in a couple years.

**DISCS ON ALL MAKES.** The few remaining  
*(Please turn to page 36)*



**THE APOLLO** goes on sale Apr. 5. With three ports on the front fenders, what else could it be but a Buick? Now all GM divisions (except Cadillac) have a compact (spelled Nova, Omega, Ventura, Apollo).

The car is 10½ inches shorter than the Century and comes in three models: hatchback, two-door coupe and four-door sedan. Standard engine is the 250-cu.-in. in-line Six with the 350-cu.-in. V8 engine optional



# freshen up



Warning: The Surgeon General Has Determined  
That Cigarette Smoking Is Dangerous to Your Health.

18 mg. "tar," 1.5 mg. nicotine av. per cigarette, FTC Report Aug. 72.

Материал, защищенный авторским правом

© 1977, BROWN & WILLIAMSON TOBACCO CORP.

# ECONOMY TRACTOR



## Man-size to give you more than just a lawn mower.

Economy tractor mows big lawns fast... but that's not all! It handles nearly every task on your place with really worthwhile man-size tools.

How? It's a special breed, that's how. Economy's extra size, weight and traction, plus the greater power-delivery of *all-gear drive* converts nearly 100% of engine horsepower into work. No fluid drive loss. Gives you more pull-power to work faster, more tool-power to operate 60" rotary mower and 20 other attachments. Write today for free catalog.

### With an Economy Tractor you can:

- Plow, till, harrow, pull heavy loads.
- Bulldoze with 4-ft angling blade.
- Load gravel, dirt; ¼-ton bucket.
- Mow 2 to 3 acres an hour with rotary mower or sickle bar.
- Clear 16" snow in one pass.



# ECONOMY TRACTOR

1005 K-4 Anoka Avenue  
Waukesha, Wis. 53186

C-31A

## DETROIT LISTENING POST

(Continued from page 34)

cars without disc or power disc brakes as standard will get the item beginning with production of the first '75 model. No exceptions.

**NEW DOOR LOCK.** One of the supplier companies, TRW, has developed a door-to-speedometer hookup that looks like a sure winner. The device automatically locks the doors of a car when its speed reaches 30 miles an hour. The item is being tested and may be offered on some '75 cars.

**PRICING THE WANKEL.** Despite GM's all-out commitment to the Wankel, the company is far from the finish line on how it's going to handle cost and pricing of the rotary.

With all the advance buildup the engine has received, GM figures it can sell the first year's output of rotary-powered cars at just about any price it wants to ask. Something like \$400 to \$600 over a conventional V8 wouldn't be out of line. Not that GM's indicated that's what the premium will be.

GM's concerned about what it will have to charge for the engine after the first rush of buyers have been satisfied. The Wankel has to be priced competitively against the piston engine, or it isn't going to sell in the numbers GM needs to recoup its investment. GM's considered all this, but has yet to come up with the figures on how it's going to price the engine after the novelty wears off.

**SAFER, CLEANER CARS** coming in '74 and '75 may run a lot noisier than current cars. Engineers say automobiles can't continue to get heavier. But they're going to get heavier because of new safety and emission-control gear coming in '74-'75. Car producers are looking at new materials—plastics and aluminum—to reduce weight, but this takes time, because new materials have to be tested over a long period.

The quickest way to pull pounds off a car would be to remove sound deadeners used to reduce road noise. Some cars use as much as 250 pounds of sound dampeners. Engineers fear this is the route they may be forced to take. If so, your next car and the one you will buy after that are going to ride a lot noisier.

And speaking of cleaner cars, April is National Check Your Emissions Month. The point is that now is the time to get an emissions tune-up.

★★★



**Any one of these four oils  
is right for your car.**



Sunoco Special takes the worry and confusion out of buying the right oil for your car. You see, Sunoco Special 10W-40 is really four oils in one.

It does all the work of a 10W, 20, 30 and 40 motor oil. Sunoco Special is one oil you can use in both summer and winter—in fact, all year round. Sunoco Special meets or exceeds the warranty

standards of all car manufacturers.

What's more, it gives you extra protection against thickening or breaking down under heavy-load, high-speed driving conditions. So change to Sunoco Special and know you're getting the right oil for your car...the right oil for all seasons, all driving conditions.

**Sunoco Special. The long mileage motor oil.**



## Get a horse... Wheel Horse of course!

There are a lot of lawn and garden tractors around. But, we feel that Wheel Horse is the best! And a better buy! Our 25 years of experienced craftsmanship help us provide you with better quality and more trouble-free tractors. Wheel Horse offers a wide selection of tractor models and attachments. Thirteen lawn and garden tractors to choose from... 7 through 18 HP for 1973.

Wheel Horse offers six automatic and seven standard transmission models, all backed by a two-year warranty for your protection... serviced by a nationwide network of over 2000 dealers. Visit your local Wheel Horse dealer today. He's listed in the Yellow Pages under "lawn mowers."

Write for your free copy of our new 1973 Wheel Horse catalog.

**Ours come with a 2 year warranty.**



## WHEEL HORSE Lawn and Garden Tractors

Wheel-Horse Products, Inc., Dept. PM, 515 West Ireland Road, South Bend, Indiana 46614

**Two-year Warranty**—Wheel-Horse Products, Inc., guarantees its tractors and attaching tools against manufacturing defects for two years from date of purchase. Parts manufactured by Wheel Horse will be replaced free if found to be defective while in normal service during the two years following the date of purchase. Products used commercially are guaranteed for 90 days from date of purchase. Drive belts are also guaranteed for 90 days from date of purchase. Engines and batteries are guaranteed separately by their manufacturers.

All claims must be handled through an authorized Wheel Horse dealer. Transportation costs and dealer service call charges are the responsibility of the owner.

# THIS CAN BE YOUR "BIG BREAK"

if you're a man who doesn't want to be...

**"Ashamed  
to go to his  
class reunion!"**

REMEMBER, DEAR, OUR  
HIGH SCHOOL REUNION  
IS THIS WEEKEND.

DO WE HAVE TO GO,  
HONEY? SUPPOSE  
SOMEONE ASKS ME  
ABOUT THAT CRUMMY  
JOB OF MINE...?



PLEASE, JACK,  
I'M DYING TO SEE OUR  
OLD FRIENDS AGAIN.

OH,  
I GUESS SO  
— O.K.

LATER

JACK! WHERE  
HAVE YOU BEEN  
KEEPING YOURSELF?

OH, YOU KNOW—  
AROUND. LOOKS LIKE  
**YOU'VE DONE**  
ALL RIGHT, THOUGH.



ONLY SINCE I GOT  
SMART AND GOT INTO  
**ELECTRONICS!** IT'S  
A BIG "GROWTH" FIELD  
TODAY.

SOUNDS GREAT.  
BUT HOW'D YOU  
BREAK IN?



EASIER THAN YOU MIGHT  
THINK. I LEARNED  
EVERYTHING I NEEDED TO  
KNOW AT HOME, IN MY  
SPARE TIME... WITH  
**CIE!** THEY EVEN  
HELPED ME GET  
MY JOB, TOO!

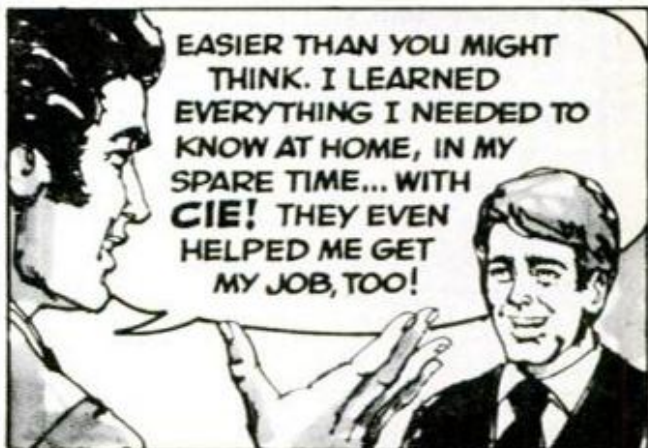

HOW ABOUT YOU? WANT A  
GREAT JOB IN ELECTRONICS?  
GET FULL FACTS IN  
**CIE'S 2 FREE  
SUCCESS BOOKS!**  
SEND REPLY CARD  
OR COUPON NOW!



Be sure to send for your 2 FREE books today. For your convenience, we will try to have a representative call. If coupon has been removed, write to Cleveland Institute of Electronics, Inc., 1776 East 17th Street, Cleveland, Ohio 44114.

FILL IN COUPON AND MAIL TODAY

**CIE** Cleveland Institute of Electronics, Inc.  
1776 East 17th Street, Cleveland, Ohio 44114  
Accredited Member National Home Study Council

Please send me your two FREE books:

1. Your school catalog, "Succeed in Electronics."
2. Your book on "How To Get A Commercial FCC License."

Name \_\_\_\_\_ Age \_\_\_\_\_  
(please print)

Address \_\_\_\_\_

City \_\_\_\_\_ State \_\_\_\_\_ Zip \_\_\_\_\_

APPROVED FOR TRAINING UNDER G.I. BILL

Veterans & Servicemen: Check here for G.I. Bill information

PM-78

# THE BICYCLE SHOP

By EUGENE A. SLOANE

**YOU WERE LEFT** with a wheel wobbly and out of true at the end of last month's column on *How to Build and Lace a Bicycle Wheel*. The instructions here will show you how to make a bicycle wheel "true," both laterally (side to side) and concentrically (in its roundness).

Even if you haven't laced up a new rim, you should know how to keep your wheels straight and true because caliper brakes work better when they can grab a rim evenly on both sides, you can steer more accurately in traffic, and tires last longer.

Here's some basic vocabulary:

- **Concentric out of round** occurs when the wheel has high and low spots on the outside diameter of the rim, so you feel a thump, thump, thump as you ride.

- **Lateral out of round** is a wheel rim that is too much to one side or the other.

- **Dishing** refers to the rear wheel and means that the wheel is moved to the right so it's centered on total width between locknuts (not the hub or axle) to compensate for the freewheel (see drawing at right). Dishing keeps the wheel centered in the bike frame, which is critical to a properly aligned bicycle.

- **Centering** applies to the front wheel and means that the rim is centered between axle locknuts, but *not* moved to the right (see drawing at right).

- **Tension** applies to the degree to which you tighten spoke nipples. Tension should be more or less even on all spokes, with perhaps the right spokes of the rear wheel having a little bit more tension than the left because you've concentrated on pulling (dishing) the wheel to the right.

- **Direction of rim movement** has to be understood before you can true a wheel. In the drawing, arrows show how the rim will move when you *tighten* a spoke. If all spokes are tight, the rim moves in the *opposite* direction when you *loosen* the same spoke. There's further explanation in the step-by-step instructions.

(Please turn to page 42)

## How to 'true' a wheel

For a safe, straight-riding bicycle, the art of 'truing' a wheel is vital

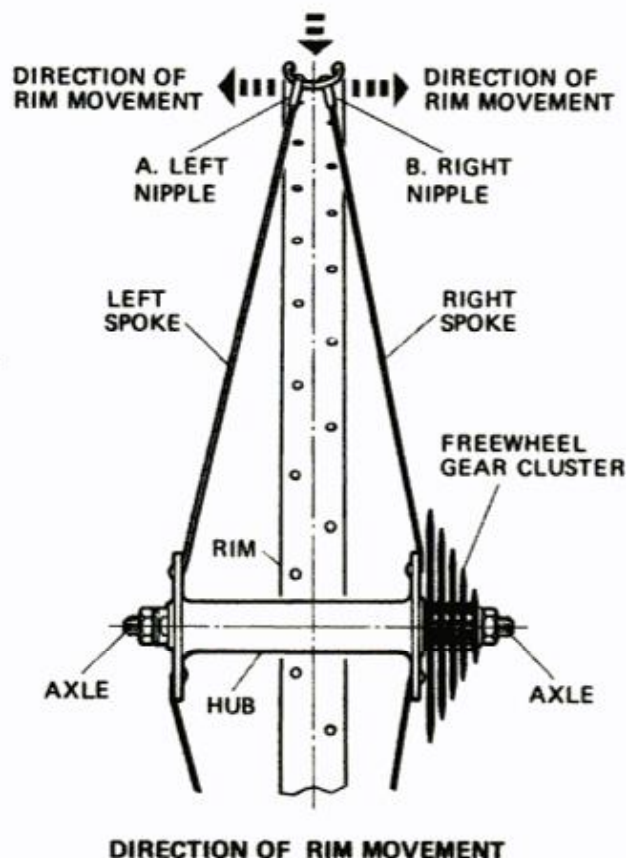
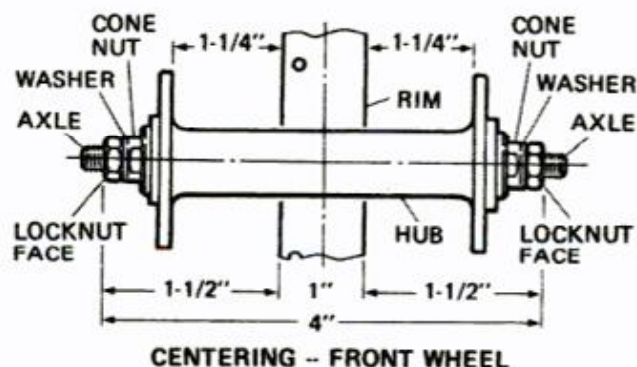
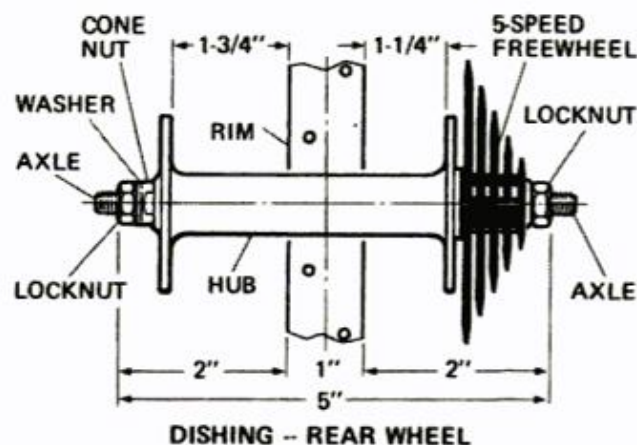

# If you've got the answers, we've got the job.

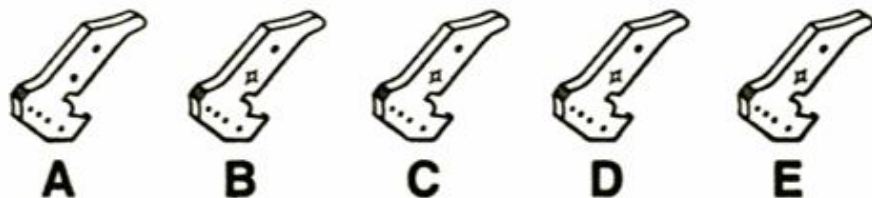

How accurate are you at spotting the difference between similar objects? If you have inborn mechanical ability, it's something you're good at. Some-

thing that should help take you fast and far in today's technically sophisticated Air Force. Quick, which of the five parts is the odd ball in the bunch? **Answer: A.**



Good technical specialists need to visualize. These "cubes" will give your visualizing talents a workout. Look at all five.

Which, if any, of the cubes on the right - A, B, C, or D - could be the cube on the left after being turned? **Answer: A.**

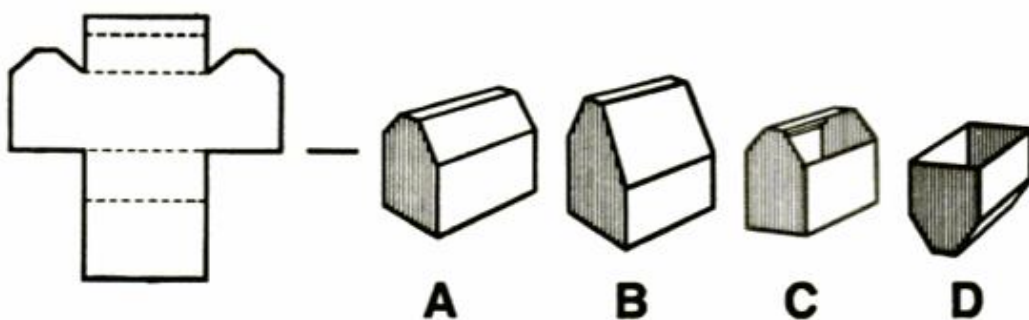

Here's one that helps show how good you'll be with blueprints. At left, you see the top, side and front views of a simple

object. Put them together in your mind's eye, and where do you wind up? With A, B, C, or D? **Answer: B.**

Illustrations Courtesy of Arco Publishing Co., Inc.

3 out of 3 right? Good work! This could be just the beginning. The next step is to take our free aptitude test to see which of over 100 Air Force jobs, from aircraft mechanic to computer operator, you qualify for.

If you find that mechanics is your thing, put it to work for you in the Air Force. You'll have a crack at the best technical education around, and provide yourself with a reusable skill for civilian life later. Just mail in the coupon, or call 800-447-4700, toll free (in Illinois call 800-322-4400) for the address of your nearest Air Force representative.

You'll get full details on how to go up in the world.

|                                      |             |           |
|--------------------------------------|-------------|-----------|
| Air Force Opportunities              |             | 1-PM-43   |
| Box A<br>Randolph AFB, Texas 78148   |             |           |
| Name _____                           | _____       |           |
| Address _____                        | _____       |           |
| City _____                           | State _____ | Zip _____ |
| High School _____                    | _____       |           |
| Soc. Sec. # _____                    | Age _____   | Sex _____ |
| I understand there is no obligation. |             |           |

## Find yourself in the Air Force.

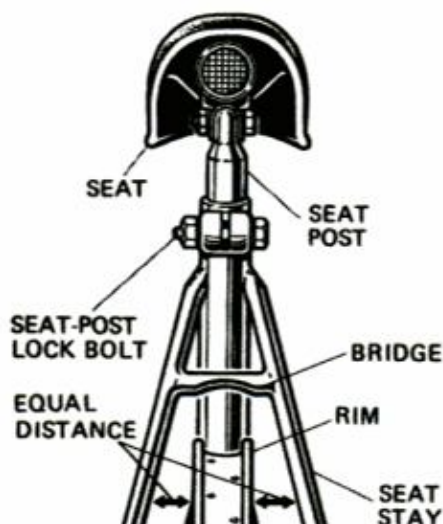

**TOOLS YOU NEED:** inch/metric vernier caliper-depth gauge (A); a spoke wrench (B); a wheel-truing stand (C); rim-centering gauge (D), and ratchet screwdriver (E) to speed nipple threading. The wheel-truing stand is about \$25 from a Raleigh dealer, or you can use an old bicycle fork. The rim-centering gauge is about

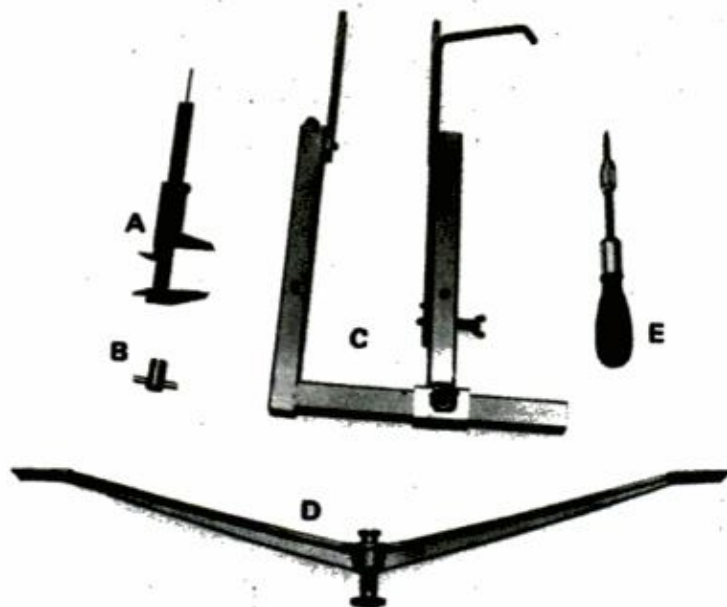

\$10, or you can make one from wood if you work carefully. (The gauge simply assures that edges of the rim are the same distance from the outer face of both axle locknuts.) You could also use the seat-stay bridge as a guide (as shown in the drawing). The rear wheel should be centered on the bridge

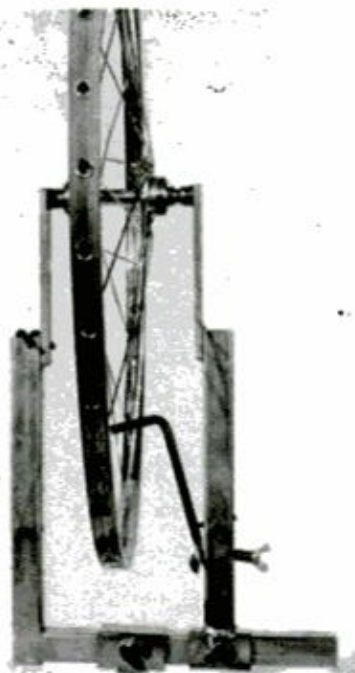

**Step 1:** These instructions will start with the rear wheel since it is more difficult to true than the front wheel because it has to be dished. (The drawings on page 40 illustrate that difference between front and rear wheels.) Put the rear wheel in the truing stand (or an old fork) with the free-wheel on the right side. From now on in instructions, the free-wheel side will be called the right side.

sides of the rim. Yet you will notice there are  $1\frac{1}{4}$  inches on the left and only  $1\frac{1}{4}$  inches on the right side of the rim so far as the hub alone is concerned. Thus you can see the rim is centered not on the hub but between the axle locknuts; the rim is dished to the right. The front wheel is centered both on the hub and between the axle locknuts (as shown in the "Centering" drawing) and is not dished. Now, adjust the movable stop on the rim gauge, following these steps. Measure distance between axle locknuts with vernier calipers. (I suggest you buy a combination inch/metric pocket inside-outside-depth vernier gauge for about \$3.50 from either Ametric Supply Co., 2309 W. Leland, Chicago, Ill. 60625, or Metric & Multi-standard Components Corp., 198 Saw Mill Rd., Elmsford, N.Y. 10523. And I suggest you use metric measurements to avoid complications.) Let's say distance between locknuts is 120.3 mm.

**Step 2:** Start at the valve hole and, using the ratchet screwdriver, turn right-side nipples till spoke threads are just out of sight. Then turn left-side nipples until the last four or five threads just show under the nipple. With spokes drawn up tighter on the right side than on the left, the rim is pulled to the right for correct dishing and centering between locknuts. (For front wheels, turn nipples on both sides to cover spoke threads.)

**Step 4:** Measure rim width with the vernier gauge. Let's say it's 19.4 mm.

**Step 5:** Subtract the Step 4 measurement from the Step 3 measurement and divide by 2. Example:

|                          |       | Inches<br>(Fraction) | Inches<br>(Decimal) |
|--------------------------|-------|----------------------|---------------------|
| Locknut-to-locknut width | 120.3 | $4\text{-}3/4$       | 4.750               |
| Hub width                | -19.4 | $-49/64$             | -.76242             |
| Remainder                | 100.9 | $3\text{-}63/64$     | 3.988               |
| Divided by 2             | 50.45 | $1\text{-}127/128$   | 1.994               |

**Step 3:** To learn the use of the rim-centering gauge, to center both rear and front rims, first study the "Dishing" drawing on page 40. Measurements given are for purposes of illustration only. Note that total distance from outer surface of both axle locknuts is 5 inches, that the 1-inch-wide rim is centered between axle locknuts because there are 2 inches on both

Obviously, the metric system makes it simpler. Good bikes are generally metric, so it makes sense to use the metric system. Remember these measurements are hypothetical; you must measure the hubs and rims you're using for accurate centering.

**Step 6:** Put the centering gauge on a table, and, with a vernier depth gauge, set the gauge's screw  
(Please turn to page 46)



# Chevrolet announces a brand-new guide to help buyers choose the right recreational vehicle.



## How to pick an RV you can live with.

The Guide can help you decide which kind of camper fits in with your recreational plans and budget. It'll help you select a type and model.

## Facts for everyone: from beginner to old pro.

The 1973 Recreational Vehicle Buyer's Guide by Chevrolet is 84 pages full of facts, figures and full-color illustrations. For the beginner, there's a complete introduction to trailering vehicles, pickup campers and motor homes. For the expert, specifications such as load limits, engine/transmission teams, axle ratios, cooling systems, tire sizes and tread patterns.



And it will help with specifics like floor plans, sleeping capacity, built-ins and options, water and electrical systems, winterizing and cold-weather use.

## Articles by writers who know what they're talking about.

You'll also find out what's new and important in the growing, changing RV field in

a series of new feature articles for the Guide by editorial writers from leading RV magazines: *Camper Coachman*, *Woodall's Trailer Travel* and *Motor Home Life*.

## From travel trailers to motor homes with stops along the way.

Our RV Buyer's Guide also gives you detailed information on ordering the Chevrolet car or truck you need to tote or tow your camper. Specifications straight from Chevy engineers cover things you ought

to know about, from horsepower to gross combined weight.



Please enclose 50¢ in coin (to cover mailing and handling) for each copy of Chevrolet's Recreational Vehicle Buyer's Guide ordered.

Mail to: Recreational Vehicle Buyer's Guide  
P. O. Box 7271  
Detroit, Michigan 48202

NAME \_\_\_\_\_

ADDRESS \_\_\_\_\_

CITY \_\_\_\_\_ STATE \_\_\_\_\_ ZIP \_\_\_\_\_

PM 259

**MY SPARE TIME HOBBY  
MAKES ME  
\$500 an hour  
CASH PROFIT**

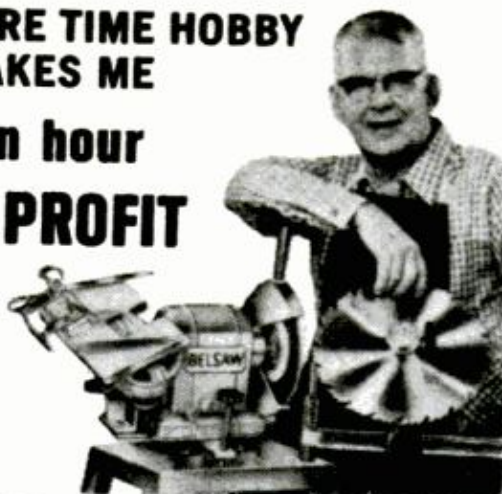

**START YOUR OWN SPARE TIME BUSINESS**  
You can turn your spare time into Big Cash Profits with your own **COMPLETE SHARPENING SHOP**... Grind saws, knives, scissors, skates, lawn mower blades... all cutting edges. Your Own Cash Business with no inventory... right at home... no experience needed. **FREE BOOK** tells how you can start your own spare time business while you are still working at your regular job. Low Cost—time payments.



Just Mail Coupon—No Salesman Will Call

**FREE BOOK**

**BELSAW SHARP-ALL CO., 714A Field Bldg., Kansas City, Mo. 64111**  
Send Free Book, "LIFETIME SECURITY." No obligation.

Name \_\_\_\_\_  
Address \_\_\_\_\_  
City \_\_\_\_\_ State \_\_\_\_\_ Zip \_\_\_\_\_

**SEND FOR NEW 144 PAGE  
CRAFTSMAN CATALOG**

Over 3500 items

Discounts on  
Power Tools!



**Finest Domestic and Imported  
HARDWOODS**  
Veneers, Hardwood Plywoods,  
Hardware, Tools, Supplies  
all at Money Saving Prices

New! We've added Clock kits, marquetry picture kits, guitar and Dulcimer musical instruments. Everything you need in cabinet hardware, lamp and upholstery supplies... 3500 items! Save on power tools—name brands! For catalog, send name, address and 50c for handling, postage to

**CRAFTSMAN WOOD SERVICE CO. Dept. A-43**  
2729 S. Mary St., Chicago, Illinois 60608

**MOLDS**

for making  
Ornamental Concrete  
Items...

Book about Aluminum  
Molds with prices and  
production trade secrets  
direct from world's largest  
mold manufacturer.



SEND  
\$3.00

**CONCRETE MACHINERY COMPANY, INC.**

P. O. BOX A99 - HICKORY, N. C. 28601

**BUILD YOUR OWN CAMPER  
SAVE UP TO 50%**



Complete, easy to follow plans, instructions, materials list.

- Camper Plans .....\$3.95
- Travel Trailer .....\$3.95
- Pickup Cover .....\$2.00
- CONVERSION PLANS:**
- Econoline Type Van..\$2.95
- Passenger Bus or
- Delivery Van.....\$2.95
- Satisfaction Guaranteed

**VIKING CAMPER SUPPLY, INC.**  
99-BP Glenwood Ave.,  
Minneapolis, Minn. 55403  
Please send \_\_\_\_\_ for  
which I enclose \$\_\_\_\_\_  
NAME \_\_\_\_\_  
ADDRESS \_\_\_\_\_  
CITY \_\_\_\_\_  
STATE \_\_\_\_\_ ZIP \_\_\_\_\_

**EQUIPMENT CATALOG \$1.00**

Refundable on First Order.  
Send Dime for Details.  
Save 50% on Camper Kit.  
All items from catalog to  
build \$1,795. Camper, 8',  
10', 10'6" or Chassis Unit.



**Are you missing  
half the joy of  
your guitar?**

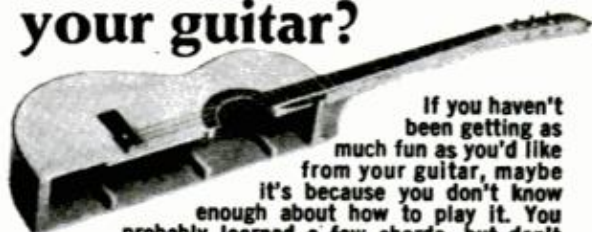

If you haven't been getting as much fun as you'd like from your guitar, maybe it's because you don't know enough about how to play it. You probably learned a few chords, but don't know how to go further. If so, let us help you. We'll teach you to read music and play pick style with both notes and chords—the way a teacher would. The difference is we teach with lessons by mail, and it costs a lot less. Courses in other instruments too—piano, spinet organ, accordion, violin, saxophone. If 17 or over, write for free booklet with more details. Send your name, address, zip code and list instrument you want to learn. Write U.S. School of Music, Studio A304, Port Washington, N.Y. 11050.

ACCREDITED MEMBER NATIONAL HOME STUDY COUNCIL  
© 1973 U.S. SCHOOL OF MUSIC

396

**USE ZIP CODES WHEN  
ANSWERING ADS**

**HEAVY DUTY WELDER**

with special \$7.00 gift offer to  
Popular Mechanics readers  
**10-DAY FREE TRIAL**  
Lifetime Guarantee



Brand New **1895**  
Model **18** POST PAID

Fits ordinary 110V outlet  
Not one - but 6 welding heats



Weld, braze, solder or cut most anything made of metal. No experience necessary. Follow simple instructions to make repairs on cars, trailers, farm and lawn equipment, bicycles, appliances, etc. Make campers, boats, furniture, hundreds of valuable items. **NOTHING ELSE TO BUY!** Comes complete with full face shield, pack of welding and brazing rods, heavy duty power cables, special electric torch attachment, ground clamp, flux, easy-to-follow illustrated instructions, rod holder, etc. Uses standard 1/4" rods to weld iron, steel, brass, bronze, aluminum, other metals. New improved **HEAVY DUTY** circuit gives more welding power. Gives 4 times the heat needed to melt toughest iron. Plugs into ordinary 110V outlet. **6 WELDING HEATS** plus continuously variable carbon-arc heat regulation control lets you weld anything from "tough" jobs to light-weight metals with ease. This important feature saves you money and time. Makes it possible for even beginners to start welding professionally the very first day. Pays for itself quickly. An excellent gift for any occasion. **IT'S AUTOMATIC:** Current is turned ON when arc is struck, OFF when rod is lifted from work. Eliminates need for troublesome foot switch. Speeds up work.

**FREE!**

Mention that you saw this ad in Popular Mechanics and receive a \$7.00 gift pack assortment of "touch weld" welding rods. Automatic arc striker. Weld with "push button" ease. Lifetime guarantee.  
10 day **MONEY BACK GUARANTEE.** You must be satisfied or return for refund. Send only \$2.00 and pay postman \$16.95 plus postage when delivered or send \$18.95 cash, check or money order for immediate postpaid shipment.

**WEL-DEX MFG. CO., Dept. W-203, Box 10776, Houston, Texas 77018**

**POPULAR MECHANICS**

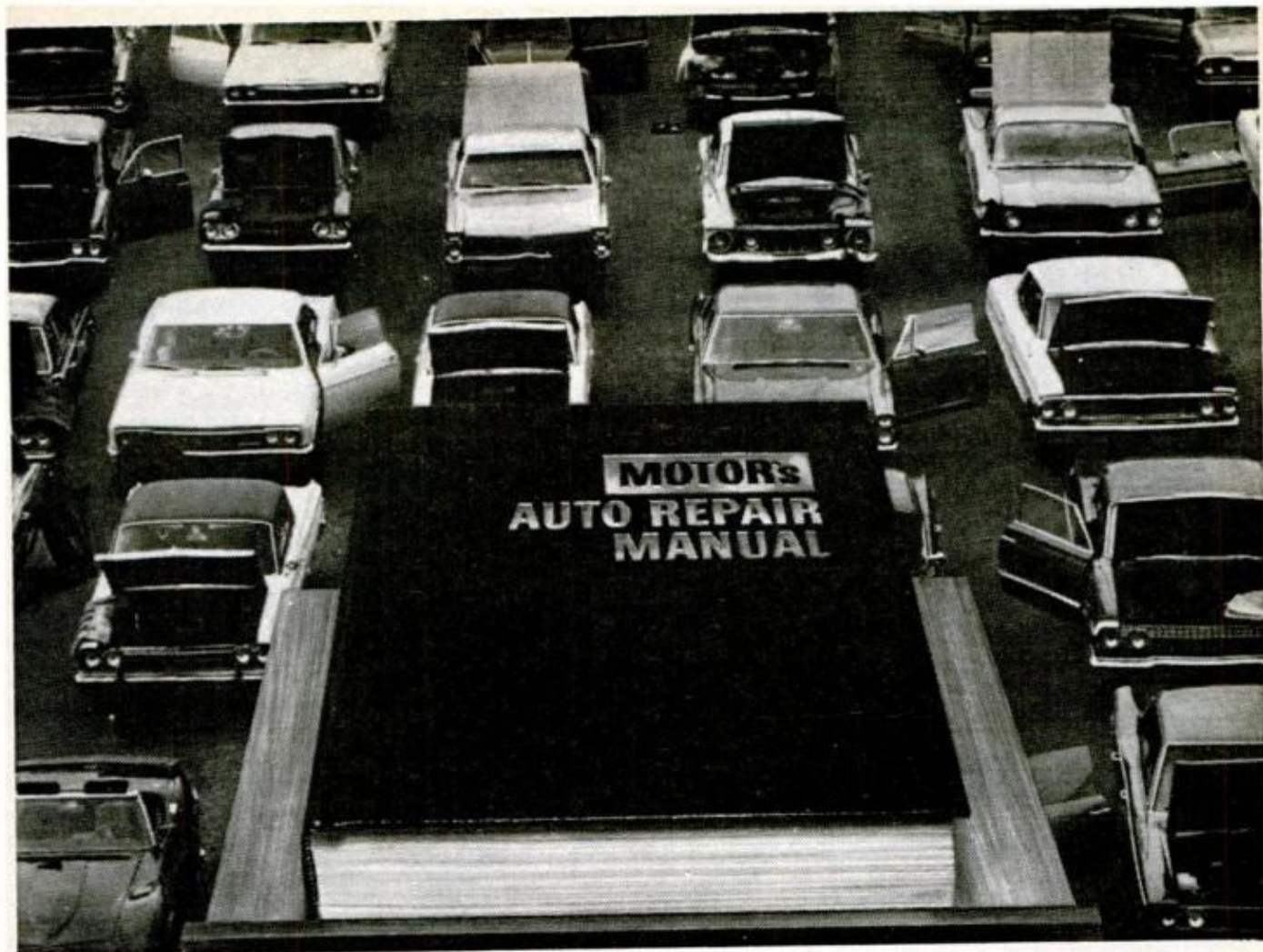

# How to fix almost any part of almost any car

Now, whether you're a green beginner or expert mechanic, you can breeze through almost any auto repair job on all the cars listed here built from 1967 to 1973.

All you need is the new 1973 Edition of **MOTOR'S AUTO REPAIR MANUAL** — the famous illustrated guide that makes practically every operation on almost any car as easy to do as A-B-C.

## Special Trouble-Shooter Section

The special Trouble-Shooter Section in **MOTOR'S MANUAL**, plus detailed troubleshooting information throughout, helps you pinpoint any of 4,200 car troubles in a jiffy... spots exactly where the trouble is in engines, transmissions, axles, etc.

## Big New 1973 Edition Over 1,000 Pages — Over 3,000 Pictures!

This newest, most up-to-date edition covers everything you need to know to fix 2,300 car models from 1967 through 1973, including compacts and intermediate cars. Plus tune-up and front-end alignment specs on all models from 1946 through 1966. Over 1,000 giant double-sized pages, over 3,000 pictures. "Quick-Check" Specification Tables for all cars, 55,000 essential service specifications. Over 225,000 service and repair facts.

## The "Meat" of 300 Official Shop Manuals

The editors of **MOTOR** gathered together a wealth of know-how from 300 official shop manuals and hundreds of factory bulletins, and boiled it down into crystal-clear terms in one big illustrated book.

## All These Makes Covered

TORONADO  
BARRACUDA  
PONTIAC  
IMPERIAL  
DART  
FORD  
CHRYSLER  
RAMBLER  
PINTO  
BUICK SPECIAL  
MARK IV  
FALCON  
TEMPEST  
COUGAR  
VOLKSWAGEN  
MAVERICK

THUNDERBIRD  
CADILLAC  
CONTINENTAL  
CHEVROLET  
PLYMOUTH  
DODGE  
COMET  
AMERICAN  
FAIRLANE  
CORVETTE  
MUSTANG  
CHEVY II  
BUICK  
MERCURY  
CHEVELLE  
GREMLIN

OLDSMOBILE  
CORVAIR  
OLDS F-85  
VALIANT  
JAVELIN  
MONTEGO  
TORINO  
LINCOLN  
FRONT-DRIVE  
CADILLAC  
MARK III  
AMX  
CHALLENGER  
HORNET  
VEGA  
More...

Not only do you get the latest up-to-the-minute "how-to" information on each car listed above, you also get service data on Transmissions, Steering, Brakes, Overdrives, Alternators, Fuel Pumps, Ignition Systems, Engines, much more!

No wonder over six million copies have been sold to mechanics, students, repair shops, etc.

## Try This Book at Our Risk — FREE

Send no money. Just mail the coupon and we'll send the giant 1973 edition of **MOTOR'S AUTO REPAIR MANUAL** right to your home or shop. Try this famous guide for 10 full days — FREE! If this book doesn't pay for itself in the first 10 days, just return it and owe nothing.

Mail coupon to **MOTOR Book Department**, P.O. Box 2316, F.D.R. Sta., N.Y., N.Y. 10022.

**Brand-New 1973 Edition ★ Used by  
Repair Shops, U.S. Armed Forces,  
Schools, Etc.**



**SAME 10-DAY FREE TRIAL ON AUTO ENGINES AND ELECTRICAL SYSTEMS.** Explains engines and electrical systems thoroughly, showing how and why they work. 700 pages. Only \$10.95.

**MOTOR BOOK DEPT. F114**  
P.O. Box 2316, F.D.R. Station,  
New York, N. Y. 10022

Please send me the Manuals checked below for ten days free examination:

- 11122 **MOTOR'S Auto Repair Manual, \$10.95**  
 12526 **MOTOR'S Auto Engines & Electrical Systems, \$10.95**

If I am not fully satisfied, I will return the shipment promptly and owe nothing. Or I will keep it and pay the total price in three monthly installments, plus a small shipping charge.

### I WANT TO SAVE SHIPPING CHARGES

- I am enclosing payment of \$..... in full and you will pay shipping charges. (Same return privileges, refund guaranteed.)

F114

Print Name \_\_\_\_\_

Address \_\_\_\_\_

City & State \_\_\_\_\_

Zip \_\_\_\_\_

Signature Please \_\_\_\_\_

Age \_\_\_\_\_

Offer available only in the Continental United States and Canada. Prices slightly higher in Canada. Delivery will normally be 3-4 weeks in Eastern U.S. and slightly longer West of the Miss.

(N.M. Books)

## THE BICYCLE SHOP

(Continued from page 42)

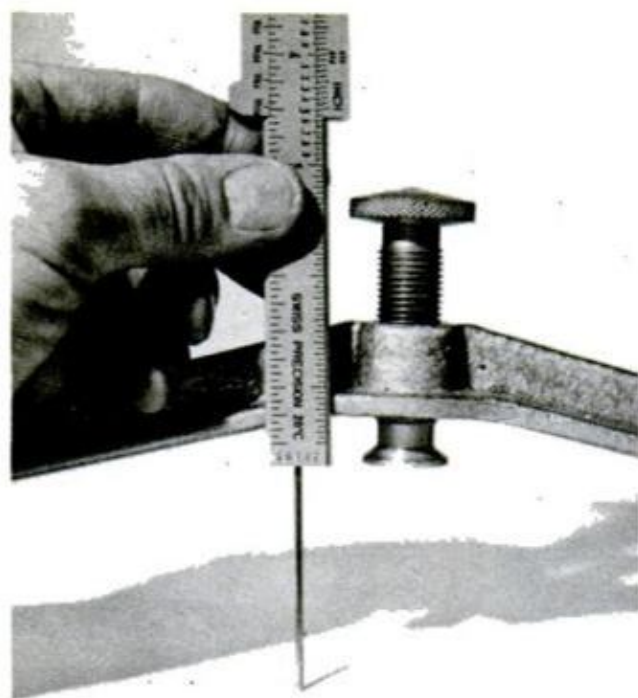

so the head of the screw that rests on the axle locknut is 50.45 mm or 1-127/128 inches from the table. (You could say 2 inches, but you'd be off a bit.) The gauge screw is hollow, so the axle fits inside and permits the gauge screwhead to rest on the axle locknut. (Again, these are hypothetical measurements.)



**Step 7:** Remove wheel from truing stand and lay it on your bench. Put the centering gauge on the wheel and try both sides to get an idea of how far the wheel rim is off to one side or the other.

**Step 8:** Put the wheel back on the truing stand. Set lateral (side to side) movement indicator so it touches the first major bump (farthest rim spot) on the left side. (If you're using an old fork, a piece of pipe cleaner or anything that will stay in place will serve as an indicator.) Tighten spoke nipple of right side from the bump one turn to pull the rim right. Find the next worst bump on the left side and repeat. Keep going until major left-side bumps are more or less removed. Don't worry about fine truing at this point.

**Step 9:** Repeat step 8 (move indicator to right side) to remove major right lateral bumps, turning nipple on the left side across from the bump one turn and continue around the wheel until the major right-side bumps are out.

**Step 10:** Remove wheel from the truing stand and again check rim alignment with gauge, as in step 7. If the rim is too far to the left, tighten all spoke nipples on the right one-half turn; if too far to the right, tighten all nipples on the left one-half turn.

**Step 11:** Put the wheel back on the truing stand. Continue working on the wheel to remove lateral untrueness, except this time turn the nipples one-half turn the first time around, then one-quarter turn the succeeding times. Do not attempt to pull out a lateral bump all at once, but work gradually around the rim. Excessive nipple tightening may cause uneven spoke tension in the finished wheel, leading to spoke breakage.

**Step 12:** Check again with the rim-centering gauge, removing the wheel from the truing stand and adjusting nipples one-quarter turn at a time, as described in step 10.

**Step 13:** With the wheel in the truing stand, move the indicator to the outside diameter of the rim so concentric out-of-roundness will show. Spin the wheel to find where the rim rides highest. At this point, refer back to the "Direction of Movement" drawing (page 40) Note that the rim moves toward the hub when two spoke nipples—A and B—are tightened the same number of turns. The idea is to remove high spots by tightening both left and right spoke nipples at the high spot, thus drawing the rim down by compression as spoke tension is increased at that point. Work around the rim to pull down all concentric high spots, tightening left and right spoke nipples at the high spots one-half turn the first time, one-quarter turn the second time around and one-eighth turn the final times.

**Step 14:** Remove the wheel, check with the rim-centering gauge as in step 7 and turn nipples one-eighth turn to bring the rim to the right or left as necessary.

**Step 15:** With the wheel out of the truing stand and with one hand on the valve side of the rim and the other hand on the opposite side, rest the axle on a workbench and press the rim vigorously down on both sides. Rotate the rim one-quarter turn, repeat the pressing-down operation and continue rotating the rim two more turns. You may hear popping sounds as the spoke heads seat into the hub flange. Check the rim alignment once more with the gauge, as in step 7.

**Step 16:** With the wheel in the truing stand, touch up lateral and concentric untrueness and rim alignment with respect to hub axle locknuts, as in preceding steps, turning nipples very slightly each time (no more than one-eighth turn). If you've gone over the rim several times and find all spokes are tight—so you can't turn the nipples any more—you will have to loosen nipples slightly to take out untrueness. Example: You have a slight bump on the left side, but can't draw up the nipple on the right-side spoke across from the bump. Instead, loosen the left-side spoke one-quarter turn. For concentric highs, loosen the right and left nipples on the side of the rim opposite the high. Later, as you take a ride on your trued wheels, you may hear twanging sounds which indicate that spokes are still seating in. You will need a touch-up truing in 50 miles or so, and, as spokes continue to stretch and nipples and spoke heads to seat in, occasional touch-ups. ★★ ★

# If you decided to spend a leisurely afternoon on the lake and this is what you remember best, your runabout was probably built with Starcraftsmanship.



The 18' Holiday runabout isn't a racing boat. It's a practical family boat. That's why men buy it.

To cruise around the shore of the lake so gently they don't even disturb a dragon fly.

To take their sons for a day long fishing trip.

To explore watery places. To watch space stretch out so far ahead they can lose sight of it.

At Starcraft we never forget reasons like those. But we also never forget this.

Sometimes a man wants to cut loose. To open up that practical boat and see what it can do. To pull skiers. That's why we build versatile runabouts.

That takes Starcraftsmanship.

Starcraftsmanship is, basically, our standard of excellence.

Coming up to that standard has required

us to build the leading research and design center in the industry. A center that learns more about its customers' needs and can design the boats to meet those needs. All of them.

For example, Starcraftsmanship is the reason Holiday runabouts are made with light weight marine aluminum. It's economical. You can put a smaller engine on your boat and still equal or better the performance of a comparable boat of another material.

You save on gas consumption and engine weight.

Aluminum is also economical because it's practically maintenance free. The aluminum hull is so durable we give you a 15 year warranty against hull defects.

In fact, we expect everything about the Holiday to be as pleasing to you years afterward as it is the day you buy it.

Our boats don't have a lot of superfluous gadgets you can get tired of or wear out.

We choose upholstery and carpeting carefully so the colors wear as well as the materials.

We put value in materials and craftsmanship. Lasting value.

Maybe that's why our Holiday runabout is such a popular boat.

Maybe. Or maybe it's simply because the Holiday can do whatever you decide you want it to do. Even if you change your mind in midstream.

Write to us for more information about the Holiday line of runabouts from 14'-21', and the name of your nearest dealer. Dept. G25-4 Starcraft Company, Goshen, Indiana 46526



**BELSAW PLANER • MOLDER • SAW**

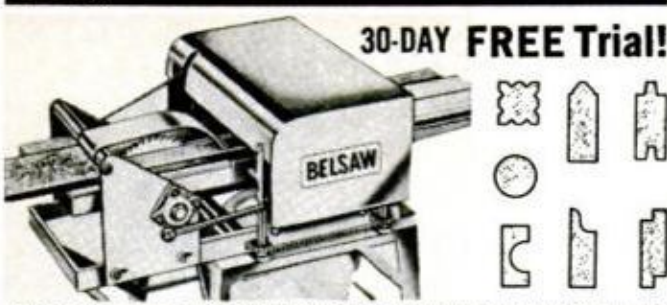

**30-DAY FREE Trial!**

Now you can use this ONE power-feed shop to turn rough lumber into moldings, trim, flooring, furniture...ALL popular patterns. RIP...PLANE...MOLD—separately or all at once with a single motor. Free 30-Day Trial. Low Cost—only \$35 down. Send Postcard Today—No Salesman Will Call. **BELSAW POWER TOOLS** 904A Field Bldg., Kansas City, Mo. 64111

**SUBSCRIBER'S**

**Change of Address Form**

Please use this form to notify us at least six weeks before you move to your new address.

**1. Present address:** Attach address label from a recent issue, or print your name and address exactly as shown on the label.

NAME \_\_\_\_\_  
 ADDRESS \_\_\_\_\_  
 CITY \_\_\_\_\_ STATE \_\_\_\_\_ ZIP \_\_\_\_\_

**2. Fill in new address:**

NAME \_\_\_\_\_  
 NEW ADDRESS \_\_\_\_\_  
 CITY \_\_\_\_\_ STATE \_\_\_\_\_ ZIP \_\_\_\_\_

**3. Mail this form to:**

**POPULAR MECHANICS**  
 Subscription Service Dept.  
 Box No. 646  
 New York, N.Y. 10019



**Print For Profit**

Cards, Stationery, Envelopes, Advertising, labels, tickets, announcements, Q.S.L. cards, greeting, sympathy, prayer cards, tags, etc. Good Profits. Pays for itself in a short time.

**Own a Printing Business**

We supply everything direct from factory only. Easily followed rules. Also raised printing like engraving. Have home shop. Add to income. Send 25c for catalogue. **KELSEY PRESSES** Meriden, Conn. 06450

**MAIL THIS COUPON TODAY!**

**KELSEY PRESSES, DEPT. 73-K, Meriden, Conn. 06450**

I enclose 25c send big catalog and samples.

Name \_\_\_\_\_  
 Address \_\_\_\_\_  
 City \_\_\_\_\_ State \_\_\_\_\_ Zip \_\_\_\_\_

**Costs Less to Use than Sandpaper Discs**

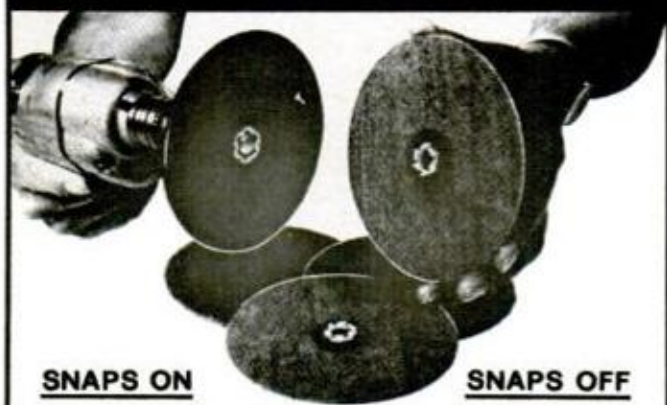

**SNAPS ON**

**SNAPS OFF**

Will outlast conventional sandpaper discs 10 to 1. Nylon backing resists tearing and snagging. Can be cleaned in paint thinner and used over and over again. Proven by the aerospace industry for over 7 years. Power-Lock discs perform equally well on wood, fiberglass or metal.

**MERIT ABRASIVE PRODUCTS, INC.**  
 SUBSIDIARY OF WASHINGTON STEEL CORPORATION  
 201 W. Marville, Compton, California 90224

**ORDER POWER-LOCK STARTER KIT BY MAIL**  
 PLK-5 5" diameter, 1 holder, 15 discs, assorted grits. For use on 1/4" drill. . . . . \$7.75  
 Add \$1.00 for postage and handling. Introductory price

**New Table Top Invention Puts You In . . . PROFITABLE RUBBER STAMP BUSINESS**

Home Operators now make **\$16.50 AN HOUR** in Business once monopolized by a few big companies

Special rubber stamps bring high prices—cost only pennies to make on new, low-cost table top machine. Take 27 cents worth of material, make perfect stamps, the kind businesses and offices now buy by the dozen at \$2.75 each. Make up to \$16.50 an hour. Start in spare time in your own home. Run machine on kitchen table using ordinary electrical outlet. Make any kind of stamp. We'll send you free information without obligation about this established, highly profitable business. We'll even help finance your start. For free information send name and address today on a postcard to: RubberStamp Div., 1512 Jarvis, Dept. R-2-CD, Chicago, Ill. 60626



**BUILD THESE BEAUTIFUL CLOCKS**



**NOW AT BIG SAVINGS!**

Send just \$1 for plans & instructions to build choice of: (A) Grandfather, (B) Steeple, (C) Grandmother—plus information-packed catalog of movements, dials, parts & kits to build these & 16 other fine clocks. All 3 plans—\$2.50. Catalog alone—25¢.

**MASON & SULLIVAN COMPANY**  
 Dept. PM, Osterville, Mass. 02655

**POPULAR MECHANICS**

# a new look

# at the fabulous Scorpion Too

\* FREE full color illustration (see coupon)



Have you heard about sport flying?  
Did you know that you can  
participate in your own  
personal helicopter

The Scorpion Too is RotorWay's  
answer to backyard flight.

Remember, the Scorpion is a  
true vertical take-off helicopter,  
it takes off straight up.

Using a 140 h.p. engine, it cruises at 75 m.p.h. and can  
carry over 400 lbs. The most exciting news about the  
twin-seat Scorpion is its low cost, but then it's about  
time a helicopter became a recreational vehicle.

- Send \$5 now  
for graphically illustrated  
color package containing:
- Fundamentals of rotorcraft flight
  - Illustrated flight maneuvers
  - How you learn to fly
  - Scorpion development history
  - Helicopter design theory
  - Engineering definitions
  - Power plant considerations
  - Price information
  - Performance specifications
  - Unique features of the Scorpion Too
  - Three-view dimensioned drawing
  - Electrical and other options
  - Exploded view of sub-assemblies
  - Description of major component areas
  - Information on how to proceed



Enclose this coupon with your \$5 and you will  
receive free, along with your package, a 25"x38"  
full color reproduction of this beautiful scaled  
cut-away drawing (as shown above). RotorWay  
commissioned Dick Aleith, one of the West's  
leading illustrators, to create this work of art.  
It's truly a collector's item.

**ROTORWAY, INC.**  
Dept. MM/14805 S. Interstate 10  
Tempe, Arizona 85281

Name \_\_\_\_\_  
Address \_\_\_\_\_  
City \_\_\_\_\_ State \_\_\_\_\_ Zip \_\_\_\_\_

## MFG

# Challenger 12

Pressure molded fiber glass tri-hull

BIA CERTIFIED **\$199.00**



**Challenger 14**  
**\$229.00**

F.O.B.  
FACTORY

- ROD HOLDERS
- INSULATED BAIT WELL
- TRANSOM DRAIN
- FOAM FLOTATION

White or Hunter Green

**SEE YOUR MFG DEALER**

MFG BOAT CO., UNION CITY, PA.

World's largest producer of fiber glass boats

## FREE Kirsten CATALOG OFFER

Send me your fully illustrated  
color catalog of the complete  
line of Kirsten pipes and  
accessories.

NAME \_\_\_\_\_  
ADDRESS \_\_\_\_\_  
CITY \_\_\_\_\_  
STATE \_\_\_\_\_ ZIP \_\_\_\_\_



**\$9**  
postpaid

**Kirsten  
PIPE CO., INC.**

P.O. Box 70526-PM-5  
Seattle, WA 98107

# APPLIANCE CLINIC

By PAUL MANN

## Testing oven temperature

*Our Tappan gas range, recently purchased, has an automatic clock that we set to operate the oven for a desired period of cooking time. At the end of this period, oven temperature automatically tapers off to keep the food warm. I don't think the holding temperature is hot enough. Can it be raised?—Donald Cooke, Nashville, Tenn.*

Yes, but first I would make certain that the setting is actually off. The degree of temperature in the holding position depends upon the setting of the temperature for the cook position. For example, if the thermostat is set for a cooking temperature of 350°, the holding temperature should be around 180° to 200°.

Test temperature with an accurate oven thermometer. Set the thermostat at 350° and let the unit get good and warm. If the thermometer shows that temperature is off by 100° or more, the thermostat should be replaced. If the temperature is off by less than 100°, the thermostat can be recalibrated.

To reset most thermostats, remove the knob which is usually held by a small conventional screw or Allen screw. In the center of the stem, you'll see a setscrew. In most cases, you turn the setscrew counterclockwise to lower the temperature; clockwise to raise it.

Only a slight turn of the setscrew is needed to vary temperature many degrees. Since turning the screw to achieve a desired temperature is trial-and-error, you should test the unit with the oven thermometer as you go along. To get an accurate reading, allow the thermostat to cycle three times before reading the thermometer. The thermostat should give an audible click as it cycles.

## If the shoe fits . . .

*While making continuity checks of a washing machine with a new ohmmeter, the meter went blooey and refused to*

*function. What recourse do I have toward the manufacturer of the meter?—William Fisk, Council Bluffs, Iowa.*

The manufacturer of your meter is an old reliable firm, and if the fault lies with the instrument, I'm sure the company will honor the warranty. However, experience shows that ohmmeter failure is often caused by incorrect application on the part of the user.

One of the mistakes frequently made is to perform the continuity test with the appliance connected to a live electrical circuit. Another is to use an ohmmeter to check a 110-volt circuit, which will knock the guts out of the ohmmeter.

Another fact frequently overlooked is that appliances often have capacitors that are energized even if the plug is pulled from wall outlet. If you hook the meter into the capacitor circuit, you'll discharge the capacitor right through the meter, which will damage the instrument. To check a capacitor circuit with an ohmmeter, you should first disconnect the capacitor leads and bypass the capacitor by throwing a jumper across the leads. Or you can discharge the capacitor by shorting across its leads to ground.

Another serious mistake often made by home mechanics is not reading the manufacturer's instruction booklet that comes packaged with a test instrument.

## Diagnosing water-valve noise

We have received letters asking us to diagnose water-valve noises coming from under-the-counter dishwashers. This is difficult to do without hearing the noise. Thus we will try to define each type of common noise, leaving it to you to do your own diagnosis. Before you start, however, check the water-heater setting because high water temperature can cause noise. Generally, water-heater thermostats should be no higher than 150° in homes having dishwashers.

Four common noises are:

1. *Water hammer.* This is caused by the abrupt closing of a water valve. It is characterized by a single loud thud. This thud creates a shock wave that is transmitted back through the plumbing system, which may cause considerable movement of piping.

To offset water hammer, manufacturers of under-the-counter dishwashers usually

*(Please turn to page 52)*



# Plymouth Gold Duster.

**You get a lot for your money.  
And a vinyl roof for no money.**



It only happens once a year. A car gets made like this one here. Plymouth Gold Duster. You get all the Duster specialties: room for five, cavernous trunk, electronic ignition. And more.

**You get a nice deep carpet to tickle your feet.**

It runs door-to-door and wall-to-wall. And it complements one of the plumpiest, poshest vinyl-seat interiors you ever saw



on a compact like our Gold Duster. (As if there were a compact like our Gold Duster.)

**You get whitewalls, wheel covers, and special trim.**

Why not? These are probably the kind of things you'd order on a car, whether or not you were getting a special deal.

Except that with Gold Duster, you're getting a special deal.



**You get a canopy vinyl roof that's right in style.**

It looks like it came off a gold reptile. You can get it at no extra charge when you buy the car as described. Since the factory doesn't charge the dealer, he doesn't have to charge you.

Gold Duster. It's a Gold Sticker value.



**Plymouth Gold Duster.**

Extra care in engineering... it makes a difference.



# LEARN TO BE A SKILLED LOCKSMITH



Change combination of pin tumbler cylinder  
EARN \$1.50 in 15 MIN.

Owner loses key; pick car trunk—  
EARN \$5.50 in 10 or 20 MIN.



Install new knob door lock—EARN \$15.00 in 30 MIN.

After-hour emergency opening—EARN \$2.50 to \$5.50 in 20 MIN.

**Hundreds have succeeded like these Belsaw Graduates:**

**R. W. Davis, St. Louis, Mo.:** "I am doing a wonderful business thanks to your course in locksmithing. Last Saturday I took in \$110.00."

**Pierson Crook, Los Angeles, Calif.:** "I am making \$200 a month extra income with the Belsaw Locksmith Course. I would recommend your course to anyone."

Big demand for skilled Locksmiths! Earn big money spare time in your own home. Be your own boss. No layoffs. Steady year 'round income. Age and schooling are no handicap.

**BELSAW INSTITUTE** training...approved by master locksmiths...helps you start faster with easy picture lessons guided by your own mail instructor.

Get thorough job training on all types of locks. We supply tools, equipment and business help: how to start, how to charge, how to get jobs, how to earn while you learn and build a lifetime cash-profit business. Accredited Member National Home Study Council. Approved by State Board of Education. Approved for Veterans.



**This \$125 key machine is yours to keep!**

**MAIL COUPON—NO SALESMAN WILL CALL**

**BELSAW INSTITUTE, 104A Field Bldg.  
Kansas City, Mo. 64111**

Send FREE book, "Keys To Your Future!"

**FREE BOOK**

Name \_\_\_\_\_

Address \_\_\_\_\_

City \_\_\_\_\_ State \_\_\_\_\_ Zip \_\_\_\_\_

## APPLIANCE CLINIC

(Continued from page 50)

install "slow-moving" water valves in their units. If water hammer is a problem in a home, the cause is probably water pressure in excess of 160 lbs. per sq. in. In this case, a water-hammer eliminator or pressure reducer should be installed in the plumbing.

2. *Chatter.* This noise and water hammer frequently go hand in hand. As the shock of water hammer is transmitted back through piping, the piping can vibrate if it isn't supported, so secure long runs of pipe with pipe clamps.

Chatter can also be created when a water-valve diaphragm fails to close on the initial movement of the solenoid armature. This noise is characterized by low-frequency pulsing sounds which are created by the pulsing of the water-valve diaphragm as it tries seal off the valve port. The noise may occur for a brief second or go on indefinitely.

The cause of this kind of chatter is frequently inadvertent use of the wrong part. For example, installing a fast-closing diaphragm intended for use in portable dishwashers in a slow-closing water valve will cause chatter. Also use of an under-size inlet pipe when the dishwasher is first installed will cause chatter. Minimum size of an inlet pipe should be 1/2 in. outside diameter.

3. *Flutter.* This noise is a low-frequency rumble that usually occurs when the water valve opens, but it can occur any time that water is flowing through the valve. Flutter is produced by variations in pressure at the water-valve flow washer. The noise is actually produced by flexing of the flow washer. Flutter is normally caused by high water temperature.

4. *Whistle.* This is a steady high-pitched noise caused by water flowing through the flow washer orifice. The noise may be anything from a hissing to a shrill whistle, depending upon pressure and temperature. If the sound is objectionable, it may be corrected by installing a small hand valve in the inlet line so the size of the pressure band can be varied. ★★★

*If you have a question about any appliance, send it to Appliance Clinic, Popular Mechanics, 224 West 57th St., New York, N.Y. 10019. Sorry, but letters cannot be answered individually. However, problems of widest interest will be answered in this column.*

# Leave The Tuning To RADIO SHACK!

These Realistic Scanning Monitors automatically tune across 8 crystal-controlled VHF channels of your choice, then "lock in" when a transmission comes on. Keep you in tune to local police, fire, weather, business and more! They feature built-in power supplies for AC and 12 VDC, channel lock-out buttons, 2-second scan delay to prevent missed call backs, crystal-lattice filters to cut interference, lots more! Accessory crystals low as \$5.95 each.

Exclusive at 1600 Radio Shack stores in all 50 states.



## PRO-88

Our best! Covers 148-174 MHz VHF, PLUS 450-470 MHz "Metro Area" UHF! Monitor 8 frequencies in either band, or in any combination! **\$189.95**

## PRO-9

Covers 148-174 MHz, has 7 crystal-controlled channels, manual tuning of entire band on its 8th channel! **\$159.95**



## PRO-77

Covers 30-50 MHz and 148-174 MHz at a single band price! Monitor bands individually, or in combination! **\$129.95**



## PRO-7A

Our lowest-priced scanner! Has all the features you need for fully automatic coverage of 8 channels from 148-174 MHz! **\$99.95**

# Radio Shack®

and ALLIED RADIO STORES

A TANDY CORPORATION COMPANY

P. O. Box 1052, Fort Worth, Texas 76107

|  |              |                          |
|--|--------------|--------------------------|
| <b>FREE '73 CATALOG! AT YOUR</b>                             |              | 161                      |
| <b>NEARBY STORE OR SEND IN THIS COUPON</b>                   |              |                          |
| <i>180 pages! Stereo Hi-Fi, CB, Ham, Kits, Radios, More!</i> |              |                          |
| Name _____   | Apt. # _____ |                          |
| Street _____   |              |                          |
| City _____   | State _____  | Zip <input type="text"/> |



**DODGE is the Number 1 builder of motor home chassis.**

Today, 80 percent of all motor homes are built on Dodge chassis. Chassis engineered by Chrysler Corporation to give you a firm foundation and dependable performance. Extra care in engineering makes a difference in Dodge... depend on it.



**The Club Cab. The Number 1 idea in pickups this year.**

The exclusive Dodge Club Cab pickup gives you over 34 cubic feet of extra storage space inside for the things you don't want to leave outside. The Club Cab Camper Special is equipped to accommodate most slide-on campers to haul you and your friends to your favorite snow trails.



**Turn to Dodge for leadership in Recreational Vehicles.**

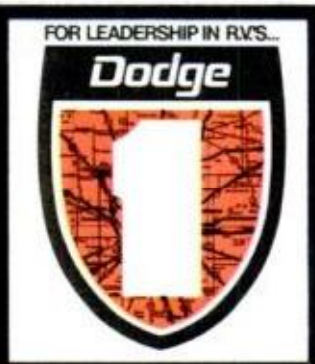

# Jobs open up for Technicians with down-to-earth training!

Opportunities are everywhere and the pay is excellent in the technical service industries. But it takes the right training to get a man started: NTS Project-Method Home Training!

You learn by building the latest equipment and test instruments (which are included in your tuition). You're guided every step of the way by easy-to-read NTS Lessons.

When you graduate, you know service and repair from the bottom up, inside-out!

You have answers on the tip of your tongue. Know-how at your fingertips. You have the down-to-earth training experience employers are willing to pay good money for!

Find out. Send card today. No obligation. No salesman will call.



Solid-State Color TV  
315 Sq. In. picture

## ELECTRONICS DIVISION

NTS offers a wide-range of training with solid-state equipment (almost all of it commercially available). Build a solid-state 315 sq. in. Color TV; solid-state B&W TV; solid-state FM multiplex Receiver and Speakers; solid-state Oscilloscope; solid-state Compu-Trainer. Plus, Amateur Phone Transceiver, FET Volt-Ohmmeter, Electronic Tube Tester, Signal Generator, and more! Get valuable experience in the latest electronics technology. Read details in catalog.



## AIR CONDITIONING/ REFRIGERATION & HEATING DIVISION

NTS provides you with the important tools of the trade! Courses include specially-designed Hermetic Unit Analyzer — a tester with multiple applications; Leak Detector-Soldering Kit — with hundreds of uses; Charging-Testing-Purging Manifold Set with dispensing and piercing valves. Plus, Socket, Wrench, Open-End Wrench, Tube Bender Sets, and more!



## MECHANICS DIVISION

NTS includes professional tools and test equipment. Earn as you learn. Make money even before you graduate! Big 109 piece Socket Wrench and Tool Set — all American made! And a Performance Kit — Timing Light, Smog Valve Tester, Compression Tester, Remote Starter Switch, Dwell Tach, Alternator-Generator-Regulator Tester. Also, "Speed Shop" lessons and diesel training.



## HOME APPLIANCE DIVISION

Multiply your experience with appliance circuitry through the exclusive NTS Circuit Trainer. Eliminates the need to buy dozens of appliances for training purposes. The 4-in-1 Appliance Tester performs many troubleshooting tasks. It includes an Ohmmeter, Voltmeter, Ammeter, and Wattmeter; measures both AC and DC currents; it will be valuable to you during training and on the job!

## APPROVED FOR VETERANS

Accredited Member: National Association of Trade & Technical Schools; National Home Study Council.

## CLASSROOM TRAINING AT LOS ANGELES

Train in sunny Southern California. NTS occupies a city block with over a million dollars in training facilities. Check box.

## NATIONAL TECHNICAL SCHOOLS

WORLD-WIDE TRAINING SINCE 1905

Resident & Home Study Schools  
4000 So. Figueroa St., Los Angeles, CA. 90037

## NATIONAL TECHNICAL SCHOOLS

WORLD-WIDE TRAINING SINCE 1905

Resident & Home Study Schools  
4000 So. Figueroa St., Los Angeles, CA. 90037

Send for color Catalog and Sample Lesson — both FREE!  
Check below. No salesman will call. No obligation.

- Electronics Division       Mechanics Division  
 Air-Conditioning, Refrigeration, Heating Division       Home Appliance Division

NAME \_\_\_\_\_ AGE \_\_\_\_\_

ADDRESS \_\_\_\_\_

CITY \_\_\_\_\_ STATE \_\_\_\_\_ ZIP \_\_\_\_\_

Dept. 201-043

- Check for Veteran Training under G.I. Bill  
 Check if interested in information on Classroom Training in Los Angeles



Water boils but lamp burns

**A "HOT" FLUORESCENT LAMP**—capable of operating at full power at temperatures up to 212° F. (boiling point of water)—has been developed for use in Skylab. The orbiting lab, scheduled to be launched later this year, requires heat-tolerant lamps because of the lack of cooling convection currents in its compartments. Conventional lamps are cooled by air currents. The new lamp was developed by Westinghouse engineers.

**A CHILD BORN TODAY IN THE UNITED STATES** can expect to live about 22 years longer than his grandparents, according to a report in *Update*, a publication of the American Medical Assn. This prediction is based on a comparison of 1971 life-expectancy data—the most recent available—with similar data for 1900. The increased longevity is ascribed to improved standards of living and advances in medicine. At the turn of the century, tuberculosis and diphtheria were among the chief causes of death. Now they're no longer listed as leading killers. Today, heart disease and cancer top the list.



Tuning in from Eifel Mountains

**WORLD'S BIGGEST MOVABLE CELESTIAL EAR** is now in full operation in the Eifel Mountains of West Germany. Its dish is 328 feet in diameter, some 80 feet bigger than Britain's famous Jodrell Bank radio telescope. The 3200-ton instrument rides on a track and can be moved as little as 1 mm. (.04 of an inch) at a time. Astronomers say the dish will open up new areas of study involving the formation of our galaxy.

**THE MOST COMPLEX INTERNATIONAL SCIENTIFIC** experiment ever undertaken will be launched in the spring of next year. Some 25 to 30 ships, a dozen aircraft, 75 to 100 land stations, satellite and instrumented ocean buoys will be used to gather meteorological data about the tropical Atlantic and adjacent land areas. It's hoped the undertaking will generate new knowledge about atmospheric circulation and the genesis of hurricanes and other storms. Among others, the United States, Canada, the Soviet Union, Britain, West Germany and France will participate.



It's a cheap washing machine

**CHEAP BUT EFFECTIVE.** That's the evaluation of a medical appliance recently created at James Cook University, Australia, by scientists who used plastic tubing to hook up a five-gal'on plastic container, an aquarium pump and a cheap thermostat. Their creation is a "scrubber" that can be used to wash out part of the intestinal tract, a procedure used in treating patients suffering from kidney failure. The device,

*(Please turn to page 60)*

# TOUGH!

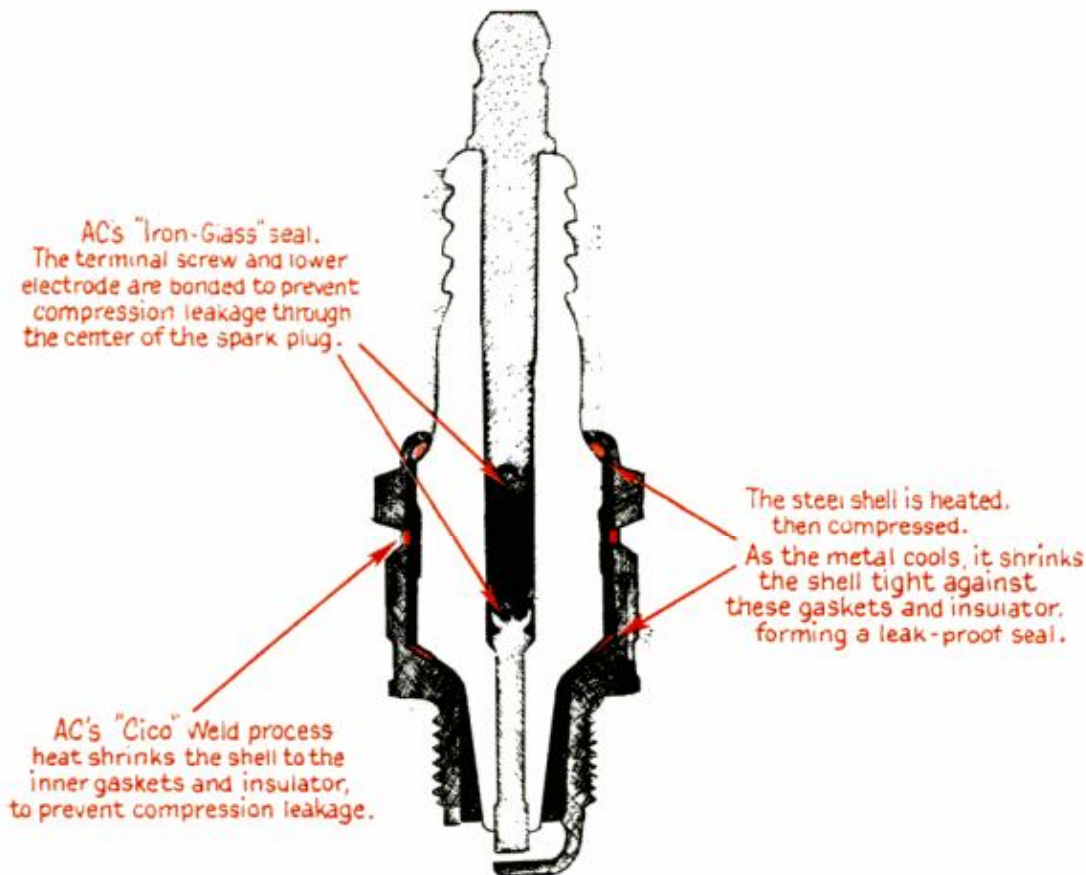

## AC Spark Plugs are sealed for leak-proof reliability

AC Spark Plugs are sealed to help prevent leakage of hot combustion gasses and loss of compression. AC's "Iron-Glass" Seal helps prevent leakage through the center of the spark plug. And, AC's "Cico" Weld helps provide a positive seal between the shell and the insulator.

These are just two of the manufacturing methods used by AC to help make sure every spark plug will perform long and efficiently under varying operating conditions.

There *is* a difference in spark plugs. The reliability of AC's sealing process is one of them. Go with the tough ones for your car . . . AC Fire-Ring Spark Plugs. AC is the original equipment spark plug for GM cars . . . and the replacement spark plug for all American-made cars, and most imports.

Next tune-up, whether you do it yourself or have it done, insist on ACs. AC Spark Plugs are available at more retail outlets than any other brand.\*

\*Based on the results of an independent survey.



**AC keeps you going when the going's tough**



**AC SPARK PLUG DIVISION**

LIVE IN THE WORLD OF TOMORROW . . . TODAY!

# UNUSUAL BARGAINS

NEW PRODUCTS • NEW MATERIALS • NEW IDEAS

## AMAZING NEW WANKEL ENGINE KIT!



No. 71,424H (41 1/2" X 5" X 9") . . . . . \$6.75 Ppd.  
 519-Page Wankel Engine Book  
 Stock No. 9,439H . . . . . \$15.25 Ppd.

Thrill to the fun of building your own see-through motorized model of revolutionary pistonless type engine . . . only engine experts think economically modifiable to meet new pollution standards. Replaces piston, cylinder, crank assemblies with rotating discs (sections removed for firing chambers). Smaller than conventional; fewer parts, greater reliability, same speed w/ less horsepower. Feat: flashing plugs, rubber fan belt, stick-shift on-off switch. Req. 2-1.5V batt. (not incl.)

## "FISH" WITH A MAGNET



Stock No. 60,215H . . . . . 11 1/2 lbs. . . . . \$5.75 Ppd.  
 Stock No. 70,570H . . . . . 31 1/2 lbs. (lifts 40 lbs.) . . . . . \$ 8.75 Ppd.  
 Stock No. 85,152H . . . . . 153 1/2 lbs. (lifts 350 lbs.) . . . . . \$33.60 FOB

Go treasure hunting on the bottom! Fascinating fun & sometimes profitable! Tie a line to our 5 1/2-lb. Magnet—drop it overboard in bay, river, lake or ocean. Troll it along bottom—you: "treasure" haul can be outboard motors, anchors, other metal valuables, 5 1/2-lb. Magnet is war surplus—Alnico V Type—Gov't cost \$50. Lifts over 150 lbs. on land.

## GIANT WEATHER BALLOONS



Stock No. 60,568H (8' size) . \$2.50 Ppd.  
 Stock No. 60,632H (16' size) \$7.00 Ppd.

"Balls of fun" for kids, traffic stoppers for stores, terrific for amateur meteorologists. Create a neighborhood sensation. Great backyard fun. Exciting beach attraction. Amateur meteorologists use to measure cloud heights, wind speed and temp. Made of heavy-duty neoprene. Inflate with vacuum cleaner or auto air hose; or locally available helium for high rise.

## HONDA 750 "FOUR" ENGINE KIT



Stock No. 71,750H . . . . . \$12.95 Ppd.

Build big 1 1/2 scale see-thru motorized wkg model of the 4-cyl engine that makes 750 Four most advanced motor-cycle on the mkt. 68 hp, engine that won Daytona revs up to 8000rpm, top speed over 125 mph. Feat: overhead cam 4-stroke engine design; 4 synch carbs, 4 upswept mufflers, & hemi heads with offset valves. Shows valve opening & closing, piston cycle, flashing plugs, etc. 187 metal & plastic pre-colored parts, display stand, instrs. Req. 2 "AA" Batt (not incl.)

## AMERICAN MADE OPAQUE PROJECTOR



Stock No. 70,199H . . . . . \$8.75 Ppd.

Projects illustrations up to 3" x 3 1/2" —enlarges them to 35" x 30" if screen is 6 1/2 ft. from projector, larger pictures if screen is farther away. No film or negatives needed. Primarily intended for children. Projects charts, diagrams, color or black-and-white in darkened room. 115 v. A.C. . . . 6 ft. cord and plug included. Size 12" x 8" x 4 1/2" wide. Weight 1 lb. 2 ozs. Plastic case.

'Bright Ideas' in Unique Lighting Big, new 100-page handbook packed with facts, loaded with illustrations. All latest developments, applications, equipment. 8 1/2" x 11" looseleaf paper to fit 3 rings. Stock No. 9100 H . . . . . \$3.00 Ppd.



## MAIL COUPON FOR GIANT FREE CATALOG!

**164 PAGES • MORE THAN 4,000 UNUSUAL BARGAINS!**  
 Completely new 1973 Catalog. Packed with huge selection of telescopes, microscopes, binoculars, magnets, magnifiers, prisms, photo components. Ecology and unique lighting items, parts, kits, accessories—many hard-to-get surplus bargains, 100's of charts, illustrations. For hobbyists, experimenters, schools, industry.

**EDMUND SCIENTIFIC CO. 300 Edscorp Building, Barrington, N. J. 08007**  
 Please rush Free Giant Catalog "H"

Name \_\_\_\_\_  
 Address \_\_\_\_\_  
 City \_\_\_\_\_ State \_\_\_\_\_ Zip \_\_\_\_\_

**EDMUND SCIENTIFIC CO. 300 EDSCORP BLDG. BARRINGTON, NEW JERSEY 08007**  
 ORDER BY STOCK NUMBER - SEND CHECK OR MONEY ORDER - MONEY-BACK GUARANTEE

## SCIENCE WORLDWIDE

(Continued from page 58)

expected to cost less than \$200, can be used in the patient's home to supplement treatment with more sophisticated kidney machines.

## The environment

**NOISE POLLUTION** is not only an outdoor phenomenon—it occurs in homes, too. Electrical appliances are the chief sources. Noise levels produced by electric shavers, garbage disposers, shop tools and a host of other gadgets may cause actual hearing damage with frequent or continual use. This information comes from a new booklet, *Noise in the Home*, which can be ordered from Consumer Product Information, Washington, D.C. 20407. Cost: 15 cents. The booklet also contains suggestions on how to reduce indoor noise levels.

"**SUNLIGHT SHOWERS**" are part of the routine at a grammar school in Hokkaido, Japan. The program was started years ago in an attempt to improve the health of schoolchildren living in a congested part of the city. Today, the artificial sunlight showers are considered more important than ever because Hokkaido, like other big cities, has a smog problem. ★ ★ ★

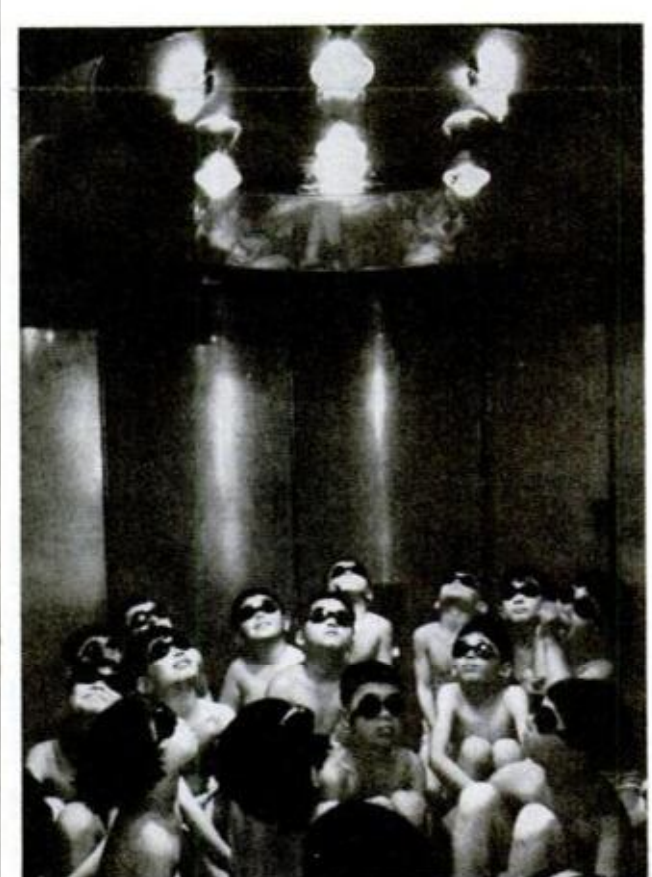



# Red Wing cut this boot apart

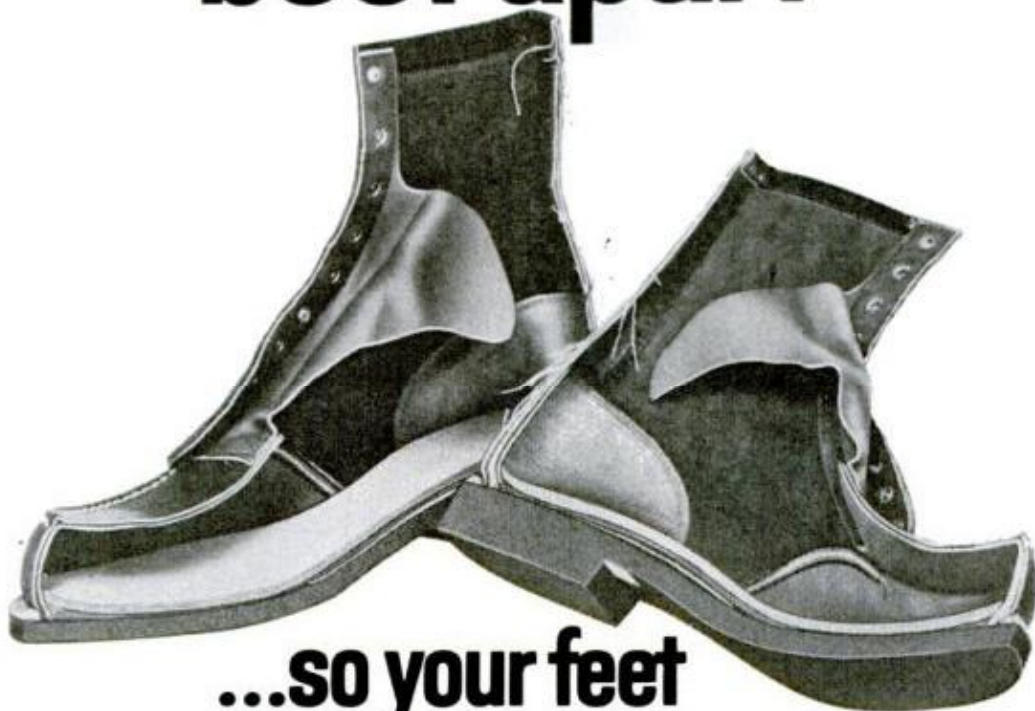

**...so your feet  
know what they're getting into.**

Red Wing work shoes and boots have long been considered tops in the trade by the hard-working men who wear them. And for good reason: fit, comfort and long lasting service. Now you can *see* some of these reasons—full-grain leathers, solid steel shanks, "Sweat-Proof" flexible split leather insoles—and more. Come try on the pair fit for your job . . . at your nearby Red Wing work shoe headquarters. Your feet will appreciate the difference.

Sure  
cure for  
**5** o'clock  
feet

**RED WING**

RED WING  
SHOES

RED WING SHOE COMPANY • Dept. PM, Red Wing, Minnesota 55066

It won't kill lions, tigers, rhinos,  
buffalo, leopards or bull elephants.  
It just looks that way.



Marlin 783, suggested retail price about \$59.95  
(clip loading Marlin 782, about \$58.95).



**The Inside Story** Castrol GTX Motor Oil—superfine lubrication for a high speed racing car—taking 200 MPH torture, proving its stamina. To win your trust. Because the demands on your car engine are tough as any race. 365 fast morning starts every year. Stop and go traffic. Air conditioners. And towing trailers. Every year, experienced race drivers like Al Unser, Joe Leonard and Mario Andretti prove Castrol GTX engine lubrication and protection is the best. But everyday, your engine demands prove you need Castrol GTX Motor Oil the most. Yes, Castrol GTX Motor Oil costs more. Quality usually does. But in the long run, Castrol Quality is still cheaper than new engine parts. Castrol Oils, Inc., New York, N.Y.



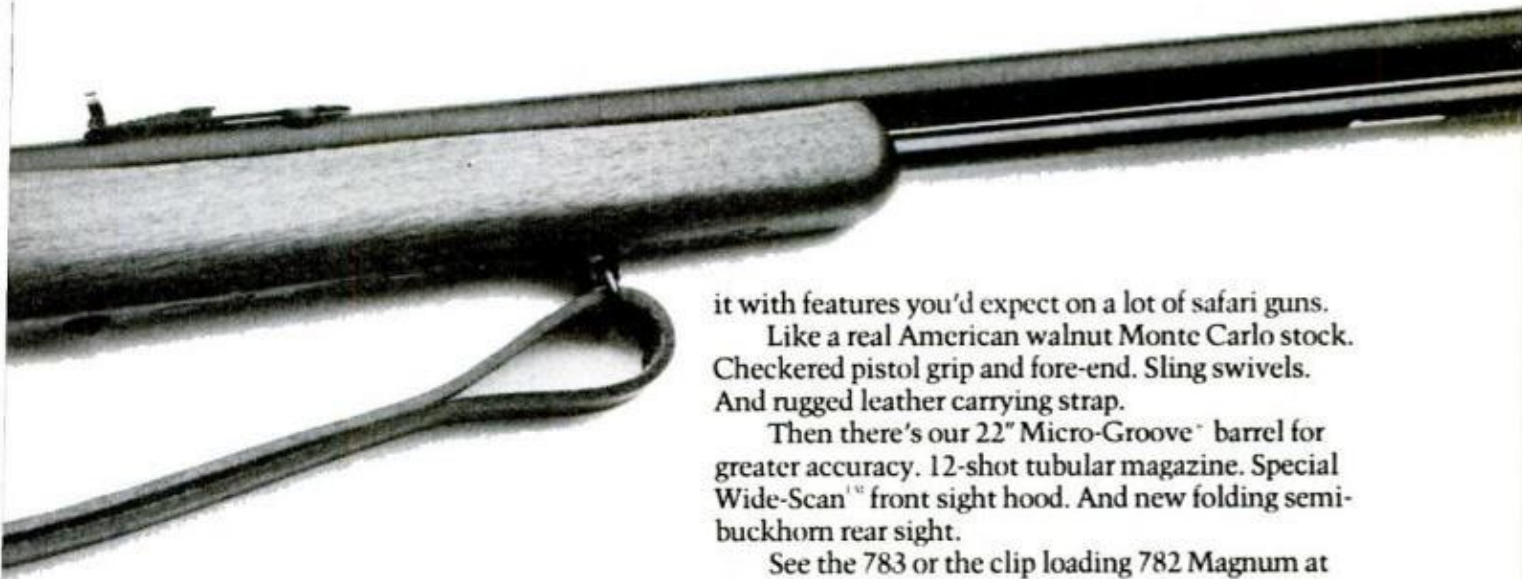

With a Marlin bolt-action .22 Magnum you'll think you're on the plains of Africa.

The reason is Marlin's big game styling. Like our 783 Magnum, for instance. We've loaded

it with features you'd expect on a lot of safari guns.

Like a real American walnut Monte Carlo stock. Checkered pistol grip and fore-end. Sling swivels. And rugged leather carrying strap.

Then there's our 22" Micro-Groove<sup>®</sup> barrel for greater accuracy. 12-shot tubular magazine. Special Wide-Scan<sup>™</sup> front sight hood. And new folding semi-buckhorn rear sight.

See the 783 or the clip loading 782 Magnum at your dealer's. And while you're there, ask to see the complete line of Marlin bolt-action .22's for Short, Long or Long Rifle cartridges from about \$37.95 to \$55.95. Ask your dealer for a free color catalog or write Marlin Firearms Co., North Haven, Conn. 06473.

**Marlin**  **Made now as they were then.**



are you headed for a time-clock number?

...or a **BIG PAY** place in

# AIR CONDITIONING

40,000 new servicemen needed  
...you can be one of them

Air conditioning, refrigeration and heating is one of America's fastest growing fields. Service and installation technicians are in desperate demand.

And you can join this force of men making big money right now by becoming a skilled technician with our help.

Top men are making 2 and 3 times more than unskilled workmen. Yet we can teach you these skills so quickly you'll be earning money long before you've finished learning.

**AMERICA'S FOREMOST COURSE  
AT A MATCHLESS LOW PRICE**

Learning at home is hailed by educators as being far superior to classroom work with all its mass production and distractions.

In our fine, professional 100-lesson textbook course you will receive the clearest instructions in unmistakable simple language. Plus self-projects, self exams and graded exams.

Directed by Roy Anderson whose experience with home study and Army-Air Force training goes back to 1935, we

have prepared material that will turn out top-notch graduates. And we do it at a cost so much lower than any comparable course that you simply will not believe it possible.

One way we do it is by not loading our students with costly equipment and tools—most of which you probably already have, or can buy locally for less than some schools charge you!

The Liberty School is a fine, professional and very intimate institution of learning-at-home, supervised in every tiny detail by Mr. Anderson.

We can't begin to tell you all of the advantages in this small space—but we'll give you all the details if you send in your name and address. Remember, we have **NO** salesmen, so no one will bother you. In the privacy of your room you can study the description of our lessons and make up your own mind without any pressure whatsoever.

A big pay future is waiting for you—grab it now.

**LIBERTY SCHOOL Dept. J-4**  
1111 W. Park, Libertyville, Illinois 60048

Be Your Own **BOSS** course includes directions on How to Own YOUR OWN Business!



Roy Anderson  
LIBERTY SCHOOL, Dept. J-4  
1111 W. Park  
Libertyville, Illinois 60048

**SEND ME YOUR NAME AND ADDRESS**  
—I'll rush you **FREE** details by mail.

Dear Mr. Anderson: Please send me description of your course on **AIR-CONDITIONING, REFRIGERATION AND HEATING**. I understand this places me under **NO** obligation and that **NO** salesman will call.

Name \_\_\_\_\_ Age \_\_\_\_\_  
Address \_\_\_\_\_  
City \_\_\_\_\_ State \_\_\_\_\_ Zip \_\_\_\_\_

**ALL RIDING MOWERS  
ARE EASY ON YOU.**



# HOMELITE RIDING MOWERS ARE EASY ON YOUR LAWN.

It's too bad you can't test drive riding mowers before you buy one.

Because if you could, you might discover that while you're up there in the seat having a grand old time, your lawn is taking something of a beating.

## HOMELITE DISCOVERS THAT THE LAWN ISN'T FLAT.

A lot of riding mowers have been designed as though the earth under them is flat. Their mower decks (where the cutting blade is) are fixed to the mower's chassis, which gives them absolutely no give. So when they run into a bump or incline, they really run into it. Turning grass into mincemeat.

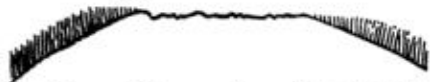

Homelite, on the other hand, attaches its mower deck to the front axle. When the wheels glide over a high spot, the deck



glides right along after them. Gently cutting your lawn instead of brutally scalping it.

## HOMELITE LETS YOU SHIFT WITHOUT SHIFTING YOUR LAWN.

To shift gears on most riding mowers, you have to clutch. And while clutching may be just

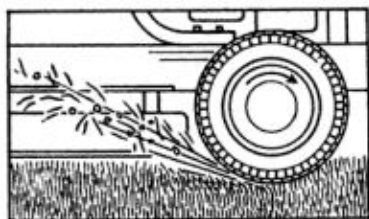

great on the drag strip, it's a drag on your lawn. Clutch into reverse, for example, and you may find your back wheels spinning out — spinning out some grass in the bargain.

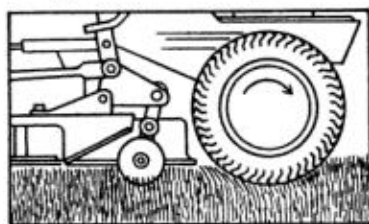

That's why Homelite's RE-8E (rear engine, 8 horse power) riding mower has a no-clutch transmission similar to the automatic transmission of a car. It enables you to shift smoothly from forward to reverse with a single lever. Leaving your lawn unscathed.

## WE NOT ONLY PAMPER YOUR LAWN. WE GIVE IT AN EVEN CUT.

The cutting blades of our Homelite riding mowers are reinforced with rigid steel. And



when you have a 30-inch cutting swath, that can be very important.

Because the steel keeps the

blade from flexing on either end. Which means that every one of those 30 inches gets cut on the same level. And your lawn ends up looking even instead of odd.



## WE DIDN'T FORGET ABOUT YOU.

Now that we've told you how good our riding mowers are for your lawn (and we've only had room to tell you part of it), it's time we paid some attention to you.

Electric starting is standard on our 7 and 8 hp. models (optional on 5 hp.). And they all have full plush seats that are actually adjustable. Practically effortless steering (the RE-8E even has a steering wheel instead of just a bar). And all kinds of safety features and operating conveniences.

But to get the full story on how easy Homelite riding mowers are on you, we suggest you go to your nearest Homelite dealer (to find him, call toll free: 800-243-6000, in Conn., 1-800-882-6500).

To get the full story on how easy they are on your lawn, we suggest you take one home.

## HOMELITE® RIDING MOWERS.

They're as easy on your lawn as they are on you.

HOMELITE A  DIVISION • 504 RIVERDALE AVE. • FORT CHESTER, N.Y. 10373

# Photo Hints

## Sections of hose make handy floodlight holders

Need a place to store your photoflood reflectors? You can rack them neatly on your wall in these homemade holders. Just cut a piece of hose about one-half the reflector's circumference, curve it to fit the light, and nail it to the wall. Coil cords around the sockets. —E.V. Reyner, Salinas, Calif.



## Film dries quicker on the bias

I dry my film diagonally, to save space (it fits across my door that way) and find it dries better, too. Hung vertically, a film's top frames dry fast, but its bottom ones stay soggy from runoff. Horizontal film dries uniformly, but not quickly enough. My way, water runs quickly down the film and off its corner (collecting on the sprockets, if anywhere). Magnets hold the film clips to double-width shelf standards, staggered as shown on my darkroom door.

—Don Anderson, Sunnyvale, Calif.

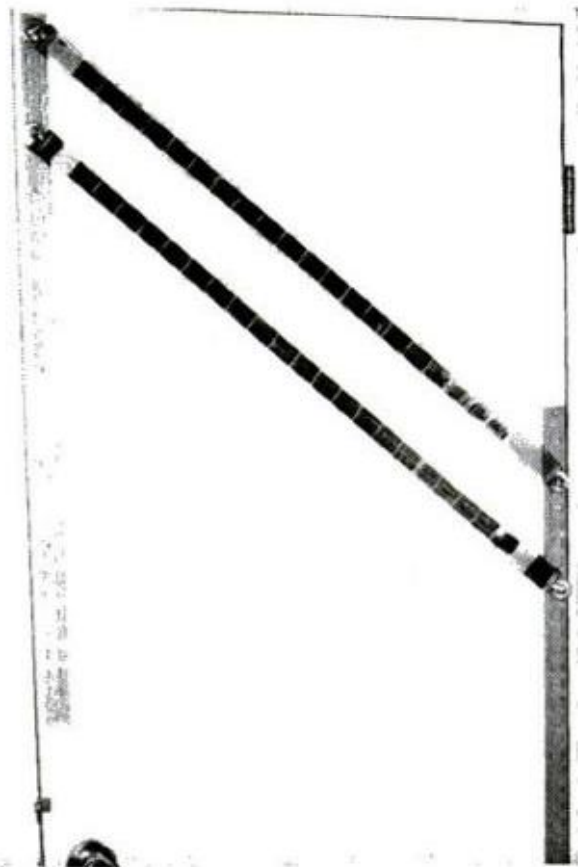

## Labels as durable as tin cans

Need labels that won't fade or wear away? Next time you mix chemicals, cut labels from the cans the dry powders came in. Trim off the sharp corners, and drill the label for a wire or chain with which to hang it on the jug or bottle neck.

—Ken Patterson, Regina, Sask.



### Letters for reading in the dark

In the dark, how can you tell one grade or type of enlarging paper from another? Weller suggests you write on the paper boxes with a hot-melt glue gun. The raised letters will be easy to "read" in the dark. Here, "F" stands for the paper surface, while the two dots signify Contrast 2. You can use any suitable code.

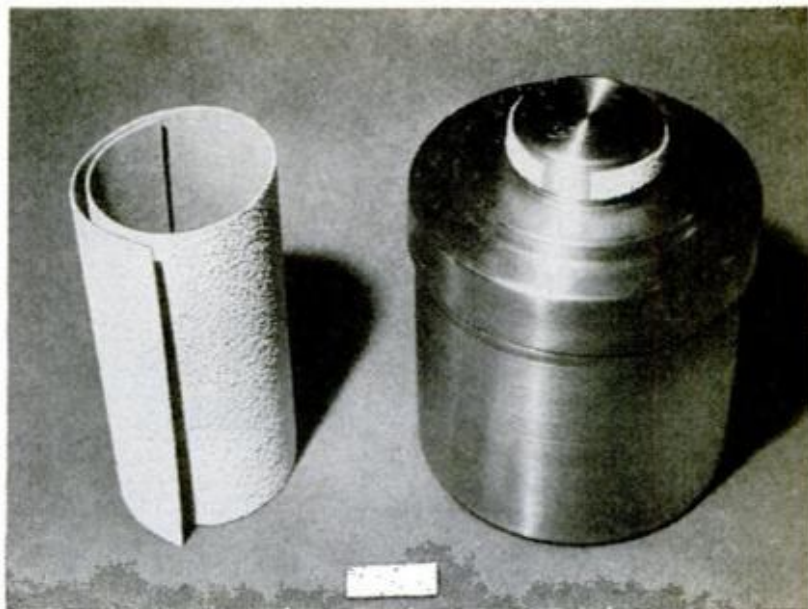

### Nonskid grip for tank lids

When the filler cap on a stainless-steel developing tank sticks, it can hold you up long enough for the film to overdevelop, or pull the whole lid off. Strips of pressure-sensitive nonskid material (sold in boating and hardware shops) give you enough grip to remove even the stickiest cap.—Don Anderson, Sunnyvale, Calif.

# Freeze-a-Ferrari.

Not all 35mm reflexes let you keep up with the action. When you look away to adjust the camera, you lose the race.

With a Minolta SR-T 101, you never lose sight of your subject.

Because you set shutter speed and lens opening

by simply aligning two indicators in the viewfinder. So you can frame, focus, adjust exposure and (Varroom!) get the shot, fast and easy.

For illustrated literature, write Minolta Corporation, 200 Park Avenue South, New York, New York 10003. In Canada: Anglophoto Limited, P.Q.

When identified by a factory-sealed "M" tag, Minolta 35mm reflex cameras are warranted by Minolta Corporation against defects in workmanship and materials for two years from date of purchase, excluding user-inflicted damage. The camera will be serviced at no charge provided it is returned within the warranty period, postpaid, securely packaged and including \$2.00 for mailing, handling and insurance.

**Minolta**



# IMPORTS AND MOTORSPORTS

BY BILL HARTFORD



**THE VERTICAL GRILLE** is the tip-off that under the hood purrs Jaguar's V12 engine. More smooth and stealthy than savage, the 12-cylinder single-overhead-cam powerplant in the new XJ12 sedan is the same as that used in the XKE convertible and 2+2 coupe (see *Are Eight Cylinders Enough?*, page 84, Jan. PM). The XJ6 sedan with double-overhead-cam, in-line Six will continue to be sold for \$9250; the new car will go for \$10,500

**DROPPING A V12** into Jaguar's XJ sedan isn't the shoehorn task it may seem. The car was designed in 1968 to take the 12, then under development, but all the first V12s went to the E-type sports cars. Last year, for Jaguar's 50th anniversary, the XJ12 went on sale in England. Now the cars have reached the colonies, and, as was the case with the XJ6, the waiting list is long. Extraordinary as the XJ6 is in performance and comfort, the XJ12 is better. The smooth torque curve of the 12 is noticeable in acceleration and cruising and the antidive front suspension geometry minimizes nosediving under hard braking; and like the XKEs, the front discs are ventilated. With the aluminum block, the V12 weighs only slightly more than the Six so the car requires only slightly stiffer front coil springs. The great delight of the car is that it is luxurious in every way but can still be

thrown around as if it were a sports car.

**GETTING BACK TO BASICS** is the best way to describe the second new British Leyland car for the U.S. market: the Austin Marina. Most popular of the company's models in Britain, the Marina uses the MGB sports-car engine and is available here in four-door sedan and two-door GT models. Prices of \$2575 and \$2625, respectively, put them in a very competitive class of compact, sporty family sedans. The four-door won't turn any heads, but the GT is distinctive, especially with the "hot setup"—a special trim kit with side stripes, alloy wheels and backlight louvers.

**BIKERS' LIBERATION** is built into the Bird 100MX. You can concentrate on takeoffs and landings without worrying about being in the right gear at the right time: A torque converter  
(Please turn to page 62H)

**AUSTIN MARINA GT** and four-door sedan model went on sale in England in 1971 and quickly became the nation's third best-selling car line after the Ford Cortina and Escort. Now being manufactured in sufficient quantity for export, the Marina has a 96-in. wheelbase. The 1798-cc engine (same as in the MGB sports car) drives rear wheels through a four-speed box with automatic optional. Brakes are disc/drum and tires are radials





**ANTI-POLLUTION  
AUTO ENGINES  
NEED SPECIAL VALVE  
PROTECTION**

**RISLONE  
GIVES  
IT...**



*Test Drive it!*



**FREE** Get some hints from a REAL engine expert, Smokey Yunick. Send large, self-addressed, stamped envelope and we will send 32-page booklet.

**THE SHALER CO.**

Waupun, Wisconsin 53963  
In Canada: Canadian Shaler Products Co., Toronto 9, Ontario

## FREE PLAN *How to Start Your Own Business*



Start a steady repeat CASH business in your basement or garage. Earn \$3 to \$6 an hour in your spare-time! Excellent profits in saw sharpening business! Automatic Foley Saw Filer, easy to operate, files combination saws, hand, band, and circular saws. No experience needed. H. C. Deibert wrote us: "Since I got my Foley Filer 5 years ago, I have averaged 4 1/2 saws each day since I started."

Every saw you sharpen brings you more customers. "I rented a two-car garage and have all the work I can do," writes Charles H. Smith.

### FREE BOOK *Shows How to Start*

Fact filled booklet tells you how to start a sparetime business immediately; how to get new business, how to advertise. Rush coupon now; get "Money Making Facts" and details on Easy Payment Plan. No Salesman will call.

Send Coupon for FREE BOOK Money Making Facts

- FOLEY MANUFACTURING CO.  
416-3 Foley Bldg. Minneapolis, Minn. 55418
- Send FREE BOOK—"Money Making Facts", and Time Payment Plan.

Name \_\_\_\_\_

Address \_\_\_\_\_



## ELECTRIC ARC WELDER \$11.99

**\$18.95 VALUE!—NOW ON SALE!** WELDS—BRAZES—SOLDERS—CUTS—MOST METALS! Plugs into ANY 110 volt socket. MAKE—REPAIR MOST ANYTHING for CAR—HOME—BUSINESS. Lifetime BURNOUT GUARANTEE 10 day money back trial (if retrnd). **HEAVY DUTY MADE!** No experience needed—FREE WELDING INSTRUCTIONS!

**SEND ONLY \$2.00**

(cash, ck. M.O.) and pay postman \$9.99 COD postage or send \$11.99 plus \$1.00 postage for paid del. in U.S.A.! COMPLETE READY TO USE—Includes BIG pack Steel, Brazing, Solder, Carbon "touch" rods and ELECTROFLAME ARC TORCH! BEST EVER MADE! OFFER LIMITED—Order TODAY! MIDWAY WELDER Dept. FPM-4 Kearney, Nebr. 68847



# Does More Than Help Shrink Swelling Of Hemorrhoidal Tissues Due To Infection

**Also gives Prompt, Temporary Relief in Many Cases from Pain, Itching in Such Tissues.**

Doctors have found a remarkably successful medication that actually helps shrink swelling of hemorrhoidal tissues when infected and inflamed. And it *does more*. In many cases it gives relief for hours from pain and itching in

these tissues. Tests by doctors proved this true in many cases.

The medication used in these tests was Preparation H. And no prescription is needed for Preparation H<sup>®</sup>. Ointment or suppositories.

# The famous Lincoln AC 225-amp welder is your best buy



Thousands of home handymen, farmers and shop fabricators buy the Lincoln AC-225 every year for these reasons.

**Hundreds of Uses.** Lincoln AC-225 welders give the ideal arc for fabrication and repair welding. Build your own tools and equipment. Fix cars, trailers, boats, farm machinery quickly. Rebuild or hardsurface worn parts. Heat metal for bending, straightening. Thaw frozen water pipes.

**Versatile.** Weld heavy plate or sheet metal, Lincoln ampere selection is right for both. Current capacity and duty cycle let you weld without delays. Use low hydrogen, stainless and mild steel electrodes with excellent arc striking and arc stability. Solder, braze, or weld copper and aluminum with the arc torch.

**Easy to Operate.** Single range control, no cranking or plug changes necessary. Electrode selection guide on top of machine.

**Long Life, Dependable Performance.** No controls to creep or wear out. Transformer is extra dipped for weather protection. Bottom screen makes the welder verminproof. Built by Lincoln Electric...world's foremost producer of arc welding equipment and supplies.

**Easy to Install.** Plug into standard 230-volt, single-phase current, just like an electric range. NEMA rated. UL approved at 230 volts, 60 hertz. Will also operate on 208 volts.

**Mobile, Lightweight.** Easy to move. Wheels optional.

**Ready to Use.** Price includes accessories, sample electrodes, power cable, instruction book.

(Suggested Zone 1 list price only \$95, subject to change without notice. Optional features, taxes, local delivery and Zone 2 freight charges may alter this price.)

SEND THIS COUPON TODAY!

**LINCOLN  
ELECTRIC**

The Lincoln Electric Company  
Dept. PM-2, Cleveland, Ohio 44117

- I am interested in a 225 AC welder  
 Send free copy of bulletin E320

Name \_\_\_\_\_

Address \_\_\_\_\_

City \_\_\_\_\_ State \_\_\_\_\_ Zip \_\_\_\_\_

## IMPORTS AND MOTORSPORTS

(Continued from page 62F)



keeps the engine operating at the peak of its power curve, does the job of the usual five-speed transmission and automatically downshifts in response to changes in engine rpm. It's mated with a 99.3-cc McCulloch engine that Bird Engineering raced successfully at several Mini-Cycle Nationals and set a 100.888-mph record on the Bonneville salt flats.

**YOU NEED A LOT OF BREAD** to go racing. The secret to winning races, according to some competitors, is not cubic inches but cubic money! Wonder Bread, made by ITT-Continental Baking, is supplying the dough for a



pair of Funny Cars that'll be running the drag strips this season. The "Wonderwagons," on Vega panel trucks, are powered by Ed Pink-prepared Chryslers displacing 494 cu. in. and churning up 1500 hp on 92 percent nitro fuel.

Quarter-mile speeds should be in the 220-mph range. Any way you slice it, that will be real competition for the Funny Car Eliminators. ★★★

New Tool  
Works Wonders  
With Wire

# WIREFORMER

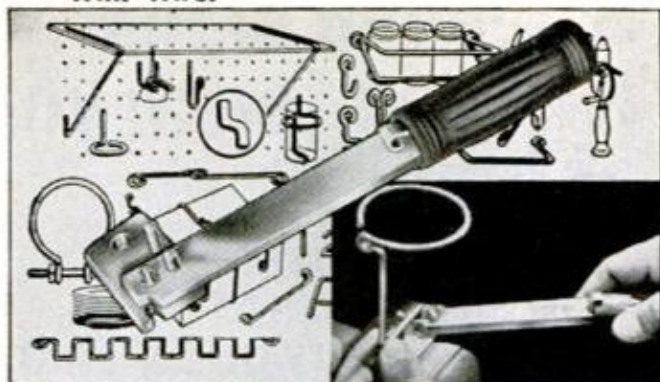

### IT BENDS! IT CUTS! IT STRAIGHTENS!

WIREFORMER is a simple, precision made, vise-held tool of innumerable uses. Make your own peg board hooks, clamps, handles, braces, brackets, etc.—any shape you want. Forms an eye of 3-16" inside diameter (just right for any nail, screw, or bolt up to that size). Even uses coat hanger wire. No pliers needed. WIREFORMER does the work with the pressure of one finger. Straightens the wire if you make a mistake. Cuts the wire just where you want it. Forms any angle, arc or circle. Bends both right and left. Tool is case hardened, plated, with a plastic handle. Fits in your pocket. Complete instructions, illustrated brochure showing many things to make.

SOLD ONLY BY MAIL. MONEY BACK GUARANTEE. Four dollar bills will get you one, or send check or money order for just **\$3.98** We pay postage and handling charges.

**VINKEMULDER TOOL CO. Dept. PM43**  
2223 Estelle Dr., S.E. Grand Rapids, Mich. 49506

## Build this good looking storage building in your own backyard!



Here's a great way to take the strain off your garage. This handsome back-yard building has plenty of room for tractors, lawnmowers, bikes, tools or whatever. You can use it for a workshop, an escape room, a bunkhouse for the kids, or even a pool house.

It measures 8 feet by 12 feet; has a second floor; and can be built by most any handyman.

Plans give detailed building instructions. You probably will want to order two sets of plans as you likely will have to submit one set to your local building department.

Mail to: Popular Mechanics  
Box 1014 Dept. CH  
Radio City  
New York, New York 10019

Please send me plans for Popular Mechanics' back-yard storage building as indicated below. Enclosed is my payment in full.

One Set \$3.95     Two Sets \$5.49

NAME \_\_\_\_\_

ADDRESS \_\_\_\_\_

CITY \_\_\_\_\_ STATE \_\_\_\_\_ ZIP \_\_\_\_\_

APRIL 1973

# May is a month to get excited about!



### 80 PAGES OF INFORMATION

And a month to start thinking about your vacation and how you'll get there. Most likely you'll take your car, but, if it's not in shape your vacation will be more headaches than fun.

To help you stay on the road, whether vacationing or not, POPULAR MECHANICS May Issue will feature a "Car Care Guide". This will be a special magazine-within-the-magazine that will include 80 pages of information and tips on engine tune-ups, body repair, cooling systems, waxes and polishes . . . in short, it will be a complete guide to car care. POPULAR MECHANICS "Car Care Guide" will be a treat for both you and your car.

Also, during the month of May, thousands of retail members of the Automotive Parts & Accessories Association (APAA) will be promoting Car Care Month to help you get your car ready for the summer months ahead. Look for their advertisements in your local newspapers.

## on sale April 26



1

# 3 needed skills NRI can teach you at home . . .

NRI courses use easy "bite-size" texts to show you how to service TV-Radio Repair Cars or Appliances

## "Hands-on" Training pays off

Learning TV-Radio, Automotive Servicing or Appliance Repair at home is easy, exciting, and profitable . . . the simplified NRI way.

NRI was the first to supply home study students with custom-designed training kits to give practical hands-on experience as you learn. You learn quickly with NRI, thanks to such features as the exclusive Achievement Kit (sent the day you enroll), "bite-size" texts, and custom training equipment.

## Practical Testing Equipment Provided

Most NRI courses include professionally engineered testing equipment. With NRI's TV-Radio Servicing course, you receive your choice of black & white or color TV Kit. The Automotive Servicing Students get an NRI scope/analyzer and other tools and Training materials. Application of this equipment allows you to earn money almost from the start of your training.

## Earn \$5 to \$7 an hour, in your spare time

Tens of thousands of NRI graduates are proof it is practical to train at home. Keep your present job while preparing for a better one and earn \$5 to \$7 an hour extra in spare time. Fix your own equipment, or earn money making repairs for friends and neighbors. NRI shows you how.

## Train with the leader—NRI

The same training innovations which have made NRI the leader in technical training at home are now available to you. You'll proceed at your own pace . . . guided and assisted wherever necessary by one of NRI's staff of home training experts. It's the convenient way to learn a skill.

But *you* must make the decision. Mail the card today for a free full-color catalog in the field of your choice. No obligation. No salesman will call. If the reply card is missing, write to NRI at the address below and ask for the catalog.



2



3

**APPROVED UNDER GI BILL**—If you have served since January 31, 1955, or are in service now, check GI line in the coupon.



**NRI TRAINING**  
3939 Wisconsin Avenue, N.W.  
Washington, D.C. 20016



## John Deere Riders. Years of freedom from "lawn lost" weekends.

On your quick John Deere Riding Mower, you'll easily cut the grass without cutting into your weekends. Move out with three-speed transmission. Mow non-scalp in five cutting heights. Trim to within a half inch of shrubs and flower beds. Ride on wide tires and an oscillating front axle. Triple-safe starting systems lead off many safety features. "Country-bred" quality keeps your John Deere running strong for years. Choice

of 6- and 7-h.p. models, from a dealer strong on service. Find him in the Yellow Pages. Ask about his financing. And have a nice weekend. Every week.

*For folder,  
write John Deere,  
Dept. LG, Moline,  
Illinois 61265.  
In Canada, write  
John Deere Limited,  
P. O. Box 638,  
London, Ontario.*

**nothing  
runs  
like a  
Deere**



# HOMEOWNERS' CLINIC

BY W. CLYDE LAMMEY

## Best time to transplant tree

*When is the best time to transplant a growing crabapple tree, spring or fall?—W. Leonard, Jefferson City, Mo.*

I favor spring as the best time for open-root transplanting. This gives the transplant time to develop an adequate new root system and attain some growth before winter comes. Balled specimens can usually be transplanted any time, but even then, spring is best.

## Locating furring strips

*I need to locate furring strips under soft-board paneling. But how? Tapping with a hammer doesn't indicate any change of sound, as it does on other types of walls.—Gene Tomey, Topeka, Kans.*

Use an ordinary pin. It can be pressed through the softboard without leaving a large, unsightly hole. Once you have located one or two strips the others should be easily found by measurement, assuming they are on 16 or 24-in. centers. If necessary, the pinholes can be filled with a spackling compound colored to match.

## Painting a stone wall

*A stone wall, laid in mortar, encloses a part of my back yard. I'd like to paint it in some attractive color to get rid of the moss and the dirt it collects. Should I use a house paint, or what?—Ted Beeman, Rochester, N.H.*

Don't use house paint. Use a water-soluble masonry paint made for the purpose. You should be able to select the color you want. But why paint a stone wall? It would be most attractive in its natural state. There's a certain natural beauty in stone work that paint hides and once paint has been applied there's no getting it off handily.

## Radiator doesn't radiate

*One radiator in my home requires bleeding frequently, but even with bleeding the air twice every week or more it doesn't heat consistently. The system is in its 15th winter. What can I do to get it*

*working for another heating season?—Wiley Short, Rochester, N.Y.*

Several factors may be involved, but I would suspect the malfunctioning radiator is nearest the boiler where it gets all, or most, of the air present in the system. If my guess is right, then installation of an automatic bleeder valve should alleviate the trouble. These valves allow air to escape but close when contacted by water.

## Removing spilled paint from bricks

*I spilled a small amount of house paint on my brick-and-concrete stoop and all my efforts at removal have failed. Can you help me?—B. Mills, Atlanta.*

Paint removers and vigorous scrubbing with a wire brush should get most of the paint, but if the bricks are rough-textured some may be difficult to remove. Make a paste by adding trisodium phosphate to water and stirring to a creamy consistency. Pour this over the splatter and keep it covered with a dampened cloth for several hours. Remove and again scrub with the wire brush. Repeat the process if necessary. This treatment may "brighten" the bricks temporarily, but weathering should return them to a matching color.

## Bringing out 'tiger-maple' graining

*On many old pieces of "tiger maple" I see the grain is strongly defined, a trick I've never been able to accomplish by staining. How did they do it?—Mrs. John Darlson, Wheeling, W. Va.*

Much of the maple you see in old pieces was cut from mature trees in which the so-called tiger grain was well defined in strong contrasting stripes of more or less uniformity. Material cut from younger trees does not always display this grain strength when finished. Early craftsmen often coated the wood with Van Dyke brown in oil to which a small amount of lampblack was added. This brings out the stripes strongly in contrast when rubbed in with the palm, with any excess immediately wiped off. A later practice is to sear the wood with a torch (a butane torch will do), charring it just enough to accent stripes without blackening lighter portions. This job must be done with care. ★★★

*Do you have a home maintenance or repair problem? Send it to Homeowners' Clinic, Popular Mechanics, 224 West 57th St., New York, N.Y. 10019. While letters cannot be answered individually, problems of wide interest will be discussed in this column.*



## Spend a milder moment with Raleigh.

A special treatment softens the tobaccos for a milder taste.

Rough it in comfort. Get a water-repellent Sportline Sleeping Bag just like the one shown for free B&W Raleigh coupons, the valuable extra on every pack of Raleigh.

To see over 1000 gifts, write for your free Gift Catalog: Box 12, Louisville, Ky. 40201.



Filter Kings, 17 mg. "tar," 1.3 mg. nicotine; Longs, 19 mg. "tar," 1.5 mg. nicotine, av. per cigarette. FTC Report August '72

APRIL 1973



RALEIGH

Warning: The Surgeon General Has Determined That Cigarette Smoking Is Dangerous to Your Health.

# Presenting Datsun 610.

## Considering the luxury, its economy is all the more remarkable.

The new Datsun 610 is something altogether new... a luxury economy car. A Datsun original.

Whether you choose the new 2-Door Hardtop, the new 4-Door Sedan or the new 5-Door Wagon, you get more power, more room, more quiet, just plain more car than any economy car has a right to be. But it comes with a Datsun price tag. And the kind of design sophistication you've come to expect from Datsun.

There's a new 1800 overhead cam engine and new power-assist front disc brakes for the perfect per-

formance combination. The 4-Door Sedan and 2-Door Hardtop have a new independent rear suspension, too.

As for the luxury, well, you've really got to drive it to believe it. The luxury touches—whitewalls, fully reclining bucket seats, tinted glass, full carpeting and custom vinyl interior—are just a beginning.

It's the new Datsun 610 series. Sporting performance, luxury accommodations and an economy car price. You've got to drive one to believe it. Drive a Datsun... then decide.



### Own a Datsun Original.

From Nissan with Pride



# What it takes to build and fly a **RADIO-CONTROLLED MODEL COPTER**

By **FRED L. WOLFF** and **JOHN F. PEARSON**

**I**T HOVERS DELICATELY for a moment, then sweeps into a smart banking turn, swoops low over the ground, comes to an abrupt halt in mid-air and finally settles gently to earth, its long, graceful rotor blades coasting slowly to a stop. It's a radio-controlled, kit-built model helicopter, one of the latest entries in the exciting new sport of R/C whirlybirding.

When R/C helicopters first came along, many fixed-wing enthusiasts considered them merely a passing novelty, too complex and costly for practical use. Now, with the introduction of precisely engineered, ready-to-assemble, relatively inexpensive kits, model whirlybirding is fast becoming a brand-new kind of hobby offering thrills, fun and challenges not possible



**WHIRLYBIRD BUILDER**  
Dave Gray (far right), designer of the Du-Bro 505, shows co-author Fred Wolff his latest creation, larger and more sophisticated than the 505. The big, colorful R/C copter will be available as kit soon.

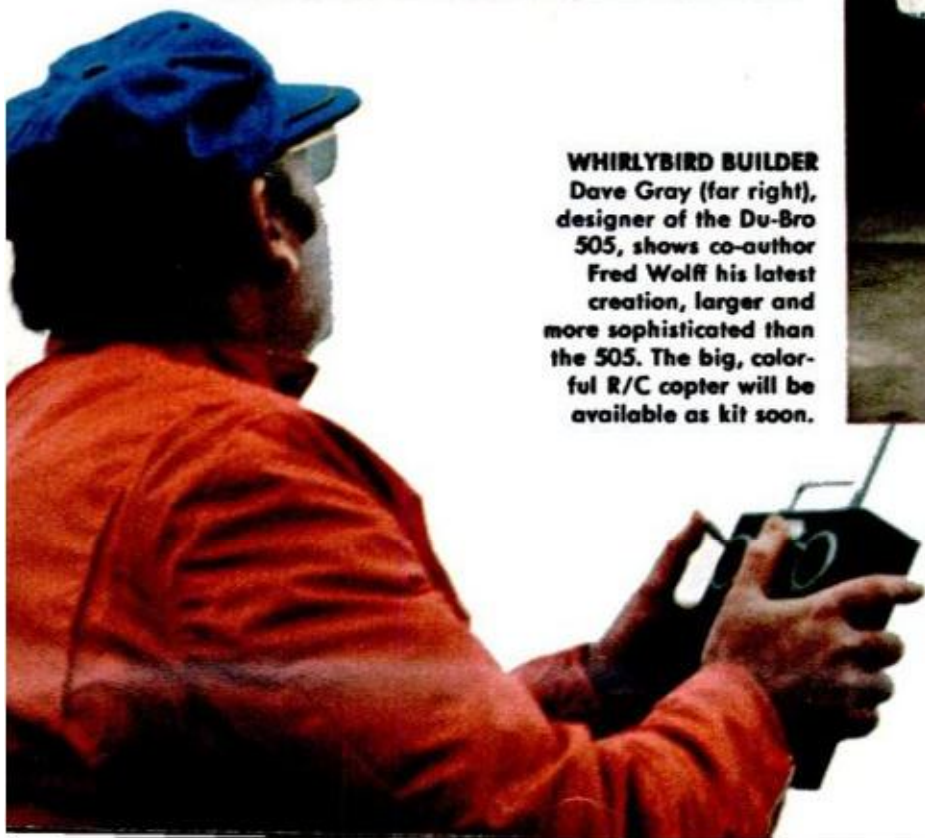

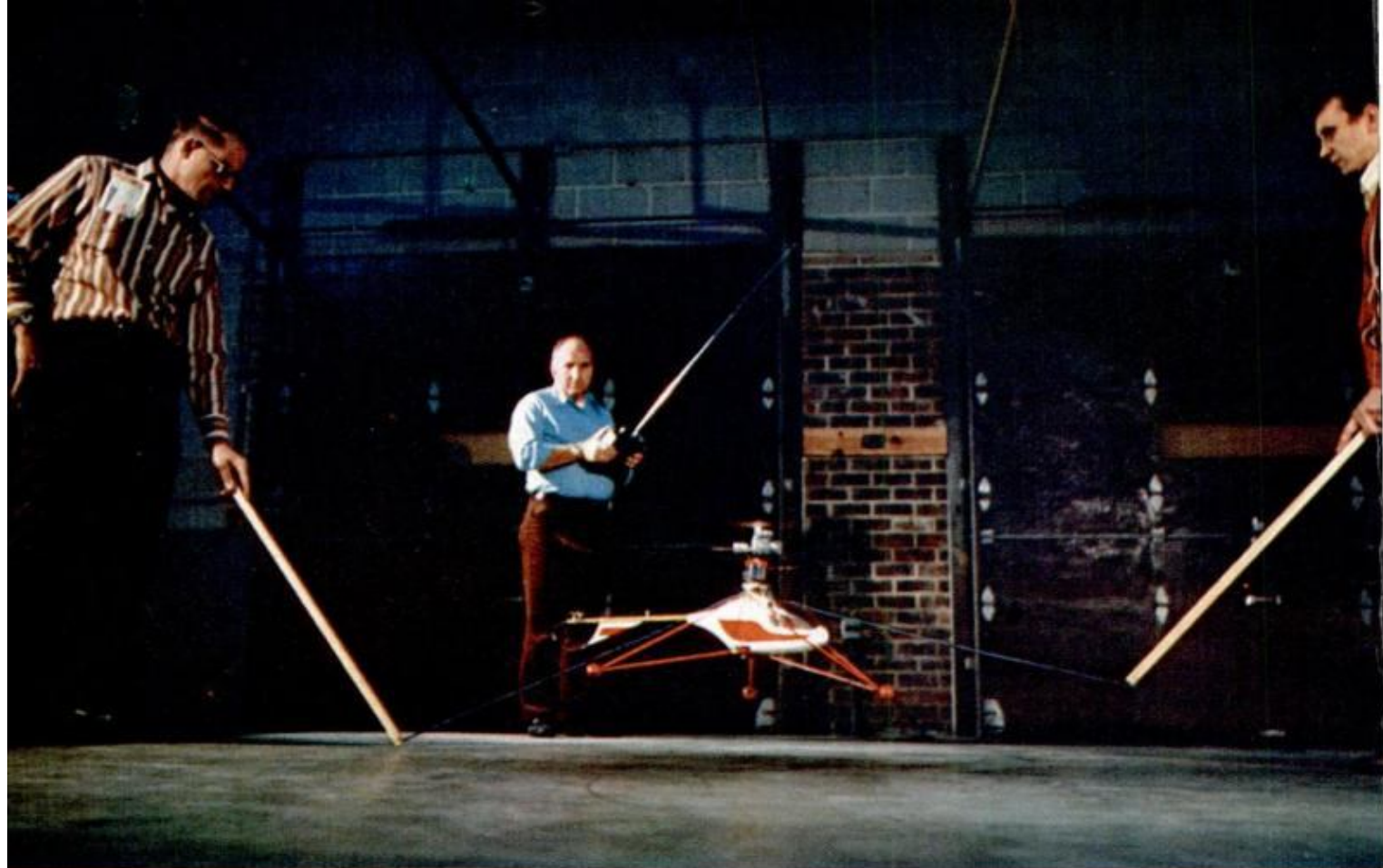

with conventional radio-controlled model planes. The reason: Like their full-size big brothers, R/C model copters require a completely different flying technique from that of fixed-wing aircraft. A four-channel transmitter control is needed to handle the complex functions of fore-and-aft rotor tilt, side-to-side rotor tilt, tail rotor pitch, and throttle.

Maneuvers call for close coordination of two control sticks. They must be moved simultane-

**NOVICE PILOT WOLFF** handles controls while "ground crew" holds sticks attached to the tether lines. At least two hours of tethered flight are required before free flight can be attempted. Garage is a good place to train



**PARTS IN KIT** (left) come separated into groups and are clearly identified. Finished Whirlybird 505 (above) is 37½ inches long, has main rotor that spans 46½ inches and a 7-inch tail rotor. Kit does not include engine or radio-control system, sells for \$125

POPULAR MECHANICS

ously—tricky at first, but that's what makes whirlybirding so intriguing and challenging.

We built the Whirlybird 505 from a kit made by Du-Bro Products, Wauconda, Ill. The kit costs \$125 and does not include the radio-control unit or engine. We used the recommended O.S. Max .40 RC engine (about \$40) and the Blue Max Mark II radio-control system—both made by World Engines, Inc., Cincinnati. This type of unit costs from about \$250 and up.

Working carefully, it took most of a weekend to assemble the Whirlybird 505. The kit is not a collection of preformed components but is made up of many metal, wood, plastic and electronic parts. Their quality is good, identification excellent. The instruction booklet is complete.

If you haven't done much soldering recently, it would be wise to practice before assembling the kit. A lot of soldering is required, and neat, effective joints are a must. You'll need a soldering gun rated at 250 watts or better.

The delicately balanced, precision machine should have a flying weight of exactly 3 pounds, 14 ounces. Much under or over, and its flight characteristics will be noticeably affected. If it's too heavy, it won't get off the ground; too light, it won't

handle well. Sloppy soldering will add unwanted weight.

Construction of the Whirlybird breaks down into three main sections: main rotor, tail rotor, body. The body is heart of the bird. It holds the wood-frame mounting for the fiberglass tailboom, the main rotor shaft assembly and swash plates. It also houses servos for the throttle, tail and main rotors, receiver and battery pack.

The Whirlybird is a true helicopter and is powered by a "torque reaction" system. The rotor head is mounted on the engine so that they rotate together. A small propeller above the rotor turns on a drive-shaft. The engine spins the prop counterclockwise. The torque created by the prop—a reactive force—causes the engine and the rotor to spin in the opposite direction. This simplified system eliminates the need for a gearbox and makes handling easier.

The torque developed by a gear-driven rotor, as on a full-sized copter, tends to cause the fuselage to rotate in a direction opposite to the rotor's spin. This force must be countered by a small prop on the tail. On the Whirlybird 505, the rear prop functions merely as a rudder.

Still, learning to fly the Whirlybird takes practice and patience. As we learned

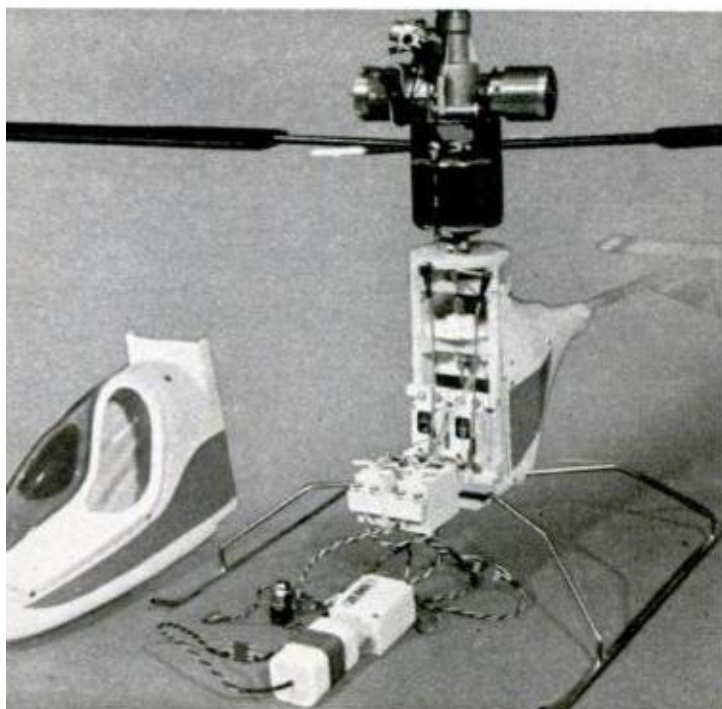

**WITH NOSE OF CRAFT REMOVED**, airborne electronic gear can be seen. The battery is up forward, ahead of the receiver and the four servos. Other radio-control systems may be used in the copter, provided the components are of the correct weight and size. Extra weight affects flight characteristics



**COMPONENTS** of the Blue Max Mark II radio-control system include the ground transmitter (at top), the flight battery package (at lower left corner of transmitter), four servos, and the receiver. On transmitter, left stick controls the throttle and tail rotor. Right stick controls the copter's main rotor

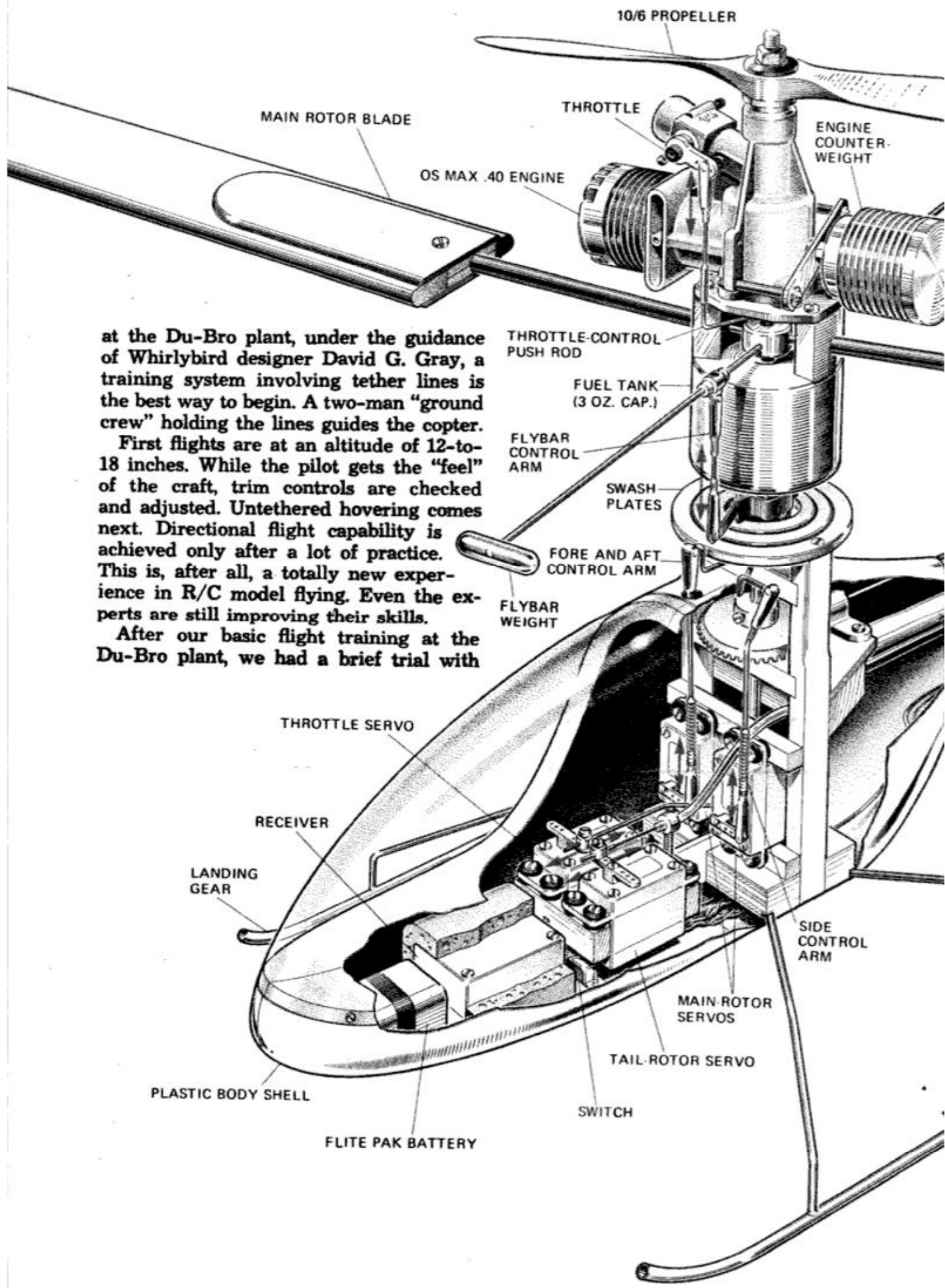

10/6 PROPELLER

MAIN ROTOR BLADE

THROTTLE

ENGINE COUNTER-WEIGHT

OS MAX .40 ENGINE

at the Du-Bro plant, under the guidance of Whirlybird designer David G. Gray, a training system involving tether lines is the best way to begin. A two-man "ground crew" holding the lines guides the copter.

First flights are at an altitude of 12-to-18 inches. While the pilot gets the "feel" of the craft, trim controls are checked and adjusted. Untethered hovering comes next. Directional flight capability is achieved only after a lot of practice. This is, after all, a totally new experience in R/C model flying. Even the experts are still improving their skills.

After our basic flight training at the Du-Bro plant, we had a brief trial with

THROTTLE-CONTROL PUSH ROD

FUEL TANK (3 OZ. CAP.)

FLYBAR CONTROL ARM

SWASH PLATES

FORE AND AFT CONTROL ARM

FLYBAR WEIGHT

THROTTLE SERVO

RECEIVER

LANDING GEAR

SIDE CONTROL ARM

MAIN ROTOR SERVOS

TAIL ROTOR SERVO

PLASTIC BODY SHELL

FLITE PAK BATTERY

SWITCH

Du-Bro's latest—a model of the Hughes 300. This bird has a gear-driven rotor, is about three times the size of the 505, weighs about 14 pounds and is powered by a 1-hp chain-saw engine that's been modified. This copter is shown in flight on our cover and on page 69.

Du-Bro officials say Hughes 300 kits will be available at dealers at about the time this article appears. The price, including engine, will be about \$350. ★ ★ ★

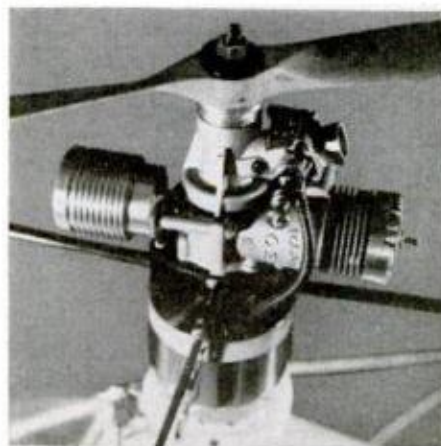
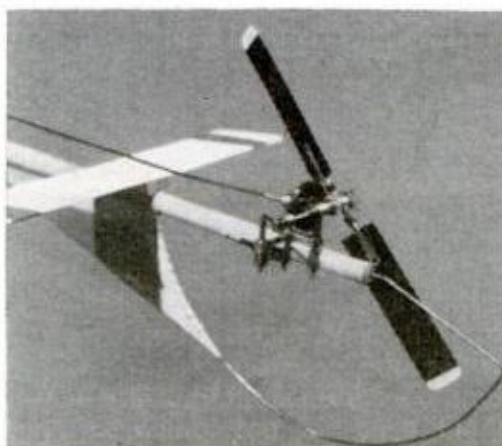
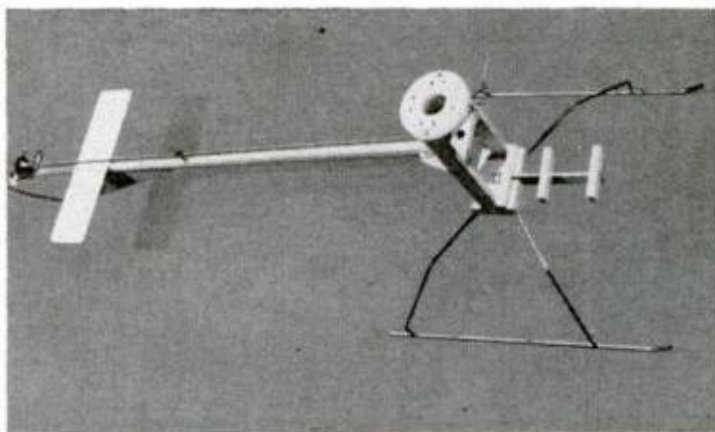
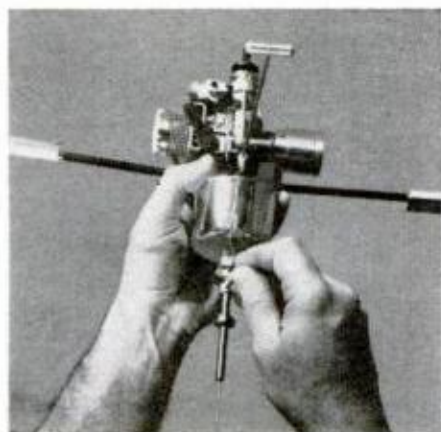
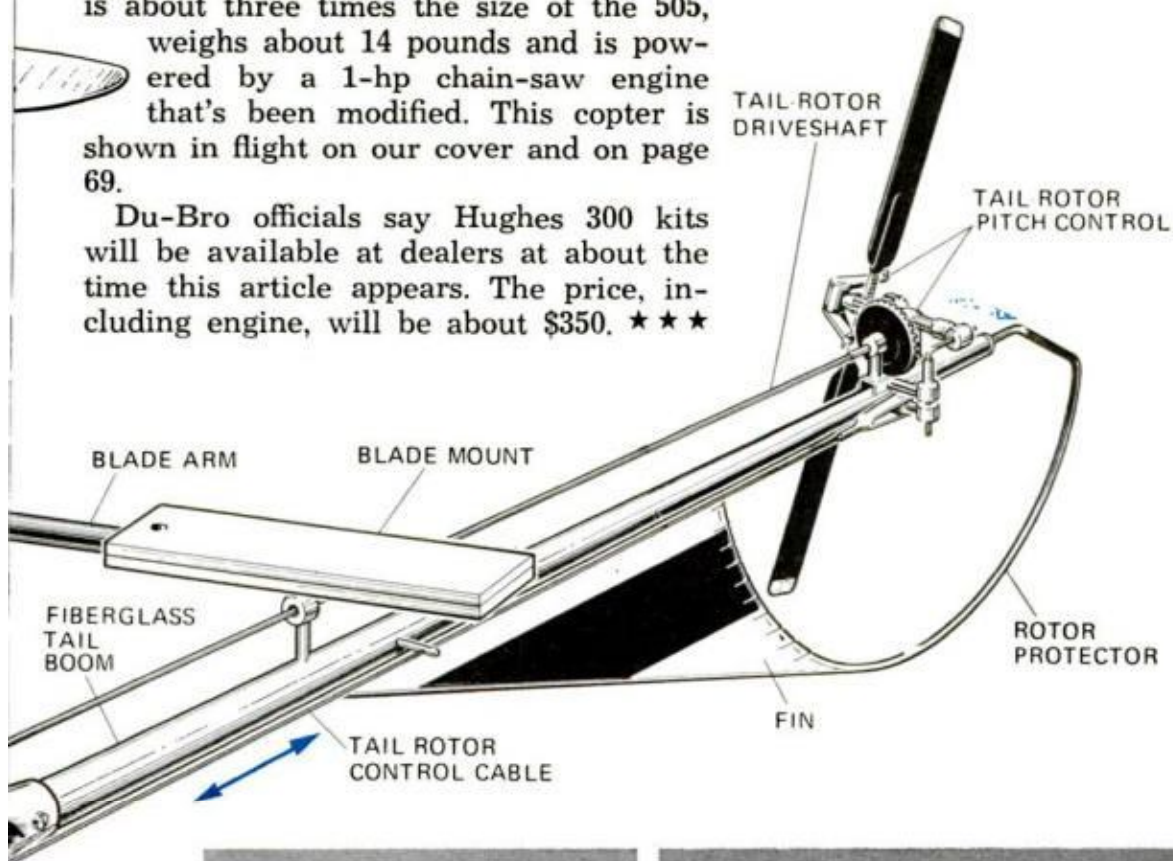

**BUILT SEPARATELY, POWER UNIT** (upper left) includes engine, shaft, tank. Precision balancing is a must in adding rotor blades. Stabilizer at end of frame (upper right) later was removed for better control in wind. Tail rotor unit (lower left) takes stress, requires effective soldering. Carburetor side of engine is seen in last photo. Tankful of fuel—mix of methanol, castor oil, nitromethane—can last up to 8 minutes.

## PM OWNERS REPORT: OLDSMOBILE OMEGA

A nationwide survey, based on 650,000 owner-driven miles



# Omega: An alpha for size,

By MICHAEL LAMM, West Coast Editor

Photos by the author

**O**MEGA SPELLS Oldsmobile's version of Chevrolet's Nova. Pontiac began offering this same basic car as the Ventura back in late 1971 (see *Owners Report: Pontiac Ventura*, page 84, March '72 PM). Now Oldsmobile has it, too.

They're three very alike cars—so

much so that an owner in Yonkers mentioned, "My Omega came through with NOVA on the dashboard." That's not surprising considering all three cars are built on the same assembly lines in Van Nuys, Calif. and Willow Run, Mich. and by the same workers. Oldsmobile *does* have its own inspectors supervising assembly. The Omega's front-end treatment, taillamps, steering wheels, and V8

**OMEGA SHARES** sheet metal and other basics with Chevrolet Nova and Pontiac Ventura. Grille marks greatest point of departure. About a third of owners had bought hatchbacks (right) and reported liking them, but shifting cargo sometimes makes for long reaches. Except for the steering wheel (below), dash is Nova's—utilitarian and clean but uninspired



engines are different from Nova's and Ventura's, but otherwise they're all carbon copies.

Base prices of Novas/Venturas/Omega range within \$230 of each other, meaning that the bare-bones Nova 6 lists for \$230 less than the least expensive Omega 6 coupe. What does an Omega owner get for those extra bucks?

The Oldsmobile name, for one thing, and it's important to a good many customers. Olds enjoys very high owner loyalty. Our survey shows that past experience with Oldsmobiles definitely influenced quite a few Omega sales.

This car also uses an Oldsmobile V8, although its displacement—at 350 cu. in.—is precisely that of Nova and Ventura V8s. Bore, stroke and outputs are different, though, for all three.

The Omega “looks Oldsmobile,” as an Ohio school teacher puts it. A New Jersey machinist: “I had a 1962 Olds F-85 for 10 years. It gave me good service. I could have bought a Nova for \$400 less, but I think Chevrolet puts them together cheaper, too.” An Alabama salesman states, “I bought the Omega because it's an Oldsmobile and because it's an economy car.”

How much of an economy car is it, though? Not everyone came away convinced. “Mileage?” wrote a retired California naval officer, “For a car that's sup-

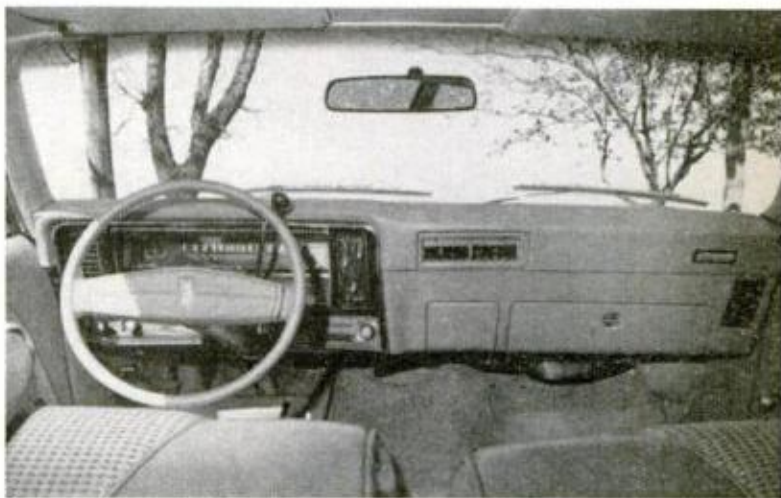

## but economy rates a delta!

posed to be ‘economy,’ 10 mpg doesn't spell economy in my dictionary. I used to get better mileage from my Delta 88.” An Ohio secretary says, “Would have bought another Opel if I'd known what a gas-eater it is.” And a Mississippi dry cleaner: “I get far better gas mileage with my 1970 Chevy station wagon with the same size engine.”

Ironically, poor gas mileage was the

main complaint from 1972 Ventura owners, too, and they averaged 2-3 mpg more with both the Six and V8. Omega owners expected a lot better than the 12-16 mpg they're getting. An Oregon retiree wrote, “We wanted a small car that would give good gas mileage. The salesman said 22-28 mpg. We're getting 13-17.”

Quite a few people bought the Omega for its size. It's neither too big nor too



**SLOTTED BUMPER** accepts the jack at its strongest point and makes the lifting steadier



**SOME OWNERS** wanted more distinctive rear styling, objected to car's looking so much like Nova/Ventura



**ALTHOUGH** Nova/Ventura also have 350-cu.-in. V8s, the Omega's isn't shared. The six, though, is Chevy's

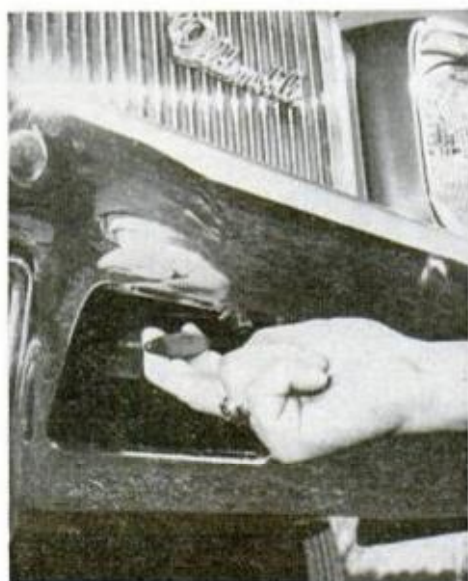

**HOOD RELEASE** in bumper slows both thieves and station attendants, should be inside car

small, they say. A North Carolina soldier opined, "Big-car ride from a small car." Many owners praised parking ease, maneuverability and handling in traffic.

On the minus side, we heard complaints (13.7 percent) that coupes lack rear legroom. A few sedan owners mentioned that both the front and rear floors were short of leg space.

Thirty percent bought Omega's hatchback coupe. Reactions: "I bought this car specifically to carry light loads, but it still looks like a car."—Nebraska cartographer. "I'd like easier access to get things in and out of the hatch. I have to climb in to get at stuff that's slid forward in braking."—Illinois accountant. "I like to be able to haul things I would in a station wagon without having to own one."—Michigan body layout man. "I do a lot of hauling, and for long trips and camping, the hatchback is hard to beat."—Missouri retiree. (Oldsmobile and several accessory manufacturers supply canvas flies and camp conversions for the hatchback.)

But then there's the seatbelt hassle. "Belt attachments are in the middle of the entryway to the back seat." This complaint was echoed by many owners of hatchbacks and standard coupes. Similar sore points: "The front inside lap belt is too short. I have to struggle to find it." And, "I have to yank retracted belt several times before I can fasten it." And, "Although I believe in seatbelts, the buzzer is quite annoying."

What do owners think of the quality of their Omegas? "Overall it's very good," reports a West Virginia insurance manager. Most buyers agree—59.4 percent gave it a better-than-good rating on





ON 111-INCH WHEELBASE, it's neither a giant nor a midget. Size ranks first as the main reason for buying

workmanship. "The car is very tightly put together," represents a typical comment. Another respondent wrote, "GM sends Omegas to Olds dealers with a few defects, and then it's up to the purchaser to ride herd on minor repairs." Lots of new-car owners feel this way: "Overall quality good, but it needs more attention in final inspection of paint and control knobs."

Ride was judged noisier than other Oldsmobiles but very acceptable nevertheless. The Omega got good marks on general comfort except for legroom plus a few gripes on rear-seat width.

Other minor annoyances included the Omega's lack of distinctive looks. "They ought to make it look less like a Nova,

especially from the rear." And we got the usual mentions of dieseling, stalling, and flat spots in acceleration. These plus much of the poor gas mileage was blamed on smog equipment. Whether that's the real trouble, though, remains a moot question. An awful lot of mechanical failings that couldn't possibly have anything to do with smog stuff also get blamed on emission-control components.

Omega stands as the last letter in the Greek alphabet, but according to 32.6 percent of Omega owners, it's not the last word in automobiles. That percentage said they wouldn't buy another Omega next time. It's a high figure compared with similar cars we've reported on in the recent past. ★ ★ ★

### Summary of 1973 Oldsmobile Omega Owners Reports\*

|                                  |         |                                     |       |                                     |       |
|----------------------------------|---------|-------------------------------------|-------|-------------------------------------|-------|
| <b>Total miles driven</b> .....  | 657,866 | <b>Size</b> .....                   | 20.4  | <b>Dealer repairs satisfactory?</b> |       |
| <b>Average miles per gallon</b>  |         | <b>Economy</b> .....                | 10.6  | <b>Yes</b> .....                    | 76.8% |
| 250-cu.-in. Six: local driving   | 13.9    | <b>Specific dislikes:</b>           |       | <b>No</b> .....                     | 23.2  |
| long trips                       | 16.7    | Poor gas mileage                    | 26.2% | <b>Is the Omega your only car?</b>  |       |
| 350-cu.-in. V8: local driving    | 12.2    | Rattles                             | 10.9  | <b>No</b> .....                     | 53.4% |
| long trips                       | 14.4    | Sloppy workmanship                  | 10.9  | <b>Yes</b> .....                    | 46.6  |
| <b>Body styles:</b>              |         | Seatbelts get in way                | 6.3   | <b>Other cars owned:</b>            |       |
| Two-door coupe                   | 51.2%   | Poor dealer service                 | 5.5   | Oldsmobile                          | 45.6% |
| Hatchback coupe                  | 30.0    | Lack of power                       | 4.7   | Chevrolet                           | 23.5  |
| Four-door sedan                  | 18.8    | <b>What changes would you like?</b> |       | Ford                                | 10.1  |
| <b>Engines:</b>                  |         | More legroom (esp. rear)            | 13.7% | Buick                               | 6.0   |
| 250-cu.-in. Six                  | 31.3%   | More distinct styling               | 13.2  | Volkswagen                          | 5.4   |
| 350-cu.-in. V8                   | 68.8    | Better fuel economy                 | 9.6   | <b>Workmanship opinion:</b>         |       |
| <b>Transmissions:</b>            |         | Seatbelts laid out better           | 6.4   | Good to excellent                   | 59.4% |
| Automatic                        | 85.0%   | <b>Had any mechanical trouble?</b>  |       | Average to poor                     | 40.6  |
| Three-speed manual               | 15.0    | <b>No</b> .....                     | 59.2% | <b>Dealer service opinion:</b>      |       |
| <b>Why did you buy an Omega?</b> |         | <b>Yes</b> .....                    | 40.8  | Good to excellent                   | 58.5% |
| Size                             | 41.9%   | <b>What type of trouble?</b>        |       | Average to poor                     | 41.5  |
| Styling                          | 26.5    | Carburetor                          | 18.4% | <b>Age distribution of owners:</b>  |       |
| Price                            | 20.0    | Electrical                          | 13.2  | 15-29 years                         | 32.5% |
| Past experience                  | 18.9    | Slipping transmission               | 13.2  | 30-49 years                         | 28.4  |
| Reputation                       | 15.8    | Windshield wipers                   | 8.8   | 50-plus                             | 39.0  |
| <b>Specific likes:</b>           |         | Alternator                          | 7.0   | <b>Would you buy another Omega?</b> |       |
| Handling                         | 62.0%   | <b>Did you repair it yourself?</b>  |       | <b>Yes</b> .....                    | 67.4% |
| Styling                          | 30.6    | <b>No</b> .....                     | 92.0% | <b>No</b> .....                     | 32.6  |
| Ride                             | 23.1    | <b>Yes</b> .....                    | 8.0   |                                     |       |
| Comfort                          | 21.2    |                                     |       |                                     |       |

\*Percentages might not equal 100% due to rounding or insufficient data.



**REAR-FOLDING WINGS** give aptly named Osprey 1 the look of a roosting bird, its wings tucked neatly along its body. The tricky arrangement, similar to that used on carrier-based World War II aircraft, makes the ship compact for easy towing and storing. Above, craft rests on a specially built trailer that permits it to be launched from any ordinary boat ramp. A single hinge pin locks each wing section in either an extended or retracted position

# Flyweight flying boat you can build yourself

By **SHELDON M. GALLAGER**  
and **HOWARD LEVY**

*Photos by Howard Levy*

**SIMPLE WOOD-FRAME CONSTRUCTION** is demonstrated by designer George Pereira, trying out the cockpit fit in his back-yard "proving ground." Swimming pool in background came in handy for flotation tests. Note planing step in hull just aft of the cockpit. Frame is shown before addition of a Styrofoam nose and a fiberglass skin

78

**M**OST HOME BUILT AIRPLANES are designed by aircraft experts. This one, however, was the brainchild of a boatbuilder so—quite naturally—it started out as a hull with wings and became a miniature flying boat. Dubbed the Osprey after the water-loving fish hawk, it's built around a center float that looks more like a step-type hydroplane racing hull than that of a conventional flying boat, being longer and flatter with a greater wetted area.

Oddly enough, the unusual design provides surprising advantages. The longer hull allows the step to be moved closer to the wing center of gravity. This helps to keep the ship stable while planing, and the flatter bottom pivots easily in the water, making possible tight-radius turns in cramped quarters. A retractable water rudder also improves maneuverability while afloat. Despite the greater wetted area, there's no problem getting the bird unstuck from the surface. It climbs up on the step fast, planes readily at low speeds and can take off in 250 feet—less than the length of a football field.

Developed by George Pereira of Sacramento, the mini single-seater flying boat is fun to build and fly because of its small size, easy handling and eye-catching appearance. Although it has no wheels and is not designed for amphibious use, its fold-back wings enable you to trailer it to any lakeside launching ramp and put it in the water just as you would a boat.

Overall length is 17 feet, 3 inches with a folded width of less than 8 feet—handily managed on any highway. Total height is a mere 5 feet, 3 inches, including the elevated pylon engine mount. Empty

*(Please turn to page 134)*

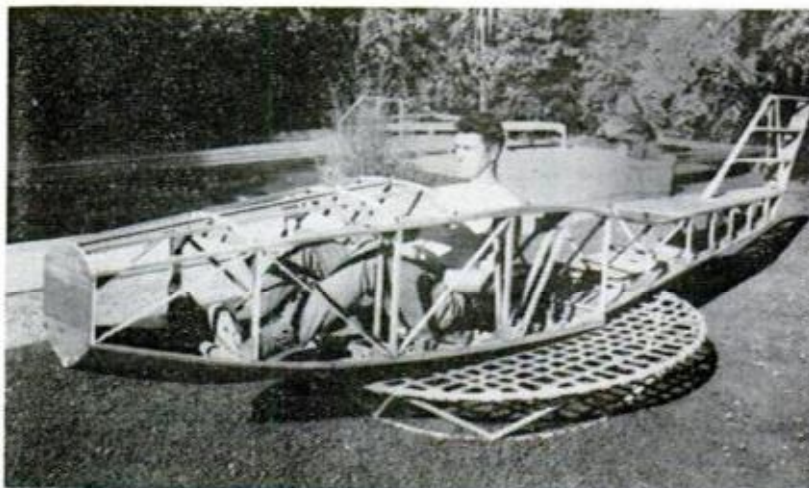

POPULAR MECHANICS

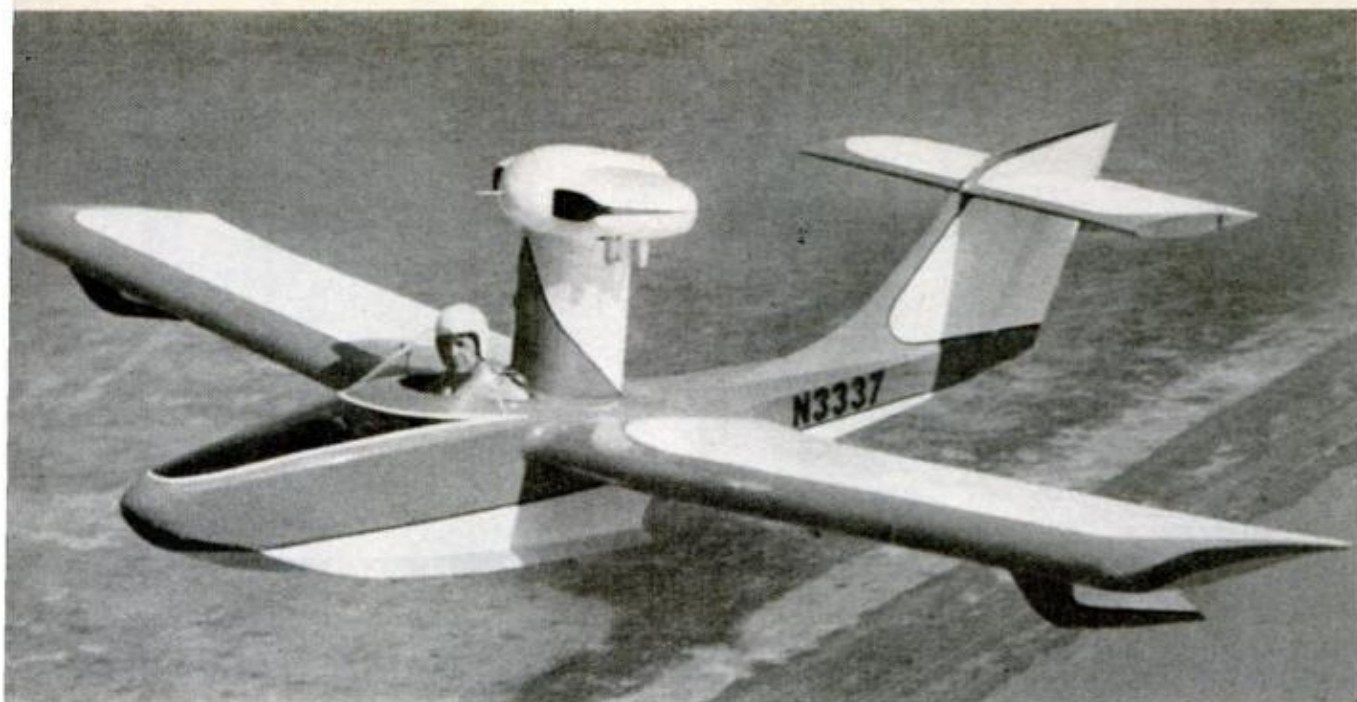

**PYLON-MOUNTED POWERPLANT**, a 90-hp Continental, spins a pusher prop—the only item that must be custom-made because of engine's reverse rotation. Pylon's shroud houses two eight-gallon fuel tanks. The U.S. insignia indicates that ship is under test for possible military use as small police patrol craft

**COCKPIT VIEW** shows single joy-stick control and simplified instrument panel. Ship is equipped only for VFR (Visual Flight Rules) instrumentation to keep the cost low. Foot pedals control the rudder directly through cable linkages without the use of hydraulic boosters—also to keep building cost to a minimum

APRIL 1973



**SITTING LOW IN WATER**, ship is protected from wind effects until it reaches planing speed. Water rudder improves surface maneuverability, then retracts into tail rudder as the craft becomes airborne





## Recorders by the pocketful

By IVAN BERGER, Electronics Editor/Photos by Robert D. Borst

**MINI CASSETTE RECORDERS** cover wide size range, but conventional-sized cassette towers over them all. Left to right: Craig 2605, Hitachi TRQ-21, Sony TC-55, GE M8700, Admiral CTR590 and mike, Realistic Minisette II, Panasonic RQ-212S, Wollensak 401, Crown CTR-381, Sony TC-40, Sony TC-45, Concord F-26, with older Sony in background. For others, see table on page 82

**R**EMEMBER HOW SMALL the first cassette recorders looked? Now, those same book-sized portables tower over the latest in cassette machines—models so compact you can slip them in your pocket.

We managed to track down 18 mini recorders using standard cassettes (skipping those ultra minis that take the special, hard-to-find cassettes with limited recording time). They ranged in size from as little as 26.5 to as much as 73.4 cubic inches; but their weights ran a shorter gamut, from just over one pound to a hair more than two—apparently size differences are due less to what's inside a machine than to how it's packed). In price, they ranged from \$65 to \$229.

Most of them record far better than they can play back. Their compact designs leave room for only tiny speakers, two to two-and-a-fraction inches in diameter, and for amplifiers with one-quarter to one-half watt of output. So they're no match for larger cassette recorders when it comes to music. With a good, commercial cassette recording, the minis will play back about as well as similar-sized portable FM radios.

But the recordings that the minis make play back surprisingly well on larger machines, including cassette decks used with hi-fi systems. For crisp sound pickup, most of the minis have built-in condenser microphones, distant relatives of those used in recording studios. And they all have

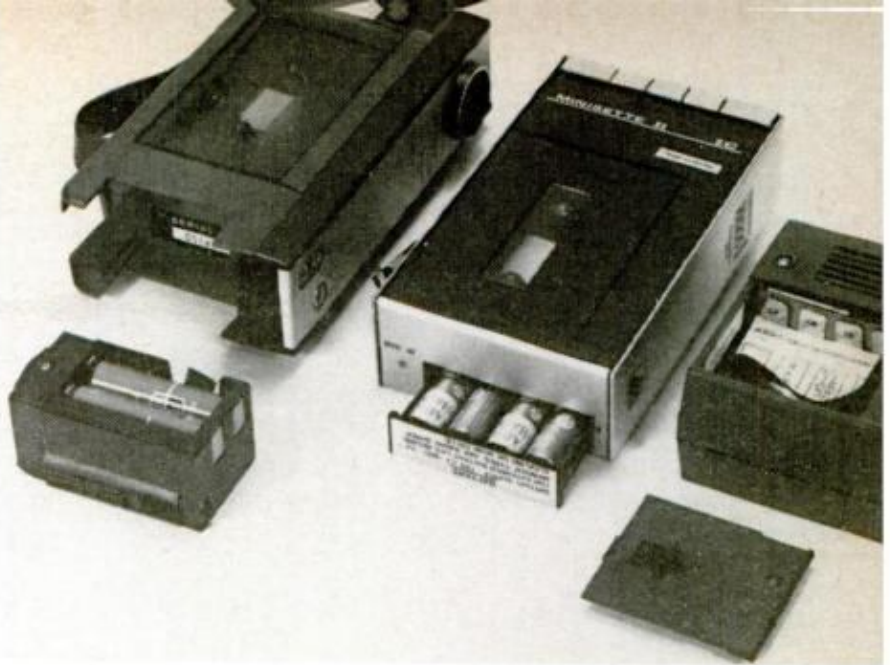

**REMOVABLE BATTERY CASES** (above) in Sony and Realistic prevent leaky batteries from causing expensive damage; sealed-off battery compartment in Crown is next-best. Adjustable automatic recording level controls (left) improve music recording; Sony switch adjusts auto control response for speech or music while Concord switch gives choice of auto or manual control

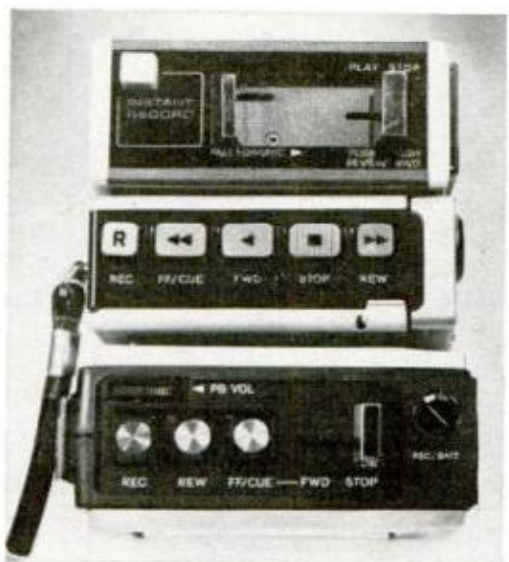

**HOLD MINI LIKE A MIKE** (right) and you can record without trailing, dangling cords or cables. Built-in mike (arrow), small size and handy controls make minis easy to use. This is Sony TC-55, only fifth smallest unit; Craig 2605, GE M8700 and both Hitachi models (TRQ-21 and TRQ-30) are even smaller

**SPECIAL CONTROLS** (left) include "Review" on Wollensak, an instant rewind that lets you rewind words you've just missed in play or just taped in record mode; "Cue" on Sonys (TC-55, middle; TC-45, bottom) that lets you skip parts you don't want to hear while listening for the next words you do want



automatic recording level circuits that keep loud sounds from overloading the tape with distortion, yet keep soft ones from being lost amid the tape noise.

Unfortunately, those automatic circuits aren't too good for music recording: designed to iron out the rapid volume fluctuations that rob speech of its intelligibility, they also suppress the volume changes that give music much of its punch. For better music taping, the Concord F-26 has manual as well as automatic level control, and the Sony TC-55's automatic level control can be switched to work slowly and imperceptibly for music, as well as rapidly for speech.

Though you needn't watch a meter to

get good recordings, nearly all the minis have meters, nonetheless. The needle's wiggling is your assurance that the mike is picking up properly. And in playback, the meters double as battery checkers. (On the Craig and GE minis, which have no meters, lights signal when the battery is about to go.)

And how those batteries do go! Doing all the work of a standard-sized recorder on three or four pen-light batteries, the minis gobble ordinary carbon-zinc batteries like peanuts, especially if you use your fast-forward or rewind controls a lot. While we didn't make precise measurements on all machines, battery life seemed roughly proportional to the number of

## SIZE, WEIGHT AND SPECIAL FEATURES OF 18 NEW

| MAKE AND MODEL         | PRICE | SIZE (in.)  | VOLUME (cu. in.) | WEIGHT <sup>2</sup> (lbs.) | BATTERIES | BATTERY HOLDER | AC POWER SUPPLY             |
|------------------------|-------|---|------------------|----------------------------|-----------|----------------|-----------------------------|
| Admiral CTR590         | \$ 90 | 1 <sup>3</sup> / <sub>4</sub> x 6 x 3 <sup>7</sup> / <sub>8</sub>                             | 40.7             | NA                         | 4 AA      | Co             | Optional, \$7               |
| Concord F-26           | 75    | 2 <sup>1</sup> / <sub>4</sub> x 7 <sup>1</sup> / <sub>4</sub> x 4 <sup>1</sup> / <sub>2</sub> | 73.4             | 2.5                        | 3 C       | Co             | Supplied                    |
| Craig 2605             | 120   | 1 <sup>3</sup> / <sub>8</sub> x 5 <sup>1</sup> / <sub>2</sub> x 3 <sup>1</sup> / <sub>2</sub> | 26.5             | 1.7                        | 3 AA      | SCs            | Optional                    |
| Crown CTR381           | 90    | 1 <sup>3</sup> / <sub>4</sub> x 6 <sup>3</sup> / <sub>4</sub> x 3 <sup>3</sup> / <sub>4</sub> | 44.3             | 1.75                       | 4 AA      | Co             | Optional                    |
| GE M8700               | 70    | 1 <sup>1</sup> / <sub>2</sub> x 6 <sup>1</sup> / <sub>8</sub> x 3 <sup>1</sup> / <sub>2</sub> | 32.2             | 1.7                        | 5 AA      | Co             | Opt., \$8                   |
| Hitachi TRQ-30         | 100   | 1 <sup>1</sup> / <sub>8</sub> x 7 <sup>1</sup> / <sub>8</sub> x 4 <sup>1</sup> / <sub>8</sub> | 33.1             | 1.5                        | 4 AA      | Cs             | Supplied                    |
| Hitachi TRQ-21         | 110   | 1 <sup>3</sup> / <sub>8</sub> x 5 <sup>1</sup> / <sub>2</sub> x 3 <sup>1</sup> / <sub>2</sub> | 26.5             | 1.3                        | 4 AA      | Cs             | Supplied                    |
| Lanier 1100            | 139   | 1 <sup>3</sup> / <sub>4</sub> x 6 <sup>3</sup> / <sub>4</sub> x 4 <sup>1</sup> / <sub>4</sub> | 50.2             | 1.7                        | 4 AA      | Cs             | Supplied                    |
| Lanier 1300            | 229   | 1 <sup>3</sup> / <sub>4</sub> x 7 <sup>1</sup> / <sub>2</sub> x 3 <sup>1</sup> / <sub>2</sub> | 45.9             | 2.0                        | 4 AA      | SCs            | Optional, \$10              |
| Panasonic RQ-212S      | 70    | 1 <sup>3</sup> / <sub>4</sub> x 6 <sup>1</sup> / <sub>2</sub> x 4                             | 45.5             | 1.6                        | 4 AA      | Cs             | Supplied                    |
| RCA YZB387             | 65    | 1 <sup>7</sup> / <sub>8</sub> x 7 x 4 <sup>1</sup> / <sub>4</sub>                             | 55.8             | NA                         | 3 AA      | Cs             | Supplied                    |
| Realistic Minisette II | 80    | 1 <sup>5</sup> / <sub>8</sub> x 6 <sup>5</sup> / <sub>8</sub> x 3 <sup>3</sup> / <sub>4</sub> | 40.4             | 1.4                        | 4 AA      | Cs             | Optional, \$6               |
| Sharp RD-428U          | 80    | 1 <sup>5</sup> / <sub>8</sub> x 6 <sup>1</sup> / <sub>4</sub> x 4 <sup>3</sup> / <sub>8</sub> | 44.4             | 1.7                        | 4 AA      | Cs             | Supplied                    |
| Sony TC-40             | 100   | 2 x 7 x 4 <sup>3</sup> / <sub>8</sub>   | 61.3             | 1.7                        | 4 AA      | Cs             | Optional                    |
| Sony TC-45             | 125   | 2 x 7 <sup>1</sup> / <sub>4</sub> x 4 <sup>3</sup> / <sub>8</sub>                             | 63.4             | 2.1                        | 4 AA      | Cs             | Optional, \$30 <sup>4</sup> |
| Sony TC-55             | 140   | 1 <sup>1</sup> / <sub>2</sub> x 5 <sup>7</sup> / <sub>8</sub> x 3 <sup>7</sup> / <sub>8</sub> | 34.1             | 1.9                        | 4 AA      | Cs             | Optional, \$30 <sup>4</sup> |
| Unisonic 711           | 70    | 1 <sup>1</sup> / <sub>2</sub> x 6 <sup>3</sup> / <sub>4</sub> x 4                             | 40.5             | 1.6                        | 4 AA      | SCs            | Supplied                    |
| Wollensak 401          | 100   | 1 <sup>3</sup> / <sub>4</sub> x 6 <sup>3</sup> / <sub>4</sub> x 4                             | 47.3             | 1.6                        | 4 AA      | SCo            | Supplied                    |

Footnotes: 1. See text; 2. Weights not strictly comparable—not all units weighed with batteries.

batteries; we'd suspect the GE, using five AA batteries might get longer than usual battery life, and the Concord, which uses three large C cells, even more. In any case, it pays to use long-lived alkaline or mercury cells, use rechargeable batteries if possible, and run a mini from an external power supply whenever you can.

A.c. power adapters are supplied with about half the minis, and are available for all the rest. Unfortunately, these adapters can't be built into the machines without making them bulky (but the Hitachi TRQ-

*(Please turn to page 135)*

**EVER-READY CASES**, like that on Realistic (near right), make tape-changing and control operation easy. Pouches supplied with other minis, such as the Hitachi TRQ-21, are almost as handy. But Wollensak (not shown) had to be removed from its ever-ready case when cassettes had to be flipped or changed

### KEY TO CHART ABBREVIATIONS

|     |                                 |
|-----|---------------------------------|
| Acc | Accessory                       |
| AC  | AC power supply                 |
| ASO | Automatic shutoff (at tape end) |
| Car | Automobile adapter              |
| Co  | Built-in battery compartment    |
| Cs  | Case                            |
| FF  | Fast forward                    |
| L   | Locking                         |
| Mic | External microphone             |
| NA  | Not available                   |
| NL  | Nonlocking                      |
| PC  | Patch cord                      |
| RC  | Rechargeable batteries          |
| RS  | Remote switch                   |
| SCo | Sealed battery compartment      |
| SCs | Sealed, removable battery case  |
| SP  | Shorting plug                   |
| TPU | Telephone pickup                |



POPULAR MECHANICS

## MINI RECORDERS THAT TAKE STANDARD CASSETTES

| BATTERY CHECK | PAUSE CONTROL    | FF REWIND TIME (minutes) | SPECIAL FEATURES  | ACCESSORIES SUPPLIED <sup>1</sup> |
|---------------|------------------|--------------------------|---|-----------------------------------|
| Meter         | —                | 2½, NL                   | Mic only, shoulder strap  | Mic, Cs                           |
| Meter         | L                | 1¼, NL                   | Switchable automatic or manual recording level                            | AC                                |
| Light         | NL               | 2¾, L                    | Tape counter  | Mic, Cs                           |
| Meter         | —                | 2¾, NL                   | Tape counter  | Cs, SP                            |
| Light         | NL               | NA                       |   | Cs                                |
| Meter         | NL               | 1½, NL/L                 | AC fits on, handy controls, ASO, tape counter                             | Mic, AC, Cs, PC                   |
| —             | —                | 3½, NL                   |   | Mic, AC, Cs, PC                   |
| Meter         | L                | 2½, NL                   |   | AC, Rc, Cs                        |
| Meter         | Yes <sup>1</sup> | 3, NL                    | Single-button record-play-rewind; printed index; tape-end light           | Cs                                |
| Meter         | —                | 2½, NL/L                 | ASO   | AC, SP, Cs                        |
| Meter         | —                | 2½, NL                   | Mic only, shoulder strap  | Mic, AC, RC, Cs                   |
| Meter         | —                | 2, L                     |   | SP, Cs                            |
| Meter         | —                | 2, NL                    |   | RS, AC, RC<br>Service manual      |
| Meter         | Acc. suppl.      | 12/2, NL <sup>1</sup>    | Cue (no FF) <sup>1</sup> , shoulder strap, beeps at end of Sony cassettes | Cs, pause switch                  |
| Meter         | L                | 1½, NL/2, L              | Cue and FF, ASO, shoulder strap, tape counter                             | Cs, PC                            |
| Meter         | L                | 2¾, 1½, L                | Cue and FF, ASO, shoulder strap, speech/music switch, tape counter        | Cs, PC                            |
| —             | —                | NA                       | Cue (no FF)   | Mic, AC                           |
| Meter         | —                | 2¼, NL                   | Review, tape-end light, ASO "instant record"                              | AC, PC, Mic, Car, TPU, Cs         |

<sup>1</sup> Earphone, batteries and cassette supplied with most models; 4. Includes nickel cadmium batteries.

**DIGITAL COUNTERS** (this one is on Sony TC-45) are great help in finding your place on the tape—if you jot down the locations of taped items as you record or find them. But counter indications are not standardized, so tape locations logged on one recorder may be irrelevant when playing on another

**BATTERY INDICATORS** tell you when short-lived batteries are due for replacement. Meter on Panasonic (left) and most others doubles as recording indicator. Lights on Craig and GE (which have no meters) are battery signal that's harder to ignore. Wollensak's light (right) signals end of tape, not of battery

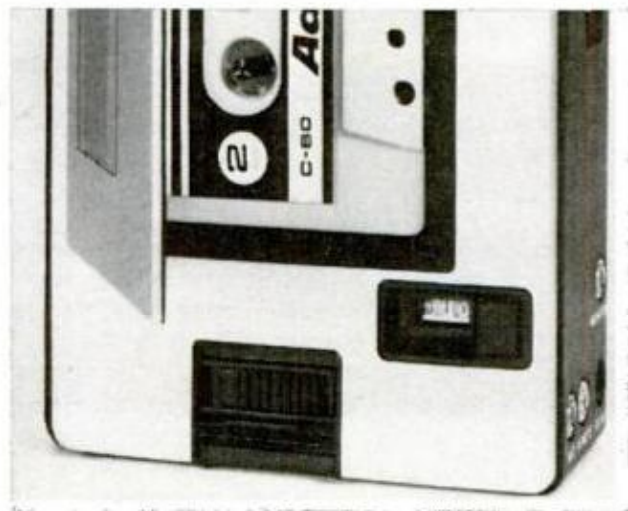

# IT'S NEW NOW

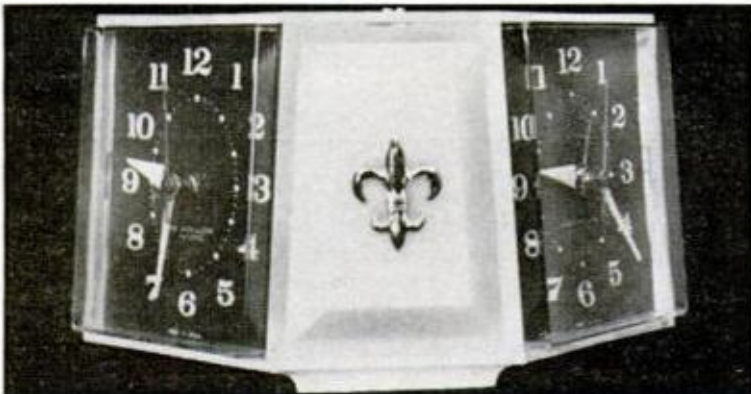

## And now a new craze: Kooky clocks

Reflecting a new interest in unusual clocks is this sampling of oddities from Hammacher Schlemmer, 147 East 57th St., New York, N.Y. At top, there's a hideaway "book clock" that folds neatly out of sight between two dummy volumes. At center left, a "satellite clock" revolves in orbit, telling times in different parts of the country. At center right, a mouse runs up the clock, indicating the hour on a scale, in a whimsical design patterned after the nursery rhyme *Hickory, Dickory, Dock*. The clever two-faced version at bottom is for twin-bed sleepers who want to see the same clock from opposite sides. Prices are \$15 for this up to \$295 for others.

84



## My! What sharp teeth you have!

If you're wondering what those little blobs of plastic are doing on the chainsaw teeth above, they're there to keep the teeth factory-sharp until use. Cutting chains often become dulled during shipment or through handling by dealers and customers. The protective coatings are applied to Omark's Oregon-brand saw chains.

POPULAR MECHANICS



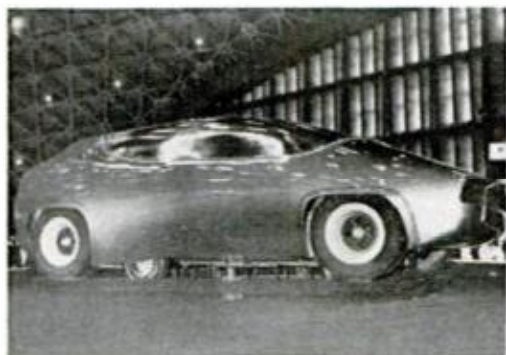

**Three for the road:  
Far-out cars  
from far-away Japan**

From Japan's recent Tokyo Motor Show comes a new crop of futuristic car designs that may eventually get to try their wheels on U.S. highways. At top is Daihatsu Kogyo's electric-powered, clear-plastic-bodied "see-through" runabout—great to show off pretty mini-skirted riders. At center, the sleek, bubble-topped bullet is Mitsubishi's entry into the powerful sports-car field. The Nissan family sport sedan at bottom has a novel rooftop periscope giving the driver a road-wide rear view.

APRIL 1973



**A plane you can crash and walk away from**

Crop dusters used to look like old biwing relics from World War I days, but not this trim little Piper designed especially for pilot safety at low altitudes. Features include extra-long impact-absorbing snout, wheel-mounted wire cutters should the craft tangle with a fence, nonflammable fuel tanks, crushproof rollover canopy.



**A 'primitive' tractor for primitive countries**

It looks crude, but it beats a team of oxen. Designed for easy, economical cultivation of backward lands in Africa, the simplified Tinkabi tractor—named after the Swazi word for "many oxen"—has only a 16-hp engine, steering wheel and one control for forward or reverse.

# NOW



## Wheelless wheelchair climbs stairs on spokes

Climbing up stairs and over other obstacles is no problem for this electric-powered, spoke-wheeled wheelchair invented at Queen Mary College in London. Spokes are spring-loaded and rubber-tipped for a sure grip and smooth ride.



## Rebirth of the dirigible?

These two new German dirigibles, developed by the WDL Airship Works at Essen, are the first in a series designed to bring lighter-than-air aircraft back into practical use. Over 200 feet long, they can carry 66,000-pound payloads—passengers or cargo—at up to 87 mph.

86

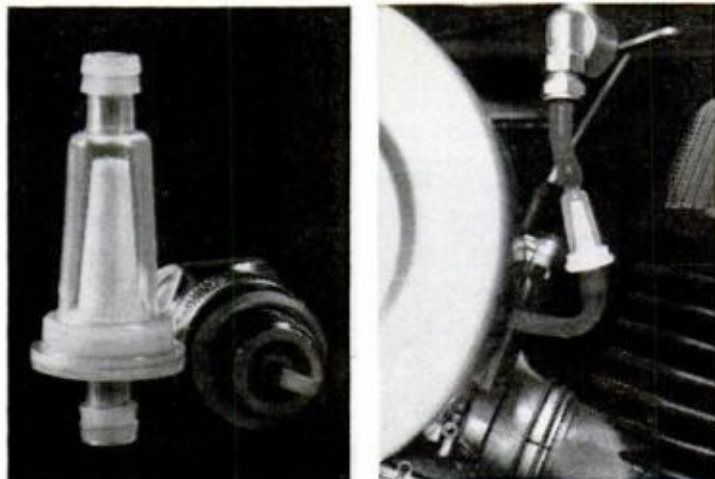

## See-through fuel filter for cars

This transparent plastic fuel filter tells you at a glance when it's dirty enough to need servicing. Its inner cone-shaped nylon-mesh strainer is said to funnel deposits to the tip, leaving the remaining area free from clogging for longer operation. Designed to fit 1/4-inch fuel lines, \$1.25. Technology Development Co., Box 66386, Houston, Tex. 77006.

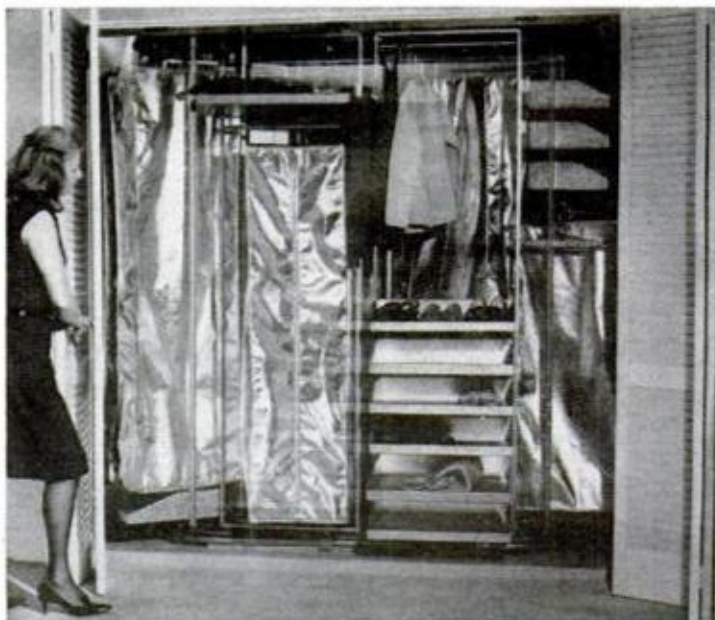

## 'Merry-go-round' clothes closet

You don't have to hunt for anything in this mechanized closet—it comes to you. Press a button and storage racks revolve around an oval track until the item is at your fingertips. \$2500 at Hammacher Schlemmer, 145 East 57th St., New York, N.Y.

POPULAR MECHANICS



### 'Instant' snowmobile from your motorcycle

You can turn your motorcycle into a snowmobile with this handy conversion kit—a bit late for use this year, perhaps, but good to know about for future winters. The kit consists of twin crawler tracks that replace the rear wheel and a ski for the front. The drive linkage pivots to permit the cycle to tilt in relation to the tracks for making banked turns or riding upright across slopes. Priced at \$778, Snow Job kits fit most cycles. Advanced Recreation Equipment Corp., 645 National Ave., Mountain View, Calif.

APRIL 1973

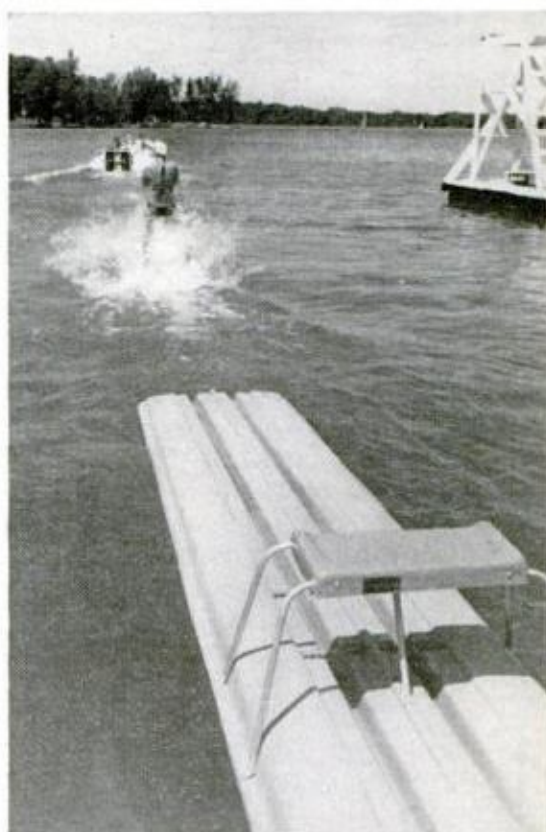

### Quick launcher for water skiers

As everybody knows, getting up on water skis is the hardest part. This floating plastic launching slide lets you take off level without even getting wet. Aqua Slide is also said to reduce power requirements, enabling a small boat to pull skiers it might not otherwise be able to handle. Price not given. Aqua Ski Corp., Box 374, Sturbridge, Mass.

87

# NOW



## Dial-a-file finds it for you —no matter where you put it

With this ingenious electronic filing system, a harried office secretary doesn't have to hunt through stacks of files to find the right one, doesn't have to put it back in the same place and doesn't have to worry about losing misfiled material. All she does is dial the number of the desired file and out it pops in clear view (far left). It can be refiled anywhere; an electro-optical scanner will still find it, making misfiling impossible. Supreme Equipment & Systems Corp., 170 53rd St., Brooklyn, N.Y. 11232, developed the automated system.

## Low-cost ham transceiver you can build from a kit

Designed especially for beginning ham operators is this low-cost, kit-built three-band CW transceiver priced at \$69.95. The HW-7 covers the 15, 20 and 40-meter amateur bands and has both VFO and crystal transmit capabilities. It can operate on 12-volt batteries or accessory a.c. power, making it ideal as a home or portable camping station. Heath Co., Benton Harbor, Mich. 49022.

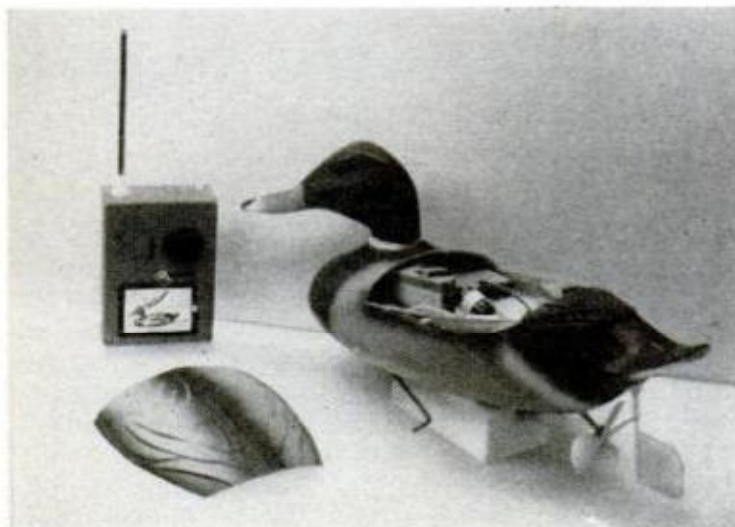

## Would you believe— now it's a radio- controlled duck decoy

It had to come. Press a button and a hunter can send this radio-controlled duck decoy swimming along like a real one instead of anchoring it in one spot. The battery-powered duck will tow a string of other, nonpowered decoys, can retrieve a dead duck for you, even trails a trolling line for remote fishing from ashore. \$300 from RaCo Enterprises, Box 182, Pittsburg, Kans.



### Amphibious trike: Not too practical but a lot of fun

If you want a tricycle you can ride right off the road and into the water, this is it. The novel three-wheeler has large rubber-ball tires with paddles on the sides. On land, the balls give good support on soft ground and a soft ride on hard ground. In water, the paddles provide the propulsion. The amphibious trike is sold in Europe by Victoria-Werft GmbH in Munich, Germany. Price: 1280 marks—about \$390 in U.S. dollars.

### Mini drivers for small, hard-to-reach screws

Two sets of tiny screwdrivers for delicate work on clocks, cameras and electronic equipment are now available from Xcelite. Set M-50 contains five drivers for slotted screws with tip widths from .040 to .100 inches. Set M-60 adds one Phillips driver and a slip-on handle for increasing torque. For prices and catalog, write Xcelite, Orchard Park, N. Y. 14127.

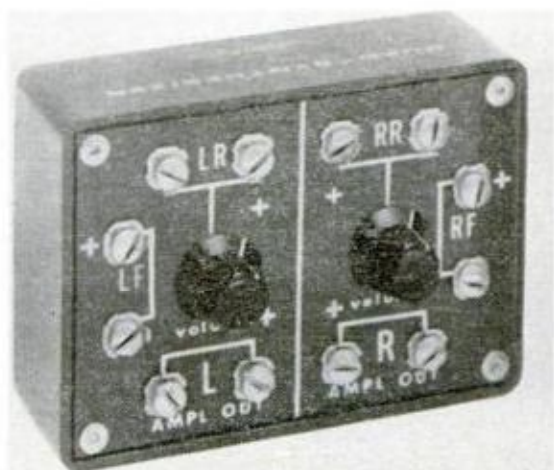

### Four-channel 'starter' attachment gives you quad sound at low cost

This simple adapter lets you try 4-channel sound at minimum cost. It requires only two additional speakers and your existing stereo system. Two added channels are "derived" through differential phase relationships of the original stereo signals. Basic model (left) \$6.95; with volume and balance controls, \$9.95. Robins Industries Corp., 75 Austin Blvd., Commack, N. Y. 11725.

# NOW

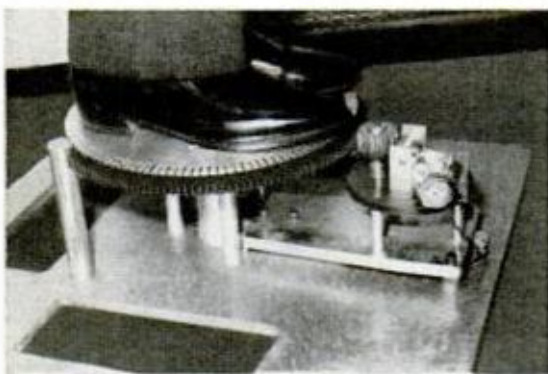
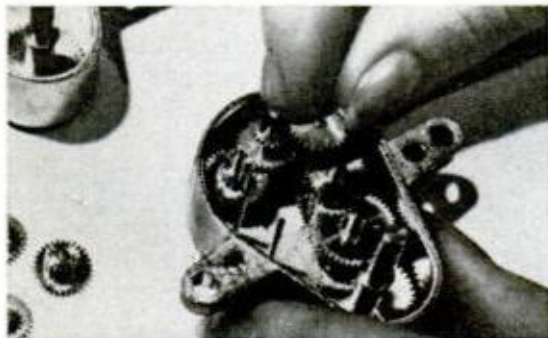
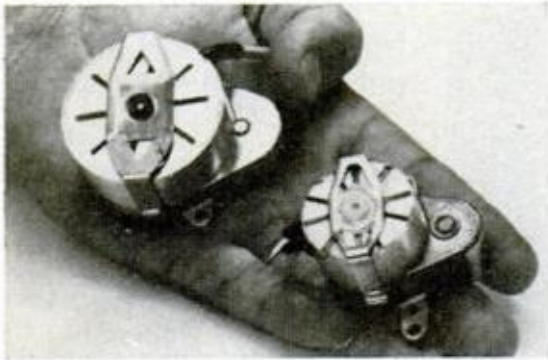

## New 'miracle' mini motor

Synchronous motors are the tiny muscles that run countless mechanisms from electric clocks to automated factories. Because they start in either direction, mechanical devices such as ratchets have been needed to keep them operating in the desired direction. These are noisy, can cause drag and frequently fail (ever see an old clock suddenly start to run backward?). Now the British firm of Elremco of Harlow, England, has come up with an electronically controlled synchronous motor that can be started either way, stopped in a fraction of a second and reversed at will—all without mechanical devices. The new mini motor comes in two sizes—small enough to fit in the palm of your hand (top photo) and powerful enough to turn a man standing on a turntable (bottom).

90



## A bit slow, but still racy-looking

Russian students at the Institute of Kharkov work on what is said to be the world's first electric-powered racing car. The flashy Khadi-5 won't set any records yet, though—top speed is a modest 80 mph.

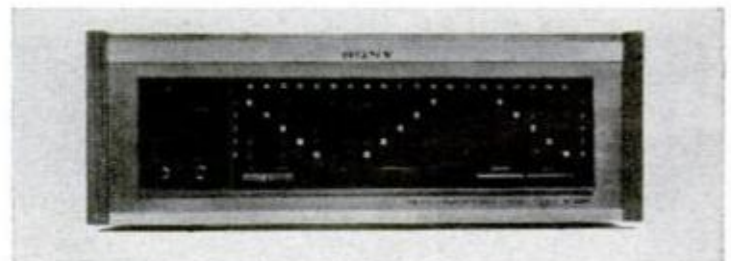
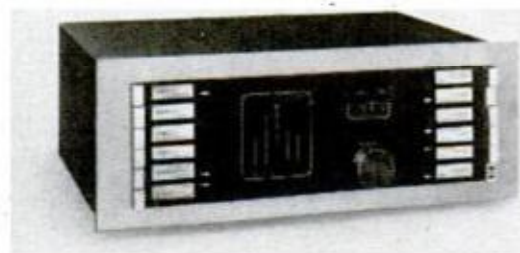

## Fancy tuners with fancy price tags

Today's most advanced and expensive tuners are the new Sequerra model (top) at \$1600 and Sony's new ST-5555 (bottom)—a mere \$1200 or so. The Sequerra tuner incorporates digital frequency read-out to show what station is tuned in, Dolby noise suppression and a built-in oscilloscope that displays tuning accuracy, signal strength, multipath, stereo separation and quadraphonic sound distribution. The Sony features computerized tuning with one pushbutton for each FM channel. Buttons corresponding to receivable stations light up, guiding your finger for one-touch channel selection. Or you can sweep automatically through all stations—except those you've specifically programmed the tuner to ignore. Sequerra Co., 71-07 Woodside Ave., Woodside, N.Y. 11377. Sony Corp. of America, 47-47 Van Dam St., Long Island City, N.Y. 11101.

POPULAR MECHANICS



### Foolproof burglar alarm

This new Panasonic burglar alarm fills a room with an invisible field of microwaves. Any movement in the room disturbs the field, setting off the alarm. Unlike previous UHF and ultrasonic alarm systems, the device will detect slow motion and can't be set off by wind.

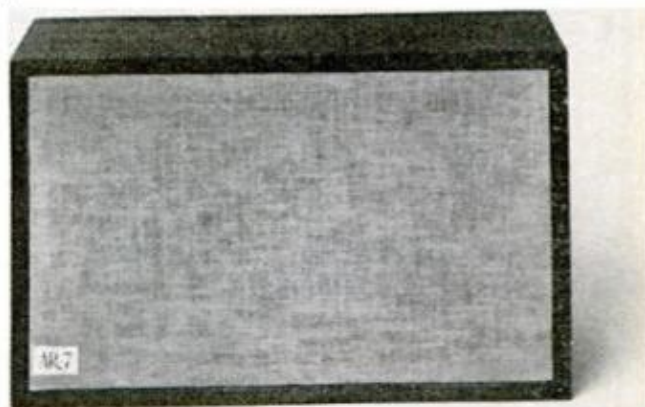

### New AR speaker—smaller than ever

AR's newest and smallest speaker is this compact AR-7 measuring 15<sup>3</sup>/<sub>4</sub> by 9<sup>3</sup>/<sub>4</sub> by 6<sup>1</sup>/<sub>4</sub> inches. Said to offer the same high-quality reproduction as larger, costlier acoustic-suspension models, the walnut-finished enclosure has an 8-inch woofer and 1<sup>1</sup>/<sub>2</sub>-inch tweeter with adjustable crossover. \$60. Acoustic Research, 24 Thorndike St., Cambridge, Mass.



### Depth sounder really sounds off

This new kit-built depth sounder beeps an audible warning as you approach shallow waters or submerged objects at any preselected depth. Two switch-selected ranges read up to 60 or 240 feet. The MI-1031 kit is \$99.95. Heath Co., Benton Harbor, Mich. 49022.

APRIL 1973



### Flashy flash is full of tricks

First of a whole new wave of flashguns coming our way is this clever Braun 200 Vario Computer. It's an automatic strobe that saves unused flash energy instead of dumping it like conventional auto flashes so it recycles as fast as 0.3 second, gets up to 700 flashes per charge. Tilts for bounce flash. \$120 and \$140 models. Braun, Cambridge, Mass.

91

# NOW



## Easy one-step wood finishes

A wood finish that combines stain and wax works wonders with any porous wood surface. In six tones, it can be blended to match any wood and hide scratches (above). \$1.29 per half ounce. Rub 'n Buff, American Art Clay Co., Box 68163, Indianapolis, Ind. 46268.



## Versatile receiver—it's got rhythm

Plug one or two electric guitars into the front panel on this new KR-6170 Kenwood stereo receiver and you can play along with the music. If nothing on the air suits your mood, you can switch on a built-in rhythm section. \$550. Kenwood, 15777 S. Broadway, Gardena, Calif. 90248.

92

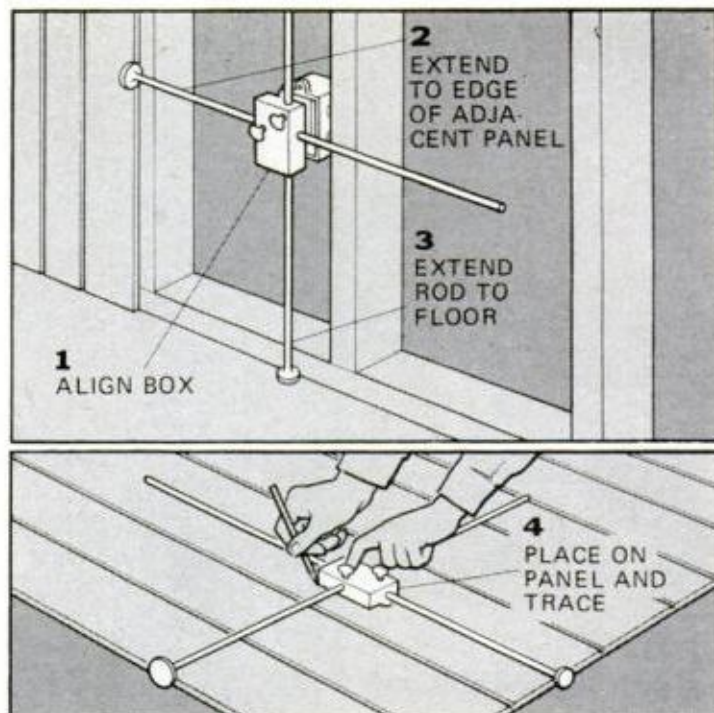

## No-guesswork way to locate outlet boxes accurately when paneling

Take the guesswork out of locating cutouts for electrical receptacles on a paneling job by using a Fox Box. Step 1 (in sketch): Box is located at desired point between wall studs, then telescoping gauge arms are extended vertically and horizontally (steps 2 and 3) to the position panel will occupy when installed. Step 4: Fox Box is laid on workpiece, and outlet box location is pinpointed and traced onto paneling for cutting. Price: \$9.50 postpaid; The Dot Box Co., 1804 Whittier, Springfield, Ill. 62704.





### Bib overalls are 'in'

Bib overalls, used by professionals for more than 40 years, are the latest find for the "now" generation. Type shown above by Sears, Roebuck and Co. features adjustable shoulder straps, watch-fob buttonhole, two utility pockets, pencil slot, pliers pocket, hammer loop and other pockets. Price: about \$6.



### Low-cost digital watch

Most digital watches cost an arm and a leg, but you can have this modest version for \$19.95. Hour and minute readouts are mechanical rather than electronic. Sharon J. Williamson Co., RR No. 8, Saint John, N.B., Canada 11B12.

APRIL 1973



### Spruce up the family chariot the spray way

Unique valve produces a car-wash gun (top) featuring precise control, automatic shutoff, spray-rinse cycles and a reservoir. \$6.95. Silicone upholstery cleaner (above) comes in a 14-oz. aerosol can; cleans leather, plastics, vinyl, fabric and floor covering; gives a dirt-repelling coating that restores finish. \$1.35. Turtle Wax, Inc., 1800 Clybourn Ave., Chicago, Ill. 60614, makes both.



### Gardener's holster

Styled like a western gun holster, this leather sheath has belt loops and brass clips for keeping your pruning shears handy on belt or pocket when you are green-thumbing it. Designed to hold Wiss shears, it's \$2.95 from J. Wiss & Sons Co., 400 W. Market St., Newark, N.J. 07107.



### Little, big 'arbor press'

Mini press incorporates principles of arbor-press design in miniature. Frame is 4 3/4 in. high, ram is 1/2 in. in diameter, travels 2 in. Leverage ratio is 15:1. \$10.95 ppd. Northwest Mfg. & Supply Co., 1285 Golf Rd. Des Plaines, Ill. 60016.

# NOW

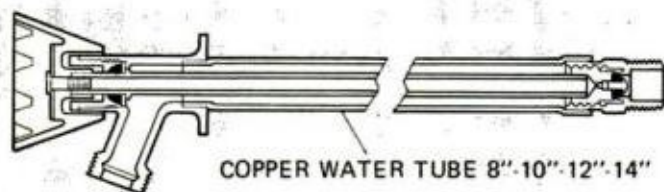
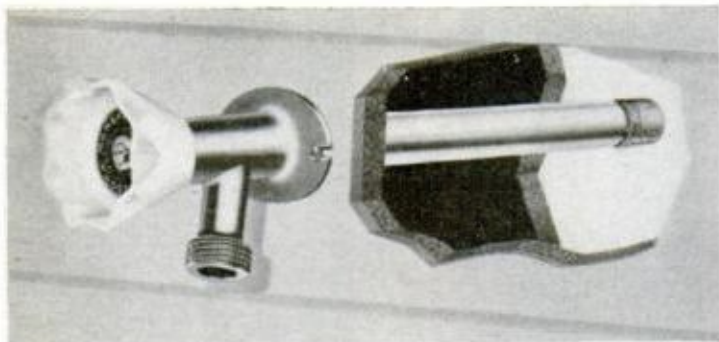

## A frostproof outside faucet

Claimed not to freeze or burst in winter, this outside faucet eliminates need for shutting off water supply because—through an elongated stem—it turns off inside the building where it is warm. Available in 4- to 18-in. lengths, faucet is priced from \$6 to \$8 depending on size. Made by Mansfield Sanitary, Inc., Perrysville, Ohio 44864.



## Lowest-priced Mini-Mac chainsaw

This ultralight, gasoline-powered chainsaw is claimed to be the first to break the \$100 price barrier. Weighing under 8 pounds, Mini-Mac sells for \$99.95. Oil for gas mix (shown with saw) is extra. At McCulloch dealers throughout the country.

94



## Angle-indicating table

Printed on sheet plastic, the accessory Angle Cutting Table Surface provides a handy protractor guide with divisions of  $\frac{1}{2}^\circ$  for cutting bevels, miters and tapers on a radial saw. The graph is cemented to plywood and placed on the saw table. Guide is priced at \$4.50 from Comparator Chart Engineering, Box 1250, Huntington Beach, Calif. 92647.



## Octagonal shelter you can customize yourself

This octagonal prefab can be a summer home, beach cabana, back-yard playroom—anything you want to make it. Interchangeable interior and exterior panels let you locate doors, windows and partitions to suit. Basic shells of 32 and 40 feet diameter are \$4950 and \$7950, panels extra. Game Time, 903 Anderson Rd., Litchfield, Mich. 49252.

POPULAR MECHANICS



### Once a boxcar, now a bridge

What do you do with an old boxcar? You make a covered footbridge out of it—at least that's what Topanga, Calif., did with this Santa Fe relic headed for the boneyard after 29 years of service.



### Get an edge on your garden tools

A yard-tool sharpener from Stanley Tools, Div. of The Stanley Works, New Britain, Conn. 06050, features a tungsten-carbide sharpening bit (above) and a stone (top photo) for deburring and final honing of blades. At most hardware suppliers for \$1.79.

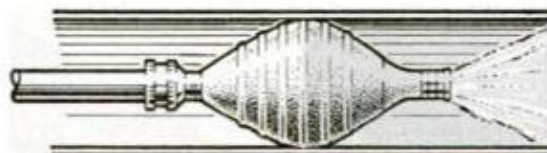
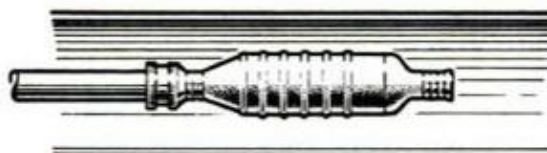

### Super-duper drain declogger

By simply connecting Drain King to your garden hose, the chore of unclogging downspouts, kitchen sinks and the like is made easy. When water is turned on, Drain King expands and locks itself in a pipe. Pressure forces strong jets of water through surge valve to dislodge blockage. \$1 ppd. G. T. Water Products, Inc., Van Nuys, Calif. 91412.

APRIL 1973



### Have wheels, will travel—anywhere

What has eight-wheel drive and can haul 15-ton loads equally well over paved roads or rugged back country? It's this giant all-terrain Dragon Wagon flat-bed trailer designed by Lockheed for go-anywhere use over wilderness trails.

95

**A SIGHTSEEING RIG** for skin divers can be a simple project when you use the plastic pontoons available from several sources. Bolt this surface skimmer together and you have a safety raft for divers. Add a little motor and it can tow you on a tour of reefs and underwater sights.

The snorkel-scooter shown here was designed by diving instructor Phil Adams, of Key Colony Beach, Fla., and measurements can be easily altered to fit your special needs. Using more of the pontoons, a raft craft or even houseboat could be constructed for sheltered waters. Cost of the tow rig shown here could come to less than \$100 if you have some lengths of 2x6s and 2x4s around.

Power for the raft is best supplied by one of the newly popular little electric trolling motors, though a tiny gas outboard can also be used. With either, it is wise to fit a wire cage around the propellers as a prop guard so that there will

# Tow rig for

Fit four plastic pontoons under a deck for less than \$100, add pint-sized power, and it is a sightseeing skiff for skin divers

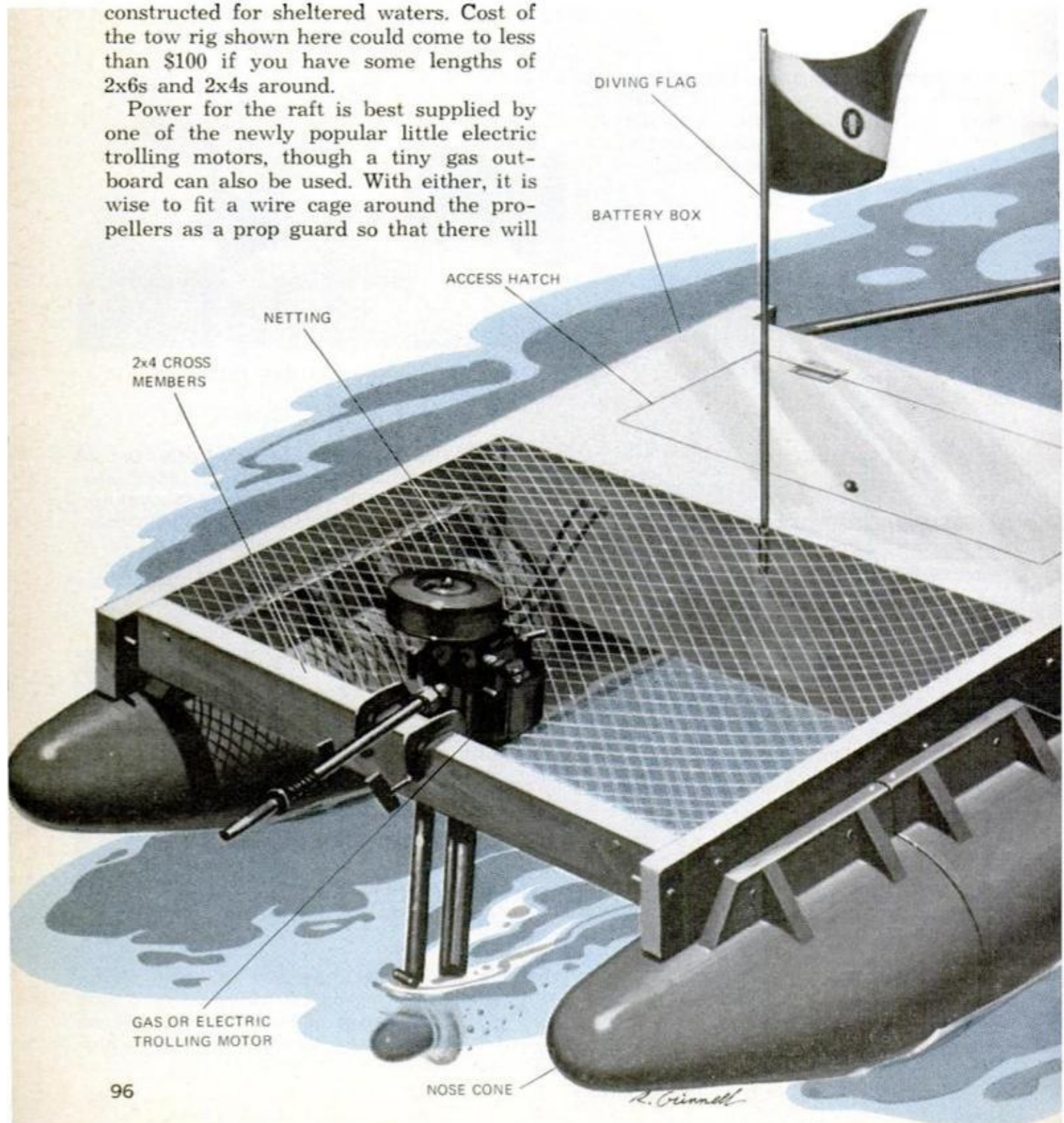

# snorkeling

By FREDERICK PHILCOX

Illustration by Roy Grinnell



be no chance of divers bumping into blades. All power is shut off, of course, when divers are below the surface. One or two divers can be towed at up to two mph for about two hours per battery charge. Steering is accomplished by the diver angling himself behind the rig. Higher speeds would make steering—and sightseeing through your face mask—difficult.

Flotation for the scooter comes from four rotationally molded polyethylene pontoon modules made by Rotocast Plastic Products, 67 N.W. 36th Ave., Miami, Fla. 33147. Two three-foot body sections and two nose sections are required. The

**STEERING** for this easily built, slow-motion raft is simply a shove or a foot-flipper kick by the swimmer. Motor is set for about 2 mph, and skin diver gets a leisurely view of the bottom with minimum effort. Pontoons have buoyancy to let swimmers rest on deck

APRIL 1973

97



**EASY TO BEACH** and light enough to be cartopped, diver's scooter can also unbolt to fit a car trunk

**FLOTATION** for almost 800 pounds allows passengers aboard, or use as a rest raft for swimmers, divers



body sections are about \$21.45 each f.o.b. and the nose sections are \$20.79 apiece. Rotocast has dealers around the country and can give you the address of the nearest local outlet. Experience in Florida waters indicates the pontoons don't deteriorate and probably have a life of many years. Antifouling paint can be applied if they show signs of barnacle buildup in some coastal waters.

For the model shown, two 5-foot lengths of 2x6 were used for the side stringers. Cross members can be three 4-foot lengths of 2x4s. These can be screwed or lagbolted in place, secured with brackets, or special cross-member brackets are available at \$1.05 each from the pontoon

manufacturer. You'll need six. For small motors, the forward 2x4 cross member provides a clamping spot for your power supply. Bolt a section of 2x6 across the front as a motor mount if you need to support a larger outboard.

The size of the afterdeck is optional, depending on your needs. As shown, a battery and equipment storage compartment with top hatch, about 4x3 feet and 1 foot deep can be constructed of 1/2-inch plywood. Swim fins, masks, snorkels and even wet suits and scuba gear could be carried along in a larger size box.

Some divers prefer simply to rest their 6 or 12-volt battery in a simple securing frame on the deck since it is easier to

## BATTERY BOX

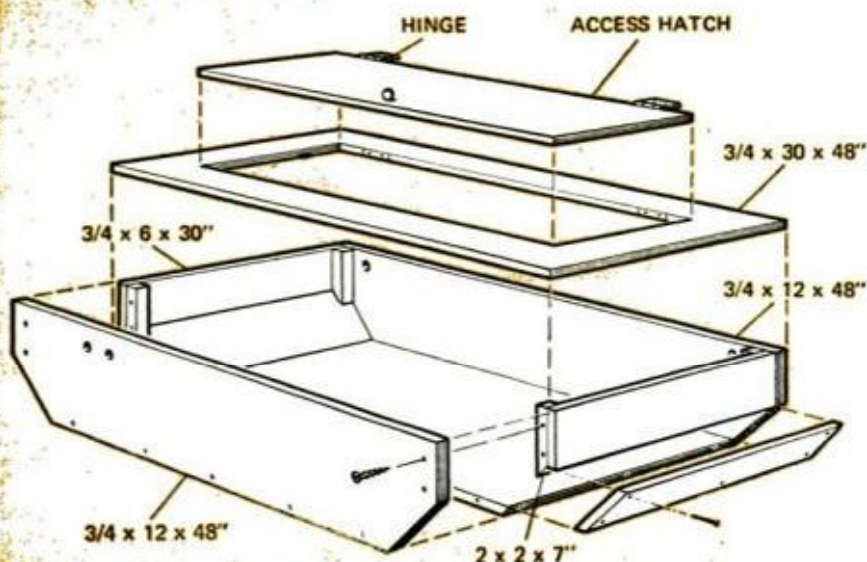

## WIRING DIAGRAM

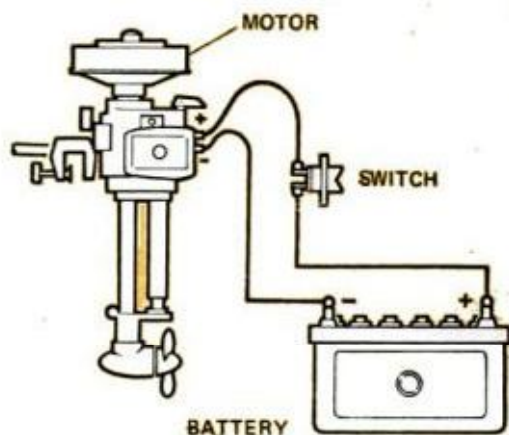



**ADD MORE PONTOONS**, and a raft large enough for double-decker sunning or fishing can result. A houseboat could also be constructed, with snorkel rig in as "dinghy"

remove than lifting from the storage box for regular charging. Though the battery on deck will be well above water level, a fiberglass battery box, that secures to the deck with nylon tie-down straps, offers more protection from spray. These boxes cost about \$5 at marine supply stores. Two batteries can be carried, of course to increase your range.

Most electric outboards come with heavy-duty battery cables and clamp grips. Keep the grips on the cables since you will be disconnecting regularly to charge the battery. Cut into one cable, however, and attach the leads from your on-off switch. This switch is mounted in the middle of your tow-handle grip. The tow handle can be a 12-foot length of

aluminum or galvanized  $\frac{3}{4}$  or 1-inch pipe bent into U shape, with wires to the kill switch run inside. We used a switch from a Crowell bilge pump but any waterproof switch should do. It can also be mounted on the back of the storage compartment.

Forward of the decking, a fish net strung between the stringers and cross members will provide a handy catchall for gear or shells and objects brought up from the bottom during a dive. Eyebolts, secured fore and aft, can secure an anchor line or tow lines if the rig is to be pulled along to the diving area behind a larger craft. The pontoons, which are sealed at each end and designed to lock together, provide nearly 800 pounds of flotation and easily support a tired diver who wants to climb up and ride on deck.

Before assembling the components, it is well to paint the wooden parts with colored fiberglass resin or marine paint for waterproofing. The pontoons come in an attractive blue. The rig is light enough for cartopping, but can also be constructed so it can be disassembled by unbolting to fit into a car trunk. ★★★

#### BILL OF MATERIALS

| No.     | Size and Description (Use)                                  |
|---------|---|
| 2       | 2x6 stock lumber 5' long (stringers)                        |
| 3       | 2x4 stock lumber approx. 4' long (cross members)            |
| 12'     | $\frac{3}{4}$ " or 1" aluminum or galvanized pipe (tow bar) |
| 1 sheet | $\frac{1}{2}$ " marine plywood (deck or storage box)        |
| 1 qt.   | 4-oz. colored fiberglass resin (waterproofing)              |
| 1       | waterproof on-off switch                                    |
| 4       | Pontoon sections  |
| 25'     | 2-wire electric cable (motor switch)                        |
| Misc.   | assorted screws and $\frac{5}{16}$ " lagbolts               |

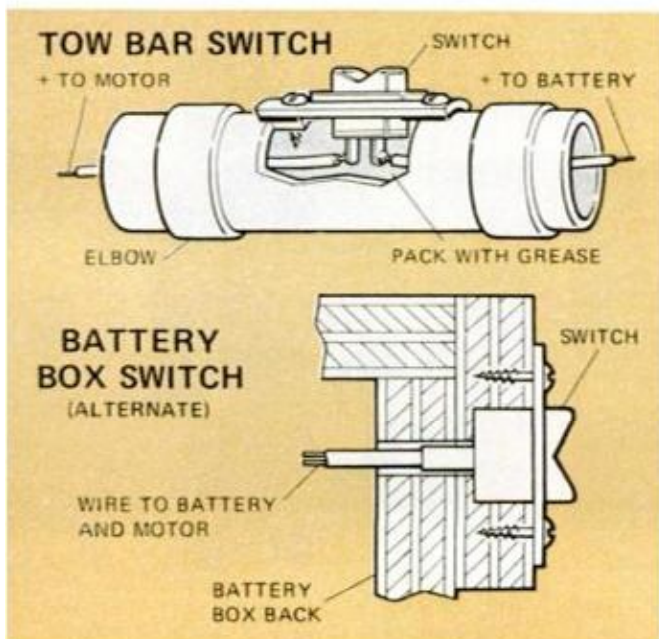

# Underwater update

New and improved devices for diving are safer and more sophisticated

By WAYNE HARRIS

**F**OR SUBSURFACE BEGINNER and old expert alike, this year's diving gear and gadgets aren't radically different—but have been notably improved.

And even expert skin divers aren't so aged from years of experience. Self-contained underwater breathing apparatus (SCUBA) arrived during World War II and even such simple items as face masks and foot fins were hardly on the market until the late 1940s and '50s, although Leonardo da Vinci gets credit for working on a diving mask, among his many other projects, and Ben Franklin is supposed to have designed hand and foot flippers to make his swimming easier.

This year, however, a diver can select from a broad assortment of upgraded items to keep him warmer, safer, breathing with less effort, and photographing more easily what he sees underwater.

Starting from the top and working



**VENTED FINS** having slots to allow water to flow through are becoming popular. Dacor calls its new Quadra-Vent models Turbo II Fins, claims improved vertical and lateral stability. A TV-K pair costs \$20

down, a diver can now wear a wet suit hood constructed to take pressure off his ears and, if necessary, add equalizing air from his back tank. Experienced divers will also check the variety of ear drops that help guard against inflammation and infection. Better face masks, in even greater assortment, can be selected in goggle form or with side glass for wide-angle vision, outside nose-pinch provision to help equalize ear pressure, plus a purge valve to expel water. Masks can be ground to eyeglass prescription, or lenses can be fitted or cemented inside. Better snorkels are now frequently topped with a fluorescent color for better visibility, and a diver may wear both snorkel and tanks to conserve his air supply while on the surface.

Regulators to provide the proper amount of air from tank to diver are offered this season with claims for even easier breath flow, more durability, a sonic reserve



**WET SUITS** now come in an assortment of colors, textures, styles and thicknesses. U.S. Divers Co. models are shown above



**AIR TANKS** of aluminum or steel are now available with a lifetime warranty



alarm to warn when tank pressure is getting low, and models that shut off free flow of air in seconds if the regulator is dropped in the water.

Tanks are more corrosion-resistant, can safely hold higher pressures, and may be fitted with harness adapters for a hookah hookup so an alternate surface air source may be attached by hose for shallow dives. Scuba tanks, regulators, and in fact all underwater gear should be chosen with the advice of an experienced dive shop, and only, of course, after the diver has had full instructions. Classes provide a chance for a diver to compare gear and get help in selection and individual fitting.

Flotation compensation is receiving more attention, and a variety of new buoyancy vests of the "Mae West" type is offered this year. Better models use one or two CO<sub>2</sub> cartridges plus a mouth tube for inflation adjustment. The new hip weights are reported to be more comfortable than smaller waist leads.

Wet suits come in a greater variety of colors, sizes and custom fittings. One remarkable new model, called the Unisuit, is available to professionals and certified divers with the claim that it combines wet, dry and hard-hat suit advantages. It can take air from a diver's tanks to inflate and balance-out buoyancy compensation. Special fin-guards are required to keep foot fins from popping off if the suit is fully inflated. The \$300-plus model is said to keep you warm enough for diving under ice.

Swim fins now come in buoyant and

nonfloating models with new rib designs and optional slots claimed to give an added venturi jet thrust to the swimmer. New flexibility is reported for rubber diver gloves.

And to keep a diver's hands full underwater—as well as decorating arms, chest and legs—there are improved spearguns, searchlights, plastic slurp guns to suck in small fish specimens, underwater metal detectors, knives, submersible decompression charts, depth indicators and compasses with tiny built-in lights, marker floats, intercom systems, and electric-powered towing rigs.

For taking pictures of the fish that got away, the well-known Nikonos now has a wide variety of wide-angle and fish-eye accessories. Most other still and movie cameras can be bottled in custom plastic cases with exposure meters and flood, flash or strobe lights attached.

For fish that will not go away, a Shark Dart or hand-held Shark Dagger will dispatch one with an internal blast of compressed CO<sub>2</sub> that is claimed to be surer and quicker than the shot-shell bang-stick.

For stings from jellyfish, sea urchins and coral, a diver's first-aid kit is also being supplied.

Ashore, sprays and powders help the diver suit-up, new compact compressors fill his tanks. But once he's in the water, the appeal of the undersurface world remains exactly the same, unspoiled by all of the clever gadgetry that makes seeing it possible. ★★★



**CUSTOM HOUSINGS**, like Giddings Cine-Mar for 8-mm movie camera, are offered for most still, movie rigs

APRIL 1973



**SUBSURFACE SYSTEM** includes Nikonos II camera, bar bracket, strobe light, exposure meter, close-up tube

101

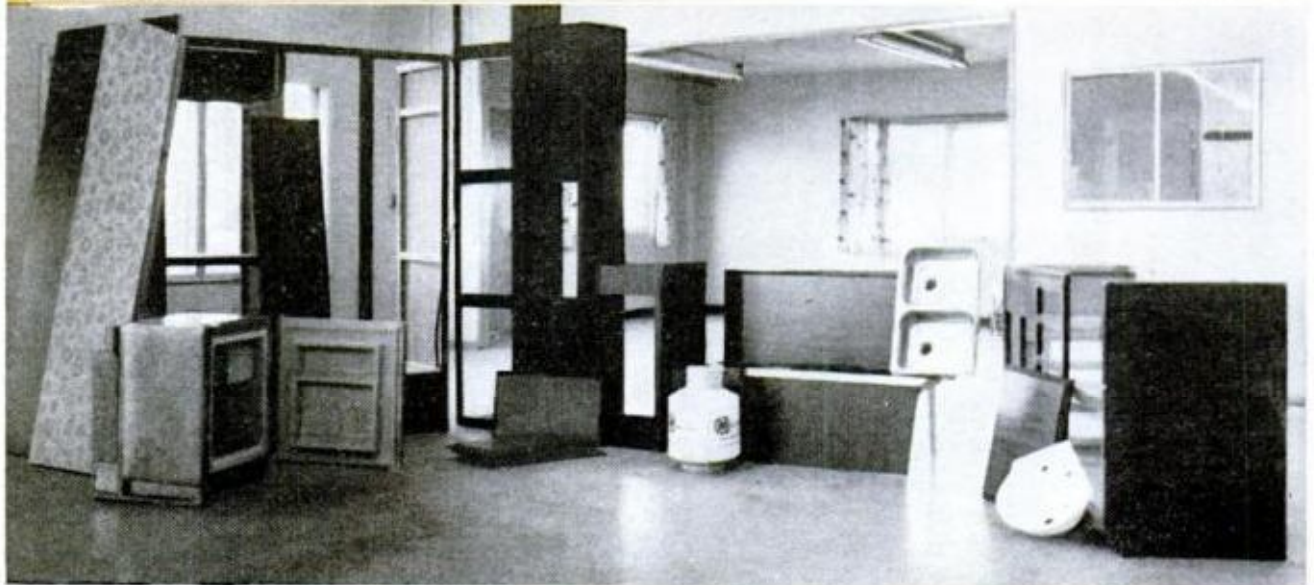
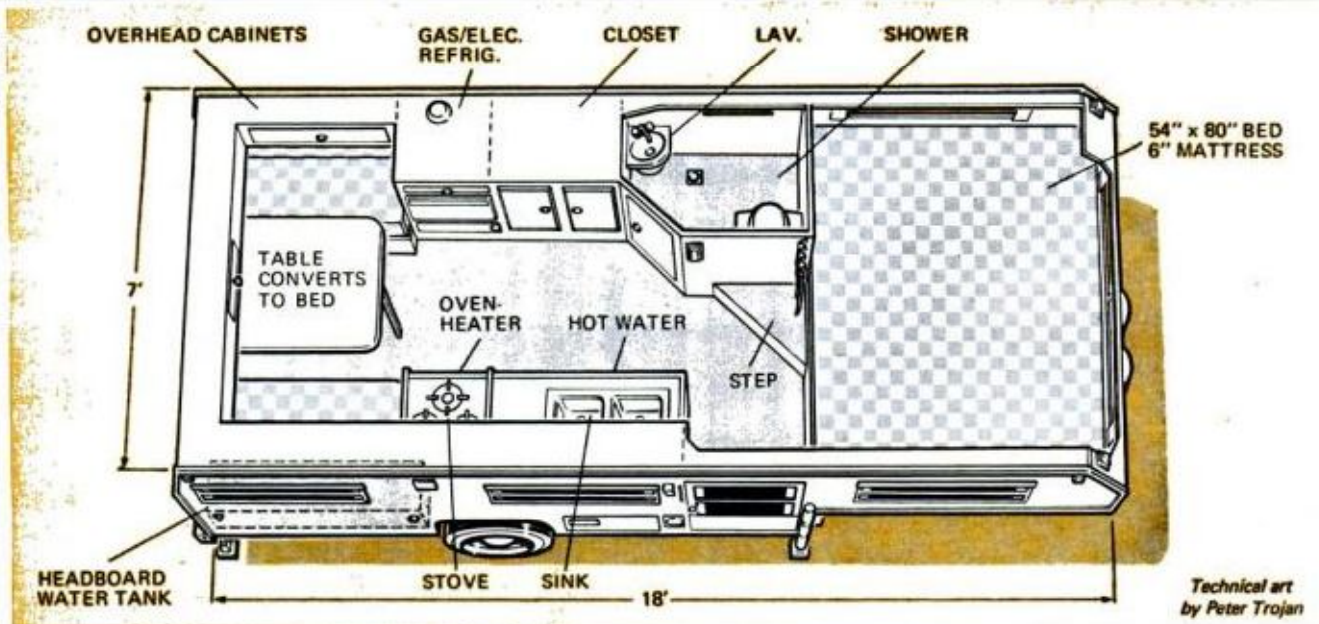

Here's a homebuilt fifth-wheeler to hitch behind half-ton and imported pickups

# Big trailer for small trucks

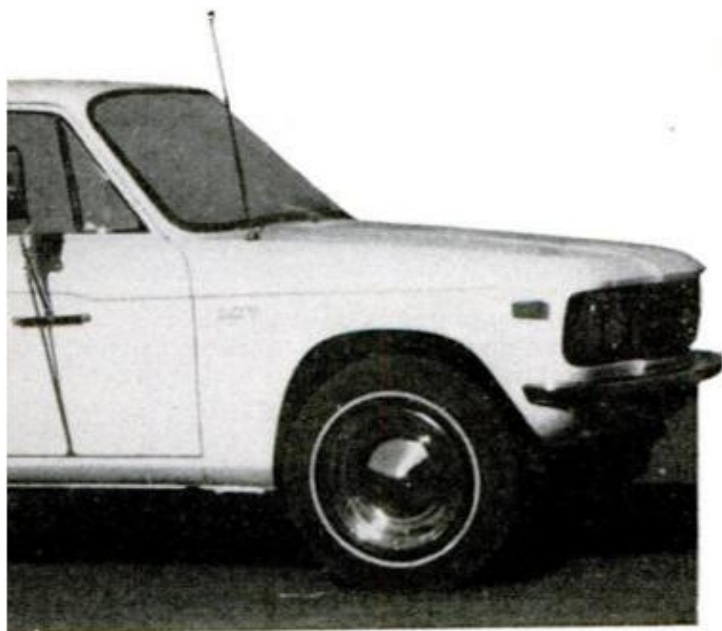

**E**VEN A COMPACT imported pickup can pull this roomy 18-foot fifth-wheel trailer you can build yourself. Only about 370 pounds of hitch load on the cargo bed of a Toyota, Datsun, Mazda, Courier or LUV is necessary to tow this 2800-pounder down the road. Or you could use your Ford Ranchero, Chevrolet El Camino or any standard pickup truck.

The trailer is called the Small Fry Fifth Wheel, and speeds of 60 mph at 15 mpg are claimed with some economy rigs. Electric trailer brakes on the Small Fry's wheels provide dependable stopping, and some states classify the fifth-wheel as a semi-unit safe enough for passengers to ride inside.

The designer, Small Fry Enterprises, Inc., of 3094 S.E. Tualatin Valley Highway, Hillsboro, Ore. 97123, estimates that an amateur builder can construct the trailer in two months of part-time work. The completed rig is fully self-contained with 25-gallon water supply, automatic pump, water heater, shower, toilet with holding tank, 10,000-B.T.U. furnace, three-burner stove with oven, gas/electric refrigerator, double stainless sink and bunks for four.

Tools needed for construction are a 1/4-inch router, 3/8-inch variable-speed reversible drill and a portable electric saw. Also helpful would be a metal-cutting saw, table saw, air staple gun, air compressor and welding rig. Building can be done from the detail plans available and parts assembled locally, or a complete kit can be ordered from Small Fry. A list of necessary components and suppliers is provided with the plans. Hitch can be purchased with the plans. Wheels and axles are obtainable from trailer suppliers.



**MORE RIG** for less cost, offering maxi space and towing stability behind a mini pickup, are among advantages claimed for the Small Fry build-it-yourself fifth-wheel trailer shown at top. Secure hitch, similar to a semi's, is mounted in truck cargo bed

**STEEL FRAME**, using channel iron and steel tubing forms basic structure. Wheels and axles can be purchased from mobile-home or travel-trailer supplier. Interior arrangement (left) shows large double bed forward, dinette aft that can convert to sleep two more, full galley with furnace and water heater below, and enclosed bathroom. Rig carries holding tank, 25 gallons of fresh water, LP tanks at front

**UTILITIES AND CABINETS** in prefab form can also be bought in a kit from Small Fry Enterprises. Included are double stainless-steel sink, water heater, 4-cu.-ft. gas electric refrigerator, toilet

APRIL 1973



**WHEEL WELLS** can be farmed out to local sheet-metal shop. When they're installed, flooring can commence

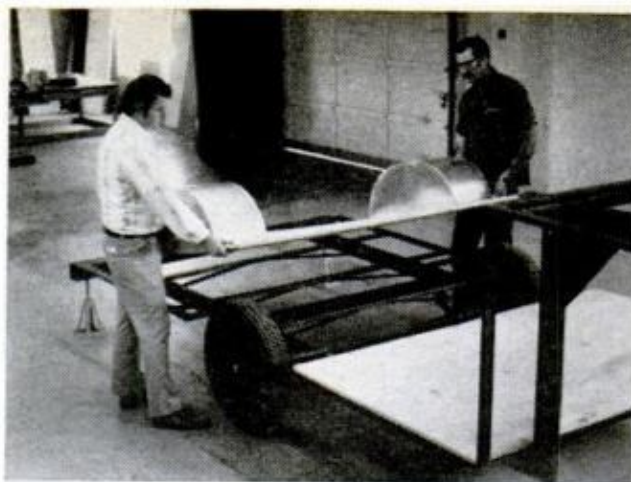

**FLOORING** is shaped from ½ to 1-in. insulation board and ¾-in. exterior plywood, fastened by screws

ers. Wheel wells can be fabricated by a local sheet-metal shop, using the detailed drawings provided.

Large-size fifth-wheelers are also available in plan form. The 18-foot and 21-foot plans are \$35 from Small Fry Enterprises. For \$40, complete plans for building a 25-foot rig or 35-footer can be purchased. Prefabricated kit parts include unassembled cabinets, plus construction materials, plumbing and electrical components and appliances. ★★★

**KITCHEN COUNTER** (below, looking forward) shows full-size cabinets and work areas, window above sink

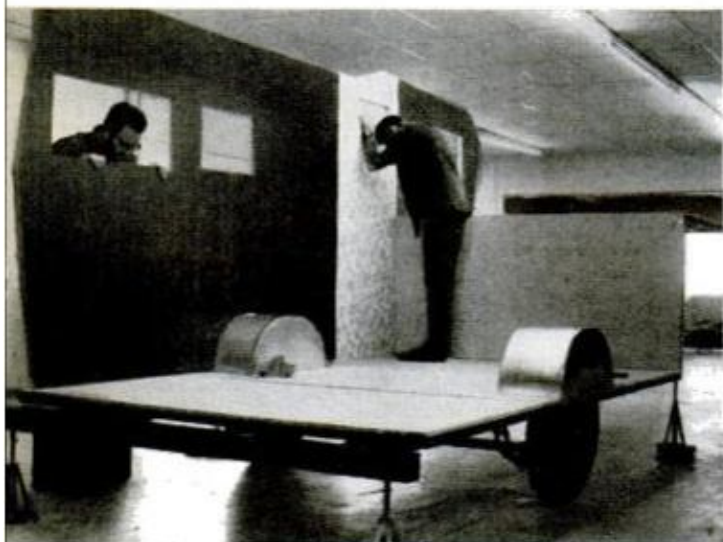

**WALLS** are framed out with 2x2s, paneling is glued and stapled or nailed. Panel bit routs edges, windows



**CLOSET** with full-length space to hang clothes (left) has been called symbol of luxury trailering



POPULAR MECHANICS



**DINETTE** at back of trailer becomes 4x6-ft. double bed. Sink is of stainless steel. On opposite wall is 4-cu.-ft. gas/electric refrigerator

**READY** for insulation and aluminum skin after plumbing and wiring are installed, left side is pattern for right with door added

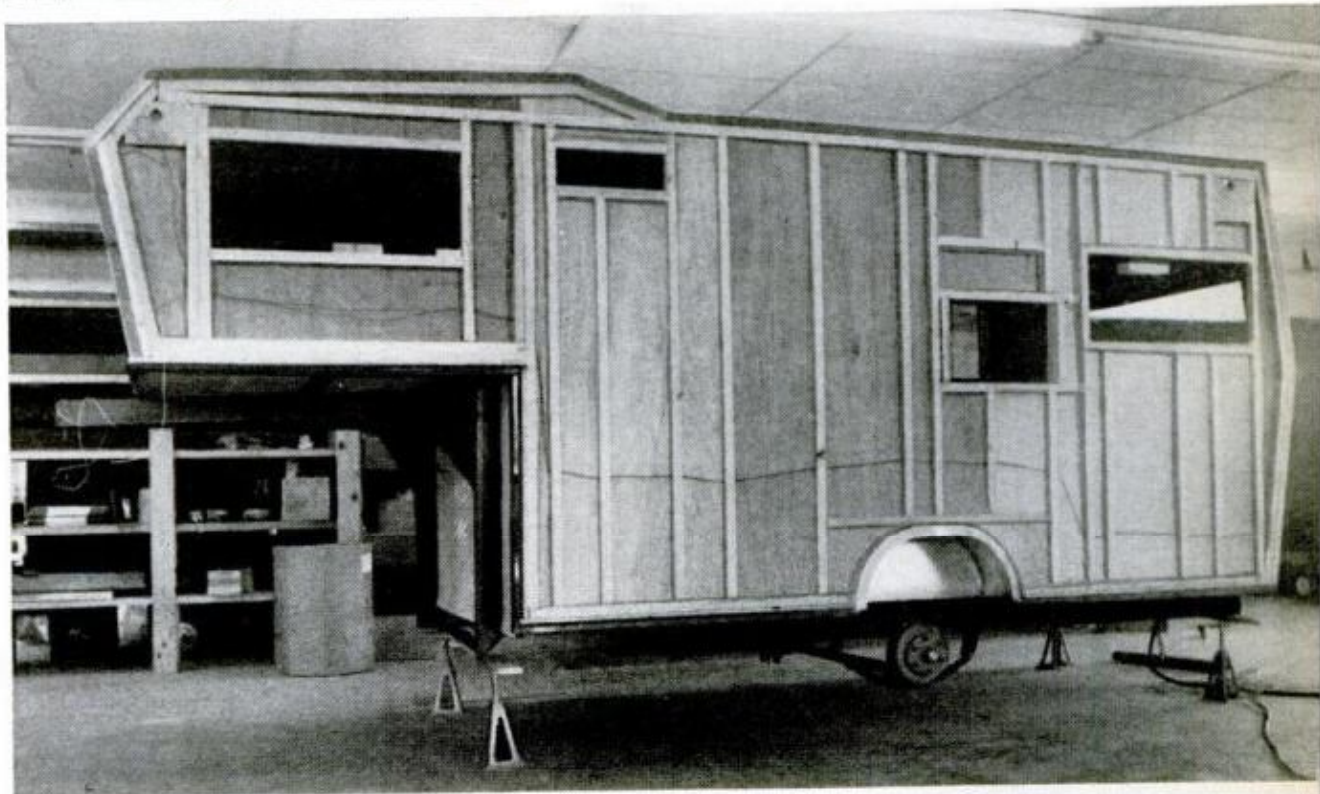

**DOUBLE BED** forward is 54 by 81 in. Water heater, furnace under sink, stove

APRIL 1973

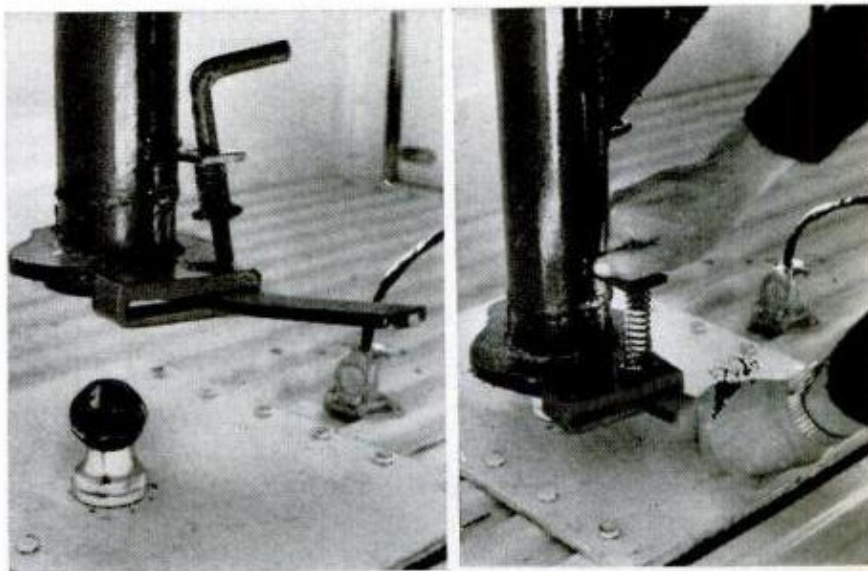

**HITCH** for fifth wheeler secures to 2-in. ball on  $\frac{3}{8}$ -in. steel plate bolted through cargo bed to truck-frame cross members underneath. The connection (right) is locked in place with an insert pin

# Movie cameras:

## What do you get for under \$100?

By BURT MURPHY

**The answer is simple operation and just enough frills to make your movies interesting**

**Y**OU DON'T HAVE TO SPEND a fortune to make good home movies. Sure, if you want to use all the tricks Hollywood has at its command, you'll have to spend a lot on your camera. But between \$50 and \$100, you'll find lots of cameras that can assure you reasonably sharp, well-exposed pictures. You'll still need ingenuity to put punch in your movies—you'd need that even with the most expensive cameras. But many of the low-price cameras are surprisingly versatile.

You'll find a fairly complete list of \$50 to \$100 cameras on page 110. But since cameras are so widely discounted, you'll often find models with higher list prices selling in the same bracket, so it's worth shopping for bargains that may not appear in the buying guide shown here.

Just about all movie cameras today—and certainly all those in this survey—

have electric film drive and electric-eye, exposure-control systems. Both are major conveniences: With electric motor drive, you can shoot scenes of any length up to the full four minutes of an entire film cartridge; earlier, spring-driven cameras were restricted to shorter scenes—sometimes unexpectedly short if you'd forgotten to rewind the spring beforehand.

The electric-eye exposure system automatically adjusts the lens aperture according to lighting conditions and the type film you're using; you never have to measure the light and adjust the lens yourself. This feature, always handy, is especially useful if lighting conditions change during a scene—if your subject moves from bright sunlight to shadow, for example.

Electric eyes work indoors, too. Almost all of them today are adapted for Kodak's



new ASA 160 High-Speed Ektachrome color film as well as for the standard Kodachrome II. Snap in a film cartridge, and the meter automatically sets itself to the film in use. (The Fujica P1 takes only Fuji Single-8 cartridges, which don't fit Super-8 cameras though both can use the same projectors; its high-speed film is 200 ASA.) With high-speed films, you can often get surprisingly good (if grainy) color movies in brightly lighted rooms, especially with the fast  $f/1.8$  or  $f/1.9$  lenses found on most cameras. And if there isn't enough light for that, or if you're using the slower, standard film, you can illuminate your subject with a movie light.

This brings up another common feature, the built-in filter. Super-8 films are balanced for color accuracy with indoor, tungsten light. But since most home movies are shot in daylight, an orange filter, built into the camera, normally converts blue daylight to the redder light the film is balanced for. (With Fuji's Single-8 system, though, you use either a daylight-balanced film or a tungsten film with an externally mounted filter.) It may seem odd to use a filter for more normal shooting conditions; but since filters cut down the light as they color it, it's more sensible to "waste" daylight—there's so much available.

To shoot by indoor light, of course, you must disengage the filter. Usually, attaching a movie light to the camera does that automatically. But when shooting by existing tungsten light, or when your movie lights are mounted off the camera, you must usually insert a filter key into the movie-light socket to disengage the filter.

Some electric eyes read the light actually passing through the lens; others have their own little windows on the world. The through-the-lens type has a slight edge, since it automatically compensates for any filters you put on the lens (which few home moviemakers bother with) and

**HOLD YOUR CAMERA STEADY** and you'll get smooth, shake-free shots. Cameras should be braced against your face, held firmly in both hands. Pistol grips are a major steadying influence, but even cameras without them (second photo from bottom) can be held securely. Awkward, top-heavy grip (bottom photo) is a sure way to get wobbly pictures, especially with zoom lenses on telephoto settings; your hand should grip the camera body well as zoom control lever. Photos here show basic hand positions and must be adjusted, of course, so fingers can easily reach the shutter-release control on your particular model



**SAMPLING OF SUPER-8s** (above) includes Bell & Howell, GAF, Hanimex, Kodak Instamatic and Mustang, in that order. See the table on page 110 for a near-complete list of cameras and features. The cameras' built-in conversion filters must be disengaged when shooting with tungsten movie lights or room light. Special keys inserted in movie-light sockets (left, Hanimex; below, left, Bell & Howell) displace filters for shooting with off-camera lights. But filters automatically disengage when you attach a movie light (shown on GAF at right below). Fuji Single-8 (not shown) has a different system: You can use daylight film without a filter, or mount a filter on the camera lens when you're switching from one type of illumination to another. Most new cameras take ASA 160 film; with fast lenses, you can shoot pictures without movie lights in brightly lighted rooms. With the filter in, the fast films will allow shooting on dim or overcast days, as well as in the evening

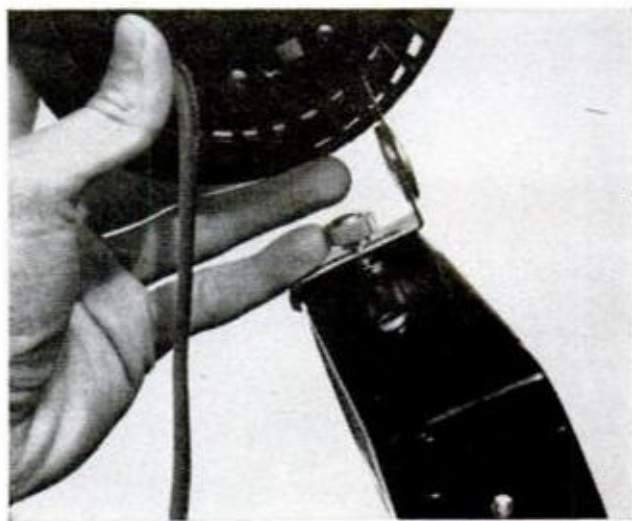

can help you get correct exposure when shooting a telephoto shot of a backlighted subject. Most of the time, though, you'll find little difference between through-the-lens and separate metering. Nor does it seem to matter much whether the electric eye has its own little battery or draws its power from the ones that run the motor—except that a separate meter cell is easier to forget accidentally when you change batteries. One meter feature that may make a difference to you, though, is a manual override that lets you deliberately under or overexpose for special moods and effects or in situations, such as backlight-

ing, where the meter might read inaccurately.

To prevent accidental exposure errors, most cameras above \$50 have warning signals in the viewfinder that tell you when there's too little light for correct exposure with the film in use: several warn when there's too much light as well. A few viewfinders give you even more data: What f/stop is in use (Eumig and Kolvex), whether or not the film is running (Eumig) and when you're out of film (Kodak).

The finders themselves are usually optical sight types, like reversed telescopes. On cameras with zoom lenses, the finders



change their angle of coverage to match the coverage of the lens. Though several cameras in this class have reflex finders that look through the lens to see exactly what the film sees, hardly any have reflex ground-glass focusing; if you want to do much tilting and closeup work, you'll want that feature. Cameras with ground-glass focusing (and some others) have diopter eyepiece adjustments that let you focus your eyes clearly on the ground glass, even if you aren't wearing your glasses. If you do wear glasses when you shoot, you'll want a rubber eyecup to protect them from being scratched. And you'll want to make sure you can see the entire finder (including exposure and other warnings) with your glasses on.

One reason few of these cameras have ground-glass focusing is that few of their lenses focus. Most are fixed-focus types, set to keep all objects from about six feet to infinity fairly sharp. The near focusing limit on zoom lenses will change as you zoom from wide-angle settings (where greater depth of field maintains focus over a greater range of distances) to telephoto (where depth of field is limited). Eumig's "Servofocus" system even changes lens distance setting as you zoom to keep depth of field always at the maximum possible.

Zoom ranges are limited, in this price class, usually from 2X to 3X ratios (if the lens zooms at all), though the Kolvex has a 4X zoom range. Even 2X will let you add some variety to your home movies—

**SLIDING ZOOM CONTROL** atop this Hanimex looks like the rocker switches used for power zooming on some more expensive cameras. But it's actually a manual control—and, if anything, a bit less conve-

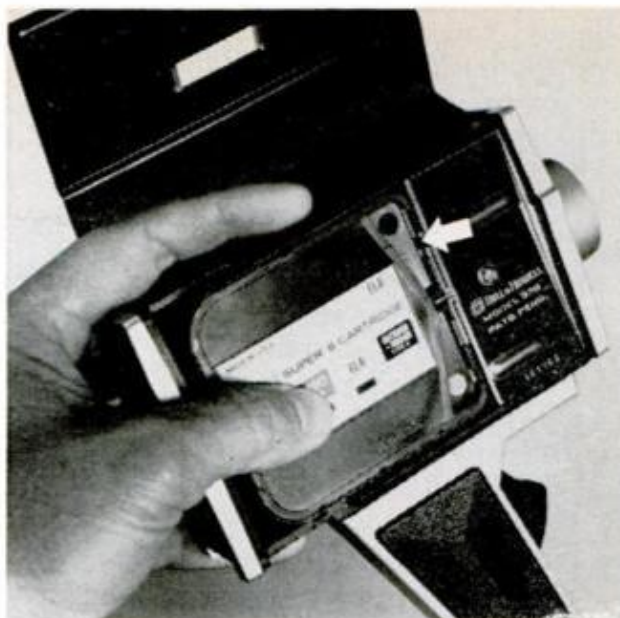

**SUPER-8 CARTRIDGES** load in a jiffy, hold 50 feet of film for four minutes of shooting. A film-speed coding notch in cartridge (arrow) adjusts camera's electric eye to match film's sensitivity. Film type can be read through a window in the film-compartment lid. Most Super-8s load like this Bell & Howell

and for beginning moviemakers, a limited zoom range may help overcome the temptation to zoom too often.

For best results, you should consider zoom lenses primarily as handy ways to carry both wide-angle and telephoto lenses, and use the zoom control to frame your scene before you shoot; zooming during a shot should be reserved for times when you need its special impact. Because telephoto settings give a bigger image, they're often thought of as equivalent to moving the camera closer; that's not com-

nient than the average. Zoom ranges on under-\$100 cameras are modest; Hanimex's 2X range is typical, though one camera has a 4X zoom (and powered at that; see chart). Many Super-8s don't zoom at all



pletely true. Move closer to your subject, and the background grows a little smaller by comparison. Zoom in, and both subject and background grow in size (move too close, though, and a subject's nearby knees or nose can loom frighteningly out of proportion).

If you do zoom while shooting, motor-driven "power zoom" controls will make the action a bit smoother. But since you may not want all your zooms done at the same speed, you'll still want manual zoom control so you can speed up or slow down at will. (Variable-speed power zooms are available—but not in this price range).

Most Super-8 camera lenses have maximum apertures of f/1.8. You'll find little differences between these lenses and those with a maximum aperture of f/1.9; but f/2.7 or f/2.8 lenses let in only about half as much light, which can make a real difference when you're using Kodachrome in comparatively dim conditions. The f/1.8's

extra "stop" of light-transmitting capability is also important with reflex cameras, whose finders see only a portion of the light coming through the lens. All reflex models on our list do, in fact, have f/1.9 or faster lenses.

Trigger locks are about the only remaining controls commonly found on these cameras. Some cameras have a safety lock that prevents accidental running of the camera. Others have run locks that let you set your camera on a tripod, start the shot, then leave the camera running while you step into the scene. And quite a few cameras have both types of lock.

Under-\$100 cameras are all fairly compact and lightweight—after all, they lack most features that add bulk to the more expensive models. That makes them handy to carry on trips. But some are easier to pack than others. The difference is in the pistol grips; on about half the cameras we surveyed, they folded or were removable

## MOVIE CAMERAS IN THE \$50 TO \$100 RANGE AND

| MAKE AND MODEL          | PRICE | LENS          | ZOOM RANGE, TYPE | METER TYPE, FILM SPEED RANGE | FOCUS, NEAREST DISTANCE | FINDER TYPE, FEATURES    | GRIP      |
|-------------------------|-------|---------------|------------------|------------------------------|-------------------------|--------------------------|-----------|
| Argus 818               | \$ 65 | 13-26mm/2.7   | 2X, M            | TTL, 25-100                  | Fixed                   | Si, Ue                   | Fixed     |
| Bell & Howell 372G      | 55    | 14mm/2.8      | None             | EE, 25-160                   | Fixed                   | Si, Ue, Ec               | Removable |
| Eumig Mini-3            | 100   | 9-28mm/1.9    | 3X, M            | TTL, 25-160                  | Servofocus*             | Rfx, Ue, F/S, RI, Di, Ec | Accessory |
| Fujica P1               | 80    | 11.5mm/1.8    | None             | EE, 25-200                   | Fixed                   | Si, Ue, Oe,              | Fixed     |
| GAF SC-100              | 55    | 15mm/1.8      | None             | EE, 25-160                   | Fixed                   | Si, Ue, Ec               | Removable |
| GAF SC-102              | 80    | 12-24mm/1.8   | 2X, M            | EE, 25-160                   | Fixed                   | Si, Ue, Ec               | Removable |
| GAF 64                  | 80    | 12-24mm/1.8   | 2X, M            | EE, 25-160                   | Fixed                   | Si, Ue, Oe, Ec           | Fixed     |
| GAF Lentar 2MZ          | 80    | NA/1.8        | 2X, M            | TTL, 25-160                  | Fixed                   | Rfx, Ue, Oe, Ec          | Fixed     |
| GAF Lentar 3PZ          | 100   | NA/1.8        | 3X, P            | TTL, 25-160                  | Guess, 5'               | Rfx, Ue, Oe, Ec          | Fixed     |
| Hanimex Load-matic M220 | 79    | NA f/1.8      | 2X, M            | EE, NA                       | Fixed                   | Si, Ue, Ec               | Removable |
| Kodak Instamatic M24    | 50    | 14mm/2.7      | None             | EE, 25-160                   | Fixed                   | Si, Ue, FE, Ec           | Folding   |
| Kodak Instamatic M26    | 65    | 13mm/1.9      | None             | EE, 25-160                   | Fixed                   | Si, Ue, FE, Ec           | Folding   |
| Kodak Instamatic M28    | 85    | 13-28mm/2.7   | 2 1/4X, M        | EE, 25-160                   | Guess, 6'               | Si, Ue, FE, Ec           | Folding   |
| Kolvex                  | 100   | 9-36mm/1.8    | 4X, P            | TTL, 16-250                  | Rfx, 4 1/2'             | Rfx, Ue, Oe, F/S, Di, Ec | Removable |
| Mustang                 | 60    | 9-23mm/1.8    | 2 1/2X, M        | EE, 25-40                    | Fixed                   | Si                       | Fixed     |
| J.C. Penney 3806        | 50    | 12-24mm/1.8   | 2X, M            | EE, NA                       | Fixed                   | Si, Ec                   | NA        |
| J.C. Penney 3809        | 65    | 12-34mm/1.8   | 2X, P            | EE, NA                       | Fixed                   | Si, Ec                   | NA        |
| Sears 3A 9128           | 50    | 11.5-22mm/1.8 | 2X, P            | TTL, 25-160                  | Fixed                   | Si, Ue, Oe, Ec           | Fixed     |
| Sears 3A 9129           | 80    | 10-30mm/1.8   | 3X, P            | TTL, 25-160                  | Rfx, 5'                 | Rfx, Ue, Oe, Di, Ec      | Fixed     |



**EUMIG MINI-3** (above) is a pocket-sized reflex. Since a pistol grip would make it too large for pocket portability, none is supplied, but one is available as an optional accessory. The Mini-3 has 3X zoom lens with unique Servofocus system that shifts the lens focus as you zoom for maximum depth of field at all zoom settings. Tripod sockets vary in position from one camera model to another. Socket at the base of this Mustang's fixed pistol grip (left) has good balance, raises camera conveniently for tall moviemakers. Some grips must be removed for tripod use, a nuisance

## THEIR FEATURES

| BATTERIES         | SPECIAL FEATURES       | ACCESSORIES             |
|-------------------|------------------------|-------------------------|
| 4 AA              | SL                     | Lt                      |
| 4 AAA             | RL, SL                 | Cs, Lt                  |
| 2 AA              | Pocket-size, SF, MO    | Cs, grip                |
| 4 AA, PX-13       | Single-8*, SL          | (Cs), Tele, Filters, CU |
| 3 AAA             | SL, RL                 | Lt, Cs                  |
| 3 AAA             | SL, RL                 | Lt, Cs                  |
| 2 AAA             |                        | Lt, Cs                  |
| 2 AA, PX-625      | SL                     | Lt, Cs                  |
| 2 AA, PX-625      | SL                     | Lt, Cs                  |
| 2 AA, PX-13       | SL, RL                 |                         |
| 2 AA, PX-13       | SL, RL                 | Cs                      |
| 2 AA, PX-13       | SL, RL                 | Cs                      |
| 2 AA, PX-13       | SL, RL                 | Cs                      |
| 4 AA, PX-13       | BC, Remote, SL, RL, MO | Cs, RC, Filters         |
| 4 AA, PX-675, BCs |                        | Cs, Filters             |
| 2 AA, PX-13       | NA                     | NA                      |
| 2 AA, PX-13       | NA                     | NA                      |
| 2 AA, PX-13       | SL, RL                 | Lt                      |
| 2 AA, PX-13       | SL, RL                 | Lt                      |

(on one, the pocket-sized Eumig Mini-3, the grip was an optional accessory).

A camera's weight makes a big contribution to its feel, too. The heavier the camera, the easier it is to hold it steady—but the harder it is to carry around on long shooting expeditions. Virtually no camera spec sheets mention weight; but in any case, none would cover the related and equally important question of balance. My preference is for cameras whose weight is biased slightly toward the rear to settle firmly against your face rather than toppling forward away from you; but see which cameras feel most comfortable.

Balance at another point—the tripod screws—is of some importance if you use cheap tripods whose tilt heads don't lock

*(Please turn to page 134)*

### KEY TO ABBREVIATIONS IN CHART

|     |                             |      |                           |
|-----|-----------------------------|------|---------------------------|
| BC  | Battery check               | Rfx  | Reflex                    |
| BCs | Battery case                | RC   | Remote control            |
| Cs  | Case                        | RI   | Run indicator             |
| Di  | Eyepiece diopter adjustment | RL   | Run lock                  |
| Ec  | Eyecup                      | SF   | Single-frame release      |
| EE  | Separate electric eye       | Si   | Optical sight finder      |
| F/S | F-stop scale in finder      | SL   | Safety trigger lock       |
| FE  | Film-end indicator          | Tele | Telephoto-lens attachment |
| Lt  | Movie light                 | TTL  | Through-the-lens meter    |
| M   | Manual zoom                 | Ue   | Underexposure indicator   |
| MO  | Manual meter override       | ( )  | Supplied accessory        |
| NA  | Not available               | *    | See text                  |
| Oe  | Overexposure indicator      |      |                           |
| P   | Power zoom                  |      |                           |

## PM OWNERS REPORT: FULL-SIZE FORDS

# Ford faithful get great ride,



By **MICHAEL LAMM**  
West Coast Editor

*Photos by the author*

**P**EOPLE SOMETIMES ASK US why we give such-and-such a car a bad, or good, writeup. We tell them we're only the instrument through which Owners Reports get written—we put together these reports from owner responses. What they say, we say. PM sends questionnaires to a random sampling of new-car owners through R.L. Polk & Co. in Detroit. When the questionnaires come back, responses are tabulated by the Statistical Service Center in Spring Valley, N.Y. Everyone involved tries to be as impartial as possible.

For this Ford report, we've decided to pick four typical owners' questionnaires and will simply run them as

A nationwide survey based on 650,000 owner-driven miles

# but pay at the pump

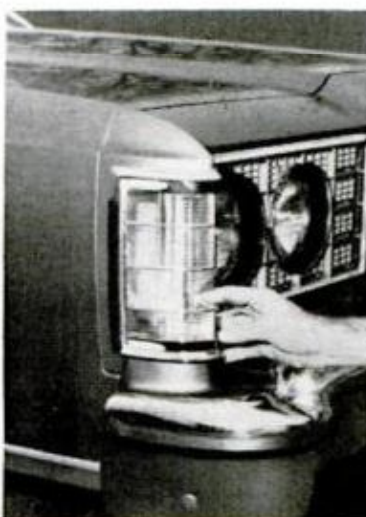

**THE FORD NAMEPLATE** was more important than styling; car's lines offended a few. Owners praise comfort, ride, layout of dashboard, and Ford's overall quiet. Many feel, though, that the engines aren't delivering full power, and gas-mileage gripes run rampant. Surprisingly, the three largest V8s all deliver similar mpg. Big bumpers, even with overrides, dip low in braking so other cars ride over, crack lamps. Handles are an unhandy reach

written. No punches. "Ask the man who owns one!" is an old advertising slogan; still a valid way to judge a car.

First is a 56-year-old architect field rep of Levittown, N.Y., who drives a two-door LTD with the 351 cu.-in. V8. Here are his answers:

*Have you had any mechanical problems with your Ford?* "Yes, dieseling after ignition turned off."

*Were the repairs satisfactory?* "Yes, but it's starting to diesel again after 3000 miles."

*What do you think of your dealer's sales and service policies?* "Satisfactory."

*Why did you choose a Ford over other cars?* "Ford

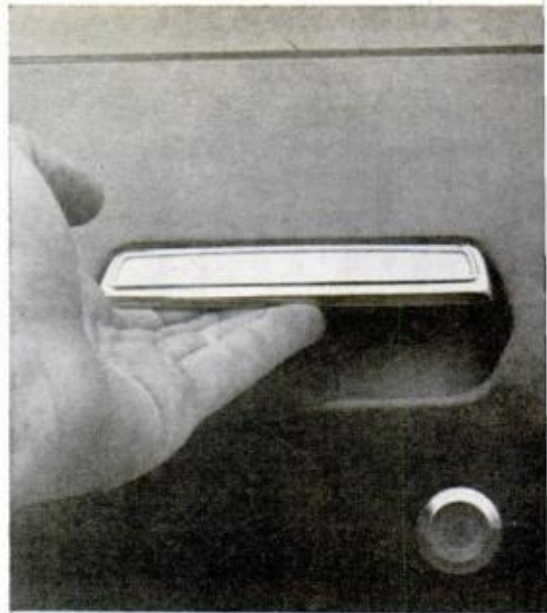
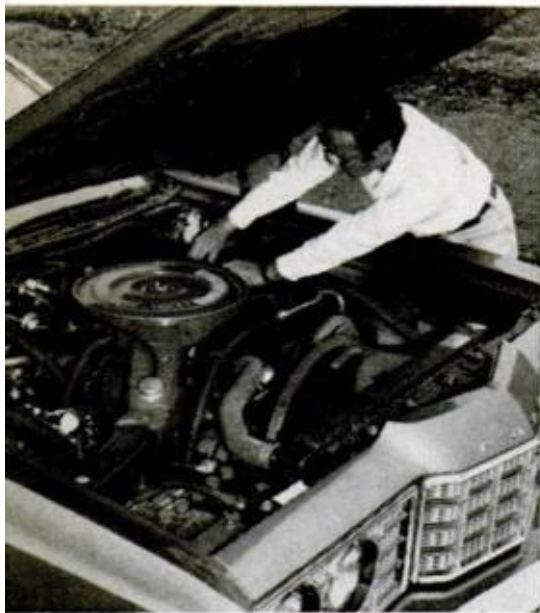

**FORD OFFERS FOUR V8s** in its full-size lines. The trunk space is mostly vertical with a 26-gallon tank behind the rear seat. Easily accessible taillamp fixtures make the bulb changes easy. Door handles are recessed

gave me the best trade-in offer on my previous car."

*What do you think of your Ford's workmanship?* "Interior is poor."

*What changes would you like to see in your car?* "Return to movable front vent windows."

*Is your car comfortable?* "Yes, and quiet, but there's not enough rear legroom in the coupe."

*What are your specific praises of the car?* "Easy handling, comfortable ride, comparative silence."

*How about specific complaints?* "It's underpowered; also needs a better adjustment device on front windows to prevent squeaking. Too, water comes up through the floor in heavy rains."

*Would you buy another Ford?* "Yes."

Next, a 35-year-old Michigan office worker (male) who owns a two-door LTD Brougham with 460-cu.-in. V8:

*Mechanical troubles?* "Engine surge, front tires misaligned and out of balance,

and right taillight filled with water."

*Repairs?* "Engine still surges but not so much. Tires shimmy at 70 mph. I emptied the taillight myself, but it's filled up again since."

*Dealer opinion:* "Salesman very courteous; service people seem too busy, but they listen and smile. On warranty work, I understand they do just what you ask."

*Why Ford?* "I like the ride, and the styling isn't too bad."

*Workmanship?* "Good but not the greatest. I found initials scratched into the underside of my hood. An upholstery button was missing. The dealer promised to replace it by October but hasn't yet."

*Changes?* "Better acceleration from the 460-cu.-in. V8 and better gas mileage."

*Comfort?* "Very comfortable."

*Praises:* "Quiet car. The stereo is great. Seats comfortable. Trunk adequate. I can use regular fuel."

*Gripes:* "Lousy acceleration and gas mileage. Window glass rubs against rubber weatherstripping and squeaks. Should



**FORD LTD MODELS** were most popular with owners, most of whom ordered 400-cu.-in. V8 engine for their car

## Summary of 1973 Ford Owners Reports\*

|   |         |
|---|---------|
| <b>Total miles driven</b> .....                     | 651,071 |
| <b>Average miles per gallon:</b>                    |         |
| Local driving .....                                 | 10.4    |
| Long trips .....                                    | 13.1    |
| <b>Average mpg by engines:</b>                      |         |
| 351-cu.-in. V8: Local driving .....                 | 11.3    |
| Long trips .....                                    | 13.8    |
| 400-cu.-in. V8: Local driving .....                 | 10.3    |
| Long trips .....                                    | 12.9    |
| 429-cu.-in. V8: Local driving .....                 | 10.5    |
| Long trips .....                                    | 12.8    |
| 460-cu.-in. V8: Local driving .....                 | 9.3     |
| Long trips .....                                    | 12.8    |
| <b>Series:</b>                                      |         |
| Custom 500 .....                                    | 1.1%    |
| Galaxie 500 .....                                   | 21.9    |
| LTD .....   | 39.6    |
| LTD Brougham .....                                  | 27.3    |
| Ranch Wagon, Country Sedan,<br>Country Squire ..... | 10.2    |
| <b>Body styles:</b>                                 |         |
| Four-door sedans .....                              | 45.8%   |
| Two-door coupes .....                               | 35.0    |
| Four-door wagons .....                              | 19.2    |
| <b>Engines:</b>                                     |         |
| 351-cu.-in. V8 .....                                | 30.7%   |
| 400-cu.-in. V8 .....                                | 54.3    |
| 429-cu.-in. V8 .....                                | 9.5     |
| 460-cu.-in. V8 .....                                | 5.5     |

|   |       |
|---|-------|
| <b>Why did you buy a new Ford?</b>      |       |
| Past experience .....                   | 46.3% |
| Price .....                             | 18.2  |
| Styling .....                           | 16.3  |
| Dealer service .....                    | 10.3  |
| <b>Specific likes:</b>                  |       |
| Handling .....                          | 49.3% |
| Ride .....                              | 45.7  |
| Style .....                             | 36.2  |
| Comfort .....                           | 32.2  |
| Silence .....                           | 21.1  |
| <b>Specific dislikes:</b>               |       |
| Poor gas mileage .....                  | 34.2% |
| Poor workmanship .....                  | 10.4  |
| Lack of power .....                     | 9.9   |
| Bad emission-control<br>equipment ..... | 8.9   |
| Rattles .....                           | 6.9   |
| <b>What changes would you like?</b>     |       |
| Better gas mileage .....                | 19.4% |
| Different styling .....                 | 8.6   |
| Vent windows standard .....             | 7.4   |
| Remove smog equipment .....             | 6.9   |
| <b>Had any mechanical trouble?</b>      |       |
| No .....                                | 63.2% |
| Yes .....                               | 36.8  |
| <b>What type of trouble?</b>            |       |
| Carburetor .....                        | 20.5% |
| Cold starts .....                       | 17.9  |
| Engine diesels .....                    | 15.4  |
| Wheel alignment .....                   | 9.0   |

|  |       |
|--|-------|
| <b>Did you repair it yourself?</b>     |       |
| No .....                               | 94.9% |
| Yes .....                              | 5.1   |
| <b>Dealer repairs satisfactory?</b>    |       |
| Yes .....                              | 71.0% |
| No .....                               | 29.0  |
| <b>Is the Ford your only car?</b>      |       |
| No .....                               | 54.0% |
| Yes .....                              | 46.0  |
| <b>Other cars owned:</b>               |       |
| Other Fords .....                      | 46.2% |
| Chevrolet .....                        | 15.4  |
| Volkswagen .....                       | 6.0   |
| Mercury .....                          | 6.0   |
| <b>Workmanship opinion:</b>            |       |
| Good to excellent .....                | 71.1% |
| Average to poor .....                  | 28.9  |
| <b>Age distribution of owners:</b>     |       |
| 15-29 years .....                      | 7.1%  |
| 30-49 years .....                      | 45.9  |
| 50-plus .....                          | 47.0  |
| <b>Would you buy another new Ford?</b> |       |
| Yes .....                              | 90.7% |
| No .....                               | 9.3   |

\*Percentages might not equal 100% due to rounding or insufficient data.

have tops to windows instead of bare glass."

*Buy another?* "Undecided."

An Illinois schoolteacher (female, 58) with 400-cu.-in. LTD Brougham coupe.

*Troubles?* "One power window wouldn't lift after being lowered, and the intermittent wiper system didn't work."

*Repairs okay?* "Yes. Window only needed an adjustment, and a part was missing from the wipers."

*Dealer opinion:* "Wonderful."

*Why Ford?* "Best car on the road. Do they make other kinds?"

*Workmanship?* "Excellent."

*Changes?* "I'd like to have a choice of colors and fabrics available in any Ford product. I wanted a white interior that was available only in Thunderbirds. I'd also like better gas mileage."

*Comfort?* "I think the car is very comfortable, but a friend with back trouble considers the seats too soft and has to use a firmer seat cushion."

*Praises:* "Handles beautifully, corners very well, starts immediately, quiet as they claim."

*Gripes:* "None."

*Buy another?* "Yes."

A 24-year-old Chicago layout engineer who drives a two-door LTD Brougham

equipped with the 460-cu.-in. V8 engine:

*Mechanical problems?* "FM radio floats and has static. Also had minor adjustments to doors to make them fit flush. Other than that she runs like a champ."

*Repairs okay?* "No charge for the first three months on this type of repair work."

*Dealer opinion:* "I believe that if you shop around for the best price and stick to your guns, you get a fair deal. If not, they take you for plenty."

*Why Ford?* "Have owned four before and liked them all."

*Workmanship?* "Ford seems to do better than the rest."

*Changes?* "A couple of inches more legroom. I'm 6-3, and my legs feel cramped on long trips."

*Comfort?* "Except as stated."

*Praises?* "Ride, handling and silence."

*Gripes:* "I'd like to see more horsepower from those engines, and that includes all makes and models."

*Buy another?* "Not sure yet."

The majority (90.7 percent) said they will buy Ford again. Most rated dealers high and thought well of workmanship.

Many of the owners blamed dieseling, poor gas mileage, and weak performance on Ford's antipollution devices. This led 6.9 percent to recommend removal of smog hardware. ★★★

**SAVE MONEY** by following a preventive maintenance program. Pull your brake drums at intervals of about 12,000 miles to make sure that brake linings are not worn so low that brake-shoe metal or rivets are chewing up the machined drum surface. As shown below, bleeding and refilling your hydraulic system with fresh fluid can be done yourself. Length of hose connects to bleeder valve at each wheel

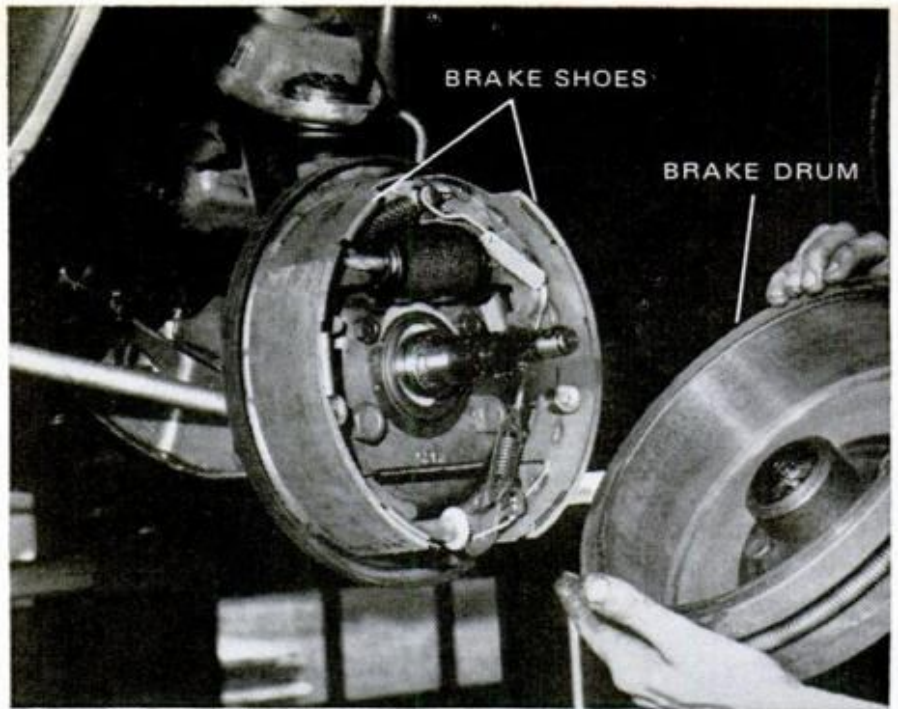

## How to get a

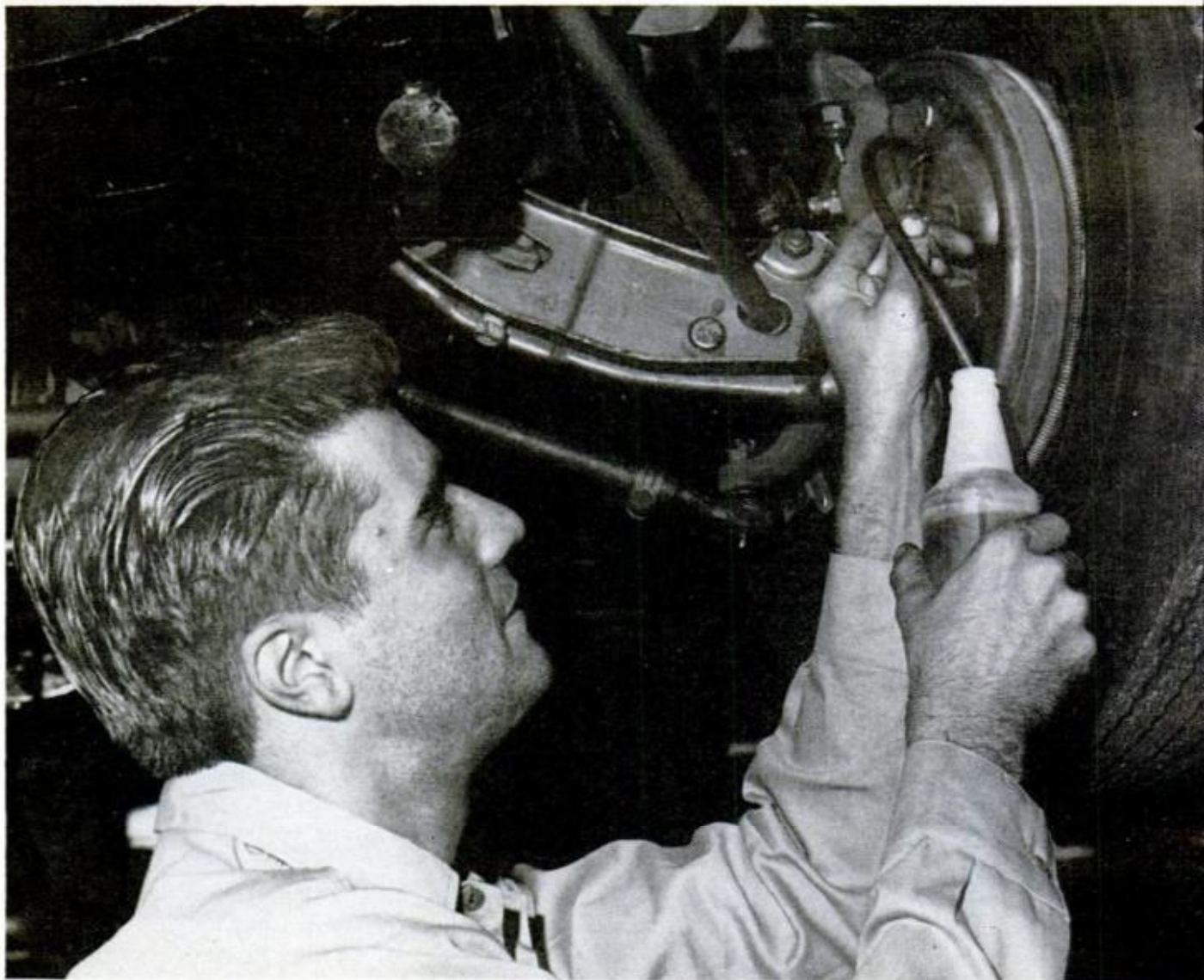





WHEEL CYLINDER CLAMP

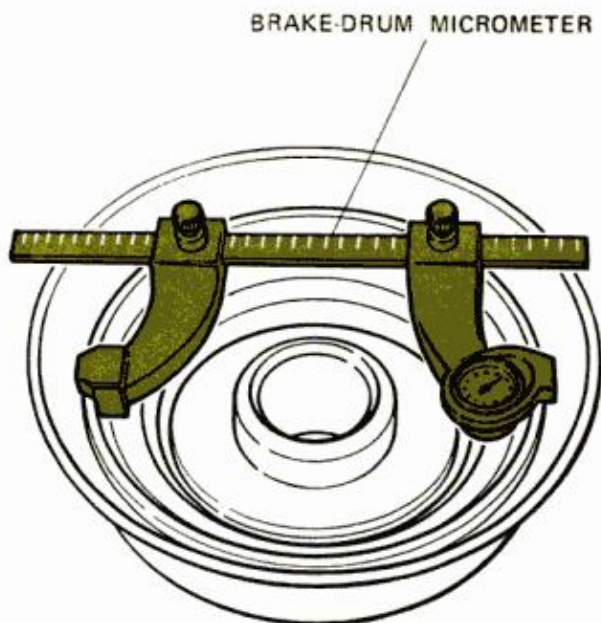

BRAKE-DRUM MICROMETER

SOME SPECIAL TOOLS are worth investment, most too expensive. Some can be rented or borrowed (see text)

# professional brake job at a do-it-yourself price

By MORT SCHULTZ

**C**AN YOU STILL SAVE MONEY when the brake job you are doing suddenly requires the use of professional mechanic's equipment that you don't have?

I got an answer to this question not long ago when I removed the brake drums from a 1968 Pontiac and found that two of them needed to be resurfaced.

Drums are resurfaced (turned on a lathe and machined) to even out wear and remove glaze, but they must be replaced if machining will cut them beyond the minimum safety specification which is stamped on most units.

I took the drums to a professional brake shop which charged me \$2.50 per unit for turning, for a total of \$5.

"How much more would it have cost me if I had brought you the car instead and had you remove the drums?" I asked the mechanic.

"Another \$10," was his reply.

I saved a quick \$10, proving that lack of major equipment is no reason for not doing your own brake work. Brake-drum resurfacing and other tasks not generally considered within the province of a Satur-

day mechanic can be done by a brake specialist, but don't let him do all the work.

The first way to avoid unnecessary costs is to avoid unnecessary damage. You can't, of course, prevent brake linings from wearing out as they are used. But brake drum and disc damage can often be prevented by replacing linings before brake-shoe metal comes into contact with drums or discs.

Examine linings every 12,000 miles and replace shoes if any part of the lining is worn to within 1/32 inch of the shoe table of a bonded lining or the rivet head of a riveted lining. Always replace brake shoes in axle pairs in order to equalize brake action.

Although you will need a set of brake-service hand tools that you may have to buy, you can still save a considerable amount of money by relining brakes yourself. Using a 1969 Chevrolet Impala with drum brakes as an example, I found that brake shops in the New York City area wanted to charge from \$40 to \$65 to replace linings.

This cost, most told me, included inspecting and cleaning of all parts of the

brake system. However, this is a task that you can do just as well.

In checking out different sources of brake parts and tools, I found that one of the best deals is offered by Sears. The company will provide tools and instructions if you buy parts from it.

A set of linings from Sears for the Chevy costs \$6.99, which is right in line with the prices of other part suppliers. They are bonded, made of brass chips and asbestos, and are guaranteed for 40,000 miles. If they wear out before this, you get a full refund or new linings free of charge.

Thus, replacing the linings on all four wheels of the Chevy would cost \$13.98; this is a saving of \$26.02 from what the least expensive brake shop wanted to charge.

If you bought your own brake-service hand tools, such as an adjusting wrench, wheel-cylinder clamps and wheel-cylinder pliers, they would cost about \$10. As I mentioned, though, Sears will provide a toolkit for either drum or disc brake-lining installation if you submit a deposit of \$30 with your order for new linings. The deposit will be refunded in full when you return the kit within 30 days. This offer applies only to American-made cars.

Before tackling brake work you should feel sufficiently confident that you can do the job without compromising safety. You'll need detailed instructions. Help is available from a number of sources if you don't have the car's service manual.

If you decide to buy linings from Sears, the company will provide installation instructions for your type and make of brake system. You can also get specific informa-

tion pertaining to your setup at your local library from an automotive repair manual such as *Motor's*.

When beginning a brake job, you should first check the condition of drums or discs. Units that are cracked or deeply grooved should be replaced.

You probably don't have brake drum and disc micrometers available, but since you have to take units to a brake specialist anyway for possible resurfacing, it really doesn't pay to buy them. Many mechanics will check the trueness of units for you free of charge.

If a drum is scored deeper than 0.020 inch or exceeds an out-of-round tolerance of 0.006 inch, it should be resurfaced, if possible, or replaced. Drums on the same axle should be turned to the same diameter although one may not need it.

In turning a drum of a Chrysler Corp. car, make sure that the wheel and tire are mounted. Other manufacturers do not require this.

Don't compromise safety for economy. Never remove more than 0.060 inch of metal from a drum's original diameter. For example, the diameter of a drum with an original diameter of 9.000 inches should never exceed 9.060 inches after resurfacing.

If too much metal is removed, the drum will be weakened seriously and its ability to shed the tremendous heat of braking will be greatly reduced.

The reason for checking drums before buying new linings is to assure that you buy the correct linings. If the diameter of a drum after resurfacing is 0.030 inch or more oversize, you should install oversize linings. If the diameter of the drum

*(Please turn to page 136)*

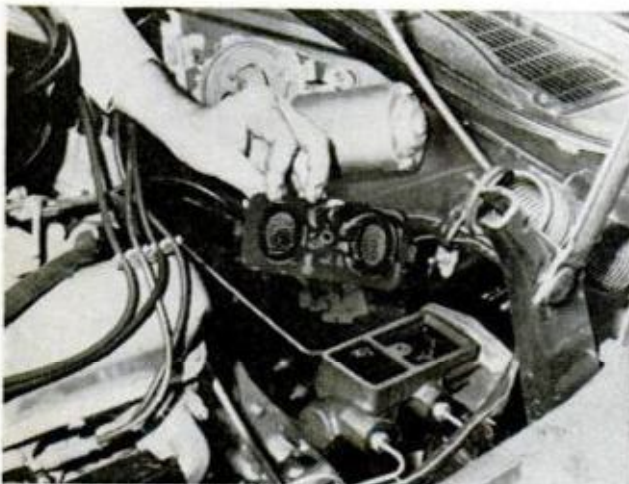

**CHECK FLUID LEVEL** at master cylinder for quick clue to troubles in your brakes' hydraulic system

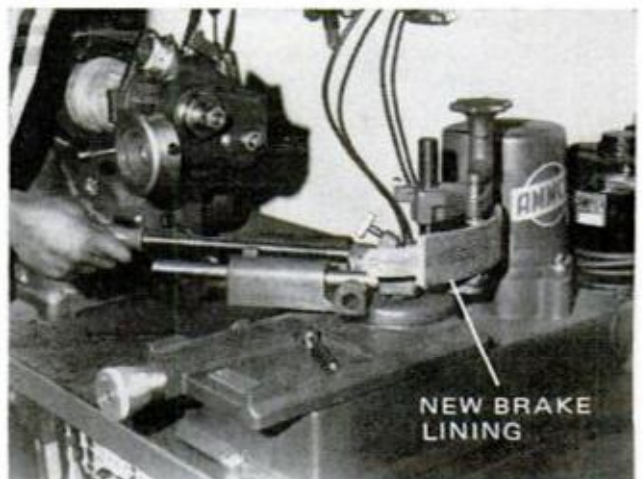

**PAY A PRO** with the right tools to arc new linings; you save in long run having full contact with drum

**POPULAR MECHANICS**

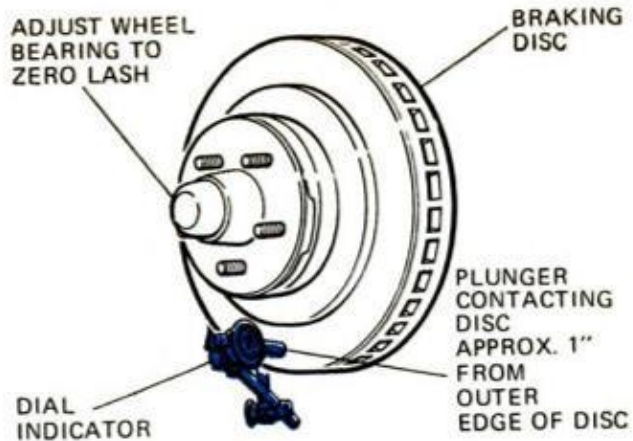

**DISC IS MACHINED** at left after being checked for lateral runout and parallelism as shown above. The cutaway shows parts of typical disc-brake assembly

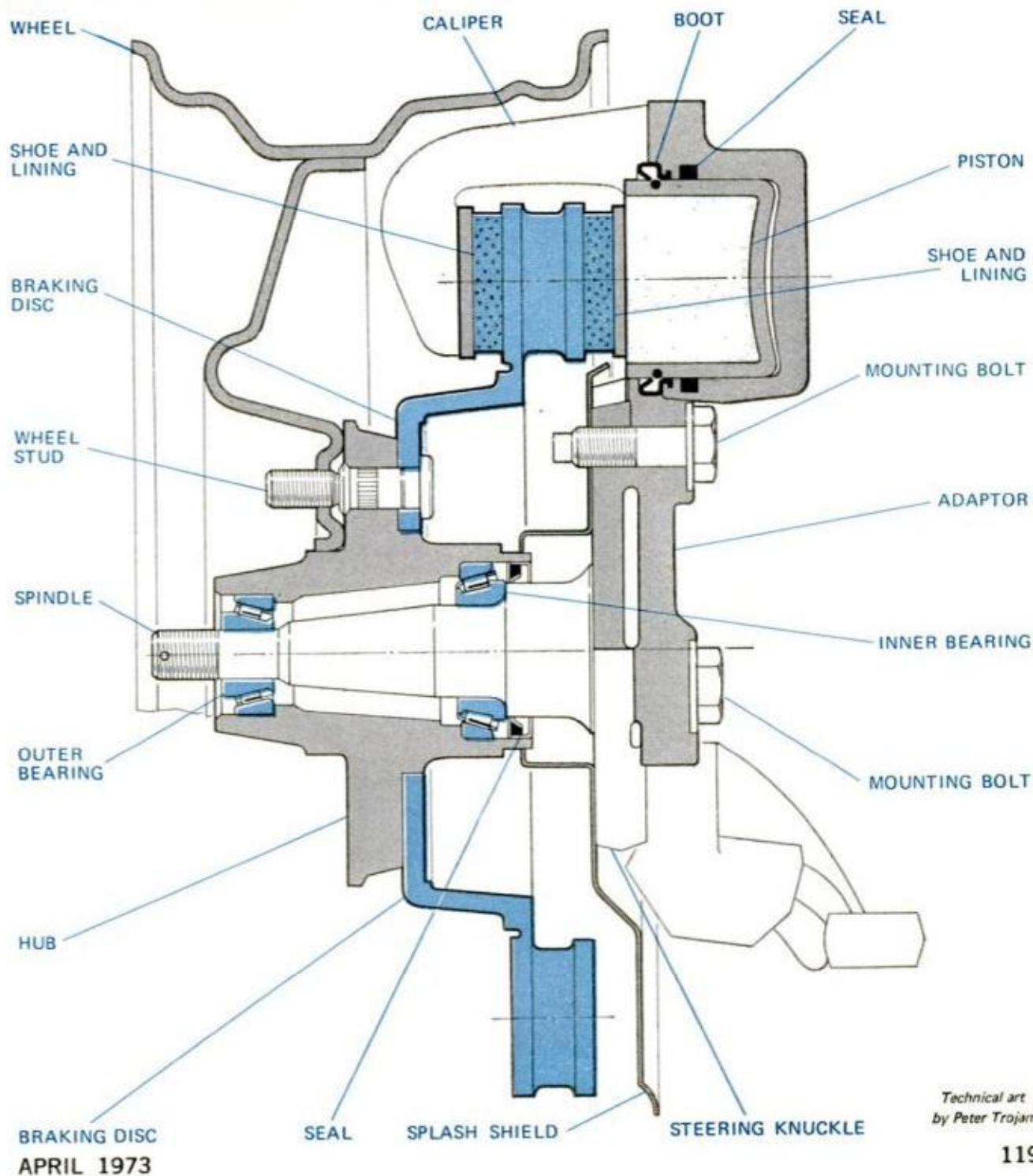

Technical art  
by Peter Trojan



# Hints from

## Pretty sharp idea

A simple clamping arrangement converts a pair of sharp-pointed scissors into a compass divider. Clamp consists of two stiff wood strips connected by a bolt with a wingnut through their centers. Install it across the handles as shown or across the blades when point separation is adequate. Clamp strips shown are 4½ in. long.

—E.B. Walters, Chicago.

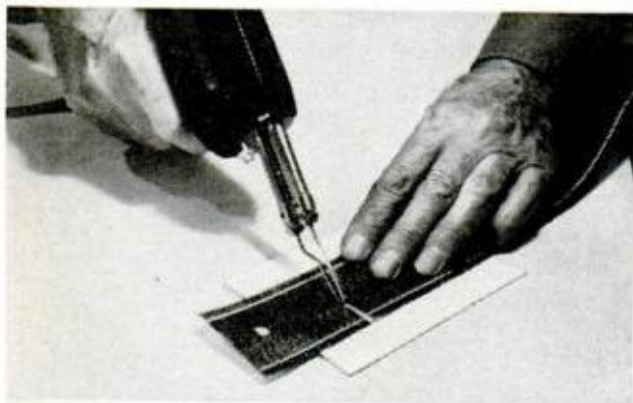

## Hot tip for cutting plastic webbing

When replacing plastic webbing on patio chairs and the like, ordinary cutting and hole-punching techniques leave frayed and raveled edges on the fabric. Run the hot tip of your soldering iron across the webbing where a cut is needed; the fiber ends will melt and join together so that you'll find it easy to make a neat cut.

—Charles Hardy, Whittier, Calif.



## Toothbrush holder in the shop

After trying several methods without success for keeping drill bits neatly corralled by my drill, I came up with the idea shown at left. I simply taped a plastic toothbrush case to my drill's line cord for use as a drill-bit holder. Since I've done this, I have never had to search for a drill bit when using the drill.

—Louis C. Davis, Albany, Ga.



## Stick with this labeling stunt

When labeling workshop jars, apply three labels equally spaced around each jar's circumference, and you can identify the contents of a container no matter what position it was returned to its shelf. If you use rectangular or square jars for small-parts storage, apply a label to each side to achieve the same results.

—W. B. May, Oak Park, Ill.

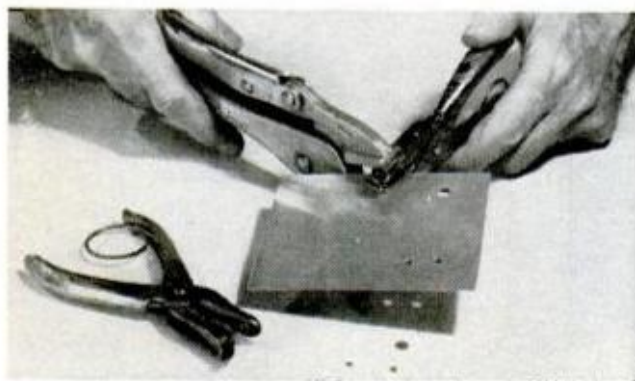

## Power to the punch

A paper punch can be used for making holes in material heavier than those for which it was designed, such as cardboard and soft-sheet aluminum. To do it, give the punch an assist by using a toggle-type wrench. The wrench is adjusted so it will squeeze the punch jaws together just enough to penetrate the material.

—B. W. Ervin, Kent, Ohio.

POPULAR MECHANICS

# readers

## Don't shrug off this lug

If you find yourself in need of spade lugs during a late-night or Sunday work session when stores are closed, make your own from a piece of brass chain as shown: A, remove link B, cut off the ends; C, cut the link in half. You'll end up with D, a neat lug that can be soldered to the end of the conductor.

—Hugh M. Gordon, Burlington, Ont.

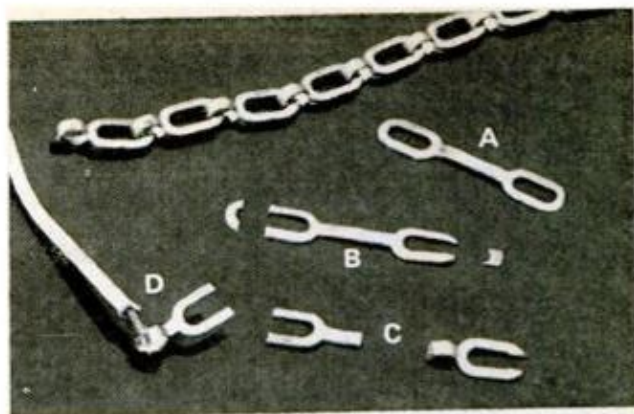

## Scratchless tube-cutting

When using a cutter on highly finished metal tubing you can minimize surface scratches by first wrapping the tubing with two thicknesses of sheet plastic (such as the type used for bread wrappers, vegetable bags and the like). Hold plastic on tubing with clear tape, use low or moderate feed-pressure on the cutting wheel.

—Burt Web., Skokie, Ill.

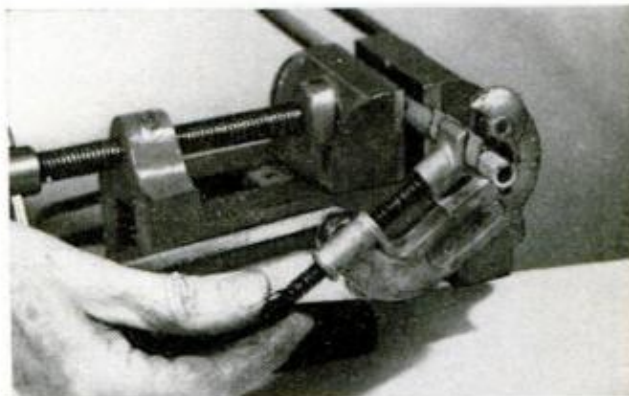

## Ballpoint barrel pins down storage

Small and fine needles are frequently lost or tend to rust easily if not protected. A good holder can be readily made from the cap of a ballpoint pen and a small cork. Trim cork to fit cap opening tightly and stick needles into the cork so that when it is pulled, the needles will come out along with it.

—Harry Radzinsky, Charlotte, N.C.

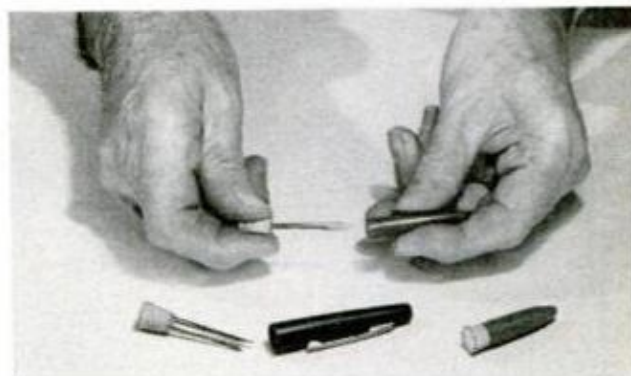

## Picture this clamp

Ordinarily, small, standard wood moldings are difficult to hold absolutely motionless in a miterbox because of their size. I've discovered that a pair of spring-type photolamp clamps will hold such pieces firmly while the molding is being cut. To do this effectively, fasten one clamp per side as shown in the photo at right.

—Ken Patterson, Regina, Sask.

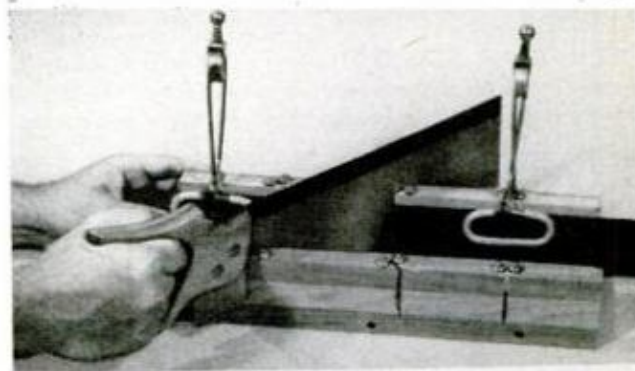

## Homemade stencils

Easy way to make stencils for use with airbrush, spatter-brush or similar applicator is to block squares selectively in a piece of wire screen. Stencil shown was made using household cement to block double rows of squares outlining figure, then painting over with lacquer. A toothbrush was used to spatter paint through.

—Walter E. Burton, Akron, Ohio.

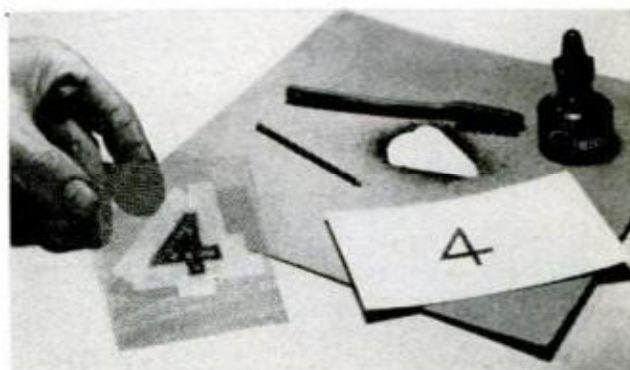

# Low-cost soil-conditioning tumbler you can make

By ROSARIO CAPOTOSTO

**Y**OU MAY HAVE some soil on your property that could stand reconditioning from time to time. Whether you're planting a tree, setting up a garden, or working over some tired, eroded soil in a good-sized planting bed, the task can be handled efficiently with a minimum of labor with the help of this tumbler. Generally, soil that is mostly clay can be improved by mixing in peat moss and sand; a sandy soil can be helped by adding peat and humus.

Whatever the condition and need of your particular soil, your local nurseryman will gladly direct you to the best course of action—specifically, what nourishment should be added to your soil.

The usual method of mixing in soil conditioners with a spade, fork or rake can, indeed, be a tough job—laborious at best with chancy results. The ingredients must be thoroughly blended, and the best way to do this

**SOIL, SAND AND PEAT** are tossed into tumbler for mixing; several turns do thorough job of mixing the material. Contents are emptied through a trap door



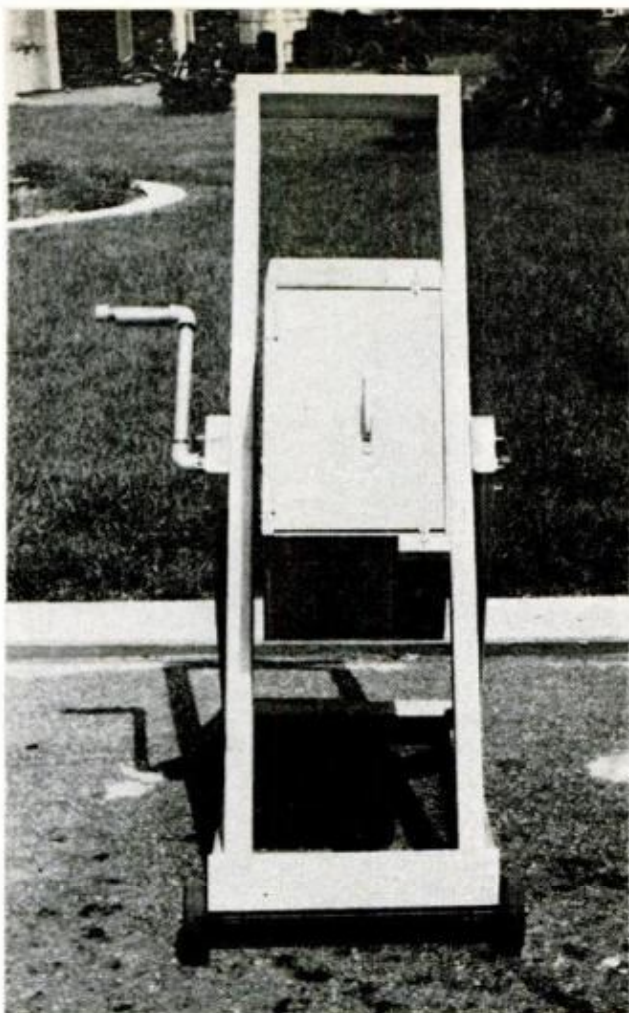

**END VIEW OF THE TUMBLER.** Though optional, the wheels are desirable if your property is good-sized



**EASIEST WAY TO CUT ANGLES**—nail a guide strip to paired plywood panels. It's important that nails are installed *before* the component parts are assembled (below) with waterproof glue, finishing nails

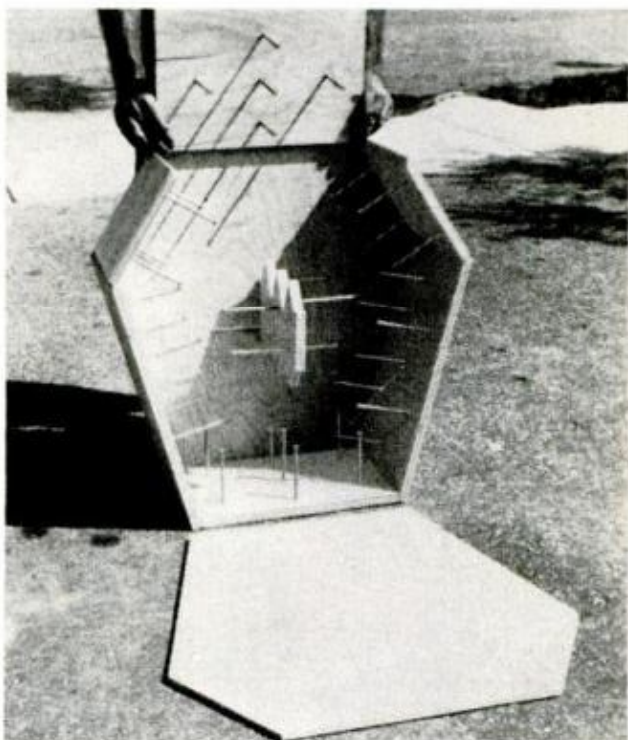

**WHAT TUMBLER DOES FOR THE SOIL.** Clayey soil below was much improved by quick treatment in tumbler. Hand-held finished product has sand and peat added, but the soil could need other ingredients as well



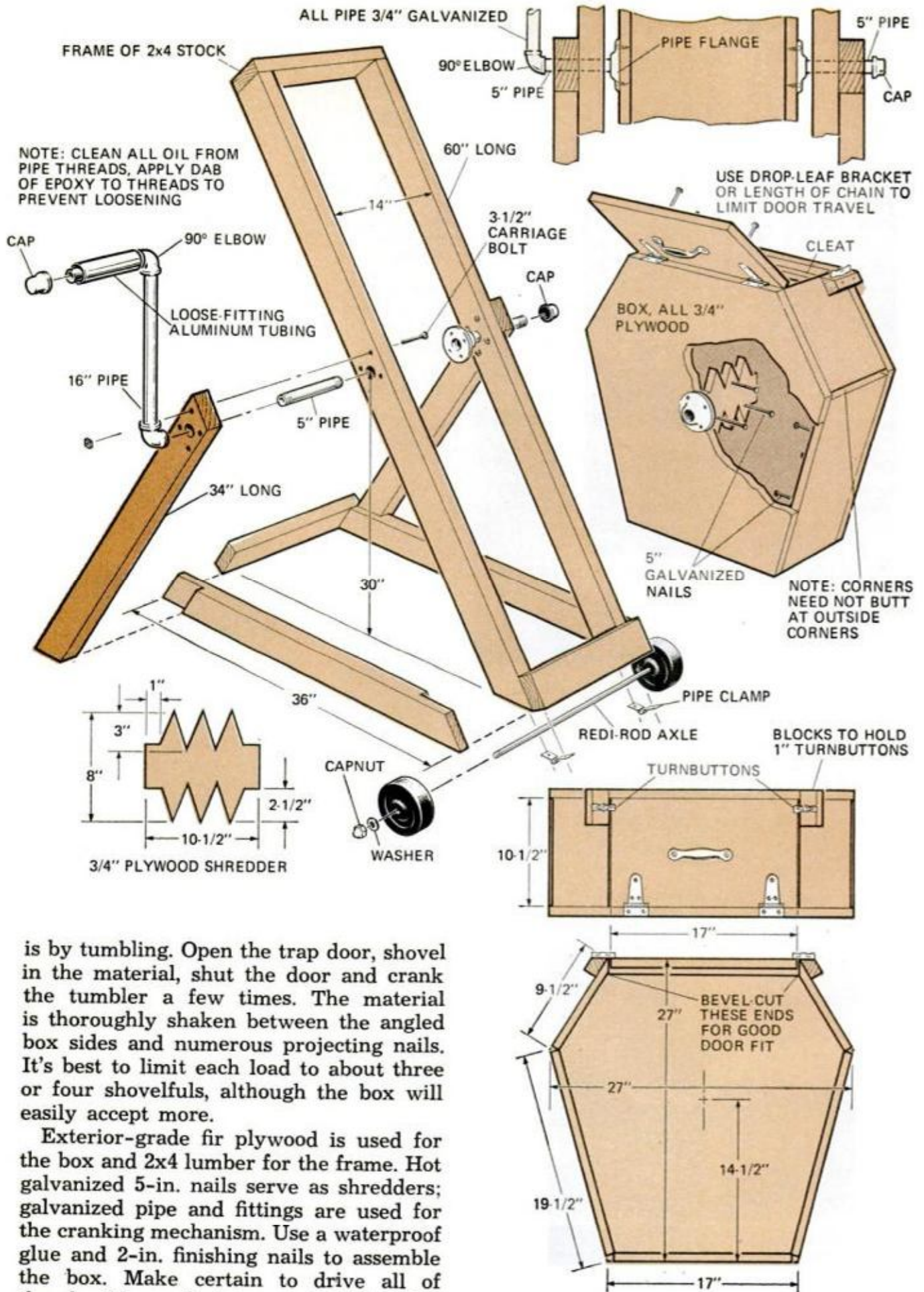

is by tumbling. Open the trap door, shovel in the material, shut the door and crank the tumbler a few times. The material is thoroughly shaken between the angled box sides and numerous projecting nails. It's best to limit each load to about three or four shovelfuls, although the box will easily accept more.

Exterior-grade fir plywood is used for the box and 2x4 lumber for the frame. Hot galvanized 5-in. nails serve as shredders; galvanized pipe and fittings are used for the cranking mechanism. Use a waterproof glue and 2-in. finishing nails to assemble the box. Make certain to drive all of the shredder nails into panels before the final assembly. ★★★



# HINTS FROM READERS



## Spraying screwheads

I've used the bottom of a cardboard box in the past for supporting screws when I wanted to paint the heads, but I've found that the bottom of a tin can does a better job. The paint soaks into the cardboard, causing the screwheads to stick to it.

—Burt Web, Skokie, Ill.



## Oiled cork holds tools

A cork from a vacuum bottle attached to a nontip base makes a dandy workbench holder for pointed tools. Saturate the cork with light oil, wipe off excess and attach it to disc made of hardboard. The oil keeps pointed ends from rusting.—W.E. Burton, Akron, Ohio



## Free toolholder

When working from a stepladder, you can waste time fumbling in pockets for small tools. Here, a tin can attached to the top step by its lid and screws makes as simple and handy a holder as you can find. Screws let you remove it easily.—William Swallow, Brooklyn

## Lint trap for clothes dryers

Here's a way to stop lint from scattering over the yard without investing a penny. I've found that by attaching an old nylon stocking to the end of the vent pipe, any lint that gets past the dryer will be collected by the stocking. It's simple to replace the stocking with another when it is filled.—Ned Killian, Costa Mesa, Calif.

## Ear syringe serves as plunger

Recently the self-defrosting condensation line on my refrigerator clogged. How to open the tiny line had me stumped until I hit upon the idea of using an ear syringe. I filled this with water, stuck it in the opening and squeezed it a few times. This worked just like a toilet plunger and opened the drain in seconds.

—Fred Woehrl, Granite City, Ill.

## Acid removes silver coating

After spending a couple of hours trying to scrape silver backing from a mirror, I was about to give up when I tried soldering acid. It worked like a charm. Be careful when using the acid; wear rubber gloves and protect eyes and clothing.—William G. Waggoner, Sacramento, Calif.

## Door pinch-hits for pasting board

Few do-it-yourself paperhangers are equipped with a regular pasting board; they use a table of some kind. But a table really isn't long enough. Instead, I remove a flush door from a closet and use that. It doesn't hurt the door at all since the paste can be easily wiped off afterward.

—Richard H. Gallot, Wantagh, N.Y.

## Glass-cutter caddy

Storing a glass cutter in kerosene between jobs is a sure way of keeping it sharp. If there's rust on it or the wheel won't turn freely, the cutter won't produce a clean score. A metal or glass cigar container makes an excellent caddy for storing the cutter. Stuff cotton in the bottom of the tube and add a little kerosene.

—Albert J. Zulowitz, Woodmere, N.Y.

## No-tangle extension cords

A heavy three-wire extension cord is particularly prone to twisting and tangling when coiled lariat-fashion or when coiled around your arm. To avoid twisting of the cord, try coiling it in the opposite direction or around the opposite arm.

—Paul D. Fiebich, Utica, Mich.

# From flush door to sofa— in a weekend

By W. M. RUDKIN

**T**HIS ATTRACTIVE SOFA is both comfortable and easy to make. The price is right, too, because the materials should cost no more than \$55. All you need to build it are a 36x80-in. solid-core door, six foam-rubber cushions, four ball-type casters and four 51-in. lengths of  $\frac{3}{4}$ -in. clear pine. The three seat cushions are 4x20x20 in., the back cushions measure 4x18x20 in.

When laying out the parts on the door, place them so any flaws or imperfections in the wood are in areas of the sofa that do not show. The cutting diagram on the opposite page shows how to lay out the pieces on the door. After marking the patterns, cut off the section to be used

for the legs. The piece remaining after the seat is cut is used for the end panels.

You may find that your solid core is not perfectly solid. The interior planks may have knot holes or spaces may appear between the planks. Fill any exposed holes or cut edges with filler compound. (Sawdust mixed with white resin glue makes a satisfactory filler; when the mixture dries, it sands easily.)

The photo at top right on the facing page shows how the end panels are positioned on the seat panel. The pieces are bonded together with polyester resin and fiberglass cloth. Wood dowels hold the pieces in position while the resin cures. A metal strap fastened across both joints underneath keeps the pieces tight while glue cures. These straps can be left on permanently.

The seat with the end panels attached is then set on the legs. Use dowels to make the joint, placing some weight on the seat while the resin cures. After it has cured, put the back-support strips in the leg notches. To complete, fasten ball-type casters to front and back bottom edges of the legs. ★★★

**FLUSH-DOOR SOFA** is handsome as well as sturdy; materials you need to build it are readily available



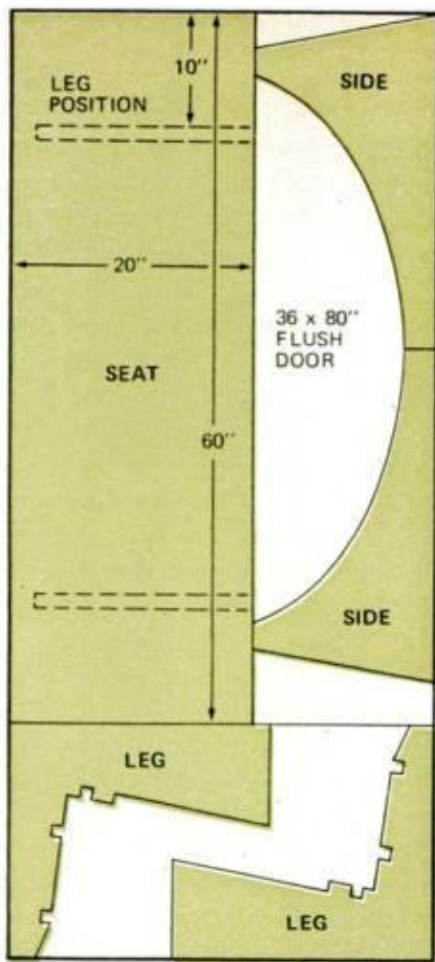

**ONE SOLID-CORE DOOR** provides the seat, panels and legs. Back-support strips are of  $\frac{3}{4}$ -in. pine stock

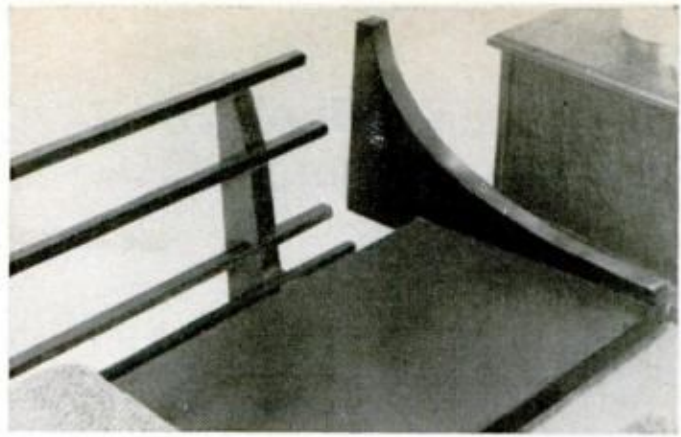

**FOUR STRIPS** are attached to back supports using glue and 4d finishing nails. The top strip is set back slightly



**SOFA-CUSHIONS**—three for seat and three for back—are of foam rubber, can be covered to suit room decor

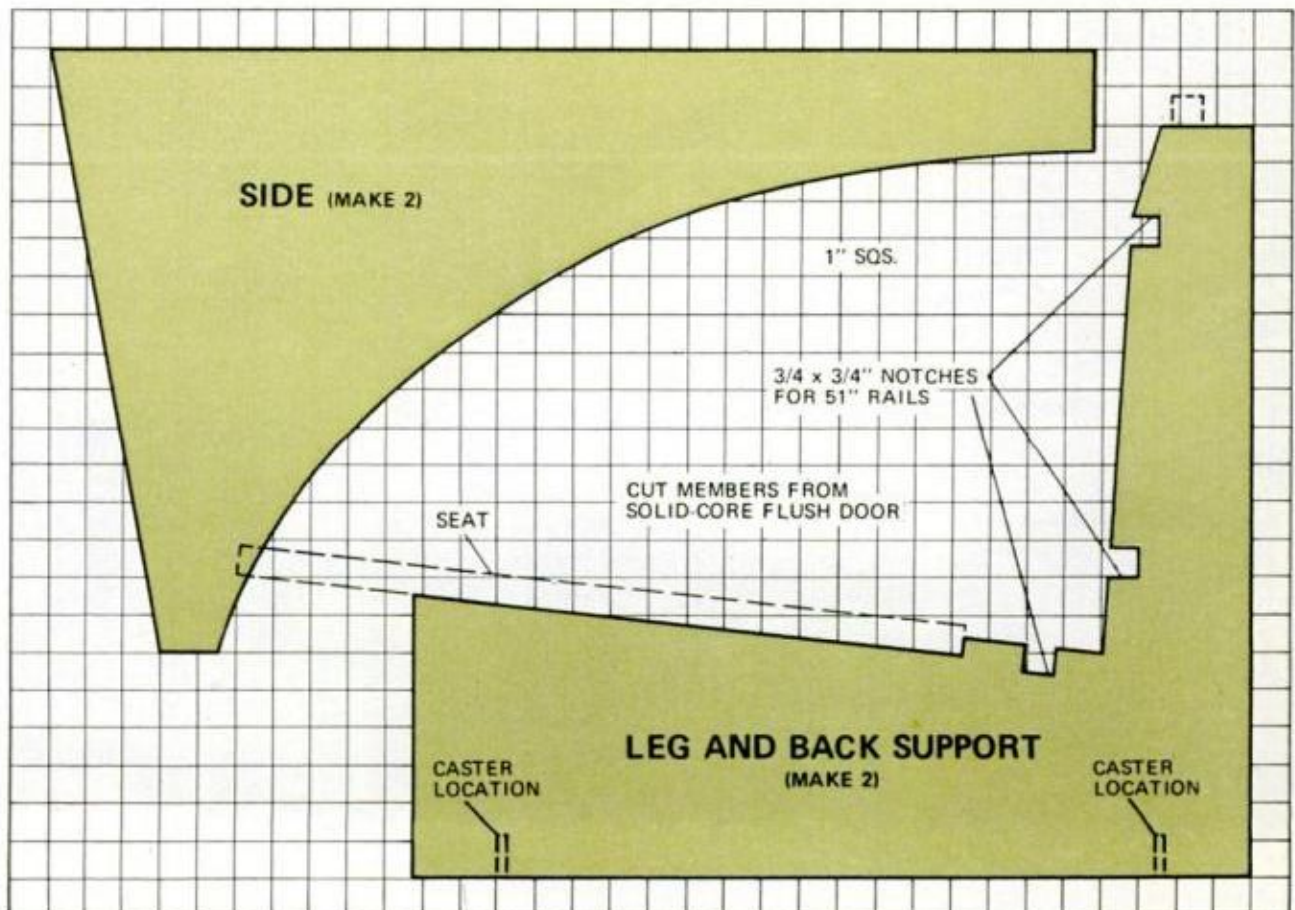

**Sanding small pieces  
is a snap when you . . .**

# Mount your sander in this handy stand

By **WALTER E. BURTON**  
*Photos by the author*

**E**VER TRY TO SAND a 1-in. wood cube with a portable finishing sander? If you have, you probably wished you had the sander firmly anchored so you could manipulate the cube instead of the machine.

The wood stand shown here provides a firm mounting for a finishing sander and a convenient means of guiding small pieces, such as model parts, against its vibrating abrasive surface. The stand was designed to fit a Rockwell sander; other makes of machines can be used, of course, although the arrangement of the mounting blocks and other elements might require some altering.

The work-supporting table is of  $\frac{1}{2}$ -in. plywood; almost all other parts are from  $\frac{3}{4}$ -in. plywood. I used ordinary  $\frac{3}{4}$ -in. pine lumber for the table column.

The sander platform was constructed first and mounted on the base with its outer longitudinal margin 1 in. from the base edge. The two vertical pieces were attached to the horizontal panel with glue and nails.

It is important that air circulate freely through the sander motor to prevent overheating. To avoid any interference with air

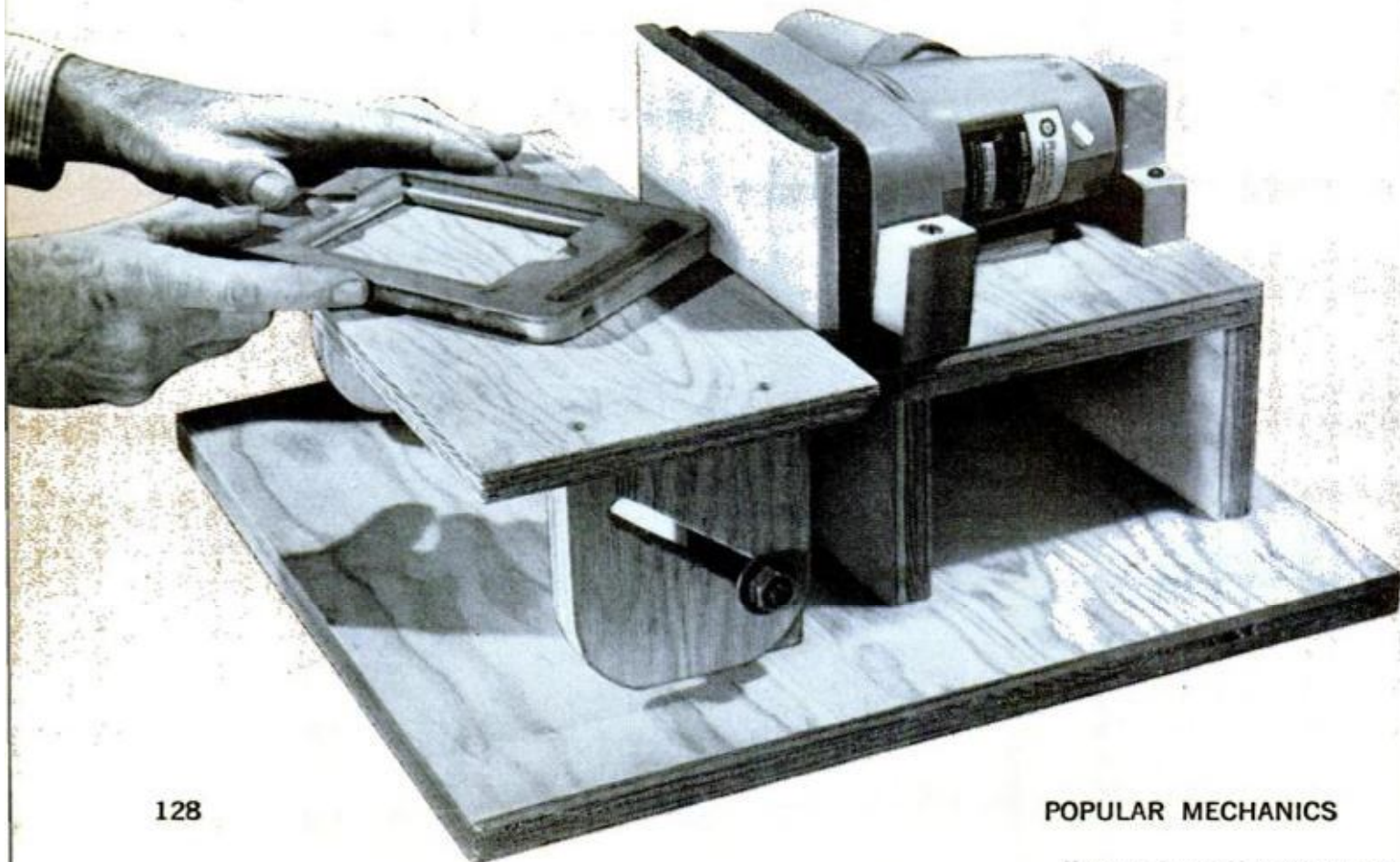

discharge from the vent openings nearer the platform when the sander is resting on its side, an opening was cut in the platform opposite these vents.

Three devices hold the sander firmly in position on its platform:

- A 1 1/4 x 8-in. strip of aluminum-siding sheet that projects 1/4 in. above the platform surface, along the edge next to the work-supporting table. A leather strip, 1/16-in. thick, was glued to the side of this strip toward the platform. This acts as a cushion to prevent marring the sander housing. This padded strip projects into the space between the sander-housing edge and the sander pad, and prevents the sander from moving toward the work table.
- Leather-faced wooden blocks installed to hold the sander against the leather-padded aluminum strip. Two of these blocks flank the housing near the sanding pad, the third presses against the outer tip of the motor portion. Two more blocks are under the sander. One supports the motor housing, the other supports the handle.
- A leather strap, attached to the platform with wood screws, and encircling the handle near the motor. Its purpose is to hold the sander in close contact with the two



**ASSEMBLING HOLD-DOWN DEVICES** on sander platform (above). Below, platform with blocks and strap in place. Note opening provided for airflow from motor

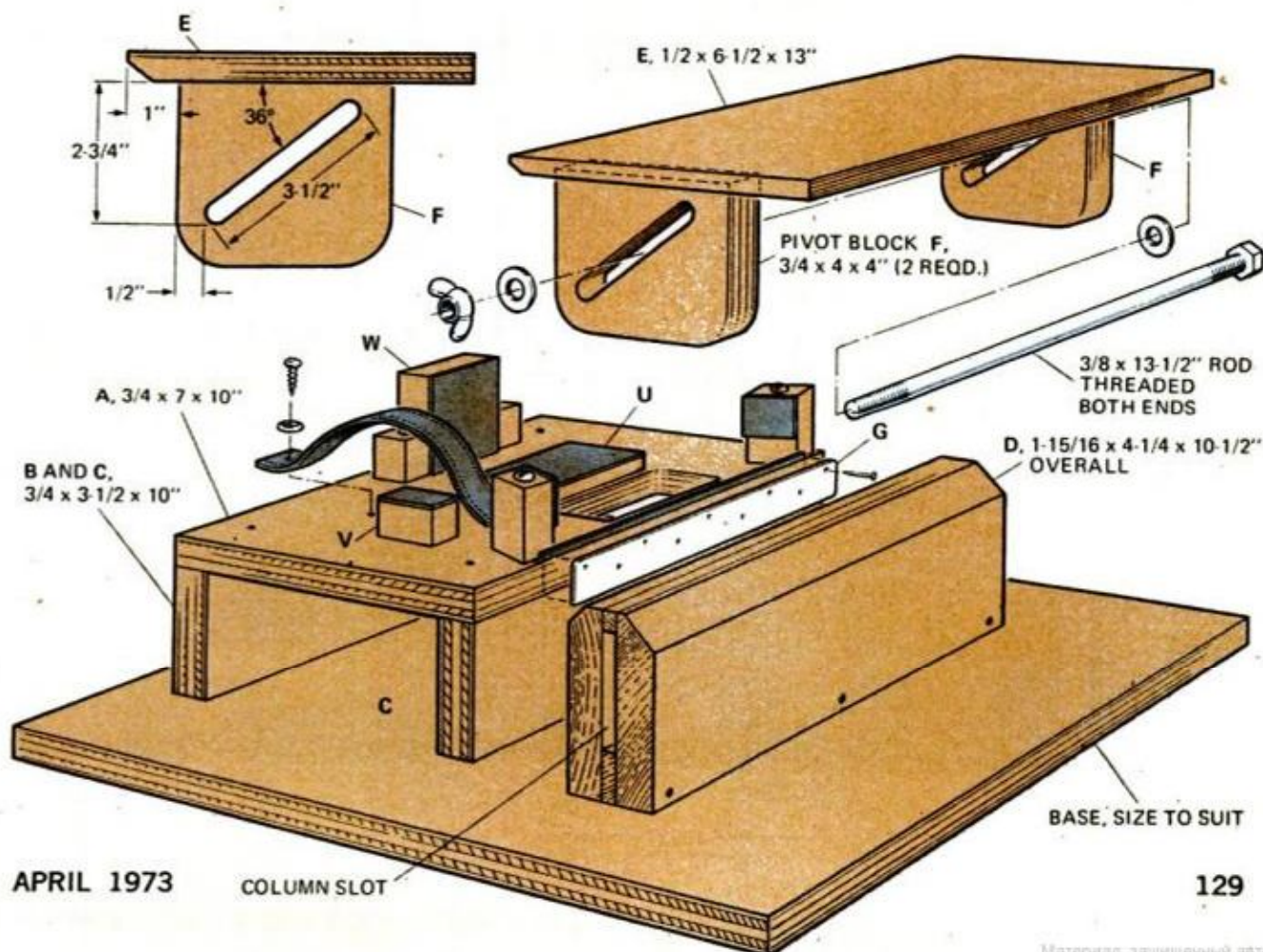
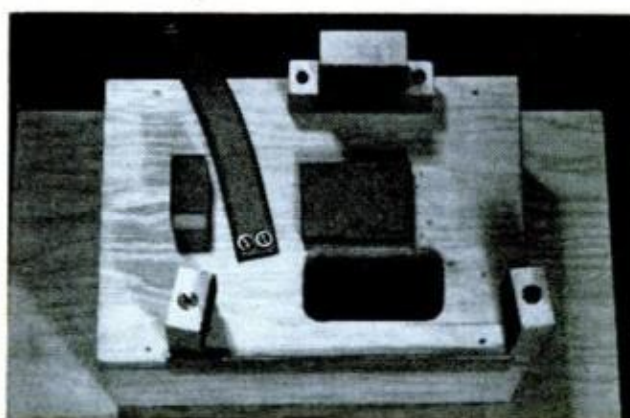

leather-faced blocks underneath. This strap should not be drawn too tight—just enough to keep the sander from moving upward. (For some sanders, it might be preferable to install the strap around the motor portion.) One end of the strap is anchored with two wood screws and washers, the other end by a single No. 8 wood screw installed after the sander is in position.

When a sander has to be removed and replaced frequently, a bolt-and-nut arrangement might be preferable.

The two blocks flanking the housing near the sander pad are secured with single, No. 12 flathead screws 3 in. long, permitting the blocks to adjust to the angle of the housing surface. The block supporting the motor housing was nailed to the platform before leather was applied, and the handle block was similarly fastened with a flathead wood screw. Two No. 8 screws hold the third block.

When the sander is running, there is some vibration transmitted to the platform.

No tests were made to determine the long-range durability of the anchoring system, but no tendencies for the blocks to loosen, or other restraints to lessen, were noted.

The workpiece is normally rested on an adjustable table made from 1/2-in. plywood. Projecting downward from the table are two "pivot blocks," each having a diagonal slot. These blocks straddle the ends of a table column in which there is a vertical slot that measures about 7/16 in. wide and 2 3/4 in. high. This slot was created by assembling the column from two 3/4-in. pieces separated by a 7/16-in.-sq. and a 7/16 x 1-in. spacing strip. The column was mounted with the vertical centerline of its slot about 1 3/4 in. from the abrasive surface.

Length of the table-supporting column is 1/2 in. greater than the length of the sander platform. This provides clearance for the slotted pivot blocks to overlap the platform when the table is adjusted to a steep angle. Pivot blocks are positioned on

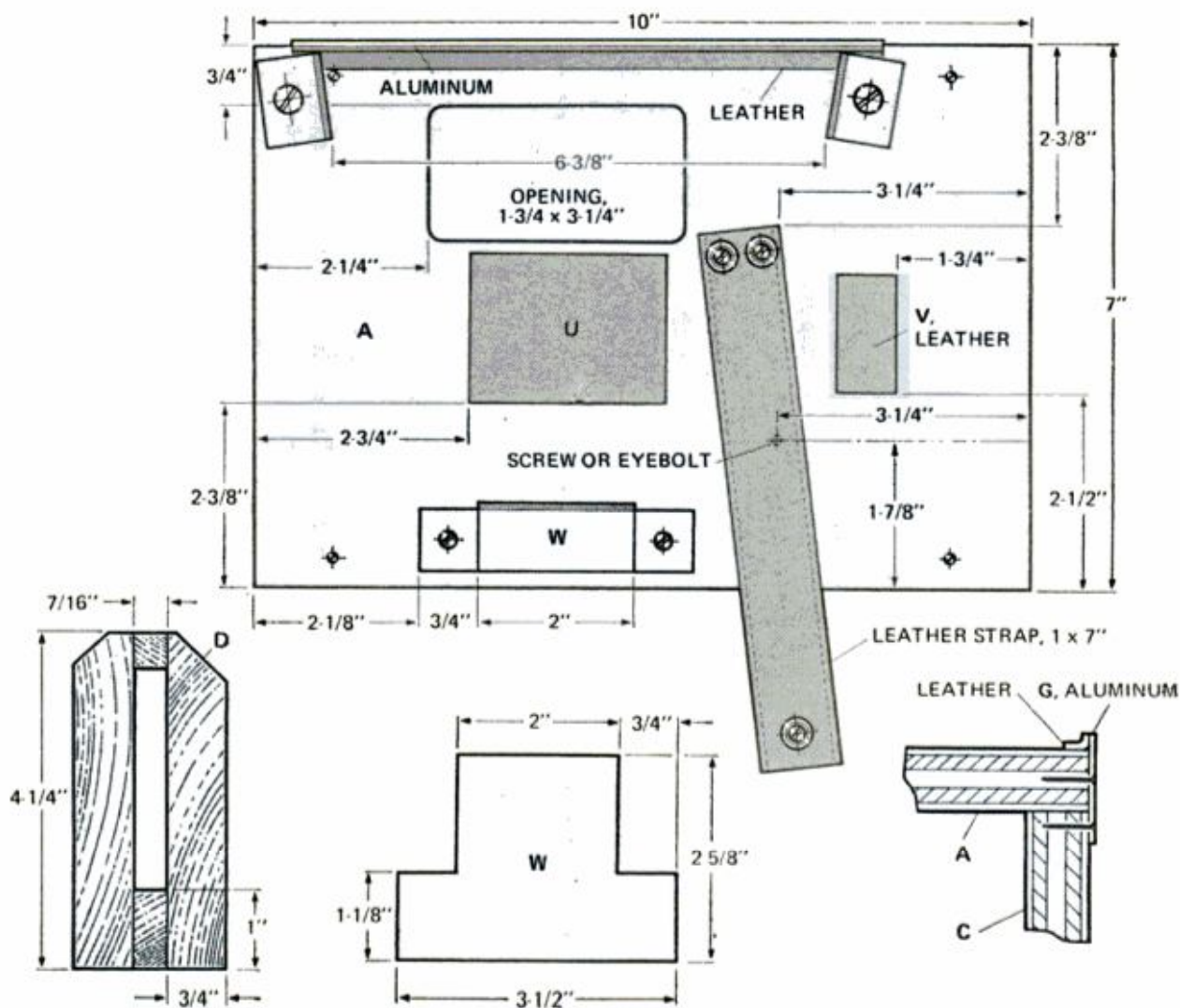

the table so the distance between them matches the column length.

The combination of diagonal slots in the pivot blocks and vertical slot in the column provides for an infinite number of settings for the table with respect to angle and vertical adjustment, and total vertical movement is nearly 2 in.

A  $\frac{3}{8}$ -in. rod, 13 $\frac{1}{2}$  in. long, threaded at both ends, runs through pivot-block and column slots. It has a wingnut on one end and an ordinary nut on the other plus two washers. Tightening the wingnut compresses the pivot blocks against the column ends, securely anchoring the table.

You may have to trim the column top by trial and error so the table can be tilted up to 45° without moving the table edge too far from the abrasive edge.

Although the sanding stand could be used without anchoring it to the bench, it does have some tendency to "walk." Use either a  $\frac{3}{4}$ -in. sponge rubber pad between base and bench or C-clamps to eliminate "walking."

\*\*\*

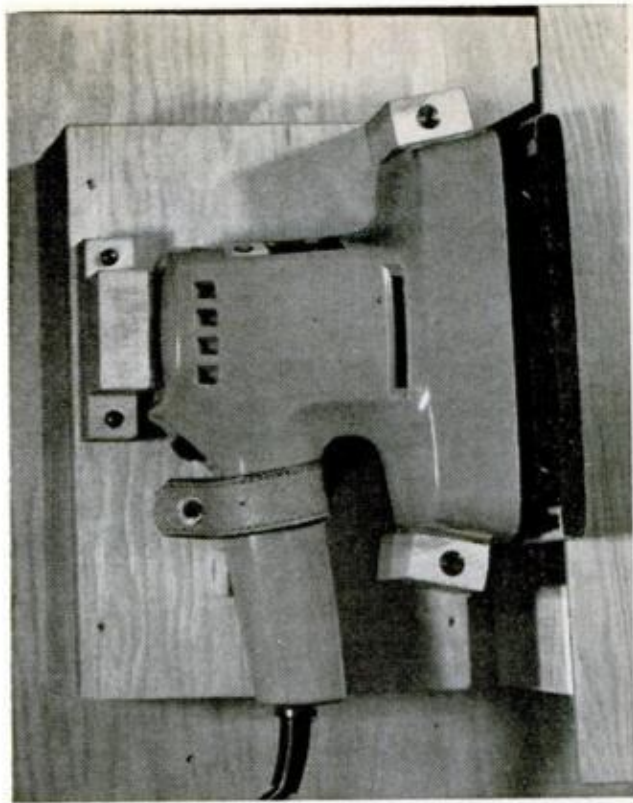

**PROTOTYPE STAND** was built to suit Rockwell's Model 65 sander, but dimensions can be altered for others

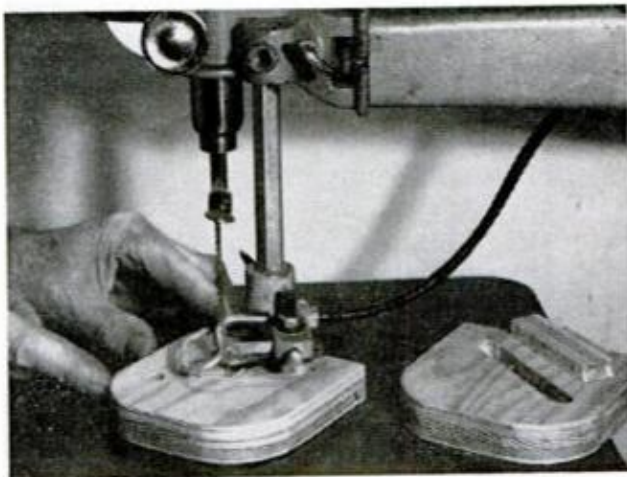

**SLOTS IN PIVOT BLOCKS** are made by boring holes at both ends and finishing with a jig (or coping) saw

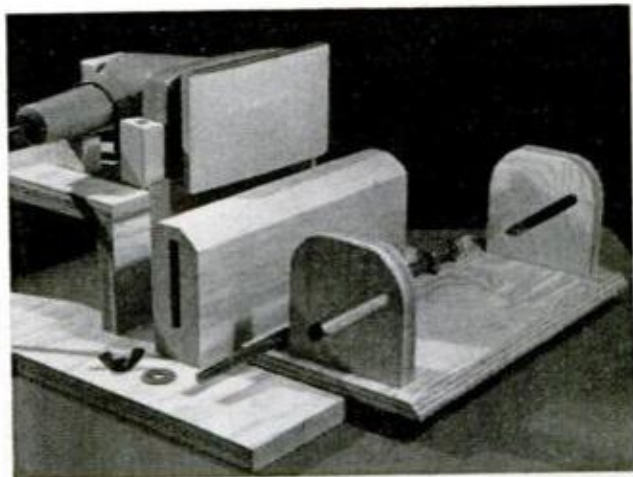

**TABLE-SUPPORT COLUMN** and table before mounting the pivot blocks. Spacing strips form a  $\frac{7}{16}$ -in. slot

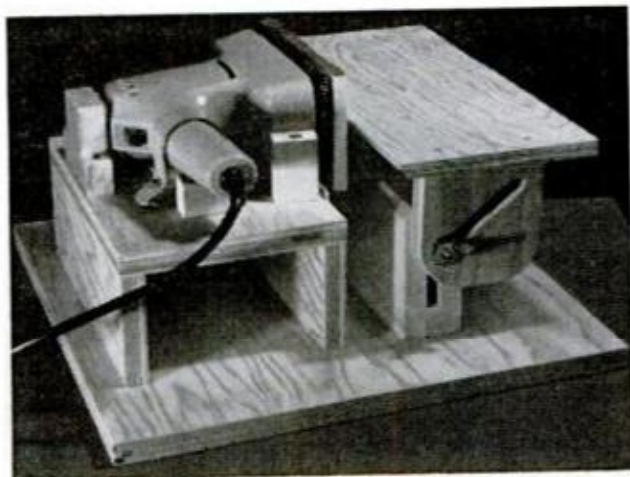

**ASSEMBLED SANDING SETUP** with table adjusted to an upper position for normal right-angle sanding  
APRIL 1973

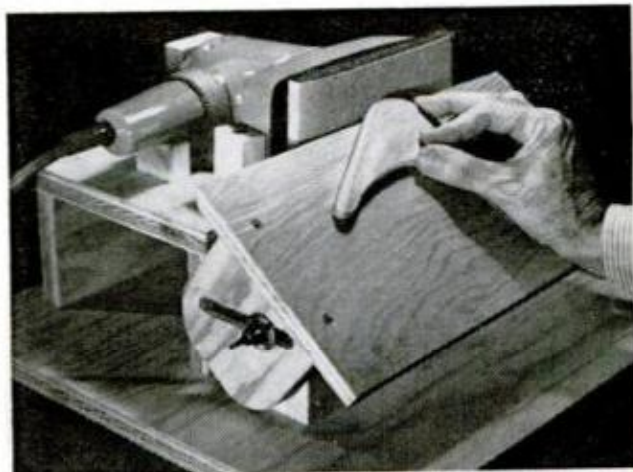

**WITH TABLE AT 45°**, the concave portions of work are easily sanded using the ends of the sander's pad

# Colorful clock kit lets you see what makes it tick

YOU'LL HAVE FUN putting this Color Clock together and more fun watching it tick. Its swinging pendulum and molded gears of red, blue, green and yellow plastic are mounted between two plexiglass sides to provide a clear see-through view front and back.

A product of West Germany, the colorful all-plastic clock is sold as a kit containing some 50 parts. It stands 11 in. tall, is spring-driven, nonstriking and has an 8-in. dial. The spring, housing and drive gear come already assembled as a unit.

The clear plastic sides are held apart by four spacers having threaded ends. A socket wrench that's part of the kit is used to screw unthreaded plastic nuts onto the threaded posts. By manipulating a regulator arm and pendulum weight, you "tune" the clock for accuracy. A scale on the back helps in adjusting the pendulum assembly to produce a uniform tick. You set the clock by moving the minute hand.

The clock has a distinct tick. No lubrication is required, other than a little soap applied to the escapement-wheel teeth. Because it's plastic, the clock should not stand in direct sun.

Besides being an accurate timepiece, the clock serves as a decorative conversation piece as well as a fine educational project for instructing youngsters in how a clock works and the measurement of time.

The kit comes with a detailed instruction sheet and sells for \$9 post-paid from Caldwell Industries, Box 170, Luling, Tex. 78648.—Walter E. Burton

132

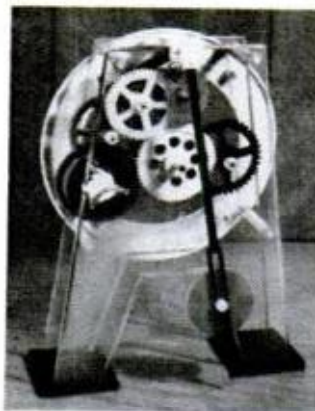
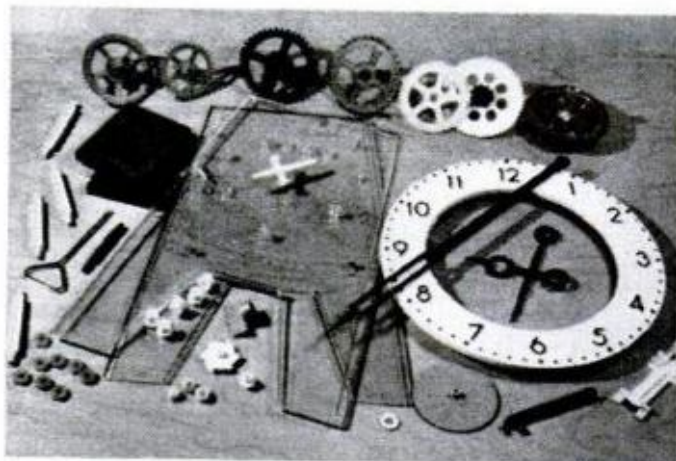
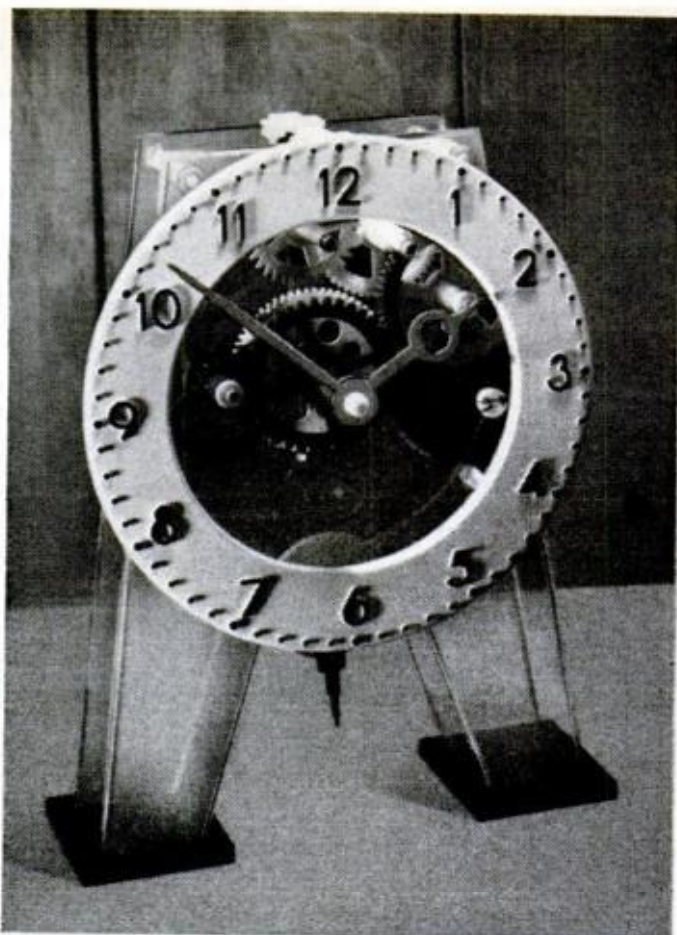

**GEAR-TRAIN ACTION** can be observed through transparent case (top photo). Except for four metal gear shafts, all parts are plastic (center photo). Pendulum weight is adjusted up and down for timing (lower left photo). Winged socket wrench is used to install threadless nuts that hold sides together (lower right photo)

POPULAR MECHANICS



# HINTS FROM READERS

## Lathe dog for threaded shafts

Clamping a standard lathe dog to a threaded shaft is a sure-fire way to ruin the threads. Traditional shop practice calls for the use of small scraps of sheet metal to protect the delicate threads, but I prefer these homemade lathe dogs because of their gentle but exceptionally strong clamping power.

The dog shown here is for a  $\frac{1}{2}$ -13-thread shaft. Holes are drilled and tapped first, then the dog is cut to shape and a saw slit made up the center. The driving tail is a section of a  $\frac{1}{2}$ -13 bolt with the head cut off. To use this dog, you simply screw it onto the shaft and tighten the clamping screw.

While a different dog is required for each size thread, you'll soon have a number of dogs in the common sizes.

—Thomas H. Benham, Joliet, Ill.

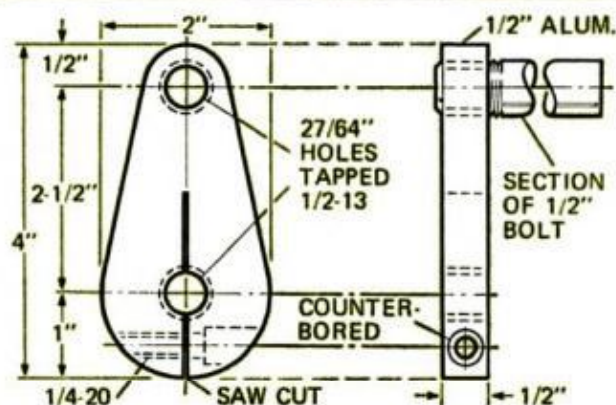
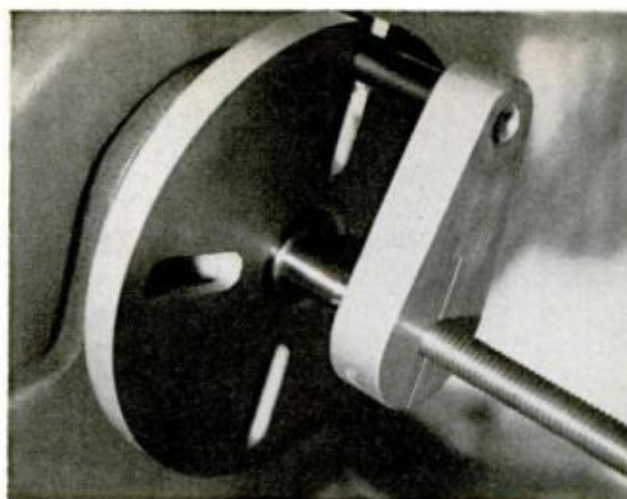

## Sabre saw requires large entrance holes for inside cuts

When cutting a rectangular or square opening in a panel with a sabre saw, you'll do the neatest job if the diameter of the blade hole is consistent with the width of the blade. When the hole is too small for the size of the blade (upper detail) you can't align the blade with the line of cut. The starting holes for a  $\frac{1}{4}$ -in. blade should

be no less than 1 in. in diameter. Only when the blade can snug up to the line (lower detail) can you be assured of a straight cut from corner to corner. When the blade hole is too small and you try to use a wood strip as a fence to guide the saw, you can't "steer" saw up to the line.—Rosario Capotosto, Greenlawn, N.Y.

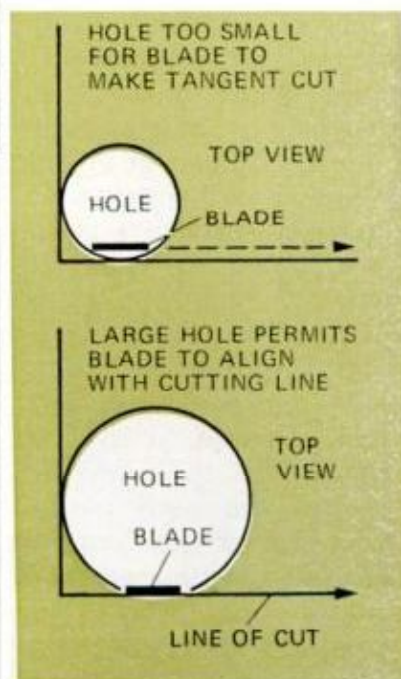
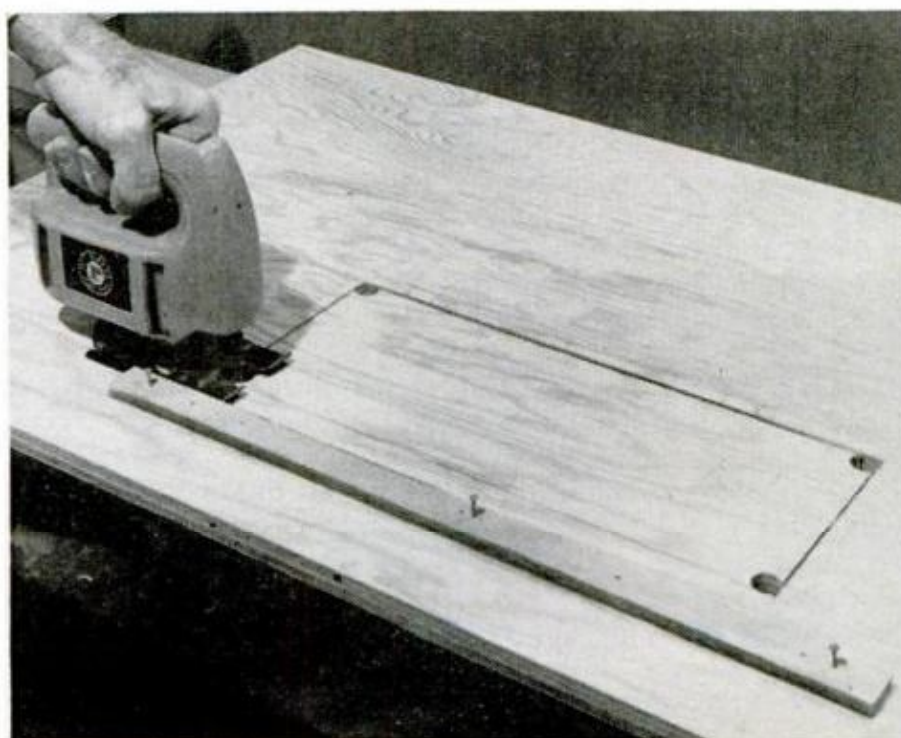

## FLYWEIGHT FLYING BOAT

(Continued from page 78)

weight is 600 pounds, with a gross of 900.

The wings are a sight to behold in themselves. They pivot birdlike in two directions at once—backward and sideways—lying snugly along the fuselage when retracted, reminiscent of the famous folding Grumman Hellcat and Avenger carrier-based aircraft of World War II. Folding the wings back instead of upward eliminates added height that would make the ship wind-sensitive on the road and difficult to stow.

Wings, hull and fuselage are all wood-framed with a fiberglass skin. The bullet-



**HIGH HORIZONTAL STABILIZER** is deliberately located at top of tail to be directly in line with the prop thrust from elevated engine mount. This helps to provide maximum of elevator control and stability

shaped nose, wingtip floats and other contoured parts are shaped from Styrofoam blocks and also fiberglassed. The engine is a 90-hp Continental, mounted backward for a pusher-type prop. Despite such modest power, the Osprey becomes airborne at 55 mph, climbs 1200 feet per minute, cruises at around 100 mph, has a range of 370 miles on 16 gallons of fuel and can reach a service ceiling of 18,000 feet. So impressive are its flight characteristics, in fact, that the Navy is testing the design for possible use as a small police patrol craft in Southeast Asia.

Flying the Osprey is tricky at first, but you get used to it quickly, says Pereira. Because of the high thrust line, the nose dips as you apply power and comes up as you ease off—the opposite of conventional aircraft. Estimated cost is \$1000, less engine and prop. Plans are \$65 from George Pereira, 3741 El Ricon Way, Sacramento, Calif. 95825. ★★

## MOVIE CAMERAS

(Continued from page 111)

properly, or if you shoot movies from a unipod. If you do much tripod shooting, it also pays to check fixed-grip cameras to make sure their grips won't interfere with tilt-head operation. On many such cameras, the tripod-screw socket is at the base of the grip, which prevents that problem and gives you an easier, stoop-free view through the eyepiece if you're tall and your tripod isn't. Some removable-grip models make you take the grip off to mount the tripod—that may be a nuisance.

Often, the grip doubles as the battery holder. But wherever the batteries go, a removable battery case is a good idea—it keeps leaky batteries from damaging the inside of the camera.

All the Super-8 cameras I've tried have windows that let you see what kind of film is loaded in their film compartments, and subtractive film counters that show you how much film is left. Most manufacturers put their film counters on the left side of the camera body, but Kodak puts its on the rear of the camera, just below the eyepiece; that sounds more convenient, but in practice it doesn't seem to make much difference because you aren't likely to look at the counter while filming anyway.

So much for what those cameras have (you'll find a complete, camera-by-camera feature breakdown in the chart). What do they lack? Wide-ranging zooms, for one thing. Move a few hundred dollars up the scale and you can find zooms with 10:1 ranges, covering everything from a really wide 6-mm to a distance-eating 70-mm telephoto. You can get faster lenses and wider-opening shutters that let you shoot High-Speed Ektachrome in even normal room light. You can get single-frame releases for homemade animation and time-lapse controls that let you "speed" action up until the opening of a flower takes only seconds on the screen. You can get close-up focusing to as little as 1 millimeter from the lens, built-in lap dissolvers, sound synchronization and slow motion. But you pay for all this versatility—in money, bulk, weight and complexity.

Even if you aspire to movies with a Hollywood touch, you'll find cameras in our under-\$100 price group that can teach you all the basics. And if you don't aspire to professionalism, you'll find about all the features you'll really use. ★★

## RECORDERS BY THE POCKETFUL

*(Continued from page 82)*

30's adapter attaches handily to the outside of the recorder). If you record in your car a lot, you can also get adapters that draw power from its cigaret lighter socket (one is provided with Wollensak's comprehensive set of supplied accessories). But be sure the adapter you buy, if not from your mini's manufacturer, is compatible with it—we blew out a Sony by trying it on Wollensak's automobile adapter, though each machine ran fine on its own power supply. Since polarities are rarely marked on recorders or adapters, you'll have to check their schematic diagrams or write to the manufacturers before you mix adapters.

The minis' closely packed controls are still easy to operate. But some minis will fit your hand better than others. The Lanier 1300, Wollensak and Hitachi TRQ-30 were especially well-arranged for dictation and note-taking: Hold the Lanier like a microphone, and your thumb

---

***I find levers easier to tell apart by feel, but buttons are less likely to snag pockets.***

---

rests on a single control that lets you record a thought, rewind it, listen to it again, then pop right back into record mode for the next idea. The Wollensak does the same, but uses separate controls, less conveniently placed. And the Hitachi TRQ-30's pushbuttons, though conventional in function, are very conveniently placed on the unit's microphone side.

The Lanier 1300 also has a paper index, with a built-in pen to mark the start and end points of letters or other items dictated: Lanier's cassette transcriber has a holder for this index strip. Several other minis have digital counters, which are useful if you write down the locations of items you'll want to find again (and if you play them back on the same machine—not all digital indicators count alike).

The Sonys had a unique "cue" feature: press the fast-forward control during playback, and the tape chatters past the heads at double speed, so you can skip unwanted material yet hear the beginning of the next item you're interested in. But one Sony, the TC-40 has no true fast for-

ward, just cue; it takes 12 minutes to wind forward through a C-60 cassette (though its rewind takes just two minutes).

Some fast-forward and rewind controls are self-locking to save fingers when winding past long stretches of tape. But nonlocking controls are handiest for short skips along the tape. The same is true of pause controls, which stop the tape without taking it out of record mode: locking controls are better for long pauses, nonlocking for shorter ones. All play and record controls lock, of course, but a growing number of them automatically disengage when the end of the tape is reached, saving wear on batteries and mechanism. As to level or pushbutton controls, take your choice; I find levers easier to tell apart by feel, but buttons are less likely to snag pockets.

Though all but the Admiral and the RCA minis have built-in microphones, all but the Lanier 1300 have external mike jacks, too. External microphones are handy when you need to hold a microphone close to your mouth in noisy environments (even the lightest minis get heavy if you hold them long enough), when you need the longer reach of a narrow-beam directional microphone (the built-ins are all more or less omnidirectional), or if you want to mount your microphone on a stand or boom. If you use a telephone pickup to tape phone calls, it plugs into the mike jack, too. But make sure any mike or phone pickup you buy will fit your recorder—we discovered at least three different styles of microphone plug in our sampling.

The remote-control sockets next to the microphone jacks on cassette recorders are basically for use with the start-stop switches built into most cassette microphones. But you can also use them with hand-operated switches (useful when taping interviews via the built-in microphone), and with foot-pedal switches for transcribing notes or dictation. If you want to buy a recorder for transcribing, check its start-stop time; some minis can start and stop between syllables of a word, while others coast to a stop and glide back up to speed, losing a syllable each way.

Would I buy a mini? Sure. In fact, as soon as I finish this story, I'll be taking off to cover another one with a mini in one pocket and a batch of cassettes in another one. ★★★

## PROFESSIONAL BRAKE JOB

*(Continued from page 118)*

is less than 0.030 inch oversize, use standard linings.

Ideally, after you buy them, bring new linings to a shop for arcing. This will remove high spots and insure full contact with the drum. Arcing will cost you about 25 to 50 cents per shoe.

If you have to install a new brake drum, wash it thoroughly with lacquer thinner to remove the antirust preservative which was applied at the factory.

Discs (rotors) should be checked for lateral runout and parallelism. Lateral runout is the movement of the disc from side-to-side as it rotates. Too much lateral runout will produce brake shudder.

Parallelism refers to the thickness of the disc over its circumference. Variations in thickness will produce brake chatter.

Have the brake specialist check these conditions by first adjusting wheel bearings so end play won't be a factor. To

---

### **Brake trouble occurs as frequently from hydraulic failure as from lining and drum or disc damage.**

---

check lateral runout, attach a dial indicator so that its stylus touches the face of the disc about 1 inch in from the edge.

Move the disc one complete turn. If the total indicator reading exceeds the maximum allowable limit for lateral runout for the particular disc, have the disc refaced, if possible, or replaced.

To check parallelism, measure the thickness of the disc in at least 12 different spots. If the total indicator reading exceeds the maximum allowable limit for the particular disc, resurface the unit, if possible, or replace it.

The allowable amount that a disc can be turned is stamped on the unit. Measure the thickness of the disc before and after turning to make sure that this amount has not been exceeded.

Doing a brake job involves a thorough inspection of the system's hydraulic part as well as replacement of linings and drum or disc refacing. Brake trouble occurs as frequently from hydraulic failure as from lining and drum or disc damage.

The hydraulic parts of drum and disc brake systems differ. Both have a master cylinder and brake lines, but a drum brake setup uses wheel cylinders while a disc brake system uses a caliper equipped with a cylinder bore and piston to bring linings into contact with the disc.

If you have disc brakes on the front of your car and drum brakes on the rear, the system probably has a metering or proportioning valve. You will have to check the car or service manual to determine which one your car uses.

A metering valve is usually positioned near the master cylinder and is installed in the hydraulic line that goes to the front disc brakes. It keeps the front discs from applying themselves until the rear drum brake linings are in contact with the drums.

Problems associated with a faulty metering valve include front brakes not fully applied, hard brake pedal and brake grab. Pull back the dust cover on the valve and make sure the valve is not leaking.

A proportioning valve is positioned in the hydraulic line that goes to the rear drum brakes. Its job is to prevent premature wheel lockup by limiting the amount of hydraulic pressure going to the rear until braking has been achieved up front.

If you are experiencing rear-wheel skidding or grabbing, suspect a bad proportioning valve. Its condition will have to be tested with professional gauges that compare inlet pressure to outlet pressure.

Check the fluid level in the master cylinder. Make sure it's up to the mark and that the cylinder is not leaking. If the fluid is above level, air or water may have gotten into the system. Bleed the brakes to get rid of trapped air.

When water gets into a hydraulic system, the upsurge in fluid level is normally accompanied by a brake pedal that fades under pressure. The hydraulic system should be drained and flushed with alcohol, and fresh brake fluid of high quality should be installed.

Examine all hydraulic lines for dents and kinks, collapsed areas, leaking connections, and ruptured spots. Pull back the boots covering the master cylinder and wheel cylinders to check for leaks. Remember, if a defective cylinder needs machining, you'll save money by removing it yourself and bringing it to a shop. ★★ ★

# Home Ideas Guide

- Exciting new ways to handle a basement recreation room
- New prefab bathtub enclosures
- Quick way to get an entry foyer
- New wall coverings
- Kitchen light fixtures you can make
- Low-cost ways to facelift your home
- How to beat attic heat
- How to lay imitation brick
- How to install a garage-door opener
- How to hang a door and install a lock
- Right way to paint a room
- How to install insulation
- New furnace that heats and cools
- How to put up ceiling beams
- New products that will give you ideas, ideas, ideas...

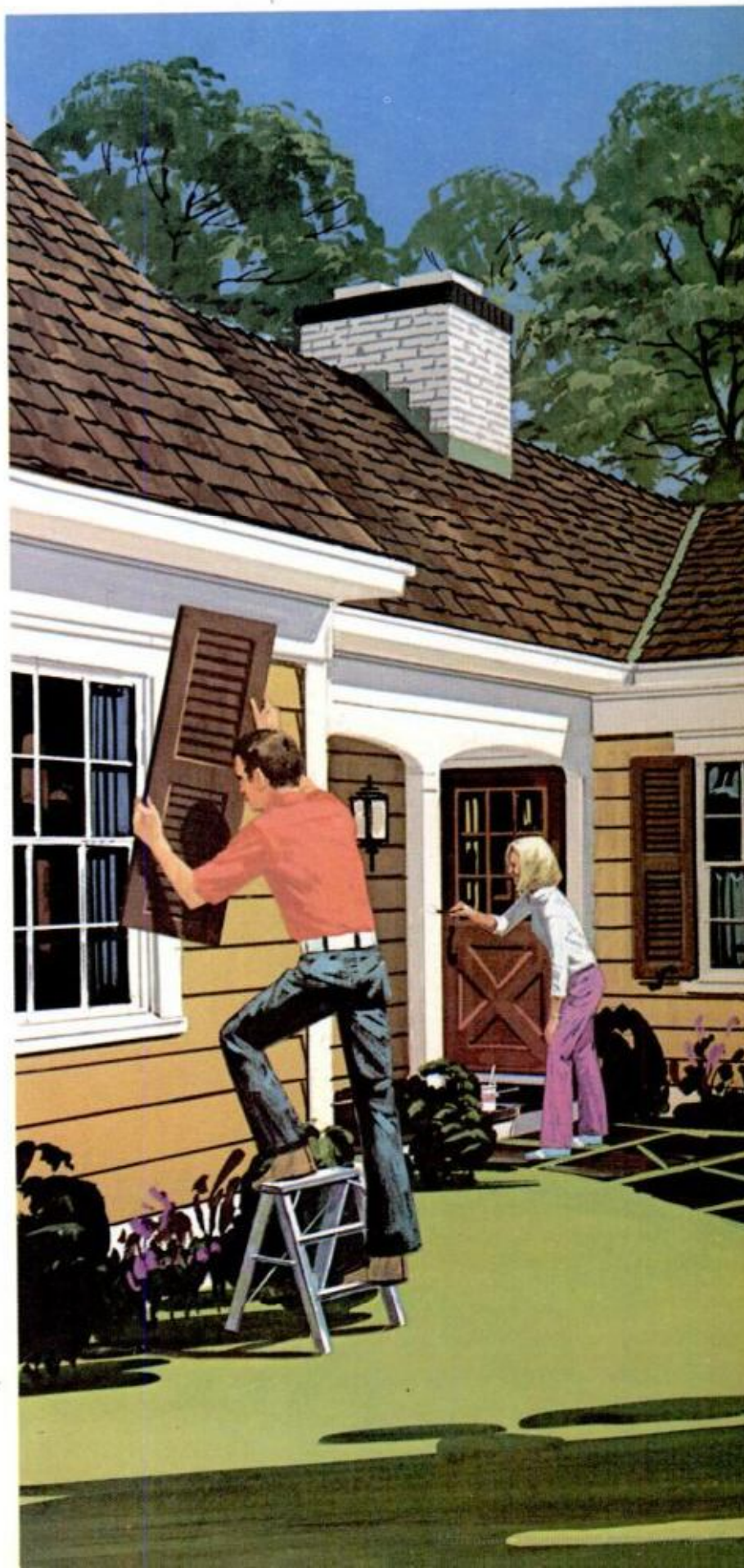



## How to put up a beautiful new ceiling this



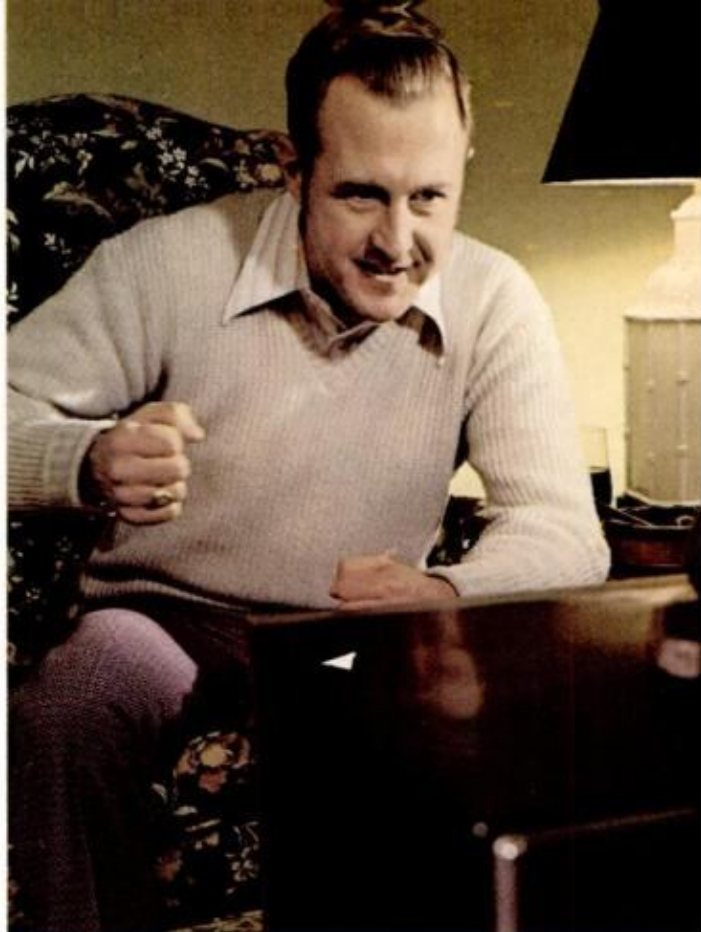

## weekend and still have time for the big game.



We have a great new way to put up a ceiling. It's called Integrid™. It's both a new method of installation and—with Armstrong Chandelier® ceiling tiles—a great new look in suspended ceilings. It can be dropped to any height you wish—in any room of your home. And best of all, the job goes faster. In most rooms you can begin installing it Saturday morning and be finished in time for the game on Sunday.

The big difference with Integrid is its hidden grid system. The Chandelier ceiling tiles fit into the grid so that it's covered completely. All you see is an elegant, uninterrupted expanse of rich-looking ceiling. It's simply beautiful.

And it's beautifully simple. To install the Integrid System, you nail up a wall molding; install the hanger wires for any height you desire; attach the main grid; and slip in the tiles and support runners. It's fast. It's easy. It's the winning play for the home team.

Want more information? Write to Armstrong, 7304 Watch Ave., Lancaster, PA 17604. We'll send our eight-page brochure and full instructions. Or, see your Armstrong Ceiling Center or other building materials dealer that carries Integrid. To find the one nearest you, call this toll-free number: 800-243-6000. (In Connecticut, call 800-882-6500.) Ask for the name of the Armstrong dealer who sells Integrid Ceilings.

# Armstrong

CREATORS OF



THE INDOOR WORLD®

140A

Материал, защищенный авторским правом

# "If you want a quality wall panel for less than \$5.99, see the Paneling People. They make 46 beauties."

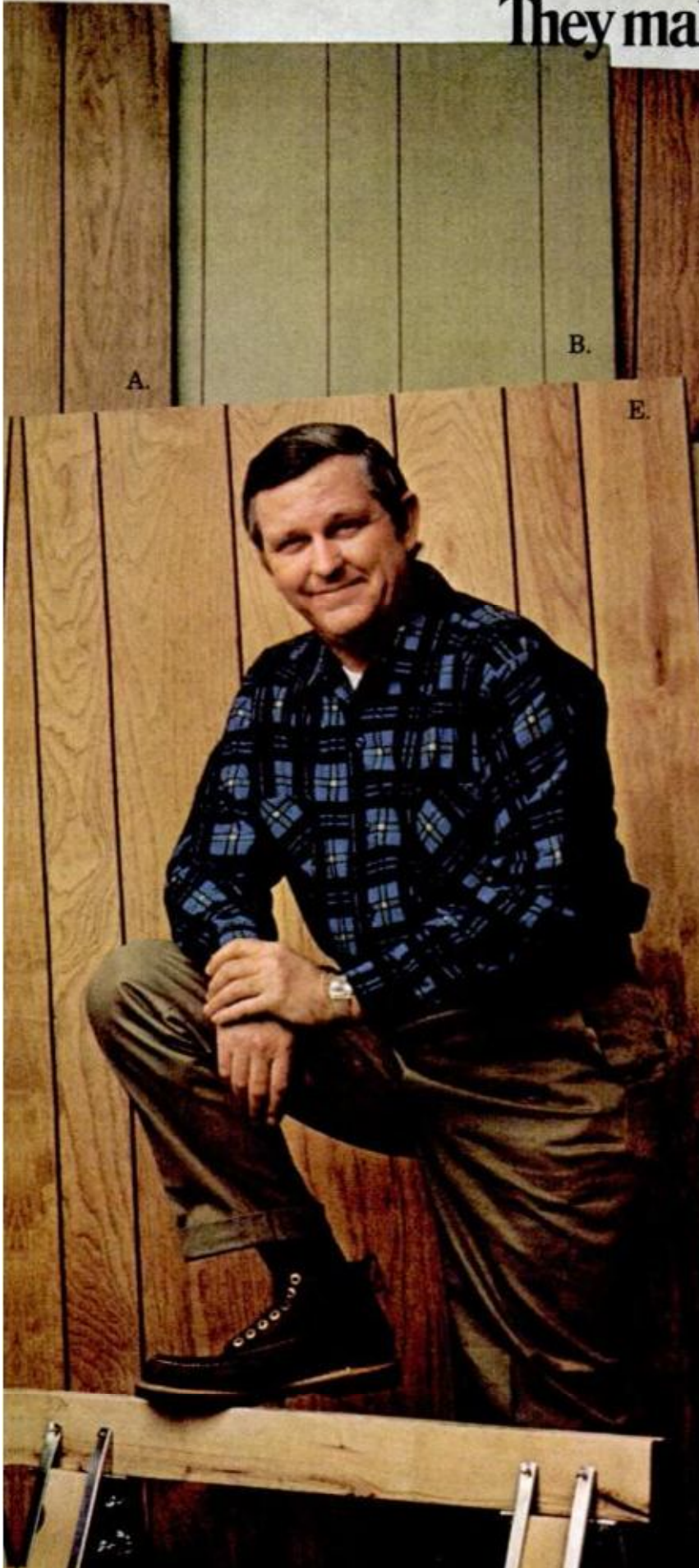

Wally Bruner, host of the do-it-yourself television show "Wally's Workshop" knows what a difference quality wall paneling like U.S. Plywood's can make in a remodeling job. He always understands your budget. "You don't have to settle for lower quality paneling to get a low price."

"U.S. Plywood makes a complete range of wall paneling. 46 of them cost \$5.99\* or less per 4' x 8' panel. And every one has that famous U.S. Plywood quality reputation behind it—the same as the most expensive panel they sell. That's why they're known as the Paneling People."

"Here are five of my personal favorites:

**A. Tidewater.** Lauan plywood with printed oak graining. Burl and plus three more.

**B. Gaslight.** A crackle antique pattern, reverse printed vinyl and laminated to lauan-plywood.

**C. Estate.** Strong, textured printed grain enhanced by a multi-coat varnish. Denniston and five more.

**D. Vinylgard.** High-fidelity reverse-printed vinyl laminated to plywood. Amarillo and nine others.

**E. Early Spring.** Printed pecan or teak grains, ranging from golden white to deep brown.

"And the Paneling People nearest you have many more. Check the Yellow Pages under Plywood for a listing of U.S. Plywood Weldwood dealers."

It's a promise—from the company that makes fine U.S. Plywood products, to the dealer in your neighborhood who carries them, you'll get quality-at-a-price from

## The Paneling People

 **U.S. Plywood**  
A Division of Champion International

\*Manufacturer's suggested retail price



## Home Ideas Guide

Smart, simple decorating ideas that can work for you



# Basement rec rooms with a family-room look

**T**HE BASEMENT used to contain the “rumpus room”—for kids on a rainy day or for that occasional Saturday night party. But you wouldn’t want to live in it. A family room is a warm, livable area of the house. If you need one—or a larger one—don’t overlook the basement. And if you want your basement to pay its way as *living* space, plan it as a family room.

The room at right is in the basement of the home of Minneapolis designer Ann Ritz. It’s not a stereotype of many basement rooms that look like empty nightclubs when they are not being



Data by Annette Sukov  
Photos by Les Turnau

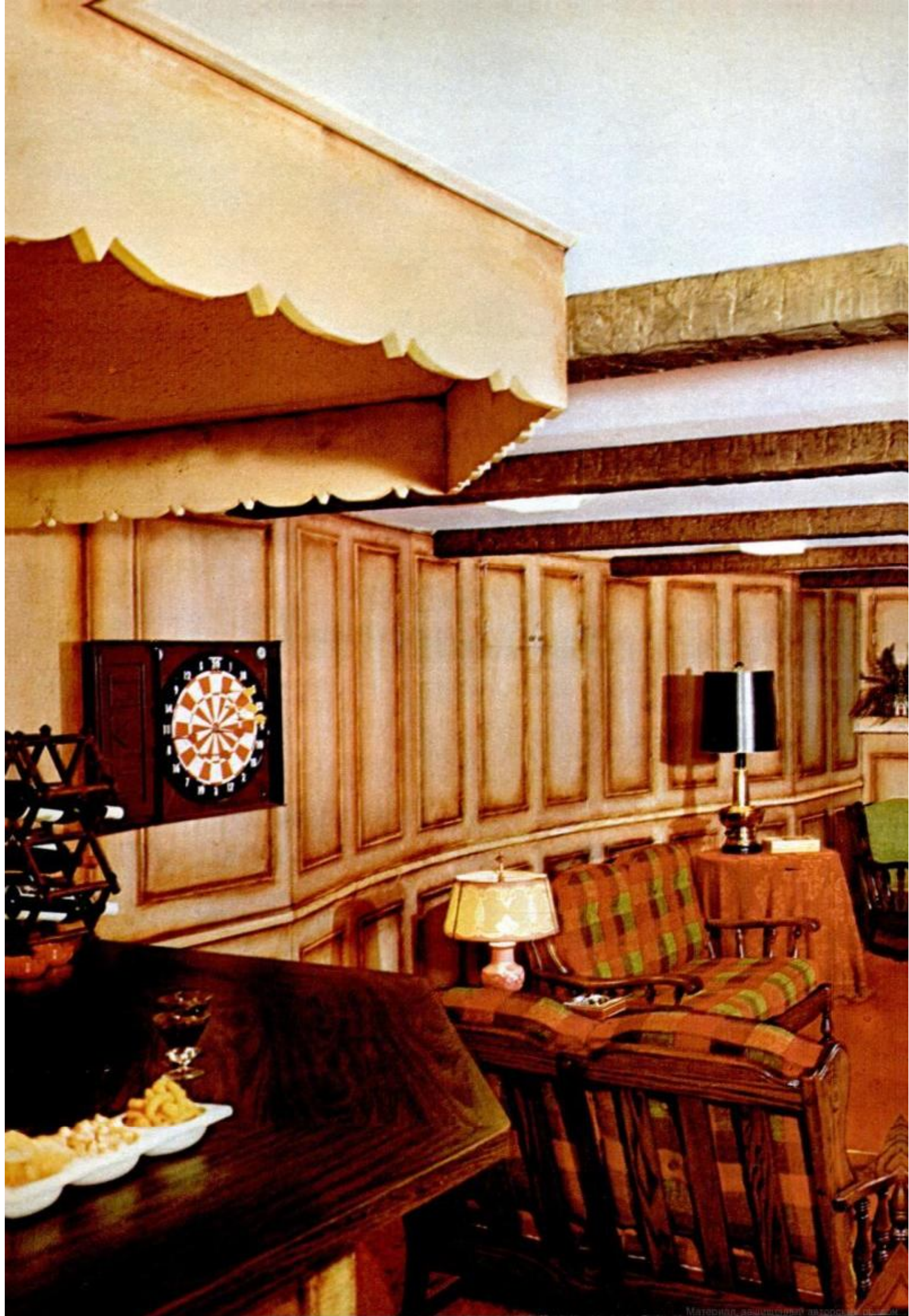

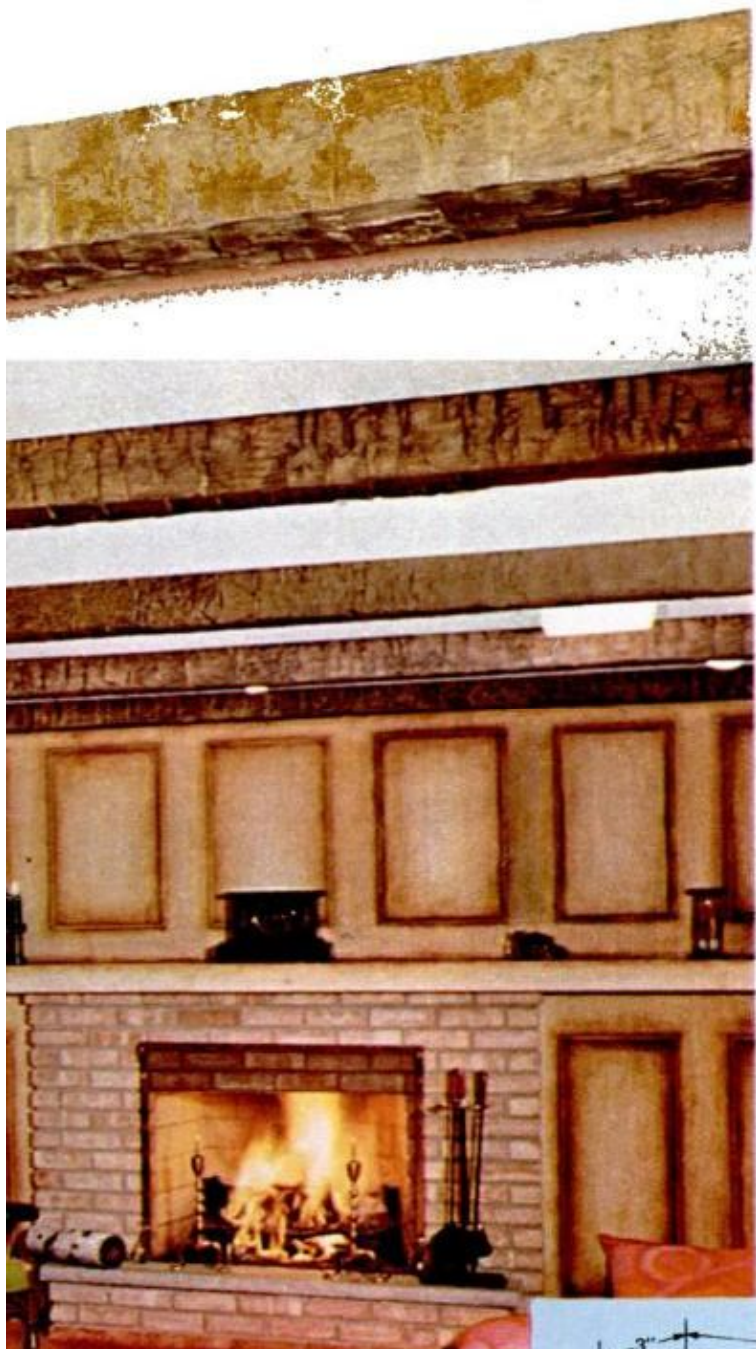

used for parties. Its warm look comes from pecky cypress planks stained to achieve a weathered effect and from a bold use of color in draperies, carpeting and upholstery fabrics. Lighting was carefully planned so it could be controlled by dimmer switches to fit the mood or occasion—whether a quiet evening at home or a big party.

In the room at left, designed by Minneapolis architect Paul Albitz to suit the taste and living style of Dr. and Mrs. Thomas Pirisch, the elegant traditional look prevails. Though the result is expensive-looking, construction costs were kept down for two reasons: Sound, modern building techniques were used throughout, and the doctor did it himself.

The rich-looking walls are actually an inexpensive grade of 1/4-in. fir-plywood paneling. For the sculptured look, standard wood moldings were glued to the plywood, then walls were stained, "antiqued" with burnt umber and varnished.

The rough-hewn simulated beams glued to conventional ceiling tiles are the foam-urethane type—easy to work with and prefinished. The attention given to small details is what "makes" the room. We have drawn three of the good ones for PM readers to duplicate. Dimensions, of course, can be altered to suit your job.

(For more family-room ideas, see page 159)

**BRICK FIREPLACE** was already in basement before facelift. Good wood-member treatments on its face now make fireplace the focal point of room. Sketches below show how they were created

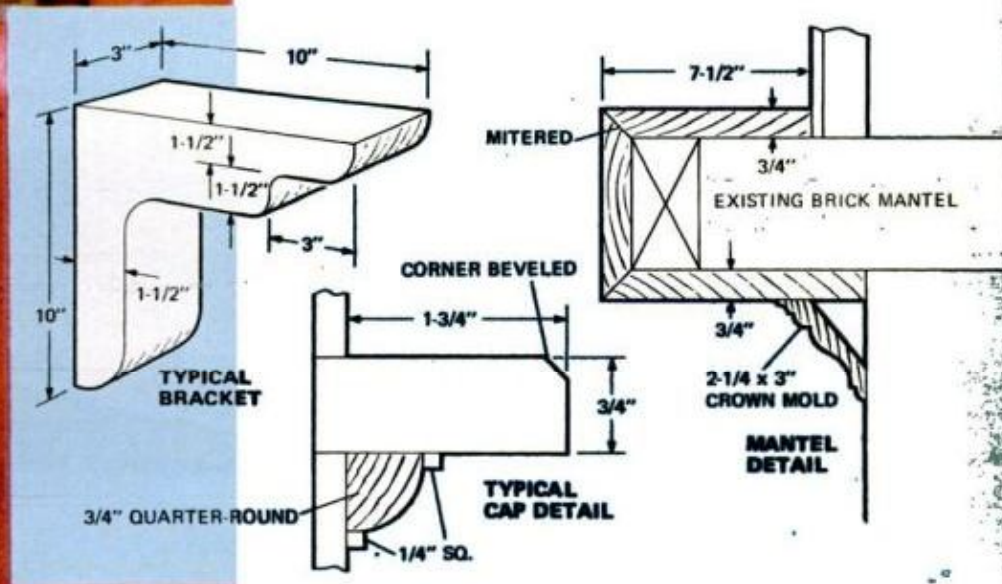

# Prefab baths: easy to install

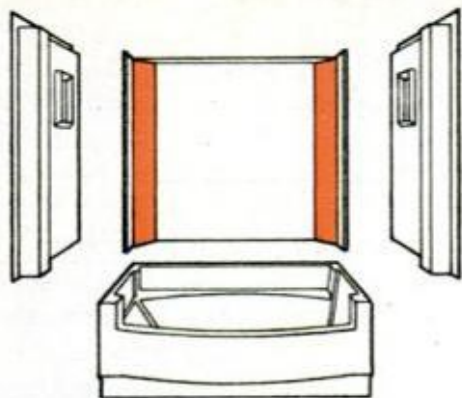

**FEATURING** color-coordinated accessory panels to complement other bath fixtures, this four-piece tub-shower has sculptured shelves, wide rim seat and slip-resistant bottom. By Owens-Corning



# and clean

## Home Ideas Guide

**C**ERAMIC TILE surrounding a bathtub looks nice, but it presents two problems for homeowners: All those grout lines between the tile are hard to clean, and as the house settles, there's the periodic job of recaulking the crack that invariably develops where the tile and tub meet.

Happily, several makers of tub/showers have done something about it and are offering sectional and unitized bath units in reinforced fiberglass. Interlocking sections become a single leakproof

*(Please turn to page 157)*

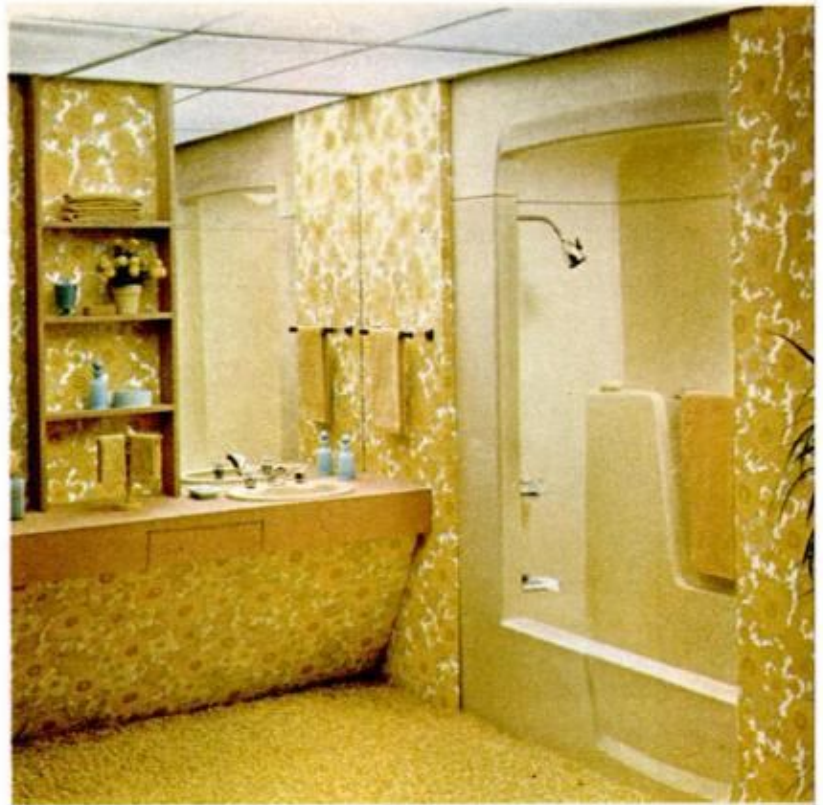

**PRIMARILY FOR NEW CONSTRUCTION**, the Concept III (above) is a one-piece tub/shower that offers optional cap to finish off walls and ceiling. By Eljer Plumbing

**IDEAL FOR MODERNIZING** existing bathrooms, four-piece Versa-Bath (below) will fit through doorways as narrow as 26 in. Strong, rigid and leakproof. By Borg-Warner

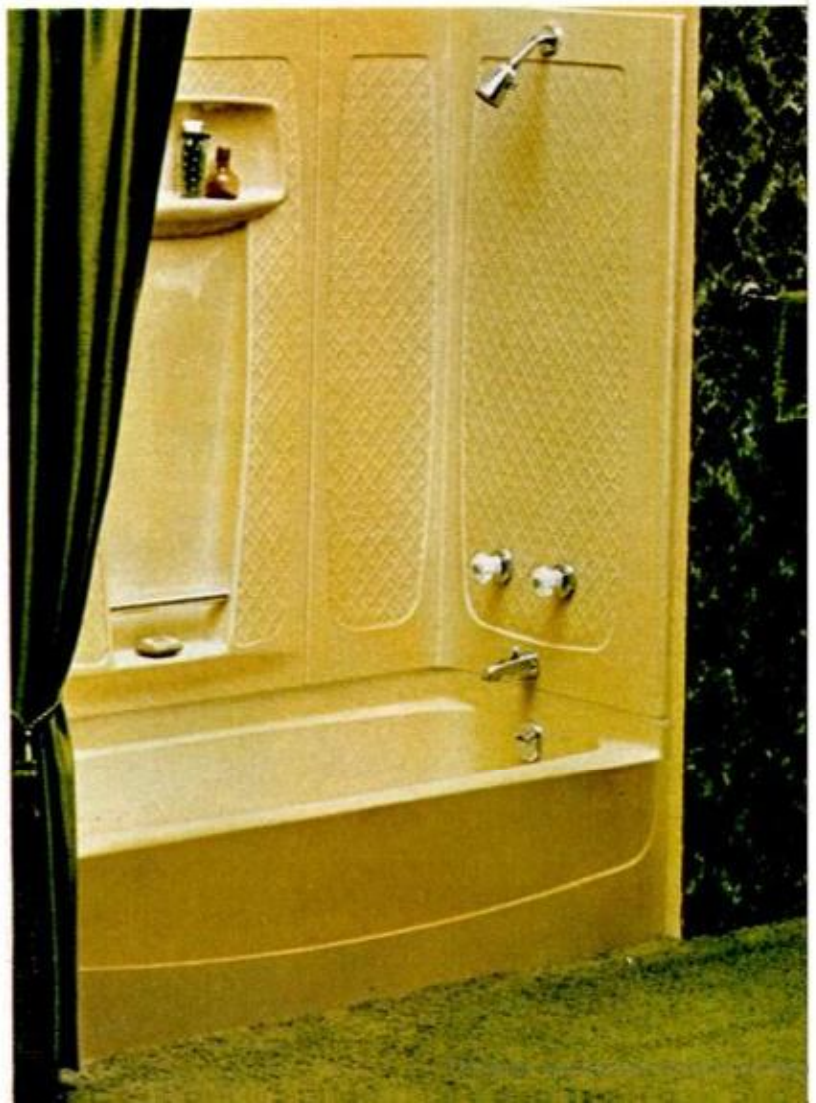
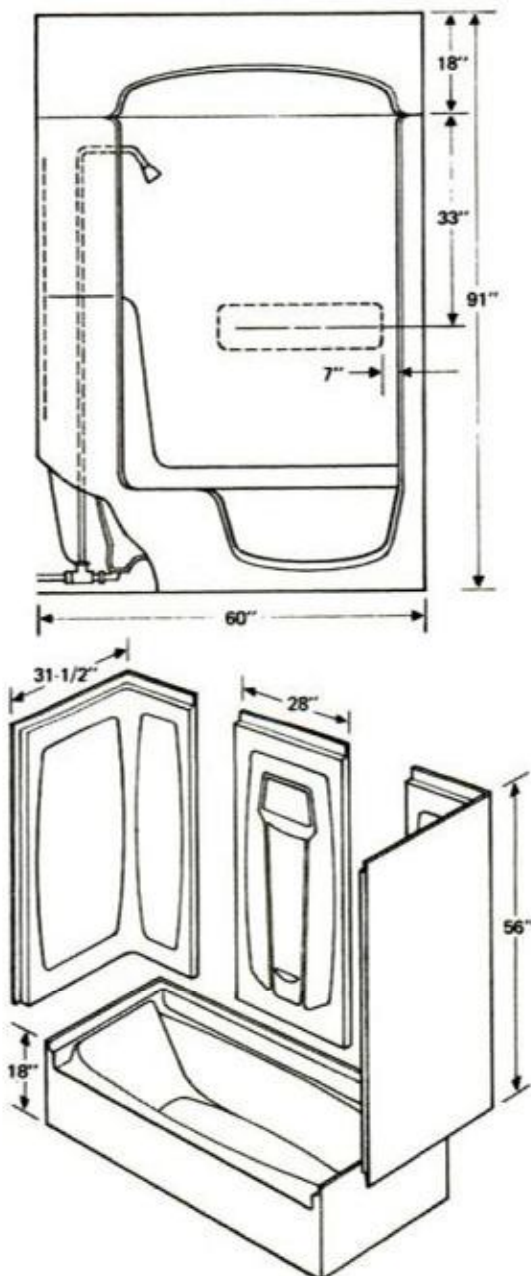

# Pretty, exciting wall coverings

Home  
Ideas  
Guide

**BORED WITH BOARD LOOK?** Consider mixing wood grains with textured panel such as Chapel White Stone (left) by Masonite. It's available at lumberyards in 4x8-ft. panels

**FOREST MURAL** consists of 12 panels pasted on a wall like a jigsaw puzzle. See text for the maker



**H**OME DECORATING is more demanding than ever today. The emphasis is on smart looks—with minimum upkeep considered a "must" by most homeowners.

When wood prices started soaring, major manufacturers turned their attention to designing and manufacturing textured panels which would permit the use of lower cost materials. Most of the panels shown—except the forest mural on the facing page—are available at almost any local lumberyard.

For the nearest source of the forest mural (plus details on other styles), write to Environmental Graphics, Div. of Pandora Productions, Inc., 1117 Vicksburg Lane North, Wayzata, Minn. 55391. ★★★



**DURABLE STONE AGGREGATE** bonded to plywood can be sawed, drilled, glued or nailed. Sansspray, by U.S. Plywood

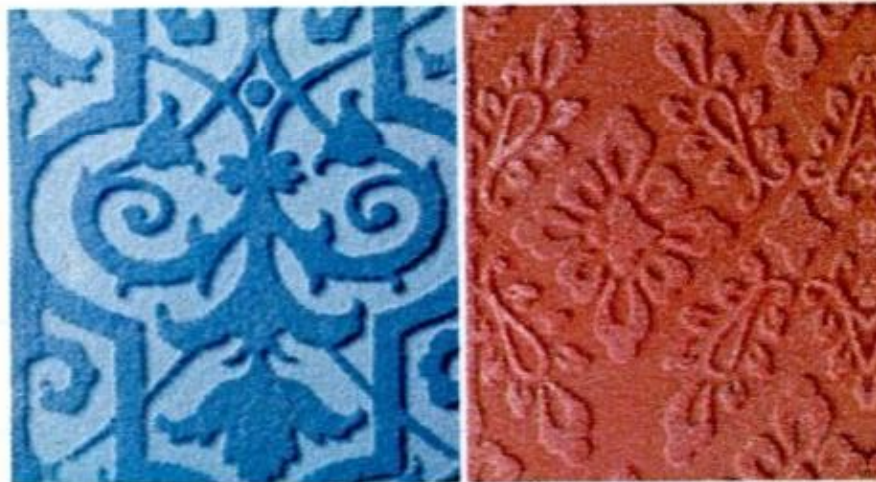
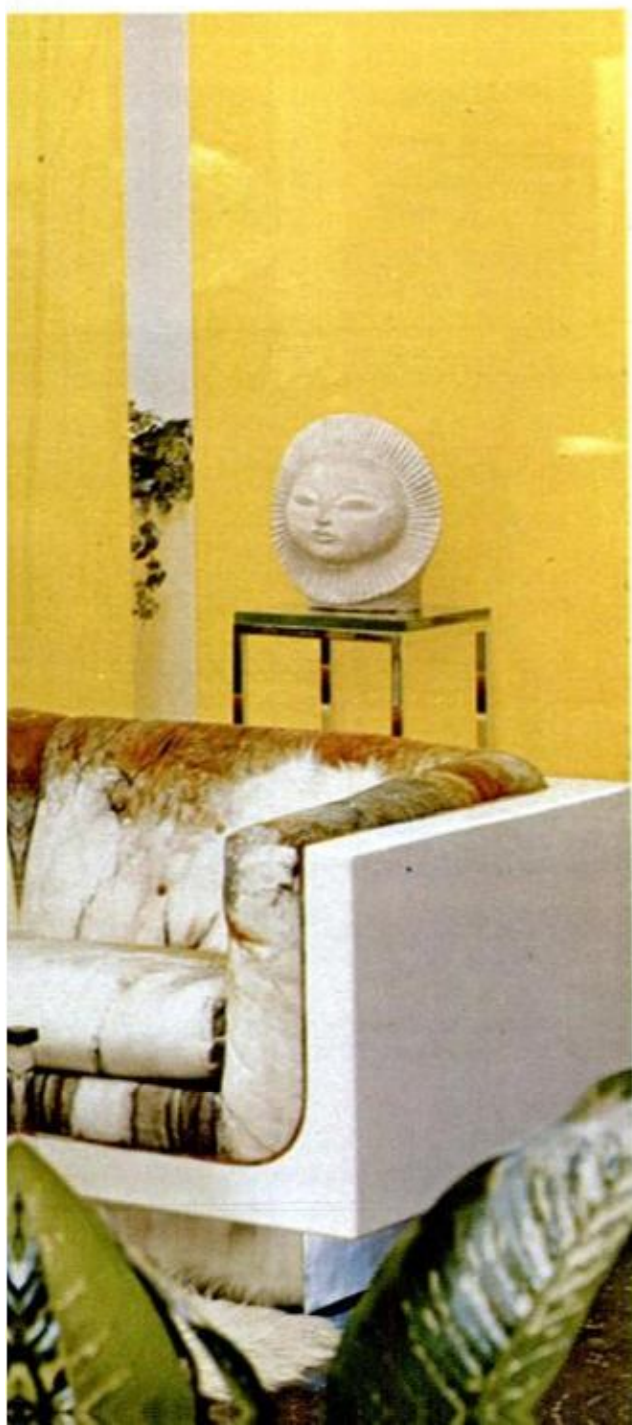

**ELEGANT PANELS** by Marlite feature lush look of velvet. Above: True Red Brocade and Royal Blue on Delphinium Blue (now being test-marketed and not immediately available)

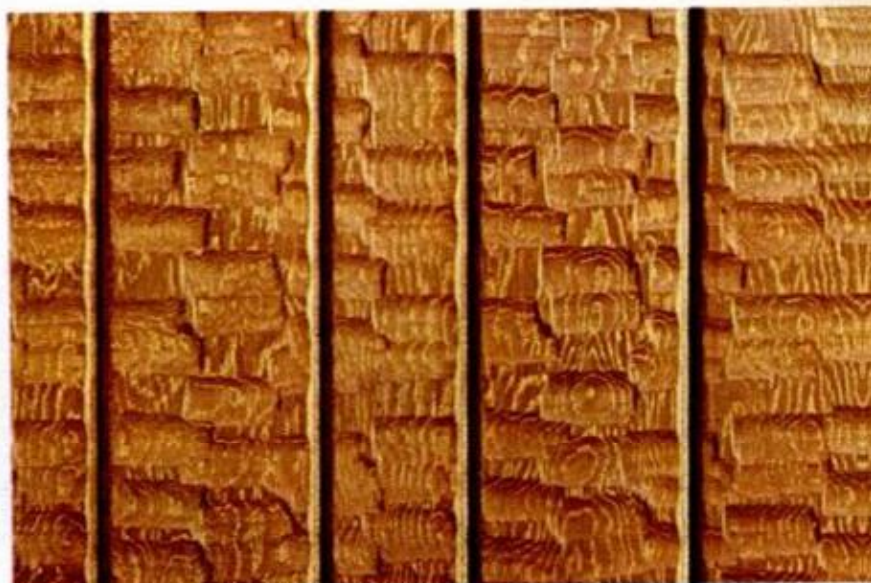

**TEXTURED OLD-BRIDGE SIDING** with the adz marks of hand-hewn timber can be used effectively indoors. U.S. Plywood

# How to make a good entry

A divider wall inside the front door will make you feel less like a fish in a bowl when someone knocks

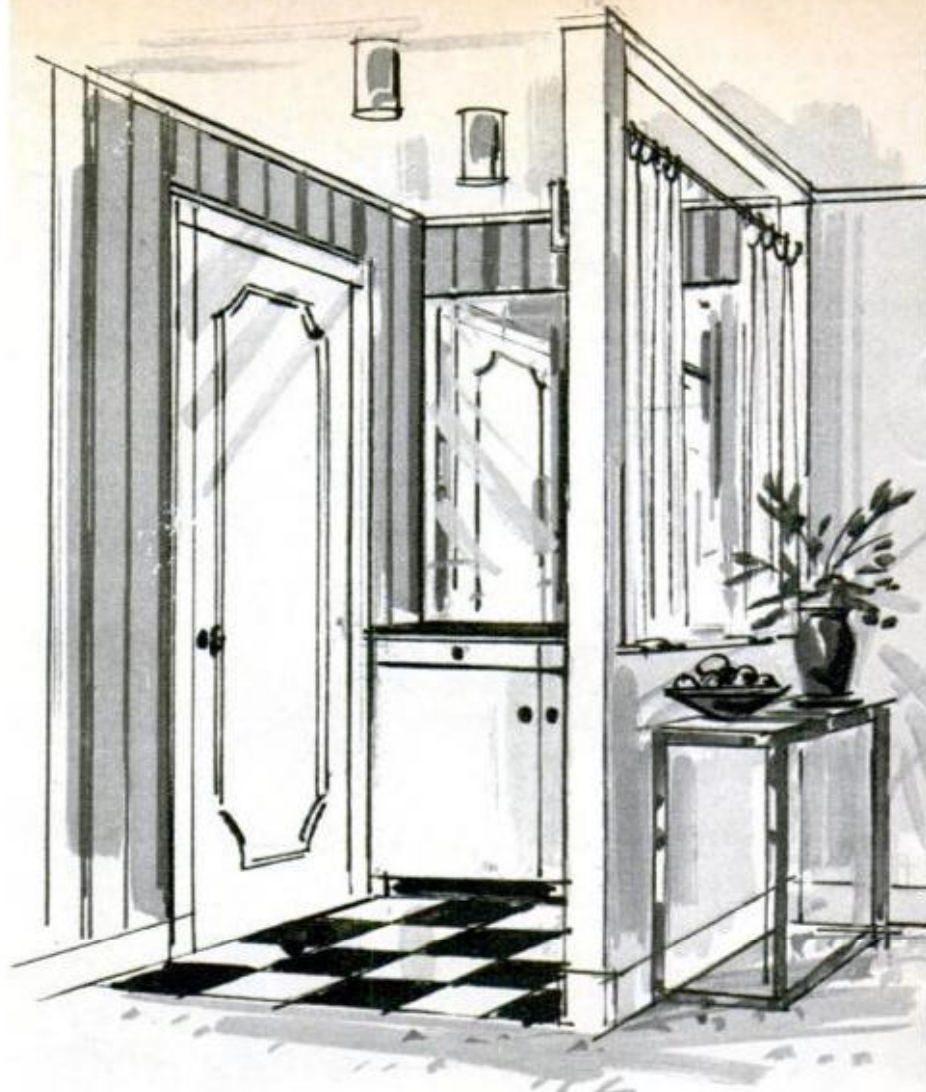

**O**NE DISADVANTAGE of most small ranch and tract-type homes is that the front door opens directly into the living room. Anyone at the door has full view of the room; family and guests have no privacy from strangers and delivery men, and in winter there's nothing to help block cold air and drafts from chilling the room.

Creating an entryway not only will provide semiprivacy, but can add convenient storage for boots, gloves, scarves and the like. Generally, a mirror can be a part of it, which guests and family members will appreciate whether coming or going.

There are many ways to add a "minifoyer" to your living room; just how depends on its shape, location of its front door and amount of wall space adjacent to the door. Here and on pages 150, 152 and 154 we present three ways to do it.

## 1. The single wall

The design shown above suggests a single, floor-to-ceiling divider wall fitted with pole drapes, a wall cabinet with drawers and shelves and a mirror installed above it. The floor is covered with tile.

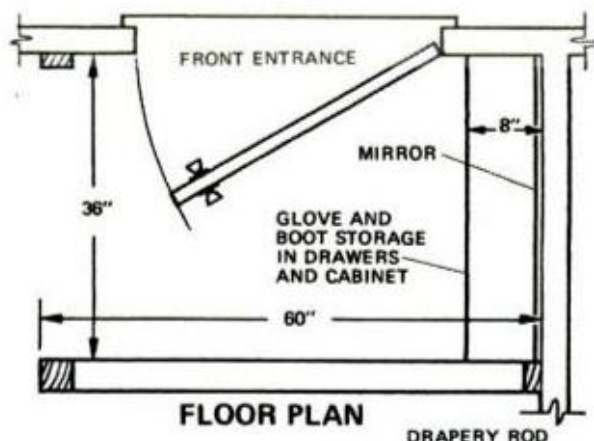

**FLOOR PLAN**

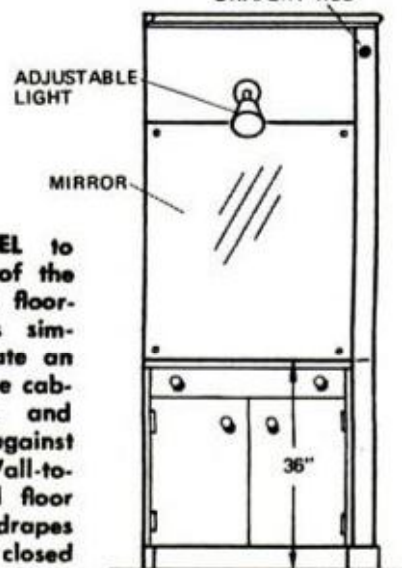

**ERECTED PARALLEL** to and 3 ft. inside of the front door, open floor-to-ceiling wall is simplest way to create an entry. Narrow base cabinet with doors and drawers goes against existing wall. Wall-to-wall mirror, vinyl floor complete job. Pole drapes add color, can be closed





# '73 Heathkit® Catalog

Shown below are only a few of the more than 350 kits fully described in the 1973 Heathkit catalog. Kits for every interest, every budget...including color TV; stereo systems; electronic organs; marine equipment; a kitchen waste compactor; home intercoms and protection systems, garage door openers; table radios; portable radios and phonographs; guitar amplifiers and accessories; educational electronic workshops for youngsters and adults; tool sets; electronic test instruments; amateur and shortwave radio gear; radio-control equipment; metal locators.

Can you build a Heathkit? For 25 years people just like you have been doing it - armed with no more than a soldering iron and a few conventional hand tools.

No matter how complex the kit, the manual reduces assembly to a simple step-by-step operation. Add to that the availability of the technical correspondence department here in Benton Harbor, and service people in 36 retail stores across the country, and you see why we say "we won't let you fail." And finally, building a Heathkit is fun, pure and simple. The coupon below gets you started.

## Here are just a few of the new kits in this new '73 edition



NEW Heathkit Ultrasonic Intrusion Alarm. \$49.95\*



Heathkit 50-watt Stereo Receiver. \$169.95\*



Heathkit VHF/FM Band-Scanning 8 channel Receiver. \$119.95\*



Heathkit Cassette Deck, Dolby Circuit. \$249.95\*



Heathkit 6-Digit Electronic Clock-Alarm. \$54.95\*



Heathkit 25V Solid-state Color TV with detent power tuning. \$599.95\*



Heathkit 2 1/2 Digit VOM. \$79.95\*



NEW Heathkit 8-digit pocket Calculator. \$92.50\*



Heathkit Inductive Timing Light. \$29.95\*



Heathkit CW QRP Transceiver - 40, 20 and 15 meters. \$69.95\*



NEW Heathkit 8-digit desktop Calculator. \$79.95\*

## Send Today for Your Free '73 Heathkit Catalog

### HEATHKIT ELECTRONIC CENTERS

ARIZ.: Phoenix, 2727 W. Indian School Rd.; CALIF.: Anaheim, 330 E. Ball Rd.; El Cerrito, 6000 Potrero Ave.; Los Angeles, 2309 S. Flower St.; Pomona, 1555 Orange Grove Ave. N.; Redwood City, 2001 Middlefield Rd.; San Diego (La Mesa), 8363 Center Dr.; Woodland Hills, 22504 Ventura Blvd.; COLO.: Denver, 5940 W. 38th Ave.; CONN.: Hartford (Avon), 395 W. Main St. (Rte. 44); FLA.: Miami (Hialeah), 4705 W. 16th Ave.; GA.: Atlanta, 5285 Roswell Rd.; ILL.: Chicago, 3462-66 W. Devon Ave.; Downers Grove, 224 Ogden Ave.; IND.: Indianapolis, 2112 E. 62nd Ave.; KANSAS: Kansas City (Mission), 5960 Lamar Ave.; MD.: Baltimore, 1713 E. Joppa Rd.; Rockville, 5542 Nicholson Lane; MASS.: Boston (Wellesley), 165 Worcester St.; MICH.: Detroit, 18645 W. Eight Mile Rd. & 18149 E. Eight Mile Rd.; MINN.: Minneapolis (Hopkins), 101 Shady Oak Rd.; MO.: St. Louis, 9296 Gravois Ave.; N.J.: Fair Lawn, 35-07 Broadway (Rte. 4); N.Y.: Buffalo (Amherst), 3476 Sheridan Dr.; New York City, 35 W. 45th St.; Jericho, L.I., 15 Jericho Turnpike; Rochester, Long Ridge Plaza; OHIO: Cincinnati (Woodlawn), 10133 Springfield Pike; Cleveland, 5444 Pearl Rd.; PA.: Philadelphia, 6318 Roosevelt Blvd.; Pittsburgh, 3482 Wm. Penn Hwy.; TEXAS: Dallas, 2715 Ross Ave.; Houston, 3705 Westheimer; WASH.: Seattle, 221 Third Ave.; WIS.: Milwaukee, 5215 Fond du Lac.

HEATHKIT  
Schlumberger

HEATH COMPANY, Dept. 17-4  
Benton Harbor, Michigan 49022

Please send FREE Heathkit Catalog.

Name \_\_\_\_\_

Address \_\_\_\_\_

City \_\_\_\_\_ State \_\_\_\_\_ Zip \_\_\_\_\_

Prices & specifications subject to change without notice.  
\*Mail order prices; F.O.B. factory. CL-466R

**2. The 'vestibule'**

When a coat closet is adjacent to the front door and there is sufficient wall space between the door and a window, two simple floor-to-ceiling walls (heavy black lines in floor plan) erected at right angles and tied into existing walls form an entry that corrals wintry blasts, blocks the view and provides a functional wall for furniture and pictures.

Walls are framed by first nailing 2x4 plates to floor and ceiling, perfectly plumb, then wedging 2x4 studs between. The doorway is framed to provide a 40x80-in. opening, with doubled 2x4 headers across the top. Both sides of the framed walls are covered with plasterboard; joints and all inside corners are sealed and taped with drywall joint compound, and a length of

metal corner bead is nailed onto the outside corner. Both sides of the doorway are trimmed in the conventional manner, by mitering and nailing casing to an inner 3/4-in. frame, which is installed in the opening first. A shallow cabinet of counter height goes on an inner wall for glove and boot storage with a mirror above it.

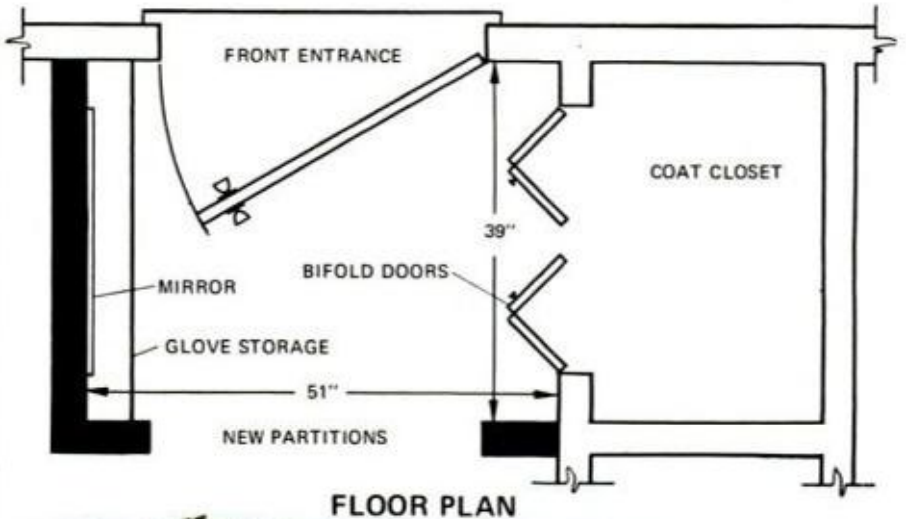

# An Aqua-Pure® Water Filter makes tap water taste spring fresh.



**You or your plumber can install it in minutes.  
And, from then on, it's like having bottled water on tap!**

You don't have to put up with funny tastes or smells, like chlorine and sulphur... or particles of dirt and rust... all of them are removed by the new Aqua-Pure Water Filter. Coffee, tea, soups and juices taste

just as they should. You'll never have to lug heavy bottled-water because you'll be getting bottle-quality water for just a fraction of a cent.



CHECK WITH YOUR LOCAL PLUMBING SUPPLY DEALER OR WRITE AMF CUNO, 400 RESEARCH PARKWAY, MERIDEN, CONN. 06450.

**3. The two-sided  
room divider**

**GROOMING MIRROR**, wide shelf and storage serve as handy "checkout" area to family members and guests, block view from door

*Designs by Carl Sigman  
Illustrations by Carl Kinschert*



Standing ceiling high and set at a right angle to the door, a two-sided room divider can create a most practical, view-blocking entryway. Useful from both sides, it provides handy shelf, drawer and storage space, plus mirror on one side and a breakfront bookcase on the other. A tiled area in front of the door adds an entry look and provides an easy-to-wipe floor when youngsters and guests enter with wet gear and boots.

Being ceiling-tall, the cabinet has to be built on the spot (a foot or so out from the wall to facilitate assembly). Plans are given on page 154. To build it from the floor up, first cut a 3/4-in. plywood bottom 22 1/2 in. wide and 46 1/2 in. long and add a 1x4 kickboard along two sides, 1 in. in from the edge. Glue and nail it to the underside.

Next, lay out two identical T-shape ends 24 in. wide and 92 1/2 in. long and cut the upper ends 12 in. wide. Cut a shelf member 24 in. wide and 48 in. long and two scalloped fascia boards 12 in. wide and 48 in. long, all from 3/4-in. plywood.

Now start adding the end pieces, butting them against the ceiling and lapping and

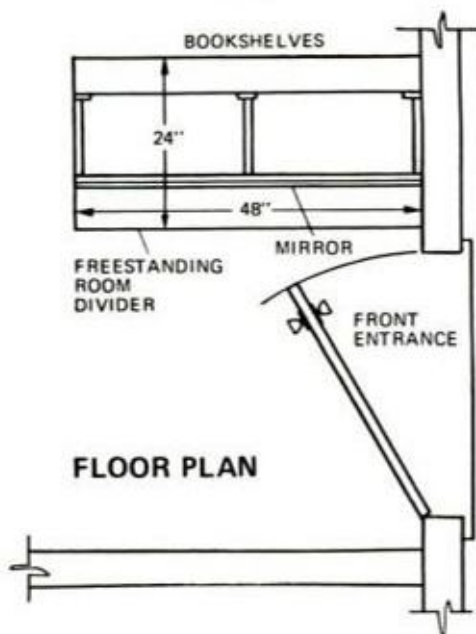

nailing the lower ends to the edges of the cabinet bottom. Place temporary braces across the upper ends and nail the top shelf in place, first notching it to fit around the narrow sections of the ends.

Slide the cabinet in position against the wall and add the two scalloped members at the top, placing them against the ceiling and nailing them even with the end members. Complete with a ceiling molding. Six

# HOLD



# IT

**POWER GUN 1000 STAPLE GUN  
FASTENS MOST EVERYTHING**

There's nothing like it. Here's the staple gun with the power lever for extra heavy duty drive. Powerful enough to do any stapling job because it even drives through hardwoods (like oak) better than other staple guns. Ceiling tile, paneling,



upholstery, fencing, insulation, name it — the Powergun 1000 does it. Easily. Uses 5 staple sizes. Sold separately or as a kit with staples plus wire, shade, screen attachments. Handsome carrying cases, too. Pick one up. It's easy to use. Hard to put down.



**EXCEPT WHAT RIVET-IT  
RIVETING PLIER FASTENS!**

It fastens anything to anything professionally — the way the factory does and you've always wanted to! Ideal for autos, boats, appliances, cycles, sleds, toys, gutters and spouts, pots, pans, etc. Holds tight. Better than nuts, bolts, screws or solder. Rivets don't come loose.



You fasten from one side. Perfect for can't get to it places.

**Rivet-It riveting plier!  
Try it!**

**Swingline®**  
32-00 Skillman Avenue Long Island City, N.Y. 11101



**PIGEON-HOLE SECTION** on bookcase side of divider becomes part of desk when latter is placed against it

## GOOD ENTRY

*continued*

12 x 22 $\frac{7}{8}$ -in. bookshelves are supported between the cabinet ends and a center divider which rests on the top shelf and extends behind the scalloped members.

A pigeon-hole and drawer assembly is made and installed as a unit under the top shelf, then edges of the center divider and end members are covered with  $\frac{3}{4}$  x 2-in. trim pieces, butting ends against the scalloped members. A solid panel closes one side of the base cabinet, while the doors are hinged to the other side. An adjustable shelf completes the cabinet construction.

A fluorescent light installed in the top of the cabinet will highlight greenery placed on the top shelves and spill out dramatically to light both the mirror and bookcase sides of the divider. A separate switch to control the light should be added and a cable brought up to it and the fixture through the cabinet from a junction box in the basement (or down from the attic). ★★★

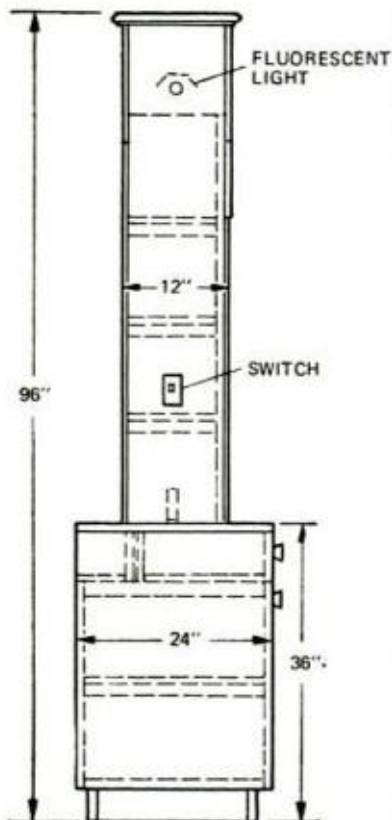

**END VIEW**

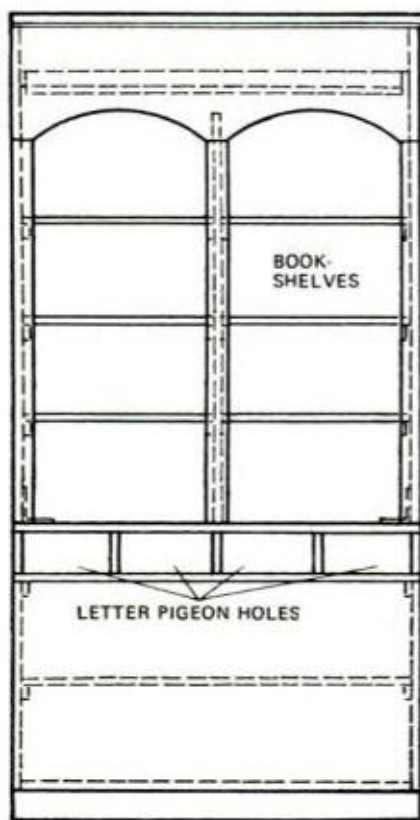

**LEFT SIDE**



**RIGHT SIDE**

POPULAR MECHANICS

# Introducing a drill for the man who does more than just drill holes in wood.



Sears Craftsman Type-1 is a  $\frac{3}{8}$ " heavy-duty drill that can do it all.

**1.** The Craftsman Type-1 has ball bearings built-in at key stress points, it develops a full  $\frac{1}{3}$  horsepower, and actually puts out more power than other similar drills.

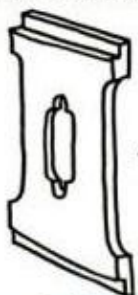

"Cut through  
an inch of pine  
in seconds"

**2.** The Craftsman Type-1 also has the variable speeds you need to start and drill a hole exactly where you want it without skipping or skittering around. Whether you're going into wood, steel, concrete, or even ceramic tile.



"Fit dowels  
with precision"

**3.** While the variable speeds also help you drive screws, the reversible action enables you to take them out, too.



"Drive or draw  
screws with ease"

**4.** And, of course, the Craftsman Type-1 is double insulated so it requires no grounding. Its two-prong plug fits any conventional outlet.

Sears Craftsman Type-1 is also unconditionally guaranteed to give complete satisfaction for one year, or return to Sears for a free replacement.

Sears  
**CRAFTSMAN  
TYPE 1**

The drill that's designed for  
the man who knows what he's doing.

The Craftsman Type-1 Drill, along with the accessories needed to build this desk, are available in Sears, Roebuck and Co. Retail Stores and in the Catalog. Craftsman Type-1 Drill Catalog Number 9GT 1145.



(Complete plans for building this Captain's Desk are available in the tool department of most Sears stores).

# Saw blades coated with TEFLON-S\* hum through the woods.

Cleaner. Smoother. Cooler. And fast. That's the cut you get with a power saw blade coated with TEFLON-S. Compare it with an uncoated metal blade. After you're through,

give the TEFLON-coated blade a quick wipe and store it without worry about rust. For a fast finish on your next project, get the blade with the TEFLON-S coat.

\*TEFLON-S is Du Pont's registered trademark for its non-stick and self-lubricating finish.



## GOOD FOR 10,000 BATHS



Rub-a-dub-dub, put GE Bath-tub Seal around your tub. It's made of silicone. So it's guaranteed for 10,000 baths or 10 years—whichever is longest. Permanently flexible, waterproof and mildewproof, it won't crack, dry or shrink. What's more, it adheres to most materials including ceramic, porcelain, metal, glass. So get a tube at your hardware counter. Squeeze it on and start counting baths. One, two, three, four, five, six, seven, eight, nine, ten.....

**GENERAL  ELECTRIC**

**POPULAR MECHANICS PM-BEE!** Plan for a radio-controlled model that flies on CO<sub>2</sub>. Fuel is nonflammable and odorless. Sophisticated and simple to build! To obtain full-scale pattern from which you can trace off the parts directly, send \$3.49 to **POPULAR MECHANICS, Dept. FA, Box 1014 Radio City, New York, N.Y. 10019.**



# At last! Garden tractors built for long life, quick hook-ups (without belts!) and easy riding — backed by a solid, no-nonsense warranty.

If you could look inside this New Holland garden tractor, you'd like what you see:



A direct-drive power system (1) to rear wheels. No old-fashioned belts!

A power-take-off shaft (2) replaces belt connections for attachments—makes hook-up surprisingly simple.

By eliminating these belts, New Holland 12 hp., 14 hp. and 16 hp. garden tractors save you trouble from slipping belts and adjusting belts and replacing belts. You get a modern, reliable power system. And, of course, attaching the mower is easier than ever—you don't even need tools.

**Now look at our drive-over mower.** You ride right over it to get it in position to connect the power



coupling. No more struggling to slide it underneath. The longer you own this tractor the more you'll appreciate this idea.

**You'll also appreciate** how easy we've made routine maintenance. The front hood and rear deck tilt up easily.



NEW 16 hp. model. Options include mower, snowthrower, tiller, more.

**Easy riding begins** with our step-thru platform. There's no big hump to climb over: You step aboard like a gentleman (or a lady). Sit down in the deluxe cushioned seat. The hy-



drostatic drive handle (one control for forward, reverse, stopping — without clutching) is right where your hand rests naturally. A hydraulic lever (optional on 12 hp. model) lets you raise and lower attachments effortlessly. It makes work almost a pleasure.



**Our warranty shows our confidence.** No nonsense. No loopholes. It covers everything except tires, tubes and battery—for one year. That means engine, transmission, electrical system—the works.

*Who's Sperry New Holland? We're a division of Sperry Rand. We've been doing business since 1895, mostly with farmers. The fact is, we're the country's #1 producer of specialized farm machinery. We build machines that work hard and last long, you can be sure of it.*

**FREE BUYER'S GUIDE.** For your copy, write to Dept. 145, Sperry New Holland, Division of Sperry Rand, New Holland, Pa. 17557. For the name of the New Holland dealer nearest you, phone toll free 800/447-4700. (In Ill. 800/322-4400.)

**SPERRY**  **NEW HOLLAND**

Now is the best time to buy a New Holland garden tractor (or riding mower). **Why?** Turn the page. 

# Buy now and select a great gift! See your New Holland dealer.

Buy a New Holland garden tractor (or riding mower) between April 2 and June 30, 1973 and we'll reward you with a bonus gift at no extra cost.



BUY A 12 HP., 14 HP., OR 16 HP. MODEL AND SELECT ONE OF THESE:



**Personal Calculator by Sperry Remington.** An electronic marvel! Adds, subtracts, multiplies, divides, and flashes answers—up to six figures—on display panel. Works on four penlight batteries. Fits in your pocket. Complete with zip carrying case.

**Quiet-riter™ Typewriter by Sperry Remington.** For every family! The portable typewriter that gives office-machine performance.

**GE® Digital Clock Radio.** Wake up to music! FM/AM reception. Brightly lighted one-inch numbers.

Sleep switch to shut off radio automatically.

**Crescent® Tool Set.** Ideal for the auto buff! Contains 50 pieces: wrenches, screwdrivers, ¼", ⅜", ½" square drives, spinner handle and extensions, spark plug socket.



WHEN YOU BUY AN 8 HP. TRACTOR, TAKE YOUR PICK HERE:



**Mark III Shaver by Sperry Remington.** Super-close shaves! Deluxe cord model has adjustable heads plus sideburn trimmer.

**Kodak Instamatic® 20.** The little camera that takes big pictures! Slips into your pocket. Takes big 3¼" color prints or slides. Double-exposure prevention.

**GE® FM/AM Portable Radio.** Carry it everywhere! Plays on batteries

or house current. 3½-inch dynamic speaker. Ear-phone jack for personal listening.

**Crescent® Tool Set.** Professional quality! Has seventeen sockets, with ⅜" drive, ratchet handle, wrench, pliers, more. All in steel carrying case.



RIDING MOWER BUYERS CHOOSE FROM THESE GIFTS:



**Hot Comb™ by Sperry Remington.** For today's dry, natural look! Gives you 20% more air flow. Includes brush and two combs.

**GE® Spherical Radio.** A fine AM battery radio—and a great conversation piece! The "Orbiter" model spins freely but weighted base always brings it upright. Can be wall-mounted.

**Springfield® Weather Station Trio.** Know what's happening—and what's coming! Thermometer,

barometer, humidity meters mounted on walnut-grained panel. Adjustable for vertical or horizontal hanging.

**Crescent® Socket Set.** Makes many home and auto jobs easy! Handy ¼" drive set with 9 sockets, ratchet handle, 2 extensions. Sturdy steel case.

See your New Holland dealer. For the name of the dealer nearest you, call toll-free 800/447-4700. In Ill. 800/322-4400.

**SPERRY NEW HOLLAND**

Turn back for more reasons to buy New Holland...



## PREFAB BATHS

*(Continued from page 145)*

assembly, making cleaning easier than ever before and ending crack filling for good.

From a remodeling and modernizing standpoint, these new no-tile tub/showers are made to order for the do-it-yourselfer. Being molded of lightweight but strong fiberglass, the tub and wall sections are easy for one man to carry upstairs, through

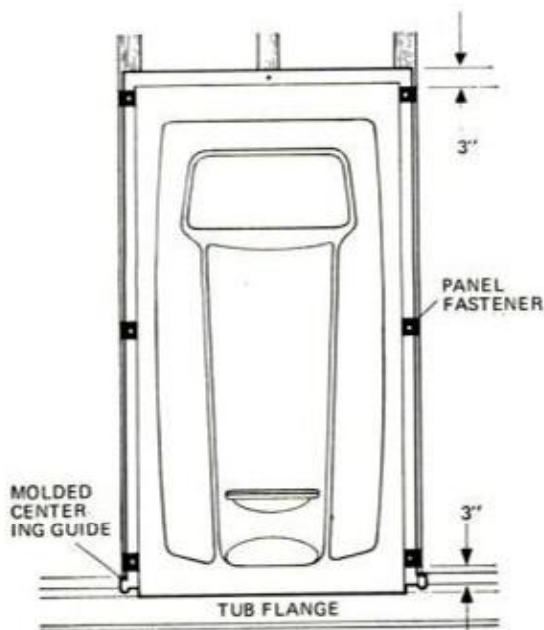

**TWO MOLDED GUIDES** in tub flange serve to position and align center panel on studs. Six panel fasteners, placed as shown in diagram, attach panels to studs

APRIL 1973

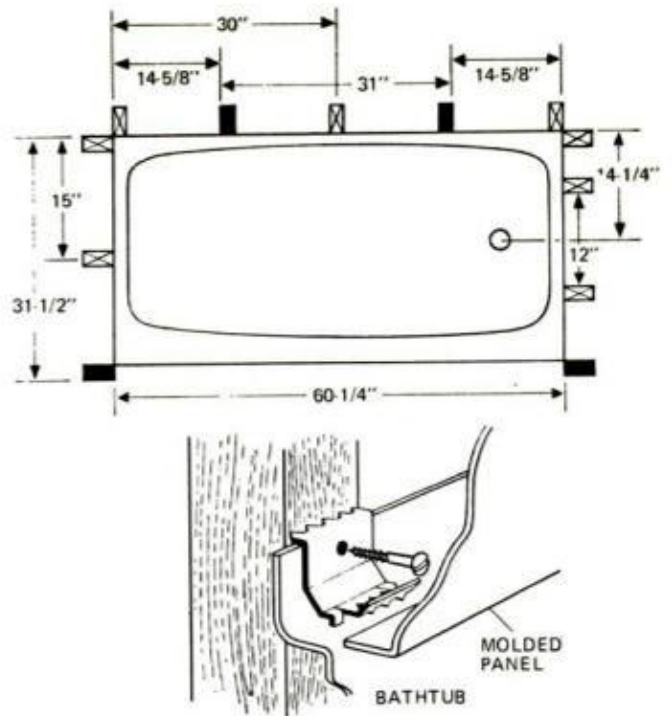

**EXISTING FRAMING** requires four additional studs (diagram) for attaching three panels in Versa-Bath system. Barbed fastener locks panel when inserted

doorways and into place. They can be installed in any standard 5-ft. alcove in a matter of hours with little more than an electric drill, screwdriver and level.

The series of pictures shown here and on page 158 show how easily Borg-Warner's Versa-Bath goes into place. Once the alcove is stripped of the old plasterboard and additional studs are added as required, installation is accomplished in four steps.

*First step:* The tub is set in place and





**TO INSTALL L-SHAPED CORNER PANEL**, place in position as shown in diagram, spring panel slightly to clear edge of center panel and let it snap into place

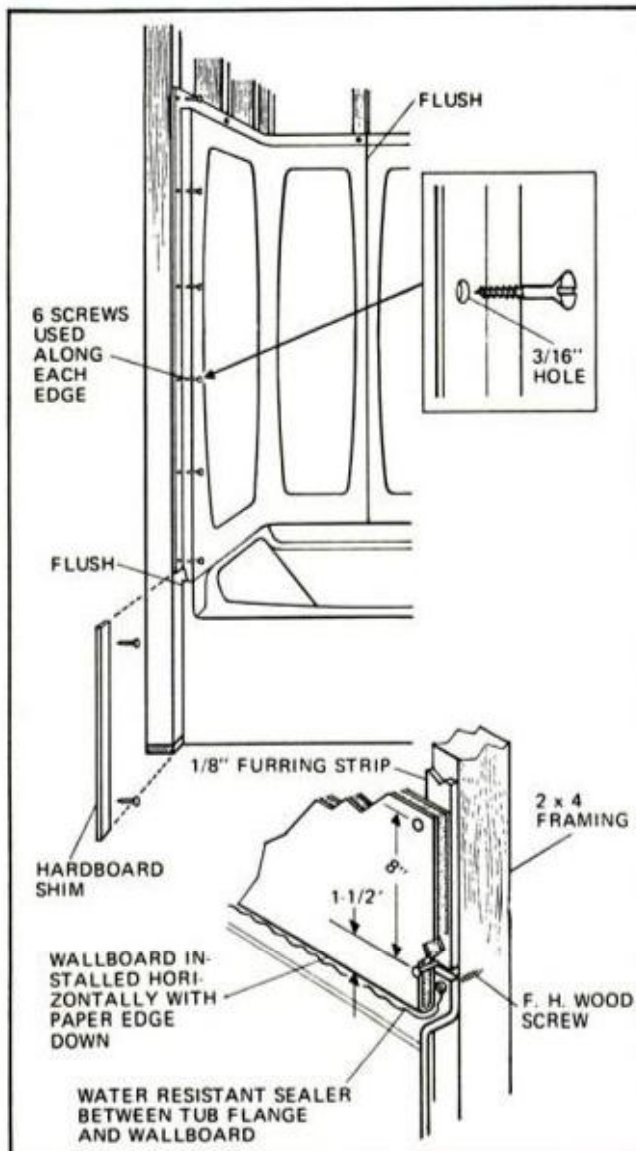

leveled. A leveling runner on the bottom of the tub permits shimming if necessary. Tub is held with four special fasteners attached to studs with screws. Overflow and drain connections are made and tested.

*Second step:* Center wall panel is attached to studs with fasteners and screws. Guides molded in flange of tub center the panel.

*Third step:* Holes for faucets, spout and shower head are located and drilled through corner panel with hole saw.

*Fourth step:* Finally, the two L-shape corner panels are inserted into fasteners along the center panel and pressed into place. Top and front edges of the panels are secured to the studs. ★★★



**WATERTIGHT JOINTS** are assured by caulking vertical and horizontal seams with mildew-resistant sealant. Surplus sealant can be removed with turpentine

**POPULAR MECHANICS**

**Handsome hearth**

Rustic elegance gives this fireplace the role of room mood-setter. The post at center is functional (actually a pine-encased Lally column); beam it supports is also pine-covered. To maintain masculine atmosphere, equally spaced urethane beams are glued to ceiling tiles. Sketch of mantel details (below) shows how simple construction really was.

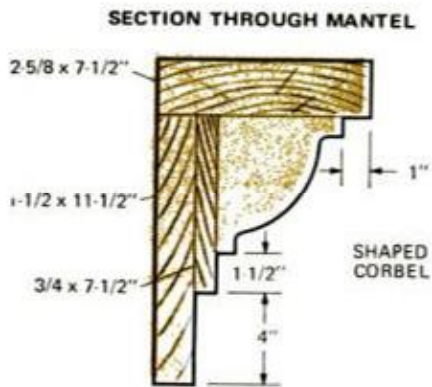

**Window disguise**

One of the easiest—and least expensive—ways to change from basement to family room is to disguise narrow basement windows. A good method is to install fixed shutters and standard window trim (casings, apron and stool) as shown. The muntins and bars over the single-panel lights are created by gluing and tacking together 1/4 x 3/4-in. lattice with members slightly longer than the sash opening. The idea is to create a force-fit when muntins are placed so they will be removable for window-cleaning chores.

# Simple lights you can make to brighten your kitchen

**S**URPRISINGLY SIMPLE homemade lighting fixtures can make a dull, drab kitchen suddenly come alive. Soft lighting under cabinets will emphasize colorful counter surfaces. Carefully spaced "spots" will capture the beauty of the cabinetry. And light spilling out from behind valance boards and cascading over draperies will add a strikingly dramatic effect.

When adding over-sink and under-cabinet lights, your biggest job will be running wires to them. This will be easier in a ranch house where wiring can be brought down from attic junction boxes; more difficult in a two-story house. Sometimes the cable can be brought up from a

basement junction box by snaking it through a hole in the kitchen floor, between a base cabinet and the wall.

You may have to remove a wall cabinet temporarily to bring cable out through a hole behind it. Or you may have to cut a 1-in.-wide slot in the plaster behind a cabinet to permit fishing the cable from one point to another. And, when you're up against a hidden obstruction with no way to bypass or bridge it, you may have to cut through an exposed portion of a wall, which can be patched later.

In working out individual wiring problems, you must keep in mind that over-sink and under-cabinet lights must be

**SHADOW-FREE LIGHT** over countertops and sink helps to take eyestrain out of food preparation, while the overhead lighting prominently illuminates appliances, enriches the natural wood tones of kitchen cabinetry

GENERAL ELECTRIC PHOTOS



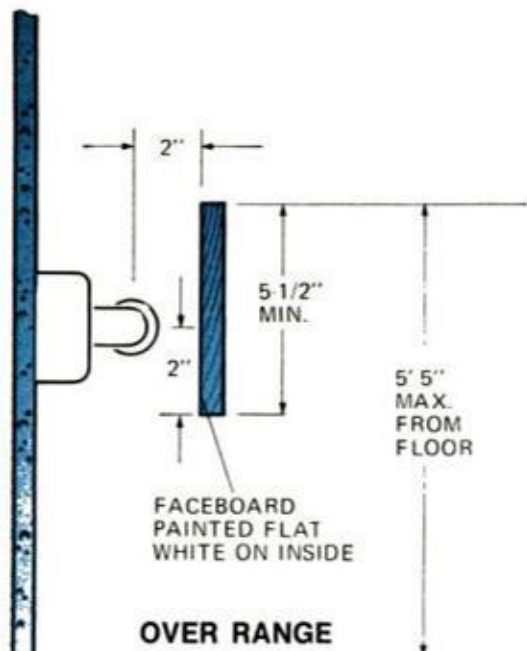

**LIGHTING, COLORS AND FABRICS** must be coordinated when kitchen and dining areas share a room. Here lighting tends to emphasize the colorful countertops, the wood tones and draperies

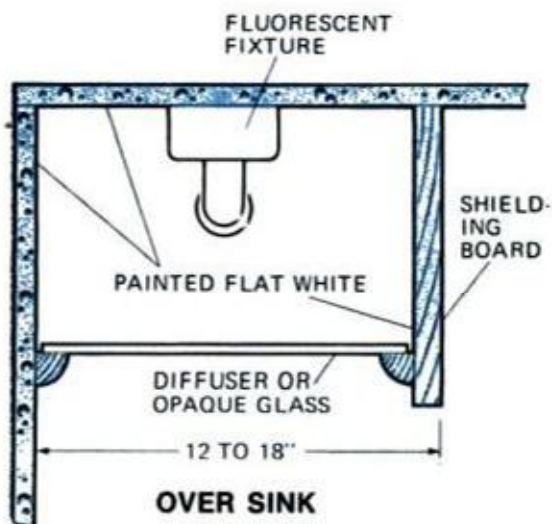
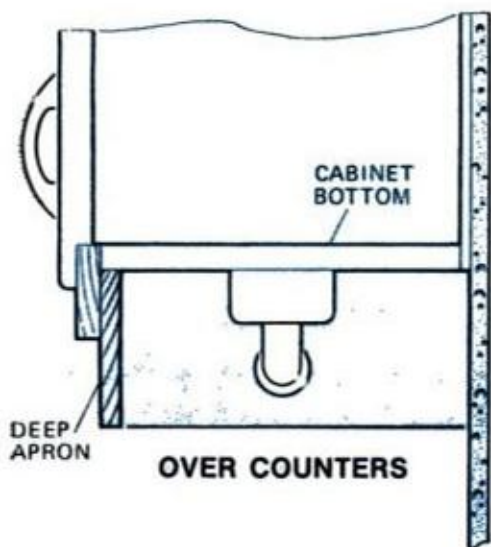

controlled by conveniently located switches which, in turn, must be connected to nearby outlets or junction boxes in basement or attic.

Romex or BX (armored) cable is generally required wherever wiring is to be concealed inside walls (some areas require that such wiring be run through conduit) and such installations must conform to your local electrical code. There are several good books that show you how to make the proper connections. One, called *Simplified Electric Wiring Handbook*, is sold by Sears for 50 cents.

Adding a fluorescent lamp over a sink often requires nothing more than fitting a faceboard across the front between cabinets. Angle brackets can be used on the inside to fasten it in place, and it can be finished to match the wood cabinets or made plain or scalloped. A diffusing glass or grid, resting loosely on strips of quarter-round molding, hides the lamp from view,

*(Please turn to page 194)*

# Facelifting—still the cheapest way to get a 'new' house

## Home Ideas Guide

**I**F YOUR HOME is due for repainting, step back and take a long, hard look at it, then decide whether a paint job alone will give you the look you really want. Chances are the house, as well as its shrubbery, can stand some "pruning"—ornate but useless gingerbread and hardware, for example. In some cases removal of an "improvement" (something a former owner made that you probably wouldn't have) might restore the house to its original architectural concept—resulting in aesthetic improvement. And older homes will nearly always benefit by grading and landscaping that brings them visually closer to the ground.

Several such low-cost ways to update your home are described here. While your particular house may not be shown here, you'll find many ideas that will work for you. ★★★



### Add charm and value

This tract-type single-level dwelling is typical of the most economical home that can be erected today. Yet its simple design lends itself to easy, inexpensive improvement. Note how colonial touches—windows, shutters, planters, lamps—add charm. Garage extension lengthens it and adds to convenience and value of the home.

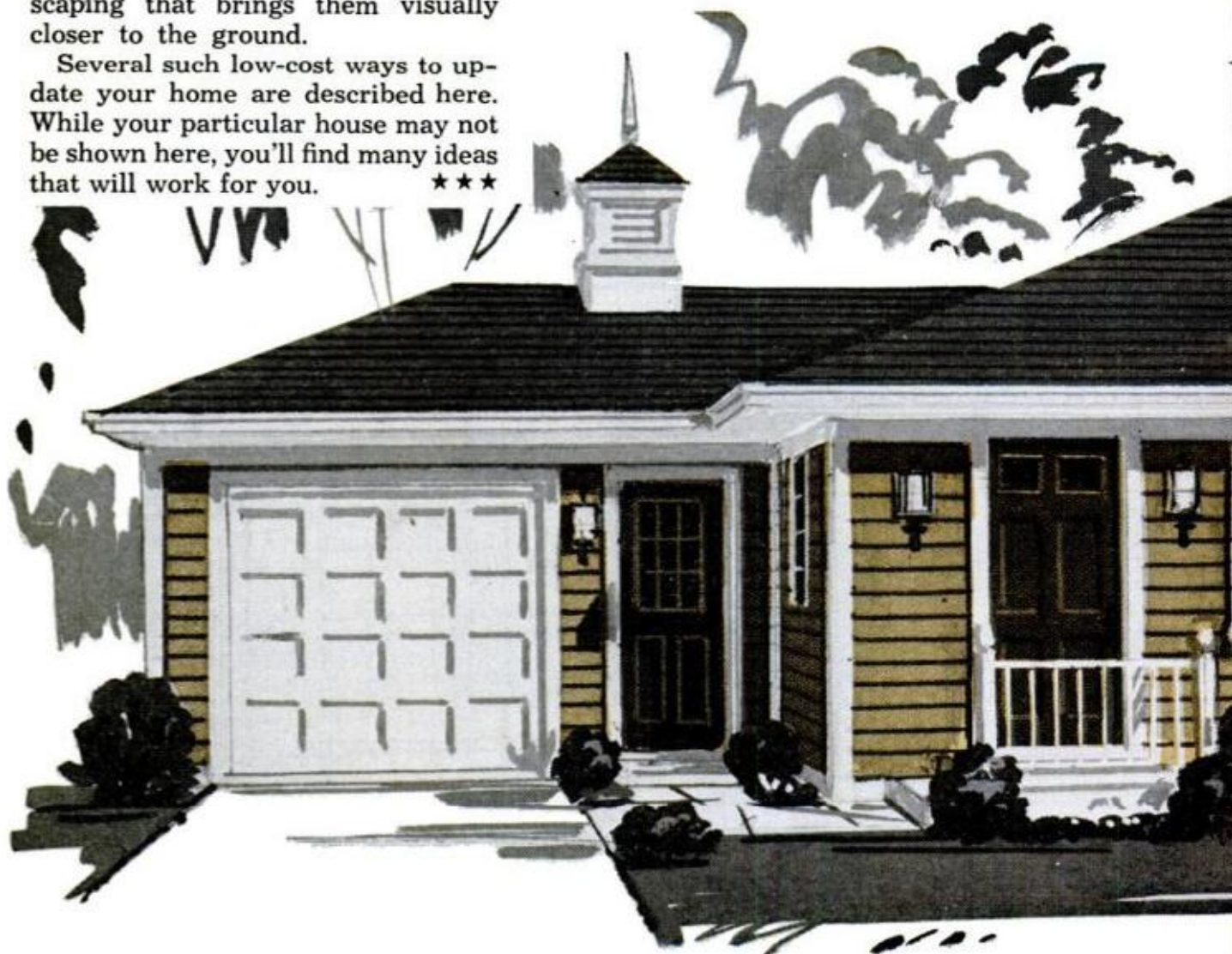





### Restore true character

Roomy, two-story frame home requires little more than a careful selection of color and removal of "improvements" that are out of character. Here removing wrought-iron railing and adding a carriage-house-style fascia restores balance and importance of the first floor.

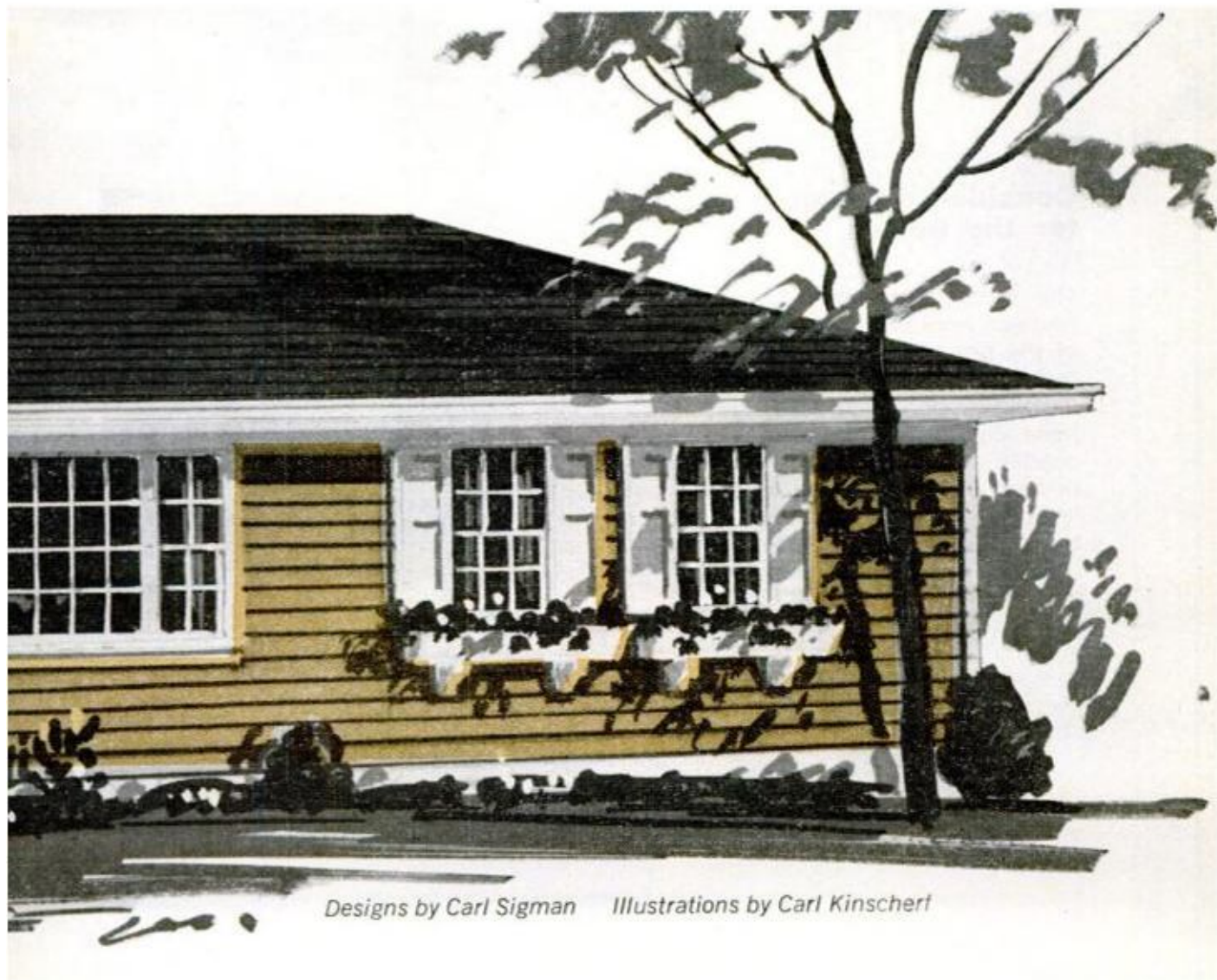

*Designs by Carl Sigman Illustrations by Carl Kinscherf*



### Consider a change for the better

The principal change recommended here is the relocation of the porch steps to give direct access to the driveway. Moving them eliminates the need for a front walk that divides the house down the middle. The clean, unbroken lines of the new porch give the facade better proportions.

Removing overgrown bushes and replacing them with low-profile foundation plantings lets the new front show to advantage. If the upkeep of a glass-enclosed porch does not



pay off in well used living space, consider a change that will simplify maintenance and improve the exterior.

## The difference a change in grade can make

The good features of this house are all but lost in its height. To bring it down to earth a retaining wall has been added parallel to the sidewalk. The area between that wall and the house has been filled and landscaped to conceal the foundation.

A colonial-style entry, new windows, (note special treatment of the bathroom window above the entry), the addition of dormers, shutters and coordinated coach lights add up to a rather ambitious remodeling but reveal the true potential of this house.

If your home has a roofed niche as shown above, it can be left as is or closed (sketch, right) for added living space.



# Wind-powered ventilators beat attic heat

Photos by Ken Rudine and Don Daily

**A**N EFFICIENT attic-cooling device, the rooftop ventilator is gaining acceptance in many energy-short areas of the country. Since it is powered by the wind, it uses no electricity. By cooling the attic continually, it eliminates oven-like heat which, in turn, saves on air-conditioning.

Since a wind-driven ventilator is turned constantly by the slightest breeze, it keeps attic air moving, preventing a heat buildup that often reaches temperatures up to 140-150° F. In a well-ventilated attic, less heat is absorbed by the insulation and there's less to radiate down through the ceilings.

Even when there's no wind, a turbine ventilator continues to draw out the heat. Being drawn in through attic vents and escaping through the ventilator, the air itself causes the unit to turn.

As a rule of thumb, one 12-in. ventilator is recommended for each 1000 sq. ft. of attic space; two units are best for 1200 sq. ft.

The series of photos on these two pages show how easy it is to install wind-powered ventilators. A product of Triangle Engineering Co., Box 7464, Houston, Tex. 77008, the ventilators sell for \$29.95 or two for \$49.95, postpaid. ★★

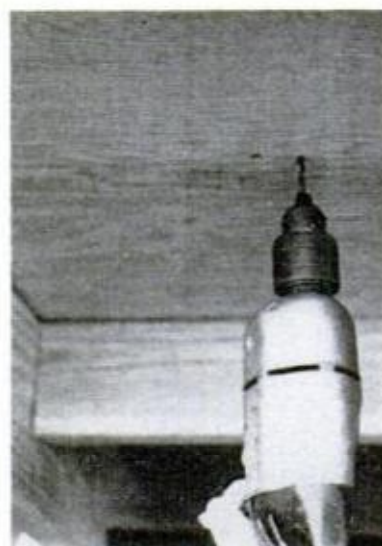
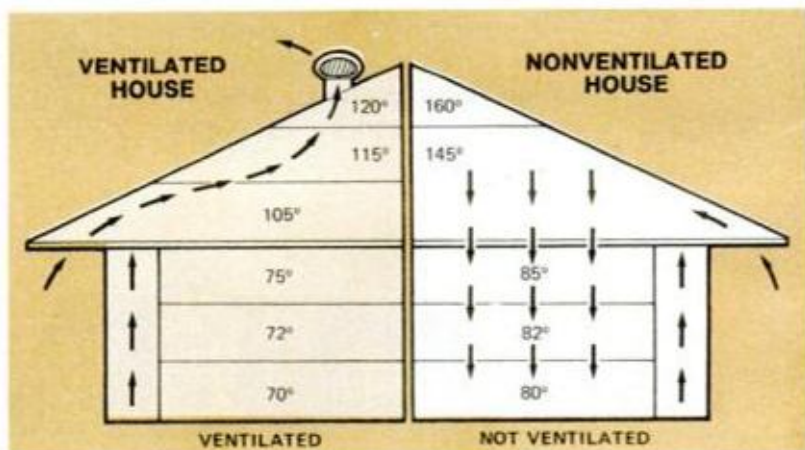

**1. LOCATE VENTILATOR** from inside attic and at least 24 in. below ridge on rear side of roof



**2. CENTER BASE** over pilot hole in roof and use inside of base to scribe hole on roof shingles

POPULAR MECHANICS



**3. USING CIRCLE AS A GUIDE,** cut away shingles with sharp knife. Cut  $\frac{1}{2}$  in. outside circle



**4. CUT HOLE** through roof boards with sabre saw or by hand with keyhole saw, following the circle



**5. WITH SCREWDRIVER,** loosen the locking screw on adjustable-pitch base so you can turn it



**6. WHEN LOOSE,** grip top section and turn sufficiently to make the top of the base level



**7. RETIGHTEN SCREW,** then slide top half of flashing up under shingles, removing nails in way

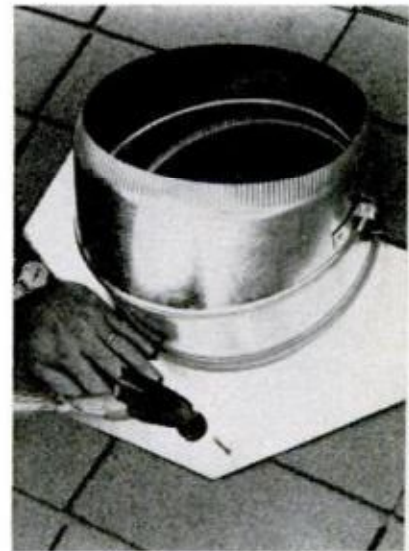

**8. SECURE BASE** to roof with eight roofing nails driven through the flange, then caulk the heads

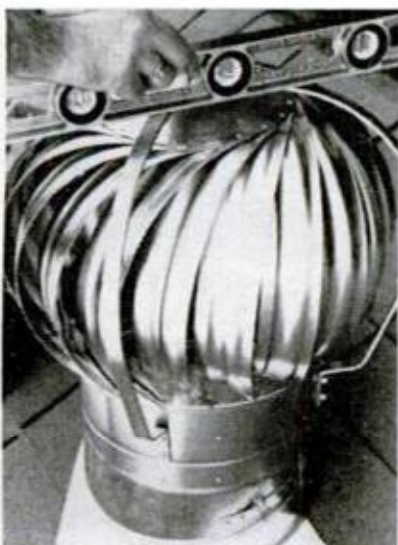

**9. PLACE VENTILATOR** over crimped base; check installation by placing level across the top  
APRIL 1973



**10. USE BASE-RING HOLES** as guide in drilling matching holes around and through base flange



**11. LOCK RING TO FLANGE** with No. 8,  $\frac{1}{2}$ -in. sheet-metal screws. Drive screws home for tight fit

**Home  
Ideas  
Guide**

# Trowel-on 'brick' looks like the real thing

Rough brick texture fools everyone; only you know it's imitation



**SEEING IS BELIEVING** and certainly so in the case of this new simulated brick, for you must see it to fully appreciate its realistic texture and authentic look. It's "laid" in the most unorthodox manner with strange "bricklayer's tools"—a putty knife or trowel, pencil and razor blade.

The brick is actually spread on like thick butter over a brick design of stick-on tape. Pulling off the tape forms individual brick shapes and mortar joints.

Dacor's Brick-In-A-Can comes in a two-

can kit, Formula I and Formula II. One is a base coat, which is troweled on first to simulate mortar joints. The other is the brick coat, which is partly removed by the tape to form the bricks.

The nine steps below show how it's done. As a final step, flat white and black spray paint can be applied here and there to add an "old" brick look. The two-can kit covers up to 35 sq. ft., costs less than \$1 per sq. ft. and is a product of Dacor Manufacturing Co., Inc., Worcester, Mass. 01601. ★★★



**1 USE TROWEL** or wide putty knife to apply thin layer of base coat (Formula I) on wall



**2 LET DRY OVERNIGHT;** use trowel to scrape off roughness, ruler to mark wall vertically



**3 MARK WALL** horizontally with special ruler that comes with kit. Instructions explain its use

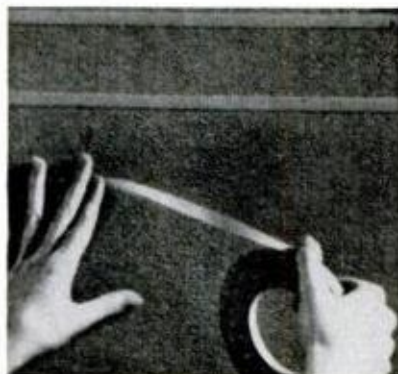

**4 WITH HELP,** stick tape to wall between series of vertical marks; then press tape in place

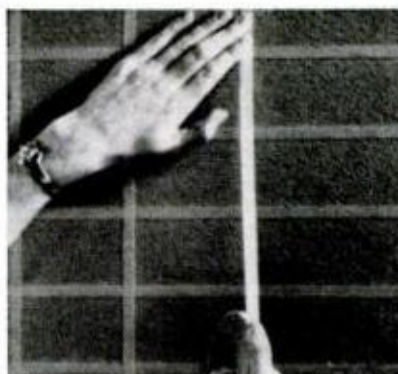

**5 IN SIMILAR MANNER,** stick tape to wall between series of horizontally made pencil marks



**6 WITH RAZOR BLADE,** cut vertical tapes at center where they cross each horizontal tape strip



**7 FORM BRICK SHAPES** by removing every other vertical tape in each row or brick course



**8 TROWEL FINISH COAT** (Formula II) over wall and tape; allow mixture to dry 2 to 4 hours

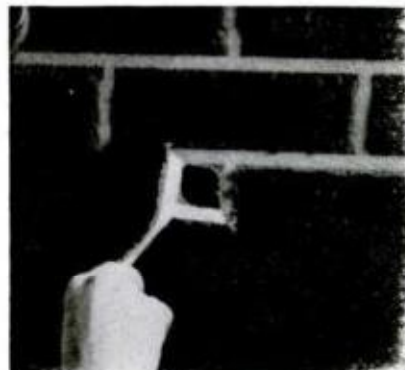

**9 REMOVE TAPE** from wall by grabbing end, pulling to produce natural-looking rough edges

# Low-cost garage-door



**1** PRESS THE TRANSMITTER (left) in the safety and comfort of car, and garage door slowly opens

PHOTOS BY ROBERT D. BORST

**A**SIDE FROM BEING a most worthwhile home improvement, a radio-controlled garage door affords you and your family the security, comfort and convenience of entering the garage without leaving the safety of your car. Press a button, the door goes up, a light comes on and you drive in. Press the button again and the door closes and locks behind you.

Getting out of the car late at night to open a garage door may be unsafe for the driver, whether it's you or your wife. And, of course, no one likes to struggle with a heavy door in a driving rain.

If a radio-controlled garage-door operator sounds too complicated for you to install yourself, you are in for a surprise. There's a simple do-it-yourself unit on the market, called Helpmate, which any handy home-owner can install in as little as four hours with common hand tools—for under \$125. It's powerful enough to open a wood, metal or fiberglass door up to 20 feet wide, and you can work the operator from a distance of 100 feet or more. It has solid-state controls, and its transmitter and receiver are precisely tuned and matched so no other UHF (ultrahigh frequency) signal can open the door.

● *How the operator works.* A 1-in. motor pulley drives a 7-in. pulley in the power head through a V-belt, reducing the motor

**POWER HEAD** hangs level from ceiling joists held by two flat iron bars. Radio receiver is fastened to ceiling so its antenna is parallel to garage door



# opener anyone can install



**2 DOOR-OPENER LIGHT** turns on at same time and then you can drive into a bright-as-day interior

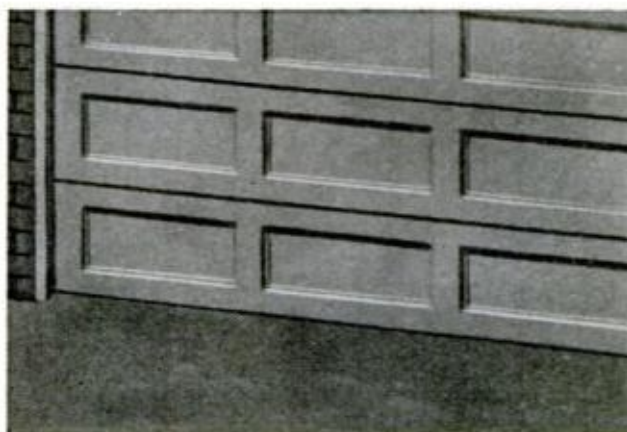

**3 PRESS TRANSMITTER AGAIN** and door slowly closes, leaving you safely behind locked door

speed by a 7:1 ratio. The larger pulley is on a shaft-and-sprocket assembly that drives a roller chain attached to a trolley. The chain moves the trolley along a 10-ft. 1¼-in.-dia. rail, and the garage door is attached to the trolley by an adjustable arm. UP and DOWN lugs affixed to the chain limit trolley travel. When the UP lug strikes its spring-loaded switch bracket, movement stops and the door is fully open. When the DOWN lug strikes its switch bracket, movement is stopped and the door is tightly closed. The instant the motor is activated by the car transmitter (or wall switch), a 75-w. lamp lights and remains on for two minutes after the motor stops. If the door meets an obstruction during down travel, the chain will tighten, causing the pivot bracket to turn and close the safety reverse switch. This trips the latching relay and instantly reverses the mechanism to open the door fully. If power fails, the door can be opened by pulling a pin to unhitch it from the trolley.

For the opener to operate without undue labor, the door can't stick or bind in its tracks or opening, and it should be made to open manually with little or no effort before the operator is installed. The door can be track-type or trackless one-piece or sectional. It is recommended that a rubber door seal be attached to the door bottom so it will close quietly and tightly. The seal will also keep out snow and rain and compensate for an uneven floor.

● *Wiring the operator.* Both the power

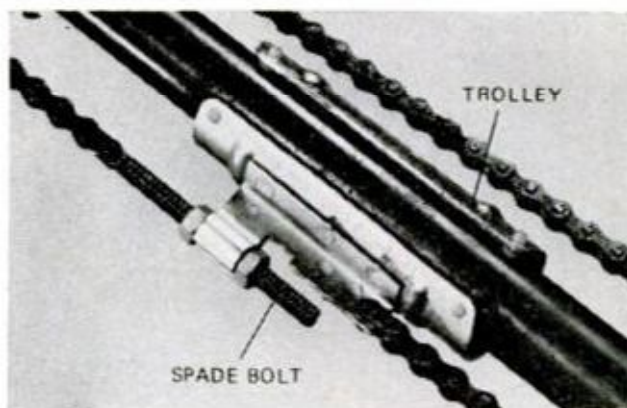

**ENDS OF ROLLER CHAIN** attach to trolley after making loop around drive sprocket and idler pulley. Chain slack is taken up by tightening spade bolt

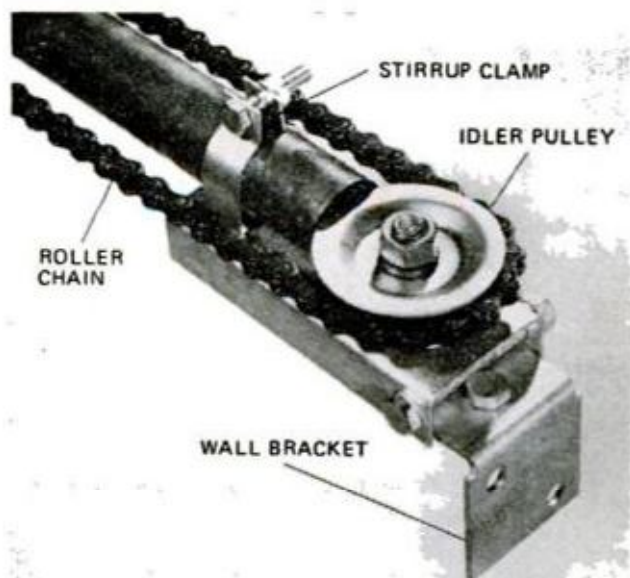

**IDLER-PULLEY ASSEMBLY**, which includes wall mounting bracket, clamps to end of trolley rail by stirrup. Pulley bears against end of the rail, does not turn

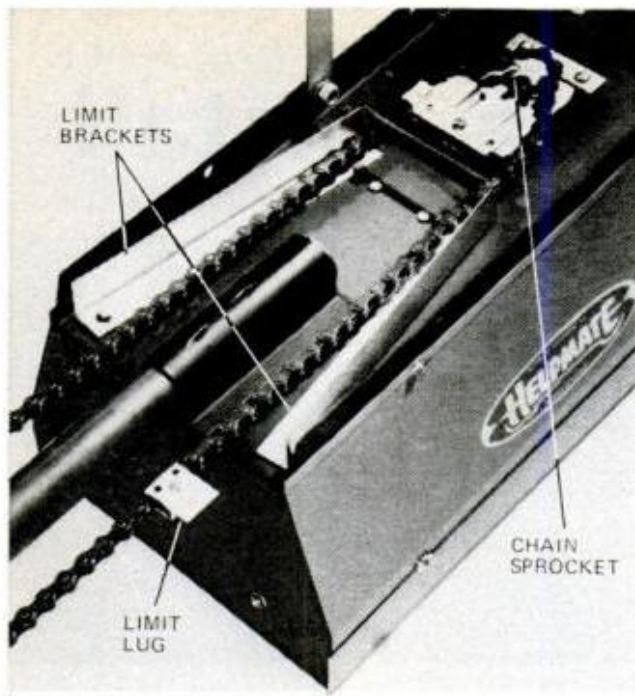

**TOP VIEW OF POWER HEAD** (left) shows how limit lugs on chain force open spring-held UP and DOWN switches as they pass and strike two pivoting brackets

head and the solid-state receiver come with 6-ft. plug-in cords that make "wiring" a simple thing when an outlet and receptacle are installed in the garage ceiling. When this is not feasible, surface-mounted extension cords can be used to plug the units into an existing nearby wall outlet. The receiver and wall switch are connected to the power head with a two-conductor wire which is furnished. Ideal location for the wall switch is at the door leading to the garage. Additional wall switches can be mounted at various locations to provide several control positions.

The diagram at the left shows how a two-conductor wire is connected to the terminal strip on the side of the receiver and to a similar one on the end of the power head. The receiver should be mounted on the ceiling, of course, on either side of the power head, so the antenna is fully exposed to the front of the garage. It is important that the receiver's antenna *not* point toward or away from the door.

Complete easy-to-follow instructions are provided with the operator along with a troubleshooting chart. For more information and exact prices, write to Helpmate Equipment Co., First and Lake St., Baroda, Mich. 49101. ★ ★ ★

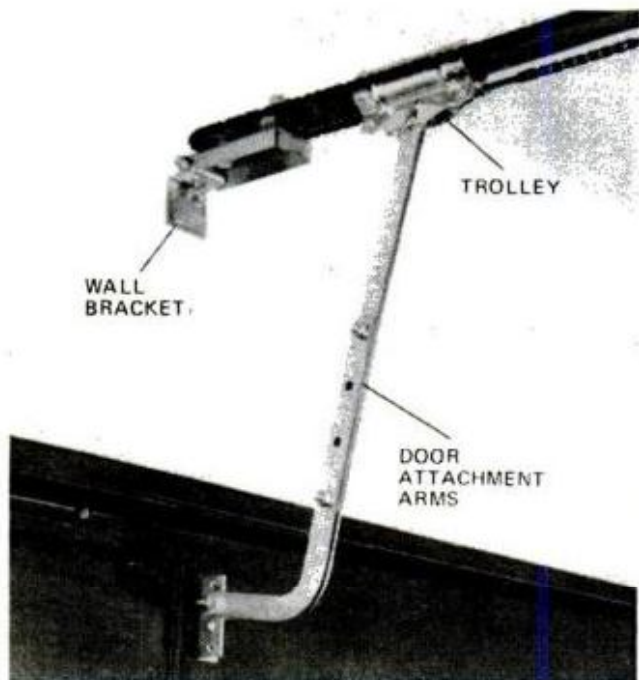
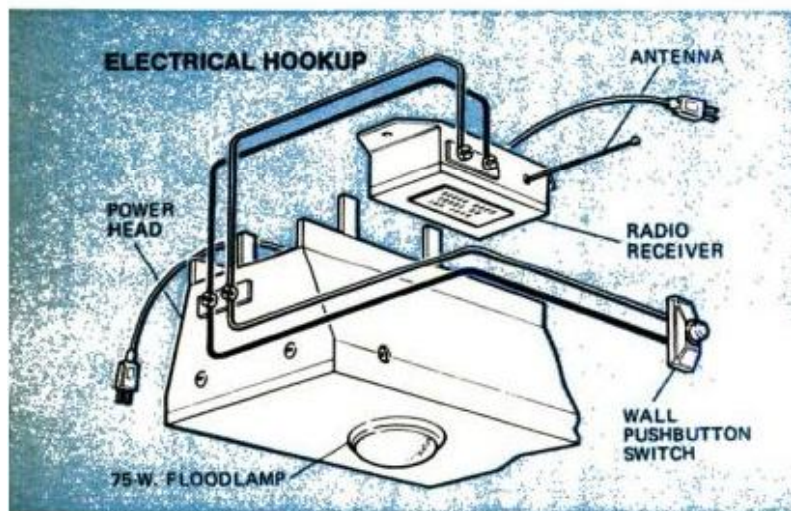

**ADJUSTABLE DOOR ARMS** attach to trolley with a clevis bolt. Arms are detachable for opening door manually and attach to door with two carriage bolts

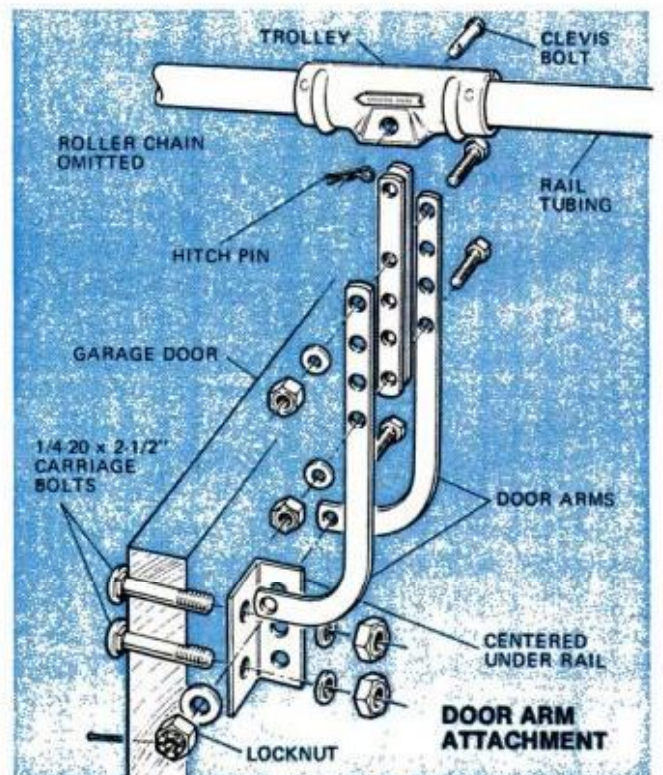

Everything you need  
to know about bathrooms but  
didn't know enough to ask



A consumer's guide to better bathrooms  
from the Eljer Plumbingware Division  
Wallace-Murray Corporation

## A consumer's guide to better bathrooms

Like most people you probably judge bathrooms more by their decor than by their plumbing fixtures. Right?

Bad move. You change bathroom decor many times but you may only get one shot at selecting the right plumbing fixtures.

To help you, Eljer has put together this new brochure. It explains the differences between good, better and best bathroom fixtures and fittings. It explains when and why it makes sense to spend more, tells what the differences are between materials, helps you select the right fixtures for your home and your needs.

The brochure isn't technical, just factual and free. It's a must if you're about to buy or build, or remodel a home. If you'd like a copy, complete the coupon below and send it to us.

Eljer, Dept. PM  
3 Gateway Center  
Pittsburgh, Pa. 15222

Please print

Name \_\_\_\_\_

Address \_\_\_\_\_

City \_\_\_\_\_

State \_\_\_\_\_

Zip \_\_\_\_\_

# ELJER®

Eljer Plumbingware Division/Wallace-Murray Corporation

# How to hang a door

**I**T TAKES CARPENTRY SKILL to hang a door so it swings properly—opening and closing as it should. But the average handyman, armed with knowledge, the right tools and a little common sense, can accomplish the job successfully. Here, PM sup-

plies the know-how (architectural standards plus techniques). Now it's up to you to supply the common sense and muscle. Once you have hung a door correctly, you have acquired a valuable basic skill.

*(Please turn to page 176)*

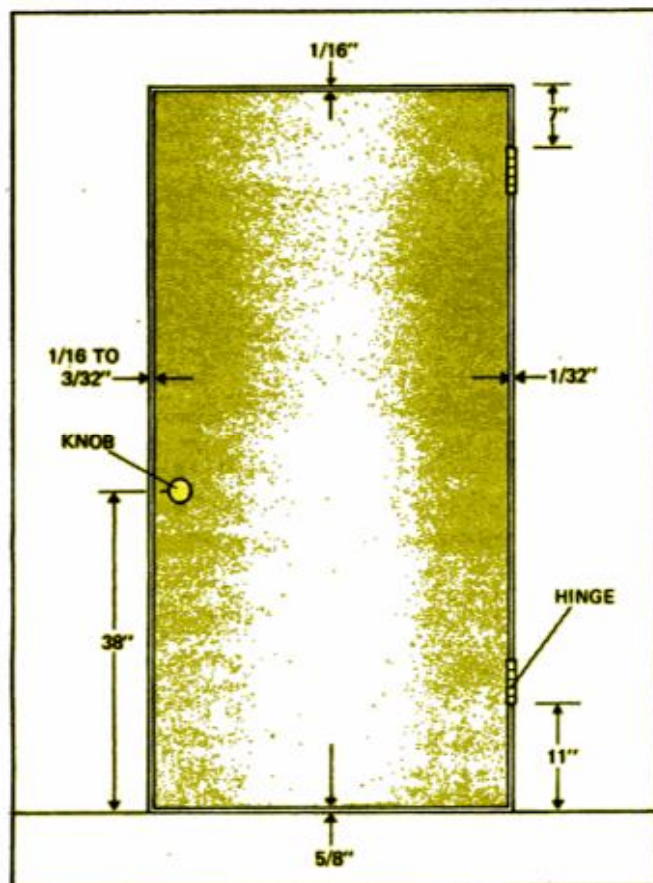

## Door clearances you should use

Door clearances and locations for door hardware are standard, as shown. If a third hinge is needed (exterior door), space it midway between top and bottom hinges. On exterior doors, allow clearance at bottom for threshold.

## General types of interior doors

Basically, there are two types of interior doors—panel and flush. Thickness is  $1\frac{3}{8}$  in. (exterior doors,  $1\frac{3}{4}$  in.) and they come in varying widths and heights. Flush doors have plywood facings, lightweight cores; panel doors have solid stiles and rails with plywood panel inserts.

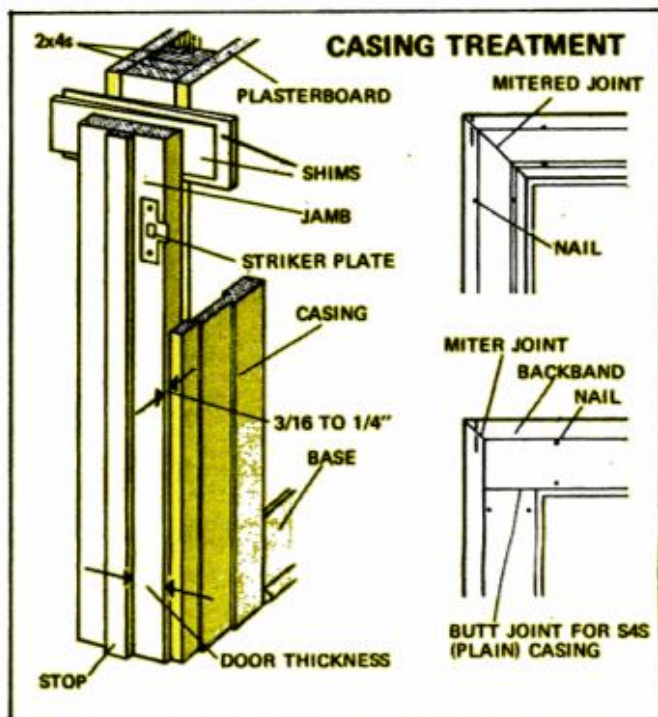

## Door frame and trim

To set an interior door frame (jamb), wedges or shingles are used between side jambs and the rough opening. When jambs are set flush and plumb, the wedges are driven tightly and jambs are nailed to studs with 8d finishing nails through the shingles. Casings are nailed to the framing studs and the jamb with 8d and 6d nails, respectively. Two types of casings are shown. Use mitered corners on shaped type, 4d finishing nails to hold miters closed tightly.

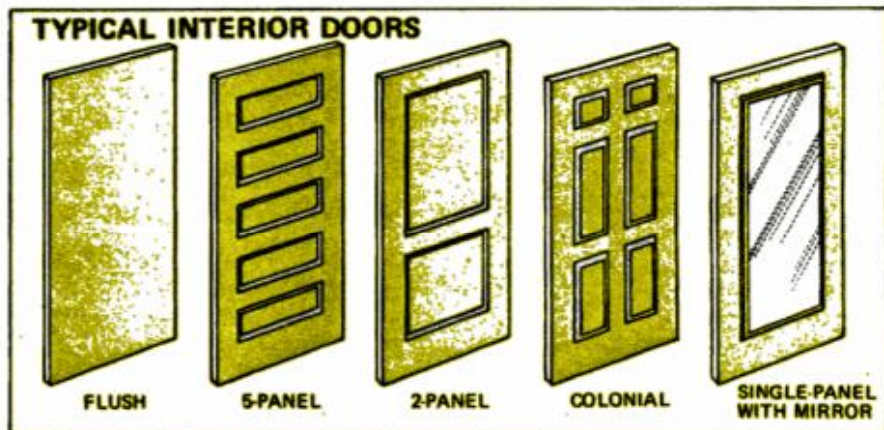

# Marlboro



Warning: The Surgeon General Has Determined That Cigarette Smoking Is Dangerous to Your Health.

Kings: 18 mg. tar, 1.3 mg. nicotine —  
100's: 19 mg. tar, 1.5 mg. nicotine — Lights: 13 mg. tar, 1.0 mg. nicotine —  
Menthol: 16 mg. tar, 1.1 mg. nicotine av. per cigarette, FTC Report Aug. '72

## How to install a common lockset in a door

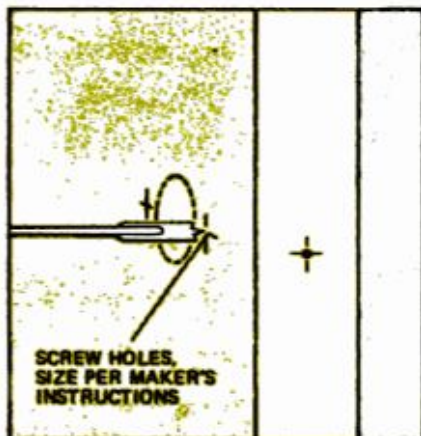

**1.** The lockset shown here is the most commonly used type. Template packed with it is used to locate exact points for drilling required holes. After marking locations, remove template and drill holes.

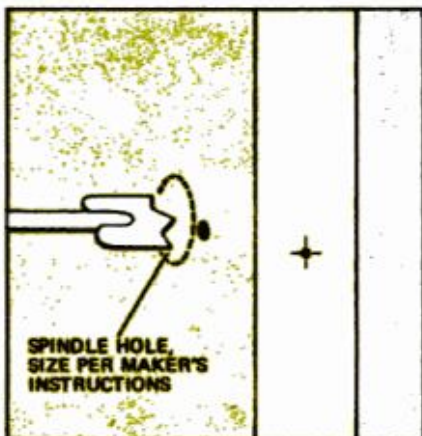

**2.** Next, bore large hole for spindle. If preferred, one large hole, usually of  $2\frac{1}{8}$  in. dia., can be used instead of 3-hole installation shown. You need a hole saw and you must drill a pilot hole for hole saw to follow.



**3.** Bore a  $\frac{7}{8}$  or 1-in. hole in edge of door to receive the latch. Insert latch and draw outline around latch-plate for the next step—mortising. Hold the drill perfectly level when boring all holes.



**4.** For craftsmanlike installation, use sharp chisel only. Remove stock and insert latch for test fit; plate must be flush with door edge or screwheads will project, effect fit.

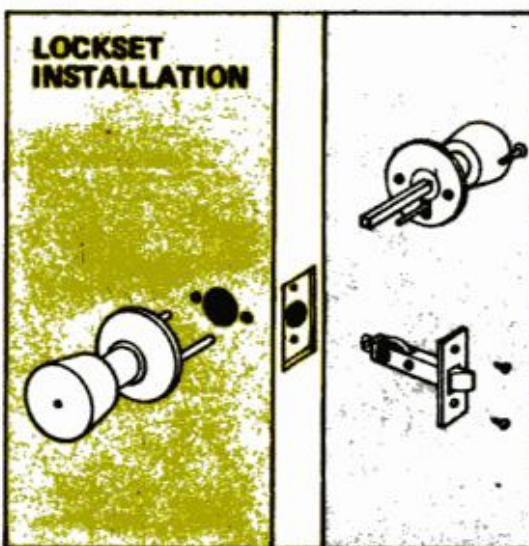

**5.** How lockset is inserted in door: Latch is permanently installed with flathead screws, then knob sections are inserted through latch mechanism and held fast by two machine screws. Swing the door to an almost closed position and mark where striker touches the jamb. Then locate the striker position. To install, drill hole for latch and mortise out jamb for plate.

## Fitting and installing the hinges

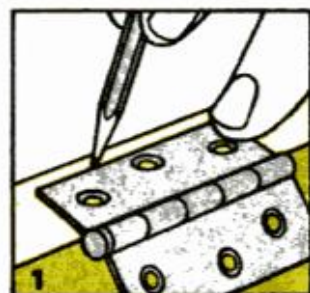

First, locate hinge positions by wedging door in opening with shingles. Then, with door on sawhorses, use a sharp pencil to outline mortise.

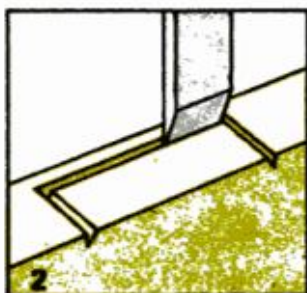

A trick professional carpenters use is to then score the pencil outline with a sharp utility knife. Next, make deeper outline, cut with your chisel.

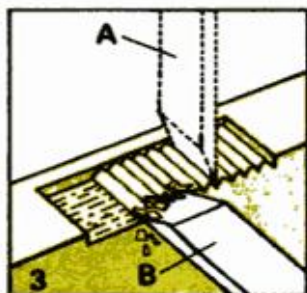

Make repeat feather cuts (A) about  $\frac{1}{4}$  in. apart to depth of the hinge thickness. Hold chisel on depth line (B) and tap to remove scored stock.

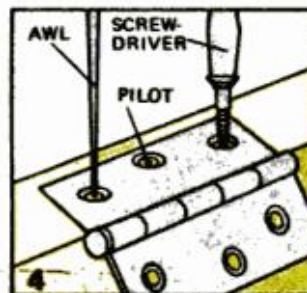

Hold hinge in place, make pilot holes with awl. Turn screws so hinge is flush with door. If mortise is too deep, raise the hinge with shims.



## A beautiful way to end paint failure.

Paint puts a film over wood.  
With time, it can crack,  
peel or blister.

When you stain with  
Olympic, the finish goes  
into the wood. Lets it  
breathe.

Never cracks, peels or  
blisters—brings out wood's  
texture instead of  
smothering it.

If your home is painted,  
you may still be able to  
refinish with Olympic Solid  
Color Stain. They're so rich  
in pigment, you can stain  
light over dark.



For your dealer's name call 800-243-6000, toll-free.  
In Connecticut dial 1-800-882-6300. For a free color folder, write:  
1148 NW Leary Way, Seattle, Wa. 98107.   
Olympic Stain. A division of COMERCO, INC. 

Insulation designed for use between furring strips on masonry walls is called Pre-Panel by Johns-Mansville



## How to install insulation

**T**HERE ARE FOUR GOOD REASONS why you should insist on adequate insulation when buying a new home or remodeling an existing one. *First:* The cost of heating and cooling in any given locale is proportional to the heat-loss/gain factor of the dwelling. You pay for heat and cooling that escapes through those walls. *Second: Comfort.* Insulation, installed properly, eliminates drafts and increases comfort appreciably and measurably (by the thermostat). *Third:* Acoustical privacy, particularly important if you own a multiple dwelling. Insulation in wall and floor cavities helps to reduce airborne noises, such as loud voices, and impact sounds, such as heavy footsteps. And *fourth:*

*(Please turn to page 181)*



# PUBLICATIONS **WORTH WRITING FOR**

**PM'S PICTURE-TOOLS** are a great new idea to take the confusion out of *what goes where* on workshop and tool panels.

The complete PM **PICTURE-TOOL KIT** consists of seven big sheets (9¾ x 11¾ in.) of a special heavy-weight paper with a pressure-sensitive adhesive on the back. On each sheet are beautiful drawings of hand tools and portable power tools—all you're likely to have in your shop (74 in total). Most are full size; the others nearly so.

Also enclosed in the kit is a blank sheet of the same special paper, printed in an overall color to match the tools. This sheet enables you to design your own drawings of special tools.

Each of the PM **PICTURE-TOOLS** is carefully die-cut. You simply peel off the backing paper and apply it to the proper spot: on painted or unpainted wood, plywood, hardboard and even perforated-hardboard surface.

Later, if you want to move a few tools or rearrange the entire panel, you can peel off the PM **PICTURE-TOOLS** and reuse them in new locations!

Once your **PICTURE-TOOLS** are in place, you'll know at a glance exactly where each tool belongs.

Order your PM **PICTURE-TOOL KIT** today. Simply send a check or money order for \$3.95 to Popular Mechanics, Dept. PT, Box 1014, Radio City, New York, N.Y. 10019. Be sure to enclose your name and address. ★★★

APRIL 1973

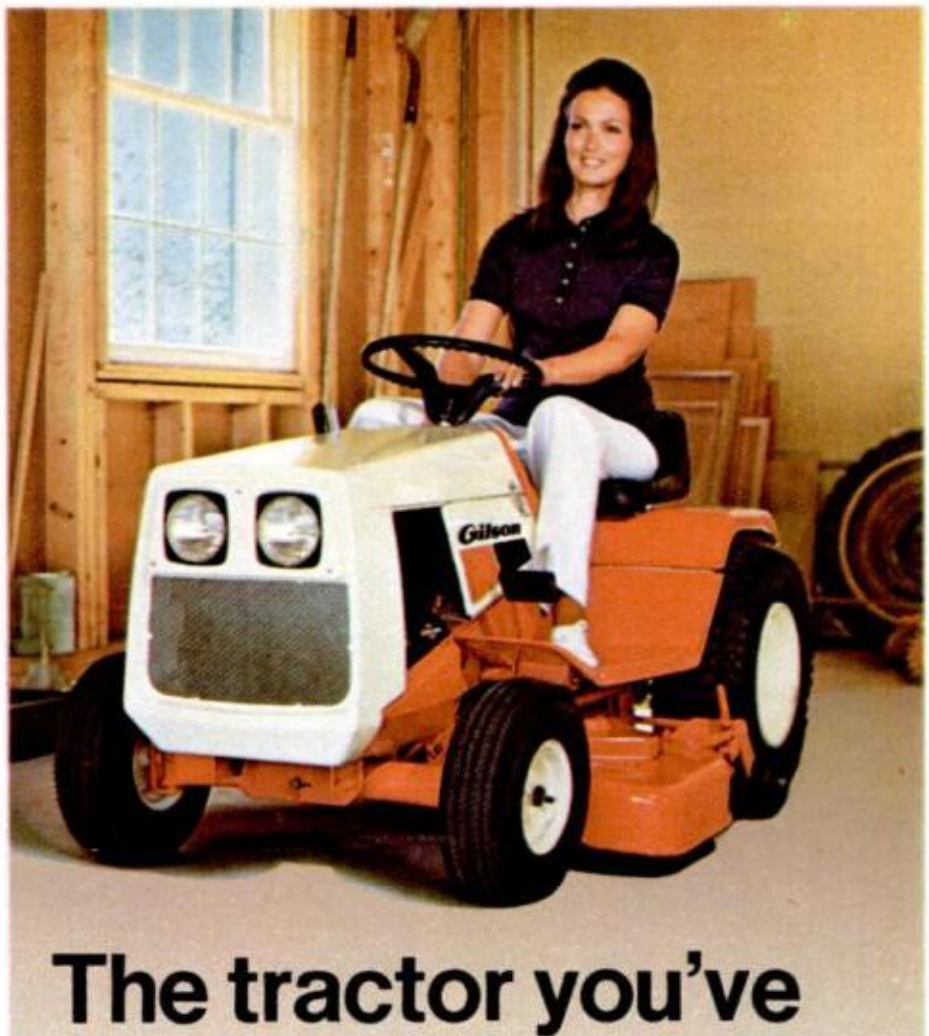

## The tractor you've been waiting for.

### Priced \$100 below what you'd expect!

Here's the new 8 hp. beauty by Gilson that's priced \$100 below comparable tractors — mower attachment included! With features that put this machine in a class far above others.

Low profile design and oversize footrests let you step on and off easily — no swinging your leg over. Gilson traction drive system delivers smooth hydro performance with a wide range of speeds, at far below hydrostatic cost.

The PTO takes hold smoothly. There's electric start, Briggs & Stratton power, built-in headlights, and much more.

Test-drive this new machine at your Gilson dealer. And invest the \$100 savings in practical attachments like a cart, dozer blade or snowthrower. Now aren't you glad you waited? Also see the Gilson 10 hp. and 16 hp. tractors with 4-speed transaxle, and 16 hp. with hydrostatic drive.

## **Gilson**

**A great machine to have in your corner.**

Name \_\_\_\_\_  
Address \_\_\_\_\_  
City \_\_\_\_\_  
State \_\_\_\_\_ Zip \_\_\_\_\_

Mail to: **Gilson Brothers Company**  
P.O. Box 152, Plymouth, WI 53073

Send name of my nearest Gilson dealer and brochure on the new 8 hp. lawn tractor.

# The Honda ATC is fun when the going's easy.

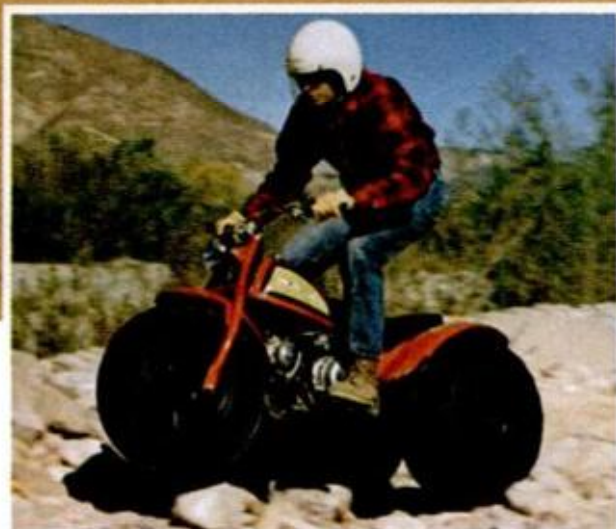

## Or rough.



Sand or rocks, snow or mud, an ATC three-wheeler conquers them all. And makes each kind of riding its own special kind of fun.

Now there are two ATC models, the larger, more powerful ATC 90 for teenagers and grownups. The brand new ATC 70 for the youngsters. They each feature those three large, fat, soft tires which gives them the ability to roll over just about anything. And, of

course, both have the Honda overhead cam four-stroke single-cylinder engine. Famous for its dependability.

Since these are off-road vehicles only, Honda has made them with the protection of the environment in mind. Both have quiet, spark-proof USDA-approved spark arrestor/mufflers. For your safety, each has an ignition cut-off switch right next to the throttle so you can stop the engine quickly. And for your convenience, they both can

be disassembled easily for transporting in a car trunk or station wagon.

To see and ride these fun, funny-looking ATC models drop by the Honda dealership near you soon. They're just two of the many different kinds of Honda motorcycles for all the different kinds of motorcycling — road, on/off road, trail, dirt or minibike. And fun is included with every one of them.

**HONDA**  
From Mighty to Mini, Honda has it all.

For safety, we recommend that you always wear a helmet and eye protection, keep your lights on and check local laws before you ride. ATC is a Honda trademark. For a free color brochure, write: American Honda Motor Co., Inc., Dept. PT, Box 50, Gardena, Calif. 90247. ©1973 American Honda Motor Co., Inc.

Материал защищен авторским правом

## HOW TO INSTALL INSULATION

*(Continued from page 178)*

A reason seldom considered when insulation is being discussed—its effectiveness as a fire barrier. Mineral-wool insulation is noncombustible; when it fills a wall cavity, it acts as a deterrent to the vertical spread of fire. In fact, if the walls in new construction are filled with insulation, then

*(Text continues on page 184)*

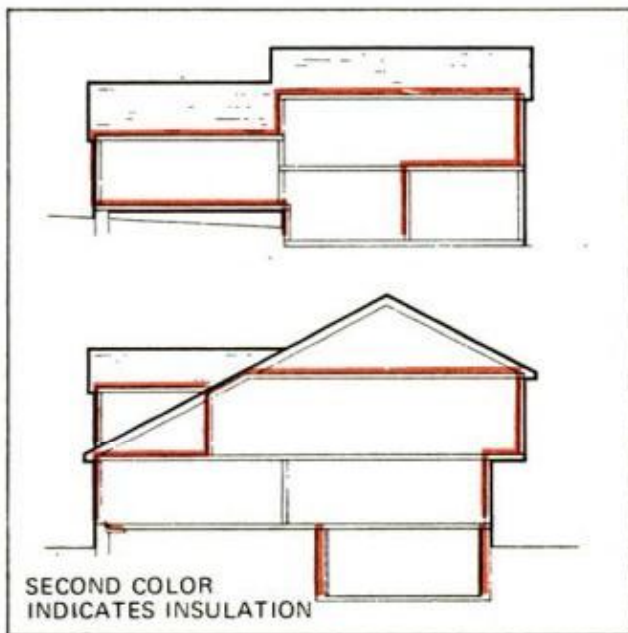

**EFFECTIVE LOCATIONS** for insulations are indicated by colored lines in the drawing above. To assure that your home is free of moisture problems, remember that you must install adequate vapor barriers. If you use one of the types of insulation that comes without a vapor barrier, install polyethylene, as described on page 182. The vapor barrier is always installed between insulation and interior of home

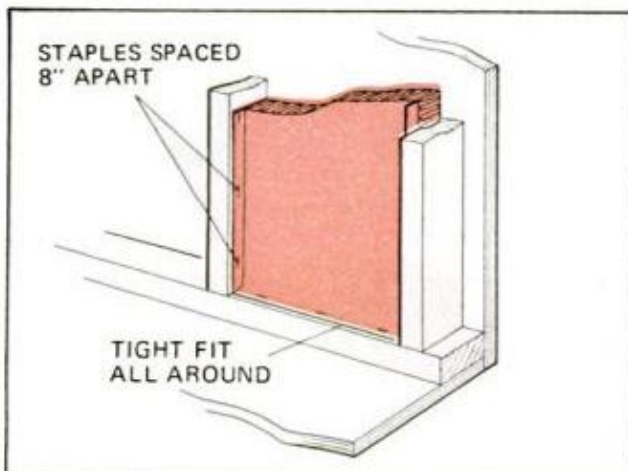

**BLANKETS** should be pushed into stud spaces so they touch siding or sheathing. Working from the top down, space the staples about 8 in. apart, pulling flanges to fit snugly over studs. Cut the blanket end slightly overlength and staple through the vapor barrier to the plates by compressing the insulation

*(Installation details continue on page 182)*

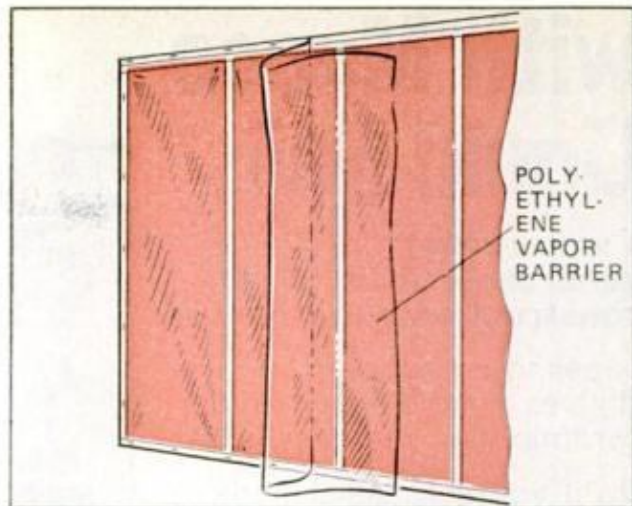

**WHEN YOU USE** pressure-fit blankets without a vapor barrier, wedge them into place and then cover the wall with 2-mil-thick polyethylene vapor barrier stapled to the top and bottom plates. Unroll the sheet to cover the entire wall area, including window and door openings, then cut to length. Staple to end studs, cut out openings and staple around openings

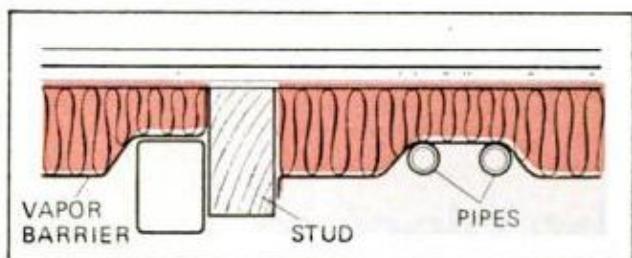

**IF OBSTRUCTIONS**—ducts, pipes and the like—are located in your wall cavities, push insulation behind (to the cold side in winter) those pipes before stapling. Or you can pack the space with loose insulation or cut a piece of blanket insulation to fit the space. If you do pack the space with loose insulation, make certain you cover it with 2-mil polyethylene



**USE SCRAPS** of insulation to stuff into small spaces between rough framing and door and window heads, jambs and sills. You can fill even the narrowest cracks by using a putty knife to force the pieces of insulation in until the crack is filled. Staple scraps of the insulation vapor barrier, or polyethylene, in place to cover those small stuffed spaces

# Stick 'em up with Macco Liquid Nails®

a waterproof general-purpose construction adhesive for

paneling • pegboard shelves • molding • drywall ceramic tiles • veneer brick

Do it yourself easier and better with the complete line of Macco adhesives and sealants. At lumber stores, hardware stores, and home improvement centers.

Available in cartridges, quarts and gallons.

PM-34



**SCM MACCO ADHESIVES**  
SCM CORPORATION, WICKLIFFE, OHIO 44092

# Patcher Upper



## Presto Patch VINYL spackling paste

Ready to use right out of the can. For patching cracks, holes, dents and joints. Available where paint is sold.

**SAVOGRAN**   
Norwood, MA. 02062

# The electric switch with the fluid transmission

SUPER SWITCH mercury contact capsule. Hermetically sealed, filled with inert gas. Inhibits arcing and contact erosion as flowing mercury makes or breaks electrical connection.



Look inside GE's new SUPER SWITCH electric control, and here's what you see:

Not the traditional movable-blade contacts. Not the usual spring assembly. Instead, you see a contact capsule that contains mercury. The same 99.99999% super-pure mercury used in missile and rocket control systems. This liquid metal flows within the capsule when the switch handle is tipped, to make or break the electrical contact.

The fluid action makes SUPER SWITCH 100% silent — no snaps or clicks. Smooth-working — no moving mechanical parts. Smaller . . . easy to install. And so long-lasting, General Electric will mail a free replacement for SUPER SWITCH if it fails for any reason, in normal home usage, within 50 years from date of purchase.

You'll find SUPER SWITCH electric controls with standard or lighted handles, for single or two-switch circuits, at electrical departments everywhere. For more information — and GE's free illustrated booklet, "Handy Tips about Electricity and Wiring" — write to Wiring Device Business Dept., General Electric Company, Hathaway St., Providence, R.I. 02904



GENERAL  ELECTRIC

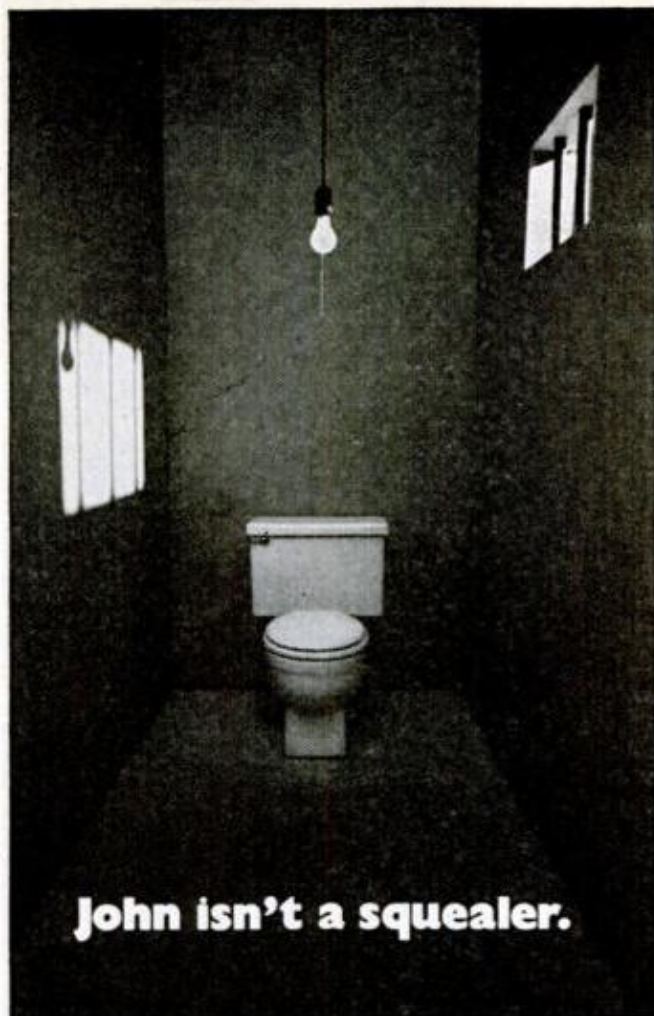

**John isn't a squealer.**

It's a crime the way some Johns operate. They leak, squeak, whistle and squeal. Usually due to out-dated ballcocks that are corroded and leaky.

But once Fluidmaster takes over, things really quiet down. Because unlike old-fashioned ballcocks with tank float and arm, Fluidmaster controls toilet tank water hydraulically. Working with water pressure, instead of against it. So shut-off is fast and positive. No leaks. No squeaks. No whistles or squeals.

Write today for full details. Before your John is found guilty of disturbing the peace.

Manufacturer of the Model 100, 200 and 400.



**FLUIDMASTER, INC.**  
1800 Via Burton  
Anaheim, Calif. 92805

## CUT PICTURE FRAMES AND OTHER WOOD JOINTS AUTOMATICALLY — PROFESSIONALLY!!

IF YOU CAN PUSH A SAW, THE AMAZING JOINTMASTER LETS YOU CUT WOOD JOINTS WITH AMAZING ACCURACY



This precision device is so unique, so revolutionary, it ran off with the **GOLD MEDAL AWARD** at the Brussels International Inventor's Fair! The **JOINTMASTER** enables you to perform all the cuts shown plus countless others, simply and precisely. No need to spend hundreds of dollars on power equipment. Cut intricate dovetails, mortise and tenons, miters and half miters. **Picture frames are easy.**



Only **\$19.95**  
(Saw not included)

**JOINTMASTER** controls the angle and depth ... and a joint can be repeated again and again after initial setting. Unlike an ordinary miter box, you always saw in the same direction. Fully illustrated, step-by-step instruction booklet included.

Works for right or left handers. 8-3/8" square base of diecast aluminum, durable yet lightweight.



**USE THIS MAILING COUPON, TODAY!**

10-day money-back guarantee. Try the **JOINTMASTER** for 10 days. If you're not completely satisfied, return for full refund. Send check or money order for \$19.95 (plus \$1.00) for postage and handling.

**Joint master**

4767 Clark Howell Highway,  
Dept. PM-4, Atlanta, Georgia 30349

Please send me the amazing **JOINTMASTER**. I am enclosing  check  money order for \$20.95

(\$19.95 plus \$1.00 for postage and handling.) **I MUST BE FULLY SATISFIED WITH MY JOINTMASTER OR I WILL RETURN IT WITHIN TEN DAYS FOR A FULL REFUND.**

NAME \_\_\_\_\_  
ADDRESS \_\_\_\_\_  
CITY \_\_\_\_\_ STATE \_\_\_\_\_ ZIP \_\_\_\_\_

# HOW TO INSTALL INSULATION

(Continued from page 181)

fire-blocking (fire stops) can be eliminated. What you will thus save on labor and materials can be deducted from your insulation cost. ★★

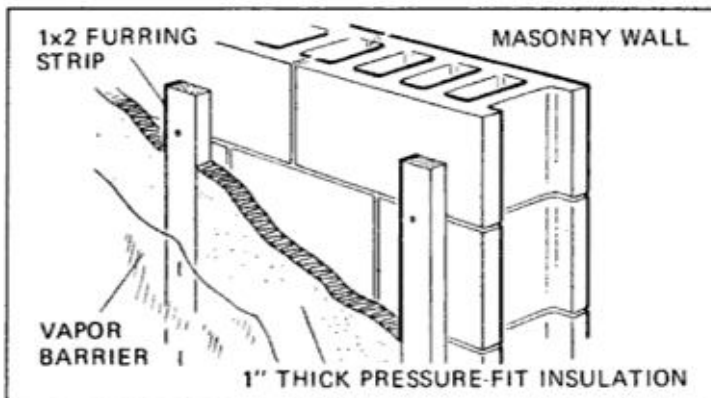

**EASIEST WAY TO INSULATE MASONRY WALLS** is to space nominal 1x2 furring strips 16 in. on center with nominal 1-in. pressure-fit masonry-wall insulation between strips. Cover with polyethylene vapor barrier. If you prefer 2x2 furring, and use R-7 insulation (with vapor barrier), strips can be spaced 24 in. o.c. This insulation backs up wall panels

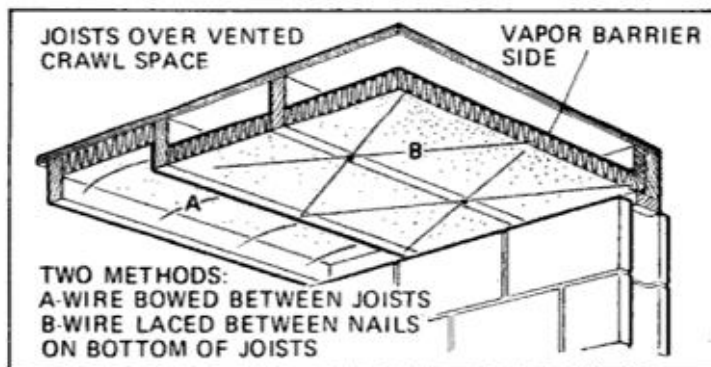

**FLOOR OVER VENTED CRAWL SPACE** can be insulated if insulating material is held between joists, using either of these methods: (A) By using heavy-gauge wires pointed at both ends, made especially for this purpose. Just bow wires and wedge them underneath insulation between joists. (B) By lacing wires between nails placed in bottom of joists

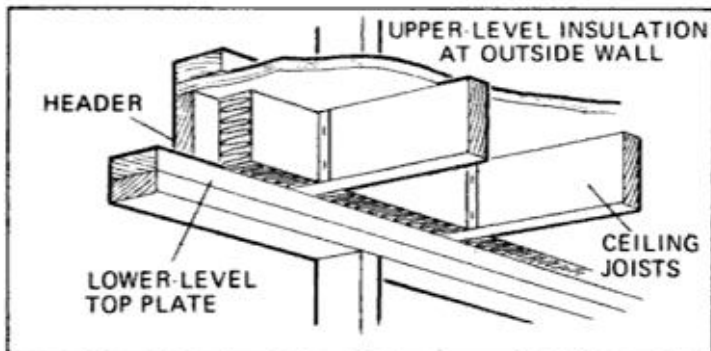

**HEADER JOIST** should be covered with insulation, too. You can do it by wedging oversize pieces of blanket insulation between joists behind the band of header joists and stapling edges to the joists. Or, when you are using insulation at the bottom of joists, you can insulate the header joist by "folding" the end of the blanket 90°, pushing it back against the header and then driving in a few staples

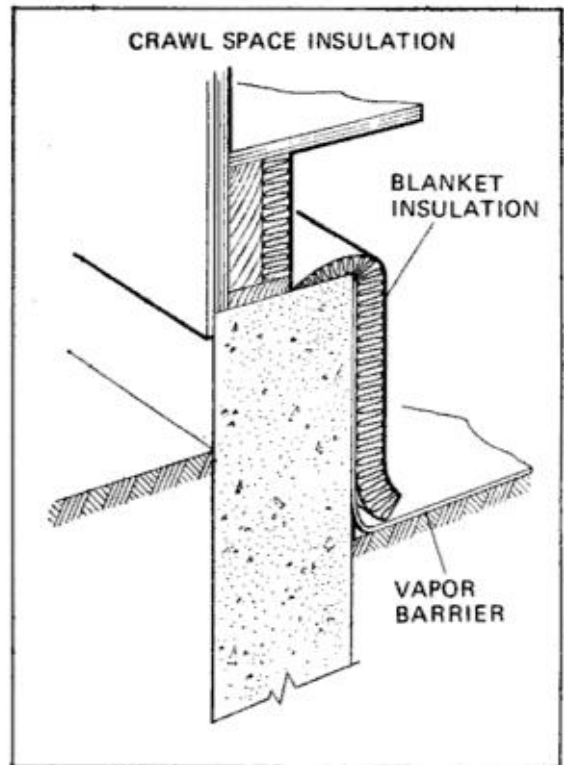

**FLOOR OVER UNVENTED CRAWL SPACE** usually can be insulated more economically as shown above than by methods given at left for floor over vented crawl space. Spread the vapor barrier over ground in crawl space, let it turn up onto the walls and hold it there with tape. Then place one edge of the blanket insulation on top of the foundation wall and let it drape over and against the inside of the wall. The vapor barrier must face inward

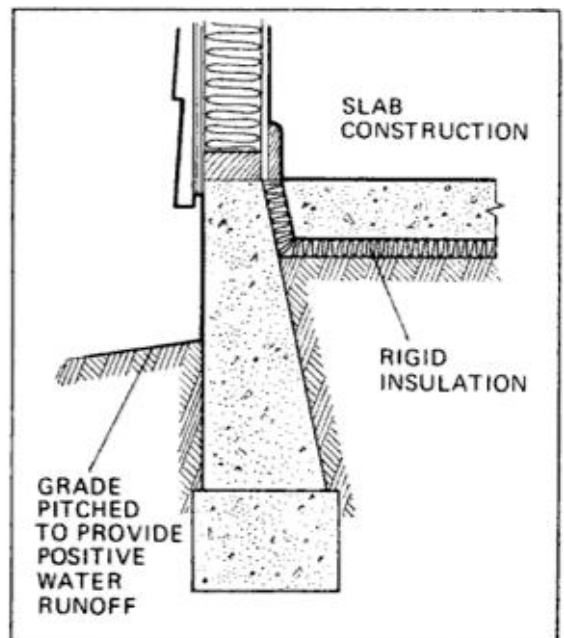

**SLAB-FOUNDATION HOMES** should always be insulated. The correct way is to lay a 6-mil polyethylene vapor barrier over tamped gravel and use rigid insulation between barrier and slab. The same material should also be used for perimeter insulation, installed as shown. For any insulating job, don't scrimp on quality or thickness. The material is relatively inexpensive and you will recoup its cost in the form of heating and cooling savings

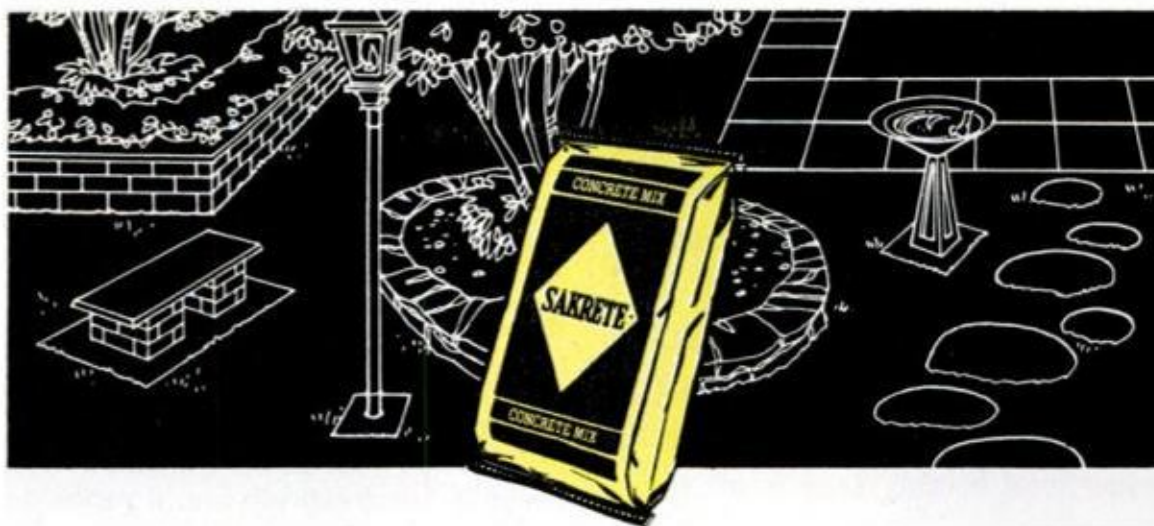

## Add beauty and value to your home with **SAKRETE**® mixes

Patios, walks, planters, barbecues and home repairs are projects you can afford to do yourself to keep your home looking beautiful. And by using SAKRETE Cement Mixes this outdoor living area worth \$3000 was built at a material cost of less than \$500.

Millions of home owners insist on SAKRETE Mixes for home repair and improvement projects. They know SAKRETE guarantees mean just what they say... high strength, workability, quality control and complete directions on use. Plus SAKRETE is packaged in a moisture-barrier sack and stores until water is added.

Always insist on SAKRETE, and be darn sure your dealer gives you SAKRETE when you ask for it.

**FREE PLAN BOOKLET** — *Easy-to-follow instructions on patio additions and many other cement projects. Free at your dealer or send 25¢ to cover handling to SAKRETE, INC., Dept. P.M., Box 1032, Dayton, Ohio, 45401.*

**SAKRETE**® *concrete and mortar mixes*

SAKRETE is a registered trademark of SAKRETE, Inc., ©1973



**Ask for SAKRETE and be very sure you get SAKRETE.**

Build **POPULAR MECHANICS'** little **CARRIAGE HOUSE!** Simply great! A back-yard building that isn't an eyesore. Styling blends in with most homes. It will take your mower, lawn furniture and tools—or the kids' overnight guests. Use it as your shop or home office. Overall outside dimensions 10-ft. 4 in. x 12-ft. 4 in. For one complete set of plans send \$3.95 to **POPULAR MECHANICS Dept. FA, Box 1014 Radio City, N.Y. 10019.** For two sets of plans (you may need one for your local building department) send \$5.49.

**An 8¢ investment can save you money. Get straight answers to your questions about aluminum siding.**



**Get Reynolds Straight-talk Home Improvements Idea book. For an 8¢ stamp.**

Reynolds Metals Company  
Dept. PM P. O. Box 27003  
Richmond, Virginia 23261

Please send your free idea booklet on aluminum building products.

Name \_\_\_\_\_

Address \_\_\_\_\_

City \_\_\_\_\_ State \_\_\_\_\_

Zip \_\_\_\_\_ Telephone \_\_\_\_\_

I am a homeowner. My house is  wood siding  other.

## The right way to paint a room

### Home Ideas Guide

**I**F WIELDING a paintbrush or roller is a new experience for you, you're apt to do a first-rate job just because you are a beginner. In their eagerness to slap on the paint, many "pros" often can't be bothered with important points of wall preparation that make the difference between a hurry-up job and a professional-looking one.

Before you lift a brush or roller, examine plaster walls for cracks and mars. Fill small hairline cracks carefully with spackling compound, using a putty knife, kitchen utensil or even your thumb and finger. Larger cracks should be filled with special patching plaster. In the case of large cracks, it is best to chisel out a triangular channel in the plaster, narrow on the surface and wider inside. Press the plaster into the channel through the narrow opening. When the patching filler is thoroughly dried, simply sand the surface smooth, and you're ready to apply an un-

*(Please turn to page 188)*

### COLOR DOS AND DON'TS

- DO** use light colors in a small room to create an impression of size.
- DON'T** use a bright color in a large area or the walls will detract from otherwise decorative furnishings and accent pieces.
- DO** have continuing color flow through your home—from room to room—using harmonious colors in adjoining areas.
- DON'T** paint woodwork and trim of a small room in a color which is different from the background color or the room will appear cluttered and even smaller.
- DO** paint ceilings of a room in a deeper color than walls, if you want it to appear lower—and in a lighter shade for the opposite effect.
- DON'T** paint unfortunate architectural features—such as radiators, pipes and similar projections—in a color which contrasts with walls or they will be emphasized.
- DO** study color swatches in both daylight and night-light, because colors often change under artificial lighting.
- DON'T** choose neutral, negative or "noncolors," just because they are safe, or you may forfeit attractive decorating.
- DO** emphasize horizontal lines in a room that is too tall, and emphasize vertical lines in a room with a low ceiling.





Wickes pre-assembled  
**VACATION HOME**

PRICES  
START AT **\$4,000**  
(DECK OPTIONAL)

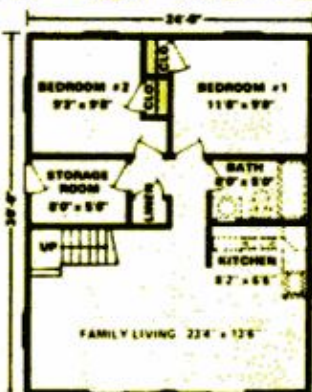

LAKE HAUS  
FIRST FLOOR PLAN

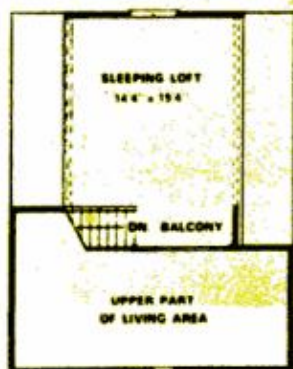

LAKE HAUS  
SECOND FLOOR PLAN

**Start making your dream  
a reality...**

Now, you can have the vacation home you've dreamed of . . . at a price you can afford. The average do-it-yourselfer can easily erect the basic shell, using many pre-assembled components. Cost of materials for the shell unit pictured (less deck) starts at \$4,000\* on your

foundation. It has two bedrooms and a large sleeping loft . . . plenty of room for the family. Other models are also available at equally affordable prices. Custom-tailored finishing packages (interior trim, plumbing, etc.) are available to complete your dream home.

\* Exclusive of taxes and delivery — slightly higher in Wisc.

Send \$1.00 for "Quick & Easy" Planning Guide.



105L4

Name \_\_\_\_\_

Address \_\_\_\_\_ Phone \_\_\_\_\_

City \_\_\_\_\_ State \_\_\_\_\_ Zip \_\_\_\_\_

I plan to build \_\_\_\_\_, at \_\_\_\_\_

(when)

(where)

THE WICKES CORP. / P.O. BOX 3244-L / SAGINAW, MICH 48605



**Wickes  
Lumber**

Sec4

Available through over 100 Wickes Centers in: Ark, Conn, Del, Ga, Ind, Me, Md, Mass, Mich, NH, NJ, NY, Ohio, Okl, Pa, RI, SC, Tex, Va, Vt, Wisc, and adjoining areas.

# DEFTHANE gives protection from the elements



Use Defthane,  
the "super hard"  
clear finish on  
wood or metal.



**DEFT** "the wood finish people"  
612 Maple Ave., Torrance, Calif. 90503

## RIGHT WAY TO PAINT A ROOM

*(Continued from page 186)*

dercoating or primer to seal the patch.

If your ceiling is quite high, it will be necessary to rig a raised platform from which you can easily reach its surface. Two sturdy stepladders and a wide plank will serve your purpose. Always remember to place your plank so that it extends at least a foot beyond the step of the ladder on which it rests.

Next, remove all hardware from doors and windows, loosen the canopies on your lighting fixtures, or cover these areas with masking tape and newspaper or cloth. This will make your painting job easier and give you a chance to clean and polish the metal until it looks like new.

Dust your walls thoroughly with a dry mop, except in the kitchen or bathroom, where walls are likely to be covered with grease, or steamed-on dirt. These walls will need to be washed with a household cleanser before they're ready to be repainted.

You're now ready to paint, but even

*(Please turn to page 203)*

### When using a roller . . .

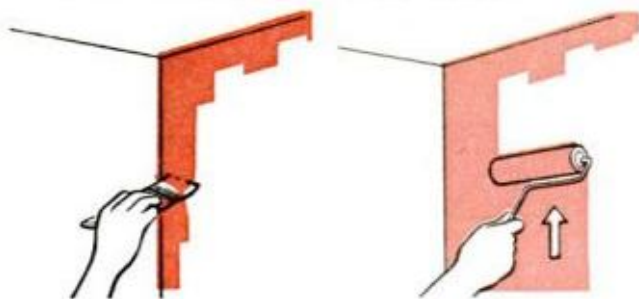

**1** Brush on a strip of color about 12 in. in width just below ceiling line. Paint out from all inside corners from the ceiling to the baseboard

**2** Always roll upward with freshly loaded roller. Start short distance from brushed area; work toward it. Limit rolling to 2-ft. strips

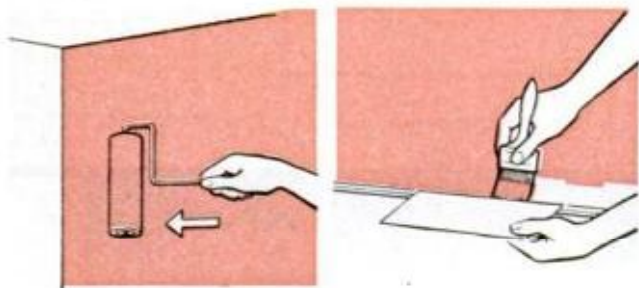

**3** After you coat area of about 2x3 ft. with up and down strokes of your roller, go over all of this area using side to side roller strokes

**4** At bottom of walls, use a brush wherever the roller can't reach. Use of cardboard guard will help to keep the paint off the woodwork

POPULAR MECHANICS

Материал, защищенный авторским правом

# Meet the payments with monthly meetings.

Monthly meetings in the Army Reserve mean a steady extra income. Money to buy a bike. Or a new car. Money to save for a son's college education. Money to salt away for a comfortable retirement.

You attend one of these weekend meetings a month in the Reserve. And you also spend two weeks each summer sharpening your skills.

This all starts, of course, after four or five months of basic and advanced training.

If long-range success is just as important to you as instant money, you can keep moving ahead in the Reserve by earning promotions.

We'll even send you to school to learn a civilian career skill. We can offer you one of 300 courses, depending upon the specific skill requirements of your local unit.

You can see that the Reserve has a lot of good deals going. So get going with the Reserve.



Army Reserve Opportunities  
P.O. Box 6834  
Philadelphia, Pa. 19132

Tell me more about how the  
Army Reserve pays.

Name \_\_\_\_\_ Age \_\_\_\_\_

Address \_\_\_\_\_

City \_\_\_\_\_

State \_\_\_\_\_

Zip \_\_\_\_\_

Phone \_\_\_\_\_

PM 4-73

**The Army Reserve.  
It pays to go to meetings.**

# New compact heating / cooling system stands outdoors

**Home  
Ideas  
Guide**

**A** BASEMENT FURNACE in your home could be a thing of the past. Amana has moved it outdoors and put it inside a standard central air conditioner to provide a combined heating-cooling system that requires only 8 sq. ft. of space.

Using an HTM (heat-transfer module) burner only 9 in. in diameter and 9 in. high, this tiny forced-air gas "furnace" (left, and below) has the capacity—120,000 B.T.U.—to heat the average home more efficiently and economically than the usually installed heating plant. Its two-stage, fuel-saving burner adjusts automatically to outside temperature. A low "fire" at 80,000 B.T.U. heats your house on mild days; a high "fire" at 120,000 B.T.U. does the work on cold days.

Starting with a sparkplug instead of a

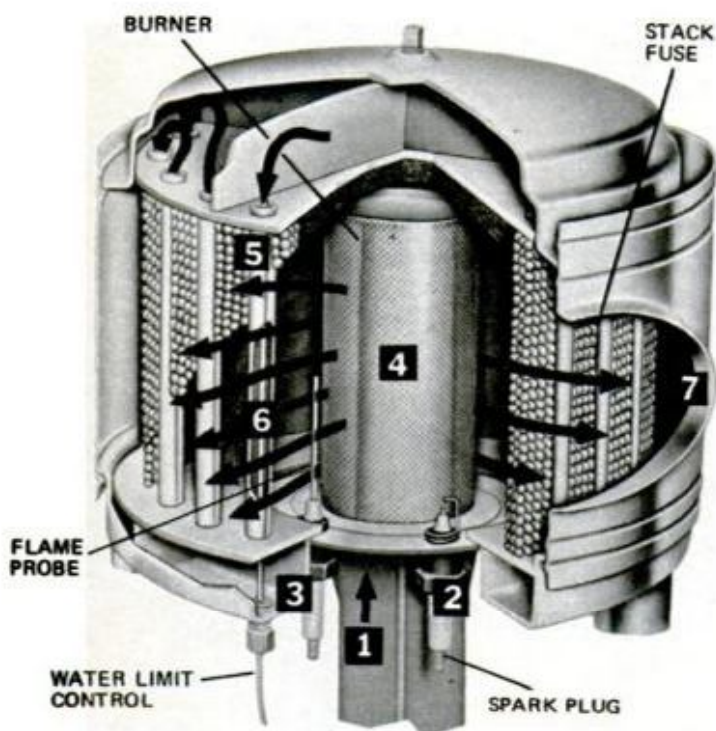

## HOW THE HTM BURNER WORKS

1. Gas is pulled from the gas valve by the combustion blower into the HTM (heat-transfer module) burner.
2. A sparkplug ignites the gas-and-air mixture in the burner.
3. A flame probe monitors the burner to give proof of combustion. If combustion doesn't occur, the flame probe will close the gas valve.
4. The stainless steel burner provides 9000 tiny flames that produce extremely hot flue gases.
5. Heat is transferred to an energy-storing liquid in the tubes as hot gases pass through a porous matrix, creating high turbulence to produce rapid heat transfer.
6. High-temperature limit control keeps solution from overheating. If it should overheat, limit control will shut down the system.
7. Gas burned produces 7 percent more usable heat because less heat escapes through the exhaust flue.

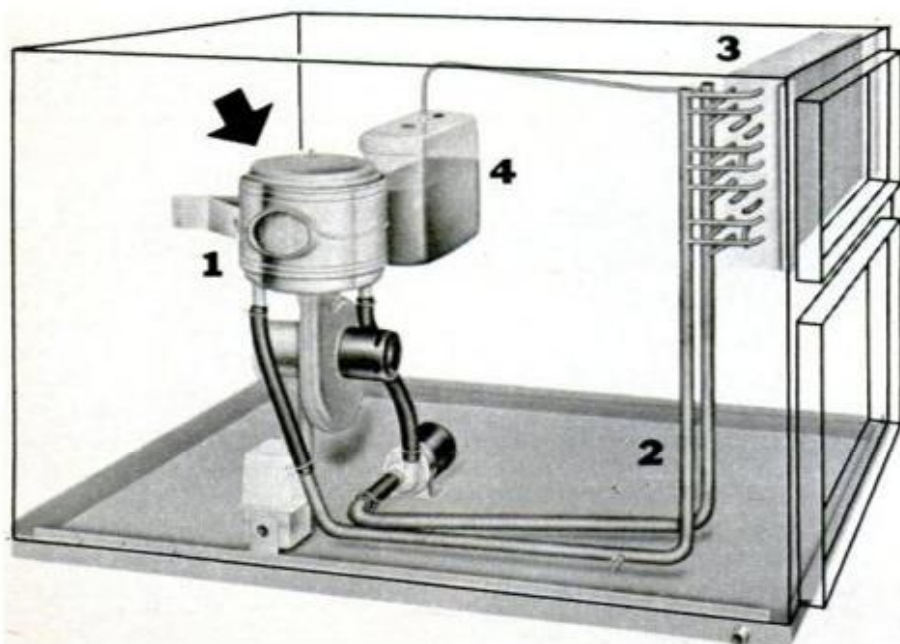

## HOW FURNACE WORKS

High-temperature gases created by the HTM burner (1) pass through a porous matrix of fused steel balls in which steel tubing is embedded. A liquid (ethylene glycol) is pumped through tubing (2) to carry off heat. Hot liquid flowing out of HTM then circulates through coil (3) and heated air is forced by blower through the fins and into ducts of the house. Cooled-down liquid is then returned to pump and another cycle begins. The increased volume of the heated liquid moves into an expansion tank (4) which provides a reserve storage area.

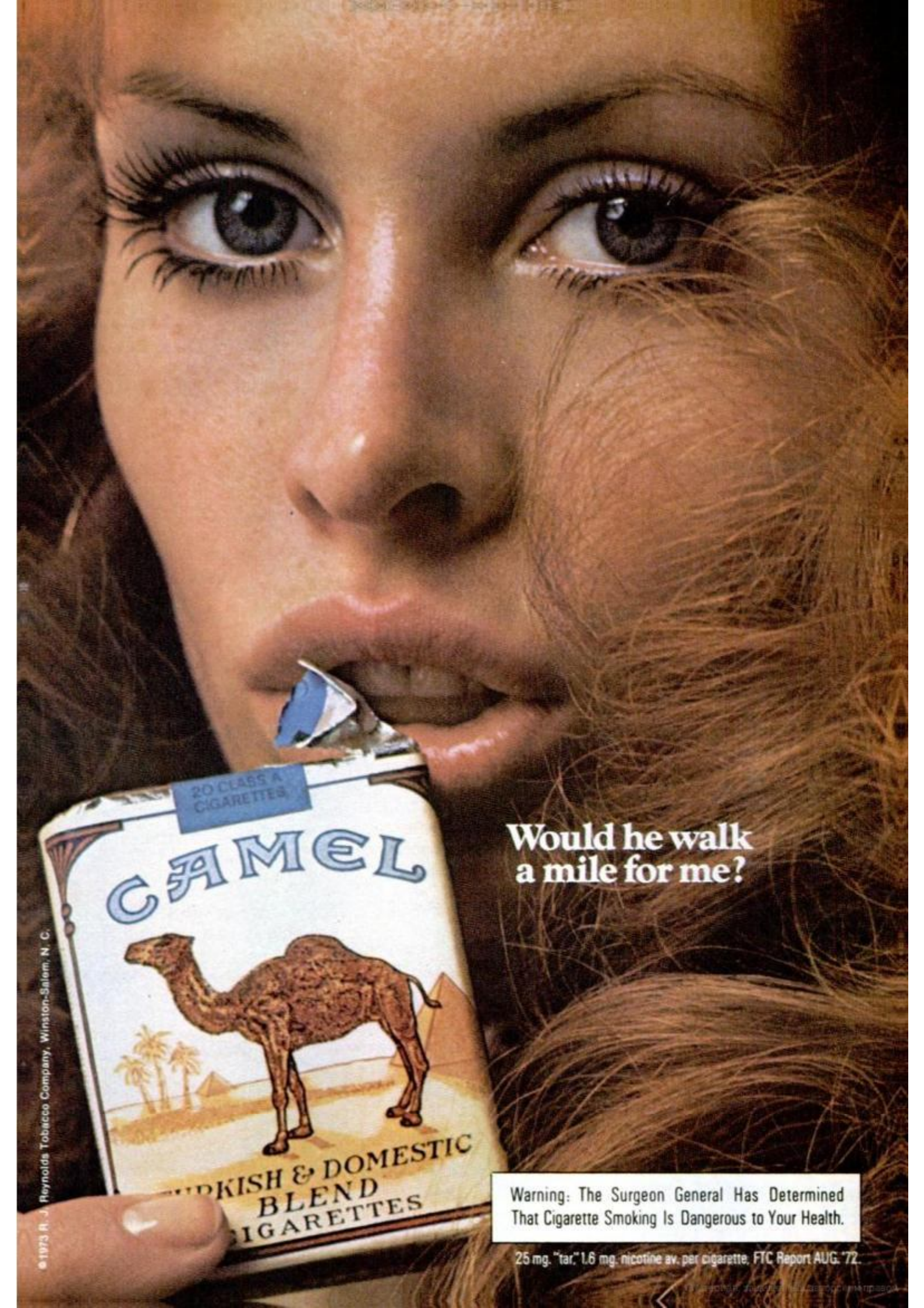

© 1973 R. J. Reynolds Tobacco Company, Winston-Salem, N. C.

20 CLASS A CIGARETTES  
**CAMEL**



**TURKISH & DOMESTIC  
BLEND  
CIGARETTES**

**Would he walk  
a mile for me?**

Warning: The Surgeon General Has Determined  
That Cigarette Smoking Is Dangerous to Your Health.

25 mg. "tar," 1.6 mg. nicotine av. per cigarette, FTC Report AUG. '72.

# HANDY LITTLE DEVILS FOR NASTY LITTLE JOBS.

Scraping . . . caulking . . . whatever the job, top-quality Red Devil tools and chemicals make it easy!

To prepare a surface for painting, remove loose, flaking or blistering paint with a Red Devil **Paint Scraper**. Its precision-ground blades reach into tight corners.



For sealing openings around door and window frames, use Red Devil **Caulk**. Unlike oil-base caulk, it flows on smoothly — and may be used under any paint without staining, bleeding-through or cracking. It requires no priming, and stays flexible for years.



It's easy . . . with the Devil!

## Red Devil

Red Devil Inc.  
Union, N.J. 07083



Replace worn entry carpet  
with beautiful TEAK Parquet

## INSTALL A FOYER FLOOR YOURSELF

FOR AS  
LITTLE AS **\$29<sup>00</sup>\***



\*Suggested  
retail;  
5'x5'  
Amazon  
Teak.

Amazon Teak™  
Clustered  
square  
pattern.

Also available in  
Singapore Teak shown at top.



- Prefinished, waxed at factory
- Lays like tile, no nailing

Greet your guests on a stylish, prestige parquet floor of colorful teak — the wood of shipdecks. Perfect for damp foot traffic, hard wear. Exotic Teak lends elegance to any room. See your lumber or floor covering dealer.

Get Free Full Color Literature. Write today.

## WOOD/MOSAIC PRODUCTS

DEPT. M

OLINKRAFT, INC. Building Components Div.  
P.O. Box 21159, Louisville, Kentucky 40221

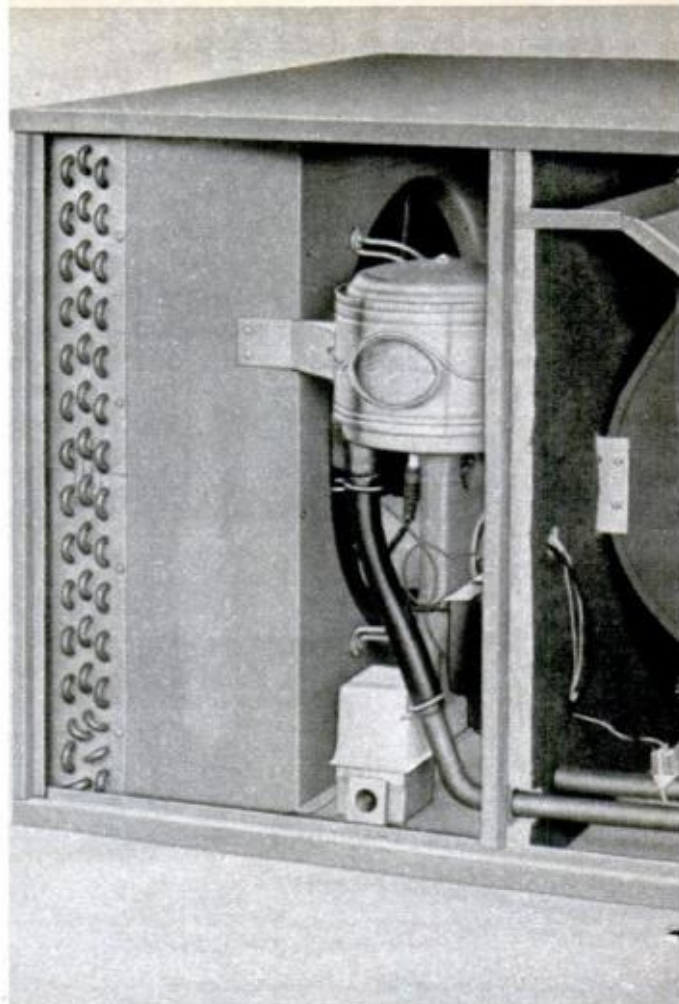

pilot light, the unit is claimed to deliver heat to registers in 15 seconds. Nine heat sensors and relay controls keep close tabs on its water thermostats and flame probes. Perhaps it's one of the safest gas furnaces made—the HTM burner holds only about 1/10 cu. ft. of gas/air mixture compared to 3 or 4 cu. ft. in a conventional furnace. And because of indirect heating with a solution, gas or combustion vapors can't get into the home.

For cooling, a standard central air conditioner (shown above, with side removed) is available in sizes ranging from 24,000 to 60,000 B.T.U. It's combined with the furnace in a case no larger than it

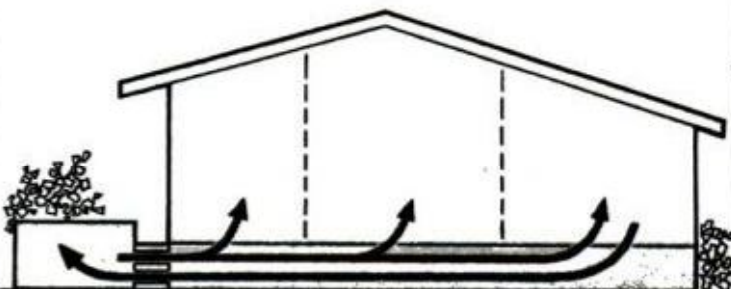

**TYPICAL INSTALLATION** shows how air flows out of home, through unit for reheating and back into rooms

POPULAR MECHANICS

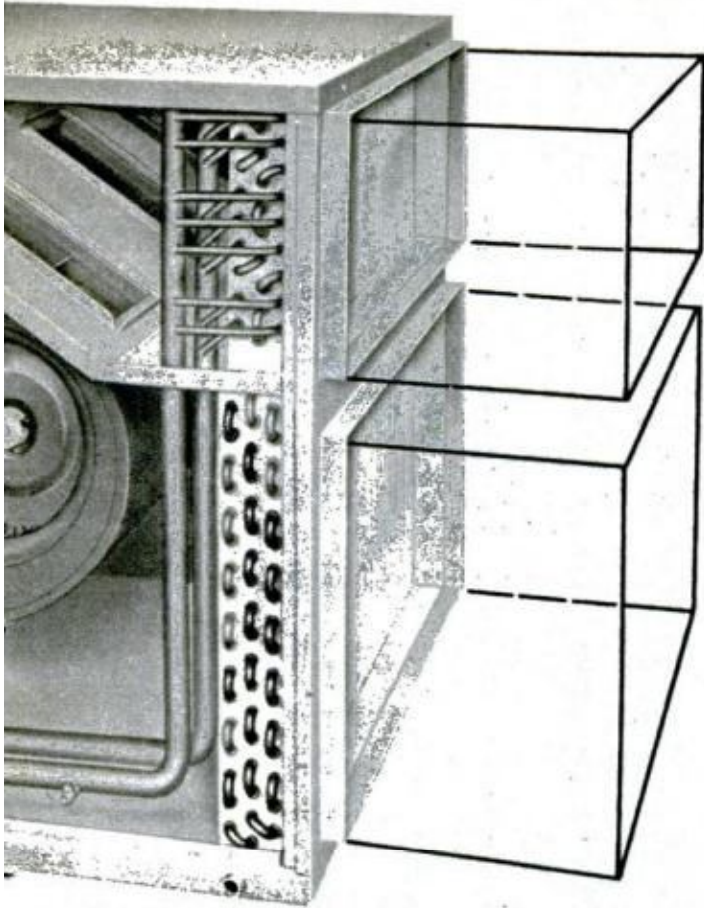

**DUCT EXTENSIONS** pass through wall of house to join unit to existing or new heating ducts installed inside

would be to house the conditioner alone.

The unit comes prewired; it needs only gas and electrical hookups. New or existing ductwork is simply extended from the house through an outside wall. For more information, write to Amana Refrigeration, Inc., Amana, Iowa. ★★★

**CONVENTIONAL GAS BURNER** shown with HTM burner that produces thousands of tiny, very hot flames

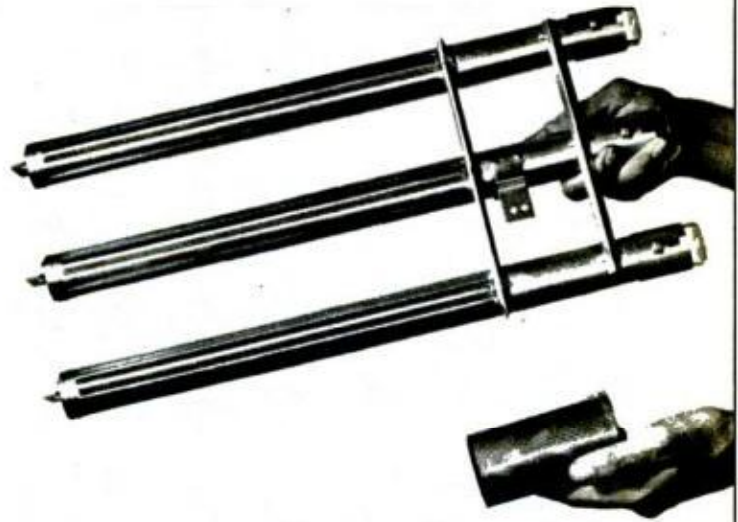

**Ridgeways come in 39 different lifestyles.**

So you can match your taste and your home with one of the eight shown, or 31 others. In your choice of 12 wood finishes, 10 decorator colors, and three chime

sets. All with fine Virginia cabinetry, precision movements from Germany's Black Forest, and surprisingly affordable prices. See them at your favorite store.

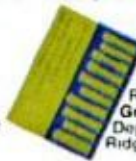

**FREE.** Send for this colorful brochure complete with decorating ideas and the dealers near you.  
Ridgeway Clocks Division  
Gravely Furniture Co., Inc.  
Dept. PM 731  
Ridgeway, Virginia 24146



# ARROW®

HEAVY DUTY T-50

## STAPLE GUN



**SHOOTS  
A STAPLE**  
Wherever You'd Drive A Nail!  
**FASTER... BETTER... CHEAPER!**

T-50  
\$13.95



**1/4" STAPLE**  
for tacking window screening, shelf papers, closet linings, window shades, draperies, etc.



**5/16" STAPLE**  
for tacking light upholstery, leatherettes, cornices, quilting for closets, wall decorations, etc.



**3/8" STAPLE**  
for fastening light insulation, roofing papers, electrical wires, weatherstripping, wire mesh, etc.



**1/2" STAPLE**  
for tacking underlayments for carpets, porch screening, felt stripping, canvas, fiberglass, etc.



**9/16" STAPLE**  
for tacking metal lathing, cornerite, wire fencing, roof coverings, insulation board, etc.



**CEILTILE**  
staple - especially made for safe, secure installation of ceiling tile.

**TRY IT-SEE FOR YOURSELF!**

Available at **HARDWARE • LUMBER • BUILDING MATERIAL**  
**• STATIONERY • VARIETY** and Other Retail Outlets

**ARROW FASTENER COMPANY, Inc.**  
Saddle Brook, New Jersey 07663

## GLAMOR KITCHEN LIGHTS

(Continued from page 161)

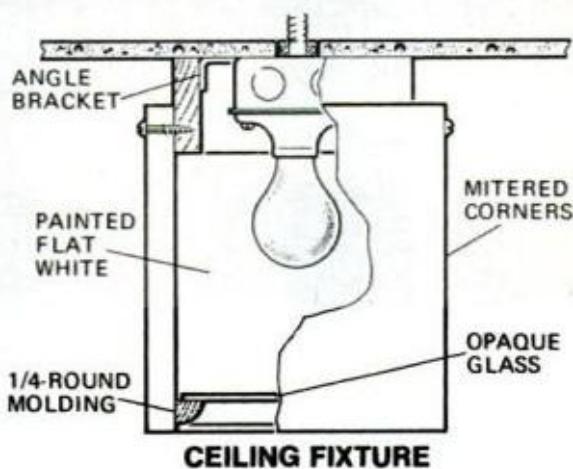

**SIMPLE BOX FIXTURES** with corners mitered are made to slip over inner wood sleeves attached to ceiling

yet makes lamp replacement an easy task.

Lamps under cabinets are shielded from view by a faceboard attached to the fronts. Use Deluxe Warm White lamps here; wattage depends on the total countertop area. Lamps over draperies are shielded so light spills out top and bottom. In all cases, rear side of faceboards should be painted flat white.

Attractive modern downlight fixtures are simple to make by placing boxlike assemblies over ceiling-mounted junction boxes fitted with porcelain sockets. ★★★



# How to install plastic 'beams'

## Home Ideas Guide

**S**IMULATED "hand-hewn" wall and ceiling beams offer one of the easiest ways to add decorator elegance to an interior remodeling job.

Available prefinished and ready-to-install, the easy-to-work beams can even be cut with a bread knife. They're applied using adhesive, nails or a clip-system designed by the manufacturer. Unfinished beams—which can be stained or painted as you prefer—are available by special order.

Ceiling beams come in 8 to 18-ft. lengths (in 2-ft. graduations); wall beams are sold in 8, 12 and 16-ft. lengths. The accessories available for use with the beams include matching corner braces with 45° mitered ends, recommended adhesive for best results, matching stains to disguise any marks, and simulated hand-hammered brackets for covering beam joints. For more information and sources, write Paeco, Inc., Dept. PM, 500 Market St., Perth Amboy, N.J. 08861.

PHOTO BY WILLIAM OAKLEY



**WARMTH AND CHARM** of 200-year-old beams is captured realistically with replicas of expanded urethane

*(Please turn to page 197)*

# "One bathroom to go please."

Introducing Versa-Bath, the latest innovation from Borg-Warner. Because the bathing area is such an important part of the total bathroom, Versa-Bath can transform an ordinary bathroom into a room that is a decorator's delight. What is Versa-Bath? It's a four-piece bath/shower cove made of fiberglass bonded together with sturdy, rigid, Miracril Acrylic®. It's leak proof, stain resistant, acid resistant, and comes in Borg-Warner decorator colors to match other Borg-Warner bathroom fixtures.

The complete four-piece cove is packaged in a single carton that's only 24" x 35" x 62" — which means you can take it home with a car as small as a Volkswagen and carry it through any standard doorway.

The unit's wall panels are rigid and self-supporting and require no extra subwalls. And because Versa-Bath assembles entirely from the front, it can be installed in a bathroom as narrow as 5'. You will find cleaning your Versa-Bath a pleasure. Just wipe it down with a mild detergent and water, and it will retain its original lustre.

This new unitized bath/shower cove system is just one of the many innovative products that make the Borg-Warner Bathroom — a concept that includes a colorful selection of coordinated bathroom fixtures for new homes or remodeling.

Remodelers will find Versa-Bath sold in carry-out form at leading building supply stores nationally. Why not stop and look at one today.

For your nearest Borg-Warner Dealer call this special number free, 800-243-6000, anytime, any day. Dial as you normally dial long distance. (In Connecticut dial 1-800-882-6500). Or write Borg-Warner Corporation, Plumbing Products Division, Mansfield, Ohio 44902.

  
*The Borg-Warner bathroom*

**BORG-WARNER**

# Johnson's 135. Quick starts. More power. Less gas.



When you plan your new bass rig, plan on a dependable, fast outboard. One that has won races. And bass tournaments. Like our top-of-the-line 135 hp.

It has MagFlash™ capacitor discharge ignition for quick, sure starts and long, long plug life.

Exhaust tuning, which uses sound waves to produce more horsepower. On less fuel.

Power Shift II for easy, hydraulic-mechanical shifting.

An automotive-type alternator to handle electrical accessories, like lights and fish finders.

Solid V-4 engineering that puts big power in a com-

pact, easy to fish-see-ski over shape. And a low center of gravity to provide more stability in turns.

And you can add an extra-cost power trim and tilt accessory for on-the-move adjustments in boat attitude as load and water conditions change.

The 135. More engine than you bargained for.

For boats rated for less horsepower, look over our 115 and 85 hp Vs with the same features. Or the mid-sized 65 and 50 hp. Our 12 power choices start at 2 hp.

At your Johnson dealer's. Your boating and fishing headquarters. **Johnson's thinking of you.**

*First in dependability.*  
**Johnson**  
outboards

Division Outboard Marine Corporation. Write for our free catalog. Johnson Outboards, Sea-Horse Drive, Waukegan, Illinois 60085. Dept. PM-473

## INSTALLING PLASTIC 'BEAMS'

(Continued from page 195)

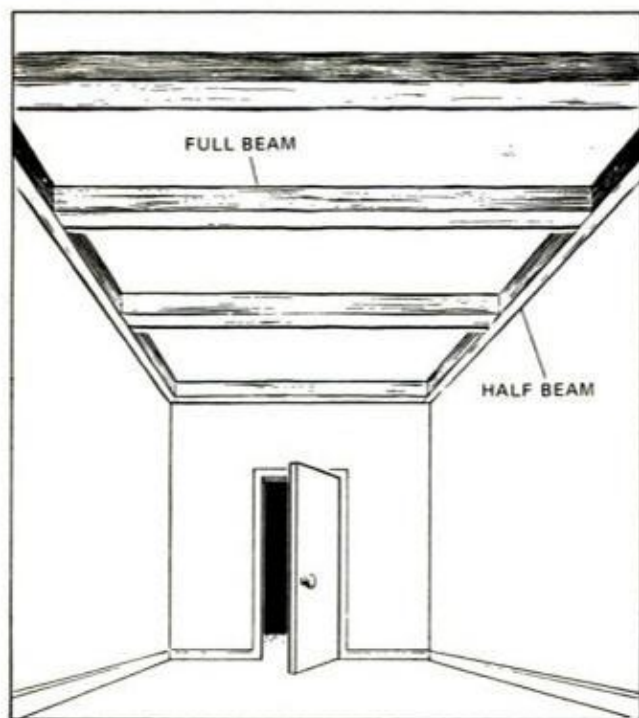

Before cutting any material, you would be wise to make a scale drawing of the room indicating beam locations. If the room is long and narrow, run the beams crosswise to provide the illusion of a wide room. The apron around the room, at the wall-ceiling angle, is created by using half-beams to make it seem that the other half is *in the wall*.

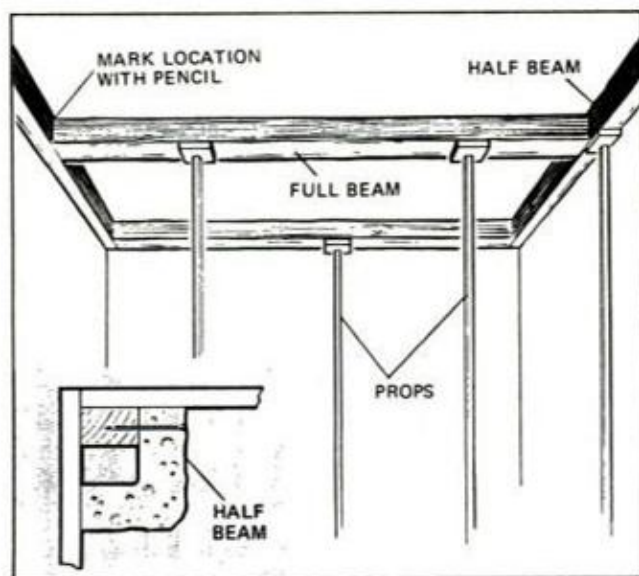

To assure snug butt joints, cut beams one at a time and temporarily prop them in position with thin sticks wedged between floor and beam (use block of wood under beam to prevent damage). To install half-beam apron permanently along ceiling line, first nail furring strip in the angle, then use adhesive and 8d finishing nails.

(Please turn to page 198)

## Try the joint fixer

from

# DAP



DAP Latex Caulk guns easily to fill cracks, joints and gaps in siding, around windows and doors. Takes paint after only two hours. Stops leaks. Won't stain, blush or bleed through paint.

### America's First Name in Home Fix-up



DAP Inc., Dayton, Ohio 45401  
Subsidiary of *Plough, Inc.*

## Try the finishing fixer

from

# DAP



INDO™ Satin Finish puts that mellow look on wood surfaces — gives a deep, satin-like glow to cabinets, furniture, antiques. Brushes smoothly. Dries fast.

### America's First Name in Home Fix-up



DAP Inc., Dayton, Ohio 45401  
Subsidiary of *Plough, Inc.*



The real beauty of Lindal Cedar Homes. . .

# Walls that were made for each other.



Our double walls of thick, pre-cut cedar planks *lock* together for fast, weather-tight assembly—with precious little nailing! Extra-thick floor and roof decking also dovetails for both savings *and* strength. For details, prices, and 82 house plans, send \$1 for your Lindal Planbook.

**LINDAL CEDAR HOMES**

10411 Empire Way S.  
Seattle, Wa. 98178  
Phone (206) 725-0900

Enclosed is \$1. for my Lindal Cedar Homes Planbook.



PM-34

Name \_\_\_\_\_

Address \_\_\_\_\_

City \_\_\_\_\_

State \_\_\_\_\_ Zip \_\_\_\_\_

Area Code \_\_\_\_\_ Phone \_\_\_\_\_

*Lindal homes are sold throughout the world.*

## INSTALLING PLASTIC 'BEAMS'

*(Continued from page 197)*

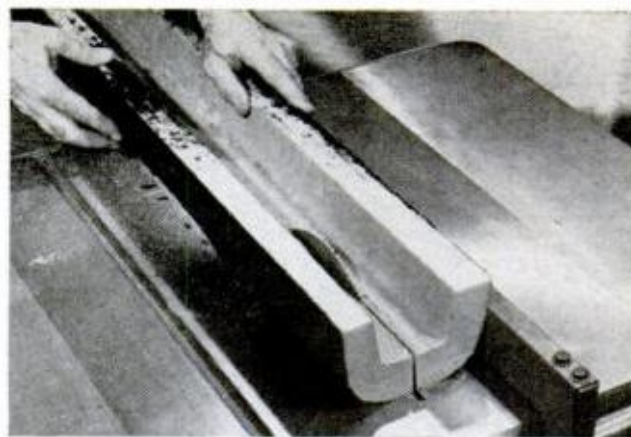

A table saw equipped with a fine-tooth combination or plywood blade is ideal for cutting urethane beams. If you don't have this equipment, the cutting will still be easy with a sharp, crosscut handsaw (and square)—it just takes slightly longer. To rip a U-shape beam, run it upside down (above) for safety and sufficient blade protection.

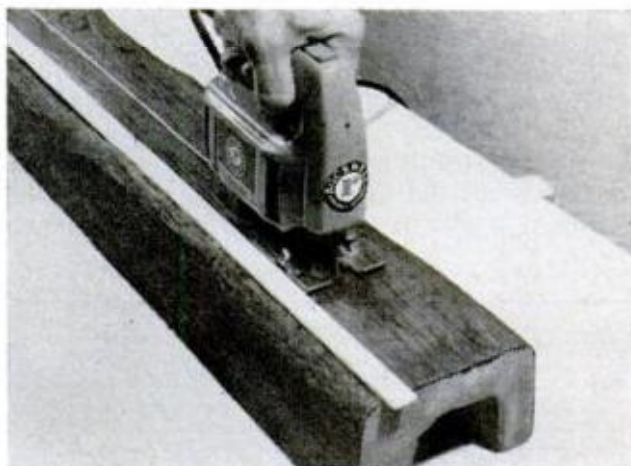

**BEAM CAN ALSO BE RIPPED** with a sabre saw after tacking a wood strip to the plastic for use as fence



**WHEN CROSSCUTTING**, if blade won't cut beam with one pass, make initial cut and turn over to complete

*(Please turn to page 200)*



**"For an amateur,  
he's a whiz.  
How'd he get  
so good?"**

Whatever practical skills you've been wanting to develop, Audel has comprehensive, step-by-step Guides to help you. They show you all the professional tricks of the trades

in clearly diagrammed and illustrated "how-to" steps. They can save for you, over and over. Here are four of Audel's many fields . . .

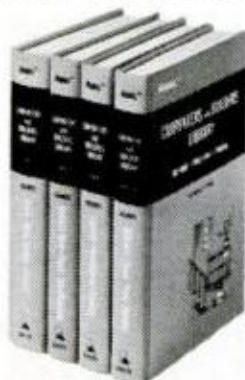

**CARPENTERS AND BUILDERS LIBRARY**

1612 pages of the latest information on modern construction in four volumes. They cover every phase of carpentry from foundations to finishing with easy-to-grasp, step-by-step instructions . . . all illustrated with thousands of diagrams, charts and photos. No. 23169 — 4 Volumes — \$18.50

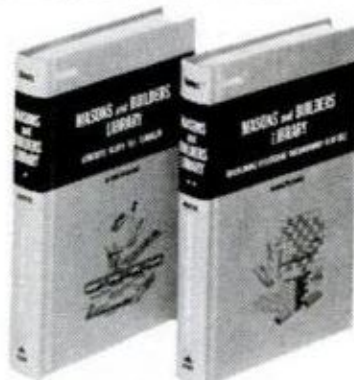

**MASONS AND BUILDERS LIBRARY**

Two illustrated volumes on the science of masonry and bricklaying. Packed with how-to information and directions, rules, processes, definitions, formulas, diagrams, tables, estimating. A complete and authentic trade reference library. 752 pages. No. 23185 — 2 Volumes — \$11.25



**PLUMBERS AND PIPEFITTERS LIBRARY**

A valuable 3-volume guide to the principles, methods and short cuts of modern plumbing. Tools, fittings, fixtures, installation, drainage, welding and much more are all covered in these fully illustrated, easy to understand volumes. No. 23155 — 3 Volumes — \$12.50

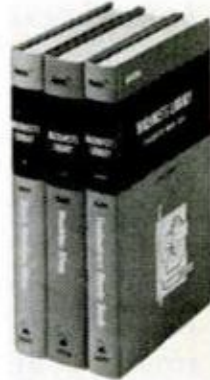

**MACHINISTS LIBRARY**

Three books covering the entire field—1216 profusely illustrated pages on practical fundamentals of basic machine shop operations, setup and operation of spot machines, down-to-earth data on toolmaking procedures, layouts, jigs and fixtures, etc. . . . equally valuable for beginners and experienced men alike. No. 23174—3 Volumes—\$16.95

**MONEY BACK GUARANTEE**

Send no money! We'll send you any Audel Guides for 10-day FREE EXAMINATION. If you keep them, you may use our easy payment plan. If not completely satisfied, return them for refund.

**THEODORE AUDEL & CO.**  
Division of  
Howard W. Sams & Co., Inc.  
Indianapolis, Indiana 46268

**SEND NO MONEY—10-day FREE EXAMINATION**

Theodore Audel & Co.—Self Improvement Publishers since 1879  
4300 West 62nd Street, Indianapolis, Indiana 46268

P043

Please mail me for 10 day's FREE EXAMINATION the books I have checked at right. I agree to mail \$3 in 10 days for each set ordered and to further mail 1/3 of the purchase price 30 days later, with balance plus shipping costs to be mailed within another 30 days. I may return the books for refund if not completely satisfied.

Save shipping costs. Check here  if you enclose full payment (plus sales tax, if any). We will pay postage charges. You have same return privilege.

Name \_\_\_\_\_  
Address \_\_\_\_\_  
City \_\_\_\_\_ State \_\_\_\_\_ Zip \_\_\_\_\_

- 23169
- 23185
- 23155
- 23174



For the man who takes care of his own yard.

All the chain saw you need costs just

**\$99.95\***



It's the **6.9 lb.\* Mini Mac 1. Only McCulloch makes a saw this light, for this little.**

The right tool for the right job — you know that's what counts. So if all you use a chain saw for is limbing, trimming and cutting firewood around your own



yard — this is *all* the saw and *all* the power you need! It's lighter than any saw in the world for the price. Its 10" bar will cut a 6" log in just 5 seconds and even zip through 20" logs. And it comes with something you just can't acquire anywhere else — McCulloch's 26 years of professional chain saw engineering know-how. So, now you can get the best saw specially designed for your yard — the Mini Mac 1 — for only \$99.95.\* Why pay more?



← 20" →

**McCulloch**

McCulloch Corporation, 6101 West Century Blvd., Los Angeles, Calif. 90045

\*Manufacturer's suggested list price, including bar and chain. Prices slightly higher in Canada and Alaska.

\*\*Weight less cutting attachments.

## INSTALLING PLASTIC 'BEAMS'

(Continued from page 198)

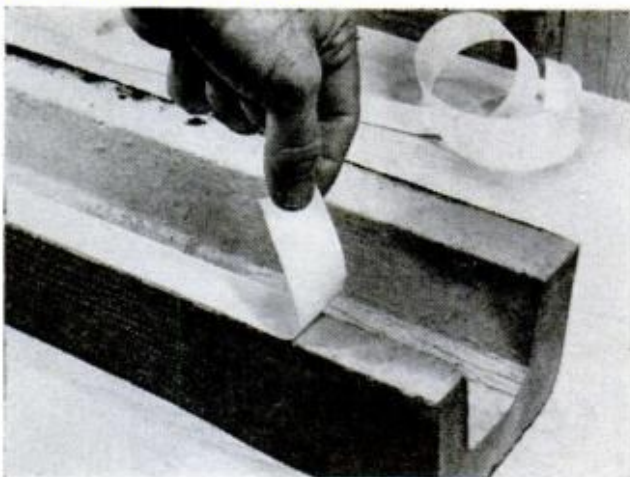

Techniques for attaching plastic beams: When using self-sticking beams (above), you just peel off tab and stick into place. If installing beams to be positioned between joists (drawing below), strike centerlines where beams will be applied, and then install suitable-width furring strips using toggle bolts. Beams are then secured to the furring strips with adhesive and 8d finishing nails. When applying adhesive with a caulking gun (photo, below), add it sparingly down the center of the beam surfaces to avoid squeeze-out on ceiling or wall when you press beams in place. Finally, set finishing nails, fill heads. ★★ ★

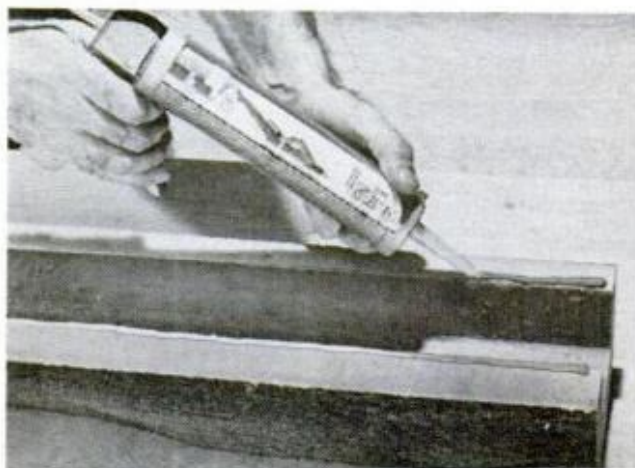
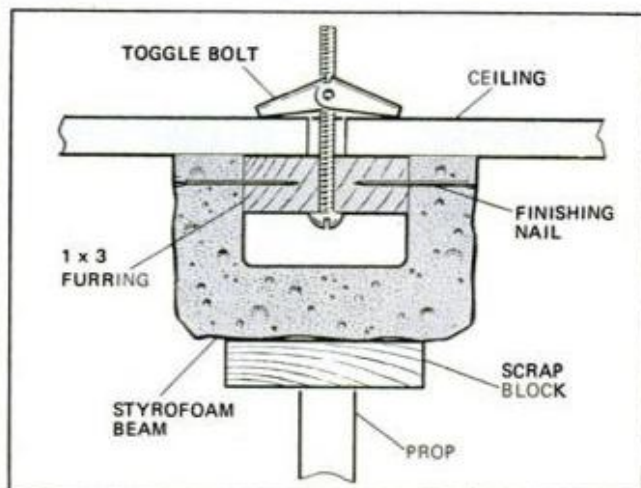

# New products for home improvement

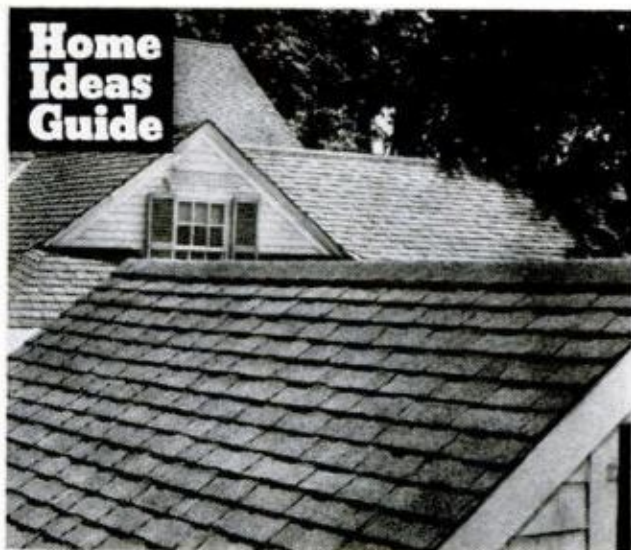

**ROOF WITH THE RANDOM**, custom-style boldness of texture blends particularly well with most types of architecture—contemporary, colonial or mansard. Labeled Architect 70 Shingle, the heavy-duty material weighs 345 lbs. per square (100 sq. ft.) and carries the Underwriters Laboratories Class C fire label. Sold with 25-year warranty against manufacturing imperfection by Bird & Son, East Walpole, Mass. 02032



**THESE SELF-ADHESIVE** foam-rubber, cushion-backed carpet tiles create pattern through the use of texture. They can be installed in-line, color-mixed to personal taste or laid for parquet effect—by laying tiles at right angles to one another. Called Colony Point Tiles, carpeting can be installed outdoors as well as in. Available in five colors, 12x12-in. tiles sell for 79 cents each. Ozite Corp., Libertyville, Ill. 60048

*(Please turn to page 202)*

APRIL 1973

For the  
man who  
needs  
power  
to go



## McCulloch Portable Generators

Here's electric power where you need it, when you need it — on camping trips, outdoor building projects, for standby power during storms, blackouts and other power emergencies. McCulloch's super lightweight generators are small enough to fit in the back of your car. And the unique design, with only one moving part, means they're the most reliable you can buy. Three sizes, all with our Double Warranty.



**H-1500.** 1,500 watt capacity. 68 lbs.  
115 volts. 60 cycles. **\$199.95\***  
Only

**H-2000.** 2,000 watt capacity. 83 lbs.  
115 volts. 60 cycles. \$289.95\*

**H-3000.** 3,000 watt capacity. 129 lbs.  
115 or 230 volts. 60 cycles. \$399.95\*

*\*Manufacturer's suggested list price. Slightly higher in Alaska and Canada.*

**McCulloch**

McCulloch Corporation  
6101 West Century Boulevard  
Los Angeles, California 90045

201

# Eureka

YOU HAVE FOUND IT

WD-40 the handy aerosol spray that:  
**Stops Squeaks**  
**Protects Metal**  
**Loosens Rusted Parts**  
**Frees Sticky Mechanisms**

Set your whole house **FREE!** WD-40 lubricates without any mess and prevents rust and corrosion. Makes sliding doors, windows or drawers work free and easy!



**WD-40 makes light oil old-fashioned**

Send 25¢ for aerosol SAMPLE to Dept. 18

**WD-40 COMPANY**

5390 Napa St., San Diego, CA 92110

## HOME IMPROVEMENT PRODUCTS

(Continued from page 201)

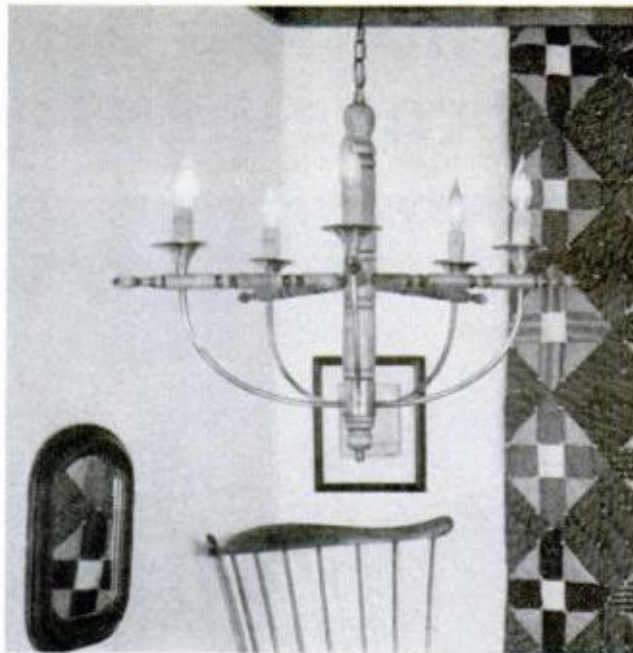

**SHAKER SIMPLICITY** in this Early American room shines brightly with a burnished brass and light oak chandelier. Available at department stores and lighting centers, fixture is priced at \$99.50. A chain-hung light and matching ceiling light accented by maple wood and a flat-black finish are also featured in its distinctive Shaker group of fixtures by Thomas Industries, 207 East Broadway, Louisville, Ky. 40202

## America's No.1 'holding' company.



No matter what Elmer's\* you use, you can be sure it's going to hold.

Elmer's Glue-All: for wood, leather, paper and cloth. Even Styrofoam\*:

Elmer's Epoxy: extra tough. For metals or bonds that need to be water-proof.

Elmer's Contact Cement: where you can't use clamps. Bonds instantly.

Elmer's. The glue that puts it all together. For good.



For Elmer's brand new handyman booklet containing ideas on how-to "make and fix" many things around the house, send 25¢ for postage and handling to Elmer's "Make-It & Fix-It" Booklet, Dept. MFS, Box 266, Medina, Ohio 44256.

\*Registered Trademark of Dow Chemical Co.



## RIGHT WAY TO PAINT A ROOM

(Continued from page 188)

before you pry the lid off the can, read the label. The paint manufacturer knows his product and the best way to apply it. Every suggestion on the label should be followed.

Before starting to paint, play it smart and rub protective hand lotion or cream onto your hands and arms. A film of lotion makes it easy to remove paint from your skin when the job is done.

Cover floors and furnishings with drop-cloths—old sheets will do. No matter how well you cover up, however, some splatters will always appear. Incidentally, paint is easier to remove when it is wet, so clean up as you go along.

When painting a ceiling, work across the width—rather than the length—of the room. This enables you to begin a second lap before the first has completely dried. Confine each strip you paint to a width of two feet, both for good lapping and to avoid unsafe reaching.

When you begin on the walls, start at an upper left-hand corner and work down toward the floor. Follow this procedure

whether using brush, roller—or both. If you are left-handed, work from right to left.

When it comes to the woodwork, use a round 1-inch brush for window sash and a 2 or 3-inch one for the rest of the trim. When you're painting paneled doors, it's a good idea to coat the panels first, then the center rail. Top and bottom rails come next, then the vertical stiles and the edges last. ★★★

### LIGHT REFLECTANCE OF VARIOUS COLORS

If you wish to make the most of the natural and artificial light within a room or to soften the sky-glare that sometimes enters through large glass areas, remember dark colors absorb light, while light ones reflect it. This chart will help you select colors that best serve your purpose. Numbers below indicate the percentage of light reflectance for 14 representative colors:

|               |    |                  |    |
|---------------|----|------------------|----|
| White         | 80 | Salmon           | 53 |
| Ivory (light) | 71 | Pale apple green | 51 |
| Apricot-beige | 66 | Medium gray      | 43 |
| Lemon yellow  | 65 | Light green      | 41 |
| Ivory         | 59 | Pale blue        | 41 |
| Light buff    | 56 | Deep rose        | 12 |
| Peach         | 53 | Dark green       | 9  |

## TEFLON-S\* coated saw blades cut quicker, cooler, easier.

When your power saw blade is coated with TEFLON-S you get a lot of work-saving advantages. With non-stick TEFLON-S finishes, you cut cleaner, smoother, cooler and faster.

A quick swipe with a rag leaves your blade ready for storage with no rust worries.

You come out ahead with saw blades coated with TEFLON-S.

\*TEFLON-S is Du Pont's registered trademark for its non-stick and self-lubricating finish.



# DISSTON

---

# TEFLON<sup>®</sup>-COATED



# WORTH WRITING FOR

LOOKING FOR IDEAS AND INFORMATION ON HUNTING, FISHING, CAMPING, BUILDING, TOOLS, ETC.? CHECK THESE LISTINGS, THEN USE THE COUPON BELOW.

## 139. INSTALL YOUR OWN SUSPENDED CEILINGS

New decorative ceilings which enhance the best rooms in the house can now be installed by the do-it-yourselfer. This illustrated product bulletin shows how easy it is to install the new Integrid ceiling system. Well worth looking into. From Armstrong Cork Co. Free.

## 140. A HOST OF WOOD STAINS

Color foldout suggests how to achieve the most from wood's natural beauty of grain and texture. Folder shows 66 colors and gives complete instructions for staining over painted rough wood and obtaining the best results on new wood. From Olympic Stain. Free.

## 141. DO YOUR HOME FIX-UP JOBS EASIER

Colorful brochure gives details on the complete line-up of DAP fixer products. DAP fixes rust, metal, gutters, panels, woods, windows, just about everything. From DAP Inc. Free.

## 142. BATHROOMS CAN BE BEAUTIFUL

Learn how to decorate your bathroom with this booklet from Borg-Warner. Contains 25 plans and innumerable suggestions to help the homeowner be his own interior designer. 50¢.

## 143. 1973 HOWARD SAMS TECHNICAL BOOK CATALOG

Catalog lists over 400 books with emphasis on electronics and allied areas. Interesting and informative. From Howard W. Sams & Co. Inc. Free.

## 144. DON'T BURN IT—BAG IT

Amerind-MacKissic offers the latest information on their rugged "Mighty Mac" shredder-grinders. Find out how these heavy-duty machines make light-duty work out of disposing of your garden waste. Free.

## 145. 6 ROOM SAVER IDEAS WITH INSTRUCTIONS

Here's a bunch of idea booklets with colorful photos on how to decorate all the rooms of your house with wood paneling. All from U.S. Plywood. 25¢.

## 146. HIT THE MARK FOR SAFETY

Excellent booklet details "Proper Uses and Common Abuses of Striking and Struck Tools". This info can save your thumb a lot of pain. 25¢.

## 147. YOUR FLOORING DOESN'T HAVE TO BE BORING

Here's beautiful wood parquet flooring you can install yourself (or have done). Either way, an exciting new look for your home. Full-color brochures show patterns, specifications and installation tips. From Wood Mosaic. Free.

## 148. STRAIGHT TALK ABOUT ALUMINUM

Get straight answers to your questions about aluminum siding. Get Reynolds Straight-Talk Home Improvements Idea Book. From Reynolds Metals Co. Free.

## 149. PM'S PLANS, PUBLICATIONS, PROJECTS

Listed in this booklet are all the famous publications offered by PM—every "how-to" booklet

you could ever want. Also offered are plans and photocopies of a thousand and more great PM articles of the past. 25¢.

## 150. HOW TO INSTALL CEILING TILES SECURELY

Informative brochure illustrates how the Arrow T-50 Staple Gun Tacker is ideal for applying ceiling tile faster, better and cheaper. T-50 model assures non-fracturing of tile flange as well as permanent holding power. Arrow Fastener Co. Free.

## 151. "STICK'EM UP" IDEAS

Illustrated booklet gives 12 work saving ideas on how you can fasten just about anything to anything with this amazing product. From Macco Adhesives, Div. SCM Corp. Free.

## 152. GARDEN PROJECT BOOKLET

Step-by-step instructions on how to build planters, decorative screen block walls, flower bed edging, patio floors, seating walls, barbecues, pools, steps and walks with Sakrete Concrete and Mortar Mixes. 19 different projects. 25¢.

## 153. EVERYTHING YOU NEED TO KNOW ABOUT BATHROOMS

New Brochure explains the differences between good, better and best bathroom fixtures and fittings and helps select the right fixtures for any home or need. Eljer Plumbingware Div. Free.

POPULAR MECHANICS 473  
BOX 1718, SANDUSKY, OHIO 44870

Please see that I receive the items checked below. I have enclosed 35¢ for the overall service charge, plus remittance for any priced items.

- |                                    |                                    |                                    |                                    |
|------------------------------------|------------------------------------|------------------------------------|------------------------------------|
| <input type="checkbox"/> 139       | <input type="checkbox"/> 143       | <input type="checkbox"/> 147       | <input type="checkbox"/> 151       |
| <input type="checkbox"/> 140       | <input type="checkbox"/> 144       | <input type="checkbox"/> 148       | <input type="checkbox"/> 152 (25¢) |
| <input type="checkbox"/> 141       | <input type="checkbox"/> 145 (25¢) | <input type="checkbox"/> 149 (25¢) | <input type="checkbox"/> 153       |
| <input type="checkbox"/> 142 (50¢) | <input type="checkbox"/> 146 (25¢) | <input type="checkbox"/> 150       |                                    |

Total items requested \_\_\_\_\_ Total money enclosed \_\_\_\_\_

Name \_\_\_\_\_  
(Please Print)  
Address \_\_\_\_\_

Town \_\_\_\_\_ State \_\_\_\_\_ Zip Code \_\_\_\_\_

(Please send cash, check or money order made out to POPULAR MECHANICS. No stamps, please.)

NOTE: POPULAR MECHANICS processes your requests for the above information and forwards these inquiries to the organization making the offer. Each company mails the material directly. Please allow 4-6 weeks for delivery.

# 8½ lbs. of Skil power cuts 24-inch thick trees. [All the important numbers aren't on the price tag].

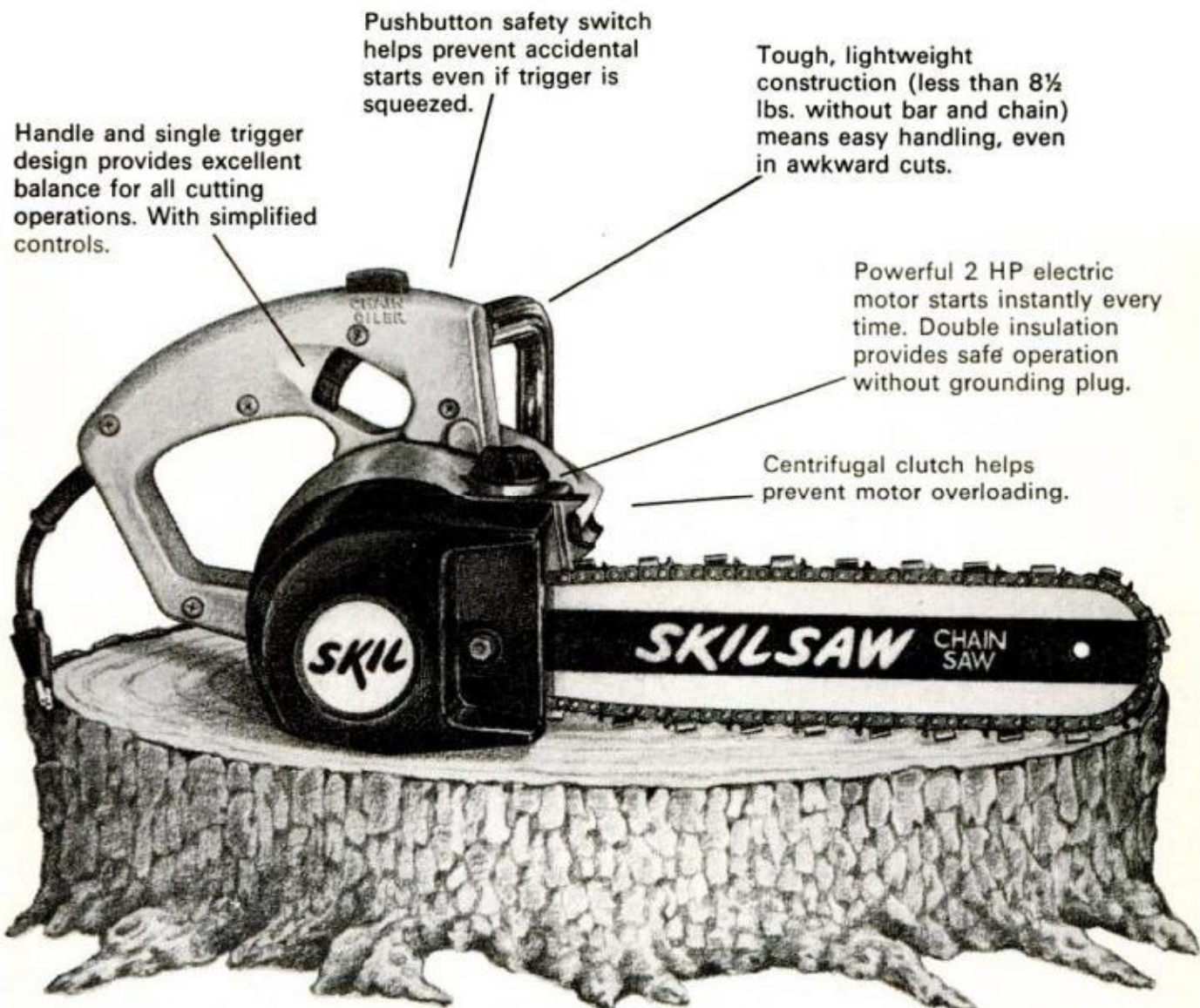

Handle and single trigger design provides excellent balance for all cutting operations. With simplified controls.

Pushbutton safety switch helps prevent accidental starts even if trigger is squeezed.

Tough, lightweight construction (less than 8½ lbs. without bar and chain) means easy handling, even in awkward cuts.

Powerful 2 HP electric motor starts instantly every time. Double insulation provides safe operation without grounding plug.

Centrifugal clutch helps prevent motor overloading.

These days almost every manufacturer puts attractive numbers on the price tags of chain saws. But the most vital numbers to look for are on the *fact* tag. Where you learn what a saw can do. Skil gives you a choice of gas

and electric saws that can handle all kinds of pruning, log cutting and brush-clearing jobs. The Model 1601 shown here, for instance, easily slices through trees up to 24 inches thick.

Skil chain saws start at just \$74.95 for electric and \$114.95 for gas.  
(Manufacturer's suggested retail price.)

# SKIL®

**Nobody was ever sorry he bought the best there is.**



# RIGHT!

A True Temper Rocket® Hammer is balanced right. It feels right. It swings right. It grips right.

You can choose from a wide range of hammers in the True Temper line. There's one that's right for every job, and there's one in the price range you need. When you're shopping for your new True Temper hammer, be sure to look for other True Temper products such as hatchets, axes, rakes, shovels and other lawn and garden tools.

**BE SAFE!** Always wear safety glasses when using a striking tool.

True Temper offers an informative booklet to help keep you safe while working with hand tools. Illustrated booklet is yours for only 25¢ to cover cost of the booklet and mailing.



*"You'll be glad you bought the best!"*

## TRUE TEMPER®

1623 EUCLID AVENUE, CLEVELAND, OHIO 44115  
A MEMBER COMPANY OF ALLEGHENY LUDLUM INDUSTRIES

Материал защищен патентным правом

# Plug-in lunch box provides hot meals



IF YOU CARRY a lunch box to work, you can still enjoy a hot meal at noontime. All you have to do is install a light bulb inside the cover and have a place to plug it in. Three rectangular Pyrex containers fit nicely in the average-size lunch box for soups, vegetables and meats, and the heat from a 150-w. bulb will make them piping hot in 30 minutes. A 15-w. bulb, plugged in when you get to work, will keep the contents warm all morning.

I used such a lunch box for years prior to my retirement, and both my girls had one in their college dormitories where regular heating units were not allowed.

To install such a heater, drill or punch a  $\frac{7}{16}$ -in. hole in one end of the cover for a  $\frac{1}{8}$ -in. pipe nipple, then add a ceramic socket and wire it to a length of heater cord and plug.

—William J. Jeffers, Jacksonville, Fla.



## Tape eraser subs as demagnetizer

Your bulk tape eraser makes an excellent demagnetizer for shop tools, watches and small steel parts such as bolts, nuts and the like. Place the tool to be so treated on the eraser and turn the power on for 30 seconds. Then slowly lift the tool until it is about two feet above the machine before turning off the power. Put the tool back on the machine end for end and repeat the power-lift cycle. After you have completed several such treatments the tool will be demagnetized.

—Parry C. Yob, Fair Oaks, Calif.

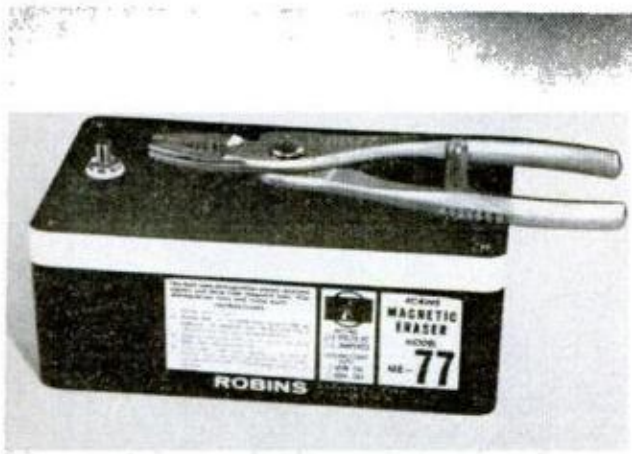

## Hinge makes improvised viewer

A handy viewer for transparencies, stamps or negatives can be made by attaching a reading glass to a large strap hinge. First peen the end of the hinge pin with a hammer until the hinge opens hard and will remain in an upright position. Then attach the lens to the end of one hinge leaf so that you can adjust it easily to the best viewing angle. The handle is removed from the glass and a suitable nut is turned onto the lens screw.

—Ken Patterson, Regina, Sask.

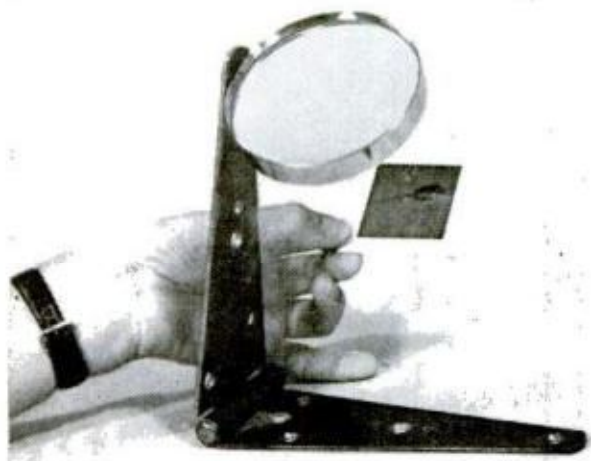

**ITT Credit Reserve can give you the security of knowing \$3,000 is available to you within 24 hours.**

ITT Credit Reserve is a personal financial service funded and established by America's eighth largest company, International Telephone & Telegraph Corporation.

On acceptance, you establish for yourself and your family a \$3,000 line of credit, all or any part of which may be drawn upon in less than 24 hours.

A payment schedule and full information on interest rates are available upon inquiry.

Your inquiry about ITT Credit Reserve will be treated in complete confidence.

**ITT CREDIT RESERVE**

a service of International Telephone and Telegraph Corporation



Please send information on ITT Credit Reserve. No obligation, of course.

NAME \_\_\_\_\_ AGE \_\_\_\_\_

ADDRESS \_\_\_\_\_

CITY \_\_\_\_\_ STATE \_\_\_\_\_ ZIP \_\_\_\_\_

Mail to: K. B. Leverly, Service Director, 2080 First Security Building, Salt Lake City, Utah 84111 or phone toll-free 800-453-9100 (24 Hours A Day—7 Days A Week).

**EARN \$20.00/HOUR**



by assembling unique 12 or 16 hp **HALF-TRAC** tractor kit for yourself or resale. 20 attachments—Loader, Plow, Cultivator, Snowblower, etc. "Build-it-yourself" plans—\$5.00. Catalog of Half-Trac and 30 other assembly kits—\$1.00 (Refunded on any purchase). **STRUCK CORP.**, Dept. P4HB3, Cedarburg, Wis. 53012

**EARN \$20.00/HOUR**



by assembling unique 7 or 12 hp **MINI-DOZER** bulldozer kit for yourself or resale. 20 attachments—Loader, Mower, Snowblower, Plow, etc. "Build-it-yourself" plans—\$5.00. Catalog of Dozer and 30 other assembly kits—\$1.00 (Refunded on any purchase). **STRUCK CORP.**, Dept. P4DL3, Cedarburg, Wis. 53012

**MAY IS CAR CARE MONTH**

**TRASH A PROBLEM?**



**BURN A WHOLE WEEK'S TRASH IN MINUTES—WITHOUT AIR POLLUTION!** "Super Clean" model meets tough new air pollution laws. Simply fill with trash, light with match, put on lid and turn on the power. Presto—no trash! Burns 3 trash cans full in 30 minutes. Uses no fuel. Plug it in like a vacuum cleaner! Costs no more than a home trash masher. **OTHER MODELS FROM \$29.95.** Write for TRASH-AWAY brochure, no risk trial offer.

**Trash-away** LEWIN & CLARK Dept. PM 5236 Wooster Rd. Cincinnati, O. 45226

**HELPMATE**

**GARAGE DOOR OPERATOR... \$89<sup>95</sup>!**

- RADIO CONTROLLED from car transmitter or wall switch
- SAFETY night and day year 'round
- SECURITY door locks tight when closed
- CONVENIENCE in car control any weather
- LIGHTING garage lights automatically
- VERSATILE fits all lifting type wood, metal or fiberglass doors sectional and 1-piece
- EASY HOME INSTALLATION in just 2-3 hours
- SAVE up to 50% direct factory purchase and PP or UPS home delivery
- GUARANTEED one year
- FREE brochure

HELPMATE Equipment Co., Box 51PM, Baroda, MI 49101

## HEARING AIDS

Huge savings on tiny, all-in-the-ear, behind the ear, eye-glass and body models. New space age models are so tiny and well concealed your closest friends may never even notice. **FREE HOME TRIAL.** Low as \$10 monthly. Money back guarantee. Order direct and save. Write today for free catalog and confidential booklet. **PRESTIGE, Dept. T-29, Box 10947, Houston, Tex. 77018.**



## LEARN MEAT CUTTING



Train quickly in 8 short weeks at Toledo for a bright future with security in the vital meat business. Big pay, full-time jobs—**HAVE A PROFITABLE MARKET OF YOUR OWN!** Time payment plan available. Diploma given. Job help. Thousands of successful graduates. **OUR 50th Year!** Send **NOW** for big new illustrated **FREE** catalog. No obligation. G.I. approved. No. 0197T

**NATIONAL SCHOOL OF MEAT CUTTING**  
Dept. 50-V, Toledo, Ohio 43604

Build **POPULAR MECHANICS'** little **CARRIAGE HOUSE!** Simply great! A back-yard building that isn't an eyesore. Styling blends in with most homes. It will take your mower, lawn furniture and tools—or the kids' overnight guests. Use it as your shop or home office. Overall outside dimensions 10-ft. 4 in. x 12-ft. 4 in. For one complete set of plans send \$3.95 to **POPULAR MECHANICS Dept. FA, Box 1014 Radio City, N.Y. 10019.** For two sets of plans (you may need one for your local building department) send \$5.49.

### WHITE'S METAL DETECTORS

**WHITE'S ELECTRONICS, INC.** manufacture the World's Largest and Finest Line of Mineral and Metal Detectors. Ghosttowning, beachcombing, bottle hunting, coin hunting—all types of **TREASURE HUNTING** or **PROSPECTING**, amateur or professional. Detect conductive metals—Gold, Silver, Copper Nuggets—Coins—Rings—Jewelry, etc. Underwater or on the land. "There are no finer at any price" 25 production models to choose from—T.R. or B.F.O.

Priced from **\$79.50** up  
—Always specify the Blue & Gold  
ASK FOR WHITE'S BY NAME

—Free Literature—  
**WHITE'S ELECTRONICS**

Rm. No. 512  
1011 Pleasant Valley Rd.  
Sweet Home, Oregon  
33784 Hazel Street  
Abbotsford, B.C., Canada  
Etc. Ave. Industrial Park  
Dexter Drive, East  
Elkhart, Indiana 46514



## MODELMAKERS MACHINING CENTER IS 5-MACHINES-IN-1

Versatile Maximat combines lathe with vertical & horizontal mill, drill press, and grinder in one rugged, compact unit! Designed for labs, precision workshops and serious hobbyists. Three models available: 7" x 18"



7" x 24", 10" x 26". The Maximat is fun and easy to use. Anyone can machine like a "pro" with our fully illustrated Maximat instruction handbook, **Precision Machining Techniques** — only \$2. Dealers in all major cities.

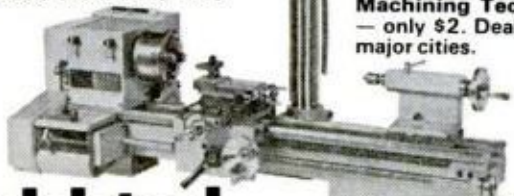

**edelstaal**

American Edelstaal, Inc. Dept. BD-3  
Tenafly, N.J. 07670

## INSTANT PROTECTION FOR STALLED VEHICLES DAY OR NIGHT

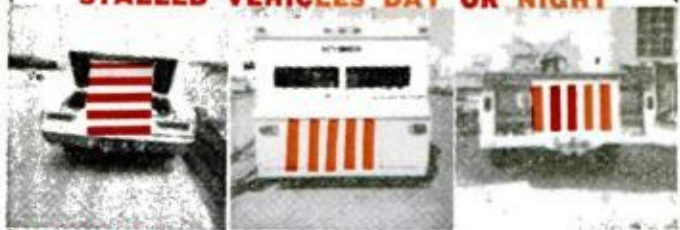

**READY TO USE:** Driver of stalled vehicle merely raises trunk lid & pulls down **SEEN 'N SAFE** unit attaching it to any metal by means of the built-in permanent magnetic tape. Ready for approaching traffic. No power source necessary. **SAFETY BILLBOARD:** Special luminous/reflective materials & board design provide immediate attention to oncoming traffic causing slowdown to cautionary speed. **DAY & NIGHT PROTECTION:** Highly reflective glass-beads give ultimate reflectivity at dusk & dark. International flame orange stripes are brilliant by day. Large size gives easy visibility—even at high speeds. Protect while removing spare tire or during emergency parking, even if tail lights are accidentally blocked. **LONGLASTING:** **SEEN 'N SAFE** fabric is water proofed-sealed, keeps off dirt and grime & is impervious to rain, snow & sun-fade, meets Federal Specifications. Easily cleaned with a damp cloth. **CONVENIENT:** Self-storing stays clean & bright while rolled up. Ready for instant use even when trunk is loaded. When not in use unique lock-pin holds **SEEN 'N SAFE** in place.

Available in three models:

Roller Model (installs permanently in car & trunk)

Send-units @ **\$13.95** ea.

Portable model (attaches to any metal surface)

Send-units @ **\$8.95** ea.

Recreational Vehicle Model (attaches to any non-metallic surface) Send-units @ **\$10.50** ea.

Master Charge           Exp. Date \_\_\_\_\_  
Send check, money order or  Bank Amer.            
(No C.O.D.'s) plus \$1.00 for postage and handling to **SEEN 'N SAFE ENTERPRISES INC., P.O. Box 4132, Pocatello, Idaho 83201**

NAME \_\_\_\_\_ ADDRESS \_\_\_\_\_  
CITY \_\_\_\_\_ STATE \_\_\_\_\_ ZIP \_\_\_\_\_

PM-3

# Aluminum screens and doors can be made to look like new with

## ALUMINUM JELLY™

### Remove oxidation without scraping.



For sale wherever fix-it products are sold  
Woodhill Chemical Sales Corp., Cleveland, Ohio 44128  
World's Finest Fix-It Products



## GOVT. SURPLUS

and other bargains  
**SAVE to 90%**

Send for this catalog



The world-famous Airborne Catalog. Fully illustrated. Contains 1000's of bargains in hydraulics, electrical, marine, automotive & hardware items ... and more! A must for mechanics, machinists, hobbyists, sportsmen, inventors, etc. Send 35¢ to cover postage & handling. In a hurry? Send \$1 for airmail delivery. Must include zip.

**AIRBORNE SALES CO.** Dept. PM73  
8501 Steller Dr., Box 2727, Culver City, Ca. 90230  
Satisfying world-wide customers since 1945

## BASEMENT TOILET FLUSHES UP



TO OVERHEAD SEWER OR SEPTIC TANK.  
NO DIGGING UP FLOORS. INSTALLS EASY. Write  
McPHERSON, INC., BOX 15133, TAMPA, FLORIDA 33614



U. S. Surplus High Speed Rotary Files. Hardened Steel, use on any metal or wood for filing, drilling, milling, carving, routing—a thousand uses in every shop. Sets assorted in sizes from 1/4" shanks. All brand new in airtight, G.I. packs. Order now!

36-pc. Tool Set, G. I. cost \$265.00, now \$15.00  
16-pc. Tool Set, G. I. cost \$109.00, now \$ 9.00  
Save Even More, Both Sets, now \$22.00

**U. S. SURPLUS CENTER**  
C-1790 Nason Avenue  
COLUMBUS, OHIO 43207

## TRY... TRI-ROD ...FOR FUN

FAR AND AWAY AMERICA'S BEST BUY IN A THREE-WHEELED VEHICLE.  
FULL LINE OF ACCESSORIES FOR YEAR-ROUND PROFIT.

THINK YOU'D LIKE TO BE A TRI-ROD DEALER? WE HAVE A COMPLETE LINE OF DEPENDABLE MODELS FOR YOU TO SELL.

FULL FIBERGLASS MULTI-COLOR METALFLAKE BODIES. PRICE RANGE \$425.00 UP.

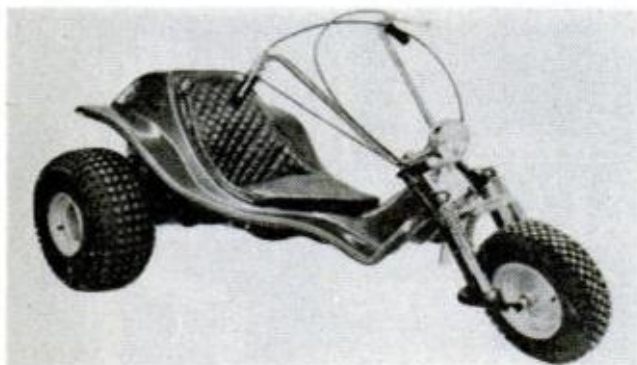

WITH OR WITHOUT FRONT AND REAR SUSPENSION

**BGW**

BOX 3683  
MANSFIELD, OHIO 44907  
Phone: (419) 522-0665

Please rush full details on how to make money as a BGW Dealer or Distributor.

Name \_\_\_\_\_  
Address \_\_\_\_\_  
City \_\_\_\_\_ State \_\_\_\_\_

NO JOKE: The trouble with shooting

## BENJAMIN'S NEW SUPER SINGLE SHOT AIR RIFLE

is that owners could talk a donkey's hind leg off in telling about its power and accuracy—far and away the most potent in its class—and how it gives you the upper hand on target and small game hunting trips, time and again!

Despite Benjamin's enviable reputation, would you believe some folks are under the impression that it can't be all that wonderful? To set things straight, once and for all, we present the impartial views of those that saw it from the business end:

Soupy Can: "Plinking tin cans is duck soup for Benjamin."

J. Rabbit: "Thanks to Benjamin, I'm in it up to my ears."

Paper Target: "Benjamin helps you improve your aim at home in off-season."

What more can we add other than to say see your sporting goods dealer now. There are many expertly crafted features in a Benjamin that set it apart for all uses—indoors or out. Choice of BB or 177 or 22. Reasonably priced.

**BENJAMIN AIR RIFLE COMPANY**  
896 Marion St., St. Louis, Mo. 63104

You Can DEPEND on BENJAMIN

**FREE CATALOG**

Walnut Monte Carlo Stock and New Design Pump Handle. Thumb Safety Behind Breach.



## ATTENTION!

Your "ideas" or "inventions" may be worth a fortune!

### READ!

Copyrighted information "What The Inventor Should Know".

Send \$2 for copy to:

**National Investors Services**

Dept. PM-1

P. O. Box 434

Bladensburg, Maryland 20710

## NEW 8 HP SUPER BRONC

THE BIG BIKE FOR ALL SEASONS



Model  
VT-8 Kit  
Price—  
\$279.95

### HEALD'S NEW "SUPER BRONC"

Model VT-8 has a new 8 HP 306 cc Tecumseh engine. Torque Converter drive, big air cushion tires, front and rear shocks, large padded seat, chrome fenders, #40 chain and chain tightener. Optional features include 21" x 12" wide, knob tires both front and rear, electric start, lights, aux. 5 qt. gas tank, front ski and quiet spark arrester muffler. Super Bronc comes in money saving easy-to-build semi-kit form. Kit price Model VT-8 — \$279.95. Ideal for farm or recreational use.

FOR MORE INFORMATION WRITE:  
**HEALD INC.**, Dept. PM-4, P.O. Box 1148,  
Benton Harbor, Michigan 49022

**FREE CATALOG**

## HOW TO FORM YOUR OWN CORPORATION WITHOUT A LAWYER FOR UNDER \$50.00

New book. Complete with tear-out forms. Hundreds of money and tax saving ideas. \$7.95. 10 day money back guarantee. Or write for more free details.

Enterprise Publishing Co.  
Dept. B-5, 2415 Allendale Rd.  
Wilmington, Delaware 19803



## LEARN UPHOLSTERY AT HOME!



Men & Women All Ages! Send for free book on learning to reupholster chairs, divans, footstools, all furniture for BIG MONEY in spare or full time. No experience needed, no age or educational limits. We show you how and provide EVERYTHING needed to start: (1) Home training covering all phases, (2) all tools and 6 big furniture kits for practice, (3) free supplies, frames & materials to build \$300 worth of furniture, yours to keep or sell. Write TODAY for big free upholstery career book. No obligation, no salesman will call. Veteran Approved. Modern Upholstery Institute Box 899-JGM, Orange, Calif. 92669.

## DETROIT IS SWITCHING TO CD IGNITION. COMPU-SPARK™ LETS YOU DO IT NOW.

Give your car a head start on Detroit. Install this thoroughly-tested, all-silicon, solid-state CD ignition and feel the difference—or money back. Remarkable computer-like memory device actually regulates spark length — long and full at cranking and idling, shorter as RPM's increase. Result: better all-around performance with fewer tune-ups. Points last 50,000 miles or more.

Money back in first 30 days. Free repair or replacement for 36 months.

Installs in minutes. No rewiring, no special tools.



\$4995 ppd Ready to install.

\$3995 ppd Kit form.

Check, money order, BankAmericard, Master Charge, American Express.

Include name and address.

GAYLORD ELECTRONICS INC.,

2314 Fourth St., Box 20AP, Berkeley, CA 94710

© 1973 All rights reserved.

## APPLIANCE REPAIR BOOKS

Written in easy-to-understand language by experts in the service field with illustrations and diagrams! Acclaimed by instructors and professionals alike! How to diagnose and repair refrigerators, air conditioners, washers, dryers, ranges, dishwashers, vacuum cleaners, motors, water heaters, coffeemakers, hair dryers, food mixers, can openers, electric irons, floor polishers and many others. Also, fundamentals of solid state, setting up a shop, using test equipment and a lot more. Only \$2.65 to \$4.90 each!

SEND FOR FREE DESCRIPTIVE PRICE LIST

CHAROUS & NIEBERGALL INC., 5841 MONTROSE, CHICAGO 60634

## HOW TO GET RICH -- AT HOME!



There is no other business like mail order. Start on a shoestring in your spare time and make a fortune fast. It strikes like a bolt of lightning! Millions read your ad and suddenly you are swamped with cash orders from all over the country. MORE MONEY in 60 days than you could earn in a lifetime! Write for free book and complete details. Mail Order Associates, Inc. Dept. 369, Montvale, N.J. 07645

## "LISTEN IN" TO POLICE-FIRE RADIO CALLS IN YOUR CAR!

WORKS with ANY CAR—Portable or HOME RADIO! Just PLUGS in—No wiring—3 minute hookup! Switch instantly from regular to ALL POLICE-FIRE-EMERGENCY-COMMERCIAL-TAXICAB-STATE-CITY-GOV'T 2 way Radio calls in YOUR AREA. DUAL-HI-LOW BANDS TUNES 36-49 & 150-175 MHS. USE Everywhere—anytime—always works.

SEND ONLY \$2.00 (cash, Ck., M.O.) and pay postman \$9.99 plus COD postg or send \$11.99 for ppd Del in USA. COMPLETE, ready to use with instructions. One Year service Warrant—10 DAY MONEY BACK TRIAL (if radio). Sold Only—DIRECT FROM FACTORY at this Low Price! WESTERN RADIO BPM-4 KEARNEY, NEBR. 68847



## EARN MONEY FAST!

### REPAIR HYDRAULIC JACKS

Earn while you learn at home. Millions of jacks in gas and auto service stations, trucking firms, body shops, riggers, factories and farms need servicing... most of which you can learn to repair. We show you HOW. Start spare time in your basement or garage. Big opportunity for mechanics. ACT NOW!

Write for folder PM4, and free bonus offer



HYDRAULIC JACK REPAIR MANUAL CO., INC. G. P. O. BOX 3 • STATEN ISLAND, N. Y. 10314

# BIG SAVING YOUR SPORT AND FAMILY CRAFT FOLBOT

WITHOUT burdens of complex trailer rig, YOU GO CAREFREE any time with COMPACT Folbot... rocky streams, lakes, marsh, surf & SEA. SUPERIOR designs GLIDE noiseless, faster, paddles, sails, motors.

Balanced low & high seating, SAFEST low gravity center, substantial construction, protective decks. EXCLUSIVE swivel-back COMFORT.. PREFAB KIT, or expertly Factory BUILT, or FOLDING. All colors.

Spacious 16 foot

NOW from \$22

BASIC KIT or Factory BUILT

\$136

Folding from \$210

NEW BIG DACRON Sail Rig \$125

FREE ACTION CATALOG

with STARTLING FACTS & FIGURES

WORLD RECORD FISHING CAREFREE cruise information

'Fabulous Folbot Holidays' 308 pages, 280 color photos. Enchanting Recreation at little cost, exceeds anything Outdoors. Covers ALL Americas from spectacular North to magnetic Tropics. INCLUDE \$2 for postpaid book, or \$2.75 at stores.

Mail coupon or address to:

Folbot Corp. PM-673 Charleston, S. C. 29405

NAME \_\_\_\_\_

ADDRESS \_\_\_\_\_

CITY \_\_\_\_\_

STATE \_\_\_\_\_

ZIP CODE \_\_\_\_\_

# If you're going to do it, do it right.

Even if you're "all-thumbs" *Popular Mechanics* new *Complete Manual of Home Repair and Improvement* will enable you to take on almost any emergency (or home-beautifying project) and come out looking like a hero. And if you're an accomplished handyman, you'll find hundreds of new, quicker, and less expensive ways to make your home more valuable. Many top consultants contributed their experience and know-how to the book. We even asked a banker to show you how to finance major home improvements. Nothing's been left out.



Here, in one book, is everything you need to know to repair and improve your home.

## EXTERIOR

- Roof and chimney repairs
- Roofing materials
- Roof patching techniques
- Special roofing problems
- Emergency roof repairs
- Drainage systems
- Gutter maintenance
- Special drainage problems
- Solving door and window problems
- How to install locks, latches
- Garage door maintenance
- Door and window weather stripping
- How to mend screens
- How to fix broken windows
- Siding repairs
- Special sidings
- Driveways, walks, porches
- Foundations
- Exterior painting techniques
- Preparing surfaces for paint
- Exterior painting equipment

## INTERIOR REPAIRS

- Ceiling repairs
- Suspended ceilings
- Insulation techniques
- Wall repairs, improvements
- Loose wallpaper
- Wall fasteners and anchors
- How to patch concrete
- Paneling materials
- Ceramic tile know-how
- Problem walls
- Special paneling finishes
- Specialty wall materials
- Quick floor repairs
- Refinishing hardwood floors
- How to lay resilient tile
- Door and window repairs
- Window shade repairs
- Special windows to build
- Condensation on windows
- Interior painting shortcuts

## REMODELING AND IMPROVEMENT

- Kitchen cabinet layout
- Kitchen cabinet hardware
- Kitchen remodeling
- Installing kitchen cabinets
- Basement improvements
- Basement moisture problems
- Basic basement planning
- Remodeling your bathroom
- Installing bathroom fixtures

## New bathroom planning

- How to install ceramic tile
- Installing a shower door
- Wall and ceiling materials
- Drapery materials
- Prefabricated fireplaces
- Basic storage ideas
- How to hang wall coverings
- Special wall treatments
- Interior lighting techniques
- How to install a garage door opener
- Attic remodeling
- How to install a dormer
- How to build stairsteps
- Room addition planning
- Room addition framing
- Sidewalls and roofing for additions
- Plumbing, electric rough-in
- How to install finish flooring
- Special construction components

## GARDENING

- Floors and ground covers
- Insect control
- Lawn sprinkler system
- How to have a better lawn
- How to lay sod
- Watering and feeding tips
- Fences, decks and patios

## Patio design

## HEATING AND AIR CONDITIONING

- How heating and cooling systems work
- Heating and cooling maintenance
- Furnace repairs you can make
- Oil burner maintenance
- How to fix a leaking faucet
- How to open a clogged drain
- Flush tank repairs
- When the electricity fails
- Minor electrical problems
- Appliance repairs
- Food disposer repairs
- Repairing electric motors
- Small appliance repairs

## FINANCING HOME IMPROVEMENTS

- Insurance loans
- Open-end mortgages
- Conventional loans

## WHERE TO GO TO SOLVE SPECIAL PROBLEMS

- Shopper's guide to tools and materials
- List of brand-name materials
- Glossary of building terms
- Complete index

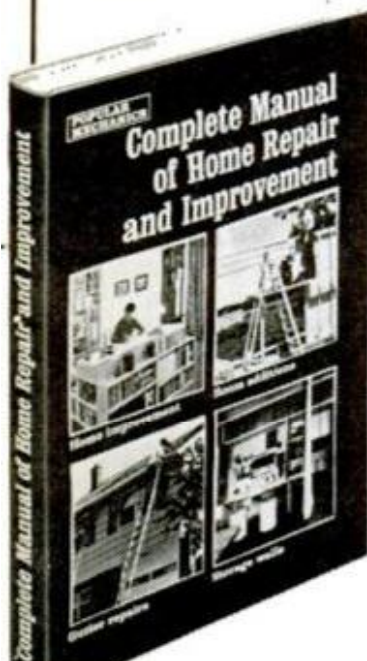

### MAIL FOR FREE 10-DAY EXAMINATION

Hearst Books  
P.O. Box 2316, F.D.R. Station  
New York, New York 10022

Please send me (30122) POPULAR MECHANICS NEW COMPLETE MANUAL OF HOME REPAIR AND IMPROVEMENT. I enclose check or money order for \$7.95. (Publisher will pay shipping charges.) If I'm not delighted, I will return book within 10 days for a full and prompt refund.

F794 Print Name \_\_\_\_\_

Address \_\_\_\_\_

City \_\_\_\_\_

State \_\_\_\_\_ Zip \_\_\_\_\_

Offer available only in the Continental United States and Canada. Prices slightly higher in Canada. Delivery will normally be 3-4 weeks in Eastern United States and slightly longer west of the Mississippi. H. M. Books

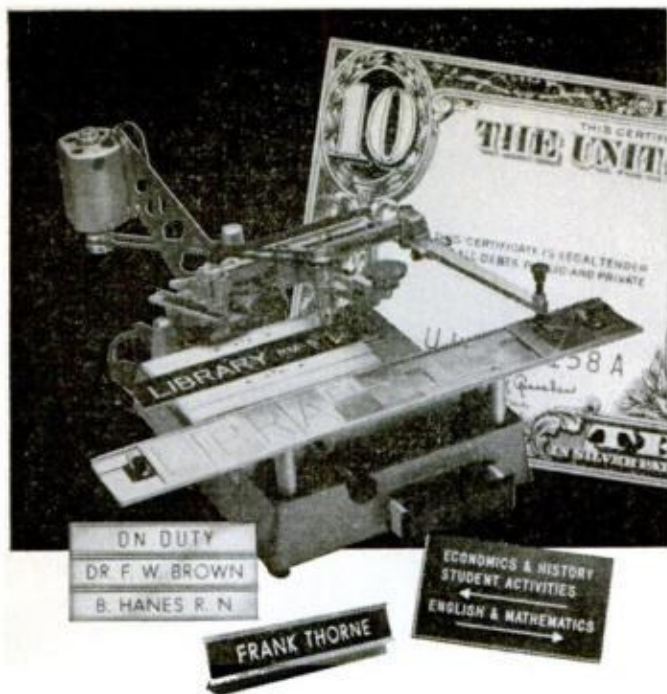

## engrave money (legally)

One dollar makes ten. Make profits up to ten times your cost—full or part time—right in your own home.

Engrave much needed nameplates, directories, signs, trophies, badges in plastic, metal and wood on the time-tested New Hermes Engravograph.

Simple to operate. It's tracer-guided.

Engraving is a permanent business — not a fad — with small investment of less than \$400; money back guarantee. Trained representatives at your service.

Write for free illustrated catalog 10.

**new  
hermes  
engravograph**

World's largest engraving machine manufacturer.  
20 Cooper Square, New York, N.Y. 10003

# WE FINANCE YOU

WE'LL START YOU IN A

## Business of Your Own



Start in sparetime; build a money-making full-time business in your garage or basement. We'll start you in business with No Money Down. Your earnings easily cover the low monthly payments. Sharpening saws is an important service in any neighborhood or small town—You can earn \$3 to \$6 an hour sharpening hand, band or circular saws.

## No Experience! No Selling

The easy-to-operate Foley Saw Filer is automatic—it does the job for you. You can be doing business the day after you receive your machine. And with a saw filing business customers will come to you. No door to door selling! You are supplying a much needed service. If you'd like more information about this unique business opportunity, return coupon (no salesman will call) and we'll send you our fact-filled

**MONEY-MAKING BOOKLET FREE!**



Foley Manufacturing Co.  
443-3 Foley Bldg., Minneapolis, Minn. 55418  
Send for FREE book on Money-Making facts about the sharpening business.

NAME \_\_\_\_\_  
ADDRESS \_\_\_\_\_  
CITY \_\_\_\_\_ STATE \_\_\_\_\_ ZIP CODE \_\_\_\_\_



## handykan

THE AEROSOL TROUBLESHOOTER

makes everything run better

- Lubricates far better than oil.
- Loosens rusted parts.
- Protects against rust.
- Dries out wet ignitions and metal.



## BUILD, FLY YOUR OWN COPTER!

It's great sport to fly a Bensen Gyrocopter — lowest cost, too. Fly high or low, fast or slow. Adapts to floats. Pilot ages range from teens into 60's. Enjoy flying this easy way! Plans, parts and factory kits available. Get colorful info packet with photo, specs, 3-View Drawings. Send \$5 today!

BENSEN AIRCRAFT CORP., Dept. PM-43  
RDU Airport, Raleigh, N. C. 27602

NAME \_\_\_\_\_  
ADDRESS \_\_\_\_\_



## HOW TO BECOME A LOCKSMITH

COMPLETE BOOK OF INSTRUCTIONS

How To Fit Keys, Change Combinations, Master Key Locks, Keys By Number, Tools To Use, etc. Detailed illustrations. Satisfaction guaranteed. Get started! Order today.

Only \$3 ppd.

A.S. Ancele, P. O. Box 69234, Los Angeles, Ca. 90069

## ACCORDIONS-1/2 OFF

of retail prices you'd expect to pay!

Over 40 Electronic, Standard & Button Models

All famous makes. All colors. Models for Students, Teachers, Professionals. Amplifiers, too! Try before you buy. Free accessories. E-Z terms. Trades welcome. Lifetime Performance Policy. FREE Color catalogs and Importer-to-You discounts. Rush coupon.

★  
5  
Day  
Home  
Trial



Buy Direct

FREE

Color  
Catalog

Discount  
Prices

42  
Models

Accordion Corp. of America—Dept. R-43  
5535 W. Belmont Ave., Chicago, Ill. 60641

Send FREE accordion catalogs and discount prices. Include special information checked:

Accordion Amplifiers  Button Accordions

Name \_\_\_\_\_

Address \_\_\_\_\_

City \_\_\_\_\_ State \_\_\_\_\_ Zip \_\_\_\_\_

# Take this \$3.49 book FREE!

Let these 257 experts show you how to attain the skills of a real pro!

You get this giant 8¼" x 11" illustrated volume of exciting "how-to" projects for your family, home, garden, car, boat, vacation—as an outright gift—nothing to buy. It is crammed with reliable shop-tested, do-it-yourself techniques and practical show-how pictures. Use these hundreds of do-it-yourself plans, projects, tips and hints to polish your own shopwork and hobby skills! Here is a brief glimpse of all your FREE Volume brings:



- Having car engine trouble? Fix 8 common problems quickly without having to pay a garage mechanic anything he chooses to charge you.
- Professional tips for expert sanding show how to bring out the best finish in woods and metals with power and hand tools.
- Complete plans help you build an inexpensive 3 x 4 foot plywood table to give any small band saw big-machine capacity and flexibility.
- Need extra space? Turn an unfinished attic or basement into handsome, usable areas with practical, money-saving plans.
- Save on band saw blade costs. Build brazing fixture to make your own blades.
- Do your own auto body repair expertly with simple tools and methods.
- Build a boat designed just for fun. Step-by-step plans and materials list included.
- Home too hot for comfort? Follow complete directions for air conditioning your home.



- Bothered by a wet basement? Cure it yourself and save \$200 to \$2,000 under what professionals charge.
- Need better burglar protection? Build effective power alarm for a safer home.
- Refinish furniture perfectly. Hands-at-work pictures show you how.
- You'll wonder how you ever got along without an air supply in your shop once you've built and used the "foot-bellows" system.
- Build a gas-fired barbecue for more back-yard fun.
- New soundproofing techniques enable you to relax in quiet.
- Anyone can hand-letter signs with the "Project-A-Plan" method.
- Special trouble-shooting chart pin points malfunctions in an auto electrical system so you can fix it quickly.
- Target practice in the living room? Believe it or not you can blast away indoors without harming anything.
- Build your children model planes that fly higher than any others.
- Special tricks-of-the-trade save you time and effort in handling power tools.
- Save hundreds of dollars on buying and servicing appliances. Plus hundreds of other exciting plans and do-it-yourself ideas to save you big money and add thousands of hours of pleasure to your hobby, sport and vacation projects.

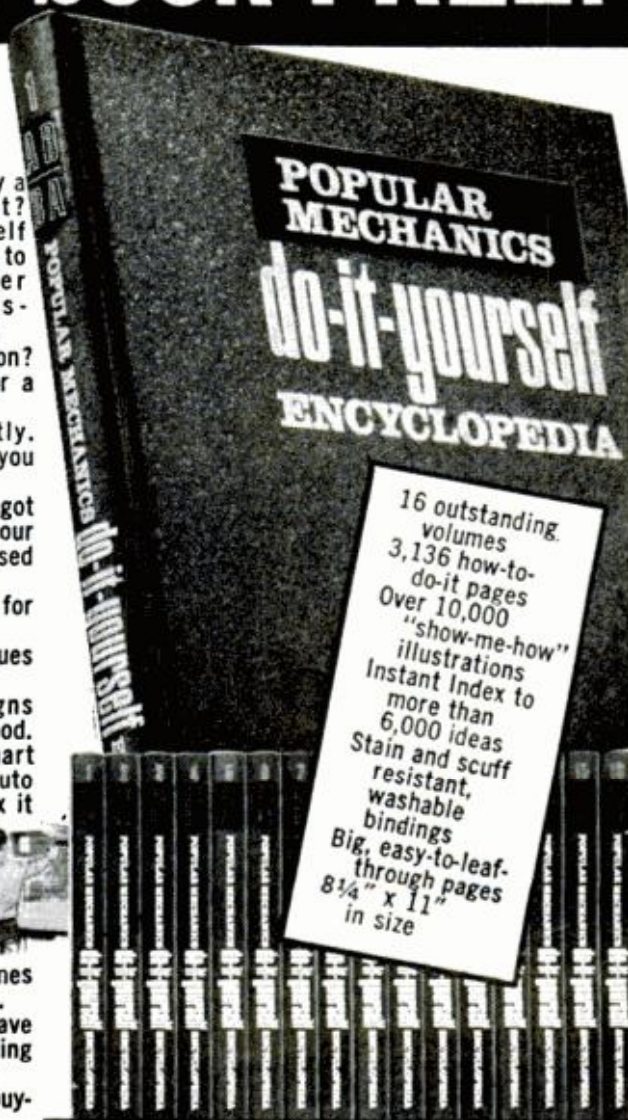

**POPULAR MECHANICS**  
**do-it-yourself**  
**ENCYCLOPEDIA**

16 outstanding volumes  
3,136 how-to-do-it pages  
Over 10,000 "show-me-how" illustrations  
Instant Index to more than 6,000 ideas  
Stain and scuff resistant, washable bindings  
Big, easy-to-leaf-through pages 8¼" x 11" in size

## FREE GIFT CERTIFICATE

**Popular Mechanics Books**  
Box 2315, F.D.R. Station, New York, N.Y. 10022

This certificate entitles you to a free gift—Vol. 1 of the 16-vol. Popular Mechanics Do-It-Yourself Encyclopedia, with no obligation to buy anything ever. As a subscriber in good standing, you'll enjoy free examination of the additional volumes as you receive them. In about 6 weeks we'll send you Vol. 2, and 4 weeks later Vol. 3. After that, at approximately monthly intervals, we'll send you shipments of Vols. 4-6, 7-9, and 10-16. Also, you'll receive annual supplementary volumes as they are published on free 14-day approval with no purchase obligation. This way you'll be able to complete the set in 6 months, and keep it up-to-date. You may cancel at any time or return any volume within 14 days for full credit and no more will be sent. Take as many volumes as you like—or none at all. For each volume you keep, you'll be billed just \$3.49 plus postage and handling. But you need never pay for more than 1 volume per month no matter how many you have received. There is no charge for this extended payment service. F014

Name \_\_\_\_\_  
(Please Print)

Address \_\_\_\_\_

City \_\_\_\_\_

State \_\_\_\_\_ Zip \_\_\_\_\_

Signature \_\_\_\_\_

## Why you receive this practical do-it-yourself handbook ABSOLUTELY FREE!

The reason you get this brand-new \$3.49 book as an outright gift is simple. This gold mine of "how-to" projects and money-saving plans is the first volume in POPULAR MECHANICS DO-IT-YOURSELF ENCYCLOPEDIA—an amazingly useful guide created by the editors of *Popular Mechanics*—experts in do-it-yourself techniques for over 65 years. The Encyclopedia gives you over 6,000 projects, repairs and improvements you can do by yourself to save hundreds of dollars on labor and materials. 257 experts lead you through every step of every project you select. They give you thousands of practical pointers to sharpen your skills in carpentry, car repair, metalwork, plumbing, masonry, electrical work, electronics, hi-fi, stereo, painting and decorating. We believe that if you browse through the first volume—select a plan or project—use it at your workbench—try some of the money-saving shortcuts, shop-tested methods—you will be anxious to receive the others. Therefore, you may enjoy future volumes as they are published for 14 days' FREE EXAMINATION. You may buy one, two, the whole set, or none at all. But the first volume is yours to keep without obligation, no matter what you decide. Mail coupon today, to be sure of getting your FREE Volume.

# DRAFTING PAYS BIG!



**Your FUTURE in DRAFTING**  
**APTITUDE TEST**  
**SAMPLE LESSON**  
**ALL 3 FREE**

U.S. Labor Dept. says "42% more Draftsmen needed in next 10 years." Easy home-study plan guides you. Send for FREE "Drafting Career Kit."  
**• APPROVED FOR VETERANS.**

NAME \_\_\_\_\_ AGE \_\_\_\_\_

ADDRESS \_\_\_\_\_

CITY \_\_\_\_\_ STATE \_\_\_\_\_ ZIP \_\_\_\_\_

**NORTH AMERICAN SCHOOL OF DRAFTING, Dept. 34174**  
 Accredited National Home Study Council 4500 Campus Dr., Newport Beach, Calif. 92663

## BLAST FURNACE—FOUNDRYETTE 2400 F

Since 1935  
**Hobbyists • Schools • Inventors, etc.**  
 Make your own castings of any metal from cast iron, down to lead and zinc. Available in 6 sizes, 1 1/2 to 50 lbs. Complete units from \$50.40 to \$162. Send 25¢ for circular—refundable.



**KANSAS CITY SPECIALTIES CO.**  
 Dept. P-4  
 P.O. Box 193  
 Middleton, Wis. 53562

## Repair any watch

... SWISS OR AMERICAN

Unique, modern Sweazey System starts you making repairs right away. Develops skill step by step at home in spare time. Diploma awarded. Free sample lesson. No obligation.



**CHICAGO SCHOOL OF WATCHMAKING**  
 Dept. 143, Fox River Grove, Ill. 60021

## BUILD YOUR OWN GRANDFATHER CLOCK

Save over 50% by building your own grandfather clock. Stately, straight-sided "AMERICAN CLASSIC" with beveled plate glass sides. Narrow waist designs: "SPIRIT OF '76" with finely sculptured crown and brass-tipped pillars; or easy to build, always popular "SPIRIT OF THE CENTURY." Our kits are Red-i-Kut, semi-assembled, hand-crafted of solid 3/4" kiln-dried mahogany, cherry or walnut. Tubular bell or Westminster rod chimes. Moving moon dials painted by our own artists, and our own original Goddess Diana or Lady Florentine pendulums. Gorgeous solid bronze dials with raised numerals and corners. Send \$2.50 for all three plans, plus description of kits and movements, as folks have for more than fifty years.



**KUEMPEL CHIME CLOCK WORKS & STUDIO**  
 Route 3, Box 240A Excelsior, Minnesota 55331

## For TOOLMAKERS who use the FINEST . . . .



**GERSTNER TOOL CHESTS**  
 Dept. D3, 20 Cincinnati Street  
 Dayton, Ohio 45407

Send 25¢ for Catalog

## UPHOLSTERING AND DECORATING FOR PROFIT!

Men & Women All Ages!

At home, we show you how, incl. tools, kits to make and sell. Accredited NHSC. Approved Veteran Training. No salesmen.

Creative Upholstery & Decorating School  
 Div. Technical Home Study Schools, Dpt.  
 5110-043, Little Falls, N. J. 07424



## GIVE OR GET A GUMOUT "Carburetoritis" T-shirt

for your manly chest . . . (or her unmanly one!) It's available only from GUMOUT. Send \$2 for yours today! State size (S-M-L).



Gumout, Cleveland, Ohio 44104

# I-N-V-E-N-T-O-R-S

## WE NEED INVENTIONS

Sell your invention for cash—need money for Patent?—Are technical problems holding you back? Universal Inventions has helped inventors all over the world—just like yourself—why not you? Inventions provide the magic spring-board to sudden riches. REMEMBER, we either sell your invention or pay you a cash bonus. Write for details.

**UNIVERSAL INVENTIONS, Dept. 13, Marion, Ohio 43302**

## MINI-BIKE PARTS

### Wholesale Prices

"Build your own" kits...Big savings...Repair parts...Welded frames & forks, enameled...Chains...Clutches...Brakes & throttle controls...Wheels...Tires...Bearings...Axles...Engines...etc. Send 50¢ for illustrations and lists...SAVE DOLLARS!

**BYCO, Dept. B, Box 6241, Omaha, Nebr. 68106**



## PUMP DRAINS pools, cellars, laundry tubs

### IRRIGATES — CIRCULATES — SPRAYS

Heavy duty ball bearing pump. All metal, rust-proof Type XB. Stainless shaft. Use 1/4 HP or larger. 1 HP 1,200 GPH 60' high or 3,000 GPH 25' well. 5,200 GPH max. 1 1/4" in; 1" out. Belt or direct drive. \$14.95

Type P won't rust or clog. Bronze bearing. To 2,400 GPH. 1" in; 3/4" out. \$9.95

P'd cash with order. Money back Guarantee.

**LABAWCO, Box 40, Belle Mead, N.J. 08502**



## locksmithing and key making

### PRACTICAL UP-TO-DATE COURSE — ONLY \$7.95

Teaches you how to pick locks, de-code, make master keys, repair, install, service, etc. New self-instruction lessons for every handyman, homeowner, carpenter, mechanic, service station operator, fix-it shop, hardware dealer, gunsmith. 53 easy illustrated lessons. Full price only \$7.95 post-paid. Satisfaction or refund guaranteed. Mail order today!



**NELSON-HALL CO., Dept. 6DX-2**  
 325 W. Jackson Blvd., Chicago 60606

## FIND BURIED TREASURE

Powerful electronic detector finds buried gold, silver, coins, etc. Financing available.



**RELCO, Dept. D-3**  
 BOX 10839, HOUSTON, TEX. 77018

Write for free catalog 1995 to 19850

## TIRES!

ALL FAMOUS BRANDS! AUTO TRUCK SPORT CAR FARM TRAILER

TREMENDOUS SAVINGS! LET US PROVE IT TO YOU! ...WRITE US TODAY...

Send for your FREE catalog!

**RELIABLE TIRE CO. 1111 Chestnut St. Camden, N.J. 08103**



## \$12.95 BLACK DIAL TELEPHONES

Complete add \$2.00 for color

Factory rebuilt Western Electric in white, beige, ivory, pink, green or blue. If 4 prong plug is required add \$2.00. Fully guaranteed.

Designs may vary.  
 Write for free list. All shipments F.O.B.

**SURPLUS SAVING CENTER**  
 DEPT. PM-43, WAYMART, PENNA. 18472



# Compressed air from car lighter!



## auto-flator

● Now have air wherever you go! Even remote areas. Emergency air for tires, air jacks, space-saver spare. Inflate mattresses, boats, rafts, pools. Plugs into 12-volt system in auto, trailer, truck, boat. Space-age size . . . only 6 1/2 inches long. Amazing pressure up to 60 lbs. Only \$29.95 (plus \$1.00 shipping) with air hose and inflator attachments. Send check or money order on 10-day, money-back, guarantee.

W. R. BROWN CORPORATION  
2773 N. Normandy Ave., Chicago, Ill. 60635

## BATTERY POWERED CONTINUITY TESTER

(Actual size 9 inches long) Ideal for Auto-Mechanics, Electricians, Maintenance.



Send Check or Money Order,

**\$3.15**

TESTS — Radio, T.V., Appliances, Electrical Circuits, Fuses, Switches, Voltage Regulators, Coils, Condensers, Armature and Alternator Diodes  
Test with power off

MEAD TOOL CO. Satisfaction Guaranteed  
444 Espanola Way Miami Beach, Fla. 33139



## PIANO TUNING MADE EASY

Excellent manual and all necessary tools, only \$22.50. Ten-day money-back guarantee. Free particulars. Stamm Industries, 297 Young, Oregon, Ill. 61061.

## Build Your Own Kit CANOE or KAYAK.

Quality Wood/Canvas Designs.  
From \$25.00

Free Literature!

SPORTSCRAFT

Box 636-PM Allentown, N.J. 08501

A \$20 Value Now Only \$9.95

Postage Paid

## 24" COPPER CROWN CUPOLA

For ventilation and/or decoration.

Has all-weather construction and anodized aluminum roof for long life. Cupola can be easily and quickly assembled. Send \$9.95 and we pay shipping.

L&M CABINET SHOP, Box 2513M, Dearborn, Mi. 48123

SAVE TIME . . .  
MAKE MONEY



## SHARPEN SAWS . . . YOURS AND OTHERS

Professional workmanship comes easy with this portable precision tool which gums, joints, and then sharpens all types of circular saw blades, including cut-off, rip and combination styles as well as carbide tipped, dado heads and blades. Indexer eliminates guess work, sharpens any angle of bevel on circular saws from 4" to 24" diameter. Write for your free copy of "THE SAW FILING MAGIC OF MICRO SHARP".

MARTIN ENGINEERING CO.  
P.O. Box 337, Caledonia, Mich. 49316

## THE AUTO ELECTRIC



with 150 V.D.C. meter  
Postage \$1.25

\$14.95

110V D.C. electricity from a vehicle alternator  
● Light Bulbs  
● Power Tools  
● Battery Charging

Auto Air Equipment, Inc.  
P.O. Box 2886—Amarillo, Tex. 79105

## EXCITING! ROCKETRY!

Fly your own solid fuel rocket!



Model rockets up to 41" tall, capable of flights to many thousands of feet. Send \$3.85 for F.S.I. Micro rocket kit and three solid fuel rocket engines plus catalog with technical data. For catalog only send 60c.

REESE INDUSTRIES Dept. M-43  
9300 East 68th Street Raytown, Missouri 64133

## "NU-THRED" FILES

\$3.50 ea.

This is the original 8 in 1 rethreader tool. Renews damaged, right or left-hand threads of any diameter fast!  
No. 1 for 11, 12, 13, 14, 16, 18, 20 and 24 T.P.I.  
No. 2 for 9, 10, 12, 16, 20, 27, 28 and 32 T.P.I.  
Satisfaction Guaranteed  
Order now! Get Both for \$6.50 Ppd.

JAW MFG. CO. Box 213, Reading, Pa. 19603



New P35 water pump. Industrial rated—continuous duty. Only 19 pounds. 1885 GPH —1" or garden hose. 2 1/2 h.p. JLO 2 cycle engine. Handles muddy, sandy salt water. SPECIAL \$139.95 & \$5.00 Shipping & Handling. N.Y.S. Add Sales Tax. 1 1/4" & 2" models available. P.E.I., 580 Macon Place, Uniondale, N.Y. 11553



Slot machine service and repair training. Top paying-fast growing course. Home study-resident or combination course available. For free information, write: Nevada Gaming Schools, 3135 Industrial Ave. Suite 106A, Las Vegas, Nevada 89109  
Phone (702) 734-6244



## TRACTOR OWNERS

Build your 10 cubic ft. trailer SAFE and SAVE money too. Sturdy design for use with lawn and garden tractors. For complete plans, instructions, and list of required materials, send \$2.95 plus 65¢ for P&H.

SUBURBAN DESIGNS INC.  
DEPT. BA-01 BOX 1146  
FAIRFIELD, CONN. 06612

## 1600 Novelties

FREE! New World Famous Catalog  
Hard-to-get Novelties, Jokes, Tricks, Hobbies, Sports, Science, Electronics, Funmakers, Psychedelia, Emblems, Posters, Magic, Games, Gifts, Models, Money Makers, Jewelry, Bargains, Gadgets, Books, Photo & Optical, Tools, Watches, etc. No letter necessary. Send name, address.  
Johnson Smith Dept. 104, Mt. Clemens, MI 48043

## BUILD YOUR OWN CANOE



WOOD & CANVAS OR FACTORY MOLDED FIBERGLASS

MANY MODELS TO CHOOSE FROM \$19.50  
BASIC WOOD KIT TRAILCRAFT, INC. FREE CATALOG  
Box 60679, Concordia, Kansas 66901

## DUNE-BUG

Complete plans & specs on how to build or buy - disc. prices on parts, kits, engines, & raw material.



Bug Send \$1 for DUNE-BUG pkg. to: Box 987P4, Azusa, Ca. 91702, Ph (213) 334-0334

## SINGLE-TWIN-JET OUTBOARD



Dual jet outlets with separate controls give exceptional slow-speed maneuverability to small boats. BUILD-UP OWN plans allow using locally available auto & hardware store parts. Also PLANS available for PORTABLE ELECTRIC POWER PLANT using auto alternator & ALT POWER, 110-volt power in your car.

FREE illustrated literature  
S.G.R.O. CO., Dept. PQ  
34161-B Coast Hwy., Dana Point, Calif. 92629



1852 "50¢ CALIFORNIA GOLD PIECES" 1882  
75¢ Each 25 Assorted ..\$12.00  
7 Different ..\$ 4.00  
DLH Sales  
422-PM3 Washington Building  
Washington, D.C. 20005

## GLASS BLOWER KIT \$23.95 ppd.

Make Glass Miniature SHIPS-BIRDS-BOTTLES ILLUSTRATED  
Instruction Book \$3.00  
Willis Glass Supply Co.  
P.O. Box 3460, Studio A  
Anaheim, Calif. 92803

# The bargain hunter

## BEST LEARN IT YOURSELF BOOKS

- Profes. Picture Framing for Amateurs, 224 pps. \$8.95
- How to Repair Small Gas Engines, 288 pps. \$8.95
- Small Appliance Repair Guide, 224 pps. \$7.95
- Using Electronic Test's for Auto Tuneup, 256 pps. \$7.95
- Electric Motor Test & Repair, 160 pps. \$6.95
- Major Appliance Repair Guide, 288 pps. \$8.95
- Designing & Building Hi-Fi Furniture, 224 pps. \$4.95
- How to Repair Home & Auto Air Cond., 208 pps. \$7.95
- Computer Technician's Handbook, 480 pps. \$10.95
- Model Car Racing... By Radio Control, 224 pps. \$6.95
- How to Become a Radio Disc Jockey, 256 pps. \$7.95
- Basic Radio Course, 224 pps. \$8.95
- 64 Hobby Projects for Home & Car, 192 pps. \$6.95
- Refrigeration, 160 pps., 53 illus. \$7.95
- Beginner's Guide to TV Repair, 176 pps. \$6.95
- How to Read Electronic Circuit Diags., 192 pps. \$7.95
- How to Test Everything Electronic, 160 pps. \$6.95
- How to Repair Music Instrument Amps, 256 pps. \$8.95
- Inst. & Svc'g Electronic Protective Syst., 256 pps. \$7.95

SEND NO MONEY! We'll invoice you on 10-DAY FREE TRIAL. Clip entire ad to order. Guaranteed—used by hundreds of thousands to learn. Same-day shipment.

TAB BOOKS, Dept. PM-43, Blue Ridge Summit, Pa. 17214

## WINDWATCH™ ANEMOMETER—WIND VANE \$19.95



Neon lights in indoor indicator show wind speed and direction. Decorative indicator with gold dial in dark mahogany case. Designed for desk use or wall mount. Outdoor instruments of durable aluminum with electrical parts enclosed in rigid vinyl housings. Easy to assemble and install. Attach directly to roof or pole. Comes with wire and materials for installation up to 60 feet. Uses regular 120V AC. Unique low amp circuit assures absolute safety. A fascinating addition to any home. Five year guarantee, 15 day trial. Your satisfaction or money back. Only \$19.95 postpaid.

DEPT. F13, 104 HEIMANN SAN ANTONIO, TEXAS 78205

## Introductory Offer! Take advantage of this low price while it's still available and **BEAT INFLATION!**

### New FLORIDA LAKEFRONT DEVELOPMENT

Beautifully Furnished 2 Bedroom 60' x 12' PERMA-MOBILE HOME With 6000 Sq. Ft. Lot Installed Ready To Occupy! All For Only

**\$9995**



- ALL THIS AND MORE AT *Orange Blossom GARDENS*
- Storm Sewers
  - Wide Paved Streets
  - Mercury Street Lights
  - Corner Street Posts
  - Garbage Collection
  - Recreational complex professionally planned
  - Underground Telephone
  - Underground Electricity
  - Underground TV Antenna
  - Central Sewage System
  - Central Water Plant
  - Private Lake Paradise
  - Bank Financing

Ideally situated—in the heart of the Orange Grove and Lake Section of Florida. Just 8 miles from Leesburg—directly on U. S. Highway #441-27. The "Gateway to Disney World."

**IMPORTANT!** Bear in mind you are not renting the lot—**YOU OWN IT OUTRIGHT!** This qualifies you for Florida Homestead Exemption—thus affording you a **BIG** tax saving!

Miami office (305) 945-2641—Property Office (904) 753-2270

## 110 Volt A.C. GENERATORS

60 cycles. Fanbelt driven from car or gas engine. Operates T.V., refrigerators, radios, all power tools, projectors, P.A. systems and fluorescent lights. Over 12,000 in service. Guaranteed six months. 1500-watt \$65.00 postpaid. 3600-watt \$105.50 postpaid. Special X-1000 watt self-excited generator \$85.00 postpaid.

### TOOL POWER™ patent pending

115 volts D.C. 5000-watts, 50 amps from your car's alternator. **Guaranteed 20 years.** Install in ten minutes. Operates all power tools, electric motors up to 2 h.p. Are welding, fast battery charging. Any like device by any name is an infringement of our patent pending. All copiers are notified. Be safe, buy from the inventor and developer. \$25.00 postpaid. Attractive dealer plan.

VIRDEN PERMA-BILT CO.,  
P.O. Box 7160PM  
2821 Mays, Amarillo, Texas 79109

## FREE Fisherman's DISCOUNT CATALOG

Hundreds of Fishing Items at the **LOWEST** Prices: **BIGGEST MONEY-SAVING VALUES!**

### SPORTS LIQUIDATORS

Box 414-W, SUN VALLEY, CAL. 91352

## HANDY DANDY Storage JARS



Handy Dandy plastic caps hook onto 1/8" peg-board to hold popular, quarter-twist food jars (such as baby food) with 1-15/16" neck. Unbreakable, clear plastic jars are also available.

PPD USA, No C.O.D.'s  
WICKLIFFE INDUSTRIES  
P.O. Box 286, PM-4  
Wickliffe, Ohio 44092

| QTY | CAPS   | JARS   | CAPS & JARS |
|-----|--------|--------|-------------|
| 10  | \$1.00 | \$2.00 | \$2.75      |
| 24  | -      | 4.50   | -           |
| 36  | 3.50   | 6.25   | 6.75        |
| 72  | 6.00   | 11.50  | 16.00       |
| 144 | 11.50  | 22.00  | 30.00       |

## YOUR OWN RADIATOR BUSINESS

"\$70,000 LAST YEAR"

says D. Carter, Lemoyne, Pa.



Complete turn-key package: training school in radiator repair technology and business management plus special power-equipped auto radiator shop.

Don Carter writes: "Averaging \$30 an hour, expect to hit \$80,000 next year." Mail this coupon for complete story.

NAME \_\_\_\_\_  
ADDRESS \_\_\_\_\_  
CITY \_\_\_\_\_ STATE \_\_\_\_\_  
ZIP \_\_\_\_\_ PHONE \_\_\_\_\_

**INLAND MFG. CO. Dept. PM-4**  
1108 Jackson Street • Omaha, Nebr. 68102

## SEND NOW FOR FREE INFORMATION

**ORANGE BLOSSOM GARDENS, Dept. 90**  
2148 N.E. 164th St., Miami, Florida 33162  
Rush complete literature.  
No Salesman will call.

NAME \_\_\_\_\_  
ADDRESS \_\_\_\_\_  
CITY \_\_\_\_\_  
STATE \_\_\_\_\_ ZIP \_\_\_\_\_

IMPORTED  
**LOCK BLADE KNIFE**

ONLY \$275 each

- 9" Overall Length  
5" When Closed
- Sharp and Tough
  - Stainless Steel Blade



**WESTBURY SALES CO.**  
P.O. Box 434, Westbury, N.Y. 11590  
Dept. L-245-PM

Locks into position to prevent accidental closing. Razor sharp tough stainless steel blade for reliable use and hard, long service. Money back in 5 days if not satisfied. Send \$2.75 plus 25¢ to cover postage and handling.

**SILVO (BRAND NAME) TOOL CATALOG**



Thousands of exciting tool values!

Stanley, Skil, Thor, Wen, Disston, Wiss, Wellsaw, Dremel, Plumb, Huot, Kennedy, Channellock, Rockwell, Helois, Vise-Grip, Crescent, Rigid, Pony Clamps, Unimat, Foredom and many other Nationally Advertised brands of Tools & Supplies. We ship Coast to Coast at prices Hard to Beat. Send \$1.00 for our big 152 page tool catalog today.

Silvo Hardware Co., PM-73  
107 Walnut St., Philadelphia, Pa. 19106

**SMALL JET ENGINE**  
G8-2 15-H.P.



**THE ZOOM-BOOM**

JET POWERED GO-KART!

REVOLUTIONARY NEW JET! ALL WHO SEE IT MARVEL AT ITS POWER, SIMPLICITY, PUSH-BUTTON STARTING, FINGER-TIP CONTROL, 100% THROTTLEABLE, SAFE, RELIABLE.

**DO-IT-YOURSELF JET-ENG.**

SEND \$5 = 1. BOOK ON G8-2 JET USES. #2. TECHNICAL HANDBOOK WITH PHOTOS, GRAPHS, POWER CURVES, DIAGRAMS, COMPARISON TO OTHER JETS. SMALL HELICOPTER LIFT CURVE AND GLIDER POWER BROCHURES & CATALOG LIST. \$3 DISCOUNT COUPON

G8-2-15 JET CONSTRUCTION PLANS \$12  
**EMG ENGINEERING CO.**  
18518-N So. Broadway, Gardena, Cal. 90248

Easy to Build PLANS AND INSTRUCTIONS for

|                         |        |
|-------------------------|--------|
| Go Kart .....           | \$2.00 |
| Mini Bike .....         | \$2.00 |
| Mini Car .....          | \$3.00 |
| Pedal Boat .....        | \$4.00 |
| Sail Boat .....         | \$2.00 |
| Snowmobile Sleigh ..... | \$3.00 |

Mini Vehicles Plans Dept. C P.O. Box 92 Chazy, N.Y. 12921

**DETROIT APPROVED PICKUP TANKS**



Original equipment type poly, now available in auxiliary tanks for pickups. Increase gas capacity 40 gals. Far superior to metal, complete hidden, no body work necessary. Easy 1 hour installation—Truck discounts pay for tanks in a short time. Two tanks, brass valve, hose, complete. Meets Federal Regulations.

**R.P.M. INC., Dept. PM-473**  
P.O. Box 7936, Waco, Texas 76710

**FACTORY CLOSEOUT!**

AIR PISTOL WITH \$6.95 FREE CAN OF PELLETS

Shoots both pellets and darts. This fine, well made .177 cal. German air pistol is just the ticket for target or Varmints. Accurate. No CO2 cartridges to replace, either. Once in a lifetime bargain. Order several. Supply limited. Only \$6.95 ppd. (Secret leather holster. \$2.95 ppd.) 600 Deluxe Pellets, \$2.40 ppd. 20 Steel Darts, \$2.00 ppd. **AIR PISTOL, Dept. PM-4** 4535 Huntington Dr. South Los Angeles, Calif. 90032



**HEARING AIDS**  
UP TO 50% OFF COMPARABLE AIDS ★

BUY DIRECT • 20 DAYS FREE TRIAL Body Aids \$39.95 up. Tiny All-in-the-Ear: Behind-the-Ear; Eye Glass Aids. No salesman will call. Write **LLOYDS** ★ Dept. PM, 905 9th St., Rockford, Ill. 61108 ★

**RAZOSHARP®**  
U.S. Pat. 3,608,195

\$2.25



PRECISION TOOL HANDLE FOR INJECTOR RAZOR BLADES

**IDEAL POCKET KNIFE—EXCELLENT OFFICE AND HOUSEHOLD UTILITY TOOL**—Only holder to use standard injector type razor blades. Only holder allowing for varying blade length exposure. Only holder allowing blade to be completely sheathed and protected. Only razor blade holder to give precision tool feel.

**ALWAYS RAZOR SHARP**—When blade dulls—pop in new blade. Re-use injector type razor blades. **SHAVE and SAVE.** Inexpensive injector type razor blades always available. To expose new sharp edge—reverse blade or clip dull edge. Excellent for cutting clippings, cardboard, trimming. Ideal for opening packages, cartons, boxes. Use for carving, whitening, sharpening, erasing, etc. Shape blade to suit use—snip edge, grind or break with pliers. Nothing to break or wear out.

**RAZOSHARP®** Dept. A-4  
421 Stockholm St., Bklyn., N.Y. 11237

**WATER WATER "HOW TO DRILL YOUR OWN WATER WELL"**

**WATER \$1.00 ppd**

**WATER SATISFACTION**

**WATER GUARANTEED**

**DEEPROCK CO.**  
OPELIKA, ALA. 36801

**Convert any U.S. Unit to Metric system in seconds!**



Amazing new educational aid instantly changes any linear, area, volume, weight, liquid, temperature value from U.S. units to metric system — or vice versa! Just set value you wish to convert on scale and directly read corresponding U.S. or metric value. No math. One pull does it all. Includes 6-page folder gives history, current status of both systems. Satisfaction guaranteed or your money back. Send check or M.O. Order 1 per child & 1 for yourself. First Class \$2.50 ea. ppd.; 3 for \$6.95 plus applicable state and/or local sales taxes.

Order today from:  
**UNION CARBIDE EDUCATIONAL AIDS**  
Box 363-M-1  
Tuxedo, N.Y. 10987

**PORTABLE STEAM CLEANER**  
Steam in 60 seconds



**CLEAN:** Engines—Air filters—lawn mowers—trucks—tractors

"Big enough to do the job, small enough to get there."

Fast, economical, ruggedly built. 3 year guarantee on coils & firebox. Propane fired. Weighs 120 lbs.

Auxiliary pump required on water pressures below 60 lbs. or on well systems.

**WEDCO MFG. INC., Dept. M-4,**  
Box D, Jackson, Wyo. 83001

**EXTRA MONEY**

**\$30 to \$50 A DAY**

Operate a community sharpening service with an investment of \$150. Work from your basement or garage. Our manual guides you in professional methods of grinding, of business promotion and in pricing your work.

- Hand Saws • Circular Saws • Knives • Chain Saws
  - Scissors • Pinking Shears • Clipper Blades
  - Planer and Dado Blades • Mower Blades
- John Rodock says: "Thanks for shipping Model 331. It has paid for itself many times since I purchased it. Please send latest price list on grinding wheels."
- TREYCO** P.O. Box 216-A  
North Tonawanda, N.Y. 14120
- START NOW...WRITE TODAY**



# CLASSIFIED ADVERTISEMENTS

Rate: \$2.20 per word payable in advance each insertion. Capitalized words—75¢ per word additional. Minimum insertion ten words. To be inserted under the proper classification, copy must be in our office by the 10th of the second month preceding date of issue. The next available issue to place an advertisement in America's No. 1. Classified Section is June. The closing date is April 10th. Send remittance and order to H. E. Kappel, Popular Mechanics, 224 West 57th Street, New York, New York 10019. Please make remittance payable to Popular Mechanics.

POPULAR MECHANICS

WHEN ANSWERING ADVERTISEMENTS PLEASE USE THE ZIP CODE NUMBER

## AUTOMOBILES

**DON'T BE CHEATED** On Cars. Ex-car Salesman Tells All. \$1.00. Car, 1111 Burke, #105, Pasadena, Texas 77502.

**WANTED To Buy:** Old Automotive Literature, 1900-1955. David Ficken, Box 11, Babylon, New York 11702.

**AUTOMOBILE SIXTY SECOND TIRE FIX. NO TOOLS—NO JACK-DEALERS INVITED. SAMPLE, DETAILS, PPD. \$3.98—WARNE, 6922 CONGRESS, DETROIT, MICHIGAN—48207.**

**1971-1972 DODGES, Fords, Chevrolets, Checkers** from \$599. to \$1099. Free catalog. Send 25¢ handling. Pan Am, 31 Hanse Ave., Freeport, N.Y. 11520, Dept. 151.

**CAPACITIVE DISCHARGE IGNITIONS. DISCOUNTED.** Rodgers, Son (PM), Box 3583, Anaheim, Calif. 92803.

**HOT ROD.** Professional Show Photos. Over 60 Sample Proofs. \$1.00. P.W. Photography, Box 562, Oak Ridge Station, Royal Oak, Michigan 48073.

**HOW TO BUY A Used Car.** Save Money. Don't get taken. Report Reveals Step-By-Step Procedure. Includes buyer's checklist. \$1.00. **TRADING POST**, Drawer 2112, Asheville, N.C. 28802.

**SEND FOR FREE CATALOG: SERVICE AND REPAIR HANDBOOKS** for Volkswagen, Datsun, Toyota, etc. And Honda, Yamaha, etc. Motorcycles. "Guide-Kit" Publications. Box 332-P, Rialto, California 92376.

**THUNDERBIRDS 1955-7 Classics.** Restorables through show cars. Local or National delivery. Custom restorations here and complete new and second-hand parts shipped anywhere. 1973 100 page illustrated catalog "Everything for the Birds" available. Write/Phone (213)393-9840 Shell's, Box 767 PM, Santa Monica, Cal. 90401.

**CAR CARE.** Step-by-Step guide to automotive maintenance. Saves time, money, effort. 112 pages, 300 photographs \$3.75. **BROOKLANNE**, Box 1071, Bloomington, Ind. 47401.

## MIDGET CARS

**YOUR AD IN POPULAR MECHANICS WILL BE SEEN** By More than 5,000,000 active buyers for your products and services. It costs only \$2.20 per word. And, if you wish to run all or part of your ad in bold capital letters—you can do so for as little as 75¢ per word additional. Act now! Send your Classified ad to: **POPULAR MECHANICS, CLASSIFIED DEPARTMENT, 224 WEST 57TH STREET, NEW YORK, N. Y. 10019.**

## AUTO SUPPLIES AND EQUIPMENT

**PARTS:** Army jeep and truck parts. Spare Parts & Equipment Co., P.O. Box 751, Lexington, Kentucky 40502.

**"DRY Wash"** Your Car With New, Miracle Vacu-Shine In Minutes. Gives 50 Cleanings. Guaranteed. \$2.98. Ar-Nor, 20 Bulwer Place 1R, Brooklyn, N.Y. 11207.

**ALTERNATOR/Generator Rebuilder's Course;** includes Tooling & Test Equipment; Write: Hedelund Engineering, P.O. Box 2127, Sepulveda, California 91343.

**RING-Valve Job** while driving. \$6.50 postpaid. (Two-\$12.00). . . . Established 1951. . . . Results Guaranteed!! Motaloy, Grantham, Penna. 17027.

**NOVEL Inexpensive Glowing Gage** Continuously Checks Ignition Performance. **QARC**, Box 47876, Los Angeles, Calif. 90047.

**RING-VALVE JOB** While You Drive!!! Fully Guaranteed \$6.00 . . . Two \$11.00 . . . Motaloy-MF, Box 1149-MA, Midland, Texas 79701

**MOTALOY, Ring-Valve Job** While Driving. \$6.00. Literature. E&G Sales, Box 18384-P, Memphis, Tennessee 38118.

**ELECTRICAL Circuit Testers,** high & low voltage, combination hi-lo with detachable ground wire to avoid shock, two spare tubes contained in handle, continuity tester, well designed, Free Brochure. Mead Tool Co., 444 Espanola Way, Miami Beach, Fla. 33139.

**RADIATOR PROBLEMS?** Heating? Leaking? Rusting? Experienced Journeyman Thoroughly Explains Cooling System. Send \$2.00 to: Radiator Care, Box 547, Whittier, Calif. 90602.

**110V. ELECTRICITY** From Your Auto. Plans \$3.00. Ellin, 161 Bonad, Chestnut Hill, Mass. 02167.

**SAVE YOUR BATTERY** Miracle Battery Additive for less than \$3.00—guaranteed—Free Information. Skitco, Box 545, Hazleton, Pa. 18201.

**1973—MOTALOY'S 20TH ANNIVERSARY!** Package of four Motaloy Tabs in gas tank replates worn pistons, rings valves. Effectively cuts oil-burning. Restores lost power and compression. One treatment good for lifetime of engine. Comes in three sizes. #1 for cars, \$5.95 PKG. #00, motorcycles, outboards, \$4.00. #2, trucks, tractors, \$7.50. Results fully guaranteed!! State size. Order now . . . from our new, fully stocked headquarters. Shipped Air Mail!! "Motaloy Division CH, RR8, Box 604, Fayetteville, North Carolina 28304."

**NEW. ACCELERATOR Selector Unit,** positively the smoothest and cleanest acceleration from preferred area "The Drivers Delight" Patented, detailed information from Inventor. John Kinney, Box 122, Humboldt, Kansas 66748.

**AUTO Parts and Tools.** Dealers Cost. Catalogs. 50¢. Auto Parts, Box 66, Hollis, New York 11423.

**\$1.00 BALANCES** 4 Car wheels perfectly. Instructions \$2.98. Fletcher—906M Lindale—Richardson, Texas 75080.

## SNOWMOBILES

**PATCHES:** Color Catalog 35¢ Shows Hundreds. Free Patch with catalog. Quotes your own design. Patches, Dept. 92, RFD 1, Littleton, N.H. 03561.

## AUTO TRAILERS

**PICKUP Camper, Trailer or Pickup—Cover . . . Build yourself.** Save! Complete plans \$3.95 each Cover plans \$2.00 Conversion Plans—econoline type van \$2.95; passenger bus or delivery van \$2.95. Satisfaction guaranteed. Equipment catalog \$1.00 (refundable). Details 10¢. Viking Camper Supply, 99-F Glenwood, Minneapolis, Minnesota 55403.

## MOTORCYCLES, BICYCLES MOTORSCOOTERS & SUPPLIES

**BUILD "Popular Mechanics" MINIBIKE** Featured June 1967. Detail plans, photographs, illustrated parts catalog \$2.00 refundable or catalog 25¢. Gilliom Minibike, St. Charles, Missouri 63301.

**HONDA!** \$25 Other Bargains. Send 75¢. Motorscooter, P443, Bend, Oregon 97701.

**BOLT-ON TORQUE CONVERTER** Makes out-dated, out-classed, mini-bikes competitive, mean machines. More Low end muscle—more high end hustle. Fits B&S, Tecumseh, most engines. 35 minute installations. \$34.95 ppd. No C.O.D. Information + decal 25¢. **MAX-TORQUE, Inc.,** 7300 Monticello, Skokie, Illinois 60076.

**BICYCLE PARTS CATALOG.** Gold mine for hard to get foreign and domestic parts, tools and accessories. Send \$2.00 for this big 8½ x 11 inch 160 page catalog. Refundable if not completely satisfied. Wheel Goods, Dept. J, 2737 Hennepin, Minneapolis, Minnesota 55408.

**SPARK PLUGS NGK.** Golden (standard) 79¢ PPD. Motorcycles and Autos, Specify. Cornucopia, P.O. Box 713, Porterville, Calif. 93257.

**KIDS** Look E-Z-Build GO-KART Plans & Instructions \$1.00. E.J. Sales, Box PM3084, Centerline, Michigan 48015.

**MINI-BIKES, Karts, Parts.** Wholesale Catalog 25¢. Loren Products, Danville, Illinois 61832.

**BICYCLE Catalog,** 1973 Edition. Accessories, tools, repair books, parts. For all bicycles. \$1.00 refundable with \$5.00 purchase. Action Accessories, Box 15, Liverpool, New York 13088.

(Continued on next page)

## MOTORSCOOTERS AND SUPPLIES

(Continued from preceding page)

ILLUSTRATED Catalog 25¢. Parts And Accessories, Custom And Stock. For Most Makes And Models. Motorcycle Supply, Box 159M, Fairbury, Ill. 61739.

## SPACE, ROCKETS AND ASTRONAUTS

ROCKETRY!!! 2,600 Feet Altitudes! Free Catalog—Kits, Parts, Motors, Accessories! Technical Information. Centuri Rockets—Box 1988—Phoenix, Arizona—85001.

ANTIGRAVITY DEVICE. Brochure rushed free. AGD, Box 3062 PM, Bartlesville, Oklahoma 74003.

FREE. Flying MODEL ROCKET Kit. Act Now. Offer Limited. Send 25¢ for Packet of Iron-ons, Decals, Literature and "Free Rocket" Details. Aerospace Vehicles, Inc., Mineral Point, Wisconsin 53565.

ANTIGRAVITY Solved! Revolutionary Spacedrive Revealed. \$2.00. Antigravity, Box 831, Avalon, Calif. 90704.



## AVIATION

AIRBOAT Engines, Propellers, Hubs, Mounts, Supplies. Corvair, VW Conversions. Removable airdrives. Propellers, Hubs for Snowmobile Engines. Catalog \$1.00. Banks-Maxwell, Box 3301E, Fort Worth, Texas 76105.

BUILD—One-Man jet helicopter. Easy inexpensive. Detailed plans, drawings—\$5.00. Helicraft, Box 7153, Baltimore, Maryland 21218.

JET Strap-On Helicopter Plans \$2.00. Information 20¢. Compco, Inc., Box 1267, Redwood City, California 94064.

ALL About Ballooning. Handbook \$3.00. Aerostation, Box 141, Long-Sault, Ontario, Canada. KOC IPO

STYROFOAM AIRCRAFT—Built For Under \$200.00. Send \$2.00 For Plans To: W. Hoagland, RD.#4, Box 541, Freehold, New Jersey 07728.

PIONEER AVIATION. Complete set of Blueprints with Original Instructions for 1915 Homebuilt White Monoplane—\$5.00. Rempel, Motley, Minnesota 56466.

HANG GLIDERS. Proven Rogallo Design. Plans—\$5.00, Kits, Accessories, Completed Kites. Free-Flight Systems, 10730 Whiteoak Ave., Granada Hills, California 91344.

HUNDREDS Aircraft Photos. Past, present. Illustrated catalogue 25¢. Astro Photographers, Box 243, Kennedy Airport, New York 11430.

HANG GLIDERS. Disappointed with what the others sent you? Try us! Highest quality for lowest prices. Plans, kits, ready-to-fly designs. Send 25¢ for large catalogue. Eipper-Formance, Inc., P.O. Box 246-M, Lomita, Calif. 90717.

## HOVERCRAFT

HIGHEST Quality Plans. Hovercraft, \$6.00, Airboat, \$5.00. "Practical Design Guide" \$5.00. (Information, \$1.00, Refundable) Palmer Aerosystems, P.O. Box 1891M4, Coral Gables, Florida, 33134.

AERO-CAR. Amazing Hovercraft built easily with ordinary tools. Lawnmower engine power. Carries one man plus. Hovers, flies forward, backward, Sideways over land/snow/water. Complete construction plans and brochure. \$5.95. Aero-Projects, Box 5118PM, Clinton, New Jersey 08809.

HOVERCRAFT Plans. All sizes; Tested designs. Photos. Information: \$1.00. Universal Hovercraft, 2611 182nd Place, Redondo Beach, California 90278.



## BOATS AND TRAILERS

FIBERGLASS BUILDERS MATERIALS Low-cost factory prices in cloth, matt, roving, resin, epoxy, foam, nails, fittings. Send \$1.00 for literature (refundable) or \$2.00 for literature plus booklet on Mold-making and "How to Fiberglass". Clark Craft, 16-P1 Aqua Lane, Tonawanda, N.Y. 14150.

BOAT KITS-PLANS AND PATTERNS-FRAME KITS, World's largest catalog. Over 300 top designs from 7-77' in plywood, ferro cement and fiberglass. Sailboats include: Windmill, Snipe, Motor Sailer, Trimarans, Catamarans. Powerboats include: Cruisers, Houseboats, Deep V's, Fishin'ski, Runabouts, Hydroplanes, Canoes, Kayaks, Inboards, outboards. Send \$1.00 for large catalog or \$2.00 for catalog plus "Boat Builders Guide". Clark Craft, 16-P Aqua Lane, Tonawanda, N.Y. 14150.

BOAT PLANS, FULL-SIZE PATTERNS, FRAME KITS With step by step written and pictorial instructions especially for amateurs. Easy to build. Send \$1.00 for HUGE 100 PAGE Illustrated Catalog. Over 125 modern designs from 8 to 49'; Includes Sail, Jets, Inboards, Outboards, Cruisers, Houseboats, Hot Boats, Catamarans, Hydros. Also available—"Boat Building With Plywood" Hard cover—219 pages \$7.50. GLEN L, 9152 MP Rosecrans, Bellflower, Calif. 90706.

FIBERGLASS Canoes, Kayaks, and Duckboats. Many exciting models. Easily assembled kits. \$39.95 up. Free Literature. Riverside Canoes, Box 5595P, Riverside, Calif. 92507.

FIBERGLASS Cloth and resin. World's finest cloth and non-run resin, at direct mill prices Flotation foam. Complete line of plastics, silicon bronze and brass screws, save 60%. No sales tax. Boat Plans. Catalog 25¢. Freight prepaid. Stiles Boat Supply, Box 11P, Linden Ave., Mantua Heights, N.J. 08051.

CANOE! Kayaks! Factory-direct quality kits, from \$25.00. Many different models. Canvas hulls. Strongest construction materials. Free literature. Sportscraft, Box 636-P, Allentown, New Jersey 08501.

SAILBOAT KITS New all glass 16 ft. Catamaran, Penguin, OK, Blue Jay, Windmill, Snipe, Lightning, and El Toro. Free catalog. Taff Marine Corporation, Dept. PM-4, 6512 Shingle Creek Parkway, Minneapolis, Minn. 55430.

LIGHTS Of all kinds, electrical accessories, portable power, cook and tableware. Free catalog. Bass, Box 901PM, Marblehead, Mass. 01945.

FREE Catalogue—plans, patterns: Canoes, sailing canoes, kayaks, 14-17' trailable cruising sailboats. Quicksilver, 255A Shamrock Blvd., Venice, Florida 33595.

PLANS, Full-Size Patterns, frame kits with step-by-step instructions specially for amateurs. Send \$1.00 for new catalog just off press—nearly 100 pages, over 125 designs 8' to 49'; Sail, Jets, Inboards, Outboards, Cruisers, Houseboats, Hot Boats, Catamarans, Hydros. Glen L, 9152 PM Rosecrans, Bellflower, Calif. 90706.

NEW 1972 Outboards... Top brands...  
6 H.P. \$278.00... 18 \$404.00... 40 \$548.00... 50 \$698.00... 65 Seielectric \$928.00... All sizes... Scott-McCulloch Parts... Literature .50¢... Electra Marine... 675 Merrick Rd. Lynbrook, N.Y. 11563.

FIBERGLASS Cloth, matt, polyester and epoxy resins. Wholesale catalog 25¢. Boat Molding book 30¢. Seifert's, Box 1206-M, Green Bay, Wis. 54305.

CANOE KITS—Wood Canvas, Molded Fiberglass—Free Catalog. Trailcraft, Inc., Box 60686, Concordia, Kansas 66901.

KAYAKS, Canoes, Plans, Kits, Finished Craft, Books. Free Catalog. Outdoor Sports, Box 1213P, Tuscaloosa, Ala. 35401.

PLANS, Patterns, Kits, Catalogs: Powerboat \$1.00, Sailboat 50¢. Pram Kits \$49.95. Marinecraft, Box 161-M, Brighton, Mass. 02135.

BOAT Kits, Molded Fiberglass. Save money—assemble yourself. Factory molded sections bond into one-piece craft. 20 models—14' to 32' Cruisers, Runabouts, Sailboats, Accessories, motors, trailers. Easy terms, Free catalog. Luger, Dept. BC-73, 3800 West Highway 13, Burnsville, Minnesota, 55337.

AUTOMATIC Boat Bailers and Transom drain checks, \$6.95 ea. plus, \$1.50 Handling. De Persia, Grand Haven, Michigan 49417.

BUILD—ONE MAN SUBMARINE. Easy Inexpensive. Complete Plans, \$5.00. JSP-3, 53050 Placid, South Bend, Ind. 46637.

CANOE and Kayak Kits. Molded ABS. \$127 complete ready to trim and assemble. Sabot Canoes, Box 4004, Huntsville, Alabama 35802.

WATER LEVEL ALARM; Detect water seepage anywhere. Easy to assemble. Plans: \$2.00. Universal Merchants, P.O. Box 386, Hawthorne, California 90250.

FIBERGLASS. Complete Supplies. Instruction-Catalogue 25¢. Custom Fiberglass Products, P.O. Box 101-PM2, Mount Juliet, Tennessee 37122.

BUILD A HOUSE BOAT FOR LESS THAN \$1000. It's a 25 footer with a graceful vee bow. Best of all, with its 8ft. beam it's trailerable. Plans \$24.50. Send to: Popular Mechanics, Dept. HO, 224 W. 57th St., New York, New York 10019.

FIBERGLASS Cloth, mat, resin. Flotation foam. Complete supplies. Catalog 25¢. Kick-Shaw, Inc., 3511 Hixson Pike, Chattanooga, Tenn. 37415.

## CAMPERS AND TRAILERS— KITS—PLANS—

PLANS & Kits—Motor Homes, Chassis Mounts, Pickup Campers, Covers, Trailers, Bus & Van Conversions, Modifications & Builtins. Complete Easy To Follow Large Scale Plans, Patterns And Detailed Instructions. Supplies, Parts & Accessories, All Your Needs At Low Discount Prices, Details Free. Lucky, Box 8657-A4, White Bear Lake, Minnesota 55110.

NEW LPG CYLS. Single 20# Std. Valve, \$12.95; 20# Double Assy. All accessories, std. Valves \$39.50. 5 yr. Guarantee. Freight Collect. Check or M.O. DeWard, Box 142, Crossville, Tenn 38555.

## MARINE EQUIPMENT AND SERVICES

MARINE Engines, conversions, parts, equipment. Catalog Free! Stokes Marine Industries, Coldwater, Michigan 49036.

CONVERT Auto engines to marine. 68 Page Catalog, 50¢. Lehman Manufacturing Company, 800 Elizabeth Avenue, Linden 4, New Jersey 07036.

FREE Brochure Conversion Kits, Propellers, gears V-Drives 1/0 Drives Gas, Diesel. Starmarine, 1931 Embarcadero, Oakland, Calif. 94606.

MARINE Supplies, Ignition Parts. Free literature. Michael's, 991 Broadway, Bayonne, New Jersey 07002.

## ATHLETIC AND BODY BUILDING COURSES

SIT And Sway The Paunch Away... Booklet, Complete With Illustrations, Shows You How—\$1.00. William H. Sarver, Box 447, Braddock, Pa. 15104.

"GIANT Arms." Dr. Young's. D.C. revolutionary discovery. \$3.00. Satisfaction or refund. Gaucho, 1769-A-7, Chicago 60690.

POWERFUL Muscles fast! Free brochure! Universal Bodybuilding, Box 4327-C, Dearborn, Michigan 48126.

AMAZING Abdominal Development. Unique Mini Exerciser Free Brochure. Cimo Box 741, Corona, N.Y. 11373.

(Continued on next page)

## **ATHLETIC AND BODY BUILDING COURSES**

*(Continued from preceding page)*

**SHORT STATURED?** Growth Height Increase Facts, Medical Details, Adults, Youngsters. 25¢ to: Physical Culture, Box 1548-PM6, Pompano Beach, Fla. 33060.

**KUNGFU**, Illustrated Instructions. \$2.00 complete. RSH, 5834 Manton, Chicago, Illinois 60646.

## **SPORTING GOODS AND EQUIPMENT**

**FREE** Catalog low direct factory prices, fishing, Hunting, Archery, reloading Camping supplies. Send today. Herters Inc., Dept. CPM, Waseca, Minn. 56093.

**FREE WHOLESALE CATALOG.** Lure parts, Molds, Rod Blanks, Reels, Archery, Metal Detectors, Rare Hardwoods. Finneysports (ME), Toledo, Ohio 43614.

**FREE 1973 Catalog!** Guaranteed lowest prices! Rods, Reels, Lures, Accessories—Thousands of items. Cabela's, Inc., Dept. S-16, Sidney, Nebraska 69162.

**OUTDOORSMEN:** Free Brochure. LEV-O-GAGE for recreational Vehicles, Aircraft, Boats. TEMP-O-GAGE for Inside-Outside Temperature. Thornton's, 1212 Aspen Street PM, Longmont, Colorado 80501.

**MOSQUITO REPELLER!** Tiny! Electronic! Jungle tested! Marker's, 25 Amariyllis, Key-West, Florida 33040.

**DYNO-TRAINER**, the new sensational German exerciser with built-in automatic FLYWHEEL-ROTOR (up to 2800 rpm). Write for **FREE** giant full-color brochure, Dept. PM-216, THYLO-CORP., P.O. Box 29, Garfield, N.J. 07026.



## **FISHING, TACKLE, LURES**

**MOLDS** For fisherman's sinkers, jigs, squids, casting and spinning lures. Free catalog. Sweet Molds, Tonawanda 1, New York 14150.

**MOLDS**—For casting your own fishing sinkers. Free illustrated booklet. Reading Instrument Co., Box P-78, Reading, Pa. 19603.

**FISHERMAN'S DREAM BOOK**—**FREE**, 170 page catalog just loaded with Hard-To-Find Fishing Tackle Specialties and Do-It-Yourself Goodies. Our 29th year. NETCRAFT Inc., Box 5510, Dept. PM-12, Toledo, Ohio 43613.

**FISH WITH THE WINNER**—Mepps Original French Spinners took 57 awards in latest Field & Stream and Sports Afield contests—more than next 4 lures combined. Discover why in 1973 Mepps Fisherman's Guide. Send 25¢ with name, address to: Sheldon's, Inc., Box 709, Antigo, Wisconsin 54409.

**FISHERMAN'S BUDDY**—Get those snagged lures back to work. Retrieves every time. So unique it's patented. Send \$3.95 to: Sav-A-Lur, P.O. 102, Avondale Estates, Georgia, 30002.

**CATCH** All the Catfish you want. My Formula \$2.00. Mr. "D," P.O. Box 104, Fort Payne, Ala. 35967.

**AUTOMATIC** Fishhooks. Free Details. Samples, \$2.00. Aron, 61PM, Mastic Beach, New York 11951.

**HANDSOME** Fishing Rod Rack—\$2.98. Professional Dry Fly Assortment 20—\$5.98. Satisfaction Guaranteed. Diane P. Anderson, 260 Crittenden Blvd, Rochester, NY 14642.

## **EARTHWORMS, LIVE BAIT**

**ANNOUNCING!** Bi-Sexual Earthworms Bringing Fast Profits! Quicker, Easier, Cheaper! Amazing Details Free. Gloworm, PO1B5, 3910 Elfin, Louisville, Kentucky 40207.

**EARN** Money raising fishworms for us! Exciting details free! Oakhaven—56, Cedar Hill, Texas 75104.

**FREE Literature.** Profitable Business Raising Fishworms, Crickets. We Teach you how to Raise and Sell. Write today. Carter Fishworms, Plains, Georgia 31780.

**HYBRID REDWORMS.** 5,000 - \$12.00; 20,000-\$24.00. Postpaid with raising instructions. Brazos Worm Farms, Route 4, Waco, Texas 76705.

**RAISE** Earthworms For Profit—Details 25¢. Wrays Worm Hatchery, 2511 Iowa, Carlsbad, New Mexico 88220.

**FISHING**, composting, Red Wigglers \$6.00-1000, smaller mixed 3000-\$9.00. Brown Nose \$8.50, African crawlers \$11.00, Grey Dancers \$23.00, Mealworms \$2.50, 3000-\$5.50 postpaid. Books \$2.00. Free overcount, literature. Jerseyites add tax. Moesel Enterprises, Box 121P, Flemington, New Jersey 08822.

## **POULTRY AND GAME BIRDS**

**GAMEBIRDS:** Eggs, Chicks, Started, Adult. Pheasant, Quail, Chukar, Waterfowl, Turkey; Game And Ornamental. Poultry. Catalogue, 35¢. Northwest Farms, Inc., Box 3003-PM, Portland, Oregon 97208.

**QUAILS**, Incubators, cages, supplies catalog. Marsh, 14216 Brookhurst, Garden Grove, Calif. 92643.

**BEAUTIFUL** Colored Brochure Helpful Hints, Rare Exotic Poultry, Enclose 1.00. Cline, Excelsior Springs, Missouri 64024.

**COLOR** Poultry Book \$2.50—"Everything—You Name It"! Official Bantam Book \$3.00; Pheasant Breeding \$5.95; Ducks, Geese, Swans of North America \$7.95. Stromberg's Pets Unlimited, Fort Dodge 25, Iowa 50501.

## **RABBITS—CHINCHILLAS—FUR BEARING ANIMALS**

**RABBIT** Equipment Catalog, 16 Pages With Pictures Showing Labor Saving Devices. Send 30¢ Refunded With First Order. Ozark Enterprises, Willard, 2R, Missouri 65781.

**RAISE** Rabbits Successfully by knowing Facts. 48 Page Illustrated Book describing 25 Breeds. Housing, Breeding, Feeding, Markets, Marketing, etc. 25 cents. American Rabbit Association, 36 Arba Building, Bloomington, Ill. 61701.

**RAISE** Chinchillas. Guaranteed income. Catalog \$1.00. DeShon Chinchilla, Route 2H, Roanoke, Indiana 46783.

**\$500-\$1000 MONTH** Plan Raising Rabbits For Us. Free Details. White's Rabbitry, Mt. Vernon, Ohio 43050.

**MAKE** Big Money Raising Chinchillas, Cavies, Rabbits for us. Catalog 25¢. Keeney Brothers, New Freedom, Pa. 17349.

**EARN** \$10,000 Yearly Raising Angora Wool and Breeding Stock. Details 25¢ coin. American Angoras, Malta 12, Montana 59538.

**TOPLESS INCOME RAISING** Mutation chinchillas. 25¢; bulletin \$1.00. Chinchilla, 11PM4, Port Richey, Florida 33568.

**RABBIT** Buyers. Any amount. Details 25¢. National Markets, Box 35855-M, Houston, Texas 77035.

## **PETS—BIRDS, CATS, HAMSTERS, ETC.**

**DOG** Coat-of-Arms—Free History of breed. Frame Crest-\$6.95. Nocturnal Owl, Box 1802, Lancaster, Pa. 17604.

**LIVE**—4 Hermit Crabs \$4.95 Postpaid. R. Minshall, Rt. 1, Box 80A, Caledonia, Ill. 61011.

**950 PICTURE** Pet Hobby Supply Catalog 50¢. "Everything—You Name It"! Cage Making Equipment. Stromberg's Pets Unlimited, Fort Dodge 25, Iowa 50501.

**LIVE** Seahorses, marine specimens, aquarium supplies, Illustrated catalog 35¢. Marine, Box 23158-G, Ft. Lauderdale, Florida 33307.

## **HORSES, LIVESTOCK**

**"HOW TO TRAIN HORSES"**—**FREE** Book tells how to break, train, make money with horses. Beery School, 1104, Pleasant Hill, Ohio 45359.

**VETERINARY** Guide to Farmers. The only book of its kind. Send \$6.95 to **POPULAR MECHANICS**, Dept. VG, 224 West 57 Street, New York, N.Y. 10019.

## **CAMPING EQUIPMENT AND TENTS**

**FREE** Jumbo 124-large camping catalog. Largest selection in the U.S.—I. Goldberg, Dept. PM, 902 Chestnut Street, Philadelphia, Pa. 19107.

**FREE** 112-Page Camping Marine Color Catalog. Laacke & Joys, 1439 N. Water, Milwaukee, Wisconsin 53202.

**CAMPER EQUIPMENT:** Discounted prices, complete selection parts, equipment, accessories. \$1.00, refundable, 200+ page catalog. **ALLWEATHER SUPPLIERS**, Dept. PM, 832 Seward, Evanston, Illinois 60202.

**FREE** Outdoorsman's Catalog. Features outdoor clothing, boots, tents, packs, hunting, fishing, hiking equipment, government surplus etc. Satisfaction Guaranteed. Write for free copy today. P & S Sales, Dept P-4, Box 45095, Tulsa, Okla. 74145.

## **TRAVEL AND RESORTS**

**GUATEMALA:** Fabulous Vacation Week at this Beautiful Country. Easy payments everything included \$200.00 person. Free Brochures. Casa Sanchinelli, Box 268, Guatemala, Central America.

## **ELECTRICAL SUPPLIES**

**METERS**—Surplus, new, used, panel and portable. Send for list. Hanchett, Box 5577, Riverside, Calif. 92507.

**DIMMER CONTROL KIT**—600 watt, easy to assemble, install. \$4.95. Pacemaker, Dept. 43M, 7808 N. 13th Avenue, Phoenix, Arizona 85021.

**LAMP** Parts. Catalog, prices, wiring instructions. 50¢. Refunded first order. Gyro, 5218P N.W. 35 Ave., Miami 42, Florida 33142.

## **BATTERIES, GENERATORS**

**NIKE** Missile Nickel Cadmium Battery Cells \$1.49 Each. Send Stamped, Self-Addressed Envelope For Listing Of Other Cells And Batteries For All Uses. Esse Surplus Co., 368 S. Meridian St., Indianapolis, Ind. 46225.

**BATTERY** Reconditioning Kit, includes molds, material, instructions. Details 25¢. Battery Shop, Box 820, La Quinta, California 92253.

## **ENGINES, MOTORS, MAGNETS**

**WINDING** Data, 275 motors, \$1.25. Data Company, 512 Kensington, Kansas City, Mo. 64124.

**STEAM** Engine Kits, Catalog-Handbook \$1.00. Reliable Industries, New Baltimore, Mich. 48047.

**MOTOR** Rewinding Supplies! Equipment plans! Modequip, Box 7266, Kansas City, Mo. 64113.

## **MACHINERY, TOOLS AND SUPPLIES**

**BUILD**-Small **BLAST** Furnace. Easy Inexpensive. Complete Plans, \$5.00. JSP-5, 53050 Placid, South Bend, Indiana 46637.

**SMALL** Foundry furnaces. Supplies. Free literature. Pyramid Products, 3736 South 7th Avenue, Phoenix, Arizona 85041.

*(Continued on next page)*

## MACHINERY, TOOLS AND SUPPLIES

(Continued from preceding page)

**END Mills.** Lathe Milling Attachments: Information. Potter, Box 73, Cedar Rapids, Iowa 52406.

**NUTS.** Bolts, Screws, Washers. Catalog 25¢. Also Assortments. Nutty Co., Box 1576SMS, Fairfield, Conn. 06430.

**TOOLS, EQUIPMENT & SUPPLIES!** We List Over **FOURTEEN-HUNDRED** Different **CATALOGS** of Materials and Accessories for Arts, Crafts, Automotive, Electronics, Industry. Send \$2.00. **MASTERLOG**, Box 24413VD, Oakland, California 94623.

**MAXIMAT.** Unimat Lathes, Metals, Micrometers. Catalogue 50¢. Industrial \$2.00. Campbell (PM) 1424 Barclay, Springfield, Ohio 45505.

**UNIMAT, MAXIMAT, DREMEL, Microflame, Etc.**—Catalog 25¢. Pioneer Electric, Box 7X, Brentwood, New York 11717.

**SOLVE** Tapping, Drilling, Cutting, Sawing, Reaming, Problems. Revolutionary cutting oil for all metals. Trial bottle \$1.00. Kane, 2906 Oak, League City, Texas 77573.

**4" METAL** Cutting Lathe Kit \$29.50. Completely assembled machining unit \$89.50. Taig Mfg., Dept. T, 15048 Proctor, Industry, Calif. 91746.

**QUALITY ULTRASONIC TESTING INSTRUMENTS.** Low, Low Prices. Thickness Measuring and Flaw Detection. Call or Write Krautkramer-Branson Inc., 76 Progress Drive, Stamford, Connecticut 06904. Phone: 203-324-6721. NDT Sales Dept. Ask for Jim Borges.

**AUTOBODY NON-SLIP** Friction Jack Set. 14 piece, lightweight, includes 8 special non-slip attachments, extensions, and jack shafts. Portable, one man handles all jobs. More ways to push and pull. Speedy trouble free performance. 15 years bodyshop proven Chicagoland. Real money making tool. Capacity 4 tons. Guaranteed. All on handy tool rack. \$72. Larson Jack Company, 1109 Fairfield, Waukegan, Ill. 60085.

**SHOPSMITH IS BACK!** Send 25¢ for Catalog. Includes Accessories, Prices, Parts. Factory Authorized Sales and Service. Hobbymodels, 418 Fulton St., Peoria, Illinois 61602.

## WELDING, SOLDERING, PLATING

**PLATING** Equipment, Portable Platers, Supplies, and "Know-How". Build your own tanks for nickel, chrome, etc. Easy-to-install PVC liners. Rectifier components—all sizes. Schematics, parts lists, formulas, operating instructions for all plating. \$10.00 post-paid. Guaranteed to save you 25%-75% or immediate refund. Some good used units for sale. Platers Service Company, 1511-A Esperanza, Los Angeles, California 90023.

**WELDERS.** Convert To Heliarc. High Frequency Unit 0-225AMP. Plans \$4.00. Convert To DC Plans \$3.00. Information Supply Co., Box 166, College Park, MD. 20740.

## GOVERNMENT SURPLUS

**TRUTH** About Surplus—Send 50¢ And Stamped Addressed Envelope To: **MALONEY ENTERPRISES**, Box 744, South Paterson, New Jersey 07503.

**"U.S. GOVERNMENT SURPLUS** Directory." How. Where to buy 100,000 items (including Jeeps) . . . low as 2¢ on dollar! Most complete information available \$1.00. **SURPLUS DISPOSAL**, Box 19107-AD, WASHINGTON, D.C. 20036.

**JEES!!! PICKUPS!!!** 100,000 Items direct from government. Your area. Latest information & surplus categories: \$2.00 **MONEYBACK GUARANTEE.** Order manual #123, from "Dependable Products", Box 113, Vista, California, 92083.

**NO CATCHES.** Buy any surplus direct from U.S. gov't. All information \$2.00. **Bridgeworth**, P.O. Box 2292-C, Vancouver, Washington 98661.

**JEES** Typically From \$53.90 . . . Trucks From \$78.40 . . . Airplanes, Typewriters, Boats, Clothing, Camping, Sporting, Photographic, Electronics Equipment. Wide Variety, Condition. 100,000 Bid Bargains Direct From Government Nationwide. Complete Sales Directory and Surplus Categories Catalog \$1.00 (Deductible First \$10.00 Order From Our Separate included Catalog). Surplus Service, Box 820-A, Holland, Michigan 49423.

**MILITARY** Surplus-Direct From Our Warehouse. Illustrated Catalog \$1.00; Lea Surplus, Dept-50, Box 679, Fairlawn, New Jersey 07410.

**1973 SURPLUS** Army, Navy store, 52 Page illustrated catalog. Send 50¢. Ruvel, 3037 North Clark, Dept. 4-J, Chicago, Illinois 60614.

**JEES** From—\$52.50; Typewriters from \$4.15; Cars from—\$31.50. Walkie-talkies, motorcycles, airplanes, boats. Typical "As Is" bid bargains from Uncle Sam. Tremendous variety. Exciting free list. Write: Enterprises, Box 402-X87, Jamaica, New York 11430.

**JEES!!! TRUCKS!! LAND!** 100,000 Amazing Bargains direct from Uncle Sam nationwide. How, where your area. Complete Sales Directory \$2.00. **MONEYBACK GUARANTEE.** Diversified Surplus, Box 27177-F, San Antonio, Texas 78227.

**JEES** \$52.40, Airplanes \$75.01, Typewriters \$6.70, Boats \$7.50, Direct from Government, Directory and Surplus Catalog \$1.00 (Refundable). Midwest Surplus, Box 401-PM, Dayton, Ohio 45401.

**GOVERNMENT SURPLUS.** How and Where to buy in your area, send \$1.00. **SURPLUS INFORMATION**, 615-PM **HEADQUARTERS BUILDING**, Washington, D.C. 20036.

**GOVERNMENT SURPLUS—TRUE FACTS ABOUT BUYING JEEPS, BOATS, ETC. YOUR OWN AREA. COMPLETE INFORMATION \$2.00. REFUNDABLE. WHITE, BOX 153, LEOLA, PENNSYLVANIA 17540.**

**JEES** . . . Buses . . . Vans . . . Trucks . . . Automobiles from \$52.50. Airplanes, Boats, Typewriters. Direct From Government. Directory and Surplus catalog \$1.00 (Refundable). Southern Surplus, Box 262PM, Manchester, Ky. 40962.

**JEES** . . . Boats . . . Camping . . . 100,000 unbelievable bargains, from Government. Latest howto your area. Guaranteed. \$2.00. Ross, Box 476314, Caseyville, Illinois 62232.

## HOBBIES AND COLLECTIONS

**MINIATURE** Hobbyst Tool Sets. Wide Variety. Top US Quality. Write: Tidewater, Box 832PM, Severna Park, Md. 21146.

**RAILROAD** Stock Certificates 5 Different \$7.50 List Available. Guarino, Box 786, Marco, Florida 33937.

**COLLECT** Military Medals, list 25¢. Vernon, Box 387PM, Baldwin, N.Y. 11510.

**NAZI** War Souvenirs Free Illustrated catalog. Delta, Box 361PS, Lafayette, Calif. 94549.

**NAZI** Medals, Photos, and Jewelry. Also War Mementos from Other Countries. Catalog and War Poster, 25¢. Hutchinson House, Box 6411, Chicago, Illinois 60680.

**50 GORGEOUS** Jungle Butterflies \$2.90. 25 Exotic Seashells \$1.25. Collectors Wonderland, Box 1170, New York 10008.

**IDAK, "INSTANT DESTROYER AND KILLER?"** Not really, but an ingenious robot. Complete Plans. Send \$4.00 To: Turman Electronics, 6517 Laird, Austin, Texas 78757.

**BOTTLE COLLECTORS:** Fantastic new book. (Soda Water and Mineral Water Bottles.) 2000 Varieties, photos, descriptions, prices Cokes, Pepsi, Vernor Springs, Etc. Send \$8.00. Cannon Books, Box 20719, AMF, Atlanta, Ga. 30320.

**GERMAN** Iron Cross Medal \$2.95, List 10¢. Abacus, 218 Northeast 1st Ave., Miami Fla. (33132).

**LUGER, COLT, MAUSER** Feature our non-firing reproductions of historic handguns. Same size, weight, balance as originals. Impressive, safe for home/office display. Brochure \$1.00 refundable first purchase. Mainbrace, 2523 Wilson Boulevard, Arlington, Virginia 22201.

## DECALS, EMBLEMS, PATCHES

**EMBLEMS** Embroidered to your own design. Leading manufacturer offers custom emblems in any quantity. Send sketch for firm quote or write for free Design-An-Emblem Guide and literature. A-B Emblem, Box 5695, Weaverville, North Carolina 28787.

**CUSTOM** Designed Embroidered Emblems, Decals. Inexpensive. Free Catalog, details. Southern Emblem, Box 8PMB, Toast, North Carolina 27049.



## STAMP COLLECTING

**FREE**—Mint British Colonials from Antigua, St. Christopher, Nevis, Sarawak, Turks Caicos, Tristan, Caymans, St. Vincent. Free with approvals. Viking, Great Neck, N.Y. 11021.

**WOW!** 110 All Different Germany 10¢. Commemoratives, Airmails. High Values, Big Catalog, Bargain Lists. Also, Fine Stamps From Our Approval Service, Which You May Return Without Purchases And Cancel Service At Any Time. Jamestown Stamp, Dept. A43PM, Jamestown, N.Y. 14701.

**MAGNIFICENT** Paintings—50 Different Breathing Beauties For Only 25¢ With Approvals. David Knower, Ferryville, Wisconsin 54628.

**SENSATIONAL** Clearance Offer. Fifty Different Packets \$2.00. Norge, Wyckoff, New Jersey 07481.

**50 FAMOUS PAINTINGS** 20¢. Approvals. Galers, Box 6188M, Hollywood, Florida 33021.

**FREE!** Big Bargain Catalog—New Edition Listing Thousands Of Bargains Including U.S. & B.N.A. Stamps, Packets, Albums, Accessories And Supplies. Also, Fine Stamps From Our Approval Service Which You May Return Without Purchases And Cancel Service At Any Time. Jamestown Stamp, Dept. E43PM, Jamestown, N.Y. 14701.

**22 TRIANGLE** Stamps Only 10¢. Get This Timeless Treasure Of Gorgeous, Colorful, Tringle Shaped Postage Stamps. Approvals included. Send Today! Stamps, Box 1444-B, Kitchener, Ontario, Canada.

**FREE**—Mammoth Collection. Scott's International Or Master Global Albums When You Buy Our Approvals. Bargain Service, Box 5345, Sant Ana, Calif. 92704.

**25 DIFFERENT ROMANIA** Pictorials 25¢ With approvals. Adventure Stamp Co., Box 1291, Mission, Kansas 66222.

**50 DIFFERENT ARGENTINA**-10¢. Approvals. Gobestamps, Box 402, Biddeford, Maine 04005.

**AMAZING** Value—"Sharjah Paintings", complete mint set, plus unbelievable topical collection, paintings, olympics, flowers, high catalog, only 10¢. approvals. Buy any or none, cancel anytime. Daniel Healy, Box 1164PM4, Arlington Heights, Illinois 60006.

**200 WORLDWIDE** 50¢ To Approval Applicants. Polze, Box 5215, Milwaukee, Wisconsin 53204.

**JAPAN, CHINA, AUSTRALIA, KOREA**—100 Different Only 25¢ With Fascinating World Approvals. Ephemera, Box 25934-P, Los Angeles 90025.

**50 DIFFERENT** Old U.S. Revenue stamps \$1.00. Winchester Stamps, Box 3592, Mansfield, Ohio 44907.

(Continued on page 226)

# Your paycheck says a lot about you

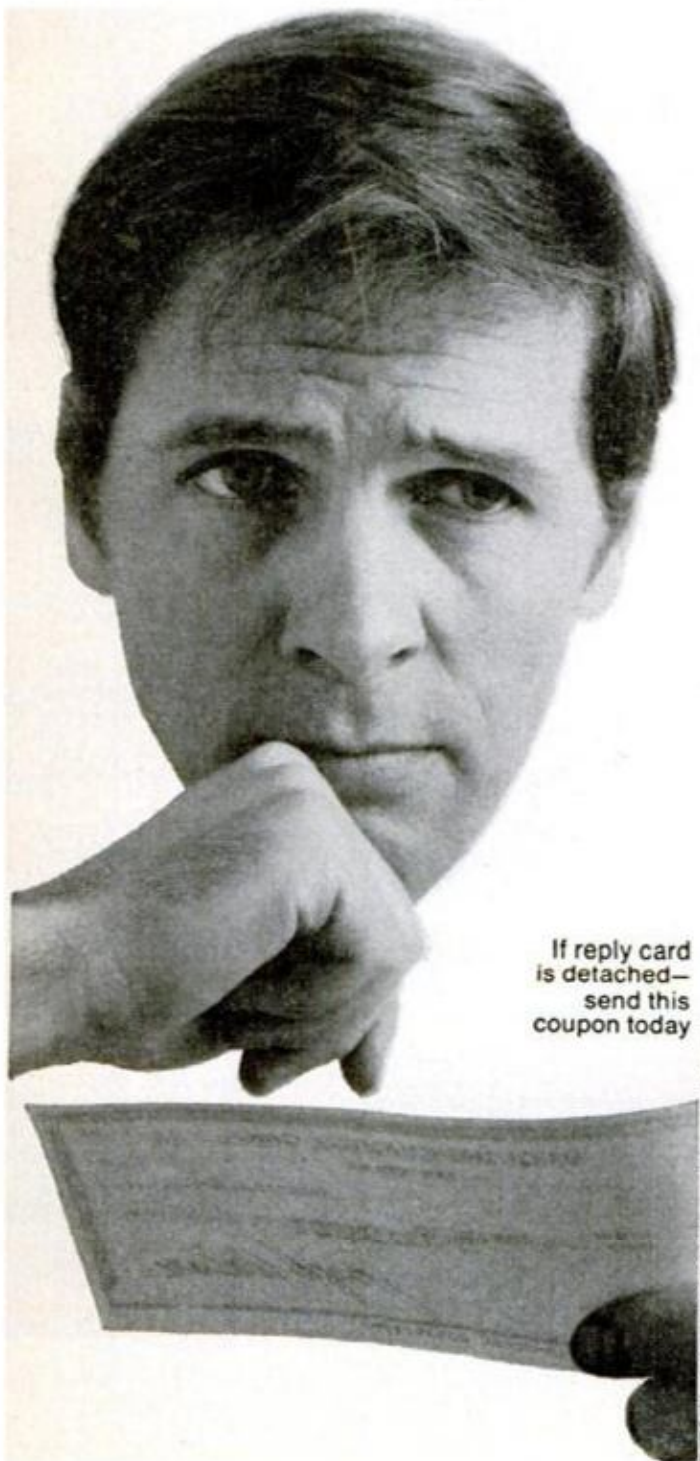

If reply card is detached—send this coupon today

It tells you more than how much you make. It tells you how far you've come. And if your paycheck looks very much the same as it did last year, or the year before, it simply means that you look very much the same as you did last year and the year before.

But times change, and you should be changing with them. Old dull jobs are disappearing. New exciting ones are being created. There are challenging fields such as computer technology, automation, television, space electronics where the work is interesting and the earnings are good.

RCA Institutes can give you the technical training you need, even if you've had no previous training or experience. RCA Institutes has a faster easy way for you to gain the technical skills and the knowledge required for an electronics career. And you don't have to quit work and go back to school. With RCA Institutes Home Study Plan you can work and study within reasonable limits. You set your own pace depending on your schedule.

Check over these RCA Institutes benefits:

- You get Hands-On Training — as many as 21 kits in RCA's Master TV/Radio Servicing Program.
- You get RCA's unique "Autotext" method of learning — individual programmed instruction, the easy, fast, simplified way to learn!
- You get a wide choice of electronics courses and programs — everything from Basic Electronics right up to Communications and Digital Electronics.
- You get a choice of low-cost tuition plans!

Sounds great, and it is. For complete information, without obligation, send in the attached postage paid card ... or return the coupon below. That will say a lot about you.

Veterans: Train under new GI Bill. Accredited Member National Home Study Council. Licensed by N. Y. State Education Dep't. — courses of study and instructional facilities approved by the State Education Department.

"Eligible Institution" under the Federally Insured Student Loan Program.

RCA Institutes, Inc. is a Subsidiary of RCA Corporation

## **RCA** Institutes, Inc.

Home Study Dept. 699-304-0  
320 West 31st Street, New York, N. Y. 10001

Please rush me FREE illustrated catalog.  
I understand that I am under no obligation.

Name \_\_\_\_\_ Age \_\_\_\_\_  
(please print)

Address \_\_\_\_\_

City \_\_\_\_\_ State \_\_\_\_\_ Zip \_\_\_\_\_

Veterans: Check here

## STAMP COLLECTING

(Continued from page 222)

**AUSTRALIA**—50 Different-10¢ With Approvals. Value Company, 10209A Tenbrook, Silver Spring, Maryland 20901.

**OLDER U.S.** stamps, covers, on approval to adults only. Surprisingly good. ENGLE, Box 208P, Lowell, Michigan 49331.

**WOW!** 1000 Different Worldwide Stamps (\$35.00 Cat. Value) \$2.00 with profit sharing approvals. Universal, Box 6MA, Kenosha, Wisconsin 53141.

**FREE**, Mint Worldwide Packet. Approvals. Hildebrand, Box 5645, Redwood City, California 94063.

**FREE** New used Congo animal set. Approvals included. Alpaughco, Highbridge, N.J. 08829.

**TEN** Different Nudes: 20¢. Approvals. Stamp Farm, 2M53, Oxford, Wis. 53952.

**50 DIFF. U.S. COMMEMORATIVES** 25¢. Fine U.S. Approvals Accompany. Craig Stamps, Box 425-N, Bellmore, N.Y. 11710.

**FOREIGN** Approvals! Gigantic values! 3¢ each. ABC, Dept. 3301-A, Box 6000, San Francisco 94101.

**3¢ PLATE** Block 25¢ with comprehensive U.S. stamp and Supply catalog. Schultheis, Box 2151C, New Hyde Park, New York 11040.

**"AFRICA"** 25 Beauties, 10¢. Approvals, Gorliz, Box 28765 PM, Memphis, Tennessee 38128.

**100 DIFFERENT** United States Stamps, 25¢ With U.S., Foreign Approvals. ShelRon, Box 547C, North Miami, Fla. 33161.

**U.S. MINT** Specials! Flag set, complete \$1.00. 1¢, 2¢, 3¢ famous Americans (21 different) \$1.00. Free list. Brooks, 2601 Avenue "U," Brooklyn, N.Y. 11229.

**PENNY!** Approvals! Regardless catalogue! Kloster, 4164 52nd St., San Diego, Calif. 92105.

**FREE** Surprise collection sent with approvals. Gould, 1784 Union, San Francisco 94123.

**PENNY** Stamps! 1000 Mounted in book at 1¢ each! Trust Stamp Company, P.O. Box 100-P, Jamaica, New York 11435.

**ABSOLUTELY** Free United States Mint Souvenir Sheet When Requesting United States Approvals. K&B, Box 70, Brooklyn, N.Y. 11223.

**500 DIFFERENT** Stamps, \$1.00. Smith, 508-A Brooks, College Station, Texas 77840.

**100 DIFFERENT** British Empire 15¢. Approvals. Gibson, Box 34, Lansdowne, Pa. 19050.

**60 DIFFERENT** United States (30 Commemoratives) 25¢. Seidenberg, Salem 169, Oregon 97308.

**"INVERTED Error"** Dag Hammarskjold, 10¢ with approvals. Belmont Stamps, Washington, D. C. 20015.

**100 OLD** United States between 1861 and 1935. \$1.00. Ed Roush, 423 Shepard, Mansfield, Ohio 44907.

**225 STAMPS** For only 10¢! Airmails. Pictorials: stamps from strange countries cataloging up to 25¢ each! Plus unusual stamps to examine. Buy any or none return balance, cancel service anytime. Mystic Stamp Co., Camden 80, New York 13316.

**NEW** Issues—Free Weekly Illustrated list. Brooks, 2601N Avenue "U," Brooklyn, N.Y. 11229.

**12,000 DIFFERENT! AMAZING** New Plan Builds Your Collection Systematically, Country By Country. Only 50¢ Weekly. Ware, Monroe, Conn. 06468.

**FREE!** 10 African Beauties! 30 Others! Approvals. Cambridge, Box 2311, Heath, Ohio 43055.

**LIECHTENSTEIN** 356-\$19.00; France #1100-\$4.00; UN 29-30-\$15.00; NH, CWO. Submit Lists Western Europe Only. All NH. Franklin, Box 467F, Jamaica, 11434.

**VALUABLE** Collection! Get scarce Red China, Pope John, Apollo 14, Antigua military costume, Iwo Jima memorial stamps, many more. 100 Different new and old issues from the world over—savage warriors, wild beasts, famous people, exotic scenes. Also stamp selections to examine. Buy any or none, return balance. Cancel service anytime. Rush 10¢ handling. Garcelon Stamp Co., OPMX, Calais, Maine 04619.

**CANADA** Sports Complete 10¢, Canadian Approvals. Harley Boardman, Little Valley, New York 14755.

**1000 PRE-1939 USA**, contains dues, revenues, commemoratives, presidentials, high values, older issues, etc. \$3.00; 5000 \$12.00. 300 pre-1940 USA commemoratives \$2.00; 700 \$4.00. 5000 foreign \$3.00; 9000 \$5.00. No approvals. Meyers, 5321 Fleming, Richmond, California 94804.

**20 HISTORICAL U.S. Commemoratives** 10¢. Bargain U.S. Approvals. PINTO, Box 111, Park Ridge, Illinois 60068.

**BETTER GRADE U.S.**, Canadian Stamps. Borgen, Box 502, Alturas, California 96101.

**FREE** Beautifully Designed Space Selection, Approvals, House of Hoke, Sebring, Florida 33870.

**RICHARD NIXON** Inauguration Day Souvenir Cover. Addressed any name your choice. Special Postal markings. 50¢ each. K.M. WALSH, Box 308A, TUCKAHOE, New York 10707.

**VIETNAM** 25 Different 10¢ approval. Sam Chazen, Box 95, Ozone Park, N.Y. 11417.

**7 COMPLETE SETS** Poland—25¢ With Approvals, Duncan Stamps, RR #1, Duncan, B.C., Canada.

**"CONQUEST Of Mars"**, Yemen's Latest Collection. 10¢ With Space Approvals. Potomac Stamps, Washington, D.C. 20015.

**MINT STAMPS**—25 All different, Worldwide, Large and Beautiful only 10¢. approvals. Cornett, P.O. Box 711, Miami Springs, Florida, 33166.

**80 DIFFERENT U.S. Stamps.** Includes 1943 flag stamp of occupied nations. Only 25¢. Approvals included. Willett Co., Box 338-M, Yorktown Heights, N.Y. 10598.

**FREE!!** 25 US Commemoratives, 2" Diameter Magnifier—10¢. Approvals. Mixdrak, 5630 Wilson, Chicago 60630.

**GIANT** Stamp Collection including: Astronauts, Satellites, Moonrocks, Boy Scout issue. Complete U.N. Set, recent Olympic and Sport issues from many countries, etc. Plus Big Stamp Dictionary and approvals. Everything 10¢! Stampex, Box 47-RM, White Plains, N.Y.

**50 YEARS** Old, fifteen different United States, over fifty years old—10¢ with approvals. Jaxon, Box 145-P, Brooklyn, New York 11230.

**KAZAM!** 25¢, 50 Mid-eastern, Approvals. ALLADIN, Box 602, Jefferson City, Tenn. 37760.

**EXCHANGE**, Send 100-200 different foreign with 35¢. Receive different. Patterson, Lancaster, New York 14086.

**FREE** 50 Worldwide. Approvals. University Stamps, P.O. Box 1471, Lake Worth, Florida 33460.

**FREE** Old U.S. Stamps. Approvals. Chapmans, Box 487-S, Galesburg, Michigan 49053.

**QUALITY AND LOW PRICE. EXCELLENT** For advanced or beginner. Mounted approvals 2¢ up, all countries in Scott's Order. Preview Stamps, P.O. Box 20667, San Diego, California 92120.

**U.S. BARGAIN**, 50 Different 10¢, with beautiful worldwide, approvals. Stamp Center, Kennebunk, Maine 04043.

**BREATHTAKINGLY BEAUTIFUL** 50 Different Mint Monaco Multicoloured Pictorials—Commemoratives \$1.00 With Mint Complete Set Approvals. Pagoda, Box 132E, Sidney, Ohio 45365.

**FREE** Mixture, Contains Many Commemoratives, Pictorials, British Colonies, Foreign. Approvals. City Stamp Co., Box 216, Station "W", Toronto 15, Ont., Canada, M6M. 4Z2

**210 DIFFERENT U.S. Commemoratives** \$1.00. Stamps, 7607 Larchview, Dallas, Texas 75240.

**1200 MISSION** Mixture \$1.00. 7000, \$5.00. Stamps, Box 9, West Union, Iowa 52175.

**40 DIFFERENT** Nudes \$1.00. No Approvals. Kemp, 9952 Tamarack, Pacoima, Calif. 91331.

**FREE** 25 Different Canada. Joseph Myers, 633 W. Michigan, Marshall, Michigan 49068.

**35 DIFFERENT U.S. 3¢ Commemoratives**, 25¢ accompanying approvals. C&L Stamps, PM2 Box 336, Maugansville, Maryland 21767.

**EXCITING** Mexican Munich Olympic Set Only 50¢ With Pictorial Approvals. Robert Hedges, Route 3, Hagerstown, Md. 21740.

**ZODIAC** Complete Set of Multicolored Stamps from Ajman, 25¢ with approvals. Judi's Stamp Company, 32 Arbor Street, Lynn, Mass. 01902.

**SPECTACULAR** 204 Worldwide 10¢! Commemoratives, Mysterious Continents! Approvals. Holland, 1227 Sixth Street, Redlands, California 92373.

**U. N. 5** Different mint 10¢! Approvals. Gordon Davison, Hillsboro, New Hampshire 03244.

**HITLER**, 100 Germany 10¢! Approvals. White Rock Stamps, 13125 24th M Avenue, Surry, B. C., Canada.

**SEND** Only 10¢ for nice collection of U.S. stamps including "\$5.00." Issue and scarce mint Sipex Souvenir Sheet. You will also receive the most wonderful catalog of stamp offers in America. Littleton Stamps, Dept. SS1, Littleton, New Hampshire 03561.

**FREE BARGAIN LISTS!** U.S. Mint single-plate blocks. Scotco, Box 855 PMG, Miami, Fla. 33147.

**STAMPS** Free! New Issues—New Countries—Triangles—Rockets—Olympics—Scouts—Birds—Flowers—Animals—Also Old Canadian and U.S. Stamps. Plus complete illustrated Canadian Stamp Catalog. Send 10¢ for mailing. Gray Stamp Co., Dept. A, Toronto, Canada.

**25 RUSSIA** Pictorials 10¢ with 2¢ approvals. Philmart, Box 3860, McGregor, Texas 76657.

**SEND** Only 5¢ for Worldwide Collection of over 50 different Singapore, Grenada, Chad, etc. Contains old and new Issues, sports, animals, etc. You will also receive interesting lists and a certificate worth 50¢ toward purchases. Goliath Co. Dept. TP-1, Bethlehem, New Hampshire 03574.

**SPECIAL!** 1,000 Different Stamps \$2.25 Guaranteed! Skevis, Box 215, Montreal 304, Quebec.

**MEXICAN** Mint Stamps with approvals. \$1.00. B&H, 24 West Calle Laurels, Santa Barbara, California 93105.

**WE BUY** Stamps. First Write. Aztec, 610 Vance, Taylor, Texas 76574.

**100 WORLDWIDE** Including Triangles 30¢. Penniston, Box 7253, Arlington, Va., 22207.

**AUTOMOBILES** On Stamps 25 different 10¢. Approvals. Susat, 1810 Glenbrook, Irving, Texas 75061.

**WORLDWIDE COLLECTIONS** Mounted in Books. Babineau, Box 124, Biddeford, Maine 04005.

(Continued on next page)

## STAMP COLLECTING

(Continued from preceding page)

**COLLECT** U.S. Stamps? The 1937 SPA Souvenir Sheet, fine mint is offered for just 25¢ to introduce our U.S. Approvals. You will like the Service and Fine Stamps. Write To: Fullmer, Box 2177, Dept. F, Virginia Beach, Virginia 23452.

**RUSSIAN** Space Collection 25¢, including Russian Approvals. Snedco, Waldwick, New Jersey 07463.

**FREE**—Worldwide \$1.00 Value. Approvals. Stamps Unlimited, Box 2338, Kalamazoo, Michigan 49001.

**307 DIFFERENT** triangles, Sports, topicals, etc. Worth near \$8.00. Only 25¢. Bargain approvals. Jayto Stamps, East Syracuse, New York 13057.

**TRIANGLES**, Latest Russian Autos—Trucks Commemoratives—Free! Approvals plus 101 Bonus Offers. William Deems, 226 Race, Ravenswood, West Virginia 26164.

**CLOSEOUT** Sale: Generous Lot \$1.00. High Value—Packet Extra Large \$3.00. 2 Packets \$5.00. Schollmeyer, 436 New York Avenue, Brooklyn, New York 11225.

**50 FAMOUS PAINTINGS** 50¢ When requesting approvals. C. F. Stamps, 655 Forbes St., East Hartford, Conn. 06118.

**TEN** Beautiful Diamonds. 10¢. Approvals. Big M Enterprises, Box 10902A-4, Ferguson, Missouri 63135.

**BWI** & British Commonwealth High Values, 205 Different, 6d-12¢ to L1-\$10.00 Face Values \$11.05. Alexander, Box 2768, GCS10, New York, N.Y. 10017.

**FREE** Pictorial Set to New Approval Applicants, Jenco, P.O. Box 242F, Wayne, N.J. 07470.

**HARRY S. TRUMAN** Memorial stamp on lovely First Day Cover addressed any name your choice. 50¢ from: **K. M. WALSH**, Box 308B, Tuckahoe, New York 10707.

**BRITISH** Bonanza! 107 exciting Colonials, magnificent Commemoratives. 25¢. Approvals. Castle, Box 15-PM4, Flushing, New York 11352.

**FREE** World Collection. Over 100 stamps. Approvals. Global, Box 427, Livermore, Cal. 94550.

**255 DIFFERENT** Worldwide: 15¢. Approvals. Tibbets, 8675 Meadow, Downey, California 90242.

## COINS, TOKENS, CURRENCY

**CARTWHEELS**. Mint Roll Of 20 Unmarred Eisenhower Dollars. \$30.00. Bauer, Box 85A, Rt. 3, Annapolis, Maryland 21403.

**CLEARANCE** Ten Canada Silver Dollars \$15.00. Lee Ltd., 331 W. Pender, Vancouver, Canada.

**OLD BUFFALO NICKEL** 25¢ + Giant Bargain Filled Coin And Stamp Catalogue. Blackburn Coin Company, 1305½ N. E. 45th, Seattle, Washington 98105.

**\$1000.00 BANKNOTE** 25¢ with comprehensive U.S. coin and supply catalog. Schultheis, Box 2151C, New Hyde Park, New York 11040.

**SILVER DOLLARS** Uncirculated, 1880-81—1883-84-85 \$5.00 Ea. Catalogue 50¢. Shultz, Salt Lake City, Utah 84110.

**LINCOLNS** 1909-1958 Every year including 1909VDB, 1922D. 50 different (Regularly \$12.60.) **SPECIAL** \$6.95. **HARRIS**, Box 2037P, Santa Cruz, California 95060.

**COINS** At Discount Prices! Free Brochure. Gene Carlton, Chandler, Okla. 74834.

**BARGAIN** Coin List, 10¢. Economy Sales, Box 92, Buzzard's Bay, Massachusetts, 02532.

**GOLD**—(1865) Mexican Maximilliano Peso, Bu \$2.95. Northwoods, Bigfork, Minn. 56628.

**100 INDIAN** And Lincoln Cents 1920's And Older \$5.00. Free Catalog. Wesley Rood, Box 9, West Union, Iowa, 52175.

**FOREIGN COIN COLLECTIONS**—21 Different \$1.00. 49 Different \$2.50. Paper Money 8 Different \$1.00. Wentz, Box 2439P, Newark, New Jersey 07114.

**UNCIRCULATED 'S'** Lincolns, three different, 10¢. Bargain lists included. Farley Coins, Metamora, Illinois 61548.

**SPANISH** Treasure catalogue. Bargains on Coins, Gold, Treasure. Special Bit of eight \$1.00 with catalogue. Colonial House, 909 Travis, Houston, Texas 77002.

**1909-VDB LINCOLN**, Fine, \$1.25. Free Catalog. Village Coin Shop, Dept. P, Plaistow, N.H. 03865.

**FREE:** Lists of Thousands of Stamps and Coins. No Approvals. Bryson, 612M White, Toledo, Ohio 43605.

**REPLICA** \$1,000 Bill 35¢. Christopher, Box 244M, Fishkill, N.Y. 12524.

**SEND** Only 5¢ for valuable booklet "How To Collect Coins" which is loaded with expert advice. You will also receive 5 different foreign coins and your copy of the most unusual and interesting collectors catalog available anywhere. Littleton Coins, Dept. VB-1, Littleton, New Hampshire 03561.

**COIN** Catalogue Free! Raibl Enterprises, 2355 Scenic Highway, Pensacola, Florida 32503.

**LARGEST** Foreign Coin List in America. 25¢ Postage. Martin, Box 11, Annandale, Virginia 22003.

**COLLECT** Coins For Profit and Investment. Booklet \$1.00. George Gropp, 1688 Mt. Everest Lane, Toms River, New Jersey 08753.

**GOLD COINS** Of the World. Beautiful Low Prices. Plus thousands of United States Coins. Free price list. Please send long, airmail envelope. Self-addressed, stamped. Silver Center, Box 22171-M, San Francisco, California 94122.

**VP INAUGURAL** Reception Medal—Proof-like \$15.00 ppd. Walroco, Box 341PM, Delavan, Wis. 53115.

**SILVER** Dollar \$3.40 Listing 25¢. Nelson, Box 306-Z, Chappaqua, New York 10514.

**1909 VDB's!** Rare Lincoln Cents, \$3.95. 3 for \$10.00. Coins West, 21 Central, Campbell 1, CA 95008.

## ANTIQUES, RELICS, INDIAN GOODS & CURIOS

**FREE!!** Lists Antiques, Indian Relics. 10 Arrowheads \$4.00. Hyde's, Box 2304, Santa Fe, New Mexico 87501.

### EVERYBODY LIKES DIXIE GUN WORKS.

**TONS** Of antique gun parts and supplies. All reproduction muzzle loading guns. Send \$2.00 for enlarged illustrated catalog No. 121. Dixie Gun Works, Union City 12, Tennessee.

**PERFECT** Flint Knife, 4 Perfect Arrowheads, Hide Tanner, \$4.00. List Free. Lear's, Glenwood, Ark. 71943.

**INDIAN** Relic list. Arrowheads \$4.00. doz. Folsom. \$5.00 each. C. Secrist, Deerfield, Missouri 64741.

**APACHE ARROWHEAD COLLECTIONS**—Perfect. 25—\$5.00, 100—\$15.00. GERONIMO, PMD1239, Apache Junction, Arizona 85220.

**ANTIQUE**, Bottle. Avon Collectors!!! Free Catalog Listing 256 books. Cleveland Book Supply, 320BBH Main, San Angelo, Texas 76901.

## MODELS—CARS, SHIPS, TRAINS, PLANES ETC.

**SHIP MODEL** Kits, Plans, Fittings from our own Workshop. Big Illustrated Catalog: 50¢. Bluejacket Shipcrafters, 145-V Water Street, So. Norwalk, Conn. 06854.

**FLY YOUR OWN MODEL ROCKETS NOW!** Watch 'em scream up and away from your own electric launch system—as high as 2500 feet on a pillar of safe, solid-propellant power. Track 'em by feather-weight instruments, recover 'em by chute, fly 'em again and again! Realism and adventure—you can even shoot pictures from up there, stills and movies, with featherlight cameras! Lift off right now with a big, full-color **ROCKET CATALOG**—Over 80 real grabbers—just 25¢ from: **ESTES INDUSTRIES**, Dept. 7H, Penrose, Colo. 81240.

**SHIP** And Airplane Model Kits Catalog 25¢. Scientific, Inc., 340 Snyder, Berkeley, Heights, N.J. 07922.

**SHIP** Models Kits, fittings, plans, books, tools, engines, motors. Big illustrated catalog 50¢. Mass. residents add 3% tax. James Bliss & Co., Dept. SM, Route 128, Dedham, Mass. 02026.

**LIVE** Steam powered backyard railroads! All sizes. Complete "bolt-together kits," and rough castings. Excellent drawings. 100 page catalog \$1.00. Little Engines, Lomita, California 90717.

**MODEL** Airplanes—Big 220 Page Catalog \$1.00. Sig Company, Montezuma, Iowa 50171.

**SHIP** And yacht model fittings: Pine construction hull kits; blueprints. Send 75¢ for illustrated catalog. A. J. Fisher, Inc., 1002 Etowah Avenue, Royal Oak, Michigan 48067.

**59 PAGE** Guide to Building Wooden Ship Model Kits. \$3.00. Pentz, 53G Lexington, Smithtown, New York 11787.

**FREE. Flying MODEL ROCKET** Kit. Act Now. Offer Limited. Send 25¢ for Packet of Iron-Ons, Decals, Literature and "Free Rocket" Details. Aerospace Vehicles, Inc., Mineral Point, Wisconsin 53565.

## MAGIC TRICKS, JOKES, VENTRILOQUISM

**HOUDINI'S** Greatest Magic! You can do them all!! Giant illustrated catalog 25¢. House Of 1000 Mysteries, P.O. Box 2026P, Pompano Beach, Florida 33061.

**COMPLETE MAGIC SET**. Two Wonder Tumblers, Cards, Silk, Gimmicks For 15 Amazing Miracles. Best Bargain In Magic Only \$2.98 Plus 50¢ Postage. PM-Motivators, 6607 Sunset, Los Angeles, California 90028.

**MAGIC MAGAZINE**. Tricks, News, Dealers Offerings. Monthly Since 1936. 2 sample Copies \$1.00. Genii, P.O. Box 36068M, Los Angeles, California 90036.

**MAGIC TRICKS** With Things Around Your House. Complete Instructions On Many Amazing Miracles. Fool Friends, Be Hit Of Party, Only \$1.50. Motivators PM, 6607 Sunset, Los Angeles, Cal. 90028.

**500 TRICKS**—Large 1973 Catalog. Newest Magic For Pocket, Parlor, Stage. Send 25¢. Fastest Mail Service. Jeffries Magicland, Dept. 11, Dallas, Texas 75221.

**LEARN VENTRILOQUISM!** Courses. Dummies, Marionettes. Catalog 25¢. **MAGIC, NOVELTY** Catalog 20¢. Rizzy's Ventriloquism Magic School, 3746 West 63rd Street, Chicago, Illinois 60629.

**FREE!** World's leading novelty catalog. 1600 Funmakers, Jokes, Tricks, Science, Sports, Hobbies, Jewelry, Psychedelia. Johnson-Smith, C-10, Mt. Clemens, Mich. 48043.

**COMPLETELY** Illustrated catalog. 84 pages. 25¢. Manhattan Magic, Box 334-M, N.Y.C. 10011.

**WORLD'S** Finest professional magic tricks. Joker's Novelties. Giant illustrated catalog 10¢. Top Hat. Evanston, Illinois.

**FABULOUS MAGIC'S** New 1973 catalogue 25¢. Our specialty orders shipped same day no substitutes. Fabulous Magic, 3319 East Charleston, Las Vegas, Nevada 89104.

(Continued on next page)

## MAGIC TRICKS, JOKES, VENTRILOQUISM

(Continued from preceding page)

**BE A Magician!** Two booklets explaining 156 tricks plus large professional catalog, \$1.00. Magic, Inc., 5082 Lincoln, Chicago, Illinois 60625.

**TWO Different Magic Catalogs** 25¢. Miami Magic, Box 1047, Miami 33133.

**TWO Novelty Tricks** plus Big Illustrated Catalog 25¢. Magicians Discount Prices. Sun Magic, Oakhill, Williston, Vermont 05495.

**SELF-TEACHING Magic Set**, with Cassette, Books, 60 tricks \$10.95. . . . Huge Professional Catalog, Free Tricks, \$1.00; Imperial, Box 623-P3, Worcester, Massachusetts 01601.

**HOUDINI'S Original Magic Shop**. Established 1856. Send 25 cents for illustrated Catalog containing 5000 Tricks, Mindreading, Puzzles, and Jokes. Flossie-Hornmann, 304 West 34th St., New York 10001.

**CATALOG 10¢**. 1,500,399 Tricks, jokes, novelties. Elbee, 7408P, San Antonio, Texas 78207.

**VENTRILOQUISM!** Learn at home! Guaranteed! Write! Information Free! Dummy Catalog 25¢. Maher, Box 9037P, Denver, Colorado 80209.

## BOOKS, CATALOGS, NEWSPAPERS

**MAILORDER Millionaire** helps beginners make \$500 weekly. Free report reveals secret plan! Executive (1A4), 333 North Michigan, Chicago 60601.

**LATEST Military Manuals/Books Catalog** 25¢. Hillcrest Publications (K-18), McDonald, Ohio 44437.

**FREE BOOK**, Prophet Elijah Coming Before Christ. Megiddo Mission, Dept. 63, 481 Thurston Road, Rochester, N.Y. 14619.

**NATIONAL Geographic Magazines**, 1888-1971, any issue. Buxbaum, Box 465-PM, Wilmington, Delaware 19899.

**FREE 306 Magazines Monthly**. Write: Diamond, Box 15473J, San Diego, California 92115.

**WIRETAPPING** and the Laws—Your Privacy Invaded—Free Brochure—Don-Q, Box 548, Dept. PMO, Seattle, Washington 98111.

**TODAY**—Now! Live life better thru Self-Improvement, Inspirational ACTION Books. FREE exciting folder. TODAY—Now! Write: DYNAMICO, 2105-AA Wallace, Bronx, N.Y. 10462.

**ESCAPE** Crowded Cities—Enjoy Country Sunshine. "Your Dream Acres" Has The Answers. \$2.00 Guaranteed. Slater, Route 2, PM4, South Whitley, Indiana 46787.

**FREE Illustrated Catalog**, Home Usefuls And Gifts. Write: Del's Country Barn, V-4 Route 4, Lee's Summit, Missouri 64063.

**NATIONAL GEOGRAPHIC MAGAZINES**, 1912-1972. Private Party. 3,000 Copies. Schmidtke, 2508 So. Quitman, Denver, Colorado 80219.

**INCLUDE YOUR CHILD'S** Drawing, Poem, or Story in the Book of Children's Creative Work we are Publishing soon. No Charge for Inclusion. Nona Trimble, 2023 Poplar, Palo Alto, California 94303.

**LIKE** Free Mail-Order Catalogs? Write to: Diane P. Anderson, 260 Crittenden Blvd., Rochester, New York 14642.

**FREE Catalog**. How-To-Books, Bargain Guides, Blue Books. Elston House, Centerville, Mass. 02632.

## PLAYS, SONGS, MANUSCRIPTS

**PUBLISHING** Contract Guaranteed on selected songs and poems. Free evaluation. Hollywood Songwriters, 6253 Hollywood, 1117-PM, Hollywood, California 90028.

**SONGPOEMS, SONGS!** Urgently Needed. Possible Recording/Publishing. 50-50 Agreement. Betty's Music Makers, 1417B, Park Building, Pittsburgh, Pennsylvania 15222.

**RECORDS** Made. Publishing Contract Guaranteed On Accepted Songs, Poems. Send: Talent Searchers Of Hollywood, 6311-X Yucca, Hollywood, Calif. 90028.

**POEMS** And lyrics of religious, reverent, inspired nature wanted for immediate recording. We are only interested in songs of hope, God's love, the comfort of His words and wisdom. Cathedral Recording, P.O. Box 78-PM, North Weymouth, Mass. 02191.

**POEMS** Set to music. Songs recorded. Send poems, songs. Crown Music, 49-C West 32, New York 10001.

## BUSINESS SERVICES

**PROFITS FROM CLASSIFIED ADVERTISING!** Booklet shows you how to start your own business with Classified Advertising. Only \$1.00 (Refundable with first order.) H. E. KAPPEL, POPULAR MECHANICS, DEPT. P, 224 WEST 57 STREET, NEW YORK, N.Y. 10019.

## BUSINESS OPPORTUNITIES

**START BIG-PAY** Business at home in spare time. No experience needed to operate little tabletop machine for bronzing baby shoes. Make \$7.95 profit on every pair. Full particulars free! Send postcard to: Mason, Room MC-2-CF, 1512 Jarvis, Chicago, Illinois 60626.

**HIGH PROFITS FOR CREATIVE WRITERS.** Start Immediately. Send Stamp. Baughan, Postbox 1426-APM, Plainfield, N.J. 07061.

**IMPORT-Export Opportunity**, profitable world-wide, mail order business from home, without capital or travel abroad. We ship plan for no risk examination. Experience Unnecessary. Free Report. Mellinger, Dept. G2704, Woodland Hills, California 91364.

**EXCITING Home Mailorder Business!** Follow The Experts With Proven Plan . . . Fantastic Opportunity. Free Details. Associates, Box 136-A, Holland, Mich. 49423.

**OPERATE A Mail-Order Business** from your home. Everything furnished. Lindner, GMO-34, 14603 Dorchester, Dolton, Illinois 60419.

**FREE**—Million Dollar Mail Order Secret. Raney—18 Oneida, Centereach, New York 11720.

**SECRETS!** Mail Order Success. Internationally famous expert reveals how to make home business fortunes. Beginners: Get free report "Make Money By Mail." Discloses free advertising profitable products. Mailco, Dept. GC704, Woodland Hills, California 91364.

**\$2,000 MONTHLY** in Fabulous New Business. Free Details. Nielsen's, Box 15894-P, Salt Lake City, Utah 84115.

**LAWS—REGULATIONS:** For Mailorder. Details—"Air-Mailed"—Free! TCR, Box 787PM, New York 11757.

**INSTALL Burglar alarms** without previous experience or costly equipment. Big profit. Free details. Nasco, Dept. G2704, Woodland Hills, California 91364.

**HUNDREDS** Unknown Businesses—Little Or No Investment, Box 2864-PM, Sepulveda, California 91343.

**TRIPLE YOUR MONEY GUARANTEED!!!** Mailing Catalogs! Jewelry Dropshipped. Beginners Get \$10.00 Profits Every Order! Sparetime. FREE RINGS Offer! Jaklagems, 2849-BPM Southport, Chicago 60657.

**AMAZING** New Home Business Earns \$1,000 Monthly. Details 25¢. Tega, Box 56 EDM, Des Moines, Iowa 50309.

**START YOUR OWN** Mailorder Business. Do It TODAY! Free Details. Hautala, 33 Roosevelt Avenue, Nesconset, New York 11767.

**QUARTER** Launches Advertising Business. Free Details. Mockerc, Box 2, Brandywine, N.Y. 12304.

**LIFETIME** Business Free Details. Midwest, 1034B Elizabeth, Jefferson City, Missouri 65101.

**MAILORDER Dealers** Wanted. Earn outstanding profits using tested promotions! Ruwtard-PD, Georgetown, Conn. 06829.

**EARN MONEY** At Home! BEGIN IMMEDIATELY! Details 25¢. Beebe, 773 E. 154 (#2), Cleveland, Ohio 44110.

**MAILORDER FAILURES** Outnumber Successes! Why? Your Future DEMANDS Reply To PATHFINDERS, Suite 205-A, 25 Van-Neipen Avenue, Jersey City, New Jersey 07306! Happy Information FREE.

**MAKE** To Triple Times your Cost. Hundreds of Products, Gifts, Novelties, Toys, many others. \$1.00 brings Giant Catalog, Refundable with First Order. DONMAH, PM-G, 809 Ravenwood, Arlington, Texas 76013.

**PIANO** Tuning Learned Quickly at Home! Tremendous field! Musical knowledge unnecessary. GI Approved. Information Free. Empire School, Box 327, Miami, 33145.

**400% PROFIT** Possible!! Sell Mailorder Books From Own Catalog. Everything Furnished. Free Details, Sample Catalog. Sullivan, Box 222A, Needham, Mass. 02192.

**MAILORDER INSTRUCTION PUBLICATIONS!!** Professional. Reliable. Profitable. Write: HOW, Box 4457 PM4, Downey, California 90241.

**EARN \$50.00** To \$100.00 Weekly possible, home typing. Complete instructions, \$2.00. Jordan, 27495 Road 176, Dept. PM-4A, Exeter, Calif. 93221.

**HOME** Portraiture. Big Money. Send Stamped Return Envelope. PHOTOGRAPHY, 5334-P Sunset, Hollywood 90027.

**\$39.00 STARTS** Profitable mailorder business selling books. Complete explanation free. Neil H. Tasker, Shamokin, Pennsylvania 17872.

**BUILD** Custom Cases at home for profit. Get orders by mail. We supply materials, instruction—everything. Free home business details. Custom Case Supply Co., 6075 CPD, De Soto Avenue, Woodland Hills, California 91364.

**I MADE \$3,000.00** Monthly in Mailorder Evenings only. You can too! Free Proof—Bryant, 8601 Bowling Green, Austin, Texas 78758.

**HOW** And Where to get capital. \$5000 + possible in one day. Free details. JPA, Box 101-BD, Park Ridge, N.J. 07656.

**HERBALISM!** The home gold mine! Free lesson. Herbalism Institute-B, 1339 Remuda, Glendora, Calif. 91740.

**WORLD'S** Largest supply, Merchandise 25% to 40% under wholesale. Bankrupts. Closeouts 10¢ on dollar. Imports. Hong Kong clothes. Automobile discounts. Free details. International Buyers, Box 16386 MM, Portland, Oregon 97233.

**SELL** Books by mail. Complete dealer set-up—25¢. Midwest Mail Sales, Box 44R2-PM, Shawano, Wisconsin 54166.

**1000% PROFIT** Bronzing Baby Shoes. Free Literature. NBC, Box C-4-PM, Coral Springs, Florida 33065.

**MAKE** A Years Income in 8 weeks Camping. No selling. Capital or Land necessary. Write: Edru's, Route 5, Box 5733, Gig Harbor, Washington 98335.

**BECOME** "Mortgage Broker." Lucrative! Capital Sources, Box 99-A, Uleta, Florida 33164.

**MAKE** Magnetic signs, Machineless method. Profits enormous. Write: R1B49APM, Bardstown, Ky. 40004.

**ADVERTISING BUSINESS—YOU** Own it. \$350 First Week or Money Back. Electric Neon Action Ad Clock, 229 W. Illinois, Chicago 60610.

(Continued on next page)



## BUSINESS OPPORTUNITIES

(Continued from preceding page)

**HOLLYWOOD CEMENTCRAFT:** Offers Highly Profitable Home Business. Experience Unnecessary. Unlimited Unique Pottery Designs Easily Made Without Moulds. Bird-baths, Fountains, Wishing-Well, Waterfalls, etc. Chemical Coloring Formulas. Marble-glazing. FREE Illustrated Brochure. **CONCRETE FACTS**, 602 Athens Street, Altadena, California 91001.

**COPUBLISH** "Mail Sale Advertiser," leading mailorder paper. Copy and details 25¢. U.S.A. only. Vanroy Shirk, Lebanon, Pa. 17042.

**VENDING** Machine big catalog. Rake, 523 A Spring Garden, Philadelphia, Pa. 19123.

**DRAFTSMEN!** Operate own **DRAFTING SERVICE!** Full, Part Time; Experience unnecessary; Details: Roberts Drafting, 1741 Circle Road, Baltimore, Maryland 21204.

**FREE** Catalogs. Repair air conditioning refrigeration. Tools, supplies, full instructions. Doolin, 2016 Canton, Dallas, Texas 75201.

**MAKE \$46** From square foot plywood: jigsaw or bandsaw necessary. Free details. Woodar, Bridgewater, Mass. 02324.

**ADDRESSERS** And Mailers needed. Details 10¢. Lindbloom, 3636 West Peterson, Chicago 60659.

**BIG PROFITS!!** **SELL ENGRAVED, METAL, SOCIAL SECURITY PLATES. FREE SALES KIT!** MYERS, 928-PM CRESCENTHILL, NASHVILLE, TENNESSEE 37206.

**\$25.00 HUNDRED** Addressing. Possible Year 'round. Complete instructions 25¢ for registration, postage. Cove, Box 1348-B, Clearwater, Florida 33517.

**\$70 TO \$200 WEEKLY**—Home, Spare Time Simplified Mail Bookkeeping. Immediate Income. Easy. Auditax, Box 34741A, Los Angeles, Calif. 90034.

**VENDING** Machines. No selling. Routes earn amazing profits. Big catalogue Free. Parkway Corporation, 715PBM Ensor Street, Baltimore, Maryland 21202.

**\$60.00 DAY.** Manufacturing Concrete Posts. Blocks. Mold Equipment Catalog \$1.00 refundable. Carlayne, Route One, Box 95, Rapid City, South Dakota 57701.

**SELL** Books by mail. 400% profit. Royal, Box 450-X, Cleveland, Ohio 44127.

**MAILORDER** Records help get increased business! Complete 32 page Record Book shows your inquiries, orders, advertising, expense, etc. Only \$1.00. H. E. KAPPEL, POPULAR MECHANICS, DEPT. R, 224 WEST 57TH STREET, NEW YORK, NEW YORK 10019.

**TAKE** Catalog orders. We drop-ship 1001 best selling specialty products. Guaranteed lowest below wholesale prices. Fantastic spare-full time home business. Free book show you how. SMC, 6061 SPD, De Soto Avenue, Woodland Hills, California 91364.

**REPAIR** Hydraulic Jacks—Details Free. Write: Hydraulic Parts Supply, Box 295, Port Isabel, Texas 78578.

**EARN \$60.00** Daily manufacturing Concrete Fence Posts. Practically no investment. Send stamped-addressed envelope. American, Excelsior Springs, Mo. 64024.

**RECEIVE MAIL** Galore! Your name on our national mailing lists, 50¢. Sullins, Box 1313, Brunswick, Georgia 31520.

**\$50.00 PLUS 50% COMMISSION** Stuffing 200 already stamped, addressed envelopes, our circulars. Information 25¢ with stamped, self-addressed envelope. Brewster-PB, Clearwater, Florida 33517.

**JOIN** The professionals. Profitable Gift Catalog Distributorship. Giftfair, 1430-40 Wells, Milwaukee, Wisconsin 53233.

**PROFITABLE BUSINESS**—Molding Rubber, Hobby Supplies. Details 10¢. Chaney's, 5415 L San Jose Blvd., Jacksonville, Fla. 32207.

**TRANSPARENCIES** Wanted. Learn **FREE-LANCING**. American Color, Box 2193, Sepulveda, California 91343.

**400,000 BARGAINS** Below wholesale! Many free. Liquidations... closeouts... job lots... single samples. Free details. Bargainhunters Opportunities, Box 730A, Holland, Michigan 49423.

**\$400.00 MONTHLY** Raising giant fishworms. Soilless method. Charlie Morgan, Bushnell, Florida 33513.

**EARN** Money raising fishworms for us! Write: Oakhaven-38, Cedar Hill, Texas 75104.

**NEW** Manual, How To Manufacture Concrete Floor Tiles For Fun, Profit. Very Small Investment, Easy Method. Complete Instructions, \$6.00, Guaranteed. Hilmar, Route One, Box 347-D, Valrico, Florida 33594.

**SELL LIFETIME METAL SOCIAL SECURITY PLATES. BIG PROFITS! SAMPLE AND SALES KIT FREE. RUSSELL PRODUCTS, MAURY COUNTY SHOPPING CENTER, DEPARTMENT P41, COLUMBIA, TENNESSEE 38401.**

**FREE** 1973 100-Page Catalog waiting to bring you Big spare-time cash commissions. Sell Advertising Book Matches. Every business a prospect... complete selling instructions furnished. Steady, repeat business. Dept. MX-473, Superior Match Company, 7530 South Greenwood Avenue, Chicago, Illinois 60619.

**FREE** Collection Agency Details. \$1000.00 Monthly Possible. Master, Drawer 77009-PM, Atlanta, Georgia 30309.

**EARN \$2,000.00** Monthly in Astonishing Spare Time Business. Details Write: James Carmack, 233 1/2 N. Main Street, Manteno, Illinois 60950.

**WATCHMAKING** Makes every day a payday. Learn this cash business at home. Free details. Chicago School of Watchmaking, YQA, Fox River Grove, Illinois 60021.

**FREE** Sample. Sell Lifetime Social Security Plates. Big Profits! Ultis, 10716 Francis, 1PM, Los Angeles, California 90034.

**BUMPER** Sticker Printer Kit puts you into bumper sticker and T-shirt printing business fast! Great at swap meets, churches, organizations and for anyone who wants to say their own thing. No stencils to cut, easy to operate. Enough materials to earn \$200! Write: Bumper Sticker Printer, Dept. 56, Box 234, Torrance, California 90501.

**DON'T DELAY.** Write today. Start your own mail-order business. Send inquiries to: Remos, Box B1-3, Garden Grove, Cal. 92640.

**MONEY** In Mail Order. Free Details. Island, Box 157-F, Bayside, N.Y. 11361.

**FREE** Details—Your Own Mailorder Business—No investment. Passco, Box 926, Fresno, California 93714.

**\$1.00 LISTS** You year sent to 1000 Importers, Jobbers, Mailers, our mailing year. Dixiem, King, North Carolina 27021.

**MAKE \$2,000** Monthly! Copy The Mail-order Experts!! Only \$3.00!!! Potomac, PM-4, Box 3083, Alexandria, Virginia 22302.

**EARN** Thousands at home. How to sell books by mail. Free details. Wisdom House, Box 1106P, Largo, Florida 33540.

**HOW** To Raise \$100.00 To \$1,000,000.00! Drawer 77009-A, Atlanta, Georgia 30309.

**\$200.00 SPARE** Time earnings with your Tablesaw. Write: Workshop Five, 3800 Harne, Vancouver, Washington 98660.

**COPYWRITING**, Ghostwriting for Mail-order Dealers. Goutell, 175 Fifth Avenue, N.Y.C. 10010.

**YOUR OWN MAIL ORDER BUSINESS!** 4 MILLION NEW PROSPECTS ANNUALLY!! 25¢ BRINGS VALUABLE DETAILS. EVANS ENTERPRISES DEPT. PM, 77 MAY STREET, IRVINGTON, NEW JERSEY 07111.

**CLOCK** Fixing Simplified, Instructions, Tools. Free details. Thiese, Genoa, Illinois 60135.

**FREE SECRET BOOK** "2042 Unique, Proven Enterprises." Tiny businesses but huge profits! How Little Fellows beat inflation with fabulous "Little Knowns." Work home! Haylings-T10, Carlsbad, California 92008.

**MAKE MONEY ON MAILORDER IMPORTS.** Report Reveals Foreign Drop-Ship Sources. Ideal Mailorder Items. Send \$1.00. Mason, Dept. 411-B, 50 Agate, East Brunswick, New Jersey 08816.

**BELOW WHOLESALE** Catalog Hundreds of best selling products. \$1.00, refundable on first order. Astro Products, Box 715-PD, College Park, Maryland 20740.

**DO SIMPLE ADDRESSING**—Mailing. Receive \$12.95 orders. Keep \$8.00 profit. Details Free! Quality, Box 9-P, East Rockaway, N.Y. 11518.

**BIG** Profits building **PICNIC-TABLES!** Complete construction-merchandising course available... Particulars \$1.00 (applicable) Plus stamped envelope. DD Enterprises, RFD-1-246, Morrisonville, New York 12962.

**\$2000.00 MONTHLY** Selling Information By Mail. Ropchan, Box 5341P, Sherman Oaks, Calif. 91413.

**MAKE** Money In Wholesale. Everything you need for full or part time business. Details Free. Raven House, Box 4277M, Burlington, N.C. 27215.

**STUFF** Envelopes. \$25 Hundred. Immediate Earnings! Beginner's Kit. \$1.00 (refundable). Lewcard, P392M, Brea, Calif. 92621.

**OPERATION:** Make Money, \$1000.00 per month possible. **FREE** Details. Maxwell, Box 10126, Houston, Texas 77010.

**MAILORDER** Expert Helps You Make \$2000 Monthly. Spare time only. Free details. Mark Scott, 2330-B, Beacon Lane, Naples, Florida 33940.

**I MADE \$3,000.00** Monthly In Mailorder... Evenings Only! Professional Secrets Revealed — Free Proof! Financial, Box 161-D, Madison, Ohio 44057.

**FREE** Money Plan. Get Secrets for \$500 to \$2 million. Business capital, loans, cash. Free details. Capital-17, Kerrville, Texas 78028.

**NEW "JEWEL CAST" PRECIOUS METAL CASTING KIT — "MAKE PROFESSIONAL QUALITY JEWELRY"**. (Rated "Excellent" in Rock and Gem Magazine). Kit contains everything you need to make castings. There's nothing more to buy. You can Make Beautiful Castings at a fraction of their retail cost. **SAVE \$ \$ MAKE BIG PROFITS!!** The Quality of Castings made with the "Jewelcast" Kit are identical to that found in the Finest Jewelry Stores. Equipment can be used on the Kitchen Table, no special hook-ups. Plugs into any 110 outlet. Fast, Safe and Simple. Full instructions. **10 DAY MONEY-BACK GUARANTEE!!** Also, complete line of casting equipment and supplies. Precious Metals (Gold & Silver) for casting. Mastercharge, American Express Charge Cards Honored. **ORDER YOUR COMPLETE "JEWELCAST" KIT NOW!!** \$99.50 + Shipping & Insurance. **SANDGREG'S PRECIOUS METAL ARTS, 2307 SOUTH LAPEER ROAD, LAKE ORION, MICHIGAN-48035.**

**MAILORDER** Publisher Wants Dealers—Big Profits! Details, 25¢. Mears-PM, 5363 Essex, Alexandria, Virginia 22311.

**MEN-WOMEN EARN TO \$20,000 ANNUALLY! HOME STUDY COURSE TRAINEES NEEDED TO MAIL OUR HOME STUDY COURSE MATERIAL! SPARE TIME! NO EXPERIENCE OR INVENTORY INVESTMENT NEEDED! INTERESTED PARTIES REPLY QUICKLY FOR FREE LITERATURE! DELILLIS TRADE CORRESPONDENCE, 2 LAFAYETTE STREET, NEW ROCHELLE, NEW YORK 10805.**

(Continued on next page)

## BUSINESS OPPORTUNITIES

(Continued from preceding page)

**WHY** spend \$300?—\$24.95 outfit makes Social Security Plates! Free Details. Idea Products, Box 69828PQ, Los Angeles 90069.

**"MAILORDER"** Laws and Regulations. "Know the Facts," \$2.00. "Bill" Lambertson, 132 Tamiami Station, Dept. 43, Miami, Florida 33144.

**MAIL** Order? We dropship books. Send stamped self-addressed envelope. Artcrafts, 910 St. Vincent, Santa Barbara, Calif. 93101.

**MY NEW** Business can easily make you \$1,500 per month. Bullitt, Dept. K, Box 111, Collingswood, New Jersey 08108.

**PREPARE** Tax Returns—Housewife Jo Ann Netzel made \$5,500 last season. Train at home. VA Approved. National Tax School, Monsey 2LD, New York 10952.

**PROFITABLE MAILORDER YOURS!** Start immediately. Everything available. Sample package, confidential details free. Lewis, Box 683A, Colfax, Washington 99111.

**GET** Business ADVICE!! Send Your Questions, \$1.00. Schleicher, 7 Dove, Albany, New York 12210.

**SELL** Selected Gifts, Merchandise With Your Own Catalog. Low Cost Start. Big Initial, Repeat Profits. Complete Details, Sample Catalog 25¢. Billou, Box 7321, 59-01 Junction Blvd., Elmhurst, New York 11368.

**MAKE 2 TO 3** times your cost on Hundreds of Products. Gift Items, Novel Toys, Carded Merchandise, 1001 others. \$1.00 brings Giant Catalog, Refundable on first Order. Ray's Specialty House, Dept. PM, 1669 Johnson Rd. N.E., Atlanta, Georgia 30306.

**MAGNETIC** Signs. Build Your Own Plastic Forming Unit. A-B-C Plans Plus Instructions. \$12 Complete. Guaranteed Results. Academy, Box 506, Miami, Florida 33157.

**UNIQUE** Mailorder, Home Business Programs. 300% Profits. Amerasian, Box 776CD, La Canada, California 91011.

**\$500.00 WEEKLY** can be yours! Safe, Steady results with proven mailorder method! Guaranteed results! Free Details! Delta, Box 24-P, Chalmette, Louisiana 70043.

**\$200 WEEKLY!** Make, Sell Bricks! Free Information! Xcito Bricks, 5715 N. Mozart, Chicago, Ill. 60659.

**FINDER'S FEES?** Turn contacts into cash. Two Survey Reports, Trial Membership Kit. Send \$2. Finderhood, (PM-73), 15 West 38th St., New York, N.Y. 10018.

**24 LESSONS** Mailorder (Moneyback Guarantee) Course \$1.00. Amroco, Box 8282-AA, Richmond, Virginia 23226.

**MAILORDER BUSINESS?** Not Easy! Education Key to Success! Consult our books. Write: Corton, 329 North 6th Street, Prospect Park, New Jersey 07508.

**DON'T** Answer This Ad! This could be too much! Free Details. Boylil—1307 Duryea, Whittier, Calif., 90601.

**FREE** Booklet, "How To Sell By Mail." Write: Ransone, Box 1719, Richmond, Virginia 23214.

**MILLIONAIRE MONEY-SECRETS!** Remove Debts, Raise Money, AAA Credit, Lifetime Income. Free Advisors, Box 616, Beverly Hills, Calif. 90213.

**NEW, "Money In The Mail".** Free master plan details. Dean, 2300 Maryland, Decatur, Georgia 30032.

**SELL BURGLAR ALARMS.** Set of Five Warning Stickers \$1.00. Lee Specialties, Box 32P, Dobbs Ferry, New York 10522.

**REUPHOLSTERY.** Profitable Home Business. Illustrated Manual \$2.00., M. Russell, P-43, 1566 South Burkhardt, Evansville, Indiana 47715.

**"MAKE MONEY" POWER** Within Your Grasp. Get What You Want. Amazing Breakthrough Using Cassettes Really Works. Write: Box 1282-PM4, Brooklyn, N.Y. 11202.

**MAILORDER** Catalogs, Your Name Imprinted. Merchandise Drop-Shipped, Details 25¢. AM Sales, 31-14-94, East Elmhurst, N.Y. 11369.

**TERRIFIC** Profits possible Selling the "Little Wonder" Electronic TV Antenna. Hottest Money Maker in Years. Write: Hanson's, Box 855-PM, N.Y.C., N.Y. 10008.

**EARN** More than many professional men! \$1000. Month Mail Order Collection Agency. Continental, Box 2023-A, Des Moines, Iowa 50310.

**HOW TO START A BUSINESS** And Succeed. Complete Details, Positive Results \$1.50. Lou Larkin, Inverness, Florida 32650.

**WE NEED GINSENG GROWERS!** \$3,000-\$30,000 annually! We Buy Your Crop. Send \$2 for seed sample and information. Glass's Ginseng Exchange, Box 336, Rochdale Station, Jamaica, NY 11434.

**EARN** money selling and installing the newest, patented church pew floor fastener in the country . . . thousands of prospects . . . protected territories . . . franchises available . . . write: Box 104 for details. B. J. Industries, Kewaunee, Wis. 54216.

**MAKE** Big Money with Home Engraving Business. Trend Craftsmen, 4901J Perrine, Midland, Michigan 48640.

**MAKE** Durable Building Plastic easily. Waterproof, Fireproof, Economical. Bays Laboratory, Cedaredge, Colo. 81413.

**MAKE \$25,000** With New Mailorder Plan! Quick Amazing Results! Only \$3.00-Moneyback Guarantee! Very Limited Offer! Order Now! Cord, POB 155, Kaneohe, Hawaii 96744.

**\$270,000 MAILORDER** Letter—just \$1.00. Guaranteed! Expert, Box 620-PM4, New York, New York 10003.

**MAIL LETTERS!!!** Address-Stuff Envelopes. Excellent Income Opportunity. Write: Stayer Enterprises, 3704B Warwick, Peoria, Illinois 61614.

**SELL** Books!! Complete Mailorder Plan. Vikari's, Box 1312PM2, Salt Lake City, Utah 84110.

**\$2,000 MONTHLY** in Fabulous new Business. Write: Blagburn, Box 681A, Decatur, Alabama 35601.

**FREE PROOF!** \$900 Mailorder profits possible—evenings! Wealthco, Box 620-PM3, New York, New York 10003.

**MAKE** Money Sparetime. Home operated Mailorder Business. News-Messenger, South Lancaster, Mass. 01561.

**WORK** At Home for us at your pace. Thrilling Details \$1.00—Refundable. Rebel Hill Farm, Box 346A, R. 1, Nineveh, Ind. 46164.

**100,000 BARGAINS** Below wholesale. Imports, U.S. Dropshippers, printing. Money-making details 25¢. Enterprises, Box 4763142 Caseyville, Illinois 62232.

**WANTED!** Dealers to supply our MONEY-MAKING MAILORDER information. Details. Marshall-Warren Company, P.O. Box 207, Warren, Ohio 44481.

**MAILORDER** Opportunity! Free Details. Trader Mike, Dept. PM-473, P.O. Box 1305, Newark, New Jersey 07101.

**TAPES,** Eight Track Stereo Tapes as low as \$1.20 each. Send \$2.00 for Sample and Catalog information. Lejeune Enterprises, Box 4353, Panorama City, Calif. 91402.

**FREE!** "Spare Time Mailorder Wealth" Secrets. Guaranteed! Midas, Box 620-PM2, New York, New York 10003.

**WRITE: STANFORD UNIVERSITY,** Box 8067, Stanford, Calif. 94305. For Information On Starting And Managing Any Specific Small Business. Instant Reply.

**GAIN** Financial Independence!!! Proven Mailorder Technique Insures Success. Free details explain. Diamond, Box 223A, Pottsboro, Texas 75076.

**\$50,000 YEARLY.** This Book yours Free. Ortiz, Box 37157, San Antonio, Texas 78237.

**BE A Winner!** Exciting New Mail Offer! Write—Zehr, 140PQ-So. Catalina, Pasadena, Calif. 91106.

**MAIL** Baby Catalogs Imprinted with your address to New Mothers for Big Profits! Details 25¢. Volz PM, Ypsilanti, Michigan 48197.

**EXECUTIVE** Mailorder Franchises Free!! Full-Line, Uncopied Baby Necessities Immediately Self-Sell, 4,000,000 Yearly Prospects. Astonishing Profits. Trinity, 1712A Lee, Detroit, Michigan 48206.

**FREE** Millionaire Book. . . . Get A Fortune in successful, little business. Work home! SBI-7, Kerrville, Texas 78028.

**I MADE \$40,000.00** Year by Mailorder! Helped others make money! Start with \$10.00—Free Proof. Torrey, Box 318-Y, Ypsilanti, Michigan 48197.

**MAILORDER LAWS REVEALED!** Booklet only \$2.00! Rehberg Associates, Box 812, PM4, Evanston, Illinois 60204.

**OPPORTUNITY** Knocks Only Once—Invite It!!! Free Information For Stamp. TBOR, Box 1692-D, F.D.R. Station, New York 10022.

**CALIFORNIA MANUFACTURER NEEDS** Man to assemble our product and be local agent, experience unnecessary. May start while presently employed. Five-figure income for responsible applicant. S.K.R.M Manufacturers, 2347 West 238 Street, Torrance, California 90501.

**MAILORDER:** How to prepare your own catalog for pennies! Free Catalog! Obie-B4, Brooklyn, New York 11219.

**FREE BOOK** "999 Successful, Little-Known Businesses." Work Home! Plymouth B4, Brooklyn, New York 11204.

**CREDIT** Cards . . . Loans . . . no credit investigation!!! Guaranteed. Free report. Continental-23, Niceville, Florida 32578.

**\$75 DAILY** Working only 5 minutes a day. Guaranteed, Professional Method. Details Free. NeWorld, Box 1446, Lafayette, Indiana 47901.

**GUARANTEED** \$25,000 first year mail-order earnings. Piten, PM4, Box 4113, Honolulu 96813.

## MONEYMAKING OPPORTUNITIES

**HOW** To Make Money Writing Short Paragraphs. Information Free on "Home Studies in Writing". Barrett, Dept. C-27-X, 6216 N. Clark, Chicago 60660.

**22 PROVEN** Home Money Making Opportunities. Send \$1.00. NOW. Dept MM1. Mailosav, 226 S 16th, Philadelphia, Penna. 19102.

**EXTRA INCOME!!** Fantastic Money-making Secrets!! Easy—Pleasant—Profitable!! Write—Zehr, 140 F-South Catalina, Pasadena, California 91106.

**MONEY MAKING**—Money Saving Publications, Foreign And Domestic Wholesale And Dropship Directories. Free Details. J & M Associates, Box 758-PD, Newark, New Jersey 07101.

**SECOND** Income Mailorder Specialist Reveals Goldmine Of Information. Free Details. Somerset, Box 1786-PM, Poughkeepsie, New York 12601.

**WIN** Sweepstakes, Skill Contests—Now! Wiemels, 325-H Elmwood, Bay Village, Ohio 44140.

**25¢ EACH,** Guaranteed, Stuffing Envelopes. Names, Postage Supplied. Complete Setup \$1.00 (refundable). Danzig, Postbox, 255PM43, Brooklyn, NY 11218.

(Continued on next page)

## MONEYMAKING OPPORTUNITIES

(Continued from preceding page)

**INEXPENSIVE** Burglar, Fire, Smoke, Auto Alarms, Extinguishers, Supplies, Watchdog Alarms, Williamsburgh, Ohio 45176.

**\$2.40 HOURLY** Making simple wood novelties. Free details! Gene's, 55 Boxwood, Falmouth, Mass. 02540.

**MAKE \$1.00 PER SALE** Selling engraved metal Social Security plates. **FREE SALES KIT.** Engravaplates, Box 10460-199, Jacksonville, Florida 32207.

**WORLD'S** Leading contest magazine, 25¢. Year, \$4.00. Prizewinner, 1315 Central, St. Petersburg, Fla. 33705.

**MAKE** Statuettes, novelties, imitation marble. Sell to stores or start gift shop. Free details. Marbleizing, 41 Waverton, St. Louis, Mo. 63124.

**HOW TO GET RICH!!** Free "Money-making Brochure"! Success International, Box 2447-C, Livonia, Mich. 48151.

**VENDING** Machines. No selling. Routes earn amazing profits. Big catalogue Free. Parkway Corporation, 715PMM Ensor Street, Baltimore, Maryland 21202.

**FREE**—Easy Ways to make money selling exciting new products—Full—spare time. Send name, age, for 5 months free subscription. Salesman's Opportunity Magazine, 1460 Hancock Center, Dept. 17-DM, Chicago 60611.

**CLIP** Newspaper items. \$1.00-\$5.00 each. Details free. Walter, Box 1360PA, Erie, Pa. 16512.

**PENNY STOCKS** Have Profit Potential. Free Information. Analyst-P.M., Box 214, Redondo Beach, California 90277.

**200% PROFIT** Selling Rings. Triple Money in 30 Days or Money Back. Free Details, Anka, P.O. Box 8036-PM, Cranston, Rhode Island 02920.

**\$40 DAILY** Possible tying fishing flies at home. Details 25¢. Flyco, Box 481PM, Albany, Oregon 97321.

**EARN MONEY**, learn mailorder, spare-time, at home, reading leading (since 1929) trade magazine, product sources, stories, tips. Sample 50¢, year \$5. Mail Trade, Box 1302, Springfield, Illinois 62705.

**ADDRESSERS**—50 Companies want Addressers. Send self-addressed envelope. Cal Enterprises, Box 4516-X, Compton, Calif. 90224.

**NEED \$80,000, \$50,000, \$30,000?** Your Lifetime Opportunity to Fabulous riches. Write airmail today for free information on our plan. MEYER, APARTADO 664, Guatemala, Central America.

**EARN 10% PER MONTH ON YOUR MONEY.** "How to Organize a Factoring Company." Our 5000 word report gives complete details, including sample forms and records. Requires only modest capital. Write: CAPITAL FACTORING CORP., PO BOX 914, Dept. L, Provo, Utah 84601.

**\$100.00 WEEKLY** At Home. Free Materials. Patterns and Instructions Guaranteed. \$2.50. Fircrest Resort, Rt. 1, Blaine, Washington 98230.

**INVITATION** To the PROFITABLE WORLD of MAILORDER. Details 25¢. Devine, Box 56069, Chicago 60656.

**PUBLICATION** Outlines Home Businesses Money-making Opportunities. Profitable Hobbies 25¢. Pearson Enterprises, 11428 Church, Chicago 60643.

**HOMEWORKERS EARN \$150.00** Weekly addressing our Sales Letters. Details 25¢. Cur-Jon Mailers, Box 523-PM, Maplewood, N.J. 07040.

**HOW** To Earn At Home Addressing Envelopes. Send Self Addressed Stamped Envelope To: R.H.M. Productions, 11 Willard Ave., Mt. Vernon, New York 10553.

**SWEEPSTAKES** Contests. How to win. Write for free information. General Contests, 1609-18 East 5th., Duluth 12, Minnesota 55812.

**FREE SECRET BOOK** "2042 Unique, Proven Enterprises." Largest successful collection! fabulous "Little Knowns." Work home! Haylings-T9, Carlsbad, Calif. 92008.

**\$200.00 FROM** Sheet 1/4" plywood (scrap). Details 25¢. Novelties, 610 So. 24th, Elwood, Indiana 46036.

**I WON** the Big Contests! Will help you win! Wiemeis, 325-G, Elmwood, Bay Village, Ohio 44140.

**ENORMOUS** Mailorder Profits! Money Back Guarantee. Tested, Proven, No Experience Necessary. Rush \$1.00. Thompson Enterprises, 1120 Cherrylawn, Pontiac, Michigan 48055.

**BEAUTIFUL** Sparkling, Gemsai Trees Use Real Gemstones! \$8.00 Kits, Retail For \$20.00 Completed. Enjoy With Pride This Easy Profitable Work At Home. Details \$1.00. Gemkraft, 10276 Tams Drive, Baton Rouge, Louisiana 70815.

**POSTCARD** Addressers Needed Immediately. Application — \$25. Meren, 2233 Lukes Lane, Baltimore, Maryland 21207.

**START YOUR OWN PROFITABLE WHOLESALE BUSINESS.** Gifts, Specialties, Toys, 1000 Others. Free Details. Redd's, Box 555-A, Colton, California 92324.

**EXTRA INCOME** Catalog \$2.00 (Refundable First Order.) Start Immediately Your Own Wholesale Business. Jesse Meek Wholesale Distributor, 310 19th Avenue, Greeley, Colorado 80631.

**FREE** Details. Your own Business. Good growth with good Products. Big Profits. LDV, 4296 Panorama Drive, La Mesa, California 92041.

**\$125.00 WEEKLY** Correcting Pupils' Lessons! Samples, \$1.00! Castle's, 507-ML Fifth, New York 10017.

**MAKE** Money with your Camera. \$1.00 (Moneyback Guarantee). Booklet explains how. Contains 300 Photo Buyers. Amroco, Box 8282-E, Richmond, Virginia 23226.

**FREE** Copy! "Home Business Digest. 1000 Opportunities! Work Home. Tory, Dept. PM, Bayonne, N.J. 07002.

**MAKE MONEY** on Government Surplus. How and Where to Buy. Directory of Surplus Offices. Sale Terms. Mail Order Items. Satisfaction guaranteed. Send \$1.00. House of Nicole, Dept. PM-43, 4056 N.W. 35 Ave., Fort Lauderdale, Florida 33309.

**\$5,660** in One Month etc., 100's Available, no Customers or Selling involved. 1972 Profits of each. Tyrone Co., Box 285, Station T, Toronto, Canada.

**SECOND INCOME—FINANCIAL INDEPENDENCE** Proven Program Free of binding Obligations or Contracts. **NO INVESTMENT** in Stocks, Inventory or Franchises. Send \$1.00 for complete details. Dave Sellars, Box 246, Pacific Grove, Cal. 93950.

**LEARN** The secrets of repairing junk batteries. "Fabulous Profits" at home. Details 25¢. Battery Shop, Box 820, La Quinta, California 92253.

**WANT A HIGH-PAYING JOB?** If you have electronics, electro-mechanical or computer training and can write, you can break into the lucrative Technical Writing field. New book discloses how Tech Writers do their work. Learn how you may qualify for this exciting high paying field. Send \$10.95 to: MARINE REGISTRY, P.O. BOX 1673, COCOA, FLORIDA 32922.

**CRAFTSMEN**—Promote your Handcrafted Products through our nationally distributed Catalog. Details 25¢. Huppcraft PM1, 10 Carmel, Saint Louis, Missouri 63044.

**MAILORDER**, Sell Engraved Social Security Plates. Complete Dealer Set-up. AM Sales, 31-14-94, East Elmhurst, N.Y. 11369.

**\$8,000** in 60 Days! Absolutely guaranteed! \$1.00. Cord, POB 155, Kaneohe, Hawaii 96744.

**HOMEWORKERS.** Make \$1.60 each, mailing envelopes. 10¢. Gemco, B-21244, Indianapolis 46221.

**FREE** Details for Starting Wholesale-Mailorder Business. The James Company, 59A James Street, Toms River, New Jersey 08753.

**CONTEST REPORT** Complete Information About Cash Prizes Offered Monthly. Send 25¢ for Current Issue. Box 307A, Ypsilanti, Michigan 48197.

**DOUBLE YOUR MONEY**—No competition. Patented magical sales booster. Send \$2.00 for informative kit (refundable). "Clancy", 2785 So. Ingalls Way, Denver, Colo. 80227.

**62% PROFIT** Mailing Brochures. Information 50¢. Cama.a, Box 841-M, Florissant, Mo. 63033.

**HOW TO SELL BOOKS BY MAIL** With Directory of Wholesale book sources. Send only \$3.00 50¢ postage today: **GREAT AMERICAN**, Scott Place, Patterson, New York 12653.

**JOIN THE MILLIONAIRES CLUB** Need money to finance a new idea, invention, toy, partnership, household item, business, expansion, movie, song, TV show, land development, oil development, franchise, etc. Our business is locating money or backing for ANY potentially profitable venture. Don't wait send idea (notarized for your protection) with \$10 listing fee, refundable if your accounts unacceptable, or for free information, Carson McMan Investments, P.O. Box 387, Walnut, California 91789. Placement fee 1% upon completion of loan or backing. **INVESTORS** and **MANUFACTURERS** welcome \$20. yearly subscription.

**MAKE** More Money—Start your own Home Business. Books-By-Mail, 333 N. Michigan, Chicago, Illinois 60601.

**EXTRA MONEY.** Sell Engraved Metal Social Security Plates. Free Kit. Beaver, 200 Polo Rd., Winston-Salem, N.C. 27105.

**400% PROFITS** Selling Books!! Advanced Publications Reveal Unexpected Mailorder Opportunities. Franchises Free. Trinity, 1712B Lee, Detroit, Michigan 48206.

**GET** World's Biggest Wholesale Import Catalog. Write: World, Medina, Washington 98039.

**\$100.00 EXTRA** Weekly Easy! Spare Time! Details. Beautiful Sample Free. Russell Products, Dept. BC133A, Columbia, Tennessee 38401.

**MY** Plan shows how to begin a terrific home business audio taping. Send \$3.00 to M. Mohr, 23 W. Oakland Ave. #0, Oaklyn, New Jersey 08107.

**FREE** Signature analysis! Discover money-making and romantic potentials. Certified handwriting agency. Profigraph, Box 503XM, Brigham City, Utah 84302.

## PROFITABLE OCCUPATIONS

**BAKE** New greaseless doughnuts in kitchen. Sell stores. Free recipes. Michael Ray, Waseca, Minn. 56093.

**FT. SMITH** Auction School. Ft. Smith, Ark. 72901. Resident & Home study. Veteran approved.

**BECOME** A Mortgage Broker. Highly respected, interesting, lucrative prestige business. For complete information write: United, Box 6284-F, Marietta, Georgia 30060.

**INSTANT** Money! Plastics are the wave of the future. Big profits now! At home! Spare time! Materials costing 11¢ bring back \$2.58 profits immediately! Free information. Rush name on postcard to: Warner, Room LC-2-CF, 1512 Jarvis, Chicago, Illinois 60626.

**HOW** To Borrow \$500 to \$2 million. Get 2,618 cash offers. Free details. Capital-25, Kerrville, Texas 78028.

(Continued on next page)

## PROFITABLE OCCUPATIONS

(Continued from preceding page)

**RETIRE ANYTIME** In Luxury! Easy, Legitimate! Free Details, Premier Enterprises, Box 10597-AD, Pittsburgh, Pa. 15235.

**SHARPEN**—Scissors, Pinkers. Light, compact equipment. Supplies. Blackhawk's, Sheldahl, Iowa 50243.

**PLASTERCRAFT!!!** Profitable home business. Molds available. Details: Lynnette, 6251C Mentor Park, Mentor, Ohio 44060.

## SALESMEN-DISTRIBUTORS

**\$100.00 EXTRA** A week easy! Spare time! Double Air Cushion shoes. Men's, women's line. Dress, work, play. Highest commissions. Shoes for yourself. Outfit Free. Bronson, Dept. H-43, Minneapolis, Minnesota 55408.

**LONG** Needed Invention. Want man contact service stations. Full or Part time. Huge Profits. Write: Cyclo Mfg., 3816 Dahlia, Dept. 150A, Denver, Colorado 80207.

**SELL** Blue ribbon Hertel Bible . . . startling cover with Nativity in full color 3-dimension. New profit bonanza plan. Sells itself! Every order pays top profit plus "bonanza" bonus. Liberal easy credit plan. No investment. Demonstrator furnished. Write for everything! International Book, Dept. PM, Box 118, Wichita, Kansas 67201.

**PUBLICATIONS** for local wholesale distribution, higher profits. Details, sample, \$1 refundable. Publisher, 404 West Jefferson, Springfield, Illinois 62702.

**MAKE MORE MONEY IN 1973.** Use your spare time to show our New Line of Specialty Advertising, Calendars and Executive Gifts to Business Firms in your area. Prompt, friendly cooperation with a low pressure, progressive firm, in our 64th year, rated AAA-1. No investment or collections. Weekly commissions and Liberal Bonus. Samples furnished. Can be developed into a full time business. Write to: John McNeer, Dept. PM-4, Newton Mfg. Co., Newton, Iowa 50208.

**SELL** Advertising Ball Pens, Calendars, Ad-Specialties—Build Own Repeat Business—Free Details—Fleming, Dept. A, 6535 Cottage Grove, Chicago 60637.

**\$50-\$100 EVERYDAY.** Commission paid daily. Changeable Electrical signs for businessmen. Associated, 137-K North Western, Los Angeles, 90004.

**RELEASE** Your Full Potential. Increase Sales by speaking voice development. Only \$2.00 brings book. Sunrise Enterprises, Blue Point, New York 11715.

**EARN** Big money calling on business-professional men. Send us their delinquent accounts for collection. General Finance, Dept. PM-11, Columbia Bank Bldg., Kansas City, Missouri 64106.

**UNIQUE** New Product. Samples 50¢. Goodrich, Box 654, Poughkeepsie, New York 12602.

**ADVERTISING** Specialty Salesman: **FREE LISTING.** Unlimited Offers. Wieder, 28 Brighton Seventh Court, Brooklyn 11235.

**\$\$\$ FIGURE** Income as Dist. W/New Fla. based Co. Going Nation-wide Invest \$6,000. Mr. Crawford, Rt. 1, Box 272A, Starke, Florida 32091. (904) 964-5771.

**HOUSEHOLD PRODUCTS ROUTE. EARN \$25** or more daily. Also Party Plan opportunities for men, women full, part time. McNess, Freeport (2633) Illinois 61032.

**NEW,** Compact fire extinguisher. Fantastic profits. Exclusive territories. Norwich Chemical, Norwich, Connecticut 06397.

## AGENTS WANTED

**YOUR** Own business. Used Suits \$1.50; Overcoats 65¢; Mackinaws 35¢; Shoes 12½¢; Ladies' Coats 30¢; Dresses 15¢. Enormous profits. Catalog Free. Superior Jobbing Company, 2111-AA West Roosevelt, Chicago, Illinois 60608.

**ESTABLISH** Your own business. Low prices on used clothing, shoes, household goods. Unlimited profits. Free catalog. Northwestern Distributors, 2129 No. Western Avenue, Chicago, Illinois 60647.

**FREE** Selling Outfit—Office Supplies, Machines, Furniture and Equipment. Oseco, 3505-PM Elston, Chicago 60618.

**PRINTING,** Advertising Salesmen—Excellent moneymaking sideline selling Decalcomania Name Plates, small quantities. Advertising Specialties, sign letters. Free Samples. Ralco XL, Boston, Mass. 02119.

**WANT TO MAKE UP TO \$100 A WEEK** Spare time, and get free shoes for life, too? No investment. Rush Card for free details. Mason Shoes, K-930, Chippewa Falls, Wisconsin 54729.

**EVERY** Man a prospect. Refundable sales kit offer showing line belt buckles, tie clasps, money clips, cuff links, lapels, identification badges, individualized with customer's name and emblems. Cap badges for trucking, bus, taxi, police, firemen, also postal letter carriers and heavy construction emblems. Choice 4000 emblems. Hook-Fast, Box 1088-PM, Providence, R.I., 02901.

**MAKE MONEY IN SPARE TIME.** As a subscription sales representative for leading national magazines, you can earn generous commissions while learning the art of selling. Instructions and supplies will be sent to you free. Send this ad with your name and address to: **POPULAR MECHANICS,** Room 1107L, 250 W. 55th St., New York, N.Y. 10019.

## EMPLOYMENT INFORMATION

**DIESEL** Mechanics: Volunteer Peace Corps. Two years: Asia, Africa, Latin America. Maintain, examine & recondition engines and parts. Diagnose trouble. Expenses paid—medical, travel, vacation, living. Information: Bruce Mazzei, ACTION, OCP Box 175, Washington, D.C. 20525.

**OVERSEAS JOBS—NOW HIRING,** 103 Countries, All Occupations, High Pay, Free Transportation, Tax Benefits, Latest Computerized Reports—\$2.00. **TRANSWORLD,** International Airport, Box 90802-E, Los Angeles, California 90009.

**AUSTRALIA—NEW ZEALAND! FREE DETAILS!** 50,000 Jobs! Paid Transportation! 1973 Information and Forms. Send Age, Occupation. Austco, Box 3623-EX, Long Beach, California 90803.

**FLORIDA WANTS YOU?** Concise, Complete Unbiased **GENERAL FACTS YOU DON'T** Know. \$2.00 Refundable. Idease, P.O. Box 171-P2, Cape Coral, Fla. 33904.

**AUSTRALIA!! AUSTRALIA!! FREE DETAILS!!** Paid Transportation. Latest Information on Jobs. Send age, occupation. Write: Associated, Box 17-B-137, Lafayette, California, 94549.

**CANADA.** Employment, Immigration, Government, Assistance. Complete Facts \$2. International, Box 556-A, Duncan, B.C., Canada.

**AUSTRALIA WANTS YOU!** Thousands of jobs! Transportation Paid! Information on government allowance, employment, housing, taxes, prices, social life, etc., and application form—\$1.00. Lloyd Meade, 618P4 Lock Ave., Louisa, Kentucky 41230.

**FLORIDA** Employment Information Booklet. \$2.00! Sunshine, 4512N Jamaica Tampa, Florida 33614.

**JOB SEEKERS.** Interviews made easy. Send \$1.00 for "Interview Guide." Don Hal & Assoc., P.O. Box 714, Morgantown, W. Va. 26505.

## HELP WANTED

**EARN** At Home Addressing Mail. Details 25¢ and Stamped Envelope. Deeco-151, Box 9308, North Hollywood, Cal. 91609.

**OVERSEAS EMPLOYMENT . . .** Australia, Europe, South America, Asia! All Occupations! \$700-\$3,000 monthly! Write: Employment International, Box 29217-AD, Indianapolis, Indiana 46229.

**OVERSEAS** Jobs—Europe, South America, Australia, Far East, etc. 2000 openings all trades. Construction, Office, Engineering Sales, etc. \$700 to \$3,000 month. Expenses paid. Free Information. Write: Overseas Jobs, International Airport, Box 536-M, Miami, Florida 33148.

**WORLD-WIDE . . . U.S.A. JOBS GALORE!!!** All occupations. Enjoy: Asia, Europe, Africa, South America, Florida, California. \$700.00 to \$3,500.00 monthly. Paid Overtime. Travel Allowance. Free Details! Send age, occupation. Write: Global Employment, Box 706-B-137, Orinda, California 94563.

**FREE DETAILS! . . . AUSTRALIA . . .** Paid Transportation!! Jobs Galore!! Send age, occupation. Write: Associated, Box 17-BA-137, Lafayette, California 94549

**BOOKEEPERS**—Part Time—your area. Bernie Schroll, 334 Coleman Drive, Monroeville, Penna. 15146.

## REAL ESTATE AND FARMS

**NEW FREE CATALOG!** Big **SPRING** Edition! Over 5,200 Properties described, pictured—Land, Farms, Homes, Businesses—Recreation, Retirement. Selected Best thruout U.S.! 73 Years' service, 648 Offices, 40 states Coast to Coast. Mailed **FREE** from the World's Largest! **STROUT REALTY,** 60-MX E. 42nd St. NY, NY 10017; 7-MX S. Dearborn, Chicago, Ill. 60603; 521-MX E. Green, Pasadena, Cal. 91101.

**CANADIAN LAND FROM \$19.00 AN ACRE CHOICE** Properties available across Canada. Low monthly payments. Ideal for farming, cottages, hunting, fishing. Free Catalogue. Canadian Estate Land. Dept. PMC-4, 286 Lawrence Ave. West, Toronto 20, Ont., Canada.

**\$1.00 ACRE!** USA and Canada. Lists, photographs mailed. Government Lands, 220 Delaware Ave., Buffalo, New York 14202.

**BOILING** Spring Lakes—America's Greatest Real Estate Value. ½ acre vacation or retirement homesites only \$900 cash price. Ten-year terms available. Money-back inspection guarantee. Carolina coast, multi-million dollar, 14,000 Acre development. 50 fresh water lakes, private ocean beach, golf course, motel, and country club. Free literature, Dept. 1-G, Boiling Spring Lakes, North Carolina 28461. (Registered under Federal Land Sales act but not offered to residents of states requiring separate registration.)

**FREE . . . NEW . . . BIG . . . SUMMER** Catalog. Hundreds of top real Estate Values Coast To Coast! **UNITED FARM AGENCY,** 612-PM West 47th St, Kansas City, Mo. 64112.

**CENTRAL** Ontario—Choice 640 acre Sportsmen's paradises still available—\$20.00 plus \$6.50 taxes yearly. Maps, pictures. \$2.00 (Refundable). Information Bureau, Norval 4, Ontario, Canada.

**GOVERNMENT LANDS FROM \$3.50 ACRE!** Vacationing, Homesteading, Investment! Exclusive "U.S. GOVERNMENT LAND BUYER'S GUIDE" plus "LAND OPPORTUNITY REVIEW" listing lands throughout U.S. Send \$1.00. Surplus Lands, Box 19107-AD, Washington, D.C. 20036.

(Continued on next page)

## REAL ESTATE AND FARMS

(Continued from preceding page)

**ARIZONA**—1/4 Acres, Hearts of Hunting And Farming Centers. \$1,100—Low Terms. Mrs. Anna Young, Glenarm Land Co., 2233 North 7th St., Phoenix, 85006.

**IDEAL 5-ACRE RANCH.** Lake Conchas, New Mexico. \$3,475. No Down. No Interest. \$29/mo. Vacation Paradise. Money Maker. Free Brochure. Ranchos: Box 2003PS, Alameda, California 94501.

**MICHIGAN 10 TO 160 ACRE TRACTS** Lake Superior-Marquette Area from \$99.00 Acre. Cabins, Trailers, camping welcome. (Acreeage anywhere in Michigan). **FREE PICTURES.** Any terms A-OK with **BLOCH BROTHERS.** Write: 3650 Dixie, Drayton Plains 16, Michigan 48020.

**\$1 ACRE**—Canadian border—hundreds campsites, islands, farmlands, directly from tax authorities. (Non-profit). Lists, photographs mailed. Register, Room 10, 110 Church Street, Toronto 1, Canada.

**CANADIAN** Vacation lands: Full price \$385.00. 40 acres. \$10 month. Suitable cottage sites, hunting, fishing, investment. Free information. Land Corporation, 3768-C Bathurst, Downsview, Ontario, Canada.

**FREE Catalog! PHOTOS!** Coast to coast farms, business, retirement. All types, sizes & prices. **SAFE-BUY** Real Estate, Box 589-PM, Little Rock, Ark. 72203.

**AMERICA'S** Finest Improved 2 1/2-5 Acre Value. Water, Roads, Utilities. Walking Distance To Hunting, Fishing, Golf. Brochure. Box 433, Blanchard, Idaho 83804.

**COUNTRY PROPERTY NEWS.** Pitfalls; Investment Opportunities. \$1 Trial Copy; \$9/12 monthly issues. 1020 Park Avenue, New York 10028.

**OSARK NATIONAL REALTY**—Homes—Farms—Investments—**FREE** Brochures. Mountainburg, Ark. 72946.

## FARM AND GARDEN EQUIPMENT

**RIDING LAWNMOWERS** Shipped from factory—New 7 Horsepower. \$189.00. Freight paid. Free brochure: Tomco, Box 72, Oak Grove, Mo. 64075.



## FLOWERS, PLANTS & NURSERY SUPPLIES

**LEARN** Flower Arranging and Floristry. Start full or part time business or hobby. Free information on home study course. Lifetime Career Schools, Dept. B-700, 2251 Barry Avenue, Los Angeles, California 90064.

**GREENHOUSES,** 12' Fiberglass and UltraViolet Shielded from \$109.95. Free catalog. Greenhouseman, Box 2666-M-4, Santa Cruz, California 95060.

**SPRINKLER** Spike watering system installs in minutes in your own hose. Free illustrated brochure. Eric Johnson Co., 67 Bonanza Rd., Palm Springs, Calif. 92262.

**LEARN** Landscaping and the growing of plants. Start a profitable business part or full time. Free information without obligation. Lifetime Career Schools, Dept. A-361, 2251 Barry Avenue, Los Angeles, California 90064.

**GINSENG** Bringing \$20.00 pound. Have seeds roots. Goldenseal. Full Information. K. Collins, Viola, Iowa 52350.

## BUILDING AID BOOKS

**POPULAR MECHANICS CATALOG** Of plans, publications and projects. Covers shop and home projects. Want to build a plane, a hovercraft, boats, swimming pools, patios and garden furniture. Fireplaces, kitchen cabinets. 32 pages crammed full of fascinating and useful projects. Send for this illustrated catalog to: **POPULAR MECHANICS,** Dept. HE, 224 W. 57th St., New York, N. Y. 10019. Price 25¢.

## CONSTRUCTION PLANS, BLUEPRINTS

**CUSTOM ARCHITECTURAL DRAFTING** Information 25¢. Russ Davis, 721 Franklin Rd., S.W., Roanoke, Va. 24016.

**HOUSE EXPANSION PLANS** And detail instruction book provide anything from an extra room to 1000 s/f addition. Build what you need at big do-it-yourself saving. Book with 1 set working blueprints \$14.50! With 4 sets (required by contractors) \$20.00. Money-Saver Projects, Box 303-44B, Chappaqua, New York 10514. Information available.

**PLANS** For pool table with extra twoface top for table tennis and model railroad. Blueprints B1209 and building instruction \$5.00. Popular Mechanics Service Bureau, 224 West 57th Street, New York, N. Y. 10019.

**WORKBENCH** And tool panel anyone can build. Complete with material list. \$1.00. Way-Mar, 58 Underhill Road, Scarsdale, New York 10583.

## LOG CABINS & HOMES

**BUILD** Log Cabins, rustic furniture, fireplaces!!! Complete manual, \$3.00 . . . "A" Frame plans. \$2.00 . . . **Guaranteed.** . . . Beels, 956 Springdale, Atlanta, Georgia 30306.

**"A" FRAME CABIN.** \$500. Material. Purchase locally. Completely illustrated instruction manual & material list: \$2.00. Moneyback Guarantee. Order plan #1918, from: "Dependable Products", Box 113, Vista, California 92083.

**"A" FRAME Cabin.** 1184 square feet: \$1950. Material. Purchase locally. Completely illustrated instruction manual, including material list: \$5.00. Moneyback guarantee. Order plan #901 from "Dependable Products" Box 113, Vista, California, 92083.

## HOME CRAFTSMEN

**WOOD**—Domestic and Imported Hardwoods, 3500 items! Clock, musical instrument kits. Tools . . . discount prices. Hard-to-find hardware. 144 page catalog, 50¢. Craftsman, Dept. AX-43, 2729 Mary, Chicago, Illinois 60608.

**SKIL-CRAFTS** Current 200 plus page catalog with world's largest, finest selection of Hobbycraft, leathercraft, artist supplies. Send \$1 for postage and handling; refunded on first \$5 minimum catalog order. Skil-Crafts, Box 105-P, Joplin, Mo. 64801.

**WORKBENCH** And Tool panel anyone can build. Complete with material list. \$1.00. Way-Mar, 58 Underhill Road, Scarsdale, New York 10583.

**CLOCK** Kits, Movements, Dials, Hands. Catalog 25¢. Newport, Box 6848A, Burbank, Calif. 91505.

**101 PATTERNS** Of Smart Gifts, Novelties, Shelves, Action Windmills, Plus "Make Money Jig Sawing". \$2.00. Mastercraft—45M, 7041 Olcott, Chicago 60631.

**PICTURE** Framing—Profitable full or spare-time business. Easy to learn with handbook-course "Guide To Picture Framing Profits." \$1.50 Guaranteed. Free framing-supplies catalog included. Japs, 126-PM Seventh North, Hopkins, Minnesota 55343.

**CABINETMAKING MADE EASY** And "How to Make Formica Counter Tops." Two excellent guides let you build kitchen cabinets and counter tops like professionals. Extraordinary guides bring master craftsmen's shortcut methods. Satisfaction guaranteed. Write: Japs, 126-P Seventh North, Hopkins, Minn. 55343.

**20 PLANS**—Full Size—Early American Novel Items for Fun or Profit. Send \$2.50. Cerbone—Box 18099—Philadelphia, Penna. 19147.

## POPULAR MECHANICS MASTER SHOP

**GUIDE.** Greatest product offered to a man with a workshop. All information printed on heavy boards, punched and ready to hang above his workbench. Covers wall fasteners, nails, screws, bolts, twist drills, abrasives, lumber, moulding patterns, plywood grades, hardboard, dry-wall plumbing supplies, electrical supplies. Plus information on score of other subjects. Send \$3.95 to: **POPULAR MECHANICS,** Dept. HE, 224 West 57th Street, New York, New York 10019.

**WOODEN CHAIN—MOVABLE LINKS!!** Easily Made from one piece **SOLID** wood! Amaze Friends, Decorative. \$1.00. Guaranteed. Brings Detailed Manual, Drawings, **PHOTOGRAPH,** Atco, Box 33-C, Floral Park, New York 11002.

**TOASTERS** Rarely Wear Out! Elements break. Fix **PERMANENTLY,** Easily. Full instructions, bonding agent for 50 toasters. Send \$1.00. Guaranteed. Airey Specialty A4, 54 Nelson, Winchester, Mass. 01890.

**SUSPENDED BEAM CEILING** 20¢ Square Foot Plans \$1.75. Box 333, Moscow, Idaho 83843.

**LATHE** Enthusiasts, five unique project patterns, \$1.00. Greene, 205 Northwest 63rd, Gladstone, Missouri 64118.

**TOOLS, EQUIPMENT & SUPPLIES!** We List Over **FOURTEEN-HUNDRED** Different **CATALOGS** of Materials and Accessories for Arts, Crafts, Automotive, Electronics, Industry. Send \$2.00. **MASTERLOG,** Box 24413-WD, Oakland, California 94623.

**CATALOG FULL SIZE FURNITURE PLANS** —\$1.00 Refunded with first order. Traditional, Early American, over 150! Furniture Designs, 1425 Sherman, Dept. CP-43, Evanston, Illinois 60201.

**AN HEIRLOOM CRADLE ANYONE CAN BUILD**—Detailed plans for this beautiful Early American cradle include full size trace-out drawings and complete instructions. Send \$2.00 to: Pioneer Projects, Box 166PM, Selma, Ala. 36701.

**WATERBED** Frame Plans for all Popular Sizes, Wholesale Catalog of all Waterbed Accessories. \$3.00. American Waterbed Company, 2700 So. Ventura Road, Oxnard, California 93030.

## HOME REMODELING

**HOUSE EXPANSION PLANS** And detail instruction book provide anything from an extra room to 1000 s/f addition. Build what you need at big do-it-yourself saving. Book with 1 set working blueprints \$14.50! With 4 sets (required by contractors) \$20.00. Money-Saver Projects, Box 303-44B, Chappaqua, New York 10514. Information available.

## DO-IT-YOURSELF

**IF YOU CAN FIX A DRIPPING FAUCET** . . . you can install central air conditioning in your forced air furnace and save up to \$200. Only ordinary hand tools needed. Complete kits cost as little as \$500\*. Write for free "how to" brochure. McGraw-Edison Co., 729B N. Clark St., Albion, Michigan 49224. \*Cost varies according to size and construction of home.

**BURGLAR-FIRE** Alarm Supplies and Information. Free Catalog. Protecto Alarm Sales, Box 357A, Birch Run, Michigan 48415.

**RED BARN** Utility Building 8' x 12' only \$75.00. Complete Plans \$3.00 or write for information on easily assembled kits. H&H Woodworking, 1683 Ohio Pike, Amelia, Ohio 45102.

**DO IT YOURSELF** Auto anti theft device for less than \$2.00 for easy to follow instructions. Send \$1.00 (no stamps) with your name and address to: A AND E Enterprise, 464 Broadway, Passaic, New Jersey 07055.

(Continued on next page)

## DO-IT-YOURSELF

(Continued from preceding page)

**WALL-SIZED TV . . .** Build a 72-INCH TV PROJECTOR for under \$15.00. Free details: Macrocoma, Dept. PM-4, Washington Crossing, Pennsylvania 18977.

**REPAIR MINIBIKES, LAWNMOWERS, BICYCLES, Sewing Machines, Auto Engines, Mazda/Wankee, Motorcycles, Magic, Boats.** Over 100 How-To-Books. Free Brochure. Sincere, Box 10422, Phoenix, Arizona 85064.

**TERRIFIC Values!** "How-To" Books. Free details. Vernco, Box 121, Whittier, California 90608.

**YOU CAN** Change Your Own Electrical Service. Save Hundreds of Dollars. Complete Plans and Instructions \$3.00. James Electric, Box 165, Sylvania, Ohio 43560.

**TOOLS, EQUIPMENT & SUPPLIES!** We List Over FOURTEEN-HUNDRED Different CATALOGS of Materials and Accessories for Arts, Crafts, Automotive, Electronics, Industry. Send \$3.00. MASTERLOG, Box 24413YD, Oakland, California 94623.

**NEW HOME SECURITY MANUAL** Tells how to keep Burglars Out! Dozens of tips. Fully illustrated. Only \$2.50 Postpaid. Details Free. Mitchell's, 456 Marlow, Spring Hill, Florida 33512.

**BUILD Your Own Wood Lathe, Plans, \$2.00.** Duckett, 1406 Travis, Plainview, Texas 79072.

**CONVERT MOWER** Engines into air compressors. Write: Showalter, Box 409, Abilene, Kansas 67410.

**POPULAR MECHANICS HOME BOOK OF REFINISHING FURNITURE.** Covers all the tricks of the trade. Only \$4.95. Send to: POPULAR MECHANICS, Dept. JM, 224 West 57 St., New York, New York 10019.

**WORKBENCH** And tool panel anyone can build. Complete with material list. \$1.00. Way-Mar, 58 Underhill Road, Scarsdale, New York 10583.

**SPINNING Wheel Kit!** Early American full-size, working replica. Actually spins! Has 18" assembled wheel and all parts of sanded solid maple. Easy instructions. Free color brochure, prices. Haltec Corporation, Dept. A, 32123 Winona Road, Winona, Ohio 44493.

## ARTS AND CRAFTS

**"GETTING Started in Stained Glass"** 25¢. Whittemore, Box 2065Y, Hanover, Mass. 02339.

**MAKE** Figurines, plaques, lawn ornaments. Molds, plastercraft kits, liquid rubber. Sample and catalogue 10¢. Wooley Company, Box 29-B, Peoria, Illinois 61601.

**FREE LITERATURE** For sculptors showing how to make molds, cast plastics. Adhesive Products Corporation, 1660 Boone Avenue, Bronx, N.Y. 10460.

**LEARN Arts & Crafts** at home. Excellent full or part time business opportunities, or hobby. Free booklets. Lifetime Career Schools, Dept. E-800, 2251 Barry Avenue, Los Angeles, California 90064.

**FREE:** New handicraft catalog. Supreme Handicrafts, Box 395-PM, Sioux Falls, South Dakota 57101.

**BRIARS.** Pretuned smoking pipes. Materials. Pimot, Box 59211, Chicago, Illinois 60659.

## BINOCULARS, TELESCOPES, MICROSCOPES, MAGNIFIERS

**TELESCOPE** (Reflectors) Complete Kits. Other accessories, request free literature. Criterion Manufacturing, Dept. PM-40, Hartford, Connecticut 06101.

**FREE Binocular, Rifle scope catalog.** Discount sale. Save 50%. Free gift with order. Write, United Binoculars, BN-6608, 9043 So. Western, Chicago 60620.

**HOLD** Camera or Binoculars safely secured to chest ready for instant use. No neck strain with patented Kuban Hitch. One size fits all. Quality made elastic straps, spring steel adapters, heavy-duty snaps. Ideal gift for fishermen, photographers, boaters, skiers, snowmobilers, hikers. \$7.50 postpaid. Satisfaction guaranteed. Free literature. Write: Kuban Hitch, Dept. PM, 5280 N.E. Main Street, Minneapolis, Minn. 55421.



## CAMERAS AND EQUIPMENT

**FREE! FREE! BARGAIN BOOK** Central Camera Co., Dept. 341, 230 S. Wabash, Chicago, Ill. 60604.

**USED** Photographic Equip. Nationwide Monthly "Shopper" Free Sample. Shutterbug Ads, Box 730-P, Titusville, Fla. 32780.

## PHOTO FINISHING

**CAMERA FANS!** Expert photofinishing by one of Country's largest labs at lowest prices. Fast service and free "Foto-Fan" Stamps you quickly redeem for valuable Photo Supplies. 8MM Kodachrome \$1.29; 8 Exp. Kodacolor \$1.79; 35MM Kodachrome 20 Slides \$1.39; 8 Exp. Black White 69¢. Satisfaction guaranteed. Send exposed film or request free mailers, complete Price List and Gift Catalog. Direct Mail Photo, Box 8352-PM, Pittsburgh, Pa. 15218.

## COLOR SLIDES

**ASTRONOMY—Space—Underwater Slides** Catalog. Roberts, Box 608, Dana Point, California 92629.

## MOTION PICTURES AND SOUND EQUIPMENT

**CLASSIC 8MM. MOVIES . . . 35MM. 2"x2" Color Slides.** . . . largest selection anywhere! Silent classics, comedy, history, sport, news, documentaries, features, others! 16MM films also Free catalog. Blackhawk Films, 690 Eastin-Phelan Bldg., Davenport, Iowa 52808.

**UNUSUAL** Movie supplies. Free circular. Esor, 47th Holly, Kansas City, Missouri 64112.

**FREE!** 64-Page catalog. 8-16MM film supplies, processing equipment. Superior, 448 N. Wells, Chicago 60610.

**8MM-SUPER 8-16MM MOVIES!** Biggest Selection! Lowest Prices! Free Catalog! Cinema Eight, Box 245-PM, N.Y.C. 10028.

**16MM, 8MM** Sound and Silent Classic Films. Free Catalog. Niles, 1019-PM So. Michigan, South Bend, Indiana 46618.

**FREE** Catalog—8mm-16mm—Top Manufacturers—G & G Film Library, Box 321, Syosset, New York 11791.

## RADIO, TELEVISION AND HAM EQUIPMENT

**36¢** RADIO & TV Tubes. Free catalog. Cornell, 4213-17 University, San Diego, California 92105.

**GIANT** Canadian Electronics Surplus Catalog. \$1.00. Etc—PM, Box 741, Montreal

**SAVE** Money on parts and Transmitting—receiving tubes, Foreign—domestic. Send 25¢ for giant catalog. Refunded first order. United Radio Company, 56-PM Ferry Street, Newark, N.J. 07105.

**GOVERNMENT** Surplus receivers, transmitters, snooper scopes, parts. Catalog. 25¢. Meshna, Nahant, Mass. 01908.

**CB RADIOS REPAIRED** Walkie-Talkie or Transistor Mobile \$10.95 plus Postage if no abusive damage. Desmond, Box 11, Chicago Ridge, Ill. 60415.

**BARGAINS** Galore—Sale of Electronic Parts inventory. Write for Free List: SAC, Box 276, S. Glastonbury, Conn. 06073.

## HIFI TAPES, RECORDS AND ELECTRONICS

**FREE** Catalogues, 2000 hard to find unusual records. Rose's Records, Box 7216, Louisville, Ky. 40207.

**FREE** Catalog—Electronic Kits—Amplifiers—Preamplifiers—Psychedelic Strobes—SCA Adaptors—Color Organs—Digital Instruments—Guitar Amplifiers. FREE Subscriptions. SWTPC, Box PM32040, San Antonio, Texas 78284.

**8-TRACK** Cartridges, Cassettes. Tremendous Discounts. Write for Free Catalogue. Exhibo West, Box 5174-PM, Mission Hills, Calif. 91340.

**OLDIES!** 45 RPM Original Hits Catalog 50¢. C. & S. Record Sales, Box 197, Wampsville, New York 13163.

**BUY 8** Track Stereo Tapes at fantastic Prices. Top Artists, Free Catalog, over 500 Tapes, Soul, Pop, Jazz, Country. New Trend, 6621 141st. Pl., N.E. Redmond, Wash. 98052.

**FREE** Catalogue, Electronic Calculators, Pocket, Desk, Name Brands, Calculators Unlimited, Box 338, Hyattsville, Md. 20781.

**TRY** Playtrade's 100 Minute Eight Track Blank Cartridge. \$1.90 including postage. PLAYTRADE, Inc., Box 5562, Toledo, Ohio, 43613.



## MUSIC AND MUSICAL INSTRUMENTS

**ACCORDIONS** And Amplifiers! New—Used. Cordovox, Excelsior—Top Makes! Save to 50%. Direct factory dealer. Terms. Trades accepted. 5 day home trial. Free catalog—Discount prices. Write: Accordions Unlimited, Dept. R, 3147 North Luna, Chicago 60641.

**SWISS** Musical Boxes, Movements. Bell Music, P.O. Box 1, Bay Station, Brooklyn, N.Y. 11235.

**LEARN** To read music in one evening. Free brochure, Jordan, 27495 Road 176, Dept. PM-4, Exeter, Calif. 93221.

**FREE CATALOG—30% DISCOUNT.** Best Names in Musical Instruments. Dial For Music, 90 North Main Street, Spring Valley N.Y. 10977.

**EASY** To Play And Make. Quality Dulcimers, Banjos, Thumb Pianos; Instruments And Kits. Can Be Profitable Hobby. HERE, Inc., #P, 410 Cedar Avenue, Minneapolis, Minn. 55404.

**ELECTRIFY** Player Pianos, Pump Organs Quickly, Inexpensively with Lee Silent Suction Units. Write: Lee Music, 525F Venezia Avenue, Venice, California 90291.

**30% TO 50% DISCOUNT!** Any Model: Guitar, Amp, Drum, Banjo, Dobro! Free Catalog! Warehouse P32, Box 16399, Fort Worth, Texas 76133.

**PLAYER** Piano Rebuilding—get details from: Vestal Press, Vestal 11, N.Y. 13850.

**POEMS** Wanted for songs. Nashville Music Productions, Box 40001-P, Nashville, Tennessee 37204.

**VIOLIN** And Guitar makers—send for latest Free Catalogue of woods & accessories. International Violin, PM1, 414 East Baltimore St., Baltimore, Md. 21202.

**WHOLESALE!** Professional Guitars, PA Systems, Altec Speakers, 240W RMS Amplifiers. Free Catalog. Carvin, Escondido, Calif. 92027.

**ACCORDION** Manufacturing, 6846-P North Avenue, Chicago, Illinois 60635. Concertinas, Hohners, Chromatics, Guitars, Drums, New, Used, Tuning, Repairing. Wholesale Catalogs Free.

(Continued on next page)

Материал, защищенный авторским правом

## MUSIC AND MUSICAL INSTRUMENTS

(Continued from preceding page)

**WHOLESALE.** Musical Instruments—Accessories. Allied, 573 Route 17, Paramus, New Jersey 07652.

**RECONDITIONED** Accordions for sale—Save \$\$\$, Top Brands. Write for free descriptive folder. A-1 Rebuilt Accordions, 31 E. 18th St. N.Y.C. 10003.

**ACCORDION** Top brands. Buy direct. Tremendous discounts. Trades accepted. Free brochure PM. Accordion-O-Rama, 874 Broadway, N.Y.C. 10003.

**SWISS** Music Boxes, Movements. Highest Quality. Spielman, 55 West 42nd, New York 10036.

**GUITAR,** Banjo, Violin, Mandolin Making Materials, Accessories, Books. Catalog 25¢. Guitar Center, Box 15444, Tulsa, Oklahoma 74115.

**NEW GUITAR MAKING BOOK & NEW TOOLS.** Overholtzer, 618 Orient, Chico, Cal 95926.

**WE** Pay All Recording Costs on accepted material! Need new Song Material for immediate recording! Grand Recording, 1354-PM Hancock St., Quincy, Massachusetts 02169.

**MUSIC LOVERS!** "Learn To Play 'Chord' Piano"—in 10 lessons. Just 39¢ per lesson. Free Details. Sylvia Beatty, One Chestnut Street, Eau Claire, Pa. 16030.

**TAPES—8** Track. Low Prices. 400 Listings. Catalog 25¢. Cardinal House, Suite 4T, 612 Bow Drive, Vandalia, Ill. 62471.

**DULCIMER** Kits, Dulcimer Books, Dulcimers. Paul Pyle Studios, Tullahoma, Tenn. 37388.

**POEMS,** Songs wanted for hit recording, guaranteed Publishing, radio release. America's most popular new talent studio. Broadway Music Productions, 11647PM, Bee Ridge, Sarasota, Florida 33578.

**MUSIC** Learning Made Simple. Details—George Sales, 12721 Willowbrook, Compton, Calif. 90222.

**FREE** Song Selling Information. Peerless Publications, Box 193-A, Bloomfield, Conn. 06002.

**30% DISCOUNT** Name Brand Musical Instruments. Free Catalog. Freeport Music, 455F Route 110, Melville, N.Y. 11746.

**I'LL** Teach you to read Music in one evening. Free brochure, Richardson, M&J Building, Suite 10, McAllen, Texas 78501.

**NEW FREE CATALOG!** Musical Instruments, Accessories, Instruction Books. Marina Music, Box 718-C, Marina Del Rey, California 90291.

## CONSERVATION TRAINING

**GAME WARDEN,** Government Hunter, Forestry, Park & Wildlife Service announce job openings regularly. Prepare at home for outdoor work, good pay, security. Approved for Veterans! FREE! "CONSERVATION CAREER KIT." North American School of Conservation, MPS, Newport, California 92663.

## EDUCATION AND INSTRUCTION

**SURVEYING PAYS BIG!!!** United States Department of Labor reports "openings for 26,000 Surveyors in next ten years." Easy home-study plan guides you. Send for Free "Surveying Career Kit." North American School of Surveying, AZS, Newport Beach, California 92663.

**LEARN ADVERTISING.** Course Like University Extension. AAI-P. 655 Teresita Blvd., San Francisco 94127.

**WELDING CAREER TRAINING—**Arc, Pipe, Gas, TIG, MIG, Plasma. Write for free bulletin. Accredited NATTS. Approved Ohio No. 70-12-0064 HT. HOBART SCHOOL OF WELDING TECHNOLOGY, BOX 73, TROY, OHIO 45373.

**COMPLETE YOUR HIGH SCHOOL** at home in spare time. Texts furnished. No classes. Diploma. Our 76th year. Free Brochure. American School, Dept. X445, Drexel at 58th, Chicago 60637.

**FINGERPRINTING—**Investigation. Exciting, secure career. Learn at home. Free book. State age. Institute of Applied Science, 1920 Sunnyside, Dept. 164, Chicago, Illinois 60640.

**PIANO** Technology—Electronic organ servicing, learned easily at home. G. I. Approved. Free booklet. Niles Bryant School, Dept. P, 3631 Stockton, Sacramento, California 95820.

**GLASS** Cutting & Glazing. Simplified Lesson. An Illustration How To Cut Glass And Install On Commercial, Residential Buildings. \$3.00. Workshop, 99 St. Marks Place, N. Y. C. 10009.

**FREE** List of low cost books. Astrology, Dreams, Cybernetics, many more. Write: R. B. Mac, Dept. 1473, 167 West Elza, Hazel Park, Mich. 48030.

**LEARN** Sewing Machine Repairing. Men, Women. Lucrative profits. Profession with bright future. Gresslin Correspondence School, Box 927, Spencer, Iowa 51301.

**MISSOURI** Auction School. Veteran Approved. Free catalog. 1600-03 Genesee, Kansas City, Missouri 64102.

**BE A** Real Estate Broker. Big Earnings. Prepare quickly, easily. Approved for Veteran Training. Free Catalog. Weaver School, 3519-PA Broadway, Kansas City, Missouri 64111.

**GET A** British Degree. Divinity, Philosophy, Radionics. 35 Courses. Prospectus free. Brainridge Forest School, Highfield, Dane Hill, Sussex, England.

**EXTENSION** And Post-Graduate Awards in Philosophy, Art, Sciences, Botanic Medicine, Homeopathy, Radionics and others. 30 subjects. Curricular free (airmail \$1.00 refundable). Registrar, Sussex College of Technology, Highfield, Dane Hill, Sussex, England.

**LEARN** Auctioneering. Term soon. Free catalog. Reich Auction College, Box 850, Mason City, Iowa 50401.

**LEARN** Massage. Home Study Course. Free Details. Massage, Box 190-PM, Quincy, Mass. 02169.

**LEARN** To SKI Within thirty Minutes!!!! Famed Instructor gives lessons about Equipment, Positions, Principles on Phonograph Record. Guaranteed—\$5.95. Sheldon's, Dept. 1, Box 1003, Lancaster, Penna. 17604.

**ORDINATIONS,** Lifetime! Church chartered 1887! Write! 708 BrARR, Monroe, North Carolina 28110.

**RELIGIOUS VOCATION?** Write: Church of Holy Light Inc., P.O. Box 4478, Pittsburgh, Pa. 15205.

**USED** Courses! Books Catalog 10¢. (Courses Bought). Lee Mountain, Pisgah, Alabama 35765.

**AUTOSUGGESTION.** Sleep-learning headquarters! Tapes, records, books, Gigantic catalog free. Research Association, Box 24PM, Olympia, Washington 90851.

**OWN** Collection agency. "Little Gold Mine!" Franklin Credit, Roanoke, Virginia 24004.

**AUCTIONEERING.** Resident or home Study Course. Free Catalog. Nashville Auction School, 1921 West End, Nashville Tennessee 37203.

**USED** Courses! Books! List 10¢. Smith's, 124 Marlborough, Salem, Massachusetts 01970.

**FREE** Book tells how you can learn camera repair and service. Home study or classroom. Write today! National Camera, Dept. EAD, Englewood, Colorado 80110.

**HIGHLY** Effective college-level home study programs in Electronics Engineering and Engineering Mathematics. (Our 27th Year). Free Literature. Cook's Institute, Dept. 10, Box 10634, Jackson, Miss. 39209.

**PERFECT** Husband-Wife Business. Learn Upholstery at home. Make \$10 in an hour. Buy-repair-sell for even bigger profits. Kits, tools, included. Free Booklet. Upholstery & Decorating School, (homestudy), Dept. 5310-043, Little Falls, New Jersey 07424.

**DETECTIVE** Profession, Easy home study; free tie-tack or lapel pin, certificate, future. GI approved. Professional Investigators, Box 41345, Dept. CP, Los Angeles Calif. 90041.

**DETECTIVE** Course. Free Information. Universal Detectives, Box 8180-F, Universal City, California 91608.

**LEARN** To Fix Typewriters. Desperate shortage trained men. Hundreds needed. Make up to \$25 in one hour. Learn at home in spare time. Industry Approved course. Facts Free. Send name. Typewriter Repair School, (homestudy), Dept. 3310-043, Little Falls, New Jersey 07424.

**PIANO** Tuning quickly learned with home study course. Diploma granted. American Tuning School, 17050 Telfer Dr., Morgan Hill, California 95037.

**DETECTIVE** And Fingerprinting Courses. Write. Detectives, Box 185-P, Fairfield, Alabama 35064.

**SHORTCUTS** To Success! Highly Effective. Profitable Short Courses. (75 Choices). Study At Home. Diploma Awarded. Our 27th Year. Free Literature. CIEE-25, Box 10634, Jackson, Miss. 39209.

**WATCH** REPAIRING. Learn at home in spare time. Diploma awarded. Free sample lesson. Chicago School of Watchmaking, Dept. YQ, Fox River Grove, Illinois 60021.

**UNLOCK** Your Future. Become professional Locksmith by spare time homestudy. Make up to \$6 per hour. All tools, equipment inc. Facts free. Send name. Locksmithing Inst., (homestudy), Dept. 1310-043, Little Falls, New Jersey 07424.

**HIGH SCHOOL DIPLOMA** For Adults. Earn State Diploma. Accepted by Civil Service, business, colleges. Low cost. No tedious study. Money-back guarantee. Details: H-S Program, Suite 2505, 1221 Avenue of Americas, New York, N. Y. 10020.

**GRAPHOANALYSIS—**Learn scientific handwriting analysis for profit, pleasure. Free sample lesson, catalog, reveals plan. Write: IGAS Inc., 325 Jackson, Dept. CX-2, Chicago 60606.

**SERVE** God's Ministry. Free. Ordination, Bible Institute, Box 744, McKeesport, Pa. 15134.

**HOW TO GET WHAT YOU WANT OUT OF LIFE.** Compact course prepared by psychologist/teacher team. Remit \$2.75: Rijac Enterprises, Dept. PM1, 17 Amherst, Smithtown, N.Y. 11787.

(Continued on next page)

## EDUCATION AND INSTRUCTIONS

(Continued from preceding page)

**COLLEGE** Degree at home. Your choice of subjects incl. Law. Easy tuition plan. Williams College, 702 West Idaho, Boise, Idaho 83702.

**MAGIC** Easily learned with home study course. Catalogue, free trick \$1.00. Magic Masters, 1859 Old Meadow Road, McLean, Virginia 22101.

**AIRCRAFT MECHANIC**—Learn engines, jets, airframes. Qualify for FAA License at nation's largest air school. Write for free catalog. Indicate if eligible for G.I. Benefits. Spartan Airschool, International Airport, Dept. AZW, Tulsa, Oklahoma 74151.

**SIGNPAINTERS!** \$80.00 Daily. Easily. Free lesson. Write: Superior, Box 365BB, New Port Richey, Florida 33552.

**"LEARN Fast As Geniuses!"** Typing! Art! Music! Dancing! Songwriting! \$1.00 each! All-\$2.95! Burke's, Brook Road, Chariton, Massachusetts 01507. Altic's, 49 Partridge Hill, Hyde Park, New York 12538. Yeakel's, #152, Silt, Colorado 81652. Kappert's, 7671 Arroyo, La Palma, California 90623. Miller's, #263, Clarksdale, Mississippi 38614. Hope's, #881, Albany, Oregon 97321.

**VETERINARY ASSISTANT**—Train at home for exciting animal care career. Send for FREE "Career Kit". North American Home-Study School of Animal Sciences, AZS, Newport Beach, California 92663.

**MILLIONS** of Sewing Machines/Vacuum Cleaners Need repair. Train now for this High-Paying trade. Three Clothbound books, over 600 pages of instructional text—hundreds illustrations. Free wholesale buyers guide parts/tools. \$26.85. Sincere, Box 10422, Phoenix, Arizona 85064.

**LEARN WELDING;** Amazing Profits, Security. Free Information. Daves Welding, 1005 South 19th, Fort Smith, Arkansas 72901.

**RELAX** Equivalent of up to 2 hours sleep in 10 minutes. Instructions \$1. Bar Enterprises, 7120 Hayvenhurst Av. Van

**LEARN** Asleep or awake! Records, tapes, equipment! Free catalog! Drawer PM-400, Ruidoso, New Mexico 88345.

**COMPUTER** Training, also Accounting and Business Administration courses are available in a private college near you. Write: National College of Business, Box 1628P, Rapid City, South Dakota 57701.

**LEARN** Yacht Design. Course takes you from Beginning to End. Teaches Both Sail and Power. Study under Well-Known Designers. Write for Brochure. Yacht Design Institute, Box 411PM, Brooklin, Maine 04616.

## FOR INVENTORS

**INVENTIONS** Wanted immediately for promoting on cash or royalty. Patented, Un-Patented. Free booklet outlines royalty rates, requirements. Write: Kessler Corporation, C-54FI, Fremont, Ohio 43420.

**IDEA**—Then What! Write: Rankin—File, Box 566M, Willoughby, Ohio 44094.

**WORTHWHILE** Inventions Marketed. Patented or Unpatented. Harvey Engineers, Cambridge, Maryland 21613.

**U.S. PATENT** Office Searches. 234 Broadway, Room 3615, New York 10007. Free invention certificates.

**IMMEDIATE** Cash, for patent applications. Free patent searches. Write for details. Universal Patents, 184-D, Marion, Ohio.

**INVENTORS!** Don't sell or license your invention until you receive our offer. Eagle Development Company, Dept. H, 83 Wall Street, New York City 10005.

**SYNTHESIS MAGAZINE**—About Invention. Write: Box 157, Manhattan Beach, California 90266.

**INVENTORS**—United States Patent Office Searches, Patent Development Engineering, marketing of inventions—ideas by Licensed Professional Engineer—Patent Engineer and United States Patent Office Former Examiner. Inventions developed for patenting and marketing. We are contacted by many manufacturers seeking to purchase appropriate new products invented by our clients. Send for Free invention Certificate and Invention Information. Serving Inventors since 1948. George Spector, Licensed Professional Engineer—Patent Engineer—3615 Woolworth Bldg., New York, N.Y. 10007.

**PATENT** Application Financing. Free patent search plan. Global Patent Division, 2420 77th, Oakland, Calif. 94605.

**PATENT** Searches including maximum speed, full airmail report and closest patent copies. Quality searches expertly administered with complete secrecy guaranteed. Free Invention Protection Form and "Patent Information." Write: Dept. 15, Washington Patent Office Search Bureau, Benjamin Franklin Substation, P.O. Box 7167, Washington, D.C. 20044.

**PROSECUTE** Your Own Patent Application. All Material Necessary—Write: Inventors Service, Box 3574, Washington, D.C. 20007.

**INVENTORS!** Either I will sell your invention before you do, (either through your own efforts or those of another firm) or I will pay you a cash bonus. For Free Invention Evaluation and information, write: Gilbert Adams, Invention Broker, Dept. 15, 81 Wall St., New York, N.Y. 10005.

**INVENTORS:** Your ideas and inventions (patented: unpatented) expertly searched, developed for commercial appeal and cash/royalty sales to manufacturers by professional Invention Developer with excellent record of experience. B. S. Industrial Engineering; United States Patent Office former Patent Examiner. United States Government former Patent Advisor. Second decade reliable service! Member: United States Council International Chamber Commerce. Free "Invention Record" and "Recommended Protection Procedure." Airmailed! Write: Raymond Lee, Invention Developer, 230P-Park Ave., New York, New York 10017.

**FREE PAMPHLET:** "Tips on Safeguarding Your Invention." Write: United States Inventors Service Company, 501-P Thirteenth Street N.W., Washington, D.C. 20004.

## INVENTIONS WANTED

**INVENTIONS** Needed immediately for manufacturers. For additional information Write: Kessler Corporation, C-541W, Fremont, Ohio 43420.

**MR. INVENTOR:** Inventions Urgently Needed by Manufacturers. Ideas Developed. Patent Searches \$25.00. Patent Application Financing if Desired. Charles S. Prince, Invention Consultant, Dept. 24, 353, West 57th St., New York, New York 10019.

**INVENTIONS** Wanted. Patented: unpatented. Tremendous manufacturers lists. Global Marketing Service, 2420G 77th, Oakland, California 94605.

**WE** Either sell your invention or pay cash bonus. Write for details. Universal Inventions, 28-E, Marion, Ohio.

**INVENTORS!** Protect your ideas! Free "Recommended Procedures." Washington Inventors Service, 422F Washington Building, District of Columbia 20005.

**FREE** "Directory of 500 Corporations Seeking new Products." For information regarding developments, sale, licensing of your patented/unpatented inventions. Write: Raymond Lee Organization, 230-N Park Avenue, New York, New York 10017.

**NEW PRODUCTS—INVENTIONS—IDEAS** Developed/Marketed by Professional Organization. **FREE INFORMATION** "How To Market Inventions To Industry". Lawrence Peska Associates, 500-C Fifth Avenue, New York City 10036.

## BUYING AND SELLING

**SACRIFICE SALE—DOCTOR'S** Orders. Ornamental Concrete business in resort area. No competition. Molds to pour \$1200.00 per day wholesale. 406-962-3432 Lawn Ornaments, Joliet, Montana 59041.

**WOULD** Like to Buy, Doble Steam Car, any model, or Doble Power Plant. Louis J. Klapka, c/o The Shoe Tree, 40 East Hinsdale Avenue, Hinsdale, Illinois 60521.

## BUY IT WHOLESALE

**HEARING** Aids, batteries, Wholesale. Catalog 25¢. Fiston, Box 1444, New Preston, Conn. 06777.

**165 FREE** Wholesale Catalogs! Mailorder Dropshippers. Your Business Imprint; Automobile Discounts. Free "Digest." Vault International, Box 7284W, Lexington, Kentucky 40502.

**WORLD'S** Largest wholesale dropship sources. U.S., foreign. Factory suppliers dropship direct to you or customers. Now! have your own catalog for pennies. Free details. International Buyers, Box 16386-M, Portland, Oregon 97233.

**NEW 1973 WHOLESALE SUPPLY DIRECTORY.** Sale Price \$2.00. Winchester Enterprises, 2807 PM Hargrave Street, Philadelphia, Penna. 19136.

**HEARING** Aid Batteries wholesale. Top Quality. List Free. Raven House, Box 4277PM, Burlington, N.C. 27215.

**"POLYNESIAN** Girl" Black Velvet Original Paintings \$3.00. Harris, Box 1567-PM, Portland, Oregon 97207.

**DIAMOND** Rings for Under \$11!! Wholesaler, Box 1391-RM, Clearwater, Florida 33515.

**FREE** Catalog. Gifts, Specialties, Toys, Buy below wholesale. Marvinte, 5275 DeLongpre, Hollywood, Calif. 90027.

**BUY** Below Wholesale. Over 1000 items. Make sensational profits. We help you start. Details 25¢. Demeter Enterprises, Box 243, Wray, Colorado 80758.

## EXPORT-IMPORT

**JAPAN:** 1200 Products directory, Illustrated Manufacturers' names, addresses. \$4.00. Send cash. Yamagata Office, 814 Togin Bldg., Marunouchi, Tokyo.

**DIRECT** From Scandinavia: Grandfather's clocks, wrist watches, Pencils, Telephones, Playing cards, colour films, colour magazines, color slides. Catalog \$2.00. Write to: Ado-Mail, Gothersgade 97, DK 1123, Copenhagen, Denmark.

## FOR THE HOME

**"MAGIC** Magnetic Soap Holder," Fastens with 3M Foam Adhesive, No Tools Needed. Eliminates Messy Soap Dishes in Showers, Baths, Basins, Kitchens, Boats, Mobile Homes. Air Dries In Minutes. \$1.59 Postpaid. Stone Industries, Box 6411, Surfside, Florida, 33154.

## OF INTEREST TO WOMEN

**\$700 MONTHLY.** Immediate Income. Stuff Envelopes At Home. Information, Send Self-Addressed Stamped Envelope. Cottage, Box 25053-CBD, Los Angeles, California 90025.



## OF INTEREST TO WOMAN

(Continued from preceding page)

**NOW! SAVE MONEY.** Learn How To Get More Use From Your "Deep Fryer" Oil. \$1.00. The Lenart Shoppe, 354 Westview, Hoffman Estates, Illinois 60172.

**1000% PROFIT** Bronzing Baby Shoes. Free literature. NBC, Box C-4PM-11, Coral Springs, Florida 33065.

**WANT A new car, color TV, new clothes?** Learn hundreds of ways to make money. 5 month subscription FREE. Write: Salesman's Opportunity Magazine, Dept. 17-DO, 1460 Hancock Center, Chicago 60611.

**\$6.00 DOZEN** Paid lacing baby boots! Cowboy, Warsaw 9, Indiana 46580.

**\$500 MONTHLY** Possible addressing—stuffing envelopes (longhand—typing) at home. \$500 monthly Clipping news items from your newspaper. Information: Send stamped self-addressed envelope. American, Excelsior Springs, Missouri 64024.

**NEW** magazine, foods, decorating, household tips, family living. Sample 25¢. Homemaker Magazine, 404 West Jefferson, Springfield, Illinois 62702.

**EARN UP TO \$150.00 WEEKLY . . .** Home addressing for us. Details 25¢. Smith's, Box 2469-PM, Newark, New Jersey 07114.

**BIG** Profits from Dolls! Start your own hobby-business dressing, making, repairing and selling dolls. Free information. Lifetime Career Schools, Dept. D-245, 2251 Barry Avenue, Los Angeles, California 90064.

**LEARN** Expert Cake Decorating, Candy Making. Free details to housewives. Candy & Cake Institute, Dept. BPD, 1600 Cabrillo Avenue, Torrance, California 90501.

**ADDRESSERS** And Mailers Needed. Details 10¢. Lindbloom, Dept. POM, 3636 Peterson, Chicago 60659.

**BINGO** Early! How to select cards with lucky numbers. Guidebook \$2.00. Gift House, Box 8095P, Ft. Lauderdale, Florida 33310.

**ASTHMA AGONY ENDED EASILY.** Drugless home treatment. Free facts airmailed. J. Mortimer, Box 1353, Winnipeg, Canada R3C 2Z1.

**PORTABLE** Electric Hairdryer, \$11.95, 69¢ postage. Weindz, RR1, Boyle, Alberta, Canada.

**INVEST \$1000.** and Double your Money within five years; residential and sports complex developing at Dominican Republic West Indies; information: Apartado 13068, Madrid, Spain.

**MAKE** Your Own Natural Cosmetics. Exciting Recipe Collection. Send \$2 to: Reto, Box 265-AW, Brooklyn, N.Y. 11220.

## GIFT SHOPPING

**FREE CATALOG** On Gift Ideas. Send to day. F & J Merchandise, 42-95 Main Street, Flushing, New York 11355.

**FREE FANTASTIC GIFT CATALOGUE.** FREE SILVER DOLLAR BONUS GIFT. TREASURE CHEST, 9321PM4, CAPE VIEW AVENUE, NORFOLK, VIRGINIA 23503.

**PROBLEM FINDING**—Gifts for Birthdays, Anniversaries, friends etc.? FREE CATALOG DORCO, 188 Arlington St., Lawrence, Mass. 01841.

**CASTILIAN** Wine Skin. Genuine Goat-skin with latex lining, braided cord. Quart capacity, \$3.98, two quart, \$4.98. Include \$.75 postage. Guaranteed. Global Creations, 1029 Carin Drive, Tallahassee, Florida 32301.

**FREE** Catalog. 101 Best Mail Order Specialties and Gifts. Buy below Wholesale. Ray's Specialty House, Dept. PM, 1669 Johnson Rd. N. E., Atlanta, Georgia 30306.

**KITES!** Quality Action Styles! Brochure 10¢. Hutchinson, PM, 83 Tremont, Barre, Vermont 05641.

**FREE** Exquisite gift catalog for all occasions featuring bonus gifts. National Trade Mart, Box 1446, Bloomfield, N.J. 07003.

## WATCHES, OLD GOLD, JEWELRY

**COMPLETE** Watchmakers'-Clockmakers'-Jewelers' Catalog. \$1.00. G/M, 1521-A West Magnolia, Burbank, California 91502.

**HIGHEST CASH** For Gold, Jewelry, Gold Teeth, Rings, Diamonds, Watches, Silver, Platinum. Mail Articles Today. Free gift with information. Chicago Gold & Precious Metals, 6 E. Monroe, Dept. 858, Chicago, 60603.

**FREE** Catalogue—Ancient Replica Clocks. Masters, 82 Doudeauville, Paris 18, France, (Airmail \$1.00).

**WATCH** And Clock repairing books. Free list. North American, Box 77-AD, Fox River Grove, Illinois 60021.

**CASH** Immediately for Old Gold, Jewelry, Gold Teeth, Watches, Diamonds, Spectacles, Silver, Platinum, Mercury. Free information. Rose Industries, 29-A East Madison, Chicago 60602.

## HEARING AIDS

**HUGE SAVINGS.** Eliminate dealer mark-ups. Free Trial. Batteries Wholesale. Terms Arranged. Lloyds-PMC, Rockford, Ill. 61108.



## SCIENCE AND CHEMISTRY

**CHEMICALS** Apparatus, Biology and Model Rockets. Both Catalogs for 50¢. Sheard Science, Dept. PM, Columbus, Wisconsin 53925.

**CHEMISTRY** And Biology Catalog 35¢. Boulevard Laboratories, Suite 302, 3114 E. 83rd St., Chicago, Ill. 60617.

**LASER** Parts Catalog 60¢. Moynihan, 107 North Brighton, Atlantic City, New Jersey 08401.

**COMPLETE** Laboratory Catalog 35¢. Laboratory Sales, Box 161-A, Brighton, Mass. 02135.

**AMAZING!** Scientific Catalog—Apparatus—Glassware—Chemicals. Catalog—50¢. Hagenow Laboratories, Manitowoc, Wisconsin 54220.

**CATALOGUE** Of those very hard-to-find chemical products, things that go boom, multi-stage rockets, 500 How-To books, 10,000 formulas of every conceivable mixture in science and industry. 50¢. Kenrus-C, Box 158M, Staten Island, New York 10309.

**FREE.** Flying MODEL ROCKET Kit. Act Now. Offer Limited. Send 25¢ for Packet of Iron-ons, Decals, Literature and "Free Rocket" Details. Aerospace Vehicles, Inc., Mineral Point, Wisconsin 53565.

## FORMULAS, PLANS, ETC.

**GUARANTEED!** Any Method-FORMULA-Information-\$5.00! Tech Research, 2505 35th, Lubbock, Texas 79413.

**139 AVAILABLE** Formulas, Supply Sources Included. \$1.00. Patare, S618 Townhouse Village, Hauppauge, New York 11787.

## PLASTICS

**LARGEST** Handicrafts Supply Catalogue \$1.00 (Refundable). R.P.H. Manufacturing, 24-M-4, Winter, Stamford, Connecticut 06905.

**CASTOLITE** Pours like water, hardens like glass without heat. Crystal clear, colors. Embed natural flowers, other objects. Make fine gitts. Form flexible molds over any pattern, size. Reproduce your own designs in plastics, candlewax, metal, plaster, cement. Profitable. Illustrated Manual and Catalog Only \$1.00. CASTOLITE, Dept. 73D/PM, Woodstock, Ill. 60098.

**PLASTIC LAMINATES.** How to work with! You can turn out elegant finished products just by using hand or power tools. Resurface kitchen countertops. Correct countertop bubbles. Shows you laminating tricks you should know about. Photocopy of PM article. Price \$1.80. Send order to: Popular Mechanics, Dept. H-M, 224 W. 57th St., New York, N.Y. 10019.

## TREASURE FINDERS

**FIND** Buried Gold, Silver, Jewelry, Coins, Relics, Magnetic Mineral deposits with Ray Jefferson's low cost, transistorized metal/mineral detectors. 3 Exciting models, all with fatigue free arm rest. Fun and profitable. Write for Free Color Catalog. Ray Jefferson, Dept. MDPM, Main and Cotton Sts., Philadelphia, Penna. 19127.

**FREE 156** Page Detector Catalog. General Electronic Detector Co., Box 67, Bellflower, California 90706.

**FISHER DETECTORS.** You deserve the best! Free literature. FRL, Dept. PM-4, P.O. Box 490, Belmont, California 94002.

**SEARCH** Treasure Finders. Locate gold, silver, coins, relics. Operate underwater. Money back guarantee. Free information. Search Electronics, Box 8396-A, St. Petersburg, Florida 33738.

**FIND** Buried treasure with revolutionary patented, analytical metal detector. Features push button and automatic tuning, negligible ground pickup, greatest range. Free catalogue. Gardiner Electronics, Dept. 9, 4729 N. 7th Avenue, Phoenix, Arizona 85013.

**DISCOVER AMERICA'S FASTEST GROWING HOBBY.** White's Electronics, Inc., would like to send you—absolutely FREE, their 42 page, fact-filled catalog on Mineral and Metal Locating Equipment. Amateurs or Professionals select from the world's largest line of metal detectors priced as low as \$79.50, up. Detect Gold, Silver, Copper—Nuggets, Coins, Jewelry, etc. Budget terms available. For your convenience we have three major factory locations in the U.S. and Canada, as well as over 1,000 authorized dealers to serve you. See your local Yellow Pages under "Metal Locating Equipment", or write: White's Electronics, Inc. Room No. 381, 1011 Pleasant Valley Road, Sweet Home, Oregon 97386—Elk-Air Industrial Park, Dexter Drive, East Elkhart, Indiana 46514—or White's Electronics Ltd., 33784 Hazel Street, Abbotsford, British Columbia, Canada.

**TREASURE** Finder locates buried gold, silver, coins, treasures. 5 powerful models. \$19.95 up. Instant financing available. Free catalog. Relco-A-40, Box 10839, Houston, Texas 77018.

**POWERFUL** Metrotech locator detect gold, silver, coins, relics. Moneyback guarantee, terms. Free information. Underground Explorations, Dept. A, Box 793, Menlo Park, California 94025.

**COINS,** Relics detected with latest electronic instruments. Lifetime Guarantee. ElectroSearch, Box 359, Agoura, Calif. 91301.

(Continued on next page)

## PRECIOUS STONES & MINERALS

**GOLD** 10 Small Nuggets Panned From Oregon Streams \$1.00. Robert Brandt, Sweethome, Oregon 97386.

**500 POLISHED** Gemstones \$5.00. Tumblercraft, 5401 James North, Minneapolis, Minn. 55430.

**GET** Free catalog no serious rockhound, gem cutter, jewelry maker, hobbyist or craftsman can be without. Full of bargains, exclusive items, low prices from largest suppliers and authorities in the field. Free new catalog just off the press, yours for the asking. Write: Grieger's, Dept. C-12, 900 South Arroyo Pkwy., Pasadena, California 91105.

## CARTOONING, COMMERCIAL ARTS, SHOWCARD & SIGN PAINTING

**"HOW TO MAKE MONEY WITH SIMPLE CARTOONS"**—Informative book sent FREE tells way to big income. Cartoonists' Exchange 94, Pleasant Hill, Ohio 45359.

**COMPACT** 23 lesson Cartoon Course and Cartoonist's Magazine. \$2.00. Hartman, Box 30367, Lincoln, Nebraska 68510.

**MODERN** Cartooning taught by mail. Write for free brochure. Cartoonorama—Box 263-5L, Branford, Conn. 06405.

**CARTOON** For Money!! Big Free Book! Success, Box 885-C, Dearborn, Mich. 48121.

**SIGNS!** Make-your-own! **SIGN-RITE** Self-Adhering Letters and numbers! 4 Types! 5 large Sizes! 8 material Styles! Choice of Colors! Inexpensive! Prompt service! **FREE BROCHURE!** Americraft Mfg. Co., Box 25034 Northgate, Seattle, Wash. 98125.

**LEARN** Sign painting at home. Free Talent test. Ben Kerns, Box 812-PM, Greenville, S.C. 29601.

**SIGNPAINTERS!** \$80.00 Daily, Easily. Free lesson. Write: Superior, Box 365B, New Port Richey, Florida 33552.

**"CARTOONING And PAINTING CLOWNS"** 50¢. Harris, Box 1567, Portiano, Oregon 97207.

**FASCINATING** Systems. Sign Painting. Cartooning. Straley, 1704 South Center, Springfield, Ohio 45506.

## ADVERTISING AGENCIES, ADV. SERVICES, MAILING LISTS

**FRESH** Lists. Cash Buyers. Free Details. Box 392PM, Brea, California 92621.

**MAILING** Lists, 1000 Gummed \$9.00. National, Box 1086, Austin, Texas 78767.

**ADVERTISING** Ratebook leading newspapers, magazines, 25¢. Chicago Advertising Agency, 28-E Jackson, Chicago 60604.

**MAILING** List, Most all Kinds, \$9.00 1000 Gummed, Circulars mailed \$5.00 1000. Dixmailers, King, North Carolina 27021.

**MAILORDER ADVERTISERS!! CLASSIFIED ADVERTISING CAN BE MOST PROFITABLE AND REWARDING. PROBLEM IS TO KNOW WHAT TO DO; WHAT NOT TO DO. COLUMBIA CAN HELP YOU WIN YOUR MAILORDER PROGRAM. OVER 20 YEARS CLASSIFIED ADVERTISING EXPERIENCE, KNOWLEDGE OF BEST PULLING PUBLICATIONS, EXPERT COPY SERVICE IS ALL YOURS AT NO INCREASE OVER PUBLISHER'S STANDARD RATES. CHANCES ARE YOU WILL SAVE MONEY. WRITE TODAY FOR FREE DETAILS PLUS YOUR FREE COPY OF "MAILORDER ADVERTISER'S RATE GUIDE". COLUMBIA ADVERTISING AGENCY, BOX 257PM4, RICHMOND, INDIANA 47374.**

**500 NEW** Customer Names \$5.00. Names, Box 9, West Union, Iowa 52175.

**YOUR AD IN POPULAR MECHANICS WILL BE SEEN** By More than 5,000,000 active buyers for your products and services. It costs only \$2.20 per word. And, if you wish to run all or part of your ad in bold capital letters—you can do so for as little as 75¢ per word additional. Act now! Send your Classified ad to: **POPULAR MECHANICS, CLASSIFIED DEPARTMENT, 224 WEST 57TH STREET, NEW YORK, N. Y. 10019.**

## RUBBER STAMPS

**POCKET** Stamp, Three Lines \$1.00. Catalog, Rush Stamps, 132-P, Rush, New York 14543.

**FREE** 48 Page Catalog. Rubber stamps, printing, office supplies. Youngers Stamp Shop, Princeton, Iowa 52768.

**ADDRESS** Stamp \$1.43. Signature Stamp \$2.95. Catalog. Carol's, McCloud, Oklahoma 74851.

**RUBBER** Stamp—four lines—\$1.49—Sunshine—2228 Saul, Jacksonville, Florida 32216.

**RUBBER STAMPS** Name and Address \$2.50. Stock Stamps 75¢ to \$1.50. Artcrafter's, Rice Station, Ky. 40474.

**FREE** Stamp Catalog. 45 type styles. Fast Service, low prices. Jackson's, Box 443A, Franklin Park, Ill. 60131.

**ADDRESS** Stamp. \$1.00, Deluxe \$2.00. A.A.A., 2995 Clague Rd., North Olmsted, Ohio 44070.

## OFFICE SUPPLIES

**MAILORDER RECORDS** Help get increased business! Complete 32 Page Record Book shows your inquiries, orders, advertising, expense, etc. Only \$1.00. **H. E. KAPPEL, POPULAR MECHANICS, DEPT. R, 224 WEST 57TH STREET, NEW YORK, N. Y. 10019.**

## PRINTING PRESSES, RUBBER STAMP OUTFITS

**SIMPLE-X RUBBER STAMP PRESSES.** Hydraulic operated, electrically heated. Sizes 5"x8", 8"x12", 10"x15". Starting outfits, Orders for presses, supplies shipped day received. Free catalog low supply prices. Send \$1.00 for postage and handling (refundable on first order). Custom Manufacturers, 406-P East Elm, Springfield, Missouri 65801.

**PRESS 'N' PRINT** Mimeograph Machines. Brand New, Complete With Supplies. Only \$34.95. Details 25¢. Devine, Box 56069, Chicago 60656.

**NEW** Catalog No. 13, 120 Pages, hand printing presses, type fonts, supplies. Send \$1.00 deductible first order. Acme Type, 732 Federal, Chicago, Illinois 60605.

**RUBBER** Stamp outfits, supplies. Kiewiet, 2025 Barney Road, Kalamazoo, Michigan 49007.

**PRINTING** Presses, type, supplies, Lists, 10¢. Turnbaugh Service, Mechanicsburg, Pennsylvania 17055.

**PRINTING MACHINES.** Offset, Mimeograph, Typewriters, Composing, Machines. Digraph, King, North Carolina 27021.

**MAKE** Your own self-molding rubber-stamps and Printing Cuts. Plexirubber, Argyle A, Wisconsin.

**RUBBER** Stamp Manufacturers Supplies. Presses, starting outfits. Best prices, service. Catalog. Jackson Supply, Box 443A, Franklin Park, Ill. 60131.

**SAME** Day shipment on rubber stamp supplies. Revised wholesale price list No. 9 free. Star Stamp Supply, 732 Federal, Chicago, Ill. 60605.

**WANTED TO BUY:** A.B. Dick 350's or 360's or ANY USED PRINTING EQUIPMENT. Fantastic Prices Paid. Churches Office and Printing Equipment, 16795 West 44th, Golden, Colorado 80401.

## PRINTING AND SUPPLIES

**ECONOMICAL** Business Cards, Forms, Labels, Stamps, Stationery. Burnfin, Weaubleau, Missouri 65774.

**BUSINESS** Cards, Rubber Stamps, Printing, Labels, Free Literature. Geers, 111 North Drive, Ottawa, Ohio 45875.

**BUSINESS CARDS** Raised Letters \$5.65 Thousand. Like Engraved. Free Samples. Kavanagh, Box 1222, Brooklyn, N.Y. 11202.

**FREE** Offset Catalog. Fast-Economical. Seaview, 212-26P 48th, Bayside, NY 11364.

**1000 EMBOSSED** Cards \$5.50. Fast. Graphics, 106H High, Westerly, R.I. 02891.

**"101 WAYS** To Save Money on All Your Printing." 136-page illustrated book \$4.95 (Calif. \$5.20.) ppd. Halls of Ivy Press, 13050 Raymer Street, North Hollywood, Cal. 91605.

**100 PERSONALIZED** Postcards \$1.35. Business printing. Longwood Press, Fort Johnson, N.Y. 12070.

**BUSINESS** Cards, Rubber Stamps, Printing. Free Literature. Robison's; 102½ East Henry, Elmira, New York 14904.

**PRINTING** By Mail Supermarket. 1000 Copies \$5.95. 5000 Copies \$22.50. 100 Copies \$2.50. 1000 Envelopes \$7.50. 200 Letterheads and Envelopes \$5.50. 1000 Letterheads and envelopes \$13. Business Forms, 10 pads, 100 sheets each \$6.25. 1000 Adv. Flyers, Free layout, typesetting, color paper \$25. 3000 with one photo \$39.50. Take extra 10% if order equals \$30. Min. order \$7.50, plus \$1.25 shipping for each 1000. We ship in 9 hours. Enclose 2 Originals with Remittance. Full Money Back Guarantee. Get Free Book, "Do you make these 18 Mistakes when you buy printing." Speedy Offset Printers, 23839 Aurora, Bedford, Ohio 44146.

**FREE** List—Stationery, Cards, Postpaid 48 States. Lexprint, Box 1735, Lexington, Kentucky 40501.

**FREE** Literature: Business Cards, Rubber Stamps, Address Labels Printing Big Selection, Jordan's, 552 West O'Connor, Lima, Ohio 45801.

**BUSINESS** Cards and Stationery—State your Occupation—we'll send appropriate samples. A.E. Lutz Co., P.O. Box 156, Dewitt, New York 13214.

## MULTIGRAPH, MIMEOGRAPH

**PROFITS FROM CLASSIFIED ADVERTISING!** Booklet shows you how to start your own business with Classified Advertising. Only \$1.00 (Refundable with first order.) **H. E. KAPPEL, POPULAR MECHANICS, DEPT. P, 224 WEST 57TH STREET, NEW YORK, N. Y. 10019.**

## GUMMED LABELS

**1,000 GUMMED ADDRESS LABELS \$1.00 FREE CATALOG,** Acme, 1238 Voskamp, Pittsburgh, Pennsylvania 15212.

**500 PRESSURIZED** Address Labels \$2.00. Walt's, Box 966A, South Bend, Indiana 46624.

**1000 GUMMED** Address Labels \$1.00. FA Enterprises, 662 Main, Woburn, Mass. 01801.

**5,000 DELUXE** Gold Stripe Gummed padded labels, printed with any Name, Address and ZipCode—\$3.00. Sylvia Beatty, Eau Claire, Pa. 16030.

**1000 GUMMED ADDRESS LABELS \$1.00;** Morgan, Box 25-PM4, Anna, Ill. 62906.

(Continued on next page)

**GUMMED LABELS***(Continued from preceding page)*

**1000 LABELS, FREE CASE, CATALOG.** ALL for \$1.00. Miller's, 504 Spotswood, Elkton, Virginia 22827.

**REMAILING SERVICE**

**INDIANA** Remails—Inquire. Mills, 915-4 North Rogers, Bloomington, Indiana 47401.

**EXOTIC HAWAII.** Remails 25¢ each. \$3.00 Monthly. Dorcliff, Inc., 736 South Street, Honolulu, Hawaii 96813.

**SECRET.** Receiving—forwarding. Discreet and confidential. Remail 25¢ single. Mail Forwarding Service, 8050 S. Main, Houston, Texas 77025.

**RECEIVING** — Forwarding — Remailing. Monthly Rates. Nortex, Drawer 5370, Ft. Worth, Texas, 76108.

**MIAMI** Remails 25¢—Monthly rates. Remails—view cards from 80 Foreign cities. Marle, Box 1266, Coral Gables, Florida 33134.

**YOUR Mail Received—Forwarded.** Hedgpath, 324-M South First, Alhambra, Calif. 91802.

**PARIS** Post Cards 5/ \$1.00. Reairmail Singles \$2.00—Rates. Masters, 82 Doudeauville, Paris 18 France.

**CHARLESTON, S.C.** Remailing, et cetera. Details. SPECTRUM, P.O. Box 3574, 29407.

**CONFIDENTIAL** New York Mail Address \$3.00 Month. Telephone Service \$5.00. Re-mails 25¢. Details Free. Birnhan, 152 West 42, New York 10036.

**CONNECTICUT CONFIDENTIAL.** 25¢ Single. Monthly and Double Remail, Details Free. Ivy Forwarding, Box 2159, Darien, Conn. 06820.

**NEW YORK CITY** Or New Jersey Remails 20¢—Monthly \$2.50. Details: Wentz, Box 2439P, Newark, New Jersey 07114.

**KENTUCKY DERBY** Day 50¢, Louisville Anytime 25¢. Jerome, Box 18109, Louisville, Kentucky 40218.

**CALIFORNIA** \$3.00 Monthly 25¢ each. Marge, Box 6972, Burbank, Calif. 91504.

**HARRIS** Remailing Service, Box 9434, Chattanooga, Tennessee 37412. Fast, confidential. 25¢ each, \$3.00 month.

**RECEIVING—Forwarding.** 25¢; \$3.00 Monthly. Confidentially Guaranteed! John Meehan Co., 1004-M Ringwood, McHenry, Illinois 60050.

**YOUR PRIVACY** Our First Consideration. Confidential Remails 25¢. Monthly Rates. Box 1052, Dept. PM, Laramie, Wyo. 82070.

**YOUR Mail** received here, forwarded to you. Wright, Box 2112-MR, Asheville, North Carolina 28802.

**FORT BRAGG** Remails, 25¢ Plus Postage. CEM, Box 1302, Fayetteville, N.C. 28301.

**CLEVELAND** Remails 25¢. B&M Services, P.O. Box 8684, Cleveland, Ohio 44135.

**LINCOLN'S HOMETOWN.** Remailing-Forwarding. Souvenir Cards. Box 2873, Springfield, Ill. 62708.

**CONFIDENTIAL.** Receiving Forwarding. Monthly Rates. Davis, Box 5012A, Reno, Nevada 89503.

**TANGIER** Morocco reairmails single \$1.00. Confidential receiving-forwarding. Kayross, BP289, Principal, Tangier, Morocco.

**REPAIRS AND SERVICING**

**PROFITS FROM CLASSIFIED ADVERTISING!** Booklet shows you how to start your own business with Classified Advertising. Only \$1.00 (Refundable with first order.) H. E. KAPPEL, POPULAR MECHANICS, DEPT. P, 224 WEST 57TH STREET, NEW YORK, N. Y. 10019.

**SPECIAL SERVICES**

**INFORMATION** On anything. Ferguson Research Specialists, 72-25 Woodside, Woodside, New York 11377.

**ARE** You filing your copies of PM? If you are, you'll want an inexpensive Annual Index, available in January, that will make your file copies much, much more useful. Refer to any article in seconds! And if you aren't filing your copies of PM—start now! Price \$1.49. Send checks to: Popular Mechanics, Dept. HE, 224 W. 57th St., New York, N.Y. 10019.

**TRADE** For what you want. Free Registration. Details. C.W. Bickhart, Box 244-1, Fairview Village, Pa. 19409.

**FREE** Government Benefits Galore! Details. Premier Enterprises, Box 10597-CD, Pittsburgh 15235.

**TOBACCO**

**ROLL** yer own. With our new cigarette rollers. Plain, filtertip, king. Less than a penny each. Free sample. Green River Tobacco, Box 954, Owensboro, Ky. 42301.

**IT'S CUSTOM** Blended pipe tobacco. Finest tobacco. Expertly blended. Factory fresh. Write for free sample. Green River Tobacco Company, since 1914, Box 991, Owensboro, Ky. 42301.

**BRIAR PIPE** Make or repair your own. Photocopy of article shows you all the details. Price \$1.00. Send order to POPULAR MECHANICS, Dept. HE, 224 West 57 St., New York, N. Y. 10019.

**PERSONAL**

**BORROW** By Mail! Up to \$1500.00. Convenient Terms. State Licensed. Postal Finance, Dept. 17-E, 6018 Military Ave., Omaha, Nebraska 68104.

**DON'T** Die without a will! Blank Will form protects your family. Only \$2—guaranteed! Order today!! Arthur Thomas, 205 North Lakeview, Dept. 1B4, Winter Garden, Florida 32787.

**FREE** Gospel Literature Foretelling Second Coming of Christ. Scheall, Box 263-PM, Duluth, Minn. 55801.

**NUMEROLOGY.** Lucky Number and Personal Reading Based On Numbers. Send Name And Birthdate. \$2.00. Dean Lawrence, Box 309, Monticello, New York, 12701.

**YOUR** High Quality Social Security Plate \$1.50, With Case \$2.00. Send Name And Number To: Geer's, 111 North Drive, Ottawa, Ohio 45875.

**LOSING HAIR? BALDING? DANDRUFF?** Free copyrighted booklet. Dr. Shiffer Laboratories, Dept. 536, Box 398, Punta Gorda, Florida, 33950.

**PSORIASIS** Sufferers: Discouraged? Write for Free important Information that is helping thousands! Pixacol, Box 38-PM, Avon Lake, Ohio 44012.

**SECRET LOANS BY MAIL.** Borrow \$100 to \$3000 for any good reason in absolute privacy. No interviews, no endorsers, no co-signers. Fast service. Write: Dial Finance Co., Dept. 3379, 405 S. 16th Street, Omaha, Nebraska 68102.

**INSTANT DEBT RELIEF** Without borrowing. Without Bankruptcy. Have excellent credit in 45 days. Free!!! Wealth Building, Box B-4, 8840, Hoyt Drive, Thornton, Colorado 80229.

**BIBLE** Questions answered. Stamped envelope. Bylon. 17167 Bentler, Detroit, Michigan 48219.

**CASH LOANS** by mail! Up to \$2,500 on signature alone. No collateral! Secret! Union Finance Company, 3608 N. 16th St., Dept. PM, Phoenix, Ariz. 85011.

**WHO** Else Wants Credit Cards? Learn how to get credit cards fast, easy! Get new credit without investigation, Box J-27, Hallandale, Florida 33009.

**INVESTIGATORS.** Latest electronic Aids. Free Literature. Clifton, 11500-P NW 7th Ave., Miami, Florida 33168.

**RUPTURED.** Relief and comfort. No understraps, elastic or steel. Write: Hand-Lock Products, Preston 4, Ont., Canada.

**TELL** Fortunes accurately—Immediately! ESP Aids, Box 21-PM, Olympia, Washington, 98507.

**"RULE** Others With Thoughts." (Telepathy) Write: Clarion, Box 1769-A7, Chicago 60690.

**TATTOO** Removing—Chemical! Do-it-Yourself Method—Free Details: Atlanta, 907P Beachpoint, Pickering, Ontario.

**AMAZING** Telagripe Complaint Kit. \$1.60. Roberson, Box 6404, Anaheim, California 92806.

**RECEIVE** Phony State Chartered University Degrees immediately. Box 11516, Tucson, Arizona 85706.

**I HELPED** Thousands Wipe Out Debts. Clear credit. Immediate relief to \$25,000. Free details. Counselor-7, Kerrville, Texas 78028.

**CONQUER** Personal Problems! Free Brochures Self-Improvement Books! James Thomas Associates, 113D Community, Dept. PM-734, Shillington, Pa. 19607.

**EARN INTEREST ON YOUR BILLS!** Fatten your savings account! New book shows how. Free details. Bestway—A432, Box 344, Stone Mountain, Georgia 30083.

**MAKE** Your Will. 4 Will Forms and attorney's Informative Book \$1.00. Money-back Guarantee. Amroco, Box 8282-EE, Richmond, Va. 23226.

**RETIRING?** Variety of Ways to Cut Expenses on running the House and the Automobile. Send \$2.00: Jacob Demler, 173 Willow St., North, East Aurora, N.Y. 14052.

**ACUPUNCTURE** Atlas. Do It Yourself Chart of Needle and Pressure Points. \$4.95. Books Available. Herbal Holding, Box 5854PM, Sherman Oaks 91413.

**NEED** Money—Debts Too Big? Quick Cash. Secret Emergency Loans. Free Consolidation Plan Application. Interstate, 28 E. Jackson, Suite 1204-X3, Chicago 60604.

**RECORD** Telephone Conversation automatically. Leaver Recorder Unattended. Robert's, Box 49PM4, Parkridge, Illinois, 60068.

**MAKE YOUR OWN WILL!** 4 Will Forms and Attorney's Instructions protect your Family. Only \$2.00—Guaranteed! Order today!! Masterman, Department 1816, 1544 Red Cedar, St. Paul, Minnesota 55121.

**ACNE?** New book tells what to do. Write: Professional Books, 2014 Cosgrove, Charleston, South Carolina 29405.

**"A STAY** Cool System For Buying Stock"—Send \$1.00: KenCo, 3448-PM3 Misty Valley Road, Decatur, Georgia 30032.

**SURPRISE, SURPRISE.** Now YOU can STOP SMOKING FOREVER. New Proven method. \$2.00. Unconditionally Guaranteed. Pacific Exclusive, P.O. Box 988PM, Coos Bay, Oregon 97420.

**WANTED-MISCELLANEOUS**

**MERCURY.** Gold, Silver, Platinum; Ores assayed. Wholesale Terminal, Norwood, Mass. 02062.

**WANTED—Hill** Model C Meat Block Resurfacing Machine. Write: 731 W. 13th St., Wichita, Kansas 67203.

*(Continued on next page)*

**WANTED—MISCELLANEOUS**  
(Continued from preceding page)

**WANTED—Old Baseball Cards.** Quote Price. Jack Smalling, 1225 Roosevelt, Ames, Iowa 50010.

**WINEMAKING & OTHER RECIPES**

**WINEMAKERS.** Free illustrated catalog of yeasts, equipment. Semplex, Box 12276R, Minneapolis, Minn. 55412.

**WINEMAKERS . . .** Free Illustrated Supply Catalog of Yeast, Equipment, Recipes. Continental, Box 18223-PM, Indianapolis, Ind. 46218.

**WINEMAKERS Yeast, Recipes & Catalog** 25¢: Kraus, Box 451-L, Nevada, Missouri 64772.

**WINEMAKERS . . .** Personalized Wine Labels, Free Samples. Grancom, Box 2929, Milwaukee, Wisconsin, 53218.

**WINEMAKER'S Supply Catalog—Free.** Bacchanalia, 273 Riverside Ave., Westport, Conn. 06880.

**WINEMAKERS:** Free informative catalog, recipes. Arbolyn, Box 663, West Columbia, S.C. 29169.

**WINEMAKING Kit—\$4.98 Free Catalog** and Recipes. JIMDANDY, Box 30230M, Cincinnati, Ohio 45230.

**WINEMAKER'S!** Free Illustrated Catalog of Quality Products. Brant's Wine Rack, Box 3256-M, Orange, California 92655.

**HOMEWINE MAKING SEND FOR FREE** informative CATALOG OF RECIPES, EQUIPMENT, and INGREDIENTS. Brewer's Yeast Lry Malt, Crystal Malt, Bottle Caps, Barrels, Chemicals, Concentrates, Over 250 Items. Winemaking Is A Fascinating Hobby. Write To: Danenberger's, Box 276-M, New Berlin, Ill. 62670.

**SUMMER'S For Winemaking.** Learn now with Minikit, \$2. Free Catalogue. FLORA, Box 325A, Ann Arbor, Michigan 48103.

**BOTTLES.** New 5 gallon glass water jugs. \$6.29 postpaid UPS. Chippewa Springs Corporation, Box 154, Chippewa Falls, Wisconsin 54729.

**FERMENTATION LOCKS—3/\$1.00.** Free illustrated catalog plus \$5.00 Credit Coupon. Werth Wine, Box 1902EN, Cedar Rapids, Iowa 52406.

**CHAMPAGNE And Wine Lovers.** Newest Booklet on how to Make Champagne and Wine in Home. Tested Recipes. Guaranteed Delicious. \$3.95. Newest Publications, F & M Associates, Box 2136, Ogden, Utah 84401.

**MISCELLANEOUS**

**RECEIVE Mail Galore!!!!!!** Your Name on our national mailing lists!!!!!! \$1.00. Mailing Associates, Dept. A-1, Box 1003, Lancaster, Penna. 17604.

**AUTHENTIC COMMISSION (15x20)** Your name enrolled as Staff Captain on Sailing Ship TYPHOON plus autographed copy "TYPHOON TRILOGY", thrilling account of voyages and refurbishment. Both for \$4.95 postpaid. Captain Harmon, Dock 8, Palm Bay, Florida 32905.

**FRANKENSTEIN Interview.** Monster's Tells Life Booklet, 20P. (Fiction) \$1.50. Norris, Postbox 44377-A, Indianapolis, 46244.

**FREE Brochure Famous 22x28 Canvas Art Reproductions \$4.95.** Arts, 1505 Alaska, Lynn Haven, Fla. 32444.

**NORELCO SHAVER SHARPENER** Gives Sharpest Cutting Edge Possible For Regular Or Floating Head. \$2.98 Postpaid. Guaranteed. Norelco Sharpener, 3737-A North Sayre, Chicago 60634.

**TAMPERPROOF** Check protection—Pocket checkwriter makes altering checks almost impossible—guaranteed—Only \$5.95—Aneva's—1C4, 4221 S. 6th—A39, Milwaukee 53221.

**BOOKS** On antiques and their prices. Free circular!! P. Warman Publishers, Uniontown, Penna. 15401.

**SUFFERING** From Arthritis? Try Ginseng: Information Free. Write: Ginseng, Asheville 53, North Carolina.

**ORNAMENTAL** Iron designs. Book of 1600 beautiful, practical designs for railings, columns, etc. Free literature. Cunningham, 3881 South 3200 West, Salt Lake City, Utah 84119.

**PRE-PACKAGED** Toys complete with free self-selling display rack. Free Details. Toys, 1916 Fifth, Sacramento, California 95814.

**BIRTH** Certificates, Marriage Certificates, Diplomas! 2 blank forms \$1.00. Sample 10¢. Standard Forms, Box 482-M, Washington, D.C. 20044.

**SLEEPATRON.** New device for inducing sleep. Gardiner Electronics, Dept. C, 4729 North 7th Avenue, Phoenix, Arizona 85013.

**U.S. \$1000 Bills!!** Obsolete Exact Replica's 5/\$4. National, Box 1391-X, Clearwater, Florida 33517.

**HEARING** Aid batteries wholesale. Free list. Habs, Box 51, York, Penna. 17405.

**WOOD BARRELS . . .** Pine Buckets, Crates, Planters, "Authentic" Barrel Banks, Spigots. Send 35¢ for 1973 catalog. Cordell Enterprises, 1622 Morse, Chicago, Illinois 60626. Jobbers Inquiries Invited.

**BLANK** High School Diploma and Birth Certificate, Only \$2.00. Kenlee, Dept. 2A4, 466 River Road, Bogota, New Jersey 07603.

**PROTECT** Your family! With simple will form. Two blank forms. Instructions only \$1.50 Guaranteed! Kenlee, Dept. 1A4, 466 River Road, Bogota, New Jersey 07603.

**NEVER WON ANYTHING?** Anyone Can Win Sweepstakes! Free details. Services, Box 644-PCD, Des Moines, Iowa 50303.

**12 TESTS \$4.00, I.Q.,** Personality, Character. Nocon, Box 183, Niles, Illinois 60648.

**LIFETIME** Social Security Plate 50¢. Perma-Plates, Box 4584, So. Daytona, Florida 32021.

**I.Q. TESTS** Selfscoring and accurate. Quick Delivery only \$2.00. G. Kelso, Jr. Co., Box 731, Sierra Madre, California 91024.

**BAD Credit?** Borrow cash you need. . . now!!! Use powerful little-known amazing method and get credit. Guaranteed. Free report. Continental-53, Niceville, Florida 32578.

**52 CERTIFICATES!!!** Birth, Marriage, Karate, Welder, Death, Cards:— I.D., registration, Driver, Student, Investigator, Diplomas:— High School, College, Technical, Medicine. Rushed airmail! Two—\$1.00, five—\$2.00. "Goldseal" versions one—\$1.00, five—\$4.00. Catalogue 25¢. Filforms, Box 1808-BN, Albany, New York 12201.

**ROACH** Killer \$1.00. Harmless to Humans and Animals. Lanceford Smith, 1842 North 2nd Street, Milwaukee, Wisconsin 53212.

**WIN** At "Blackjack" other Gambling Games. Write: Palmer Enterprises, Rural Route 3, Box 98, Clinton, Iowa 52732.

**FREE** World famous gift catalog. Lakeside, Box B11, Silver Lake, Minnesota 55381.

**EYEGLASSES** Slip? Unique Product installed in Seconds Solves the Problem. Send \$1.00 for Pair to "Grip," Box 417A, Jacksonville, Arkansas 72076.

**1001 THINGS YOU CAN GET FREE!** 64 Page Book. \$1.00. Gifts For Happiness (1A4), 3987 East 64th Street, Cleveland, Ohio 44105.

**WIN** At Horse Racing, my method is complicated but worth the price. Write: Palmer Enterprises, Rural Route 3, Box 98, Clinton, Iowa 52732.

**EMERGENCY** Highway Kit Plastic Pts. ers adhere to car windows. "Accident," "Blow Out", "Need Gas" "Mechanical Trouble". \$2.00 set. Guaranteed. Rojod Sales, Box 636, Santee, Calif. 92071 Dept. CD4

**PLAY** Chess By Mail! Cash Prizes! Details 50¢. Lindo, DPM, Box 691, No. Hollywood, Calif. 91603.

**ATTENTION CREATIVE INVENTORS!** citing New Ideas In A "Flash" With "Magic Spark" Idea Computer. Program Your Mind For New Products! 30 Component System In Case \$5.00. Or Send For Free Details. **BOB OLSON SYSTEM**, 205 Chisolm Trail Stagecoach Acres, Prescott, Arizona 86301.

**AUTOMATIC** Doggy Scoop—Litter touches bag only! \$6.95. Lawson's, 403-PD Harding, Lyndhurst, N.J. 07071.

**EYEGLASSES** wholesale—Free Catalog. A-Z Optical Company, Box 175, Dept. R2, Bay Station, Brooklyn, N.Y. 11235.

**FASCINATED** By Astrology, ESP, UFOS, Occult? Six Issues—\$2.95. Spaceview Magazine, 103-S Goodhue Building, Beaumont, Texas 77701.

**RINGS—65% OFF!!!** Diamond-Like! Lifetime Guaranteed! Home Trial. **FREE CATALOG . . .** Jaklagems, 2849-MPM Southport, Chicago 60657.

**BURGLAR ALARMS & HOME PROTECTION**

**CHAIN BURGLAR ALARM**, attach door or window. Loud, piercing alarm, crooks run. Postpaid \$3.50. Stauffer's, Box 1187, Salina, Kansas 67401.

**LOCKSMITHING** Supplies—Buyers Guide \$1.00. Despubs, Box 22005H, Phoenix, Arizona 85028.

**FREE** Catalog on Burglar-fire Alarm Equipment. Protecto Alarm Sales, Box 357-D, Birch Run, Michigan 48415.

**1973 BURGLAR & FIRE ALARM EQUIPMENT CATALOG, 62 PAGES, JUST \$1.00.** (Refunded With First Order). **K-TRONICS INDUSTRIES, BOX 391, DEPT. PM, FAIRFIELD, CONN. 06430.**

**SCARE BURGLARS AWAY!!** Authentic Alarm Decals. 4/\$1. —10/\$2. Andover Enterprises, 4729 Andover Square, Indianapolis, Indiana 46226.

**PROTECT** Family, Home! Authentic, illustrated manual explains how. Save, Do-It-Yourself. Guaranteed—\$2.50 P.P.D. Better Things, Box 24252-A, Lyndhurst, Ohio 44124.

**FIRE?! DON'T DIE!!** Protect your family. Compact fire alarm gives loud warning at 135°. Use anywhere! Just plug it in! \$9.95—Satisfaction guaranteed. Order now! **REGAL-GRIFFIN, Dept. A-211C, 10344 Pelham Street, Westchester, Ill. 60153.**

**SECRET** Equipment Protects You. Write: Breck, Box 2 946, Las Vegas, Nevada 89104.

**YOUR CLASSIFIED AD IN POPULAR MECHANICS** will be seen by more than 5,000,000 active buyers for your products and services.



New (A) Power Porting  
fuel/air flow couples with  
(B) normal cylinder charging.

## NEW POWER PORTING. MAKES MERC'S FASTER. NOT FATTER.

Direct from our competition proved racing winners—Power Porting. The secret? A port or hole in the skirt of each piston, and a matching passageway in the cylinder wall, which admits a secondary fuel/air charge (A) with increased efficiency. Combined with normal cylinder charging (B), this Power Porting “boost” gives Mercs even more power per cubic inch, per dollar, per gallon. And lets us build lighter, more compact outboards. Lean. Efficient. Economical. Power Porting did it all! Without any increase in pounds or displacement. Faster . . . not fatter. The Power Ported Mercs: 1500, 850 and 650.

Complete range of power: 4, 7.5, 9.8, 20, 40, 50, 65, 85, 115, 150 HP.  
For nearest Mercury Dealer, see the Yellow Pages under  
“Outboard Motors.” Mercury Marine/Division of Brunswick Corporation,  
Fond du Lac, Wisconsin/Canada/Australia/Belgium.

**MERCURY**  
OUTBOARDS

  
**THIS YEAR'S  
MERC'S SET NEXT  
YEAR'S STANDARDS.**

*Let's*  
**GO**  
**Boating**

*Share the fun of the great outdoors.  
Take a friend boating.*

Yes, longer yet milder

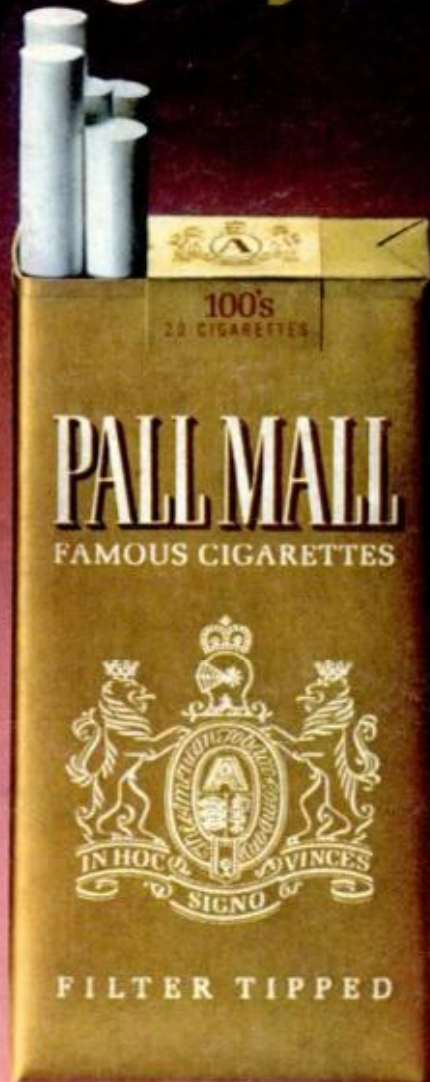

**PALL MALL**  
**GOLD 100's**

Longer length, milder taste

Warning: The Surgeon General Has Determined  
That Cigarette Smoking Is Dangerous to Your Health.

20 mg. "tar" 1.4 mg. nicotine av. per cigarette, FTC Report AUGUST '72.