

# Popular Mechanics

**AEROSOLS aren't  
for kids** Page 82

FEB. 1973  
50 CENTS

**Mini calculators—  
how to choose the right one** Page 86

**18 pages of new boats and gear** Page 106

**We show you how to make  
'expensive' frames for very little money** Page 73

Andrew Wyeth print: \$8  
Frame: \$17

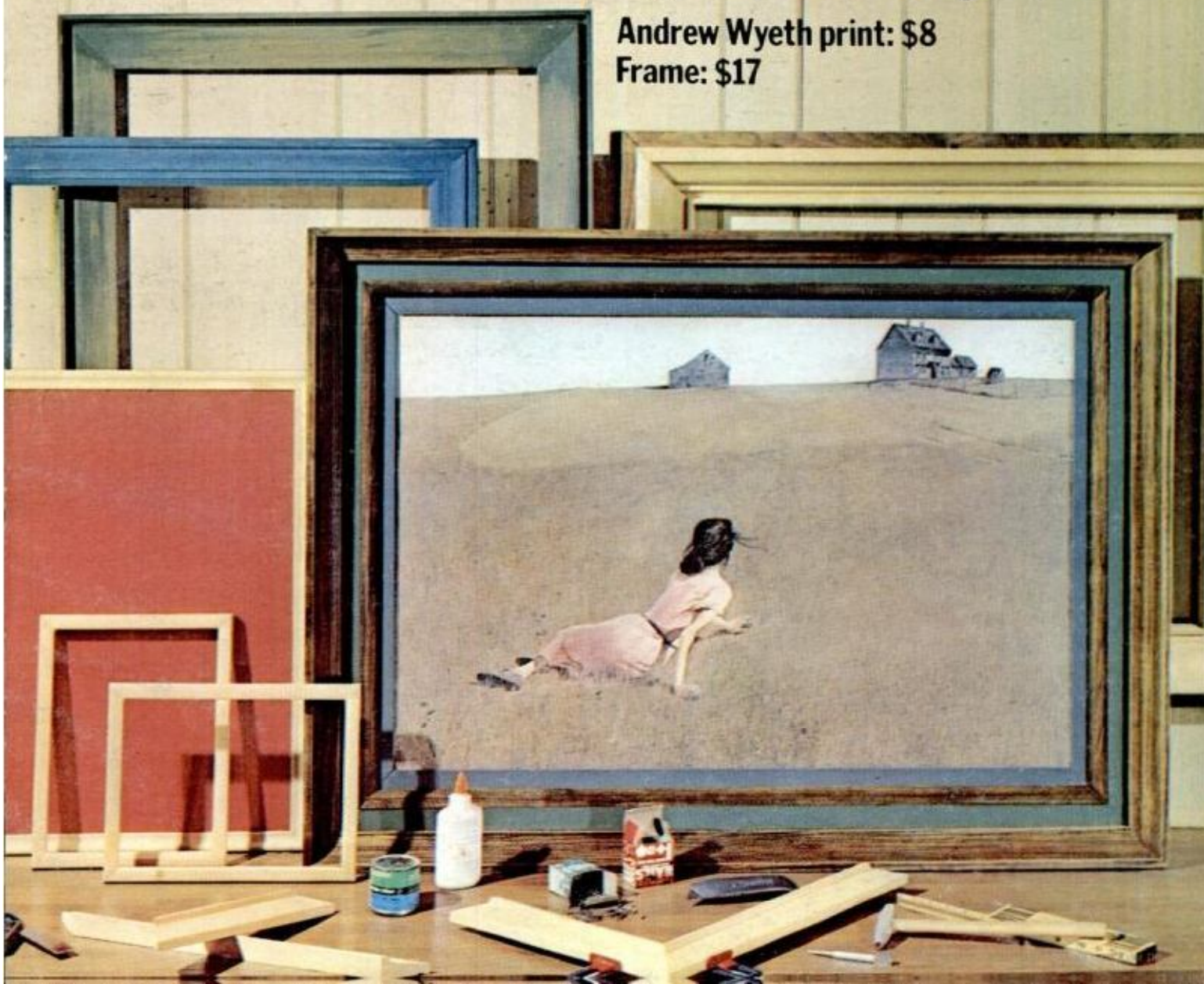



**Come to  
Marlboro Country.**



Warning: The Surgeon General Has Determined  
That Cigarette Smoking Is Dangerous to Your Health.

18 mg. "tar," 1.3 mg. nicotine av. per cigarette, FTC Report Aug. '72

Материал, защищенный авторскими правами

Two more reasons MerCruiser runs rings around all other stern drives

## MerCruiser 120 and 140. The fours that outrun competitive sixes.



When you think stern drive power, here's the place to start. The MerCruiser 120 and 140 stern drives are light and compact, but they'll give you all the full, free power on the water you would want.

Performance comparisons show why. On identical hulls the 140-horsepower MerCruiser outruns competitive 6-cylinder engines rated up to 170 HP . . . and uses less gas while it's at it.

Jet-Prop exhaust makes power quieter and more efficient. Power Trim puts you in command—dig in to snap skiers out of the water, then plane up and go. Check these standard features against any competitor. And these

MerCruiser safety features: an ignition switch that allows starting only in neutral, a flame-proof distributor.

If you want out-front performance—with a light and easy trailing boat—power up with a MerCruiser 120 or 140. Or, team up a pair to move out a medium-size cruiser. When you talk boats with your dealer, start with the stern. Start with the MerCruiser 120 or 140.



YFGQ-P57-PKSZ

**MERCUISER**  
STERN DRIVES

COMMAND POWER LINEUP FOR '73: 120, 140, 165, 188, 225, 255 HP. For nearest MerCruiser dealer, see the Yellow Pages under "Outboard Motors." Mercury Marine/Division of Brunswick Corporation, Fond du Lac, Wisconsin/Canada/Australia/Belgium

# Clean air: good reason to use a great oil.

Today's anti-pollution systems are making the temperature of your motor oil higher than ever before. And if your system isn't working properly, that makes it even tougher on your oil and your engine. Today you should name your oil. By type. By SAE Grade. By brand.

Briefly, here's what's happening.

When the PCV valve is working properly, your car's engine is running cleaner than ever. Blowby

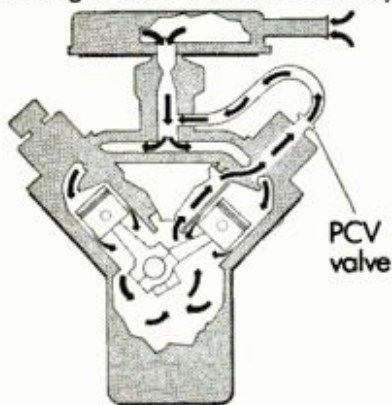

gasses that once seeped into the crankcase are recycled back to the combustion chamber. This not only keeps the air cleaner; it also keeps your oil cleaner.

**Keep your PCV Valve clean.** On the other hand, if the PCV valve gets clogged, combustion or blowby gasses are trapped in your crankcase and form damaging corrosive acids. What's more, today's engines must operate on a leaner fuel/air mixture than did engines in cars without anti-pollution devices. So today, your engine, and its motor oil, are operating under much higher temperatures.

**Other systems, more heat.** Today's improved combustion systems, supplemental air injection systems, lower compression ratios, air conditioning and power equipment are all "hot items." They put extra stresses on your engine that can send your motor oil's temperature over the 300° level.

**What heat can do to motor oil.** Heat is motor oil's number one enemy. Because, when heated, oil has a tendency to oxidize. Excessive oxidation causes oil to thicken—and not lubricate properly.



The newest service designation—see the chart—is "SE." It meets 1973 requirements and it's vitally important that you use it when recommended.

Then, especially these days, ask for the highest quality brand you can find. By name.

Old designation	New designation	Oil description
ML (Motor Light)	SA	Oil without additive, except that it may contain pour and/or foam depressant
MM (Motor Medium)	SB	Provides some antioxidant and antiscuff capabilities
1964 MS (Motor Severe)	SC	Oil meeting the 1964-67 requirements of the automobile manufacturers. Provides low-temperature antisludge and antirust performance
1968 MS (Motor Severe)	SD	Oil meeting the 1968-71 requirements of the automobile manufacturers. Provides greater low-temperature antisludge and antirust performance
1971-73 (none)	SE	Oil meeting the 1972-73 requirements of the automobile manufacturers. Provides high-temperature antioxidation, plus greater low-temperature antisludge and antirust performance.

**Remedy #1. Change oil frequently.** Consider your car manufacturer's oil change recommendations as absolute minimums—under ideal conditions. Take careful note of the warnings against severe operations—such as heavy loads, sustained high-speed driving, constant heavy traffic, dusty roads, and extra cold weather. You might not be changing your oil often enough.

**Remedy #2. Know your motor oils.** First ask for the service designations and viscosity recommended in your owner's manual.

**Why Quaker State offers quality protection:** Quaker State is refined from 100% Pure Pennsylvania Grade Crude Oil, the world's choicest. Then it's put through an elaborate refining process.

Finally, it's fortified with a blend of additives, scientifically selected to retard oxidation, clean and disperse harmful deposits and to neutralize acids.

So ask for it, by name: Quaker State.



**Quaker State your car to keep it running young.**

POPULAR MECHANICS

# Jeep<sup>®</sup> Wagoneer. Bound for the snow, not snowbound.



**It's the original snowmobile...and it's got luxury and comfort besides.**

With the Jeep Wagoneer, you don't have to head for the crowds. You can head for the fun, wherever it is. That's because it's got the most experienced 4-wheel drive ever made—Jeep 4-wheel drive. It can take you places that would stop ordinary family wagons cold.

The high ground clearance helps you skim through snow that hasn't seen a snowplow. The frame, of hot-rolled steel with five rugged cross-members, resists unseen rocks and ruts along the

way. And the Jeep engine packs the extra power you need to keep on moving.

There's an inside story, too, with plush seats for comfort. And a fully-padded instrument panel for safety, with new easy-to-read gauges for convenience. You can order just about any option, from air conditioning to a snowplow. With the Jeep Wagoneer, you're bound to have a good time.

**Toughest 4-letter word on wheels.**

**Jeep**

Buckle up for safety...drive your Jeep vehicle with care and keep America the Beautiful.

INTERNATIONAL EDITIONS  
AUSTRALIA • CARIBBEAN  
DENMARK • MEXICO • SWEDEN  
SOUTHERN HEMISPHERE

## HOW TO . . .

Get art at a price  
you can afford . . . 73



Select your new  
slide projector . . . 140



Pick an electronic  
calculator . . . 86



Take good care  
of your skis . . . 50



## AUTOMOBILES, DRIVING

- [24 Detroit Listening Post](#)
- [52 Imports and Motorsports](#)
- [78 Tomorrow: Tailgate](#)  
warning on the windshield
- [94 PM Owners Report:](#)  
Volvo 140 series
- [102 Can Detroit save the i-c](#)  
engine?
- [144 Saturday Mechanic: How to](#)  
stop an engine that  
won't stop

## SHOP AND CRAFTS

- [42B Setscrew chucks to make](#)
- [50J Hints from readers](#)
- [56 Hints from readers](#)
- [73 Good art at a price you](#)  
can afford
- [80 Lucite sculpturing](#)
- [98 One \(young\) man's shop](#)
- [148 Hints from readers](#)
- [160 Now: A plastic injector for](#)  
your drill press
- [162 Tiny steam engine](#)
- [164 A real drum table](#)
- [168 A \\$50 aquarium that's](#)  
really different

## PHOTOGRAPHY

- [46 Photo hints](#)
- [140 Slide projectors get](#)  
smarter all the time

## SPACE, AVIATION, MILITARY

- [91 Homebuilt aircraft:](#)  
Thorp's two-seater is a  
flying "Tiger"

## SCIENCE, INVENTIONS

- [82 Don't take chances with](#)  
aerosols!

ON THE COVER: Some of the 27 picture frames created in the PM Shop by our Workshop Editor for you to duplicate (see page 73). The framed reproduction in the photo is *Christina's World* by Andrew Wyeth, which is copyrighted by the Museum of Modern Art, New York. Cover photo by Robert D. Borst.

WORTH WRITING FOR: SEE PAGE 56C

AS A SERVICE TO READERS, Popular Mechanics publishes newsworthy products, techniques and scientific and technological developments. Because of possible variance in the quality and condition of materials and workmanship, Popular Mechanics cannot assume responsibility for proper application of techniques or proper and safe functioning of manufactured products or reader-built projects that result from plans published in this magazine.

## BOATING, OUTDOORS

- [50 Ski care now—and later](#)
- [106 New for 1973 waterways](#)
- [112 Gadgets for better boating](#)
- [114 This gas burner can go](#)  
electric
- [115 Canoe cart](#)
- [116 So you want to build](#)  
your own boat
- [120 Boat that always floats](#)
- [122 Hoist your hull on air](#)
- [123 For cartopping—here's](#)  
the catch

## HOME AND YARD

- [100 Flower garden on your wall](#)
- [152 How to replace a broken](#)  
window pane
- [154 How to add a new](#)  
convenience outlet
- [156 How to unclog drains and](#)  
stop leaks
- [158 How to trim and plane](#)  
sticking doors

## ELECTRONICS, RADIO, TV

- [86 Electronic calculators:](#)  
Choosing the right one
- [124 Short course in antennas](#)  
for shortwave listening

## EVERY MONTH

- [8 Letters](#)
- [20 All Outdoors](#)
- [28 Science Worldwide](#)
- [32 Appliance Clinic](#)
- [62 The Bicycle Shop](#)
- [66 Homeowners' Clinic](#)
- [69 Automobile Clinic](#)
- [128 It's New NOW: The latest](#)  
products and developments  
(A 12-page roundup)

# Is tomorrow the morning you break the double-edge habit?

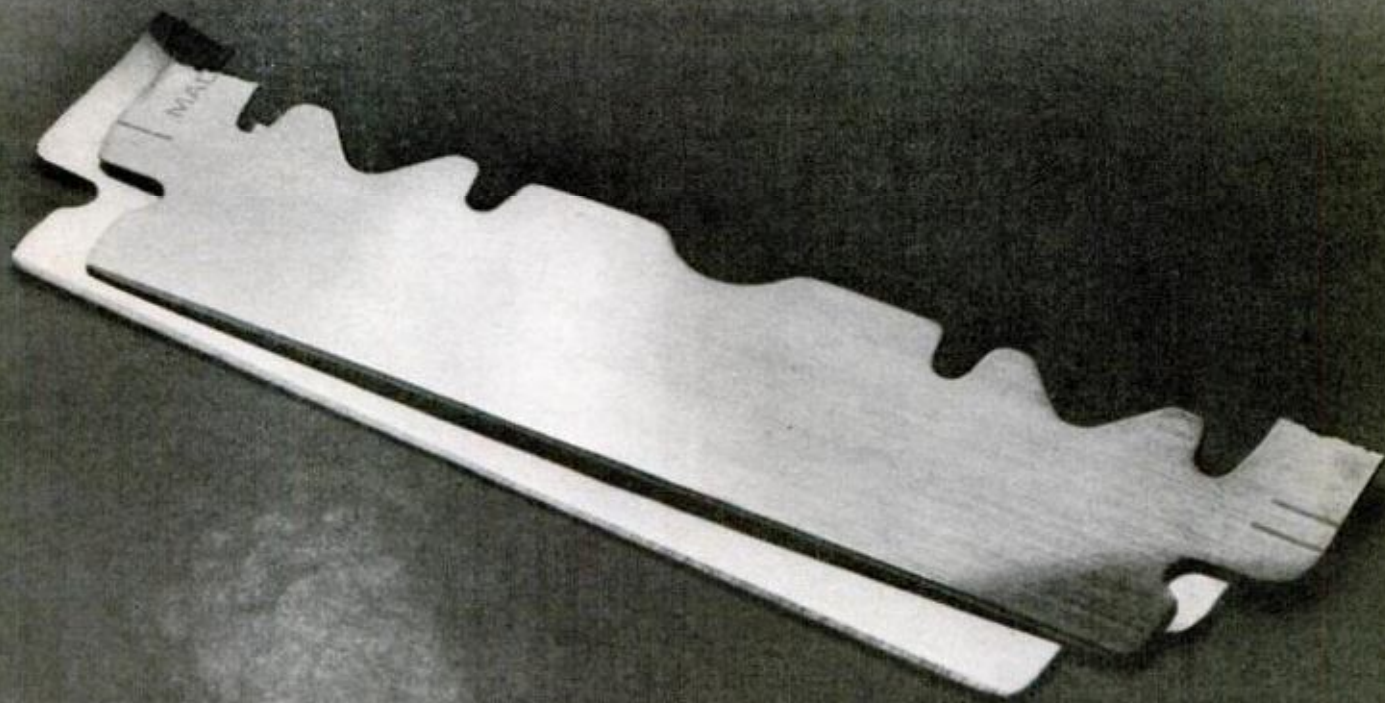

©Schick Safety Razor Co., Div. Warner-Lambert Co.

Is tomorrow the morning when you stop to think: What good is a double edge if you can only shave with one edge at a time?

Schick's put both edges on your side. In the Schick Super II twin blade shaving system. With two Super Chromium blades locked in a replaceable cartridge.

What one blade might miss, the other one gets.

The new Schick Super II. It's enough to make you break an old habit.



Put both edges on your side.  
**Schick Super II**

# MEET ARIENS 7 MEMBER ENVIRONMENTAL TRAC-TEAM

7 HP  
power  
source

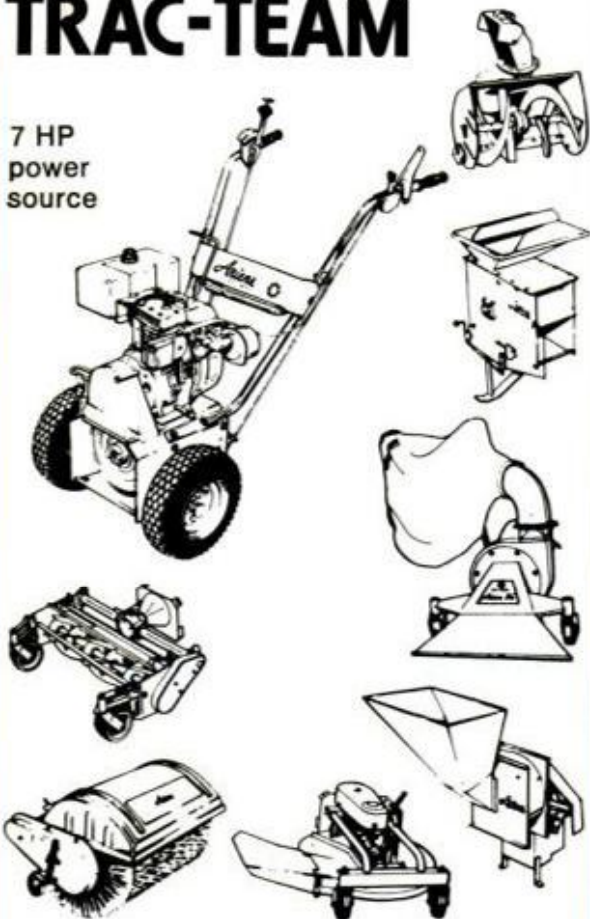

The Ariens Environmental Trac-Team is a single 5 HP or 7 HP power source to which attachments can be added. Seven attachments, namely, a 26" Rotary Mower, 30" Reel Mower, 24" Sno-Thro, 30" Lawn Vacuum, 36" Brush-Sweeper, Shredder-Bagger and a Shredder-Grinder can be added to the 7 HP tractor. A 30" Reel Mower, 20" Sno-Thro and a Shredder-Bagger can be added to the 5 HP tractor.

The Ariens, Four-Season, Environmental Trac-Team offers the ecology minded person an opportunity to start building a year 'round GARD-N-YARD® working team. Write for complete line catalog today.

Ariens Company, 806 West Ryan  
Brillion, Wisconsin, 54110  
Phone 1 (414) 756-2141



Applies to mowers only

A CUT ABOVE THE REST!

# Ariens

**JIM LISTON**

Editor

**SHELDON M. GALLAGER** **JOHN A. LINKLETTER**

Executive Editor

Managing Editor

**WAYNE C. LECKEY**

Home and Shop Editor

**ALVIN KIETZ**

Art Director

Published by The Hearst Corporation

**RICHARD E. BERLIN, PRESIDENT**

**RICHARD E. DEEMS**

President, Magazines Division

**JOSEPH F. KERN**

Publisher

**BILL HARTFORD** \_\_\_\_\_ Automotive  
**JOHN F. PEARSON** \_\_\_\_\_ Science and Engineering  
**WM. T. McKEOWN** \_\_\_\_\_ Boating and Outdoors  
**IVAN BERGER** \_\_\_\_\_ Electronics and Photography  
**HARRY WICKS** \_\_\_\_\_ Home Workshop  
**MICHAEL LAMM** \_\_\_\_\_ West Coast  
**ROBERT LUND** \_\_\_\_\_ Detroit Automotive  
**GARRY WINTER** \_\_\_\_\_ Copy Chief  
**RICHARD H. FUNK** \_\_\_\_\_ Production  
**ALFREDO VEGA** \_\_\_\_\_ Assistant Production  
**DON EVANS** \_\_\_\_\_ Technical Art Director  
**FRED A. LEERS** \_\_\_\_\_ Assistant Art Director  
**JOSEPH P. BEATON** \_\_\_\_\_ Assistant Art Director  
**DAVID KOMITAU** \_\_\_\_\_ Assistant Art Director  
**CLIFFORD B. HICKS** \_\_\_\_\_ Special Projects  
**SOPHIE GRONOWICZ** \_\_\_\_\_ Director, Bureau of Information  
**EVERETT JOHNSON** \_\_\_\_\_ Cabinetmaker

**ADDRESS ALL EDITORIAL COMMUNICATIONS TO:** 224 West 57th St., New York, N.Y. 10019. For additional sources of information on the articles and products in this issue, write to Bureau of Information, Popular Mechanics, for free "Where-to-Find-It" list.

**DANIEL J. COLEMAN**

Director of Advertising

**ADVERTISING OFFICES:** New York: 224 West 57th St., 765-6850; Chicago: 520 N. Michigan Ave., 527-2400; Detroit: General Motors Bldg., TRinity 5-8711; Cleveland: 20310 Chagrin Blvd., Shaker Heights, 283-7788; Los Angeles: 601 North Vermont Ave., 666-6263.

**JOHN A. REGINA** \_\_\_\_\_ Advertising Production Manager

**SUBSCRIPTION SERVICE:** Mail all subscription orders, changes of address, correspondence concerning subscriptions, and Postmaster notices of undeliverable copies to Popular Mechanics, Box 646, New York, N.Y. 10019. Please enclose your latest address label for quickest service when writing about your subscription.

**POPULAR MECHANICS IS PUBLISHED MONTHLY** by The Hearst Corporation, 57th St. at 8th Ave., New York, N.Y. 10019, U.S.A. Richard E. Berlin, President; Richard E. Deems, President of Magazines; John R. Miller, Executive V-Pres. of Magazines; Raymond J. Petersen, Senior V-Pres. of Magazines; William S. Campbell, V-Pres. of Magazines; Albert A. Rachol, V-Pres. and Director of Circulation; Joseph F. Kern, V-Pres. for Popular Mechanics, Frank Massi, Executive V-Pres. and Treasurer; Harvey L. Lipton, Secy. Single copy in the United States and Canada, 50 cents. Subscription prices: United States and Possessions \$5.00 for one year; \$9.00 for two years; \$12.00 for three years. Canada, add \$2.00 for each year. All other countries, add \$4.00 for each year. When changing address, give old address as well as the new, with postal-zone number, if any, and allow six weeks for change to become effective. Second-class postage paid at New York, N.Y., and at additional mailing offices. Authorized as second-class mail by the Post Office Department, Ottawa, and for payment of postage in cash. Registered as second-class matter at the Post Office at Mexico D.F., Mexico, June 20, 1950. © 1973 by The Hearst Corporation. All rights reserved. Printed in U.S.A.

**POPULAR MECHANICS**



# Have you seen this coupon before?

© 1972 LaSalle Extension University - A Correspondence Institution

## MAIL THIS HANDY POSTAGE-PAID COUPON-ENVELOPE

Cut coupon along dotted lines, fill in your name and address . . . fold, seal (tape, paste or staple) and mail. No stamp or envelope is necessary.

Please rush me, without obligation, FREE booklet on the field I have checked:

- |   |  |  |  |   |
|---|--|--|--|---|
| <p><b>ACCOUNTING</b></p> <input type="checkbox"/> Complete Accounting<br><input type="checkbox"/> Income Tax<br><input type="checkbox"/> CPA Training<br><input type="checkbox"/> Bookkeeping | <p><b>COMPUTER PROGRAMMING</b></p> <input type="checkbox"/> Basic Training   | <p><b>AIR CONDITIONING &amp; REFRIGERATION</b></p> <input type="checkbox"/> Basic Training | <p><b>LAW COURSES</b></p> <input type="checkbox"/> Bachelor of Laws Degree<br><input type="checkbox"/> Business Law<br><input type="checkbox"/> Claim Adjusting Law<br><input type="checkbox"/> Law for Police Officers<br><small>No state accepts any law home study course, including LaSalle's, as sufficient education to qualify for admission to practice law.</small> | <p><b>MOTEL/HOTEL MANAGEMENT</b></p> <input type="checkbox"/> Motel Management<br><input type="checkbox"/> Hotel Management |
| <p><b>BUSINESS MANAGEMENT</b></p> <input type="checkbox"/> Management Training  | <p><b>DRAFTING</b></p> <input type="checkbox"/> Complete Training  | <p><b>INTERIOR DECORATING</b></p> <input type="checkbox"/> Complete Training               |  | <p><b>RESTAURANT MANAGEMENT</b></p> <input type="checkbox"/> Management Training  |
| <p><b>REAL ESTATE</b></p> <input type="checkbox"/> Complete Real Estate<br><input type="checkbox"/> Real Estate Brokerage   | <p><b>DIESEL MECHANICS</b></p> <input type="checkbox"/> Basic Training   | <p><b>DENTAL OFFICE ASSISTANT</b></p> <input type="checkbox"/> Complete Training           |  | <p><b>WRITING</b></p> <input type="checkbox"/> Fiction<br><input type="checkbox"/> Non-Fiction                              |
| <p><b>TRAFFIC &amp; TRANSPORTATION</b></p> <input type="checkbox"/> Complete Training   | <p><b>LANGUAGE INSTRUCTION</b></p> <input type="checkbox"/> French <input type="checkbox"/> Spanish                              | <p><b>ART TRAINING</b></p> <input type="checkbox"/> Complete Training                      |  | <p><b>HIGH SCHOOL</b></p> <input type="checkbox"/> High School Diploma  |
| <p><b>AUTOMOTIVE MECHANICS</b></p> <input type="checkbox"/> Basic Training  | <p><b>MUSIC INSTRUCTION</b></p> <input type="checkbox"/> Piano <input type="checkbox"/> Guitar<br><input type="checkbox"/> Other | <p><b>STENOTYPE</b></p> <input type="checkbox"/> Machine Shorthand                         |  |   |

Print Name ..... Age .....

Address ..... Apt. No. ....

City & State ..... Zip .....

46D FOLD HERE ↓ (DO NOT CUT) SEAL AND MAIL TODAY - NO STAMP NEEDED. 7

FIRST CLASS  
PERMIT NO. 27  
CHICAGO, ILL.

BUSINESS REPLY MAIL

No postage stamp required if mailed in the United States

Postage will be paid by

**LA SALLE EXTENSION UNIVERSITY**  
*A Correspondence Institution*  
**417 S. DEARBORN STREET**  
**CHICAGO, ILLINOIS 60605**



It has helped to start many men and women on the road to higher pay.

Just looking at it won't get you anything . . . but putting it in the mail may change your whole future!

The LaSalle coupon is one of the most often-seen coupons in America. To many who have mailed it, it has proved a first step to opportunity and good fortune.

If your goals are bigger pay and more frequent promotion, you owe it to yourself to find out without delay, what LaSalle home study can do for you. LaSalle gives you modern, comprehensive instruction in many well-paid, fast-growing fields where there is a continuing demand for trained personnel. You learn at home; lessons come to you by mail. You are a class of one. For more than sixty years, LaSalle has been a leader in home study. It has a large staff of experi-

enced instructors. The cost of training is low. A LaSalle diploma is a respected credential. *You should act now.* LaSalle training may make a big difference in your future. One student reports: "I received a \$2,000 yearly increase since enrollment with LaSalle. My regret is that I didn't enroll before." Many letters like this come to LaSalle. Get full information now on the field that interests you. Mail postpaid coupon above to LaSalle, 417 S. Dearborn St., Chicago, Illinois 60605.

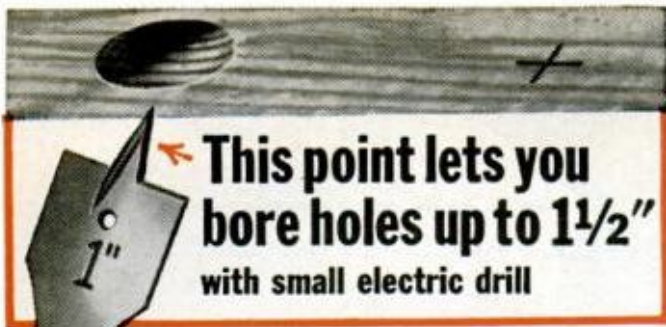

**This point lets you bore holes up to 1½" with small electric drill**

**IT'S HOLLOW GROUND** to bore cleaner, faster at any angle

Now step-up the boring range of your small electric drill or drill press to 1½" with Irwin Speedbor "88" wood bits. ¼" shank chucks perfectly. No wobble. No run-out. Sharp cutting edges on exclusive hollow ground point start holes faster, let spade type cutters bore up to 5 times faster. You get clean, accurate holes in any wood at any cutting angle.

Each Irwin Speedbor "88" forged from single bar of finest tool steel. Each machine-sharpened and heat tempered full length for long life. 17 sizes, ¼" to 1½", and sets. See your Irwin hardware or building supply dealer soon.

**\$.98 each** ¼" to ⅜"    **\$1.10 each** ⅜" to 7/8"    **\$1.15 each** 1⅜" to 1"    **\$1.70 each** 1½" to 1½"

**IRWIN SPEEDBOR "88" WOOD BITS**  
at Wilmington, Ohio 45177, since 1885



**MFG**

# Challenger 12

Pressure molded fiber glass tri-hull

BIA CERTIFIED

**\$199.00**\*

**Challenger 14**

**\$229.00**\*

F.O.B. FACTORY

- ROD HOLDERS
- INSULATED BAIT WELL
- TRANSOM DRAIN
- FOAM FLOTATION

White or Hunter Green

**SEE YOUR MFG DEALER**

MFG BOAT CO., UNION CITY, PA.

World's largest producer of fiber glass boats

# LETTERS

TO THE EDITOR

## Something fishy about the fluke

On the cover of your November issue you have pictures of whales sculptured in wood. The sculptor made one major goof. Fish have vertical tails, and whales have horizontal flukes. The whales on the cover have vertical flukes.

HOLLIDAY, MO.

MARK WILSDORF

*We call that artistic license, Mark.*

## Two-way static

*Two-way radio—tool or toy?* (page 120, Dec. PM) had a few errors in it.

Channel 9—not 19—is the official Citizens Band emergency channel. Before a CBER commences transmission, he should be aware of this and of whatever other channels may be monitored in his community and should commit those channels to memory.

Also, Class D licenses were authorized by Congress in 1958, and service commenced immediately (the article said 1965).

Any person desiring to become a CBER or renew his license may write us, as we have a substantial quantity of the required forms on hand.

MOTIVATION COMMUNICATIONS

88 BALLANTYNE ROAD

D. MOSKOWITZ

ROCHESTER, N.Y. 14623

*There were several mentions of emergency Channel 9 in the article and only one with the erroneous figure 19. Unfortunately, the wrong one turned out to be the most prominent.*

## Big wheels

I came from the Isle of Man and have seen the *Big wheel* (page 15, Dec. PM) pump water out of the lead and silver mines in Laxey. My father told me that the wheel was designed by a Manxman, Robert Casement. Its name is *Lady Isabella*.

FRANKLIN, IDAHO

GEORGE E. MYLROIE

We didn't match that water wheel in overall diameter, but we went three better

*(Please turn to page 10)*

RICHARD PETTY says:

# “If you want to really learn how to repair cars... check out NRI home training”

“NRI provides the most up-to-date complete course in Auto Mechanics I've ever seen.”

“My dad made auto mechanics out of us long before he'd let us enter a race. I know the importance of a good mechanic... and the opportunities that are out there for men with the right training. That's why I'm sure glad to see home training like the NRI courses come along. With NRI training behind you, when you open that hood, hands-on experience is going to come fast, and come right. It's a lot of training for a very few bucks.”

Earn \$5 to \$7 an hour in your spare time.

As a trained mechanic you can command good money working for yourself or doing spare time jobs. And you'll save a lot on your own car upkeep. NRI gives you a choice of a complete Master Automotive Technician course or a shorter Automotive Tune-up and Electrical Systems training program. Both courses give you the essential training and diagnostic equipment you need for good car repairs. No other school gives you as much training and equipment for your money.



**APPROVED UNDER GI BILL**

If you have served since January 31, 1955, or are in service now, check GI line in the coupon.

You will especially like the bite-size lesson texts, and how NRI has programmed shopwork into them. You can learn with your hands, lesson by lesson, at your own speed. Your NRI instructor carefully hand grades each test and returns it to you with his suggestions. You get more personalized attention than you'd get in lots of classrooms. And you learn the “why” as well as the “how to”... from changing plugs to running your own garage.

FEBRUARY 1973



Richard Petty, America's Winningest Stock Car Racer

All the equipment and training you need.

In the Master Course, you receive ten pieces of auto service equipment, including a dwell-tachometer, timing light, complete set of tools, a volt-amp tester, an ignition-analyzer and assorted gauges. Tune-Up home training includes eight important service items. You pay nothing extra for the professional tools and equipment, and they're yours to keep.

Train with the leader—NRI.

Richard Petty says: “I'm a great believer in being number one. That's why I look to the school that's out in front. And no other school has NRI's experience in home training with professionally developed educational kits. They've graduated hundreds of thousands of students.” Mail the coupon and learn how you can keep your present job while training in your spare time. **NRI AUTOMOTIVE DIVISION, Washington, D. C. 20016**  
**NO SALESMAN WILL CALL.**

SEND FOR **FREE**  
NRI CATALOG



**NRI TRAINING**

3939 Wisconsin Avenue, N.W.  
Washington, D.C. 20016



946-023

Please send me your new Automotive Mechanics catalog. I understand there is no obligation. **NO SALESMAN WILL CALL.**

I am interested in  Master course  Tune-Up course

Name \_\_\_\_\_ Age \_\_\_\_\_

Address \_\_\_\_\_

City \_\_\_\_\_ State \_\_\_\_\_ Zip \_\_\_\_\_

Send me facts on GI Bill.

**ACCREDITED MEMBER NATIONAL HOME STUDY COUNCIL**

## LETTERS

(Continued from page 8)

in quantity. Four 68-foot-diameter tailing wheels went into operation in 1912 at the Kennedy Mine in the Mother Lode of California. They continued until 1942. Of the original four, two are still standing and are now classified as historical monuments, a tribute to the pioneers of the West.

WEST SACRAMENTO, CALIF. LEE A. HUNT

### Pilbara's 1500 years of iron

Now I am confused! In your very interesting account of the *World's mightiest iron mine* (page 90, Nov. PM) is the forecast that "still unexplored regions of the vast Pilbara are expected to yield additional reserves sufficient to keep man in steel for another 1500 years!"

In the best-seller, *The Limits to Growth*, among other alarming conclusions of the present pattern of exponential growth there is a potential conclusion respecting iron, that presently known reserves, used at present consumption, have a possible short life of 93 years.

Further, the same index of consumption projected by an optimistic margin of five times known reserves, will last 173 years.

Author Richard Dunlop should be more respectful of basic facts than evidenced in an otherwise fascinating story. I lean more to the MIT boys in sounding a basic alarm.

INDIANAPOLIS, IND. WALTER L. SHIRLEY

"I can't blame Mr. Shirley for being confused," comments author Dunlop. "Until I went to Western Australia, I would have joined him in responding in alarm to the MIT iron-ore projections, but fortunately their researchers were apparently not familiar with the vast iron ore discoveries in the Pilbara.

"Today the world uses 600 million tons of iron ore a year. In 10 years' time it may use 1200 million tons, and it is possible that the consumption of iron ore may double every 10 years after that. Given the world's energy and environmental problems, this is not likely to be the case, but let us assume that these problems may be either exaggerated or solutions to them may be found.

"The reserves of iron ore in the Pilbara are estimated by competent authorities to be an incredible 125,000,000 million tons.

Simple arithmetic would indicate that I was extremely conservative in my statement concerning these reserves. Obviously they can more than satisfy even the most unlikely expansion of the iron and steel industry for far more than 1500 years."

### Forget that can opener

A Photo Hint in the November issue (page 15) suggests making a film tank agitator from an electric can opener. Don't do it! Any periodic motion, whether tilting or twisting, will produce standing waves of heavier products in the developer and cause unequal development.

The most reliable agitation for a small tank is to pick it up once a minute and give it a combined twisting and tilting motion for three or four seconds.

DANVERS, MASS.

WILLARD ALLPHIN

### That 'bullet-nosed beauty'

They've finally built the airplane of my dreams, I thought when I saw *BD-5: Bullet-nosed beauty* (page 174, Nov. PM). But a closer look at the specs revealed a problem which I feel is misleading.

The aircraft is said to have a range of 1000 miles at 50 mpg, hence a 20-gallon fuel tank. It also professes a useful load of 290 pounds.

With a full tank of gas, the pilot can weigh a maximum of 170 pounds. I know you say that the fuel supply can be reduced to compensate for a heavier pilot or baggage, but what happens to that lovely 1000-mile range?

Don't get the idea, though, that I'm down on the BD-5. I fully intend to build one myself.

SOLEDAD, CALIF.

DANIEL R. PIETZ

Kiekhaefer Aeromarine Motors, Inc., is not "a division of the firm in Fond du Lac, Wis., that developed the Mercury outboard engine." It is not a division of any other company or corporation.

Our president, E. C. Kiekhaefer, was the founder of Kiekhaefer Corp. (now called Mercury Marine) and was president for 31 years, until his resignation in 1970. After resignation, he started a completely new endeavor, Kiekhaefer Aeromarine Motors, Inc. Work was started on a two-cycle, air-cooled engine that would be suitable for snowmobile, ATV, ACV and other small, recreation-type vehicles. The result

(Please turn to page 12)

# The secret of teaching yourself music

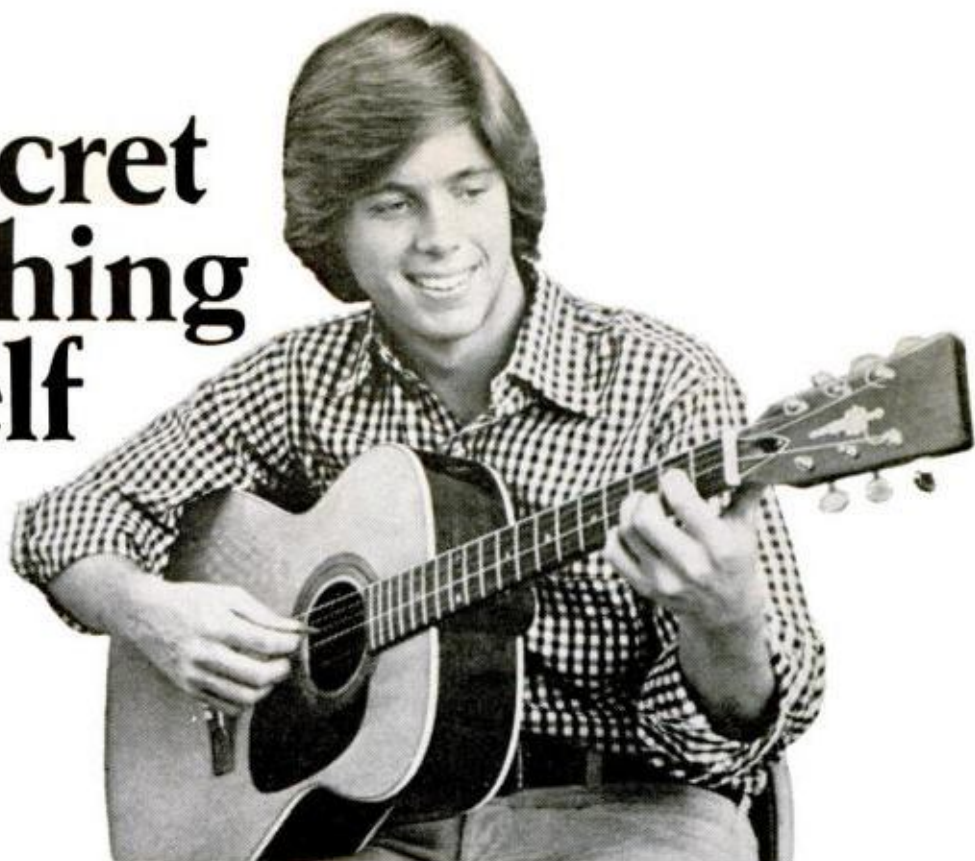

It may seem odd at first—the idea of teaching yourself music. You might think you need a private teacher at \$4 to \$10 an hour to stand beside you and explain everything you should do—and to tell you when you've made a mistake.

But, the fact is, you don't. Thousands have taught themselves to play with the lessons we give by mail. And you can too. Guitar, piano, accordion—you can learn any of several popular instruments.

The secret lies in the step-by-step way our lessons teach you. Starting right from scratch, they show you with simple words and pictures exactly what to do. You'll learn to play the right way—by note, from sheet music. Without any gimmickry.

But how do you know you're doing it right? Easy. A lot of the tunes you'll practice first

are simple songs you've heard many times. Since you know how they're supposed to sound, you can tell right away when you've "got them right."

By the time you go on to more advanced pieces, you'll be able to tell if your notes and timing are right, even without being familiar with the songs. Sooner than you may think, you'll be able to play whatever kind of music you like. Popular. Classical. Folk music. Hymns.

If you're 17 or over and would like more information, just mail the coupon. We'll send you our free booklet, *Be Your Own Music Teacher* and a free Piano "Note-Finder." No obligation.

## U. S. School of Music.

A HOME STUDY SCHOOL SINCE 1898.

LICENSED BY N. Y. STATE

©1972 U. S. SCHOOL OF MUSIC

### Be your own music teacher

Several courses available. Learn the guitar, piano, organ, accordion or other instrument for just pennies a day.



**U. S. School of Music, Studio A302**  
Port Washington, New York 11050

I'm interested in learning to play the instrument checked below. Please send me, FREE, your illustrated booklet *Be Your Own Music Teacher*. Also include your free Piano "Note-Finder." I am under no obligation. The instrument I would like to play (*check only one*):

- |  |   |                                    |
|--|---|------------------------------------|
| <input type="checkbox"/> Piano               | <input type="checkbox"/> Spinnet Organ<br>(2 keyboards) | <input type="checkbox"/> Violin    |
| <input type="checkbox"/> Guitar (pick style) | <input type="checkbox"/> Saxophone                      | <input type="checkbox"/> Accordion |

Mr. \_\_\_\_\_ Age \_\_\_\_\_  
Mrs. \_\_\_\_\_ PRINT NAME (17 OR OVER)  
Miss \_\_\_\_\_

Address \_\_\_\_\_

City \_\_\_\_\_ State \_\_\_\_\_ Zip \_\_\_\_\_

Do you have an instrument? Yes  No   
Instruments, if needed, supplied to our students on convenient terms.  
Accredited Member National Home Study Council

## LETTERS

*(Continued from page 10)*

was the Kiekhaefer 440 engine, perhaps the most thoroughly engineered and tested snowmobile-type engine built in the world. It went into production in 1971.

There was no "delivery snag" in producing the engine for the BD-5. There was no time allowed for what we consider to be essential and vital testing of a man-carrying aircraft and its components.

Our decision to reject the Bede Aircraft engine order in no way indicates a lack of interest by our company in the experimental aircraft market. Our engines are currently being flight tested in several applications.

KIEKHAEFER AEROMARINE D. V. THOMPSON  
MOTORS, INC. DIRECTOR OF  
FOND DU LAC, WIS. MARKETING

### No pump

We are sorry to say this company does not sell a "two-piston open-type pump" even though we were given as a source in *How to build an air compressor for \$70* (page 140, June PM).

CANADIAN TIRE CORP. R. W. ROSE  
TORONTO, ONT.

*We regret that Canadian Tire Corp. was erroneously listed as one of the two sources for that pump.*

### Five tons, not 10

The *Hand-operated arbor press* (page 154, Sept. PM) is well designed, but the text indicating a 10-ton work capacity is perhaps an overstatement. A quick engineering stress check shows that at 10 tons, excessive stress levels occur. Sheared-off pivot pins and elongated holes could be expected. Anyone planning to operate the press at this level should plan on beefing up the design. Operating up to five tons would be the limit for the design shown.  
LOS ALTOS, CALIF. J. H. McVERNON

*An engineering study commissioned by PM indicates your figures are correct. "In order for this press to operate at 10 tons capacity," it states, "the following changes in design must be accomplished:*

1.  $1\frac{3}{16}$ -in.-diameter pins in lieu of  $\frac{5}{8}$ -in.-diameter pins;
2. Tie rod walls are to be  $\frac{1}{2}$  in. thick in lieu of  $\frac{1}{4}$  in.

### Surform sculpturing

I was impressed with *Now Surform makes anyone a sculptor* (page 81, Nov. PM). Surform tools play an important part in the training programs set up by the National Carvers Museum. A handicapped person is unable to use the normal inventory of carving tools without danger of injury, so he resorts to other means to shape wood. Thus, Surform is playing an important part in the rehabilitation of seriously handicapped persons.

ELIOT, ME.

WAYNE ERVIN

Thank you for the fine article. Among your subscribers, do you have any whittlers in Ohio?

NORTH OLMSSTEAD, OHIO FRANKLIN SMITH

*Yes. The best way to get in touch with fellow whittlers is through these two organizations: Stephen E. LePage, National Publicity Director, National Carvers Museum, Box C, Monument, Colo. 81032, and Edward F. Gallenstein, Editor, National Wood Carvers Assn., 7424 Miami Ave., Cincinnati, Ohio 45243.*

The latest book by John Matthews, *Sculpture With Surform Tools*, is not being handled by St. Martin's Press. They handle all other books by Matthews, but not the latest.

WHITESTONE, N.Y.

T. J. McCARTHY

*At the time PM went to press, the editors at St. Martin's Press were sure they would be handling the new book. However, according to a spokesman, they "were not able to get together with the British publisher." Inquiries about Matthews' new book should go to Edward Arnold Ltd., 41 Maddox St., London, England.*

### Who has Volume 3?

I was very disappointed to learn that I cannot replace Volume 3 of *The Home Handyman Encyclopedia* because it's out of print. I would appreciate any suggestions you have for getting a copy of this volume.

READING, MASS.

STEPHEN BRYLINSKY

*Any reader who has a copy to spare may write to Mr. Brylinsky, c/o Letters to the Editor. And don't forget, we do have in print the newer 16-volume Do-It-Yourself Encyclopedia for \$52.35.* ★ ★ ★



**FINE QUALITY, COLORFUL, CLOTH PATCHES**  
 Only 75¢ Each—Special Price, 5 for \$3.00  
 Dazzling color, silk-like embroidered emblems. Permanent color, completely washable. Wear on jackets, shirts, pants, jeans, vests, etc. Durable. All about 3". Order by number under each emblem. 75¢ each. Bargain price, 5 for \$3.00.

**Pocket Radio & Transmitter**  
 Broadcast talking, music, etc. over regular AM band. Also receive all AM radio stations. Complete with speaker & microphone. Wired, just connect & use. Also use as walkie-talker, intercom, detectorphone to monitor sounds in remote places, etc. **Surplus bargains!** (See \$30.00) 6258. Each \$2.95 Postpaid... 2 for \$5.75

**Psychic Light**  
 Gives objects, posters, rooms that "turned on" eerie, psychedelic black light effect. 40 watt, 110 volt long lasting bulb. Fits any socket. Flasher makes light blink every few seconds. 6369. Pay-Lite (13 or more 75¢ ea.) 30¢ ea. 6112. Flasher..... 65¢

**Flying Helicopter**  
 Goes Over 100' High! Only \$1.50  
 Flying authentic replica of helicopter used by armed forces. Giant 16" wingspan. Goes over 100 feet high. High impact plastic. Unlimited life. 2065. Flying Helicopter..... \$1.50

**POCKET RADIO**  
 Midget self-powered radio with full range dial tuner. Ready to operate. Nothing to plug in. No batteries. Plays forever at no cost. Listen in bed, school, all most anywhere. Privacy guaranteed. Price includes. Size of cigarette package 3 1/2 x 2 1/2". 6098. Pocket Radio..... \$1.95

**SECRET BOOK SAFE**  
 Looks like attractively bound book, but opens to reveal combination lock safe. Keep valuable papers, jewelry, money, etc. hidden away. 4 x 6 x 1 1/2". 4012. Price Postpaid..... \$1.25

**Stop Watch 98c**

IMPORT BARGAIN—WHOLE TUNE LAST. IDEA STOP WATCH. Excellent split-second timer for non-professional events such as model races, sports, etc. Full pocket-watch size with chain link. Spring operated. Start and stop button. Sweep hand. Calibrated dial. Made to sell for much more. 2029. Stop Watch..... 98¢

**Hearing Aid**  
 7006. Air Cushion Haver Craft..... \$9.95

**SURPLUS MILITARY EMBLEMS**  
 7003. Military Emblems..... \$1.25

**10" THROWING KNIFE**  
 7003. Military Emblems..... \$1.25

**CANNON**  
 REALLY SHOTS! Replica 24-pound Royal Cannon. Fourth of July noisemaker. Starting gun, etc. Ruggedly built, metal, chrome and black. 900A—\$2.50 each (2 for \$4.50) 906A Ammo-80 Shots 75¢ 13 Item \$2.

**Learn Self Defense**  
 50¢  
 1265. 50 Tricks of Self Defense..... 50¢  
 1056. Mighty Muscle Course..... 50¢  
 1271. How to Box..... 50¢  
 1286. Police Jiu-Jitsu..... 50¢  
 1284. Combat Judo..... 50¢  
 1287. Professional Wrestling Methods 50¢

**Electric Laughing Bag**  
 Roars with Laughter! Happy, hysterical, or surprising. Battery operated. Laughs indefinitely. 3070. \$3.95

**Air Car**  
 Rides On Air!  
 New AIR CAR slides like magic above table tops, floors, sidewalks, EVEN WATER!  
 7006. Air Cushion Haver Craft..... \$9.95

**BLACK FOREST CUCKOO CLOCK**  
 Cuckoo every 15 minutes. Genuine import from the Black Forest of Germany. Beautifully made in authentic design. Chime bird and loud cuckoo. With weight and adjustable pendulum for accurate time keeping. About 14" overall. 6117. German Cuckoo Clock..... \$9.95

**2-Way Citizens' Band Radio**  
 Only \$21.95  
 Listen, talk on 23 citizens band channels.  
 Send to and receive from other stations and walkie-talkies. Highest quality superheterodyne receiver. Over 50 mw of audio output for most sensitive, loud, clear reception. Self-contained, extra long life battery supply. Meets all F.C.C. requirements. No license required. Full factory warranty. 116434\* 6810. Base Station Radio..... \$21.95

**GIANT BALLOONS**  
 8' & 16' BALLOONS  
 Capable of tremendous lifting power. Do entertainment stunts, advertising effects, science fun. See for miles. 3010. 8 Ft. (24 ft. around)..... \$1.95  
 3082. Super 16 Ft. (almost 50 ft. around!)..... \$6.95

**Hear Police, Fire, Aircraft Calls on ANY Radio**  
 Tuner-Converter Module. Use with standard radio. Solid state circuit. Use 9 v. transistor battery. 6120. Police, Fire Calls (30-50 MHz)..... \$5.95  
 6117. Police, Fire Calls (150-164)..... \$5.95  
 6118. Aircraft & Tower (118-128)..... \$5.95

**SPANISH WINE FLASK**  
 3.50  
 Thirst Quencher. By squeezing or tilting, liquid comes out like a fountain so you can drink without touching your lips. Carry to ball games, camps, on hikes, skiing, etc. Favorite drink cool and fresh. Hand made in Spain. Imported. Airtight plastic cap. Over 1 quart. 4311. Wine Flask..... \$3.50

**MIDGET SPY CAMERA**  
 Takes secret or regular pictures. Size of pocket watch. Conceal in hand. Imported bargain. Solid metal construction, chrome trim. 2100. Takes ten pictures on each roll. 4897. Camera & Leather Case..... \$1.25  
 4898. Film & Rolls (60 pic)..... \$1.25

**POLICE HANDCUFFS**  
 Regulation size and style. Heavy duty, steel, with lock and keys. Chrome plated. 9048. Set Postpaid..... \$1.25  
 9048. Leather Handcuff Case..... \$1.25

**2000 Insights for All Occasions**  
 Master the perfect "outdown." 2000 wisecracks, comebacks, comebacks, comebacks for all situations, any type person. Find the one you need—FAST! 241 pages. 1172. Insight Encyclopedia..... 75¢

**Powerful Pocket SHRIEK ALARM**  
 Almost knock 'em down with sound. 4" mighty mite releases unbelievable blast. Stops attackers in their tracks and summons help fast. Fool-proof personal protection. Easy to conceal. Use to break up salesmen occasions. 9079. Shriek Alarm..... \$1.95

**Midget Microphone**  
 Transmitter  
 They capture microphone picks up sounds almost anywhere. Use as sound detector, photo pickup, amplifier, telephone, etc. Complete except for battery & earphone or speaker. Instructions, experiments included. 2988. Midget Carbon Microphone..... 98¢  
 2970. Earphone, each..... 98¢

**Sun Battery & Solar Cell**  
 Generates electricity from light. Powers radios, motors, lights, etc. No batteries necessary. Also use as a powerful photocell or electric eye. Turn lights on or off, operate electric appliances, open or close doors, etc. Get several for added power. 4924. 50¢ each..... 4 for \$1.75  
 6099. Complete Computer..... \$9.95

**XRAY GLASSES**  
 Scientific wonder. It can't be true, but look for yourself. 98c  
 Greatest illusion of the century! Apparently see bones thru skin, see thru clothes, etc. Amaze and embarrass everyone! Regular eye glasses with built-in optical device. 3762. XRAY Glasses Only..... 98¢ per Pair

**U-Control 7-Foot Life-Size GHOST**  
 Only 95¢  
 Ghows Commands Indoors & Outdoors Acts Life-Like!  
 Stays 30 to 40 feet or more in air. You control in secret. Conceal in pocket, ready to operate. Runs, Falls, Floats, Dances, Spooky Effects. 7-foot head & body, white stoned, secret control. 3747. U-Control Ghost..... 95¢

**Live Sea-Monkeys**  
 Hatch a family of Sea-Monkeys in only 5 minutes. Bore alive so tiny you can take an entire family in ordinary glass of water (only three quarts of sea water fully grown.) Easy to care for. Watch them anytime, share each other in playful game of tag. FREE illustrated "Instant Live" handbook of tips, tricks, training and amusing history of Sea-Monkeys, PLUS a FULL YEAR'S SUPPLY of special Sea-Monkey growth food. Guaranteed 3760. Complete set only..... \$1.00

**Black Light Bulb**  
 Psychedelic, Fluorescent Effects. Only \$2.95  
 Black Light intensive ultra violet ray bulb. Makes objects, posters, paintings, makeups, memorabilia, etc. fluoresce in dark in brilliant, fire-like colors. Create psychedelic "turned on" and supernatural effects. Many practical uses, scientific, 75 watt, 110 volt, long-life. Use with FLASHER for wild, psychedelic, blinding effects. 6316. Black Light (2 or more, \$2.50 each)..... each \$2.95  
 6112. Flasher..... 65¢

**High School Graduation Ring**  
 Only \$1.00! Deluxe, Massive Men's Military Style Ring with inscription. Red Rubie. Sparkles with brilliant red fire. Heavy mounting with raised "HIGH SCHOOL" in panel. American Eagle on each side. Antique gold like finish. Sizes 7 through 12. 8215. Deluxe High School Ring..... \$1.00

**VARSITY SPORTS RING**  
 Massive Military Style. Gives rugged, athletic look. Handmade engraved. Sparkling engraved. Sparkling engraved. Sparkling engraved. Sparkling engraved. 5327. Sizes 5 to 11..... \$1.95

**Two Headed Nickels**  
 Real nickels with heads on both sides. Food your friends. Not to be used for gambling! Also available, real nickels with 2 tails. 5975. 2 Headed Nickel..... \$1.95  
 5976. 2 Tailed Nickel..... \$1.95

**POCKET SPY TELESCOPE**  
 Magnifies 64 times area. 8 Power. Traffic power just as small as fountain pen. All metal, chrome finish. Reverse and use as microscope magnifying 900 times! 6724. Super Spy Scope..... \$1.95

**SURPRISE PACKAGE**  
 Pleasant surprise & bargain. Fun or useful. Includes new specialties, factory surplus, special novelties, etc. Most worth much more. Money back if not delighted. 2987. Surprise Bargain..... \$1.00  
 2983. Super Surprise..... \$2.95

**SLOT MACHINE**  
 Jack Pot Bank  
 Las Vegas Replica. Like a chance. Insert coin, pull. Turn and watch. Spin. Big money if you play! 4082. 14.54. 10¢ Slot Game..... \$2.95

**Sorry, We Cannot Ship C.O.D., Canadian or Foreign Orders**  
**Johnson Smith Co.**  
 Dept. 102, 35075 Automation Dr., Mt. Clemens, Michigan 48043  
 MONEY BACK GUARANTEE © 1973 JSC. Registration Prohibited

**FLY-WEIGHT WET CELL BATTERY**  
 Postage stamp size battery of ounces, but it packs super power. Size indefinitely. Ready to release tremendous electric energy any time. 1.5 volt. 7082. Wet Cell Battery (10 for \$3.00) 354

**PORTABLE LIE DETECTOR & LOVE TESTER**  
 Measure your friend's heart secret emotions. Get truthful answers to even the most embarrassing questions. Easy-to-read gauge registers inner responses which, with practice, enable you to know what is really going on inside them. Uses the galvanic principle just like famous lie detector polygraphs. For fun at parties, psychological experiments. Carrying case. Dual hand held electrodes. Test "compatibility" of any two people at once. 9108. Portable Lie Detector..... \$9.95

**Spy "Pen" Radio**  
 Listen Almost Anywhere  
 Hear SPORTS, MUSIC, NEWS in bed, office, school, etc. Featured on NBC-TV. Wear in pocket like fine pen. Tiny earphone for private listening. Self-powered, solid-state circuit. No electricity. No batteries. Plays forever at no cost. Money back guarantee. 7052. Complete, Ready to Play, Postpaid..... \$1.95

**Free 1973 Catalog 1600 Novelties**  
 World famous catalog of novelties, pranks, jokes, mood, psychedelic items, cloth patches, peace & love gear, hobbies, scientific supplies, funmakers, plans & books, gadgets, timesavers, photo & optical goods, jewelry, dioramas, music items, stamps, coins, puzzles, fortune tellers, radios, bikes & accessories, telescope, books, office & artist supplies, engines, motors, sports, books, games, tools, magic tricks, models, surplus bargains, etc. YES! I want FREE Catalog. My Name & Address Attached or on Envelope.  
**MONEY BACK GUARANTEE**  
 Please RUSH to me the following things:

How Many	Item Number Only	Total Price

Minimum order \$1.00. Send check or money order. No C.O.D. No Canadian or Foreign orders. Add 4% sales tax in Michigan.  
 Name \_\_\_\_\_  
 Address \_\_\_\_\_ Apt. # \_\_\_\_\_  
 City \_\_\_\_\_  
 State \_\_\_\_\_ Zip \_\_\_\_\_  
 Johnson Smith, Dept. 102, Mt. Clemens, Mich. 48043  
 ADD HANDLING 35¢ TOTAL \$

Материал защищенный авторским правом



10143



13708



12014



22983



30080



03316



13873

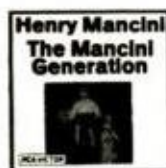

13713



13792



20084



13193



03313



03379



02143



03422

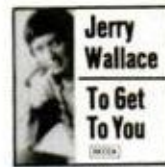

13983



10393

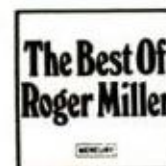

13582



14136



20234



13781



22486

**More Hits To Choose!**

- Neil Diamond: Gold ...04118
- Jim Reeves: My Friend ...13869
- Love Story .....04219
- Johnny Cash: Original Golden Hits, Vol. 1....04024
- Three Dog Night: Harmony .....00079
- Porter Wagoner & Dolly Parton: Together Always. 23359
- The Partridge Family Shopping Bag .....13889
- The Best Of Mancini ..00222
- The Best Of Jerry Reed. 13911
- Iron Butterfly: In-A-Gadda-Da-Vida .....03415
- The Best Of Charley Pride, Vol. 2 .....13385
- The Sound Of Music ...00046
- A. Fiedler: Pops Serenade .....03542
- Elton John: Honky Chateau .....13298

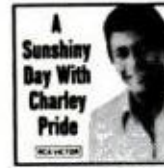

13866



00237

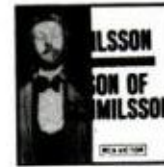

13429

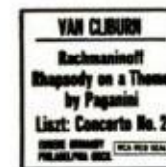

01292



12528

**Spectacular Hits... Spectacular Savings!**

Take Any 8-Track Tape **8 CARTRIDGES** for only **99¢**

Worth up to \$74.84 at regular Music Service prices. You merely agree to select as few as eight more top hits at regular Music Service prices in the next three years from hundreds to be offered.

**Enjoy Top Hits at Top Savings!**

**Start Saving Now!** Take any 8 tapes for 99¢ with trial membership. Indicate your choices on the coupon; mail it today!

**Colorful Magazine! Free Choice!** Every four weeks, illustrated MEDLEY brings news of over 350 selections and features a "Selection of the Month" in your favorite music category. And, four times a year, you receive sale issues featuring a "Bonus Selection" and alternates at great savings. No need to buy a selection every time. You merely agree to buy 8 more tapes in the next three years at regular Music Service prices—usually \$6.98. Choose from top labels like RCA, A&M, Reprise, Atlantic, Atco, Warner Bros., London, Parrot... over 40 more!

**Automatic Shipments!** To get the regular "Selection of the Month" or the special sale "Bonus Selection," do nothing; it will be sent automatically. If you want other selections, or none, advise us on the card always provided and return it by the date specified. (You always have at least 10 days to decide.)

**Cancel whenever you wish after completing your membership agreement** by notifying us in writing. If you remain a member, choose 1 selection FREE for every 2 you buy at regular Music Service prices! (Small shipping-service charge is added to each order.)

**Free 10-Day Trial!** If not satisfied you may return your 8 hits after 10 days and owe nothing.



MSC225 TRADEMARKS USED IN THIS ADVT. ARE PROPERTY OF VARIOUS TRADEMARK OWNERS, TMKSI © RCA CORPORATION.





13296



12039

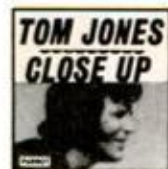

13257

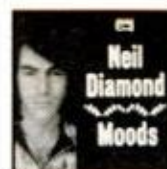

13919



10391



03292



04306

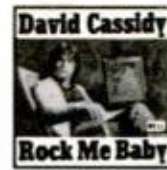

02500

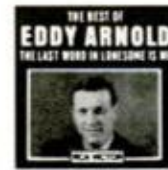

02318



04204

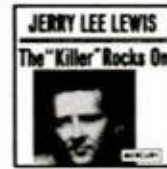

13807



00295



13295

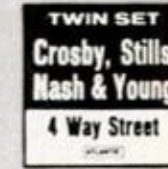

04359



22335



00267



22889



03682

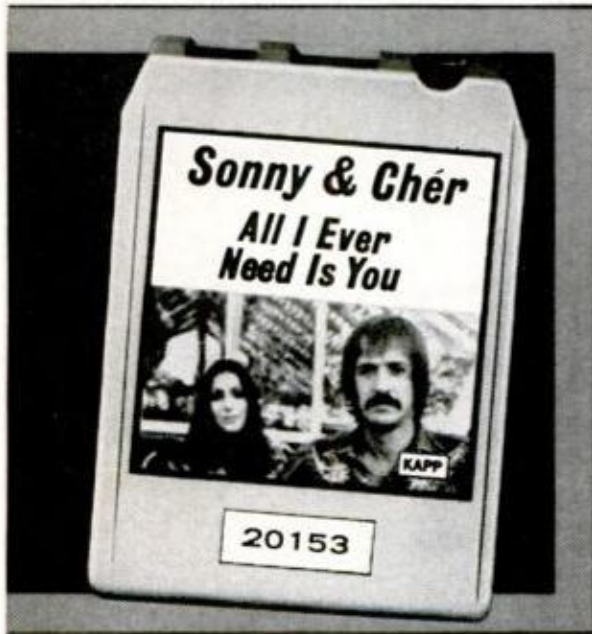

### WOULD YOU PREFER YOUR 8 HITS ON RECORDS OR CASSETTES?



Yes, you can take your 8 hits for 99¢ on records or cassettes instead of cartridges! (Sorry, no mixing.) Check box in coupon. You still enjoy all benefits described here, and take future selections (usually \$5.98 for records, \$6.98 for cassettes) in your preferred type of music.

### SEND NO MONEY—MAIL COUPON TODAY!

Mail to: RCA MUSIC SERVICE, P. O. Box RCA 1, Indianapolis, Ind. 46291

Please accept my membership application in the RCA Music Service and send me the 8 hits I have chosen for 99¢. I agree to buy as few as eight more at regular Music Service prices in the next three years, after which I may cancel my membership. I understand I may refuse the automatic shipment of each "Selection of the Month," order other selections, or none, by returning the dated card always provided. (Small shipping-service charge added to each order.)

RUSH ME THESE 8 SELECTIONS (indicate by number):

I am most interested in the following type of music—but I am always free to choose from every category (check one only):  Popular (Instrumental/Vocal Moods)  Classical  Country & Western  Today's Sound (Rock/Soul/Folk)  Broadway-Hollywood-TV

SEND ME THESE SELECTIONS ON (check one only):

8-Track Tape CARTRIDGES

RECORDS

CASSETTES

Mr.  Mrs.  Miss } ..... (Please Print)

Address .....

City ..... State.....

Phone (.....) ..... Zip.....  
Area Code

Limited to new members, continental U.S.A. only; one membership per family.



If you've ever said...

# "There must be a better

Send for a free Career Guidance Booklet that could start you on the road to success in a rewarding new career.

It happens to all of us, sooner or later. No matter what kind of job we have.

One day, it suddenly strikes home that we're going to have to work for a living, the rest of our lives. And most of us are horrified at the thought of forever being locked into the jobs we now hold.

"Surely," we tell ourselves, "there must be a way to earn enough extra dollars each month to balance the family budget. Surely, there must be

a way to get the kind of position where you don't have to worry about job security."

"Surely," in other words, "there must be a better way to earn a living!"

If you, too, have been thinking these same thoughts, you'll find one of our free Career Guidance Booklets very helpful at this time. We invite you to send for one.

Your free booklet will describe the opportunities for higher income and greater job security you might ex-



# way to earn a living..”

pect in one of the career fields listed on the coupon below. It will also explain why ICS can prepare you for this new career field...right in your own home...in your spare time...*regardless of your education or past experience.*

In addition, you will receive a free "Demonstration Lesson" that lets you see for yourself why preparing for a more rewarding career—the ICS way—may be a lot easier than you think.

Please bear in mind, as you check off your career choice on the coupon below, that ICS has a long and distinguished record of success. In fact, more than 8,500,000 men and women have turned to ICS for career training, since 1891.

## Major corporations use ICS Career Training

ICS has provided training programs for various divisions and branches of companies like Ford; U.S. Steel; Chrysler; Mobil; DuPont; etc.

ICS Career Training is approved for Veterans and Servicemen under the new G.I. Bill, and is Accredited by the Accrediting Commission of the National Home Study Council.

Now it's your turn to discover how ICS training can start *you* in a rewarding new profession. Just fill in the postpaid card or coupon below and mail it today for your free Career Guidance Booklet and free "Demonstration Lesson."



## Mail attached card or coupon for Free Career Guidance Booklets and Free "Demonstration Lesson."

These free Career Guidance Materials are yours without obligation. They will help you find out what you should know about the career field of your choice. They will also let you see for yourself why preparing for a more rewarding career—the ICS way—may be easier than you think.



Mail attached postage-free card today. If card is missing, please mail coupon to: ICS, Scranton, Pa. 18515.

## ICS International Correspondence Schools Scranton, Pennsylvania 18515

Please send me a free Career Guidance Booklet, and a free "Demonstration Lesson" for the field I have checked below. I understand that I am under no obligation.

- |   |  |
|---|--|
| <p><b>1. ACCOUNTING</b><br/> <input type="checkbox"/> Business Accounting<br/> <input type="checkbox"/> Bookkeeping <input type="checkbox"/> CPA Training<br/> <input type="checkbox"/> Income Tax Specialist</p> <p><b>2. BUSINESS MANAGEMENT</b><br/> <input type="checkbox"/> Business Administration<br/> <input type="checkbox"/> Executive Management<br/> <input type="checkbox"/> Industrial/Production Mgt.<br/> <input type="checkbox"/> Marketing/Advertising/<br/>                 Sales Management</p> <p><b>3. MOTEL/HOTEL MANAGEMENT</b><br/> <input type="checkbox"/> Motel Management<br/> <input type="checkbox"/> Club/Restaurant Management<br/> <input type="checkbox"/> Resort Manager <input type="checkbox"/> Hotel<br/>                 Executive</p> <p><b>4. COMPUTER PROGRAMMING</b><br/> <input type="checkbox"/> Programming Concepts<br/> <input type="checkbox"/> COBOL <input type="checkbox"/> System 360<br/> <input type="checkbox"/> Fortran IV</p> <p><b>5. INTERIOR DECORATING<br/>&amp; DESIGN</b><br/> <input type="checkbox"/> Interior Decorator<br/> <input type="checkbox"/> Interior Designer<br/> <input type="checkbox"/> Advanced Interior Designer</p> <p><b>6. ELECTRICIAN</b><br/> <input type="checkbox"/> Master Electrician<br/> <input type="checkbox"/> Practical Electrician</p> <p><b>7. SECRETARIAL</b><br/> <input type="checkbox"/> Medical <input type="checkbox"/> Legal <input type="checkbox"/> Executive</p> | <p><b>8. DRAFTING</b><br/> <input type="checkbox"/> General Drafting <input type="checkbox"/> Specialized<br/>                 Training (Arch., Mech., Struct.,<br/>                 Electrical, Aircraft, Electronics)</p> <p><b>9. AUTOMOTIVE</b><br/> <input type="checkbox"/> Master Mechanic<br/> <input type="checkbox"/> Air Conditioning Specialist<br/> <input type="checkbox"/> Body Rebuilding Specialist<br/> <input type="checkbox"/> Diesel/Gas Mechanic</p> <p><b>10. ENGINEERING</b><br/> <input type="checkbox"/> Mechanical <input type="checkbox"/> Civil <input type="checkbox"/> Chemical<br/> <input type="checkbox"/> Industrial <input type="checkbox"/> Electrical-<br/>                 Electronics<br/> <input type="checkbox"/> Surveying &amp; Mapping</p> <p><b>11. ELECTRONICS</b><br/> <input type="checkbox"/> Electronics Technician<br/> <input type="checkbox"/> Specialized programs in<br/>                 Computer Servicing, Communi-<br/>                 cations/Broadcasting, CATV<br/> <input type="checkbox"/> FCC Licensing</p> <p><b>12. TV SERVICING</b><br/> <input type="checkbox"/> Color TV Technician<br/> <input type="checkbox"/> Stereo/Hi-Fi Specialist<br/> <input type="checkbox"/> CATV/MATV Specialist</p> <p><b>13. AIRCONDITIONING/HEATING</b><br/> <input type="checkbox"/> Air Conditioning/Refrigeration<br/>                 Technician <input type="checkbox"/> Heating Specialist</p> <p><b>14. HIGH SCHOOL</b><br/> <input type="checkbox"/> For those who want to earn an<br/>                 ICS High School Diploma</p> |
|---|--|

Check here for special information, if age 16 or under

Miss \_\_\_\_\_ XA604N  
 Mrs. \_\_\_\_\_  
 Mr. \_\_\_\_\_ Age \_\_\_\_\_

Address \_\_\_\_\_ Apt. \_\_\_\_\_

City \_\_\_\_\_ State \_\_\_\_\_ Zip \_\_\_\_\_

Approved for Veterans Training. Approved for Federally Insured Loans.  
 Accredited Member National Home Study Council.

Canadian residents use this address for service from ICS Canadian, Ltd.  
 In Hawaii: 931 University Ave., Honolulu, Hawaii 96814

# ALL By BILL McKEOWN OUTDOORS

**THE CALL OF THE OPEN ROAD** this coming spring will reveal a number of new trends in recreational vehicles. Many are smaller, lighter and less expensive to own and operate. Others are bigger than ever before, with room for a lot of kids or friends. One California motor home sports a second-story observation penthouse. Another is a sort of split-level fifth-wheel triplex that extends over the pickup bed of the tow truck for a bedroom with one more step up over the pickup cab for the bed. The sturdy tow characteristics of fifth-wheelers plus all that extra space seem to appeal, but watch, too, for undersize models to match the popular little imported pickups. Both compact fifth-wheel trailers and cargo-bed camper coach bodies are now being made for them.

Bigger chassis for larger motor homes are available from all the truck companies. International has introduced a rear-engined model that is claimed to allow living space inside all on one level without the step up for driver and copilot seats or the hump that covers the engine in between. As predicted here, Mercedes-Benz is supplying the first diesel-powered chassis, and the new 25-foot Motoroam Monarch giving a reported 17 miles per gallon of diesel fuel.

Look for a lot more mini-motor homes and chopped vans. Many RV buyers seem to want to try the outdoor trend with minimum outlay to see first how they like it.

**SOME LIKE IT COLD**, it seems, from winter reports already in from KOA, largest of the campground chains. KOA reports over 200 of its Campgrounds open all year, including snowbelt resort areas such as Stowe, Vt., Aspen, Colo., Sun Valley, Idaho, and Jackson Hole, Wyo. At Steamboat Springs, Colo., 175 miles west of Denver, winter campers can try downhill and cross-country skiing, snowmobiling, snowshoeing, cutter racing, ice fishing or the February Winter Carnival the second week of this month. An economical winter camping vacation no longer has to mean heading south.

**FOR BOATMEN**, two strong trends this year are likely to be "performance" and "preservers."

Tip-off on new higher marine horsepowers came

last November at the Hennessy Cognac-Key West Race that ranks as the last event of the international championship series and the first contest for the American offshore title. In it Dr. Bob Magoon of Miami, driving an Aronow Cigarette with a pair of Carl Kiekhaefer's Aeromarine 468s, topped 73 mph average for the 189-mile run over open ocean. K.A.M. is reported to be getting over 600 hp from the 468-cu.-in. engines. With his pair, Magoon won a good head start toward his fifth consecutive national offshore title and the big No. 1 the champion can wear for the year as his racing number. The winning engines were forerunners of the Kiekhaefer Aeromarine production high-performance mills just being introduced for general use.

Outboard motor forecasts for the coming season were also previewed in November at the annual Lake Havasu City Pepsi-Cola Outboard World Championship. Factory teams from Evinrude, Johnson and Mercury showed up for the eight-hour Arizona desert event, and this year rigs were limited to single engines and tunnel-type hulls. Total distance traveled for four hours on two successive days determines the enduro winner. This time Johnny Sanders from Abilene drove his Scotti-Craft 696 miles at a record 87 mph with a Johnson Stinger for power. Over 200 hp is estimated to come from these super-tuned racing rigs, and every year more of it is passed down to regular production outboards.

Preservers are called personal flotation devices (PFDs) by the Coast Guard, but the aim is still to keep you afloat. Preferably that means with your face out of the water, even though you may have slipped on deck and knocked yourself out while falling in.

The ideal device would support an unconscious person so he would be floating slightly on his back with his head up and well supported. Flotation seat cushions with arm straps are often worn on the back and do just the opposite. They, eventually, will be phased out. The "Mae West" inflatables will probably never be officially accepted since they, too, require you to be conscious and alert to activate them.

Every person aboard any boat—and even some that aren't, like water skiers—are required to have an approved-type PFD accessible aboard the boat for them. Since different-size boats require special life preservers, it is best to check with your boat and equipment dealer to find the PFD that is legally correct for you. Eventually the strict new law is likely to save a number of lives.

**WARMING FOOD** is a year-round necessity but in the past many backpacker-sized stoves

*(Please turn to page 22)*



## The number of people you can get into our boat isn't the only beautiful thing about it.

It's beautiful how many people you can sit comfortably in a tri-hull bowrider.

But, for most tri-hulls, that's where the beauty ends.

They're about as exciting to look at as an old washtub.

At Starcraft, we make our bowriders beautiful to look at as well as comfortable to sit in.

We call it Starcraftsmanship.

The standard of excellence that sets a Starcraft apart from any other boat.

And designers, engineers and craftsmen dedicated to the proposition that bowriders can be beautiful as well as practical.

Starcraftsmanship is why our 20' Capri is the best-looking tri-hull made.

It's got a white and blue exterior, a white deck and a sky-blue interior.

Inside, the Capri is loaded with luxurious features.

There's a fully instrumented automotive-type dash and steering wheel.

A removable table for dining, cards or crosswords.

A built-in beverage cooler. And storage wells molded into the stern to hold everything from ski ropes to hair spray.

Our 20' Capri seats 11.

The bow-compartment has vinyl-

covered foam seat cushions and backrests. A safety glass walk-through windshield lets you get easily from the bow to the stern. In back are reclining sleeper seats and stern seats. There's luxurious marine pile carpeting throughout.

A convertible top, tonneau covers and side curtains keep you dry when it rains. A camper top converts it to a part-time home.

But, with Starcraftsmanship, comfort only starts inside the Capri.

We designed it with our wide-stance tri-hull to give your family a safe, smooth stable ride even in rough water.

And we built it with fiberglass that's not only beautiful but pound for pound stronger and more durable than steel. To give you years of maintenance-free operation.

Starcraftsmanship gives you more after you buy, too. Like our excellent warranties.

Our high resale values. Service from our 1200 dealers and 30 distributor service centers.

The Capri comes in 20' and 17' I.O. and O.B. and 15' and 14' O.B.

See the complete line of Capri bowriders at your Starcraft dealer.

Or write to the Starcraft Company, Dept. G29-2, Goshen, Indiana, 46526, for further information.

The Starcraft Capri. The beauty of it is in the beholding as well

as the holding.

**STARCRAFT** 



Starcraft. The more you live with it, the more you appreciate it.

## NEW FREE BOOK DISCUSSES

# HOW TO SELL YOUR INVENTION

If you have an invention (whether patented or unpatented) that you believe has commercial value, our Free Booklet entitled "How to Go About Selling Your Invention" may help you save time and money.

We are specialists in representing inventors and submitting their inventions to manufacturers. We work with scores of manufacturers who are seeking new products or new product ideas, and we therefore know which firms may be interested in your particular invention. Our service is designed to do all those things the average inventor lacks the knowledge or facilities for doing, or does not have time to do. We prepare your sales letters, folios, duplicate drawings, handle correspondence, select the firms.

We charge the standard commission (on sales) and a modest fee for the submitting service. This fee is refunded if a manufacturer buys your invention through our efforts. We are a nationally known concern with an impeccable reputation for ethics and integrity.

The Free Booklet we have prepared especially for inventors contains such information as current royalty rates being paid by manufacturers, discusses many types of inventions, the possible market for them, tells the effective methods of presenting your invention for sale, whether you employ us or do it yourself, and outlines how we may be able to help you.

You can obtain this booklet "How to Go About Selling Your Invention" by mailing the coupon below. And if you wish to write us for comments on your invention, please do so. We make no charge for consultation. But please do NOT send drawings or models. Just describe the purpose and nature of your invention. Mail the coupon to K. O. Kessler, Pres., Kessler Sales Corporation, Dept. D-52, Fremont, Ohio 43420.

You are welcome to ask your lawyer, local Bank, Chamber of Commerce to carefully check on our reputation for honesty and fair-dealing.

### MAIL THIS COUPON

Mr. K. O. Kessler, President, Dept. D-52  
Kessler Sales Corp., Fremont, Ohio 43420

Please mail me a copy of your Free Booklet "How to Go About Selling Your Invention." It is understood that this does not obligate me in any way to use your Service.

My Name .....

Street Address .....

City .....State.....Zip.....

## ALL OUTDOORS

(Continued from page 20)

were compact and inefficient. Now several make sense and plenty of heat. Primus has a little stove, heater and light operating from a small can of LP-gas and stowing snugly in a backpack. One Gerry model opens to use LP, while a doughnut-shaped pocket model with its fuel inside, stays lit in a wind but shuts off automatically if turned over.

Campers with an eye for color should like two-tone tents introduced this spring by Sears, Roebuck and Wenzel. European campgrounds still show the most color per foot of camp-space but domestic tentmakers are catching up.

Outdoor action abroad seems to be the goal of many campers, according to a lot of letters we have recently received. Most countries supply good campground information and often hunting and fishing data through their consulate tourist offices in Washington and New York. For RV touring in Europe, write Wilsons Motor Caravans, 36 Acre Lane, London, S.W.2, England, for info.

A photo safari in Africa that includes an Avis car with unlimited mileage for tracking down animals is provided by Swissair and E-Car Tours. Braniff Airlines also plans special sportsman tours in South Africa. Details are available from the carriers involved.

**BOATING BASS** is becoming such a big sport that tournaments are already being scheduled throughout the coming summer. Last year's big winner at the Bass Masters Classic, sponsored by the Bass Anglers Sportsman Society (B.A.S.S.), was Don Butler of Tulsa, Okla. His first place on Percy Priest Reservoir near Nashville, Tenn., also netted him \$10,000. James Trewick Jr., of Abbeville, Ala., took the Evinrude Bass Buster Tournament top spot on fabled Toledo Bend Reservoir, Hemphill, Tex. And at the All-American Bass Tournament on Lake Eufala, Roland Martin, Tulsa, Okla., caught and released 30 pounds of bass the first day to help haul in his win.

**WISE OUTDOORSMEN** can learn a lot free or at minimum cost from catalogs. Occasionally an exceptional one comes along, and our unofficial award goes to Wolverine Shoes of Rockford, Mich., for a set of bound-in photos by famous outdoor photographer Ansel Adams, as a salute to him on his 70th birthday. Runner-up catalog kudos should probably go to Sierra Designs for its display of new equipment photographed in the California ghost town of Bodie, and to Silverline Boats for pages that show some of the special pleasures of days on the water. ★★★

# WHEN YOU NEED A NEW BATTERY, THINK OF THE ONE GM STARTS WITH.

If you drive a General Motors car, it started with a Delco battery. When it's time for a new one, it's only smart to replace your battery with one which meets the specifications of the battery GM put in originally.

Get a new Delco Energizer. You can be sure it's designed and built with the peak power that's right for your car. To back up Delco's quality there are thousands and thousands of Delco outlets all over the country where Delco warranty service is available and can be performed.

Even if you don't drive a GM car, get the battery GM puts in all its cars.

Get the battery GM starts with.

Get a Delco.

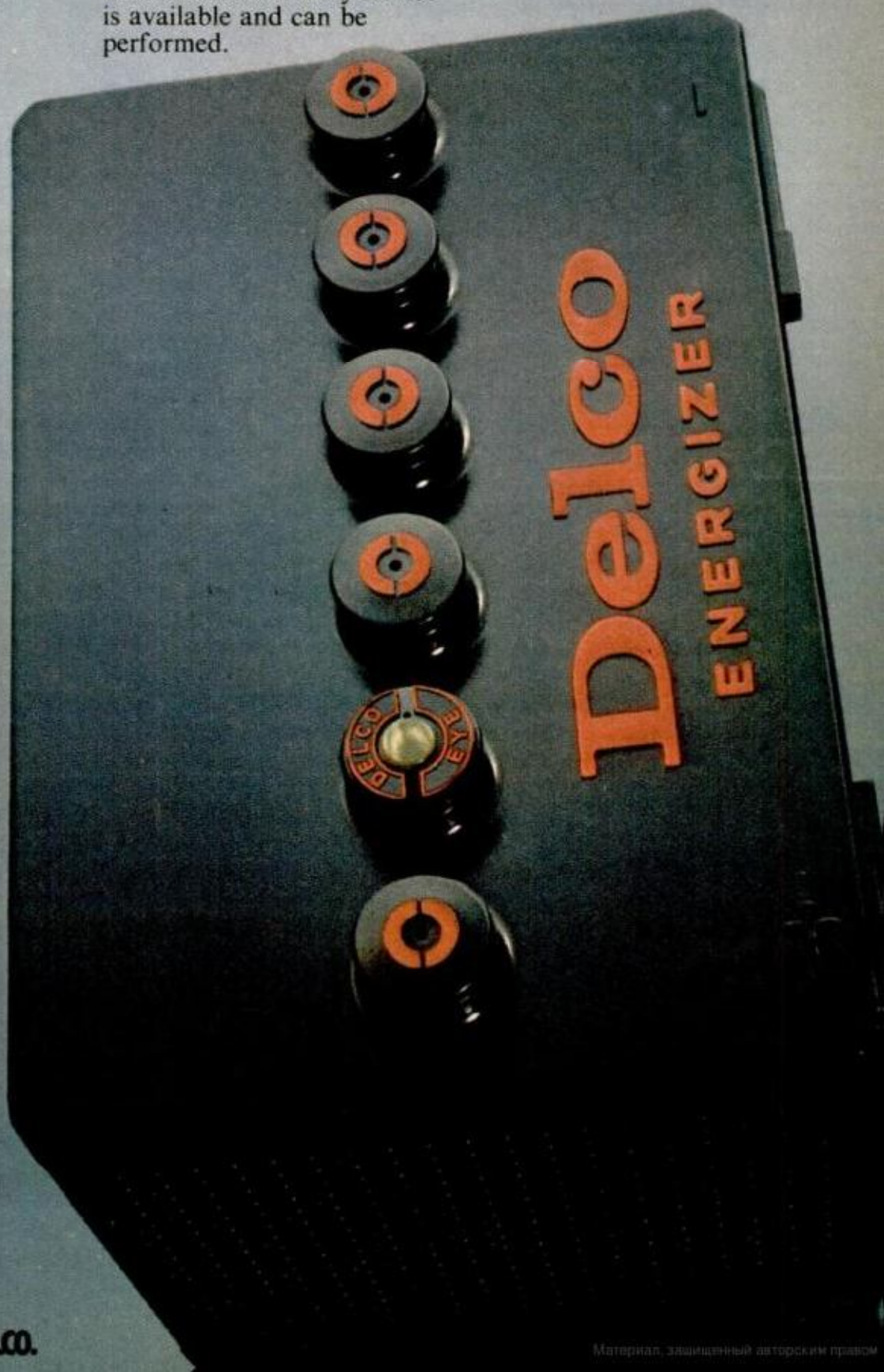

THE MORE YOU KNOW,  
THE MORE YOU'LL WANT DELCO.

DETROIT

# LISTENING POST

BY ROBERT LUND

**AMC READYING NEW MINI.** Assuming GM can supply the engines, American Motors could have a Wankel-powered minicar—smaller than Gremlin—on the road as early as 1975, carrying a 1976 model designation. The car itself is almost ready to go. It's being tested and the company is looking at prices on tooling. If GM can't supply the Wankels by mid-summer of 1975, AMC may go ahead with the car, using an existing engine, and offer the Wankel at a later time, when rotaries become available from GM or elsewhere.

**GM RESTYLING STANDARDS.** Lion's share of the money GM's allocated for styling changes this year will go into new bodies for the standard-size cars. On the outside, the cars will get new roofs and new metal front and rear. On the inside, GM's expected to go to a more masculine look, like the Levi trim used in American Motors' Gremlin. But that's only a for instance, because GM won't use the same cloth used in Gremlin.

**CADILLAC-CORVETTE MERGER?** Some GM-watchers figure it'd be a smart move if GM pulled two cars off the new body being worked up for Corvette. A new Vette for one and the long-promised junior car from Cadillac for another. To swing this, Corvette would probably have to drop its fiberglass body—unique among Big Four cars—and go to metal. This ties in with GM's goal of getting maximum mileage out of its bodies, of building several "makes" of cars



**COMPACT, ECONOMY CARS** don't have to look that way. Among new dealer options to give compacts the muscle-car look is this front styling option for Pontiac Ventura and Ventura Custom. Does the twin-grille remind you of the Firebird? That's the point

off the same shell. All of which makes a neat package of conjecture. But at this point, we'd still bet the cut-down Cadillac with (1) share a body with another GM car, other than Corvette or, (2) emerge as a luxury, Americanized version of a new Opel.

**BIG ENGINE FOR BIG FORDS.** Ford's prepping a more powerful engine for its big ticket cars—Mark IV, Lincoln and Thunderbird. Company hopes to have it ready by fall, in time for the '74s. But if the plant can't be put into volume production in time for '74 introductions, the first part of the run will probably go into Mark IV, with Lincoln and Thunderbird getting the unit later as production revs up.

**THOSE SERVICE PROGRAMS** the auto companies launched with such fanfare last fall that were supposed to make it easier to get your car fixed—actually no more than you're entitled to under the warranty—are already bearing fruit. But for the carmakers, not the customers. The service mess hasn't improved two cents worth. But there's already talk of using the service programs as pegs for advertising campaigns to tell the public what a great shake they're getting on service. The big-shooters in Detroit who are in a position to do something about service don't know what it's like to have a car repaired in the real world. In the first place, they drive company cars. After 3000 miles or three months, they turn the "old" car in for a new one. But if they have a problem, it's fixed at the factory garage. No pain, no strain, no waiting, no charge.

**COMEBACK OF THE FUN CAR.** You've read about the new engines Detroit's working on and the great gobs of gear coming on cars to make them safer and to curb pollution. But what about the fun stuff? Not engines, not by-decree devices the government says you have to take because they're good for you. But fun features to make driving easier, more exciting, more pleasant, less of a drag and more of an adventure.

The word from here is wait a couple years. Insiders at the auto and supplier companies say there's a whole phantasmagoria of fancies coming in 1975 and '76. Nobody will say what the

*(Please turn to page 27)*



# Salem refreshes naturally!

Natural Menthol Blend  
(means naturally fresh taste)



© 1972 R. J. REYNOLDS TOBACCO CO.

Warning: The Surgeon General Has Determined That Cigarette Smoking Is Dangerous to Your Health.

KING, SUPER KING: 20 mg. "tar", 1.4 mg. nicotine, av. per cigarette, FTC Report AUG '72.

Материал, защищенный авторским правом.

*Make waves...  
go Larson in '73*



**VOLERO SPORT.** This 17' beauty has every standard feature you could want, plus performance!



**1650 SHARK.** A speedy, stable tri-hull designed to carry a six-man crew comfortably in its spacious cockpit.

People have been "making waves" with Larson boats for over 54 years. There's a reason! Larson offers more boat for the money. That's what the boater wants! That's what we give him!

Larson offers a complete range of runabouts from 14' to 21' in three different hull styles . . . all loaded with more standard features at no extra cost.

POWERED BY  
**MERCURY**  
STERN DRIVES



**1500 SABER.** Wet, wild, and raring to go. Perfect boat for fishing, skiing, or all around utility use.

LIFE/GUARD CONSTRUCTION . . .  
for your safe boating pleasure.



PRODUCT OF LARSON INDUSTRIES, INC.  
Plants at Little Falls, Minnesota and Nashville, Georgia

POPULAR MECHANICS

Материал, защищенный авторским правом

## DETROIT LISTENING POST

(Continued from page 24)

surprises will be, what they'll do, how they'll be used, although many of them apparently involve use of electronics. But they'll be for the good times and the pleasure of it and not basics, like engines, and not castor oil equipment mandated by government.

Why the sudden spurt of creativity by car-makers? And if Detroit really has a box of surprises, why should it take two to three years to get them out?

It's not as if somebody issued a command to invent and the marvels came pouring out of a tap. Many of the innovations coming on cars in the next few years have been in development since 1966, when the government stepped in to regulate the industry. This was a new experience for Detroit. The industry had never been regulated before. For the past six years, car-makers say they haven't had the time, manpower or facilities to pursue nonessentials. The fun stuff had to go on the back burner. Detroit still isn't certain how it's going to handle the antipollution goal the government's set for mid-decade. But other than that, the industry feels it's in good shape in satisfying government requirements. It's learned to live with regulation and is beginning to see ways of integrating government objectives with the total vehicle.

Two more years and automakers figure they'll be in a position to get back to the baubles and imagination stuff. Build cars that won't foul the air and combine safety with *joie de vivre*.

**TESTS FOR MECHANICS.** This is for readers who have asked for more information on tests for mechanics (see *Detroit Listening Post*, Oct. '72 PM). There are four tests and each one costs \$10—a total of \$40. But you don't have to sign up for all four—you can take just those you want. You take them one at a time, not all four at one shot. To find out when the next test will be given in your area, write Certified Mechanic Program, Box 2611, Princeton, N.J. 08540.

**CHRYSLER SEEKING WANKEL SOURCE.** Despite its blasts against the Wankel, Chrysler has scouts in Europe and Japan shopping to see what's available in the way of Wankel capacity should the company decide to offer a rotary on a token basis. So Chrysler dealers can say, "We've got one, too." This is just a foot-in-the-door arrangement and shouldn't be interpreted to mean Chrysler's wavering on its conviction that the Wankel will be a short-term proposition in the United States. ★ ★ ★

## Wood Craftsmen/Hobbyists



### NEW 144 PAGE CATALOG HARDWOODS

Domestic and Imported  
Short Dimensions or Long Lengths  
Wood Panels—Fine Hardwood Plywoods

Inlays, Turning Blocks, Pre-cut Veneer Picture Kits, Moldings

Pre-cut Wood Kits—Picture frame stock, Banding, Ornaments

Everything in fine kiln dried woods for the serious craftsman

Power tools—name brands at big discounts

Wood finishing products—Hundreds of woodworking hand tools

Hard-to-find Cabinet Hardware...pulls, casters, slides, locks hinges, glides — and more!

Full line—Lamp Parts—Upholstery Supplies

Clock and music box movements

Special picture section — 32 fine woods in color

#### NEW COMPLETE KITS! 3 STRING DULCIMER GUITAR

Big choice Wood Inlay  
Marquetry Pictures  
and Table Tops

..PRE-CUT..



MANY MORE!

Over 2000 Items! Mail Coupon for Catalog

Craftsman Wood Service Co., Dept. A-12  
2729 South Mary Street, Chicago, Illinois 60608

Rush new 144 page color catalog. I enclose 50¢ for handling.

Name \_\_\_\_\_

Address \_\_\_\_\_

City \_\_\_\_\_ State \_\_\_\_\_ Zip \_\_\_\_\_

## MAKE BIG MONEY

IN EITHER OF THESE TWO FIELDS



### TRACTOR-TRAILER DRIVER

We can train you to operate the big diesel rigs. Study at home followed by practical training at school-owned facilities in Miami, Fla. Accredited Member NHSC. Home Office—Miami, Fla.

APPROVED FOR VETERANS AND INSERVICE PERSONNEL

### HEAVY EQUIPMENT OPERATOR

Learn to operate cranes, draglines, scrapers, clamshells, bulldozers, backhoes, trenchers. Study at home followed by practical training at school-owned facilities in Miami, Fla. Accredited Member NHSC. Home Office—Miami, Fla.



UNIVERSAL TRAINING SERVICE, Dept. PM  
1901 N.W. 7 St., Miami, Fla. 33125 • Phone: (305) 642-0800

- TRACTOR-TRAILER DRIVER  
 HEAVY EQUIPMENT OPERATOR

PLEASE PRINT

Name \_\_\_\_\_

Address \_\_\_\_\_

City \_\_\_\_\_ State \_\_\_\_\_

Zip \_\_\_\_\_ Phone \_\_\_\_\_ Age \_\_\_\_\_

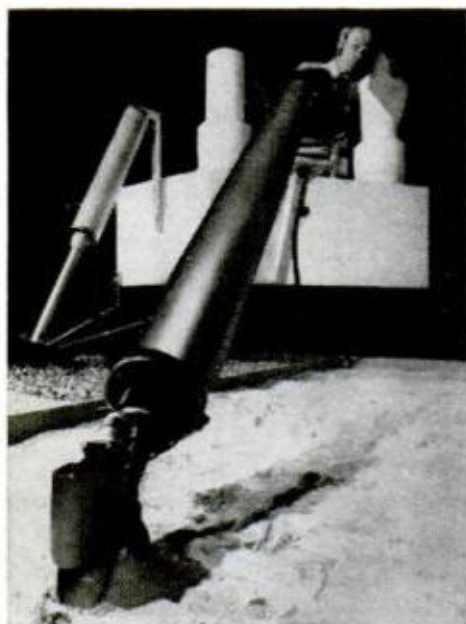

**Test run for Martian sampler**

**IF THE VIKING MARS VEHICLES** land in good shape, they will deploy booms capable of scraping samples of Martian soil and transferring them to processing units for chemical and biological analysis. Results of the tests will be radioed to scientists in the United States. Models of the sampling mechanisms are now undergoing tests at the Martin Marietta Aerospace plant in Denver. The Viking program calls for two unmanned spacecraft to land on Mars in 1976.

**IN SEVERE STORMS**, some tall buildings sway with sufficient force to cause occupants to suffer from motion sickness, according to Robert J. Hansen, an MIT engineer. Designers should test models of their buildings in wind tunnels, says Prof. Hansen, "and if the building response is inadequate, the building should be redesigned."



**Installing bite-size receiver**

**HEARING THROUGH YOUR TEETH** is made possible by a miniaturized system developed by University of California scientists. A transmitter-receiver—worn on the body or carried in a pocket—picks up the sound signal and transmits it to a receiver installed in the mouth. Tiny enough to be inserted in a false tooth, the receiver drives sound impulses through the bones of the upper jaw to the inner ear. Research has shown that teeth are better conductors of sound than are the bone structures behind the ear, where some hearing aids are worn. The new device could be used to help some victims of hearing loss, or to cue actors or signal athletes in certain sports.

**EASTERN NORTH AMERICA IS OVERDUE** for a big earthquake if past history is used as an indicator. That's the opinion of Pennsylvania State University's Dr. B.F. Howell Jr., a geophysicist who explains that there have been "four damaging earthquakes in the region every 50 years for the last 200 years." The last occurred in 1944, causing \$2-million in damage in and around Massena, N.Y. The next eastern quake, according to Dr. Howell, may occur within 400 miles of the Appalachian Mountains, within an area extending from the coast to points as far inland as Chicago.



**Fuel capsule goes into cooler**

**FIRST USE OF NUCLEAR ENERGY** to operate a refrigerator was recently demonstrated by the Atomic Energy Commission and the Hughes Aircraft Co. The nine-pound unit, which can provide spot cooling as low as minus 320°F., is designed to cool microwave, laser and radiation detection systems. The device is similar in concept to a gas refrigerator in that cooling is pro-

*(Please turn to page 30)*

# TOUGH!

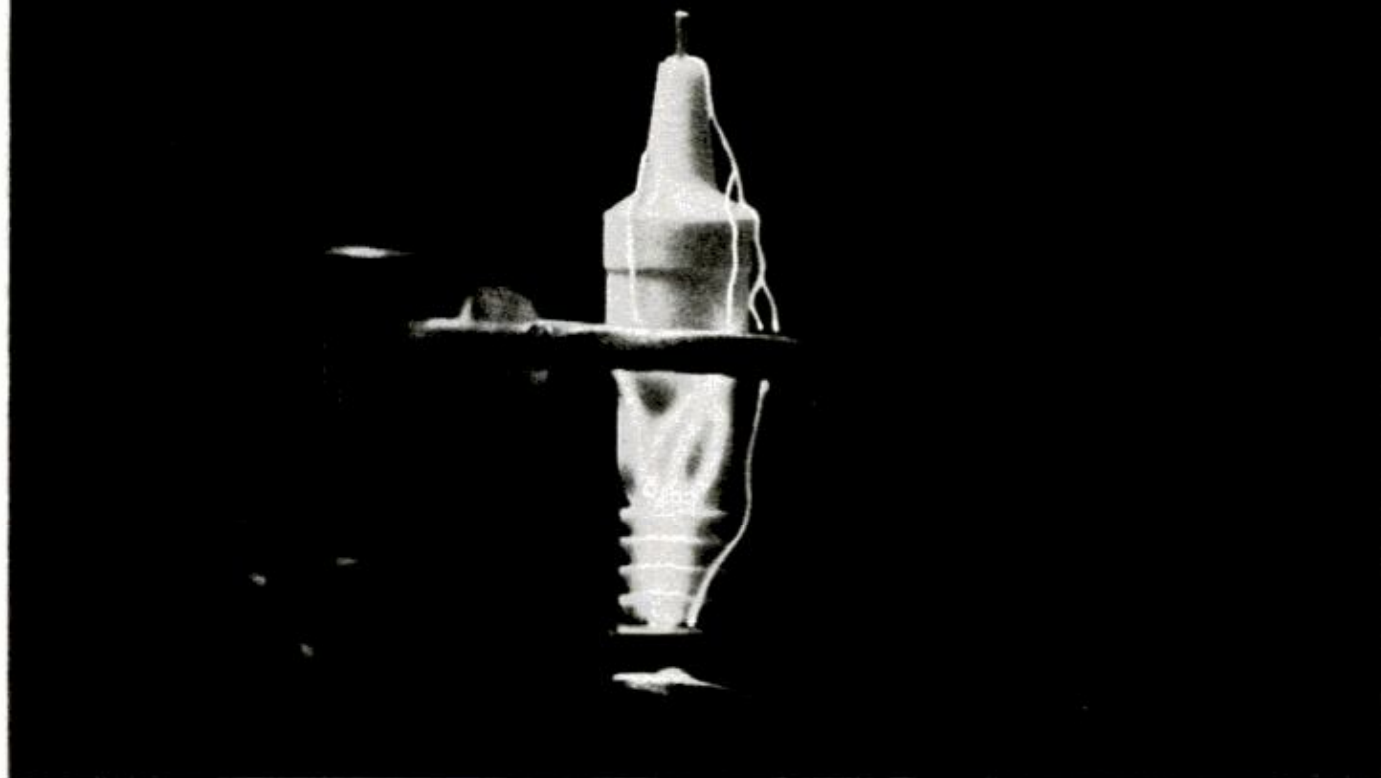

## Another reason you can rely on AC... the "electrical test"

AC Spark Plug insulators are subjected to tough "electrical tests" of up to 38,000 volts . . . more severe than the voltage normally required under actual operating conditions. It's a standard AC Quality Control check for electrical strength. Any imperfection in the AC Super-Ceramic Insulator would be detected by this high voltage test.

This is but one of the many stringent Quality Control checks that AC uses from raw material to finished product.

Severity of the electrical test is just another indication that AC Spark Plugs are not only built tough but tested tough. There *is* a difference in Spark Plugs.

AC Fire-Ring Spark Plugs . . . built tough, tested tough to help assure you quick starts and a smooth-running engine.

Next time you change spark plugs, whether you do it yourself or have it done, insist on ACs.



AC SPARK PLUG DIVISION OF GENERAL MOTORS

LIVE IN THE WORLD OF TOMORROW . . . TODAY!

# UNUSUAL BARGAINS

NEW PRODUCTS • NEW MATERIALS • NEW IDEAS

## "FISH" WITH A MAGNET



Go treasure hunting on the bottom! Fascinating fun & sometimes profitable! Tie a line to our 5½-lb. Magnet—drop it overboard in bay, river, lake or ocean! Troll it along bottom—your "treasure" haul can be outboard motors, anchors, other metal valuables. 5½-lb. Magnet is war surplus—Alnico V Type—Gov't cost \$50. Lifts over 150 lbs. on land.

Stock No. 70,571H . . . . \$14.00 Ppd.

Stock No. 60,215H . . . 1½ lbs. . . . . \$ 5.75 Ppd.  
 Stock No. 70,570H . . . 3½ lbs. (lifts 40 lbs.) . . . \$ 8.75 Ppd.  
 Stock No. 85,152H . . . 15¾ lbs. (lifts 350 lbs.) . . . \$33.60 FOB

## GIANT WEATHER BALLOONS

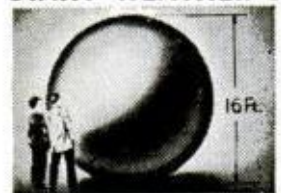

"Balls of fun" for kids, traffic stoppers for stores, terrific for amateur meteorologists. Create a neighborhood sensation. Great backyard fun. Exciting beach attraction. Amateur meteorologists use to measure cloud heights, wind speed and temp. Made of heavy-duty neoprene. Inflate with vacuum cleaner or auto air hose; or locally available helium for high rise.

Stock No. 60,568H (8' size) . \$2.50 Ppd.

Stock No. 60,632H (16' size) \$7.00 Ppd.

## AMAZING NEW WANKEL ENGINE KIT!



Thrill to the fun of building your own see-through motorized model of revolutionary pistonless type engine . . . only engine experts think economically modifiable to meet new pollution standards. Replaces piston, cylinder, crank assemblies with rotating discs (sections removed for firing chambers). Smaller than conventional; fewer parts, greater reliability, same speed w/less horsepower. Feat: flashing plugs, rubber fan belt, stick-shift on-off switch. Req. 2—1.5V batt. (not incl.).

(4½"X5"X9") . . . . . \$6.75 Ppd.

No. 71,424H . . . . . \$15.25 Ppd.  
 519-Page Wankel Engine Book  
 Stock No. 9,439H . . . . . \$15.25 Ppd.

## HONDA 750 "FOUR" ENGINE KIT



Build big ¼ scale see-thru motorized wkg model of the 4-cyl engine that makes 750 Four most advanced motor-cycle on the mkt. 68 hp. engine that won Daytona revs up to 8000rpm, top speed over 125 mph. Feat: overhead cam 4-stroke engine design; 4 synch carbs, 4 upswept mufflers, & hemi heads with offset valves. Shows valve opening & closing, piston cycle, flashing plugs, etc. 187 metal & plastic pre-colored parts, display stand, instrs. Req. 2 "AA" Batt (not incl.).

Stock No. 71,750H . . . . \$12.95 Ppd.

## AMERICAN MADE OPAQUE PROJECTOR



Projects illustrations up to 3" x 3½" —enlarges them to 35" x 30" if screen is 6½ ft. from projector, larger pictures if screen is farther away. No film or negatives needed. Primarily intended for children. Projects charts, diagrams, color or black-and-white in darkened room. 115 v. A.C. . . . 6 ft. cord and plug included. Size 12" x 8" x 4½" wide. Weight 1 lb. 2 ozs. Plastic case.

Stock No. 70,199H . . . . \$8.75 Ppd.

'Bright Ideas' in Unique Lighting Big, new 100-page handbook packed with facts, loaded with illustrations. All latest developments, applications, equipment. 8½" x 11" looseleaf paper to fit 3 rings. Stock No. 9100 H . . . . . \$3.00 Ppd.



## MAIL COUPON FOR GIANT FREE CATALOG!

164 PAGES • MORE THAN 4,000 UNUSUAL BARGAINS!

Completely new 1973 Catalog. Packed with huge selection of telescopes, microscopes, binoculars, magnets, magnifiers, prisms, photo components. Ecology and unique lighting items, parts, kits, accessories—many hard-to-get surplus bargains. 100's of charts, illustrations. For hobbyists, experimenters, schools, industry.

**EDMUND SCIENTIFIC CO. 300 Edscorp Building, Barrington, N. J. 08007**  
 Please rush Free Giant Catalog "H"

Name \_\_\_\_\_  
 Address \_\_\_\_\_  
 City \_\_\_\_\_ State \_\_\_\_\_ Zip \_\_\_\_\_

**EDMUND SCIENTIFIC CO. 300 EDSCORP BLDG. BARRINGTON, NEW JERSEY 08007**  
 ORDER BY STOCK NUMBER • SEND CHECK OR MONEY ORDER • MONEY-BACK GUARANTEE

## SCIENCE WORLDWIDE

(Continued from page 28)

duced from a heat source. Heat is produced by decaying radioisotopes in capsules containing plutonium-238—a fuel supply that's good for more than 85 years. The Nuclear refrigeration is planned only for space applications.

## The environment

IT SEEMS MANURE can have a variety of smells. The goal of an unusual research group in Sweden is to determine the least offensive form of manure for use by farmers. The research team is composed mainly of women. Some work in a specially



equipped bus, an "atmosphere laboratory," while others sit in fields at "smelling stations." When a trailer loaded with manure passes, they compare its odor with that of control samples.

BIRDS EXPOSED to a San Francisco Bay oil spill in 1971 died from ingesting large amounts of oil or from infections and stress related to their exposure and handling. Those are the conclusions of a Stanford University medical team that examined tissues and organs of 119 birds that had died after being brought to the San Francisco Zoo for cleaning. Sea birds ingest oil when they clean their feathers.

FIVE TIMES EACH MINUTE, scientists at Argonne (Ill.) National Laboratory transmit a narrow beam of sound into the air to study the structure of the lower atmosphere. The "acoustic radar" draws a continuous picture of the atmosphere over the laboratory site to a height of 6000 feet. The picture shows temperature inversion layers that allow a buildup of pollutants which can be hazardous to health. ★★

# when I planned to retire before fifty

this is the business that made it possible

a true story by John B. Haikey

Starting with borrowed money, in just eight years I gained financial security, sold out at a profit and retired.

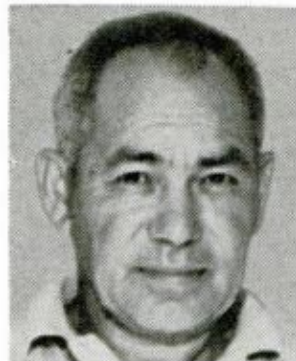

"Not until I was forty did I make up my mind that I was going to retire before ten years had passed. I knew I couldn't do it on a salary, no matter how good. I knew I couldn't do it working for others. It was perfectly obvious to me that I had to start a business of my own. But that posed a problem. What kind of business? Most of my money was tied up. Temporarily I was broke. But, when I found the business I wanted I was able to start it on a little over a thousand dollars of borrowed money.

"To pyramid this investment into retirement in less than ten years seems like magic, but in my opinion any man in good health who has the same ambition and drive that motivated me, could achieve such a goal. Let me give you a little history.

"I finished high school at the age of 18 and got a job as a shipping clerk. My next job was butchering at a plant that processed boneless beef. Couldn't see much future there. Next, I got a job as a Greyhound Bus Driver. The money was good. The work was pleasant, but I couldn't see it as leading to retirement. Finally I took the plunge and went into business for myself.

"I managed to raise enough money with my savings to invest in a combination motel, restaurant, grocery, and service station. It didn't take long to get my eyes opened. In order to keep that business going my wife and I worked from dawn to dusk, 20 hours a day, seven days a week. Putting in all those hours didn't match my idea of independence and it gave me no time for my favorite sport—golf! Finally we both agreed that I should look for something else.

"I found it. Not right away. I investigated a lot of businesses offered as franchises. I felt that I wanted the guidance of an experienced company—wanted to have the benefit of the plans that had brought success to others, plus the benefit of running my own business under an established name that had national recognition.

"Most of the franchises offered were too costly for me. Temporarily all my capital was frozen in the motel. But I found that the Duraclean franchise

offered me exactly what I had been looking for.

"I could start for a small amount—a little over a thousand dollars—and that amount I could borrow. I could work it as a one-man business while getting a start. No salaries to pay. I could operate from my home. No office or shop rent or other overhead. For transportation I could use the trunk of my family car. (I bought the truck later, out of profits.) But, best of all, there was no ceiling on my earnings. I could build a business as big as my ambition and energy dictated. I could put on as many men as I needed to cover any volume. I could make a profit on every man working for me. And, I could build this little by little, or as fast as I wished.

"So, I started. I took the wonderful training furnished by the company. When I was ready I followed the simple plan outlined in the training. During the first period I did all the service work myself. By doing it myself, I could make much more per hour than I had ever made on a salary. Later, I would hire men, train them, pay them well, and still make an hourly profit on their time that made my idea of retirement possible—I had joined the country club and now I could play golf whenever I wished.

"What is this wonderful business? It's Duraclean. And, what is Duraclean? It's an improved, space-age process for cleaning upholstered furniture, rugs, and tacked down carpets. It not only cleans but it enlivens and sparkles up the colors. It does not wear down the fiber or drive part of the dirt into the base of the rug as machine scrubbing of carpeting does. Instead it *lifts* out the dirt by means of an absorbent dry foam.

"Furniture dealers and department stores refer their customers to the Duraclean Specialist. Insurance men say Duraclean can save them money on fire claims. Hotels, motels, specialty shops and big stores make annual contracts for keeping their carpets and furniture

fresh and clean. One Duraclean Specialist recently signed a contract for over \$40,000 a year for just one hotel.

"Well, that's the business I was able to start for a little over a thousand dollars. That's the business I built up over a period of eight years. And, that's the business I sold out at a substantial profit before I was fifty."

Would you like to taste the freedom and independence enjoyed by Mr. Haikey? You can. Let us send you the facts. Mail the coupon, and you'll receive all the details, absolutely without obligation. No salesman will ever call on you. When you receive our illustrated booklet, you'll learn how we show you STEP BY STEP how to get customers; and how to have your customers get you more customers from their recommendations.

With no obligation, we'll mail you a 24-page brochure explaining the business. Then you, and you alone, in the privacy of your home, can decide. Don't delay. Get the facts before your location is taken by someone else. Mail the coupon, now.

**DURACLEAN INTERNATIONAL**  
3-162 Duraclean Bldg., Deerfield, Ill. 60015



send  
name  
for  
full  
facts

**DURACLEAN INTERNATIONAL**  
3-162 Duraclean Building  
Deerfield, Illinois 60015

WITHOUT OBLIGATION mail letter and 24-page illustrated booklet explaining how I can increase my income and family security with a Duraclean Dealership. No salesman is to call.

Name \_\_\_\_\_  
Address \_\_\_\_\_  
City \_\_\_\_\_ State \_\_\_\_\_ Zip \_\_\_\_\_

# APPLIANCE CLINIC

By PAUL MANN

## Germ of an idea

*My Hamilton automatic gas clothes dryer is about 10 years old. The bulb which lights when the door is opened blew out. I replaced it with one of the same kind—a 40-watt appliance bulb. The new bulb doesn't go on. Where's the problem?—Harlen Underwood, Providence, R. I.*

There is a second bulb—a germicidal lamp—in the circuit which is wired together with the door bulb. When one goes bad, the other won't go on. The germicidal lamp creates the flashes of light you see as the drum revolves. In Hamilton dryers that are "about 10 years old," the germicidal lamp is positioned in a housing right next to the door bulb. Replace the germicidal lamp and both will probably now work.

## Soft food on the door

*We have a Ward's Signature side-by-side refrigerator-freezer combination about a year old. When the outside temperature is over 85°, articles stored on the door of the freezer, such as hot dogs, buns and orange juice, soften considerably. Roasts and steaks in the main cabinet remain hard. A repairman has told me that the unit is in good condition. Is he right?—Mrs. B. Ramsden, Arlington Heights, Ill.*

I would say so. Food kept on a freezer door has a tendency to remain "softer" than foods kept in the main cabinet. This is more pronounced and more noticeable during warm weather. There are no refrigerating coils in a freezer door as there are in the main part of the unit. Food kept on the door, therefore, must rely on "residual cold" passed to it from the main part of the freezer. Try setting the unit on a colder setting or move food from the door to the main cabinet until the warm weather subsides.

## Rusting stove

*We bought an O'Keefe & Merritt stove*

*about three years ago, but are very disappointed because components (chrome, side panels, racks and surface) are rusting. The manufacturer has told us the condition is caused by our climate and claims there is nothing he can do. Is he right?—M. Palmisano, Metairie, La.*

Appliance Clinic has obtained two different theories regarding this problem. One leading manufacturer of stoves told us this problem is neither unique nor confined to your type of area, but it is nationwide. He contends that climate has nothing to do with it, but that heat from the pilot assembly gets trapped beneath the main deck, because vent holes are "too small." Trapped heat causes condensation that leads to rusting.

"There is nothing you can do," a representative of this company says.

Public Service Electric and Gas Co. of New Jersey disagrees. A representative contends that the 2 by 6-inch vent slot in the rear of the stove that allows heat to escape was either not blanked out at the factory or has been inadvertently plugged up. Make sure this vent is open.

In addition, Public Service says, it's a good idea to leave the door of the stove open a bit the first four or five minutes of preheating to let moisture escape.

## 'Building' a new housing

*My Whirlpool automatic clothes washer is equipped with the brush filter. I want to replace a damaged filter housing, but would not like to tackle the task without having a clear understanding of how to do it. Can you help?—Thomas Danberry, Franconia, Va.*

Easy enough. The brush filter assembly housing is held in the top of the washer by a gasket that has to be dislodged. Start by removing the brush filter itself—a task you should be familiar with since this should be done to clean the filter after every wash. With a screwdriver, carefully dislodge and push the gasket through the top of the washer. This frees the filter housing.

To install the new housing position the gasket on the bottom ridge of the housing and push the assembly into place from the underside of the top.

## Dirty dishes

*Our Tappan model 61-0016 dishwasher*  
(Please turn to page 34)



# TOM McCAHILL says: "If your pay check's thinner than a 10 cent hamburger...fatten it up by earning extra money repairing appliances."

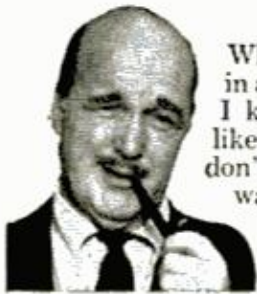

When a fellow tells me his wallet's in about the same shape as my hair, I know how he feels. Salaries are like \$50 Caribbean cruises . . . they don't go very far. But I know one way a guy with get up and go can make himself some real money . . . by learning Appliance repair.

**Earn \$5 to \$7 an hour in your spare time.**

NRI has a low-cost, home study plan that covers every type of Appliance repair in detail. Even if you're all thumbs and don't know a soldering iron from a steam iron, NRI can lead you through the course one step at a time. Before you know it, you'll be servicing electric appliances for cold, hard cash.

The lessons come to you fully illustrated . . . and the NRI staff of experts gives you more personal attention than you'd get in many classrooms. You learn basic electricity and how to use test instruments, at your own speed. The course covers the electrical and mechanical operation of every type of appliance from toasters and coffee makers to dishwashers; from vacuum cleaners and automatic laundry equipment to air conditioning and refrigerators.

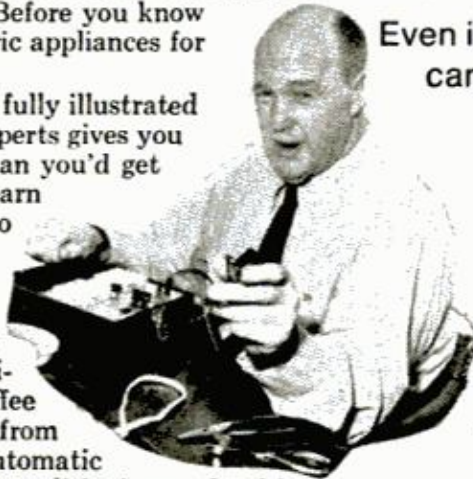

They even show you how to fix farm and commercial appliances and small, one-lung engines. Their staff of experts work with you every step of the way. NRI even includes a professional Appliance tester in the low tuition.

**Turn off the TV and learn at home in your spare time, the easy NRI way.**

You won't make a buck off the boob tube, but you can make a bundle in the Appliance repair field. (If you're really out to learn, they've got a special course on air-conditioning and refrigeration repair, too.)



**Even if you can't wire a plug, NRI experts can teach you all you need to know.**

Thousands of guys like yourself have studied with NRI, and they all had one thing in common. They were looking for a way to learn a new skill that would pay off. The Appliance Division of NRI can teach you that skill. Just send in the coupon below for the free catalog that gives you all the details. Send it today and they'll have the book in your hands in no time. Then, it'll be up to you. No salesman will call. The only knocking you'll hear will be opportunity.

*Tom McCahill*

**Grab this FREE BOOK and see what NRI can do for you**



## NRI TRAINING

3939 Wisconsin Avenue, Washington, D.C. 20016

Send me the free book on Professional Appliance Servicing. **NO SALESMAN WILL CALL.**

Name \_\_\_\_\_ Age \_\_\_\_\_

Address \_\_\_\_\_

City \_\_\_\_\_ State \_\_\_\_\_ Zip \_\_\_\_\_

Accredited Member National Home Study Council  Check for facts on GI Bill

600-023

**AVAILABLE UNDER NEW GI BILL**  
If you served since January 31, 1955 or are in service, check GI line below.

## APPLIANCE CLINIC (Continued from page 32)

doesn't run—no hum, nothing, dead. Is the motor burned out?—Raymond Greenberg, Asbury Park, N.J.

Check the two most common reasons for this trouble: a blown fuse or tripped circuit breaker, and an improperly adjusted or defective door switch. If the circuit is protected by a fuse, be certain that the correct fuse is being used—specifically, a 15-amp. slow-blow type.

The door switch is positioned within the door panel, directly behind the latch. The switch is activated by the door latch strike. After removing the control panel, bend the switch arm a bit and see if the dishwasher will run. If not, the door switch has probably gone bad and should be replaced by disconnecting the wires (pull the plug from the outlet, or remove the fuse or trip the circuit breaker before you do) and unscrewing the switch. You can get a new switch from a Tappan dealer.

### Water, water everywhere

*I am getting water puddles on the in-*

## Try the tub fixer

from **DAP**



DAP KWIK-SEAL®. A bright white tub and tile caulk that seals joints and cracks watertight around tubs, sinks, showers, tiled areas. Beautifies bath and kitchen. Stays flexible. Resists mildew.

**America's  
First Name in  
Home Fix-up**



DAP Inc., Dayton, Ohio 45401  
Subsidiary of *Plough, Inc.*

## Try the window fixer

from **DAP**



DAP '33' Glazing. Best way to replace broken glass. Seals glass in wood or metal sash, primed or unprimed. Stays flexible. Outlasts ordinary putty by years.

**America's First Name  
in Home Fix-up**



DAP Inc., Dayton, Ohio 45401  
Subsidiary of *Plough, Inc.*

*side of my Hotpoint refrigerator. Why?*  
—J. Domituovits, Catasauqua, Pa.

If the unit is a nonfrost-free type, there may be an air leak because of a bad seal or warped door. To check the seal, place a dollar bill in the door and shut it. If there is no resistance as you pull the bill from the door, the seal is faulty or the door is warped. Do this around the entire door.

To straighten a warped door, the inner door panel should be unscrewed from the outer door panel, and the outer door panel must be twisted.

If the unit is a frost-free model, puddles will result if outside drainage is impeded by a clogged drain. Some models have drain holes that can be reamed out . . . a drill bit makes a suitable reamer. If the model has a long drain tube instead of drain holes, a snake-type device will have to be used to clean it out. An old speedometer cable serves nicely. ★★

*If you have a question about any appliance, send it to Appliance Clinic, Popular Mechanics, 224 West 57th St., New York, N.Y. 10019. Sorry, but letters cannot be answered individually. However, problems of widest interest will be answered in this column.*

# Chrysler makes it easy to leave your everyday world behind.



Get away from the noise, the crowds, the hustlebustle of the workaday world. Forget the pressure, tension and hectic pace.

Chrysler makes it easy to leave it all behind. And enter a refreshing new world.

A world that's serene and silent as a moonbeam dancing on a wave. Or sizzling with the excitement of a speeding pair of skis kicking up a spray.

Take command of the watery world that awaits you. It's easy. With Chrysler.

# Chrysler Hi-Performance: Engineered to make things easy.

Get away from the everyday—far away. Head for the horizon. Water ski. Fish for the big ones on the outer limits. Chrysler's Hi-Performance line of dependable 1973 outboards makes it easy.

Five exciting outboards, starting with the 3-cylinder action of the 70 and working up to the most horsepower you'd want to hang on most any popular-sized boat—the sizzling 4-cylinder 130. In between, you've got the 85, America's most powerful 3-cylinder outboard, and two more 4-cylinder models, the 105 and 120.

They're all Chrysler engineered to make things easy. Easy starting with Magnapower C-D ignition. Easy going with a new remote-



control cruise range indicator for maximum economy, a new fastback leg design with big 14" prop capability, and cleaner, more attractive styling. Easier servicing with new integrally designed 2-stage fuel pump, too.



They're also easy on the environment. Complete fuel recycling helps keep the water clean, and super-silencing helps keep the peace and quiet.

And if you're the kind of boater who likes the ultimate in easy operation, Chrysler's Power Trim/Power Tilt option adds a new dimension of performance to the Hi-Performance line. Tilt and trim functions are at your instantaneous command, operating off a single switch.

Power Trim lets you trim motor under power for optimum performance and Power Tilt allows you to raise it full-up for beaching, trailering, or shallow water operation at low speeds.





## HI-PERFORMANCE SPECIFICATIONS

	130	120	105	85	70
Cert. BIA hp. @ rpm	130 @ 5250	120 @ 5250	105 @ 5000	85 @ 5000	70 @ 4750
No. of Cylinders	4	4	4	3	3
Piston Displacement, cu. in.	96.55	96.55	96.55	72.39	72.39
Net Weight, lbs.	250	248	248	221	221
RPM Range — full throttle	5000-5600	5000-5500	4500-5500	4500-5500	4400-5100
Ignition	Magnapower	Magnapower	Magnapower	Magnapower	Magnapower
Amp. Output @ rpm	10 amp. @ 4000	10 amp. @ 4000	10 amp. @ 4000	10 amp. @ 4000	10 amp. @ 4000
No. of Carburetors	2	2	2	3	3
Std. Prop Dia. X Pitch; Number of Blades	13 x 17; 3	13 x 17; 3	13 x 17; 3	13 x 15; 3	13 x 15; 3

# Chrysler makes it easy to get family plans off the ground.

If fishing's not fast enough and racing's not your style, Chrysler has a complete choice of mid-range power that makes it easy to plan your kind of family fun.

These Chryslers will let you go the limit from ski to cruise, from wide open to trolling speed. And you've got a pick of power ranging from 35 to 55 horsepower in 24 different models.

Over the years Chrysler 35's have proven themselves consistent winners in national APBA powerboat racing. The versatile 45 provides high performance at a medium price. And the 55 offers the highest



BIA-certified 2-cylinder horsepower rating you can get. Anywhere.

Underneath those handsome new fiberglass hoods, Chrysler Mid-Ranges are engineered to make life easy with new features like built-in rear handles for easier tilt up, new upper gear housing for more efficient cooling and an integrally designed fuel pump for easier maintenance. And the 45 and 55 are available with Magnapower C-D ignition, Chrysler's exclusive ignition system that assures quick starts even in freezing temperatures or with a weak battery.

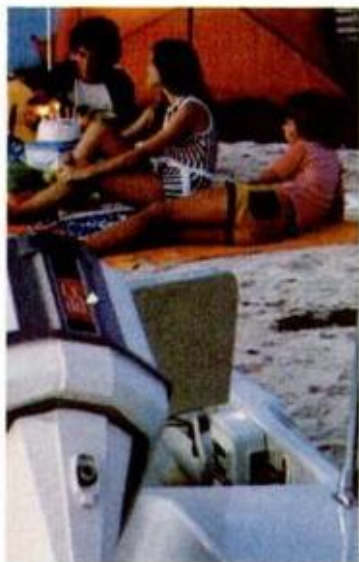

And, of course, they're all Chrysler engineered to take it easy on the environment. With greatly improved silencing to keep things calm and fuel recycling and dripless carburetors to keep the water clean.



## MID-RANGE SPECIFICATIONS

	55 MAGNAPOWER	55	45 MAGNAPOWER	45	35
Cert. BIA hp. @ rpm	55 @ 5250	55 @ 5250	45 @ 4750	45 @ 4750	35 @ 4750
No. of Cylinders	2	2	2	2	2
Piston Displacement, cu. in.	44.7	44.7	42.18	42.18	35.9
Net Weight, lbs.*	151	148	151	148	148
RPM Range—full throttle	5000-5500	5000-5500	4400-5100	4400-5100	4400-5100
Ignition	Magnapower	Batt.   Mag.	Magnapower	Batt.   Mag.	Batt.   Mag.
Charging System	Alt.	Alt.   None	Alt.	Alt.   None	Alt.   None
No. of Carburetors	1	1	1	1	1
Std. Prop Dia. X Pitch; Number of Blades	10-3/8x12- 1/2: 3	10-3/8x12- 1/2: 3	10 3/8x12- 1/2: 3	10-3/8x12- 1/2: 3	10-3/8x11- 1/2: 3
*alternator model.					



# Chrysler makes it easy from every angle.

Everything's easy with Chrysler Lo-Profiles. Their low, transom-hugging design makes it easy to cast a line in any direction. Their light weight makes them easy carry-outs. Fold-up-down tillers make them easy stowaways. And features like curved, weed-free legs, self-releasing choke and no-shearpin props make them easy to enjoy.



It's the only full line of lo-profile outboards on the market. With 6, 8, 9.9 and 12.9 horses to choose from. The goingest, quietest, most compact power on the water.

The Lo-Profiles are powered to do the job, whether it's quiet, steady trolling, bringing a sailboat back to shore, moving a fisherman to his favorite spot fast, or just plain fun-running. Chrysler's shallow-water drive keeps you going in as little as six inches of water. And the forward-neutral-reverse gearshift and front-mounted controls make for easy handling.



And even though the Lo-Profiles are lightweight and compact, we still found room enough to build in Chrysler's fuel recycling system to help make your boating good clean fun.



Chrysler's big little 3.6-hp. "Swinger" is proof positive that good things come in small packages. Just 33 lbs., the very portable



"Swinger" is nevertheless loaded with outstanding features: simple air-cooled design with water-cooled exhaust; stainless steel shaft; dripless carburetor; heavy-duty prop hub and shearpin; 360° pivot

steering; self-relieving choke; built-in carrying handle, and much more. It's perfect for breaking in the youngsters, unbecalming a sailboat or getting the canoe or rowboat back upstream.





### LO-PROFILE SPECIFICATIONS

	12.9 AUTOELECTRIC	12.9	9.9 AUTOELECTRIC	9.9	8	6	3.6
Net. BIA hp. @ rpm	12.9 @ 5000	12.9 @ 5000	9.9 @ 4750	9.9 @ 4750	8 @ 5000	6 @ 5000	3.6 @ 4500
No. of Cylinders	2	2	2	2	2	2	1
Station Displacement, cu. in.	13.62	13.62	13.15	13.15	10.2	8.99	5.18
Net Weight, lbs.	77	59	74	56	49	47	33
RPM Range — at full throttle	4500-5500	4500-5500	4300-5200	4300-5200	4500-5500	4500-5500	4000-5000
Fuel Tank — w/Gauge	6 U.S. gals. steel	6 U.S. gals. steel	6 U.S. gals. steel	6 U.S. gals. steel	6 U.S. gals. steel	6 U.S. gals. steel	Integral 7 U.S. pints
Propeller Drive	Shearproof spline	Shearproof spline	Shearproof spline	Shearproof spline	Shearproof spline	Shearproof spline	Shear pin
Std. Prop Dia. X Pitch: Number of Blades	8-1/8 x 8-1/4: 3	8-1/8 x 8-1/4: 3	8-1/4 x 8-1/4: 2	8-1/4 x 8-1/4: 2	7-1/2 x 6-1/2: 2	8 x 5; 2	7-1/2 x 4-1/2: 2

# Want a little more power for a lot more fun? Chrysler's new 25 and 30 make it easy.

Boaters have been looking for a modern outboard in this power/performance/price range for years.

Now Chrysler makes it easy for you with two brand-new 2-cylinder outboards that let you do a lot more on water. Surprisingly lightweight and compact, they still pack enough punch to take you fishing one minute and skiing the next. Combined with the quiet-running 20, you've got a wider choice of power than before.

And they're loaded with Chrysler-engineered



features that make the going easy. Heavy-duty components. Water-cooled heads. Full gearshifts. Integrally designed 2-stage fuel pumps. Push-to-stop buttons. All topped off with handsome fiberglass hoods with built-in tilt handles.

The 25 and 30 are both available in manual and electric start models with standard or long shaft. See them at your Chrysler Crew dealer today. Then try one on your transom tomorrow.



## 30 25 20 SPECIFICATIONS

	30	25	20 AUTOELECTRIC	20
Cert. BIA hp. @ rpm	30 @ 5000	25 @ 5000	20 @ 5000	20 @ 5000
No. of Cylinders	2	2	2	2
Piston Displacement, cu. in.	29.99	28.57	19.96	19.96
Net Weight, lbs.	113	105	103	79
RPM Range—full throttle	4500-5500	4500-5500	4500-5500	4500-5500
Ignition	Magneto	Magneto	Magneto	Magneto
Charging System	None	None	Starter-generator	None
No. of Carburetors	1	1	1	1
Std. Prop Dia. X Pitch; Number of Blades	10-3/8 x 13-1/2: 3	8-1/2 x 10: 3	8-1/2 x 8-1/2: 3	8-1/2 x 8-1/2: 3

**FREE.** At your Chrysler Crew dealer's.

### The 1973 Buyer's Guide: "How To Buy The Right Boat"

Everything you ought to know about  
boats. Before you buy.

- The right boat for your needs.
- What to look for in boat construction.
- Extra equipment you'll want to have.
- Choosing the right motor and trailer for your boat.

MARINE PRODUCTS



**CHRYSLER**  
CORPORATION

The Chrysler Crew makes things easy for you.

## Get the facts about Midas Frolic Low-Flite



Get the facts.  
You'll go Midas.

**MIDAS** International Corporation  
an IC Industries Company / 222 South Riverside Plaza / Chicago, Illinois 60606

Smokey/Frolic/Grizzly/Volunteer/Norris/Travelmaster/Ken-Craft

- It's lighter and stronger . . . Thermo-Core laminated sidewall construction makes it that way.
- Frolic is more roadable . . . the Cushion-Torque suspension absorbs bumps independently and reduces sway.
- It's roomier . . . Frolic's spacemaker frame gives you a large unobstructed floor space.
- Frolic contour seats are comfortable . . . they fit the sitting position more naturally.
- Mortise and tenon cabinets are standard! They won't separate like conventional cabinets with varying climatic conditions.

**Frolic is priced right . . . \$1993.00.\***

\*Manufacturers suggested retail price.

Get the facts about Frolic Low-Flite,  
write to:

**Sales Manager  
Midas-International Corp.  
RV Group / Dept. FP-2  
2600 S. Nappanee Street  
Elkhart, IN 46514**



### Makes Over \$60 EXTRA a Week In His Own Sharpening Shop

"My Belsaw Sharp-All made me an extra \$3,500 last year. Now I am going full time. It's great to be your own boss."

**DAVID SWANSON — Utica, Michigan**



## Let Belsaw prove YOU can do it, too! On our 30-DAY FREE TRIAL OFFER

### JOIN THESE SHARP-ALL MONEYMAKERS

"I average \$5.00 an hour part time and business gets better all the time."

*Robert Barrett, Jr.  
W. Springfield, Mass.*

"My Sharp-All shop is now averaging me \$300.00 a month."

*Roy Jennings  
Sandwich, Illinois*

"Think the world of my Sharp-All. Am grossing \$4,000 a year on a part-time basis."

*Lawrence Stevenson  
E. Syracuse, New York*

"There's excellent profit in sharpening . . . we now do about \$600.00 a month."

*Ed Kistler, Jr.  
Sarasota, Florida*



You risk nothing by accepting this offer to see how easily you can turn your spare time into big Cash Profits with your own Complete Sharpening Shop. No selling . . . no previous experience needed. Our famous Sharp-All and show-how instruction set you up to make \$200, \$500, \$700 a month CASH sharpening Saws, Knives, Scissors, Lawnmowers, Shop and Garden Tools . . . all cutting edges.

### SEND FOR FREE FACTS!

Our Free Book tells how to start a profitable, lifetime home sharpening business, how we help you grow, how we'll finance you. **BELSAW SHARP-ALL CO. 713-FField Bldg. Kansas City, Mo. 64111 RUSH COUPON TODAY!**

### No Obligation . . . No Salesman Will Call

**BELSAW SHARP-ALL CO. 713-FField Bldg., Kansas City, Mo. 64111**  
Send details of FREE TRIAL OFFER and Free Book "Lifetime Security"

NAME \_\_\_\_\_

Address \_\_\_\_\_

City \_\_\_\_\_ State \_\_\_\_\_ Zip \_\_\_\_\_

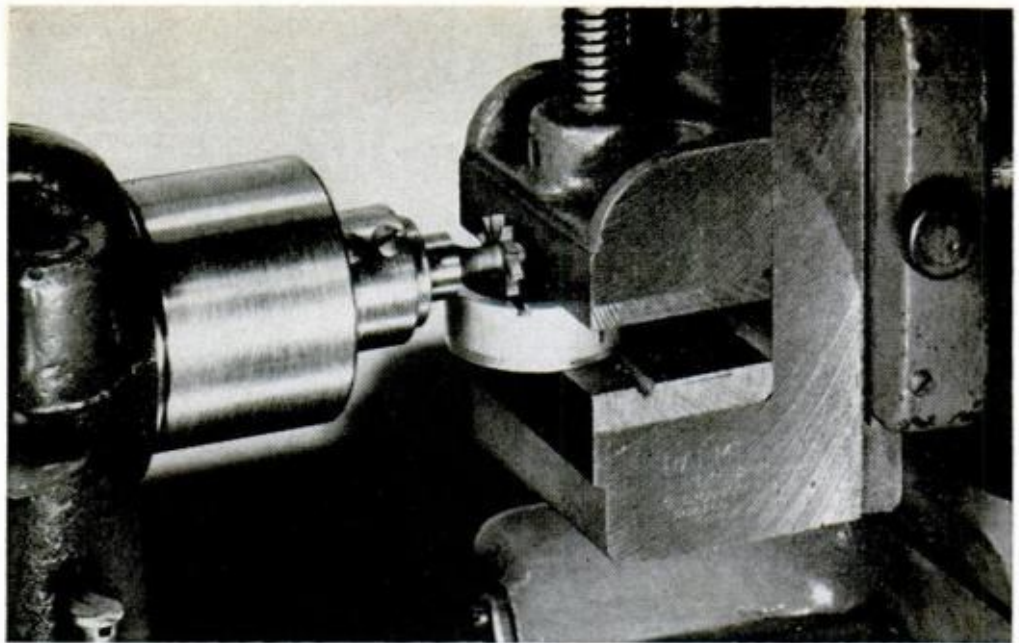

**MOUNTED** in screw-on setscrew chuck (top photo), a Woodruff keyway cutter is used to slot a ring. Work is held in carriage-mounted milling attachment. Taper-shank setscrew chuck (bottom photo) is better suited for drilling and other operations in which the pressure is mostly lengthwise

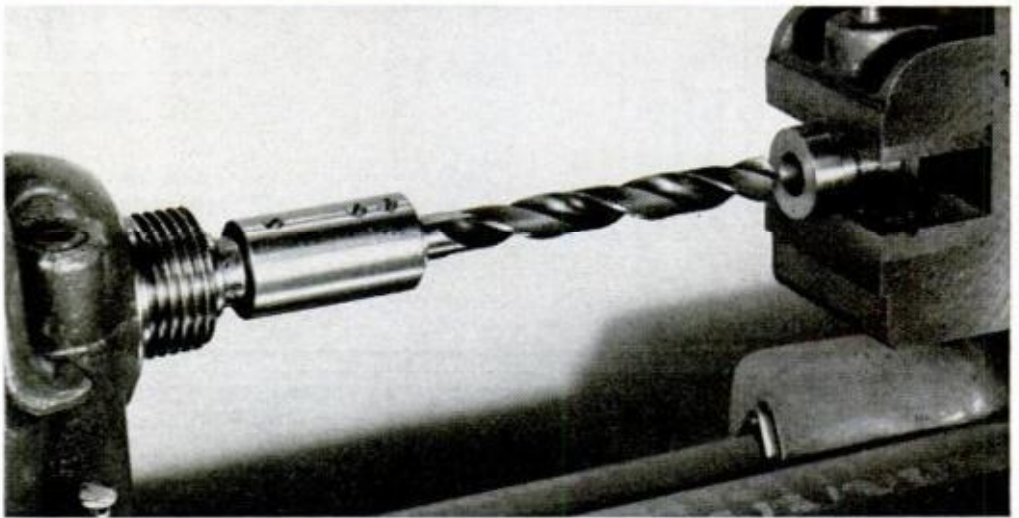

## Setscrew chucks you can make

By WALTER E. BURTON

A SIMPLE SETSCREW CHUCK for the headstock spindle of a lathe can be as useful as a costly three-jaw chuck. A setscrew chuck is commonly used for holding drill bits, end mills and Woodruff-keyway cutters. It can also hold workpieces, such as shafting, for turning or drilling. Setscrews bearing against the tool shank lock it in the chuck bore.

Setscrew chucks are often used in connection with a carriage-mounted milling attachment, with an angle plate or other arrangement for clamping and moving work in proper relation to drill bit, reamer, milling cutter, slitting saw, or other tool. Tools with shanks smaller than  $\frac{1}{2}$  in. can be mounted in the chucks with

split bushings. The taper-shank type can be provided with two or more interchangeable heads having different hole diameters. A setscrew chuck can accommodate a conventional geared drill chuck with a  $\frac{1}{4}$ -in. shank projecting an inch or two.

There are two general types of setscrew chucks. As detailed here, chuck A screws over the spindle nose, and is preferable where minimum overhang is desirable and where the tool might be subjected to considerable side pressure. Chuck B has a taper shank fitting the spindle bore and a somewhat greater overhang. It is useful where cutting pressure is mostly endwise, as in drilling.

# What tire does a man who drives for a living buy for his own car?



Carlyle Smith of Hemet, California had 37 years of experience behind the wheel of a Greyhound bus.

So when he shopped for new tires for his family car and bought Firestone Radial V-1's over all the other tires he saw, we wanted to know "why us?" and here's what Carlyle said:

**"...when you drive a bus all day you learn how to judge tires. And these Radial V-1's are great! They changed the whole ride of my car. I'm sure I should get 40,000 miles."**

Convincing? Wait until you drive Radial V-1's yourself.

## **OUR 40,000 MILE GUARANTEE**

The Radial V-1 tire by Firestone is guaranteed to give you 40,000 miles of treadwear in normal passenger use on the same car. If it doesn't, take your guarantee to any Firestone Store or participating Dealer. He'll replace the tire with a new one and give you credit at the current exchange price plus Federal excise tax for the mileage not received (a small service charge may be added). Subject to proper maintenance and care of your car and tires.



**Firestone**  
**RADIAL V-1**  
Another people tire.

Carefully made and fitted, either type can run as true as the average multijaw chuck or conventional drill chuck fitted with a taper shank.

● **Screw-on setscrew chuck.** This is screwed on the threaded end of the headstock spindle until firmly seated against the spindle shoulder. Cutting its thread is tricky. To fit a 9-in. lathe spindle, the thread is 1½-8 in a 1-in.-deep hole.

A 2-in. round steel blank about 2½ in. long is clamped in a three-jaw chuck, the end faced, and a ½-in. axial hole drilled 1 in. deep. With larger drills and a boring bar the hole is enlarged as required by the spindle-nose thread—here to about 1.345 in. dia., slightly larger than the standard 1.3376-in. for this thread. The bore diameter is further enlarged to a generous 1½ in. at both ends. Length of the inner, 1½-in.-diameter bore is determined by the clearance required by the threading tool—about ⅜ in. To determine various dimensions of the threaded bore, the spindle nose and back plate of a chuck that fit the nose were used as guides.

The internal thread is cut next. Care must be taken not to jam the end of the threading tool against the bore bottom. For each cut (average depth about 0.0025 in.), the lathe is stopped a bit short of the end, and the cut finished by pulling the headstock belt by hand. A 60° point

threading bit is used.

Careful measurements can produce a precise fit of threads, but a gauge threaded like the spindle nose is handy for testing the internal threads, especially when final cuts are being made. For another test remove the lathe chuck without loosening its jaws, turn it and the setscrew-chuck blank end for end, and try to screw the blank onto the spindle.

When the threading fits the spindle nose snugly, remove the workpiece from the chuck and drill a radial wrench hole (for a ¼-in. rod) as shown. This hole enables the chuck body to be loosened readily if it should stick.

The chuck blank is installed on the spindle, and the outer end machined to the form shown. Then a hole is drilled through its center, starting with a small bit, to a diameter of about ⅞ in. Because it is possible for a drill bit to produce a hole slightly out of line, a boring bar is used to bring the hole to final diameter of ½ in. This diameter depends on the tool-shank diameter and clearance necessary for easy installation or removal of the tool, and might be around 0.501 or 0.502 in. (Many cutting tools have precise ½-in. shanks.) Another way to achieve an accurate, true-running hole is by internal grinding. If such a chuck is hardened, final grinding would be done afterward.

After the outside surface has been

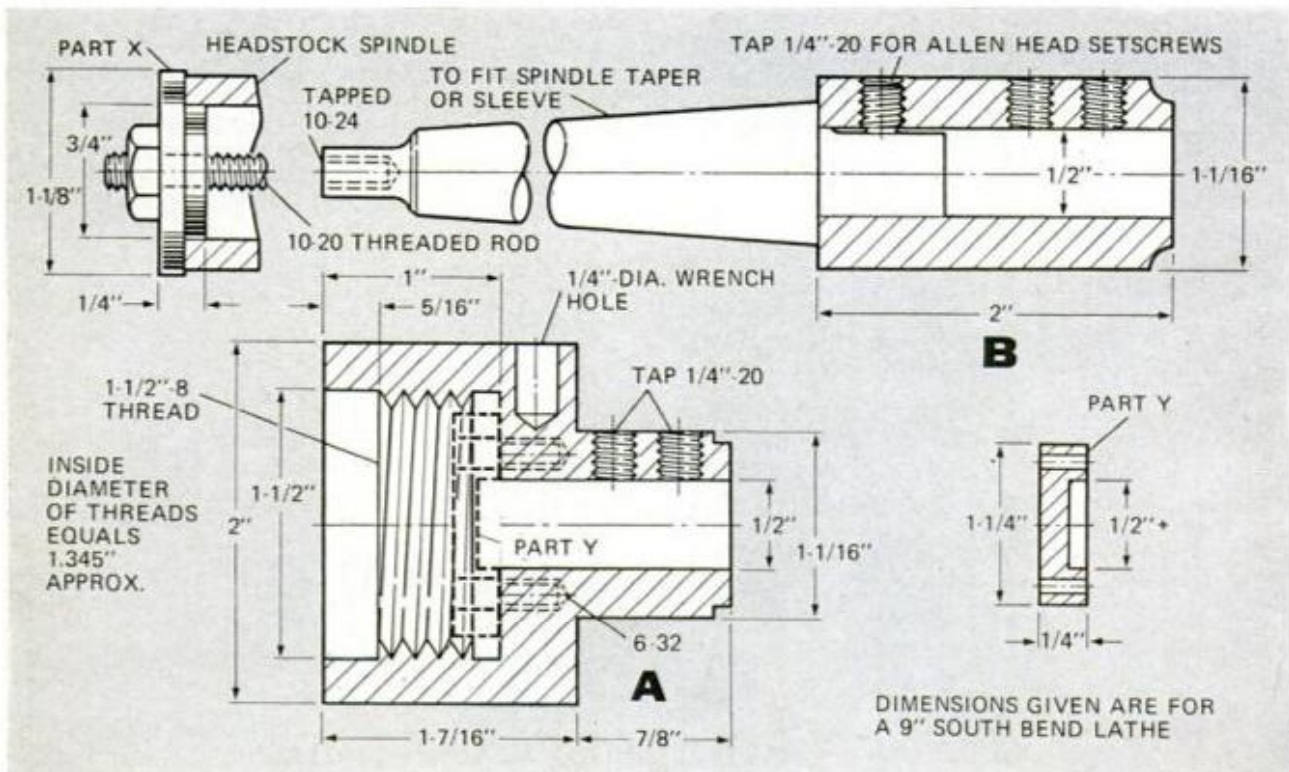

For the man who takes care of his own yard.



All the chain saw you need costs just **\$99.95\***



**It's the 6.9 lb.\*\* Mini Mac 1. Only McCulloch makes a saw this light, for this little.**

Why \$99.95\* is all you need to spend. The Mini Mac 1 was built for just one job — your yard. The 10" bar is easier to work with, cuts a 6" log in just 5 seconds and even zips through 20" logs. No gimmicks you don't need. Just all the saw and all the power you do need. So why pay more?



Why light weight counts. When you're out there cutting, even half-a-pound makes a *big* difference. A professional timber cutter would tell you this: next to reliability, nothing is as important as light weight. The Mini Mac 1 is the lightest saw you can buy at the price. Even the bar and chain are lighter. So why pay more?

Why YOU need a Mini Mac 1. When you cut your own firewood and clean up storm damage and cut back overgrowth, Mini Mac 1 will save you money. And it works so efficiently, it'll help you save something even more important. Your weekends.



Why McCulloch is for you. McCulloch simply builds the best chain saws. The big-timber pros know it. They earn their livings with McCulloch. So, when you can get the best for \$99.95\* — why pay more?

Why McCulloch makes different models for non-professional users. The \$99.95\* Mini Mac Electric can be used indoors as well as outdoors. The \$119.95\* Mini Mac 1 Automatic has a 12" bar for extra cutting capacity. The \$129.95\* Mini Mac 6 Automatic has a 14" bar for heavier jobs and has many unique deluxe features. The \$159.95\* Power Mac 6 Automatic with a 14" bar and chain is the only professional saw in the six pound class.

\$99.95

\$119.95

The \$184.95\* Mac 10-10 Automatic has a 16" bar and a powerhouse 3.3 cubic inch engine to handle the toughest jobs. And easily. It

\$129.95

\$159.95

\$184.95

weighs only 12.6 lbs. Note: All McCulloch automatic models oil their own bars and chains while you cut.

*For best performance, always use McCulloch power-matched chains, bars and sprockets.*

**McCulloch**

McCulloch Corporation, 6101 West Century Blvd.,  
Los Angeles, Calif. 90045

\*Manufacturer's suggested list price, including bar and chain. Prices slightly higher in Canada and Alaska.  
\*\*Weight less cutting attachments.



**FLOOD THE WORK** with a sulfurized cutting oil when you bore the spindle-nose recess in the chuck body

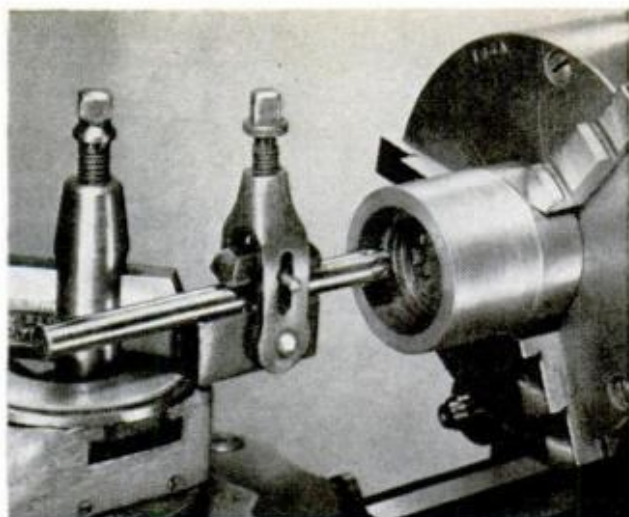

**AFTER RECESS IS BORED** 1½-in. x 8 threads are cut into the chuck body to fit the 9-in. lathe spindle

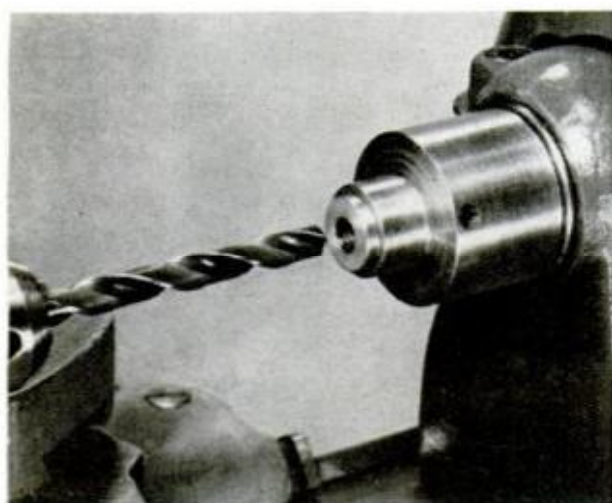

**REGULAR TWIST DRILL** is used to bore a slightly undersized axial hole in body of the screw-on chuck

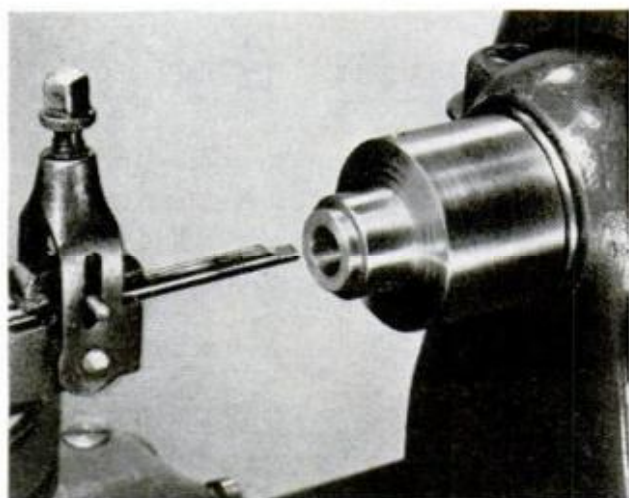

**BORING BAR** is used to finish-bore the axial hole. The hole in the side is for a chuck-removing wrench

smoothed with file and abrasive cloth, remove the chuck body from the spindle and drill and tap the two ¼-20 setscrew holes. Make an internal back-up disc (part Y) to help the setscrews handle end thrust such as that which is produced when a large-diameter drill is driven by the chuck.

The steel disc covers the hole and has an outside diameter that fits inside the headstock-spindle hole without jamming. Two 6-32 bolts with heads filed for clearance anchor it in place. (Four would be stronger.) Disc can be removed when chucking long shanks or rods.

● **Taper-shank setscrew chuck.** This is sometimes used on drill-press spindles. The shank shown is from a broken No. 2 Morse taper twist drill. The drill is annealed and the flute section sawed off. Then the shank is installed in the lathe spindle, and punch-marked for later alignment with spindle sleeve and spindle itself.

The projecting portion is machined to ½-in. diameter and a setscrew-flat filed on it.

The chuck body is made from 1⅝-in. steel rod. It is chucked, and an axial hole about 7/16 in. in diameter bored through. The outer ¾ in. of this hole is bored so that the taper-shank end, previously machined to ½ in., will fit snugly. Then the piece is unchucked, and a hole for the setscrew that clamps it to the shank is drilled and tapped for a ¼-20 thread. The two parts are assembled and installed in the lathe spindle for final boring of the ½-in. tool-shank hole, and finishing the surface.

Because the taper shank might come loose when in use, a safety feature is added—a long, threaded rod extending from the tapered shank through a cap machined to fit the outer end of the headstock spindle. A nut tightened against this cap, part X, locks the shank in place. ★ ★ ★





## We built Ford Pinto to live up to Dr. Gibson's indestructible Model T.

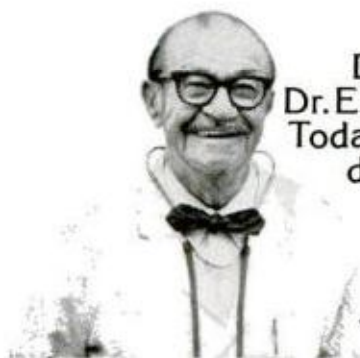

Down in Coffee County, Alabama, about fifty years ago Dr. E.L. Gibson made his rounds in a solid reliable Ford Model T. Today at 83, Dr. Gibson is still making his rounds, and still driving a solid reliable car: the Ford Pinto.

That's not so surprising when you know how Pinto is built. With a rugged engine we've developed and perfected in small Fords all over the world for more than ten years. With a solid four-speed full synchromesh transmission. (Or you can also opt for automatic.)

All inside Pinto's sturdy unitized body that's welded into one solid piece of steel, reinforced with guard rails, and covered with six coats of paint. See the 1973 Pinto Sedan, Wagon and Runabout, at your Ford Dealer's.



Shown here is a 1973 Pinto Runabout with optional whitewall tires, luxury decor and protection groups.

When you get back to basics,  
you get back to Ford.

# FORD PINTO

FORD DIVISION



# BRADLEY GT



## ...VW IN DISGUISE! BUILD YOUR OWN SPORTS CAR!

... WITH THE exciting Bradley GT sports-body kit — designed for easy, fast assembly on a stock VW chassis. No welding or special tools required. The dynamically designed body is pre-finished in a choice of 50 lustrous colors. The Bradley GT resembles a VW only in respect to its economy and reliability. The stock VW engine gives surprising performance and handling because of the Bradley GT aerodynamic body design reduced weight and lower center of gravity. With a stock VW engine, the Bradley GT will cruise at 80 m.p.h. at 28 miles per gallon.

The comprehensive kits include all parts, hardware, nuts and bolts, and full assembly manual. The assembly manual includes over 150 photos and diagrams covering all phases of preparation and complete assembly.

Easily assembled on a stock VW chassis, the Bradley GT is fascinating and practical, blending beauty and function into a truly creative and exciting motoring experience.

FOR FULL INFORMATION, FULL-COLOR POSTER AND BROCHURE  
SEND \$1.00 TO  
AMERICA'S LEADING KIT-CAR BUILDER

### BRADLEY AUTOMOTIVE

DEPT. PM2, 10 W. 38th ST., 612-825-2417 MPLS., MINN. 55409

ENCLOSED IS \$ \_\_\_\_\_ PLEASE RUSH \_\_\_\_\_

POSTER, BROCHURE AND COMPLETE INFO. (\$1.00)  ASSEMBLY MANUAL \$7.00

NAME \_\_\_\_\_

ADDRESS \_\_\_\_\_

CITY \_\_\_\_\_ STATE \_\_\_\_\_ ZIP \_\_\_\_\_

MY PHONE NUMBER \_\_\_\_\_



You can make money in

## WATCH REPAIR

### Learn at home the low cost Swezey Way

Develop your skill step by step in your spare time at home. Chicago School of Watchmaking's exclusive Swezey System shows you how to repair all types of Swiss and American watches. Practical shop training. No previous experience needed. Age no barrier. Diploma awarded. Send today for free information and sample lesson. No obligation. No salesman will call.

**CHICAGO SCHOOL OF WATCHMAKING**  
Dept. 123 Fox River Grove, Illinois 60021

### FREE BOOK and SAMPLE LESSON

CHICAGO SCHOOL OF WATCHMAKING  
Dept. 123, Fox River Grove, Illinois 60021  
Please rush FREE BOOK and Sample Home Study Lesson.

Name \_\_\_\_\_ Age \_\_\_\_\_  
Address \_\_\_\_\_  
City \_\_\_\_\_ State \_\_\_\_\_ Zip \_\_\_\_\_

## MOLDS

for making  
Ornamental Concrete  
Items...



Book about Aluminum  
Molds with prices and  
production trade secrets  
direct from world's larg-  
est mold manufacturer.

SEND  
\$3.00

CONCRETE MACHINERY COMPANY, INC.

P. O. BOX A99 - HICKORY, N. C. 28601

### FREE FISHING

**CATALOG**  
**170 PAGES**  
**OVER 5,000**  
**FISHING ITEMS**

Hard to find Fishing  
Specialties and Kits  
Please don't miss this  
great 1973 Catalog  
**NETCRAFT CO.**  
BOX 5510 DEPT. PM2  
Toledo, Ohio 43613



## APPLIANCE REPAIR BOOKS

Written in easy-to-understand language by experts in the service field with illustrations and diagrams! Acclaimed by instructors and professionals alike! How to diagnose and repair refrigerators, air conditioners, washers, dryers, ranges, dishwashers, vacuum cleaners, motors, water heaters, coffeemakers, hair dryers, food mixers, can openers, electric irons, floor polishers and many others. Also, fundamentals of solid state, setting up a shop, using test equipment and a lot more. Only \$2.65 to \$4.90 each!

SEND FOR FREE DESCRIPTIVE PRICE LIST  
CHAROUS & NIEBERGALL INC., 5841 MONTROSE, CHICAGO 60634

# People pay a lot of money to these men. You can be one of them soon.



**Electronics Technician.**



**Automotive Technician.**



**Air Conditioning  
Refrigeration Technician.**



**Home Appliance  
Technician.**

You know what technicians charge to repair your TV set, your car, refrigerator or washing machine. The men who can do the job — and do it right — get paid very well indeed.

**Join them!** Be a technician and let people pay **you** for a change.

National Technical Schools will train you at home the professional way — with profes-

sional instruction, tools and test equipment, the kind of equipment you'll be using on actual jobs. It makes home training practical and more fun. And you get to **keep** all of the tools and equipment.

Choose the kind of technician you want to be. **Then** mail the card for free color catalog. No obligation. No salesman will call.



### NTS Electronics Division

Multiply your income with space age skills in Computer Electronics. Color TV & Radio Servicing, Automation/Industrial Electronics or Electronic Communications. Courses include valuable kits such as 315 sq. in. Solid State Color TV, Solid State B&W TV, 2-way Radio Transceiver, Compu-Trainer, Oscilloscope, and more. Check card for new **FREE** Color Catalog, complete details.



### NTS Mechanics Division

NTS puts you into America's #1 industry fast. Start earning almost as soon as you begin. You get 109-piece Socket Wrench & Tool Set with case and professional 8-unit diagnostic test equipment, yours to keep. Plus bonus Speed Shop lessons. Check card for new, free color catalog and complete details on all four courses and equipment.



### NTS Air-Conditioning/ Refrigeration, Heating Division

Install and maintain today's complex air-conditioning, refrigeration, and heating systems. As an NTS master technician you can handle any job. Or you can go into your own business. "Project Method" makes your training interesting with all new Hermetic Analyzer, tester, and other valuable instruments. Send for new catalog. Check card today.



### NTS Home Appliance Division

Boost your income, build a new career, start a business of your own. Learn the professional way to service ranges, washing machines, dryers, home air-conditioners, and other appliances. We'll supply everything you need, including the New Exclusive Circuit Trainer, 4 in 1 Appliance Tester and complete set of fine hand tools. Check Card.

**MAIL CARD NOW  
FOR FREE  
CATALOG &  
SAMPLE LESSON**



**APPROVED FOR VETERAN TRAINING**

FEBRUARY 1973

### Classroom Training at Los Angeles.

Train in sunny Southern California. NTS occupies a city block with over a million dollars in training facilities. Check special box on card.

## NATIONAL TECHNICAL SCHOOLS

WORLD-WIDE TRAINING SINCE 1905

Resident & Home Study Schools

4000 So. Figueroa St., Los Angeles, Calif. 90037

Accredited Member: National Association of Trade & Technical Schools, National Home Study Council.

# Photo Hints

## Borderless enlarging easel

I don't like print borders. They're unsightly and they waste paper. So I made this borderless easel in one evening.

The paper's natural curl holds it in place against the overhanging bevels of the two wood stops—but the bevels are so slight that they cast no shadows on the edges of the print.

I made the easel big enough to hold an 8x10 sheet of enlarging paper in either direction, so I can make horizontal or vertical format prints without having to rotate the easel. And I put one of the beveled stops on a sliding "T-square," so it would adjust to hold any paper size.

Dimensions aren't really critical—you can use whatever scrap lumber you have around. But it's important that all pieces be properly squared, both to keep the easel level under the enlarger and to make sure the T-square will slide freely, without binding or chattering. The spring clamp mounts to the bottom of the slider, and rides under the easel platform, providing the tension needed to keep the paper's curl from lifting the sliding stop. I used a 1½-inch speed-nut, with extra holes drilled in it, but any springy metal strip will do if it's longer than the slider slot is wide.

Paint the easel flat white or yellow for easier focusing, and paint the undersides of the bevels black, to prevent reflections. —Lorne C. Bannister, Sarnia, Ont.

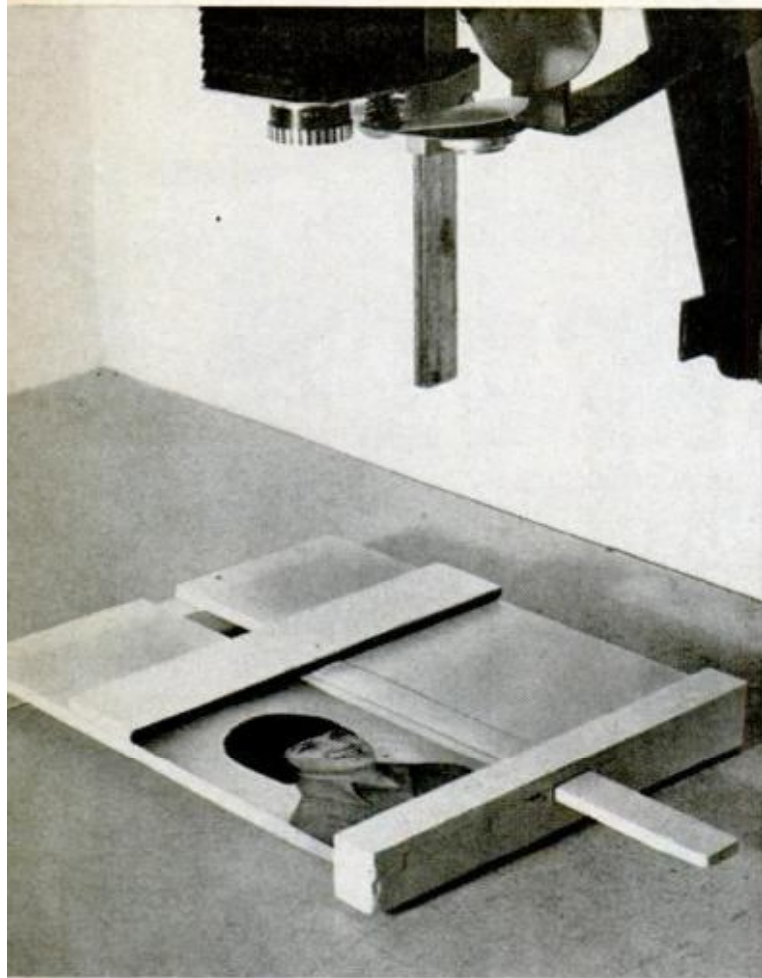

**OVERHANGING BEVELS** on the two stops that contact the enlarging paper hold the paper flat without casting a border shadow onto it. The "T-square" stop slides to adjust for any size of enlarging paper

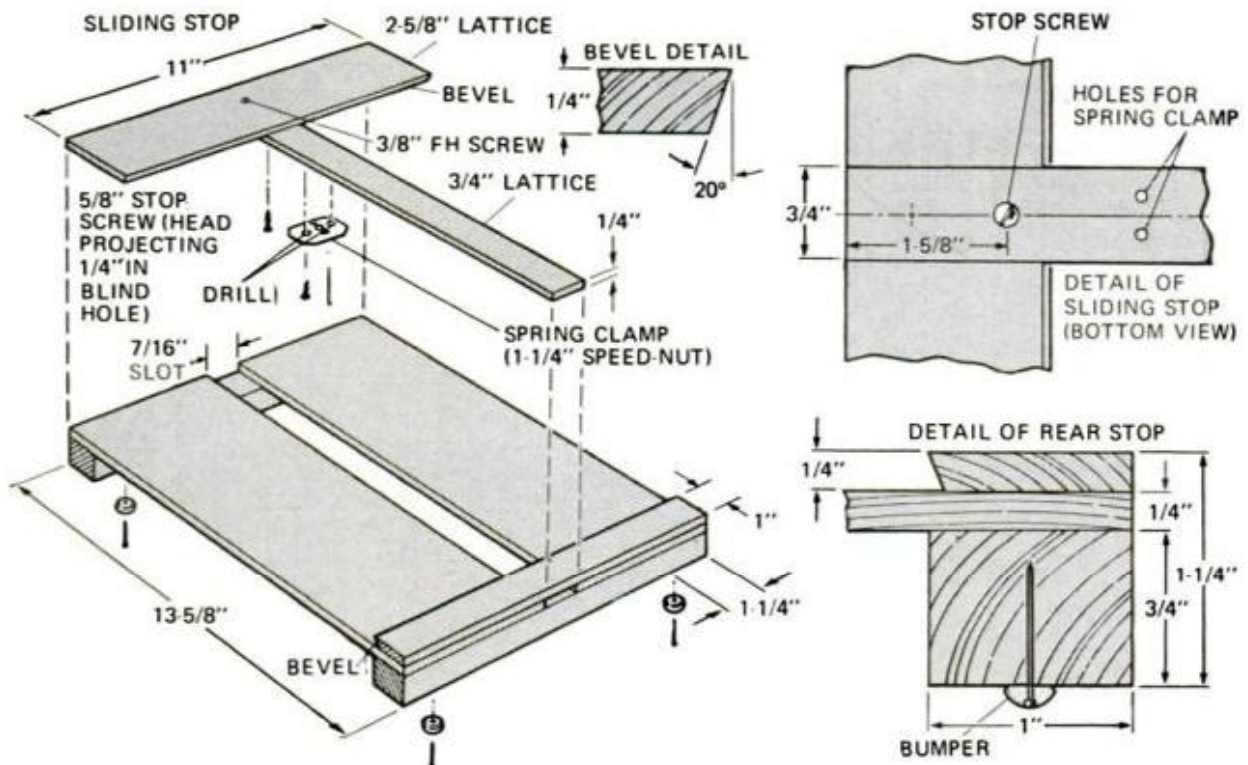

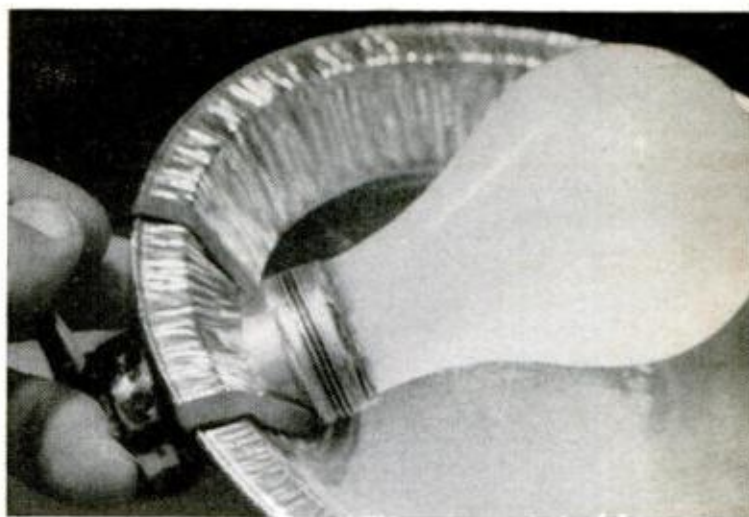
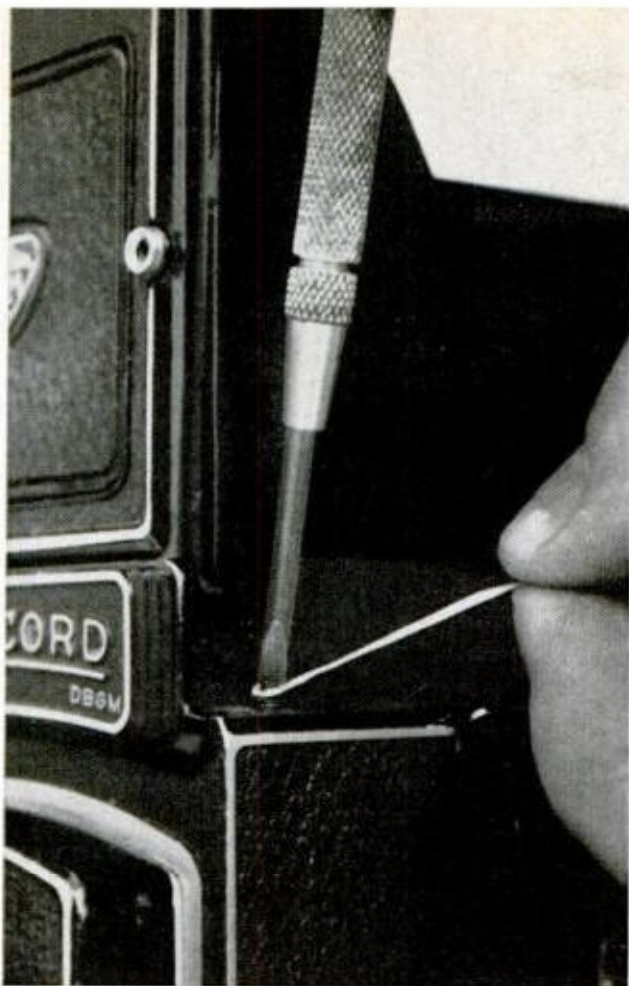

### Pie tin makes hot light

For a fast, cheap spot reflector, mount a light socket in a pie tin and hold it in place with a heavy rubber band.—Glen F. Stillwell, Manhattan Beach, Calif.

### Holder for miniature screws

A heavy paper strip holds tiny screws where fingers can't. Punch hole to hold the screw and rip off paper once it's started.—Arthur Rouleau, Fullerton, Calif.

# Freeze-a-Ferrari.

Not all 35mm reflexes let you keep up with the action. When you look away to adjust the camera, you lose the race.

With a Minolta SR-T 101, you never lose sight of your subject.

Because you set shutter speed and lens opening

by simply aligning two indicators in the viewfinder. So you can frame, focus, adjust exposure and (Varroom!) get the shot, fast and easy.

For illustrated literature, write Minolta Corporation, 200 Park Avenue South, New York, New York 10003. In Canada: Anglophoto Limited, P.O.

*When identified by a factory-sealed "M" tag, Minolta 35mm reflex cameras are warranted by Minolta Corporation against defects in workmanship and materials for two years from date of purchase, excluding user-inflicted damage. The camera will be serviced at no charge provided it is returned within the warranty period, postpaid, securely packaged and including \$2.00 for mailing, handling and insurance.*

**Minolta**



# WORTH WRITING FOR

LOOKING FOR IDEAS AND INFORMATION ON HUNTING, FISHING, CAMPING, BUILDING, TOOLS, ETC.? CHECK THESE LISTINGS, THEN USE THE COUPON BELOW.

## 123. "HOW TO BUY A FLOOR"

A 16-page, four-color booklet describes the various types of resilient materials for the home. Booklet also contains hints on how to select the right floor for your needs and gives valuable advice on floor maintenance. Armstrong Cork Company. Free.

## 124. "DELUXE OFFICIAL BARTENDER'S GUIDE"

Old Mr. Boston offers their handsome, hardbound drink-recipe book with 150 color-filled pages including all the old favorites as well as many new and exotic concoctions. The handbook for bartenders professional or amateur. \$1.50.

## 125. PULL IT, FREEZE IT OR BOIL IT!

Brochure introduces you to Tedlar, a solid-sheet vinyl fluoride finish for house siding. Sample is included so that you can test its durability yourself. E. I. DuPont Co. 10¢.

## 126. "GUARDIN' YOUR GARDEN"

Written by America's Master Gardener, Jerry Baker. 16 pages of expert advice on sprays and sprayers for your lawn and garden. From H. D. Hudson Mfg. Co. 10¢.

## 127. BUILD YOUR OWN MINI TRAIL BIKE

Here's a wealth of information that gives all the data on various models of kits available. Includes optional accessories as well as where to have it built if you don't want to build it yourself. Heald Inc. Free.

## 128. MINOLTA SR SYSTEM

Information kit features the

Minolta SR System of 35mm single lens reflex photography. Includes color brochures and price list for the SR-T 101, SR-T 100, SR-M cameras, Rokkor lenses and accessories. Free.

## 129. AIR CONDITION THE ENTIRE HOUSE

Informative brochure describes how you can control the temperature and filter the air in homes of all styles and sizes with a new Champion III air-conditioning system. York Div., Borg-Warner. 10¢.

## 130. "THE HOW-TO OF WELL DRESSED WINDOWS"

Whatever your choice in types of curtains or draperies, this how-to kit shows you the hardware you need, and where to install it. Comprehensive. From Kirsch. 15¢.

## 131. POPULAR MECHANICS PICTURE-TOOLS

PM Picture-Tools are a great new idea to take the confusion out of what goes where on workshop tool panels. The complete kit consists of 7 big sheets depicting 74 tools in all. Each sheet has sure-stick adhesive on the back for easy application. \$3.95.

## 132. THE GARDEN OF EDEN IS IN SOUTH CAROLINA

Send for folder and fact book that tells all about South Carolina's gardens and historic homes, not to mention everything else. South Carolina Div. of Tourism. Free.

## 133. MAP-OUT YOUR OWN FUTURE

Learn surveying and mapping at home. Send for your Surveying

Career Kit, including 20-page fact book. North American School of Surveying & Mapping. Free.

## 134. COPPER DOES IT ALL

Two separate booklets give solid reasons why copper is your best bet in plumbing and in wiring. Both are from the Copper Development Assoc. and are Free.

## 135. DO-IT-YOURSELF WEATHERSTRIPPING

20-page booklet describes and illustrates how you can weather-strip your own home and increase your comfort and reduce your expense. Thermwell Products Co. 10¢.

## 136. NEW, 1973 RECREATIONAL VEHICLE KIT CATALOG

Contains hundreds of RV parts, kits and accessories. Also included in this 56-page catalog are plans, specifications, pictures and diagrams. Kit Kar Inc. \$1.00.

## 137. CATALOG OF FASCINATING & UNUSUAL BOOKS . . .

Describes books on world records, facts, science, fads, curiosities, freaks, graffiti. This catalog is as entertaining and interesting as the books it contains. From Broadway Bookfinders. Free.

## 138. GUIDE TO LAWNS AND MOWERS

Here's an excellent, new brochure that offers many helpful hints for lawn care and selection of lawn equipment. Complete line of Toro power equipment is also featured. From The Toro Co. 25¢.

This coupon expires April 30, 1973

POPULAR MECHANICS 173  
BOX 1718, SANDUSKY, OHIO 44870

Please see that I receive the items checked below. I have enclosed 35¢ for the overall service charge, plus remittance for any priced items.

<input type="checkbox"/> 123	<input type="checkbox"/> 127	<input type="checkbox"/> 131 (\$3.95)	<input type="checkbox"/> 135 (10¢)
<input type="checkbox"/> 124 (\$1.50)	<input type="checkbox"/> 128	<input type="checkbox"/> 132	<input type="checkbox"/> 136 (\$1.00)
<input type="checkbox"/> 125 (10¢)	<input type="checkbox"/> 129 (10¢)	<input type="checkbox"/> 133	<input type="checkbox"/> 137
<input type="checkbox"/> 126 (10¢)	<input type="checkbox"/> 130 (15¢)	<input type="checkbox"/> 134	<input type="checkbox"/> 138 (25¢)

Total items requested \_\_\_\_\_ Total money enclosed \_\_\_\_\_

Name \_\_\_\_\_  
(Please Print)  
Address \_\_\_\_\_

Town \_\_\_\_\_ State \_\_\_\_\_ Zip Code \_\_\_\_\_

(Please send cash, check or money order made out to POPULAR MECHANICS. No stamps, please.)

NOTE: POPULAR MECHANICS processes your requests for the above information and forwards these inquiries to the organization making the offer. Each company mails the material directly. Please allow 4-6 weeks for delivery.

**MAKE EXTRA \$\$\$ EVERY DAY!**

Get into the big, year-round

**EXTRA MONEY BUSINESS**

that's EASY to learn - EASY to do  
-and EASY ON YOU!

**Be a LOCKSMITH!**

Make Up to \$10 an Hour - even while learning! Train FAST at Home!

Never before have money-making opportunities been so big for qualified Locksmiths. Now lucrative regular lock and key business has multiplied a thousandfold as millions seek greater protection against zooming crime. Yet there's only one Locksmith for every 17,000 people!

**LEARN THE QUICK AND EASY BELSAW WAY**

to take advantage of this tremendous opportunity for year-round EXTRA INCOME in sparetime-or in a fulltime, high-profit business of your own... now and for THE REST OF YOUR LIFE! All tools plus professional Key Machine given you with course. These plus practice equipment, plus easy illustrated lessons, plus personalized help from expert teachers, plus business-getting guidance-enable you to make \$5 to \$10 an hour almost from the start! Hundreds we've trained have done it. So can YOU!

**JOIN THESE BELSAW MONEYMAKERS**

"I earned \$500 while learning. My best week was \$125. Business gets better and better."  
V. Tizio, Brooklyn, N.Y.

"I cleared \$110 last Saturday! I'm doing wonderful. Locksmithing is a great business."  
R. W. Davis, St. Louis, Mo.

**FIND OUT ALL ABOUT IT**

**No Obligation -**

**No Salesman Will Call**

Discover what's in Locksmithing for you with Belsaw training...how you can depend on this urgently needed skill for MORE INCOME, EASIER, MORE ENJOYABLE LIVING now and for retirement. Just fill in and send the coupon to receive full information by return mail.

Do it TODAY!



Approved for Veteran Benefits

Accredited Member  
National Home  
Study Council



Also available in Canada

**Clears \$75 a Week Sparetime!**

"I'm proud to be a Belsaw graduate and a success in this great profession. I'm making over \$300.00 a month in my sparetime with your training-the best there is."

Henry Rivas - Los Angeles, Cal.



**THIS PRO KEY MACHINE - YOURS TO KEEP**

can add \$25 to \$40

a week to your income...

and doesn't cost you a penny extra!



**FREE**

KEYS TO YOUR FUTURE

**SEND FOR EXCITING FACTS**

Tells how to Make Money in Locksmithing - Spare Time or Full Time - Almost from the Start.

CUT ALONG DOTTED LINES... FOLD IN HALF... SEAL AND MAIL

**Mail This Card Today - No Stamp Needed!**

**LOCKSMITHS ENJOY ALL THESE ADVANTAGES:**



- You're part of a firmly established, vitally necessary professional trade.
- Shortage of qualified locksmiths everywhere.
- Clean, respected work that's easy to do-and easy on you.
- You collect cash for work-no credit losses, no collection expenses, no employment problems.
- Business-getting methods are simple. No salesmanship required.
- You're a trusted member of your community.

Please send me free of cost or obligation your publication "Keys to Your Future" on how Belsaw can train me to quickly make money in Locksmithing and how all tools and Key Machine are given me to keep. I understand no salesman will call.

Name \_\_\_\_\_

Address \_\_\_\_\_

City \_\_\_\_\_ State \_\_\_\_\_ Zip \_\_\_\_\_

FOLD IN HALF HERE

FIRST CLASS  
PERMIT NO. 1014  
KANSAS CITY, MO.

**BUSINESS REPLY MAIL**

No Postage Stamp Necessary if Mailed in the U.S.

Postage will be paid by-

**BELSAW INSTITUTE**

103F Field Building

Kansas City, Missouri 64111

CUT ALONG DOTTED LINES



## Ski care now—and later

Proper bottom maintenance puts skis in top shape and keeps them there during off-season and on

By JACK VAN VLECK

**Y**OU CAN WHANG UP even the toughest pair of skis, no matter what they're made of and no matter what the salesman says. Even the best equipment, worn by a downhill expert or touring novice skier, is subject to scraping, crossing, bottom gouging, edge dulling and burring. If you believe the "maintenance free" stories you're going to shorten the life of your equipment. And at a price tag of \$150-plus for some of today's top-design FRP (fiberglass reinforced plastic) "schusslatzen" for instance, you'll be throwing away money if you skip the simple preventive maintenance that keeps skis going in winter and safely stored off season.

"Proper waxing tops your checklist," says Garcia Ski Corp.'s Jeff Garluck. Waxing comes after the edges have been sharpened (since filings can become embedded in paraffin) and can be done hot or cold. Satisfactory cold methods include the old rub-on stick wax technique as well as more modern paste and spray treatments. Cold waxing is easy and convenient, especially for touch-ups on the slopes, and should be done a couple times during the ski day, often matching wax type to snow conditions.

Hot wax coats, applied by iron-on or paint-on methods, last longer. An iron at medium heat is held,

*(Please turn to page 50B)*

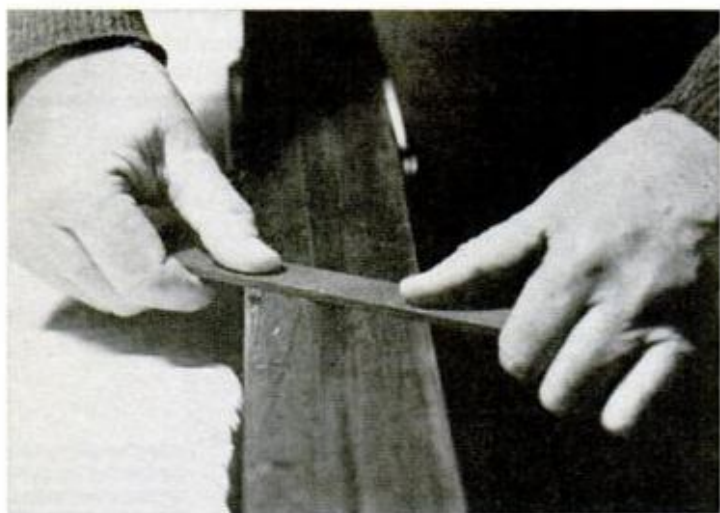

**TO GO AIRBORNE** like ace Stein Eriksen it's necessary to start from snow level with well-maintained skis. File burrs and scratches from the edges with flat No. 10 as shown. Hold at 45° angle to bottom and use light thumb pressure



For  
easier  
starting,  
lower  
emissions,  
smoother  
idling,  
no stalling,  
faster  
take-offs and  
better mileage.



# THE CARBURETOR CLEANER.



**Inside.** Just pour a pint of GUMOUT into your gas tank. It cleans out all the jets and passages, removes the gum and varnish while you drive.



**And out.** It takes less than a minute to clean the outside of your carburetor with Jet Spray GUMOUT. Throat, automatic choke, linkage, throttle plate—all clean like new.

**GUMOUT** Division, Pennsylvania Refining Company, Cleveland, Ohio 44104



**SHARPEN SIDE EDGE** with flat No. 10, removing rough spots, nicks. Result should be even edge that forms 90° angle between bottom edging surface and side



**TIP EDGING** of ski should not be sharp. Starting even with front end of center groove, round edging forward toward "shovel" tip to prevent tip-tripping



**DEEP GOUGES** require more than waxing to fill and repair. First use knife or other sharp tool to dig out any loose foreign matter before starting repair

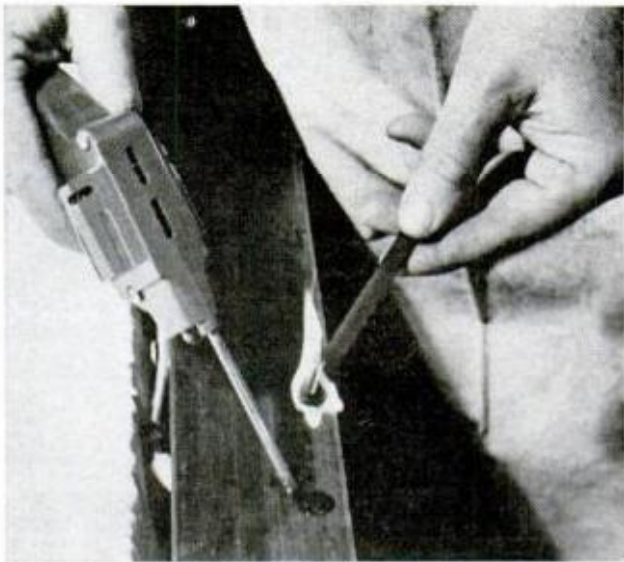

**FOR BEST BOND**, a clean soldering iron is used to heat base around gouge edges. Molten repair-stick "spaghetti" is dripped in. Extinguish burning drops

## SKI CARE NOW

*(Continued from page 50)*

point down, over ski bottoms and wax pressed against it until the wax melts and can be dribbled down one side of the ski, outside the groove, and up the other. Ribbons of wax are ironed out evenly over the entire surface—keep the iron moving so the base won't loosen its bond with the ski. Afterward you'll have to buy your wife a new iron, of course.

To paint on wax, melt it in an old pot and with a ski-width brush dip in and then press out any bubbles against the pot. Paint skis from tail to tip in 18-inch overlapping strokes. After any hot-process application, scrape the cooled coating, tip

to tail, to even the finish. A knife or coin can scrape the center groove. Use plastic or wood to clean edges.

Waxing keeps polyethylene bases from wearing down quickly, prevents oxidation, helps turning by avoiding tip-scrape. Tops of skis can use car wax to help guard against road salt when skis are carried on exterior racks. Northland's Jerry Gruggen notes that almost as much minor damage can happen while toting equipment as during actual use. Off the rack, skis should be carried bottom to bottom and strapped together to prevent edge scissoring. Transporting them inside the car is dangerous to skis and riders in case of a sudden stop. When using a public carrier,

*(Please turn to page 50D)*

Need More Money? Want to Be Your Own Boss?

# START SAW SHARPENING BUSINESS

Of Your Own - in Your Sparetime



Turn your spare hours in the evening or weekends into extra dollars, this proven practical way—start your own money-making sharpening business—No selling or canvassing—No experience required. You can do it automatically with the Foley Saw Filer or Lawn Mower Sharpener.

## Beginners Earn \$3 to \$6 an Hour

People, just like yourself, all over the United States are making extra cash—\$20 to \$30 a week—right now in their spare time. "My sparetime saw filing business has made me \$952 these first ten months," says R. T. Chapman. Many start part-time, find it so profitable that they build year-round service business. You can, too, simply by following easy Foley plan.

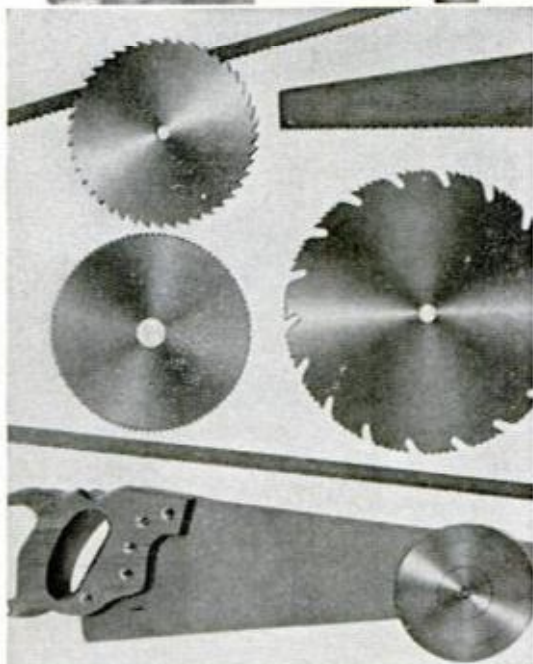

## Town of 150 Supports Profitable Business

Here's the story from Dick and Jo Ann Koester after being in business less than a year. "We have acquired another Foley Saw Filer and for the past two months we have been in full-time operation. As we live in a small town of 150 population in farm area we use our truck to pick up saws in five nearby towns. With a family to support and plans for building to our house we had to pick up a business fast and already sharpen an average of 15-20 saws a day. Business for the future looks even better as good machine filing is our best advertising."

## CASH for Sharpening Mowers

Every neighbor with a lawn needs his lawn mower sharpened at least once a year. No experience is needed to start—anyone can operate and turn out professional jobs. All operations are handled quickly, easily and accurately.



## Sharpen These Professionally with amazing Foley Saw Filer

You can sharpen combination (rip and crosscut) circular saws, band saws, hand saws, crosscut circular saws—and do a perfect job every time without experience or special training. The precision Foley Filer does it for you automatically! A complete repair shop in one machine! Set up in basement or garage, work your own hours in your own way and earn big sparetime profits.



# FREE

## BOOKLET TELLS HOW!

Free Book "Money Making Facts" shows just how you can start at home in spare time. Small investment—time payments if desired. Get this booklet—study it! Send coupon today. No salesman will call on you.

Foley Manufacturing Co., 216-3 Foley Bldg.  
Minneapolis, Minnesota 55418

Send Free Booklet on  Saw Sharpening Business  Lawn Mower Sharpening

Name \_\_\_\_\_

Address \_\_\_\_\_

City \_\_\_\_\_

State \_\_\_\_\_

Zipcode \_\_\_\_\_



**SHAVE OFF** excess polyethylene with knife or metal scraper to bring fill down to ski level. Use repair sticks without soldering iron for field patch



**IRON-ON WAX METHOD** uses wax held against iron at medium setting. Drips from iron are dribbled on surfaces each side of groove, ironed out smooth



**CENTER GROOVE** is scraped out and smoothed with coin or knife. Wax runs in during ironing. Keep hot iron moving over bottom during smoothing of wax

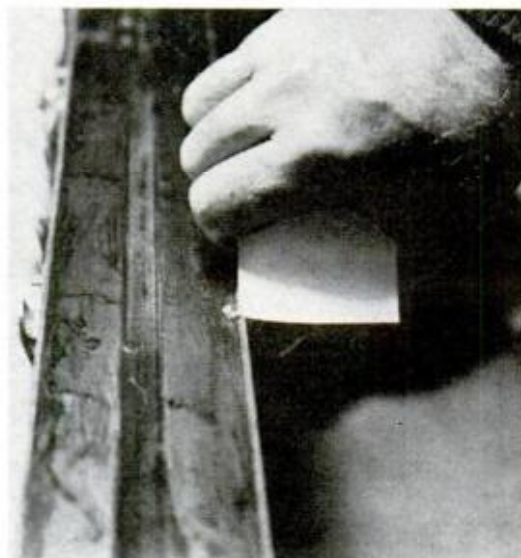

**PEEL WAX** from edges with plastic or wood scraper to guard against scratches. Full surfaces of the ski are then leveled with metal scraper for even coat

## SKI CARE NOW

*(Continued from page 50B)*

"Box your gear or use a ski bag," says Blizzard spokesman Frank Moran. Wrap newspapers between skis to avoid marring waxes' bases. Bagged in canvas, burlap or plastic on a roof rack, skis are protected from flying stones, ice and road salt.

Store skis vertically in wood racks at ski areas and at home so snow can drain off and no one will trip over them. When finished for a weekend—or season—wipe skis dry, wax tops and bottoms lightly and coat edges with light oil or Vaseline. Modern skis don't need to be blocked in the middle to maintain camber, but should be stored away from temperature extremes.

Strap together and suspend from cellar beams or closet hooks. Wall racks from skis stores are good. Rest ski tails on wood blocks rather than concrete floors.

Edges and bases take the worst beating. After each trip, knock off edge burrs with emery paper or a file. Run your fingernail crossways over the edges and bottom. If it sticks against an edge, you have the start of a "railing" problem—bottom wear has exposed the inside steel edge corners. To remedy this and other edge faults yourself (and save about \$4 each time), get a No. 10 flat crosscut mill bastard file. Then clamp your skis, one at a time, base up in a vise.

Lay the file flat on the base and angled

*(Please turn to page 50F)*



CARPET DETERGER



UPHOLSTERY DETERGER



WALL DETERGER

# 3 proven ways to your own money-making business

**You offer a service everybody needs . . . work full time or part time . . . own your equipment . . . keep all you earn . . . start with just a small investment . . . and we help you every step of the way!**

Have your own money-making business and make the kind of income you probably thought impossible. You can when you clean carpeting or upholstery or walls with Von Schrader professional cleaning equipment. Every home, every building, are potential customers. And every customer represents repeat business.

Moreover, we help you every step of the way . . . just as we have helped thousands of other Von Schrader Associates build money-making businesses for almost 40 years.

There are three easy-to-operate Von Schrader Detergers. Each offers a proven way to a growing income. (1) *Von Schrader Carpet Deterger* gives deep-level cleaning to carpeting. (2) *Von Schrader Upholstery Deterger* cleans fabrics and synthetics beautifully (3) *Von Schrader Wall Deterger* cleans walls (and ceilings) five times faster than by hand.

You can start with just one Deterger. Then, as your business keeps growing, you may want to add the other two and thus offer a complete cleaning service.

There are no fees, royalties, or contracts. You own your equipment, the finest of its kind. And your investment is so small you may find it hard to believe. For complete information—without any obligation—send for the free booklet described below.



**“Let me send you our free booklet that gives all the facts”**

—Francis von Schrader, President

Read about the big demand for on-location cleaning, see why Von Schrader Detergers are the finest of their kind, how easy they are to operate. Learn how other men have become financially independent, how Von Schrader helps you every step of the way. Fill in the coupon and send for free booklet.

**Extra! Special Recorded Message included with booklet.** Listen as Francis von Schrader talks to you personally about your growing future with Von Schrader Detergers.



**VON SCHRADER company**

1023 Place, Racine, Wisconsin 53403

Please send complete information on Von Schrader Detergers.

Name \_\_\_\_\_

Address \_\_\_\_\_

City \_\_\_\_\_

State \_\_\_\_\_ Zip \_\_\_\_\_



**PROFESSIONALS** take waxing seriously. Here service manager prepares racing skis using special bench

## SKI CARE NOW

(Continued from page 50D)

about 45° in the direction the ski is pointing. Keep weight on your thumbs at the middle of the file and push easily in long strokes down the length of the ski. Don't shift pressure to file ends or press hard. You're working for a flat-edge surface flush with the base. If the base is worn too far, you'll have to build it up with layers of wax.

Next, clamp the ski with one edge up. File ski edge flat down the ski length to get a 90°-angle edge flat on the base and the side. At the front, from a point parallel to the groove end, bevel the edging as far as it runs up the "shovel" (tip). This keeps ski tips from grabbing.

Deep gouges and scrapes caused by "fast grass and rock garden" conditions need special attention since moisture can work into holes and start delamination. Kofix or P-Tex candles (often called spaghetti) are the answer, and come in colors to match your ski bottoms. Clean base with a rag and benzine or a brass pot cleaner (never use steel wool). Heat damaged area with a clean soldering iron. Split repair candle (for smaller drips), light and drip melted polyethylene into gouge until it's higher than base layer. Smooth cooled material with knife or gadget like Stanley

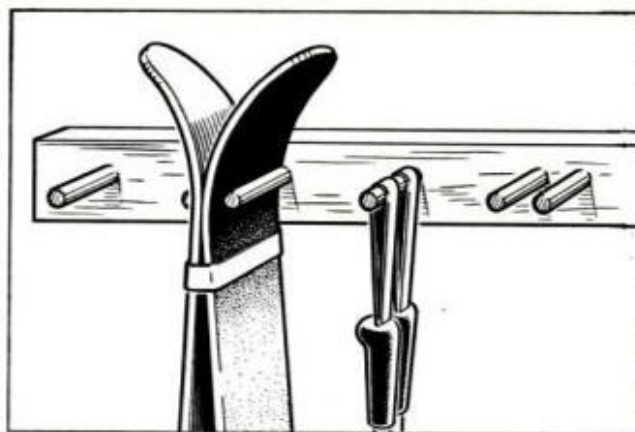

**HIGH AND DRY** is a good way to store skis evenings or off-season alike. Wall pegs can be made or bought. Today's skis don't need middle-block to keep camber

Pocket Surform. Very gently sand patched area with fine sandpaper, rewax as usual.

Today's fancy top ski surfaces can be scratched, "but that won't affect performance," says Ron Guisick of Hart Skis. "The melamine (finish coat) can chip but good skis have plastic or metal strips running along the outside edges to prevent excessive damage if skis cross during a run." Scratches can be sanded and waxed. Deeper cuts may mean relacquering.

Your warranty may require professional repair for major damage like delamination or edge separation. But most modern skis can last a number of season with minimum—but regular—basic maintenance. ★★

# The Super Doer

## The Power Gun 1000

If you're a homeowner you've got to own the new Swingline Power Gun 1000, the first extra heavy duty staple gun that does it all. It's a cinch to put up ceiling tile or cork. Power Gun 1000 drives into harder wood with less effort and greater force.

There's a Power Lever for heavy duty drive, Power Dot for Super Drive, Load-a-matic one piece loading chamber, Swing-open bottom loading, At-a-glance window to check load and a built-in staple extractor. No jam problem—easy to clear.

Suggested Retail Price \$13.95  
Kit \$19.25



Power Gun 1000 is sold separately... or as a kit with three attachments—one to grip and hold wire, one to repair or make screens, one to repair or make shades. Kit comes in handsome carrying case.

## 2 More Super Doers!

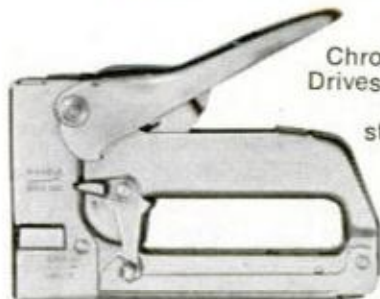

**The 800X** Heavy Duty Chrome Finished Staple Gun. Drives 5 sizes of staples. Open channel loading for easy staple replacement. Power Dot for extra penetration. New improved handle lock. Suggested Retail Price \$10.50

**The 101** Fastens fabric to walls or woodwork. Easy to use. Lets the wife pitch in. Thousands of uses around the home, from fix-it to decorating. Suggested Retail Price \$6.95

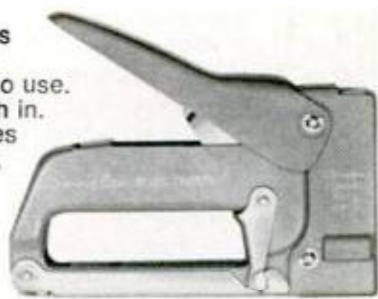

# Swingline

Write for FREE "Tips for Tackers" booklet.

Consumer Products Division 32-00 Skillman Avenue, Long Island City, New York 11101

# MARCH **Preview** OF POPULAR MECHANICS



## Camper for a compact pickup

You can build this camper from plans and patterns for \$607. It fits Datsun, Toyota, Courier and LUV pickups.

## Yardpower roundup for '73



If you're in the market for a new mower, you won't want to miss this buyer's guide to the new mowers and tractors. A specifications chart lists models of the major manufacturers so you can compare their features and prices.

## A pool for all seasons



Ever dream of having an indoor swimming pool? Here's how one family enlarged the basement and made the plunge. Many grade-level basements offer the possibility of an extension that brings the pool indoors.



## Those wild new airplane wings!

They're the strangest-looking designs you have ever seen, but they may be just crazy enough to usher in a new age of jet travel.

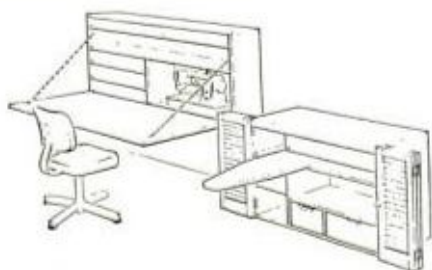

## Build a sewing center for your wife

We offer plans for four excellent sewing centers. They're all designed so you can take them with you if you move.

# PLUS

Owners Report on the Pontiac Grand Am • How to adjust a Pinto carburetor • How to cut and splice wires • How to erect a basement partition • How to patch a hole in sheet flooring • How to hang drapery traverse rods • How the new Polaroid Land camera works • "Model" plane you can really fly • How cars are designed for radials • The "right" soldering tools • More

*Buy it on your newsstand. Better yet, make sure you'll keep getting this kind of exciting fare. Send this coupon with your check to:*

**POPULAR MECHANICS**  
250 West 55th Street  
New York, New York 10019

Please enter my subscription for  1 yr. \$5 or  2 yrs. \$9

Name \_\_\_\_\_ (Please print)

Address \_\_\_\_\_

City \_\_\_\_\_ State \_\_\_\_\_ Zip \_\_\_\_\_

Payment of \$\_\_\_\_\_ is enclosed.  New  Renewal

On new subscriptions, first copy will arrive in about 8 weeks.

(Above prices apply in U.S. and Possessions only. Canada, add \$2 per year. All other countries, add \$4 per year.)

WPM3B1

POPULAR MECHANICS





are you headed for  
a time-clock number?

...or a **BIG PAY**  
place in

# AIR CONDITIONING

**40,000 new servicemen needed  
...you can be one of them**

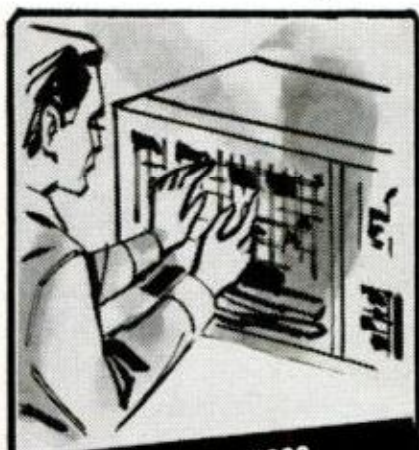

**Be Your Own BOSS**  
course includes directions on  
How to Own YOUR OWN Business!

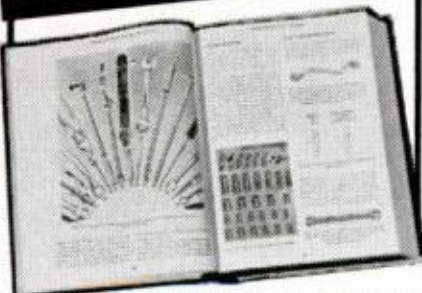

Air conditioning, refrigeration and heating is one of America's fastest growing fields. Service and installation technicians are in desperate demand.

And you can join this force of men making big money right now by becoming a skilled technician with our help.

Top men are making 2 and 3 times more than unskilled workmen. Yet we can teach you these skills so quickly you'll be earning money long before you've finished learning.

### AMERICA'S FOREMOST COURSE AT A MATCHLESS LOW PRICE

Learning at home is hailed by educators as being far superior to classroom work with all its mass production and distractions.

In our fine, professional 100-lesson textbook course you will receive the clearest instructions in unmistakable simple language. Plus self-projects, self exams and graded exams.

Directed by Roy Anderson whose experience with home study and Army-Air Force training goes back to 1935, we have prepared material that will turn out top-notch graduates. And we do it at a cost so much lower than any comparable course that you simply will not believe it possible.

One way we do it is by not loading our students with costly equipment and tools — most of which you probably already have, or can buy locally for less than some schools charge you!

The Liberty School is a fine, professional and very intimate institution of learning-at-home, supervised in every tiny detail by Mr. Anderson.

We can't begin to tell you all of the advantages in this small space — but we'll give you all the details if you send in your name and address. Remember, we have NO salesmen so no one will bother you. In the privacy of your room you can study the description of our lessons and make up your own mind without any pressure whatsoever.

A big pay future is waiting for you — grab it now.

**LIBERTY SCHOOL, Dept. J-2, Technical Division, 1111 W. Park, Libertyville, Illinois 60048**

Roy Anderson  
Liberty School, Dept. J-2  
Technical Division, 1111 W. Park  
Libertyville, Illinois 60048

**SEND ME YOUR NAME AND ADDRESS — I'll rush you FREE  
details by mail. WE HAVE NO SALESMEN.**

Dear Mr. Anderson: Please send me description of your course on AIR CONDITIONING, REFRIGERATION AND HEATING. I understand this places me under NO obligation and that NO salesman will call.

Name \_\_\_\_\_ Age \_\_\_\_\_  
Address \_\_\_\_\_  
City \_\_\_\_\_ State \_\_\_\_\_ Zip \_\_\_\_\_

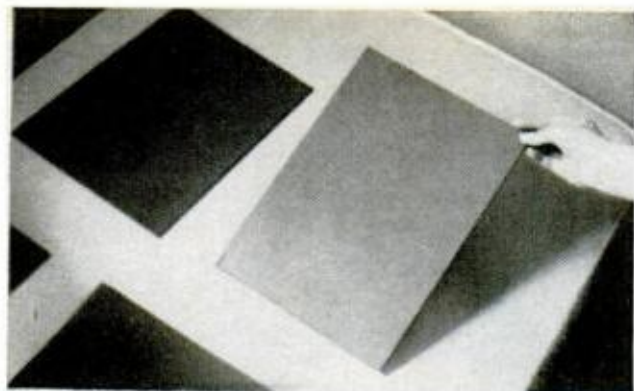

# HINTS FROM READERS

## Multiple bedboard works better

If you can't sleep on the bedboard your doctor prescribed, ask him to let you try this stunt. Instead of a one-piece board, insert several plywood squares between the springs and mattress. You'll find the squares provide the necessary support, but reduce the rigidity associated with a one-piece bedboard.

—*J. Ronald Mikels, Knoxville, Tenn.*

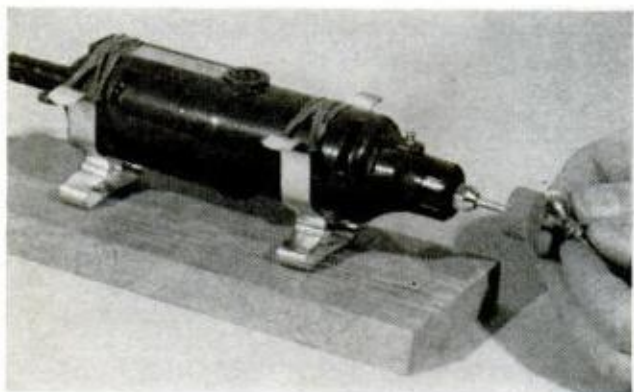

## Broom-clamp holder for hand grinder

A hand grinder such as the Handee or Moto tool becomes a small bench grinder when you attach a couple of spring broom clamps to a board to support it horizontally. If necessary, you can stretch rubber bands across the clamps for a better grip. The grinder also makes a great little polisher.—*Ken Patterson, Regina, Sask.*

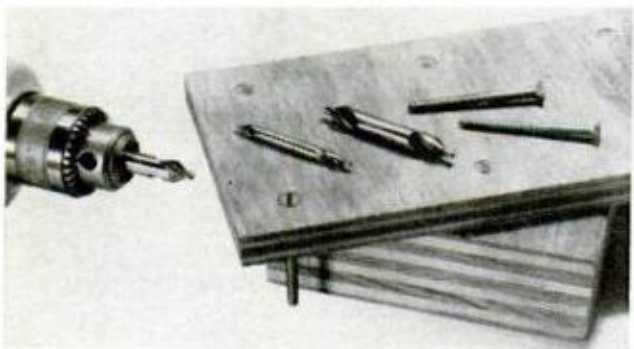

## Center drills serve as screw bits

In a pinch, center drills used in lathe work can serve as wood-screw pilot bits when you're countersinking holes for fh screws. Such drills come in a range of diameters that can match almost any screw-head normally used. After using a center drill, make the hole for the screw body with a twist drill of the proper size.

—*Hugh Perkins, Chicago.*



## Sponges save the knees

One way of avoiding "housemaid's knee" when doing work that requires constant kneeling, is to wear two pieces of sponge rubber cut from kneeling pads. Simply make "garters" of elastic to fit the knees and attach the bands to the pads with rubber cement.

Another way of attaching these pads is to cut slots in the pads for the elastic.

—*Bill Burd, New York.*

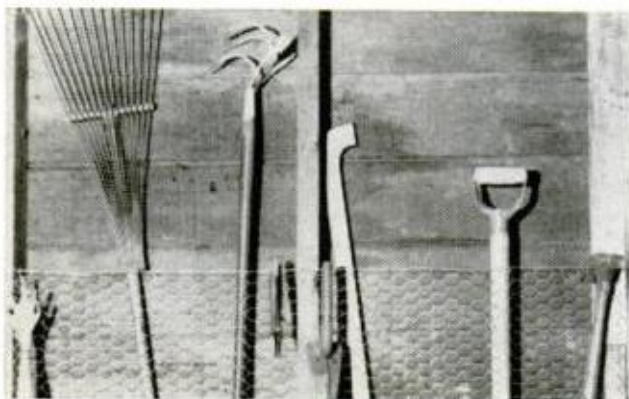

## Chicken wire holds flock of tools

If your garden tools are hard to keep handy and neatly stored, nail a length of common chicken wire to the open studs of your garage or workshop walls. The wire mesh lets you stand long-handled tools behind it; smaller tools can be hung on the wire in clear view.

—*William Swallow, Brooklyn.*

## PUBLICATIONS **WORTH WRITING FOR**

**PM'S PICTURE-TOOLS** are a great new idea to take the confusion out of *what goes where* on workshop and tool panels.

The complete PM **PICTURE-TOOL KIT** consists of seven big sheets (9¾ x 11¾ in.) of a special heavy-weight paper with a pressure-sensitive adhesive on the back. On each sheet are beautiful drawings of hand tools and portable power tools—all you're likely to have in your shop (74 in total). Most are full size; the others nearly so.

Also enclosed in the kit is a blank sheet of the same special paper, printed in an overall color to match the tools. This sheet enables you to design your own drawings of special tools.

Each of the PM **PICTURE-TOOLS** is carefully die-cut. You simply peel off the backing paper and apply it to the proper spot: on painted or unpainted wood, plywood, hardboard and even perforated-hardboard surface.

Later, if you want to move a few tools or rearrange the entire panel, you can peel off the PM **PICTURE-TOOLS** and reuse them in new locations!

Once your **PICTURE-TOOLS** are in place, you'll know at a glance exactly where each tool belongs.

Order your PM **PICTURE-TOOL KIT** today. Simply send a check or money order for \$3.95 to Popular Mechanics, Dept. PT, Radio City, New York, N.Y. 10019. Be sure to enclose your name and complete address. ★★★

FEBRUARY 1973

# Winners

have a style all their own.



**Jack Nicklaus does...  
and Murray does**

with riding mowers that handle with the ease of golf carts,  
plus new safety features.



See the full line of Murray Mowers at the Jack Nicklaus sign, or write for name of nearest dealer.

**THE MURRAY OHIO MFG. CO., BRENTWOOD, TENN. 37027**

# IMPORTS AND MOTORSPORTS

BY BILL HARTFORD



**FIRST AMERICAN-MADE CAR** to win an event in the International Rally Championship of Makes series is . . . a white whale! Competing against the likes of Datsun 240Zs, Saabs and other experienced rally cars and teams, the Jeep Wagoneer, tagged "Moby Dick I," pressed on to take the Press On Regardless Rally in northern Michigan. The grueling 2000-mile endurance challenge was on the international calendar for the first time. Gene Henderson and Ken Pogue teamed the winner for Henderson Competition Ltd. A second Jeep, Moby Dick II, naturally, was third with Erhard Dahm driving, Jim Callon navigating

**GENTLEMEN, START YOUR ENGINES!** You kids and moms, too! Even if you've never jumped on a kick starter before, you can learn how to ride a motorcycle simply and safely—and it's free. Yamaha has started a Learn-to-Ride program that will be coming to over 60 cities this year. They provide the bikes, the helmets and the instructors. All you do is write to Yamaha's Learn-to-Ride Program, 3425 Wilshire Blvd., Suite 700, Los Angeles, Calif. 90010, to find out when Yamaha will have its machines in a park or stadium near you.

**IT'S A HAPPY BIRTHDAY YEAR** for NASCAR, the National Assn. for Stock Car Auto Racing, and the 25 candles should be stuck in the sand at Daytona Beach. That's where the racing started, believe it or not, on a course laid out on the hard-packed sand. Not far from the beach is the huge Daytona International Speedway where special events and a festive air will compete with the roar of the traditional February Speed Weeks right up to the Daytona 500 on Feb. 18.

**MAZDA SWEEP NEARLY COMPLETE.** The rising sun has reached Sunrise Hwy. and the only rotary-engined cars available in the United States are now in almost every state. Driving the RX-2 and RX-3 models is an extraordinary experience that sums up: little engines, big performance! (Want to see my speeding ticket?) There's a 24/24 warranty on the Wankel engines and a new automatic transmission for '73. Mazda has been coming on strong since 1961 when it became the



**MAZDA RX500:** Test bed for engineering and styling and a teaser for Wankel and sports-car enthusiasts

first auto company to sign a licensing agreement to use the Felix Wankel invention. And we hope it won't be long before there's a Mazda with looks to match its performance—especially if it happens to be a production car based on the ex-  
*(Please turn to page 54)*

**ANOTHER TEASER:** German Hercules motorcycle has Fichtel & Sachs single-rotor, air-cooled Wankel, but it isn't being imported to the United States as yet





With available full-time four-wheel drive, Blazer has excellent traction and towing ability on road or off. Just tell your dealer what weight trailer (up to 6,000 lbs.) and he'll help you order the right Blazer equipment: a big 350 V8; power steering; Turbo Hydra-matic or 4-speed transmission; load distributing hitch platform; trailering axle ratio. Power front disc brakes, standard.

## Chevy Blazer. Go where nothing follows you but your trailer.



New Cheyenne interior you can specify. Comfortable, quiet, roomier than ever before. Seating available for up to five with lots of cargo space left over.



Removable hardtop available in black or white. Includes new tailgate with roll-down rear window. Accessory luggage rack carries 300 pounds.

**Chevrolet**

**Building a better way to see the U.S.A.**

## THE SCOTT ENGRAVER

### Your spare time money-maker

Scott's SM100 turns 10¢ worth of plastic laminate into a product you can sell for 75¢ to \$1.00. Every business is a prospect. Make name plates, signs, plaques and more . . . in just minutes, using just one hand. A complete, ready-to-operate engraving shop to help you make big money in your spare time!

To find out more, send for free catalog, today.  
Dept. PM-72

**SCOTT MACHINE DEVELOPMENT CORP.**  
P. O. Box 217  
Walton, New York 13856

*Scott fills every engraving need—  
from stock to fonts.*



## Stripper Offer



## Strypeeze SEMI-PASTE paint remover

Clings and softens old finishes from every angle . . . for easy scrape-off or wash-off removal. Available where paint is sold.

**SAVOGRAN**   
Norwood, MA. 02062

## IMPORTS AND MOTORSPORTS

*(Continued from page 52)*

perimental, mid-engine RX500 shown on page 52.

**THE SMALL CAR** is the car of the future; just ask anyone at Fiat. The company put Italy on four wheels with its pre- and post-war mini-cars: They were a step up from the family



**BIGGER THAN A BREADBOX** but hardly bigger than the Fiat 600 it replaces, the 126 is to be, according to Fiat chief, Giovanni Agnelli, the bread and butter car for the Italian market for next 10 years

motorcycle. The new 126 (two-cylinders, 23 hp, top speed about 65 mph, \$1400) should be perfect for straddling a couple of square meters of sidewalk to park in congested Italian cities. Sorry, Manhattanites, but the 128 is the smallest Fiat you can buy here.

**MADE IN THE USA** in 1906, the only remaining "American Mercedes" is back in the United States. The car came off the assembly line in Long Island City, at the Steinway factory. The piano manufacturer, William Steinway, was enthused about Gottlieb Daimler's early motor cars and arranged to assemble them here from parts made in Germany. This 1906 model was in the Daimler-Benz museum in Stuttgart until it was brought back for display in the lobby of the new Mercedes-Benz of North America headquarters in Montvale, N.J. You can see it there. ★★



**HANDLE WITH CARE:** It's last known Mercedes-Benz model that was built in . . . Long Island City, N.Y.?

POPULAR MECHANICS

*Материал защищен авторским правом*



## Get away fast. On less gas.

Turn the key on our top-of-the-line 135 hp V-4.

Up to 35,000 volts of spark hit the plugs in less than five millionths of a second.

Our MagFlash™ capacitor discharge ignition system lets you get away quicker. Troll smoother. Perform better, top speed or idle. With long, long plug life.

Now move off. Powerfully. Our exhaust tuned 135 uses sound waves to help pack more fuel charge into the

cylinders. For more horsepower, without using more gas.

And shifting effort is substantially less with our hydraulic-mechanical Power Shift II. Add our single-lever engine command center and you have one-hand control of power from start to wide-open.

This is the way outboarding ought to be. And is.

With all high-performance Johnsons: 50 to 135 hp. At your Johnson dealer. **Johnson's thinking of you.**

*First in dependability.*  
**Johnson**  
 outboards

Division Outboard Marine Corporation Write for our free catalog Johnson Outboards, Sea-Horse Drive, Waukegan, Illinois 60085 Dept PM-273

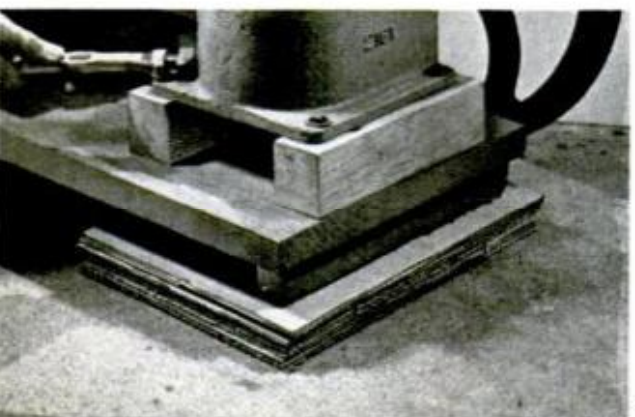
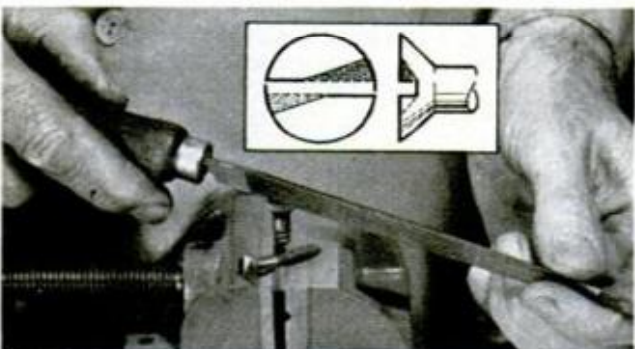
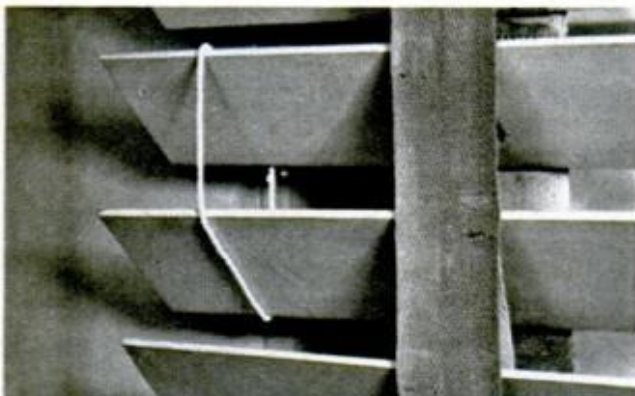
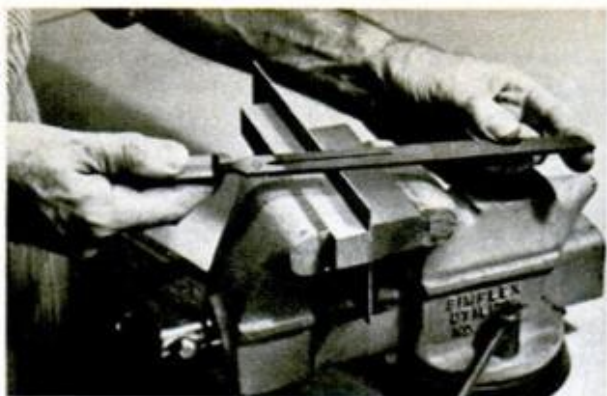

# HINTS FROM READERS

## Reverse filing prevents clogging

When filing aluminum or other material that tends to load file teeth, frequent reverse filing—pulling the file against the work instead of pushing—may keep the teeth clean without the use of a file card. Most ordinary files will cut aluminum to some extent on the reverse stroke, smoothly and quickly, without clogging the teeth.

—Joseph Winn, Richmond, Va.

## First aid for Venetian blind

When a Venetian-blind slat drops because of a broken cross member in the tape, it can be supported temporarily by a cord looped around it and the slat above it. If long enough, a rubber band can be used instead of string. Such a repair makes the blind normally usable until the tape can be replaced or repaired.

—Phillip Maynard, Miami

## One-way wood screws

By filing a bevel on the upper half of the slot in a flathead wood screw and then rotating the screw a half turn and filing away an equal amount on the lower half, you can increase the security of locks, hasps and hinges. Such altered screws can be driven with a regular screwdriver but they cannot be backed out with one.

—Dan D. Powell, Des Moines, Iowa.

## Dustless rust removal

One whiff of rust dust can irritate the respiratory tract of some persons for days. If you are troubled this way, remember this stunt. Before sanding, scraping or wire-brushing a rusty surface, wet it with shellac thinner (alcohol) and the rust will not turn to dust. The alcohol will soon evaporate and not interfere with later finishing.—Ted Behr, Utica, N.Y.

## Cardboard 'blocks' cushion machine

I found that by gluing together several thicknesses of ordinary corrugated cardboard to form blocks about 1½ in. thick and placing them under a small air compressor, the vibration is lessened considerably. If you glue every other piece at a right angle, you'll be surprised what a solid block results and the cushion value it has.—Warren Pease, Parkersburg, W. Va.



# Presenting Datsun 610.

## Considering the luxury, its economy is all the more remarkable.

The new Datsun 610 is something altogether new... a luxury economy car. A Datsun original.

Whether you choose the new 2-Door Hardtop, the new 4-Door Sedan or the new 5-Door Wagon, you get more power, more room, more quiet, just plain more car than any economy car has a right to be. But it comes with a Datsun price tag. And the kind of design sophistication you've come to expect from Datsun.

There's a new 1800 overhead cam engine and new power-assist front disc brakes for the perfect per-

formance combination. The 4-Door Sedan and 2-Door Hardtop have a new independent rear suspension, too.

As for the luxury, well, you've really got to drive it to believe it. The luxury touches—whitewalls, fully reclining bucket seats, tinted glass, full carpeting and custom vinyl interior—are just a beginning.

It's the new Datsun 610 series. Sporting performance, luxury accommodations and an economy car price. You've got to drive one to believe it. Drive a Datsun... then decide.



**Own a Datsun Original.**  
From Nissan with Pride



**John doesn't say  
much anymore.**

John used to be pretty obnoxious. He'd leak, squeak and sometimes even whistle.

He never knew when to shut up. Or shut off, for that matter. John had no self-control.

Finally, someone got smart and looked into his toilet tank. The problem was obvious. John's insides consisted of an ancient ball cock, rod arm and float ball. Complete with corrosion and leaks.

Once rid of those, John got what was coming to him: a Fluidmaster. The simple hydraulic device that eliminates old-fashioned rod arm, float ball, and other corrosive parts. To work with water pressure, instead of against it. For fast, positive shut-offs. And no leaks, squeaks, or whistles.

Write today for full details. And change your John into the strong, silent type.

Manufacturer of the  
Model 100, 200 and 400.



**FLUIDMASTER, INC.**  
1800 Via Burton  
Anaheim, Calif. 92805



### WORLD'S MOST POPULAR HOMEBUILT AIRCRAFT

Now you can afford your own personal Copter! More than 3000 Bensens have been built by people like you, in this country and abroad. The Gyrocopter costs no more to operate than a car. Stores in the garage, requires little space for take-offs and landings. Interchange floats with wheels for extra fun. Fly slow as 20 mph or zip along fast and high. Flying instructions come with complete plans. Kits and parts available. Send \$5 for 3-View Drawings, specs, photo.

**SEND \$5 NOW** BENSEN AIRCRAFT CORP., Dept. PM23  
Raleigh-Durham Airport, Raleigh, N. C. 27602

NAME \_\_\_\_\_  
ADDRESS \_\_\_\_\_

## SUBSCRIBER'S

### Change of Address Form

Please use this form to notify us at least six weeks before you move to your new address.

**1. Present address:** Attach address label from a recent issue, or print your name and address exactly as shown on the label.

NAME _____		
ADDRESS _____		
CITY _____	STATE _____	ZIP _____

**2. Fill in new address:**

NAME _____		
NEW ADDRESS _____		
CITY _____	STATE _____	ZIP _____

**3. Mail this form to:**

**POPULAR MECHANICS**  
Subscription Service Dept.  
Box No. 646  
New York, N.Y. 10019

# We've written the book on kits



## You can get a copy FREE

Shown below are only a few of the more than 350 kits fully described in the 1973 Heathkit catalog. Kits for every interest, every budget...including color TV; stereo systems; electronic organs; marine equipment; a kitchen waste compactor; home intercoms and protection systems, garage door openers; table radios; portable radios and phonographs; guitar amplifiers and accessories; educational electronic workshops for youngsters and adults; tool sets; electronic test instruments; amateur and shortwave radio gear; radio-control equipment; metal locators.

Can you build a Heathkit? For 25 years people just like you have been doing it - armed with no more than a soldering iron and a few conventional hand tools.

No matter how complex the kit, the manual reduces assembly to a simple step-by-step operation. Add to that the availability of the technical correspondence department here in Benton Harbor, and service people in 36 retail stores across the country, and you see why we say "we won't let you fail." And finally, building a Heathkit is fun, pure and simple. The coupon below gets you started.

### Here are just a few of the new kits in this new '73 edition



Heathkit 50-watt Stereo Receiver. \$169.95\*



Heathkit Deluxe Metal Locator has submersible sensing head. \$89.95\*



Heathkit VHF/FM Band-Scanning 8 channel Receiver. \$119.95\*



Heathkit Dolby Cassette Deck. \$249.95\*



Heathkit 6-Digit Electronic Clock-Alarm. \$54.95\*



Heathkit 25V Solid-state Color TV with detent power tuning. \$399.95\*



NEW Heathkit Ultrasonic Intrusion Alarm. \$49.95\*



Heathkit 2 1/2 Digit VOM. \$79.95\*



Heathkit Microwave Oven. \$379.95\*



Heathkit Inductive Timing Light. \$29.95\*



Heathkit CW QRP Transceiver - 40, 20 and 15 meters. \$69.95\*



Heathkit Electronic Calculator. 8-digit readout. \$129.95\*

### Send Today for Your Free '73 Heathkit Catalog

#### HEATHKIT ELECTRONIC CENTERS

ARIZ.: Phoenix, 2727 W. Indian School Rd.; CALIF.: Anaheim, 330 E. Ball Rd.; El Cerrito, 6000 Potrero Ave.; Los Angeles, 2309 S. Flower St.; Pomona, 1555 Orange Grove Ave. N.; Redwood City, 2001 Middlefield Rd.; San Diego (La Mesa), 8363 Center Dr.; Woodland Hills, 22504 Ventura Blvd.; COLO.: Denver, 5940 W. 38th Ave.; CONN.: Hartford (Avon), 395 W. Main St. (Rte. 44); FLA.: Miami (Hialeah), 4705 W. 16th Ave.; GA.: Atlanta, 5285 Roswell Rd.; ILL.: Chicago, 3462-66 W. Devon Ave.; Downers Grove, 224 Ogden Ave.; IND.: Indianapolis, 2112 E. 62nd Ave.; KANSAS: Kansas City (Mission), 5960 Lamar Ave.; MD.: Baltimore, 1713 E. Joppa Rd.; Rockville, 5542 Nicholson Lane; MASS.: Boston (Wellesley), 165 Worcester St.; MICH.: Detroit, 18645 W. Eight Mile Rd. & 18149 E. Eight Mile Rd.; MINN.: Minneapolis (Hopkins), 101 Shady Oak Rd.; MO.: St. Louis, 9296 Gravois Ave.; N.J.: Fair Lawn, 35-07 Broadway (Rte. 4); N.Y.: Buffalo (Amherst), 3476 Sheridan Dr.; New York City, 35 W. 45th St.; Jericho, L.I., 15 Jericho Turnpike; Rochester, Long Ridge Plaza; OHIO: Cincinnati (Woodlawn), 10133 Springfield Pike; Cleveland, 5444 Pearl Rd.; PA.: Philadelphia, 6318 Roosevelt Blvd.; Pittsburgh, 3482 Wm. Penn Hwy.; TEXAS: Dallas, 2715 Ross Ave.; Houston, 3705 Westheimer; WASH.: Seattle, 221 Third Ave.; WIS.: Milwaukee, 5215 Fond du Lac.

HEATH COMPANY, Dept. 17-2  
Benton Harbor, Michigan 49022

Please send FREE Heathkit Catalog.

Name \_\_\_\_\_

Address \_\_\_\_\_

City \_\_\_\_\_ State \_\_\_\_\_ Zip \_\_\_\_\_

Prices & specifications subject to change without notice.  
\*Mail order prices; F.O.B. factory. CL-460R

THE  
**BICYCLE  
SHOP**  
By EUGENE A. SLOANE

This month Gene catches up on some of the many cards and letters from readers and answers their questions about bike repairs, tools and touring

**Q.** My new Chiorda bike started out with both wheels wobbling and rubbing against the brake shoes. What can I do?—Doug Stewart, Greenwich, Conn.

**A.** Wheels need alignment or brake caliper arms need repositioning. First make sure wheels are in line. If not, tune up by tightening spokes on the side away from where rim is too far to one side. That is, if the rim is too far to the left, tighten a spoke or two on the right side. You may have to loosen a spoke or two on left side. Ditto on a wheel rim too far to the right, but reverse spoke adjustment sequence. If the rim still rubs on brake shoes, loosen the brake-bolt nut where the brake is fastened to the fork or rear chain stays and reposition the brakes. Brake caliper arms may need repositioning, which can be done by giving the brake cable about 1/4-inch slack to permit brake shoes to be held further away from the rim.

**Q.** A bike I want to buy has had all emblems and decals removed for cosmetic reasons, and it was given to the current owner. It has Campagnolo components and Weinmann 999 brakes. How can I tell if it has Reynolds 531 or Columbus tubing?—The frame is chrome-plated.—Mark Trombino, Staten Island, N.Y.

**A.** I would guess this is a Schwinn Paramount, since few others chrome a frame. Take it to a Schwinn dealer for a check. It's almost impossible to test, short of a metallurgical check, whether it's a Reynolds or Columbus frame metal. Thin seat and chain stays and forged-steel dropouts would be additional clues. If the bike weighs no more than 23 pounds, this would indicate Reynolds or Columbus tubing.

**Q.** My rear-derailleur cable keeps coming out of the rear derailleur. Tightening the cable retain-



**RECENTLY INTRODUCED** in a new line of John Deere bicycles was this 27-inch, five-speed two-wheeler that features a unique frame style which is popular in Europe. Center-pull hand brakes are mounted on the handlebars and the speed shift is located on the handlebar stem. John Deere, long known as a farm-equipment manufacturer, entered the recreation field with snowmobiles in 1971. Now, it's bicycles

ing nut doesn't seem to help.—Paul Thomas, Midvale, Utah.

**A.** You may have stripped the cable retaining nut on the derailleur. Or, if the cable does not come out of the derailleur but simply goes slack when you shift to the high-speed gear, the derailleur body parts may be dirty and need cleaning and relube with light oil. Or the derailleur spring may be weak or broken so that the derailleur body won't shift down. Check all these points. Push the derailleur in and out, sideways. If it's slack, you may need a new derailleur spring. If it sticks, cleaning may be the answer.

**Q.** This isn't a question, but a tip. Loctite's Lock n' Seal keeps derailleur adjusting nuts, pannier carrier nuts and bolts and other nuts on a bike from coming loose, yet a wrench will break the seal.—Lisbeth Simpson, Warwick, R.I.

**A.** Thanks. If you can't find Loctite products in a hardware store, the firm is located at 705 Mountain Rd., Newington, Conn. 06111.

**Q.** My plastic saddle is very painful. Shaving it thinner from underneath helps some, but I may try drilling holes in it. Instructions with Simplex Criterium derailleurs say not to touch tension springs. So when renewing the derailleur I pulled off the spring plate, releasing the spring. Attempts to replace the spring ruined the spring hole in the plastic housing. To save the derailleur, I filed out the plastic tip and filed an alumi-

(Please turn to page 64)

# The big Dodge.

**Extra care in engineering  
makes a difference in Dodge  
...depend on it.**

The 1973 Dodge Polara. It's the big Dodge. One of the biggest, roomiest, most comfortable cars in America. And there's a reason for that. Extra care in engineering. That's what makes the big Dodge the kind of car in which you can feel confident.

For dependable, trouble-free starting in all weather—the revolutionary Electronic Ignition System. For stability, silence,

and control—Torsion-Quiet Ride. For strength—Unibody construction.

These are only a few of the many engineering advances that make the big Dodge so rewarding. You get them all, plus automatic transmission, power front disc brakes, and power steering as standard equipment on the 1973 Polara. The big Dodge. Test-drive one at your nearby Dodge Dealer's today.



## THE BICYCLE SHOP

*(Continued from page 62)*

num D-shaped washer to replace it. It works well and tension is okay.—Mike Redfern, Niagara Falls, N.Y.

**A.** There's no way you can break in a plastic saddle. You might try covering it with leather, but it's still going to be hard underneath. Some Japanese plastic saddles have a foam cover topped with vinyl plastic covers, but can't be shaped to one's configuration. Regarding ruining a Simplex derailleur plastic housing spring hole, join the club. I've done it myself. Your solution is excellent!

**Q.** Where can I get an exploded view of a Huret-Allvit derailleur?—Alan George, Amherst, Mass.

**A.** Ask your bike dealer to order one from his wholesaler. Schwinn uses a similar derailleur, so a local Schwinn dealer may let you look at his shop manual.

**Q.** I just bought a 10-speed. In testing it, I noticed the chain skips every now and then on some gears. I tried adjusting the shift levers, and the chain tension spring on the derailleur is into the tightest slot.—Martin Otterson, Sayward, B.C.

**A.** You didn't state whether this is a new or used bike. If used, the problem could be worn gears. Check to see if gears have wear on inside of teeth, causing a "lip" which lifts the chain off and throws it on another gear. If new, check the shift-lever handle locknut. The shift lever should move stiffly; otherwise the derailleur tends to shift by itself. Or the chain could be too long. When the chain is on large front and rear gears, the rear derailleur pulleys should be flattened and parallel with the chain. If not, squeeze the chain until the derailleur is so aligned, remove the two or three links as needed, with a chain rivet remover which you can buy from a good bike store for about \$2.50.

**Q.** To your knowledge, has anyone ever tried to operate both front and rear (caliper) brakes with a single lever? Seems to me this would be simpler and safer.—Ken Greenberg, Chicago.

**A.** No, not that I know of, so far as conventional mechanical caliper brakes are concerned. The problem is that you need to be able to be selective, in that back brakes should be applied slightly ahead of front brakes.

And in going downhill at high speed, you should apply first the rear and then the front brakes alternatively to keep from overheating the rims. Shimano (Shimano American Corp., 1133 Avenue of the Americas, New York, N.Y. 10036) makes a really good hydraulic caliper bike brake which one lever operates. It's separately ported so the back brake is actuated a second before the front brake, and each brake has its own cylinder. These are really fantastic brakes; they even work well in wet weather. They aren't in use on American bikes, which is too bad because my tests show these hydraulic brakes to be superior even to \$75 Campagnolo brakes; they cost about \$20 less.

**Q.** How do I remove a gear cluster so I can put on wider range gears? With a hammer and brass punch?—Cornille Vanosch, New Bedford, Mass.

**A.** Whoa, hold it! Don't use a hammer and anything else on any bike part! You need a freewheel remover. Trouble is there are many freewheel makes, each needing a special tool, with some overlap. Look at your freewheel; is it Atom . . . Regina . . . Shimano? Whatever the name, tell your bike dealer, who should have the right tool in stock or order one. To use it, remove the quick-release skewer, insert the tool, replace the skewer and turn the removing tool counterclockwise to remove the freewheel. On some slotted designs, such as Shimano, you won't need to reinstall the skewer to remove the freewheel. The tool costs about \$2.

**Q.** I have never been able to align the derailleur with my inside chain ring. Can I move the chain ring in or out without buying a new axle?—George Heskey, Newtonville, Mass.

**A.** I assume you mean the front derailleur. If so, it should have plenty of adjustment so you can center the derailleur chain guide over the inner chain ring (the small one). Some front-derailleur chain guides are also adjustable on the chain-guide shaft. If not, try the Campagnolo Record front derailleur, which should work. If the rear derailleur is the problem, just add or remove thin washers from between the axle cone locknut and axle cone nut to align transmission. Correct alignment is when the third gear of the rear five-gear cluster is lined up between the two front chainwheels. ★ ★ ★

---

**GOT A PROBLEM WITH YOUR BIKE?** Ask Gene about it. Send your question to Bicycle Shop, *Popular Mechanics*, 224 West 57th St., New York, N.Y. 10019. Letters cannot be answered individually, but problems of general interest will be published in this column.

## Solid State.



'73 Apache Ramada, \$1995\*

## Soft State.



'73 Apache Eagle 8, \$1595\*

## Only Apache gives you a choice like this!



From the greatest name in camping trailers comes a greater selection—two kinds of Apaches for '73! New Solid State models with exclusive wall and roof construction of space-age thermoplastic. Plus, a totally new line of hardtop tent trailers, with super comfort interiors patterned after the Solid States. A total of seven different models . . . four body sizes . . . five prices, from \$795\* to \$1995\*. And every one of these new Apaches gives you more for the money. Like sliding screened windows, full draperies and power ventilator on the Solid States. New continental-style spare tire compartment and

110/12-V electrical system on the hardtop tent models. So if you want more of a choice—and more of a camper—see your Apache dealer soon. Check the Yellow Pages under "Trailers—Camping and Travel." Or write for one of our 1973 catalogs. Vesely Company, Box 332, Lapeer, Michigan 48446.



**APACHE** **VESELY COMPANY**



\*Higher in Canada. Does not include freight charges. Wheel covers and window awnings shown are extra cost.

# HOMEOWNERS' CLINIC

BY W. CLYDE LAMMEY

## Why more moisture?

*I've installed electric forced-air heat, replacing an oil-fired furnace. Now the windows sweat and occasionally in cold weather there is moisture on the walls near the ceiling. I've never had this problem before. Why now?—Ed Tripps, Buffalo.*

You're no longer heating with a natural flame, which normally exhausts some of the warm, moist air through the chimney flue and also pulls in colder, dryer air from outside through opened doors, tiny openings around window frames and the fireplace flue. Your electric furnace is unvented and the only heat source is the heated elements at times when the unit is cycling. This accounts for the rise in moisture content of room air. If you use a humidifier, you may find you no longer need it, except possibly in extremely cold weather.

## Flattening warped plywood

*A choice piece of plywood got wet in my flooded basement. The plys did not separate, but the piece warped. Is there some way to flatten the panel?—R.J. Kinsman, Lancaster, Pa.*

Place the panel on a level floor, table or bench, then clamp or weight the piece sufficiently to flatten it. Dampen the top face uniformly and allow it to dry. Your chances are fairly good that the panel will remain flat after drying.

## Toilet tank leaks

*Recently my plumber installed a new ball cock and float in my toilet tank. This worked for a time but now water in the tank rises above the overflow, resulting in a constant leak into the bowl. The float is nearly submerged before the thing shuts off. Can I correct this trouble myself?—Manly Benson, Des Moines, Iowa.*

Hold the float arm in closed position and unscrew the float. There may be water in it. If not, turn it back on the rod tightly. Then bend the rod down slightly and flush to check. If water still rises above the

water-level mark, bend the rod a little more. This usually solves the problem, but not always.

At the end of the pivoted arm that actuates the ball valve you'll see an adjusting screw. Turn this down a turn or two and flush to check. If not sufficient, turn the screw down until the valve shuts off completely at, or slightly below, the water-level mark.

## Replacing bulb in lighted globe

*I have a lighted world globe on a pedestal and recently the bulb burned out. Close examination reveals no way to remove the globe from the stand or to reach the socket to replace the dead bulb. Can you enlighten me?—George Meade, Los Angeles.*

Originally, the switch, socket and bulb were installed inside the globe, so there must be a way to remove the fixture. Incidentally, remember these globes are usually of glass so proceed with care! Usually there's a pivot screw at the top—turning this out will release the globe from its peripheral support. At the bottom of the globe you'll likely find a removable flanged disc to which the socket and switch are attached. Remove this disc, replace the bulb and remount the parts in the reverse order.

Work carefully to avoid damaging the gasket between disc and bottom of the globe. When replacing the fixture, be sure to put the gasket back in the same position that you found it.

## Paint peels from plaster patch

*A roof leak has led to a plaster patch on a bedroom ceiling. I painted this patch with the same paint that was used originally on the ceiling. Now the paint is peeling. How can I solve this problem?—J.E. Snelling, Denver.*

I'm afraid you didn't wait long enough for the plaster to dry thoroughly. This takes time, as much as two months or more, depending on local conditions. Scrape and sand off all the loose paint, wait another month or so, then apply an undercoater or shellac, and repaint. You'll likely have no further trouble. ★★★

*Do you have a home maintenance or repair problem? Send it to Homeowners' Clinic, Popular Mechanics, 224 West 57th St., New York, N.Y. 10019. While letters cannot be answered individually, problems of wide interest will be discussed in this column.*



# Spend a milder moment with Raleigh.

A special treatment softens the tobaccos for a milder taste.



A down-to-earth idea. "Forrester" Hunting Boots by Wolverine. Get a pair for free B&W Raleigh coupons, the valuable extra on every pack of Raleigh.

To see over 1000 gifts, write for your free Gift Catalog: Box 12, Louisville, Ky. 40201.



Warning: The Surgeon General Has Determined That Cigarette Smoking Is Dangerous to Your Health.

© 1973 BROWN & WILLIAMSON TOBACCO CORP.

Filter Kings, 17 mg. "tar," 1.3 mg. nicotine; Longs, 19 mg. "tar," 1.5 mg. nicotine, av. per cigarette, FTC Report August '72

FEBRUARY 1973

67



## There are more than two pickups to choose from.

It seems that whenever most people consider buying a pickup they only consider the two biggies, Ford and Chevy.

Unfortunately, they don't know what they're missing.

The Other Pickup—International.

The Other Pickup has everything going for it except a familiar name. We have a smooth ride. Easy handling. Safety features like a collapsible steering column and a fuel tank located outside the cab.

We give you 13 colors to choose from, four different color-keyed interiors, and luxuries you don't often see in a truck.

You can have torsion bar suspension for easy handling or leaf spring suspension for heavy loads.

Or automatic transmission. Power steering. Power brakes. Or our exclusive anti-skid system.

After you've looked at the Ford and Chevy Pickup, look at us. The Other Pickup.

At your International dealer.

You just might end up thinking we're the Only Pickup.



**International. The Other Pickup.**

# SOLUTIONS FOR MECHANICAL HEADACHES

# AUTOMOBILE CLINIC

BY MORT SCHULTZ

## Well water

*Water accumulates in the well of the tailgate of my 1971 Oldsmobile Custom Cruiser when it rains. Can you suggest a way of getting it to drain?—Jay W. Miller, Largo, Fla.*

There's a drain hole in the bottom of the tailgate on the right-hand side. Dirt and mud have apparently clogged it, allowing water to back up. To clean out the drain, you must remove the back body lower housing access hole covers, and lower housing drain sealing strip.

## Changing vinyl top color

*Is there a paint I can use to change the color of a vinyl top?—Ralph Wethli, Hollywood, Fla.*

There are probably other paint companies that make such kits, but the one I'm familiar with is the VR-1 system distributed by Young Paint and Varnish Co., 1 South Ave., Fanwood, N.J. 07023. It contains a conditioner (cleaner), paint and luster finish. The paint should be sprayed on with professional-type paint spray equipment. Price of the kit is \$13.25.

## Water injection

*I have a 1965 Chevrolet Impala with a hangover brought about by water in its gasoline. I have changed the carburetor and flushed out the fuel tank. The car has a new gas cap. The problem continues. Help.—J. W. Rezendes, Union City, Calif.*

If you've been buying gasoline from one service station, switch on the remote possibility that it's responsible for pumping water into your car. After again flushing out the gas tank to assure that no water remains, fill the tank to the very top with gas and check carefully from gas cap to carburetor for a fuel leak. Pay particular attention to the filler pipe. If gas is leaking from a spot, water could be leaking in through the same spot. Finally, don't overlook the likelihood of condensation, especially if you're in the habit of keeping the fuel level low. Keep the tank topped off.

## Tuning in

*The AM-FM radio in my Mercedes-Benz needs a new transformer that no one I have contacted here can supply. You're my last hope.—Carl N. Gotch, Phoenix.*

Apparently, you've done some troubleshooting and don't have to pack up the whole radio to send it back to the manufacturer, who I would guess is Becker. The majority of radios in late model Mercedes have been supplied by Becker Auto Radio—USA, 613-19 South 24th St., Philadelphia, Pa. 19146.

## To stop a leak

*There is an oil leak from the rear of the intake manifold of my Ford's 352-cu.-in. V8 engine. My mechanic has replaced the gasket twice, but the repairs last only for six months. Has a service bulletin been issued concerning this?—Stanley Green, Union, N.J.*

Not that I know of, but let me give you a few things to think about. When a new gasket is installed, both the block and intake manifold surfaces must be perfectly clean. The mechanic should use a high-grade sealer, such as Permatex No. 2, on both surfaces. During the installation, the gasket must not shift even slightly. If it does, it may pinch and lead to leakage. Finally, it may prove beneficial to re-torque the intake manifold attaching bolts periodically.

## Hot foot for a cold carb

*My problem is carburetor icing with a 1969 Datsun 1600-cc sedan. When the engine quits on a cold morning, you can actually see ice inside of the carburetor. What should I do about this?—L. Sargent, Belfair, Wash.*

If you have a Datsun dealer in or near Belfair, ask him to install the carburetor de-icer kit issued by the company to correct this problem. If you don't, turn the carburetor air breather around toward the firewall. This will permit some hot

*(Please turn to page 70)*

## AUTOMOBILE CLINIC

(Continued from page 69)

air to get inside the carburetor to help control the icing.

### Grounding out

*My 1971 Pontiac 350-cu.-in. engine has an electrical problem. The headlights dim badly and flutter as I slow the car down. When it is brought to a complete stop, the lights get brighter. The same thing happens to the directional signals when they are operating. The faster I stop, the worse the condition. The alternator, battery and voltage regulator are top draw. Any suggestions?—Phil Phillips, Fort Worth, Tex.*

Four conditions commonly cause this problem. You have eliminated three; now check into the fourth—a loose ground.

### Oil burner

*Have you determined why the Ford Pinto with 2000-cc engine is an oil user? Ours guzzles a quart every 600 miles.—Gordon W. Battey, Fort Worth, Tex.*

So do others, but a Ford service bulletin, No. 22 (8/4/72), has been issued to stop this. It provides for the installation of a new type of valve stem seal.

### Chatterbox

*The posi-traction rear end of my 1972 Chevrolet ½-ton pickup truck has had the clutch plates replaced twice within 12,000 miles because of chatter. Is there something I can do to prevent a recurrence of the problem?—Paul Shampine, San Antonio, Tex.*

It's not your problem alone, Paul. Other owners of Chevrolet passenger cars and trucks with posi-traction rear ends have been experiencing the same condition. Clutch plates aren't meshing properly. However, there could be a simple solution. If the chatter begins again, immediately drain the fluid and refill the rear end with fresh posi-traction lubricant, but this time add a can of GM Posi-Traction Rear End Additive (part No. 1050428).

### Exhausting problems

*Over the years you have helped me solve*

*many problems through Automobile Clinic, and I am grateful. Now I would like to return the favor by passing along information concerning a difficult-to-diagnose problem I had with a 1971 Buick, 400-cu.-in. engine. This engine, in warranty, developed a high-pitched whistle which made us think it had a vacuum leak. It lost power at about 50 mph. The dealer kept the car about two weeks and finally in desperation cut out a section of the exhaust pipe leading from the left bank to the right bank ahead of the muffler. This section of pipe was laminated and the inside had collapsed, almost closing off the passage. What do you think?—W. E. Garrison, Aiken, S.C.*

This is good information for Buick owners to stick in their bonnets. Thanks.

## Service tips

● **Volkswagen** is one manufacturer that has spelled out its position on additives. They tell owners, "No additives of any kind should be mixed with the fuel, the lubricating oils or fluids. Buy a name-brand oil labeled 'For Service SD (or MS).'"

● **Plymouth** wants to clear up the confusion concerning use of the manual choke in the 1971-72 Cricket. Pull the choke control out all the way and turn the knob clockwise to lock it in position. It is not necessary to place your foot on the accelerator pedal. Start the engine and let it idle for about 15 seconds. Unlock and push the choke in three-quarters of the way. Drive the car until proper engine heat has been reached. Then deactivate the choke completely.

● **Chevrolet** says that the clear translucent spots on windshields and windows of some new models are probably not imperfections, but may have been caused by the spilling of primer which is used in production to obtain adhesion between the glass and caulking compounds. If it is this, the "stain" can be removed by rubbing it with a pencil eraser or by carefully scraping the spot with a razor blade.

● **1971 Comet** engines with the 200-cu.-in. engine and an automatic transmission may be stumbling and hesitating despite tune-ups. If yours is, replace the accelerator pump cover assembly with a new one. It's part No. D1DZ-9528-A. ★★★

---

**GOT A PROBLEM WITH YOUR CAR?** Ask Mort about it. Send your question to Auto Clinic, Popular Mechanics, 224 West 57th St., New York, N.Y. 10019. Letters cannot be answered individually, but problems of general interest will be published in the column.

# "Yeah, but station wagons are so dull."

That's what people used to say.

But now there's the Hornet Sportabout, the anything but dull Sportwagon from American Motors.

It's just the right size outside and inside there's plenty of cargo space.

And it has four doors and a standard six cylinder engine that leaves other little wagons behind.

Sportabout is easy to handle, easy on gas, easy on your pocketbook and very easy to fall in love with.

And only American Motors makes this promise: The Buyer Protection Plan backs every '73 car we build, and we'll see that our dealers back that promise.



Buckle up for safety.

## AMERICAN MOTORS BUYER PROTECTION PLAN

1. A simple, strong guarantee, just 101 words!

When you buy a new 1973 car from an American Motors dealer, American Motors Corporation guarantees to you that, except for tires, it will pay for the repair or replacement of any part it supplies that is defective in material or workmanship. This guarantee is good for 12 months from the date the car is first used or 12,000 miles, whichever comes first. All we require is that the car be properly maintained and cared for under normal use and service in the fifty United States or Canada, and that guaranteed repairs or replacement be made by an American Motors dealer.

2. A free loaner car from almost every one of our dealers if guaranteed repairs take overnight.

3. Special Trip Interruption Protection.

4. And a toll free hot line to AMC Headquarters.

**AMC**  **Hornet**

We back them better because we build them better.

# Introducing the Hornet Hatchback. A sports car with room to travel in.

Isn't that a nice idea? A car that does everything a sports car should do.

It moves like one. It handles like one. But it doesn't cost like one.

And the Hornet Hatchback gives you

lots of extra room when you need it. Just fold down the back seats and load up through the hatch.

And only American Motors makes this promise: The Buyer Protection Plan backs every '73 car we build, and we'll see that our dealers back that promise.



Buckle up for safety.

## AMERICAN MOTORS BUYER PROTECTION PLAN

1. A simple, strong guarantee, just 101 words!

When you buy a new 1973 car from an American Motors dealer, American Motors Corporation guarantees to you that, except for tires, it will pay for the repair or replacement of any part it supplies that is defective in material or workmanship. This guarantee is good for 12 months from the date the car is first used or 12,000 miles, whichever comes first. All we require is that the car be properly maintained and cared for under normal use and service in the fifty United States or Canada, and that guaranteed repairs or replacement be made by an American Motors dealer.

2. A free loaner car from almost every one of our dealers if guaranteed repairs take overnight.

3. Special Trip Interruption Protection.

4. And a toll free hot line to AMC Headquarters.

## AMC Hornet

We back them better because we build them better.

# Good art at a price you can afford

We tell you where to get low-cost prints, how to mat them and how to make 27 different frames from standard wood moldings.

By **HARRY WICKS**  
Workshop Editor

Photos by Robert D. Borst  
Stylings by the author

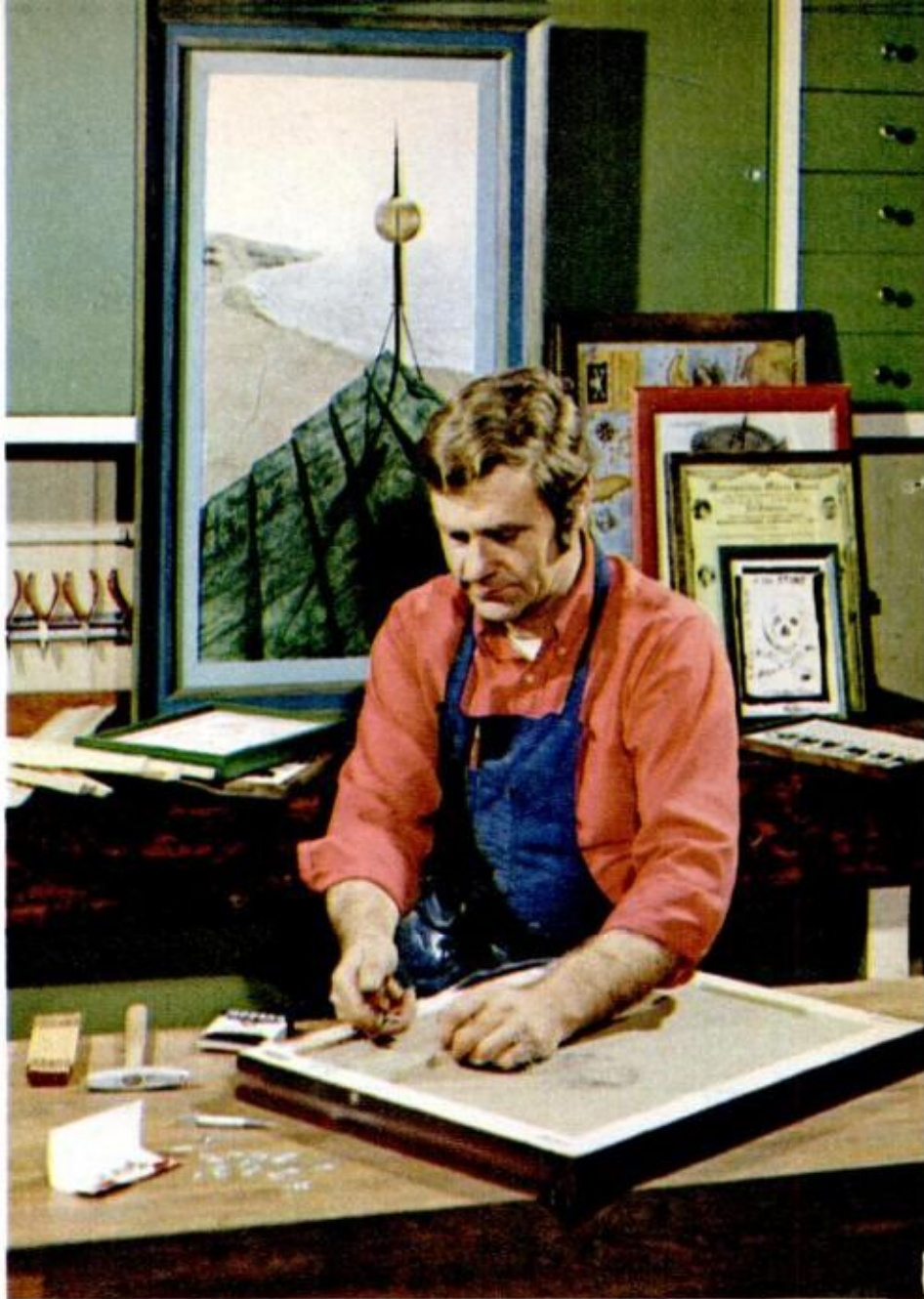

**T**HE HANDSOME FRAME for *Christina's World* by Andrew Wyeth on the cover of this issue closely duplicates the original which hangs in New York's Museum of Modern Art.

A professional framing shop would charge about \$75 for such a frame; our actual cost to make and finish it in the *PM* shop was \$16.83. A reproduction of the painting is available from the Museum of Modern Art for \$8.

Similarly, the frame for Wyeth's *Northern Point* (above) was created using a spinoff design of the first frame. This one cost about \$16 to make. The print is available for \$16.

All 27 frames shown in this issue in color (cover and pages 73, 74, 75 and 76) were created in the *PM* shop. We have

made framing easier by using a basic two-part assembly: surfaced-four-sides (S4S) lumber for a subframe and standard pine moldings for the decorative front frame. Happily, these moldings are available at low cost at all lumberyards.

How the frames were made, plus other picture-frame know-how, is detailed in text and illustrations that follow. The concluding section of the article tells how each was finished.

If you are interested in any of the reproductions that we have framed, you'll be happy to know that they are available by mail. Sources are listed on page 190.

*Tools and materials.* Because construction techniques have been kept simple, the frames can be made using hand tools only. If you own power tools, the job will go



Ballet Girls/Duteurte

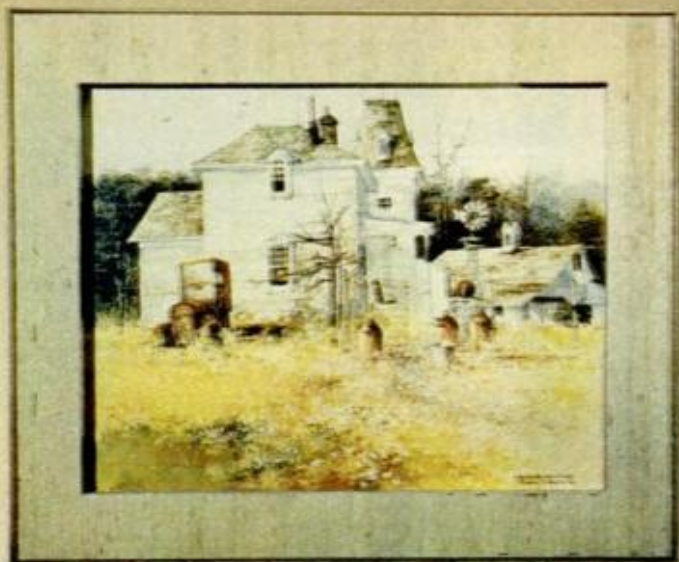

Gone for the Summer/Hamilton



Amber Field/Russell

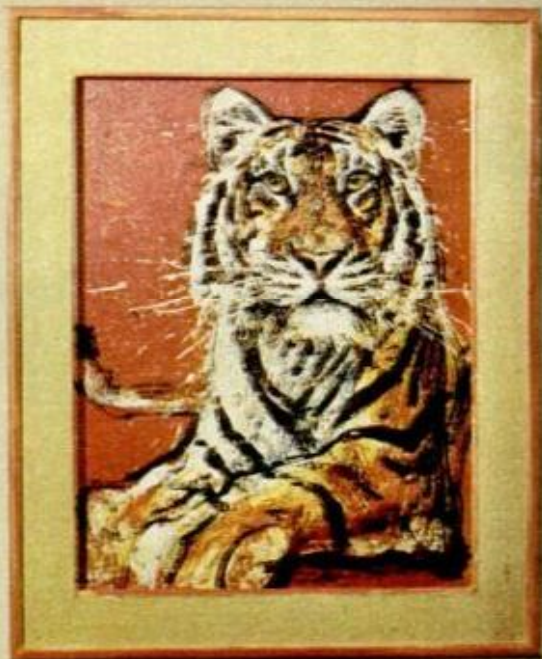

Tiger with Red Background/Hug



Island Silhouette/Ross



Passenger/Martin

**ALL FRAMES** were created using moldings for front frames, surfaced-four-sides (S4S) lumber for the sub-frames. Each of the 12 moldings at left was used on at least one of the frames in this story. From top: cove (2¼ in.), glass bead, backband, clamshell stop, mullion casing, quarter-round, corner guard, picture mold, clamshell base, dripcap, solid cove and a 3¼-in. crown/bed molding. Using instructions given in text, you can duplicate or create your own.







Still Life with Pitcher/Chailloux

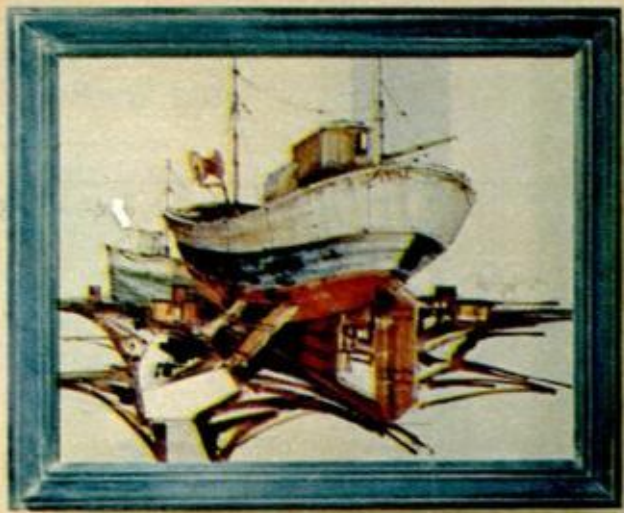

Ship in Drydock/Listri



Still Life/Salinas



World War II Tank Print



Pirate Treasure Map



Buddha/Lee



Courtyard/Felmart



Nature Morte Avec Three Fruits/Genis



Sailboats/Bria

**PRINTS AND REPRODUCTIONS** selected for use in story are all available by mail order. Five pieces of art, such as lithograph directly above, are original works. Complete details for making and finishing frames (and where you can buy prints) are given in text and how-to section.

**MORE** →



MAKING YOUR OWN FRAMES is just half the fun; creating attractive wall groupings is another reward. Above: old-time posters, woodcut and tools (from

author's collection) on burlap. Below: a Charlie Chaplin and three other posters. Most are available at bookstores; they can also be mail-ordered



faster, but the techniques remain unchanged.

**Selecting stock.** Standard pine moldings are the key to creating a good-looking frame; this factory-shaped stock eliminates the need for a router or shaper, or having to pay to have this work done by a cabinet shop. If possible, when you buy your moldings, pick out the materials yourself. Or at the least, take a sighting along each length of molding to assure its being straight and free of twists and bows. If you don't, you will quickly learn that warped moldings will give you trouble when you attempt to close a mitered joint. Also, avoid moldings that are excessively sappy; these will not take stain evenly, and you'll be disappointed with the finished product no matter how fine your carpentry.

**Selecting the right frame for the picture.** Since styles and tastes are constantly changing, you do have considerable "artistic license" when it comes to creating a frame. The basic rule to keep in mind is that the frame should complement the picture it will contain. Thus, a wide frame utilizing bold moldings is best suited to heavy, bold prints and oil paintings; narrow, simple frames should be used on small, delicate pictures.

## BASIC FRAME

(VIEWED FROM THE BACK)

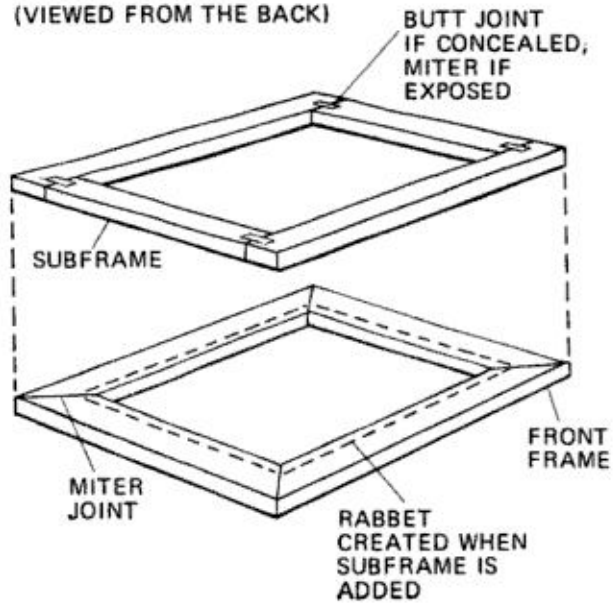

**BUTT JOINTS** are used on subframe, mitered corners on moldings. Rabbet is formed when these are joined

To focus attention on a decorative object or display, such as the antique tools (opposite), use either an appropriately textured backing or make a frame with a shadow-box effect (that is, with the front frame protruding an inch or so from the framed objects). A decorator rule-of-  
*(Please turn to page 178)*

## HOW TO MAT PICTURES

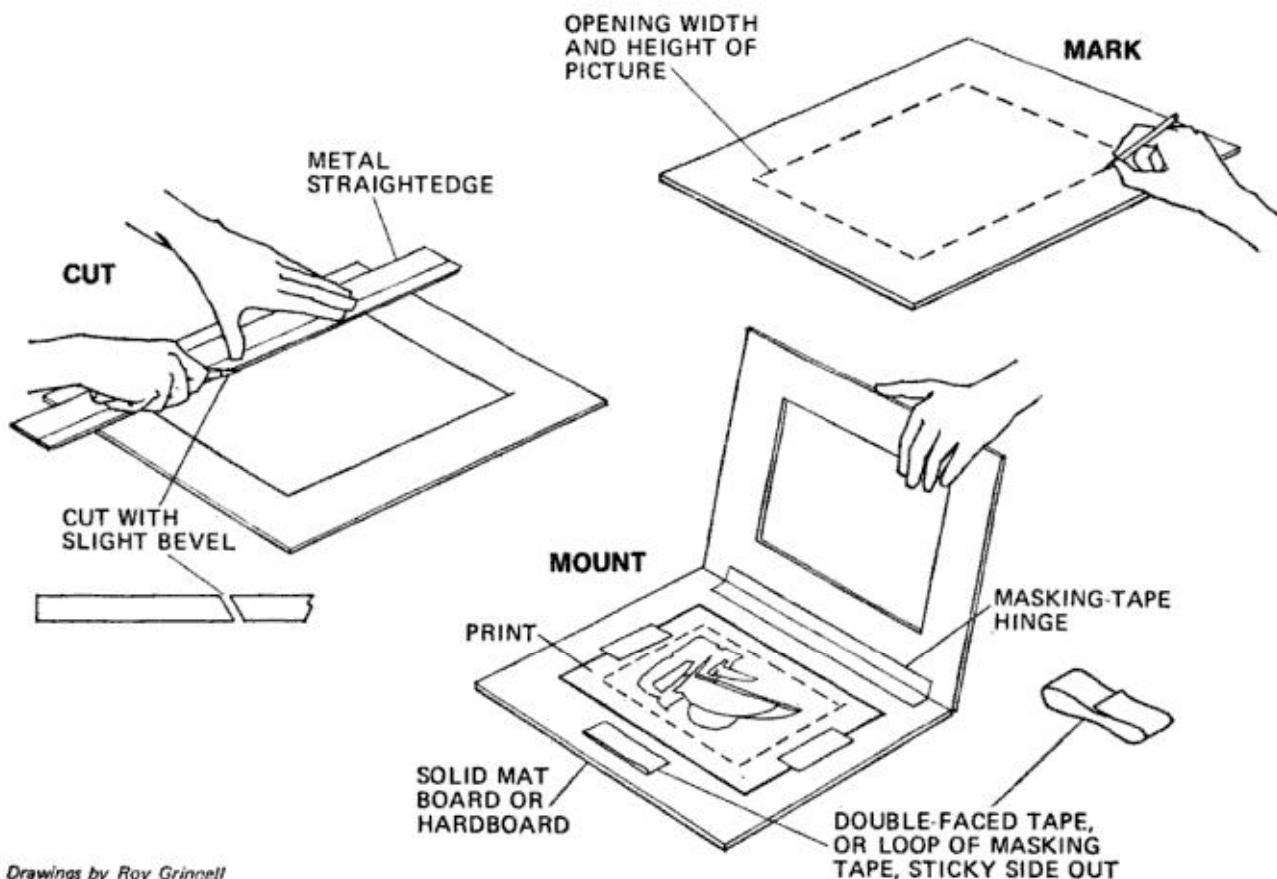

# Tomorrow: Tailgate warning on the windshield

By DAVID LAMPE

It's hard to break the tailgating habit, and a group of British traffic experts know it: They've come up with a simple system that will help you keep your distance

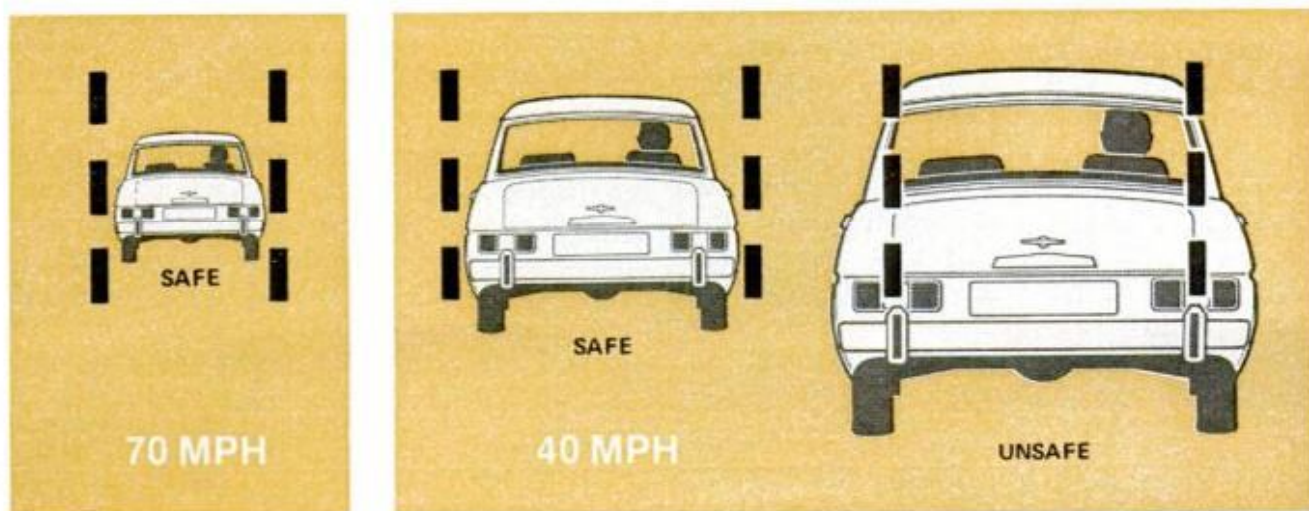

**VERTICAL LINES** projected on the windshield will move closer together or farther apart, depending on the speed of your car; closer together as your

speed increases and farther apart as you slow down. As long as the outline of the car ahead is between the lines, you are following it at a safe distance

**YOUR CAR'S DASHBOARD** is supposed to place before you all the information you need to know about the auto's performance at a glance. But a series of tests by the British government's Road Research Laboratory indicates that the present-day dashboard is a distraction.

What's needed is a completely new kind of automobile instrumentation, and the laboratory's technicians believe they have created it. Right now it's being adapted to fit specific models of tomorrow's British autos. And its effect on road safety and driving ease is going to be dramatic.

The British investigators discovered the inefficiency of present-day dashboards about five years ago, when they adapted a device used in American industry, the Polymetrics Eye-marker Recorder, to study what they call "the driving task."

The recorder, which nobody anywhere else had used for this particular purpose, is basically a pair of closed-circuit television cameras that simultaneously photograph and record on tape what a person sees and his eye movements: "When you're driving fast," one of the scientists at the Road Research Laboratory explained, "you hardly ever glance down at your speedometer—although you *think* that you keep a close watch on it. In tight situations, hemmed in by other cars, you never look down at it at all. You can't—because you haven't the time. Whenever your eyes are moving, they're not transmitting information to your brain. Just to glance down from the road ahead to your speedometer, register your speed and then look back down the roadway again takes you at least a second and a half.



**IN THE EXPERIMENTAL WORKING SYSTEM** all of the apparatus, including optical projector and sloping screen, is exposed. In production models, projec-

tor will be concealed in dashboard and will beam speed and vertical headway markers directly onto windshield. Here, car is following at right distance

"At speed in excess of 70 mph you just don't have the time to take your eyes off the road at all. The study of drivers' eye movements indicate that even on a test track, under ideal weather conditions and with no other cars around, taking into account blinking, 12 percent of the time you're behind the wheel you're not seeing anything at all. And 95 percent of the time you're taking in no information from your dashboard at all. Little wonder that on crowded freeways you're usually driving faster than you think you are.

"Clearly what was needed was some way to place a statement of a moving car's precise speed right in its driver's immediate field of vision." Other Road Research Laboratory studies had indicated that most drivers would be safer if they had some help in stationing their cars on the

road to prevent tailgating at normal speeds. And at speeds in excess of 74 mph *all* motorists could use such help.

The Eye-marker Recorder indicated that drivers usually focus on the roadway about 120 feet ahead of their autos. So the laboratory technicians devised a projector that can be mounted inside a car, in front of the steering wheel, to flash the car's speed on the inside of the windshield or on a rearward sloping plastic or glass screen just inside the windshield.

The British researchers also incorporated into the "head-up" instrumentation system a simple antitailgating device. It projects two vertical lines on the windshield or on the sloping reflector, just above the auto's speed. The lines come closer together when the car races, sepa-

*(Please turn to page 193)*



**ARTIST CHARLES LE NORREYS** uses diamond-impregnated grinding wheel to shape leaves and stems

## Lucite sculpturing

**DIAMONDS** are an artist's best friends when he etches and sculpts in Lucite acrylic resin. This is proved by Charles Le Norreys, a young French Canadian whose works are shown here. In fashioning the song sparrow on a milkweed stem (above), Le Norreys first etched in the outline lightly with a diamond-pointed scribe, then he ground the leaves and stems with diamond-impregnated wheels. Seed pods were etched with a hand scribe, the sparrow ground with a steel cutter and final shaping and "feathering" done with a special diamond tool.



**SCRIBER** (left) is used initially to etch in entire outline lightly, then to etch in details. The "Lancer" shown has interchangeable diamond points, set at different angles—90°, 70° and 60°—for different types of work. In shaping stem of mushroom (below), artist uses flexible-shaft drill with round head impregnated with De Beers natural diamond powder



**ARTIST'S WORKS** have been on exhibit in New York, San Francisco and Paris. He says he likes to work with diamond tools because of their long life. Most people tend to abuse the scribe, he warns; they use it like a glass cutter rather than the delicate etching instrument that it is. Le Norreys uses both hand and power-driven tools. His flexible-shaft machine is operated from 14,000 to 40,000 rpm, depending on the effect that he is trying to achieve

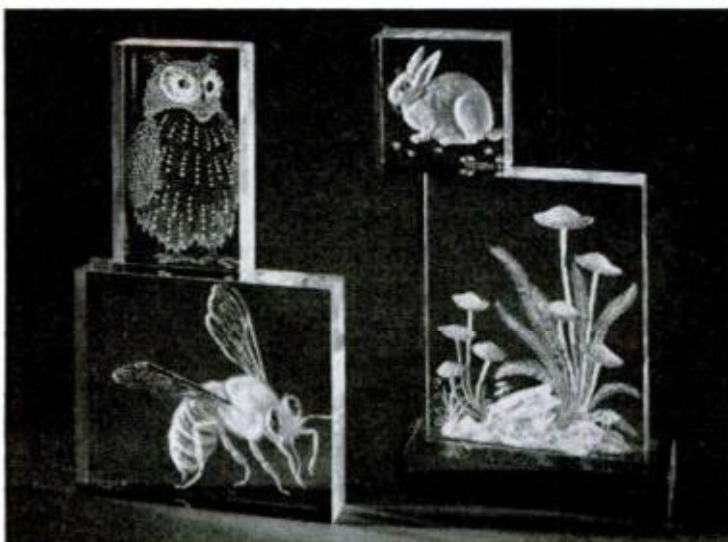

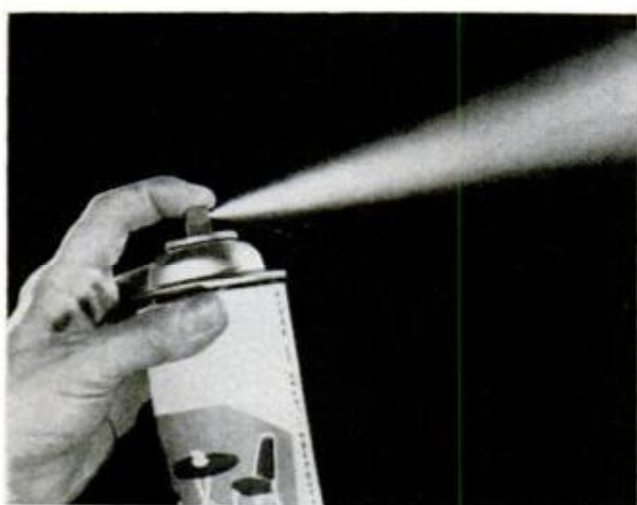

One scientist suspects that lacquer in hair sprays may collect in human lung tissue. Others are concerned about toxicity of gases commonly used as propellants

By JOHN ENNIS

**T**HE AVERAGE HOME HOLDS small arsenals of aerosol cans in the kitchen, bathroom, basement and garage. This type of dispenser has become so much a part of the American scene that to question its safety seems as gratuitous as an attack on Santa Claus.

But the familiar aerosol dispenser is under investigation. The Food and Drug

## Don't take

Administration (FDA) reportedly spends up to \$350,000 a year on aerosol studies and the industry itself is setting aside \$800,000 for related investigations.

The aerosol dispenser first came on the market in the mid-1940s, and since then some 20 billion have been used in the United States. Each year more are sold. In 1970, the last year for which figures are available, an amazing 2.6-billion cans were marketed. More than 300 types of aerosol products are available today, including foods, cosmetics, medicines, paints, insecticides and a host of other household items.

Hair sprays—one of the best sellers—have recently come under suspicion. Dr. John Gowdy of the Food and Drug Administration's division of cosmetic technology says that lacquer from hair sprays may have a tendency to collect in human lung tissue and cause an abnormal condition known as thesaurosis or "storage disease."

The physician made this report after screening 227 beauticians in Montgomery County, Md. X-rays indicated lung abnormalities occurring at a rate 10 to 20 percent greater than in the general population. A number of cases of borderline heart enlargement were also detected.

"One may speculate that the (body's) attempt to remove absorbed spray material imposes a strain on the heart," Dr. Gowdy told a newspaper reporter. The

POPULAR MECHANICS





# chances with aerosols!

FDA physician said there are no restrictions on the use of hair sprays because the suspected health problem is without symptoms. He recommends, however, that users take precautions against inhaling the spray.

If you examine half a dozen different brands of hair spray, you're likely to find a variety of warnings on the cans. Some warn against inhalation, some don't.

In the case of hair sprays, it is the lacquer—the product in the can—that causes concern. But how safe is the propellant, the gas used to pressurize the container? Researchers are seeking ways to answer this question.

Among the most widely used propellants are the fluorocarbons, gases composed of fluorine, carbon and hydrogen. They are generally thought of as being inert. Nitrous oxide is said to be used as a propellant in some food products and shaving creams, and a gas called methylene chloride in some hair sprays. If administered in sufficient quantities, the last two gases have an anesthetic effect.

One recent investigation—at the Medical College of Georgia by Dr. Nancy C. Flowers and Dr. Leo G. Horan—was focused on the effect of fluorocarbon propellants on heart action. Dr. Flowers is chief of the cardiology section at the Veterans Administration Hospital, Augusta, Ga.

Sixteen dogs were used. Six were al-

lowed to breathe a combination of oxygen and fluorocarbon gases, while 10 breathed the same aerosol propellants mixed with room air. Heart action was

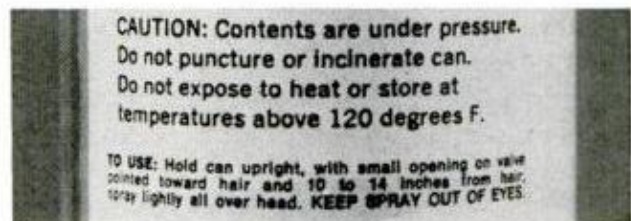

**NO WARNING** against inhalation of vapor appears on hair spray bought for purposes of this article

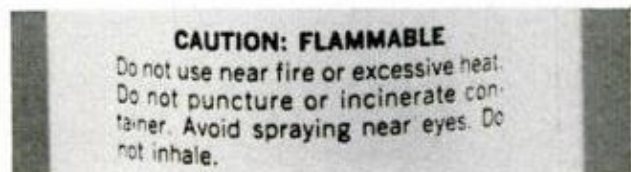

**A FULLER WARNING** is carried on second brand. All cans purchased cautioned against heating container

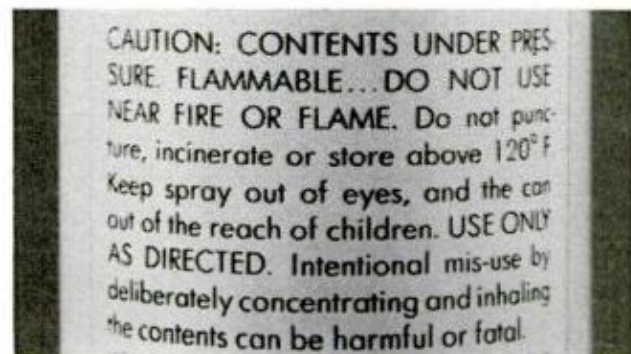

**NEW ANTISNIFFING WARNING** appears on third can. You can expect to see this caution on more sprays

closely monitored by means of cardiograph machines.

"Within seconds to minutes of aerosol inhalation," the researchers report, 13 of the animals developed irregular heartbeats. Administration of the propellant gases was stopped at the first sign of cardiac irregularity. Despite that, eight of the dogs died.

The data obtained in this investigation led the two researchers to say that "the would-be sniffer cannot depend upon subjective warning sensations in order to stop 'in time.'"

The safety aspect of aerosols was never questioned until the late '60s, when cases of deaths due to the deliberate sniffing of aerosol vapors began to crop up. Since then an estimated 200 persons—most of them under 20—have died while attempting to get "high" by inhaling aerosols.

Needless to say, the industry is concerned. Since 1969 it has conducted an educational campaign to warn young people and adults of the dangers involved in aerosol abuse.

The Aerosol Education Bureau, an industry group, sends out warning memorandums and brochures to the press, law enforcement and health officials, schools, colleges and civic groups. A typical fact sheet warns that "deliberate inhalation . . . of concentrated amounts of aerosol vapors with the intent of intoxication can lead to death. The major cause of death

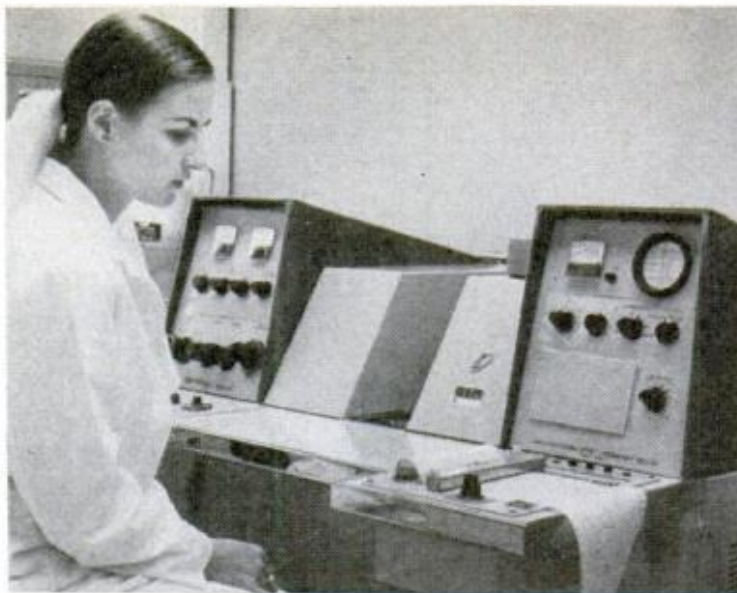

**TEST TO IDENTIFY CHEMICALS** in lung tissue is done at the Southwest Research Institute, where aerosol study is underway

is heart arrest, although it can come through asphyxiation. Death comes without warning. It can happen the first time or the fifth. There are no safeguards. There are no antidotes."

In the summer of 1972, Dr. Charles Edwards, commissioner of the FDA, made it known that his agency was considering making it a requirement that spray cans carry a specific antisniffing warning. Many manufacturers took the hint.

"Eighty to 85 percent of units on the shelves have or soon will carry an anti-sniffing warning," says James Merritt, president of the Cosmetic, Toiletry and Fragrances Assn., a trade organization. The warning, shown in the bottom label on page 83, states: "Intentional misuse by deliberately concentrating and inhaling the contents can be harmful or fatal."

Deliberate abuse is one aspect of the problem. But—as indicated by the beautician study—scientists are also concerned about the possible harmful effects the normal use of aerosols have on lung tissue. Another investigation focused on this aspect is being carried out at the Southwest Research Institute in San Antonio, Tex., under the direction of Dr. James Bollinger, senior biochemist. The National Institute of Environmental Health Services is sponsoring the study.

In one part of the investigation, rabbits and rabbit lung tissue are exposed to various airborne substances, including aerosol propellants. Molecular structural changes in tissues are being studied by means of sophisticated spectroscopic tech-

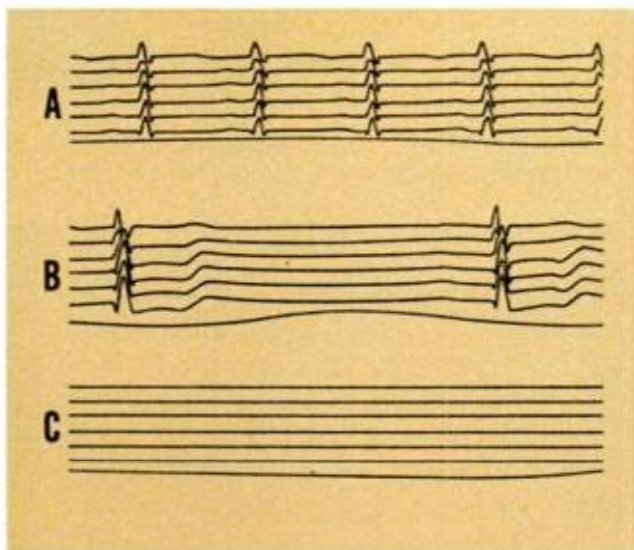

**ELECTROCARDIOGRAM** shows a normal heart rate (A) of laboratory animal. After breathing gas mixtures, heart action slows (B) before coming to a stop (C)



### New dispenser needs no gas

The gas propellant in the typical aerosol can may contaminate a food product and change its taste. If heated, the container can explode. These shortcomings reportedly are eliminated in a new type of dispenser called Selvac, which does not use a gas. According to its maker—Plant Industries, Inc.—Selvac contains a patented elastomeric bladder that stretches like a balloon when filled with a product and takes the shape of the outside container. When the valve is opened, the bladder squeezes out the product. Because of relatively low pressure, Selvac works best with thick substances such as shampoo and suntan lotion. The company claims the bladder squeezes out up to 98 percent of its contents. In photo, dispenser at extreme left is empty; the bladder in container next to it is filled.

niques. Since the study is still in progress, no results have been reported.

But, in a telephone interview, Dr. Bolinger told *PM*: "While no one knows the harm done by normal daily use of aerosol products, the ingredients in many of them appear to cause alteration in lung tissues."

Some scientists fear that even in normal use fine sprays may go deep into the lungs, where chemicals can damage tissue and invade the bloodstream. Some spray products—notably deodorants—contain talcum powder or metals like zinc and aluminum. Recently, FDA investigators discovered asbestos and other foreign particles in several aerosol cosmetic products. Asbestos is a toxic substance.

Hexachlorophene (HCP), which was first marketed in 1940, was not banned

by the FDA until 1972. The once-common ingredient in feminine sprays and family deodorants was taken off the market, according to Dr. Edwards, "because under certain circumstances, HCP is a very, very potent neurotoxin." In short, it's capable of damaging nerve tissues.

The Givaudan Corp. of Switzerland, which produces tons of HCP yearly, charged that the FDA's decision was based on an "emotional or perhaps hysterical reaction to a gross human error in France," where the chemical was responsible for the deaths of 40 infants. A company official said that to deny the world the use of this product is "a tragedy in itself."

Dr. Sidney Wolfe, director of the Ralph Nader Health Research Group, charged that the FDA's ban was "tragically tardy" in view of his organization's earlier findings. The Nader group had issued a warning 10 months prior to the FDA ban.

While antisniffing warnings may become a familiar sight on cans, the FDA will not require spray products to carry a warning about potential dangers resulting from everyday use. "The reason for this," says an FDA official, "is that we do not believe that normal use of aerosols presents a significant health problem."

That view is shared by Dr. F.A. Bower, director of aerosol research and development at the DuPont Corp.'s Freon Div. DuPont Corp. is the nation's largest producer of fluorocarbon propellants. Writing in *Aerosol Age*, a trade publication, Dr. Bower states that evidence accumulated to date indicates that physiological effects are not produced by fluorocarbon gases at the low levels of concentration associated with normal use.

"Some recent tests performed by Freon Products Laboratory using commercial aerosol products," he continues, "show that when used normally, the exposure level to propellant is very low . . . Other studies designed to assess the exposure level of a high-exposure group—professional hair dressers—showed that these workers were exposed to no more than .005 of 1 percent fluorocarbons."

The aerosol controversy has just begun. Americans will continue to use this handy dispenser, but until more is known about the possible hazards, caution is the consumer's best protection. ★★★

MITS 1440  
\$199.95 kit  
\$249.95 assembled

Miida 1214  
\$199.95

Crown CL-120T  
calculator/clock-radio  
\$229.95

Canon  
Pocketronic  
\$249

Panasonic 850  
\$139.95

Heathkit  
IC-2008  
\$109.95

Aries AR-410K  
kit \$99

Bowmar Ten  
\$150

Casio Mini  
\$59.95

Phoenix Mini  
\$100

## Electronic calculators:

They add, subtract, multiply and divide—silently, accurately, as fast as you can push their buttons. Now they're at prices you can afford. But with hundreds to choose from, which is right for you?

By IVAN BERGER, Electronics Editor  
Photos by Steve Fay



STYLISH PANASONIC is a bit big for most pockets. It comes with case, recharger and two battery cases

POPULAR MECHANICS

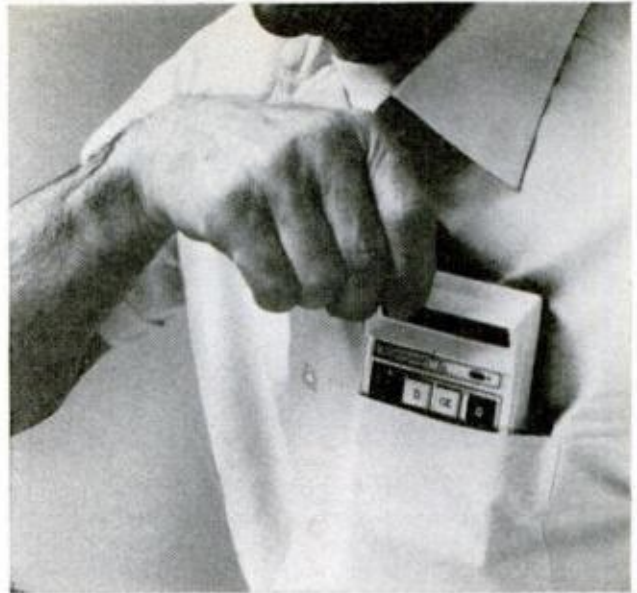

**POCKET-SIZED CALCULATORS** live up to name (top). Battery-powered, they can be used anywhere (left). But their numerical displays are smaller, and their keys more cramped than those on desk models

## How to choose the right one



**SMALLEST PRINTING CALCULATOR** is Canon Pock-e-tronic. But more are coming, from other companies

**C**ALCULATORS used to be heard more than they were seen, kerchunking like consumptive time bombs in large offices. Today, you'll see calculators in almost every office, office-supply store and department store, and in thousands of homes. But you won't hear them: Aside from an occasional, muffled keyboard click, they're totally silent. And today's calculators are ultrafast (you get most answers before you've even finished releasing the keys), inexpensive (starting at around \$60) and so compact you may have seen housewives whip them from their purses to check price totals, or relative per-ounce costs at your local supermarket.

Adding machines have been available at comparable prices for a few years now,



**DECIMAL SWITCH** (arrow) on Miida can be set for fixed or floating decimals. Floating-decimal answer (left) shows all decimal places that will fit



on the display, cuts off others. Fixed decimal settings demonstrate round-off: two-place setting (center), useful for dollars and cents, rounds 1.555

but a calculator does a lot more. It adds (though usually without the paper tape that helps the adding-machine operator recheck his figures), subtracts (showing negative results directly as a "credit balance," not as the puzzling "reciprocal" at the end of a long string of 9s that most home adding machines give you), and multiplies and divides, too.

It took two electronic developments to make today's calculators so swift, silent, versatile and cheap. One was the invention of whole families of readout devices that can light up (or reflect light) to show any number from 0 to 9. The other, and more important one, is Large Scale Integration (LSI), that can put thousands of transistors, diodes, resistors and capacitors on a silicon square no wider than two lines of this type are high.

As new LSI chips, readouts and keyboards are developed, the calculators become ever more sophisticated. But their prices are dropping so fast we could only include the roughest price guide-lines in this article—and even they are certain to be outdated by the time this reaches you.

As prices drop, calculators are finding their way to more and more unusual applications. Bowmar, probably the largest calculator manufacturer, found many such uses in a recent survey: Salesmen use them to compute estimates and prices for carpeting and fences. A professional pilot carries one for navigational calculations. A housewife with three skeet-shooting sons checks shooting-record cards. A lawyer carries one abroad for foreign currency conversions. An amateur astronomer checks star position angles. A teen-

aged girl adds up the individual times of records she's copying onto cassettes. An accountant's girl friend uses his when she plays banker in Monopoly games.

People in all walks of life use them to check bank statements, telephone and credit card bills, restaurant bills and tips, income taxes and automotive mpg.

You probably have a use for a calculator, yourself. But with about a hundred brands on the market, how do you pick the right one?

You start by deciding how you'll use it. Will you need to carry it from class to class in school, to use it in your car, to carry it with you to the supermarket? Then you'll need a battery-operated pocket-sized model (\$60-\$400); just make



**EXTRA FUNCTIONS** on MITS 1440 include square root, square, memory (with + and - inputs, independent clearing). EXC key exchanges dividend and divisor for some complex calculations. D key sets decimal

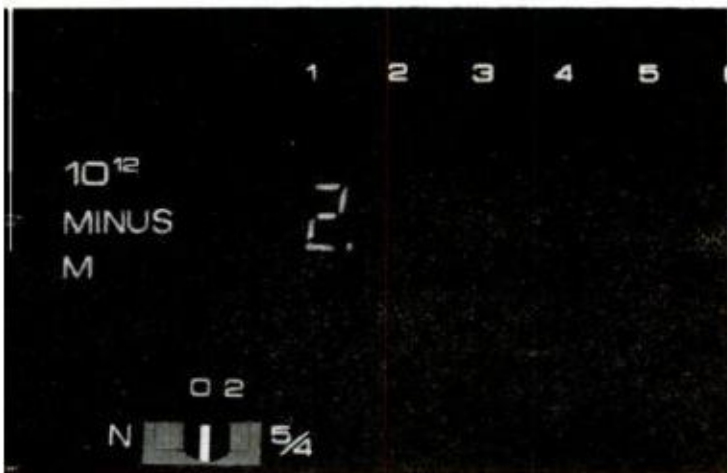

. . . to 1.56; whole-number setting (right) rounds it to 2.0. Most of the machines just cut off remaining digits (as does the Miida, if they're 4 or under)

sure it's small enough to fit the pocket you intend to carry it in (Basicom and Ragen have cigaret-pack-sized models—any smaller and you couldn't work their keys), yet big enough not to fall out.

If you'll use your calculator in one place all the time, try a desktop model (\$80-\$5000). Powered by a.c., it never needs battery charging or replacement, and its larger numbers and wider keys are more convenient for long work sessions.

More elaborate (and expensive) desktop models have many extra features, such as one-step percentage and square-root keys, 12-digit and larger displays (most pocket calculators have 8 digits, though the Bowmar Ten and the Hewlett-Packard have 10), several memories and even

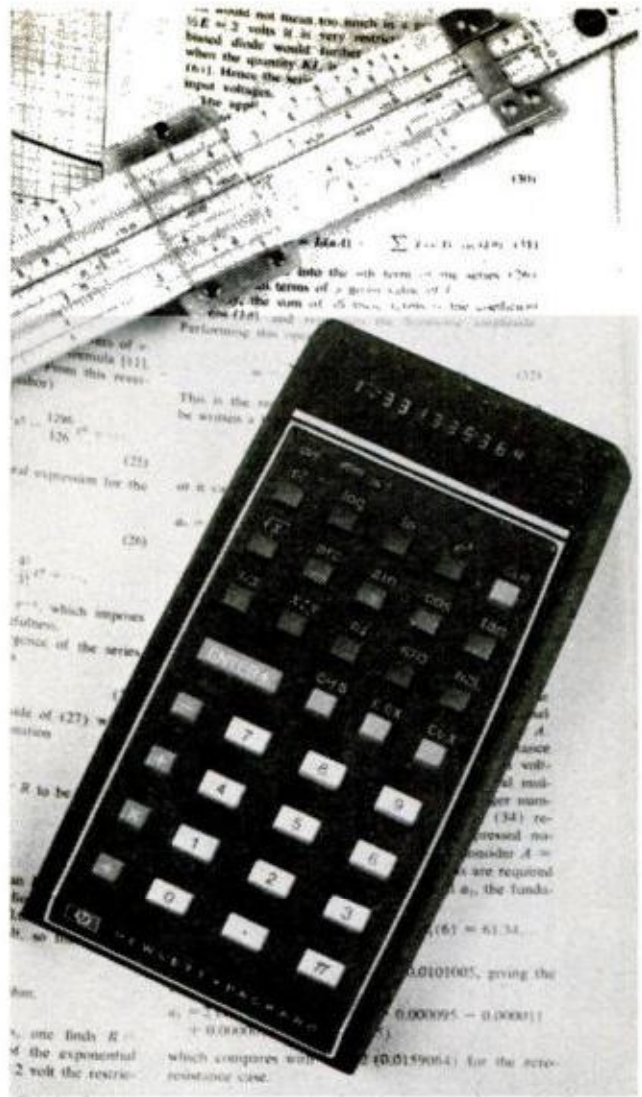

**ELECTRONIC SLIDE RULE**, \$395 Hewlett-Packard HP-35 holds "stack" of four complex numbers, does trig functions, logs, natural logs, square roots, inversions, pi, decimal powers, and powers of e, expresses numbers in normal or scientific (powers of 10) notation



**SUN-SHADE** on this apf Mark V (under \$100) is linked to on-off switch; close it, and the calculator shuts off. Between keyboard and display are battery meter, constant switch, fixed/floating decimal switch

FEBRUARY 1973



**THE PERFECT EXECUTIVE TOY**, this Crown CL-120 is a handy compendium of electronics for the desk: a calculator combined with an AM/FM clock-radio. Also available: a calculator/cassette combination

89

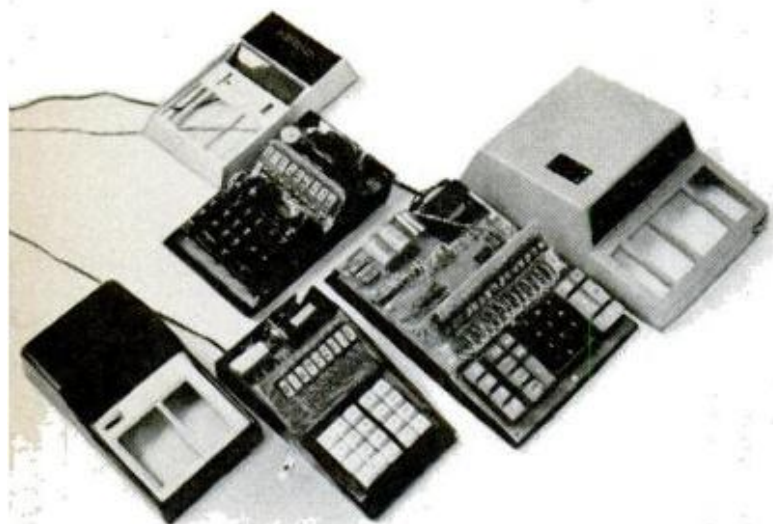

**KITS:** Heath IC-2008 (rear) is \$110, has fixed and floating decimals, takes six hours to build. Aries (lower left) costs \$99, takes six hours. MITS 1440 (\$200 kit, \$250 wired) takes 15 hours because of memory and other functions (see page 88)



**COMPONENTS** shown build Aries calculator with fixed decimal, 16-digit overflow, zero suppression

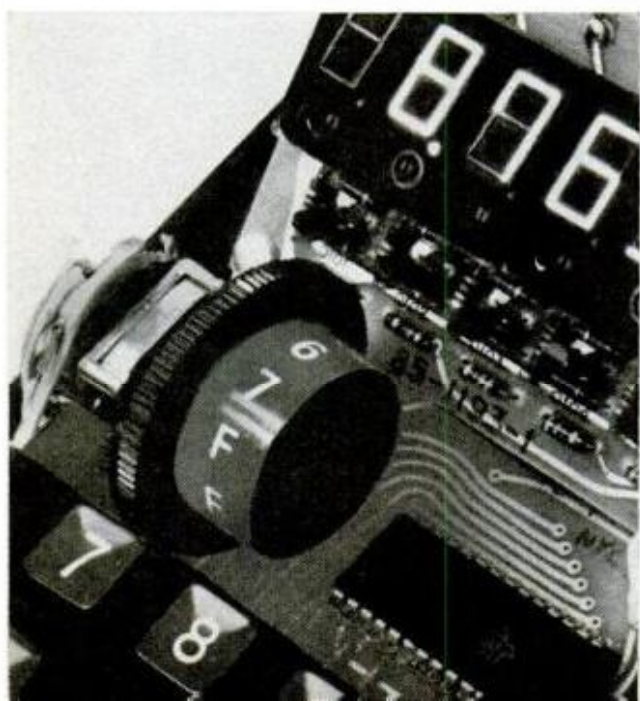

programmers that store the instructions for complex calculations, so all you have to enter are the figures themselves.

There are also portable models (about \$80-\$300), basically small, desktop machines that run on batteries and a.c.; they're great if you keep one at your desk but must occasionally bring it home for weekend overtime.

If you buy a battery-operated model, make sure its batteries will run long enough between charges or replacements for your intended use; portables, having room for more batteries, generally run longer. Some models use throwaway, replaceable batteries; make sure these batteries are of a readily available type, and that the battery compartment is sealed (or, better yet, removable) to confine damage from leaky cells.

Check the required charging time for units with rechargeable batteries—some machines need less charging time than others (but most calculators can be used while they're being charged). For maximum convenience, look for models (like the Panasonic) which supply both rechargeable and dry-cell power packs. Since low batteries can cause calculating errors, most portable and pocket models have some sort of low-battery indicator on the display or as a separate meter.

The display can affect battery life, too. Self-illuminated displays, though the easiest to see in dim light, use more power than liquid crystal types, which work by reflected light (and which are less likely to "wash out" in bright light). But some self-illuminated units have battery-savers that shut the display off after 15 or 30 seconds, turning it on again when you press a key. A few machines, such as the \$249 Canon Pocketronic (see page 87), have no readouts. Instead, they print out their results, with thermal printers that make no more noise than gently popping corn.

The keyboard can tell you a lot about what a machine can do. If there's a decimal point and a switch marked "0-2-4" or something of that nature, the unit has *fixed decimals*, and the decimal point in the answer will fall as many places from the right edge of the display as you've

*(Please turn to page 192)*

**SINGLE INTEGRATED CIRCUIT** (lower right) holds all calculator circuitry of this Heathkit; other circuits shown drive the display. Thumbwheel selects floating decimals (F) or 0-7 place fixed decimals



# Thorp's two-seater is a flying 'Tiger'

This little beauty combines sleek looks, zippy performance and easy construction

By **SHELDON M. GALLAGER** and **HOWARD LEVY**

*Photos by Howard Levy*

**O**NE THING YOU CAN SAY about the Thorp T-18 *Tiger*—it really gets around. Ninety of the popular home-grown two-seaters have already been built and flown, and more than 100 more are reported under construction. Nine are operating in rugged Australian and Canadian bush country, and others are flying far and wide throughout the world. One doctor uses his T-18 to make house calls in the vast, remote regions of rural Nebraska.

There are reasons for the praise and affection homebuilders have for this gutsy little low-winger. Developed by aeronautical engineer John Thorp, it's designed especially for easy homebuilding, making it a natural for beginners. It also has im-

pressive flight characteristics, living up to its name as a tough, tigerish, scrappy performer. With a 150-hp Lycoming engine, it hits up to 190 mph, cruises at a brisk 170 and climbs 2000 feet a minute to a service ceiling of 18,000 feet—that's really getting up in the wild blue yonder! It has a range of 550 miles on a 29-gallon tank, weighs 1450 pounds fully loaded and takes off in 800 feet. Its dual controls are handy for sharing flying chores with a companion on long hops.

Underneath the deceptively sleek exterior is a surprisingly simple airframe. The all-metal parts need no jigs for assembly and go together like an Erector set. The fuselage is straight-sided and

**DESPITE CLASSY LOOKS**, plane is designed for easy home building by eliminating tricky compound curves



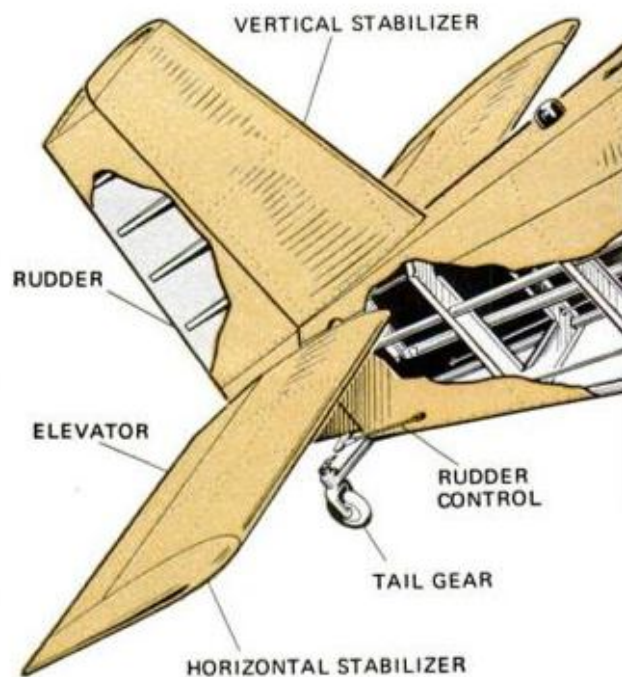

**SIMPLE FUSELAGE** (top photo, left) shows why T-18 is so easy to build. Ship is slab-sided with minimum of curves and bends. Streamlined nose cowling, prop spinner, wheel pants and other smart touches are what turn this plain Jane into the jazzy-looking little beauty shown at bottom. Cockpit view (center photo at left above) shows dual joy stick controls and elaborate instrument panel. Powerplant is a 150-hp Lycoming engine, giving the fleet-winged Tiger an impressive top speed of nearly 200 mph

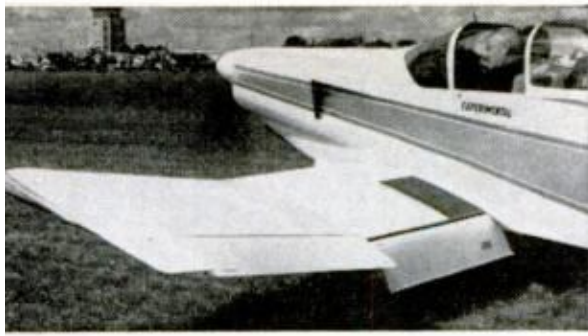

**WINGS SPORT BOTH FLAPS** and ailerons hinged side-by-side in trailing edge. Inner one above is speed-reducing flap in down position; outer one is aileron for banking. Note unusual mid-span dihedral with wing upturning slightly toward tip

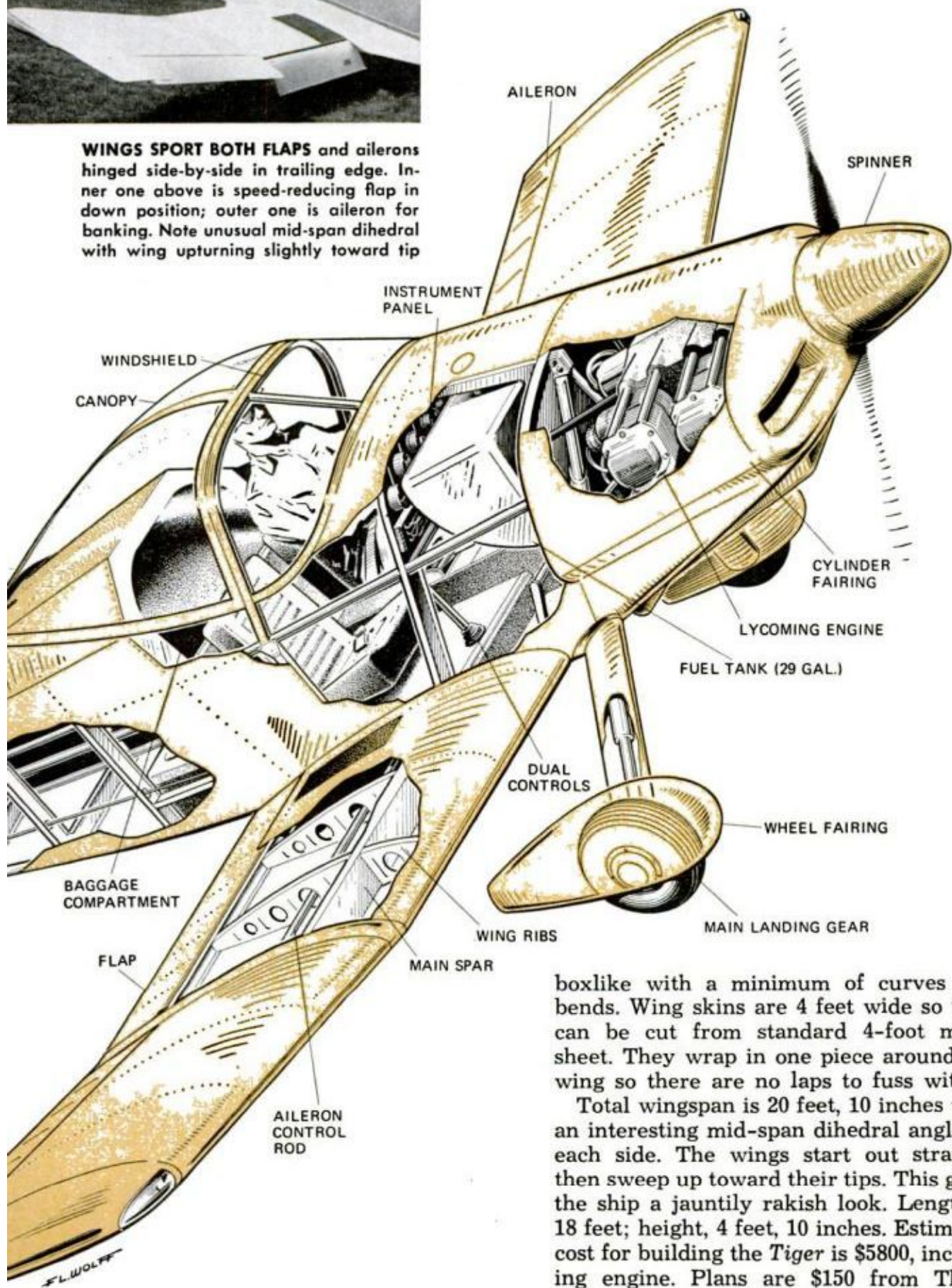

boxlike with a minimum of curves and bends. Wing skins are 4 feet wide so they can be cut from standard 4-foot metal sheet. They wrap in one piece around the wing so there are no laps to fuss with.

Total wingspan is 20 feet, 10 inches with an interesting mid-span dihedral angle on each side. The wings start out straight, then sweep up toward their tips. This gives the ship a jauntily rakish look. Length is 18 feet; height, 4 feet, 10 inches. Estimated cost for building the *Tiger* is \$5800, including engine. Plans are \$150 from Thorp Engineering Co., Box 516, Sun Valley, Calif. 91352.

★★★

## PM OWNERS REPORT: VOLVO 140 SERIES

# Owners toast long life and



**BREADBOXY LINES** don't quicken much blood, but owners didn't complain about styling either. Volvo has face-lifted basic 1966 144's unit body several times, but all years tend to look alike. Squared lines give great trunk capacity, with even a hidden well opposite the spare tire. Among praiseworthy features are 360° visibility, thick steel panels, stainless trim, standard radial tires. Some owners complained of easy-to-scratch paint, but everyone agreed that it was well sprayed and smooth.

By **MICHAEL LAMM**  
West Coast Editor

*Photos by the author*



**VOLVO OWNERS** aren't the fickle sort who trade cars every couple of years. Half those we surveyed figure they'll keep their cars at least five years; 25.6 percent said they plan to hang on 10 years or more.

Volvo ads claim that in Sweden, Volvos last an average of 11 years. Here in the United States, the average life span of a car is eight years. Does that mean Volvo is better-built than domestic makes? Read on and make up your own mind.

Volvo enjoys a worldwide reputation

for quality and good value. It grew mostly during the 1950s and early '60s when the PV series and the 122-S became popular. The PV and 122-S were relatively inexpensive, very well put together, lively cars that gave long, troublefree service.

In 1966, Volvo introduced the 144, for the 1967 model year. It used basically the same B-18B four-cylinder engine and unitized body shell as today's 144 sedan. Since 1966, Volvo has added two more body styles in the 140 series—a two-

POPULAR MECHANICS

A nationwide survey based on 2,500,000 owner-driven miles

## wish for shorter ETs

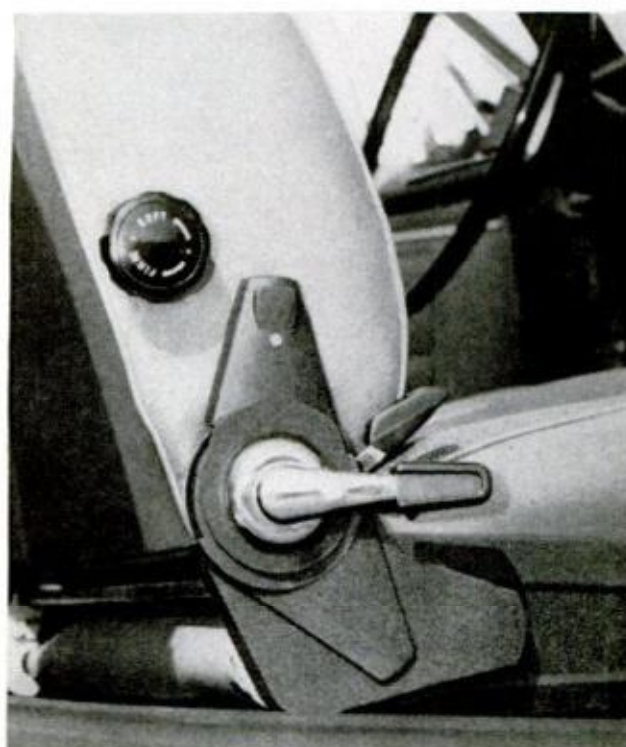

**HIGH-SPEED CORNERING** rates average, and many owners agree ride is stiff and bumpy. Seats, though, come in for lavish praise. They're adjustable for rake, fully reclining and have adjustment (above) to set firmness of the backrest—a few twists of the knob do it. Dashboard has been entirely redone for 1973 (1972 shown here), with much jazzier decor. Emergency brake handle at left of the driver's seat is unhandy, say many, especially since it's not accessible to passenger. On the other hand, combination lap belt and shoulder harness with inertia reel ranks among the best in the industry. Volvo owners expressed their appreciation for car's solid construction and its safety items

door sedan (142) and a five-door wagon (145).

In 1972, all Volvos in the 140 series were available with or without Bosch electronic fuel injection, but because of California smog laws, you could buy only the injected (E) version west of the Mississippi. For 1973, fuel injection is standard equipment in all Volvos, but our survey is of owners of 1972 Volvos who bought their cars during April '72.

The 1972 injected engine was slightly

more powerful than its carbureted cousin—112 bhp vs. 97 bhp net. Our survey shows that owners with carbs got a bit better fuel mileage than those with injectors. But the fuel-consumption advantage of carburetors was offset by their need to burn high-test gasoline. The injected engine's compression ratio of 8.7:1 gets by nicely on regular, while carburetors at 9.3:1 need a high-octane premium.

About a third of all 1972 Volvo owners with carbureted engines reported prob-

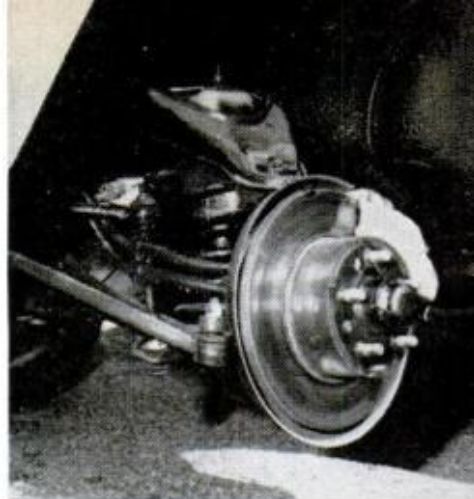
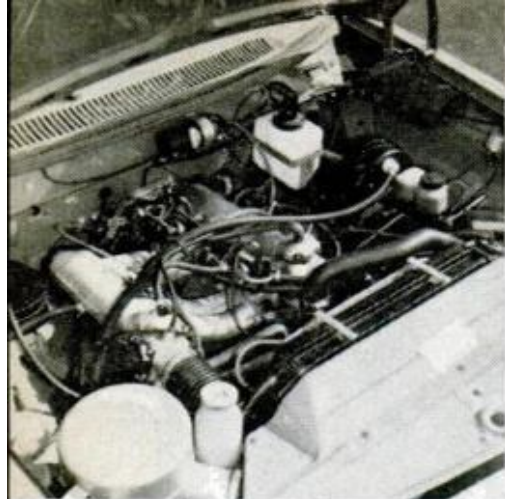

**ALL 1973 VOLVOS** use Bosch electronic fuel injection, which gives increased horsepower and fewer pollutants than previous two-carb setup. Tall items

lems keeping the standard two-carb setup in tune. Rough idle, dying and hesitation on acceleration were common symptoms. There don't seem to be enough qualified mechanics to go around—another common complaint. "I once broke down near a small town in Pennsylvania and couldn't find anyone who knew enough about the car to do more than tinker with it," says a Virginia college professor. Other owners gripe that Volvo dealers too often "dual" with other makes—sell other brands of cars in addition, which makes Volvo something of a bridesmaid.

The fuel-injection setup, as opposed to twin carburetion, is relatively troublefree. Interestingly, the electronic control unit ("computer") for the f.i. rests beneath the driver's seat, away from engine heat, fumes and possible moisture.

Most Volvo owners bought their cars unemotionally. Styling ordinarily plays an important role in choosing a new car, but not this time. Volvo's conservative styling didn't turn anyone on, but no one com-

can't be stored in door pocket because of armrest. Four-wheel disc brakes make for sure, fast stops, and there weren't many gripes about rotor squeal

plained about it either. Volvo's breadboxy look gives it tremendously usable interior space, and owners appreciate the cavernous trunk (15.6 cubic feet) and generous legroom front and rear.

Other points of praise were the four-wheel disc brakes and the excellent seat-belt shoulder-harness arrangement. Volvo owners tend to be safety conscious, and many cited the car's good all-around visibility.

In our survey, 13.2 percent bought new Volvos on the basis of past experience. What do these owners think of their new cars in comparison with older models? "I previously owned a 1970 145-S and must say the '72 injected car is much more satisfactory," says a Wisconsin artist/instructor. A Massachusetts architect: "This '72 feels much stronger than my 1970 Volvo without fuel injection—I highly recommend fuel injection." And an Ohio draftsman: "Much more responsive than my '68."

Even so, "more power" came up as the



**THE 142 SEDAN** is only one of the 140 series. Other models are 144 four-door and the 145 station wagon



**IT'S A LONG REACH** to glovebox for driver, but it holds plenty with its drop-down, breadbasket design

primary would-like-to-see. Volvo owners aren't actual racing types who run elapsed time (ET) in the quarter-mile, and the plea for more horses isn't desperate, but it is consistent. Perhaps part of their reasoning springs from an on-paper decrease in Volvo's horsepower rating last year. For 1971, all automakers still advertised gross horsepower ratings, and Volvo's figures were 130 bhp for the injected four-cylinder and 118 for the carbureted version. In 1972, with the industry's switch to net figures, these same engines rated 112 and 97 bhp respectively. Actual power remained the same. So the lack-of-power complaint might be partly the effect of semantics and partly based on the reality of having to row in emergency situations and at stoplight drags.

Solid, sturdy construction came up time and again as one of Volvo's more praiseworthy qualities. To back this up, here's a comment from an Alabama conservation analyst: "We had our 145 wagon less than two months when we were hit in the side by an Oldsmobile. Although it did \$700-worth of damage, no one was injured. The seat belts did their job well. We feel these and the Volvo's construction were responsible. Since then it has been repaired and runs like new."

On the general topic of quality, these comments: "Superior design assembled from quality materials by men who take pride in their work." "Excellent; stainless steel trim and heavy-gauge body metal resist denting." "Outstanding," says a Colorado Air Force administrator, "because my father bought a top-line 1972 Chevy, and the Volvo is far superior in workmanship and attention to detail."

As to comfort, a New York school teacher says, "Reclining front seats with lumbar adjustment are very comfortable." A Brooklyn physician: "Plenty of room in the wagon for long trips." A Massachusetts photographer: "Hard ride and noisy engine." A New Jersey veterinarian: "Steering is very heavy; needs power steering."

A New Jersey insulation engineer wraps it up: "I feel cars like the Volvo, Saab, Audi, etc., will continue to get a good percentage of U.S. sales until American manufacturers can produce a reliable, quality car that has a long list of comfort and safety features that are standard not just because the government requires them but because they make a better, safer car." That plus the high regard for workmanship and longevity pretty well sums up Volvo ownership. ★ ★ ★

### Summary of Volvo 140-Series Owners Reports\*

Total miles driven	2,504,888
<b>Average miles per gallon</b>	
Carbureted:	
Local driving	19.6
Long trips	22.7
Fuel-injected:	
Local driving	18.9
Long trips	21.7
<b>Engines:</b>	
Carbureted	43.3%
Fuel-injected	56.7
<b>Transmissions:</b>	
Four-speed manual	64.8%
Automatic	35.2
<b>Series :</b>	
142 (two-door)	35.5%
144 (four-door)	23.4
145 (wagon)	41.1
<b>Why the Volvo?</b>	
Economy	23.9%
Reputation	20.6
Workmanship	15.6
Size	14.4
Quality	13.6
Past experience	13.2
<b>Specific likes:</b>	
Handling	53.0%
Comfort	48.2
Economy	33.6
Workmanship	24.3
Brakes	21.9
Performance	15.8

Size	15.0
Ride	15.0
<b>Specific dislikes:</b>	
Rattles	19.5%
Dealer service poor	18.3
Hard steering	8.1
Lack of power	8.1
Poor gas mileage	6.1
Cold starting	6.1
<b>What changes would you like?</b>	
More power	12.4%
Better airconditioner	8.9
Better materials	8.0
Power steering	8.0
Bigger engine	7.6
<b>Had any mechanical trouble?</b>	
Yes	62.5%
No	37.5
<b>What kind of trouble?</b>	
Carburetor	15.6%
Airconditioner	11.7
Transmission	9.7
Clutch	7.8
Brakes	7.1
Cold starts	6.5
<b>Did you repair it yourself?</b>	
No	92.3%
Yes	7.7
<b>Dealer repairs satisfactory?</b>	
Yes	70.6%
No	29.4

<b>Dealer service opinion:</b>	
Good to excellent	47.6%
Fair to poor	52.4
<b>Is the Volvo your only car?</b>	
No	54.9%
Yes	45.2
<b>Other cars owned:</b>	
Volkswagen	18.4%
Chevrolet	17.6
Volvo	13.2
Ford	8.8
Pontiac	8.1
<b>How long do you plan to keep your Volvo?</b>	
0-1 year	2.5%
2 years	3.4
3 years	5.9
4 years	13.9
5-6 years	24.8
7-9 years	20.2
Over 10 years	25.6
"As long as it lasts"	3.8
<b>Workmanship opinion:</b>	
Good to excellent	83.1%
Average to poor	16.0
<b>Age distribution of owners:</b>	
15-29 years	38.0%
30-49 years	43.7
50-plus	18.4
<b>Would you buy another Volvo?</b>	
Yes	87.1%
No	12.9

\*Percentages might not equal 100% due to rounding and/or insufficient data.

Workshop Editor  
Popular Mechanics  
224 West 57th Street  
New York, N.Y. 10019

Dear Editor:

I am 15 years old. I built my shop one year ago with the supervision of my uncle. Neither of us were greatly skilled in carpentry, and no plans were drawn, (we planned as we went along).

My shop is a replica of an old English barn. It is 12' wide and 17' long; it has a gambrel roof, double doors, and a hayloft where lumber is stored. On one wall a bench runs the full length of the shop with my woodworking tools hanging above it. On this bench is my drill press and vise. In the middle of the shop is my table saw. On the opposite wall is my woodworking lathe with the lathe tools hanging above it. Next to the lathe is my metalworking bench. In the rear of my shop is a window with a cabinet beneath it that houses my power tools. In front of my table saw, in the center of my shop is an empty space where large projects can be set up on sawhorses.

My shop is not the world's largest, nor can its interior compare to those published in your magazine, but its architectural design makes it a very unique shop, and I am sure no other teen-ager in the world owns a shop quite like mine.

Sincerely,

*Jim Wilson*  
Jim Wilson

**ACTUAL LETTER** from 15-year-old craftsman proves it's never too early to start taking an interest in tools and shop work

# One (young) man's shop

By JAMES H. PICKERELL



**YOUNG JIM WILSON** works at wood lathe in his shop



**J**IM WILSON is 15 years old. The only thing unusual about this is that he's a 15-year-old who owns and operates his own workshop. Some novel features are that it's a separate outbuilding attractively patterned after a quaint Old English barn with gambrel roof, was built by Jim himself with help from an uncle, and is well equipped with tools and machines picked up here and there at modest prices, proving you don't need to spend a fortune to have a good workshop.

Jim, who lives in Laurel, Miss., has been following PM's "Great Workshop" series and thought we might like to see the results of his own efforts. We think PM readers might, too. Jim's shop is not as fancy as some, but it's a start—and a good one—one to be justifiably proud of. Not many teen-agers have their own places for constructive work; if they did, there would be fewer hangups in today's harried world. A common interest in tools and hobbies and an enthusiastic pride in good craftsmanship are great gap closers between generations.

Jim started out by commandeering a corner of the family garage for a workbench, but it soon became obvious that this would not provide the kind of space and facilities the young craftsman had in mind. Besides, people kept wanting to put a car in his "shop." When Jim's father passed away a few years ago, an uncle offered to help the boy build his own shop, and an aunt agreed to contribute.

It was decided that a separate building

in the back yard would be the only solution—something with big doors to move bulky gear through, enough open floor space to maneuver around in easily and plenty of storage room for lumber and supplies. For a pleasant, rustic appearance, the building was to be styled after an Old English barn, calling for a gambrel roof. The choice proved both a blessing and a headache. The complicated, multiangled roof, though tricky to build, provides good headroom and storage.

Construction was begun with nothing more than a picture of a typical English barn to work from. Floor area was determined to some extent by the size of concrete blocks available for foundation walls. Since no one wanted to get into cut-

*(Please turn to page 200)*

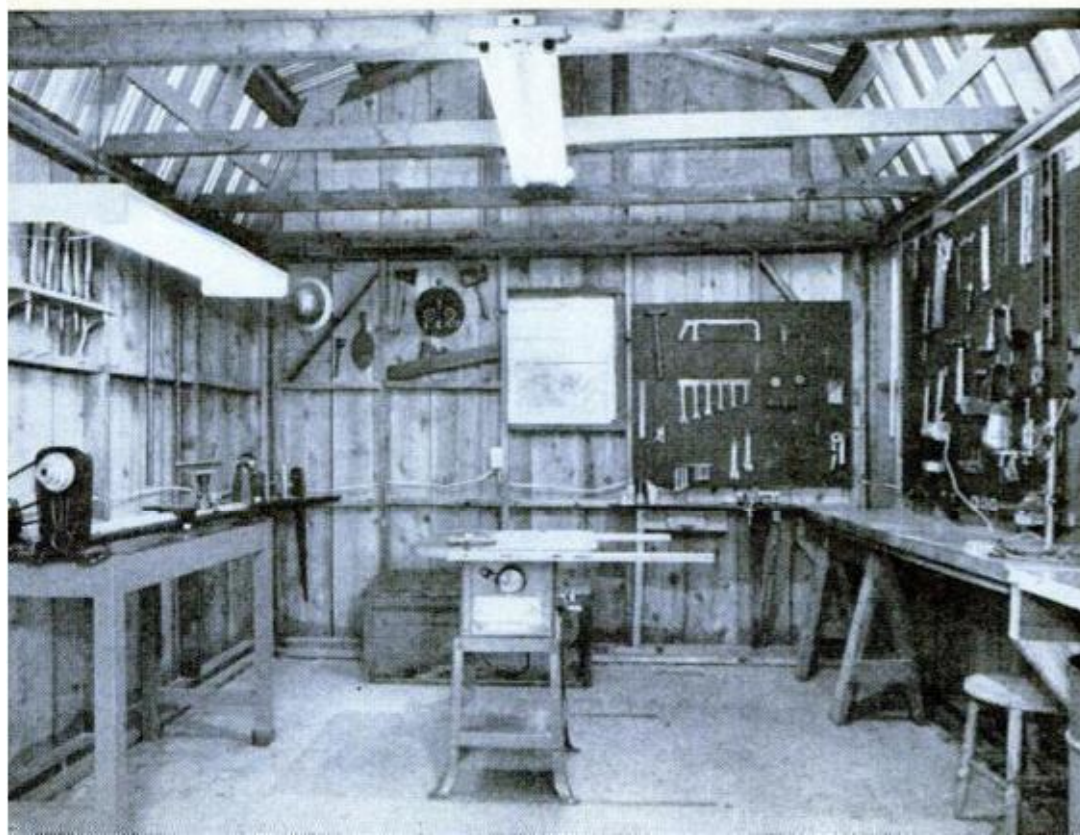

**GAMBREL-ROOFED** workshop in back yard of Jim Wilson's home in Laurel, Miss., is rustic and homey as well as providing roomy work area. Note bench-lined walls with table saw in center for easy access from all sides (left). High-rising gambrel-roof design adds spacious upper loft for storage of lumber and supplies. Workshop size is 12x17 feet

# Flower garden on your wall

**T**HIS COLORFUL PLANT TRELLIS is a decoration that literally "grows" on the wall. Fifteen potted plants give it an ever-changing look as new foliage and blossoms appear.

It consists of two identical frames of crisscrossed strips spaced apart by 15 shelves. The strips are lumberyard moldings which measure approximately  $\frac{1}{2} \times \frac{3}{4}$  in. You'll need 16 strips (39 in. long)—8 dadoed  $\frac{3}{16}$  in. deep and 8 dadoed  $\frac{1}{16}$  in.

deep—to automatically register one strip over the other. The dadoes are cut with a table or radial saw, and with a stop attached to the fence to space the cuts uniformly  $9\frac{3}{4}$  in. on centers. The blade, or the miter gauge, as the case may be, is set  $11^\circ$  left of  $90^\circ$ ; the same setting is used in dadoing all 16 pieces. The ends of the shelves are beveled to suit and then the shelves are glued even with the front and back strips. ★★★

## Construction details

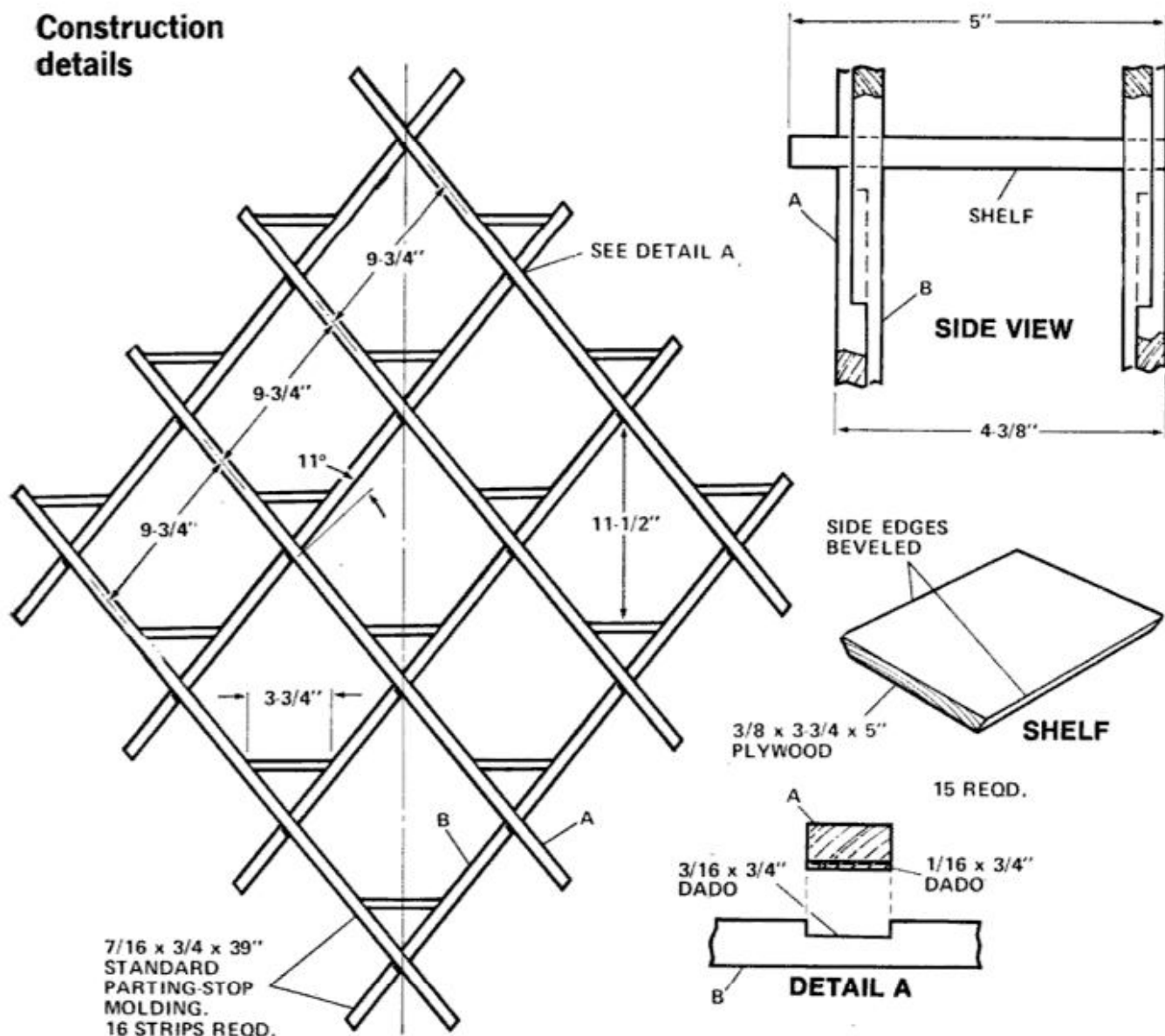

**WHITE-PAINTED TRELLIS** with its red, yellow and green pots contrasts beautifully when hung on a dark paneled wall (right). A couple of screws through holes in back strips are used to hang the unit. The plastic pots, measuring  $3\frac{1}{2}$  in. in diameter and  $3\frac{3}{8}$  in. tall, cost 39 cents each at S.S. Kresge stores



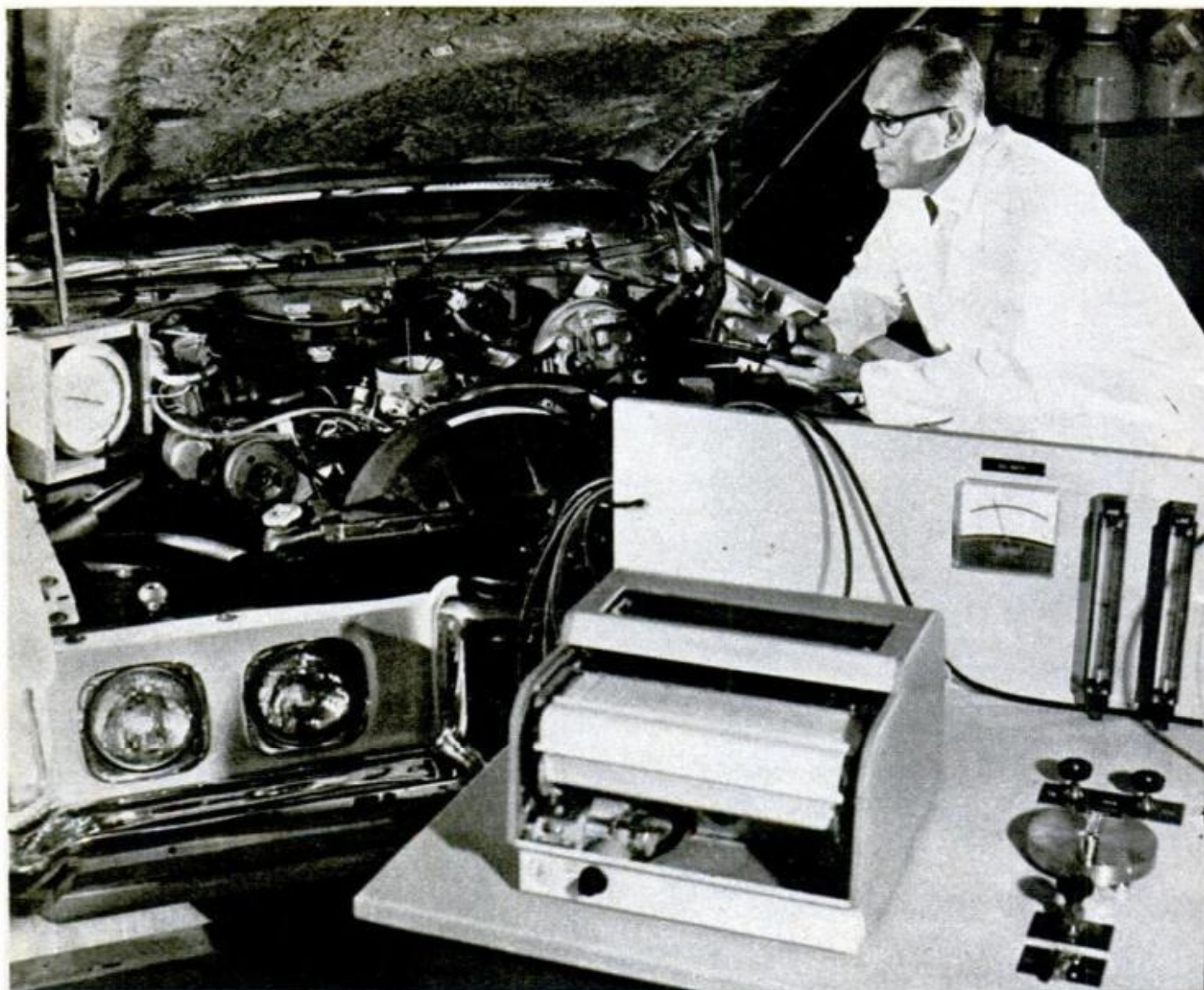

EMISSIONS TEST of an i-c engine with electronic fuel injection is conducted at the Bendix laboratories

## Can Detroit save the i-c engine?

By ROBERT LUND, Detroit Auto Editor

**H**OW LONG BEFORE DETROIT junks the internal-combustion engine? How many more model runs can the old geezer survive before he's put to pasture—or can he be saved?

The i-c engine has been around forever, longer than the automobile itself. He's been a hard worker, loyal, dedicated and all the other compliments they engrave on the retirement watch. But the years have caught up with him and he has developed a long list of afflictions in his old age.

He has become a lush with an insatiable thirst for gasoline. His parts wear out or conk out. He's expensive to repair. He's gone to fat and become too big for the space he has to be squeezed into under

the hood. He's a maze of makeshift plumbing, attachments and tentacles. Noisy. Cantankerous in cold and damp weather. If that's not enough to qualify him to be pensioned off, consider the charge that he's a leading contributor to air pollution and a threat to human health.

Before Detroit can dump the i-c engine, it has to come up with something to replace it. Something better. But what?

The answer is that there isn't anything better than the i-c engine—piston version or Wankel—in prospect for the next four or five years.

Since the federal government moved into the auto business, it has received more than 100 proposals for engines to replace the i-c engine. Most have been paper projects or theories. Few of these

ideas have been accompanied by working models.

The best idea of the lot is the turbine, which some authorities foresee coming on cars in small volume around 1976-77.

That's not to say all the other ideas for engines to succeed the i-c engine are without merit or that they'll never be put in production. But steam cars, battery/electric cars, solar-powered cars and the 90-some other candidates vying to take over are long-range propositions.

You'd expect Detroit to take that position, to look down its nose at any alien recruit that might threaten the billions the auto companies have invested in plants and machinery to produce i-c engines. Self-protection. But listen to an expert who looked at all the alternate forms of power for cars without personal interest in who wins the race. The speaker is Dr. Lee A. DuBridge, former science advisor to President Nixon:

"No one has yet invented a replacement for the i-c engine that has adequate performance, reliability and safety, or that can be produced at a reasonable cost and require a minimum of maintenance.

"When you get down to the hard facts of life—considering all sources of energy and the present state of the art—the most practical avenue for real progress in vehicle emission in this decade is to finish cleaning up the internal-combustion engine."

If Dr. DuBridge and other champions of the i-c engine are right, that puts a different twist on the question. It's not a matter of when Detroit's going to dump it. It's what can be done to save it, patch it up and keep it going until an acceptable replacement comes along.

The i-c engine might be forgiven its other faults if it could be cleaned up. That's what most of the opposition amounts to. It's a polluter. The auto firms figure if they can correct the pollution problem, most criticism will disappear.

What's the industry doing to reform the old reprobate?

The engine is being redesigned and refined. New hardware is being developed to change the way gas burns inside the engine and to purify emissions before they're discharged into the atmosphere. The oil companies are being asked to develop new fuels that will burn cleaner.

The engine add-ons will include elec-

tronic ignition (standard on Chrysler cars now, coming on all other makes within two years) and electronic fuel injection (e.f.i.). Electronic ignition prevents misfiring at low speeds. You don't let go with a blast of blue fumes when you start the car.

E.f.i. senses all operating conditions and gives optimum combustion at every speed. The mixture of air and fuel is adjusted according to need. Increasing the amount of air mixed with the fuel results in more complete combustion, reducing output of carbon monoxide and hydrocarbons.

E.f.i. is probably not more than a year away. Not as a mass production proposition, but in limited volume that, over a period of say three to four years, will extend to all cars. In this regard, Detroit is just catching up to the import manufacturers who have been using the Bosch fuel-injection system for several years.

Here, Bendix, a big name among suppliers to the automakers and a leader in developing e.f.i., says it has signed contracts for 15,000 e.f.i.s for 1974 and looks for orders to jump tenfold to 150,000 units in 1975. "After that, e.f.i. will probably be standard equipment on most V8s in 1976," the company predicts.

Bendix doesn't resort to any weaseling in discussing its fuel injector. The company put the unit on a test car last year

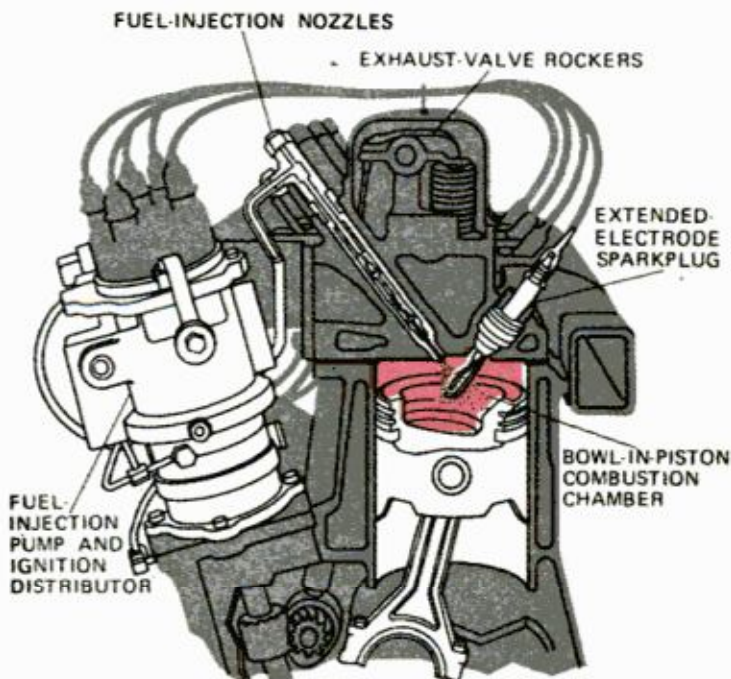

**PROGRAMMED COMBUSTION** or "Proco" engine, as Ford calls it, uses fuel injection, a long sparkplug electrode and a specially shaped combustion chamber to get complete burning of fuel for low emissions



**EMISSIONS MEASUREMENTS** at Bendix laboratories are for unburned hydrocarbons, carbon monoxide, NO<sub>x</sub>

and says it accomplished a feat the auto firms haven't been able to equal—meeting government clean-air standards for 1975. "By a comfortable margin," Bendix adds. (The test car carried other smog-control hardware in addition to e.f.i. The complete rig consisted of catalytic converter, exhaust recirculation system, special air pump and manifold reactors.)

About the same time e.f.i. begins to come in—maybe before—automobiles will have with catalytic converters. This device converts carbon monoxide and hydrocarbons into water and carbon dioxide.

GM is currently testing a fleet of cars equipped with catalytic converters in California. The cars carry different catalysts being evaluated by GM, most of them utilizing platinum and other noble metals. In addition to the catalytic converters, some cars have been equipped with electronic, high-energy ignition systems, super carburetors to provide precise fuel metering and an early fuel evaporation system to vaporize gas more completely in the manifold and reduce emissions during start-up. The plumbing gets pretty complicated. In addition to the new hang-ons, the test cars carry three additional emission control items standard on GM's '73 cars—exhaust gas recirculation, positive crankcase ventilation and evaporation emission control.

There are a couple of problems with the converters. You must use unleaded gas. If you don't the lead in gas coats the catalytic element and you put more gunk in

the air than you would with a current car. GM specifies the California test cars must run on unleaded gas.

Second problem: The catalyst is supposed to function troublefree for 25,000 miles. That's down from the 50,000 miles originally decreed by the government. The auto companies say they haven't even been able to come within a country mile of the lower figure thus far.

In their efforts to rehabilitate the i-c engine auto manufacturers have enlisted the aid of the petroleum industry. (Detroit hasn't been that pleasant about it, the refineries say. They accuse the auto companies of arm-twisting.) Automakers are



**TEST CELL** at GM Research Laboratory "road tests" engine, computer-duplicating actual road conditions

pushing the petroleum industry to innovate, to develop new types of fuel that will (1) put out less pollution and (2) provide more power from the same gallon.

Detroit claims it's trying to kill two birds with one stone. The petroleum companies say it's a case of the carmakers wanting their cake and eating it too.

Detroit wants new and better fuels for two reasons. First, it's concerned about car performance. The more pollution-control gear hung on a car, the more sluggish it becomes. Performance is degraded and you get fewer miles to the gallon. Second, the carbuilders say they'll have a better chance of meeting the tough 1975-76 pollution-control standards established by the government if the gas companies will

eliminate more hydrocarbons from fuel.

Petroleum products say if they take out the hydrocarbons, economy will decline—cars will use more gas. Detroit doesn't want that, so it's asking petroleum firms to change their formulas, develop new chemistry. The petroleum people say you can't get both white milk and chocolate out of the same cow without getting into some pretty expensive surgery.

One of the most knowledgeable men in Detroit on what can be done to clean up cars, Chrysler's Charles M. Heinen, says the surgery's going to run into millions, if not billions. Heinen, who developed the basic emission-control apparatus used on

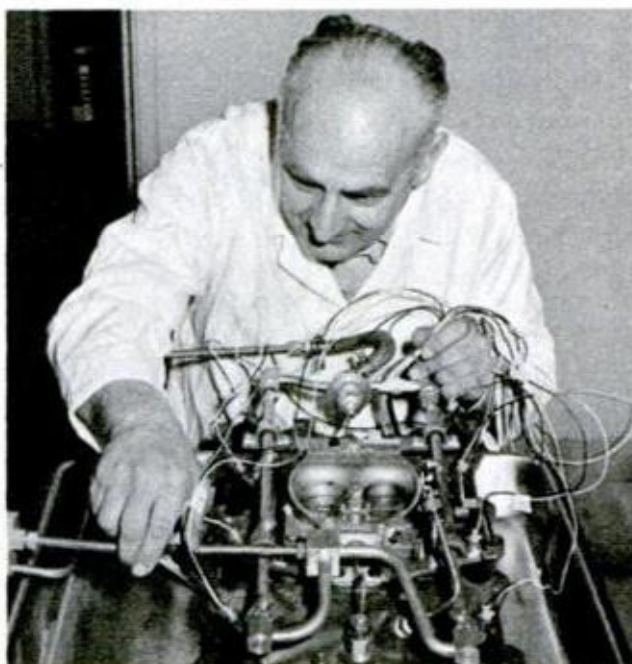

**FUEL INJECTION SYSTEMS** meter fuel precisely. Here, electronic unit is shown installed in Bendix test car

all cars, says removing the lead from gasoline is only a first step. Any residue of lead left in the equipment used to store, transport and dispense gasoline could destroy the effectiveness of the catalytic element. This means that even if the petroleum companies change the "brew," the industry would have to start almost from scratch—design and build new gas pumps, new underground tanks at filling stations, new rail cars and trucks to carry unleaded gas, new storage tanks, new pipelines.

"The public, public officials and the environmentalist have yet to find out the magnitude of the task that remains," Heinen declares.

In their quest for improved fuels, auto firms have gone so far as to explore the

possibility of putting three spigots on the cow. GM has conducted tests using liquid petroleum gas (LPG), compressed natural gas (CNG) and regular out-of-the-pump gas in the same vehicle.

The results were a mixed bag. The cars operated on LPG and CNG did a good job reducing emissions. But fuel economy was cut 30 percent and there was a 38 percent loss in performance. "Unacceptable driveability compared with gasoline-powered cars," GM commented. To use a dual-fuel system—LPG and conventional gas—the car would have to carry an extra 50-pound container to hold the LPG.

In addition to the work Detroit's doing to save the i-c engine, the auto companies have been besieged with ideas from outsiders. While most suggestions are pipe dreams, a few ideas may have merit and the car firms are checking them out. The checkout list includes:

- *A pollution-control system developed by Questor Corp.* Questor claims its system surpasses government standards for 1976, doesn't require use of noble metals (palladium or platinum), will operate on leaded fuel, requires no major changes in the engine and does away with exhaust gas circulation.

- *An engine developed by International Materials Corp.* The IMC engine incorporates a device that's said to reduce gasoline to hydrocarbon and carbon dioxide. This nonpolluting combination, along with air, is then fed to the engine. IMC claims the engine will meet 1976 standards and can be used with leaded gas.

- *A hybrid eight-cylinder engine being worked up by Cornell University.* Six of the cylinders are internal to supply power, two cylinders are external to burn off pollution. Cornell says this configuration will eliminate pollution from carbon monoxide and hydrocarbons.

- *An engine developed by Honda Motor Co., Tokyo,* equipped with what Honda calls compound vortex controlled combustion. The engine has a small secondary combustion chamber at the top of each cylinder. This is capped by an intake valve. The sparkplug screws into the auxiliary chamber. The additional intake valve allows a rich fuel/air mixture to enter the auxiliary chamber. The regular intake valve brings an offsetting lean mixture into the main chamber. At the point

*(Please turn to page 194)*



**FASTEST OFFSHORE** speedster is runabout version of Don Aronow's 1972 world champion Cigarette racers



**FINE FLAT HULLS** of johnboats haven't gone out of style inland as this MonArk model with cabin shows



## New for 1973 waterways

Speed, style and seaworthiness (most of the time) are the signs of the times for pleasure craft this year

By **BILL McKEOWN**, Boating Editor

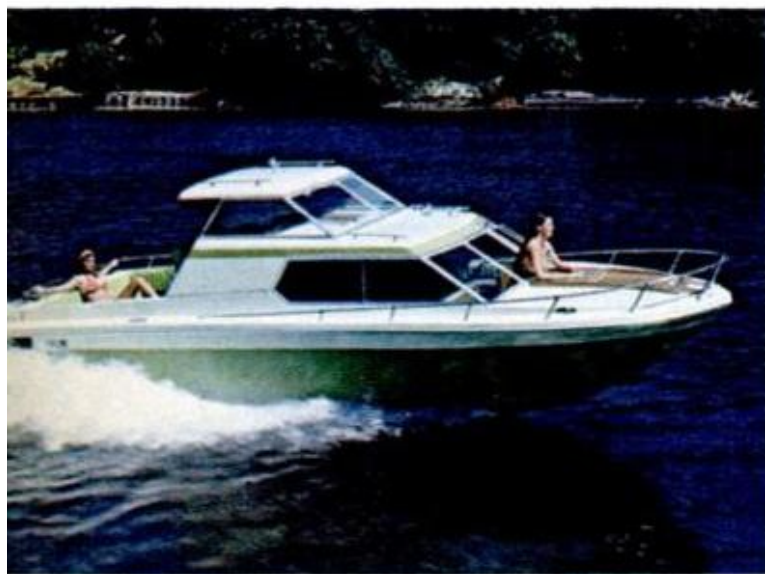

**STERN-DRIVE CRUISER** from Reinell, largest builder of stern drives, also features new flybridge models

**VACATIONER**, 19-footer (above) from Cruisers, is a cuddly cabin and cockpit camper with canvas added

**WRAPAROUND WINDSHIELD**, popular styling feature, (left) is added attraction of a Scat-Craft runabout

**OUTBOARDS** now travel safely far offshore aboard the new fishing utilities like the S-22, Robalo and Pro-Line models shown at right. With high-enough freeboard to keep the water out and the anglers in, plus space for the crewmen to move around in the cockpit while battling gamefish, these models have the speed and seakindliness to make long passages





**DECK BOATS** are also growing up and this V-239 Sport Deck from Viking seats 12 and can top 35 mph



**FISHING IN COMFORT** is feature of new bass craft like Chrysler's 16-foot 1973 Professional Bass Boat

**FIRST LOOK** at this year's pleasure craft, and you might think you've seen them before. But there are improvements, changes and big new trends. PM's pick shows new popularity for everything from inflatables to flashy runabouts, speedsters with long curved windshields and boom-

ing bass boats with no windscreens at all. Most boats are basically safe if used with the horsepower, weather conditions and number of passengers for which they were designed. But a wise choice is a bigger cruiser or utility for open water. Look for more use of fiberglass. Fine





boats are being made out of aluminum, wood, other plastics and even new fabrics (in inflatables), but there are fewer craftsmen around to build wooden craft—and then give them the maintenance they require. Aluminum, ABS and other materials usually need more extensive manufacturing facilities. Good dependable hulls can now be well fabricated by established builders in fiberglass reinforced plastics, often referred to as FRP.

Note that your new boat should have a small plaque giving recommended horsepower and load-carrying capacity, as well as the builder's registration number. This year federal regulations require this, and



Silverline Aruba GTV



Uniflite Salty Pup



Checkmate



Sears Inflatable



Sidewinder XL

**SILVERLINE's** outboard and stern-drive Aruba GTVs come in 16 and 18-foot lengths using engines as big as a 260-hp jet

**UNIFLITE** has added this 23-foot trailerable fisherman to its extensive line of big boats

**CHECKMATE** flash is a result of performance plus a metallic glitter finish to the runabouts

**SEARS** is adding inflatables, like this one being tested by sports adviser Ted Williams, to its growing boat and motor line

**SIDEWINDER** offers one model of this open-foredeck runabout with a fiberglass deck covering

**STARCRAFT** adds high styling with new 24-foot flying bridge stern-drive-power cabin cruiser

**MFG** now has cat, sloops and catamaran rigs in its sailboat division. Dingo is a new 15-foot one-design, twin-hull addition

Starcraft Esprit 24

MFG Dingo



108



manufacturers and dealers must keep a record of purchasers in case any craft needs to be recalled to correct deficiencies. Dealers who install additional accessories may, in some cases, be considered a "manufacturer" and assume some of the new responsibility for correct workmanship. There is even a possibility that a dealer who might talk you into buying his over-size outboard for your undersize and underrated boat, might assume some responsibility if the overpowering of your hull results in failure of the boat. Final interpretation of the new laws is still being worked out, but it looks as if the boat buyer should benefit from the conscientious

work of established companies, as usual, and own a craft with serial numbers that may make it harder to steal and easier to recover.

A beneficial trend is a change in design in small craft above and below the waterline. Beamier tri-keel hulls, with assorted names like cathedral, tri-V multi-keel and rest, are offering a boat that is less likely to tip, although also less likely to ride smoothly sometimes in rough water. But the broadened bow allows an added cockpit forward of the windshield. Notice the many craft that are opening up the foredeck for seating.

Pontoon boats, deck boats and similar

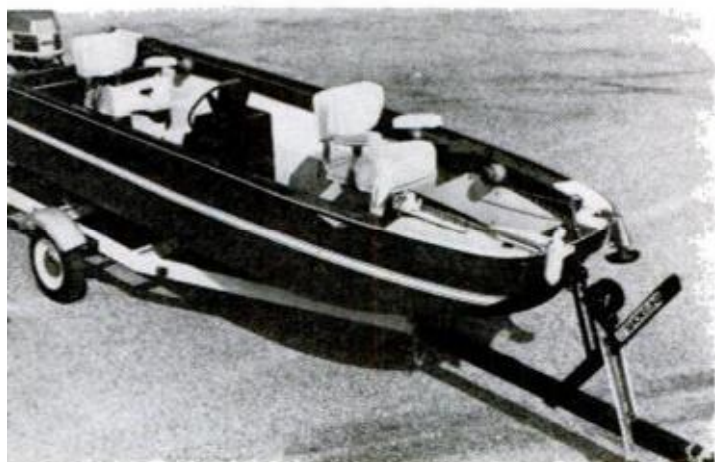

Ouachita Convincer



Starcraft American

**OUACHITA** now has a line of six bass boats with UT model shown certified for 95 hp and 1750-lb. load. It's 16 feet long

**STARCRAFT's** extensive new line includes the 16-foot Open Bow American, outboard with cushioned deck seats forward

**GLASTRON/CARLSON** 21-footer CV model offers swivel forward seats, stern transom ladder, a wraparound shield, jet power

**GLASTRON's** Vagabond Camper-Cruiser V-215 sleeps five with camper curtains up. Hatch and bowrider foredeck are provided

**CHRYSLER** sport fisherman for offshore, the 20-foot Commando 300 is rated for outboards up to 180 hp, has 50-gal. gas tank

**SYLVAN** 824HT is a 28-footer with hardtop sundeck and diving platform. Rated for up to 85 hp, it could pull water skiers

FEBRUARY 1973



Glastron CV-21



Glastron Camper-Cruiser

Chrysler Commando 300



Sylvan Sundeck



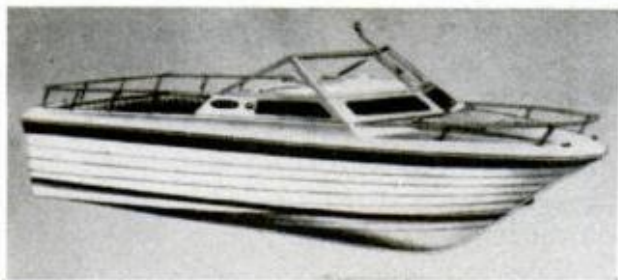
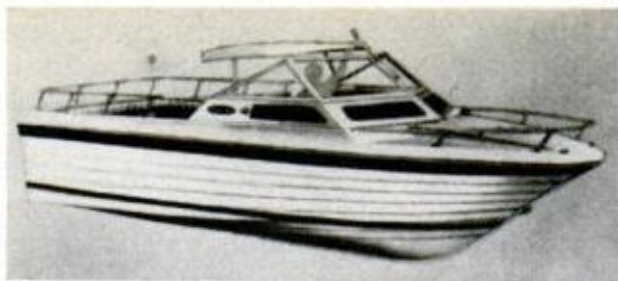

Penn Yan Montego Cuddy

modern-day party rafts are also being improved. Cruising aboard them is now possible by pitching a tent or erecting an awning that can create privacy by mounting camper curtains. Boatmen and fishermen alike also like to come in out of the sun and rain, and now there are convertible navy tops, hardtops and even inventions like Penn Yan's dual-purpose pop-top that flips down from above the windshield to roof the cuddy cabin. Small cabins are popular. The cruiser with its big staterooms looks attractive at a boat show but may be less practical for fair-weather boating. Open utilities that provide plentiful cockpit space plus a small



Tri-Sonic Weekender



Aqua-Nymph



Mirro-Craft Ranger



Kayot Executive Cruiser



Duo Capitan

**PENN YAN**, of Tunnel-Drive fame, now has introduced an ingenious top that pivots down to cover the cuddy cabin of the Montego MR220 model

**TRI-SONIC's** deck cruiser, the Weekender 2200, is a 30-mph plush 22-footer that's offered with an optional galley

**AQUA-NYPH**, built by Aqua-Cycle, rides on two 10-foot pontoons in as little as 6 inches of water with 20 hp

**MIRRO-CRAFT** tops its line with the 17½-foot Ranger. The forward cuddy cabin can be locked. Craft will carry up to 1980 lbs. and use up to 145 hp

**KAYOT** calls its pontoon Executive Cruiser a 25-foot overnigher. This craft will sleep up to five aboard

**DUO** takes the cabin of its 1973 Capitan 20 trihull model and moves it forward to make use of foredeck

**WELLCRAFT** Weekender 24-footer has an Airslot hull, employs stern-drive power up to a dual 140, and comes with or without hardtop and galley

Wellcraft Weekender



cuddy cabin forward for overnighting or locking up gear, are a practical solution.

For today's boats, even small ones can do extended fishing and cruising. Bigger, better engines make long passages shorter, and additional advantages of the big boats—like flying bridges, twin engines, galleys, heads, and electronic gear—now make sense aboard a hull that can handle the open water that tempts today's skipper.

Craft we have already tested show added performance and safety features in many cases. Before buying, try your own test program by driving as many new models as possible. One should be best for you. ★★★



Chris-Craft Four-Sleeper



Glasspar Citation



MonArk Bass Boats

**CHRIS-CRAFT** introduces a new fiberglass 25-footer cabin model that's designed to sleep four and provides inboard power from a 200-hp engine

**GLASSPAR** outboard Citation is an open-foredeck 17-foot model that is designed for 2250 lbs. and 115 hp

**MONARK** displays its new Super Pro Ltd., Riviera IV, Mark II, Delta Target and Delta II bass boats (bottom to top)

**SILVERLINE 18T** Antigua converts from canvased camper sleeping four or more to an 18-foot open utility seating eight with a stern-drive rated to 165 hp

**SEARS** Gamefisher, of ABS plastic, is now available in 12 and 14-foot sizes. The flotation, as shown, tests out well

**LARSON** Baron, a trailable 21-footer, has deep-V hull, double bunks forward in cuddy cabin, 165 stern-drive power

**REINELL** is introducing a number of command bridge-station models like this 21-foot RV3240. Camper-back canvas can enclose cockpit for weekending aboard

FEBRUARY 1973



Silverline Antigua



Sears Gamefisher



Larson Baron



Reinell RV3240

# Gadgets for better boating



THE EXTRA GEAR that goes aboard can cure a lot of problems afloat while making boating safer and more pleasant. Here's an early-

season selection of new items, plus older ones with new applications for boat owners. Engines are hardly accessories, but a number are being harnessed for new propulsion tricks. Others offer more power from smaller, lighter packages. Even sailboats are seeing new developments. ★★



**KEEPING COMFORTABLE** aboard, or afloat in water, is a new advantage of better designed life jackets like CG-approved Gentex Guardian

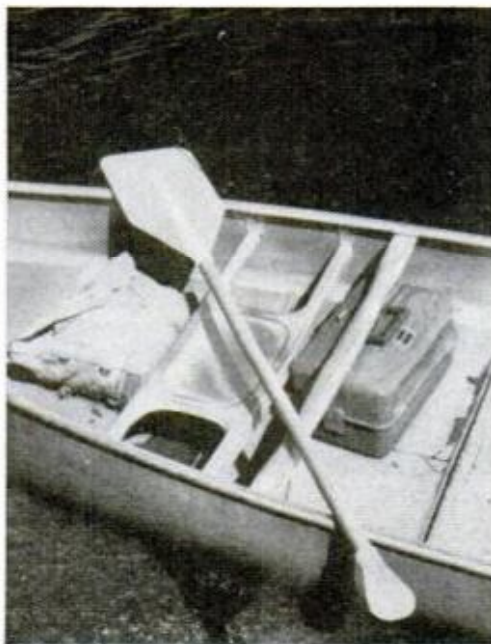

**LIGHTWEIGHT POWER** includes 235-cu.-in. engine—290 lbs. (427 with jet drive shown)—by American Challenger. Lighter yet: Cannon's Magnum ABS paddle

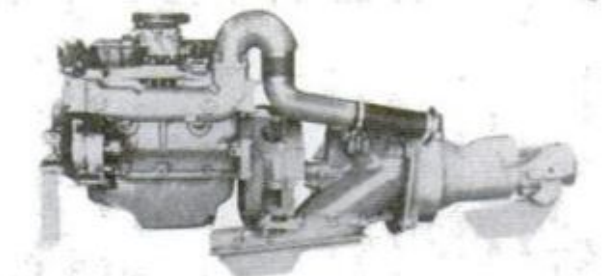

**PULL** on dashboard handle (top) opens transom trap to drain bilge of a boat traveling at speed or being trailed down the road. New \$20 Bilge Bailer from Northwest Marine is reported easy to install in any hull having a 1-inch drain tube



**THERMOS** has noted its Space Sportsman's Blanket will serve as warm-weather sunshade or wet-weather cockpit cover that folds compactly in tackle box

**PUSH** from a compact power package is advantage of latest OMC J-140 Jet Drive engine and pump unit. Four-cylinder inboard cranks 140 hp into water-jet impeller. Size is especially suitable for smaller hulls. Fin on jet nozzle improves lower-speed steering in forward, reverse. Angle of jet adjusts for top performance with trimming control to deflect engine and jet up, down

POPULAR MECHANICS

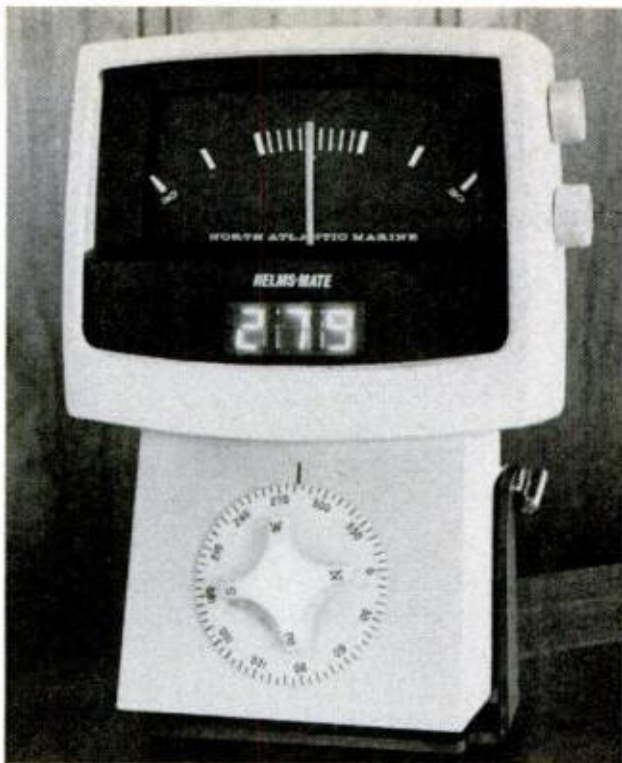

**COMPASS-HATING SKIPPERS** who would give anything to replace the spinning dial can now pay \$1150 for Helms-Mate computer with digits and course pointer



**UNDERWATER AIDS** include straight-line chart recorder, Model 470, from Ray Jefferson that draws distortion-free picture of bottom and fish. \$225

**SST PROPELLERS** of stainless steel and Teflon S (right) are five times as strong as aluminum, add up to 3 mph speed, according to OMC Accessories



**SUPER BEACHER** slides under a sailing surfboard or boat and rolls it to and from the water with little effort. Unit is \$40; Metadyne, Garfield Heights, Ohio  
**FEBRUARY 1973**



**CONVERSION TO SAIL** for any rowboat or canoe is claimed for Michi-Craft's \$245 kit, with sail, spars, leeboards, rudder, motor-mount bracket



**EXTINGUISHER SYSTEM** for engine-compartment fires is FiQuench, a rechargeable automatic unit for owner installation. \$400, Pike Metal Products

AQUABUG'S SYSTEM 1  
POWERS OUTBOARD WITH  
GAS OR ELECTRICITY, OR  
RECHARGES BATTERY



GASOLINE  
POWERHEAD

COUPLER

6 OR 12-VOLT  
BATTERY

6 OR 12-VOLT  
GENERATOR

OUTBOARD  
LOWER UNIT

ELECTRIC  
POWERHEAD



ELECTRIC  
POWER-  
HEAD



GASOLINE  
OUTBOARD

**MULTIPURPOSE MOTOR** can run on gas and electricity, swap power heads back and forth, or couple gasoline head to electric to become a 6 or 12-volt generator and run appliances or recharge a storage battery for trolling motor

# This gas burner can go electric

SMALLER OUTBOARDS have been made, but probably none more versatile than Aquabug's new combo. Now the gasoline outboard has added options that can turn it into an electric trolling motor or a 6 or 12-volt gasoline-powered generator. Aquabug/System I is the name for this little three-way waterway act.

First came the 1.2-hp Aquabug gas outboard, an 8½-pounder with adjustable height bracket, anodized lower unit and self-lubricating Nylatron gears, all covered with an unconditional one-year guarantee. The new Aquabug electric uses the same type lower unit and claims protection from motor seal leaks by keeping the power unit above the water. Switches are reported to be both water and vaporproof. The electric retails for \$75.

Put them all together, however, add a coupler that mates the gas and electric power heads, and the result is a generator that can recharge your 6 or 12-volt storage battery or power accessories such as a bilge pump. Suggested uses include standby emergency lighting ashore or recharging boat batteries afloat.

As a package, System I weighs 14 pounds and costs \$175 complete. This will include the Aquabug gas powerhead, electric head, lower unit to fit either interchangeably, and converter to mate gas power head to the electric for generator use. All three options are available by mail from Seaborne Systems, 4413 Austin Blvd., Island Park, N.Y. 11558 and selected dealers. ★★★



# Canoe cart



By **BOB HICKORY**

**PORTAGING** is a lot easier for paddlers with this handy canoe mule built to fit a hull bottom



**YOUR CANOE OR BOAT** can get around easily ashore with this carrier. You'll need a pair of bicycle wheels with tires and axles, two lengths of 1½-inch angle iron 52 inches long and four 38-inch lengths (old bed-frame iron will do); also two 38-inch pieces of 2x2 softwood, eight 1¼-inch wood screws and eight ¼x1-inch bolts with lock washers and nuts.

Pair the four pieces of 38-inch iron so that vertical surfaces are facing each other. Drill holes in dead center of the verticals

to accept axles. Mount axles and wheels. At each end of 52-inch cross members align wheel support pairs and drill ¼-inch holes to bolt them together. Don't be tempted to weld the joints since wheels cannot then be removed for possible tire repair. Drill four holes in horizontal surfaces of each 52-inch crosspiece and secure 2x2 lengths with screws from below. Notch 2x2s in center to fit canoe's keel.

Small marks on your hull can show how to load it for best balance. ★★★



**LAUNCHING** or hauling out can become one-man job

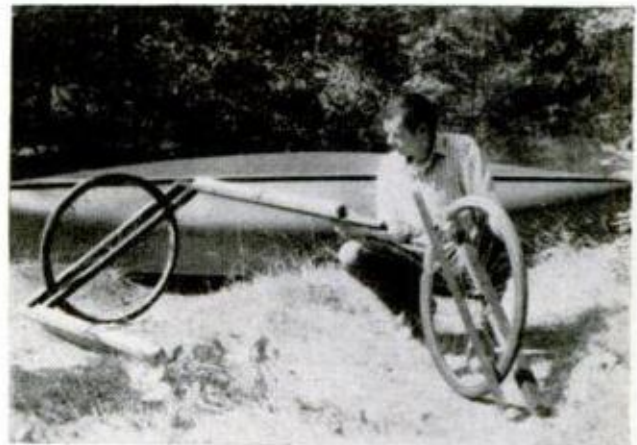

**CART UNBOLTS** for stowing in car trunk or aboard



**KEEL NOTCHES** in cross members help center the hull  
FEBRUARY 1973



**FOR SHORT TRIPS** cart can ride on a cartopper canoe

# So you want to build your own



Should you or shouldn't you? Here an expert lists important pros and cons that you'll need to know.

By **BOB WHITTIER**



**BIG SAILBOATS** this size may take years but could then cruise you around world



**BOLERO**, a racy new 24-footer from Glen-L Marine with twin bunks forward, costs \$40 for full-sized plans, \$250 for frame kit

**T**HE URGE TO BUILD your own boat is a strong one. Even with the wide assortment of factory-built pleasure craft on the market, many handsome and able boats are constructed every year by amateurs. But it's also true that do-it-yourselfers have produced floating monstrosities, after starting projects hastily and blindly. It is important to learn what you are about to undertake *before* you start.

Reasons for wanting to build your own boat are varied. For some it is a challenge for their skill with tools. Others do it because a specialized boat is not commercially available. Many hope the do-it-yourself route will save lots of money.

Let's be realistic about costs. There is no fixed rule for determining the final expense of a homemade boat. Be warned—sometimes you can save, but sometimes not. Much depends on the particular

boat's design, size, materials required, and whether you're starting from scratch, building a kit or finishing off a premolded hull. Modern boat factories buy material in carload lots at low prices and put it through very efficient production lines. If you buy all your components at retail prices and use your tediously erected building jig only once, the cost in dollars and time for your completed boat may be such that you'd be better off to buy a used boat—or a new one at an end-of-the-season reduced price.

To illustrate, materials for a well-made plywood rowboat would run to around \$100. An aluminum johnboat able to do much the same job can be bought for less! On the other hand, no company mass-produces certain types of craft, from fine round-bottom rowboats to heavily-built ketches suitable for ocean crossings. Hav-



**TAKE YOUR PICK:** a would-be boat owner with a little skill and a lot of spare time could build a racing hull, dory, outboard cruiser, fishing skiff or all of them if his basement, bedroom or back yard is big

ing such craft custom-built today can be very costly. Building your own specialty boat, as much for the love of it as the labor-cost savings, may then be worthwhile. But when a friend tells you how much he saved, remember he isn't putting a price on all his hours of effort.

Once you decide on a particular boat, evaluate the building cost as accurately as possible. Plans for smaller craft usually have bills of materials. Obtain local prices for these materials, and don't forget things like lumber for the building jig, special tools and shop overhead or rental. Often plans for large boats do not include bills of material, for good reason. Boat lumber sometimes comes in rough-sawn boards that must be picked over when selecting for curved members of a hull. Because of selection, waste and breakage, a materials list can be misleading. Contact persons who have built similar craft, through your source of plans, to get some idea what it cost them.

Good plans are vital to successful boat building, however, and are not the place to economize. Amateurs have been drowned by boats they designed and created "by eye." Good results require a scientific knowledge of hull stability, water-

flow characteristics, hull balance, hull shape, power needed for desired performance, safety requirements and best use of materials. Pleasure-boat naval architects are often members of the Society of Small Craft Designers. Look under "Naval Architects" in the your local directory. The *Boat Owners Buyers Guide*, Dept. PM, 50 West 44th St., New York, N.Y. 10036 (\$1.95) lists American naval architects as well as most companies producing items for pleasure-boat construction and maintenance.

Additional sources of plans include *Plans, Publications, Projects*, a 25-cent catalog from Popular Mechanics Service Bureau, 224 West 57th St., New York, N.Y. 10019; the free *Catalog of Motor Boating Books*, Box 2316, New York, N.Y. 10019, or the \$3 *Designs for 363 Boats You Can Build* from the same address. Then there are the Glen-L Marine plans. Send \$1 to Glen Designs, 9152 Rosecrans Ave., Bellflower, Calif. 90706, for the *Catalog of Plans, Patterns and Frame Kits*. For 25 cents the American Plywood Assn., 1119 A St., Tacoma, Wash. 98401, has a *Plywood Boat Plans Directory*. Send 50 cents to the International Amateur Boat Building Society, 3183 Merrill, Royal Oak,

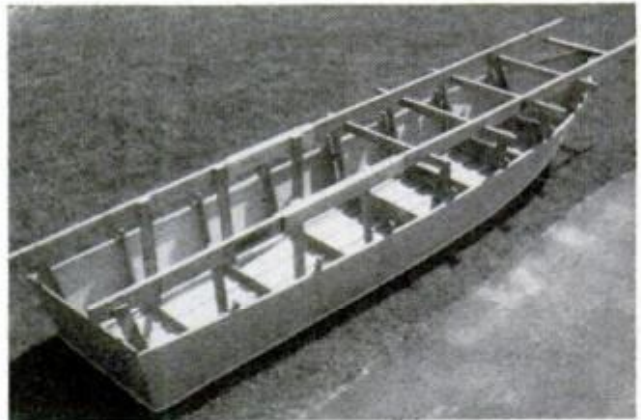
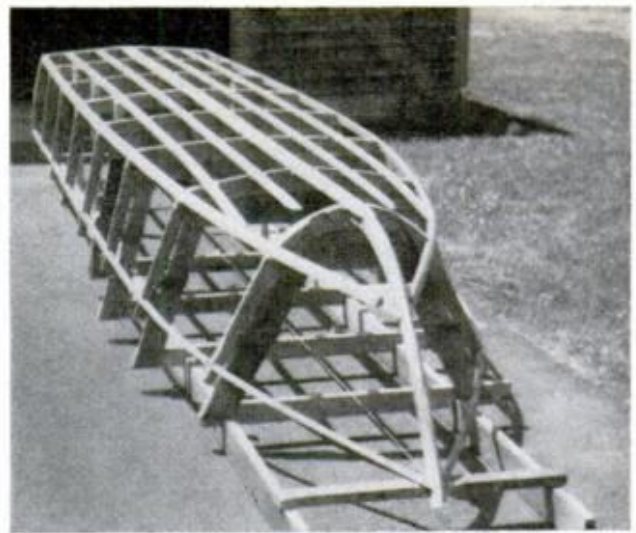
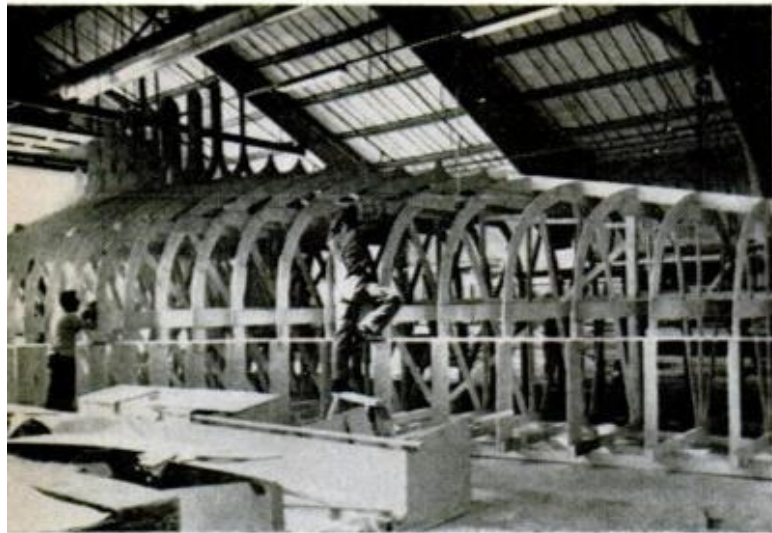

**PREPARATIONS** for framing out may require space of a rented warehouse. Figure you'll start job upside down, then right the planked hull for final decking

Mich. 48072, for a sample copy of its magazine *Amateur Boat Builder* in which plans are advertised. Capt. Jim Orrell, Box 720, Galveston, Tex. 77550, has plans for dory-type boats of all sizes and styles. Or for \$1, a *Plan Kit Catalog* is available from Clark Craft, 16-P Aqua Lane, Tonawanda, N.Y. 14150.

When studying plan catalogs, remember some boats are designed to be built of traditional woods which may be hard to get. Maurice L. Condon Co., 252 Ferris Ave., White Plains, N.Y. 10603 has a 10-cent pamphlet, *How to Select the Right Boat Lumber*. Harbor Sales Co., 1409 Russel Rd., Baltimore, Md. 21230 also stocks marine plywoods of all common domestic and imported types.

Boats of common lumberyard wood should be copiously treated with antirot preservatives. Write to Forest Products Laboratory, Madison, Wis. 53700 for its pamphlet, *Decay of Wood in Boats*. And a source of information on painting is the pamphlet, *Boat Paintenance*, available for 50 cents from the Baltimore Cooper Paint

Co., 501 Key Hwy., Baltimore, Md. 21230.

Purchasing various specialized materials can be simplified by building from a kit. Though there are fewer kit suppliers than a number of years ago, excellent kits are still available. Luger Marine, 3800 West Highway 13, Burnsville, Minn. 55378, sells fiberglass boats in kit form and has a free catalog. These kits consist of port and starboard hull halves plus other fiberglass moldings nested for crating, and the builder fastens these together with usual fiberglass techniques. Glen-L also offers frame kits that can get the amateur over the hurdles of obtaining material and erecting accurate frames. Sheet plywood is bulky to ship and suitable kinds are often available from plywood warehouses through local lumber dealers. As a result, frame kits are easier and cheaper to ship. Kits for additional kayaks, canoes and sailboats can be found in the classified section of this magazine each month.

So-called ferro-cement boats are becoming more common in the amateur

boatbuilding field. The process is basically simple, but study is necessary to learn how to do it properly. This material is considered too heavy for fast planing boats in the small powerboat category. As size increases, however, ferro-cement compares more favorably with other materials because the numerous internal frames and stringers that add weight to large wooden craft are not needed. Home-made fiberglass boats can also be built from scratch after an amateur has carefully studied the specialized techniques.

To begin learning about fiberglass and ferro-cement, send \$2.50 to International Marine Publishing Co., 21 Elm St., Camden, Me. 04843, for a copy of *Reprint on the Use of Ferro-Cement in Boatbuilding*, and \$3 for *Reprint on the Use of Plastics in Boatbuilding*. Ask them to also enclose a copy of their useful boat book catalog with your order. Bare fiberglass hulls of inboard powerboats and sailboats that can be finished off by the buyer are now available from some firms. Many advertise in the monthly trade paper, *National Fisherman*, at the same address above in Camden. A sample copy is 50 cents, and the paper carries many boatbuilding articles.

Building a boat differs from other kinds of carpentry in that so many pieces of wood must be curved and beveled. One way to get the knack is to construct a small boat before attempting a more ambitious one. Good boatbuilding books describe such specialized tasks as drawing full-size hull lines, steaming ribs, spiling the planking, caulking seams and plugging screwheads—all techniques that some beginners seem to expect to find described on the set of plans they buy.

Libraries, book stores and International

Marine mentioned above are a few of the sources for good books. Also write to Sailing Book Service, 34 Oak Ave., Tuckahoe, N.Y. 10707, and to Boatman's Bookstore, 21 West 46th St., New York, N.Y. 10036. Describe the kind of boat you want to build and what you need to learn about boat-building. Ask them to suggest appropriate books. Also look up mail-order firms that supply building supplies in *Boat Owners Buyers Guide*. Then order a few of the \$1 catalogs. Each will contain listings for all sorts of hardware, compounds, tools and accessories. Leafing through them is a liberal, and very pleasant, education in boat fittings and gear.

And now there is something else you will need to know. It appears that many homemade boats are going to have to comply with design and equipment requirements currently being formulated by the Coast Guard under the Safe Boating Act of 1971. Ask a local boat yard or your post office for the address of the district Coast Guard headquarters nearest you, and contact the Coast Guard for up-to-date advice on how new requirements might apply to your boat. If building a larger boat, send \$10 to American Boat & Yacht Council, 15 East 26th St., New York, N.Y. 10010, for *Safety Standards for Small Craft*.

And finally, save sales slips when buying materials. They will be useful in proving ownership and meeting sales tax requirements when registering your completed boat. If it's large enough to be insured, ask your insurance company to send a man around to look at it early in the project. That way you can prevent unforeseen red tape from making it difficult or impossible to insure your pride and joy dreamboat when it's finished. ★ ★ ★

## BOATBUILDERS' REFERENCE GUIDE

AMERICAN BOAT & YACHT COUNCIL, 15 East 26 St., New York, N.Y. 10010

AMERICAN PLYWOOD ASSN., 1119 A St., Tacoma, Wash. 98401

BOAT OWNERS BUYERS GUIDE, Dept. PM, 50 West 44 St., New York, N.Y. 10036

BOATMAN'S BOOKSTORE, 21 West 46 St., New York, N.Y. 10036

CLARK CRAFT, 16-P Aqua Lane, Tonawanda, N.Y. 14150

MAURICE L. CONDON CO., 252 Ferris Ave., White Plains, N.Y. 10603

FOREST PRODUCTS LABORATORIES, Madison, Wis.

GLEN L MARINE, 9152 Rosecrans Ave., Bellflower, Calif. 90706

FEBRUARY 1973

HARBOR SALES CO., 1409 Russel Rd., Baltimore, Md. 21230

INTERNATIONAL AMATEUR BOAT BUILDING SOCIETY, 3183 Merrill, Royal Oak, Mich. 48072

INTERNATIONAL MARINE PUBLISHING CO., 21 Elm St., Camden, Me. 04843

LUGER MARINE, 3800 West Highway 13, Burnsville, Minn. 55378

MOTOR BOATING & SAILING BOOKS, Box 2316, New York, N.Y. 10019

NATIONAL FISHERMAN, 21 Elm St., Camden, Me. 04843

CAPT. JIM ORRELL, Box 720, Galveston, Tex. 77550

POPULAR MECHANICS SERVICE BUREAU, 224 West 57 St., New York, N.Y. 10019

SAILING BOOK SERVICE, 34 Oak Ave., Tuckahoe, N.Y. 10707



# Boat that floats no matter what

It would be easy to play odd couple afloat in Shakespeare's new WonderCraft 12 with flotation to spare

By BILL McKEOWN, Boating Editor



**SPLIT PERSONALITY** is possible, though not normal condition, of this foam-strengthened ABS plastic hull

**I**T'S PLASTIC—but not fiberglass. It's not a "bass boat"—but could catch plenty. It can mount motors at both ends, carry three passengers and 15 horsepower easily, and even if swamped, you'd need to make an effort to sink it. Built-in flotation keeps the rig afloat even when level full of water and with passengers, gas and electric kickers, gas tank, battery and gear aboard. You'd probably need a load of 600-plus-plenty pounds of lead sinkers to get this new little model to go down.

Shakespeare, long famed for fishing tackle, archery gear, depth and fish finders and electric fishing motors, has now gone into the boat business with a neat 12-

foot tri-V-hulled utility. It's called a WonderCraft 12, probably in honor of its many features plus just possibly because there are already WonderTroll electric fishing motors, Wonderods, Wonderpoles, and Wondercast reels using Wonderline from Shakespeare's sporting-goods division.

We went to Washington, N.C., for a sneak advance look at how they put this novel newcomer together, and then a chance to run the rig for a performance check. Seacrest Marine builds the boat to specifications from Shakespeare's new boat division (Box 242, Columbia, S.C.). Requirements included a slick-finished hull that could be turned out in quantity and still have high quality control. Seacrest also makes the well-regarded Gamefishers for Sears, Roebuck out of ABS Cycloc thermoplastic, and Shakespeare decided on the same process for its design.

Inner and outer hulls are heat-formed



**BOTH GAS AND ELECTRIC MOTORS** can be mounted same time on transom; (both even ran submerged)

from the plastic sheeting in one of the most modern computerized and instrumented plants in the business. Cockpit and outer hull, when mated, are foam-filled under pressure to become a solid unit of notable strength with good ability to float.

How good? Years ago Boston Whaler may have been the first to cut its boat in half on purpose, though since then a number of companies have claimed similar tests. It seemed a shame to saw up a handsome new WonderCraft, but it also was a sure way to put a small boat's flotation on the line. Out from shore on the Pamlico River two brave Seacrestmen sawed away until bow and stern sections parted and floated free. Now the good stability of the hull was lost and the little WonderTroll motors dipped occasionally underwater, but without shorting out.

Fine—but who's going to chop up his boat? The next experiment was almost more impressive. A boat was flooded and a trusty little 9½-hp Evinrude on the stern started up. Gunning it caused the bow to rise and momentarily submerge the Evinrude completely, but it never quit! As speed increased water spilled out, and a fisherman who'd caught a wave aboard could have bailed and run the boat dry without capsizing.

Testing over a chop, we found the boat handled well for the size, and timed runs report 20 mph from 10 hp. A lot of inshore fisherman should take to this one, and look forward to additions to the new line. ★★



**CENTER STORAGE COMPARTMENTS** also divide hull with water barriers, and can serve as fish-bait wells



**MOTOR MOUNTS** are molded into bow (background) and stern. Plugs allow draining center compartments



**TWO FOR THE PRICE OF ONE**, but with limited free-board, is result of cut-up test of hull's flotation  
FEBRUARY 1973



**STORAGE BOXES** in bow and under center seat have seat tops secured with shock cord to prevent loss



# Hoist your hull on air

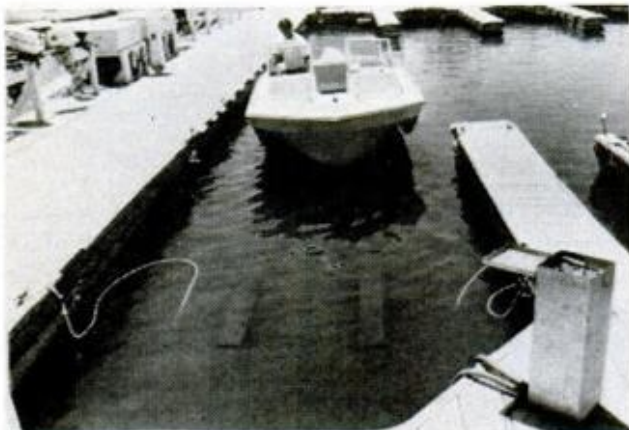

**INSTALLED** in slip, hoist unit is completely submerged and only hoses to blower pump can be seen



**AIR DISPLACES WATER** in twin fiberglass tanks and boat bow rises first on padded cradle of the hoist

By PENNY NICOLAI

**DRY DOCKING** is no longer only for big ships. An Oklahoma outfit has developed a fiberglass tank system that can become an aquatic elevator for the family runabout.

Drive into a slip rigged with a Hydro-Hoist and only a pair of small hoses running up to a pump box on the dock will hint at the clever gadgetry waiting underwater. A water depth of 3½ feet is required; more is needed for keel sailboats.

Two 16-foot fiberglass tanks lift a framework which mounts supporting pads for the boat, and the unit slides up and down on brackets clamped to the dock. Installation takes about 2½ hours. Air pumped into the tanks from a dockside blower does the work and there is no strain on the dock. Width of the slip needs to be between 7 and 12 feet. The two-stage blower requires 110-volt a.c. current and a 12-volt d.c. model is being developed. Units for 2000, 4000, 6000 and 8000-pound boats are available. The 2000-pound hoist shown costs \$970 installed, plus shipping charges from nearest dealer.

After driving into his slip, a boatman can switch on the blower while still aboard if the control is mounted nearby. First bow and then stern are lifted above the water, clear of summer fouling or winter ice. Lowering the boat is equally simple.

For details, write Hydro Hoist Co., 820 West 10 St., Claremore, Okla. 74017. ★★ ★



**LIFTED CLEAR OF WATER**, fouling and ice, the hull is stable enough for passengers to climb aboard

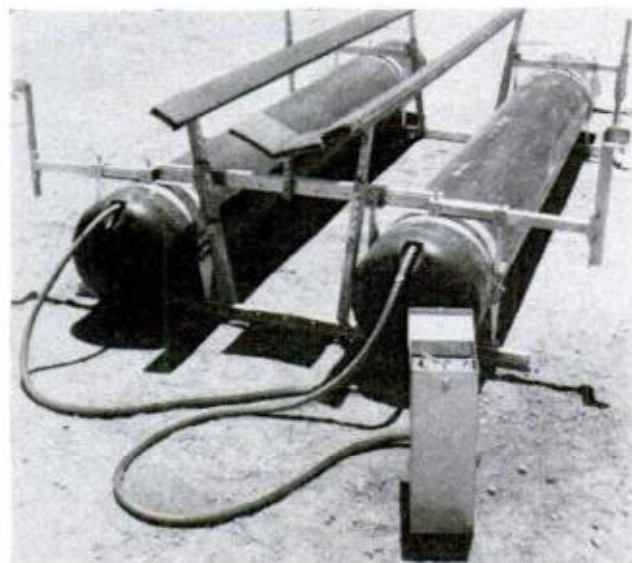

**HOIST GUIDES** on each side slide up, down in dock brackets. Installation takes less than three hours



# For cartopping— here's the catch



By MARK SOSIN



**SECURE** without a spiderweb of tie-down lines, this cartopper is held in place with ropes to clips under hood and trunk-lid edges

**TIE-DOWNS, TOO OFTEN,** are a tangle of ropes that have been woven in a spider web over and around a cartop boat or other over-size gear on the roof. Then they come down and through windows and around door handles and bumpers in an attempt to keep the boat or luggage from shifting forward and aft or side to side while traveling down the road. Sometimes the rigging is so extensive that doors, hood or trunk of the car can't be opened until the launching ramp is reached. Checking the oil, unloading a spare tire or even getting out for a stretch presents a problem.

But Les Hodax of New Shrewsbury, N.J., worked out this simple solution. He fashioned light-gauge metal clips, as shown, that seat in the joint between car hood and fenders and in the recesses at either side of the trunk lid. A rectangular opening is cut in each catch to hold a premeasured line knotted to it. Position catches, close hood and trunk and the boat is secured. Open them for instant release. ★★ ★

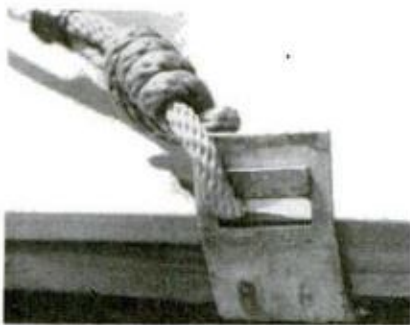

**METAL CATCH** is bent to fit hood or trunk lip. Opening in catch is cut and bent to prevent slicing rope



**TIE-DOWN ROPE** is measured for tight fit, permanently knotted to cutout in clip for bow, stern lines

**ENGINE SERVICING** is a cinch since neither metal catches nor tie lines need to be removed now when raising hood for checking water and oil



**TRUNK ACCESS** is even more convenient. With no tie-downs knotted to the trunk handle or rear bumper, gear can be unloaded at any time without un-lashing the cartopper. Tension on transom of boat remains the same each time trunk lid is closed with rope clips in place



# Short course in antennas for shortwave listening

By FOREST BELT

**T**HERE'S A LOT to listen to on shortwave: musical programs you can't get on regular radio, ham talk, the drama of police, fire and aircraft calls, and news and propaganda with unusual foreign slants (including our own Voice of America broadcasts). Shortwave radios are available in all price ranges. But none of them can do a good job without a good antenna.

Sometimes that's just a wire hung across the yard (but a precisely cut wire—see next page). Or it might be a fancy-looking gadget on a rooftop mast. Your choice depends on what you want to listen to.

## Frequency and wavelengths

A long piece of wire picks up certain stations well, but a shorter version suits others better. Indeed, a 16-inch wire works best for most police, fire and ambulance broadcasts.

Why? The reason involves *frequency*, *wavelength* and *resonance*. If you're a shortwave or even a hi-fi fan, you may already know what those terms mean.

*Frequency* is marked on the dials of

radios. On older sets, they're in kilocycles (KC) or megacycles (MC), which stand respectively for thousands of cycles per second and millions of cycles per second. Many recent radios have the modern equivalents: *kilohertz* (kHz) and *megahertz* (MHz). A megahertz (1 MHz) equals a thousand kilohertz (1000 kHz).

Radio stations everywhere operate on their own assigned frequencies. When you "tune in" a station, you're actually setting special circuits inside the radio to *resonate* at the station's frequency. They let you make your receiver sensitive to that one frequency and no other.

*Wavelength* is just what its name suggests: the length of the radio wave a station transmits, expressed in meters. The higher a station's frequency, the shorter its wavelength. To calculate the wavelength for any station, just divide 300 million (a radio wave's velocity in meters per second) by its frequency in hertz (the number of waves broadcast per second).

For example, if your favorite station operates at 15 MHz (15 million hertz), divide 300 million by 15 million. The an-

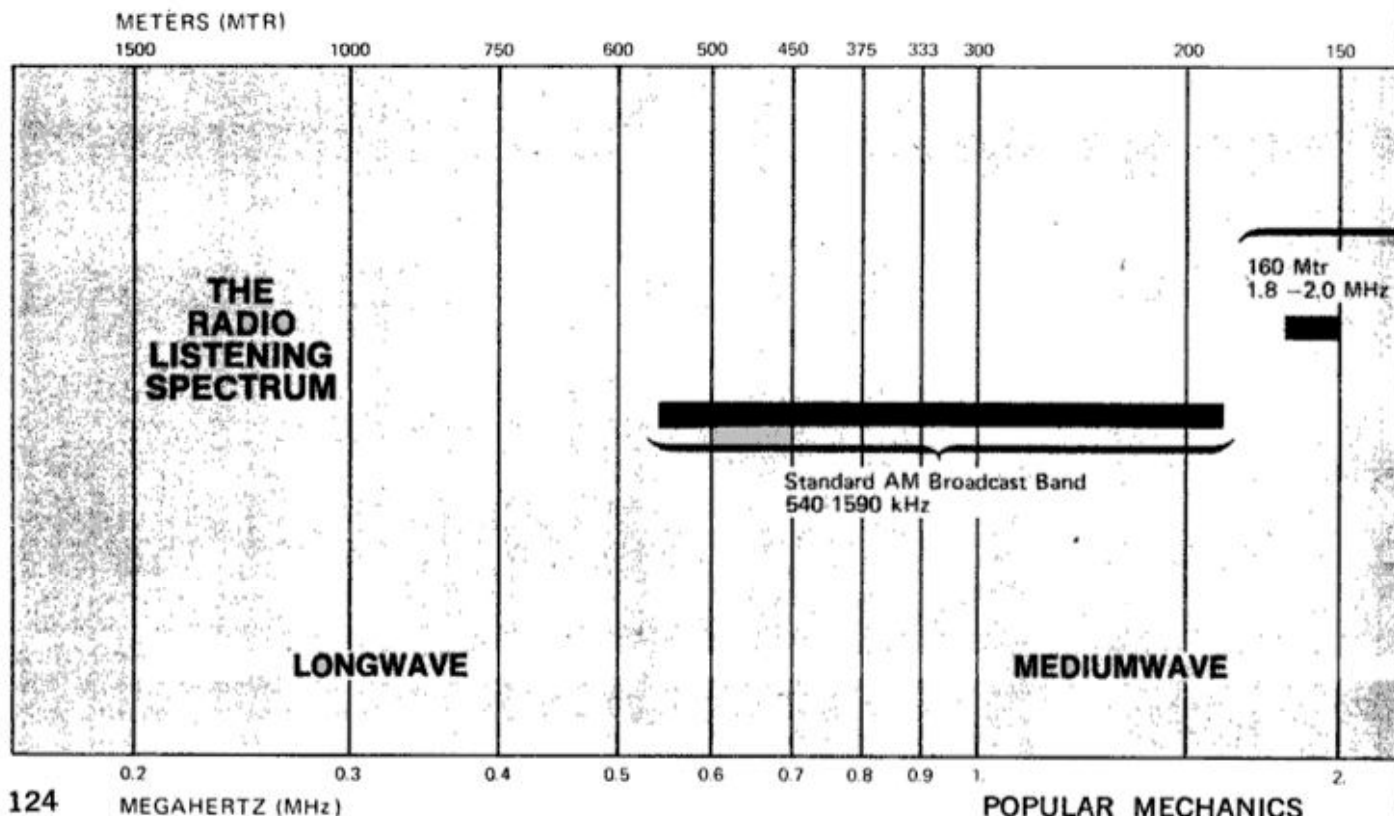

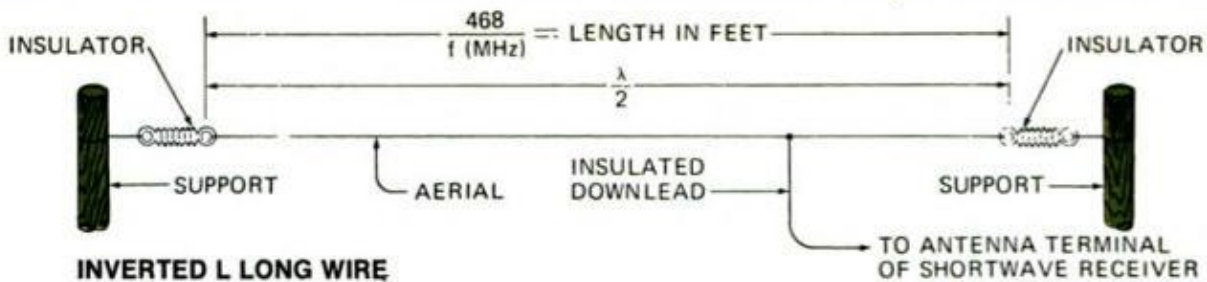

**INVERTED L LONG WIRE**

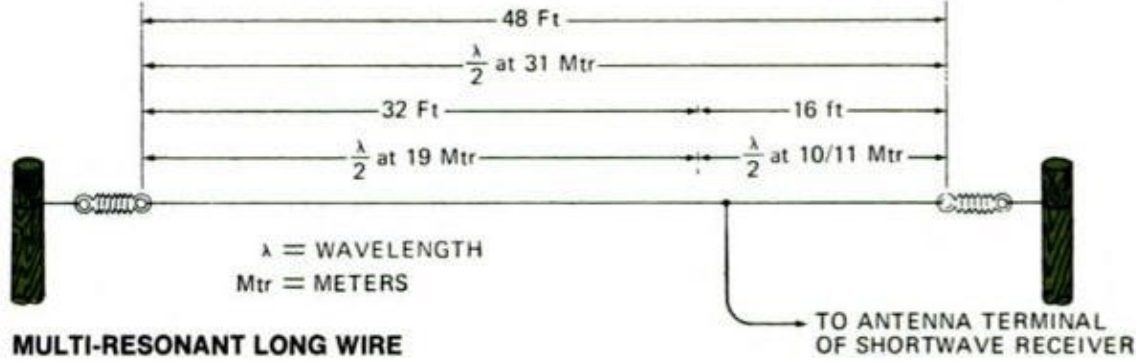

**MULTI-RESONANT LONG WIRE**



**ANTENNA KITS** have all materials needed for long-wire antennas. This Calctro kit costs \$2.75



**ALLIGATOR CLIP** is a good temporary connection to set. Plain wire or spade lug is more permanent

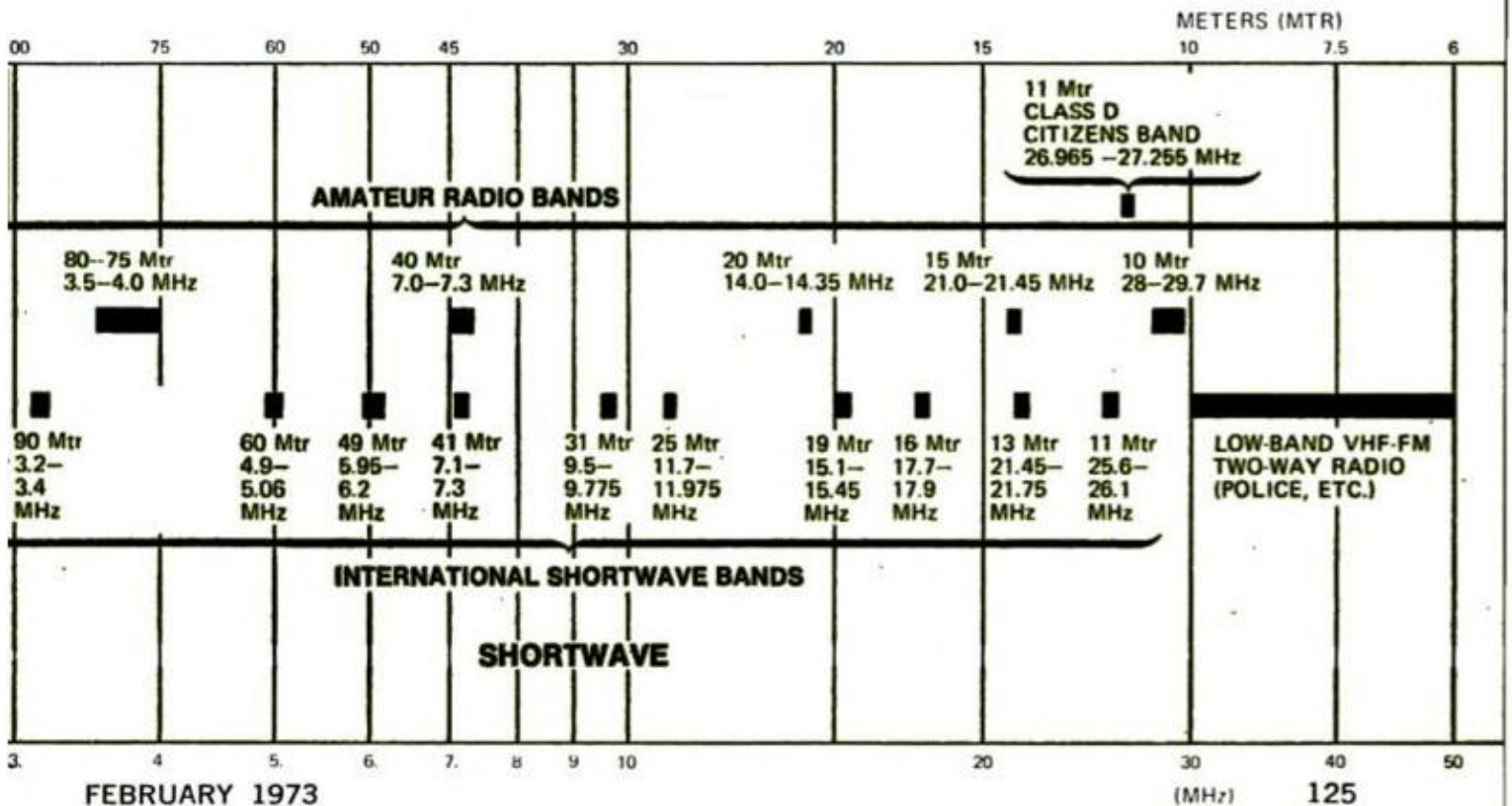

swer is 20, so the station's wavelength is 20 meters.

To calculate the wavelength of a broadcast station operating at 750 kHz, divide 300 million by 750,000 (or 0.75 million); this station's wavelength is 400 meters. The chart on page 125 graphically illustrates the relationship between megahertz (frequency) and meters (wavelength).

### Antennas and half-waves

A radio signal is an electromagnetic wave traveling through the air. When a radio signal encounters any metal object, the forces in the wave set up corresponding "pulsations" in the metal. The more closely the object's size matches the signal's wavelength, the more strongly these pulsations are induced. The metallic antenna is *resonant*—or tuned—to that radio wave.

You can cut a metal rod or wire to a length that resonates at whatever frequency you wish; then you feed the induced radio signal down another wire to your receiver. The resonant rod or wire is the *aerial* part of your antenna, and the feed wire is the *downlead*.

Simple shortwave antennas come in two types: *long-wire* and *vertical*. For stations below 25 MHz, the long-wire seems most practical, and easiest to construct. Above 25 MHz, verticals are feasible; but you'll probably buy one ready-made rather than build your own.

The aerial portion of a long-wire antenna works mainly on a half-wave theory. That is, you make it half as long as the wavelength it should pick up. (The earth beneath the aerial "reflects" the other half-wavelength.)

The simple "inverted-L" shown on the preceding page installs easily. You need two insulators, a length of sturdy wire and a downlead wire. The kit shown with the antenna sketch has bare aerial wire, stranded for strength, and a downlead that's insulated so it won't be accidentally shorted or grounded out. Two standoff knobs support the downlead, and a flat insulated strip passes it under the window sash.

How long should the aerial be? That depends on what you listen to. Suppose you listen a lot to overseas broadcasts from Great Britain on a frequency of 6110 kHz (same as 6.11 MHz). Wavelength of that station (300,000,000 divided by 6,110,000) is 49.1 meters. A half-wavelength is 24.55 meters. Actually, a long-wire antenna should only be 0.95 times as long as this, due to capacitance of its end insulators, so your net length would be 23 $\frac{1}{2}$  meters, or 76.5 feet (a meter equals 39.37 inches, or 3.28 feet). If you want to calculate the wire's length in feet directly, there's an even simpler way: just divide 467.5 by the station frequency in megahertz, and you get the aerial length in feet. (In this example, 467.5 divided by the

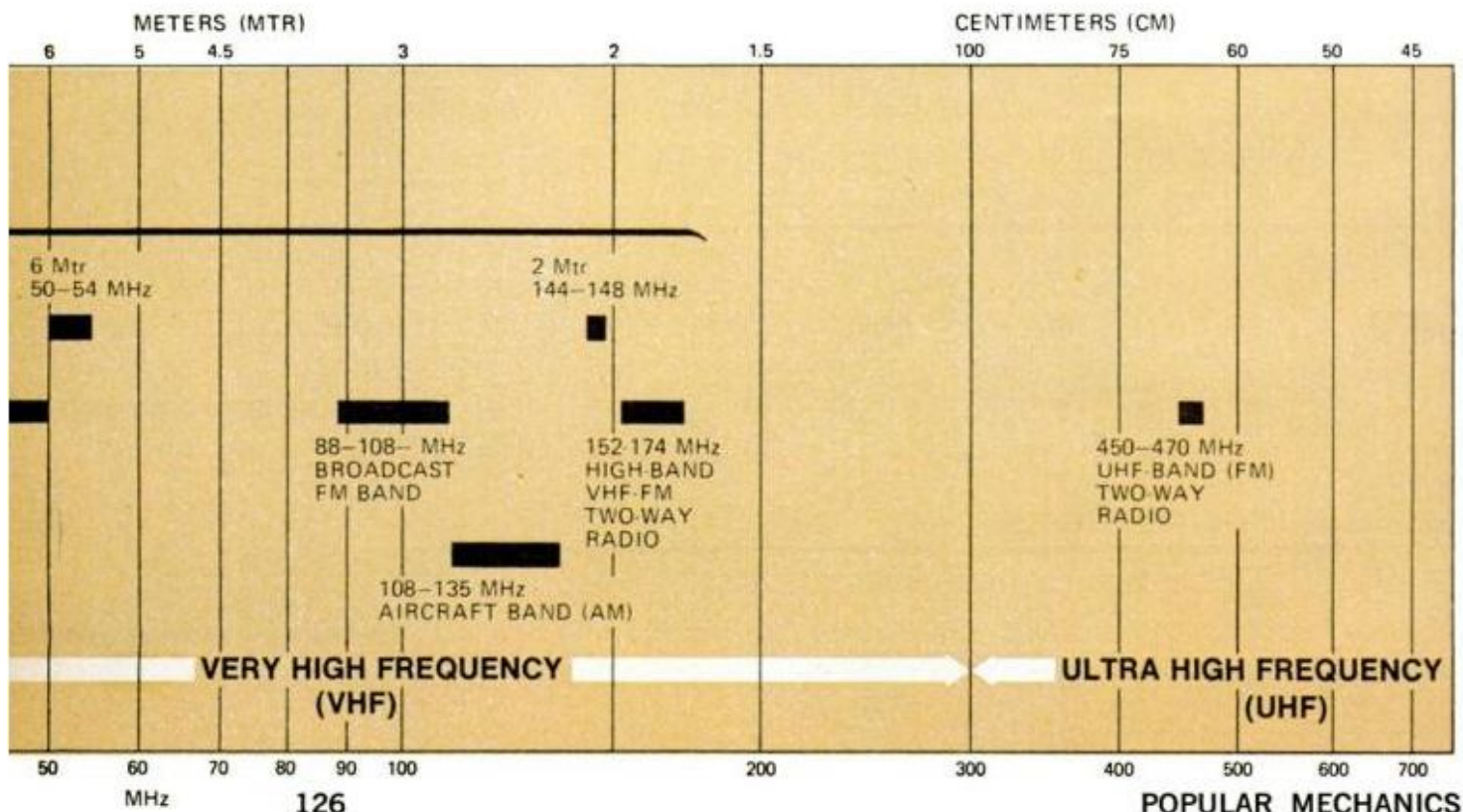



**GROUND-PLANE** antenna's horizontal rods serve as reflectors

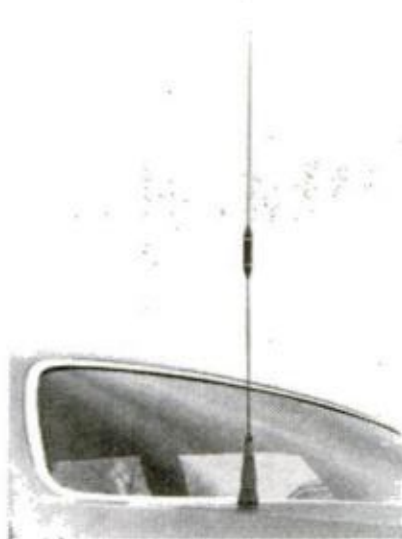

**LOADING COIL** in middle of whip electrically "extends" its length

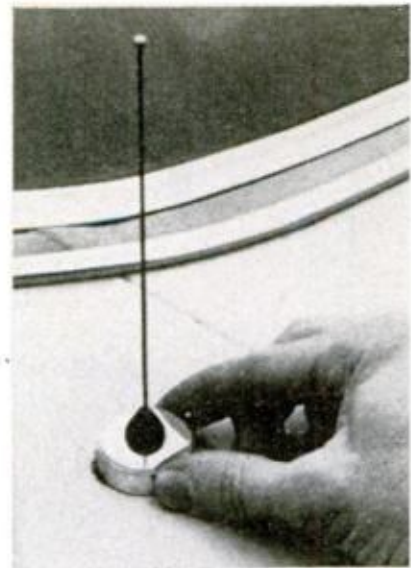

**MINIATURE WHIP** is quarter-wave aerial for 450-470 MHz 2-way FM

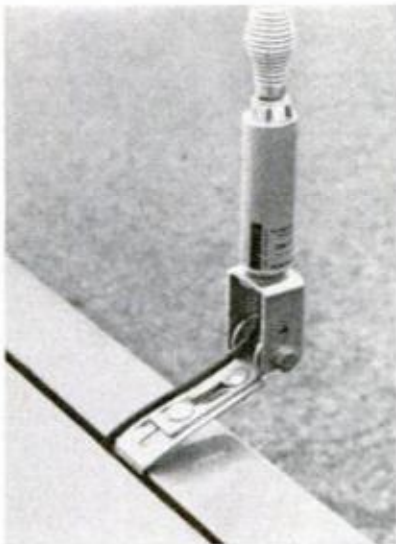

**TRUNK-EDGE CLIP** mounts mobile antenna without drilling the body



**PL-259 PLUG** is commonest for CB and other coaxial antenna leads



**HIGH-GAIN** antenna can be costly. This Avanti Moonraker is \$130

6.11 MHz frequency is about 76.5 feet.)

The inverted-L works well both at *and near* its resonant frequency, so the 76-footer is effective for any frequency in the 49-meter shortwave band. But the antenna is sensitive at multiples, too: The wire tunes two half-wavelengths near 12 MHz, the 25-meter shortwave band, and stations near 18 MHz (the 16-meter band) resonate the wire at three half-wavelengths.

Connecting the downlead at a point other than the end may suit a similar purpose. An accompanying sketch shows a wire cut for the 31-meter band, about 9.6 MHz (with a 48-foot, 15.5-meter half-wave). The full length also makes two half-wavelengths for 15 meters. Connecting the downlead 16 feet from the end helps the aerial "divide up." The short section operates on a half-wavelength

near 10 (and 11) meters, and the longer one resonates close to 19 meters.

However, exact aerial length is not always necessary. With many shortwave radios tuning frequencies below 25 or 30 MHz, you can use any reasonable length of long-wire antenna, because they include *trimmer* knobs that tune the antenna electronically. Your receiver instruction book tells what lengths of aerial will suffice. If you only have room for a short wire, or perhaps a telescoping rod, you can add a *loading coil* that makes the antenna electrically longer. The coil compresses some antenna length into a smaller space.

#### Quarter-wave verticals

Most shortwave receiving antennas would work better upright instead of

*(Please turn to page 194)*

IT'S NEW

# NOW



**Latest in flat-screen TV is only 0.63 inches thick, lights with neon**

Next to the television set at far left is a screen that matches its contrast and resolution, but is only  $\frac{5}{8}$  inch thick (see side view, near left). The new panel has the same dot-spacing (shown full size, lower far left) as a 25-inch TV screen, but is only 5 percent as large (full-size screen has been masked off to match it). Though bright enough for viewing in normally lighted rooms, it's dimmer than conventional tubes, glows red instead of white. Developed by Burroughs and adapted for experimental TV use by Zenith, it uses cells filled with neon gas instead of conventional tube's phosphor dots. Cells light at intersection of charged cathodes and anodes.

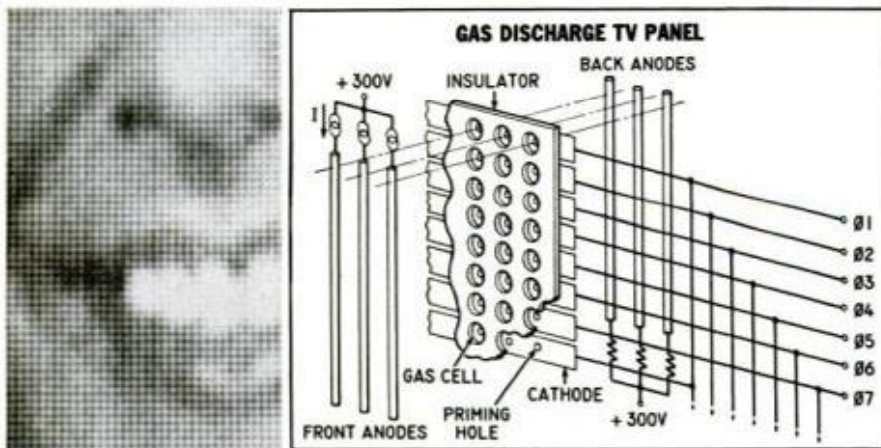

**Go to blazes, they said, and this fire truck does—any way it can get there**

Taking a shortcut up some steps and across a park is this mini fire engine's way of getting to fires quickly without bogging down in traffic jams on main city streets. The Swiss-made truck, currently under test by London's Fire Brigade in England, is deliberately designed to be short and narrow so it can race down side roads, cut through back alleys, squeeze between buildings and turn sharp corners without having to use heavily traveled routes. Special low reduction gearing and a powerful engine enable the vehicle to climb steep grades—up to 45 percent. Equipment includes ladders, a variety of fire-fighting gear, emergency breathing apparatus and two-way radio. Mini or not, the tiny engine holds a crew of four—and they don't have to hang on outside, either.



## THE LATEST PRODUCTS AND DEVELOPMENTS



### Laser sight sharpens repairman's aim

Straightening an accident-damaged car chassis is tricky because it's difficult to tell when a twisted frame has been properly realigned. Now the Swedish firm of AGA in Stockholm has come up with a laser-operated sighting device that makes it possible to check frame alignment to within a fraction of an inch, using the beam as a super-accurate "yardstick" to measure with.



### Hybrid forklift/tractor does many jobs in one

This all-purpose industrial machine not only functions as a regular forklift (bottom above), but takes a variety of attachments for handling barrels and other odd-shaped loads (top). With lift removed, it becomes a tractor for hauling carts, plowing snow and doing other plant chores. To top it off, GE Elec-Trak runs entirely on battery power.

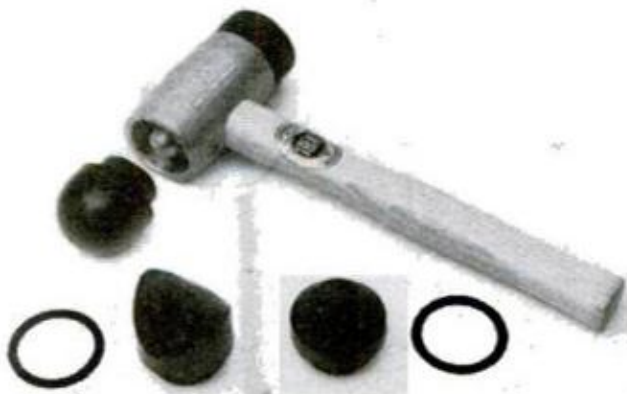

### Soft-faced mallet for a soft touch

You get four screw-in rubber heads for this versatile soft-faced mallet. Shapes include flat, dome, cone and wedge. Three weights are 14 ounces, \$5.99; 1½ pounds, \$6.99; and 3 pounds, \$9.49, all postpaid. Creative Educational Services, Box 663, West Caldwell, N. J. 07006.

FEBRUARY 1973

129



**TV chair entertains you while you wait, but you better have some coins ready to feed it or you'll get only a blank screen**

Novel TV lounge chair at left sports a small, coin-operated television set mounted on an outboard arm so you can while away the time watching your favorite programs during long waits. The manufacturer plans to install the chairs in laundry centers, beauty parlors, airport waiting rooms, hotel lobbies, doctor's offices and other public places where you spend a lot of time doing nothing. They can also be used in schools to bring students educational programs over closed-circuit TV. Not yet announced are chair's price or how many coins it will take to keep you happily occupied. Whisper Aire Corp., 11847 Levan St., Livonia, Mich. 48150. Now if they'd just put one in a dentist's chair . . .

## **Anyone can now hone a chisel or plane iron like an expert**

You can hone a true, square edge on plane irons and chisels the very first time with this clever fixture that holds the cutter at the proper angle as you roll it back and forth over the stone with a figure-8 motion. The accessory accepts blades up to 2½ in. wide. You can get one for \$3.55 plus postage from Brookstone Co., Peterborough, N.H. 03458.

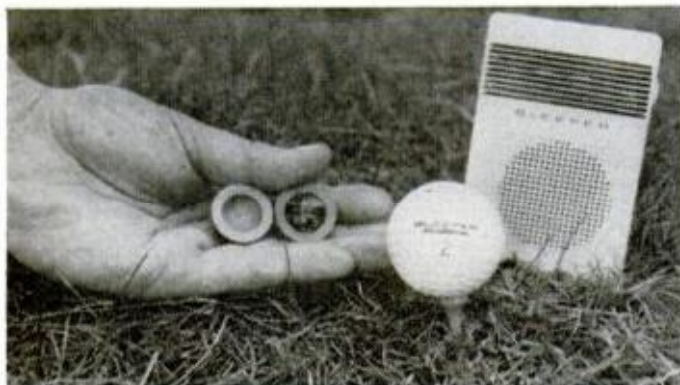
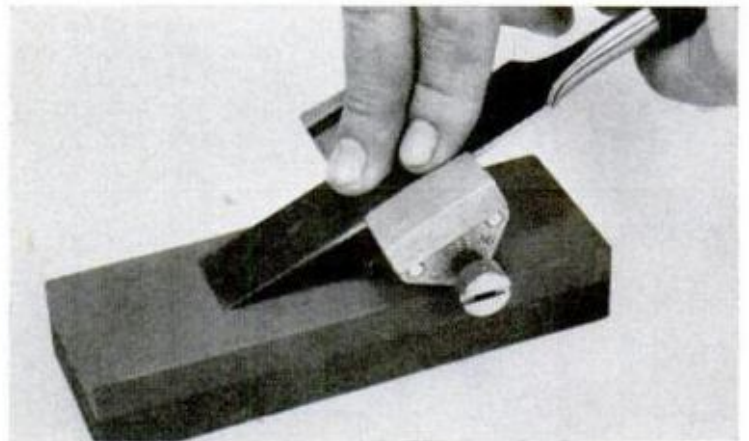

## **Lose your golf ball? Just follow its beeps and you'll find it**

A tiny transmitter inside this new golf ball sends out beep signals picked up by a pocket receiver you carry with you. If you land in the rough, the ball is easily found by following the beeps as they become louder and louder. A British invention, the "talking" ball is not yet on sale.



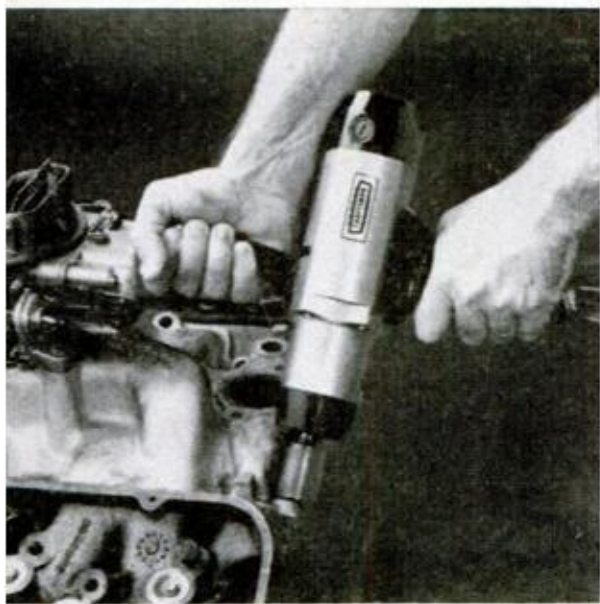

**Electric impact tool does work of air-driven one**

Double-insulated for greater safety, Sears' new square-drive impact tool can perform jobs done by air-driven models. Heavy-duty, 1/2-hp motor operates on forward or reverse with ball and roller-bearing drive. Features adjustable torque and speed trigger. About \$80.



**Fingers too big? Use these long-nose tweezers**

Anything hard to reach is easy to get at with these giant (10-in.-long) stainless-steel tweezers. Indispensable for chassis and other intricate assembly work, they have slender tips with rounded ends and serrations for a sure grip. \$4.85. Brookstone Co., Peterborough, N.H. 03458.

FEBRUARY 1973



**Speeding? Well, at least you can't say they didn't warn you**

If you get a speeding ticket after going through this maze of warnings, you have only yourself to blame. In addition to prominently posted speed-limit signs, a big radar-controlled speedometer-like dial shows your exact speed as you approach. Los Angeles police, testing the device, report it really impresses the motorists.

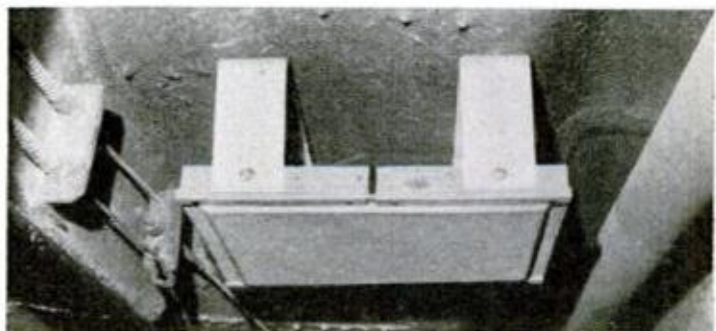

**Nonstop toll-taker speeds bridge traffic**

Cars crossing San Francisco's Golden Gate Bridge may no longer have to stop to pay a toll—they'll just roll over an electronic detector and be billed later by mail. To identify itself, each car is fitted with a device underneath (above) that reflects a keyed signal back to the detector. The system is designed for regular bridge users such as buses and commuting drivers.

131



## Computer and laser make paint-by-number personal paintings from favorite photos

If the only way you can paint is "by the numbers," you no longer need restrict yourself to landscapes, clowns and flowers. Now you can paint your own family (or any other subject of your choice) that way. In a new process, a computer analyzes any color photo or slide, then a laser prints it as a series of numbered color zones on 16x20-inch paper. The computer also determines which 40 or so of 100 available colors are needed and packs them with the picture, instructions, brushes and practice panel. "Personal Paintings" are \$19.95 from Craft Master Div., General Mills, Box 123, Toledo, Ohio 43695. Delivery takes three weeks. Itek developed the "Chroma-Guide" process.



## Quickie kit-built R/C sailplane

It's big, but easy to build. This powered, radio-controlled AS K14 model has a whopping 90½-inch wingspan and fully operating control surfaces. \$159.98. General Hobbies, Philadelphia.



## It may scare you stiff, but it will take you anywhere

Riders cringe in terror as this strange contraption plunges over a cliff edge to apparent destruction. Actually, it's so completely articulated it can cling to and climb over virtually any terrain. Each wheel moves up and down independently, and swivel-linked front and rear sections can be hydraulically "jackknifed" to straddle ridges and gullies. Inventor Ken Wallar of Miranda, Calif., hopes to find forestry and military uses.



### Jet-propelled swimming: Just hang on and away you go

If you like your swimming both fast and lazy, this jet-powered Swimobile will pull you along at speeds up to 15 mph—all you do is hang on. A 5-hp engine drives twin jet pumps, eliminates hazardous prop. \$329.50. Hammacher Schlemmer, 147 East 57th St., New York.

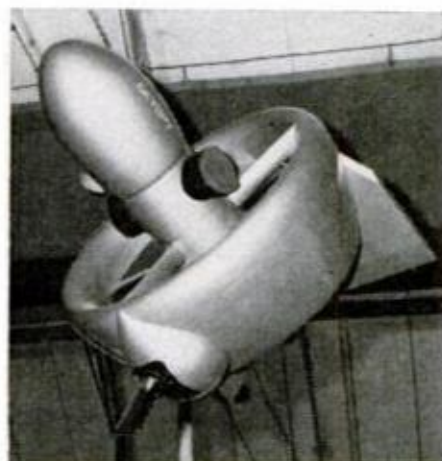

### TV eye spies in the sky

Almost literally an eye in the sky, this pilotless hovercraft can "park" over a battlefield, send back television pictures of enemy activity. The British-developed "Skyspy," only three feet wide, is virtually invisible to enemy ground gunners.



### 3-in-1 tubing cutter works in tight places

Made of hardened and tempered tool steel, this handy tool not only cuts tubing and reams it, but its handle serves as a wrench to loosen the valve on all standard propane-gas cylinders. Three cutting wheels will cut aluminum, copper, brass and plastic tubing from  $\frac{3}{16}$  to  $\frac{5}{8}$  in. o.d.. For convenience, the tool requires only 120° turns to cut tubing in tight spots. Sells for \$4.98 from Kastar, Inc., Bellport, N.Y.



### The first hers and his tool set

Women aren't supposed to know the difference between a jigsaw and a coping saw. But these days a lot of them do, so X-acto has created two new tool sets designed to appeal to a woman as well as a man. Each kit, (one for \$18.75, deluxe type for \$27.50) comes in finished tray that can sit in drawer. X-acto, 48-31 Van Dam St., Long Island City, N.Y. 11101.



**Combination seat belt and air bag protects you two ways—if one doesn't work, the other may**

This inflatable seat belt not only restrains you in the conventional way (far left), but it blows up in a crash (near left) to provide the added protection of shock-absorbing cushioning. Under development by Allied Chemical Corp., the double-duty device is designed to combine the best features of seat belts and air bags. Belt inflates instantly on impact by an inertia-triggered compressed-air cartridge.

**If it sticks, slips, squeaks or shorts, Kure-Kit will take care of it**

Packaged in a handy carrying case, four spray cans provide you with silicone lubricant, belt dressing, moisture repellent and penetrating oil. The moisture repellent produces a waterproof film barrier, the belt dressing dries clear, the penetrating oil cleans as it penetrates, the silicone lubricant makes anything slide easier. Price: \$5.80 postpaid, L.H. Shingle Co., 1300 Walnut St., Camden, N.J. 08103.

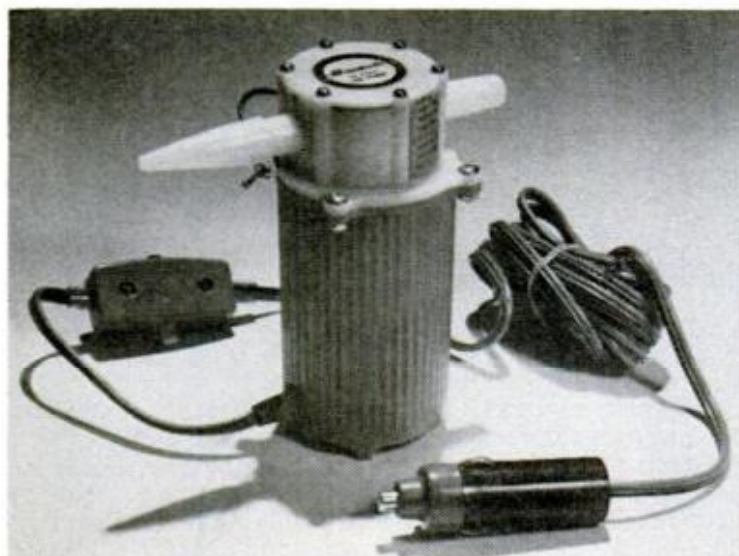

**Air pump takes the huff and puff out of blowing things up—and down**

Specially designed for low-pressure inflatables such as air mattresses, wading pools, beach toys and furniture, the Goodwin air pump and exhauster has a regulated compression valve to prevent overinflation. Powerful 12-volt motor plugs in any car or boat cigaret-lighter socket, comes with 10-ft. cord, lighter plug, on-off switch, two plastic nozzles. \$9.95 postpaid from Glen-Bel Enterprises, Dept. PM, Route 5, Crossville, Tenn. 38555.

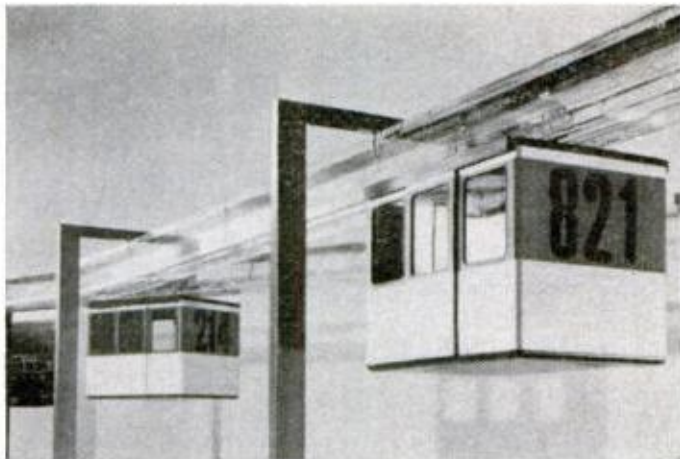

### **New computer-controlled rapid-transit monorail system practically thinks for itself**

If you think you've seen 'em all, here's a monorail with a few surprises. Developed by the German firm of Siemens in Munich, it consists of small passenger pods whizzing along an overhead track completely controlled by computer. The computer automatically switches pods to different destinations, adds cars as traffic demands them. You just tell the computer where you want to go and it will get you there.

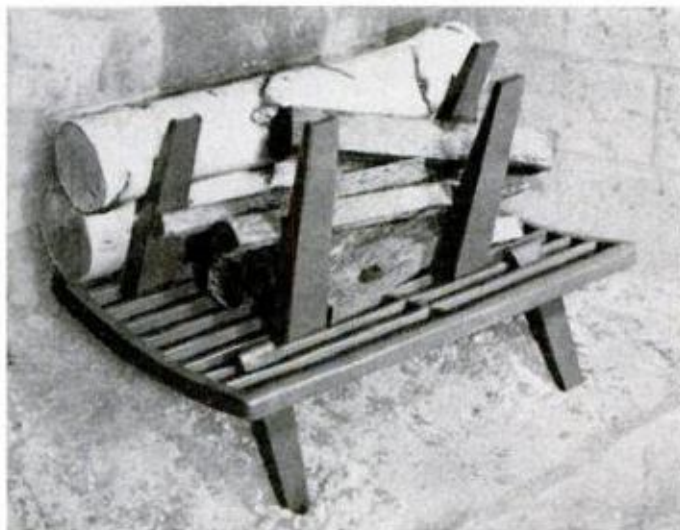

### **New-type fireplace grate cures most smoking problems**

Adjustable log supports in this unique grate let you build fires far to rear of your fireplace where there's better draft, greatly reducing smoldering and smoking. Logs can't roll out. \$25. Garden Way Research Associates, Box W-116, Charlotte, Vt. 05445.

FEBRUARY 1973

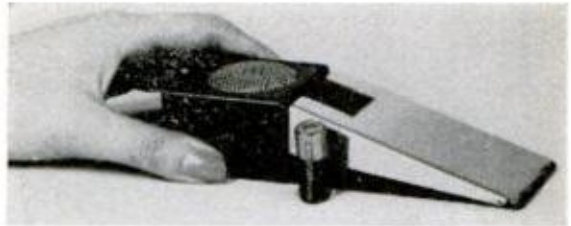

### **Take-it-with-you burglar alarm**

You can carry this portable battery burglar alarm with you for use on any door. Wedged underneath, it jams the door from opening, also sounds a high-pitched warning beep. \$5.95. Mallory Battery Co., Tarrytown, N.Y.

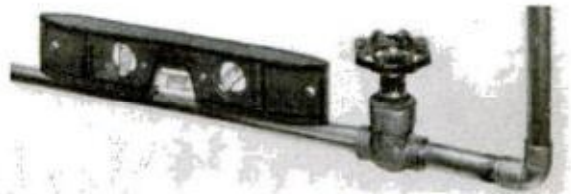

### **Pocket level stays put**

Stanley's new 7-in. torpedo level has a magnet along one edge to hold it to any flat steel surface and a V-groove along the other to make it stay put on water and electrical pipes. Has replaceable vials; \$4.15.

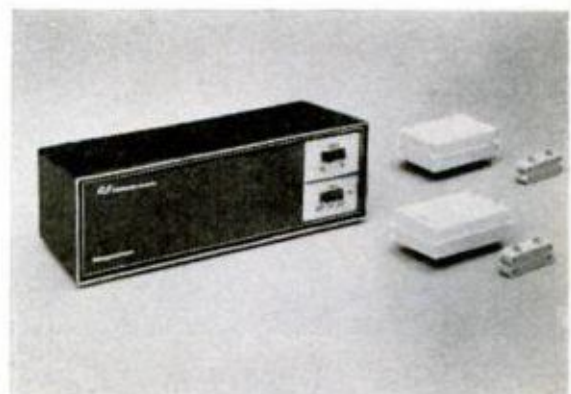

### **Four aids to protect your home**

Four new home security systems are especially designed by Magnavox for do-it-yourself installation. There are two sensor types for guarding doors and windows, electronic motion detector, and fire and smoke alarm.

135

# NOW

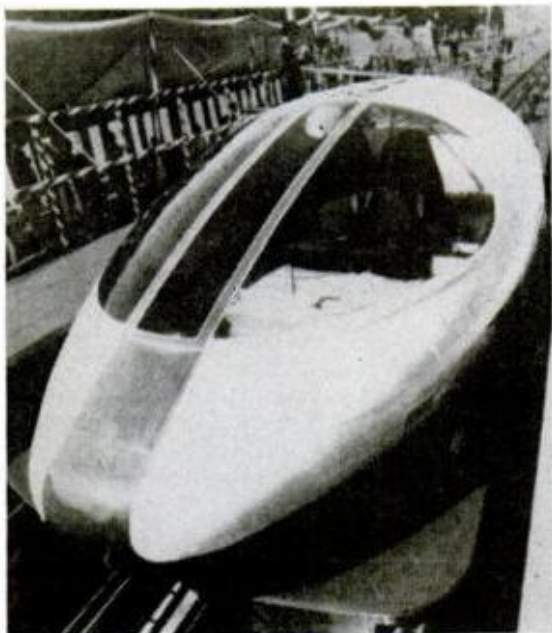

**If this is just a sample,  
watch out for the real thing!**

Powered by a linear motor, the sleek rail car above is a 1/5-scale prototype of a new high-speed Japanese transportation system. In effect, the rails are the motor's "stator" and the moving car the "rotor." The model is 23 feet long and has hit 40 mph in tests. At this rate, the full-size version will be 115 feet long and may reach 200 mph!

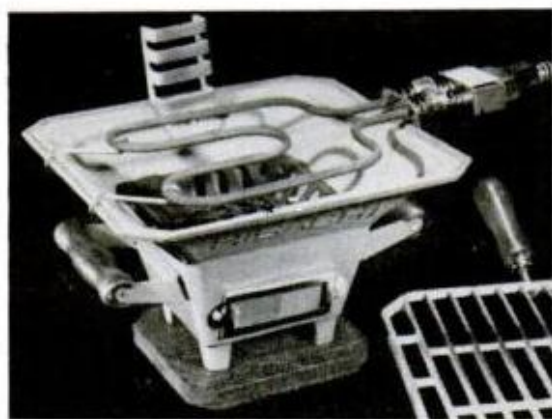

**Hibachi for all seasons**

Now you can have year-round Hibachi cookery with a plug-in convertor that lets you switch from charcoal to electricity for indoor use. Hooks across any standard 10-in.-sq. hibachi. With convertor, hibachi retails for \$12.95; convertor alone, \$6.95. Noma-World, 3838 West 51 St., Chicago, Ill.

136



**Dual-control chainsaw—first of its kind**

Heretofore all chainsaws have had just one trigger, but Homelite's new XL-2 (12-incher) has two, a front and rear one. The front trigger is used for close quarters and tricky angles, the rear one for firewood cutting, pruning and felling. Both provide firmer control and greater leverage. \$119.95 at Homelite dealers.



**New epoxy sealant ends basement leaks**

Zap, a two-part formula used by professional waterproofers, is now packaged for home use. It brushes on, dries quickly, withstands water pressure of two tons per sq. ft. Great for licking leaks in basement walls and swimming pools. Half-gallon kit (\$13.95) covers 100 sq. ft. Construction Chemical Corp., 39 Ross St., Danbury, Conn.

**POPULAR MECHANICS**

**What will they think of next—  
an 8-ft. toboggan  
you can roll up**

Cold, numb fingers tying the old wooden toboggan to the cartop are a thing of the past. This one of polyethylene can be rolled up and carted to the hills in a car trunk. Called Sliding Machine, it's made of a very smooth material having a paraffin base that never needs waxing. It's available in 6 and 8-ft. models at \$27.95 and \$31.95 f.o.b. A snowmobile tow bar and 2-in.-thick vinyl pad are optional accessories. Write International Corp., 1442 East Outer Drive, Detroit, Mich. 48234.

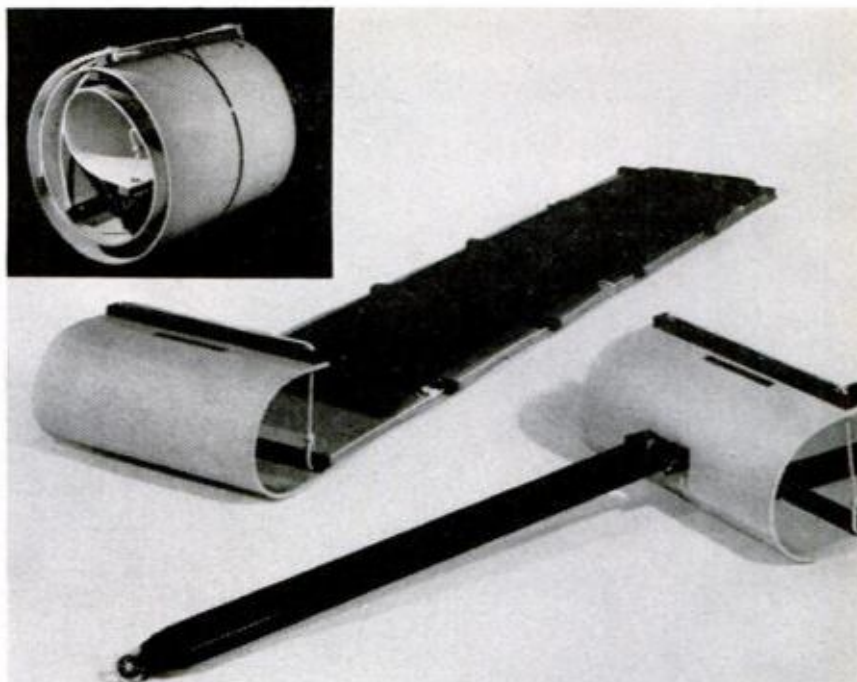

**Small speakers get  
big sound from  
built-in amps, feedback**

These speakers have built-in, 15-watt power amplifiers with direct feedback links that sense speaker motions. When the motions (and, therefore, the output signal) don't match the input signal, the feedback comparator circuit feeds the amplifier a correction signal. According to the manufacturer, this circuit also corrects for the effects of speaker enclosure resonance on frequency response, allowing flat response from an enclosure only  $7\frac{1}{8} \times 11\frac{1}{8}$  inches. The speaker/amplifiers, which cost \$160 each, can be used with any preamplifier, tuner or tape deck with a volume control. The preamp shown above them is \$160 separately, \$400 with two speakers. Servo-Sound, Route 222, North Ephrata, Pa. 17522.

FEBRUARY 1973



**Old tires never die—they just become grass**

Well, they've finally figured out what to do with old auto tires. Goodyear Tire & Rubber Co. of Akron, Ohio, grinds them up into tiny shreds, mixes the particles with a green-colored latex binder and out comes—you guessed it—rubber "grass." A roll of the new artificial turf is shown above being laid down over a playground test area to check its durability under rough use.

137



## Parking indicator warns cars behind you're about to stop

Many rear-end collisions occur when a car signals to pull over and park. The following car, assuming the driver plans to turn at the next intersection, is caught off guard and is often unable to stop in time. This British Park-O-Matic indicator leaves no doubt about a driver's intentions. Mounted inside the rear window, it has two separately illuminated arrows that read "Park," one pointing left and one right. When a driver wants to park to the right, he simply flips on the right-hand arrow. About \$7. Tragonic Sales, 112 Pkwy., London N.W., 17 A.N.

## The blind can hear what they can't see in this audio meter

You don't have to see to "read" this VU meter used in controlling sound levels. Designed primarily to aid blind console operators in recording and broadcasting studios, the special instrument generates an audible tone whenever a monitored signal exceeds the desired volume. The tone varies in frequency according to the amount of signal variation so an operator can easily tell by ear how much the level is off and what adjustment is needed to bring it back to normal. The Audible VU-Meter was developed by Acoustics and Magnetics, a CBS subsidiary.

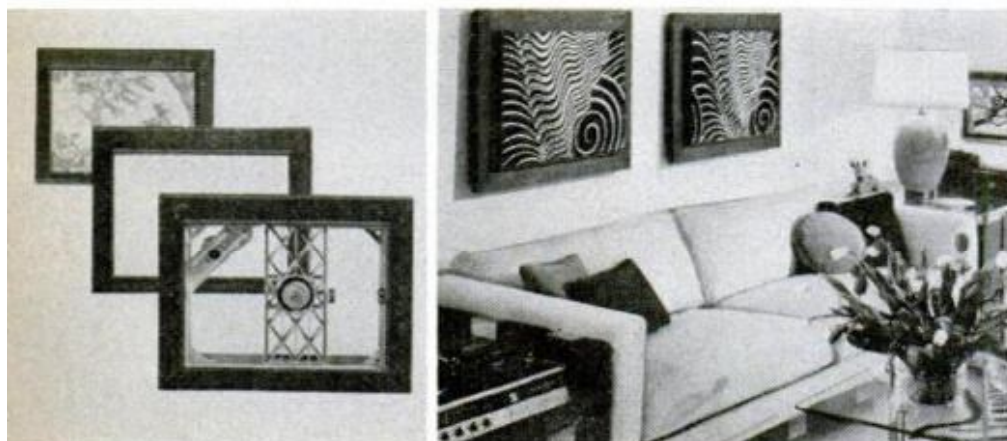

## Wall-hung stereo speakers look like colorful pictures

They look like pictures, but are actually speakers. The slim panels, less than three inches deep, provide both woofer and tweeter and come in eight scenic and abstract patterns. \$138 each. Accessory floor stands also available. Fisher Radio, Long Island City, N.Y.





### There's nothing worse than cold pizza

Pizza has to be kept hot from the start, and the Salton Hot-Pizza Keeper keeps every slice hot and flavorful for hours. Its thermostatically controlled tray is perfect for hot hors d'oeuvres too. \$14.95.

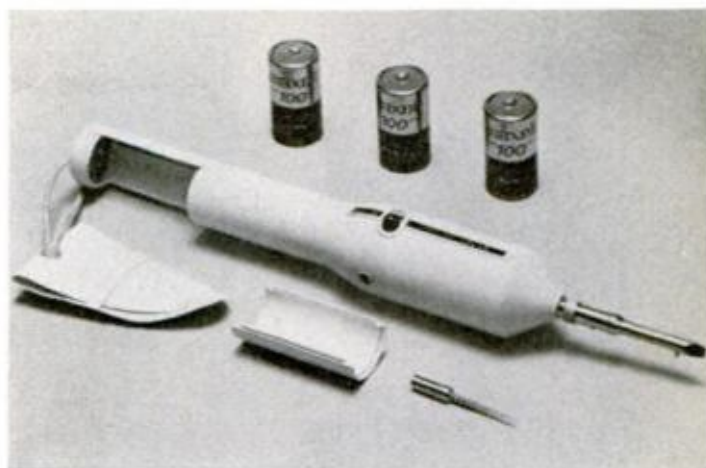

### Cordless reversible screwdriver

Operating on three flashlight batteries, this powerful no-cord screwdriver will either drive screws or back them out by its two-way switch. Comes with standard and Phillips blades, plus a wood bit. \$10.70 postpaid. Honor House, 35 Wilbur St., Lynbrook, N.Y. 11563.



### One-piece abrasive wheel fits any contour

San-Buf is a sanding-buffing wheel that comes with 12 groups of nonreplaceable abrasive-coated fabric strips anchored in a plastic hub. The strips conform to contours as the wheel spins, and when the strips are worn out, hub and all are thrown away. The wheel can be used in a portable drill, drill press, lathe or flexible shaft, and is particularly useful for cleaning corrosion from metal house gutters, car bodies and other nonflat surfaces. Tool comes in three grits—coarse, medium and fine—and is \$2.98. Ali Industries, Inc., 235 Glaser St., Fairborn, Ohio 45324.

FEBRUARY 1973



### No, operator, I'm just calling my furnace at home to ask it if it's okay. Doesn't everybody?

With this thermostatic monitor by your phone, you can call home and find out if your heating system is working properly, eliminating the chance of costly damage from freezing, bursting water pipes in case of a furnace breakdown. The device plugs easily in between your phone and wall jack and in no way affects normal phone use. If house heat has fallen below a preset temperature when you call, you hear a warning beep, telling you to hurry home. If all's well, the phone just rings—and you're not even charged for the call. \$59.70 postpaid. Atrion Industries, Box 100, Carle Place, N.Y. 11514.

139

La Belle Professional 88, \$154.95



GAF Anscorama 980, \$174.50



GAF 1680  
\$99.95



Kodak Carousel 850H, \$204.50



Rollei P37A, \$149.50

## Slide projectors get

By **BURT MURPHY**, /Photos by the author

**S**LIDE SHOWS are getting more creative nowadays, and the projectors can claim a great deal of the credit. When you don't have to feed slides one by one into a carrier, refocus each slide as the lamp's heat makes it pop, and simultaneously worry about a running commentary, you can concentrate on putting a good show together. But as projectors get smarter, so must you, to make sure you get the one that suits you best. Here's a summary of the more common buypoints, to help you select the right model:

*Slide-handling devices* for automatic projectors come in three forms: rotary, straight trays and stack loaders.

*Rotary trays* usually offer the least expensive way to store slide shows—about 3 to 4 cents per slide—but they're also the bulkiest, wasting space in the middle of the circle and at its corners.

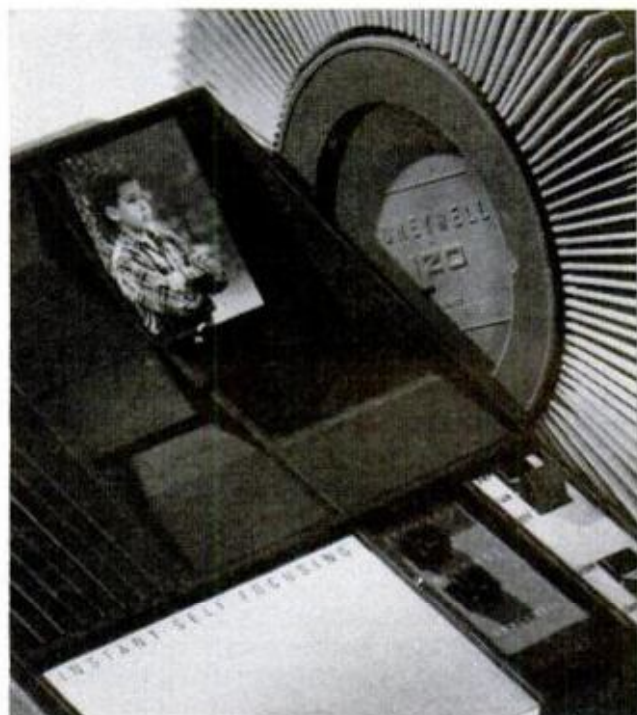

**PREVIEWER** on Honeywell shows you what slide is coming next, and whether it's right-side up or not

POPULAR MECHANICS

Airequipt 670, \$149.50



Honeywell Preview 620, \$144.50

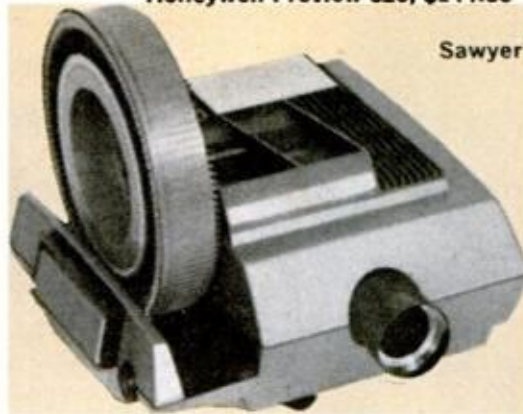

Sawyer's 747AQ  
\$177.50



Sawyer's Grand Prix 570AF  
\$124.95



Bell & Howell Slide Cube 977Q  
\$119.95



Cavalier 1001, \$74.50

## smarter all the time

*Straight trays* cost more (about 6 to 7½ cents per slide (though Bell & Howell Slide Cubes cost only about 1¼ cents per slide, and La Belle trays hold slides for less than 1½ cents each). But they're a much more compact storage medium (especially Slide Cubes, which hold 640 slides in about the same space as a single round tray). Short trays let you arrange your slide shows more flexibly and gauge their length to your audience's enthusiasm: After you finish a tray, you needn't insert another unless they ask for more.

*Stack loaders* (about \$6 to \$10) are quick editing devices; you don't have to load slides one by one as you do with trays—just dump in a stack and run them through to cull the bad ones. But you can't run the slides through backwards as you can with most trays.

Knowing which slide-handling options you need will help you pick the right projector. By and large, projectors that

use upright, Ferris-wheel-type rotary trays take straight trays and loaders, too. Projectors with horizontal, merry-go-round trays usually take stack loaders, but no straight trays. And units with upright straight trays, like the Slide Cube and La Belle, take no rotary trays, but their trays can double as stack loaders.

*Editing ease* is worth looking for, too. Some projectors make it easy to remove and replace slides in mid-show (handy, if a slide is accidentally out of sequence or inverted). Others make it just about impossible. And a few, such as the Honeywell Preview and Bell & Howell Slide Cube projectors, let you see each slide just before showing it, so you can correct errors before the audience sees them.

*Autofocus* keeps your slides in focus if the projection lamp's heat warps them out of focus, or if you mix different slide mounts that hold the slides in slightly different planes. But it adds about \$30

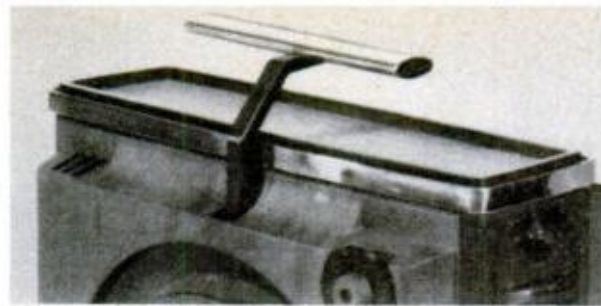

**SLEEK STYLING** of Kodak Custom Carousel lets you leave projector out in plain sight without disturbing room decor. Handle (above) folds down when not in use, plastic dust-cover snaps on, and doors cover both lens and remote-cord storage compartment. Power cord wraps around base, leaving only slide tray to be stored. Bell & Howell projectors are also furniture-styled, but are shaped as wood cubes

or \$40 to the cost of your projector, so before you buy, see whether the manual-focus version of the projector you want does make slides pop (some projectors pre-warm each slide before projection to prevent this) and to see how swiftly, silently and accurately the autofocus does its job. (Autofocus systems that grind noisily back and forth for several seconds before settling down are more annoying than the disease they're meant to cure—check this in the store.) A few projectors let you shut off the autofocus system.

*Remote control* is often a more useful, if more expensive (\$25-\$60), option. Some remotes just advance slides, others let you review previous slides, too, and still others adjust focus, too, walking as close to the screen as the cord permits for maximum focusing accuracy. Almost all remote-control projectors can also be operated by slide-change signals recorded, with your narration, music and sound effects, on tape (see *Liven up your slide shows with sound*, page 126, Nov. '72 PM). Another way to control slide advance is with a timer that triggers a new slide every few seconds. But since different slides normally require different viewing times, it's rarely worth the \$15 or so it usually costs.

*Brightness* depends not only on the bulb wattage and the f-stop of the lens (which you can determine from the spec sheets), but also on the design of the optical system (which you cannot so determine). A projector with the usual 500-watt lamp and f/3.5 lens may be as bright as one with a more powerful bulb or faster lens—or may not be as bright as others in its own class. So check before

you buy. Some projectors have lamp dimmer switches, which let you use the lamp at less than its full wattage. This lengthens lamp life, gives warmer colors (which you may or may not want, depending on the subject), and makes overexposed slides look less washed out. Many projectors also let you run the cooling fan awhile after switching the lamp off; cooling the lamp this way before you move the projector lengthens the lamp's life. Another way to lengthen lamp life is to buy a projector with a quartz-halogen (or quartz-iodine) lamp; such bulbs cost twice as much, but have twice the rated life of normal bulbs and don't dim or change color as they age.

*Lenses* on most projectors have 4-inch focal lengths, which fill the average 40-inch screen with a 35-mm frame from a distance of about 10 feet. But if you show a lot of 35-mm half-frame slides, or must keep your projector less than 10 feet from the screen, you'll need a short-

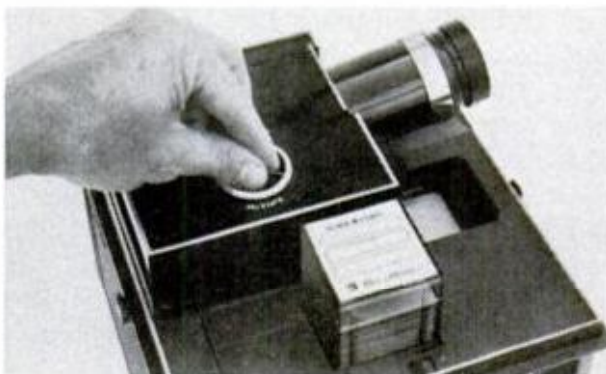

**TILTING LENS** aims Bell & Howell Slide Cube projectors up at screen, takes less effort than tilting entire projector. Note preview window next to lens

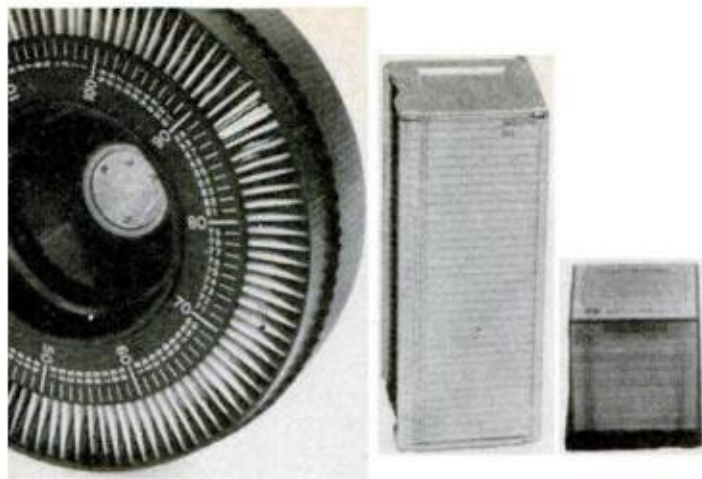

**IN SAME SPACE** as 80 to 140-slide round tray, four 40-slide trays can hold 160 slides; 16 Slide Cubes, 640

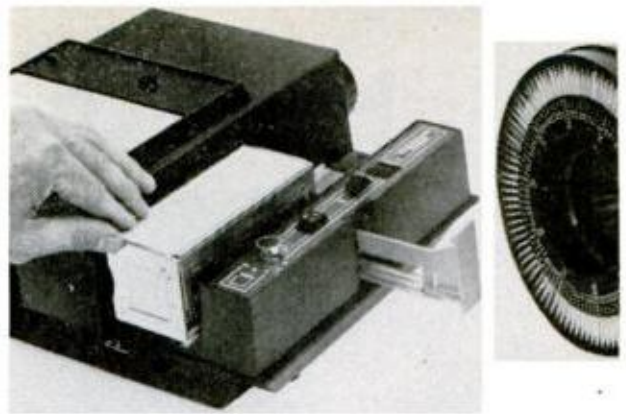

**AIREQUIPT** and other projectors take both round and flat trays, so you can plan your shows more flexibly

er lens; if you show many 126 instant-load slides or 127 Super Slides, or if you'll be projecting across an extra-long room, you'll prefer a longer one. If you intermix several slide sizes, or use your projector in several different-sized rooms, you might want to spend the extra \$30 or so for a zoom lens.

Other convenience features include outlets that turn a lamp off when the projector is on, and *vice versa*, side-to-side leveling adjustments, and slide-storage compartments in the projector case. Some projectors make standard features more convenient, too, as La Belle, with its quick-release projector tilt (and Bell & Howell, with its tilt that elevates the lens instead of the entire machine), or the Anscorama, Cavalier and Honeywell, whose remote controls double as built-in control panels when remote use isn't required.

Some projectors have built-in storage compartments for remote and power

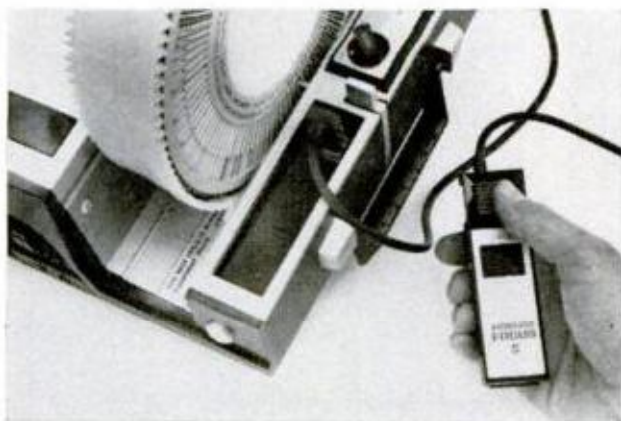

**REMOTE SLIDE ADVANCE** and reverse control on this Sawyer doubles as projector's own control panel. Autofocus projectors usually lack remote focus

FEBRUARY 1973

cords (with power-cord retracting reels, on such machines as the GAF Anscorama and Sawyer's Rotomatic 747AQ), which speed up the task of putting the projector away after each show. But wood-grain styling and covers for both lens and changing mechanism on the Kodak Carousel Custom and Bell & Howell Slide-Cube models turn them into handsome boxes that can be left in plain sight—so you don't have to put them away at all. The same might be said of the sleek, modern styling of Rollei's P37 Autofocus, though its design leaves no doubt that it's a slide projector.

All of the points we've covered so far can be learned from manufacturer's spec sheets. But before you make your final selection, make a few simple checks in person, at the store. Listen to the projectors you're considering, and see if you find their noise annoying. Pick them up by their handles, and check them for weight, balance and handle security (the handle should be part of the projector, not part of its lid); if you have to store your projector on a high shelf, try lifting it above your head, too. See how long it takes to load a box of slides into a tray, and whether the slides will stay securely there, with no danger of spilling. Crumple a cardboard slide, then smooth it out with your hands and run it through the projector, to see how jam-resistant it is: If it does jam, see how easily the jam can be cleared. And compare how two projectors, side by side, project two similar slides—see which is sharper and brighter, how long the focus holds before it drifts, and how long it takes the autofocus (if any) to correct it. ★★★

# How to stop an engine

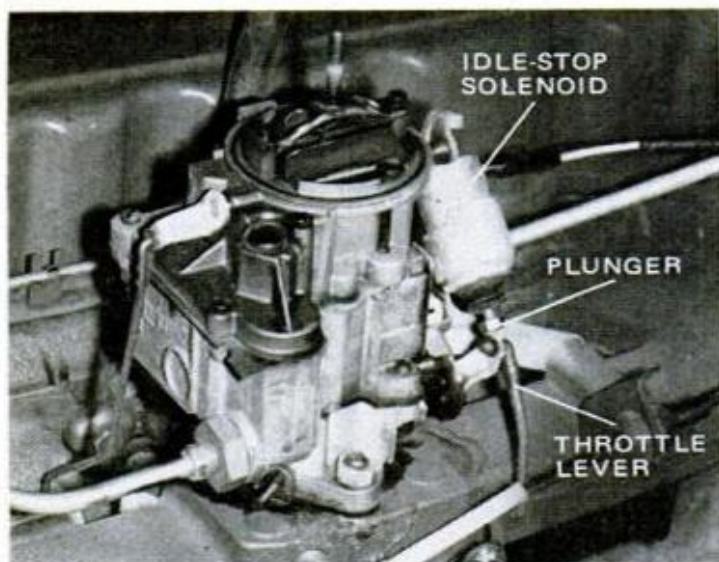
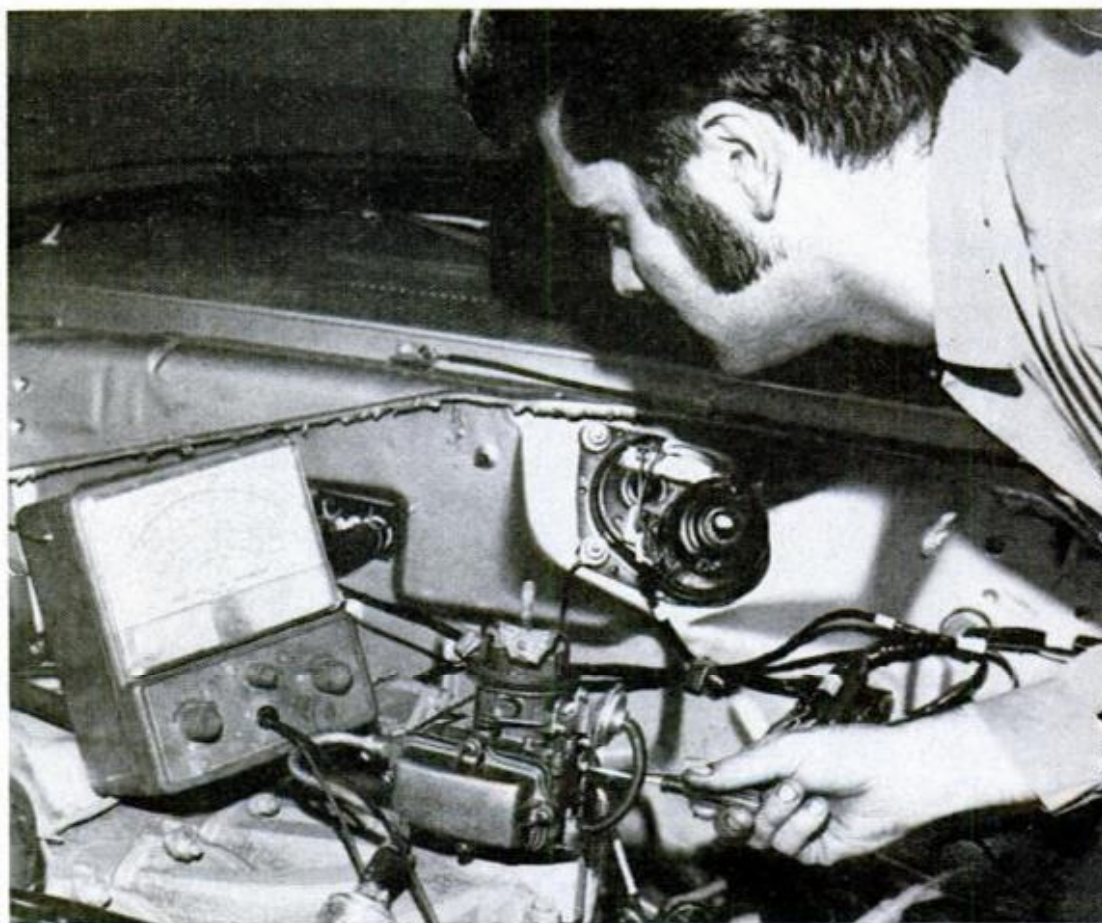

**FAST IDLE** and curb idle speeds should be set at the carburetor using a tachometer (top) to meet manufacturers' specifications exactly. While engine idles, plunger of the idle-stop solenoid (above) is against the throttle lever. When the engine is turned off, plunger should retract. Adjust the hot idle speed by turning plunger (right)



# that won't stop

**A**N ENGINE THAT WON'T START is annoying, but it doesn't scare you. The same can't be said for an engine that won't stop when the ignition key is turned off. It has alarmed many drivers.

The condition is commonly referred to as "dieseling," and is also called "run-on" and "after run." Although frightening, it is not harmful, according to Champion Spark Plug Co. "Engineers are pretty well agreed that the condition, so far as research has been able to determine, does not damage the engine."

Still, it isn't normal for an engine to sputter for several seconds after switch-off, and the vibrations can be fierce.

Dieseling is ignition in the absence of spark. It occurs when fuel in the combustion chambers is ignited by heat.

The problem is particularly common to 1968 and later models that have engine idling speeds set higher than in previous models. Higher engine idling speeds are needed to prevent rough idling that could be caused by the leaner fuel mixtures required to reduce exhaust emissions.

The increase in engine idling speed gives unburned fuel a greater opportunity to enter and remain in the cylinders when the ignition is turned off. The only thing needed to cause dieseling, then, is heat to ignite this unburned fuel.

Present-day ignition timing settings contribute some of the heat. To compensate for the lean fuel mixture, which burns more rapidly than a rich fuel mixture, timing is more retarded than in previous models; that is, it is set to occur later, closer to top dead center (TDC).

Because spark does occur later in the combustion cycle, the period of time heat has to escape is reduced. Thus, some heat is retained in the cylinders.

Some drivers think that dieseling can be prevented by readjusting the idle mixture (making it richer) and advancing the timing. This should not be done, because it defeats antipollution efforts.

Idle mixture screws of late-model cars have caps over them to prevent anyone from readjusting the mixture to an excessively rich condition. Removing the caps is illegal unless it is done to readjust the mixture in order to

'Round and round she goes,  
and where she stops nobody  
knows . . .' Don't gamble  
that your engine won't shake  
right off its mounts: Stop  
that dieseling condition now!

By **MORT SCHULTZ**

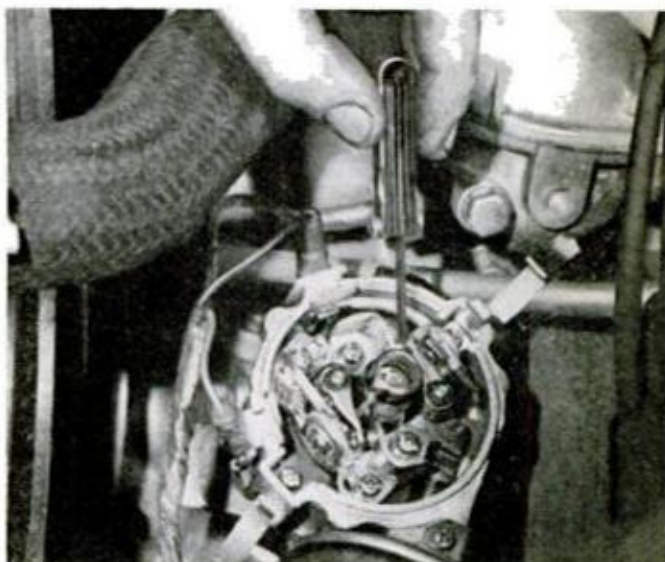

**CHECK FOR DIESELING** should include general tune-up procedures like setting distributor-point gap with a feeler-gauge. Gap should be set while checking the point dwell angle

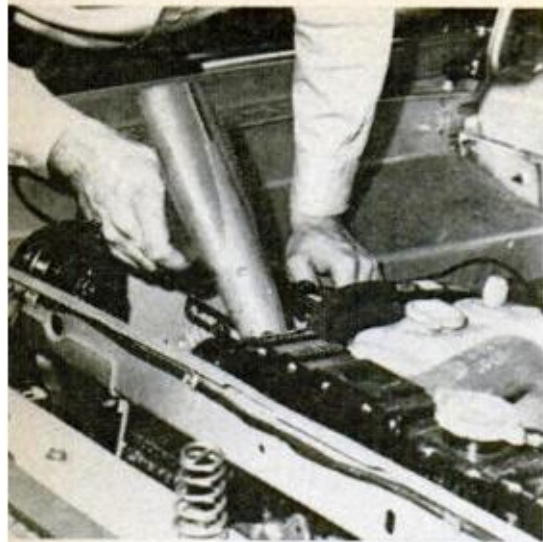

**IGNITION TIMING** should be checked with a timing light (top). Sight directly down center of the light to the timing marks on the pulley or vibration damper. Periodically clean and check the carburetor linkage and choke area. Dirt or a damaged linkage could keep throttle slightly open which would increase the chances of dieseling

bring it into line with emission standards. Once the re-adjustment is done, the law states that new caps must be placed over the idle mixture screw(s).

Another source of heat that helps to ignite unburned fuel in the combustion chambers comes from the higher temperatures at which modern engines operate for more efficient performance. Most cooling system thermostats are set to open when coolant reaches 195°F.

In addition, more and more engines are running on lower octane fuel. Lower octane fuel burns hotter than higher octane fuel, so this too contributes to the high temperatures present in the combustion chambers.

Cars with automatic transmissions are particularly susceptible to dieseling. Before a driver switches off the ignition, he usually places the transmission selector level in **PARK** or **NEUTRAL**. This takes a load off the engine and causes an increase in idle speed, giving unburned fuel a greater chance to enter the combustion chambers.

One method that helps prevent dieseling in cars with automatic transmission is to shut off the ignition with the transmission selector in **DRIVE**. Be sure the parking brake is set and your foot is solidly placed on the brake pedal.

Some drivers of cars with manual transmissions have found that stalling the engine by engaging the brake and releasing the clutch with the transmission in gear has prevented dieseling. Another operational trick to try is to let the engine idle for several minutes before shutting off the ignition following a long, high-speed trip. These, of course, are temporary measures that can be used until the problem is corrected.

Naturally, not every post-1968 car diesels. However, the problem is widespread enough to cause concern.

The step taken by manufacturers to eliminate dieseling has been the addition of an idle-stop solenoid on some carburetors, especially in those cars with automatic transmissions. The purpose of the solenoid is to let the throttle close when the ignition is shut off, preventing excessive fuel from entering the cylinders.

When the ignition is turned on, a solenoid coil is activated. This drives a plunger against the throttle lever and sets the throttle valve to provide an adequate idling speed. However, when the ignition is turned off, which de-energizes the solenoid, the plunger retracts. This closes the throttle valve.

If your car is dieseling and it has an idle-stop solenoid, the first thing to do is observe the operation of the plunger as the engine is started and turned off. If the plunger doesn't come against the throttle lever with the engine idling and doesn't retract as soon as the ignition is turned off, there is a malfunction or the idle-stop solenoid isn't adjusted properly.

The importance of setting an engine to the idle speed and ignition timing settings recommended by the manufacturer cannot be overemphasized. They must be set perfectly to minimize the chance of dieseling.

Don't confuse engine idle speed, which is also called



curb idle speed or hot idle speed, with the fast idle setting. The fast idle adjustment is made with the engine cold by adjusting the position of the fast idle screw on the fast idle cam. The fast idle speed permits the engine to warm up quickly.

The curb idle speed is set with the engine at normal operating temperature. This means that the engine should be permitted to warm up for about 30 minutes before the adjustment is made.

The curb idle specification for your car, if it is a post-1968 model, is printed on a decal in the engine compartment.

Unlike the old days when every carburetor was set pretty much the same way (an experienced mechanic could do it by ear), you now need the instructions of the manufacturer to set curb idle properly, because adjustment methods differ from one carb to another.

Some models with airconditioning, for example, require that the airconditioner be turned on while the adjustment is being made. Other manufacturers want the airconditioner off. Some manufacturers require that the carburetor air cleaner be in place. Others want it off. Some manufacturers want the transmission in DRIVE, while others want it in NEUTRAL; and some want the headlights on to load the engine with the charging alternator.

The curb idle of cars with idle stop solenoids is usually made by adjusting the plunger of the solenoid. In cars without an idle-stop solenoid, the setting is made by means of a conventional idle speed screw.

Ignition timing should be set with a power timing light after distributor breaker points are adjusted. The relative position of the timing indicator in respect to fixed marks allows you to determine the timing setting. The timing light is connected to the ignition system—normally to No. 1 sparkplug. The other leads are hooked to the battery.

If the indicator is aligned correctly, the timed pulses of the timing light will make the indicator and the timing mark appear stationary. If there is wavering, timing is not set properly and should be readjusted.

To do this, loosen the distributor housing and turn it. Turning the distributor against the rotor rotation retards timing. After tightening the housing, recheck timing with the timing light.

Any mechanical hangup that allows excessive unburned fuel to enter the cylinders or permits an increase in engine heat could make the difference between having or not having a dieseling condition. One such problem is a carburetor linkage that is dirty and sticking, and is keeping the throttle from closing.

Another contributor to dieseling is a driver who keeps his foot on the accelerator pedal as he turns off the ignition key. This, of course, keeps the throttle open wider than necessary.

A manifold heat control valve stuck in closed position will trap hot exhaust gases in the engine. Be sure the

*(Please turn to page 198)*

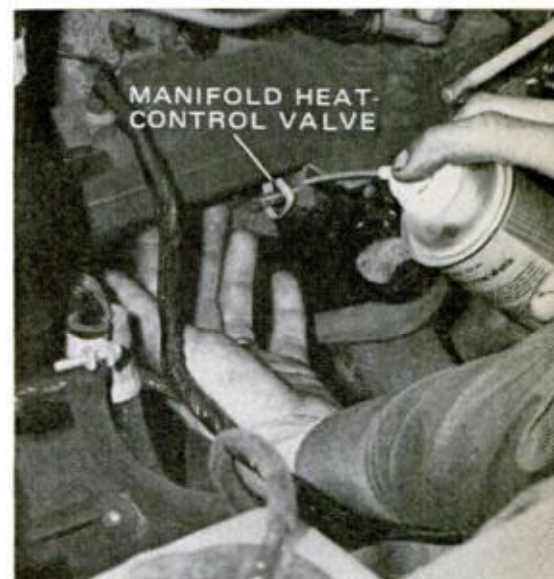
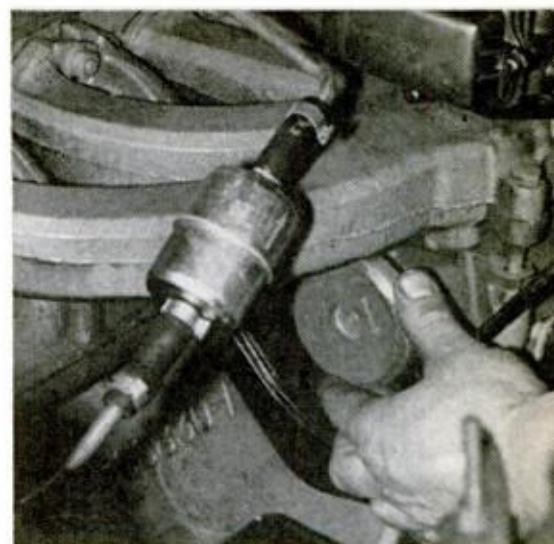

**MANIFOLD HEAT CONTROL** valve can be checked for proper operation by turning counterweight by hand with engine cold (top). It should operate freely with no binding. Manifold heat control valve lubricant will help free stuck valve

# HINTS FROM READERS

## Scraper from plane iron

You get double duty from a hand-plane blade when you fit it with a bolt handle. Attach the bolt ( $\frac{5}{8}$  x 7 in.) at the bottom of the slot with two nuts and washers. The blade does its cutting when pulled with the bevel side of the edge trailing. A piece of slotted broomstick provides an optional grip.—*Hedy Irwin, Boston*

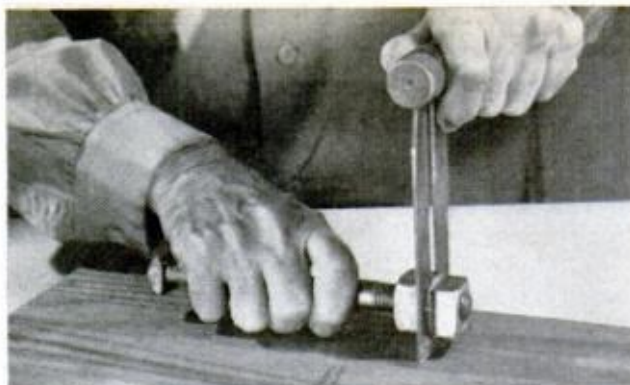

## Indexer for milling flats on rods

When machining square or hexagon ends on rods in a milling machine, I use this simple indexing setup consisting of a calibrated disc and a witness mark.

Here's how it works: The disc is first slipped over the rod and its setscrews tightened. Then the rod is positioned and clamped in the V-jaws of the vise with the disc against them, and a piece of tape with a line drawn on it is stuck to the vise where it will align with the disc calibrations.

In use, one flat is milled, the vise loosened, rod and disc turned to the next index mark and the second flat milled. If you are milling four flats (square) follow the solid lines on the disc; if five flats (hexagon), follow the dotted lines in conjunction with two solid lines. The disc bearing against the vise serves as a stop for the rod.

The 1½-in. aluminum disc with the center cut out is riveted to a brass ring which in turn is fitted with three 6-32

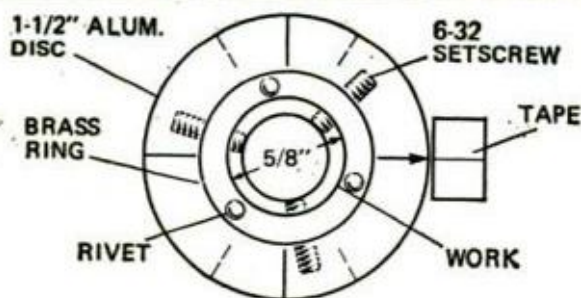
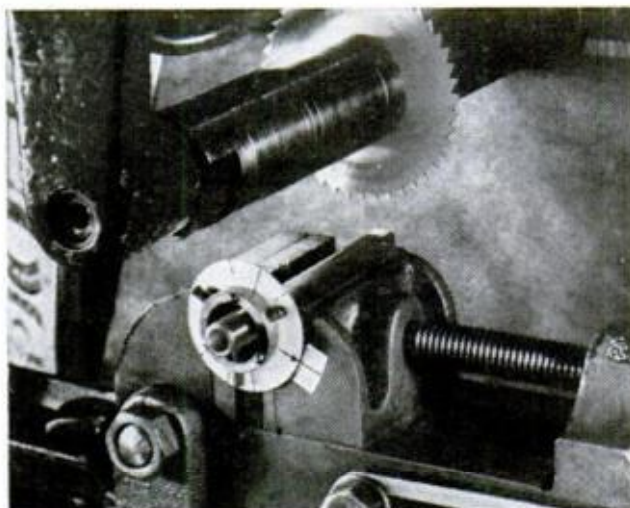

setscrews 120° apart. The indexer will handle rods up to  $\frac{5}{8}$  in. in diameter.—*Walter E. Burton, Akron, Ohio.*

## NEXT MONTH IN SHOP AND CRAFTS

**THE PLEASURE OF CLEAN AIR.** Your home will be a cleaner and more healthful place to live when your furnace is equipped with an electronic air cleaner. It traps the microscopic particles of dirt, dust and smoke the usual fiberglass filter can't, cuts decorating needs and drapery cleaning, and costs less to operate than a 40-w. light bulb. You can add one to almost any forced-air furnace.

**CHOICE OF FOUR SEWING CENTERS.** Like any work center, the more organized it is the more convenient a place it is to work. This is certainly so in the case of a sewing center when everything is in one handy place. Designs range from a simple fold-down wall affair to a 6-ft., freestanding cabinet with compartments galore for storing the machine, cutting board, dress form, iron and pressing board, material, patterns—the works. Have your wife take her pick—and build it for her.

**HOW TO** make a high-low drill-press fence, cut and splice wires, frame a new basement partition, hang drapery hardware, fix a bad spot in a linoleum or vinyl floor.

# Go Fishing,



# Hunting,



# Camping,

with

# Sports Afield...

*where the action is  
great . . . with top  
experts in the field!*

*Special Introductory Offer to  
Popular Mechanics readers...*

**ONE YEAR (12 ISSUES)  
of SPORTS AFIELD**

for only **\$2.50** (HALF-PRICE!)

*less than  
21¢ a copy—  
see card  
opposite  
for details*

# How to replace a broken window pane



1 Heating old putty with flame of torch softens it, makes it easier to remove. Avoid scorching wood by using shield of scrap tin and move it as you go.

**B**ASEBALLS and other flying objects have a way of breaking windows, and sooner or later most homeowners can count on having to replace a shattered pane. Knowing how to loosen the old putty, bed the new glass, hold it with glazier's points and strike a neat bevel when applying the putty seal will save you the frustrating job of trying to get someone to come and fix it—and let you pocket the savings. A propane torch and caulking gun make the job go faster, but they are not essential. If you work carefully, you can remove the old putty with a sharp chisel, and you can apply the putty by hand without a gun. A hammer and a putty knife are the only other tools you'll need.

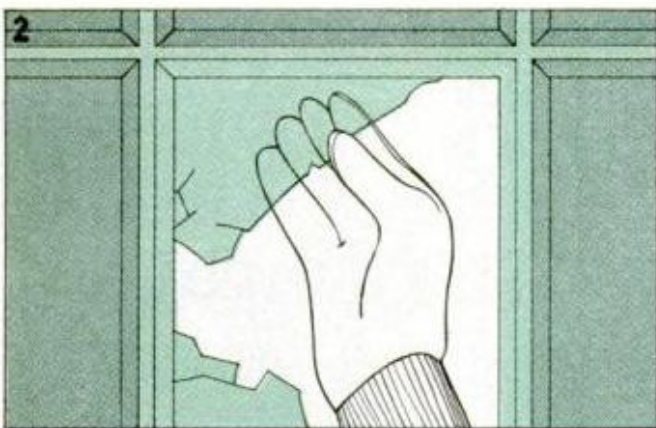

2 Safe way to remove a cracked pane is to cover it with strips of masking tape and crack further with hammer. Wear glove when pulling out broken pieces.

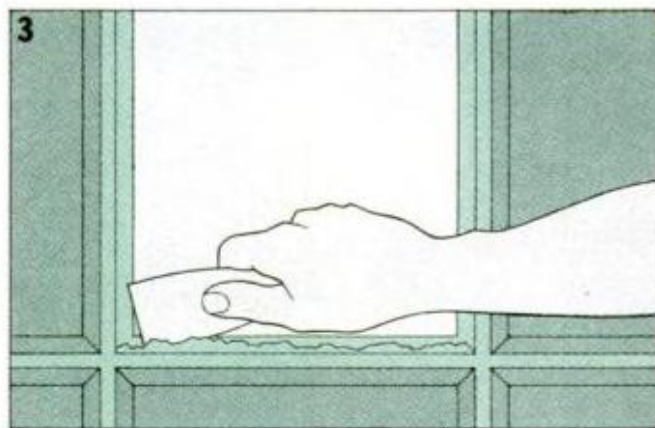

3 Scrape putty clean from rabbet with knife or chisel, pry out old glazier's points and brush rabbet clean. Seal bare wood with thinned oil-base paint.

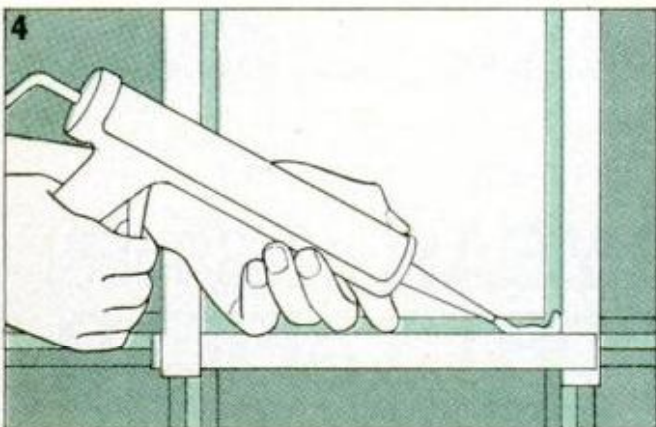

4 Silicone rubber sealant or regular putty can be used to bed the glass. If silicone is used, outline opening with tape to keep off adjacent panes.

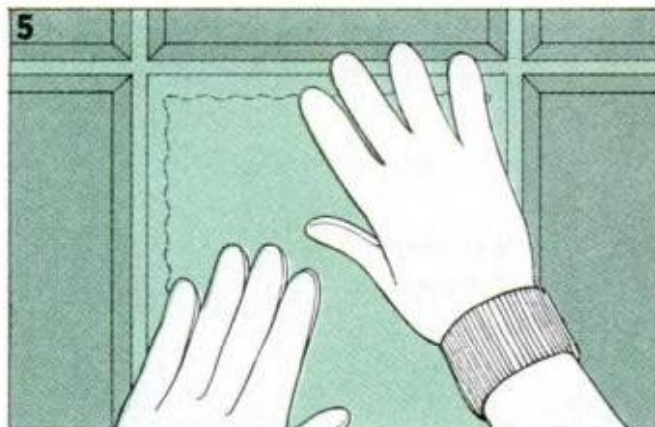

5 Press new pane (with 1/16 in. allowance all sides) in place until sealant oozes around edges for tight seal. Excess on inside is removed with putty knife.



6 Drive glazier's points, size 1 or 2, using driving tool packaged with points. On small pane use one point along short sides of glass, two on long.

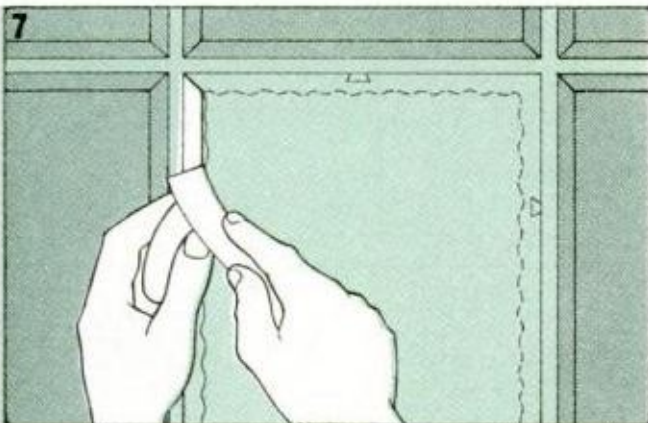

7 For final bevel, silicone or putty is smoothed with putty knife dipped in solvent or turpentine to keep material from sticking to the knife blade.

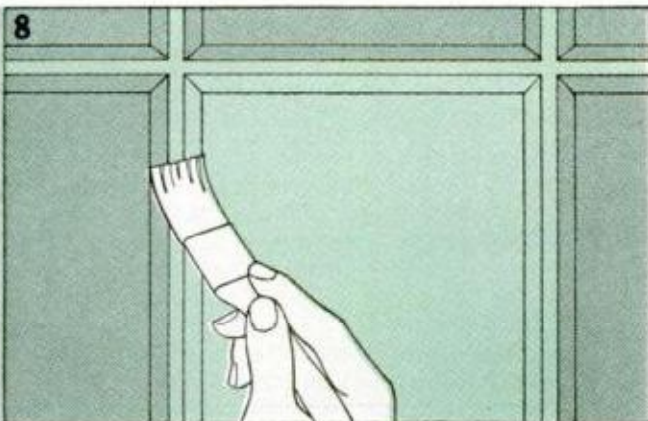

8 If putty is used, it should be painted several days later when it's dry. Painting the new putty improves appearance and keeps it from shrinking.

## Facts about window glass

**THE GRADE OF GLASS** that's used in a particular window has a lot to do with the location of the window. A living-room window, for example, calls for better glass than a basement window. Optical ripples in the glass of a basement window would be unimportant, but you wouldn't want such imperfections in a living-room window.

*Polished plate* is generally used in windows you look through, whereas *common*, or *grade B sheet*, is for basement and attic windows, which are primarily for light. Knowing a few simple facts about the different types and grades of glass will help when a window has to be replaced.

Window glass is drawn while molten in sheets through an annealing oven. In the process, it's almost impossible to avoid slight variations in thickness that cause optical ripples. *Grade AA* has the fewest, *grade A* has more and *grade B*, known as *common*, even more.

Plate glass is annealed like regular window glass, but afterward it's ground and polished.

Recommended weight (or thickness) will depend on the size of the pane. Sheet window glass is single-weight ( $3/32$  in. thick) and is safe normally in sizes up to 2x2 ft.; double-weight ( $1/8$  in.) will go to 3x5 ft.; heavy-weight ( $7/32$  in.) is recommended where there are high winds or other dangers of breaking.

Plate glass ranges through weights of  $3/16$  in.,  $7/32$  in. and  $1/4$  in. on up to commercial weights. The  $1/4$ -in. weight is for large window walls and sliding glass doors. Heavy sheet glass is a useful grade for special applications where slight distortions won't be noticeable, such as table tops and shelves. Its fired surface is less likely to scratch than that of polished plate. It's available in  $3/16$  and  $7/32$ -in. thicknesses and it comes in grades AA and B. ★★★

# How to add a new convenience outlet



## Anchoring outlet box in a wall

If the wall is lath and plaster, you simply attach the outlet box to the wood lath with small screws. If the wall is plasterboard, the box is anchored in the hole with special metal supports, as shown below. To install the metal supports, you work one along each side of the box and move it up and down until it is against the inside surface of the wall. Then bend the projecting ears inside the box, as shown in the lower left-hand drawing. All hardware is available at electrical supply stores.

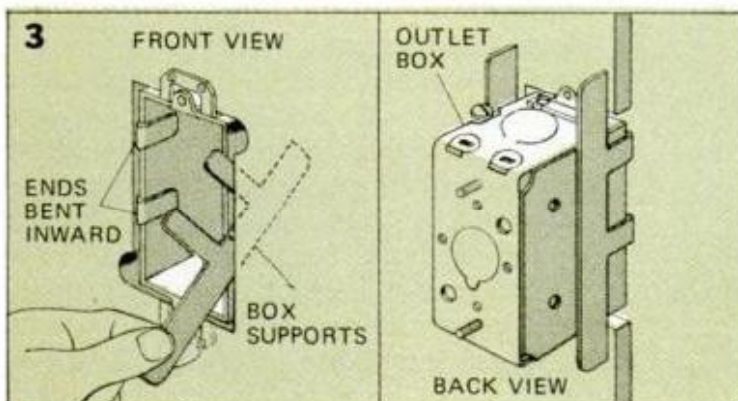

**R**OOMS in older homes never seem to have enough electrical outlets, and many times you end up using a long extension cord to plug in a lamp across the room. Adding another outlet and tying it to an existing one is a job you may not really hate to do but one you may not know how to do. The steps illustrated and described here show how simple it is to cut the hole, install the box, prepare the wire and make the actual connection. And you can say good-bye to hazardous extension cords.

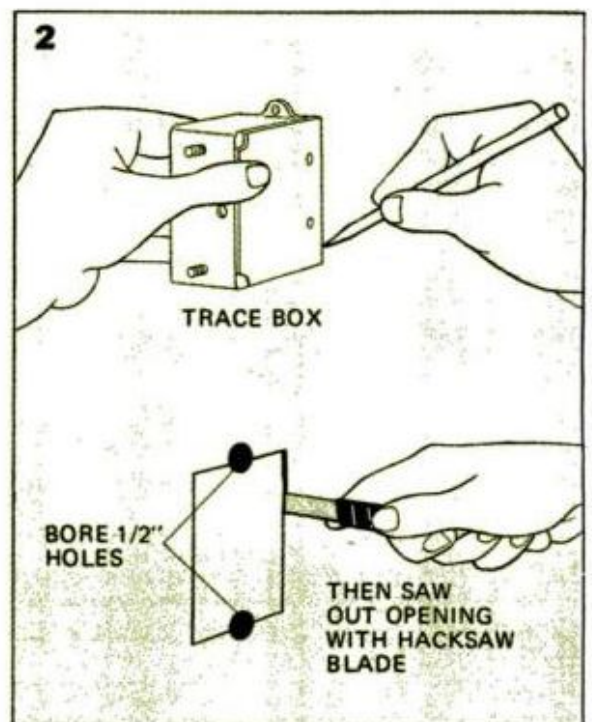

## Cutting hole for box

If wall is plasterboard, it's not necessary to chip hole to locate and center the box over a full lath. Simply trace around the box and drill two ½-in. holes through the wall at the top and bottom half-round notches. Similar holes are made in a lath-and-plaster wall. The box opening is cut out with a hand-held hacksaw blade. If sawing lath, draw the saw teeth toward you. Wrap the saw blade with several turns of tape for a more comfortable grip, or wear a glove. The drilled holes provide clearance for the projecting tabs at the top and bottom of all outlet boxes. They also make it easy to insert a hacksaw blade or keyhole saw.

**How to install armored cable**

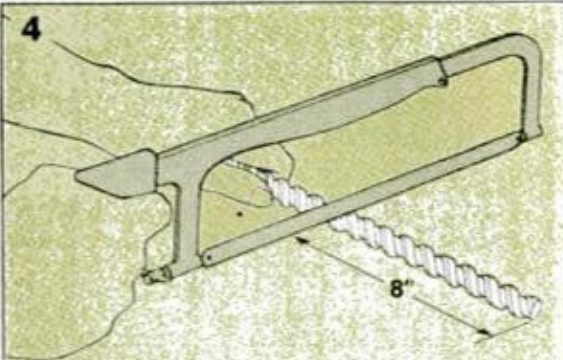

To cut armored (BX) cable, hold your hacksaw at approximately a 45° angle, cut through one section of the armor, then twist to break the armor. Do not cut into the wires.

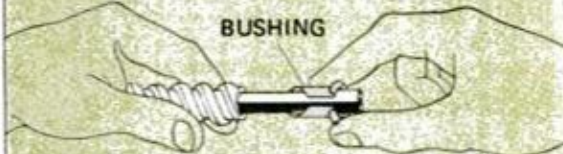

Pulling off an 8-in. section exposes the paper-wrapped wires. Insert an antishort bushing between the paper and cable to protect the wires from the barb end of the metal cable.

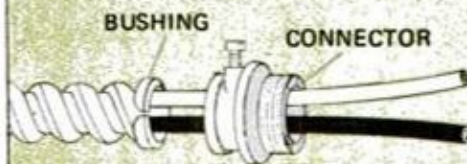

Remove paper from wire, slip a connector with locknut remover over end of cable and tighten screw. Be sure bushing is against connector.

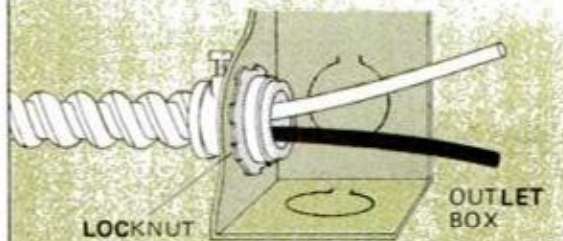

Connector is inserted through knockout hole in outlet box. Locknut is slipped over connector and drawn up tight with hammer and screwdriver.

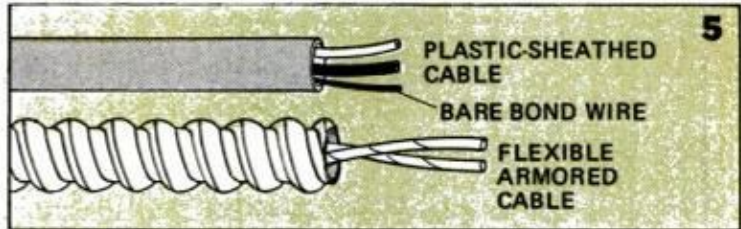

**Two kinds of cable you can use**

You have a choice of using armored cable or plastic cable to wire your new outlet. Armored (also called BX) has a flexible-steel covering that requires a hacksaw to cut. The covering on plastic cable can be cut with a knife and it's easy to pull and strip. The national code requires a cable having a bond wire, as shown above. In the case of armored cable, the cable armor itself serves as the bond. In the case of plastic-sheathed cable, a separate bonding wire is attached to the outlet box with a screw or special clip, or the cable is connected to a box that's equipped with a bonding jumper. Thus your new outlet will have continuous bond, provided the rest of the system was originally bonded. Be sure that when you connect the cable to the terminals on the old outlet that you connect black wire to black wire and white wire to white wire.

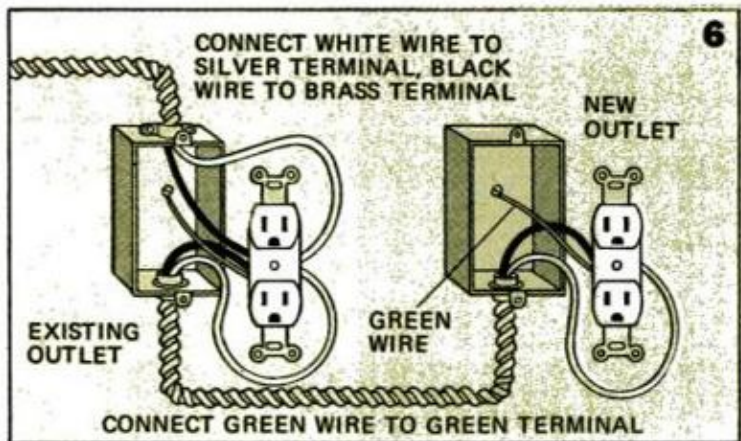

**Routing the cable from box to box**

How you run the cable from existing box to new one depends on where the boxes are located. If they're on the same wall, you can remove the baseboard, notch each stud to accept the cable and cover with metal kick plates for protection. If boxes are on different walls and there's a basement below, it's easier to bore up into the walls from underneath and run the cable across under the joists. If the new outlet is on the other side of a doorway, the cable can be concealed behind the trim, usually by chipping out the plaster or wallboard, and run up and over the door. Be careful, though, in reattaching the trim not to nail into the cable. To connect the cable to the old box, pry open a knockout and fish a thin wire through the hole to pull the cable into the box. Remember to turn off the electricity before you make the final connections.

# How to unclog drains and stop leaks



## When a sink won't drain

When a sink or lavatory won't drain, there may be a stoppage in the trap (that U-shape fitting right below the bowl). Often a force cup will dislodge it without your having to touch the trap. Fill bowl up to 8 in. or so with hot water and temporarily plug the overflow hole (if there is one) with an old towel. Then pump forcibly up and down until the water flows normally. If pumping fails, you'll have to syphon water from the bowl and take off the trap.

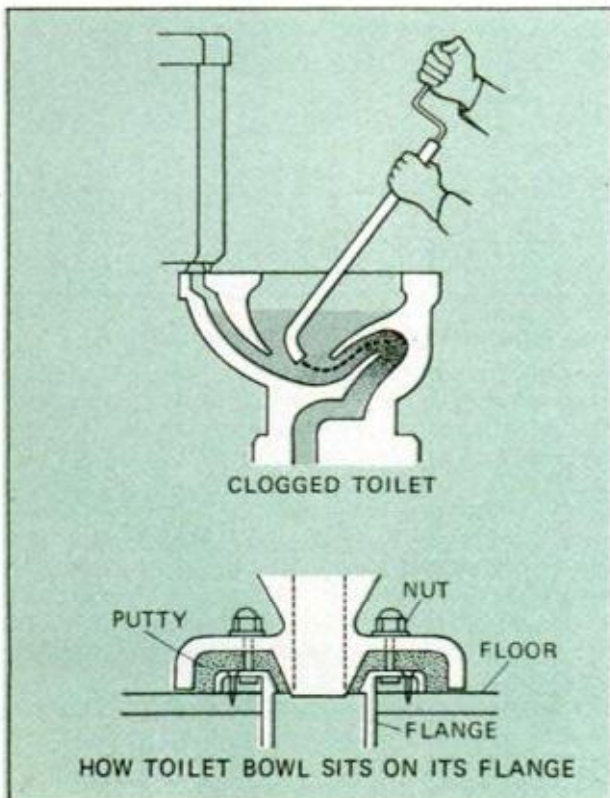

**P**ROBABLY of all the jobs one hates to do, cleaning clogged drains and stopping leaky faucets top the list. They are surely messy jobs, but most necessary—for a household can't function long without plumbing that works. To keep it working, every home needs four common plumbing aids—force cup (often called a plumber's friend), large-jaw wrench, sink-drain auger and toilet auger. They'll save you some costly bills.

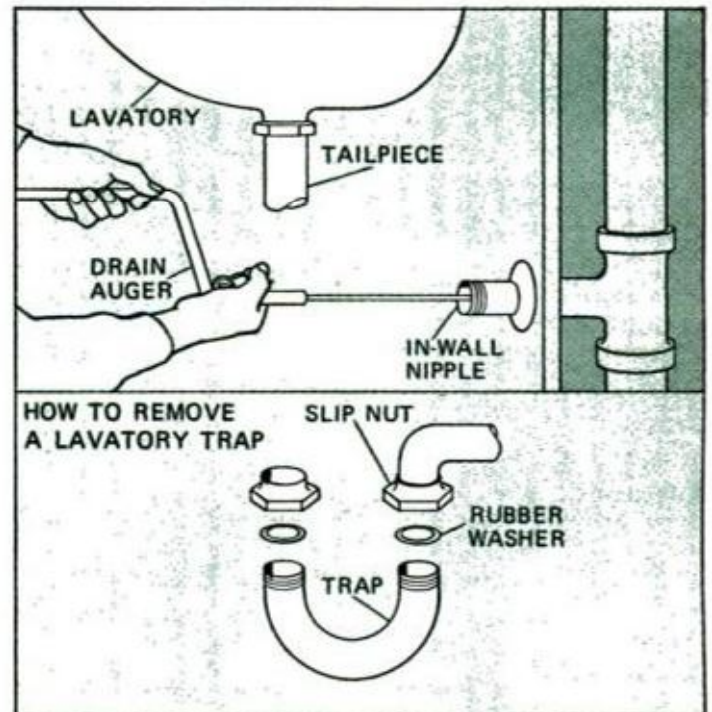

## When the trap is clogged

Some sink and lavatory traps have a cleanout plug on the bottom that lets you clean them out without removing them; others don't. If you have to remove the trap itself, unscrew the two large slip nuts at the top with your large-jaw wrench. If you find the stoppage is beyond the trap, you'll have to use your drain auger and go into the waste pipe that enters the wall.

## When the toilet is clogged

Youngsters can play havoc with a toilet by dropping something in it and clogging the trap. Too much paper will clog a toilet, too. The first thing to try is the force cup. If the obstruction is just paper, pumping the cup forcefully will generally dislodge it. If the stoppage appears to be more than paper, see if your toilet auger will reach the item so it can be pulled back out. If these methods are not successful, then you'll have to lift the toilet from its flange and remove the obstruction from the underside.



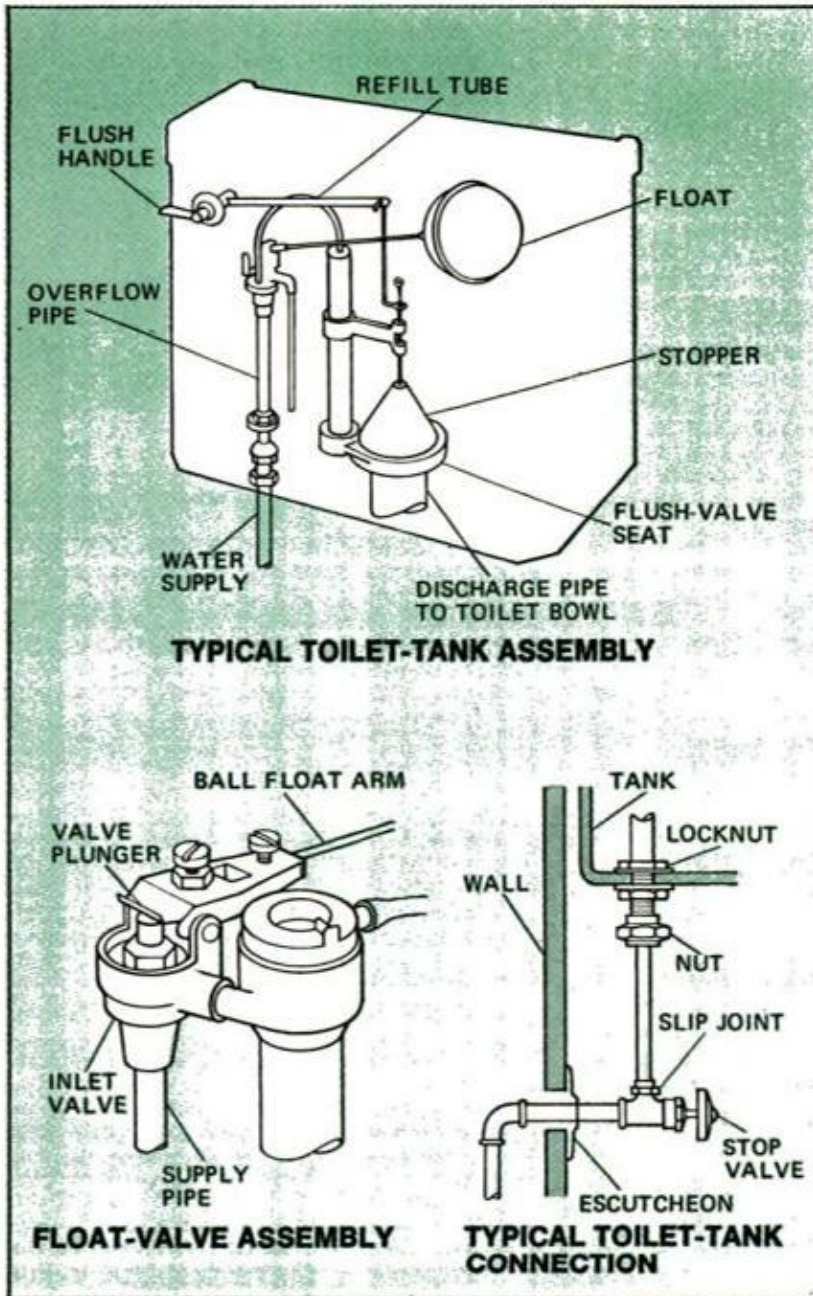

**When a faucet starts to drip**

To reach a worn faucet washer at the end of the stem of a compression-type valve, you first remove the screw on the top of the handle. Next you pry the handle off the ribbed end of the stem and lift off the packing nut. Some packing nuts screw on, in which case you protect the chrome finish from wrench marks by first wrapping it with adhesive tape. Now you simply back out the stem with the fingers, turning it *counterclockwise*. To replace the washer, you back out the r.h. bibb screw that holds it.

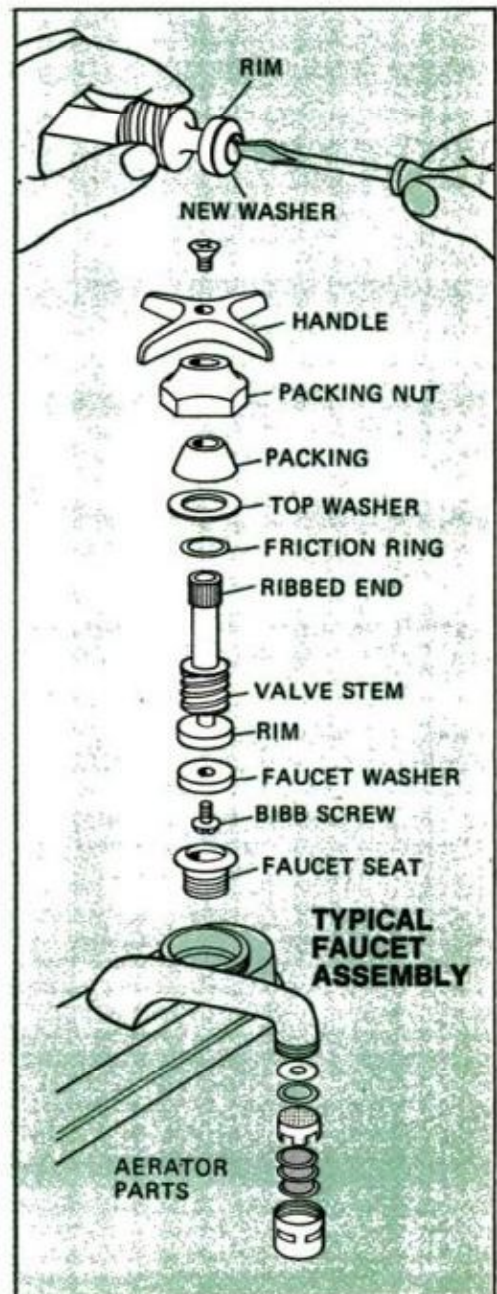

**When a toilet continues to trickle**

When water trickles into the toilet bowl after flushing, it may indicate that the rubber stopper valve (see drawing) has become "water-logged" (mushy) and needs replacing. If the trickle persists, examine the stopper seat; it may be corroded and gritty around the edge, letting water escape. If so, clean it with emery cloth. If it's not the stopper or seat, then it could be a worn washer in the valve assembly. To replace it, you will have to shut off the water. Most toilets have their own shut-off valve right below the tank. Older ones don't, in which case you'll have to shut off the water at the meter. If the toilet is old, it may be best to replace the entire float-valve assembly. Removal of the nut and washer from the end of the assembly will make it easy for you to lift out the entire unit. Use the nuts and washers that come with the new assembly to install it.

# How to trim and plane sticking doors

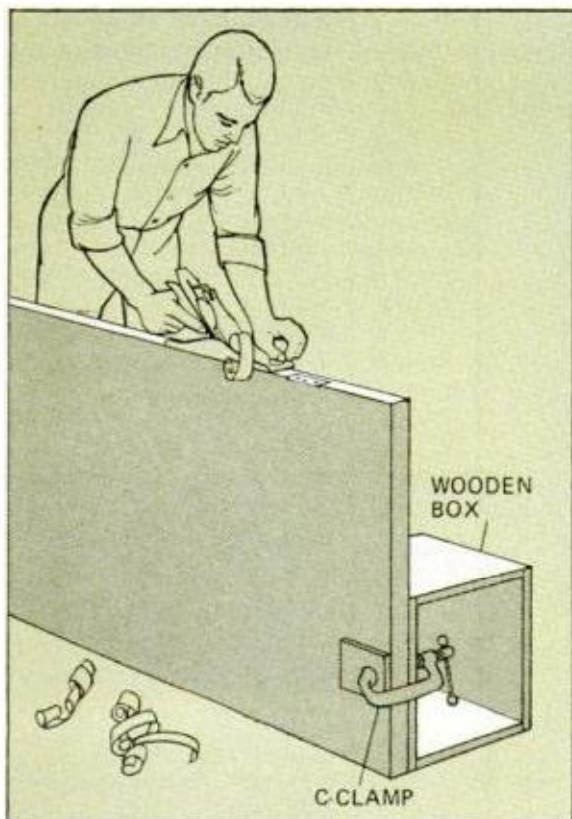

## When a door must be planed

When a door continues to stick even during dry weather and is hard to open, the only way to fix it is to plane it. Planing is done along the hinge edge of the door since you can't disturb the lock. Take down the door, remove its hinges and support it on edge. A wooden box is a good thing to clamp it to. If you must plane top and bottom, work from edge to center so you won't chip the corners.

**E**VER HAD a door bind so it wouldn't close, or it wouldn't swing over a thick, new carpet? Few homeowners haven't had these problems with doors—particularly binding, for most wood doors swell periodically. Sometimes they expand so much they never shrink back to their former size. When that happens, you have no recourse but to remove the door and plane it. Or you must trim it with a saw if it's binding on a carpet. Not all doors bind because of moisture. Sometimes one won't operate properly because the screws have worked loose in a hinge, allowing the door to droop enough so that it won't open and close the way it should.

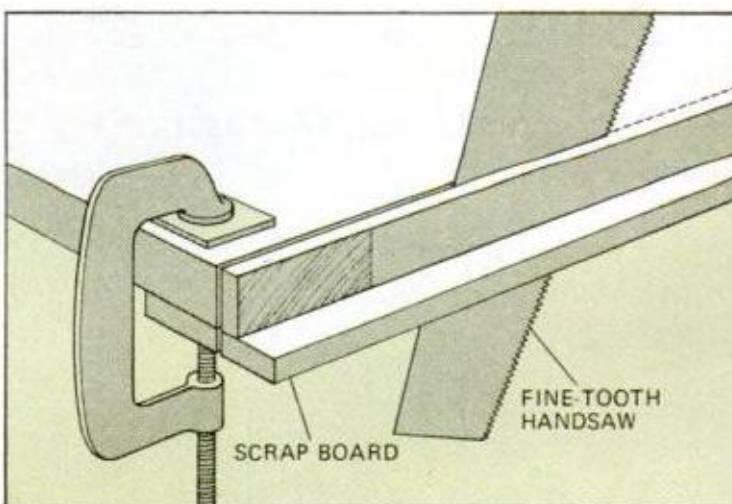

## When you have to shorten a door

When a new carpet is thicker than the old and a door drags on it, watch that you don't chip one side when you cut the door. Determine the amount you must take off, and draw a line across the door. Take the door down by knocking out the hinge pins, support it on a couple of padded sawhorses or boxes and clamp a scrap board to the underside of the door. The board not only prevents chipping the thin plywood facing on interior doors but helps keep the saw from running off the line when sawing as little as  $\frac{1}{4}$  in. Use a fine-tooth saw.



## When a door needs sealing

Doors usually swell during prolonged periods of rain, ice and snow. When the top and bottom edges of a door are not sealed, excessive moisture can enter the open end grain and cause the wood to expand and the door to widen. Common shellac is good for sealing the wood against moisture and it dries quickly, but you should wait for a dry spell; you don't want to seal the edges and trap any moisture that may be in the door at the time. Of course, to coat the bottom edge you must take the door down.

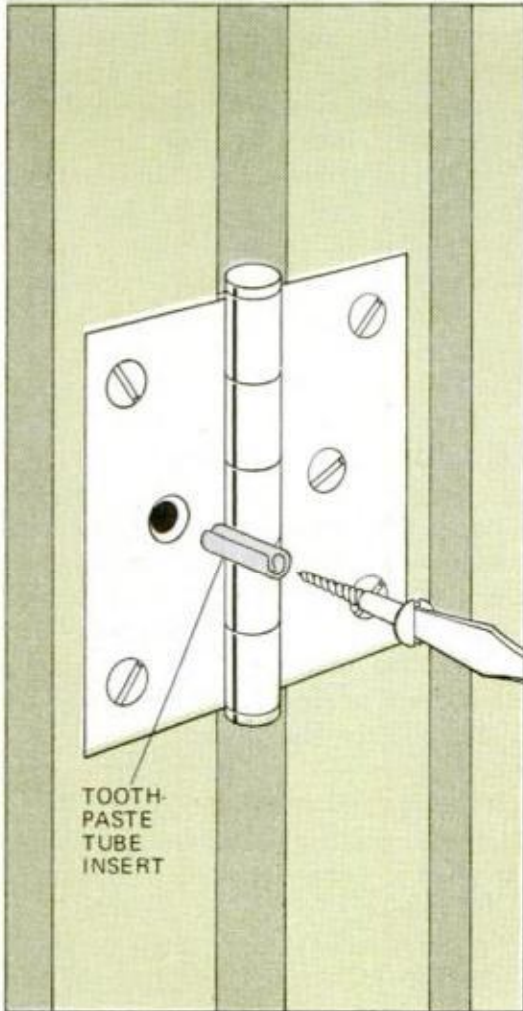

**When hinges work loose**

Like anything that is used a great deal, a door that is opened and closed frequently puts a strain on the hinges that can eventually cause the door to bind. Usually you will find that a screw or two has worked loose, even to the point where it will no longer hold. When the trouble is found to be an enlarged hole, this hole must be shimmed. Sometimes a wooden matchstick and a little glue will do the trick, but an even better shim is one that's rolled from the soft metal of a toothpaste tube. Like a lead anchor, it will let the screw threads cut into the shim and spread it to fill the hole. Regular plastic screw plugs also can be used to shim an enlarged hole. In this case, the screw makes the plug expand and anchor itself tightly in the hole.

*Illustrations by Adolph Brotman*

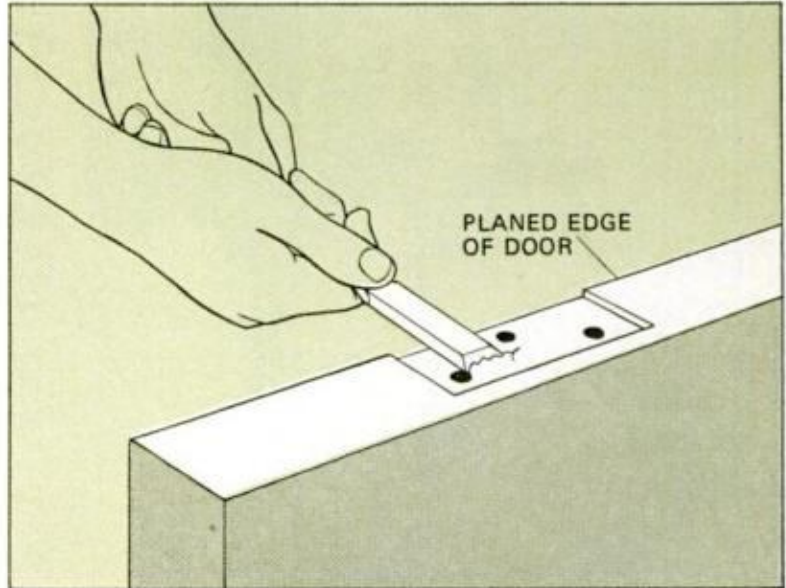

**When you have to plane off a lot**

When you have to plane off more than a little to relieve a binding door, you have to chisel the hinge pockets deeper to compensate for the amount you take off. Try to pare them an even amount. A properly set hinge leaf should be slightly deeper than flush. When the door has been planed enough to close properly, repaint the planed edge.

**When a door drags on its threshold**

If you can sand the bottom of a heavy exterior door that rubs on the threshold without removing it from its hinges, it's worth a try. A stunt that often does the trick is to work a sheet of coarse garnet paper under the door as shown below and then move the door back and forth. Little by little it will sand enough off to relieve the rubbing. When the dragging is beyond the sandpaper trick, you'll have to plane it.

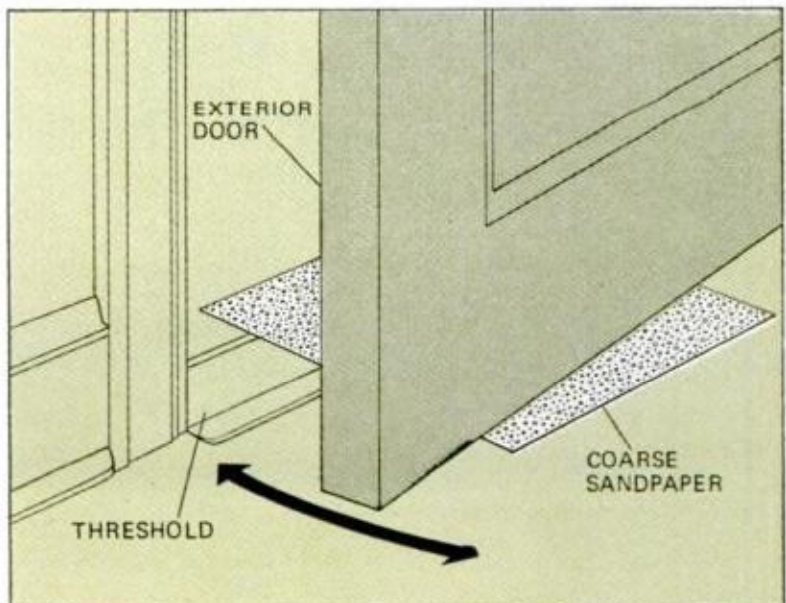

# Now: A plastic injector

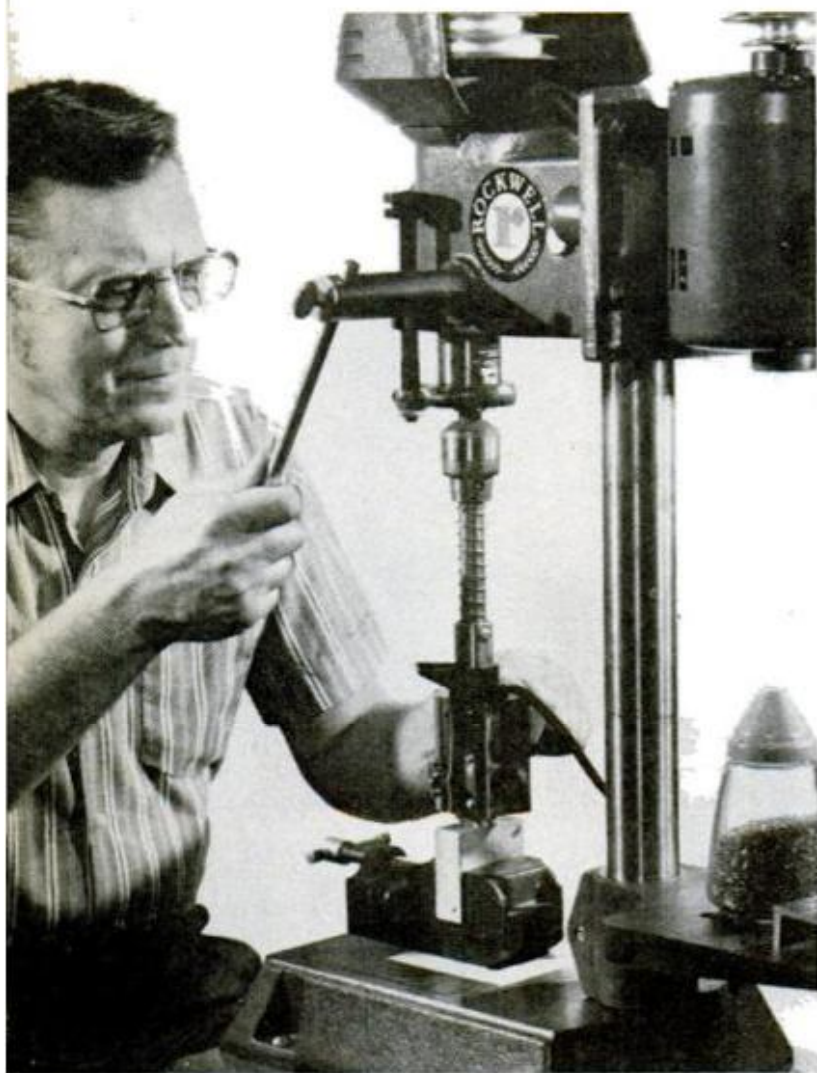

**STRIPS OF TAPE** on drill-press base provide quick way of positioning mold each time when making production run. Drill press must be sturdy to exert needed pressure



**SAMPLING OF MOLDS AVAILABLE** show few of many plastic items you can mold and sell: star tree ornaments, sign and nameplate letters and novel hosiery hangers

**Y**OUR WORKSHOP DRILL PRESS becomes even more versatile with a unique new accessory, called Quick Shooter, which converts any suitable drill press into an efficient injection molding machine.

You just tighten its plunger rod in the drill-press chuck, plug the unit into a 115-v. outlet, wait until it's hot enough and you're ready to mold by pressure countless items in thermo-plastic materials in ready-made take-apart molds. The drill-press table supports the mold which is held in a regular drill-press vise (or C-clamp) and the drill-press handle works the injector plunger.

To ready the injector, it must be "pre-packed" to assure ample molten plastic down and around the torpedo spreader at the bottom of the heating chamber.

To do this, first unplug the drill press for safety reasons and set the thermostat on the heating chamber a little past medium. Then position the mold so it blocks the hole in the nozzle when the injector is lowered.

When the temperature dial reads 350° F., the proper melting temperature, pour enough plastic pellets in the fill spout and pull down on the drill-press handle. Raise the handle, add a few more pellets and pull it down again. The injector is now ready for use.

To mold a part, line up the fill hole in the mold with the nozzle and pull down on drill-press handle until nozzle seats in the retaining ring on top of the mold. Now with a continued steady pull force the hot molten plastic into the cavity in the mold. When it's full, hold the pressure two or three seconds, then raise the handle. The hot plastic cools and hardens quickly and you can open the mold and remove the part immediately. When you want to switch color or type of plastics, the injector is emptied by purging with the block provided.

The kit includes the injector, sample star mold, purging block, nozzle retaining ring, plastic pellets and instruction booklet. For information on additional molds and price of the kit write Haygean Machine Corp., 2175 South 170th St., New Berlin, Wis. 53151. ★★

# for your drill press

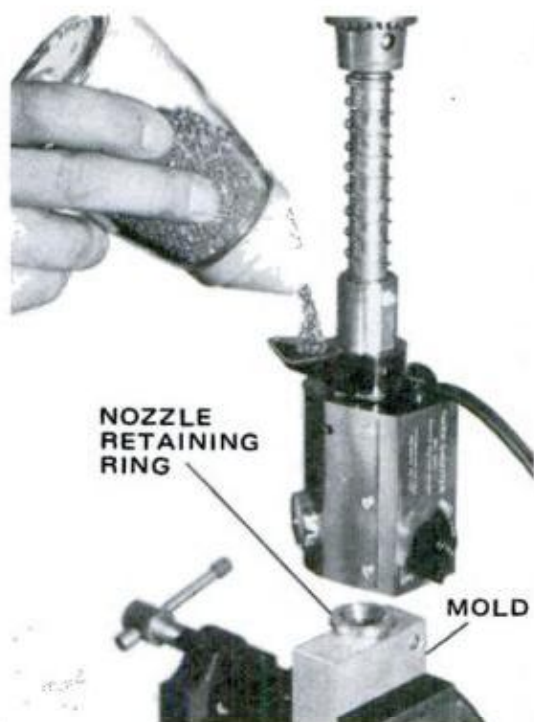

**INJECTOR IS FILLED** with plastic pellets through top filler spout, holds  $\frac{1}{2}$  ounce

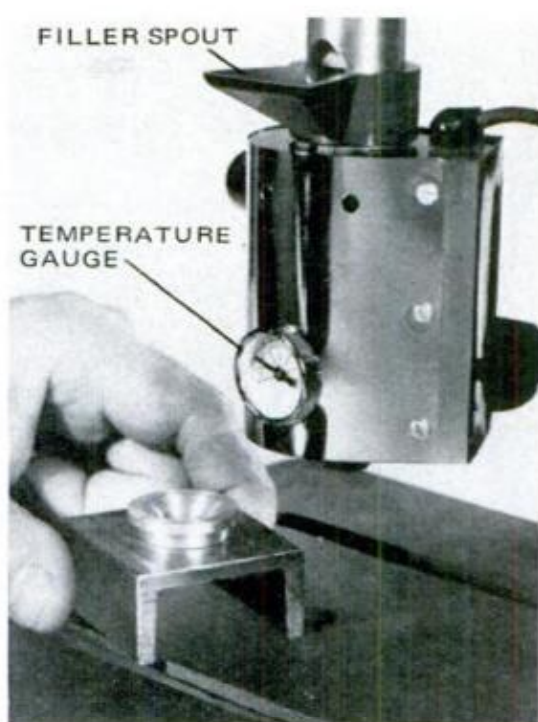

**INJECTOR IS CLEANED** of leftovers by placing purging block and ring under the nozzle

PHOTOS BY ROBERT D. BORST



**EVERYTHING YOU NEED** is provided in this kit, including a sample mold. Additional molds are available  
**FEBRUARY 1973**

**161**

# Tiny steam engine

By JOHN BURROUGHS

**T**HIS LITTLE STEAM ENGINE (a mere 3 in. long) is a simplified version of a vertical open-column marine engine that was used in the 1800s to power chugging steam launches such as the *African Queen*. It makes a good starting project for the new owner of a modelmaker's lathe. The step-by-step photos show how simple it is to machine. It has a single-acting  $\frac{1}{2}$ -in. bore and an easy-to-fit rotary valve. The completed engine will run either with steam from a small boiler or with air from a paint-spray compressor.

A kit packaged by Caldwell Industries includes everything you need—cut chunks of metal, screws, nuts, drawings and instructions. It's available at Unimat dealers or from American-Edelstaal, Inc., 1 Atwood Ave., Tenafly, N.J. 07670 for \$4.95 post-paid. Plans and instructions alone, \$1. ★★★

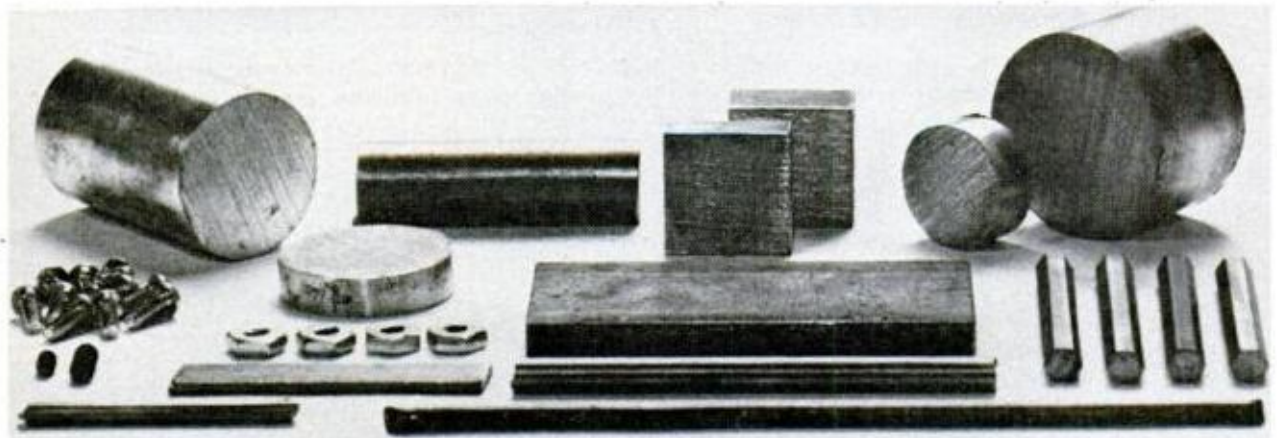

- 1** PACKAGED FOR YOUR CONVENIENCE (if you can't find the materials locally) is a kit that includes rough-cut metal plus fastenings. It is available at Unimat dealers. Look in local directory for address

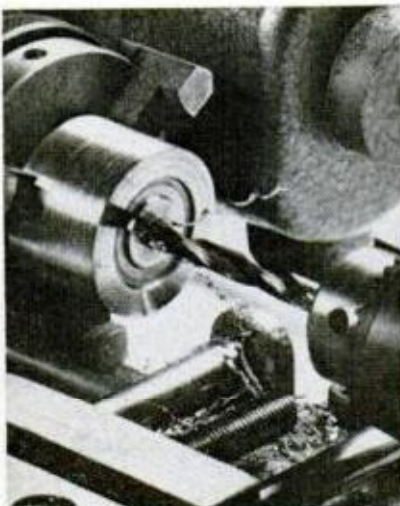

- 2** BORE FLYWHEEL for a  $\frac{3}{16}$ -in. shaft hole and finish-turn it on shaft to make it run true

162

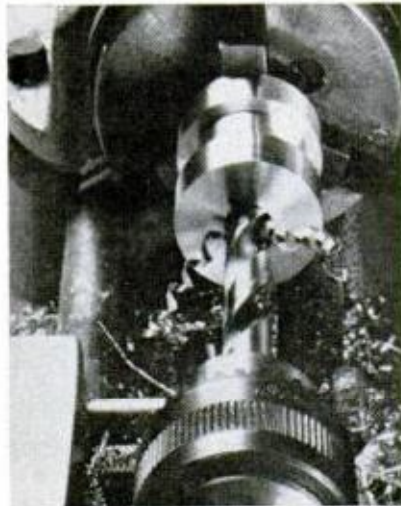

- 3** TURNING SHORT TENON on the cylinder will simplify chucking for turning and boring

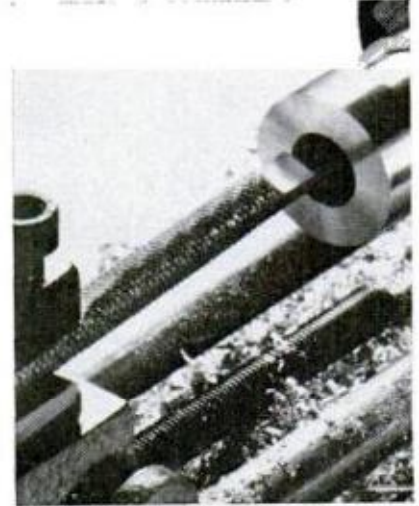

- 4** FINISH-BORE CYLINDER to accept piston. If you lack a boring tool, grind an old file
- POPULAR MECHANICS

# for the beginning 'machinist'



**5** DRILL BASE PLATE, use it as a template to locate holes for the cylinder, block, bearing



**6** TO TAP HOLES, chuck, tap, turn chuck by hand, remove work, finish tapping hole by hand

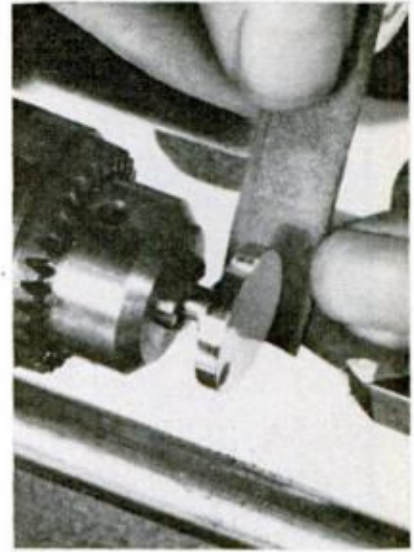

**7** SCREW CRANK-DISC on the shaft, chuck it in the lathe and then turn disc to run true

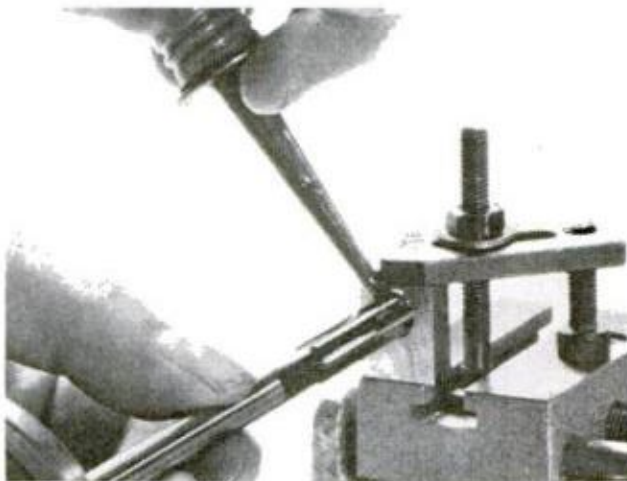

**8** VALVE-BLOCK HOLE must be smooth. Drill it undersize, then follow with a  $\frac{5}{16}$ -in. reamer

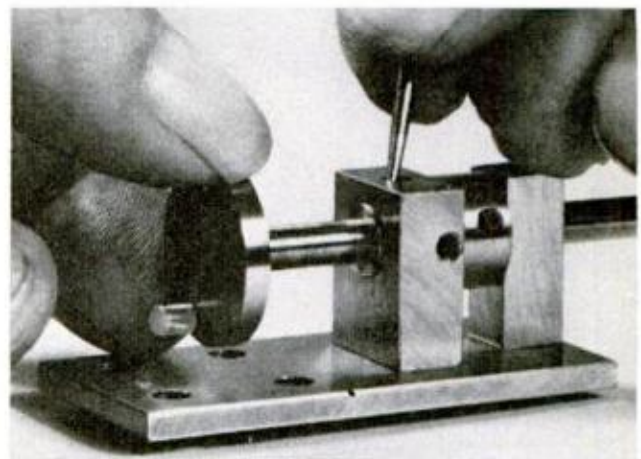

**9** TO SLOT PISTON for a connecting rod, use a slotting saw or cut  $\frac{1}{16}$ -in. slot with hacksaw

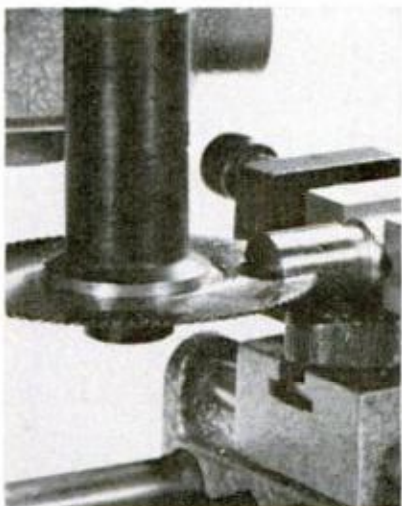

**10** CUT CONNECTING ROD so it just clears cylinder head with crank pin (top center)  
FEBRUARY 1973

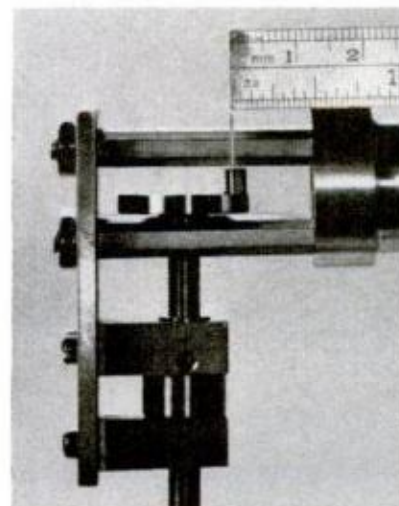

**11** CONNECTING - ROD length is taken from model. Piston should just clear the head



**12** BEND CONNECTING ROD to a slight offset that will allow it to clear the crank disc

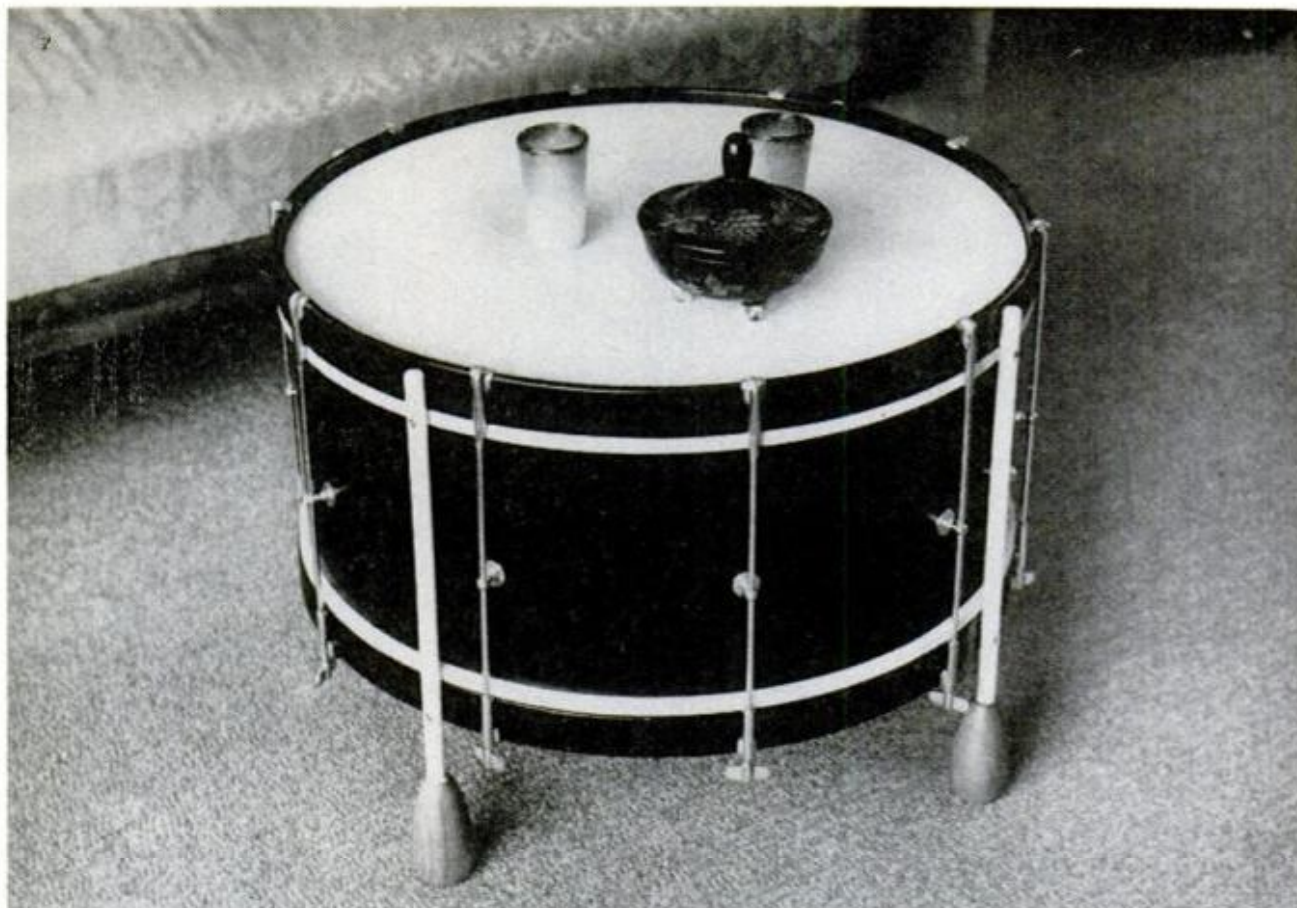

## A real drum table

By ROSARIO CAPOTOSTO

**H**ERE'S THE REAL McCoy in a drum table. Not only is it made from a bass drum, but it looks like a drum. For this reason it makes a most appropriate coffee table for a game or recreation room. It has a spillproof, laminate top and three novel drumstick legs.

While you may not "just happen" to have an old, spare drum lying around,

old drums are available. Musical-instrument repair shops, pawn and thrift shops and especially the classified ads in your local buy and sell publications are good sources. You need only the shell; the skin, therefore, can be in any state of wear and tear so you should be able to pick up one quite reasonably.

If the drum is in need of refinishing,

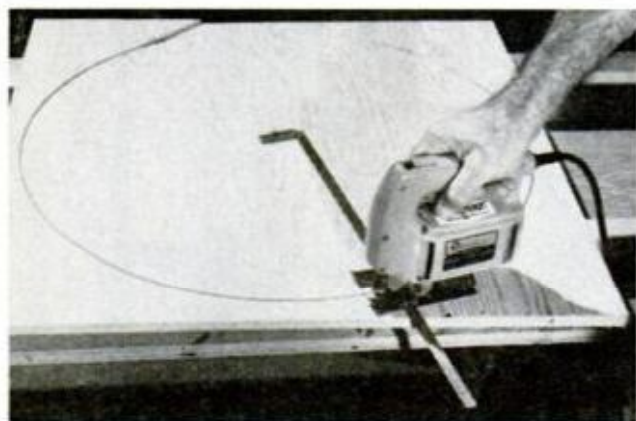

**1** PIVOT JIG used with sabre saw makes an easy job of cutting plywood tabletop perfectly round

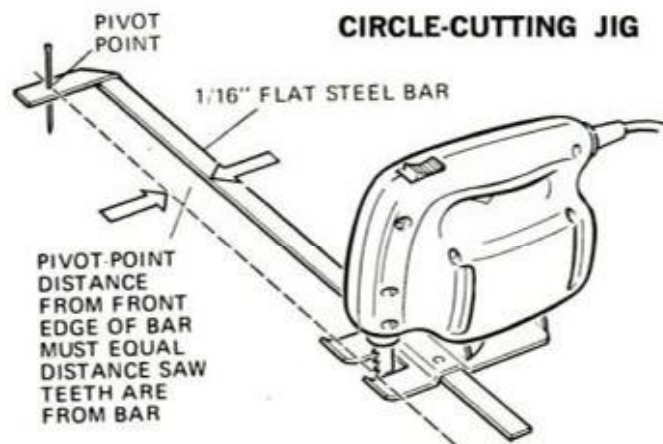

POPULAR MECHANICS



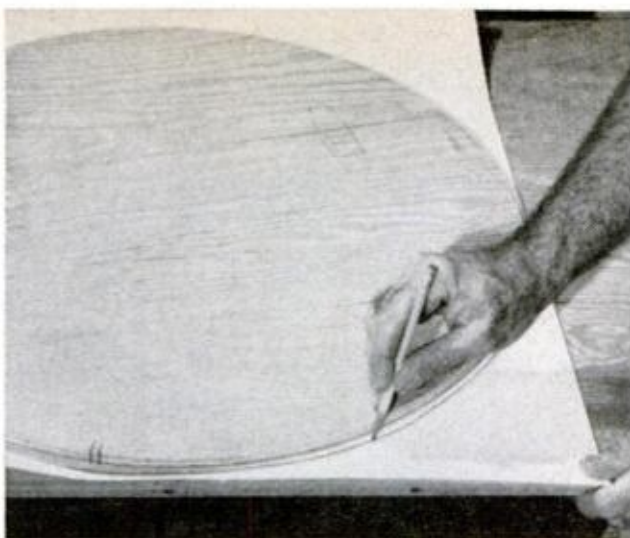

**2** TOP OUTLINE is traced a bit oversize on laminate to allow for an error in placement on work

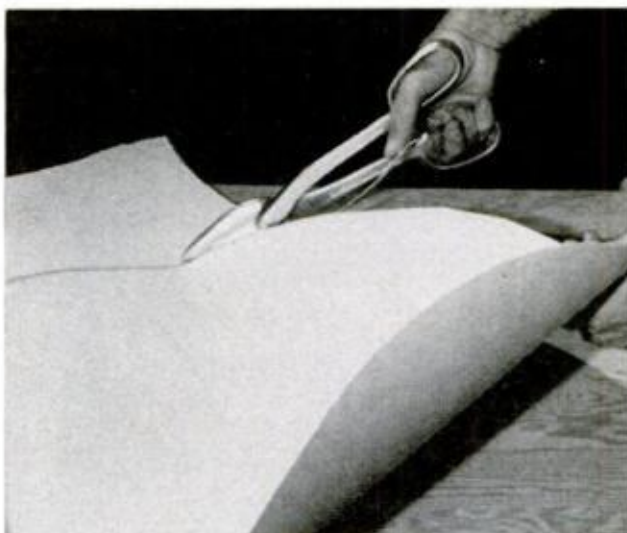

**3** THIN CONOLITE LAMINATE is easily cut with common tin shears. Sharp knife can also be used

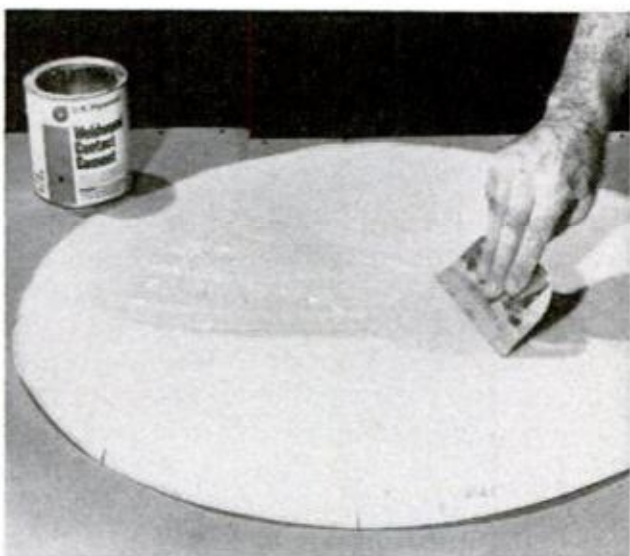

**4** "L-SHAPE" NAILS are used to hold edge of the curled laminate flat when applying cement



**5** AFTER LAMINATE IS BONDED to plywood, use bevel cutter in router to trim the laminate flush

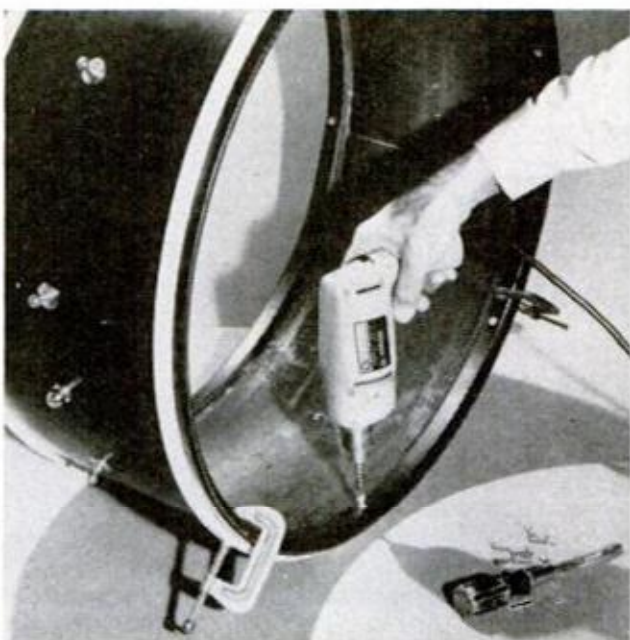

**6** MOVABLE BANDS, which are part of drum, are permanently fastened with screws from inside  
FEBRUARY 1973



**7** ANGLE BRACKETS ARE ATTACHED to be flush with shell's top. Tabletop is  $\frac{1}{2}$  in. below rim  
165

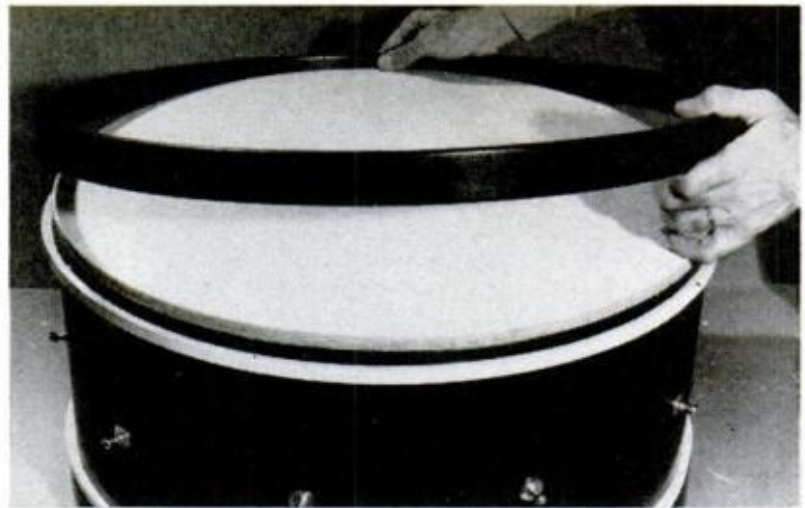
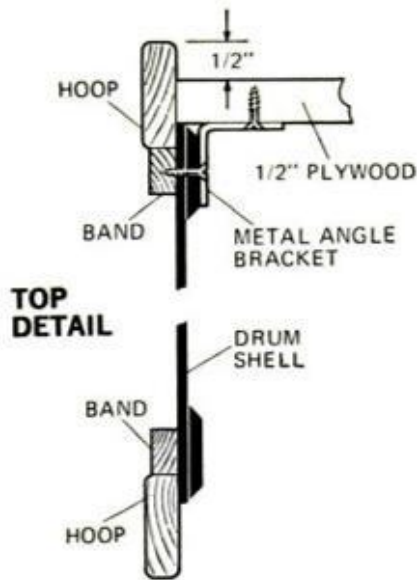

**8** TOP BAND is positioned on the drum so that it will support the top hoop  $\frac{1}{2}$  in. above the laminate-covered tabletop

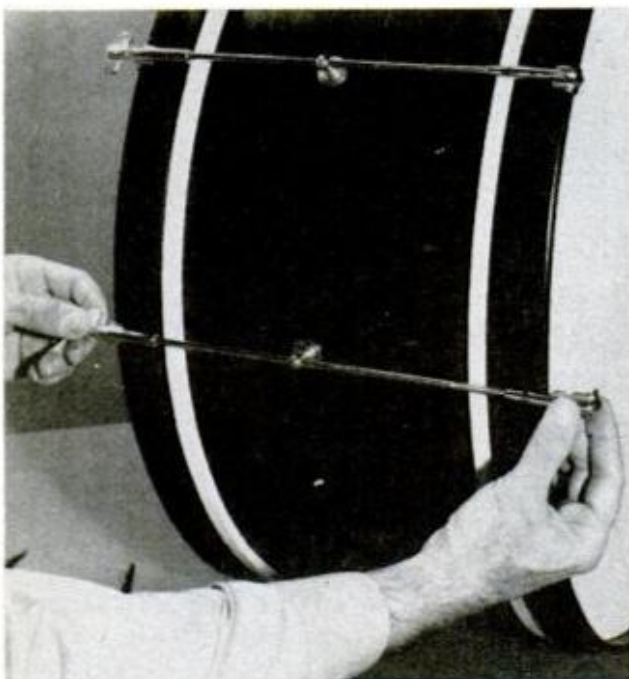

**9** TOP AND BOTTOM HOOPS will be held tightly against bands when drum clamps are replaced

strip it down as far as you can go so you can do a thorough job of it. The typical parts—shell, hoops, bands and clamps—come apart easily.

#### Fir plywood and laminate top

The tabletop is made of  $\frac{1}{2}$ -in. fir plywood cut about  $\frac{1}{16}$  in. short of the inside diameter of the shell. Although your drum may seem to be perfectly circular, it may not be. You can check this out by tracing the shape of the shell onto a piece of cardboard and carefully cutting it out.

Test fit this pattern on the shell in varying positions. If the pattern indicates there are no discrepancies you can proceed to cut the wood perfectly round with a sabre saw guided with a pivoting jig as shown. If you discover the shell to be slightly out of round, you'll have to cut the top freehand

*(Please turn to page 200)*

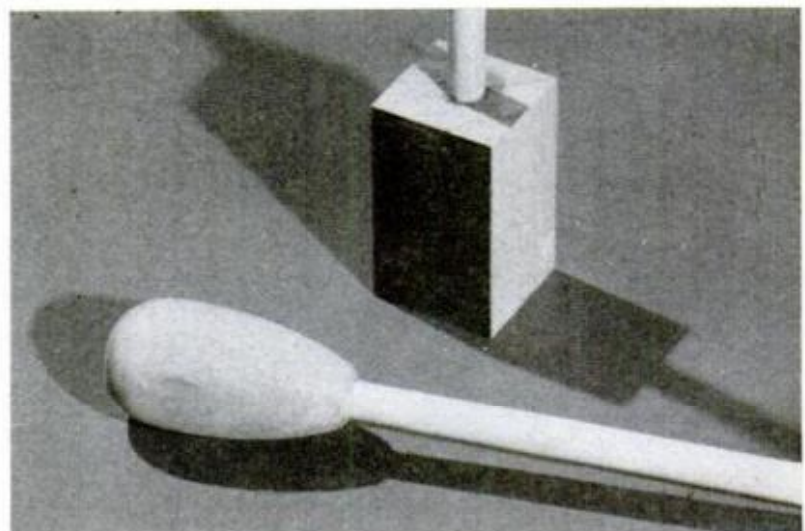
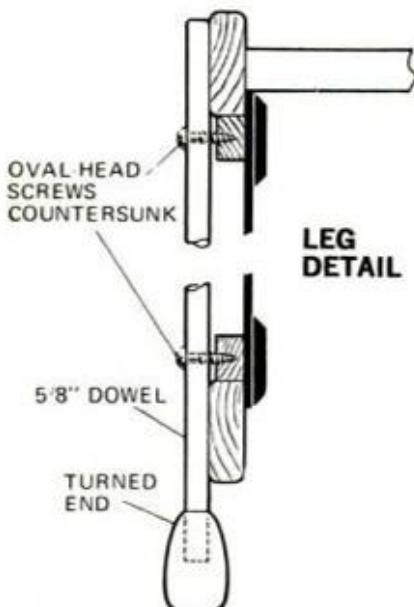

**10** FOR DRUMSTICK LEGS bore holes in  $1\frac{1}{2}$ -in.-sq. blocks, turn blocks to shape and glue to ends of  $\frac{5}{8}$ -in. dowels

POPULAR MECHANICS



**Today, a man needs a good reason to walk a mile.**

**Start walking.**



Warning: The Surgeon General Has Determined That Cigarette Smoking Is Dangerous to Your Health.

25 mg. "tar," 1.6 mg. nicotine av. per cigarette, FTC Report AUG. '72.

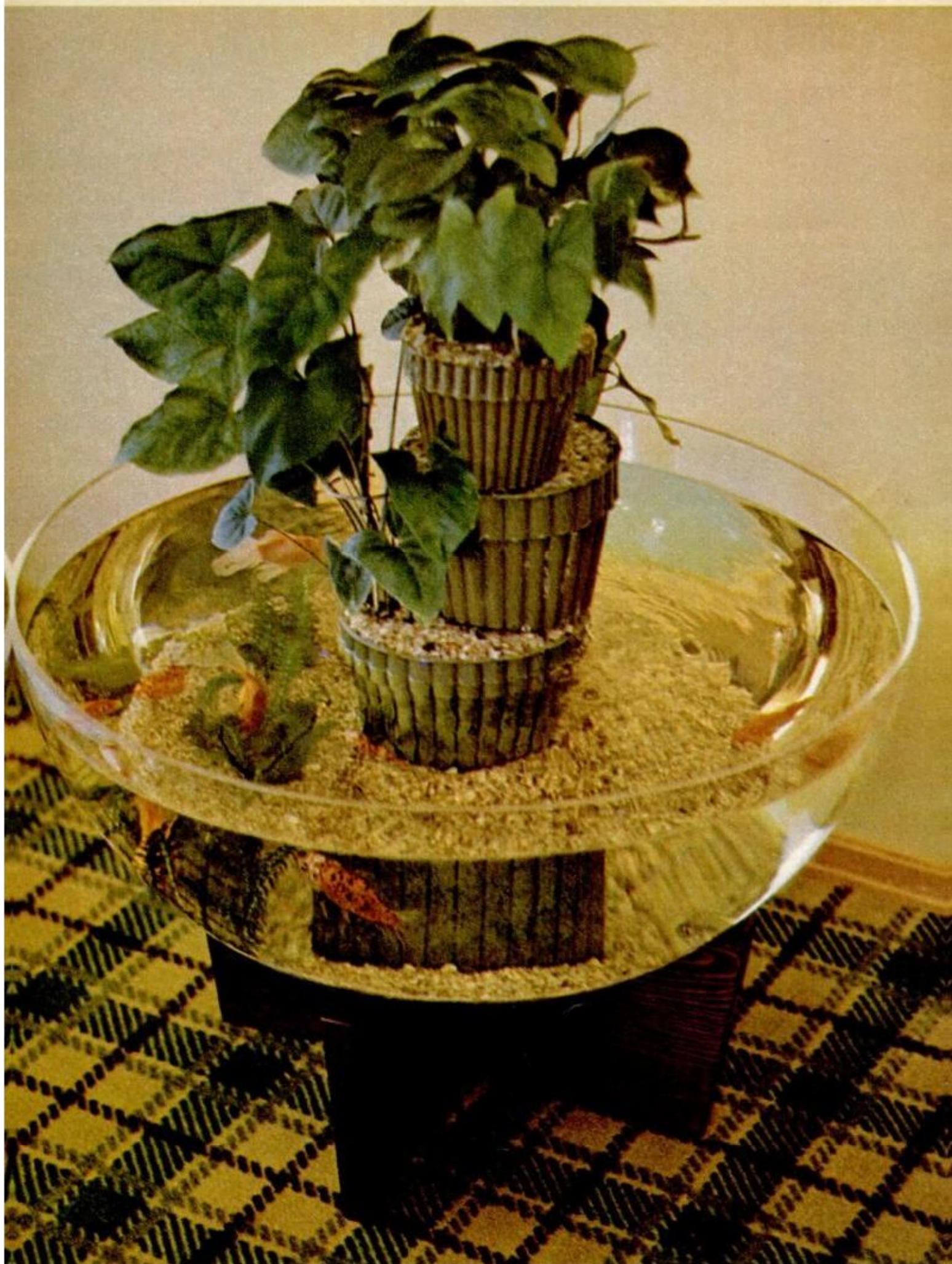

**YOU CAN BUY** a conventional 30-gal. fish tank with stand for about what it will cost to build this beauty, but that's what you'll have—a conventional-looking aquarium.

Not so with this bubble pond. It's as different and unconventional as you'll find. Resembling a king-size salad bowl, it consists of a 30-in. diameter plastic bubble you buy and cradle in a simple half-lapped stand. When viewed from certain angles, the curved sides of the bubble magnify and produce weird and unusual effects that are fascinating to watch while the fish are swimming around a cascading waterfall.

The bubble comes with the edge

and outside edges of the lip by rubbing them lightly with the sanding block held at a 45° angle. Then rinse away any grit that may be clinging to the bubble by flushing the area with water and by swabbing it lightly with a wet sponge. Your bubble is now ready for mounting on a stand.

I made the stand of 5/4 x 10-in. premium-quality redwood and later finished it to look like walnut. The two legs of the stand are identical except for the interlapping notches. Lay out the pattern for the legs on cardboard, making the curve match the bubble. Nominally, this curve will be the same as the diameter of the bubble (15-in. radius) so you can use the

# A \$50 aquarium that's really different

By **RONALD KONIECZYNSKI**

Technical art by *Fred L. Wolff*

trimmed and partially sanded so that it requires final finishing with fine sandpaper (150-grit followed by 220-grit) wrapped around a wood block. A sturdy cardboard box, about 18 in. square with the open end up and covered with a soft throw rug, makes a good marproof holder for your bubble while you work on it.

To get a professional-looking frosted finish on the lip, your sanding strokes should follow the curve of the bubble's rim. Your arm will sweep in a natural arc if you reach over the bubble and sand the far edge from the inside. Sand lightly and rapidly, changing sandpaper frequently. This job should take no more than 30 minutes.

When you are satisfied with the finish, break the sharp corners on both the inside

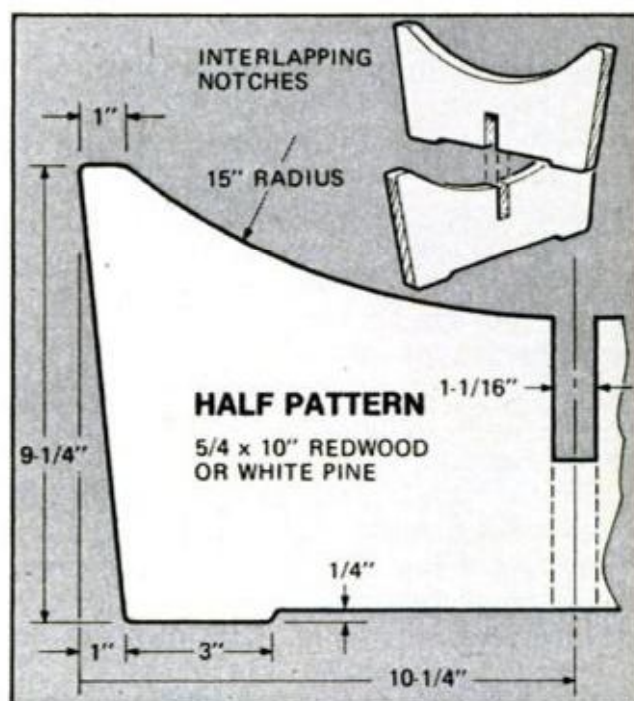

bubble's lip to trace the curve on your cardboard.

After you cut out the template, check it to see how well it fits the bubble. While a perfect fit is not critical, there should be no more than a 1/16-in. gap at any point.

Next, trace the pattern for both legs on the wood; saw out and round all edges and corners before cutting the notches. The notches are formed by making two straight saw cuts and breaking out the wood between with a chisel. After notching, finish-sand the flat faces prior to assembly. Notching is done most accurately on a table saw, running up the blade as high as possible and feeding the work with the saw's miter gauge. Two parallel saw cuts will result in both members of the cradle. However, you must remember to

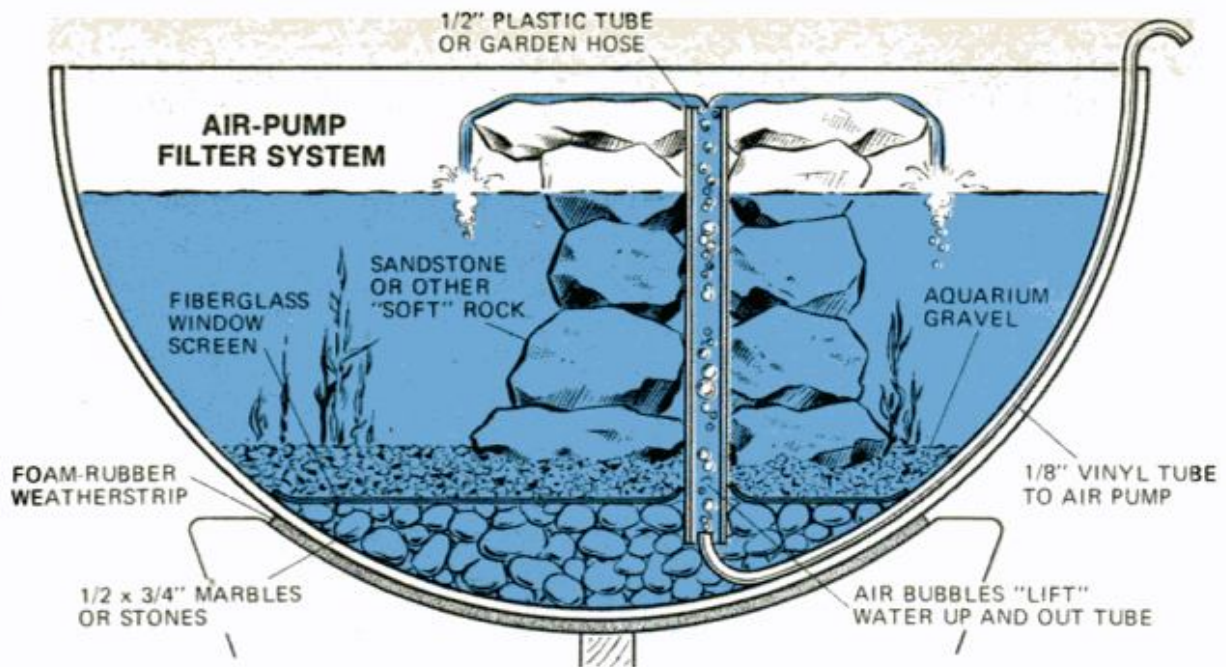

stop the cut short of its mark on the top side of the work to allow for the curvature of the blade which makes a deeper cut on the underside of the work. A handsaw is used to finish and even up the cuts.

If the notches are a snug fit, you won't need glue—simply slide one into the other. If the notches happen to fit loosely, use some resorcinol resin glue to help fill the gaps and strengthen the joint. Wipe off any excess glue right away with a slightly damp rag.

Fruitwood oil stain produces a handsome walnut finish when applied to redwood. After the stain is dry, apply three coats of satin-finish urethane varnish. Sand lightly with fine sandpaper between the second and third coat and burnish the latter coat with No. 00 steel wool after it is thoroughly dry. Finally, apply paste wax.

The bubble rests on  $\frac{5}{16} \times \frac{3}{4}$ -in. sponge-rubber weatherstripping which has a self-stick backing. The self-stick side is placed up and its protective paper covering is left intact while the strip is cemented to the stand. Coat the strip with contact cement and press it in place while the cement is still tacky. This will give you time to shift the strip when centering it.

While the rubber strips are drying, you can go ahead and mount the bubble. The rim of the bubble must be parallel to the base of the stand because any slant will be obvious when the bubble is filled with water.

First, set the bubble in its wooden cradle on the floor where it will be used and shift its position until a level placed across the rim shows it to be level. Now mark the position of the bubble with respect to the

*(Please turn to page 172)*

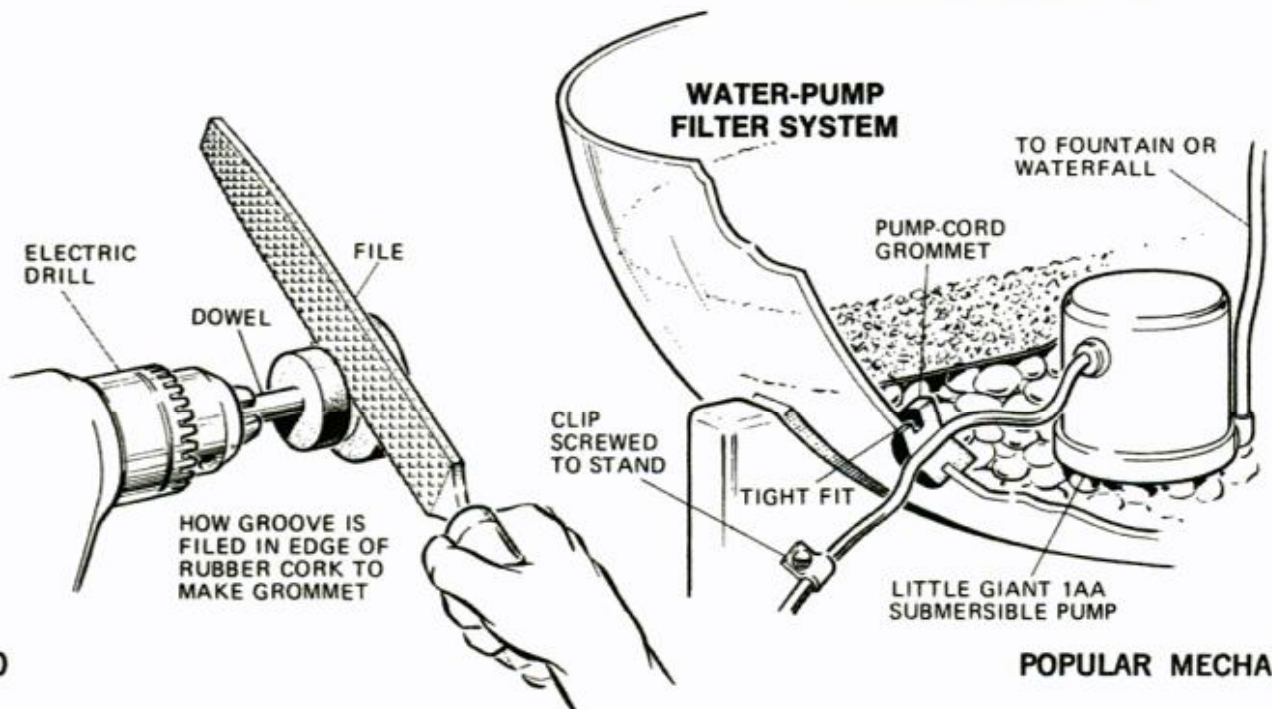

# Dodge makes pickup history.



*The Club Cab. Our newest addition to the Dodge pickup line.*

**The exclusive DODGE CLUB CAB gives you an extra 34 cubic feet of storage space inside for the things you don't want to leave outside.**



The extra carrying space behind the seats of every Dodge Club Cab means that when it rains, you store. This useful space is ideal for keeping valuable equipment secure, out of the way, and out of the weather. There's room for everything from tools to groceries to optional auxiliary jump seats. And Dodge does it all without

taking any room from the box. What's more, you can get that Club Cab with a full-sized pickup box into any standard 20-foot garage.

The Club Cab, like all Dodge Sweptline pickups, gives you front disc brakes, double-wall construction all around, and independent front suspension. You also get the new Electronic Ignition System for surer starts in any weather. This system is not affected by cold or rain. It eliminates points and condensers that wear out and is virtually maintenance-free. The Electronic Ignition... another example of how extra care in engineering makes a difference in Dodge... depend on it.

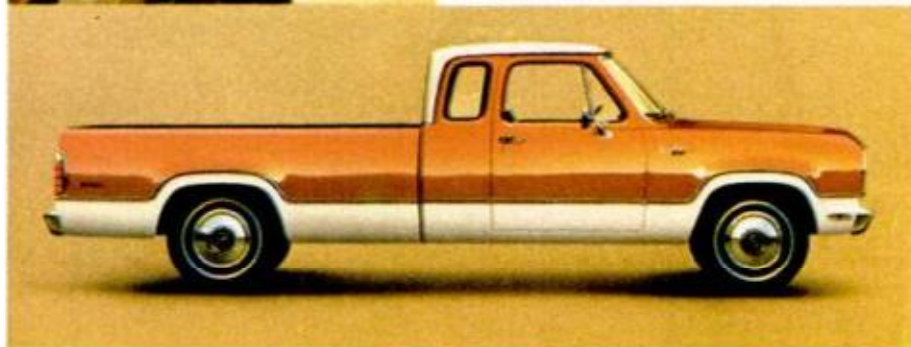

AGAIN THIS YEAR

**WHAT'S NEW IN PICKUPS COMES FROM DODGE...DEPEND ON IT.**

FEBRUARY 1973

171

## \$50 AQUARIUM

(Continued from page 170)

cradle by sticking pieces of masking tape on the inside and in line with the legs. Lift the bubble, remove the protective paper from the weatherstripping and place the plastic shell back in the cradle as it was.

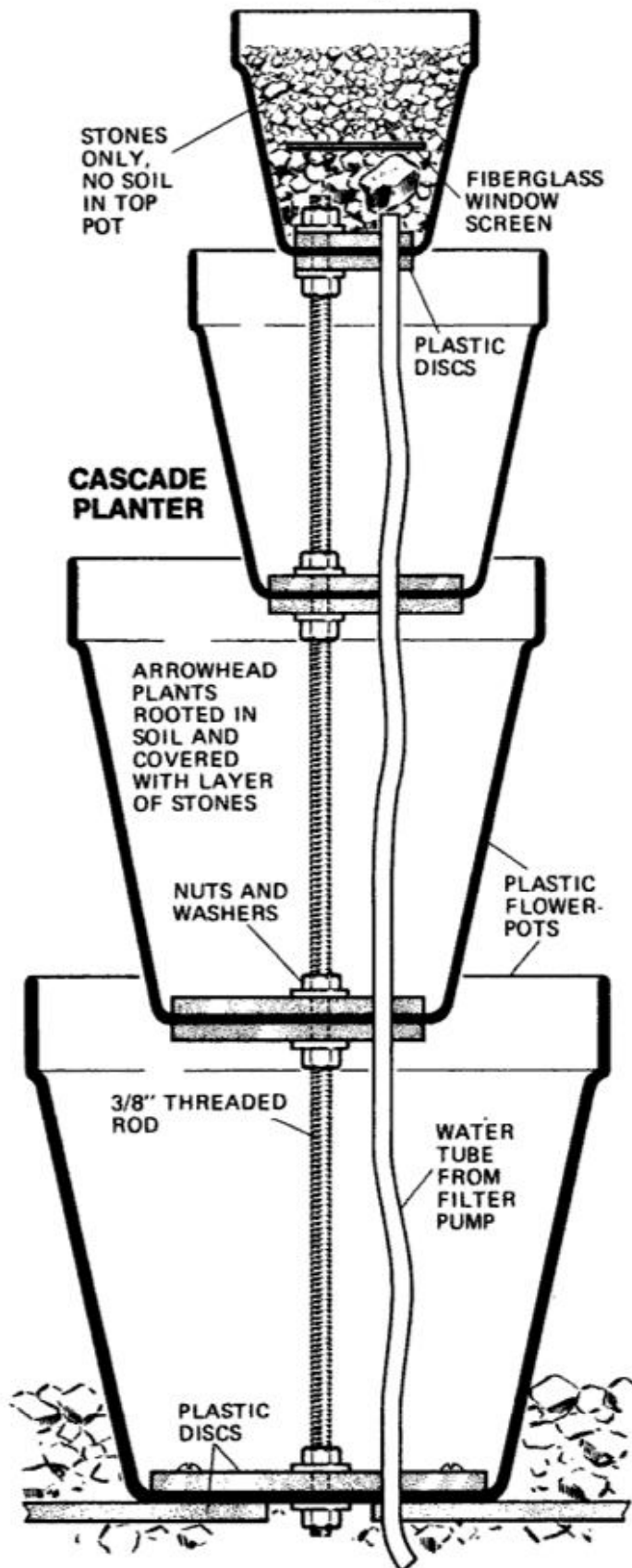

Finally, fill the bubble with water to weight it and bring it firmly against the sticky strips.

You have a choice of two filter systems. One employs an air pump located outside the bubble; the other a submersible water pump placed in the middle of the bubble. Each system has its advantages; the clear vinyl tubing used with the air pump is inconspicuous and doesn't need hiding, whereas the electric cord to the water pump is not easily concealed and requires running it out a hole in the bottom of the bubble. Boring a hole in the plastic for a watertight grommet is not difficult if you use a saw-type hole cutter in a slow-speed drill and exert only light pressure.

The drawings show two ways of creating planter islands in the center of your bubble.

The cascade planter at left consists of a tier of plastic flowerpots joined by a threaded rod. The lower end of the rod is attached to a plastic disc, which in turn is weighted with stones and aquarium gravel. Here water bubbles up through the stones in the top pot and cascades from pot to pot.

The arrowhead plants in the two lower pots are rooted in soil that is covered by a layer of stones to keep the dirt from washing out. The vine in the top pot is bedded directly in the stones without dirt and thrives on the continuously circulating water. Discs of plastic or hardboard are placed inside and under each pot and used to clamp the pots to the threaded rod with nuts and washers. The tubing from the filter pump is snaked up through holes in pots and the discs. A disc of fiberglass window screen in the top pot deflects the water and prevents it from dislodging the stones.

When filled with water, your bubble pond will weigh up to 300 lbs. so decide on a permanent location before you fill it. Moving it afterward would surely be difficult.

Follow the usual rules in maintaining an aquarium: Avoid overstocking with fish and overfeeding. A couple dozen small goldfish and a dime-store turtle or two make a fine beginning. Turtles need a rock or two to climb onto.

You can order a 30-in. plastic bubble from E. F. P. Products, Box 8243, North Royalton, Ohio 44133. It is priced at \$34.95 plus shipping. ★★★





Get away from the crowd.  
Get the flavor you want in  
Old Gold Filters.

Warning: The Surgeon General Has Determined  
That Cigarette Smoking Is Dangerous to Your Health.

20 mg. "tar," 1.3 mg. nicotine  
av. per cigarette, FTC Report Aug. '72.

© 1972 Lorillard

**WHITE'S METAL DETECTORS**

WHITE'S ELECTRONICS, INC. manufactures the World's Largest and Finest Line of Mineral and Metal Detectors. Ghost-towning, beachcombing, bottle hunting, coin hunting—all types of **TREASURE HUNTING** or **PROSPECTING**, amateur or professional. Detect conductive metals—Gold, Silver, Copper, Nuggets—Coins—Rings—Jewelry, etc. Underwater or on the land. "There are no fines at any price" 25 production models to choose from—T.R. or B.F.G.

Priced from **\$29.50** up  
—Always specify the Blue & Gold  
ASK FOR WHITE'S BY NAME

—Free Literature—  
**WHITE'S ELECTRONICS**  
Rm. No. 512  
1011 Pleasant Valley Rd.  
Sweet Home, Oregon  
23784 Hazel Street  
Albionford, B.C., Canada  
Elk Air Industrial Park  
Dexter Drive, East  
Elkhart, Indiana 46514



**New! 3-D Sight Magnifiers**  
**ENLARGES CLOSE WORK ONLY \$1.98**  
**SMALL PRINT!**

**WORTH MUCH MORE!**

See clearer, work faster, more accurately with less eye strain, less fatigue and tension with **HEAD BAND MAGNIFIER**. Wear like glasses, they'll magnify about 3x and leave hands free to work.

Produces a 3-dimensional effect, where each detail appears to stand out. **FOR CLOSE WORK, REPAIRS, SEWING, HOBBIES**, etc. Sturdy, lightweight, adjusts to all sizes. With or without glasses. Powerful prismatic polished lenses. Only \$1.98 + 50c for Post. and Hdg. PFD. (2 for \$3.50, 3 for \$5.00) **WORTH MUCH MORE! MONEY BACK GUARANTEE.**

See Find Prod., Dept. H8978 Box 205, Church, N.Y.C. 10008



**INSTALL ALARM SYSTEMS**

**Beginners Make Big Money — Your Own Boss**

New plan opens multi-million dollar burglar fire alarm business to small home operators. Guides beginners step by step.

Starts you full or spare time without previous experience or big investment. See how to cash in on invisible web of protection that stops crooks cold, makes big profits. No salesman will call. Write for free details!

**NASCO, 6100 Varlei Avenue, Dept. G2252, Woodland Hills, Calif. 91364**



**BUILD YOUR OWN CAMPER**  
**SAVE UP TO 50%**

Complete, easy to follow plans, instructions, materials list.

- Camper Plans ..... \$3.95
  - Travel Trailer ..... \$3.95
  - Pickup Cover ..... \$2.00
  - CONVERSION PLANS:**
  - Econoline Type Van... \$2.95
  - Passenger Bus or Delivery Van..... \$2.95
- Satisfaction Guaranteed

**EQUIPMENT CATALOG \$1.90**

Refundable on First Order. Send Dime for Details. Save 50% on Camper Kit. All items from catalog to build \$1,795. Camper, 8', 10', 10'6" or Chassis Unit.

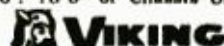

**VIKING CAMPER SUPPLY, INC.**  
89-8P Glenwood Ave.,  
Minneapolis, Minn. 55403  
Please send \_\_\_\_\_ for  
which I enclose \$\_\_\_\_\_  
NAME \_\_\_\_\_  
ADDRESS \_\_\_\_\_  
CITY \_\_\_\_\_  
STATE \_\_\_\_\_ ZIP \_\_\_\_\_

**UPHOLSTERING AND DECORATING FOR PROFIT!** Men & Women All Ages!

At home, we show you how, incl. tools, kits to make and sell. Accredited NHSC. Approved Veteran Training. No salesmen.

Creative Upholstery & Decorating School  
Div. Technical Home Study Schools, Dpt.  
5110-023, Little Falls, N. J. 07424



**BUILD THESE BEAUTIFUL CLOCKS**

**NOW AT BIG SAVINGS!**

Send just \$1 for plans & instructions to build choice of: (A) Grandfather, (B) Steeple, (C) Grandmother—plus information-packed catalog of movements, dials, parts & kits to build these & 16 other fine clocks. All 3 plans—\$2.50. Catalog alone—25¢.

**MASON & SULLIVAN COMPANY**  
Dept. PM, Osterville, Mass. 02655



**HEAVY DUTY WELDER**  
with special \$7.00 gift offer to Popular Mechanics readers  
**10-DAY FREE TRIAL**  
**Lifetime Guarantee**  
Brand New **1895** POST PAID  
Model **1895**  
Fits ordinary 110V outlet  
Not one - but 6 welding heats



Weld, braze, solder or cut most anything made of metal. No experience necessary. Follow simple instructions to make repairs on cars, trailers, farm and lawn equipment, bicycles, appliances, etc. Make campers, boats, furniture, hundreds of valuable items. **NOTHING ELSE TO BUY!** Comes complete with full face shield, pack of welding and brazing rods, heavy duty power cables, special electric torch attachment, ground clamp, flux, easy-to-follow illustrated instructions, rod holder, etc. Uses standard 1/8" rods to weld iron, steel, brass, bronze, aluminum, other metals. New improved **HEAVY DUTY** circuit gives more welding power. Gives 4 times the heat needed to melt toughest iron. Plugs into ordinary 110V outlet. 6 **WELDING HEATS** plus continuously variable carbon-arc heat regulation control lets you weld anything from "tough" jobs to light-weight metals with ease. This important feature saves you money and time. Makes it possible for even beginners to start welding professionally the very first day. Pays for itself quickly. An excellent gift for any occasion. **IT'S AUTOMATIC:** Current is turned ON when arc is struck, OFF when rod is lifted from work. Eliminates need for troublesome foot switch. Speeds up work.

**FREE!** Mention that you saw this ad in Popular Mechanics and receive a \$7.00 gift pack assortment of "touch weld" welding rods. Automatic arc striker. Weld with "push button" ease. Lifetime guarantee. 10 day **MONEY BACK GUARANTEE.** You must be satisfied or return for refund. Send only \$2.00 and pay postman \$16.95 plus postage when delivered or send \$18.95 cash, check or money order for immediate postpaid shipment.

**WEL-DEX MFG. CO., Dept. W-203, Box 10776, Houston, Texas 77018**

**locksmithing and key making**

**PRACTICAL UP-TO-DATE COURSE — ONLY \$7.95**

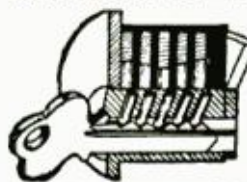

Teaches you how to pick locks, de-code, make master keys, repair, install, service, etc. New self-instruction lessons for every handyman, homeowner, carpenter, mechanic, service station operator, fix-it shop, hardware dealer, gunsmith. 53 easy illustrated lessons. Full price only \$7.95 plus postage. Satisfaction or refund guaranteed. Mail order today!

**NELSON-HALL CO., Dept. 6BX-2**  
325 W. Jackson Blvd., Chicago 60606

**At Last a New Amazingly Simple**

**GAS TURBINE JET ENGINE**

Build from easy to follow plans. Length 15", Dia. 8 1/2", Wt. 15 lbs. Fuel: Gasoline or Kero.



"Screamin' Demon" develops 20 H.P. Ideal project for serious-minded hobbyists, students; scientific and industrial arts classes. Make on 9" metal cutting lathe with milling attachment. For use on small racing boats, midget cars, etc. Full size assembly drawings with critical dimensions, bill of materials and photos. Price \$5.00. No C.O.D.

**SAVOY SCIENTIFIC, BOX 1398, SANTA MONICA, CALIF. 90408**



**IF YOU CAN SING, WHISTLE, OR HUM A TUNE...**

you can play the Musical Saw. No notes to read, no musical knowledge required. Since 1921 we have furnished the entire world this unusual, sweet-toned instrument. If you are 10 or 70, you play or no pay. Musical Saw, soft hammer, bow, resin and lessons mailed on 5 days' trial. Write today for details and free copy of "Sawing News of the World," picturing successful saw musicians. **MUSSEHL & WESTPHAL, 107 Fort St., Fort Atkinson, Wisconsin. 53538.**

# You get more for your money from NRI



**SOLID STATE TRAINING**—Learn-by-doing with NRI equipment. TV-Radio Servicing course includes 25" color TV, with handsome woodgrained cabinet at no extra cost; wide-band service type oscilloscope, color bar crosshatch generator, transistorized volt-Ohm meter, and solid-state radio kit. Other courses equally complete.

## NRI Programmed Equipment Gives You Priceless Confidence, Makes Learning TV-Radio, Electronics Fast and Fascinating

NRI pioneered the idea of supplying home-study students with custom designed training kits to give practical on-the-job experience as you learn. Today, NRI's "3-Dimensional" training can't be equalled. You get more value—from the exclusive Achievement Kit sent the day you enroll, to "bite-size" texts and custom training equipment. Learning TV-Radio, Electronics or Communications at home is easy, exciting, the NRI simplified, dramatized way.

### BE A SKILLED TECHNICIAN IN AMERICA'S FASTEST GROWING INDUSTRY

Regardless of your educational background, you can learn the Electronics field of your choice the practical NRI way. The NRI color catalog, sent to you free and without obligation, tells you how you can qualify quickly to be a part of the fast growing Electronic Age; about engineering jobs in business, industry, broadcasting, government, now offered to men without college degrees. It will open your eyes to the great number of success opportunities available right now in the high-pay world of TV-Radio Servicing, Broadcasting-Communications and Industrial-Military Electronics. With NRI technical training, you can take your choice of a wide variety of career

openings or have a business of your own. And if you choose one of five NRI courses that include FCC License preparation, you must earn your FCC License or NRI refunds your tuition!

### MAKE \$5 TO \$7 AN HOUR EXTRA IN SPARE TIME STARTING SOON

Tens of thousands of NRI graduates are proof it is practical to train at home in your spare time. Keep your present job while preparing for a better one, and earn \$5 to \$7 an hour extra in spare time while you train, fixing sets for friends and neighbors. NRI shows you how. Equipment you build and keep becomes useful in your work.

### STEP UP TO BETTER PAY, A BRIGHTER FUTURE

NRI can help you, but the decision to act must come from you. Decide now to move ahead . . . mail the postage-free card today for your FREE NRI color catalog. No obligation. No salesman will call. NATIONAL RADIO INSTITUTE, Electronics Division, Washington, D.C. 20016.

#### APPROVED UNDER GI BILL

If you served since January 31, 1955, or are in service, check GI line on postage-free card or in coupon.

### CASH IN ON THE BOOM IN COLOR TELEVISION



The NRI TV-Radio Servicing course includes your choice of black and white or color TV training equipment. Color TV needs thousands of trained men to keep pace with millions of sets being sold every year. NRI prepares you quickly. Cash in on the boom.

## Mail insert card for your FREE NRI color CATALOG

No salesman will call

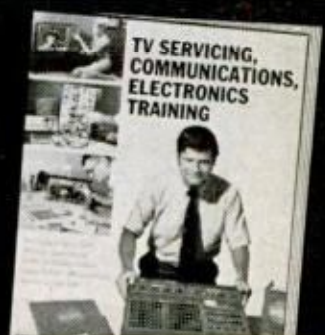

## PICTURE FRAMES

(Continued from page 77)

thumb (and in my opinion a correct one) is that *any picture will look good—in any room decor—if properly framed.*

**How to mat.** In general, delicate prints, watercolors and fine reproductions are enhanced by the addition of a mat. Mat board comes in 30x40-in. sheets in a variety of colors and textures from smooth to grass cloth in shiny or dull finish. If you decide that your picture needs a mat, it is the first step in picture framing because its outside dimensions will determine frame measurements.

Two "musts" when cutting a mat: First, the bottom horizontal is *always* slightly wider than the top horizontal and the verticals. The average mat is usually 3 in.

wide at sides and top and 3½ in. wide at bottom. Second, the cutout should always be made with a bevel cut as shown on page 77. The sloped edge enhances the picture and also visually minimizes any minor irregularities if your cutting tool should wander from the straightedge even slightly.

Measure the picture to be framed and transfer the marks to the mat board. Make the cutout as shown, then decide the mat's width. Don't forget to add ½ in. in height and width to allow for the portion which will be in the ¼-in. rabbet. Cut a backing board, tape the print to its center and secure the mat.

As a rule, matted pictures are covered with nonreflecting glass. When you buy picture glass, make certain it is clear and free of any bubbles or waves. And, be-

### Picture-framing tools and supplies



**TOOLS YOU'LL NEED** include a backsaw, miterbox, glass cutter, combination square, utility knife, corner clamp, ruler, pencils, nailset and light hammer. An electric drill, optional, is a desirable addition



**BUILDING AND FINISHING SUPPLIES:** White glue, oil (or water) stain, varnish, assorted brushes (bristle for oil paints, nylon for latex), filler, paint, clear spray finish, sandpaper, cheesecloth, Scotch connectors, picture hangers, brads, picture wire and, for "antiquing," tubes of burnt umber and black



**GOOD VARIETY OF CLAMPS** is nice to have around; they're a sound investment if you are planning to make a lot of frames. Clamps shown here are spring-type (center), three-way edging, handscrew, web and a pair of miter clamps—which hold a frame square

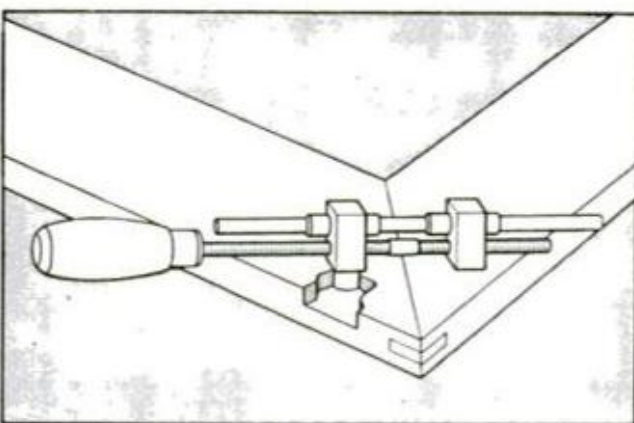

**MITER CLAMPS** are designed for use on flat stock (S4S). You must drill two 5/8-in. holes in back of the frame for seating each clamp. All clamps shown here are available at hardware suppliers. If you cannot find one locally, write to Adjustable Clamp Co., 422 North Ashland Ave., Chicago, Ill. 60622

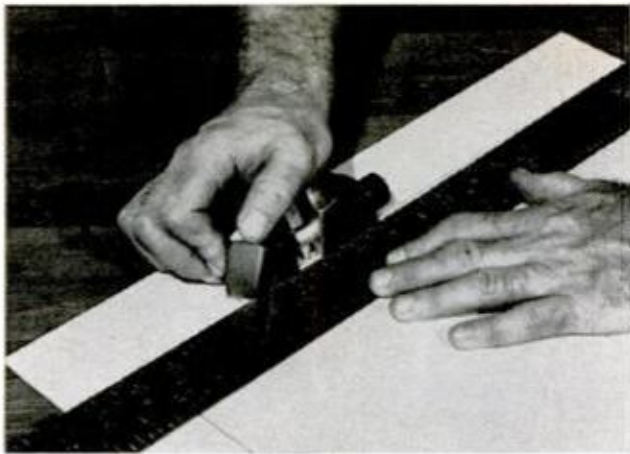

**MAT CUTOUT** should be made with slight bevel. The cutter shown lets you do this accurately and quickly



**CUTTER**, called a Dexter Mat Cutter, costs about \$6 at artists' supplies stores. It's made by the Russell Harrington Cutlery Co., Southbridge, Mass. 01550

cause picture glass is particularly fragile, handle it with care. Work on a clean, flat surface; preferably your workbench after it has been covered with cardboard. Take accurate measurements of the frame's rabbet opening, and don't forget to sub-

tract  $\frac{1}{8}$  in. in length and width so that the glass won't shatter when you insert it. (If you prefer, let glazier do the cutting.)

*Making a picture frame.* Most frames have a rabbet to contain the picture  
[\(Please turn to page 180\)](#)

## Making a picture frame

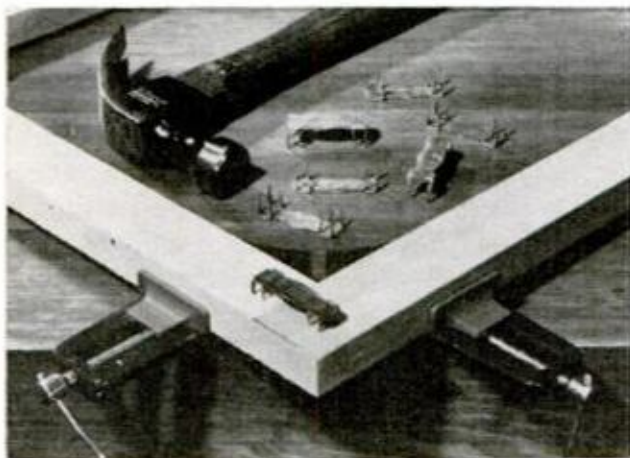

**TO ASSEMBLE SUBFRAME**, use glue and Scotch connectors on the back side. If subframe will be seen from the front, use mitered (instead of butt) joints

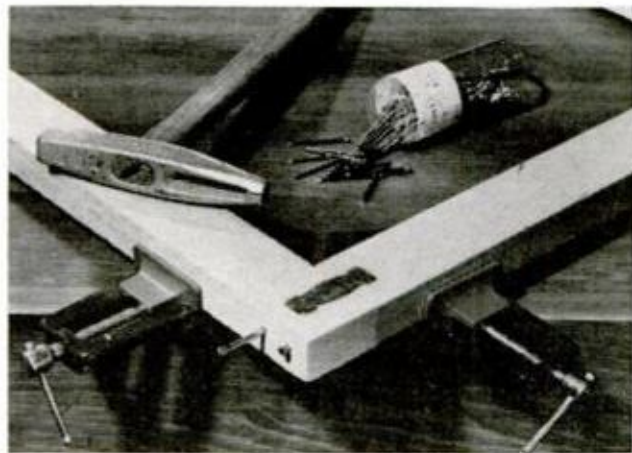

**AFTER ASSEMBLY**, drive in two finishing nails at each corner. Allow the nails to protrude  $\frac{1}{16}$  in. above the surface and then set them  $\frac{1}{16}$  in. deep

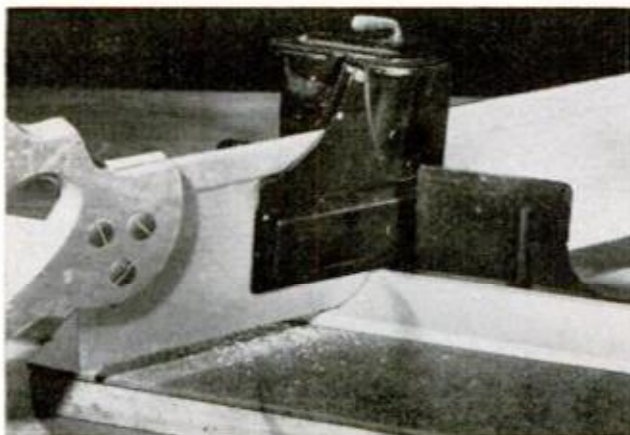

**CUT FRONT-FRAME MOLDING** using a miterbox and backsaw. For stability, clamp miterbox to workbench

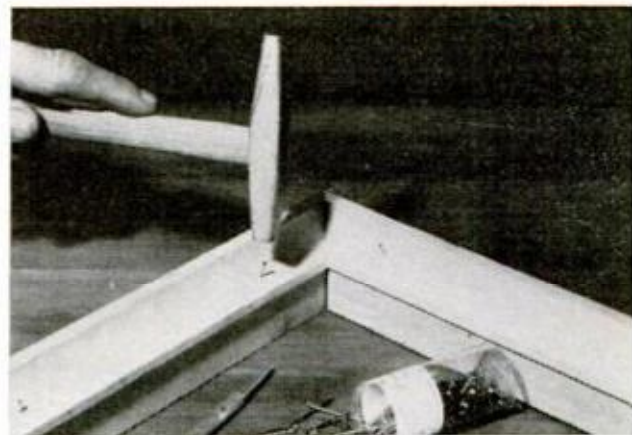

**FASTEN FRONT FRAME TO SUBFRAME** with glue and suitably sized brads. Molding overhang forms rabbet

## Finishing tips and hints



**TO "ANTIQUE" STAINED FRAME**, darken the corners with burnt umber. Use a clean cheesecloth to blend the umber carefully into the adjacent stained wood



**TO COLOR-TONE PAINTED FRAME**, apply a wash of second color (above, blue over white). After a few minutes, wipe off the color with a clean cheesecloth

## PICTURE FRAMES

*(Continued from page 179)*

(all of those shown do). In some cases, a single molding such as back band—used on a simple poster—does the job. But for more sophisticated frames, you make a two-piece frame consisting of a back (subframe) and front frame (with an opening  $\frac{1}{2}$  in. less in width and height to create the  $\frac{1}{4}$ -in.-wide rabbet).

A subframe can be joined using simple butt joints if it will be fully covered by

the front frame, Bainbridge board or cloth. If the subframe will be in view, however, miter-cut these corners as well as the moldings.

Use a miterbox to make the cuts and assemble the frames using a corner clamp as shown in photos. The clamp is fastened to the workbench and when the moldings are secured in its jaws, they're held square while you do the gluing and nailing. When all four sides are assembled, check the frame with your square and temporarily

*(Please turn to page 182)*

## Mounting and hanging pictures

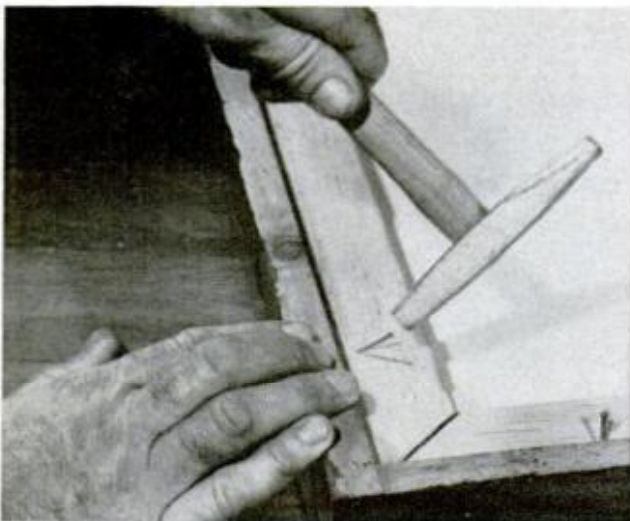

**OIL PAINTING ON STRETCHERS** is held in frame by driving 4d nails through stretchers into the frame

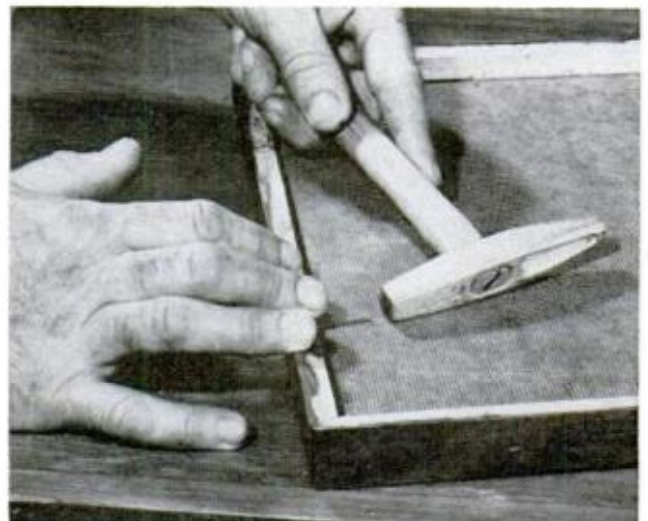

**MOUNTED PRINTS** (on cardboard or hardboard) are secured in the rabbet with eight brads (two per side)

# Want a job doing what comes naturally? Take this test.



Think you're a "natural" technician? Then you should be a lot better than average at spotting the differences between similar objects. For example, which part, A, B, C, D, or E has a visible defect?

Answer: D

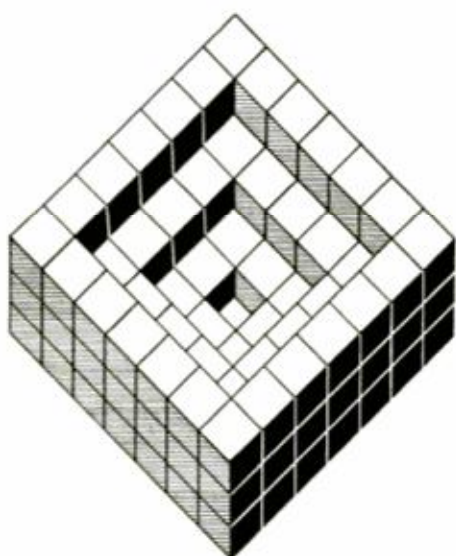

Here's a tougher one. Give us the right total of cubes in this figure. You'll be proving to yourself you have the kind of clear head and mechanical aptitude that really count for something in the Air Force.

Answer: 112

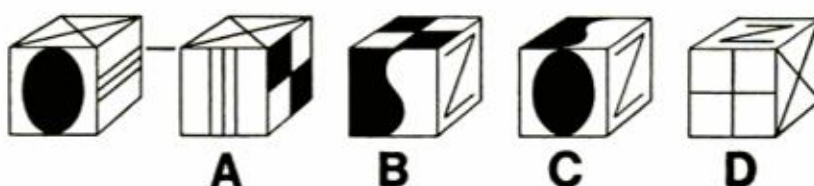

Good imagination and deductive powers? They'll help you fly through the Air Force's many types of advanced technical training. Think—which ones of cubes A, B, C, or D could be the same cube as the one on the left, only turned?

Answer: A, B, C, D

Illustrations Courtesy of Arco Publishing Co., Inc.

Got them right? Then you might rack up high scores on the Air Force Aptitude Test. And that could do you a lot of good. Now, by qualifying you for outstanding technical training in one of over 100 Air Force jobs, from aircraft mechanic to medical specialist. And later, when you offer prospective employers a reusable skill.

Think it over. Mail in the coupon, or call 800-447-4700, toll free (in Illinois call 800-322-4400) for the nearest Air Force representative, and get the details. If you have natural mechanical talents, the Air Force will see to it those talents get

trained. Neither you nor the Air Force can afford to let them go to waste.

Air Force Opportunities	1-PM-23
Box A	
Randolph AFB, Texas 78148	
Name _____	
Address _____ (Please Print)	
City _____	
State _____ Zip _____ High School _____	
Soc. Sec. # _____ Age _____	

**Find yourself in the Air Force.**

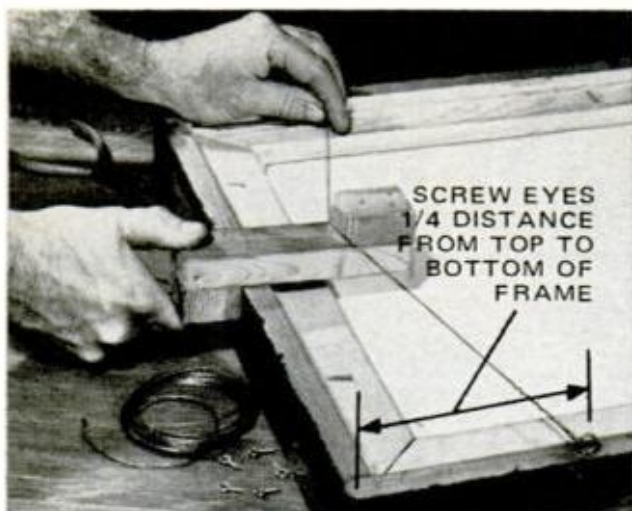

INSTALL PICTURE WIRE below top of frame so that picture hanger on wall will not show. A simple jig assures that wire length is on the money every time

PICTURE-WIRE JIG is quickly fashioned from scrap. Distance A must suit frame to be fitted with wire

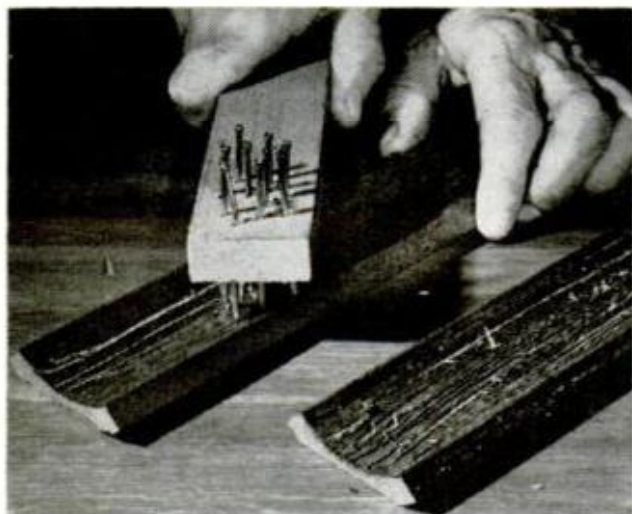
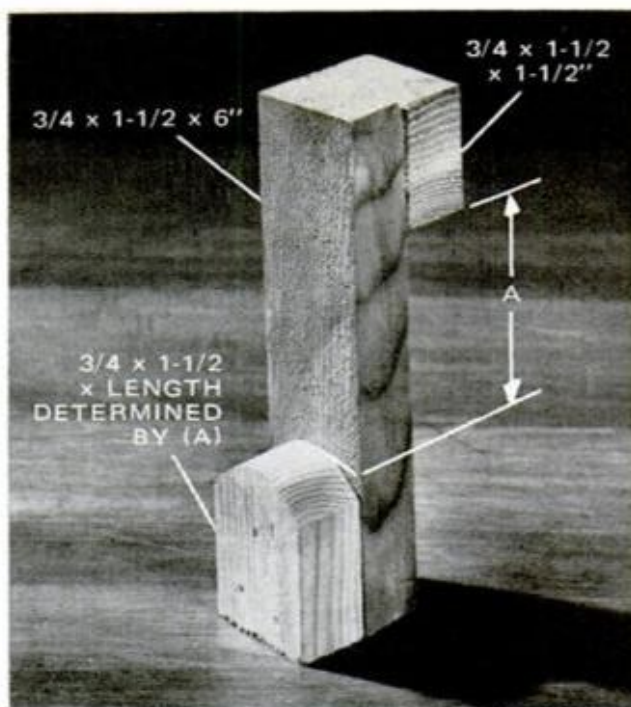

STRIATING "TOOL," conceived by author, consists of 8d finishing nails driven through  $\frac{3}{4}$ -in. pine strip



TEXTURED BAINBRIDGE BOARD used on some frames in story (from left): burlap, grass cloth and linen

## PICTURE FRAMES

*(Continued from page 180)*

tack two diagonals across the frame back to hold it square while the glue dries. Finally, set all nails  $\frac{1}{16}$  in. below the surface, fill and sand.

Next, attach the front frame to the subframe with glue and appropriate-size nails. When the glue is dry, sand frame well with a fine-grit sandpaper and dust it thoroughly before finishing.

*Finishing a frame.* There are three basic finishes you can use: natural, stained and painted. Materials are a matter of personal preference; oils or alkyds give you a longer time to work the finish (when rubbing off an antiquing wash, for example), but latex materials let you do the job a bit

faster and with less cleanup to be done when you have completed the job.

*Natural finish:* Apply either thinned shellac or varnish. Allow to dry overnight, rub lightly with 4/0 steel wool, wipe off dust and apply a second, nonthinned coat of the same finish. After 24 hours, apply wax and buff to a sheen.

*Stained finish.* Apply a stain of your choice, allow it to set 15-20 minutes, then wipe off the excess. Let this dry at least 24 hours, then apply a coat of shellac thinned 50-50 with alcohol. Wait a day, then rub lightly with steel wool, dust and apply a finish coat of varnish.

*"Antiqued" stain finish.* Follow the same steps described above, but after staining apply burnt umber directly from the tube,

*(Please turn to page 184)*



# HOW COULD YOU FORGET

## MILT MARION?

1936 was a very good year for a race fan. The very first race on the famous Daytona Beach-Road Course was held.

The purse was 5,000 bucks, and lest you think this was a minor-league affair, remember the price of groceries in '36. This kind of important money attracted a pretty hot field, including: the Indy 500 winner, Bill Cummings; the dirt track champions Bob Sall, Doc Mackenzie and Ben Shaw; Major Goldie Gardner; the Collier brothers, Miles and Sam; and an obscure service station operator named Bill France.

The winner? Good old boy Milt Marion, in a Ford V-8, the Permatex Special. (That France fellow was not only Milt's mechanic, but drove another Ford to fifth place.)

The interesting thing about Milt's car was that the engine was literally stuck together with Permatex products. To prove they worked, the engine was assembled without any gaskets, using our Form-A-Gasket products instead (Form-A-Gasket #1, hard-setting, and Form-A-Gasket #2, pliable-setting). Obviously, it held together.

It really wasn't much of a gamble for Permatex. After all, the company got its start helping Barney Oldfield, back in '09. And today, you'll find Permatex products in service stations, NASCAR garages, and wherever automotive products are sold.

You'll find the same Form-A-Gasket that helped Barney and Milt. And you'll find the latest additions to our long line. Like the new Silicone Form-A-Gasket. With this handy tube, you can actually *make* any size or shape gasket for any application. And being silicone rubber, it is resistant to a greater variety of chemicals, higher pressures, and higher and lower temperatures than anything else you can buy. It is the most versatile adhesive-sealant there is.

Want a free racing decal? You can have one if you promise to remember Milt. Just send us a self-addressed stamped envelope. Don't forget.



**Permatex**  
our name is our bond

PERMATEX COMPANY, INC.  
P. O. Box 1350, West Palm Beach,  
Florida 33402 305/686-0880

Courtesy of Museum of Speed, Daytona Beach, Florida



## PICTURE FRAMES

(Continued from page 182)

using a cheesecloth. Corners and crevices should appear darkest and the umber should be carefully blended to "disappear" as you work it toward the center. Then, you can proceed with finishing as indicated above.

**Paint finish:** Apply a wash-coat of shellac (thinned 50 percent with alcohol) and let it dry. Rub lightly with steel wool, dust and apply color of your choice. You can use oil-base enamel or, if you prefer, latex. The latter, though, should be followed with a coat of varnish. **Caution:** use *varnish only* over latex paint or the paint will lift off. As you prefer it, the varnish finish can range from dull to high gloss.

**"Antiqued" paint finish:** After applying the basic color, allow it to dry overnight. Then, mix a black paint with appropriate thinner to a *slightly heavier than water* consistency. Apply this wash to the frame,

*Specific instructions for all frames shown start in the column at right and continue on pages 188, 189 and 190. Bold type at the start of each caption gives picture size; the number in parentheses refers to the source for the art in that frame. (See page 190.)*

wait five minutes and wipe it off with a clean cloth. If desired, the antiquing can be done with another color instead of black. (For example, the frame surrounding the Tiger with Red Background (page 74) was finished by wiping orange over Chinese red.) Finally, proceed with an appropriate clear finish.

In general, when limited quantities will be needed, I've found that spray varnishes, lacquers and the like are easier to use than their brush-on counterparts. They eliminate a great deal of clean-up time and they set faster, which means that there's less time for dust to settle on your new frame during the drying time.

**Hanging pictures.** The easiest way to hang a picture is to use two screw eyes no longer than three-quarters of frame's thickness. Insert them about a quarter of the distance from top to bottom of the frame. Attach picture wire as shown and the picture is ready to hang. To keep picture from tilting, use a pair of picture hooks on the wall—spaced 6 in. or so apart—instead of just one. Make certain that the screw eyes, wire and hooks are strong

(Please turn to page 188)

### On the cover

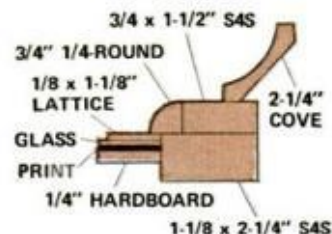

**24x36 in. (1).** Assemble subframe using the dimensioned stock shown. Cut and fit all moldings, and temporarily tack them in position. When you're satisfied with fit, remove moldings from the subframe. Striate the quarter-round and cove molds (see page 182), sand thoroughly and wipe off dust. Stain moldings dark walnut, let them dry; then finish with varnish. Seal the lattice and subframe with shellac wash. Apply charcoal gray latex paint to lattice and dark green (latex) to subframe. When parts are dry, permanently assemble the frame using glue and brads

### Frame on page 73

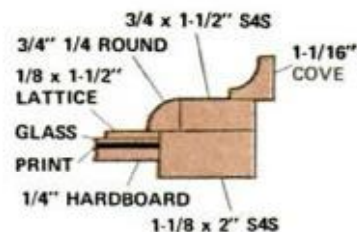

**18x36 in. (2).** Follow construction details above. Finishing details are also the same as above, except for a driftwood stain on moldings and dark blue latex on subframe

### Frames on page 74

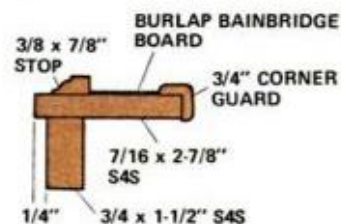

**22x28 in. (3).** Assemble the subframe and glue on white burlap board. Cut and fit moldings, remove and seal with shellac. Apply white latex, let it dry, antique with pink latex. Varnish and permanently assemble



**22x28 in. (3).** Assemble the subframe, then glue and tack 3/4-in. stock to the frame. Cut and temporarily tack bead moldings in position to check fit, then remove. Apply sandalwood grass-cloth board to frame, stain and varnish moldings, then permanently attach them to frame's inside and outside edges as shown

# The day Bill told off his boss

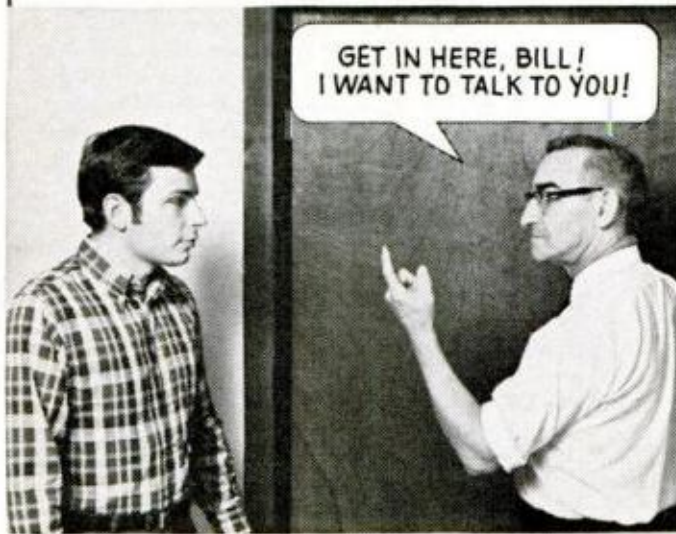

ARE YOU WORKING FOR PEANUTS IN A DEAD END JOB? GET SMART. SEND FOR **2 FREE BOOKS** LIKE BILL DID!

Be sure to send for your 2 FREE books today. For your convenience, we will try to have a representative call. If coupon has been removed, write to Cleveland Institute of Electronics, Inc., 1776 East 17th Street, Cleveland, Ohio 44114.

**CIE** Cleveland Institute of Electronics, Inc.

1776 East 17th Street, Cleveland, Ohio 44114  
Accredited Member National Home Study Council

Please send me your **2 FREE BOOKS** describing the opportunities in Electronics and how to prepare for them.

Name \_\_\_\_\_  
(Please print)

Address \_\_\_\_\_

City \_\_\_\_\_

State \_\_\_\_\_ Zip \_\_\_\_\_ Age \_\_\_\_\_

**APPROVED FOR TRAINING UNDER G. I. BILL**

**Veterans and Servicemen:**  
Check here for G.I. Bill information.



PM-76

## PICTURE FRAMES

(Continued from page 184)

enough to hold the weight of the picture.

Instructions for all of the frames shown in the photos are given. Bold type at the



1-3/8" CLAMSHELL STOP



**18x28 in. including mat (4).** Assemble frame; sand, dust and apply a driftwood stain. After 15 minutes, wipe off the excess.

When dry, size the frame with

shellac, brush on a yellow latex paint, wait 5 minutes and wipe off frame. Finish frame with varnish

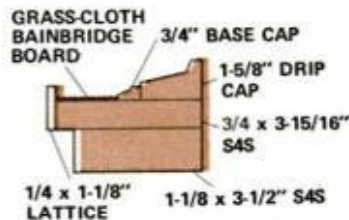

**22x28 in. (3).** Assemble subframe and 3/4-in. stock. Cut, fit and temporarily assemble the moldings; then remove them. Cover frame with tan grass-cloth Bainbridge board. Striate and sand the drip cap, then apply a dark pine stain. Seal the lattice with a shellac wash; paint it mustard yellow. Finish moldings with varnish; permanently attach them to frame

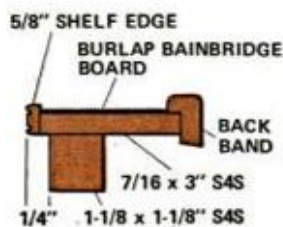

**22x28 in. (3).** Assemble subframe and 7/16-in. stock.

Cut and fit moldings, then remove. Size the frame with thinned shellac, allow it to dry, then cover it with gold burlap board. Seal moldings with shellac and apply Chinese red latex. When dry, antique with yellow latex, tinted slightly with black. Varnish moldings and permanently attach them to the frame.

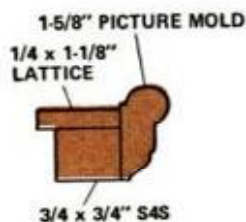

**18x32 in. including mat (4).** Assemble all parts and size with thinned shellac. Finish the frame using buttercup yellow and chocolate brown on picture molding and lattice, respectively. When dry, antique the yellow with an avocado green and varnish frame.

## Frames on page 75

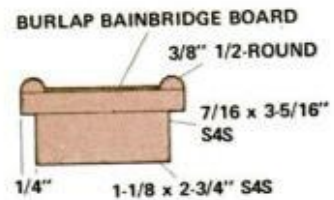

**22x28 in. (3).** Assemble the subframe and 7/16-in. stock. Glue rust-colored burlap board to the frame, using brads where necessary. Miter cut and fit half-round moldings, then remove them. Size moldings with thinned shellac, then apply white latex paint. When dry, finish with varnish and attach moldings

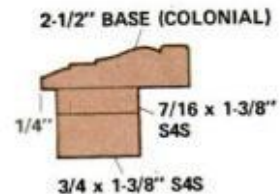

**22x28 in. (3).** Assemble the subframe, attach front-frame moldings (miter corners). Seal wood with a thinned shellac. Brush on colonial blue latex and let it dry. Next, apply a slightly thinned white latex and, after five minutes, wipe it off with clean cloth. When completely dry, finish wood with varnish

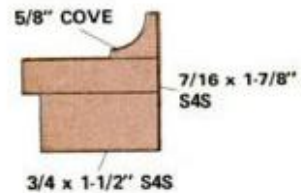

**15x20 in. (5).** Glue print to 1/4-in. hardboard. Assemble frame and size it with shellac. Using latex paints, brush on olive green, allow it to dry, then antique with thinned red latex paint. Use varnish as a finish and picture glass to protect the print

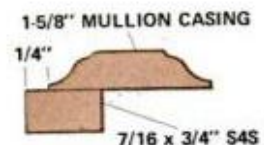

**15x21 in. (6).** Assemble the subframe and mullion casing. Brush on pine stain, wait 15 minutes and wipe off excess. Antique corners with burnt umber; allow 24 hours to dry. Finish the frame with lacquer

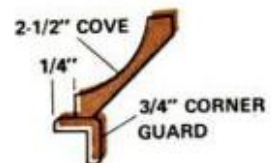

**21x27 in. including mat (4).** Assemble the frame from moldings, using miter cuts at all corners. Size the frame with a thinned shellac and allow it to dry. Apply a mustard yellow latex paint to the liner (corner guard) and use avocado green latex paint on the cove. Apply varnish to the frame for a finish

POPULAR MECHANICS

start of each caption refers to the picture's size. Following the size is a number in parentheses that refers to a where-to-buy source listed on page 190. ★ ★ ★

Instructions for more frames and a list of where-to-buy-sources appear on page 190.

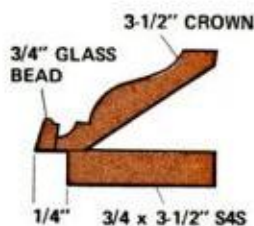

23x28 in. including mat (4).

Because the subframe is visible, use miter joints throughout. After assembling frame, apply dark walnut stain to subframe. Next, seal entire frame with thinned shellac. Paint crown molding and bead (liner) with white latex and let it dry. Then apply thinned orange paint to crown only, wait five minutes, wipe, When dry, spray on varnish

Frames on page 76

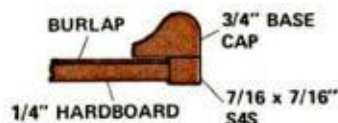
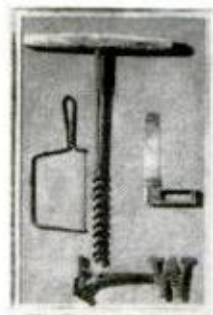

15x22 in. (framing a collection). Arrange objects to determine size of 1/4-in. hardboard. Glue red burlap to hardboard using staples at edges. Assemble the frame, striate wood moldings

and sand. Apply driftwood stain, then wait 15 minutes and wipe off excess. When dry, apply lacquer. To hold objects, drill holes through board (bracketing a part of each object). Run thin copper wire around objects and through holes; knot wire on back of board. Wire each object in at least two places.

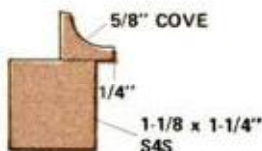

22x28 in. (3). Assemble the frame using miters on all corners. Size entire frame with a thinned shellac and

set it aside to dry. Next, using latex paints, apply a dark yellow to the cove molding and a flat black to the subframe. When dry, antique cove molding with a thinned black. Finally, varnish all parts



8x10 in. (7). Simple object, extra simple frame; assemble it with glue and brads at mitered corners. Apply pine stain, antique with burnt umber and finish with lacquer. Back up the print with cardboard

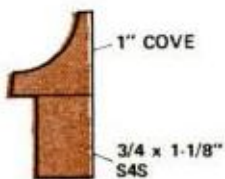

17 1/2 x 23 1/2 in. (3). Assemble frame, fill holes and sand thoroughly. Apply a walnut stain, wait 15 minutes and

wipe off. Finish with two coats of a semigloss lacquer. Rub lightly with 4/0 steel wool between coats. Wait 24 hours; rub on paste wax and buff to sheen



6 1/2 x 9 1/2 in. (7). Assemble the subframe and add stop molding at front. Size all wood with shellac and allow to dry. Sand it lightly and brush on avocado green latex paint. Let dry, finish with varnish. Print should be backed with cardboard and, if desired, covered with glass

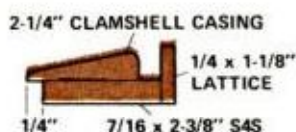
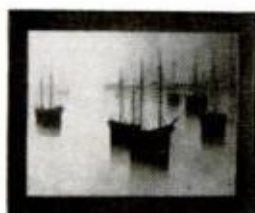

22x28 in. (3). Assemble the frame as shown above. Set

all nails, fill nail holes and thoroughly sand wood. Size with thin shellac, allow to dry. Brush on dark green latex paint and let dry. Antique frame with thinned black latex. When dry, finish with varnish

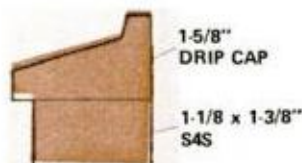

18x29 in. including mat (4). Assemble the subframe and frame using stock shown. Fill holes, sand, seal with shellac wash. Apply dark red latex paint, allow to dry and then antique with black-latex wash. Finish with two coats of varnish, protect the woodcut with picture glass

## PICTURE FRAMES

(Continued from page 189)

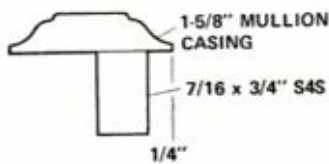

12x16½ in. (8). Assemble the frame, sand and seal with a shellac wash. Brush on reddish-orange latex, let dry, antique lightly with burnt-umber wash. Varnish when dry; use hardboard backing, glass to protect print

that the poster will be perfectly flat and that there will be no air bubbles under it. Assemble the frame directly to hardboard and seal it with thinned shellac. Apply mustard yellow latex paint to the frame, let this dry and antique it with burnt-umber wash. Use this same wash to slightly antique the print around its edges. For a finish, apply a spray-type varnish (dull) to the frame as well as the poster

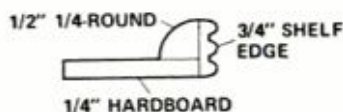

19x28 in. (9). Glue poster to piece of ¼-in. hardboard cut to the same size. Use a straight-edge and clean cloth to assure

that the poster will be perfectly flat and that there will be no air bubbles under it. Assemble the frame directly to hardboard and seal it with thinned shellac. Apply mustard yellow latex paint to the frame, let this dry and antique it with burnt-umber wash. Use this same wash to slightly antique the print around its edges. For a finish, apply a spray-type varnish (dull) to the frame as well as the poster

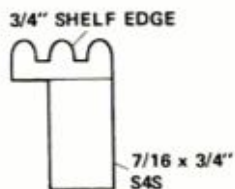
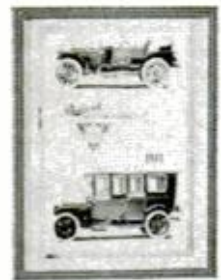

12x16 in. (8A). Using a white glue, affix poster to same-size piece of hardboard. Assemble

frame and size with thinned shellac. Brush on orange semigloss enamel and allow to dry overnight. If desired, frame can be antiqued with burnt-umber wash, but make sure you follow this with a varnish finish



8x10 in. (7). Assemble back-band frame with mitered corners, seal it with thinned shellac, then finish with bright green enamel. Back print with cardboard

12x16 in. (8B). This first-performance opera poster has the same frame construction and finish as that used for Reward poster. Glue reproduction to hardboard and cover poster with picture glass if desired

## Where-to-buy-it information

Note: Send a check or money order; allow two to three weeks for delivery.

1. Print *Christina's World* (Wyeth), \$8. The Museum of Modern Art, Publication Sales, 11 West 53 St., New York, N.Y. 10019. (New York City residents add 53 cents sales tax.)

2. Print *Northern Point* (Wyeth), \$16. For nearest source, write New York Graphic Society, Print Dept. PM, 140 Greenwich Ave., Greenwich, Conn. 06830. (Nine other Wyeth prints are also available.)

3. Oil painting reproductions: varnished canvas on stretchers, \$10; rolled canvas, \$5 ppd. Specify name of reproduction and artist when ordering. The Donald Art Co., Dept. PM, 90 South Ridge St., Port Chester, N.Y. 10574.

4. Original woodcuts and signed lithos, \$30 and up. Specify name of work and artist. Associated American Artists, Dept. PM, 663 Fifth Ave., New York, N.Y. 10022.

5. World War II tank prints, four styles available, \$3.25 each or four for \$9.95 ppd. Mar-Star Enterprises, Box 724, Wheaton, Ill. 60187.

6. Pirate treasure map, \$3.95 ppd. Virgil Hammonds, 23735 Donald-C, East Detroit, Mich. 48201.

7. *Reward, Join or Die, Stamp Act* reproductions, 50 cents each or three for \$1.25 ppd. Hinsdale Craftsman, Box 282, Elmont, N.Y. 11003.

8. Temple rubbing, 10 styles available, \$3 each or two for \$5 ppd. (8A). 1911 Packard advertisement, 10 old-time posters available, \$1 each or five for \$3 ppd. (8B). First-performance opera posters, 12 styles available, \$1.25 each or 12 for \$11 ppd. Fiesta Arts, Inc., Greenvale, N.Y. 11548. Free brochure on all styles available.

9. Chaplin poster; limited quantity available. Write Marboro Books, Dept. PM, 205 Moonachie Rd., N.J. 07074, for poster catalog listing 350 styles available and prices.

Bainbridge board, textured and smooth. Available at art-supply and department stores, or write Charles T. Bainbridge's Sons, Dept. PM, 20 Cumberland St., Brooklyn, N.Y. 11205.

Frame-making tools (shown on page 178). Available at hardware suppliers or write Stanley Tools Div., The Stanley Works, 195 Lake St., New Britain, Conn. 06050, for nearest source.

**“This pocket-sized masterpiece explains what electronics is all about...a marvelous little book...”** **Electronic Buyers' News**

**“For \$2.95, it will take a novice from basic electricity through MOS and linear ICs... as good a basic book as we've seen.”**

**Electronics magazine**

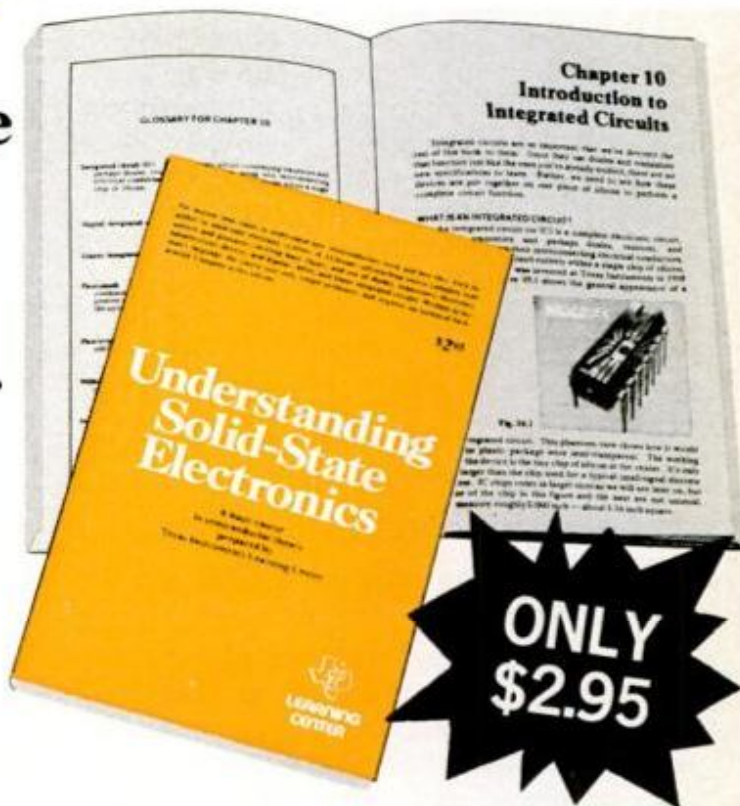

*Understanding Solid-State Electronics* is a self-teaching text which begins at the beginning and explains every new idea and technical subject in terms you can understand.

This book was created for anyone who wants or needs to understand solid-state electronics, but can't devote years to the study.

Texas Instruments prepared the course for its own non-engineering employees and customers—and thousands have proven its effectiveness.

It's a practical course. Engineering concepts are explained without using mathematics—just a little simple arithmetic. Technical terms are used, but each one is explained—in plain English.

**12 lessons plus quizzes, glossaries—250 pages**

The lessons cover: What Electricity Does in Every Electrical System • Basic Circuit Functions • How Circuits Make Decisions • Relating Semiconductors to Systems • Diodes: What They Do and How They Work • Transistors: How They Work, How They Are Made • Transistor Specifications

• Thyristors • Optoelectronics • Introduction to Integrated Circuits • Digital Integrated Circuits • MOS and Linear Integrated Circuits.

**Award-winning course**

Tens of thousands of readers have followed the serialization of this book in *Electro-Procurement* magazine—for which it won the 1972 Jesse H. Neal Editorial Achievement Award, the “Pulitzer Prize” of the business press.



**Send coupon today for your copy**

**LEARNING CENTER**

Texas Instruments Learning Center  
P.O. Box 3640 • Dallas, Texas 75222

Please send \_\_\_\_\_ copies of **Understanding Solid-State Electronics**. I have enclosed \$2.95 for each copy ordered (check or money order only). Total amount enclosed is \$ \_\_\_\_\_.

NAME \_\_\_\_\_

ADDRESS \_\_\_\_\_

CITY \_\_\_\_\_ STATE \_\_\_\_\_ ZIP \_\_\_\_\_ **PM**

**TEXAS INSTRUMENTS**  
INCORPORATED

## ELECTRONIC CALCULATORS

(Continued from page 90)

preset the switch for. That's handy for dollars and cents calculations, among others.

If there's a decimal point and no switch (or an "F" position on the decimal selector), the unit has *floating decimals*, which automatically drop off all zeroes beyond the decimal point, and move the remaining figures all the way to the right. Most fixed-decimal machines have floating-decimal inputs, so you can multiply a three-digit and a four-digit number to get a two-digit result; but check: A few units (like the \$99 Aries and \$200 MITS kits) have fixed-decimal inputs, too.

Fixed-decimal machines usually just drop away any digits beyond the prese-

---

### **Memories are found on some more elaborate calculators, usually from about \$150 up.**

---

lected number; set to two places, they render both 0.210 and 0.219 as just, plain "0.21." More sophisticated units round off numbers whose first suppressed digit is four or lower, and round up one digit if the digit suppressed is five or more.

Most calculators *underflow*: if an answer has more digits than will fit on the display, the last and least important digit is dropped and (usually) some sort of indicator tells how many digits were dropped. Some units show all the significant digits the display will hold, then display the remaining digits when you press a special *overflow* key.

The *clear key* wipes out any figures or answers in the machine (most machines also clear themselves when you turn them on, and when you enter a new figure after a multiplication or division); but in case you make a false entry in the middle of a long problem, most calculators have keys (CE, CI, CD or CL  $\times$ ) which erase only the figure on the display, but leave any previous subtotals intact.

Most calculator operations are done in "algebraic order": Just punch the keys in the order you'd use to write the equation on paper ( $2 \times 3 = 6$ , for example). But on calculators with combination "+=" keys, there's an exception: numbers being subtracted are *followed* by a minus sign, not

preceded by it as in normal figuring. If you don't use your calculator often, this can get confusing. Machines with separate "=" keys use normal order and are more versatile, too. They clear automatically if you enter a number after any completed operation, and (if they have any sign-change or "+/-" key) let you multiply, divide, add and subtract negative numbers as well as positive ones.

*Chain calculations* are possible with all calculators. You can run through an hour-long string of operations ( $6 \times 5 \div 3.2 + 6.6 \dots$ ) without touching the equals key till the chain is complete; and every time you touch a function key, you see the subtotal of the previous operation. If you do push the equals key ahead of time, just enter the next function key to continue the chain (that is, you can key either " $2 \times 3 \div 5 =$ " or " $2 \times 3 = 6 \div 5 =$ " and still get the same result: 1.2). Again, subtraction is different: If you have a combination "+=" key, you must total each transaction before subtracting the next element.

A key or switch marked "K" lets you multiply or divide by *constants* without re-entering the constant each time. To multiply 2, 3 and 4 by 3.14159, you need only do the whole multiplication the first time, with the constant switch on. After that, each time you enter a new number and press the equals key, that number is multiplied by the constant.

*Memories* are found on some more elaborate calculators, usually from about \$150 or so up. In their simplest form, they can store any number on the display—but entering a new number wipes out the old one. Such memories are useful for constants you don't want to use in every operation, or to store subtotals for later reference. More common memories have separate "M+" and "M-" keys that let you add to or subtract from the memory total, and buttons that clear the memory without affecting the main register.

On expensive office machines, you may even find accumulative (or "sigma") memories which store the results of a series of independent, nonchain multiplications and divisions to provide a grand total. And you may find "item count" memories which count how many items have been added or subtracted (handy for finding your place when adding up a list) or how many multiplications and divisions have been carried out. ★★



## WARNING ON THE WINDSHIELD

(Continued from page 79)

rate when it slows down. All the driver must do is use the lines like a gunsight, positioning the car in front between them.

"When we announced that we'd worked out how to project these two separate items of information onto windshields," the Road Research Laboratory man said, "we were urged to project other information about the car's performance there. But we've resisted doing this because it seems more sensible to keep to a minimum the information we put before drivers. In fact, we'd like to convey only one other piece of information through the head-up system—and that's a general warning, a red spot of light, probably, that'll flash into the windshield the moment anything in the car goes wrong.

"We think that in the car of the future the instrument cluster will be out of sight of the driver altogether, possibly tucked away in a console with a lid on it. He'll only need to check the instruments when the general warning light flashes and he pulls to the side of the road."

What does driving with a head-up speedometer feel like? "At first you're struck by the fact that for the first time you really do know at any given moment exactly how fast you're going," one test driver commented. "Then, when you've driven for several days with your speed always projected in your field of vision, you stop thinking about it. All you're aware of is that after a long drive you feel less tired, more relaxed than you used to."

Numerals indicating a car's speed will be projected in shocking pink—which to totally color-blind drivers will appear light gray. Antitailgating sight lines will be bright yellow, the trouble warning light red. The only adjustment in the system will be one that raises and lowers projected images for different-height drivers. Sliding the driving seat back and forth won't alter the motorist's position in relation to the antitailgating lines enough to matter.

The British aircraft industry is installing a variation of the system in commercial planes. On the road it will become more and more useful as automatic steering, transmissions, suspensions and sound insulation turn cars more and more into gliding, noiseless cocoons. ★ ★ ★

**GOVT. SURPLUS**

and other bargains  
**SAVE to 90%**



Send for this catalog

The world-famous Airborne Catalog. Fully illustrated. Contains 1000's of bargains in hydraulics, electrical, marine, automotive & hardware items . . . and more! A must for mechanics, machinists, hobbyists, sportsmen, inventors, etc. Send 35¢ to cover postage & handling. In a hurry? Send \$1 for airmail delivery. Must include zip.

**AIRBORNE SALES CO.** Dept. PM73  
8501 Steller Dr., Box 2727, Culver City, Ca. 90230  
Satisfying world-wide customers since 1945



## LEARN MEAT CUTTING

Train quickly in 8 short weeks at Toledo for a bright future with security in the vital meat business. Big pay, full-time jobs—**HAVE A PROFITABLE MARKET OF YOUR OWN!** Time payment plan available. Diploma given. Job help. Thousands of successful graduates. **OUR 50th YEAR!** Send illustrated **FREE** catalog. No obligation. No. 01971

NUW for big new G.I. approved.

**NATIONAL SCHOOL OF MEAT CUTTING**  
Dept. 50-T Toledo, Ohio 43604

## HELPS DRAW OUT BOILS

Here's quick, proven relief when unsightly and painful boils make you feel miserable. Soothing BOIL-EASE with 7 medicated ingredients helps reduce swelling and pain. Protects against infection, so you look and feel better fast.

**BOIL-EASE**



**HEADQUARTERS FOR EVERY TYPE & SIZE AT REAL DOWN-TO-EARTH MONEY SAVING PRICES!**

**ALL FAMOUS BRANDS!**

**TIRES!**

**AUTO TRUCK SPORT CAR FARM TRAILER**

**TREMENDOUS SAVINGS!**  
LET US PROVE IT TO YOU!  
... WRITE US TODAY ...

Send for your **FREE** catalog!

**RELIABLE TIRE CO.** 1111 Chestnut St. Camden, N.J. 08103



## Print For Profit

Cards, Stationery, Envelopes, Advertising, labels, tickets, announcements, Q.S.L. cards, greeting, sympathy, prayer cards, tags, etc. Good Profits. Pays for itself in a short time.

### Own a Printing Business

We supply everything direct from factory only. Easily followed rules. Also raised printing like engraving. Have home shop. Add to income. Send 25¢ for catalogue. **KELSEY PRESSES** Meriden, Conn. 06450

MAIL THIS COUPON TODAY!

**KELSEY PRESSES, DEPT. 73-E, Meriden, Conn. 06450**

I enclose 25¢ send big catalog and samples.

Name \_\_\_\_\_

Address \_\_\_\_\_

City \_\_\_\_\_ State \_\_\_\_\_ Zip \_\_\_\_\_

## SHORTWAVE ANTENNAS

*(Continued from page 127)*

horizontal; and above 25 MHz, wavelengths are short enough to allow such vertical antennas—stiff rods or wires called “whips.”

A different resonant principle applies here. The vertical aerial operates at one-fourth (a quarter) wavelength. The “other” quarter of the wave reflects on added metal elements called a *ground plane*. (Mother Earth doesn't much affect this kind of antenna.)

Calculating the resonant length of the whip resembles the procedure for long-wire antennas. Take the Citizens Band (CB) for example. Its center falls close to 27.1 MHz, where the wavelength is close to 11 meters. A quarter-wavelength figures out to 2.77 meters, or about 109 inches. In practice, though, various electrical effects make whip antennas a bit shorter—how much shorter depends on both the thickness of the whip (the thicker the shorter) and the material it's made from (fiberglass whips are shorter than aluminum).

The radial rods that form a ground plane for a vertical antenna are about as long as the whip. But sometimes, they aren't necessary: on a car, for example, the body metal, insulated from the whip, simulates a ground reflector.

You've seen plenty of quarter-wave vertical antennas. The whips on police cars, fire trucks and taxicabs are quarter-wave. A whip from 16 to 18 inches long resonates in the high VHF band. Longer whips, from 55 to 90 inches, counting a heavy spring at the bottom, cover the low VHF band from 30 to 50 MHz. Sometimes a loading coil at the bottom or in the center of the whip allows a short whip to cover these frequencies. Several modern two-way radio systems operate in the UHF, above 450 MHz; their whips are only 5 to 6 inches long.

You don't have to deface your car to mount a VHF antenna on it. Though some mobile antennas for shortwave require holes drilled in the car body, there are special mounts that clamp onto the bumper or trunk-edge instead. And few short vertical whips have magnetic bases, some with stick-on adhesive.

A plain wire download doesn't do for quarter-wave verticals. They take *coaxial*

*cable*. “Coax” comprises a wire surrounded by a layer of insulation, then a layer of metallic-braid shield, and covered by an insulated (usually vinyl) coating—similar to hi-fi cables, but thicker.

The cable end at the receiver terminates in some kind of coaxial connector. At the antenna, the center wire attaches to the bottom tip of the aerial whip; the braided shield goes to the ground plane—or to whatever serves as reflector for the quarter-wave vertical.

### VHF listening

If your pleasure comes from police calls, fire runs, aircraft landing chatter and the like, you probably use a monitor receiver. If the station is not far away, you may get by with a cut-to-length bit of stiff wire fastened at the antenna screw on the back of the radio.

For more distance, use an outside antenna, which you can buy pre-cut for whatever band you listen to most. Clamp it to a tail pipe mast or a special tower, or use a mounting that fits on the end of the house.

“Gain” antennas offer more sensitivity than a simple ground plane. Their designs build up a stronger resonance than a plain whip does. Extra-sensitive antennas may have whips tuned at some odd fraction—like  $\frac{5}{8}$ ths of a wavelength. More than one whip may form an “array”—sometimes in X-shapes. And if you're interested in one station only, you can get an antenna that concentrates its gain in one direction.

Your window to shortwave listening opens only as wide as your antenna permits, so make sure the aerial fits the stations you want to hear. And if you need to, you can put up more than one. ★★★

## I-C ENGINE

*(Continued from page 105)*

where the two chambers come together, a rich fuel/air mixture is formed. Ford is interested in this approach and has proposed a let's-swap-information arrangement with Honda. GM is also nibbling for a look at the Honda engine

Ford's also looking at an idea that's supposed to be the supercure for making the i-c engine respectable again—the Proco engine. Proco's supposed to be the second-to-none solution to all problems

*(Please turn to page 196)*

**HALF PRICE SALE**



**was \$39.95**

**1/2 PRICE SALE \$19.97 POST PAID**

Welds, brazes, solders, cuts all metals. Repair cars, appliances, plumbing, household items. Easy to operate. Plugs into any 110V outlet. This **HEAVY DUTY** American made arc welder comes complete with welder's mask, cables, ground clamp, arc-torch, flux, welding and brazing rods and easy-to-follow welding instructions. **NOTHING ELSE TO BUY.** Uses up to 1/8" rods. 10 day **MONEY BACK GUARANTEE.** Adjustable heat feature gives right temperature for the job. Lifetime parts and service guarantee. Send only \$2.00 and pay postman \$17.97 plus small C.O.D. or send \$19.97 cash, check or M.O. for immediate post paid shipment to **MUSTANG MFG. CO., Dept. G-9, Box 10947, Houston, Tex. 77018.**

**1¢ SALE**

**GUARANTEED 10 YEARS**



The knife for hunting, fishing and all around use. Mirror polished, imported stainless steel blade honed to a razor's edge. Rugged. Opens quickly, easily. Locks into position. Blade will not close when in use. Press button in handle to close. Safety finger guard. Sure-grip handle. Balanced for target throwing. **IF BROKEN WITHIN 10 YEARS WE WILL REPLACE AT NO CHARGE!** Use 30 days. Money back if not pleased. Special 1¢ sale. **REG. PRICE \$1.98. Send \$1.99 & receive 2 knives.** Add 49¢ postage, handling. **Remit TOTAL \$2.48 for 2 knives.** **ORDER NOW!** Midwest Knife Co., 9043 S. Western Ave., Dept. DD-6108, Chicago, Ill. 60620. Est. 1936.

**TABLE-TOP MACHINING CENTER IS 5-MACHINES IN-1**



Over 100,000 Unimats in use make it the most popular modelmakers machine in the world! It converts from lathe to vertical mill, drill press, grinder & polisher in seconds.

Miniature compact size makes it ideal even for small apartment and mobile home hobby shops. Machine small parts from all metals, plastic, wood. Unimat lets you do it quickly and accurately. Unimat is fun and easy to use. Anyone can machine like a "pro" with our fully illustrated Unimat instruction hand book, **Miniature Machining Techniques** — only \$2. Use coupon for immediate information.

**edelstaal**

American Edelstaal, Inc., Dept. BB-3  
Tenafly, N.J. 07670

Please send me:

- Miniature Machining Techniques handbook. \$2 encl  
 Complete catalog information

Name \_\_\_\_\_

Address \_\_\_\_\_

City \_\_\_\_\_

St. \_\_\_\_\_

Zip \_\_\_\_\_



**ITT Credit Reserve can give you the security of knowing \$3,000 is available to you within 24 hours.**

ITT Credit Reserve is a personal financial service funded and established by America's eighth largest company, International Telephone & Telegraph Corporation.

On acceptance, you establish for yourself and your family a \$3,000 line of credit, all or any part of which may be drawn upon in less than 24 hours.

A payment schedule and full information on interest rates are available upon inquiry.

Your inquiry about ITT Credit Reserve will be treated in complete confidence.

**ITT CREDIT RESERVE**

a service of International Telephone and Telegraph Corporation

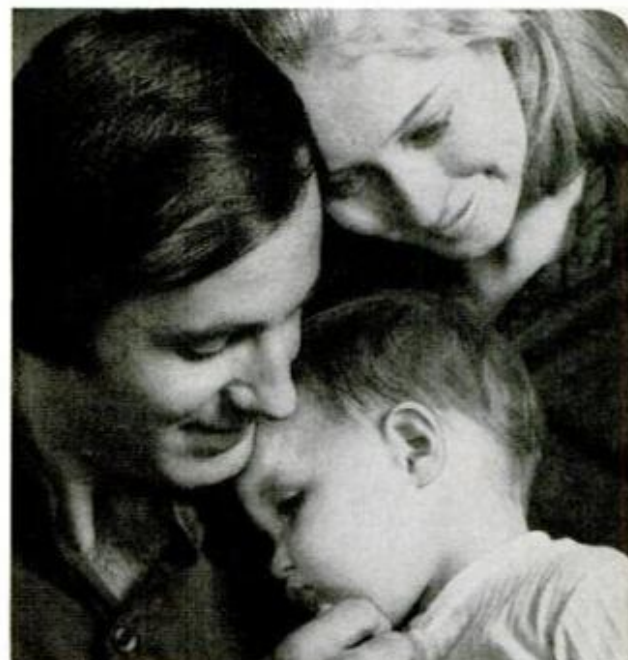

Please send information on ITT Credit Reserve. No obligation, of course.

NAME \_\_\_\_\_ AGE \_\_\_\_\_

ADDRESS \_\_\_\_\_

CITY \_\_\_\_\_ STATE \_\_\_\_\_ ZIP \_\_\_\_\_

Mail to: K. B. Leverly, Service Director, 2080 First Security Building, Salt Lake City, Utah 84111 or phone toll-free 800-453-9100 (24 Hours A Day—7 Days A Week).

# 20 WOOD SAMPLES with woodworkers Catalog

ENJOY woodworking more! Let Constantine's big picture-packed Catalog-Manual help you build new furniture — refinish, restore beat-up cabinets, chairs, chests, tables, etc. Find instantly whatever you need. Buy at money-saving prices from world's largest catalog source for imported and domestic woods. Cabinet lumber, carving blocks, veneers, plywood, pipe briar, inlays and more!

Newest Catalog features new tools, materials, shop devices. Fabulous all-purpose clear finish. Glue that needs no clamps. Inlay picture kits, 99¢. Needed products found nowhere else. Plus woodworking instructions, plans, patterns!

**Catalog & Wood Samples Only \$1**

Dollar Fully Refunded on First Order

Accept this offer to own fascinating set of 20 2x4 specimens of world's glamorous veneers — Rosewood, Satinwood, Lacewood, Teak, etc! Compare! Then instantly identify finest woods wherever you go. Send only \$1 for Wood Samples and Woodworkers Catalog. Dollar refunded on first order.

## CONSTANTINE

2051 Eastchester Rd., Bronx, N.Y. 10461

Enclosed \$1 for Wood Samples & Woodworkers Catalog. (\$1 refunded)  Catalog only 50¢



**2,000**

PRODUCTS FOR SHOP & HOME  
Woods — Veneers — Finishes  
Furn. Hardware — Lamp Parts  
Cane — Upholstery — Tools  
Picture Molding — Clock Kits

**FREE WITH CATALOG**  
"101 PROJECT IDEAS"



Name \_\_\_\_\_

Address \_\_\_\_\_

Zip \_\_\_\_\_

## BLAST FURNACE—FOUNDRYETTE 2400 F



Since 1935  
Hobbyists • Schools • Inventors, etc.  
Make your own castings of any metal from cast iron, down to lead and zinc. Available in 6 sizes, 1 1/2 to 50 lbs. Complete units from \$50.40 to \$162. Send 25¢ for circular—refundable.

**KANSAS CITY SPECIALTIES CO.**  
Dept. P-2  
P.O. Box 193  
Middleton, Wisc. 53562



## BUILD THIS POPULAR 19 ft. MOTORHOME AND SAVE \$\$\$

Designed especially as a do-it-yourself project. (See cover

story Jan 1971 PM) Twenty pages 18 x 24 blueprints, step by step INSTRUCTION BOOK with many in-process photos. Includes CUTTING LISTS for wood and steel parts and KIT CATALOG. \$35.00. Plans also available for 23 and 25 ft models. All materials available at big discount.

**LariDel Enterprises, Rt. 2, Box 123,  
Gaston, Oregon 97119. Ph 503-985-7273.**

## FIND BURIED TREASURE

Powerful electronic detector finds buried gold, silver, coins, etc. Financing available.



Write for free catalog **1995 to 19850**  
**RELCO,** Dept. D-3

BOX 10839, HOUSTON, TEX. 77018

## I-C ENGINE

(Continued from page 194)

besetting i-c engine. According to some enthusiasts, Detroit says hogwash.

Proco stands for programmed combustion. Ford is credited with coming up with the name and is the leader in development of the engine. But Ford isn't the only company working on the idea. Chrysler has one too. Where Ford's going it alone, the Chrysler engine is a joint venture with Texaco.

Proco is a conventional internal-combustion engine with unconventional carburetion. The engine combines a stratified-charge combustion process, fuel injection direct to cylinders and electronic ignition.

The fuel injector sprays a precise amount of fuel into the cylinders. The swirl of fuel is caught in a current of air and stratified. The first shot of fuel burns rich, after which the burn becomes lean. The result is a marked reduction in the discharge of emissions—surpassing the clean air standards coming in 1975-76.

Proco has the distinction of being the only engine to receive an endorsement from a President of the United States. In a talk in Detroit two years ago, President Nixon hailed Proco as the auto industry's answer to Ivory Soap—99 44/100ths percent pure.

The folks at Ford have been trying to hand the bouquet back to the President ever since. They say Mr. Nixon was premature—by perhaps as much as 10 years.

Ford has had trouble keeping the engine going on a test stand, let alone in a car. It has to maintain a crew of technicians on standby to keep Proco from puttering out. The company won't even say what the experimental version cost to build. The bill for just one part of the injection system ran \$15,000.

The most optimistic prediction by Ford on when the engine may be ready is an unenthusiastic, vague "sometime after 1976."

Detroit denies it's stalling on Proco or other ideas to clean up the combustion engine. "Give us time and we'll save the old knave," the auto companies declare. They are obviously convinced the old renegade can be saved, as evidenced by the millions of dollars being poured into research—something like \$400 million last year, alone. ★★★

# This book has helped 2½ million drivers pay less for car repairs than you do.

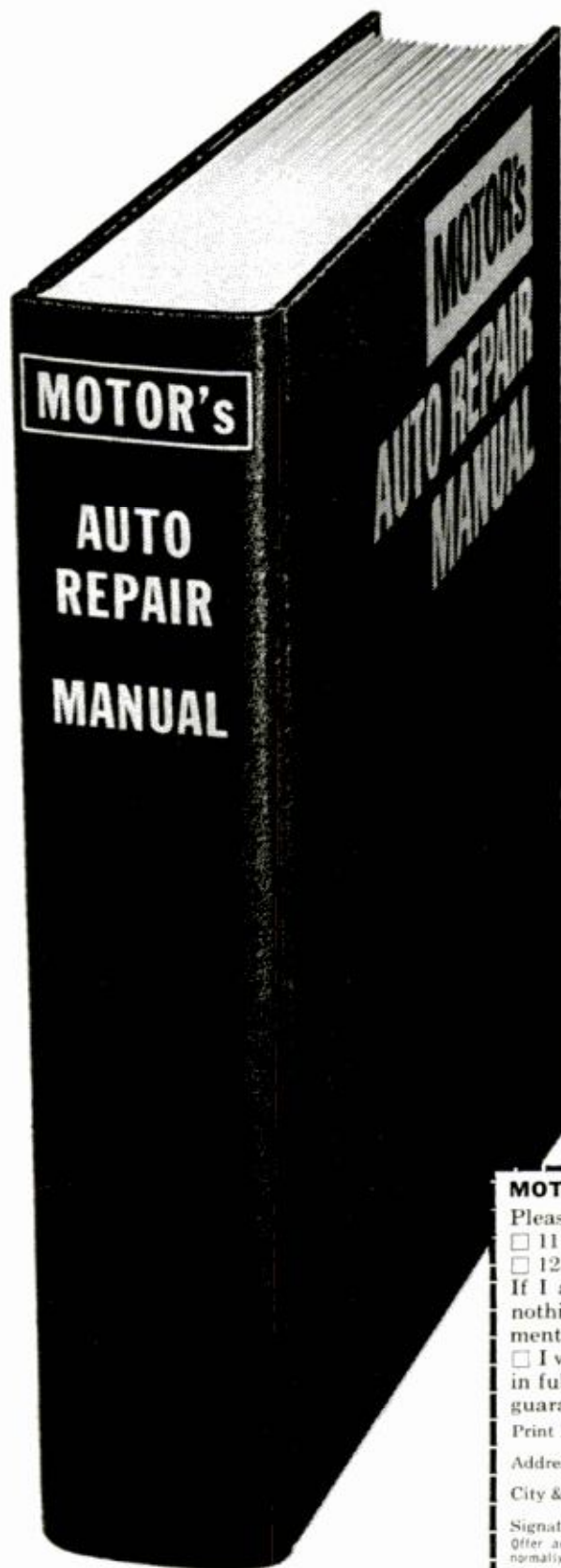

Nothing can hit you in the wallet faster than car trouble. You think you're on easy street and . . . Bang! You've got to shell out fifty bucks for a tune-up. Or a hundred for a clutch. Well, there are millions of guys who pay a fraction of what you do for car repairs. Excluding tools and materials, it's costing some of them absolutely nothing. Because they own a copy of MOTOR's Auto Repair Manual.

### Knowing what's wrong is often half the job.

The big Trouble-Shooter section in MOTOR's Manual (plus trouble-shooting information throughout the book) can show you how to figure out what's wrong with your car *before* you take it to a mechanic.

It helps you pinpoint any of 4,200 car problems. So you can talk intelligently with any mechanic. Instead of being talked at.

Then, if you're handy with a screwdriver, MOTOR's Manual can show you how to replace fanbelts, fix carburetors, and adjust your spark plugs.

And if you're really ambitious, you can tackle transmissions, brakes, steering gears, even overdrives and universals.

Over 3,000 "here's how" pictures and cutaway diagrams show you where to start. Which tools to use. Exactly what to do, step by step. So you can't go wrong.

### Covers 2,300 car models.

MOTOR's gives you 225,000 service and repair facts, plus 300 quick-check specification charts, covering 2,300 American car models built between 1967 and 1973. Dodge, Chevy, Valiant, Mercury, Imperial, Cadillac, Ford, Pontiac, Buick, Corvette, AMX, Challenger, Mustang, and Cougar. Plus Volkswagen. You get tune-up specs for foreign makes. Tune-up and front-end alignment data for 1946-1966 cars.

Every bit of information is the last word, boiled down from more than 300 official factory and service manuals. MOTOR's is so comprehensive, no wonder it's a 6 million copy bestseller with students, professional mechanics, and car buffs.

### Try book for 10 days, free.

Clip the coupon below and mail it. We'll send you a copy of MOTOR's 1973 Auto Repair Manual to look over, and use free, for 10 days. After that, you can return the book and owe nothing. Or, if you and your car are satisfied, it's yours to keep for just \$10.95 plus postage and handling.

### SAME 10-DAY FREE TRIAL ON MOTOR's Auto Engines & Electrical Systems.

Ideal basic book for enthusiasts, students, engineers, mechanics. Explains engines and electrical systems thoroughly, showing exactly how and why they work. Over 700 pages, 1,300 illustrations. Only \$10.95.



**MOTOR Book Dept., P.O. 2316, F.D.R. Sta., New York, N. Y. 10022**

Please send me the Manuals checked below for ten days free examination:

- 11122 MOTOR's Auto Repair Manual, \$10.95  
 12526 MOTOR's Auto Engines & Electrical Systems, \$10.95

If I am not fully satisfied, I will return the shipment promptly and owe nothing. Or I will keep it and pay the total price in three monthly installments, plus a small shipping charge.

I want to save shipping charges. I am enclosing payment of \$..... in full and you will pay shipping charges. (Same return privileges, refund guaranteed.) F112

Print Name \_\_\_\_\_

Address \_\_\_\_\_

City & State \_\_\_\_\_ Zip Code \_\_\_\_\_

Signature Please \_\_\_\_\_ Age \_\_\_\_\_

Offer available only in the Continental United States and Canada. Prices slightly higher in Canada. Delivery will normally be 3-4 weeks in Eastern United States and slightly longer west of the Mississippi. (H.M. Books)

# THIS LITTLE OLD MAN IS A MURDERER AND CANNIBAL!

His name is Albert Fish. In 1928 he murdered and cannibalized little 10 year old Grace Bud.

He was arrested six years later. Albert was also believed to be involved in killing at least 15 other children.



This is only one of hundreds of fascinating police cases of the last 150 years described in **A Pictorial History Of Crime** by Julian Symons — one of the world's foremost authorities on crime.

In about 750 pictures and 80,000 words of text are the authenticated cases of **Jesse James, Jack the Ripper, Bonnie & Clyde, Sacco & Vanzetti, Al Capone, Dutch Schultz, Dillinger, Ma Barker, "Baby Face" Nelson, "Pretty Boy" Floyd, "The Scottsboro Boys," Leopold and Loeb, The Lonely Hearts Murders, Caryl Chessman, Christine Keeler, The Assassination of JFK, the Great Train Robbery, plus hundreds more!** Even includes chapters on police methods, detection, punishment, and corruption.

This hard covered, oversized (8½"x11½"), fascinating volume is only \$5.95 (plus post. and hand.) and is sold with a full moneyback guarantee. *Orig. pub. at \$10.* ----- please print -----

**BROADWAY BOOKFINDERS, DEPT. P-23  
1966 BROADWAY, NEW YORK, N. Y. 10023**

Please rush me \_\_\_\_\_ **Pictorial History(s) of Crime** at \$6.50 ea. (\$5.95 plus 55 cents post. and hand.) Enclosed is my payment of \$\_\_\_\_\_. If not satisfied, I'll return the book within 10 days for a full refund.

name \_\_\_\_\_

address \_\_\_\_\_

zip \_\_\_\_\_

Make check/M.O. payable to **Broadway Bookfinders**  
© Broadway Bookfinders, 1972  
Member Better Business Bureau



\$130-78" high  
**GRANDMOTHER  
CLOCK**  
(Pre-cut wood parts)  
Fruitwood (freight coll)



\$17.15 ppd.  
11½" high



\$19.50 ppd.  
15" high

## FINE WOOD KITS BEST GERMAN DIALS AND MOVEMENTS

**MINI SCHOOL  
CLOCK** (Pre-cut  
wood parts)  
Cherry, Maple,  
Mahogany  
(W/works & dial)  
\$31.25 ppd

**STEEPLE CLOCK**  
(Pre-cut wood parts)  
Cherry, Maple, Mahog.

Send 25¢ for 68-page catalog of full-size patterns, dials, moulding, hardware, barometers, music box movements.

## CRAFT PRODUCTS

Dept. I  
Elmhurst, Illinois 60126

## ENGINE THAT WON'T STOP

(Continued from page 147)

valve, found beneath the exhaust manifold, is operating freely by seeing that the counterweight moves easily by hand with the engine cold. If the valve is stuck, try to free it with manifold heat control valve lubricant.

If none of the solutions mentioned so far helps to stop a dieseling problem, it is possible (but not likely) that the cause is internal. So-called surface ignition occurs when fuel in the cylinders is ignited by a glowing deposit, such as carbon. It is often accompanied by a knock.

However, don't run to have the engine torn down before you make absolutely sure that after-run isn't being caused by some less serious problem or that it can't be stopped by one of the operational tips noted above.

Dieseling is seldom caused by deposits in the combustion chambers. For one thing, these seldom get hot enough to ignite the fuel mixture. For another, it is most unlikely that a glowing deposit would be present in more than one cylinder. ★★★



"I've never had such a handy tool organizer!"  
"Helps me decide the next tool to buy."



**PM PICTURE  
TOOL KIT**

**\$395**

**POSTPAID**

That's the kind of feedback we get from readers who have bought the PM PICTURE-TOOL KIT. PM PICTURE-TOOLS are a great new idea to take the confusion out of what goes where in your shop. They are beautiful die-cut drawings of the 74 most-used hand and portable power tools. You just peel the drawings from their backing and press them into place on any painted or unpainted surface—even perforated hardboard. A glance tells you when a tool is missing. The kit also contains a big, colored sheet of matching adhesive-backed paper so you can cut silhouettes of any special tools you may have. See how dramatically PICTURE-TOOLS enhance the appearance of your shop!

POPULAR MECHANICS Dept. PT  
Box 1014, Radio City, N.Y., N.Y. 10019  
Enclosed is my check (or M.O.) for \$3.95.  
Please rush my PM PICTURE-TOOL KIT to:

Name \_\_\_\_\_

Address \_\_\_\_\_

City/State \_\_\_\_\_ Zip \_\_\_\_\_

# New Rubber Stamp Business Pays Beginners <sup>UP</sup><sub>TO</sub> \$16.50 an hr.

**START AT HOME IN SPARE TIME WITH  
THIS LITTLE TABLE TOP MACHINE . . .**

**WE'LL EVEN HELP FINANCE YOU**

**. . . at less than bank rates!**

The multi-million dollar Rubber Stamp Business—once controlled by a few big companies—is now being taken over by small home operators—one in each community throughout the U.S. Men and women who have this inexpensive machine can turn out huge quantities of Rubber Stamps with special wording that buyers once were forced to order from big cities. Material costing only 27c makes a stamp that sells for \$2.75. The machine that does the work is simple and easy to operate and it turns out as many as six Rubber Stamps at a time each with different wording such as names, addresses, notices, stock numbers, prices and other "copy" needed by offices, factories and individuals. Working full capacity, it can earn as much as \$33.00 an hour for the operator! Now you can get into the big-pay business yourself, with your own home as headquarters. You don't need any experience. We supply everything, including complete instructions and eight ways to get business coming in fast. Start making up to \$16.50 an hour from the very beginning. Cash in on the profitable Rubber Stamp business right away.



**WE HELP  
FINANCE YOUR  
START IN BUSINESS**

**TAKES  
ONLY 2  
SQUARE FEET  
OF SPACE**

● Read the complete and fascinating Rubber Stamp story in the big, over-100-page book. Learn how we even help finance your start. The book contains over 100 illustrations and photographs. And you can read it for a full thirty days without risking a penny!

*They tell it Like it is . . .*

● H. D. B. writes: "It all started from an initial \$11.00 deposit on your kit. From your spare-time home business to \$62,000.00 last year I consider excellent progress. And, I am still growing. I've never been successful until you came along . . ."

● . . . and, E. H. T. now has five dealers working for him in order to supply all the stamps that were ordered as a result of an advertisement. He says, "Success is assured when you manufacture a commodity that everybody needs. There is no better way to build a business than manufacturing your own product."

● "If I could not get another Warner Rubber Stamp Shop, you couldn't beg, borrow or steal the one I have now," writes D. R. N. of California. "I am even getting business away from competitors because I do good work and give a guarantee."

Have you neglected looking into an opportunity that gives you additional income while you are employed, and that will go on giving you additional income even after you're collecting Social Security? Now is the time.

**SEND THE COUPON TODAY!**

**NOW!** Read the *NEW Warner Success Plan* for 30 days—**ENTIRELY AT MY RISK!**

**Find out how YOU can build, step-by-step, to  
BIG PROFITS — and PERSONAL INDEPENDENCE.**

In this amazing Plan you will find exact and detailed instructions for starting a Home Business in spare time—without giving up your present job and without risking the loss of a single paycheck. The Warner Success Plan shows you—with photographs and drawings—just how to make Rubber Stamps just as good as those turned out by the big companies. It shows you how to get orders **without canvassing or house-to-house selling**. It shows you how to expand, how to get others to work for you and how to be **SURE** of at least twice the money you make on your present job for a life of personal independence.

**OVER 100  
FACT-FILLED  
PAGES . . .**

**MORE THAN 100  
ILLUSTRATIONS**



But don't make any decision now. Read the Plan first—entirely at my risk. Then—after you have made a careful investigation, after you have talked things over with your family—only then do you decide what you want to do.

The thing to do now is to get the full details which I'll send you **FREE**. No salesman will call to urge you to buy anything. Mail the coupon today—or just send a postcard—and I'll see that complete information goes out to you by return mail—**postpaid**.

**RUBBER STAMP DIVISION, Dept. R-000-00  
1512 Jarvis Avenue, Chicago, Ill. 60626**

**SEND  
NO MONEY**

Rubber Stamp Division, Dept. R-2-CB  
1512 Jarvis Ave., Chicago, Ill. 60626

Please rush full particulars. Tell me about your less-than-bank-rate Credit Plan and about the little machine that can get me started in the profitable Rubber Stamp Business at home in my spare time. Everything you mail me is **FREE**. No salesman will call.

NAME \_\_\_\_\_

ADDRESS \_\_\_\_\_

CITY/STATE/ZIP \_\_\_\_\_

## A REAL DRUM TABLE

*(Continued from page 166)*

if you want to be sure of a good match.

The pivot jig is made with a piece of 1/16-in. mild-steel flat stock of suitable width to fit the accessory slot of your saw. The jig will track the saw properly only if the pivot point is exactly in line with the teeth of the blade.

To accomplish this, fold over the end of the metal into a short right angle so that you can bore the pivot hole offset an amount that is equal to the distance from the front edge of the bar to the teeth of the blade.

I used Conolite "white leather" plastic laminate for the top. This is a flexible laminate that is thinner than high-pressure laminate. It comes in rolls 30 in. wide and can be purchased by the linear foot.

Using tin snips cut the laminate about 1/4 in. oversize. Because this material has a stubborn curl (tendency to reroll), drive a few nails at angles part way into the worktable to hold the piece flat while you apply contact cement. Apply two coats to both the plywood and the laminate, allowing each to dry until it is not tacky.

Once the contact is made, the pieces will be inseparable, so line them up carefully. The use of two sheets of wrapping paper overlapped at the center will aid you in your lineup. Position the laminate centered on the paper-covered wood top. Pull out one of the sheets, allowing the laminate to make partial contact with the wood. Then slide out the remaining sheet of paper.

Trim the overhanging edge of the laminate flush to the wood. If a router is not available, a block plane and file can be used for edge trimming.

### Angle brackets hold top

Use a half-dozen metal angle brackets and screws to attach the top to the drum shell. The screws should penetrate through the shell and into one of the bands, as shown in detail at top of page 166. Position the top hoop so it will project about 1/2 in. above the tabletop.

The four drumstick legs are made by inserting 3/8-in. dowels into blocks of wood which are then turned to shape on the lathe (see Fig. 10 and the leg detail on page 166). Use a pair of oval-head, plated screws through each leg to attach them to the hoops. ★★★

## ONE (YOUNG) MAN'S SHOP

*(Continued from page 99)*

ting half blocks, they were used full length—to whatever shape this happened to produce. Wall height was established by a particularly good buy the team got on 1x12 red cedar in 16-foot lengths, which they cut in half for 8-foot vertical wall planking. The rest of the building was "designed to fit" as it went along.

In final form, the structure measures 12 by 17 feet with a roof peak height of about 12 1/2 feet. The roof covering is aluminum to save cost, but Jim splurged on the floor—pouring a concrete slab after deciding that dirt would become muddy when wet and kick up dust when dry.

Jim began moving in his first power tool almost before the concrete had set—an old broken-down table saw his uncle wangled from a friend for nothing. Repaired and painted, it now looks like new. The saw is the shop's work center both in frequency of use and location. Occupying the center of the floor area, it provides plenty of clearance around it for easy handling of long boards and large sheet materials. Anything too big to fit in the shop itself simply sticks out the huge barn doors. Lining the walls are long workbenches, each with a toolboard and parts racks for a particular type of shop work. Along one wall is a wood lathe with its own rack for chisels and accessories. Additional spaces are planned for a bandsaw and jointer.

Young Wilson's shop is so organized and tidy, in fact, that Jim's uncle complains that his nephew's neatness sometimes causes problems. "I'll lay a tool down temporarily while I'm working on a project and when I reach for it a minute or two later, it'll be gone. Jim will have already hung it neatly in its proper place on the toolboard!" Jim and his uncle estimate that the building—including a professionally poured concrete floor—cost about \$800 and tools cost \$400 to \$500.

Among the projects Jim has already built in his newly acquired shop are doghouses, letter holders, benches, tables and chopping blocks—some for sale, but most as gifts for friends and relatives. During summers, he does odd jobs to help earn money to buy more tools. If what he has now at 15 is any indication of what he'll have in a few years, you can watch these pages for another "Great Workshop" that will really be an eye-ful! ★★★





BUILD YOUR OWN  
**GRANDFATHER CLOCK**

Save over 50% by building your own grandfather clock. Stately, straight-sided "AMERICAN CLASSIC" with beveled plate glass sides. Narrow waist designs; "SPIRIT OF '76" with finely sculptured crown and brass-tipped pillars; or easy to build, always popular "SPIRIT OF THE CENTURY." Our kits are Red-i-Kut, semi-assembled, hand-crafted of solid 3/4" kiln-dried mahogany, cherry or walnut. Tubular bell or Westminster rod chimes. Moving moon dials painted by our own artists, and our own original Goddess Diana or Lady Florentine pendulums. Gorgeous solid bronze dials with raised numerals and corners. Send \$2.50 for all three plans, plus description of kits and movements, as folks have for more than fifty years.

**KUPEL CHIME CLOCK WORKS & STUDIO**  
Route 3, Box 240 • Excelsior, Minnesota 55331

**WOOD MARKING GAUGE  
LAYS OUT MORTISES, TOO!**



Woodworker's Combination Marking Gauge does it all! Rosewood with solid brass hardware and face inlays. Single pin for general marking on one side of post; opposite side has two pins, adjustable to over 2" for mortise layouts. 7 3/4" long. No. 12C02-M \$7.65 ppd. (In Mass., add 3% tax)

New catalog, 1,000 fine tools, 25¢  
**WOODCRAFT SUPPLY CORP., Dept. 23-M**  
313 Montvale Ave., Woburn, Mass. 01801

**NEW ANTI-SKID SAFETY DEVICE**



**SAFETY BRAKER**

Straighter, Shorter, Safer  
Stops under any road condition. It could save your life!

- EVERY VEHICLE THAT IS DRIVEN ON A FREEWAY SHOULD HAVE A SAFETY BRAKER!
- EVERY VEHICLE THAT TOWS A TRAILER SHOULD HAVE A SAFETY BRAKER!
- EVERY VEHICLE THAT IS DRIVEN IN HAZARDOUS ROAD OR WEATHER CONDITIONS SHOULD HAVE A SAFETY BRAKER!

**Installation in less than 15 minutes**

Safety Braker is simple in design. Never needs adjustment. Can't wear out. Prevents single wheel lock-up. Eliminates dangerous swerve or sideways skid of vehicle. Precision engineered to guarantee you no more panic stops or freak rear end collisions.

**SPECIAL INTRODUCTORY OFFER** only \$29.95 ppd. (Calif. residents add 5% Sales Tax.) Allow 14 days for delivery. **MONEY-BACK GUARANTEE.**

Mail today. Print clearly.

**PRODUCT DEVELOPMENT CO.**

P.O. Box 4125, Burlingame, Calif. 94010

Please send me \_\_\_\_\_ Safety Braker(s). Check or Money Order Enclosed. (No C.O.D.s.)



BANKAMERICARD Acct. #

Exp. date \_\_\_\_\_

Make & Yr. of Car \_\_\_\_\_ Disc or Drum \_\_\_\_\_

Name \_\_\_\_\_

Address \_\_\_\_\_

City \_\_\_\_\_ State \_\_\_\_\_ Zip \_\_\_\_\_



What if I'm laid off?  
Will automation take my job?  
Am I too old to change jobs?  
Can I learn a new skill?  
Will my job ever pay more?

**BE A SKILLED LOCKSMITH!**

... and Solve ALL Your "FUTURE" Problems

No question about it... with Locksmithing skill YOU'LL HAVE IT MADE! You'll do light, clean, always-fascinating work in this fascinating security profession that urgently needs YOU — where your choice of steady, high-pay job opportunities, or a big-profit spare-time or full-time business of your own is virtually unlimited. As a Locksmith you have your own "built in" pension plan. You go on enjoying the work as long as you like, knowing that layoffs, automation, slack times, minor disabilities, forced retirement can't affect your ability to EARN MORE and LIVE BETTER in good times and bad.

Locksmithing is SO EASY TO LEARN — Enables You to EARN Extra Money RIGHT FROM THE START! The better, more secure future you want can be yours FAST as a Locksmith, regardless of age, education, previous experience, minor physical handicaps. Fun and earnings begin AT ONCE as you learn quickly, easily to CASH IN on all kinds of locksmithing jobs. As little as one hour a week at home working on all kinds of lock and key problems under the guidance of experts brings quick mastery—a quick lifetime solution to ALL your "future"

problems. All locks, keys, parts, picks, special tools and equipment as well as complete fully-illustrated lessons supplied with course.

**FREE Illustrated Book, FREE Sample Lesson Pages Give Exciting Facts.** Find out how being a skilled Locksmith can put a quick end to your worries. Locksmithing Institute graduates now earning more, enjoying life everywhere. You can, too. Send coupon TODAY for illustrated book and sample lesson pages without cost or obligation. No salesman will call.

**LOCKSMITHING INSTITUTE**

Division of Technical Home Study Schools  
Little Falls, N. J. 07424

Licensed by N.J. State Dept. of Education; Accredited Member, National Home Study Council, State Approved Diploma, Approved for Veterans.

LOCKSMITHING INSTITUTE, Dept. 1110-023  
Div. Technical Home Study Schools  
Little Falls, New Jersey 07424

Please send FREE Illustrated Book — "Your Big Opportunity in Locksmithing," complete Equipment folder and sample lesson pages, FREE of all obligation, (no salesman will call).

Name \_\_\_\_\_ (Please Print)

Address \_\_\_\_\_

City \_\_\_\_\_ State \_\_\_\_\_ Zip \_\_\_\_\_

Check here if eligible for veteran benefits

"Locksmithing Institute is a fine school with an efficient and effective method of teaching the beginner not only the basis of locksmithing but also the finer points."  
Raymond Gapinski  
East Gary, Ind.

"Qualified me for position of locksmith at a State College. Received full cooperation from the Institute's staff."  
Richard Hiddleston  
West Chester, Pa.

**YOU LEARN ALL ABOUT**

- KEY MAKING
- MASTER KEY SYSTEMS
- LOCK REPAIR
- PICKING LOCKS
- TUMBLER CHANGE
- COMBINATIONS
- CAR LOCKS
- SAFES
- VAULTS
- SECURITY SYSTEMS



Everything necessary:  
KEY MACHINE  
locks, picks,  
tools—supplied  
with course.  
State Approved Diploma



# RESTORE JUNK FURNITURE

This was a beat up sofa I bought for \$5.00 — and sold for \$3000



MAKE UP TO \$1000 AN HR. OR MORE!

... and make a week's pay IN A SINGLE DAY!

## FURNITURE UPHOLSTERY AND REFINISHING ARE PROFIT-PACKED SKILLS YOU CAN NOW EASILY LEARN AT HOME!

If you can tie a knot and hammer a tack, you can learn how to reupholster and refinish furniture. And you can learn quickly — the practical MUI Home Study way. Join thousands who have mastered this fascinating craft in their spare time . . . while keeping their regular jobs.

Once you are skilled in Upholstery you'll never be in want of "something to do" — whether for pleasure or profit! You'll find fun and excitement searching for discarded furniture — and restoring it to like-new condition. Upholstery is much more than just a highly profitable occupation . . . it can be a satisfying, creative hobby for both men and women. GET STARTED NOW . . . MAIL THIS COUPON TODAY! You get FREE, our 32-page book, "BIG PROFITS IN UPHOLSTERY." Free sample lessons and complete details. There's no obligation — and no-one will call.

## UPHOLSTERY IS A BIG BOOMING BUSINESS!

Today, Upholstery is known as a "high demand skill" — for Upholsterers are needed desperately — everywhere. Every home, office, public building . . . even cars, campers, boats and planes all need the Upholsterer's skills from time to time. Yet this highly-paid craft is one that you can speedily learn at home in your spare time!

Upholstery is a safe, secure profession . . . whether you are working for yourself — or for others. Find out more about this fascinating field . . . mail the coupon TODAY!



ALL THESE FURNITURE KITS TOOLS AND SUPPLIES INCLUDED AT NO EXTRA CHARGE!

You Get This AUTHORIZED DIPLOMA When You Graduate. MUI is approved by the California Superintendent of Public Instruction and is authorized to issue a Diploma in Upholstering.

M.U.I., Box 899-HFS. Orange, Calif. 92669

GET STARTED NOW! MAIL COUPON TODAY!

### MODERN UPHOLSTERY INSTITUTE

Box 899-HFS Orange, Calif. 92669

Please mail me a copy of your book, BIG PROFITS IN UPHOLSTERY. I understand no one will call and there is no obligation.

Name \_\_\_\_\_ Age \_\_\_\_\_

Address \_\_\_\_\_

City \_\_\_\_\_ State \_\_\_\_\_ Zip \_\_\_\_\_

626-1 APPROVED FOR VETERANS & NON VETS.

ALSO APPROVED FOR VOCATIONAL REHABILITATION

## CATALOG and IDEA BOOK FREE!

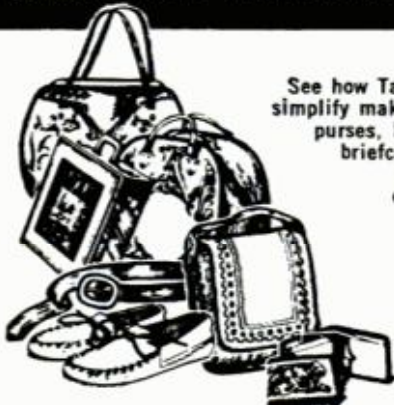

See how Tandy's exclusive kits simplify making belts, billfolds, purses, holsters, moccasins, briefcases and more from genuine leather. No expensive equipment required. Write for 96 page leathercraft catalog today. It's FREE!

TANDY LEATHER COMPANY

1001 Foch, Dept. KW  
Fort Worth, Texas 76107

## BELSAW PLANER • MOLDER • SAW



30-DAY FREE Trial!

Now you can use this ONE power-feed shop to turn rough lumber into moldings, trim, flooring, furniture... ALL popular patterns. RIP... PLANE... MOLD—separately or all at once with a single motor. Free 30-Day Trial. Low Cost—only \$35 down.

Send Postcard Today—No Salesman Will Call.

BELSAW POWER TOOLS, 903F, Field Bldg., Kansas City, Mo. 64111

## ARROW T-50

### All-Purpose STAPLE GUN

SHOOTS A STAPLE

Uses 6 Staple Sizes 1/4" to 9/16" including Ceiltile.

WHEREVER YOU'D DRIVE A NAIL!

At Hardware, Lumber & Building Supply, Stationery, Variety and other retail outlets.

ARROW FASTENER COMPANY, INC.  
271 Mayhill Street, Saddle Brook, N. J. 07663

## HELPMATE

### GARAGE DOOR OPERATOR... \$89.95!

- RADIO CONTROLLED from car transmitter or wall switch
- SAFETY night and day year 'round
- SECURITY door locks tight when closed
- CONVENIENCE in car control any weather
- LIGHTING garage lights automatically
- VERSATILE fits all lifting type wood, metal or fiberglass doors sectional and 1-piece
- EASY HOME INSTALLATION in just 2-3 hours
- SAVE up to 50% direct factory purchase and PP or UPS home delivery
- GUARANTEED one year
- FREE brochure

HELPMATE Equipment Co., Box 51PM, Baroda, MI 49101

## AIR CAR FOR KIDS



- BUILD IT YOURSELF FOR LESS THAN \$10.00 out of household items.
- Build it in less than one hour with common hand tools
- Operates on any hosed vacuum cleaner
- Glides across any smooth surface
- Can carry over 200 pounds
- Same principle used in real air-cushioned vehicles
- Great father-son project • Great gift

SEND FOR PLANS • HOURS & HOURS OF FUN

Illustrated step-by-step, easy to follow, easy to build. FOR PLANS—send only \$3.00 cash or money order, plus self-addressed, stamped envelope to:

VALE ENTERPRISES, P.O. Box 98155 Des. Br.,  
Seattle Washington 98188

## Do-It-Yourself Siding



Learn how you can earn up to \$1000.00 for a single order showing our quality aluminum, steel, and vinyl siding on your home. Small investment required for your own siding. No further investment. Mail coupon for free information without obligation.

**ALUMINUM INDUSTRIES**  
of ARKANSAS, Dept. P-14  
Little Rock, Arkansas 72205

Please send me free information concerning your quality do-it-yourself kits.

name.....

street.....

city.....state.....zip.....



## MINI-BIKE PARTS

Wholesale Prices

"Build your own" kits...Big savings...Repair parts...Welded frames & forks, enameled...Chains...Clutches...Brakes & throttle controls...Wheels...Tires...Bearings...Axles...Engines...etc. Send 50¢ for illustrations and lists...SAVE DOLLARS!

BYCO, Dept. B, Box 6241, Omaha, Nebr. 68106

## I-N-V-E-N-T-O-R-S WE NEED INVENTIONS

Sell your invention for cash—need money for Patent?—Are technical problems holding you back? Universal Inventions has helped inventors all over the world—just like yourself—why not you? Inventions provide the magic spring-board to sudden riches. REMEMBER, we either sell your invention or pay you a cash bonus. Write for details. UNIVERSAL INVENTIONS, Dept. 13, Marion, Ohio

## I'd like to give this to my fellow men ...while I am still able to help!



In my youth I knew the pinch of poverty—the cold stare of the creditor who would not take excuses for money. Today, all that is past, and behind my city house, my summer home, my Cadillacs, my Winter-long vacation — behind this wealth of cash and this deep, inner satisfaction I enjoy—there is one simple secret I would like to impart to you. If you are satisfied with a humdrum life of service to another master, read no further. But, if you are interested in a fuller life—a life free from bosses, fear and worries—then read carefully. My message may be for you.

There is no mysticism in my message. I offer no occult formula that will sweep you to success and riches over night, I am a realist. And I hope you are. And if you are, you have learned there is no reward without effort—that anything worthwhile has to be earned. If you have learned this, you may be ready for the next step—to learn and use the secret I have to impart.

### I have all the money I need

I have two businesses that pay me an income far beyond my needs. In addition, I have the satisfaction of knowing that I have put more than three hundred other men in businesses of their own.

Please do not misunderstand me. I am not a

philanthropist. Frankly, I'm going to charge you something for the secret I give you. Not a lot—but enough to make me believe that you are willing to sacrifice something to achieve success.

Briefly, my secret is a "one man" business that you can operate from your own home in spare time. It is a business that is good winter and summer. Two hours of manual work will keep your "factory" running 24 hours, turning out a product that has a steady and ready demand in your community. Just 98¢ spent for raw materials can bring you \$8.95 in cash—six times a day!

### I'll send you the facts... you make the decision

It is impossible for me to tell you the entire story here. And I do not want you to spend a penny now to learn this secret. But I shall be glad to send you all the information free. So—if you think there is a destiny that shapes men's lives, send me your name and address right away. I will merely write you a long letter, giving you the complete facts about the business that I have found to be so successful, and you can make your own decision in the privacy of your own home. No salesman will call on you.

**VICTOR B. MASON**

1512 Jarvis Ave., Suite M-2-CB  
Chicago, Illinois 60626

THE WORLD'S FASTEST, MOST SUCCESSFUL WAIST SHAPER EVER

# "Eating the foods I love I lost 6 inches off my waistline in only 21 days

by doing just one 5 minute exercise with the most ingenious waist slimmer ever invented."



"With Joe Weider's 5 Minute Slimming Plan I improved my appearance and got back my self-confidence in just 21 days. "Lying on the floor in the privacy of my own home, I did one exercise for only 5 minutes a day. I went from 241 pounds to 219, and my waistline went down from 44" to 38". "Joe Weider's 5 Minute Slimming Plan really gave me a new chance at life. I just can't say enough good things about it."

Michael Benedict

## What is this ingenious 5 minute waist shaper plan?

It's based on a patented 1 pound waist slimming exerciser. You lie on your back on the floor, wherever and whenever you wish—even while watching TV. And doing just one enjoyable, rhythmic, continuous movement only 5 minutes a day, you are able to work all your body muscles in one coordinated movement. That's all there is to it.

The Weider Plan is much safer than strenuous gym workouts and is designed to produce a slimmer waistline faster than time-consuming jogging or any other sport.

Forget sauna wraps, inflated pants, or weight belts. The Reader's Digest (September, 1971) has exposed all these "effortless exercisers" as frauds. As Dr. Kenneth Rose, Chairman of the AMA Committee on Fitness, explains: "You have to work off the inches." And that's what this plan is all about...but the "work" you do is easy and pleasant.

## How much can you expect to lose in 14 days?

You can lose up to 4" off your waistline and about 10 pounds of excess weight in just 14 days. You see, your waist area performs the least work of your body. And because it is usually the most neglected, fat easily accumulates there, giving you a flabby, weak, distorted midsection.

But the rhythmical, continuous movement of the 5 minute Slimmer makes up for all the years you have neglected your body. This concentrated exercise speeds up your body's metabolism, and utilizes your reserve fat to create an oxidation process that burns up excess fat in your body cells. It also helps to release excess water trapped there, too. The results are fantastically rapid waistline losses and a younger looking body for you.

And remember, the Weider 5 Minute Slimming Plan also strengthens your heart, lungs, and helps improve your digestion and stamina. It delivers a lot for just 5 minutes of enjoyable exercise.

## Expert testimonials

"The finest, thought out waist-slimming plan ever."

J. STEINMAN, M.D., Renowned Swiss Physician

"Because the exercises are carried out while lying on the back, dangerous straining motions are virtually eliminated while the slimming and reshaping of the waistline is taking place."

GERALD KLAZ, M.D., Director of Westside Medical Group

"No other exerciser I know of is so accurately based on physiological and medical principles. It burns up excess body weight and reduces the waistline without any strain to the heart or other vital organs."

PIERRE GRAVEL, D.C., Pres. Canadian Council of Chiropractic Research

"My waist measurement went down 4" in just 18 days, and I feel more energetic than I have in years. It sure beats working out in gyms with heavy equipment."

JIM HANLEY, Athletic Coach

## Living Proof of Fantastic Results



BEFORE  
WAIST 36"

KEN WALLER (AGE 26) LOST 6 LBS.



AFTER  
WAIST 33"

AFTER  
5  
DAYS



BEFORE  
WAIST 37"

BILL RUSSELL (AGE 38) LOST 10 LBS.



AFTER  
WAIST 34½"

AFTER  
10  
DAYS



BEFORE  
WAIST 44"

MICHAEL BENEDICT (AGE 55) LOST 22 LBS.



AFTER  
WAIST 38"

AFTER  
21  
DAYS

# 5 minute waist slimmer

This is not another "gimmick" reducer.

Forget all those "Effortless Gimmick Exercisers." They never work and have been exposed as frauds. The only way to lose inches and pounds is through exercise and you might as well be doing the one revolutionary exercise that's the easiest, safest, fastest and most effective. Try it for three days—if you do not see immediate measurable waistline and weight losses return it for a full refund. Mail coupon and start slimming instantly.

WEIGHS ONLY 1 LB.



FREE TRIAL OFFER

In this handy pocket size wallet is the undisputed and most ingenious waist slimmer ever created. Take it anywhere. It weighs only 1 pound.

Joe Weider, Dept. PM-2  
"5" Minute Waist Shaper,  
21100 Erwin Street,  
Woodland Hills, Ca. 91364

Dear Joe: Rush me your 5 minute Waist Shaper and Slimmers Course in plain wrapper, with your money back guarantee offer!

I ENCLOSE \$9.95 FOR THE ABOVE.  
 CASH  CHECK  MONEY ORDER  
Send \$1.00 extra for Air Mail. (No COD's Accepted)  
Calif. residents add 5% sales tax. (\$10.50)

Name \_\_\_\_\_

Address \_\_\_\_\_

City \_\_\_\_\_

State \_\_\_\_\_ Zip \_\_\_\_\_

IN CANADA: "5" Minute Waist Slimmer Plan,  
2875 Bates Road, Montreal, Quebec

Pat. Pend. © 1972 Body Persuasion System, Inc.



PLUMBING

SAILBOATS

# FREE

## TO READERS OF POPULAR MECHANICS

# POPULAR MECHANICS do-it-yourself ENCYCLOPEDIA

Volume 1 of the All-New, Profusely Illustrated "Do-It-Yourself" Reference Library for Home Handyman, Craftsman, Hobbyist, Sportsman—Chock-Full of Step-by-Step "How-to-Do-It" Ideas, Plans, Projects and Shopping Tips to Save You Money...

**16 DELUXE VOLUMES**  
3,136 "How-To-Do-It" Pages  
OVER 10,000 "SHOW-ME-NOW" ILLUSTRATIONS  
"Instant Index" of More Than 6,000 Entries  
STAIN AND SCUFF RESISTANT, WASHABLE DIMENSIONS  
HUGE 8 1/2" x 11" VOLUMES

# FIX your appliances, car, house, SAVE on air conditioning, guns, home improvements, power tools and more

Now... we are proud to offer you the product of POPULAR MECHANICS' most ambitious publishing venture. And we are delighted to send you Volume 1 Free—and future volumes for Free Trial—so you can see for yourself, without risk or cost, just how valuable, useful to you and your family the New POPULAR MECHANICS DO-IT-YOURSELF ENCYCLOPEDIA can be.

Your Free Volume 1 gives you a wealth of valuable illustrated "how-to" information to help you solve common car ailments... add a bedroom... collect antique guns... use power tools... make musical instruments... build and use backyard barbecues... antique furniture... catch fish... anchor boats... make models and toys... build a boat... letter your own signs... repair auto bodies... buy and fix home appliances... load your own ammunition... fix a leaky basement... plus "Project-a-Plans" for animal cut-outs and lettering—and ever so much more!

Consider the thrill of owning a more modern, more beautiful home... a handsome boat... a smoother running car... a cabin in the woods or at the shore. Imagine your wife's joy with a more efficient kitchen...

a more luxurious porch or patio. Think of your children's pleasure with custom-built water-skis or a new mini-car. All these can be yours for the cost of materials alone when you have this exciting new DO-IT-YOURSELF ENCYCLOPEDIA.

**Save High Labor Charges—  
Up to \$12 an Hour**

Best of all, you save such high costs of labor as electricians at \$4.79 an hour, painters at \$4.05 an hour, plumbers at \$4.31 an hour, TV repairmen at rates up to \$12.00 an hour—even more.

You can actually use this Encyclopedia to save \$15.00-\$20.00 on a TV adjustment, \$75.00 on laying a slate walk, \$300.00 on enclosing a porch. You can build a professional-looking desk for just \$19.00 in materials, a big barbecue for just \$12.00, a sturdy cabin boat for only \$600.00, a whole new garage or porch for only \$500.00 to \$700.00—and this "know-how" is there when you want it!

Every imaginable subject of value to your "do-it-yourself" talents is covered. Whether you're a home handyman—or not very handy at all—there are illustrated, easy-to-follow, step-by-step instructions for all your home

maintenance problems: plumbing... wiring... painting... papering... decorating... and more. Money-saving, up-to-the-minute information and diagrams on appliance repair... TV adjustments... automobile repair... power tools, to mention a few.

**Every Page Offers an Exciting New  
Benefit for Your Home and Family**

Turn to any of the 3,136 big pages in this fabulous Encyclopedia, and you'll discover new ways to have more fun out of life... to live better for less money. You'll find countless ideas and plans to increase leisure-time enjoyment for you and every member of your family—plus ideas for earning a substantial spare-time income.

**Your First Volume FREE—No Obligation**  
Accept your Free first volume now—entirely at our expense. Thumb through it—select a plan or project—use it at your workbench. Try to imagine 16 such magnificent volumes side-by-side, offering you money-saving tips... labor-saving information... time-saving advice... plus a host of valuable home-improvement ideas.

Here are just a few of more than 6,000 specific entries in the "Instant Index" covering projects, plans and ideas for better living, greater savings for you and your family...

**APPLIANCES**—Complete money-saving fix-it instructions plus "Before You Buy" tips.

**BASEMENTS**—Waterproofing; finishing walls, ceiling, floor; adding laundry, workshop, darkroom, bar, music center, built-ins.

**BATHROOMS**—Money-saving remodeling ideas.

**BEDROOMS**—How to increase sleeping quarters, storage space.

**CEILING**—All about materials, installation.

**CONCRETE**—The ABC's of how to mix, use and cast.

**DOORS**—How to hang a door, choose hardware, decorate.

**76 Picture-Filled  
Articles on BOATS**

**ELECTRIC WIRING**—All the basics of home wiring.

**GARAGES**—Build carport or garage with step-by-step plans.

**GARDENING**—How to build equipment, control weeds, mulch, propagate shrubs.

**KITCHENS**—Step-saving layouts.

**LANDSCAPING**—Build retaining walls, patios; plant shrubs; fell trees.

**FIX YOUR CAR! 538  
"show-how" photographs,  
drawings, diagrams on automobile  
care and repair.**

**MOTORCYCLES**—Care and repair.

**MOVIES**—Add a soundtrack to home movies. Novel titling techniques.

**PLUMBING**—How to do your own plumbing.

**POWER TOOLS**—How to use, repair all kinds. "Before You Buy" tips.

**REFINISHING**—How to get the professional-looking finish you want.

**ROOFS**—Everything you should know about roofs and roofing.

**68 Detailed Articles  
on ELECTRONICS,  
RADIO, TELEVISION,  
HI-FI, TAPE, STEREO.**

**SHELVES**—Decorative storage—permanent or adjustable.

**STAIRS**—Here are the secrets of expert stair construction.

**SWIMMING POOLS**—How to construct the pool to fit your budget.

**TOYS**—Make all kinds—wheel toys, pull-toys, powered toys, action-toys, dollhouses.

**USED CARS**—Recondition your old car and add dollars to its worth.

**WOODWORKING**—Use the methods the experts use.

**YARD IMPROVEMENTS**

...AND EVER SO MUCH MORE!

### Mail Now for Your FREE Volume 1!

**Popular Mechanics Books  
Box 2315, F.D.R. Station, New York, N.Y. 10022**

This certificate entitles you to a free gift—Vol. 1 of the 16-vol. Popular Mechanics Do-It-Yourself Encyclopedia, with no obligation to buy anything ever.

As a subscriber in good standing, you'll enjoy free examination of the additional volumes as you receive them. In about 6 weeks we'll send you Vol. 2, and 4 weeks later Vol. 3. After that, at approximately monthly intervals, we'll send you shipments of Vols. 4-6, 7-9, and 10-16. Also, you'll receive annual supplementary volumes as they are published on free 14-day approval with no purchase obligation. This way you'll be able to complete the set in 6 months, and keep it up-to-date. You may cancel at any time or return any volume within 14 days for full credit and no more will be sent. Take as many volumes as you like—or none at all. For each volume you keep, you'll be billed just \$3.49 plus postage and handling. But you need never pay for more than 1 volume per month no matter how many you have received. There is no charge for this extended payment service.

F012

Name

Address

City & State  Zip Code

Signature

HM Books

POPULAR MECHANICS BOOKS Box 2315, F.D.R. Station, New York, N.Y. 10022

# The bargain hunter



## SAVE HUNDREDS OF DOLLARS

Build this attractive Little Red Barn for work shop, garden tractor, tool storage, play house, dog kennel, motorcycle garage. 8 ft. x 12 ft. x 9 ft. high. Mounted on skids for portability. 4 ft. sliding door. Quick to build using 1/2 in. exterior plywood. No expensive tools needed. Simple step by step plans. Send \$2.50 for barn plans and material list. Also petite 6 ft. x 8 ft. x 8 ft. high with dutch doors for \$2.50. Both plans for \$4.00.

**HAMMOND BARN**  
Dept. PM5, Box 39027  
Indianapolis, Indiana 46239



Thousands of exciting tool values!

## SILVO (BRAND NAME) TOOL CATALOG

Thousands of Exciting Tool Values! Stanley, Millers Falls, Skil, Thor, Wen, Disston, Wiss, Wellsaw, Dremel, Speedy Sprayers, Plumb, Huot, Kennedy, Channellock, Porter-Cable, Rockwell, Melios, Vise-Grip, Crescent, Ridgid Pony Clamps, Unimat, Foredom and many other Nationally Advertised brands of Tools & Supplies. We ship Coast to Coast at prices Hard to Beat. Send \$1.00 for our big 152 page tool catalog today. Silvo Hardware Co., PM-2, 107 Walnut St., Philadelphia, Pa. 19106.



## HEARING AIDS

1/2 PRICE CATALOG FREE!

**SUPER SAVINGS!** Newest. Finest. All types. Buy DIRECT & save up to HALF! No salesmen. Sold by AIR MAIL on HOME TRIAL. FREE Catalog. Write: **MONEYSAVERS**, Dept. PM-2, 9530 Langdon Ave., Sepulveda, Cal. 91343



## FREE!!! POWERFUL MUSCLES FAST!

Fantastic New Discoveries in the science of bodybuilding. Now, in the privacy of your bedroom, our method will add inches of powerful muscles to arms, chest, shoulders & legs. Learn secrets on trimming the waist with ultra-modern methods—fast! Results Guaranteed! Send for free brochure. Universal Bodybuilding, Box 485-M1, Dearborn, Mich. 48121.

## IMPORTED LOCK BLADE KNIFE

ONLY \$275 each

9" Overall Length  
5" When Closed

- Sharp and Tough
- Stainless Steel Blade



Locks into position to prevent accidental closing.

Razor sharp tough stainless steel blade for reliable use and hard, long service. Money back in 5 days if not satisfied. Send \$2.75 plus 25¢ to cover postage and handling.

**WESTBURY SALES CO.**  
P.O. Box 434, Westbury, N.Y. 11590 Dept. L-236-PM

## SAVE! BUILD YOUR OWN POWER TOOLS



**METAL PARTS KITS AT FACTORY DISCOUNT PRICES**

- 10-in. TILT/ARBOR SAW
- 6-in. BELT SANDER
- SPINDLE SHAPER

- 18-in. BANDSAW
- 12-in. BANDSAW
- COMB. DRILL PRESS-LATHE

SAVE \$50 OR MORE

PLANS, \$200 with FULL-SIZE PATTERNS per Plan Deductible

Kits from \$19.99 to \$49.99. Featured in Popular Science, Mechanix Illustrated. Sold for 26 years. Thousands in use. Satisfaction guaranteed. Send \$2 each for Plans (state tools wanted). Catalog included. Or, send 25¢ for Catalog!

**GILLIOM MFG. CO.**

Dept. PMT-2 St. Charles, Mo. 63301

## GLASS BLOWER KIT \$23.<sup>95</sup> ppd.



Make Glass Miniature SHIPS-BIRDS-BOTTLES ILLUSTRATED

Instruction Book \$3.00  
Willis Glass Supply Co.  
P.O. Box 3460, Studio A  
Anaheim, Calif. 92803

## New! PIPE and FITTING WRENCH

Rotating handle, for instant jaw control. Up to 2" O.D. cap. One-hand operation; speeds-up plumbing and auto jobs on pipe, coils, bolts & fittings... esp. in close quarters. PIPELOK™ ratchets on pipe; can't jam! Money-back guarantee. \$9.90 ppd.

PORTAGE SPECIALTY CO.  
Box 314-A, Portage, Michigan 49081



## WINDWATCH™ ANEMOMETER-WIND VANE \$19.<sup>95</sup>



Neon lights in indoor indicator show wind speed and direction. Decorative indicator with gold dial in dark mahogany case. Designed for desk use or wall mount. Outdoor instruments of durable aluminum with electrical parts enclosed in rigid vinyl housings. Easy to assemble and install. Attach directly to roof or pole. Comes with wire and materials for installation up to 60 feet. Uses regular 120V AC. Unique low amp circuit assures absolute safety. A fascinating addition to any home. Five year guarantee. 15 day trial. Your satisfaction or money back. Only \$19.95 postpaid.

**WINDWATCH** DEPT. F11, 104 HEIMANN SAN ANTONIO, TEXAS 78205

## 110 Volt A.C. GENERATORS

60 cycles. Fanbelt driven from car or gas engine. Operates T.V., refrigerators, radios, all power tools, projectors, P.A. systems and fluorescent lights. Over 12,000 in service. Guaranteed six months. 1500-watt \$65.00 postpaid. 3600-watt \$105.50 postpaid. Special X-1000 watt self-excited generator \$85.00 postpaid.

### TOOL POWER™ patent pending

115 volts D.C. 5000-watts. 50 amps from your car's alternator. Guaranteed 20 years. Install in ten minutes. Operates all power tools, electric motors up to 2 h.p. Arc welding, fast battery charging. Any like device by any name is an infringement of our patent pending. All copiers are notified. Be safe, buy from the inventor and developer. \$25.00 postpaid. Attractive dealer plan.

**VIRDEN PERMA-BILT CO.,**

P.O. Box 7160PM  
2821 Mays, Amarillo, Texas 79109

## FIX CLOCKS, WATCHES

FOR FUN & PROF-

IT! Fascinating new Handbook by master craftsman H. Harris gives you the knowledge skilled watch-



makers learn. OVER 200 ILLUSTRATIONS show how to install hands, dials, crystals, main-springs, stems—rehouse old movements in modern cases—clean timepieces, etc.

INSTRUCTIONS COVER every popular watch and clock, chimes, grandfathers, cuckoo, everyday alarm and electric clocks. Handbook tells you where to buy parts... where to send "overflow" work for repairs at wholesale prices as business expands!

Friends gladly pay \$5 to \$50 for restoring cherished timepieces. Try the HANDBOOK OF WATCH AND CLOCK REPAIRS. Rush only \$1.95, plus 30¢ handling, on 10-day money-back guarantee. **EMERSON BOOKS, Inc.**, Dept. 628-X, Reynolds Lane, Buchanan, N.Y. 10511

## BUILD YOUR OWN CANOE

WOOD & CANVAS OR FACTORY MOLDED FIBERGLASS  
MANY MODELS TO CHOOSE FROM \$19.<sup>50</sup> FREE CATALOG  
BASIC WOOD KIT: TRAILCRAFT, INC.  
Box 60679, Concordia, Kansas 66901

## BUILD YOUR OWN

Cabover Campers • Covers  
16' & 20' Travel Trailers

• PLANS •  
PATTERNS • KITS  
★ FREE CATALOG ★  
**GLEN L** Recreational Vehicles



9152P Rosecrans, Bellflower, Calif. 90706

## THE AUTO ELECTRIC



with 150 V.D.C. meter Postage \$1.25

\$14.<sup>95</sup>

Auto Air Equipment, Inc.  
P.O. Box 2886—Amarillo, Tex. 79105

110V D.C. electricity from a vehicle alternator  
• Light Bulbs  
• Power Tools  
• Battery Charging

## PIANO TUNING MADE EASY

No tedious theory. Excellent manual and all necessary tools, only \$22.50. Ten-day money-back guarantee. Free particulars.

**STAMM INDUSTRIES** Box 324-M, Oregon, Ill. 61061

## DROP FORGED MULTIWRENCH

**SAVE!**  
**ONLY**  
**\$5.95!**  
(PLUS 75¢ UPS)  
**3 for**  
**\$16.00!**  
POST PAID

Both ends swivel for quick sizing, swivel permits use on all hex & square sizes through 180"!



"THE PERFECT HOLIDAY GIFT"

8 wrenches in 1!  
Tough, deep cut socket teeth.

You get all these sizes: 7/16, 1/2, 9/16, 5/8, 11/16, 3/4, 13/16, 7/8 & 15/16.

Send for catalog on thousands of tools only 40¢—free with order.

SCHLESINGERS FOR TOOLS LTD.  
1020 EAST 54TH STREET BROOKLYN, N.Y. 11234  
TEL: (212) 241-7482

## FREE FEL-PRO GASKET MANUAL

... for top performance in all gasket applications

Learn about the latest gasket materials and trouble-free gasket installation techniques from Fel-Pro... for 50 years a leader in gasketing improvements. Improve engine... transmission... and rear end performance with these helpful tips. 36 fact-filled pages.

Write: **FEL-PRO INC.**

7452 N. McCormick Blvd. Dept. 73PM-2 Skokie, Illinois 60076

## PORTABLE STEAM CLEANER

Steam in 60 seconds



CLEAN: Engines—Air filters—lawn mowers—trucks—tractors

"Big enough to do the job, small enough to get there."

Fast, economical, ruggedly built. 3 year guarantee on coils & firebox. Propane fired. Weighs 120 lbs.

Auxiliary pump required on water pressures below 60 lbs. or on well systems.

**WEDCO MFG. INC., Dept. M-3,**

Box D, Jackson, Wyo. 83001

## FACTORY CLOSEOUT!

**Air Pistol \$6.95**  
ppd.

Shoots both pellets and darts. This fine, well made .177 cal. German air pistol is just the ticket for target or Varmints.

Accurate. No CO2 cartridges to replace, either. Once in a lifetime bargain. Order several. Supply limited. Only \$6.95 ppd.

(Secret leather holster, \$2.95 ppd.)

600 Deluxe Pellets, \$2.40 ppd.

20 Steel Darts, \$2.00 ppd.

**AIR PISTOL, Dept. PM-2**

4535 Huntington Dr. South

Los Angeles, Calif. 90032

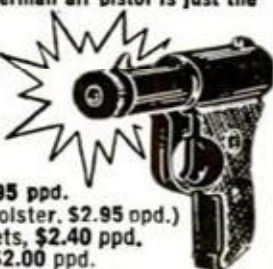

# How to get rich

Start your own business right from your home—and make a future in mail order!



## Beginners Get Cash by Mail!

Have you ever thought of operating a little mail order business of your own? Something you could start on a shoestring right from home in your spare time. It's a fabulous business!

Bob Carter of Newark, N.J. ran his first small mail order ad in House Beautiful magazine—offering an auto clothes rack. Business Week reported that his ad brought in \$5,000 in orders. By the end of his first year in Mail Order, he had grossed over \$100,000!

Another beginner—a lawyer from the midwest, sold a mail order item to fishermen. Specialty Salesman magazine reveals, "he made \$70,000 the first three months!"

There is no other business where you can make a fortune so fast. Come up with a 'hot' new item . . . and WHAM!

It strikes like a bolt of lightning!

Millions of people read your ad and suddenly, you are swamped with cash orders from all over the country . . . MORE MONEY in 60 days than you could earn in a

lifetime!

Like the Vermont dealer who ran one ad in Sports Afield magazine. His ad pulled 22,000 orders—over A HALF MILLION DOLLARS IN CASH!

Yes, Mail Order is the fastest-growing, most profitable business in America! And now with the population explosion . . . the huge teenage market . . . and more people moving to the suburbs—we are on the verge of the BIGGEST BOOM in Mail Order history!

### FREE

If you are sincerely interested in starting a lucrative business of your own ACT NOW! We can help you get rich in Mail Order just as we've helped others. Mail the coupon or send a postcard. We'll send you a free book, catalog, ads and complete facts about our offer. No salesman will call. No obligation. You don't need previous experience but you must be over 21. Write to:

**MAIL ORDER ASSOCIATES, INC., DEPT. 321**  
MONTVALE, NEW JERSEY 07645

### RUSH COUPON FOR FREE BOOK

Plus reprints of  
Mail Order Articles

**MAIL ORDER ASSOCIATES, INC., DEPT. 321**  
Montvale, New Jersey 07645

Please rush complete details on your Mail Order Program. I understand everything is free and there is absolutely no obligation. I am over 21.

Name \_\_\_\_\_

Address \_\_\_\_\_

City \_\_\_\_\_ State \_\_\_\_\_ Zip \_\_\_\_\_

**ROGER**



**A POWERFUL CO<sub>2</sub> PISTOL**

- Precision Made
- Quality Materials
- Checkered Target Grips
- Adjustable Rear Sight
- Positive Safety Catch
- Velocity Regulator
- Midnight Black Finish

**1995**  
plus postage

A powerful semi-automatic CO<sub>2</sub> BB Pistol that gives you low cost target shooting. Precision-made of finest materials with quality features: 10½" long, 6" barrel, checkered target grips, positive safety catch, adjustable rear sight, velocity adjustment, handsome midnight black finish. Fires 100 shots without reloading! Comes with CO<sub>2</sub> cartridge and BBs.

No. 2077—ROGER CO<sub>2</sub> BB Pistol Outfit... 19.95  
No. 2077A—Split Cowhide Custom Holster... 3.95

Please add 95¢ postage & handling on all orders. Not sold in N. Y. State or in localities where prohibited by law.

**Foster-Trent**  
2345 Boston Post Road, Dept. 522-A,  
Larchmont, N.Y. 10538

**HEARING AIDS**  
UP TO **50% OFF** COMPARABLE AIDS \*

BUY DIRECT • 20 DAYS FREE TRIAL Body Aids \$39.95 up. Tiny All-in-the-Ear: Behind-the-Ear; Eye Glass Aids. No salesman will call. Write **LLOYDS** \* Dept. PM, 905 9th St., Rockford, Ill. 61108 \*

**ELECTRONIC TV ANTENNA**

This electronic miracle turns your ordinary house wiring system into a **SUPER POWER TV ANTENNA**. Brings in every channel sharp and clear without an expensive roof antenna or unsightly "rabbit ears." Attaches in seconds. Plugs into the nearest wall outlet. No more ghosts, fuzzy images, or jumping pictures—now everyone can have truly **OUTSTANDING TV** reception for the amazing low cost of only \$2.95. **EARN EXTRA MONEY**. People are selling thousands of this revolutionary new antenna by running mail order ads in their local newspapers and TV magazines. **AND YOU CAN DO THE SAME!** Order wholesale at these low prices: 1 sample antenna \$2.00; 1 dozen units \$15.00; 3 dozen \$41.40; 12 dozen \$147.00. Postpaid. Free glossy photos included with all orders. Lakeside Company: Dept. PV-23; 6800 N. Campbell; Chicago, Ill. 60645.



**SINGLE/TWIN-JET OUTBOARD**

Dual jet outlets with separate controls give exceptional slow-speed maneuverability to small boats. **BUILD-UP OWN** plans allow using locally available auto & hardware store parts. Also **PLANS** available for **PORTABLE ELECTRIC POWER PLANT** using auto alternator & ALT POWER, 110-volt power in your car.

**FREE** illustrated literature  
B-UR-O CO., Dept. PN  
34161-B Coast Hwy., Dana Point, Calif. 92629



**FOOT LONG BOWIE KNIFE**

With hand-tooled cowhide sheath. Hand-forged and individually engraved heavy steel blade. Hand-made EAGLE grip with genuine horn inserts. Perfect for camping & hunting. We import these knives — they're made one at a time! You can't find this knife in any collection outside of a museum

**\$5.95** Ppd  
Add 5% tax in Calif  
**BOWIE KNIFE, Dept. PM2**  
4535 Huntington Dr. So.  
Los Angeles 90032



**TURBO-BLAST SPARK PLUG CLEANER**

**GET UP TO 50,000 MILES ON YOUR SPARK PLUGS**

Use the new **TURBO-BLAST** machine to clean all types of spark plugs — including platinum-tipped plugs. Operates on (110 v) household current. Rugged 12,000 RPM motor drives a fan which blasts a stream of tiny glass beads to scour a plug clean in seconds. Kit also includes illustrated instruction booklet, special thread-cleaning brush and a supply of glass beads for over 250 plugs. Additional beads are readily available. If not completely satisfied, unit may be returned within 10 days and your money will be refunded. Complete kit is only \$19.95 including handling and postage.

Mail this coupon for your **TURBO-BLAST** cleaner to:

**JAYCRAFT CORPORATION \$19.95**  
760 North Marshall Ave. Ppd  
El Cajon, CA 92020

Name \_\_\_\_\_  
Address \_\_\_\_\_  
City \_\_\_\_\_  
State \_\_\_\_\_ Zip \_\_\_\_\_

California Residents add \$1.00 Tax. 1

**DETROIT APPROVED—PICKUP TANKS**

Original equip. type poly. now avail. in aux. tanks for pickups. Increase gas capacity 40 gals. Easy 1 hour installation—completely hidden—no body work necessary. Let truck discounts pay for tanks.

**R.P.M. INC., Dept. PM-273**  
P.O. BOX 7936, Waco, Texas 76710



*The Metric System is Coming*  
**Use the New DIAL-A-CON® ANGLO-MET CONVERTER (Reversible)**



In heavy duty plastic-6" Post Paid \$5.95 Each  
Check or money order NO C.O.D.  
Order from manufacturer  
**FELSENTHAL INSTRS. CO.**  
7450 W. WILSON AVE.  
CHICAGO ILL. 60656

U.S. PAT. 3,544,718  
Metric to English on back side

NAME \_\_\_\_\_  
ADDRESS \_\_\_\_\_  
ZIP \_\_\_\_\_

**SS Save Money! SS**  
\*Repair your own Electric Motors!\*  
New Copyrighted book, pictures & Text. Money back guarantee. Send \$4.95.  
**The Gift House**  
Dept. PM, Blacksburg, S.C. 29702  
\*\*\*\*\*

**PARTS PLANS**  
**BILLIARD SUPPLIES**



SEND 50¢ FOR CATALOG M73—GIFT COUPON  
**CAMPBELL BILLIARDS**  
Box 368 Rt. 2 Hartland, Wisc. 53029

**WATER WATER "HOW TO DRILL YOUR OWN WATER WELL"**  
**WATER WATER \$1.00 Ppd**  
**WATER WATER SATISFACTION GUARANTEED**  
**DEEPROCK CO.**  
OPELIKA, ALA. 36801

**the modular wine rack**

Modular Add A Rack fits into any corner, cupboard, or decorates a whole wall. You add to the rack by simply sliding the interlocking rectangular units together. For every module added you create space for two bottles.

Capacity	Price	Colors:
7 bottles	\$ 4.98	Yellow,
14 bottles	8.98	Black or
22 bottles	13.38	Red.
38 bottles	21.98	
55 bottles	53.00	
190 bottles	98.00	

Free Brochure, Winemaker's Catalog  
**ALFA RACKS** Box 30230 Waco, Cincinnati, O. 45230

Build **POPULAR MECHANICS'** little **CARRIAGE HOUSE!** Simply great! A back-yard building that isn't an eyesore. Styling blends in with most homes. It will take your mower, lawn furniture and tools—or the kids' overnight guests. Use it as your shop or home office. Overall outside dimensions 10-ft. 4 in. x 12-ft. 4 in. For one complete set of plans send \$3.95 to **POPULAR MECHANICS Dept. FA, Box 1014 Radio City, N.Y. 10019**. For two sets of plans (you may need one for your local building department) send \$5.49.

**POPULAR MECHANICS**



**\$30 to \$50 A DAY**  
with TREYCO 6-in-1 Sharpener

Sharpen  
HAND SAWS  
CIRCULAR SAWS  
CHAIN SAWS  
KNIVES  
PAPER BLADES  
PAPER CUTTERS  
SCISSORS  
PINKING SHEARS  
CLIPPER BLADES  
ROTARY MOWERS  
SKATES



For 2" to 48" circular saws

Write for Factory-to-You Prices  
Money Back Guarantee

**TREYCO Products, Inc. Est. 1945**  
332-A Niagara St.  
N. Tonawanda, N.Y. 14120

Easy to Build PLANS AND INSTRUCTIONS for

Go Kart .....\$2.00  
Mini Bike .....\$2.00  
Mini Car .....\$3.00  
Pedal Boat .....\$4.00  
Sail Boat .....\$2.00  
Snowmobile Sleigh \$3.00

Mini Vehicles Plans Dept.-C P.O. Box 92 Cnazy, N.Y. 12921



**SAVE UP TO 92%**



**L66K**

JEOP and Gov't. Surplus Buying Manual (Jeeps Pictured) 75¢ Surplus Bargain Catalogue 60¢. Both for \$1. Surplus Jeeps, Dept. P2, Box 789, York, Penna. 17405

1852 "50¢ CALIFORNIA GOLD PIECES" 1882

**75¢ Each** 25 Assorted ..\$12.00  
7 Different ..\$ 4.00

DLH Sales  
422-PM3 Washington Building  
Washington, D.C. 20005



**Buy New Electric Motors, now at Half Price!**



For use with BENCH SAWS, ATTIC EXHAUSTS, FANS, BLOWERS, PUMPS, SMALL LATHES, DRILL PRESSES and many others. Operate on 110-120 V., 60 Hz. Reversible, automatic reset overload protector. Single end 1/2" shaft. Sleeve Bearings. Thru bolts for direct drive fans. Mounting: 3" x 4 3/4" NEMA 56 frame.

**WESTINGHOUSE SINGLE SPEED 1725 rpm** shipping wt. 20 lbs. **10<sup>95</sup>**

**GENERAL ELECTRIC TWO SPEED 1725/1140 rpm** shipping wt. 22 lbs. **14<sup>95</sup>**

Limited Quantities! Send Check or Money Order to:

**TOPE INDUSTRIES** P.O. Box 176  
Keyport, N.J. 07735

All prices F.O.B. Keyport, N.J. with economical shipments arranged through the following distribution areas: Chicago, L.A., Atlanta, Denver, Boston, Pittsburgh

**BUY YOUR OWN KART OR MINI BIKE FRAME \$15!**  
for less than

**SAVE UP TO \$50 IN COSTS...**

HOW YOU CAN BUILD, BUY OR MODIFY your own recreational vehicle... Go Kart, Mini Bike or ATV... at **NEW LOW PRICES!** Giant new catalog includes hundreds of **FINEST QUALITY U.S.** made parts, kits and accessories. All welded Kart or Mini Bike Frames only \$14.95 (plus ship.). Catalog complete with plans, illustrations, pictures, diagrams & specifications only \$1.00 postpaid. Rush coupon today! (Calif. res. add 5% sales tax)

Send only \$1.00 for Catalog & Plans

Send check, cash or money order to → **KIT KAR, INC.** Dept. PM 2  
2521 W. Burbank Blvd. / Burbank, Calif. 91505

Print Name \_\_\_\_\_  
Street \_\_\_\_\_  
City \_\_\_\_\_ State \_\_\_\_\_ Zip \_\_\_\_\_

**MONEY BACK GUARANTEE**

**YOUR OWN RADIATOR BUSINESS**  
"\$70,000 LAST YEAR"



says D. Carter, Lemoynne, Pa.

Complete turn-key package: training school in radiator repair technology and business management plus special power-equipped auto radiator shop. Don Carter writes: "Averaging \$30 an hour, expect to hit \$80,000 next year." Mail this coupon for complete story.

NAME \_\_\_\_\_  
ADDRESS \_\_\_\_\_  
CITY \_\_\_\_\_ STATE \_\_\_\_\_  
ZIP \_\_\_\_\_ PHONE \_\_\_\_\_

**INLAND MFG. CO. Dept. PM-2**  
1108 Jackson Street • Omaha, Nebr. 68102

**ACCORDIONS-1/2 OFF**  
of retail prices you'd expect to pay!

Over 40 Electronic, Standard & Button Models

All famous makes. All colors. Models for Students, Teachers, Professionals. Amplifiers, too! Try before you buy. Free accessories. E-Z terms. Trades welcome. Lifetime Performance Policy. **FREE** Color catalogs and Importer-to-You discounts. Rush coupon.



**FREE Color Catalog**  
• Discount Prices  
• 42 Models

Accordion Corp. of America—Dept. R-23  
5535 W. Belmont Ave., Chicago, Ill. 60641

Send **FREE** accordion catalogs and discount prices. Include special information checked:

Accordion Amplifiers  Button Accordions

Name \_\_\_\_\_  
Address \_\_\_\_\_  
City \_\_\_\_\_ State \_\_\_\_\_ Zip \_\_\_\_\_

★ 5 Day Home Trial Buy Direct

**What Do Many Doctors Use When They Suffer Pain Of Hemorrhoidal Tissues?**

**Exclusive Formula Gives Prompt, Temporary Relief In Many Cases from Such Pain. Also Helps Shrink Swelling of Such Tissues Due to Infection.**

In a survey, doctors were asked what they use to relieve such painful symptoms. Many of the doctors reporting said that they either use Preparation H themselves or in their office practice.

Preparation H gives prompt, temporary relief for hours in many cases from pain, itching in hemorrhoidal tissues. And it actually helps shrink painful swelling of such tissues when infected and inflamed. Just see if doctor-tested Preparation H® doesn't help you.

Preparation H gives prompt, tem-

# Unadorned power tools.

4' Wood Lathe  
at \$29.95

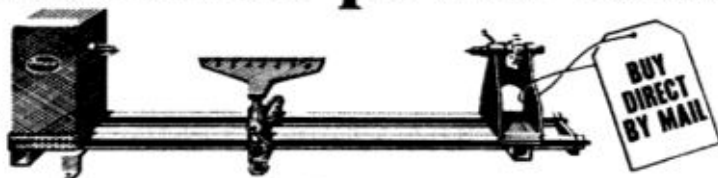

## They do the same job as tools costing up to 5 times as much.

We skipped the chrome to save you money . . . but we did not skip anything on performance. Actually, we skipped more than just chrome, we cut out every costly frill that wasn't absolutely needed.

The lathe shown above isn't exactly flashy. We admit it. But in a recent article, Popular Science used it to demonstrate wood lathe technique and said: "You won't go wrong with this economical introduction to wood turning." It is typical of our tools which in spite of low prices, are full scale and offer full performance and precision.

**HERE'S HOW WE DO IT . . .** First, we don't claim our tools should sell for five times the price! Just that our tools do the same job . . . with the same accuracy, ease and speed . . . and will last at least as long. AMT tools cost less to make and are sold direct. They are bona fide quality power tools used by serious amateurs and professionals alike and if sold in retail stores would be much higher in price. We use no magic, let's be specific:

**SIMPLICITY . . .** AMT tools are soundly engineered to eliminate every frill and gimmick—to minimize material and production costs. Machined parts are used only where they're needed. Unadorned cast iron and aluminum save you a fortune.

**DIRECT-FROM-FACTORY SAVINGS . . .** You save a bundle, yet, we offer a double guarantee backed by a 38-year-old company with millions of satisfied customers . . . and hundreds of orders pour in daily.

**LARGE VOLUME . . .** Our own foundry and large mass production facilities plus large buying power all work to keep costs down.

**STANDARD PARTS . . .** Our designs use standard hardware items wherever possible. By avoiding custom-made parts we pass on tremendous savings to you.

If you are looking for power tools that perform like units costing many times our low prices, order today and you'll be one step closer to many hours of woodworking satisfaction.

*Bill Morley*

### POWER SAW 8" tilt arbor saw

... crosscuts, rips, mitres, cuts compound angles, dadoes, coves, moldings. Completely assembled with ground cast iron table, safety guard, splitter, mitre gauge. Less blade, motor. Rip fence for easier work alignment, \$3.50 add'l. Ball bearing model, \$5.00 add'l. Takes 1/3 h.p. motor or larger, standard blades, attachments. Wt. 26 lbs., f.o.b. factory



**\$19.95**



**FREE OFFER, cabinet base plans, . . .** with one piece of 3/4" plywood, convert your \$19.95 saw into a floor model with a huge 27" x 24" top. Takes cabinet rip fence, \$4.50 add'l.

### 3' WOOD LATHE . . . 6" swing.

Same precision and speed as \$40 units. Sturdy cast iron with tubular steel bed. Lever action tail stock, two-speed pulley, fits any motor. Set of 3 high speed turning chisels, \$4.95 add'l. 4" face plate, \$2.50 add'l. 15 lbs., f.o.b. factory



**\$14.95**

### 4' WOOD LATHE . . . 12" swing.

Industrial size, does the same job as \$75 units. Tubular steel bed rails, screw action tail stock, three-speed pulley. Use any motor. 3 high speed turning chisels, \$4.95 add'l. 4" face plate, \$2.50 add'l. 30 lbs., f.o.b. factory



**\$29.95**

### JOINTER-PLANER 4 1/8" x 22".

Cast iron and steel, precision ground adjustable tables. For planing, joints, bevells. Rabbits to 3/8" depth. Fence adjustable 0° to 50°. Steel knives, dual guards. Use any motor. Precision ball bearing industrial model, \$5.00 add'l. Wt. 19 lbs., f.o.b. factory



**\$29.95**

### BELT SANDER A precision unit.

It changes from horizontal to vertical in seconds. Heavy, sander includes 4" x 36" sanding belt. Uses 1/3 h.p. or larger motor. V-pulley drive and multi-purpose drive spindle.



Disc sander accessory, \$7.95 add'l. Mitre gauge, \$1.95 add'l. 15 lbs., f.o.b. factory

**\$19.95**

### DRILL PRESS Precision 32" radial

unit has standard features and many extras. Depth of throat up to 16". Head tilts and table stays level. Drills to center of a 32" circle. All cast iron and steel. Takes standard motor. 32 lbs., f.o.b. factory.



**\$34.95**

### WOOD SHAPER KIT Makes beads, coves, moldings, tongue-and-groove joints, etc. Accurate cuts at high speeds. Sealed greased-for-life ball bearings. Less wood. Takes 1/4 h.p. motor or larger, standard cutters. Optional hold



down assembly, \$2.75 add'l. 15 lbs., f.o.b. factory

**\$19.95**

### TWO GUARANTEES

**10-DAY MONEY BACK GUARANTEE**  
Try any of these power tools and compare it with any similar machine at any price. If not satisfied, return it for prompt, no questions asked refund. We pay the return shipping charges.

**10-YR. FULL SERVICE GUARANTEE**  
Any part or parts of these AMT power tools (except motor which carries a one year guarantee) which become inoperative for any reason within ten years after purchase date will be repaired or replaced by the factory with no cost to the purchaser other than postage.

**AMERICAN MACHINE & TOOL CO.**  
4th & Spring St., Royersford, Pa. 19468

**Brand new electric motor** developing full 1 h.p. 17 lbs. (Purchased separately, \$24.85). With any AMT machine here. **\$19.90**

**BUY DIRECT**  
... USE THIS HANDY ORDER COUPON NOW

- AMERICAN MACHINE & TOOL CO., Dept. PM-23, Royersford, Pa. 19468  
Please send me the units checked. Payment in full enclosed \$\_\_\_\_\_ or \$3 deposit each item enclosed, balance C.O.D. I must be fully satisfied or will return unit within 10 days for full refund. No questions asked.
- |   |  |
|---|--|
| <input type="checkbox"/> 8" Power Saw at \$19.95  | <input type="checkbox"/> Jointer Planer at \$29.95             |
| <input type="checkbox"/> Standard Rip Fence at \$3.50   | <input type="checkbox"/> Ball Bearing Spindle at \$5.00        |
| <input type="checkbox"/> Long Cabinet Rip Fence at \$4.50   | <input type="checkbox"/> Wood Shaper Kit at \$19.95            |
| <input type="checkbox"/> Ball Bearing Spindle at \$5.00   | <input type="checkbox"/> Opt. Hold Down Assembly at \$2.75     |
| <input type="checkbox"/> Belt Sander at \$19.95   | <input type="checkbox"/> 6" Swing 3' Lathe at \$14.95          |
| <input type="checkbox"/> Disc Sander Attachment at \$7.95   | <input type="checkbox"/> 12" Swing 4' Lathe at \$29.95         |
| <input type="checkbox"/> Mitre Gauge for Sander at \$1.95   | <input type="checkbox"/> Face Plate \$2.50 (either Lathe)      |
| <input type="checkbox"/> Drill Press at \$34.95   | <input type="checkbox"/> Turning Chisels \$4.95 (either Lathe) |
| G.E. Motor <input type="checkbox"/> \$19.90 (with other item) <input type="checkbox"/> \$24.85 (purchased separately) |  |

NAME \_\_\_\_\_  
ADDRESS \_\_\_\_\_  
CITY \_\_\_\_\_ STATE \_\_\_\_\_ ZIP \_\_\_\_\_

# TAKE ANY 4 (up to \$42.35 worth of books) FOR ONLY \$1

## when you join the Popular Science Book Club

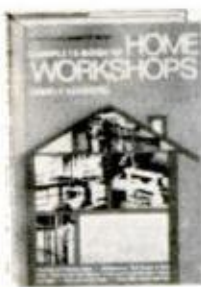

044



326



050

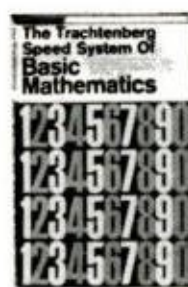

310

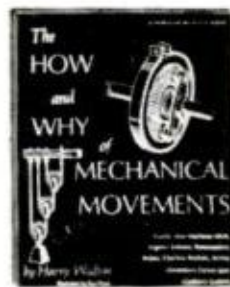

036



062



054



027



1016

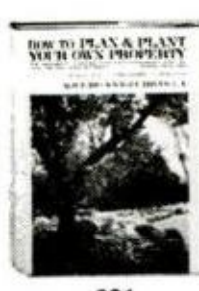

291



038

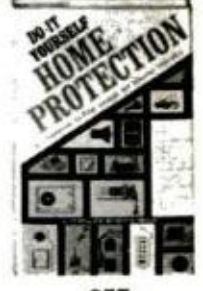

057

**044. COMPLETE BOOK OF HOME WORKSHOPS.** How to design, build, improve or expand your home workshop, build equipment, select tools, more.  
Retail: \$8.95

**062. THE POPULAR SCIENCE ILLUSTRATED ALMANAC FOR HOMEOWNERS.** Guide to indoor & outdoor chores; plus do-it-yourself tips—spiced with humor.  
Retail: \$8.95

**291. HOW TO PLAN & PLANT YOUR OWN PROPERTY.** Hundreds of ideas covering approaches, garden rooms, terraces, paths, hedges, poolside and woodland sites.  
Retail: \$7.95

**326. PICTORIAL HANDBOOK OF TECHNICAL DEVICES.** Over 8,000 detailed construction designs for machines, tools, etc.  
Retail: \$12.50

**1016. CAR OWNER'S TAKE-ALONG LIBRARY.** Five paperbacks. What to Do When Your Car Won't Run. When Your Car Gets Stuck. How To Buy A Car. How To Buy Services For Your Car. How To Drive To Prevent Accidents.  
Retail: \$5.95

**036. THE HOW AND WHY OF MECHANICAL MOVEMENTS.** How six basic mechanical elements power every machine ever invented.  
Retail \$7.95

**050. COMPLETE BOOK OF HOME REPAIRS AND MAINTENANCE.** Learn to make home repairs, expertly, work with today's new materials, modernize.  
Retail: \$8.95

**310. THE TRACHTENBERG SPEED SYSTEM OF BASIC MATHEMATICS.** An amazingly simple and accurate system for adding, multiplying, dividing, etc. that can be mastered in only a few hours.  
Retail: \$5.50

**054. COMPLETE BOOK OF HOME IMPROVEMENT.** How to improve floors, walls, doors, windows, bathroom, kitchen, electrical system, storage areas, more.  
Retail: \$11.95

**038. ELECTRONICS FOR EVERYBODY.** All about do-it-yourself electronics. How to build kits or your own projects — simple printed circuits to complete home systems.  
Retail: \$6.95

**027. HOW TO DO YOUR OWN WOOD FINISHING.** Finish new wood, restore surfaces, antiques, refinish floors. more.  
Retail \$1.95

**057. DO - IT - YOURSELF HOME PROTECTION.** How to plan, choose, buy or build and install all home and auto security systems from a simple window lock to an ultrasonic alarm.  
Retail: \$7.95

### HOW THE CLUB WORKS

First, you get your four books for only \$1. Then every four weeks you'll receive a bulletin describing the coming Club selection and alternate books also available. If you want the current selection only, do nothing. It will be sent to you automatically. If you don't want the selection, or want alternate books, or

no books, simply indicate your wishes on the card provided and return it by the date indicated. You may return any book within 10 days, after examining it, and may cancel your membership at any time after buying one regular selection. You need buy only one book per year to retain all membership privileges.

MAIL THE POSTCARD TODAY OR WRITE TO THE ADDRESS BELOW

POPULAR SCIENCE BOOK CLUB · 44 Hillside Avenue, Manhasset, N. Y. 11030

## Briggs & Stratton—Clinton New Gas Engine Sale

Never before and perhaps never again—this offer of brand new genuine Clinton and Briggs & Stratton engines including 1 yr. factory warranty at less than cost. Perfect power for go-carts, scooters, tractors, mowers, generators, pumps, sprayers, etc. We bailed out 3 big factories who needed cash and the savings are yours while quantities last. Act fast.



Clinton 2 1/2 hp. Mdl. 500—Re-coil starter Std. 3/8 shaft w. keyway—ready to go. Reg. price \$59.50 Special (item 1002)

**\$39.95**

2 for ..... \$78.95  
6 for ..... \$229.50



Briggs & Stratton 23 1/4 hp. Mdl. 81106 ratchet start. 3/4 shaft. Sturdy 4 cycle engine. Reg. price \$69.50 Spec Item #1518

**\$39.50**

2 for ..... \$78.95  
6 for ..... \$229.50

Briggs & Stratton 7 hp. Mdl. 143302. Recoil start. Std. 1" shaft w. keyway, and adjustable governor—a rugged big engine ready to tackle any job.

Regular price \$97.60  
Special (item 1059) ... **\$84.50**

**\$84.50**

**7 hp.  
Briggs  
&  
Stratton**



Same engine with 12 v. elec. starting.

(Item #1571) **\$109.50**

**8 h.p. Kohler—\$139.95**

Model K181T, rugged cast iron, continuous duty engine, recoil start, 1 1/8" dia. shaft.

Item #2166 ..... **139.95**  
2 for ..... **249.50**

**3 1/2 h.p. Clinton—44.95**

A big engine with big power. Model 404, 4 cycle, rope start, 3/8" std. shaft, industrial ball bearing engine.

Item 404 ..... **44.95**  
2 for ..... **87.95**

Remember these engines are absolutely perfect and standard and under factory warranty. Money back guarantee. Order now while stocks are complete. Factories—we buy new engines.



## STANDARD DIAL PHONES WITH BELL

Bell System late model dial phones same as used by all telephone companies, deal as extensions on any system. Easy to connect. Several may be connected on one line. Easily modified for private inter-com system. Cost \$40.00 new—guaranteed excellent condition.

ITEM 855 NC. Wt. 8 lbs. .... **\$8.95**



**TRUCK OR BOAT  
WINCH 2000**

A powerful, compact winch which installs easily even in limited space. Works with any 12, 24 or 32 volt system. Reverses under power—gear train holds load. Drip proof cover. 20' remote control if desired, \$15.00 addnl. Drum holds 100 ft. of 3/4" cable. Speed 30 ft. per minute. A terrific winch at an economy price.

Item 1263—Wt. 55# **\$99.50**

## RECHARGE ALL BATTERIES

**Only Everlite**

- Charges 6 batteries
- Charges 3 times faster
- Charges all batteries

MODEL 75  
Including hearing aid, flashlight, lantern, radio, in fact any battery up to 12V. Save Money and have the convenience of fresh batteries always. Simple and 100% Safe. Plugs into any 115V. outlet. Guar. for one year. Send \$7.95 plus \$.65 for shipping. **795**



Send check or MO

**MASTER MECHANIC MFG. CO., Dept. A-23, Burlington, Wis.**  
Box A, Burlington, Wis. 53105 or Box 65, Sarasota, Fla. 33578

## MAKE UP TO \$12 AN HOUR AT HOME

**Let Me Prove It To You FREE!**

I'll show you how Plastic Laminating at home, spare time, can give you as much as \$12 each hour you operate. Table-top machine sets up anywhere. Easy. Fun. No experience needed. We furnish everything. We'll even help finance you. No house-to-house selling. Orders come by mail. Write for facts FREE. No salesman will call.



**WARNER ELECTRIC, Dept. L-2-CB, 1512 Jarvis, Chicago, IL 60626**

**GOVT SURPLUS**

**SAVE UP TO 98%!!**



**JEEPS, TRUCKS & CARS**  
Typically From \$75.00 ... Typewriters, Auto Parts, Tools, Aircraft, Clothing, Boats, Camping, Sports, Photographic, Electronics Equipment, Wide Variety And Condition ... 100,000 Amazing Bid Bargains Direct From The Government Nationwide. Complete Sales Directory And Surplus Categories Catalog \$1.00 (Deductible On Your Orders From Our Separate Included Surplus Catalog).

**SURPLUS SERVICE**  
Box 820-AX Holland, Michigan 49423

## HEARING AIDS

Huge savings on tiny, all-in-the-ear, behind the ear, eye-glass and body models. New space age models are so tiny and well concealed your closest friends may never even notice. **FREE HOME TRIAL.** Low as \$10 monthly. Money back guarantee. Order direct and save. Write today for free catalog and confidential booklet.



**PRESTIGE, Dept. T-29, Box 10947, Houston, Tex. 77018.**

## MAN-SIZE TRACTOR does tough jobs faster

More pull-power, more tool-power with 14 hp and all-gear drive (no belts, no fluid power loss). Bigger frame, bigger wheels, more weight and traction. 20 big attachments—32" tiller, 48" snow blow, 48" and 60" mowers, loader, dozer, plow, harrow, seeder, etc. More for your money. Write for free catalog.



**ECONOMY  
TRACTOR**

1005K-2 Anoka Avenue  
Waukesha, Wis. 53186

**TOOL CHESTS  
of the  
HIGHEST QUALITY  
for your  
PRECISION TOOLS..**

**GERSTNER TOOL CHESTS**  
Dept. B-3, 20 Cincinnati Street  
Dayton, Ohio 45407



Send 25c for Catalog

**MAKE  
MONEY!**

**REPAIR  
HYDRAULIC  
JACKS**



Earn while you learn at home. Millions of jacks in gas and auto service stations, trucking firms, body shops, riggers, factories and farms need servicing... most of which you can learn to repair. We show you HOW. Start spare time in your basement or garage. Big opportunity for mechanics. **ACT NOW!**

Write for Folder #M-2, and Free Bonus Offer

**Hydraulic Jack Repair Manual Co., Inc.**

G.P.O. BOX 3 • STATEN ISLAND, N.Y. 10314

**PUMP DRAINS pools, cellars, laundry tubs  
IRRIGATES — CIRCULATES — SPRAYS**



Heavy duty ball bearing pump. All metal, rust-proof Type XB. Stainless shaft. Use 1/4 HP or larger. 1 HP 1,200 GPH 60' high or 3,000 GPH 25' well. 5,200 GPH max. 1 1/4" in. 1" out. Belt or direct drive. **\$14.95**  
Type P won't rust or clog. Bronze bearing. To 2,400 GPH. 1" in. 3/4" out. **\$9.95**  
P'd cash with order. Money back Guarantee.

**LABAWCO, Box 40, Belle Mead, N.J. 08502**



**U. S. Surplus High Speed Rotary Files.** Hardened Steel, use on any metal or wood for filing, drilling, milling, carving, routing—a thousand uses in every shop. Sets assorted in sizes from 1/8" shanks. All brand new in airtight, G.I. packs. Order now!

36-pc. Tool Set, G. I. cost \$265.00, now \$15.00  
16-pc. Tool Set, G. I. cost \$109.00, now \$ 9.00  
Save Even More, Both Sets, now \$22.00

**U. S. SURPLUS CENTER**  
C-1790 Nason Avenue  
COLUMBUS, OHIO 43207

U.S. Bureau of Labor Statistics predicts shortage of 50,000 civil engineering technicians (Surveyors, etc.) by 1975. Send for FREE "SURVEYING CAREER KIT."

**LEARN SURVEYING AT HOME**



NAME \_\_\_\_\_ AGE \_\_\_\_\_  
ADDRESS \_\_\_\_\_  
CITY \_\_\_\_\_ STATE \_\_\_\_\_ ZIP \_\_\_\_\_

**NORTH AMERICAN SCHOOL OF SURVEYING & MAPPING**  
4500 Campus Drive - Dept. 34172 Newport, Calif. 92660

**Learn Profitable Profession in few months at Home**



**MEN AND WOMEN, 18 TO 60**

Earn big pay as a skilled operator in Scientific Massage. Many employment opportunities. Easy to learn and do. Diploma awarded. Open your own office or earn good income from Doctors, Hospitals, Clubs and other health or recreational centers. Wonderful part-time profession. Low monthly payments. Write today for free Anatomy Charts and catalog. No obligation.

**ANDERSON SCHOOL OF SCIENTIFIC MASSAGE**  
Dept. B-1, Princeton, Illinois 61356

**BASEMENT TOILET FLUSHES UP**



TO OVERHEAD SEWER OR SEPTIC TANK. NO DIGGING UP FLOORS. INSTALLS EASY. Write McPHERSON, INC., BOX 15133, TAMPA, FLORIDA 33614

**CHARLES ATLAS Says: MY FREE BODY-BUILDING BOOK**

**Shows How YOU Can Become A REAL HE-MAN**

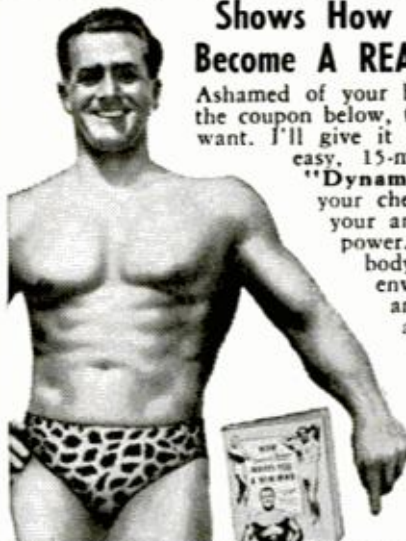

Ashamed of your body? Then tell me, in the coupon below, the kind of body you *do* want. I'll give it to you FAST—with my easy, 15-minutes-a-day method of "Dynamic-Tension." I'll make your chest and shoulders bulge, your arms and legs surge with power. I'll give you the kind of body women admire and men envy. *Your friends* will be amazed. *You* will feel like a tiger!

**FREE BOOK.** Learn how "Dynamic-Tension" made me "World's Most Perfectly Developed Man"—and how I can change YOU. Mail coupon to me: **CHARLES ATLAS, Dept. 8B, 115 E. 23rd St., New York, N.Y.**

**CHARLES ATLAS, Dept. 8B**  
115 East 23rd St., New York, N. Y. 10010

Dear Charles Atlas, Here's the Kind of Body I Want: (Check as many as you like)  
 Broader Chest, Shoulders  Powerful Arms, Legs  
 Iron-Hard Biceps, Grip  More Solid Weight

Show me how "Dynamic-Tension" can make me a new man. Send your famous 32-page FREE book, full of pictures, valuable advice. No obligation.  
PRINT NAME \_\_\_\_\_ AGE \_\_\_\_\_  
ADDRESS \_\_\_\_\_  
CITY & STATE \_\_\_\_\_ ZIP \_\_\_\_\_  
In England: Atlas, 21 Poland St., London, W.1



**IT'S ALMOST LIKE PRINTING YOUR OWN MONEY!**

**9c WORTH OF RAW MATERIAL becomes \$1.25 in less than 60 seconds—and ANYONE can LEARN to do it in a FEW SHORT HOURS!**

Since 1922, Warner has enabled thousands of men and women to establish a business of their own—to reap the benefits of their own labor

and have the personal satisfaction, and independence, that comes with operating a business of their own. Now, a revolutionary new machine makes it possible for an Independent Business Man with no "PULL" . . . No Big Money to Invest . . . and, No Experience—to start a business of his own, at home in his spare time. Here's what J. H. of Pennsylvania says:

\$7,280.00 for 1 to 1 1/2 hours work an evening in my spare time—and without advertising. When I start to advertise I will have my own full-time business. Now the extra income gives my family the luxuries my present job does not afford.

everything. The new Warner Success Program, "Engraving as a Profitable Business," is now ready for you. Send for your FREE illustrated brochure. No salesman will call. Send your name and address on the coupon or a postcard. Be first in your area to cash in on this ground floor opportunity. SEND NO MONEY

**WARNER ELECTRIC CO., DEPT. E-2-CB**  
1512 Jarvis Ave., Chicago, Ill. 60626

Engraving Division, Dept. E-2-CP  
1512 Jarvis Ave., Chicago, Ill. 60626  
Please rush your free illustrated brochure to:

Name \_\_\_\_\_  
Address \_\_\_\_\_  
City, State, Zip \_\_\_\_\_

Now you can get into this highly lucrative business, using your home as headquarters. No experience needed because we supply

**WESTERN HAIG .12 CALIBER SPECIAL FACTORY OFFER!**



**\$300** post-paid

**USES POWDER CHARGE**

This small bore gun shoots .12 cal. steel bullets fired by small 4.4 mg. powder charge. Not a CO<sub>2</sub> gun. You'll like the handsome lines, grip, and balance. Western in style, but patented ball and cap action allows this low price. 9 1/4" steel barrel cased in knurled styrene stock, overall 13 1/2". Develop pistol form, accuracy at a fraction of cost of large cal. pistols. Comes with 50 steel bullets. Satisfaction guaranteed. Send \$3.00 to:

**HAIG MFG. CO., P.O. Box J-26 Alhambra, Calif. 91802**

**EARN \$20/HOUR**

by assembling unique 7 or 12 hp **MINI-DOZER**® bulldozer kit for yourself or resale. 20 attachments—Loader, Mower, Snowblower, Plow, etc. "Build-it-yourself" plans—\$5.00. Catalog of Dozer and 30 other assembly kits—\$1.00 (Refunded on any purchase). **STRUCK CORP., Dept. P2DP3, Cedarburg, Wis. 53012**



# The famous Lincoln AC 225-amp welder is your best buy



Thousands of home handymen, farmers and shop fabricators buy the Lincoln AC-225 every year for these reasons.

**Hundreds of Uses.** Lincoln AC-225 welders give the ideal arc for fabrication and repair welding. Build your own tools and equipment. Fix cars, trailers, boats, farm machinery quickly. Rebuild or harden worn parts. Heat metal for bending, straightening. Thaw frozen water pipes.

**Versatile.** Weld heavy plate or sheet metal, Lincoln ampere selection is right for both. Current capacity and duty cycle let you weld without delays. Use low hydrogen, stainless and mild steel electrodes with excellent arc striking and arc stability. Solder, braze, or weld copper and aluminum with the arc torch.

**Easy to Operate.** Single range control, no cranking or plug changes necessary. Electrode selection guide on top of machine.

**Long Life, Dependable Performance.** No controls to creep or wear out. Transformer is extra dipped for weather protection. Bottom screen makes the welder verminproof. Built by Lincoln Electric... world's foremost producer of arc welding equipment and supplies.

**Easy to Install.** Plug into standard 230-volt, single-phase current, just like an electric range. NEMA rated. UL approved at 230 volts, 60 hertz. Will also operate on 208 volts.

**Mobile, Lightweight.** Easy to move. Wheels optional. **Ready to Use.** Price includes accessories, sample electrodes, power cable, instruction book.

(Suggested Zone 1 list price only \$95, subject to change without notice. Optional features, taxes, local delivery and Zone 2 freight charges may alter this price.)

SEND THIS COUPON TODAY!

**LINCOLN**  
ELECTRIC

The Lincoln Electric Company  
Dept. PM-1, Cleveland, Ohio 44117

- I am interested in a 225 AC welder  
 Send free copy of bulletin E320

Name \_\_\_\_\_

Address \_\_\_\_\_

City \_\_\_\_\_ State \_\_\_\_\_ Zip \_\_\_\_\_

Walnut Monte Carlo Stock  
and New Design Pump Handle.  
Thumb Safety Behind Breach.

## NO JOKE: The trouble with shooting BENJAMIN'S NEW SUPER SINGLE SHOT AIR RIFLE

is that owners could talk a donkey's hind leg off in telling about its power and accuracy—far and away the most potent in its class—and how it gives you the upper hand on target and small game hunting trips, time and again!

Despite Benjamin's enviable reputation, would you believe some folks are under the impression that it can't be all that wonderful? To set things straight, once and for all, we present the impartial views of those that saw it from the business end:

**Soupy Can:** "Plinking tin cans is duck soup for Benjamin." **J. Rabbit:** "Thanks to Benjamin, I'm in it up to my ears."

**Paper Target:** "Benjamin helps you improve your aim at home in off-season."

What more can we add other than to say see your sporting goods dealer now. There are many expertly crafted features in a Benjamin that set it apart for all uses—indoors or out. Choice of BB or 177 or 22. Reasonably priced.

**BENJAMIN AIR RIFLE COMPANY**  
896 Marion St., St. Louis, Mo. 63104

You Can **DEPEND** on **BENJAMIN**

**FREE**  
CATALOG

## ELECTRIC ARC WELDER \$11.99

**\$18.95 VALUE!—NOW ON SALE!**  
WELDS—BRAZES—SOLDERS—  
CUTS—MOST METALS! Plugs  
into ANY 110 volt socket. MAKE  
—REPAIR MOST ANYTHING for  
CAR—HOME—BUSINESS. Life-  
time BURNOUT GUARANTEE 10  
day money back trial (if retnd).

**HEAVY DUTY MADE!** No experience needed—**FREE WELDING INSTRUCTIONS!**

**SEND ONLY \$2.00**

(cash, ck. M.O.) and pay postman \$9.99 COD postage or send \$11.99 plus \$1.00 postage for paid del. in U.S.A.: **COMPLETE READY TO USE!**—Includes BIG pack Steel, Brazing, Solder, Carbon "touch" rods and ELECTROFLAME ARC TORCH! **BEST EVER MADE!** OFFER LIMITED—Order TODAY!  
**MIDWAY WELDER Dept. FPM-2 Kearney, Nebr. 68847**



You can make  
this  
**MODEL  
STEAM  
TRACTOR**



**yourself and it actually runs!**

This beautiful scale model of the old smoke-belching steam tractors used after the turn of the century is fun to build . . . makes a handsome display piece . . . and really runs!

For a complete set of plans (16 sheets measuring 12 x 18) plus instruction booklet, simply mail the coupon below together with \$10.00.

This is an intriguing project that will capture the fancy of the real model builder.

**TO: Popular Mechanics Magazine**  
224 West 57th Street Dept. ST12  
New York, N.Y. 10019

Please send me complete plans and instructions for the 3/4-inch scale steam tractor. Enclosed is \$10.00 payment.

NAME \_\_\_\_\_

ADDRESS \_\_\_\_\_

CITY \_\_\_\_\_

STATE \_\_\_\_\_

ZIP \_\_\_\_\_

# CLASSIFIED ADVERTISEMENTS

Rate: \$2.20 per word payable in advance each insertion. Capitalized words—75¢ per word additional. Minimum insertion ten words. To be inserted under the proper classification, copy must be in our office by the 10th of the second month preceding date of issue. The next available issue to place an advertisement in America's No. 1. Classified Section is April. The closing date is February 10th. Send remittance and order to H. E. Kappel, Popular Mechanics, 224 West 57th Street, New York, New York 10019. Please make remittance payable to Popular Mechanics.

POPULAR MECHANICS

WHEN ANSWERING ADVERTISEMENTS PLEASE USE THE ZIP CODE NUMBER

## AUTOMOBILES

**40%-60% Automotive Savings.** Nationwide. Free Brochure. CRA/NASCO, Box 262, Dallas, Texas 75221.

**AUTOMOBILE SIXTY SECOND TIRE FIX. NO TOOLS—NO JACK-DEALERS INVITING. SAMPLE, DETAILS, PPD. \$3.98—WARNE, 6922 CONGRESS, DETROIT, MICHIGAN—48207.**

**1971-1972 DODGES, Fords, Chevrolets, Checkers** from \$599. to \$1099. Free catalog. Send 25¢ handling. Pan Am, 31 Hanse Ave., Freeport, N.Y. 11520, Dept. 151.

**POLLUTION Free Automobile Engine, Information \$1.00.** Box 413, Altadena, Calif. 91001.

**SAVE Hundreds Pickup Trucks.** \$1.00 brings information. RR1, Box 93, Annandale, Minn. 55302.

**CAPACITIVE DISCHARGE IGNITIONS. DISCOUNTED.** Rodgers, Son (PM), Box 358J, Anaheim, Calif. 92803.

**POLLUTION DOWN—PERFORMANCE UP.** New California Accredited Exhaust Smog System. Built-in Electronic Ignition. Save Gas. Easy Installation. ECO-PM, Box 6121, Orange, California 92667.

**FOR The Lowest prices on 1973 Pontiacs, Mercurys and Lincoln Continentals.** Write: Earl Shell, Jim Causley Pontiac, 17677 Mack, Detroit, Michigan 48224. (313) 886-1700.

**CAR-DISCOUNTS!** 1973 Important Information FREE. Car-Discounts, 2500 Channing, Cleveland, Ohio 44118.

## MIDGET CARS

**YOUR AD IN POPULAR MECHANICS WILL BE SEEN** By More than 5,000,000 active buyers for your products and services. It costs only \$2.20 per word. And, if you wish to run all or part of your ad in bold capital letters—you can do so for as little as 75¢ per word additional. Act now! Send your Classified ad to: **POPULAR MECHANICS, CLASSIFIED DEPARTMENT, 224 WEST 57TH STREET, NEW YORK, N. Y. 10019.**

## AUTO SUPPLIES AND EQUIPMENT

**REPAIR Automatic Gasoline Shut-Off Nozzles—Details Free—Vass, Box 102, Tamiami Station, Miami, Florida 33144.**

**PARTS: Army jeep and truck parts.** Spare Parts & Equipment Co., P.O. Box 751, Lexington, Kentucky 40502.

**ALTERNATOR/Generator Rebuilder's Course;** includes Tooling & Test Equipment. Write: Hedelund Engineering, P.O. Box 2127, Sepulveda, California 91343.

**RING-Valve Job while driving,** \$6.50 postpaid, (Two-\$12.00). . . . Established 1951. . . . Results Guaranteed!! Motaloy, Grantham, Penna. 17027.

**NOVEL Inexpensive Glowing Gage Continuously Checks Ignition Performance.** QARC, Box 47876, Los Angeles, Calif. 90047.

**\$1.00 BALANCES 4 Car wheels perfectly.** Instructions \$2.98. Fletcher—906M Lindale—Richardson, Texas 75080.

**RING-VALVE JOB While You Drive!!! Fully Guaranteed \$6.00 . . . Two \$11.00 . . . Motaloy, Box 1149-MF, Midland, Texas 79701.**

**MOTALOY, Ring—Valve job while driving—\$6.00.** Free literature. E&G Sales, Box 18384-P, Memphis, Tenn. 38118.

**AUTO Parts and Tools.** Dealers Cost. Catalogs, 50¢. Auto Parts, Box 66, Hollis, New York 11423.

**D-FROST Automobile Windshield, Refrigerator Defroster, Giant Aerosol \$1.00.** Marches, 2355 Harrodsburg, Lexington, Kentucky 40504.

**6,000-MILE LUBRICANT—Ring—Valve Benefits, 60% Less Friction—more compression, more M/P/G—No Dry Starts.** Guaranteed. \$5.50, two \$10.00. Micro-Moly, Box 882, Hyannis, Massachusetts 02601.

**SUPER Ignition Device Guaranteed mileage increase.** Brochure 25¢ refundable—Super, Box 7225, Kansas City, Mo. 64113.

**STOP Auto Theft! Auto Protector protects your car from all common theft techniques.** Easily installed. . . . Solid State. . . . \$7.98. . . . year guarantee. . . . M&B Mail Order, 1032-55th Street, Brooklyn 11219.

## SNOWMOBILES

**PATCHES: Color Catalog 35¢ Shows Hundreds.** Free Patch with catalog. Quotes your own design. Patches, Dept. 92, RFD 1, Littleton, N.H. 03561.

## MOTORCYCLES, BICYCLES MOTORSCOOTERS & SUPPLIES

**BUILD "Popular Mechanics" MINIBIKE** Featured June 1967. Detail plans, photographs, illustrated parts catalog \$2.00 refundable or catalog 25¢. Gilliom Minibike, St. Charles, Missouri 63301.

**HONDA! \$25 Other Bargains.** Send 50¢. Motorscooter, P443, Bend, Oregon 97701.

**BOLT-ON TORQUE CONVERTER** Makes out-dated, out-classed, mini-bikes competitive, mean machines. More low end muscle—more high end hustle. Fits B&S, Tecumseh, most engines. 35 minute installations. \$34.95 ppd. No C.O.D. Information + decal 25¢. MAX-TORQUE, Inc., 7300 Monticello, Skokie, Illinois 60076.

**DISCOUNT Harley Parts.** Details \$1.00. HD Supply, 5603 West National, Milwaukee Wisconsin 53214.

**MAKE Your Bike Electric,** plans \$2.95. Kielian, 130 Drake, South San Francisco, Calif. 94080.

**MINIBIKE.** Build your own. Bolted Construction. No Welding required. Kits available. Plans \$2.95. Stapleton Manufacturing, Lumber City, Georgia 31549.

**MINI-CYCLES ATV'S Go-Carts.** Supplies. Wholesale Catalog 25¢. Lorenzo, Danville, Illinois 61832.

**ILLUSTRATED Catalog 25¢.** Parts And Accessories, Custom And Stock. For Most Makes And Models. Motorcycle Supply, Box 159M, Fairbury, Ill. 61739.

## SPACE, ROCKETS AND ASTRONAUTS

**ANTIGRAVITY Solved! Scientific Experiments Reveal Amazing New Propelling Force for Spacecraft.** \$2.00. Spacedrive, Box 831, Avalon, Calif. 90704.

**ROCKETS: Real flying models—flights up to 2500 ft.** New illustrated catalog 25¢. Single and multistage kits, cones, engines, launchers, trackers, rocket aerial cameras, technical information. Fast service. Estes Industries, Dept. 7FS, Penrose, Colorado 81240.

**ANTIGRAVITY DEVICE.** Brochure rushed free. AGD, Box 3062 PM, Bartlesville, Oklahoma 74003.

**FREE. Flying MODEL ROCKET Kit.** Act Now. Offer Limited. Send 25¢ for Packet of Iron-ons, Decals, Literature and "Free Rocket" Details. Aerospace Vehicles, Inc., Mineral Point, Wisconsin 53565.



## AVIATION

**AVIATION Surplus Big Bargain Catalogue** 60¢. Box 52PM4, Thomasville, Penna. 17364.

**AIRBOAT Engines, Propellers, Hubs, Mounts, Supplies.** Corvair, VW Conversions. Removable airdrives. Propellers, Hubs for Snowmobile Engines. Catalog \$1.00. Banks-Maxwell, Box 3301E, Fort Worth, Texas 76105.

**ALL About Ballooning.** Handbook \$3.00. Aerostation, Box 141, Long-Sault, Ontario, Canada. KOC 1P0

**INCREDIBLE PARAPLANE.** Build, Fly with 8 Horsepower! Information, \$3.00 Refundable. Palmer Aerosystem, P.O. Box 1891M2, Coral Gables, Florida 33134.

**BUILD—One-Man jet helicopter.** Easy inexpensive. Detailed plans, drawings—\$5.00. Helicraft, Box 7153, Baltimore, Maryland 21218.

**JET Strap-On Helicopter Plans \$2.00.** Information 20¢. Compco, Inc., Box 1267, Redwood City, California 94064.

(Continued on next page)

## HOVERCRAFT

**AERO-CAR.** Amazing Hovercraft built easily with ordinary tools. Lawnmower engine power. Carries one man plus. Hovers, flies forward, backward. Sideways over land/snow/water. Complete construction plans and brochure. \$5.95. Aero-Projects, Box 5118PM, Clinton, New Jersey 08809.

**EFFICIENT HOVERCRAFT** Takes Lawnmower, Gokart, Snowmobile Power. Planes Two on 15 Horsepower. Instructions, Plans, \$6.00. **FAST 15 Horsepower Airboat.** Instructions, Plans, \$5.00. "Practical Design Guide for Airboats and ACV's, \$5.00. (Information, \$1.00 Refundable). Palmer Aerosystems, P.O. Box 1891M2, Coral Gables, Florida 33134.

**SUPPLIES/DEALERSHIPS/PLANS** - Single (\$6.00), Two (\$10.50), and Four Passenger (\$25.00). Catalog-\$2.00 (Refundable). Manufactured, Single Passenger "Stingray"-\$795.00 (Enclose Advertisement-\$695.00). Hoversport, 313 Balsam, Palm Beach Gardens, Florida 33403.

**HOVERCRAFT** Plans. All sizes; Tested designs. Photos. Information: \$1.00. Universal Hovercraft, 2611 182nd Place, Redondo Beach, California 90278.



## BOATS AND TRAILERS

**PROFESSIONAL** Plans Instructions: Lightweight Cedar/Fiberglass Canoes, Kayaks. \$2.50. Hazem, Friend, Oregon 97025.

**FIBERGLASS BUILDERS MATERIALS** Lowest factory prices in cloth, matt, roving, resin, epoxy, foam, nails, fittings. Send \$1.00 for literature (refundable) or \$2.00 for literature plus booklet on Mold-making and "How to Fiberglass". Clark Craft 16-P1 Aqua Lane, Tonawanda, N. Y. 14150.

**BOAT KITS-PLANS AND PATTERNS-FRAME KITS,** World's largest catalog. Over 300 top designs from 7-77' in plywood, ferro cement and fiberglass. Sailboats include: Windmill, Snipe, Motor Sailer, Trimarans, Catamarans. Powerboats include: Cruisers, Houseboats, Deep V's, Fishin'ski, Runabouts, Hydroplanes, Canoes, Kayaks, inboards, outboards. Send \$1.00 for large catalog or \$2.00 for catalog plus "Boat Builders Guide". Clark Craft, 16-P Aqua Lane, Tonawanda, N. Y. 14150.

**BOAT PLANS, FULL-SIZE PATTERNS, FRAME KITS** With step by step written and pictorial instructions especially for amateurs. Easy to build. Send \$1.00 for **HUGE 100 PAGE** Illustrated Catalog. Over 125 modern designs from 8 to 49'. Includes Sail, Jets, Inboards, Outboards, Cruisers, Houseboats, Hot Boats, Catamarans, Hydros. Also available—"Boat Building With Plywood" Hard cover—219 pages \$7.50. **GLEN L,** 9152 MP Rosecrans, Bellflower, Calif. 90706.

**FIBERGLASS** Canoes, Kayaks, and Duckboats. Many exciting models. Easily assembled kits. \$39.95 up. Free Literature. Riverside Canoes, Box 5595P, Riverside, Calif. 92507.

**FIBERGLASS** Cloth and resin. World's finest cloth and non-run resin, at direct mill prices Flotation foam. Complete line of plastics, silicon bronze and brass screws, save 60%. No sales tax. Boat Plans. Catalog 25¢. Freight prepaid. Stiles Boat Supply, Box 11P, Linden Ave., Mantua Heights, N.J. 08051.

**CANOE!** Kayaks! Factory-direct quality kits, from \$25.00. Many different models. Canvas hulls. Strongest construction materials. Free literature. Sportsraft, Box 636-P, Allentown, New Jersey 08501.

**SAILBOAT KITS** New all glass 16 ft. Catamaran, Penguin, OK, Blue Jay, Windmill, Snipe, Lightning, and El Toro. Free catalog. Taft Marine Corporation, Dept. PM-2, 6512 Shingle Creek Parkway, Minneapolis, Minn. 55430.

**LIGHTS** Of all kinds, electrical accessories, portable power, cook and tableware. Free catalog. Bass, Box 901PM, Marblehead, Mass. 01945.

**FREE Catalogue—plans, patterns:** Canoes, sailing canoes, kayaks, 14-17' trailable cruising sailboats. Quicksilver, 255A Shamrock Blvd., Venice, Florida 33595.

**PLANS, Full-Size Patterns, frame kits** with step-by-step instructions specially for amateurs. Send \$1.00 for new catalog just off press—nearly 100 pages, over 125 designs 8' to 49': Sail, Jets, Inboards, Outboards, Cruisers, Houseboats, Hot Boats, Catamarans, Hydros. Glen L, 9152 PM Rosecrans, Bellflower, Calif. 90706.

**NEW 1973 Outboards . . . Top brands . . .**  
6 H.P. \$278.00 . . . 18 \$404.00 . . . 40 \$548.00 . . . 50 \$698.00 . . . 65 Selectric \$928.00 . . . All sizes . . . Scott-McCulloch Parts . . . Literature .50¢ . . . Electra Marine . . . 675 Merrick Rd. Lynbrook, N.Y. 11563.

**BOAT Kits.** Molded Fiberglass. Save money-assemble yourself. Factory molded sections bond into one-piece craft. 20 models-14' to 32' Cruisers, Runabouts, Sailboats, Accessories, motors, trailers. Easy terms. Free catalog. Luger, Dept. BC-73, 3800 West Highway 13, Burnsville, Minnesota, 55337.

**70 MPH Landsailer Thrills!** Build Quickly, Inexpensively! Completely Detailed Plans With Photographs, Only \$5.00. Kits Available. Shelby Industries, Box 6034, Albany, California 94706.

**FIBERGLASS** Cloth, matt, polyester and epoxy resins. Wholesale catalog 25¢. Boat Molding book 30¢. Seifert's, Box 1206-M, Green Bay, Wis. 54305.

**FIBERGLASSING?** Complete Instructions! "Craftmans Fiberglass Manual." Only \$2.00. Postpaid! Edryn Corporation, Box 537-PM, Cocoa Beach, Florida 32931.

**200 PLANS, Patterns, Some Kits.** Deep V Plywood, Ferro-Cement. Catalogs: Powerboat (2) \$1.25, Sailboat 50¢, Ferro-Cement Boat Building Book, \$12.50. Pram Kits, \$49.95. Marinecraft, Box 161-M, Brighton, Mass. 02135.

## CAMPERS AND TRAILERS—KITS—PLANS—

**PLANS & Kits—Motor Homes, Chassis** mounts, Pickup Campers, Covers, Trailers, Bus & Van Conversions, Modifications & Buitins. Complete Easy to Follow Large Scale Plans, Patterns and Detailed Instructions. Supplies, Parts & Accessories, all your Needs at Low Discount Prices. Details Free. Lucky, Box 8657 A2, White Bear Lake, Minnesota 55110.

## MARINE EQUIPMENT AND SERVICES

**MARINE** Engines, conversions, parts, equipment. Catalog Free! Stokes Marine Industries, Coldwater, Michigan 49036.

**CONVERT** Auto engines to marine. 68 Page Catalog. 50¢. Lehman Manufacturing Company, 800 Elizabeth Avenue, Linden 4, New Jersey 07036.

**MARINE** Supplies, Ignition Parts. Free literature. Michael's, 991 Broadway, Bayonne, New Jersey 07002.

**FREE Brochure** Conversion Kits, Propellers, gears V-Drives 1/0 Drives Gas, Diesel, Starmarine, 1931 Embarcadero, Oakland, Calif. 94606.

## ATHLETIC AND BODY BUILDING COURSES

**SIT And Sway The Paunch Away** . . . Booklet, Complete With Illustrations, Shows You How—\$1.00. William H. Sarver, Box 447, Braddock, Pa. 15104.

**"GIANT Arms."** Dr. Young's, D.C. revolutionary discovery. \$3.00. Satisfaction or refund. Gaucho, 1769-A-7, Chicago 60690.

**DESTRUCTIVE** Power Punch Professional Secrets by Registered Black Belt plus Membership Card \$3.00. Karate Academy, Highway 35, Wannamassa, New Jersey 07712.

**POWERFUL** Muscles fast! Free brochure! Universal Bodybuilding, Box 4327-C, Dearborn, Michigan 48126.

**REGAIN FITNESS!** Scientific Exercise Instrument Conditions Muscular, Cardiovascular-Respiratory, Neurological Systems Simultaneously **10 MINUTES OF EASY RHYTHMIC MOTION EQUIVALENT IN "AEROBIC" BENEFIT TO JOGGING A MILE IN 8 MINUTES.** Safe. Adaptable To All Ages. Can Be Used By Handicapped Or Heart Patients. Backed By University Research. Write For Full Color Brochure. **CISCO,** Dept. H-1, Box 403, Lincoln, Illinois 62656.

**PLANS WRISTWIST ARM-SHOULDER DEVELOPER.** How to make. Send \$2.00 to: J.J. Johnson, General Delivery, Thunder Bay 'F', Ontario, Canada.

**AMAZING** Abdominal Development. Unique Mini Exerciser Free Brochure. Cimo Box 741, Corona, N.Y. 11373.

**KUNGFU,** Illustrated instructions, \$2.00 complete. RSH, 5834 Manton, Chicago, Illinois 60646.

## SPORTING GOODS AND EQUIPMENT

**ARKANSAS** Stones, Pocket-Hunting Knives, Unusual Cutlery. Catalog \$1.00. Custom Cutlery, 907PM Greenwood, Dalton, Georgia 30720.

**FREE** Catalog low direct factory prices, fishing, Hunting, Archery, reloading Camping supplies. Send today. Herbers Inc., Dept. CPM, Waseca, Minn. 56093.

**FREE WHOLESALE CATALOG.** Lure parts, Molds, Rod Blanks, Reels, Archery, Metal Detectors, Rare Hardwoods. Finnyports (ME), Toledo, Ohio 43614.

**FREE 1973** Catalog! Guaranteed lowest prices! Rods, Reels, Lures, Accessories—Thousands of items. Cabela's, Inc., Dept. S-14, Sidney, Nebraska 69162.

**AIR GUNS!** Most name brands. At discount prices. Free price list. Toby's, Box 3100-E, Miami, Fla. 33169.

**BILLIARD CUES & Accessories,** Catalog Free. Murphys' 32, Box 5352, Santa Monica, California 90406.

**FREE "TENNIS EVERYONE".** Bumper Sticker & Catalog. Cash In On Fastest Growing Pro Sport. Rush Stamped Envelope. Sedco, Box 386P, Corona Del Mar, California 92625.



## FISHING, TACKLE, LURES

**MOLDS—**For casting your own fishing sinkers. Free illustrated booklet. Reading Instrument Co., Box P-78, Reading, Pa. 19603.

**FISHERMAN'S DREAM BOOK—FREE,** 170 page catalog just loaded with Hard-To-Find Fishing Tackle Specialties and Do-It-Yourself Goodies. Our 29th year. **NETCRAFT** Inc., Box 5510, Dept. PM-12, Toledo, Ohio 43613.

**FISH** With The Winner—Mepos Original French Spinners took 57 awards in latest **Field & Stream** and **Sports Afield** contests—more than next 4 lures combined. Discover why in 1973 Mepos Fisherman's Guide. Send 25¢ with name, address to: Sheldons', Inc., Box 707, Antigo, Wisconsin 54409.

## EARTHWORMS, LIVE BAIT

**HOW** To Make Money Raising Fishworms! Details Free. Gloworm, Department P01B3, 3910 Elfin, Louisville, Kentucky 40207.

**EARN** Money raising fishworms for us! Exciting details free! Oakhaven—56, Cedar Hill, Texas 75104.

**HYBRID** Redworms, 5000—\$12.00; 20,000—\$24.00. Postpaid with raising instructions. Brazos Worm Farms, Route 4, Waco, Texas 76705.

**RAISE** Earthworms For Profit Details 25¢. Wray, 2511 Iowa, Carlsbad, N.M. 88220.

(Continued on next page)



## EARTHWORMS, LIVE BAIT

(Continued from preceding page)

**LARGER EARTHWORM PROFITS.** Compare Facts. Soilless. Costless. Organics. Route #1-M, Texarkana, Arkansas 75501.

**GROW** Fishworms. Outstanding new breed produces great profits. Free Literature. Fain's Hatchery-31, Edison, Ga. 31746.



## HUNTING, GUNS, DECOYS

**THROWING** Knife, 10". Pierces metal. Balanced, Hard-hitting. Double edge. Cutlery steel. Leather handle. \$1.25 (2/\$1.95). Sheath, 65c. Johnsonsmith, D10., Mt. Clemens, Mich. 48043.



## DOGS AND KENNELS

**LOOKING** For a Special Puppy—Send \$2.00 for catalog with prices and information on more than 100 breeds. Hoppe's Kennels—Rt. 2A—Hill City, Kansas 67642.

## POULTRY AND GAME BIRDS

**QUAILS**, Incubators, cages, supplies catalog. Marsh, 14216 Brookhurst, Garden Grove, Calif. 92643.

## RABBITS—CHINCHILLAS—FUR BEARING ANIMALS

**RAISE** Rabbits Successfully by knowing Facts, 48 Page Illustrated Book describing 25 Breeds, Housing, Breeding, Feeding, Markets, Marketing, etc. 25 cents. American Rabbit Association, 36 Arba Building, Bloomington, Ill. 61701.

**RAISE** Chinchillas. Guaranteed income. Catalog \$1.00. DeShon Chinchilla, Route 2H, Roanoke, Indiana 46783.

**AMAZING PROFITS!** \$10,000 Yearly Raising Rabbits for Wool and Breeding. Details 25c coin. American Angora, Malta 12, Montana 59538.

**\$500-\$1000 MONTH** Plan Raising Rabbits For Us. Free Details. White's Rabbitry, Mt. Vernon, Ohio 43050.

**MAKE** Big Money Raising Chinchillas, Cavies, Rabbits for us. Catalog 25c. Keeney Brothers, New Freedom, Pa. 17349.

**TOPLESS INCOME RAISING** Mutation Chinchillas. 25c; Bulletin \$1.00 (Refundable). Chinchilla, 11PMT, Port Richey, Florida 33568.

## PETS—BIRDS, CATS, HAMSTERS, ETC.

**UNUSUAL** Pets—Monkeys, Skunks, Flying Squirrels, Wolves, Snakes, Turtles. Catalog 25c. Ray Singleton, Riverview, Fla. 33569.

**PETS**, Reptiles, raccoons, skunks, squirrels. Catalogue 25c. Trails End Zoo, St. Stephens, S.C. 29479.

**LIVE** Seahorses, marine specimens, aquarium supplies, illustrated catalog 35c. Marine, Box 23158-G, Ft. Lauderdale, Florida 33307.

## HORSES, LIVESTOCK

**"HOW TO TRAIN HORSES"**—FREE Book tells how to break, train, make money with horses. Beery School, 1102, Pleasant Hill, Ohio 45359.

## CAMPING EQUIPMENT AND TENTS

**FREE** Outdoorsman's Catalog. Features outdoor clothing, boots, tents, packs, hunting, fishing, hiking equipment, government surplus etc. Satisfaction Guaranteed. Write for free copy today. P & S Sales, Dept. P-2, Box 45095, Tulsa, Okla. 74145.

**FREE** 112-Page Camping, Marine Color Catalog. Laacke & Joys, 1439 N. Water, Milwaukee, Wisconsin 53202.

## TRAVEL AND RESORTS

**FREE** Information **FLORIDA VACATION**, Motel Discounts, Vacation Enterprises, 2500 Channing, Cleveland, Ohio 44118.

## ELECTRICAL SUPPLIES

**METERS**—Surplus, new, used, panel and portable. Send for list. Hanchett, Box 5577, Riverside, Calif. 92507.

**LAMP** Parts. Catalog, prices, wiring instructions. 50c. Refunded first order. Gyro, 5218P N.W. 35 Ave., Miami 42, Florida 33142.

## BATTERIES, GENERATORS

**BATTERY** Reconditioning Kit, includes molds, material, instructions. Battery Shop, Box 820, La Quinta, California 92253.

**BATTERY** Terminal Protectors Stop Battery Corrosion. Free Literature. Pracna's, 3301 Buchanan Road, #83, Antioch, California 94509.

**NIKE** Missile Nickel Cadmium Battery Cells \$1.49 Each. Send Stamped, Self-Addressed Envelope For Listing Of Other Cells And Batteries For All Uses. Esse Surplus Co., 368 S. Meridian St., Indianapolis, Ind. 46225.

**COMPLETE** Hydraulic Jack Repairing Manual \$3.00. Moneyback Guarantee. Bayerco, 938-DW Betty Avenue, Neenah, Wisconsin 54956.

## ENGINES, MOTORS, MAGNETS

**OPERATE** Three Phase Motors From Single Phase, Many Ways. \$3.00. Don Howell, Barnesville, Ohio 43713.

**WINDING** Data, 275 motors, \$1.25. Data Company, 512 Kensington, Kansas City, Mo. 64124.

**MOTOR REWINDING INFORMATION!** Supplies! Equipment Plans! Modequip, Box 7266, Kansas City, Mo. 64113.

**STEAM** Engine Kits, Catalog-Handbook \$1.00. Reliable Industries, New Baltimore, Mich. 48047.

## MACHINERY, TOOLS AND SUPPLIES

**UNIMAT**, Specially designed Precision Accessories. Also, Parts and Plans for building a **GEMSTONE** faceting machine. Send 25c for brochure. Mechtronics Research, 104 ViaSego, Redondo Beach, Calif. 90277.

**SURPLUS 4"** Metal Cutting Lathe, Ball Bearing Spindle—\$39.50. Taig Mfg., 15048 Proctor, Industry, Calif. 91746.

**SMALL** Foundry furnaces. Supplies. Free literature. Pyramid Products, 3736 South 7th Avenue, Phoenix, Arizona 85041.

**END** Mills. Lathe Milling Attachments: Information. Potter, Box 73, Cedar Rapids, Iowa 52406.

**MAXIMAT, UNIMAT**, Micro-Flame Torches, Dremel, Flexible Shaft Tools, Riffler Files. Save At Our Low Discount Prices. Pioneer Electric, Box 7X, Brentwood, New York. 11717.

**MAXIMAT**, Unimat Sale. Amazingly low prices. Deco-M, 562 Howard Avenue, Staten Island, N.Y. 10301.

**SANDBLASTING** Outfit \$29.95 (Air-compressor required). Free brochure. Inka, Box 66573-X, Houston, Texas 77006.

**3"** METAL CUTTING LATHE. Made in USA. Money Back Guarantee. Childs & Co., Conyers, Georgia 30207.

**NUTS**, Bolts, Screws, Washers. Catalog 25c. Also Assortments. Nutty Co., Box 1576SMS, Fairfield, Conn. 06430.

**TOOLS, EQUIPMENT & SUPPLIES!** We List Over **FOURTEEN-HUNDRED** Different **CATALOGS** of Materials and Accessories for Arts, Crafts, Automotive, Electronics, Industry. Send \$2.00. **MASTERLOG**, Box 24413BA, Oakland, California 94623.

**PAINT** Mixer. Exclusive Design Mixes Horizontally, Vertically. Power With Electric Drill. \$1.00 Postpaid. Prairie Industries, Box 358, Lind, Washington 99341.

**MAXIMAT**, Unimat Lathes. Metals. Micrometers. Catalogue 50c. Industrial \$2.00. Campbell (PM) 1424 Barclay, Springfield, Ohio 45505.

**CHAIN** Saw Service Manual—step-by-step care, repair of 360 models. 240 pages, profusely illustrated. \$5.95 postpaid. Chain saw parts catalog free. Zip-Penn, Box 179-S2, Erie, Pennsylvania 16512.

## WELDING, SOLDERING, PLATING

**PLATING** Equipment. Portable Platers, Supplies, and "Know-How". Build your own tanks for nickel, chrome, etc. Easy-to-install PVC liners. Rectifier components—all sizes. Schematics, parts lists, formulas, operating instructions for all plating. \$10.00 post-paid. Guaranteed to save you 25%-75% or immediate refund. Some good used units for sale. Platers Service Company, 1511-A Esperanza, Los Angeles, California 90023.

**LEARN** Professional Electroplating Techniques! New Manuals! \$5.95 Electroplating Kit! Write: Qrew, Box 8-PP, Bourbonnais, Illinois 60914.

**WELDERS**. Convert To Heliarc. High Frequency Unit 0-225AMP. Plans \$4.00. Convert To DC Plans \$3.00. Information Supply Co., Box 166, College Park, MD. 20740.

## GOVERNMENT SURPLUS

**JEEP** And Gov't. Surplus Buying Manual (Jeeps Pictured) 75c. Surplus Bargain Catalogue 60c. Both \$1.00. Surplus Bargains, Box 789PM3, York, Penna. 17405.

**GOVERNMENT LANDS** . . . Low as \$3.50 acre! Vacating . . . Homesteading . . . Investment! Exclusive "Government Land Buyer's Guide" plus "Land Opportunity Review" listing lands throughout U.S. Send \$1.00 Surplus Lands, Box 19107-AN, Washington, D.C. 20036.

**JEES!!! PICKUPS!!!** 100,000 Items direct from government. Your area. Latest information & surplus categories: \$2.00 **MONEYBACK GUARANTEE**. Order manual #121 from "Dependable Products", Box 113, Vista, California, 92083.

**NO CATCHES**. Buy any surplus direct from U.S. gov't. All information \$2.00. Bridgeworth, P.O. Box 2292-C, Vancouver, Washington 98661.

**JEES** Typically From \$53.90 . . . Trucks From \$78.40 . . . Airplanes, Typewriters, Boats, Clothing, Camping, Sporting, Photographic, Electronics Equipment. Wide Variety, Condition. 100,000 Bid Bargains Direct From Government Nationwide. Complete Sales Directory and Surplus Categories Catalog \$1.00 (Deductible First \$10.00 Order From Our Separate included Catalog). Surplus Service, Box 820-A, Holland, Michigan 49423.

**GOVERNMENT** Surplus. How and Where to buy in Your Area. Send \$2.00. Surplus Information, Headquarters Bldg., Box 30177-PM, Washington, D.C. 20014.

**MILITARY** Surplus-Direct From Our Warehouse. Illustrated Catalog \$1.00; Lea Surplus, Dept-50, Box 679, Fairlawn, New Jersey 07410.

**"U.S. GOVERNMENT SURPLUS** Directory." How, Where to buy 100,000 items (including Jeeps) . . . low as 2c on dollar! Most complete information available. \$1.00. **SURPLUS DISPOSAL**, Box 19107-AB, WASHINGTON, D.C. 20036.

**JEES** . . . Buses . . . Vans . . . Trucks . . . Automobiles from \$52.50. Airplanes, Boats, Typewriters. Direct From Government. Directory and Surplus catalog \$1.00 (Refundable). Southern Surplus, Box 262PM, Manchester, Ky. 40962.

(Continued on next page)

## GOVERNMENT SURPLUS

(Continued from preceding page)

**1973 SURPLUS** Army, Navy store, 52 Page illustrated catalog. Send 50¢. Ruvel, 3037 North Clark, Dept. 2-J, Chicago, Illinois 60614.

**JEEPS** From—\$52.50; Typewriters from—\$4.15; Cars from—\$31.50. Walkie-talkies, motorcycles, airplanes, boats. Typical "As Is" bid bargains from Uncle Sam. Tremendous variety. Exciting free list. Write: Enterprises, Box 402-X85, Jamaica, New York 11430.

**JEEPS!!! TRUCKS!!! LAND!** 100,000 Amazing bargains direct from Uncle Sam nationwide. How, where your area. Complete Sales Directory \$2.00. **MONEYBACK GUARANTEE.** Diversified Surplus, Box 27177-F, San Antonio, Texas 78227.

**MAKE MONEY** On Government Surplus. How and where to buy. Directory of surplus offices. Sale terms. Mail order items. Send \$1.00. Evans Enterprises, Dept. 5PM2, 77 May Street, Irvington, New Jersey 07111.

**SURPLUS BARGAINS**—War, government, industrial surplus at savings to 80%! Clothes, boots, coats, tents—bargains for farm, home, outdoors. **SEND FOR FREE CATALOG**—must give zip code. **SURPLUS STORE,** Sioux Falls, S.D. 57102.

**JEEPS** \$52.40, Airplanes \$75.01, Typewriters \$6.70, Boats \$7.50, Direct from Government, Directory and Surplus Catalog \$1.00 (Refundable). Midwest Surplus, Box 401-PM, Dayton, Ohio 45401.

**DON'T** Let Some Middleman Make Money! Buy Surplus Direct from Gov't. Our Course complete with Personal Hints on Cassette Tape. Only \$3.00. Long's Surplus, 4900 Scenic View, Birmingham, Ala. 35210.

**JEEPS . . . BOATS . . . CAMPING . . .** 100,000 items, from Government. Latest howto your area. Dealerlist. Guaranteed. \$2.00. Ross, Box 476312, Caseyville, Illinois 62232.

## HOBBIES AND COLLECTIONS

**HOBBI-CARVE**—Home workshop wood carver—create beautiful wood reproductions of sculptures, plaques, figurines, sconces and bookends. Hundreds of work patterns available. Send 25¢ for "How To Make Quality Wood Carvings" booklet. Refunded with order. Write: Hobbi-Carve, 930 Duluth Street, Dept. PM, St. Paul, Minnesota 55106.

**COLLECT** Military Medals, list 25¢. Vernon, Box 387PM, Baldwin, N.Y. 11510.

**NAZI** War Souvenirs Free Illustrated catalog. Delta, Box 361PS, Lafayette, Calif. 94549.

**NAZI** Medals, Photos, and Jewelry. Also War Mementos from Other Countries. Catalog and War Poster, 25¢. Hutchinson House, Box 6411, Chicago, Illinois 60680.

**FREE** American Amateur Winemakers Association Membership. Roles Remain Open To Adults Till Spring. Rush Request To: Suite 569, 1629 K Street N.W., Washington, D.C. 20006.

**50 GORGEOUS** Jungle Butterflies \$2.90. Collectors Wonderland, Box 1170, New York 10008.

## DECALS, EMBLEMS, PATCHES

**NASA** Contract supplier offers authentic Apollo 4" diameter flight patches at \$2.00 each. Souvenir 3" size, \$1.00 each. Apollo 7—16 set of ten in 4" size, \$17.50. 3" size set \$8.00. As supplier to the World's largest corporations, we offer custom embroidered patches from 25 pieces to 25 million. Lowest prices. Fastest delivery. Design-An-Emblem Guide plus free sample emblem: 50¢. A-B Emblem Corporation, Box 5695, Weaverville, North Carolina 28787.

**PROMOTE.** Identify Your Group with Your Own Embroidered Emblem or Decal. Free Design Service. Inexpensive. Details, catalog free. Southern Emblem, Box 8PMA, Toast, North Carolina 27049.



## STAMP COLLECTING

**88 COUNTRIES—ONLY 10¢!** Worth \$5.00 at catalog prices!! Incredible collection of genuine postage stamps from 88 different countries—from Afghanistan to Zambia, North to South Pole! British, French, Portuguese, Spanish Colonies. Old 19th Century, New Issues, Moon and Outer Space stamps, etc. All for only 10¢! Also, other exciting stamps to examine free. Buy any or none, return balance, cancel service anytime. Plus Wonderful Free Catalog! H. E. Harris, Dept. SS-46, Boston, Mass. 02117.

**YOURS FREE!** 20 Almost Rare Stamps from 12 Lost Nations—Most a Half-Century Old! Nations overrun by invaders and never freed again. Stamps so appealing that experienced and beginning collectors alike will want them. You get 110 other stamps from Britain's Lost Empire plus illustrated Album to keep as a Bonus should you buy \$1 from our Approval Selection. Or return Album and 110 stamps with selection and buy nothing. Cancel Service anytime. But Lost Nations stamps are yours to keep! Send 10¢ for mailing while supplies last. Kenmore, Milford LN-293, New Hampshire, 03055.

**200 DIFFERENT** 25¢ When Requesting Approvals. Polze, Box 5215, Milwaukee, Wisc. 53204.

**CHINA (Mainland)** 100 Different 25¢ Approvals. Erickson, 736 Cottage, St. Paul, Minnesota 55106.

**FREE** Worldwide Packet. Penny Approvals. Froehlich, Box 7, Waukegan, Illinois 60085.

**STAMPS** Free! New Issues—New Countries—Triangles—Rockets—Olympics—Scouts—Birds—Flowers—Animals—Also Old Canadian and U.S. Stamps. Plus complete illustrated Canadian Stamp Catalog. Send 10¢ for mailing. Gray Stamp Co., Dept. A, Toronto, Canada.

**START** Your Own Stamp Business!! Write: International, 6767LL South Atlanta, Tulsa 74136.

**JAPAN, CHINA, AUSTRALIA, KOREA**—100 Different Only 25¢ With Fascinating World Approvals. Ephemera, Box 25934, Los Angeles 90025.

**FREE**—Mint British Colonials from Antigua, St. Christopher, Nevis, Sarawak, Turks Caicos, Tristan, Caymans, St. Vincent Free with approvals. Viking, Great Neck, N.Y. 11021.

**FREE!** Big Bargain Catalog—New Edition listing thousands of bargains including U.S. & B.N.A. stamps, packets, albums, accessories and supplies. Also, fine stamps from our approval service which you may return without purchases and cancel service at any time. Jamestown Stamp, Dept. E23PM, Jamestown, New York 14701.

**50 DIFFERENT** Old U.S. Revenue stamps \$1.00. Winchester Stamps, Box 354, Mansfield, Ohio 44907.

**AUSTRALIA**—50 Different-10¢ With Approvals, Value Company, 10209A Tenbrook, Silver Spring, Maryland 20901.

**50 BRITISH EMPIRE** 10¢ Approvals. Becker, Box 8993-MP, Portland, Oregon 97208.

**SOUVENIR** Sheets Czechoslovakia 1937 Plus Japan 1947 Plus Yugoslavia Set 25¢ Approvals. Kingman, 65 Page, Yonkers, N.Y. 10704.

**OLDER U.S.** stamps, covers, on approval to adults only. Surprisingly good. ENGLE, Box 208P, Lowell, Michigan 49331.

**WOW!** 110 All Different Germany 10¢ Commemoratives, Airmails, High Values, Big Catalog, bargain lists. Also, fine stamps from our approval service, which you may return without purchases and cancel service at any time. Jamestown Stamp, Dept. A23PM, Jamestown, New York 14701.

**WOW!** 1000 Different Worldwide Stamps (\$35.00 Cat. Value) \$2.00 with profit sharing approvals. Universal, Box 6MA, Kenosha, Wisconsin 53141.

**ANTIGUA, Cayman, Turks, Grenada**—over 100 different British Commonwealth, 10¢ with low-priced approvals. KAYCO, P.O. Box 437, Flushing, N.Y. 11367. Dept. M-3.

**WOW!** 100 Different Canadian Stamps Used 50¢ With Approvals. Stamps, Box 1405, Kingston, Ontario, Canada.

**FREE,** Mint Worldwide Packet. Approvals. Hildebrand, Box 5645, Redwood City, California 94063.

**FREE** New used Congo animal set, Approvals included. Alpaughco, Highbridge, N.J. 08829.

**TEN** Different Nudes: 20¢ Approvals. Stamp Farm, 2-M51, Oxford, Wis. 53952.

**50 DIFF. U.S. COMMEMORATIVES** 25¢. Fine U.S. Approvals Accompany. Craig Stamps, Box 425-N, Bellmore, N.Y. 11710.

**FOREIGN** Approvals! Gigantic values! 3¢ each. ABC, Dept. 3301-A, Box 6000, San Francisco 94101.

**3¢ PLATE** Block 25¢ with comprehensive U.S. stamp and Supply catalog. Schultheis, Box 2151C, New Hyde Park, N.Y. 11040.

**APOLLO** 11 Moonlanding. Seven multi-colored giants from Guinea, catalog value \$3.41. Only 10¢. Topical approvals. LeBlanc, Box 110-P1, Glen Cove, New York 11542.

**ONE CENT STAMPS.** Write for jumbo books of stamps at 1¢ each, mounted in Scott order. **BULLOT APPROVALS,** 6815 Bay Pkwy, Brooklyn, N.Y. 11204.

**"AFRICA"** 25 Beauties, 10¢ Approvals, Gorliz, Box 28765 PM, Memphis, Tennessee 38128.

**100 DIFFERENT** United States Stamps, 25¢ With U.S. Foreign Approvals. ShelRon, Box 547C, North Miami, Fla. 33161.

**U.S. MINT** Specials! Flag set, complete \$1.00. 1¢, 2¢, 3¢ famous Americans (21 different) \$1.00. Free list. Brooks, 2601 Avenue "U," Brooklyn, N.Y. 11229.

**PENNY!** Approvals! Regardless catalogue! Kloster, 4164 52nd St., San Diego 5, Calif. 92105.

**FREE** Surprise collection sent with approvals. Gould, 1784 Union, San Francisco 94123.

**PENNY** Stamps! 1000 Mounted in book at 1¢ each! Trust Stamp Company, P.O. Box 100-P, Jamaica, New York 11435.

**ABSOLUTELY** Free United States Mint Souvenir Sheet When Requesting United States Approvals. K&B, Box 70, Brooklyn, N.Y. 11223.

**500 DIFFERENT** Stamps, \$1.00. Smith, 508-A Brooks, College Station, Texas 77840.

**100 DIFFERENT** British Empire 15¢ Approvals. Gibson, Box 34, Lansdowne, Pa. 19050.

**60 DIFFERENT** United States (30 Commemoratives) 25¢. Seidenberg, Salem 169, Oregon 97308.

**"INVERTED** Error" Dag Hammarskjold, 10¢ with approvals. Belmont Stamps, Washington, D.C. 20015.

**100 OLD** United States between 1861 and 1935. \$1.00. Ed Roush, 423 Shepard, Mansfield, Ohio 44907.

**225 STAMPS** For only 10¢! Airmails. Pictorials: stamps from strange countries cataloging up to 25¢ each! Plus unusual stamps to examine. Buy any or none return balance, cancel service anytime. Mystic Stamp Co., Camden 80, New York 13316.

**NEW** Issues—Free Weekly Illustrated list. Brooks, 2601N Avenue "U," Brooklyn, N.Y. 11229.

**12,000 DIFFERENT! AMAZING** New Plan Builds Your Collection Systematically, Country By Country. Only 50¢ Weekly. Ware, Monroe, Conn. 06468.

(Continued on next page)

## STAMP COLLECTING

(Continued from preceding page)

**FREE! 10 African Beauties! 30 Others!** Approvals. Cambridge, Box 2311, Heath, Ohio 43055.

**WORLDWIDE Philatelic—Numismatic Publications!** Free List. Bedard, #5215-A, Detroit, Michigan 48236.

**LIECHTENSTEIN** 356-\$19.00; France #1100-\$4.00; UN 29-30-\$15.00; NH, CWO. Submit Lists Western Europe Only. All NH. Franklin, Box 467F, Jamaica, 11434.

**VALUABLE** Collection! Get scarce Red China, Pope John, Apollo 14, Antigua military costume, Iwo Jima memorial stamps, many more. 100 Different new and old issues from the world over—savage warriors, wild beasts, famous people, exotic scenes. Also stamp selections to examine. Buy any or none, return balance. Cancel service anytime. Rush 10¢ handling. Garcelon Stamp Co., OPMX, Calais, Maine 04619.

**CANADA** Sports Complete 10¢, Canadian Approvals. Harley Boardman, Little Valley, New York 14755.

**1000 PRE-1939 USA**, contains dues, revenues, commemoratives, presidentials, high values, older issues, etc. \$3.00; 5000 \$12.00. 300 pre-1940 USA commemoratives \$2.00; 700 \$4.00. 5000 foreign \$3.00; 9000 \$5.00. No approvals. Meyers, 5321 Fleming, Richmond, California 94804.

**20 HISTORICAL U.S. Commemoratives** 10¢. Bargain U.S. Approvals. PINTO, Box 111, Park Ridge, Illinois 60068.

**BETTER GRADE U. S.**, Canadian Stamps. Borgen, Box 502, Alturas, California 91601.

**FREE** Beautifully Designed Space Selection, Approvals, House of Hoke, Sebring, Florida 33870.

**SIERRA LEONE** Diamond-Shaped Scout Stamp, Bhutan Steel Foil, Apollo Moon-landing, Dominica Animal, Virgin Islands Pirate, Cook Islands Christmas Painting plus 100 others. Only 10¢ when requesting approvals; select those desired, return balance. Cancel service anytime. Douglas Cook, Dept. PM-9, Las Vegas, Nevada 89112.

**WORLDWIDE COLLECTION.** 2,000 Different \$7.00. Larbig, Box 2617, Lakewood, Ohio 44107.

**YOUR Choice—40** Different U.S. Commemoratives or Packet Interesting World Pictorials 10¢ with FOREIGN Approvals. R. Hadley, 564 Market, San Francisco 94104.

**RICHARD NIXON** Inauguration Day Souvenir Cover. Addressed any name your choice. Special Postal markings. 50¢ each. K.M. WALSH, Box 308A, TUCKAHOE, New York 10707.

**307 DIFFERENT** triangles, Sports, topicals, etc. Worth near \$8.00. Only 25¢. Bargain approvals. Jayto Stamps, East Syracuse, New York 13057.

**VIETNAM** 25 Different 10¢ approval. Sam Chazen, Box 95, Ozone Park, N.Y. 11417.

**FREE—Worldwide \$1.00 Value.** Approvals. Stamps Unlimited, 101 W. Inkster, Kalamazoo, Mich. 49001.

**7 COMPLETE SETS** Poland—25¢ With Approvals, Duncan Stamps, RR #1, Duncan, B.C., Canada.

**50 FAMOUS PAINTINGS** 50¢ When requesting approvals. C. F. Stamps, 655 Forbes St., East Hartford, Conn. 06118.

**"CONQUEST Of Mars"**. Yemen's Latest Collection. 10¢ With Space Approvals. Potomac Stamps, Washington, D.C. 20015.

**MINT STAMPS—25** All different, Worldwide, Large and Beautiful only 10¢, approvals. Cornett, P.O. Box 711, Miami Springs, Florida, 33166.

**80 DIFFERENT U.S. Stamps.** Includes 1943 flag stamp of occupied nations. Only 25¢. Approvals included. Willett Co., Box 338-M, Yorktown Heights, N.Y. 10598.

**FREE!! 25 US Commemoratives, 2"** Diameter Magnifier—10¢. Approvals. Mixdrak, 5630 Wilson, Chicago 60630.

**GIANT** Stamp Collection including: Astronauts, Satellites, Moonrockets, Boy Scout issue. Complete U.N. Set, recent Olympic and Sport issues from many countries, etc. Plus Big Stamp Dictionary and approvals. Everything 10¢! Stampex, Box 47-RM, White Plains, N.Y.

**50 YEARS** Old, fifteen different United States, over fifty years old—10¢ with approvals. Jaxon, Box 145-P, Brooklyn, New York 11230.

**255 DIFFERENT** Worldwide: 15¢. Approvals. Tibbets, 8675 Meadow, Downey, California 90242.

**100 WORLDWIDE.** 10¢. Approvals. Jenco, Box 242, Wayne, N.J. 07470.

**FREE.** 100 Different with Approvals. Shill, 8511 Cedel, Houston, Texas 77055.

**1000 WORLDWIDE,** 200 Different U.S., 15 Different Sets, 10 Different Packets. \$2.00 Postpaid. DW Supply, Box 83, Osceola, Wis. 54020.

**JUMBO** Approvals. 30,000 Different 1-3¢ Each. Covey, 1953 Thornwood, Northbrook, Illinois 60062.

**14,000 DIFFERENT** Astonishing new method Builds your collection systematically country by country. Associates, Box 82568-3P2B, Atlanta, Georgia 30354.

**FREE** Mammoth Collection, Scott's International or Master Global Albums, when you buy our approvals. Bargain Service, Box 5345, Santa Ana, Calif. 92704.

**SEND** Only 10¢ for nice collection of U.S. stamps including "\$5.00." Issue and scarce mint Sipex Souvenir Sheet. You will also receive the most wonderful catalog of stamp offers in America. Littleton Stamps, Dept. SS1, Littleton, New Hampshire 03561.

**CANADA:** .50¢ Textile, Only .10¢. Approvals. Rheaum, 91 Valois, Vimont, Laval, Que. Canada.

**KAZAM!** 25¢. 50 Mid-eastern, Approvals. ALLADIN, Box 602, Jefferson City, Tenn. 37760.

**25 RUSSIA** Pictorials 10¢ With 2¢ Approvals. Philmart, Box 3863, McGregor, Texas 76657.

**PERSIA** 20 Different 20¢. Approvals. Gant, Box 1385, Shreveport, La. 71164.

**200 DIFFERENT** Worldwide 25¢ With Approvals. Associates, Box 82568-3P2A, Atlanta, Georgia 30354.

**SEND** Only 5¢ for Worldwide Collection of over 50 different Singapore, Grenada, Chad, etc. Contains old and new issues, sports, animals, etc. You will also receive interesting lists and a certificate worth 50¢ toward purchases. Goliath Co., Dept. TP-1, Bethlehem, New Hampshire 03574.

**TIMELESS TREASURE.** 22 Tempting Triangles 10¢. Approval Stamps, Box 1444-B, Kitchener, Ontario, Canada.

**NAPOLEON!** His Wars and Amours graphically depicted—an amazing Collection of Four Impressive Sets—Only Dollar Bill to Approval Applicants. Scott Service, 22 Strathearn Boulevard, Toronto, Canada, M5P 1S7.

**EXCHANGE,** Send 100-200 different foreign with 35¢. Receive different. Patterson, Lancaster, New York 14086.

**MYSTERY PACKET!** 100 Different Large World Pictorials With PRIZE SOUVENIR SHEET Dollar Bill. Scott Service, 22 Strathearn Boulevard, Toronto 349, Canada.

**FREE BARGAIN LISTS!** U.S. Mint singles-plate blocks. Scotco, Box 855-PME, Miami, Fla. 33147.

**50 DIFFERENT** Breathtaking Paintings only 50¢ when requesting approvals. Horizon, Box 349-S4, Flushing, New York 11355.

**U. N. 5 DIFFERENT** Mint 10¢! Approvals. Gordon Davison, Hillsboro, New Hampshire 03244.

**FREE! 50 DIFFERENT WORLDWIDE.** Also receive the most Dynamic Catalog of Foreign Stamp Offers in Existence. Free Bonus Plan. No Approvals. B&S Stamps, Box D-11, Morton Grove, Ill. 60053.

**FREE!** Surprise Gift Sent With Penny Approvals. Boudreau, Box 244, Dartmouth, N.S., Canada.

**U. S. PLATE** Blocks, Seven Different 3¢ Commemoratives \$1.00! Approvals. Gordon Davison, Hillsboro, New Hampshire 03244.

**APPROVALS—**United States, Foreign Collections. Gains, Box 788-A, Mattoon, Illinois 61938.

**FREE 50** Worldwide. Approvals. University Stamps, P.O. Box 1471, Lake Worth, Florida 33460.

**ABSOLUTELY FREE** Australian Collection When Requesting Approvals. Low Prices. Tom & Jerry, Box 27946-PM, Los Angeles, Calif. 90027.

**EARN \$60.00 DAILY PROFIT** From your Own Spare Time Mailorder Stamp Business!! Buy Stamps Wholesale . . . Get Free Advertising . . . Learn Trade Secrets! Information Free. Write: Bureau BSM, 2 Deepdale, Great Neck, New York 11021.

**NINE** American Space Issues Value: 65¢. 40¢. Approvals. Middle Earth Stamps, Box 1173-P, Evansville, Indiana 47713.

**FREE** Old U.S. Stamps. Approvals. Chapmans, Box 487-S, Galesburg, Michigan 49053.

**50 DIFFERENT** Argentina-10¢. Approvals. Gobestamps, Box 402, Biddeford, Maine 04005.

**BRITISH** Bonanza! 107 Exciting Colonials, Magnificent Commemoratives. 25¢. Approvals. Castle, Box 15-PM2, Flushing, New York 11352.

**RUSSIAN** Space collection 25¢. Russian Approvals. Snedco, Box 68-P, Waldwick, N.J. 07463.

**CANADA** 50 Different 15¢ To Approval Applicants. Lewis, 339 Beaconsfield Crescent, Saint John, New Brunswick.

**QUALITY AND LOW PRICE, EXCELLEN** For advanced or beginner. Mounted approvals 2¢ up, all countries in Scott's Order. Preview Stamps, P.O. Box 20667, San Diego, California 92120.

**U.S. BARGAIN,** 50 Different 10¢, with beautiful worldwide approvals. Stamp Center, Kennebunk, Maine 04043.

**TEN** Beautiful Diamonds, 10¢. Approvals. Big M Enterprises, Box 10902A-2, Ferguson, Missouri 63135.

**2 NUDE** Sets Plus 100 Others Only 25¢. Paschall, 3035 McGowan, Marion, Iowa 52302.

**FREE** World Collection. Over 100 stamps. Approvals. Global, Box 427, Livermore, Cal. 94550.

## COINS, TOKENS, CURRENCY

**1973-S CENT** Free with 3 1955-S Cents \$1.00. Pricelists. Edel's, Carlyle, Illinois 62231.

**FREE COPY** Interesting Coin Publication. Wholesaler, Box 893, Chattanooga, Tenn. 37401.

**MEXICO:** Silver Dollars Dated 1957 To 1967 In Nice Condition. Ten For \$3.95 Delivered Postpaid. El Paso Coin Co. Inc. Suite 108, El Paso National Bank Bldg., El Paso, Texas 79952.

**\$1000.00** Banknote 25¢ with comprehensive U.S. coin and Supply catalog. Schultheis, Box 2151C, New Hyde Park, N.Y. 11040.

**SILVER DOLLARS** Uncirculated, 1880-81—1883-84-85 \$5.00 Ea. Catalogue 50¢. Shultz, Salt Lake City, Utah 84110.

**LINCOLNS** 1909-1958 Every year including 1909VDB, 1922D. 50 different (Regularly \$12.60.) SPECIAL \$6.95. HARRIS, Box 2037P, Santa Cruz, California 95060.

(Continued on next page)

## COINS, TOKENS, CURRENCY

(Continued from preceding page)

**COINS** At Discount Prices! Free Brochure. Gene Carlton, Chandler, Okla. 74834.

**BARGAIN** Coin List, 10¢. Economy. Sales, Box 92, Buzzard's Bay, Massachusetts, 02532.

**GOLD—(1865)** Mexican Maximiliano Peso. Bu \$1.95. Northwoods, Bigfork, Minn. 56628.

**5 V-NICKELS**, Good, \$1.25. Free Catalog. Village Coin Shop, Dept. P, Plaistow, N.H. 03865.

**CLEARANCE** Ten Canada Silver Dollars \$15.00. Lee Ltd., 331 W. Pender, Vancouver, Canada.

**100 INDIAN** And Lincoln Cents 1920's And Older \$5.00. Free Catalog. Wesley Rood, Box 9, West Union, Iowa, 52175.

**REPLICA** \$1,000 Bill 35¢. Christopher, Box 244M, Fishkill, N.Y. 12524.

**CRISP** New \$2.00 Bill \$3.98. 1972-S Proof Set \$6.89, Bargain Lists \$18c. Bebee's, Incorp. Omaha, Nebraska 68111.

**COIN** Catalogue free! Raibl Enterprises, 2355 Scenic Highway, (PC) Pensacola, Florida 32503.

**SEND** Only 5¢ for valuable booklet "How To Collect Coins" which is loaded with expert advice. You will also receive 5 different foreign coins and your copy of the most unusual and interesting collectors catalog available anywhere. Littleton Coins, Dept. VB-1, Littleton, New Hampshire 03561.

**FIVE** Indianheads \$1.95; Terrific Listing 25¢. Nelson, Box 306-J, Chappaqua, New York 10514.

**LINCOLNS:** 50 Mixed 1909-40 \$2.00. 35 Different Uncirculated \$2.00. Nayko, 172-15D Effington, Flushing, New York 11358.

**1909 VDB'S!** Rare Lincoln Cents. \$3.95. 3 for \$10.00. Coins West, 21 Central, Campbell, California 95008.

**UNCIRCULATED** Silver Dollars, 1878-1935. Dates of our choice \$4.75, or ten \$47.00. Aurora, 507 3rd Ave. #5, Seattle, Wash. 98104.

**GOLD COINS** Of the World. Beautiful Low Prices. Plus thousands of United States Coins. Free price list. Please send long, airmail envelope. Self-addressed, stamped. Silver Center, Box 22171-M, San Francisco, California 94122.

**FOREIGN COIN COLLECTIONS—**21 Different \$1.00. 49 Different \$2.50. Paper Money 8 Different \$1.00. Wentz, Box 2439P, Newark, New Jersey 07114.

**UNCIRCULATED 'S'** Lincolns, three different, 10¢. Bargain lists included. Farley Coins, Metamora, Illinois 61548.

**PRICE** Lists of Thousands of Stamps and Coins. Send 25¢ Refundable with purchase. No Approvals. Bryson, 612M White, Toledo, Ohio 43605.

**SPANISH** Treasure catalogue. Bargains on Coins, Gold, Treasure, Special Bit of eight \$1.00 with catalogue. Colonial House, 909 Travis, Houston, Texas 77002.

## ANTIQUES, RELICS, INDIAN GOODS & CURIOS

**FREE!!** Lists Antiques, Indian Relics, 10 Arrowheads \$4.00. Hyde's, Box 2304, Santa Fe, New Mexico 87501.

### EVERYBODY LIKES DIXIE GUN WORKS.

**TONS** Of antique gun parts and supplies. All reproduction muzzle loading guns. Send \$2.00 for enlarged illustrated catalog No. 121. Dixie Gun Works, Union City 12, Tennessee.

**PERFECT** Flint Knife, 4 Perfect Arrowheads, Hide Tanner, \$4.00. List Free. Lear's, Glenwood, Ark. 71943.

**INDIAN** Relic list, Arrowheads \$4.00, doz. Folsom. \$5.00 each. C. Secrist, Deerfield, Missouri 64741.

**BARGAIN!** Much Sought after Official Guide to Antiques, Curios. Featuring prices to buy and sell thousands of Antiques in massive 416 page volume with 1500 illustrations. Low price \$5.90 post-paid. Decamps Specialties, 356A Princeton, San Francisco, California 94134.

**ANTIQUE** Barbed Wire. 20 Different 18" pieces \$5.00 or stamp for illustrated list. Richard Duitsman, Route 3, Beatrice, Nebr. 68310.

**APACHE ARROWHEAD COLLECTIONS—**Perfect. 25—\$5.00, 100—\$15.00. GERONIMO, PMD1239, Apache Junction, Arizona 85220.

## MODELS—CARS, SHIPS, TRAINS, PLANES ETC.

**LIVE** Steamers. A Man's Hobby. Big Engines Scaled to Model Sizes. Stationary, Marine, Boilers, Gauges, Pumps, Fittings. Catalog \$1.00. H.P.K., "P", Centuck 34, Yonkers, New York 10710.

**SHIP** Models Kits, fittings, plans, books, tools, engines, motors. Big illustrated catalog 50¢. Mass. residents add 3% tax. James Bliss & Co., Dept. SM, Route 128, Dedham, Mass. 02026.

**MODEL** Airplanes—Big 220 Page Catalog \$1.00. Sig Company, Montezuma, Iowa 50171.

**SHIP** Models Catalog 25¢. Scientific, Inc., 340 Snyder, Berkeley Heights, N. J. 07922.

**LIVE** Steam powered backyard railroads! All sizes. Complete "bolt-together kits," and rough castings. Excellent drawings. 100 page catalog \$1.00. Little Engines, Lomita, California 90717.

**SHIP** And yacht model fittings: Pine construction hull kits; blueprints. Send 75¢ for illustrated catalog. A. J. Fisher, Inc., 1002 Etowah Avenue, Royal Oak, Michigan 48067.

**ROCKETS:** Real flying models—flights up to 2500 ft. New illustrated catalog 25¢; Singles and multistage kit, cones, engines, launchers, trackers, rocket aerial cameras, technical information. Fast Service. Estes Industries, Dept. 7FM, Penrose 7, Colorado 81240.

**FREE.** Flying MODEL ROCKET Kit. Act Now. Offer Limited. Send 25¢ for Packet of Iron-Ons, Decals, Literature and "Free Rocket" Details. Aerospace Vehicles, Inc., Mineral Point, Wisconsin 53565.

**LIONEL TRAINS,** Used. Buy-Sell-Repairs. Details free. Toby's, Box 3100-PMTB, Miami, Fla. 33169.

**WOODEN** Ship Model Kits Catalog 20¢. Lexington Distributors, 53D Lexington Avenue, Smithtown, New York 11787.

## GAMES, TOYS, PUZZLES, NOVELTIES

**NOVELTIE** Catalog. Send 8 cent stamp. Tam Enterprises, Box 66278, Los Angeles, California 90066.

**GAMES AND PUZZLES,** Magazine sent Monthly \$9.00/yr. Sample Issue \$1.00. Box 1176-F, Palo Alto, California 94302.

**NEW PUZZLE** For Amateurs and Pros. Send \$1.50. Beltov, 5 Morley, Greenfield Park, Quebec, Canada.

## MAGIC TRICKS, JOKES, VENTRILOQUISM

**HOUDINI'S** Greatest Magic! You can do them all! Giant illustrated catalog 25¢. House Of 1000 Mysteries, P.O. Box 2026P, Pompano Beach, Florida 33061.

**LEARN VENTRILOQUISM!** Courses. Dummies, Marionettes. Catalog 25¢. MAGIC, NOVELTY Catalog 20¢. Rizzy's Ventriloquism Magic School, 3746 West 63rd Street, Chicago, Illinois 60629.

**CATALOG** 25¢. 1,500,399 tricks, jokes, novelties. Eibee, 7408-P San Antonio, Texas 78207.

**FREE!** World's leading novelty catalog. 1600 Funmakers, Jokes, Tricks, Science, Sports, Hobbies, Jewelry, Psychedelia. Johnson-Smith, C-10, Mt. Clemens, Mich. 48043.

**COMPLETELY** Illustrated catalog. 84 pages. 25¢. Manhattan Magic, Box 334-M, N.Y.C. 10011.

**WORLD'S** Finest professional magic tricks. Joker's Novelties. Giant illustrated catalog 10¢. Top Hat, Evanston, Illinois.

**FABULOUS MAGICS** New 1973 catalogue 25¢. Our specialty orders shipped same day no substitutes. Fabulous Magic, 3319 East Charleston, Las Vegas, Nevada 89104.

**BE A Magician!** Two booklets explaining 156 tricks plus large professional catalog, \$1.00. Magic, Inc., 5082 Lincoln, Chicago, Illinois 60625.

**LARGE** Catalog—Latest Magic for pocket, parlor, stage. Send 25¢. Be popular. Entertain. Fastest service. Jefferies Magicland. Dept 11, Dallas, Texas 75201.

**HOUDINI'S** Original Magic Shop. Established 1856. Send 25 cents for illustrated Catalog containing 5000 Tricks. Mindreading, Puzzles, and Jokes. Flosso-Hornmann, 304 West 34th St., New York 10001.

**ABRACADABRA** Magic Set \$5.00, Television Trick Cards \$1.75. Catalog 25¢. Wayne's Trick Shop, Warren, Penna. 16365.

**TWO!** Different Magic Catalogs. 25¢. Miami Magic, Box 1047, Miami 33133.

## BOOKS, CATALOGS, NEWSPAPERS

**NEW!** "How to Set Up and Operate a Home Budget." Informative book, helps eliminate money worries. \$1.95. Satisfaction Guaranteed. Fisher Specialties, 1109 Fairacres Road E., Richmond, Indiana 47374.

**FREE BOOK.** Prophet Elijah Coming Before Christ. Megiddo Mission, Dept. 63, 481 Thurston Road, Rochester, N.Y. 14619.

**MILITARY** Manuals/Books Catalog 25¢. Hillcrest Military Publications (K-18), McDonald, Ohio 44437.

**NATIONAL** Geographic Magazines, 1888-1971, any issue. Buxbaum, Box 465-PM, Wilmington, Delaware 19899.

**CO-PUBLISH** "Timely Tips" a mail order man's magazine. Diane Gargas, 4719 Kennedy Ave., East Chicago, Ind. 46312.

**RACING FANS** America's Most Profitable Systems Subscription Rate \$5.00 1 YR. Systems Catalog, 78 Merchant Street, Newark, New Jersey 07105.

**FREE** Catalog. How-To-Books, Bargain Guides, Blue Books. Elston House, Centerville, Mass. 02632.

**FREE** 306 Magazines Monthly. Write: Diamond, Box 15473J, San Diego, California 92115.

**BOOKS** On any Subject. Send for Free Information. Byrne Sales, 5445 W. 64th St., Dept. 1P11, Chicago, Ill. 60638.

**AMAZING** Offer!! Hundreds Unusual Books. Free Details. Vanhook Enterprises, Etna Green, Ind. 46524.

**WIRETAPPING** and the Laws—Your Privacy Invaded—Free Brochure—Don-Q, Box 548, Dept. PMO, Seattle, Washington 98111.

**BOOK SALE!** Free List Low Cost Family Books. Music Self-Improvement. Hobbies Etc. Winchester Enterprises, 2807PM Hargrave Street, Philadelphia, Penna. 19136.

**FIFTY YEARS TO ERASE.** The dramatic memoir of the Author's successful struggle to have his court-martial erased. \$3.00 plus 30¢ for postage. Fifty Years To Erase, 31 Oak Drive, Dept. A, Sicklerville, N.J. 08081.

**"IT IS Easier To Succeed Than To Fail!"** Techniques Bring AUTOMATIC Results! Free Details. Premier Enterprises, Box 10597-BB, Pittsburgh, Pa. 15235.

(Continued on next page)

## NEWSPAPERS BOOKS, CATALOGS, (Continued from preceding page)

**FREE Brochure** low cost Books: Astrology, Bowling, Chess, Coins, Dogs, Dreams, Golf, Cook Books, Horses, Memory, Prophecy, Secrets, "How To Stop Smoking Permanently", Stamps, How-To-Books, Many More. Write Now. James Stanley, Dept. A12B, 14044 Marsh Lane, Dallas, Texas 75234.

**FORTUNE** In Your Home. Old Comic Books, Medals, Buttons, Toys, in Demand. Book of Prices, Where to Sell, \$2.25. Includes Postage and Handling. Imperial Sales Co., 16 B Emerson St., Old Bridge, N.J. 08857.

## PLAYS, SONGS, MANUSCRIPTS

**POEMS** And lyrics of religious, reverent, inspired nature wanted for immediate recording. We are only interested in songs of hope, God's love, the comfort of His words and wisdom. Cathedral Recording, P.O. Box 78-PM, North Weymouth, Mass. 02191.

**PUBLISHING** Contract Guaranteed on selected songs and poems. Free evaluation. Hollywood Songwriters', 6253 Hollywood, 1117-PM, Hollywood, California 90028.

**SONGPOEMS, SONGS!** Urgently Needed. Possible Recording/Publishing, 50-50 Agreement. Betty's Music Makers, 1417B, Park Building, Pittsburgh, Pennsylvania 15222.

**RECORDS** Made. Publishing Contract Guaranteed On Accepted Songs, Poems. Send: Talent Searchers Of Hollywood, 6311-X Yucca, Hollywood, Calif. 90028.

**POEMS** Set to music. Songs recorded. Send poems, songs. Crown Music, 49-C West 32, New York 10001.

## BUSINESS SERVICES

**PROFITS FROM CLASSIFIED ADVERTISING!** Booklet shows you how to start your own business with Classified Advertising. Only \$1.00 (Refundable with first order.) C. A. MARTIN, POPULAR MECHANICS, DEPT. P, 224 WEST 57 STREET, NEW YORK, N.Y. 10019.

**CHECKING** Account—4½% Interest. F.D.I.C. Chicago Address: 50¢. 714W Janisch, Houston, Texas 77018.

**SAVE Cash!** Advertising copy, Layout, Production, Sales-Clinching Letters, Coupons, Catalogs. Data \$2.00. Baughan Creative Services, Box 1426-Z, Plainfield, New Jersey 07061.

## BUSINESS OPPORTUNITIES

**EASY-To-Start** rubber stamp business at home in spare time. Make up to \$16.50 an hour without experience. Facts free! Write to: Roberts, Room RC-2-CC, 1512 Jarvis, Chicago, Illinois 60626.

**INSTALL** Burglar alarms without previous experience or costly equipment. Big profit. Free details. Nasco, Dept. G2702, Woodland Hills, California 91364.

**FREE** Millionaire Book . . . Get A Fortune in successful little business. Work home! SBI-7, Kerrville, Texas 78028.

**YOUR OWN WHOLESALE BUSINESS!** 1000 Specialties! Product Catalog, Details, \$2.00. Rosenbergs, Dept. J108, 6162 Peterson, Woodland Hills, Cal. 91364.

**\$\$\$ MACHINE!** New, Easily Built, Cheap! REPRODUCES, CARVES, ENGRAVES! Economy Enterprises, Box 23P, Highland, Maryland 20777.

**SECRETS!** Mail Order Success. Internationally famous expert reveals how to make home business fortunes. Beginners! Get free report "Make Money By Mail." Discloses free advertising profitable products. Mailco, Dept. GC702, Woodland Hills, California 91364.

**AMAZING NEW** Home Business. Make \$1,000 monthly! Details \$1.00, refundable. Investigate today! Tega Co., Box 56, EDM Station, Des Moines, Iowa 50309.

**HOW AND WHERE TO GET CAPITAL. GET** \$500 to \$2 million. Free information. Counselor-17, Kerrville, Texas 78028.

**\$650.00 WEEK MAILING CATALOGS.** Details \$1.00. (refundable). HAROLD, P.O. Box 22313, Cleveland, Ohio 44122 Dept. M.

**311 FAST,** Easy ways to make money! Free! Rush name, address, zip. Perry, 13263-D Ventura Blvd. Studio City, Calif. 91604.

**BECOME** Tax consultant. Our students earn \$1,000-\$3,000 every tax season preparing returns evenings. State approved. National Tax School, Monsey 2JD, New York 10952.

**I MADE \$3,000.00** Monthly in Mailorder Evenings only. You can too! Free Proof—Bynant, 8601 Bowling Green, Austin, Texas 78758.

**TURN** Spare time into extra cash home business. Others make money for you. Free Report. Morgan, Dept. G2702, 6100 Variel, Woodland Hills, California 91364.

**BUILD** Custom Cases at home for profit. Get orders by mail. We supply materials, instruction—everything. Free home business details. Custom Case Supply Co., 6075 CPB, De Soto Avenue, Woodland Hills, California 91364.

**HOW** And Where to get capital. \$5000 + possible in one day. Free details. JPA, Box 101-BB, Park Ridge, N.J. 07656.

**OWN YOUR OWN** Light manufacturing business. Operate full or part time from home. Free information. Box 11214, Charlotte, N.C. 28209.

**HERBALISM!** The home gold mine! Free lesson. Herbalism Institute-B, 1339 Remuda, Glendora, Calif. 91740.

**WORLD** Import Directory \$3.00. Woodrow Wilson, 1812-PM Halifax Road, Woodbridge, Virginia 22191.

**OPPORTUNITY** Knocks Only Once—Invite It!!! Free Information For Stamp. TBOR, Box 1692-D, F.D.R. Station, New York 10022.

**\$500-\$1000 MONTH** Plan raising rabbits for us. Free details. White's Rabbitry, PM, Mt. Vernon, Ohio 43050.

**WORLD'S** Largest supply, Merchandise 25% to 40% under wholesale. Bankrupts. Closeouts 10¢ on dollar. Imports. Hong Kong clothes. Automobile discounts. Free details. International Buyers, Box 16386 MM, Portland, Oregon 97233.

**INSTANT** Mailorder!! Complete. Profitable. Proven. Starter kit 25¢. KS Promotions, 8156AE, Milwaukee, Wisconsin 53224.

**SELL** Books by mail. Complete dealer set-up—25¢. Midwest Mail Sales, Box 44R2-PM, Shawano, Wisconsin 54166.

**1000% Profit** Bronzing Baby Shoes. Free Literature. NBC, Box C-4-PM, Coral Springs, Florida 33065.

**MAILORDER** Millionaire helps beginners make \$500 weekly. Free report reveals secret plan! Executive (IA2), 333 North Michigan, Chicago 60601.

**MAKE** A Years Income in 8 weeks Camping. No selling. Capital or Land necessary. Write: Edru's, Route 5, Box 5733, Gig Harbor, Washington 98335.

**BECOME** "Mortgage Broker." Lucrative! Capital Sources, Box 99-A, Uleta, Florida 33164.

**MAILERS** Needed! Big money! Send 10¢ for information. Andrew Sales, Box 152, Blue Island, Ill. 60406.

**MAKE** Magnetic signs, Machineless method. Profits enormous. Write: R1B49APM, Bardstown, Ky. 40004.

**PIANO** Tuning Learned Quickly At Home! Tremendous field! Musical knowledge unnecessary. GI approved. Information free. Empire School, Box 327, Miami, Florida 33145.

**ADVERTISING BUSINESS—YOU** Own It. \$350 First Week or Money Back. Electric Neon Action Ad Clock, 229 W. Illinois, Chicago 60610.

**HOLLYWOOD CEMENTCRAFT:** Offers Highly Profitable Home Business. Experience Unnecessary. Unlimited Unique Pottery Designs Easily Made Without Moulds. Bird-baths, Fountains, Wishing-Well, Waterfalls, etc. Chemical Coloring Formulas. Marble-glazing. FREE Illustrated Brochure. **CONCRETE FACTS**, 602 Athens Street, Altadena, California 91001.

**COPUBLISH** "Mail Sale Advertiser," leading mailorder paper. Copy and details 25¢: U.S.A. only. Vanroy Shirk, Lebanon, Pa. 17042.

**VENDING** Machine big catalog. Rake, 523 A Spring Garden, Philadelphia, Pa. 19123.

**DRAFTSMEN!** Operate own **DRAFTING SERVICE!** Full, Part Time; Experience unnecessary; Details: Roberts Drafting, 1741 Circle Road, Baltimore, Maryland 21204.

**FREE** Catalogs. Repair air conditioning refrigeration. Tools, supplies, full instructions. Doolin, 2016 Canton, Dallas, Texas 75201.

**I MADE \$40,000.00** Year by Mailorder! Helped others make money! Start with \$10.00—Free Proof. Torrey, Box 318-Y, Ypsilanti, Michigan 48197.

**MAIL** Baby Catalogs Imprinted with your address to New Mothers for Big Profits! Details 25¢. Volz PM, Ypsilanti, Michigan 48197.

**MAKE** \$46 From square foot plywood: jigsaw or bandsaw necessary. Free details. Woodar, Bridgewater, Mass. 02324.

**\$25.00 HUNDRED** Addressing. Possible Year 'round. Complete instructions 25¢ for registration, postage. Cove, Box 1348-B, Clearwater, Florida 33517.

**\$70 TO \$200 WEEKLY**—Home, Spare Time Simplified Mail Bookkeeping. Immediate Income. Easy. Auditax, Box 34741A, Los Angeles, Calif. 90034.

**ADDRESSERS** And Mailers Needed. Details 10¢. Lindbloom, 3636 West Peterson, Chicago 60659.

**VENDING** Machines. No selling. Routes earn amazing profits. Big catalogue Free. Parkway Corporation, 715PBM Ensor Street, Baltimore, Maryland 21202.

**\$60.00 DAY.** Manufacturing Concrete Posts, Blocks. Mold Equipment Catalog \$1.00 refundable. Carlayne, Route One, Box 95, Rapid City, South Dakota 57701.

**MAIL** Order Collection Agency can make you \$1000.00 monthly. Free Details. Continental, Box 2023-A, Des Moines, Iowa 50310.

**SELL** Books by mail. 400% profit. Royal, Box 450-X, Cleveland, Ohio 44127.

**CLIP** Short newspaper items. To \$10.00 each. Details free. Foster, 272-M-2, Brooklyn 11235.

**MAILORDER** Records help get increased business! Complete 32 page Record Book shows your inquiries, orders, advertising, expense, etc. Only \$1.00. C. A. MARTIN, POPULAR MECHANICS, DEPT. R 224 WEST 57TH STREET, NEW YORK, NEW YORK 10019.

**BIG PROFITS!!** SELL ENGRAVED, METAL, SOCIAL SECURITY PLATES. FREE SALES KIT! MYERS, 928-PM CRESCENTHILL, NASHVILLE, TENNESSEE 37206.

**HOMEWORKERS.** \$100.00 Weekly Addressing for firms. Begin immediately. Details—send stamped, addressed envelope. Hamilton, 272-TMA2, Brooklyn 11235.

**\$200.00 DAILY** in your mailbox! Your opportunity to do what mailorder experts do. Free details. Associates, Box 136-A, Holland, Michigan 49423.

**TAKE** Catalog orders. We drop-ship 1001 best selling specialty products. Guaranteed lowest below wholesale prices. Fantastic spare-full time home business. Free book show you how. SMC, 6061 SPB, De Soto Avenue, Woodland Hills, California 91364.

(Continued on next page)

## BUSINESS OPPORTUNITIES

(Continued from preceding page)

**REPAIR Hydraulic Jacks**—Details Free. Write: Hydraulic Parts Supply, Box 295, Port Isabel, Texas 78578.

**EARN \$60.00 Daily** manufacturing Concrete Fence Posts. Practically no investment. Send stamped-addressed envelope. American, Excelsior Springs, Mo. 64024.

**RECEIVE MAIL** Galore! Your name on our national mailing lists, 50¢. Sullins, Box 1313, Brunswick, Georgia 31520.

**\$50.00 PLUS 50% COMMISSION** Stuffing 200 already stamped, addressed envelopes, our circulars. Information 25¢ with stamped, self-addressed envelope. Brewster-PB, Clearwater, Florida 33517.

**JOIN** The professionals. Profitable Gift Catalog Distributorship. Giffair, 1430-40 Wells, Milwaukee, Wisconsin 53233.

**MAILORDER Catalogs**, Your Name Imprinted. Merchandise Drop-Shipped, Details 25¢. AM Sales, 32-28 100th, East Elmhurst, N.Y. 11369.

**PROFITABLE BUSINESS**—Molding Rubber, Hobby Supplies. Details 10¢. Chaney's, 5415 L San Jose Blvd., Jacksonville, Fla. 32207.

**400,000 BARGAINS** Below wholesale! Many free. Liquidations . . . closeouts . . . job lots . . . single samples. Free details. Bargainhunters Opportunities, Box 730A, Holland, Michigan 49423.

**HOMEWORKERS** Wanted. Details 16¢ Stamps. Brodin Company, 28P Rainbow Village, Columbia, Mo. 65201.

**TRANSPARENCIES** Wanted. Learn **FREE-LANCING**. American Color, Box 2193, Sepulveda, California 91343.

**\$400.00 MONTHLY** Raising giant fishworms. Soilless method. Charlie Morgan, Bushnell, Florida 33513.

**REUPHOLSTERY**. Profitable Home Business. Illustrated Manual \$2.00. M. Russell—P-23, 1566 So. Burkhardt, Evansville, Indiana 47715.

**EARN** Money raising fishworms for us! Write: Oakhaven-38, Cedar Hill, Texas 75104.

**BIG PROFITS LEARN** Underground Lawn Sprinkler Business Using Plastic Pipe, No Costly Equipment, Write For Details. Sprinkler, Box 121, Dunedin, Fla. 33528.

**FREE BOOK** "2042 Unique, Proven Enterprises." Largest successful, money-making collection! Beat inflation with fabulous "Little Knowns." Work home! Haylings-T6, Carlsbad, Calif. 92008.

**RUBBER Stamp Business**, Starting Outfits. Free Manufacturing Catalog. Northwest Stamp, Box 16417-PM1, Portland, Oregon 97233.

**900% PROFIT** In Magnetic Signs, Candle Molds, Packaging plus 1000s of plastic items. Free details. NPC, Dept. 291, 4200 Panamint, Los Angeles, California 90065.

**ONLY \$39.00** Starts proven successful mailorder business selling books. (Dropship method) Sample imprint circulars free. Neil H. Tasker, Shamokin, Pennsylvania 17872.

**MEN-Women Make Big Profits At Home!** In Plastics, part or full time! Unique process teaches you with equipment we give you free to make hundreds of 3-D plastic products, candy and candle molds, plaques, signs. Skin and Bubble package. Also resin casting. Write today for free details. Nationwide Plastics, Dept. ATW, 4140 Eagle Rock Blvd., Los Angeles, Calif. 90065.

**NEW Manual**, How To Manufacture Concrete Floor Tiles For Fun, Profit. Very Small Investment, Easy Method. Complete Instructions, \$6.00. Guaranteed. Hilmar, Route One, Box 347-D, Valrico, Florida 33594.

**MAILORDER** Book Publisher Wants Dealers. Details 25¢ (refunded). Jan Enterprises, 76P, Wild Rose, Wisconsin 54984.

**SELL LIFETIME METAL SOCIAL SECURITY PLATES. BIG PROFITS! SAMPLE AND SALES KIT FREE. RUSSELL PRODUCTS, MAURY COUNTY SHOPPING CENTER, DEPARTMENT P41, COLUMBIA, TENNESSEE 38401.**

**MONEY MAKING OPPORTUNITIES GALORE!** Read Mail Order's **TIMELY TIPS** Magazine, 48th year! Sample copy 25¢. Major, 1310 Bloomfield, Hoboken, New Jersey 07030.

**FREE 1973 100-Page Catalog** waiting to bring you Big spare-time cash commissions. Sell Advertising Book Matches. Every business a prospect . . . complete selling instructions furnished. Steady, repeat business. Dept. MX-273, Superior Match Company, 7530 South Greenwood Avenue, Chicago, Illinois 60619.

**MAIL LETTERS!!!** Make \$8.00 Profit Every Order. Everything Furnished. Write: Stayer Enterprises, 3704 Warwick, Peoria, Illinois 61614.

**STUFF Envelopes**, \$25 Hundred. Immediate Earnings! Beginner's Kit, \$1.00 (refundable). Lewcard, P392M, Brea, Calif. 92621.

**FREE** Collection Agency Details. \$1000.00 Monthly Possible. Master, Drawer 77009-PM, Atlanta, Georgia 30309.

**EARN \$2,000.00 Monthly** in Astonishing Spare Time Business. Details Write: James Carmack, 233 1/2 N. Main Street, Manteno, Illinois 60950.

**WATCHMAKING** Makes every day a payday. Learn this cash business at home. Free details. Chicago School of Watchmaking, YOA, Fox River Grove, Illinois 60021.

**MEN—Women!** Fill out income tax forms at home in own business. We show you how. Simple, easy to learn, \$700 per month earnings, possible. Details mailed free. No salesmen. Hurry. Federated Tax Home Training School, 2065 Montrose, Chicago 60618.

**MAILORDER!!** Enjoy Wonderful Income, Financial Security! Everything furnished. Start making money now. Write: Allen, 554CS-6 Spruce, Garwood, New Jersey 07027.

**MAILORDER Dealers** Wanted. Earn outstanding profits using tested promotions! Executive type business. Details Free. Rutward, Box 735-PD, Norwalk, Conn. 06852.

**FRANCHISE**, Information for any Company or entire Industry. Write now: Box 262, Hicksville, New York 11802.

**FREE** Booklet, "How To Sell By Mail." Write: Ransone, Box 1719, Richmond, Virginia 23214.

**FREE** Sample. Sell Lifetime Social Security Plates. Big Profits! Utis, 10716 Francis, 1PM, Los Angeles, California 90034.

**BUMPER** Sticker Printer Kit puts you into bumper sticker and T-shirt printing business fast! Great at swap meets, churches, organizations and for anyone who wants to say their own thing. No stencils to cut, easy to operate. Enough materials to earn \$200! Write: Bumper Sticker Printer, Dept. 40, Box 234, Torrance, California 90501.

**DON'T DELAY**, Write today. Start your own mail-order business. Send inquiries to: Remos, Box B1-3, Garden Grove, Cal. 92640.

**\$500 WEEKLY**, Mail Order Plans. Free. Raney, 18 Oneida, Centereach, New York 11720.

**DEVELOP SALES OUTLETS** For Your Crafts, Hobbies, Antiques, Small Business. Send Product Information To: Conestoga Supply House, 1014C, Willow St. Pike, Lancaster, Pa. 17602.

**MAKE** Gorgeous original candles for all holidays and special occasions. Learn expert Candle decorating, candlemaking, use of professional molds. Free details on home instruction method. Candle Institute, Dept. C-72, 1600 Cabrillo, Torrance, Calif. 90501.

**MAILORDER:** How to prepare your own catalog for pennies! Free Catalog! Obie-B2, Brooklyn, New York 11219.

**INTERNATIONALLY KNOWN MANUFACTURER 1972 SALES 357 MILLION DOLLARS OFFERS YOU A Chance To Be In Your Own Business High Profits**—New mobile auto parts distribution—152 Now Operating Nationwide. Valley Forge Products, Div. Avnet Inc., Dept. S, Box 96, Inwood, N.Y. 11696.

**\$1000 MONTHLY** From your own home, write: Jordan, 27495 Road 176, Dept. PM2, Exeter, Calif. 93221.

**HOMEWORKERS—MAKE UP TO \$10 IN AN HOUR ALL PROFIT**, doing Invisible Re-weaving/Reknitting on holes, cuts, tears in any fabric, even knits. Oldest, largest home study reweaving school shows you how, helps you get customers fast. Details mailed free. FABRICON, 2008 Montrose, Chicago 60618.

**MONEY** In Mail Order. Free Details. Island, Box 157-F, Bayside, N.Y. 11361.

**MAIL ORDER DISTRIBUTORSHIPS** available for \$150 investment Free brochure. Dept. F104, Audit Controls, 28 Brookside Ave., Fair-Lawn, New Jersey 07410.

**CALIFORNIA MANUFACTURER NEEDS** Man to assemble our product and be local agent, experience unnecessary. May start while presently employed. Five-figure income for responsible applicant. S.K.R.M. Manufacturers, 2347 West 238 Street, Torrance, California 90501.

**MAILING ORDER**, That's the Booming Business Today. \$1000, \$2000 a Month, or More: No Limit. R.R. Smith, P.O. Box 2202, San Francisco, Calif. 94126.

**"HOW To Make Money In Mailorder"** Information Free. London House, 2566 Colden Ave., Bronx, N.Y. 10469.

**\$2,000 MONTHLY** in Astonishing spare Time Business. Robert Ober, 660 Groff Ave., Elizabethtown, Pa. 17022.

**SELL** Your Photos. Report Tells How, Where. Color Slide Markets. Only \$1.00. Cherokee House Of Gifts, 3130 Blue Springs Road, Cleveland, Tenn. 37311.

**EASIEST** Money You Ever Made. Begin Instantly. Free Report and Proof. Send Self-Addressed Stamped Envelope. Morgan, Box 25053-CAB, Los Angeles, California 90025.

**FREE** List Low Cost Books. How to Get in on Some Easy Living. Brokaw's Country Corner, Dept. PM, Route 3, Marengo, Ohio 43334.

**IMPORT-export** Opportunity, profitable world-wide, mail order business from home, without capital or travel abroad. We ship plan for no risk examination. Experience unnecessary. Free Report. Mellinger, Dept. G2702, Woodland Hills, California 91364.

**SPARETIME** Profits. Literature free. Raibl Enterprises, 2355 Scenic Highway, (PB) Pensacola, Florida 32503.

**MAILORDER SUCCESS** Can be yours. Get the Facts, Start the Right Way. Free Details. Mister Unique Mail, Box 555, Dept. PM2, Los Alamitos, California 90720.

**FREE** Details—Your Own Mailorder Business—No investment. Passco, Box 926, Fresno, California 93714.

**\$300 UP** Part Time Home. Computerized bookkeeping. We teach, any age, experience unnecessary. Calektronik, 5606PN-Paramount, Long Beach, Calif. 90805.

**\$1000 LISTS** You year sent to 1000 Importers, Jobbers, Mailers, our mailing year. Dixiem, King, North Carolina 27021.

**MAKE** To Triple Times your Cost. Hundreds of Products, Gifts, Novelties, Toys, many others. \$1.00 brings Giant Catalog, Refundable with First Order. **DONMAR, PM-E**, 809 Ravenwood, Arlington, Texas 76013.

**WRITE: STANFORD UNIVERSITY**, Box 8067, Stanford, Calif. 94305. For Information On Starting And Managing Any Specific Small Business. Instant Reply.

(Continued on next page)

## BUSINESS OPPORTUNITIES

(Continued from preceding page)

**HUNDREDS** Home Businesses Described. Stamp. Bakers, 313 Harrison, Sullivan, Ill. 61951.

**MAKE \$2,000 Monthly!** Copy The Mail-order Experts!! Only \$3.00!!! Potomac, PM-2, Box 3083, Alexandria, Virginia 22302.

**EXECUTIVE** Mailorder Franchises Free!! Full-Line, Uncopied Baby Necessities Immediately Self-Sell. 4,000,000 Yearly Prospects. Astonishing Profits. Trinity, 1712A Lee, Detroit, Michigan 48206.

**EARN \$1000.00 Monthly** Furnishing Stamps To Collectors By Mailorder!!! Free Details. International, 6767LM South Atlanta, Tulsa 74136.

**FRUSTRATED?** Unique publication guides opportunity seekers. Free details. Sherwood Publishing, Box 517, Brundidge, Alabama 36010.

**FANTASTIC** Mailorder! Professional Kit Free. Schroeder, 2131 Wisconsin, Peoria, Illinois 61603.

**EARN \$2000.** Monthly in Amazing, Interesting Businesses. Details: Mohawk, 45 Douglas St., Dept., PM2, Tiffin, Ohio 44883.

**"MAILORDER** Laws And Regulations." Know The Facts. \$2.00. "Bill" Lambertson, 132 Tamiami Station, Dept. PM23, Miami, Florida 33144.

**LAWS—REGULATIONS:** For Mailorder. Details—Free. TCR, Box 787PM, New York 11757.

**OPERATION:** Make Money. \$1000.00 per month possible. FREE details. Maxwell, Box 10126, Houston, Texas 77010.

**\$500.00 WEEKLY** Can Be Yours! Safe, Steady results with proven mailorder method! Free Details! Delta, Box 24-P, Chalmette, Louisiana 70043.

**EARN** Thousands at home. How to sell books by mail. Free details. Wisdom House, Box 1106P, Largo, Florida 33540.

**HOW To Raise \$100.00 To \$1,000,000.00!!** Drawer 77009-A, Atlanta, Georgia 30309.

**FREE** Mailorder, Home Business Treasure Book catalog. Amerasian, Box 776CB, La Canada, California 91011.

**BUSINESS** Manual reveals formation methods. Explains patents, copyrights, idea protection. \$2.00—Primer, Box 238, Shiremanstown, Pa. 17011.

**MAILORDER** Dealers Wanted! **SUPPLY** Money-making information to **OTHERS**. Complete program. Details, Marshall-Warren, P.O. Box 207, Warren, Ohio 44481.

**MAKE** Big Profits in Business. Small investment. No inventory. Visionfax, Box 62-B2, Midland Park, New Jersey 07432.

**LEARN MAILORDER.** Earn Thousands Sparetime! Stop Just Wishing For Higher Income. Free Details. Avalon, Dept. 312-1, 1185 Washington Street, Newton, Massachusetts 02165.

**MAILORDER LAWS REVEALED!** Booklet Only \$2.00! Rehberg, Box 812, Evanston, Illinois 60204.

**\$200.00 WEEKLY** Selling Mens Hairpieces Sparetime. Your Own Business. Must Wear Hairpiece To Qualify. Information Free. Piroff, Box 21091, Philadelphia, Penna. 19154.

**DROP** Ship Your Way To A Mail Order Fortune With "Drop Ship Buyer's Guide." \$3.00. Cazin, 526 Maple, Redwood City, Calif. 94063.

**MAILERS** Wanted!! Free Information. A. Allen, 2418 Lori, Santa Ana, California 92706.

**WE NEED GINSENG GROWERS!** \$3,000-\$30,000 Annually! We Buy Your Crop. Send \$2 For Seed Sample And Information. Glass's Ginseng Exchange, Box 336, Rochdale Station, Jamaica, NY 11434.

**DEALERS.** Winemaking, Government Surplus. Import, U.S. wholesale directories, Dropshipped. Details, sample circulars 25¢. Ross, Box 4763122, Caseyville, Illinois 62232.

**INCREASE** Your Income Now. Unique New Business. Details 25¢. Rowland, Box 923, Newton, Iowa 50208.

**YOUR** Own Home Business. Make Profits Two Ways. Buy Below Wholesale On Gift Items, Novelties, Toys, Etc. Sell Instruction Manuals. Everything Dropshipped. Thrift House, 1010B President Street, Brooklyn, New York 11225.

**CAPITAL** secured for you. Applications \$1.00 (refundable). Beecorp. Dansville, N. Y. 14437.

**UNIQUE** Opportunity. Make \$1500 Monthly at 2 Home. Details, Wemco, Box 294, Pawtucket, R.I. 02861.

**FREE BOOK** "999 Successful, Little-Known Businesses." Work Home! Plymouth-B2, Brooklyn, New York 11204.

**STEADY** Profits from home engraving. Supply business. industry. Trend Craftsmen, 4901G Perrine, Midland, Michigan 48640.

**\$200.00 SPARE** Time earnings with your Tablesaw. Write: Workshop Five, 3800 Harne, Vancouver, Washington 98660.

**SELL** Books!! Complete Mailorder Plan. Vikari's, Box 1312PM2, Salt Lake City, Utah 84110.

**COPYWRITING.** Ghostwriting for Mailorder Dealers. Goutell, 175 Fifth Avenue, N.Y.C. 10010.

**MANY** New Plans. Details Free. Homecraft, 2350 W47N. Denver, Colo. 80211.

**AUTO** Parts. Sell below wholesale. Factory direct filters, shocks, chemicals, etc. Catalogs \$2.00 (Refunded first order). Petro, 1221 No. Lake, Aurora 60506.

## MONEYMAKING OPPORTUNITIES

**HOW** Much Does being your own boss or making \$25,000.00 per year interest you? The Warner breakthrough in the engraving field could be your future. Write: Warner, Room EC-2-CC, 1512 Jarvis, Chicago, Illinois 60626.

**HOW TO MAKE MONEY** At Home in mail-order imports, Coins, Photos, Paragraphs. FREE Information. Sherman, Dept. RS-2, 73 Notre Dame, Hudson Falls, New York 12839.

**FREE! ADVERTISING!** No Charge Printing! 10¢ and Stamped Envelope, Ramco, Box 231, East Haven, Conn. 06512.

**MAILORDER IMPORTS.** Report Reveals Foreign Drop-Ship Sources. World Trader's Digest. Ideal Mailorder Items. \$1.00. Abbotts For Gifts, 2325 Bourbon Drive, Hayward, California 94545.

**EARN** Spare Time Income. Many Opportunities. Free Information. Brooktown Company, Dept. 18, Lake Katrine, New York 12449.

**MONEYTREE** Is \$500 In Your Pocket. Get gifts, money, aids, other free offers. Free details. Moneytree-6, Kerrville, Texas 78028.

**MAKE MORE MONEY**—Start your own Home Business. Our publications show you how. Books—by—Mail. 333 N. Michigan, Chicago, Illinois 60601.

**HOMEWORKERS.** Make \$1.60 each. mailing envelopes. Rush 10¢. Gemco, B-21244A, Indianapolis, 46221.

**FREE SOCIAL SECURITY PLATE.** Send us your Name and Number. Kern Products, 246A Richmond Avenue, N. Massapequa, N.Y. 11758.

**INEXPENSIVE** Burglar, Fire, Smoke, Auto Alarms, Extinguishers, Supplies. Watchdog Alarms, Williamsburgh, Ohio 45176.

**WE BUY NEWSPAPER CLIPPINGS** of Wedding Announcements for 50¢ each. Details \$1.00. Clippings, Box 3146DC, Odessa, Texas 79760.

**HOMEWORKERS FOR TELEPHONE SALES.** \$2.25 COMMISSION EACH SALE. NO INVESTMENT! Apply: Esse Enterprises, 18059 San Juan, Detroit, Michigan 48221.

**3,000 IN 60 Days—Legally—No Fees** or Investments. Details \$2.00. Guaranteed. Brodin Company, 28 Rainbow Village, Columbia, Missouri 65201.

**SPARE** Time Cash. Sell Famous Hanover Shoes. Actual Samples and sales kit Free. No experience needed. No age limit. Lowest prices for highest quality makes selling easy. Every man a prospect. Big daily commissions. For full details, write: Hanover Shoe, 972 Carlisle, Hanover, Pa. 17331.

**BIG** Money Writing Jokes. Enormous demand. We show you how. Free Facts. Laffs, Dept. G92, Pleasant Hill, Ohio 45359.

**\$2.40 HOURLY** Making simple wood novelties. Free details! Gene's, 55 Boxwood, Falmouth, Mass. 02540.

**LEARN** The secrets of repairing junk batteries "Fabulous Profits" at home. Battery Shop, Box 820, La Quinta, Cal. 92253.

**MAKE \$1.00 PER SALE** Selling engraved metal Social Security plates. **FREE SALES KIT.** Engravaplates, Box 10460-199, Jacksonville, Florida 32207.

**CONTEST REPORT** Complete Information About Cash Prizes Offered Monthly. Send 25¢ for Current Issue. Box 307A, Ypsilanti, Michigan 48197.

**WORLD'S** Leading contest magazine, 25¢. Year. \$4.00. Prizewinner, 1315 Central, St. Petersburg, Fla. 33705.

**MAKE** Statuettes, novelties, imitation marble. Sell to stores or start gift shop. Free details. Marbleizing, 41 Waverton, St. Louis, Mo. 63124.

**HOW TO GET RICH!!** Free "Money-making Brochure"! Success International, Box 2447-C, Livonia, Mich. 48151.

**VENDING** Machines. No selling. Routes earn amazing profits. Big catalogue Free. Parkway Corporation, 715PMM Ensor Street, Baltimore, Maryland 21202.

**FREE**—Easy Ways to make money selling exciting new products—Full—spare time. Send name, age, for 5 months free subscription. Salesman's Opportunity Magazine, 1460 Hancock Center, Dept. 17-BM, Chicago 60611.

**\$200.00 FROM** Sheet 1/4" plywood (scrap). Details 25¢. Novelties, 610 So. 24th, Elwood, Indiana 46036.

**GET** World's Biggest Wholesale Import Catalog. Write: World, Medina, Washington 98039.

**CLIP** Newspaper items. \$1.00-\$5.00 each. Details free. Walter, Box 1360PA, Erie, Pa. 16512.

**HOW** To Make Money Writing Short Paragraphs. Information Free. Barrett, Dept. C-27-S1, 6216 N. Clark, Chicago 60660.

**PENNY STOCKS** Have Profit Potential. Free Information. Analyst-P.M., Box 214, Redondo Beach, California 90277.

**200% PROFIT** Selling Rings. Triple Money in 30 Days or Money Back. Free Details, Anka, P.O. Box 8036-PM, Cranston, Rhode Island 02920.

**BECOME** Notary Public! Have dignified sideline. Free details. Stationers Exchange, Box 617, Kilgore, Texas 75662.

**EARN MONEY,** learn mailorder, sparetime, at home, reading leading (since 1929) trade magazine, product sources, stories, tips, Sample 50¢, year \$5. Mail Trade, Box 1302, Springfield, Illinois 62705.

**RUBBER** Stamp Business. Starting Outfits. Free Manufacturing Catalog. Northwest Stamp, Box 16417-PM2, Portland, Oregon 97233.

**BIG** Easy Quick Profits, assembling costume jewelry at home, spare time. Simple to do; easy selling. Create family business. Details free! Don-Bar, 2934 Fullerton, Dept. A-743, Chicago 60647.

(Continued on next page)

## MONEYMAKING OPPORTUNITIES

(Continued from preceding page)

**HAVE FUN** Making Extra Money in your Spare Time. Potential unlimited. We provide your start. Send \$5 To: J&G Enterprise, P.O. Box 667, Sierra Vista, Arizona 85635.

**NET \$397.50 Weekly Mailing Brochures.** Information 35¢. Camala, Box 841-M, Florissant, Mo. 63033.

**NEED MONEY??** Easy, Smart-Money Methods to Skyrocket Your Income! Write: Stayer Enterprises, 3704A Warwick, Peoria, Illinois 61614.

**HOW To Clip Newsitems For Cash.** \$1.00 Brings complete manual. Confidential Reports, Box 147-PM, Hanson, Mass. 02341.

**\$40 DAILY** Possible tying fishing flies at home. Details 25¢. Flyco, Box 481PM, Albany, Oregon 97321.

**\$100.00 POSSIBLE** Using \$2.00 glue. Regluing Chairs etc. for self, extra income. my methods \$6.00. Hettinger, 3823 N. Southport, Chicago 60613.

**MAILORDER.** Sell Engraved Social Security Plates. Complete Dealer Set-up. AM Sales, 32-28 100th, East Elmhurst, N.Y. 11369.

**HIGHER INCOME.** Security and Power. 256 Page Book "THINKING BIG" Reveals Secrets That Make Men Rich! Send \$2.00 E. M. Hutson Enterprises, 8807 Jackwood, Houston, Texas 77036.

**HOW To Make Money:** "Write Short Articles." "Sell Your Photos." "Collect Coins." "Government Surplus." "Mail Order Imports." Instructions Tell How and Where. Only \$1.00 Each Subject. James Stanley, Dept. A12A, 14044 Marsh Lane, Dallas, Texas 75234.

**ADDRESSERS**—50 Companies want Addressers. Send self-addressed envelope. Cal Enterprises, Box 4516-X, Compton, Calif. 90224.

**SELL Your Pictures.** Work Your Camera. Enormous Demand. \$1.00 Booklet Tells What, How and Where to Sell. JOVER'S Shop-a-log, 10 West Glenside Avenue, Glenside, Penna. 19038.

**MONEYMAKING At Home with MAIL-ORDER, WRITING, COINS, PHOTOGRAPHY.** Booklets telling how \$1.00 each. J. Prentice, 4311A Chetwin Terrace, Easton, Penna. 18042.

**INCREASE Your Income—Part Or Full Time Easy Profits**—Send \$1.00 For Complete Details. Bobco, Box 2486, Sanford, N.C. 27330.

**HOME Addressing: \$75.00 Thousand Profit.** Information 50¢. Rausch, Box-H, Port Jefferson Station, New York 11776.

**\$200 DAILY** In Your Mailbox. Proven Mailorder Business—Never Fails. Beginners. Free Details. Pen's, Box 86609-PM, North Vancouver, B.C.

**SCIENTIFIC Massages:** Big Earnings uncrowded profession. Learn spare time at home. Diploma awarded. Free catalog. Write: Anderson School, Dept. B-1C, Princeton, Illinois 61356.

**400% PROFITS** Selling Books!! Advanced Publications Reveal Unexpected Mailorder Opportunities. Franchises Free. Trinity, 1712B Lee, Detroit, Michigan 48206.

**50¢ INVESTMENT** Could Bring Thousands In Days Legally! Details \$1.00. Continental, 3425-P North Detroit, Toledo, Ohio 43610.

**MAKE Money at home!** 49 Ways. Write-Coach Publishers, Box 834H - Bangor, Maine 04401.

**SPORTS Fans**—Have Fun and Make Extra Money by selling new exciting sports games. Ideal for College and High School Students. Wil-Croft Sports, P.O. Box 1711, Carson City, Nevada 89701.

**HOW To Earn at Home Addressing Envelopes.** Rush 10¢: Nozuye, PM, 60 Massey, Toronto, Canada.

**FREE Catalog—Start Own Business Part Time.** The James Company, 59 James Street, Toms River, New Jersey 08753.

**NEED \$80,000, \$50,000, \$30,000?** Your Lifetime Opportunity to Fabulous riches. Write airmail today for free information on our plan. MEYER, APARTADO 664, Guatemala, Central America.

**START** Small, highly profitable electronic production in your basement. Investment, knowledge unnecessary. Postcard brings facts. Barta-PMF, Box 248, Walnut Creek, California 94597.

**MAIL Letters** Featuring Real Merchandise. Get \$12.00 dollar orders in every mail. \$8.00 Profit. Everything furnished! Write: Jesco Products, Dept. C, Wyncote, Pa. 19095.

**EARN Extra Income!** Selling by Mail. Free Information. Tradin' Post, Box 190PB, Flint, Texas 75762.

**PERSONALIZED BEAD BRACELETS MEAN \$\$\$**—write: R&B Creations, Box 22128PM, Cleveland, Ohio 44122.

**TREMENDOUS PROFITS POSSIBLE** Distributing Advertising Flyers for Publishing Co., At Colleges In Your Area. Details 10¢. The Student Aid Reporter, P.O. Box 130, Brooklyn, New York 11204.

**SELL YOUR PHOTOS. REPORT Tells HOW, WHERE. COLOR SLIDE MARKETS. ONLY \$1.00.** EARL McPHEE, 1760-B LEXINGTON Ave., NEW YORK, NEW YORK 10029.

**DROP Ship Your Way To A Mail Order Fortune With "Drop Ship Buyer's Guide".** \$3.00. Cazin, 526 Maple, Redwood City, Calif. 94063.

**MAKE \$1000 Monthly Writing Letters!** Details 25¢. Dale's (BPM), 739 Carroll Dale, Sykesville, Md. 21784.

**HOMEWORDERS EARN \$150.00 WEEKLY ADDRESSING OUR SALES LETTERS. DETAIL 25¢. CUR-JON MAILERS, BOX 523-PF, MAPLEWOOD, NEW JERSEY 07040.**

**MAKE Money, Your Camera.** Free Catalogue. Park Avenue Products, 3615 South Park Ave., Springfield, Illinois 62704.

**HELP YOURSELF SUCCEED!** Books explain proven METHODS. "How You Can Have Confidence and Power". "Master Keys to Success, Popularity and Prestige". "Magic of Thinking Big". \$2.00 each. A. V. Ramil, 1161, Wailuku, Hawaii 96793.

**MONEYMAKING Manuals—Work at Home!** Mears, PM-5363 Essex, Alexandria, Virginia 22311.

**EARN 10% PER MONTH ON YOUR MONEY.** "How to Organize a Factoring Company." Our 5000 word report gives complete details, including sample forms and records. Requires only modest capital. Write: CAPITAL FACTORING CORP., PO BOX 914, Dept. L, Provo, Utah 84601.

**NEW! Profits in Wooden Toys. Easy! Income. Gifts. Details Free!** Toys, 4213MB Castle, Midland, Michigan 48640.

**TELEPHONE REPORTERS** Needed immediately. Set own fees. Enjoy prestige. Information \$1.00. Dollarsavers, 10 Paddock, Hudson, N.Y. 12534.

**\$100.00 WEEKLY At Home.** Free Materials. Patterns and Instructions Guaranteed. \$2.50. Fircrest Resort, Rt. 1, Blaine, Washington 98230.

## PROFITABLE OCCUPATIONS

**HOW To Finance Your Own Business.** Get \$500 to \$2 million. Free offer. Capital-25, Kerrville, Texas 78028.

**MAKE MONEY IN SPARE TIME.** Earn generous commissions as a subscription sales representative for leading magazines. For full details and instructions, send this ad with your name and address to: POPULAR MECHANICS, Room 1107M, 250 W. 55th St., New York, N.Y. 10019.

**BAKE** New greaseless doughnuts in kitchen. Sell stores. Free recipes. Michael Ray, Waseca, Minn. 56093.

**FT. SMITH Auction School.** Ft. Smith, Ark. 72901. Resident & Home study. Veteran approved.

**BECOME A Mortgage Broker.** Highly respected, interesting, lucrative prestige business. For complete information write: United, Box 6284-F, Marietta, Georgia 30060.

**HOW To Make Money Writing Short Paragraphs.** Information Free. Barrett, Dept. C-27-S2, 6216 N. Clark, Chicago 60660.

**WE MAKE Over 650 Fiberglass Molds** for Ornamental Concrete Products. Catalog \$2.00. Plycrete Mold Co., Elk Rapids, Michigan 49629.

**LEARN GUN REPAIR GUNSMITHING** In spare time. Book, details 10¢. Modern Gun Repair School, Dept. 2108, 4225 N. Brown, Scottsdale, Arizona 85251.

**PLASTERCRAFT!!!** Profitable Home Business. Molds available. Details: Lynette, 6251C Mentor Park, Mentor, Ohio 44060.

**SHARPEN Scissors, Pinkers.** Inexpensive equipment, tools, supplies. Blackhawk's, Sheldahl, Iowa 50243.

**SELL Your Photos.** Report Tells How, Where. Color Slide Markets. Only \$1.00. Rebel Hill Farm, R1, Box 346, Nineveh, Ind. 46164.

**FREE Government Benefits Galore!** Details. Premier Enterprises, Box 10597-CB, Pittsburgh 15235.

**RETIRE ANYTIME** In Luxury! Easy, Legitimate! Free Details. Premier Enterprises, Box 10597-AB, Pittsburgh, Pa. 15235.

**FIX, SELL, TYPEWRITERS.** Book \$2.95. United Typewriters, 12429 Southeast Stephens, Portland, Oregon 97233.

## SALESMEN-DISTRIBUTORS

**PUBLICATIONS** for local wholesale distribution, higher profits. Details, sample, \$1 refundable. Publisher, 404 West Jefferson, Springfield, Illinois 62702.

**EARN Big Commission Full or Part Time.** Show America's largest line Low Priced Business Printing and Advertising Specialities Plus Calendars in season. No experience. No investment. No collections or Deliveries. On-the-spot commissions. Big Free Sales Kit Samples hundreds items used daily by businessmen. Merchandise bonuses for you. Build profitable repeat business. Start now. National Press, Dept. 73B, North Chicago, Ill. 60064.

**HOUSEHOLD PRODUCTS ROUTE. EARN \$25 or more daily.** Also Party Plan opportunities for men, women full, part time. McNess, Freeport (2623) Illinois 61032.

**BIG EARNINGS** Showing Exquisite Brass Antique Finish Lamps and Clocks. TAL-GLO, 2A Washington Street, East Orange, New Jersey 07017.

**BECOME A Successful Manufacturer's Representative.** Manufacturers' Agents Newsletter tells you which firms are looking for representatives, the firms products line and territories available. For information write: Manufacturers' Agents' Newsletter, Dept. 152A, 23573 Prospect Ave., Farmington, Michigan 48024.

**NEW, Compact fire extinguisher.** Fantastic profits. Exclusive territories. Norwich Chemical, Norwich, Connecticut 06397.

**BIGGEST SELLER OF ALL TIME** Men-Women show new Hertel reference Bible with astonishing 3-dimension Nativity cover. Fully referenced scripture text commands instant attention. Liberal credit plan makes selling easy. No investment. All year money maker. Extra bonanza profits now. Demonstrator furnished. Write: International Book, Dept. PM, Box 118, Wichita, Kansas 67201.

**EARN Big money** calling on business-professional men. Send us their delinquent accounts for collection. General Finance, Dept. PM-11, Columbia Bank Bldg., Kansas City, Missouri 64106.

**DISTRIBUTORS** Needed. Unlimited Income. Details 35¢. Ace Distributors, Box 933, Greensburg, Pa. 15601.

(Continued on next page)



## SALESMEN-DISTRIBUTORS

(Continued from preceding page)

**TEXAS** Refinery Corp. offers opportunity for high income Plus cash bonuses and convention trips to mature man in your area. Regardless of experience, air mail W. K. Pate, Pres., Texas Refinery Corp., Box 711, Fort Worth, Texas 76101.

**LONG** Needed Invention. Want man contact service stations. Full or part time. Huge Profits. Write: Cyclo Mfg., 3816 Dahlia, Dept. 128, Denver, Colo. 80207.

**SELL** Advertising Ball Pens, Calendars, Ad-Specialties—Build Own Repeat Business—Free Details—Fleming, Dept. A, 6535 Cottage Grove, Chicago 60637.

**CRIME** Deterrent Personal Security Weapons. Distributors earnings unlimited. Sheriff Protection Devices, Box 113, Twinsburg, Ohio 44087.

**\$100.00 EXTRA** A week easy! Spare time! Double Air Cushion shoes. Men's, women's line. Dress, work, play. Highest commissions. Shoes for yourself. Outfit Free. Bronson, Dept. H-23, Minneapolis, Minnesota 55408.

**HOTTEST** Jewelry Teenager Market. Fund Raising, Incentive, Direct, Retail. Details 25¢ refundable. Guaranteed Products, Box 7225, Kansas City, Mo. 64113.

## AGENTS WANTED

**WILL** You test new items in your home? Surprisingly big pay. Latest conveniences for home, car. Send no money, just your name. Kristee 140, Akron, Ohio 44308.

**FREE** Selling Outfit—Office Supplies, Machines, Furniture and Equipment. Oseco, 3505-PM Elston, Chicago 60618.

**DO** Friends A Favor—Make good money. Sell Home Products, Cosmetics to friends in spare time. Buy wholesale. We send 4 full-size products plus sample Rug Cleaner for Free Trial. Rush Name, Address to: Blair, Dept. 31AC, Lynchburg, Va. 24505.

**EVERY** Man a prospect. Refundable sales kit offer showing line belt buckles, tie clasps, money clips, cuff links, lapels, identification badges, individualized with customer's name and emblems. Cap badges for trucking, bus, taxi, police, firemen, also postal, letter carriers and heavy construction emblems. Choice 4000 emblems. Hook-Fast, Box 1088-PM, Providence, R.I. 02901.

**YOUR** Own business—Used Suits \$1.50; Overcoats 65¢; Mackinaws 35¢; Shoes 12½¢; Ladies' Coats 30¢; Dresses 15¢. Enormous profits. Catalog Free. Nathan Portnoy Assoc., 2109-AA Roosevelt Road, Chicago, Illinois 60608.

**PRINTING**, Advertising Salesmen—Excellent moneymaking sideline selling Decalcomania Name Plates, small quantities. Advertising Specialties, sign letters. Free Samples. Raico XL, Boston, Mass. 02119.

**TOOL POWER** 110 Volts 5000 Watts from your cars alternator. Guaranteed 20 years. Install 10 minutes \$25.00 postpaid. Good discounts. Permabilt, Box 7160, Amarillo, Texas 79109.

**WANT TO MAKE UP TO \$100 A WEEK** Spare time, and get free shoes for life, too? No investment. Rush Card for free details. Mason Shoes, K-930, Chippewa Falls, Wisconsin 54729.

**REPRESENT** Largest manufacturer of magnetic signs spare or full time. **TRIME-TRIC**, 337 El Roblar, Ojai, California 93023.

**FAST** Selling Novel Fishing Items. Draco M-82, Box 4022, Dallas, Texas 75208.

## EMPLOYMENT INFORMATION

**AUSTRALIA WANTS YOU NOW**—Thousands of jobs. Government paid transportation. Latest booklet with employers list, housing, prices, taxes, transportation, social life, etc. \$1.00. Vonst, Box 237P, Santa Ana, California 92702.

**LEARN MOTEL** Business, Great Career Opportunities Worldwide. For Placement Details Send \$2.00. Crest Motel, Box 65, Bayard, Fla. 32224.

**OVERSEAS JOBS—NOW HIRING**, 103 Countries, All Occupations, High Pay, Free Transportation, Tax Benefits, Latest Computerized Reports—\$2.00. **TRANSWORLD**, International Airport, Box 90802-E, Los Angeles, California 90009.

**AUSTRALIA—NEW ZEALAND! FREE DETAILS!** 50,000 Jobs! Paid Transportation! 1973 Information and Forms. Send Age, Occupation. Austco, Box 3623-EX, Long Beach, California 90803.

**BRITISH** Columbia Employment and Immigration Information. Complete details; \$3.00. Doyle Associates, Box 2702, Williams Lake, B.C., Canada.

**FLORIDA WANTS YOU?** Concise, Complete Unbiased **GENERAL FACTS YOU DON'T** Know. \$2.00 Refundable. Idlease, P.O. Box 171-P2, Cape Coral, Fla. 33904.

**FLORIDA** Employment Opportunities! Disneyworld! Newspaper Classifieds! Booklet \$1.00. Sunshine, 4512N Jamaica, Tampa, Florida 33614.

**FREE** "1,000 American Companies Overseas" (\$24 value) to new subscribers. World's Largest International Employment Monthly. Thousands of jobs, all countries, occupations. Articles, free services, discounts. Subscribe today. Year \$12. Satisfaction guaranteed. **OVERSEAS JOB JOURNAL**, Box 25488-P, Phoenix, Arizona 85002.

## HELP WANTED

**OVERSEAS** Jobs—Australia, Europe, South America, Far East. Openings in all trades and professions. Free information Write: Foreign Jobs Co., Box 2235 AMF, Miami, Florida 33159.

**OVERSEAS EMPLOYMENT** . . . Australia, Europe, South America, Asia! All Occupations! \$700-\$3,000 monthly! Write: Employment International, Box 29217-AB, Indianapolis, Indiana 46229.

**OVERSEAS** Jobs—Europe, South America, Australia, Far East, etc. 2000 openings all trades. Construction, Office, Engineering Sales, etc. \$700 to \$3,000 month. Expenses paid. Free information. Write: Overseas Jobs, International Airport, Box 536-M, Miami, Florida 33148.

**EXCITING JOBS AVAILABLE!!** . . . U.S.A. . . . Australia . . . Worldwide! \$10,000-\$39,000 Yearly. Adventure . . . Travel! All Occupations. Information Free: Universal BHM, 2 Deepdale, Great Neck, New York 11021.

## REAL ESTATE AND FARMS

**CANADIAN LAND FROM \$19.00 AN ACRE** CHOICE Properties available across Canada. Low monthly payments. Ideal for farming, cottages, hunting, fishing. Free Catalogue. Canadian Estate Land, Dept. PMC-2, 286 Lawrence Ave. West, Toronto 20, Ont., Canada.

**CENTRAL** Ontario—Choice 640 acre Sportsmen's paradises still available—\$20.00 plus \$6.50 taxes yearly. Maps, pictures. \$2.00 (Refundable). Information Bureau, Norval 4, Ontario, Canada.

**GOVERNMENT LANDS FROM \$3.50 ACRE!** Vacationing, Homesteading, Investment! Exclusive "U.S. GOVERNMENT LAND BUYER'S GUIDE" plus "LAND OPPORTUNITY REVIEW" listing lands throughout U.S. Send \$1.00. Surplus Lands, Box 19107-AB, Washington, D.C. 20036.

**BOILING** Spring Lakes—America's Greatest Real Estate Value. ½ acre vacation or retirement homesites only \$900 cash price. Ten-year terms available. Money-back inspection guarantee. Carolina coast, multi-million dollar, 14,000 acre development. 50 fresh water lakes, private ocean beach, golf course, motel, and country club. Free literature, Dept. 1-E, Boiling Spring Lakes, North Carolina 28461. (Registered under Federal Land Sales act but not offered to residents of states requiring separate registration.)

**IDEAL 5-ACRE RANCH.** Lake Conchas, New Mexico. \$2,975. No Down. No Interest. \$25/mo. Vacation Paradise. Money Maker. Free Brochure. Ranchos: Box 2003P, Alameda, California 94501.

**ARIZONA—1¼ Acres, Heart Of Hunting** And Farming Centers. \$1,095—Low Terms. Mrs. Anna Young, Glenarm Land Co., 2233 North 7th St., Phoenix 85006

**CANADIAN** Vacation lands: Full price \$385.00. 40 acres. \$10 month. Suitable cottage sites, hunting, fishing, investment. Free information. Land Corporation, 3768-C Bathurst, Downsview, Ontario, Canada.

**\$1 ACRE**—Canadian border—hundreds campsites, islands, farmlands, directly from tax authorities. (Non-profit). Lists, photographs mailed. Register, Room 10, 110 Church Street, Toronto 1, Canada.

**OWN YOUR OWN FORESTED ACREAGE** Better quality 5 to 40 acre parcels forested recreation land in North Minnesota. Selected for 1972 sale by Timber Country, Inc., a subsidiary of First Federal Savings and Loan Ass'n., Hibbing, Minnesota. Direct access township/county roads. 1971 offerings sold out. 1 Year full money back guarantee. Camping, well stocked fishing lakes and canoeing rivers. Priced \$150 to \$250 acre. Reasonable terms available. For photos, references and maps by mail, write: Ellen Uebel, Dept. PM, Timber Country, Inc., 2015 3rd Ave. E., Hibbing, Minn. 55746. (Member: Nat'l Ass'n. Real Estate Boards.)

**MICHIGAN 10 TO 160 ACRE TRACTS** Lake Superior-Marquette Area from \$99.00 Acre. Cabins, Trailers, camping welcome. (Acreage anywhere in Michigan). **FREE PICTURES.** Any terms A-OK with **BLOCH BROTHERS.** Write: 3650 Dixie, Drayton Plains 16, Michigan 48020.

**FREE** Catalog! **PHOTOS!** Coast to coast farms, business, retirement. All types, sizes & prices. **SAFE-BUY** Real Estate, Box 589-PM, Little Rock, Ark. 72203.

**SOUTHEASTERN** Missouri, \$250. Acre. Field, Box 292, Midwood, Brooklyn, N.Y. 11230.

**\$1.00 ACRE!** USA and Canada. Lists, photographs mailed. Government Lands, 220 Delaware Ave., Buffalo, New York 14202.

**FREE.** . . . 264-Page **SPRING** Catalog. Hundreds of top real estate values coast to coast! **UNITED FARM AGENCY**, 612-PM West 47th St., Kansas City, Mo. 64112.

**ARIZONA**—Beautiful 2½ acres, \$995, easy terms. For investment, retirement or vacation. Lake Havasu-Kingman area. Ev King, Broker, 202-M East McDowell Road, Phoenix 85004.

**NEW FREE CATALOG!** Big **SPRING** Edition! Over 5,200 Properties described, pictured—Land, Farms, Homes, Businesses—Recreation, Retirement. Selected Best thruout U.S.! 73 Years' service. 648 Offices, 40 states Coast to Coast. Mailed **FREE** from the World's Largest! **STROUT REALTY**, 60-MX E. 42nd St. NY, NY 10017; 7-MX S. Dearborn, Chicago, Ill. 60603; 521-MX E. Green, Pasadena, Cal. 91101.



## FLOWERS, PLANTS & NURSERY SUPPLIES

**LEARN** Flower Arranging and Floristry. Start full or part time business or hobby. Free information on home study course. Lifetime Career Schools, Dept. B-698, 2251 Barry Avenue, Los Angeles, California 90064.

**GREENHOUSES**, 12' Fiberglass and UltraViolet Shielded from \$109.95. Free catalog. Greenhouseman, Box 2666-M-2, Santa Cruz, California 95060.

**SPRINKLER** Spike watering system installs in minutes in your own hose. Free illustrated brochure. Eric Johnson Co., 67 Bonanza Rd., Palm Springs, Calif. 92262.

**LEARN** Landscaping and the growing of plants. Start a profitable business part or full time. Free information without obligation. Lifetime Career Schools, Dept. A-359, 2251 Barry Avenue, Los Angeles, California 90064.

(Continued on next page)

## CONSTRUCTION PLANS, BLUEPRINTS

**HOME PLANS** Custom Drawn. Free Quotations. Homebuilders, 136-49 Scott, Dundee, Illinois 60118.

**HOUSE EXPANSION PLANS** And detail instruction book provide anything from an extra room to 1000 s/f addition. Build what you need at big do-it-yourself saving. Book with 1 set working blueprints \$14.50! With 4 sets (required by contractors) \$20.00. Money-Saver Projects, Box 303-44B, Chappaqua, New York 10514. Information available.

## LOG CABINS & HOMES

**BUILD** Log Cabins, rustic furniture, fireplaces!!! Complete manual, \$3.00 . . . "A" Frame plans, \$2.00 . . . Guaranteed. . . . Beels, 956 Springdale, Atlanta, Georgia 30306.

**"A" FRAME CABIN.** \$500. Material. Purchase locally. Completely illustrated instruction manual & material list: \$2.00 Moneyback Guarantee. Order plan #116 from: "Dependable Products", Box 113, Vista, California 92083.

## HOME CRAFTSMEN

**WOOD**—Domestic and Imported Hardwoods, 3500 items! Clock, musical instrument kits. Tools . . . discount prices. Hard-to-find hardware. 144 page catalog. 50¢. Craftsman, Dept. AX-23, 2729 Mary, Chicago, Illinois 60608

**101 PATTERNS** Of Smart Gifts, Novelties, Shelves, Action Windmills, Plus "Make Money Jig Sawing." \$2.00. Mastercraft, 25M, 7041 Olcott, Chicago 60631.

**PICNIC TABLE PATTERN** Seats Eight Disassembles for Storage. Full Instructions. Send \$1.00 to: Crossroads Supply, Crossroads Square, Wentzville, Mo. 63385.

**PICTURE Framing**—Profitable full or spare-time business. Easy to learn with handbook-course "Guide To Picture Framing Profits." \$1.50 Guaranteed. Free framing-supplies catalog included. Japs, 126-PM Seventh North, Hopkins, Minnesota 55343.

**WOODWORKING** Catalog and Manual 50¢. Plus free "101 Project Ideas." World's most beautiful veneers, lumber, plywood! Wood finishing, upholstery supplies, Cane, Lamp Parts, Furniture hardware, Animal whittling blocks, 2,000 workshop products. Constantine, 2051-C Eastchester Road, Bronx 10461.

**CABINETMAKING MADE EASY** And "How to Make Formica Counter Tops." Two excellent guides let you build kitchen cabinets and counter tops like professionals. Extraordinary guides bring master craftsmen's shortcut methods. Satisfaction guaranteed. Write: Japs, 126-P Seventh North, Hopkins, Minn. 55343.

**SKIL-CRAFTS** Current 200 plus page catalog with world's largest, finest selection of Hobbycraft, leathercraft, artist supplies. Send \$1 for postage and handling: refunded on first \$15 minimum catalog order. Skil-Crafts, Box 105-P, Joplin, Mo. 64801.

**20 PLANS**—Full Size—Early American Novel Items for Fun or Profit. Send \$2.50. Carbone—Box 18099—Philadelphia, Penna. 19147.

**C.D.I. LAMP BUTLER**—Complete Plans—Control both Bedside Lamps from Either Side of the Bed. Especially nice for King and Queen Size Bedroom Suites. Special Achievement Certificate included Worth 50¢. Complete Plans \$2.00. Craftsman's Dreamprints, Inc., P.O. Box 16232, Charlotte, N.C. 28216.

**CATALOG FULL SIZE FURNITURE PLANS**—\$1.00 Refund with first order. Traditional, Early American, over 135! Furniture Designs, 1425 Sherman, Dept. CP-23, Evanston, Illinois 60201.

**BIRD HOUSES** For Fun And Profits. 20 Projects And Plans. \$1.00. Infoco, Box 34260, Washington, D. C. 20034.

**SUPER EAVESDROPPER** Hear Intimate Conversations Hundreds of Feet Away. Complete How To Build Instructions. Send One Dollar To: Zelner Associates Today. 1488 Vallombrosa Avenue, Chico, Calif. 95926.

**UNUSUAL PROJECT, BUILD FULL SIZE KNIGHT** From Scrap Wood, Send \$2.00 For Plans. Womack, 2103 Hellbeck Dr., Pueblo, Colo. 81005.

**PICTURE FRAMERS!!** Seascape Prints, Also Model Ship And Cannon Kits, Illustrated Catalog 20¢. Studio House, Dept. 1023, Box 185, Deer Park, New York 11729.

**WOOD WORKS WALL CLOCK**/Twelve Inch Dial/Hand Tools Only/Most Worthwhile—Plans & Instructions (27 Pages) \$7.50—Dual Design, Box 3828, Granada Hills, Calif. 91344.

**WOOD CHAIN—MOVABLE LINKS!!** Easily Made From SOLID Wood! Amaze Friends, Decorative. \$1.00, Guaranteed, Brings-Detailed Manual, Drawings, PHOTOGRAPH. Atco, Box 33-A, Floral Park, New York 11001.

**CLOCK** Kits, Movements, Dials, Hands. Catalog 25¢. Newport, Box 6848A, Burbank, Calif. 91505.

**HAND** Paint Your Own Beautiful Wall Murals. For Colorful Brochure With Complete Directions, Send 1.00 To: Modern Murals—205 No. 1st, Brainerd, Minnesota 56401.

**TOOLS, EQUIPMENT & SUPPLIES!** We List Over FOURTEEN-HUNDRED Different CATALOGS of Materials and Accessories for Arts, Crafts, Automotive, Electronics, Industry. Send \$2.00. MASTERLOG, Box 24413-BB, Oakland, California 94623.

**100 JIGSAW** Patterns For Pleasure-Profit-\$1.25. Lynds, Medway, Mass. 02053.

**POPULAR MECHANICS MASTER SHOP GUIDE.** Greatest product offered to a man with a workshop. All information printed on heavy boards, punched and ready to hang above his workbench. Covers wall fasteners, nails, screws, bolts, twist drills, abrasives, lumber, moulding patterns, plywood grades, hardboard, dry-wall plumbing supplies, electrical supplies. Plus information on score of other subjects. Send \$3.95 to: POPULAR MECHANICS, Dept. HE, 224 West 57th Street, New York, New York 10019.

**BEST WORKBENCH PLAN** Ever. Plus Free Lumber Conversion Chart. \$1.00. WAY-MAR, Dept. 45, 58 Underhill Road, Scarsdale, New York 10583.

## DO-IT-YOURSELF

**CENTRAL AIR CONDITIONING FOR AS LITTLE AS \$500\*** Install It Yourself in your forced air furnace with ordinary hand tools—save up to \$200 on installation costs. Free brochure illustrates step-by-step procedure. McGraw-Edison Co., 729 N. Clark St., Albion, Michigan 49224. \*Cost varies according to size and construction of home.

**BURGLAR-FIRE** Alarm Supplies and Information. Free Catalog. Protecto Alarm Sales, Box 357A, Birch Run, Michigan 48415.

**REPAIR MINIBIKES, LAWNMOWERS, BICYCLES,** Sewing Machines, Auto Engines. Build concrete, Plywood, boats, trailers. Over 100 How-To-Do books. Free brochure. Sincere, Box 10422, Phoenix, Arizona 85016.

**CONVERT MOWER** Engines into air compressors. Write: Showalter, Box 409, Abilene, Kansas 67410.

**SAVE MONEY!** "How-To" books. Free details. Vernco, Box 121, Whittier, Calif. 90608.

**CENTRAL** Air Conditioning, Equipment, Humidifiers, Ductwork, Electronic Air Cleaners, Free Catalogue. Air-Ways, 32 Washington Ave., Port Jeff. Sta., N.Y. 11776.

**END EXPENSIVE** Auto Repairs! Book by auto expert explains how. Order now. Save! \$1.95. Ben-Mar Gifts, 8 Woodrow Avenue, Staunton, Virginia. 24401.

**SAVE MONEY!** End Expensive Auto Repairs! Nationally known Auto Expert shows you how easy it can be with the help of Auto Repair Book. \$1.95, add .50¢ postage. Satisfaction Guaranteed. Florian Gabor, Dept-K., 150 W. Girard, Philadelphia, Pa. 19123.

**FIBERGLASS.** Complete Supplies. Catalogue 25¢. Custom Fiberglass Products, P. O. Box 101-PM1, Mount Juliet, Tennessee 37122.

**NEW!** Reflective Decals! Letters, Numbers! Free Price List! Xcito Decals, 5715 N. Mozart, Chicago, Illinois 60659.

**BOTTLE** Cutter works electrically—Plans \$2.00. Planz, 8725 Virginia Ave. S., Minneapolis, Minn. 55438.

**ADEMCO** Smoke And Gas Detector. No Outlet Required. Mounts To Ceiling In Minutes. U.L. LISTED. SPECIAL \$69.95 PPD. Free Literature. Maran Systems, Box 125, Meacham Branch, Elmont, N.Y. 11003.

**LOCKSMITHING** Supplies—Wholesale Buying Guide \$1.00. Despubs, Box 22005 C, Phoenix, Arizona 85028.

## ARTS AND CRAFTS

**"GETTING** Started in Stained Glass" 25¢. Whittemore, Box 2065Y, Hanover, Mass. 02339.

**MAKE** Figurines, plaques, lawn ornaments. Molds, plastercraft kits, liquid rubber. Sample and catalogue 10¢. Woolley Company, Box 29-B, Peoria, Illinois 61601.

**FREE LITERATURE** For sculptors showing how to make molds, cast plastics. Adhesive Products Corporation, 1660 Boone Avenue, Bronx, N.Y. 10460.

**LEARN** Arts & Crafts at home. Excellent full or part time business opportunities, or hobby. Free booklets. Lifetime Career Schools, Dept. E-798, 2251 Barry Avenue, Los Angeles, California 90064.

**FREE:** New handicraft catalog. Supreme Handicrafts, Box 395-PM, Sioux Falls, South Dakota 57101.

## BINOCULARS, TELESCOPES, MICROSCOPES, MAGNIFIERS

**HOLD** Camera or Binoculars safely secured to chest ready for instant use. No neck strain with patented Kuban Hitch. One size fits all. Quality made elastic straps, spring steel adapters, heavy-duty snaps. Ideal gift for fishermen, photographers, boaters, skiers, snowmobilers, hikers. \$7.50 postpaid. Satisfaction guaranteed. Free literature. Write: Kuban Hitch, Dept. PM, 5280 N.E. Main Street, Minneapolis, Minn. 55421.

**FREE** Binocular, Rifle scope catalog. Discount sale. Save 50%. Free gift with order. Write: United Binoculars, BN-6408, 9043 So. Western, Chicago 60620.

**TELESCOPES** (Reflectors) Complete Kits. Other accessories, request free literature. Criterion Manufacturing, Dept. PM 38, Hartford, Connecticut 06101.



## CAMERAS AND EQUIPMENT

**FREE CATALOG!** Lowest price, all brands, Dickson Company, Box K-3979, Kowloon, Hong Kong.

**PHOTOGRAPHY** For pleasure or profit. Learn at home. Practical basic training. Long established school. Free booklet. American School of Photography, 555 E. Lange St., Dept. 820-01, Mundelein, Illinois 60060.

**FREE! FREE! BARGAIN BOOK** Central Camera Co., Dept. 321, 230 S. Wabash, Chicago, Ill. 60604.

**SELL** Your Pictures To National Magazines. LATEST Booklet Includes Names, Addresses, And Other Good Information. \$1.00. BOSWELL HOUSE, 312 BOSWELL AVENUE, DEPT. CE, NORWICH, CONN. 06360.

(Continued on next page)

## PHOTOS AND PHOTO SUPPLIES

**FRAMES FOR YOUR FAVORITE POLAROID PHOTOS.** You May Have Attractive, Durable Frames FREE of Additional Cost. Only \$1.00. J O Graphics, Box 3833M, Granada Hills, Calif. 91344.

**SELL Your Photos.** Report Tells How, Where. Color Slide Markets. Booklet #Mo-54P, \$1.50. Free Thai Temple Pictures Post Card, Signet Enterprises, 152 West 42, Suite 536, New York, New York 10036.

## PHOTO FINISHING

**CAMERA FANS!** Expert photofinishing by one of Country's largest labs at lowest prices. Fast service and free "Foto-Fan" Stamps you quickly redeem for valuable Photo Supplies. 8MM Kodachrome \$1.29; 8 Exp. Kodachrome \$1.79; 35MM Kodachrome 20 Slides \$1.39; 8 Exp. Black White 69¢. Satisfaction guaranteed. Send exposed film or request free mailers, complete Price List and Gift Catalog. Direct Mail Photo, Box 8352-PM, Pittsburgh, Pa. 15218.

## COLOR SLIDES

**35MM COLOR Slides.** 10,671 Individually sold. Described, Encyclopedia catalog 10¢. Wolfe Worldwide, Dept. 14-23, Los Angeles, Calif. 90025.

## MOTION PICTURES AND SOUND EQUIPMENT

**UNUSUAL Movie supplies.** Free circular. Esor, 47th Holly, Kansas City, Missouri 64112.

**FREE!** 64-Page catalog. 8-16MM film supplies, processing equipment. Superior, 448 N. Wells, Chicago 60610.

**CLASSIC 8MM. MOVIES . . . 35MM. 2"x2" Color Slides.** . . . largest selection anywhere! Silent classics, comedy, history, sport, news, documentaries, features, others! 16MM films also. Free catalog. Blackhawk Films, 569 Eastin-Phelan Bldg., Davenport, Iowa 52808.

**8MM-SUPER 8-16MM MOVIES!** Biggest Selection! Lowest Prices! Free Catalog! Cinema Eight, Box 245-PM, N.Y.C. 10028.

**16MM, 8MM Sound and Silent Classic Films.** Free Catalog. Niles, 1019-PM So. Michigan, South Bend, Indiana 46618.

**"HANDBOOK FOR 16MM FILM COLLECTORS"** . . . Free Circular. P.S.F. Enterprises, Dept. PM-7, 4476 Kingspark Drive, San Jose, California 95136.

**FREE Catalog—8mm-16mm—Top Manufacturers—G & G Film Library, Box 321, Syosset, New York 11791.**

## RADIO, TELEVISION AND HAM EQUIPMENT

**36¢ RADIO & TV Tubes.** Free catalog. Cornell, 4213-17 University, San Diego, California 92105.

**HEAR POLICE/FIRE Dispatchers.** Catalog Shows Receivers: Exclusive Directories Of "Confidential" Channels. Send 8¢ Stamp. Communications, Box 56-PM, Commack, N.Y. 11725.

**GIANT Canadian Electronics Surplus Catalog.** \$1.00. Etco—PM, Box 741, Montreal

**SAVE Money on parts and Transmitting—receiving tubes, Foreign—domestic.** Send 25¢ for giant catalog. Refunded first order. United Radio Company, 56-PM Ferry Street, Newark, N.J. 07105.

**REMEMBER OLD RADIO?** Three 30 Minute Programs On Cassette Plus Catalog Only \$2.00. Historical Radio, Box 6866, Birmingham, Ala. 35210.

**BEGINNERS Electronic Kits, Crystal Radio \$2.50.** Others. Lectronix, Box 42, Madison Heights, Mich. 48071.

**RESISTOR Color Coder 50¢.** Norvex Co., 3920 Larkin St., Norfolk, Va. 23513.

## HIFI TAPES, RECORDS AND ELECTRONICS

**FREE Catalogues, 2000 hard to find unusual records.** Rose's Records, Box 7216, Louisville, Ky. 40207.

**FREE Catalog—Electronic Kits—Amplifiers—Preamplifiers—Psychedelic Strobes—SCA Adaptors—Color Organs—Digital Instruments—Guitar Amplifiers.** FREE Subscriptions. SWTPC, Box PM32040, San Antonio, Texas 78284.

**8-TRACK Cartridges, Cassettes.** Tremendous Discounts. Write for Free Catalogue. Exhibo West, Box 5174-PM, Mission Hills, Calif. 91340.

**ANSWER YOUR TELEPHONE FROM 1/2 MILE A Way.** Change Over Any Walkie-Talkie. When Your Telephone Rings In Your Home Or Office It Also Rings In Your Pocket; Then Just Pull Up The Antenna And Talk. Simple To Build. Complete Diagrams \$7.50. Kit \$55.—Assembled \$150.—SPOTS, 4880 49 Street North, St. Petersburg, Florida 33709. 525-5586

**RECORDS Promoted Nationally Through Unique, Money-Saving Method.** Comprehensive Coverage Gets Best Results For Less. EJM Record Promotions, Box 19193, Denver, Colo. 80219.

**OLDIES 45rpm.** Free Catalog. Corny's, 335D, Mason, Ohio 45040.

**OLDIES! 45 RPM Original Hits Catalog** 50¢. C. & S. Record Sales, Box 197, Wampsville, New York 13163.

**OLD Radio On Tape.** Catalog \$1.00. (Refundable). Radio Vault, Box 9032-PM, Wyoming, Michigan 49509.

**8 TRACK Tapes Latest Hits, Auto, Home Players.** Lowest Prices, Free List. APPOLLO Distr., 19150 Niver, OAKLEY, Mich. 48649.



## MUSIC AND MUSICAL INSTRUMENTS

**WE Pay All Recording Costs on accepted material!** Need new Song Material for immediate recording! Grand Recording, 1354-PM Hancock St., Quincy, Massachusetts 02169.

**ACCORDIONS And Amplifiers! New-Used.** Cordovox, Excelsior—Top Makes! Save to 50%. Direct factory dealer. Terms. Trades accepted. 5 day home trial. Free catalog—Discount prices. Write: Accordions Unlimited, Dept. R, 3147 North Luna, Chicago 60641.

**FREE CATALOG—30% DISCOUNT.** Best Names In Musical Instruments. Dial For Music, 90 North Main Street, Spring Valley N.Y. 10977.

**EASY To Play And Make.** Quality Dulcimers, Banjos, Thumb Pianos; Instruments And Kits. Can Be Profitable Hobby. HERE, Inc., #P. 410 Cedar Avenue, Minneapolis, Minn. 55404.

**ELECTRIFY Player Pianos, Pump Organs** Quickly, Inexpensively with Lee Silent Section Units. Write: Lee Music, 525F Venezia Avenue, Venice, California 90291.

**GUITAR MAKING Books, Imported Woods, Supplies, Accessories.** Catalog 25¢. Guitar Center, Box 15444, Tulsa, Okla. 74115.

**30% TO 50% DISCOUNT!** Any Model: Guitar, Amp, Drum, Banjo, Dobro! Free Catalog! Warehouse P30, Box 16399, Fort Worth, Texas 76133.

**PLAYER Piano Rebuilding—get details** from: Vestal Press, Vestal 11, N.Y. 13850.

**POEMS Wanted for songs.** Nashville Music Productions, Box 40001-P, Nashville, Tennessee 37204.

**VIOLIN And Guitar makers—send for latest Free Catalogue of woods & accessories.** International Violin, PM1. 414 East Baltimore St., Baltimore, Md. 21202.

**WHOLESALE! Professional Guitars, PA Systems, Aitec Speakers, 240W RMS Amplifiers.** Free Catalog. Carvin, Escondido, Calif. 92027.

**ACCORDION Manufacturing, 6846-P** North Avenue, Chicago, Illinois 60635. Concertinas, Hohners, Chromatics, Guitars, Drums. New, Used. Tuning, Repairing. Wholesale Catalogs Free.

**NEW FREE CATALOG!** Musical Instruments, Accessories, Instruction Books. Marina Music, Box 718-C, Marina Del Rey, California 90291.

**LEARN Faster.** Guitar or dulcimer. Without reading music. Hour-long instructional CASSETTE Plus illustrated fingering guide. \$5.49. State instrument. Only SOUND Can teach tuning. Improve seven days or money back. Hobbs Productions, 1003 Sanchez, Edgewater, Florida 32032.

**FREE Song Selling Information.** Peerless Publications, Box 193-A, Bloomfield, Conn. 06002.

**POEMS, Songs wanted for hit recording.** guaranteed Publishing, radio release. America's most popular new talent studio. Broadway Music Productions, 11647PM Bee Ridge, Sarasota, Florida 33578.

**WHOLESALE.** Musical Instruments—Accessories. Allied, 573 Route 17, Paramus, New Jersey 07652.

**SONGWRITERS Top royalty paid:** Recordorama, 2005PM St. Anne, Santa Ana, California 92704.

**KITS! Build dulcimers, guitars, balalaikas, thumb pianos, harps.** From \$2.95. Finished dulcimers from \$19.95. 8665 West 13th Avenue, Denver, Colorado 80215.

**30% DISCOUNT Name Brand Musical Instruments.** Free Catalog. Freeport Music, 455F Route 110, Melville, N.Y. 11746.

**LEARN Banjo.** 5-String Bluegrass. No music. Makes learning easy. Free details. Blaylock, Box 25-M, Marietta, Georgia 30060.

**RECONDITIONED Accordions for sale—Save \$\$\$.** Top Brands. Write for free descriptive folder. A-1 Rebuildt Accordions, 31 E. 18th St. N.Y.C. 10003.

**ACCORDION Top brands.** Buy direct. Tremendous discounts. Trades accepted. Free brochure PM. Accordion-O-Rama, 874 Broadway, N.Y.C. 10003.

## CONSERVATION TRAINING

**GAME WARDEN, Government Hunter, Forestry, Park & Wildlife Service** announce job openings regularly. Prepare at home for outdoor work, good pay, security. Approved for Veterans! Free! "Conservation Career Kit." North American School of Conservation, MPW, Newport, California 92663.

## MOTEL HOTEL MANAGEMENT TRAINING

**MOTEL MANAGERS** Wanted by leading chains, resorts, motels-hotels everywhere. Men, women, couples enjoy free rent, plenty of free time. Easy home-study plan. Approved for Veterans. Free! "Motel Career Kit." North American School of Motel-Hotel Management, AZW, Newport, California 92663.

## EDUCATION AND INSTRUCTION

**FINGERPRINTING—Investigation.** Exciting, secure career. Learn at home. Free book. State age. Institute of Applied Science, 1920 Sunnyside, Dept. 162, Chicago, Illinois 60640.

**AIRCRAFT MECHANIC—Learn engines, jets, airframes.** Qualify for FAA License at nation's largest air school. Write for free catalog. Indicate if eligible for G.I. Benefits. Spartan Airschool, International Airport, Dept. AZW, Tulsa, Oklahoma 74151.

**LEARN Sewing Machine Repairing.** Men, Women. Lucrative profits. Profession with bright future. Gresslin Correspondence School, Box 927, Spencer, Iowa 51301.

(Continued on next page)

## EDUCATION AND INSTRUCTIONS

(Continued from preceding page)

**LEARN Auctioneering.** Term soon. Free catalog. Reisch Auction College, Box 850. Mason City, Iowa 50401.

**AUCTIONEERING.** Resident or home Study Course. Free Catalog. Nashville Auction School, 1921 West End, Nashville Tennessee 37203.

**USED Courses! Books! List 10¢.** Smith's, 124 Marlborough, Salem, Massachusetts 01970.

**RELIGIOUS VOCATION?** Write: Church Of Holy Light Inc., P.O. Box 4478, Pittsburgh, Pa. 15205.

**OWN Collection agency.** "Little Gold Mine!" Franklin Credit, Roanoke, Virginia 24004.

**GET A British Degree.** Divinity, Philosophy, Radionics. 35 Courses. Prospectus free. Brantridge Forest School, Highfield, Dane Hill, Sussex, England.

**ORDINATIONS.** Lifetime! Church chartered 1887! Write! 708 Bragg, Monroe, North Carolina 28110.

**EXTENSION** And Post-Graduate Awards in Philosophy, Art, Sciences, Botanic Medicine, Homeopathy, Radionics and others. 30 subjects. Curricular free (airmail \$1.00 refundable). Registrar, Sussex College of Technology, Highfield, Dane Hill, Sussex, England.

**SERVE God's Ministry.** Free. Ordination, Bible Institute, Box 744, McKeesport, Pa. 15134.

**LEARN Massage.** Home Study Course. Free Details. Massage, Box 190-PM, Quincy, Mass. 02169.

**PIANO Technology**—Electronic organ servicing, learned easily at home. G. I. Approved. Free booklet. Niles Bryant School, Dept. P, 3631 Stockton, Sacramento, California 95820.

**GRAPHOANALYSIS**—Learn scientific handwriting analysis for profit, pleasure. Free sample lesson, catalog, reveals plan. Write: Igas Inc., 325 Jackson, Dept. 2AX-2, Chicago 60606.

**DETECTIVE Profession.** Easy home study; free tie-tack or lapel pin, certificate, future. GI approved. Professional Investigators, Box 41345, Dept. CP, Los Angeles Calif. 90041.

**AUTOSUGGESTION.** Sleep-learning headquarters! Tapes, records, books, Gigantic catalog free. Research Association, Box 24PM, Olympia, Washington 90851.

**GAME WARDEN.** Government Hunter, Forestry, Park & Wildlife Service announce job openings regularly. Prepare at home for outdoor work, good pay, security. Approved for Veterans! Free! "Conservation Career Kit." North American School of Conservation, AZW, Newport, California 92663.

**HIGHLY Effective college-level home study programs** in Electronics Engineering and Engineering Mathematics. (Our 27th Year). Free Literature. Cook's Institute, Dept. 10, Box 10634, Jackson, Miss. 39209.

**DETECTIVE Course.** Free Information. Universal Detectives, Box 8180-F, Universal City, California 91608.

**HIGH SCHOOL DIPLOMA** For Adults. Earn State Diploma. Accepted by Civil Service, business, colleges. Low cost. No tedious study. Money-back guarantee. Details: H-S Program, Suite 2505, 1221 Avenue of Americas, New York, N. Y. 10020.

**SHORTCUTS To Success!** Highly Effective, Profitable Short Courses. (75 Choices). Study At Home. Diploma Awarded. Our 27th Year. Free Literature. CIEE-25, Box 10634, Jackson, Miss. 39209.

**USED Courses! Books. Catalog 10¢.** (Courses Bought). Lee Mountain, Pisgah, Alabama 35765.

**DETECTIVE And Fingerprinting Courses.** Write. Detectives, Box 185-P, Fairfield, Alabama 35064.

**VETERINARY ASSISTANT**—Train at home for exciting animal care career. Send for FREE "Career Kit". North American Home-Study School of Animal Sciences, AZW, Newport Beach, California 92663.

**FREE Book** tells how you can learn camera repair and service. Home study or classroom. Write today! National Camera, Dept. EAD Englewood, Colorado 80110.

**PIANO Tuning** quickly learned with home study course. Diploma granted. American Tuning School, 17050 Telfer Dr., Morgan Hill, California 95037.

**LEARN ACCOUNTING!** U.S. Labor Department reports "33,000 NEW Accountants, 78,000 NEW Bookkeepers needed EACH YEAR for next ten years". Easy home-study plan prepares you. Approved for Veterans. Send for FREE "Accounting Career Kit". North American School of Accounting, AZW, Newport Beach, California 92663.

**FREE Introductory Course.** God's Great Salvation. Home Bible Studies, Box 370PM, Elkhart, Ind. 46514.

**UNLOCK Your Future.** Become professional Locksmith by spare time home-study. Make up to \$6 per hour. All tools, equipment inc. Facts free. Send name. Locksmithing Inst., (homestudy). Dept. 1310-023, Little Falls, New Jersey 07424.

**SUPERIOR Auction School.** Nation's top Auctioneers own and instruct. Box 1281, Decatur, Ill. 62525.

**PERFECT Husband-Wife Business.** Learn Upholstery at home. Make \$10 in an hour. Buy-repair-sell for even bigger profits. Kits, tools, included. Free Booklet. Upholstery & Decorating School, (homestudy). Dept. 5310-023, Little Falls, New Jersey 07424.

**WATCH REPAIRING.** Learn at home in spare time. Diploma awarded. Free sample lesson. Chicago School of Watchmaking, Dept. YO, Fox River Grove, Illinois 60021.

**LEARN To Fix Typewriters.** Desperate shortage trained men. Hundreds needed. Make up to \$25 in one hour. Learn at home in spare time. Industry Approved course. Facts Free. Send name. Typewriter Repair School, (homestudy). Dept. 3310-023, Little Falls, New Jersey 07424.

**MISSOURI Auction School.** Veteran Approved. Free catalog. 1600-03 Genesee, Kansas City, Missouri 64102.

**COMPLETE YOUR HIGH SCHOOL** At Home in spare time. Texts furnished. No classes. Diploma. Our 76th year. Free Brochure. American School, Dept. X245, Drexel at 58th, Chicago 60637.

**OIL Painting**—Easy! Career Opportunity! Hobby. Make Money. Learn at home. Free illustrated brochure. Artmasters, Box 1121DN, Redlands, Calif. 92373.

**LEARN ADVERTISING.** Course Like University Extension. AAI-P. 655 Teresita Blvd., San Francisco 94127.

**DRAFTING**—Blueprint Reading (Mechanical, Electronic, Architectural). Home Courses \$25.00. Send \$2.00 first lesson. Prior Inc., 23-09 169th Street, Whitestone, New York 11357.

**\$250.00-\$350.00** Per week is what Highly Skilled Furniture Refinishers Earn. All large furniture and department stores must employ them. 18 Week home study course features "Hands On" experience. Complete assortment of supplies used in modern furniture refinishing (wood samples etc.) Complete course \$36.00 plus \$8.00 shipping cost for supplies. Bodan Company, P.O. Box 793, New Haven, Conn. 06503.

**LEARN WELDING.** Certified Welder tells how to: Learn at home. Select Equipment. Open Shop for \$300.00 Plus Valuable Information Learned through experience. \$4.00 Postpaid. Daves Welding, 1005 South 19th, Fort Smith, Arkansas 72901.

**BE A Real Estate Broker.** Big Earnings. Prepare quickly, easily. Approved for Veteran Training. Free Catalog. Weaver School, 3519-PA Broadway, Kansas City, Missouri 64111.

**SCHOOLS FOR BAKERS: BAKING—HOME STUDY** Announcing Home Study Course in Commercial Baking. Practical basic training. Good field for those with aptitude. Nearly depression-proof. Send for free booklet "Opportunities in the Baking Industry." National Baking School, 555 E. Lange Street, Dept. 820-00, Mundelein, Illinois 60060. A Home Study School

**LEARN To Ski** within thirty minutes!!!!!! Famed Instructor gives Lessons about Equipment, Positions, Principles!!! Free Charts!!! Money Back Guarantee.—Only \$5.95. Sheldon's, Dept. 4 B, Box 1848, Lancaster, Penna. 17604.

**READ COMPUTER SECRETS.** Decode Punched Hole Code In Your Checks, Bills. Programmed Lesson \$4.00 Postpaid. Spectrum-ABA, P.O. Box J, Euless, Texas 76039.

**BWARE.** Choose an approved trade or technical school. Complete list \$1.00. Education Consultants, 9110 Gayle, Louisville, Ky. 40272.

**COLLEGE** Degree at home. Your choice of subjects incl. Law. Easy tuition plan. Williams College, Parker, Arizona 85344.

**"QUICK-Learning Laws Discovered!"** \$1.00! Gill's, 109-15 142nd Street, Jamaica, New York 11435. Tanimoto's, Box 95, Ewa Beach, Hawaii 96706.

**"LEARN Fast As Geniuses!"** \$1.00! Burke's, Brook Road, Charlton, Massachusetts 01507. Albrecht's, 2653-S Hoover, Los Angeles 90007.

**BREAK INTO ANNOUNCING, NEWSCASTING, SPORTSCASTING!** I will show you how! Send \$4.95 today—complete! Bob Doner Productions, Box 654, Elk Rapids, Michigan 49629.

**DEGREES** Without residence requirements! Honorary degrees. Catalog: \$3.00. United States University Of America, Box 4552-PM, Washington, D.C. 20017.

**LEARN Asleep or awake!** Records, tapes, equipment! Free catalog! Drawer PM-400, Ruidoso, New Mexico 88345.

## FOR INVENTORS

**INVENTORS**—If you have an invention for sale, patented or unpatented, write for free brochure outlining manufacturers requirements, royalty rates. Kessler Corporation, C-52FI, Fremont, Ohio 43420.

**INVENTORS:** Your ideas and inventions (patented; unpatented) expertly searched, developed for commercial appeal and cash/royalty sales to manufacturers by professional Invention Developer with excellent record of experience. B. S. Industrial Engineering; United States Patent Office former Patent Examiner. United States Government former Patent Advisor. Second decade reliable service! Member: United States Council International Chamber Commerce. Free "Invention Record" and "Recommended Protection Procedure." Airmailed! Write: Raymond Lee, Invention Developer, 230P-Park Ave., New York, New York 10017.

**U.S. PATENT Office Searches.** 234 Broadway, Room 3615, New York 10007. Free invention certificates.

**FREE PAMPHLET:** "Tips on Safeguarding Your Invention." Write: United States Inventors Service Company, 501-P Thirteenth Street N.W., Washington, D.C. 20004.

(Continued on next page)

## FOR INVENTORS

(Continued from preceding page)

**IMMEDIATE** Cash, for patent applications. Free patent searches. Write for details. Universal Patents, 184-D, Marion, Ohio.

**INVENTORS!** Don't sell or license your invention until you receive our offer. Eagle Development Company, Dept. H, 83 Wall Street, New York City 10005.

**SYNTHESIS MAGAZINE**—About Invention. Write: Box 157, Manhattan Beach, California 90266.

**INVENTORS**—United States Patent Office Searches, Patent Development Engineering, marketing of inventions—ideas by Licensed Professional Engineer—Patent Engineer and United States Patent Office Former Examiner. Inventions developed for patenting and marketing. We are contacted by many manufacturers seeking to purchase appropriate new products invented by our clients. Send for Free Invention Certificate and Invention Information. Serving Inventors since 1948. George Spector, Licensed Professional Engineer—Patent Engineer—3615 Woolworth Bldg., New York, N.Y. 10007.

**PATENT** Application Financing. Free patent search plan. Global Patent Division, 2420 77th, Oakland, Calif. 94605.

**PATENT** Searches including maximum speed, full airmail report and closest patent copies. Quality searches expertly administered with complete secrecy guaranteed. Free Invention Protection Form and "Patent Information." Write: Dept. 15, Washington Patent Office Search Bureau, Benjamin Franklin Substation, P.O. Box 7167, Washington, D.C. 20044.

**FREE PROTECTION** On invention before applying for patent. Forms and Instructions \$1.00. Inventors Research Association, Suite B-214, 1280 West 54th Street, Hialeah, Florida 33012.

**PROSECUTE** Your Own Patent Application. All Material Necessary—Write: Inventors Service, Box 3574, Washington, D.C. 20007.

**HOW TO Apply, Obtain And Promote Patents And Inventions.** Complete Do-It-Yourself Professional Guide. \$1.00. Infoco, Box 34260, Washington, D. C. 20034.

**INVENTORS—EARN MONEY WITH YOUR IDEAS.** Industry pays for new products and ideas. We use proven successful methods to evaluate, develop and sell your inventions. Send for free information: Promotion Services Company, P.O. Box 383, Dept. D, Fort Lee, New Jersey 07024.

**INVENTORS!** Either I will sell your invention for cash and/or royalties or pay you cash bonus. For **FREE INVENTION EVALUATION** and information, write: **GILBERT ADAMS, INVENTION BROKER,** Dept. 15, 81 WALL ST., N.Y., N.Y. 10005.

## INVENTIONS WANTED

**INVENTIONS** Wanted immediately for promoting on cash or royalty. Patented. Un-Patented. Free booklet outlines royalty rates, requirements. Write: Kessler Corporation, C-521W Fremont, Ohio 43420.

**INVENTIONS** Wanted. Patented: unpatented. Tremendous manufacturers lists. Global Marketing Service, 2420G 77th, Oakland, California 94605.

**INVENTORS!** Protect your ideas! Free "Recommended Procedures." Washington Inventors Service, 422F Washington Building, District of Columbia 20005.

**WE** Either sell your invention or pay cash bonus. Write for details. Universal Inventions, 28-E, Marion, Ohio.

**FREE** "Directory of 500 Corporations Seeking new Products." For information regarding developments, sale, licensing of your patented/unpatented inventions. Write: Raymond Lee Organization, 230-N Park Avenue, New York, New York 10017.

**MR. INVENTOR:** Inventions Urgently Needed by Manufacturers. Idea Developed. Patent Searches \$10. Patent Application Financing if Desired. Charles S. Prince, Invention Consultant, 353-A, West 57th St., New York, New York 10019.

**NEW PRODUCTS—INVENTIONS—IDEAS** Developed/Marketed by Professional Organization. **FREE INFORMATION** "How To Market Inventions To Industry". Lawrence Peska Associates, 51-C East 42nd Street, New York City 10017.

## MANUFACTURING

**INVENTORS** Ideas Developed. Research. Models. Manufacturing. Sales. Free Brochure. Since 1942. William Parker, Box 6305, Orlando, Fla. 32803.

## BUYING AND SELLING

**WOULD** Like to Buy, Double Steam Car, any Model, or Double Power Plant. Louis J. Klapka, c/o The Shoe Tree, 40 E. Hinsdale Ave., Hinsdale, Ill. 60521.

**PROFITS FROM CLASSIFIED ADVERTISING!** Booklet shows you how to start your own business with Classified Advertising. Only \$1.00 (Refundable with first order.) **C. A. MARTIN, POPULAR MECHANICS, DEPT. PMP, 224 WEST 57th STREET, NEW YORK, N. Y. 10019.**

## BUY IT WHOLESALE

**HEARING** Aids, batteries, Wholesale. Catalog 25¢. Fiston, Box 1444, New Preston, Conn. 06777.

**165 FREE Wholesale Catalogs!** Mailorder Dropshippers. Your Business Imprint. Automobile Discounts. Free "Digest." Vault International, Box 7284W, Lexington, Kentucky 40502.

**WORLD'S** Largest wholesale dropship sources. U.S., foreign. Factory suppliers dropship direct to you or customers. Now!, have your own catalog for pennies. Free details. International Buyers, Box 16386-M, Portland, Oregon 97233.

**FABULOUS** Wholesale Club!! Save on thousands of famous brands: jewelry, tools, appliances, stereos, etc. 40-50% off retail; same wholesale prices retailers pay! Purchase for yourself or resell for fantastic profits. Free information. Homestead, Dept. 73B, 18 Westcliff Drive, Mount Sinai, New York 11766.

**FREE CATALOG.** Gifts, Specialties, Money-making Manuals, Buy Below Wholesale. Richard, 5275 DeLongre, Hollywood, Calif. 90027.

**SACRIFICE SALE—DOCTOR'S** Orders. Ornamental Concrete business in resort area. No competition. Molds to pour \$1200.00 per day wholesale. 406-962-3432 Lawn Ornaments, Joliet, Montana 59041.

**PLASTIC BAGS—WHOLESALE PRICES** 300 Stocked sizes—fast shipment. Catalog 20¢. Milvan Company, 7921 D Enterprise, Newark, Calif. 94560.

**8 TRACK** Tapes Latest Hits, Auto, Home Players. Lowest Prices. Free List. **APPOLLO** DISTR. 19150 Niver, OAKLEY, Mich. 48649.

## EXPORT-IMPORT

**JAPAN:** 1200 Products directory. Illustrated Manufacturers' names, addresses. \$4.00. Send cash. Yamagata Office, 814 Togin Bldg., Marunouchi, Tokyo.

**DIRECT** From Scandinavia: Grandfather's clocks, wrist watches, Pencils, Telephones, Playing cards, colour films, colour magazines, color slides. Catalog \$2.00. Write to: Ado-Mail, Gothersgade 97, DK 1123, Copenhagen, Denmark.

**PRODUCTS**—Gifts From Mexico. \$1.00 For Catalog. The Parlor Shop, P.O. Box 14367, San Antonio, Texas 78214.

## FOR THE HOME

**KEEP** Your copies of PM—and watch for the inexpensive Annual Index, available in January 1972. It will enable you to locate any article which appeared in 1971 or find information on any particular subject in just a few seconds. The Annual Index will make your copies of PM even more valuable! Price \$1.49. Send checks to: Popular Mechanics, Dept. HE, 224 W. 57th St., New York, N. Y. 10019.

## FOR PARENTS

**PROFITS FROM CLASSIFIED ADVERTISING!** Booklet shows you how to start your own business with Classified Advertising. Only \$1.00 (Refundable with first order.) **H. E. KAPPEL, POPULAR MECHANICS, DEPT. P, 224 WEST 57TH STREET, NEW YORK, N. Y. 10019.**

## OF INTEREST TO WOMEN

**MAKE MONEY** At Home—100 Ways—No Investment. Full Details in Manual. Guaranteed! \$2.00. Crossroads, Box 504PM, Palmdale, Calif. 93550.

**\$25.00 DAILY** Possible addressing-stuffing envelopes. Typewriter-longhand, also Clipping News items at home. Information: Send stamped addressed envelope. Ame-38, Box 310, Le Mars, Iowa 51031.

**1000% PROFIT** Bronzing Baby Shoes. Free literature. NBC, Box C-4PM-9, Coraf Springs, Florida 33065.

**WANT** A new car, color TV, new clothes? Learn hundreds of ways to make money. 5 month subscription **FREE.** Write: Salesman's Opportunity Magazine, Dept. 17-B0, 1460 Hancock Center, Chicago 60611.

**\$6.00 DOZEN** Paid lacing baby boots! Cowboy, Warsaw 9, Indiana 46580.

**HOW** To Make Money Writing Short Paragraphs. Information Free. Barrett, Dept. C-27-S3, 6216 N. Clark, Chicago 60660.

**HOMEWORKERS!** \$100.00 Weekly addressing for firms. Begin immediately. Details—send stamped, addressed envelope. Hamilton, 272-TM-2, Brooklyn 11235.

**HOME** Newspaper clippers needed. \$500 monthly possible. Details free. Foster, 272-MA-2, Brooklyn 11235.

**\$500 MONTHLY** Possible addressing—stuffing envelopes (longhand—typing) at home. \$500 monthly Clipping news items from your newspaper. Information: Send stamped self-addressed envelope. American, Excelsior Springs, Missouri 64024.

**NEW** magazine, foods, decorating, household tips, family living. Sample 25¢. Homemaker Magazine, 404 West Jefferson, Springfield, Illinois 62702.

**EARN UP TO \$150.00 WEEKLY . . .** Home addressing for us. Details 25¢. Smith's, Box 2469-PM, Newark, New Jersey 07114.

**\$100 WEEKLY** Possible! Sewing At Home—Spare Time. Unlimited Need For Hand-sewn Items. Details Free! Enterprises, Box 8-PM, East Rockaway, N. Y. 11518.

**BIG** Profits from Dolls! Start your own hobby-business dressing, making, repairing and selling dolls. Free information. Lifetime Career Schools, Dept. D-243, 2251 Barry Avenue, Los Angeles, California 90064.

**SPARE TIME** Profits for Women! Free Details. Stayer Enterprises, 3704 Warwick, Peoria, Illinois 61614.

**LEARN** Expert Cake Decorating. Candy Making. Free details to housewives. Candy & Cake Institute, Dept. BOL, 1600 Cabrillo Avenue, Torrance, California 90501.

(Continued on next page)

## OF INTEREST TO WOMAN

(Continued from preceding page)

**MAILORDER** Firms need names and addresses for mailing lists. Typewrite or longhand. Information 25¢ with stamped, self-addressed envelope. Turner-PM, POB 26917, El Paso, Texas 79925.

**ADDRESSERS** And Mailers Needed. Details 10¢. Lindbloom, Dept. POM, 3636 Peterson, Chicago 60659.

**\$100 WEEKLY** Possible . . . Homework, Addressing, Sparetime! Details Send Self-addressed, Stamped Envelope. National, 14-2LB, Brooklyn 11214.

**GRAPEFRUIT DIET**—Lose A Pound A Day. Programmed Diet \$3.00 Postpaid. Spectrum-ABA, P.O. Box J, Euless, Texas 76039.

**BIG PROFITS!** Sparetime Enterprises For Women. Free Details. Avalon, Dept. 312-3, 1185 Washington Street, Newton, Massachusetts 02165.

**\$100 WEEKLY** Possible! Typing—Addressing Envelopes. Free Bonus: \$50 per 1000 Addressing Plan. Send stamped—addressed envelope. Service, Box 721-A, Lynbrook, N. Y. 11563.

## GIFT SHOPPING

**FREE FANTASTIC GIFT CATALOGUE. FREE SILVER DOLLAR BONUS GIFT. TREASURE CHEST, 9321PM2, CAPE VIEW AVENUE, NORFOLK, VIRGINIA 23503.**

**FREE** Gift Catalog. Write: Norman Goetsch, Box 473, Sturtevant, Wisconsin 53177.

**LOOKING** For a special gift? Free Catalog and Bonus. Leskens, 1709 West Miner, Arlington Heights, Ill. 60005.

**GIFTS**—Novelties. Free Catalog! Lawson's, 403—PM Harding, Lyndhurst, N.J. 07071.

**LOWEST PRICED NOVELTIES**, Catalog 25¢. Marcon Novelty, 2216 Clover Dr., Brookmall, Pa. 19008.

**FREE** Exquisite gift catalog for all occasions featuring bonus gifts. National Trade Mart, Box 1446, Bloomfield, N.J. 07003.

## WATCHES, OLD GOLD, JEWELRY

**HIGHEST CASH** For Gold, Jewelry, Gold Teeth, Rings, Diamonds, Watches, Silver, Platinum. Mail Articles Today. Free gift with information. Chicago Gold & Precious Metals, 6 E. Monroe, Dept. 658, Chicago 60603.

**FREE** Catalogue—Ancient Replica Clocks, Masters, 82 Doudeauville, Paris 18, France, (Airmail \$1.00).

**WANTED** . . . Gold, Silver, Platinum (any form), Coins. Information Free. Wilmot's, 1067-A Bridge, Grand Rapids, Mich. 49504.

**WATCH** And Clock repairing books. Free list. North American, Box 77-AB, Fox River Grove, Illinois 60021.

## WEARING APPAREL

**PROFITS FROM CLASSIFIED ADVERTISING!** Booklet shows you how to start your own business with Classified Advertising. Only \$1.00 (Refundable with first order.) H. E. KAPPEL, POPULAR MECHANICS, DEPT. P, 224 WEST 57TH STREET, NEW YORK, N. Y. 10019.

## HEARING AIDS

**HUGE SAVINGS.** Eliminate dealer mark-ups. Free Trial. Batteries Wholesale. Terms Arranged. Lloyds-PMC, Rockford, Ill. 61108.

**WHOLESALE** Discounters! Famous Aids! Batteries! Repairs! AidMart, Box Z, St. Petersburg, Florida 33731.

**BATTERIES** Discounted! **FREE** Hearing Information, Madison, Box 53-C, Hopkins, Minnesota 55343.

**HEARING Aids**—Huge savings on tiny, all in the ear, eyeglass, behind the ear and body models. Free home trial. Low as \$10 monthly. Write for free catalog. Prestige, Dept. R-6, Box 10947, Houston, Texas 77018.



## SCIENCE AND CHEMISTRY

**LABORATORY** Supplies at discount prices. Catalogue—35¢. Deluxe Scientific, Manitowoc, Wisconsin 54220.

**AMAZING!** Scientific Catalog—Apparatus—Glassware—Chemicals. Catalog—50¢. Hagenow Laboratories, Manitowoc, Wisconsin 54220.

**CHEMISTRY** And Biology Catalog 35¢. Boulevard Laboratories, Suite 302, 3114 E. 83rd St., Chicago, Ill. 60617.

**CATALOGUE** Of those ver-ry hard-to-find chemical products, things that go boom, multi-stage rockets, 500 How-To books, 10,000 formulas of every conceivable mixture in science and industry. 50¢. Kenrus-C, Box 158M, Staten Island, New York 10309.

**FREE.** Flying **MODEL ROCKET** Kit. Act Now. Offer Limited. Send 25¢ for Packet of Iron-ons, Decals, Literature and "Free Rocket" Details. Aerospace Vehicles, Inc., Mineral Point, Wisconsin 53565.

**COMPLETE** Laboratory Catalog 35¢. Laboratory Sales, Box 161-A, Brighton, Mass. 02135.

**CHEMICALS** Apparatus, Biology and Model Rockets. Both Catalogs for 50¢. Sheard Science, Dept. PM, Columbus, Wisconsin 53925.

## FORMULAS, PLANS, ETC.

**MAILORDER RECORDS** Help get increased business! Complete 32 Page Record Book shows your inquiries, orders, advertising, expense, etc. Only \$1.00. H. E. KAPPEL, POPULAR MECHANICS, DEPT. R, 224 WEST 57TH STREET, NEW YORK, N. Y. 10019.

## PLASTICS

**LARGEST** Handicrafts Supply Catalogue \$1.00 (Refundable). R.P.H. Manufacturing, 24-M-2, Winter, Stamford, Connecticut 06905.

**CASTOLITE** Pours like water, hardens like glass without heat. Crystal clear or colors. Embed natural flowers, other objects. Make fine gifts. Reproduce your own designs in plastics, wax, metal, plaster, cement, etc. Make flexible molds over any pattern, any size. Profitable. Manual: 25¢. **CASOLITE**, 73B/PM, Woodstock, Illinois 60098.

## TREASURE FINDERS

**TREASURE** Finder locates buried gold, silver, coins, treasures. 5 powerful models. \$19.95 up. Instant financing available. Free catalog. Relco-A-40, Box 10839, Houston, Texas 77018.

**POWERFUL** Metrotech locator detect gold, silver, coins, relics. Moneyback guarantee, terms. Free information. Underground Explorations, Dept. A, Box 793, Menlo Park, California 94025.

**FREE 156** Page Detector Catalog. General Electronic Detector Co., Box 67, Bellflower, California 90706.

**FISHER DETECTORS.** You deserve the best! Free literature. FRL, Dept. PM-2, P.O. Box 490, Belmont, California 94002.

**SEARCH** Treasure Finders. Locate gold, silver, coins, relics. Operate underwater. Money back guarantee. Free information. Search Electronics, Box 8396-A, St. Petersburg, Florida 33738.

**FIND** Buried treasure with revolutionary patented, analytical metal detector. Features push button and automatic tuning, negligible ground pickup, greatest range. Free catalogue. Gardiner Electronics, Dept. 9, 4729 N. 7th Avenue, Phoenix, Arizona 85013.

**TREASURE** Locators. Most complete line. Free information. Book "All you need to know about Treasure" \$4.95. Twelfth Edition. Tesoros, Apartado 7-905. Mexico 7, Mexico.

**DISCOVER AMERICA'S FASTEST GROWING HOBBY.** White's Electronics, Inc., would like to send you—absolutely **FREE**, their 42 page, fact-filled catalog on Mineral and Metal Locating Equipment. Amateurs or Professionals select from the world's largest line of metal detectors priced as low as \$79.50, up. Detect Gold, Silver, Copper—Nuggets, Coins, Jewelry, etc. Budget terms available. For your convenience we have three major factory locations in the U.S. and Canada, as well as over 1,000 authorized dealers to serve you. See your local Yellow Pages under "Metal Locating Equipment", or write: White's Electronics, Inc. Room No. 381, 1011 Pleasant Valley Road, Sweet Home, Oregon 97386—Elk-Air Industrial Park, Dexter Drive, East, Elkhart Indiana 46514—or White's Electronics Ltd., 33784 Hazel Street, Abbotsford, British Columbia, Canada.

**FORTUNE, FUN, HEALTH**—Find Money, Gold, Silver, All Metals With Super Sensitive 1973 Excelsior Models. Transistorized For Hi-Performance, Least Weight, Compact Design, Long Life. Best Guarantee, Lower Cost. Write For **FREE** Literature Now! Excelsior Electronics—The Detector Center—7448 Deering, Dept. 10, Canoga Park, Calif. 91303.

**PROSPECTORS:** Fantastic New Machine Makes Gold Extraction efficient, profitable. Using Redox Process, 100% Extraction Possible. Simplified Construction, Inexpensive, Portable. Plans \$4.00 check or moneyorder. Kits available. Can be easily adapted for silver extraction. Centaur Systems Engineering, P. O. Box 5003, Oxnard, Calif. 93030.

—**SPANISH** Treasure—Authentic Bit of 8, Cut Spanish Bit 1 real \$1., Book of Spanish Treasure, Coins, USA, Silver Dollars, Artifacts, Gold Doubloons For Sale. Colonial Treasure, 25¢, 909 Travis, Houston, Texas, 77002.

**TREASURE** Hunters—greatest news! The junk iron curse is over. Our select Medic detector is guaranteed to locate 10 times more money. Instantly rejects iron, tin foil. Patented. Literature-Pictures \$1.00. Treasuretronics, Box 56MN, Benton, La. 71006.

## PRECIOUS STONES & MINERALS

**GET** Free catalog no serious rockhound, gem cutter, jewelry maker, hobbyist or craftsman can be without. Full of bargains, exclusive items, low prices from largest suppliers and authorities in the field. Free new catalog just off the press, yours for the asking. Write: Grieger's, Dept. C-12, 900 South Arroyo Pkwy., Pasadena, California 91105.

**500 POLISHED** Gemstones \$5.00. Tumblecraft, 5401 James North, Minneapolis, Minn. 55430.

**EARTH** Science Rockhound Magazine. Subscription \$3.00. Sample \$4.00. Box-550-PM, Downers Grove, Ill. 60515.

**ROCKHOUNDS!** Receive Interesting, Valuable Specimens Monthly. Free Information. Minerals, Box 487YC, Yucaipa, California 92399.

(Continued on next page)

## CARTOONING, COMMERCIAL ARTS, SHOWCARD & SIGN PAINTING

**"HOW TO MAKE MONEY WITH SIMPLE CARTOONS"**—Informative book sent FREE tells way to big income. Cartoonists' Exchange 92, Pleasant Hill, Ohio 45359.

**FASCINATING** Systems. Sign Painting-Cartooning. Straley, 1704 South Center, Springfield, Ohio 45506.

**COMPACT** 23 lesson Cartoon Course and Cartoonist's Magazine. \$2.00. Hartman, Box 30367, Lincoln, Nebraska 68510.

**MODERN** Cartooning taught by mail. Write for free brochure. Cartoonorama—Box 263-3L, Branford, Conn. 06405.

**CARTOON** For Money!! Big Free Book: Success, Box 885-C, Dearborn, Mich. 48121.

**SIGNS!** Make-your-own! **SIGN-RITE** Self-Adhering Letters and numbers! 4 Types! 5 large Sizes! 8 material Styles! Choice of Colors! Inexpensive! Prompt service! **FREE BROCHURE!** Americraft Mfg. Co., Box 25034 Northgate, Seattle, Wash. 98125.

**SIGN** Painting—\$1000 per Month Part-Time. Free Catalogue. Kaufmann Supply, Centertown, Missouri 65023.

**LEARN** Sign painting at home. Free Talent test. Ben Kerns, Box 812-PM, Greenville, S.C. 29601.

## ADVERTISING AGENCIES, ADV. SERVICES, MAILING LISTS

**ADVERTISING** Ratebook leading newspapers, magazines, 25¢. Chicago Advertising Agency, 28-E Jackson, Chicago 60604.

**MAILING** List, Most all Kinds, \$9.00 1000 Gummed, Circulars mailed \$5.00 1000. Dixmailers, King, North Carolina 27021.

**10,000 MAILORDER** Buyers on gummed labels. \$9.00 per 1,000. Gemco., B-21244AA, Indianapolis, 46221.

## RUBBER STAMPS

**POCKET** Stamp, Three Lines \$1.00. Catalog. Rush Stamps, 132-P, Rush, New York 14543.

**FREE** 48 Page Catalog. Rubber stamps, printing, office supplies. Youngers Stamp Shop, Princeton, Iowa 52768.

**ADDRESS** Stamp \$1.43, Signature Stamp \$2.95. Catalog. Carol's, McLoud, Okla. 74851.

**EVERY FAMILY NEEDS A** Rubber Stamp! 3 or 4 line address stamp PLUS ink pad (any color)—**BOTH** only \$2.00 Postpaid. **FREE** catalog. ACE, Box 3333, Shreveport, La. 71103.

**FREE** Stamp Catalog. 45 Type Styles. Fast Service. Low Prices. Jackson's, Box 443A, Franklin Park, Ill. 60131.

**ADDRESS** Stamp—Four Lines—\$1.49—Sunshine 2228 Saul, Jacksonville, Florida 32216.

## OFFICE SUPPLIES

**MAILORDER RECORDS** Help get increased business! Complete 32 Page Record Book shows your inquiries, orders, advertising expense, etc. Only \$1.00. **H. E. KAPPEL, POPULAR MECHANICS, DEPT. R, 224 WEST 57TH STREET, NEW YORK, N. Y. 10019.**

## PRINTING PRESSES, RUBBER STAMP OUTFITS

**SIMPLE-X RUBBER STAMP PRESSES.** Hydraulic operated, electrically heated. Sizes 5"x8", 8"x12", 10"x15". Starting outfits. Orders for presses, supplies shipped day received. Free catalog low supply prices. Send \$1.00 for postage and handling (refundable on first order). Custom Manufacturers, 406-P East Elm, Springfield, Missouri 65801.

**LOW Priced Rubber Stamp Manufacturing** Supplies. Starting Outfits. Martin, 1432 Major, Jefferson City, Missouri 65101.

**SAME** Day shipment on rubber stamp supplies. Revised wholesale price list No. 9 free. Star Stamp Supply, 732 Federal, Chicago, Ill. 60605.

**RUBBER** Stamp outfits, supplies. Kiewiet, 2025 Barney Road, Kalamazoo, Michigan 49007.

**NEW** Catalog No. 13. 120 Pages, hand printing presses, type fonts, supplies. Send \$1.00 deductible first order. Acme Type, 732 Federal, Chicago, Illinois 60605.

**RUBBER** Stamp Manufacturing Supplies: Equipment. Free Catalog. Northwest Stamp, Box 16417-PM, Portland, Oregon 97233.

**MAKE** Your own self-molding Rubber Stamps and Printing Cuts. Plexirubber, Argyle A, Wisconsin.

**PRINTING** Presses, type, supplies. Lists. 10¢. Turnbaugh Service, Mechanicsburg, Pennsylvania 17055.

**RUBBER** Stamp Manufacturers Supplies. Presses, Starting Outfits. Best Prices. Service. Catalog. Jackson Supply, Box 443A, Franklin Park, Ill. 60131.

**PRINTING MACHINES.** Offset. Mimeograph, Typewriters, Composing. Machines. Dixgraph, King, North Carolina 27021.

## PRINTING AND SUPPLIES

**BUSINESS CARDS** Raised Letters \$5.65 Thousand. Like Engraved. Free Samples. Kavanagh, Box 1222, Brooklyn, N.Y. 11202.

**BUSINESS** Cards, Rubber Stamps, Printing. Free Literature. Jordan's, 552 West O'Connor, Lima, Ohio 45801.

**500 QUALITY** Business Cards, \$2.95. Other Printing Values, Free List. Sprint, P.O. Box 6044, Sherwood, Arkansas 72116.

**FREE** Offset Catalog. Fast-Economical. Seaview, 212-26P 48th, Bayside NY 11364.

**ECONOMICAL** Business Cards, Forms, Labels, Stamps, Stationery. Burnfin, Weableau, Mo. 65774.

**1000 EMBOSSED** Cards \$5.50. Fast! Graphics, 106A High, Westerly, R.I. 02891.

## GUMMED LABELS

**1,000 GUMMED ADDRESS LABELS** \$1.00 **FREE CATALOG**, Acme, 1238 Voskamp, Pittsburgh, Pennsylvania 15212.

**500 PRESSURIZED** Address Labels \$2.00. Walt's, Box 966A, South Bend, Indiana 46624.

**1000 LABELS** \$1.00. Eldee Printing, 152 W. 42 St., N.Y.C. 10036.

**500 BETTER QUALITY LABELS** \$1.00! Specify Gold, Script, or Monogrammed. Regular labels—1000-\$1.00. Name & address or any 10 word message. Enos Miles, 2911 Charles, St. Joseph, Missouri 64501.

**1000 LABELS.** Guaranteed. Only 75¢!! Free Catalog. Kruger, Box 2244, Palos Verdes Peninsula, California 90274.

## REMAILING SERVICE

**SECRET.** Receiving—forwarding. Discreet and confidential. Remail 25¢ single. Mail Forwarding Service, 8050 S. Main, Houston, Texas 77025.

**CONFIDENTIAL** New York City mail address \$3.00 month. Remails 25¢. Details Free. Birnhan, 152 W. 42, New York City 10036.

**LET A Disabled Veteran Do Your** Remails 25¢ Each. \$3.00 Monthly. Chas. W. Miller, Michigan Veterans Facility, Grand Rapids, Michigan 49505.

**RECEIVING** — Forwarding — Remailing. Monthly Rates. Nortex, Drawer 5370, Ft. Worth, Texas, 76108.

**HAWAII** Reairmails, \$1.00. Houston, 25¢. Allstate, 714W Janisch, Houston, Texas 77018.

**EUROPEAN** Guaranteed Reairmails! Singles \$1.00. Gary Taylor, 652 Worms/Herrnsheim, Herrnsheimer Hauptstrasse 122, West Germany.

**ICELAND.** Letter re-airmailing \$2.00. Box 814, Reykjavik, Iceland.

**LINCOLN'S HOME** Remailing-Forwarding. Letters, Souvenir cards. Box 2873, Springfield, Ill. 62708.

**MEXICO** Remails 20¢. Airmails 40¢. Gonzalez, 2692 Apartado, Monterrey, Mexico.

**CONFIDENTIAL** Remailing Service. Write: Spectrum, P.O. Box 3574, Charleston, S.C. 29407.

**MIAMI** Remails 25¢—Monthly rates. Remails—view cards from 80 Foreign cities. Marle, Box 1266, Coral Gables, Florida 33134.

**CONFIDENTIAL.** Receiving Forwarding. Monthly Rates. Davis, Box 5012A, Reno, Nevada 89503.

**WASHINGTON, D.C.** Remails 25¢ Single. Sharp Services, Box 697, Bowie, Maryland 20715.

**YOUR** Mail Received—Forwarded. Hedgpeh, 324-M South First, Alhambra, Calif. 91802.

**HARRIS** Remailing Service. Box 9434, Chattanooga, Tennessee 37412. Fast, confidential. 25¢ each, \$3.00 month.

**PARIS** Post Cards 5/ \$1.00. Reairmail Singles \$2.00—Rates. Masters, 82 Doudeauville, Paris 18 France.

**FREE:** First Month's Remailing Services. Wright, Box 2112-M, Asheville, N.C. 28802.

## REPAIRS AND SERVICING

**PROFITS FROM CLASSIFIED ADVERTISING!** Booklet shows you how to start your own business with Classified Advertising. Only \$1.00 (Refundable with first order.) **H. E. KAPPEL, POPULAR MECHANICS, DEPT. P, 224 WEST 57TH STREET, NEW YORK, N. Y. 10019.**

## SPECIAL SERVICES

**INFORMATION** On anything. Ferguson Specialists, 72-25 Woodside, Woodside, New York 11377.

**LIFETIME** Ordination, Doctor of Divinity, **CHARTERS, DETAILS** 25¢. Life Science Church, 2207 Cardinal, Rolling Meadows, Illinois 60008.

## TOBACCO

**ROLL** yer own. With our new cigarette rollers. Plain, filtertip, king. Less than a penny each. Free sample. Green River Tobacco, Box 954, Owensboro, Ky. 42301.

**1 PINT** Sweet Flakes Chewing-Smoking. 50¢ Each PostPaid. Jolley Farms, Dresden, Tennessee 38225.

**IT'S CUSTOM** Blended pipe tobacco. Finest tobacco. Expertly blended. Factory fresh. Write for free sample. Green River Tobacco Company, since 1914, Box 991, Owensboro, Ky. 42301.

## PERSONAL

**BORROW** By Mail! Up to \$1500.00. Convenient terms. State Licensed. Postal Finance, Dept. 17-A, 6018 Military Ave., Omaha, Nebraska 68104.

**KNOW** Your I..Q??? Test. Instructions \$2.00. Improvement Booklet \$2.00. Order Today!!! Paramount House, Box 9664—B2A, Little Rock, Arkansas 72209.

**I HELPED** Thousands Wipe Out Debts. Clear credit. Immediate relief to \$25,000. Free details. Counselor-7, Kerrville, Texas 78028.

(Continued on next page)

## PERSONAL

(Continued from preceding page)

**PSORIASIS** Sufferers: Discouraged? Write for Free important information that is helping thousands! Pixacol, Box 38-PM, Avon Lake, Ohio 44012.

**INSTANT DEBT RELIEF** Without borrowing. Without Bankruptcy. Have excellent credit in 45 days. Free!!! Wealth Building, Box B-2, 8840, Hoyt Drive, Thornton, Colorado 80229.

**BIBLE** Questions answered. Stamped envelope. Bylon, 17167 Bentler, Detroit, Michigan 48219.

**RECORD** Telephone conversations automatically. Leave recorder unattended. Write—Robert's, Box 49-PM-2, Parkridge, Illinois 60068.

**CASH LOANS** by mail! Up to \$2,500 on signature alone. No collateral! Secret! Union Finance Company, 3608 No. 16th St., Dept. PM, Phoenix, Ariz. 85011.

**WHO** Else Wants Credit Cards? Learn how to get credit cards fast, easy! Get new credit without investigation, Box J-27, Hallandale, Florida 33009.

**INVESTIGATORS.** Latest electronic Aids. Free Literature. Clifton, 11500-P NW 7th Ave., Miami, Florida 33168.

**RUPTURED.** Relief and comfort. No understraps, elastic or steel. Write: Hand-Lock Products, Preston 4, Ont., Canada.

**FREE** Gospel Literature foretelling second coming of Christ. Scheall, Box 263-PM, Duluth, Minn. 55801.

**MATHEMATICS STUMP YOU?** Startling Revelation Teaches You How To Do Lightning Mathematical Equations FAST. My System Works. Write, I'll Prove It. Marlos, Dept. PM, Box 111, Harwinton, Conn. 06790.

**KOREAN GINSENG** Legendary body and mind rejuvenator. Brochure 25¢. Herbal Holding, Box 5854PM, Sherman Oaks, California 91413.

**NEED** Money-Debts Too Big? Quick Cash, Secret Emergency Loans. Free Consolidation Plan. Interstate, 28 E. Jackson, Suite 1204-X3, Chicago 60604.

**TELL** Fortunes accurately—Immediately! ESP Aids, Box 21-PM, Olympia, Washington, 98507.

**WOW!** Free Illustrated Occult Catalogue! Stanray, Dept-A2, GPO Box 3317, NYC 10001.

**HOW** To Have Confidence and Power with Other People. 164 Page Book. Only \$2.00. Edd-Lou Enterprises, 4615 N. Braeswood 104D, Houston, Texas 77035.

**CONQUER** Personal Problems! Free Brochures Self-Improvement Books! James Thomas Associates, 113D Community, Dept. PM-732, Shillington, Pa. 19607.

**"RULE** Others With Thoughts." (Telepathy) Write: Clarion, Box 1769-A7, Chicago 60690.

**DON'T DIE** Without a will! Blank Will form protects your family. Only \$2—Guaranteed! Order today! J & J Associates, Box 82568-3P2C, Atlanta, Georgia 30354.

**AUTOGRAPH** Analysis Service. Certified Agency answers handwriting questions. Thrifty signature analysis. Profilgraph, Box 5032M, Brigham City, Utah 84302.

**PERSPIRATION** Problems? Try Self-Control. Booklet \$2.00. Exchange, Box 22124, Seattle, Washington 98122.

**IDENTIFICATION TAG**—with 24" neck chain. Up to five lines. \$1.00. Attention Sportsman! Free Catalog. Associated, 206 Hillside, Johnson City, Tenn. 37601.

**TATTOO** Removing—Chemical Do-it-Yourself Method—Free Details: Atlanta, 907P Beachpoint, Pickering, Ontario.

**STOP!!** Don't die without a will! Blank will form protects your family. Only \$2—guaranteed!! Order today! Willform, Dept. 1A2, BX 38172, Houston, Texas 77088.

**MAKE YOUR OWN WILL!** 4 Will Forms And Attorney's Instructions Protect Your Family. Only \$2.00—Guaranteed! Order Today!! Masterman, Department 1B14, 1544 Red Cedar, St. Paul, Minnesota 55121.

**SMOKERS!!** I did, now don't, you shouldn't. Need Help? \$2.00. Box 651, Brighton, Ill. 62012.

**FEEL** Better—Live Longer! Vital Facts. Recipes, Meal Planning, Shopping Hints. **NATURAL FOODS** Book, \$1.95 **SHATTUCK'S** Route 9, Sevierville, Tenn. 37862.

**WANT** A better job? Blank replaces lost High School Diploma!! Only \$2.00—guaranteed! Supplyhouse West, 11220 El Merriedel, Dept. 2C1, Sylmar, California 91342.

**PREVENT** Colds, Sinusitis. Proven plan. Write: David Borrell, 161 Oak, Maple Lake, Minnesota 55358.

**DEATH,** Birth, Marriage, Divorce Records. How to Obtain, State-by-State. Send \$1.00. Documents, 514 Rutherford, Redwood City, Calif. 94061.

## WANTED-MISCELLANEOUS

**MERCURY,** Gold, Silver, Platinum; Ores assayed. Wholesale Terminal, Norwood, Mass. 02062.

**WANTED** Old Penny Arcade Equip. Send Information, Price to: Box 4 F, San Gabriel, California 91776.

## WINEMAKING & OTHER RECIPES

**HOMEWINE MAKING SUPPLIES** And **INGREDIENTS CATALOG** With **RECIPES** For Year Round Winemaking. It's A Fascinating Hobby. We Also Have Supplies And Concentrates For Your Wine Kit. Send For Free Catalog. Danenberger, Box 276-M, New Berlin, Illinois 62670.

**WINEMAKERS.** Free illustrated catalog of yeasts, equipment, Semplex, Box 12276R, Minneapolis, Minn. 55412.

**WINEMAKERS . . .** Free Illustrated Supply Catalog of Yeast, Equipment, Recipes. Continental, Box 18223-PM, Indianapolis, Ind. 46218.

**WINEMAKERS** Yeast, Recipes & Catalog 25¢; Kraus, Box 451-L, Nevada, Missouri 64772.

**WINEMAKERS . . .** Personalized Wine Labels, Free Samples. Grancom, Box 2929, Milwaukee, Wisconsin, 53218.

**WINEMAKERS!!** Fermentation locks—3/\$1.00. Free Illustrated Catalog plus \$5.00 Credit Coupon. Werth Wine, Box 1902AV, Cedar Rapids, Iowa 52406.

**WINEMAKER'S** Supply Catalog—Free. Bacchanalia, 273 Riverside Ave., Westport, Conn. 06880.

**WINEMAKERS:** Free informative catalog. recipes. Arbolyn, Box 663, West Columbia, S.C. 29169.

**MAKE** Your own Wines of Distinction. Tested, specific instructions guaranteed. \$3.50. McGuire Sanders, Box 2485, Orcutt, Calif. 93454.

**WINE LOVERS—FREE** Supply Catalog. Our Book of Delicious Wine Recipes using easy simple methods and kitchen equipment, \$2.00. Unconditionally Guaranteed—Vintner, Box 611G, Pomona, Calif. 91769.

**WINEMAKING WHOLESALE AND** Retail Equipment, Supplies, Ingredients. Send for **FREE** color catalog and ordering forms: Little Monk Sales, Box 362P, Winnetka, Ill. 60093.

**HYDROMETER USERS:** Take The Pain Out of Measuring Gravities With The Revolutionary **VINTECH** Hydrometers. **NO POURING!** Precision Plus Temperature Compensation.

tion. \$7.50 Postpaid. Information On Request. Vintech, 28 N. Halsted St., Suite 1200, Chicago, Illinois 60606.

**"NEW DISCOVERY"** New, **QUICK!! EASY!!** way to make **WINE** and **CHAMPAGNE**, using only standard kitchen equipment. **GUARANTEED DELICIOUS!!!** Instruction book \$2.00. **FREE!!!** wine labels, Frazier Enterprises, Box 302-4C2, Leominster, Mass. 01453.

**WINEMAKING Kit—\$4.98** Free Catalog and Recipes. **JIMDANDY**, Box 30230M, Cincinnati, Ohio 45230.

## MISCELLANEOUS

**WIN** At Blackjack? Pocket device selects correct strategy. Really works! Write: Royce, 14603 Dorchester, Dept. GB-23, Dolton, Illinois 60419.

**DON'T DIE** Without a Will! Blank Will Form Protects Your Family. Only \$2—Guaranteed! Order Today!! Belco, 2040 Associated Rd., Dept. A2, Fullerton, Calif. 92631.

**TAMPERPROOF** Protection for your checks—Pocket checkwriter, precision built, businesslike, guaranteed—Only \$5.95—Order today! Aneva's—1C2, 4221 S. 6th A39, Milwaukee 53221.

**BOOKS** On antiques and their prices. Free circular!! P. Warman Publishers, Uniontown, Penna. 15401.

**SUFFERING** From Arthritis? Try Ginseng; Information Free. Write: Ginseng, Asheville 53, North Carolina.

**ORNAMENTAL** Iron designs. Book of 1600 beautiful, practical designs for railings, columns, etc. Free literature. Cunningham, 3881 South 3200 West, Salt Lake City, Utah 84119.

**PRE-PACKAGED** Toys complete with free self-selling display rack. Free Details. Toys, 1916 Fifth, Sacramento, California 95814.

**BIRTH** Certificates, Marriage Certificates, Diplomas! 2 blank forms \$1.00. Sample 10¢. Standard Forms, Box 482-M, Washington, D.C. 20044.

**SLEEPATRON.** New device for inducing sleep. Gardiner Electronics, Dept. C, 4729 North 7th Avenue, Phoenix, Arizona 85013.

**TREMENDOUS** Profits, Selling Books By Mail. Lakeside, Dept. B1, Silver Lake, Minn. 55381.

**PROJECTION TV . . .** Convert Your Portable to **SEVENTY INCH** TV Projector for Under \$10.00. Free Details: Macrocoma, Dept. PM-2, Washington Crossing, Pennsylvania 18977.

**NOW—Remarkable** New Discovery does over 50 Car Cleanings Without Water—Summer or Winter. Guaranteed. \$2.98 **AR-NOR**, 20 Bulwer Place, 1R, Brooklyn, N.Y. 11207.

**OVER 100** Distinctive Gifts Mail Ordered. Illustrated Catalog. **"HORESH"**, 105-24 64th Road, Forest Hills, New York 11375.

**PROTECT** Your Checks!! Pocket Check Writer Prints Businesslike Numbers. Can't Be Altered!! Small, Compact. Guaranteed. \$5.95. Roberts Company, Box 2261, Amarillo, Texas 79105.

**RECEIVE** Phony State Chartered University Degrees immediately. Box 11516, Tucson, Arizona 85706.

**FORTUNE** IN YOUR ATTIC? Official antiques guide. 416 Pages. 1500 Illustrations. Prices of thousands of antiques \$4.98. Gifts For Happiness, 3987 East 64 Street, Cleveland, Ohio 44105.

★★★**RECIPES** From The **DEEP SOUTH** \$ For \$2.00. Recipes, Box 2965, Lafayette, Louisiana 70501.

**47 CERTIFICATES!!!** Driver License, Birth, Marriage, Divorce, High School, College, Medicine, Death, Karate. Rushed Air-mail! Two—\$1.00, five—\$2.00. Deluxe "Goldsealed" versions one—\$1.00, five—\$4.00. Catalogue 10¢. Filiforms, Box 1808-Z, Albany, New York 12201.

(Continued on next page)



**MISCELLANEOUS**

(Continued from preceding page)

**WHAT'S YOUR IQ?** Self-scoring test reveals IQ in minutes!! 99.9% accuracy. Test friends, relatives. Only \$2.00 Three for \$5.00. Jalco, Dept. 1A23, Box 5217, San Mateo, California 94402.

**AUTHENTIC Las Vegas Casino Dice Keychain**, \$1.50. Dicecop, Box 12688, Las Vegas, Nev., 89112.

**LEARN CHESS!!!** "Chess Made Easy" 150 Page Book, 1973 Edition, Pictures—illustrations By "Hanauer" \$2.00 Postpaid. Moneyback Guarantee. Write for **FREE** List. Valuable "How-To" Books, Crown House, 19212 Santa Maria, Suite 1A2, Hayward, California 94546.

**HOW INTELLIGENT ARE YOU?** Amazing self-scoring test reveals I.Q. in 45 minutes! Send \$2 today—guaranteed!! Balery Company, Dept. PM2, 2 West Street, Fairport, N.Y. 14450.

**U.S. \$1000 Bills!!** Obsolete Exact Replica's 5/\$4. National, Box 1391-X, Clearwater, Florida 33517.

**"COIN-AID,"** Fast, Easy Way for Counting & Wrapping Coins, use flat or tubular wrappers, used by bank tellers. \$3.95 Traweek Coin Tray Co., 1732 Forest Hill, Houston, Texas 77023.

**DON'T PAY INCOME TAX. LEGALLY!** No Matter what your income. Rich men's Methods adapted for anyone's use. Free Details. Trauhhaus—43, Box 3004, Duluth, Minnesota, 55803.

**ATTENTION CREATIVE INVENTORS!** Exciting New Ideas In A "Flash" With The "Magic Spark" Idea Computer. Program Your Mind For New Products! 30 Component System In Case \$5.00. **BOB OLSON SYSTEM**, 205 Chisolm Trail Stagecoach Acres, Prescott, Arizona 86301.

**TO 90% Discount on Nearly Everything**—send \$6 for Catalogs or \$3 for Sample Catalogs. Lifetime Free to \$20,000.00 Life Insurances offer available now & to \$60.00 daily Incomes while totally Disabled offers later. **AMERICAN COMPANY**, 150 Broadway, Suite 915, New York, New York 10038.—(Agents also wanted.)

**STOP FLAT TIRES!** Tire Guard Seals Punctures . . . Stops Slow Leaks. Newly Patented Liquid Sealant For Trucks . . . Cars . . . Bikes. Only \$2.95. Guaranteed! Order Today. Palmer, Dept. 101 B, 769 Grand, Canton, Miss. 39046.

**DELICIOUS WINE And CHAMPAGNE!** Homemade, Proven Recipes Using Standard Kitchen Utensils. Only \$2.00—Guaranteed! Order Today!! Masterman, Department 2B14, 1544 Red Cedar, St. Paul, Minnesota 55121.

**NEW, Easy Method Of Keeping Income And Expense Records For Tax Purposes!** Bookkeeping Experience Unnecessary. \$3.25 Brings Complete Income Tax Record Book. Californians Add Sales Tax. Mari Mountgarden, Room 18-F, 320 Elwood Avenue, Oakland, California 94610

**TYPE with 1/2 Inch Reusable Carbon Typewriter Ribbon For Attractive Letters, Sharp Offset Copies, School Work.** \$1.75 P.P. For 18 Yards. Send Stamped Envelope For Free Sample. Box 552, Pomona, Calif. 91769.

**EYEGASSES Wholesale—Free Catalog.** A-Z Optical Company, Box 175, Dept. R26, Bay Station, Brooklyn, N.Y. 11235.

**UNIVERSITY DEGREE. UNIVERSITY OF LOUISIANA**, P.O. Box 50, FRANKLIN, LA. 70538, Immediately, Send For Research On Education And Curricular. \$1.00.

**BURGLAR ALARMS & HOME PROTECTION**

**FREE Catalog on Burglar-fire Alarm Equipment.** Protecto Alarm Sales, Box 357-D, Birch Run, Michigan 48415.

**1973 BURGLAR & FIRE ALARM EQUIPMENT CATALOG. 62 PAGES. JUST \$1.00.** (Refunded With First Order). **K-TRONICS INDUSTRIES, BOX 391, DEPT. PM, FAIRFIELD, CONN. 06430.**

**BURGLAR Alarm Supplies—sacrifice.** Enclose stamp. Sootin, 1700 Southwest-65th Avenue, Miami, Florida 33155.

**"HOW To Install Protective Alarm Devices"—Just Published . . . \$2.50 . . . Reveals Professional Secrets . . . Over 150 Illustrations—FREE Catalog—Alarm Supply, 7294 Glenview, Fort Worth, Texas 76118.**

**FIRE?! PROTECT Your Family!** Small Alarm Plugged Directly Into Outlet Sounds Loud Warning at 135°. Plenty of Time for Action! For Home, Garage, Motel. Only \$9.95—Guaranteed. Order Today!! Green, Box 105, Pinson, Ala. 35126.

**"LISTEN IN" TO POLICE-FIRE RADIO CALLS IN YOUR CAR!**

**WORKS with ANY CAR—Portable or HOME RADIO!** Just PLUGS in—No wiring—3 minute hookup! Switch instantly from regular to **ALL POLICE-FIRE-EMERGENCY-COMMERCIAL-TAXICAB-STATE-CITY-GOV'T** 2 way Radio calls in YOUR AREA. **DUAL—HI-LOW BANDS TUNES 36-49 & 150-175 MHS.** USE Everywhere—anytime—always works. (cash, Ck., M.O.) and pay post. **SEND ONLY \$2.00** man \$9.99 plus COD pstg or send \$11.99 for ppd Del in USA. **COMPLETE**, ready to use with instructions. One Year service Warranty—**10 DAY MONEY BACK TRIAL** (if rtdn). Sold Only—**DIRECT FROM FACTORY** at this Low Price! **WESTERN RADIO BPM-2 KEARNEY, NEBR. 68847**



**Be a VETERINARY ASSISTANT**

... Lab Aide, Zookeeper, Pet Shop/Kennel Owner  
**MEN - WOMEN!** Train at Home in Spare Time . . .  
**Send for Career Kit—ALL FREE!**

Name \_\_\_\_\_ Age \_\_\_\_\_  
Address \_\_\_\_\_  
City \_\_\_\_\_ State \_\_\_\_\_ Zip \_\_\_\_\_  
North American School of Animal Sciences, Dept. 34172  
Careers by Home Study  
4500 Campus Dr., Newport Beach, CA 92663 234



**MOTORCYCLE MECHANICS TRAINING EARNINGS**

**\$7,000-\$15,000 YEARLY**

Home study and residence training available on all types of motorcycles. For information write:

**STUDENT DIVISION**  
**AMERICAN MOTORCYCLE INSTITUTE**  
P.O. Box 2628 Daytona Beach, Fla. 32015  
904/255-0295

**FREE**

**1973 CATALOG 730**  
ALL THE LATEST IN  
**4 CHANNEL STEREO**

**1973 LAFAYETTE CATALOG 730**

**The World's Largest Consumer Electronics Catalog**

**Your Complete Electronics Buying Guide**

- Stereo/Hi-Fi Components
- Musical Instruments and Amplifiers
- CB & Ham Gear
- Tools & Test Equipment
- Public Address Systems
- Photography Equipment
- TV Antennas
- Books, Semiconductors & Parts
- Plus Much More!

**Send Today!** Lafayette Radio Electronics  
P.O. Box 10, Dept. 15023  
Syosset, L.I., N.Y. 11791

15023

NAME \_\_\_\_\_  
ADDRESS \_\_\_\_\_  
CITY \_\_\_\_\_  
STATE \_\_\_\_\_ ZIP \_\_\_\_\_



# THESE 3 BIG DRAFTING KITS\* GIVEN TO YOU!

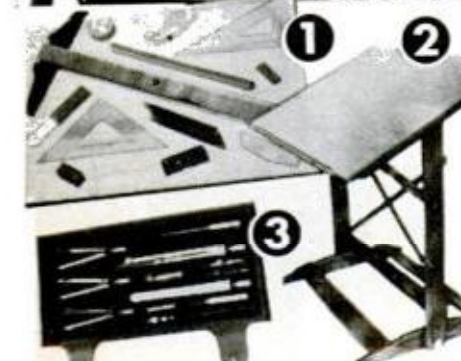

\* Precision Drawing Instrument Set, Professional Drafting Board Outfit and Fingertip Tilting Drafting Table are given to you with your complete North American Course in Drafting.

## U. S. LABOR DEPT. REPORTS SERIOUS SHORTAGE OF DRAFTSMEN

(The following quotes from U. S. Labor Dept. point out nationwide shortage for Draftsmen):

"The dearth of qualified applicants has resulted in increasing calls for trainees, as employers in many areas relaxed hiring specifications. Experience requirements have been virtually eliminated, along with age barriers."

"Steadily growing employer requirements...were accompanied by marked reductions in the supply of draftsmen available."

## TOP AMERICAN EMPLOYERS WELCOME NASD GRADUATES

"We would be interested in interviewing your grads as potential employees." **REMINGTON**

"At the present time we have several openings available for qualified Draftsmen. I look forward to considering graduates of your institution." **WESTINGHOUSE**

"We have immediate openings for designers and Draftsmen and have a definite interest in interviewing candidates immediately." **AMERICAN MACHINE & FOUNDRY**

# ...when you train at home with us for a HIGH PAY JOB IN DRAFTING!

## Coast-to-Coast Shortage of Trained Draftsmen Opens Thousands Big Salary Jobs for Beginners!

Now you can take your pick of thousands of big salary jobs open to Draftsmen (see "help wanted" sections of metropolitan newspapers). Huge nationwide demand... U.S. Dept. of Labor reports "42% more Draftsmen needed in next 10 years—not enough applicants to fill drafting jobs available now!" Our easy "Quick-Learn" Method has helped hundreds toward good income, security and prestige as Draftsmen. Why not you?

## You Need No Drawing Skill—No Technical Ability

Our staff of Professional Draftsmen guide you step-by-step. With our spare time home-study plan you work on actual projects. Makes learning fun—easy to remember, too. Many graduates have succeeded with only grade school training. Others report good earnings drafting part time while still learning. Rush postpaid card today for **FREE "DRAFTING CAREER KIT," Sample Lesson, Drafting Aptitude Test** including intriguing new **5-Way Drafting Instrument** and **20 page Book "Your Future in Drafting"**—jam-packed with revealing facts on your opportunity to win top pay and job security in Drafting. Everything mailed to you **FREE** and **WITHOUT OBLIGATION**.

### (3) High School Draftsmen

NO EXPERIENCE REQUIRED!  
Trainees who transfer to our course will receive a basic stipend and accept employment with average or high salary. An excellent salary of \$10,000 per year is available to graduates who immediately accept employment.

### NO EXPERIENCE REQUIRED!

Trainees who transfer to our course will receive a basic stipend and accept employment with average or high salary. An excellent salary of \$10,000 per year is available to graduates who immediately accept employment.

**The FLUOR Corporation, Ltd.**  
 INTERNATIONAL BUSINESS CONTRACTORS  
 1300 S. Alhambra Blvd.  
 Los Angeles, Calif. 90025

**Design Draftsmen**  
Requires one year in field of mechanical design.

**DRAFTSMAN Architectural**  
**WESTERN GEAR**

## Take Your Pick of 2 EXCITING FIELDS

### 1 Architectural Drafting

Today's population explosion guarantees boom in building of homes, churches, schools, factories, office buildings & warehouses is just starting. Thousands Architectural Draftsmen needed NOW because drawings must be made of every part of every building before ground can be broken.

### 2 Mechanical Drafting

Skyrocketing U.S. mass production requires millions of drawings & thousands of Mechanical Draftsmen all along the way. Drawings must be made of every PART of every product used in the U.S. (as well as of the machines that make these parts) before production can be started.

### HERE'S WHAT STUDENTS SAY

**Gets Three Raises!**  
 "Since completing my course I have been transferred from the foundry to the Engineering Department and had three raises."  
**R. C., Ohio**

**Job Awaits Serviceman!**  
 "Your Drafting Course has given me a good start. I already have a job waiting for me when I leave the service."  
**L. I., FPO, New York**

**Big Promotion!**  
 "18 months ago I was a laborer. Now I am foreman of 22 people in the Drafting Room. Thanks for making this possible."  
**S. D., Mass.**

"I've had 2 boosts in salary and a \$300 bonus in 11 months. Wish I could shake hands with your staff in person."  
**A. C., Calif.**

Authorized to issue diplomas by California Superintendent of Public Instruction.

Accredited Member, National Home Study Council.

Veterans, Servicemen you may be eligible for Gov't education benefits in association with Cleveland Engineering Institute.

**ALL 4 FREE! Rush Postpaid Card Now**

**Your FUTURE in DRAFTING**

- 5-Way Drafting Instrument—yours to keep as a FREE GIFT without obligation.
- 20-Pg. Drafting Career Fact Book — packed with details about career opportunities.
- Self-Scoring Drafting Aptitude Test — tells if you are suited for high-pay Drafting Career.
- Sample Lesson — a "sneak preview" of things to come.

**APITUDE TEST SAMPLE LESSON**

**NORTH AMERICAN SCHOOL OF DRAFTING**  
 4500 Campus Dr., Dept. 34172 University Plaza, Newport Beach, CA 92663

**IF CARD HAS BEEN DETACHED, MAIL THIS COUPON**

**NORTH AMERICAN SCHOOL OF DRAFTING, Dept. 34172,**  
 4500 Campus Dr., University Plaza, Newport Beach, Calif. 92663

Rush "DRAFTING CAREER KIT" including Book, Sample/Lesson, Aptitude Test & Drafting Instrument — **ALL FREE!**

Name \_\_\_\_\_ Age \_\_\_\_\_

Address \_\_\_\_\_

City \_\_\_\_\_ State \_\_\_\_\_ Zip \_\_\_\_\_



Zack and Karen Taylor, whose hobby is home movies, help put Montego's ride to a rugged test. First a movie camera is mounted on the axle.



Then Karen drives the 1973 Montego through scenic California horse breeding country, while Zack shoots from inside the car.



At 15 to 20 mph, it's easy to see the wheel camera is getting a bumpy ride. The pictures it takes show how rough that road really is.



But Zack, shooting at the same time, is getting sharp, steady pictures that show how smoothly this personal size Mercury rides.



Demonstration supervised by Nationwide Consumer Testing Inst., 1973 Montegos now available with optional engines and power trains.

# We filmed wild horses from a moving 1973 Mercury Montego to demonstrate our personal size car has the ride of a big car.



The 1973 Montego is about a foot trimmer than most big cars. Yet this personal size Mercury has a smooth, steady ride that rivals the best of them.

That's because Montego is built to Lincoln-Mercury's high standards. On an extra-wide track. And the same type high stability suspension system used in our most expensive luxury cars.

Front disc brakes and flight bench seat are standard on the 1973 Montego MX Brougham. The vinyl roof, white sidewalls, luxury wheelcovers and bumper rub strip (shown) are optional. Try a test ride at your Lincoln-Mercury dealer. Bring your own camera.

**Built better to ride better.**

## MERCURY MONTEGO

LINCOLN-MERCURY DIVISION





## Some of our fishing motors are hard to catch.

This 50-mile-an-hour Evinrude 65, for example.

In bass country, where people fish for fame and money as well as for fun, it's one of the real movers behind the bass boat revolution.

It's tournament class all the way. As a fishing motor. A ski motor. And a world marathon record racing motor. It does things better by doing them more efficiently.

Part of the secret is a loop-charged powerhead that eliminates the deflector hump on the piston and in the combustion chamber.



For free catalog — write Evinrude Motors  
4234 N. 27th St., Milwaukee, Wis. 53216

Part is a new kind of piston ring that seals with combustion pressure instead of spring tension.

Part is super-sophisticated exhaust tuning that turns exhaust energy into usable power.

It all adds up to more performance on less fuel.

Now you can be a hot dog on a hot dog budget.

**EVINRUDE**   
DIVISION OF OUTBOARD MARINE CORP  
*first in outboards*