

Get a new home without moving Page 63

Electric, Smokeless
**INDOOR BARBECUE
CART** Page 134

Popular Mechanics

FEB. 1972
50 CENTS

New water-cooled (!) bike:
SUZUKI'S 750

SAVE \$\$:

The simple way to do ignition
timing yourself Page 116

Do-it-yourself cassette
recorder repairs Page 110

Appliances you can fix:
electric knives, toasters,
washing machines

New model plane
flies on CO₂

Page 144

New
outboards:
more power,
less pollution

Page 98

Easy-to-build
COLONIAL DRY SINK
makes you look
like a real craftsman

Page 138

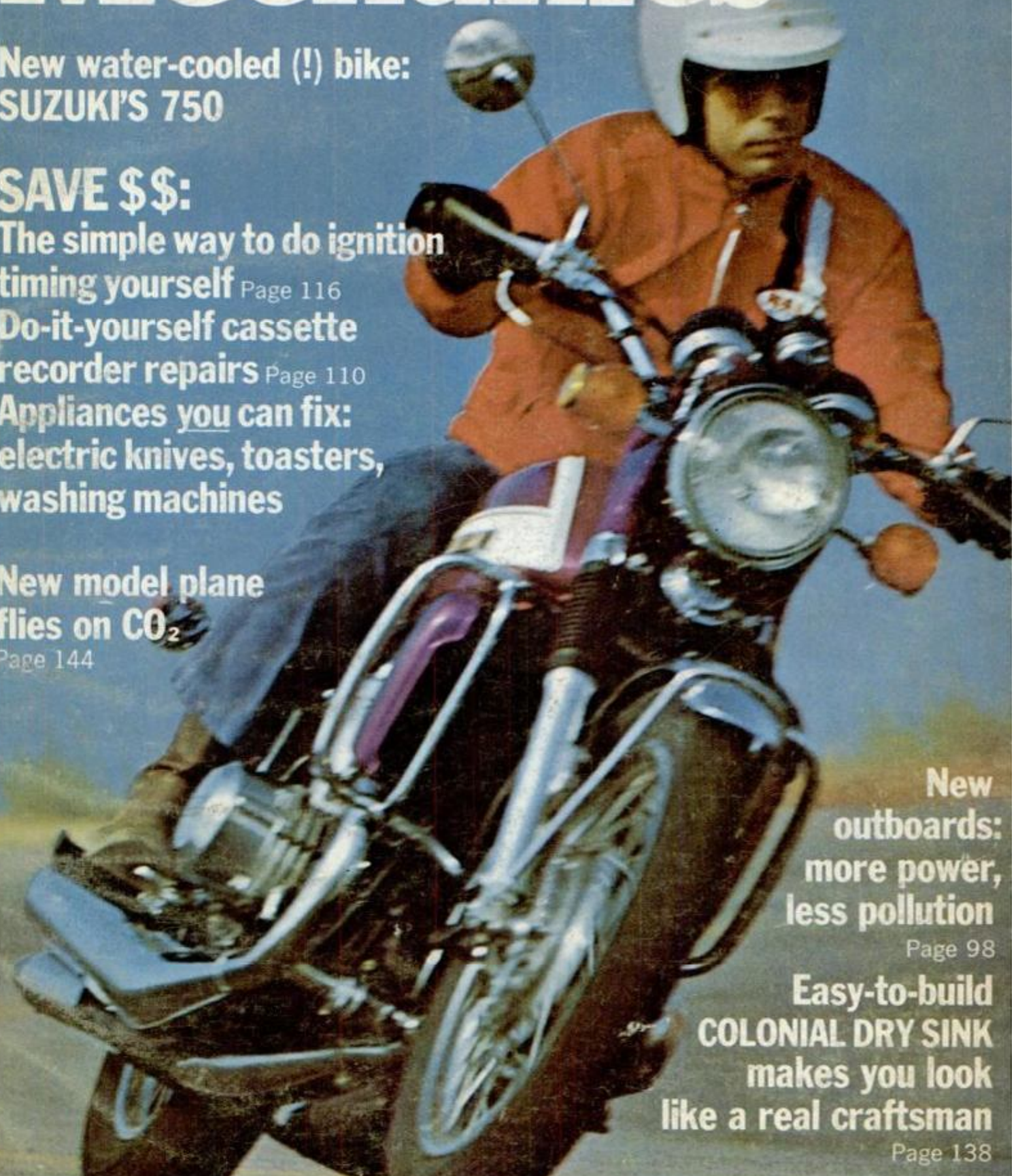

Come to where the flavor is. Marlboro Country.



Marlboro Red
or Longhorn 100's—
you get a lot to like.



Warning: The Surgeon General Has
Determined That Cigarette Smoking
Is Dangerous to Your Health

Kings: 20 mg. tar, 1.3 mg. nicotine—
100's: 22 mg. tar, 1.5 mg. nicotine av. per cigarette, FTC Report Aug. '71

Материал, защищенный авторским правом

The nice thing about our small economy truck is all the extras you can suddenly afford.



Our small economy half-ton offers you 3 big advantages. A small price. A small gas bill. And small truck maneuverability.

But just because we're smaller and less expensive doesn't mean we're not tough. We hold a full 1,000-pound load just like bigger half-tons do. What's more, our small truck has a big-on-power single OHC engine that can haul a full load at maximum highway speeds. And a special heavy-duty suspension system for smoother riding. Empty or all filled up.

Our low-priced Toyota Half-Ton also comes

with an easy-to-handle 4-speed synchromesh transmission. 6 ply-rated tires. Flo-thru ventilation. A full 6-foot bed. Padded dash. A towhook that bolts to the front of the truck. Tie hooks all round the bed. And a spare tire under the truck that you lower with a hand crank.

In short, when you buy our small Toyota Half-Ton, you get a lot of truck. With enough money left over for some other nice things as well. Things you can't always afford when you buy big.

Toyota Half-Ton.

Camper and special outside mirrors not standard equipment.

For your nearest Toyota dealer, call 800-243-6000 toll-free. (In Connecticut, 1-800-882-6500.)



How do you like your new car, Fred?

Fred Schwartz worked nights in a machine shop to buy a new Pontiac Firebird Formula 400, with all the high-performance options.

As soon as he got it, he started "improving" it. With

things like "mag wheels," "zoom" gears, traction bars and a wild cam.

Two weeks after he got the car he went "halves" with a friend on a whole case of Champion Spark Plugs.

"All the big pros race with Champions," said Fred. And zoomed off into the sunset.



Toledo, Ohio 43601

20 million people have switched to Champion Spark Plugs.



Allstate
life insurance
says if you die,
your girl keeps
rolling along.

Allstate Life Insurance Company

Allstate. The young man's life insurance.

We know what a young man wants.
No high prices. No high pressure. No
appointment needed. Just walk in. Soon?

If you're 28 and
you pay this much
each month:

\$5
\$10
\$15
\$20

Here's how much you get.
20-year decreasing term
insurance.

\$13,000
\$32,000
\$64,000
\$88,000

This One



2BDT-FPR-DQ10

(Even more if you're younger.)



You're in good hands with Allstate

Материал, защищенный авторским правом

INTERNATIONAL EDITIONS

AUSTRALIA DENMARK
BRAZIL MEXICO
CARIBBEAN SWEDEN
SOUTHERN HEMISPHERE

HOW TO . . .

Tune-up your engine . . . 116



Repair your cassette recorder . . . 110



Build a cabinet workshop . . . 125



Get a well-trained dog . . . 84



AUTOMOBILES, DRIVING

- 16 New for your car
- 40 Drivin' with Dan
- 48 After the convertible—what?
- 72 Owners Report: Fiat 124
- 116 Saturday Mechanic:
 - Ignition timing simplified
- 120 New tools for tune-ups and troubleshooting
- 128 Car-bumper bike rack
- 130 Big banger from Suzuki is water-cooled!
- 156 Make a 'G-meter' you can add to your dashboard

HOME AND YARD

- 63 You don't have to move to get a new home
- 122 Exciting new products
- 134 Cook where the fun is
- 142 Better Ways to Do It

BOATING, OUTDOORS

- 14 Carpet your outboard motor
- 90 How to choose a marine compass
- 98 The new outboard motors: more power—less pollution
- 101 Outdoor hints
- 104 Dollar duck decoy

SCIENCE, INVENTIONS

- 82 Plastic teeth that take root
- 84 How to get a well-trained dog
- 88 Just Patented: PM's pick of the new inventions
- 95 Firefighters' sky hook

SPACE, AVIATION, MILITARY

- 68 A fast fleet that rides on air
- 76 Up, up and away! Very slowly

SHOP AND CRAFTS

- 104 Dollar duck decoy
- 124 A modelmaker's workshop in a cabinet
- 127 Hints from readers
- 129 Hints from readers
- 138 A little colonial charmer you can build for \$45
- 144 This radio-controlled model flies on CO₂
- 149 Hints from readers
- 150 Make this shaper for \$60
- 156 Make a 'G-meter' you can add to your dashboard
- 160 How to muzzle lathe dogs
- 162 Hints from readers
- 166 This radial-saw bench features built-in stops
- 168 Hints from readers
- 170 New tools you should know about

ELECTRONICS, RADIO, TV

- 54 Electronic hints
- 110 Cassette recorder repairs
- 114 New in electronics

PHOTOGRAPHY

- 12 New in photography
- 108 Photo hints: Roll-around camera dolly

ENVIRONMENT

- 22 Pollution Fighters Newsletter

EVERY MONTH

- 6 Letters
- 22 Automobile Clinic
- 34 Science Worldwide
- 36 Detroit Listening Post
- 52 All Outdoors
- 58B Appliance Clinic
- 60 Homeowners Clinic

ON THE COVER: Photo by David Gooley

New water-cooled (!) bike—Suzuki's 750-cc, three-cylinder two-stroker

AS A SERVICE TO READERS, Popular Mechanics publishes newsworthy products, techniques and scientific and technological developments. Because of possible variance in the quality and condition of materials and workmanship, Popular Mechanics cannot assume responsibility for proper application of techniques or proper and safe functioning of manufactured products or reader-built projects that result from plans published in this magazine.

JIM LISTON

Editor

SHELDON M. GALLAGER **JOHN A. LINKLETTER**

Executive Editor Managing Editor

WAYNE C. LECKEY

ALVIN KIETZ

Home and Shop Editor

Art Director

Published by The Hearst Corporation

RICHARD E. BERLIN, PRESIDENT

RICHARD E. DEEMS

President, Magazines Division

JOSEPH F. KERN

Publisher

BILL HARTFORD _____ Automotive
JOHN F. PEARSON _____ Science and Aerospace
WM. T. McKEOWN _____ Boating and Outdoors
SHELDON GALLAGER _____ Electronics and Photography
HARRY WICKS _____ Home Workshop
MICHAEL LAMM _____ West Coast
ROBERT LUND _____ Detroit Automotive
GARRY WINTER _____ Copy and Production
RICHARD H. FUNK _____ Associate Copy and Production
ALFREDO VEGA _____ Assistant Copy and Production
DON EVANS _____ Technical Art Director
FRED A. LEERS _____ Assistant Art Director
JOSEPH P. BEATON _____ Assistant Art Director
DAVID KOMITAU _____ Assistant Art Director
CLIFFORD B. HICKS _____ Special Projects
SOPHIE GRONOWICZ _____ Director, Bureau of Information
EVERETT JOHNSON _____ Cabinetmaker

ADDRESS ALL EDITORIAL COMMUNICATIONS TO: 224 West 57th St., New York, N.Y. 10019. For additional sources of information on the articles and products in this issue, write to Bureau of Information, Popular Mechanics, for free "Where-to-Find-It" list.

DANIEL J. COLEMAN
Director of Advertising

ADVERTISING OFFICES: New York: 224 West 57th St., 765-6850; Chicago: 520 N. Michigan Ave., 527-2400; Detroit: General Motors Bldg., TRinity 5-8711; Cleveland: 20310 Chagrin Blvd., Shaker Heights, 283-7788; Los Angeles: 601 North Vermont Ave., 666-6263.

JOHN A. REGINA _____ Advertising Production Manager

SUBSCRIPTION SERVICE: Mail all subscription orders, changes of address, correspondence concerning subscriptions, and Postmaster notices of undeliverable copies to Popular Mechanics, Box 6146, New York, N.Y. 10019. Please enclose your latest address label for quickest service when writing about your subscription.

POPULAR MECHANICS IS PUBLISHED MONTHLY by The Hearst Corporation, 57th St. at 8th Ave., New York, N.Y. 10019, U.S.A. Richard E. Berlin, President; George Hearst, V-Pres.; Richard E. Deems, President of Magazines; John R. Miller, Executive V-Pres. of Magazines; Raymond J. Petersen, Senior V-Pres. of Magazines; William S. Campbell, V-Pres. of Magazines; Albert A. Rachol, V-Pres. and Director of Circulation; Joseph F. Kern, V-Pres. for Popular Mechanics; Frank Massi, Executive V-Pres. and Treasurer; Harvey L. Lipton, Secy. Single copy in the United States and Canada, 50 cents. Subscription prices: United States and Possessions \$5.00 for one year; \$9.00 for two years; \$12.00 for three years. Canada, add \$0.75 for each year. Pan American Postal Union countries, add \$1.00 for each year. All other countries, add \$2.00 for each year. When changing address, give old address as well as the new, with postal-zone number, if any, and allow six weeks for change to become effective. Second-class postage paid at New York, N.Y., and at additional mailing offices. Authorized as second-class mail by the Post Office Department, Ottawa, and for payment of postage in cash. Registered as second-class matter at the Post Office at Mexico D.F., Mexico, June 20, 1950 © 1972 by The Hearst Corporation. All rights reserved. Printed in U.S.A.

Build yourself a better drink.

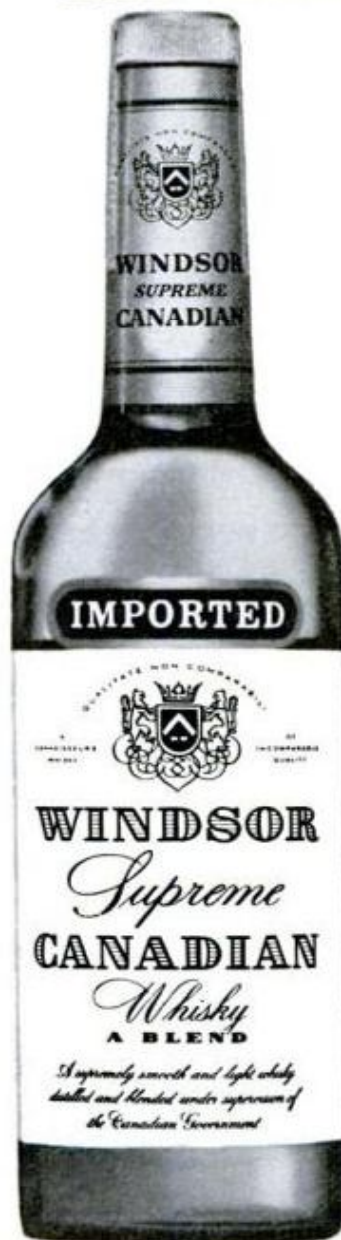

CANADIAN WHISKY—A BLEND • 80 PROOF • IMPORTED BY NATIONAL DISTILLERS PRODS. CO., N. Y.

WINDSOR CANADIAN

Canada's smoothest whisky

FREE! RADIO SHACK Accessories & Parts Catalog

NEW 1972 Edition!

THE buying guide for kit builders, CB'ers, installers, experimenters, fix-it men, hobbyists, electricians — anyone in electronics in any way!



Electronics A to Z—Antennas, Batteries, Capacitors, Diodes, Educational Kits, Fiber Optics, Grille Cloth, Hi-Fi Speakers, IC's, Jacks, Knobs, L-Pads, Mikes, Needles, Oscillators, P-Boxes, Quadracs, Resistors, Semiconductors, Telephones, Ultrasonic Alarms, VHF Antennas, Wire, Xenon Strobe, "Y" Adapters, Zener Diodes plus our Science Fair and Knight-Kit electronic kits!

	Dept. PM-11 2725 W 7th St. Fort Worth, Texas 76107
	Send me your FREE 1972 Catalog #215 Please PRINT Clearly Name _____ Apt. # _____ Street or Rte. & Box _____ City _____ State _____ Zip _____

MAXIMAT 7 GEARED HEAD LATHE & MILL

Turn, face, bore, thread, drill, mill, grind—to accuracies within .0002" on famous Maximat combination metal-working lathe/mill/drill machine shop! Features geared lathe & mill heads, 2 built-in 115V motors. Swings 7", 18" between centers. (10" x 26" quick-change model available.) Max. vertical cap. 10". Drill to center 12" circle.
NOW YOU CAN MACHINE ALL PARTS YOURSELF!



Maximat 7" x 18"
 Maximat 10" x 26"

AMERICAN EDELSTAAL, INC. TENAFLY, N.J. 07670
 DEPT. BB-2

Name _____
 Address _____
 City _____ State _____ Zip _____

LETTERS TO THE EDITOR

Keep the power at home

How to have power when there is none (page 156, Dec. PM) is very timely and informative, but there's a very misleading statement in the first paragraph, page 158, regarding a transfer switch preventing power from escaping back into the utility line and "raising some poor workman's hair." Apparently the author is not fully aware of the extreme danger to an unsuspecting lineman working on "dead" power lines. The 115/230-volt output of the home generator is stepped up to 4160, 7200 or even higher voltages as the current passes through the utility's distribution transformer.

Alternator users should be very certain that any connection to the power company is open before feeding standby power into house circuits.

SOUTH WHITLEY, IND. MEREDITH SLATER
 SUPT., MUNICIPAL UTILITIES

We did say that a transfer switch is a must (with "must" in italics)—but we'll repeat your lengthier warning in the interest of safety.

Fantastic race cars

Your article about radio-controlled racing cars is great (*Now you can be a race driver—at any age*, page 69, Dec. PM). Those little cars are truly fantastic!

SHREVEPORT, LA. JOE CALDWELL

Twice 300

In the July *Letters* column, John G. Lattire boasts 300 copies of *PM*. As a boy, I bought my first copy in September 1913 for 15 cents. I now have twice as many as 300, and most of them bound in my library.

OKLAHOMA STATE UNIV.
 STILLWATER HASKELL PRUETT, PhD
 PROFESSOR

Nonessential machines, spoiled riders

I have enjoyed your magazine for a number of years, but recently, especially in the October and November issues, you have plugged and promoted minibikes and snowmobiles. I am not in favor of either of these vehicles as family sport or recreation. They are noisy! They despoil the wilderness! They frighten wild ani-

(Please turn to page 8)

Have you seen this coupon before?

© 1972 LaSalle Extension University, A Correspondence Institution

It has helped to start many men and women on the road to higher pay.

Just looking at it won't get you anything... but putting it in the mail may change your whole future!

The LaSalle coupon is one of the most often-seen coupons in America. To many who have mailed it, it has proved a first step to opportunity and good fortune.

Cut Along Dotted Line - Seal (Tape, Paste or Staple) and Mail Today.

MAIL THIS HANDY POSTAGE-PAID COUPON-ENVELOPE

Cut coupon along dotted lines, fill in your name and address . . . fold, seal (tape, paste or staple) and mail. No stamp or envelope is necessary.

Please send me, without obligation, FREE booklet on the field I have checked:

ACCOUNTING

- Complete Accounting
- Income Tax
- CPA Training
- Modern Bookkeeping

LAW COURSES

- Bachelor of Laws Degree
- Business Law
- Insurance Law
- Claim Adjusting Law
- Law for Police Officers

No state accepts any law home study course, including LaSalle's as sufficient education to qualify for admission to practice law.

DRAFTING

- Complete Drafting

TRAFFIC AND TRANSPORTATION

- Complete Traffic Management

REAL ESTATE

- Complete Real Estate
- Real Estate Brokerage
- Real Estate Management

Print Name

..... Age.....

Address..... Apt. No.....

City & State..... Zip.....

COMPUTER PROGRAMMING

- Basic Training

ART TRAINING

- Commercial Art
- Oil, Water Color Painting
- Complete Training

RESTAURANT MANAGEMENT

- Complete Executive Training

INTERIOR DECORATING

- Complete Training

STENOTYPE

- Machine Shorthand

BUSINESS MANAGEMENT

- Introduction to Business Management

DENTAL OFFICE ASSISTANT

- Complete Training

HIGH SCHOOL

- High School Diploma

HOTEL/MOTEL MANAGEMENT

- Hotel Executive Training
- Motel Management

DIESEL MECHANICS

- Basic Training

Dept. 74-069

46D FOLD HERE ↓ (DO NOT CUT) SEAL AND MAIL TODAY - NO STAMP NEEDED.

FIRST CLASS
PERMIT NO. 27
CHICAGO, ILL.

BUSINESS REPLY MAIL

No postage stamp required if mailed in the United States

Postage will be paid by

LA SALLE EXTENSION UNIVERSITY

A Correspondence Institution

417 S. DEARBORN STREET
CHICAGO, ILLINOIS 60605



If your goals are bigger pay and more frequent promotion, you owe it to yourself to find out without delay, what LaSalle home study can do for you.

LaSalle gives you modern, comprehensive instruction in many well-paid, fast-growing fields where there is a continuing demand for trained personnel. You learn at home; lessons come to you by mail. You are a class of one.

For more than sixty years, LaSalle has been a leader in home study. It has a large staff of experi-

enced instructors. The cost of training is low. A LaSalle diploma is a respected credential.

You should act now. LaSalle training may make a big difference in your future. One student reports: "I received a \$2,000 yearly increase since enrollment with LaSalle. My regret is that I didn't enroll before." Many letters like this come to LaSalle. Get full information now on the field that interests you. Mail postpaid coupon above to LaSalle, 417 S. Dearborn St., Chicago, Illinois 60605.

SOLDER SEAL
LIQUID WRENCH



Liquid Wrench is the super-penetrating rust-solvent that loosens rusted nuts, bolts, screws and parts—in seconds! Safe on all metals, use it on a bulldozer or even your watch!



Lan-Lin gets down deep—removes paint, grease, grime, ink!



Trans-Medic stops transmission troubles! You'll feel the difference!

RADIATOR SPECIALTY CO., CHARLOTTE, N. C. 28201

Look for **GUNK**



when you want to clean anything!

... Like engines, power mowers, concrete driveways, parts.

There's a **GUNK** product for almost any degreasing job in factory, shop or home.



B.O.P. Small Parts Cleaner with dip basket... soaks parts clean.



GP cleans oil, grease, dirt from garage floors, driveways, power mowers, machinery.

Engine Brite Engine Cleaner. Spray it on... hose it off! "Dirt and grease wash away."

GUNK LABORATORIES, 5829 W. 66, CHICAGO, ILL. 60638
Gunk Chicago Co. River Forest, Ill. Radiator Specialty Co. Charlotte, N. C.

LETTERS

(Continued from page 6)

mals! They are unnecessary! And more often than not, the people who herd them around are rude and thoughtless and care little for others or their surroundings.

As cheap transportation, cycles can be forgiven. As emergency vehicles, snowmobiles can be forgiven. But for sport—no. They are dangerous to the many young, spoiled riders who have duped their parents into buying these nonessential machines (except, of course, to the manufacturer who is reaping his harvest).

SALINAS, CALIF.

GEORGE RAGSDALE

Shingle builder

I recently completed the *Saucy Shingle* (page 144, March '65 PM), which was featured in project book H102. It was built with few changes—the most noticeable being the addition of a hinged-cover



storage compartment forward of the steering wheel. Cost was just under \$35, not including gear. My Shingle looks great painted bright yellow, and with a 20-hp Mercury, it really flies!

DELAND, FLA.

NOBLE BIELBY

Some are ridiculous

I liked '72 *Cars: Why You Should Buy Now* (page 114, Oct. PM). I think this is how Americans think about safety. But I feel some of the ideas are ridiculous and some are good.

ELROY, ARIZ.

HARRY BUCHANAN

Wanted: noise penetrator

I'd like to see incorporated in every motor vehicle a sensing device to warn its driver of a police siren, fire siren, or train whistle.

With manufacturers making cars quite soundproof and with stereo players and

(Please turn to page 10)

**I can buy
passenger car tires
for less than truck
tires and get the same
mileage out of them.**

**I can buy truck
tires for less than
car tires and get
more mileage
out of them.**

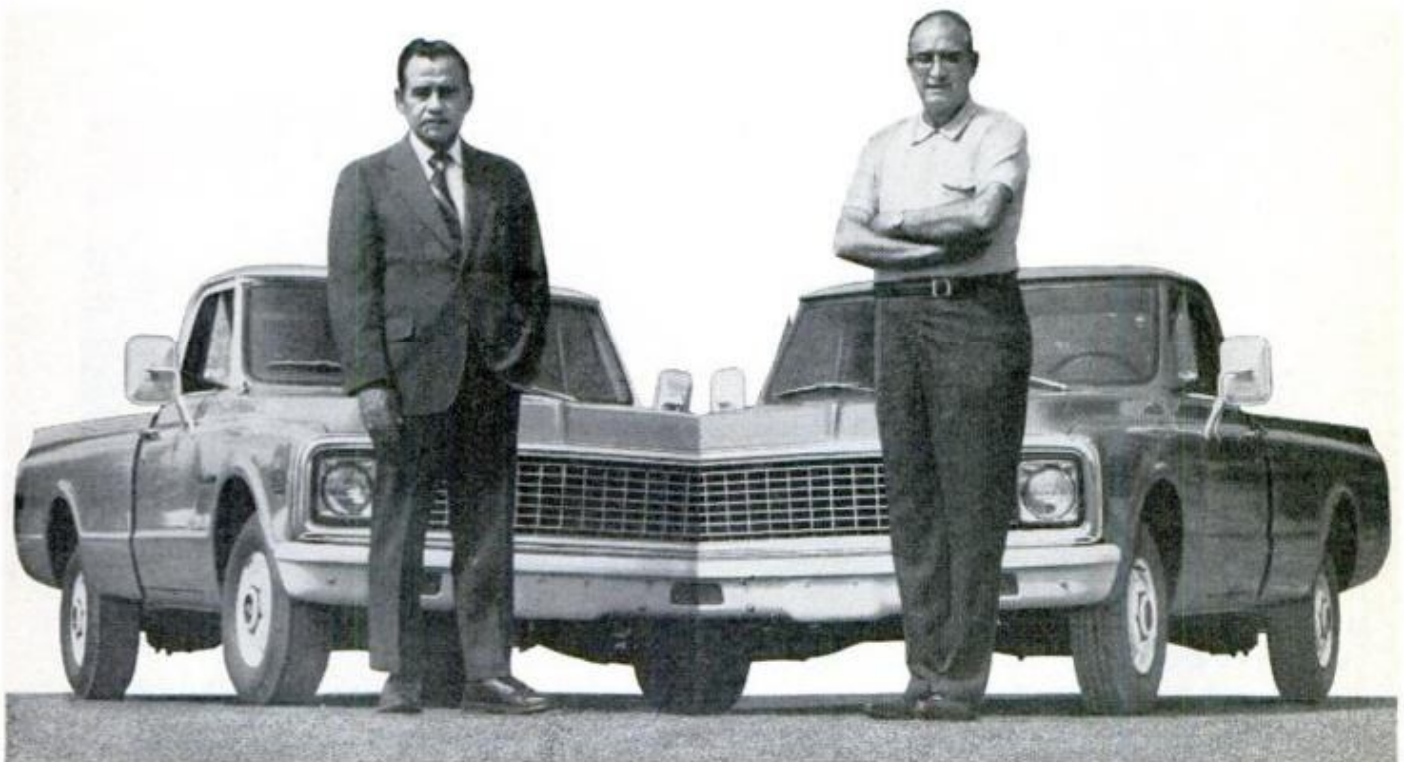

Do you know which man is right?

To a lot of people, "truck tire" sounds expensive, and because passenger tires will fit their pickups or vans, they reason they can save money with them.

Did you know you can buy a real truck tire—the Firestone Transport—with a 6-ply rating, for about \$8 to \$10 less than a comparable size original equipment passenger car tire? And get longer mileage in truck service with the truck tire?

Why? Because the Transport is designed for truck use, with Shock-Fortified nylon cord body plies and heavier construction to handle the road hazards with a tread made from a

specially compounded Sup-R-Tuf® long mileage rubber, and with reinforced beads and sidewalls.

See your Firestone Dealer or Store. Ask about the truck tire that costs less and lasts longer than a comparable passenger car tire, in truck service, the Firestone Transport. And yes, it also comes in whitewalls. Transport ®



Firestone

Transport®

LETTERS

(Continued from page 8)

radios blasting away, it is next to impossible for outside noise to penetrate the vehicle and its dense operator. I've had many a harrowing experience with such a deaf and blind driver—as has many an emergency vehicle, I'm sure, trying to expedite their services through traffic.

COUNTY SHERIFF DEPT. W. W. HENRICK
LAGRANGE, IND. CHIEF DEPUTY

Very accurate measurements

Thank you very much for publishing *A Bumper-Pool Table You Can Build* (page 146, Jan. '70 PM). I am 13 years



old and I am very pleased with the measurements that were very accurate. The table brings me a great deal of enjoyment.
NEW YORK IRA FOX

Vicious and vindictive

The Pollution Fighters' Newsletter (page 42, Dec. PM) is vicious, vindictive and anti-American. It should not be allowed to pollute the pages of your magazine.

The author threatens the use of an old law which dangles monetary reward in front of persons with a weakness for easy money so as to catch and punish their "greedy" neighbors. Encouraging neighbors to spy on one another, children to spy on their parents, etc., is a method of terrorism that has been developed and used extensively in every communist, fascist and other totalitarian country. Until recently it had not been the practice in the United States.

In recent years a number of instances have been reported of persons having been caught deliberately pouring jars of concentrated poison into lakes and streams. Why would a man do this? The obvious reason is that he wants to cause the shores to be lined with dead fish and birds so

they can literally raise a stink about pollution. Undoubtedly there have been cases of this where the miscreant was not caught but it was generally assumed that nearby residents or industries polluted the water. Framing of innocent persons is a distinct possibility here.

The most effective and cheapest way to do something about pollution is for citizens to work voluntarily on the problems on a local basis.

BURLINGTON, W. VA. LEO D. PATTERSON

Home for a pet

Here's a picture of the doghouse I built recently from the plans in *Insulated Home for Your Dog* (page 172, April '58 PM). I ordered the plans (No. X232) from



your *Plans, Publications, Projects* catalog.
LEESBURG, VA. BOB F. HENSLEY

Anyone else who has a dog without a home can buy the plans for 45 cents from Popular Mechanics, Dept. JL, 224 West 57th St., New York, N.Y. 10019.

Needs lightweight chain

Six months ago I purchased a 10-speed bicycle. So far, I've had two robbery attempts on it. I bought a three-foot, half-inch chain with heavy-duty lock. Together they weigh seven pounds. Since my bicycle is lightweight, this chain destroys the purpose. Do you know of any case-hardened and cutter-resistant lightweight chain?

MONTCLAIR, N.J. SCOTT POPPELE

Offhand, no, though we do know about other heavy ones. Maybe our readers can help. (And we'll file this question away for best-selling author Eugene Sloane who'll be solving bicycle problems every month (beginning next month) in PM's new Bike Shop column.) ★★

Read what two of America's foremost car experts say about

NEW NRI HOME TRAINING IN AUTOMOTIVE MECHANICS

After more than two years in preparation, NRI presents what are considered to be the most up-to-date, comprehensive and easy-to-learn home training programs in Automotive Mechanics. Not content with simply paralleling what others offer, NRI commissioned one of America's best-known automotive writers* to prepare the training material . . . then asked two of the country's foremost car experts to act as consultants and "critics" of the courses *before* we presented them to the public.

Here is what "Bill" France has to say:

"I'm very pleased to find that someone has finally developed a home training program for mechanics that's right up with the times. The new NRI Master Automotive Technician course for mechanics is amazingly complete and seems to cover all major aspects of today's complex cars. Certainly, a man with an NRI diploma in automotive mechanics is well on his way to a solid career in a field where his knowledge is in demand. The texts are great, and the equipment you get is top-quality — and essential. This program promises to make real mechanics out of men seeking a solid profession."

Tom McCahill is equally enthusiastic:

"This baldheaded bearcat has been worrying for years about the condition of our automotive repair industry, so it's a great relief to see a highly qualified school like NRI come up with home training that should do much to help ambitious guys become top mechanics. It either takes a lot of years of dirty hands or a comprehensive training program to come to grips with car repair and know what you're doing. NRI has done it. I particularly like the way the use of essential equipment is worked into 'bite-sized' lesson texts. After over a quarter of a century in this business, I'm beginning to have some hope about finding good mechanics again — I'll just look for an NRI diploma on the repair shop wall."

*William H. Crouse, author of NRI mechanics training, has written nearly two dozen outstanding books on automotive subjects, and has been Editor of Technical Education Books for McGraw-Hill Book Co., including *The McGraw-Hill Automotive Mechanics Series*.



NRI'S TWO AUTOMOTIVE CONSULTANTS: Tom McCahill, America's foremost automotive editor/critic, with William H. G. France, President of NASCAR and the International Speedway Corp., at Mr. France's famous Speedway.

Two Training Programs Offered

New NRI training gives you a choice of a complete, Master Automotive Technician course for the man interested in seeking a full or part-time career in this well-paying field . . . or a shorter Automotive Tune-Up and Electrical Systems training program for the man interested in doing much of his own repairs or simply learning more about cars. Both courses include — at no extra cost — training and diagnostic equipment essential for both education and car care.

In the Master course, you receive ten pieces of auto service equipment, including a dwell-tachometer, timing light, complete set of tools, a volt-amp tester, an ignition-analyzer and assorted gauges. Tune-Up home training includes eight important service items.

If you're not moving ahead in your present job, or want to turn your interest in cars into a solid, well-paying career, take a tip from Tom McCahill and Bill France and look into the wide-open automotive repair market.

Mail coupon for full details. NRI AUTOMOTIVE DIVISION, Washington, D.C. 20016.

No salesman will call.

In Canada write: NRI Canada, 330 Progress Ave., Scarborough, Ont.



NRI AUTOMOTIVE DIVISION
3939 Wisconsin Avenue, N.W.
Washington, D.C. 20016

946-022

Please send me your new Automotive Mechanics catalog. I understand there is no obligation. No salesman will call. I am interested in
 Master course Tune-Up course

Name _____ Age _____

Address _____

City _____ State _____ Zip _____

ACCREDITED MEMBER NATIONAL HOME STUDY COUNCIL

NEW IN PHOTOGRAPHY

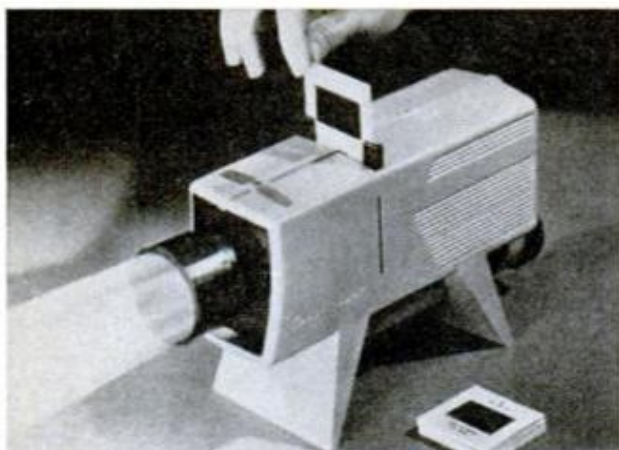

CORDLESS PROJECTOR for 35-mm slides can be carried with you wherever you go without requiring external power. It operates on three ordinary D-size flashlight batteries that can be replaced as needed to keep the projector lamp burning brightly. Mounted slides are slipped one at a time into a slot on top, or continuous strip film can be fed through the projector from the side. \$9.95 postpaid, Force Ten Imports, Box 4743, Hialeah, Fla. 33014.



ANYTHING YOU SPOT through these 7x50 binoculars can be captured on film just as you see it merely by pressing a button. A built-in half-frame 35-mm camera provides equivalent of a 231-mm telephoto lens. A motorized drive makes up to 72 shots on 36-exposure film as fast as you press the trigger—handy for nature photographers and sports fans. Speeds are 1/60th to 1/250th. \$325, Braun North America, 55 Cambridge Pkwy., Cambridge, Mass.



KIT-BUILT CAMERA for low-cost snap-shooting has a simple plastic housing that snaps onto a standard 126-size film cartridge. Bubble-packed parts (far left) include lens, shutter and a film-advance knob that engages film's winder sprocket. The kit, expected to sell for not much more than the price of the film itself, is made by Plastics Development Corp., 9810 Ashton Ave., Philadelphia, Pa. 19114.

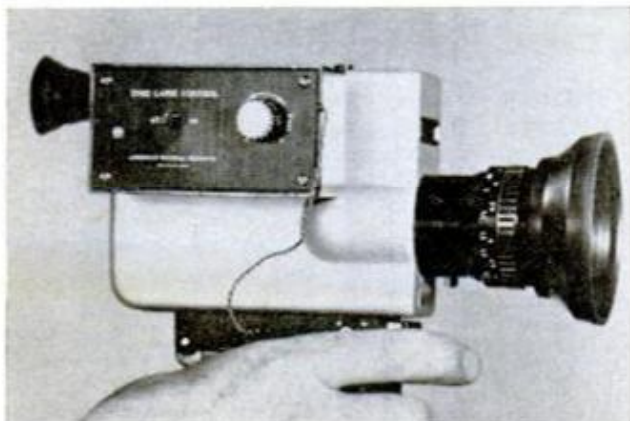

LOW-COST TIME-LAPSE ATTACHMENT fits most Super-8, 8-mm and 16-mm movie cameras, enabling you to make "speeded-up" films of eggs hatching, flowers blooming, sunsets, and so forth. Exposure intervals range from one a second to one every five minutes. Thus action sequences spanning days can be compressed into several minutes of viewing time. Time-Trigger can be used with cameras having remote electrical single-frame control or, by using an accessory, with those having cable-release controls. Timer is \$49.50; the accessory, \$59.50. American General Products, 1000 1st Ave. S., Seattle, Wash.

START YOUR NEW CAREER NOW! WITHOUT OVERHEAD! ANY PLACE! ANY AGE!

UPHOLSTERING JUST ONE

you don't even have to quit your present job!!!

Start learning now. At home, or in the garage, in your spare time — no outside classes to attend. If you can tie a knot and drive a tack, you can learn this business, quickly, easily. You start learning the basics **right away** through the proven MUI Home Training Plan. And before you're barely into it, you can start doing the simple upholstery jobs that are all around you waiting to be done. Chairs, cushions, seats, footstools. Even before MUI students finish their training, people start bringing upholstery jobs to them, and remember—the world is full of furniture that needs fixing and re-upholstering and more is wearing out all the time!

CHAIR can pay you as much as your present weekly paycheck!

"What started as a hobby, now pays me \$10 an hour"
 Yes, many MUI graduates make better than \$10 an hour turning old wornout furniture into bright new decorator pieces! **Stack it up against what you're doing now!** Are you making \$150 a week? \$200? \$250? Do you put in long hours of dull work, with small raises? Is that the way you want to spend the rest of your life? Just imagine, you can make \$150, \$200, \$250 upholstery just **one chair or sofa** these days! And if you're the kind of person who likes to work and earn, you can sometimes finish a job like this in a day. That's pay... and it beats what most college graduates make!

AS YOU LEARN, YOU JUST SLIP INTO THE IMMENSE FLOW OF UPHOLSTERY WORK! Think of all there is! . . . Sofas, lounging chairs finished in beautiful fabrics, which MUI tells you how to get at the right price — even leather and all the new vinyls. And then you have built-ins and breakfast nooks, boats, trailers and all the millions of automobiles in America. Yes, you learn all this and more! When we finish teaching you, (in your own home in your spare time) and when you get our California state approved diploma, you know this business . . . as a **real professional!** You will then have one of the most fantastic moneymaking skills in America built into your head and hands! No one can ever take this skill away from you . . . and no one can ever fire you, because you're the boss of a business that you can take with you . . . You can make big money from then on . . . any time, anyplace you want to put out your shingle!

When you read the papers you see there's a strike here, a lockout there. Detroit lays off 150,000 men. A plant is shut down and moved out of state. A new automated machine eliminates 5,000 jobs. They talk about dislocated workers and try to do something about it. What pays the bills if you get caught up in one of these situations? When you know upholstery, life gets very simple and lots of fun. It's simple because where there are people, there are upholstery jobs and lots of them. It's fun because life is fun when the bills are paid and there's money in the bank, even enough to buy those things you've always wanted for yourself.

YOU GET SIX BIG FURNITURE KITS FREE



YOU GET THIS AUTHORIZED DIPLOMA WHEN YOU GRADUATE



MUI IS APPROVED BY THE CALIFORNIA SUPER-INTENDENT OF PUBLIC INSTRUCTION AND IS AUTHORIZED TO ISSUE A DIPLOMA IN UPHOLSTERY.

MODERN UPHOLSTERY INSTITUTE
 Box 899-FBC, Orange, Calif. 92669

WORK THE HOURS YOU LIKE TO WORK!!

If you favor a regular 35 hours a week, upholstery lets you do it and make a really fine living. On the other hand, if you're really ambitious and want to work 60 or 70 hours a week, you are starting to talk about some big, big money! The important thing is that the choice is yours, not somebody else's! (Not like when you're working for someone else.) Many students of retirement age just do a few pieces now and then just to keep things nice and comfortable.

TO GET STARTED, JUST GET THE COUPON IN THE MAIL . . . TODAY!

It costs you nothing to get the information and there's no obligation. No salesman is going to call you. This much and this much only, every successful MUI graduate must do for himself — send the coupon today!

YOU'LL GET A BIG ILLUSTRATED 32 PAGE BOOK ON UPHOLSTERY

and the upholstery business, and an actual free sample lesson showing how the fabulously successful MUI system is taught. For your sake and the sake of your future, do it now. Cut out the coupon, fill it out, put it in an envelope and mail it now. Air mail reaches MUI about two days sooner!

ALL THE SPECIAL "TOOLS OF THE TRADE" ARE YOURS . . . FREE

THIS FREE UPHOLSTERY BOOK may be the most important information you ever read.

MAIL COUPON NOW!

MODERN UPHOLSTERY INSTITUTE, Box 899-FBC Orange, Calif. 92669

Please send the FREE UPHOLSTERY CAREER BOOK, the FREE SAMPLE LESSON. I understand I am under no obligation whatever and am just sending for the free facts on job and career opportunities in Upholstering and the MUI home training program. I understand that no salesman will call.



APPROVED FOR VETERANS

Name _____ Age _____
 Address _____
 City _____ State _____ Zip _____



By BOB STEARNS

Carpet your outboard motor

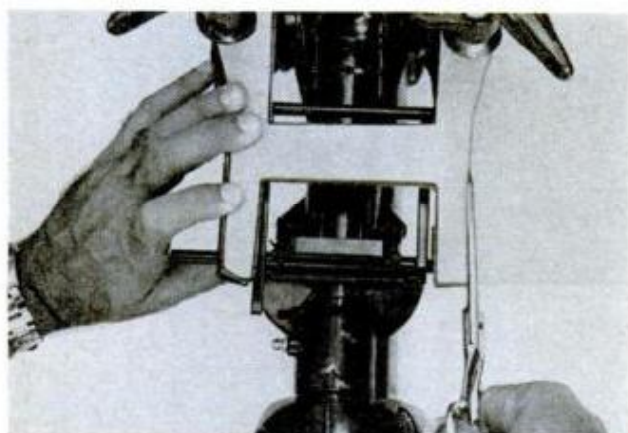

SKETCH shape of bracket on cardboard; trim to size

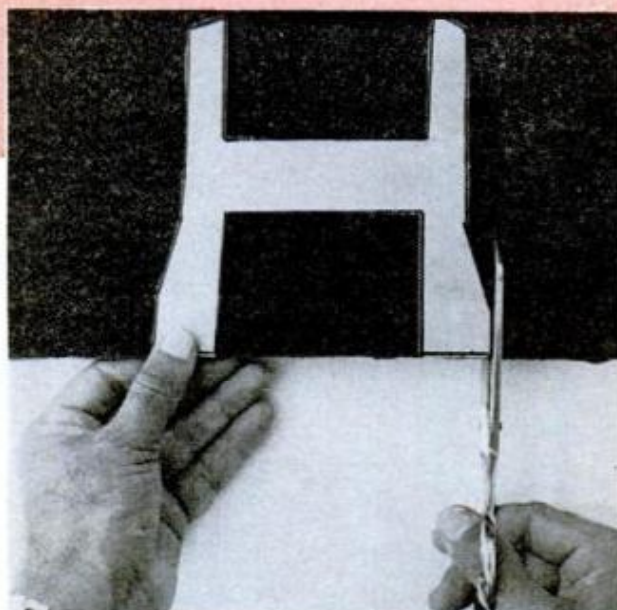

CUT rough-surface outdoor carpet to template shape

SMALL SPARE ENGINES for trolling or getting you home are becoming more popular. You may want to mount one of these 2 to 20-hp units—which use clamp brackets—alongside your standard kicker but find no protective pad on the transom. Teeth on your outboard bracket, designed to grip a wooden transom, can bite into fiberglass and the abrasions may allow dry rot to start in inner wood stiffeners. Such

ridges will also chew up an aluminum transom.

So, buy a dollar's worth of rough-textured synthetic fiber carpet and spend another dollar for contact cement and a pure bristle brush—some cement solvents dissolve nylon. Paint both cut-to-fit carpet and brackets with cement and let dry before joining. New pad grips even better when wet, but use safety chain. ★★★



APPLY contact cement to carpet and metal bracket

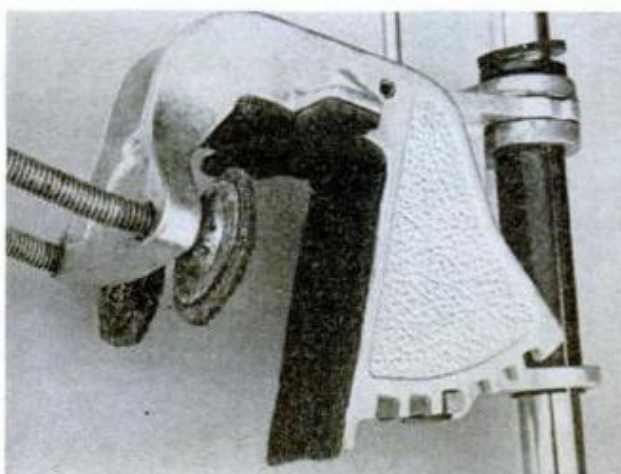

PASTE carpet discs to round screw clamps as well

There may be a great future in your past.



Think back to that time in your life when you felt like you belonged, had enthusiastic friendships, and a sense of contributing to your country's strength. When you could actually look forward to a secure and comfortable future.

Chances are, the last time you felt like that was when you were in the service. The question now is, is it too late to do something about bringing back the good old days of military life?

In a word, the answer is "No." The Air Force Reserve needs good men with their service skills intact. And, if you've got what we're looking for, you can look forward to a second income, specialized training, and rediscover what benefits and rewards an Air Force career can bring to your life.

Think it over. For one weekend a month and 15 active duty days a year, you could find yourself in the Air Force

Reserve with a great future to look forward to.

For more information, mail in the coupon below. Or, call 800-631-1972 toll free* for the address of your local Air Force Reserve unit.

Do it now. And let your future catch up to you. *In New Jersey call 800-962-2803.

U.S. AIR FORCE RECRUITING SERVICE ^{3-PM-22}
DIRECTORATE OF ADVERTISING (APV)
RANDOLPH AIR FORCE BASE, TEXAS 78148

Please send me more information about joining the Air Force Reserve.

I was formerly in the Air Force Navy Coast Guard Marines Army

My grade was _____

My specialty was _____

NAME _____

ADDRESS _____

CITY _____ STATE _____ ZIP _____

PHONE (area code) _____

I understand there is no obligation.

**Find yourself
in the Air Force Reserve.**

NEW FOR YOUR CAR



HANDY THREE-IN-ONE GAUGE gives individual readings of amperage, oil pressure and water temperature on a single dial face. The smartly styled, space-saving instrument mounts easily on the steering column or dashboard and is electrically operated with no

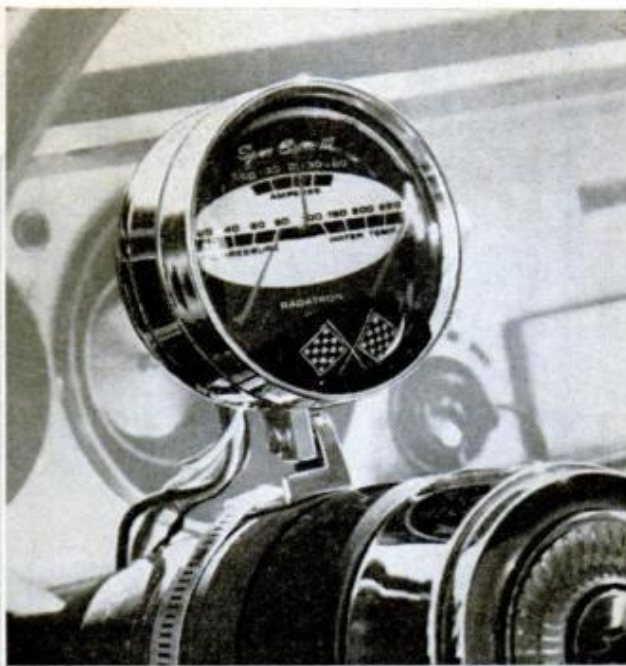

tubing to connect. Installation kit (left, above) includes hookup wire and all necessary sensor fittings. It can be used with any 12-volt negative or positive-ground electrical system. \$19.95, Lafayette Radio, 111 Jericho Turnpike, Syosset, N.Y. (Catalog No. 11R42033).



MINI-COMPRESSOR is small in size, but provides a powerful air supply for inflating tires and pneumatic jacks in an emergency or for blowing up rafts, air mattresses and beach balls used on camping or vacation trips. It operates on 12 volts d.c. and plugs into a



car's cigaret-lighter socket (left, above). Auto-Flator produces pressures up to 80 pounds p.s.i. and comes with 10-foot air hose. Interchangeable nozzles enable the hose to fit most inlet valves. \$29.95, W. R. Brown Corp., 2701 N. Normandy Ave., Chicago, Ill. 60635.



STRANDED MOTORISTS can indicate their need for help with this brightly colored sign that simply clips to the edge of a window. Made of plastic, it's painted a highly reflective fluorescent orange, folds up for easy storage in a glove compartment. The window sign is designed to eliminate the hazard of getting out of your car to raise the hood or tie a handkerchief to the antenna, said to produce many roadside injuries. It's \$2 from INH Corp., Box 2564, Milwaukee, Wis. 53214.

Are you missing out on the extra pay of an ICS graduate?



Recently we mailed out a questionnaire to a group of our graduates, two years after they had received their ICS diplomas.

The main objective of this questionnaire was to determine if spare-time study had helped them get ahead faster.

- Those who answered the questionnaire reported that they were earning *almost \$1200 more* (median) than the day they'd received their diplomas.
- Over 18% said their annual pay had grown *\$2000 or more*.
- The number of graduates making over \$10,000 *had more than doubled*.

All this proves one thing. Bosses—who give the raises—know the value of ICS training. (More than 8500 have proved it by entering formal training arrangements with us.)

If you study with ICS, will your pay grow as fast? It may grow even faster. So take the first step toward higher pay right now. Mail the coupon.

ICS[®] International Correspondence Schools Scranton, Pa. 18515

ICS, Scranton, Pa. 18515
Canadian residents use above
address for service from ICS
Canadian, Ltd. In Hawaii: use
P.O. Box 418, Honolulu.

<input type="checkbox"/> ARCHITECTURE-ART Here's your opportunity to get practical, professional training that can turn you into a well-paid specialist... in fields with a tremendous future. Learn at home! Your first step is to get complete, free information now, from ICS.	<input type="checkbox"/> ACCOUNTING The classified section of your own newspaper will make it clear to you—there's a real demand for men and women trained in the skills of accounting. A real future... where the action is. Learn accounting now, at home, through ICS!	<input type="checkbox"/> ENGINEERING ICS-trained engineers are known and respected in industry, government. Options include Civil, Mechanical, Electrical, or Chemical. Learn thorough, recognized, professional engineering skills now, at home, through ICS!	<input type="checkbox"/> COMPUTERS To get a head start in tomorrow's world... get in the rapidly expanding world of computers now. Specialists in computers are needed today... will be in even more demand tomorrow! Learn this exciting field through practical at-home training, through ICS!	<input type="checkbox"/> HIGH SCHOOL A high school diploma is a "must" in today's world... it opens new doors for you... and it's worth up to \$100,000 over a lifetime. Get yours now, at home, through ICS—here's a diploma that is recognized and respected!	<input type="checkbox"/> AUTO MECHANICS Every year there is a growing shortage of skilled professional mechanics needed to keep this nation's cars and trucks rolling. Here is good pay, advancement, and enjoyment. Learn the basics and highly rewarding special skills, the world-famous ICS way!
<input type="checkbox"/> ELECTRONICS The whole exciting world of tomorrow opens up to the man or woman trained in electronics! Learn this field and you can just about write your own ticket. Get your thorough, professional training now at ICS.	<input type="checkbox"/> DRAFTING Every new product, every improved product in today's world begins on the drawing boards—requires the professional skill of a capable draftsman. Learn this satisfying, rewarding career now the proven-successful ICS way!	<input type="checkbox"/> BUSINESS ADMINISTRATION The business world can never find enough capable people trained to step up to better pay and greater responsibility. Here's where every man or woman can get the training to move ahead confidently—through ICS!	<input type="checkbox"/> SECRETARIAL Here's your way to land a good job, to advance in your present job—or to find a very special new job in the business world. ICS training is practical, up-to-date, and very helpful in making your life pleasant, rewarding, secure.	<input type="checkbox"/> ELECTRICIAN The electrical maintenance, repair, and building fields call for more and more trained electricians. Here is real security doing a job you like to do. ICS is famous for its training in electricity, step-by-step from basics to full professionalism.	<input type="checkbox"/> INTERIOR DECORATING Here's your opportunity to take natural talent and interest... and turn it into a rewarding career that's "fun" instead of "work". ICS training is thoroughly professional, and as modern as tomorrow. Learn decorating now, at home—the perfect place to learn it—through ICS!

ACT NOW! INFORMATION FREE! Mail coupon to ICS, Scranton, Pa. 18515.

Please send me, without cost or obligation, FREE booklet and full information on the field I have checked.

Miss _____ Age _____
Mrs. _____
Mr. (Please print) _____

Address _____ Apt. # _____

City _____ State _____ Zip _____

Approved for Veterans for Tuition Refund • Approved for Federally Insured Loans • Accredited Member National Home Study Council

A1331A

Over 200 Others Including:

- Building Trades
- Plumbing, Heating, Air Conditioning
- Shop Practice

If your field is not included, please specify here:

NEWS BRIEFS



Pilotless bomber

The Defense Department is experimenting with pilotless drone bombers at its White Sands, N. M., test grounds to find out if they can deliver bombs accurately to high-risk targets. The drones, carrying 500-pound bombs, are directed by remote control from safe areas.

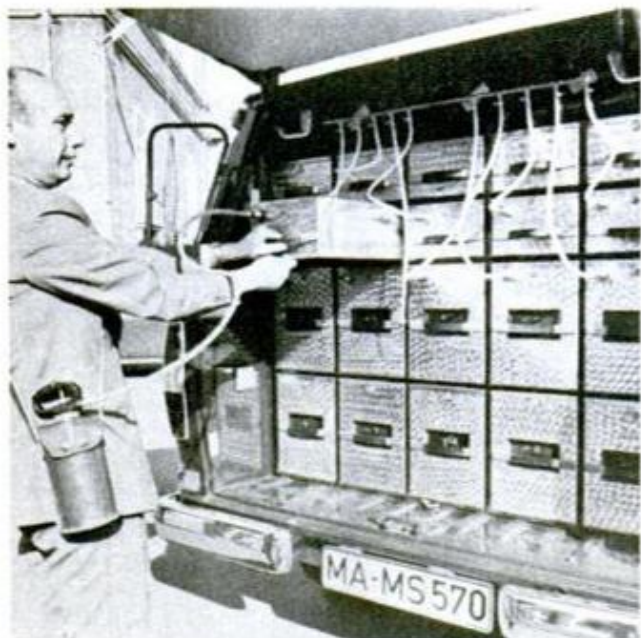

Dye in the money

German bank officials in Darmstadt are transferring money in a new antiholdup bank van that carries a vat of dye in the top. If a bandit tries to snatch a strongbox connected to the container by hose, the dye is released, splashing colorfully over the banknotes to make them easily spotted as stolen money.



Driving by the digits

Today's instrument panel, with its sweep needle, revolving numbers and gas gauge may soon be replaced by a digital readout. Monsanto's version, made of 1500 diodes, tells the driver at a glance how many gallons are in the tank, his speed, number of miles driven and the status of his seatbelts and doors.

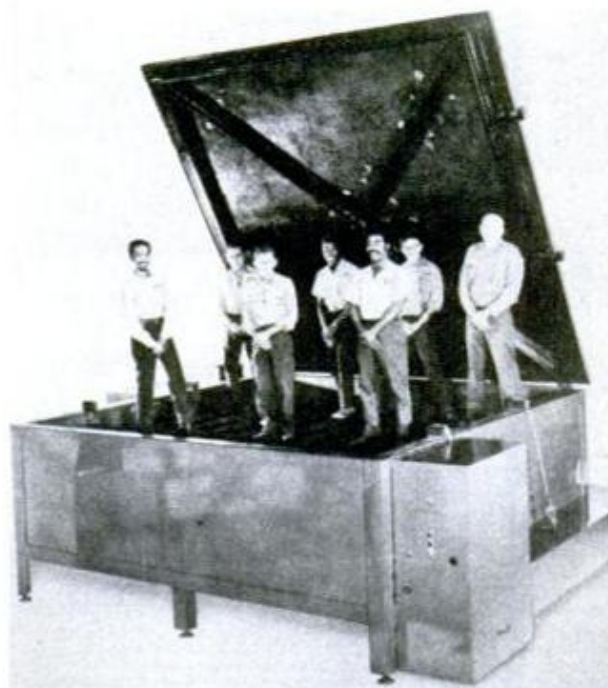

Radiator bathtub

Built for the Atomic Energy Commission, this huge tank is used to boil out clogged radiators of the large earthmoving equipment at the Nevada testing-grounds. The tub, built by the Barbee Co., can handle radiators up to 8 by 10 by 1½ feet. Gas burners, in heating the tank's water, generate enough energy to warm 10 average-size homes.

POPULAR MECHANICS

WINSTON'S DOWN HOME TASTE!

So Real. So Rich. So Good.

**Winston tastes good
like a cigarette should.**

29 CLASS A
CIGARETTES

KING SIZE

Winston

FILTER · CIGARETTES

FULL · RICH
TOBACCO FLAVOR

Warning: The Surgeon
General Has Determined
That Cigarette Smoking Is
Dangerous to Your Health.

© 1972 W. J. REYNOLDS TOBACCO COMPANY, WINSTON-SALEM, N. C.

19 mg. "tar", 1.3 mg. nicotine av. per cigarette, FTC Report AUG. '71.

Материал, защищенный авторским правом

POLLUTION FIGHTERS'

NEWSLETTER

By SUSAN MAZUR

THE FIRST "PLASTIC" BRIDGE using recycled plastic bottle-concrete, which collapsed Nov. 30 as it was nearing completion at Elgin, Ill., is expected to be rebuilt this spring, or as soon as the cause of the failure can be determined.

The 100-foot-long, 7-foot wide footbridge joining Walton Island in the Fox River with the city's civic center grounds is part of a project begun in 1969 by students of Larkin High School. After they restored the island, once a favored picnic spa, to its natural beauty, they joined the city to launch a "bridge the gap" fund drive. Next, 25,000 plastic bottles were collected from the public and local industry for the plastic-concrete mix: 30 percent sawdust-like plastic flakes; 70 percent concrete.

Experiments with the material indicate it weighs 10 percent less than an equal volume of concrete, with an insignificant loss of strength. Plastic-concrete also has a zero "slump" when wet, says Robert Layer, architect; i.e., the material won't distort because of gravity.

Such recycling is the best answer right now to the plastics disposal problem in America (3.5 billion tons are generated yearly), says Ralph Harding, Jr., executive vice-president, The Society of the Plastics Industry, Inc., since we've a shortage of landfill sites and inadequate incinerators and incinerator management.

ENZYMES IN DETERGENTS are safe, effective and nonpolluting, concludes the Committee on Enzyme Detergents of the National Academy of Sciences after a nine-month study requested by the Federal Food and Drug Administration and the Federal Trade Commission to determine whether there was any evidence that stain-removing enzyme materials posed a toxic hazard to users of enzyme detergents. The committee reports "it has been demonstrated the enzymes provide an additional benefit" in their ability to "remove many protein-based stains, and soil in general, more effectively than will detergent products without enzymes."

The study also established that when enzymes are discharged from washing machines into sewage treatment systems, they biodegrade within 24 hours. It suggested that in the absence of a solution to the current problem of the ecological effects of the phosphate builders, enzymes (as biodegradable agents) may assume a larger role in the laundering process.

"URGENCY OF PROTECTING THE OCEANS is one of the prime tasks that the Stockholm Conference is determined to meet, for marine pollution fits into the larger picture of the overall global environmental challenge—it is a part of the urgent need to defend the integrity of the biosphere." Maurice F. Strong, secretary-general of the United Nations Conference on the Human Environment so addressed delegates in Ottawa at the second session of the Intergovernmental Working Group to consider ways to save the seas. Jack Davis, Canadian Minister of the Environment, emphasized the need for unilateral action by coastal nations to prevent further marine pollution, pointing out that our marine environment comprised 70 percent of the biosphere.

The IWG discussed the following measures to preserve the oceans: priority research needs; identification of critical pollutants; developing systems to monitor the oceans; collection, retrieval and dissemination of information. Also examined were practical measures for control and abatement of pollution at the national regional and global levels. The first international conference is scheduled to begin June 5, 1972. (See PFN, page 76D, Oct. '71 PM.)

YOUR GOVERNMENT AND THE ENVIRONMENT is a book by Matthew Kerbec (Output Systems Corp., Dept. R, Box 2407, Arlington, Va. 22202) providing major federal-government environment information, such as appendices with names, addresses, and phone numbers of key congressional, federal and state personnel involved in pollution control; environmental budgets in nine federal agencies and the Environmental Protection Agency programs. Also included is a digest of air, water, radiation, pesticides and solid-waste pollution effects, technology and penalties; a glossary of terms used in pollution control and an index for fact-finding. Price is \$9.95.

DO YOU KNOW about some action being taken to fight pollution that we don't know about? In your community? On the job? Tell us about it. Write Environment Editor, *Popular Mechanics*, 224 West 57th St., New York, N.Y. 10019. ★ ★ ★

Exhaust tuning and CD ignition.

Two reasons Johnson wins races and friends around the world.



Race drivers know it takes a hot engine to push a hot hull.

So many of them use Johnson V-4 power in international races and marathons. Paris, Berlin, Lake Havasu, Miami.

Our Sea-Horse 125 hp offers the same kind of championship performance for water skiing, fishing and cruising. With features like:

Exhaust tuning. It'll give you more horsepower with less weight and fuel.

Capacitor discharge ignition. For fast, sure starts and longer plug life. And no points to change. Ever.

Single-lever power shifting that's up to 30 percent easier than manual systems.

V-4 design with happy advantages like a short, rigid crankshaft to reduce vibration and friction. Plus a compact size that's six inches shorter above the transom than some competitive motors.

If you need more reasons than that, see your Johnson dealer. He's got 'em. Along with two smaller Vs: 100 and 85 hp.

Or write for our 50th anniversary catalog.

First in dependability.
Johnson

Johnson Motors, Waukegan, Ill. 60085. Dept. PM-272.

Division Outboard Marine Corporation — makers of OMC Stern Drives



We've got over 300 good, steady jobs.

Jobs in construction, transportation, communications, computers.

Jobs for photographers, printers, truck drivers, teachers, typists, TV cameramen and repairmen. Cooks, electricians, medical aides, meteorologists. Motor and missile maintenance men.

Jobs for young men. And young women.

Jobs in Europe, Hawaii, Panama, Alaska. And just about any place in the States.

We'll train you to do the jobs. Train you well, in good schools, under excellent instructors, with the best equipment obtainable.

And you get full pay while you train.

You also get unusually good fringe benefits, including a chance to continue your education. In many cases at our expense. In all cases with at least 75% of your tuition paid.

And if you qualify we'll give you your choice of training. We'll put it in writing, before you sign up.

**Today's Army
wants to join you.**

Army Opportunities Dept. 200, Hampton, Va. 23369	Date _____
I'd like to know more about the job-training and promotion opportunities in today's Army.	
Name _____	Date of birth _____
Address _____	
City _____	County _____
State _____	Zip _____ Phone _____
Education _____	

SOLUTIONS FOR MECHANICAL HEADACHES

AUTOMOBILE CLINIC

BY MORT SCHULTZ

Not what it seems

I wonder how many of the thousands of 1970 Buick LeSabre and Wildcat owners realize it will cost them \$15 to replace a 25-cent rear stoplight bulb. From what I can see, the rear bumpers must be removed to reach the outboard tail lamps. Or am I wrong?—G.C. Dreizler, Utica, N.Y.

Yes sir—you're wrong. Although Buick hasn't made it overly conspicuous, there is a way of getting to the outboard tail lamps without removing the bumper. Raise the trunk lid and lift up the rubber baffle. The lamp socket can be reached through the scalloped opening in the bumper. If by chance the bumper-to-body clearance is too tight for you to get your fingers in, loosen the bumper-to-frame brace bracket and push the bumper down.

Unneutral

I have a 1970 Ford Ranger LLT pickup. The neutral switch has been replaced six times. It works for two days to three weeks; then it will stick in Park or the engine won't start in any position but Park. Is there a cure for this? I'm not only going crazy, but I'm driving my dealer crazy.—H.E. Mead Sr., Denison, Tex.

That's his fault, not yours. I would think that after installing six new switches he would conclude that something besides the switch is giving the trouble. Here are three possibilities he can start with. First, maybe the attaching screws that hold the switch to the mast jacket aren't tight enough, so that when the activator hits the switch, it causes the switch to shift. Second, maybe the hole in which the activator rides in the shift tube is elongated, keeping the activator from making good contact with the switch. Third, maybe the switch retaining screws have stripped. If so, the switch can be held in place with a radiator hose clamp. Whatever, the trouble is not the switch. Look elsewhere.

Quarterbacking

Hey, Mort, here's a tip to pass on to 1971 Opel 1900 owners being troubled by flooding brought on by percolation. The cause can often be traced to fuel pump overheating. The pump is located behind

a splash pan. If they will have the dealers drill six or eight 3/4-in. holes in two rows in the pan, air will get through to the pump, reducing the heat that builds up. This procedure is recommended by the Buick zone office in Philadelphia.—Coleman Pont, Marlton, N.J.

The tip is passed. Thanks.

Whoa, baby

Ever since the car's been new, I've had problems with the brakes of my 1970 Chevelle Malibu. It has self-adjusting drum brakes. More than ample pressure is needed to stop or slow the car, and at times I have to pump the pedal during a stop. The service shop has been of no help. They say the condition is caused by drum expansion because of heat, but that braking is normal. You're my last hope.—Larry Bruce, Portland, Ore.

I'm wondering if you switched to the Malibu from a bigger car. Although brakes of the Chevelle are adequate for stopping, former larger-car owners can't seem to get used to them. I suggest you have a power-brake assist unit installed. If this doesn't help the situation, I'd have the present brake drums replaced with drums used on the Buick Special. They dissipate heat at a faster rate and should provide a shorter stopping distance.

Car has a mind of its own

I have a 1968 Chrysler New Yorker with 440-cu.-in. engine and four-barrel 4160 Holley carburetor. When I accelerate for passing, the carburetor sticks and the vehicle continues at 50 to 60 mph without my assistance. Placing it in neutral and turning off the ignition rectifies the situation until I accelerate for passing again. The carburetor linkage isn't binding. Can you help?—Hobson S. Lewis, Washington, N.C.

The trouble is probably being caused by an internal leak in the carburetor or sticking secondary throttle blades. Have the carburetor disassembled and inspected for nicks and cracks. Check for varnish on the throttle shafts, nicks on the sec-

(Please turn to page 28)

Get a taste of what it's all about.

**Get the
full taste
of Viceroy.**

17 mg. "tar," 1.2 mg. nicotine av. per cigarette,
FTC Report Aug. 71.

AUTOMOBILE CLINIC

(Continued from page 26)

ondary throttle blades and proper centering of the blades in the throttle bores.

Jumpy transmission

My headache is with a 1969 Dodge Dart Six with standard transmission that jumps out of high gear as I take my foot off the accelerator pedal to slow down. If I hold the shift lever down with my hand, it won't jump out, but I can feel something trying to push it out. I paid Dodge service \$16, but still have trouble. Any solution?
—Harry Urbanick, East Detroit, Mich.

Chances are Dodge service adjusted the

gearshift rods, checked for linkage interference and for a clutch housing bore or face out of alignment. Other possibilities:

Some of these transmissions got into the field with an oversize lever that prevents full travel of the sliding clutch into high gear. To check on it, the transmission top cover should come off the transmission placed in third gear. Note if the poppet ball seats fully in the third speed detent. There should be .002-in. to .015-in. clearance between the face of the lever and the end of the interlock sleeve. If the transmission fails this test, replace the lever with a new one (part No. 1949352).

If this is not so with your transmission, there's one other possibility—worn synchronizer clutch teeth. The transmission will have to be overhauled.

Service Tips

● **Scratch in a car's glass?** How can you tell if it's deep enough to warrant replacement? Chevrolet suggests you run a fingernail over the scratch. If it can be drawn across without catching, then the scratch can often be polished out. See a glazier or try to do it yourself by rubbing the scratch with jeweler's rouge. If your fingernail catches as you draw it over the scratch, the damage is probably too deep and the glass will have to be replaced.

● **A squeaking noise coming from the front of your 1971 Oldsmobile F-85 with V8 engine** may be caused by bolts that are too long and contacting the lower flange of the motor mounts. These bolts retain the mounting bracket to the frame. To cure, install an additional washer under each bolt head.

● **To combat radio interference**, automobile manufacturers agreed in the 1960s to specific electrical emission standards. Resistor cables (Photo 1) were installed in all vehicles. This type cable replaced the then standard cable with a metallic conductor cable (Photo 2). A resistor cable usually has a conductor made of carbon-linen strands, covered by neoprene; this is encased with rubber with a rayon braid for strength, followed by a final jacket of neoprene. Champion Spark Plug Co. advises that care and caution be exercised in replacing cables and has established the following guidelines:

1. Replace a resistor cable only with another resistor type.
2. In removing the cables, loosen the boot first by a twisting action, then grasp it while

carefully removing the cable and terminal.

3. Never puncture suppression cable with a sharp tool.

4. When installing a new cable, insert a wire staple or connector in the end of the cable to make connection between conductor and terminal. (Photo 3). ★ ★ ★

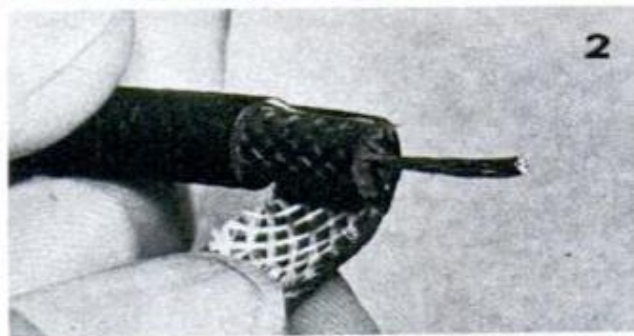

GOT A PROBLEM WITH YOUR CAR? Ask Mort about it. Send your question to Auto Clinic, Popular Mechanics, 224 West 57th St., New York, N.Y. 10019. Letters cannot be answered individually, but problems of general interest will be published in the column.

WHEN YOU BUY A JAVELIN YOU GET SOMETHING YOU CAN'T GET WITH A MUSTANG, CAMARO OR FIREBIRD.



You get a lot more than a good-looking sporty car when you buy a Javelin.

You get a car that's been road-tested and checked over so thoroughly, we make this promise: If anything goes wrong and it's our fault, we'll fix it. Free.

And, if we have to keep your car overnight to fix it, over 1900



When you buy a new 1972 car from an American Motors dealer, American Motors Corporation guarantees to you that, except for tires, it will pay for the repair or replacement of any part it supplies that is defective in material or workmanship.

This guarantee is good for 12 months from the date the car is first used or 12,000 miles, whichever comes first. All we require is that the car be properly maintained and cared for under normal use and service in the fifty United States or Canada and that guaranteed repairs or replacements be made by an American Motors dealer.

**AMERICAN MOTORS
BUYER PROTECTION PLAN**

dealers will loan you a car. Free.

Finally, you get a name and toll-free number to call in Detroit if you have a problem. And you'll get action, not a runaround.

Nobody in the business does all this for you after you buy a car.

Which is probably why people who've never bought a car from us before are buying one now.

NEW FREE BOOK DISCUSSES HOW TO SELL YOUR INVENTION

If you have an invention (whether patented or unpatented) that you believe has commercial value, our Free Booklet entitled "How to Go About Selling Your Invention" may help you save time and money.

We are specialists in representing inventors and submitting their inventions to manufacturers. We work with scores of manufacturers who are seeking new products or new product ideas, and we therefore know which firms may be interested in your particular invention. Our service is designed to do all those things the average inventor lacks the knowledge or facilities for doing, or does not have time to do. We prepare your sales letters, folios, duplicate drawings, handle correspondence, select the firms.

We charge the standard commission (on sales) and a modest fee for the submitting service. This fee is refunded if a manufacturer buys your invention through our efforts. We are a nationally known concern with an impeccable reputation for ethics and integrity.

The Free Booklet we have prepared especially for inventors contains such information as current royalty rates being paid by manufacturers, discusses many types of inventions, the possible market for them, tells the effective methods of presenting your invention for sale, whether you employ us or do it yourself, and outlines how we may be able to help you.

You can obtain this booklet "How to Go About Selling Your Invention" by mailing the coupon below. And if you wish to write us for comments on your invention, please do so. We make no charge for consultation. But please do NOT send drawings or models. Just describe the purpose and nature of your invention. Mail the coupon to K. O. Kessler, Pres., Kessler Sales Corporation, Dept. D-52, Fremont, Ohio 43420.

You are welcome to ask your lawyer, local Bank, Chamber of Commerce to carefully check on our reputation for honesty and fair-dealing.

---MAIL THIS COUPON---

Mr. K. O. Kessler, President, Dept. D-52
Kessler Sales Corp., Fremont, Ohio 43420

Please mail me a copy of your Free Booklet "How to Go About Selling Your Invention." It is understood that this does not obligate me in any way to use your Service.

My Name

Street Address

CityState.....Zip.....



Paint
brush
cleaning
a
problem?



We've
got
the
product...

AVAILABLE WHERE PAINT IS SOLD

SAVOGRAN 

Norwood, Massachusetts 02062

Don't change your address without notifying us!

To insure uninterrupted service on your Popular Mechanics subscription, please notify us at least six weeks before you move.

1. Attach your address label from a recent issue in the space provided below... (If label not available, be sure to give us your old address, including Zip Code)
2. Print your name and new address below (be sure to include your Zip Code).

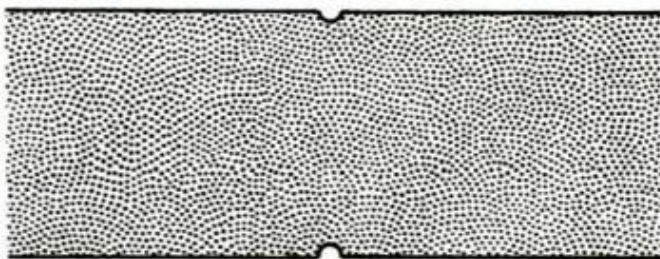

Mail entire notice to: Subscription Service Dept.
Box No. 648
New York, N.Y. 10019

Name _____ *Please Print*

New Address _____

City _____

State _____ Zip Code _____

People pay a lot of money to these men. You can be one of them soon.



Electronics Technician.



Automotive Technician.



**Air Conditioning
Refrigeration Technician.**



**Home Appliance
Technician.**

You know what technicians charge to repair your TV set, your car, refrigerator or washing machine. The men who can do the job — and do it right — get paid very well indeed.

Join them! Be a technician and let people pay **you** for a change.

National Technical Schools will train you at home the professional way — with profes-

sional instruction, tools and test equipment, the kind of equipment you'll be using on actual jobs. It makes home training practical and more fun. And you get to **keep** all of the tools and equipment.

Choose the kind of technician you want to be. **Then** mail the card for free color catalog. No obligation. No salesman will call.



**NTS Electronics
Division**

Multiply your income with space age skills in Computer Electronics. Color TV & Radio Servicing, Automation/Industrial Electronics or Electronic Communications. Courses include valuable kits such as 315 sq. in. Solid State Color TV, Solid State B&W TV, 2-way Radio Transceiver, Compu-Trainer, Oscilloscope, and more. Check card for new FREE Color Catalog, complete details.



**NTS Mechanics
Division**

NTS puts you into America's #1 industry fast. Start earning almost as soon as you begin. You get 109-piece Socket Wrench & Tool Set with case and professional 8-unit diagnostic test equipment, yours to keep. Plus bonus Speed Shop lessons. Check card for new, free color catalog and complete details on all four courses and equipment.



**NTS Air-Conditioning/
Refrigeration, Heating
Division**

Install and maintain today's complex air-conditioning, refrigeration, and heating systems. As an NTS master technician you can handle any job. Or you can go into your own business. "Project Method" makes your training interesting with all new Hermetic Analyzer, tester, and other valuable instruments. Send for new catalog. Check card today.



**NTS Home Appliance
Division**

Boost your income, build a new career, start a business of your own. Learn the professional way to service ranges, washing machines, dryers, home air-conditioners, and other appliances. We'll supply everything you need, including the New Exclusive Circuit Trainer, 4 in 1 Appliance Tester and complete set of fine hand tools. Check Card.

**MAIL CARD NOW
FOR FREE
CATALOG &
SAMPLE LESSON**



High School at Home. Accredited programs. Everything included in one low tuition. Check special box on card for free catalog. **Classroom Training at Los Angeles.** Train in sunny California. NTS occupies a city block with over a million dollars in training facilities. Check box on card.

NATIONAL TECHNICAL SCHOOLS

WORLD-WIDE TRAINING SINCE 1905
4000 So. Figueroa St., Los Angeles, Calif. 90037

APPROVED FOR VETERANS

Accredited Member: National Association of Trade & Technical Schools, National Home Study Council.

science worldwide

By JOHN PEARSON

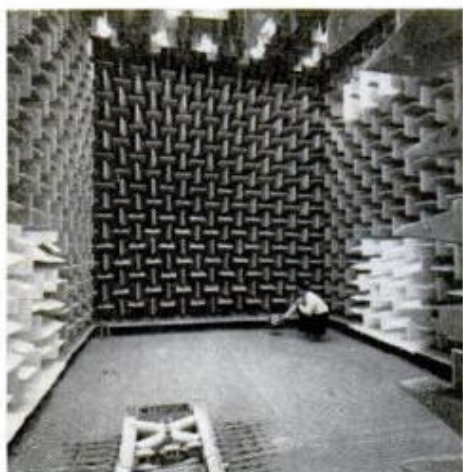

Fiberglass wedges deaden room

AN ANECHOIC CHAMBER—a “dead” room virtually free of echoes—is one of many sophisticated lab facilities in General Electric’s new Applied Research and Design Center in Louisville. The chamber, encased in concrete and mounted on steel springs to minimize ground vibrations, will be used to measure noise levels of refrigerators, airconditioners and other appliances.

IF YOU EXERCISE 15 MINUTES A DAY, 3 days a week, you’re getting the minimum amount of exercise needed to protect you against the possibility of a premature heart attack. So says Dr. Samuel M. Fox III, professor of cardiology at George Washington University, Washington D.C. In exercising, a man should work hard enough to raise a sweat and deepen his breathing, but not hard enough to make the heart pound and lungs gasp. Much research remains to be done to determine the precise benefits of exercise, according to Dr. Fox.

HOW DO YOU OBSERVE SEA ORGANISMS without removing them from their environment? You build a microscope system that can be used underwater for on-the-spot examinations. That’s exactly what scientists at the University of California, Santa Barbara, have done. The ‘scope is enclosed in a transparent plastic box with controls operated by means of watertight apertures. Batteries power the viewing light. The instrument, to be used for the study of sea life and pollution effects, reportedly has worked well in tests run in a swimming pool.

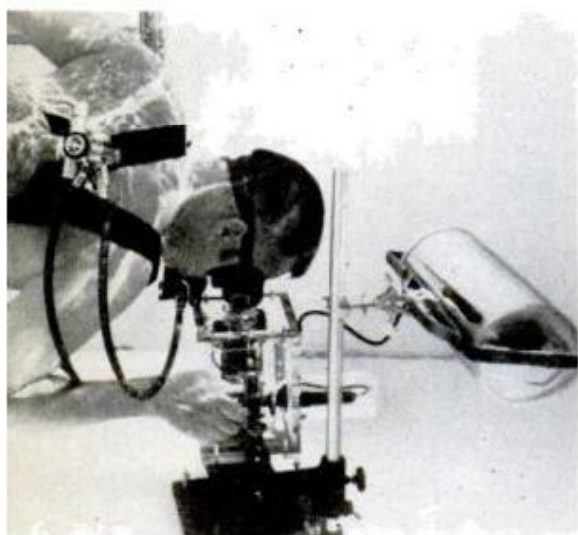

Novel way to study sea life

A NEW METHOD OF DRYING FOODS, reportedly more economical than freeze-drying, has been developed by General Foods Corp. researchers. Called “pressure freezing-air drying,” the method involves saturating foodstuffs, under pressure, with nitrogen. After the food is frozen, it’s air-dried. Retention of shape and appearance is similar to that of freeze-dried products but the new method is less costly because it does not require processing in a vacuum, as does freeze-drying. The new process can be used on foods such as carrots, celery, rice and chicken.



Chair that “reads” contours

AN ELECTRIC CHAIR—designed to produce comfort instead of a lethal jolt—has been developed by a research team at Kiel University, West Germany. By means of a system of sensors, the chair registers every flexing and contraction of a sitter’s muscles. The muscle movements are electronically converted into visual data, read from a TV screen. The “electric” chair will be used to provide information needed for the design of modern body-fitting chairs. ★★★



ROTO-HOE SHREDDER FOR ONLY \$152.00

The Roto-Hoe Cut 'N Shred's patented side hopper is exclusive in first cutting, then shredding the most fibrous garden wastes: tree prunings, stalks, vines, leaves, etc., into useable mulch or compost. The 3/4 H.P. Model can make up to 80 gallons of wood mulch per hour from prunings. Do not be misled by our low price. Out performs much higher priced machines. Also available with Tiller, Mower or Snow Thrower attachments and now the new larger capacity 5 and 8 H.P. Models.

Write the Roto-Hoe Company,
Newbury 9, Ohio 44065

NEW 1972 ARC WELDER 19⁹⁵ 5 WELDING HEATS



Plugs in any ordinary 110 volt outlet. Buy direct from the factory and save \$5. Complete - nothing else to buy. Includes *heavy duty cables *electrode holders *ground clamp *extra welding rods *full face mask. Heavy duty - 5 heats for welding, soldering, cutting and heating. Easy to operate; step-by-step instructions included. Ideal for the home handyman or craftsman - pays for itself repairing cars, trailers, lawn equipment, boats, etc.

10-DAY MONEY BACK GUARANTEE. Send only \$2 and pay postman \$17.95 plus postage when delivered, or send \$19.95 for prompt postpaid shipment. Return within 10 days for refund if not completely satisfied. Orders filled promptly - check or money order. **LIFETIME GUARANTEE.**

MINI 5 ARC WELDER Department A, 2635 Main Street, Houston, Texas 77002

\$25⁰⁰ HOURLY PROFIT IN YOUR OWN BUSINESS

Product 1 . . . **VINYL WELD**, for invisible repairing of vinyl, naugahyde, plastic or leather car tops, interiors, also upholstery and apparel.

Product 2 . . . **LIQUID "WIPE-ON VINYL COLORS"** for instant color change and/or restoration of vinyl, naugahyde, plastic or leather car tops, interiors, also upholstery and apparel.



No experience needed. Customers delighted because you save them money. Our professional kits provide you with all the materials you need to do the job like a "pro" full or part-time. We show you how to make big profits every step of the way. Work can be done on customer's premises or from your own home or business. Under \$30 starts you in this lucrative high earning career.



INTERNATIONAL FIBERGLASS Write for complete FREE details. Dept. PM-1 - 34 E. 12th Street New York, N.Y. 10003

LIVE IN THE WORLD OF TOMORROW . . . TODAY!

UNUSUAL BARGAINS

NEW PRODUCTS • NEW MATERIALS • NEW IDEAS

\$15,000 RANGEFINDER



ONLY \$450.

TREMENDOUS WAR SURPLUS VALUE in excellent condition. Mark 57, Mod O. 1-meter Erect Image Coincidence Range-finder—ranges from 10-10,000 yds., accurate to 12-arc seconds. Optics & mount alone worth more than price. Fabulous precision optical instrument. 5 1/2" X 7" dia. Yellow, dark neutral, polarizing & clear ray glass filters. Non-magnetic constr.; 2 bearing mounting surfaces (1 1/2" X 5 3/4" O.D. & 1 1/2" X 5 1/4" O.D.). Storage box, instrs. No. 85,208H . . . (Shppg. Wt.—200-lbs.) \$470.00 F.O.B.
\$1,250 HAND HELD 50 CM MODEL No. 85,213H . . . (Shppg. Wt.—11-lbs.) \$600.00 F.O.B.

AMAZING NEW Wankel Engine KIT!



Thrill to the fun of building your own see-through motorized model of revolutionary pistonless type engine . . . only engine experts think economically modifiable to meet new pollution standards. Replaces piston, cylinder, crank assemblies with rotating discs (sections removed for firing chambers). Smaller than conventional; fewer parts, greater reliability, same speed w/less horsepower. Feat: flashing plugs, rubber fan belt, stick-shift on-off switch. Req. 2—1.5V batt. (not incl.).

No. 71,424H . . . (4 1/2" X 5" X 9") . . . \$6.75 Ppd.

WAR SURPLUS ELECTRIC GENERATOR



Brand new Signal Corps Electric Generator. Generates up to 90 volts by turning crank. Use in high impedance relays. Charge ground & bring up night crawlers for bait or study. 2 Alnico Magnets alone now worth more than original gov't cost of \$15. Wt. 2 lbs. Stock No. 50,225H . . . \$8.50 Ppd.

GIANT WEATHER BALLOONS

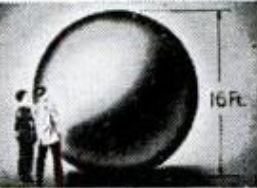

"Balls of fun" for kids, traffic stoppers for stores, terrific for amateur meteorologists. Create a neighborhood sensation. Great backyard fun. Exciting beach attraction. Amateur meteorologists use to measure cloud heights, wind speed and temp. Made of heavy-duty neoprene. Inflate with vacuum cleaner or auto air hose; or locally available helium for high rise.

Stock No. 60,568H (8' size) . . . \$2.00 Ppd.
Stock No. 60,632H (16' size) . . . \$7.00 Ppd.

AMERICAN MADE OPAQUE PROJECTOR



Projects illustrations up to 3" x 3 1/2" —enlarges them to 35" x 30" if screen is 6 1/2 ft. from projector, larger pictures if screen is farther away. No film or negatives needed. Primarily intended for children. Projects charts, diagrams, color or black-and-white in darkened room. 115 v. A.C. . . . 6 ft. cord and plug included. Size 12" x 8" x 4 1/2" wide. Weight 1 lb. 2 ozs. Plastic case.

Stock No. 70,199H . . . \$8.75 Ppd.

"FISH" WITH A MAGNET



Go treasure hunting on the bottom! Fascinating fun & sometimes profitable! Tie a line to our 5 1/2-lb. Magnet—drop it overboard in bay, river, lake or ocean. Troll it along bottom—your "treasure" haul can be outboard motors, anchors, other metal valuables. 5 1/2-lb. Magnet is war surplus—Alnico V Type—Gov't cost \$50. Lifts over 150 lbs. on land.

Stock No. 70,571H . . . \$14.00 Ppd.

Stock No. 60,215H . . . 1 1/2 lbs. . . . \$ 5.75 Ppd.
Stock No. 70,570H . . . 3 1/2 lbs. (lifts 40 lbs.) . . . \$ 8.75 Ppd.
Stock No. 85,152H . . . 15 3/4 lbs. (lifts 350 lbs.) . . . \$33.95 F.O.B.

'Bright Ideas' in Unique Lighting Big, new 100-page handbook, packed with facts, loaded with illustrations. All latest developments, applications, equipment. 8 1/2" x 11" looseleaf paper to fit 3 rings. Stock No. 9100 H . . . \$3.00 Ppd.

MAIL COUPON FOR GIANT FREE CATALOG

148 PAGES! MORE THAN 4,000 UNUSUAL BARGAINS.

Completely new 1972 Catalog. Packed with huge selection of telescopes, microscopes, binoculars, magnets, magnifiers, prisms, photo components. Ecology and unique lighting items, parts, kits, accessories—many hard-to-get surplus bargains. 100's of charts, illustrations. For hobbyists, experimenters, schools, industry.

EDMUND SCIENTIFIC CO.
300 Edscorp Building, Barrington, N. J. 08007
Please rush Free Giant Catalog "H"

Name

Address

City State Zip



EDMUND SCIENTIFIC CO. 300 EDSCORP BLDG. BARRINGTON, NEW JERSEY 08007
ORDER BY STOCK NUMBER - SEND CHECK OR MONEY ORDER - MONEY BACK GUARANTEE

DETROIT

LISTENING POST

BY ROBERT LUND

WILL OLDS GET THE NOD over Chevy as the first GM division to offer a Wankel? Probably not, although the idea isn't as far out as it seems. In the latest phase of its Wankel development program, GM's teamed the rotary piston with front-wheel drive. An agent on the inside says the front-wheel-drive version has it all over conventional rear-wheel drive in handling. Olds has more experience with front-wheel drive than any other GM division. But GM figures all the angles and one question it's sure to consider in tossing the coin to decide which division gets first crack at the Wankel is what the repercussions will be if the engine bombs out. Chevy has the volume so it could recover from an Edsel-size flop. Olds isn't that big. So you can put Olds down as a candidate to pioneer the Wankel, but don't bet big.

There's still the problem of developing seals for the Wankel before it can be put in production. GM's far from satisfied with the seals it's come up with so far, contrary to reports that the sealing problem's been solved. A supplier who has a remote connection with the GM program describes the situation on seals this way: "When they started out, seals were blowing at 8000 miles. Now they're up to 30,000 to 40,000 miles. But that's still 10,000 miles short of what GM would consider a minimum, and they're shooting for something well above the minimum."

PINTO STATION WAGON will be in Ford showrooms within the month. The Squire model shown below is the dress-up version featuring simulated-

wood side panels. Standard in the wagons will be the larger Pinto engine, the 2000-cc (121.6-cu.-in.) in-line Four. On the same wheelbase as the Pinto sedan models, the wagon will have increased rear overhang to bring overall length to 172.7 inches. Cargo area dimensions with rear seat folded are 69.2 inches long, 42.5 inches between wheel-houses and 31.5 inches maximum cargo height. Cargo volume is 60.6 cu. ft. Tailgate is one-piece, top-hinged with fixed rear window.—B.H.

WHAT THE AUTO BUSINESS NEEDS now is another Mustang. Not the current Mustang, but the original—a sporty, new-shaped, new-looking car priced as close to \$2500 as possible and definitely under \$3000. Three of the four auto firms—Chrysler's the exception—are working on son-of-Mustang-type cars for 1974-1975. Make that plural, because GM has three of them on the boards. Don't confuse the "economy" sportsters with the smaller-than-Vega, smaller-than-Pinto cars coming in a few years. They're in addition to the sub-shavetails, not replacements for the American-style VWs.

SUB-MINIS MAY BE DELAYED a year or two. They're coming for sure. But when? The finance committees at GM and Ford want their money back on Vega and Pinto before approving new outlays for still smaller cars. The sales departments argue that they need the minimachines by fall of '73, as '74 models. But the money men want the tooling bills paid off on the little cars that came out two years ago before they reach in the sock

(Please turn to page 38)



Peace of mind.

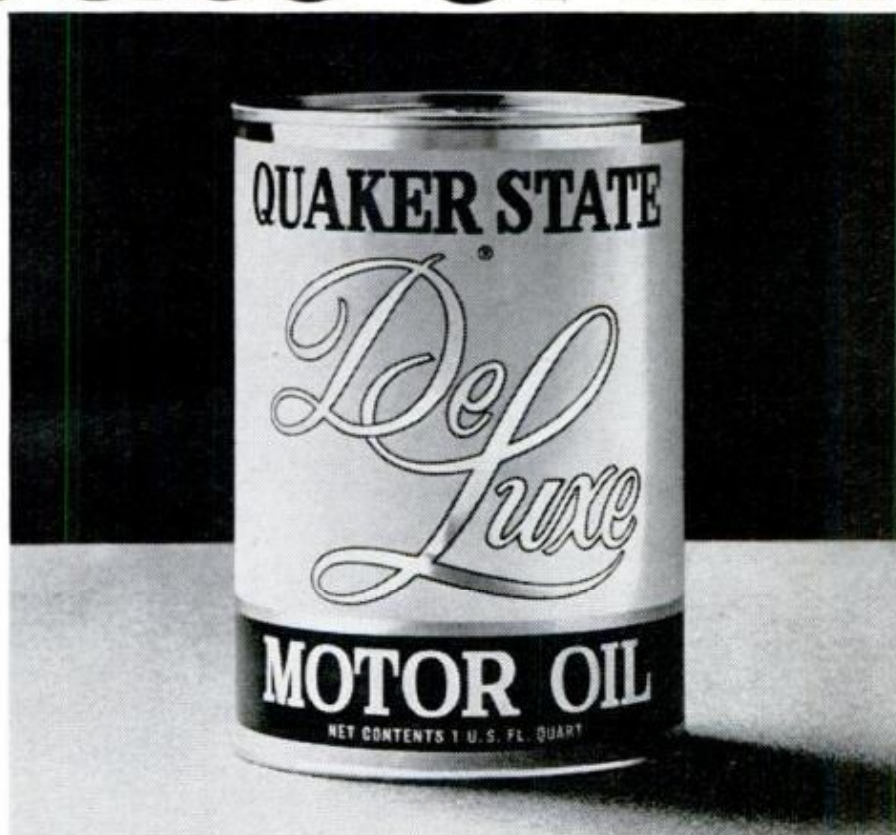

This is peace of mind by the quart. Use it and you know you're giving your engine the best protection money can buy.

Quaker State DeLuxe 10W-40 Motor oil is deliberately designed to exceed the motor oil requirements of today's more demanding engines. Quaker State is refined only from 100% Pure Pennsylvania Grade Crude Oil, the world's choicest. Then it's fortified by oil specialists to protect your engine under tough driving conditions.

This year, buy yourself some peace of mind. Ask for Quaker State wherever they care about cars. The times demand it.



Quaker State your car to keep it running young.



This point lets you bore holes up to 1 1/2" with small electric drill

IT'S HOLLOW GROUND to bore cleaner, faster at any angle

Now step-up the boring range of your small electric drill or drill press to 1 1/2" with Irwin Speedbor "88" wood bits. 1/4" shank chucks perfectly. No wobble. No run-out. Sharp cutting edges on exclusive hollow ground point start holes faster, let spade type cutters bore up to 5 times faster. You get clean, accurate holes in any wood at any cutting angle.

Each Irwin Speedbor "88" forged from single bar of finest tool steel. Each machine-sharpened and heat tempered full length for long life. 17 sizes, 1/4" to 1 1/2", and sets. See your Irwin hardware or building supply dealer soon.

\$.90 each	\$1.00 each	\$1.50 each
1/4" to 5/16"	5/8" to 1"	1 1/8" to 1 1/2"



IRWIN SPEEDBOR "88" WOOD BITS
at Wilmington, Ohio 45177, since 1885

EARN HIGH WAGES as a HEAVY EQUIPMENT OPERATOR

Train your way to high pay in the booming construction industry! Learn the skills you need to qualify, by actual field training on machines like the ones used by the industry. Huge training grounds in North Carolina, a million dollars worth of school-owned diesel-engined machines, experienced instructors, full 220-hour and 440-hour courses. National, the original school of heavy equipment operation, is a recognized leader. Member American Road Builders Assn., Services and Supply Division. Associate Member A.G.C. Full-time Job Advisory and Counseling Director on staff. Accredited for VA benefits. For men ages 17 and up. Train Now-Pay Later plan . . . other payment plans also available. Write TODAY for FREE catalog and FREE copy of school newspaper reporting news of National School graduates. Accredited member National Association of Trade and Technical Schools.

NATIONAL SCHOOL OF HEAVY EQUIPMENT OPERATION, Dept. D-59
Phone 704/392-1359
P. O. Box 8529, Moores Chapel Road, Charlotte, N. C. 28201

Please send me FREE illustrated school catalog and complete information. I understand there's no obligation.

Name _____ Age _____
Address _____ Phone _____
City _____ State _____ Zip Code _____

DETROIT LISTENING POST

(Continued from page 36)

for another stake. Henry Ford II has the clout to override the finance committee at Ford. But nobody tells the finance committee what to do at GM.

SINGLE ACCESS DOOR for front and rear seats—one big door instead of two little slabs—is an idea Ford's looked at for its under-Pinto-size car. Forward edge would be hinged at the A pillar; back section at C post. Sounds like a try-it-on-for-size idea that's likely to get pitched out in the final wrap-up.

THE DOUBLE-DOOR IDEA makes sense, if auto companies hope to salvage the two-door car. This body style appears doomed because of an upcoming government regulation requiring a solid metal bar mounted across the back of the front seat to protect the driver against rear impact. Using a solid bar, front seats couldn't be folded forward to allow entry to the rear. GM's already let leak it will convert its two-door hardtops to four-doors this fall. But the two-door may be "re-invented" in a few years. Engineers are trying to work out a compromise to satisfy the safety regulation and permit two-door production. How? By designing the impact bar across the back of the front seat so it can be released to telescope or fold when the front doors open.

GOVERNMENT GOOF-UP? Has anyone in the Department of Transportation, where they write the rules for the auto companies, tumbled to the fact that rear bumpers on the '73 cars may not be as good as those on the '71s and '72s? The DOT standard effective next September requires rear bumpers to take an impact of 2.5 mph without damaging the sheet metal. Many current cars, and even some earlier models, can take a 2.8-mph ram in the rear without crinkling the sheet metal. So if the industry follows the DOT standard on '73 models, rear bumpers will be more fragile than now. This is progress?

FORD'S ABOUT DECIDED to give up on its mid-engine Pantera, despite a ready market for all copies coming in from Italy. It will market the car as long as the law allows, but the cost of making it over to comply with regulations for '74 and '75 indicates a phase-out.

MISERY DETROIT-STYLE, as defined by Bob Orben: "That's when you spend \$50 million to bring out a new car and the first one off the line is sold to Ralph Nader!" ★★★

Jeep Truck. When you work it over, you don't overwork it.



With Jeep guts, this husky 4-wheel drive truck is no stick-in-the-mud.

The Jeep Truck is built for hard and unusual punishment. It comes through, come mud, water, snow, or sand. With a load that'd bog down most others. The reason: Jeep guts.

That means go-anywhere Jeep 4-wheel drive. A rugged suspension, with strong multi-leaf springs all around for greater stability. And a rugged frame with 5 cross-members.



The Jeep Truck gives you a choice of powerful straight-6 or V-8 engines. Plus your choice of transmissions geared to your field of work—

3-speed, heavy-duty 4-speed, or automatic.

And there's a selection of wheelbases—120" or 132". A choice of 4 GVW's—5000 to 8000 lbs.

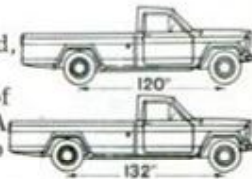

All in all, this has to be the choicest of trucks. There's a lot more, too. Find out all about it from your Jeep dealer. He'll work out a choice deal for you.

Toughest 4-letter word on wheels.

Jeep

Drive your Jeep vehicle with care and keep America the Beautiful.

Drivin' with Dan

What are roll understeer, oversteer? Which courses should new race drivers study? Does experience in drag racing help drivers in oval or road races? Dan Gurney answers these and other automotive questions

Q: *If you have a stock 1968 Chevy Malibu with a 200-hp, 307-cu.-in. engine and a stock 1970 Chrysler 300 with a 375-hp 440-cu.-in. engine, both with automatic transmissions, which would win in a quarter-mile race? What would you say is the fastest American production car?—John Haynes, Northridge, Calif.*

A: Of course, at first glance the Chrysler looks like the winner, but you must race them to be sure. I'd guess the fastest production car in the United States would be the big Corvette.

Q: *In November's PM you told a young man how to start driving. I've been an avid racing student for two years and have been around demolition derby cars and stock cars, as well as supermodified hardtops. Are there any driving schools for women?—Edith Casterline, Dixon, Calif.*

A: I don't believe there are any such schools that are exclusively organized for women. Most of the existing schools would be happy to have a young lady have a go at embarrassing the men.

Q: *Has the Indy 500 ever been won on any other tires than Goodyear?—Rusty Ketchum, Canoga Park, Calif.*

A: Sure. Firestone has won Indy many times;

in fact, for quite a spell it was the only company building Indy tires. Goodyear has been at Indy since 1964 and its participation has heated up the competition to a real fever pitch. From Indy this competition has spread to Grand Prix and Can-Am racing. Goodyear has won more NASCAR stock-car races than any other outfit by far in recent times.

Q: *What do roll understeer and roll oversteer mean? And what does roll have to do with a car's stability on the road?—Benjamin Chouake, Forest Hills, N.Y.*

A: The first two terms usually refer to what happens to the wheels (mostly rear wheels) when the car is forced down on the suspension on the side nearest to the outside of a turn, and forced up on the suspension on the inside of a turn. The wheels actually steer a little bit. Understeer turns the wheels slightly toward the inside of the turn; oversteer turns them toward the outside. Roll affects different cars in varying amounts. Most racing cars roll less than passenger cars. Some drivers prefer more roll than others.

Q: *Could you name some of the important engineering courses that relate to auto racing? What other courses should be studied if you are*
(Please turn to page 42)



DAN DRIVES AGAIN! In the Cannonball Baker Sea to Shining Sea Memorial Trophy Dash (New York to Los Angeles), Dan and co-driver Brock Yates took first place with a time of 35 hours and 54 minutes—a new unofficial record! The car was a Kirk F. White Motor Racing Ferrari 365 GTB/4 Daytona. (This drawing of the car was done by artist John W. Barnes Jr. For information about prints, write to him at Box 323, Scarsdale, N.Y. 10583)

AC ACnitters...

the spark plugs that are original equipment on '72 GM cars

Again in 1972, Chevrolet, Pontiac, Oldsmobile, Buick and Cadillac engineers have selected AC ACniter Spark Plugs for their new line of cars.

AC ACnitters have been original equipment spark plugs on these General Motors cars since 1969.

And with good reason.

AC ACnitters have a built-in suppressor that meters the spark energy for more reliable performance and longer electrode life.

The exclusive ACniter suppressor also helps reduce radio frequency interference. This means improved car radio reception for you and your fellow drivers ... and improved TV reception for everyone.

AC ACnitters are available as replacement spark plugs for all GM cars and most other makes and models.

When it's time to tune up your car, insist on AC ACniter Spark Plugs—the ones that are original equipment on GM cars.



AC SPARK PLUG DIVISION OF GENERAL MOTORS



Get into metalworking

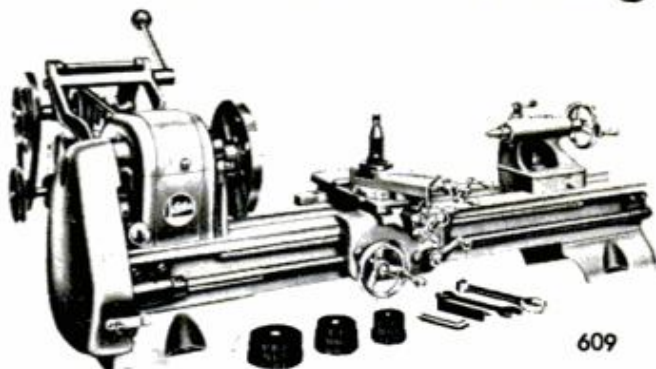

with an Atlas 6" Lathe

... it handles turning, screw cutting, drilling, milling, boring — a host of operations — with speed and precision. Equips you for making metal parts, repairs, models — can pay for itself in a few "moonlight" jobs. Best of all, with an Atlas back-geared 6" lathe, you develop your skill for the metal age for a small investment — only \$268.00 F.O.B. factory.

Write for free catalog

CLAUSING

LATHES
DRILLS
MILLS
GRINDERS

2-24 N. Pitcher St. • Kalamazoo, Mich.

FREE!

LAFAYETTE 1972 Catalog

468 Pages

Our 51st Year



Stereo Hi-Fi ■ Citizens Band
■ Ham Gear ■ Tape Recorders
■ Test Equipment ■ TV and Radio Tubes and Parts
■ Cameras ■ Auto Accessories
■ Musical Instruments
■ Tools ■ Books

Your Complete Buying Guide to Everything in Electronics

Lafayette Radio Electronics
Dept. 15022 P.O. Box 10
Syosset, L.I., N.Y. 11791

Send me my FREE Catalog

15022

Name

Address

City

State Zip

DRIVIN' WITH DAN

(Continued from page 40)

planning to become a race driver?—Ken Demartyn, Enola, Pa.

A: There are more courses available than I could possibly suggest. Some that would be helpful are metallurgy, chassis engineering, suspension engineering, aerodynamics, heat dynamics and machine design.

Q: I can't see that drag racing, even in the AA fuel dragster or funny cars, is of any help to someone who wants to race ovals or road courses. What do you think?—Lee Osterman, Rockford, Ill.

A: I think it is bound to teach you many things about vehicles that will help you on ovals and road courses. On the other hand, oval and road-course experience would not necessarily make you a great drag racer.

Q: I run a VW off-road and I'm curious as to how much "straight pipe" length you can run without burning up your valves.—James Perkins, Rutland, Vt.

A: To the best of my knowledge there is no limit.

Q: I am interested in the Chaparral Ground-Effect Car. Could you tell me where I can get information on it?—Bill Schuck, New York.

A: Write to Don Gates of Antares Engineering, Jackson, Mich. He is the originator of the Ground-Effect Chaparral.

Q: There was a race on television where cars were racing on a frozen lake without special tires or adjustments. I think it was in Michigan. What type race was this and where can I get information about it?—Dennis Matt, Lyndhurst, N.J.

A: I'll bet there were plenty of bent fenders and that slowing down was a real chore! You can find out more about it by reading Dick Bauer's *Learn About Winter Driving from the Ice Racers* (page 76, Dec '71 PM).

Q: Recently, I read that a good way to get the motor started on cold mornings is to turn the lights on for about 30 seconds, and then off. The article said this motivated the electrical system and provided a good charge for the motor when

(Please turn to page 44)

MAKE EXTRA \$\$\$ EVERY DAY!

Get into the big, year-round

EXTRA MONEY BUSINESS

that's EASY to learn—EASY to do—and EASY ON YOU!

Be a LOCKSMITH!

You Can Make Up to \$10 an Hour—even while learning!
Train FAST at Home!

Never before have money-making opportunities been so great for qualified Locksmiths. Now lucrative regular lock and key business has multiplied a thousandfold as millions seek more protection against zooming crime. Yet there's only one Locksmith for every 17,000 people!

Start Collecting CASH PROFITS Right Away

You're "in business" ready to earn \$5 to \$10 an hour a few days after you begin Belsaw's shortcut training. Take advantage of today's unprecedented opportunities in Locksmithing for year-round EXTRA INCOME in spare-time—or fulltime in a high-profit business of your own. Hundreds we've trained have done it. So can YOU! All tools plus professional Key Machine given you with course. These plus practice materials and equipment,

THIS PRO KEY MACHINE—YOURS TO KEEP—

can add \$25 to \$40 a week to your income . . . and it won't cost you a cent with your training.

ALL TOOLS, MATERIALS AND PRACTICE EQUIPMENT COME TO YOU WITH YOUR COURSE.



FREE



Tells how to make money in Locksmithing almost from the start!

"War injuries left me badly handicapped, but now I'm a financial success as a Locksmith, thanks to your training. Besides, the work is fascinating. If I can do it anybody can." — Glen Johnson, Larned, Kan.



plus simple, illustrated lessons, plus expert supervision, plus business-building guidance will enable you to KEEP THE MONEY COMING IN! Ideal for retirement—good jobs, too.

SEND FOR EXCITING FACTS—No Obligation

Discover what's in Locksmithing for you—how Belsaw's master-locksmith-approved training can give you the skill you can depend on to EARN MORE—ENJOY LIFE MORE. Just fill in and mail the coupon below to receive full information by return mail. Do it TODAY!

BELSAW INSTITUTE, 102F Field Bldg., Kansas City, Mo. 64111
Accredited Member National Home Study Council
Approved for all Veteran Training

MAIL THIS COUPON—NO SALESMAN WILL CALL

**BELSAW INSTITUTE, 102F Field Bldg.
Kansas City, Missouri 64111**

Please send me free of cost or obligation your publication "Keys to Your Future" on how Belsaw can quickly train me to make money in Locksmithing and how all tools and Key Machine are given me to keep.

Name _____

Address _____

City _____ State _____ Zip _____

Check here if eligible Veteran.

START A NEW CAREER NOW—AT HOME *Nothing like this taught anywhere!*

Learn AUTO UPHOLSTERING & Vehicle Interior Customizing

U.S. & FOREIGN CARS, CAMPERS, TRAILERS, BOATS, PLANES

Upholster Any Vehicle, Start With Your Own Car!

Now—AUTO UPHOLSTERY INSTITUTE (A.U.I.) trains you right in your own home for the high profits and great satisfactions of the fabulous, booming, Auto Upholstery—Vehicle Customizing industry. You learn step-by-step, start on your own car if you wish, then start taking in outside jobs for extra cash. Finally open a full time auto trim shop that will earn you TOP MONEY year after year—or just keep this skill as a hobby.

THINK OF ALL THE VEHICLE UPHOLSTERING TO BE DONE! TRAINING KITS INCLUDED WITH COURSE! Cars, both custom and standard, boats, campers, trailers, planes, bucket seats, regular seats, convertible & landau tops, headliners, auto glass, headrests, carpeting, diamond tufting, tuck & roll, channel backs, pleated seats—all this and more—you learn the tried & proven A.U.I. way, with step-by-step-illustrated instruction, plus ingenious training kits that teach you to do all these fascinating trim jobs right at home! When you get the A.U.I. diploma, you are a REAL PROFESSIONAL.

CLEAN, LIGHT WORK! NO GREASE! NO BIG INVESTMENT NEEDED! WE SHOW YOU HOW, in your spare time. And, once you have learned (just a few short months) your skill will ALWAYS be in demand. This is hand work—no computer will ever take your trade away—and there is an unlimited demand for skilled men and women in this field right now. No age limit—no special education needed.

NO NEED TO QUIT YOUR PRESENT JOB! NO AUTOMATION LAYOFFS. Since the birth of the automobile, training in vehicle upholstery and customizing has been neglected. In the past, you had to spend YEARS as an apprentice to learn this wonderful field. Now, thanks to A.U.I.'s step-by-step, practical home training method, you don't even have to quit your present job to learn!

**AUTO UPHOLSTERY INSTITUTE,
BOX 64-GE, Orange, Calif. 92669**



NOTE TO SERVICE STATION MEN! MAKE YOUR INTEREST IN CARS PAY OFF!
Now—add substantially to your income with auto trim. No additional big space needed—just use your present facilities! Make BIG additional income without extra overhead! . . . without dirt, grease, fuss or muss!

STARTED AS A HOBBY, NOW PAYS ME BIG MONEY!



SPECIAL OFFER TO COUPLES—TEAMS DO WELL TOGETHER! (RELATED OR NOT) Women, as well as men, seem to do beautifully in auto trim and vehicle upholstery work. Husband & wife teams often add substantial extra cash to the family budget. Therefore, A.U.I. makes it possible for couples (can be a relation or friend, too) to enroll together, study together, each get a separate diploma upon graduation.

TO GET STARTED JUST SEND IN THE COUPON TODAY! You'll get our big, illustrated booklet telling all about opportunities in this big paying, fun-filled field of Auto Trim Vehicle Customizing. Send for it now!

TOOLS OF THE TRADE INCLUDED. A.U.I. sends you hand tools of the trade needed to get started with your auto trim work—no extra charge!



You get this State Authorized Diploma When You Graduate

AUTO UPHOLSTERY INSTITUTE, BOX 64-GE, Orange, Calif. 92669

Please send me your big free illustrated booklet giving me full information about present and future opportunities for earning big money and enjoying a hobby in auto trim and vehicle customizing. I understand I am under no obligation, and no salesman will call upon me, in person or by phone.

Name _____ Age _____

Address _____

City _____ State _____ Zip _____

SEND FOR FREE BOOK

Briggs & Stratton — Clinton New Gas Engine Sale

Never before and perhaps never again—this offer of brand new genuine Clinton and Briggs & Stratton engines including 1 yr. factory warranty at less than cost. Perfect power for go-carts, scooters, tractors, mowers, generators, pumps, sprayers, etc. We hauled out 3 big factories who needed cash and the savings are yours while quantities last. Act fast.



Clinton 2 1/2 hp. Md. 500—Re-coil starter Std. 5/8 shaft w. keyway—ready to go. Reg. price \$59.50
Special (item 1002)

\$39.95

2 for \$78.95
6 for \$229.50



Briggs & Stratton 6 hp. Md. 81100 recoil start. 3/4 shaft. Sturdy 4 cycle engine. Reg. price \$69.50
Spec Item = 1518

\$39.50

2 for \$78.95
6 for \$229.50

\$84.50

**6 hp.
Briggs
&
Stratton**



Same engine with 12 v. elec. starting.

(Item = 1571) **\$109.50**

Briggs & Stratton 5 3/4 hp. Md. 143302. Re-coil start. Std. 1" shaft w. keyway, and adjustable governor—a rugged big engine ready to tackle any job. Regular price \$97.60
Special (item 1059) ... **\$84.50**

8 h.p. Kohler—\$139.95

Model K181T, rugged cast iron, continuous duty engine, recoil stock, 1 3/8" dia. shaft.

Item #2166 **139.95**
2 for **249.50**

3 1/2 h.p. Clinton—44.95

A big engine with big power. Model 404, 4 cycle, rope start, 3/4" std. shaft. Industrial ball bearing engine.

Item 404 **44.95**
2 for **87.95**

Remember these engines are absolutely perfect and standard and under factory warranty. Money back guarantee. Order now while stocks are complete. Factories—we buy new engines.



STANDARD DIAL PHONES WITH BELL

Bell System late model dial phones same as used by all telephone companies. Deal as extensions on any system. Easy to connect. Several may be connected on one line. Easily modified for private inter-com system. Cost \$40.00 new—guaranteed excellent condition.

ITEM 855 NC. Wt. 8 lbs.

\$8.95



TRUCK OR BOAT WINCH 2000=

A powerful, compact winch which installs easily even in limited space. Works with any 12, 24 or 32 volt system. Reverses under power—gear train holds load. Drip proof cover. 20' remote control if desired. \$15.00 addnl. Drum holds 100 ft. of 3/4" cable. Speed 30 ft. per minute. A terrific winch at an economy price.

Item 1263—Wt. 55# **\$74.50**



RECHARGE ALL BATTERIES

Only Everlite

- Charges 6 batteries
- Charges 3 times faster
- Charges all batteries

Including hearing aid, flashlight, lantern, radio, in fact any battery up to 12V. Save Money and have the convenience of fresh batteries always. Simple and 100% Safe. Plugs into any 115V. outlet. Guar. for one year. Send \$6.95 plus \$.65 for shipping. Send 25c for 90pg. catalog

695



Send 25c for 100 page Catalog FREE with order. Prices f.o.b. factory—Send check or MO

MASTER MECHANIC MFG. CO., Dept. A-22, Burlington, Wis.
Box A, Burlington, Wis. 53105 or Box 65, Sarasota, Fla. 33578

DRIVIN' WITH DAN

(Continued from page 42)

the starter is activated. Does this make sense to you?—Warren A. Reeder Jr.

A: No. Don't do it.

Q: I am only 14 and would like to know if I can get a license for a trail bike in Pennsylvania.—T.J.R., Hazelton, Pa.

A: Check your State Dept. of Motor Vehicles to be sure, but most states do not require that a motorcycle be licensed if it is not to be used on public streets or highways. In other words, you probably don't need a license at all, regardless of your age.

Q: How do you get information about Grand Prix racing, Formula 1 cars and international Grand Prix tracks? Which racing magazines do you think have best coverage?—Glenn Brooks, Calhoun, Ga.

A: I subscribe to several racing publications which should answer both your questions. They are, Auto Sport, Craven House, 34 Foubert's Place, London W.I., England; Motoring News, Standard House, Bonhill St., London E.C. 2, England; Competition Press & Autoweek, Autoweek Building, Lafayette, Calif. 94549; Road & Track, Bond Publishing Co., 1499 Monrovia Ave., Newport Beach, Calif. 92663; and Motor Sport, Standard House, Bonhill St., London E.C. 2, England. A publication giving thorough coverage of U.S. racing of all types as well as international events is National Speed Sport News, News Building, Ridgewood, N.J. 07451.

Q: What is the "Olsonite" that I have seen on your cars for years? Is that the type of Eagle?—Jimmy Scott, Kildare, Wyo.

A: The word stands for the Olsonite Co., one of our long-time major sponsors in racing and the world's largest manufacturer of toilet seats. It is a derivative of the name of the owner, "Ozzie" Olson. His companies also make many other plastic and steel products, such as steering wheels, steel castings, air-conditioning duct and insulating and packaging materials. ***

If you have questions on racing, high-performance and everyday driving techniques, send them to "Drivin' with Dan," c/o Popular Mechanics, 224 West 57th St., New York, N.Y. 10019. Questions cannot be answered by individual letters. Questions on maintenance and repair should be addressed to the Auto Clinic (see page 26).



CARPET DETERGER



UPHOLSTERY DETERGER



WALL DETERGER

3 proven ways to your own money-making business

You offer a service everybody needs . . . work full time or part time . . . own your equipment . . . keep all you earn . . . start with just a small investment . . . and we help you every step of the way!

Have your own money-making business and make the kind of income you probably thought impossible. You can when you clean carpeting or upholstery or walls with Von Schrader professional cleaning equipment. Every home, every building, are potential customers. And every customer represents repeat business.

Moreover, we help you every step of the way . . . just as we have helped thousands of other Von Schrader Associates build money-making businesses for almost 40 years.

There are three easy-to-operate Von Schrader Detergers. Each offers a proven way to a growing income. (1) *Von Schrader Carpet Deterger* gives deep-level cleaning to carpeting. (2) *Von Schrader Upholstery Deterger* cleans fabrics and synthetics beautifully (3) *Von Schrader Wall Deterger* cleans walls (and ceilings) five times faster than by hand.

You can start with just one Deterger. Then, as your business keeps growing, you may want to add the other two and thus offer a complete cleaning service.

There are no fees, royalties, or contracts. You own your equipment, the finest of its kind. And your investment is so small you may find it hard to believe. For complete information—without any obligation—send for the free booklet described below.



“Let me send you our free booklet that gives all the facts”

—Francis von Schrader, President

Read about the big demand for on-location cleaning, see why Von Schrader Detergers are the finest of their kind, how easy they are to operate. Learn how other men have become financially independent, how Von Schrader helps you every step of the way. Fill in the coupon and send for free booklet.

Extra! Special Recorded Message included with booklet. Listen as Francis von Schrader talks to you personally about your growing future with Von Schrader Detergers.



VON SCHRADER company

1022 Place, Racine, Wisconsin 53403

Please send complete information on Von Schrader Detergers.

Name _____

Address _____

City _____

State _____ Zip _____

For a guaranteed choice of jobs call 800-631-1972 toll free.*



Now you can get information on Air Force opportunities by calling this number anywhere in the country — toll free. And it can be a real hot line as far as your future is concerned.

For instance, any job you're trained for, any skill you learn in the Air Force will be valuable to you in or out of the service. Air Force skills are lifetime skills. Right now, your Air Force Recruiter has a special listing of select jobs that he can guarantee to you before you join up. No more chance, just choice.

Give the Air Force a call. It could be the most important call you ever made. (*In New Jersey call 800-962-2803.)

Find yourself in the Air Force.

Need More Money? Want to Be Your Own Boss?

START SAW SHARPENING BUSINESS

Of Your Own - in Your Sparetime

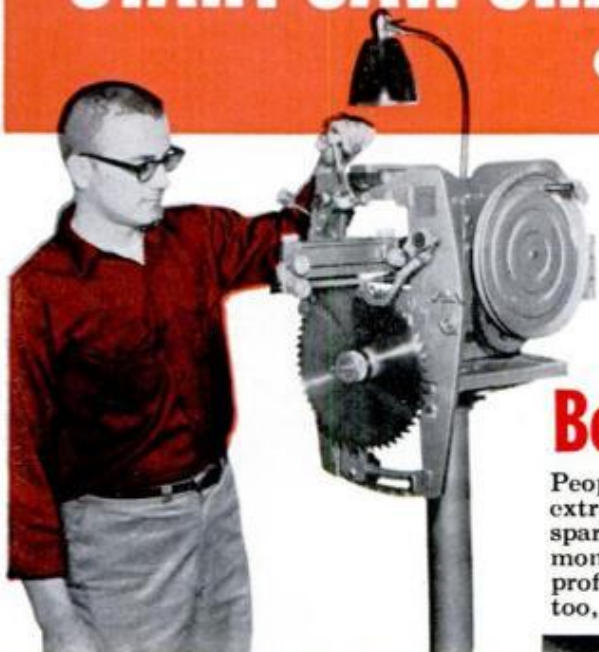

Turn your spare hours in the evening or week-ends into extra dollars, this proven practical way—start your own money-making sharpening business—No selling or canvassing—No experience required. You can do it automatically with the Foley Saw Filer or Lawn Mower Sharpener.

Beginners Earn \$3 to \$6 an Hour

People, just like yourself, all over the United States are making extra cash—\$20 to \$30 a week—right now in their spare time. "My sparetime saw filing business has made me \$952 these first ten months," says R. T. Chapman. Many start part-time, find it so profitable that they build year-round service business. You can, too, simply by following easy Foley plan.

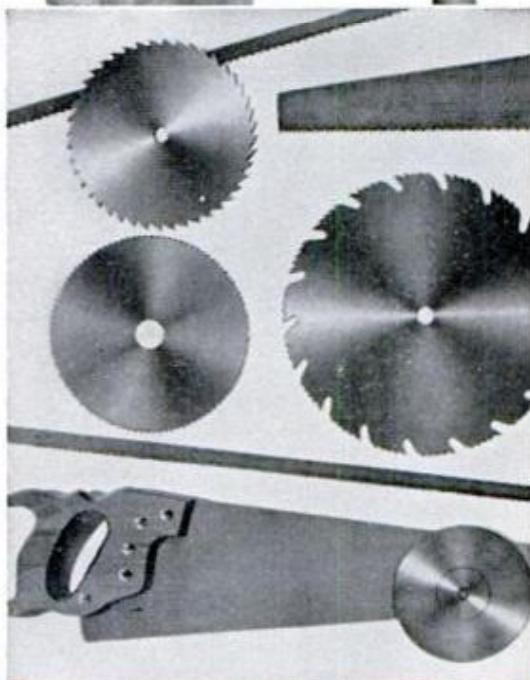

Town of 150 Supports Profitable Business

Here's the story from Dick and Jo Ann Koester after being in business less than a year. "We have acquired another Foley Saw Filer and for the past two months we have been in full-time operation. As we live in a small town of 150 population in farm area we use our truck to pick up saws in five nearby towns. With a family to support and plans for building to our house we had to pick up a business fast and already sharpen an average of 15-20 saws a day. Business for the future looks even better as good machine filing is our best advertising."

CASH for Sharpening Mowers

Every neighbor with a lawn needs his lawn mower sharpened at least once a year. No experience is needed to start—anyone can operate and turn out professional jobs. All operations are handled quickly, easily and accurately.



Sharpen These Professionally
with amazing

Foley Saw Filer

You can sharpen combination (rip and crosscut) circular saws, band saws, hand saws, crosscut circular saws—and do a perfect job every time without experience or special training. The precision Foley Filer does it for you automatically! A complete repair shop in one machine! Set up in basement or garage, work your own hours in your own way and earn big sparetime profits.



FREE

BOOKLET TELLS HOW! Free Book "Money Making Facts" shows just how you can start at home in spare time. Small investment—time payments if desired. Get this booklet—study it! Send coupon today. No salesman will call on you.

Foley Manufacturing Co., 216-2 Foley Bldg.
Minneapolis, Minnesota 55418

Send Free Booklet on Saw Sharpening Business Lawn Mower Sharpening

Name _____

Address _____

City _____ State _____ Zipcode _____

After the

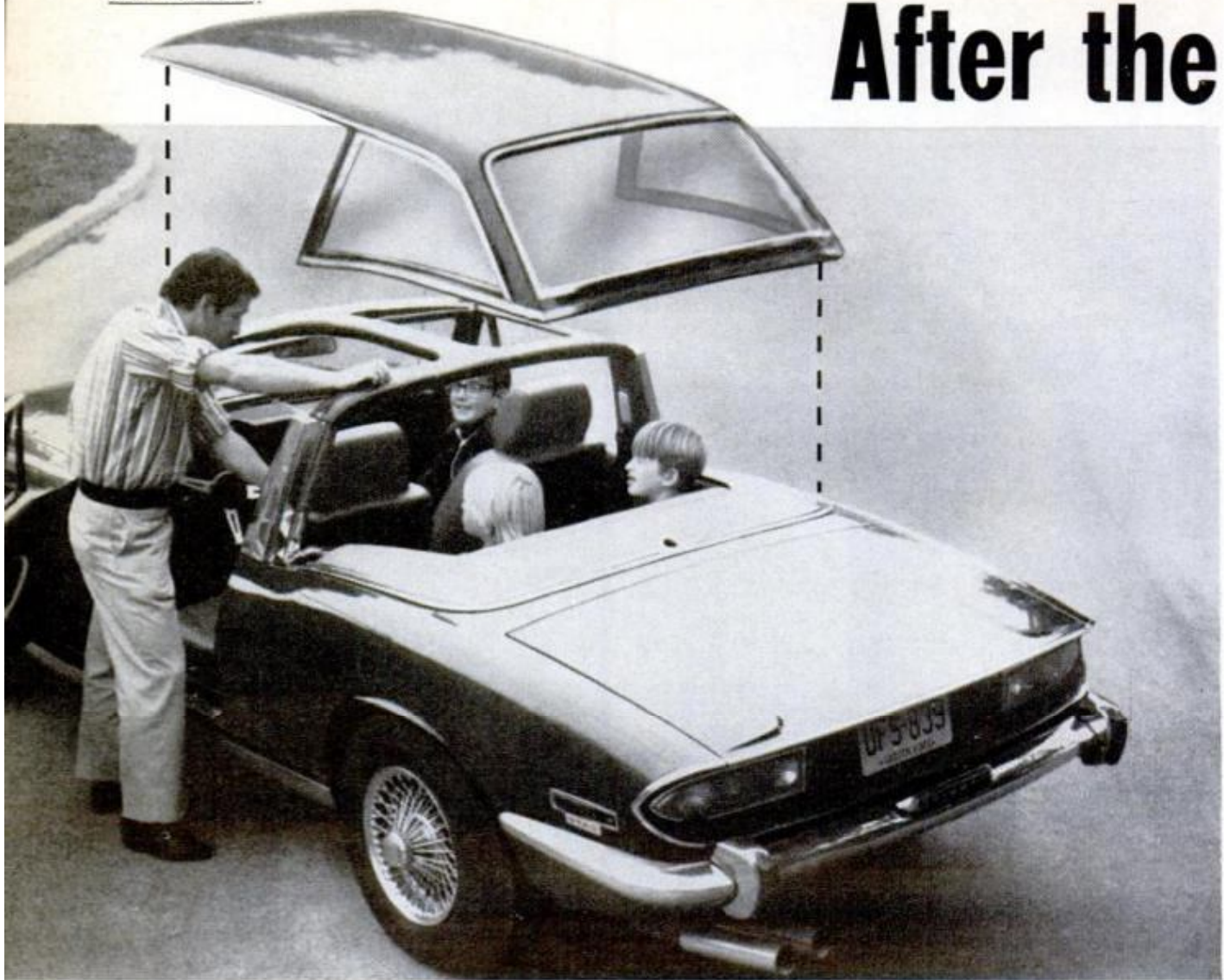

LIFT-OFF TOP of the new Triumph Stag leaves a padded roll bar for protection in rollover accidents, and increased structural rigidity of the entire car. Less stressing and twisting of the body means fewer potential rattles to develop. The British-built Stag offers the versatility of an open car/closed car and is one of the few "convertibles" now available that has the additional feature of a respectably sized and comfortable back seat. The attentive, belted-in young boys are getting the idea that driving can be safe and still be fun!



SNEAK PHOTO of a '73 General Motors intermediate hardtop during tests reveals a wide "B" post between front and rear side glass. Beefed-up pillar will help the hardtops meet the 1973 federal rollover standards. Reported to be an Oldsmobile Cutlass model, the car is likely to be offered with sunroof option. Sunroof installations in new cars for the '72 model year will more than triple those for '71



SLIDING STEEL SUNROOF on more expensive domestic models is electrically operated. Those offered on compact and subcompact cars are most often of folding vinyl. Vinyl isn't burglarproof so insurance companies don't like it. The big boom for '73 and '74 model years will be the manually operated sliding steel roof such as that used by VW—solid, tight and easily rolled back with a folding hand crank

convertible-what?



LOOK MA, ONE HAND! Removable fiberglass roof on the mid-engine Porsche 914 (above) is lightweight and one piece. It stows in the car's rear trunk on special clips (below), leaving luggage space under it. The ideal configuration for open-car sportiness and closed-car comfort, the Porsche solution is also solid and safe since the disguised roll bar and backlight are integral with the car body. Two hooks on windshield frame and two in roll bar firmly secure the roof and quickly release so that it can be removed

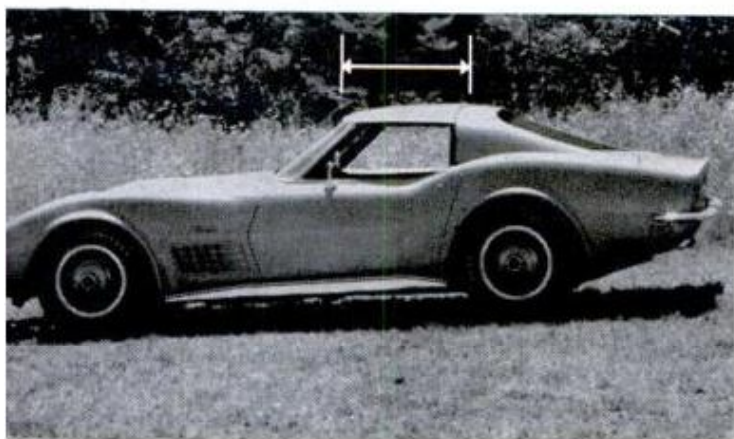

TWO ROOF PANELS on either side of Corvette lift off and leave an integral roll bar and a center support between roll bar and windshield. Backlight also pops out and stows behind seats with roof panels

Alas, there are no more Dodge, Chrysler-Plymouth or American Motors ragtops; Ford's 1973 convertibles are likely to be their last and GM's will be next to go. How's a sport going to get some wind in his face?

By **BILL HARTFORD**, Auto Editor

WHO KILLED THE CONVERTIBLE? It was all of us easy riders who opted for the soft ride over the soft top: We'd rather shut out the sun and turn on the airconditioner; rather power up the side window than choke on gusts of soot; and rather drive the high-speed pikes aerodynamically buttoned down than top down.

Or maybe you've had your soft top slashed? If it hasn't happened to you, your insurance man can tell you how often it's happened to others. And how about the structural problems and rattles of topless cars—and leaks and drafts?

Maybe you don't mind a draft and a stiff neck, but how about saving your neck in a rollover accident. Government safety requirements for occupant protection will smite the final blow to the soft top. If you can remember laying on that ol' top dressing and squinting through a discolored and cracked backlight—zap!—you're an old-timer. Domestic convertible sales are down to about 76,000 in '71 from their big peak in '65 of 507,000!

But the dream of the "red convertible" is practically genetic. And therefore the soaring demand for more practical yet exciting solutions to the perennial open car/closed car dilemma, some of which are shown here.

The hottest option for open-air driving is the sunroof. Long popular in Europe, the hole in the roof is proliferating here. Likely to be available soon on most if not all domestic models, the sunroof is either folding vinyl, manually operated sliding steel or electrically operated sliding steel.

Other approaches are removable roof panels or even completely removable tops that let in the sun but still leave a built-in roll bar.

Whatever the configuration, sporting motorists, you can still have the option of being rained on! ★★★

Find the answers to 1001 workshop questions

quickly, easily with the **POPULAR MECHANICS MASTER SHOP GUIDE**

24 hangup boards, coated with wipe-clean plastic keep vital how-to-do-it information always at your finger tips.



Here in an easy to use, last-forever format are the answers to everything you'll ever need to know about: nails, screws, bolts, wall-fasteners, drills, abrasives, lumber, hardwoods, moldings, plywood, hardboard, gypsum, adhesives, plumbing, electrical work, floor and wall tile, glass. Facts on remodeling measurements, gutters, concrete, garden chemicals. Plus—all on one board—a ruler, protractor, 45-degree triangle, and compass for accurate circles! You'll reach for the **MASTER SHOP GUIDE** for every job you tackle!

What nail should you use? How many pounds will a 1/4-inch toggle bolt hold? How can you save money ordering lumber? What size quarter-rounds are available? How do you bleach close-grained hardwoods? What glue is best?

Repairs, too! Illustrations on plumbing, electrical, floor or wall tile, plastic laminates, glass, remodeling. All the basic dimensions you'll need!

By the editors of *Popular Mechanics*—order yours now—you'll use it the rest of your life!

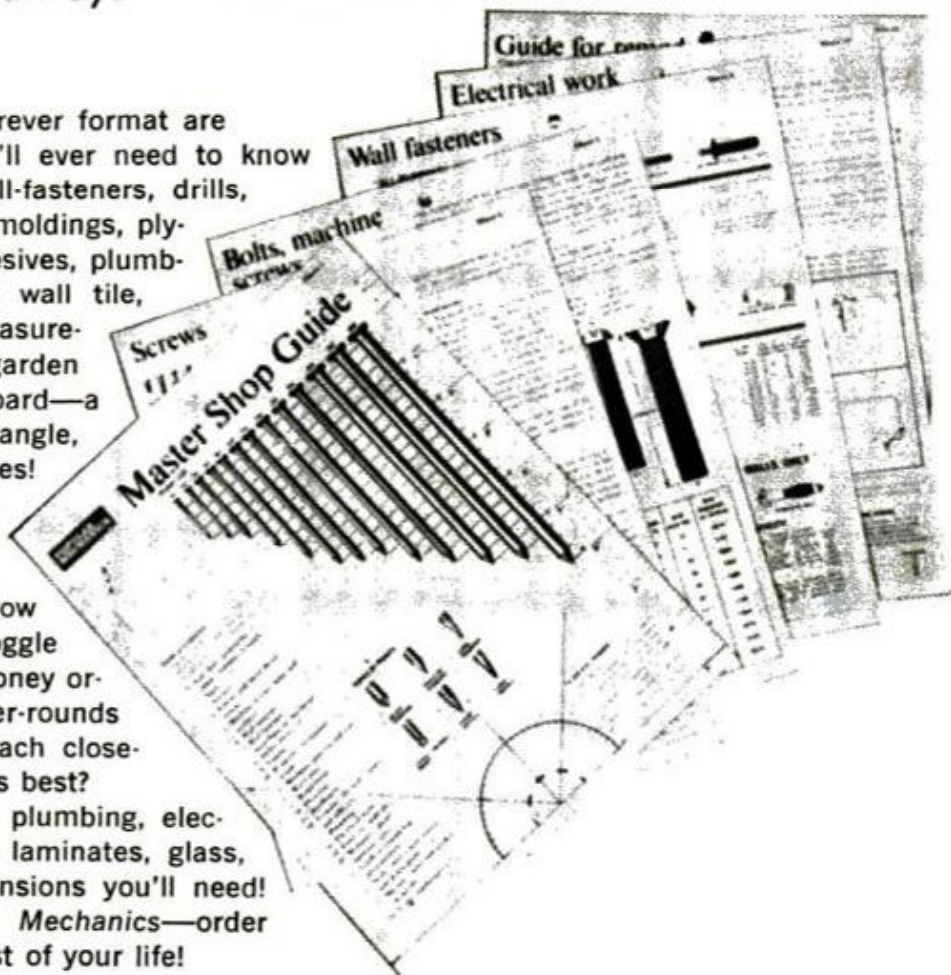

Popular Mechanics, Dept. SG-2,
224 W. 57th St.,
New York, N.Y. 10019

Rush me _____ sets of the
MASTER SHOP GUIDE.

I enclose check or money order
for \$3.95 for each set ordered.

NAME _____

ADDRESS _____

CITY _____ STATE _____ ZIP _____

REVISED EDITION

Popular Mechanics Catalog Plans, Publications, Projects

Want to build a boat, garage, sidewalk classic, plane or a clock, kayak, fireplace, kite, patio, coffee table aquarium, kitchen cabinet, organ, swimming pool, telescope, children's play furniture, camping trailer, science project, electronic project?

Send for the NEW Popular Mechanics illustrated catalog! 32 pages crammed full of fascinating and useful projects you can build yourself!

For more than 67 years, Popular Mechanics has been the world's leading authority on how-to information. In this helpful catalog you'll find the very best of Popular Mechanics plans and publications. In step-by-step text, photos and drawings, these plans show you how to build something for everyone in the family.



Above are shown a runabout boat you can build for less than \$75; a four-place plane you can construct yourself; a patio-garage and the famous sidewalk classic for youngsters that rolls along at 5 m.p.h.

For information on scores of other exciting projects, order the new catalog today! Send only 25c to cover postage and handling.

Enclose 25¢ in coin, no stamps please, to cover postage and handling.

Mail to: **Popular Mechanics** Dept. MM-2
224 West 57 Street
New York, New York 10019

Please Print:

Name _____

Address _____

City _____ State _____

Zip _____

ALL OUTDOORS

By BILL McKEOWN

BACKPACKING IS BOOMING as more outdoorsmen try to get away from crowds of other less-athletic campers. The backpackers are being helped by a number of new, extra-light, extra-strong items.

Tenting used to mean toting a bundle of weighty canvas. Now it's been pared down to a neat nylon stuffsack or handful that needs to check in under five pounds to meet the competition. Coleman, Camp Trails, Trailblazer by Winchester, Sears, Thermos, L.L. Bean, Wenzel, Himalayan of The Leisure Group are among designer-producers of the small one and two-man shelters that tie to a pack or fit in one. Then for carefree kids or emergency use, there are plastic jobs that can be folded to the pocket-size of a pack of cigarettes.

A plastic man-length with a ridgepole rope strung through it between two trees is just about minimum overnight protection. Unfortunately, however, discarded tube scraps are already starting to litter wilderness areas. Ski Hut in Berkeley, Calif., has come out with a 34-oz. waterproofed fabric tube with longer life that's reported to weigh even less than the easy-to-tear plastic.

FOUR-WHEEL CONVERSION KITS now available mean that snowmobiles don't need to go into warm storage. It's no secret that some owners drive their machines as-is on grass in summer and use them over dry leaves during hunting season in the fall. But ski steering is difficult without snow, and some makers will void your warranty since gravel can tear up the belt track. The kits, however, lift the machine to convert it into a kind of go-cart. Land-Grabber in Windon, Minn., has a new fat-tire wheel kit for about \$320, and for \$40 more it can convert a snomo trailer when winter rolls around again. Kiekhaefer Aeromarine is also reported to be developing a high-speed conversion.

PROFITS FROM OUTDOORS PRODUCTS are mounting up and it may be time for some of the big producers to help in outdoor facility development and environmental protection. As John Ebeling of Winnebago Industries pointed out recently, an organization of outdoor recreation industry members could do a lot to promote procurement and development of public lands for best public use. Sounds like good sense as well as good business. Here's one vote in favor.

FINDING WHERE THE ACTION ISN'T is supposed to be a real chore, as anyone at Yellowstone or Yosemite last year would agree. But the National Park Service has come up with a list of less-visited parks, monuments and recreational areas that we rate as an outdoors insider's tip sheet of best bets for uncrowded camping this summer.

Sure, Grand Canyon facilities can get crowded, but have you seen the Canyon from the equally spectacular North Rim? . . . Just 130 miles east of Yellowstone National Park are the wild gorges and landscapes of Bighorn Canyon National Recreation Area. It extends 41 miles through river canyons and around the reservoir formed by the Yellowstone Dam as it straddles the border between Wyoming and Montana. . . . Or only 80 miles north of the Great Smoky Mountains National Park is the lesser known Cumberland Gap National Historical Park, site of Daniel Boone's Wilderness Road where Kentucky, Tennessee and Virginia come together. . . . It's blazing in the summer, but winter visitors can enjoy the remote Big Bend National Park in Texas along the Mexican border following the Santa Elena Canyon of the Rio Grande. . . . Save summer for a visit to the thermal springs and mountains of Lassen Volcanic National Park in Northern California, the North Cascades Park and National Recreational Areas around Ross Lake and Lake Chelan near Washington's Canadian border, or Mount McKinley National Park in Alaska if you really want to get away from it all.

Want to skip the country? Outside the continent are Haleakala National Park on Maui in Hawaii and Virgin Islands National Park on St. John, and you still haven't left the United States. . . . Get away from it all on an island that doesn't even allow Detroit's machines by heading north from that city to Michigan's Canadian border and Isle Royale National Park, accessible only by boat or float plane. . . . Then camp Mexico and Canada before complaining again about crowds.

WHEN YOU HAVE TO STAY INDOORS, there are still plenty of vicarious outdoor kicks in a number of new books and directories available for planning ahead. Makers' Guide to U.S. Canoe Trails describes thousands of miles of suitable waterways along 900 rivers in 49 states. It is \$4.95 at bookstores or through Grumman Rent-a-

Canoe dealers. Winchester Hunter's Handbook, 1972 has 100 pages of complete state and provincial game regulations, seasons and prospects for all 50 states and 11 Canadian provinces, as well as bow-hunting seasons and regulations and a section of Winchester ballistic tables. It's \$1.95 at bookstores, sporting goods dealers and newsstands. A good introductory booklet for boys and girls is available for 25 cents from the National Shooting Sports Foundation, Riverside, Conn. Called Shooting's Fun for Everyone, it gives basics in safety, selecting a beginner's rifle and where to find expert instruction.

REMEMBER WHEN you drew a blank or a deluge of double talk from your friendly car dealer a few years ago if you asked about trailer towing or pickup camper capabilities? Now all the majors have bulletins or booklets like Ford's 24-page *Recreation Vehicles 1972*, Chevy's quarterly *Chevy Camper* magazine, Dodge truck brochures, Oldsmobile's *Your Way to Tow in '72*, American Motors' *1972 Trailer-Towing Bulletin* and others. Any dealer should have them on hand, and a pleasant evening's homework with them will tell you the questions to ask and maybe the rig to buy as well.

GOOD REMINDERS for long-time recreational vehicle owners and useful tips for beginners are included in a checklist from the RV Industry's Recreational Vehicle Institute. Backing up is the biggest initial bugaboo with any new oversize vehicle, and an empty weekend parking lot is a good place to practice before you hit the highways. Going forward in traffic, stay about 200 feet behind the car ahead and pull over if you're slowing a line of traffic behind. When passing, give yourself a lot more open road before pulling out and then use your big mirrors before turning in ahead.

Use the good campground directories like those from Rand McNally, Woodall's or AAA, and pick your evening stop early. An RV trip isn't supposed to be a marathon so, particularly at first, don't try for more than 200 to 300 miles a day. Noon is none too soon to call it a day if you want space mid-season at a popular campsite. Fifty mph is a good cruise speed.

When loading up, don't forget water and LP tanks. Fill water slowly to prevent an air block. Stow heavy items down low, of course, toward the center of your rig. Stuff crumpled newspapers, blankets and pillows into shelves and cupboards that hold breakables. And for more good advice? Ask the man at the next campsite. ★ ★ ★

ANOTHER SUPERB VALUE from **Olson** Electronics

ONLY **\$22⁹⁸**



SOLID STATE **STEREO AMPLIFIER**

Low priced stereo amplifier that looks and sounds great. An ideal unit for office, children's room, or second stereo system. Has separate volume and tone controls with inputs for phono and tuner.

Olson Electronics, Dept. J2-260

260 S. Forge St., Akron, Ohio 44308

I enclose \$22.98 plus \$1 for postage and handling. Send me the AM-400 Stereo Amplifier.

Send me the next seven issues of the Olson Catalog, without cost or obligation. **FREE**

Name _____

Address _____

City _____

State _____ Zip _____

MAKE BIG MONEY OPERATING HEAVY EQUIPMENT



**BULLDOZERS
CLAMSHELLS
TRENCHERS
DRAGLINES
BACKHOES
SCRAPERS
GRADERS
CRANES**

The Construction Industry is Booming! Earn top money in this fast moving, action-packed field. Keep present job and train at home in spare time followed by practical training on our machines under project conditions at our facilities. Nationwide placement assistance. For **FREE** information fill out and mail coupon today!
Member American Road Builders' Assn.

APPROVED FOR VETERANS AND INSERVICE PERSONNEL

UNIVERSAL HEAVY CONSTRUCTION SCHOOLS, Dept. PM
1901 N.W. 7 STREET / MIAMI, FLORIDA 33125
Phone: (305) 642-0800 (24 Hours)

Please Print

Name _____ Age _____

Address _____

City _____ State _____

Phone _____ Zip _____

Electronic Hints

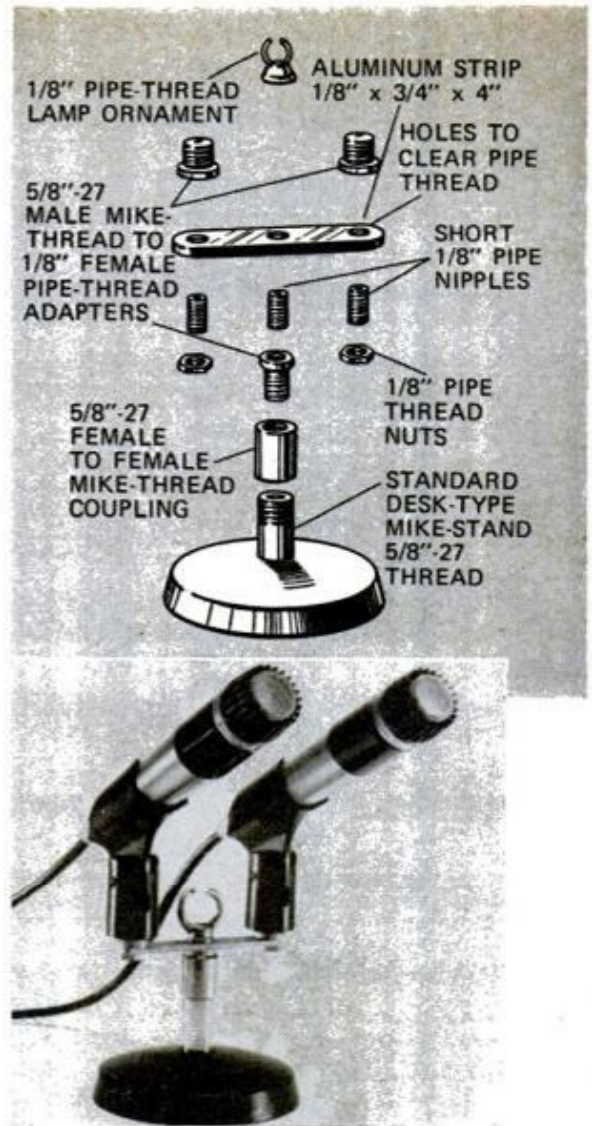
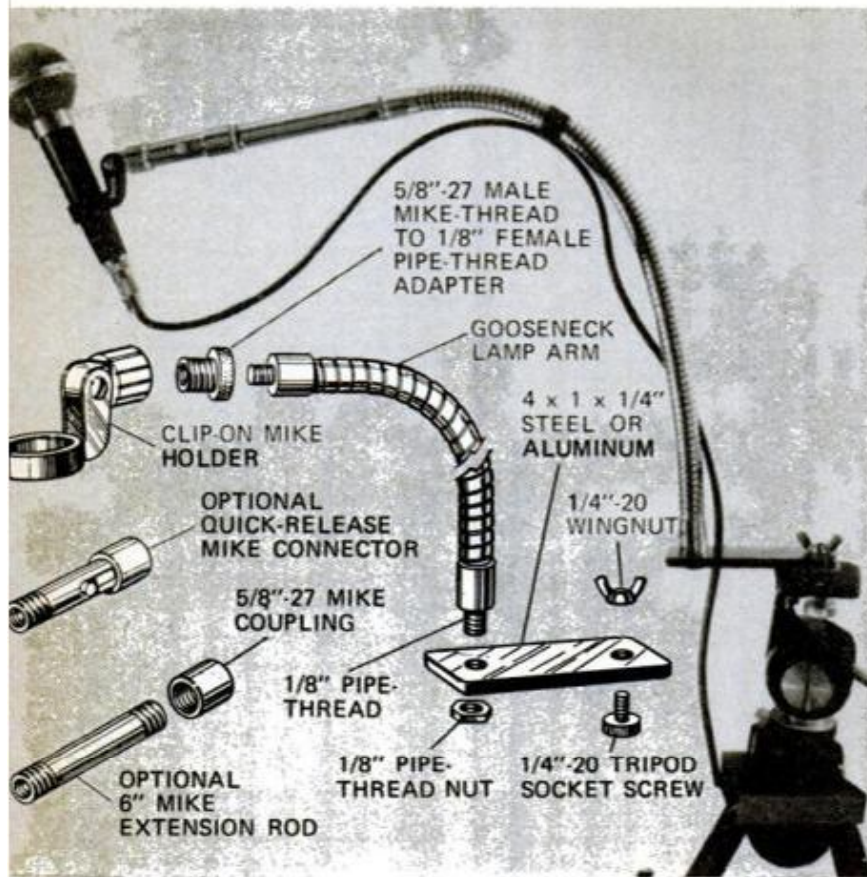

Three special types of mike holders you can make yourself

Professional mike stands are expensive, but you can make these simple holders for practically nothing from readily available hardware. The one at left, above, uses an ordinary lamp gooseneck with a bracket that can be attached to a tripod. The tripod provides a steady floor stand, and the gooseneck serves as a flexible boom, leaving your hands free to operate recording or other equipment.

The dual mike holder at right, above, is handy for stereo recording and is adapted to fit on a standard, inexpensive desk-type mike stand. For wider separation in recording, one or both mikes can be slipped out of their clips and held far-

ther apart. The hand boom below, made from an old broomstick, is useful for picking up sounds at long reach, such as from different musical instruments in a band or different voices in a party crowd.

The gooseneck and 1/8-inch brass pipe are stock lamp items available at hardware and electrical stores. All three holders require one special adapter fitting to mate the 1/8-inch pipe thread to 5/8-27 mike thread. These adapters are made by Atlas and available from Lafayette Radio, 111 Jericho Turnpike, Syosset, N.Y. 11791 (Type AD-2; No. 44R10197; 62 cents).—Norman Fallon, New York, N.Y.

(For more Electronic Hints, see page 56)

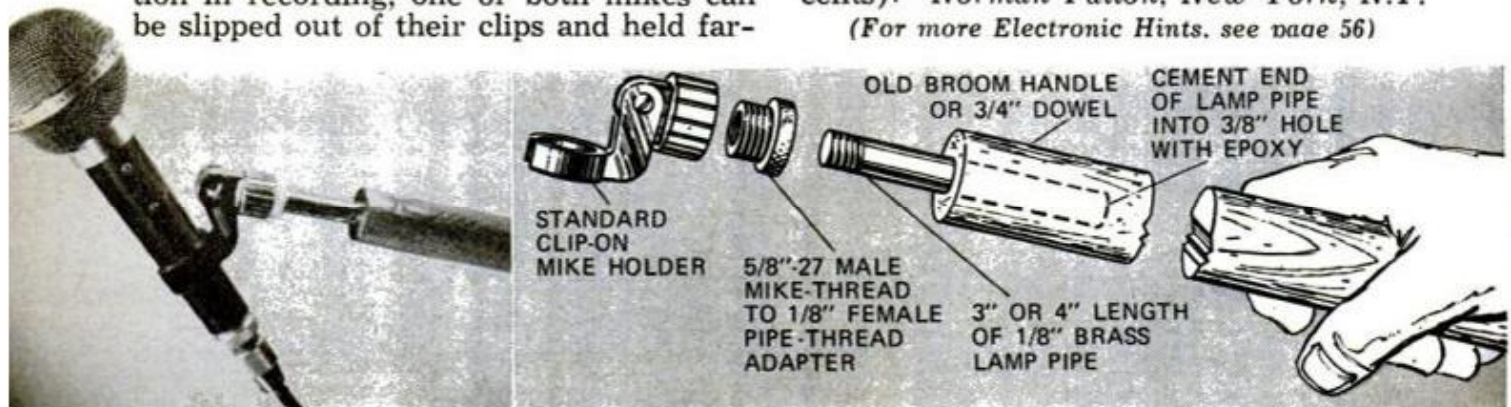

Only RCA Institutes offers you all these advantages:

1 A broad range of courses to help you qualify for good-paying jobs in such rewarding fields as communications, color TV servicing, automation, nuclear instrumentation, space electronics, drafting, computer programming.

2 RCA's exclusive Autotext training method—the easy, faster, simplified way to learn electronics at home.

3 Personal supervision throughout your training.

4 Over 250 experiments and up to 22 kits in some programs

5 Easy monthly payment plans

6 Over 60 years of leadership in technical training.

7 Recognition from leaders in the field as an RCA Institutes graduate.

Veterans can train under new G.I. Bill. Licensed by the State of New York. Accredited Member National Home Study Council.

If you've ever thought about getting into electronics...

you owe it to yourself to see what RCA home training has to offer.

This entire fold-over coupon makes a no-postage-required business-reply envelope. Fill in your name and address ...then cut out along dotted lines...fold, seal and mail.

RCA INSTITUTES, Inc., Home Study School
320 West 31st St., New York, N. Y. 10001

699-202-0

Send me free illustrated career catalog. No salesman will call.

Name _____ Age _____

(please print)

Address _____

City _____ State _____ Zip _____

- Check here if interested in Classroom Training. (N.Y. or Phila.)
 Veterans check here

NO STAMP NEEDED

You must seal (Staple, tape or glue) before mailing.

FOLD HERE

DO NOT CUT HERE

FIRST CLASS

Permit No. 10662
New York, N.Y.

BUSINESS REPLY MAIL

No Postage Necessary if Mailed in United States

Postage will be paid by

RCA INSTITUTES

Home Study School
320 West 31st St.
New York, N. Y. 10001

699-202-0

Electronic Hints continued



Toothbrush makes handy cleaner

An old toothbrush is a perfect tool for cleaning up printed circuit boards after soldering connections. It will remove loose bits of solder and wire that might be the cause of damaging shorts in the circuit. It will also brush away dust and corrosion from those hard-to-reach places in electronic equipment and electrical appliances.

—Marshall Lincoln, Wickenburg, Ariz.

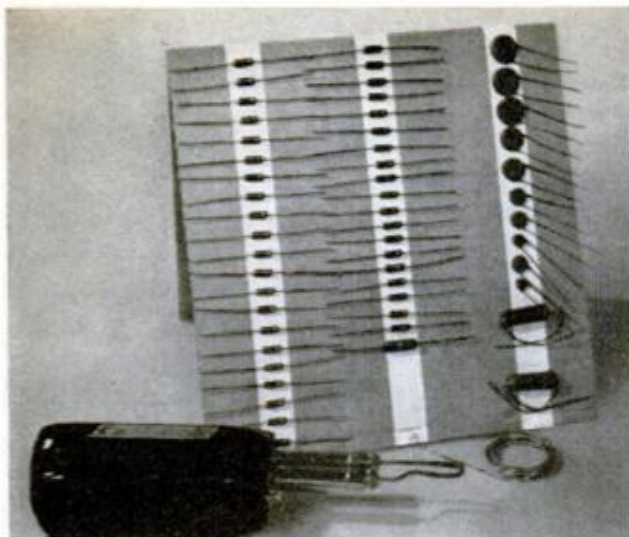

Neat organizer for small parts

Searching for tiny parts in electronic kits takes considerable time. This simple rack makes such parts easy to organize and identify. Tape two pieces of cardboard together to form a V-shaped stand. A string keeps the bottom edges from spreading too far apart. Use double-sided tape and stick the parts on the exposed side in neat rows.

—Ken Patterson, Regina, Sask., Canada.

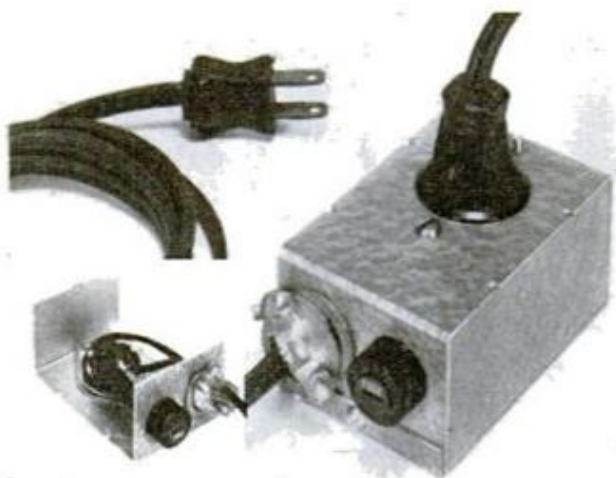

Portable fuse box goes with you

If you have unfused electronic equipment or electrical appliances and aren't sure how much current they draw, this accessory fuse box will give you portable protection wherever you go. Mount a cartridge-type fuse holder in a small metal box along with a flush-mount receptacle and a power-cord clamp. The fuse holder is simply wired in series with one lead from the power cord to the receptacle. Fuses of various values can be inserted interchangeably in the holder to suit different conditions, such as to protect a specific piece of equipment or to avoid overloading a circuit that might cause fire.—Norman Fallon, New York, N.Y.



'Manicured' contacts work better

The emery boards ladies use for manicuring fingernails are ideal for cleaning corrosion off appliance plugs, batteries, radio-tube pins and other electrical contacts. They're much safer than the use of files, which tend to remove too much metal.—Robert Hertzberg, Flushing, N.Y.

Asbestos padding holds in heat

When clamping parts to be soldered in a vise, pad the jaws with bits of sheet asbestos. They'll prevent heat from being conducted rapidly away by the metal jaws, thus making the soldering job easier.—Wilfred Beaver, St. Anne, Ill.

FREE

25th year

HEATHKIT



Heathkit Electronics, 2014, 49022
 Factory direct prices, including 50% off

world's largest electronic kit catalog

Save on over 350 kits you can build

COLOR TV — Low cost tube-type and incomparable solid-state models. From 14 through 25-in. all with exclusive Heathkit built-in self-service capability. All cabinet styles, including new "hide-away" Custom Wall Mount kit.

HOME APPLIANCES — The new Heathkit "Minimizer" Waste Compactor joins the popular Microwave Oven in the kitchen. Both offer all the features of fine assembled appliances plus, since you build them, you can perform normal service and maintenance. Other kits for the home include clock radios, wireless and conventional intercoms, home protection systems and garage door openers.

TRAIL BIKES — For exciting off-the-road transportation, choose either the economical Heathkit Boonie Bike or the bold, beautiful Hilltopper. Accessories include lighting kits, automotive bumper carrier, front-wheel snow ski.

AUTOMOTIVE — A cost-saving lineup of auto accessories and tune-up kits, includes 2-way radio, siren, cab-to-camper intercom, battery charger, timing light, tune-up meter, ignition analyzer, tachometer.

PORTABLE RADIOS & PHONOS — Three portable phonos to choose from, including a Stereo/AM Radio Phono combination. Four portable solid-state radios from a simple AM kit to a 10-band AM/FM/Shortwave receiver.

TEST INSTRUMENTS — For the home hobbyist or the professional technician at substantial savings. Everything from famous Heathkit oscilloscopes and meters through vector-monitors and color bar generators. And there's sophisticated scientific equipment for educational and industrial labs.

SHORTWAVE & HAM RADIO — For the listener, Heath has a brand new solid-state SWL receiver. For the radio amateur, there's the complete line of Heathkit receivers, transmitters, transceivers, novice rigs and accessories.

FISHING & BOATING — The new Heathkit Thermo Spotter lets anglers find the specific water temperature level where trophy fish feed. The new Digital Depth Sounder reading to 199 ft., costs about half the price of other units. In addition there are Heathkit flasher-type depth sounders and fish spotters, power inverters, hailers, VHF phones, etc.

STEREO — The new Heathkit AR-1500 stereo receiver experts hail as the most sensitive and powerful, heads up a complete line of receivers, amplifiers, tuners, turntables and speakers in every price range, 4-channel and tape components, too.

More than 350 products with build-it, service-it savings.

All Heathkit products are designed around quality components... your assurance of outstanding performance, long, reliable service. And the famous Heathkit manual makes the most complex kit a simple check-by-step project. But it doesn't stop there. You're given the information you need to get your kit operating at peak efficiency, and keep it that way. (If you know someone who owns a Heathkit color TV, take a close look at that picture). Should the need arise,

technicians at every Heathkit Electronics Center, the Technical Correspondence Department here in Benton Harbor, and the new Heathkit "Plain Language" Warranty stand behind your purchase. Clip and use the coupon below to order your free 1972 Heathkit Catalog. Discover the creative fun, satisfaction, and pride of achievement that Heathkit building brings... and save yourself a bundle in the bargain. We won't let you fail.

Visit your local Heathkit Electronic Center... or send for your FREE Catalog.

HEATHKIT ELECTRONICS CENTERS

ARIZ.: Phoenix, 2727 W. Indian School Rd.; **CALIF.:** Anaheim, 330 E. Ball Rd.; El Cerrito, 6000 Potrero Ave.; Los Angeles, 2309 S. Flower St.; Redwood City, 2001 Middlefield Rd.; San Diego (La Mesa), 8363 Center Dr.; Woodland Hills, 22504 Ventura Blvd.; **COLO.:** Denver, 5940 W. 38th Ave.; **FLA.:** Miami (Hialeah), 4705 W. 16th Ave.; **GA.:** Atlanta, 5285 Roswell Rd.; **ILL.:** Chicago, 3462-66 W. Devon Ave.; Downers Grove, 224 Ogden Ave.; **KANSAS:** Kansas City (Mission), 5960 Lamar Ave.; **MD.:** Rockville, 5542 Nicholson Lane; **MASS.:** Boston (Wellesley), 165 Worcester St.; **MICH.:** Detroit, 18645 W. Eight Mile Rd. & 18149 E. Eight Mile Rd.; **MINN.:** Minneapolis (Hopkins), 101 Shady Oak Rd.; **MO.:** St. Louis, 9296 Gravois Ave.; **N.J.:** Fair Lawn, 35-07 Broadway (Rte. 4); **N.Y.:** Buffalo (Amherst), 3476 Sheridan Dr.; New York, 35 W. 45th St.; Jericho, L.I., 15 Jericho Turnpike; Rochester, Long Ridge Plaza; **OHIO:** Cincinnati (Woodlawn), 10133 Springfield Pike; Cleveland, 5444 Pearl Rd.; **PA.:** Philadelphia, 6318 Roosevelt Blvd.; Pittsburgh, 3482 Wm. Penn Hwy.; **TEXAS:** Dallas, 2715 Ross Ave.; Houston, 3705 Westheimer; **WASH.:** Seattle, 2221 Third Ave.; **WIS.:** Milwaukee, 5215 Fond du Lac.

HEATHKIT

Schlumberger

HEATH COMPANY, Dept. 17-2
 Benton Harbor, Michigan 49022

Please send FREE Heathkit Catalog.

Name _____

Address _____

City _____ State _____ Zip _____

Prices & specifications subject to change without notice.

*Mail order prices; F.O.B. factory. CL-426

APPLIANCE CLINIC

By PAUL MANN

Throwing knives

Every time I use my Sunbeam electric carving knife the blades fall out when I turn it on and try to cut a piece of meat. I would appreciate knowing why this happens and what I should do about it.
—Paul McAlear, Jamaica Plain, Mass.

There is a small outward protrusion near the rear of each blade that snaps into a rectangular hole in a flat spring. This provides spring tension to hold the blade in position. Your problem may be that you are simply not pushing the blades in all the way. Push in each blade individually until it snaps into position. Handle blades only by grasping the plastic drip guards. If this fails to solve your problem, the protrusions on the blades may be worn or the flat springs may need adjustment.

Popped out corn popper

We received a West Bend automatic see-through corn popper as a gift last year. It worked only once, so we sent it back to the factory. After it was returned, we used it—once. After that, it again refused to work. What can be wrong, and how can it be corrected?—John H. Young, Dixon, Neb.

A corn popper is one of the most uncomplicated of appliances. The lower part of the unit is a metal bowl that contains a single heating element, while the upper part usually consists of a dome-shaped glass cover that you can look through to see when all the corn has been popped.

What can keep the instrument from working? The line cord may be faulty, which is probably not the case with your unit. Neither is it likely that there's a short circuit. You don't complain of fuses blowing or circuit breakers tripping. This leads us to the possibility that there is a bad thermostat or an open circuit within the heating element. The element should be tested with a voltmeter or a multimeter.

If the test shows an open circuit, the question that has to be answered is why is it happening after the appliance is used

one time only? Unless actual physical damage is being done to the unit, an open circuit most times will occur if the appliance is drawing excessive current. Resistance is purposely built into the unit to safeguard against this. Thus, there is the chance that the defect may have been in the manufacture. Perhaps a resistance wire was accidentally omitted or a wrong resistance used.

Before you ship the unit back to the factory with a complete explanation, check one other thing. Is there anything peculiar with the electrical service in your area that may be causing voltage surge? Call the service department of your electric company and describe your problem. Maybe they can explain it.

Cooked toast

How about a rundown on a two-slice pop-up Toastmaster toaster, model 1B12, that suddenly stopped ejecting on time, leaving us with burnt toast?—Oscar C. Cook, Oklahoma City.

Sure. When you place bread on the rack of a pop-up toaster and push the handle down, dropping the rack and bread, the rack closes contact points on a timer and current begins to flow through the elements (see the accom-

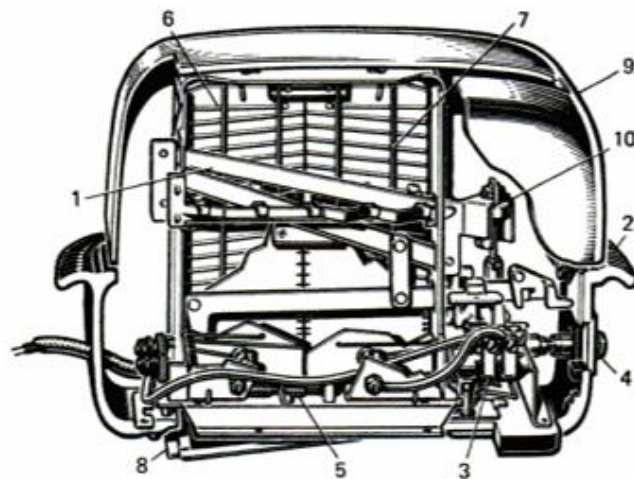

1, rack; 2, operating handle; 3, timer; 4, timer adjustment; 5, spring; 6, heating element; 7, guard wires; 8, bottom cover; 9, housing, and 10, damper

panying diagram). At the same time, the rack engages a mechanical latch that holds it down.

Length of the toasting time is controlled by the timer adjustment. When the cycle is completed, the timer trips the latch and a spring raises the rack. The rack slides up, opens the circuit shutting off current to the elements, and provides you with toast.

What can upset all this electrical and
(Please turn to page 58D)

TOM McCAHILL SAYS:

"The appliance repair field is so uncrowded it's almost lonely!"

Someone once said that if you build a better mousetrap, the world will beat a path to your door. In the home appliance business, a lot of enterprising companies have gotten rich peddling a list of handy electrical gadgets for the home longer than Wilt Chamberlain's arm. The trouble is, the dozen or more appliances in the average American home can go on the fritz, and men with the proper training to do repairs are as scarce as knee-length skirts on teen-agers.

Good Appliance Repairmen are a rare breed these days. Those with a little ambition are booked so solidly you can wait days to get somebody to fix a balky refrigerator or cantankerous toaster. Sometimes, you have to settle for a bum job from a guy who had no business calling himself an Appliance Repairman in the first place.

This brings me to my point. If you want to make money in a field that's begging for trained technicians, there's a fine, low-cost home-study plan available that teaches you how to handle every type of Appliance repair in detail—including refrigeration, air conditioners, and even small gas engines. The course was prepared by the instructors at National Radio Institute. This is the oldest and largest home-study school in the Electronics/Electrical fields with more than fifty years' experience training men like yourself for new careers or spare-time or full-time businesses of their own.

A few years ago, NRI recognized the increasing demand for trained Appliance Repairmen. They set about preparing well-illustrated, easy-to-understand lessons that teach you how to repair home, commercial and farm Appliances. NRI even added a professional Appliance Tester that's included in their low tuition. With the Tester and a few basic tools you probably already have,

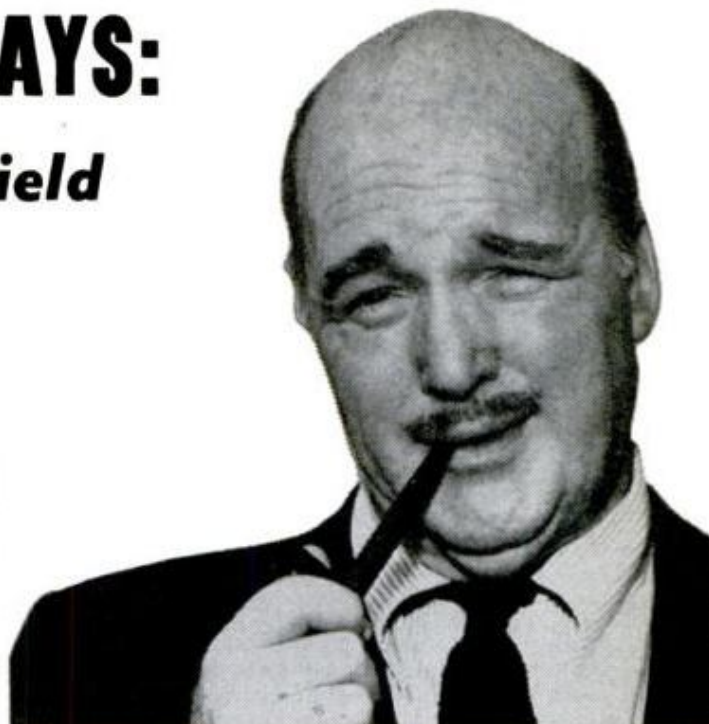

you're equipped to service most Electrical Appliances. If you aren't making as much as \$4 to \$6 an hour in spare time fixing Appliances for friends and neighbors within a few months after enrolling, my name isn't McCahill.

The reason I'm no doubting Thomas, is because the staff at NRI is composed of experienced instructors who guide you through the course with more personal attention than you'd get in many classrooms. With the kind of help they give a student and the kind of course they have, you can be the man in demand in this field—even if you've never tried to rewire a plug, or got fed up with school at the 9th grade.

The best advice I can give you is to clip the coupon below and send for the NRI Appliance Training Catalog. It's free, and there's no obligation. NRI doesn't employ salesmen, so nobody will be knocking at your door. All it will cost you is a postage stamp. Take it from Uncle Tom, the Appliance Repair field needs good men. Now.

TOM McCAHILL

APPLIANCE DIVISION, NATIONAL RADIO INSTITUTE
3939 Wisconsin Avenue, Washington, D.C. 20016

APPROVED UNDER NEW GI BILL.
If you served since January 31, 1955, or
are in service, check GI line below.

600-022

OK—I want to see for myself. Send me the free book on Professional Appliance Servicing. No salesman will call.

Name..... Age.....

Address.....

City..... State..... Zip Code.....

Accredited Member National Home Study Council.

Check for facts on new GI Bill.

START A MONEY-MAKING BUSINESS FOR LESS THAN \$50!



You can have your own lifetime business right at home . . . work in spare time . . . and make up to \$200 a month CASH! My FREE PLAN gives you all the facts: How to start, how to grow. You don't need previous experience. You don't have to sell. I'll even finance you. People bring you the work and pay cash. Over 90¢ of every dollar you collect is clear cash profit. And you work when you want to. Let me prove you can't find a more certain, lower cost, higher paying business of your own.

Just Mail Coupon—No Salesman Will Call

BELSAW SHARP-ALL CO., Stan Field, Pres.
812F Field Bldg., Kansas City, Mo. 64111

Name _____

Address _____

City _____ State _____ Zip _____

FREE
BOOK

BUILD IT YOURSELF

MINI-DOZER®

Rugged, compact bulldozer. Smooth lawn or cleared dozer tracks. Unique transmission allows 360° turns in its own length. 7 & 12 hp engine models. Attachments include lawn mower, dozer blade, snow blower, etc. "Build-it-yourself" Plans — \$5.00.



12 hp Kit
\$698.95



12 hp Kit
\$598.95

TURF-RIDER®

Man-sized tractor for tough lawn and garden use. Attachments include lawn mower, snow blower, plow, cultivator, etc. Complete kit with 12 hp electric start engine — \$598.95. Plans — \$5.00.

TS-5 TRAIL BIKE®

Rugged 7 hp 'two-wheeler' with 12" wide x 21" dia. low pressure tires to take you there and back with safety. Plans — \$2.00.

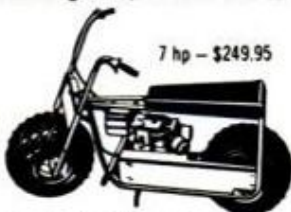

7 hp — \$249.95

COMPLETE 48-PG CATALOG

of all 30 tractor assembly kits — \$1.00.
(Note: Plans and Catalog prices refunded on any purchase.)

POWER HACKSAW — KIT \$24.95



\$24.95

Also 51 other money-saving projects to be built for the home workshop. Lathes, drill presses, vises, etc. Complete 28-pg 'homeshop' Catalog — 50¢.

STRUCK CORP., Dept. PM-22, Cedarburg, Wis. 53012

APPLIANCE CLINIC

(Continued from page 58B)

mechanical ingenuity? First of all, are you sure the timer adjustment (that knob on the side of the toaster) hasn't been turned all the way over to the dark side? Has one of the kids been fooling around?

If the adjustment is okay, the problem probably lies with the thermostat contact points of the timer. They may be sticking. The unit should come apart. If points are bad, replace them.

Iceberg

I own a General Electric refrigerator, model TB 14 SDB, that is 3 years old. From the start, blocks of ice have formed on the refrigerator section cooling coils. This is most upsetting since this is supposed to be a self-defrosting unit. The problem is not being caused by bottles touching the coils. The cooling compartment is maintained at 37° F., and the freezer stays between 0° to minus 10° F. Can you tell me what's wrong?—Dennis A. DesRosiers, Willingboro, N.J.

The General Electric model TB14S is not a completely automatic defrost unit. The freezer compartment has to be manually defrosted. Automatic defrosting of the refrigerator fresh food compartment takes place when the refrigerator turns off. The "on" cycle of the temperature control is set so that the cooling coil is slightly above freezing temperature at the point of "turn on," permitting accumulated frost to melt. Two low-wattage heaters attached to the cooling coil are energized during the off cycle to assure complete defrosting of the coil. Possibly these heaters aren't operating, so I would consult an authorized G.E. serviceman.

First, though, check the possibility you are operating the refrigerator at an abnormally low temperature, which could cause ice to form. Normal temperatures are around 39° F. in the fresh food compartment and 0° to minus 5° F. in the freezer compartment. Consult the use and care instruction manual that came with the unit to determine how to adjust the temperature control. If you've misplaced this booklet, write the Refrigerator Products Marketing Dept., General Electric Co., Appliance Park, Louisville, Ky. 40225, for a new one.

If you have a question about any appliance, send it to Appliance Clinic, Popular Mechanics, 224 West 57th St., New York, N.Y. 10019. Sorry, but letters cannot be answered individually. However, problems of widest interest will be answered in this column.

It pays to go to meetings.

The Army Reserve pays in a lot of ways.

You're paid for every Army Reserve meeting you attend. Each unit training assembly is equal to a full day's Active Army pay, according to your rank and length of service.

Your pay goes up as you go up. And in the Reserve things are happening faster now. We're making more promotions than ever because the men who served in the Army during World War II are retiring.

The Reserve gives you a chance to move ahead in civilian life, too. We can offer you one of 300 job training courses, depending upon the specific skill requirements of your local unit. From accounting to communications. From finance to mechanics.

So if you're about to fulfill your military obligation, or if you're in the Individual Ready Reserve, or have prior service with *any* of the Armed Services, check into the Army Reserve.

It pays. **The Army Reserve.**

Army Reserve Opportunities	Date _____
P. O. Box 6834	
Philadelphia, Pa. 19132	PM 2-72
Please send me all the information on what the Army Reserve can offer me.	
Name _____	
Address _____	
City _____	
State _____	Zip _____



The two family car.

The great American dream used to be two cars in every garage. But INTERNATIONAL[®] changed all that with the new SCOUT[®] II.

The new Scout II lets you be two families in one (weekday and weekend).

All week long the Scout II works just like the rest of your weekday family—going to the station, supermarket, cleaners and school. And that's where the

fold down rear seat for extra carrying space comes in mighty handy. Of course, so does the smooth ride and optional creature comforts like automatic transmission, air conditioning, power steering and power brakes.

But come the weekend, the Scout II is as ready to play as the rest of your weekend family.

The Scout II loves to go fishing, skiing, hunting, camping or just exploring.

And with four-wheel drive you'll discover a lot of fun begins where the road ends.

So when you stop and think about it, you really don't need two cars do you?

In fact, you don't need a car. You need a Scout II.

The one for both of your families. Get 'em up Scout!

International **Scout II**
International Harvester Company, Chicago, Illinois 60611



6 GOOD REASONS

Why You Should Get Into

AIR CONDITIONING



We've stopped counting the reasons why men are flocking to air conditioning as a career—because every day some grateful student writes to tell us of a new one.

But rock-bottom basic are these BIG SIX that prove air conditioning is today's most brilliant opportunity for ambitious men who want to make a lot of money.



1. If you want a career, not just a job. Thousands of opportunities opening up to meet tremendous unfilled demands.
2. Part-time or full time. Whatever you prefer.
3. Make MORE money than you ever did in your life.
4. Operate your own business, as a part-time sideline or full time.
5. Earn as you learn—keep your present job until ready.
6. Only average education required.



There are so many reasons why a career in air conditioning is the answer to the ambitious dreams of thousands of American men, it is hard to say which is the most important. As America's brightest, fastest growing and highly respected industry, you can be a PROFESSIONAL, in contact with interesting people every day and not chained to a dull routine or desk.

Even if your education is just average, if your desire is above average, you can quickly qualify for high pay and rapid advancements. More than that, you can be making a solid income WHILE YOU ARE LEARNING.

LIBERTY SCHOOL, Dept. J-2B,

Technical Division,
1111 W. Park, Libertyville, Illinois 60048



There is a crying need for 33,000 new men this year—more next year. What a glorious hope for men like you fed up with tired jobs, unreasonable bosses. It's a whole new way of life with possibilities of 2 and 3 times your present earnings and the chance to work part time, full time or even organize your very own business.

We've seen men pick up fees at small jobs in a matter of just a few weeks—going on from there to becoming a fullfledged pro with the chance to pick from dozens of job and business offers. And what wonderful "job insurance" to have available.

No course offered today is more complete, more thoroughly expert or lower in price than the fine schooling offered you at Liberty. Not one tiny detail of installing, maintaining, servicing or repairing is overlooked in showing you how to take care of air conditioners, refrigerators and heating units or plants.

We're looking for men who say, "Prove it!" because that is exactly what we can do. All you have to do is tell us you want the facts. We'll rush them to you by mail. WE HAVE NO SALESMEN.

LIBERTY SCHOOL, Dept. J-2B
Technical Division, 1111 W. Park
Libertyville, Illinois 60048

YES! I want to discover the steps to a big pay position in Air Conditioning! Please send me the description of your course in AIR CONDITIONING, REFRIGERATION AND HEATING. This places me under NO obligation and NO salesman will call.

Name _____ Age _____
Address _____
City _____ State _____ Zip _____

CONVERT YOUR TRAIL BIKE to a SNOW-CYCLE or All-Terrain Vehicle

SHREW
\$49⁹⁵ FOB
FACTORY

**COMPLETE TRACTION
UNIT AND SKI**

- Convert your Trail Bike (90cc and over) to a snow machine.
- Design your own Dune-Buggy or Snow Mobile
- Ski & Front strut furnished with each track
- 1/4" Rubber belt track 16 1/2 x 42" with steel cleats
- Shipping weight 145 lbs.
- Send \$25 deposit and balance C.O.D.
- Specification drawings available \$3.00

NEPELO, inc. GARFIELD, WA. 99130

At Last a New Amazingly Simple GAS TURBINE JET ENGINE

Build from easy to follow plans. Length 15",
Dia. 8 1/2", Wt. 15 lbs. Fuel: Gasoline or Kero.

"Screamin' Demon" develops 20 H.P. Ideal project for serious-minded hobbyists, students; scientific and industrial arts classes. Make on 9" metal cutting lathe with milling attachment. For use on small racing boats, midget cars, etc. Full size assembly drawings with critical dimensions, bill of materials and photos. Price \$5.00. No C.O.D.

SAVOY SCIENTIFIC, BOX 1398, SANTA MONICA, CALIF. 90408



PLANER • MOLDER • SAW

30-DAY FREE Trial!

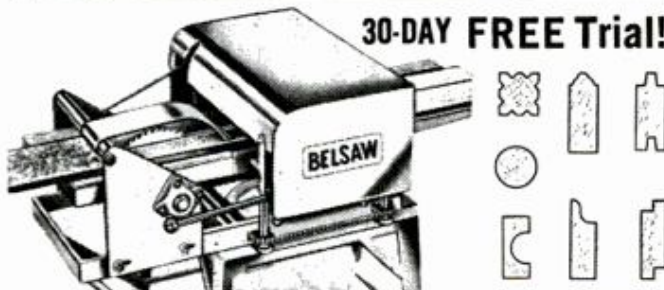

Now you can use this ONE power-feed shop to turn rough lumber into moldings, trim, flooring, furniture...ALL popular patterns. RIP...PLANE...MOLD—separately or all at once with a single motor. Free 30-Day Trial. Low Cost—only \$35 down.

Send Postcard Today — No Salesman Will Call.

BELSAW POWER TOOLS, 902F Field Bldg., Kansas City, Mo. 64111

ARROW T-50

All-Purpose
**STAPLE
GUN**

SHOOTS A STAPLE

Uses 6
Staple Sizes
1/4" to 9/16"
including
Ceiltile.

WHEREVER YOU'D DRIVE A NAIL!
At
Hardware,
Lumber & Building Supply,
Stationery, Variety and
other retail outlets.

ARROW FASTENER COMPANY, INC.
271 Mayhill Street, Saddle Brook, N. J. 07663

Unadorned power tools.

4' Wood Lathe
at \$29.95



They do the same job as tools costing up to 5 times as much.

We skipped the chrome to save you money . . . but we did not skip anything on performance. Actually, we skipped more than just chrome, we cut out every costly frill that wasn't absolutely needed.

The lathe shown above isn't exactly flashy. We admit it. But in a recent article, Popular Science used it to demonstrate wood lathe technique and said: "You won't go wrong with this economical introduction to wood turning." It is typical of our tools which in spite of low prices, are full scale and offer full performance and precision. **HERE'S HOW WE DO IT . . .** First, we don't claim our tools should sell for five times the price! Just that our tools do the same job . . . with the same accuracy, ease and speed . . . and will last at least as long. AMT tools cost less to make and are sold direct. They are bona fide quality power tools used by serious amateurs and professionals alike and if sold in retail stores would be much higher in price. We use no magic, let's be specific: **SIMPLICITY . . .** AMT tools are soundly engineered to eliminate every frill and gimmick—to minimize material and production costs. Machined parts are used only where they're needed. Unadorned cast iron and aluminum save you a fortune.

DIRECT-FROM-FACTORY SAVINGS . . . You save a bundle, yet, we offer a double guarantee backed by a 38-year-old company with millions of satisfied customers . . . and hundreds of orders pour in daily.

LARGE VOLUME . . . Our own foundry and large mass production facilities plus large buying power all work to keep costs down.

STANDARD PARTS . . . Our designs use standard hardware items wherever possible. By avoiding custom-made parts we pass on tremendous savings to you.

If you are looking for power tools that perform like units costing many times our low prices, order today and you'll be one step closer to many hours of woodworking satisfaction.

Bill Monte

POWER SAW 8" tilt arbor saw . . . crosscuts, rips,

mitres, cuts compound angles, dadoes, coves, moldings. Completely assembled with ground cast iron table, safety guard, splitter, mitre gauge. Less blade, motor. Rip fence for easier work alignment, \$3.50 add'l. Ball bearing model, \$5.00 add'l. Takes 1/2 h.p. motor or larger, standard blades, attachments. Wt. 26 lbs., f.o.b. factory **\$19.95**



FREE OFFER, cabinet base plans, . . . with one piece of 3/4" plywood, convert your \$19.95 saw into a floor model with a huge 27" x 24" top. Takes cabinet rip fence, \$4.50 add'l.

TWO GUARANTEES

10-DAY MONEY BACK GUARANTEE

Try any of these power tools and compare it with any similar machine at any price. If not satisfied, return it for prompt, no questions asked refund. We pay the return shipping charges.

10-YR. FULL SERVICE GUARANTEE

Any part or parts of these AMT power tools (except motor which carries a one year guarantee) which become inoperative for any reason within ten years after purchase date will be repaired or replaced by the factory with no cost to the purchaser other than postage.

AMERICAN MACHINE & TOOL CO.
4th & Spring St., Royersford, Pa. 19468



Brand new electric motor

developing full 1 h.p. 17 lbs. (Purchased separately, \$24.85).

With any AMT machine here. **\$19.90**

BUY DIRECT
... USE THIS HANDY
ORDER COUPON
NOW

AMERICAN MACHINE & TOOL CO., Dept. PM22, Royersford, Pa. 19468

Please send me the units checked. Payment in full enclosed \$_____ or \$3 deposit each item enclosed, balance C.O.D. I must be fully satisfied or will return unit within 10 days for full refund. No questions asked.

- | | |
|---|--|
| <input type="checkbox"/> 8" Power Saw at \$19.95 | <input type="checkbox"/> Jointer Planer at \$24.95 |
| <input type="checkbox"/> Standard Rip Fence at \$3.50 | <input type="checkbox"/> Ball Bearing Spindle at \$5.00 |
| <input type="checkbox"/> Long Cabinet Rip Fence at \$4.50 | <input type="checkbox"/> Wood Shaper Kit at \$19.95 |
| <input type="checkbox"/> Ball Bearing Spindle at \$5.00 | <input type="checkbox"/> Opt. Hold Down Assembly at \$2.75 |
| <input type="checkbox"/> Belt Sander at \$19.95 | <input type="checkbox"/> 6" Swing 3' Lathe at \$14.95 |
| <input type="checkbox"/> Disc Sander Attachment at \$7.95 | <input type="checkbox"/> 12" Swing 4' Lathe at \$29.95 |
| <input type="checkbox"/> Mitre Gauge for Sander at \$1.95 | <input type="checkbox"/> Face Plate \$2.50 (either Lathe) |
| <input type="checkbox"/> Drill Press at \$34.95 | <input type="checkbox"/> Turning Chisels \$4.95 (either Lathe) |
| G.E. Motor <input type="checkbox"/> \$19.90 (with other item) <input type="checkbox"/> \$24.85 (purchased separately) | |

NAME _____

ADDRESS _____

CITY _____

STATE _____

ZIP _____

3' WOOD LATHE . . . 6" swing.

Same precision and speed as \$40 units. Sturdy cast iron with tubular steel bed. Lever action tail stock, two-speed pulley, fits any motor. Set of 3 high speed turning chisels, \$4.95 add'l. 4" face plate, \$2.50 add'l. 15 lbs., f.o.b. factory **\$14.95**



4' WOOD LATHE . . . 12" swing.

Industrial size, does the same job as \$75 units. Tubular steel bed rails, screw action tail stock, three-speed pulley. Use any motor. 3 high speed turning chisels, \$4.95 add'l. 4" face plate, \$2.50 add'l. 30 lbs., f.o.b. factory **\$29.95**



JOINTER-PLANER 4 1/8" x 22".

Cast iron and steel, precision ground adjustable tables. For planing, joints, bevells. Rabbits to 3/8" depth. Fence adjustable 0° to 50°. Steel knives, dual guards. Use any motor. Precision ball bearing industrial model, \$5.00 add'l. Wt. 19 lbs., f.o.b. factory **\$24.95**



BELT SANDER A precision unit.

It changes from horizontal to vertical in seconds. Heavy, sander includes 4" x 36" sanding belt. Uses 1/2 h.p. or larger motor. V-pulley drive and multi-purpose drive spindle.

Disc sander accessory, \$7.95 add'l. Mitre gauge, \$1.95 add'l. 15 lbs., f.o.b. factory **\$19.95**



DRILL PRESS Precision 32" radial

unit has standard features and many extras. Depth of throat up to 16". Head tilts and table stays level. Drills to center of a 32" circle. All cast iron and steel. Takes standard motor. 32 lbs., f.o.b. factory. **\$34.95**



WOOD SHAPER KIT Makes

beads, coves, moldings, tongue-and-groove joints, etc. Accurate cuts at high speeds. Sealed greased-for-life ball bearings. Less wood. Takes 1/4 h.p. motor or larger, standard cutters. Optional hold down assembly, \$2.75 add'l. 15 lbs., f.o.b. factory **\$19.95**



You get more for your money from NRI

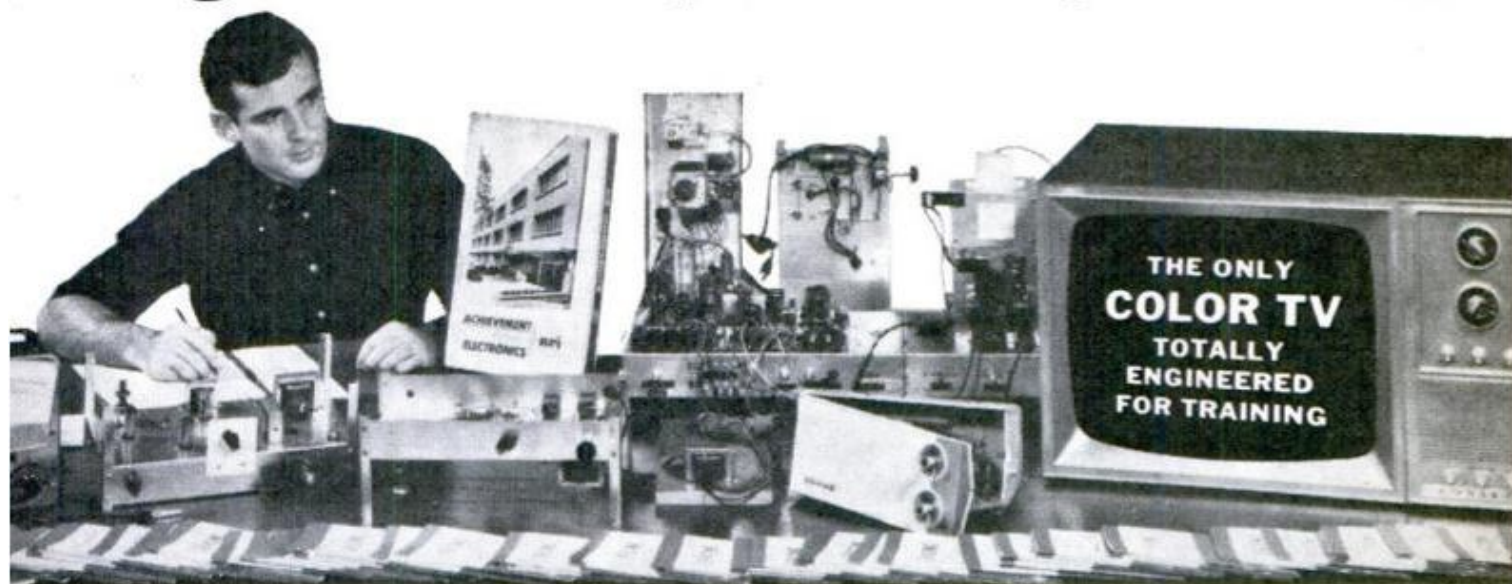

BUILD • TEST • EXPLORE All this is yours — from Achievement Kit, to solid state Radio, to training-engineered Color TV set—when you enroll for NRI's TV-Radio Servicing course. Other courses equally complete. Unique training methods, "bite-size" texts, many personal services have made NRI the leader in its field for over 50 years.

NRI Programmed Equipment Gives You Priceless Confidence, Makes Learning TV-Radio, Electronics Fast and Fascinating

NRI pioneered the idea of supplying home-study students with custom designed training kits to give practical on-the-job experience as you learn. Today, NRI's "3-Dimensional" training can't be equalled. You get more value— from the exclusive Achievement Kit sent the day you enroll, to "bite-size" texts and custom training equipment. Learning TV-Radio, Electronics or Communications at home is easy, exciting, the NRI simplified, dramatized way.

BE A SKILLED TECHNICIAN IN AMERICA'S FASTEST GROWING INDUSTRY

Regardless of your educational background, you can learn the Electronics field of your choice the practical NRI way. The NRI color catalog, sent to you free and without obligation, tells you how you can qualify quickly to be a part of the fast growing Electronic Age; about engineering jobs in business, industry, broadcasting, government, now offered to men without college degrees. It will open your eyes to the great number of success opportunities available right now in the high-pay world of TV-Radio Servicing, Broadcasting-Communications and Industrial-Military Electronics. With NRI technical training, you can take your choice of a wide variety of career

openings or have a business of your own. And if you choose one of five NRI courses that include FCC License preparation, you must earn your FCC License or NRI refunds your tuition!

MAKE \$5 TO \$7 AN HOUR EXTRA IN SPARE TIME STARTING SOON

Tens of thousands of NRI graduates are proof it is practical to train at home in your spare time. Keep your present job while preparing for a better one, and earn \$5 to \$7 an hour extra in spare time while you train, fixing sets for friends and neighbors. NRI shows you how. Equipment you build and keep becomes useful in your work.

STEP UP TO BETTER PAY, A BRIGHTER FUTURE

NRI can help you, but the decision to act must come from you. Decide now to move ahead . . . mail the postage-free card today for your FREE NRI color catalog. No obligation. No salesman will call. NATIONAL RADIO INSTITUTE, Electronics Division, Washington, D.C. 20016.

APPROVED UNDER GI BILL

If you served since January 31, 1955, or are in service, check GI line on postage-free card or in coupon.

CASH IN ON THE BOOM IN COLOR TELEVISION



The NRI TV-Radio Servicing course includes your choice of black and white or color TV training equipment. Color TV needs thousands of trained men to keep pace with millions of sets being sold every year. NRI prepares you quickly. Cash in on the boom.

Mail insert card for your **FREE NRI color CATALOG**

No salesman will call

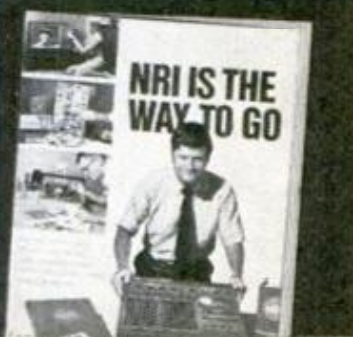

HOMEOWNERS' CLINIC

BY W. CLYDE LAMMEY

Toothpick fillers for nail holes

I want to use two finely finished walnut boards in a home-shop project. Because they have a lot of small nail holes, all going clear through the wood, I'll need to stain the boards very lightly. How can I fill these holes so they won't show in the finish?—H.O., Cal.

You didn't say what kind of walnut—black, California, French, Circassian? All these varieties differ in texture, grain and color. While I think immediately of ordinary fillers or stick shellac, I once solved a similar problem by cutting short lengths from skewer toothpicks and driving them into the holes, just flush. Then I sanded the surface and tinted the lighter ends of the toothpick plugs to match the wood. When finished, the plugs showed only under very close examination.

When and how to seed a lawn

It's about time to think about what to do with my lawn. I don't know how long it's been in existence, but it's thinning and I'm told it needs to be renewed. How do I seed an existing lawn?—D.L., Mo.

Your lawn also needs, no doubt, to be renewed by a scheduled fertilization program, starting this coming spring. I've had good success by mixing grass seed with the fertilizer in the spreader: a layer of fertilizer, a layer of seed successively in the hopper, then hand mixing until both seed and fertilizer are uniformly distributed. Don't expect immediate results. You may see little improvement the first season other than that brought about by feeding existing plants. But if you follow through you will notice a thickening of the sod the second season.

Small areas with few or no plants should be spot-seeded by first working the top soil, spreading the seed and covering lightly. Keep these areas well watered.

What to do with lawn clippings

When I ask what to do with lawn clippings I get confusing answers. Some say leave them at each mowing; others say gather the clippings and compost them. What do you say?—P.G., N.J.

There are differences of opinion. Some authorities put it this way: If, after drying, you can see the clippings, then they should be gathered at each mowing and composted, along with leaves, garden refuse, and the like. I can go along with this procedure. On the other hand I was once told by a greenskeeper that "if you wait until your lawn appears to need mowing, you've already waited too long. Keep it clipped short, never less than 1½ in., excepting the bent grass, and don't gather the clippings."

I can see advantages in both procedures, mainly that in both instances the enriching and mulching elements present in the clippings are returned eventually to the soil.

Concrete patch didn't hold

Last summer I patched a step on my concrete stoop, a corner that broke away. It didn't hold; just fell out of place. I'd like to try again, as I don't want to replace the stoop. Can you tell me the right procedure?—C.T., R.I.

Did you use a concrete patcher especially prepared for the purpose? New concrete won't always bond to old, even though you may have cleaned out all dirt and loose material. Obtain a concrete-patching material which comes as a dry mix and add water in a measured proportion. Again clean the area to be patched thoroughly and make an L-shaped form, bracing or staking the form so it will stay in place until the concrete mix sets. When mixing, be sure to follow instructions on the container in all details. After troweling the mix in place, cover with burlap or coarse cloth and keep damp several days.

When to fertilize trees and shrubs

I think it best to fertilize ornamental trees and shrubs in spring, but I'm told that fall is best. Am I right?—O.D., Md.

You've answered your question. I agree that spring is usually, if not always, the best time to feed trees and shrubs, especially if the soil is a loose, sandy or gravelly loam. If you apply plant food to such soils in the fall, some of it is sure to be lost to the plant by leaching to levels below the root systems. In heavier soils it may be permissible to feed in the fall, but I'd rather rely on early spring. ★★

Do you have a home maintenance or repair problem? Send it to Homeowners' Clinic, Popular Mechanics, 224 West 57th St., New York, N.Y. 10019. While letters cannot be answered individually, problems of wide interest will be discussed in this column.

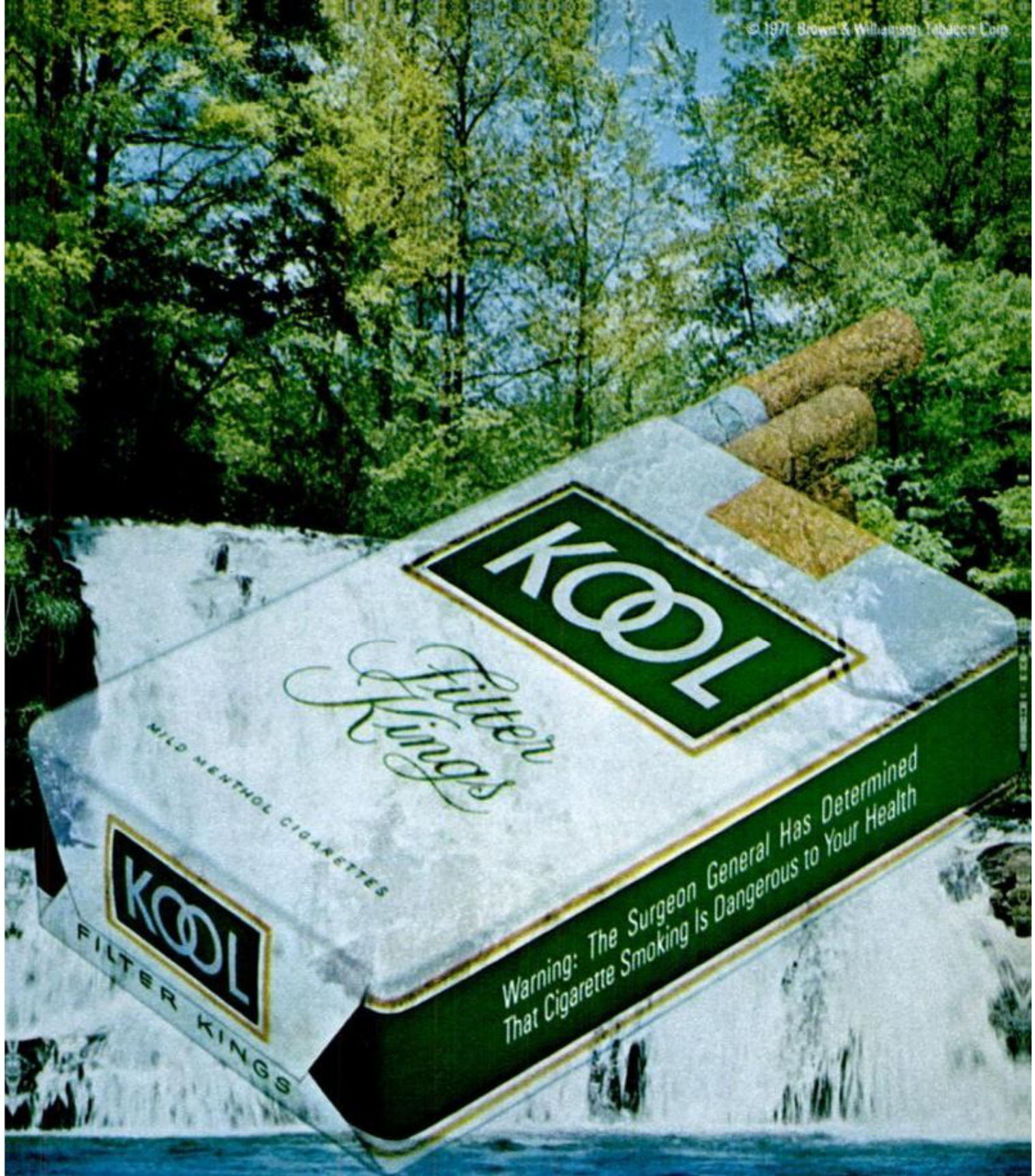

The taste of extra coolness
is why no other menthol of any size
has as many smokers as KOOL Filter Kings.
Come all the way up to KOOL.

18 mg. "tar," 1.4 mg. nicotine
av. per cigarette, FTC Report Aug. 71.

The Suzuki 750 water-cooled three. It gets competition hot trying to keep up.

And if trying to keep up with a GT-750 is hard, you know that passing one is out of the question.

The Suzuki 750 will wind out to 120 mph, scream through a quarter mile in 12.6 seconds. It delivers 20% more low-end torque.

And it'll run hard all day without getting hot.

Thanks to water-cooling.

Water-cooling lets the 750 run 30%

cooler than any competitive machine.

Water-cooling also gives us the closest engine tolerances we've ever made. So the 750 runs virtually noise-free. And sounds like no two-stroke you've ever heard.

Water-cooling also means the 750 won't lose any of its 67 horses due to engine heat distortion.

You can bend corners with a 750 that you've only wrinkled before. That's how good it handles.

Brakes are Gran Prix racing type: double cam, double panel. Lots of chrome

and brightwork. Outstanding paint job. Electric starter. Engine cut-off switch, CCI automatic lube.

And of course, that radiator.

Get hot, get a Suzuki GT-750.

And say goodbye to competition.

In the U.S. you can find the Suzuki dealer nearest you for free. Dial 800-631-1972.

U. S. Suzuki Motor Corp.,
13767 Freeway Dr., Dept. 2018,
Santa Fe Springs, CA 90670. 

In Canada, Radco Sales Ltd., 1107
Homer St., Vancouver, B.C.

Member: Motorcycle Industry
Council, Inc.

Suzuki: built to take on the country.



You don't have to move to get a new home

High interest rates, commuting, the desire to stay where you are: These are all good reasons for improving instead of moving

By **HARRY WICKS**, Workshop Editor

*Data, Annette Sukov
Photos by Dean Paris*

SKETCH shows the original porch that was enlarged to 16 by 30 feet to yield family room and larger kitchen



TODAY, ADDING TO OR REMODELING your home, rather than searching for a newer, larger house, is often the wiser choice for a homeowner. Depending upon size and selection of finishing materials, it is almost certain to be the less expensive approach—particularly if your own mortgage interest rate is well below the eight (or more) percent most banks are now charging.

Money isn't the only factor. Most of us like where we live, and if you have youngsters in school, a family shift will require more than a few adjustments.



Since the property that this Minneapolis family owned would permit them to build the room they needed, their decision was to stay put and add on. They also increased their living area by adding a lighted patio. And, since the original house was due for a re-roofing, the entire house was covered with hand-split cedar shakes.

The vaulted ceiling is simply ½-in.-thick plasterboard over 2x6 collar beams. To finish, the plasterboard was heavily textured with paint and the joints covered with decorative oak beams.

For general use, the lighting concealed behind the wood soffit close to the ceiling gives sufficient illumination. It consists of fluorescent strips which reflect off the painted ceiling. For decorative appeal, oak dentil molding was used around the room where walls and ceiling meet.

The original heating plant was capable of handling the new room; thus, it was not necessary to install new heating equipment. But the builder did relocate the thermostat, placing it in the new room. The single thermostat handles the entire house adequately from this location.

Desiring overall, even lighting, rather than one or two ceiling fixtures, the homeowner chose a luminous ceiling for the kitchen. (See *Luminous ceilings—shadowless and beautiful*, page 116 Jan. PM). Even here, the owner decided to "customize." The plastic, which comes in 2x4-ft. sheets, was halved to create 2x2-ft. sections. Installation was standard using the metal grid system. For visual tie-in with the family room, simulated beams were spaced at intervals across the ceiling.

The kitchen cabinets, custom-made, are also of oak. As seen in the photos and floor plan, strategically placed accordion doors can be kept open for general everyday use or closed when

CAREFULLY PLANNED ADDITION has bypassing doors located to give best view of the outdoors. Fireplace is built of kasota stone and has an oak mantel



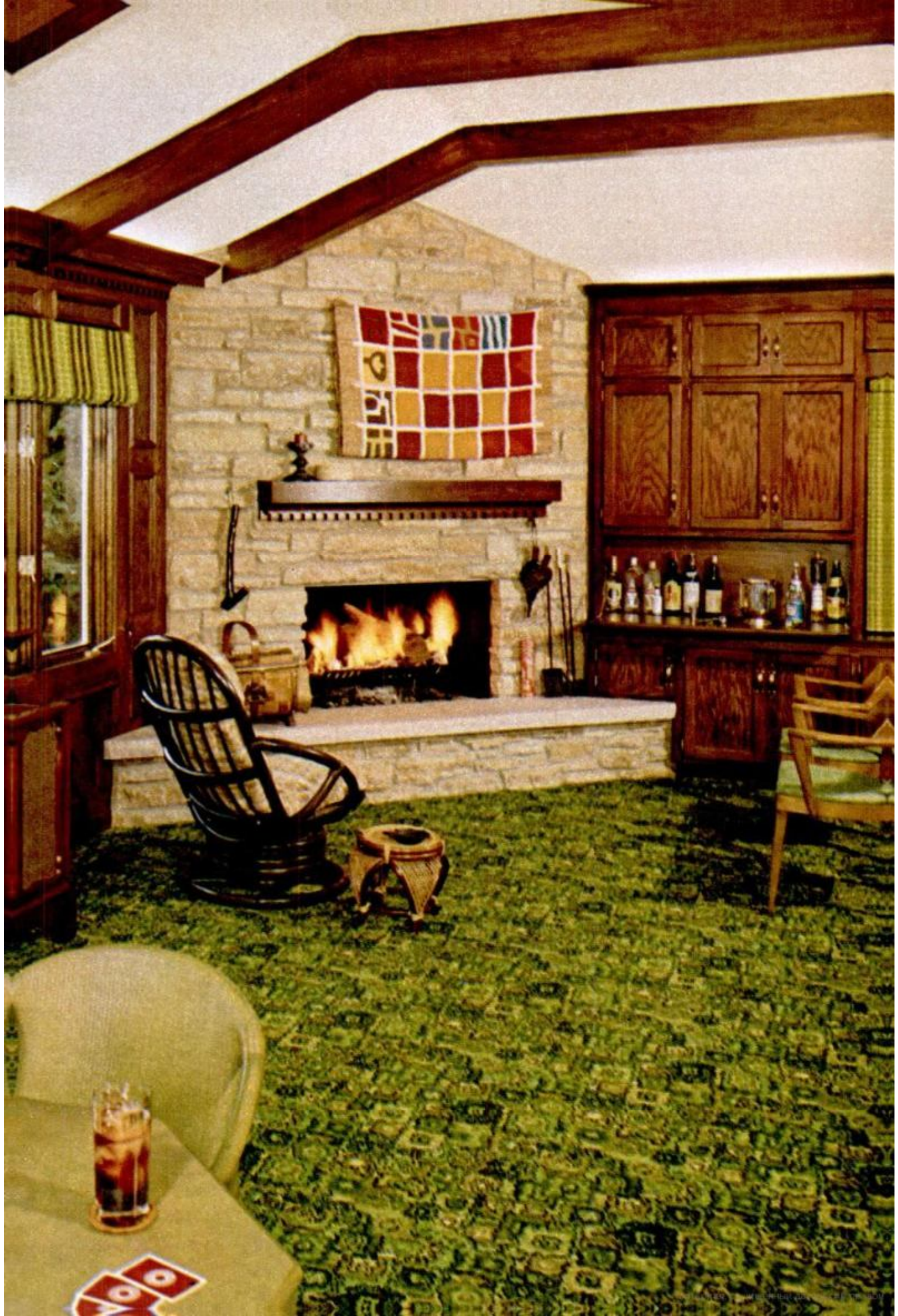



ENLARGED KITCHEN features a luminous ceiling. Oak beams were added for a visual tie-in with the new room. The cabinets are also of oak, and a suede-finish, white plastic laminate was used on the countertop

desired. They were placed at the peninsula counter so that area can be left open and used as a pass-through when wanted.

The brick-patterned vinyl flooring was picked up from the old kitchen and relaid.

To make the step platform by the sliding doors, slate was simply embedded in concrete. The concrete patio has a smooth steel-trowel finish and raked lines radiating from the platform. The outdoor lighting was solved by simply setting a plastic globe on steel pipe, which, of course, is erected in a footing.

What makes this addition particular-

ly attractive is continuity of design, both indoors and out. It is obvious that the homeowner and builder worked closely together on the project and it shows in the finished product. The new hip roof ties in perfectly with the existing house roofline. And that is important. A poorly or hastily conceived addition will almost always result in a structure that has a tacked-on look. This is something to avoid if you want to add to, rather than detract from, the value of your home.

It might even pay to have an architect look at your home and make suggestions so that you will avoid this common pitfall. ★★★

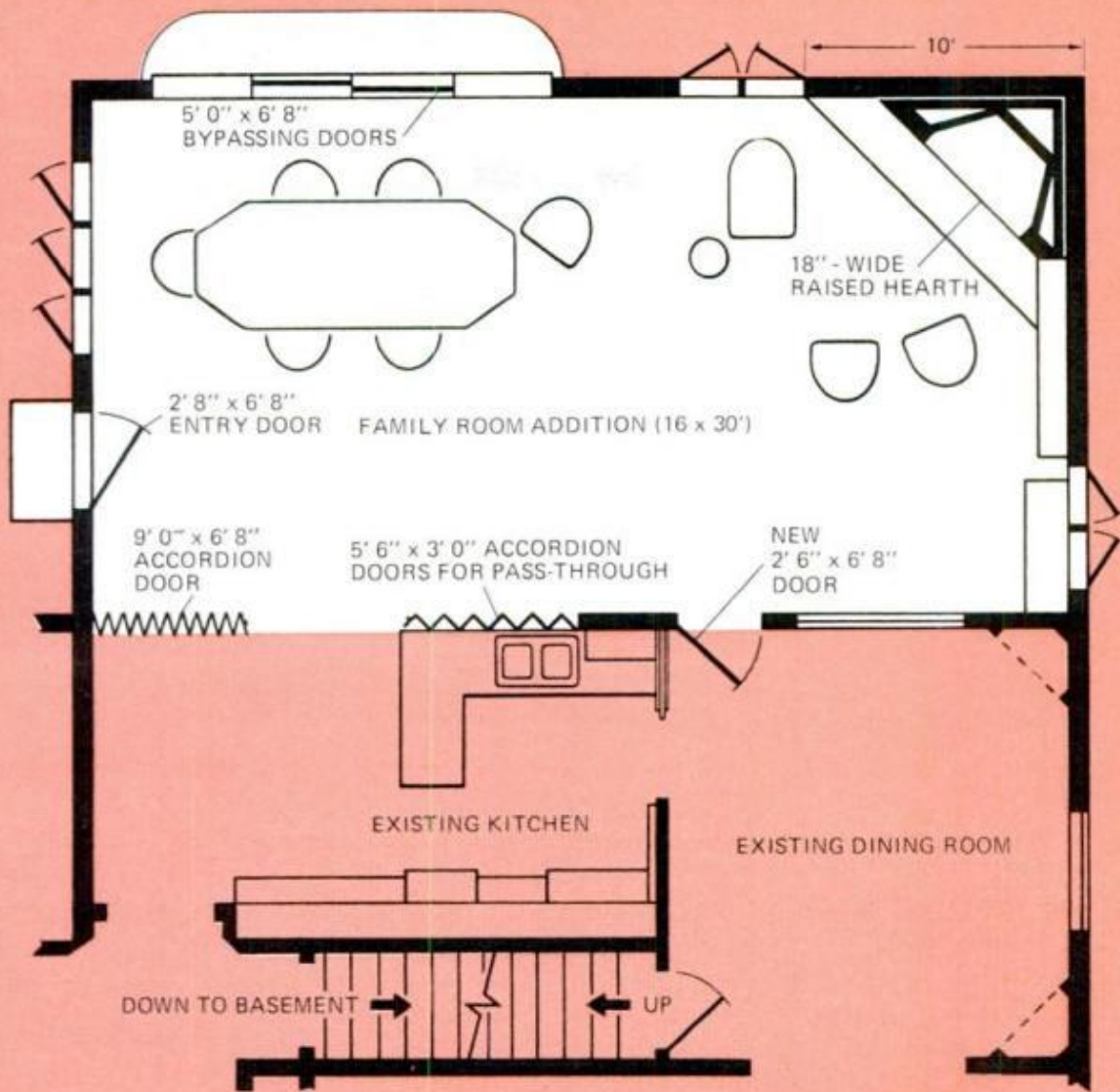

ACCORDION DOORS are used when it is desirable to hide the kitchen from view. The floor plan shows how careful planning insured that this addition would become a part of the home and not look tacked on



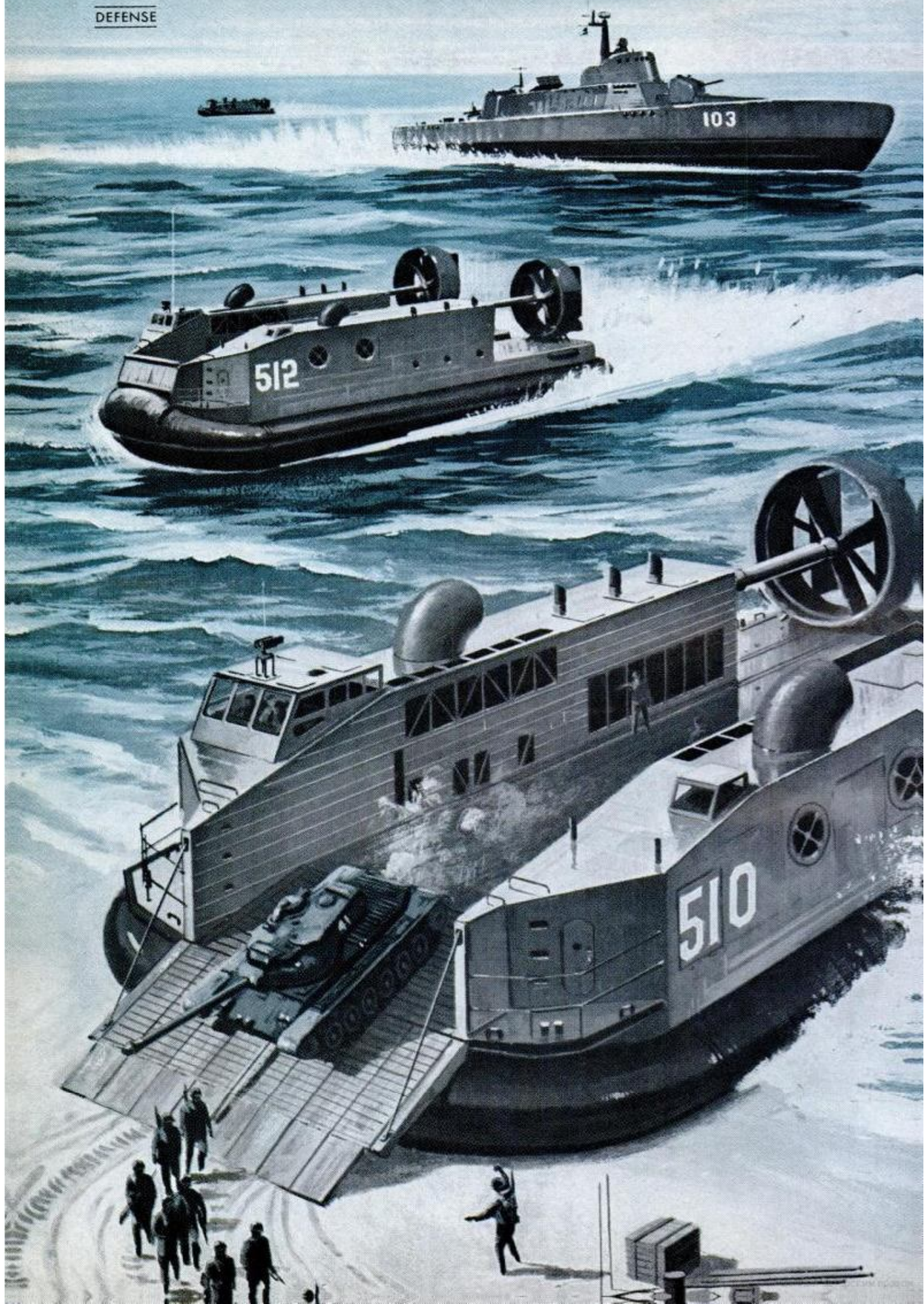



A fast fleet that rides on **AIR**

Warfare on the high seas will never be the same if Navy's revolutionary plan to launch 100-knot ships is successful

By MORT SCHULTZ

TO MEET the seagoing challenges of the 1980s, the Navy is developing an armada of small vessels able to ride on a cushion of air while doing 100 knots—a speed conventional ships can never hope to equal.

The Navy calls them surface-effect ships (SES), and foresees the day when they will swiftly hunt down and destroy nuclear submarines, act as fast-moving missile launching platforms, or safely haul cargo and troops from a mother ship to an inland point after hopping over the beach.

In asking for \$40-million this fiscal year to push the SES project, Rear Adm. William H. Livingston, director of the Navy's Air, Surface and Electronics Warfare Div., told Congress that "almost all Navy missions can be

enhanced by surface-effect ships. They can go faster."

Conventional ships waste a large portion of their power simply pushing water out of the way, particularly at high speeds. A streamlined destroyer, for example, can make 27 knots with 15,000 hp. Doubling the horsepower doesn't help that much; the ship reaches only 32 knots.

SEs, however, use the additional power to rise above the water, reducing or eliminating hull drag while substantially improving their speed.

Right now, the Navy brass is keeping an eye on two SES types being developed by Bell Aerospace Co. and Aerojet-General Corp. One craft "flies" over the water on a cushion of air. The other uses an air bubble to lift the front of the hull above the waves, leaving two thin sidewalls in the aft section extending several feet below the waterline to add stability and prevent skidding during turns.

The two aerospace outfits are building slightly different 100-ton prototypes of the air-bubble vessel—scale models of transoceanic ships weighing 4000 to 5000 tons, the approximate size of a destroyer escort.

Bell's version, SES-100B, a 77-foot-long, 35-foot-wide aluminum craft, rides on a cushion of air trapped by catamaran-style side hulls and flexible nylon-rubber bow and stern seals. The air is generated by eight lift fans driven by three 500-hp ST6J-70 marine gas turbine engines made by United Aircraft of Canada.

When cruising, the bow and center portion of the hull clears the water,

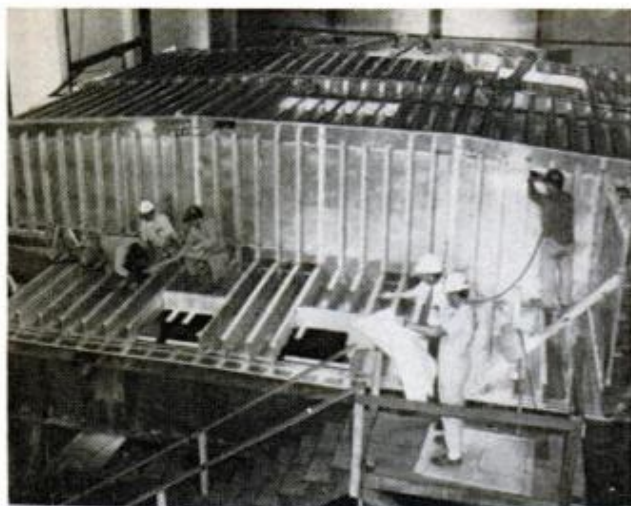

HULL STRUCTURE of Bell Aerospace's 100-ton prototype surface-effect ship is completely aluminum

entirely supported by the trapped air bubble.

Propulsion comes from three Pratt & Whitney 4500-hp FT12A-6 marine gas turbines that drive two semisubmerged, controllable-pitch, supercavitating propellers in the stern.

Trial runs of the Bell midget carrying a crew of four, six observers and a 10-ton payload are being held this year in the Gulf of Mexico to determine if the craft can be routinely pushed to 80 knots. If that speed is easily reached, engineers will try for 100 knots.

Aerojet-General's pioneer will be slightly longer than the Bell version—80.5 feet long, and 38 feet wide—but more significant is the difference in propulsion. Instead of semisubmerged props, the Aerojet-General SES-100A has a propulsion system that uses two powerful water-jet pumps. Both pumps and the three lift fans get their juice from four 3500-hp gas turbines.

If the SES prototypes prove them-

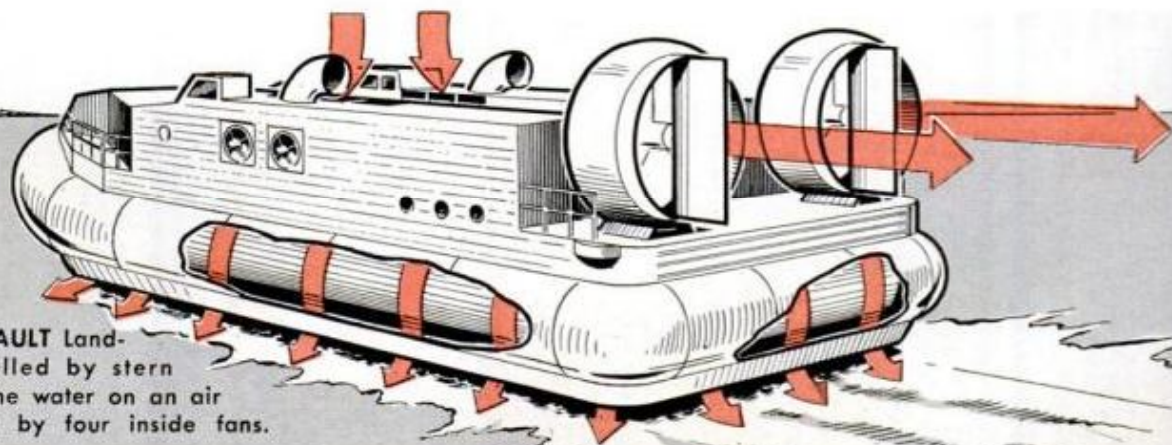

AMPHIBIOUS ASSAULT Landing Craft, propelled by stern fans, skims over the water on an air cushion generated by four inside fans.



LANDING CRAFT (shown in a full-scale mock-up) designed to carry a 60-ton tank plus fighting men

selves, it's likely the first application will be SES antisubmarine vessels. A full-grown 100-knot SES would be much faster than the nuclear submarines that now outrun today's 40-knot subchasers, and would be able to twist and turn tightly, thanks to their underwater sea legs. They'd also be less vulnerable to enemy sub sonar and wouldn't present much of a torpedo target because only a small portion of their hull is in the sea.

In the rush to develop 100-knot SESs, the Navy hasn't forgotten a primary mission—landing troops and their backup cargo on an invasion beach. Bell and Aerojet-General have contracts to work out two amphibious assault landing craft, nicknamed JEFFs.

The boats, designated C150-50, are based on the Navy's combat experience in Vietnam in 1966 and 1967 when 10 air-cushion patrol vehicles were tried out (see *'Tiger Sharks' strike in the Vietnam swamps*, page 131, Nov. '67 PM). Called hovercraft, the vessels

were awkward-looking, small pancakes 39 feet long, 24 feet wide, and powered by a single 1150-hp General Electric gas turbine that sent them skimming four feet above the Delta at 60 knots.

Today's JEFF has come a long way from those early experiments. Bell's prototype calls for a craft 90 feet long and 47 feet wide, able to carry 75 tons of cargo above the water or beach while riding completely on a cushion of air. Top speed: 50 knots, or five times faster than the assault boats that hit the beach at Normandy.

Six 2800-hp marine gas turbines will drive a pair of 14-foot diameter propellers mounted above the stern to push the boat while four five-foot fans on the sides maintain the air cushion.

The Navy will run boats from mother ships able to stand 200 miles off the invasion beach, safely out of range of crippling shore batteries. While JEFFs won't be as fast as the early hovercraft, they'll carry much more cargo—vital when supporting an invasion.

These SES projects make up the giant portion of the Navy's small ship program. Other projects include a \$12.9-million program for hydrofoil experiments plus \$3-million for work on "sea control" ships—small seagoing platforms able to launch helicopters and short takeoff jet attack aircraft.

But the lion's share is going to SES projects. Reason: A report to the Pentagon by the Institute of Defense Analysis concluded that "the principle of air-cushion vehicles appears to offer more potential for naval military surface vehicles than any other development during the last two centuries." ★★★

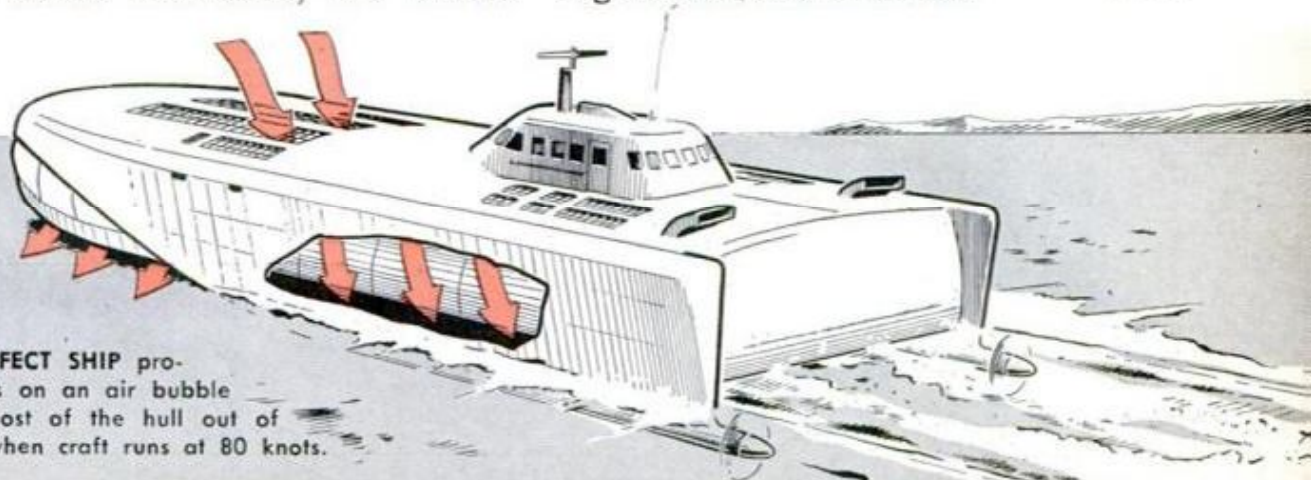

SURFACE-EFFECT SHIP prototype rides on an air bubble that lifts most of the hull out of the water when craft runs at 80 knots.

PM FIAT 124
OWNERS REPORT...

A nationwide survey based on
 1,700,000 owner-
 driven miles

It's a car for all seasons but owners yearn for more power



By **MICHAEL LAMM**,
 West Coast Editor

Photos by the author

F IAT LUMPS THEM all together simply as 124s, but there's as much difference between the two sport versions and the family models as between Ford's Mustang and the Galaxie 500.

Two basic body types in four models make up the Fiat 124 line: a sport convertible (Spider), Sport Coupe, a four-door sedan and four-door wagon. The Spider and coupe look almost like twins and so do the sedan and wagon, but neither set resembles the other. Spider and coupe are low and pointed; sedan and wagon stand tall and square.

Fiat's 124 sportsters share a 104-hp double-overhead-cam Four, and this same basic block also powers the 124 family cars. But in the sedan and wagon Fiat tops off the engine with overhead

FIAT FUEL-MILEAGE CHART

Averaged for all models

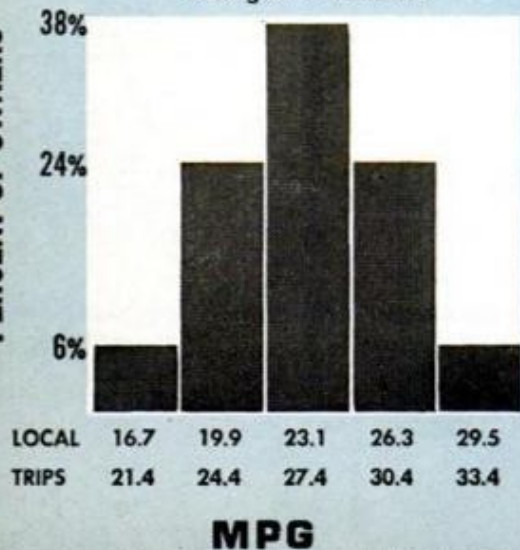

valves, not double overhead cams, the result being 28 fewer horses. For other differences and similarities, check the specifications chart on page 74.

To give our Fiat 124 *Owners Report* more validity, we'll separate the opinions of sport-model owners from those who drive the family versions. We'll begin by listing comments for the Spider and Sport Coupe.

"Brakes are the best I've ever felt," says a Sacramento graphic artist. They're four-wheel discs and give excellent fade resistance and stopping power. This same braking system is used on all Fiat 124s.

"Fifth gear is tremendous for long trips," comments a San Antonio metal-smith. Both the Spider and Sport Coupe come with five-speed transmission as standard equipment. High is an overdrive ratio at 0.91:1 (fourth is 1.1).

"The Spider is a beautiful driving experience . . .," writes a Connecticut marketing vice president, ". . . with the small-sports-car handling I had hoped for. On the open highway the automobile is smooth and responsive. Trips over winding country roads are a popular pastime with the Spider. Each member of the family enjoys it very much." Most owners did say good things about the Fiats' handling. Suspension systems on all 124s use four-wheel coils, with a solid rear axle. Fiats boast stabilizer bars fore and aft and come with radial tires.

"Excellent workmanship—built with an accent on safety because of its solid, sturdy design and construction." So affirms a New York secretary. Fiats use unitized bodies; no separate frames.

"Seat height should be lowered so the steering wheel position can be changed by tilting it down more," opines a Michigan ad copywriter. Yet most owners do find the front buckets very comfortable. This is one of the few cars in its class with a rear bench. Although the back seat tends to be cramped, most owners anticipated this and don't consider it a drawback. It's fine for kids and even an occasional

FEBRUARY 1972



SEDAN AND WAGON use familiar overhead valves in four-cylinder engine; sports models, overhead cams



SEDAN TRUNK pleased almost all owners. Sedan and wagon have breadbox lines for good space utilization



124 ECONOMY was big buying factor for sedan and wagon owners, but then they found fun of handling

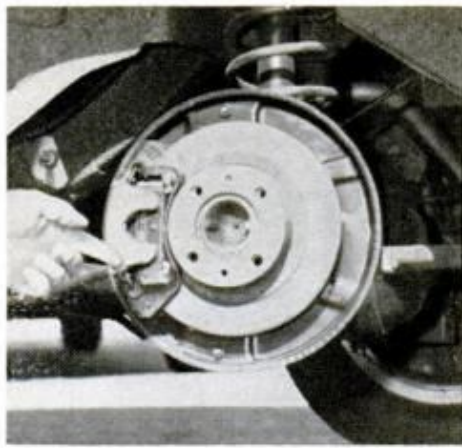

DISC BRAKES on all four wheels were praised by owners of all 124 models



DRIVING POSITION, COMFORT got fine ratings from sedan owners, even more enthusiastic comments from Spider and Coupe owners



JACK SLOTS on sides are positive and secure as on most imported cars



EXHAUST VENTS in the C-pillar are for a flow-through ventilation system

short-hop adult, so its presence is generally appreciated.

"Would like a V6 put into the American version," suggests a Nebraska budget analyst. "About 50 more horsepower would be nice," echoes a Florida attorney. "Could use a higher fifth gear and a 2000-cc engine," is the way a Washington dentist sees it. And a Los Angeles writer writes: "I hate to admit it, but I'd like a bigger dohc engine; 1600-cc just isn't enough in present fast company, namely the Datsun 240-Z. Fiat's mid-range power curve and gearing are wrong for the city." Some 14 percent of all Fiat owners say they'd appreciate more oomph.

Asked if they'd had mechanical troubles, 55.3 percent said yes—a rather high incidence. Most persistent were electrical ills. Quite a number of Spider and Sport Coupe owners said that the engine drowned out easily after driving through puddles. Several mentioned that the windshield wipers worked fine until it rained; then, in the wet, the wiper motors wouldn't budge, most likely because of shorts.

A significant number also complained of noises from the exhaust manifold and from the speedometer cable. Six percent noted they'd had transmission trouble, most saying the gearbox was hard to shift into reverse. A few of the Spiders

FIAT 124 SPECIFICATIONS

Model	Type of Engine	Displacement	Bhp & Torque @ Rpm	Transmission	Wheelbase (in.)	Dry Weight (lbs.)
Spider	dohc 4	1608 cc 96.5 cu. in.	104@6500 94@4200	5-speed manual	89.8	2046
Sport Coupe	dohc 4	1608 cc 96.5 cu. in.	104@6500 94@4200	5-speed manual	95.3	2110
Sedan Special	ohv 4	1438 cc 87.8 cu. in.	76@5400 81@3300	4-speed manual or automatic	95.3	2085
Wagon	ohv 4	1438 cc 87.8 cu. in.	76@5400 81@3300	4-speed manual or automatic	95.3	2084



124 SPORT SPIDER is an enthusiasts' car chosen by owners for its style and handling. Despite the good performance of the new 1608-cc, dohc engine, many owners would like to see a still larger engine, more power

and Sport Coupes suffered from broken gear cogs, and the factory warranty specifically excludes these teeth from coverage. Dealers usually warn enthusiastic new owners not to speed shift or drag-race the 124.

Moving along now to the sedan and wagon—owners had these remarks:

"I was apprehensive about dealer service when I first bought the car," says a New York planning consultant, "but I find my dealer excellent in every way." Most Fiat owners do, a few saying they'd like to see a larger dealer network and shorter waits for parts. "Very good dealer relations here," writes a California plastics fabricator, "except the free service at 1000 and 2500 miles cost me \$3 and \$4.50."

"I am most impressed by the big-car feel, yet my sedan handles and parks like a small one," states a North Carolina lab administrator. And a Kansas student: "I am amazed at the amount of room the trunk contains. Once we had four suitcases, three sleeping bags, a trumpet case, and a guitar case in the trunk and still had room for odds and ends."

Again, owners of the sedan and wagon lavish great praise on their cars' handling, maneuverability, stopping and steering. All 124s use the same systems, so in effect you get the genuine sports car basics, even in the wagon. Quite a number of sedan and wagon owners mentioned that cross-

(Please turn to page 178)

Summary of 1971 Fiat 124 Owners Reports*

Total miles driven1,734,351

Average miles per gallon

Local driving23.1
Long trips27.4

Body styles

124 Spider convertible40.3%
124 coupe30.3
124 Sedan Special21.7
124 station wagon7.7

Why the Fiat 124?

Styling35.4%
Economy23.0
Price21.1
Handling17.4
Reports and ads14.0
Size9.3
Performance8.7

Specific likes:

Handling67.0%
Economy43.7
Style43.7
Comfort36.1
Performance17.9
Brakes17.6
Power12.6
Ride12.3

Specific dislikes:

Rattles11.9%
Dealer service11.1
Quality of materials9.9
Cold starts7.7
Lack of power7.7
Brake squeal7.4
Radio6.5
Poor workmanship6.3

What changes would you like?

More power13.8%
Better materials11.3
Bigger engine8.5
Better seat comfort6.3
Less slippery steering wheel5.4
Headlight dimmer on floor5.0

Had any mechanical trouble?

Yes55.3%
No44.7

What kind of trouble?

Electrical17.1%
Exhaust manifold11.6
Speedometer cable9.6
Brakes9.1
Windshield wipers8.5
Carburetor6.0
Transmission6.0

Did you repair it yourself?

No91.3%
Yes8.7

Dealer repairs satisfactory?

Yes65.5%
No34.5

Is the Fiat your only car?

No57.2%
Yes42.8

Other cars owned:

Chevrolet18.2%
Volkswagen14.3
Ford11.8
Oldsmobile8.9
Pontiac8.9
Buick8.4
Fiat7.4
Dodge6.4

Age distribution of owners?

15-29 years56.4%
30-49 years31.5
50-plus12.1

Would you buy another Fiat?

Yes83.2%
No16.8

*Percentages might not equal 100% due to rounding and/or insufficient data.

IN AN ERA when most people are familiar with how men get to the moon, the blimp remains an enigma.

A teen-ager, after recently watching a blimp float majestically over New York City, asked how the "big balloon" got there, and if it carried people. In California, a would-be hijacker demanded a blimp crew fly him to Colorado. He dropped the idea when told the craft would never climb high enough to clear the 11,000-foot peaks of the Rocky Mountains.

Even experienced pilots are puzzled by the slow-moving, silver-colored, flying sausages. "When we're out for a ride," says Joe Hajack, a pilot for Goodyear Tire and Rubber Co.'s blimp squadron, "we attract every private plane in the sky. They try to fly alongside or circle around us. Either way, they can't win.

"We cruise at 25 miles an hour, and there aren't many planes that can go that slow without stalling. When they try to circle us, they're out of luck again because my blimp can turn on a dime. As the plane circles me, I turn the blimp. Everytime the pilot looks at us, our nose is pointed at him."

Hajack is one of 15 pilots who fly Goodyear's three blimps—the world's only operating fleet of lighter-than-air ships. He was recruited from the

IN THE BAG, employees (right) complete building Goodyear's 300th blimp, to be launched this summer

USING WHEEL, pilot (bottom right) adjusts blimp altitude by changing trim of elevators on the tail

GROUND CREWMEN must pull airship via dangling lines (bottom) into the wind before blimp takes off

Up, up and away! Very slowly

By DIANA and
HARVEY SHAMAN





VALVE releases air as the blimp rises, allowing more space for expanding helium

ON GROUND, blower is required to maintain proper pressure in ship's air bags



Navy after it abandoned blimps in 1962.

The lighter-than-air ship, at times called a dirigible or zeppelin, goes back to 1852 when the first power-driven airship successfully flew above Paris. The ungainly craft's golden age began in 1900 when the first zeppelin, a hydrogen-filled balloon with a rigid internal frame made of aluminum, was launched in Germany.

World War I spurred development, especially in Germany which used zeppelins to bomb England. Further research after the war produced the

Graf Zeppelin for commercial transatlantic service in 1928. The huge ship made 144 crossings before being retired after nine years. A sister airship, *Hindenburg*, was launched in 1936, but crashed one year later when her flammable hydrogen gas exploded while she was landing in New Jersey, killing 36 persons aboard.

The U.S. Navy had two large rigid airships between the world wars, but the *Akron* crashed in 1933, and the *Macon* went down in 1935, causing officers to reduce large-scale airship

operations. Blimps were revived for coastal patrol in World War II, and by 1945 the Navy had a fleet of 168.

The Navy kept a few flying until improvements in electronics and aircraft eliminated their usefulness, leaving the skies to the Goodyear blimps.

The company's sisterships *America* and *Columbia*, both built in 1969, are 192 feet long, 59 feet high, and 50 feet wide. The *Mayflower*, commissioned in 1968, is slightly smaller. The trio can each carry six passengers and a pilot in a car slung under the bag. The gas bag is filled with helium, but does not have a metal supporting skeleton inside as did the zeppelins. Gas pressure keeps the walls rigid.

Although able to do 50 mph, the flying Goodyear billboards average a placid 25 to 35 mph while cruising comfortably at 1000 to 3000-foot altitudes. Maximum ceiling is 7500 feet, but pilots seldom go that high since people on the ground wouldn't be able to read the company's name splashed the length of the ship. Advertising is the fleet's purpose.

Each blimp is assigned five pilots plus 12 to 16 ground crewmen who help during takeoffs, landings, and moorings plus doubling as mechanics, riggers and radio technicians.

At takeoff, the ground crew grabs

ropes dangling from the blimp, and walks the craft downwind to the end of the field, then swings the nose into the wind. The pilot revs up the twin 210-hp, six-cylinder aircraft engines, and taxis down the runway on a single swiveling wheel attached to the gondola's underbelly. When the blimp is going fast enough to develop lift, the pilot raises the blunt nose, and the ship is airborne.

To land, the pilot points the airship downward into the wind, and eases it into the open end of a "V" formed by the ground crew, and cuts the engine. The crew grabs the lines, holding the blimp down until it is moored.

Navigation is line-of-sight with pilots following a highway, railroad track or river. Flying is limited to clear days when ground winds do not go over 15 to 20 mph.

The ponderous blimp may be an aviation anachronism in a time when men routinely fly faster than the speed of sound, but not at Goodyear. The company that pioneered blimp development in the United States, is currently constructing a fourth modern airship, the 300th to be built by Goodyear, which will be christened *Europa*. After assembly in England this summer, the ship will be stationed permanently in Europe. ★★★

ANATOMY OF THE GOODYEAR BLIMP

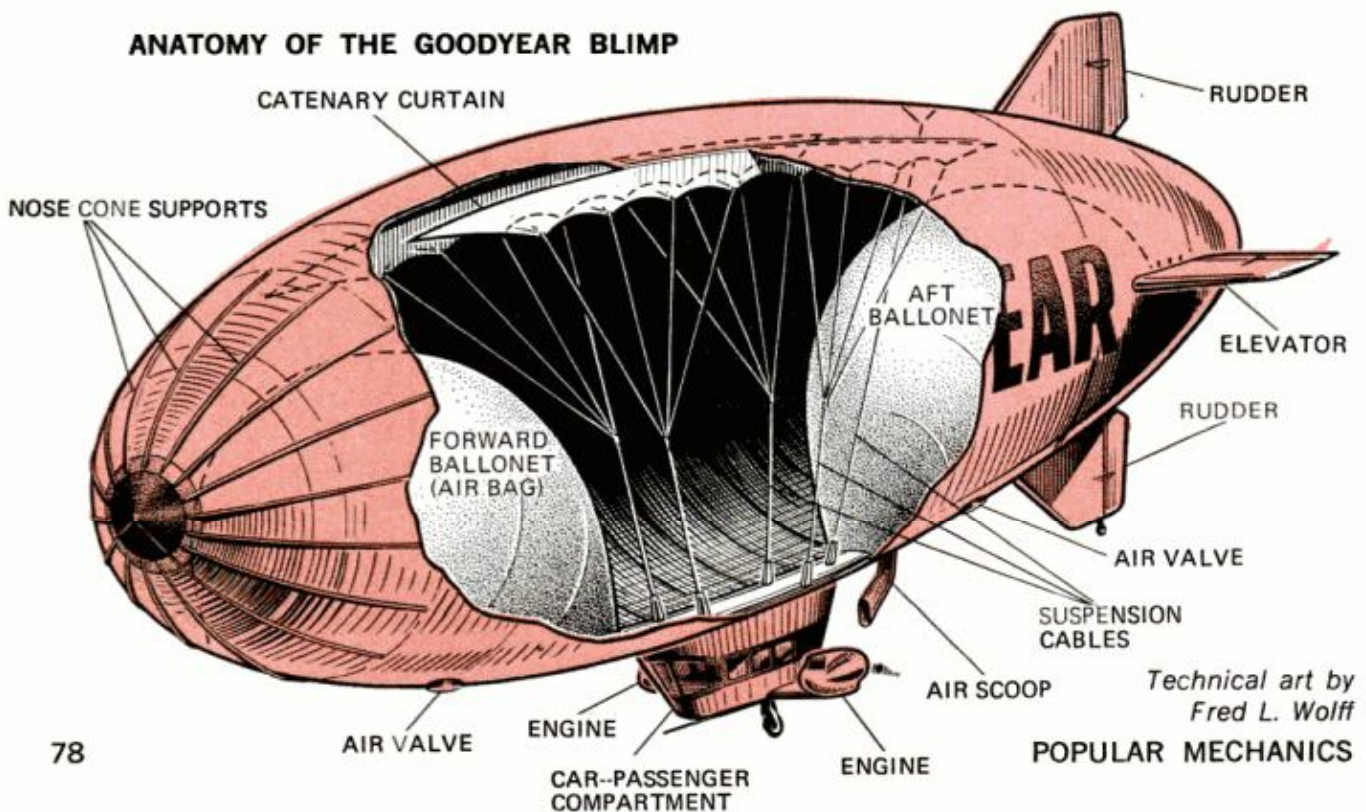

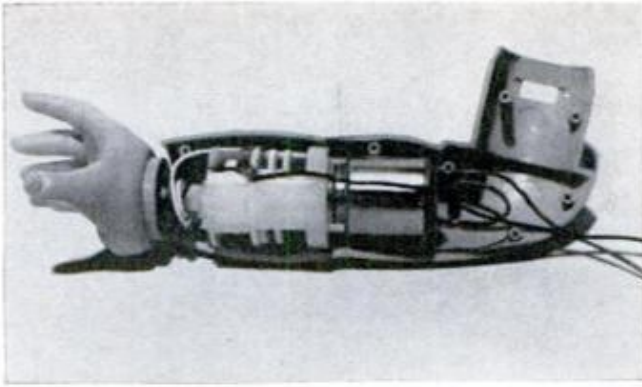

Dice-rolling dolly

Here's one solution for children bored during a rainy day: Lucky Lisa, a doll able to "throw" dice. The doll plays after her right arm is extended parallel to the surface she is sitting on, and the dice are dropped into her cup. The doll shakes the dice, then tosses them on the table. Behind Lucky Lisa's roll is a battery-powered motor hidden in her right arm (above). The motor uses six sets of spur-tooth gears to give the arm a lifelike motion when it is shaking and tipping the cup. Lisa is manufactured in Great Britain.



S-curved bridge

German road builders erected this curving bridge over the Autobahn near Hannover, contending it will be stronger than a straight span while costing the same to construct. Because drivers must slow their cars when crossing, fewer weakening vibrations will be sent down through the concrete structure.



Government collects gripes

Amsterdam citizens with a gripe or a suggestion about their local government can put them in "ideeën" (idea) boxes placed around the Dutch city. Messages are picked up daily and delivered to a government agent who forwards good ones to the appropriate city department. In one year, officials considered 127 out of 200 submitted, and adopted 11.

NEWS BRIEFS



Driver's license by computer

Rather than ask a person to drive a real car before issuing a license, Washington state examiners sit an applicant in an auto simulator and flash emergency scenes in front of him on a movie screen (top). A computer scores the applicant's reaction. The written test is taken with a computer keyboard and a small screen displays questions (left); the applicant simply hits a button to answer. One instructor can give 16 tests per hour.



Tallest gravity dam

When the Army Corps of Engineers completes construction this year, the Dworshak Dam in northern Idaho will be the highest straight-axis concrete gravity dam in the Western Hemisphere. To build the 549-foot wall across the Clearwater River's north fork, engineers dug the world's second deepest rock quarry—480 feet. The crushed rock was used in the 6.5 million cubic yards of concrete for the dam.



Secretary's cradle

As a step toward the paperless office, a German designer has come up with this self-contained "office" that includes chair, desk and typewriter. The secretary can receive information through terminals at her ears, or from a computer readout. The typewriter can be replaced by a telex machine, microfilm reading equipment, or a computer terminal. This futuristic arrangement cost \$20,000 to make.



Vintage-car decor

When not restoring vintage Morgan sports cars (upper left), English engineer Jack Brown turns to redecorating his home with antique auto parts. He has replaced his living-room fireplace with distinctive headlights and grille from an old Rolls-Royce (left) and added a dining room chandelier (above) made from connecting rods and pistons of an old Lancia.



Railroad empire builder

Sixty-three locomotives, plus passenger and freight cars, run on this British model railroad that Victor Martin (left) and his wife spent 20 years hand-making in their garden shed. The trains travel on 3000 feet of track laid over 24,000 ties imbedded in fine gravel. A 12-volt d.c. system powered by old railroad batteries supplies electricity.

Plastic teeth that

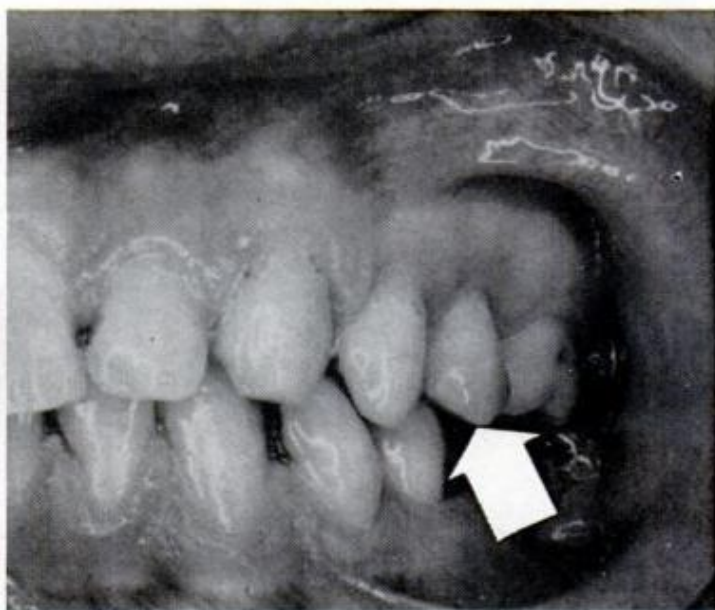
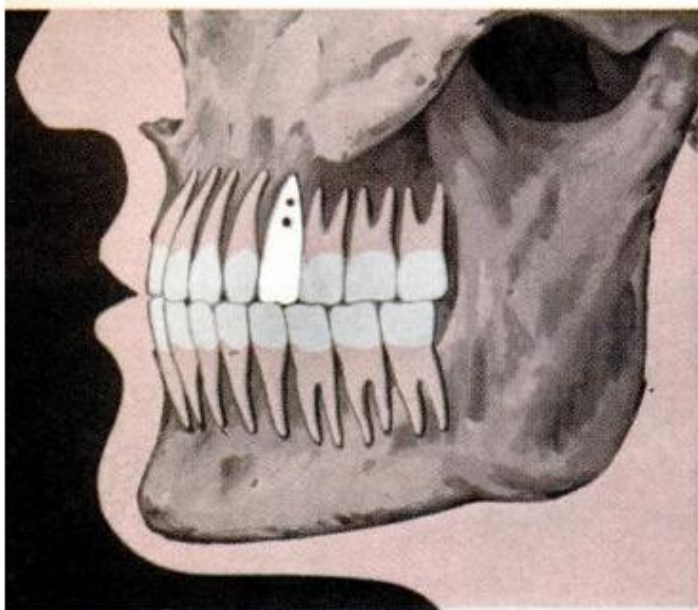

POP-IN TOOTH WAS IMPLANTED in a patient's upper jaw (drawing) following an extraction. Two years later, an examination revealed that healthy gum tissue had surrounded the acrylic replacement (arrow)

IF YOU'VE EVER LOST a permanent tooth, you may know how expensive and uncomfortable a false one can be. The removable plate or fixed bridge holding the tooth is apt to be awkward, not very tasty, and may occasionally slip out of position.

But help is on the way. Dentists are successfully experimenting with a

permanent implant that "fools" the body into locking a false tooth to the jaw through new bone and tissue growth, thereby eliminating the need for a bridge or plate.

The regeneration of bone and tissue is what really excites dental researchers. The jawbone tends to recede when a tooth is pulled or when gums become diseased. Until relatively recently, dentists believed that the "lost" bone was never regained. Now the implants—in contrast with the effect of a bridge or plate—seem to trigger the regeneration of bone.

Dr. Arthur Ashman, a research dentist at Columbia University, has come up with one version of a single tooth implant formed with acrylic, a plastic resin found in everyday items from clothes to plexiglass. Following experiments with dogs, Ashman has implanted single false teeth in 15 patients who have worn them for more than four years without complaint.

After pulling a damaged tooth using routine dental techniques, Ashman forms the acrylic replacement in a mold on the spot. But rather than at-

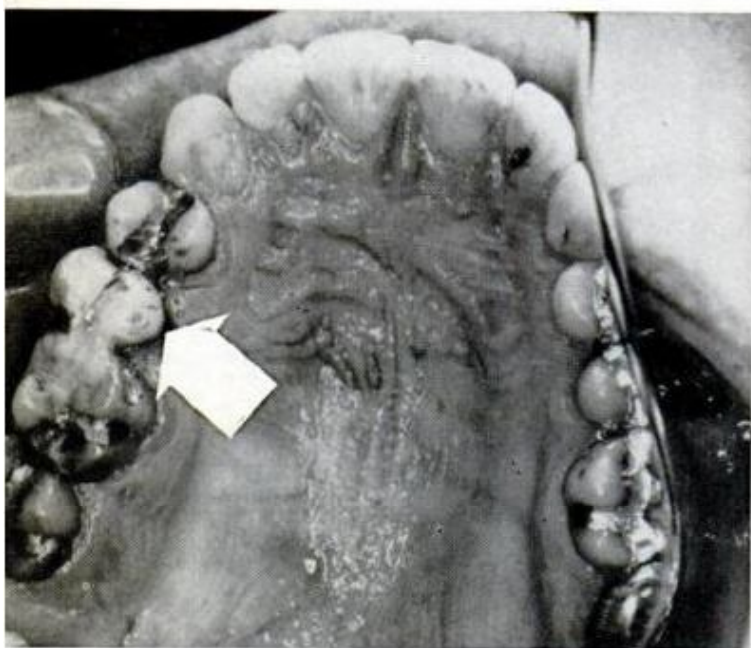

SINGLE FALSE TOOTH (arrow) is held tightly in place by wires and acrylic resin after the insertion

'take root'

By ARTHUR S. FREESE

Technical Illustration by Roy Grinnell

tach the replica to a plate or bridge, he drills one or two holes in the plastic "root," then pops the replacement into the space that was left by the pulled tooth.

The acrylic tooth is wired to an adjacent natural one, and the wire covered with acrylic. The wire acts as an anchor, holding the false tooth firmly until bone grows through the "root" holes, and gum tissue tightly surrounds it. The two permanently bond the false tooth to the jaw.

Dr. Ashman's pop-in tooth is much easier to install than a conventional bridge since a patient does not have to return to his office for repeated fittings, and it is cheaper because gold and silver are not used.

To further his research, Ashman recently teamed up with Dr. Milton Hodosh, a Tufts University dental professor who has also been experimenting with pop-in teeth, but on baboons. Hodosh, however, has concentrated on growing new gum tissue around and into an implanted tooth as well as stimulating new jawbone growth.

From their combined previous studies, the two hope to learn why the body will accept an acrylic tooth that keeps the jawbone from receding.

And, having grown bone horizontally, either through "root" holes or tiny porous openings produced with chemicals, Hodosh and Ashman will try to induce bone growth vertically. If successful, the technique would help persons suffering from gum diseases that weaken the jawbone structure holding teeth.

Today, Hodosh and Ashman are confining most of their new work to laboratory animals. But their future research could make dental gold and silver "old-fashioned," and plates and bridges as obsolete as the buggy whip—all with acrylic pop-in teeth.

★ ★ ★

FEBRUARY 1972

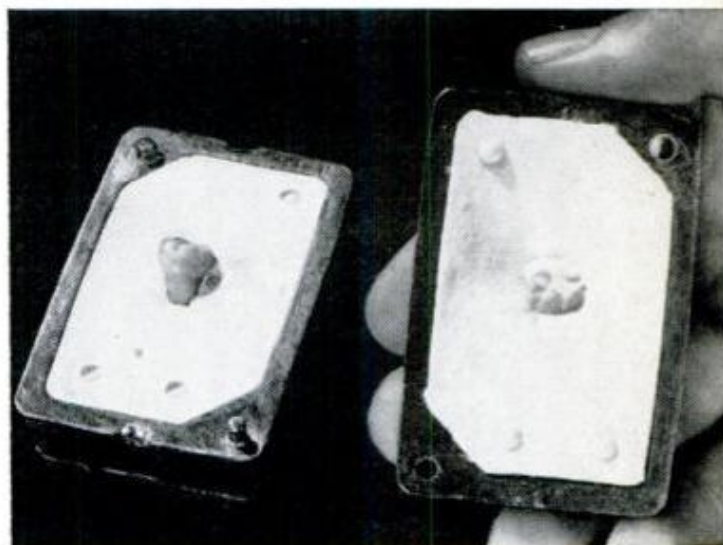

PLASTER MOLD OF TOOTH is made immediately after extraction. Mold is used to form acrylic replica

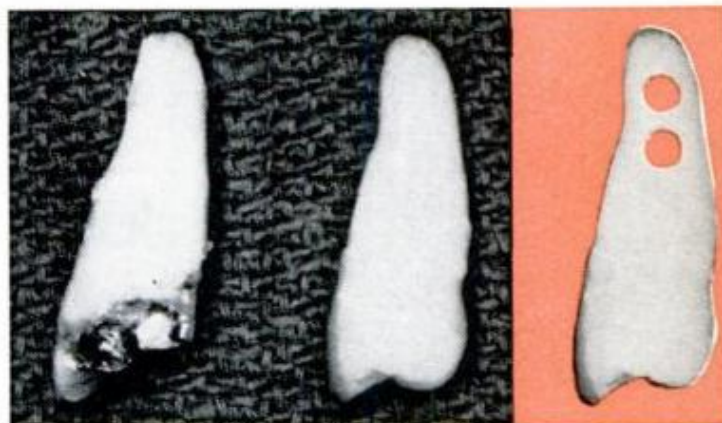

AFTER PULLED TOOTH (left) is duplicated in plastic (center), two holes are drilled in "root" end

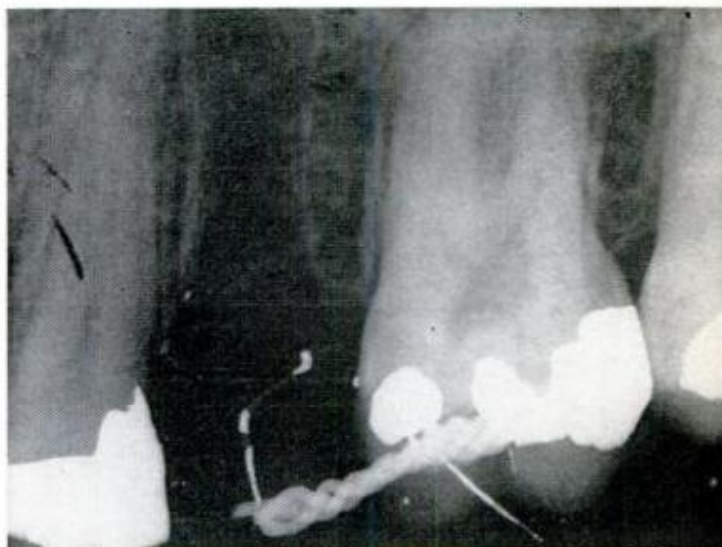

FOLLOWING INSERTION, false tooth is wired to natural neighbor, and the wire covered with acrylic

How to get

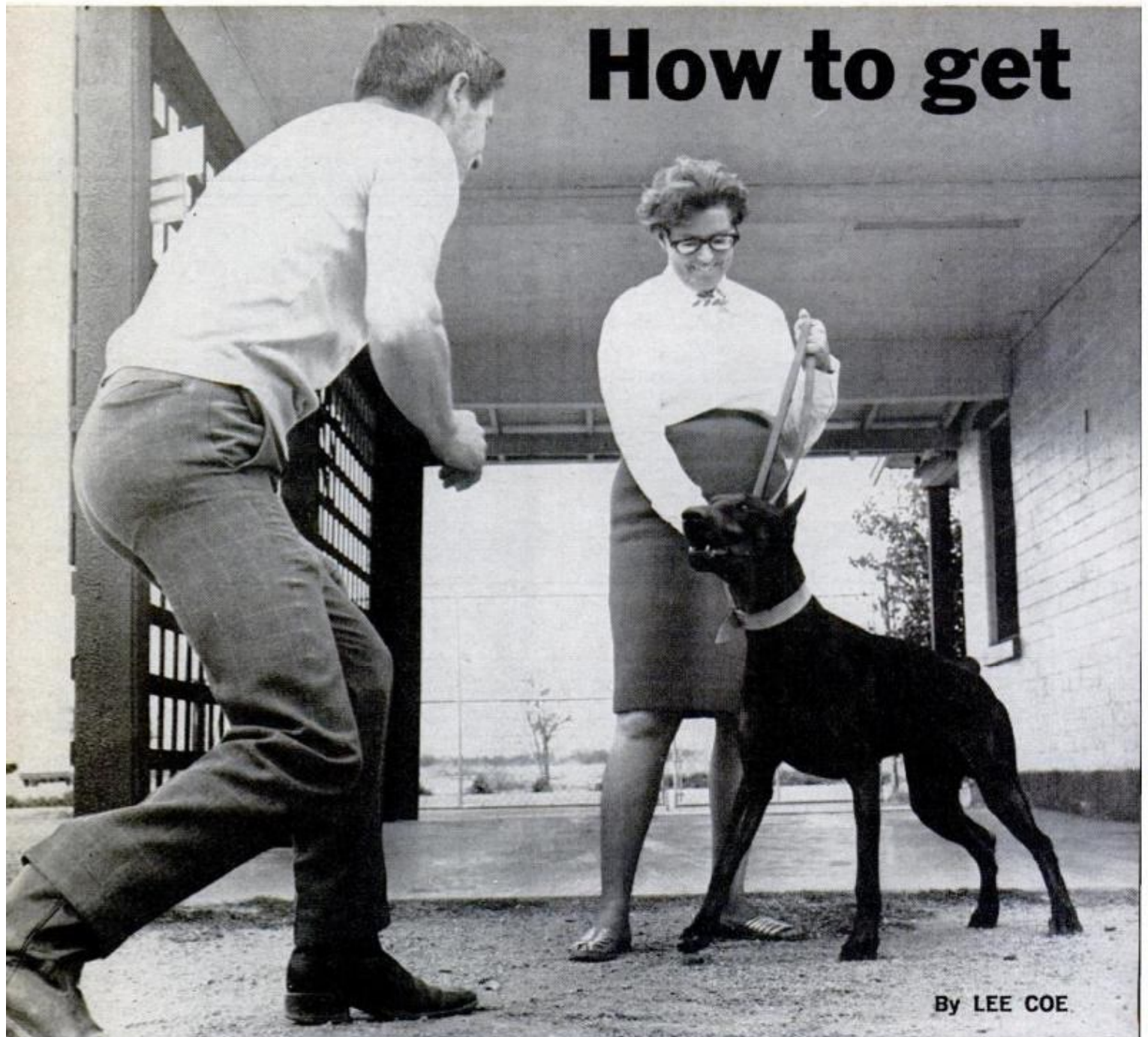

By LEE COE

Doing it yourself usually isn't the best way. Hire an expert to give both you and the dog obedience lessons

AS THE CRIME RATE soars, many worried citizens are buying dogs for protection. But too often, new dog owners end up with pets that are really pests.

To be sure, a dog can be an ideal protector and companion. But where many owners go wrong is in the selection and training of their dogs. As a result, they live with animals that are ill-mannered and uncontrolled, that tug on the leash when walked,

jump on neighbors and occasionally even nip a visitor.

Would the owner be better off with a professionally trained guard dog? Not really. Such dogs—used by the military, police and security agencies—are taught to attack, and to respond only to commands given by their trainer.

Consider Duke, a German shepherd assigned to guard duty in an Ohio gas station. The dog took his job so seri-

a well-trained dog



A WELL-TRAINED DOG WILL remain seated at his owner's foot (left), regardless of the distraction, until released. Instructors combine control with leash and hand signal (center) to teach dog to lie down. Even without leash, disciplined dog will walk beside owner's left knee (right) when told to heel

ously that even after being shot three times recently by would-be thieves, he pressed his attack until they fled. When police arrived, he refused to allow them to enter the station until his owner came and ordered him away.

Professional dog trainers are well aware of the dangers inherent in giving a guard dog to the average family. Instead, they suggest a well-trained compromise that will be the companion and pet that 90 percent of the new dog owners today have in mind, but seldom get.

One reason for their disappointment is poor selection. Most dogs will instinctively protect what they feel they "own"—your family, house and surrounding area. Size doesn't make much difference. Even the toy breeds will make enough racket to scare most strangers away.

But when choosing a dog, remember

that many American canines are overbred. Steadiness and reliability, the most desirable qualities in a pet, are often sacrificed for physical standards needed to win blue ribbons at dog shows.

It's best to deal with the owner of a reputable breeding kennel. He can be worth many times his fee in helping to select the best individual dog for your family, rather than just a fashionable breed.

Remember, protection comes automatically to a dog, whatever the breed. The key is obedience, and that's what the owner has to add, since almost any dog can be taught to obey.

If you start with a pup, he should be taught to *come*, *sit*, *stay*, and understand the word *no*.

Trainers urge that dogs always be called by name when given commands. When they respond, professionals praise



HAND SIGNALS are a vital part of a dog's training, reinforcing an instructor's verbal commands



GENTLE TUGS on a leash and a soft push on the hindquarters help a dog understand the order sit

the dog, and occasionally reward him with a tidbit.

Teaching a pup to sit is simply a matter of holding him by the collar, saying his name, then adding the word *sit* while pushing his hindquarters down.

To emphasize disapproval, the word *no* may be accompanied with a cuff. A rolled-up newspaper is better than the owner's hand. The point is to frighten the animal, and he may not fear the hand that also rewards him with petting. Never wait to discipline a dog. When he does something wrong, correct him immediately because the dog must associate discipline with wrongdoing.

When a pup is six to seven months old, he's ready for formal training by a professional able to instruct owner and dog to work as a team. Obedience training on an individual basis costs about \$25 a week and takes an average of 10 weeks. A cheaper way is to join a group class.

Many organizations such as the YMCA or a chapter of the American Kennel Club sponsor obedience courses. They usually call for one class

a week for 10 weeks, but these instructions cost only one-tenth as much as individual lessons.

John Webb, an Arizona trainer with almost 30 years of teaching experience, estimates that about half the owners who attend a group course will graduate with an obedient pet. Another 25 percent will see a marked improvement in their pet's response to commands. The remainder will note little, if any, progress.

Courses are designed to teach the owner how to train his dog to come when called, walk at heel, sit or lie down on command, and remain in position when told to stay.

Professionals stress that commands must be given in a clear, forceful tone. Orders spoken in a timid way sound like suggestions, and a dog will usually ignore them. At the same time, teachers emphasize that firmness should not be confused with roughness, and they advise owners to use no more force than necessary to get the dog to respond.

The first command demonstrated in most group training classes is *heel*. Placing the dog in position at his left

leg, the instructor pulls the untrained animal's head up to get his attention while speaking his name and giving the order *heel*. As he gives the command, the trainer steps forward, moving his left leg first to give the dog the idea of motion. Then he jerks the leash.

Owners following the instructor's example soon find that a quick jerk is more effective than a steady pull, which the dog resists. After a few tugs, a dog learns that the tugging will stop if he continues to move forward beside his owner.

At the second session, instructors lead the class through the command *sit*. The owner walks his dog at heel. Upon stopping, he gives the command *sit*. The owner walks his dog at heel. quarters. A halt-sit habit means the dog must rise before charging off, giving the owner more time to correct him.

Down is an extension of *sit* and is taught next. The pet is placed in a sitting position with the leash coming from under his chin and looped under one of the trainer's feet. The trainer, saying *down*, pushes his foot to the ground, forcing the dog's head to follow. Simultaneously, the trainer puts firm pressure on the animal's shoulders, pressing him down.

Professionals warn that dogs often confuse *sit* and *down* at first, and urge



TODAY'S CUTE PUPPY will be tomorrow's 100-pound nuisance to adults unless he's taught the command no
FEBRUARY 1972



A DOG CAN BE MORE than a pal. Sharpen his protective instincts, and he'll be a loyal guardian

pupils to be patient, and to continue to demonstrate the two commands until the dog has learned what the difference is.

One of the most important orders taught in any class is *stay*. It is also one of the most difficult, and usually requires two persons working together—one holding the leash and the other enticing the dog. After having the dog sit, the owner places his right palm in front of the dog's nose and says *stay*. He then moves away until the dog tries to join him. At this moment, the trainer who holds the leash tugs back so that the animal resumes his sitting position.

If the dog cannot be repositioned, the instructor goes through the drill again until the dog understands the command. Eventually, a hand signal will be sufficient, and the owner can practice the command without another person.

Probably the most necessary command, the easiest to teach, and the hardest to enforce off-leash is *come*. In group classes, owners place their dogs in the sit position, then walk to the end

(Please turn to page 182)

Now it's ferry trains for

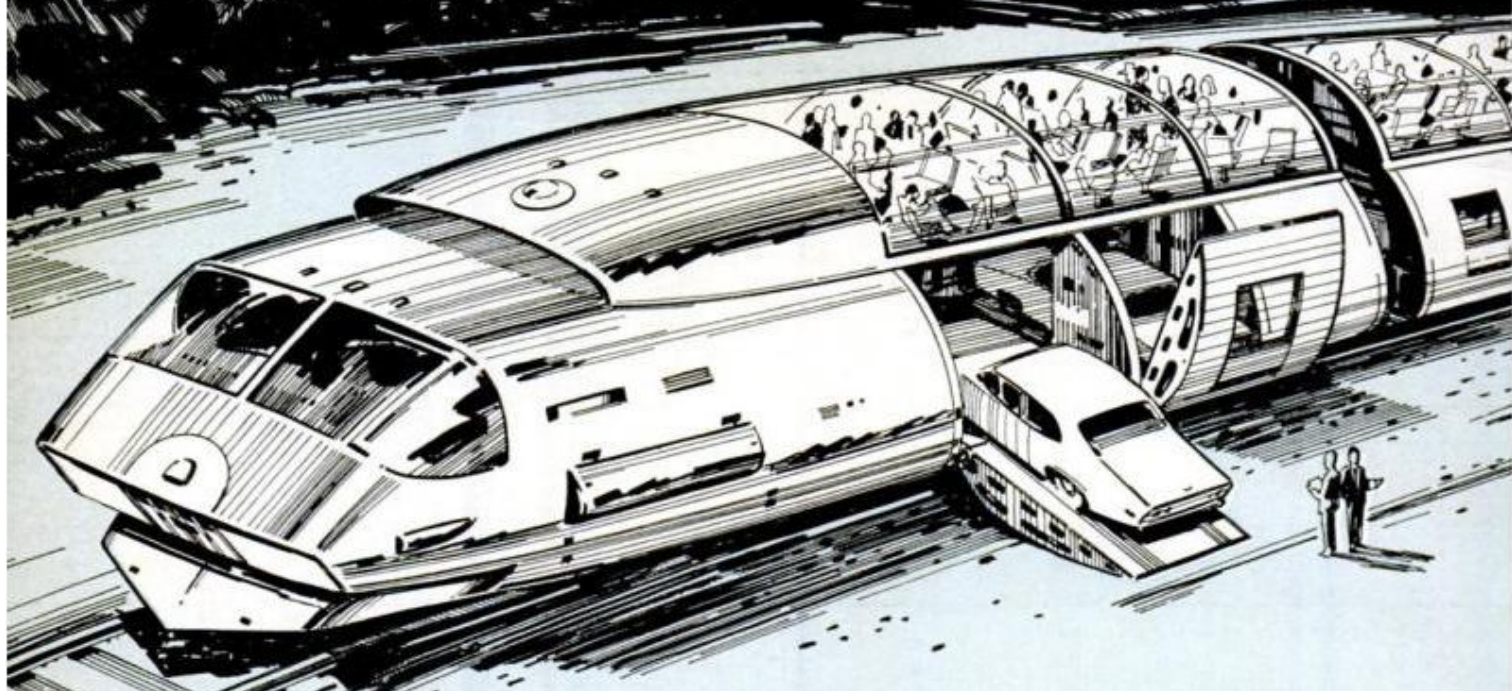

You drive your car right on board the novel ferry train above, enjoy a fast, relaxed ride to your destination, then drive off again, ready to continue your trip by road. The new concept of combined road-and-rail travel is designed to provide high-speed transportation between distant points without long and tiring highway driving, yet enable you to take your car along with you for local touring and sightseeing when you arrive. While on board the train, you can rest in your car or visit an upper-level observation deck where there are comfortable lounge chairs and snack-bar facilities. Hinged, swing-down hatches in the sides of the train form ramps so you can drive on and off easily. The idea was conceived by Veljko Milenkovic of Boulder, Colo.



Quick-release belt

Motorists who hate to wear shoulder-type safety belts because they're so awkward to get in and out of will go for this ingenious idea. The upper end of this belt slides in a U-shaped track overhead. To put on the strap, you just swing it around the track across your shoulder until it locks into a small S-shaped bend. Reversing the process releases the belt quickly and easily without undoing the clasp. There's no need to adjust belt tension each time since the length can be preset and left alone. Inventor is John R. Hane, Box 444, Shalimar, Fla.

cars yet!

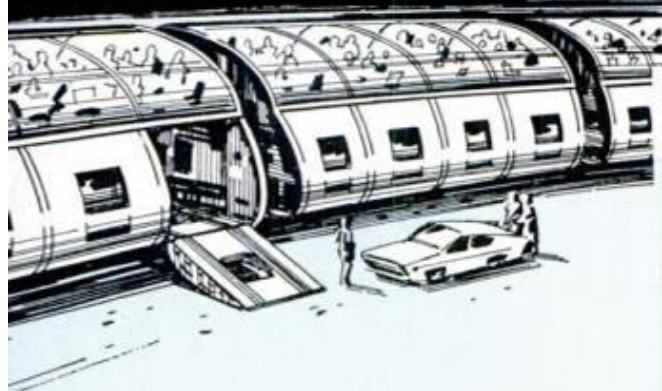

UPPER
OBSERVATION
DECK AND
LOUNGE

HATCH SWINGS
DOWN FROM
EITHER SIDE
OF RAILWAY CAR
TO FORM RAMP

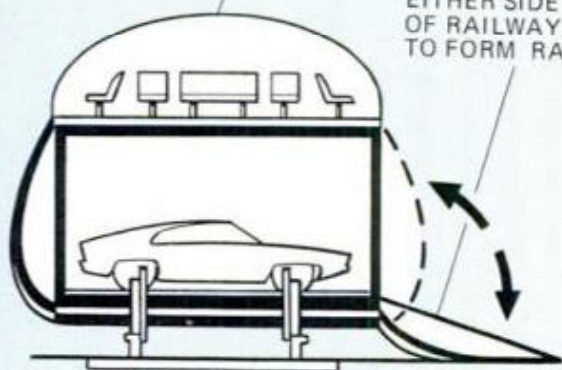

Illustrations by Roy Grinnell



COMPARTMENT
DEFLATED

HULL FLAT FOR
HIGH-SPEED PLANING
ON CALM WATER

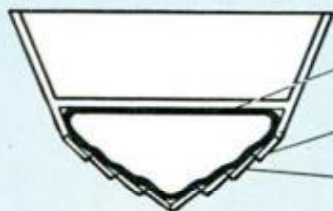

INFLATABLE AIRTIGHT
COMPARTMENT

HINGED SLATS WITH
FLEXIBLE LINING

HULL V-SHAPED FOR SMOOTH
RIDING IN ROUGH WATER

Self-adjusting boat hull

You want a flat planing hull for high speed on calm water, but a deep V-bottom for smooth going in rough seas. With this adjustable hull, you could have both. It consists of flexibly hinged strips with an inflatable air bag inside. As the water roughens, a motion-sensitive device automatically inflates the bag to force the strips into a V shape. Harold L. Walker, Whitestone, N. Y., is the inventor.

Electronic 'money'

No money changes hands when you fill up at this electronic gas pump. You simply insert a coded card in a slot and the pump "draws off" or erases a number of magnetic pulses equal to the number of gallons you purchased. When all the pulses are used up, you take the card back to your bank and have it "recharged." The pump totals up the pulses "taken in" each day and records them on a card the garage owner can convert into cash at his bank. The system, now in use at some British gas stations, is being considered for restaurants, supermarkets and other stores. It was devised by Bernard Hunn, Revenue Systems, Luton, England.

FEBRUARY 1972



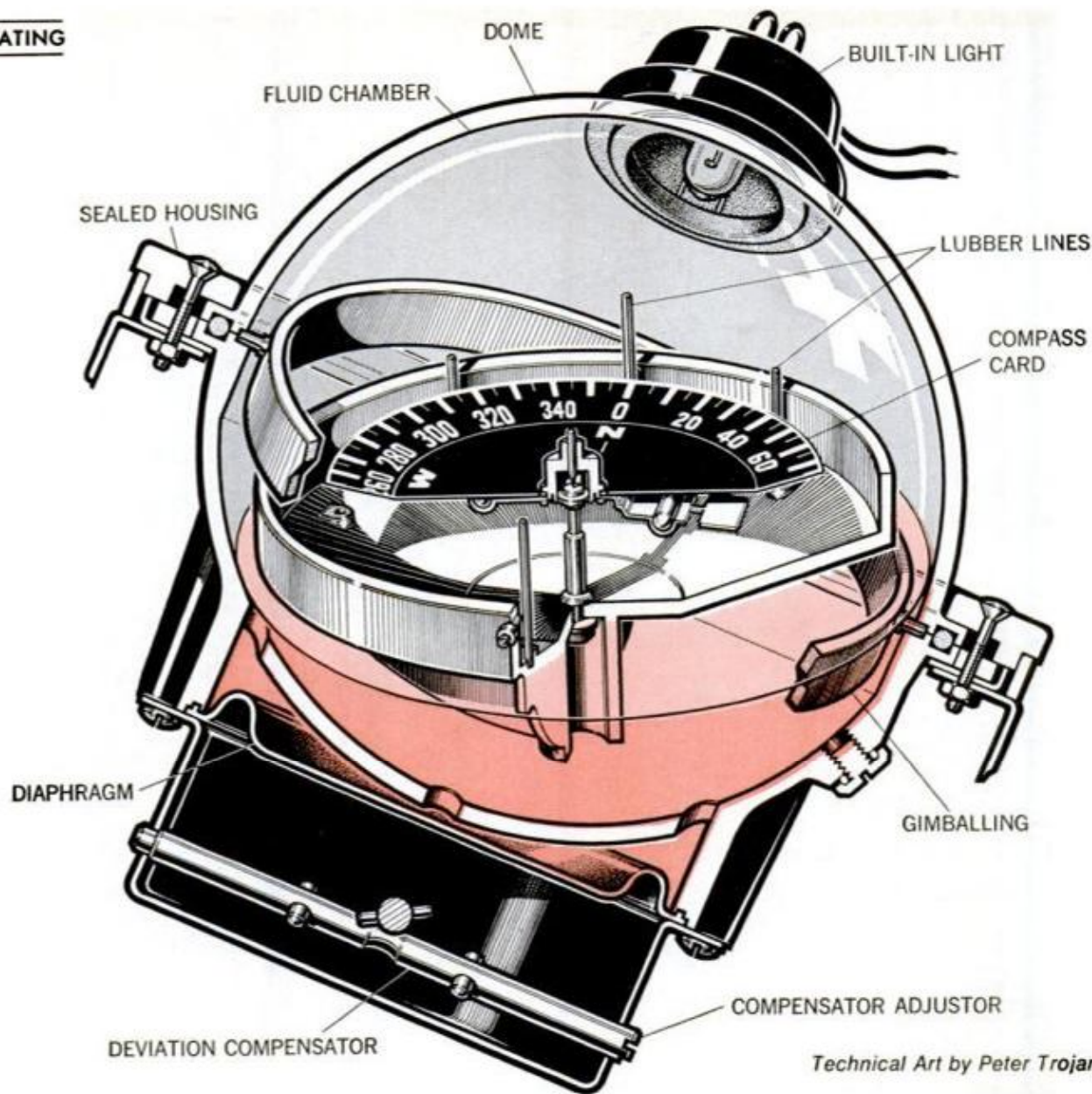

Technical Art by Peter Trojan

How to Choose a Marine

By MORT SCHULTZ



CUPPED CARD COMPASS, sometimes referred to as the direct-reading type, has the lubber line facing the pilot. This type ranges in price from \$10 to \$50



FLAT (OR DISHED) COMPASS CARD has lubber line opposite helmsman, ranges in price from \$20 to \$300. One above is designed for binnacle mounting

POPULAR MECHANICS

ALTHOUGH MOST OF US never take our boats out of sight of land, our whereabouts situation can deteriorate mighty fast if fog or bad weather suddenly sets in. Many boatowners have had to grope for a shoreline they could no longer see.

Safety, then, is obviously served by installing a magnetic compass in your craft—large or small, power or sail.

According to the Coast Guard at Sandy Hook, N. J., boats operated in semisheltered waters (bays, for example) and in the ocean should always be equipped with compasses.

The Coast Guard also believes that a compass is a necessary instrument in large bodies of sheltered water. As one Coastguardsman put it, "Boatowners have been known to go around in circles for hours after being caught by fog in the middle of large lakes."

Since compasses range from \$10 to \$300, there is apparently more to buying one than simply deciding to do so. You could spend money needlessly by equipping your boat with a compass that has unnecessary features, such as a finely graduated card (1° increments), brass construction, full gimbal (the part that keeps the compass steady when everything else is heeling), built-in deviation compensators and nighttime illumination.

Yet, an expensive compass doesn't usu-



IF DEVIATION BECOMES A FACTOR due to nearby metallic equipment, external deviation compensators (top picture) will offset error. A compass that's readily removed (middle and just above) provides easy storage and consequent theft protection. Bracket design permits attachment to vertical or slanted surfaces—ideal for small, uncabined boats

Compass

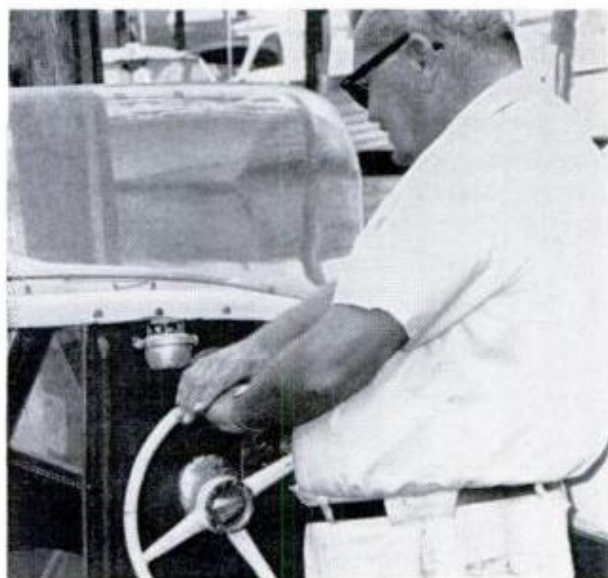

FEBRUARY 1972



FOR QUICK CHECK of accuracy, move a screwdriver close to compass. It should pull card around 10°. Take tool away and card reverts to original setting

WHATEVER WAY you mount your compass, it will serve you best if situated close to the helm (left)

ally possess any stronger internal parts than an inexpensive compass. That's what one leading manufacturer says.

"The basic components used by reputable compass manufacturers that bear on the instrument's reliability are generally the same from model to model," B. L. Sherman of E. S. Ritchie & Sons claims. This company has been making marine compasses since 1850.

"For example," Sherman points out, "our \$20 compass uses the same hardened-steel pivot and pivot bearing as our \$300 compass."

You can get a pretty good idea of what price compass you need by the type of boat you own. If it is powered and under 15 feet, a compass in the \$10-to-\$20 range will probably be adequate. These have cupped cards that are graduated in 5° increments.

Compasses with cupped (or conical)

Price of the compass depends pretty much on the size of the card and its incrementation

cards resemble those used in airplanes. Often called direct-reading compasses, they have the lubber line aft, nearest the helmsman. The card rotates under this fixed reference line, which allows you to take eye-level readings.

Compasses that have flat cards are intended for larger powerboats. Regarded as the more traditional instrument, their lubber lines are forward so that the helmsman has to look across the card to get a reading.

Flat-card compasses provide greater magnification than cupped-card instruments and give a more detailed reading. The price of the compass depends pretty much on the size of the card and its incrementation.

Cards are 3 to 6 inches (or more) in diameter. The larger and most expensive compasses are graduated in 1° increments. They are intended for boats that are designed for far-ranging, open-water cruising. The dished card is simply a variation of the flat card.

Be aware that you will probably find some fairly expensive (\$40-\$50) compasses that have cupped cards. They have more features than the less expensive

cupped-card instruments, such as bronze construction, internal compensators, or what have you. We'll speak of the need for these features in a minute.

But first, let's discuss compasses that are designed for sailboats. They can have cupped or flat cards, but should possess two features that owners of power craft don't need and would waste money getting: full gimbaling and multiple lubber lines.

Unlike a powerboat owner, a sailboat owner has heel to consider when selecting a compass. A compass with limited or semigimbaling can compensate quite nicely for the limited angling that a power craft may experience. Not so with heeling.

Full gimbaling can either be external or internal, with the latter providing a maximum degree of hold-steadiness. It is therefore intended for more than the straight pleasure type of sailboat. Racers, for instance, would be best served by a compass having full internal gimbaling.

With internal gimbaling, the card itself is mounted on a full gimbal arrangement to assure levelness at any angle of heel. These compasses sell for \$50 and more.

With external gimbaling, an external ring provides for four pivot points. This compass costs about \$15 to \$20.

Multiple lubber lines make it possible to sight relative headings from any position in the boat. This is important for sailboats since the crew as well as the helmsman should be able to take compass readings in order to detect wind shifts.

What else should you look for in a compass? This depends pretty much on your boat and what use you make of it. However, the following list of check points will guide you to the one compass you need:

- *Built-in deviation compensators* are nice to have if the compass is to be mounted where the engine or equipment will cause deviation. However, if you have an outboard, you can save \$5 to \$10 by not getting this feature. Since the engine is located in the stern, it won't cause much, if any, deviation. Sailboats don't need internal compensators either.

However, should deviation occur, the problem could be caused by steel cores in a plastic steering wheel, electric windshield wipers (only when operating), steel framing in a folding canvas top, a steel shaft in the steering controls, or untwisted electric wiring that's within a foot of the

(Please turn to page 176)

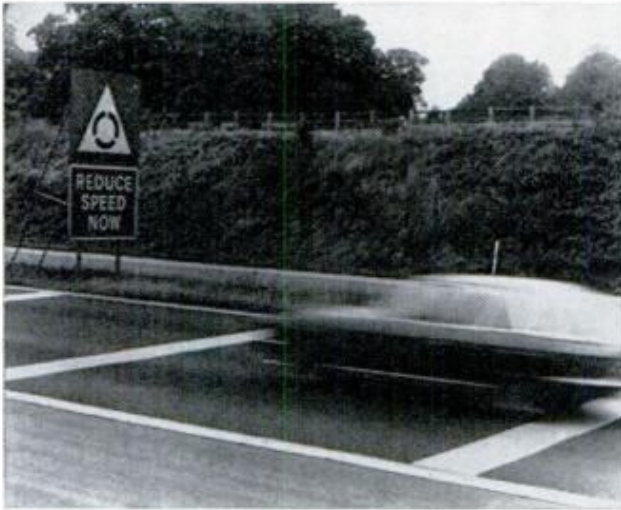

Painted stripes make hazardous road safer

Researchers at Britain's Road Research Laboratory painted stripes across a notoriously dangerous section of highway and found the accident rate "dropped dramatically." Key to the system is the spacing. In the first series, stripes are 30 feet apart to alert the driver. Next is a series 15 feet apart, which make the driver feel he's still going too fast. Finally, they're 7½ feet apart, causing the driver to slow enough for the hazard.



High flier

Recently released by the Navy is this artist's rendering of a proposed patrol aircraft, the "very high-altitude, ocean-surveillance-system aircraft." Most details are classified. Wingspan is about 200 feet; fuselage length, about 80 feet. With a two-man crew, the plane would fly at high subsonic speed at 100,000 feet, scanning the ocean on flights of up to eight hours.

ACV on ice

Tests to determine how air-cushion vehicles perform in the Arctic are being carried out by the Navy and Coast Guard. This vehicle was disassembled in San Francisco, flown north to Point Barrow, then re-assembled. Tests cover operations over ice, snow, water, tundra.



NEWS BRIEFS



Japan's first supersonic jet

The first supersonic aircraft designed and built in Japan is Mitsubishi's tandem two-seater, the XT-2. Intended for use as a trainer and fighter, the Mach 1.6 craft is powered by two Rolls-Royce turbofan engines. Design features include the use of spoilers rather than ailerons.

Each wheel has a motor

Running on a one-third-mile test track near Madrid, the *Vertebrado*, an unusual elevated train, has hit speeds of 125 mph. Each rubber-tired wheel of the train carries its own motor. The train can be made up of 6, 12 or 24 sections to hold 3.7 passengers per linear yard of train.



Can't hide from Friskem

That long knife tucked inside Denise Vickery's hot pants would not get by an Eastern Airlines passenger gate equipped with Friskem. Its glowing black box held at right shows there's a metal object being carried on her person.



FIREFIGHTERS' SKY HOOK



The L. A. fire department uses helicopters as command posts, pumpers, ladders, ambulances, hose pullers—and even instant hydrants

By RALPH EMERSON

THE HELICOPTER IS A VERSATILE BIRD—ambulance, rescue vehicle, gunship, passenger carrier, airborne crane. Now it's proving itself as a "fire engine."

Some years ago the Los Angeles City Fire Dept. acquired its first copter for use as an aerial command post. Today, the department's helicopter unit comprises five multipurpose machines, seven flying firefighters, three relief pilots and a rescue crew.

Directing operations from the air is now only one of many duties that the choppers perform. They've





"WATERBOY" HELICOPTER refills 1000-gallon portable bag dropped to firemen far from a hydrant



proved valuable as flying "pumpers." Equipped with an aluminum or fiberglass belly tank, the copters can "bomb" a hot spot by releasing more than 100 gallons of water in one shot, or they can spray a larger area to retard the fire until ground units take over.

Once firemen are on the scene, especially in outlying areas, the helicopters become flying workhorses hauling hose. The choppers can pull and lay 1200 feet of 2½-inch hose in three minutes over rough terrain from a truck or large reel. Firemen hauling and tugging that much hose over similar ground would take up to an hour to do the job—and probably arrive too exhausted to wage an all-out fight on the fire.

But what if the fire is in one of Los Angeles City's remote canyons where brush fires are frequent and water hydrants scarce? Using their helicopters, firefighters can drop an empty, collapsible rubber tank, plus a portable pump and some hose. A "waterboy" copter flies in next to fill the 1000-gallon tank. Using the airlifted hydrant, firemen can pump 80 gallons per minute on the blaze as helicopters form a high-flying bucket brigade to keep the tank replenished.

The L.A. department's helicopter squadron began with a Bell 47B-3B bird able to cruise at 70 to 80 mph for approximately 2½ hours. Initial success led to another Bell 47B-3 with a slightly longer range. In addition to a pilot, both ships can carry two pas-



SPECIALLY TRAINED FIREFIGHTER leaps from helicopter 15 feet above the ground if ship can't land



HELICOPTER AMBULANCE can carry two injured persons on stretchers plus an equipped first-aid man

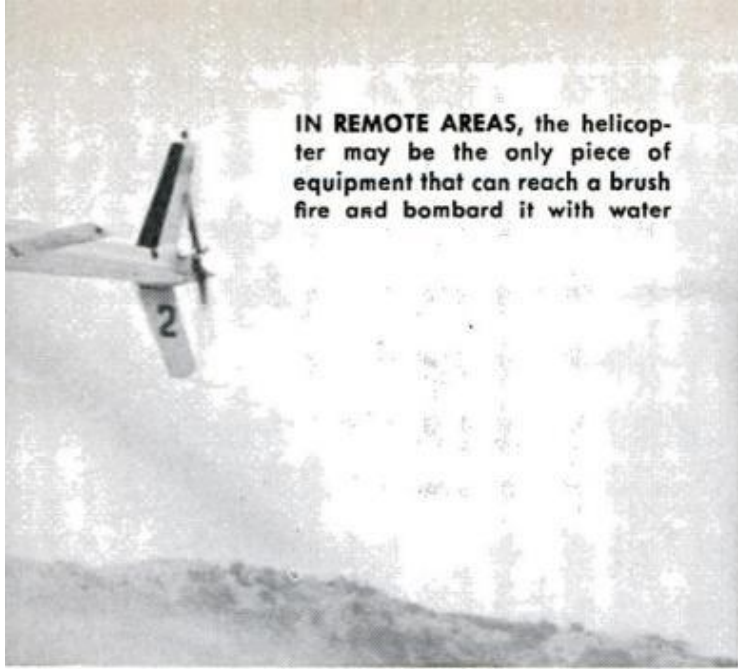

IN REMOTE AREAS, the helicopter may be the only piece of equipment that can reach a brush fire and bombard it with water

sengers, or two stretcher baskets that are strapped outside the cabin.

Three Bell Jet Rangers able to stay aloft for three hours while flying 140 mph make up the rest of the fleet. The Rangers can carry three firemen in the rear seat and a fourth in front.

To earn their wings as firefighting pilots, candidates must have a minimum of 500 hours' flying time, a commercial rating and at least five years' experience in the fire department.

Firefighting know-how as well as flying ability is necessary because pilots often act as the airborne eyes of the department, helping to coordinate equipment on the ground. At other times when flying "high hazard patrols" over California's tinderbox hills, pilots must act as aerial fire lookouts.

When not fire-spotting or firefighting, the helicopter brigade flies a number of mercy missions, easing into secluded or remote areas out of reach of ground rescue crews.

To meet those challenges, the department has organized specially trained "helitack" crews. These firefighters, highly skilled in first aid, personnel rescue and spot-fire control, are able to jump off a copter flying 15 feet above the ground.

The ships have also been specially equipped to handle such rescues, carrying a powerful spotlight attached to the belly, and an electrically operated hook that can be lowered to lift an injured person out of a tight spot, or

FEBRUARY 1972



WHEN FIRE KNOCKS OUT elevators, firemen call on helicopters to hoist lifesaving gear to the roof



LAYING 1200 FEET of hose in under three minutes by helicopter eases firefighting in rough terrain

hoist lifesaving equipment to the top of high-rise buildings where fires have knocked out the elevators.

Los Angeles firemen are reluctant to put a limit on the tasks their air brigade can do. They point to last year's earthquake in southern California as an example of its versatility.

When the local Veterans Administration hospital collapsed, all telephone lines went dead, and the Civil Defense radio was knocked out. But flying firefighters spotted the damage, and radioed in a ground rescue team. ★★★

The new outboard motors: more power— less pollution

Harness up to 140 horses on the back
of your boat this year with an
engine that keeps fuel spills to itself



THAT COMPACT POWER PACKAGE you hang on the stern of your boat has gone up in power again and, once more, pole position in the horsepower derby goes to Mercury Motors for 1972. Mercury supplies a record 140 hp of two-cycle torque with its strongest production kicker ever—and that's just the official rating. Set up a racing rig and you can special order a throaty 150-hp Chrysler with dual open-stack tuned exhausts, or high-performance limited production mills made by Evinrude, Johnson and Merc as well.

How many horses are hidden under the cowls of these exotic race-course rigs? You only get a grin when you ask plant engineers, but Molinari-type tunnel hulls



JOHNSON 125 leader has low cowl. Mercury's "tower of power" is 140 hp

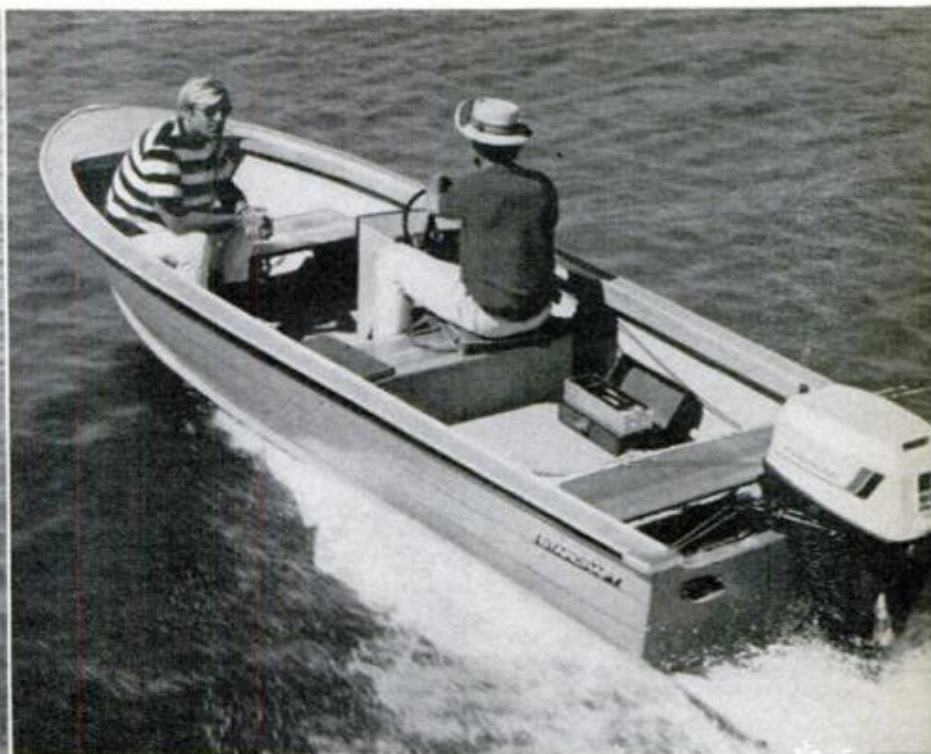

NORSEMAN is new name for Evinrude's versatile 40-horse unit designed for fishing, skiing or specialty-boat power

have topped 100 mph with them and good guesses rate the compact herd of stallions inside at around 175—plus a few more squeezed in by the factory tuners after almost every race. That's more push than your rowboat should ever try to pack along, but these competition rigs do good development work for the dependable big-muscle mills that are turning houseboats and cruisers into outboard craft.

This year nearly all outboard companies have also modified their motors so no unburned fuel is dumped. Despite scare stories by a newspaper columnist, there has never been proof that the small amount of gas-oil spill from pleasurecraft outboards caused ecological damage or stopped the fish from biting. But the major makers are now engineering their two-cyclers to recycle any fuel not initially burned through the engine. As of now, however, they warn against the use of unleaded gas in two-cycle mills. Chemicals replacing the lead might critically damage metals inside your motor.

As for straight production outboards your dealer is sure to stock, Mercury offers the six-cylinder Model 1400 with 140 hp, swinging down through 10 models to a 4-hp kicker that even has surface-gap sparkplugs and capacitor-discharge ignition developed

FEBRUARY 1972

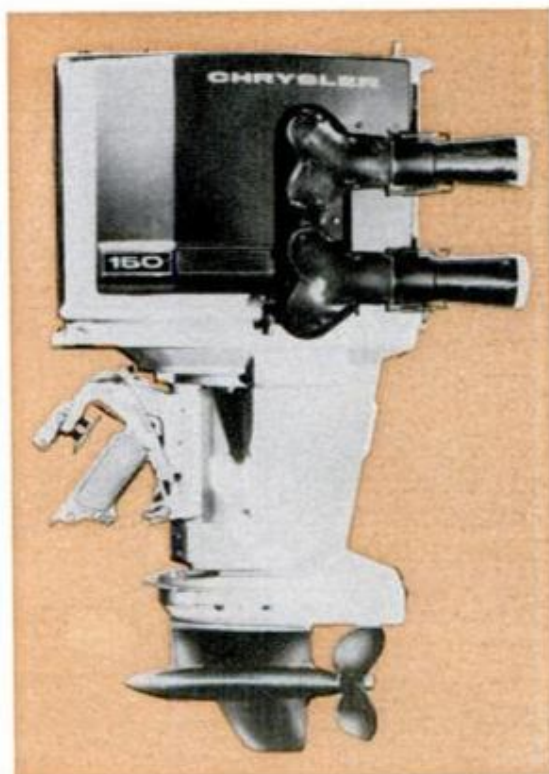

CHRYSLER'S 150-hp, high-performance race model is a honker with dual tuned exhausts

for the big jobs. In the middle is an all-new three-cylinder direct-charged 650 with 65 hp from its 49.8-cu.-in. engine.

Chrysler's big one for the family rig has 130 hp. Others range



AUTOLECTRIC is Chrysler's name for motors like this 9.9-hp with key start and cowling dome light



MERC 650 is a new 49.8-cu.-in. three-cylinder Mercury mill designed for a compact package of 65 hp



LARGEST standard Chrysler is 130-hp motor mounted on 16-foot Conqueror from Chrysler boat division



NEW SEAHORSE by Johnson is 65-hp three-cylinder model claiming better fuel economy than former 60

down to the Chrysler 3.6 Swinger in seven power selections (eight, counting the racing 150). The 9 and 12.9-hp models provide the Autolectic features: key starting, domelight and 10-amp generator. All engines come in standard or long shaft models.

Evinrude has 13-plus models, a big plus since its special-order, high-performance Strangler has been taking on Merc's Twister and Johnson's Stinger at the all-out enduros. Regular production motors run from a tiny two-horse Mate to the 125-hp Starflite. Tuned exhaust of the new 49.7-cu.-in. Triumph 65 adds 5 hp to last year's 60 with no increase in size or weight.

Johnson's 50th anniversary line has 12 hp classifications. A new Seahorse 65 is claimed to use less gas and deliver more power than last year's 60. The Seahorse 20 has a two-horse edge on Evinrude's Fastwin 18. Other 2-to-125 powers are similar to Evinrude's.

Sears, Roebuck, among six models, offers a stronger 3½-hp and others to 7.5. Small-hp brands start with the 1-hp Mini Motor and 1.7 Mighty Mite, and Eska, Golden Jet, Clinton, Triton, Aeroceanic and Commando. The 55 and 85-hp Bearcats are four-cycle, and an outboard claimed to burn diesel fuel or gas is under development by Dynatech. Imports will include British Seagull, German Zundapp and Swedish Archimedes Penta. ★ ★ ★

OUTDOOR HINTS



Canvas top for shady trolling comfort

When they're biting, a fisherman wants cockpit room to maneuver. This canvas top mounted on a light aluminum tubing framework allows a small-boat luxury: standing headroom. Side curtains can give added rain and sun protection.—*Lee Schrimpf, Tulsa, Okla.*



Prescription for organizing pack stowage

Plastic prescription vials can keep dry your fishing swivels, snaps, sinkers, hooks, monofilament, thread, fiberglass repair tape, battery, silicone cloth—and medicine. Containers fit neatly into pocket or backpack.—*H.O. Davidson, Washington, D.C.*

Campfire hang-ups

Backpackers can use a short length of easy-to-stow brass jack chain or 50-lb.-test stainless leader wire to hold a pot over a fire. Form 8 and 12-in. lengths in loops joined with center ring, "S" hooks.

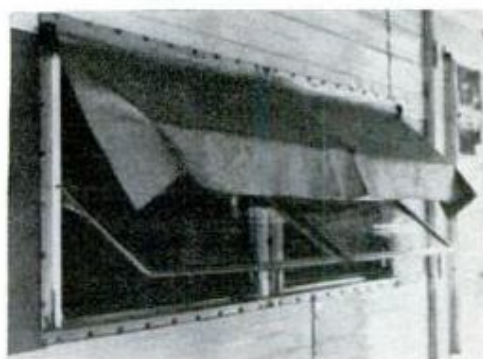

Easy mini-awning

No space in a crowded campground for a full-sized awning? To get some shade, drape aluminum-colored rubberized nylon cloth or other fabric over the top panes of a sunny window, letting the edge hang down about 4 in. Hold it in place with clothespins.—*Francis T. Hiner, Sidney, Neb.*



Musical fence

A resident of North London, who felt that his house was too dull, decided to brighten up the place with a "musical fence." With the aid of a local ironworker, he erected a fence on which the opening bar of *Home Sweet Home* appears.

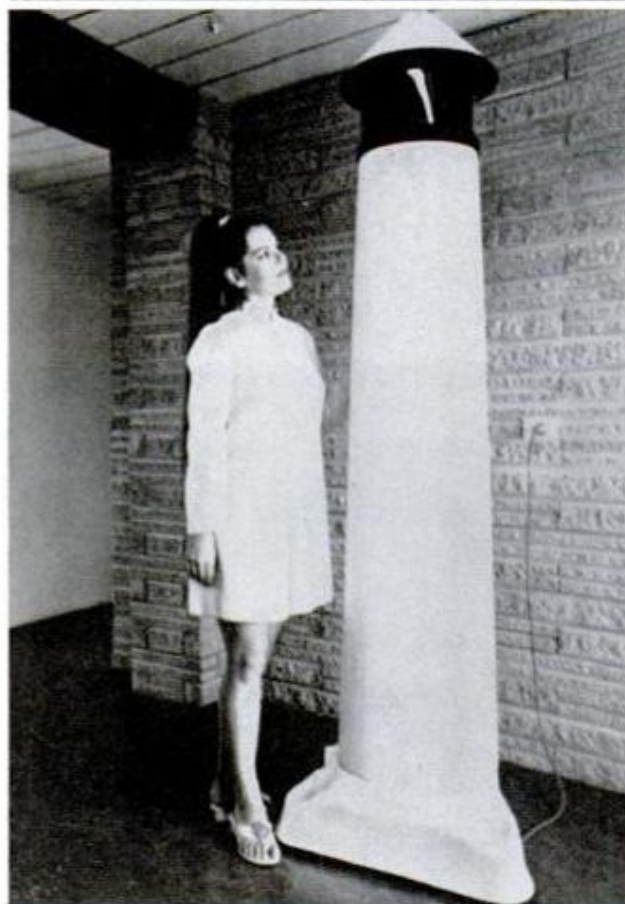
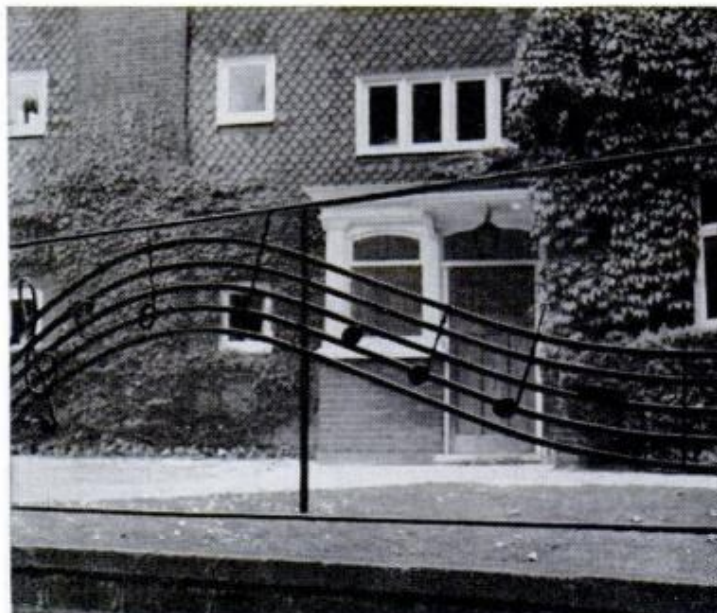

Laser-beam lighthouse

The world's first laser-beam lighthouse, which is just 7½ feet high (bottom photo), stands 146 feet above sea level on a platform supported by the columns of a memorial at Point Danger, Australia. The compact light uses only 200 watts of electricity.

102



Green means parking space

The city of Aachen, Germany, has added a lighted-arrow system to municipal parking-lot direction signs so that motorists will know in advance which lots are full and which have space. A red arrow means that parking lot is full; a green one means there's space.

POPULAR MECHANICS



Floating skimmer slurps oil

They call it SLURP (for self-leveling unit for removing pollution), a name that graphically describes its function: gobbling up oil spills. Developed by British research scientists, the 60-pound device floats on the surface and sucks in the surface liquid, which is pumped to a container ashore. As pumping rate is increased or decreased, the skimmer floats higher or lower in the water, enabling the operator to skim off a thick or thin oil slick more efficiently.



Dangerous silos

Radioactive waste from an experimental station in Denmark is stored in 126 concrete silos that must remain closed indefinitely—or until a system is developed to make the waste harmless. Radioactivity disappears only as the isotopes exhaust their working lives.

FEBRUARY 1972

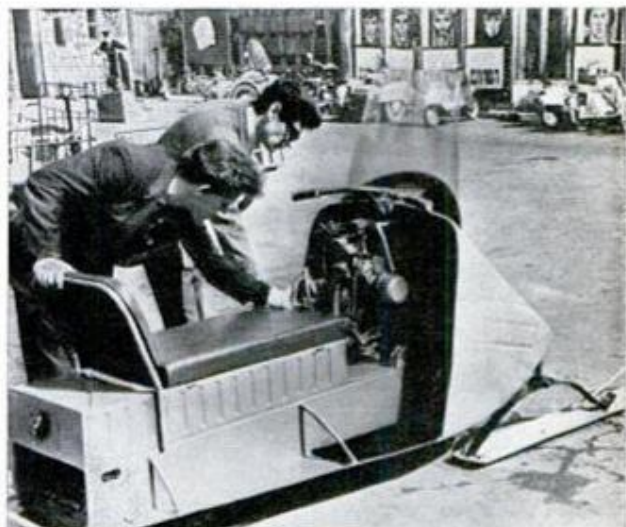

Russian snowmobile

A new Soviet snow machine, the Amuret, made the Promsvyaz Works in Khabarovsk, performed well in a long-distance test run, according to the maker. The 20-mph vehicle, designed to operate in temperatures as low as minus 50°C., can be fitted with wheels.

103

Dollar duck decoy



More duck for the buck is your bonus when you build your own. This life-size bufflehead should bring in flocks of real ones to your blind

By NICK KARAS

THERE ARE FEW THRILLS greater than the sight of a flock of ducks coming into a rig of decoys, especially when you made the spread yourself. Decoys, and plenty of them, are as important to a waterfowler as shotguns

and shells. Today's prices make a full rig of decoys expensive, however. The easy solution is to make the decoys yourself, and while you're at it you can make them hollow to decrease the weight.

DRAW THE PATTERNS of decoy head and body on 1 $\frac{1}{4}$ or 1 $\frac{7}{8}$ -inch board of the wood stock selected



FOLLOWING THE LINES traced from around the patterns, cut sections with a sabre or jigsaw



JOIN TOGETHER both duck body pieces using long screws. Brass screws give decoy a longer life



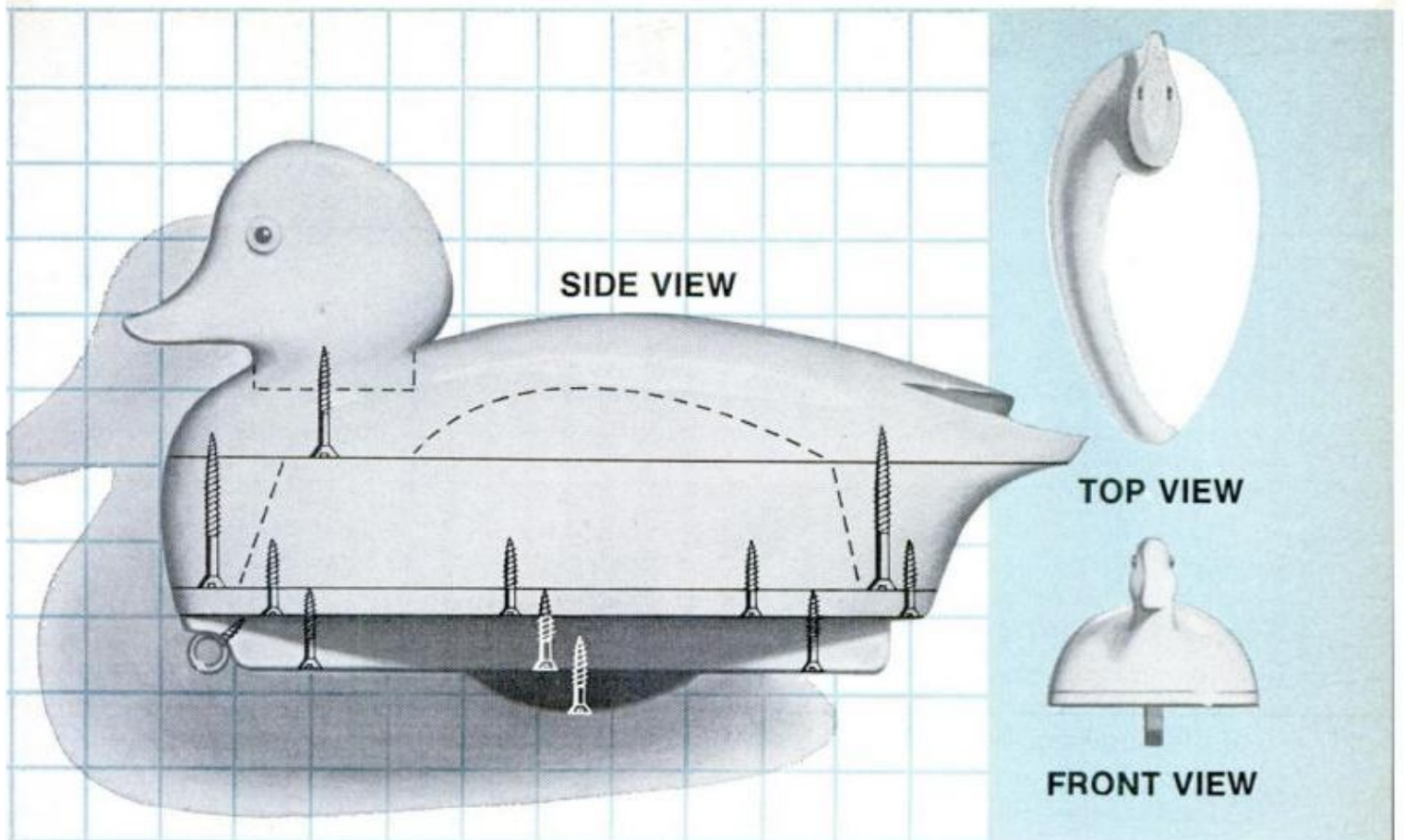

Shown here is a bufflehead decoy, a small diving duck found along many of our coastal marshes as well as large inland lakes and rivers. The cost of this model was 96 cents (wood, 55 cents, screws, 18 cents, paint, 8 cents, eyelet, 2 cents, eyes, 6 cents a pair, plus about 7 cents' worth of lead). Costs may vary slightly depending on your choice of wood and whether you use brass or iron screws.

A good pattern is the first essential in making a decoy of any goose or

duck species. You can design your own patterns or develop them from photographs of ducks or some books on duck hunting that show top profiles of various ducks.

The pattern chosen should produce a decoy with a high body silhouette when the decoy is on the water and easily seen by flying ducks. The head should be in a natural at-rest position and not so high or extended that it might resemble the bird's alarm position. The pattern should also yield a

IF YOU USE NAILS to hold body sections together for shaping, they can then be rescrewed, glued

DRAW-BLADE KNIFE or spokeshave gives the decoy an initial shape before smoothing, sanding

DRUM SANDER WAS MADE from an old washing-machine motor. A coarse sandpaper covers the drum





WINGS ARE SKETCHED on body of decoy. Books on duck hunting will have photos of wing shapes



FOLLOWING THE TRACINGS, now groove the outlines of each wing using a fine gouge to show shape



ON BOTTOM PIECE, cut out the center portion about one inch in from the edge using a sabre saw

body wide enough to give the decoy lateral stability in rough water, keeping unnatural roll and pitch at a minimum.

There are several types of wood suitable for making your decoys. Each offers some advantages and problems. Cedar is rather light in weight and will hold up to prolonged periods in water. Heavy-density balsa is very lightweight and easy to work, but quite expensive and easy to mar. While northern spruce is cheap, it has a tendency to be knotty and splits after being in the water too long. Sugar pine is easy to work, won't split in water, waterproofs easily but can be expensive and difficult to obtain.

But white pine is probably the best compromise. It is easy to work, moderate in cost, fairly light in weight, especially with a hollow decoy, and when

properly treated, the wood will be water-resistant for its lifetime.

Before following these step-by-step photos, carefully select pieces of lumber that are as free of knots as possible. If knots can't be avoided, place the knots in the middle of the patterns toward the bottom where they will later be cut out. The top body piece must be knot-free.

As shown, the tools for the job are simple and inexpensive. A draw blade or spokeshave is your most valuable tool, followed by a half-round bastard file, a wood rasp and a small rattail file. For power equipment, a good jig-saw or fine bandsaw is ideal, but a sabre saw is handier. It should be capable of cutting through two-inch stock. The most valuable tool on the power side is a sanding sleeve or drum mounted on a motor. Mine is an old

REASSEMBLE the two body halves after cutting center out of lower half to give decoy lighter weight



DECOY HEAD CAN BE shaped to near completion with the sanding sleeve. Outline bill with gouge

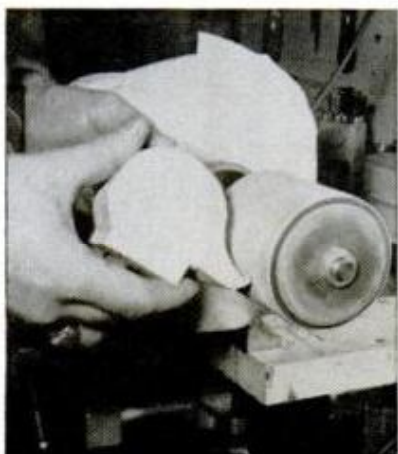

CUT RECESS IN BODY and fit head into the slot, securing it in place with waterproof glue, screw





SCREWS ARE USED in the final assembly to hold head to body and all sections glued together

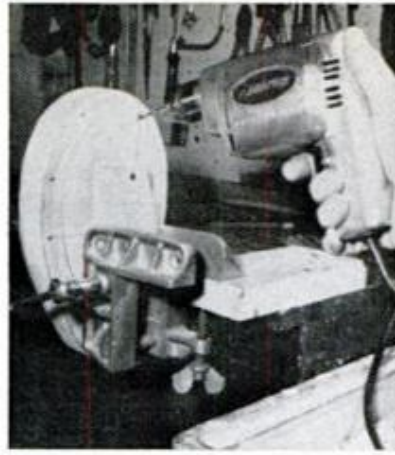

PREDRILL HOLES for screws so they secure easily with little chance of splitting the light wood



BOTTOM PLATE IS GLUED and screwed on, followed by keel. A lead-weighted keel steadies decoy

washing-machine motor and a drum with coarse sandpaper.

After head, top and bottom body parts have been shaped out and assembled, painting should be done with a completely no-gloss finish that can be obtained from hunting supply houses. Matching the exact colors of the live birds is less important than using paints that reflect no light. Sunlight bouncing from floating decoys can spook an incoming flight of birds, so household glossy or semigloss paints are unsuitable. Decoy eyes can be obtained from supply houses that offer taxidermist equipment. Good glass eyes are much superior to painted nailheads. Add more lead aft if the decoy tilts forward.

For quick production of my decoy flock, here are the steps I follow. On a plank of 1 $\frac{3}{4}$ or 1 $\frac{7}{8}$ -in. cedar I trace the body and head patterns I have

worked out. Using a sabre saw I follow the scribed lines to cut out the two-piece body and single head. Wood screws join the two body sections; then the top of the body is rounded to shape with a draw-blade knife.

As refinements, wing outlines are drawn on the body and grooved with a fine gouge. I cut out an oval from the center section of the lower body piece to lighten the decoy and then, with shaping finished, rescrew and glue the body sections together.

For this and other shaping jobs, I use the motor from a discarded washer with a drum fitted on the shaft and covered with coarse sandpaper. Head shaping is easy with this drum.

Weighted keels to give level floating, glass eyes, and several dunkings in hot linseed oil are followed by a finish coat of nonreflective paint. ★★★

GLASS EYE from taxidermist supply house is more authentic than nailhead painted to match



TO WATERPROOF DECOYS, dunk each bird in hot linseed oil for five minutes. Repeat three times



PAINT DECOYS WITH EXTERIOR flat colors and dry completely before floating them in water



Roll-around camera dolly lets you sit

By ROSS SCOTT

THIS WHEELED DOLLY not only rolls you easily into position for any camera angle, but it even lets you sit down while you work. The sliding camera arm can be moved up and down on the main column to any desired height and can also swivel sideways in any direction. In addition, the short upper camera post can itself be rotated and tilted to any position. The combination of movements enables you to put the camera anywhere you want it and to switch quickly to other positions when shooting objects from a variety of angles and levels.

The column, arm and post are all made from standard pipe and fittings. The size you use depends on how sturdy a rig you want and the weight of your camera. One-inch pipe provides a rug-

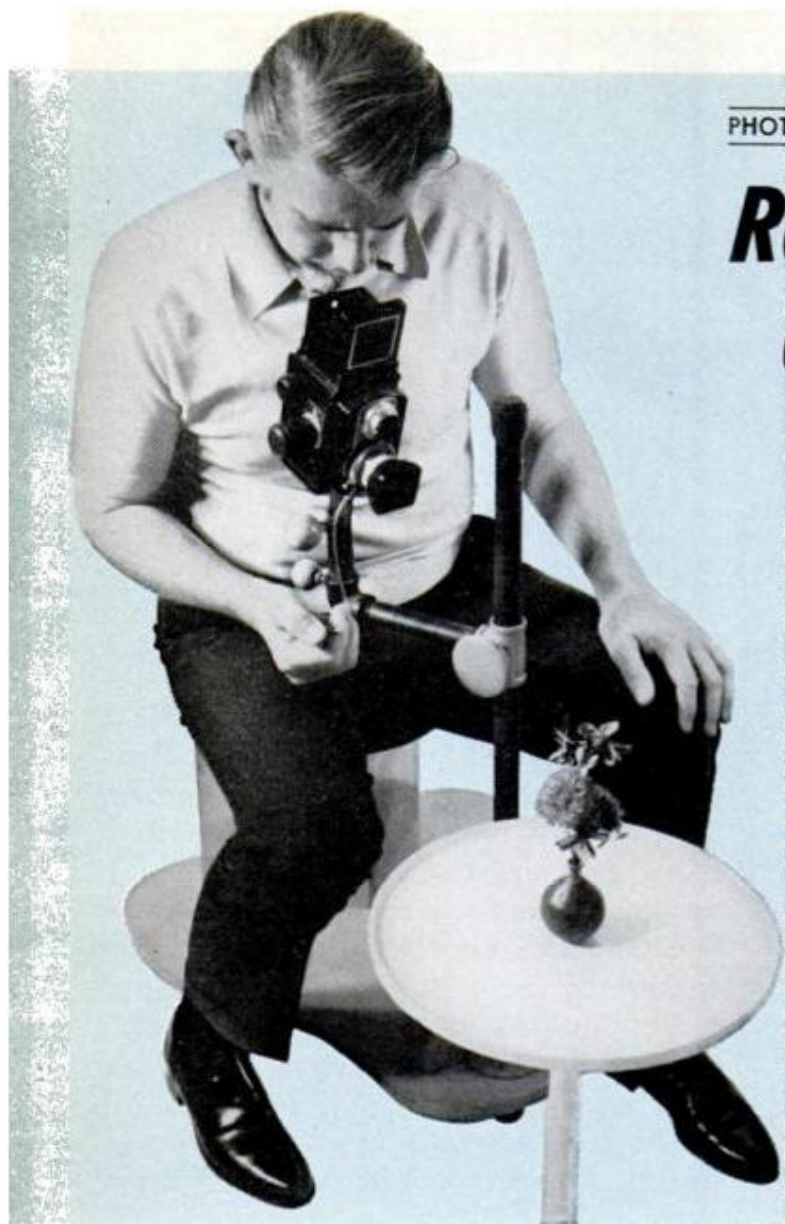

Key holder prevents loss

The thin filter key supplied with many Super-8 movie cameras is easily mislaid. You can prevent this by strapping the key to the camera with a loop of elastic tape. Feed the loop ends through the key openings, then around the camera body. —Walter E. Burton, Akron, Ohio

Handy darkroom tanks from food containers

The plastic containers you buy ice cream in make ideal auxiliary tanks for using and storing darkroom solutions. The snugly fitting squeeze-on lids seal the containers tightly enough to provide long life for such chemicals as fixer, hypo eliminator and antistatic rinses. Leaving the solutions right in the containers saves the bother of pouring them back and forth between jars and tanks. The containers will take most sizes of developing reels up to those used for 2¼x2¼ negatives.—Jackson Hand, Westport, Conn.





ALL PARTS 3/4" PLYWOOD

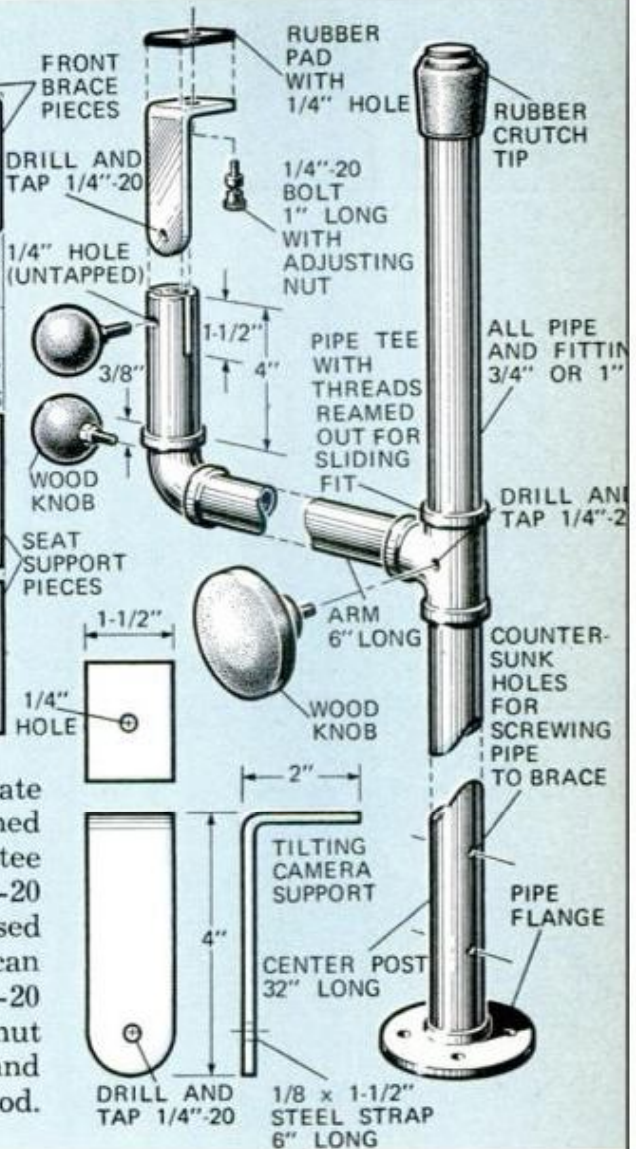
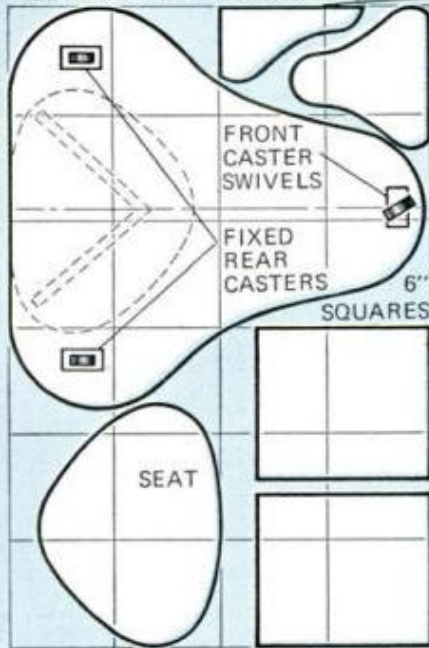

ged support for big cameras, but 3/4-inch is adequate for most uses. The sliding tee fitting must be reamed out for a smooth slip fit on the main column. The tee and elbow must also be drilled and tapped for 1/4-20 locking screws. Ordinary thumbscrews can be used here, but smarter-looking, easier-to-use controls can be made from wood furniture knobs. Cement 1/4-20 headless bolts into the knobs with epoxy and run a nut on each to provide bearing collars. Seat, base and braces are cut from a 2x3-foot scrap of 3/4-inch plywood.

Quick way to make multiple enlargements

The normal procedure of setting your darkroom timer by eye is fine for one or two prints, but when making 15 or 20 duplicates, it becomes slow and clumsy and you have to be careful to set the timer hand at exactly the same point each time for uniform results. You can speed up the job by drilling and tapping a series of small holes around the timer dial—



one at each second mark. A 10-32 tap is a good size for this. Screw in a small bolt at the desired number of seconds to act as a stop. Switch on the timer, turn the knob until the hand hits the stop, then let go. For multiple prints, simply leave the timer on and keep turning the knob and letting go—as fast as you can change paper in the easel.—Richard Kent, East Natick, Mass.



Improvised floodlight

Need an emergency photo-flood reflector? You can make one up quickly if your wife has a heat or sun lamp—the type with a wire guard around the bulb. Wrap guard with aluminum foil, pressing it firmly in place inside and outside.—Robert Hertzberg, Flushing, N. Y.

Cassette recorder repairs? Most are simple. Many you can do.

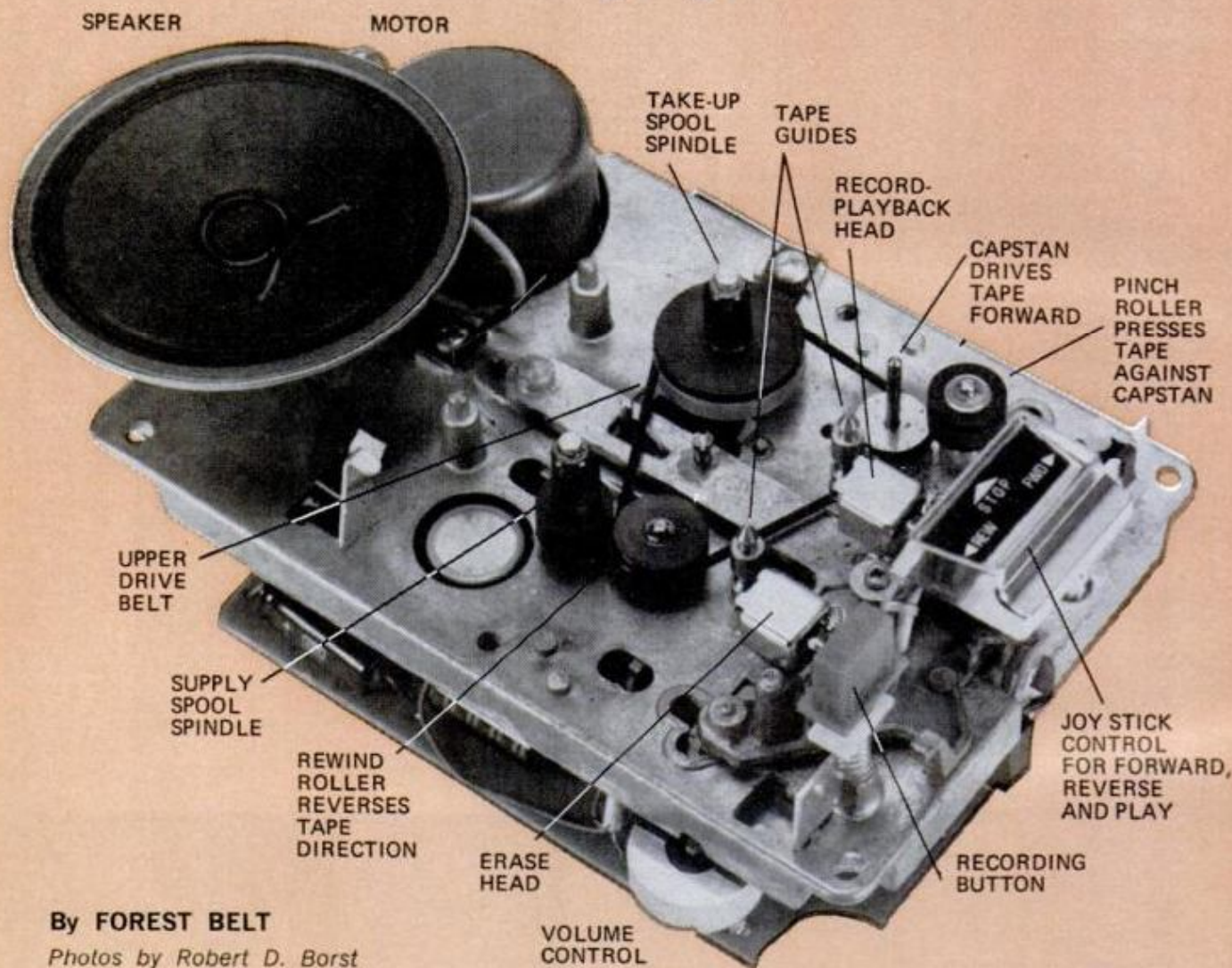

By **FOREST BELT**

Photos by Robert D. Borst

CASSETTE RECORDERS may seem complicated, but actually they're basically simple. They all work pretty much alike, and in most cases their parts are readily accessible. Before you throw up your hands at a balky machine, try these quick and easy fixits. Chances are, they'll get an ailing machine back in shape with out your having to resort to major repairs.

Weak or dead batteries in a portable recorder cause more problems than you may realize. This may sound a little silly

—like checking to see if the power cord is plugged in on a dead appliance—but it's such a simple thing it's often overlooked—just like the power cord that *did* unknowingly pull loose. Run-down batteries cause variations in tape speed that produce "wow" sounds or make the musicians seem to be playing in a tub of molasses.

If the drive spindles turn normally when the machine is empty, but stop or slow down the minute you insert a cassette, this generally indicates the batteries



JUST DROP IT IN and special cassette tape above automatically wipes heads clean as it runs through the machine. Such aids, while not a substitute for

more thorough hand cleaning, are convenient for occasional use. Also available are test tapes that check for wow, frequency response and other factors

are weak—just strong enough to drive the spindles freely, but unable to take the added load of the tape.

If your recorder has a 117-volt a.c. adapter, make a quick check by switching to this. If it performs well on house current, the batteries are obviously the culprit. In replacing them, change the whole set—batteries in series wear out about evenly. Also make sure the battery terminals are clean and make firm contact.

When the machine won't budge with a tape inserted, but purrs along smoothly when you take it out, the cassette itself may be at fault. The tiny tape inside sometimes snarls or spills so it runs sluggishly or jams the drive mechanism. The answer here is to try several other cassettes. If the machine checks out okay on these, you can blame the first cassette. But don't throw it away. A snarled tape can often be cleared by running it rapidly back and forth. Try to get it to move on "Fast Forward," then reverse it and run it backward on "Rewind." Do this several times, then see if it will run through at

normal forward speed. If your recorder doesn't have a Fast Forward, rewind the cassette in one direction, then flip it over and rewind it the other way. This has the same effect as running the tape forward at fast speed.

The next most common cassette trou-

TYPICAL CASSETTE-MAINTENANCE AIDS are shown below. They include cleaning and testing tapes, a cleaning and lubricating kit and a demagnetizer. In left background is special stroboscopic test tape





WEAK BATTERIES can cause more problems than you may think. Replace them frequently and in sets—not one at a time. Be sure cells are correctly inserted according to polarity markings inside case

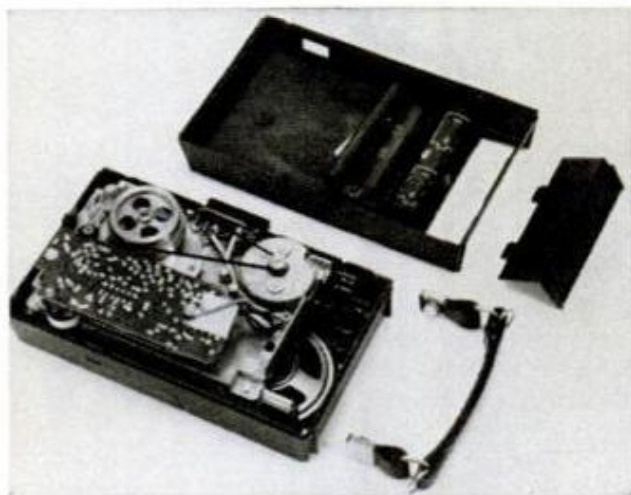

REMOVING BOTTOM of case usually exposes underside of chassis, motor and flywheel (above). It may also release handle and other small parts. Note how they fit together to facilitate reassembly. Using a cotton swab dipped in alcohol, clean oil and grime off motor pulley and flywheel (below). Such dirt can cause belt slippage, varying drive speed

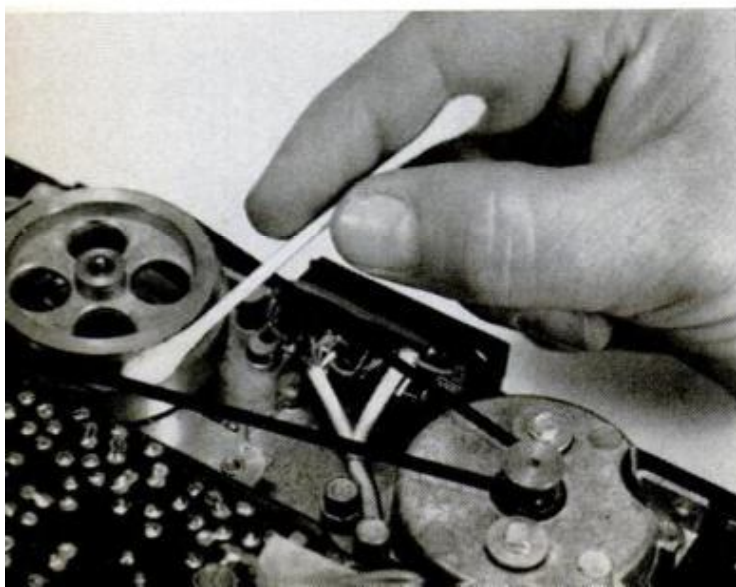

bles are the periodic buildup of magnetism on the heads and the dirt and grime that collect on the heads and in the drive mechanism. Dirt on the heads prevents the tape from making good contact, clogs the delicate head gaps and quickly reduces sound quality. Oily grime on the capstan, pulleys and drive belts causes tape slippage that, like weak batteries, results in wow, erratic tape speed and annoying fluctuations in musical pitch.

Cleaning and demagnetizing the heads can be done on most recorders without dismantling them. This should be done at least twice a year—more if you give your machine heavy use. The heads pick up magnetic charges as the tape moves past which interfere with proper recording and playback of magnetic signals on the tape, resulting in poor sound reproduction.

Small demagnetizing tools cost a few dollars at electronics and hi-fi shops. You plug the tool into 117-volt a.c. and move its tip back and forth a few times across each head. Keep the tool from actually touching the heads to avoid damaging the delicate surfaces. The tip should just brush lightly by them. Be sure no prerecorded tapes are lying nearby as they may be demagnetized and erased accidentally.

For cleaning the heads, you can use ordinary denatured alcohol or special solvent sold for the job. Apply it gently with a cotton swab, as shown in the accompanying photos. Particles of magnetic oxide rub off the tape during playing and must be thoroughly cleaned out of the

TO REACH TOP SIDE of mechanism, remove screws holding chassis frame to case, then carefully lift chassis out and turn it over. Watch out for fine wires that may run to battery contacts in the case

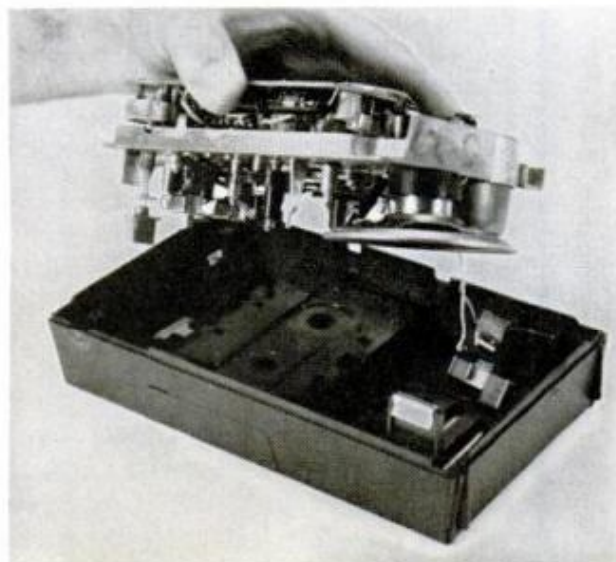

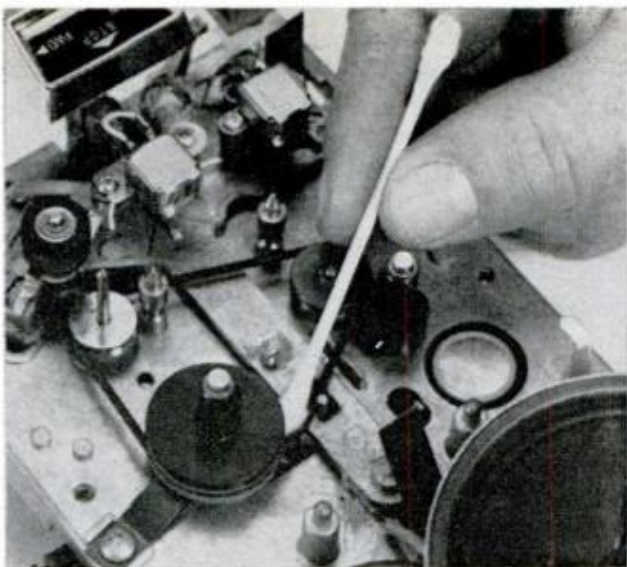

CLEAN UPPER PULLEYS in same way as lower ones with an alcohol swab. Also wipe the capstan, pinch roller and tape guides. Gently check belt tension

tiny head gaps or they'll clog them. A silicone head lubricant is also available to provide a smooth, gliding surface for the tape. Other aids you can buy include test tapes for checking on various performance characteristics and head-cleaning tapes that do the cleaning job for you. The latter are handy, but should not replace an occasional thorough hand cleaning.

For inside cleaning, you'll need to remove the mechanism from its housing. In some models, the chassis is exposed by removing a cover. In others, the chassis lifts out of the enclosure from the top. Be careful on the more intricate autoreversing and changer models not to damage the delicate machinery. Portable machines are much simpler. Their housings are usually in two shell-like halves. You remove the bottom shell first, exposing the underside of the chassis. Then you take the chassis out of the top shell and turn it over to reach parts on the upper side. Battery contacts are usually in the form of springy clips that can be slipped off plastic posts to free the chassis.

Using swabs and solvent, clean all pulleys, capstans, pinch rollers, spindle hubs, drive belts and other moving parts. Gently check the belts for good tension. Replace any that are loose. Exact replacements can be ordered through hi-fi dealers or the maker of your particular recorder. But don't attempt to open a machine still in warranty as this will void your guarantee. Problems involving extensive repairs are jobs for a trained serviceman. ★★★

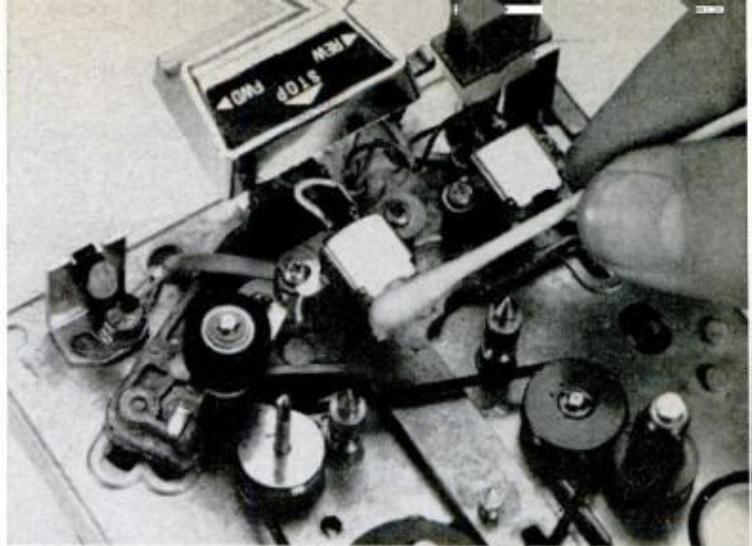

HEADS CAN BE CLEANED with special solvent or ordinary denatured alcohol. Wipe them alternately with wet and dry swabs until no traces of dirt remain

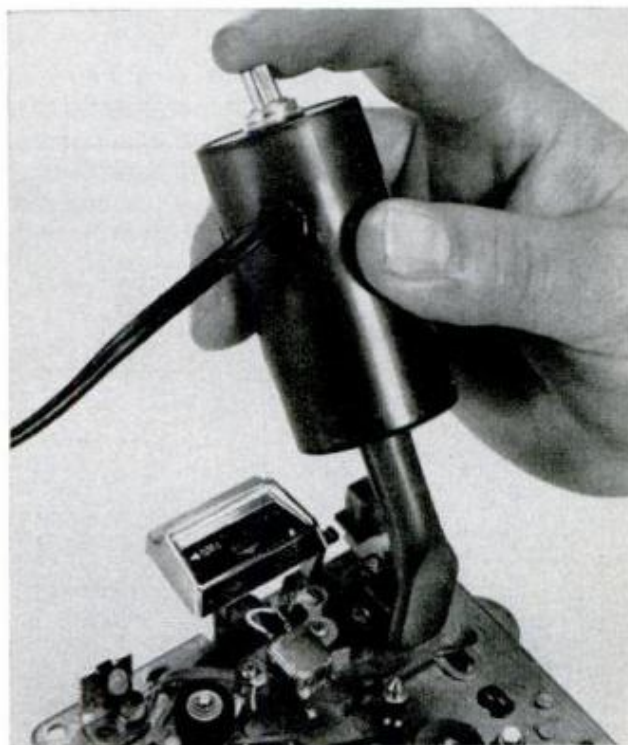

PERIODIC DEMAGNETIZING of heads is easy with small demagnetizing tool like Audiotex's above. Tip should just brush past—but not actually touch—each head. Pinch roller should press tape firmly against capstan for smooth, uniform drive. You can check pressure by drawing a thin strip of paper between the roller and the capstan, as shown below

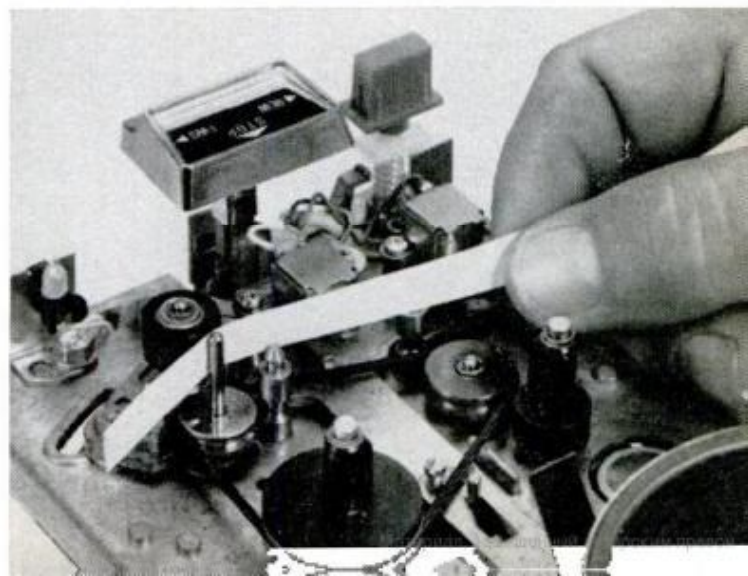

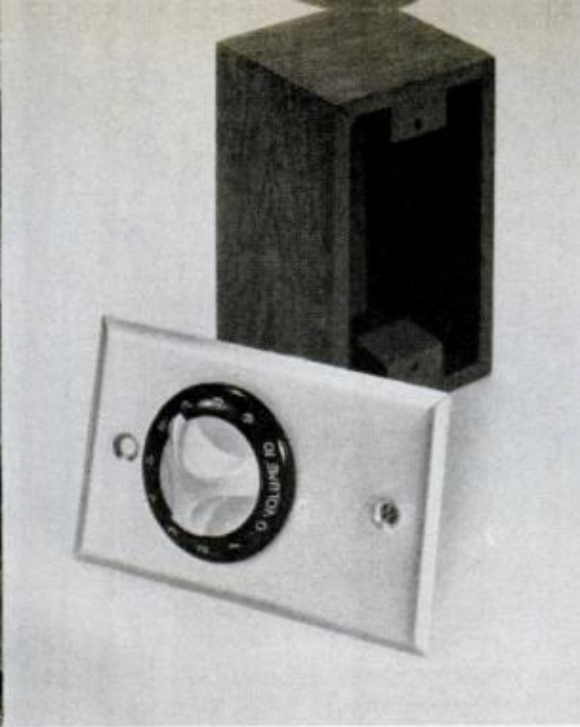

IT'S ONLY A SMALL BOX, but so handy and clever it's a wonder no one thought of it before. It's a walnut-finished minicabinet sized to take the many switches, dimmers, timers and other controls that come mounted on standard wall outlet plates. You just fasten on a plate and have a handsome miniature enclosure. It's shown at left, above, with speaker selector switch and at right with light dimmer for a bed lamp. \$7.95, Audiotex, GC Electronics, Rockford, Ill.

NEW IN ELECTRONICS

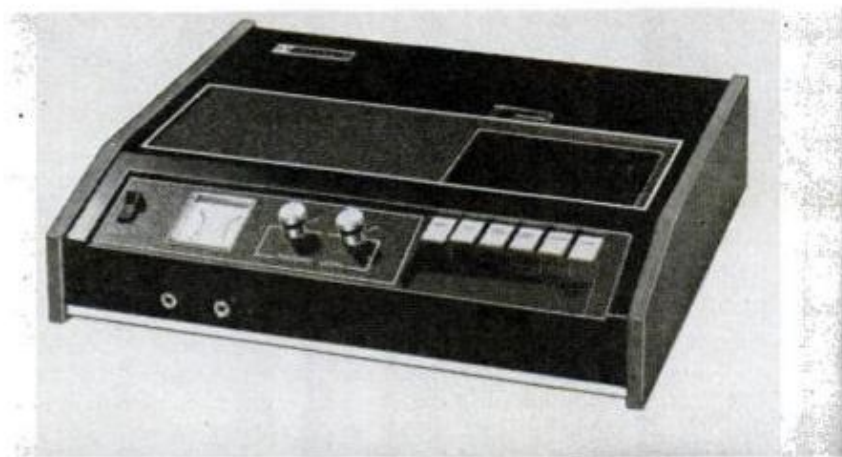

A FIRST IN KIT FORM, this cassette recorder is Heath's AD-110, said to match many reel-to-reel recorders in quality. Stereo unit with adjustable bias allows use of new high-performance chromium dioxide tapes, also has pushbutton controls and dual recording meters. Prebuilt transport mechanism and single circuit-board wiring make assembly easy. \$119.95, Heath Co., Benton Harbor, Mich.

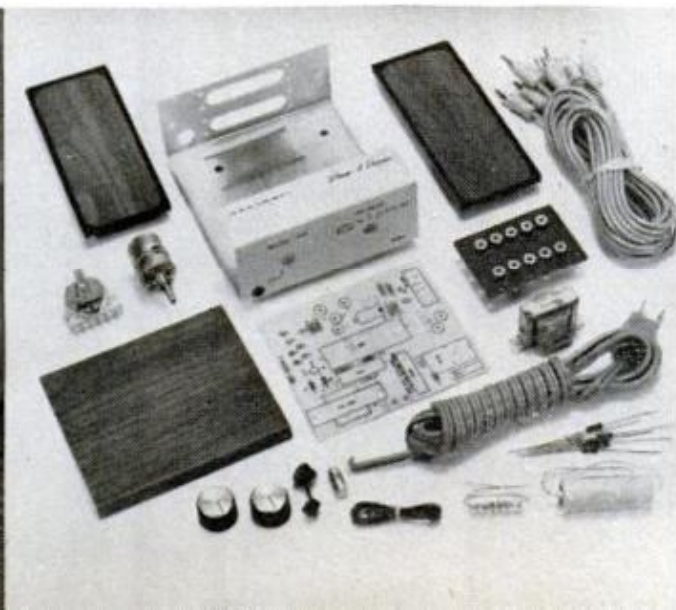

YOU CAN NOW BUILD your own four-channel matrixing decoder. The Heath AD-2002 at left is essentially a kit version of the well-known Electro-Voice EVX-4 decoder. The unit, used with two stereo amplifiers and four speakers, provides four sound channels from matrixed two-channel recordings and broadcasts. Price is \$29.95—about half that of ready-made unit. Heath Co., Benton Harbor, Mich.



NOW YOU SEE IT, NOW YOU DON'T: An ingenious "pop-up" control panel on this combination Zenith cassette recorder and AM/FM/FM stereo receiver swings up at an angle for easy accessibility, then retracts out of sight when not in use. A touch of a finger releases the spring-loaded mechanism to raise it for playing. Called the Latham, the stereo unit offers 20 watts per channel, has dual recording-level meters, 12-inch-square speaker enclosures. \$269.95.



STREAMLINED TV ANTENNA has a tiny electronic receiving circuit in a slim, winglike plastic housing only 34- $\frac{1}{8}$ inches wide. This eliminates the need for long, ungainly arms, yet is said to provide equal or superior signal-grabbing power. Because of its small size, the Stellar 2001 can be used indoors in attics as well as on rooftops. \$75, JFD Electronics Corp., 1462 62nd St., Brooklyn, N. Y. 11219.

FEBRUARY 1972

115

YOU CAN OPERATE the tape recorder below from across the room with a new accessory remote control. The control, designed for use with Ampex's Model AX-300 reel-to-reel recorder, consists of a six-button keyboard on a 15-foot cord that exactly duplicates keyboard functions on the machine itself. The accessory is about \$40; AX-300 recorder, \$649.95. Ampex Corp., Elk Grove Village, Ill.



Ignition timing simplified

By MORT SCHULTZ

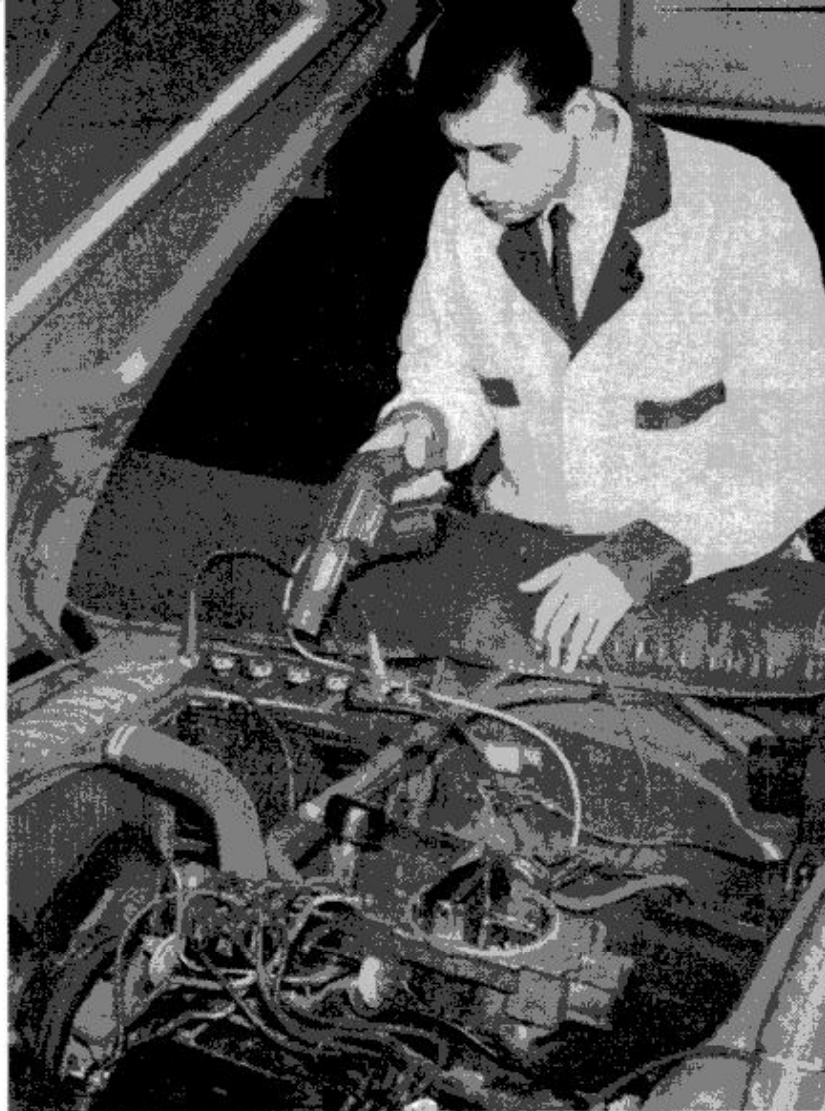

The instruments you'll need will pay for themselves in a couple of tune-ups, so go out and get them and start saving money! All the theory you need is in the diagram

YOU HAVE NO CHOICE when timing a late-model car—if you want to do your share in controlling air pollution: Timing must be done by the book to set the optimum point in ignition for maximum combustion and therefore minimum exhaust emissions.

Timing refers to the instant when sparks are delivered to the cylinders for combustion of fuel. Not long ago, it was okay to deviate from manufacturer's specifications. It was common, for example, to advance timing beyond specs so the sparks occurred earlier in the compression stroke—an attempt to get maximum power from the engine.

It's possible to time ignition two ways. Static timing is done with the engine off and a test light connected into the ignition circuit. The distributor is rotated until the test lamp lights

(distributor points open), at which time the distributor is tightened. Static timing specifications, when provided, are frequently given as a range, such as 5° to 10° BTDC. It is very difficult to stop the timing mark exactly on the timing pointer as you turn the engine manually. Today's high-compression engines offer more chance for error due to greater timing-chain or gear lash.

Power timing, on the other hand, done with a timing light, "freezes" a moving timing mark on the crankshaft pulley in relation to stationary marks. The rapid flash of light is initiated at the instant of ignition.

The 1968 and later-model cars with exhaust emission control systems have made timing a new ball game. Engines with pollution-control devices operate generally on a leaner fuel mixture and

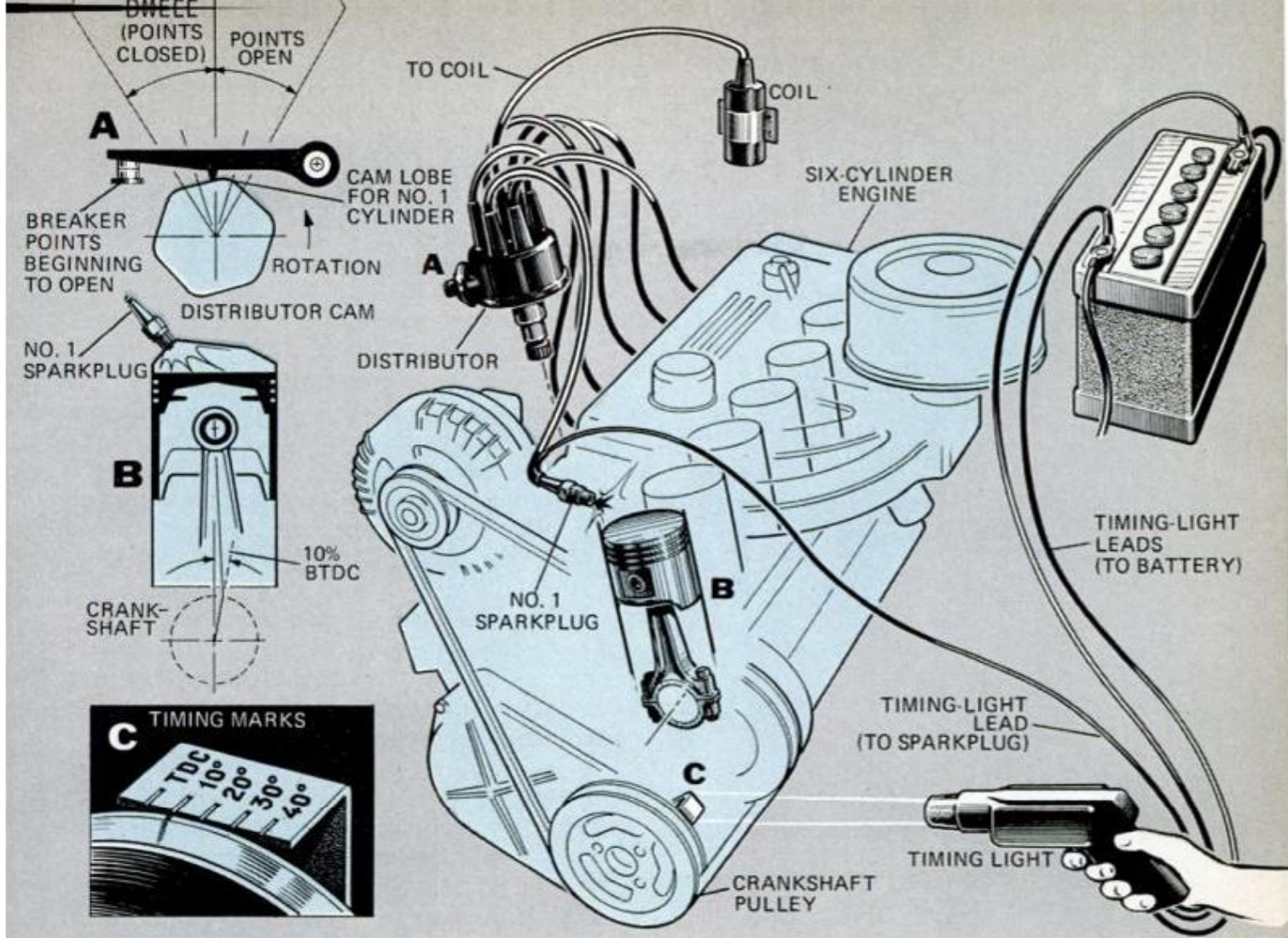

INSTANT OF IGNITION— 10° before top dead center (BTDC)—is illuminated by a stroboscopic timing light. Action at A (the distributor), B (in the cylinder) and C (at the timing marks) happens simultaneously. As points open, the sparkplug in the No. 1 cylinder fires. At this time, piston is 10° BTDC and timing mark on the crankshaft pulley is opposite 10° mark stamped on stationary indicator. Plug voltage triggers light

a slightly more retarded (later) timing.

Timing an engine to other than manufacturer's specs will upset the effectiveness of the car's pollution-control equipment. According to the research department of Champion Spark Plug Co., "Advancing the timing settings beyond those specified in the manual by the engine manufacturer can result in an increase of from 10 to 30 percent in the emission of unburned hydrocarbons."

You will also upset the fuel-mixture/timing relationship. This can lead to a rough-running engine, unnecessary waste of fuel and damage to sparkplugs.

A power timing light stops the action, so to speak, so that the repetitive sparks occurring in a cylinder appear stationary to the eye. In effect, the eye sees a series of repetitive pulses as one.

The relative position of the timing indicator in terms of degrees of engine rotation is read from the fixed marks on the engine block. By comparing the

position of the timing indicator relative to these marks, you are able to tell where ignition occurs in respect to top dead center of the cylinder being timed.

If your car is a '68 or later model, you will find the timing specification and other pertinent tune-up information on a decal in the engine compartment.

The circuit of a power timing light usually consists of a xenon tube that's connected to a high-energy storage capacitor. To operate the light, you connect it directly to the car's ignition system—normally to the No. 1 sparkplug.

Some voltage given off by the plug as it fires is transferred to the xenon tube, causing ionization in the tube. This permits the tube to conduct energy from the storage capacitor. It's this energy that is converted to the high-intensity light output you see beaming from the light's lens.

For the storage capacitor to function, it must be connected to an electrical

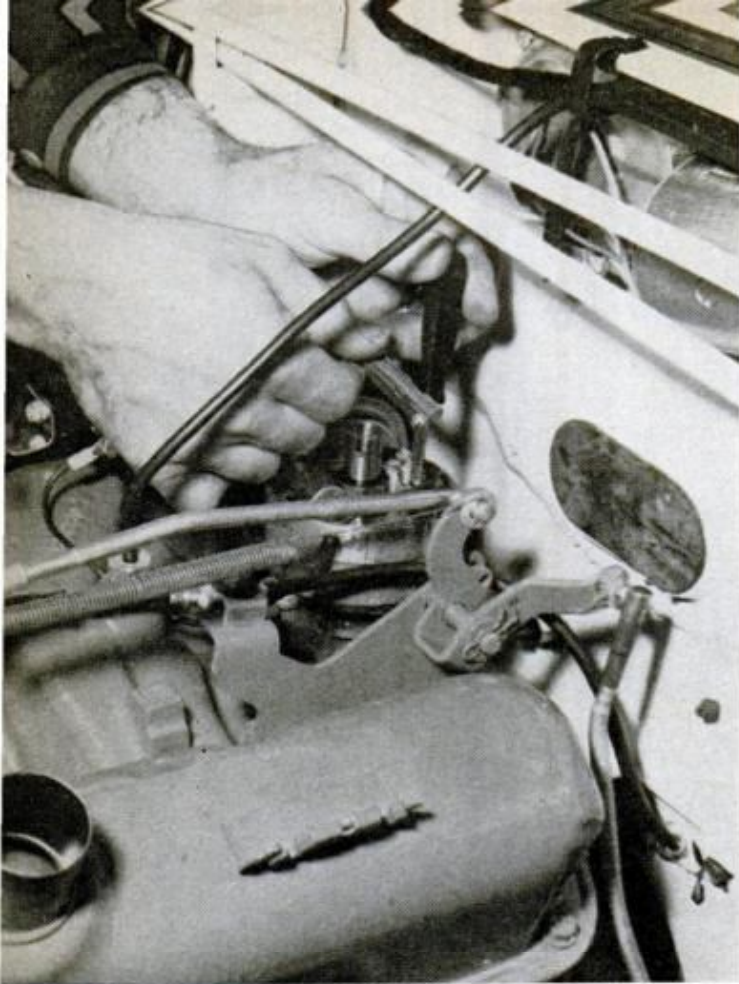

SET POINTS TO SPECIFICATION before timing ignition. Be sure to keep inside of distributor clean

source in one of two ways, depending upon the type of light you have.

With some lights, the energy source for the capacitor is 110 volts a.c. Other types of timing lights have a d.c. circuit that allows you to tap energy directly off the car's battery.

Speaking of cost, power timing lights are priced from \$13 to as high as \$185 for professional models. The most costly are not only better built, but usually combine two or more test instruments.

For example, the Fox Valley Instrument Co., Kal-Equip Co., Simpson Electric Co. and Sun Electric Co. make instruments that combine a timing light with a tachometer and/or dwell meter (degrees advance tester) in a single case.

As I see it, a timing light should have certain features. For example:

- **Brightness.** My light must have a beam intense enough for me to see in daylight. Watch out for timing lights with neon lamps. You may be unable to see the light in anything but a dark room.

Make sure that a timing light doesn't dim out at higher speeds. One thing you'll use it for is to test the functioning of the distributor's mechani-

cal advance. You can't do this if the light dims out at higher rpm (about 2000).

- **Focus.** The only way to determine if focus is right for you is to test the light before buying it. The timing marks should be easy to find with the light. If the beam is too narrow, you will have trouble finding the marks. If the beam is too broad, the intensity of the light will be diminished.

- **Shockproof.** Any light I use has to be shockproof. A car's coil can produce an arc that will jump to the case, and give you a jump, too.

- **Pushbutton on-off switch.** This feature extends the life of the xenon tube, which is expensive to replace. The switch allows you to switch off the light when it's hooked up and not being used.

- **Overload protection.** The light should have protection for its circuitry against a surge of high battery voltage and accidental reversing of leads.

- **Solid-state power supply.** For my money, I want a well-designed, solid-state power supply rather than a vibrator type. Solid state is much more reliable.

- **Warranty.** What does the warranty say? How long is it good for and what does it cover? Where must you take the unit if it needs repair and how much will it cost? An instruction book will come with your timing light. However, here are some tips that will help you get full use from the instrument.

Use the light like a pistol. Make sure

BEFORE TIMING IGNITION, on most cars, close spark advance vacuum line. A pencil makes good plug

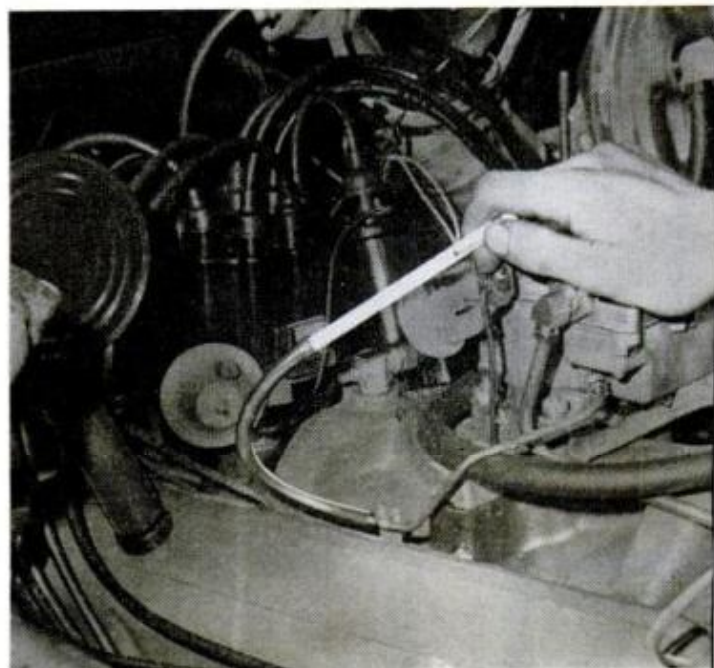

you sight straight down the beam to the timing mark. Sighting at an angle could throw timing off as much as 3°.

Go by the book. If the manufacturer says to time the car with the engine running at 900 rpm with the spark-advance vacuum line disconnected and closed off, do exactly that.

As we said, tune-up specs are usually attached to a spot beneath the hood. Many owner's manuals also contain these requirements. As a last resort, consult the car's service manual, call a dealer who sells your make of car or write the manufacturer.

Before timing the car, check the distributor point gap and dwell. Dwell angle is the number of degrees through which the distributor points remain closed. If the dwell of your distributor is not to specification, timing will be inaccurate.

So, in addition to a power timing light, anyone doing his own tune-up work needs a tachometer and dwell meter. You can get the details about these instruments (normally combined into one unit) in the February 1971 issue of *PM* (*How to Use the Tach-Dwell for Perfect Tune-Ups*, page 126).

To get a good idea of overall distributor condition, watch the timing marks as you gradually increase engine speed to about 2000 rpm. Excessive flutter means that there is a malfunction, such as bad distributor bearings,

POINT DWELL must be adjusted before timing. This dwell/tach combines both functions in single meter

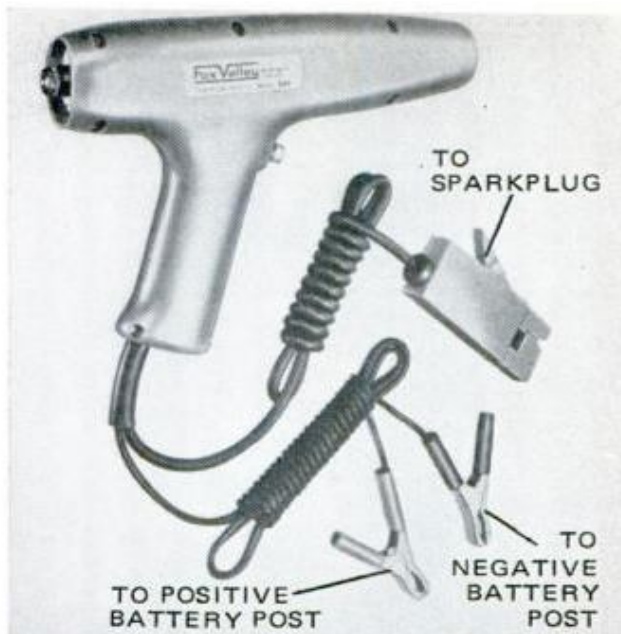

TYPICAL TIMING LIGHT is pistol-shaped, has on/off trigger. This top-of-the-line model includes built-in dwell tester; some models also include a tach

and the unit should come out of the car for work.

To check out the spark-advance unit, be sure the vacuum line is connected and blip the throttle. The timing indicator should shift rapidly. If not, the spark advance is bad and should be replaced.

If you are working on a V8 engine, after setting timing for the No. 1 cylinder, connect the timing light to the fifth cylinder in the firing order. The timing mark should line up at the same spot that it did for the No. 1 cylinder. In a six-cylinder engine, connect the timing light to the fourth cylinder in firing order after checking No. 1.

More than 3° of variation in timing from one cylinder to the other means that you have a distributor cam or bushing problem.

The following is a list of power timing light manufacturers you can write for data sheets. Specs are good for making comparisons while shopping. Also check auto-parts departments of stores such as Sears, Roebuck. Sears' new line of Penske performance products includes a timing light.

TIMING LIGHT SOURCES

Fox Valley Instrument Co., Cheboygan, Mich. 49721.
Heath Co., Benton Harbor, Mich. 49022.
Kal-quip Co., 411 Washington St., Otsego, Mich. 53140.
King Electronics Co., 9123 Inman Ave., Cleveland, Ohio 44105.
Simpson Electric Co., Automotive Div., 5200 West Kinzie St., Chicago, Ill. 06644.
Snap-On Tools Corp., Kenosha, Wis. 53140.
Sun Electric Corp., Harlem and Avondale Aves., Chicago, Ill. 60631. ★★ ★

New tools for tune-ups and

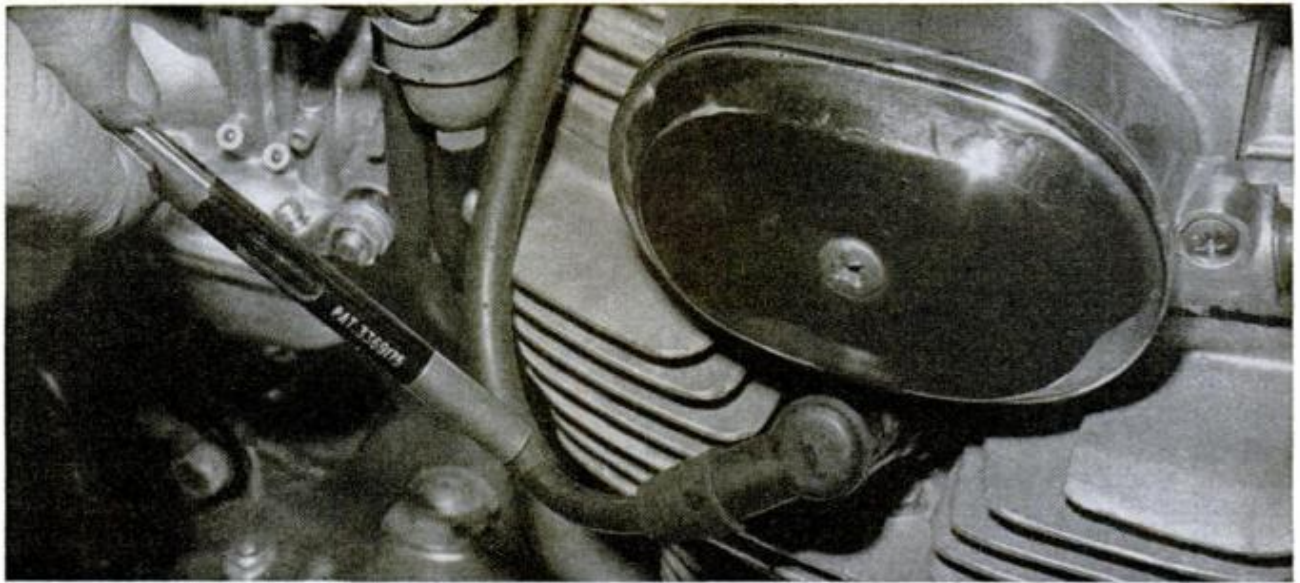

SPARKPLUG FIRING INDICATOR that can help locate a misfire on any engine is about the size and weight of a ballpoint pen and has a small neon tube built in its case. When a sparkplug fires, there should be a bright flash in the tube. When a weak spark (or no spark) occurs, the flash will be dim.

Intensity and frequency of flashes point out various ignition conditions: 1. Single brilliant flashes occurring each time the plug fires indicate normal ignition and full voltage buildup; 2. Uneven intensity of flashing as speed increases indicates possibly faulty breaker points, coil, condenser or cable con-

nections; 3. Weak flashing becoming intermittent as speed increases indicates a partly fouled plug; 4. Very weak, uniform flashing indicates complete fouling; 5. Extra flashes between main firing flashes indicate voltage induced from nearby ignition cables.

As you move the indicator along the ignition cable and around coil and distributor towers, very weak flashing indicates a normal condition; bright flashing at the point passed, a faulty insulation or broken element in resistor-type cable. Made by Champion, the inexpensive CT-436 indicator is available wherever its sparkplugs are sold.—*Bill Neumann*

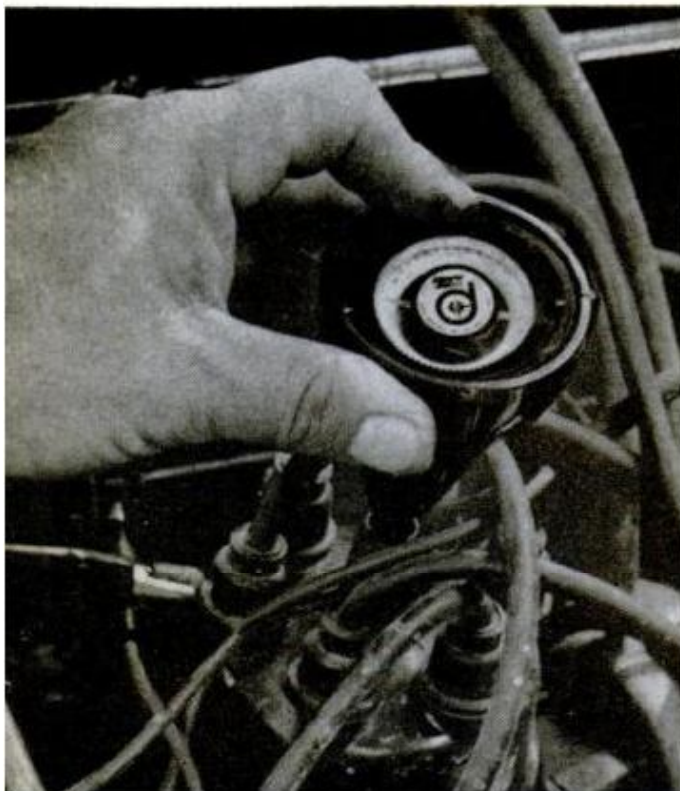

POINT DWELL AND IGNITION TIMING can be done quickly without running your engine. Compu-Dwell consists basically of an on/off lamp and a magnetic compass. Opening and closing of your car's ignition points turn the lamp on and off, and when you rotate the distributor, the compass measures dwell angle. Much more sophisticated and expensive instruments do these things, but in general, none is more accurate. To time your engine with Compu-Dwell, you first set the timing pointer (on the engine vibration damper or crankshaft pulley) to the specified mark. Then loosen your distributor with the Compu-Dwell in place, rotate the distributor until the lamp goes off and retighten the distributor.

To measure dwell angle, you first turn the distributor until the lamp just lights. Then you set the compass on zero. It's an ordinary magnetic compass, but it's calibrated in degrees of dwell instead of in N-S-E-W. Now turn the distributor again until the lamp goes off. Degrees of rotation will show on the compass face. This is your dwell angle; if not to spec, you simply adjust the points setting. Retail price is \$14.95. Compu Industries, 932A North Brand Blvd., Glendale, Calif. 91202.

—*Mike Lamm*

troubleshooting

SEE-THROUGH SPARKPLUG lets you see into the cylinder while your engine is running. The test plug replaces your normal sparkplug while you do a tune-up by watching the color of combustion in the cylinder. After installing the Colortune 2, connecting your sparkplug cable to the tungsten electrode and starting the engine, look straight down at the plug through the special Borosilicate glass into the cylinder. Since gasoline and air mixtures burn at known colors depending on the fuel/air ratio, you can determine how lean or rich your carburetor mixture is. Very lean mixture burns with a whitish-blue color, which becomes more intense as mixture is richened. At maximum engine power the flame becomes Bunsen blue, an intense light blue. Richer mixtures burn with increasing orange tinge in the blue until flame is all orange and then all yellow. Point of maximum economy is intense whitish-blue, which is just a little lean from the Bunsen-blue maximum power point. The Colortune 2 can also troubleshoot other engine functions and is perfect for dual carburetor setups. Comes with necessary adapters and a cleaning kit. Price is \$15.50. Write: Donald W. Abercrombie, Import-Export, Box 632, Oak Ridges, Ontario.—B. H.

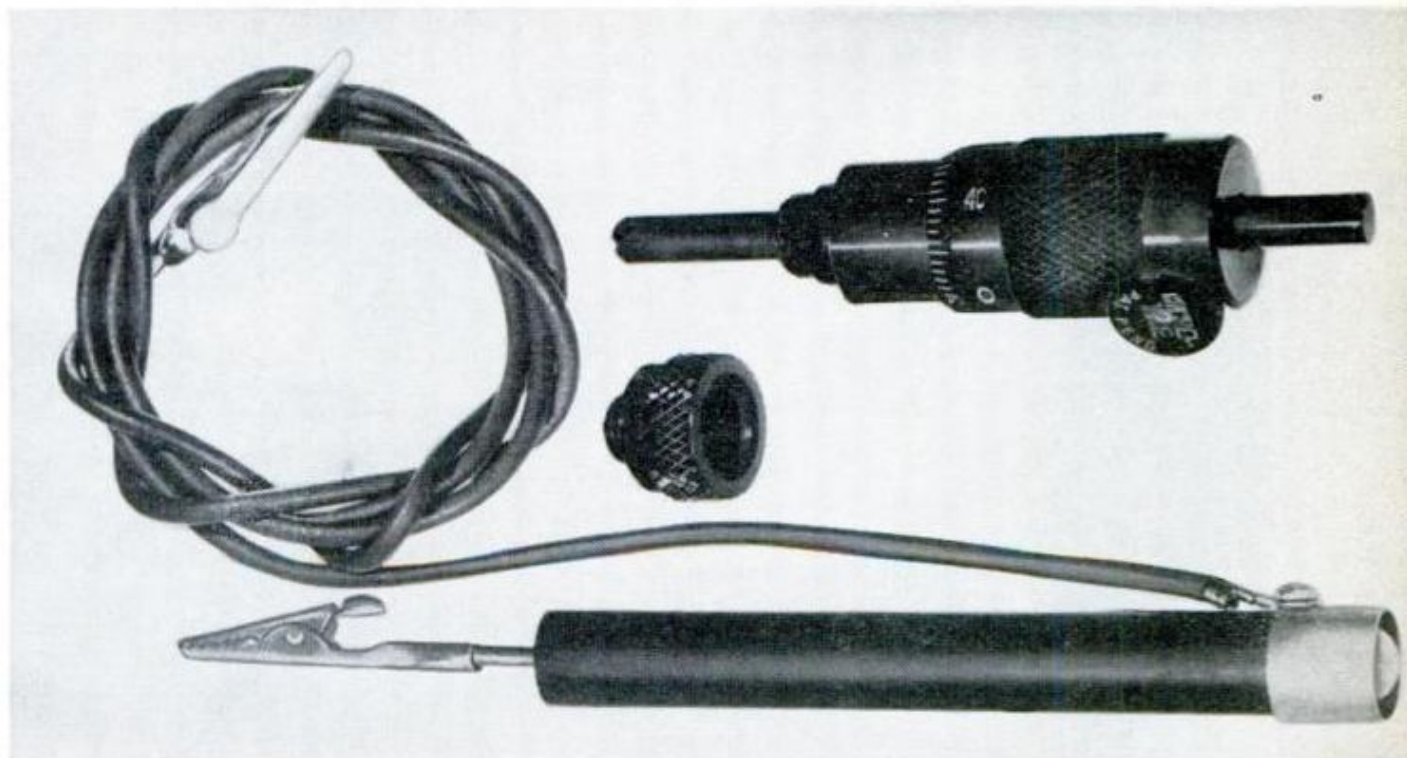
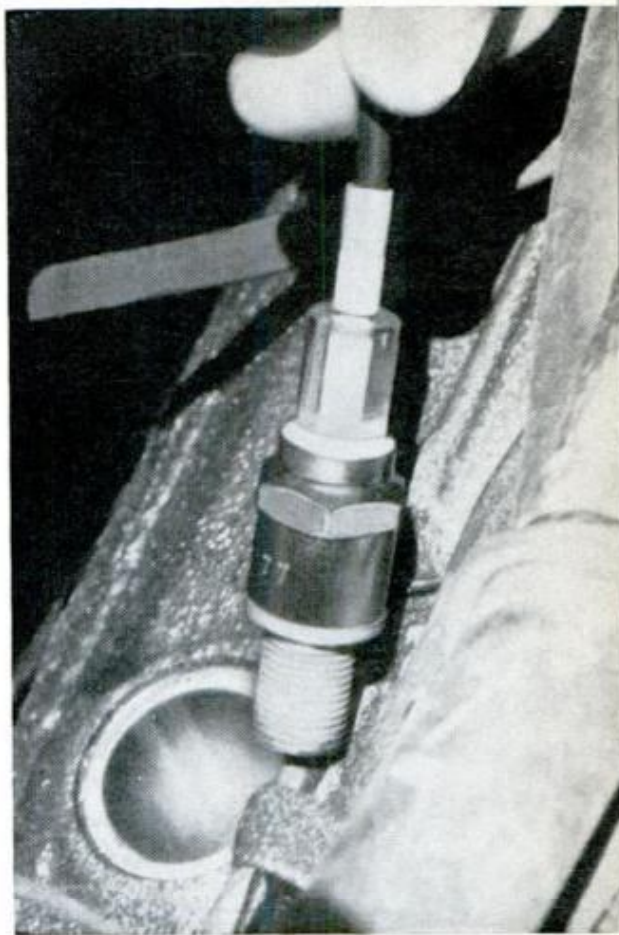

TUNE-UP MICROMETER KIT can measure piston position in cylinders of two or four-cycle engine. Designed for small engines on motorcycles, snowmobiles, lawn mowers and other recreational vehicles, the kit includes a micrometer and continuity tester with lead and alligator clip. Micro-Time is inserted in the sparkplug hole and a sliding rod extends to touch the top of the piston. The piston

is positioned at the required specification by reading the micrometer markings on the barrel of the unit. The continuity tester is attached to the points to set timing. The unit fits 10, 12, 14 and 18-mm sparkplug holes and can be used on magneto or distributor-type engines. Retail price is \$15.95. Compu-Industries, Inc., 932A North Brand Blvd., Glendale, Calif. 91202.—B. H.

EXCITING NEW PRODUCTS

BY CATHERINE BILSKI



THIS TELEPHONE AMPLIFIER eliminates the need for being "chained" to the telephone while you are working or waiting for your party to answer. Once connected to the phone you simply turn up the volume; anyone in the room can hear both sides of the conversation. Ideal at home or for those conference calls at the office. \$9.95 from Wolleys of St. Petersburg, 5200 Joe's Creek Drive N., St. Petersburg, Fla. 33709.



THOSE MENDING REPAIR JOBS can be quickly and easily bonded with a superglue called Pow'r Grip. It's quick setting, has high water resistance, excellent bridging performance and there's no mixing or waiting for curing. It can be used effectively on glass, wood, paper, cloth, brick, veneer, metal and most plastic. A 2½-oz. tube sells for \$1.25. The H.B. Fuller Co., 2400 Kasota Ave., St. Paul, Minn. 55108, is the maker.



PROTECT YOUR CLOTHES while painting, cleaning, gardening, whatever, by wearing the Protector Coverall. Made of 100 percent Tyvek fiber from Dupont, it's water, acid and tear-resistant, strong even when wet, and reusable. Handy when kept in the car for use in case of engine trouble or flats, it retails for about \$2. The manufacturer is Bulkley Dunton Linde Lathrop, Inc., 295 Fifth Ave., New York, N.Y. 10016.



WHILE YOU'RE AT HOME OR AWAY the Mark-Time Timed Extension Cord provides automatic preselected time-control "shutoff" for TV, radio, lamps, fans and other electrical household devices. Just turn the knob to the time period you want (up to four hours) and a switch will turn off the electricity at time selected. For use as ordinary extension cord, set knob at "manual"; \$8 from M.H. Rhodes, Inc., 99 Thompson Rd., Avon, Conn. 06001.



PRACTICE TENNIS by yourself. With the Wonder Tennis Trainer you don't need a partner and because the ball is attached to an elastic cord for self return, there's no chasing it. The \$7.95 device, which helps improve your serve, coordination, grip, balance and stroke, can be used at home, on a tennis court or playground—wherever there's room. General Home Products Corp., 745 Salem Rd. at Route 130, Burlington, N.J. 08016.



BUILT LIKE A BICYCLE ON SKIS, the Wooster Sno-Bob is a thrilling new ride for winter fun. It's so easy to handle that even a first-time rider can race it down hills or make lazy loops in the snow simply by turning the handlebars and leaning into the turns. The front ski floats through a 60° arc to slide over bumps and provide steering control. Made by Wooster Ltd., Div. of Rubbermaid, Inc., Wooster, Ohio 44691, it retails for \$39.95.

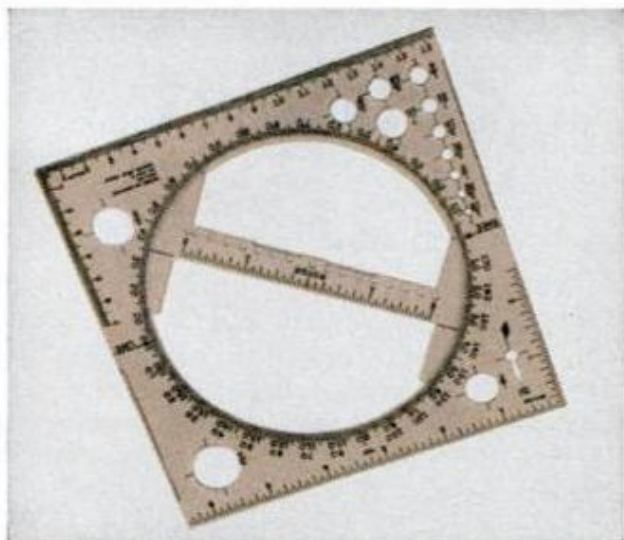

PACEMAKER PROTRACTOR is a multiple use space-age instrument designed to give fast, accurate angle construction details and measurements. It has a full 360° floating rotor (easily removed for compass action), with 4-inch ruler, finger lifts, wraparound metric and inch rulers, circle and arrow symbol templates. Retail price is \$1.95, from Frey Educational Research, Inc., 7434 Craigmere Dr., Cleveland, Ohio 44130.

FEBRUARY 1972



PUT AN END to scraping and time-consuming defrosting of your ice-covered car windshield with Hot-Melt De-Icer. You simply spray your windshield and hot de-icing fluid immediately goes to work removing ice and snow. It's claimed to be safe for all auto finishes, wiper blades and glass, also to work great on frozen fuel lines, locks and door handles. Can retails for \$2.29, is manufactured by Aeroseal Corp., Box 308, York Haven, Pa. 17370.

123



A modelmaker's 'workshop' in a cabinet

By RUDY KOUHOPT

Photos by Robert D. Borst

IF YOU NEED a good place to work on miniature engines, models or other small projects, this neat little cabinet will fill the bill nicely. It's an efficient and inexpensive (it cost me about \$27) cabinet workshop that takes up just 3½ sq. ft. of floor space and provides a place for everything. And your metal lathe, vise and large tools can be stored in the roomy bottom compartment between work sessions. Fourteen shallow drawers place all hand tools, lathe accessories and measuring devices at your fingertips. You will have more than enough bench space when you raise the hinged drop leaf to obtain the full 17 x 44-in. work surface.

All members of the cabinet are cut from ½-in. A-D plywood and are fastened

together with glue and brads. Start with the sides which are 16¾ x 26½-in. Dado the sides 7 in. from the bottom so the shelf will be well supported. Scribe and cut the sides to clear your baseboard when the cabinet is against the wall. Fasten the 16 x 29¼-in. shelf in the dados in the sides and use a length of dowel in front to give center support to the shelf.

The center divider is attached to the top of the shelf. Cut a piece 17 x 32 in. for the top. Put it in place nailing into the sides and center divider. Use a 4-in. triangle of ½-in. plywood at each corner in the rear to reinforce the shelf, sides, top and center divider.

Cover the exposed edges of the plywood with ½-in. half-round molding for ap-



IF FINISHED NEATLY, your cabinet workbench will look well in any room that you want to keep it

SMALL TOOLS and lathe accessories are at hand in shallow drawers. Use thin wood for partitions

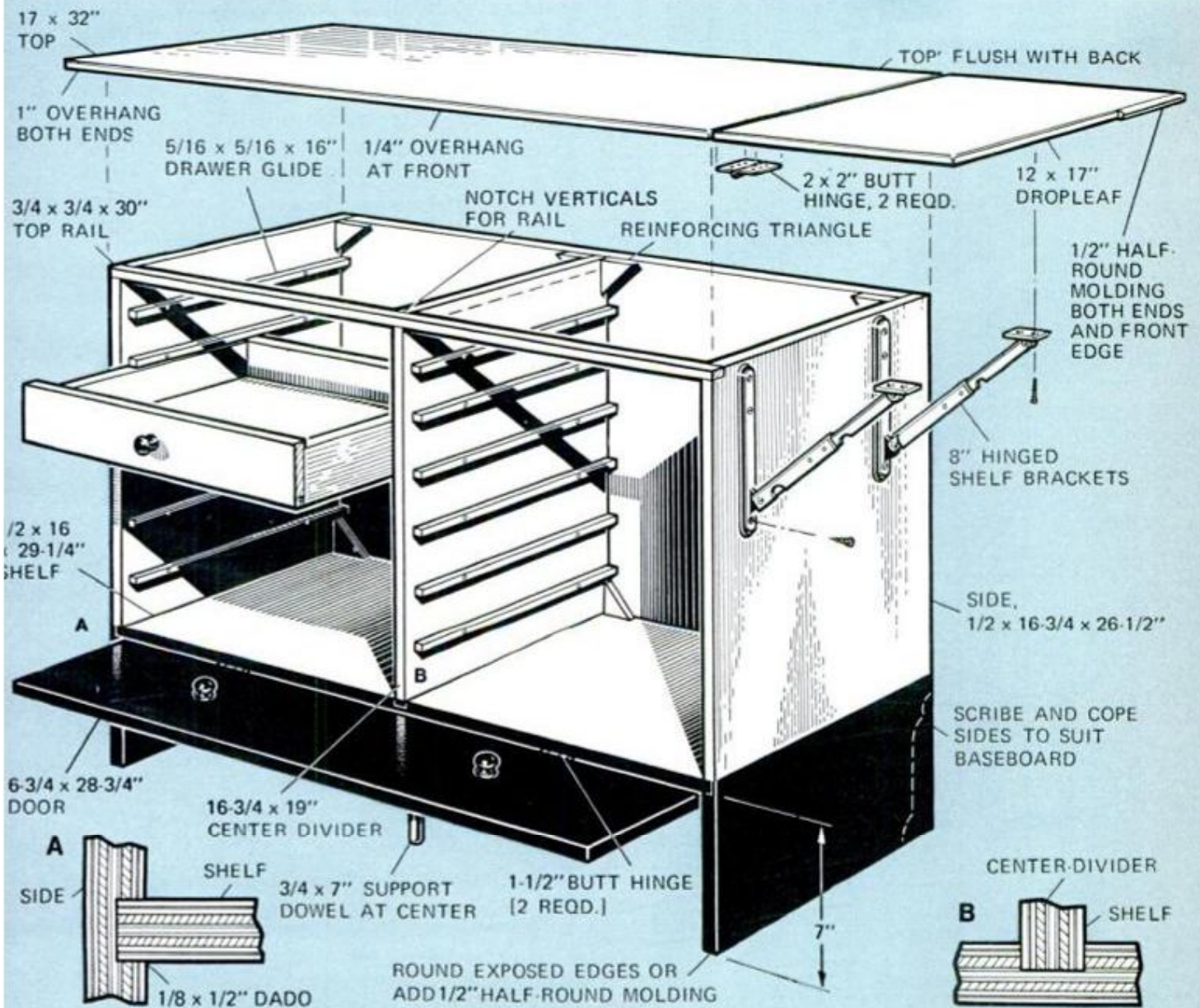

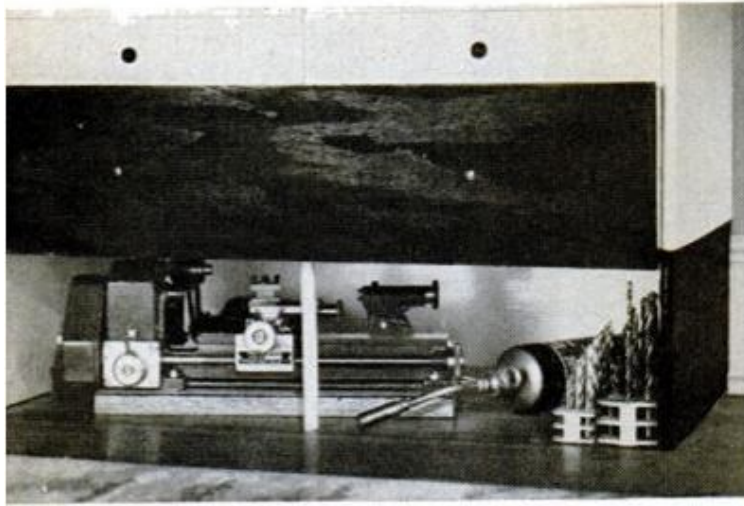

SMALL PERRIS LATHE (18½ in. long) is quickly and easily stored out of view behind the hinged door

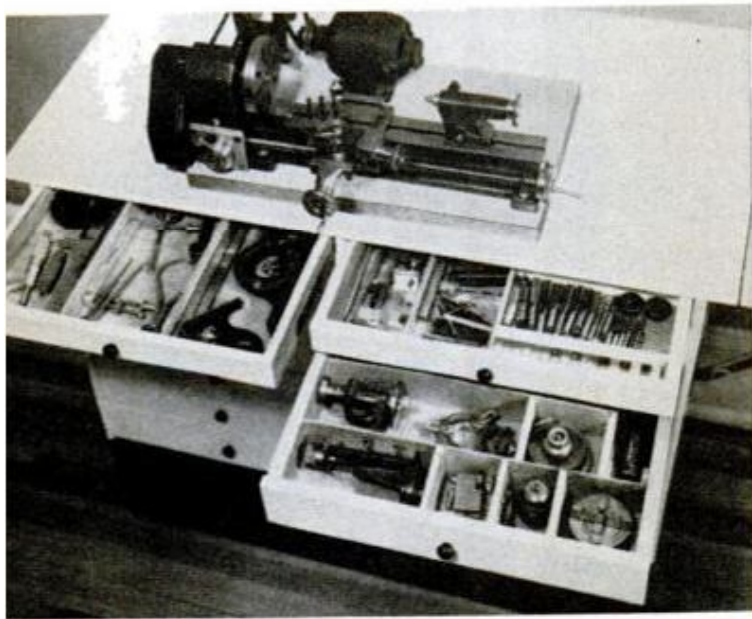

DRAWER CONSTRUCTION is simple as shown in drawing below. Partitions suit the owner's tools

	A	B
TOP DRAWER	1-1/2"	1-1/8"
SECOND DRAWER	2-1/2"	2-1/8"
LOWER DRAWERS	3"	2-5/8"

1/8 x 13-1/2 x 15-1/4"
DRAWER BOTTOM,
LET INTO
DADOS

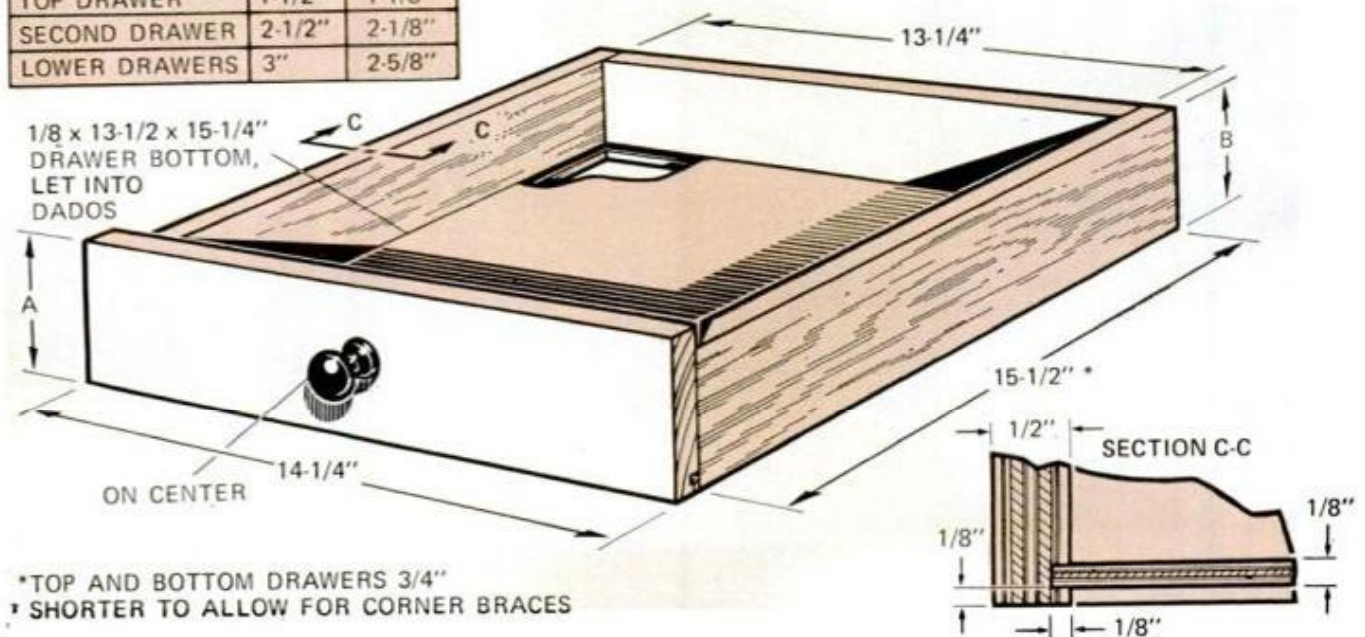

*TOP AND BOTTOM DRAWERS 3/4"
SHORTER TO ALLOW FOR CORNER BRACES

pearance. Rip 5/16-in.-sq. strips to use as drawer slides on the sides and center divider. Fasten the strips with glue and brads.

The drawer sides, fronts and backs are also cut from 1/2-in. plywood with a 1/8 x 1/8-in. groove dadoed in 1/8 in. from the lower edge to receive the bottoms. Take drawer dimensions from the cabinet. Assemble the drawers and drill the fronts for the knobs. Add partitions and dividers to the drawers to suit your lathe accessories and tools.

Use butt hinges to attach the door to the bottom shelf so it swings down to close the large bottom compartment. Use 8-in. folding shelf brackets and another pair of butts as shown to attach the drop leaf. Put 1/2-in. half-round molding around the top and drop leaf. If you have the space, a drop leaf could be fitted to the other end also. Cover the top and drop leaf with plastic laminate. The cabinet receives a coat of enamel undercoater followed by a durable semigloss enamel.

Modelmakers who build engines and similar projects will require the use of a small metal-cutting lathe. The one shown is a British lathe built by Perris Engineering Ltd. and imported by Caldwell Industries, Box 170, Luling, Tex. 78648. It sells for \$300. A full range of accessories is available for this back-gearred, screw-cutting lathe which measures just 18½-in. long. It is capable of handling a workpiece 9-in. long between centers and has a 4¾-in. swing in the gap and a 3½-in. swing over the bed. ★★★

HINTS FROM READERS

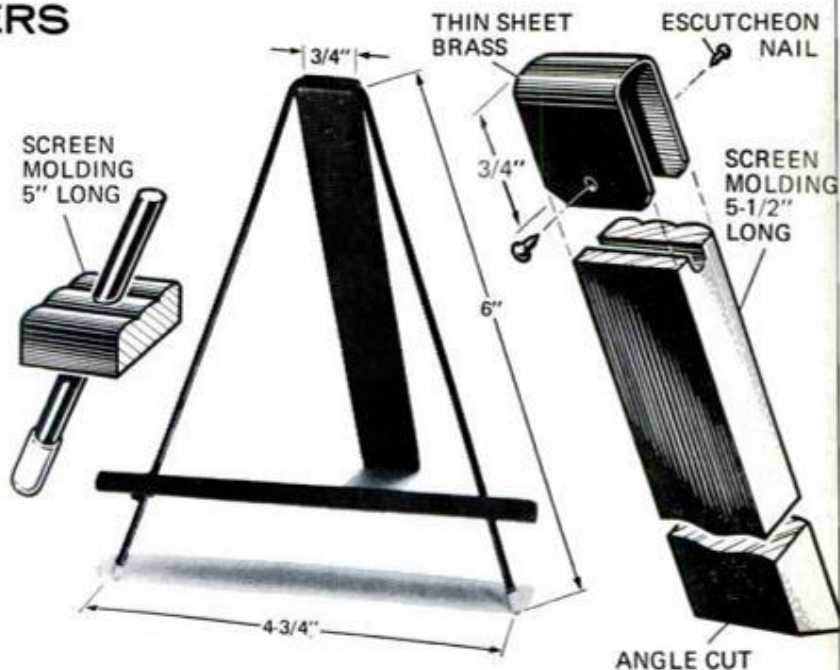
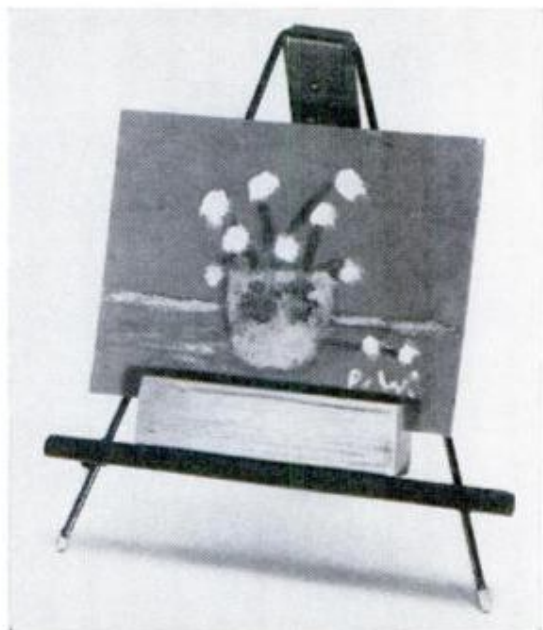

Miniature easels easily made from screen molding, sheet brass and wire

Having need for a dozen or more small easels to hold nameplates and postcard paintings, I mass-produced them from screen molding, coathanger wire and sheet brass. Holes for the wire are made a tight fit, and the support leg is hinged with a U-shaped clip so that the leg can be adjusted to the desired angle. When not in use, the easels can be folded flat.

—Henry Stainken, Staten Island, N. Y.



Substitute for layout dye

For an occasional job of marking and scribing metal, I have found that a felt-tip marking pen makes a good substitute for regular layout dye. You can scribe it when it dries and it wipes off easily with a lacquer thinner.

—Doug Blodgett, St. Charles, Mo.

FEBRUARY 1972



Support for tall potted plant

A philodendron grew so tall that supporting it became a problem; soil in the pot wouldn't hold a stake. I welded three metal rods (one 24-in., the others 12-in.) to an 8-in.-dia. steel plate as shown above, removed the plant from the pot, put the welded affair in the bottom and repotted the plant. I stuck lengths of bamboo fishing pole over pointed ends of the rods and changed to longer lengths as the plant grew.—G. H. Willard, Seattle.

127

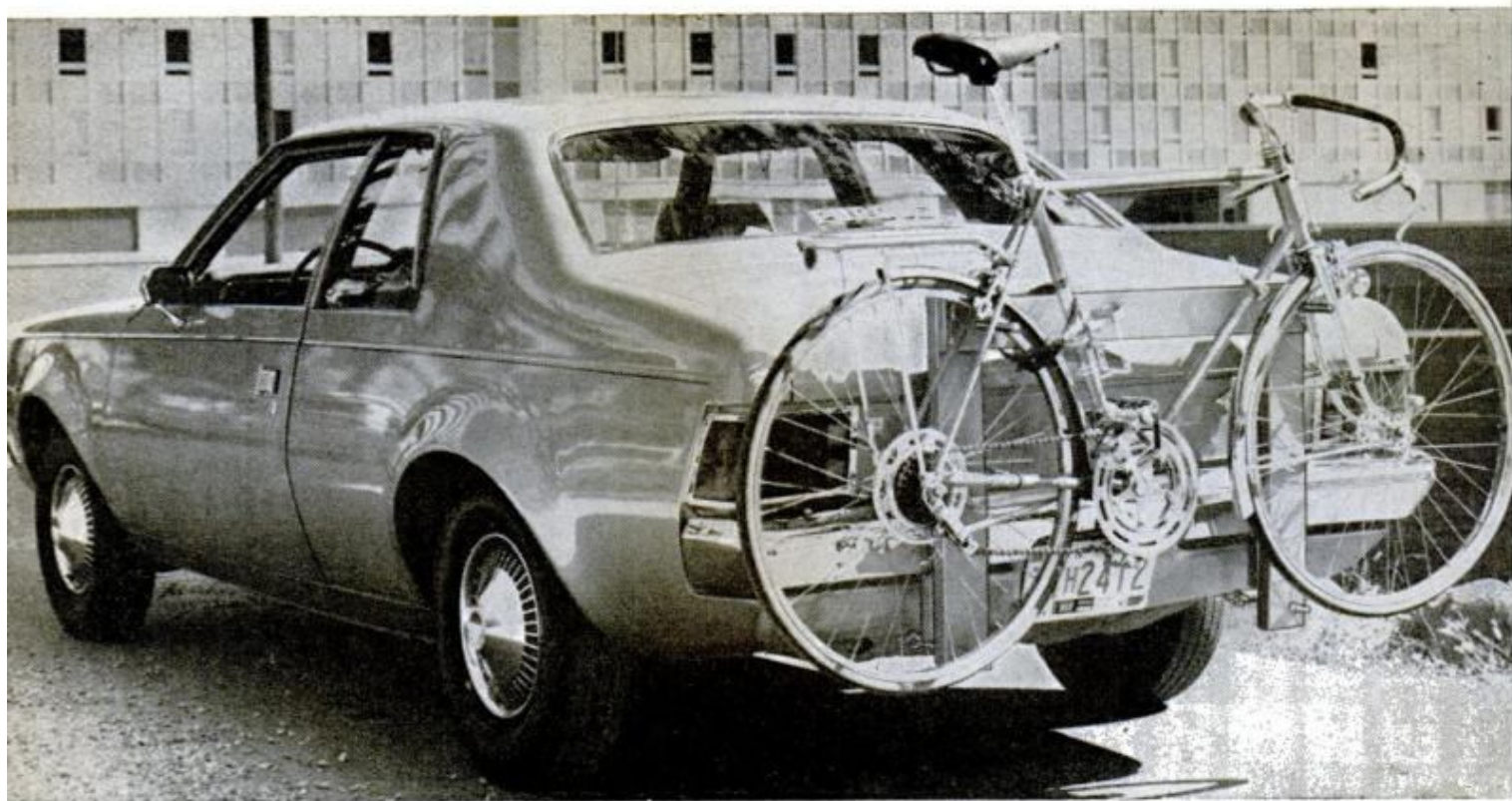

Car-bumper bike rack

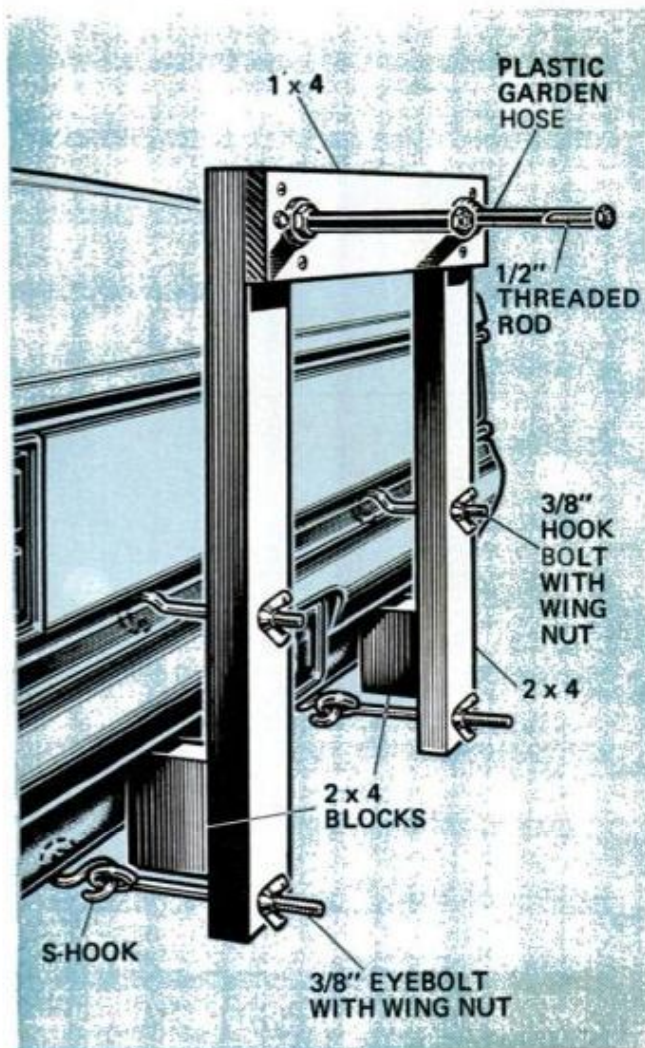

WITH A RESURGENCE in bicycling interest, you often see people carrying bikes—usually stuffed in the trunk with the lid tied down—to the local repair shop or with them on a vacation trip.

To make it easy to carry a bike, I decided to make the rack shown above. Its simplicity of design lets you attach the sturdy carrier to the rear bumper without using any tools. It consists of two uprights, a 1x4 crosspiece and about \$4 worth of hardware. The exact dimensions will depend upon the car and the style bike to be hauled.

The crosspiece is fastened to the uprights with glue and screws. Then the carrier is secured and supported by two hook-bolts that pass through the uprights and hook over the bumper. Wood blocks must be fastened to the bottoms of the uprights. These bear against the lower part of the bumper and can be contoured if desired. The lower hooks catch behind the rear sheet metal or lowest edge of the bumper. The hooks are a combination of an S-hook, long eyebolt and wingnut. Clinch the S-hook so it won't get lost. The bike is supported under its wheel rims by the two studs at top. Lash it in place using straps and a lock.—Peter F. Dexter

HINTS FROM READERS

'Bell clapper' helps cut bottle

A steel ball swinging on a cord, like a clapper, can be used to cut a bottle neatly in two. Solder a wire loop to a $\frac{5}{8}$ -in. cold-rolled steel ball and affix a length of cord to the loop. Fasten the other end to a cork that fits the bottle. After scoring the bottle outside with a glass cutter, gently swing the ball so it strikes the mark.

—B.W. Ervin, Kent, Ohio

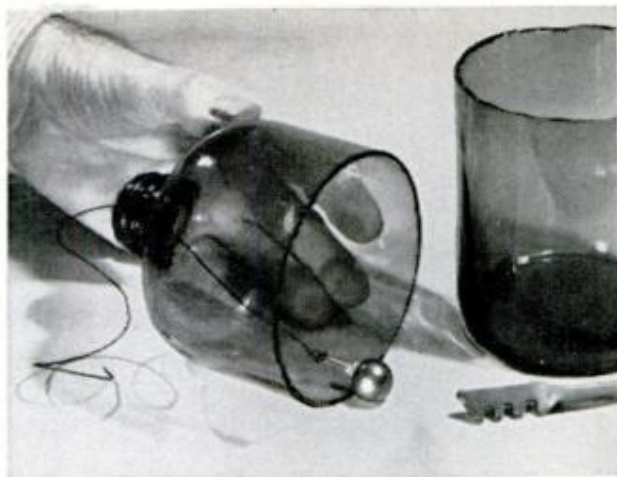

Taper reamer eases pipe taps

Next time you have to tap through-holes for $\frac{1}{8}$ or $\frac{1}{4}$ -in. pipe threads, try this stunt for surer starts and deeper cuts, with resulting leakproof joints. Start by reaming the holes lightly with a taper reamer, but be sure to ream only three or four threads deep since the taper will not match exactly the taper of the pipe threads. I've used the idea often with great success. It should work for anyone after a little practice.

—John F. Pilznienski, Dearborn Heights, Mich.

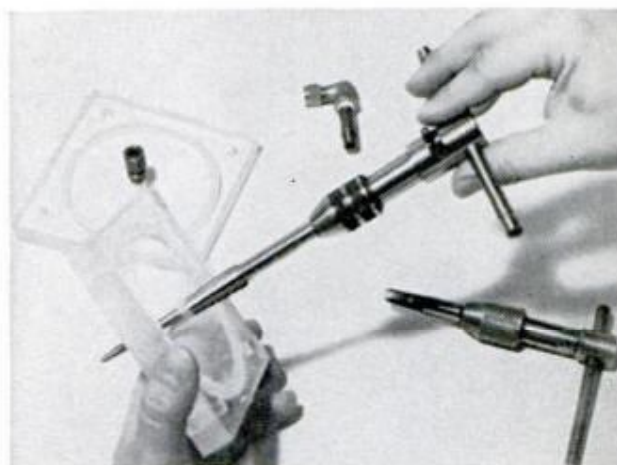

Holding hasp open

Often, when a toolbox is kept locked with a padlock and hasp, the latter can be quite a nuisance when you want to keep the box open. Just turn a screw eye in the lid to hold the hasp leaf out of the way. A quarter turn releases it.

—Jim Rudd, Chicago.



Plastic weights

Neat weights for counterbalancing a mechanism or powering a clock can be made from plastic tumblers with tight-fitting caps. Drill two holes in the bottom for a wire staple and anchor it with concrete.—Walter E. Burton, Akron, Ohio.



Slowing setscrew slip

When a setscrew bears against a flat area on a shaft it may be better not to run the flat all the way to the end of the shaft, especially when the assembly runs in a vertical position, as with the drill press shown.—W. B. May, Oak Park, Ill.



Big banger from Suzuki is water-cooled!

Quiet and quick, the GT-750J Le Mans gets its go from three cylinders displacing 750 cc. Instant Japanese punch —just add water!

By JOHN ETHRIDGE

Photos by David Gooley



SUZUKI'S CHARGE into the superbike field with a water-cooled two-stroke promises to make waves for some time. Anyone remembering Suzuki's 50-cc water-cooled, two-stroke Grand Prix machines will agree that if you want the maximum power possible from a given-size engine, this is the way to go. The last of these produced a reliable 19 hp—better than 6 hp per cubic inch—in the region of 20,000 rpm!

The nature of two-strokes is such that by "stuffing" the crankcase for increased supercharge and altering the ports and exhaust tuning to move the power higher on the rpm scale, seemingly endless increases in power can be obtained. But with an explosion at the top of every stroke and every downward stroke a power stroke, overheating becomes the limiting factor. It's been tried with air-cooled two-strokes, but when taken too far results in a "Dixie cup" engine—the kind you use once and throw away. But with efficient water-jacketing and a radiator, demon heat is dissipated, lowering operating temperature and leaving room for power increases.

In the case of the Suzuki GT-750J Le Mans (doubtless too much of a mouthful for even a bike of this stature), lowering the operating temperature was more of a design objective than was a large power increase. Suzuki claims it runs 30-percent cooler than any air-cooled motorcycle engine, which is quite believable. On the average, it took 15 minutes of running before the thermostat opened and the radiator became warm to touch. But the surest indication that water cooling vastly changes the nature of a two-stroke came

POPULAR MECHANICS

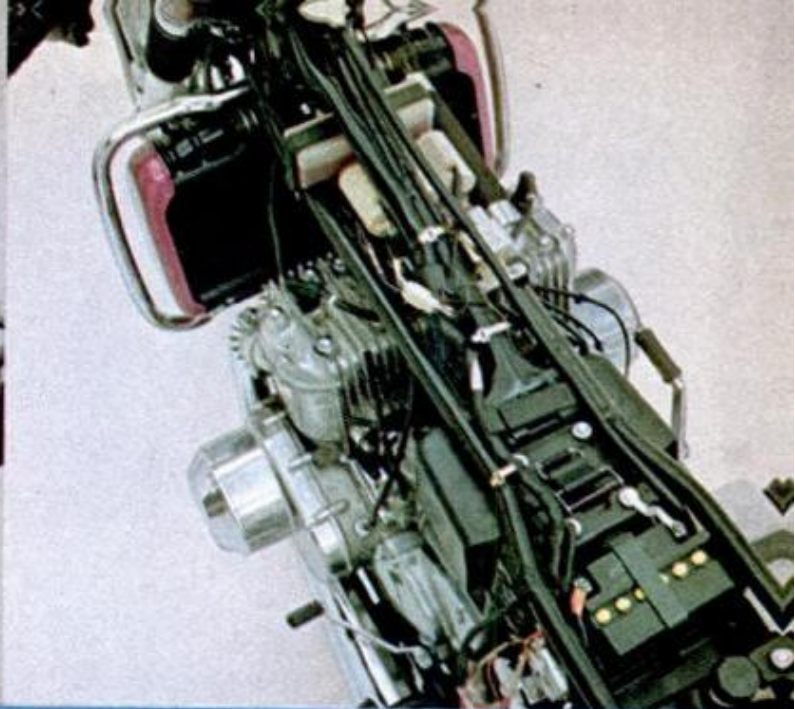
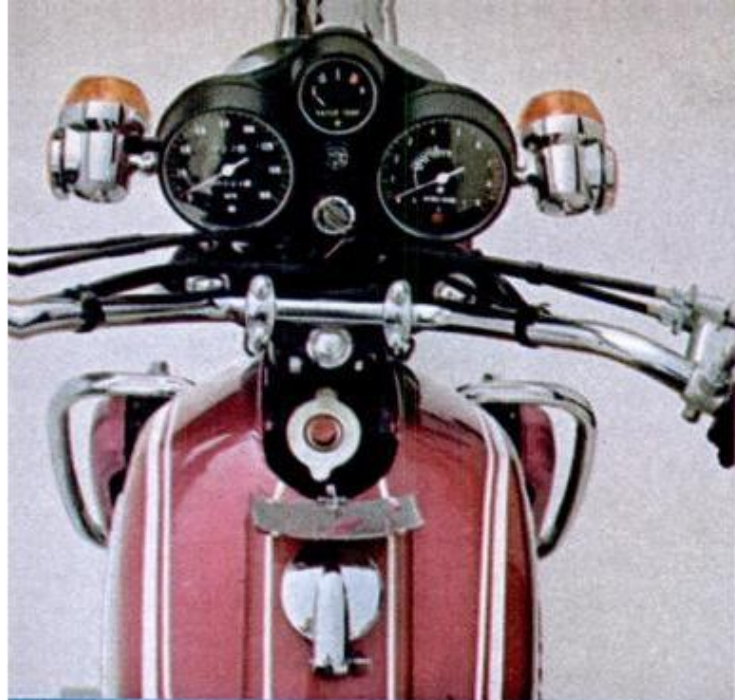

RADIATOR CAP hides under flip-up flap on front end of the four-and-a-half-gallon fuel tank. The five-quart radiator is prominent but protected by sturdy chromed crash bars. Water-temperature gauge is above the tach and speedo. Battery and electrics are packed under the saddle. Small expansion tank for radiator is just behind the radiator filler neck





DUAL FRONT BRAKE is actually two brakes on a common drum. We'd prefer an efficient, simpler disc

during the acceleration test. Contrary to the usual case, the cool-head "Zuke" got faster after a few runs, with the best times always coming after at least three trips through the quarter-mile in quick succession. The thermostatically controlled electric fan never came on during any phase of the test, and according to a Suzuki mechanic, it takes 45 minutes of idling in a closed room to make it come on. This bodes well for desert or mountain touring as well as any future power increases deemed necessary.

As it is, the GT-750 has power to spare for any situation. Wondering where the power would come in ceased as soon as the throttle was cracked a few degrees. It's right there, and smoothly increases as the tach needle wipes the face until the mid-6000 point, marking this engine as a low-ender, which was surprise No. 1.

No. 2 was the eerie quietness of the blatant-looking quartet of exhaust pipes as the engine wound out to redline. This bike is a whoosher, not a screamer, and will appeal to those who like to speak quietly and carry a big stick. It's possible to grab large handfuls of throttle accelerating away from traffic signals and get all of the performance, short of wheelspin, the engine is capable of delivering without attracting attention. The three exhaust headers are interconnected just ahead of where the center one branches into two pipes, neatly combining efficiency, noise abatement and symmetry.

Surprise No. 3, perhaps the nicest of all, was the smoothness and lack of transmitted engine vibration throughout most of the rev range, particularly at cruising speeds, ranking this machine with the best on the road in this regard.

Handling on twisty roads is very acceptable for a bike of this weight, but you can't lean it over to the tire tread limit because the kickstand or the pipes drag. Also, the front brakes—actually two brakes acting on a common drum—really aren't up to this sort of thing. The brakes,

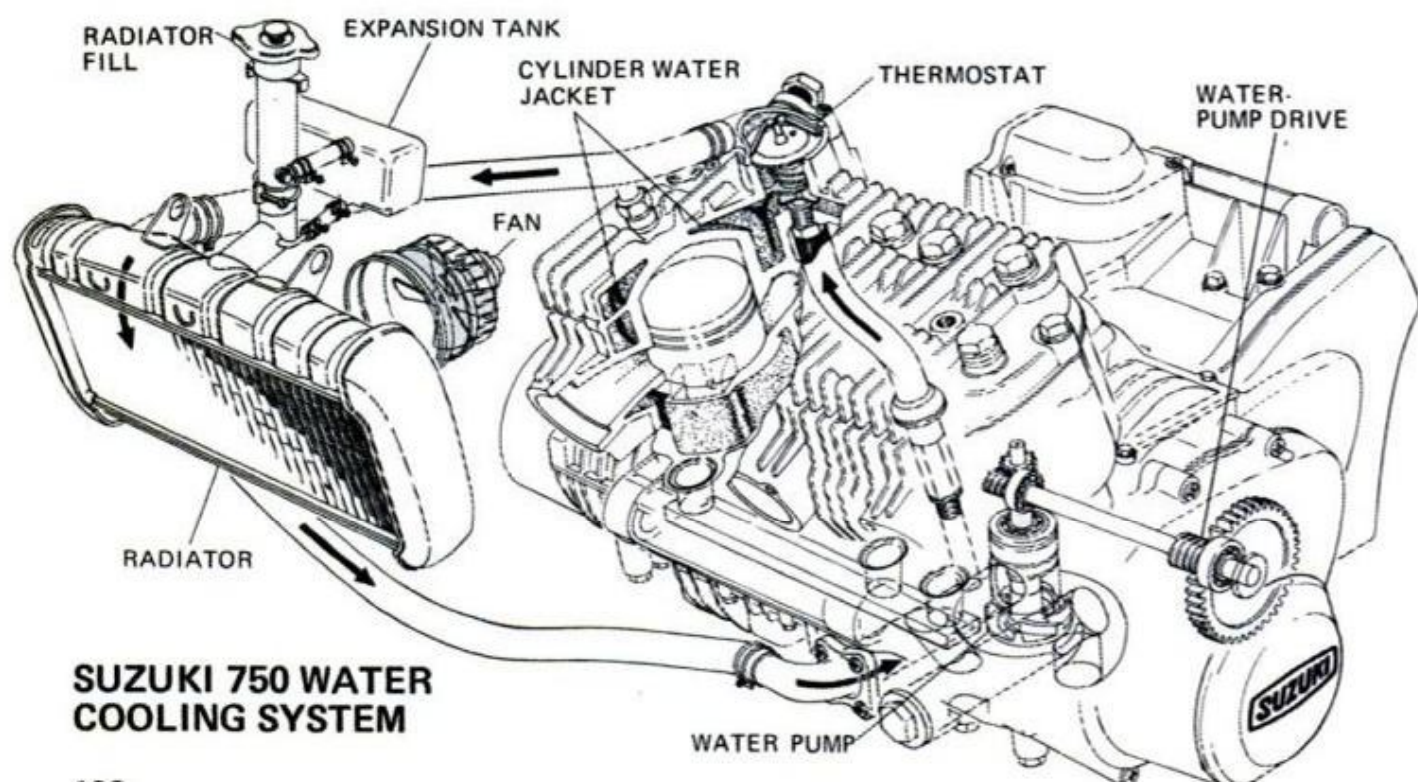

SUZUKI 750 WATER COOLING SYSTEM

however, are adequate for touring, which is what the bike was designed for.

The center of gravity is quite far forward. When on the center stand, it takes a hefty person astride the rear of the saddle to bring the front wheel off the ground. With this weight distribution, you have to try hard to pop a wheelie and there is a strong tendency toward wheel-spin getting off the line. Slipping the clutch quite a bit so there was little or no wheel-spin netted the best acceleration times.

Robust engines call for robust clutch spring pressures, but force required to operate the clutch lever wasn't as brutal as you might expect, considering the

torque it has to handle. Only in stop-and-go traffic did the left hand get a bit tired. Finding neutral on the foot shift proved to be the easiest of any bike we've ridden because of the rather long throws between it and first and second speeds. But for the same reason it's necessary to remember to toe the lever good and hard on the upshift from first to second or you'll often find yourself in neutral.

Another thing to remember about this and other Suzukis is never leave the fuel cock in the "prime" position any longer than it takes to fill dry carburetors or there is risk of fuel getting in the crankcase and creating a hydra-lock. There is

(Please turn to page 178)

SUZUKI GT-750J LE MANS SPECIFICATIONS



PROFILE OF BIKE reveals a center of gravity that is farther forward than that of most 750s. Center exhaust header of three-cylinder machine splits into two for symmetry of two pipes on either side of motorcycle

PERFORMANCE

Quarter-mile acceleration:	
Elapsed time, sec.	13.23
Speed, mph	100
Top speed, mph	115

ENGINE

Type .. water-cooled, 3-cyl., 2-stroke, piston valve	
Bore and stroke, in. (mm) ...	2.76 x 2.52 (70 x 64)
Displacement, cu. in. (cc)	45 (738)
Compression ratio	6.7:1
Horsepower @ rpm	67 @ 6500
Torque, ft.-lb. @ rpm	55.7 @ 5500
Ignition system ...	battery, triple coils and points

TRANSMISSION

Type	5-speed, constant mesh, return
Pattern	1-N-2-3-4-5
Internal ratios:	
1st	2.846
2nd	1.736
3rd	1.363
4th	1.125
5th	0.923
Reduction ratios:	
Primary	1.673
Final	3.133
Overall (in top gear)	4.84

Mph per 100 rpm in top gear	16.0
Clutch	wet, multiplate

FRAME AND SUSPENSION

Front suspension	telescopic, 2-way
Rear susp. ...	swingarm, adj. 2-way spring/shock
Frame	double cradle tubular steel

WHEELS AND BRAKES

Tire size, front	3.25-19
Tire size, rear	4.00-18
Brakes, front. drum, 2-panel, double leading shoe	
Brakes rear	drum
Brake size, in., front	7.75 dia.
Brake size, in., rear	7.00 dia.

DIMENSIONS AND WEIGHT

Length, in.	88.5
Width, in.	33.0
Height, in.	45.0
Wheelbase, in.	58.2
Test weight, lbs.	526

CAPACITIES

Fuel, gal., including .5-gal. reserve	4.5
Engine oil, qts.	1.9
Gearbox oil, qts.	2.3
Coolant, qts.	5.0

PRICE AS TESTED	\$1575
-----------------------	--------

Cook where the fun is...

... in living room or family room with this portable electric grill. A 'porthole' in the outside wall vents cooking odors outdoors

By WAYNE C. LECKEY, Home and Shop Editor

Photos by Robert D. Borst



HIDDEN UNDER FOLD-OVER TOP, grill masquerades as handsome piece of furniture when not being used

FOR PERMANENT INSTALLATION, grill can be placed in your kitchen counter (see page 152, Dec. '70 PM)

WHEN YOUR GUESTS are having a ball and you're slaving over a hot stove in the kitchen, entertaining friends is not all fun. With this electric grill-on-wheels the host can join the fun from the start and charbroil mouth-watering steaks right in the center of the party.

The drop-in grill is the same one we told you about earlier (See *Now: Cookout Fun Indoors Anytime!*, page 152, Dec. '70 PM), only this time you install the grill in a smart roll-about cabinet (which we show you how to build) rather than in a kitchen counter.

To enjoy this exciting, modern indoor cooking, you roll the cabinet up to a "porthole" in an outside wall, connect the grill to it with a 24-in. flexible duct and plug the cord into a 240-v. outlet. In seconds you have 2800 watts of clean radiant heat which will charbroil steaks, hamburgers, hot dogs, fish or fowl faster than an outdoor grill. A powerful below-the-surface fan pulls smoke and fumes directly into the exhaust system without a trace in the room.

The grill is made by Jenn-Air Corp., 3035 Shadeland Ave., Indianapolis, Ind. 46226, and has a suggested retail price of \$235 at Jenn-Air dealers. (It may be slightly higher in some areas.) Besides including a cast-aluminum nonstick griddle, the grill features a lighted fan switch and grill pilot light, a built-in timer and a convenience outlet.

There are several gourmet accessories you can add, including a rotisserie, shish kebab and french fryer. A kit of parts for wiring and ducting the grill outdoors is

YOU CAN HAVE GUESTS over for a "cookout" in the middle of winter with this elegant flip-open grill. When vented outside and plugged in as shown at the right, you can char-grill succulent steaks indoors in a party atmosphere without smoke or cooking odors

POPULAR MECHANICS





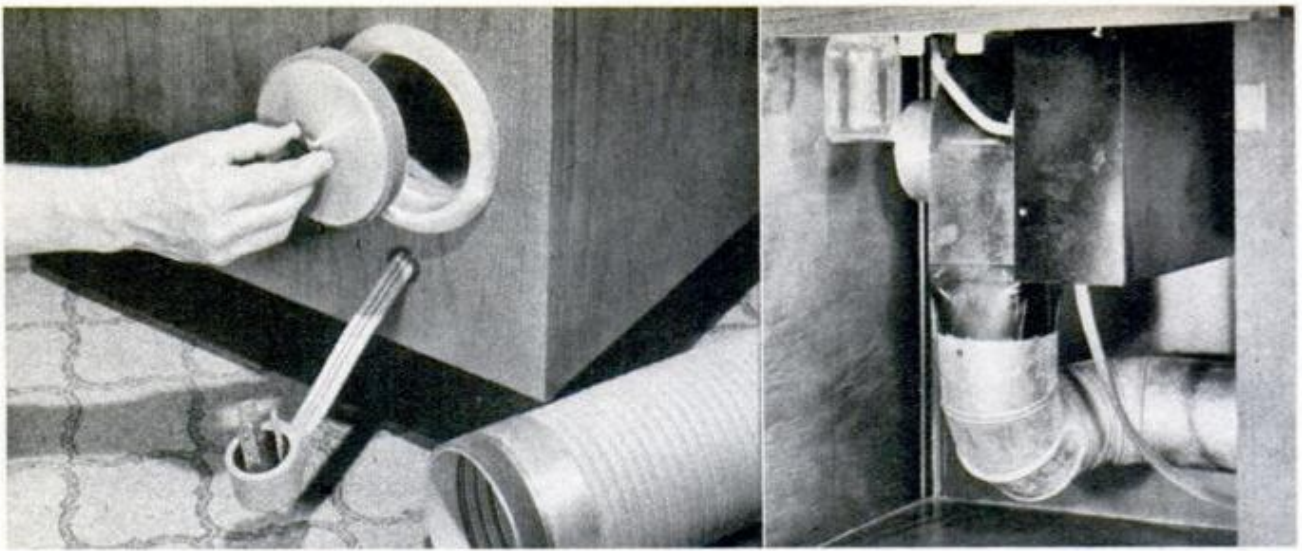

SNUG-FITTING CAP (above) plugs duct hole in cabinet when grill is not used. Interior view (right) shows how the grill blower is piped outside of cabinet with two 5-in.-dia. galvanized furnace-pipe elbows

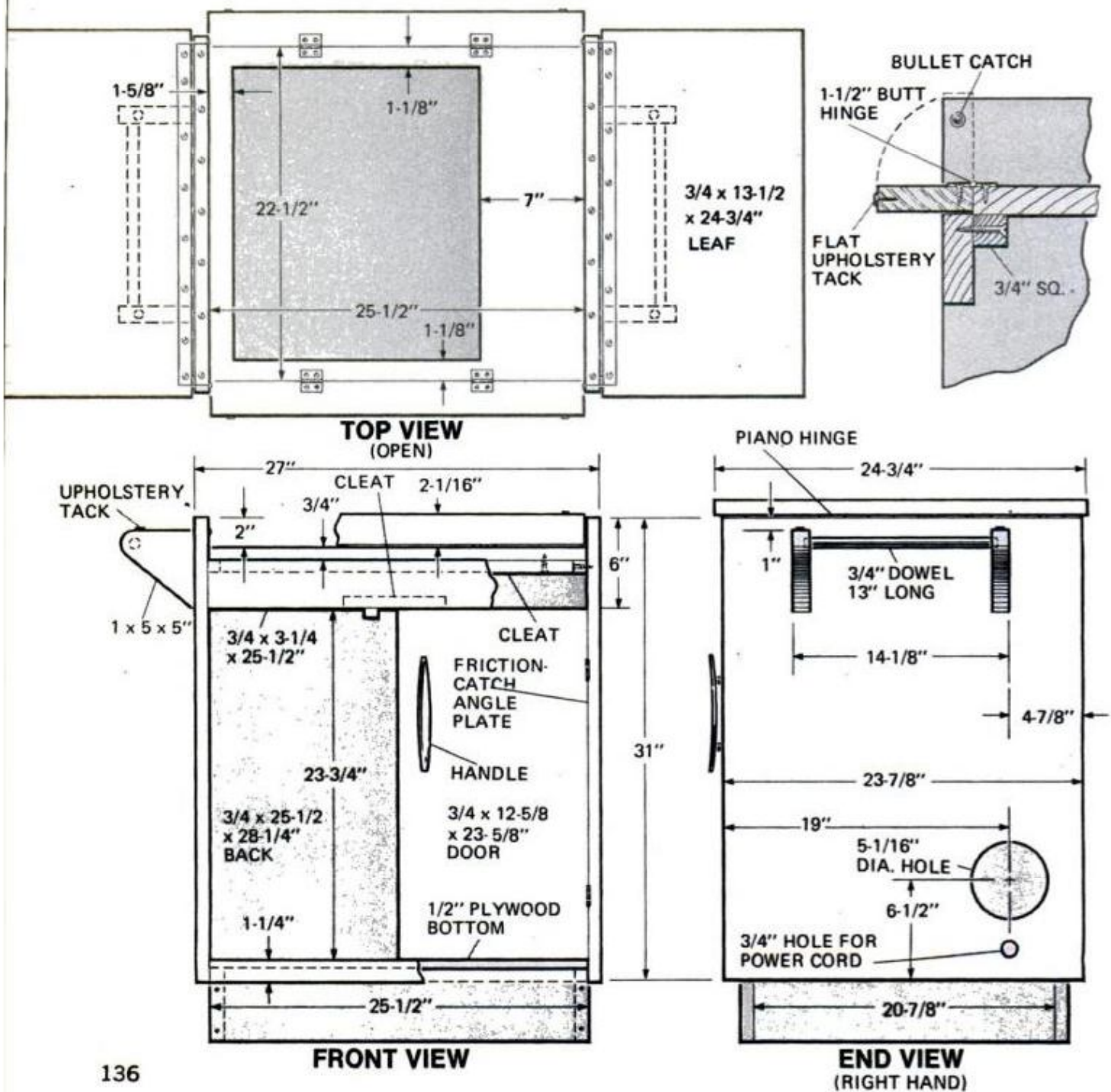

available from Jenn-Air for \$23 postpaid.

When the grill is not in use, snug-fitting caps plug the exhaust ports in both the wall and cabinet. The duct and cable store inside and the cabinet top folds shut to hide the grill.

The boxlike design of the handsome Danish-modern cabinet helps simplify construction. It's made entirely of oak-veneer plywood, (stained dark brown) except for the black-painted base and the bottom shelf. Butt joints are used for the most part and reinforced on the inside with square blocks glued in the corners. Both ends are the same size, but right and

left-hand, with a 5-in.-dia. hole being cut in the right-hand one. Both are blind-grooved on the inside at the front for the bottom crossrail. The back butts between the ends, as do the grill cutout, the 3 $\frac{3}{8}$ -in. crossrail and the bottom. The storage section of the cabinet is fitted with twin doors and equipped with suitable pulls and magnetic catches.

The two-piece top is joined with piano hinges and supported when open by handles on the ends of the cabinet. Flip-down aprons hinged to the grill cutout, front and back, support the top when closed;

(Please turn to page 172)

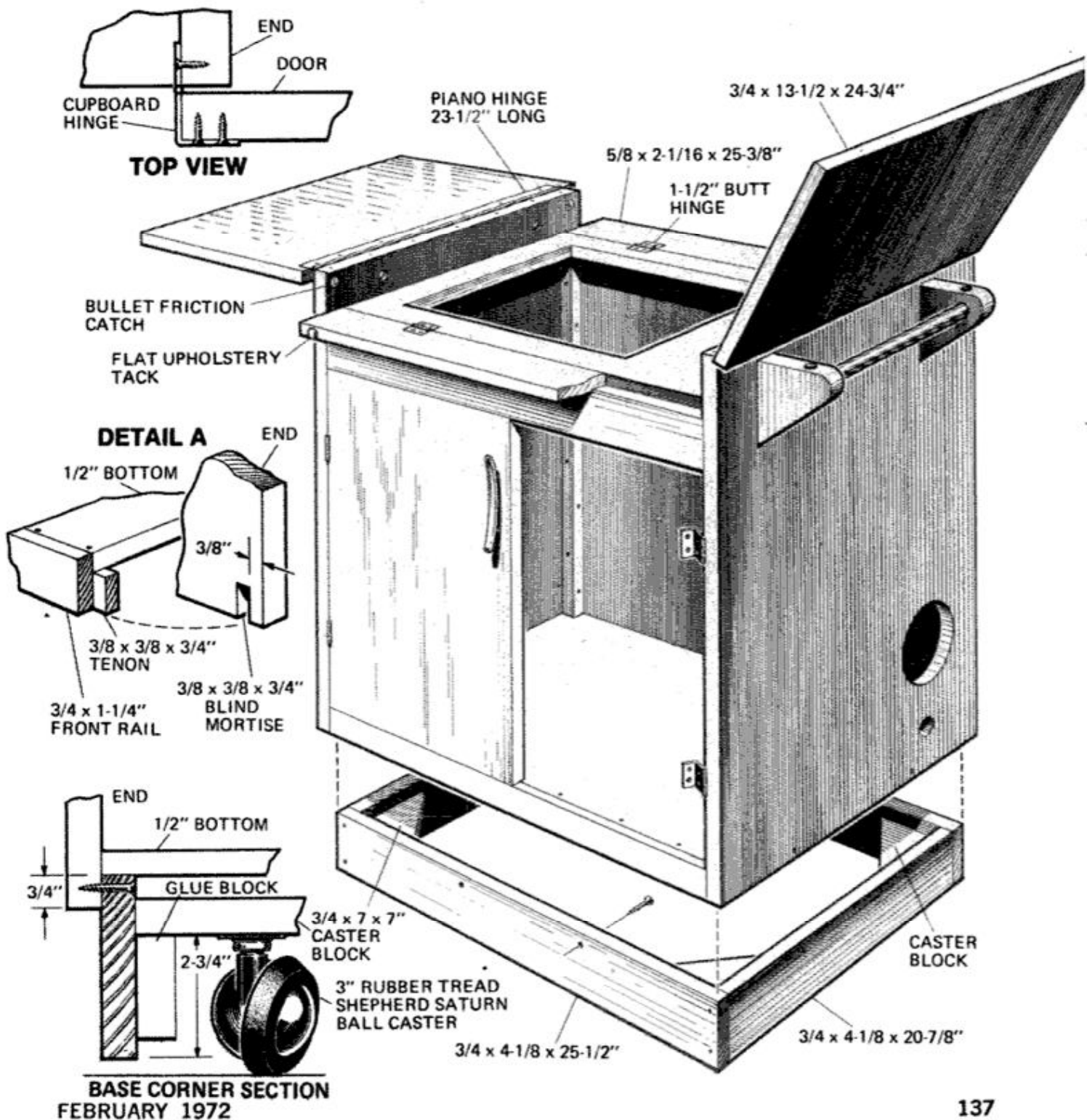

A little colonial charmer you can build for \$45

By WAYNE C. LECKEY, Home and Shop Editor

Photos by Robert D. Borsl/Cabinetry by Everett Johnson



SERVING ORIGINALLY as a place to wash and to store a porcelain water pitcher and bowl, the charming colonial dry sink of yesteryear continues to be a graceful and useful piece of furniture some hundred years later.

Today it provides a perfect place to display your indoor plants; it has two roomy drawers felt-lined for silverware and there is ample storage below for linens behind two raised-panel doors.

We built the little beauty you see here for about \$45 from common pine which you can buy at any lumberyard. Its authentic design makes it a collector's item, and its simple construction makes it a natural for the home craftsman to duplicate.

The ends require pieces which measure 17½ in. wide. Since you can't buy pine this wide, you will have to glue and dowel several 1x8 (¾ x 7½ in.) boards together. With the possible exception of the doors, the ends are the only members you will have to build up. The wide pieces for the sink top, shelf, bottom and back are cut from plywood. Both ends are worked as right and left-hand members when you run the dadoes across the inside, cut the rabbets for the plywood back and rip the set-back edges at the front. The latter is done on your table saw to assure a straight cut. Here the work is ripped ¾ in. in from the edge for a distance of 26½ in., then

backed off and the stopped cut is finished by hand. Notice that the ¼-in.-wide rabbets along the rear edges are made ¾ in. wide for a distance of 7 in. down from the top.

The scroll design at the top of the ends is cut with your sabre saw, then both inside and outside edges are antiqued (distressed) by rounding and sanding.

When you have the sink top and bottom plywood members cut to size, you can glue them in the dadoes of the solid-pine ends. Use long clamps if you have them and check the assembly with a square before setting it aside.

While the glue is drying, make the scroll-cut member for the back. This is cut from a 1x10 pine board to rest in the ¾-in. end rabbets previously made and has a rabbet cut along the bottom edge to fit over the sink top. Round and sand the edges of the scroll as you did the ends and then glue and nail the piece in place, driving the nails from the back.

Next, make the framework for the front. This is a separate unit made from ¾-in.-pine strips to fit flush with the ends of the cabinet and even with the top surfaces of the sink top and bottom. Butt, dowel and glue the joints; if you have clamps, use them to pull the joints together. When the framework is completed, glue it to the cabinet.

Now you can add the scroll-cut base to

REAR VIEW shows how back panel is cut to provide "legs" that support corner glue blocks on the inside

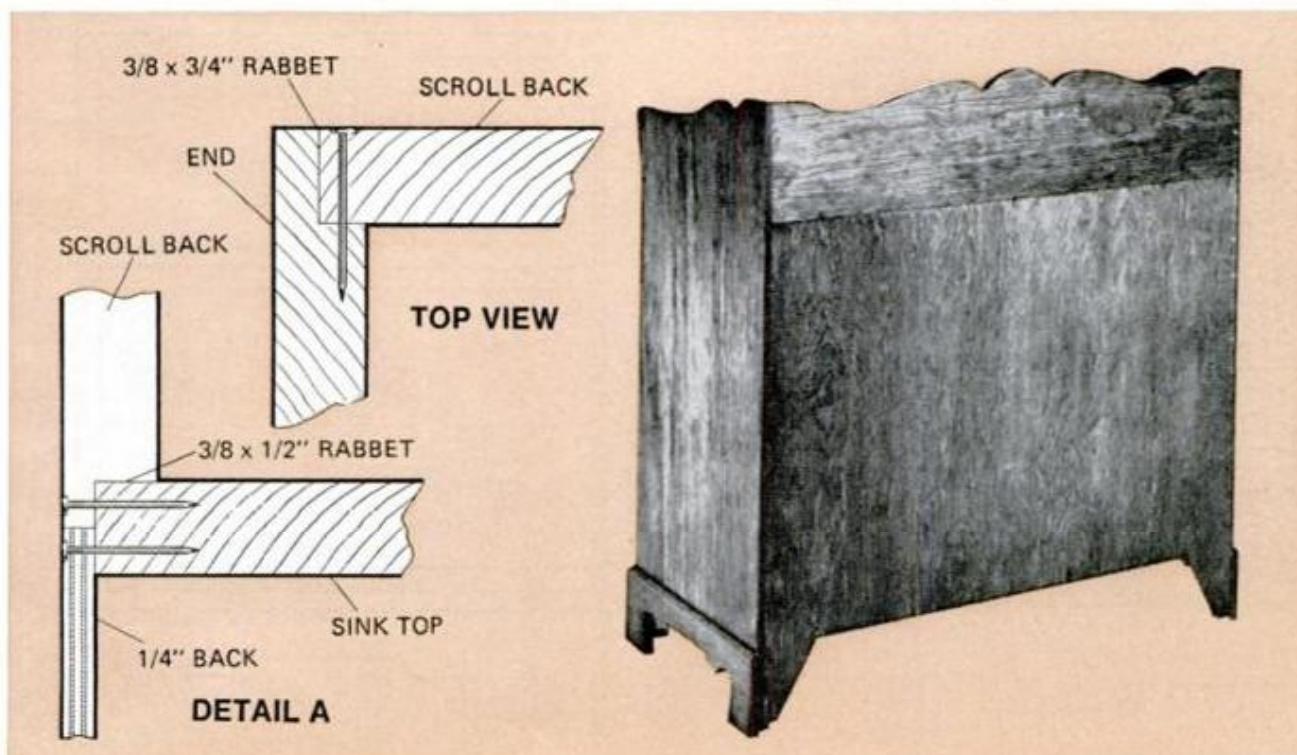

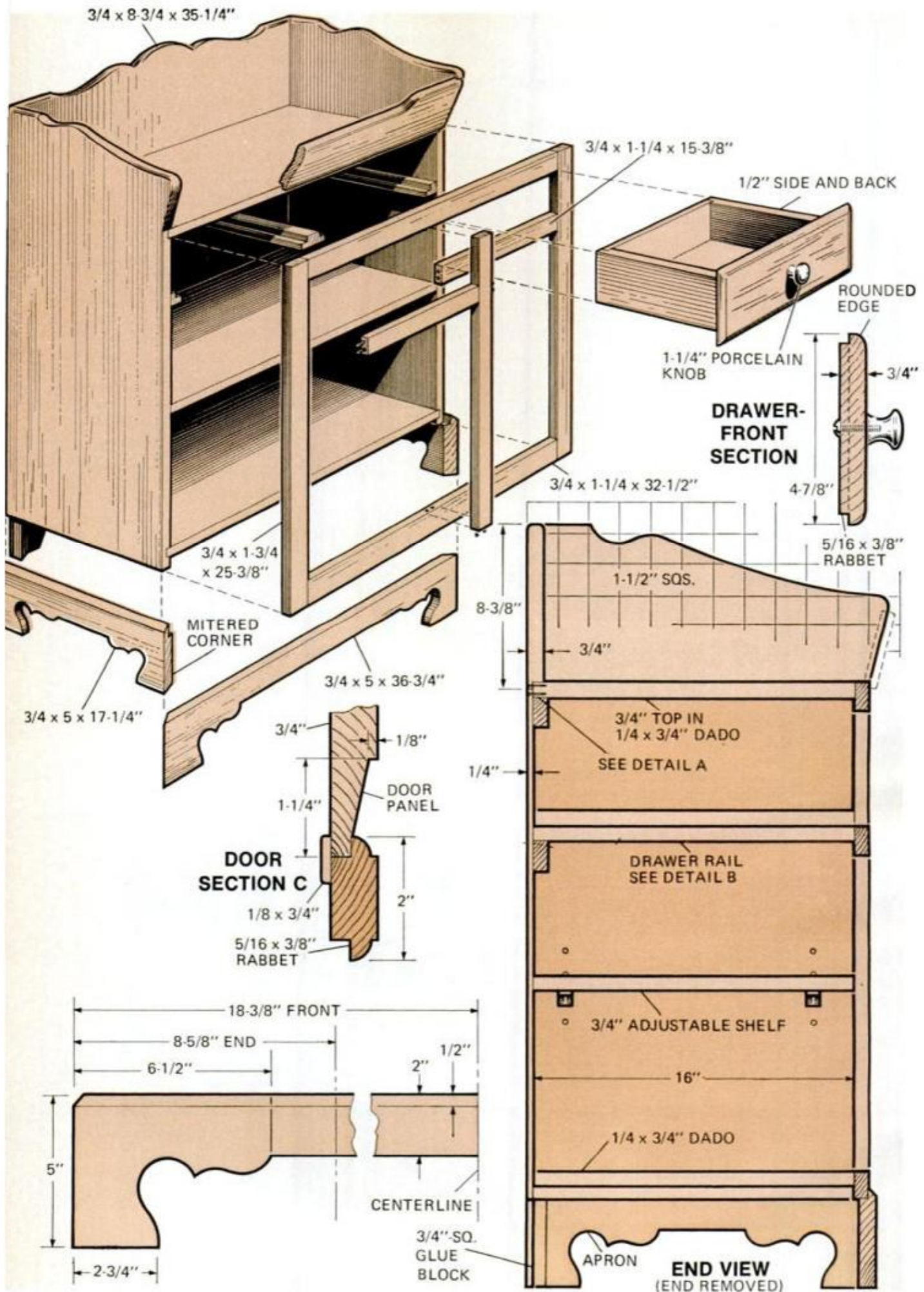

the front and ends. Rip a board long enough to make the three pieces, rabbet one edge so it will lap the base and bevel the outer edge as shown. The pieces are mitered at the front and sawed off even at the back. Attach the members with glue and screws from the inside.

A 1/4-in. back is added to the cabinet next. Notice that it has "legs" at each side

which continue past the sink bottom. The legs provide support for the base members at the rear corners. After the back is glued and nailed in place, add glue blocks to these inside corners.

Now you can make the slanting front piece. It is rabbeted along three edges to lap the front frame and the cabinet ends, and

(Please turn to page 180)

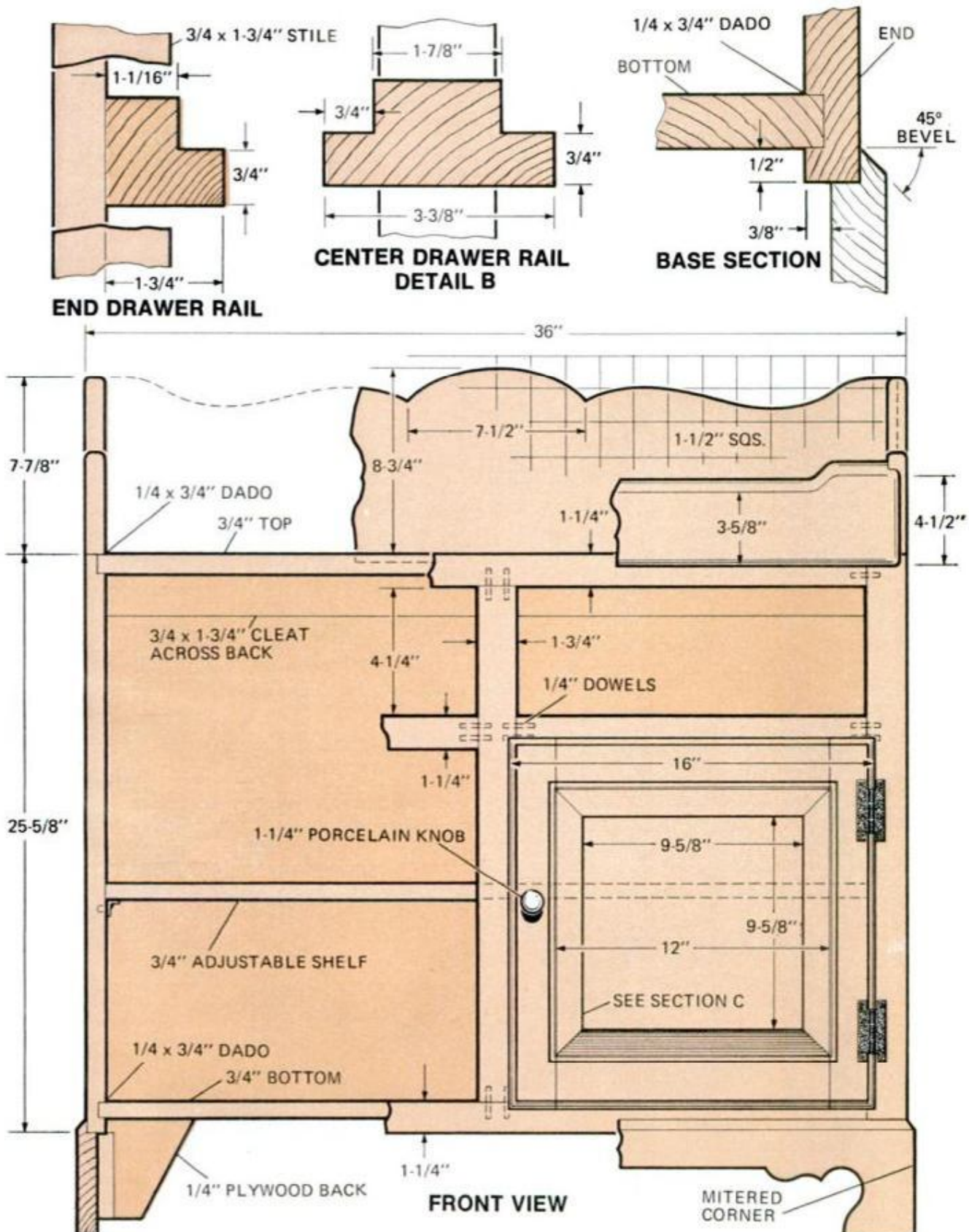

BETTER WAYS TO DO IT!

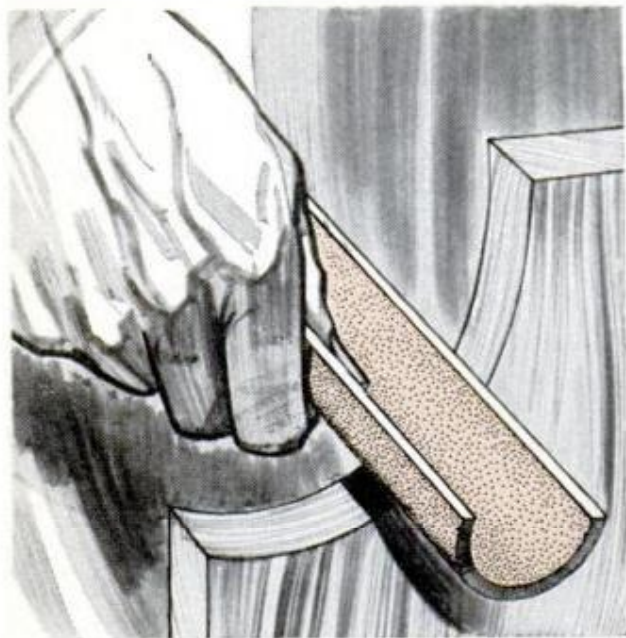

CONVEX AND CONCAVE PROFILES are easy to sand if you cement sandpaper to both sides of a piece of garden hose slit in half lengthwise. The flexible hose adapts readily to curves.—*Frank Shore, New York*

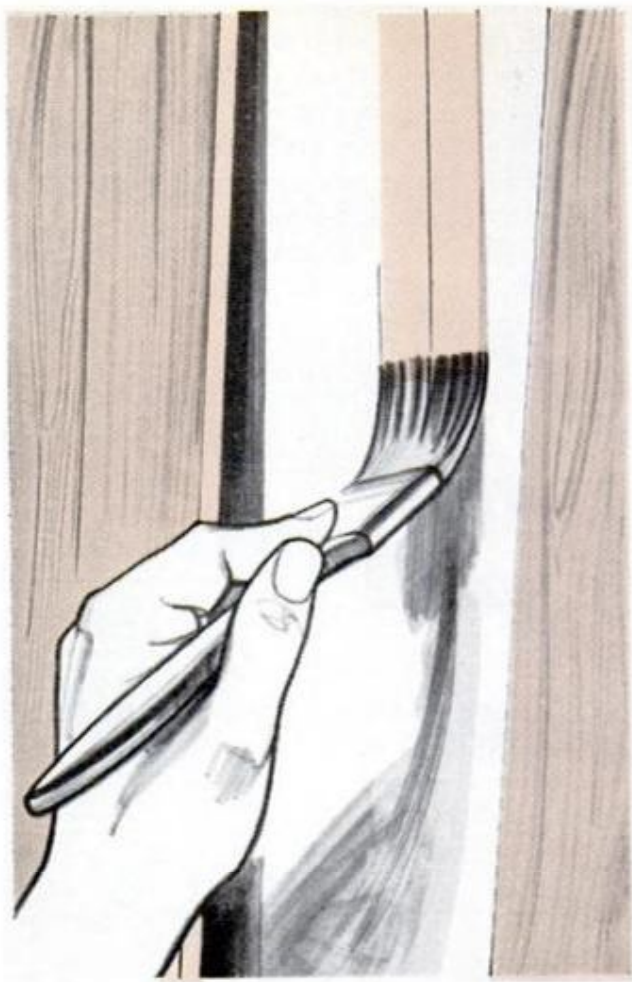

BEFORE PANELING over plaster, run paint stripes down the wall where the 1/4-in. panels will butt, so wall won't show should panels shrink. Color should match panels.—*Mitchell Feldman, New Hyde Park, N.Y.*



FOLDED TROUSERS will stay on wooden hangers if you try this trick. Simply rub on a coat of silicone cement or liquid rubber. After the liquid dries, you'll have a nonslip surface.—*R.S. Tupper, Canton, S.D.*

142



KEEP YOUR EYEGLASSES SLIP-PROOF by adding a strip of adhesive-backed foam material to the bows. Since you need little material, the strips can be renewed as necessary.—*Harry Radzinsky, Charlotte N.C.*

POPULAR MECHANICS

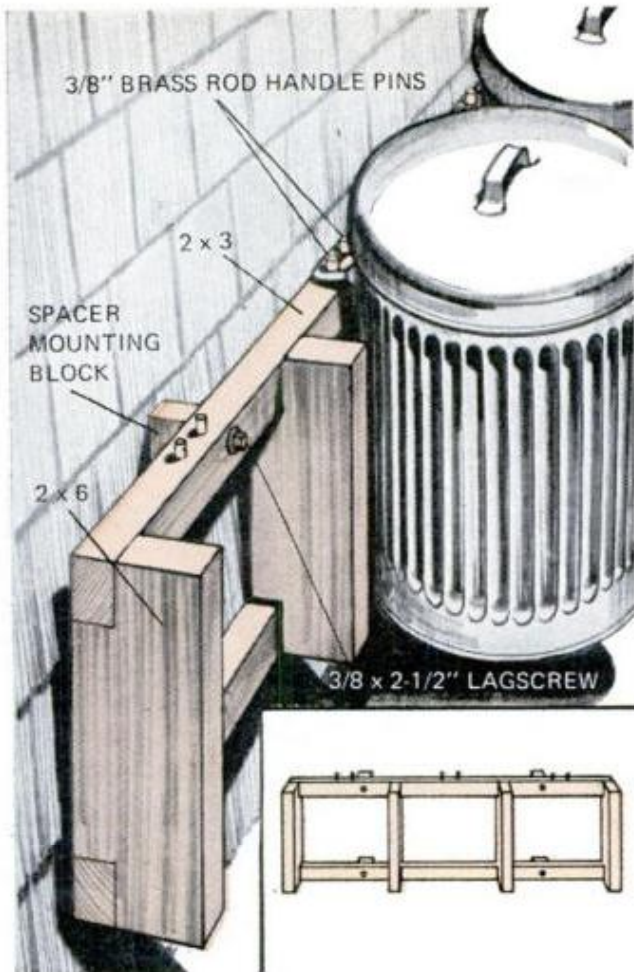

TRASH-CAN RACK, if built as shown and installed on the side of a garage, will eliminate the messy problem of your trash and garbage being upset by animals or the wind.—*W.J. Therrien, Amesbury, Mass.*

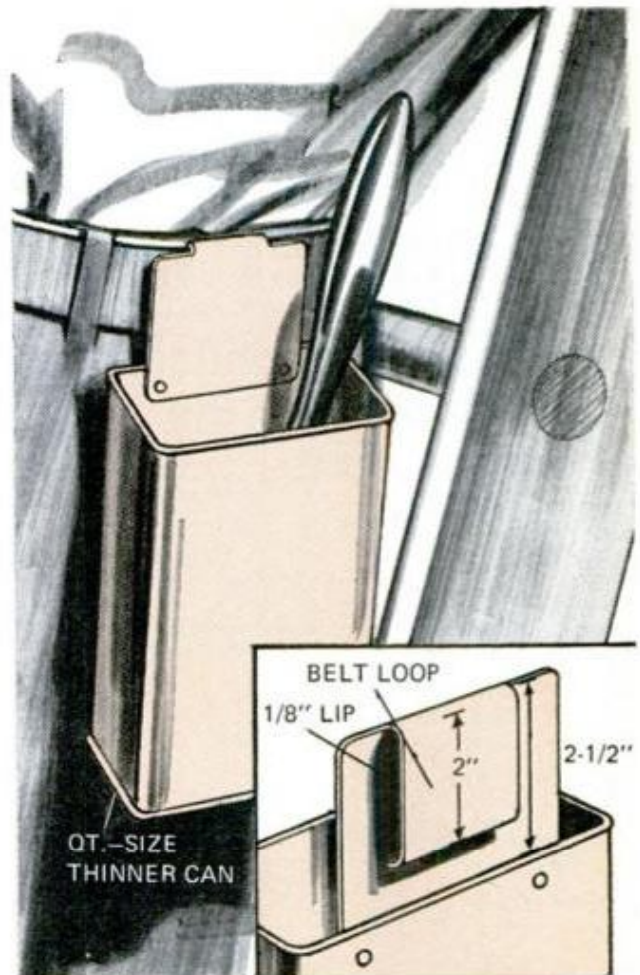

HANDY PAINTBRUSH HOLDER can be made from a used quart thinner can for use when you work on a ladder. Cover any sharp edges with electrician's tape to prevent cuts.—*Al H. Nefzger, Elk Mound, Wis.*

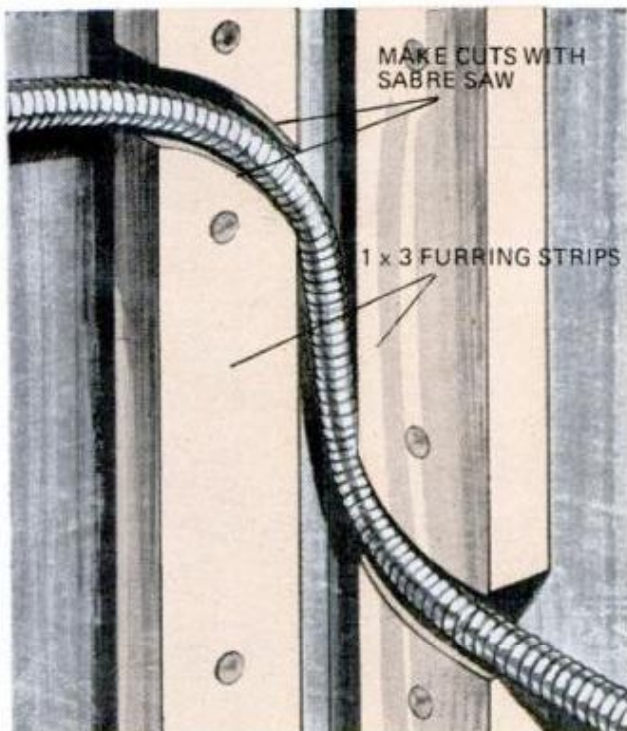

TO INSTALL BX CABLE at inside corners on the face of a furred wall, notch the furring as shown; then cover the cable with safety (metal) plates nailed to the furring.—*Wallace H. McClay, Pasadena, Calif.*
FEBRUARY 1972



WHEN ROOFS BLEW OFF a few neighbors' patios, I decided to make mine more secure by pouring post-anchoring footings as shown. The trick has worked and our roof is intact.—*George Oxford, Boise, Idaho*

This radio-controlled model flies on CO₂

The fuel is nonflammable and odorless, and the model emits no more than a buzz in flight.

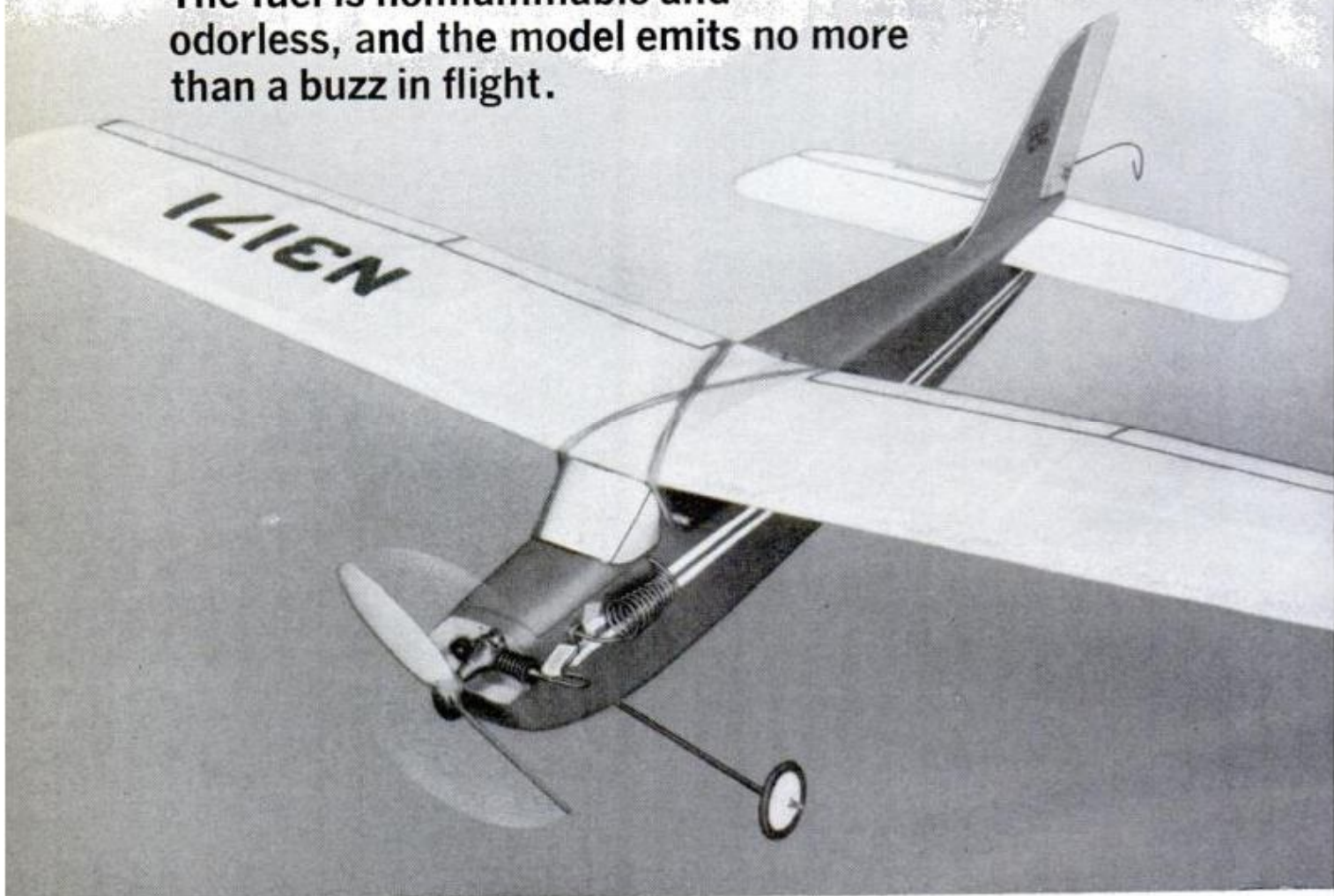

By **HOWARD G. McENTEE**

Technical Art by Fred L. Wolff

WHETHER YOU CONSIDER yourself a typical, experienced model-builder, or are an "ace" at local model plane meets, you might like to add this little engine-driven plane to your squadron.

- You can fly it just about anywhere. Its powerplant is scarcely louder than a bee.
- Fueling is a simple, odorless operation. There is no smoke problem.
- It's sophisticated but fairly simple to build. (For a still easier job, you can get full-size patterns; see page 148.)

Carbon dioxide gas (CO₂) is the fuel. Under pressure—as it is in the containers

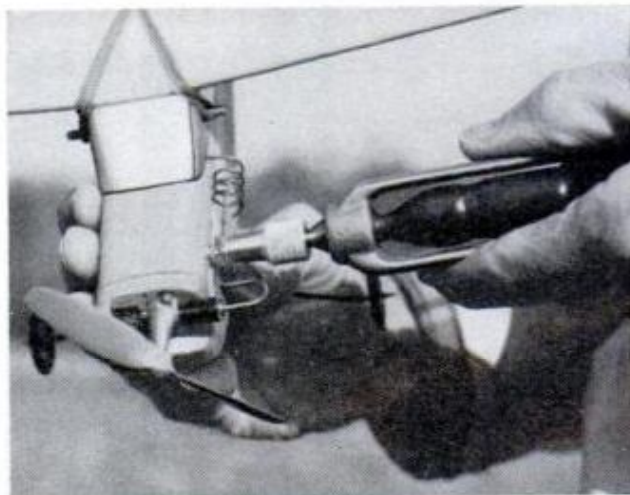

TO FUEL THE TANKS, press cartridge holder against filler tube. Valves open automatically to let fuel in

POPULAR MECHANICS

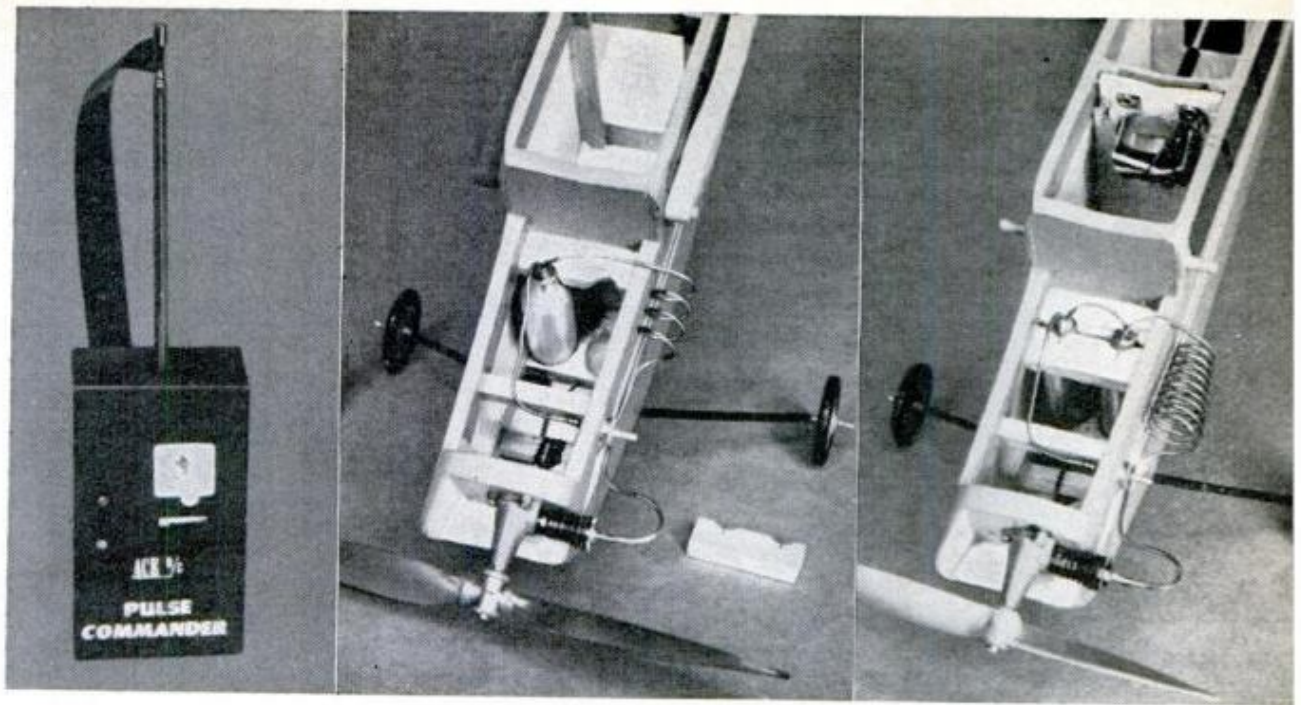

TRANSMITTER (left) used in this model is part of a control system that's too large for this plane; thus, stick works backward here. In free-flight version (center) only one tank is used. Provisions are made for installing two tanks for a complete, radio-controlled version (right)

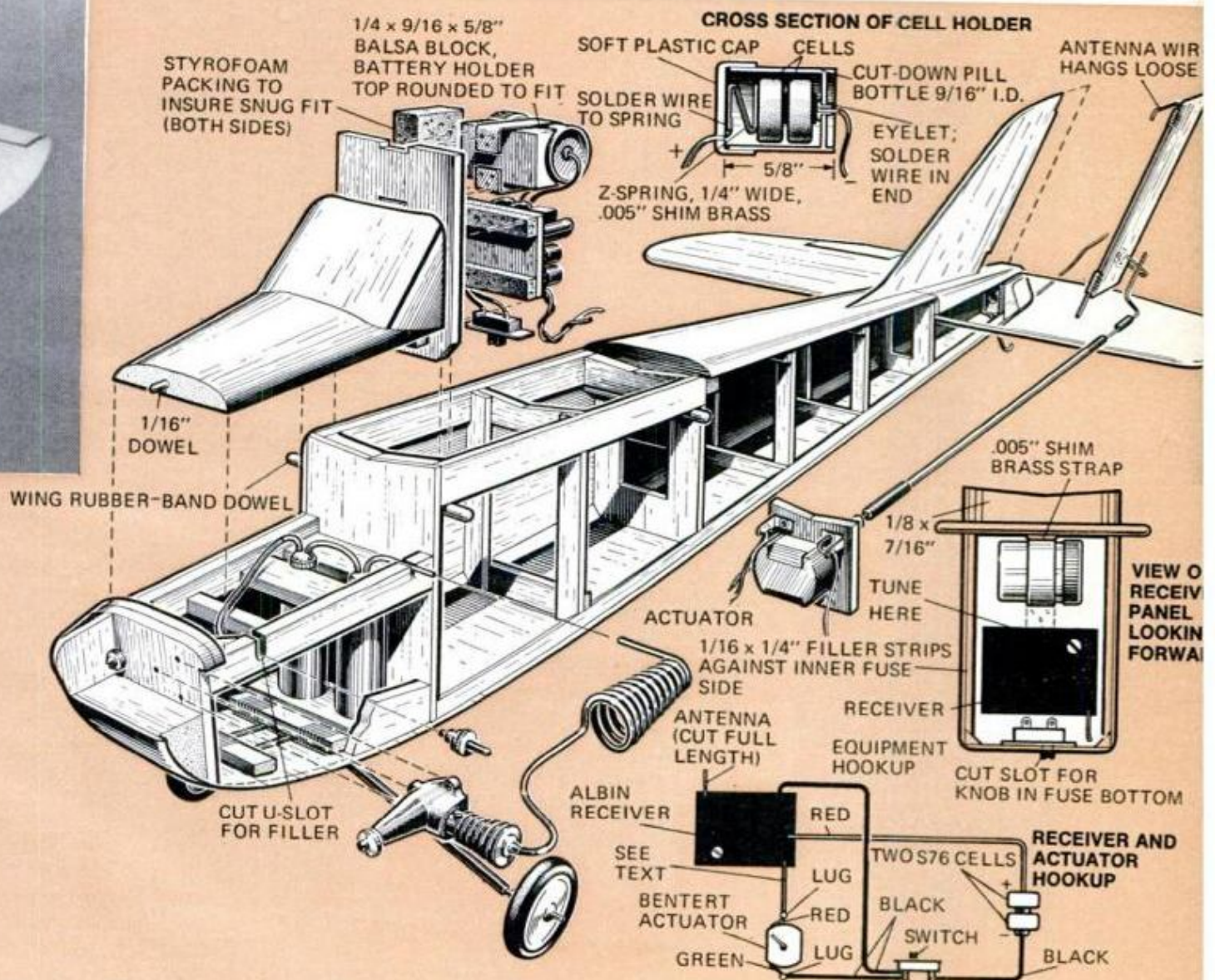

SCALE: 1/2" EQUALS 1"

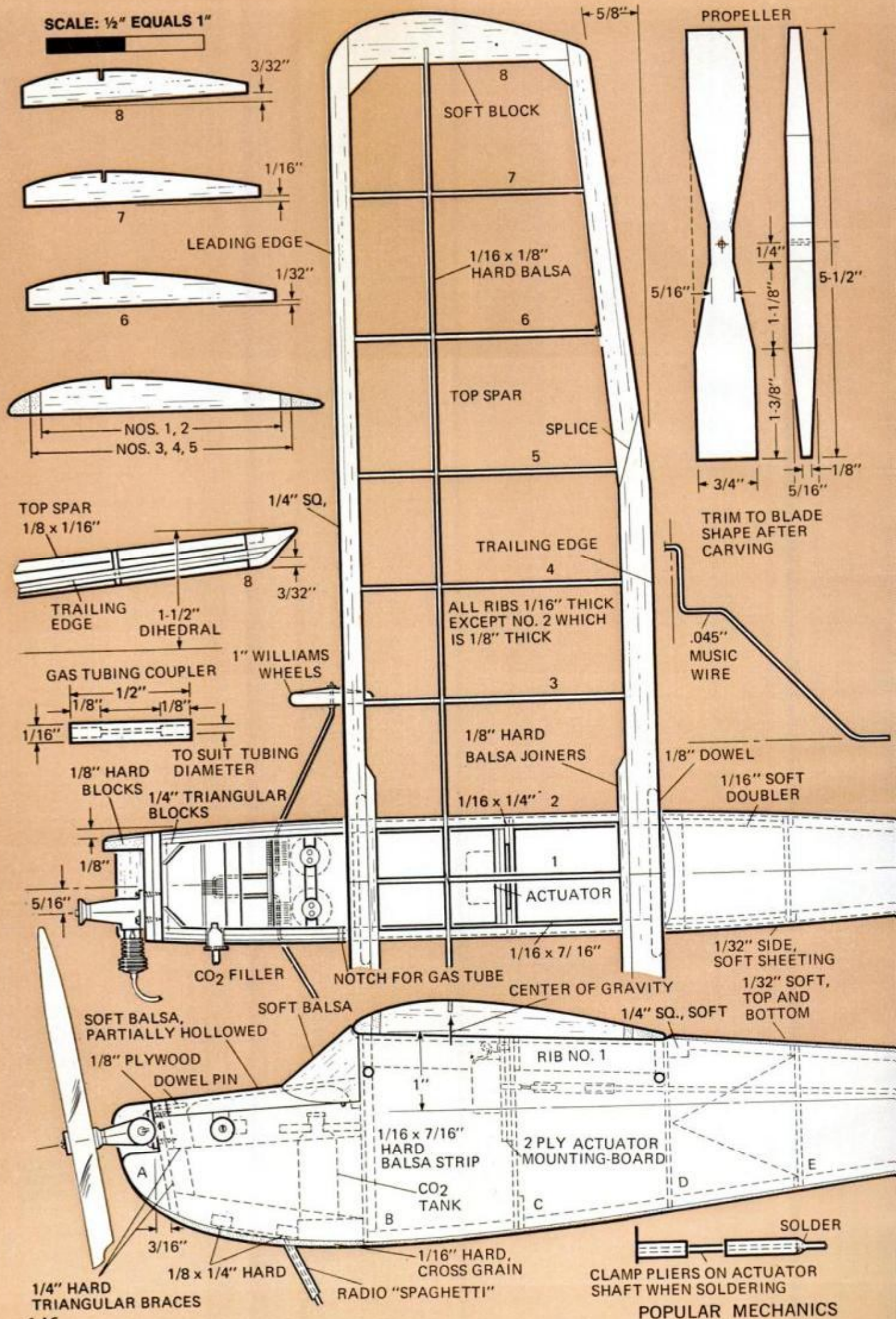



RUDDER LINKAGE holds the rudder full-left with receiver off. Antenna end simply hangs free

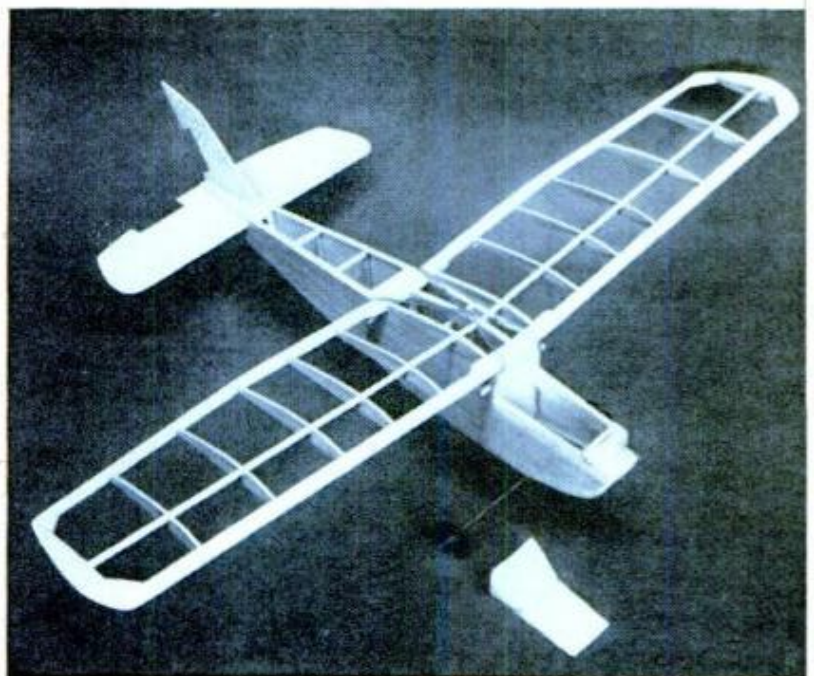

READY FOR FINISHING, hatch cover and "windshield" are near the wheel. The trim tabs are not yet attached

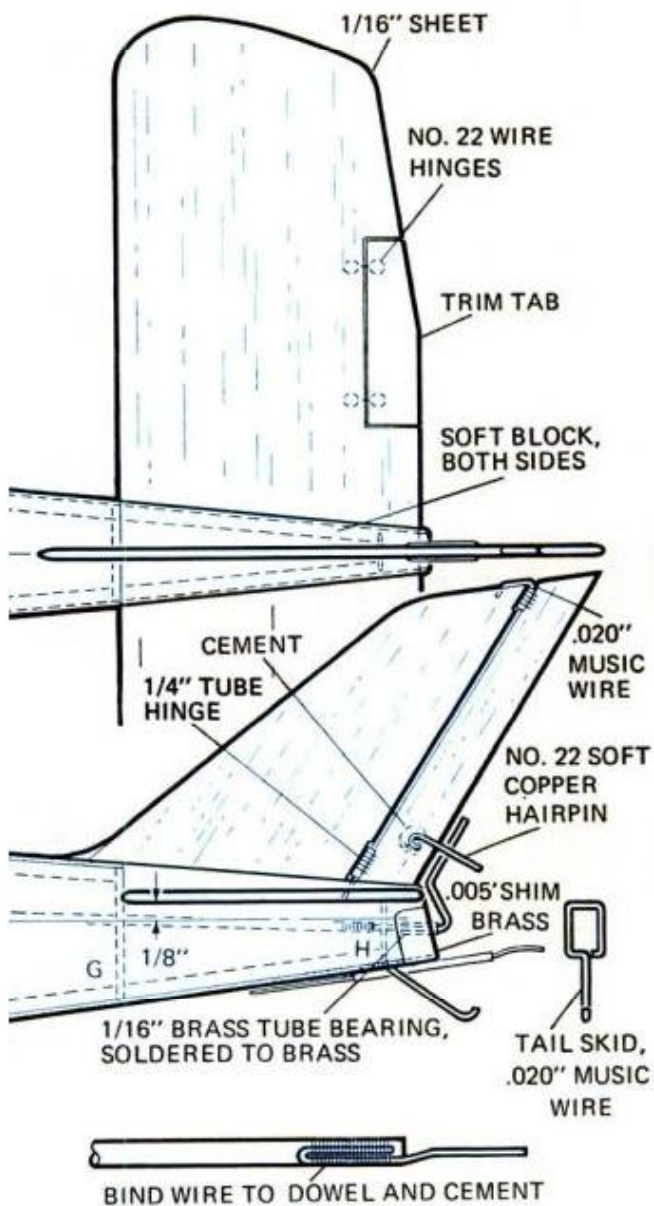

FEBRUARY 1972

you buy—the gas is a liquid, which means enough can be carried in a small tank for long flights. (The liquid vaporizes as it expands to drive the engine.)

The powerplant is similar to a steam-propulsion unit in that the tiny CO₂ tank in the plane acts as a "boiler" and the surrounding air as the "fire." Under high pressure in the tank, the liquid CO₂ travels through an exposed coil in which it is warmed to outside temperature. When it reaches the engine, it is a high-pressure gas. A tiny ball valve in the cylinder head, opened when the piston reaches the top of its stroke, meters the gas into the cylinder as needed.

This little plane, which we've named the *PM-Bee*, can be built as a free-flight model or as a radio-controlled flier. Very lightweight commercial equipment is now available to make R/C flying of such tiny planes quite practical.

While of simple construction, the *Bee* is not a first project for beginners; its delicate balance acquires some skill to achieve. But for the powerplant, cost of materials is low.

Keeping weight down is a must to obtain best flying qualities. Pick all wood carefully. Use a minimum of cement (just enough for firm joints) and as little dope on the completed plane as necessary.

The fuselage sides and doublers (the latter run forward from station E to the nose) are of soft 1/32-in. sheet; the heavier outline on the fuselage side view shows exact shape to cut the sides. The doublers are the same, but taper off between stations

147

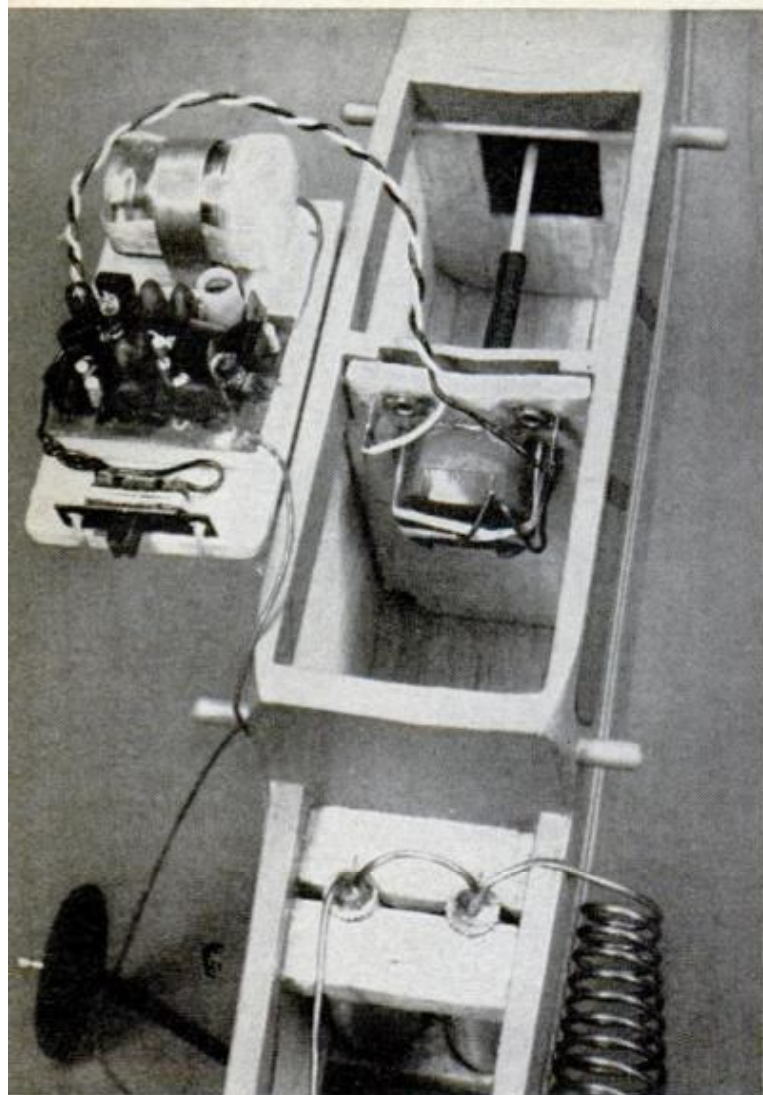

RADIO-COMPONENT BOARD is taped along fuselage; note actuator on mount, torque rod, tubing coupler

D and E. The two are fastened together with a light coat of spray contact cement; apply to both pieces, let dry for five minutes, then carefully fit and press together.

The upper firewall is backed up with another piece of the same plywood to hold tiny screws that fasten the engine in place. The engine may then be shimmed with small washers under one or two screws to the exact angle required for best flight. The nose compartment is braced with $\frac{1}{16}$ -in. strips on upper edges, and $\frac{1}{8}$ -in. at the bottom.

Bottom strips first must be notched to hold the landing gear cross strips. Triangular strips cut from $\frac{1}{4}$ -in.-sq. hard balsa further bind the firewall to the fuselage sides. Complete the nose area with a scrap of $\frac{1}{8}$ -in. sheet vertically inside the right-hand sheeting, and fit the hard lower block.

Bend the main landing gear as shown in the flat view, bind it to a hardwood (spruce or hard balsa) crosspiece and

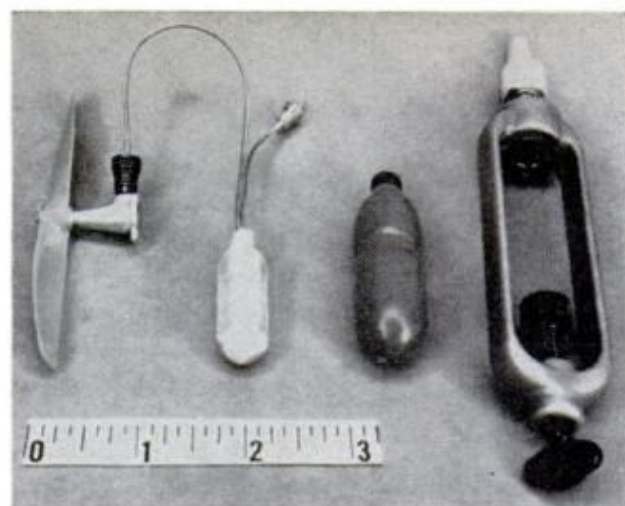

LEFT TO RIGHT: powerplant, tank filler tube, CO₂ cartridge (sold locally) and a cartridge holder

cement into place. Install the forward crosspiece and bind the wire tongue to it.

The hatch cover is cut from soft balsa, trimmed to match fuselage sides and fitted with a dowel pin at the front end. The "windshield" is also soft balsa with grain as indicated; the lead edge of the wing clamps the entire hatch assembly in place.

For free-flight operation, one gas tank will serve well, but if you will add radio control, provide *now* for two tanks. The powerplant, small propeller and cartridge holder are available from Brown Junior Motors, Inc., Box 44, Pine Grove Mills, Pa. 16868. CO₂ cartridges may be purchased at department stores.

A radio-controlled plane requires a second tank because the radio adds about an ounce to total weight (the plane shown weighs 3.3 oz. ready to fly). An RC model must be operated "wide open" to keep it aloft and fuel is used at a faster rate.

Additional parts needed for conversion to radio control are a Pulse Commander rudder-only transmitter, one Eveready 276 9-v. battery, one Ace Albin receiver kit, two Eveready S76 silver oxide cells, one Bentert small actuator and one Switchcraft sub-mini SPST slide switch. These parts are available from Ace Radio Control, Box 301, Higginsville, Mo. 64037. You can get a nylon propeller for the Brown CO₂ engine from W. C. Hannan Graphics, Box A, Escondido, Calif. 92025. ★★★

FULL-SIZE PATTERN AVAILABLE

To obtain a full-scale pattern from which you can trace off the parts directly, send \$3.49 to Popular Mechanics, Dept. PM-Bee, 224 West 57th St., New York, N.Y. 10019. Price includes postage and handling. Allow two to three weeks for delivery.

POPULAR MECHANICS

HINTS FROM READERS

Improved 'depth gauge'

A simple gauge for checking the depth of a bored hole can be made by slipping a pencil pocket-clip over the shank of a Phillips-type screwdriver. As the driver is pushed into the hole the ball end of the clip against the hole rim forces the clip to slide. After removing tool, simply measure distance between the tip and the ball end.

—W. B. May, Oak Park, Ill.



Substitute for masking tape

Next time you run out of masking tape while painting, try using scraps of self-adhering shelf lining. After cutting it into strips, position the material where it's wanted and use a sheet of newspaper under a portion of it away from the edge to be painted. The paper trick makes removing the liner a snap after paint has dried.

B. W. Ervin, Kent, Ohio



Increasing pry-bar range

I've found that by providing an adjustable, sliding collar on my pry bar, the distance through which it can effectively operate is increased considerably. The bar shown is of 1/2-in.-steel rod and the 3/8 x 1 3/4-in. collar was salvaged from my scrap box. The collar was drilled and fitted with two 1/4-in. setscrews to lock it in place.—Walter E. Burton, Akron, Ohio

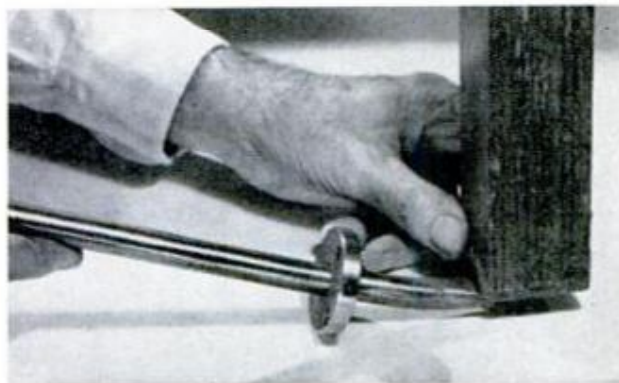

Pipe clamp serves as a vise

By attaching several 3/4-in. pipe flanges to my workbench at various locations, I can now use my 3/4-in. pipe bar clamps (and assortment of pipe lengths) as a sort of "portable" vise. The flange provides a strong, stable base for the clamp; when the extra vise is not needed, I simply unscrew the clamp and hang it on the wall.

—Paul R. Roman, Maple Heights, Ohio

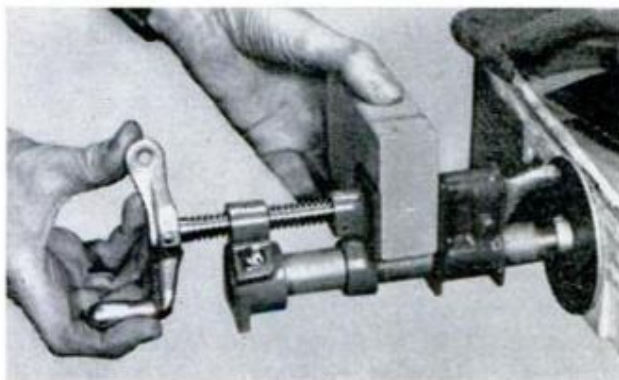

Notched nut cleans threads

If a half-dozen or so notches are spaced at intervals across the threads of a nut, the nut may be easier to screw on a bolt having clogged threads. The notched nut removes rust and dirt by scraping action (much like a die chip trap), and once the bolt threads are clean, the nut can be replaced by an unmodified nut.—Walter E. Burton, Akron, Ohio



Make this shaper for \$60

Starting with a used motor, the author built this handy tool for making his own moldings.

By RONALD R. GUY

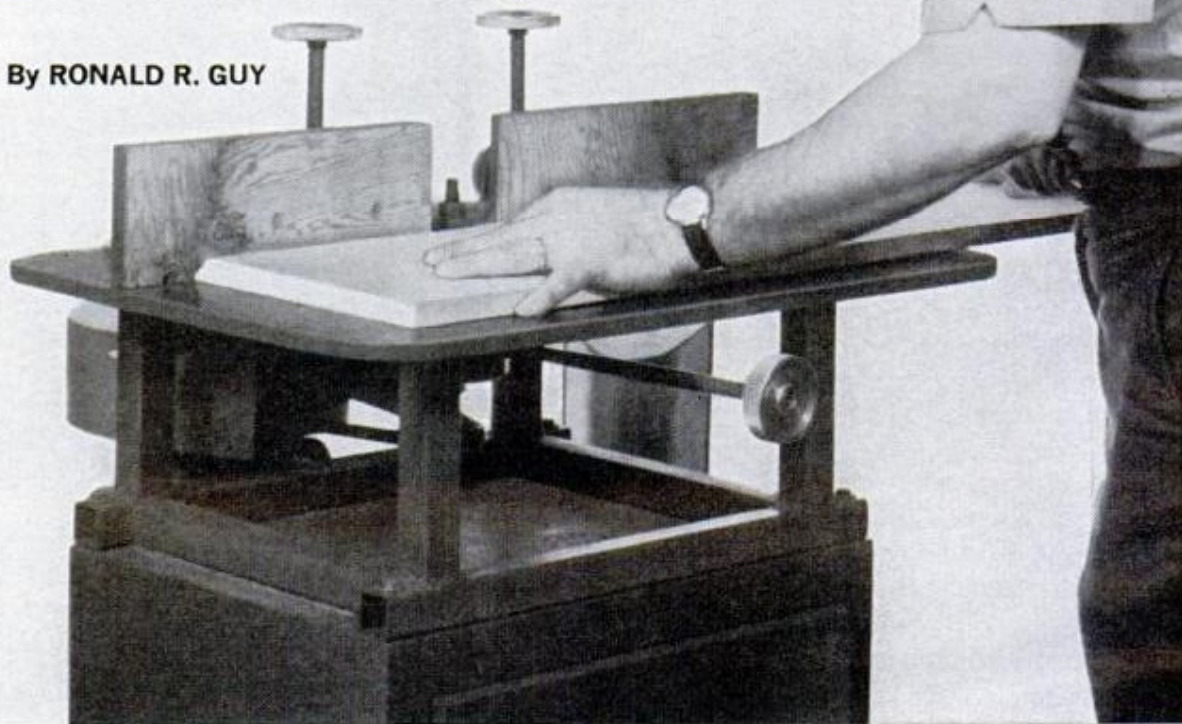

Photos by the author and Rose Marie Guy

TO THE SHOP CRAFTSMAN who takes his woodworking seriously, a shaper is a necessary machine—not just a luxury. Substitute measures, such as putting a molding-head cutter on a table saw or speeding up a drill press and using it as a shaper, are adequate for occasional use, but as your woodworking output increases, the urge to have a shaper at-the-ready will justify owning one.

If you have a couple of hundred dollars burning a hole in your pocket the solution is easy: Simply buy one. But, if you would prefer investing time—instead of money—this shaper is the answer. If you don't own a metal-turning lathe, the few turned parts required can be farmed out to a lo-

cal machine shop. You may even know of a fellow craftsman who has a lathe.

Begin construction by making the spindle housing from a 3¼-in.-dia. bar of mild steel. Turn this to a 3.121-in.-dia. using a round-nose finishing tool and a fine feed to obtain a very smooth finish. Now place this in a four-jaw chuck and, using a dial indicator, adjust the chuck until the part runs dead true. Bore the first bearing seat, being careful to get a smooth press fit with the bearing, then reverse the piece in the chuck. Again adjust until it runs *dead true* (this is very important) and bore the second bearing seat, again getting a smooth press fit. Follow this by boring a hole all the way through (see plans) and

you will have completed all the difficult work to be done on the spindle housing.

Tackle the spindle next. This is a simple job, and for maximum accuracy should be done between centers or with collets. It is important that you get a smooth press fit into the bearing races so take the time to get a good, smooth finish on the part that fits the bearings. File or mill a flat on the section where the pulley fits and also put four flats around the top of the spindle so it can be held with a wrench when you're changing cutters. It is advisable to case-harden the flats where the wrench goes; also the 1/2-13 nut that holds the cutter on the spindle (to avoid burring).

Now you can proceed to the housing height-adjustment tube that controls the vertical adjustment of the cutter. It is made from a piece of heavy-wall-steel tubing and a 5-in.-dia. disc of 1/4-in. steel. After boring it out to 3.125 in. it should have a smooth sliding fit with the spindle housing. Finish up by cutting the angled slot with a 1/2-in. end mill.

Next, make the knob and shaft used to

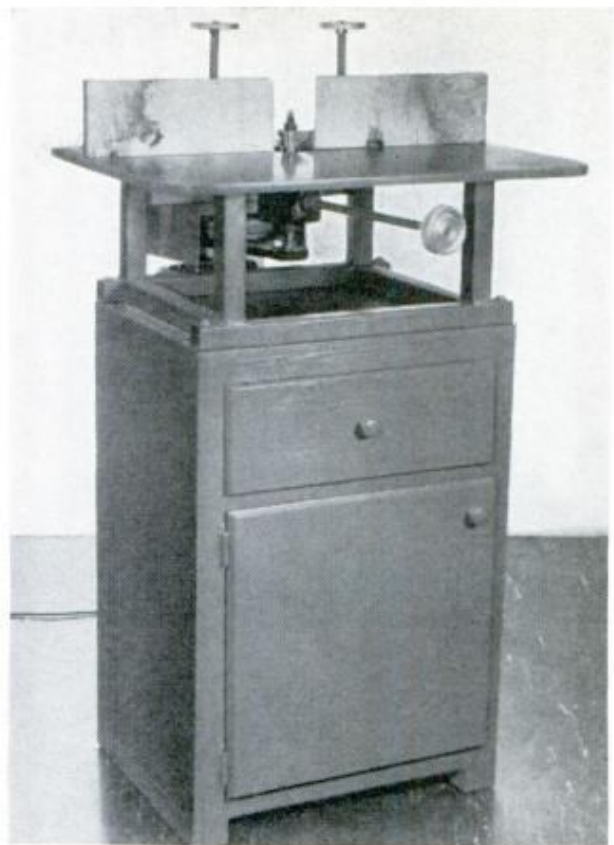

CABINET BENEATH SHAPER is of a simple, boxlike construction. Drawer can be partitioned for cutters

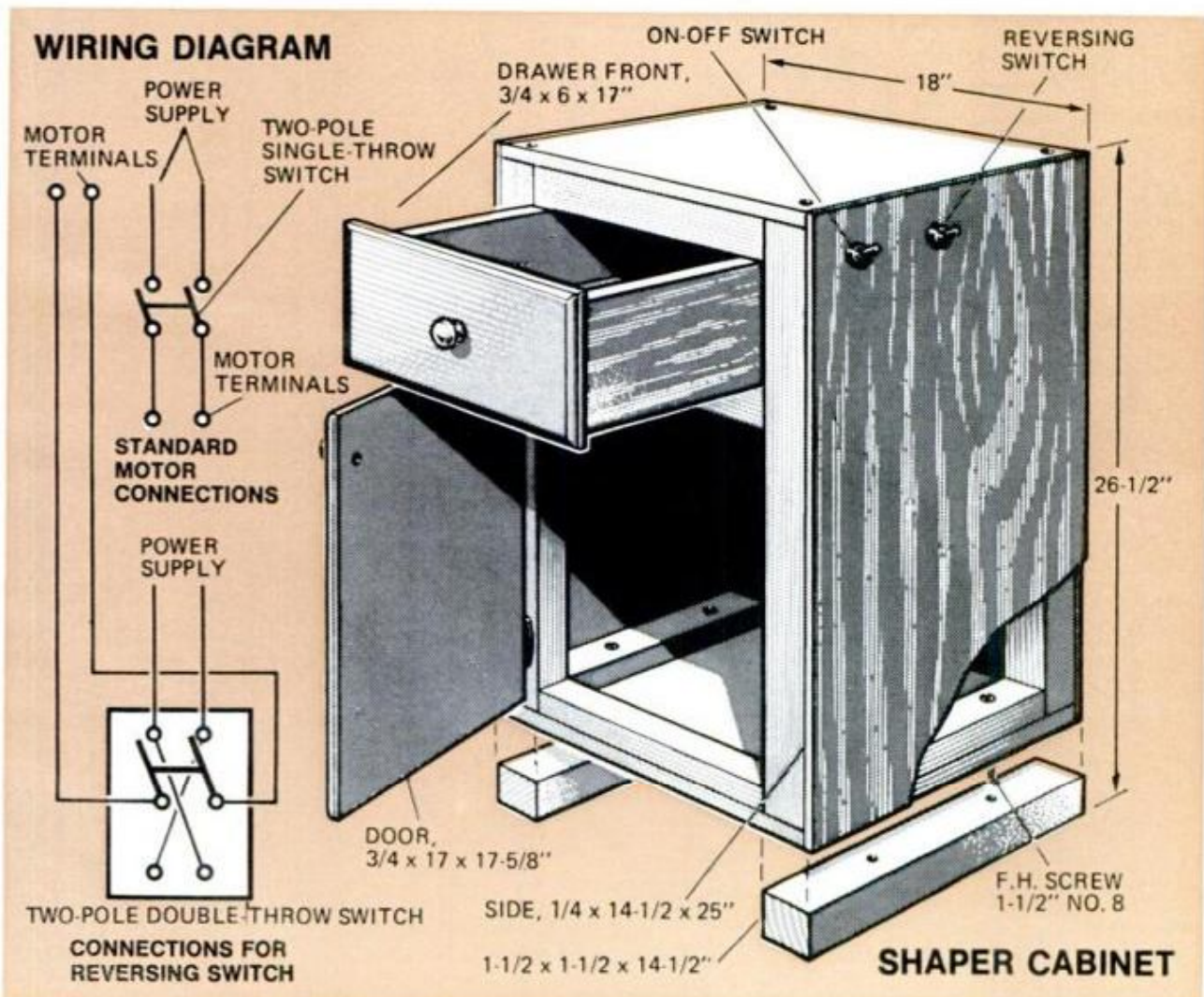

SHAPER ASSEMBLY

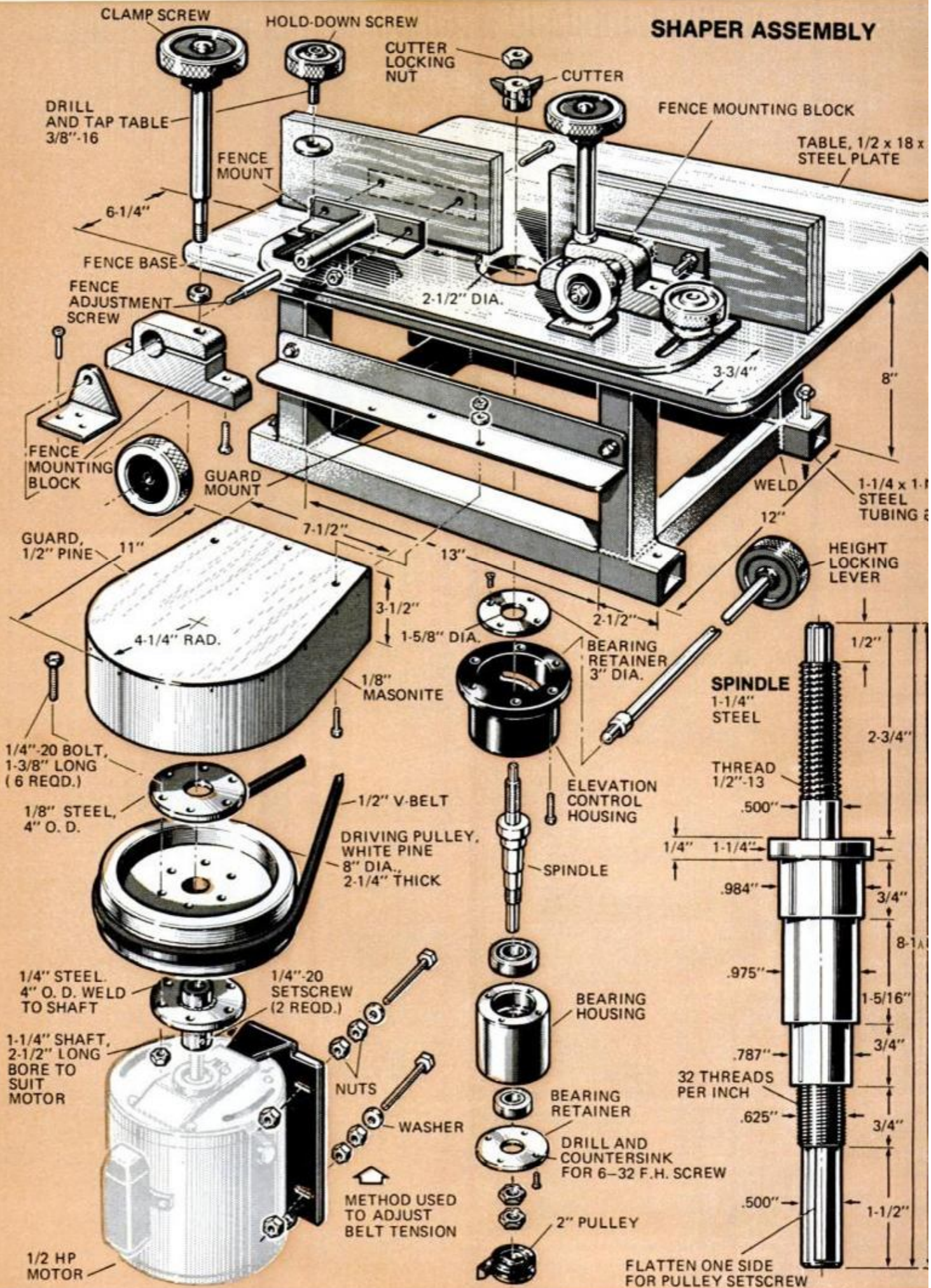

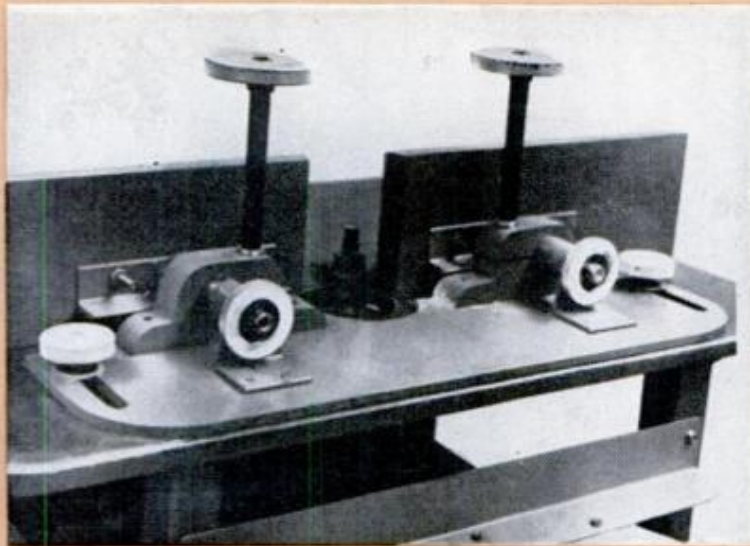

ALL SHAPER PARTS were machined in the author's shop using dimensions shown in drawings. Fence, of course, is adjustable

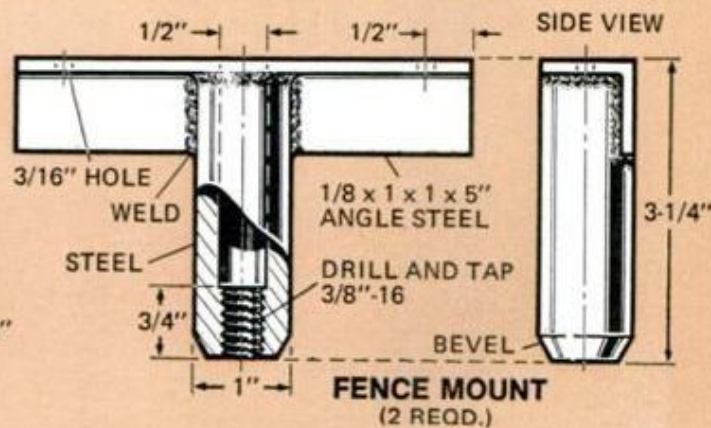
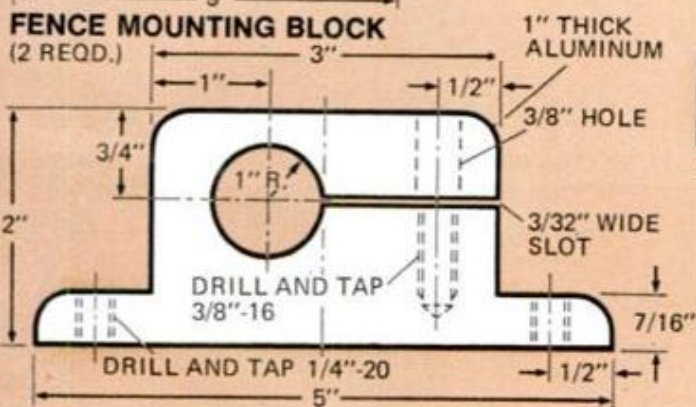
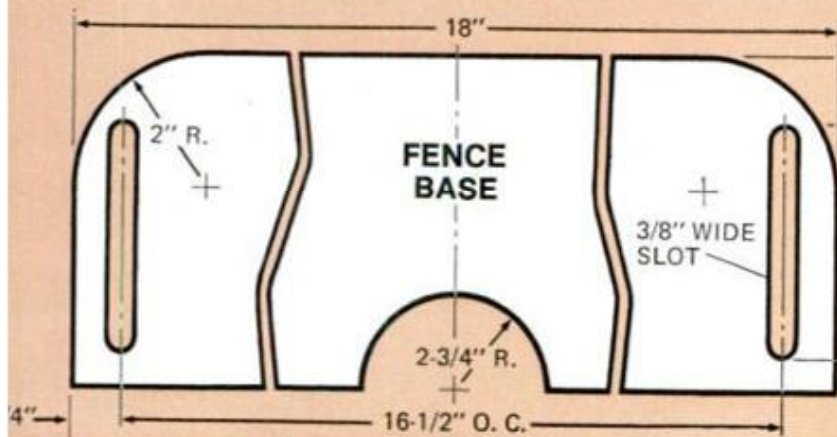
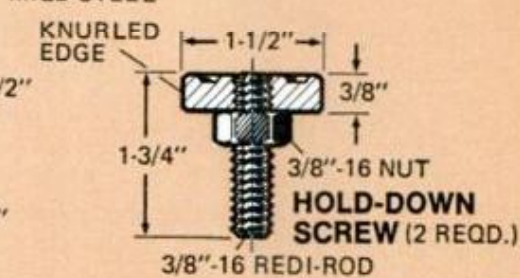
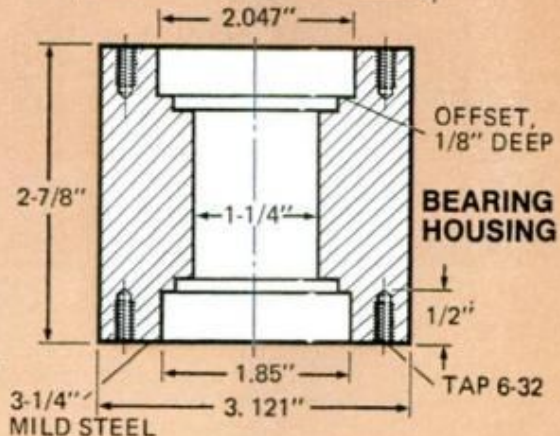
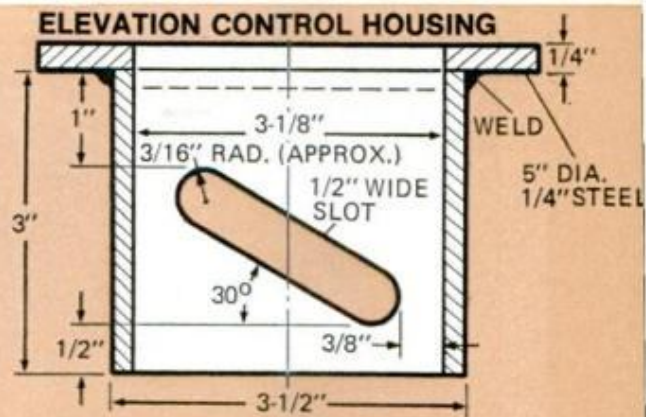

adjust and lock the spindle housing in the tube. Then machine the discs used to hold the bearings in the spindle housing. At this stage, you've finished the most difficult part of the shaper construction and you can start on the table, frame, fence, base and the like. Ask your steel supplier to cut a piece of 1/2-in. steel plate to 18 x 24 in. Round the corners and cut the hole for the spindle. A sabre saw will do all this nicely, and beeswax makes a fine lubricant. Finish the hole smooth with a

small drum sander or grinding wheel chucked in an electric drill. Use a disc sander for the corners.

Now you can lay out, drill and tap the holes for mounting the fence on the table. Then turn the table over and position the spindle assembly over the hole (a wood disc on the spindle that fits the hole is a great help), making sure the slot faces the front of the table. Drill and tap the holes for bolting the vertical adjustment tube to the bottom of the table. Bolt it down tight,

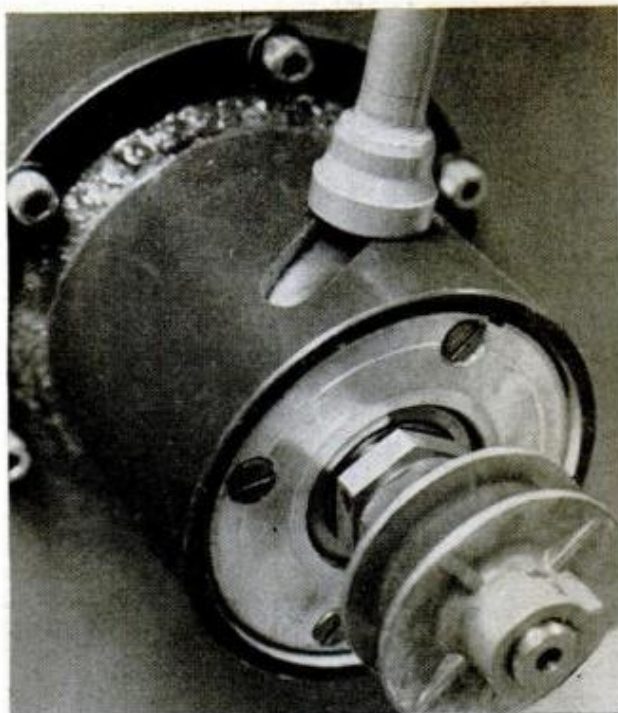

CLOSE-UP PHOTO shows height adjustment control, take-up nuts on spindle and the small, 2-in. pulley

then flop the table and grind off the bolts flush with the table surface. Make the frame from $1\frac{1}{4}$ x $1\frac{1}{4}$ -in.-sq. steel tubing and weld it to the table bottom. Avoid too much heat or you may warp the table.

The base is made from plywood and hardboard. Basically it's a simple box fitted with a drawer and door. The motor is mounted on the back of this cabinet base. Since there is great variance in bases of different motors, dimensions for mounting the motor are not given. Use four $\frac{1}{4}$ -in. bolts for this, placing them so as to position the motor at the correct height. This must be determined after the shaper is mounted on the base.

When assembling the fence, try to keep everything as straight as possible. Be sure to countersink the screws that hold the wood fences in place, then take a light pass over your jointer to align both wood pieces perfectly.

The pulleys are next. The driven pulley is a stock 2-in.-dia. V-belt type with a $\frac{1}{2}$ -in. bore. The driver pulley is made from steel and wood, its size determined by the rpm of your motor. For a 1725-rpm motor use an 8-in. pulley; for a 3450-rpm motor use a 4 or $4\frac{1}{2}$ -in.-dia. pulley. The plans call for a 1725-rpm motor. To make the wooden part cut a disc of $\frac{3}{4}$ -in. white pine a little oversize and glue a ring of pine the same diameter on either side of it. Mount this on the steel hub and flange assembly; then mount the entire assembly on the shaft of the electric motor.

The motor is used as a sort of lathe to enable you to turn the o.d. (outside diameter) to correct size and finish up the inside edges of the outside rings. This wooden pulley must have flat sides because the belt rides up and down on the pulley as cutter height is adjusted. If the pulley is out of balance, you can correct it quickly by using a little modeling clay on the inside edge of the rings. It's a trial-and-error method for sure, but it is easy to do and works effectively.

Finish construction by making the belt guard. Mount the shaper on its base by using bolts or screws, adjust spindle height to middle position and mount the motor so the belt rides in the middle of the wooden pulley. Adjust belt tension until the belt is just fairly tight. (This is

(Please turn to page 183)

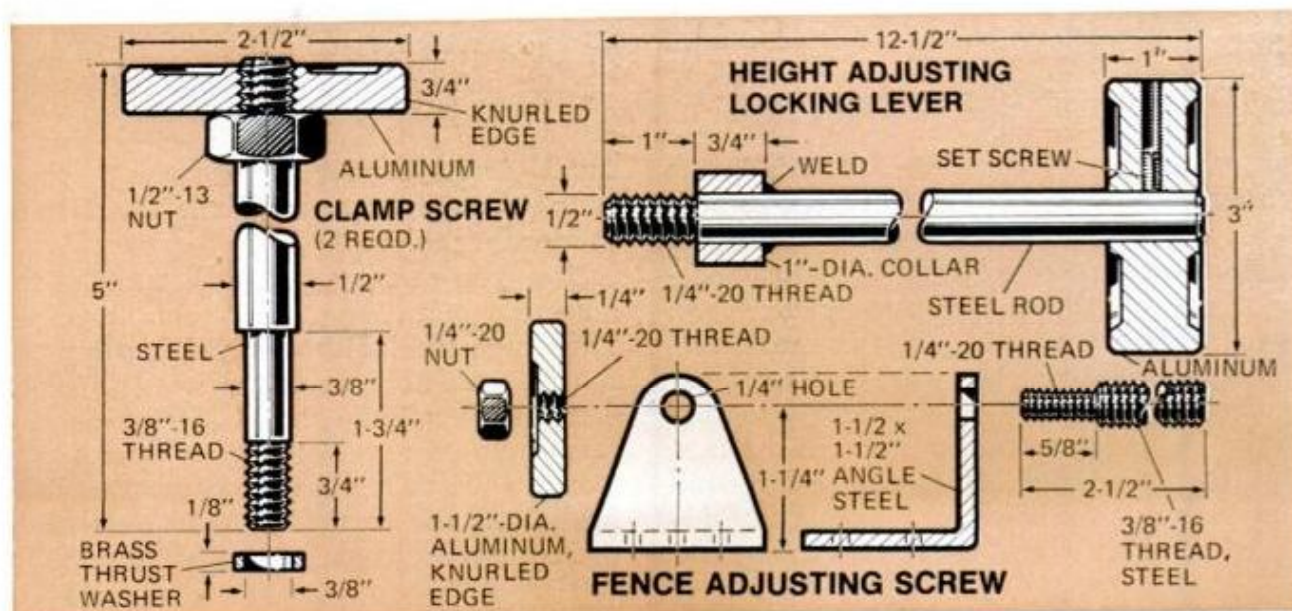



Today, a man needs a good reason to walk a mile.

Start walking.



25 mg. "tar," 1.5 mg. nicotine
av. per cigarette, FTC Report AUG. '71.

A 'G-meter' you can add to your dashboard



With an accelerometer you'll measure pickup, detect flat points in acceleration and know when your car needs tuning

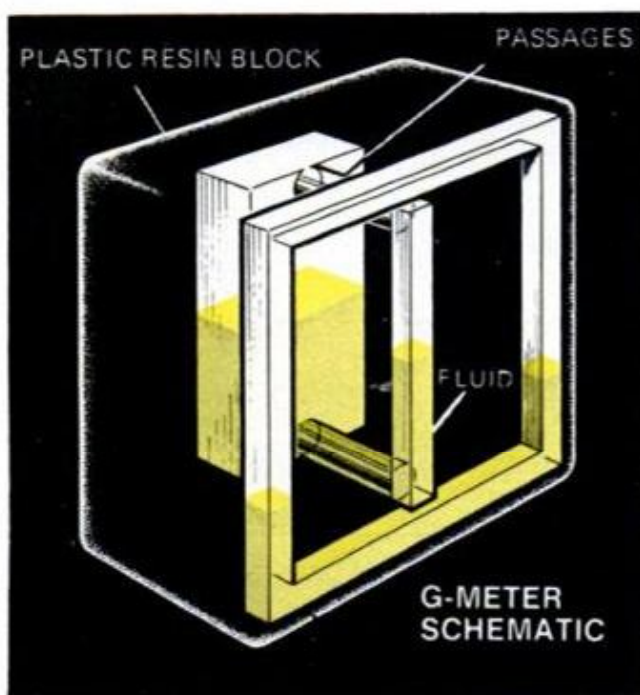

YOUR CAR is constantly being tugged by the forces of acceleration. Each time you step on the gas, hit the brakes or make a turn, your auto is either shoved forward, dragged back, or yanked from side to side. These forces can be measured by an accelerometer similar to those the astronauts use for navigation. Race-car mechanics now have begun to use accelerometers in the final tune-up of their machines.

You can build your own accelerometer, which I've called the "G-meter," by casting clear resin in a simple mold. The resulting block of plastic encloses two sets of fluid-filled passages which measure ac-

SCHEMATIC shows channels which contain an ethylene glycol antifreeze (without stop-leak additive)

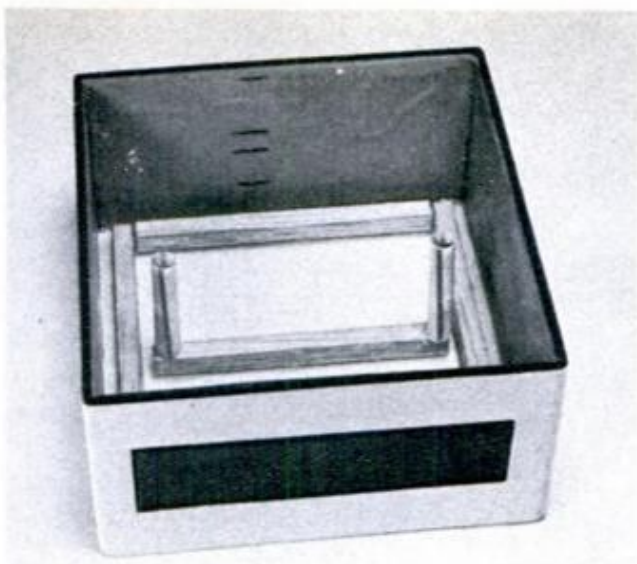

COMPLETED MOLD, with balsa and soda straws in position, is ready for the first pour of clear resin

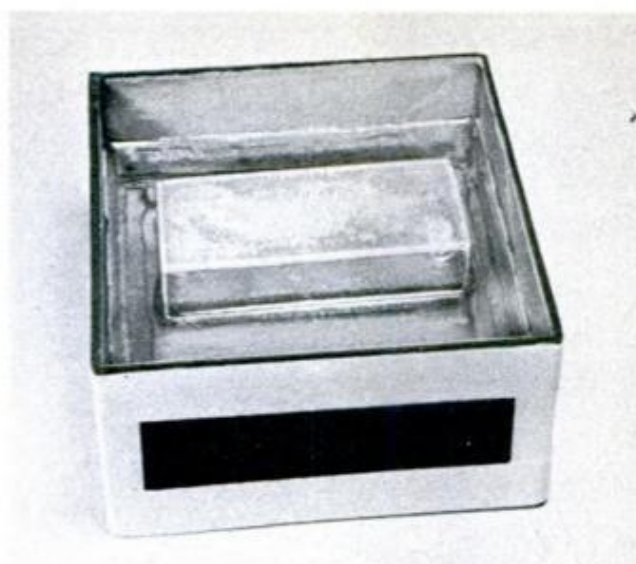

AFTER PLASTIC BOX is placed over ends of straws, the last pour of the casting resin can be made

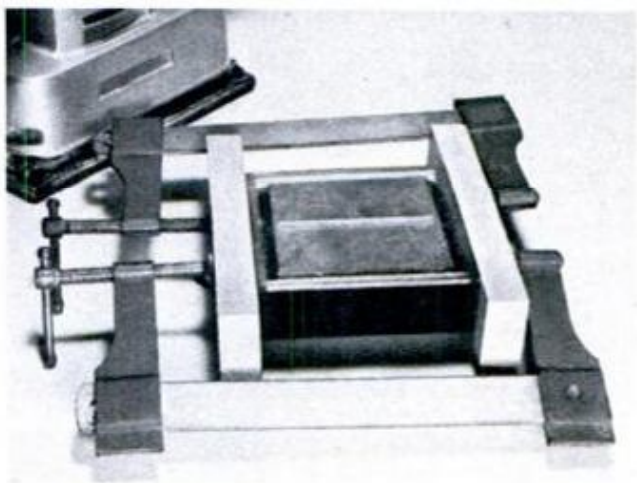

HARDWOOD BLOCKS clamped to each side of meter body (above) insure that the sander will leave a flat surface. Drawing at right gives all dimensions for making the G-meter mold for casting operation

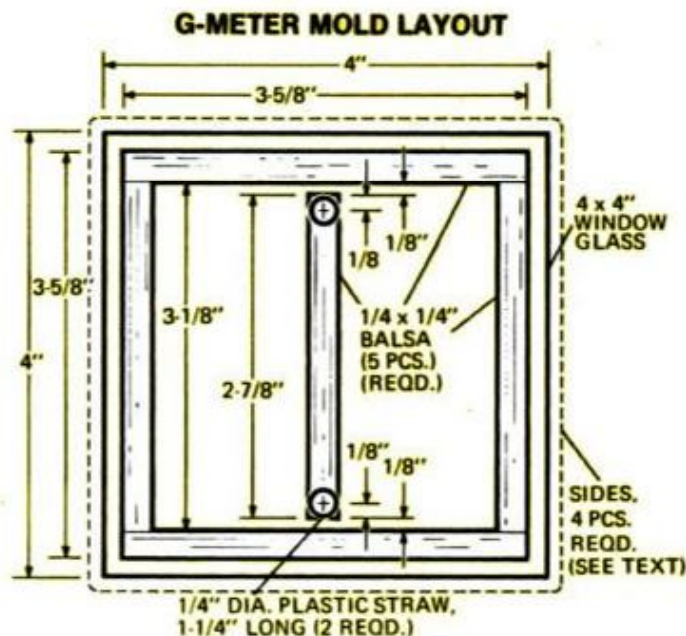

celeration forces along two axes: longitudinal (forward-reverse) and lateral.

The force scales are calibrated in Gs, making them universal. A force of 0.25 G, for example, will accelerate a roller skate, car or locomotive from zero to 60 mph in 11 seconds.

To find out what the accelerating force will be in pounds, multiply the G reading by the vehicle weight. In the top photo on the facing page, the meter reads 0.3 G acceleration and 0.1 G pull to the left as the car merges from the right and picks up speed.

The longitudinal system gives you an instant check on your car's performance under operating conditions. It detects flat points in acceleration, evaluates changes made to engine or power train and helps

select shift points. It can tell you when a tune-up is needed and whether the tune-up was done right.

You can also check your brakes with this system. (Braking results in negative longitudinal G readings.)

You don't need a level road to use the G-meter. On hills (up to 15 percent slope) the meter still reads the total go-power being put out by the car. Only the measured time to reach a certain speed will be affected. But strong winds will disturb the readings.

The lateral system of the G-meter is more interesting than functional. As your car rounds a turn, the meter will read the centrifugal force being resisted by your tires. The readings will be reduced by a properly banked turn. There is one speed

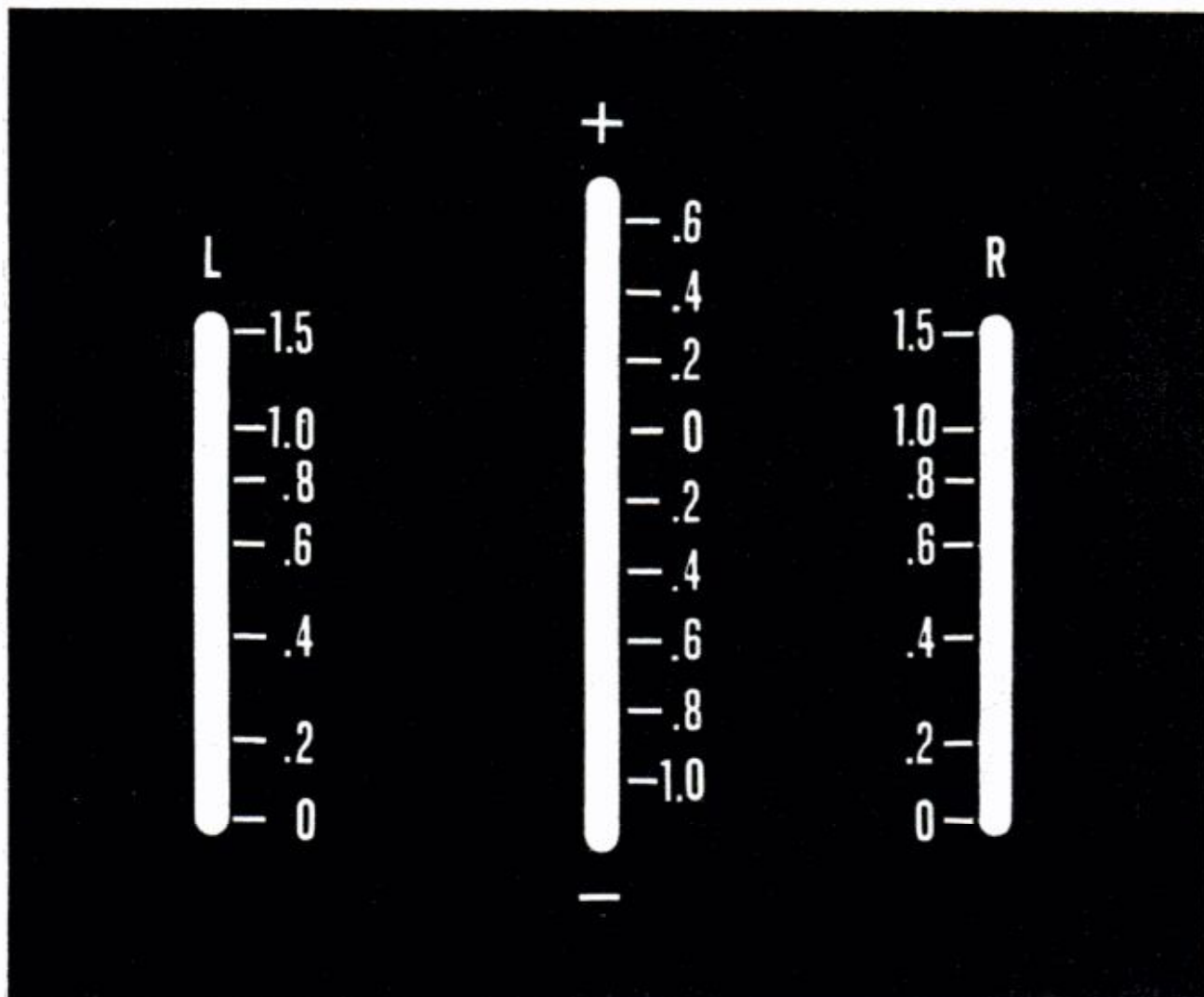

SCALES SHOWN ABOVE are actual size, can be cut out and pasted on the meter or, better yet, copied on film by a litho service shop. The latter method will give you back-lighted, easy-to-read lettering

on banked turns where the reading will be zero.

A skilled race driver on a good track could use the G-meter to evaluate his car's cornering ability. The average driver in a standard car on a public road could come to an untidy end trying the same thing. But you can use the G-meter lateral reading as an indicator of passenger comfort on turns.

Clear casting resin is molded to make the meter. We used materials sold by American Handicraft Co., 1011 Foch St., Fort Worth, Tex. 76107. You need only minimum quantities: one quart of "Clear Cast," a pint of "Surface Coating Resin," an ounce of catalyst and a half-ounce of red transparent dye.

The liquid resin pours just like corn syrup and will set in a few hours when catalyzed, after which it can be sanded and machined.

Follow the health and safety instructions on the label. The various materials

are flammable, toxic, caustic and potent smelling. All measurements given are for Clear Cast; if you use another product, adjustments may be called for.

First make a mold. On a 4-in. sheet of window glass, position five strips of ¼-in. balsawood as shown in the mold layout and tack them down with dabs of rubber cement. Cut four pieces of plastic laminate 2¼ x 4 in. for the mold sides. Use freezer tape and the laminate (finished surface inward) to make an open-topped box with the glass as the bottom. Warm the box, melt paraffin in a double boiler, and then coat the entire inside of the box with the paraffin.

Next, cut the two lengths of plastic drinking straw and stuff them with tissue. Dip the straws in paraffin, position them as shown in the layout, and hold them until the paraffin hardens. Mark the inside of the completed mold at heights of ½, 1, 1¼ and 2 in. above the glass. These are

(Please turn to page 180)

The clean team

Take a typically dirty carburetor (like yours maybe) clean it...and get easier starting, smoother idling, no stalling, faster take-offs and better mileage.

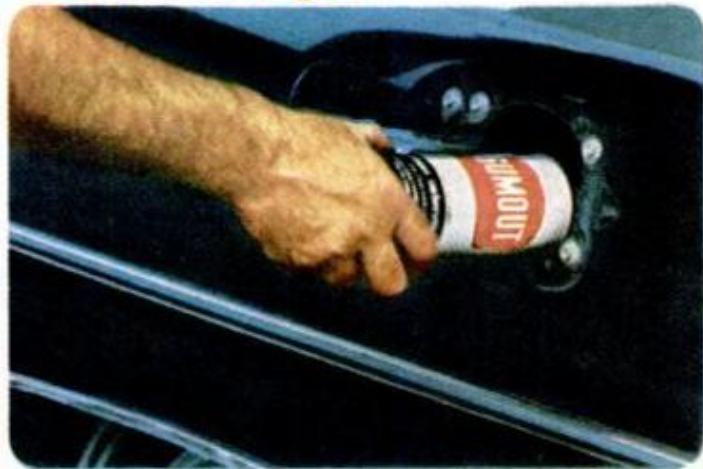
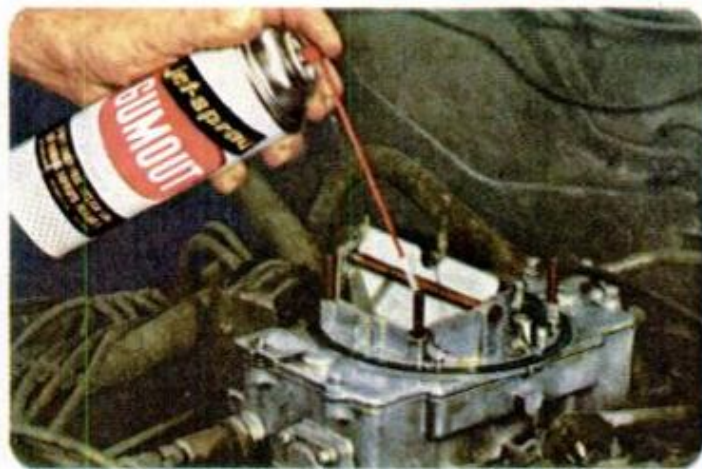

1 Clean it outside in seconds with Jet-Spray Gumout. Takes less than a minute to get this! Throat, choke valve, linkage, throttle plate—all clean like new. Grime and gum that can foul up the carburetor's job are gone. Completely.

2 Now pour a pint of Gumout in your gas tank. It does the same great job inside your carburetor as you drive. Cleans out all the jets and passages, removes the gum and varnish.

GUMOUT Division
PENNSYLVANIA REFINING COMPANY, Cleveland, Ohio 44104

Материал, защищенный авторским правом

How to muzzle your lathe dogs

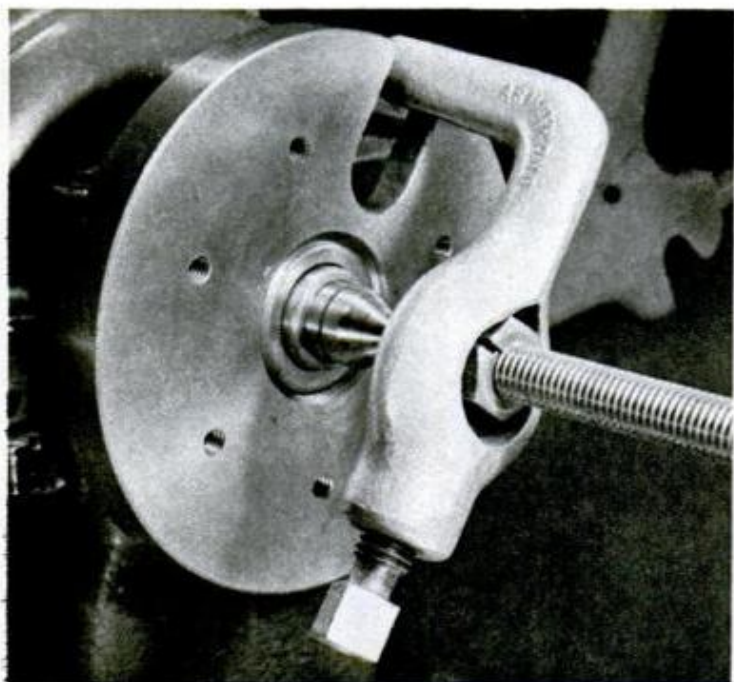

LIKE its canine counterpart, a bent-tail lathe dog often tends to chew on things. If you cinch the setscrew up hard, it usually cuts the workpiece. And if you ease up on tightening, the piece might slip under a heavy cut and get badly scored in the process. I've found that shielding the work with brass pads (as they taught you in shop class) is troublesome to set up, especially on repeat jobs. Instead, I use one of the three homemade fittings shown below and at left. The drawings are self-explanatory and using them you'll be able to teach the old dog a few new tricks and put an end to its bite.

—E. Dussault, Oak Park, Ill.

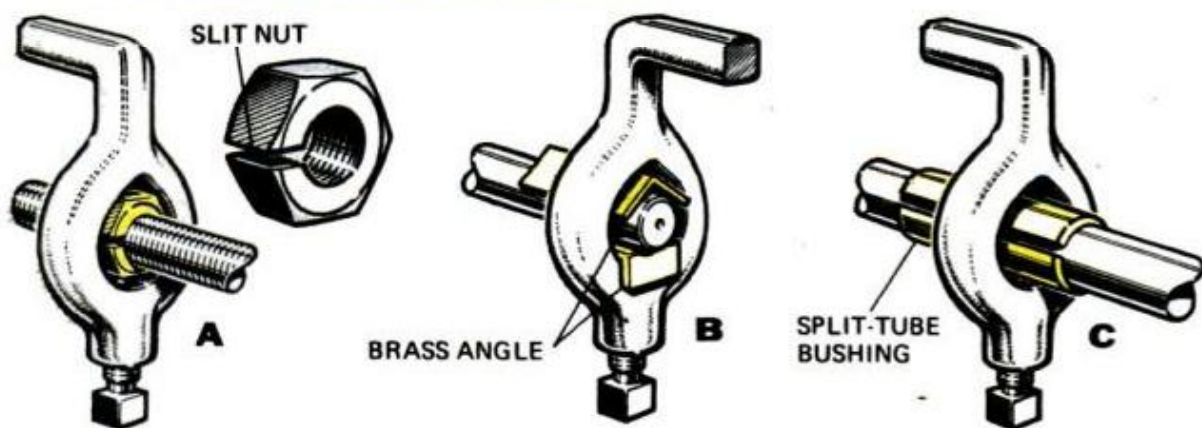

NEXT MONTH IN SHOP AND CRAFTS

FROM PM'S WORKSHOP: A RADIAL-SAW ACCESSORY CABINET: Designed and built in our shop for *PM* readers to duplicate, this cabinet lets you make use of that valuable, wasted space beneath your radial saw—no matter what make it is. Pick up the March issue and add this "luxury" to your own shop.

WHAT YOU SHOULD KNOW . . . BEFORE TERMITES PUT THE BITE ON YOU. Subterranean termites are hungrily at work in every state but Alaska, and the annual price tag for their appetites is estimated at \$500 million dollars. More important, if you don't know how to spot them, extermination and repairs can cost you from \$500 to \$1000. In next month's *PM*, you'll learn the telltale signs, what you can do as a homeowner and when it's time to call in the pros.

THINGS TO MAKE FOR FUN AND FUNCTION. A collection of quickie weekend projects that includes a doggie bookrack, brain-teasing puzzle, Early American minishelf, "flying" duck weathervane, rotating teeter-totter, salt shakers and a fruit dish.

BUILD PM'S BACK-YARD CARRIAGE HOUSE. It's designed with all the charm of yesteryear, yet it can be put to practical use as a pool cabana, a den (or home office) for Dad, playhouse for the youngsters or for yard and garden equipment storage. Pick up next month's *PM* and build yourself a lawn house that will be the envy of the neighborhood.

Decisions...decisions...

I've made my decision-

PALL MALL GOLD 100's
Longer...yet milder

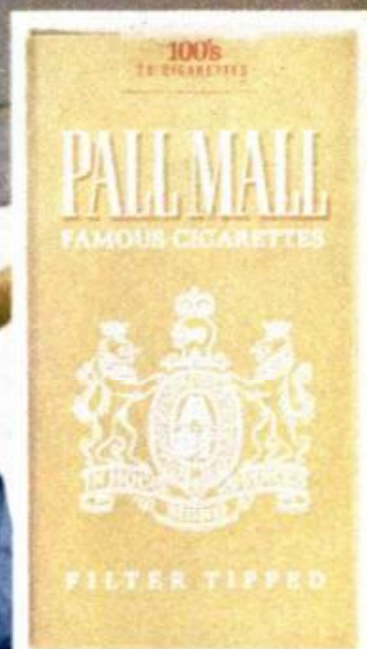

Longer length
...milder taste

Also first class flavor in a filter king
New PALL MALL white



Gold 100's
19 mg. "tar", 1.3 mg. nicotine
av. per cigarette, FTC Report AUG. '71.

20 mg. "tar", 1.4 mg. nicotine
av. per cigarette by FTC method.

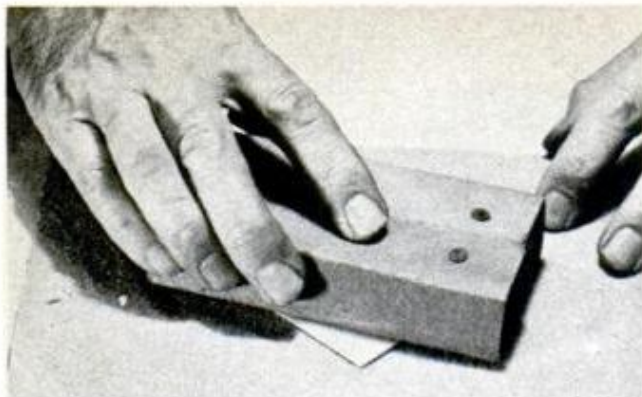

HINTS FROM READERS

Reducing cardboard thickness

When using cardboard for shims, it is often necessary to slightly reduce its thickness. An easy method I use is to place the cardboard on a sheet of sandpaper and rub it with a sandpaper-covered block of the same grit.—*B. W. Ervin, Kent, Ohio*

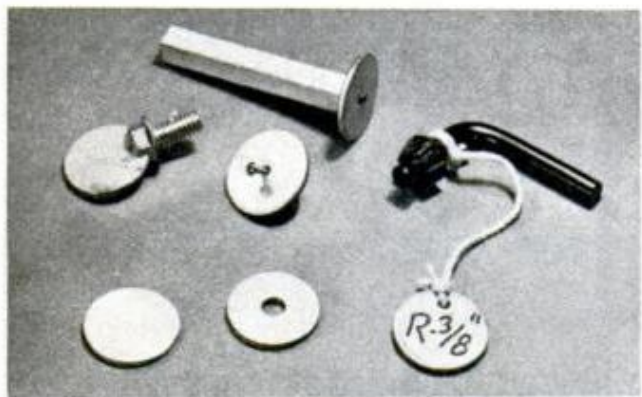

Uses for knock-out plugs

Knock-out discs from electrical boxes can frequently be put to emergency use in the home and shop. Four possibilities shown are wheels for toys, washers (after drilling holes), tag for a drill-chuck key and a thumbscrew. For the latter, flatten the disc edge and simply solder the disc in a screw slot.

—*W. B. May, Oak Park, Ill.*

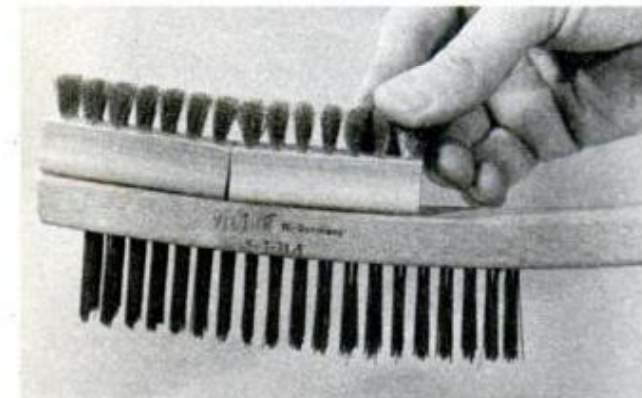

Dual-purpose wire brush

An ordinary wire brush is certainly a must in every craftsman's toolbox, but for certain jobs the bristles are too coarse. Rather than buy another tool, I simply glued and screwed a pair of suede leather brushes—the type used for suede shoes—to the back of the wire brush I owned. Result—a dual-purpose, fine/coarse brush.

—*Ken Patterson, Regina, Sask.*

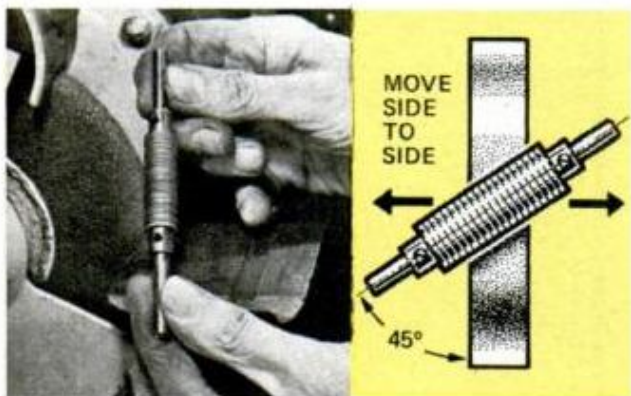

Gang-grinding washers

When you need a lot of same-size washers in a hurry, you can grind an assortment by slipping them on a rod (with a flat ground on one side). Then, with washers held by means of two collars, grinding can proceed. Hold washers at an angle and move them back and forth across the wheel. They will spin as they are ground.—*Frank Rothmann, Anderson, S.C.*

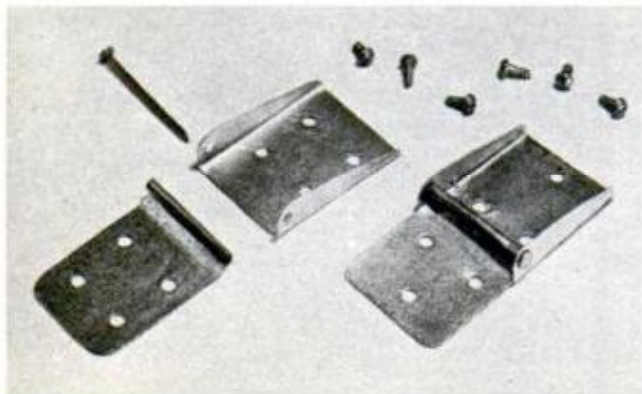

Improvised surface hinge

Recently, when I needed a couple of surface hinges in a hurry on a Sunday, I fashioned my own out of tin-can material as shown. Stock for one leaf is ½ in. wider than the other to allow for right-angle bends. To finish, drill mounting and hinge-pin holes, and use an appropriate-size nail for the "hinge pin."

—*Walter E. Burton, Akron, Ohio*

THE DODGE MAXIVAN STRONG BOX...

Largest compact van built in the United States.

AND VERY BIG IN FEATURES, TOO.

Cargo Area

Largest of any van built in the U.S.

Brakes

New, optional power disc front brakes for improved stopping power.

Floor Space

Greatest load length between engine cover and rear door.

Engines

Largest optional V8 (360 cu.-in.).

Wider Doorway and Step

Easier entrance and exit for driver and passenger.

Independent Front Suspension

Smooth, independent front suspension can be easily aligned on passenger-car equipment, if necessary.

More Legroom

Heater is located under hood instead of under dash to give you ample legroom.

Ease of Loading

Front passenger seat does not intrude into side cargo door entrance. Side doors are widest of any domestic van.

Fuel Capacity

Largest gas tank of any domestic van (26 gallons).

Turning Circle

Tightest turning circle of any domestic van, yet has the longest wheelbase for smoother ride and handling. Easy to park.

Service Repairs

Large hood opening for outside servicing.

Plus More

The Dodge Strong Box has many more fine features which this space does not permit us to list. See your Dodge Truck Dealer. He'll be happy to show them to you.



Dodge Strong Boxes are available in 109-inch-wheelbase, 127-inch-wheelbase, and 127-inch-wheelbase Maxivan versions.

Who gives you toughness that's just your style?

Dodge. Depend on it.





I'd like to give this to my fellow men... while I am still able to help!

I was young once, as you may be—today I am older. Not too old to enjoy the fruits of my work, but older in the sense of being wiser. And once I was poor, desperately poor. Today almost any man can stretch his income to make ends meet. Today, there are few who hunger for bread and shelter. But in my youth I knew the pinch of poverty; the emptiness of hunger; the cold stare of the creditor who would not take excuses for money. Today, all that is past. And behind my city house, my

summer home, my Cadillacs, my winter-long vacations and my sense of independence—behind all the wealth of cash and deep inner satisfaction that I enjoy—there is one simple secret. It is this secret that I would like to impart to you. If you are satisfied with a humdrum life of service to another master, turn this page now—read no more. If you are interested in a fuller life, free from bosses, free from worries, free from fears, read further. This message may be meant for you.

By Victor B. Mason

I am printing my message in a magazine. It may come to the attention of thousands of eyes. But of all those thousands, only a few will have the vision to understand. Many may read; but of a thousand only you may have the intuition, the sensitivity, to understand that what I am writing may be intended for you—may be the tide that shapes your destiny, which, taken at the crest, carries you to levels of independence beyond the dreams of avarice.

Don't misunderstand me. There is no mysticism in this. I am not speaking of occult things, of innumerable laws of nature that will sweep you to success without effort on your part. That sort of talk is *rubbish!* And anyone who tries to tell you that you can think your way to riches without effort is a false friend. I am too much of a realist for that. And I hope you are.

I hope you are the kind of man—if you have read this far—who knows that anything worthwhile has to be *earned!* I hope you have learned that there is no reward without effort. If you have learned this, then you may be ready to take the next step in the development of your karma—you may be ready to learn and use the secret I have to impart.

I Have All The Money I Need

In my own life I have gone beyond the need of money. I have it. I have gone beyond the need of gain. I have two businesses that pay me an income well above any amount I have need for. And, in addition, I have the satisfaction—the deep satisfaction—of knowing that I have put more than three hundred other men in businesses of their own. Since I have no need for money, the greatest satisfaction I get from life is sharing my secret of personal independence with others—seeing them achieve the same heights of happiness that have come into my own life.

Please don't misunderstand this statement. I am not a philanthropist. I believe that charity is something that no proud man will accept. I have never seen a man who was worth his salt who would accept something for nothing. I have never met a highly successful man whom the world respected who did not sacrifice something to

gain his position. And, unless you are willing to make at least half the effort, I'm not interested in giving you a "leg up" to the achievement of your goal. Frankly, I'm going to charge you something for the secret I give you. Not a lot—but enough to make me believe that you are a little above the fellows who merely "wish" for success and are not willing to sacrifice something to get it.

A Fascinating and Peculiar Business

I have a business that is peculiar—one of my businesses. The unusual thing about it is that it is needed in every little community throughout this country. But it is a business that will never be invaded by the "big fellows." It has to be handled on a local basis. No giant octopus can ever gobble up the whole thing. No big combine is ever going to destroy it. It is essentially a "one man" business that can be operated without outside help. It is a business that is good summer and winter. It is a business that is growing each year. And, it is a business that can be started on an investment so small that it is within the reach of anyone who has a television set. But it has nothing to do with television.

This business has another peculiarity. It can be started at home in spare time. No risk to present job. No risk to present income. And no need to let anyone else know you are "on your own." It can be run as a spare time business for extra money. Or, as it grows to the point where it is paying more than your present salary, it can be expanded into a full time business—overnight. It can give you a sense of personal independence that will free you forever from the fear of lay-off, loss of job, depressions, or economic reverses.

Are You Mechanically Inclined?

While the operation of this business is partly automatic, it won't run itself. If you are to use it as a stepping stone to independence, you must be able to work with your hands, use such tools as hammer and screw driver, and enjoy getting into a pair of blue jeans and rolling up your sleeves. But two hours a day of manual work will keep your "factory" running 24 hours turning out a product that has a steady and

ready sale in every community. A half dollar spent for raw materials can bring you six dollars in cash—six times a day.

In this message I'm not going to try to tell you the entire story. There is not enough space on this page. And, I am not going to ask you to spend a penny now to learn the secret. I'll send you all the information, free. If you are interested in becoming independent, in becoming your own boss, in knowing the sweet fruits of success as I know them, send me your name. That's all. Just your name. I won't ask you for a penny. I'll send you all the information about one of the most fascinating businesses you can imagine. With these facts, you will make your own investigation. You will check up on conditions in your neighborhood. You will weigh and analyze the whole proposition. Then, and then only, if you decide to take the next step, I'll allow you to invest \$15.00. And even then, if you decide that your fifteen dollars has been badly invested I'll return it to you. Don't hesitate to send your name. I have no salesmen. I will merely write you a long letter and send you complete facts about the business I have found to be so successful. After that, you make the decisions.

Does Happiness Hang on Your Decision?

Don't put this off. It may be a coincidence that you are reading these words right now. Or, it may be a matter that is more deeply connected with your destiny than either of us can say. There is only one thing certain: If you have read this far you are interested in the kind of independence I enjoy. And if that is true, then you must take the next step. No coupon on this advertisement. If you don't think enough of your future happiness and prosperity to write your name on a postcard and mail it to me, forget the whole thing. But if you think there is a destiny that shapes men's lives, send your name now. What I send you may convince you of the truth of this proverb. And what I send you will not cost a penny, now or at any other time.

VICTOR B. MASON
1512 Jarvis Ave., Suite M-2-BB
CHICAGO, ILLINOIS 60626

LET MOTOR'S NEW 1972 AUTO REPAIR MANUAL SHOW YOU How to fix almost any part of almost any car



**Shows You Where To Start...
Which Tools To Use...
Exactly What To Do!
Quickly...Easily...Right!**

Over 1,000 pages, over 3,000 pictures and diagrams cover 2,300 models (1966-1972) ... 225,000 facts that make those "tough" repairs come easy

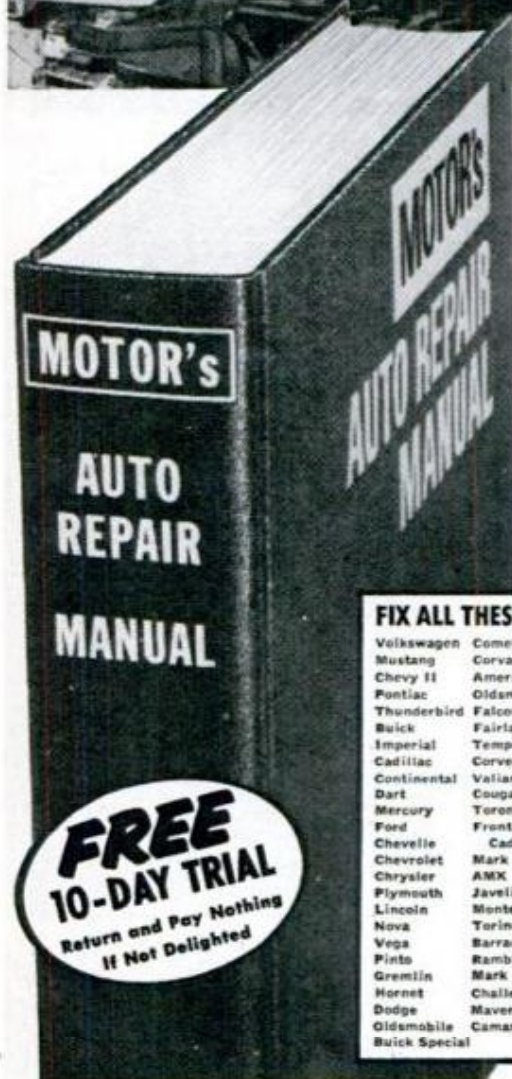

MOTOR's great new illustrated 1972 **AUTO REPAIR MANUAL!** Here is the "meat" of over 300 factory manuals, brought together for you in the most complete, up-to-date auto repair guide ever prepared! Here are the easy directions and "see-how" pictures that help you sail through virtually every auto repair... from a simple carburetor adjustment to a complete transmission overhaul! Here are over 1,000 almost-foot-high pages that can lick your toughest problems—quickly, easily, right the first time!

Yes — fix practically any part of any car! This revised, improved 1972 edition immediately identifies 2,300 models (1966-1972) for you. Just look up make, model, and repair in the handy Instant-Reference Index—and go to it! **MOTOR's AUTO REPAIR MANUAL** takes you all the way—shows where the trouble is, which tools to use, what to do to fix it fast. Over 3,000 pictures and diagrams detail the parts... clear, simple

language puts over 225,000 service and repair facts at your fingertips! A special Trouble-Shooter section and detailed trouble-shooting information thruout help pinpoint in a flash over 4,200 causes of car trouble: transmissions, brakes, engines, electrical systems.

Saves You Time, Money, Work

You get hundreds of compact tables... over 55,000 essential specifications and dimensions... tune-up and adjustment charts... tables of measurements and clearances... overhauling and replacement facts... adjusting and servicing guidance, and much, much more!

Here is the step-by-step help every beginner needs. And here are the labor-saving methods and shortcuts that get old pros over the "tight spots" and save time and money. No wonder more than 6,000,000 copies of this great book have been sold all over the world — to garages, schools, armed forces!

New Illustrated 1972 Edition

FIX ALL THESE CARS

- | | |
|---------------|----------------|
| Volkswagen | Comet |
| Mustang | Corvair |
| Chevy II | American |
| Pontiac | Oldsmobile F85 |
| Thunderbird | Falcon |
| Buick | Fairlane |
| Imperial | Tempest |
| Cadillac | Corvette |
| Continental | Valiant |
| Dart | Cougar |
| Mercury | Toronado |
| Ford | Front Drive |
| Chevelle | Cadillac |
| Chevrolet | Mark III |
| Chrysler | AMX |
| Plymouth | Javelin |
| Lincoln | Montego |
| Nova | Torino |
| Vega | Sarracuda |
| Pinto | Rambler |
| Gremlin | Mark IV |
| Hornet | Challenger |
| Dodge | Maverick |
| Oldsmobile | Camaro |
| Buick Special | |

Same Offer on MOTOR's AUTO ENGINES & ELECTRICAL SYSTEMS



1,300 big pictures. Clear text explains how parts work; principles involved; design; construction; maintenance. Covers all parts of engines & entire electrical system. For FREE trial, check box in coupon.

SEND NO MONEY

Use Manual FREE for 10 Days

Put **MOTOR's** big new **AUTO REPAIR MANUAL** to work for you. See for yourself how quickly and easily it gets the work done! We'll send you this 1972 edition to use **FREE** for 10 days. If it doesn't start paying for itself in even this short time, return the **MANUAL** and owe nothing. Just mail the coupon below **TODAY** to **MOTOR Book Dept., P.O. Box 2316, F.D.R. Station, New York, N.Y. 10022.**

MAIL COUPON NOW FOR 10-DAY FREE TRIAL

**MOTOR Book Dept., Desk D112
P.O. Box 2316, F.D.R. Sta., N.Y. 10022**
Please send me the Manuals checked below for ten days free examination:

- MOTOR's Auto Repair Manual, \$19.95**
 MOTOR's Auto Engines & Electrical Systems, \$10.00

If I am not fully satisfied, I will return the shipment promptly and owe nothing. Or I will keep it and pay the total price in three monthly installments, plus a small shipping charge.

- I want to save shipping charges. I am enclosing payment in full and you will pay shipping charges. (Same return privileges, refund guaranteed.)

Print Name.....

Address.....

City.....

State.....Zip.....

Signature Please.....Age....



COMPLETE AND SIMPLE. "I always rely on my **MOTOR Books**. They're well illustrated — and complete and simple."
—Mr. Ervo Jones, Minnesota (Garage Owner)



DEPENDS ON IT. "MOTOR's Auto Repair Manual is invaluable to me. I depend on it for all makes and models."
—Mr. W. W. Fortines, Virginia (Mechanic)

\$ JOB ADVANTAGE \$

...FOR YOU.

This can be yours through our planned vocational training. Automotive, Electronic, Carpentry, Business Management—Veteran Approved. Learn at home in spare time. Write for information—give your choice.

AMERICAN TECHNICAL SOCIETY (M)
(Established 1898)
850 E. 58th St., Chicago, Ill. 60637



INVENTORS

INVENTIONS—NEW PRODUCTS—IDEAS
DEVELOPED & PREPARED

For Commercial appeal & sales
DESIGN—MARKETING—PATENT RESEARCH—DRAWINGS
Second Decade of Reliable Service To
INVENTORS—MANUFACTURERS—ATTORNEYS

Director: United States Patent Office Former Examiner
United States Dept. of Army Former Patent Adviser
Member: United States Council Int'l Chamber of Commerce
FREE CONSULTATION

THE RAYMOND LEE ORGANIZATION
230-Z Park Ave., New York 10017 (212) MU 6-8500

SEND FREE "Invention Record" Form &
"Product Marketing" Brochure

Name.....
Address.....
City.....State.....
Zip.....

WOOD

EVERYTHING FOR THE WOODSHOP TOOLS-SUPPLIES



World's Largest Selection of Finest Domestic and Imported Hardwoods, Veneers, Hardware—
at MONEY SAVING PRICES

Over 2000 items! Your money saving hardwood and woodshop buying guide. We've added new Clock kits, wood picture kits, musical instrument kits, many more. Complete selection of hard-to-find hardware, lamp and upholstery supplies, etc. Big savings on name brand power tools. Send name, address and 50¢ for handling and postage to:

CRAFTSMAN WOOD SERVICE CO.
DEPT. A-22
2729 S. Mary St., Chicago, Illinois 60608

New Catalog!
Write Today!...



BUILD THESE BEAUTIFUL CLOCKS



NOW AT BIG SAVINGS!

Send just \$1 for plans & instructions to build choice of: (A) Grandfather, (B) Steeple, (C) Grandmother—plus information-packed catalog of movements, dials, parts & kits to build these & 16 other fine clocks. All 3 plans—\$2.50. Catalog alone—25¢.

MASON & SULLIVAN COMPANY
Dept. PM2, Osterville, Mass. 02655

162D

POPULAR MECHANICS

Hard-to-Find TOOLS



New 1972 Catalog

Contains unique collection of hand tools, small-power tools rarely found in stores or other catalogs. Hundreds of items to make projects easier, more fun. All finest qualities, sold with money-back guarantee. Send 50¢ for 1 year subscription (3 issues).

Brookstone Company
2224 Brookstone Building
Peterborough, N.H. 03458

WRIST ROCKET

AMERICA'S HARDEST HITTING SLING
Range 225 yd. - 232 fps.
Matched replacement rubbers and LEATHER pouch assembly \$1.00
At dealers or order direct.



WRIST ROCKET Mfg.
P.O. BOX 21-B
Columbus, Nebraska 68601

\$3.00 Post. Pk. in U.S.A. No C.O.D.'s
Orders outside U.S.A. add \$1.00 for postage and handling.

PUMP DRAINS pools, cellars, laundry tubs IRRIGATES — CIRCULATES — SPRAYS

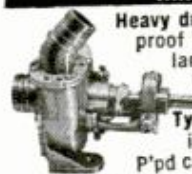

Heavy duty ball bearing pump. All metal, rust-proof Type XB. Stainless shaft. Use 1/4 HP or larger. 1 HP 1,200 GPH 60' high or 3,000 GPH 25' well. 5,200 GPH max. 1 1/4" in; 1" out. Belt or direct drive. **\$13.95**
Type P won't rust or clog. Bronze bearing. To 2,400 GPH. 1" in; 3/4" out. **\$9.95**
P'd cash with order. Money back Guarantee.

LABAWCO, Box 40, Belle Mead, N.J. 08502

NOW! BUY 1970-71 Chevys, Dodges, Fords (From \$799 to \$999)

Delivery arranged anywhere.
Free catalog. Send self-addressed stamped envelope to:

PAN AM CAR DIST. CORP. ME-34
31 Hanse Ave., Freeport, N.Y. 11520

MAKE MONEY!

REPAIR HYDRAULIC JACKS



Earn while you learn at home. Millions of jacks in gas and auto service stations, trucking firms, body shops, riggers, factories and farms need servicing... most of which you can learn to repair. We show you HOW. Start spare time in your basement or garage. Big opportunity for mechanics. ACT NOW!

Write for Folder #M2 and Free Bonus Offer

Hydraulic Jack Repair Manual Co., Inc.
G.P.O. BOX 3 • STATEN ISLAND, N.Y. 10314

BUILD YOUR OWN CAMPER SAVE UP TO 50%



Complete, easy to follow plans, instructions, materials list.

Camper Plans\$3.95
Travel Trailer\$3.95
Pickup Cover\$2.00
CONVERSION PLANS:
Eonoline Type Van..\$2.95
Passenger Bus or
Delivery Van.....\$2.95
Satisfaction Guaranteed

VIKING CAMPER SUPPLY, INC.
99-BP Glenwood Ave.,
Minneapolis, Minn. 55403
Please send _____ for
which I enclose \$ _____
NAME _____
ADDRESS _____
CITY _____
STATE _____ ZIP _____

EQUIPMENT CATALOG #100

Refundable on First Order.
Send Dime for Details.
Save 50% on Camper Kit.
All items from catalog to
build \$1,795. Camper, 8',
10', 10'8" or Chassis Unit.



BLAST FURNACE 2400 F



Since 1935
Hobbyists • Schools • Inventors, etc.
Make your own castings of any metal from cast iron, down to lead and zinc. Available in 6 sizes, 1 1/2 to 50 lbs. Complete units for \$50.40 to \$162. Send 25¢ for circular—refundable.

Dept. P-2
P.O. Box 193
Middleton, Wis. 53562
KANSAS CITY SPECIALTIES CO.

Who'd have thought I'd make so much money without going to college?



I still have to pinch myself every week when I open my pay envelope—it seems too good to be true!

Especially when I remember how sorry everyone felt for me because I couldn't go on to college with the others in my high school class. "How are you ever going to make it now?" people kept asking me. "Without college, it's a losing battle. Everybody knows that!"

Well, the college boys left for school, and I got my first job. And it was tough going for a while, I'll admit that—one dull, routine thing after another. From pumping gas to driving a cab to working on an assembly line in a factory. I worked hard but never "struck it big."

Then I read an announcement like this one about the opportunities in Electronics.

I discovered that, with proper training, I could have my pick of thousands of glamour jobs—in fields like radio and TV broadcasting, automation, computer servicing, or even the aerospace program.

And I found out that as you move up the ladder in this booming field of Electronics, you can earn the kind of money that even a college man could be proud of—up to \$5, \$6, \$7 an hour...\$200, \$250 a week...\$10,000, \$11,000, even \$12,000 a year!

And—most important—I realized how easy it would be to get the training I needed to break into this great field. The announcement said I could learn everything I needed to know, right at home in my spare time, with a home study course from the Cleveland Institute of Electronics.

Well, to make a long story short, I enrolled with CIE. I found that their courses had taken what seemed like a complicated subject and broken it down into easy steps. Sympathetic instructors sent me letters helping me over the rough spots. I really learned fast. And here I am now, a respected Electronics man—earning so much money I still have to pinch myself.

Thanks to CIE, I don't have to envy the college boys anymore. In fact, there are some that envy me!

Send for 2 FREE BOOKS

This composite story is typical of hundreds told by CIE students who are now enjoying exciting new careers in Electronics.

Most of them decided on their new careers after reading our famous books, "How To Succeed In Electronics," and "How To Get A Commercial FCC License." These books describe in detail the many electronics careers open to men with proper training. And they tell which CIE courses will best prepare you for the work you want.

Both books are *FREE* when you mail the bound-in card, or with the coupon above. So send for them, and get ready to pinch yourself for not writing to us sooner. CIE, 1776 E. 17th St., Cleveland, Ohio 44114.

ENROLL UNDER NEW G.I. BILL—All CIE courses are available under the new G.I. Bill. If you served on active duty since January 21, 1955, or are in service now, check box for G.I. Bill information.

CIE Cleveland Institute of Electronics

1776 East 17th Street, Cleveland, Ohio 44114

Please send me 2 FREE books describing opportunities in Electronics and how to prepare for them.

Name _____
(Please print)

Address _____

City _____

State _____ Zip _____ Age _____

Check here for G.I. Bill information.

Accredited Member National Home Study Council. A Leader in Electronics Training
... Since 1934



PM-62



KING-SIZE BENCHES flanking a Delta radial saw provide an ideal support for extra-long workpieces. Construction includes fence equipped with "built-in" tape measure for speedy and accurate setting of the stops

This radial-saw bench features

The stops give measurement readings quickly and can be relocated with the twist of a knob

By **HARRY L. COLLINS**



SHORT LENGTHS, as well as long, are easily handled by author's setup. Benches are built using basic construction techniques, could be fitted with drawers

THE VERSATILE and time-saving radial-arm saw can be even more versatile if a couple of sturdy benches, adjustable table fences with gauge rails and stop clamps are set up flanking the rig. The tables shown can be used with any radial saw, the only limitations being saw-table height and length of the wall against which it stands. The setup shown is built around a Delta-Rockwell saw positioned against a 15-ft.-long wall. Thus, I was able to build two 6-ft. tables, one for each side of the saw.

Construction techniques are basic. After deciding height and length of your tables, build a framework of 2x3s or 2x4s and skin the top surface with $\frac{3}{4}$ -in. plywood. For added rigidity, install a 6-in.-wide apron across the front (just below the worktop). Tables, of course, should be level when placed next to the saw, and

POPULAR MECHANICS

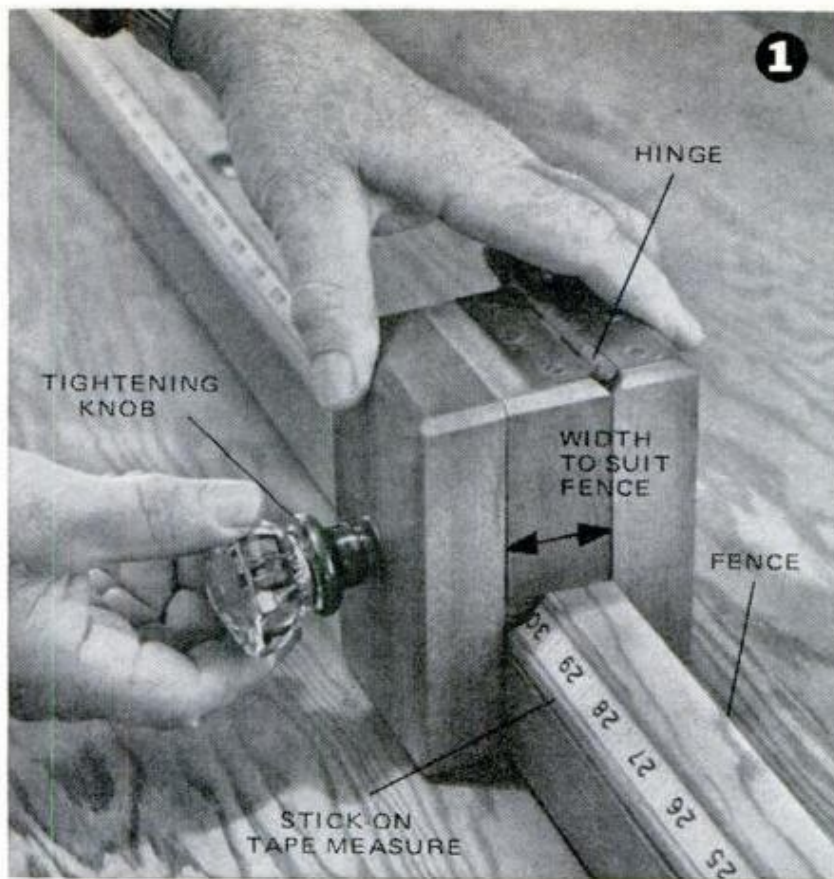

1. ADJUSTABLE STOP-CLAMP is an improvement on the hinged fixed-position type found in lumberyards (which are usually spaced at 1-ft. intervals). Here the stop is being set at exactly 30¼ in. Clamping "knobs" used by author are glass doorknobs salvaged from old door. For safety, stops should be sturdily constructed of hardwood and joined with flathead screws, glue

2. RADIAL-SAW SETUP has benches that support workpieces whether they are cut right or left-handed. Benches are built using standard 2x3-frame construction, and then skinned with plywood. Lengths of benches are limited only by the wall space available in your shop

3. TO BRIDGE GAP between end of fence and saw blade when you make short cutoffs, a 20-in. gauge strip must be used. If you want to cut several 10-in. pieces from a long board, for example, the stop is clamped at 30 in. and the strip brought into use for workpiece to butt against. Strip can be drilled and hung in a convenient location

built-in stops

at least 1-in. clearance should be allowed between the benchtops and the radial-saw top.

The gauge stop-clamps should be made from hardwood. One stop-clamp is required for the fence on each bench and (as can be seen in the photo above) each is made up of three pieces of wood and a butt hinge. The clamp dimensions will be determined by the height and thickness of your fence.

Doorknobs shown have ⅜-16 internal threads (standard on most doorknobs). Knobs are held on the clamp with a ⅜-16 x 4½-in. carriage bolt inserted from rear to front. For a good hold, use a flat washer beneath each bolt head.

Although I used a standard tape set into routed-out recesses, the new self-stick type could be used. Just make certain that measurements are accurate when you position the tapes and that they are installed after the benches have been fixed in one position so that any movement is impossible. ★★★

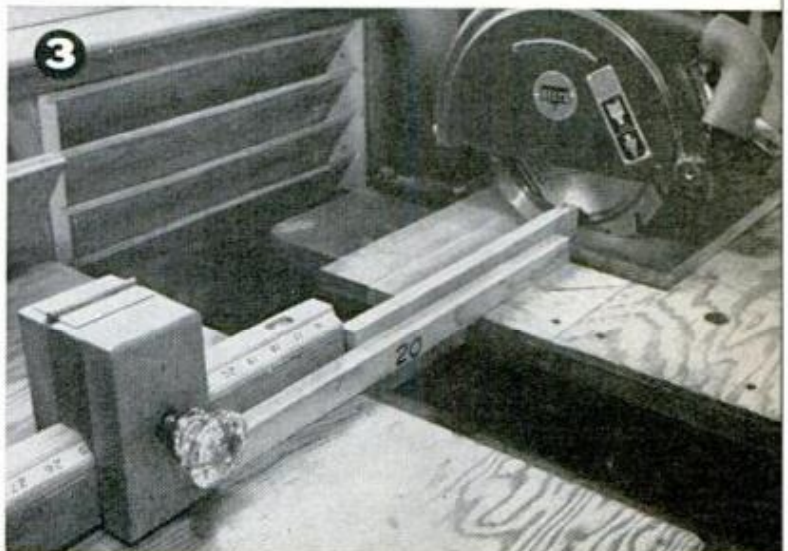
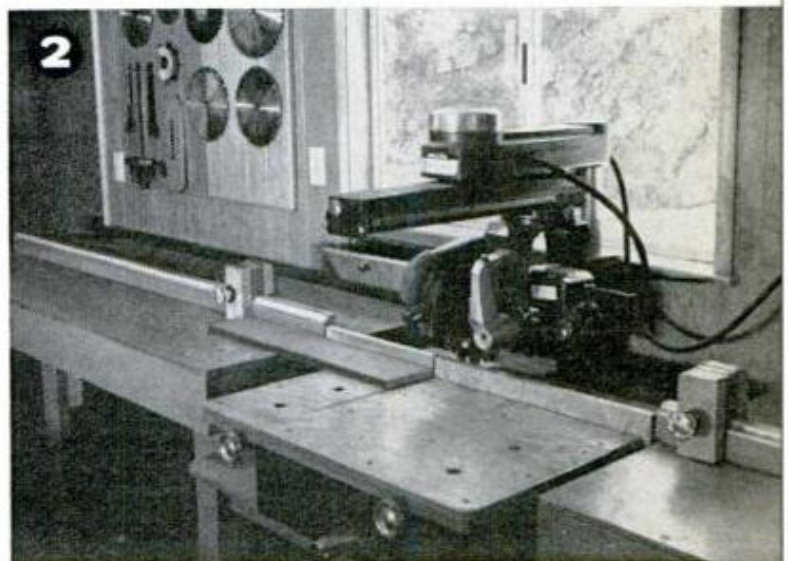

HINTS FROM READERS

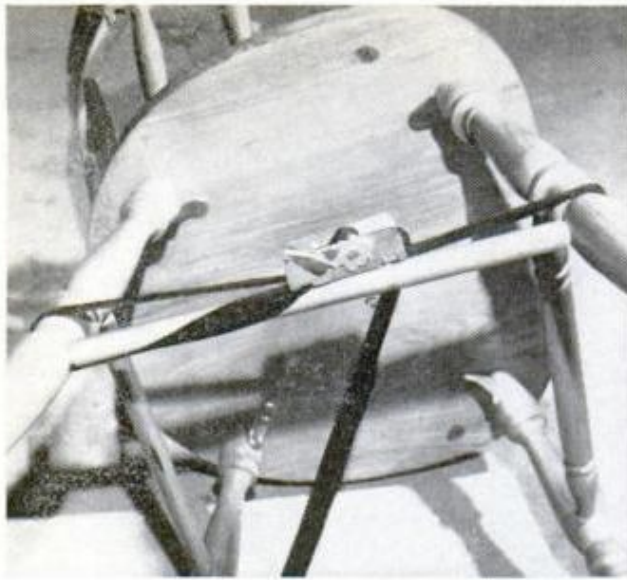

Stopping belt-clamp slippage

It's not unusual—and it can be pretty frustrating—to have a belt-clamp slip after you have all parts glued and aligned. Though this clamp is ideal for such repair jobs as wobbly legs on a chair, it does tend to slip due to leg taper. You can stop this from happening by looping one end of the clamp around a chair rung as shown. The stunt works for me every time I use it.
—Robert Brightman, Great Neck, N.Y.



Totable anchor takes no space

Because the slightest current or breeze will cause our rubber boat to drift when we want to fish a particularly good spot, an anchor is a necessity. Shown at left is the simple one that we use. It consists of an old fishing bag filled with rocks found at the fishing site and a length of sturdy rope. When you're through for the day, simply dump out the rocks and store the fishing bag for your next outing. To make certain that it's always at hand, keep the fishbag inside of the deflated and folded boat.

—John Krill, North Lima, Ohio

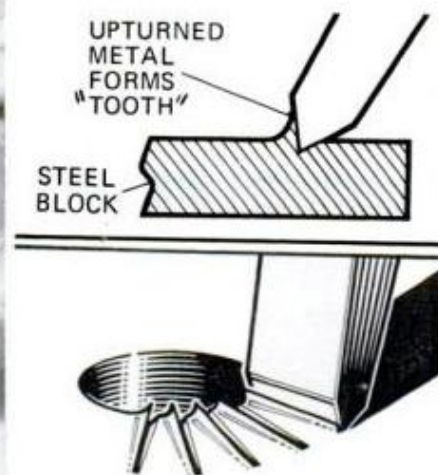
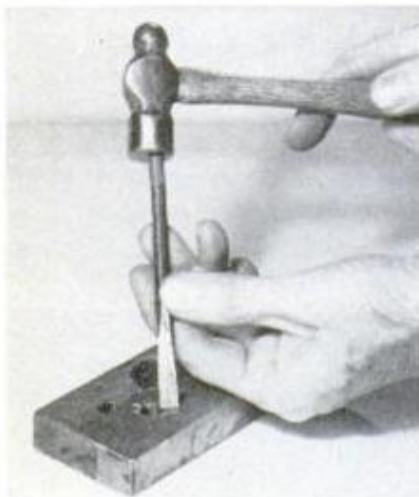

Scrap-steel 'tool' provides easy method for cutting tenons

A scrap steel block can be converted in minutes into a "tool" for forming tenons on the ends of wood dowels and rungs. A hole with the diameter of the desired tenon is drilled through the block. Then, a sharp cold chisel is used to form a series of cutting edges around the hole on the block surface. The resulting teeth resemble

those on a rasp and are positioned so they cut when the dowel is rotated clockwise against them. After tapering the tip of the dowel, you can chuck it in a drill press or hand brace-and-bit to do the cutting. When the teeth wear out, simply flop the block and use the other side.

—Walter E. Burton, Akron, Ohio

67 FANTASTIC VALUES!

Buy Below Wholesale

3D POWER TELESCOPE & TRIPOD
Sturdy Metal Construction

ELECTRIC RAZOR
Product of Swiss Craftsmanship.

ELECTRIC CARVING SET
Self contained power.

MINK COAT
Full Length from Scandinavia.

TENNIS RACKETS
Laminated hard wood Precision balanced.

OPERATES THROUGH HOME, OFFICE, FARM

WIRELESS INTERCOM

BEDFORDLEX CAMERA
Twin lens reflex.

ELECTRIC TRAIN SET
Sixteen piece set.

NYLON TIP PENS
Fast writer. All colors available.

ELECTRIC GUITAR
True amplification. Great electric sound.

CABIN CRUISERS AND SAIL BOATS, TOO
Models 18 feet to 56 feet

RIVIERA BIKINI
American girls go wild over European Bikinis.

FISHING KITS
Sectional bamboo spinning and fly rod.

Many delicate fragrances

FRENCH PERFUME

BURGLAR ALARM
For office or home.

INTERPHONE SET
Closed circuit phones for home or office.

CALENDAR WATCH
Swiss movement. Tells time and date.

REAL SAPPHIRE RING
Sterling Silver mounting.

FLASH CAMERA
Black and White or Color.

FLASHLIGHTS
Ideal for outdoor or recreational use.

CASSETTE TAPE UNIT
Snap in cartridge ready to play.

FIELD GLASSES
7 x 35 G.C.F. Clear and powerful.

ADDING MACHINES
Famous design.

JADE RING
Hand set in delicate mounting.

DUTCH MOTORCYCLE
Deluxe Spring master model.

1000's of dazzling imports like these help you, spare or full time, start your own BIG PROFIT HOME IMPORT BUSINESS

MEN - WOMEN . . . you can start fast without product investment! My proved plan guides you every step. No experience needed; age, location doesn't matter. Make first import transaction 10 minutes after you get my Drop Ship Plan.

More examples of 1000's of import bargains you can get to make fantastic profits up to 200% and more.

Big Savings on Personal Purchases for Your Own Use . . . Examples

Save \$95 on ROLEX GMT Perpetual Watch

Save \$87 on OMEGA Constellation Watch

Save \$157 on NIKON Model F Photomic TN Camera

More savings on SONY, SEIKO, LEICA, hundreds other products like: Swords, Oil Paintings, Elec. Scissors, Golf Balls, Digital Watches, Diamonds, TV Camera, Tailored Suits, Typewriters, Dinnerware. Also cars and cycles:

Honda - Volkswagen - Yamaha - Porsche

TELEPHONE AMPLIFIER
Hear conversation across room.

BICYCLE
Latest style, powerful frame.

LAMP RADIO
Combination Lamp and six transistors for radio.

FREE Specialty Merchandise Catalogs

For fast start to profit . . . I send you free catalogs of big selling specialty merchandise you can order at once from wholesale warehouse in U.S. while you are setting up overseas contacts. NO fat fees for "privilege" of buying! Only Mellinger offers this exclusively to International Traders Members!

FREE Catalog

Mail This Coupon Today - GET MY FREE REPORT!

How to Import Export

The Mellinger Co., Dept. F2292
6100 Variel, Woodland Hills, CA 91364

Send FREE report showing how I can buy imports below wholesale. Show me how to start a business of my own and make big profits. No obligation. No salesman will call. (If under 21, state age.)

Name _____ Age _____

Address _____

City _____ State _____ Zip _____

Save 3 Days . . . Give Zip for Fastest Reply

THE MELLINGER CO., Dept. F2292 6100 Variel, Woodland Hills, CA 91364

FINISH CORNERS • CUT MOULDING

WITH ANY ELECTRIC DRILL

NO \$50 ROUTER OR \$6 BITS NEEDED!

You don't have to buy an expensive Router to finish corners, moulding & trim. ARCO Corner Finishing & Moulding Cutters do the work at a fraction of the cost. Simply slip the Cutter's 1/4" shank in any drill chuck and it's ready to produce! Special Dual Guides assure accurate cuts along entire length & width of workpiece. Cuts wood, plastics, soft metals. Quality-made in U.S.A. of hardened steel. These Cutters will fit & work with all Electric Routers, of course.

No. 6—3 PIECE CUTTER SET
CUTS 3/16" CONTOURS **\$4.35**

FANCY COVE-CUTTER

ROMAN OGEE-CUTTER

RABBET-CUTTER

No. 7—3 PIECE CUTTER SET
CUTS 3/16" CONTOURS **\$4.35**

BEADING-CUTTER

COVE-CUTTER

OGEE-CUTTER

SPECIAL SAVING!

Order all of above 3 Sets at our Special Money-Saving Price. No. 6715, total **\$12.95** of 10 Cutters, only . . .

These & over 300 other Arco Tools available at Hardware Depts. everywhere, or order direct on 20-day Money Back Guarantee

No. 15—4 PIECE RADIUS & BEVEL CUTTER SET
\$6.15

ADJUSTABLE BEVEL-CUTTER
cuts 45° bevels from 1/32" to 3/16" wide.

RADIUS CUTTERS
3 SIZES for 1/8", 3/16", 1/4" Radius Cuts.

MAIL THIS COUPON TODAY!

ARCO TOOLS, INC. Dept. PM-2,
421 West 203rd St., N.Y., N.Y. 10034

Ship on your 20-day Money Back Guarantee:

No. 6, 3-Piece Cutter Set . . . \$4.35

No. 7, 3-Piece Cutter Set . . . 4.35

No. 15, 4-Piece Cutter Set . . . 6.15

No. 6715. All 10 Cutters . . . 12.95

I enclose Check, M.O.—SHIP PPD. (No C.O.D.'s)

Name _____

Address _____

City _____ State _____ Zip _____

New tools you should know about

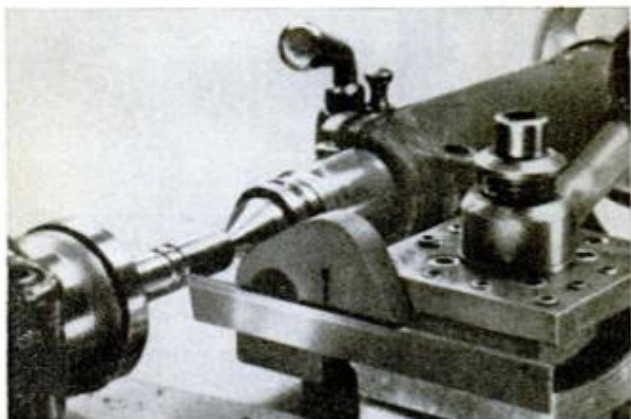

LATHE TOOLHOLDER is designed to use standard cutoff blade and fit any four-way toolpost ($\frac{3}{8}$ -in. or larger slot). E-Z Cut-Off comes in four models, \$18 to \$23; with blades, \$3.70 to \$5.80, from Wanjo, Gilmanon, N.H.



MACHINE SPUR BITS of selected steel feature brad point and two cutting spur-lips. Approximately 6 in. long, bits are available in eight-piece set (from $\frac{1}{4}$ to $\frac{3}{4}$ ") for \$39.95. Rockwell Manufacturing Co., Pittsburgh, Pa.



LOW-COST SNAKE, claimed to let you clear clogged drains like a plumber, has bright galvanized, flexible $\frac{1}{4}$ -in. spring wire. Six-foot auger costs \$1.59 at hardware stores. Chicago Specialty Mfg. Co., Skokie, Ill. 60076.

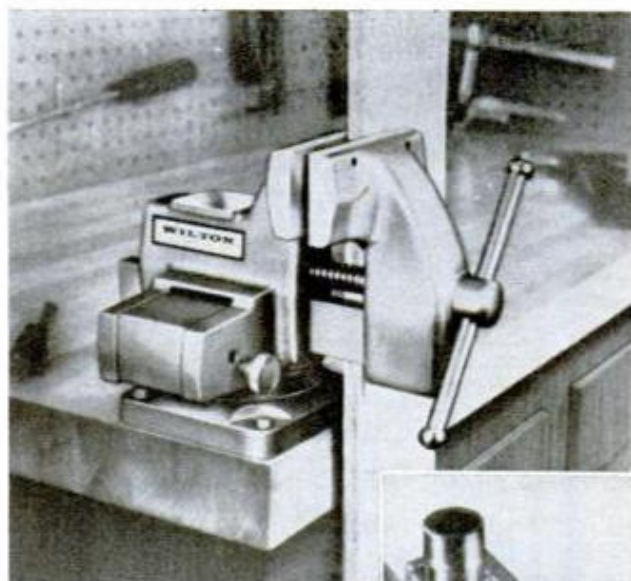

MULTI-POSITION VISE flips, swivels and is claimed to provide more versatility than any other vise. Made by Wilton Tool, 9525 Irving Park Rd., Schiller Park, Ill. 60176, it's sold through hardware stores and building supply dealers.

The Flip-Grip bench vise is priced at \$22.50. Boasting replaceable serrated steel jaws and removable, hardened-steel pipe jaws, it can be used for metalworking and to hold pipe of $\frac{1}{4}$ to $2\frac{1}{2}$ -in. capacity. For woodworking, steel jaws are removed and the unit's 2x4-in. smooth jaws are used. The vise can be used vertically or horizontally for all three vise operations.

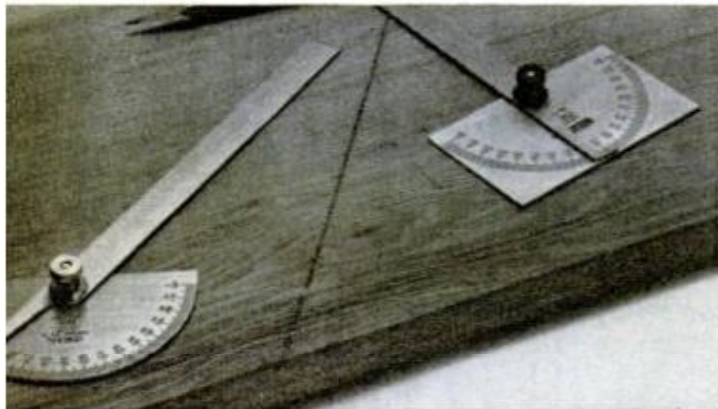

STAINLESS-STEEL PROTRACTORS have etched graduations from 0 to 180° in opposite directions. At hardware stores, Models 18 (left) and 17 are \$2.90 each. General Hardware Co., 80 White St., New York, N.Y.

MOST ECONOMICAL MIG WELDING PACKAGE EVER OFFERED!
 Less Than \$550.00
MILLERMATIC 35
 Works like lightning!
BUILT TO LAST —
FINEST QUALITY —



USED BY INDUSTRY NATIONWIDE

MILLERMATIC 35 is the ideal MIG welding package — all-in-one power source and wire feeder, complete with torch. Works like lightning on any steel that needs welding including engines, trans, bodies, frames — and without distortion. 100's of other uses: sheet metal shops . . . air conditioning contractors . . . garages . . . auto body and fender repair . . . maintenance welding . . . ornamental metal work . . . steel sculpture . . . etc. **EASY TO OPERATE. NO SPECIAL TRAINING REQUIRED.** Pressing the torch trigger starts gas flow, wire feed, and weld current. Exclusive MILLER voltage-ampere control system simplifies settings. No special wiring . . . operates from 208 or 230 volt service. Uses .030" and .035" hard wire in either 8" or 12" diameter spools. MILLERMATIC MODEL 35S has added controls for MIG spot welding — permits rapid, simplified tack welding of assemblies before high speed MIG for the finished seam weld. MODEL 35 less than \$550.00. MODEL 35S less than \$625.00. Built by MILLER, creators of the world's finest welders for over 40 years. Worldwide sales and service.

FREE! MILLERMATIC 35 AND 35S BROCHURE. Ask your nearest MILLER Distributor — find him in the Yellow Pages under welding or write:
miller ELECTRIC MANUFACTURING COMPANY
 Advertising Dept. PM, 718 S. Bounds St., Appleton, Wis. 54911

We'll train you in your spare time for an exciting OUTDOOR CAREER



FREE kit shows how to qualify in your spare time for exciting outdoor career. Approved for GI's and Vets. Write National School of Conservation, 1129 20th St., N.W., Washington, D.C. 20036, Dept. 42592

Use Zip Code When Answering Ads

SURVEYING PAYS BIG



U. S. Dept. of Labor reports "openings for 26,000 Surveyors in next 10 years." Send for FREE "SURVEYING CAREER KIT." **APPROVED FOR VETERANS**

Name _____ Age _____
 Address _____
 City _____ State _____ Zip _____

NORTH AMERICAN SCHOOL OF SURVEYING & MAPPING
 4500 Campus Dr., Dept. 24172, University Plaza, Newport Beach, CA 92663

MAGIC MAIL PLAN

that comes with this Little Machine

CAN MAKE YOU \$1200 AN HOUR

The machine is turning out a job that will bring operator \$2.58, by mail. Material cost, only 11c



Write today for free facts about the newest and most fascinating of all new home operated businesses. For the first time, a simplified machine brings the fabulous profits of Plastic Sealing and Plastic Laminating within reach of the small operator. Anyone can learn to operate it with a few minutes practice. Then—with our MAGIC MAIL PLAN—can get mail orders pouring in daily with cash in every envelope.

No Canvassing or Selling

Fill orders at home in spare time to start. Then expand to full time business. We even supply circulars to bring back cash and orders. Rush name for all the facts you need to start. A postcard will do. No charge.

WARNER ELECTRIC CO., Dept. L-2-BB
 1512 Jarvis, Chicago, Ill. 60626

A FASCINATING BUSINESS OF YOUR OWN



Send for FREE Illustrated Book

This deluxe, illustrated brochure you (and your husband or wife) will read and look at with excitement and pleasure TELLS AND SHOWS YOU . . .

- how to make good money in your spare time
- the successful business you can own
- the fascinating places where you and your family can live and work
- how to make 65% to 70% profit on every job
- how to save hundreds of dollars doing your own upholstery
- the tools you work with
- how to get all your upholstery supplies wholesale
- the outfits you get FREE of extra charge
- the fine furniture you can make
- 17 ways you can make money in upholstery
- HOW EASY IT IS TO LEARN
- success stories you can follow

TOOLS MATERIALS AND FRAMES INCLUDED WITH COURSE!

REUPHOLSTER CHAIRS . . . SOFAS . . . TO KEEP OR SELL FOR HIGH PROFITS



IN UPHOLSTERING—DECORATING

SLIPCOVER, DRAPERY MAKING AT HOME
BE YOUR OWN BOSS—MAKE YOUR OWN HOURS
EARN MORE MONEY—RIGHT OFF—IN SPARE TIME AT HOME

Right at home—in spare time—you alone or husband-wife together can learn upholstery—combine your skills for a steady lifetime income or big extra earnings in the booming field of CUSTOM UPHOLSTERY & DECORATING. It's easy to become a fine custom upholsterer and earn as you learn WITHOUT special skill or previous experience—a grade school education is all that's necessary.

YOUR OWN BUSINESS—RIGHT IN YOUR OWN HOME

Pick up spare time cash almost from the start of your training—earn big profits for your skills—because your UDS course includes ALL tools, materials, fabrics, etc. You learn by making beautiful upholstered furniture or slipcovers you can use or sell.

Upholstery skill is always in demand. You'll be earning more money than you ever dreamed possible. With this N.J. state-approved home study course, you'll be upholstering from the start—making money as you learn—in upholstery and decorating.

Creative UPHOLSTERY & DECORATING SCHOOL
 Division Technical Home Study Schools
 Dept. 5110-022
 Little Falls, New Jersey 07424

THE UPHOLSTERY SCHOOL licensed by N.J. Dept. of Education • Accredited, National Home Study Council • Approved for Veterans and for Vocational Rehabilitation • Established 1939.

Creative UPHOLSTERY & DECORATING SCHOOL,
 Little Falls, N.J. 07424 Dept. 5110-022

ESTABLISHED 1939

Please send FREE BOOKLET with full details of Upholstery opportunities. No salesman is to call.

Name _____
 Address _____
 City & State _____ Zip _____

MAIL COUPON TODAY

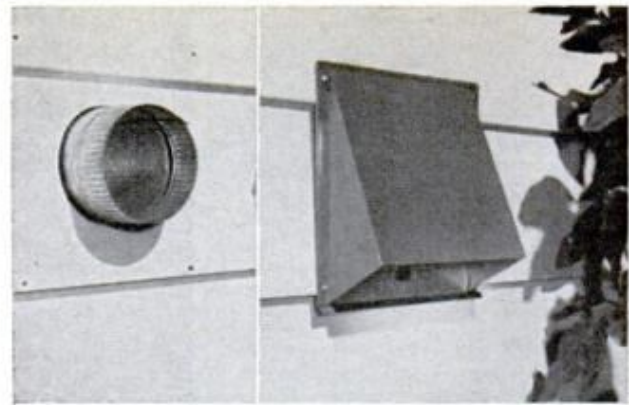
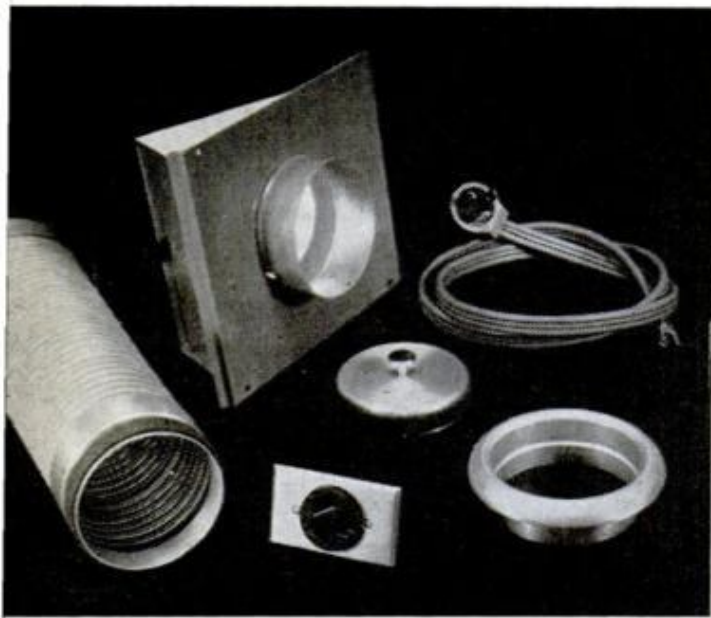

DUCT THROUGH HOUSE WALL (above, left) is capped outside with butterfly damper attached with screws

KIT OF PARTS (left) includes two rings, two caps, flexible duct, damper, power cord and fittings, plus a 240-v. receptacle. Price of kit is \$23 postpaid

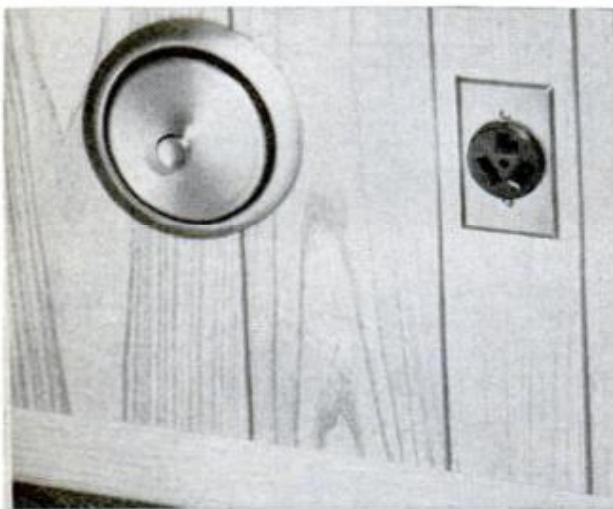

EXHAUST PORT in outside wall is located 12 in. from floor. The 240-v. receptacle is shown adjacent

COOK WHERE THE FUN IS

(Continued from page 137)

spring-loaded friction catches placed at the ends of the aprons hold them in an upright position.

The electric grill sits in the hole provided and is secured in place with locking screws. Two standard 5-in. elbows and a straight section of galvanized smoke pipe are needed to duct the ventilating fan through the hole in the side of the cabinet. An aluminum ring that comes with the kit fits the hole on the outside. The outdoor exhaust port is installed by cutting a 5-in. hole through the wall and inserting a 5-in. section of 5-in. galvanized pipe. The pipe is then fitted with a ring on the inside and a damper on the outside. ★★★

HANDY CONDIMENT RACK is attached to left-hand door. Details (below) show how the rack is assembled

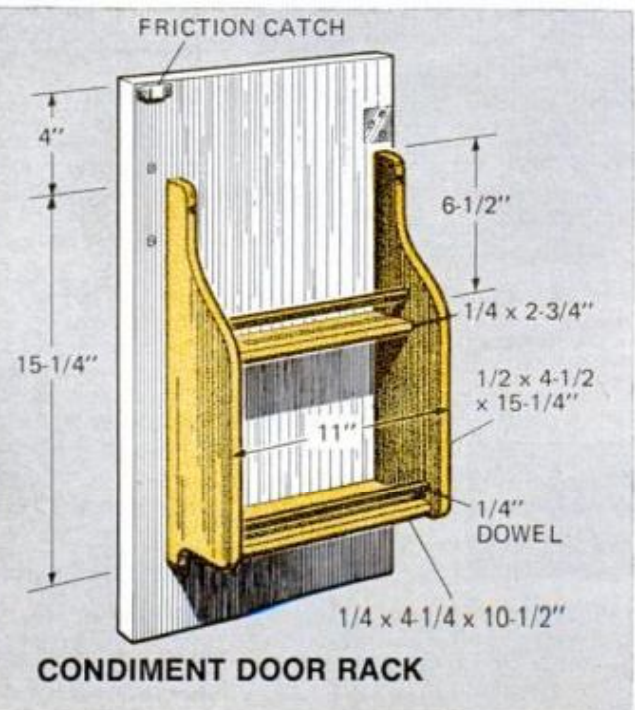

TAKE ANY 4 (up to \$49.45 worth of books) FOR ONLY \$1

when you join the Popular Science Book Club



044

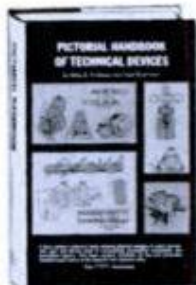

326



050



058

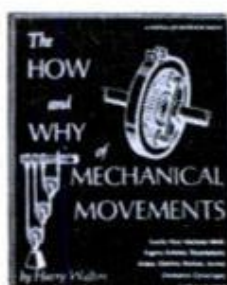

036



1019



054



027



312

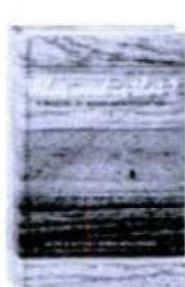

293



302



318

044. COMPLETE BOOK OF HOME WORKSHOPS. How to design, build, improve or expand your home workshop, build equipment, select tools, more.

Retail: \$8.95

326. PICTORIAL HANDBOOK OF TECHNICAL DEVICES. Over 8,000 detailed construction designs for machines, tools, etc.

Retail: \$12.50

050. COMPLETE BOOK OF HOME REPAIRS AND MAINTENANCE. Learn to make home repairs, expertly, work with today's new materials, modernize.

Retail: \$8.95

1019. SET OF 3 APPLIANCE REPAIR BOOKS. Become your own appliance fix-it man with 3 books on repairing small and major appliances.

Retail: \$10.85

058. HOMEOWNER'S COMPLETE OUTDOOR BUILDING BOOK. 265 easy outdoor projects — patios, fences, walls, furniture, pools, more.

Retail \$8.95

036. THE HOW AND WHY OF MECHANICAL MOVEMENTS. How six basic mechanical elements power every machine ever invented.

Retail \$7.95

302. HOME APPLIANCE SERVICING. How to repair, maintain, install and service all your appliances like a pro.

Retail: \$6.95

027. HOW TO DO YOUR OWN WOOD FINISHING. Finish new wood, restore surfaces, antiques, refinish floors, more.

Retail \$1.95

293. WHAT WOOD IS THAT? How to identify wood, select and use it. How wood is processed. 40 actual wood samples are included in the book.

Retail: \$7.95

312. THE NEW INTELLIGENT MAN'S GUIDE TO SCIENCE. Covers virtually every scientific discovery, invention, breakthrough in the history of modern science.

Retail: \$12.50

054. COMPLETE BOOK OF HOME IMPROVEMENT. How to improve floors, walls, doors, windows, bathroom, kitchen, electrical system, storage areas, more.

Retail: \$11.95

318. ENCYCLOPEDIA OF AMERICAN AUTOMOBILES. Covers every make of car ever produced in the U.S. and Canada in colorful, authoritative detail.

Retail: \$12.50

HOW YOUR CLUB WORKS

First, you choose any four of these 12 best-selling books for only \$1 to start your PSBC membership. Thereafter, you'll be offered a book a month from the very best books published today on all your favorite subjects. You need accept only one more selection in the next year to retain all membership privileges. And every single Club selection you accept comes to you at your special reduced member's price. (Discounts range from 30% on up to 70% for the books you like to read best.)

EXTRA MONTHLY BONUS! With every selection you accept from the Club, you'll receive an exciting surprise gift — compact tool, science chart, key ring, or some equally handy, practical item.

MAIL THE POSTPAID CARD TODAY
or write to address below

POPULAR SCIENCE BOOK CLUB · 44 Hillside Avenue, Manhasset, N. Y. 11030

CHOOSING A MARINE COMPASS

(Continued from page 92)

compass. You can often eliminate error by relocating the compass. If this isn't practical, small external magnets can be mounted about the compass to correct deviation.

● *If you do any nighttime sailing*, a built-in compass light is far more convenient to use than a flashlight. Be sure that the light is protected since salt spray and weather can cause corrosion and failure. Daytime sailors can save themselves a couple of dollars by omitting the light.

● *If you own a small boat*, easy removal of the compass may be a consideration to protect it from theft and vandalism. Check the demounting procedure to be sure it isn't complicated.

● *Compass mounts*. Some compasses require mounting to a horizontal, flat sur-

U-shaped bracket allows compass to be mounted horizontally or vertically

face, but some boats don't have this readily available. Consider the surfaces in your boat on which you can mount a compass. A compass having a U-shaped bracket may be needed. This allows the compass to be mounted on a horizontal or vertical surface, or side-mounted or front-mounted at any angle.

Other compasses can be surface-mounted on the dashboard, installed in the dashboard or mounted on the deck.

The best advice anyone can offer about mounting a compass is to follow the manufacturer's instruction book, which should accompany the instrument. Compass companies spend money and time on research to find out under what conditions their instruments will work best.

● *If the mounting location is exposed to the weather and salt spray*, the compass binnacle should be finished with baked enamel paint or be made of plastic. Chrome and polished brass require a great deal of attention to retain their appearance and are impractical in exposed locations.

Most instruments come with complete instructions regarding care and maintenance. Follow these closely for best results. If you've misplaced these instructions or happen to have an older compass,

the following suggestions will be helpful:

When laying up the boat for the winter, try to remove the compass from its mounting on a day of moderate temperature. This will prevent unnecessary strain on gaskets.

Check the compass on occasion for bubbles and a broken pivot or jewel. A marine compass card is almost invariably enclosed in a liquid-filled chamber. The liquid dampens the movement of the card—that is, it acts as a shock absorber and slows down the action of the card so that in rough water the card won't rock excessively or hunt back and forth.

When a bubble forms—you'll see it—it doesn't indicate any inaccuracy although it may cause some distortion in readings. The cause is either low temperature or worn gaskets.

Allow the compass to wait for a warmer day to see if the bubble disappears. If not, send it to the manufacturer or take it to a competent instrument repair shop for replacement of gaskets. Do-it-yourself compass repair is not recommended.

The condition of the pivot and jewel can be established by placing the compass on a level surface away from magnetic objects. Allow the card to come to rest on a degree mark.

When the card is no longer moving, bring a jackknife or screwdriver close enough to pull the card off the reading by about 10°. Remove the disturbance and check to see if the card returns to its original position. If not, consult a repair company.

As for using a marine compass, there are several excellent sources you can consult. Most can be found in a library. The following are widely recognized:

1. *Piloting, Seamanship and Small Boat Handling* by Chapman—published by *Motor Boating and Sailing Magazine*.

2. *American Practical Navigator* by Bowditch—published by the U. S. Navy Hydrographic Office.

3. *Navigation and Piloting* by Dutton—published by the U. S. Naval Institute.

4. *Handbook of Magnetic Compass Adjustment* by Spencer—published by U. S. Navy Hydrographic Office.

Some manufacturers you might want to write about their marine compasses:

Airguide Instrument Co., 2210 Wabansia Ave., Chicago, Ill. 60647.

Aqua Meter Instrument Corp., 465 Eagle Rock Ave., Roseland, N.J. 07068.

Danforth White, 500 Riverside Industrial Parkway, Portland, Me. 04103.

E. S. Ritchie & Sons, Inc., Pembroke, Mass. 02359.

Hull Manufacturing Co., Logan and High, N.E., Warren, Ohio 44481.

OMNI Laboratories, Inc., 31 Green St., Marblehead, Mass. 01947.

Sherrill Corp., River Ave., Mexico, Ind. 46958. ★ ★ ★

CUT-TO-FIT HOMES SAVE LABOR COSTS UP TO 100%

Save labor cost up to 100%, reducing completed home cost. You can assemble any of 57 designs from easy-to-follow plans. No measuring or cutting . . . every piece precision machine pre-cut and marked. **BUY DIRECT FROM MILL.** Eliminate all between overhead, profit and labor

costs. Nothing to plan or figure. Complete with all lumber, hardware, paint, nails, glass, roofing, etc. Sterling Home quality material throughout. Freight paid most areas. Write today. Send 25c for illustrated, color catalog, floor plans and details. **CHOICE OF 57 DESIGNS**

PRICED FROM \$2295 UP

Prices do not include carpentry labor, heating, lighting, plumbing and masonry materials. FIVE EASY-PAYMENT PLANS,

THIS HOME \$6535



INTERNATIONAL MILL & TIMBER CO. Bay City, Michigan, DEPT. PM-22

NEW 80 AMP DYNAMIC MARK 88 INDUSTRIAL TRANSFORMER ARC WELDER

IDEAL GIFT — EDUCATIONAL, ENJOYABLE, PROFITABLE WELD, BRAZE, CUT, SOLDER, HEAT STEEL, BRASS, ALUMINUM, AND MOST OTHER METALS.

Build and repair anything of metal. Save time & money with this BRAND NEW, PROFESSIONAL ARC WELDER! Rugged metal cabinet, baked Hammerloid finish. Ideal for home, shop, farm and industrial use. **POWERFUL** glass insulated transformer welds most metals up to 1/2" thickness with multi-pass weld, with 3/8" rods. 4 heat settings 20 to 80 amps. Operates on 110 Volt AC line fused for 30 amps. Complete with fibre glass helmet, electrode holder, ground clamp and cables, solder, assorted rods and simplified welding manual. **DOUBLE PROTECTION GUARANTEE.** 10 day money back trial plus full 5-yr. warranty. If inoperative return prepaid, we will repair or replace without charge & reship collect. **ORDER TODAY.** Complete ready to weld. Only \$59.50 F.O.B.



SEND ONLY \$6.00. Pay Balance plus C.O.D. and Delivery Charges

FREE

Write for illustrated color literature and welder details.

DYNAMIC WELDER CO. 1808 S. FEDERAL ST. Dept. PM22 CHICAGO, ILL. 60616

Two or four-wheel drive
JEEP or SCOUT
owners

REPOWER with a 6 or V-8. H.D. ADAPTORS for using Car, Compact and some Truck engines. "State year & model, Jeep or Scout." Want fast action? Give us **FULL INFORMATION.** Send \$25.00 Dep. and we will ship correct kit, bal. COD. Send full amount for prepaid shipment. Wire, phone or write today. Details **FREE**

HOOSIER MACHINE PRODUCTS CO.

312 S. E. 6th St., Phone 276-3442, Pendleton, Oregon 97801

BUILD THE CLOCK YOU'VE ALWAYS WANTED



Select from 26 clock case patterns, 100 movements, dials, hard-to-get hardwood moldings, fine brass hardware, barometer fit-ups and music box movements. Easy-to-assemble wood kits are available too.

Send 25c for 66 page catalog.

CRAFT PRODUCTS

Dept. 1
Elmhurst, Ill. 60126



You can make money in

WATCH REPAIR

Learn at home the low cost Swezey Way

Develop your skill step by step in your spare time at home. Chicago School of Watchmaking's exclusive Swezey System shows you how to repair all types of Swiss and American watches. Practical shop training. No previous experience needed. Age no barrier. Diploma awarded. Send today for free information and sample lesson. No obligation. No salesman will call.

CHICAGO SCHOOL OF WATCHMAKING
Dept. 122 Fox River Grove, Illinois 60021

FREE BOOK and SAMPLE LESSON

CHICAGO SCHOOL OF WATCHMAKING
Dept. 122, Fox River Grove, Illinois 60021
Please rush **FREE BOOK** and Sample Home Study Lesson.

Name _____ Age _____

Address _____

City _____ State _____ Zip _____

INSTALL ALARM SYSTEMS

Beginners Make Big Money — Your Own Boss

New plan opens multi-million dollar burglar fire alarm business to small home operators. Guides beginners step by step.

Starts you full or spare time without previous experience or big investment. See how to cash in on invisible web of protection that stops crooks cold, makes big profits. No salesman will call. Write for free details!

NASCO, 6100 Variel Avenue, Dept. F2252, Woodland Hills, Calif. 91364



Print For Profit

Cards, Stationery, Envelopes, Advertising, labels, tickets, announcements, Q.S.L. cards, greeting, sympathy, prayer cards, tags, etc. Good Profits. Pays for itself in a short time.

Own a Printing Business

We supply everything direct from factory only. Easily followed rules. Also raised printing like engraving. Have home shop. Add to income. Send 25c for catalogue. **KELSEY PRESSES Meriden, Conn. 06450**

MAIL THIS COUPON TODAY!

KELSEY PRESSES, DEPT. 72-D, Meriden, Conn. 06450

I enclose 25c send big catalog and samples.

Name _____

Address _____

City _____ State _____ Zip _____

BIG BANGER FROM SUZUKI

(Continued from page 133)

no "off" position on the fuel valve, with fuel being turned on and off automatically with a diaphragm working off intake vacuum.

Starting, hot or cold, was always practically instantaneous. The choke lever is conveniently located near your left thumb on the handlebar, a commendable improvement over the down-under types. The instrument cluster, consisting of a 160-mph speedometer with odometer and trip indicator, a 9000-rpm tachometer, and a coolant temperature gauge, is legible, well lighted and noticeably vibrated only at or near idle. The coolant is a special brew of antifreeze, water and other chemicals to protect the aluminum engine. The gauge has no numbers, but two tiny dots indicate temperature at which the thermostat opens and where the fan comes on.

Except for water jackets in the cylinder head and cylinder block and the gear and shaft-driven water pump set deep in the lower half of the case, the general engine layout is not remarkably different from other three-cylinder two-strokes. The electric starter nestles between the engine and gearbox sections, and a conventional ignition setup works off one end of the crankshaft and an alternator off the other. A lot of the tinkling noise we hear from air-cooled two-strokes comes from the fins resonating. The water jacket dampens and eliminates mechanical noise from this engine, and the decorative fins on the head, block and crankcase are too short and stubby to resonate.

A final surprise came on looking into gas mileage. At highway speed it gets close to 40 miles out of every gallon of economical regular gasoline, a far cry from what we've learned to expect from gas-guzzling air-cooled two-stroke superbikes. With them, you are lucky to go 100 miles before fuel, including reserve, is depleted. With the Suzuki water-cooled, you can go 160 miles and still have 20 miles to find a gas station on reserve. The convenience of this outstrips even the economy for long-distance touring where service stations are few and far between.

It also becomes apparent why higher performing air-cooled two-strokes get such poor gas mileage. They are made to run very rich to aid in cooling, permitting higher power output than otherwise possible without damage. This is a standard procedure for air-cooled aircraft piston engines, where the mixture control is set to "rich" at higher power settings to aid in engine cooling. But they are throttled back and leaned out at every opportunity,

or else fuel consumption becomes atrocious.

The most negative reaction from bike people who've seen the new bike concerns styling. Practically to a man, those commenting didn't like the looks, but all agreed that water cooling is a good idea. One summed up the mixed feelings when he said, "I'd probably get one anyway. At least I wouldn't have to look at it while I'm riding it." It may take a model change or two before stylists learn what to do with skinny engines, half hidden by a black slab of radiator, that will please eyes accustomed to finny, sculptured, air-cooled engines fully exposed to view.

It's easy to forget that water-cooled motorcycles are not new. In fact, the earliest ones were water-cooled. The simplicity of air cooling won out because metallurgical and other limitations restricted power outputs, making liquid cooling not an absolute necessity. But now, with the demand for lots of power without sacrificing economy or adding much to weight or purchase price, the time seems ripe for water-cooled two-strokes. For this reason it's likely that the Suzuki will catch on where the Scott and its predecessors did not. ★★

FIAT 124 OWNERS REPORT

(Continued from page 75)

winds don't affect stability, nor does the backwash from big trucks. More power, particularly for passing, was the main wish from this same group. All Fiat drivers rate workmanship and overall quality generally superior to U.S. cars and several other imports.

On the minus side: "Pedals too close together." "I don't like the dimmer switch on the steering column; sometimes I turn the lights off accidentally at night when my hand bumps the switch." "Engine noisy at 60 mph." "Torque converter whines at 60 mph." "Engine is cold natured, too slow to warm up."

"I think they should improve the quality of the radio—the Japanese make much better ones." "I like the standard equipment: reclining bucket seats, carpeting, lights under the hood and trunk."

Most owners of the sport versions were attracted initially by the Spider's and Sport Coupe's looks—sporty appearance. For owners of the Fiat 124 sedan and wagon, the initial appeal was economy. But owners found that driving could be fun again. As one respondent put it: "My main reason for buying the Fiat was economy. But after I drove one, economy didn't matter anymore!" ★★

BIG

YACHT-SMART
Sail Rig
DACRON
from
\$114

WINTER SAVINGS NOW

FOLBOT

TRAVEL CRAFT
fits in every
home or car

FOR YOUR SPORT AND FAMILY FUN

and
**RECORD
FISHING**

GENUINE Folbot RECREATION for just ONE small investment, WITHOUT the continuous burdens of complicated 'big rig' operation. You GO CAREFREE anytime with COMPACT Folbot . . . rocky streams, lakes, marsh, surf & open sea. Superior non-sinkable designs provide SAFEST low gravity center, balanced low & high seating, substantial construction, protective decks & EXCLUSIVE swivel-back COMFORT. ALL within your reach. In handy Folbot YOU GLIDE smoother, faster & NOISELESS with paddles, oars, or sails and ride softly w. 1 to 10 HP. motors. Many styles & sizes from 1 to 4 seaters, FOLDING or rigid PORTABLE come in PREFAB KIT, or expertly FACTORY BUILT

Just a few Dollars start
YOU right away. From

ONLY \$19 NOW

for BASIC KIT

16 feet long

'CAYAT'
car top
YACHT.

NEW
Fabulous
16 foot
\$117

Factory BUILT

FREE
ACTION CATALOG

**STARTLING
FACTS & FIGURES**
Mail coupon or address

to: FOLBOT CORP.
Dept. PM-272, Charleston, S. C. 29405

Name _____

Address _____

City _____

State _____

FREE FISHING

CATALOG

**170 PAGES
OVER 5,000
FISHING ITEMS**

Hard to find Fishing
Specialties and Kits
Please don't miss this
great 1972 Catalog

NETCRAFT CO.
Toledo, Ohio 43613



**IF YOU CAN SING, WHISTLE,
OR HUM A TUNE . . .**

you can play the Musical Saw. No notes to read, no musical knowledge required. Since 1921 we have furnished the entire world this unusual, sweet-toned instrument. If you are 10 or 70, you play or no pay. Musical Saw, soft hammer, bow, resin and lessons mailed on 5 days' trial. Write today for details and free copy of "Sawing News of the World," picturing successful saw musicians. **MUSSEHL & WESTPHAL**, 107 Fort St., Fort Atkinson, Wisconsin. 53538.

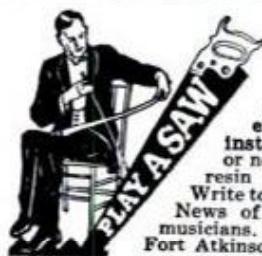

IT'S EASY TO WELD

With the New **HEAVY-DUTY
4-WAY WELDER**

\$18⁹⁵

FULL PRICE!
**Lifetime
Guarantee**

**OVER
200,000
SOLD**



You can weld, braze, solder, cut almost anything made of metal, including aluminum. Operates on ordinary home 110V outlet, 30A fuse. Repair cars, boats, farm equipment, home repairs, furniture, bicycles . . . just about anything. Adjustable carbon arc torch easily regulates heat up to 11,000° for any type of welding without changing heats or cables. **HUNDREDS OF THOUSANDS SOLD IN 35 YEARS, PROOF YOU CAN'T BUY A BETTER WELDER FOR LESS.** Lifetime Guarantee: If ever inoperative, return prepaid, we will repair and reship without charge.

READY TO USE—NO MORE TO BUY: You get welder in rugged metal cabinet, heavy duty cables and ground clamp, full face helmet, adjustable torch and rod holder and simplified welding manual. **FREE**, two big bonus packs of instant arc welding rods, brazing rods, 1/4" carbons, solder & flux.

SPECIAL FREE TRIAL OFFER: If not completely satisfied, return in 10 days and we'll refund purchase price. Send only \$2.00, then pay \$16.95 plus C.O.D. and delivery charges, or send \$18.95 for prepaid shipment in Continental U.S.A. Illinois residents add 5% sales tax.

FOUR-WAY WELDER CO., 1810 Federal St., Dept. PM22, Chicago, Ill. 60616

I-N-V-E-N-T-O-R-S

WE NEED INVENTIONS

Sell your invention for cash—need money for Patent?—Are technical problems holding you back? Universal Inventions has helped inventors all over the world—just like yourself—why not you? Inventions provide the magic spring-board to sudden riches. **REMEMBER**, we either sell your invention or pay you a cash bonus. Write for details. **UNIVERSAL INVENTIONS**, Dept. 13, Marion, Ohio

A LITTLE COLONIAL CHARMER

(Continued from page 141)

is shorter than the overall length of the cabinet. Cut the top edge as indicated, round the edges as before and glue in place.

The drawers ride on rails installed along each side of the openings. They are cut on the table saw from 2x4 stock and rest on a cleat glued and nailed to the cabinet back. The outer rails are glued and screwed to the cabinet sides. The center rails (actually two rails in one) are glued at the front and nailed to the cleat at the back. Notice that the rails project $\frac{1}{16}$ in. into the opening on each side. Follow typical drawer construction when you make the drawers and take dimensions directly from the cabinet. The drawer fronts are rabbeted all around so they will lap the openings.

Unless you happen to have a shaper and a set of regular sash cutters, it will be almost impossible for you to duplicate a factory-made raised-panel door in which the panel sits in a groove and the molded, mortised members are undercut to fit perfectly at the corners. The best a home craftsman can do is to assemble simple frames of $\frac{3}{4}$ -in. stock, butt-glue the joints and use a portable router to run the rabbet on the back for the panel and to shape the molded edge on the front. The overall effect is practically the same and few will notice any change. The main difference is that the cutter will leave a rounded inside corner instead of a square one.

Another way to make the doors is to run the stock like picture-frame molding and simply miter the corners. However, this makes a somewhat less authentic-looking door.

The raised panel is a simple thing to run on your table saw by tilting the blade and passing the work through on edge. Then the shallow shoulder cut is made with the work flat on the table and against the fence. A $\frac{1}{8} \times \frac{3}{4}$ -in. flat molding holds the panel in the frame and covers the joint. As with the drawers, the doors are rabbeted all around so they will lap the openings.

Appropriate hand-wrought hinges should be picked for the doors. You'll need the kind which are offset to accommodate the door lip. White porcelain knobs carry out the colonial feeling.

If you plan to use live potted plants in the sink which require watering and tending, you should fit the top with a shallow sheet-metal tray. A lift-out copper lining could also be considered.

To finish your dry sink, first sand the wood until you are satisfied with its smoothness. You can start with a medium

grit and finish with a fine-grit paper. (If you prefer an early American "primitive" look, don't oversand the wood.) After the sanding has been completed, wipe off all sawdust.

For a natural or stained finish apply the color stain you prefer, following directions on the can label. Allow to set for approximately 15 to 20 minutes and then—using a clean rag—wipe off all excess, rubbing *with* the grain. Allow the piece to dry overnight (24 hours). If desired, the piece can be antiqued by blending in burnt umber with a rag. (This, too, must be allowed to dry for 24 to 48 hours.) To finish, apply two coats of McCloskey Heirloom semigloss varnish. Allow 24 hours drying time between coats. After approximately three weeks, rub lightly with double-O steel wool saturated with Butcher's Wax and buff to a sheen.

Antiquing hints: Use burnt umber—direct from the tube—to simulate any surfaces that will be exposed to the most dirt accumulation over a long period of time (in corners or crevices, for example). And always blend the burnt umber into the mating stain so that there is no visible "line" or joint. ★★★

'G-METER' FOR YOUR DASH

(Continued from page 158)

the limits of the successive resin pours.

First pour. Clear Cast or its equivalent (but not the surface coating resin) is cast in the mold to make the meter body. Mix 5 oz. resin and 10 drops catalyst and pour to the $\frac{1}{2}$ -in. mark. Be sure no bubbles are trapped between the balsa and the sides of the mold. This is a slow-curing mix and it should be allowed to set for several days.

All the remaining pours will cure in a few hours and one may follow the other as soon as the heat of the chemical reaction has dissipated.

Next, mix 5 oz. resin and 20 drops catalyst and pour to the 1-in. mark, then mix 3 oz. resin and 15 drops catalyst. Pour just enough to fill the shrinkage space around the previous pours. Then add 5 drops red dye and pour to the $1\frac{1}{4}$ in. mark. While this is setting, find a clear plastic box (like those used for small hardware and jewelry) about 1 x 3 in. and $\frac{1}{2}$ in. deep (with the lid off). Discard the lid and grind away the hinges and latch.

Mix 1 oz. resin, 4 drops catalyst and 1 drop red dye. Pour only a thin coating. Position the plastic box, open side down, over the protruding straws. Bed the box well in the fresh resin and weight it to keep it centered until the resin sets. Fi-

nally, mix 7 oz. resin, 28 drops catalyst and 10 drops red dye. Pour to the 2-in. mark and let the mold set for several days.

Remove the mold sides. Remove the glass by twisting, pick out the balsa with a sharp tool and pull out the straws with needle-nose pliers. The meter face will be curved due to shrinkage so sand it flat with a coarse sandpaper. Two blocks of hardwood clamped to opposite sides of the meter body (see photo on page 157) will limit the depth of cut and prevent rounding the edges.

Covering face of the meter

Cut $\frac{1}{16}$ -in.-wide strips of thin clear-plastic sheet to barely cover the channels in the face of the meter. If a clear sheet of 4x5-in. photographic film is used, the strips can be cut without joints where the channels turn.

Don't try to cover the meter face with a sheet of plastic; this invites leakage between systems. Cement the strips down with surface coating resin (not Clear Cast). When hard, paint several layers of surface coating resin over the entire meter face. Drill small filler holes from the top of the meter body into each of the two systems of fluid passages.

Applying the scales

You can roughen the meter face, draw the scales and then restore the shine with another coat of resin. Or you can cut out the illustrated scales and paste them on. The neatest approach is to have a litho service reproduce the scales on film to attain backlighted lettering.

You can make a decorative bezel or a glare hood for the meter. Holes can be drilled and tapped in the body for mounting brackets and if the meter is mounted in a dash panel, it will have to be back-lighted.

With the meter mounted in the car—and the car level—fill the passages with green ethylene glycol antifreeze (without a stop-leak additive) using a precision oiler. Fill just to the zero marks of each set of scales. Ethylene glycol has the right viscosity to respond quickly but will not slosh about and it won't attack the plastic unless water is added.

After you've built the G-meter, make some full-throttle acceleration runs within safe and legal bounds. Have a passenger record G readings at various speeds for future comparisons. Get an idea of braking Gs. They'll be at least twice as high as acceleration Gs because all four wheels are acting. Again, don't try to measure lateral G capability. The lateral scales are just for fun.—*John P. Reid*

MY SPARE TIME HOBBY MAKES ME \$500 an hour CASH PROFIT

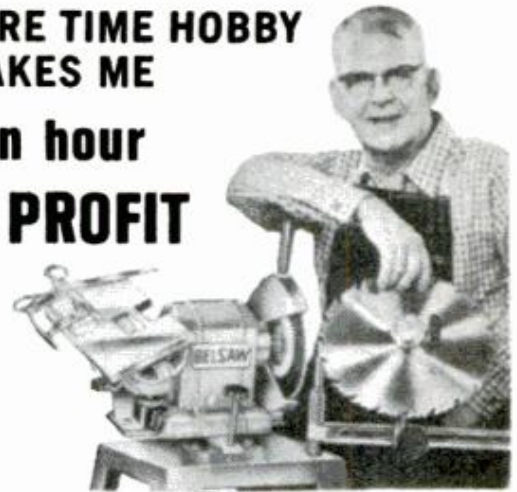

START YOUR OWN SPARE TIME BUSINESS

You can turn your spare time into Big Cash Profits with your own **COMPLETE SHARPENING SHOP**... Grind saws, knives, scissors, skates, lawn mower blades... all cutting edges. Your Own Cash Business with no inventory... right at home... no experience needed.

FREE BOOK tells how you can start your own spare time business while you are still working at your regular job. Low Cost—time payments.

Just Mail Coupon—No Salesman Will Call

FREE BOOK

BELSAW SHARP-ALL CO., 712 Field Bldg., Kansas City, Mo. 64111
Send Free Book, "LIFETIME SECURITY." No obligation.

Name _____

Address _____

City _____ State _____ Zip _____

CHARLES ATLAS Says: MY FREE BODY-BUILDING BOOK

Shows How YOU Can
Become A REAL HE-MAN

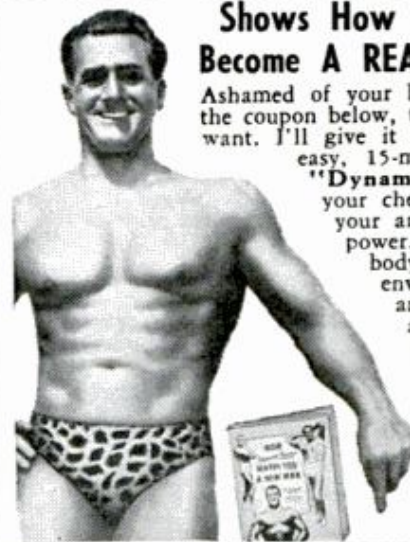

Ashamed of your body? Then tell me, in the coupon below, the kind of body you *do* want. I'll give it to you FAST—with my easy, 15-minutes-a-day method of "Dynamic-Tension." I'll make your chest and shoulders bulge, your arms and legs surge with power. I'll give you the kind of body women admire and men envy. *Your friends* will be amazed. *You* will feel like a tiger!

FREE BOOK. Learn how "Dynamic-Tension" made me "World's Most Perfectly Developed Man"—and how I can change YOU. Mail coupon to me: **CHARLES ATLAS, Dept. 82, 115 E. 23rd St., New York, N.Y.**

CHARLES ATLAS, Dept. 82,

115 East 23rd St., New York, N. Y. 10010

Dear Charles Atlas, Here's the Kind of Body I Want:
(Check as many as you like)

Broader Chest, Shoulders Powerful Arms, Legs

Iron-Hard Biceps, Grip More Solid Weight

Show me how "Dynamic-Tension" can make me a new man. Send your famous 32-page FREE book, full of pictures, valuable advice. No obligation.

PRINT NAME..... AGE.....

ADDRESS.....

CITY & STATE..... ZIP CODE.....

In England: Atlas, 21 Poland St., London, W.1

20 WOOD SAMPLES with woodworkers Catalog

ENJOY woodworking more! Let Constantine's big picture-packed Catalog-Manual help you build new furniture — refinish, restore beat-up cabinets, chairs, chests, tables, etc. Find instantly whatever you need. Buy at money-saving prices from world's largest catalog source for imported and domestic woods. Cabinet lumber, carving blocks, veneers, plywood, pipe briar, inlays and more! Newest Catalog features new tools, materials, shop devices. Fabulous all-purpose clear finish. Glue that needs no clamps. Inlay picture kits, 99¢. Needed products found nowhere else. Plus woodworking instructions, plans, patterns!



2.000

PRODUCTS FOR SHOP & HOME
Woods — Veneers — Finishes
Furn. Hardware — Lamp Parts
Cane — Upholstery — Tools
Picture Molding — Clock Kits

FREE WITH CATALOG
"101 PROJECT IDEAS"

Catalog & Wood Samples Only \$1

Dollar Fully Refunded on First Order

Accept this offer to own fascinating set of 20 2x4 specimens of world's glamorous veneers — Rosewood, Satinwood, Lacewood, Teak, etc! Compare! Then instantly identify finest woods wherever you go. Send only \$1 for Wood Samples and Woodworkers Catalog. Dollar refunded on first order.

ALBERT CONSTANTINE AND SON, INC.
2051 Eastchester Rd., Bronx, N.Y. 10461

Enclosed \$1 for Wood Samples & Woodworkers Catalog. (\$1 refunded) Catalog only 50¢



Name _____

Address _____

Zip _____

FIND BURIED TREASURE

Powerful electronic detector finds buried gold, silver, coins, etc. 5 new models. Write for free catalog.



RELCO, Dept. D-3 19⁹⁵
BOX 10839, HOUSTON, TEX. 77018

HEAVY DUTY WELDER

with special \$7.00 gift offer to

Popular Mechanics readers

10-DAY FREE TRIAL

Lifetime Guarantee

Brand New **1895**

1972 Model **1895** POST PAID

Fits ordinary 110V outlet

Not one • but 3 welding heats



Weld, braze, solder or cut most anything made of metal. No experience necessary. Follow simple instructions to make repairs on cars, trailers, farm and lawn equipment, bicycles, appliances, etc. Make campers, boats, furniture, hundreds of valuable items. **NOTHING ELSE TO BUY!** Comes complete with full face shield, pack of welding and brazing rods, heavy duty power cables, special electric torch attachment, ground clamp, flux, easy-to-follow illustrated instructions, rod holder, etc. Uses standard 3/8" rods to weld iron, steel, brass, bronze, aluminum, other metals. New improved HEAVY DUTY circuit gives more welding power. Gives 4 times the heat needed to melt toughest iron. Plugs into ordinary 110V outlet. **3 WELDING HEATS** . . . Not just one as with other low cost models. Use "high" for tough jobs "medium" or "regular" for lighter work. This important feature saves you money and time. Makes it possible for even beginners to start welding professionally the very first day. Pays for itself quickly. An excellent gift for any occasion. **IT'S AUTOMATIC:** Current is turned ON when arc is struck, OFF when rod is lifted from work. Eliminates need for troublesome foot switch. Speeds up work.

FREE!

Mention that you saw this ad in Popular Mechanics and receive a \$7.00 gift pack assortment of "touch weld" welding rods. Automatic arc striker. Weld with "push button" ease.

10 day MONEY BACK GUARANTEE. You must be satisfied or return for refund. Send only \$2.00 and pay postman \$18.95 plus postage when delivered or send \$18.95 cash, check or money order for immediate postpaid shipment.

WEL-DEX MFG. CO., Dept. W-203, Box 10776, Houston, Texas 77018

WELL-TRAINED DOG

(Continued from page 87)

of the leash—wait a moment—then say the dog's name and the command *come*, at the same time giving a gentle tug on the leash. When the dog responds properly from this position, he may be put on a long leash—a 50-foot clothesline is good—and permitted to wander around. Then he is called by his name and ordered to come.

Dog owners in a group class are always urged to work their pet daily for at least 15 to 20 minutes on a leash. Without day-after-day practice, dogs forget what they've learned. Continual work with the dog in all phases of his training will reinforce his responses until he is considered to be reliable enough to work without a leash.

Owners should also work a dog off-leash in an enclosed area until sure their pet will not run away. And they should always run their pet through the entire command routine before removing the leash.

Even a well-trained older dog should be run through the command series occasionally on a leash to keep his responses from getting sloppy.

But even well-trained dogs can get out-of-hand at times. Overly friendly dogs often jump up on people to show their enthusiasm. This can be easily handled. When the dog jumps up, place your knee firmly against his chest and shove him backwards, saying *no* at the same time. Stepping on the dog's hind toes is equally effective.

Excessive barking can also be controlled, especially if discipline is begun early, by holding the dog's mouth closed and firmly saying *no*. A dog must bark sufficiently to warn of an intruder, but he should obey his owner's command to be quiet once the alarm is sounded.

If your dog doesn't show enough protective qualities, there are ways a professional trainer can rouse this instinct. But experts caution that this should not be done by the dog owner because he may end up with an overly protective pet who could be dangerous.

Aging dogs can be trained as well as young ones, but it's more difficult. Often, a professional trainer has to be called in to make the older pet socially acceptable, but there is no guarantee this will work unless an owner changes his own permissive personality.

The behavior of a dog often reflects the personality and attitudes of his owner. The choice between a pet and a pest is largely up to you.

★★★

MAKE THIS SHAPER FOR \$60

(Continued from page 154)

necessary to allow the belt to ride on the flat pulley). Make the electrical connections as shown. This includes an easy way to reverse the motor, using an inexpensive double-throw, double-pole toggle switch. A reversing motor is a "must" on a wood shaper, and this method will cost only a dollar or so to bring it off. A store-bought one costs about \$8. After making all electrical connections, put a cutter on the spindle and turn the machine by hand to make certain everything works freely and nothing hits or drags anywhere. (Caution: While doing this, make certain the shaper is not plugged into a power source). Next, mount the belt guard and turn on the machine.

The shaper should run fairly quietly, with very little vibration. For accurate cutter-height adjustment, I recommend buying a good set of 1/2-in. bore shaper collars and using them to set the cutter at approximately the height you need. Then, use the height adjustment on the machine for final, precise changes.

Though it runs quietly, don't let the lack of noise lull you into carelessness. The shaper is a potentially dangerous tool and should be accorded all the caution and respect you would give a saw, jointer, router or other power tool. When operating it, keep your hands and fingers out of line with the spindle. Then, if you make a slip or hit a knot, your fingers won't go into the cutter. ★★★

NEXT MONTH IN PM

Know your bike, and how to fix it

Here's the first of a continuing series, *The Bicycle Shop*, by Eugene A. Sloane, author of the best-selling *Complete Book of Bicycling*.

Save money on your next auto loan

Different lending institutions charge different amounts for the money they lend. A PM reporter made the rounds—and saved over \$200 on the cost of a \$3000 loan.

All you want to know about tires

This is a complete buyer's guide to help you get the best tires at the best price.

Throw a little light on the subject

A simple reflector will do wonders to soften harsh shadows in outdoor photography.

Boats, boats, boats

The new inboards and outboards (in color), new sailboats, unusual inflatables, exciting accessories. Plus tips on propellers, PVC and life preservers. 22 pages in all!

GOVT. SURPLUS AND OTHER BARGAINS SAVE UP TO 90%



HYDRAULIC CYLINDER 32 1/2" stroke, 2" bore, 1" shaft. Operating pressure 3000 P.S.I. Top and bottom of cylinder contain 1/4" ID mounting hole with self-aligning bearings. Closed 43". Inlet and outlet ports 9/16 - 18 (#6). Will produce 9000 lbs. thrust. GOVT. COST \$269.60. Govt. overhaul cond. Shpg. wt, 16 lbs. (Stk. #2932) **\$32.50.**



DUAL DRIVE GEAR MOTOR Heavy duty. Rated 5 HP @ 26 V.D.C. @ 270 RPM under load. Turns 125 RPM @ 12 V.D.C. Top shaft turns @ twice straight shaft speed. Shaft dia. 5/8". Gear reduction 33 to 1. Reversible. 18" L x 5" dia. Exc. for winches, capstans or small elect. car motors. Shpg. wt. 39 lbs. GOVT COST \$580 ea. Like new **\$32.50** (Stk.#2391)



ELECTRIC PUMP WITH CONTROL SWITCH For boats, campers & trailers. Output 300 GPH. Can be used in fuel or water. 1/2" pipe bronze inlet. 12 or 24 V.D.C. Explosion-proof motor. Comes with wiring diagram. Approx. GOVT COST \$150. Shpg. wt. 9 lbs. **\$14.50** (Stk. #1164)



NEW! BIG 1972 CATALOG

Send 35c (\$1 for airmail). Catalog contains 1000's of bargains in hydraulics, electrical, marine, automotive items, etc. 90 day guarantee. ORDER FROM AD. Prices FOB Culver City. 50% dep. for COD. Cal. res. add 5% sales tax. Incl. zip. Satisfying customers world-wide since 1945

AIRBORNE SALES CO. Dept. PM272
8501 Steller Dr. • P.O. Box 2727 • Culver City, Ca. 90230



AUSTRALIA, WHAT'S IT REALLY LIKE?
Book by 4 Americans living there describes things they wish they had known before migrating. Truth about wages, living costs, housing, 26 vital topics. 64 pgs. illus. \$2.95.

SOUTHERN CROSS PUB

Dept. M, Box 99, Orlando, Fla. 32802

MOLDS

for making
Ornamental Concrete
Items...



Book about Aluminum
Molds with prices and
production trade secrets
direct from world's larg-
est mold manufacturer.

SEND
\$2.00

CONCRETE MACHINERY COMPANY, INC.

P. O. BOX 99 • HICKORY 2, N. C. 28601



"AT the track I met this guy who won \$1870 with \$20 stakes. I thought at first that he was a racing EXPERT, but I later discovered that he WASN'T, he simply owned a PENCLIFF race computer. Now, I'm ALSO a winner with PENCLIFF."

FOR FABULOUS WINS SIMPLY feed into PENCLIFF race computer details from race programs. Get FACTS—over 4,000 BIG PENCLIFF WINS incl. with \$20 stakes on all PENCLIFF picks, PROFITS ON THE DAY of \$1130, \$1180, \$1210, \$1340, \$1410, \$1510, \$1870, etc., (up to \$187 profit a day with \$2 stakes). Learn how an accident on the inventor's yacht, 25 yrs. Racing 'know-how', aid of 12 other experts and a giant I.B.M. computer, all led to the invention of AMAZING PENCLIFF. R.H.P. Co. Box 5715-PME27 Carmel, Calif. 93921. (Tear out this ad NOW—mail with name, address, zip, for FULL EXCITING details)

FIX your appliances,
car,
house,

SAVE

on home improvements,
air conditioning,
power tools and more

WITH THIS

FREE \$3.49
VALUE
GIFT VOLUME

Just look back over the past few years and figure how much you have spent on repairs for your home, your car, your appliances. Wouldn't you like to keep these high-priced repair fees for yourself? Well, now you can.

As a reader of *Popular Mechanics* the chances are that you already have a considerable degree of skill with tools. Nevertheless, you may have hesitated to tackle more complicated repairs, improvements or hobby projects.

Now, however, this FREE Book—packed with the combined skill and know-how of 257 *Popular Mechanics* expert editors, consultants and designers—can put a professional edge on your do-it-yourself skills.

The most difficult jobs will soon become easy

Before you know it, you'll be able to fix car engine troubles... transform unfinished attic space into an extra bedroom... catch more fish using homemade lures... learn "tricks-of-the-trade" in handling power tools... save hundreds of dollars when buying and servicing appliances.

These are just a few of more than 6,000 exciting "how-to" ideas, plans, and valuable projects you'll find in POPULAR MECHANICS DO-IT-YOURSELF ENCYCLOPEDIA. You'll learn how to get more professional-looking results than ever before in your carpentry, metalwork, plumbing, masonry, electrical wiring, electronics, hi-fi, stereo, car repair, painting, decorating... PLUS exciting new ways to help you get more fun out of your hobbies, sports, vacations. Experts lead you step-by-step through every project you select. Without question, here is the most helpful, reliable, "how-to-do-it" guide you've ever seen—and Volume 1—a \$3.49 value—is yours ENTIRELY FREE!

You risk nothing on this FREE Book offer!

As soon as your gift book comes, browse through it—try some of the exciting ideas—use some of the money-saving tips. We're sure you'll get so much valuable help from this book, you'll want to see the other volumes as they are published. You can see future volumes without risk—on a 14-day FREE TRIAL basis. But this first volume is yours as an outright gift—whether you buy one, two, five, the whole set, or none at all. But please hurry. Our supply of gift volumes is definitely limited. To be sure of getting your copy FREE, mail the coupon today.

Here is a brief glimpse of all your FREE Volume brings you:

- Fix 8 common car engine problems and save garage fees
- Save money air conditioning your entire home
- Cure a wet basement and save \$200 to \$2,000 under what professionals charge
- Burglarproof your home with special power alarm
- Professional tips for expert sanding
- Learn arc welding basics in 6 hours of easy practice
- How to save on band saw blade costs by making your own
- Build a gas-fired barbecue for more back-yard fun

PLUS much, much more

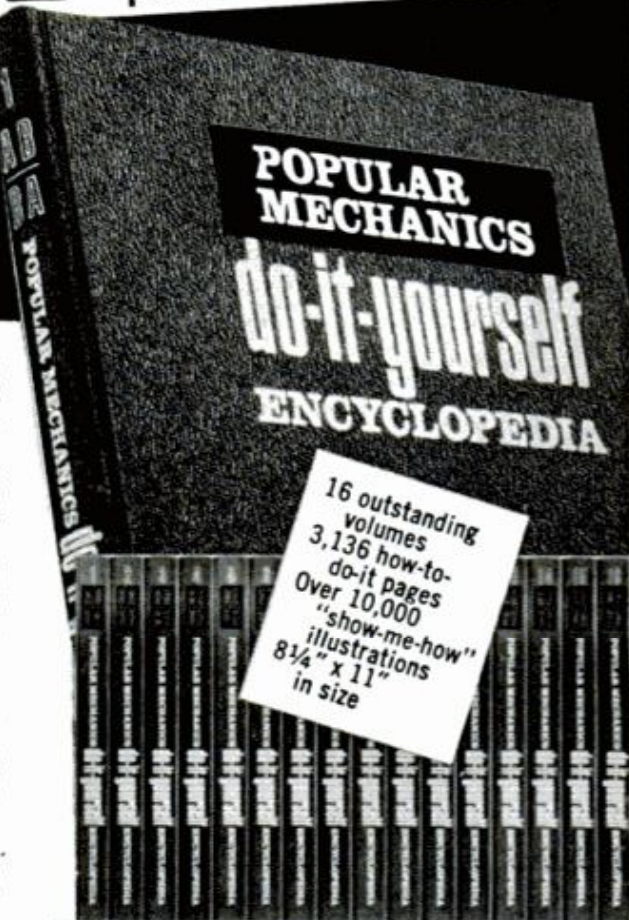

MAIL COUPON TODAY!

Popular Mechanics Book Division, Dept. DO 12
250 West 55th St., New York, N.Y. 10017

This certificate entitles you to a free gift—Vol. 1 of the 16-vol. POPULAR MECHANICS DO-IT-YOURSELF ENCYCLOPEDIA, with no obligation to buy anything.

As a subscriber in good standing, you'll enjoy free examination of the additional volumes. In about 6 weeks we'll send you Vol. 2, and 4 weeks later Vol. 3. After that, at approximately monthly intervals, we'll send you shipments of Vols. 4-6, 7-9, 10-16. Also, you'll receive annual supplementary volumes as they are published on free 14-day approval with no purchase obligation. This way you'll be able to complete the set in 6 months, and keep it up-to-date. You may return any volume within 14 days for full credit, and you may cancel at any time. Take as many volumes as you like—or none at all. For each volume you keep, you'll be billed just \$3.49 plus postage and handling. You need never pay for more than 1 volume a month no matter how many you have received. There's no charge for this extended payment service.

Name _____ (Please Print)

Address _____

City _____

State _____ Zip _____

Signature _____

This offer available in Canada at a slightly higher price. Canadian residents mail coupon to New York address. Shipment of books and all services will be handled within Canada.

NEW RUBBER STAMP BUSINESS PAYS BEGINNERS UP TO \$16.50 AN HR. START AT HOME IN SPARE TIME

The multi-million dollar Rubber Stamp business—once controlled by a few big companies—is now being taken over by small operators—one in each community throughout the United States. Men and Women who have this inexpensive machine can turn out huge quantities of Rubber Stamps with special wording that buyers once were forced to buy from big cities. Material costing only 27c makes a stamp that sells for \$2.75. The machine that does the work is simple and easy to operate and it turns out as many as six Rubber Stamps at a time, each with different wording such as names, addresses, notices, stock numbers, prices and other "copy" needed by offices, factories and individuals. Working full capacity, it can earn as much as \$33.00 an hour for the operator! Now you can get into the big-pay business yourself, with your own home as headquarters. You don't need experience. We supply everything, including complete instructions and eight ways to get business coming in fast. **We even help finance your start.** Start making up to \$16.50 an hour from the very beginning. Cash in on the profitable Rubber Stamp business in your community, right away. We'll mail full particulars FREE and no salesman will call. Be first in your locality. Rush coupon or send your name on postcard now to:

RUBBER STAMP DIV., Dept. R-2-BB
1512 Jarvis Ave. • Chicago, Illinois 60626

THIS LITTLE TABLE TOP MACHINE
MAKES EVERYTHING SIMPLE & EASY

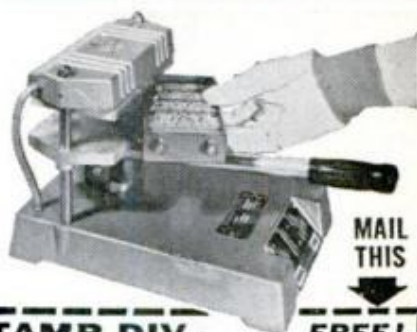

MAIL
THIS

RUBBER STAMP DIV. FREE!

1512 Jarvis Avenue Dept. R-2-BB, Chicago, Ill. 60626

Please rush full particulars about your financing plan and the little machine that can get me started in the profitable Rubber Stamp business at home in spare time. Everything you send me is FREE and no salesman will call.

Name _____
Address _____
City _____
State _____ Zip Code _____



TOOL CHESTS
of the
HIGHEST QUALITY
for your
PRECISION TOOLS..
GERSTNER TOOL CHESTS
Dept. B-2, 20 Cincinnati Street
Dayton, Ohio 45407

Send 25c for Catalog

KEEP YOUR JOB WHILE YOU BUILD YOUR OWN BUSINESS

Own and manage a nationally advertised business in your area. Each full-time serviceman adds several thousand dollars to your job salary. We equip them for 7 on-location services in homes, motels, offices, stores. We train, guide, help finance, back you. Just \$1195 cash puts you in prestige, lifetime business. Get full facts by mail. Write TODAY before your area is taken.

DURACLEAN INTERNATIONAL, 2-162 Deerfield, Ill. 60015



**LEARN
MEAT CUTTING**

Train quickly in 8 short weeks at Toledo for a bright future with security in vital meat business. Big pay full-time jobs — **HAVE A PROFITABLE MARKET OF YOUR OWN!** Time payment plan available. Diploma given. Job help. Thousands of successful graduates. **OUR 49th YEAR!** Send now for big new illustrated FREE catalog. No obligation. G.I. Approved. **NATIONAL SCHOOL OF MEAT CUTTING** #01977
Dept. 50-F, Toledo, Ohio 43604

1¢ SALE GUARANTEED 10 YEARS



The knife for hunting, fishing and all around use. Mirror polished, imported stainless steel blade honed to a razor's edge. Rugged. Opens quickly, easily. Locks into position. Blade will not close when in use. Press button in handle to close. Safety finger guard. Sure-grip handle. Balanced for target throwing. **IF BROKEN WITHIN 10 YEARS WE WILL REPLACE AT NO CHARGE!** Use 30 days. Money back if not pleased. **Special sale. REG. PRICE \$1.98. Send \$1.99 & receive 2 knives. Add 49c postage, handling. Remit TOTAL \$2.48 for 2 knives. ORDER NOW! Midwest Knife Co., 9043 S. Western Ave., Dept. DD-1508, Chicago, Ill. 60620. Est. 1936.**

locksmithing and key making

PRACTICAL UP-TO-DATE COURSE — ONLY \$7.95

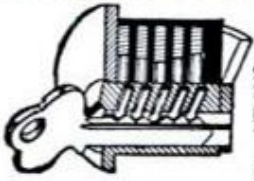

Teaches you how to pick locks, de-code, make master keys, repair, install, service, etc. New self-instruction lessons for every handyman, homeowner, carpenter, mechanic, service station operator, fix-it shop, hardware dealer, gunsmith. 53 easy illustrated lessons. Full price only \$7.95 postpaid. Satisfaction or refund guaranteed. Mail order today!

NELSON-HALL CO., Dept. BY-2
325 W. Jackson Blvd., Chicago 60606

THE AUTO ELECTRIC

Power-For-Tools. 110 V.D.C. Electricity from a car's alternator. Installs on—Most late model cars, trucks or tractors. Will operate power tools, light bulbs, heating devices, etc. Operates any brush-type 110 V. A.C.-D.C. electric motor. Battery charging. Easily installed.

Checks or Money Order:
\$16.95 Without 150 V. D.C. Meter
\$19.95 With 150 V. D.C. Meter

Plus Postage \$1.25 and Sales Tax
Auto Air Equipment Inc., P.O. Box 2886, Amarillo, Texas 79105

BASEMENT TOILET FLUSHES UP



TO OVERHEAD SEWER OR SEPTIC TANK. NO DIGGING UP FLOORS. INSTALLS EASY. Write McPHERSON, INC., BOX 15133, TAMPA, FLORIDA 33614

FEBRUARY 1972



EASY TO BUILD AND FLY — MOST FUN, TOO!

Enjoy the exhilarating thrill of personal flying in the world's most popular homebuilt aircraft, the Bensen Gyrocopter. Store it in your garage, go aloft when you like—high and fast or low and slow. Send \$5 for Copter (\$3 for Glider) colorful "Info Packet", with 3-View Drawings; General Specifications; Design Information; Construction Hints; in-flight photo; 6-page "Bulletin" with numerous pictures plus descriptions of Plans, Kits, Engines; Condensed Price List . . . and a Certificate for \$5 (or \$3) toward the purchase of Construction Plans.

SEND \$5 OR \$3 **BENSEN AIRCRAFT CORP., Dept. PM-22**
RDU-Airport, P. O. Box 2746, Raleigh, N. C. 27602

NAME _____
ADDRESS _____

WHITE'S ELECTRONICS INC.

THE
WORLDS LARGEST
LINE OF MINERAL
& METAL DETECTORS



Goldmaster 66 TR

\$269.50



PRICES START AT \$9.50 AND UP.

BUDGET TERMS - BANK AMERICARD - MASTER CHARGE

WHITE'S ELECTRONICS
INC., U.S.A. Room 512 LTD., CANADA Room 512
1711 Pleasant Valley Road 33784 Hazel Street
Sweet Home, Oregon 97386 Abbotsford, B.C. Canada

THERE ARE NO FINER AT ANY PRICE.

ATTEX. THE ONE ALL-TERRAIN VEHICLE THAT REALLY MEANS ALL-TERRAIN.



An Attex will go anywhere, do anything. Climb steep hills, blast over sand dunes, fly through the snow and even navigate lakes and streams with ease. Think you'd like to be an Attex Dealer? We have a complete line of six dependable models for you to sell. Prices range from \$995. to \$1695. There's one just right for your customer. That's Attex. Write us.

ATV Manufacturing Company PM 2
1215 William Flynn Highway—Route 8
Glenshaw, Pa. 15116.

Name _____
Address _____
City _____ State _____ Zip _____

drafting as a career

Train in everything from basic technical drawing through graphic arts and engineering mechanics. Associate degree in Machine Design Technology received upon graduation. Tri-State College also offers degrees in Engineering, Business Administration, Secondary Education, Liberal Arts, Computer Technology and Secretarial Science. Accredited. Co-educational. Approved for Veterans. For information, write Director of Admissions.



TRI-STATE COLLEGE

422 College Ave., Angola, Ind. 46703

Be a VETERINARY ASSISTANT

... Lab Technician, Zoo Keeper, Pet Shop/Kennel Owner

MEN - WOMEN! Train at Home in Spare Time...

Send for Career Kit—ALL FREE!

Name _____ Age _____

Address _____

City _____ State _____ Zip _____

North American School of Animal Sciences, Dept. 24172

4500 Campus Dr., Newport Beach, CA 92663



Emergency
First
Aid
For
Pets
Careers
in
Animal
Care

INVENTOR'S NEWSLETTER

Is a "meeting place" that can be worth a Fortune to Inventors, Idea People, Mfgs., Promoters, Advertisers, etc., Inventors and Innovators get FREE publicity. Published Bi-Monthly. Subscription \$5.00 year. Sample copy \$1.00. INVENTORS NEWSLETTER, 10B Chapel Gate Lane, Glen Head, New York 11545.

GET INTO ELECTRONICS

V.T.I. training leads to success as technicians, field engineers, specialists in communications, guided missiles, computers, radar, automation. Basic & advanced courses. Electronic Engineering Technology and Electronic Technology curricula both available. Assoc. degree in 29 mos. B.S. obtainable. G.I. approved. Start Sept., Feb. Dorms, campus. High School Graduate or equivalent. Catalog.

VALPARAISO TECHNICAL INSTITUTE

DEPARTMENT D, VALPARAISO, INDIANA 46383

LIFTS
LIKE A HOIST
PULLS
LIKE A WINCH



1001
USES
VERTICALLY
OR
HORIZONTALLY

TERN ROPEHOIST

eliminates the snarls, rope burns and cuss words caused by make-shift block and tackle. Great for lifting, pulling, dragging, stretching or tying down just about anything. Ideal on farms, in garages or shops. Keep one in your car. A low cost, trouble free-helper for every home handyman. 750 lb. capacity.

Write for Bulletin 75A

TERN, INC., Box FF347
Winona, Minn. 55987

GRIND-O-FLEX Flexible Abrasive FLAP WHEEL

Unique abrasive action polishes or grinds all metals. Removes paint, rust, shapes wood. Unlimited applications on flat or irregular surfaces.

MERIT ABRASIVE PRODUCTS, INC.
201 W. Manville, Compton, California 90224

ORDER 6" DIA. WHEEL BY MAIL \$7.95

Fits 1/4" drill also 1/2" or 3/4" Arbor. Special offer price includes postage and handling. Specify coarse, medium or fine grit. No C.O.D.'s.

FREE Home Workshop Brochure



CAPTAIN BEEFHEART THE SPOTLIGHT KID

NEW ON REPRISE
RECORDS

(and tapes distributed by Ampex)

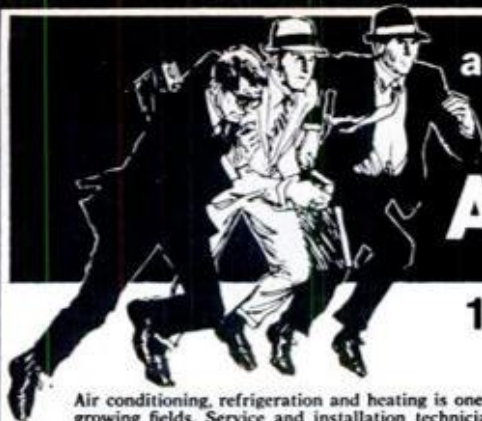

are you headed for a time-clock number?
 ...or a BIG PAY place in
AIR CONDITIONING

140,000 new servicemen needed
 ...you can be one of them

Air conditioning, refrigeration and heating is one of America's fastest growing fields. Service and installation technicians are in desperate demand.

And you can join this force of men making big money right now by becoming a skilled technician with our help.

Top men are making 2 and 3 times more than unskilled workmen. Yet we can teach you these skills so quickly you'll be earning money long before you've finished learning.

**AMERICA'S FOREMOST COURSE
 AT A MATCHLESS LOW PRICE**

Learning at home is hailed by educators as being far superior to classroom work with all its mass production and distractions.

In our fine, professional 100-lesson textbook course you will receive the clearest instructions in unmistakable simple language. Plus self-projects, self exams and graded exams.

Directed by Roy Anderson whose experience with home study and

Army-Air Force training goes back to 1935, we have prepared material that will turn out top-notch graduates. And we do it at a cost so much lower than any comparable course that you simply will not believe it possible.

One way we do it is by not loading our students with costly equipment and tools — most of which you probably already have, or can buy locally for less than some schools charge you!

The Liberty School is a fine, professional and very intimate institution of learning-at-home, supervised in every tiny detail by Mr. Anderson.

We can't begin to tell you all of the advantages in this small space — but we'll give you all the details if you send in your name and address. Remember, we have NO salesmen so no one will bother you. In the privacy of your room you can study the description of our lessons and make up your own mind without any pressure whatsoever.

A big pay future is waiting for you — grab it now.

LIBERTY SCHOOL Dept. J-2A
 Technical Division, 1111 W. Park, Libertyville, Illinois 60048

Be Your Own BOSS course includes directions on How to Own YOUR OWN Business!

Roy Anderson
LIBERTY SCHOOL, Dept. J-2A
 Technical Division — 1111 W. Park
 Libertyville, Illinois 60048

SEND ME YOUR NAME AND ADDRESS
 — I'll rush you FREE details by mail.

Dear Mr. Anderson: Please send me description of your course on AIR CONDITIONING, REFRIGERATION AND HEATING. I understand this places me under NO obligation and that NO salesman will call.

Name _____ Age _____
 Address _____
 City _____ State _____ Zip _____

IGNORANCE is a CRIME when it results from lack of proper reading material. In today's complicated society it pays to know the "rules"—the LAW. Blackstone offers a program of reading assignments for adults who should be informed on essential law subjects. It is designed for people who are in earnest and who expect to accumulate property, lead in business, or take an active part in community life. **NOT A CORRESPONDENCE COURSE.** Program may be scheduled to your interests and time covering any or all law subjects. **FREE BOOKLET—The People vs. You** —mailed on request. No salesman will call. Dept. 52.

BLACKSTONE SCHOOL,
 307 N. Michigan Ave., Chicago, 60601

GARAGE DOOR OPERATORS
 EASY HOME INSTALLATION
 RADIO CONTROLLED

Chain & Screw Drive Models

\$99⁹⁵

FOUR MODELS FROM
 THOUSANDS IN USE - FREE BROCHURE
HELPMATE EQUIPMENT COMPANY
 Dept. PM-16 First & Lake St., Baroda, Mich. 49101

Shipped PP or UPS

MICRO-MINI MIKE

Self-Contained. Picks up slightest sound & transmits it without wires up to 450 ft., thru any FM radio. Tunable 88-108 mcs. Use as a silent monitor, burg. alarm, music amplifier, intercom, baby sitter, hot line, etc. Only 1 7/8 x 1/2 x 5/8". Complete with batt. Money back guarantee.

Only **\$12.95** ELLIS INDUSTRIES, P. O. Box 17
 postpaid. ALTADENA, CA. 91001.

Learn LANDSCAPE GARDENING
 AND THE GROWING OF PLANTS

Latest information on propagation, soil-testing, plant growth regulators, garden design. Start a profitable business or wonderful hobby. Unique and modern home study course — simplified. Send for **FREE BOOKLET.** No obligation. Approved for Veteran Training. **Norm Morris' LIFETIME CAREER SCHOOLS**

Dept. A-165, 2251 Barry Ave., Los Angeles, California 90064

ONE-SECOND PENDULUM
 ALL WOOD WEIGHT DRIVEN

The **CLOCK WORKS**

CLOCK \$135.00
 KIT \$ 35.00
 PLANS \$ 6.00

BOX 6724 BURBANK, CA. 91505

APPROVED FOR VETERANS EDUCATION

LEARN TO BE A DENTAL MECHANIC

SECURITY • PRESTIGE • GOOD PAY

Learn at home, in your spare time, to make Crowns, Plates, Bridgework, etc. Dental Mechanics are employed by Dentists, Dental Laboratories or open your own shop, full or spare time. **FULL EQUIPMENT OF TOOLS AND MATERIALS INCLUDED WITH COURSE.** Low tuition. Easy Terms. Write for **FREE BOOK** about this money-making profession that's not affected by automation.

McCARRIE SCHOOL OF MECHANICAL DENTISTRY
 P. O. BOX 1951—DEPT. PM-22—PHILA., PA. 19105

5 DAY HOME TRIAL

DISCOUNT BREAKTHROUGH ON ACCORDIONS

SAVE 1/2 OFF retail prices of comparable accordions. Buy direct from world's largest dealer. Over 40 models for Student, Teacher, Professional. Electronic, Standard & Button Models—Amplifiers too! All Big Names. Try before you buy. Free accessories. E-Z Terms. Trades. Lifetime Performance Policy. **FREE** Color Catalogs/Discount price list. Rush coupon.

ALL BIG NAMES

FREE Color Catalog

• Discount Prices

• 42 Models

Accordion Corp. of America—Dept. R-22
 5535 W. Belmont Ave., Chicago, Ill. 60641

Send **FREE** accordion catalogs and discount prices. Include special information checked:

Accordion Amplifiers Button Accordions

Name _____
 Address _____
 City _____ State _____ Zip _____

NEWS BRIEFS



Vacuum sweeper for grapes

German winemakers are showing great interest in a vacuum machine that harvests grapes. Four persons, operating suction tubes, first vacuum the leaves from the vines. Then they change nozzles, empty the container of leaves, and suck in the grapes. Growers hope the machine will reduce the cost of grape-picking, now done manually.

Stamp out messy tub joints

Easy. Just grab a tube of DAP Kwik-Seal® Tub & Tile Caulk. Squeeze a neat, white, watertight bead around tubs, sinks, showers. Stays flexible. Resists mildew. Money-back guarantee. America's favorite.

the tub fixer from

DAP

DAP Inc.,
Dayton, Ohio 45401
Subsidiary of *Plough, Inc.*



Stamp out leaky windows

Lasting seals. That's what you get with DAP "33" Glazing. Use it instead of ordinary putty to replace broken glass or dried-out putty. It stays flexible for airtight, watertight seals around window glass. Lasts years longer. Takes paint.

the window fixer from

DAP

DAP Inc.,
Dayton, Ohio 45401
Subsidiary of
Plough, Inc.



Un-sound highway

If all goes according to plan, people living along a new intercity highway near Cologne will see no traffic and—more important—hear almost none of it. Noise muffer screens, made up of green sheets of sound-absorbing plastic material fitted into steel frames, are expected to cut down noise to a bearable level.



What if I'm laid off?
 Will automation take my job?
 Am I too old to change jobs?
 Can I learn a new skill?
 Will my job ever pay more?



"The \$400 part time money I earned while enrolled has gone into equipment and advertising for the business I'm setting up. I am making contacts with people in all walks of life."
 John Nachreiner Buffalo, N.Y.

"To better my position I enrolled in Locksmithing Institute. Before I completed the training program I had already earned \$800.00."
 John P. Plata Elyria, Ohio.

BE A SKILLED LOCKSMITH!

... and Solve ALL Your "FUTURE" Problems

No question about it... with Locksmithing skill YOU'LL HAVE IT MADE! You'll do light, clean, always-fascinating work in this fascinating security profession that urgently needs YOU — where your choice of steady, high-pay job opportunities, or a big-profit spare-time or full-time business of your own is virtually unlimited. As a Locksmith you have your own "built in" pension plan. You go on enjoying the work as long as you like, knowing that layoffs, automation, slack times, minor disabilities, forced retirement can't affect your ability to EARN MORE and LIVE BETTER in good times and bad.

Locksmithing is SO EASY TO LEARN — Enables You to EARN Extra Money RIGHT FROM THE START! The better, more secure future you want can be yours FAST as a Locksmith, regardless of age, education, previous experience, minor physical handicaps. Fun and earnings begin AT ONCE as you learn quickly, easily to CASH IN on all kinds of locksmithing jobs. As little as one hour a week at home working on all kinds of lock and key problems under the guidance of experts brings quick mastery—a quick lifetime solution to ALL your "future"

problems. All locks, keys, parts, picks, special tools and equipment as well as complete fully-illustrated lessons supplied with course.

FREE Illustrated Book, FREE Sample Lesson Pages Give Exciting Facts. Find out how being a skilled Locksmith can put a quick end to your worries. Locksmithing Institute graduates now earning more, enjoying life everywhere. You can, too. Send coupon TODAY for illustrated book and sample lesson pages without cost or obligation. No salesman will call.

LOCKSMITHING INSTITUTE

Division of Technical Home Study Schools
 Little Falls, N. J. 07424

Licensed by N.J. State Dept. of Education; Accredited Member, National Home Study Council, State Approved Diploma, Approved for Veterans.

LOCKSMITHING INSTITUTE, Dept. 1110-022
 Little Falls, New Jersey 07424

Please send FREE Illustrated Book — "Your Big Opportunity in Locksmithing," complete Equipment folder and sample lesson pages. FREE of all obligation, (no salesman will call).

Name _____ (Please Print)
 Address _____
 City _____ State _____ Zip _____
 Check here if eligible for veteran benefits

YOU LEARN ALL ABOUT 

- KEY MAKING
- MASTER KEY SYSTEMS
- LOCK REPAIR
- PICKING LOCKS
- TUMBLER CHANGE
- COMBINATIONS
- CAR LOCKS
- SAFES
- VAULTS
- SECURITY SYSTEMS



Everything necessary: **KEY MACHINE** locks, picks, tools—supplied with course. State Approved Diploma



HELP DRAW OUT BOILS

Boils look unsightly and feel even worse. Soothing BOIL-EASE helps make discomfort and pain disappear fast. Protects against infection as it helps reduce swelling. Proven medication, used by thousands, helps get rid of ugly boils so you look better and feel better.

BOIL-EASE®

LOWEST BELOW WHOLESALE PRICES

- | | |
|----------------------------|-----------------------------|
| Perm. Match26¢ ea | 52 Art Cards ...19¢ deck |
| 10¢ Comb1¢ ea | Burglar/Fire Alarm 93¢ ea |
| 2 Cell Flashlight ..22¢ ea | Elect. Percolator ..1.90 ea |
| Elect. Scissors87¢ ea | Watch Bands11¢ ea |

Spectacular Profits

Thousands of Bargains — Immediate Delivery — Complete Stock on Hand — Extra Discounts for Quantity—Extra Discounts for 1st Order—Write for Free Book and Ordering Instructions. Specialty Merchandise Corporation • Dept. S-202 6963 Hayvenhurst Ave., Van Nuys, Calif. 91406

FREE Book Mail Now

Learn Profitable Profession in few months at Home

MEN AND WOMEN, 18 TO 60

Earn big pay as a skilled operator in Scientific Massage. Many employment opportunities. Easy to learn and do. Diploma awarded. Open your own office or earn good income from Doctors, Hospitals, Clubs and other health or recreational centers. Wonderful part-time profession. Low monthly payments. Write today for free Anatomy Charts and catalog. No obligation.

ANDERSON SCHOOL OF SCIENTIFIC MASSAGE
 Dept. B-1, Princeton, Illinois 61356



SAVE!  U. S. Surplus High Speed Rotary Files. Hardened steel, use on any metal or wood for filing, drilling, milling, carving, routing—a thousand uses in every shop. Sets assorted in sizes from 1/4" to 1" cutting edge. All 1/4" shanks. All brand new, in air-tight, G.I. packs.

36 Tool Set, G.I. cost \$265.00, now \$15.00
 16 Tool Set, G.I. cost \$109.00, now \$ 9.00
 Save Even More. Both Sets now \$22.00
 100% Guaranteed. We Pay the Postage. Order Now!

DAKOTA SURPLUS CENTER
 Cooperstown, N.D. 58425 U.S.A.

TROUBLE SHOOT YOUR CAR PROBLEMS WITH VOLT-I-CATOR A MINI DIAGNOSTIC CENTER



A precision voltmeter with an easy to read color-coded slide rule dial. It plugs into cigarette lighter to accurately indicate condition of battery, regulator, alternator, charging system and

other internal problems as speed, load and operating conditions vary and warns you before a major breakdown occurs. VOLT-I-CATOR is used on any 12 volt negative ground system; it tilts for easy visibility and indicates at a glance if tune-up services are needed. \$12.95 plus 50¢ postage and handling. Money back guarantee.

J. F. IVAN CO.

Dept. 2PM2, 10918 Governor Avenue, Cleveland, Ohio 44111 Use your BankAmericard

name _____
 address _____
 city _____ state _____ zip _____

SAVE MONEY EXPERT'S 3 IN 1 TOOL



KLEEN-A-ROLL'S 3 in 1 tool kit puts your 1/4" electric drill to work EXPERTLY cleans paint rollers; oil paint too RECYCLES rollers, solvent SPIN-DRIES wet rollers MIXES paint colors.

- 5 YR. GUARANTEE ●

RECOMMENDED BY:
Family Handyman Mag.
POPULAR MECHANICS
Mechanix Illustrated
WE SHIP WITHIN 24 HOURS

SAVE MONEY... RECYCLE... ORDER NOW

\$3.98 postpd.
Your check is o.k.

KLEEN-A-ROLL, Inc.
Box 727 PM
SUMMIT, NJ 07901

PERMANENT MATCH

AMAZING INVENTION SELLS LIKE MAD!



Lights up to 15,000 times. Pull this ingenious metal wonder out of its case, strike on side, and presto!—it's lit. Amazes everyone who sees it. **MAKE BIG PROFITS.** Show to friends, fellow-workers, in stores, offices, taverns, factories, sell on sight for \$1.00. Order at low wholesale prices ONLY \$4.90 per doz.; \$14.25 for 3 doz.; \$49.20 for 12 doz. (2 samples \$1.00). Catalog of 100 other fast sellers included free! Lakeside Company, Dept. PY-22, 6800 N. Campbell Ave., Chicago, Ill. 60645.



SAVE HUNDREDS OF DOLLARS . .

Build this attractive Little Red Barn for work shop, garden tractor, tool storage, play house, dog kennel, motorcycle garage. 8 ft. x 12 ft. x 9 ft. high. Mounted on skids for portability. 4 ft. sliding door. Quick to build using 1/2 in. exterior plywood. No expensive tools needed. Simple step by step plans. Send \$2.50 for barn plans and material list. Also petite 6 ft. x 8 ft. x 8 ft. high with dutch doors for \$2.50. Both plans for \$4.00.

HAMMOND BARN
Dept. PM3, Box 39027
Indianapolis, Indiana 46239

HIGH SPEED DRILL BIT MIX

50 Drills For Only **\$4.00**

Add 35¢ postage & handling

A fabulous buy. You get 50 assorted American made high speed drills from 1/64" to 1/4" in varying lengths. All sharp and ready to go.

Order Today—Check or M.O.

AMERICAN TOOL CO.
Dept. DB-390-A, P.O. Box 126
BETHPAGE, L. I., N. Y. 11714

DEALER INQUIRIES INVITED

MIRACLE FLASHLIGHT

ONLY 1" LONG—LIGHTS 50,000 TIMES!



New space age flashlight only 1" long. Gives a brilliant beam that lights over 50,000 times! Powered by a deluxe silver energy cell (replaceable) that lasts for years. Comes with gold snake style key chain. Ideal for finding house or car keyholes on the darkest nights. MANY other uses. You can make \$50, \$100, \$150 or more showing Miracle Light to friends, neighbors, people at work. Sell hundreds at only \$1.00 each. Your low cost: 1 doz. \$5.40; 3 doz. \$14.40; 12 doz. \$49.20 (2 samples \$1.00). We pay postage. Lakeside Co.; Dept. PY-22; 6800 N. Campbell; Chicago, Ill. 60645.

BUILD YOUR OWN CANOE



WOOD & CANVAS OR FACTORY MOLDED FIBERGLASS

MANY MODELS TO CHOOSE FROM \$19.50

FREE CATALOG

TRAILCRAFT, INC.
PHONE: 913-243-1313 P.O. BOX 6039 CONCORDIA, KANSAS 66011

FIX CLOCKS, WATCHES

FOR FUN & PROFIT! Fascinating new Handbook by master craftsman H. Harris gives you the knowledge skilled watch-makers learn. OVER 200 ILLUSTRATIONS show how to install hands, dials, crystals, mainsprings, stems—rehouse old movements in modern cases—clean timepieces, etc.

INSTRUCTIONS COVER every popular watch and clock, chimes, grandfathers, cuckoo, everyday alarm and electric clocks. Handbook tells you where to buy parts . . . where to send "overflow" work for repairs at wholesale prices as business expands!

Friends gladly pay \$5 to \$50 for restoring cherished timepieces. Try the **HANDBOOK OF WATCH AND CLOCK REPAIRS.** Rush only \$4.95, plus 39¢ handling, on 10-day money-back guarantee. **EMERSON BOOKS, Inc.,** Dept. 752-T, 251 West 19 St., New York, N. Y. 10011.



USE THIS HANDY DANDY STORAGE IDEA!



Handy Dandys are plastic caps that hook onto 1/8" pegboard and hold quarter-twist jars, such as popular food jars with 1-15/16" neck. Nothing better for storing workshop supplies, parts, small tools, kitchen and household items, hobby supplies. Sample pack, caps only: 10-\$1 • 36-\$3.50 • 72-\$6 • 144-\$11.50. Unbreakable, clear plastic jars only: 10-\$2 • 24-\$4.50 • 36-\$6.25 • 72-\$11.50 • 144-\$22 • 500-\$72. Ppd USA. No C.O.D.'s.

WICKLIFFE INDUSTRIES, INC.
Box 286-PM-2, Wickliffe, Ohio 44092

"BALANCE YOUR OWN WHEELS"

"DO IT BETTER AND DO IT FOR LESS—BE ASSURED OF AN ACCURATE JOB!"

\$19.95 Versatile Model Will accommodate all wheels with center holes up to 5" in diameter including the Saab & V. W. (4 & 5 hole) holes. **\$14.95** For American passenger cars only with center holes up to 4 1/2" in diameter. **\$4.95** V. W. Adapter available.

\$24.95 Heavy-Duty Model Will accommodate all wheels with center holes up to 6" in diameter (small trucks). **\$19.95** Balancer designed for the Renault only. Versatile Model (Illustrated) All prices prepaid. Complete instructions. Satisfaction Guaranteed.

JACOBSEN MANUFACTURING
P.O. Box 6143, 15025 Pacific Hwy. So.
Seattle, Washington 98188

TOOL POWER™ 110 VOLTS D.C.



3,000 Watts 0-50 amps from your car's alternator. Operates heavy duty drills, saws, and lights, battery charging. Arc welding. Does not operate A.C. motors on refrigerators and air conditioners. Installed in 10 minutes. Guaranteed 3 years. \$25.00 Postpaid. Dealerships available.

Patent Pending

A.C. Generators
60 Cycles, 110 Volts, Fanbelt driven. Runs power tools, T.V.'s, refrigerators, radios, A.C. motors to 1/2 H.P. Cannot operate air conditioners. 1,500-watt \$60.00 plus \$5.00 postage. 3,000-watt \$89.50 plus \$6.00 postage. P.O. Box 7066, 2821 Mays St.

VIRDEN PERMA-BILT CO.
PM Amarillo, Texas 79109

Leather Covered COMBINATION KNIFE \$1.75



Model K-31 **\$1.75**

NEW Leather Covered Knife opens to a sharp scissor that really cuts, a screwdriver, bottle opener, nail file & razor-sharp knife. Wafer thin, slim & ultra smart, this knife is of top quality drop forged steel for durability. Only 2 1/2" when closed. \$1.75 plus 25¢ post. & hdlg.

WESTBURY SALES CO., Dept. K-10-PM
P.O. Box 434, Westbury, N.Y. 11590.

SAVE! BUILD YOUR OWN POWER TOOLS



METAL PARTS KITS AT FACTORY DISCOUNT PRICES

- 10-in. TILT/ARBOR SAW
- 6-in. BELT SANDER
- SPINDLE SHAPER
- 18-in. BANDSAW
- 12-in. BANDSAW
- COMB. DRILL PRESS-LATHE

SAVE \$50 OR MORE PLANS \$1.00 FULL-SIZE EACH PATTERNS Deductible

Kits from \$17.99 to \$47.99 As featured in Popular Science and Workbench Magazines. Built and sold for 25 years, thousands in use. Send \$1.00 for Plans or 25c for Catalog!

GILLIOM MFG. CO.
Dept. PMT-2 St. Charles, Mo. 63301

FREE FEL-PRO GASKET MANUAL

... for top performance in all gasket applications

Learn about the latest gasket materials and trouble-free gasket installation techniques from Fel-Pro... for 50 years a leader in gasketing improvements. Improve engine... transmission... and rear end performance with these helpful tips, 36 fact-filled pages.

Write: **FEL-PRO, INC.**

FEL-PRO

7452 N. McCormick Blvd. Dept. PM Skokie, Illinois 60076

BUILD YOUR OWN BOAT & SAVE

- ★ BOAT PLANS
- ★ PATTERNS
- ★ FRAME KITS

SEND \$1 FOR 96 PAGE CATALOG NOW!

GLEN-L
9152 ROSECRANS' T'

BELLFLOWER, CA 90706

Make your own gems!

Fun - Easy - Profitable



Kit includes Gem Maker with 6" iron lap wheel, all grinding, shaping and polishing wheels, diamond blade, accessories, instr.

\$49.90 less motor, fob Fctry.

B & I MFG.

Box 1267-P, Galesburg, IL 61401



Easy to Build PLANS AND INSTRUCTIONS for

Go Kart	\$2.00
Mini Bike	\$2.00
Mini Car	\$3.00
Pedal Boat	\$4.00
Sail Boat	\$2.00
Snowmobile Sleigh	\$3.00

Mini Vehicles Plans Dept.-C P.O. Box 92 Chazy, N.Y. 12921



PSYCHEDELIC LIGHT BULB

Gives Objects, Posters, that "Turned-on" Black Light Look. Fits any socket. 40W, 110V. Flashers Make Bulbs Blink Wildly. Bulb, \$1.50 ea., 3 or more, ea. \$1.00. Flasher, 65c ea. (35c hand.) Johnson Smith, Dept. 102, Mt. Clemens, Mi. 48043.

U-Control Life-Size Ghost 95c



Floats, Dances, Soars High in Air. Do spooky tricks from secret place. 6 ft. tall. "Invisible" control. 95c ea., 2 for \$1.75 (10c hand.) Johnson Smith, Dept. 102, Mt. Clemens, Mi. 48043

2000 NOVELTIES Free Catalog

FREE! World famous catalog of hard-to-get Novelties, Tricks, Jokes, Pranks, Hobbies, Sports, Science, Electronics, Peace & Love Gear, Mod, Psychedelic, Cloth Patches, Shirt Transfers, Lights, Jewelry, Bargains, Gadgets, Books, Games, Photo & Optical, Tools, etc. No letter necessary. Send ad, name address. Johnson Smith Co., Dept. C-102, Mt. Clemens, Mich. 48043

FEBRUARY 1972



KLEEN LINE BOTTLE CUTTER

Make your own glasses, goblets, vases from discarded bottles. Do your bit for ecology. Sell for profit, give as gifts. Give your friends glasses made from their favorite beverage bottle. Any round bottle can be safely and easily cut in less than 5 min. Abrasive paper included to smooth the cut edges. Precision tool of NI plated steel comes with 3 cutters. \$9.95 plus 50c post. In Calif. add 55c tax. 3" or 4" wooden handles \$2.95/4 pak. plus 30c post. Epoxy \$1.00. Macramae Kit \$4.45 pp. Candle Kit \$6.50 pp.

ANDERSON ASSOC., Dept. PM2
1370 Logan, Costa Mesa, CA. 92626

LET'S SWAP IDEAS FIRST EDITION



Over 600 sparkling ideas, to make living, hobbies, entertaining, home-making easier and brighter. Collected from people just like you. Offered for the first time in book form. Send \$1.00 [include one of your ideas, if you like]. LET'S SWAP IDEAS BOOK mailed post paid.

THE IDEA EXCHANGE

p.o. box 104 York Harbor, Me. 03911

SMALL JET ENGINE 68-2 15-H.P.

★ NEW BREAKTHRU IN JET-ENGINE DESIGN! Nothing like it in the World! All who see it, marvel at its POWER... and SIMPLICITY! Push-Button Starting! Finger-Tip Control... Idle to Maximum Throat and back to Idle! SAFE! Reliable, nothing to wear out! No Smoke, No toxic exhaust! Made of durable Stainless-Steel. 3-Foot Long... Weighs ONLY... 5 Lbs.



★ DO-IT-YOURSELF... 68-2 JET ENGINE Construction Plans, Kits, and Individual Parts, or Completely assembled Ready to Operate JET ENGINES available.

Send \$5.00 today for Complete Information. Includes: Book on 68-2 Jet uses, with Photos and Drawings - 22 page Technical Handbook with Photos, Graphs, Schematic Diagrams, Performance Charts, Comparison to other Types of Jets, List of Plans & Prices.

OR send \$1 for 8x10 Photo of 68-2 JET and Descriptive Brochure & List of Plans & Prices.

Different Throat Engines available.

EMG ENGINEERING CO.
18518 So. Broadway, Gardena, Cal. 90248

SIMPLE, FAST

Point and timing tune-up with engine off. 100% accurate with

COMPU DWELL MICRO TIME

(See Oct. '71 Innovative Systems ad.)

FACTORY CLOSEOUT!

Air Pistol \$5.95 ppd.

Shoots both pellets and darts. This fine, well made .177 cal. German air pistol is just the ticket for target or Varmints. Accurate. No CO2 cartridges to replace, either. Once in a lifetime bargain. Order several. Supply limited. Only \$5.95 ppd.

(Secret leather holster, \$2.95 ppd.)
500 Deluxe Pellets, \$2.00 ppd.
AIR PISTOL, Dept. PM-2
4535 Huntington Dr. South
Los Angeles, Calif. 90032



BOAT PLANS-KITS



World's largest catalog, over 200 top designs for the amateur. Inboards, outboards, sail, deep vees, 8' to 57' - hydros, cruisers, house boats, ferro cement, plywood. Send \$1.00 for catalog or \$2.00 for catalog plus Boat Builder's Guide.

Other helpful books: Fiberglass-Boat Builder's Material, \$1.00 or send \$2.00, we include book, How to Fiberglass; Motor Installation - Boat Trailer Book with free plan, \$5.00; Ferro Cement-Plywood boat building book, \$6.00.

CLARK CRAFT BOAT CO.

16PP Aqua Lane Tonawanda, N.Y. 14150

FIND BURIED TREASURE

FIVE PATENTED MONEY SAVING DETECTORS

TRANSISTORIZED FROM 1795 TO 4995

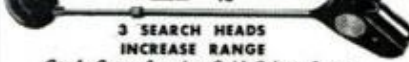

3 SEARCH HEADS

INCREASE RANGE

Finds Coins, Jewelry, Gold, Silver, Bronze

Write For FREE Catalog

SOLIDTRONICS DEPT PA2B TENNENT, NJ 07763

WATER CLOCKS

Booklet contains:

- Detailed plans for the self-contained acrylic water clock shown here. 19" high. Easy to build from readily available inexpensive materials.
- General instructions and a mechanical schematic for a self-contained "Grandfather-type" water clock.
- A history of water clocks throughout the world.

Send \$2 to
WEBER SPECIALTIES,
Box 11081,
Indianapolis, Ind. 46201



METALS

- Every type, shape, size, quantity
- Cut to your exact requirements
- All uses—home, boat, repair, shop, crafts
- Low cost, direct delivery; orders filled day received
- Send for catalogue today

Now, buy the metal piece you need when you need it. Bar, rod, tube, plate, pipe, expanded, perforated, sheet, foil, angles, molding, beams. You name it, we have it. Satisfaction guaranteed or money back.

Brass, copper, aluminum, bronze, steel, stainless, cold finished, alloy. If we don't have it, it isn't made.

Send for free brochure or mail \$1.00 for detailed catalogue, refundable with first purchase. Tells you what to buy, how to buy, how to use.

As nationally-known pros, we solve your metal problems. Write or call.

U.S. METALS CENTER Dept. A
275-A Adams Boulevard
Farmingdale, New York 11735
Telephone: (516) 293-2651

How to get rich

Start your own business right from your home—and make a future in mail order!



Beginners Get Cash by Mail!

When Bob Carter of Newark, N.J. ran a small mail order ad in House Beautiful magazine he and his wife started on a shoestring. His ad cost \$50. By the end of his first year in mail order he took in over \$100,000!

Another beginner—a lawyer from the mid-west, sold a mail order item to fishermen. Specialty Salesman magazine reveals, "he made \$70,000 the first three months!"

Have you ever thought of operating a little mail order business of your own? Something you could start on a shoestring right from home in your spare time. It's a fabulous business!

There is no other business where you can make a fortune so fast. Come up with a 'hot' new item . . . and WHAM!

It strikes like a bolt of lightning!

Millions of people read your ad and suddenly, you are swamped with cash orders from all over the country . . . MORE MONEY in 60 days than you could earn in a

lifetime!

Like the Vermont dealer who ran one ad in Sports Afield magazine. His ad pulled 22,000 orders—over A HALF MILLION DOLLARS IN CASH!

Yes, Mail Order is the fastest-growing, most profitable business in America! And now with the population explosion . . . the huge teenage market . . . and more people moving to the suburbs—we are on the verge of the BIGGEST BOOM in Mail Order history!

FREE

If you are sincerely interested in starting a lucrative business of your own ACT NOW! We can help you get rich in Mail Order just as we've helped others. Mail the coupon or send a postcard. We'll send you a free book, catalog, ads and complete facts about our offer. No salesman will call. No obligation. You don't need previous experience but you must be over 21. Write to:

MAIL ORDER ASSOCIATES, INC., DEPT. 157
MONTVALE, NEW JERSEY 07645

**RUSH
COUPON FOR
FREE BOOK**

Plus reprints of
Mail Order Articles

MAIL ORDER ASSOCIATES, INC., DEPT. 157
Montvale, New Jersey 07645

Please rush complete details on your Mail Order Program. I understand everything is free and there is absolutely no obligation. I am over 21.

Name _____

Address _____

City _____ State _____ Zip _____

Tiller Users!



If the tiller you've been using has its revolving blades in FRONT and NO power to the wheels (See 'TORTURE!' above left), you won't ever be happy with it again once you try the TROY-BILT® Roto Tiller-Power Composter which has its revolving blades in the REAR and POWER DRIVEN WHEELS — and is SO EASY to use you guide it with just ONE HAND! (See 'JOY' above right). You do NOT have to walk behind it, leaving foot-prints! It does NOT shake you half to death! It leaves NO wheelmarks! There's NO unbearable tangling! The TROY-BILT® is now in its 11th great year. SO if you want tilling to be a JOY instead of TORTURE from now on, please clip this ad now and send today for the whole story of this wonderfully different and better design in tillers! We'll send complete details, including prices and OFF-SEASON SAVINGS now in effect for a limited time! Just ask for FREE BOOKLET.

TROY-BILT® Roto Tiller-Power Composters
Dept. 1112
102nd St. & Ninth Ave., Troy, N.Y. 12180



Thousands of
exciting tool
values!

SILVO (BRAND NAME) TOOL CATALOG

Thousands of Exciting Tool Values! Stanley, Millers Falls, Skil, Thor, Wen, Disston, Wiss, Wellsaw, Dremel, Speedy Sprayers, Plumb, Huot, Kennedy, Channellock, Porter-Cable, Rockwell, Helios, Vise-Grip, Crescent, Ridgid, Pony Clamps, Unimat, Foredom and many other Nationally Advertised brands of Tools & Supplies. We ship Coast to Coast at prices hard to beat. Send 50¢ for our big 146 page tool catalog today. Silvo Hardware Co., PM2 107 Walnut St., Philadelphia, Pa. 19106.



SAVE UP TO 92%
JEEP and Gov't. Surplus Buying Manual
(Jeeps Pictured) 75¢. Surplus Bargain Catalog 60¢. Both for \$1. Surplus Jeeps,
Dept. P5, Box 1563, York, Penna. 17405



HENLEY'S

20th Century Book of
10,000 Recipes, Formulas & Processes

Here is a wealth of practical, accurate and clear information and instruction that can save you thousands, or make you a fortune! Housewives, manufacturers, farmers, handymen, home experimenters, electricians, chemists, people in every walk of life, refer to Henley's daily. In this gold-mine of a book, you too will find formulas and recipes for almost everything used in the home, farm, workshop or industry. Discover the trade secrets of thousands of commercial products—learn new money-saving and exciting ways of doing things. As indispensable as a dictionary. Satisfaction guaranteed. 900 pages hard cover—cloth binding. Only \$6.95 postpaid.

EMBASSY SALES, Dept. PM-17
Box 67, East Elmhurst, N.Y. 11369



GRANDFATHER CLOCKS
SAVE 50%
BUILD YOUR OWN GRANDFATHER AND GRANDMOTHER WEIGHT DRIVEN CLOCKS

- Highest Quality Imported Movements from Germany
- Tubular or Rod Chimes
- Moving Moon Dials
- Pre-cut Semi-assembled Handcrafted Case Kits (No power tools required)
- Dials, Barometers, Hygrometers, Templates and Case Plans.

All movements and dials in stock.
 Send 50c for complete catalog
H. DeCOVNICK & SON,
 P.O. Box 68, Dept. M22
 Alamo, Calif. 94507
 EST. 1947

Get your bills



WE CAN HELP YOU!

We are not a loan company, so poor credit is no problem! (Maximum total debt accepted is \$20,000.)
 Send your name and address. We'll mail more information and a CONFIDENTIAL application.



UNITED SECURITY CORPORATION

Dept. PM 2, 36 Kennedy Pl. Providence, R.I. 02903

HEARING AIDS

UP TO **50% OFF** COMPARABLE AIDS

• BUY DIRECT • 20 DAYS FREE TRIAL
 Body Aids \$39.95 up. Tiny All-in-the-Ear; Behind-the-Ear; Eye Glass Aids. One of largest selections. Battery prices low as \$2.00 for six No. 675. No salesman will call.
 Write: **LLOYD Corp.**
 Dept. PM, 905 9th St., Rockford, Ill. 61108

HOW TO MAKE MONEY WRITING Short Paragraphs



No tedious study. I tell you what to write, where and how to sell, and supply list of editors buying from beginners. Many small checks add up to spare time income. Write to sell, right away. Send name for free facts.

BENSON BARRETT Dept. 27-E
 6216 N. Clark St. Chicago, Ill. 60660

CHINA DOLLAR only 10c

Uncirculated nickel silver dollar minted in 1960 to Commemorate 50th anniversary of the Republic of China (Formosa)... only one to a customer... a beautiful coin and ONLY 10c. SUPPLY LIMITED! SEND TODAY. You will also receive the most wonderful catalog of coin offers in America. It lists hundreds of coins and collector's accessories to make your hobby more enjoyable. Send name, address & zip number and 10c for your China Dollar to: **LITTLETON COIN CO.**
 Dept. C-27, Littleton, N. H. 03561.

FEBRUARY 1972



HUNDRED BUCK BUGGY

Practical, fun Super-Bug easy to build. Plans inc. front ski, lawn mower attach. Complete case drawings, photo, supply sources and costs, assembly steps. Model shown carries 1000 lbs., climbs 60% hills. Orders mailed immed. \$5.00

PMB / SUPER BUG

806 S. 80th Ave., Yakima, Wash. 98902

WINDWATCH™ ANEMOMETER - WIND VANE \$19.95



Neon lights in indoor indicator show wind speed and direction. Decorative gold panel indicator comes factory wired and sealed in black finished wood frame. Designed for desk use or wall mount. Outdoor instruments of durable aluminum with electrical parts enclosed in rigid vinyl housings. Easy to assemble and install. Attach directly to roof or pole. Comes with wire and materials for installation up to 60 feet. Uses regular 120V AC. Unique low amp circuit assures absolute safety. A fascinating addition to any home. Five year guarantee. 15 day trial. Your satisfaction or money back. Only \$19.95 postpaid.

WINDWATCH Dept. F4, 104 Heimann
 San Antonio, Texas 78205

NEW WATER BEDS

• BUY DIRECT FOR LOWEST PRICE •
 Revolutionary new sleep-comfort principle. Like sleeping on a cloud. Build your own with plans & basics we supply. Details 30c U.S. Certified Products Dept. PM22
 1812 Hillhurst Ave., Los Angeles

RAZOSHARP®

U.S. Pat. No. 3,608,195

\$2.25



PRECISION TOOL HANDLE FOR INJECTOR RAZOR BLADES

IDEAL POCKET KNIFE—EXCELLENT OFFICE AND HOUSEHOLD UTILITY TOOL—Only holder to use standard injector type razor blades. Only holder allowing for varying blade length exposure. Only holder allowing blade to be completely sheathed and protected. Only razor blade holder to give precision tool feel.

ALWAYS RAZOR SHARP—When blade dulls—pop in new blade. Re-use injector type razor blades. **SHAVE and SAVE.** Inexpensive injector type razor blades always available. To expose new sharp edge—reverse blade or clip dull edge. Excellent for cutting clippings, cardboard, trimming. Ideal for opening packages, cartons, boxes. Use for carving, whittling, sharpening, erasing, etc. Shape blade to suit use—snip edge, grind or break with pliers. Nothing to break or wear out.

RAZOSHARP® Dept. A-2

421 Stockholm St., Bklyn., N.Y. 11237



WHAM-O \$198
 HITS LIKE A RIFLE—KILLS RABBITS, SQUIRRELS
 Powerful, silent, accurate
 For hunting, target, routing pests.
 Sportsman's choice sold world over!
 NEW! Surgical quality pure gum rubber
 40 heavy extra steel balls—20+
HUNTING SLINGSHOT
 Heavy duty 7" ash stock, 40-heavy steel balls, extra rubber, adapter for shooting arrows.
GUARANTEED Professional model of Nat'l Slingshot Assn. At dealers, or write
WHAM-O MFG. CO., P.O. BOX X-15 San Gabriel, Calif. 91778

WESTERN HAIG

.12 CALIBER SPECIAL FACTORY OFFER!

\$300 post-paid



USES POWDER CHARGE

This small bore gun shoots .12 cal. steel bullets fired by small 4.4 mg. powder charge. Not a CO₂ gun. You'll like the handsome lines, grip, and balance. Western in style, but patented ball and cap action allows this low price. 9 1/4" steel barrel cased in knurled styrene stock, overall 13 1/2". Developed pistol form, accuracy at a fraction of cost of large cal. pistols. Comes with 50 steel bullets. Satisfaction guaranteed. Send \$3.00 to:

HAIG MFG. CO., P.O. Box J-26, Alhambra, Calif. 91802

WHAM-O Powermaster®

"Since 1948" POWERFUL • SILENT • ACCURATE
 RANGE: 225 yds.

WRIST SLINGSHOT



Most powerful wrist slingshot in the world! With wrist lock support. at Dealers or write:

\$298 POST PAID

50 lb. pull

WHAM-O MFG. CO., P.O. BOX X-16 San Gabriel, Calif. 91778

WITH A LOW PRICED WOOD CARVING

MACHINE YOU CAN ADD TO YOUR INCOME BY REPRODUCING ALMOST ANY ITEM OR BY CARVING SIGNS. FOR FREE BROCHURE WRITE

MARLIN INDUSTRIES
 7351 ADAMS ST., DEPT. PM-5
 PARAMOUNT, CALIFORNIA 90723

WATER WATER "HOW TO DRILL YOUR OWN WATER WELL"
WATER WATER \$1.00ppd SATISFACTION GUARANTEED
WATER WATER DEEPROCK CO. OPELIKA, ALA. 36801

NEW... Improved... Accurate! Scope-Shot

SCOPE-SHOT COMPLETE WITH 50 EXPLODING PELLETS
 They crack like a rifle when they hit—leave mark—pull of smoke!
\$2.50 P.P.

Big Bag of 250 EXTRA Pellets \$1.00 P.P.
 Millions Sold! Patent No. D-178,837

World's Finest Precision SLINGSHOT Scope-type Sight!
Order Now!

Pure gum rubber slings. Beautifully polished cast aluminum stock. Pistol grip. So powerful it kills small game. Fits pocket perfectly, Guaranteed. FREE shooting manual. EXTRA RUBBER SLINGS, 3 pairs \$1.00 p.p. Leather Pouch & Sling assembly only 50c p.p. Genuine Buffalo Hide Belt Holster only \$1.00 p.p. Official Slingshot Targets 15/\$1.00. 1/4" Steel Hunting Balls 120/\$1.00. Order NOW from:

GENERAL SPORTS
 4184-MB Apple St., Cincinnati, Ohio 45223



Folds to four inches wide. Rigid double aluminum hull. Opens to five feet wide. Lengths 8, 10, 12 & 14 feet. FREE BROCHURE. Write to:

FOLD-A-BOAT
Dept. PM-2, Box 2096,
San Leandro, Calif. 94577

RUBBER STAMP KIT
DO IT YOURSELF—SAVE MONEY. Make in minutes—makes a 3 line stamp—simple and easy like stringing beads—Reusable type—custom made stamps when you need them. Includes stamp pad 3 line holder—180 characters—extra rods. Send check or M.O. \$5.95 to

AMLAST DISTRIBUTORS
P.O. Box 546
Fairlawn, New Jersey 07410

BUILD YOUR OWN

Cabover Campers • Covers
16' & 20' Travel Trailers

• PLANS •
PATTERNS • KITS
★ FREE CATALOG ★
GLEN L Recreational Vehicles



9152 P-2 Rosecrans, Bellflower, Calif. 90706

GET SOMETHING FOR NOTHING!

DRYERAIDE

GIVES FREE HEAT & HUMIDITY

YOU are wasting MONEY NOW by exhausting the warm moist air from your clothes dryer to the outside. Let NEW "DRYERAIDE" save it for you. Just slip it on the vent pipe in place of an elbow or mount vertically. DRYERAIDE vents warm moist air into your house where you need it. Flip a lever to vent outside for summer. LOW COST . . . NO NOISE . . . NO WATER TO CHECK . . . FOOLPROOF—NOTHING TO WEAR OUT . . . NO ADDED POWER COST . . . HAS LINT TRAP . . . EASY INSTALLATION SAVES MONEY . . . OPERATES FREE . . . Dealers Invited . . . HELP ECOLOGY and ORDER TODAY!

Only \$9.95 plus 50¢ P&H or \$1 Airmail
BRIGHTON HOUSE, Dept. D,
5200 Greenfield Avenue,
St. Paul, MN 55112



FREE!!! POWERFUL MUSCLES FAST!

Fantastic New Discoveries in the science of bodybuilding. Now, in the privacy of your bedroom, our method will add inches of powerful muscles to arms, chest, shoulders & legs. Learn secrets on trimming the waist with ultra-modern methods—fast! Results Guaranteed! Send for free brochure. Universal Bodybuilding, Box 485-M1, Dearborn, Mich. 48121.

USE ZIP CODES
WHEN
ANSWERING ADS.

MAN-SIZE TRACTOR

Works fast,
saves you
time



Whiz through tough jobs with this big, powerful tractor. Mow 3 acres an hour; plow, till, bulldoze, remove snow, etc. fast with 21 big attachments. 14 H.P. More work-power with all-gear drive (no fluid power loss), automotive clutch, transmission and differential. Send coupon for free catalog, prices.

NAME _____

ADDRESS _____

CITY, STATE, ZIP _____

C-21

SEND TO

ECONOMY TRACTOR

10000 10-20 Reelco Corp • Milwaukee • Wisconsin 53186

Kirsten
The pipe that never loses its cool.

Kirsten's exclusive radiator stem tames the smoke . . . makes it milder . . . cooler. It also traps impurities and allows you to remove moisture with a flick of your wrist.



\$9

postpaid.

Imported aged Mediterranean briar. Hand finished vulcanite bit. Order your Kirsten pipe and you'll keep your cool forever.

KIRSTEN PIPE CO., INC.

Dept. PM2, P.O. Box 5227, Seattle, Wn. 98107

Please send me your 1972 catalog showing all of the Kirsten Pipes and accessories.

Name _____
Street _____
City _____ State _____ Zip _____

Live Like A King!

Enjoy Life On A Small Income. Legal government facts on how to live, retire, own property or land in Mexico. Package also includes map of locations for all American colonies in Mexico. To cover postage and handling send \$1.00 money order to: J.P. Clark

5 DeFbrero 911 PTE.
Durango, Dgo., Mexico

Free rent, resort living, great food, unlimited recreation . . . and plenty of time to enjoy them! Easy home-study plan. 1000s men, women, couples needed. Age no barrier. (Or, own your own motel.) Send for FREE "Career Kit." No salesman will call.

MOTEL-HOTEL CAREER

NORTH AMERICAN SCHOOL OF MOTEL-HOTEL MANAGEMENT
4500 Campus Dr., Dept. 24172,
Newport, Ca. 92660

NAME _____ AGE _____
ADDRESS _____
CITY _____ STATE _____ ZIP _____

Your Future in MOTEL HOTEL Management
YOURS FREE

ELECTRIC ARC WELDER \$9.99!

NATIONALLY ADVERTISED \$18.95 VALUE!—NOW 1/2 PRICE! WELDS—BRAZES—SOLDERS—CUTS—ALL METALS! Plus into ANY 110 volt socket. MAKE REPAIR 1001 items for CAR—HOME—BUSINESS. Lifetime BURNOUT GUARANTEE 10 day money back trial (if retnd.)

HEAVY DUTY Design—No experience needed—FREE WELDING LESSONS!

SEND ONLY \$2.00 (cash, ck, M.O.) and pay postman \$7.99 (11D) postage or send \$9.99 plus \$1.00 postage for paid del. in U.S.A.: **COMPLETE READY TO USE—Includes BIG pack steel, Brazing, Solder, Carbon "touch" rods, ELECTROFLAME ARC TORCH!** OFFER LIMITED—Order TODAY!

MIDWAY WELDER Dept. EPM-2 Kearney, Nebr. 68847

GOVT SURPLUS SAVE UP TO 98%!!

JEEPS, TRUCKS & CARS Typically From \$75.00 . . . Typewriters, Auto Parts, Tools, Aircraft, Clothing, Boats, Camping, Sports, Photographic, Electronics Equipment. Wide Variety And Condition . . . 100,000 Amazing Bid Bargains Direct From The Government Nationwide. Complete Sales Directory And Surplus Categories Catalog \$1.00 (Deductible On Your Orders From Our Separate Included Surplus Catalog).

SURPLUS SERVICE
Box 820-AX Holland, Michigan 49423

"LISTEN IN" TO POLICE-FIRE RADIO CALLS IN YOUR CAR!

WORKS with ANY CAR—Portable or HOME RADIO! Just PLUGS in—No wiring—3 minute hookup! Switch instantly from regular to ALL POLICE-FIRE-EMERGENCY-COMMERCIAL-TAXICAB-STATE-CITY-GOVT 2 way Radio calls in YOUR AREA. DUAL-HI-LOW BANDS—OVER a MILLION Radio Cars/stations. USE Everywhere—anytime—always works!

SEND ONLY \$2.00 (cash, Ck., M.O.) and pay postman \$7.99 plus COD pstg or send \$9.99 for ppd Del in USA. **COMPLETE**, ready to use with instructions. One Year service Warranty—10 DAY MONEY BACK TRIAL (if retnd). Limited offer includes "Plug in" for ALL RADIOS.

WESTERN RADIO Dept. BPM-2 KEARNEY, NEBR. 68847



CLASSIFIED ADVERTISEMENTS

Rate: \$2.00 per word payable in advance each insertion. Capitalized words—75¢ per word additional. Minimum insertion ten words. To be inserted under the proper classification, copy must be in our office by the 15th of the second month preceding date of issue. The next available issue to place an advertisement in America's No. 1 Classified Section is April. The closing date is February 10th. Send remittance and order to C. A. Martin, Popular Mechanics, 224 West 57th Street, New York, New York 10019. Please make remittance payable to Popular Mechanics.

WHEN ANSWERING ADVERTISEMENTS PLEASE USE THE ZIP CODE NUMBER

AUTOMOBILES

CHEVROLET, \$25.00. Other Bargains. Send 50¢. Auto, B443, Bend, Oregon 97701.

ANTIQUE Classic Car ads. Appeared during the turn of century. Ready for framing. Send \$5.95 for set of 6. Two sets \$9.95. Money Back Guaranteed. Eagle Co., 28719 Ramblewood, Farmington, Mich. 48024.

MIDGET CARS

ARE You filing your copies of PM? If you are, you'll want an inexpensive Annual Index, available in December, that will make your file copies much, much more useful. Refer to any article in seconds! And if you aren't filing your copies of PM—start now!

AUTO SUPPLIES AND EQUIPMENT

NEW! "AUTO SAFETY ELECTRICAL CIRCUIT." PUSHBUTTON BATTERY SHUTOFF. PREVENTS THEFT, PREVENTS SHORT CIRCUITS, SAVES BATTERY CHARGE. Send \$3.00 for plans, \$39.95 for complete Unit (patented). GENERAL VEHICLE SAFETY, DEPT. PP, 1020 East Wayne Street, Ft. Wayne, Indiana 46803.

PARTS: Army jeep and truck parts. Spare Parts & Equipment Co., P.O. Box 751, Lexington, Kentucky 40502.

BURNING Oil?? . . . Smoking?? . . . Pep-less?? . . . Hard Starting?? . . . Save with Ring-Valve job while driving \$6.50. (Special: Two for \$12.00 postpaid.) Results guaranteed!! Motaloy, Grantham, Penna. 17027.

JEEP Owners—V8 conversions. Read Jeep Owner's ad, page 177.

GYROMATIC WHEEL BALANCERS Continually adjust themselves under all driving conditions. They will adjust the second your tire picks up a tiny stone. Each balancer is in the form of a circular tube filled with material that moves. As the tire turns, centrifugal force causes the material to move to unweighted area, automatically balancing the tire. No installation tools needed. Fits any size tire. Instructions included. \$8.95 for set of two. AY-LOR ENTERPRISES, 3318 Martin Road, Amarillo, Texas 79107.

OPERATE Power Tools From Car Alternator. Plans \$2.00. Ambrose Fisher, 921 Wakefield, St. Paul, Minn. 55106.

STOP BURNING OIL! . . . Raise Compression! . . . Increase Gas Mileage! . . . Save with Ring-Valve Job While You Drive \$6.00. Two for \$11.00 . . . Guaranteed!! Motaloy, Box 1149, Midland, Texas 79701.

VACATION On Wheels? Auto Organizers, Plus Other Interesting Items. FREE Catalog. Schneider Associates, Box 443-PM, San Leandro, California 94577.

MOTALOY, Ring—Valve job while driving—\$6.00. Free literature. E&G Sales, Box 18384-P, Memphis, Tenn. 38118.

SAVE! Time-gas-money! Use fabulous travel calculator or power-speed calculator. Free-unique-catalog! ADS Specialties Div. E-2, 2922 North Pulaski, Chicago 60641.

BEAT the tuneup game with novel IGLIT, Q-Arc, Box 47876, Los Angeles, Calif. 90047.

AUTO TOOL—POWER 110 VOLTS, 3000 Watts. Alternator Adapter Powers Brush-Type Motors, Drills, Saws, Lights, Welder. \$14.95 PPD. SPACO, Box 673-M, Seabrook, Texas 77586.

PATCH Rust Holes Permanently. Metal Patching Kit Send \$5.95. Witz Ent., 18613 Fox, Detroit, Mich. 48240.

SNOWMOBILES

PATCHES: Free catalog showing hundreds. Quotes on your design. A. T. Patch, Dept. 92, RFD 1, Littleton, New Hampshire 03561.

SNOWMOBILE Hop up accessory CATALOG. Speed and performance equipment—manifolds, exhaust systems. Send 25¢. G.E.M. PRODUCTS, Box 845, Carol Stream, Ill. 60187.

DUNE BUGGY

MINIATURE Dune Buggy for kids. A 3 H-P, recoil rope, 4 cycle engine, with off-on switch on dash makes this miniature dune buggy go 12 M.P.H. at governed engine speed. Approx. 3/16" thick fiberglass body with colors available in Royal Blue, Emerald Green, and Apricot Metalflake colors. Length-65", width 40", height to top of windshield-25", shipping weight-175 lbs. sent freight collect, allow 8-10 weeks for delivery. Send certified check or money order for \$388.65 to: Linden Manufacturing Company, 25 Freed Avenue, R. D. #1, Spring City, Pennsylvania 19475.

AUTO TRAILERS

PICKUP Camper, Trailer or Pickup—Cover . . . Build yourself. Save! Complete plans \$3.95 each Cover plans \$2.00 Conversion Plans—economy type van \$2.95; passenger bus or delivery van \$2.95. Satisfaction Guaranteed. Equipment catalog \$1.00 (refundable). Details 10¢. Viking Camper Supply, 99-F Glenwood, Minneapolis, Minnesota 55403.

MOTORCYCLES, BICYCLES MOTORSCOOTERS & SUPPLIES

REPAIR Your Bicycle, Or Mini-Bike, with New Junior Edition Book. 99¢ each. Sincere, Box 10422, Phoenix, Arizona 85016.

HONDA! \$25 Other Bargains. Send 50¢. Motorscooter, P443, Bend, Oregon 97701.

FUN-BUGGY Catalog. Just out. World's first, biggest, featuring ATV's, Mini-bikes, Karts. \$1.00. "How-to" plans \$1.00. Complete parts stock. Bargain prices. Brown's Motorsports, 19P Central St., Worcester, Mass. 01608.

ILLUSTRATED Catalog 25¢. Parts, Accessories. Custom Stock, most makes, models. Cycle Supply, Box 192M, Fairbury, Ill. 61739.

BUILD "Popular Mechanics" MINIBIKE featured June 1967 issue. Detail plans, photographs \$2.50 refundable. Kits, parts, engines; factory discount prices. Catalog 25¢. Gilliom Mfg.; PMC; St. Charles, Missouri 63301.

INDIAN PARTS. Rebuilding. Accessories. Indian Motorcycle Sales, Kansas City, Missouri 64127.

MOTORCYCLE Turn Signals. Accessories Catalog 35¢. Houston PM Lockport, Illinois 60441.

BUILD 20HP Snowmobile, Motorbike or Go-Kart Plans, \$2.00 Each. Go-Bykco, Barnesville, Minn. 56514.

MINI-BIKES, Go-Carts, Plans \$1.00. Parts Catalog 25¢. Loren Products, Danville, Illinois 61832.

SPACE, ROCKETS AND ASTRONAUTS

ANTIGRAVITY DEVICE. Brochure 35¢. AGD, Box 16126-PM, Wichita, Kansas 67216.

MOON Landing Pictures, other historic space fantasies! Free Brochure! Box 234-PM, Merritt Island, Florida 32952.

MODEL ROCKETRY MANUAL by world expert Harry Stine. How to build and fly them. 96 pages, photos, charts, drawings. \$1.50. Sentinel PM, 21 East 22 St., New York 10010.



AVIATION

GOVERNMENT SURPLUS Radios, Hydraulics, Tents, Typewriters, Sleeping Bags, Clothing, Tools, Electronics, Aircraft Components & Instruments. Catalogue. Sabre Industries, Winnipeg, Canada. R3EOGS.

BE A Government licensed aviation mechanic. Practical training. Free Information. Atlantic Aero Mechanics School, Dept. PM-081, Municipal Airport, Kansas City, Missouri 64116.

BUILD—One-Man jet helicopter. Easy inexpensive. Detailed plans, drawings—\$5.00. Helicraft, Box 7153, Baltimore, Maryland 21218.

AIRBOAT, Propellers, Hubs, Mounts. Plans. Supplies. 90—125—150—220 H.P. engines and parts. Corvair—Volkswagen conversions. 15—25—50 H.P. removable air-drives \$265.00 — \$341.00 — \$570.00. Catalog \$1.00. Banks-Maxwell, Box 3301E, Ft. Worth, Texas 76105.

BALLOONING Anyone? Fact Filled Manual \$3.00. Aerostation, Box 141, Long Sault, Ontario, Canada.

(Continued on next page)

AVIATION

(Continued from preceding page)

BUILD YOUR OWN HELICOPTER From our drawings and assembled components. Not a toy. Uses aircraft engines. Send \$5.00 now for our educational information package. Contains Aerodynamics, Stress Analyses, Photos, Prices, Helicom, Inc., 4411 Calle De Carlos, Palm Springs, Cal. 92262. (Since 1954.)

HOVERCRAFT

AERO-CAR. Amazing Hovercraft built easily with ordinary tools. Lawnmower engine power. Carries one man plus. Hovers, flies forward, backward, Sideways over land/snow/water. Complete construction plans and brochure. \$5.95. Aero-Projects, Box 5118PM, Clinton, New Jersey 08809.



BOATS AND TRAILERS

BOAT PLANS-BOAT KITS-FRAME KITS World's largest 1972 catalog. Over 200 top designs. Sailboats 7-45'. Windmill, Snipe, etc. Motor Sailers, Trimarans, Catamarans, Power Cruisers, Houseboats, Deep V's, Fishing Boats, Runabouts, Hydroplanes, inboard and outboard. Ferro Cement 33-57', sail and power. Send \$1.00 for Plan Kit Catalog or \$2.00 for catalog plus Boatbuilder's Guide to: Clark Craft, 16-P Aqua Lane, Tonawanda, N.Y. 14150.

PLANS, Patterns some kits Plywood, fiberglass, cement. Catalogs: Powerboat \$1.25, Sailboat 50¢. Marinecraft, Box 161-M, Brighton, Mass. 02135.

AIRBOATS—Engines, Propellers, Hulls, or Complete Fiberglass Airboats. Color catalogue, \$1.00. (Refundable with order). Aircat, Lake Hamilton, Florida 33851.

KAYAKS, Canoes, Sailboats, Surfboards, Complete Plans, Instructions. Catalogue 25¢. Outdoor Sports, Box 1213-P, Tuscaloosa, Alabama 35401.

FIBERGLASS Canoes, Kayaks, and Duck-boats. Many exciting models. Easily assembled kits. \$39.95 up. Free Literature. Riverside Canoes, Box 5595P, Riverside, Calif. 92507.

FIBERGLASS Cloth and resin. World's finest cloth and non-run resin, at direct mill prices Flotation foam. Complete line of plastics, silicon bronze and brass screws. save 60%. No sales tax. Boat Plans. Catalog 25¢. Freight prepaid. Stiles Boat Supply, Box 11P, Linden Ave., Mantua Hts., N.J. 08051.

NEW 1971 Outboards . . . Top Brands
4 H. P. \$139 . . . 6 . . . \$273 18 . . .
\$399 . . . 40 Selectric \$638 . . . 60 Selectric
\$899 . . . All Sizes . . . Literature 50¢ . . .
Scott-McCulloch Parts. Electra Marine, 675
Merrick Rd., Lynbrook, New York 11563.

CANOES! Kayaks! Factory-direct quality kits, from \$25.00. Many different models. Canvas hulls. Strongest construction materials. Free literature. Sportsraft, Box 636-P, Allentown, New Jersey 08501.

PLANS, FULL-SIZE PATTERNS, FRAME KITS With step-by-step instructions specially for amateurs. Send \$1.00 for new catalog just off press—nearly 100 pages, over 100 designs 8' to 42': Sail, Jets, Inboards, Outboards, Cruisers, Houseboats, Hot Boats, Catamarans, Hydros. Glen Designs, 9152 Rosecrans, Bellflower, Calif. 90706.

CANOE Kits—Wood Canvas, Molded Fiberglass—Free Literature. Trailcraft, Inc., Box 60679, Concordia, Kansas 66901.

FIBERGLASS Cloth, matt, polyester and epoxy resins. Wholesale catalog 25¢. Boat Molding book 30¢. Seifert's, Box 1206-M, Green Bay, Wis. 54305.

FIBERGLASS Cloth, mat, resin. Flotation foam. Complete supplies. Catalog 25¢. Kick-Shaw, Inc., 3511 Hixson Pike, Chattanooga, Tenn. 37415.

ENJOY Tax Free Boating Power and Sail 15' to 45' Write: Texas Dory Boat Plans, Box 720, Galveston, Texas 77550.

FIBERGLASS AND BOAT BUILDERS SUP-PLIES At factory prices. Fiberglass, matt, resins, foams, bronze brass screws, nails, fittings, marine plywood, mahogany, trailers, boat plans. Send \$1.00 for literature or \$2.00 for large catalog plus book on fiberglass uses, boat coverings, molds, etc. to: Clark Craft, 16-P1 Aqua Lane, Tonawanda, N.Y. 14150.

CAMPERS AND TRAILERS—KITS—PLANS—

CABOVER Campers, Pick-Up Covers, 16' & 20' Trailers. Build and Save. Large scale Plans and Full-size Patterns with written & pictorial instructions. Complete accessory and aluminum covering kits. Free Literature. Glen L. 9152 PM2 Rosecrans, Bellflower, Calif. 90706.

MARINE EQUIPMENT AND SERVICES

MARINE Engines, conversions, parts, equipment. Catalog Free! Stokes Marine Industries, Coldwater, Michigan 49036.

CONVERT Auto engines to marine. 68 Page Catalog, 50¢. Lehman Manufacturing Company, 800 Elizabeth Avenue, Linden 4, New Jersey 07036.

MARINE Supplies, Ignition Parts. Free literature. Michael's, 991 Broadway, Bayonne, New Jersey 07002.

FREE Brochure Conversion Kits, Propellers, gears V-Drives 1/0 Drives Gas, Diesel. Starmarine, 1931 Embarcadero, Oakland, Calif. 94606.

ATHLETIC AND BODY BUILDING COURSES

IMPRESSIVE MUSCLES FAST. Easy plans for home gym from inexpensive materials. \$2.00. G.I.P., 5951 Grace, Chicago, Ill. 60634.

MUSCLE Building Power Course—\$1.00. William Hinbern, 18959 Inkster, Livonia, Michigan 48152.

"GIANT Arms." Dr. Young's, D.C. revolu-tionary discovery. \$2. Satisfaction or refund. Gaucho, 1769-S7, Chicago 60690.

POWERFUL Muscles fast! Free brochure! Universal Bodybuilding, Box 4327-C, Dearborn, Michigan 48126.

BODY Building Enthusiasts. PHYSICAL CULTURE MEDIA Newsletter Lists Physique Events, Itinerary Of Physique Stars. 18 Issues \$6.25 Year. PCM, 11848 Burke Highway, Diamondale, Mich. 48821.

ZAMBO, The Russian Version Of Judo. Complete Course \$6.95. Eastview Book Service, P.O. Box 7053, Ottawa-Vanier, Ontario, Canada K1L 5A0.

SPORTING GOODS AND EQUIPMENT

FREE 1972 Catalog! Guaranteed lowest prices! Rods, Reels, Lures, Accessories—Thousands of items. Cabela's, Inc., Dept. S-1, Sidney, Nebraska 69162.

FREE Catalog low direct factory prices, fishing, Hunting, Archery, reloading Camping supplies. Send today. Herters Inc., Dept. CPM, Waseca, Minn. 56093.

ARCHERY Lowest Discount Prices. All top brands. Orders shipped same day received. Money-back guarantee. World's Largest Supplier. Free catalog. Anderson Archery Corporation, Grand Ledge, Michigan 48837.

FREE WHOLESALE CATALOG. Lure parts, Molds, Rod Blanks, Reels, Archery, Metal Detectors. Rare Hardwoods. Finnyports (ME), Toledo, Ohio 43614.

CROSSBOWS Powerful Accurate. Catalog 25¢. Crossbowman, Box 723PM11, Manteca, California 95336.

BILLIARD CUES & Accessories, Details Free. Murphy's Cues-B32, Box 5352, Santa Monica, California 90406.

SCUBA. Save over 50% on new Scuba Tanks Government Inspected. Send for free brochure. Scuba Sales, 1750 Meade St., Denver, Colorado 80204.



FISHING, TACKLE, LURES

ELEC-TRIC-LURE (Mercury battery lighted). "Fish-Catchingest" lure you ever tried—free catalog. Fen Brown Company, Box B 5, Willingboro, N. J. 08046.

MOLDS—For casting your own fishing sinkers. Free illustrated booklet. Reading Instrument Co., Box P78, Reading, Pa. 19603.

FISHERMAN'S DREAM BOOK—FREE, 170 page catalog just loaded with Hard-To-Find Fishing Tackle Specialties and Do-It-Yourself Goodies. Our 28th year. NETCRAFT Inc. Box 5510, Toledo, Ohio 43613.

BARGAIN! 12 Different World Famous Spinning Lures. \$8.00 Value Only \$3.95. Hurry! Limited Offer! Lynn, (PM-2), 1806 Gaviota, Simi, California 93065.

EARTHWORMS, LIVE BAIT

GROW Fishworms. Outstanding new breed produces great profits. Free Literature. Fain's Hatchery-31, Edison, Ga. 31746.

EARN Money raising fishworms for us! Exciting details free! Oakhaven—56. Cedar Hill, Texas 75104.

GROW Larger Earthworms, Faster Easier—More Profit—Nograin—Soilless Method. Organic Enterprises . . . Route #1 . . . Box 393 . . . Texarkana, Arkansas . . . 75501.

BIG Profits Raising Worms, Soilless Method. Three Oaks, Dresden, Tennessee 38225.

HYBRID Redworms 5000 \$10.00, 20,000 \$20.00 Postpaid with Raising Instructions, Worms, Route 9, Waco, Texas 76705.

FROGS, FISH, REPTILES

MAILORDER Records help get increased business! Complete 32 Page Record Book shows your inquiries orders, advertising, expense, etc. Only \$1.00. C. A. Martin, Popular Mechanics, Dept. PMR, 224 West 57 Street, New York, N.Y. 10019.

HUNTING, GUNS, DECOYS

UNIQUE GUN RACK Two nails, 3 1/2" with reproduction of Mexican Coin Set of two, \$3.95 PPD. Nulking, Box 1643, Indianapolis, Indiana 46206.

DOGS AND KENNELS

LOOKING For a Special Puppy—Send \$1.00 for catalog with prices and information on more than 100 breeds. Hoppe's Kennels—Rt. 2A—Hill City, Kansas 67642.



POULTRY & GAME BIRDS

QUAILS, Incubators, cages, supplies cat-alog. Marsh, 14216 Brookhurst, Garden Grove, Calif. 92643.

WILD Game Recipes, Venison And Other Large Game, Small Game, Fowl, (All Kinds). Southern Red Eye Gravy, Beer Batter For Fish. Specify. Send \$1.00. Hunter Sam, P.O. Box 17066, St. Paul, Minn. 55117.

APPALACHIAN Wild Turkey eggs, 6—\$10.00. Meadowbrook, Richfield 4, Pa. 17086.

FANCY ORNAMENTAL POULTRY

WATERFOWL, Gamebirds, Poultry Ga-lore! Information 50¢. Sunny Creek, Red Lake Falls, Minnesota 56750.

RABBITS—CHINCHILLAS—FUR BEARING ANIMALS

\$600-UP MONTHLY. People needed. Raise rabbits, other laboratory animals for us. Huge market. We supply equipment, breeders and instructions. Details 25¢. National Research Farms, PNMA-2, Box 309, Milwaukee, Wisc. 53201.

(Continued on next page)

RABBITS—CHINCHILLAS—FUR BEARING ANIMALS

(Continued from preceding page)

RAISE Rabbits successfully by knowing facts. 48 page illustrated book describing 25 breeds. Housing, breeding, feeding, markets, marketing etc. 25 cents. American Rabbit Association, 36 Arba Building, Pittsburgh, Penn. 15217.

AMAZING PROFITS! \$10,000 Yearly Raising Rabbits for Wool and Breeding. Details 25c coin. American Angora, Malta 12, Montana 59538.

RAISE Rabbits for us, \$500 month home plan. Free details. White's Rabbitry, Mt. Vernon, Ohio 43050.

MAKE Big Money Raising Chinchillas, Cavies, Rabbits for us. Catalog 25c. Keeney Brothers, New Freedom, Pa. 17349.

PETS—BIRDS, CATS, HAMSTERS, ETC.

HAWKS, Reptiles, raccoons, skunks, squirrels. Catalogue 25c. Trails End Zoo, St. Stephens, S.C. 29479.

950 PICTURE Pet Hobby Supply Catalog 50c "Everything—You Name It." Stromberg's Pets Unlimited, Fort Dodge 25, Iowa 50501.

LIVE Seahorses, Marine Specimens, Aquarium Supplies. Illustrated catalog 30c. Marine, Box 23158-G, Fort Lauderdale Florida 33307.

AQUARIUM SUPPLIES. World Champion Guppies, Bettas, Seahorses, Catalog 25c. Land Hermit Crabs (Playful!) \$4.95 pair. Fishmart, Ortonville, Mich. 48462.

AQUARISTS Supply Manual 35c. Daleco, 416-P Glenalby, Tonawanda, N.Y. 14150.

WILDLIFE Pets—Mammals, Birds, Reptiles. Catalog 25c. Ray Singleton, Riverview, Fla. 33569.

HORSES, LIVESTOCK

"HOW TO TRAIN HORSES"—FREE Book tells how to break, train, make money with horses. Beery School, 1102 Pleasant Hill, Ohio 45359.

CAMPING EQUIPMENT AND TENTS

BACKPACKING Equipment Send for prices. Oregon Recreational Enterprises Inc., 8103 N. Denver, Portland, Oregon 97217.

NEW! Swiss type army knife, with 12 amazing tools. Free details! Bonant, 18301 Kinzie, Northridge, California 91324.

FREE Catalog! Camping, Boating, Sailing Supplies; Gadgets, Hardware and Gifts. Laacke and Joys, 1439 N. Water St., Milwaukee, Wisconsin 53202.

CAMPING

PAK TENTS—Inexpensive. Free Literature. Martins—Box 141, Fremont, Calif. 94537.

TRAVEL AND RESORTS

PROFITS FROM CLASSIFIED ADVERTISING! Booklet shows you how to start your own business with Classified Advertising. Only \$1.00 (Refundable with first order.) C. A. Martin, Popular Mechanics, Dept. PMP, 224 West 57 Street, New York, N.Y. 10019.

"AMERICA BY CAR" what to see, where to go, SCENIC roads, HISTORIC sights. BEST places to stay, large as 3 novels! only \$3.50. BRADLEY SPECIALTIES, 2405 LEWIS, FORT WORTH, TEXAS 76103.

CANOE Trips—\$11.00 per day. Write, Rom's Outfitters, Ely, Minnesota 55731.

ELECTRICAL SUPPLIES

METERS—Surplus, new, used, panel and portable. Send for list. Hanchett, Box 5577, Riverside, Calif. 92507.

LIGHT Bulbs burn 50,000 hours or 5 years with New Socket Adaptor. Sample \$2.98. Ganther Enterprises, PM-2, Granton, Wisconsin 54436.

LAMP Parts. Catalog, prices, wiring instructions. 50c. Refunded first order. Gyro, 5218P N.W. 35 Ave., Miami 42, Florida 33142.

LAMP Parts for building, repairing converting. Catalog 50 cents. Refunded first order. Brown Lamp Co., Box 12511, Creve Coeur, Missouri 63141.

BATTERIES, GENERATORS

BATTERY Reconditioning Kit, includes molds, material, instructions. Battery Shop, Box 820, La Quinta, California 92253.

ELECTRIC Generator Sets. 5-KW To 60-KW, Gasoline And Diesel. K. A. Weimer, Route 1, Tucker Mill Road, Conyers, Georgia 30207.

"BATTERIES" Six Used Rechargeable 1½V \$3.00. Trowbridge, P.O. Box 418, Oaklawn, Illinois 60455.

ENGINES, MOTORS, MAGNETS

ELECTRIC MOTOR SUPPLIES! Rewinding data! Catalog! Modequip, Box 7266, Kansas City, Mo. 64113.

WINDING Data, 275 motors, \$1.25. Data Company, 512 Kensington, Kansas City, Mo. 64124.

MACHINERY, TOOLS AND SUPPLIES

UNIMAT, Maximat sale. Amazingly low prices. Dumas, 562 Howard Avenue, Staten Island, New York 10301.

MICROMETERS—Indicators. Steel—Aluminum—Brass. Maximat, Unimat Lathes. Complete mailing—50c. Campbell, 1424 Barclay, Springfield, Ohio 45505.

SMALL Foundry furnaces. Supplies. Free literature. Pyramid Products, 3736 South 7th Avenue, Phoenix, Arizona 85041.

NUTS, Bolts, Screws, Washers, Gross Lots. 10c for Catalog. Also large assortment. Send \$9.95 PP Money Back Guarantee. Nutty Co., 1576 SMS, Fairfield, Conn. 06430.

WINCHES And HOISTS. Choice of 12 volt or 110. Reversible, compact, fast. ¼ ton to 1 ton capacity, from \$49.95. 25c brings 16 page full color catalog. Refundable. Superwinch, Inc., Dept. PM, Pomfret, Connecticut 06258.

OSCILLATING SPINDLE SANDER. Rivals commercial models. Plans and instructions, \$4.00. Foster, e. g. Box 2599, Des Moines, Iowa 50315.

END Mills. Lathe Milling Attachments: Information. Potter, Box 73, Cedar Rapids Iowa 52406.

MICROMETERS—Limited Supply. Guaranteed. 0-1"—\$4.45; 1"-2"—\$9.45. PPD. Intranasal Micrometer, 6512 N. Clark, Chicago, Ill. 60626.

SAVE! High Speed Drill Sets, Circular Saw Blades. Free Literature. Dalco, Box 207F, Racine, Wisconsin 53401.

FREE Catalog—Micrometers, Dial Calipers, Indicators, Unimat Lathes—Raymond Leung, Room 136, 664 King's Road, Hong Kong.

"CHINE-ALL" CUTTING FLUID A craftsman's dream. Engineered for Ultra-fine and Precision finishes on all Metals except aluminum. Drilling, Tapping, Boring, Facing, Threading, Engraving, etc. Excellent for Steel, Bronze, Brass, Monel, Titanium, Stainless, Gold, Silver, etc. Non-flammable. 8 oz., \$2. Send check or M.O. to: R.D.D., P.O. Box 203, 580 Dena, Newbury Park, California 91320.

CUTTING TOOLS, Mills, Reamers, Short Drills. Catalog 25c. Red, White, Blue. Box 654M, Flagstaff, Arizona 86001.

WELDING, SOLDERING, PLATING

BUILD your own Portable Spot Welder for less than \$10.00. Plans \$1.00. Spot-it, Box 262, Ford City, Pa. 16226.

PLATING Manual! New! Complete! Copper, nickel, chrome! \$3.00. Guaranteed! Qrewh, Box 8, Bourbonnais, Illinois 60914.

MORRIS—Welders—110/220, 150 Amperes, \$53.50. 1070 Inner, Schenectady, New York 12303.

WELDERS, Convert To Heliarc, Weld All Kinds Of Metals. You Can Build This 0-225AMP High Frequency Heliarc Unit From Junk Box And Approximate \$9.00. Picture Of Completed Unit. Plans And Where To Get Parts. Send \$4.00 To: Information Supply Company, Box 166, College Park, Maryland 20740.

PLATING Equipment, Portable Platers, Supplies, and "Know-How". Build your own tanks for nickel, chrome, etc. Easy-to-install PVC liners. Rectifier components—all sizes. Schematics, parts lists, formulas, operating instructions for all plating. \$10.00 post-paid. Guaranteed to save you 25%-75% or immediate refund. Some good used units for sale. Platers Service Company, 1511-A Esperanza, Los Angeles, California 90023.

WELD Aluminum and diecast without flux. Make your own rods. Instructions \$2.00. Alco, Box 4654, Toledo, Ohio 43620.

WELDINGIRON Unique Arc Welder, plans \$3.00, Complete \$18.00. AEC, Box 493, Bronxville, New York 10708.

GOVERNMENT SURPLUS

JEEP And Gov't. Surplus Buying Manual (Jeeps Pictured) 75c. Surplus Bargain Catalogue 60c. Both \$1.00. Surplus Bargains, Box 789PM2, York, Penna. 17405.

GOVERNMENT SURPLUS Radios, Hydraulics, Tents, Typewriters, Sleeping Bags, Clothing, Tools, Electronics, Aircraft Components & Instruments. Catalogue. Sabre Industries, Winnipeg, Canada. R3EOG5.

JEEPS Typically From \$53.90 . . . Trucks From \$78.40 . . . Airplanes, Typewriters, Boats, Clothing, Camping, Sporting, Photographic, Electronics Equipment, Wide Variety, Condition. 100,000 Bid Bargains Direct From Government Nationwide. Complete Sales Directory and Surplus Categories Catalog \$1.00 (Deductible First \$10.00 Order From Our Separate Included Catalog). Surplus Service, Box 820-A, Holland, Michigan 49423.

NO CATCHES. Buy any surplus direct from U.S. gov't. All information \$2.00. Bridgeworth, P.O. Box 2292-C, Vancouver, Washington 98661.

GOVERNMENT Surplus. How and Where to buy in Your Area. Send \$1.00, Surplus Information, Headquarters Bldg., Box 30177-PM, Washington, D.C. 20014.

1972 SURPLUS Army, Navy store, 52 Page illustrated catalog. Send 50c. Ruvel, 3037 North Clark, Dept. 2-J, Chicago, Illinois 60614.

JEEPS!!! Pickups!!! 100,000 items direct from Government. How? Where? Your area. Latest information. Moneyback guarantee. Send \$2.00 to: DEPENDABLE, MANUAL #108, Box 113, Vista, California 92083.

GOVERNMENT Lands . . . low as \$1.00 Acre! Vacationing . . . Homesteading . . . Investment! Exclusive "Government Land Buyer's Guide" . . . plus "Land Opportunity Review" listing lands throughout U.S. Send \$1.00. Surplus Lands, Box 19107-AN, Washington, D.C. 20036.

JEEPS \$52.40, Airplanes \$75.01, Typewriters \$6.70, Boats \$7.50, Direct from Government. Directory and Surplus Catalog \$1.00 (Refundable). Midwest Surplus, Box 401-PM, Dayton, Ohio 45401.

GOVERNMENT Surplus. Complete Sales Directory \$1.00. Surplus Publications, Box 26062-M, Los Angeles, California 90026.

JEEPS From—\$52.50; Typewriters from—\$4.15; Cars from—\$31.50. Walkie-talkies, motorcycles, airplanes, boats, Typical "As Is" bid bargains from Uncle Sam. Tremendous variety. Exciting free list. Write: Enterprises, Box 402/73, Jamaica, New York 11430.

(Continued on next page)

GOVERNMENT SURPLUS

(Continued from preceding page)

NEW MANUAL!!! Most Complete!! Shows Where . . . How!! Government Bargains . . . You, Nationwide!! Guaranteed, Mail \$1.00—Hampshire's, Box 14443-P412, Saint Louis, Missouri 63178.

SURPLUS BARGAINS—War, government, Industrial surplus at savings to 80%! Clothes, boots, cots, tents—bargains for farm, home, outdoors. SEND FOR FREE CATALOG—must give zip code. SURPLUS STORE, Sioux Falls, S.D. 57102.

SAVE! Buy Surplus direct from U.S. Government at giveaway prices. Details free. Carco, Box 244PM, Boston, Massachusetts 02187.

HOBBIES AND COLLECTIONS

FREE Catalogue Hobby Books.—Railroad, Marine, Mining, Western History. Howell—North, 1050 Parker, Berkeley, California 94710.

COLLECT Military Medals. List 25¢. Vernon, Box 387PM, Baldwin, N.Y. 11510.

HOBBY CARVE—Home workshop wood carver—create beautiful wood reproductions of sculptures, plaques, figurines, scones and bookends. Hundreds of work patterns available. Free information. Write: Hobbi-Carve, 930 Duluth Street, Dept. PM, St. Paul, Minnesota 55106.

NAZI Medals and Photos. Also U.S. War Surplus. Catalog and War Poster, 25¢. Hutchinson House, Dept. PM3, Box 6411, Chicago, Illinois 60680.

50 GORGEOUS Jungle Butterflies \$2.90. Collectors Wonderland, Box 1170, New York 10008.

HISTORICAL CHESS SET. Collectors' Series. Chessman of Ancient Rome. Includes booklet giving historical outline of each chessman \$7.98. Birkemark, 14362 Bushard P140, Westminster, Calif. 92683.

DECALS, EMBLEMS, PATCHES

NASA Contract supplier offers authentic Apollo 4" diameter flight patches at \$2.00 each. Souvenir 3" size, \$1.00 each. Apollo 7-16 set of ten in 4" size, \$17.50. 3" size set \$8.00. As supplier to the world's largest corporations, we offer custom embroidered patches from 25 pieces to 25 million. Lowest prices. Fastest delivery. Design-An-Emblem Guide plus free sample emblem: 50¢. A-B Emblem Corporation, Box 5695, Weaver-ville, North Carolina 28787.



STAMP COLLECTING

FREE! 55 Different stamps—worth \$3.00 at Catalog Prices!—from 26 present and former French Colonies. Across the flaming African deserts of the French Foreign Legion to romantic Polynesia and desolate Antarctica. Also, exciting stamps on approval, returnable without purchases, cancel service anytime—but this valuable collection (plus Big Illustrated Catalog) are yours to keep—FREE! Send 10¢ for mailing. H. E. Harris, FF-4, Boston, Mass. 02117.

YOURS Free! 20 Almost Rare Stamps from 12 Lost Nations—Most a Half-Century Old! Nations overrun by invaders and never freed again. Stamps so appealing that experienced and beginning collectors alike will want them. You get 110 other stamps from Britain's Lost Empire plus illustrated Album to keep as a Bonus should you buy \$1.00 from our Approval Selection. Or return Album and 110 stamps with selection and buy nothing. Cancel Service anytime. But Lost Nations stamps are yours to keep! Send 10¢ for mailing while supplies last. Kenmore, Milford LN-956, New Hampshire 03055.

SURPRISE COLLECTION! Exotic mint British Colonials absolutely free with approvals. VIKING, Great Neck, 8 N.Y.

198 POPULAR MECHANICS

FREE—10 Large Pictorials, Approvals. Pickrell, Box 19129, Norfolk, Virginia 23513.

WOW! \$30.00 Value! 1000 Different Worldwide Stamps. \$1.50 with profit sharing approvals. Universal, Box 6-MA, Kenosha, Wisconsin 53141.

APPROVAL Buyers No Gifts-Just Discounts. Never Pay Postage. Save Yourself Money And Build Your Collection. Paul Terry, 247 Cambridge Avenue, Staten Island, New York 10314.

U.S. AT BELOW WHOLESALE PRICES. SEND 8¢ STAMP FOR PRICE LIST OF OLDER ISSUES BEFORE YEAR 1930. COMPARE FOR PROOF OF LOWEST PRICES BEFORE ORDERING. LOWELL DONALD CO., BOX 728, RUTLAND, VERMONT 05701.

FREE 50 Stamps including Grenada, Antigua, Iceland, Approvals. Moublow, 1834-A Bassett, Anaheim, California 92805.

FREE 149 Flag Stamps with approvals. W-B Stamp Company, Wilkes-Barre, Penna. 18703.

FREE List. Large Assortment \$1. High value packet \$2. Schollmeyer, 436 New York Ave., Brooklyn, N.Y. 11225.

EXCHANGE. Send 100 different with 50¢. Receive Different Packet, Brennan, Thomasville, Pa. 17364.

FINE Worldwide used Quality mounted approvals. Reasonably priced at 2¢ up. Free gift with initial selection. Franklin, Box 467, Jamaica, New York 11434.

704 U.S.A. (Plenty Commemoratives)—25¢. Approvals. Horace Gatewood, Winston-Salem, N.C. 27102.

300 DIFFERENT Stamps 30¢ Bargain lists included. No approvals. Stamps, Box 27, Fremont, Michigan 49412.

GIANT Stamp Collection including: Astronauts, Satellites, Moonrocks, Boy Scout issue. Complete U.N. Set, recent Olympic and Sport issues from many countries, etc., Plus Big Stamp Dictionary and approvals. Everything 10¢! Stampex, Box 47-RM, White Plains, N.Y.

OLDER UNITED STATES Approvals to adults only. Intriguing, worthwhile. Engle, Box 208P, Lowell, Michigan 49331.

GREATEST U.S. Philatelic event since Moon Landing issue. Twin Space stamps on lovely first day cover. 60¢ from K. M. WALSH, Box 308-J, Tuckahoe, N.Y. 10707.

50 DIFFERENT Canada: 10¢ With approvals. Oroszky, P.O. Box 1-C, Sarnia, Ontario, Canada.

100 DIFFERENT United States Stamps, 25¢ with U.S., Foreign Approvals. SheiRon, Box 547C, North Miami, Fla. 33161.

LIECHTENSTEIN 356-\$12.00; France #1100-\$4.00; UN 29-30-\$15.00; NH, CWO. Submit Lists Western Europe Only. All NH, Franklin, Box 467F, Jamaica, 11434.

WOW! 110 ALL DIFFERENT GERMANY 10¢ Commemoratives, Airmails, High Values. Big catalog, bargain lists. Also, fine stamps from our approval service, which you may return without purchases and cancel service at any time. Jamestown Stamp, Dept. A-22-PM, Jamestown, N. Y. 14701.

FREE! BIG BARGAIN CATALOG—NEW EDITION listing thousands of bargains including U.S. & B.N.A. stamps, packets, albums, accessories and supplies. Also, fine stamps from our approval service which you may return without purchases and cancel service at any time. Jamestown Stamp, Dept. E-22-PM, Jamestown, N. Y. 14701.

FAMOUS Painting collection 15 different—depicts work of art found in museums of the world—10¢ with worldwide approvals. Modern Stamps, Dept. 57H, Ferrysburg, Michigan 49409.

SENSATIONAL Clearance. Forty different packets \$1.00. No approvals. Norge, Wycokoff, New Jersey 07481.

225 STAMPS For only 10¢! Airmails, Pictorials: stamps from strange countries cataloging up to 25¢ each! Plus unusual stamps to examine. Buy any or none return balance, cancel service anytime. Mystic Stamp Co., Camden 80, New York 13316.

U.S. MINT Specials! Flag set, complete \$1.00. 1¢, 2¢, 3¢ famous Americans (21 different) \$1.00. Free list. Brooks, 2601 Avenue "U," Brooklyn, N.Y. 11229.

PENNY! Approvals! Regardless catalogue! Kloster, 4164 52nd St., San Diego 5, Calif. 92105.

"AFRICA." 25 Beauties, 10¢. Approvals. Gorliz, Box 1915PM, Naples, Florida 33940.

U.S. BARGAIN, 50 Different 10¢, with beautiful worldwide, approvals. Stamp Center, Kennebunk, Maine 04043.

50 DIFFERENT Old U.S. Revenue Stamps 50¢. Winchester Stamps, Box 1592, Mansfield, Ohio 44907.

FREE Surprise collection sent with approvals. Gould, 1784 Union, San Francisco 94123.

PENNY Stamps! 1000 Mounted in book at 1¢ each! Trust Stamp Company, P.O. Box 100-P, Jamaica, New York 11435.

ABSOLUTELY Free United States Mint Souvenir Sheet When Requesting United States Approvals. K&B, Box 70, Brooklyn, N.Y. 11223.

500 DIFFERENT Stamps, \$1.00. Smith, 508-A Brooks, College Station, Texas 77840.

210 DIFFERENT U.S. Commemoratives \$1.00. Stamps, 7607 Larchview, Dallas, Texas 75240.

14,000 DIFFERENT! AMAZING New plan builds your collection systematically, country by country. Only 50¢ weekly. Ware, Monroe, Conn. 06468.

TEN Different Nudes: 20¢. Approvals. Stamp Farm, 2M39, Oxford, Wis. 53952.

AMERICANS On foreign stamps, Presidents, Kennedy, Roosevelt, Lincoln, U.S. Spacemen, Princess Grace and others, 10¢ with approvals. Roseland Stamps, Dept. 57, Spring Lake, Michigan 49456.

FAR EAST ASSORTMENT—VIET NAM, JAPAN, KOREA, Formosa and others only 10¢ with world wide approvals. Clark Stamps, Dept. 57V, Muskegon, Michigan 49444.

100 CANADA 25¢. Excellent value. Approvals. Continental, Limehouse, Ontario, Canada.

FREE Duplicate Exchange—2¢ Approvals. Belden, Box 4175B, Dearborn, Michigan 48126.

"WHOLESALE" U.S.—Foreign Pricelist and catalog Free! Everything Guaranteed. Schneider, Box 1240, Grand Rapids, Michigan 49501.

100 DIFFERENT British Empire 10¢. Approvals. Gibson, Box 34, Lansdowne, Pa. 19050.

"INVERTED Error" Dag Hammarskjold, 10¢ with approvals. Belmont Stamps, Washington, D. C. 20015.

1500 FOREIGN \$1.00; 5000 \$3.00; 9000 \$5.00. 5000 USA, Contains airs, dues, presidentials, revenues, 19th Century, high values, etc. \$3.00. 300 pre-1940 USA Commemoratives \$2.00; 700 \$4.00. No approvals. Meyers, 5321 Fleming, Richmond, California 94804

80 DIFFERENT U.S. stamps. Includes 1943 flag stamp of occupied nations. Only 25¢. Approvals included. Willett Co., Box 338-M, Yorktown Heights, N.Y. 10598.

50 DIFF. U.S. Commemoratives 25¢ Approvals. We Pay Postage. Craig Stamps, Box 118-N, Bellmore, New York 11710.

50 YEARS Old, fifteen different United States, over fifty years old—10¢ with approvals. Jaxon, Box 145-P, Brooklyn, New York 11230.

(Continued on next page)

STAMP COLLECTING

(Continued from preceding page)

307 DIFFERENT Triangles, Sports, Topicals, etc. Worth near \$8.00. Only 25¢. Bargain approvals. Jayto Stamps, East Syracuse, New York 13057.

MILLIONS Foreign Stamps! 2¢ each! Send for gigantic approvals! ABC, Box 6000-MB, San Francisco, California 94101.

NEW! Get scarce Vietnam, Tanzania, Cook Islands Royal Visit, Monaco Royal Wedding plus F.D.R., Stalin, Churchill memorial issues, many more. Valuable collection of 100 different stamps from far-away places. Strange beasts, famous people, rare paintings. Also stamp selections to examine. Buy any or none, return balance. Cancel service anytime. Rush 10¢ handling. Garcelon Stamp Co., PM9K, Calais, Maine 04619.

100 OLD United States between 1861 and 1935. \$1.00. Ed Roush, 423 Shepard, Mansfield, Ohio 44907.

60 DIFFERENT UNITED States (30 Commemoratives) 25¢. Seidenberg, Salem 169, Oregon 97308.

"50 FAMOUS PAINTINGS 50¢ when requesting approvals. C. F. Stamps, 655 Forbes St., East Hartford, Conn. 06118."

QUALITY AND LOW PRICE. EXCELLENT For advanced or beginner. Mounted approvals 2¢ up, all countries in Scott's Order. Preview Stamps, P.O. Box 20667, San Diego, California 92120.

AUSTRALIA—Fifty Different. 10¢ When requesting approvals! Value, 10209A-Tenbrook, Silver Spring, Maryland 20901.

RUSSIAN Space collection 25¢. Russian Approvals, Snedco, Box 68-P, Waldwick, N.J. 07463.

BEAUTIFUL TOPICAL COLLECTION—Includes Olympic sport stamps, wild animals, bicolor triangles, colorful birds, outer space stamps, Poland kitten stamp and others. 10¢ with approvals. Sunny Stamps, Dept. 57A, Fruitport, Mich. 49415.

PAINTINGS On Stamps—25 different 25¢; approvals accompany. Northern Stamps, Box 565, Hull, Quebec, Canada.

COLORFUL COLLECTION Of 75 different stamps. Includes sets, paintings, animals, flowers. 25¢ with worldwide approvals. Gibs Company, 4713 N. Albany Avenue, Chicago 60625.

FREE 50 Worldwide Approvals. University Stamps, P.O. Box 1471, Lake Worth, Florida 33460.

FREE, Complete Illustrated list of all United States, Canal Zone, Philippine airport stamps. L'Amérique, P.O. Box 6661, Milwaukee, Wisconsin 53216.

BARGAIN—\$12.00 Catalog Value, Different Better Stamps Only \$1.00 Cash. Gains, Box 788, Mattoon, Ill. 61938.

200 DIFFERENT 10¢ With Approval. Polze, Box 5215, Milwaukee, Wisc. 53204.

"APOLLO 12" SPACE SET on giant Yemen Souvenir Sheet, 25¢ with approvals. Degler, R.D. #2 (300), Pottstown, Penna. 19464.

SPECIAL CLEARANCE: 300 Different Including Many Large Pictorials And Topicals Only 10¢, With Interesting Packet Approvals. McCoy, Box 887-M, Chicago, Illinois 60690.

SAVE TO 60% on stamps! Join our fantastic discount club. Send \$3 for two-year membership or 25¢ for details, samples. Satisfaction or refund. Potomac, Box 34204, West Bethesda, Maryland 20034.

STOP HERE For Good Pickings. Worldwide Or British Empire. Send For Large Selection On Approval, Henry Oudolf, 96 Woodland, River Edge, New Jersey 07661.

FREE Worldwide Packet. Penny Approvals, Froehlich, Box 7, Waukegan, Illinois 60085.

CANADA 50 Different Including Dollar Totem 10¢ To Approval Applicants, Maritime, Box 662, Saint John, New Brunswick.

VIETNAM 25 Different 10¢ approval. Sam Chazen, Box 95, Ozone Park, N.Y. 11417.

FREE!! 25 US Commemoratives, 2" Diameter Magnifier, 10¢. Approvals. Mixdrak, 5630 Wilson, Chicago 60630.

350 DIFFERENT Stamps 35¢ With Approvals. Thompson, 105½ West Curtis, Sainas, Calif. 93901.

STAMP Kit For Fun & Profit. \$2.00. Sparacia, 3845 Montevista, Cleveland Heights, Ohio 44121.

FREE World Collection. Over 100 stamps. Approvals. Global, Box 427, Livermore, Cal. 94550.

WOW! 25 Canada, 10¢. Lewis, 339 Beaconsfield Crescent, Saint John West, New Brunswick.

STAMPS Free! New issues—New Countries — Triangles — Rockets — Olympics — Scouts — Birds — Flowers — Animals—Also, old Canadian and U.S. Stamps. Plus complete illustrated Canadian Stamp Catalog. Send 10¢ for mailing. Gray Stamp Co., Dept. A, Toronto, Canada.

SEND Only 5¢ for Worldwide Collection of over 50 different Singapore, Grenada, Chad, etc. Contains old and new issues, sports, animals, etc. You will also receive interesting lists and a certificate worth 50¢ toward purchases. Goliath Co., Dept. TP-1, Bethlehem, New Hampshire 03574.

SEND Only 10¢ for nice collection of U.S. stamps including "\$5.00." Issue and scarce mint Sipex Souvenir Sheet. You will also receive the most wonderful catalog of stamp offers in America. Littleton Stamps, Dept. SS1, Littleton, New Hampshire 03561.

400 MIXED U.S. 20¢ Approvals, Wright, Box 753-M, Hagerstown, Maryland, 21740.

"CONQUEST Of Mars". Yemen's Latest Collection. 10¢ With Space Approvals. Potomac Stamps, Washington, D.C. 20015.

UNBELIEVABLE \$25.00 Catalog Value \$2.00. 333 Different United States \$3.00. 1000 Different Worldwide \$3.00. James Cash, Box 63, Nineveh, Indiana 46164.

THREE Mint Vatican Sets \$1.00. Penniston, Box 5502, Arlington, Va. 22205.

RAILWAY Souvenir Sheet—historic locomotives from faraway Fujeira—complete, superbly beautiful cancelled sheet, plus other foreign stamps, all for 25¢ with approvals. Scott Service, 22 Strathearn Boulevard, Toronto 349, Canada.

AMAZING! Over 100 Different Including Qatar, Apollo Space Astronauts Set 10¢. Approvals Accompany. Shellmar, 2015 Shore Parkway, Brooklyn, New York 11214.

VALUABLE Premium 15¢ with Worldwide Approvals. White, Box 88, Costa Mesa, California 92627.

U.N. 5 DIFFERENT Mint 10¢. Approvals. Gordon Davison, Henniker, New Hampshire 03242.

100 DIFFERENT Turkey-15¢. Approvals. Gobestamps, Box 402, Biddeford, Maine 04005.

"SPACE" Pictorials, others. 110 Different—10¢! Approvals. Shaw, Drawer E-64, Montevallo, Alabama 35115.

FIFTY United States Stamps, including 19th Century, 25¢ to approval applicants. Littleflower, Dept. B, Box 771, Royal Oak, Michigan 48068.

QUALITY Packets \$2.00 Each. Africa, British Colonies, Far East, Latin America, U.S.A., Europe. Wilson Sales, Lockhart, S. Car. 29364.

MILLIONS of stamps 2¢ each. Write today for gigantic selection. CSC, Box 9384, No. Hollywood, Calif. 91606.

RUSSIA! 25 Different Classics plus Bonus Nudes only 10¢ with worldwide approvals. FREE DUPLICATE EXCHANGE PLAN. Markwell Stamp Mart, P.O. Box 921, Schenectady, New York 12301.

BHUTAN 3-D ANTIQUE CAR Set Only 25¢ With Approvals. Robert Hedges, Route 3, Hagerstown, Md. 21740.

ENVELOPES: CLEAR POLYETHYLENE: 100 Lots 2x4 70¢, 3x5 75¢, 4x6 90¢. Other Sizes. Quantity Discounts! List 20¢. Nelson, 346-JS, Rye, New York 10580.

TONGA'S Banana-Shaped Stamp. Bhutan Foil, Botswana Elephant, President Kennedy, Moon Landing, Honduras Easter Flowers, German Child Painting, plus 100 others! Only 10¢ when requesting approvals. Select those desired, return balance. Cancel service anytime. Douglas Cook, Dept. PM-1, Las Vegas, Nevada 89112.

WORLDWIDE Space Collection 25¢ with Approvals. Lorries, 12728 S. E. 163rd, Renton, Wash. 98055.

COMMEMORATIVE DeGaulle Series Air-mails. Bargain List. Send \$1.00. Masters, 82 Rue Doudeauville, Paris 18 France.

\$2.81 VALUE—10¢ with approvals. Chapman Stamps, Box 487R, Galesburg, Michigan 49053.

PLANES! Trains! Cars! Ships! Space! Sports! Spectacular Stamp collection. Just 10¢. With great approvals. Castfe, P. O. Box 15-PMF, Flushing, N.Y. 11352.

"25 AIRMAILS 10¢. Approvals. Dean, 508 Snow, Richland, Wash. 99352."

WALT DISNEY Memorial Mint Set Plus Gigantic Mystery Packet—10¢! Attractive Bargain Approvals. Free Bonus Plan!—Write Today! Kenneth Feldman, Box 48798, Los Angeles, California 90048.

SAN MARINO'S Latest 1972 Gigantic "Bicolored Flowers" Commemoratives—Free! "Approvals" plus 101 Bonus Sets. William Deems, 226C Race, Ravenswood, West Virginia 26164.

INDIA, 50 Diff. 10¢. Approvals. Metzger, 8 Crag Knob, St. Louis, Mo. 63122.

50 U.S. COMMEMORATIVES. 15¢. Approvals. Cambridge, Box 2311, Heath, Ohio 43055.

COINS, TOKENS, CURRENCY

BRILLIANT Proof Sets—1957, 1960, 1964 each \$5.89, 1961, 1962, 1963 each \$4.48, 1971-S \$7.89. Bargain Lists 18¢. Bebee's Incorp., Omaha, Nebraska 68111.

COLLECT COINS for profit! How to start, where to sell. Lists of valuable coins. Check your change! Send \$1.00. Westchester House, 360 Westchester Avenue, Dept. A, Port Chester, New York 10573.

INDIANHEADS: 2 Diff., Below 1900. 75¢. Stevens, Box 546F, North Miami, Fla. 33161.

SILVER DOLLARS Uncirculated, 1880-81—1883-84-85 \$5.00 Ea. Catalogue 50¢. Shultz, Salt Lake City, Utah 84110.

COIN Clearance! Bargain List 10¢. (Refundable). Economy Sales, Mansfield, Massachusetts 02048.

4 DIFFERENT Indianhead Pennies. \$1.50, Catalog 25¢. Village Coin Shop, Dept. P, Plaistow, N.H. 03865.

LINCOLNS: 28 Different Before 1940 \$1.70; 50 "S" Including 1955-S \$1.95; 33 Different UNCIRCULATED \$1.85. Nickels: 40 Mixed Buffalos \$4.95; 12 Different "S" Jeffersons \$1.70. Dimes: 20 Different Mercurys \$3.95; 10 Different "S" Roosevelts \$2.95. Anthony, Box 9804-PB, San Jose, California 95117.

1955-S LINCOLN And 18 Different "S" Pennies—\$1.00. Edmund Molzan, Box 275, Alameda, California 94501.

WORLD'S GREATEST Coin Collector's Magazine and wooden nickel 10¢. Lawrence, Anamosa, Iowa 52205.

FIVE Indianheads \$1.80; Five V-nickels \$1.85; Eisenhower Dollar \$1.85; Silver Certificate \$1.85; Silver Dollar \$3.10; Catalog 25¢. Fairway, 121-K, Rye, New York 10580.

(Continued on next page)

COINS, TOKENS, CURRENCY

(Continued from preceding page)

SEND Only 5¢ for valuable booklet "How To Collect Coins" which is loaded with expert advice. You will also receive 5 different foreign coins and your copy of the most unusual and interesting collectors catalog available anywhere. Littleton Coins, Dept. VB-1, Littleton, New Hampshire 03561.

COMPLETE U.S. Coin List 25¢. Lincoln Starter Sets 50 Different \$1.75, 100 Different \$3.50. Schultheis, Box 151M, New Hyde Park, N.Y. 11040.

PRICE Lists of Thousands of Stamps and Coins. Send 25¢ Refundable with purchase. No Approvals. Bryson, 612M White, Toledo, Ohio 43605.

COLLECT Coins for Profit! How to Start, where to Sell. Lists of Valuable Coins. Check Your Change! Send \$1.00. #MO-53C. The Ziegler, 6237 Acton Rd., Indianapolis, Ind. 46259.

SELLING My Barrel Of Indian And Lincoln Cents (1860's Thru 1920's All Mints) At \$8.95 Per Pound! Maximum 10 Pounds. Sample Bag Of 30 \$2.00. Pavley, Box 518, Cupertino, Calif. 95014.

CHOICE ROOSEVELT DIMES!—1949S-70¢, 1955D-50¢, 1955-S 35¢, 1955P-\$1.30. All others 25¢ each. Complete set, 55 different with album, only \$13.49! Satisfaction Guaranteed! Premier, Box 7776-PM, Spokane, Washington 99208.

30 MIXED Indianheads—Lincolns 1890s to 1944. Includes Wartime Steel Cents. \$2.00. HARRIS, Box 2037P, Santa Cruz, California 95060.

ANTIQUES, RELICS, INDIAN GOODS & CURIOS

CUSPIDOR, Solid Brass. Authentic Replica. 5½" \$8.95, 7¾" \$10.95 Postpaid. Trader Rik, 7380 Clay, Westminster, Colorado 80030.

OFFICIAL ANTIQUE GUIDE. WHOLESALE And retail prices listed on every item. FEATURES hundreds of illustrations, thousands of prices, 224 pages. SEND \$1.98: CARLOS RAMOS, 250 19th STREET, BROOKLYN, NEW YORK 11215.

APACHE Arrowhead Collection 9, \$2.00. 25 for \$5.00. Epanco, PM 1239, Apache Junction, Arizona 85220.

INDIAN Relic list. Arrowheads \$4.00. doz. Folsom. \$5.00 each. C. Secrist, Deerfield, Missouri 64741.

EVERYBODY LIKES DIXIE GUN WORKS.

TONS Of antique gun parts and supplies. All reproduction muzzle loading guns. Send \$2.00 for enlarged illustrated catalog No. 120. Dixie Gun Works, Union City 12, Tennessee.

LIST Indian relics. 10 Arrowheads \$3.00. Hyde's, Box 2304, Santa Fe, New Mexico 87501.

10 PERFECT Arrowheads \$4.00. Smith, 9825 Conway Drive, Indianapolis, Indiana 46236.

SELLING 20,000 Indian relics, Arrowheads, spearheads, tomahawks, ceremonies, etc. List 10¢. Lear's, Glenwood, Arkansas 71943.

RESTORE ANTIQUES—190 Pages Of Professional Secrets. A Collector's Must. \$1.50. Tracy Treasures, 8541A Judy Circle, Huntington Beach, California 92647.

INDIAN Relic List. Arrowhead Identification Guide \$3.98. Antiquities, Rt. 1, Box 14A-2M, Princeton, W. Va. 24740.

ANTIQUITY GUIDE TO PROFITABLE BUSINESS. Never Pay Over Or Sell Under Market Again! Experience Cost Dollars Via "Trial And Error." Hundreds of Illustrations. Thousands Of Prices. Know Your Market! Only \$1.98. Golden Rule, 1028 Boulevard, Mexico, Missouri 65265.

FREE Story of the LIZZARD STICK. Wright The OLD TIMER, 3216 East Washington, Phoenix, Arizona 85034.

200 POPULAR MECHANICS

MODELS—CARS, SHIPS, TRAINS, PLANES ETC.

UNIMAT, Maximat sale. Amazingly low prices. Duman, 562 Howard Avenue, Staten Island, New York 10301.

SHIP Models Kits, fittings, plans, books, tools, engines, motors. Big illustrated catalog 50¢. Mass, residents add 3% tax. James Bliss & Co., Dept. SM, Route 128, Dedham, Mass. 02026.

SHIP And yacht model fittings: Pine construction hull kits; blueprints. Send 50¢ for illustrated catalog. A. J. Fisher, Inc., 1002 Etowah Avenue, Royal Oak, Michigan 48067.

MODEL Airplanes—Big 220 Page Catalog 50¢. Sig Company, Montezuma, Iowa 50171.

LIVE Steam powered backyard railroads! All sizes. Complete "bolt-together kits," and rough castings. Excellent drawings. 100 page catalog \$1.00. Little Engines, Lomita, California 90717.

SHIP Models catalog 25¢. Scientific, Inc., 340 Snyder, Berkeley Heights, N. J. 07922.

LIVE Steam engine Kits. Fascinating hobby for model mechanics. Boilers, fittings, accessories. Pictured catalog \$1.00. H.P.K. Models, Centuck 34, Yonkers G, New York 10710.

GAMES, TOYS, PUZZLES, NOVELTIES

FUNNIEST New novelty in 20 years! Sell thousands, make huge profits. Send 25¢ for sample, large wholesale catalog. Lakewood; 6800 North Campbell, Chicago, Ill. 60645.

JIGSAW Puzzles. Beautiful wood and fiberboard to 2000 pieces. Free catalog. Hasset's, 3-C Hilltop Drive, Cherry Hill, N. J. 08034.

FREE . . . Quality gift and novelty catalog. K&K Distributors—M, 2064 S. Mannheim, Des Plaines, Illinois 60018.

MAGIC TRICKS, JOKES, VENTRILOQUISM

HOUDINI'S Greatest Magic!! You can do them all!! Giant Illustrated Catalog 25¢ with Free Trick!! Vick Lawston, Box 2026P, Pompano Beach, Florida 33061.

NEW 1972 large Catalog. Be popular! Amaze! Have fun! Send 10¢. Latest Magic for pocket, parlor, stage. Douglas Magicland, Dept. 11, Dallas, Texas 75201.

VENTRILOQUISM! Learn at home! Guaranteed! Write! Information Free! Dummy Catalog 25¢. Maher, Box 9037P, Denver, Colorado 80209.

LEARN VENTRILOQUISM! Information free. Ventriloquism, Magic Catalog 25¢. Izzy Rizzy's School of Ventriloquism, 3746 W. 63rd Street, Chicago, Illinois 60629.

COMPLETELY Illustrated catalog. 84 pages. 25¢. Manhattan Magic, Box 334-M, N.Y.C. 10011.

BE A Magician! Two booklets explaining sixty-eight tricks plus large professional catalog. \$1.00. Magic Inc., 5082 Lincoln, Chicago, Illinois 60625.

WORLD'S Finest professional magic tricks. Joker's Novelties. Giant illustrated catalog 10¢. Top Hat, Evanston, Illinois.

FREE! World's Leading Catalog 2000 Novelties, Jokes, Tricks. Scientific Gadgets, Hobbies. Johnson-Smith, C-10, Detroit, Michigan 48224.

MAGIC MAGAZINE—Monthly since 1936. 44 pages. All phases. 3 month trial \$1.00. Genii, P.O. Box 36068, Los Angeles, Calif. 90036.

FABULOUS MAGICS New 1971 catalogue 25¢. Our specialty orders shipped same day no substitutes. Fabulous Magic, 3319 East Charleston, Las Vegas, Nevada 89104.

HOUDINI'S Original Magic Shop. Established 1856. Send 25 cents for illustrated Catalog containing 5000 Tricks. Mindreading, Puzzles, and Jokes. Flossie-Hornmann, 304 West 34th St., New York 10001.

FREE Tricks with 50¢ catalog. DEAN, Box 14, New Brighton, Penna. 15066.

BOOKS, CATALOGS, NEWSPAPERS

"KEY To Perfect Putting" 156 pages. Lower Scores! The First Time the Secret of Perfect Putting has been Analyzed. Putt like a Pro. \$2.00. Russells, 1508 Dorchester Rd., Havertown, Pa. 19083.

HOW TO GET SUCCESS, WEALTH, HAPPINESS, HEALTH. HOW TO SOLVE PERSONAL PROBLEMS. SEND FOR FREE LIST OF LOW COST BOOKS. HAUBERT-HULL, 1428 FORT AVE., BALTIMORE, MD. 21230.

"PSYCHO-CYBERNETICS" This Book Shows and Clearly Explains a New Way to get more Living out of Life HR-2 Only \$2.00. Russells, 1508 Dorchester Rd., Havertown, Pa. 19083.

HOW TO Develop A Winning Personality. \$2.00. Mansfeld, 1344 Broadway, Detroit, Mich. 48226.

MASTER YOUR LIFE. Free Details. Mansfeld, 1344 Broadway, Detroit, Mich. 48226.

CATALOGS! Receive many! Catalog Directory \$1.00. Box 305, Plymouth Meeting, Penna. 19462.

FREE BOOK. Prophet Elijah Coming Before Christ. Megiddo Mission, Dept. 63, 481 Thurston Road, Rochester, N. Y. 14619.

NATIONAL Geographic Magazines, 1888-1971, any issue. Buxbaum, Box 465-PM, Wilmington, Delaware 19899.

FREE! List of Low Cost Popular Books. Success, Happiness, Personality, Wealth, Personal Problems. Chris-Anne Sales, 701 Ave. C, Dept. 1-D, Brooklyn, N.Y. 11218.

EXCELLENT Low cost Books: Mind, Health, "How-To", Self-Improvement, much more. Request Free Catalog M-2, Gracer's, 1528 East Colter, Phoenix, Arizona 85014.

SALE!!! BOOKS—Prints—Records! Entertaining. Useful—All Subjects. Entire Family! FREE Illustrated Discount Catalogue! Books, Box 186-A, Brooklyn 11230.

FREE List! 757 Low Cost Books! All Subjects! Pierdale, 1901 J Braeburn, Salem, Virginia 24153.

HOW TO UNDERSTAND YOUR DREAMS Book. Be Amazed. Learn Mysterious Inner Meanings Of Your Dreams. Send \$2.00. Maywood Enterprises, Box 36, Maywood, New Jersey 07607.

FREE List! 142 Inexpensive self-improvement books: Bowling, Golf, Billiards, Poker, Chess. Gopherland, 10 Eleventh St., Faribault, Minnesota 55021.

FREE Circular! Self Improvement, Educational Books, many others. Harmony House, Dept. 221, 125 South Lincoln, Loveland, Colorado 80537.

"U.S. ARMY Special Forces Operations" FM 31-21 @ \$4.50. Satisfaction Guaranteed. Military Manuals and Publications catalog 25¢. Hillcrest Publications (PM-2), McDonald, Ohio 44437.

FREE Catalog. Self Improvement Books. Many Others. Total Company, 6609 Kindred, Philadelphia, Penna. 19149.

FREE Brochure Books, Every Subject 20¢ to 50¢. Winchester Enterprises, 2807PM Hargrave Street, Philadelphia, Penna. 19136.

SKYROCKET YOUR INCOME! Double your money making power. 256 page book "Thinking Big" reveals secrets that make men rich. Send \$2.00. ENJAY, Dept. 17, 11 E. 36, N.Y.C. 10016.

PLAYS, SONGS, MANUSCRIPTS

WRITERS TIRED OF REJECTION SLIPS? Let us change that, details 10¢. Refundable. Sam Fowler, Evesboro Rd., Marlton, New Jersey 08053.

SONGWRITER! Poets! Spiritual and religious poems, songs wanted for recording by Chapel Symphony Orchestra and Choir. We pay all recording costs! Dept. PM, Chapel Recording, P.O. Box 162, Wollaston, Mass. 02170.

(Continued on next page)

PLAYS, SONGS, MANUSCRIPTS

(Continued from preceding page)

POEMS And lyrics of religious, reverent, inspired nature wanted for immediate recording. We are only interested in songs of hope, God's love, the comfort of His words and wisdom. Cathedral Recording, P.O. Box 78-PM, North Weymouth, Mass. 02191.

BUSINESS OPPORTUNITIES

IMPORT-EXPORT Opportunity, profitable world-wide, mail order business from home, without capital or travel abroad. We ship plan for no risk examination. Experience unnecessary. Free details. Mellinger, Dept. F2702, Woodland Hills, California 91364.

HOW To Finance Your Own Business. Get \$500 to \$2 million. Free offer. Capital-17, Kerrville, Texas 78028.

BECOME Tax consultant. Our students earn \$1,000—\$3,000 every tax season preparing returns evenings. State approved. National Tax School, Monsey 2VC, New York 10952.

FREE 1972 100-Page Catalog waiting to bring you Big spare-time cash commissions. Sell Advertising Book Matches. Every business a prospect . . . complete selling instructions furnished. Steady, repeat business. Dept. MX-272, Superior Match Company, 7530 South Greenwood, Chicago, Illinois 60619.

400,000 BARGAINS Below wholesale! Many free. Liquidations . . . closeouts . . . job lots . . . single samples. Free details. Bargainhunters Opportunities, Box 730A, Holland, Michigan 49423.

SEVEN Complete Mail Order Opportunities. \$2.00. Or write: AM Sales, 32-28 100th St., East Elmhurst, N.Y. 11369.

"\$15,000-\$30,000 YEAR: Send \$2.00: BOOK: "Raising Rabbits for Us." Rabbit Ranchers of America, Box 265-X, Haysville, Kansas 67060."

MAKE 100% Profit. Toys, novelties, specialties, \$2.00. Giant catalog. Value House, Luzerne St., Greenville, Ky. 42345.

SUPER STEAM New carpet cleaning method. Cuts Costs in half. Cleans synthetic Fibers. Moonlighters write now. Care-A-Van Mfg. Co., 891 So. Monroe, San Jose, Calif. 95128.

"\$ASK" FOR Money! (Never Repay!) Derby, 33701 Bethel Avenue, Hemet, California 92343.

INSTALL Burglar Alarm Systems. Big profit home business. Beginners start spare time, without mechanical experience or costly equipment. Free starter plan. Nasco, Dept. F2702, Woodland Hills, California 91364.

HOW To Make Money in Your own fascinating Home Mail Order Business mailing catalogs. \$300 weekly possible spare time, everything supplied. Sample Catalog, Profit Details 25¢. Southwest, Box 553, Scottsdale, Arizona 85252.

300% PROFIT POSSIBLE on 1,001 Products!! Volume sales easy! Sell mailorder dealers, local merchants, or direct to consumers. Ideal for party plan method. All items dropshipped if desired. No need to invest your money in merchandise. Giant Catalog, ordering details, \$2.00 (Refunded first order). deKelley, 769PM2 Alvarado, Sunnyvale, California 94086.

MAILORDER Moneymaking Kit. Home Business. Valuable lists, concrete information, detailed steps. Capital unnecessary. Free Details, Pictures. Prudential Box 327-PM2, Boston 02199.

MAILORDER Millionaire helps beginners make \$500 weekly. Free report reveals secret plan! Executive (1A-2), 333 North Michigan, Chicago 60601.

CAREER OPPORTUNITIES Get facts not pipedreams on fast changing Franchise, Small Business, Job Opportunities. Two 160 page books BUYERISM and CAREERISM. Only \$2.50. WWWWW/Information Services, Box 3660, Dept. 2001, Rochester, NY 14609.

FANTASTIC New Product For Motorists From: Resu Sales, Box 101, Laval, Quebec, Canada.

MAILORDER: How to prepare your own catalog for pennies! Free catalog! Obie-ADA, Brooklyn, New York 11219.

\$2.40 HOURLY Making simple wood novelties. Free details! Gene's, 55 Boxwood, Falmouth, Mass. 02540.

FREE Millionaire Book. Dollars in successful, little businesses. Work home! SBI-7, Kerrville, Texas 78028.

SECRETS! Mail Order Success. Internationally famous expert reveals how to make home business fortunes. Beginners: Get free copy "Make Money By Mail." Discloses free advertising, profitable products. Mailco, Dept. F2702, Woodland Hills, California 91364.

MAILORDER Dealers Wanted. Earn outstanding profits using tested promotions! Executive type business. Details 25¢. Rutward, Box 735-PD, Norwalk, Conn. 06852.

STUFF Envelopes. Average \$25.00 hundred. Experience unnecessary. Customers furnish stamped, addressed envelopes. Beginner's Kit, \$1.00. Moneythree, Box 392PM2, Brea, Calif. 92621.

MAILERS Needed! Big money! Send 10¢ for information. Andrew Sales, Box 152, Blue Island, Ill. 60406.

SPARE TIME EARNINGS!\$!\$ With table-saw, bandsaw, etc. . . . Write: Woodcraft, 956 Springdale, Atlanta, Ga. 30306.

SELL Books by Mail. Tremendous Profits. Free Details. Products-Unique, Box 48-F-2, Malden, Mass. 02148.

\$600-UP MONTHLY. People needed. Raise rabbits, other laboratory animals for us. Huge market. We supply equipment, breeders and instructions. Details 25¢. National Research Farms, PNMB-2, Box 309, Milwaukee, Wisc. 53201.

PORTABLE Sandblaster \$21.00 (air-compressor required). Free brochure. Inka, Box 66573-A, Houston, Texas 77006.

MAKE Magnetic signs. Machineless method. Profits enormous. Write: R1B49APM, Bardstown, Ky. 40004.

HOLLYWOOD CEMENTCRAFT: Offers Highly Profitable Home Business. Experience Unnecessary. Unlimited Unique Pottery Designs Easily Made Without Moulds. Bird-baths, Fountains, Wishing-Wells, Waterfalls, etc. Chemical Coloring Formulas. Marble-glazing. FREE Illustrated Brochure. CONCRETE FACTS, 602 Athens Street, Altadena, California 91001.

EARN \$60.00 Daily manufacturing Concrete Fence Posts. Practically no investment. Send stamped-addressed envelope. American, Excelsior Springs, Mo. 64024.

MAKE A Years Income in 8 weeks Camping. No selling. Capital or Land necessary. Write Edrus, Route 5, Box 5733, Gig Harbor, Washington 98335.

MAILORDER—Profitable products, dropshipped. No merchandise investment. Everything supplied—catalogs, ads, mailing lists. Gif-Guide, 1137½ Crenshaw, Dept. 283, Los Angeles 90019.

PIANO Tuning Learned Quickly At Home! Tremendous field! Musical knowledge unnecessary. GI approved. Information free. Empire School, Box 327, Miami, Florida 33145.

\$400.00 MONTHLY Raising giant fishworms. Soilless method. Charlie Morgan, Bushnell, Florida 33513.

EARN Money raising fishworms for us! Write: Oakhaven-38, Cedar Hill, Texas 75104.

ADVERTISING BUSINESS—YOU Own it. \$350 First Week or Money Back. Electric Neon Action Ad Clock, 229 W. Illinois, Chicago 60610.

WORLD'S Largest supply. Merchandise 25% to 40% under wholesale. Bankrupts. Closeouts 10¢ on dollar. Imports. Hong-kong clothes. Automobile discounts. Free details. International Buyers, Box 16386 MM, Portland, Oregon 97233.

SELL Lifetime, Metal, Social Security Plates. Big Profits! Sample and Sales Kit Free. Russell, Box 286-PM, Pulaski, Tennessee 38478.

COPUBLISH "Mail Sale Advertiser," leading mailorder paper. Copy and details 25¢. U.S.A. only. Vanroy Shirk, Lebanon, Pa. 17042.

\$200.00 DAILY In your mailbox! Your opportunity to do what mailorder experts do. Free details. Associates, Box 136-A, Holland, Michigan 49423.

DRAFTSMEN! Operate own DRAFTING SERVICE! Full, Part Time: Experience unnecessary; Details: Roberts Drafting, 1741 Circle Road, Baltimore, Maryland 21204.

MAILORDER Book Publisher Wants Dealers. Jan Enterprises, 76P, Wild Rose, Wisconsin 54984.

FREE Catalogs. Repair air conditioning refrigeration. Tools, supplies, full instructions. Doolin, 2016 Canton, Dallas, Texas 75201.

SELL Beautifully colored Social Security Plates. Big Profits! Free Sample. Paul Wright, 1075 Ringwood Avenue, Pompton Lakes, N.J. 07442.

BUILD Custom Cases at home for profit. Get orders by mail. We supply materials, instruction—everything. Free home business details. Custom Case Supply Co., 6961 CPB Hayvenhurst Avenue, Van Nuys, California 91406.

TAKE Catalog orders. We drop-ship 1001 best selling specialty products. Guaranteed lowest below wholesale prices. Fantastic spare-full time home business. Free book shows you how. SMC, 6963 SPB Hayvenhurst Avenue, Van Nuys, California 91406.

VENDING Machine big catalog. Rake, 523 A Spring Garden, Philadelphia, Pa. 19123.

I MADE \$40,000.00 Year by Mailorder! Helped others make money! Start with \$10.00—Free Proof. Torrey, Box 318-Y, Ypsilanti, Michigan 48197.

MAIL Baby Catalogs Imprinted with your address to New Mothers for Big Profits! Details 25¢. Volz PM, Ypsilanti, Michigan 48197.

MAKE Money from old tires. Operators clearing \$800, weekly. Equipment costs \$1500. Get facts. S & S Patents, Inc., 3752 N. Damen, Chicago 60618.

MAKE \$46 From square foot plywood: jigsaw or bandsaw necessary. Free details. Woodar, Bridgewater, Mass. 02324.

CALIFORNIA MANUFACTURER NEEDS Man to assemble our product and be local agent, experience unnecessary. May start while presently employed. Five-figure income for responsible applicant. S.K.R.M. Manufacturers, 2347 West 238 Street, Torrance, California 90501.

SUPERIOR Auction School. Nation's top Auctioneers own and instruct. Box 1281, Decatur, Ill. 62525.

\$200.00 SPARE Time earnings with your Tablesaw. Write: Workshop Five, 3800 Harney, Vancouver, Washington 98660.

\$25.00 HUNDRED Addressing. Possible Year 'round. Complete instructions 25¢ for registration, postage. Cove, Box 1348-B, Clearwater, Florida 33517.

\$1,000.00 PROFIT From 1,000 Mailings! George, Box 2188-PM, Cypress, California 90630.

\$70 TO \$200 WEEKLY—Home, Spare Time Simplified Mail Bookkeeping. Immediate Income. Easy. Auditax, Box 34741A, Los Angeles, Calif. 90034.

VENDING Machines. No selling. Routes earn amazing profits. Big catalogue Free. Parkway Corporation, 715PBM Ensor Street, Baltimore, Maryland 21202.

"MORTGAGE Brokerage." Lucrative Profits! Obtain Capital Sources. Chase, Uleta, Florida 33164.

(Continued on next page)

BUSINESS OPPORTUNITIES

(Continued from preceding page)

MAIL Galore! Money-making offers! Your name on national mailing lists, 35¢. Three months, 50¢. Sullins, Box 206-M, Forsyth, Georgia 31029.

\$60.00 DAY. Manufacturing concrete Posts. Blocks. Mold Equipment Catalog \$1.00 refundable. Carlayne, Route One, Box 95, Rapid City, South Dakota 57701.

1100% PROFIT. Bronzing or Pearl Finishing Anything. Free Proof! Kiktavi, Box 2127D, Inglewood, Calif. 90305.

MAIL Order Collection Agency can make you \$1000.00 monthly. Free Details. Continental, Box 2023-A, Des Moines, Iowa 50310.

BRONZED Shoes cost 25¢. Retail \$6.00—Free literature—NBC, Box 11069-PM, Kansas City 64119.

SELL Books by mail. 400% profit. Royal, Box 450-X, Cleveland, Ohio 44127.

MAILORDER Records help get increased business! Complete 32 Page Record Book shows your inquiries, orders, advertising, expense, etc. Only \$1.00. C. A. Martin, Popular Mechanics, Dept. PMR, 224 West 57 Street, New York, New York 10019.

INEXPENSIVE, Home-Auto Fire, Burglar Alarms, Extinguishers. 200% Profits. Nation's Watchdog, Williamsburg, Ohio 45176.

PREVIEWING Business deals for others as their personal representative earns large fees. Non-sales. Free information. Omnifax, Box 31625, Dallas, Texas 75231.

MAILORDER Will make you Wealthy. Part Time. Free explanation. A. Kelly Sales Company, 5211 N. Kenmore, Chicago, Illinois 60640.

CLIP Short newspaper items. To \$10.00 each. Details free. Foster, 272-M-2, Brooklyn 11235.

HOMEWORKERS. \$100.00 Weekly Addressing for firms. Begin immediately. Details—send stamped, addressed envelope. Hamilton, 272-TMA-2, Brooklyn 11235.

SELL "Mailorder Beginners Library." (Seven books.) Sample imprint circulars free. Neil H. Tasker, Shamokin, Pennsylvania 17872.

DISCOVER Second Income Road to Wealth. Fascinating! SINA, Box 2506, Santa Rosa 95405.

MAILORDER GOLDMINE!! Exceptional Opportunity! "Different." Camar, 40-PM8 Driftway, Danbury, Connecticut 06810.

CANDLECRAFT, Today's Big Profit making home-hobby business! Extremely low cost Club Membership helps you start your own big-profit business by giving you complete self-study course, advice and guidance of world's top experts. Includes exclusive Mold-of-the-Month, Kit of Supplies & authoritative monthly Newsletter. Find out how hundreds of members have achieved success! Free details. Write. Candle Institute, Dept. C-17, 1600 Cabrillo Avenue, Torrance, California 90501.

WATCHMAKING Makes every day a payday. Learn this cash business at home. Free details. Sweazey, YBA, Fox River Grove, Illinois 60021.

200% PROFIT. Sell Man-Made Diamonds. NO Investment. NO Obligations. Lady's Gems, Box 3333PM, Anderson, S.C. 29621.

MEN-Women Make Big Profits At Home! In plastics, part or full time! Unique process teaches you with equipment we give you free to make hundreds of 3-D plastic products, candy and candle molds, plaques, signs. Skin and bubble package. Also resin casting. Write today for free details. Nationwide Plastics, Dept. ANN, 4140 Eagle Rock Blvd., Los Angeles, Calif. 90065.

FRANCHISE And DEALERSHIP Listing. \$3.00 to: A And D Distributors, Box 1564, New London, Conn. 06320.

900% PROFIT For Men And Women with your own Magnetic Sign Shop! Big demand for 3-D magnetic signs on cars and trucks. Start in garage, kitchen or camper. Spare or full time. Financing available. Write today for free details. Nationwide Plastics, Dept. 173, 4200 Panamint, Los Angeles, Calif. 90065.

EARN \$240.00 A month at home, spare time, doing only two \$5.00 Invisible Reweaving/Reknitting jobs a day. Big money paid for service that makes cuts, tears disappear from fabrics. Steady demand. Details free. Fabricon, 2065 Montrose, Chicago 60618.

YOU'RE CRAZY to risk one cent in the mail order business before you write for free information: Mail Order News, 400 East 80th St., New York 10021.

EARN \$700 Per Month Spare Time as Tax Preparer with new quick-learn income tax home training. Men-Women, all ages, make big money. Full facts by mail—no salesman. Federated Tax Service, 2065 Montrose, Chicago 60618.

PROFITABLE Parttime Businesses To Operate From Your Home. For Catalog Send 10¢. Informative Publications, Box PA-187, Painted Post, N.Y. 14870.

MAILORDER . . . IMPORTING . . . FRANCHISING . . . Plus many little-known moneymaking opportunities! Free Brochure! Success Research, Box 29263-AM, Indianapolis, Indiana 46229.

TREMENDOUS Profits. Start Your Own Wholesale Business. Details Free. FN. Wholesale, Silver Lake, Minn. 55381.

BECOME PROFESSIONAL DRIVING INSTRUCTOR \$400.00 Weekly. Your own Business Part-Full Time. Write: Howard David, 1818 Everts, Philadelphia, Penna. 19152.

OPPORTUNITY TO EARN \$230 WEEKLY Thru Classified Advertising! Free Details. Marpel Co. Inc., Dept. PMB2, 5302 Park Avenue, West New York, New Jersey 07093.

MAILORDER IMPORTS Report Reveals Foreign Drop-Ship Sources. World Trader's Digest. Ideal Mailorder Items. \$1.00. Ernest A. Veuthey, 1140 Wilcox Place, Los Angeles, Cal. 90038.

EARN \$70.00 up weekly. Your own Wholesale Business at home. No Investment. Details and Catalog. Send only \$3.00 (refundable). Hewitt Co., Box 75PM, Hazlet, N.J. 07730.

PROTECT YOUR MONEY . . . SECURE YOUR CHECKS with this portable check-writer. Dial dollars and cents. Professional Appearance. Complete with attached ink pad and instruction sheet. Guaranteed one year. Get a PROTECT-A-Check just \$5.98 plus \$1.00 Handling. Four G Company, Box 472, Princeton, N.C. 27569.

GET Rich in Mailorder Business—Evenings only. Free Proof! Success, P.O. Box 641, Lake Alfred, Florida 33850.

CAMERA owners earn BIG money. Photography, 5334-P Sunset, Hollywood, Cal. 90027.

WHY Spend \$300?—\$24.95 Outfit Makes Social Security Plates! Free Details. Idea Products, Box 69828-PB, Los Angeles 90069.

LEARN Auto Upholstering A Vehicle Interior Customizing. Save Big Money, earn big money! Start With Your Own Car, Learn At Home, Spare Time, Through A. U. I. Proven Home Instruction Course. Includes Custom And Standard Cars, Boats, Campers, Trailers, Bucket And Standard Seats, Tops, Headliners, Auto Glass, Carpeting, Diamond Tufting, Tuck A Roll—Everything To Make You A Real Auto Trim Expert In Few Short Months! Tools & Do-It-Yourself Kits Included. Send For Free Facts And Auto Trim Career Booklet. Auto Upholstery Institute, Box 64-GH, Orange, California 92669.

ADDRESSERS And Mailers Needed. Details 10¢. Lindbloom, 3636 West Peterson, Chicago 60659.

PROFITS In Population Explosion! Complete Mailorder Setup! Free Details! Enterprises, (PM-2), 3924A McRee, St. Louis, Missouri 63110.

FREE Ring Catalog 50% Off. Anderson, POB 32PM, Randallstown, Maryland 21133.

OPERATE Home Mail Order Business. Write: SCHROEDER'S, Box 205, Greendale, Wisc. 53129.

\$150 WEEKLY Possible Collecting Names! No Selling! Details 10¢. Associates, Box 2482-P, Great Falls, Montana 59403.

MAIL Gift Catalogs imprinted with your address. Big Profits. No investment in inventory. Sample catalog and details—25¢. Crown, Box 634PM2, DeKalb, Illinois 60115.

HOW To Make Money Without Working—legally and honestly! Write: Colonel Lewis, Box 218, Youngtown, Arizona 85363.

\$2500 EXTRA Without Work. Free. Homecraft, 2350 W. 47, Denver, Colorado 80211.

WEALTH BUILDERS—Unique Business Ideas. Full or part time; Details—stamped, addressed envelope. Lee 10C, 617 Big Tree Road, South Daytona, Florida 32019.

"BIG Income and Security, full or part time from home with entrance mat rental, carpet cleaning and Janitorial Service business. Guaranteed detailed book from successful owner, \$3.98 to: Allied Management Incorporated, Box 292P, Hatboro, Penna. 19040."

FREE BOTTLES SELL FOR \$\$\$ When Converted Into Gifts With ELECTRIC BOTTLE KUTTER. Complete Assemble-Yourself Kit Plugs Into Auto Cigarette Lighter. Only \$9.95. CANNON-CRAFTS, Box 119, Reseda, California 91335.

\$100.00 WEEKLY Selling magnetic signs! SPN, Box 15, Murray Hill, New Jersey 07974.

NOW!! \$1,000.00 Monthly Operating Successful Collection Agency!! Master, Drawer 7709-P2, Atlanta, Georgia 30309.

FREE Advertising! Amazing Proof, 25¢. Deem, Box 9308, North Hollywood, Calif. 91609.

"POPULAR Trading Post"—almost anything, everyone! Latest copy 25¢ from: Ap. Chervence, Route One, Cabool, Mo. 65689.

WE NEED GINSENG GROWERS! \$3,000-\$30,000 Annually! We Buy Your Crop. Send \$2 for seed sample and information. Glass's Ginseng Exchange, Box 336, Rochdale Station, Jamaica, NY 11434.

START Wholesale Business. \$1.00 (Refundable) Brings Catalog. Mebel, Pine Drive, Georgetown, Mass. 01833.

PROFITABLE SCREEN PRINTING \$4.00 to learn. Meadowlark, 3601-B Roselawn, Dayton, Ohio 45430.

SELL Books!! Complete Mailorder Plan. Vikari's, Box 1312PM2, Salt Lake City, Utah 84110.

SELL By Mail Order For Extra Income And Future Security. Details Free. Humphrey, P.O. Box 306, Roselle, Illinois 60172.

MAILORDER Catalogs. 150 Profitable Products Drop-Shipped Under Your Label. No Inventory. Details Free. RAM, Dept. 1102, Box 12597, Pittsburgh, Pennsylvania 15241.

MAILORDER! COMPLETE OPERATION \$25.00 (EXCITING DETAILS \$1.00) Lassiters, Richmond, Virginia 23222.

\$1000 MONTHLY. Amazing, Interesting Businesses. Details: Diversified, Box 212, Pompano Beach, Fla. 33061.

MAILORDER—Carry No Stock. Companies Will Pack, Ship Under Your Label. One-Man Operation Capable Of \$10,000-\$20,000 Year. Details Free! Distributors, Box 9-A, East Rockaway, N.Y. 11518.

(Continued on next page)

BUSINESS OPPORTUNITIES

(Continued from preceding page)

CLASSIFIED Ads can make money for you, too. Guaranteed. Professional Method. \$1.00 (COMPLETE). NeWorld, Box 1446, Lafayette, Ind. 47905.

HOMEWORKERS—Mailables Wanted! Information for stamp. Allen, 2418A Lori, Santa Ana, California 92706.

NEW 1972 Giant below wholesale catalog. 1000 items drop-shipped. \$1.00 refundable. Futurity Wholesale Co. PM-1A, 824 South Second, Raton, New Mexico 87740.

FREE Booklet, "How To Sell By Mail." Write: Ransone, Box 1719, Richmond, Virginia 23214.

MAKE Durable building plastic easily. Waterproof, fireproof, economical. Bays Laboratory, Cedaredge, Colo. 81413.

INTERESTING Book Tells How I Made \$63,000 First Year Selling Carpeting. No Investment! No Overhead! \$2.00. Money Back Guarantee. National Carpets, 7260 Fannin (=2140), Houston, Texas 77025.

MAKE Big Money Fast Part-Full-Time By Mail Order Without Capital. Free Details. Unique, Box 6094 P, Duluth, Minn. 55806.

BUILD Profitable Mailorder Business! Vital Information Free! Thompson, 105½ West Curtis, Salinas, California 93901.

YOU Can be RICH and very IMPORTANT. Don't Wait, just \$2.75 brings complete information. R. Niewada, Box 5428, Postal Station "A," Toronto, Ontario.

GET RICH QUICK In MAILORDER! Inexpensive Books Tell How! FREE Details! Rackliffe, Pondmeadow, Westbrook, Conn. 06498.

BURGLAR Alarms You can install. Big profits. Catalogue \$1.00 Refundable. Armstrong Alarms, 300 N. E. 44 St., Ft. Lauderdale, Florida 33308.

SAVINGS—1972 Wholesale Bargains. Buy for Yourself or Start a Home Business. Huge Profits! Details 10¢. Midwest Industries, Box 231TA, Arlington Heights, Illinois 60005.

PROFITS In Mail Order. Free Details. Island, Box 157F, Bayside, N. Y. 11361.

ANSWERS To Mailorder Success. Knowledge is the key. Learn the Secrets of the Pros. Free Proof. Powell Enterprises, Box 1188-M, Rosenberg, Texas 77471.

MAKE Up to \$1000 month from home. Write: Robertson Co., Box 3868, Birmingham, Ala. 35208.

MAIL ORDER! LEARN How to operate Your Own Business the Right Way. Free details. Beckwith School—Dept. 40, 515 Route 46, Fairfield, N.J. 07006.

REPAIRMAN? \$15.00 Hourly. Vacuum Appliance Servicing. H.H.S. Company, 7241B-1st Avenue South, Minneapolis, Minnesota 55423.

MAILORDER, \$250 Daily. Homebusiness. Free Advertising. Dollar Getting Plans. Free Details. Rhodes (A2A), 545 East 88 Street, Chicago, Illinois 60619.

MAILORDER Catalog No Inventory. Products dropshipped. AAA, Box 1212, W. Babylon, New York 11704.

NEED MONEY TO OPERATE? ON-WITH-IT-INC., WILL Furnish money and "Know-How" to the person who started in business and was unable to go ahead because he lacked Working Capital and complete "Know-How". Contact: J. Neil Nichols, Post Office Box 49591, Atlanta, Georgia 30329.

LATEST Moneymaking Opportunities. Bulletin 10¢. Westbrook, 275 West St., Stoughton, Mass. 02072.

MONEYMAKING OPPORTUNITIES

HOMEWORKERS. Make \$50. every 150 envelopes you mail. Rush 25¢. Gemco, B-21244A, Indianapolis 46221.

EARN \$700 Per Month Spare Time as Tax Preparer with new quick-learn income tax home training. Men-Women, all ages, make big money. Full facts by mail—no salesman. Federated Tax Service, 2039 Montrose, Chicago 60618.

FREE LISTS! Low Cost Popular Books. Business, Health, Etc. Mann, 7-F Wilste, Hillsdale, N.J. 07642.

ADDRESS AND MAIL Our Literature. Supplies, Stamps Furnished. \$100.00 Weekly Possible. Rush 10¢ And Stamped. Addressed Envelope For Application. Details. Crown, Box 634PM, DeKalb, Illinois 60115.

NEW Candle Business pays BIG money. Operate from home—Easy. Full or Spare Time. Sell Stores, etc. Experience unnecessary. We show you how. Everything furnished. CANDLE'S, Dept. B-14, Waseca, Minn. 56093.

BE A MONEYMAKER! Revealing booklets in report form tell how. Select your preference. \$1.00 each. ACT NOW! 50 Government Surplus . . . 51 Writing Fillers . . . 52 Mail Order Imports . . . 53 Collecting Coins . . . 54 With Your Camera. BERTCO, Dept. 115, 16406 8th Place South, Seattle, Washington 98148.

\$2,000.00 MONTHLY Possible, details free. Write, G. C. Sams, Box 52-B, Star, Idaho 83669.

\$100.00 DAILY Possible Bronzing Keepsakes. Free Literature. . . . NBC, Box 11069-PM-1, Kansas City 64119.

NOVELTY IMPORTS Sell like mad! Make huge profits. Nine samples and large wholesale catalog—\$1.00. Lakeshore Imports; 6800 North Campbell; Chicago, Ill. 60645.

\$600-UP Monthly. People needed. Raise rabbits, other laboratory animals for us. Huge market. We supply Equipment, breeders and instructions. Details 25¢. National Research Farms, PNM-2, Box 309, Milwaukee, Wisc. 53201.

WE BUY NEWSPAPER CLIPPINGS Of Wedding Announcements for 50¢ each. Details \$1.00. Clippings, Box 53BE, Chalmette, Louisiana 70043.

WINNING Horse Racing Statistics—FREE. Duma, 562 Howard Avenue, Staten Island, New York 10301.

FREE Brochure!! 26 Ideas For Extra Income. Self Support. ALMARC HOUSE, 1429-PM2 Pemberton, Fort Wayne, Indiana 46805.

MONEY. Make hundreds extra spare-time home by mail. Opportunities, tips in magazine that tells how, leading mail-order magazine since 1929. Sample \$1. Year \$5 with free what is mailorder opportunities folio. Mail Trade, P.O. Box 1302, Springfield, Illinois 62705.

ADDRESSERS Needed! Postage, Envelopes, Etc. Furnished! Details \$1.00. New England Sales-B, P.O. Box 1573, Worcester, Mass. 01601.

WANTED! ADDRESSERS-COMMISSION Mailers. Stamp Required. Ooton Distributors, 4120-P Duke, Portsmouth, Va. 23703.

FREE—Easy Ways to make money selling exciting new products—Full—spare time. Send name, age, for 5 months free subscription. Salesman's Opportunity Magazine, 1460 Hancock Center, Dept. 17-BM, Chicago 60611.

BIG Money writing Jokes. Enormous demand. We show you how. Free Facts. Laffs, Dept. G-92, Pleasant Hill, Ohio 45359.

CIGARETTES 15¢ A pack. Improved roller makes 20 filtertip, plain, king or regular for 15¢. Facts free. Green River Tobacco, Box 953, Owensboro, Kentucky 42301.

MAKE Statuettes, novelties, imitation marble. Sell to stores or start gift shop. Free details. Marbleizing, 41 Waverton, St. Louis, Mo. 63124.

LEARN The secrets of repairing junk batteries "Fabulous Profits" at home. Battery Shop, Box 820, La Quinta, Cal. 92253.

HOW TO GET RICH!! Free "Money-making Brochure"! Success International, Box 2447-C, Livonia, Mich. 48151.

\$200.00 FROM Sheet ¼" plywood (scrap). Details 25¢. Novelties, 610 So. 24th, Elwood, Indiana 46036.

GET World's Biggest Wholesale Import Catalog. Write: World, Medina, Washington 98039.

AMAZING Information, 315 magazines free, MacMillan, 3401-R Barr Street, Columbus, Ohio 43224.

VENDING Machines. No selling. Routes earn amazing profits. Big catalogue Free. Parkway Corporation, 715PMM Ensor Street, Baltimore, Maryland 21202.

\$25.00 HOUR Servicing vacuum cleaners, spare time! Baron, Box 863, Portales, New Mexico 88130.

EARN \$40.00 DAILY, Manufacture concrete Bricks. Very Small Investment. Free Details—Send Stamped Envelope—Bricks, Rt. One, Box 347-D, Valrico, Florida 33594.

BEGINNERS and professionals. Increased profits are yours after reading "100 Mail Order Success Secrets." Only \$3.00. Jeboco, Box 6542-MB, Surfside, Florida 33154.

WIN CONTESTS! Prizewinner Will Help You! Sample Copy, 25¢. Year, \$4.00. Spence, 1315 Central, St. Petersburg, Florida 33705.

CLIP Newspaper items. \$1.00-\$5.00 each. Details free. Walter, Box 1360PA, Erie, Pa. 16512.

SCIENTIFIC Messages: Big Earnings uncrowded profession. Learn spare time at home. Diploma awarded. Free catalog. Write Anderson School, Dept. B-1C, Princeton, Illinois 61356.

SPARE Time cash. Sell Famous Hanover Shoes. Actual samples and sales kit Free. No experience needed. No age limit. Lowest prices for highest quality makes selling easy. Every man a prospect. Big daily commissions. For full details, write Hanover Shoe, 774 Carlisle, Hanover, Pa. 17331.

START Big-Pay Business at home in spare time. No experience needed to operate little tabletop machine for bronzing baby shoes. Make \$7.95 profit on every pair. Full particulars free! Send postcard to: Mason, Room MC-2-BC, 1512 Jarvis, Chicago, Ill. 60626.

BIG PROFITS AND BONUSES Selling Lifetime Metal Social Security Plates. Free Sample! Duraplate, 200-PM East 127th Street, Kansas City, Mo. 64145.

EARN \$240.00 A month at home, spare time, doing only two \$5.00 Invisible Re-weaving/Reknitting jobs a day. Big money paid for service that makes cuts, tears disappear from fabrics. Steady demand. Details free. Fabricon, 2039 Montrose, Chicago 60618.

1000 PROFITUNITIES!—Join "Money-Getters Guild"; Receive offers, Samples, Magazines, Homework: Years Membership only \$1.00. (Refundable). Tory, Desk 710, Bayonne, New Jersey 07002.

YOU CAN BE RICH!!! Hundreds of little-known methods! Free Brochure! Success Research, Box 29263-AB, Indianapolis, Indiana 46229.

GUARANTEED \$25.00 every 100 envelopes you stuff! Everything furnished! Complete starting kit—\$1.00 (Refundable). Troy Company, Desk 610, Bayonne, N.J. 07002.

HOW TO HAVE CONFIDENCE and Power with other People. Make them say Yes. Get What You Want. Good First Impressions. 164 Page Book Reveals Ways. Send \$2.00. Terry Simpson, 971 Old Indian Tr., Dept. 22, Aurora, Illinois 60506.

MONEY Drilling Holes In Glass. Make. Sell Lamps From Old Bottles, Instructions And Special Drill Bit. Rush \$3.98: Village Craftsmen, Fiskeville, Rhode Island 02823.

(Continued on next page)

MONEYMAKING OPPORTUNITIES

(Continued from preceding page)

SHARP \$\$\$ Opportunity! One low-cost machine sharpens, serrates, knives, scissors, pinking shears. Earn \$6-\$9 hourly in spare time. Professional results without experience. Free details. Beaver Grinder, 2P2 Nielsen Building, Eugene, Oregon 97402.

MAKE BIG MONEY Wholesaling Exciting Gifts, Novelties, And Toys. Send \$1.00. (Refundable With First Order) For Giant Catalog And Complete Instructions To: Regal Discount House, 2568 East 21st Street, Brooklyn, N.Y. 11235.

SAVE MONEY. Pocket Timer Prevents Overparking, Overcooking Or Missing Appointments \$5.49, plus 60¢ Postage And Handling. Huntington House, 119 North Cedar, Little Rock, Arkansas 72205.

MAKE Money Writing Short Fillers. Detailed Booklet \$1.00. Grimm Enterprises, Latisquama, Southboro, Mass. 01772.

PROBLEMS Wanted. Prizes Are Given For The TOP TEN Problems (Household, etc.) Please Submit Problems To: Problems, 2681 W. Park Drive, Baltimore, Md. 21207.

EXTRA Vacation Cash *Winter *Summer* Full Profits. Details 25¢. Richer, Box 1872- Albany, New York 12201.

\$100.00 DAILY Possible Selling Information By Mail. Instructions \$1.00. Jones, Box 292, Independence, Va. 24348.

SUPERB Money-Making Books—Banish Money Worries! Details Free. Laser International Incorporated, 79 Wall Street, New York 10005.

BIG Profits! Fast Sales! Ingenious Burglary And Theft Preventer. Sample And Sales Kit Free. Kurth Security Products, Dept. D28, Rt. 3, Albert Lea, Minn. 56007.

\$10,000 YEARLY Possible! Consignment Selling. Full-Spare Time. Others Sell For You. Details Free. Elite Service, Box 715-A, Lynbrook, N.Y. 11563.

SELL YOUR PHOTOS—Report Tells How, Where, Color Slide Markets. Only \$1.00. Patin & Bond, Breaux Bridge, Louisiana 70517.

SUCCESS Method shows how to make \$1,000,000 in only 10 years. Start with \$10. Free proof. Opportunities, Box 721A, Lynbrook, N.Y. 11563.

MAILORDER—Carry No Stock. Companies Will Pack, Ship Under Your Label. One-Man Operation Capable Of \$10,000-\$20,000 Year. Details Free! Distributors, Box 9-A, East Rockaway, N.Y. 11518.

NOW Start your own business. No experience needed. We supply everything you need. New complete plan. Four big business manuals show you how, also giant below wholesale catalogs, office furniture and equipment catalogs, gift catalogs, much more. Complete outfit only \$10.00 refundable. Mail today—limited memberships. Futurity, PM-1, 824 South Second, Raton, New Mexico 87740.

GUARANTEED \$25,000 1st Year mail order earnings. Details Free. Glenwood, 4721C Indiana NE, Salem, Oregon 97303.

TAX Preparation NEW! SHORT EASY METHOD Faster, Higher Earnings starting FIRST WEEK. Free Information. Advance, Box 262, High Springs, Florida 32643.

GET DOLLARS IN MAIL. No inventory investment. Guaranteed to work or we refund. Send 50¢ for details. Keller, 29-PM Daye View, Bellefonte, Pa. 16823.

NEVER WON ANYTHING? Read "Anyone Can Win Sweepstakes!" Reveals prize-winner's methods! Free details. Services, Box 644-PC1, Des Moines, Iowa 50303.

234 PHOTO Buyers Pay Big Money For Your Snapshots. Free Details. Foley, 99 Sixth Ave., San Francisco, California 94118.

\$10.00 DAILY Writing Short Articles At Home. Begin Immediately! Copyrighted Report Reveals How And Where. PLEASE Send \$1.00. SATISFACTION GUARANTEED. 32-Page Catalog FREE. Martain Sales, 355 Star Route, Grand View, Idaho 83624.

HOW To Make Money Writing Short Paragraphs. Information Free. Barrett, Dept. C-27-D1, 6216 N. Clark, Chicago 60660.

UP TO \$100.00 paid for Jokes, Poems and Songs. 100 market directory \$4.00. Flam Publications, 2702 Chew, Houston, Texas 77020.

HOMEWORKERS. Sell Books by mail for Fantastic Profits. Complete instructions. Money-making Tips, ads, etc. \$3.00. Aquarius International, 1835 K Street Northwest, Washington, D.C. 20006.

BUY AND SELL GOV'T. SURPLUS. We have 27 years experience in this fascinating work. We can help you! Details free. MIDLAND LIQUIDATORS, INC., 340 Oakwood Court, Wichita, Kansas 67208.

FIX Typewriters from home. Repairs available. Easily learned. Athey, Tarentum, Pa. 15084.

EASIEST Money Profitable Mailorder Plans. Details 50¢. Eames Enterprises, P.O. Box 74832A, Los Angeles, Calif. 90004.

AMAZING INFORMATION BOOKLETS: How to make money in Mailorder Imports, Government Surplus, Collecting Coins, Writing Fillers, with your camera. \$1.00 each, 2 \$1.75. Jasin Unlimited, Dept. PM-2, 111-22 121st. Street, So. Ozone Park, New York 11420.

MAKE Your Knowledge Pay Off. Scientific Research, 4229 Pro, Shreveport, Louisiana 71109.

OPPORTUNITY: Small Towns, Rural Areas. Easy operation, Short hours, no capital. Send Stamp. Titus, Box 259, Menlo Park, Calif. 94025.

PROFITABLE OCCUPATIONS

MAINTENANCE SUPERVISION COURSE Home study. Prepares custodial workers for supervisory responsibilities and cleaning maintenance management careers. APPROVED FOR VETERANS. Accredited member National Home Study Council. Easy terms. Free brochure: American Institute of Maintenance, Dept. P, P. O. Box 2068, Glendale, Calif. 91209.

\$600-UP Monthly. People needed. Raise rabbits, other laboratory animals for us. Huge market. We supply equipment, breeders and instructions. Details 25¢. National Research Farms, PNMC-2, Box 309, Milwaukee, Wisc. 53201.

BECOME A Mortgage Broker. Highly respected, interesting, lucrative prestige business. For complete information write: United, Box 6284-F, Marietta, Georgia 30060.

MAKE \$300 CLEAR MONTH Few hours from 10 customers, representing us in your community. No individual selling. Repeats forever. Customers waiting. \$1 for sample, details. Our 40th year. Progressive, Box 1302, Springfield, Illinois 62705.

BAKE New greaseless doughnuts in kitchen, sell stores. Free recipes. Michael, Ray, Waseca, Minn. 56093.

FT. SMITH Auction School, Ft. Smith, Ark. Residents & Home study. Veteran approved.

SHARPEN Scissors, Pinkers. Inexpensive equipment, tools, supplies. Blackhawk's, Sheldahl, Iowa 50243.

LEARN GUN REPAIR GUNSMITHING in spare time. Book, details 10¢. Modern Gun Repair School, Dept. 1208, 4225 N. Brown, Scottsdale, Arizona 85251.

INSTANT Money! Plastics are the wave of the future. Big profits now! At home! Spare time! Materials costing 11¢ bring back \$2.58 profits immediately! Free information. Rush name on postcard to: Warner, Room LC-2-BC, 1512 Jarvis, Chicago, Ill. 60626.

EARN \$240.00 A month at home, spare time, doing only two \$5.00 Invisible Re-weaving/Reknitting jobs a day. Big money paid for service that makes cuts, tears disappear from fabrics. Steady demand. Details free. Fabricon, 2040 Montrose, Chicago 60618.

EARN AS YOU LEARN. Part-time subscription representatives for leading magazines earn generous commissions while developing skills of salesmanship. For full details, send this ad with your name and address to: POPULAR MECHANICS, Room 1107M, 250 W. 55th St., New York, N.Y. 10019.

PROBLEMS In Your Industry? Try Mine. LIQUORS and WINES. Business Always good. Write: Norstedt Company, Box 37366, San Antonio, Texas 78237.

\$\$\$\$ MANUFACTURING AT HOME Ten proven items. Mayco, Box 57, Belleville, Ontario.

BECOME A PROFESSIONAL GAMBLER. Learn all phases. Covers the track, all sports, all games. You start, learn fast. Only 10 lessons. Mail \$2.00 first lesson. Professional, 625-A S. Wells, Reno, Nevada 89502.

FREE Facts—Extra Cash raising Christmas trees. 3¢ seedlings yield high Profits. Backyard/Plantation programs. Tremendous market. Pioneer, Box 666-NB, Aptos, California 95003.

FREE GOVERNMENT BENEFITS GALORE For Everyone. Details. Premier Enterprises, PostBox 10597-C, Pittsburgh, Pa. 15235.

SPARETIME Bicycle Repairing. Enormous Earnings. Tools, Parts, Instructions. Wholesale Catalogue \$49.95. Brookclev Cycle Supply, 3510 West 105th, Cleveland, Ohio 44111.

HOW To Make Money Writing Short Paragraphs. Information Free. Barrett, Dept. C-27-D2, 6216 N. Clark, Chicago 60660.

SALESMEN-DISTRIBUTORS

SELL Hertel Bibles—Part Time. Finest reference Bible available. Demonstrator and Supplies furnished. Excellent commissions. Write International Book, Dept. PM, Box 118, Wichita, Kansas 67201.

LONG Needed Invention. Man to contact service stations. Full or part-time. Huge profits. Write: Cyclo Mfg., 3816 Dahlia, Dept. 126, Denver, Colo. 80207.

SELL Sensational Car Thief Signal. Lightning Seller. Samples for trial. Northwest Electric, Ave. 811, Mitchell, S. Dak. 57301.

EARN Big Commission Full or Part Time. Show America's largest line Low Priced Business Printing and Advertising Specialties Plus Calendars in season. No experience. No investment. No collections or Deliveries. On-the-spot commissions. Big Free Sales Kit samples hundreds items used daily by businessmen. Merchandise bonuses for you. Build profitable repeat business. Start now. National Press, Dept. 72D, North Chicago, Ill. 60064.

THERE'S Money in selling office supplies and equipment, full or part time. Steady repeat commissions. Free selling outfit. Write. Oseco, 3505-PM North Elston, Chicago 60618.

SELL Advertising Ball Pens, Calendars, Ad-Specialties—Build Own Repeat Business—Free Details—Fleming, Dept. A, 6535 Cottage Grove, Chicago 60637.

EARN Big money calling on business-professional men. Send us their delinquent accounts for collection. General Finance, Dept. PM-11, Columbia Bank Bldg., Kansas City, Missouri 64106.

SHOPLIFTING! ROBBERY! THEFT! Every business needs protection. Earn \$1,000-up monthly! Demonstrate revolutionary security system. Free Details. Kurth Security Products, Dept. D26, Rt. 3, Albert Lea, Minn. 56007.

(Continued on next page)

SALESMEN—DISTRIBUTORS

(Continued from preceding page)

NOW Available our new 1972 full color giant office furniture and equipment catalog. Mail today \$1.00 refundable. Futurity Furniture Division, PM-1B, 824 South Second, Raton, New Mexico 87740.

AGENTS WANTED

WILL You test new items in your home? Surprisingly big pay. Latest conveniences for home, car. Send no money, just your name. Kristee 131, Akron, Ohio 44308.

EVERY Man a prospect. Refundable sales kit offer showing line belt buckles, tie clasps, money clips, cuff links, lapels, identification badges, individualized with customer's name and emblems. Cap badges for trucking, bus, taxi, police, firemen, also postal, letter carriers and heavy construction emblems. Choice 4000 emblems. Hook-Fast, Box 1088PM, Providence, R.I. 02901.

YOUR Own business—Used Suits \$1.50; Overcoats 65¢; Mackinaws 35¢; Shoes 12½¢; Ladies' Coats 30¢; Dresses 15¢. Enormous profits. Catalog Free. Nathan Portnoy Assoc., 2109-AA, Roosevelt Road, Chicago, Illinois 60608.

PRINTING, Advertising Salesmen—Excellent moneymaking sideline selling Decalcomania Name Plates, small quantities. Advertising Specialties, sign letters. Free Samples. Raico XL, Boston, Mass. 02119.

WANT TO MAKE UP TO \$100 A WEEK Spare time, and get free shoes for life, too? No investment. Rush card for free details. Mason Shoes, K-882, Chippewa Falls, Wisconsin 54729.

LIFETIME Income. Be our loan representative. Free Copy "Financial Freedom". Send \$1.00 refundable. Financial, Suite 1204-X3, 28 E. Jackson, Chicago 60604.

TRIPLE Investment—Electronic Letter Opener, \$4.95. Brings sample and details. Lucky Seven, Horseshoe Dr., Brookfield, Conn. 06804.

EMPLOYMENT INFORMATION

AUSTRALIA NEEDS YOU—Government Assisted Passage, Settling Allowance. Opportunities all Jobs, Farming-Ranching. Guaranteed. Information and Forms \$1.00. Australia-MF, Box 1149, Midland, Texas 79701.

CHICAGO Employment. Booklet. Plus Newspaper Classifieds. Send \$3.00 to: Cineb Press, Box 8134, Chicago, Illinois 60680.

EXCITING AUSTRALIA—LAST FRONTIER! Government Assisted Passage! Generous Relocation Allowance. Handbook Includes Information On Taxes, Wages, Schools, Housing Etc., Plus List Of Employers And Application Form. Send \$1.00: Desco, Box 3021, Mankato, Minnesota, 56001.

LATEST REPORTS ON BOOMING AUSTRALIA AMAZING HIGH WAGES. OVER 50,000 JOBS. HUNDREDS OF U.S. COMPANIES housing, education, TRANSPORTATION PAID BY GOVERNMENT. EQUAL OPPORTUNITIES FOR ALL information. RUSH \$1.00. Box 3164PM2, WEST TEXAS ASSOCIATES, AMARILLO, TEXAS, 79106.

ADVANCED Method used to obtain top salaried overseas jobs. Men-women needed. All occupations, 3200 Companies, 100 countries. Worldwide Index, Lakeview, Wash. 98491.

NEW ZEALAND EMPLOYMENT OPPORTUNITIES—Government Assisted Passage, Giant American Employers List, Includes Information On Business, Farming, Housing, Education, Maps, Etc., Complete Details \$1.00. Newzco, Box 444-A, National City, California 92050.

AUSTRALIA Wants You!!! Government Assisted Passage. 1972 Government Information and Forms—Most Complete Information Available—\$1.00. Reports on Employment, Business, Taxes, Education, Teaching, Housing, Ranching, Maps, etc. Austco, Box 3623-E, Long Beach, California 90803.

AUSTRALIA!! AUSTRALIA!! AUSTRALIA!! Government PAID Transportation!! Growing Australia Needs you!! Latest, illustrated Handbook and forms explain Employment, Housing (Buying-Renting), Education, Ranching (Capital Required), start a business. Lists hundreds of American Companies in Australia and Employment Agencies. Explains Government PAID Transportation. Free Details! Write: Associated, Box 17-B123, Lafayette, California 94549.

FLORIDA Employment Opportunities! Disneyworld! Newspaper Classifieds! Booklet \$1.00. Sunshine, 4512N Jamaica, Tampa, Florida 33614.

BRITISH Columbia employment and immigration information. Complete details, \$3.00. Doyle Associates, Box 2702, Williams Lake, B. C. Canada.

AMAZING AUSTRALIA! Information Publication on Employment, Housing, Social Life, Transportation, Taxes etc. Guaranteed. \$2.00. Barnett Agency, Box 207P, Godfrey, Ill. 62035.

AUSTRALIA NEEDS YOU! Government Assisted Passage. 1972 Australian Handbook Gives Most Accurate Information Available. Details About Settling-In-Allowance, \$1,000 and up, Wages, Housing, Schools, Plus Employers List and Forms. Send \$1.00. McBrearty, Box 11645 PM2, Tampa, Florida 33610.

CAREERS!! ADVENTURE!! SURPRISING AUSTRALIA Needs You, PAY\$ YOU TO relocate. Handbook Details Include "Employment Directory" Listing job Opportunities Galore. \$1.00. MIDWEST, Box 1834, Kansas City, Missouri 64141.

TREMENDOUS Opportunities Australian Employment Directory \$1.00. K.L.W. Enterprise, Box #527, Kearny, New Jersey 07032.

OVERSEAS Jobs Directory—Now Hiring—High Pay, Adventure. \$1.00. Transworld, Box 90802-E, International Airport, Los Angeles, California 90009.

EXCITING OPPORTUNITIES IN AUSTRALIA! New copyrighted booklet reveals complete employment information. Send \$1.00 to: Mahlon Rissler, Dept. 110, 1311 Greystone Street, Harrisonburg, Va. 22801.

HELP WANTED

EARN At Home Addressing Mail. Details 25¢ and Stamped Envelope. Deeco-151, Box 9308, North Hollywood, Cal. 91609.

OVERSEAS EMPLOYMENT . . . Australia, Europe, South America, Asia! All Occupations! \$700-\$3,000 monthly! Write: Employment International, Box 29217-AB, Indianapolis, Indiana 46229.

WORLD-WIDE. . . U.S.A. Jobs Galore!! Students, all professions and occupations. Enjoy Paris, Rome, Tokyo, Mexico City, Miami, San Francisco. \$700.00 to \$3,000.00 monthly. Paid Overtime, Travel Allowance, Sightseeing. Free Details!! Write: Global Employment, Box 706-B123, Orinda, California 94563.

OVERSEAS Jobs—Europe, South America, Australia, Far East, etc. 2000 openings all trades. Construction, Office, Engineering Sales, etc. \$700 to \$3,000 month. Expenses paid. Free Information. Write Overseas Jobs, International Airport, Box 536-M, Miami, Florida 33148.

"AUSTRALIAN OPPORTUNITIES HANDBOOK" . . . Latest authentic information about Government Paid Transportation, Employment, Business, Farming, Housing plus "Employers List" and Forms. Send \$1.00 (Guaranteed). International Services, Box 19107-AB, Washington, D.C. 20036.

FREE DETAILS . . . AUSTRALIA . . . Government assisted transportation. Latest Handbook and forms . . . Free Details . . . Write: Associated, Box 17-BA123, Lafayette, California 94549.

AUSTRALIA—Complete information and employers list \$1.00. K. Leeson, 1001 Sunset Drive, Norwalk, Iowa 50211.

OVERSEAS Jobs—Australia, Europe, South America, Far East. Openings in all trades and professions. Free information, write: Foreign Jobs, Box 2235 AMF, Miami, Florida 33159.

REAL ESTATE AND FARMS

CANADIAN HUNTING/FISHING PROPERTIES, From \$9.00 an acre. Choice properties across Canada. Low monthly payments. Ideal hunting, fishing, timber, investment. FREE CATALOGUE. Canadian Estate Land, Department PMC-2, 194 Wilson Avenue, Suite 101, Toronto 380, Canada.

SUNNY Arizona vacation retreat. Full 2½ acres, \$895. Low terms. Mrs. Anna Young, Glenarm Land Company, 2233 North 7th St., Phoenix, 85006.

LAKE CONCHAS NEW MEXICO 5 Acres Available. No Down. No Interest. \$15/mo. for 131 mo's. Full Price \$1,975. Moneyback Guarantee. Vacation Paradise—Camp, Fish, Hunt, Water and Winter Sports. Write Mrs. Mills, Box 1044PM, Conchas Dam, New Mexico 88416.

GOVERNMENT LANDS Low as \$3.50 acre. Millions Acres! For exclusive "Copyrighted Report" . . . plus "Land Opportunity Digest" listing lands throughout U.S.; and VALUABLE 17 X 22 TREASURE MAP OF U.S.; send \$1.00. Land Disposal, Box 9091-PM, Washington, D.C. 20003. Satisfaction Guaranteed.

CANADIAN Vacation lands: Full price \$385.00. 40 acres. \$10 month. Suitable cottage sites, hunting, fishing, investment. Free information. Land Corporation, 3768-C Bathurst, Downsview, Ontario, Canada.

\$1 ACRE—Canadian Border—hundreds campsites, islands, farmlands, directly from tax authorities. (Non-profit). Lists, photographs mailed. Register. Room 10, 110 Church Street, Toronto 1, Canada.

GOVERNMENT Lands . . . low as \$1.00 Acre! Millions Acres! For exclusive "Government Land Buyer's Guide" . . . plus "Land Opportunity Review" listing lands available throughout U.S., send \$1.00. Satisfaction Guaranteed! United Lands, Box 19107-AA, Washington, D.C. 20036.

CENTRAL Ontario—Choice 640 acre Sportsmen's paradises still available—\$20.00 plus \$6.50 taxes yearly. Maps, pictures. \$2.00 (Refundable). Information Bureau. Norval 4, Ontario, Canada.

BOILING Spring Lakes—America's Greatest Real Estate Value. 1/3 acre vacation or retirement homesites only \$750 cash price. Ten-years to pay. Money-back inspection guarantee. Carolina coast, multi-million dollar, 14,000 acre development. 50 fresh water lakes, private ocean beach, golf course, motel, and country club. Free literature, Dept. 1-R, Boiling Spring Lakes, North Carolina 28461. (Registered under Federal Land Sales act but not offered to residents of states requiring separate registration.)

FIREPROOF Apartments, Good Return. Large, Small Acres. Cardwell, New Florence, Mo. 63363.

MICHIGAN 10 TO 160 ACRE TRACTS Lake Superior-Marquette Area from \$99.00 Acre. Cabins, trailers, camping welcome. (Acreage Anywhere in Michigan). FREE PICTURES. Any Terms A-OK with BLOCH BROTHERS write 3650 Dixie, Drayton Plains 16, Michigan 48020.

OCALA FOREST CAMPSITES Deep in the heart of the Great Ocala National Forest. Excellent hunting and fishing. Free maps and photos. (Unavailable in States requiring separate registration). AD70LB710E. W. H. Vernor, Inc., P. O. Box 760, Dept. E, DeLand, Florida 32720.

NEW! 1972 Spring Catalog. Coast to coast bargains in farms, retirement, business, resort, investments. Actual property photos! Your copy FREE! (Zip please) SAFE-BUY Real Estate Agency, Box 589-PM, Little Rock, Ark. 72203.

(Continued on next page)

REAL ESTATE AND FARMS

(Continued from preceding page)

CANADIAN Lands, seized and sold for taxes. Our 55th annual series of lists, describe many choice properties, situated from coast to coast. Priced as low as ten dollars per acre, guaranteed perfect titles, small monthly payments, no mortgage. Beautifully situated hunting and fishing camps, where there is real sport, summer cottage sites, heavily wooded acreages. Now is the time to invest in Canada's minerals, forests and farms. Write to-day for free booklet with full explanation. Tax Sale Service, Room 301-D, 85 Bloor St., E., Toronto 5, Canada.

BEAUTIFUL Cabin Sites And Homestead Land available from British Columbia government to homestead and lease. Complete details \$2.00. Tim Doyle, Horsefly B.C., Canada.

FREE CATALOG! Big SPRING edition! Over 5,000 Properties described, pictured—Land, Farms, Homes, Businesses—Recreation, Retirement. Selected Best throughout the U.S.! 72 Years' service, 582 Offices, 40 states Coast to Coast. Mailed FREE from the World's Largest! **STROUT REALTY**, 60-MX E. 42nd St., NY, NY 10017; 7-MX S. Dearborn, Chicago, Ill. 60603; 521-MX E. Green, Pasadena, Cal. 91101.

FREE . . . 256-Page SPRING catalog. Hundreds of top real estate values coast to coast! **UNITED FARM AGENCY**, 612-PM West 47th St., Kansas City, Mo. 64112.

LAND! EASY TERMS LESS THAN BANK RATES. NORTHWEST TIMBERED ACREAGES As low as \$1550 Total Price. 5-10-20-40 Acres. For people who love the land—A tract of Recreation Land to have for your very own! In Northern Idaho, Northeastern Washington, and Beautiful Montana. In the heart of lakes and big game country. All covered with growing timber. Access and Title Insurance with each tract. This is select land with natural beauty, recreational and investment values. Plan for the future and retirement recreation. We have tracts of many types and sizes from which to choose, including beautiful Northwest Waterfront property. Your inspection is welcomed. Write us for free list, maps, and complete information. Write to: Dept. PC, Reforestation, Inc., P.O. Box 14006, Opportunity Station, Spokane, Wash. 99214.

DRINKING WATER-PURIFIERS

WATER PURIFIED. PROTECT Your family's health. Converts water from home kitchen tap to **SPRING FRESHNESS**—instantly. No plumbing. 5 second faucet attachment. Always ready. Portable. Take it anywhere. Removes and filters out bad taste-odors-detergent contaminants-chlorine. Enjoy drinking water again, coffee, tea, soups, ice cubes etc. Why buy and lug bottled water. **GUARANTEED.** Practical products of scientific research. **SENSATIONAL \$8.95.** Send postpaid to Water Purified, P.O. Box 1082, Dept. A, Miami Beach, Florida 33139.

UNIQUE. Activated carbon dripolater filter kit. Portable Guaranteed. \$6.95. Box P2251, Noroton Heights, Conn. 06820.



FLOWERS, PLANTS & NURSERY SUPPLIES

FIBERGLASS And Plastic Greenhouses —From \$110! (12' long!) Accessories. Free Catalog. Greenhouseman, Box 2666-MB, Santa Cruz, California 95060.

INSECT (Meat) Eating Plants, 42 kinds, illustrated brochure 25¢ postpaid. Peter Pauls Nurseries, Macedon Canandaigua, N.Y. 14424.

MINIATURE Greenhouse grows fresh Herbs and Colorful Flowers all year round! \$2.98. Pioneer Gift Shop, 507 Mohawk Drive, Lancaster, Ohio 43130.

GINSENG Bringing \$20.00 pound. Have seeds roots. Goldenseal. Full information. K. Collins, Viola, Iowa 52350.

LEARN Landscaping and the growing of plants. Start a profitable business part or full time. Free information without obligation. Lifetime Career Schools, Dept. A-137, 2251 Barry Avenue, Los Angeles, California 90064.

W. F. ALLEN Company has been Standard of the Strawberry Industry for 87 years. What YOU need to know to grow the best berries, you will find in the new 1972 Berry Book. There's something for everyone in the Berry Book—variety descriptions, cultural directions for the standard and everbearing varieties, helpful hints, some yummy recipes on the Berry Patch page, as well as a history of the strawberry. Send for your copy now. It's free! **W. F. Allen Company**, 23 Strawberry Lane, Salisbury, Md. 21801.

LOG CABINS & HOMES

"BUILD Log Cabins, rustic furniture, fireplaces!!! Complete manual, \$3.00 . . . "A" Frame plans, \$2.00 . . . Guaranteed . . . Beels, 956 Springdale, Atlanta, Georgia 30306."

"A" FRAME Cabin. \$500 for material. Any lumber yard. Completely illustrated instruction manual, including material list. Moneyback guarantee. Send \$2.00 to Dependable, Plan #1904, Box 113, Vista, California 92083.

CONSTRUCTION PLANS, BLUEPRINTS

PREFAB—Build your own Home, Garage, or Addition. New easily understood approach to building that you can do yourself and save money. Plan Catalogue and Details \$1.00. **Builder's Drafting Co.**, 1487 Old Hickory Rd., Memphis, Tennessee 38116.

HOME CRAFTSMEN

WOOD—Domestic and Imported Hardwoods! Clock, musical instrument kits. Tools . . . discount prices! Hard-to-find hardware. 144 page catalog, 50¢. **Craftsman**, Dept. AX-22, 2729 Mary, Chicago, Illinois 60608.

101 PATTERNS Of Smart Gifts, Novelties, Shelves, Action Windmills, Plus "Make Money Jig Sawing". \$1.50. **Mastercraft**, 25M, 7041 Olcott, Chicago, 60631.

WOODWORKING Catalog and Manual 50¢. Plus free "101 Project Ideas." World's most beautiful veneers, lumber, plywood! Wood finishing, upholstery supplies. Cane. Lamp Parts. Furniture hardware. Animal whittling blocks. 2,000 workshop products. **Constantine**, 2051-C Eastchester Road, Bronx 10461.

CABINETMAKING MADE EASY And "How to Make Formica Counter Tops." Two excellent guides let you build kitchen cabinets and counter tops like professionals. Extraordinary guides bring master craftsmen's shortcut methods. Satisfaction guaranteed. Write: **Japs**, 126-P Seventh North, Hopkins, Minn. 55343.

PICTURE Framing—Profitable full or spare-time business. Easy to learn with handbook-course "Guide To Picture Framing Profits." \$1.50 Guaranteed. Free framing-supplies catalog included. **Japs**, 126-PM Seventh North, Hopkins, Minnesota 55343.

MAKE Money Building and selling Bird Houses. Send \$1.90 for 39 page book of plans covering 19 projects. **Yeager**, 1665 Linden, Homewood, Ill. 60430.

SKIL-CRAFTS Current 200 plus page catalog with world's largest, finest selection of Hobbycraft, leathercraft, artist supplies. Send \$1 for postage and handling; refunded on first \$15 minimum catalog order. **Skil-Crafts**, Box 105-P, Joplin, Mo. 64801.

WALNUT Bowls, Legs, Round Picture Frames, Gun-Stocks Lumber Moulding. **Midland Walnut**, Box 262, Savannah, Missouri 64485.

136 FULL SIZE FURNITURE PLANS. Traditional, Early American, Danish Modern. Catalog 50¢. **Furniture Designs**, Dept. P-22, 1425 Sherman, Evanston, Illinois 60201.

POPULAR MECHANICS MASTER SHOP GUIDE. Greatest product offered to a man with a workshop. All information printed on heavy boards, punched and ready to hang above his workbench. Covers wall fasteners, nails, screws, bolts, twist drills, abrasives, lumber, moulding patterns, plywood grades, hardboards, drywall, plumbing supplies, electrical supplies. Plus information on scores of other subjects. Send \$3.95 to: **POPULAR MECHANICS**, Dept. HE, 224 West 57th Street, New York, New York 10019.

WIND Speed Indicating Weather Vane. Aluminum Or Wood. To 100 MPH. Easy Construction. Prints—Calibration. Send \$3.00 M.O. "Scope Aids", Box 491 P, Rahway, N. J. 07065.

NEW—Clock Kits, Dials, Movements. Free Brochure. **House Of Clermont**, 2282 Woodville Pike, Goshen, Ohio 45122.

100 JIGSAW Patterns for Pleasure—Profit—\$1.00. **Lynds**, Medway, Massachusetts 02053.

BUILD Lazy Susan Dining Table. Home Shop Tested Plans And Instructions, For Two Tables In Three Styles. Literature 25¢, Plans \$5.00. **Design Craftsman**, Box 226, Lumberton, North Carolina 28358.

"CLOCK Kits, Movements, Dials. Free Catalog. **Newport**, Box 6848A, Burbank, Calif. 91505."

"WROUGHT IRON WORK." Make Lamps, Tables, Chairs for Home or Sale. Versatile toolset performs seven operations without welding. Featured this Magazine March 1970-July 1971. Free Brochure or send \$1 for Project Manual. **Wrought Iron Tool Co.**, Box 663, West Caldwell, New Jersey 07006.

COMPLETE HOME WORKSHOP PLANS. Workbench, Tool Cabinet, Drawers, etc. Completely Illustrated. \$2.00. **Erickson's**, 506 Court, Ida Grove, Iowa 51445.

HOME REMODELING

HOUSE EXPANSION PLANS and detail instruction book provide anything from an extra room to 1000 s/f addition. Build what you need at big do-it-yourself saving. Book with 1 set working blueprints \$14.50; with 4 sets (required by contractors) \$20.00. **Money-Saver Projects**, Box 303, Chappaqua, N.Y. 10514. Info available.

DO-IT-YOURSELF

SAVE! INSTALL YOUR OWN CENTRAL AIR CONDITIONING. More than \$200 savings with do-it-yourself installation kit for use with forced air furnace. Free brochure shows how to do it easily with common hand tools. **McGraw-Edison Co.**, 714 N. Clark St., Albion, Mich. 49224.

REPAIR MINIBIKES, LAWNMOWERS, BICYCLES, Sewing Machines, Auto Engines. Build concrete, Plywood, boats, trailers. Ten additional How-To-Do books. Free brochure. **Sincere**, Box 10422, Phoenix, Arizona 85016.

BEST WORKBENCH PLAN Ever, Plus Free Lumber Conversion Chart, \$1.00. **WAY-MAR**, Dept. 46, 58 Underhill Road, Scarsdale, New York 10583.

BURGLAR Alarm—for doors and windows—no wiring—self contained units—model 715 chrome \$6.95 model 402 white \$5.95—**Jeffrey Morford**, 1631 N.E. 171st Street, North Miami Beach, Florida 33162—Dept. A

CONVERT MOWER Engines into air compressors. Write **Showalter**, Box 409, Abilene, Kansas 67410.

BURGLAR—Fire alarm systems and supplies. Free Catalog. **Informer Mfg.**, 200a S. Eden Street, Baltimore, Maryland 21231.

BURGLAR-FIRE Alarm Supplies and Information. Free Catalog. **Protecto Alarm Sales**, Box 357D, Birch Run, Michigan 48415.

STEAM Engines, boilers, burners. Pictures, descriptions, drawings. \$2.00 Prepaid. **Travis Tool Co.**, Box 118, Sidney, Iowa 51652.

(Continued on next page)

DO-IT-YOURSELF

(Continued from preceding page)

"HOW TO" Books. Catalogue 25¢. Elston House, 35 Stonycliff, Centerville, Mass. 02632.

PROTECT FAMILY AND POSSESSIONS. Send \$59.95 for your Do-It-Yourself Burglar or Fire alarm system kit. Accessory catalog 25¢. CDS, P.O. Box 790, Pearland, Texas 77581.

HEADQUARTERS For fine clock kits. Send 25¢ for catalog to Selva, Dept. PM; 487 Armour; Atlanta, Georgia 30324.

T.V. GHOSTS? Adapt Present antenna for Manual aiming Gunsight accuracy. Plans \$2.00. Owens, 147 Brookside Rd., Newtown Square, Pa. 19073.

"MAKE Intercom system with radio. Minor changes, plans \$2.00. Dennis Garland, Dept. 252B, 1141 Claude, St. Dorothee, Que. Canada."

BURGLARY PROTECTION—Professional Alarm System Components, Safes, Accessories. New free catalog. TPC, Box AE-2, Cupertino, California 95014.

VOLKSWAGEN BUS Expandable Top. Solid State. Instructions And Full Size Templates \$5.00. Details 25¢. Macgeeco, Box 5403, Midland, Texas 79701.

ELEVATORS Build for your home from simple parts. Save Thousands. Plans \$8.00. J.P.F., 2908 11th NW, Canton, Ohio 44708.

UNBREAKABLE Watch Crystal Scratches Removed \$1.25. CharNa, 158 Cherry St., Framingham, Mass. 01701.

CREATE Children Furniture, Toys from plywood, 5 plans \$2.00. Projects, Box 145, Middleville, New York 13406.

ARTS AND CRAFTS

FREE: New handicraft catalog. Supreme Handicrafts, Box 395-PM, Sioux Falls, South Dakota 57101.

MAKE Figurines, plaques, lawn ornaments. Molds, plastercraft kits, liquid rubber. Sample and catalogue 10¢. Wooley Company, Box 29-B, Peoria, Illinois 61601.

"GETTING Started in Stained Glass" 25¢. Whittemore, Box 2065Y, Hanover, Mass. 02339.

500 FIBERGLASS Molds for casting ornamental concrete products. Catalog \$1.00. Plycrete Molds—Elk Rapids, Michigan 49629.

LARGEST Handicrafts Supply Catalogue \$1.00 (Refundable). R.P.H. Manufacturing, 24-M-2 Winter, Stamford, Connecticut 06905.

LEARN Arts & Crafts at home. Excellent full or part time business opportunities, or hobby. Free booklet. Lifetime Career Schools, Dept. E-663, 2251 Barry Avenue, Los Angeles, California 90064.

CANDLE Making supplies. Wholesale catalogue. Design Dimensions, Pinewoods Road, Granby, Connecticut 06035.

ANTIQUES, Refinishing, Restoring learn professional methods. 190 Page Book, \$1.50—FREE CIRCULAR. Hilton House, P-S 51 Schaefer Road, Maplewood, New Jersey 07040.

GLASSBLOWING Equipment And Kits For Amateurs And Professionals. Illustrated Introductory Instruction Book \$1.00. (Free To Schools And Institutions). Willis Glass Supply Company, Box 3460, Dept. A, Anaheim, California 92803.

BRIAR Blocks for smoking pipes. Pimo, Box 59211, Chicago, Illinois 60659.

BINOCULARS, TELESCOPES, MICROSCOPES, MAGNIFIERS

FREE Binocular, Riflescope catalog. Discount sale. Save 50%. Free gift with order. Write, United Binoculars, BN-4208, 9043 So. Western, Chicago, 60620.

TELESCOPES (Reflectors) complete kits. Other accessories, request free literature. Criterion Manufacturing, Dept PM-26, Hartford, Connecticut 06101.



CAMERAS AND EQUIPMENT

PHOTOGRAPHY FOR PLEASURE Or profit. Learn at home. Practical basic training. Long established school. Free booklet. American School of Photography, 555 E. Lange St., Dept. P401, Mundelein, Illinois 60060.

SELL Your photos. Report tells how, where. Let your camera provide a second income. Booklet MO 54-P Only \$1.00. Eagle Enterprises, 26 Lincoln Avenue, Staten Island, New York 10306.

FREE! FREE! BARGAIN BOOK—Central Camera Co., Dept. 311, 230 S. Wabash, Chicago, Ill. 60604.

POLAROID Owners, 3-D Stereo Pictures. Free Brochure. Box 42, Bridgeport, Conn. 06601.

CAMERAS, RADIOS, HI-FI. Original Japanese and German equipment shipped directly to you by our agents overseas. Exceptional Savings. Free Catalog. Photo and Radio Imports, Box 1135-M, Chicago, Illinois 60611.

PHOTO & PHOTO SUPPLIES

ALBUM MESS? Rearrange at will! Clinging, transparent cover sheets hold photos where placed—no glue, no tape! A great buy NOW at \$4.50 postpaid! Complete satisfaction guaranteed. Qualdesco, Dept. 1A2, 202 South Meade, Greenville, N. Car. 27834.

PHOTO FINISHING

CAMERA FANS! Expert photofinishing by one of Country's largest labs at lowest prices. Fast service and free "Foto-Fan" Stamps you quickly redeem for valuable Photo Supplies. 8MM Kodachrome \$1.29; 8 Exp. Kodacolor \$1.79; 35MM Kodachrome. 20 Slides \$1.39; 8 Exp. Black White 69¢. Satisfaction guaranteed. Send exposed film or request free mailers, complete Price List and Gift Catalog. Direct Mail Photo, Box 8352-PM, Pittsburgh, Pa. 15218.

COLOR SLIDES

35MM COLOR Slides. 10,671 Individually sold. Described, Encyclopedia catalog 10¢. Wolfe Worldwide, Dept. 14-22, Los Angeles, Calif. 90025.

MOTION PICTURES AND SOUND EQUIPMENT

8MM SOUND feature pictures. Catalog. Hart, Box 452-A, Birmingham, Michigan 48012.

16MM SOUND Features, Shorts, New, used for Sale. Free Catalog. National Cinema, 333 W 57th St.—N.Y.C., N.Y. 10019.

FREE! 64-Page catalog. 8-16mm film, supplies, processing equipment. Superior, 448 N. Wells, Chicago 60610.

UNUSUAL Movie supplies. Free circular. Esor, 47th Holly, Kansas City, Missouri 64112.

STAMP Brings You List, 8MM 16MM Movies. Film Classic, 1926 South Vermont, Los Angeles, 90007 Cal.

ADD Taped Sound to your home projections. For instructions send \$1.00 to: R. Scherer, Box #218, Jamaica, N.Y. 11434.

RADIO, TELEVISION AND HAM EQUIPMENT

36¢ RADIO & TV tubes. Free catalog. Cornell, 4213-17 University, San Diego, California 92105.

YOU CAN Master ELECTRONICS—Theory And Operation—With Unique Self-Study Texts. One-Idea-Per-Page Method, 1000 Color Illustrations Insure Understanding. Complete 7-volume Course, \$14.95. (Need ELECTRICITY? Basic Course, \$7.95.) Or Try Introductory Volume (Either Course)—Only \$3.00. Money-Back Guarantee. Unitext, Box 188-P, Glen Ridge, N. J. 07028.

GOVERNMENT Surplus receivers, transmitters, sniperscopes, parts. Catalog. 25¢. Meshna, Nahant, Mass. 01908.

SAVE Money on parts and Transmitting—receiving tubes. Foreign—domestic. Send 25¢ for giant catalog. Refunded first order. United Radio Company, 56-PM, Ferry Street, Newark, N.J. 07105.

HIFI, RECORDS AND ELECTRONICS

FREE Catalogues, 2000 hard to find unusual records. Rose's Records, Box 7216, Louisville, Ky. 40207.

FREE Catalog—Electronic kits—amplifiers—preamplifiers—psychedelic strobes—metal detectors—color organs—digital instruments—guitar amplifiers. FREE Subscription, SWTPC, Box PM32040, San Antonio, Texas 78216.

REMEMBER Old Time Radio?? Catalog 50¢—TBOR, Box 1692-D, FDR Station, New York 10022.

GOLDEN Age Radio. Complete taped shows. Box 8404-M, St. Louis, Missouri 63132.

BIG BAND RECORDS. Swinging Years, 1936 To 1960. We'll Tape Your Favorite Numbers For You. List Of 2,000 To Select From, \$1.00. Refundable. Souvenir Recordings, Box 37215-20, Los Angeles 90037.

STEREO 4/8 Track Cartridge Tapes. Sample & list \$1.99. Gorda's, Box 282, Duquesne, Pa. 15110.



MUSIC AND MUSICAL INSTRUMENTS

30% DISCOUNT Name Brand Musical Instruments. Free Catalog. Freeport Music, 127F Sunrise Highway, Freeport, New York 11520.

ACCORDIONS And Amplifiers! Excelsior and other Famous Makes. Save 50%. Buy Direct. Factory Distributor. Terms, Trades, New—Used. Free Home Trial. Free Catalog and Discount Prices. Excelsior, Dept. R, 3147 North Luna, Chicago 60641.

SHOW BUSINESS NEEDS NEW Combos, Singers! Write: Central State Talent, Box 216-P, Rock Island, Illinois 61201.

ACCORDION Top brands. Buy direct. Tremendous discounts. Trades accepted. Free brochure PM. Accordion-O-Rama, 874 Broadway, N.Y.C. 10003.

POEMS And Songs Wanted By America's Most Popular Studio. Broadway Music Productions, Tin Pan Alley PM, Lake Grove, New York 11755.

EASY To Make, Play and Sell Musical Instruments. Kits From \$5.00. Instruments From \$10.00. Here, Inc., P. 410 Cedar Avenue, Minneapolis, Minn. 55404.

ACCORDION Manufacturing. 6846-P North Avenue, Chicago, Illinois 60635. Concertinas, Hohners, Chromatics, Guitars, Drums. New, Used, Tuning, Repairing. Wholesale Catalogs Free.

WHOLESALE Professional Guitars, Amplifiers, PA Systems. Free Catalog. CARVIN, Escondido, Calif. 92027.

PLAYER Piano Rebuilding—get details from: Vestal Press, Vestal 11, N.Y. 13850.

VIOLIN And Guitar makers—send for latest Free Catalogue of woods & accessories. International Violin, PM1, 414 East Baltimore St., Baltimore, Md. 21202.

ELECTRIFY Player Pianos, Pump Organs Quickly. Inexpensively with Lee Silent Suction Units. Write Lee Music, 525F Venezia Avenue, Venice, California 90291.

LEARN Banjo. 5-String Bluegrass. No music. Makes learning easy. Free details. Blaylock, Box 25-M, Marietta, Georgia 30060.

POEMS Wanted For songs. Nashville Music Productions, Box 40001-P, Nashville, Tennessee 37204.

(Continued on next page)

MUSIC AND MUSICAL INSTRUMENTS

(Continued from preceding page)

GUITAR MAKING Books, Imported Woods, Supplies, Accessories. Catalog 25¢. Guitar Center, Box 15444, Tulsa, Okla. 74115.

30% TO 50% DISCOUNT! Any model: Guitar, Amp, Drum, Banjo, Dobro! FREE Catalog! Warehouse P-18, Box 9352, Fort Worth, Texas 76107.

FREE, Song Selling Information. Peerless Publications, Box 193-A, Bloomfield, Conn. 06002.

POEMS Set to Music. Songs Recorded. Details: Three Jay Music, Box 742, Dexter, Michigan 48130.

SING FOR MONEY. Home popular singing course. Send \$1.00 for Introductory Record. Accent Records, 6533 Hollywood Blvd., Hollywood, California 90028.

GUITARISTS!!! Save 30% on guitars; amplifiers. MONEY BACK GUARANTEE!!! Send 25¢ (postage-handling) for 32 page illustrated discount catalog: Guitars Unlimited, Box 343PB, Richland, Washington 99352.

WE Pay All Recording Costs on accepted material! Need new Song Material for immediate recording! Grand Recording, 1354-PM Hancock St., Quincy, Massachusetts 02169.

"LEARN TO Read Music In One Evening". Amazing new book shows how. \$3.00 postpaid. Money back guarantee. Hodges, 8636 South Jeffery Blvd., Chicago, Illinois 60617.

SONGS—Poems Wanted! Top Royalty! Recordorama, 2005 St. Anne, Santa Ana, Calif. 92704.

FREE Discount Catalogue. Guitars, Banjos, Mandolins, Parts, accessories. Send 50¢ postage, handling. Bell Guitars, 201 W49, New York 10019.

READ Music In One Evening!! (Exciting Information Free!!) Reavis, Dept. PM, Box 19796, Philadelphia, Penna. 19143.

OLD Country Classics 8 track. Send \$5.50—40 minute cartridge. House of York, 2360 Loucks Rd., York, Pa. 17404.

CONSERVATION TRAINING

OUTDOOR CAREER—Train at home in spare time for Conservation-Ecology Career as Game Warden, Government Hunter, Fish-Wildlife Manager, Forestry Aid or exciting outdoor Technician Type Position. Protect forests and wildlife! Arrest violators! Enforce Conservation laws! Adventure, public service, good pay, regular advances, no layoffs! Free "Conservation-Ecology Career Kit" shows you how you can start now. Approved for Veterans! Write: North American School of Conservation - AZW - Newport Beach, California 92663.

MOTEL HOTEL MANAGEMENT TRAINING

MOTEL MANAGER TRAINING—Men, women, couples wanted by leading resorts, motels-hotels everywhere. Enjoy free rent, plenty of free time. Easy homestudy plan. Free! "Motel Career Kit." No salesman will call. North American School of Motel-Hotel Management, AZW, Newport, California 92663.

ACCOUNTING TRAINING

ACCOUNTING PAYS BIG! Easy homestudy plan prepares you for thousands high pay prestige positions open now to trained Accountants. Or open your own profitable full, part time Accounting practice. Send for "ACCOUNTING CAREER KIT"—ALL FREE! North American School of Accounting, Dept. AZW, Newport Beach, California 92663.

EDUCATION AND INSTRUCTION

TEACH preschoolers reading! Write Gold Coach, Box 251, Sarnia, Ontario.

LIFETIME Ordination, Church Charters, DOCTOR of DIVINITY. DETAILS 25¢. Life Science Church, 2207 Cardinal, Rolling Meadows, Illinois 60008.

ANNOUNCING HOME Study course in commercial baking. Practical basic training. Good field for those with aptitude. Free Booklet, "Opportunities in the Baking Industry." National Baking School, 555 E. Lange Street, Dept. P402, Mundelein, Illinois (60060).

WATCH REPAIRING. Unique home study course. Free information. Chicago School, YB, Fox River Grove, Illinois 60021.

PROGRAMMING At Home. Practical Courses. Actual Computer Use. FREE Booklet. CCI-D, Box 30277, Washington, D.C. 20014.

COLLEGE Degree at home. Law, other subjects. Easy tuition. Williams College, Williams, Arizona 86046.

PIANO Technology—Electronic organ servicing, learned easily at home. G. I. Approved. Free booklet. Niles Bryant School, Dept. P. 3631 Stockton, Sacramento, California 95820.

EARN College degrees at home. Many Subjects. FLORIDA STATE CHRISTIAN COLLEGE, Post Office Box 1674, Fort Lauderdale, Florida 33302.

THOMAS A. EDISON COLLEGE Master's & Doctor's "OFF CAMPUS" Degree Programs in Religion & General Education. Write: TAEC, Box 688, Palm Beach, Fla. 33480 For Catalogue send \$1.00.

EXTENSION And Post-Graduate Awards in Philosophy, Art, Sciences, Botanic Medicine, Homeopathy, Radionics and others. 30 subjects. Curricular free (airmail \$1.00 refundable). Registrar, Sussex College of Technology, Highfield, Dane Hill, Sussex, England.

GET A British Degree. Divinity, Philosophy, Radionics. 35 Courses. Prospectus free. Brantridge Forest School, Highfield, Dane Hill, Sussex, England.

PIANO Tuning quickly learned with home study course. Diploma granted. American Tuning School, Gilroy, Calif. 95020.

LEARN Auctioneering. Term soon. Free catalog. Reich Auction College, Box 850, Mason City, Iowa 50401.

DETECTIVE Course. Free Information. Universal Detectives, Box 8180-F, Universal City, California 91608.

AUCTIONEERING. Resident or Home Study Course. Free Catalog. Nashville Auction School, 2004 West End, Nashville, Tennessee 37203.

AUTOSUGGESTION. Sleep-learning headquarters! Tapes, records, books, Gigantic catalog free. Research Association, Box 24PM, Olympia, Washington.

USED Courses! Books! List 10¢. Smith's, 124 Marlborough, Salem, Massachusetts 01970.

UNLOCK Your Future. Become professional Locksmith by spare time homestudy. Make up to \$6 per hour. All tools, equipment incl. Facts Free. Send name. Locksmithing Inst., Dept. 1310-022, Little Falls, New Jersey 07424.

GRAPHOANALYSIS—Learn scientific handwriting analysis for profit, pleasure. Free sample lesson, catalog, reveals plan. Write: Igas Inc., 325 Jackson, Dept. 2AY-2, Chicago 60606.

LEARN Asleep or awake! Records, tapes, equipment! Free catalog! Drawer PM-400, Ruidoso, New Mexico 88345.

PERFECT Husband-wife business. Learn Upholstery at home. Make \$10 in an hour. Buy-repair-sell for even bigger profits. Kits, tools included. Free Booklet. Upholstery & Decorating School, Dept. 5310-022, Little Falls, New Jersey 07424.

OWN Collection agency. "Little Gold Mine!" Franklin Credit, Roanoke, Virginia 24004.

RELIGIOUS VOCATION? Write: Church Of Holy Light Inc., P.O. Box 4478, Pittsburgh, Pa. 15205.

DETECTIVE Profession, Easy home study; free tie-tack or lapel pin, certificate, future. GI approved. Professional Investigators, Box 41345, Dept. CP, Los Angeles, Calif. 90041.

LEARN To Fix Typewriters. Desperate shortage trained men. Hundreds needed. Make up to \$25 in one hour. Learn at home in spare time. Industry Approved course. Facts free. Send name. Typewriter Repair School, Dept. 3310-022, Little Falls, New Jersey 07424.

LEARN TO WELD—Arc, Pipe, Oxyacetylene, TIG, MIG, Plasma Arc. World's Outstanding (non-profit) Welding School. Free school booklet. Write, phone or visit. Approved Ohio No. 70-12-0064-HT HOBART SCHOOL OF WELDING TECHNOLOGY, BOX 72, TROY, OHIO 45373.

BE AN Independent Remodeler-Builder. Free Details. Professional Institute. Box 1524-PM, Kansas City, Missouri 64141.

HIGHLY EFFECTIVE Home study courses in Electronics Engineering Technology and Electronics Engineering Mathematics. Earn your Degree. Write for Free Descriptive literature. Cook's Institute of Electronics Engineering, (Dept. 10), P.O. Box 10634, Jackson, Miss. 39209. (Established 1945).

COMPLETE YOUR HIGH SCHOOL at home in spare time. Texts furnished. No classes. Diploma. Founded 1897. Free Brochure. American School, Dept. X245, Drexel at 58th, Chicago, Illinois 60637.

BE A Real Estate Broker. Big Earnings. Prepare quickly, easily, GI approved. Free Catalog. Weaver School, 3519-P Broadway, Kansas City, Missouri 64111.

HIGHLY Effective Specialized Home Study Courses. Fast, Inexpensive, and Complete. Many Categories: Electrical, Electronics, Mechanical, Building Trades, Etc. Diplomas Awarded. Our 27th Year. Free Literature. CIEE—Dept. 25—Box 10634, Jackson, Miss. 39209.

WANT Success? Happiness? Wealth? IMPROVE YOURSELF! FREE BROCHURES Tell How. Darslin, Box 291, Hales Corners, Wisconsin 53130.

PHOTOGRAPHY Needs trained service technicians. Learn camera repair at home, earn extra income while studying. Catalog free. National Camera, Dept. EAA, Englewood, Colo. 80110.

HOW INTELLIGENT Are You? Self-scoring Test Reveals I.Q. In 45 Minutes! Send \$2.00 Today—Guaranteed! B & A Supply, Box 24211, Fort Lauderdale, Florida 33307.

FREE Bible Course! Degree! Request information! 708 Bragg, Monroe, North Carolina 28110.

OPERATE Profitable Bookkeeping Tax Service. Details Free. Universal, Box 664-M, Springfield, Missouri 65801.

VETERINARY ASSISTANT—Train at home for exciting animal care career. Send for FREE "Career Kit", North American School of Animal Sciences, AZWX, Newport Beach, California 92663.

FIRST Time offered. Unique instructions on Sewing Machine and Vacuum Cleaner Repair. Lucrative profits. A profession with bright future. Gresslin Correspondence School, Box 927, Spencer, Iowa 51301.

IMPROVE Your Personality! 110 Page Book—"Dynamic Thinking" Shows How. Send \$1.00. Hickory, Dept. PM-272, 324 South First Street, Alhambra, Calif. 91802.

FREE B.D., M.D., D.D. with Lifetime Ordination. Box 744 PM, McKeesport, Penna 15134.

DETECTIVE INVESTIGATOR. Homestudy Course. Free Details. Write: Global Detectives, Box 415-B123, Lafayette, California 94549.

FREE List, used courses, books. Ellie, 1002 Central, Lowell, Massachusetts 01852.

(Continued on next page)

Материал, защищенный авторским правом

EDUCATION AND INSTRUCTION

(Continued from preceding page)

EARN A Recognized High School Diploma awarded by your State Department of Education. Prepare at home. Free revealing information. CIEE—Dept. 50—Box 10634—Jackson, Miss. 39209.

DRAFTING—Blueprint Reading (Electronic, Mechanical, Architectural). Home Courses \$25.00. Send \$2.00 first lesson. Prior Inc., 23-09 169 Street, Whitestone, New York 11357.

COMPUTER Facts. Inexpensive easy self-taught method, includes Job Secrets. Free information, sample lesson. Databank, Box 19305P, Granger, Utah 84120.

HOW INTELLIGENT Are You? Self-scoring Test Reveals I. Q. In 45 Minutes. Send \$2 Today—Guaranteed. Tests, 4163 Rincon, 3PM1, Campbell, Calif. 95008.

USED Courses! Books. Catalog 10¢ (Courses Bought). Lee Mountain, Pisgah, Alabama 35765.

LEARN SPANISH: 10 lessons \$1.00. Address envelope & stamp—Post Office Box 5131, San Francisco, California 94101.

FOR INVENTORS

IF YOUR Invention is adaptable to promoting we will contract for selling on cash or royalty. Free booklet outlines royalty rates, requirements. Kessler Corporation, C-52F1, Fremont, Ohio 43420.

INVENTORS: Your ideas and inventions (patented; unpatented) expertly searched, developed for commercial appeal and cash/royalty sales to manufacturers by professional Invention Developer with excellent record of experience. B.S. Industrial Engineering; United States Patent Office former Patent Examiner. United States Government former Patent Advisor. Second decade reliable service! Member: United States Council International Chamber Commerce. Free "Invention Record" and "Recommended Protection Procedure." Airmailed! Write: Raymond Lee, Invention Developer, 230P-Park Ave., New York, New York 10017.

IMMEDIATE Cash, for patent applications. Free patent searches. Write for details. Universal Patents, 184-D Marion, Ohio 45750.

U.S. PATENT Office Searches. 234 Broadway, Room 3615, New York 10017. Free invention certificates.

PATENT Application Financing. Free patent search plan. Global Patent Division, 2420 77th, Oakland, Calif. 94605.

FREE PAMPHLET: "Tips on Safeguarding Your Invention." Write: United States Inventors Service Company, 501P Thirteenth Street N.W., Washington, D.C. 20004.

LEARN How Inventors Earn Big Profits. Free Details. Apko, Box 876-A, Richardson, Texas 75080.

DON'T BE CHEATED out of your invention! Comprehensive steps; Protect, Patent, Market YOURSELF. \$3.50. United Inventors, Box 2256, Whittier, Calif. 90606.

INVENTORS: PROFESSIONAL Engineering Development and Marketing Service of your inventions—ideas by Licensed Professional Engineer and U.S. Patent Office Former Examiner, specializing in U.S. Patent Office Searches and Patent Engineering Development of inventions—ideas for patenting and sale to manufacturers as new products. We represent inventors in presenting and selling inventions to manufacturers. Send for free Invention Certificates and Invention information. George Spector, Licensed Professional Engineer—Patent Engineer, 3615 Woolworth Building, New York, N. Y. 10007.

HANDLE Your patent arrangements from home, using free services of U.S. Patent Office. Illustrated instruction manual \$3.00 (refundable). Independent Inventors Association, 1199 Broadway, New York, N.Y. 10001.

LOW RISK INVENTOR'S PROGRAM. Everything You Need To Know To Promote And Develop Your Own Inventions. Write: Quantum Group, 1529 Greenleaf, Evanston, Illinois 60202.

PATENT SEARCHES Including maximum speed, full airmail report and closest patent copies, \$6.00. Quality searches expertly administered with complete secrecy guaranteed. Free Invention Protection forms and "Patent Information." Write Washington Patent Office Search Bureau, Dept. 15, 711 14th Street N.W., Washington, D.C. 20005.

INVENTIONS WANTED

INVENTORS—Do you want to sell or license your invention on cash or royalty basis. Write: Kessler Corporation, C-521W, Fremont, Ohio 43420.

\$\$\$\$ AVAILABLE for inventions, businesses, etc. Unlimited amounts. Consultants, Box 2531, Toluca Lake, California 91602.

INVENTIONS Wanted. Patented: unpatented. Tremendous manufacturers lists. Global Marketing Service, 2420G 77th, Oakland, California 94605.

WE Either sell your invention or pay cash bonus. Write for details. Universal Inventions, 28-E, Marion, Ohio 45750.

INVENTORS! Protect your ideas! Free "Recommended Procedures." Washington Inventors Service, 422F Washington Building, District of Columbia 20005.

FREE "Directory of 500 Corporations Seeking new Products." For information regarding development, sale, licensing of your patented/unpatented inventions. Write: Raymond Lee Organization, 230-N Park Avenue, New York, New York 10017.

INVENTORS! Don't sell your invention, patented or unpatented until you receive our offer. Eagle Development Company, Dept. H, 83 Wall Street, New York, New York 10005.

INVENTORS! Sell your invention for cash or royalties! Our client manufacturers eagerly seek new items. Patented. Unpatented. Financial assistance if needed. 25 years proven performance. For free information, write Dept. 15, Gilbert Adams, Invention Broker, 81 Wall St., New York, N.Y. 10005.

INVENTORS! We will develop, sell your idea or invention. Our national manufacturer-clients are urgently seeking new items for highest outright cash sale or royalties. Financial assistance available. 15 years proven performance. For free information write: Dept. 47, Wall Street Invention Brokerage, 79 Wall Street, New York, N.Y. 10005.

PATENTS FOR SALE

MAILORDER Records help get increased business! Complete 32 Page Record Book shows your inquiries orders, advertising, expense, etc. Only \$1.00. C. A. Martin, Popular Mechanics, Dept. PMR, 224 West 57 Street, New York, N.Y. 10019.

MANUFACTURING

PROFITS FROM CLASSIFIED ADVERTISING! Booklet shows you how to start your own business with Classified Advertising. Only \$1.00 (Refundable with first order.) C. A. Martin, Popular Mechanics, Dept. PMP, 224 West 57 Street, New York, N.Y. 10019.

INVENTORS Ideas developed. Research. Models. Manufacturing. Sales. Free brochure. Since 1942. William Parker, Box 8873, Dixie Village Station, Orlando, Florida 32806.

WIRE Forming, Progressive dies, send print, part or sketch, short runs. Lindberg, 413 26th Street, Union City, New Jersey 07087.

BUYING AND SELLING

MAILORDER Records help get increased business! Complete 32 Page Record Book shows your inquiries orders, advertising, expense, etc. Only \$1.00. C. A. Martin, Popular Mechanics, Dept. PMR, 224 West 57 Street, New York, N.Y. 10019.

BUY IT WHOLESALE

PLASTIC BAGS—WHOLESALE PRICES 300 Stocked sizes—fast shipment. Catalog 20¢. Milvan Company, 7921 D Enterprise, Newark, Calif. 94560.

WHOLESALE—Buy 40% To 50% Off Retail—same prices retailers pay! Thousands of name brands! Watches, cameras, jewelry, radios, phonographs, tape recorders, etc. Buy for yourself or resell at fat profit. Big wholesale catalog, Confidential Wholesale Price List. Free details. Wholesale Merchandise Club of America, Dept. 421, 154 Jericho Turnpike, Floral Park, N.Y. 11001.

HEARING Aids, Batteries, Wholesale. Catalog 25¢. Fiston, Box 1444, New Preston, Conn. 06777.

WORLD'S Largest wholesale dropship sources. U.S., foreign. Factory suppliers dropship direct to you or customers. Now! have your own catalog for pennies. Free details. International Buyers, Box 16386-M, Portland, Oregon 97233.

BARGAINS! Buy wholesale and below. Name brands. Appliances, furniture, sports equipment, televisions, cameras, watches, jewelry, thousands more. Huge discounts to \$1,000.00 on new automobiles. All makes. Free details. Write today: Worldwide Bargainhunters, Box 730-A, Holland, Michigan 49423.

1971 FORDS, Dodges, \$999, 1970 cars only \$699. For free catalog Ex-taxis, Associated Dealers, 50 Swalm, Dept. 6, Westbury, N.Y. 11590.

SAVE To 50%—Buy first quality, factory fresh, name brand products like televisions, hi-fi stereos, appliances, tools, jewelry and thousands more. Buy wholesale and resell for huge profits. Free information. Homestead Merchandising Club, Dept 30-D, 18 Westcliff Drive, Mount Sinai, New York 11766.

165 FREE Wholesale Catalogs! Unbeatable Bargains. Automobile Discounts. Free Details. Vault International, Box 7284M, Lexington, Kentucky 40502.

STOP—SAVE HUNDREDS!!! In Declares Revolutionary New Buying Club. All WHOLESALE! Send 25¢ For Tons Of Information To: Declare, Dept. 5, 319 Prospect St., Watertown, N.Y. 13601.

MANHATTAN'S Wholesale Center, 800-000 Bargains Available! Free details. Wholesalers, 1265-M Broadway, New York, N.Y. 10001.

300,000 PRODUCTS. Buy "Direct" Through: Midland Purchasing Services, Grimes, Iowa 50111.

EXPORT-IMPORT

ORIGINAL Oil Paintings 16x20" \$72 dozen. Details 25¢. McDaniel, 3632 Topax, Claymont, Delaware 19703.

WHOLESALE Catalog free. Illuminated artificial flowers, 4 1/4" novelty loving cups, mirror lens sunglasses, etc. Stores only. Imports, 1916 Fifth, Sacramento, California 95814.

JAPAN: 1200 Products directory. Illustrated Manufacturers' names, addresses. \$3.00. Send cash, Yamagata Office. 814 Togin Bldg., Marunouchi, Tokyo.

FOR THE HOME

FREE NOVELTIES Color Catalog. FREE Bonus Gifts. Ellenbogen Giftwares, 450 Seventh Avenue, New York 10001.

SCIENTIFIC Compounds for Plumbing, Septic Tanks, Composters, Odor Elimination, Digesters, Stains. Free catalog. Write: Open Market, 965 Commercial, Astoria, Oregon 97103.

NEW—ALUMINUM BILLIARD CUE ALCOA-Made, remains permanently straight. Will Never Warp Or Rust. Helps Your Game. With Black Grained Carrying Case, \$24.95 Postpaid. Free Literature. R-J Distributors, Box 3396, Anaheim, California 92804.

(Continued on next page)

OF INTEREST TO WOMEN

30 SMALL Towels \$1.88, Large \$2.98. Lassiter Wholesale, Richmond, Virginia 23222.

\$46.00 DAILY possible addressing-stuffing envelopes (typewriter or longhand) information. Send stamped, addressed envelope. American, Excelsior Springs, Mo. 64024.

\$500 MONTHLY Possible—Clipping news at home. No experience—send stamped-addressed envelope. American, Excelsior Springs, Mo. 64024.

WANT a new car, color TV, new clothes? Learn hundreds of ways to make money. 5 month subscription FREE. Write: Salesman's Opportunity Magazine, Dept. 17-80, 1460 Hancock Center, Chicago 60611.

HOMEWORKERS DIRECTORY! 262 National firms seeking help. Send stamped, self-addressed envelope. Economy "AD", 629 Franklin, Clearwater, Florida 33517.

\$150.00 WEEKLY Possible! Homeworkers needed urgently! Send stamped, self-addressed envelope. Schoen, Box 1963-P, Chicago, Illinois 60690.

\$100 WEEKLY Possible addressing mailing. Sparetime. Free details. Send self-addressed stamped envelope. Newby Publications, Box 20427-PM, San Antonio, Texas 78220.

\$6.00 DOZEN Paid lacing baby boots! Cowboy, Warsaw 9, Indiana 46580.

HOMEWORKERS! \$100.00 Weekly addressing for firms. Begin immediately. Details—send stamped, addressed envelope. Hamilton, 272-TM2, Brooklyn 11235.

HOME Newspaper clippers needed, \$500 monthly possible. Details free. Foster, 272-MA-2, Brooklyn 11235.

BIG Profits from Dolls! Start your own hobby-business dressing, making, repairing and selling dolls. Free information. Doll Hospital School, Dept. D-44, 2251 Barry Avenue, Los Angeles, California 90064.

WOMEN! Make big money at home. \$10.00 profit in an hour possible with Invisible Reweaving/Reknitting. Make holes, tears disappear from fabrics. Steady year-round demand from cleaners, laundries, homes. Details free. Fabricon, 2073 Montrose, Chicago 60618.

\$75.00 THOUSAND. Home Addressing! Longhand, typewriter. Information 25¢ with stamped, self-addressed envelope. Brewster-TF, Clearwater, Florida 33517.

HOME Workers Wanted. Details—16¢ Stamps. E. Alleva Sales, 107 Blue Ridge Rd., Ashland, N.J. 08034.

\$25.00 HUNDRED Mailing! Everything Supplied. Information 35¢. Dixi-PMB, B-38, Hallandale, Fla. 33009.

HOMEWORKERS DIRECTORY! 150 Pages. 300 companies seeking homeworkers. Genuine \$3.00 value. Special closeout. \$1.00. Troy Company, Dept. ZM, Bayonne, New Jersey 07002.

\$700 MONTHLY. Immediate income. Stuff envelopes at home. Information send self-addressed stamped envelope. Cottage, Box 2084-DBB, Seal Beach, California 90740.

PERSONALIZE Letters, Invitations. Announcements, etc. with PHOTOSTAMPS—miniature (1x3/4) gummed glossy photos from any photograph. HUNDRED-\$2.00. Dane, 745 Third Avenue, Lynherst, New Jersey 07071.

HOMESEWERS! Buy your Fabrics Direct from Wholesaler. DFCO, Box 171, New York 10018.

"ENTERPRISES FOR WOMEN," \$3. Details for stamp. Raymond Brooks, EM-20864, St. Petersburg, Florida 33742.

\$\$\$ ADDRESSING Mailing Circulars. Send self-addressed envelope. Fay's, 182 North Wood Street-PM, Battle Creek, Michigan 49017.

HOW To Make Money Writing Short Paragraphs. Information Free. Barrett, Dept. C-27-D3, 6216 N. Clark, Chicago 60660.

COMMISSION MAILERS WANTED! Rush 10¢ for Details. Smyre's, Box 953-PM, Newark, N.J. 07101.

GIFT SHOPPING

QUALITY Gifts That Are Cherished! All Products Fully Guaranteed. FREE Gift With Minimum Purchase. Catalog Sent FREE. Custome Mail Order House, 1569 North Vista Avenue, Rialto, California 92376.

FREE CATALOG Of Sensational Gifts and Novelties. J. & L. Co., 73-B Main St., New Paltz, New York 12561.

TOMAHAWK! Free Literature. Shawnee \$13.00 Postpaid. Beejay, BX8711M, Canton, Ohio 44711.

FREE Color Catalog Of DISTINCTIVE Gifts-NOVELTIES For Every Occasion. E. Bryant, Box 4209-B, Jersey City, N. J. 07304.

WATCHES, OLD GOLD, JEWELRY

HIGHEST CASH For Gold, Jewelry, Gold Teeth, Rings, Diamonds, Watches, Silver, Platinum. Mail Articles Today. Free gift with information. Chicago Gold & Precious Metals, 6 E. Monroe, Dept. 658, Chicago, 60603.

WATCH And clock repairing books. Free catalog. North American, Box 77-AO, Fox River Grove, Illinois 60021.

COMPLETE Watchmakers'-Jewelers' Catalog \$1.00. Bengal's, 5816-A, Lankershim, North Hollywood, California 91601.

CASH Immediately for Old Gold, Jewelry, Gold Teeth, Watches, Diamonds, Spectacles, Silver, Platinum, Mercury. Free information. Rose Industries, 29-A East Madison, Chicago 60602.

WANTED . . . Gold, Silver, Platinum (any form). Coins. Information Free. Wilmot's, 1067 Bridge, Grand Rapids, Mich. 49504.

WEARING APPAREL

PROFITS FROM CLASSIFIED ADVERTISING! Booklet shows you how to start your own business with Classified Advertising. Only \$1.00 (Refundable with first order.) C. A. Martin, Popular Mechanics, Dept. PM, 224 West 57 Street, New York, N.Y. 10019.

HEARING AIDS

YOUR Ad in Popular Mechanics will be seen by more than 5,000,000 active buyers for your products and services. It costs only \$2.00 per word. And, if you wish to run all or part of your ad in capital letters—you can do so for as little as 75¢ per word additional. Act now! Place your Classified ad in Popular Mechanics today.

HEARING AIDS, Batteries, Discount Prices. Rhodes, Box 518-PM, Paducah, Ky. 42001.

HUGE SAVINGS. Eliminate dealer mark-ups. Free Trial. Batteries Wholesale. Terms Arranged. Lloyds-PMC, Rockford, Ill. 61108.

HEARING Aids, Batteries, Wholesale. Free Literature. Supreme, Box 206M, Derrick City, Penna. 16727.



SCIENCE AND CHEMISTRY

COMPLETE Chemistry Catalog, 25¢. Laboratory Sales, Box 161-A, Brighton, Mass. 02135.

FIBER OPTICS Color Organ. Plans. \$1.00. NIMBUS, 4391 Old Dominion Drive, Arlington, Virginia 22207.

CHEMISTRY And Biology Catalog 35¢. Boulevard Laboratories, Suite 302, 3114 E. 83rd St., Chicago, Ill. 60617.

CHEMICALS And apparatus for industrial, analytical, and private laboratories. Catalog 50¢. Dept. M-50. Biological Supply Co., 1176 Mt. Hope Ave., Rochester, N.Y. 14620.

LABORATORY Supplies at discount prices. Catalogue—35¢. Deluxe Scientific; Manitowoc, Wisconsin 54220.

CATALOGUE Of those very hard-to-find chemical products, plus things that go boom, unusual formulas, multi-stage rockets,—loads more! 50¢ (Price refundable, first order) Kenrus-C, Box 158M, Staten Island, New York 10309.

CHEMICALS Apparatus, Biology and Model Rockets. Both Catalogs for 50¢. Sheard Science, Dept. PM, Columbus, Wisconsin 53925.

10,000 FORMULAS! Gigantic Reference. Over 800 Pages. 2 1/2" Thick, hard cover. Every Conceivable Mixture, Compound, and Formula in Industry and Science. Only \$6.95. Kenrus-H, Box 158M, Staten Island, New York 10309.

OCEAN PLANKTON Collections, preserved specimens with descriptive identification booklet. \$3 mini-kit, \$11 maxi-kit. Satisfaction Guaranteed. Oregon Ocean Supply, Dept. PM, PO Box 485, Warrenton, Oregon 97146.

SEARCHING For Economically Priced Laboratory Supplies? Catalog—50¢. Hagenow Laboratories, Manitowoc, Wisconsin 54220.

FORMULAS, PLANS, ETC.

ANY FORMULA—\$5.00. Catalog—Manufacturing Treatise 25¢. Belfort, 192 N. Clark, Chicago 60601.

PLASTICS

EMBED Flowers, sea shells, minerals, anything, in Castolite. Create unusual gifts, paperweights, desksets, tiles, keytags, jewelry. No heat, tools. Manual 25¢. CASTOLITE, 72B/PM1, Woodstock, Ill. 60098.

MAILORDER Records help get increased business! Complete 32 Page Record Book shows your inquiries, orders, advertising, expense, etc. Only \$1.00. C. A. Martin, Popular Mechanics, Dept. PMR, 224 West 57 Street, New York, New York 10019.

EARN Money at home. Project-MO. Free. CASTOLITE, 72B/PM3, Woodstock, Ill. 60098.

PROFITS FROM CLASSIFIED ADVERTISING! Booklet shows you how to start your own business with Classified Advertising. Only \$1.00 (Refundable with first order.) C. A. Martin, Popular Mechanics, Dept. PMP, 224 West 57 Street, New York, N.Y. 10019.

MAKE Flexible molds over any pattern. Professionally reproduce, repair, restore with clear or colored Castolite, metal, synthetic marble and wood, candlewax, plaster, cement. No tools. Manual 25¢. CASTOLITE, 72B/PM2, Woodstock, Ill. 60098.

TREASURE FINDERS

METAL Detectors, largest selection. Radiac Company, Center Moriches, N.Y. 11934.

POWERFUL Metrotech locator detect gold, silver, coins, relics. Moneyback guarantee, terms. Free information. Underground Explorations, Dept. A, Box 793, Menlo Park, California 94025.

TREASURE Hunters! Prospectors! Relco's new instruments detect buried gold, silver, coins, minerals, historical relics. Transistorized. Weighs 3 pounds. \$19.95 up. Free catalog. Relco-A40, Box 10839, Houston, Texas 77018.

GOLDAK Treasure locators—Pleasure and profit in a hobby you'll enjoy. Find coins, relics, gold, silver. Charge on BankAmericard. GOLDAK, Dept. PM 1101-A, Air Way, Glendale, California 91201.

SEARCH Treasure Finders. Locate gold, silver, coins, relics. Operate underwater. Money back guarantee. Free information. Search Electronics, Box 8396-A, St. Petersburg, Florida 33738.

(Continued on next page)

TREASURE FINDERS

(Continued from preceding page)

FREE 140 Page Detector Catalog. General Electronic Detection Co., Box 67, Bellflower, California 90706.

FISHER DETECTORS Introduces new 1972 models! Free literature. FRL, Dept. PM-2, Palo Alto, California 94303.

TREASURE Hunters! Prospectors! Rock-hounds! Hobbyist! Find gold, silver, relics with world famous Detron Metal Detectors. Free information. Delivery immediate. Detron, Dept. 2-PM, Box 243, San Gabriel, California 91778.

NOW! Enjoy the great outdoors in comfort with your pocket size electronic Skeeter Skat mosquito repeller. \$9.95 postpaid, U.S.A. Satisfaction guaranteed. Detron, Dept. F-2, P. O. Box 243, San Gabriel, California 91778.

FREE Catalog. Treasure Finder Books. Stamp. Frontier Publishers, Fort Davis, Texas 79734.

FREE: Jetco Electronics 24-Page treasure finder catalog. Find gold, silver, coins, metals, minerals, relics. Jetco, Dept. PMC, 3933 Barranca, El Paso, Texas 79935.

PRECIOUS STONES & MINERALS

BUILD GIANT Rock Tumbler For Under \$20.00. Complete plans \$1.00—Grayrock, Box 195, Carthage, Mo. 64836.

GOLD 10 Small nuggets panned from Oregon Streams \$1.00. Robert Brandt, Sweethome, Oregon 97386.

500 POLISHED Gemstones \$5.00. Tumblecraft, 5401 James North, Minneapolis, Minn. 55430.

EARTH Science Rockhound Magazine. Subscription \$3.00. Sample \$.40. Box-550-PM, Downers Grove, Ill. 60515.

GET Free catalog no serious rockhound gem cutter, jewelry maker, hobbyist or craftsman can be without. Full of bargains, exclusive items, low prices from largest suppliers and authorities in the field. Free new catalog just off the press, yours for the asking. Write Grieger's, Dept. C-12, 1633 E. Walnut, Pasadena, California 91106.

MINERALIGHT Lamps, free Catalog. Styleline, 11770 24 Mile, Utica, Michigan 48087.

DIAMOND Look alike! \$15 carat. Free Catalog. Ree, Box 667, La Puente, Calif. 91747.

CARTOONING, COMMERCIAL ARTS, SHOWCARD & SIGN PAINTING

"HOW TO MAKE MONEY WITH SIMPLE CARTOONS"—Informative book sent Free tells way to big income. Cartoonists' Exchange, 92, Pleasant Hill, Ohio 45359.

COMPACT 23 lesson Cartoon Course and Cartoonist's Magazine. \$2.00. Hartman, Box 30367, Lincoln, Nebraska 68510.

MODERN Cartooning taught by mail. Write for free brochure. Cartoonorama—Box 263-7F, Branford, Conn. 06405.

SIGN Painting—\$1000 per Month Part-Time. Free Catalogue. Kaufmann Supply. Centertown, Missouri 65023.

CARTOON For Money!! Big Free Book: Success, Box 885-C, Dearborn, Mich. 48121.

LEARN Sign painting at home. Free Talent test. Ben Kerns, Box 812-PM, Greenville, S.C. 29601.

SIGNS Make-your-own! SIGN-RITE Vinyl Self-adhering Letters and Numbers! 5 Large Sizes! 4 Types! 8 Colors! Over 20,000 to select from! Inexpensive! Prompt Service! FREE BROCHURE! Americraft Mfg. Co., Box 25034 Northeast, Seattle, Wash. 98125.

MAGNETIC SIGN MACHINE KIT Assemble Your own. Free Information. Reddi-Kits, Box 292P, McCalla, Ala. 35111

ADVERTISING AGENCIES, ADV. SERVICE, MAILING LISTS

ADVERTISING Ratebook leading newspapers, magazines, 25¢. Chicago Advertising Agency, 28-E Jackson, Chicago 60604.

POWERFUL RADIO STATION Will Trade Advertising For Your Products. WFIV, Box 5519, Orlando, Florida 32805.

OFFICE SUPPLIES

ENGRAVED Door, Desk, Badges, Name Plates. Free Catalogue. J. P. Engraving, Williamstown, New Jersey 08094.

PROFITS FROM CLASSIFIED ADVERTISING! Booklet shows you how to start your own business with Classified Advertising. Only \$1.00 (Refundable with first order.) C. A. Martin, Popular Mechanics, Dept. PMP, 224 West 57 Street, New York, N.Y. 10019.

RUBBER STAMPS

ADDRESS Stamp 85¢. Signature \$2.80. Catalog. Carol's, McCloud, Okla. 74851.

FREE 48 Page Catalog. Rubber stamps, printing, office supplies. Youngers Stamp Shop, Princeton, Iowa 52768.

POCKET Stamp \$1.50. Harold's, 48124 Van Dyke, Utica, Michigan 48087.

NEW! 3 Line Pocket Stamp \$1.00. Renlee, 215P Golf Lane, Hewlett Harbor, New York 11557.

FREE Stamp Catalog, 45 type styles. Fast service, low prices. Jackson's, Box 443A, Franklin Park, Illinois 60131.

FREE Stamp Catalog. Beckley's, 522 S. Midler Ave., Syracuse, N.Y. 13206.

PRINTING PRESSES, RUBBER STAMP OUTFITS

SAME Day shipment on rubber stamp supplies. Revised wholesale price list No. 7 free. Star Stamp Supply, 732 Federal, Chicago, Ill. 60605.

SIMPLE-X RUBBER STAMP PRESSES, Hydraulic operated, electrically heated. Sizes 5"x8", 8"x12", 10"x15". Starting outfits Orders for presses, supplies shipped day received. Free catalog low supply prices. Send \$1.00 for postage and handling (refundable on first order). Custom Manufacturers, 406-P East Elm, Springfield, Missouri 65801.

RUBBER Stamp outfits, supplies. Kiewiet, 2025 Barney Road, Kalamazoo, Michigan 49007.

PRINTING Presses, type, supplies, Lists, 10¢. Turnbaugh Service, Mechanicsburg, Pennsylvania 17055.

TYPE Catalog No. 12, 120 pages. Send One Dollar. Deductible First Order. Acme Type, 732 Federal, Chicago, Illinois 60605.

MAKE Your Own Self-Molding Rubber Stamps And Printing Cuts, Plexirubber, Argyle-1, Wisconsin.

RUBBER Stamp Manufacturers Supplies. Press, starting outfits. Best prices, service. Catalog. Jackson Supply, Box 443A, Franklin Park, Illinois 60131.

PRINTING AND SUPPLIES

DISTINCTIVE "Embossed" Letterheads. Inexpensive Postpaid. Universal, 226-B Myrtle, Scotch Plains, New Jersey 07076.

AMAZING Business printing values. Quotations. Print Shop, Box 576, Greenville, R.I. 02828.

BUSINESS CARDS Raised Letters \$5.65 Thousand. Like Engraved. Free Samples. Kavanagh, Box 1222, Brooklyn, N.Y. 11202.

FREE Booklet "Secrets of Cutting Printing Cost" Nationwide Speed Printing, Atlanta, Illinois 61723.

PRINTING. Reasonable prices. Samples free. Fowlo, 3515 Walnut, Muncie, Indiana 47302.

GET Free literature-business cards, letterheads, envelopes, rubber stamps, labels. Big Selection. Jordan's, 552 West O'Connor, Lima, Ohio 45801.

PRINTING—Guaranteed 8 hour service. Allstate Press, 3733-PM North Kimball, Chicago 60618.

STATIONERY . . . New Personalized. Information Free! Longwood Press, D-47B2 Fort Johnson, N.Y. 12070.

BUSINESS Cards 1,000 \$4.00 Postpaid. Free Samples. Impressions, 249 Queen South, Minneapolis, Minn. 55405.

200 PRINTED Business Carr's. Letterheads, or Envelopes, \$3.95. Studio, 935 "B", Hayward, Calif. 94541.

1000 GUMMED Address Labels \$1.00. Gifts-O-Plenty 582, 1814 Pine Village, Houston, Texas 77055.

INEXPENSIVE! Stationery, Forms, Cards, Invitations. Lexprint, Box 1735, Lexington, Kentucky 40501.

GUMMED LABELS

1,000 GUMMED Address Labels \$1.00. Walt's, Box 966A, South Bend, Indiana 46624.

1000 GOLD Stripe Address Labels, \$1.00. Grimsley's, 111 Roselle Ave., Hanahan, S. Car. 29405.

REMAILING SERVICE

\$1000.00 PROFIT From 1,000 Mailings!!! "Proven" Products Dropshipped!! Everything Furnished!—Catalogues—Advertisements—Mailing Lists. Free Details. Sel-More, Box 186-PM, Brooklyn, 11230.

HOLY CITY, Calif. 95026 25¢ each. Moore, Box 88B.

ILLINOIS, Missouri. 25¢. Monthly rates. Prompt. RE. Box 476, Caseyville, Illinois 62232.

ARIZONA Remails 25¢. Robert Darnell, Box 22065, Phoenix, Arizona 85028.

REMAIL From Pennsylvania 25¢ single \$3.00 monthly. McWilliams, 560 North Darby, Sharon, Pennsylvania 16146.

ST. PETERSBURG Florida "Sunshine City" 25¢ each, \$3.00 Month. Brooks, Box RM20864, St. Petersburg 33742.

RECEIVING-Forwarding. Monthly rates. Hedgpeh, 324-M South First, Alhambra, Calif. 91802.

MIAMI Remails 25¢. Monthly rates. Marle, Box 1266, Coral Gables, Fla. 33134.

CONFIDENTIAL New York City mail address \$3.00 month. Remails 25¢. Details Free. Birnhan, 152 W. 42, New York City 10036.

SECRET. Receiving—forwarding. Discreet and confidential. Remail 25¢ single. Mail Forwarding Service, 8050 S. Main, Houston, Texas 77025.

DENVER Receiving—Forwarding. 25¢, \$3.00. Details free. Rich, Box 26099, Denver, Colorado 80226.

REMAILS FROM ALASKA 25¢. Monthly rates, Confidential. Hannon's Mailservice: P.O. Box 2602, Fairbanks, Alaska 99701.

TEXAS Remails 25¢. Complete mailing service, economical rates. Nortex, Drawer 5370, Fort Worth, Texas 76108.

YOUR Mail Received-Forwarded Confidentially. Individuals, Businesses. Wright, Box 2112-M, Asheville, North Carolina 28802.

"LONG ISLAND Remails 25¢ Each, \$3.00 Monthly. Peterson, Box 145, Baldwin, New York 11510."

MIAMI BEACH Remails 25¢ Special Services. Reeves, Box 67, Miami Beach, Florida 33139.

MINNESOTA Remails—25¢. P.O. Box 17066, St. Paul, Minn. 55117.

JUAREZ Mexico Re-Airmails, \$1.00. Yadzia, P.O. Box 4614, El Paso, Texas 79924.

"RECEIVING, Forwarding. Discreet. Monthly rates. Kochli, 252 Lorenzen Rd., Port Richey, Florida 33568."

(Continued on next page)

REMAILING SERVICE

(Continued from preceding page)

PUERTO RICO Remails. 50¢ Each. Monthly And Bulk Rates. Bowman, GPO Box 986, San Juan, Puerto Rico 00936.

HOLY CITY, Calif. 25¢ each! 5/1.00. Prompt! Jim Moore, Box 88B, 95026.

REMAILS 25¢. Letters. \$3.00 Monthly. R. Johnson, Box 03326-A, Cleveland, Ohio 44103.

PARIS Re-Airmails Singles \$1.00, Postcards. Masters, 82 Rue Doudeauville, Paris 18 France.

LOS ANGELES Remails 25¢. \$3.00 Month. Literature! Clark, (000-MAX), Box 57190, Los Angeles, California 90057.

CHICAGO Remails 25¢. Monthly rates. Hanley, 8014 Wolcott, Chicago, Illinois 60620.

SAN DIEGO—25¢ Each. \$3.00 Monthly. H. Lang, Box-405, San Diego, California 92101.

REPAIRS AND SERVICING

MAILORDER Records help get increased business! Complete 32 Page Record Book shows your inquiries orders, advertising, expense, etc. Only \$1.00. C. A. Martin, Popular Mechanics, Dept. PMR, 224 West 57 Street, New York, N.Y. 10019.

PLAYER Piano Mechanism Rebuilt By Professionals. Also Key Recovering. Mayhew Piano Service, Mayville, Mich. 48744.

SPECIAL SERVICES

INFORMATION On anything. Ferguson Research Specialists, 83-45 Vietor Ave., Elmhurst, N.Y. 11373.

KEEP Your copies of PM—and watch for the inexpensive Annual Index, available in December. It will enable you to locate any article which appeared in 1971 or find information on any particular subject in just a few seconds. The Annual Index will make your copies of PM even more valuable!

BYARS Mail Formulae and Recipes. 28 Keney Ter., Hartford, Conn. 06112.

CANADIAN Information Or Service On Anything. Purchasing Services, 388 Duffield, Winnipeg, Canada.

TOBACCO

PROFITS FROM CLASSIFIED ADVERTISING! Booklet shows you how to start your own business with Classified Advertising. Only \$1.00 (Refundable with first order.) C. A. Martin, Popular Mechanics, Dept. PMP, 224 West 57 Street, New York, N.Y. 10019.

CIGARETTES Free! Join Smoking Club, Smoke Free! Application \$1.00 Refundable. Write: Pleasure, P.O. Box 477, Norlina, N.C. 27563.

DEALERS Wanted; earn to 22% Selling high quality Cigars. For details write: A World of Gifts, Tobacco Div., 9401 Hartwell, Detroit, Michigan 48228.

PERSONAL

PAY Bills! Borrow to \$1500 by mail! Convenient terms! State licensed. Postal Finance, 6018 Military Avenue, Dept. 17-A, Omaha, Nebraska 68104.

I HELPED Thousands Wipe Out Debts. Clear credit. Immediate relief to \$25,000. Free details. Counselor-7, Kerrville, Texas 78028.

HIGHER INCOME. Security and Power. 256 page book, "Thinking Big" reveals secrets that make men Rich! Send \$2.00 D. E. Franklin, 833 PM E. Meadowlawn Blvd., Seven Hills, Ohio 44131.

HICCUPS: Only way to stop prolonged hiccup seizure is through your subconscious mind. You can stop overnight. No drugs, No herb, no tricks. \$5.00. Beacon Research, 1627 4th Ave. W., Seattle, Wash. 98119.

HARD to stop smoking? Send for the four step booklet for real help. \$1.00 to Box 264F, Baldwin Park, Calif. 91706.

MAKE YOUR WILL. Get 4 Will Forms and attorney's informative book. \$1.50. Legal Forms Company, Department 124, 1830 Guardian Building, Detroit, Michigan 48226.

BIBLE Questions answered. Stamped envelope. Bylon, 17167 Bentler, Detroit, Michigan 48219.

INVESTIGATORS. Latest electronic Aids. Free Literature. Clifton, 11500-P NW 7th Ave., Miami, Florida 33168.

RUPTURED. Relief and comfort. No understraps, elastic or steel. Write Hand-Lock Products, Preston 4, Ont., Canada.

RECORD Telephone conversations automatically. Leave recorder unattended. Write—Robert's, Box 49-PM2, Parkridge, Illinois 60068.

IMPROVE YOUR PERSONALITY. Write for free information: PERSONALITY SUCCESS, Dept. C-9, Box 1946, El Paso, Texas 79950.

"RULE Others With Thoughts." (Telepathy) write: Clarion, Box 1769-S7, Chicago, 60690.

CASH Loans by mail! Up to \$2,500 on signature alone. No collateral! Secret! Union Finance Company, 3608 No. 16th St. Dept. PM, Phoenix, Ariz. 85011.

FAMILY TREE CHARTS—Genealogy Supplies, Books. Free "How To" Catalog. FORMCO, Box 3828-XE, Long Beach, California 90803.

FREE Discount Catalogue!!! Books—Prints—Records. All Subjects!! Entertaining, Useful. Entire Family! "Books", Box 186-T, Brooklyn, 11230.

DON'T DIE Without A Will! Protect Your Family! Attorney's Authoritative Booklet And 4 Will Forms, Only \$2.00—Guaranteed! Order Today! B & A Supply, Box 24211, Fort Lauderdale, Florida 33307.

IMPROVE YOUR PERSONALITY. Details: SUCCESS ACHIEVEMENT, Box 3J-742, Dexter, Michigan 48130.

HAVE Triple-A credit in thirty days! Get new credit without investigation! Continental, Box J-24, Hallandale, Florida 33009.

KNOW Your Own IQ. Self-scoring test and instructions. Send \$2. Testing, Box 191, Auburn, New York 13021.

WIPE out debts! Anyone (bankrupts included) can have excellent credit in 45 days and build a fortune. Free!!! Wealth Building, Box B-2, 8840 Hoyt Drive, Thornton, Colorado 80229.

LUCKY RABBITS FOOT—With Chain, Genuine Hair. Send \$1.00 to Alberta, Box 334, Highland Park, Ill. 60035.

H-WAR Before 1987. Matthew 24:1-22. Zechariah 5:1-4. Daniel 12:6-13. Marantha!

STOP SMOKING! 1000's Have Quit. Use Method Based Upon Research Reported In Several National Magazines. Moneyback Guarantee. Send \$2.00. Universal Sales Company, Box 11332A, Columbia, South Carolina 29211.

DRINKING Wrecking your life? Your higher power, prayer and some practical help can change your life. Send \$2 to: Frank, Box 3094A, Darien, Connecticut 06820.

TAXPAYERS Reduce Your Income Taxes. Checklists With Hundreds Of Deductions And Nontaxable Items Plus Tips. \$1.00. (Tax Deductible). Infosearch, 8121 Iris, Oakland, California 94605.

HOW TO SLEEP Without Pills! Simple Exercises, 64 Page Book. Send \$1.00. Satisfaction Guaranteed. Fairest Merchandise Company, 3606 E½ Road, Palisade, Colorado 81526.

DON'T DIE Without A Will. Blank Will Form Protects Loved Ones. \$2.00—Guaranteed. Order Today. . . . Formco, 4163 Rincon, 2PM1, Campbell, California 95008.

DON'T Die without a Will!! Blank Will forms protect your family. Booklet. Family Planner. Send \$1.00. Guaranteed!! Dinolfo, 64 Parson, Clifton, N.J. 07012.

STOP Smoking! Send for our 4-Step program, or 5-Day formula. No medicines to take. \$1.00 each. Specialty Items, Box 2305, Pueblo, Colorado 81004.

IMPROVE PERSONALITY AND LIFE. Scientifically sound. Seven keys, used diligently, open locked areas of mind. \$2.00 to: M. T. Wain, 403 N. Alice, Dothan, Ala. 36301.

CLIMB Safely. Sturdy, 14" Step Stool. Brochure. Schockco, Dept. P252, Box 9538, San Diego, California 92109.

DISTINCTIVE GIFTS. INFORMATION BOOKLET \$1.00. QUANTITY LIMITED. BOOKLET, DEPARTMENT 2, ROUTE 3, B-222, JASPER, ALABAMA 35501.

MAGNETIC ATTRACTION. Get Free lesson. Institute, Box 37012, Los Angeles, Calif. 90037.

ENJOY Simple, pleasant life. Retire without money. Details free. NAGGO, Box 11478, Chicago, Illinois 60611.

WANTED-MISCELLANEOUS

MERCURY, Gold, Silver, Platinum; Ores assayed. Wholesale Terminal, Norwood, Mass. 02062.

MISCELLANEOUS

YOUR NAME . . . on mailing list! 25¢ three months. 75¢ year! Motion Enterprises PX1, Box 347, Redwood Valley, Calif. 95470.

BEEN Looking For Real Chili? Recipe Kept Secret 23 Years. But No Longer. So Good It Is Now Copyrighted. Details: P.O. Box 3051, Ft. Worth, Texas 76105.

MAKE Wines, Champagnes. Inexpensively complete instructions. Handbook \$3.00. Guaranteed. Ross, Box 476, Caseyville, Illinois 62232.

WINEMAKER'S Supply Catalog—Free. Bacchanalia, 273 Riverside Ave., Westport, Conn. 06880.

CHAMPAGNE, Wines, latest handbook! Amazingly simple, gourmet-delight recipes. Exquisite wines at low cost, using kitchen-items. Delicious! New, bulletin-fresh — \$2.98 — Absolutely guaranteed! Free catalog. Tellier, Box 8439-B, Capitol Heights, Md. 20027.

WINEMAKERS!! Fermentation Locks—3/\$1.00. Free Illustrated Catalog Plus \$5.00 Credit Coupon. Werth Wine, Box 1902AV, Cedar Rapids, Iowa 52406.

CIGARETTES 15¢ a pack. Improved roller makes 20 filtertip, plain, king or regular for 15¢. Facts free. Green River Tobacco, Box 954, Owensboro, Kentucky 42301.

WINEMAKING Kit—\$4.98 Free Catalog and recipes. JIMDANDY, Box 30230M, Cincinnati, Ohio 45230.

SUFFERING From Arthritis? Try Ginseng: Information Free. Write Ginseng, Asheville 53, North Carolina.

WINEMAKERS Yeast. Recipes & Catalog 25¢; Kraus, Box 451-L, Nevada, Missouri 64772.

ORNAMENTAL Iron designs. Book of 1600 beautiful, practical designs for railings, columns, etc. Free literature. Cunningham, 3881 South 3200 West, Salt Lake City, Utah 84119.

WINEMAKERS. Free illustrated catalog of yeasts, equipment, Sempex, Box 12276, Minneapolis, Minn. 55412.

BOOKS On antiques and their prices. Free circular!! P. Warman Publishers, Uniontown, Penna. 15401.

IDENTIFICATION Cards. Send stamped self-addressed envelope for samples. Identification, Box 12117, Las Vegas, Nevada 89112.

HEARING Aid batteries wholesale. Free list. Habs, Box 51, York, Penna. 17405.

(Continued on next page)

MISCELLANEOUS

(Continued from preceding page)

WINEMAKERS. . . . Free Illustrated Supply Catalog of Yeasts, Equipment, Recipes. Winemaker, Box 11211-PM, Indianapolis, Ind. 46201.

BIRTH Certificates, Marriage Certificates, Diplomas! 2 blank forms \$1.00. Sample 10c. Standard Forms, Box 482-M, Washington, D.C. 20044.

U.S. \$1000 BILLS!! Obsolete Replicas 5 For \$4. National, Box-141-X, New London, Connecticut 06320.

WINEMAKERS: Free informative catalog, recipes. Arbolyn, Box 663, West Columbia, S. C. 29169.

HOME WINE Making SUPPLIES and INGREDIENTS CATALOG with RECIPES for year round winemaking. It's a fascinating Hobby. Makes A good conversation. Send for free catalog. Danenberger, Box 276B, New Berlin, Illinois 62670.

SUPER MEMORY Overnight! Guaranteed! \$1.00. Refundable! Bijou, Box 1727-P, Hollywood, Cal. 90028.

SEE Without being seen—Thru walls, doors. Protect yourself! Two way mirror. Giant 8" x 10" size. Send \$2.00 today . . . Guaranteed. Miller Sales, Dept. D2, Box 2242, Grand Junction, Colorado 81501.

PROTECT Your Loved Ones! Make Your Will Now! Four Latest Do-It-Yourself Forms, Informative Booklet, Only \$1.98. Ross Forms, Box 355, Largo, Florida 33540.

CERTIFICATES—High School, College Diplomas, Baptism, Birth, Divorce Certificates, Marriage License, Will. Any three —\$1.00, Five—\$1.50. Order today!!! Free Surprise!!! Malizia Enterprises, 87-30 204 Street, PM2, Hollis, N.Y. 11423.

WIN CONTESTS. There Is A Secret. Manual Shows How To Increase Your Chances. Send \$1.00. Pollard Enterprises, 4335 Clark, Wanamaker, Ind. 46239.

MAKE Your Will. Three Will Forms And Instructions. Send \$1.00 To: Legal Forms, P.O. Box 17066. St. Paul, Minn. 55117.

CREDIT Cards! Receive all kinds fast, easy. Get new credit without investigation! Continental, Box J-23, Hallandale, Florida 33009.

WINEMAKERS. Delicious Homemade Wine. 68c Gallon. Complete Instructions \$3.00. Danese, 6453 Akron, Philadelphia 19149.

EXCELLENT DOCUMENTS!!! Karate Black-belt—Birth—Marriage—Divorce Certificates. High School—College Diplomas. Model—Photographer Licenses. Rushed Air mail! Two—\$1.00; Five—\$2.00. Deluxe (Goldseals) Documents \$1.00 Each. Money-back Guarantee!!! Filiforms, Box 1332-BA, Albany, New York 12201.

WINEMAKING—200 Recipes, instructions—\$1.00. E&G Sales, Box 18384-T, Memphis, Tennessee 38118.

WRINKLES GONE! Make fabric wrinkles disappear like a professional!—Clothes, draperies. Hand-held electric steamer. Ideal for home and travel. TODAY a bargain at \$6.50 postpaid! Complete satisfaction guaranteed. Qualdesco, Dept. 3A2, 202 South Meade, Greenville, N. Car. 27834.

RESTAURANT Bakery Equipment Wholesale. Feola, 9A Pearl Street, Somerville, Massachusetts 02145.

PERCOLATE Delicious coffee. Save half the cost. Complete instructions. Send one dollar. P.O. Box 1354, Coral Gables, Fla. 33134.

CANDLELIGHT By Electricity, Exotic Flicker-Flame for chandeliers, sconces, post lanterns. Latest in effective lighting. Standard or small base. \$2.25 each. Maron, Inc., Box 14567, Baton Rouge, La. 70808.

PREVENT HOUSE TRAILER wind damage. Details \$5.00. P.O. Box 1152, Bloomington, Indiana 47401.

BAD TV Tubes? Dial-A-Fix identifies instantly . . . even color! Send \$2.98 today—guaranteed!! Avco, 5135 Kenwood Ave., Dept. 1A2, Chicago 60615.

WAGON Wheels. Reasonable. Esquire, Box 971, Nameoki Station (L), Granite City, Illinois 62040.

PHASE III: DUMP NIXON Bumperstrip. Three \$2.00, Dozen \$5.00. Terra, Box 3233, New York 10017.

BEEF JERKY Prize Recipe, Delicious Only \$1.00. "Recipe," 10 W. 92nd, Minneapolis, Minn. 55420.

COMMUNICATION Problem? For Understanding And Solutions Send \$2.00 for 80-Page Illustrated Book: Vae's Specialities, Dept. 4R2, Box 4183, San Jose, California 95126.

3 8x10 ORIGINAL Color Scenic Prints \$24.00. Daytone Studio, Village Terrace H188, Cortland, New York 13045.

MAKE WINE & SPARKLING CHAMPAGNE. Easy to do. Use every day kitchen utensils. Complete illustrated instruction. Guaranteed delicious or money back. Send \$1.75 today. Harper House, Dept. E2, P.O. Box 11412, Kansas City, Mo. 64112.

DON'T PAY INCOME TAX. Legally. No matter what your income. Rich men's methods adapted for anyone's use. Free details. Treehouse-23, Box 3004, Duluth, Minnesota 55804.

STOP SMOKING! Our new book gives step by step method. Guaranteed. \$2.00. Atlanta Associates, P.O. Box 1412, Atlanta, Georgia 30301.

SPEED READ magnifies type and increases reading speed!!! \$3.00 GUARANTEED!!! Roberts, 6349 North Western, Dept. 1A2, Chicago 60645.

ORTHOPEDIC 7 Ft. Round Beds. \$250. Freight Paid. Credit Cards or Cash. Mattress House, 7260 Fannin (#2140), Houston, Texas 77025.

HOW INTELLIGENT Are you? Self-scoring test reveals I.Q. in 45 minutes! Send \$2 today—Guaranteed!! Ross, Box 121, Warminster, Pa. 18974.

TREMENDOUS Income Opportunity. Start your own wholesale business. Details free. FN "Wholesale", Silver Lake, Minnesota 55381.

HANDYCAN Tuff all purpose 6 qt. flexible plastic can with lid. Waterproof. \$1.25 postpaid. 8104 Newton, Overland Park, Kansas 66204.

CHAMPAGNE And WINEMAKERS! New step-by-step easy instructions using kitchen items only. Many potent recipes. Only \$2.98. Guaranteed delicious or refunded. O'Meara's, Box 271PM, Dania, Florida 33004.

"DIETING SECRETS" How to Diet Successfully. Guaranteed!!! Manual \$1.00. A. House, 3706 Itaska, Corpus Christi, Texas 78415.

FANTASTIC Invention—Take our Paint, Brush, Canvases—Follow Unbelievable Instructions—60 seconds later, life-size portraits of anyone! Complete Kit, \$3.98: Jiffy Portrait, 1315 Ronan, Wilmington, California 90744.

FIND OUT What those COMPUTER punched holes in Gas, Light Bills, Paychecks mean. Send \$1.00 for Tab Card Decoder. Hinsdale, P.O. Box 3044, Santa Fe Springs, California 90670.

BEN FRANKLIN Magnifying Glasses, perfect aid in reading fine print, makes close work clear and big. Styled so you can look over top with regular vision. Send \$4.98 plus 50c postage. A-Z Optical Co., Dept. 11H, Box 175, Bay Station, Brooklyn, N.Y. 11235.

BURGLAR ALARMS & HOME PROTECTION

FREE Catalog on Burglar-fire Alarm Equipment. Protecto Alarm Sales, Box 357-D, Birch Run, Michigan 48415.

REVOLUTIONARY ENTRANCE TRILOK GUARANTEES AGAINST FORCED ENTRY! Money Back guarantee, introductory booklet advises how to save, where to obtain components for DO-IT-YOURSELF installation instructions on home burglar-fire alarm systems. Send two dollars for copy "How to Fight Crime and Secure Your Family" Burglary & Fire Preventive Systems, 221 Nassau St., Princeton, N.J. 08540.

What Do Many Doctors Use When They Suffer Pain Of Hemorrhoidal Tissues?

Exclusive Formula Gives Prompt, Temporary Relief In Many Cases from Such Pain. Also Helps Shrink Swelling of Such Tissues Due to Infection.

In a survey, doctors were asked what *they* use to relieve such painful symptoms. Many of the doctors reporting said that they either use Preparation H themselves or in their office practice.

Preparation H gives prompt, tem-

porary relief for hours in many cases from pain, itching in hemorrhoidal tissues. And it actually helps shrink painful swelling of such tissues when infected and inflamed. Just see if doctor-tested Preparation H® doesn't help *you*.

PREPARE NOW in Spare Time
for a Rewarding Future in one of

CHOOSE BETWEEN

2 EXCITING CAREERS!

Now you can prepare in spare time for a rewarding career in one of America's two fastest-growing opportunity fields—Drafting or Accounting. Thousands have found North American's "Learn-by-Doing" home-study method makes these subjects easy to master — exciting and fun to learn. You'll find North American training can unlock the door to success and prestige for you in a field where daily work is fun and challenging—where opportunity has no limits.

Take a few moments to read about the exciting opportunities awaiting you. Then choose your career on the Postpaid Card and mail it today for FREE "CAREER KIT" of your choice. There's no cost, no obligation and no salesman will call.

This Fully Automatic ELECTRIC ADDING MACHINE GIVEN TO YOU!

when you train at home with us for a HIGH INCOME Career in ACCOUNTING...

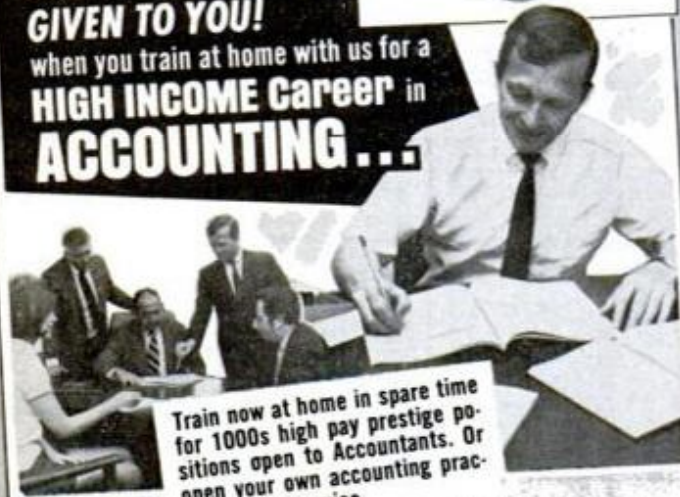

Train now at home in spare time for 1000s high pay prestige positions open to Accountants. Or open your own accounting practice or tax service.

Accountants move up fast in business. As an Accountant you'll do important work and get important pay. No worry about layoffs or recessions because there's always a job waiting for the trained Accountant. He is the one indispensable man whose work is essential to the operation of every business. Thousands of good Accounting jobs are going begging right now. The U. S. Dept. of Labor forecasts 33,000 new Accountants and 78,000 new Bookkeepers will be needed each year for the next ten years!

YOU NEED NO PREVIOUS EXPERIENCE

We show you how computers and other business machines can simplify your work and make you more valuable to your company. We reveal how to "set up books" for every type of business and profession. We disclose the secrets of using computer reports. We even give you a fully automatic electric adding machine which adds, subtracts and multiplies figures in seconds...helps you make good money part time while still learning.



MAIL POSTPAID CARD FOR FREE "ACCOUNTING CAREER KIT"

... including 24-page Career Fact Book, packed with startling details on how to win top pay, prestige and security as an Accountant. No salesman will call.

IF POST CARD HAS BEEN DETACHED, MAIL THIS COUPON

Accredited Member, National Home Study Council



THESE 3 BIG DRAFTING KITS GIVEN TO YOU!

when you train at home with us for a HIGH PAY JOB IN DRAFTING!

APPROVED FOR G.I.S. AND VETERANS

Take your pick of thousands of big salary jobs open to Draftsmen. U.S. Labor Dept. reports "42% more Draftsmen needed in next 10 years — not enough applicants to fill jobs available now." Easy home-study plan has helped hundreds of beginners toward good income, security, prestige as Draftsmen—many with only grade school training. Others report good earnings drafting part time while still learning. The door is open to you now.

GOOD PAY — SECURITY Drafting is a profession of good pay right from the start. Salaries for beginners are often above those paid office workers & factory help who have years of seniority and experience. Drafting is secure—once you are trained, you can apply your knowledge to any industry. Drafting is virtually "automation proof" as even machines must be designed by a Draftsman. He is the originator of them all!

Mail Postpaid Card for FREE "DRAFTING CAREER KIT" ... 20-page Book, "Your Future in Drafting." Sample Lesson, Aptitude Test, 5-way Drafting Instrument. Packed with startling facts on your opportunity to win top pay and security as a Draftsman.



North American Correspondence Schools, Dept. B4172

4500 Campus Dr., Newport Beach, CA 92663

Please send me FREE "CAREER KIT" I have checked below. PLEASE CHECK ONLY ONE Drafting Accounting

NAME _____ AGE _____

ADDRESS _____

CITY _____

STATE _____ ZIP _____

Presenting the case against rough weather:



the new Remington-Peters "Power-Pak."

100 pocketproof powerful "golden" 22 long rifle cartridges in a specially designed plastic case that really earns its keep... even when it's empty.

First, we made our 22 long rifle cartridges "pocketproof" with a special high-temperature lubricant that resists lint, dirt and grit. Now... thanks to a specially designed, golden, plastic package our 22s are just about everything-proof. The case keeps the cartridges securely in place and bad weather, moisture and dust out. And it was designed to fit neatly in the breast pocket of a



hunting shirt or jacket. The lid of a "Power-Pak" slides back with a series of positive "click" stops... you can dispense 5 cartridges (or 10 or 15 or however many you need) without fumbling with loose cartridges or packages that are more than a handful. And when the "Power-Pak" is empty, just flip the tray out, and you've got a great place to keep small spare parts, larger cartridges, trout flies, fishing lures, whatever needs keeping. We think the "Power-Pak" is right on target... worth looking for wherever you buy your ammunition.

Remington® DU PONT® PETERS®

Great guns deserve great ammunition. We make both.

"Power-Pak" and "golden" are trademarks of the Remington Arms Company, Inc.



Evinrude just put a lot more fun in a lot less space.

The classic way to make a motor more powerful is to make it bigger. Now there's a better way.

Evinrude has discovered how to make outboards more powerful by making them cleaner and smaller and more efficient. By doing things nobody knew how to do a few years ago. Our new Evinrude 50 is exhibit A.

It's loop-charged — so the pistons don't have deflector humps and the combustion chamber doesn't have to be shaped to accommodate them.

It re-cycles and burns the fuel condensate that once drained overboard.

Lower unit shape and gearing are computer-matched to the power curve of the motor. You get *more*

power at every speed — and you get *more* speed.

You get more of everything — from power shifting to Firepower ignition.

More of everything — except size.

Free color catalog: Send your name on a post card to Evinrude Motors, 4020 N. 27th St., Milwaukee, Wis. 53216.

CLEAN WATER: *our future is riding on it* **EVINRUDE** **first in outboards**

Div. of Outboard Marine Corp., makers of OMC Stern Drives