

How to Keep From Getting Killed in the Fog

POPULAR MECHANICS

SEPT. 1970
50 CENTS

How to
Phone
Vietnam
—Free

PM 'Helps' Chevy
Test the VEGA



First Report on '71 FORDS and MERCURYS Including the Pint-Sized PINTO

**28 Pages of Ideas
To Make Your Home
More Livable**

- Making a Room Out of a Porch
- Building a Bar in the Basement
- Hiding Trash Cans
- Installing Plastic Pipe
- Sealing Your Driveway
- Building Storage Into Walls

New Radio-Controlled Mower

'Sensible' Station Wagons

How to Sight-In Your Rifle

How to Choose a Speaker

Robot Auto Factory

Owners Reports: Hornet, Riviera

America's Most Vicious Storm

Dan Gurney Answers Your Questions on Racing and Driving

Weekend over, this beachcomber turns into a city slicker.



The 'Jeep' Universal: With this baby, fun isn't just something you talk about—you have it! Nothing's going to hold you back. Not when you have 'Jeep' 4-wheel drive. In fact, the fun begins the second you turn on the ignition. You'll end up in some of the most far out places. Back on the road, it's an entirely different car. Makes the city scene in style. Options like 160 hp. V-6, racing stripes, roll bar, wide fiber glass tires. See your 'Jeep' dealer. Test drive the 'Jeep' Universal, a 2-Car Car. Just one in the world's first, finest and only complete 4-wheel drive family.

'Jeep'
4-WHEEL DRIVE
**The 2-Car
Car.**

 **Jeep**
Products from American Motors

Make yourself comfortable.



Comfort is what you get with our miracle plastic coating.

The Spoiler.[®]

This One



B939-EL1-ALK5

© The Gillette Company, Boston, Mass.

SEPTEMBER 1970

1

Owens-Corning explains the high cost of not enough insulation.

Fiberglas 6&3 insulation could save over \$3,000 toward your mortgage

6" of Fiberglas* insulation in ceilings and 3" in walls can cut heating and cooling costs as much as 30% a year.

Fiberglas 6&3 insulates so well, it could save a homeowner more than \$3,000 toward payments over the term of a 25-year mortgage. Yet it costs only around \$200 more than requirements of FHA minimum property standards.

How much you might save depends on size and location of your house. To find out, locate your zone on the map—then estimate your savings on the charts.

Free booklet tells you more. It's called The Full Story of Full Insulation. Write Owens-Corning Fiberglas Corporation for it today, Attn: C.N. Meeks, Box 901, Toledo, Ohio 43601. Then ask your dealer or builder for Fiberglas 6&3.

*T. M. Reg. O-C. F.

Calculate possible savings in your area—add heating and cooling savings for total.



HEATING ZONES**			
Floor Area, Sq. Ft.	Zone A	Zone B	Zone C
1000	\$1,650.	\$1,150.	\$475.
1500	\$2,225.	\$1,575.	\$625.
2000	\$2,700.	\$1,925.	\$775.

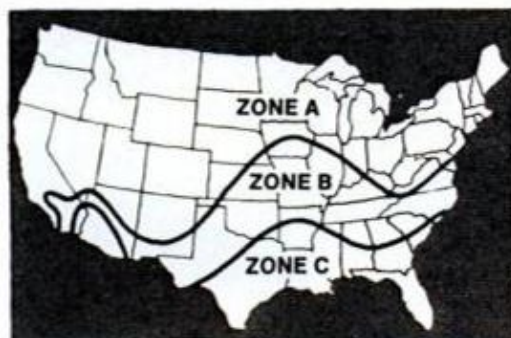

COOLING ZONES**			
Floor Area, Sq. Ft.	Zone A	Zone B	Zone C
1000	\$200.	\$425.	\$650.
1500	\$275.	\$550.	\$825.
2000	\$325.	\$650.	\$950.

**Estimated savings: Ranch house on slab, 15% glass area, over 25-year term of mortgage. Heating costs, 10¢ per therm, cooling costs 0.02¢ per KWH. 6" & 3" versus FHA minimum property standards.

Owens-Corning is Fiberglas





Exhibitionist.

This Atlas fiberglass belted tire gives a performance you never thought possible. It delivers thousands more miles than even our best selling tire.

The new Atlas Plycron 2 *plus* 2* was put through one of the industry's toughest road testing programs.

Result: The Atlas Plycron 2 *plus* 2 delivered an average of 35%† more miles than even the famous Atlas Plycron. (This is the tire that, traditionally, has outperformed 4-ply major brand replacement tires in mileage tests.)

New construction puts the Atlas 2 *plus* 2 ahead. Two fiberglass belts are bonded onto a tough Vicron polyester cord body.

And for traction, the unique wide tread design literally puts hundreds of gripping edges on the road at all times.

These features add up to less tread squirm, extra mileage.

For good value you can't beat the 4-ply Atlas Plycron tire. And, for even greater value get the new Atlas Plycron 2 *plus* 2. You'll like the way it performs. You'll like the money you save with every extra mile.

And remember, Atlas batteries and accessories as well as tires are sold at over 50,000 leading service stations.

ATLAS
PLYCRON 2 PLUS 2

Trademarks "Atlas," "Plycron," "Vicron," Reg. U.S. Pat. Off.
*Trademark. © 1970 Atlas Supply Company.

†Average of all tests run simultaneously by independent test fleet during last 12 months.

INTERNATIONAL EDITIONS: AUSTRALIA, BRAZIL, CARIBBEAN, DENMARK, FRANCE, MEXICO, SOUTHERN HEMISPHERE, SWEDEN

AUTOMOBILES AND DRIVING

- [24 Drivin' With Dan](#)
- [36 Detroit Listening Post](#)
- [74 Automobile Clinic](#)
- [81 Made in Ohio by Robots](#)
- [84 Too Fast in Fog](#)
- [96 PM Owners Report: Buick Riviera](#)
- [112 The Minis Are Out to Rule the Road](#)
- [116 The '71 Ford, Lincoln-Mercury Lineup](#)
- [124 PM Owners Report: AMC Hornet](#)
- [134 Those 'Sensible' Station Wagons](#)
- [148 Saturday Mechanic:](#)
How to Solve Sudden Stall

ELECTRONICS, RADIO AND TV

- [108 How to Talk to Vietnam—Free](#)
- [140 Switch Your Stereo Speakers](#)
With This Self-Balancing Control
- [144 Now: Home TV Films in Full Color](#)
- [144 Four-Channel Stereo From](#)
Cartridge Tapes

BOATING, OUTDOOR RECREATION

- [44 Keep Both Eyes On the Birdie!](#)
- [50 What's New Outdoors](#)
- [120 Fishing With a Gypsy](#)
- [123 Boating Tips](#)
- [132 How to Sight-In a Rifle](#)
- [152 Aquanaut Makes Diving Easy](#)
- [198 On-the-Go Camping](#)

PHOTOGRAPHY

- [14 New Self-Firing Flashcubes](#)
Never Miss
- [146 Rotary Print Washer Anyone Can Build](#)
- [147 Photo Hints](#)
- [196 New Tabletop Viewer Shows](#)
Color Prints

ENVIRONMENT

- [34 Pollution Fighters' Newsletter](#)

HOME AND YARD

- [128 'Mighty Mo,' a No-Nonsense Machine](#)
With a Sense of Humor
Special: 27 Pages of Do-It-Yourself Home Improvements
- [156 Porch to Family Room for](#)
Under \$900
- [160 A Handsome, Space-Saving Bar](#)
- [164 Pretty, Use-Full Walls](#)
- [167 Home Improvement Ideas](#)
- [168 Four Ways to Hide Trash Cans](#)
- [170 Benches You'll Want to Build](#)
for Your Deck
- [172 Plastic Piping Makes You an](#)
'Instant Plumber'
- [176 New Products](#)
- [178 How to Make a Blacktop Drive](#)
Look Like New
- [182 Solving Home Problems](#)
- [194 Homeowners' Clinic](#)

SHOP AND CRAFTS

- [155 Hints From Readers](#)
- [180 Hints From Readers](#)
- [181 New Tools You Should Know About](#)
- [184 What You Can Do With an](#)
Injection Molding Machine
- [187 Hints From Readers](#)
- [188 Hot Tips for Using Glue Guns](#)

SCIENCE AND INVENTIONS

- [20 Science Worldwide](#)
- [90 Camille: the Storm They Still Don't](#)
Believe
- [100 Just Patented: PM's Pick of the](#)
New Inventions
- [104 Now: Atomic Power to Keep Your](#)
Heart Beating

REGULAR FEATURES

- [6 Letters](#)

Cover Photo by Michael Lamm, West Coast Auto Editor

*PM helps Chevy test the Vega on shakedown cruise from desert lowlands to the high Rockies***NEXT MONTH IN POPULAR MECHANICS**

More '71 Cars in Color! Another chapter in PM's continuing coverage of Detroit.
 What's Watt in Choosing a Hi-Fi. How much output do you really need?
 Will You Lose Your Right to Fly? Are private pilots being forced out of the air?
 New Snowmobiles and New Outboards: Two roundups on the '71 models.
 A Jeep Dune Buggy? Rugged, 4-wheel-drive Jeep dressed up in slick, sports-car body.

ROBERT P. CROSSLEY

Editor

JAMES M. LISTON

Executive Editor

JOHN A. LINKLETTER

Managing Editor

WAYNE C. LECKEY

Home and Shop
Editor

SHELDON M. GALLAGER

Assistant Executive
Editor

THOMAS G. DAUER

Art Director

Published by The Hearst Corporation

RICHARD E. BERLIN, PRESIDENT

RICHARD E. DEEMS

President, Magazines Division

JOSEPH F. KERN

Publisher

BILL HARTFORD _____ Automotive

JOHN F. PEARSON _____ Science and Aerospace

GEORGE W. REIGER _____ Boating and Outdoors

SHELDON GALLAGER _____ Electronics and Photography

HARRY WICKS _____ Home Workshop

MICHAEL LAMM _____ West Coast Automotive

ROBERT LUND _____ Detroit Automotive

GARRY WINTER _____ Copy and Production

RICHARD H. FUNK _____ Associate Copy and Production

JOHN ADKINS _____ Assistant Copy and Production

ALVIN KIETZ _____ Assistant Art Director

DON EVANS _____ Assistant Art Director

FRED A. LEERS _____ Assistant Art Director

GEORGE W. BLOW _____ Technical Art Director

CLIFFORD B. HICKS _____ Special Projects

SOPHIE GRONOWICZ _____ Director, Bureau of Information

EVERETT JOHNSON _____ Cabinetmaker

ADDRESS ALL EDITORIAL COMMUNICATIONS TO: 224 West 57th St., New York, N.Y. 10019. For additional sources of information on the articles and products in this issue, write to Bureau of Information, Popular Mechanics, for free "Where-to-Find-it" list.

DANIEL J. COLEMAN

Director of Advertising

ADVERTISING OFFICES: New York: 224 West 57th St., 768-6850; Chicago: 520 N. Michigan Ave., 527-2400; Detroit: General Motors Bldg., Trinity 5-8711; Cleveland: 20310 Chagrin Blvd., Shaker Heights, 283-7788; Los Angeles: 601 North Vermont Ave., 666-6263.

SUBSCRIPTION SERVICE: Mail all subscription orders, changes of address, correspondence concerning subscriptions, and Postmaster notices of undeliverable copies to Popular Mechanics, Box 646, New York, N.Y. 10019. Please enclose your latest address label for quickest service when writing about your subscription.

POPULAR MECHANICS IS PUBLISHED MONTHLY by The Hearst Corporation, 57th St. at 8th Ave., New York, N.Y. 10019, U.S.A. Richard E. Berlin, President; George Hearst, V-Pres.; Richard E. Deems, President of Magazines; John R. Miller, Executive V-Pres. of Magazines; Raymond J. Petersen, Senior V-Pres. of Magazines; William S. Campbell, V-Pres. of Magazines; Albert A. Rachol, V-Pres. and Director of Circulation; Joseph F. Kern, V-Pres. for Popular Mechanics; Frank Massi, Executive V-Pres. and Treasurer; Harvey L. Lipton, Secy. Single copy in the United States and Canada, 50 cents. Subscription prices: United States and Possessions \$5.00 for one year; \$9.00 for two years; \$12.00 for three years. Canada, add \$0.75 for each year. Pan American Postal Union countries, add \$1.00 for each year. All other countries, add \$2.00 for each year. When changing address, give old address as well as the new, with postal-zone number, if any, and allow six weeks for change to become effective. Second-class postage paid at New York, N.Y., and at additional mailing offices. Authorized as second-class mail by the Post Office Department, Ottawa, and for payment of postage in cash. Registered as second-class matter at the Post Office at Mexico D.F., Mexico, June 20, 1950. © 1970 by The Hearst Corporation. All rights reserved. Printed in U.S.A.

SEPTEMBER 1970

Planter or playroom, Nicholson makes it easy.

Whether you're building a planter or a playroom, you're only as good as the tools you use. When you choose Nicholson tools, you choose the best.

Nicholson saws zip through wood with effortless ease. Nicholson files help you fit joints like a pro. Result: the job turns out just the way you expected. Sometimes better.

You don't buy a saw or a file collection every day, so it makes sense to get the world's finest cutting tools . . . Nicholson . . . at your hardware or building supply dealer.

Nicholson  

Nicholson File Co., Providence, R. I.

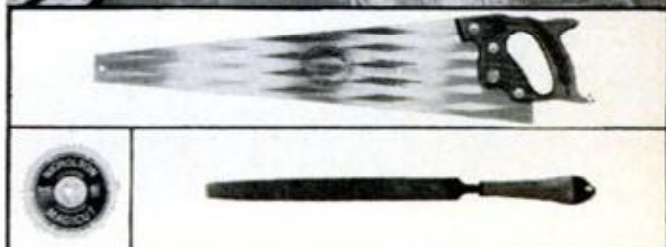

When your daughter
says that Field &
Stream's aroma reminds
her of a great autumn
day in the woods...

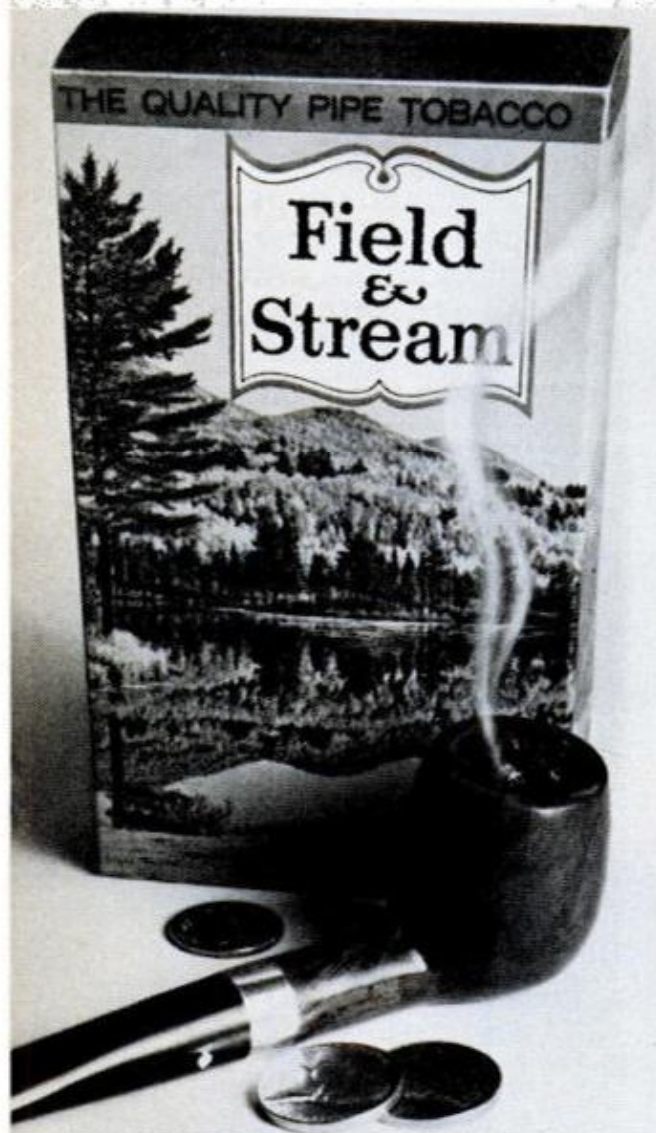

**start
saving up
the dowry.**

A quality product of Philip Morris U.S.A.

LETTERS TO THE EDITOR

Cheers and tears

Man, what an exciting story that was, entitled *The Face in the Mustang Window* (page 88, July PM).

I couldn't put it down, and could hardly wait to get to the end of the story. I found myself holding my own breath as I read about Fireman Larry Norton holding his breath to effect the rescue.

Let's have more, more, more!
OAKBROOK, ILL. JOHN R. VANDERVELDE

Yeah, but pretty soon you'll get all of our rivers filled up with Mustangs.

I cried for 10 minutes. It's the best I've read yet, but please don't write stories like this and make me cry. I'm ashamed that I cry so easy, so I will not sign my name. But I like your magazine.
ROMULUS, MICH.

Holds the patent

Regarding the Michigan *One-Wheel Cycle* (page 104, April PM), I am the inventor and hold the patent (No. 3,380,755) on the one-wheel cycle.

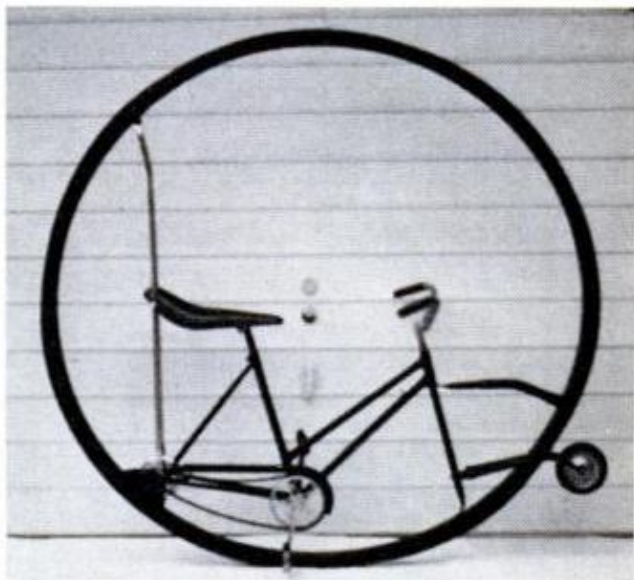

The model shown in this photo was finished late in June.
LONG BEACH, CALIF. J. M. POUND

Overcautious overload?

If all the items mentioned in *What You Need in a Roadside Emergency Kit* (page 120, July PM) were carried by the author, he would need several of them just to take
(Please turn to page 8)

POPULAR MECHANICS

Are you still working for peanuts while others are making it big?

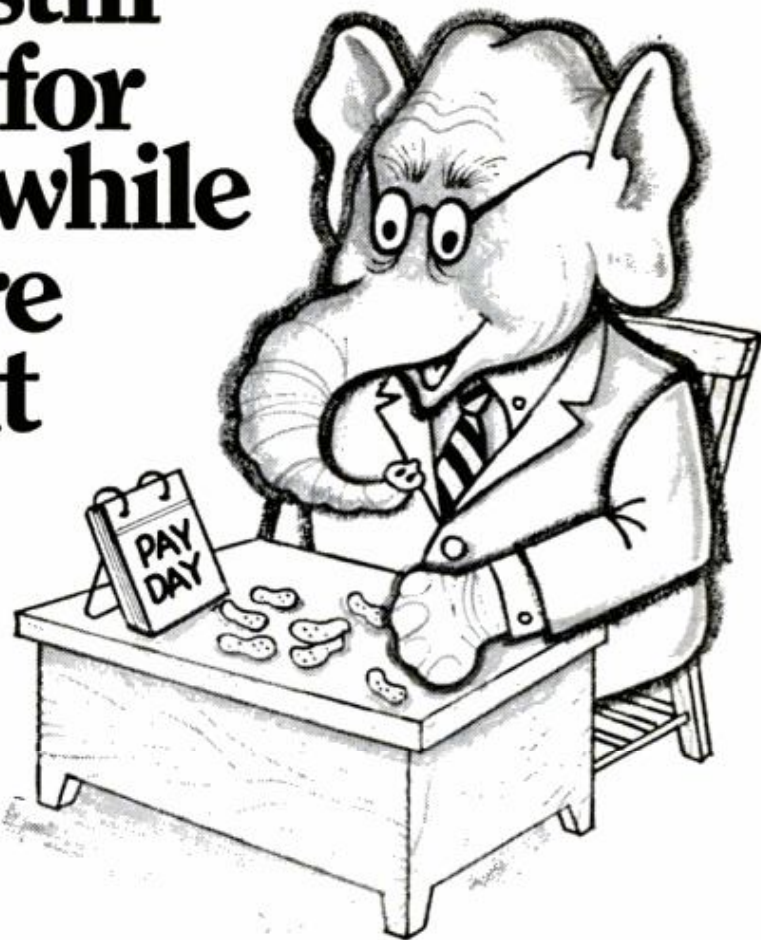

Why put up with a dead-end job and low pay while other men forge ahead to exciting promotions and big incomes?

There are more key positions waiting around today than there are people to fill them. Do you know how easily you can train for one of these positions? You can do it without giving up your present job, or going back to class.

LaSalle training at home will give you the specialized skills that lead to the best-paid positions in the business world. So that you'll have enough money for the good things in life—and plenty left over for your savings account.

Many LaSalle graduates report increases of two and three times

their former salaries. Frequently students report big increases during the first year of training. You can do the same.

LaSalle has been an acknowledged leader in home study for over 60 years. More than 2,000,000 ambitious men and women have enrolled in its many courses. Your

training is in experienced hands. Your LaSalle diploma is a credential you can be proud of.

Check the subject you are interested in—then send the coupon below for FREE booklet. No obligation, of course. Mail to LaSalle, 417 S. Dearborn Street, Chicago, Illinois 60605.

© 1969 LaSalle Extension University

LA SALLE EXTENSION UNIVERSITY

A Correspondence Institution • 417 S. Dearborn Street, Dept. 57-106, Chicago, Illinois 60605

Please send me, without cost or obligation, FREE booklet and full information on the field I have checked below:

ACCOUNTING

- Complete Accounting
- Income Tax
- Accounting Fundamentals
- CPA Training
- Modern Bookkeeping

BUSINESS MANAGEMENT

- Complete Business Management
- Credit and Collections
- Office Management
- Personnel Management
- Sales Management

REAL ESTATE

- Complete Real Estate
- Real Estate Brokerage
- Real Estate Management

Interested in a career not listed? Write here: _____

COMPUTER PROGRAMMING

- Complete Training

LAW COURSES

- Bachelor of Laws Degree
- Business Law
- Insurance Law
- Claim Adjusting Law
- Law for Police Officers

STENOTYPE

- Machine Shorthand

RESTAURANT/CLUB MANAGEMENT

- Executive Training

TRAFFIC & TRANSPORTATION

- Complete Traffic Mgt. Truck, Air, Rail, Sea

DRAFTING

- Complete Drafting

INTERIOR DECORATION

- Professional Training

ART TRAINING

- Commercial Art
- Oil, Water Color Painting
- Complete Training

Mr. _____

Mrs. _____

Miss _____

HIGH SCHOOL

- High School Diploma

LANGUAGE INSTRUCTION

- French German
- Spanish Italian
- Other _____

HOTEL/MOTEL MANAGEMENT

- Executive Training

CAREERS FOR WOMEN

- Accounting
- Bookkeeping
- Commercial Art
- Computer Programming
- Dental Assistant
- Hotel/Motel Mgmt.
- Interior Decorator
- Real Estate
- Secretarial
- Stenotype

Address _____ Apt. No. _____

City & State _____ Zip _____

(Circle title and please print)



Wherever you find 'em, targets are big and bright with a K Model.

Weaver's famous K Models make the difficult shots look easy.

You see a magnified target. You aim quickly and easily. You shoot with consistent accuracy — and safety.

Precision lenses are all designed, ground, magnesium fluoride-coated, and inspected by Weaver craftsmen. Micrometer click adjustments are dependable and accurate.

Exclusive triple weatherproofing means outstanding performance under all conditions. Lightweight steel tubes are hand-polished and gun-blued. Choice of five most popular reticles in most K Models.

Find a K Model for your rifle. Eight models, from 1.5-power to 12-power, priced from \$29.95, at your dealer.

Write for free 1970 catalog:
W. R. Weaver Company, Dept. 91,
El Paso, Texas 79915.

WEAVER SCOPES

The trophy takers.



LETTERS

(Continued from page 6)

care of problems incurred from overloading. Why doesn't he simply tow a spare-parts car along behind him?

WINCHESTER, MASS. DAVID E. WALTERS

Immeasurably puzzling

I want to thank you for driving me nuts by not giving the complete dimensions of *A Puzzle to Stump You* (page 160, May PM).

WATERBURY, CONN. HANK RONCARTI

After working for hours, I looked at the answer. It seems as though some information has been left out of your puzzle.

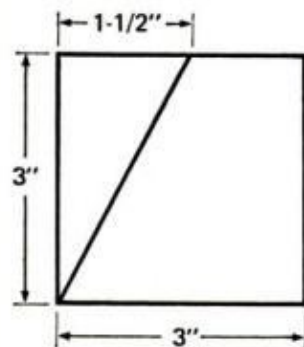

You failed to dimension, or include in the text, that the split side (marked $1\frac{1}{2}$ " on the drawing enclosed) needs to be half the square side (marked 3"). I can assure you that many readers are puzzled by this puzzle.

DALLAS, TEX. DON PERKINS

Yes, you are right, and, yes, they are puzzled.

Stiletto builder

Using only the directions and plans in *Building the Stiletto* (page 166, Jan. '67 PM), our son, Michael—who was then 15—went to work in the winter and fin-



ished the boat by the first of July.

The picture will tell you more than a million words. That's Michael in the boat; he is quite proud of his achievement and so are his father and I.

BALTIMORE, MD. MRS. STEPHEN FISCHER

You should be. He did a great job.

As we were about to say

Congratulations on a wonderful and enjoyable magazine. I look forward every month to the new issue, and I always find

(Please turn to page 10)

POPULAR MECHANICS

LEARN THE PROFESSIONAL METHOD OF APPLIANCE REPAIR

For extra income, a job skill in demand, a business of your own—or to save money on your own appliance repairs.

SEND FOR FREE CATALOG

Appliance Division, National Radio Institute
Washington, D.C. 20016

600-090

Send me your illustrated free book that tells about opportunities in Servicing Electrical Appliances, and gives details of NRI's simplified training plan. I understand there is no obligation, no salesman will call.

Name _____ Age _____

Address _____

City _____ State _____ Zip _____ Code _____

Check here for facts on New GI Bill.

Accredited Member National Home Study Council

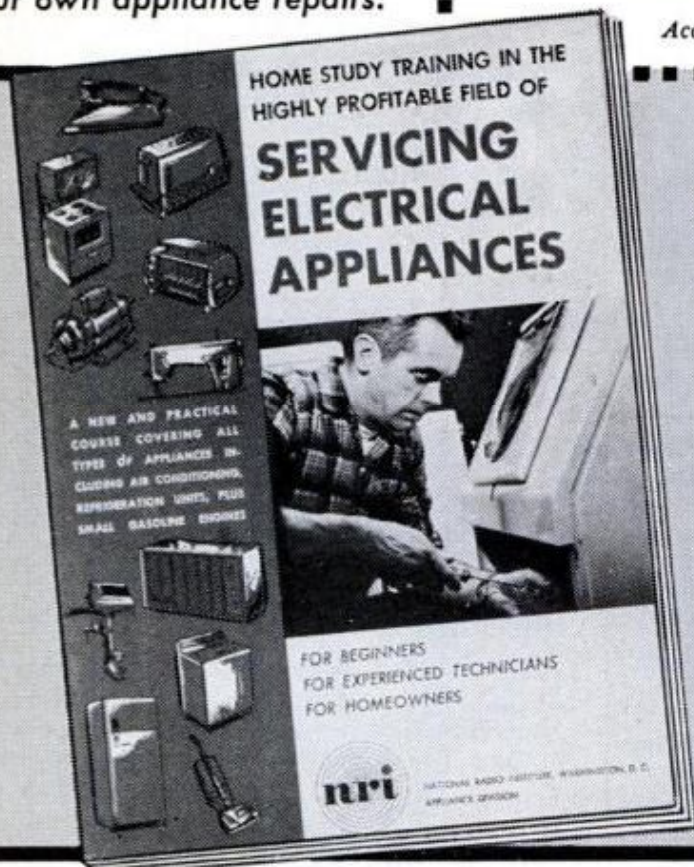

MAIL COUPON ABOVE
FOR THIS
FREE
NRI
CATALOG

AVAILABLE UNDER NEW GI BILL
If you served since January 31, 1955,
or are in service now, check GI line
in coupon above.

A new, short, easy course trains you at home

Now you can prepare quickly to do professional appliance servicing at home in your spare time.

You are ready to start servicing appliances after only a few lessons. The entire course can be finished in a matter of months.

This is the fastest way to a new job or skill or extra income or a business of your own. Wherever you live or want to live, you'll find a demand for top-notch appliance servicemen.

There are probably thousands of broken appliances right in your neighborhood. These can mean cash profits for you starting soon. Use your spare time

to make \$5 to \$7 an hour fixing appliances for friends and neighbors.

Low-cost training plans cover —

- Small and large home appliances
- Farm and commercial equipment
- Portable electric tools
- Small gasoline engines

— there is even special training to prepare you for air conditioning and refrigeration.

Special NRI appliance testing equipment is included in your course at no extra cost. Mail coupon for your FREE NRI Catalog. No salesman will call.



NATIONAL RADIO INSTITUTE • APPLIANCE DIVISION

Washington, D. C. 20016

EARN BIG MONEY IN AIR CONDITIONING REFRIGERATION & HEATING

25 KITS SENT TO BUILD THIS
COMPLETE REFRIGERATION SYSTEM



APPROVED FOR GI TRAINING
If you served since January 31, 1955 or are
in service, check GI line in coupon

A better job, top pay and steady work are easily within your reach. Learn to repair and install air conditioning systems, refrigerators and freezers. Air conditioning is one of America's fastest-growing industries. Millions of autos and homes are being air-conditioned. The need for trained men is immediate and great.

Make Home Your Training Center—Learn by practicing. CTI sends 25 kits of tools and parts to build a complete refrigeration system—which you later convert into a refrigerator or freezer. The course is easy!

Earn Money As You Train—Since the CTI course includes training with real equipment, many students earn money repairing units soon after enrolling. On completing training they go into top pay jobs. Many get started in their own business.

Mail Coupon Today for FREE book. No obligation. Prove to yourself that the air conditioning, refrigeration and heating field is best for you—the easiest training to master and loaded with top pay opportunities.

Commercial Trades Institute, Chicago, Ill. 60626

COMMERCIAL TRADES INSTITUTE
1400 Greenleaf Avenue
Chicago, Illinois 60626 Dept. PM970



Send book, Be a Success in Air Conditioning,
Refrigeration & Heating. No obligation.

Name _____ Age _____

Address _____ Zip _____

City _____ County _____ State _____

Check for facts on GI Bill
Accredited Member National Home Study Council

LETTERS

(Continued from page 8)

an informative article that pertains to my interests or to the interests of my friends.

I'm particularly interested in automobile repair. Because I'm the owner of a new automobile (as, I'm sure, are thousands of your readers), I feel there is a need for a good, thorough article on the theory and repair of present engines that have emission-control and other antipollution devices.

OAK PARK, ILL.

MARIO A. PETRONE

Funny you should mention it. Servicing emission-control devices is the subject of next month's Saturday Mechanic.

Some balloon!

Using a vacuum cleaner to inflate lots of balloons quickly is a good idea (*Solving Home Problems*, page 156, June PM), provided you do not use an explosive gas. About 20 years ago a man near here used an explosive gas to fill a balloon and a spark from the vacuum cleaner caused an explosion. It caused him to be deaf, blew the shingles off his house, blew the front door through the back door and demolished his car.

FREMONT, N.C.

C. E. DAVIS

Birds and bees

In *Solving Home Problems* (page 156, June PM), you show an easy-to-make hummingbird feeder. I was told that sugar is bad for birds—so try using honey.

LA MIRADA, CALIF.

RICHARD SUMMERS

Wrong country

In *Cranking Transforms Trailer* (page 123, June PM), you state that Lugano is in Italy. Lugano is in the Italian-speaking state of Ticino, Switzerland.

WHITE PLAINS, N.Y.

MRS. G. HOFER

Likes new binding

Your changes in the binding and layout are very welcome. For years I have pulled staples and separated the pages I wanted to keep. I file them in letter file boxes that are just the size of the magazine page. The new binding has been a great help.

MEMPHIS, TENN.

HENRY W. PEABODY

Glad you like it—and have you noticed that the magazine lies open much better when you're using it in your workshop? With the June issue, we quit using staples to bind the magazine and went to the hot-melt glue process in order to make PM handier for readers to use. ★★★

POPULAR MECHANICS



RCA STEREO 8 TAPE CLUB

Fabulous Savings! Spectacular Get-Acquainted Offer!

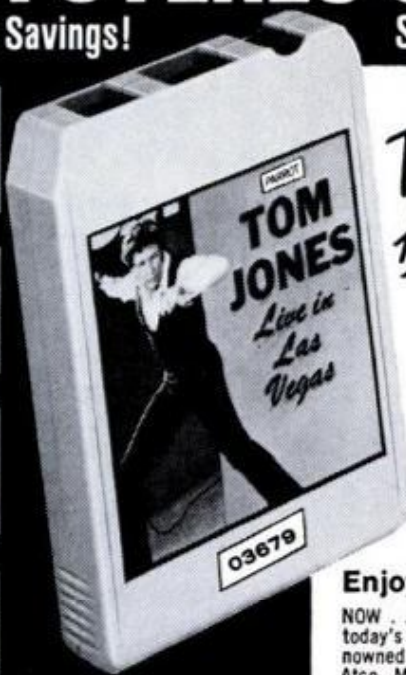

Take Any **5** STEREO 8 TAPE CARTRIDGES for only **\$6.95** Worth up to \$49.75 at regular Club prices!

You merely agree to buy as few as six more cartridges within a year from hundreds to be offered.

Enjoy Great Tapes — at Great Savings!

NOW . . . start a library of today's greatest Stereo 8 hits by today's biggest stars . . . at top savings! Choose from such renowned labels as RCA, Warner Bros., Reprise, London, Atlantic, Atco, Mercury — in every music category. Just look at these exclusive membership benefits:

- **Start savings RIGHT NOW!** Choose FIVE tapes for only \$6.95 (worth up to \$49.75 based on suggested manufacturers' list prices . . . optional with dealers). After trial membership, receive one tape of equivalent value FREE for every two you buy at regular Club price (usually \$6.95) — a 33 1/3% average saving!
- **Keep posted!** MEDLEY — the Club's free magazine — brings news of almost 300 Stereo 8 releases, featuring a Selection of the Month in the musical category you prefer. If you want this tape, do nothing — it will be shipped automatically. If you want other tapes, or no tapes, indicate your choice on the card always provided, and return it by the date specified.
- **All tapes guaranteed.** The Club's own Warranty unconditionally guarantees you perfect tapes for one year after purchase, regardless of label.
- **Enjoy a charge account!** We'll open a "pay later" account in your name; pay after you receive tapes and are enjoying them.
- **Send no money!** Just choose 5 of the 50 top-label hits shown here; we'll bill you \$6.95 plus small shipping-service charge later. You may cancel membership after receiving six more tapes . . . or keep enjoying savings of one-third for years to come with no obligation to buy.



TRADEMARKS USED IN THIS ADVT. ARE PROPERTY OF THE VARIOUS TRADEMARK OWNERS. ©1970 RCA CORPORATION.



00243

03197

03571

10278

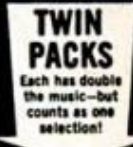

MAIL THIS COUPON TODAY!

MAIL TO: THE RCA STEREO 8 TAPE CLUB, P.O. Box 26888, Lawrence, Indiana 46226
 Yes, please accept my application for trial membership in The RCA Stereo 8 Tape Club, and send me the 5 cartridges I have selected for only \$6.95 plus small shipping-service charge and applicable tax. I understand I need buy as few as six more cartridges within a year to fulfill my trial membership, after which I will get one tape of equivalent value FREE for every two I buy at regular Club prices.

MAIL ME THESE 5 CARTRIDGES (indicate by number)

--	--	--	--	--

I am most interested in the following type of music: (check one only)

- Popular (Instrumental/Vocal Moods)
 Country & Western Today's Sound (Rock/Soul/Folk)

Mr. }
 Mrs. }
 Miss } (Please Print)

Address
 City & State Zip

Phone (.....)
 Area Code
 One Membership Per Family. APO/FPO addresses write for special offer.

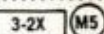

**MY SPARE TIME HOBBY
MAKES ME
\$500 an hour
CASH PROFIT**

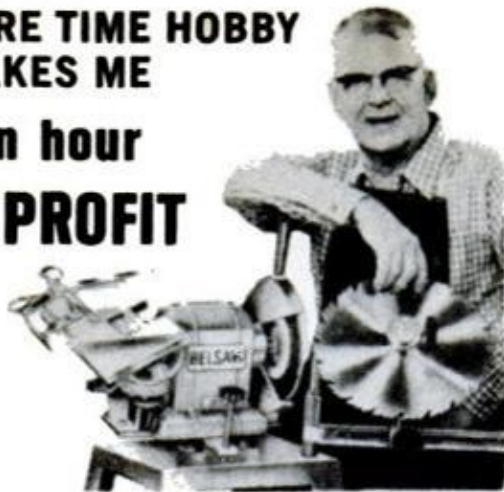

START YOUR OWN SPARE TIME BUSINESS
You can turn your spare time into Big Cash Profits with your own **COMPLETE SHARPENING SHOP**... Grind saws, knives, scissors, skates, lawn mower blades... all cutting edges. Your Own Cash Business with no inventory... right at home... no experience needed. **FREE BOOK** tells how you can start your own spare time business while you are still working at your regular job. Low Cost—time payments.

Just Mail Coupon—No Salesman Will Call

FREE BOOK

BELSAW SHARP-ALL CO., 711SField Bldg., Kansas City, Mo. 64111

Send Free Book, "LIFETIME SECURITY." No obligation.

Name _____

Address _____

City _____ State _____ Zip _____

**New 1970
HEAVY DUTY
ARC WELDER**

LIFETIME
GUARANTEE

10 DAY
MONEY BACK
TRIAL



Only \$18.95 Prepaid Complete Ready To Use

Every home, shop and hobbyist needs this quality metal working machine. Weld, Braze, Solder, cut almost anything metal. Follow simple instructions to make or repair 1001 items including furniture, toys, auto bodies, fenders, trailers, boats, farm and garden tools and equipment. Operates in 110 V. 30A. for pennies—Adjustable Twin Carbon Arc Torch easily **REGULATES HEAT FOR EACH JOB**. Eliminates changing cables—replaces gas torches—no tanks or refills to buy—produces to 11,000° heat. **YOU CAN PAY MORE BUT YOU CAN'T GET A BETTER LOW COST WELDER.** Over 500,000 in use. Manufactures of welders for over 30 years. **LIFETIME GUARANTEE.** Simply return prepaid. We will repair and reship **FREE** of charge. **YOU GET:** heavy duty welder in rugged metal cabinet, ground clamp, cables, combination torch and rod holder, welding manual, helmet. Free \$2.00 pack "TOUCH WELD" rods for instant automatic arc, brazing rods, 1/4" carbons, solder, flux.

PLUS EXCLUSIVE ON/OFF SAFETY FOOT SWITCH \$3.95 VALUE INCLUDED AT NO EXTRA COST

ORDER TODAY ON MONEY BACK TRIAL. IF NOT COMPLETELY SATISFIED, RETURN IN 10 DAYS AND WE WILL REFUND PURCHASE PRICE. SEND ONLY \$2.00 and pay \$16.95 plus C.O.D. and delivery charges, or send only \$18.95 for postpaid shipment in Continental U.S.A. FOUR-WAY WELDER CO., 1810 Federal St., Dept. R2-J, Chicago, Ill. 60616

the tub fixer

T.M.

sealing compound

DAP Kwik-Seal® Tub & Tile Caulk. Easiest and best way to put neat, white, watertight seals around tubs, sinks, showers. Stays flexible. Points tile, fills joints around window, door frames, trim and molding.



DAP

DAP Inc., Dayton, Ohio 45401/Subsidiary of Plough, Inc.

Also available in Canada

SANDING BELTS

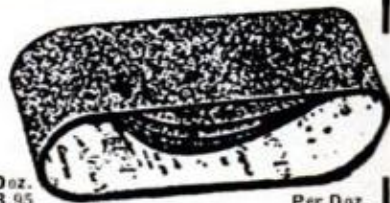

	Per Doz.		Per Doz.
1x42 Mead, etc.	\$3.95	4x21 1/2 Skil, etc.	5.95
2-17 1/2 Burgess	3.95	4x24 Misc.	6.50
2x21 Porter Cable, etc.	3.95	4x27 Porter Cable, etc.	6.50
2 1/4 x 21 5 16 Skil, etc.	4.50	4 1/2 x 26 Skil, Thor, etc.	6.50
3x18 Wen, etc.	4.50	4x36 Hammond, etc.	7.50
3x21 Porter Cable, etc.	4.95	4x37-13 1/2 Atlas, etc.	7.50
3x23 1/2 Skil, Thor, etc.	4.95	4x52 1/2 Walker Turner	9.95
3x24 Porter Cable, etc.	4.95	4x54 Porter Cable, etc.	9.95
3x27 Porter Cable, etc.	4.95	6x48 Delta-Sears, etc.	13.95

1—All belts cloth backed.
2—Please specify for wood or metal.
3—We will ship these belts assorted or with grit specifications from 24 to 400 grit.
4—**MONEY BACK GUARANTEE**
5—All other belt sizes available at lowest prices—Please inquire. Include 65¢ for postage and handling. Send check or money order. **DEALERS INQUIRIES INVITED.**

JACKSON TOOL CORP.

27-55 Jackson Ave., Dept. JG, L. I. City 1, New York

**BE SURE TO USE ZIP
CODES WHEN ANSWERING ADS**

FREE 2000 BIG NEW CATALOG OF **NOVELTIES TRICKS * JOKES**

FREE! World Famous Catalog of hard-to-get Novelties, Hobbies, Science & Electronics, Sports, Auto-Bike Items, Live Animals, Fantastic Jewelry & Medals, Bargains. Many pages in color. Send 10¢ mailing cost.
No Letter Necessary. Send Ad with Name & Address
JOHNSON SMITH CO., Dept. C-109, Detroit, Mich. 48224

TEAR OUT MAIL TODAY

**Ordinary drivers ordinary cars,
ordinary roads, ordinary turnpike speeds.
For 50,000 miles. To prove
Firestone's Sup-R-Belt is no ordinary tire.**

The Drivers. Firestone wanted non-professional drivers, so we chose a group of boys from The University of Akron.

The Cars. Three different makes of new cars. Cars like yours. Sedans and hardtops with standard automatic transmissions.

The Road. Interstate 71. From Akron to Columbus. And back. Wet and dry pavement, day and night, for 50,000 miles. We rotated the tires every 5,000 miles, kept the front ends aligned, and maintained suggested air pressures. But we drove the way you drive — maybe a little harder.

The Sup-R-Belt Tires. Firestone's Sup-R-Belt is a double-belted, bias-ply tire. (Double-belted for mileage, double-belted

for strength.) And Firestone has a special way of reinforcing the side walls and bonding the tread to the body. Extra steps for us but extra security for you.

Firestone's Sup-R-Belt will give you important extra margins of security and mileage. Prices vary according to size, but they cost far less than you'd expect. (Sup-R-Belts are also available with raised white letters.)

FREE! Firestone's Consumer Tire Guide. Get it at Firestone Dealers and Stores or write: Firestone, Akron, Ohio 44317.

Firestone
The Mileage Specialist.

NEW SELF-FIRING FLASHCUBES NEVER MISS

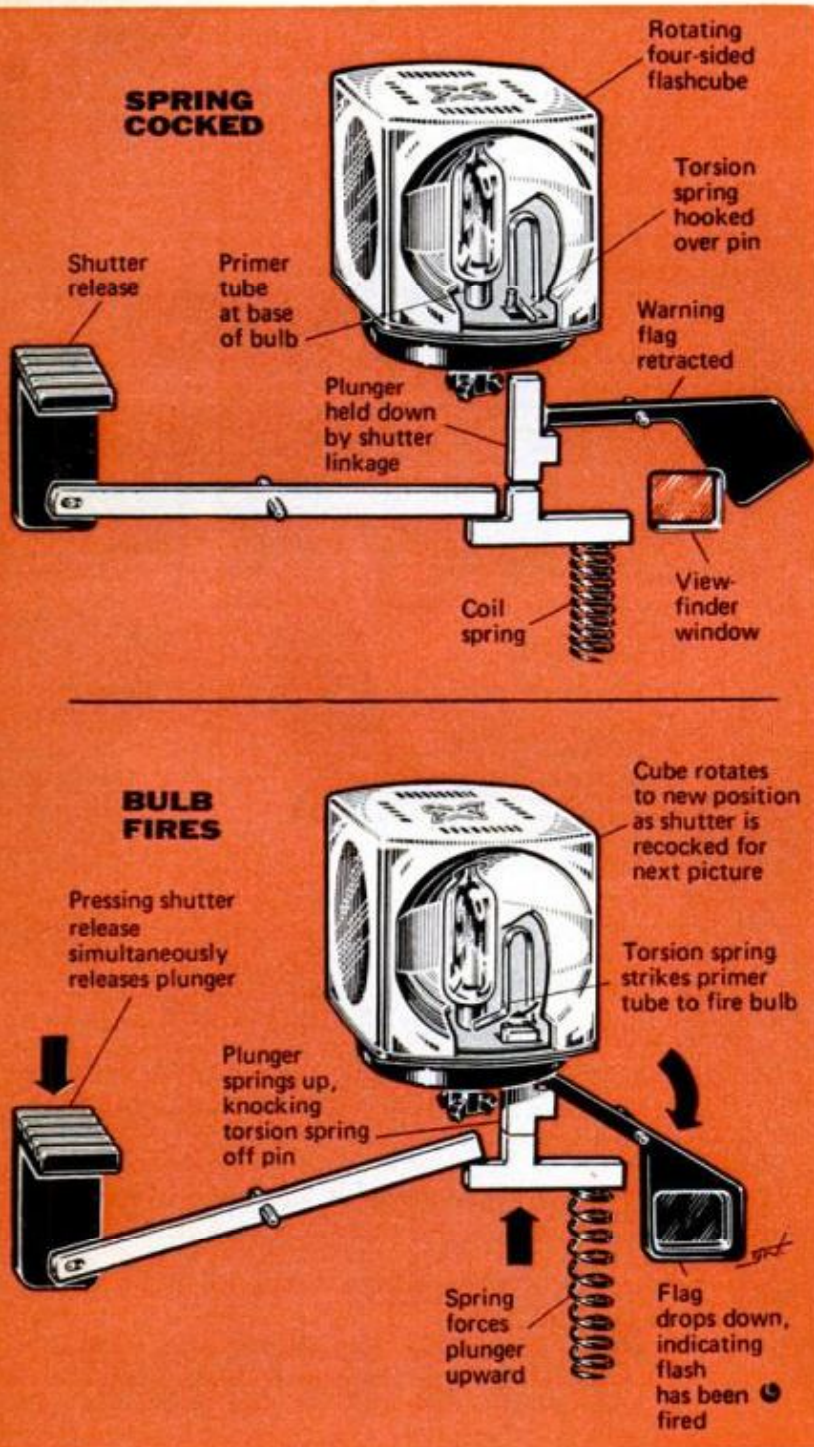

YOU DON'T have to worry whether your flash will fire with this revolutionary new flashcube-camera combination. The bulbs are fired mechanically by impact instead of electrically by batteries. This eliminates the chance of a rundown battery or corroded electrical contacts—frequent causes of flash failure—and gives you a sure shot every time.

The system was previewed last month in PM in a special advance report (see "The Flashcube That Fires Itself," Aug. '70, p. 68). Now the flashcubes are on the market, along with five new Kodak Instamatic cameras engineered to take them. Two major flashbulb makers—Sylvania and GE—are both producing the four-shot, battery-less lamps under the same trade name—Magicubes.

How the system works is shown at left. Alongside each bulb is a tiny torsion spring held by a pin. When you press the shutter release, a plunger is driven up through a slot in the cube, knocking the spring arm off the pin. The spring strikes a percussive primer in the base of the bulb, producing a spark that fires the flash.

The five new Instamatic cameras range in price from \$20.95 for the simple fixed-focus X-15 shown above to \$144.50 for an automatic model with power drive and exposure control. All take 126-size instant-load film cartridges. As an added feature, a red warning flag drops down in the viewfinder as each bulb is fired and stays down after the last is used, indicating a new cube is needed.—Sheldon M. Gallager

START YOUR NEW CAREER NOW! WITHOUT OVERHEAD! ANY PLACE! ANY AGE!

UPHOLSTERING JUST ONE

you don't even have to quit your present job!!!

CHAIR can pay you as much as your present weekly paycheck!

Start learning now. At home, or in the garage, in your spare time — no outside classes to attend. If you can tie a knot and drive a tack, you can learn this business, quickly, easily. You start learning the basics **right away** through the proven MUI Home Training Plan. And before you're barely into it, you can start doing the simple upholstery jobs that are all around you waiting to be done. Chairs, cushions, seats, footstools. Even before MUI students finish their training, people start bringing upholstery jobs to them, and remember—the world is full of furniture that needs fixing and re-upholstering and more is wearing out all the time!



"What started as a hobby, now pays me \$10 an hour"

Yes, many MUI graduates make better than \$10 an hour turning old wornout furniture into bright new decorator pieces! **Stack it up against what you're doing now!** Are you making \$150 a week? \$200? \$250? Do you put in long hours of dull work, with small raises? Is that the way you want to spend the rest of your life? Just imagine, you can make \$150, \$200, \$250 upholstering just one chair or sofa these days! And if you're the kind of person who likes to work and earn, you can sometimes finish a job like this in a day. That's pay... and it beats what most college graduates make!

AS YOU LEARN, YOU JUST SLIP INTO THE IMMENSE FLOW OF UPHOLSTERY WORK! Think of all there is! . . . Sofas, lounging chairs finished in beautiful fabrics, which MUI tells you how to get at the right price — even leather and all the new vinyls. And then you have built-ins and breakfast nooks, boats, trailers, and all the millions of automobiles in America. Yes, you learn all this and more! When we finish teaching you, (in your own home in your spare time) and when you get our California state approved diploma, you know this business . . . as a real professional! You will then have one of the most fantastic moneymaking skills in America built into your head and hands! No one can ever take this skill away from you . . . and no one can ever fire you, because you're the boss of a business that you can take with you . . . You can make big money from then on . . . any time, anyplace you want to put out your shingle!

When you read the papers you see there's a strike here, a lockout there. Detroit lays off 150,000 men. A plant is shut down and moved out of state. A new automated machine eliminates 5,000 jobs. They talk about dislocated workers and try to do something about it. What pays the bills if you get caught up in one of these situations? When you know upholstery, life gets very simple and lots of fun. It's simple because where there are people, there are upholstery jobs and lots of them. It's fun because life is fun when the bills are paid and there's money in the bank, even enough to buy those things you've always wanted for yourself.

MUI IS APPROVED BY THE CALIFORNIA SUPER-INTENDENT OF PUBLIC INSTRUCTION AND IS AUTHORIZED TO ISSUE A DIPLOMA IN UPHOLSTERY.

MODERN UPHOLSTERY INSTITUTE
Box 899-DNZ Orange, Calif. 92669



YOU GET SIX BIG FURNITURE KITS FREE

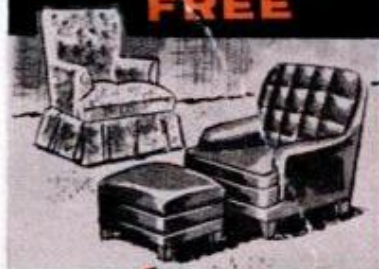

YOU GET THIS AUTHORIZED DIPLOMA WHEN YOU GRADUATE

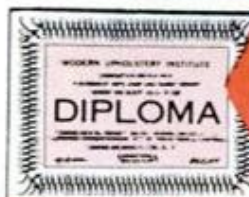

WORK THE HOURS YOU LIKE TO WORK!!

If you favor a regular 35 hours a week, upholstery lets you do it and make a really fine living. On the other hand, if you're really ambitious and want to work 60 or 70 hours a week, you are starting to talk about some big, big money! The important thing is that the choice is yours, not somebody else's! (Not like when you're working for someone else.) Many students of retirement age just do a few pieces now and then just to keep things nice and comfortable.

TO GET STARTED, JUST GET THE COUPON IN THE MAIL . . . TODAY!

It costs you nothing to get the information and there's no obligation. No salesman is going to call you. This much and this much only, every successful MUI graduate must do for himself — send the coupon today!

YOU'LL GET A BIG ILLUSTRATED 32 PAGE BOOK ON UPHOLSTERY and the upholstery business, and an actual free sample lesson showing how the fabulously successful MUI system is taught. For your sake and the sake of your future, do it now. Cut out the coupon, fill it out, put it in an envelope and mail it now. Air mail reaches MUI about two days sooner!

ALL THE SPECIAL "TOOLS OF THE TRADE" ARE YOURS . . . FREE

THIS FREE UPHOLSTERY BOOK may be the most important information you ever read.

MAIL COUPON NOW!

MODERN UPHOLSTERY INSTITUTE, Box 899-DNZ Orange, Calif. 92669

Please send the FREE UPHOLSTERY CAREER BOOK, the FREE SAMPLE LESSON. I understand I am under no obligation whatever and am just sending for the free facts on job and career opportunities in Upholstering and the MUI home training program. I understand that no salesman will call.



APPROVED FOR VETERANS

Name _____ Age _____

Address _____

City _____ State _____ Zip _____

APPROVED FOR VETERANS
 These 3 BIG DRAFTING KITS GIVEN TO YOU!
 ... when you train at home with NASD for a HIGH PAY JOB IN DRAFTING!

1 Take your pick of 1000s big salary jobs open to Draftsmen. U.S. Labor Dept. reports "42% more Draftsmen needed in next 10 years—not enough applicants to fill jobs available now." Easy home-study plan has helped 100s beginners toward \$\$\$\$\$, security, prestige as Draftsmen—many with only grade school training. Others report good earnings drafting part time while still learning. Why not you?

2 RUSH COUPON FOR FREE KIT!
 Mail coupon for FREE "DRAFTING CAREER KIT," Sample Lesson, Drafting Aptitude Test including new 5-Way Drafting Instrument & 20-Page Book, "Your Future in Drafting"—ALL FREE. No salesman will call. G.I. approved. Write today.

3 NORTH AMERICAN SCHOOL OF DRAFTING, Dept. 04179
 4500 Campus Drive, Newport, California 92660
 Rush "Drafting Career Kit," including Book, Sample Lesson, Aptitude Test & Drafting Instrument—All Free!

NAME _____ AGE _____
 ADDRESS _____
 CITY _____ STATE _____ ZIP _____

Free rent, resort living, great food, unlimited recreation... and plenty of time to enjoy them! Easy home-study plan. 1000s men, women, couples needed. Age no barrier. (Or, own your own motel.) Send for FREE "Career Kit." No salesman will call.

MOTEL-HOTEL CAREER

NORTH AMERICAN SCHOOL OF MOTEL-HOTEL MANAGEMENT
 4500 Campus Dr., Dept. 04179, Newport, Ca. 92660

NAME _____ AGE _____
 ADDRESS _____
 CITY _____ STATE _____ ZIP _____

Your Future in MOTEL HOTEL Management
YOURS FREE

"Buy auto air conditioning now? You're kidding."
 "When you can save \$200 or more - why not? Write Comfy-Kit, Box 8585, Dallas, Tex."

GLASS BLOWERS KIT \$13.95^{pdd}
 SPECIAL TRIAL SIZE KIT
 Contains assorted crystal and colored glass with complete instructions, diagrams and actual glass model. Learn to make beautiful ships, birds, bottles for fun and profit.
 SEND \$13.95 TO
WILLIS GLASS SUPPLY CO.
 BOX 3460 — ARTIST STUDIO — A
 ANAHEIM, CALIFORNIA 92803

USE ZIP CODES
 WHEN ANSWERING ADS

AMAZING NEW TUNGSTEN CARBIDE BLADES MAKE YOUR SABER SAW A SUPER SAW!

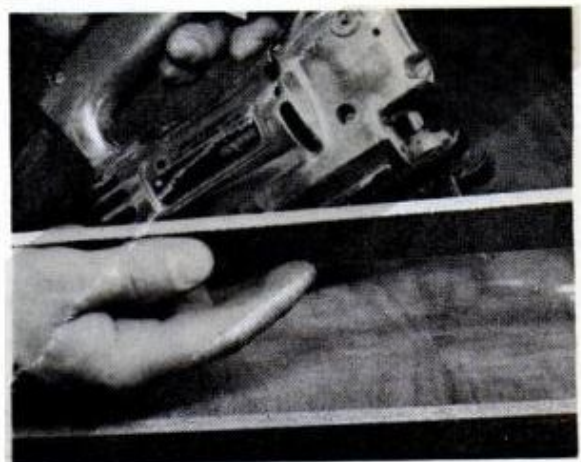

Finer finished cuts in plywood.

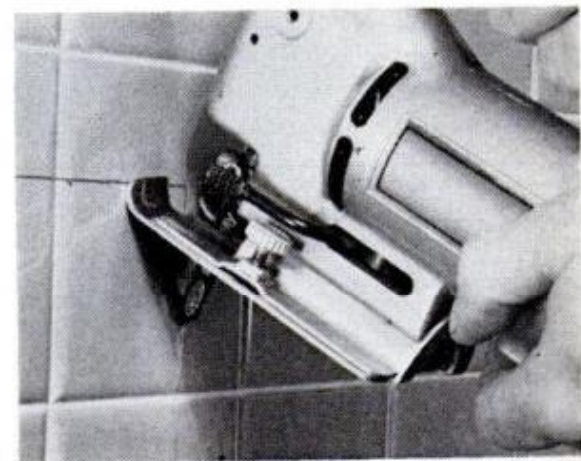

Plunge-cuts tile walls.

- Get smoother, more finished cuts in plywood, paneling and counter-top materials. Less work, waste, damage.
- Cut ceramic tile (even plunge cuts), asbestos cement, slate, things you couldn't cut before.
- Better cuts in all do-it-yourself materials, including metals.
- No teeth to dull or break.
- Up to 10 times more cutting life.
- Works like the famous Remington Rod Saw. Hard tungsten carbide particles eat through the toughest materials.
- Remington Saber Saw Blades and Rod Saws are at hardware stores now.
- If you don't see them, ask.

Remington DU PONT
 Made in U.S.A. U.S. Patent 3,023,490. Application Pending.

Are you missing out on the extra pay of an I.C.S. graduate?

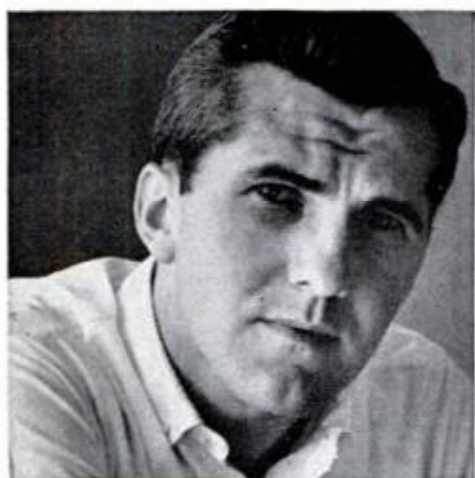

Recently we mailed out a questionnaire to a group of our graduates, two years after they had received their I.C.S. diplomas.

The main objective of this questionnaire was to determine if spare-time study had helped them get ahead faster.

- Those who answered the questionnaire reported that they were earning *almost \$1100 more* (median) than the day they'd received their diplomas.
- Over 18% said their annual pay had grown *\$2000 or more*.
- The number of graduates making over \$10,000 *had more than doubled*.

All this proves one thing. Bosses—who give the raises—know the value of I.C.S. training. (More than 7000 have proved it by entering formal training arrangements with us.)

If you study with I.C.S., will your pay grow as fast? It may grow even faster. So take the first step toward higher pay right now. Mail the coupon.

ICS[®] International Correspondence Schools Division of Intext

ICS, Scranton, Pa. 18515
Canadian residents:
Send coupon to Scranton.
Our affiliate in Canada
will reply.

Take your first step . . . mail this coupon today . . . ICS, Scranton, Pa. 18515.

I'm interested in a program of independent study. Send me your free 3-booklet Success Kit: (1) "How to Succeed," 30 pages of valuable job tips, (2) Sample text demonstrating famous ICS method, (3) Catalog for subject checked below . . .

Miss _____
Mrs. _____
Mr. (Please print) _____ Age _____

Address _____

City _____ State _____ Zip Code _____

Occupation _____ Employed by _____ Working Hours _____ A.M. to _____ P.M.

ACCOUNTING

- Accounting (U.S. or Can.)
- Cost Accounting
- General Accounting
- Practical Accounting
- Public Accounting

ARCHITECTURE and BUILDING TRADES

- Air Conditioning
- Air Conditioning Maint.
- Architecture
- Arch. Drawing & Design
- Building Contractor
- Carpenter-BUILDER
- Carpentry & Millwork
- Heating & Air Conditioning with Drawing
- House Planning, Int. Design
- Plumbing
- Plumbing & Heating
- Reading Arch. Blueprints
- Refrigeration

ART and D...SIGN

- Commercial Art
- Commercial Cartoning

- Interior Decorating
- Sign Painting & Design
- Sketching & Painting

AUTOMOTIVE

- Auto Body Rebuilding & Refinishing
- Auto Mechanic-Techn. Vehicle Engines
- Diesel-Gas-Motor Vehicle Engines
- Auto. Electrical Techn. Engine Tune-Up
- Transmission Specialist

BUSINESS

- Advertising
- Business Administration
- Business Law
- Business Management
- Industrial Psychology
- Inventory Control
- Managing a Small Store
- Personnel-Labor Rel's
- Purchasing Agent
- Retail Business Mgmt.
- Traffic Management

BUSINESS: SALES

- Creative Salesmanship

- Real Estate Sales
- Sales & Sales Mgmt.

CHEMICAL

- Chemical Analyst
- Chemical Engineering
- Chem. Lab Technician
- General Chemistry
- Plastics Technician

CIVIL ENGINEERING

- Civil Engineering
- Highway Eng. Tech.
- Sewer Plant Operator
- Surveying & Mapping
- Water-Works Operator

COLLEGE COURSES

- American History
- Calculus
- Economics

COMPUTERS

- COBOL Programming
- Fortran Programming
- Programming for Digital Computers
- Programming the 360
- Programming the 1401

DRAFTING

- Aircraft Drafting
- Architectural Drafting
- Blueprint Reading
- Design Drafting
- Drafting Technology
- Electrical and Electronic
- Mechanical
- Structural

ELECTRICAL

- Electrical Engineering
- Appliance Servicing
- Elec. Eng. Technician
- Industrial Electrician
- Motor Repairman
- Practical Electrician
- Practical Lineman

ENGINEERING (Refresher Courses for Graduates Engineers)

- Chemical
- Civil
- Electrical
- Industrial
- Mechanical
- Sanitary
- Structural

HIGH SCHOOL

- High School Business
- High School General
- High School Math.
- High School Secretarial
- High School Vocational
- College Preparatory
- Preparatory Course for H.S. Equivalency Test

MACH. SHOP PRACTICE

- Machine Shop Practice
- Maintenance Mechanic
- Reading Shop Prints
- Tool & Die Maker
- Welding, Gas & Elec.

MECHANICAL

- Mechanical Engineering
- Aircraft Mechanic
- Hydraulic, Pneumatic Power
- Industrial Engineering
- Industrial Instrumentation
- Machine Design
- Power Plant Engineering
- Quality Control

Approved for veterans for tuition refund.

Accredited member, Nat'l Home Study Council.

Easy pay-as-you-learn plan.

Special rates to members U.S. Armed Forces.

ICS has over 266 career-related courses

A1848H

- Refrig., Air Conditioning
- Tool Design

SECRETARIAL

- Clerk-Typist
- Secretary, Legal
- Secretary, Medical
- Secretary, Professional
- Shorthand
- Stenographic
- Typist

TV-RADIO-ELECTRONICS

- Electronics Fundamentals
- Electronic Technician
- General Electronics
- Indust. Electronics Tech.
- Radio Telephone License
- Telephony
- TV and Radio Servicing with Equip. Training

WRITING and ENGLISH

- English and Writing
- Free-Lance Writing
- Reading Improvement
- Other (tell us)

SCIENCE worldwide

by JOHN F. PEARSON

The person who drinks to forget may be doing a better job of it than he thinks. That's one conclusion that can be drawn from the results of research on white mice by the University of Florida's Dr. Gerhard Freund. He reports that mice, given "cocktails" with their food over a period of months, showed deterioration of brain function and loss of memory—damage that appeared permanent. The mouse brain, according to Dr. Freund, is similar to man's and "the basic biochemistry is the same." He says his studies tend to cast doubt on the notion that it's malnutrition that causes brain damage in alcoholics. His mice showed damage whether well fed or not.

NASA is helping to collect facts for the 1970 U.S. census by carrying out high-altitude aircraft flights over 26 cities—Denver, Salt Lake City, Atlanta and New Orleans, among others. Purpose of the missions is to gather standardized data on urban areas so that land usage can be correlated with statistical data gathered in the census.

A continuous record of the ocean bottom in a 3500-mile-long strip from Cape Hatteras, N.C., to Cap Blanc, Mauretania, in northwest Africa, is being made by the Discoverer, a survey ship operated by the Environmental Science Services Administration. Electronic instruments on the Discoverer record the shape of the ocean bottom and subbottom, including rock layers several miles below the ocean floor, and their magnetic and gravity fields. Scientists think that evidence gathered during the two-month trip will cast new light on the theory that the continents once were joined.

Is the Earth losing its oxygen supply? No, say Department of Commerce scientists after completing a three-year study and comparing the results against tests made as long ago as 1910. Despite the heavy burning of oil and coal, there has been no discernible change in the atmosphere's oxygen content. The scientists report that air at sea level contains 20.946 percent of oxygen by volume. Earlier measurements made since 1910 range from 20.945 to 20.952. Projecting their research results, the Department of Commerce investigators say that even when all recoverable fossil fuels have been consumed, the concentration of atmospheric oxygen will still be about 20.8 percent by volume. The direct effect of this slightly lowered concentration on human breathing would be negligible.

If you're a lepidoptera fancier, you'll be happy to know that color photos of all the 10,000 species of moths found in the United States, Canada and Greenland will appear in a 14-volume work now in preparation. Called *The Moths of America North of Mexico*, the reference set will be published in England over the next 12 years. The driving force behind the monumental venture comes from a South Carolina physician, Richard B. Dominick, a life-long collector of moth and butterfly specimens.

"Polywater" is still a puzzle. First produced by Russian scientists in 1962, the substance is regarded as a new and peculiar form of water by some scientists. Others think its unusual characteristics may be due to the presence of inorganic contaminants. Polywater's controversial status remained unchanged after an international symposium recently held at Lehigh University, Bethlehem, Pa. Of interest to American scientists was a report by a Russian researcher that the liquid he has been working with has a boiling point of 482°F. In addition, it has a molecular weight 10 times that of ordinary water, a high viscosity and a very low freezing point.

A new world's record for "dry" dives is claimed by two young English researchers, who recently spent 10 hours at a simulated depth of 1500 feet. Scientists say the achievement indicates man has yet to reach the physiological limits of deep diving. ★★★

POPULAR MECHANICS

KEEP PACE WITH SPACE AGE! SEE MOON SHOTS—LANDINGS, SPACE FLIGHTS, CLOSE-UP!

AMAZING SCIENCE BUYS

for FUN, STUDY or PROFIT



TERRIFIC BUY! TOP QUALITY!
PRICE BREAKTHROUGH IN LARGE SIZE



OPAQUE PROJECTOR

"Best Opaque of its Kind Under \$200"

Projects brilliant, sharp $\frac{1}{2}$ foot square image from 8 feet away using up to 5"X5" color, b & w illustrations. Retains all original colors and proportions. Enlarges drawings, blueprints, watercolors, pictures, stamps, coins, other objects. Features high speed, 200mm anastigmatic projection lens (f3.5, 8" F.L.); powerful peanut-size quartz halogen lamp

(50hr. life); unique internal reflecting system. Gives maximum brightness, entire field focus. Flat stage and removable magnetic platen enable use upside down. Turbo-blower cooled. Tough plastic case. 5 1/2 ft. cord.

Stock No. 71,272H (8 3/4" x 6" X 12 1/2" — 11 1/2 lbs.) \$89.75 Ppd.

BLACK-LIGHT MIGHTY MITES

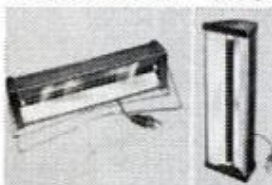

Relatively small (12") fixtures give surprisingly bright blacklight. Mirror-finished reflector makes instant starting 8-watt, high-intensity bulb look like 40-watter. Up to 5,000 hours of safe, long-wave (3660A) blacklight to really turn-on parties, light & theatrical shows, psychedelic decors, holiday decorations. Shockproof end-caps remove for safe, easy replacement of bulb and starter. Stands upright or horizontal. Aluminum case.

Stock No. 71,274H \$14.95 Ppd.

DELUXE OUTDOOR/INDOOR MODEL \$19.95 Ppd.

AMERICAN MADE OPAQUE PROJECTOR

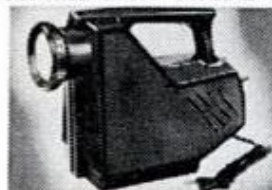

Projects illustrations up to 3" x 3 1/2" —enlarges them to 35" x 30" if screen is 6 1/2 ft. from projector, larger pictures if screen is farther away. No film or negatives needed. Primarily intended for children. Projects charts, diagrams, color or black-and-white in darkened room. 115 v. A.C. . . . 6 ft. cord and plug included. Size 12" x 8" x 4 1/2" wide. Weight 1 lb. 2 ozs. Plastic case.

Stock No. 70,199H \$8.75 Ppd.

HOT-AIR FLYING SAUCER KIT



Giant 9 ft. model rises to amazing heights. Easy to assemble and launch. Use over and over. Low cost. Lots of fun. Can carry 1/2 lb. objects with string tether. Fly school colors at games, use for advertising, attach mirror—play "spy in the sky." Includes complete instructions, 16 pre-cut ± 1 white model paper gores, 8 red panels for portholes, wire, cord. Easily repaired if damaged.

Stock No. 71,175H \$3.00 Ppd.

9 FT. HOT AIR BALLOON KIT \$2.00 Ppd.

WAR SURPLUS ELECTRIC GENERATOR



Brand new Signal Corps Electric Generator. Generates up to 90 volts by turning crank. Use in high impedance relays. Charge ground & bring up night crawlers for bait or study. 2 Alnico Magnets alone now worth more than original gov't cost of \$15. Wt. 2 lbs.

Stock No. 50,225H \$8.50 Ppd.

SUPER 6" SPACE CONQUEROR

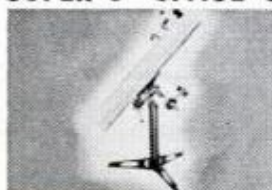

Share the wonders of space exploration. Capable of revealing faint stars of nearly 13th magnitude, split double stars separated by less than 1 sec. of arc. Features aluminized & overcoated 6" f/8 ground and polished pyrex parabolic mirror accurate to 1/4 wave, 48 F.L. 6X achromatic finder scope, 4 eyepieces—48X Keilner, 1 1/2" 96X & 1 1/4" 192X Ramsdens. Barlow to double or triple power—rack & pinion focusing mount. 47 3/4" aluminum tube. Electric clock drive w/ manual slow-motion control. Setting circles. Heavy-duty equatorial mount. Pedestal base.

Compares to \$295-\$350 models.

Stock No. 85,086H \$239.50 FOB

Stock No. 85,105H 4 1/4" Astronomical Telescope \$ 94.50 FOB

Stock No. 85,050H 3" Astronomical Telescope \$ 29.95 Ppd.

GREAT INTERNATIONAL PAPER PLANE BOOK

Official fly-them-yourself book of paper airplanes from **SCIENTIFIC AMERICAN'S** "1st International Competition." Includes plans of all winning entries, time-aloft records, photos, technical data, commentaries. Has 20 unusual designs on perforated pages for easy tear-out. You won't believe how some of them fly! Amusing, entertaining. 128 pages, 9" x 11 3/4".

Stock No. 9391H \$2.95 Ppd.



GIANT WEATHER BALLOONS

"Balls of fun" for kids, traffic stoppers for stores, terrific for amateur meteorologists. Create a neighborhood sensation. Great backyard fun. Exciting beach attraction. Amateur meteorologists use to measure cloud heights, wind speed and temperature. Made of heavy duty neoprene. Inflate with vacuum cleaner or auto air hose or locally available helium for high rise.



Stock No. 60,568H (8 Ft. diameter) \$2.00 Ppd.

Stock No. 60,632H (16 Ft. diameter) \$7.00 Ppd.

CHROMATIC "MACHINE-GUN" STROBE

Red, Green, Blue & White light barrage the eyeballs every 6 seconds with this low-cost mechanical strobe that can run continuously without fear of burning up. Devastating effects over 500 sq. ft. area. Created by rotating color wheel in front of 100W, 120v reflector floodlamp (incl.)—elements seem to flash on & off as colors fluctuate. Turns store windows, posters, parties into flashing, pulsating productions. Convection cooled. Walnut cabinet. Brass handle, Reg. house current.

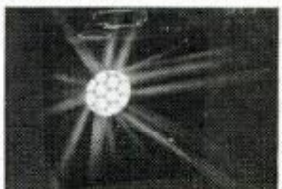

Stock No. 71,271H (9 X 10 X 6 1/4") \$28.50 Ppd.

4 GIANT 180" DAY GLOW TAPES!

1" bands of fluorescent pink, green, red, yellow. Brilliant in normal light —wild and exciting "hot" glow under blacklight. Self adhesive. Easily removed. All kinds of uses—decorate clubs, dances, parties; highlight posters, costumes; design "op" pictures, wall decorations; ideal for safety markers, shelf strips. Medium strength tape, paper flatback. 720 feet in all.



Stock No. P-71,303H \$9.50 Ppd.

PLASTIC MODEL V-8 ENGINE

Hours of fun! Get thrill of building your own easily assembled engine from over 350 parts. Then push starter and watch it run. Crankshaft revolves, pistons move, valves open and close in sequence with spark plugs. Does everything but burn oil. 1/4 scale, molded in 4 colors. Used in many auto-mechanic courses. Excellent, easy-to-understand "tech manual."



Stock No. 70,448H \$13.50 Ppd.

"FISH" WITH A MAGNET

Go treasure hunting on the bottom! Fascinating fun & sometimes profitable! Tie a line to our 5-lb. Magnet—drop it overboard in bay, river, lake or ocean. Troll it along bottom—your "treasure" haul can be outboard motors, anchors, other metal valuables. 5-lb. Magnet is war surplus—Alnico V Type—Gov't cost \$50. Lifts over 150 lbs. on land—greater weights under water.



Stock No. 70,571H \$14.00 Ppd.

Stock No. 70,570H 3 1/2 lbs. (lifts 40 lbs.) \$ 8.75 Ppd.

Stock No. 85,152H 15 3/4 lbs. (lifts 350 lbs.) \$33.60 FOB

MAIL COUPON FOR GIANT FREE CATALOG

148 PAGES! MORE THAN 4,000 UNUSUAL BARGAINS.

Completely new 1971 Catalog. Packed with huge selection of telescopes, microscopes, binoculars, magnets, magnifiers, prisms, photo components, unique lighting items, parts, kits, accessories—many hard-to-get surplus bargains. 100's of charts, illustrations. For hobbyists, experimenters, schools, industry.

EDMUND SCIENTIFIC CO.

300 Edscorp Building, Barrington, N. J. 08007

Please rush Free Giant Catalog "II"

Name

Address

City State Zip



EDMUND SCIENTIFIC CO.

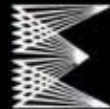

ORDER BY STOCK NUMBER • SEND CHECK OR MONEY ORDER • MONEY-BACK GUARANTEE

300 EDSCORP BLDG. BARRINGTON, NEW JERSEY 08007



He agreed to tell about our tire. We agreed not to tell his name.

This is a true story about a tire almost too good to be true. A tire that's 33% stronger—that gives 30% better mileage—than even our fiberglass-belted tire.

The story's from a state trooper. An expert on highway driving . . . and highway safety. We can give you his story but not his name. Because neither the trooper nor his state can lend their names to any product. So his face is masked, his uniform disguised.

"I've been driving a patrol car for 14 years now, and I guess I've tried every kind of tire. But never anything like these Lifesaver Radials. The way they hold the road on curves and in the rain is . . . well, it's fantastic. But the really amazing thing

is the mileage. We get three or four times as much wear out of Lifesavers as we do from specially built patrol tires."

You can hear the same kind of testimony from troopers across the country now riding on B. F. Goodrich Radials. Exactly the same tires you can buy.

Lifesavers are like no other tires you've ever ridden on. They're made a whole new way with a belt of Dynacor® Rayon Cord. So they corner better. Take curves better. Stop quicker. Lifesavers handle better and run cooler at high speed than fiberglass tires—even our own.

Lifesavers are the safest tires we've ever made. They're the tires your life should be riding on.



The New BFG Lifesaver Radials. Your life should be riding on them.

Drivin' with Dan

What's different about the '70 Can-Am cars? Do wide wheels make an appreciable change in performance? Are the bigger engines okay for small-car use? Dan Gurney answers these and other automotive questions

Q. I was happy to see you walk away with the first two races in the Can-Am series, but was also anticipating tougher competition in the series with the entry of Jim Hall's Chaparral 2J at Watkins Glen. What really happened to it?—Neil Sonenberg, Douglaston, N.Y.

A. The 2J with Jackie Stewart driving got off to a good start in the race, turning several really hot laps. The vacuum fans were disabled early in the race when asphalt chunks breaking off the track surface jammed the belt-drive system from the fan motor. Without the atmospheric down force acting on the car to "glue" it to the road, the brakes were overtaxed and the car had to retire.

Q. Since wings were banned from the 1970 Can-Am cars, what kind of driving "feel" difference do you notice?—Kelly McCurnin, Long Beach, Calif.

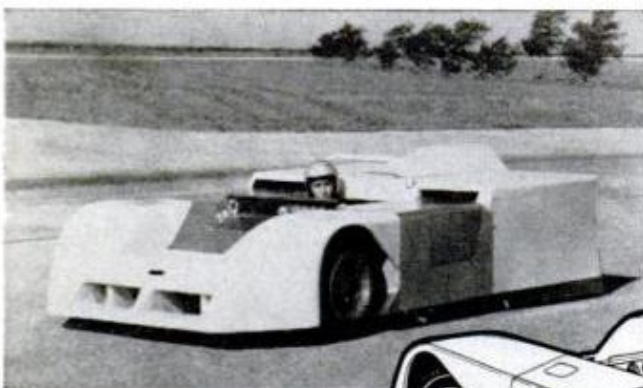

CHAPARRAL 2J is held against the road by atmospheric pressure when partial vacuum is created under the car. An auxiliary motor drives the two fans in the aft end which evacuate the air. Rugged Lexan "skirts" extend down from the car body almost to the road, thus providing enough of a seal for the system to work. The skirts are articulated to allow some freedom of movement since they do on occasion come in contact with the road

A. Actually wings are still allowed, but they can no longer be mounted directly on the suspension. There's a limit as to their height and they must attach to the chassis or body. This means heavier springs are needed, the car's ride is stiffer and the front-to-rear balance of the car is harder to achieve throughout the speed range.

Q. Is appearance the only reason for the wide wheels so many people buy or is there any appreciable performance difference?—Greg Hogan, Milwaukee.

A. Wide wheels have evolved out of racing right along with wider tires and more rubber on the ground. Many passenger cars suffer adverse effects from wider wheels along with bigger tires. Usually wider wheels and tires are heavier, possibly rougher riding and sometimes not as good in wet weather.

Q. Did you notice any significant changes in Grand Prix racing when you returned this year after a two-year absence?—Randy Erickson, Cleveland.

A. Yes. I was two years older and rustier. The cars are not much faster in top speed, but are quicker around corners and brake *(Please turn to page 26)*

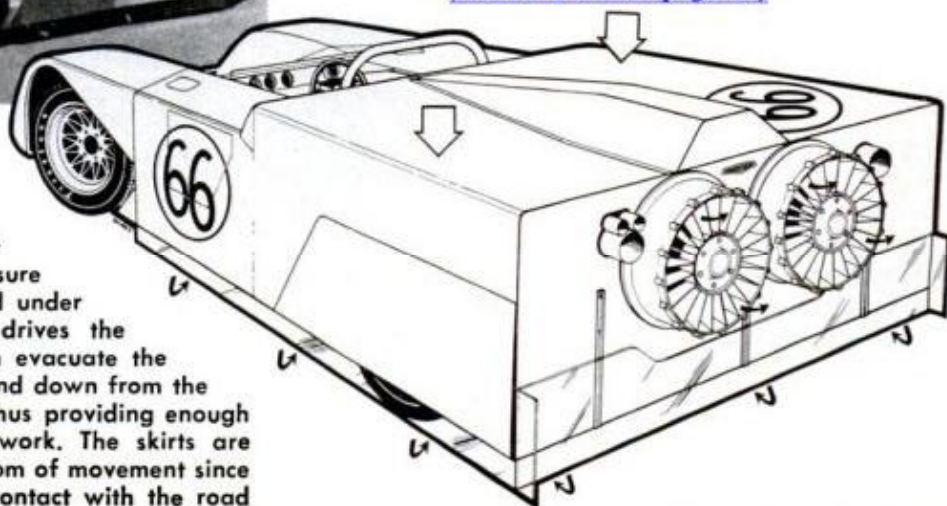

If you can't come to the world's newest, largest and most exciting electronics department store, we'll mail the store to you!

Exclusive! Knight-Kit and Science-Fair Kits. Exciting build-your-own kits made to our own exacting standards. Stereo, CB, automotive, ham radio, science, hobby, test equipment, photography and more!

Exclusive! Realistic Life-time Tubes. Never worry about buying another tube. We guarantee ours will last as long as your set—or we replace it FREE!

Exclusive! Battery-A-Month Club. Join the Allied Radio Shack Club and receive a powerful battery every month for a full year—FREE!



Exclusive! Quality Audio Products at Factory-Direct Savings

Allied TD-1099 3-Head Stereo Tape Deck. New one-piece head makes tape threading a snap. With case. Spectacular value! \$179.95

Realistic STA-120 Wideband AM, FET-FM Stereo Receiver. 140 Watts. With case. \$269.95



New Allied Radio Shack Catalog! Thousands of electronic values!

Allied Radio and Radio Shack have joined forces to form the largest electronics distributing company in the world! This new 1971 460-page catalog offers you the best of both companies: famous-name brands, exclusive new products you'll find nowhere else (including some items you didn't even think were invented yet), and special money-saving prices that only the combined buying power of these two great companies could offer!

World's Largest Electronic Department Stores. Over 800 stores in 48 states. See your phone book for store nearest you.

Mail Coupon To Address Below

...or bring to Allied Radio Shack store for new catalog!



ALLIED RADIO SHACK 100 N. Western Avenue
Chicago, Illinois 60680 638

Yes! I want your big new 1971 catalog. I enclose \$1 for mailing and handling (refundable with my first purchase of \$1 or more).

NAME _____
First Middle Last

ADDRESS _____
Street or Route and Box No.

CITY _____ STATE _____ ZIP _____

I enclose check money order cash

RIDGID

Tubing Cutters give "pro" results!



Midget Tubing Cutters

- No. 103
1 $\frac{5}{16}$ " turning radius
- No. 104
1 $\frac{11}{16}$ " turning radius

For extra-close-quarters cutting of hard and soft copper, aluminum, brass and plastic tubing. Dual rollers opposite hardened cutter wheel center tubing for smooth, fast, accurate cuts.

3 Tools in 1!

- No. 10 — $\frac{1}{8}$ " thru 1" O.D.
- No. 15 — $\frac{3}{16}$ " thru 1 $\frac{1}{8}$ " O.D.

Quickly, smoothly cut copper, brass and aluminum tubing — also thin-wall conduit. Have handy, fold-in reamer with gas cylinder wrench key cut into blade. For larger capacities ($\frac{5}{8}$ " through 4 $\frac{1}{8}$ " O.D.) see Nos. 20, 30 or 40. Cutters for plastic also available.



Enclosed Feed Tubing Cutter

- No. 105 — $\frac{1}{8}$ " thru 1 $\frac{1}{8}$ " O.D.

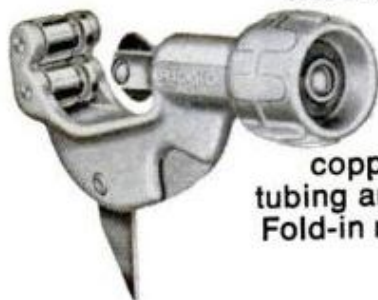

Grooved rolls for close flare cut-offs. Only 5" long! For copper, brass, aluminum tubing and thin-wall conduit. Fold-in reamer. Spare cutter wheel in handle.

Buy RIDGID Tubing Cutters at your quality Hardware Store, and be sure to see the other RIDGID Work Saver Tools from The Ridge Tool Company, Elyria, Ohio 44035, U.S.A.

RIDGID®

 Ridge Tool Subsidiary
Emerson Electric Co.

DRIVIN' WITH DAN

(Continued from page 24)

harder. There are still standouts, but the so-called second echelon is much closer to the fastest people, and there are many more of them. It is tough competition.

Q. I am making a study of whether or not there is any problem in handling small automobiles equipped with engines more powerful than the standard engine normally installed in them. What's your opinion?—Ervin D. Sacks, Philadelphia.

A. How do you plan to carry out this study? Drivers have a lot to do with problems in car handling. I believe a more powerful engine need have no detrimental effect on the car's handling. As a rule, however, higher speeds require better handling, brakes and so on.

Q. How much do smog-reducing devices reduce performance in ordinary automobiles?—Paul Olson, Newark, N. J.

A. I don't know the exact percentage reduction in economy and performance (very slight), but the various devices enable the engine to meet minimum requirements for air pollution. They work; they're not all hokum. Don't disconnect the plumbing!

Q. I just bought a 3 $\frac{1}{2}$ -hp mini-bike. What are the advantages of taking off the governor?—Howard Truckman, West Hempstead, N.Y.

A. It should let you reach higher speeds; it should also enable you to wear it out sooner. It might be more fun. You can probably smoke off your neighbor or his mini-bike if he still has a governor on his.

Q. What is the difference between the Triumph Spitfire Mk II and the Mk III?—John Engstrom, Corning, N.Y.

A. Obviously, in addition to having one more mark, the Mk III, introduced to replace the Mk II in 1967, has many differences that do not, however, affect the basic appearance of the car. The Mk III has a different cylinder head, various trim and badge changes, higher bumpers and a soft top that folds back into the rear well as opposed to the old type that had to be removed and stowed in the luggage boot. The Mk III, has had

(Please turn to page 30)

"With my budget when the engine packs it in so do I."



Tom Davey's in racing for the fun of it. He's not a pro with a spare engine and a big fancy pit crew. He pays his own way. And he knows that a cham-

pionship he's been chasing all year can go up in smoke — right out the tailpipe.

That's why he uses Gulfpride® Formula G. Formula G's low ash content helps keep plugs and rings clean. And it won't turn to foam or break down when the old mill is turning over 30% faster than it was designed to.

Which is more than Tom can say for other racing oils he could name. Because he's come face to face with bearings that were the victims of oil breakdowns.

And that's why he switched to Formula G.

Not a bad reason for you to switch, either — whether you're driving a muscle car or the family wagon. Because chances are your oil is going to be running hotter around town or on the highway than the oil in a race car equipped with an oil cooler.

It's nice to know, too, that we sell Formula G at Gulf stations. Because not only is it a racing oil, but it also meets all passenger car manufacturers' new car warranty standards.

Tom knows. Which is why he uses Formula G in the car he drives to the track, as well as the car he drives on the track.

He knows that if he blows the engine in one, he loses the race. But if he blows it in the other, he rides the bus.

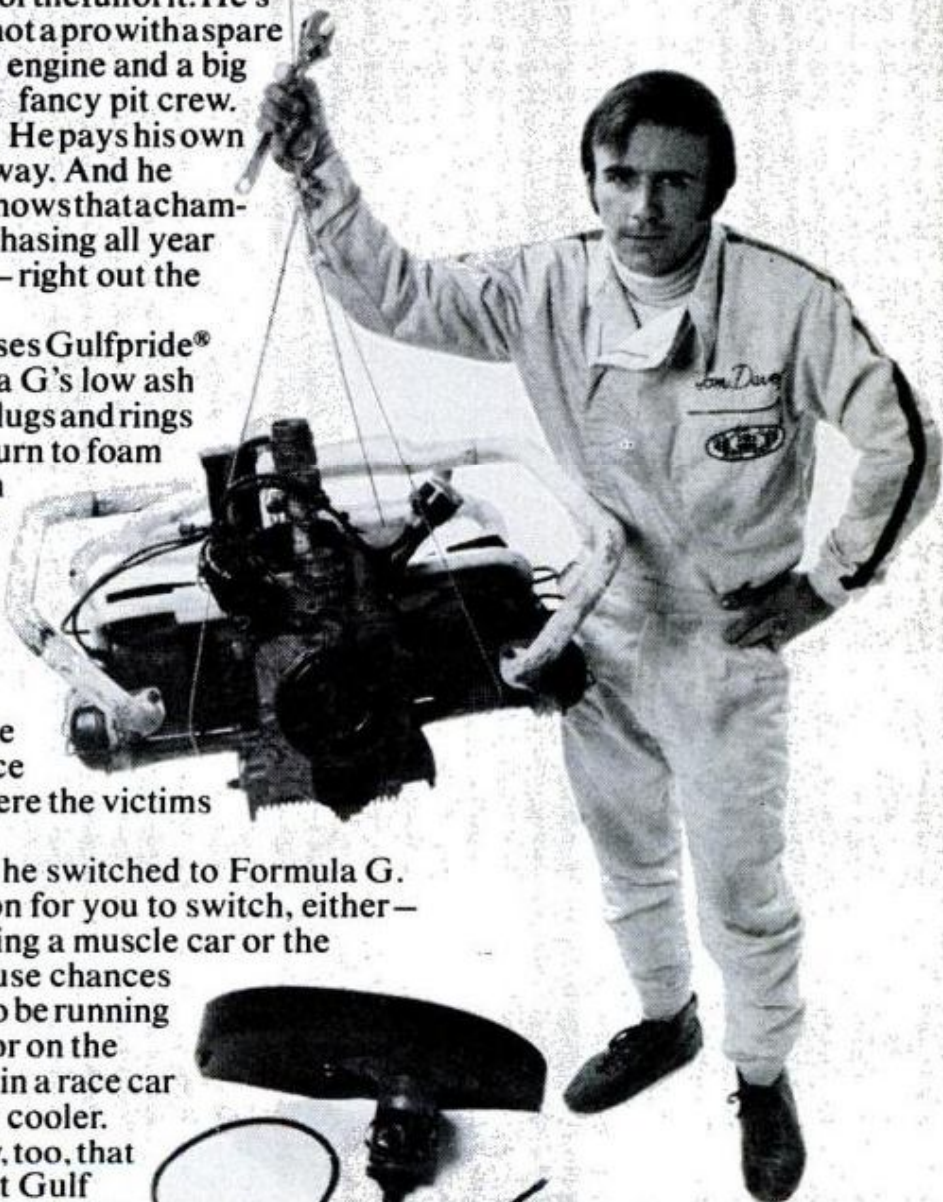

GULF OIL COMPANY — U.S.

Shopper's special

Shopping means stop-and-go driving. And that can take your engine apart. Change to the 100% Pure Pennsylvania Oil fortified to keep grit out of your engine—when the stopping and going gets rough. Buy your oil the way you bought your car. Carefully. Wolf's Head Oil Refining Co., Oil City, Pa. 16301.

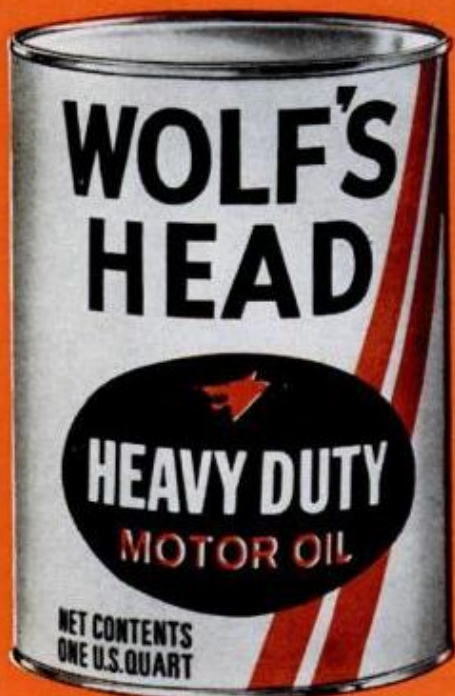

the uncommon motor oil
Exceeds car makers'
warranty requirements.

DRIVIN' WITH DAN

(Continued from page 26)

annual changes since its introduction, among them the change to high-back seats and more effective emission-control plumbing.

Q. How come Wally Dallenbach is sponsored by a soda company? You can't use soda in a radiator.—Wally Simpson, Waldwick, N.J.

A. You can surely run it in the driver and pit crew! It's just a good way to get the "Sprite" name before the public. AAR's Olsonite Eagle Indy cars are sponsored by the world's largest manufacturer of toilet seats, Olsonite. Mr. Olson's companies make many other products also. How's that?

Q. When did you start your racing career and how did you get into racing?—Linn Bishop, Tulsa, Okla.

A. Nov. 1955, at Torrey Pines, Calif. It took me about 3½ years to get my first big breaks with other people's cars. In the meantime I raced my own little Triumph and Porsche and did a lot of practicing and begging and politicking.

Q. In the SCCA Trans-Am car, is there a regular roll bar or a complete roll cage, as is found in the NASCAR stockers?—Joe Norris, Wisconsin Rapids, Wis.

A. A roll cage similar to NASCAR is in our Plymouth Barracudas, but I don't think the rules require that much. The cage is much stronger and safer, of course.

Q. I recently read that a race driver should have a "mean edge." What do you mean by that?—Sam Matsuda, West Jenkins, Minn.

A. After going through all the training, all the preparation, testing and adjusting, sooner or later you must race. When that moment comes, you are in effect isolated in the car and you have to be aggressive, maybe vicious, but at least, violent. It all gets pretty basic and animalistic at those moments. ★★★

If you have questions on racing, high-performance and everyday driving techniques, send them to "Drivin' with Dan," c/o Popular Mechanics, 224 West 57th St., New York, N.Y. 10019. Questions cannot be answered by individual letters. Questions on maintenance and repair should be addressed to the Auto Clinic (see page 74).

ear pollution solutions

Friends!
Motorists!
Countrymen!
The ears of America have taken such a beating lately that they're worn down to the drums! Are we going to stand by while our senses are dulled by the ugly din of ear pollution? No! We're going to fight the threatening noises on our streets and highways with the ear pollution solution—a Craig Car Stereo Tape Player.

SUGGESTED
RETAIL PRICES
FROM \$59.95
TO \$179.95



With a Craig in the car, you control what you hear. Listen to tape cartridge albums of your favorite recording artists whenever you want to. Just roll up the windows and your car becomes a beautiful stereo sound chamber.

Act now! Visit your Craig dealer's Ear Pollution Control Center and see the many different Craig Car Stereo Tape Players on display. Your Craig dealer knows he must make sacrifices, too, if we're going to end ear pollution, so he's featuring special prices on all models beginning at just \$59.95, suggested retail for the 8-track model 3126. You'll find a Craig for every car including models with AM and FM Stereo radios. Choose your weapon now while the price is right and make music, not noise. Remember Craig.

The Ear Pollution solution!



CRAIG
CAR STEREO



I'd like to give this to my fellow men...

while I am still able to help!

I was young once, as you may be—today I am older. Not too old to enjoy the fruits of my work, but older in the sense of being wiser. And once I was poor, desperately poor. Today almost any man can stretch his income to make ends meet. Today, there are few who hunger for bread and shelter. But in my youth I knew the pinch of poverty; the emptiness of hunger; the cold stare of the creditor who would not take excuses for money. Today, all that is past. And behind my city house, my

summer home, my Cadillacs, my winter-long vacations and my sense of independence—behind all the wealth of cash and deep inner satisfaction that I enjoy—there is one simple secret. It is this secret that I would like to impart to you. If you are satisfied with a humdrum life of service to another master, turn this page now—read no more. If you are interested in a fuller life, free from bosses, free from worries, free from fears, read further. This message may be meant for you.

By Victor B. Mason

I am printing my message in a magazine. It may come to the attention of thousands of eyes. But of all those thousands, only a few will have the vision to understand. Many may read; but of a thousand only you may have the intuition, the sensitivity, to understand that what I am writing may be intended for you—may be the tide that shapes your destiny, which, taken at the crest, carries you to levels of independence beyond the dreams of avarice.

Don't misunderstand me. There is no mysticism in this. I am not speaking of occult things, of innumerable laws of nature that will sweep you to success without effort on your part. That sort of talk is *rubbish!* And anyone who tries to tell you that you can *think* your way to riches without effort is a false friend. I am too much of a realist for that. And I hope you are.

I hope you are the kind of man—if you have read this far—who knows that anything worthwhile has to be *earned!* I hope you have learned that there is no reward without effort. If you have learned this, then you may be ready to take the next step in the development of your karma—you may be ready to learn and use the secret I have to impart.

I Have All The Money I Need

In my own life I have gone beyond the need of money. I have it. I have gone beyond the need of gain. I have two businesses that pay me an income well above any amount I have need for. And, in addition, I have the satisfaction—the deep satisfaction—of knowing that I have put more than three hundred other men in businesses of their own. Since I have no need for money, the greatest satisfaction I get from life is sharing my secret of personal independence with others—seeing them achieve the same heights of happiness that have come into my own life.

Please don't misunderstand this statement. I am not a philanthropist. I believe that charity is something that no proud man will accept. I have never seen a man who was worth his salt who would accept something for nothing. I have never met a highly successful man whom the world respected who did not sacrifice something to

gain his position. And, unless you are willing to make at least half the effort, I'm not interested in giving you a "leg up" to the achievement of your goal. Frankly, I'm going to charge you something for the secret I give you. Not a lot—but enough to make me believe that you are a little above the fellows who merely "wish" for success and are not willing to sacrifice something to get it.

A Fascinating and Peculiar Business

I have a business that is peculiar—one of my businesses. The unusual thing about it is that it is needed in every little community throughout this country. But it is a business that will never be invaded by the "big fellows." It has to be handled on a local basis. No giant octopus can ever gobble up the whole thing. No big combine is ever going to destroy it. It is essentially a "one man" business that can be operated without outside help. It is a business that is good summer and winter. It is a business that is growing each year. And, it is a business that can be started on an investment so small that it is within the reach of anyone who has a television set. But it has nothing to do with television.

This business has another peculiarity. It can be started at home in spare time. No risk to present job. No risk to present income. And no need to let anyone else know you are "on your own." It can be run as a spare time business for extra money. Or, as it grows to the point where it is paying more than your present salary, it can be expanded into a full time business—overnight. It can give you a sense of personal independence that will free you forever from the fear of lay-off, loss of job, depressions, or economic reverses.

Are You Mechanically Inclined?

While the operation of this business is partly automatic, it won't run itself. If you are to use it as a stepping stone to independence, you must be able to work with your hands, use such tools as hammer and screw driver, and enjoy getting into a pair of blue jeans and rolling up your sleeves. But two hours a day of manual work will keep your "factory" running 24 hours turning out a product that has a steady and

ready sale in every community. A half dollar spent for raw materials can bring you six dollars in cash—six times a day.

In this message I'm not going to try to tell you the entire story. There is not enough space on this page. And, I am not going to ask you to spend a penny now to learn the secret. I'll send you all the information, free. If you are interested in becoming independent, in becoming your own boss, in knowing the sweet fruits of success as I know them, send me your name. That's all. Just your name. I won't ask you for a penny. I'll send you all the information about one of the most fascinating businesses you can imagine. With these facts, you will make your own investigation. You will check up on conditions in your neighborhood. You will weigh and analyze the whole proposition. Then, and then only, if you decide to take the next step, I'll allow you to invest \$15.00. And even then, if you decide that your fifteen dollars has been badly invested I'll return it to you. Don't hesitate to send your name. I have no salesmen. I will merely write you a long letter and send you complete facts about the business I have found to be so successful. After that, you make the decisions.

Does Happiness Hang on Your Decision?

Don't put this off. It may be a coincidence that you are reading these words right now. Or, it may be a matter that is more deeply connected with your destiny than either of us can say. There is only one thing certain: If you have read this far you are interested in the kind of independence I enjoy. And if that is true, then you must take the next step. No coupon on this advertisement. If you don't think enough of your future happiness and prosperity to write your name on a postcard and mail it to me, forget the whole thing. But if you think there is a destiny that shapes men's lives, send your name now. What I send you may convince you of the truth of this proverb. And what I send you will not cost a penny, now or at any other time.

VICTOR B. MASON
1512 Jarvis Ave., Suite M-2-K
CHICAGO, ILLINOIS 60626



Put these on in only 28 weeks.

Sergeant's stripes. Yours. In the U.S. Army. If you're a high school graduate it can happen. In the Army's new NCO Candidate Program.

After 16 weeks of basic and advanced individual training you start a 12 week academic course as a corporal. When you complete this phase successfully, you'll be promoted to sergeant.

The Army needs leaders in the ranks. Men who can make quick decisions. Accept responsibilities. Earn the respect that goes with them. And the extra cash.

Serve your hitch wearing sergeant's stripes. See your Army recruiter about the NCO Candidate Program. Send the coupon or write: Army Opportunities, Dept. 200A, Hampton, Va. 23369.

Your future, your decision... choose ARMY.

Army Opportunities
Dept. 200
Hampton, Va. 23369

2PM9-73

How can I be wearing sergeant's stripes in 28 weeks?

Name _____ Age _____

Address _____

City _____

County _____ State _____

Zip _____ Phone _____

Education _____

CALVERT CITY, KY.—Mobile detection units are being employed by the State Air Pollution Control Commission to survey air pollution, test and evaluate pollution's effects, conduct on-the-spot studies and provide mobile lab facilities for specialists. The sophisticated monitoring tools, housed in two vans and several supporting trailers, include hydrocarbon analyzers, anemometers, colorimeters and infrared analyzers. One unit is stationed outside Calvert City. The other van and trailers, along with six rooftop facilities, establish monitoring bases in key domestic and industrial locations. Armed with "fume brooms," Kentucky can constantly check the external combustion of industries, powerplants, home heating and incineration.

BOSTON, MASS.—A special "scrubber" device will be used in an experimental plant to recover sulphur dioxide pollutant from powerplant smoke and convert it into resalable commercial chemicals. If approved by the state, the "scrubber" will be installed early next year at Boston Edison's Mystic power station where it is expected to convert 90 percent of the irritating pollutant into 50 tons of raw sulphur and sulphuric acid daily. Cost of the project will be shared by local utilities and the National Air Pollution Control Administration. Sulphur dioxide accounts for about 17 percent of all air pollutants by weight, second only to motor-vehicle emissions.

SACRAMENTO, CALIF.—Steam-operated buses will be used to curb pollution in smog-stifled cities of California, under a federal grant from the Department of Transportation. International Research and Technology Corp. and the Lear Corp. are among the firms contracted for development work. Two San Francisco Bay Area transit fleets will donate buses and operating personnel for initial testing, scheduled for next year. The state legislature has stipulated that the buses be powered by External Combustion Engines (ECE).

MISHAWAKA, IND.—Wheelabrator Corp. announces it will market a system for collecting liquid contaminant particulate matter from the air in heavy industrial areas. Ultra-Dyne, developed in conjunction with Johns-Manville Corp., uses high-velocity air to impact particles onto glass-fiber filters, where they are captured. First commercial trials disclosed a 98 percent efficiency at air velocity of 500 feet per minute. Ultra-Dyne removes not only particles, but the odor associated with oil, grease and tar processes.

DO YOU KNOW about some action being taken to fight pollution that we don't know about? In your community? On the job? Tell us about it. Write Environment Editor, Popular Mechanics, 224 W. 57th St., New York, N.Y. 10019.

AUDEL

LEARN MORE
EARN MORE!

SKILL-BUILDING PRACTICAL GUIDES

POPULAR AUTOMOTIVE GUIDES

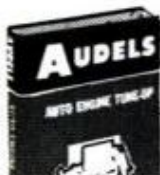

Auto Engine Tune-up

Complete tune-up procedures for all types of auto engines. Full adjustment data for carburetors, ignition, valves, etc. For the car owner who wants to do his own tune-up, as well as for the experienced mechanic. Fully illus. 416 pages. \$5.95
Circle 103 in Coupon



Diesel Engine Manual

Complete practical guide to modern Diesel engines. Explains principles, operation, and maintenance. Covers starting and scavenging air compressors; fuel injection; valve timing; air starting and fuel valves, etc. Illus. 544 pgs. \$6.95
Circle 024 in Coupon

PRACTICAL AUTO GUIDE

Biggest Value! **\$7.95**

FIX ANY CAR FAST!

STEP-BY-STEP REPAIR GUIDE COVERS:

Troubleshooting—unique symptoms-and-causes charts • Spark Plugs • Batteries • Tune-up • Distributors • Ignition Testing • Starters & Generators • Lighting • Tire Servicing • Brakes • Power Brakes • Front Suspension • Steering Systems • Wheel Alignment • Chassis, Springs & Shocks • Fuel Pumps • Carburetors • Cooling Systems • Lubricating Systems • Pistons & Rings • Crankshafts and Connecting Rods • Camshafts • Valves • Clutches • Automatic & Manual Transmissions • Drive Shafts & Universal Joints • Rear Axle Assemblies—ABSOLUTELY EVERYTHING YOU SHOULD KNOW TO FIX ANY CAR! Hundreds of illus. 736 p. \$7.95
Circle 015 in Coupon

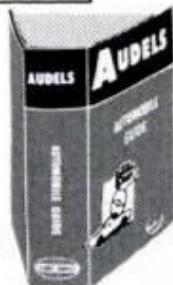

Truck and Tractor Guide

A guide for mechanics, drivers and maintenance men. Gas & Diesel repair, service and operation. Illus. 928 pages. \$6.95
Circle 020 in Coupon

Foreign Auto Repair Manual

Up-to-date service data for all popular imports: English, French, German, Italian, Swedish. Illus. 592 pages. \$5.95
Circle 078 in Coupon

Outboard Motor Guide

Practical details on all phases of outboard motor repair, maintenance and operation. Up-to-date. Illustrated. 446 pages \$4.95
Circle 168 in Coupon

Practical Electricity

Complete handbook; practical, simplified ready reference on all electrical subjects. Many illustrations. 496 pages. \$5.95
Circle 160 in Coupon

Mathematics for Mechanics

A complete guide to the mastery of practical math. Simplified method makes learning fast and easy. Illustrated. 704 pages. \$5.50
Circle 026 in Coupon



MACHINISTS LIBRARY

Three volumes of ready reference on all the latest shop practices for machinists and toolmakers. Vol. 1—Practical Fundamentals of Basic Machine Shop Operations. Vol. 2—Setup and Operation of all the widely used, important shop machines. Vol. 3—Toolmakers Handybook with down-to-earth data on layouts, specifications, jigs and fixtures, gear forming, cams, etc. Illus. 1310 pages. 3-Vol. Set \$15.50
Circle 174 in Coupon



CARPENTERS & BUILDERS GUIDES

Four all-inclusive volumes provide latest inside trade information on modern construction. Vol. 1—Tools, Steel Square, Joinery. Vol. 2—Builders Math, Drawings, Specs. Vol. 3—Layouts, Foundations, Framing, Roofing, Flooring. Most practical guide available. Thousands of diagrams, charts, graphs and photos. 1612 pages. 4-Vol. Set \$16.95
Circle 169 in Coupon

Millwrights & Mechanics Guide

Practical information on plant installation; operation and maintenance data for foremen & workers. Illus. 1236 pgs. \$7.95
Circle 056 in Coupon

Sheet Metal Pattern Layouts

Modern guide to all phases of sheet metal work, including pattern development. 350 layouts. Illus. 1152 p. \$11.95
Circle 045 in Coupon

MONEY BACK GUARANTEE

SEND NO MONEY! We'll send you any Au-del Guides for 10-day FREE examination. If you decide to keep them, use our easy-pay plan. Absolute no-risk MONEY-BACK GUARANTEE!

THEODORE AUDEL & CO.
division of HOWARD W. SAMS & CO., INC.
Indianapolis, Ind. 46268



Home Appliance Servicing

How to test, service, and repair all modern gas & electric appliances such as refrigerators, washers, dryers, ranges, irons, hot water heaters. Gives up-to-date methods, wiring diagrams, complete servicing data. Fully illustrated. 608 pages. \$6.95
Circle 016 in Coupon



Home Refrigeration & Air Conditioning

Complete and practical information on installing, servicing, and maintaining gas and electric refrigerators and all types of home and auto air conditioners, water coolers, freezers. Many tables of useful data. Illustrated. 576 pages. \$6.95
Circle 133 in Coupon



Electric Library

10 volume electrical encyclopedia. Presents basic principles, rules and applications of applied electricity. Answers questions on thousands of electrical problems. Fully illustrated with diagrams and tables. 5600 pages. Set \$35.00
Circle 030 in Coupon

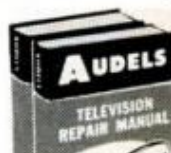

TV-Radio Library

Two vols. of practical and theoretical knowledge including basic electronics, basic radio receiver repair. Covers entire subject of television, both black & white and color, from theory thru repair. Illustrated. 960 pages. 2-Vol. Set \$10.95
Circle 161 in Coupon

Blueprint Reading

For mechanics & construction men. Step-by-step explanation of how to read all types of blueprints. 416 pages \$5.25
Circle 041 in Coupon

Welders Guide

Practical guide to theory; operation; maintenance all types—electric, oxy-acetylene & Thermit. Illus. 626 pages. \$5.50
Circle 025 in Coupon

Masons and Builders Guides

4 practical volumes for bricklayers, masons, cement workers, plasterers. Includes shortcuts and job estimating. 2000 illus. 1488 pages. 4-Vol. Set \$14.95
Circle 076 in Coupon

Plumbers and Pipefitters Guides

3 vols. of ready reference for plumbers, pipe & gas fitters, sheet metal workers. Explains all principle of modern plumbing. 540 illustrations. 928 pages. 3-Vol. Set \$12.50
Circle 155 in Coupon

SEND NO MONEY—10-DAY FREE EXAMINATION!

THEODORE AUDEL & CO.—Self Improvement Publishers Since 1879—
4300 W. 62nd Street, Indianapolis, Indiana 46268 P-090
Please mail me for 10 days' FREE EXAMINATION the books I have circled at right. I agree to mail \$3 in 10 days for each book or set ordered, and to further mail 1/2 of the total purchase price 30 days later, with the balance plus shipping costs to be mailed within another 30 days. If I am not completely satisfied with my Au-del Guides I may return them for refund.

SAVE SHIPPING COSTS—Check here if you enclose full payment with order (plus sales tax, if any). We pay postage charges. You have same return privilege.

Name _____

Address _____

City _____ State _____ Zip _____

- | | | |
|-----|-----|-----|
| 015 | 041 | 155 |
| 016 | 045 | 160 |
| 020 | 056 | 161 |
| 024 | 076 | 168 |
| 025 | 078 | 169 |
| 026 | 103 | 174 |
| 030 | 133 | |

I have bought Au-del books before

LISTENING POST

BY ROBERT LUND

POP-OUT ENGINES COMING SOON? One of the "discomforts" of plowing head-on into another car or an unyielding object is having the engine land in your lap. Better you should try to field a shell out of a hot howitzer one-handed. But you may not have to worry about the engine cannonballing onto your knees much longer. The auto companies are working on an idea to prevent it from penetrating the passenger compartment. There are test cars around now in which the engine has been installed with breakaway mountings. In a severe collision, the motor pops out and drops on the pavement instead of hurtling rearward into the front seat.

The National Highway Safety Bureau is pushing the industry to adopt the idea immediately. The auto companies are asking for time to run additional tests and check their calculations. But pop-out engines are a fair bet for '73 or '74.

NEW LOOK FOR JEEP? American Motors is said to be working on it now that the car's in the AMC catalog. The new version will be less boxy and more contemporary in appearance than its predecessors. But AMC won't try to change the image. The mechanical hero of World War II will continue to be a utility vehicle first, a pleasure car second.

SMALL CARS AT NOT-SO-SMALL PRICES. If you decide to go for one of the new small cars in the next few months, don't expect to buy it for the skinny price quoted in the ads. Not if you want early delivery. There's always a waiting list of free spenders when the new cars come out. It usually takes six weeks to two months to satisfy 'em. The auto companies make the most of the market while it lasts and turn out more expensive cars at the beginning of a model run than at any other time. First cars off the line are usually loaded with options and the extras will be especially important to automakers on the mini machines. GM and Ford figure to take a beating on Vega and Pinto on the basic vehicle, but they expect to make money on optional equipment. They'll turn out enough plain numbers to provide dealers with sample copies. But until the bloom wears off, the emphasis will be on high-ticket cars, not the economy specials pictured in the ads.

DUAL LAMPS ARE ON THE WAY OUT. While you're looking at the new ones, notice the number of cars with single headlights and where they're positioned. Pontiac, Vega, Pinto and Mustang, for example. You'll see more of this over the next few years. At the same time, there's a movement to engineer headlights out of the grille, by stacking them above it or tucking them in fenders. The idea is to position lights—recessed, if possible—so they're less susceptible to damage in a front-end accident.

IF AND WHEN THE VENT WINDOW COMES BACK, it may be about a third the size of the old vent and on a sliding track in the lower corner of the side glass. You'll be able to open and close it with two fingers. Ford's working on it. Another novelty Ford is looking at is an elliptically-shaped (egg on its side) steering wheel with notched sections for the driver's hands.

THE NEW-CAR WARRANTY GETS WORKED OVER every year at this time—just as the new cars. But where the cars are improved, the warranty becomes more complicated and incomprehensible. The footnotes, the qualifiers and disqualifiers, the fudging and the fine type become more bewildering and unintelligible model year after model year. The auto companies realize the new-car guarantee is written in gobbledygook and if you ask what they're doing to demystify it, they beg off with the explanation, "We're studying it." They may have run the string on that stall, because there's a movement

(Please turn to page 38)



Vista[®] gives your car a shine like sterling.

Get real deep-down, hard-wax kind of shine—a dazzling shine like sterling with Simoniz[®] Vista.

Vista is a special paste-wax blend of jeweler's polish and high gloss silicones. You clean and wax in one easy step... for a dazzling shine that lasts.

Get Simoniz Vista. Paste, Liquid, or new Soft and Easy formula. Give your car a shine like sterling.



**NEW! Soft and Easy Vista
with handy applicator.**

SIMONIZ is a registered Trade Mark of Texize Chemicals, Inc.

SEPTEMBER 1970

37

Материал, защищенный авторским правом

SAVE \$2.29 NOW!

Special Introductory Offer Direct from General Electric:

GE's new UL-approved Incandescent Light Dimmer and decorator-styled Colonial Night Light, both at one bargain price, if you act now!

Add excitement, convenience, attractive styling to your home lighting decor with these top-quality UL-approved items from GE.



Made to retail at \$10.95 and \$1.29 . . . GE's special mail-order price for both now just \$9.95! A savings to you of \$2.29, while supplies last.

The new improved General Electric Dimmer offers solid-state reliability and convenience in dramatically controlling light level from OFF to full brightness. For work or play . . . bright light. For candlelight dining, entertaining, TV . . . a soft, dim glow.



Simple to operate, easy to install—GE's UL-listed Dimmer fits any standard 2" switch box. Just push to turn ON or OFF . . . without disturbing a pre-selected brightness setting.



GE's decorator-styled Colonial Night Light brings charm of Early American decor to bedroom, bathroom, nursery, hall. Unbreakable shade snaps off easily for bulb replacement. 7-watt, 3,000-hour bulb burns six times longer than bulbs used in other night lights. UL-listed.

995-71

GENERAL ELECTRIC

To: General Electric Co., Section 243, WD-23, Schenectady, N. Y. 12305
Enclosed is my check or money order for _____ pairs of Incandescent Light Dimmers/Colonial Night Lights, @ \$9.95 each, plus applicable sales tax in my area. Please ship postpaid to:

Name _____
Address _____
City _____ State _____ Zip _____

DETROIT LISTENING POST

(Continued from page 36)

afoot to get the government to force all manufacturers to write their guarantees in everyday English.

But if there's still time for the auto firms to act on their own, Listening Post suggests they get a copy of the fall-winter catalog put out by Sears and check the guarantee printed on page 767. It happens to be for a dishwasher, but Sears uses the same guarantee, same language, for a long list of products. It runs exactly 74 words, including the name of the item guaranteed, how long the guarantee is good for, what it covers, what the buyer must do to collect, what Sears will do and who is responsible for paying off on a legitimate complaint.

All that in 74 words! If a mail-order house dealing in a couple million products can put it that succinctly, why can't auto manufacturers lay it on the line in a few hundred words?

REMOTE PRESTARTERS. When is Detroit going to develop a time-controlled, remote-controlled starter so you can turn on your car's engine at a predetermined time and activate the heater in the winter or the airconditioner in the summer? The idea's been around for years and Cadillac once considered putting it in a production car. Some wheels around town have such a device on their personal cars as a toy. There have been a couple of drawbacks to the prestarters developed up to now. With the car running, a thief could hop in and drive it away. Second, there has to be an automatic shutoff if the driver doesn't get to the car in a certain length of time; otherwise the engine could be damaged if it were allowed to run indefinitely.

A PM reader in Marion, Ky., Willard Mott, says he's solved both problems. Mott has prestarters on both his cars. He's used one on his '67 Pontiac something over 500 times, another about 200 times on his '70 Olds. Mott, who built the units in his garage, admits the hardware is pretty cumbersome and primitive because the components came right off the shelf at the local hardware store. But he says the gear could be slimmed down to a compact package if the parts were tailored for the purpose.

A LOT OF WORTHWHILE IDEAS for cars still come out of garages, basements and the research departments of supplier companies who sell to the auto firms. Not many of 'em make it. The economics are (Please turn to page 40)

You may be strong enough to tear a telephone book, but you'll never tear our tape.

That's because new Mystik Mend-Aid™ is a super-strong, super-clear mending tape that fixes things cellophane tape could never fix.

And this unbelievably versatile tape won't ever crack, yellow or peel.

So, if you have something to mend or repair (like rubber boots, books, shower curtains, car seats or toys) get new Mend-Aid.

And put some muscle in your mending.

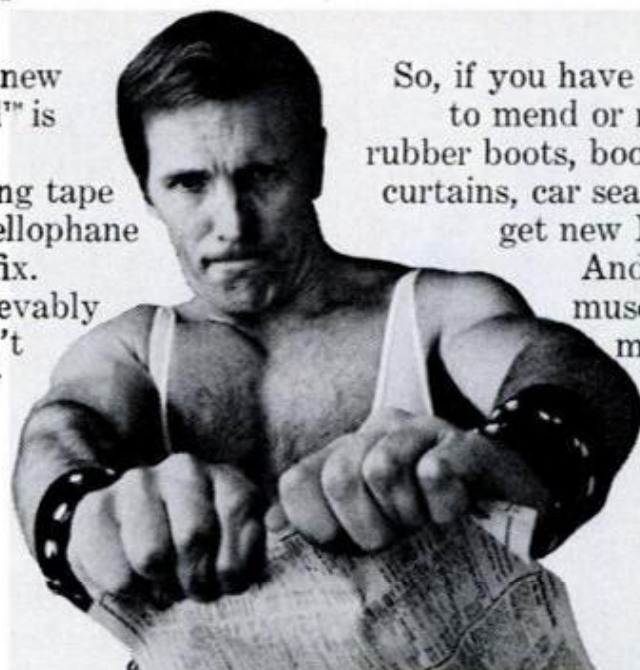

Mystik Mend-Aid Tape from the makers of Elmer's® Adhesives and Krylon® Coatings.

NEW 80 AMP DYNAMIC MARK 88 INDUSTRIAL TRANSFORMER ARC WELDER

IDEAL GIFT — EDUCATIONAL, ENJOYABLE, PROFITABLE

WELD, BRAZE, CUT, SOLDER, HEAT STEEL, BRASS, ALUMINUM, AND MOST OTHER METALS.

Build and repair anything of metal. Save time & money with this BRAND NEW, PROFESSIONAL ARC WELDER! Rugged metal cabinet, baked Hammerloid finish. Ideal for home, shop, farm and industrial use. POWERFUL glass insulated transformer welds most metals up to 1/2" thickness with multi-pass weld, with 3/8" rods. 4 heat settings 20 to 80 amps. Operates on 110 Volt AC line fused for 30 amps. Complete with fibre glass helmet, electrode holder, ground clamp and cables, solder, assorted rods and simplified welding manual. DOUBLE PROTECTION GUARANTEE. 10 day money back trial plus full 5-yr. warranty. If inoperative return prepaid, we will repair or replace without charge & reship collect. ORDER TODAY. Complete ready to weld. Only \$59.50 F.O.B. SEND ONLY \$6.00. Pay balance plus C.O.D. & delivery charges or write for easy "PAY AS YOU WELD" Low Down Payment Plan. Welder details FREE.



DYNAMIC WELDER CO. 1808 S. FEDERAL ST. Dept. D2-J CHICAGO, ILL. 60616

learn ACCOUNTING at home

1000's high pay "Big Future" jobs open now to men, women in Accounting. Send for FREE "ACCOUNTING CAREER KIT." No salesman will call.

GIVEN TO YOU



NAME _____ AGE _____
 ADDRESS _____
 CITY _____ STATE _____ ZIP _____
 NORTH AMERICAN SCHOOL OF ACCOUNTING, Dept. 04179
 Accredited Member, National Home Study Council • 4500 Campus Dr., Newport, CA. 92663

DEAR MR. MAIL ORDER:

I have never sold anything by mail but I would like your Free Report on how to start a big profit, spare time business at home without buying inventory.

NAME _____
 ADDRESS _____
 CITY _____ STATE _____ ZIP _____

NOTE: Mail this coupon for "How to Make Money in Mail Order" to Mr. Mail Order, 1554 S. Sepulveda, Dept. D2259, Los Angeles, Calif. 90025.

5 Day Home Trial



WORLD'S LARGEST DEALER

"NEW SOUND" ACCORDIONS - SAVE 1/2*

42 NEW ELECTRONIC/STANDARD MODELS *SAVE 1/2 off retail prices of comparable accordions! 42 exciting new models—Standard, ELECTRONIC, Amplifiers, too! All famous makes. Try before you buy. Free Accessories. E-Z Terms. Trade-ins. Lifetime Performance Policy. Money back guarantee. FREE Color Catalogs and Importer-to-You Discount Prices. Rush coupon.

ACCORDION CORP. of AMERICA, Dept. R-90 5535 W. Belmont, Chicago, Illinois 60641

Accordion Corporation of America, Dept. R-90 5535 W. Belmont, Chicago, Ill. 60641 Send FREE Catalog of Accordions, Amplifiers—Discount Price List.

FREE New Color Catalogs—Discount Prices
 Name _____
 Address _____
 City _____ State _____
 Check here if you have Trade-in

The Swingline Tacker Gun can finish off every room in your house...

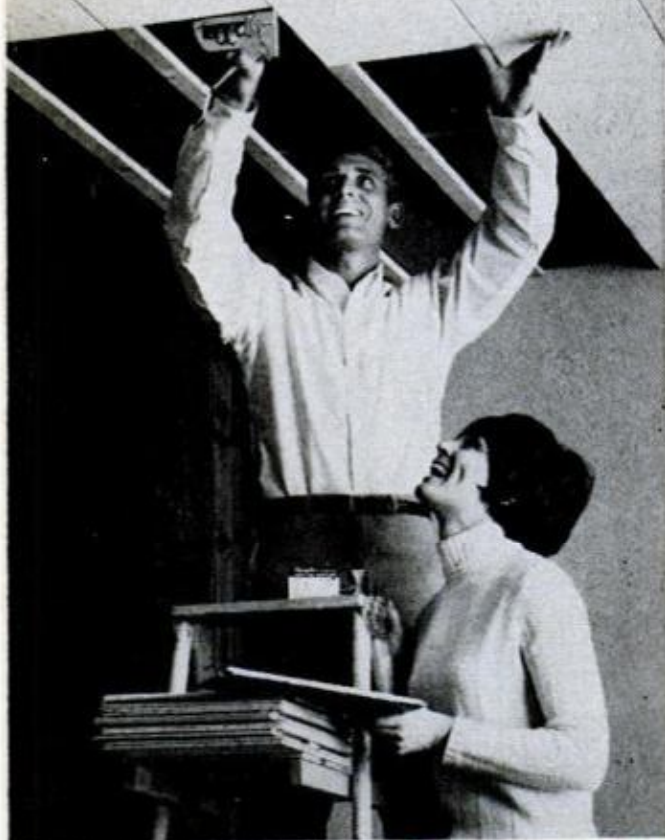

for only \$9.95

Use the Model 800 Heavy-Duty Tacker Gun to install ceiling tile... repair screens... lay carpet... insulate... weather-strip... upholster... you-name-it!

Takes 5 staple sizes, from $\frac{1}{4}$ " to $\frac{5}{16}$ " — plus special Loktile® staples for ceiling tile installation. Easy to load — easy to operate.



Model 800

Write for free booklet,
TIPS ON TACKING
Dept. P-9

Also available:

Model 101 Tacker Gun. Only \$6.95.
Takes 2 Staple Sizes $\frac{1}{16}$ " and $\frac{5}{16}$ "

Swingline

Consumer Products Division, 32-00 Skillman Ave.,
Long Island City, N.Y. 11101.

DETROIT LISTENING POST

(Continued from page 38)

wrong—the devices cost too much to produce—or carbuilders have already experimented with something similar and discovered a drawback not evident to outsiders. Case in point: a periscope rear-view mirror. Plymouth and Lincoln have produced show cars with over-the-top mirrors, but nobody's put one on the market at a price of less than an arm and a leg. Until now. A Michigan company will bring one out next month. It will give the driver a virtually unlimited view of the road from the rear. The firm making the mirror, Para-Vue Co., of Roseville, Mich., hasn't landed any orders from car producers, but it hopes to stir up interest by selling the device as an add-on requested by car owners.

WANT TO TOUCH-UP your car? You can get a booklet explaining how to prepare the surface, wet and dry sanding methods, the spray-shield technique, feather edging and other pointers used by professional painters by sending a self-addressed envelope to Dupli-Color, 1601 Nicholas Blvd., Elk Grove Village, Ill. 60007. Ask for the do-it-yourself book.

NEW PASSIVE RESTRAINT CONCEPT developed by the Firestone Tire & Rubber Co. that covers passengers from knees to shoulders and door to door with a "security blanket" in a collision was recently demonstrated. A blanket stored in the back of the front seat is activated by a sensor which sets off propellant cartridges in pistons mounted on either side of the inside of the trunk. Blanket, deployed in one-thirtieth of a second, is designed to restrain three 200-pound persons in a head-on crash at 40 mph. Photo below shows the O-ring a passenger pulls to free himself from the blanket and leave car after it stops. ★★★



THE TRACKER- NEW FIBERGLASS BELTED TIRE FOR CAMPERS

You've heard a lot about fiberglass belted passenger car tires, and the long mileage they deliver. Most 1970 cars come equipped with them.

Now here's a belted tire for your camper. From Goodyear, the leader in belted tires.

The Tracker. A tire that runs with the tread firm against the road. Two strong fiberglass belts circle the tire, like hoops reinforcing the tread. To help hold the tread grooves open and fight tread squirm.

That's why The Tracker tire wears more evenly, and delivers up to 40% more mileage than our best non-belted tires for campers. Better wet traction, braking and cornering ability, too.

See your Goodyear Dealer or Goodyear Service Store for The Tracker.

Hi-Miler Wide Tred Nyloglas tire (left) or Custom Xtra Grip Wide Tred Nyloglas tire (right) for mud and snow. Available in the following sizes: 8.00-16.5, 8.75-16.5, 9.50-16.5.



Nyloglas tire: Four nylon cord body plies and two fiberglass belts that extend around the tire to help hold the tread firm and fight squirm. Two tread designs: For highway or mud and snow.

GOODYEAR

Hi-Miler, Nyloglas, Tracker - T.M. © The Goodyear Tire & Rubber Company, Akron, Ohio



IT COULD SAVE YOUR VACATION

Материал, защищенный авторским правом

LEARN TO BE A SKILLED LOCKSMITH



Change combination of pin tumbler cylinder
EARN \$1.50 in 15 MIN.



Owner loses key; pick car trunk—
EARN \$5.50 in 10 or 20 MIN.

TYPICAL JOBS EARN YOU \$271 PART TIME (in only 53 hours!)



Install new knob door lock—**EARN \$15.00 in 30 MIN.**



After-hour emergency opening—**EARN \$2.50 to \$5.50 in 20 MIN.**

Hundreds have succeeded like these Belsaw Graduates:

R. W. Davis, St. Louis, Mo.: "I am doing a wonderful business thanks to your course in locksmithing. Last Saturday I took in \$110.00."

Pierson Crook, Los Angeles, Calif.: "I am making \$200 a month extra income with the Belsaw Locksmith Course. I would recommend your course to anyone."

Big demand for skilled locksmiths! Earn big money spare time in your own home. Be your own boss. No layoffs. Steady year 'round income. Age and schooling are no handicap.

BELSAW INSTITUTE training... approved by master locksmiths... helps you start faster with easy picture lessons guided by your own mail instructor.

Get thorough job training on all types of locks. We supply tools, equipment and business help: how to start, how to charge, how to get jobs, how to earn while you learn and build a lifetime cash-profit business. Accredited Member National Home Study Council. Approved by State Board of Education. Approved for Veterans.



This \$125 key machine is yours to keep!

MAIL COUPON—NO SALESMAN WILL CALL

**BELSAW INSTITUTE, 101S Field Bldg.
Kansas City, Mo. 64111**

Send **FREE** book, "Keys To Your Future!"

FREE BOOK

Name _____

Address _____

City _____ State _____ Zip _____

New Welding & Cutting Torch Kits

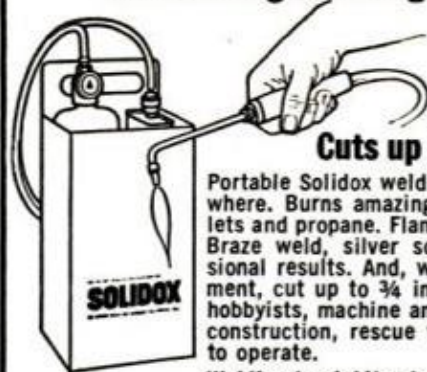

**5000° Flame
Cuts up to 3/4" steel!**

Portable Solidox welding torch goes anywhere. Burns amazing solid oxygen pellets and propane. Flame exceeds 5000°F. Braze weld, silver solder, with professional results. And, with cutting attachment, cut up to 3/4 inch steel! Ideal for hobbyists, machine and tool repair, field construction, rescue work. Simple, safe to operate.

Welding torch kits start at \$24.95 ppd.

"Standard Kit" (#500A), torch, propane, pellets, braze rods, glasses, instructions. (No cutter) \$34.95 ppd.

"Thrifty Kit" (#500AT) converts your propane torch. (No propane or cutter) \$24.95 ppd.

Deluxe Kit (#500D) two tips, extra pellets, rods, etc. (No cutter) \$39.95 ppd.

Complete Welding & Cutting Kit (#5800) \$69.95.

Cutting Attachment alone (#800) (for Solidox torch owners) \$34.95.

Send only \$5. Indicate kit of your choice. Pay postman remainder plus postage on delivery. Write for free brochures.

Money back guarantee. Use BankAmericard.

Cleanweld Products Co., 9220 S. Atlantic
Box 1061, South Gate, California 90280, PM-9

Be a SURVEYOR & MAP MAKER

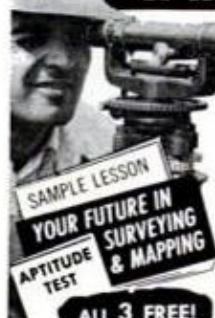

Join a Surveying Team—get in on planning of America's highways, bridges, dams, subdivisions, etc. Wonderful outdoor work. Ideal for those who like to work with their hands. 1000s exciting big pay jobs open now to qualified men. U.S. Bureau of Labor Statistics predicts shortage of 50,000 civil engineering technicians (Surveyors, etc.) by 1975 as construction of highways, airfields, waterways skyrockets upward. Our easy step-by-step home-study plans have helped 1000s beginners toward prestige salary, security. Big 68-piece Surveying Kit (training transit, drawing, instruments, etc.) given to you when you enroll. Thousands of Surveyors got their start through home-study. You can too! Send for "SURVEYING CAREER KIT"—ALL FREE! No salesman will call. Write & state age.

NORTH AMERICAN SCHOOL OF SURVEYING & MAPPING
4500 Campus Dr. • Dept. 04179, University Plaza, Newport, Calif. 92660

ELECTRIC ARC WELDER \$9.99!



NATIONALLY ADVERTISED \$18.95 VALUE!—Now 1/2 PRICE! WELDS—BRAZES—SOLDERS—CUTS—ALL METALS! Plugs into ANY 110 volt socket. **MAKE—REPAIR 1001 items for CAR—HOME—BUSINESS.** Lifetime **BURNOUT GUARANTEE** 10 day money back trial (if retnd). **HEAVY DUTY Design—Does \$85.00 welder work.** No experience needed—**FREE WELDING LESSONS!** (cash, ck, M.O.) and pay postman \$7.00
SEND ONLY \$2.00 COD postage or send \$9.99 plus \$1.00 postage for paid del. in U.S.A. **COMPLETE READY TO USE—Includes BIG pack steel, Brazing, Solder, Carbon "touch" rods, ELECTROFLAME ARC TORCH! OFFER LIMITED—Order TODAY!**
MIDWAY WELDER Dept. EPM-9 Kearney, Nebr. 68847

Career in ELECTRONICS?

Career training at home the new easy way with RCA Institutes. Lab work with first lesson. Easy payment plans. Send for free 64-page book.

RCA Institutes, Dept. 699-009-0
320 W. 31 St., N.Y., N.Y. 10001

RCA

POPULAR MECHANICS

Материал защищен авторским правом

Here's what
VON SCHRADER
 has to offer YOU...

if you would like to go into
 a profitable business
 of your own (full or part-time)

1 • **VON SCHRADER** offers you these 3 money-making businesses: **RUG CLEANING, UPHOLSTERY CLEANING, WALL WASHING.**

2 • **ALL DETERGERS** are reasonably priced. Many **VON SCHRADER** Associates make more than the price they paid in the first month and from the original supplies that come with the Deterger.

3 • **SOME VON SCHRADER** Associates start spare-time . . . and later on change to full time.

4 • **NO SHOP** is needed . . . all work is done in customers' homes or on their premises.

5 • **NO COSTLY OVERHEAD** . . . you work from your own home and hire helpers only when your business justifies.

6 • **YOU ALWAYS OWN** your Detergers . . . no one can ever take them from you.

7 • **ALL THE MONEY** you take in is yours alone . . . you never pay any fees, or dues, or royalties to anyone; you are truly **YOUR OWN** boss in **YOUR OWN** business.

8 • **YOU WORK WHEN** and where you care to . . . you have no quotas to meet, no extensive forms to keep, no reports to make.

9 • **FULL OPERATING INSTRUCTIONS** come with the detergers. They are easy to read and to follow; anyone can operate; you need no special skill or training.

10 • **VON SCHRADER BUSINESS MANUAL** is complete; it tells everything you need know to make a success out of your venture, including how to go about getting business, suggested sales letters, who to call on, tips on keeping your books and tax records, suggested telephone book and newspaper advertisements, radio announcements, etc. Handout literature is also included.

11 • **VON SCHRADER** cooperation and assistance is always at your service. We continue to help you solve unusual problems regardless of nature. Training and consulting with experts is also available at no extra cost.

12 • **VON SCHRADER** perfected the first **RUG DETERGER** and we are by far the oldest and largest company manufacturing machines of this type.

VON SCHRADER MFG. CO.



• Read below what a few of our many Associates have to say about the success of **VON SCHRADER'S FREE ENTERPRISE PLAN.** Then return the coupon or write **TODAY.** It costs nothing to get the details.

HOMER KENDALL, Indiana • "Your business helps and training are really wonderful. How could anyone fail?"

LESTER VERNON, Wisconsin • "Have had my Rug Deterger almost two weeks, have earned 2/3 its cost already."

J. M. ROGERS, Pennsylvania • "Worked 7 hours yesterday, earned \$85.56. Part-time last week netted \$103.70."

ROY NELSON, No. Carolina • "I am doing real well with the Upholstery Deterger. I grossed \$204 in four days last week and have plenty more work. Everyone is very well satisfied."

BOB GREENBERG, California • "First month I made over \$800; now 80% to 90% are old customers."

EMMET FREMONT, Colorado • "It's amazing what the Wall Deterger will do. I'm more than satisfied."

SEND FOR THE FACTS TODAY

VON SCHRADER MFG. CO.
 1091 Place, Racine, Wis. 53403
 Please rush information about your

_____ **DETERGER(S)**
 (Write in name of detergent(s))
 and how I can start my own profitable business.

Name _____

Address _____

City _____ State _____ Zip _____

Keep Both Eyes On the Birdie!

By **GEORGE REIGER**,
Outdoors Editor

Both eyes must be open to use this revolutionary sight made to order for the reflex shooter

LAST DEER I SHOT was in thick brush at less than 30 yards. The rifle I used had a scope I looked over, *not through*. It was a running shot, a reflex shot—a common shot for Eastern whitetail or Western blacktail hunters. And that's for whom the Normark Singlepoint is made.

Experienced gunners will use the sight to correct flaws in holding or stance; novices will find it excellent in building confidence. And, if you *know* you can hit what you aim at, you tend to do just that. Your reflexes are right and Singlepoint reinforces their judgment.

Invented in Sweden and manufactured in Great Britain where it's used by that country's armed forces, Singlepoint will come to the United States this fall. Whether or not American hunters use the sight, rumor has it the U.S. Army is conducting tests for possible inclusion of Singlepoint in its own inventory.

BRITISH ARMY has adopted Singlepoint for ground troops. Note both eyes remain open for aiming. Diagram below shows how brain fuses two independently seen objects: Singlepoint dot and your target

Singlepoint blanks out your view of the target with one eye and substitutes an aiming point for it. The target and aiming point are seen independently by closing alternately each eye, or seen simultaneously with both eyes open. The shooter sees a spot of light, apparently floating in air. He superimposes this on his target.

Floating spots are not new. Thirty years ago British aircraft used reflector sights to claw the Luftwaffe from the skies. Nor is the sight-collimator concept new. We all can bore-sight a rifle. (See *How to Sight In a Rifle*, page 132.) But fusion of these two concepts in one sight is new.

For further information write Normark Corp., 1710 E. 78th St., Minneapolis, Minn. Believe me, it's worth the postcard. ★★



HOW IT WORKS: Shooter's eyes focus on target. Sight gives all-round vision but for limited blind area (shaded). Eye in front of sight gathers bead of light for brain to transpose on target image



How to fix almost any part of any car

Now, whether you're a green beginner or expert mechanic, you can breeze through almost any auto repair job on all the cars listed here built from 1964 to 1970.

All you need is the new 1970 Edition of **MOTOR'S AUTO REPAIR MANUAL**—the famous illustrated guide that makes practically every operation on almost any car as easy to do as A-B-C.

Special Trouble-Shooter Section

The special Trouble-Shooter Section in **MOTOR'S MANUAL**, plus detailed troubleshooting information throughout, helps you pinpoint any of 4,200 car troubles in a jiffy . . . spots exactly where the trouble is in engines, transmissions, axles, etc.

Big New 1970 Edition Over 1,000 Pages— Over 3,000 Pictures!

This newest, most up-to-date Edition covers everything you need to know to fix 2,300 car models from 1964 through 1970, including all compacts and intermediate cars. Plus tune-up and front-end alignment specs on all models from 1946 through 1963. Over 1,000 giant double-sized pages, over 3,000 pictures. "Quick-Check" Specification Tables for all cars, 55,000 essential service specifications. Over 225,000 service and repair facts.

The "Meat" of 300 Official Shop Manuals

The editors of **MOTOR** gathered together a wealth of know-how from 300 official shop manuals and hundreds of factory bulletins, and boiled it down into crystal-clear terms in one big illustrated book.

All These Makes Covered

TORONADO	THUNDERBIRD	OLDSMOBILE
BARRACUDA	CADILLAC	CORVAIR
PONTIAC	CONTINENTAL	OLDS F-85
IMPERIAL	CHEVROLET	VALLIANT
DART	PLYMOUTH	JAVELIN
FORD	DODGE	MONTIGO
CHRYSLER	COMET	TORINO
RAMBLER	AMERICAN	LINCOLN
BRONCO	FAIRLANE	FRONT-DRIVE
BUICK	CORVETTE	CADILLAC
(SPECIAL)	MUSTANG	MARK III-AMX
FALCON	CHEV II	BLAZER
TEMPEST	BUICK	CHALLENGER
COUGAR	MERCURY	HORNET
VOLKSWAGEN	CHEVELLE	SCOUT
JEEP	CAMARO	REBEL

Not only do you get the latest up-to-the-minute "how-to" information on each car listed above, you also get service data on Transmissions, Steering, Brakes, Generators, Alternators, Fuel Pumps, Ignition Systems, Engines, much more!

No wonder over five million copies have been sold!

Try This Book at Our Risk—FREE

Send no money. Just mail the coupon and we'll send the giant 1970 Edition of **MOTOR'S AUTO REPAIR MANUAL** right to your home or shop. Try this famous guide for 10 full days—FREE! If this book doesn't pay for itself in the first 10 days, just return it and owe nothing.

Mail coupon to **MOTOR Book Department**, 250 West 55th Street, New York, N.Y. 10019. (Schools, Bookstores: Write for discounts.)

Brand-New 1970 Edition ★ Used by Repair Shops, U.S. Armed Forces, Schools, Etc.,



SAME 10-DAY FREE TRIAL ON AUTO ENGINES AND ELECTRICAL SYSTEMS. Explains engines and electrical systems thoroughly, showing how and why they work. 700 pages. Only \$10.00.

MOTOR BOOK DEPT. Desk 0019
250 W. 55th St., New York, N.Y. 10019

Please send me the book(s) checked below, for 10-day free examination. If I decide to keep them, I will remit payment as indicated.

MOTOR'S AUTO REPAIR MANUAL, \$9.95, for which I will remit \$2.00 in ten days, \$3.00 monthly for two months, and a final payment of \$1.95 (plus delivery charge and sales tax, if any).

MOTOR'S AUTO ENGINES & ELECTRICAL SYSTEMS, \$10.00. I will remit \$2.50 in ten days and \$2.50 monthly for three months (plus delivery charges and sales tax, if any).

Please Print Name _____ Age _____

Address _____

City _____ State _____ Zip Code _____

Save shipping charge by enclosing WITH coupon in envelope entire payment of \$9.95 for **AUTO REPAIR MANUAL** (or \$10.00 for **AUTO ENGINES & ELECTRICAL SYSTEMS**) plus sales tax, if any. Same 10-day return-for-refund privilege applies.

Anywhere . . .
Anytime . . .
Any Place . . .
It Can Happen
And when it
does you are
needed in
HIGH PAY
positions as an



ACCIDENT INVESTIGATOR

Make big money investigating accidents. Car furnished, expenses paid. No selling. No tedious study. Full or spare time. I train you directly by mail and provide free placement service. (Liberty School is State Licensed and fully approved for Veteran Educational Benefits).

Mail For Free Information

Jim Edwards, Director, Dept. 59
Liberty School
162 E. Cook, Libertyville, Illinois 60048

Send me your FREE Brochure Showing how I can quickly get into the Booming Accident Investigating Field and enjoy the job security and professional prestige offered Accident Investigators. This does NOT obligate me in any way and no salesman will call.

Name _____ Age _____
Address _____
City _____ State _____ Zip _____

BELSAW PLANER • MOLDER • SAW



30-DAY FREE Trial!



Now you can use this ONE power-feed shop to turn rough lumber into moldings, trim, flooring, furniture... ALL popular patterns. RIP... PLANE... MOLD—separately or all at once with a single motor. Free 30-Day Trial. Low Cost—only \$35 down.

Send Postcard Today — No Salesman Will Call.
BELSAW POWER TOOLS, 901S Field Bldg., Kansas City, Mo. 64111

WOOD EVERYTHING FOR THE WOODSHOP TOOLS-SUPPLIES

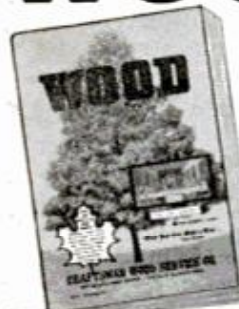

World's Largest Selection of Finest Domestic and Imported Hardwoods, Veneers, Hardware—

at MONEY SAVING PRICES

Over 2000 items! Your money saving hardwood and woodshop buying guide. We've added new Clock kits, wood picture kits, musical instrument kits, many more. Complete selection of hard-to-find hardware, lamp and upholstery supplies, etc. Big savings on name brand power tools. Send name, address and 35¢ for handling and postage to:

CRAFTSMAN WOOD SERVICE CO.
DEPT. A-90
2729 S. Mary St., Chicago, Illinois 60608

New Catalog!
Write Today!...

**Don't change
your address
without notifying us!**

To insure uninterrupted service on your Popular Mechanics subscription, please notify us at least six weeks before you move.

1. Attach your address label from a recent issue in the space provided below... (If label not available, be sure to give us your old address, including Zip Code)
2. Print your name and new address below (be sure to include your Zip Code).

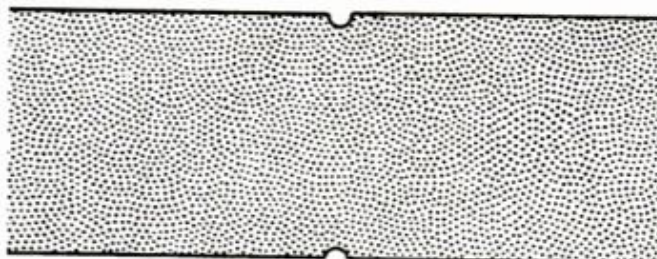

3. Mail entire notice to: **Subscription Service Dept.**
Box No. 646
New York, N.Y. 10019

Name _____
New Address _____ *Please Print*
City _____
State _____ Zip _____
Code _____

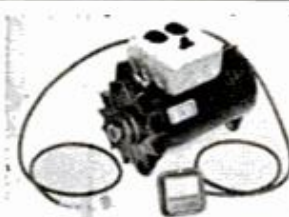

110-120 VOLT A.C. LIGHT PLANTS—60 CYCLES

Fanbelt driven from pickup or small gas engine. Operates saws, drills, pumps, freezers, T.V. X1000 Watts—Needs No Battery. Now \$70.00. 1500 Watts—8 and 12 volt vehicles. Now \$80.00. 8000 Watts—12 volt vehicles only. Now \$99.50. Guaranteed. Check or Money Order.

VIRDEN PERMA-BILT, Box 7066 P.M., Amarillo, Texas 79109

HELP WANTED IN YOUR AREA

Men and Women—Make up to \$700 per month spare time at home

Help friends and neighbors fill out their income tax forms. Hundreds of taxpayers right in your neighborhood need and want help. Most can't do this work. Help them and make big money. We'll show you how.

Federated Tax training will show you, simply and clearly, how to prepare tax returns, how to make allowable deductions that save money for your customers and for you, too.

MAKE BIG MONEY—REALLY BIG MONEY—IN JUST 3½ MONTHS. Do this spare time in your own home or work for one of the tax companies who need help every year and pay big money. Helping only 3 taxpayers a day or evening—at \$10 apiece—in about 2 hours spare time at home—can easily make \$700 per month for you!

Get free details now—by mail. No salesman will call. Be ready to make big money this tax season. Write today!

FEDERATED TAX TRAINING, Dept. 329, 1555 Howard Street, Chicago, Ill. 60626.

THIS IS A TRUE STORY*

All details in our file #3789. Only the name of the Universal graduate has been changed to respect his desire for privacy . . . Ed.

HOW TED VERNON AVERAGES \$20,000 WORKING 6 MONTHS A YEAR

**NO COLLEGE!
NO EXPERIENCE!
NO SELLING!**

When Ted Vernon* walked to a mailbox that day, the things he wanted seemed far beyond his reach. Like lots more money, freedom from his dead-end job, independence and security, a new future.

Chances looked dim. Ted had no college. His only experience was his old job. And he was already past 40.

Yet, when Ted Vernon mailed his envelope, everything he dreamed of became possible. All he did was mail a coupon like the one below.

Free book put Ted on road to big income

The coupon brought Ted the same fascinating Free Book you can have in just a few days. It tells about opportunities all around you in the booming Accident Investigation field.

It was all new to Ted. He'd hardly even heard of Accident Investigation. Yet he felt he had found his perfect opportunity.

And he had! His first full year he made \$14,768.72. Since then he's averaged \$20,000 working about six months a year. The rest of the time he just relaxes and takes it easy.

He learned secrets of success in 30 minutes

Ted skimmed through Universal's Free Book in 30 minutes. He learned three big points that changed his life.

- Accident Investigation is a \$19 billion dollar industry safe from layoff, recessions and automation.
- More and more men are urgently needed to investigate and settle some 22 million accidents each year.
- Universal's training-by-mail has been the path to success for thousands of men in this high-pay field, mostly men with no college and no experience.

It was the opportunity of a lifetime. Ted enrolled for Universal's correspondence training at the mere cost of cigarette money.

It was easy. Ted simply studied his brief, interesting lessons at home in his spare time. He kept right on with his old job until he could start making money quickly in Accident Investigation.

Ted Vernon's income is unusually high and not typical of the industry. He's a busy specialist in storm loss adjusting. But it does show the big potential in this great field even for men with no college and no experience.



READ WHAT RECENT STUDENTS SAY:

"My income averages \$1,200 to \$2,000 a month."

—Ed Crouch of California.

"Thanks to you, I was contacted by 17 top companies."

—Donald Doris of Illinois.

"A raise every three months for the next two years, plus new car and expense account."

—Oscar Singletary of Georgia.

Send for your free opportunity book today

Mail coupon below to get your copy of the Free Book that started Ted Vernon to new big-money success. Read about the exciting full time or part time opportunities, about other successful Universal students, about Universal's Free Placement Service, and how to start your own full or part time business.

But act quickly. Take the first step to the big money field. Mail your coupon today.

MAIL NOW FOR YOUR BIG, FREE BOOK

Universal Schools, Dept. PM-9
6801 Hillcrest, Dallas, Texas 75205

Please rush my Free Book on earnings and opportunities in Accident Investigation. No obligation. No salesman will call.

Name _____ Age _____

Address _____

City _____ State _____ Zip _____ Code _____



APPROVED FOR VETERANS' TRAINING

Accredited Member National Home Study Council





**EARN
HIGH
WAGES**
as a **HEAVY
EQUIPMENT
OPERATOR**

Train your way to high pay in the booming construction industry! Learn the skills you need to qualify, by actual field training on machines like the ones used by the industry. Huge training grounds in North Carolina, a million dollars worth of school-owned diesel-engined machines, experienced instructors, full 220-hour and 440-hour courses. National, the original school of heavy equipment operation, is a recognized leader. Member American Road Builders Assn., Services and Supply Division. Associate Member A.G.C. Full-time Job Advisory and Counseling Director on staff. VA approved. For men ages 17 to 56. Train Now-Pay Later plan... other payment plans also available. Write TODAY for FREE catalog and FREE copy of school newspaper reporting news of National School graduates. Accredited member NATTS.

NATIONAL SCHOOL
OF HEAVY EQUIPMENT OPERATION, Dept. D-43
P. O. Box 8529, Moores Chapel Road, Charlotte, N. C. 28201

Please send me FREE illustrated school catalog and complete information. I understand there's no obligation.

Name _____ Age _____

Address _____ Phone _____

City _____ State _____ Zip Code _____

A New Spare Time Income For The Home Handy Man Sharpen Carbide

Saws and Tools
with famous

Foley

Carbide Grinder

Excellent potential in this super growth industry! Manufacturing firms of all sizes are switching to carbide.

They use hundreds of different carbide tipped saws and tools. All need sharpening. Amazing profits are yours for just minutes of easy work.

We Will Finance You! Easy finance plan helps you start in this highly profitable field. Part time could lead to full time. No special skills required. Foley shows you how. Write now for full information.



Foley

Carbide Service Center

Room 943-O, 3300 N.E. 5th Street
Minneapolis, Minnesota 55418

WHAT'S NEW OUTDOORS

BY ROB KINSON



A **RADIO** especially for outdoorsmen, RCA's new "Camper" is one compact unit in a black plastic case that includes a battery-powered AM radio, built-in flashlight for night hikes and map reading, detachable compass plus twin metal sighting guides to keep you on the right track. The radio dial lights up so you can identify the station. Other highlights include four-inch speaker, jack for 6 or 12-volt battery operation, carrying strap, metal hanging clip, external antenna. Available at most department stores and radio-TV shops for \$39.95.



TWO SPORTS MANUFACTURERS are showing their good will by participating in worthwhile projects. The Garcia Corp. is making Handi-Gear, a small, lightweight aluminum harness for fishermen who have the use of only one arm. Handi-Gear is sold only to individuals on a nonprofit basis. For information write the Garcia Corp., 329 Alfred Ave., Teaneck, N.J. 07666.

Kiekhaefer Mercury donates two days of a nine-month marine technicians' course for disadvantaged teen-age boys, offered by the Florida Ocean Sciences Institute of Deerfield, Fla. Kiekhaefer also provides outboard engines so FOSI boats can take the boys on diving and research trips.

One of a kind



No other distiller makes his whiskey the same way we make Seagram's 7 Crown.

So no other whiskey has the same smooth taste.

Or the same consistently fine quality.

And guess what.

No other brand of whiskey is asked for as often as 7 Crown.

It figures, doesn't it?

Say Seagram's and Be Sure.

Seagram Distillers Co., N.Y.C.
Blended Whiskey. 86 Proof.
65% Grain Neutral Spirits.

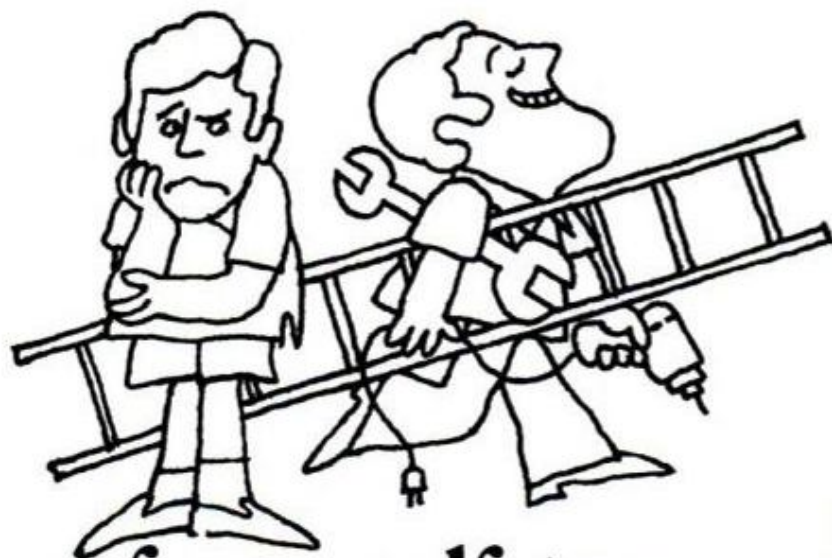

Lendproof yourself, \$9.95

"Are they marked?"—permanent marking tells people, in a subtle way, they should return whatever they borrow. And with the Burgess Vibro-Marker, permanent marking is so easy. Just plug in. It handles like a pencil.

You can engrave unerasable, unmistakable impressions on power tools, wrenches, hub caps, even glass—

quickly. Because the Burgess Vibro-Marker is tough enough to do it all, on all hard surfaces. Priced at \$9.95,* we also have a model for heavy-duty and commercial uses at \$12.95.* Sold at discount, hardware, and department stores. Burgess Vibrocrafters, Inc., Grayslake, Illinois 60030.



*manufacturer's suggested retail price.

UNCOMMON



products

The bargain hunter



FREE MUSCLE COURSE!

Want a new Jet-Charged body? In 15 minutes I'll prove you can slap on 4" of muscles to your chest—3" to each arm—give you life-guard shoulders, trim your waist to athletic size—give you speedy athletic legs. I don't care if you're short or tall (skinny or fat) young or not so young, expect a muscle building miracle when you send for my free course. Send only 25¢ to cover postage and handling to Joe Weider, Dept. 38-90D2, 531 32nd St., Union City, N.J.

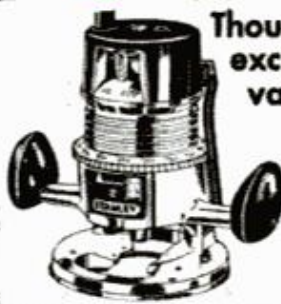

Thousands of exciting tool values!

SILVO (BRAND NAME) TOOL CATALOG

Thousands of Exciting Tool Values! Stanley, Millers Falls, Skil, Thor, Wen, Disston, Wiss, Wellsaw, Dremel, Speedy Sprayers, Plumb, Hoot, Kennedy, Channellock, Porter-Cable, Rockwell, Helios, Vice-Grip, Crescent, Ridgid, Pony Clamps, Unimat, Foredom and many other Nationally Advertised brands of Tools & Supplies. We ship Coast to Coast at prices Hard to Beat. Send 50¢ for our big 146 page tool catalog today. Silvo Hardware Co., PM-9, 107 Walnut St., Philadelphia, Pa. 19106.

COUNTERFEIT GUNS DISASSEMBLE LIKE ORIGINALS

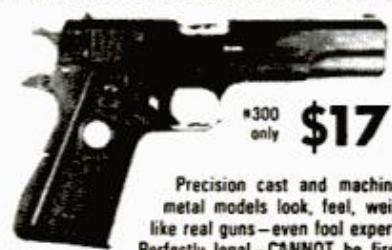

*300 only \$17

Precision cast and machined metal models look, feel, weigh like real guns—even foot experts. Perfectly legal—CANNOT be fired. Great for decorating den, office, rec. room. Send 50¢ for color brochure of 28 models of famous historical to modern military firearms. Dealer inquiries welcome.

REPLICA MODELS, Inc.

Dept. PM-9, 610 Franklin Street
Alexandria, Virginia 22314

ONE MINUTE CLEANS YOUR PAINT ROLLER PROFESSIONALLY



\$3.98

Postpaid U.S.A.
N.J. Res. add 20¢ tax

KLEEN-A-ROLL—the exciting new attachment for your electric drill — squeezes the fuzz

• 2000 TIMES •

- Especially for water paints but oil too—even 9" rollers
- All you need are drill and buckets
- Money-back GUARANTEE
- Free 7" DYNEL® roller cover with your purchase
- By Mail Order Only

KLEEN-A-ROLL
Dept. PM-744

Box 727, Summit, N.J. 07901

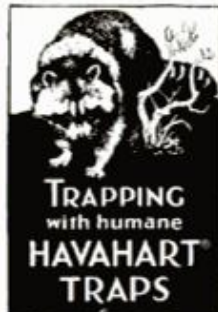

TRAPPING
with humane
HAVAHART
TRAPS

Learn about humane trapping from **Havahart**

It's sure, simple, and safe! Did you know—rabbits like rolled oats? Woodchucks can't resist string beans? Gophers go for peanut butter? Corn lures coons? Snapping turtles kill game birds? Rats can be controlled? Skunks can't spray without lifting their tails? These are a few of the fascinating facts from the HAVAHART Trapping Guide! New edition contains a wealth of useful information as well as price list for the complete line of cages, traps, and animal carriers. Send 25¢ for your copy! Learn the secrets of trapping success. HAVAHART, 136-S Water Street Ossining, New York 10562 Here's my 25¢. Send price list, guide.

Name _____
Address _____
City _____ State _____ Zip _____

WATER! "How to Drill Your Own Water Well and Save up to 75%."

\$1.00 postpaid

DEEPROCK COMPANY
2010 Poplar St.
OPELIKA, ALA. 36801

HOME BOOK OF REFINISHING FURNITURE. All your questions are answered in this authoritative volume. Price \$4.95. Send to: POPULAR MECHANICS Dept. FA, 224 W. 57th St., New York, N.Y. 10019.

COLOR CONVERTER FOR BLACK AND WHITE TELEVISION. NEW PATENTED SYSTEM. AN IDEAL DO-IT-YOURSELF ELECTRONIC KIT, FOR HOBBYISTS AND EXPERIMENTERS. WRITE FOR FREE BROCHURE. BELE ELECTRONICS CORP. P.O. BOX 2469. MAIN OFFICE, MIAMI, FLA. 33101

SAVE \$\$ in REPAIR BILLS



Save hundreds of dollars in repair bills. New 28-page 8 1/2" x 11" book reveals, shows how to beat high cost of repairs. Do-it-yourself tips that make the job easy. Over 50 illustrations. Special emergency road section to get you home. Guaranteed to save you many times the small cost. Only \$3.00 postpaid.

JACK NICHOLS, Dept. K, Carmel, N.Y. 10512

HANDBOOK OF

Knots & Splices

By Charles E. Gibson... Now tie knots for every purpose—useful, ornamental, fun-to-make! Book gives complete "1-2-3" sketches and instructions for every hitch, splice, bend, lashing, sling on whipping you'll ever need for boating, camping, climbing, fishing, hunting... for patio awnings, swings, hammocks, rope fences, "welcome" mats... ornamental lamps, vases, bell ropes, key chains, buggy whips, cat-o-nine tails, rope handcuffs, play quoits, etc. They're all here... over 100 kinds of knots and ropework! From the simple square knot to such fancy numbers as the Manrope, Stopper, Shroud, Crown, Turk's Head and Pine-apple knots. Also covers plaiting, braiding, much more. "Highly recommended"—Library Journal. Profusely illustrated. ORDER NOW! \$4.95, plus 25¢ handling + 10-Day Money-Back Guarantee.



EMERSON BOOKS, Inc., Dept. 743-S

251 W. 19th Street, New York, N.Y. 10011



HOW MANY HANDY DANDYS CAN YOU USE?

Handy Dandys are plastic caps that hook onto 1/4" pegboard and hold quarter-twist glass jars, such as used for baby food. Suggestions for getting FREE JARS in every package. Nothing better for storing supplies, parts and small tools. Keeps workshop neat. Sample pack 10 for \$1 ** 36 for \$3.50 ** 72 for \$6 ** 144 for \$11.50. Caps only. No jars. Postpaid U.S.A. No C.O.D.'s. WICKLIFFE INDUSTRIES, Box 286-PM-9, Wickliffe, Ohio 44092

IMPORTED LOCK BLADE STILETTO

ONLY \$2.75 Ea.

9" Overall Length
5" When Closed

- Opens instantly
- Sharp and Tough
- Stainless Steel Blade

Flips open instantly and locks automatically to prevent accidental closing. Razor sharp tough stainless steel blade for reliable use and hard, long service. Money back in 5 days if not satisfied. Send \$2.75 plus 25¢ to cover postage and handling.



WESTBURY SALES CO.

P.O. BOX 415 WESTBURY, N.Y. 11591
DEPT. L-5-PM

POPULAR MECHANICS

STOP WORRYING

Why be at the mercy of layoffs and overtime cutbacks?

START YOUR OWN Sharpening Business NOW



Housewives, hobbyists, barbers, beauty and pet shops, sportsmen, markets, restaurants, contractors, rental shops, farmers—everybody is your customer. **TREYCO 6-in-1 MACHINE** hollow-grinds knives, saws, tools, scissors, pinkie shears, clippers, garden tools, rotary mowers, etc. Make as much as \$6 an hour. **6 MACHINES IN 1** for price of one. Thousands of users since 1946. Write for **FREE CATALOG AND Factory-To-You Prices.**

TREYCO 332-A Niagara St. N. Y. 14120

RAZOSHARP

Pat. Pend.

\$1.89



PRECISION TOOL HANDLE FOR INJECTOR RAZOR BLADES

IDEAL POCKET KNIFE—EXCELLENT OFFICE AND HOUSEHOLD UTILITY TOOL—Only holder to use standard injector type razor blades. Only holder allowing for varying blade length exposure. Only holder allowing blade to be completely sheathed and protected. Only razor blade holder to give precision tool feel.

ALWAYS RAZOR SHARP—When blade dulls—pop in new blade. Re-use injector type razor blades. **SHAVE and SAVE.** Inexpensive injector type razor blades always available. To expose new sharp edge—reverse blade or clip dull edge. Excellent for cutting clippings, cardboard, trimming. Ideal for opening packages, cartons, boxes. Use for carving, whitening, sharpening, erasing, etc. Shape blade to suit use—snip edge, grind or break with pliers. Nothing to break or wear out.

RAZOSHARP 421 Stockholm Street, Brooklyn, New York 11237

Buy Direct from Hong Kong and Save!

CAR VACUUM CLEANER



27-303 \$4.39ppd.

Plug into Cigarette Lighter Outlet. Have an Immaculate Car in a Jiffy! Complete with Brush, Nozzle Attachment and extra long cord.

27-304 Similar style. But bigger and with high-Power Motor. \$5.79 ppd.

AIRMAIL ORDER TODAY WITH CHECK OR BANK DRAFT. Free catalog sent with order or send \$1 for catalog only.

FRANCIS CHAN & SON LTD. Dept. 101 P.O. BOX K1301 KOWLOON HONG KONG

25-202 \$5.50ppd.

Add \$1.25 for Airmail dispatch. **MEN'S DAY-DATE WATCH.** Chrome or gilt case. Stainless steel back. Sunburst dial. Metal Band. Swiss Movt.

MR. WIZARD'S SCIENCE SECRETS.

Book of science experiments. Exciting fun and safe. Price \$4.95. Send to: **POPULAR MECHANICS Dept. FA, 224 W. 57th St., New York, N.Y. 10019.**

Fantastic Swiss Measuring Tools

Model 70-D

NEW

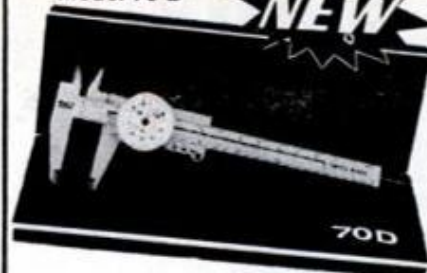

Dial Caliper 5 1/2" RANGE

Measures inside, outside, depth & step readings. Dial graduated in .001" unbreakable, rust proof, patented construction.

ONLY \$ 8.95

3 for \$ 26.00
12 for \$100.00 postpaid

Includes case, catalog & shipping

Send 25c for Money Saving Catalog of hundreds of tools

SCHLESINGERS FOR TOOLS LTD.

1020 East 54th Street, Brooklyn, N.Y.
TEL.: (212) 241-7482



FREE!!! POWERFUL MUSCLES FAST!

Fantastic New Discoveries in the science of bodybuilding. Now, in the privacy of your bedroom, our method will add inches of powerful muscles to arms, chest, shoulders & legs. Learn secrets on trimming the waist with ultra-modern methods—fast! Results Guaranteed! Send for free brochure, Universal Bodybuilding, Box 485-MI, Dearborn, Mich. 48121.



Bartlett Flying Saucer ultra-light hovercraft powered by ordinary lawn mower engine—easy to build—fun to fly—complete plans, kit brochure, photos and supply sources \$4.00. All orders returned via airmail. Write:

HERB BARTLETT

Box 3339-M, Scottsdale, Arizona 85257

MAKE BIG MONEY

MAKING COSTUME JEWELRY AT HOME!

Thrilling spare-time. **MONEY-MAKING** hobby! Make newest, beautiful jeweled earrings, necklaces, bracelets, pins, pendants, cuff links, tie clips! Quick, easy to make—easier to sell to friends, neighbors, stores, at big profit! Details **FREE!**



DON-BAR CO., Dept. G-200
2934 W. Fullerton Ave., Chicago, Ill. 60647

Searching?

Should you wait years to meet your match?? Establish new friend **NOW!**

The computer has smashed the social time barrier. Request free questionnaire. \$15 fee payable when you return questionnaire.



COM/PAIR SYSTEMS, Inc., PM-X
194 Nassau St., Princeton, N.J. 08540

OR use new West Coast address
234 Cazares Circle, Sonoma, Calif. 95476

Name _____

Address _____

City _____ State _____

© COM/PAIR

Stamp Your Name PERMANENTLY

\$4.50
ppd.



Hardened tool steel. Lasts a lifetime. Comparable to a \$10 die tool, still available at this special price. Stamps almost anything you own with a single blow. Made only by the **Henry A. Evers Co., Inc.**, makers of quality marking devices since 1898.

USE THIS FORM FOR ORDERING
Reg. Size 1/4"



Up to 10 spaces @ \$4.50 ppd.
11 to 15 spaces add 25c ea. space.
Large Size 3/8"



Up to 10 spaces @ \$5.75 ppd.

HENRY A. EVERS CO., INC.
Dept. P, 72 Oxford St., Prov., R. I. 02905

DISCOVER HIDDEN TREASURE

WITH A JETCO ELECTRONIC METAL DETECTOR

A powerfully sensitive instrument—detects gold, silver, coins, relics, etc. Fully tested—transistorized—guaranteed.



Send for Free Catalog

\$29.95

JETCO, P.O. Box 132 PM, Huntsville, Texas 77340



BUILD YOUR OWN MODEL ENGINE. Got a lathe? You can do it!! From high quality castings & drawings you can machine beautiful high performance engines. A wide selection is available including 9 gas & 3 steam engine designs. Single cylinders, twins, four's, & a V-8 with HP ranges from .25 to 3 HP. Air cooled and water cooled in both 4 cycle & 2 cycle designs. Send \$1.25 for catalog.

Lancer Engineering,
P.O. Box 544, Pekin, Illinois 61554

CLASSIFIED ADVERTISEMENTS

Rate: \$1.85 per word payable in advance each insertion. Capitalized words—75¢ per word additional. Minimum insertion ten words. To be inserted under the proper classification, copy must be in our office by the 15th of the second month preceding date of issue. The next available issue to place an advertisement in America's No. 1 Classified Section is November. The closing date is September 15th. Send remittance and order to C. A. Martin, Popular Mechanics, 224 West 57th Street, New York, New York 10019. Please make remittance payable to Popular Mechanics.

POPULAR MECHANICS

WHEN ANSWERING ADVERTISEMENTS PLEASE USE THE ZIP CODE NUMBER.

AUTOMOBILES

AUTO MARKET REPORT Shows how to buy and sell your car, new or used, American or Foreign. Current wholesale listing of all cars plus much more! Only \$2.50. Auto Market, Box 495, Lebanon, Penna. 17042.

STARTING hard? Losing power? Get back to normal without cost. New service technique. Instructions \$1.00. Karfax, Box 82C, Guilderland, N.Y. 12084.

MIDGET CARS

PROFITS FROM CLASSIFIED ADVERTISING! Booklet shows you how to start your own business with Classified Advertising. Only \$1.00 (Refundable with first order.) C. A. Martin, Popular Mechanics, Dept. PM, 224 West 57 Street, New York, N.Y. 10019.

AUTO SUPPLIES AND EQUIPMENT

PARTS: Army jeep and truck parts. Spare Parts & Equipment Co., P.O. Box 751, Lexington, Ky. 40502.

HYDRAULIC Jack repair kits, parts and supplies. Catalog 50¢ (in coin). Hydraulic Jack Packing & Tool Co. Inc. General, P.O. Box 3, Staten Island, N.Y. 10314.

CROSLEY, Foreign, American, Parts. Discounts Accessory Catalog 616 Burnside, Inwood, New York 11696.

AUTO Parts for old and new Cars. All makes. Catalogue \$1.10. Antique Auto, Milwaukee, Wisconsin 53204.

BE Your own ignition expert. Free details. Q-arc, Box 47876, Los Angeles, Calif. 90047.

VOLKSWAGEN and Dune Buggy Accessories. Catalog 50¢. Gem Products, Box 845P, Carol Stream, Ill. 60187.

UNBELIEVABLE Huge Savings!! (Repairs, Gas, Oil) with Ring-Valve Job while driving, \$6.50 postpaid. Lasts 100,000 miles! Order Confidently. Results guaranteed! Motaloy, Grantham, Penna. 17027.

CAPACITOR Discharge Ignition System, automobiles, motorcycles, snowmobiles, under \$25.00. Sydmar: Midwood Station, Brooklyn 11230.

SERVICE STATIONS write for SPECIAL FREE Price List Containing Spark Plugs, Contact Sets, Tire Valves, Bulbs, Flashers, Thermostats, Coils, Caps, Rotors. UNIVERSAL BERNAL, 117-18A Rockaway Boulevard, Ozone Park, New York 11420.

AUTOMATICALLY TESTS BRAKES & TIRES DAILY! BRAKE-O-METER is scientifically tested; mounts on car door permanently. 99¢ or 3 for \$1.99; 2 dozen \$11.99. No COD's. EsKay Industries, Inc., Dept. 1, 2138 Biscayne Blvd., Miami, Fla. 33137.

ELECTRONIC Lo/Hi Shift and Red-Line Indicators. Free Information, Data Enterprises, Box 1105, Springfield, VIRGINIA 22151.

AMERICAN Flag Decals. Vivid, no-fade colors. Display with pride on car, trailer, airplane, boat. 2 3/4x4". Specify inside (glass) or outside mounting. Send \$1.00 for three. T S E DECALS, 609 ARCADE BLDG., SPRINGFIELD, OHIO 45502.

IGNITION MONITOR "TINKLEMATE" \$1.00. Instantly pinpoints trouble, saves false repair bills. Foolproof. De-luxe model \$3.00. Rear engine \$1.00 extra. AUTO THEFTPROOFING unit \$2.00. New principle cancels ignition. All products money back guaranty, easily installed on all ignition systems, cars, trucks, boats. Frank Enterprises, 11106 Franklin, Culver City, Calif. 90230.

TARP 9X12 Ft. Clear plastic \$1.00. Martin's, Box 141, Fremont, California 94537.

JEOP Owners—V8 conversions. Read Jeep Owners' ad, page 223.

SNOWMOBILES

SNOW VEHICLE & KART Hop up accessory CATALOG. Speed and performance equipment—manifolds, engine mounts, exhaust systems. Send 25¢. G.E.M. PRODUCTS, Box 845, Carol Stream, Ill. 60187.

AUTO TRAILERS

BUILD Your Pickup Camper. Precut Kits. Blueprints, Supplies, Literature 25¢. Comstock Trailers, Dept. 664, Parsons, Kansas 67357.

PICKUP Camper, Trailer or Pickup—Cover . . . Build yourself. Save! Complete plans \$3.95 each Cover plans \$2.00. Conversion Plans—econoline type van \$2.95; passenger bus or delivery van \$2.95. Satisfaction Guaranteed. Equipment catalog \$1.00 (refundable). Details 10¢. Viking Camper Supply, 99-F Glenwood, Minneapolis, Minn. 55403.

CAMPER & Trailer Kits—Assemble yourself, save 1/2 over factory built. 12 models; Pickup Truck Campers, Pickup Covers, Travel Trailers, Folding Tent Trailers. Big line of accessories. E-Z terms, money-back guarantee. Free 24 page color catalog, Luger, Dept. TW-70, 1300 East Cliff Road, Burnsville, Minnesota 55378.

CAMPER plans and full sized patterns. The most detailed available with written and pictorial instructions. Various models and accessory kits offered. Send for literature—Glen L. 9152—PM-9—Rosecrans, Bellflower, California 90706.

TRAILER AXLES 54" long 5" offset for flat hub Rambler spindles \$19.95 26 lbs. FOB. West Bend Iron Works P.O. Box 33, West Bend, Wis. 53095.

MOTORCYCLES, BICYCLES, MOTORSCOOTERS AND SUPPLIES

BUILD Motorbike From Bicycle! Plans . . . \$2: Go-Cart Plans . . . \$2: Snowmobile Plans . . . \$3: Go-Byk Industries, Rothsay, Minn. 56579.

ELECTRIC Bicycle. Ride All Day For Nickel. Complete Plans \$3.00. Electro, B 27203P, Indianapolis, Indiana 46227.

BUILD "Popular Mechanics" MINIBIKE featured June 1967 issue. Detail plans, photographs \$2.50 refundable. Kits, parts, engines; factory discount prices. Catalog 25¢. Gilliom Mfg.; PMC; St. Charles, Missouri 63301.

BARGAIN PRICES. Every part. Kart or Mini-bike. Giant Catalog \$1.00. New, "how to" plans \$1.00. Both, \$2.00. Brown's Motorsports, 19P Central St., Worcester, Mass. 01608.

ILLUSTRATED Catalog 25¢. Parts, Accessories. Custom Stock, most makes, models. Cycle Supply, Box 192M, Fairbury, Ill. 61739.

MOTORCYCLE Turn Signals. Accessories Catalog 35¢. Houston PM Lockport, Illinois 60441.

MOTORIZED your Bicycle with Lawn Mower Engine. No Welding. Easy Plans \$2.00. Motor's, Box 415, Baraboo, Wisconsin 53913.

INDIAN PARTS. Rebuilding. Accessories. Indian Motorcycle Sales, Kansas City, Missouri 64127.

HONDA—Ossa—Hodaka Parts. Literature \$1.00. Bristol Motors, Clarendon, Vermont 05759.

MINI-Bikes. Chain Saws. Wholesale Catalog 25¢. Loren Products, Danville, Illinois 61832.

MINI-BIKE Non-Racing Competitive Games For All Ages. Compete Alone Or Against Your Friends. Send \$2.00 To: Innovations & Development Inc., 2357 Lemoine Avenue, Fort Lee, New Jersey 07024.

MOTORCYCLE SPEED & PERFORMANCE Equipment for 2-cycle engines. Catalog, 25¢. G.E.M. Products, 496 E. St. Charles Rd., Carol Stream, Ill. 60187.

SPACE, ROCKETS AND ASTRONAUTS

MOON Landing pictures, other fantastic space unusuals! Free brochure! Astroland, Box 234-PM, Merritt Island, Florida, 32952.

ROCKETS: Real flying models—flights up to 2500 ft. New illustrated catalog 25¢: Singles and multistage kit, cones, engines, launchers, trackers, rocket aerial cameras, technical information. Fast service. Estes Industries, Dept. 15-J, Penrose 7, Colorado 81240.

(Turn to next page)

SPACE, ROCKETS AND ASTRONAUTS

(Continued from preceding page)

ROCKETS!! Real flying models—2500 feet altitude with powerful motors. Terrific Science Projects. Tubes—Cones—Parachutes—Launchers—Igniters. Gigantic catalog—rocket data—diagrams—25¢. Fast Delivery. Centuri Rockets, Box 1988, Phoenix, Arizona 55001.

LIQUID FUELED ROCKETS: Authentic high performance single and multi-stage kits, rocket plane kits, ready-to-fly jet planes. Use unique non-flammable propellant. No special permit or license required. Send 25¢ for catalog. Vashon Industries, Inc., Box 309-C, Vashon, Wash. 98070.

REAL FLYING MODEL ROCKETS! Over 1½ feet long! Completely assembled and painted. Flights to 2500 feet! Only \$2.75 plus 25¢ shipping. Includes complete illustrated flying instructions, altitude finder and flight log. Uses Estes, Centuri, Cox, MPC engines and launchers. Satisfaction guaranteed! **ROCKETWORLD-C** Box 13254, Phoenix, Arizona 85002.



AVIATION

BE A Government licensed aviation mechanic. Practical training. Free information. Aero Mechanics School. Municipal Airport. Kansas City, Missouri 64116.

AIRBOAT, Propellers, Engines, Plans, Kits, Supplies. Complete Airboats Outboard Airdrives. Catalog \$1.00. Banks-Maxwell, Box 3301E, Ft. Worth, Texas 76105.

AVIATION Surplus Big Catalogue 50¢ (Refundable). Box 1TFPM, Spring Grove, Penna. 17362.

HELICOPTER, One-Man, Portable, Bubble canopy, Kits, Plans Information 10¢. Photos and three-view drawings \$1.00. COMPACOP, Box 1267PM, Redwood City, California 94064.

AERO-CAR, Amazing Hovercraft built easily with ordinary tools. Lawnmower engine power. Carries one man plus. Hovers, flies forward, backward, sideways over land/snow/water. Complete construction plans and brochure. \$5.25. Aero-Projects, Box 5118PM, Clinton, N.J. 08809.



BOATS AND TRAILERS

FREE Catalog! Camping, Boating, Sailing Supplies; Gadgets, Hardware and Gifts, Laacke and Joys, 1439 N. Water St., Milwaukee, Wisconsin 53202.

BOAT PLANS, FRAME KITS, BOAT KITS. World's largest catalog—Over 200 top design for the amateur builders. New catalog includes Cruisers, Runabouts, Deep vee's, Catamarans, Trimarans, Houseboats, Sailboats from small sail fish to 34 ft. motor sailers, large selection of inboard and outboard Hydroplanes. Send \$1.00 for large new plan & kit catalog or \$2.00 for catalog plus Boat Builder's Guide. Clark Craft Boat Company, 16-P Aqua Lane, Tonawanda, New York 14150.

BUILD Your own boat from our large-scale blueprints. Books of plans give how-to-build help. Hundreds of professional designs—motor, sail or auxiliary—for amateur builders. Free catalog. MoToR Boating, 959 Eighth Ave., Dept. PM-RS, New York, N.Y. 10019.

FIBERGLASS Cloth and resin. World's finest cloth and non-run resin, at direct mill prices. Flotation foam. Complete line of plastics, silicon bronze and brass screws, save 60%. No sales tax. Boat Plans. Catalog 25¢. Freight prepaid. Stiles Boat Supply, Box 11P, Linden Ave., Mantua Hts., N.J. 08051.

CANOES, Kayaks, kits, plans. Sailing Rigs, accessories. Free catalogue. Quicksilver, 115 McGavock Pike, Nashville, Tennessee 37214.

BOAT Kits, Molded Fiberglass. Save money—assemble yourself. Factory molded sections bond into one-piece craft. 20 models—14' to 32'. Cruisers, Runabouts, Houseboats, Sailboats. Big line accessories, motors, trailers. Easy terms. Free 80 page catalog. Luger, Dept. BC-70, 1300 East Cliff Road, Burnsville, Minnesota 55378.

PLANS, FULL-SIZE PATTERNS, FRAME KITS with step-by-step instructions specially for amateurs. Send \$1.00 for new 96 page catalog of over 80 designs: 8' to 36' Sail, Jets, Inboards, Outboards, Cruisers, Houseboats, Hot Boats, Catamarans, Hydros, Glen Designs, 9152 Rosecrans, Bellflower, Calif. 90706.

SAIL BOAT KITS. Molded fiberglass and wood for Snipe, Lightning, Penguin, and many others. Free catalogue on sail boats, canoes, ice boats, and fiberglass and sail making supplies. Taft Marine Corp. 636¾ 39th Avenue, Minneapolis, Minnesota 55421.

"FIBERGLASS Cloth, matt, polyester and epoxy resins. Lowest prices. Seifert's, Box 1206-M, Green Bay, Wis. 54305."

FIBERGLASS Canoes, Kayaks, and Duckboats. Many exciting models. Easily assembled kits. \$39.95 up. Free Literature. Riverside Canoes, Box 5595P, Riverside, Calif. 92507.

NEW Outboards 1970 & 1969 McCulloch & others. 4 H.P. \$120, 9 Electric \$295, 18 . . . \$368, 60 Electric \$848, all sizes. Literature 50¢. Electric Marine, 1427 Broadway, Brooklyn, New York 11221.

AMATEUR Boat Building Magazine. Plans, Discounts, books, instructions. 3183 Merrill, Royal Oak, Michigan 48072.

MARINE EQUIPMENT AND SERVICES

MARINE Engines, conversions, parts. Catalog free. Charles F. Stokes Enterprises, Coldwater, Michigan 49036.

CONVERT Auto engines to marine. 68 Page Catalog, 50¢. Lehman Manufacturing Company, 800 Elizabeth Avenue, Linden 4, New Jersey 07036.

ATHLETIC AND BODY BUILDING COURSES

FEAR No Bully! Master Authentic Chinese Kungfu Unbeatable Techniques! Defeat Within Seconds Any Attacker Including Giant Judo-Karate Experts. Free Details By Air Write Asia's Greatest Master. Leongfu (MI/45) 119, Anderson Road, Ipoh, Malaysia.

ZAKAL, Russian toughening system. \$4.00. Eastview Book Service, P.O. Box 7053, Ottawa 7, Ontario, Canada.

POWERFUL Muscles fast! Free brochure! Universal Bodybuilding, Box 4327-C, Dearborn, Michigan 48126.

"GIANT Arms." Dr. Young's, D.C. revolutionary discovery. \$2. Satisfaction or refund. Gaucho, 1769-S7, Chicago 60690.

"MIGHTY muscles" fast without weights! Complete illustrated course \$4. Guaranteed! Avron, 9315 Avenue "A", Brooklyn, New York 11236.

CATALOGUE—\$1.00, KungFu, GungFu, Karate, Books, Equipment: Orient East Weapons, 3577 West Lyndale, Chicago, Illinois 60647.

NEW! High-Speed Whipper-Joggers 3 minute figure trimming "Work-Out" beats jogging, calisthenics, belts, diets! Free details! W-J's, 2515 Euclid, Santa Monica, Calif. 90405.

"SHORT STATURED? Free Growth, Height Increase Facts, Adults, youngsters, medical details, etc. Send 25¢ to cover postage, handling. Physical Culture Products—PM, Box 1548, Pompano Beach, Florida 33061."

SPORTING GOODS AND EQUIPMENT

FREE Wholesale Catalog. Arrow Shafts, Broadheads, Fletchings Fisharrow Parts, Tools, Bows, Finnyports. (22G), Toledo, Ohio 43614.

FREE 1970 Catalog. Guaranteed Lowest Prices! Rods Reels, Lures, Accessories—Thousands of Item. Cabela's Inc., Dept. S, Sidney, Nebraska 69162.

ARCHERY Lowest Discount Prices. All top brands. Orders shipped same day received. Money-back guarantee. World's Largest Supplier, Free catalog. Anderson Archery Corporation, Grand Ledge, Michigan 48837.

FREE Hunting, fishing catalog. Features outdoor clothing, tents, packs, hunting, fishing equipment, government surplus, etc. Satisfaction guaranteed. Write for free copy today. P & S Sales, Dept. P-9, Box 45095, Tulsa, Okla. 74145.

MR. FISHERMAN Rod Racks For Camper And Trailer. Details, James Fox, 526 Iris, Stockton, Calif. 95207.



FISHING, TACKLE, LURES

SEND for FREE Wholesale Catalog. The most complete and fully illustrated catalog of reels, rods, beads, spinners, jigs, bodies and parts, sinker molds, feathers, tools, hooks, rod blanks, rod parts, swivels, wire, etc. FINNYSPTS, ME Sports Bldg., Toledo, Ohio 43614.

MOLDS—For casting your own fishing sinkers. Free illustrated booklet. Reading Instrument Co., Box P78, Reading, Pa. 19603.

MUSKY Spinners. Information Free, Blackstone, 403 Powers Ave., Madison, Wis. 53714.

GET These FISHERMAN'S SHEARS into your Tackle Box, NINE TOOLS IN ONE. Hook Remover, Weight Crimper, Line Cutter, Awl, Weight Opener, Shears, Screw Driver, Cigar Cutter, Bottle Opener, Cutlery Steel, plated and polished. \$3.50 Postpaid. Lyndale Enterprises, PMM-970, Box 18833, Phila., Penna. 19119.

BIG Money Maker. Ceramic Christmas Tree (Electrified). Retail \$14.95. Sample, Details, \$9.95. Emel Studio's, 10 Vesper Hill, Trumbull, Connecticut 06611.

EARTHWORMS, LIVE BAIT

EARN Money raising fishworms for us! Exciting details free! Oakhaven—56, Cedar Hill, Texas 75104.

HYBRID Redworms 5000 \$10.00, 20,000 \$20.00 Postpaid with Raising Instructions, Worms, Route 9, Waco, Texas 76705.

BIG Profits Raising Nightcrawlers, Redworms, Soilless Method. Three Oaks, Dresden, Tenn. 38225.

FROGS, FISH, REPTILES

YOUNG Frogs and Giant Breeders. Stock your lakes and ponds. Nu-Tex Frog Farm, Box 4601, Corpus Christi, Texas 78408.

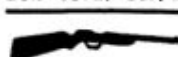

HUNTING, GUNS, DECOYS

YOUR Ad in Popular Mechanics will be seen by more than 5,000,000 active buyers for your products and services. It costs only \$1.85 per word. And, if you wish to run all or part of your ad in capital letters—you can do so for as little as 75¢ per word additional. Act now! Place your Classified ad in Popular Mechanics today.



DOGS AND KENNELS

GUARANTEED Hunting hounds. Picture Catalog \$25. Clayco Kennels, Henrietta, Texas 76365.

(Continued on next page)



POULTRY & GAME BIRDS

QUAILS, Incubators, cages, supplies catalog, Marsh, 14216 Brookhurst, Garden Grove, Calif. 92640.

RABBITS—FUR BEARING ANIMALS

RAISE Rabbits successfully by knowing facts. 48 page illustrated book describing 25 breeds, Housing, breeding, feeding, markets, marketing etc. 25 cents. American Rabbit Association, 36 Arba Building, Pittsburgh, Penn. 15217.

MAKE Big Money raising chinchillas, rabbits, guinea pigs for us. Catalog—25¢. Keeney Brothers, New Freedom, Pa. 17349.

RAISE Rabbits for us on \$500 month plans. Free details. White's Rabbitry, Mt. Vernon, Ohio 43050.

INFORMATION 25¢/Raise for Staloch's Rabbitry, Box 6302, Rochester, Minn. 55901.

\$500-\$800 MONTHLY Raise small Laboratory-breeding stock for us. We supply equipment, breeders, and instructions. Illinois Research Farms, Dept. MPB-9, Barrington, Illinois 60010.

AMAZING PROFITS! \$10,000 Yearly Raising Rabbits for Wool and Breeding. Details 25¢ coin. American Angora, Malta 12, Montana 59538.

PETS—BIRDS, CATS, HAMSTERS, ETC.

LIVE Seahorses, marine specimens, aquarium supplies. Illustrated catalog 25¢. Marine, Box 248-010, Dania, Florida 33004.

HAWKS, Reptiles, raccoons, skunks, squirrels. Catalogue 25¢. Trails End Zoo, St. Stephens, S.C. 29479.

FANCY True Breeding Guppies, Fancy Livebearers, Live Seahorses, Aquarium Supplies. Aquarius Ranch, Box 6506, Ft. Myers, Florida 33902.

SKUNKS Wholesale. Monkeys, Animals, Birds, Snakes. Catalogue 25¢. The Bazar, Box 3173, Fort Worth, Texas 76105.

HORSES, LIVESTOCK

"HOW To Train Horses"—Everyone who likes horses or ponies should have this book; Free. Write Beery School, 1109, Pleasant Hill, Ohio 45359.

MAILORDER Records help get increased business! Complete 32 Page Record Book shows your inquiries orders, advertising, expense, etc. Only \$1.00. C. A. Martin, Popular Mechanics, Dept. PM, 224 West 57 Street, New York, N.Y. 10019.

CAMPING EQUIPMENT AND TENTS

PROFITS FROM CLASSIFIED ADVERTISING! Booklet shows you how to start your own business with Classified Advertising. Only \$1.00 (Refundable with first order.) C. A. Martin, Popular Mechanics, Dept. PM, 224 West 57 Street, New York, N.Y. 10019.

CAMPING

SAVINGS Plus dividends! Campers-fishermen-outdoorsmen cooperative. Free 68-page catalog. Recreational Equipment, Inc., 1525-P 11th, Seattle, Washington 98122.

TRAVEL AND RESORTS

EUROPE On a Shoestring is the Tourists "Bible" What to See, Where to Eat, Sleep, Customs, Money, Tips, Clothing, Passport, Low Cost Tours, Ship, Send 2.00. Universal Products, 507 Fifth Ave., N.Y. 10017.

AMERICA BY CAR. ALL INFORMATION NEEDED 170,000 word book Only \$2.95. Send to: VERNONIA ASSOCIATE, 900 Madison, Vernonia, Oregon 97064.

WILDERNESS Canoe Trips—Outpost Cabins. Write Bill Rom, Ely, Minnesota 55731.

ELECTRICAL SUPPLIES

LAMP Parts. Catalog, prices, wiring instructions. 50¢. Refunded first order. Gyro, 5218P N.W. 35 Ave., Miami 42, Fla. 33142.

METERS—Surplus, new, used, panel and portable. Send for list. Hanchett, Box 5577, Riverside, Calif. 92507.

HARD To Find Light Bulbs Send Requirements To: Jetronics, 2691 Patricia, Los Angeles, Cal. 90064.

LAMP Parts for building, repairing converting. Catalog 40 cents. Refunded first order. Brown Lamp Co., Box 12511, Creve Coeur, Mo. 63141.

BATTERIES, GENERATORS

BATTERY Reconditioning Kit, includes molds, material, instructions. Battery Shop, Route 1-188D, Blythe, Calif. 92225.

ENGINES, MOTORS, MAGNETS

LIVE Steam powered backyard railroads! All sizes. Complete "bolt-together kits," and rough castings. Excellent drawings. 100 page catalog \$1.00. Little Engines, Lomita, Calif. 90717.

WINDING Data, 275 motors. \$1.20. Data Company, 512 Kensington, Kansas City, Mo. 64124.

PRACTICAL PLANS! Motor! Generator! Battery! Electroplating! Motor! Box 7266, Kansas City, Mo. 64113.

MACHINERY, TOOLS AND SUPPLIES

PI TAPE calibrated to give direct diameter reading from circumference. .001 accuracy. Pi Tape, Box 397, Lemon Grove, Calif. 92045.

MICROMETERS — Indicators — Steel — Aluminum — Brass, Maximat, Unimat Lathes, Accessories. Lists free: Complete mailing—50¢. Campbell, 1424 Barclay, Springfield, Ohio 45505.

LATHE Milling attachments. Blueprints too! Write. Potter, Box 73, Cedar Rapids, Iowa 52406.

PLUMBERS — HOMEOWNERS — HANDY-MEN — SAVE COSTLY REPAIRS On Walls In Kitchens Or Baths. To Remove Worn Drain Pipes. MECHANICS Remove Worn Screw Sleeves Or Liners With Our New Type ADJUSTABLE EXTRACTOR. Send \$8.25 Money Order Only To: ADVANCE TOOLS, 1752 North Miro, New Orleans, La. 70119.

SAVE Dollars, Enjoy Building Horizontal Bench Mill—Plans \$2.00 Microm, Box 2313-Q Santa Ana, Calif. 92707.

SMALL Foundry furnaces. Supplies. Free literature. Pyramid Products, 3736 South 7th Avenue, Phoenix, Arizona 85041.

WELDING, SOLDERING, PLATING

WELDERS—110/220, 150 Amperes, \$53.50. Morris, 1070 Inner, Schenectady, New York 12303.

CHROME Plating equipment, supplies. All other finishes. Home workshop and production sizes. Send \$2.00 (refundable) for formulas, operating data, equipment guide and catalog. HBS Equipment Division L50, 3543 East 16th, Los Angeles, Calif. 90023.

GOVERNMENT SURPLUS

JEEPS From—\$52.50; Typewriters from—\$4.15; Cars from—\$31.50. Walkie-talkies, motorcycles, airplanes, boats, Typical "As Is" bid bargains from Uncle Sam. Tremendous variety. Exciting free list. Write: Enterprises, Box 402X62, Jamaica, New York 11430.

GOV'T Surplus. How and where to buy in your area. Send \$1.00. Surplus information, Headquarters Building, P.M., Washington, D.C. 20036.

JEEP and Gov't. Surplus Buying Manual (Jeeps Pictured) 50¢. Surplus Bargain Catalogue 50¢. Both \$1. Surplus Bargains, Box 789PM, York, Penna. 17405.

1970 SURPLUS Army, Navy store illustrated catalog. Send 25¢ (refundable with first \$5.00 order). Ruvel, 3037 North Clark, Dept. 9-J, Chicago, Illinois 60614.

100 AMAZING SURPLUS BARGAINS. Government Surplus never before offered! Buy for PENNIES on the DOLLAR. Hardware—Tools—Motors—Electronics—Optics—Hobbycraft! Illustrated List 50¢ Refundable first order. SEND TODAY! SURPLUS WORLD, 1025 Chili Ave., Dept S, Rochester, N.Y. 14611.

SAVE UP TO 80% or more. Buy surplus direct from U.S. gov't. Complete information \$2.00. Bridgeworth, P.O. Box 2292-C, Vancouver, Wash. 98661.

JEEPS Typically From \$53.90 . . . Trucks From \$78.40 . . . Airplanes, Typewriters, Boats, Clothing, Camping, Sporting, Photographic, Electronics Equipment, Wide Variety, Condition. 100,000 Bid Bargains Direct From Government Nationwide. Complete Sales Directory and Surplus Categories Catalog \$1.00 (Deductible First \$10.00 Order From Our Separate Included Catalog). Surplus Service, Box 820-A, Holland, Michigan 49423.

JEEPS, Boats \$50.00, Guns Telescopes \$5.00, Catalog \$1.00. Bargains, Hawthorne, N. Y. 10532.

SURPLUS BARGAINS—War, government, Industrial surplus at savings to 80%! Clothes, boots, cots, tents—bargains for farm, home, outdoors, SEND FOR FREE CATALOG—must give zip code. SURPLUS STORE, Sioux Falls, S. D. 57102.

HOBBIES AND COLLECTIONS

NOSTALGIA, Six Hours Old Radio Shows On Tape For \$8.00. Catalog Of 1000 Shows 25¢. Radio Specialties, Box 29, Peoria, Ill. 61601.

POSTCARD Catalog, \$3.95. Postcards bought, sold. Deltiology Club, Folsom, Pa. 19033.

LIVING Color Railroad Train post cards. Mamta, 2050 Hutchinson, Chicago 60618.

SHOULDER PATCHES—Collectors items: Official Apollo patches one dollar each Postpaid. U.S. Army and Air Corps patches. Special patches made to order. 10 assorted patches, price list and catalog \$2.50. Catalog only, 25¢. SPRINGER'S, Box 577-PM, El Paso, Texas 79944.

50 GORGEOUS Jungle butterflies \$2.75. Collectors Wonderland, Box 1170, New York 10008.



STAMP COLLECTING

MAKE MONEY Selling Stamps. Wholesale details 25¢. Davis, 847 Main, Tiverton, Rhode Island 02878.

100 DIFFERENT British Empire 10¢. Approvals, Gibson, Box 34, Lansdowne, Pa. 19050.

INDONESIA 50 different 10¢. Catalogues \$2.75. Approvals, Hijop, Box 505, Norristown, Pa. 19404.

EISENHOWER MEMORIAL or APOLLO XI stamp on lovely first day cover addressed in your name. 50¢ each. K.M. WALSH, Box 308A, TUCKAHOE, N.Y. 10707.

(Continued on next page)

STAMP COLLECTING

(Continued from preceding page)

FREE! International assortment of over 50 different Singapore, Chad, Grenada, etc. Plus lists and special certificate worth 50¢. Goliath Co., Dept. IA-1, Bethlehem, N. H. 03574.

RARE Stamp Free! Also new packet Aden to Urundi, with Kennedy, Triangles, Space, Sports, Ships, Dogs, Cats, Reptiles, Plus Others. All Free. Send 10¢ for mailing. Empire Stamp Co., Dept. 1, Toronto, Canada.

50 YEARS In The Stamp Business. So We Have A Wonderful 50th Anniversary Offer. Details From: Bileski, Station B, Winnipeg, Manitoba, Canada.

FREE Stamp Wallet with approvals. Wide choice collections by Countries. Clark, Box 428, Northbrook, Illinois 60062.

SEND Only 10¢ for your copy of the most unusual and interesting collectors catalog available anywhere. You will also receive a wonderful special bonus of over 150 different stamps from Nigeria, Mauritius, Congo, etc. Littleton Stamp & Coin Co., Inc., Dept. SG-1, Littleton, N. H. 03561.

ICELAND, 30 Different only \$1.00. Tucker, Box 6622, Greensboro, N.C. 27405.

50 DIFFERENT Canada: 10¢ with approvals. Oroszky, P.O. Box 1-C, Sarnia, Ontario, Canada.

YOURS FREE! 20 Almost Rare Stamps from 12 Lost Nations—Most a Half-Century Old! Nations overrun by invaders and never freed again. Stamps so appealing that experienced and beginning collectors alike will want them. You get 110 other stamps from Britain's Lost Empire plus illustrated Album to keep as a Bonus should you buy \$1 from our Approval Selection. Or return Album and 110 stamps with selection and buy nothing. Cancel Service anytime. But Lost Nations stamps are yours to keep! Send 10¢ for postage while supplies last. Kenmore, Milford LN 591, New Hampshire 03055.

"AFRICA." 25 beauties. 10¢. Approvals. Gorliz, Box 1915PM, Naples, Florida 33940.

FREE 50 Worldwide Approvals. University Stamps, P.O. Box 1471, Lake Worth, Florida 33460.

210 DIFFERENT U.S. Commemoratives \$1.00. Stamps, 7607 Larchview, Dallas, Texas 75240

ASIA—100 Different, including pictorials, 10¢. Approvals. Tarheel Philatelics, Siler City, North Carolina 27344.

ONE CENT a Stamp. Write for a jumbo book of Foreign stamps at 1¢ each, mounted in Scott order. PP, Bullof, 6815 Bay Parkway, Bklyn., N.Y. 11204.

PENNY! Approvals! Regardless catalogue! Kloster, 4164 52nd St., San Diego 5, Calif. 92105.

50 YEARS Old, fifteen different United States, over fifty years old—10¢ with approvals. Jaxon, Box 145-P, Brooklyn, New York 11230.

GIANT Stamp Collection including: Astronauts, Satellites, Moonrockets, Boy Scout issue. Complete U.N. Set, recent Olympic and Sport issues from many countries, etc., Plus Big Stamp Dictionary and approvals. Everything 10¢! Stampex, Box 47-RM, White Plains, N.Y.

FREE! Big Bargain Catalog—New Edition listing thousands of bargains including U.S. & B.N.A. stamps, packets, albums, accessories and supplies. Also, fine stamps from our approval service which you may return without purchases and cancel service at any time. Jamestown Stamp, Dept. E90PM, Jamestown, N.Y. 14701.

WOW! 110 All Different Germany 10¢. Commemoratives, Airmails, High Values, Big catalog, bargain lists. Also, fine stamps from our approval service, which you may return without purchases and cancel service at any time. Jamestown Stamp, Dept. A-90PM, Jamestown, N.Y. 14701.

1500 FOREIGN \$1.00; 5000 \$3.00; 9000 \$5.00; 5000 USA, Contains airm. dues. 19th Century, presidentials, revenues, high values, etc. \$3.00, 300 pre-1939 USA commemoratives \$2.00, 200 pre-1926 USA \$1.00; 700 \$3.00; 3000 \$12.00. No approvals. Meyers, 5321 Fleming, Richmond, Calif. 94804.

UNITED STATES commemorative collection containing 33 different—10¢. Approvals. White, 516-A Avenue L, Brooklyn 30, New York.

U.S. Bargain, 50 different 10¢, with beautiful worldwide approvals. Stamp Center, Kennebunk, Maine 04043.

14,000 DIFFERENT! AMAZING new plan builds your collection systematically, country by country. Only 50¢ weekly. Ware, Monroe, Conn. 06468.

"INVERTED ERROR" Dag Hammarskjold. 6¢ with approvals. Belmont Stamps, Washington, D.C. 20015.

50 DIFFERENT Old U.S. Revenue stamps 50¢. Winchester Stamps, Box 1592, Mansfield, Ohio 44907.

FREE Surprise collection sent with approvals. Gould, 1784 Union, San Francisco 94123.

APPROVALS: Plus collections by year. Martus, Box 158, Centuck, Yonkers, New York 10710.

500 DIFFERENT Stamps, \$1.00. Smith, 508-A Brooks, College Station, Texas 77840.

PENNY Stamps! 1000 Mounted in book at 1¢ each! Trast Stamp Company, P.O. Box 100-P, Jamaica, New York 11435.

ABSOLUTELY Free United States Mint Souvenir Sheet When Requesting United States Approvals. K&B, Box 70, Brooklyn, N.Y. 11223.

DEFECTIVE Old used U.S. bargains. Karl Swartz Stamps, Mountain Home, No. Car. 28758.

MILLIONS Foreign Stamps! 2¢ each! Send for gigantic approvals! ABC, Box 6000-MB, San Francisco, California 94101.

PAINTINGS—Multicolored set 10¢. Approvals. Philatelics, Box 2061, South Bend, Indiana 46615.

HITLER—Infamous Commemorative Set 25¢. Approvals. Iannuzzi, Box 76241-C, Los Angeles 90005.

100 DIFFERENT United States, only 25¢ with Approvals. Shelton, Box 547C, North Miami, Florida 33161.

100 OLD United States between 1861 and 1935. \$1.00. Roush Stamps, 423 Shepard, Mansfield, Ohio 44907.

RUSSIAN Space collection 10¢. Russian Approvals. Snedco, Box 68-P, Waldwick, N.J. 07463.

YOU Will be pleased with our generous cash offer for your stamp collection. Ship today anything \$15.00 to \$15,000. Stamp Enterprises, P.O. Box 474-P, San Mateo, Calif. 94401.

PICTORIALS! 50 Different Large 10¢. With Interesting World-Wide Approvals. McCoy, Box 887-P, Chicago, Illinois 60690.

ALL World 1,000 Different Stamps, Only \$2.00. With Approvals. Durocher, Box 130, Aymer East, Que., Canada.

SLIGHTLY Defective U.S. before 1899. \$12.00 catalogue value \$2.00. Nelson, Box 746, Warner Robins, Georgia 31093.

250 STAMPS 50¢. Approvals. Moran, 602 Highway 9s, Ben Lomond, California 95005.

PICTORIAL Packet approvals. Pennies per stamp—discounted! Agrian, Folcroft, Penna. 19032.

THREE Mint Vatican Sets \$1.00. Penniston, Box 5502, Arlington, Va. 22205.

THOUSANDS Of stamps, 1¢ up. Bonuses. Fisk, Box 35, Elmhurst "A" N.Y. 11373.

EXCHANGE Send 100-200 Different stamps with 25¢. Receive different. Patterson, Lancaster, New York 14086.

"SPACE"—Fantastic Collection: 10¢! Approvals, Shaw, Drawer E-74, Montevallo, Alabama 35115.

VIETNAM 25 Different 10¢ approval. Sam Chazen, Box 950, Ozone Park, N.Y. 11417.

2,000,000 STAMPS, 150 Countries, 2¢ and up. Free duplicate exchange to regular customers. Belden, Box 4175B, Dearborn, Michigan 48126.

DIRECT FROM VATICAN free special souvenir cover with Italian area realistic offers. Marengi, via Bagnara Calabria 12, 00178 Roma, Italy.

25 U.S. FREE with Approvals. Collier, Box 755, Folkston, Ga. 31537.

50 STAMPS from 50 different countries 25¢ with approvals. Quynn's, Scotland, Penna. 17254.

FIFTH Pound U.S. or Foreign Mixture, \$1.00. Stamps, Box 452, Parkersburg, W. Va. 26101.

STAMPHUNTER'S DREAM! Offered to new applicants for our great low-cost approvals. 25¢ buys gorgeous assortment of high-values, topicals, sets, pictorials, old & new—the unexpected. Remarkably high catalogue. Rivertown Stamp Co., Drawer 188P, Lowell, Michigan 49331.

WORLD Collection. 511 Different Stamps \$1.00. Monjar, Westknolls, Cincinnati, Ohio 45211.

EXCITING First Day Cover. Approvals, BCS, Box 9131, Chicago, Illinois 60690.

NUDES, Nudes and more nudes free! Yes for the opportunity of showing you our stamp "approvals" we will give you five beautiful, colorful nude paintings free. Send to Roll, PM9, 26855 Trask River, Tillamook, Oregon 97141.

25 FAMOUS Paintings 25¢ with approvals. Philmart, Box 262A, McGregor, Texas 76657.

FREE 100 Different With Bargain Approvals. State Interests; Ohlsen, Box 103, Fairfield, Ill. 62837.

FREE Moon Stamp. Fine approvals. Chapman Stamps, Box 633, Galesburg, Mich. 49053.

"FREE Russian to approval customers." Stroud, Box 8133, Montgomery, Alabama 36110.

TEN Different Nudes: 20¢. Approvals. Stamp Farm, 2M22, Oxford, Wis. 53952.

50 STAMPS From 50 Countries 10¢. Approvals. Miller, Box 2084M, Falls Church, Virginia 22042.

"NUDE Paintings" Hungary's latest Gigantic Bicolored Commemoratives—Free! Approvals plus 101 Bonus Sets. William Deems, 226X Race, Ravenswood West Virginia 26164.

500 DIFFERENT Stamps 35¢. Request Approvals. Stamps, Box 4155M, Tulsa 74104.

"WHOLESALE" U.S.—Foreign Pricelist and catalog Free! Everything Guaranteed. Schneider, Box 1240, Grand Rapids, Michigan 49501.

WORLDWIDE Packet free. Penny approvals. Froehlich, Box 7, Waukegan, Illinois, 60085.

WHOLESALE CATALOG 25¢; U.S. Mints, Postmarked, Covers, common and the rare. Stamp Exchange, (PMH) Box 8185, Columbus, Ohio 43201.

QUALITY AND LOW PRICE. EXCELLENT For advanced or beginner. Mounted approvals 2¢ up, all countries in Scott's Order. Preview Stamps, P.O. Box 9809M, San Diego, California 92109.

FAR EAST ASSORTMENT—VIET NAM, JAPAN, KOREA, Formosa and others only 10¢ with world wide approvals. Clark Stamps, Dept. 57V, Muskegon, Michigan 49444.

500 DIFFERENT Stamps, \$1.00. Smith, 508-A Brooks, College Station, Texas 77840.

(Continued on next page)

STAMP COLLECTING

(Continued from preceding page)

RUSSIA High-Value Collection. 32 different Russia—some over 50 years old! Commemoratives, Czarist Issues, Airmails, Catalog price \$2.50. Special Get Acquainted Offer—all for only 10¢! H. E. Harris, Dept. GG 49, Boston, Mass. 02117.

225 STAMPS for only 10¢! Airmails. Pictures: stamps from strange countries cataloging up to 25¢ each! Plus unusual stamps to examine. Buy any or none return balance, cancel service anytime. Mystic Stamp Co., Camden 80, New York 13316.

FREE Stamps with U.S. Commemorative and Worldwide Approvals. Send 15¢ to Cover postage and handling. Fran's, Box 367, Raymond, New Hampshire 03077.

COINS, TOKENS, CURRENCY

SEND Only 5¢ for U.S. "Lincoln Smoking a Pipe" penny. You will also receive a copy of the most wonderful catalog of coin offers in America. Littleton Stamp & Coin Co., Inc. Dept. PS-1, Littleton, N.H. 03561.

"COINS"—Investment and Profit! booklet \$1.00. "Petersen-House" 2249-4A Street, Rock Island, Illinois 61201.

SILVER Dollar Key Chain only \$4.95. 5 for \$22.50. Guaranteed. Jay, Box 85194, Los Angeles, California 90072.

SILVER Dollars, three different uncirculated \$10.00 or 4 different used \$10.00. Illustrated Catalogue 50¢. Shultz, Salt Lake City, Utah 84110.

1909-VDB LINCOLN \$1.25. Price list 25¢. Village Coins Shop, Dept. P, Plaistow, N.H. 03865.

"S" LINCOLNS, 1941S Through 1970S \$1.25. Morehead, 208B Houston, Thousand Oaks, Calif. 91360.

1955-S LINCOLN 25¢. FREE bargain list. Ron Farley, Metamora, Ill. 61548.

BARREL of Pennies found on ranch! All before 1956 (mostly "S")—includes Indianheads! 50 mixed 2.00. HARRIS, 2775P Park, Santa Clara, California 95050.

LINCOLN'S: 25¢ Each. 1917DS, 1918DS, 1920DS, 1925DS, 1928DS, 1943DS. Stevens, Box 546F, North Miami, Florida 33161.

COIN List, Bargain Prices. 10¢ (Refundable). Economy Sales, Mansfield, Mass. 02048.

100 INDIAN And Lincoln Cents 1920's and older \$5.00, 40 Mixed Buffalo Nickels \$5.00; Wes Rood, West Union, Iowa 52175.

COLLECTORS' Guides for exact date, market value U.S. coins, stamps, paper money. \$2.98. Elbru, 422 Chester Avenue, Annapolis, Maryland 21403.

20 UNCIRCULATED Foreign Coins \$1.00. Coins, Box 35041, Minneapolis, Minnesota 55435.

ARROWHEAD and **INDIANHEAD** CENT \$1.00 postpaid. Neal, Box 8892, Nashville, Tennessee 37211.

GOLD COINS of the World. Beautiful low prices. Plus thousands of United States Coins. Free price list. Please send long, airmail envelope, self-addressed, stamped. Silver Center, Box 22171-M, San Francisco, California 94122.

TEN Indianheads \$3.15; Five V-Nickels \$1.50; Silver Dollar \$2.95; Bargain Lists! Coins Wanted! Fairway, 121-P, Rye, New York 10580.

ROOSEVELT Dime Specials. All Very Good Or Better. 1949S-80¢, 1955-\$1.50, 1955D-65¢, 1955S-40¢. All Other Dates Are 25¢ Each. Complete Set Of 55 Different With Album For \$14.50. Satisfaction Guaranteed. Bryson Inc., 612A White, Toledo, Ohio 43605.

SILVER Dollars Choice Uncirculated—Ten different Dates 1880 to 1902 \$33.85. 1971 Redbook \$2.29. Bargain Lists 15¢. Bebee's, Inc. Omaha, Nebraska 68111.

25 DIFFERENT Foreign Coins \$1.00. Hoffman, PM9, Box 98, Clarence, New York 14031.

ANTIQUES, RELICS, INDIAN GOODS & CURIOS

LIST Indian relics. 10 Arrowheads \$3.00. Hyde's, Box 2304, Santa Fe, New Mexico 87501.

TONS Of antique gun parts and supplies. All reproduction muzzle loading guns. Send \$1.00 for enlarged illustrated catalog No. 119B. Dixie Gun Works, Union City 12, Tennessee.

EVERYBODY LIKES DIXIE GUN WORKS.

FREE List, books on Antiques. Beck, Griffin Rd., Hometown, Ind. 46748.

10 BEAUTIFUL Arrowheads \$2.00. Guajardo's, 8713 Shaver, El Paso, Texas 79925.

INDIAN Relic list. Arrowheads \$4.00, doz. Folsom, \$5.00 each. C. Secrist, Muscatine, Iowa 52761.

REFINISHING AND **RESTORING** ANTIQUES 190 Page Instruction Book \$1.00. MILLERS BARGAIN HOUSE, 427A RAILROAD AVENUE, WEST JEFFERSON, NORTH CAROLINA 28694.

DEALERS Confidential Prices. Book "Buy And Sell Antiques" Only, \$4.98. SELECTO, 1438 N. Harrison St., Algonquin, Illinois 60102.

MODELS—CARS, SHIPS, TRAINS, PLANES ETC.

SHIP MODELS/SHIP PLANS Over 1200 items. Catalog 45¢. P.C. Coker, Box 124, Charleston, S.C. 29402.

STUART Steam engines, castings, catalog 75¢. Carolus Models, 1131 Wilson Avenue, Salt Lake City, Utah 84105.

ROCKETS: Real flying models—flights up to 2500 ft. New illustrated catalog 25¢. Single and multistage kits, cones, engines, launchers, trackers, rocket aerial cameras, technical information. Fast service. Estes Industries, Dept. 15-J, Penrose, Colorado 81240.

SHIP Models Kits, fittings, plans, books, tools, engines, motors. Big illustrated catalog 50¢. Mass. residents add 3% tax. James Bliss & Co., Dept. SM, Route 128, Dedham, Mass. 02026.

SHIP And yacht model fittings: Pine construction hull kits: blueprints. Send 50¢ for illustrated catalog. A. J. Fisher, Inc., 1002 Etowah Avenue, Royal Oak, Michigan 48067.

SHIP Models catalog 25¢. Scientific, Inc., 100 Monroe, Newark, N.J. 07105.

MODEL Airplanes—Big 220 Page Catalog 50¢. Sig Company, Montezuma, Iowa 50171.

LIVE Steam engine kits. Fascinating hobby for model mechanics. Boilers, fittings, accessories. Pictured catalog \$1.00. H.P.K. Models, Centuck 34, Yonkers V, New York 10710.

GAMES, TOYS, PUZZLES, NOVELTIES

"NOVELTY Gizzditty Insect Exterminator \$1.49 Eberty House, Madison & E. Hoosier, North Vernon, Indiana 47265.

"ROULETTE DICE" . . . Roulette decision-makers! \$1.00 a pair. D.E. Products, Box 562, Worcester, Mass. 01613.

AT Last, **THREE NEW GAMES** to improve your hand-eye coordination. \$2.00. Vaccaro, Box 571, Rockledge, Fla. 32955.

PEACE Button, 350 Novelty Buttons, Bumper Stickers, Catalogue 10¢. Harrison, Box 233N, Bethpage, New York 11714.

MAGIC TRICKS, JOKES, VENTRILOQUISM

MAGIC MAGAZINE—Monthly since 1936. 44 pages. All phases. 3 month trial \$1.00. Genil, P.O. Box 36068, Los Angeles, Calif. 90036.

COMPLETELY Illustrated catalog. 84 pages. 25¢. Manhattan Magic, Box 334-M, N.Y.C. 10011.

HOUDINI'S Greatest Magic Tricks!! You can do them! Giant Illustrated Catalog and Free Secret Trick. 25¢ House of 1000 Mysteries, Dept. PM70C, Ft. Lauderdale, Florida 33308.

BE A Magician! Two booklets explaining sixty-eight tricks plus large professional catalog. \$1.00. Magic Inc., 5082 Lincoln, Chicago, Illinois 60625.

WORLD'S Finest professional magic tricks. Joker's Novelties. Giant illustrated catalog 10¢. Top Hat, Evanston, Illinois.

MAGIC Catalog. World's finest 3000 tricks. (340) pages \$2.50. Beginners, amateurs, professionals. Kanter's, A-200 South 13th St., Philadelphia, Pa. 19107.

FABULOUS MAGIC new 1970 catalogue 25¢. Our specialty orders shipped same day no substitutes. Fabulous Magic, 3319 East Charleston, Las Vegas, Nevada 89104.

VENTRILOQUISM! Information free! Dummy catalog 25¢. State age. Maher, Studio I, Box 9037, Denver, Colorado 80209.

MAGIC Trick and 500 Item Catalog. Both 35¢. Mystic Magic Company, Box 2824, Plainfield, New Jersey 07062.

FREE Trick and magic catalog. 25¢. Magic, Box 329, Evanston, Ill. 60204.

NEW 1970 catalog. 500 tricks, now ready! Send 10¢ for catalog showing latest magic for pocket, parlor, stage. Douglas Magicland Dept. 11, Dallas, Texas 75201.

HOUDINI'S Original Magic Shop. Established 1856. Send 25 cents for Illustrated Catalog containing 5000 Tricks. Mindreading, Puzzles, Hypnotism and Jokes. Flossie-Hornmann, 304 West 34th St., N.Y. 10001.

FREE! World's Leading Catalog 2000 Novelties, Jokes, Tricks, Scientific Gadgets, Hobbies. Johnson-Smith, C-10, Detroit, Michigan 48224.

FREE! \$1.00 Handling charge brings beautiful "Crystal ball". Gift boxed. Fletcher, 5105C Belmont, Dallas 75206.

"VENTRILOQUISM! Unique "listen-and-learn" method. Write, Show-Biz, 1735-P East 26th Street, Brooklyn, N.Y. 11229.

150 MAGIC Tricks fully explained. Perform them right away. 99¢. Magic, Box 1204, Station A, Toronto 116, Canada.

BOOKS, CATALOGS, NEWSPAPER

FREE List of Low Cost Books. Success, Happiness, Personality, Wealth, Personal Problem. Universal Products, 507 Fifth Ave. N.Y. 10017.

BOOKS On All Subjects. FREE Circular. GENERAL SERVICE COMPANY, 443 WEST 8th STREET, PM1, SAN BERNARDINO, CALIFORNIA 92401.

FREE BOOK. Prophet Elijah Coming Before Christ. Megiddo Mission, Dept. 63, 481 Thurston Road. Rochester, N.Y. 14619.

FREE Brochure. Lists over 70 low cost self improvement books. Skyline Enterprises, 5814 Skyline Drive, Morning-side, Maryland 20023.

FREE Information on self improvement. Wilkinson Enterprise, 422 New York Ave., Norfolk, Virginia 23508.

IMPROVE YOUR PERSONALITY! 110 page book—"Dynamic Thinking" shows how. Send \$1.00. Chantilly Gifts, 14702 Batavia Drive, Centreville, Va. 22020.

SELF Improvement and How To Books—Free details—G. G. Associates—39 Brooklawn Drive, Milford, Conn. 06460.

(Continued on next page)

BOOKS, CATALOGS, NEWSPAPER

(Continued from preceding page)

BOOK ENDS Used by Libraries Schools. Enameled steel gold color \$1. Postpaid. Free catalog: Roger Direct Mail Co., Two Thousand Lee Road, Cleveland, Ohio 44118.

DIRECTORY OF CLOSE-OUT FIRMS 20,000 items at close-out prices, \$1.00. Winchester Enterprises, 2807 PM Hargrave Street, Phila. Pa. 19136.

FREE Catalogue! Gifts, Books, Folios. Southern Gifts House, 919 East Gulf Terra Drive, Dept. D, Mobile, Alabama 36605.

MONEYMAKING Self-Improvement do it yourself books. 25¢ coin brings list, 73 titles. Opal Singleton Gifts, 2007 Brack Street, Box 837, Kissimmee, Florida 32741.

CHRISTIAN Book Exchange, List \$1.00. 2516 J, Sacramento, Calif. 95816.

INTRODUCTION TO ENGINEERING MEASUREMENTS AND INSTRUMENTATION. A fundamental approach to a complex subject. Ideal for students and amateurs. 134 pages with 38 illustrations, \$3.95. Edrede Corporation, Box 129, Colorado Springs, Colorado 80901.

FREE Circular "Self Development" and "How To". Garrett Assoc., 1110 Fidler Lane, Silver Spring, Maryland 20910.

FREE Gift Catalog. Staron House, 17 Roy St., Fairhaven, Mass. 02719.

NATIONAL Geographic Magazines, 1888-1967, any issue. Buxbaum, Box 465-PM, Wilmington, Delaware 19899.

FREE List. Popular self improvement books. Nish Enterprises, 2538 Tennyson, Anaheim, Calif. 92806.

PLAYS, SONGS, MANUSCRIPTS

SONGS, SONGPOEMS Wanted for Radio show. Hollywood Music Productions, 6425-PM Hollywood Boulevard, Hollywood, California 90028.

BUSINESS OPPORTUNITIES

250,000 NEW MOTHERS EVERY MONTH! Bonanza for Bronzed Baby Shoes! \$50.00 a day profit. No investment, no inventory. Full or spare time. Exciting details Free. Senti-Metal, 1919 Memory Lane, Dept. 8J, Columbus, Ohio 43209.

SECRETS! Mail Order Success. Internationally famous expert reveals how to make home business fortunes. Beginners: Get free copy "Make Money By Mail." Discloses free advertising, profitable products. Mailco, 1554 Sepulveda, Dept. D2709, Los Angeles 90025.

FREE Millionaire Book. Get plans, set-ups, little-known businesses. Write: National-7, Kerrville, Texas 78028.

RAISE Hard to get colored Canaries, Budgies. Exciting profitable hobby or business. Big profits. We furnish everything. Details free. Glenmere Aviaries, Box 402, Grahamsville, New York 12740.

NEW Plan! Pays up to \$25.00 an hour! Little as 4 hours weekly. Place Luxko self-service displays in stores. No cost to merchants. No experience needed. Free details. Lux Company Incorporated, Dept. 1500, Elkhart, Indiana 46514.

IMPORT-Export opportunity, profitable world-wide mailorder business from home, without capital; or travel abroad. We ship proven plan for no risk examination. Experience unnecessary. Free details, Mellinger, Dept. D2709, Los Angeles, 90025.

OPERATE Restaurant. Free booklet reveals profitable plan. Write Restaurant Business School, Dept. EC-90, 1920 Sunnyside, Chicago, Illinois 60640.

INSTALL Burglar alarms without previous experience or costly equipment. Big profit. Free details. Nasco, 11071 Massachusetts, Dept. D2709, Los Angeles 90025.

MAILORDER! How anyone can prepare catalogs for \$8 per 1000. Free proof! Obie-MKI, Brooklyn, New York 11219.

MAKE Durable building plastic easy. Waterproof. Fireproof. Economical. Bays Laboratory, Cedaredge, Colorado 81413.

HOW To Finance Your Own Business Offers of \$500 to \$2,000,000. Free details, Capital-17, Kerrville, Texas 78028.

AMAZING \$1,000.00 Profit Possible every 1,000 mailings! Complete free details; write today. West, Box 447H, Falls Church, Virginia 22046.

MAKE Money At Home. Details 10¢. R. A. Allen, 2418 Lori, Santa Ana, California 92706.

ACQUIRE ADEQUATE INCOME for life. Details free. Bazaar, Dept. P9, Box 496, Chico, Calif. 95926.

BLACK Widow Spider Ranchers needed! Big guaranteed market! Complete program \$1.00 (Refundable). NBWC, Box 260 CPMI, Brigham City, Utah 84302.

VINYL REPAIRING A golden opportunity. The world is knocking at your door. Free information. AMH Industries, P.O. Box 5386, Santa Ana, Calif. 92704.

HOMEWORKER Magazines. Directory 25¢. Arseneau, Box 21, Dalhousie, New Brunswick, Canada.

PIANO Tuning learned quickly at home! Tremendous field! Musical knowledge unnecessary. GI approved. Information free. Empire School, Box 327, Miami, Florida. 33145.

INCREASE Your income by using your ideas. Details free. Wilson Sales, 843-B McNeilly Road, Pittsburgh, Pennsylvania 15226.

SPARE Time Cash—Sell Advertising Book Matches—every business a prospect—no investment—no experience needed—build steady, repeat business. Powerhouse selling kit with new complete catalog free. Quick sales—big cash commissions. Dept. MX 970, Superior Match, 7530 S. Greenwood, Chicago, 60619.

JANITORIAL Accounts!! Free brochure. AMCI, Box 4145, Dept. 201, Torrance, Cal. 90510.

MAKE Gorgeous original candles for all holidays and special occasions. Learn expert Candle decorating, candlemaking, use of professional molds. Free details on home instruction method. Candle Institute, Dept. A-53, 1600 Cabrillo, Torrance, Calif. 90501.

\$25.00 HUNDRED Addressing. Possible! Year 'round. Special Information included, 25¢ and self-addressed stamped envelope. Cove, 627-BE Franklin, Clearwater, Florida 33517.

JEWELRYCRAFT—It's easy! Big profits! Catalog, 25¢. Modern Craft, 12790 US 19; Clearwater, Florida 33516.

CALIFORNIA MANUFACTURER NEEDS man to assemble our product and be local agent, experience unnecessary. May start while presently employed. Five-figure income for responsible applicant. S.K.R.M. Manufacturers, 2347 West 238 Street, Torrance, California 90501.

FREE FRANCHISE JOURNAL magazine with over 100 franchise opportunities in every issue. Franchise Journal, Dept. G, Box 1790, Newport Beach, Calif. 92663.

MAILORDER—Profitable products; drop-shipped. No merchandise investment. Everything supplied—catalogs, ads, mailing lists. Gif-Guide, 1137 1/2 Crenshaw, Dept. 237, Los Angeles 90019.

\$15.00 HOURLY Profit—Own Business with one serviceman. Quickly learned. Easy to do. Operate from home. Few hundred dollars builds your own nationally advertised business while continuing present job. Investigate immediately before your territory is taken. Free booklet explains everything. Send today. Then decide. Duraclean, CO-169 Duraclean Building, Deerfield, Illinois 60015.

\$400.00 MONTHLY Raising giant fish-worms. Soilless method. Charlie Morgan, Bushnell, Florida 33513.

EARN Money raising fishworms for us! Write: Oakhaven-38, Cedar Hill, Texas 75104.

400,000 BARGAINS Below wholesale! Many free. Liquidations... closeouts... job lots... single samples. Free details. Bargainhunters Opportunities, Box 730A, Holland, Michigan 49423.

ADVERTISING BUSINESS—YOU own it. \$350 First Week or Money Back. Electric Neon Action Ad Clock, 229 W. Illinois, Chicago 60610.

JOIN "MONEY GETTER'S GUILD". Receive hundreds money-making. Business Building Propositions. Year's membership only 25¢. Write: Fourstars, Box 839, Long Beach, New York 11561.

WANT To make big money at home? \$10.00 profit in an hour possible with invisible mending. Make tears, holes disappear from clothing, fabrics. Steady year-round demand from cleaners, laundries, homes. Details free. Fabricon, 1585 Howard, Chicago 60626.

CLIP Newspaper items, \$1.60-\$5.00 each. Details free. Walter, Box 1360-PA Erie, Pa. 16512.

SELL Lifetime, Metal, Social Security Plates. Big Profits! Sample and Sales Kit Free. Russell, Box 286-PM, Pulaski, Tennessee 38478.

COPUBLISH "Mail Sale Advertiser," leading mailorder paper. Copy and details 25¢. U.S.A. only. Vanroy Shirk, Lebanon, Pa. 17042.

\$200.00 DAILY in your mailbox! Your opportunity to do what mailorder experts do. Free details. Associates, Box 136-A, Holland, Michigan 49423.

DRAFTSMEN! Operate own DRAFTING SERVICE! Full, Part Time; Experience unnecessary; Details: Roberts Drafting, 1741 Circle Road, Baltimore, Maryland 21204.

RAISE Rabbits for us on \$500 month plan. Free details. White's Rabbitry, Mt. Vernon, Ohio 43050.

VACUUM Plastic Molding & Liquid Plastic Casting—At Home! Make Hundreds of full 3-D plastic products. Big profit in spare time. Facts. Nationwide Plastics, Dept. SR, 4140 Eagle Rock Blvd., L.A., Calif. 90065.

56 ACTIVE Franchise opportunities available all over USA. Brochure details 56 franchise chances for you to have your own business tied with successful national companies. Send name, address to P. Stewart, 1085 Walnut, Des Plaines, Illinois 60016.

MAIL ORDER Sell books. Fascinating, profitable, details. Jobre, Box 27, Great Neck, N.Y. 11023.

WORLD'S Largest supply. Merchandise 25% to 40% under wholesale. Bankrupts. Closeouts 10¢ on dollar. Imports. Hongkong clothes. Automobile discounts. Free details. International Buyers, Box 16386-MM, Portland, Oregon 97233.

HOLLYWOOD CEMENTCRAFT: Offers Highly Profitable Home Business. Experience Unnecessary. Unlimited Unique Pottery Designs Easily Made Without Moulds, Bird-baths, Fountains, Washing-Wells, Waterfalls, etc. Chemical Coloring Formulas, Marble-glazing. FREE Illustrated Brochure. CONCRETE FACTS. 602 Athens Street, Altadena, California 91001.

SELL Books by mail. 400% profit. Royal, Box 450-X, Cleveland, Ohio 44127.

FREE Catalogs. Repair air conditioning refrigeration. Tools, supplies, full instructions. Doolin, 2016 Canton, Dallas, Texas 75201.

VENDING Machines. No selling. Routes earn amazing profits. Big catalogue Free. Parkway Corporation, 715PBM Ensor Street, Baltimore, Maryland 21202.

ADDRESSERS And mailers needed. Send stamp for information. Lindbloom, 3636 West Peterson, Chicago 60645.

MAKE Magnetic car signs. Write Route 1, Box PM-49A, Bardstown, Ky. 40004.

(Continued on next page)

BUSINESS OPPORTUNITIES

(Continued from preceding page)

SELL Beautifully colored Social Security Plates. Big Profits! Free Sample. Paul Wright, 1075 Ringwood Avenue, Pompton Lakes, N.J. 07442.

\$70.00 WEEKLY—home, spare time. Simplified mail bookkeeping. Immediate income easy. Auditax, 34741A, Los Angeles 90034.

CLIP Short newspaper items. To \$10.00 each. Details free. Foster, 272-M9, Brooklyn 11235.

BUILD Custom Cases at home for profit. Get orders by mail. We supply materials, instruction—everything. Free home business details. Custom Case Supply Co., 6961 CPI Hayvenhurst Avenue, Van Nuys, California 91406.

TAKE Catalog orders. We drop-ship 1001 best selling specialty products. Guaranteed lowest below wholesale prices. Fantastic spare-time home business. Free book shows you how. SMC, 6963 SPI, Hayvenhurst Avenue, Van Nuys, California 91406.

VENDING Machine big catalog. Rake, 523 A Spring Garden, Philadelphia, Pa. 19123.

MAKE a year's income in 8 weeks camping. No capital investment, no selling, no land ownership necessary. 9 different ways. Write EDU'S, Rt. 5, Box 5733, Gig Harbor, Washington 98335.

MAIL Galore! Money-making offers! Your name on national mailing lists. 25¢. Sullins, Box 2066-M, Forsyth, Georgia 31029.

1000% PROFIT Bronzing Shoes. Free Literature—N.B.C. Box 11069-PM, Kansas City 64119.

HOW Much does being your own boss or making \$25,000.00 per year interest you? The Warner breakthrough in the Engraving field could be your future. Write: Warner, Room CE-2-F, 1512 Jarvis, Chicago, Ill. 60626.

HUGE Profits! Mail order importing. Free information. ITIS, PM-9, Box 454, Hollywood, Calif. 90028.

\$60.00 DAY. Manufacturing concrete Posts. Blocks. Mold Equipment Catalog \$1.00 refundable. Carlayne, Route One Box 95, Rapid City, South Dakota 57701.

MAILORDER SELLING: What, where, how. Details Doorbar-PM, 3364 Northwest 35 Street, Fort Lauderdale, Florida 33309.

MAIL Baby Or Gift Catalogs. Imprint. Big Profits! Details \$1.00. Krefski, 609-A Lee, Plymouth, Penna. 18651.

"MAKE The Most Money" Vince, 189 Maple Street, New Bedford, Mass. 02740.

400% PROFIT!! Hundreds Famous Reproductions!! "Antiqued" Banknotes-Documents!!! Garen's, Xenia, Ohio 45385.

"WORLD'S EASIEST MAIL ORDER BUSINESS." Nothing Better. Nothing Easier. Only \$1.00 Postpaid. Descriptive Literature Free. Pioneer, 401 Edgewood, Marietta, Ohio 45750.

I MADE \$40,000.00 Year by Mailorder! Helped others make money! Start with \$10.00—Free Proof. Torrey, Box 318-Y, Ypsilanti, Michigan 48197.

MAIL Baby Catalogs Imprinted with your address to New Mothers for Big Profits! Details 25¢. Volz PM, Ypsilanti, Michigan 48197.

MAILORDER Records help get increased business! Complete 32 Page Record Book shows your inquiries, orders, advertising, expense, etc. Only \$1.00. C. A. Martin, Popular Mechanics, Dept. PM, 224 West 57 Street, New York, N.Y. 10019.

FORTUNE! In Mailorder! Beginners Easy Step-By-Step Guide \$2.00. Promotional Services, 1913-M2AD Eleventh St., Altoona, Penna. 16601.

NEW Canadian oil leases. \$1.00 acre. Free information. Northern, Box 70-F, Montreal 206.

MAKE \$10.00 Hourly Demonstrating portable sandblaster. Inka, Box 66573, Houston, Texas 77006.

MAILORDER! Make big money working home. Free report reveals millionaire's trade secrets! Executive (1A9), 333 North Michigan, Chicago 60601.

\$10,000 PER year in your own Second-hand Business. Free Information. Empire, 205 Main, Rio Nido, California. 95471.

EARN \$700 Per Month Spare Time as Tax Preparer with new quick-learn income tax home training. Start now. Be ready for January earnings. Full facts by mail—no salesman. Federated Tax Service, 1585 Howard, Chicago 60626.

MAIL Order Collection Agency can make you \$1000.00 monthly. Free Details. Continental, Box 2023-A, Des Moines, Iowa 50310.

TREMENDOUS \$1,000.00 Profit From 1,000 Mailings! Tested! Free Proof! George, POB 2188PM, Cypress, California 90630.

BOOKKEEPERS Earn \$500.00 week. Operate Bookkeeping Tax Service. Details free. Universal, Box 664-M, Springfield, Missouri 65801.

MAKE Money from old tires. Operators clearing \$800. weekly. Equipment costs \$1500. Get facts. S & S Patents, Inc., 3752 N. Damen, Chicago 60618.

PROFITABLE SPARETIME BUSINESSES! Details—10¢. Universal Enterprises, Dept. PM, 103 Park Avenue, New York City 10017.

SECOND Income . . . Mailorder Work Home!!! A. A. Bates, Box 3223, Detroit, Michigan 48214.

MAIL Letters Featuring Real Merchandise!! Get \$12.00 orders in every mail. \$8.00 Profit! Everything furnished. Write: Myco House, 7106PM Hillsboro, Houston, Texas 77020.

RAISE Crickets, Fishworms!!! Anyone, anywhere can do. Big Profits. Lionel's, 406P Guarard, Abbeville, Louisiana 70510.

MAILORDER Books—Free Lists—Smith's, 725 Emeline, Fayetteville, N.C. 28303.

\$20.00 HOUR in your own professional tax business. No experience necessary—Experts give easy to learn secrets and instructions. Franchises available. Free details. Allstate, Box 782, Pensacola, Florida 32502.

FREE Synopsis of 38 leading MAIL-ORDER And IMPORT-EXPORT books, directories and programs. Klatt, Box 31190-A, Washington, D. C. 20031.

MAKE \$1,000,000.00 in 10 years. \$10.00 start. Free proof! Wallace, Box 288P9, Gladstone, Oregon 97027.

NEW!! "Ideas For Self Support" Details Eddie's, 4809-PMS N. Montclare, Chicago, Illinois 60656.

MAILORDER Business, Literature—25¢ (coin). Andrews, Box 485, New York, New York 10013.

NOW You can own a cooperative distributorship in a billion dollar consumer market. Selling Nationally for \$5000 without investing a dime of your money. Details free. American Houseware Company, 9454 Wilshire Blvd., Suite M-1, Beverly Hills, California 90212.

MAILORDER Book publisher wants dealers. Wonderful "drop-ship" proposition. Sample imprint circulars free. Neil H. Tasker, Shamokin, Pennsylvania 17872.

BIG Money-making new greaseless donuts in kitchen. Everything furnished. Sell stores. Free recipes. Montgomery Ray, Waseca, Minn. 56093.

"HOW To Operate Your Own Home Mail-order Business"; Latest Exclusive Report reveals successful methods. Free details: Paul's, Box 5273-AA, Phoenix, Arizona, 85010.

\$1,000.00 MONTHLY Operating Collection Agency. Master, Drawer 77009-A, Atlanta, Georgia 30309.

ESTABLISH Profitable Home Mailorder Business. No Inventory! Details 25¢. Hall Associates, R-1, Box 133-D, Pendleton, Oregon 97801.

FREE 60-question checklist on evaluating franchise offers. Write now. No obligation. Masterfile, Box 293, 6700 France So. Edina, Minn. 55435.

NEW Products Foreign Trade Thesaurus. Baker's, 313 Harrison, Sullivan, Illinois 61951.

START Profitable Home Business Your Opportunity! Free Literature. Peavy, #K10, Box 12387, Las Vegas, Nevada 89112.

DISCOVER Mailorder profits. Comprehensive instruction manuals. Free details. Ken, Box 1112-PM, Alhambra, California 91802.

FREE \$1000.00 American 1840 Bill Reproduction when requesting details How To Start Own Business. Supply limited. Write now. Island House, Box 157F, Bayside, N.Y. 11361.

MAILORDER Dealers Wanted. Earn outstanding profits using tested promotions! Executive type business. Details 25¢. UNICUS, Box 735-PL, Norwalk, Conn. 06852.

"HOW To build your own Mail Order Business!! Informative Booklet free!! Act now—W., Hasting, Box 1055, Bonita Springs, Florida 33923.

START A home business in spare time. MAKE extra money. Experience not essential. Send TODAY for FREE circular outlining several ways to make a FORTUNE. Telemarketing Systems, Dept. P366, 2038 Old Gulph Road, Villanova, Pa. 19085.

MAKE \$1.00 per Sale selling Engraved Metal Social Security Plates. Free sample kit. Engrava-Plates, Dept. 20, 3386 Phillips, Jacksonville, Florida 32207.

MAILORDER-HOME BUSINESS GUILD. Receive hundreds money-making, business building propositions. Year's membership only 25¢. DIGEST, Box 839-PMI, Long Beach, New York 11561.

START Profitable Mailorder Business. Write: Vikari's, Box 1312-PM, Salt Lake City, Utah 84110.

FREE REPORT!! 609 Unusually successful businesses, indoor-outdoor, evenings!! Write: Associated, Box 238-B90, Lafayette, California 94549.

MILLIONS of Dollars in U.S. Government Benefits go unclaimed each year, simply because people are unaware of them. Details Free. Fred Smith, Chestnut Grove, King, N.C. 27021.

ART Factory In Your Home. Fascinating! Profitable! Starting Instructions Free. Hobby Studios, Box 937-X9, Memphis, Tenn. 38101.

IMPORT-EXPORT! . . . Start Profitable Home Mailorder Business! Free Details! World-Wide, Box 6732-BP21, Richmond, Virginia 23230.

BUJLD Your own plastic vacuum forming machine. Make 3D magnetic signs, molds, etc., information \$1.00—Grays, 7500 Evelyn, Ft. Worth, Texas 76118.

SELL YOUR PHOTOS. Over one million photos and color slides are bought by newspapers and magazines every year. Report tells how and where to sell. Only \$1.00. LEIGH EDWARD, Dept. PM 970, 9912 Chautaugua Avenue, Lanham, Maryland 20801.

\$2,000.00 MONTHLY Possible, details. Ropchan, Box 5341P, Sherman Oaks, Calif. 91413.

106 SUCCESS OPPORTUNITIES. WRITE: VINCE, 189 Maple Street, New Bedford, Massachusetts 02740.

AMAZING Profits!! Establish successful moneymaking home mail-order business easily. Write: Josephson-Won, 673-AB Second Avenue, Williamsport, Pennsylvania 17701.

(Continued on next page)

BUSINESS OPPORTUNITIES

(Continued from preceding page)

EARN \$60.00 Daily Manufacturing Concrete Fence Posts. Practically no investment. Send stamped, addressed envelope. American, Excelsior Springs, Mo. 64024.

YOUR Own Business!! Really only way to make it big. Write today; valuable details free. PM9 Distributors, Box 273, Burlington, Vermont 05401.

BE YOUR OWN BOSS. Our instructional manuals show you how. Thousands of business opportunities. Free catalog. Informative Publications, Box 187, Painted Post, New York 14870.

PROFITABLE Tested Business. Beginners Mailorder Package-What-Where-How. Start Small—Grow Big. \$5.00. Schlitz Mailorder Enterprises, 426-CA Sandy, Des Plaines, Illinois 60016.

MAKE Money sparetime. Home operated Mailorder Business. News-Messenger, South Lancaster, Mass. 01561.

1,000,001 MAIL Order opportunities. Free list! Specialty, Box 45PM, Lakeside, Iowa 50588.

FRANCHISE 116 Locations Printing While-U-Wait. Offers Free Brochure. \$15,000 Cash D. P. Required. Postal Instant Press, P.O. Box 35155-P, Los Angeles, Calif. 90035.

PREPARE Tax Returns—Policeman Albert Myers made \$2000 his very first season. Train at home. VA Approved. National Tax School. Monsey, 2YC, N.Y. 10952.

FABULOUS Profit! Growing Beansprouts Full, PartTime. Write: TSO, Box 288-P9, Gladstone, Oregon 97027.

PROFIT With Popular Mechanics' subscription plan. No investment, no experience needed. Earnings begin immediately when you obtain subscription for Popular Mechanics, Good Housekeeping and others. High commissions, bonus. No experience needed. Deal directly with the publisher. Write Popular Mechanics, Room 9B, 250 West 55th St., New York 19, N.Y.

START Sauna business in your spare or full time. Make extra money. Experience not essential. Literature free. ERLANDER'S, Box 183-F, Richmond, N.Y. 10306.

MAILORDER-Home Business Guild. Receive hundreds money-making, business building propositions. Year's membership only 24¢. Digest, Box 839-PM1, Long Beach, New York 11561.

"TEFION" Service! Vastly needed! Details! FMC, Box 1464S, Lancaster, Penna. 17604.

\$500-\$800 MONTHLY Raise small Laboratory-breeding stock for us. We supply equipment, breeders, and instructions. Illinois Research Farms, Dept. MPD-9, Barrington, Illinois 60010.

MOLDING Rubber Liquid Plastic. Hobby Supplies. Details 10¢. Chaney's, 5415-L San Jose Blvd., Jacksonville, Fla. 32207.

MAKE \$46 from square foot plywood: jigsaw or bandsaw necessary. Free details. Woodar, Bridgewater, Mass. 02324.

MONEYMAKING OPPORTUNITIES

JEEPS \$60.00, typewriters \$4.00, boats, guns, cars, all at a fraction of their cost! These are typical Government Surplus bargains. "How to Make Money on Government Surplus" tells how and where to buy it in your area. How Mail Order fortunes were made on surplus! How to buy for your own use or for resale. Complete Directory of Surplus Depots included with Mail Order case histories! Booklet #MO-50S, only \$1.00. Robert Witt, 813 Laramie, Dept. 789, Wilmette, Illinois 60091.

CASH Paid for newspaper clippings. \$30.00 daily possible. Steady demand. Thousands enjoying profits! Start immediately! Free Information—send stamp. Opportunities, Box 16143-PM, Phoenix, Arizona 85011.

\$30 AN Evening Easily Earned At Home filling out income tax forms. Simplified Home Course shows you how—helps you get customers. Everything by mail. No salesmen. Federated Tax Service, 1503 Howard, Chicago 60626.

CASH For short paragraphs. How, what to write, where to send. \$5.35. Guaranteed. Free information. Ree Enterprises, Box 667, 402-L Whiteford, La Puente, Calif. 91747.

FREE List Profitable, Informative, Books. Crain, 1670 Mulberry, Elgin, Ill. 60120.

COPYRIGHTED REPORT Starts you writing fillers for pay! Send \$1.35. Moon Street Mart, Room 122, 2730 Luna Avenue, San Diego, California 92117.

CLIP Newspaper items. \$1.00-\$5.00 each. Free Details. Richard, Box 111-PM, New Baltimore, Michigan 48047.

CIGARETTES 12¢ a pack. Improved roller makes 20 filtertip, plain, king or regular for 12¢. Facts free. Moberly, Box 953, Owensboro, Kentucky 42301.

\$15.00 HOURLY Profit—Own Business with one serviceman. Quickly learned. Easy to do. Operate from home. Few hundred dollars builds your own nationally advertised business while continuing present job. Investigate immediately before your territory is taken. Free booklet explains everything. Send today. Then decide. Duraclean, CO-169B Duraclean Building, Deerfield, Illinois 60015.

SENSATIONAL Car Thief Signal. Lightning Seller. Samples for trial. Northwest Electric, Ave. 653, Mitchell, South Dakota 57301.

EARN \$240.00 a month at home, spare time, doing only two \$5.00 invisible mending jobs a day. Big money paid for service that makes cuts, tears disappear from fabrics. Steady demand. Details free. Fabricon, 1532 Howard, Chicago 60626.

MAKE Statuettes, novelties, imitation marble. Sell to stores or start gift shop. Free details. Marbleizing, 41 Waverton, St. Louis, Mo. 63124.

HOW To Make money writing short paragraphs. Information free. Barrett, Dept. C-27-G1, 6216 N. Clark, Chicago 60626.

FREE Copy of world's leading contest magazine! Write prizewinner, Box 11569, St. Petersburg, Fla. 33733.

FREE. 206 Easy Ways to make money taking orders for exciting new products—spare time. Send name, age for 5 months free subscription. Opportunity Magazine, 1460 Hancock Center, Dept. 17-JM, Chicago 60611.

HOMEWORK. Mailing circulars. Free details! Cam Company, Dept. 155-KP, Verona, N.J. 07044.

SCIENTIFIC Massages: Big Earnings uncrowded profession. Learn spare time at home. Diploma awarded. Free catalog. Write Anderson School, Dept. L-1C, Princeton, Illinois 61356.

CLIP Newspaper items. \$1.00-\$5.00 each. Details free. Walter, Box 1360-P, Erie, Pa. 16512.

MAKE: \$12.00 Profit each dozen assembling Belts. Details Free. (Stamp appreciated.) Redikut's-40, Richland Center, Wis. 53581.

HOW TO GET RICH!! Free "Money-making Brochure"! Success International, Box 2447-C, Livonia Mich. 48151.

\$200.00 FROM Sheet 1/4" plywood (scrap). Details 25¢. Novelties, 610 So. 24th, Elwood, Indiana 46036.

VENDING Machines. No selling. Routes earn amazing profits. Big catalogue Free. Parkway Corporation, 715PMM Ensor Street, Baltimore, Maryland 21202.

LEARN The secrets of repairing junk batteries "Fabulous Profits" at home. Battery Shop, Route 1-188 D, Blythe, Calif. 92225.

EASY-To-Start rubber stamp business at home in spare time. Make up to \$16.50 an hour without experience. Facts free. Write to: Roberts, 1512 Jarvis, Room CR-2-F, Chicago, Ill. 60626.

HOW TO GET RICH! Amazing plan revealed! \$2.00 Refundable. Seco, Box 144, Walkerton, Indiana 46574.

MONEY BY MAIL. Mailtrade magazine been telling 40 years. Tips, ideas. Sample 50¢. Year \$4 with bonus offer. Mailtrade, Sheboygan, Wisc. 53082.

SWEEPSTAKES Contests. How to Win. Write for free particulars. General Contests, 1609-18 East Fifth, Duluth, Minnesota 55812.

MILITARY PERSONNEL! Excellent, profitable part-time opportunity. Write: MGR Studios, Box 15036, Fort Worth, Texas 76119.

\$2.40 HOURLY Making simple wood novelties. Free details! Gene's, 55 Boxwood, Falmouth, Mass. 02540.

SELL Lifetime, Metal, Social Security plates. Sample and sales kit Free. Lady McGuire, Rt. #6-PM, Anderson, S.C. 29621.

HOW To Make Money Sketching Photos. Free Information. Gem, 365-F Longhill, Shelton, Conn. 06484.

LYRIC WRITERS write songs with writers who write hits for top Nashville artists. Globe, 420 Broad, Dept. PM, Nashville, Tenn. 37203.

START A profitable subscription business in spare time! We need men and women (young and old) as representatives for all leading national magazines. Liberal commissions on all subscriptions. Supplies free. No experience needed. Send this ad with your name and address to Popular Mechanics, Room 8-0, 250 W. 55th St., New York, N.Y. 10010.

8mm MOVIE Camera Owners: Earn up to \$100.00 week part time. Start immediately. Complete Guide \$1.00. Adrian Richards Co., 710-PM Division Street, Gloucester City, N.J. 08030.

GET World's Biggest Wholesale Import-Merchandise Catalog. Write: Northwest-K, Medina, Washington 98039.

MAILORDER Knowhow. Free Catalog. Roll, 26855 Trask River, Tillamook, Oregon 97141.

LIQUID Laundry Bleach Formula \$1.00. Granda, Rt. #4, Reidsville, N.C. 27320.

"START" Mailorder Business Booklet, 50¢. Rizdin, 1520 Ash, Detroit, Mich. 48208.

\$10 DAILY Writing short articles at home. Begin immediately! Copyrighted report reveals how and where. Send \$1.00 to James W. Holden's, 1626 West Providence, Spokane, Washington 99205.

PHOTOGRAPHIC Income. Use instamatic. Photo preparation, market directory. \$1.00 Tom Breen, 207 Wellington Rd., Garden City, New York 11530.

OTHERS WILL say yes to you. Have confidence in your powers. Book teaches how. \$2.00. House of Hester, 415 6th St., Rapid City, S.Dak. 57701.

"FOR Just \$7.50 you can buy this quick and easy to learn manual. Repair Hydraulic Jacks, equipment and air tools." Box 2383, La Mesa, Calif. 92041.

MAKE Money writing short articles at home. Begin immediately! Copyrighted report reveals how and where. Send \$1.00. Green Acres, Dept. 7401, 77 Ingleside Dr. Hamden, Conn. 06514.

WHAT'S The Big Secret About Big Money? Get The Information you need to start your Fortune. No Obligation. Write Frank Frazier, P.O. Box 27131, Los Angeles, Calif. 90027.

MAKE MONEY On Government Surplus. How and Where to Buy. Directory of Surplus Offices. Sale Terms. Mail Order Items. Send \$1.00. Clivedon, 152 West 42nd Street, New York, N.Y. 10036.

SELL Lifetime Social Security Plates. Free sample. Capitol, Box 9091, Austin, Texas 78757.

(Continued on next page)

MONEYMAKING OPPORTUNITIES

(Continued from preceding page)

FABULOUS Prize Opportunities. One Year Subscription "Sweepstakes Bulletin" \$5.00. Benro Enterprises, Box 6656-PM, Philadelphia, Pa. 19149.

NOW Beginners Make \$10.00+ Daily Writing Short Articles At Home! Booklet Reveals How. Send \$1.00: Robert's Gifts, 4507 20 Street, West, Bradenton, Fla. 33505.

EXTRA Income Vending. Booklet tells How To Start. \$2.00. Vending, Box #48, Carmel, Ind. 46032.

CAMERA OWNERS! Sell Your Photos, Color Slides. Report Tells How. Where. Only \$1.00. Dickerson Company, Route 1-PM, Bridgeville, Delaware 19933.

\$20,000.00 INCOME Making cosmetics at Home. Complete instructions. \$2.00. T. Lockett, 4153 Lancaster Ave., Philadelphia, Pa. 19104.

MAKE MONEY Selling your photographs. Millions sold each year. Booklet tells how. Booklet MO54P \$1.00. S & M Gifts, 4071 Datcho, San Diego, Calif. 92117.

HIGHER INCOME, Security and Power. 256 Page Book Reveals Secrets that make men rich. \$2.00. Graeff Enterprises, Dept. 335 Leesport, Pa. 19533.

CASH For Your Photos. Booklet explains how, where. Only \$1.00. E. Brooks, Dept. PM-9, 6021-7th Place, N.W. Washington, D.C. 20011.

NO Overnight Bonanza, Sideline Mail-order Is Strictly Business. Read Our Story. Summary Free. Eveningshade, Drawer 5350-C, San Antonio, Texas 78201.

\$5.00 HOURLY Guaranteed; Product Demonstrators. Details \$1.00. How-Mar Associates, Box 18123, San Antonio, Texas 78218.

FREE MAIL ORDER catalogs Profitable Hongkong products wearing apparels, watches, radios, cameras, oil paintings, carpets, wigs, ivory ware, jewelry, etc. drop-shipped from Hongkong. Make big money! Airmail inquiries CHANSON INTERNATIONAL, P.O. Box K-1732, Kowloon, Hongkong.

PROFITABLE! FULL OR PART TIME. Represent largest manufacturer of magnetic signs for cars and trucks. Trimetric, Department D, 2640 Saddle, Oxnard, California 93030.

SPARE Time cash. Sell Famous Hanover Shoes. Actual samples and sales kit Free. No experience needed. No age limit. Lowest prices for high quality makes selling easy. Every man a prospect. Big daily commissions. For full details, Write Hanover Shoe, 650 Carlisle, Hanover, Penna. 17331.

PROFITABLE Sparetime Business Opportunities! Free Particulars. Publisher, Box 118-MC, Brooklyn 11203.

"FOR Just \$7.50 You can buy this quick and easy to learn Manual. Repair Hydraulic Jacks, Equipment and Air Tools." HYDRAULIC, Box 2383, LaMesa, Calif. 92041.

\$500-\$800 MONTHLY Raise small Laboratory-breeding stock for us. We supply equipment, breeders, and instructions. Illinois Research Farms, Dept. MP-9, Barrington, Illinois 60010.

MAKE Extra money with your camera. Sell your pictures, slides. Booklet tells how, where. Send \$1.00 to Eckart Sales, Dept. PM-970, 737 Sunny Hills Road, Fullerton, California 92632.

MONEYMAKING Mailorder! Exciting details. 10¢. Kam's, Box 64A, Meriden, Conn. 06450.

PROFITABLE OCCUPATIONS

MULTIPLY your moneymaking powers! Greater wealth through our "No Inventory" mail-order INCENTIVE plan. Kapco, 3515 W. Market, Louisville, Ky. 40212.

\$15.00 TO \$30.00 an hour de-liming steamcleaner and laundromat coils. Little competition, large profit, total investment less than \$100.00. One steamcleaner coil can pay for total investment. Write for free information. CHAMPAIGN COIL COMPANY, 305 West Springfield Avenue, Urbana, Illinois 61801. Dept. 5.

FREE Book "990 Successful, Little-Known Businesses." Work Home! Plymouth 47-J, Brooklyn, New York 11218.

CHROME Plating Instructions, equipment and supplies. Platers' Supply, P.O. Box 565, Lugo Station, Los Angeles, Calif. 90023.

FT. SMITH Auction School. Ft. Smith, Ark. Residents & Home study. Veteran approved.

BECOME A mortgage broker. earn \$10,000 to \$50,000 a year. Details free. United, Box 6284A, Marietta, Georgia 30060.

SHARPEN Scissors, Pinkers. inexpensive equipment, tools, supplies. Blackhawk's, Sheldahl, Iowa 50243.

MAKE \$300 CLEAR MONTH few hours from 10 customers, representing us in your community. No individual selling. Repeats forever. Customers waiting. \$1 for sample, details. Our 40th year. Progressive, Box 1302, Springfield, Ill. 62705.

HOW To Make Money writing short Paragraphs. Information Free. Barrett, Dept. C-27-G2, 6216 N. Clark, Chicago 60626.

LEARN COMPUTERS at home. 55 page introduction for \$3.00. Aids, Box 5192-A, Willowick, Ohio 44094.

BAKE New greaseless doughnuts in kitchen. Sell stores. Free recipes. Michael Ray, Waseca, Minn. 56093.

FIBERFORMING Inexpensive Hobby or Business. Details 50¢. Kinney Machine. 105 Filmore Avenue, Endicott, New York 13760.

\$500-\$800 MONTHLY Raise small Laboratory-breeding stock for us. We supply equipment, breeders, and instructions. Illinois Research Farms, Dept. MPA-9, Barrington, Illinois 60010.

SALESMEN—DISTRIBUTORS

LONG Needed invention. Man contact service stations. Huge profits. Write Cyclo, 3816 Dahlia, Dept. 174, Denver, Colorado 80201.

HOUSEHOLD Products Route. Earn \$25.00 or more daily. Larger repeat orders. Man, woman. Full, part time. McNess, Freeport 2690, Illinois 61032.

GET New shirt outfit free! \$90 weekly on 5 average orders a day. Famous quality made-to-measure dress and sport shirts at \$5.95 up, sell to all men. No experience needed. Full or part time. Write: Packard Shirt Co., Dept. 417, Terre Haute, Indiana 47808.

MAKE Extra \$25 to \$75 spare time! Take orders for double air cushion Bronson Shoes. Men's, women's line for dress, work, play. Highest commissions. Shoes for yourself. Outfit Free. Bronson, Dept. 209, Minneapolis, Minnesota 55408.

SELL Hertel Bibles—Part Time. Finest reference Bible available. Demonstrator and supplies furnished. Excellent commissions. Write International Book, Dept. PM, Box 118, Wichita, Kansas 67201.

PERSONAL Protective Devices Now In Big Demand due to increased crime rate. Proven. Sell easy to Drive-ins, Stores, Nurses, Night Workers, Motorists. Sales experience unnecessary. Get profit details now. Hagen Supply, Dept. CLA-90, St. Paul, Minn. 55107.

EARN big money calling on business-professional men. Send us their delinquent accounts for collection. General Finance, Dept. PM-11, Columbia Bank Bldg., Kansas City, Mo. 64106.

100% PROFIT—Sweet Georgia Brown Cosmetics sell fast. Write for Sample Case offer. Valmor, Dept. H, 2411 Prairie, Chicago 60616.

EARN Big Commission Full or Part Time. Show America's largest line Low Priced Business Printing and Advertising Specialties Plus calendars in season. No experience. No investment. No collections or deliveries. On-the-spot commissions. Big Free Sales Kit samples hundred items used daily by businessmen. Merchandise bonuses for you. Build profitable repeat business. Start now. National Press, Dept. 01D, North Chicago, Ill. 60064.

PRINTED Business Forms all kinds. Free kit. Soundertypn, Box 1, Bronx, New York 10472.

ZIPPEEEDOODAH! \$75 Commission per sale. Ten a week, no sweat, B'r'er Bear. D. M. Associates, Box 12007, Houston 77017.

THERE'S Money in selling office supplies and equipment, full or part time. Steady repeat commissions. Free selling outfit. Write. Oseco, 3505-PM North Elston, Chicago 60618.

WORLD'S LARGEST WHOLESALE SUPPLY! 10,853 American, European, Japanese wholesalers. Hongkong clothes. 123 Drop-ship catalogs. Rockbottom prices. Free details. International Buyers, Box 16386-M3, Portland, Oregon 97233.

SELL The safe device to dispose of empty aerosols—SAF-CAN, Box 18066, Cincinnati, Ohio 45218.

AGENTS WANTED

WILL You test new items in your home? Surprisingly big pay. Latest conveniences for home, car. Send no money, just your name. Kristee 120, Akron, Ohio 44308.

HOW To make money distributing gift catalogs. Send for Free sample. Terry Gifts, A1-22 Union Avenue, Westfield, Mass. 01085.

3-D MAGNETIC signs by Jay. Most complete line in the industry. 150 stock signs. Jay's 3-D Signs, G-8, Gorham, Maine 04038.

PRINTING, Advertising Salesmen—Excellent moneymaking sideline selling Decalomania Name Plates, small quantities. Advertising Specialties, sign letters. Free Samples. Ralco XL, Boston, Mass. 02119.

EVERY Man a prospect. Refundable sales kit offer showing line belt buckles, tie clasps, money clips, cuff links, lapels, identification badges, individualized with customer's name and emblems. Cap badges for trucking, bus, taxi, police, firemen, also postal, letter carriers and heavy construction emblems. Choice 4000 emblems. Hook-Fast, Box 1088PM, Providence, R.I. 02901.

LIFETIME Income. Business Loan Representative Write: Financial, 28 E. Jackson, Suite 1204-X3, Chicago 60604.

YOUR own business—Used Suits \$1.50; Overcoats 65¢; Mackinaws 35¢; Shoes 12½¢; Ladies' Coats 30¢; Dresses 15¢. Enormous profits. Catalog Free. Nathan Portnoy Assoc., 2109-AA Roosevelt Road, Chicago, Illinois 60608.

CHRISTMAS CARDS—Business and Personal. Customer's name imprinted. Beat inflation—earn unusually high commissions from this medium- and high-priced line. No investment. No inventory. Free Sample Album. Process Corp. (our 49th year) 3440 S. 54th Ave., Chicago, Illinois 60650.

WANT TO MAKE UP TO \$100 A WEEK spare time, and get free shoes for life, too? No investment. Rush card for free details. Mason Shoes, K-797, Chippewa Falls, Wisconsin 54729.

SELL Lifetime metal Social Security cards. Big Profits! FREE sales kit. Acme Engraving, 624 A, Arch Street, New Britain, Conn. 06051.

RAWLEIGH EXCLUSIVES Highest Rate of profit . . . 300 Quality products for family and home . . . money-back guarantee . . . no door to door selling . . . unique order taking plan . . . credit extended . . . write W. T. Rawleigh Co., Dept. PM-970 Freeport, Ill. 61032.

(Continued on next page)

AGENTS WANTED

(Continued from preceding page)
GET Rich Selling Liquid Shoe Stretch. Write: Harold Morgan, 732 West 82nd Street, Chicago, Illinois 60620.

ESTABLISH your own business. Low prices on used clothing, shoes, household goods. Unlimited profits. Free catalog. Northwestern Distributors, 2129 No. Western Avenue, Chicago, Illinois 60647.

PROFITABLE! FULL OR PART TIME. Represent largest manufacturer of magnetic signs for cars and trucks. Trimetric, Department C, 2640 Saddle, Oxnard, California 93030.

EMPLOYMENT INFORMATION

AUSTRALIA WANTS YOU! Government Assisted Passage. 50,000 Jobs. Latest Government Information and Forms \$1.00. Special Reports on Employment, Business, Taxes, Housing, Education, Ranching, Farming, Teaching, Maps, Etc. AUSTCO, Box 3623-E, Long Beach, California 90803.

FOREIGN And USA job opportunities available now. Construction, all trades. Earnings to \$3,000.00 monthly. Paid overtime, travel bonuses. Write: Universal Employment, Woodbridge, Conn. 06525

JOBS! JOBS! and more Jobs! OVERSEAS. U.S.A. Year-round and Summer Jobs. Jobs with Money. Challenge. Opportunity. Travel. All occupations and trades. For Information, write: "JOBS," Box 475. (PM-7), Lodi, California 95240.

"AUSTRALIAN OPPORTUNITIES HANDBOOK" . . . latest information about Government Paid Transportation, Employment, Land, Farming . . . plus "Employers List and Forms." Send \$1.00. International Services, 306-AI Carry Building, Washington, D.C. 20005.

OVERSEAS Jobs. High Pay, Travel, Adventure. Directory of Over 100 American Firms Now Hiring for Foreign Projects. \$1.00 (Guaranteed!!!) TRANSWORLD, Box 90802-E, International Airport, Los Angeles, Cal. 90009.

BRITISH COLUMBIA employment opportunities for construction, oil workers, refinery, pulp mill, plant and machine operators, technicians. Full details \$3.00. Doyle Associates, Box 2702, Williams Lake, B.C., Canada.

AUSTRALIA! AUSTRALIA!! Government assisted transportation!! Jobs Galore!! Latest Handbook. Free Information!! Write: Associated, Box 17-B90, Lafayette, California 94549.

INTELLIGENCE Employment opportunities with Government agency. US, overseas. Free information. Western Distributors, Box 6293-X, San Jose, California 95150.

WEST Coast job hunting? 105-page GUIDE rates 270 employers—includes valuable job hints, more! \$2.00 840 Floravista, Santa Barbara, Calif. 93105.

SUNNY SOUTHERN CALIFORNIA EMPLOYMENT OPPORTUNITIES—Classified Ads—\$1.00 Send Name and Address to Dave, 3585 Schirra, Imperial-Beach California 92032.

FREE AUSTRALIA CALLING. Send stamped, self-addressed envelope. Box 582, San Francisco 94101.

HIGH Paying overseas jobs. Construction, other projects. Bonuses. Travel Expenses. Extras. International Information, 124, Cortez, Florida 33522.

HELP WANTED

HOMEWORKERS: Mail circulars. Details free. ITEMS UNLIMITED, 829 Madison Avenue, Redwood City, California 94061.

OVERSEAS Jobs—Europe, South America, Australia, Far East, etc. 2000 openings all trades, Construction, Office, Engineering Sales, etc. \$700 to \$3,000 month. Expenses paid. Free Information. Write Overseas Jobs, International Airport, Box 536-M, Miami, Florida 33148.

OVERSEAS Jobs—Australia, Europe, South America, Far East, Etc. Openings in all trades and professions. \$400. to \$2,500 monthly, free information write Foreign Employment Mart, Box 2235 A.M.F. Miami, Florida 33159.

OVERSEAS EMPLOYMENT . . . Australia, Europe, South America, Asia! All Occupations! \$700-\$3,000 monthly! Write: Employment International, Box 29217-AI, Indianapolis, Indiana 46229.

WORLD-WIDE . . . U.S.A. Thousands of jobs now!!! \$700.00 to \$3,000.00 monthly. Travel allowance, Paid Overtime. Write: Global, Box 706-CA90, Orinda, California 94563.

REAL ESTATE & FARMS

FREE CATALOG! Exciting Fall-Holidays edition! Over 4,600 properties described, pictured—Land, Farms, Homes, Businesses—Recreation, Retirement, Selected Best thruout the U.S.! 70 Years' service, 541 Offices, 40 States Coast to Coast. Mailed FREE from the World's Largest! STROUT REALTY, 60-RX E. 42nd St, NY, NY 10017; 7-RX S. Dearborn, Chicago, Ill. 60603; 521-RX E. Green, Pasadena, Cal. 90013.

CANADIAN LAND INVESTMENT. FROM \$9.00 an acre. Choice properties available across Canada. Acquired through estate liquidations. Low monthly payments. Ideal farming, timber, minerals, cottages hunting, fishing. Write for free catalogue. Canadian Estate Land, Department PMC9, 194 Wilson Ave., Suite 101, Toronto 380, Canada.

NEW FALL & WINTER CATALOG FREE! New 1970 Fall & Winter Real Estate Catalog. Hundreds of bargains in farms, ranches, retirements, business. Investment & resort property in many states. Actual property photos! Write for your FREE copy today! SAFE-BUY Real Estate Agency, Box 589-PM, Little Rock, Ark 72203.

ARIZONA Ranch: beautiful acreage for homesite or vacation, near Prescott National Forest. 2 acres, \$1,395, low terms. Mrs. Young, Glenarm Co., 2233 No. 7th St., Phoenix. 85006.

OCALA FOREST CAMPSITES Deep in the heart of the Great Ocala National Forest. Excellent hunting and fishing. Free maps and photos. (Unavailable in states requiring separate registration) AD70LB710E. W. H. Vernor, Inc., Dept E, DeLand, Florida 32720.

LAND! EASY TERMS LESS THAN BANK RATES. NORTHWEST TIMBERED ACREAGES as low as \$950 Total Price. 5-10-20-40 Acres. For people who love the land—A tract of Recreation Land to have for your very own! In Northern Idaho, Northeastern Washington, and Western Montana. In the heart of lakes and big game country. All covered with growing timber. Access and Title insurance with each tract. This is select land with natural beauty recreational and investment values. Plan for the future and retirement recreation. We have tracts of many types and sizes from which to choose, including beautiful Northwest Waterfront property. Your inspection is welcomed. Write us for free list, maps, and complete information. Write to: Dept. PC Reforestation, Inc. P.O. Box 106, Opportunity Station, Spokane, Wash. 99214.

CANADIAN Vacation lands: Full price \$385.00. 40 acres. \$10 month. Suitable cottage sites, hunting, fishing, investment. Free information. Land Corporation, 3768-C Bathurst, Downsview, Ontario, Canada.

\$1 ACRE—Canadian Border—hundreds campsites, islands, farmlands, directly from tax authorities. (Non-profit). Lists, photographs mailed. Register, Room 10, 110 Church Street, Toronto 1, Canada.

GOVERNMENT LANDS . . . Low as \$1.00 acre. Millions acres. For exclusive copyrighted report . . . plus "Land Opportunity Digest" listing land available throughout U.S., send \$1.00. Satisfaction guaranteed. Land Disposal, Box 9091-PI, Washington, D.C. 20003.

CENTRAL Ontario—Choice 640 acre Sportsmen's paradises still available—\$20.00 plus \$6.50 taxes yearly. Maps, pictures. \$2.00 (Refundable). Information Bureau, Norval 4, Ontario, Canada.

\$1 ACRE—U.S.A.—CANADA Millions Acres. Direct from Government Agencies. No middlemen. . . . Family vacationing. Fishing, Hunting, Homesteading, Investing. . . . For amazing "where" and "how" "ALL STATES—ALL CANADA GOV'T LANDS DIGEST" . . . plus invaluable Canadian maps. Rush \$1.25 (Guaranteed): Can-Am-Lands, P.O. Box 1147, Buffalo, New York 14240.

CANADIAN LAKE Frontage, Shoreline Properties with well wooded acreage on Lakes teeming with fish. Suitable for Hunting, Fishing, and Investment. Small monthly payments. Free booklet. Canadian Shoreline, 33 Rosehill Avenue, Suite 2507, Dept. PMC, Toronto 270, Canada.

NEW Canadian oil leases. \$1.00 acre. Free information. Northern, Box 70-F, Montreal 206.

ARKANSAS—5-10-20 Acre wooded tracts on 70 mile long BEAVER Lake. Great hunting, fishing. Farms, Ranches, Homes, Investments. Mild Climate, Low Taxes. Job Opportunities. Good Terms. Free Catalog. JIM TUCKER "The Land Man" Rogers, Ark. 72756.

GOOD Farm For Sale, Cheap, in Canada. Write: Batten, Woodmore, Manitoba.

FREE . . . NEW FALL-WINTER catalog. All types real estate coast to coast! UNITED FARM AGENCY, 612-PM West 47th St., Kansas City, Mo. 64112.

BUY With confidence for Retirement, Vacation, or Investment—under America's only "No-Risk Land Purchase Plan"—in Carolina Coast multimillion dollar, 14,000-acre development. 10 year money-back guarantee. 1/3-acre homesites as low as \$750.00 cash price; \$10.00 down. \$8.22 monthly for 120 months, including interest at an annual percentage rate of 6%. Motel, hunting, fishing, golf, country club, right on property. Private ocean beach, 50 fresh water lakes. Write for free literature. Dept. 1-D, Boiling Spring Lakes, North Carolina 28461. (Registered under Federal Land Sales Act but not available to residents in states requiring separate registration.)

SELECTIVE BARGAINS! Choice ARKANSAS properties! FREE Journal! Statewide Realty Co., 507-AE Pyramid Bldg., Little Rock, Ark. 72201.

FREE! Real Estate Catalog! Farms, Ranches, Business, Recreational and Investment Property. 18 States, pictures galore. Note State Desired, BANNER Adv., Box 3333, 19-A, Springfield, Mo. 65804. "Real Estate Our Specialty"

GOVERNMENT Lands . . . low as \$1.00 Acre! Millions Acres! For exclusive "Government Land Buyer's Guide" . . . plus "Land Opportunity Review" listing lands available throughout U.S., send \$1.00. Satisfaction Guaranteed! United Lands, Box 19107-AI, Washington, D.C. 20036.

LEARN Real Estate At Home Get your license. Become a Salesman or Broker. Approved for Veterans. Write National Institute Of Real Estate, Inc., 3330-M Peachtree Rd., Atlanta, Ga. 30326.

10 TO 80 ACRES—Lake Superior, Marquette, Michigan area, \$99 acre. Any terms A-OK. Cabins, Trailers, Camping welcome. Hiawatha Forest Lake Acres, 3650 Dixie, Drayton Plains 16, Michigan 48020.

FARM & GARDEN EQUIPMENT

PROFITS FROM CLASSIFIED ADVERTISING! Booklet shows you how to start your own business with Classified Advertising. Only \$1.00 (Refundable with first order.) C. A. Martin, Popular Mechanics, Dept. PM, 224 West 57 Street, New York, N.Y. 10019.

(Continued on next page)



FLOWERS, PLANTS & NURSERY SUPPLIES

LEARN Landscaping and the growing of plants. Start a profitable business part or full time. Free information without obligation. Lifetime Career Schools, Dept. A-822, 2251 Barry Avenue, Los Angeles, California 90064.

SICK Trees, Plants? Free Mineral Sample! Vita-Spike (PM), 3527 Aquila, Minneapolis, Minnesota 55426.

GINSENG Bringing \$18 Pound. Have Seeds, Roots, Goldenseal. Full Information. K. Collins, Viola, Iowa 52350.

INDOOR fruitbearing Dwarf Orange Tree, \$2.48. Valentine, R-4, Riverview, Florida 33569.

CARNIVOROUS (Insectivorous) Plants, 28 kinds. Illustrated Catalog 25¢. Peter Pauls, Macedon, Canandaigua, N.Y. 14424.

HOME CRAFTSMEN

SPECIALIST in WOOD FINISHES. Refinishing, restoring. Many related items. Factory type materials. Small or large quantities. Send 40¢ for catalog. Free on shop letterhead. Gaston Wood Finishes, Drawer PM 1246, Bloomington, Indiana 47401.

101 PATTERNS Of smart Gifts, Novelties, Shelves, Action Windmills, plus "Make Money Jig Sawing". \$1.25. Mastercraft, 95M, 7041 Olcott, Chicago 60631.

BUILD GRANDFATHER CLOCKS. Send \$1.50 for detailed plans of two beautiful designs. We have ample stock of movements, and guarantee prompt shipment. Emperor Clock Co.; P. O. Drawer A-T, Dept. 3; Fairhope, Alabama, 36532.

BUILD PLAY FORT for children. Six feet square, three levels. Meeting room, lookout tower, secret passageway. Plans \$1.00. Play World Technology, Dept. P3, Box 99131, San Diego, Calif. 92109.

WOODWORKING Catalog and Manual 25¢ plus free "101 Project Ideas." World's most beautiful veneers, lumber plywood! Wood finishing, upholstery supplies, Cane Lamp parts. Furniture hardware. Animal whittling blocks, 2,000 workshop products. Constantine, 2051-N Eastchester Road, Bronx 10461.

FULL SIZE FURNITURE PLANS. Traditional, Early American, Danish Modern. Catalog 50¢. Furniture Designs, Dept. P-90, 1425 Sherman, Evanston, Illinois 60201.

SKIL-CRAFTS new 200 page catalog with world's largest, finest selections of hobby-craft, leather-craft, artist supplies. Send 50¢ (refunded plus free gift with first \$5 minimum catalog order). Skil-Crafts, Box 105-P, Joplin, Mo. 64801.

FOUNDRYETTE 2400 F. 1 1/2 to 48 lb. capacity. Circular 10¢. Kansas City Specialties, Box 193-P-9, Middleton, Wisconsin 53562.

CABINETMAKING MADE EASY and "How to Make Formica Counter Tops." Two excellent guides let you build kitchen cabinets and counter tops like professionals. Extraordinary guides bring master craftsmen's shortcut methods. Satisfaction guaranteed. Write: Japs, 126-P Seventh North, Hopkins, Minn. 55343.

MAKE Money Building and selling Bird Houses. Send \$1.90 for 39 page book of plans covering 19 projects. Yeager, 1665 Linden, Homewood, Ill. 60430.

DO-IT-YOURSELF

RELAXA-BATH. BUILD YOUR OWN, for under \$10.00. Convert your bathtub into a hydrotherapeutic bath. Enjoy real relaxation! Plans \$2.00. RELAXA-BATH, Box 791, Arcadia, Calif. 91006.

CONVERT MOWER Engines into air compressors. Write Showalter, Box 409, Abilene, Kansas 67410.

"HIGH PRESSURE WATER CLEANER, 700 PSI, complete kit ready to build, 1 H.P. electric motor, pump, all fittings, you supply assembly only no special tools needed. Complete Kit \$138.50 or send \$2.00 for drawings, bill of material, specifications and buy only parts you need. Send to General Hydraulics Corporation, South Beloit, Illinois 61080."

REFRIGERATOR Door gaskets—Electric Range and Washer Parts. Send Make and model for cost. Box 5465, Hamden, Conn. 06518.

ELECTROPLATE Small metal objects, initials, designs, repair metal worn spots. Kits. Nickel silver, gold, others. Rapid Electroplating, 1524 Merchandise Mart, Chicago 60654.

BURGLAR-Fire Alarm Supplies and information. Free Catalog. Protecto Alarm Sales, Box 357, Birch Run, Michigan 48145.

MINIATURE WIRELESS MICROPHONES. AM and FM. Plans and parts list for one of each—\$1.00. PC board—\$1.50 each. Plans, parts list, and two PC boards—\$3.50. N.C.M. Associates, PO Box 8162, San Antonio, Tex. 78208.

"LOUD, Quick, small, safe, permanent fire alarms made easily at home for half cent each. Sell \$7.50 per dozen. Better than best electrical system. Hang on walls. Bang Co., P115 New Montgomery St., San Francisco, Calif." 94105.

"HOW TO" Books. Catalogue 25¢. Elston House, 35 Stonycliff, Centerville, Mass. 02632.

WALLPAPER PASTER. Paste, Cut Double Roll in One Minute, \$19.95, Morley's Cochran, Penna. 16314.

SUPERHARD Handknife cuts Formica laminate. Easily cuts circles, curves. No need for power tools. \$4.50 postpaid. Lamicut Products, P.O. Box 43166, Cleveland, Ohio 44143.

ARTS AND CRAFTS

"GETTING Started in Stained Glass" 25¢. Whitemore, Box 2065Y, Hanover, Mass. 02339.

FREE: New 136 page handicraft catalog. Supreme Handicrafts, Box 395-PM, Sioux Falls, South Dakota 57101.

300 FIBERGLASS Molds for casting ornamental concrete. Catalog \$1.00. Plycrete Molds, Elk Rapids, Michigan 49629.

MAKE Figurines, plaques, lawn ornaments. Molds, plastercraft kits, liquid rubber. Sample and catalogue 10¢. Wooley Company, Box 29-B, Peoria, Illinois 61601.

BINOCULARS, TELESCOPES, MICROSCOPES, MAGNIFIERS

BINOCULAR Sale! Free color catalog 100 models \$9.95-\$250.00. Write United, 9043 So. Western, BCAT-1808, Chicago 60620.

SCIENCE Bargains! Lenses, telescopes, binoculars, microscopes, kits, parts, war surplus. Send \$1.50 for beginner's 10-lens kit with instruction booklet. Order Stock 2-CH. Request free 148 page Catalog CH. Edmund Scientific Co., 300 Edscorp Bldg., Barrington, New Jersey 08007.

BINOCULARS Direct from manufacturer. Finest quality, tremendous savings! catalog 25¢. Koyu, 3860 Crenshaw Blvd., Los Angeles, Calif. 90008.

TELESCOPES (reflectors) complete kits. Other accessories, request free literature. Criterion Manufacturing Dept. PM-7, Hartford, Connecticut 06101.



CAMERAS AND EQUIPMENT

SELL Your Photos. Report tells How, Where, Color Slide Markets. Only \$1.00. G.L. Enterprises, Dupuyer, Mont. 59432.

WORLD'S Largest Buying Guide—800 Illustrations—50¢—Deductible With Your Order—Olden Camera—1265 Broadway, New York, N.Y. 10001.

XMASKIT'S 25th Anniversary catalog for making Photo Greeting Cards, etc. 20¢ LaFrance Productions, 8150 Commercial, LaMesa, Calif. 92041.

SUPER-SECRET AERIAL RECONNAISSANCE CAMERA Brand New Air Force Surplus! \$1200.00 GOVERNMENT COST Contains 2 Bausch & Lomb wide-angle 6" metron lenses. (Value over \$500.00.) Can operate remotely on 24 Volt DC or 110 Volt AC with transformer. SPECIAL \$59.50, 2 for \$99.00. Shipping box alone worth \$25.00. Shipped freight collect 55 lbs. Cash—Check—no C.O.D.s. SURPLUS WORLD, 1025 Chili Avenue, Rochester, New York 14603.

PHOTO SUPPLIES

NEW Film Catalog. Write Chai Photo Supply Co., 14-03 Berdan Avenue, Fair Lawn, New Jersey 07410.

"MAGNETIC" PHOTO ALBUM—Like magic!!! Photos cling to treated pages—protected under plastic film. Change or rearrange at will. Deluxe woodgrain vinyl cover—11 1/2" x 9 1/2". Regular \$6.98. INTRODUCTORY PRICE \$3.98 plus 40¢ postage—two \$7.50 plus 80¢. Remaco Ltd., Dept. 290, Box 5481, San Francisco, Cal. 94101.

PHOTO FINISHING

CAMERA FANS! Expert photofinishing by one of Country's largest labs at lowest prices. Fast service and free "Foto-Fan" Stamps you quickly redeem for valuable Photo Supplies. 8MM Kodachrome \$1.29; 8 Exp. Kodachrome \$1.79; 35MM Kodachrome. 20 Slides \$1.39; 8 Exp. Black White 69¢. Satisfaction guaranteed. Send exposed film or request free mailers, complete Price List and Gift Catalog. Direct Mail Photo, Box 8352-PM, Pittsburgh, Pa. 15218.

COLOR SLIDES

"COMING Attraction" Silent Movie theatre ad slides, 35MM, color. Sample, 10¢. Lists Free. Also Currier and Ives slides. WICP, Box 392PM, Elmira, N. Y. 14902.

MOTION PICTURES AND SOUND EQUIPMENT

FREE! 64-page catalog. 8-16mm film, supplies, processing equipment. Superior, 448 N. Wells, Chicago 60610.

8MM-16MM BARGAINS! Free Catalog! Cinema Eight, Box 245-PM, NYC. 10028.

16MM SOUND Features, Shorts, New, used for Sale. Free Catalog. National Cinema, 333 W 57th St.—N.Y.C., N.Y. 10019.

UNUSUAL Movie supplies. Free circular. Esor, 47th Holly, Kansas City, Missouri 64112.

RADIO, TELEVISION AND HAM EQUIPMENT

TUBES—Lowest prices. Foreign-American, obsolete, receiving, special purpose, transmitting tubes. Send for tube, parts catalog. United Radio Company, 56-PM Ferry St., Newark, N. J. 07105.

33¢ RADIO & TV tubes. Free list. Cornell, 4213-17 University, San Diego, California 92105.

GOVERNMENT Surplus receivers, transmitters, snooper scopes, parts. Catalog. 25¢. Meshna, Nahant, Mass. 01908.

HIFI, TAPES, RECORDS AND ELECTRONICS

EIGHT Track Tapes—Regular \$5.98—\$6.98. All titles \$3.99 each. It's Tapes, 153, Balboa Island, California 92662.

(Continued on next page).

HIFI, TAPES, RECORDS AND ELECTRONICS

(Continued from preceding page)

Free Electronics Catalog. Tremendous Bargains. Edu-Kits, Department C-729B, Hewlett, New York 11557.

FREE Catalogues, 2000 hard to find unusual records. Rose's Records, 128 Breckenridge Lane, Louisville, Ky. 40207.

TAPE Recorders. Tapes: blank, pre-recorded. Catalog 25¢, Tower, Lafayette Hill, Pa. 19444.

OLD Phonographs, Records, Catalogs, Piano Rolls. George Moran, Lodi, Wisconsin 53555.



MUSIC AND MUSICAL INSTRUMENTS

POEMS And Songs wanted by America's most popular studio. Tin Pan Alley, Broadway Productions Division, PM, Lake Grove, New York 11755.

SONGS, Poems wanted! Accepted songs published, recorded at our expense! Talent, 17-PM, Longwood Road, Quincy, Mass. 02169.

ACCORDIONS And Amplifiers. Excelsior And Other Famous Makes. Save 50%. Buy Direct. Factory Distributor. Terms. Trades. New-Used. Free Home Trial. Free Catalog And Discount Prices. Excelsior, Dept. R, 3147 North Luna, Chicago 60641.

SWISS Musical Movements Mechanical-Electrical. Spielman, 131 West 42nd, New York 10036.

VIOLIN and Guitar makers—send for latest Free Catalogue of woods & accessories. International Violin. PMO. 414 East Baltimore St., Baltimore, Md. 21202.

ACCORDION Manufacturing. 6846-P North Avenue, Chicago, Illinois 60635. Concertinas, Hohners, Chromatics, Guitars, Drums, New, Used, Tuning, Repairing. Wholesale Catalogs Free.

PLAYER Piano Rebuilding—get details from: Vestal Press. Vestal 11, N.Y. 13850.

GUITARS, MANDOLINS, BANJOS. Complete stock of Gibson Martin guitars. Free 100 page catalog, parts and accessories. Big Savings. New York discount prices. Send 50¢ postage handling. Eddie Bell Guitar, Dept. PM, 201 West 49, New York 10019.

ELECTRIFY Player Pianos, Pump Organs Quickly, Inexpensively with Lee Silent Suction Units. Write Lee Music, 525F Venezia Avenue, Venice, California 90291.

LEARN Banjo. 5-String Bluegrass. No music. Makes learning easy. Free details. Blaylock, Box 25-M, Marietta, Georgia 30060.

PROFESSIONAL 674 Watt Amplifiers. Guitars. Free Wholesale Catalog. Carvin, PM70, Escondido, Calif. 92025.

DOBRO Type guitar—world's best acoustical. The Guitar. 4668 Hollywood Blvd., Hollywood 90027.

30% DISCOUNT Any Name Brand Musical Instrument. Free Catalog. Freeport Music, 127 F. Sunrise Highway, Freeport, New York 11520.

POEMS Wanted for new songs, records. FIVE STAR MUSIC, 6M Beacon, Boston, Mass. 02108.

GUITAR, Banjo Making books, Plans, woods, necks, tools. List 25¢. Satinwood, 510 East 11th Street, New York, N.Y. 10009.

ACCORDION Top brands. Buy direct. Tremendous discounts. Trade accepted. Free brochure PM. Accordion-O-Rama, 874 Broadway, N.Y.C. 10003.

STRAP-EZ Holds Guitar Securely in chip-board case. Quickly installed—easily operated. Guaranteed, \$1.00. J & R Enterprises, Box 361, Lawndale, California 90260.

LEAD Guitar Course. Diagrams, Lead Chords, Improvising. More! \$1.00! Vern, 18 Redcoat, Lexington, Mass. 02173.

VIOLINS GUITARS STRING INSTRUMENTS MAKER MUSICIANS! INSTANT STRAD TONE GUARANTEE OR MONEY REFUNDED. DO-IT-YOURSELF \$10.00. SGT. ROLEX USAF (RET.) POST OFFICE BOX 2381, LAS VEGAS, NEVADA 89104.

GUITAR MAKING Books. Imported Woods, Supplies, Accessories. Catalog 25¢. Guitar Center, Box 15444, Tulsa, Okla. 74115.

GUITAR MAKER'S Mould aluminum, electric heated, for bending & glueing sides etc. Free catalog. Overholtzer, 618 Orient, Chico, Calif. 95926.

FREE PAMPHLET "How to Sell Your Hit Song." Publishing-recording secrets. RSVP, Box 10365, New Orleans, La. 70121.

BAND INSTRUMENTS, and Accessories. New and used. Discounts to 75%. Band Instruments, Box 142, Scotland, Indiana 47457.

SONGPOEMS Needed, recording—publishing. Free Booklet. Betty's Music Makers, M 945 Central, St. Petersburg, Florida 33705.

EDUCATION AND INSTRUCTION

DEEP SEA DIVING: Worlds Most Advanced Deep Sea Diving course. Learn to Earn: Free Brochure. Commercial Diving Center (Dept. A), 201 W. Water Street, Wilmington, California 90744.

LIFETIME ORDINATIONS. Send stamp for information. Church, 2207 Cardinal, Rolling Meadows, Ill. 60008.

AIR-CONDITIONING, Refrigeration, Correspondence, tutoring by licensed instructor. Risa, 1202 58th, Brooklyn, New York 11219.

GAME WARDEN, Government Hunter, Forestry, Park & Wildlife Service announce job openings regularly. Prepare at home for outdoor work, good pay security. Complete information Free! Write North American School of Conservation—Dept. AZ, Newport, California 92660.

FINGERPRINTING—Investigation. Exciting, secure career. Learn at home. Free book. State age. Institute of Applied Science, 1920 Sunnyside, Dept. 169, Chicago, Illinois 60640.

EARN College degree at home. All subjects. Ohio Christian College, 1156 Striebel Road, Columbus, Ohio 43227.

COMPLETE YOUR HIGH SCHOOL at home in spare time. Texts furnished. No classes. Diploma. Approved for Veteran Training. Founded 1897. Free Brochure. American School, Dept. X645, Drexel at 58th, Chicago, Illinois 60637.

GRAPHOANALYSIS—Learn scientific handwriting analysis for profit, pleasure. Free sample lesson, catalog, reveals plan. Write: Igas Inc., 325 Jackson, Dept. 2JP-2, Chicago 60606.

PENMANSHIP Corrector. Improve Poor penmanship quickly. Details free. Ozment, Box 2344, St Louis, Mo. 63114.

LEARN Auctioneering. Term soon. Free catalog. Reisch Auction College, Box 850, Mason City, Iowa 50401.

PIANO Tuning quickly learned with home study course. Diploma granted. American Tuning School, Gilroy, Calif. 95020.

OWN Collection agency. "Little Gold Mine!" Franklin Credit, Roanoke, Virginia 24004.

MISSOURI Auction School. GI Approved. Free Catalog! 424-03 Nichols Road, Kansas City, Mo. 64112.

EARN \$125 A week and up. Learn a trade with a future. Learn auto diesel mechanics in our shops. You learn with tools on real equipment. Earn while you learn. Many of our graduates earn \$125 a week and up. Write for free bulletin: Dept. 256, Auto Diesel College, Nashville, Tennessee 37219.

SUPERIOR Auction School. Nation's top Auctioneers own and instruct. Box 1281, Decatur, Ill. 62523.

HIGHLY EFFECTIVE home study courses in Electronics Engineering Technology and Electronics Engineering Mathematics. Earn your Degree. Write for Free Descriptive Literature. Cook's Institute of Electronics Engineering, (Dept. 10), P.O. Box 10634, Jackson, Miss. 39209. (Established 1945).

USED Courses! Books! List 10¢, Smith's, 124 Marlborough, Salem, Mass. 01970.

AUCTIONEERING Resident or Home Study Course Free Catalog. Nashville Auction School, 2004 West End, Nashville, Tennessee 37203.

DETECTIVE Course. Free Information. Universal Detectives, Box 818U-F, Universal City, California 91608.

PROFITABLE Camera service training at home. National Camera, Dept. PM, Englewood, Colo. 80110.

EXTENSION And Post-Graduate Awards in Philosophy, Arts, Sciences, Botanic Medicine, Homeopathy, Radionics and others. 30 subjects. Curricular free (air-mail \$1.00 refundable). Registrar, Sussex College of Technology, Highfield, Danehill, Sussex, England.

WATCH REPAIRING. Learn to repair American and Swiss watches in spare time at home. Diploma awarded. Free sample lesson. No obligation. Chicago School, Dept. YJ, Fox River Grove, Illinois 60021.

FREE Bible course! Degree! Request information! 708 Bragg, Monroe, North Carolina 28110.

PIANO Technology—Electronic organ servicing, learned easily at home. G.I. Approved. Free booklet. Niles Bryant School, Dept. P, 3631 Stockton, Sacramento, California 95820.

HIGH SCHOOL diploma at home. Licensed teachers. Send age, highest grade completed for free details. No salesman will call. Southern States Academy, 5300 W. Belfort, Dept. 16-J, Houston, Texas 77035.

LEARN Asleep or awake! Records, tapes, equipment! Free catalog! Drawer PM-400, Ruidoso, New Mexico 88345.

LEARN Massage. Home study course. Free details. Massage, Box 190-PM, Quincy, Mass. 02169.

PERFECT Husband-wife business. Learn Upholstery at home. Make \$10 in an hour. Buy-repair-sell for even bigger profits. Kits, tools included. Free Booklet. Upholstery Institute, Dept. 5310-090, Little Falls, New Jersey 07424.

LEARN To Fix Typewriters. Desperate shortage trained men. Hundreds needed. Make up to \$25 in one hour. Learn at home in spare time. Industry Approved course. Facts free. Send name. Typewriter Repair School, Dept. 3310-090, Little Falls, New Jersey 07424.

UNLOCK Your Future. Become professional Locksmithing by spare time home-study. Make up to \$6 per hour. All tools, equipment incl. Facts Free. Send name. Locksmithing Inst. Dept. 1310-090, Little Falls, New Jersey 07424.

FCC FIRST Class License in six weeks—Nations highest success rate—Approved for Veteran's Training. Schools in Dallas, Atlanta, Chicago, New Orleans, Minneapolis and Houston. Write Elkins Institute, 2603D Inwood Road, Dallas, Texas 75235.

BOOST Your potential. The MATURE PERSON. Free lessons. Home Bible Studies, Box 370-PM, Elkhart, Indiana 46514.

EARN College degrees at home. Many Subjects. FLORIDA STATE CHRISTIAN COLLEGE, Post Office Box 1674, Fort Lauderdale, Florida 33302.

MAKE MONEY in real estate! Complete home study course designed to start you on new career. Opportunities waiting! Write: Career School of Real Estate Studies, 1825PM E. Seminole, Springfield, Mo. 65804.

COLLEGE Degree at home. Free catalog. North American University, Box 376, Salome, Arizona 85348.

(Continued on next page)

EDUCATION AND INSTRUCTION

(Continued from preceding page)

COLLEGE Degrees thru extension. State Chartered. Prospectus Free, Box 682, Palm Beach, Florida 33840.

EARN University degrees through experience—All subjects... details \$1.00. St. Matthew University. . . . Box 9734 . . . Columbus, Ohio 43206.

PIANO Tuning pays. Big money in spare time. Learn at home. No musical knowledge necessary. Phonograph, records, tools and instructions furnished. Electronic tuning also taught. Free catalog. Capital Tuning School, 3160 S.W. 16th Court, Ft. Lauderdale, Fla. 33312.

USED CORRESPONDENCE Courses and Books sold and rented. Money back guarantee. Catalog free. (Courses bought.) Lee Mountain, Pisgah, Alabama 35765.

PHOTOGRAPHIC RETOUCHERS are in demand. Qualify for interesting, profitable career at home. Easily learned. Free information. Hamilton Studios, Dept. PR-39, Claymont, Del. 19703.

THE Exam Secret. Pass Every Exam, Book Gives you Astonishing New Study Techniques. Hit Target Every Time. FREE CIRCULAR Universal Products 507-D Fifth Ave. N.Y. 10017.

HOW To Develop An Exceptional Memory. Quickly mastered memory systems help you easily remember names, faces, 100 objects. \$2.00. Amberson's, Dept. P87,465 East Columbia, Pomona, California 91767.

CORRESPONDENCE Course: Scientific Development of Mind, Memory, Personality, Wealth. Over 750,000 students. Details and psychological test Free. Imperial, Dept. AAJ, 501 Wayoata, Winnipeg 25, Canada.

CERTIFIED HIGH SCHOOL DIPLOMA the quickest and most economical way. Send a stamped self-addressed envelope for application. Bedford Academy, Box 221, Bedford, Va. 24523.

EARN College degree at home. All subjects. Alpha Psi Omega, 1161 South Yearling Road, Columbus, Ohio 43227.

BARTENDER Cocktail Waitress Correspondence School. 711A North Magnolia, Orlando, Florida 32803.

LATEST Bricklaying Information, Programmed Instruction, Retirement Information. Send 6c. The Pretio Services, Durham, North Carolina 27702.

COLLEGE DEGREES THROUGH HOME STUDY Varied And Flexible Courses. Write: Marlowe University, Box 614M, Mount Holly, New Jersey 08060.

INVESTIGATOR Training. Includes Civil, Criminal, Espionage. Diploma. National, Box 353, Fiskdale, Mass. 01518.

LEARN Handwriting analysis. International, Dept. 700, 11749 Eldridge, Lake View Terrace, Calif. 91342.

EARN Up To \$700 A Month. Learn tax preparation at home in your spare time with H&R Block, America's largest tax service. No previous experience necessary. Anyone may enroll. Low tuition. Job opportunities for qualified graduates. Write for free information. H & R Block Tax Training Institute, Suite 301-A, 4410 Main, Kansas City, Missouri 64111.

GET A British Degree. Divinity. Philosophy, Radionics. 35 Courses. Prospectus free. Brantridge Forest School, Highfield, Dane Hill, Sussex, England.

AUTOSUGGESTION. Sleep-learning headquarters! Tapes, records, books, Gigantic catalog free. Research Association, Box 24PM, Olympia, Washington.

BIBLE & Seminary Correspondence Degree Colleges Catalog! (\$1.00) Box 647, Morgantown, Kentucky 42261.

FOR INVENTORS

INVENTORS—Do you want to sell or license your invention on cash or royalty basis, Write Kessler Corporation, C-59-F1, Fremont, Ohio 43420.

PATENT Searches complete and thorough. Related copies Air Mailed with maximum speed \$6.00. Free "Protection Forms" and "Patent Information." Write American Patent Search Company, Dept. 27, 711 14th St., N.W. Washington, D.C. 20008.

PATENT Application Financing. Free patent search plan. Global Patent Division. 2420 77th. Oakland, Calif. 94605.

U.S. Patent Office Searches, 234 Broadway, Room 3615, New York. Free invention certificates.

PATENT And invention development by licensed professional patent engineer and U.S. Patent Office former examiner, and engineering specialists. Your inventions and ideas engineered for patent protection and commercial value. Inventions developed by us negotiated for cash or royalties with our nationwide contacts. Send for free protection "Invention Certificates" and further interesting, valuable patent information. George Spector, Licensed Professional Patent Engineer, Woolworth Building, New York 10007.

IMMEDIATE Cash, for patent applications. Free patent searches. Write for details. Universal Patents, 184-D, Marion, Ohio 45750.

NEW INVENTION PROTECTION program by the U.S. Patent Office. For indisputable invention protection you just fill out disclosure form, mail with \$10.00 directly to Patent Office. Complete information and one disclosure form \$1.00. Additional forms \$.50 each from Kurt Frank, 11106 Franklin Ave. Culver City, Calif. 90230.

INVENTORS! Free Promotion Analysis helps you sell for highest royalty value. Extensive Manufacturer's lists. Complete Invention Service. 10 years proven performance. Financing available. Free information: International Invention Institute, Dept. M, 160 Broadway, New York, New York 10038.

INVENTORS: Your ideas and inventions (patented: unpatented) expertly searched, developed for commercial appeal and cash/royalty sales to manufacturers by professional Invention Developer with excellent record of experience. B.S. Industrial Engineering; United States Patent Office former Patent Examiner. United States Government former Patent Advisor. Second decade reliable service! Member: United States Council International Chamber Commerce. Free "Invention Record" and "Recommended Protection Procedure." Airmailed! Write: Raymond Lee, Invention Developer, 230P-Park Ave., New York City 10017.

FREE PAMPHLET: "Tips on Safeguarding Your Invention." Write: United States Inventors Service Company, 501P Thirteenth Street N.W., Washington, D.C. 20004.

PATENT Searches, including copies of related U.S. patents. Inventors, attorneys, manufacturers use our "worldwide" airmail service! "Invention Record" form and "Information Every Inventor Needs." Sent free! Hayward Company, 1029P Vermont, Washington 5, D.C.

MANUFACTURERS NEED New Products! FREE Literature explains "How to Submit Your Invention," Congress Invention Company, 911-C Warner Building, Washington, D.C. 20004.

MARKET Your Product. Over 300 Magazines provide FREE New Product Advertising. Send \$2.00 for booklet and instructions. Data Enterprises, Box 1105, Springfield, Va. 22151.

PATENT Drawings \$20.00. Models, reasonable. Pen-Ink, 50 East 42, New York City 10017.

INVENTION, New Product, Mail Order Sales, Details \$1.00. Guide, Box 5149, Spokane, Washington 99205.

INVENTORS: What is "anti-shelving protection"? Should your royalty be 3%, 6%? Are you serious inventor desiring an agreement reflecting protection and royalty your invention merits? Our manual "Invention Licensing and Royalty Rate Structure" will be invaluable source of information on factors involved. Complete commentary on sample license agreement, examples of royalty rate makeup, cash sale formulae, information on patents, pending patents, steps to patent application, directories for locating manufacturers, making contacts. Inventor-written for inventors. \$6.50 Postpaid. Inventors' Manuals-PM, Box 3387, Norland Station, Miami, Florida 33169.

INVENTORS: SELL YOUR Creations through National Mail Shopping Promotions. Win \$1000.00 in Prizes. Project your Invention to Potential Manufacturers during their leisure time. Entries will be exhibited to Thousands of People. Aside from triggering interest among potential manufacturers you also qualify for Hard-Cash. For full information Write or Phone: National Mail Promotions, Haddonfield Road, Pennsauken, N.J. 663-4800.

INVENTIONS WANTED

IF Your Invention is adaptable to promoting we will contract for selling on cash or royalty. Free booklet outlines royalty rates, requirements. Kessler Corporation, C-59-IW, Fremont, Ohio 43420.

INVENTORS! Sell your invention for cash or royalties! Our client manufacturers eagerly seek new items. Patented, Unpatented. Financial assistance if needed. 25 years proven performance. For free information, write Dept. 15, Gilbert Adams, Invention Broker, 80 Wall St., New York, N.Y. 10005.

INVENTIONS Wanted. Patented: unpatented. Tremendous manufacturers lists. Global Marketing Service, 2420G 77th, Oakland, California 94605.

INVENTORS! We will develop, sell your idea or invention patented or unpatented. Our national manufacturer-clients are urgently seeking new items for highest outright cash sale or royalties. Financial assistance available. 10 years proven performance. For free information write Dept. 47, Wall Street Invention Brokerage, 79 Wall Street, New York, N.Y. 10005.

WE Either sell your invention or pay cash bonus. Write for details. Universal Inventions, 28-E, Marion, Ohio.

INVENTORS! Don't sell your invention, patented or unpatented until you receive our offer. Eagle Development Company, Dept. H, 79 Wall Street, New York 5, N.Y.

INVENTORS! Don't sell or license your invention for cash or royalty until you receive our offer. Financial assistance available. For free information write: Dept. M-1, Wall Street Promotions, Inc., 99 Wall Street, New York, New York 10005.

INVENTORS Needing help with any problem, financial, securing manufacturer, obtaining patent. Write the organization that delivers action and results—not promises. Pioneer Invention Service, Dept. M2, 150 Broadway, New York, New York 10038.

FREE "Directory of 500 Corporations Seeking new Products." For information regarding development, sale, licensing of your patented/unpatented invention. Write: Raymond Lee Organization, 230-N Park Avenue, New York City 10017.

INVENTORS! Protect your ideas! Free "Recommended Procedures." Washington Inventors Service, 422F, Washington Building, District of Columbia 20005.

PATENTS FOR SALE

PROFITS FROM CLASSIFIED ADVERTISING! Booklet shows you how to start your own business with Classified Advertising. Only \$1.00 (Refundable with first order.) C. A. Martin, Popular Mechanics, Dept. PM, 224 West 57 Street, New York, N.Y. 10019.

(Continued on next page)

MANUFACTURING

INVENTORS Ideas developed. Research. Models. Manufacturing. Sales. Free brochure. William Parker. 32 Westminster, Worcester, Mass. 01605.

BUY IT WHOLESALE

DIRECT. Manufacturer. Detergents, polishes, 42 others. Permaglaze, 1555 Kinneys Lane, Portsmouth, Ohio 45662.

WHOLESALE—Buy 40% To 50% Off Retail—same prices retailers pay! Thousands of name brands! Watches, cameras jewelry, radios, phonographs, tape recorders, etc. Buy for yourself or resell at fat profit. Big wholesale catalog. Confidential Wholesale Price List. Free details. Wholesale Merchandise Club of America, Dept. 405, 154 Jericho Turnpike, Floral Park, N.Y. 11001.

HEARING Aids, Batteries, Wholesale. Catalog 25¢. Fiston, Box 1444, New Preston, Conn. 06777.

BARGAINS! Buy wholesale and below. Name brands. Appliances, furniture, sports equipment, televisions, cameras, watches, jewelry thousands more. Huge discounts to \$1,000.00 on new automobiles. All makes. Free details. Write today: Worldwide Bargainhunters, Box 730-A, Holland, Michigan 49423.

WORLD'S Largest wholesale dropship sources. U.S., foreign. Factory suppliers dropship direct to you or customers. Now! have your own catalog for pennies. Free details. International Buyers, Box 16386-M, Portland, Oregon 97233.

TOOLS—Buy wholesale. Mechanics tools, Pullers, Pulleys, Valve tools, Pre-setting Torque Wrenches, Tool Boxes. National brands. Send 50¢ for catalog, refundable on first purchase, Mitchell Tool Company, Box 672, Post, Texas, 79356.

FREE Costume Jewelry, Price List, 1225 McDowell, Phoenix, Arizona 85006.

BUY, SELL—Purchase Inquiry Free. List Surplus SIX MONTHS: \$2/Item. Sooper Swap, Tunkhannock, Pennsylvania, 18657.

EXPORT-IMPORT

JAPAN: 1200 Products Directory. Illustrated Manufacturers' names, addresses. \$3.00. Send cash. Yamagata Office, 814 Togin Bldg., Marunouchi, Tokyo.

WORLD-WIDE Suppliers—Directory \$3.95. World Shoppers, Box 151-W, Oklahoma City 73123.

FOR THE HOME

CHANCES Are, YOUR home may be robbed next! PROTECT it. Free details. Value Valley, 2141-P Sherwood Avenue, St. Paul, Minnesota 55119.

CHECKBOOK TRICKS! For Money Control. Simple methods within checkbook earmark funds for necessities, tell what's left, more. Booklet \$2.00, J. Jaquith, 751 Greenbrier, Orange, Conn. 06477.

PERMANENT Furnace Filter Of SCOTT-FOAM Treated With DUPONT Thiuram. Details Free. The Sherrord Company, 14 Pimlico Road, Greenville, S.C. 29607.

OF INTEREST TO WOMEN

\$100.00 WEEKLY ADDRESSING! Long-hand Typewriter. Send stamped addressed envelope. Midwest-TC, 4209 Esch, Madison, Wisconsin 53704.

\$500.00 MONTHLY Possible—clipping news at home. No experience. Send stamped-addressed envelope. American, Excelsior Springs, Mo. 64024.

HOMEWORKERS Directory! 262 National firms seeking help. Send stamped, self-addressed envelope. Economy, 629-AD Franklin, Clearwater, Florida 33517.

\$25.00 HUNDRED Addressing, Possible! Year 'round. Special Information included. 25¢ and self-addressed stamped envelope. Cove, 627-B Franklin, Clearwater, Florida 33517.

\$100 WEEKLY Possible addressing mailing circulars. Send self address stamped envelope. Details Free! Ayers Opportunities, Box 1591PM, Denton, Texas 76201.

WOMEN! Make big money at home. \$10.00 profit in an hour possible with invisible mending. Make holes, tears disappear from clothing fabrics. Steady year-round demand from cleaners, laundries, homes. Details free. Fabricon, 1533 Howard, Chicago 60626.

HOW To make money writing short paragraphs. Information free. Barrett, Dept. C-27-G3, 6216 N. Clark, Chicago 60626.

DRIVE New car, wear new clothes, buy color TV. Get daily cash income. Put spare hours to work. Write for 5 months free subscription Opportunity Magazine, see hundreds easy ways to make money. Opportunity, 1460 Hancock Center, Dept. 17-JO, Chicago 60611.

HOME Newspaper clippers needed, \$500 monthly possible. Details free. Foster, 272-MA9, Brooklyn 11235.

MAKE COLORFUL NECKLACES of newspaper. Instructions \$1.00. Bennett, P. O. Box 307M, South Vineland, N. J. 08360.

HOMEWORKERS' Paint novelties. Good profits. Free details. Roland, 10-V Lakeview, Hammonton, N.J. 08037.

EARN \$700 Per Month Spare Time as Tax Preparer with new quick-learn income tax home training. Start now. Be ready for January earnings. Full facts by mail—no salesman. Federated Tax Service, 1533 Howard, Chicago 60626.

\$85 WEEKLY Possible spare time addressing envelopes for firms. Work home. Start immediately. Details, send stamped self addressed envelope. Enterprises, Box 16143-PM, Phoenix, Arizona 85011.

\$150.00 WEEKLY Possible Addressing mail for firms. Start now. Send stamped self-addressed envelope. Davis, Box 6992-PM, Phoenix, Arizona 85005.

\$6.00 PER DOZEN Paid Lacing Baby Boots, Baby Moks! Write: Cowboy, Warsaw 9, Indiana. 46580.

\$100.00 WEEKLY Possible. . . . Easy typing, addressing you can do at home. Immediate income! Send 25¢ for details. Reiss, G.P.O. Lockbox 2174, Dept. B-2, New York, N. Y. 10001.

\$100 WEEKLY Possible—Home Typing. Immediate earnings! Details 25¢ handling. Typing, Box 593 PM9, Bettendorf, Iowa 52722.

CASH—For Boxtops, Labels, Etc. Stamped Self-Addressed Envelope Brings Details. DeJorio, 25 Vineyard, Highland, N. Y. 12528.

STAY Home—Make Money! 25 Ways! Details Free! Finley's, Ferndale, Calif. 95536.

LEARN Expert cake decorating, catering, candymaking. Free details on home instruction. Candy & Cake, Dept. BBW, 1600 Cabrillo, Torrance, Calif. 90501.

HOMEWORKERS! \$100.00 Weekly addressing envelopes for firms. Begin immediately. Details: send stamped, addressed envelope. Hamilton, 272-TM9, Brooklyn 11235.

\$350 MONTH ADDRESSING! Companies Supply Everything. Details, Mail Stamped Self-Addressed Envelope and 25 Cents. Happy, Box 1161-CC, Battle Creek, Michigan 49106.

HOUSEWIVES, Teachers, students, office workers. If you need extra cash each week but household or other duties prevent you from taking a part-time job, learn how you can earn by accepting orders to Popular Mechanics, Good Housekeeping and all other magazines. No experience needed. Write Popular Mechanics Room 9W, 250 West 55th St., New York 19, New York.

GIFT SHOPPING

GIFT CATALOG, The Shirley Shoppe, 17 Rundel Park, Rochester, New York 14607.

GIFT Catalogue Reminder Service. Send \$1.00. 3758A Creadyhill, Pittsburgh, Pa. 15236.

DISTINCTIVE Gift Catalog, Send 50¢, R-Z Gift House, Suite 428, 1825 Connecticut Avenue, N.W., Washington, D.C. 20009.

FREE Gift Catalog. Featuring the Unusual. Write GIFTS GALORE, 1572 Willowdale, San Jose, California 95118.

GIFTS From usefulness to foolishness. Free Catalog. Gift Haven, 515 East Cedar, Olathe, Kansas 66061.

FREE! Brochure "40 EXCITING GIFTS" Write to DeLisle Associates, 229-P North Cragmont Ave., San Jose, California 95127.

POODLE Radio \$9.95. Details: Universal Distributors, Box 156, Brooklyn, New York 11226.

FREE DISTINCTIVE GIFTS CATALOG. Write: Steve Nelson, Box 58, Richwood, Ohio 43344.

FREE Distinctive Gift Catalog. Write: Novak, 18720 Hatteras, Tarzana, California 91356.

BLACK Forest Gifts, Jewelry. Free literature. Dorf Importers, 8317 Western, Omaha, Nebr. 68114.

FREE! Illustrated Gift Catalog. Many choices. Get your copy now. Lyle J. Oldenburg Enterprises, 2542 Dove Drive,

FREE! Illustrated gift catalogue. 32 pages of unique and useful items for yourself and friends. Send today! Juday Enterprises, Dept. PM-9, 150 Sunset Drive, Pittsburgh, Penna. 15235.

FREE CATALOG! Popular Gifts and Novelties. Write: Dept. 6090, Pembroke Shoppe, 202 South Main, Pembroke, Kentucky 42266.

FREE catalog unusual gifts. Harry Haines, Rt. 1 Mill Hall, Pennsylvania 17751.

"CREAM OF THE CROP" High quality merchandise. Something for everyone. 32 page catalog 25¢ (Refundable on first order.) Heiberger-Robesh Enterprises, 6311 Yucca, Hollywood, California 90028.

ATTRACTIVE, Useful Gifts. Free brochure. Sea Trek Trading Company, Dept. B2, Box 9765, San Jose, Calif. 95117.

FREE Catalog-Esoteric Gifts and books. Humboldt House, Ferndale, Calif. 95536.

UNUSUAL Gifts from the Southwest. Send for free brochure. The Roadrunner West, Dept. PM2, 5962 E. 24th St., Tucson, Arizona 85711.

FREE CATALOG of Unique Gifts. Tradewinds Ltd., 181 Schoolhouse Road, Albany, New York 12203.

GIFTS And gag's. \$1.00 Brings your novelty drinking duck. Sorensen's of California P. O. Box 3487, Hayward, Cal. 94544.

FREE Distinguished Gifts Catalogue. Walden, 150 Sage, Citrus Heights California 95610.

FREE Gift Catalog. Write: LEA HOUSE, D-19 3112 Wenatchee St., Bakersfield, Calif. 93306.

WATCHES, OLD GOLD, JEWELRY

WATCHMAKERS' — Jewelers' Catalog: Surprise: \$1.00. Watchmaking Course; Tools: \$35.00. Bengal's 17942 Ventura, Encino, California 91316.

HIGHEST CASH for Gold, Jewelry, Gold Teeth, Rings, Diamonds, Watches, Silver, Platinum. Mail Articles Today. Free gift with information. Chicago Gold & Precious Metals, 6 E. Monroe, Dept. 158, Chicago 60603.

INSTANT Time Swiss-Made Digital Calendar Watch Leather Strap \$19.95. Kent Fair, PM, 1910 Pasadena Drive, Austin, Texas 78757.

WANTED: gold, silver, platinum (any form), mercury. Information free. Wilmot's, 1067 Bridge St., Grand Rapids, Mich. 49504.

CASH Immediately for old gold, jewelry, gold teeth, watches, diamonds, silverware, spectacles, platinum, mercury. Free information, Rose Industries, 29-A East Madison, Chicago 60602.

(Continued on next page)

WATCHES, OLD GOLD, JEWELRY

(Continued from preceding page)

WATCH And clock repairing books. Free catalog. North American, Box 77-AW, Fox River Grove, Illinois 60021.

MERCURY! Top price paid. Free information: Mercury (PM-73), Fairfield, Ohio 45014.

WEARING APPAREL

MEN Buy your Outerwear Coats and Jackets **WHOLESALE** directly from manufacturer. Write now for free illustrated booklet showing styles for Fall 1970. Sharob Corp., Carbondale, Penna. 18407.

NYLON PANTIES—Elastic leg brief—ladies sizes 5 - 6 - 7 - 8 - 9 - 10 White 2 pairs \$1.00 postage paid. **EXCELLENT VALUE—SATISFACTION GUARANTEED.** House of Milcraft, Box 483W, Murray Hill Station, New York 10016.

HEARING AIDS

HEARING Aid Batteries. Factory-Fresh. Wholesale Price List 25¢. Walters, 2 Maureen Drive, Greensburg, Indiana 47240.

HEARING AIDS—Batteries Wholesale! Brochure—Hearing Center, Box 211, St. Petersburg, Florida.

HEARING Aids below wholesale. Regular, eyeglass, completely hidden models. Smallest, most powerful. Free home trial. No Salesman will call. Free details. Write Prestige-C6, Box 10880, Houston, Texas 77018.

All Type hearing Aids \$89.00. Rhodes, 333 North 9th, Paducah, Ky. 42001.



SCIENCE AND CHEMISTRY

CHEMICALS And apparatus for industrial, analytical, and private laboratories. Catalog 50¢. Dept. M-50. Biological Supply Co., 1176 Mt. Hope Ave., Rochester, N.Y. 14620.

CHEMICALS, Apparatus, Biological Supplies, Microscopes, etc. Catalog 50¢. Sheard Science, Dept. PM, Columbus, Wisconsin 53925.

CATALOGUE Of ver-ry interesting products, 35¢. Things that go boom, things that go zoom, also books all about them. Kenrus-C, Box 158M, Staten Island, New York 10309.

LASER Parts Catalog 60¢. Moynihan, 107 North Brighton, Atlantic City, New Jersey 08401.

ELECTRONIC Pistol squirts jets of electrified water. Battery operated. Plans \$2. Kilmer, Pinos Altos Road, Silver City, New Mexico 88061.

LABORATORY Supplies At Discount Prices, Catalogue—35¢. Deluxe Scientific; Manitowoc, Wisconsin 54220.

SEARCHING For Economically Priced Laboratory Supplies? Conversion Charts And Catalogue—35¢. Hagenow Laboratories; Manitowoc, Wisconsin 54220.

ILLUSTRATED Catalog: Chemistry, mineralogy, biology 35¢. Tracey Laboratories, Evanston, Illinois 60204.

BIG BANG Cannons. Safe, Harmless. Celebrate Fourth. Nine inch \$8.50; Seventeen inch \$14.50; Twenty-five inch \$19.95. Bangsite (Ammunition) 60¢. Catalog 25¢. Bilton PM, River Edge, New Jersey 07661.

LASER PISTOL—\$1.00. How to build PHASER PISTOL—\$1.00. MOON MAN (ROBOT), Build now. Complete plans \$2.00. (add 25¢ postage.) New catalogue—25¢. Roy Davis Laboratories, Dept. PM, 118 West Adams Street, Jacksonville, Florida 32202.

FORMULAS, PLANS, ETC.

ANY FORMULA \$5.00. Catalog—Manufacturing Treatise 10¢. Belfort, 192 N. Clark, Chicago 60601.

MAILORDER Records help get increased business! Complete 32 Page Record Book shows your inquiries orders, advertising, expense, etc. Only \$1.00. C. A. Martin, Popular Mechanics, Dept. PM, 224 West 57 Street, New York, N.Y. 10019.

PLASTICS

CASTOLITE Pours like water, hardens like glass. Without heat. Embed natural flowers, photos, coins. Many other money-making projects. Manual 25¢. CASTOLITE, 70/101 K, Woodstock, Ill. 60098.

VAC-MASTER—a quality low cost machine to vacuum form thermoplastics. Ideal for home shops, labs, schools. Comes ready to operate. Write for illustrated brochure. Loveland Research Corp., 505 E. Eisenhower, Loveland, Colorado 80537.

PLASTIC Embedders, jewelry workers. We have everything. Findings, moulds. New Catalog 25¢. David Co.; 861 Broad St., Dept. M, Providence, R.I. 02907.

CRAFT Kits—Supplies, Casting Resin, Molds, Cookin' Crystals, Dippity-Glas, etc. New enlarged catalog—50¢ (refundable). Specialty Products, Dept. 7, 731 Brooks Road, Muskegon, Michigan 49442.

TREASURE FINDERS

FREE 128 Page detector catalog. General Electronic Detection Co., Box 67, Bellflower, California 90706.

SEARCH Metal Detectors. Ultra sensitive. OPERATES UNDERWATER. Free literature. Search Electronics, Box 8396, St. Petersburg, Florida 33738.

TREASURE LOCATORS MOST COMPLETE LINE. FREE INFORMATION. TESOROS, APARTADO 7-948, MEXICO 7, MEXICO.

FREE TREASURE GUIDE! Fact-filled collectors edition; send 50¢ for postage. Also request free literature on ultrasensitive, professional Fisher Detectors. FISHER RESEARCH, Dept. PM-9, Palo Alto, California 94303.

POWERFUL Metrotech locator detect gold, silver, coins, relics. Moneyback guarantee, terms. Free information. Underground Explorations, Dept. A, Box 793, Menlo Park, California 94025.

ULTRA-SENSITIVE AND POWERFUL METAL DETECTORS—join the many who are finding buried coins, minerals, relics and artifacts. Don't buy till you see our FREE catalog of new models. Write Jatco—Box 132, PM, Huntsville, Texas 77340.

"TREASURE BOOKLET. Excellent information on treasure hunting and metal detectors. Send 25¢. BOOKLET, Dept.—PM-9, Box 243, San Gabriel, California 91778.

FIND Buried treasure with new revolutionary analytical metal detector. Features push button tuning, automatic tuning, loudspeaker, negligible ground pickup greatest range. Free catalog. Gardiner Electronics, Dept. 9, 4729 N. 7th Ave., Phoenix, Ariz. 85013.

TREASURE Hunters! Prospectors! Relco's new instruments detect buried gold, silver, coins, minerals, historical relics. Transistorized. Weighs 3 pound. \$19.95 up. Free catalog. Relco-A40, Box 10839, Houston, Texas 77018.

TREASURE, Gold, silver, relics. New 1970 detectors now available. Free information. Excelsior Electronics Company, 7448 Deering Avenue, Canoga Park, California 91303.

NEW Canadian oil leases, \$1.00 acre. Free information. Northern, Box 70-F, Montreal 206.

NOW AVAILABLE—Superior metal locators from \$19.95. EDI, 1918D, 49th Street East, Palmetto, Florida 33561.

BILLIONS! Sunken and Buried Treasure. Thousands of Exact Locations. Complete list of information. \$2.00. Bran Limited, Box 546, Hampton, N.H. 03842.

GOLDAK Treasure locators—Pleasure and profit in a hobby you'll enjoy. Find coins, relics, gold, silver. Charge on BankAmericard. GOLDAK, Dept. PM 1101-A Air Way, Glendale, California 91201.

PAN FOR GOLD! Just ONE dollar sends complete instructions. Write: PANNING, Box 5483, Arlington, Texas 76011.

POWERFUL New Instruments Detect Gold, Silver, Coins, Treasures. Transistorized. Free Catalog! Dajco, Box 2812Y, Santa Clara, California 95051.

PRECIOUS STONES AND MINERALS

DIAMONDS 10 Small specimens reclaimed industrials \$1.00. Jackson, 1919 Phillips Mill Road, Forest Hill, Maryland 21050.

GET Free catalog no serious rockhound, gem cutter, jewelry maker, hobbyist or craftsman can be without. Full of bargains, exclusive items, low prices from largest suppliers and authorities in the field. Free new catalog just off the press, yours for the asking. Write Grieger's, Dept. C-12, 1633 E. Walnut, Pasadena, California 91106.

500 BEAUTIFUL POLISHED GEMSTONES \$1.50. Floodstones, P.O. 1673, Fremont, California 94538.

500 POLISHED Gemstones \$5.00. Tumblecraft, 5401 James North, Minneapolis, Minn. 55430.

EARTH Science Rockhound Magazine. Subscription \$3.00. Sample \$.40. Box-550-PM, Downers Grove, Ill. 60515.

SILVER, Dendritic crystals, several in plastic box for \$1.00. Free lists. Prospectors Shop, 201 San Francisco, Santa Fe, New Mexico 87501.

CARTOONING, COMMERCIAL ARTS, SHOWCARD & SIGN PAINTING

MODERN Cartooning taught by mail. Write for free brochure. Cartoonorama—Box N, 263 Branford, Conn. 06405.

COMPACT 23 lesson Cartoon Course and Cartoonist's Magazine, \$2.00. Hartman, Box 30367, Lincoln, Nebraska 68510.

LEARN sign painting at home. Free talent test. Ben Kerns, Box 812-PM, Greenville, S.C. 29601.

SIGN Painting Matthews' big new 18 lesson course \$5.00 postpaid. Circulars free. Sign Book Co., 470 Oak Street, St. Louis, Mo. 63119.

"HOW TO MAKE MONEY WITH SIMPLE CARTOONS"—Everyone who likes to draw should have this book: FREE. Write Cartoonists' Exchange, 99 Pleasant Hill, Ohio 45359.

MAKE MONEY IN ART. Free brochure outlines 15 ways. Write American Studios, Dept. P6, Spring Park, Minn. 55384.

HAVE FUN, Earn cash, Drawing Cartoons. 128 page manual shows how. \$2 Guaranteed Satisfaction. Hart Company, 3242-K Hennepin, Minneapolis, Minn. 55408.

PAINT Money-making Signs! Easy with Illustrated Booklet, \$2.95. Distinctive Letter Patterns, Catalog Free! PauLow, 1935 Stardust, Waukesha, Wis. 53186.

\$200.00 MONTHLY Sparetime possible making signs, posters, silkscreen printing. Learn quickly—easy instructions. Information free! Hampton 105PM, Box 112, New York, N.Y. 10012.

SIGN Painting—Latest Free Catalogue explains everything. write: Kaufmann Supply, Centertown, Missouri 65023.

ADVERTISING AGENCIES, ADV. SERVICE, MAILING LISTS

85,000 NAME Mailing list. Proven. Accurate. Many Classifications. 10¢ per Name. 100 Name minimum. Send payment with order. E. Price, 63 South Leyden Street, Brockton, Mass. 02402.

ADVERTISING Ratebook leading newspapers, magazines, 25¢. Chicago Advertising Agency, 28-E Jackson, Chicago 60604.

MAILING Lists most all kinds 1000 \$5.00. Free folder Your circulars mailed \$4.00 1000. Dixie Mailers, King, N.C. 27021.

(Continued on next page)

TYPEWRITERS, DUPLICATORS, OFFICE EQUIPMENT

FREE Plan. Start printing, lettershop. Offset Presses. Mimeograph Copy machines. DixieGraph. King. N. Car. 27021.

MYLAR Copy film, outdates carbon paper. 20, 8 1/2 x 11 1/2 sheets. \$3.95. Cornucopia, 1009 Dorsey, Melbourne, Florida 32901.

RUBBER STAMPS AND OFFICE SUPPLIES

ADDRESS Stamp with Handle. Four lines \$1.25. House Tom Henry, Bensenville, Illinois 60106.

FREE 40 Page catalog. Rubber stamps, office supplies. Youngers Stamp Shop, Princeton, Iowa 52768.

ADDRESS Stamp 85¢. Signature \$2.80. Catalog, Carol's, McLoud, Okla. 74851.

FREE Rubber Stamp Catalog. Beckley's, 430 South Avery, Syracuse 7, New York 13219.

4LL-2" STAMP \$3.00, Catalog 25¢. Craig, Box 511, Mt. Vernon, Illinois 62864.

QUALITY Rubber address stamps \$1.50. Denton's, Box 3594, Albuquerque, New Mexico 87110.

RUBBER Stamps. Any Copy. 4 Lines \$1.00. Phillips, Box 164A, Staten Island, New York 10314.

PRINTING PRESSES, RUBBER STAMP OUTFITS

RUBBER Stamp manufacturers supplies. Presses, starting outfits. Best prices, service. Catalog, Jackson Supply, Box 443A, Franklin Park, Illinois 60131.

PRINTING Presses, type, supplies. Lists. 5¢. Turnbaugh Service, Mechanicsburg, Pennsylvania 17055.

TYPE Catalog No. 12, 120 pages. Send One Dollar. Deductible First Order. Acme Type. 732 Federal, Chicago, Illinois 60605.

SAME Day shipment on rubber stamp supplies. Revised wholesale price list No. 7 free. Star Stamp Supply, 732 Federal, Chicago, Ill. 60605.

RUBBER Stamp outfits, supplies. Kiewiet, 2025 Barney Road, Kalamazoo, Michigan 49007.

PRINTING AND SUPPLIES

50 COPIES \$1.95, 100 COPIES \$2.95. Send camera-ready original with money order. City Printing, 521 S. 3rd St., Louisville, Kentucky 40202.

OFFSET Printing. Free catalog. Speedy Print, 1906 Swede, Norristown, Pa. 19401.

AMAZING business printing values. Quotations Print Shop, Box 576, Greenville, R.I. 02828.

FREE Literature. Address Labels, Business Cards, Printing, Rubber Stamps: Jordan's, 552 West O'Connor, Lima, Ohio 45801.

PRINTING—8 Hour service. Any quantity. Lowest prices. Allstate Press, 120-PM South LaSalle, Chicago 60603.

1,000 EMBOSSED Business Cards \$5.25 Postpaid, Robert Gersh, Box 105, Allston, Massachusetts 02134.

FREE Illustrated Circular about Personalized Printing. Longwood 4790, Fort Johnson, New York 12070.

BUSINESS Cards, 1000—\$3.33, 5000—\$13.33. Superior, Avon Lake, Ohio 44012.

FREE—100 personal cards with 100 5 1/2 x 7 letterheads, envelopes. 3 lines each. \$4.75. Buddy's, 711 So. Hampton, Dallas, Texas 75233.

WHOLESALE Sources directory \$2.00 ppd. O & M Sales, Box 980, Pablo, Montana 59855.

PRINTING—Offset; Letter-press; All type Business forms, Details-Kapco, 3515 West Market, Louisville, Ky. 40212.

PRINTING, Free Literature, 1000 Address Labels \$1.00. Crowther's, 291-PH North Oak, Orange, California 92667.

8 HOUR PRINTING—Free Booklet "Secrets of Cutting Printing Cost." Nationwide Printing, Atlanta, Ill. 61723.

MULTIGRAPH, MIMEOGRAPH

MAILORDER Records help get increased business! Complete 32 Page Record Book shows your inquiries orders, advertising expense, etc. Only \$1.00. C. A. Martin, Popular Mechanics, Dept. PM, 224 West 57 Street, New York, N.Y. 10019.

GUMMED LABELS

1000 GUMMED Address Labels \$1.00. Walt's, Box 966A, South Bend, Indiana 46624.

1000 PERSONALIZED Address labels 50¢. 3 sets \$1.25. Fabrico-PI-1, 1, 1512 N.E. 29th Street, Ocala, Florida 32670.

1,000 DELUXE Gummed address labels. Cleveland, 3108 Ross, Dallas, Texas 75204.

1,000 DISTINCTIVE GOLD STRIPE Address Labels. GUARANTEED. \$1.00. Brink Products, Box 850 PM9, Humble, Texas 77338.

1000 ADDRESS Labels, Deluxe! \$1.00. Gamor's, Box 264-AB, Lexington, Massachusetts 02173.

FREE!! 1,000 Address Labels With National Zip-Code Directory, \$1.00!! Silpe, 10 Washington, Livingston, New Jersey 07039.

REMAILING SERVICE

MICHIGAN Remails 1/25¢. Additional services. Motor City, Drawer 890, Dearborn, Michigan 48121.

PHOENIX, Remailing, Forwarding, Confidential Valley of the Sun address. Troen, Box 2386, Phoenix, Ariz. 85002.

MIAMI Remails 25¢. Monthly rates. Marie, Box 1266, Coral Gables, Fla. 33134.

CONFIDENTIAL New York City mail address \$3.00 month. Remails 25¢, Details Free. Birnhan, 152 W. 42, New York City 10036.

SECRET, Receiving-forwarding. Discreet and confidential. Remail 25¢ single. Mail Forwarding Service, 8050 S. Main, Houston, Texas 77025.

RECEIVING—Forwarding. Monthly Rates. Hedgpath, 406-M, South Second, Alhambra, Calif. 91802.

PRIVATE, Receiving—Forwarding, remails 25¢. Wellington, 3227 Kearny Villa, San Diego, California 92123.

NIAGARA FALLS—BUFFALO, NEW YORK—Remails 25¢. MULTI-Colored Cards Niagara Falls—7—\$1.00. Receiving—Forwarding—Special Services—Inquiries Invited. S. S. Sprague, 260 Prospect Avenue, Buffalo, New York 14201.

TIMELY Remailing 25¢. Monthly \$4.00. Confidential, Schoen, Box 1963-P, Chicago, Illinois 60690.

MICHIGAN Remails 25¢, \$3.00 monthly. Confidential, Details free. Box 4361, Flint, Michigan 48504. . .

CHESTER Remail 30¢ Each. P.O. Box 7, Chester, Calif. 96020.

CONFIDENTIAL Remails 25¢, \$3.00 Monthly, Sidler, 2813B West 83rd, Chicago, Ill. 60652.

SECRET Address, \$4.00 Monthly, Wright House, Box 2112, Asheville, N.C. 28802.

WASHINGTON D. C. Remails 25¢. Monthly \$3.00, Postcards 7/\$1.00. Data Enterprises, Box 1105, Springfield, Va. 22151.

HONOLULU Remails 50¢ Re-Mac, Box 715, Wahiawa, Hawaii 96786.

TUCSON Remails 25¢. Confidential. \$3.00 Monthly, Henson, Box 6325, Tucson, Arizona 85716.

ALASKA Remails 25¢. Answering and forwarding. Scenic postcards. M. Carlson, Box 552, Kodiak, Alaska 99615.

MIAMI BEACH Remails 25¢. Monthly Rates. Special Services, Reeves, Box 67, Miami Beach, Fla. 33139.

SCOTLAND Remails, 25¢ each. Lara, Box 142, Scotland, Indiana 47457.

N.Y.C.—GREENWICH, Conn. Remails 25¢. Special services available. Town & Country, 953 King Street, Greenwich, Conn. 06830.

MONTREAL Remails; Monthly Rates—Seville, Box 1121, Montreal 379, Canada.

JAY'S Remails 25¢. Receiving—Forwarding. Monthly Rates. Box 28574, Atlanta, Ga. 30328.

SECRET Dependable Compton Remails 25¢ letter, Box 4772, Compton, Calif. 90224.

REPAIRS AND SERVICING

PROFITS FROM CLASSIFIED ADVERTISING! Booklet shows you how to start your own business with Classified Advertising. Only \$1.00 (Refundable with first order.) C. A. Martin, Popular Mechanics, Dept. PM, 224 West 57 Street, New York, N.Y. 10019.

SPECIAL SERVICES

HELP Yourself to a Better Sight. Some Vision Can be Improved Without Corrective Eyeglasses. Detail Free. Universal Products, 507—B Fifth Ave. N.Y. 10017.

AUSTRALIAN OPPORTUNITIES NEWSLETTER. Box 6428, Torrance, Calif. 90504. (June/July '70 on extensive opportunities tour Down Under—preparing comprehensive report.) Interim copy free.

INFORMATION On anything. Ferguson Research Specialists, 83-45 Vietor Ave., Elmhurst, N.Y. 11373.

LOCATING Service! Any item, product, Jake Barraco, 478 Gardner, South Beloit, Illinois 61080.

WE WILL Sign Mail . . . ThankYou Notes, —Any Occasion! Christmas Cards, Business, Personal, Doctors Patient Reminders, Business Brochures, Birthday Club. 10 Cards Mailed Yearly: \$1.75!! Free Details—Geiers, Box 3069, Poughkeepsie, New York 12603.

TOBACCO

LARGE Samples SweetChew, Smoking 10¢ Each. Jolly Farms, Dresden, Tenn. 38225.

PERSONAL

SLEEP Without Pills. Simple Exercises. Free Details. Universal Products, 507—A Fifth Ave., New York 10017.

"LONELY? 200 Names, Addresses, Descriptions, either sex. \$1.00. Free Membership. Mention Popular Mechanics, receive 50 extra names. California Club, Box 314, Long Beach, California 90801."

BORROW up to \$1500 by mail on convenient terms! State licensed. Postal Finance, Dept. 17-N, 200 Keeline Building, Omaha, Nebraska 68102.

BORROW Up To \$1,600 By Mail. Money on your signature for any purpose. Write: Budget Finance Company, Dept. MB0145, 228 City National Bank Bldg., Omaha, Nebraska 68102.

YOU May be eligible. Get details of U.S. Government Benefits. Details free. The House of Grayson, 9129-C, South Merrill Ave., Chicago, Ill. 60617.

STOP Smoking New Book presents Medical and Psychological Methods. Free Circular. Universal Products, 507—C Fifth Ave., N.Y. 10017.

SECRET Law Wipes Out All Debts. Immediate relief. Clear credit. Free details. Counselor-7, Kerrville, Texas 78028.

STAND Up to your creditors. Important facts you should know. Send \$1.00 to REBOUND, Box 66252, Portland, Oregon 97266.

SECRET LOANS BY MAIL. Borrow \$100 to \$1500 for any good reason in absolute privacy. No interviews, no endorsers, no co-signers. Fast service. Write Dial Finance Co., Dept. J-214, 410 Kilpatrick Bldg., Omaha, Nebraska 68102.

(Continued on next page)

PERSONAL*(Continued from preceding page)*

BIBLE Questions answered. Stamped envelope. Bylon, 17167 Bentler, Detroit, Michigan 48219.

DRIVERS License. Birth, Marriage Divorce, High School, College, University Certificates. 2 for \$1.00, any 5 \$2.00. Cohick's Forms, Box 80, Dewart, Penna. 17730.

INVESTIGATORS. Latest electronic Aids. Free Literature. Clifton, 11500-P NW 7th Ave., Miami, Florida 33168.

RUPTURED. Relief and comfort. No understraps, elastic or steel. Write Hand-Lock Products. Preston 4, Ont., Canada.

MAKE NEW FRIENDS Worldwide. Meet Marriage minded Girls through our illustrated Catalog. 1200 Ladies' Fotos and Descriptions \$2.00. I. C. B., Box 12, Sta. O Toronto, 375, Ont. Canada.

MAKE YOUR WILL. Get 4 Will Forms and attorney's informative book. \$1.00. Legal Forms Company, Department 124, 1830 Guardian Building, Detroit, Michigan 48226.

ARE YOU REALLY SINCERE about wanting to find a marriage partner? **SOCIAL INTRODUCTION SERVICE**, P.O. Box 1547, Eugene, Oregon 97401.

ELECTRONIC LISTENING DEVICES. Miniature transmitters, microphones, telephone devices, recorders, wall amplifiers, bug locators, etc. \$24.00-Up. Complete catalog. PCP Electronics 27597-P9 Bahama, Hayward, Calif. 94545.

SIMPLE pleasant way to Health and Vitality. Details free. **THORNGREN'S**, 4515-D 23rd Avenue, Moline, Illinois 61265.

TOO Many Debts? Want to lower your payment and pay off the bills? Write Continental, Dept. PM, Box 2116, East Chicago, Indiana 45312.

ANSWERED GOD'S CALL. Become an Ordained Minister of the Gospel for Christ. We Ordained Worthy Christians. Calvary Grace Christian Church, Post Office Box 1674, Fort Lauderdale, Florida 33302.

ARE YOU AFRAID TO DIE? Send \$1.00 for book "The Will of God" for self or perplexed friend. LeRoi Publishers, Box 1165, Jefferson City, Missouri 65101.

CONFIDENCE. Power with people pays dividends. 164 page book tells how to get them saying yes. Send \$2.00. A.T. McClure Co., 4020-A Hazelcrest, Springfield, Ill. 62703.

"**SUCCESS—Your motto for the seventies.** Free details Conscience. 244-P, Lincroft, N.J. 07738."

RETIRE in 3 months with income. Information \$10.00. Fortune, P.O. Box 366-P, Redwood Valley, Calif. 95470.

GET OUT OF DEBT in 90 minutes, legally without borrowing or bankruptcy, facts so explosive, credit syndicate tried suppressing, free details. Anderson, 5818-E Hamilton, Cincinnati, Ohio 45224.

SUCCESS, Popularity and Prestige can now be yours! A formula that will guarantee success in any endeavor and double your income. Amazing book only \$2.00. Folder free. Shoppers' Selections Co. Dept. 719A, 6038 Annunciation, New Orleans, La. 70118.

FREE Circular describes 73 exciting low-cost self-improvement books. Triple Bar C Enterprises, Route 1, Box 390-B, Broken Arrow, Oklahoma 74012.

WORLD Elections! Now!! Write: **WORLD ELECTIONS**, P.O. Box 8769, Honolulu 96815.

SERVE Christ. Become an Ordained Minister. Write Holy Light, Dept. D, Box 4478, Pittsburgh, Pennsylvania, 15205.

BEAUTIFUL Girls. Free Information "International Introductions." Apartado 950, Guadalajara, Mexico.

IMPROVE YOUR PERSONALITY! 110 Page book—"Dynamic Thinking" shows how. Send \$1.00. Thomas A. Ward, 101 Ranchette Estates, Keller, Texas 76248.

HOW TO STOP SMOKING. through self-hypnosis. Safe and medically approved book. \$2.00, Satisfaction Guaranteed. Christophers, Dept. 3, 51 Beechwood Ave., Port Washington, N.Y. 11050.

STOP Smoking! New book presents Medical and Psychological step-by-step method. Money back guarantee. Send \$2.00. Gene Louis, Dupuyer, Montana 59432.

FIND Success, Wealth and Happiness. No Gimmicks. Send for free list of books. Quality House, Dept. PM-02, 5222-3 Vera Lane, San Jose, California 95111.

HYPNOSIS And E.S.P. Home Study. Specify Tape, Record, Cassette. \$4.95. Mental Dynamics, 2842 Whaleneck Drive, Merrick, N.Y. 11566.

SUBCONSCIOUS Conditioning remakes personality while you sleep. Free details. Sleep-Learning, Box 24N, Olympia, Washington 98511.

WANTED—MISCELLANEOUS

WE Buy Bottles, Coins, Antiques, Books, fruit jars, magazines (anything). Send \$1.00 (refundable) for Huge Buying Lists. Schroeder's, R-4, Paducah, Ky. 42001.

MERCURY. Gold, Silver, Platinum; Ores assayed. Wholesale Terminal, Norwood, Mass. 02062.

MISCELLANEOUS

WINEMAKERS. . . . New Illustrated Supply Catalog of Yeasts, Equipment, etc. Free. Winemaker Box 11071-P1, Indianapolis, Ind. 46201.

THE COIN TOSS HAS SETTLED MANY THINGS Learn how to control the toss of a coin and predict the outcome. A skill easily learned. Send \$5.00 for postpaid illustrated book and instructions to—H&W Publishing & Distributing Company, P. O. Drawer 988, Raymondville, Texas 78580.

150 COPIES Possible with single sheet of new carbon paper creates SAVINGS for anyone with typewriter. Single package, 20 sheets, \$4.50 send: DMS Enterprises, 301 Main Dunstable Road, Nashua, N.H. 03060.

PSYCHEDELIC Catalog of Posters, Lighting, Jewelry, Etc. Send 50¢. Hole, 6055 Lankershim, N. Hollywood, Calif. 91606.

WINEMAKERS Yeast, Recipes & Catalog 25¢. Kraus, Box 451-L, Nevada, Missouri 64772.

WANT Greatest Cash Crop working for you? Write Ginseng, Asheville 53, N.C.

YOUR Name sent to 1000 importers, publishers, mailers, wholesalers, etc. on our mailing list. Year \$1.00. Dixie Mailers, King, N. Car. 27021.

CIGARETTES 12¢ a pack. Improved roller makes 20 filtertip, plain, king or regular for 12¢. Facts Free. Moberly, Box 954, Owensboro, Kentucky 42301.

BIRTH Certificates, Marriage Certificates, Diplomas! 2 blank forms \$1.00. Sample 10¢. Standard Forms, Box 482-M, Washington, D.C. 20044.

WINEMAKING . . . Grape, Elderberry, Dandelion, Frozen Juices, etc. Brewmasters' secrets revealed! Powerful Methods! Instructions, Recipes, and Supplies Catalog, \$1.00. Continental, Box 11071 P1, Indianapolis, Indiana 46201.

ORNAMENTAL Iron designs. Book of 1600 beautiful, practical designs for railings, columns, etc. Free literature. Cunningham, 3881 South 3200 West, Salt Lake City, Utah 84119.

WINEMAKERS. Free illustrated catalog of yeasts, equipment. Semplex, Box 12276, Minneapolis, Minn. 55412.

WINEMAKING Kit—\$4.98 Free Catalog and recipes. JIMDANDY, Box 30230M, Cincinnati, Ohio 45230.

MUSICAL Beer Steins ¼, ½, 1 Ltr. sizes \$16.80, \$19.95, \$24.95. Canadian Global Co., 256 James Street, Hawkesbury, Ontario, Canada.

IDENTIFICATION CARDS—Send stamped self-addressed envelope for free samples & details to: E.C.S.M., P.O. Box 12117, Las Vegas, Nevada 89112.

"**FREE!** Exciting new illustrated catalog of unusual gifts & novelties. Free! Coffco. Dept. P-100, Box 522, Lake Zurich, Illinois 60047"

STOP Smoking and watch your weight. Booklets tell how? \$1.00 each. Staron House, PM1, 17 Roy Street, Fairhaven, Mass. 02719.

PSYCHEDELICS . . . From around the home \$1.00. Faber's, 7715 Southwest 69th, Portland, Oregon 97223.

FREE—Instructions—Make Money. Clayton's—1415 Jefferson Hgts., Pittsburgh, Pennsylvania 15235.

INEXPENSIVE Home Proved Winemaking Techniques Revealed \$2.00. Restless II, Box 506, Merritt Island, Florida 32952.

SPACEMAN From another planet. Send \$3.00 for actual photograph. 14102 13th Avenue East, Tacoma, Washington 98445.

HOME Winemaking Supply Guide Catalog—Free. Bacchanalia, 321-Y-7 Saugatuck Station, Westport, Conn. 06880.

DRIVER'S License, Birth Certificate, H.S. & College Diplomas, Marriage & Divorce Certificates—Blank Forms. Fill them in yourself. Highest quality you can buy! Confidential 3 day service! \$2.00 each; any four—\$5.00, postpaid. Formco, Box 834-DA, Warren, Mich. 48090.

WARNS BEFORE FIRE BEGINS! FIRE ALARM for home, boat, factory, etc. No wiring or batteries needed. \$9.95; 3 for \$23.95. No COD's. Gift wrapped. EsKay Industries, Inc., Dept. 2, 2138 Biscayne Blvd., Miami, Fla. 33137.

NEW! "Picture Book Of Pine Cone Projects". \$1.00. Wildcrafters, B-7-M, Looneyville, W.Va. 25259.

YOUR STATE'S LAWS of Divorce, Annulment, Separation: Comprehensive Digests of Rights, Obligations, Procedures. \$2.00. Cosent, Box 142, St. Augustine, Fla. 32084.

AUTHORITATIVE Winemaking Booklet—Winemakers Yeast—Supplies Catalogue—50¢. Werth Wine, Box 1902-B, Cedar Rapids, Iowa 52406.

HEARING Aid batteries wholesale. Free list. Habs, Box 51, York, Penna. 17405.

SWISS Army type Knife. 12 Amazing Tools! Stainless steel. \$3.98. JJ&S-PM, Box 8632, St. Louis, Mo. 63126.

REVOLUTIONARY New Idea in insect killing, guaranteed or double your money back. Enclose \$1.25 postage paid. Ko-Lac Products, 5485 Clydesdale, Las Vegas, Nevada 89109.

RACING Fans—Amazing profits from simplified handicapping methods. Howard, 575 Church St., Raynham, Mass. 02767.

MAGNETS. All types. Specials—20 disc magnets, or 2 stick magnets, or 10 small bar magnets, or 8 assorted magnets, \$1.00. Maryland Magnet Company, 5412-A Gist, Baltimore, Maryland 21215.

KEY-BEAM SELF-REGENERATING. The Key Chain With 12,000 Lights! Unconditionally Guaranteed. No More Fumbling In The Dark Looking For House Or Car Key Holes! This Tiny Miracle Of Light Fits Instantly Over Any Key. Developed For Computers. It's Powered By A Self-Charging Silver Cell. No Bulbs Or Batteries To Buy—Ever! Wired With Platinum It's Virtually Indestructible! A Fabulous Gift With A Life Time Guarantee. Only \$3.95 Postpaid. Free Catalogue. Mail Request To: Bill "Chappy" Williams & Company, Dept. 102-1404 Custer Road, Junction City, Kansas 66441.

BOOKS On antiques and their prices. Free circular! P. Warman Publishers, Uniontown, Penna. 15401.

You get more for your money from NRI

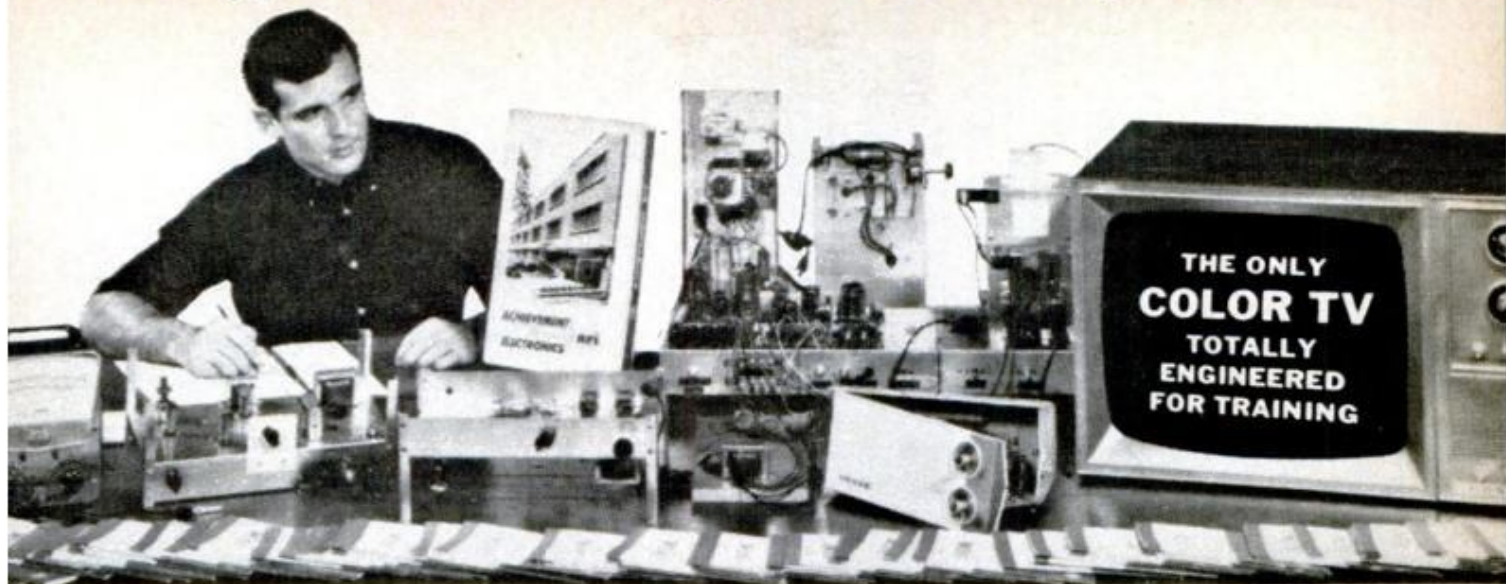

BUILD • TEST • EXPLORE All this is yours — from Achievement Kit, to solid state Radio, to training-engineered Color TV set—when you enroll for NRI's TV-Radio Servicing course. Other courses equally complete. Unique training methods, "bite-size" texts, many personal services have made NRI the leader in its field for over 50 years.

NRI Programmed Equipment Gives You Priceless Confidence, Makes Learning TV-Radio, Electronics Fast and Fascinating

NRI pioneered the idea of supplying home-study students with custom designed training kits to give practical on-the-job experience as you learn. Today, NRI's "3-Dimensional" training can't be equalled. You get more value— from the exclusive Achievement Kit sent the day you enroll, to "bite-size" texts and custom training equipment. Learning TV-Radio, Electronics or Communications at home is easy, exciting, the NRI simplified, dramatized way.

BE A SKILLED TECHNICIAN IN AMERICA'S FASTEST GROWING INDUSTRY

Regardless of your educational background, you can learn the Electronics field of your choice the practical NRI way. The NRI color catalog, sent to you free and without obligation, tells you how you can qualify quickly to be a part of the fast growing Electronic Age; about engineering jobs in business, industry, broadcasting, government, now offered to men without college degrees. It will open your eyes to the great number of success opportunities available right now in the high-pay world of TV-Radio Servicing, Broadcasting-Communications and Industrial-Military Electronics. With NRI technical training, you can take your choice of a wide variety of career

openings or have a business of your own. And if you choose one of five NRI courses that include FCC License preparation, you must earn your FCC License or NRI refunds your tuition!

MAKE \$5 TO \$7 AN HOUR EXTRA IN SPARE TIME STARTING SOON

Tens of thousands of NRI graduates are proof it is practical to train at home in your spare time. Keep your present job while preparing for a better one, and earn \$5 to \$7 an hour extra in spare time while you train, fixing sets for friends and neighbors. NRI shows you how. Equipment you build and keep becomes useful in your work.

STEP UP TO BETTER PAY, A BRIGHTER FUTURE

NRI can help you, but the decision to act must come from you. Decide now to move ahead . . . mail the postage-free card today for your FREE NRI color catalog. No obligation. No salesman will call. NATIONAL RADIO INSTITUTE, Electronics Division, Washington, D.C. 20016.

APPROVED UNDER GI BILL

If you served since January 31, 1955, or are in service, check GI line on postage-free card or in coupon.

CASH IN ON THE BOOM IN COLOR TELEVISION



The NRI TV-Radio Servicing course includes your choice of black and white or color TV training equipment. Color TV needs thousands of trained men to keep pace with millions of sets being sold every year. NRI prepares you quickly. Cash in on the boom.

Mail insert card for your **FREE NRI color CATALOG**

No salesman will call

JOB AND BUSINESS OPPORTUNITIES IN ELECTRONICS COMMUNICATIONS RADIO-TELEVISION

SOLUTIONS FOR MECHANICAL HEADACHES

AUTOMOBILE CLINIC

BY MORT SCHULTZ

Longevity

Thanks to good maintenance, my 1963 Buick Electra is still going strong at 90,000 miles. However, a problem has cropped up. Even with a tune-up, the engine cuts out at 60-70 mph. I've discovered that the distributor points slip and close. What's the hang-up?—Gus Daskalakis, Santa Ana, Calif.

Worn cam lobes, a worn shaft bushing or both. Give in, Gus. Get a new distributor, and your car could go another 90,000.

Cool it

My 1967 Dodge 318-cu.-in. V8 with 2-barrel WW-3 Stromberg carburetor has a percolation problem you wouldn't believe. It starts without trouble when cold, but restarting when the engine is hot is very hard. Two rebuilt carburetors and one new one haven't improved the situation. The heat riser is okay, and apparently so is everything else. A fuel-line pressure regulator has even failed, and my mechanic has thrown in the sponge. Can you help?—Daniel J. Baird, Philadelphia.

Raise the carburetor off that hot intake manifold and I think your trouble will be over. Start by using two carburetor base gaskets; that is, double the thickness. If that doesn't work, add a third.

Which wrench?

I have a 1969 Chevelle Malibu V8, 307-cu.-in. How do I loosen the distributor so I can time the ignition? My conventional socket and wrench set won't fit.—John A. Sego, Hickory, N.C.

You'll have to use a flex socket, an offset wrench or a box wrench that has a short handle.

Cagey gauge

Over the years you've answered questions about troublesome fuel gauges. I was about to buy a new gauge for my 1964 Plymouth Fury when I decided to make one more check. I jacked up the rear of the car and found that the gas-tank unit and the main line to the fuel pump were connected by a piece of rubber hose that

broke the ground and made it necessary to use a spring-steel grounding clip that was attached to the fuel line on each side of the rubber. This clip was badly rusted, so I cleaned it and also cleaned the area of the fuel line to which it connected. My fuel gauge trouble disappeared with the rust.—John Tek, Cleveland.

Good show.

Tanked

My 1968 Torino GT with 390-cu.-in. engine and Holley 4-bbl. carburetor won't keep its idle. The car starts to run like a tank a week after a tune-up. Should I have the carburetor rebuilt?—Sgt. Fred Dominey, Okinawa.

No. If the carburetor was causing the trouble, the car would "run like a tank" all the time. Something is affecting the idle jets of the carburetor—probably dirt or water which is being put there by the fuel. I'd have everything from the fuel tank to the carburetor cleaned out, especially the fuel tank.

Sprung valve springs

I have a 1969 Pontiac GTO with ram air, 4-bbl. carb, a close-ratio 4-speed and heavy duty limited-slip rear end with 3.90 gear ratio. At 10,000 miles two valve springs broke and a push rod bent. About 800 miles later, I found two more broken valve springs. What gives?—John P. Dealy, Burrton, Kans.

Probably the whole engine if you're not more careful. I don't know of any reason why valve springs on this high-torque engine should break, with one exception—overpeaking. If you like to surpass the red line on the car's tach, I suggest you install a high-performance kit that contains a set of specially hardened racing springs. You can buy such a kit at a speed shop.

Temper, temper, temper

You were wrong, wrong, wrong in indicating that front windshields are of tempered glass in the piece, Creeping crack (Auto Clinic, page 82, March PM). Wind-
(Please turn to page 78)

Correct your engine's idle ways.



At idle, your engine does a lazy job of burning the gasoline. So there's a build-up of abrasive soots and unburnt resins that might cause engine trouble.

Quaker State Motor Oil has a special ability to protect against these trouble-makers. Because it's refined only from 100% Pure Pennsylvania Grade Crude Oil, the finest natural lubricant in the world. It's specially blended and fortified to neutralize acids, prevent rust, and keep abrasive deposits in harmless suspension.

Correct your engine's idle ways. Ask for Quaker State wherever they care about cars. It's America's most preferred motor oil.

Quaker State your car to keep it running young.



the Great Ones at DAYTONA!



The perfect combination... the Petty Crew, driver Pete Hamilton and S-K Tools hit the jackpot at Daytona

The race is a grueling test of skills, but getting that car in perfect shape is an even greater test of talent. Days and nights before a big race like Daytona, Maurice Petty and his great crew are tooling this baby to perfection. It's a great sight to watch. Every part is checked with a knowing eye and sensitive ear. Just as an artist

expresses talent through a brush, a mechanic expresses his through tools . . . like the famous S-K ratchet . . . the one that has a racing mechanic's feel, lets you get into tight places . . . the one that's dependable. The ratchet you'll enjoy using on those mechanical fix-up jobs. Now is the time to buy your S-K tools!



Mechanics: Be proud of your profession. Display this colorful 5" x 7" decal. Enclose 25¢ for handling and mailing with your request. We'll also send you an illustrated catalog free.

S-K[®] TOOLS

**HAND TOOL DIVISION,
DRESSER INDUSTRIES, INC.
Chicago, Illinois 60604**



FAMOUS RATCHET & SOCKET SET

No. 4520XL (20 pcs.,
3/8" drive)

SAVE \$10.78

Total user price, if
purchased separately:
\$30.76

\$19.98

Suggested
User Price

Save \$10.78 on this popular all-purpose socket set. Wide range of sizes for almost every maintenance job. Consists of famous S-K reversible ratchet, 9 standard sockets, 8 deep sockets, 2 extensions; all 3/8" drive. Fully warranted.



...the Great Ones at HOME!

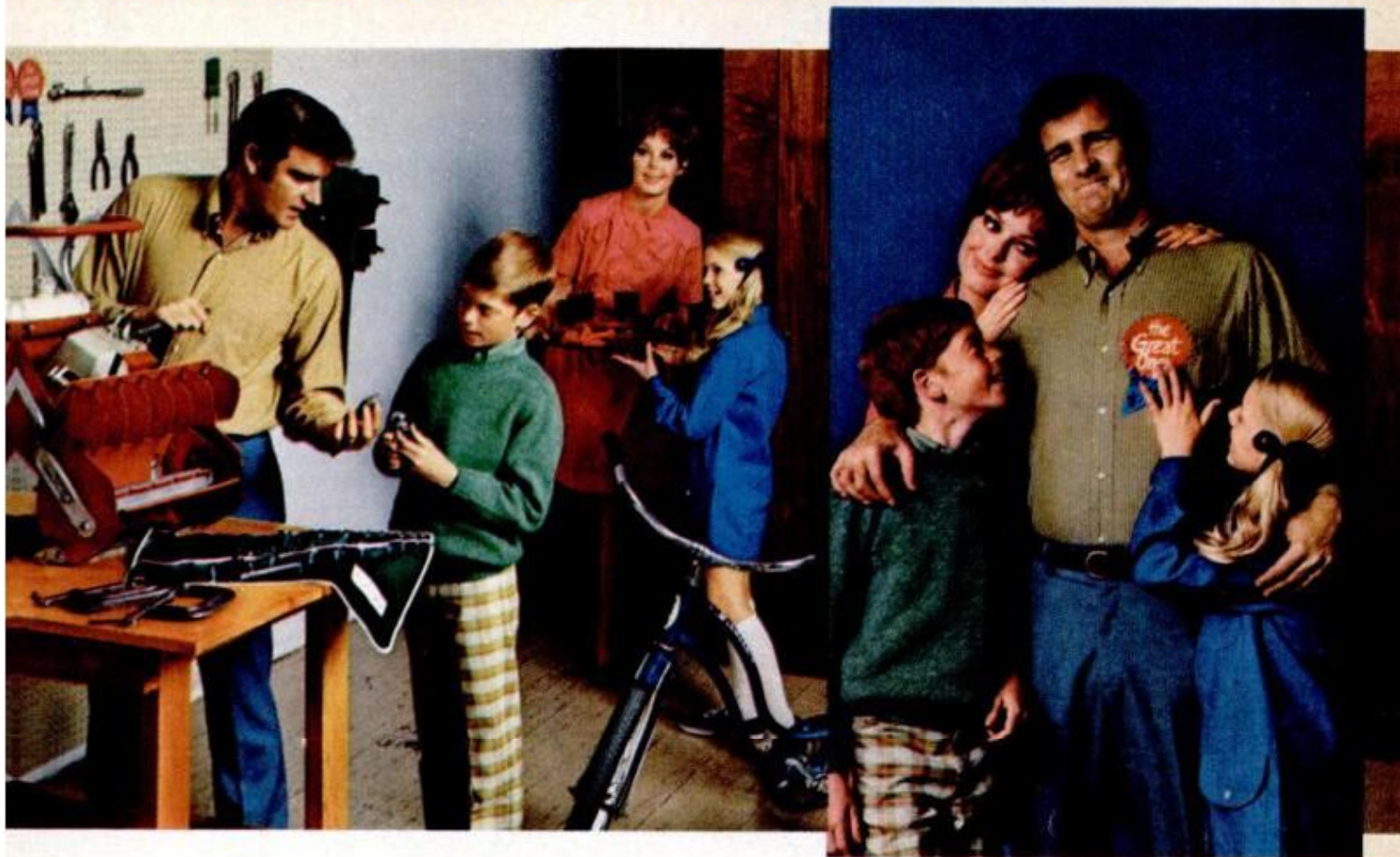

This Money-Saving Special... A famous S-K ratchet set can help you hit the jackpot at home!



41-PC. MIXED TOOL SET SAVE \$12.00
 No. 7041 (1/4" and 1/2" drive)
\$29⁹⁸
 Suggested User Price

Total user price, if purchased separately: \$41.98

Save \$12.00 on this versatile mixed tool set. Contains a full range of socket sizes and the famous S-K 1/2" drive ratchet. Plus a selection of hex key wrenches, screwdrivers and tongue 'n groove plier to handle all types of jobs around the home, auto or farm. Fully warranted. In steel hip roof box.



National Retail Hardware Association - approved! Shop for tools where you see this sign. It means S-K Fall Specials are top value buys!

COMBINATION WRENCH SET WITH FREE MAGNA SCREWDRIVER

No. 7013 (12-pc. set) SAVE \$8.87
 Total user price, if purchased separately: \$28.85
\$19⁹⁸
 Suggested User Price

Free 4-in-one Magna screwdriver (magnetic tips) with set of 12 alloy combination wrenches. Wrench size range from 1/4" to 1 5/16". Save \$8.87 on this ideal tool roll for home, auto, truck or farm use. Fully warranted.



AUTOMOBILE CLINIC

(Continued from page 74)

shields are laminated. Other glass in a car is tempered.—Harold A. Perilstein, Perilstein glass Co., Philadelphia.

I know, know, know. But the other thing I said is right. Once the windshield is damaged, the crack will spread and the windshield will eventually have to be replaced.

Fickle fan

I own a 1969 144 Volvo with B20B engine. On three different occasions, the slip-coupling fan has loosened and has damaged the radiator. The dealer hasn't been able to solve the problem.—John Masoncup, Gallup, N.M.

Perhaps the lock washer is bad or missing, and your dealer hasn't thought of it. But if he has, it is possible that high temperature is causing the metal fan to contract and vibration is doing the rest. A new fan has been issued which overcomes this problem. Its part number is 140-683541. Hardware needed to attach it consists of a spacer (part No. 140-686104) and four screws (part No. 140-940161).

Hog-tied

The heat-control valve in my 1966 Ford pickup developed an annoying rattle, so my mechanic tied it in the open position. Although this has stopped the noise, it's given me some starting troubles on cold mornings. Is there any way to lick the problem all around?—Ben J. Wekenborg, Argyle, Mo.

Install a new heat-control valve. The spring used in this one has lost tension. I wouldn't ride with it wired open for too long, because it will cause hesitation and bad performance.

A shocker

What can I do to keep from getting a shock every time I get out of my 1970 Chevelle SS?—R.J. Welsh, Essex, Md.

You could try placing a ground strap beneath the car, or you could try spraying antistatic electricity compound on the

vinyl. This is available at auto supply stores. I find the best shock reducer is to keep hold of the door handle until I get my feet on the ground.

Bungled blinker

I got the surprise of my life the other day when I took my 1969 Oldsmobile through inspection. Although the dash light blinked and I heard the inevitable clicking, I was told by the inspector that my right-turn signal was not working. I had had it repaired a few days before. Did the repairman do something wrong?—John Bellagio, Camden, N.J.

He probably installed the wrong flasher. Whenever a new flasher is installed, be sure that its part number is the one called for.

Service Tips

● **1970 Eldorados** may make you think you're seeing double, but you're not. There are two crankcase drain plugs, and both of them must be removed in order to drain the oil completely. The two are necessary because of the off-beat contoured design of the oil pan.

● **Buick's new cooling system** for 1970 can throw you if you're not careful. It's a translucent plastic reservoir that you can look through to see the coolant level. You don't have to remove the cap. However, it should be checked with the engine at operating temperature. All earlier-model Buicks are checked with the engine cold.

● **AMC**, remember, put ball joints on the 1970 models. Previous models used trunnions. These ball joints are equipped with lube plugs. Use them every 24,000 miles unless you drive in an area where things are dusty or wet. In that event, lube every 12,000 miles.

● **Chevrolet station-wagon rear bumpers** that need a new plastic reflector have to be well cleaned to assure good adhesion. Remove all the old adhesive from the bumper and clean the recess area with mineral spirits. Then, with the bumper at a temperature of 70° to 90° F., peel off the backing of the new reflector, but be careful not to touch the adhesive. Place the reflector into the recess in the bumper and press it firmly.

GOT A PROBLEM WITH YOUR CAR? Ask Mort about it. Send your question to Auto Clinic, Popular Mechanics, 224 West 57th St., New York, N.Y. 10019. Letters cannot be answered individually, but problems of general interest will be published in the column.

New from the makers of GUMOUT ...

PTA

HI-PERFORMANCE OIL TREATMENT

This revolutionary, multi-purpose oil improver sets new high performance standards for all other oil additives. PTA stops oil burning, increases compression, reduces exhaust smoke, and quiets noisy engines. It does all these things with superior efficiency. But it does much more! Here's the story and

... HERE'S THE PROOF!



PTA



Additive A



Additive B



Additive C

These four steel blocks have been subjected to identical test conditions to determine the load bearing limits of the four leading oil additives. During this standard film strength test a hardened steel roller was rotated against a steel block at a constant pressure. All blocks were tested for the same length of time and with the same amount of lubricant. Note the small wear scar on the PTA lubricated block—and the severe scoring on the other blocks. **Proof** that PTA maintains its lubricity after other additives lose theirs.



HERE'S WHAT PTA WILL DO FOR YOUR CAR

—As engines begin to wear, even the best motor oil can drain away from vital areas and be unavailable when needed most—at start up. PTA treated oil clings to these areas and provides instant lubrication. This means easier starting, less wear and a quieter engine. In older cars PTA reduces the blow-by which occurs with worn piston rings. You'll get increased power, improved mileage, less oil burning and less smoke.

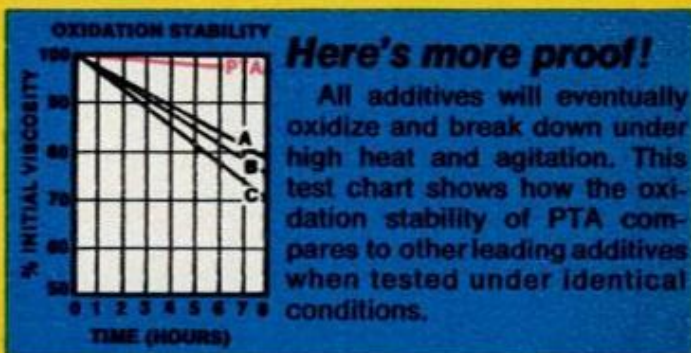

PTA DELIVERS THESE EXTRA BENEFITS

—Multi-purpose PTA contains a unique dispersant that holds dirt in suspension, keeping engines clean and valve lifters free. An oxidation inhibitor is also included to retard the formation of sludge. As a result, PTA lasts longer than other additives.

A can of PTA added to your oil will provide vitally needed extra protection and do it more effectively than any other leading additive. ASK for PTA at your auto supply store or wherever fine auto products are sold. Prove to yourself that it really works better.

GUMOUT PENNSYLVANIA REFINING COMPANY, CLEVELAND, OHIO 44104

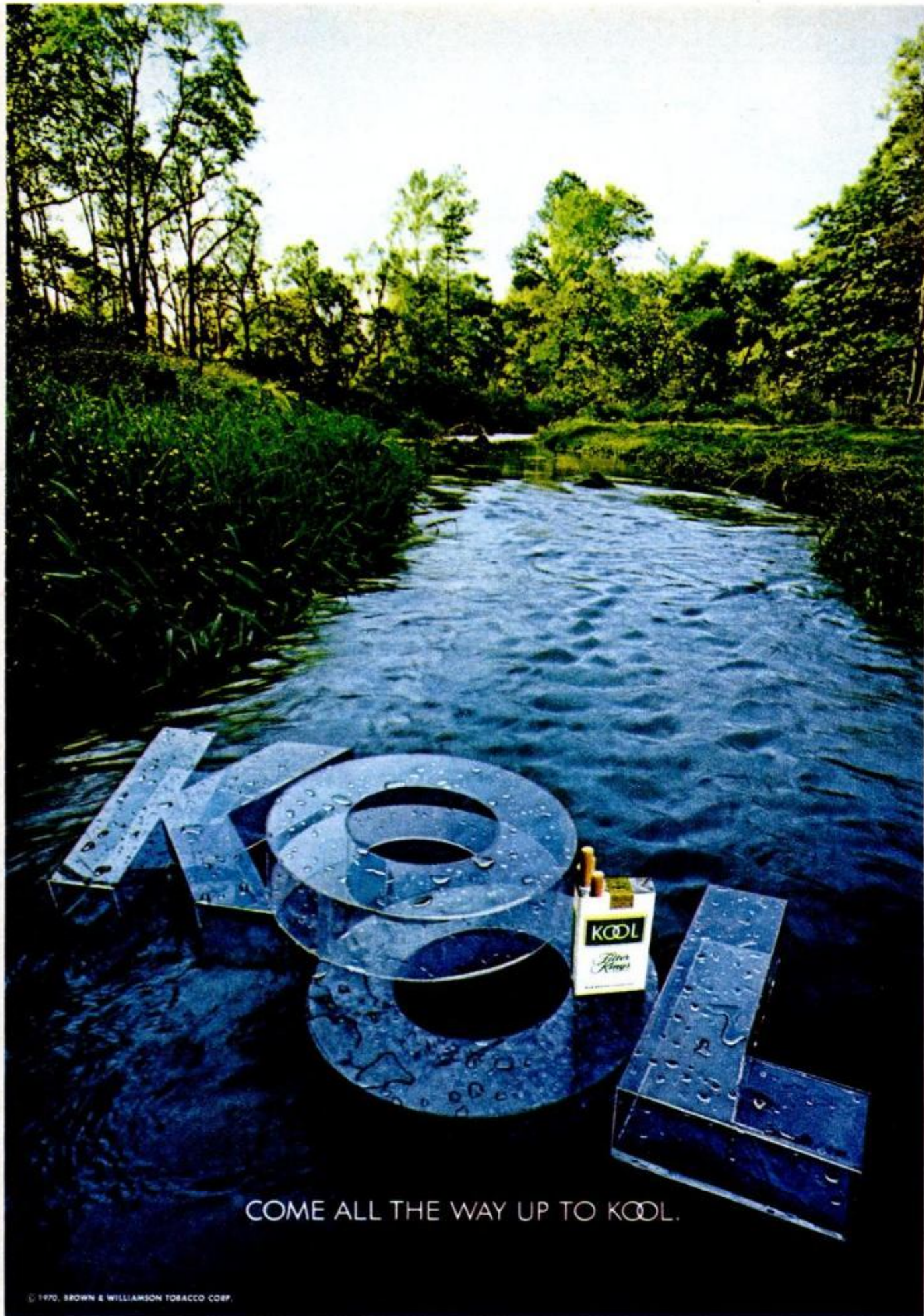

COME ALL THE WAY UP TO KOOL.

© 1970. BROWN & WILLIAMSON TOBACCO CORP.



MADE IN OHIO BY ROBOTS

Chevrolet's new Vega—a one-ton wonder on a 97-inch wheelbase—is getting the quality built in on an assembly line 'manned' by machines with hands

By ROBERT LUND, Detroit Auto Editor

Illustration by Roy Grinnell

THEY'RE NOT MAKING THEM like they used to at General Motors' new Lordstown, Ohio, assembly plant. They're making them in the most modern, automated, robotized carmaking complex in the world, a plant that could become the copybook layout for new auto factories for the next 25 years.

GM is using apprentice robots at Lordstown, an idea that may be as much of a milestone in automaking as the

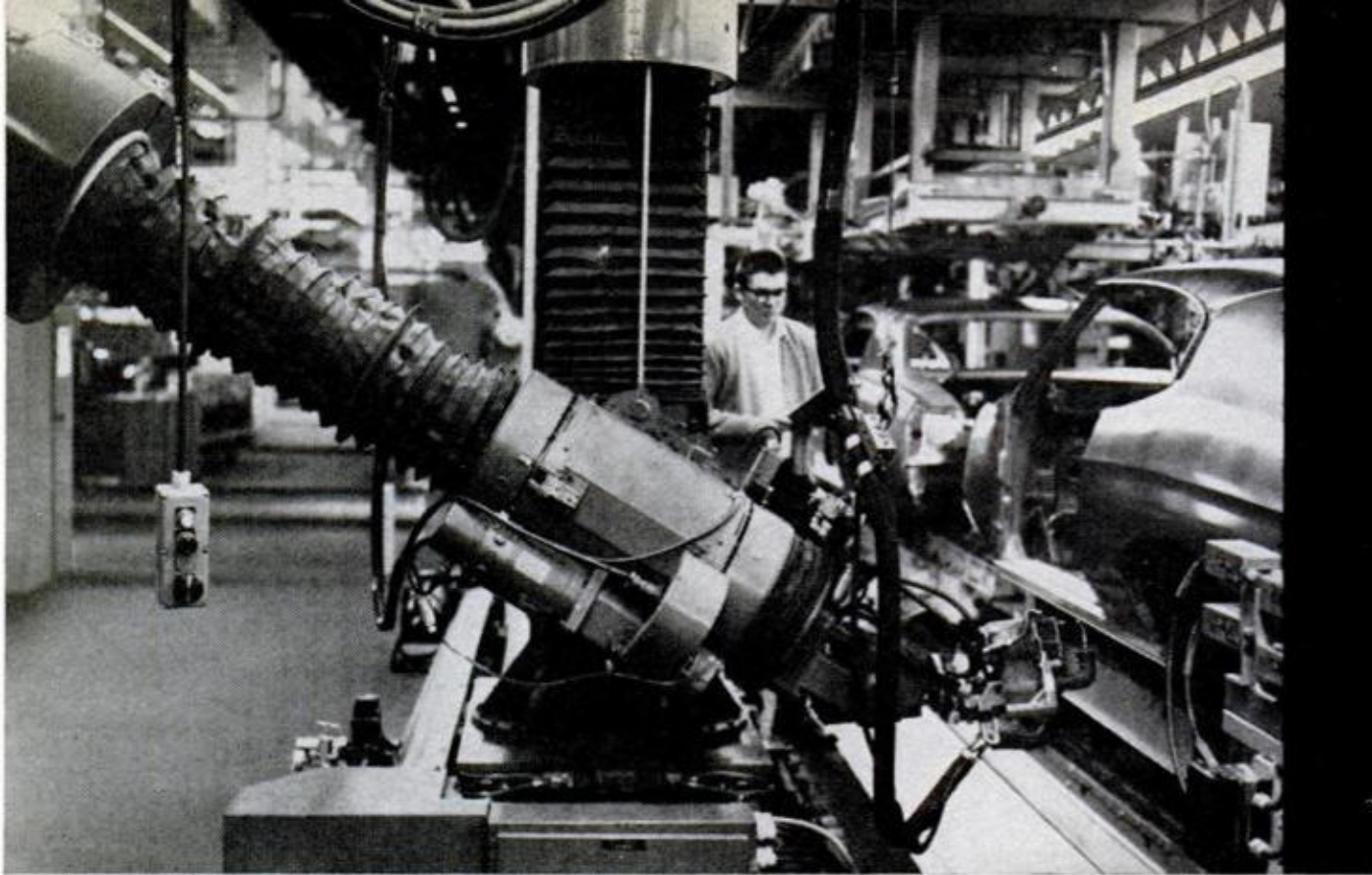

continuously moving assembly line. Where the moving assembly line brought the car to the worker so he could get his hands on it from a stationary position, Lordstown is a step toward producing cars virtually untouched by human hands.

Detroit visionaries are convinced the day will come when an automobile salesman will take your order, punch out the specifications on a machine that will feed a tape directly into the nearest assembly plant, programming the vehicle for production. From this point on, the machine will take over. As soon as the salesman completes his description of the order, the machine will flash back an acknowledgement: "Shipment scheduled for Sept. 27, 14:23 hours."

GM's response to such speculation is a haughty, "Bosh!" The untouched-by-human-hands theory is so farfetched, GM contends, it doesn't deserve the dignity of a "No comment."

The reason GM is reticent about claiming credit for its pioneering at Lordstown is obvious. The United Auto Workers Union is opposed to any movement that might take jobs away from its members. GM has had problems in the past trying to automate its

plants and it doesn't want to fuel the fire by discussing the idea of robot factories.

But Lordstown is the most robotized auto assembly plant ever, whether GM claims the title or declines it.

Lordstown is actually two plants. One is a metal fabricating plant operated by Fisher Body Div. Fisher stamps out sheet metal and does much of the sub-assembly work on body parts—doors, deck lids, fenders.

A second facility, where the car is assembled, is about a city block away from the Fisher plant. The second plant is operated jointly by Fisher and Chevrolet. Both plants are devoted to production of a single car—Chevrolet's mini, the Vega. The main assembly plant has a single production line, off of which GM can produce Vega in four body styles—sedan, fastback, wagon and panel truck.

The two plants are connected by a covered conveyor line. Finished sheet metal can be shipped off the end of the line at the Fisher factory to the appropriate station in the assembly plant without being exposed to the elements. There's no waiting for parts to be trundled from one plant to another, no tie-

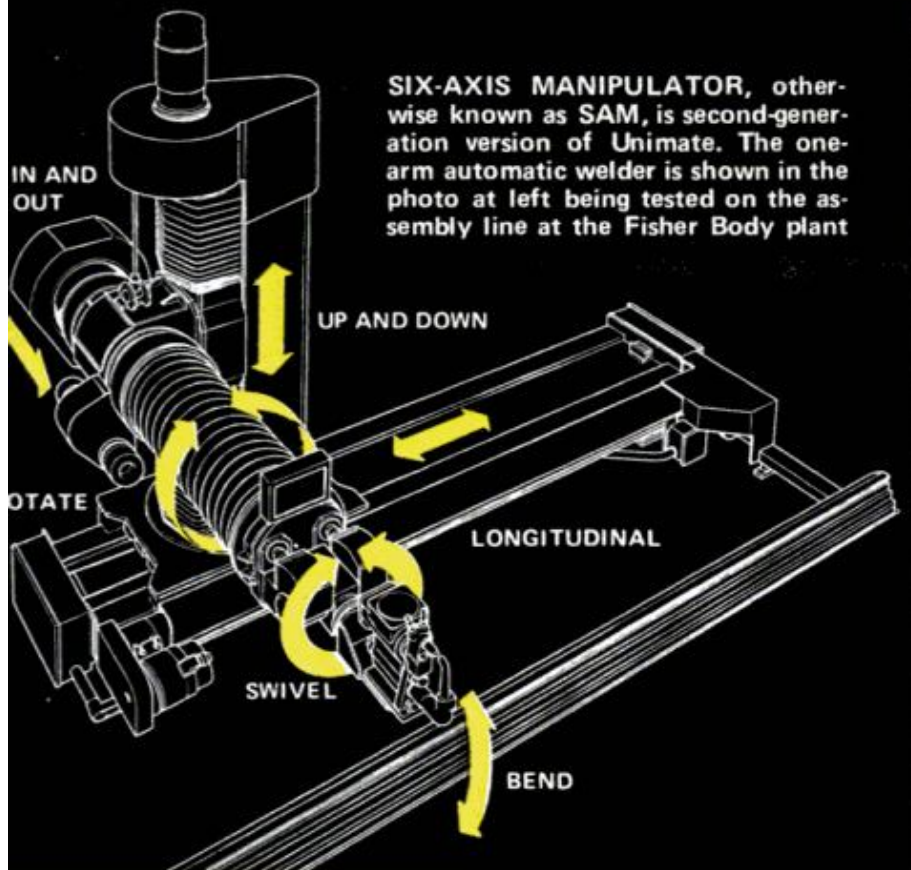

SIX-AXIS MANIPULATOR, otherwise known as SAM, is second-generation version of Unimate. The one-arm automatic welder is shown in the photo at left being tested on the assembly line at the Fisher Body plant

welded. Jigs and fixtures are then removed and the Unimates take over, welding the vehicle together. Something over 85 per cent of all welding on Vega is done by machine.

GM avoids making any gee-whiz claims for machine welding over hand welding, but there are definite advantages with the machine method. The weld is always the same, leading to better quality and presumably a more reliable product, and the machine never takes a day off, although it is subject to wear and down-

time for replacement or repair.

ups because trains or trucks can't travel, no risk of parts being damaged in handling or transit, no panic phoning back and forth between feeder plant and mother plant. Except for the Vega engine, which is made at Tonawanda, N.Y., Lordstown is a self-contained operation.

GM doesn't want to take a position of championing machine over man. It's not good politics. But it's significant that GM claims Vega, the least expensive car in its catalog, will be as fine and tight an automobile in terms of quality construction as any car GM has ever produced. Including Cadillac. In a company where the powers-in-command inevitably soft-pedal and understate, that's a mouthful.

The machines-in-lieu-of-men that cause GM to bite its tongue when the word "robot" comes up are located in the assembly plant. The machines are called Unimates. The name comes from the Danbury, Conn., company, Unimation, Inc., that produces the equipment.

Automatic welding is not new to the auto industry and the limited use to which GM is putting its robots is not likely to win the auto firm an award for trailblazing. The Unimates are capable of far more complicated jobs than GM has assigned to them. As I gathered on an unofficial trip to Lordstown, the company appears to be feeling its way with its benign Frankensteins. What can they do? How reliable are they? How will the union react?

GM has 26 Unimates at Lordstown, the largest crew of industrial robots in a single plant in the United States. It might be more accurate to say the company owns up to having 26 machines, because it would be unlike GM not to have a spare or two on standby for emergency duty if one of the "soldier" machines conks out. The robots are paired up opposite each other in twos, 13 on each side of the line.

Initially, the 26 units will be limited to a single function—welding body parts. Just before the line reaches the Unimates, the underbody and sides of the car are brought together and tack

The company that supplied GM with the equipment says it has some of the answers. The robot's "birth certificate" as supplied by Unimation, Inc., reads:

"The Unimate robot is a mechanical arm controlled by a solid-state memory

(Please turn to page 204)

Too *Fast* in **FOG**



A truck swept out of the mist and hit the convertible from behind: the start of a fantastic 29-car collision on the New Jersey Turnpike. Toll: 6 persons dead, 20 cars demolished, 6 trucks destroyed or damaged.

By E. D. FALES JR./Illustration by Roy Grinnell

ONE DAMP MORNING TWO YEARS AGO Dr. Edward Jaffee was driving between two points in New Jersey—from his home in Cherry Hill to his office in Pennsville, 30 miles to the south. It was a familiar, routine trip for the 34-year-old dentist. But as he approached Woodbury, he ran into fog and immediately dropped his speed to below the legal 60 mph.

Just beyond Woodbury he braked hard when he saw that the fog ahead looked more orange than gray. Fire! Then he heard the bang of metal against metal, and he could see that cars and trucks were piling up. At least one car was aflame.

A huge gray tank truck loaded with volatile propane tried to stop, but it skidded off the road and landed in a gully. Dr. Jaffee spun his wheel, managed to miss the wreck and kept roll-



ing. He had narrowly escaped disaster in a chain collision—an experience he would never forget.

A year later—Saturday, Nov. 29, 1969—Dr. Jaffee again was southbound on the Jersey Pike. Again, he was driving to his office. A small box on the seat beside him contained a patient's dental plate—a piece of work he was particularly proud of.

At 7:28 a.m. he passed the place where the 1968 chain collision had occurred. Soon he approached Exit 2, which leads off to the right toward Swedesboro. He had just topped a small hill in his blue '69 Mercury convertible when he hit fog. It was a light mist, but he slowed to 50.

In the next 10 minutes the fog thickened. It now was a low-hanging "pea souper." Cars that passed him quickly vanished in the gray mist ahead. Painfully remembering the year before, he chopped his speed to 30 and checked that his seat belt was fastened.

He watched his rear-view mirror closely. He was proceeding cautiously at 7:40 a.m., when he became aware that something big was sweeping up from behind. Within seconds he saw in his mirror that it was a huge flat-front truck. It was coming fast—too fast. He knew it could not stop in time.

Dr. Jaffee kicked the accelerator in an effort to get away. But it was too late. He was hit from behind. The roof of his car was peeled back, like the top of a sardine can. He felt the car spinning and tilting briefly on two wheels. It came down again on all four wheels and headed left toward the steel guard rail that separates northbound and southbound lanes.

Then the Mercury was hit again, and Dr. Jaffee blacked out. Police say that the car had spun and rolled backwards and that a truck had scraped it from front to rear, raking the driver's side . . .

At 6:30 a.m. Trooper Harry Winkler, driving north, had seen no fog. During the next hour he

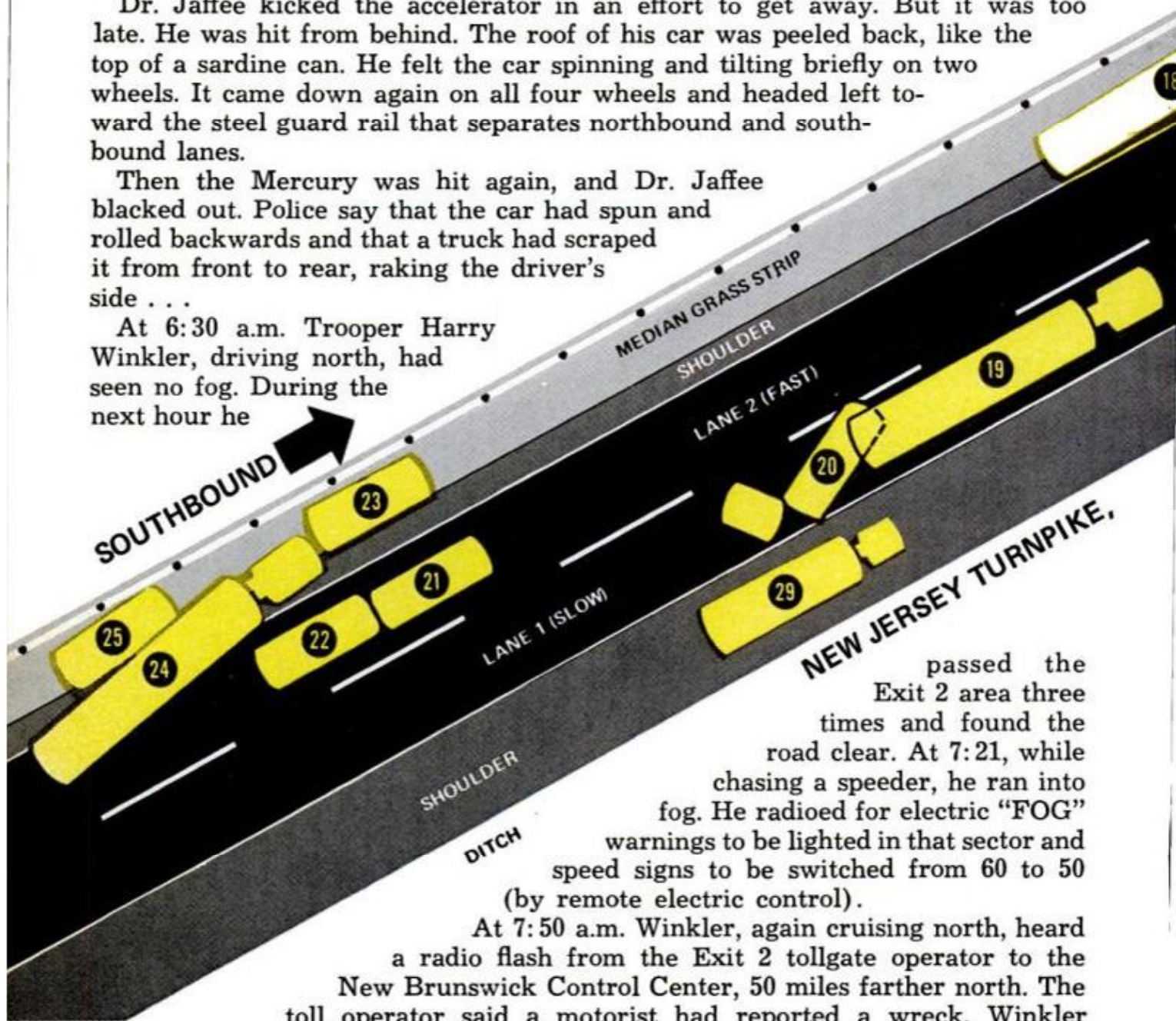

passed the Exit 2 area three times and found the road clear. At 7:21, while chasing a speeder, he ran into fog. He radioed for electric "FOG" warnings to be lighted in that sector and speed signs to be switched from 60 to 50 (by remote electric control).

At 7:50 a.m. Winkler, again cruising north, heard a radio flash from the Exit 2 tollgate operator to the New Brunswick Control Center, 50 miles farther north. The toll operator said a motorist had reported a wreck. Winkler

raced north at close to 100 mph, but soon hit fog and had to slow down.

Coming up behind Dr. Jaffee at the time he was hit had been the usual assortment of weekend traffic:

- A 1970 Barracuda from New York with less than 500 miles on its odometer.
- A Rhode Island '65 Chevy II

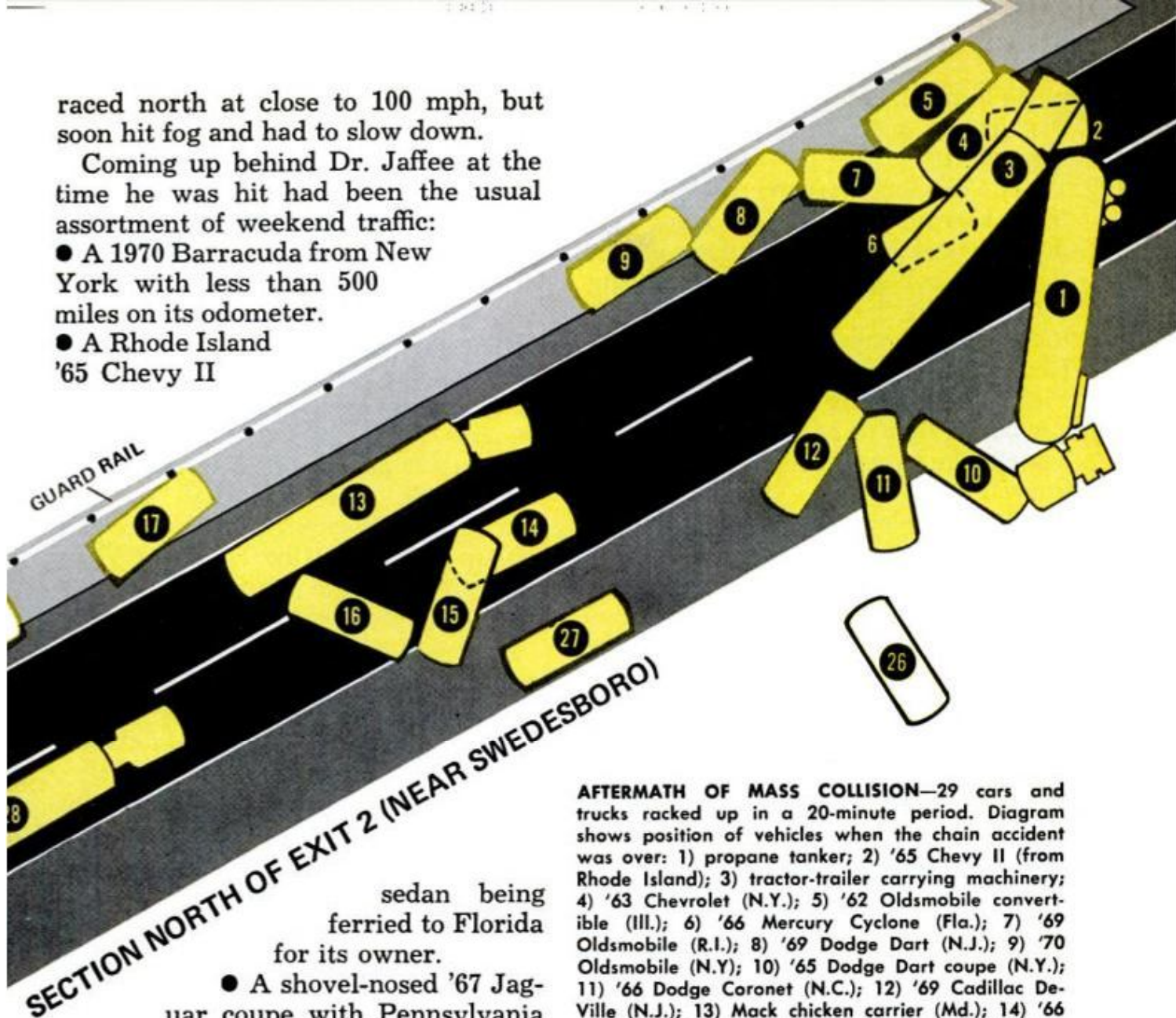

sedan being ferried to Florida for its owner.

- A shovel-nosed '67 Jaguar coupe with Pennsylvania plates.
- A '63 Tempest from New Jersey towing a two-wheel U-Haul trailer.

In addition, there were families in cars from several states. A station wagon from Virginia contained several children and was driven by a young mother.

With the first impact, Dr. Jaffee's seat broke, and he was torn from the safety belt and hurled into the rear seat.

No one can say which truck, or trucks, hit Dr. Jaffee's Mercury. There is evidence, however, that a gray propane tank-trailer and its tractor also veered left, as Dr. Jaffee had, across the two southbound lanes. Perhaps it hit the steel center rail, for its left front wheel later was found smashed and the rail dented.

Whatever happened, the tanker seems

AFTERMATH OF MASS COLLISION—29 cars and trucks racked up in a 20-minute period. Diagram shows position of vehicles when the chain accident was over: 1) propane tanker; 2) '65 Chevy II (from Rhode Island); 3) tractor-trailer carrying machinery; 4) '63 Chevrolet (N.Y.); 5) '62 Oldsmobile convertible (Ill.); 6) '66 Mercury Cyclone (Fla.); 7) '69 Oldsmobile (R.I.); 8) '69 Dodge Dart (N.J.); 9) '70 Oldsmobile (N.Y.); 10) '65 Dodge Dart coupe (N.Y.); 11) '66 Dodge Coronet (N.C.); 12) '69 Cadillac DeVille (N.J.); 13) Mack chicken carrier (Md.); 14) '66 Plymouth Valiant (N.J.); 15) '69 Jaguar (Pa.); 16) '70 Barracuda (N.Y.); 17) '69 Mercury Monterey (N.J.), Dr. Jaffee's car; 18) GMC tractor-trailer (Md.); 19) White tractor-trailer (Md.); 20) '63 Pontiac Tempest (N.J.) with U-Haul; 21) '66 Pontiac station wagon (Ga.); 22) '66 Ford Fairlane (N.J.); 23) '69 Pontiac station wagon (Md.); 24) Mack tractor-trailer (Mass.); 25) '68 Pontiac Bonneville (Conn.); 26) '68 Camaro (Md.); 27) '67 Chevelle (Md.); 28) Mack leasing tractor-trailer (Pa.); 29) Cabrini moving van (N.J.).

to have rebounded heavily across the road, the tank itself falling on its side.

It was an enormous tank and U.S. safety investigators say it carried propane gas under pressure—a dangerous cargo. According to police, it was overloaded and weighed roughly as much as 28 automobiles—76,340 pounds. It stopped 85 feet beyond the dentist's car, its tractor section still attached. The tractor had snapped around so that it faced backwards. But it was still right side up. The windshield had ex-

ploded outward, a good indication that the driver may have been thrown through it.

For a moment after the truck crashed there was silence. But both lanes were now blocked, a hidden fog trap set, and the chain collision was about to begin.

One of the first cars to come out of the fog was the '65 Chevy II from Rhode Island—the one being ferried to Florida. Its young driver may have stopped in time or he may have bumped against the overturned tanker; no one knows.

Then, suddenly, the others were there. Out of the fog they came, one by one, sliding, spinning, crashing, until soon 10 cars were bunched. Not all had collided, but one or two had hit the tanker hard. And suddenly, in one wreck, there was the yellow flicker of flame.

People popped out of cars. Someone noticed the tanker cab: It was burning inside. But most frightening was a little plume of white gas that danced weirdly about the tank itself. A hair-

line crack had opened in its top, near the midsection, and the dangerous liquid propane was leaking out under pressure, turning to gas as it hit the air. Heavier than air, it drifted to the road, where, according to police, it began feeding the fire.

Above other sounds, people at the scene now heard a second truck. Through the gray veil came a tall, green tractor-trailer filled with machinery—a monster that weighed as much as 20 automobiles, or about 57,000 pounds. The truck had a "cab-over" control cockpit, with the driver's cab up front over the engine. (When engine repairs are needed, the whole cab is tilted forward.)

A driver and a woman companion rode in the cab-over. The driver's first warning of danger, he testified later, was "two little red lights—taillights, I guess . . . I hit the brakes with everything I had, but I never got to see the car. I just hit it." He said he had been running 55-60 mph but had "backed off" to 35 in the fog.

No one knows which car this truck hit first, but it rammed ahead and cut a swath through the bunched cars. There was a hollow, rolling sound followed by the tinkle of glass. Then the truck smashed against the propane tanker. The impact spun the enormous tanker around, opening the left lane.

The machinery truck now swerved toward the open lane, sweeping cars before it. Some cars were thrown to the right, and a man in one of them was killed. The truck driver and his companion were hurled into the road ahead. (Investigators think the cab-over may have spilled forward.) He and the woman landed 25 feet beyond the wreckage. Though hurt, he picked up the injured woman and ran, carrying her away from the propane truck.

Spilled gasoline mixed with the propane and fed the flames. Soon tall yellow tongues of flame reached through clouds of oily smoke, and in the blast-furnace heat the machinery truck began to melt.

WHEN YOU DRIVE IN FOG

In researching this article, writer Ed Fales drew on long experience in driving in everything from "pea soups" to light mists. His first rule of driving in a super-highway fog: Don't, if you can avoid it.

Second rule: Know how to recognize four basic fog conditions and the problems they create. Cut speed to suit the conditions.

● Condition 1 Fog:

You can see $\frac{3}{4}$ mile. At 60 mph you cover that distance in 45 seconds. **CAUTION.**

● Condition 2 Fog:

You can see $\frac{1}{10}$ mile. At 60 mph you cover that distance in 6 seconds. **DANGER.**

● Condition 3 Fog:

You can see 100 feet (5 car lengths). At 60 mph you cover that distance in 1.1 seconds. Even at 30 mph you cover it in 2.2 seconds. Pull off the road as soon as you can. **EXTREME DANGER.**

● Condition 4 Fog:

NO VISIBILITY. Get off road, beyond the shoulder, if possible.



GRIM JOB OF PROBING SMOLDERING WRECKAGE fell to troopers and firemen. Five victims perished in fires

In chain collisions trucks have been known to grind up on top of cars and then slide forward upon them. One car now was seen jammed under the tractor's front. Trapped inside the car was a young male driver, burning to death. This was the Chevy II bound for Florida. A few feet farther back the truck's trailer was on top of a second car: a '66 Mercury Cyclone. A young woman was trapped inside.

About this time a man was seen standing by the gas truck, holding his head. This may have been the propane truck driver. It may have been the same man who then was seen dragging victims to safety. While he was doing that, a car came out of the fog and hit him, sending him sliding.

People now were jumping from cars, screaming and crying. Some wandered in dazed circles.

Trooper Winkler, approaching from the south, saw the fog turn from gray to fiery orange. He knew he'd found the accident. After he'd scanned the area, he ran back to his car and sent a highway SOS. His tense voice was recorded on tape at the New Brunswick control center: "I've got a propane truck here, and one, two, three, four—about six cars on fire. I'm going to need help!"

Within seconds, troopers were enroute from as far as 30 miles away. So were firemen from Swedesboro, Murphysboro and several other New Jersey towns.

After sending his alarm, Winkler ran north up the road, lighting flares.

A shadow slid by: a '68 Camaro bound for Maryland. It went into a spin and landed in the ditch.

A Maryland car, a '67 Chevelle driven by a young family man named Blake, also went by. Blake cut left, saw the way blocked, then dodged right and made a skillful stop on the shoulder. His family jumped out and ran. Then a car hit young Blake.

A '66 Valiant with Jersey plates proceeded cautiously. The driver spotted the wreck in time and stopped. Then, noticing the overturned tanker, he put his car in reverse and backed away. Moments later his car was hit, its rear tossed high in the air. The Jaguar from Pennsylvania had rammed it.

All this happened in the right ("slow") lane. Over in the left lane a New York driver brought his sleek '70 Olds, just out of the showroom, to a stop. But coming up behind him was a third truck, a big Maryland chicken-carrier. When it bumped the Oldsmobile, the Olds shot ahead and hit a '69 Dodge Dart. Next came the '70 Barracuda from New York. Possibly trying to miss the chicken truck, its driver veered to the right. With a resounding crash, his car struck the Jaguar, which had just knifed under the Barracuda.

Meanwhile, only a few feet away, Dr. Jaffee's car lay smashed against the

(Please turn to page 212)

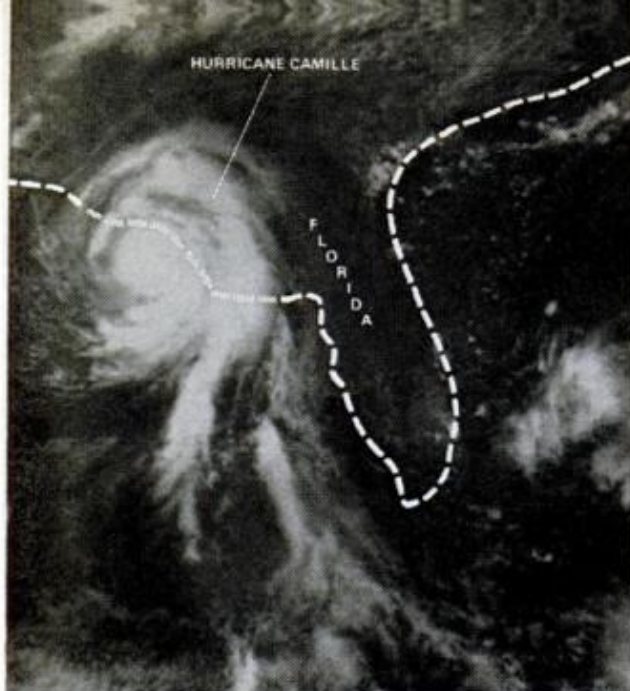

HURRICANE CAMILLE WAS TRACKED by weather satellite ESSA 9 and photographed as it swept up from Cuba and hit the U.S. coast (shown by dotted line)

The most vicious wind ever to hit the U.S. mainland, it roared up from the Gulf, blasted Mississippi and flooded Virginia, killing hundreds and smashing \$1 billion in property. They called it Hurricane Camille

By E. D. FALES JR.

THE WIND ROARED DOWN from the Mississippi hills and blew the Gulf of Mexico away. It emptied rivers and swept bayous dry. The end of the world seemingly had come on Sunday, Aug. 17, 1969, for never before in memory had the bayous been without water.

Three hours later, at 8:00 p.m., the wind reversed itself. The Gulf of Mexico rushed back. House-high waves slammed ashore—15-foot waves on a 30-foot tide. Frightened residents retreated to second floors, then to attics. When the sea followed, people kicked holes in roofs and climbed out to seek escape. They were blown away.

In Pass Christian a man vanished in a seacloud and landed on a schoolhouse roof a mile away. Another man saw his neighbor's big brick house rise off the ground as if pulled up by a crane.

By 9:00 p.m. four cities along 50 miles of Mississippi's lovely "chain

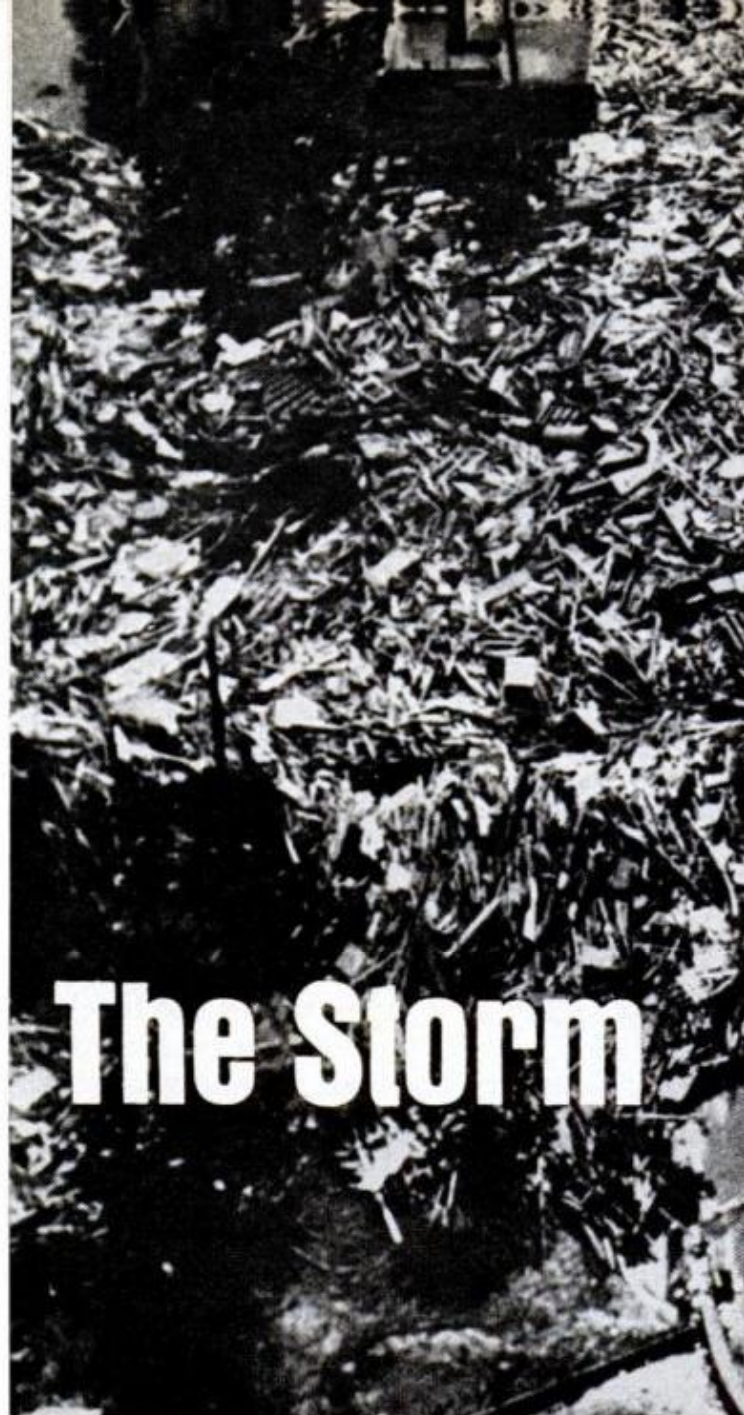

The Storm

of pearls" coast—Pascagoula, Biloxi, Gulfport and Pass Christian—were being blown apart. Seventy miles south, down in Louisiana's Mississippi Delta, the captain of an oil company LST felt a great shock. His ship had collided with two big freighters. The frightening thing was that he couldn't see them.

Near the beach in Biloxi, a gasoline station had been built for strength against the sea. It was anchored by big steel I-beams sunk in four feet of concrete. As the wind rose above 180 mph, the station blew away and the steel beams were bent back until they lay along the concrete.

This was a wind. Weather Bureau men called it the worst storm in his-

They Still Don't Believe



GREATEST DAMAGE was done along Mississippi coast (inset) but the mighty storm still had punch when it reached Virginia, causing more death and destruction. It finally petered out in the Atlantic. Fantastic collection of debris (photo above) litters bridge at Bay St. Louis, Miss. This picture was taken the day after killer storm ripped the area

tory. They called it Hurricane Camille.

But Camille was not a typical hurricane. It was a compact bomb, only about 50 miles wide; hurricanes usually are hundreds of miles across. It was like a supertornado that spawned many lesser tornadoes. As any Oklahoman knows, even the smallest tornado is an explosion of the first order.

Tornadoes explode when nature gets wound up too tight. Something was clearly wound too tight on Saturday, Aug. 16, when Weather Bureau men, probing the Gulf with radar, found a monster that had come up from Cuba during the night. Characteristically, it was whirling in a lazy circle.

Navy, Air Force and Weather Bu-

reau planes sped out to meet it. "We've got 50 knots of wind out here," radioed an Air Force crew. Soon shore-based radars were picking up a twister of a cloud 10 miles tall. It glittered in the morning sun, 200 miles west of Florida. Then it steamed north, a juggernaut aimed at Mississippi's sandy coast.

The Weather Bureau issued frequent warnings as Saturday wore on. Residents were told that this was one of the worst storms ever spotted in the Gulf; everyone should prepare to flee.

Still, many people along the coast thought Camille would surely turn east toward Alabama and Florida. But at 4:30 a.m., Sunday, it was still pushing north. That's when lanky Bill Tilson, head of the Mobile, Ala., Weather Bureau office, pulled out all stops. He sent messages alerting the Mississippi coast: *The storm is coming your way. Get out!*

Sunday brought the usual nervous jokes. People scared by hurricanes like to phone the Weather Bureau and ask, "Will this be a one-bottle storm or a three-bottle storm?" They get together for hurricane parties, which sometimes become brawls. But mostly, hurricane parties give frightened people a

WIND AND RAGING FLOODS gutted this double row of houses in Biloxi, leaving empty shells standing



THREE OCEANGOING FREIGHTERS were blown ashore at Gulfport, at the north end of the harbor

chance to huddle together (with or without a drink) in the face of danger.

One who joined no group was owner Paul Hearon of Biloxi's Amoco gas station, two blocks from the sea. At 8:00 a.m. he decided he'd better move his tires uptown on the hill. It was slow work because people kept buying white gasoline for lanterns and stoves. Everyone knew that the electrical power would fail.

At noon Hearon finished his job and

FANTASTIC MOUNTAIN OF DEBRIS filled main street of Pass Christian the day after Camille passed by





PIRATED BY FUGITIVE, this shrimper was carried 14 miles to Biloxi yard. Its home port is Morgan City, La.

switched off the Amoco sign. "You'd better go north while you can," he told his customers. "It's starting to rain hard." Then he locked up and headed for the hills.

Down on the beach, where U.S. 90 skirts the Gulf, owner George Pattison of the Pontiac agency told his men to move 75 cars uptown to a lot behind a hotel. Next door at the Biloxi Yacht Club, owners who had not moved their boats inland were tying them down. The club had a hurricane wall of steel and concrete.

On U.S. 90, behind the Yacht Club,

STORM UPROOTED OIL storage tanks in Biloxi's back bay area, floating them away like huge corks

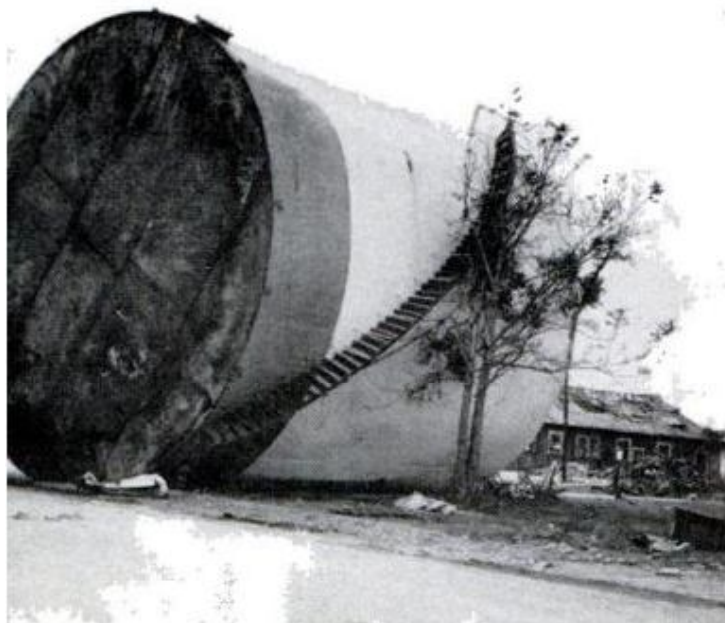

Mr. and Mrs. Bill Hood checked out 53 scared guests from their T-shaped Towne House Motel. Seven other guests lingered. "This looks like a strong place," one of them said. "If the tide gets high we'll go upstairs. Are you going to leave?"

Mrs. Hood said no.

"Then we'll stay, too," said an Air Force lieutenant and his bride. So did five others. They decided to immediately move upstairs into Rooms 11 and 12, close to U.S. 90. At noon a young couple came to the motel. "We have no car to escape in and no place to stay," they told Hood. "May we come in?" Hood gave them Room 16 on the second deck.

A half mile east, at the armory, 100 young National Guard trainees nervously checked the rescue boats they might need later. On a pier, two visitors watched the tossing sea in delight. Friends pleaded with them to join the thousands now heading inland. They refused. "We want to see a good storm," they said.

Boats hurried for port. A 50-foot yacht with only an old man and a boy aboard headed for the drawbridge in the mile-long Biloxi Bay Bridge, in an attempt to reach safety well up in the bayous.

The *Wade Klein*, an 85-foot trawler out of Morgan City, La., met the storm off Biloxi and sneaked in to anchor behind an offshore island. One of the crew, a fugitive wanted by the F.B.I.,

had pirated the ship from its owner a few days earlier.

By 3:00 p.m. Sunday the beachfront—really a 50-mile-long city of 100,000 people—was feeling a 35-mph north-east half-gale. Some of those on shore noticed three black snakelike funnels twisting toward the coast, working against the wind. They were waterspouts—tornadoes over water. At 5:00 p.m. the wind suddenly jumped to 60 mph.

Twenty-five miles west of Biloxi, at Pass Christian, Civil Defense Director Parnell McKay began urging people who had not already escaped to move into two big schools. McKay asked Police Chief Gerald Peralta to try to drive to the swank three-story Richelieu apartments and urge the 24 occupants

Then the LST was hit with a barrage. 'The wind is blowing rocks!' a crewman shouted.

still there to go inland. The Richelieu lay only 750 feet from the Gulf.

McKay then turned to the problem of getting food to 1000 people in the Catholic and public high schools. He learned that a small group was also in the Episcopal church.

The wind was piping up, and U.S. 90 was blocked now, but Chief Peralta and another officer nudged their car down the beach, dodging waves. Soon they reached the brightly lighted Richelieu. In one room a father and son played with a toy airplane. Music came from another. In still another room a few people had started a hurricane party and one man offered Peralta a drink. He declined.

"We went to each door and knocked and asked everybody to get out while they still could," he says. About half complied. Then Peralta radioed to the firehouse and told McKay: "The others insist on staying."

McKay was angry. "Chief, you go back and tell them I want the names of next of kin for everybody there.

We'll have to know who to notify when this is over."

When Chief Peralta finally returned to the firehouse, he found it full of people. Though the building was on a hill, water came in and soon people were climbing on the fire trucks to stay above it.

At 5:00 p.m. the eye of the storm, surrounded by winds of over 200 mph, was still 90 miles south of the coast and passing the mouth of the Mississippi, where the oil company LST, an offshore drilling tender, lay anchored. At one time the eye passed so close to the ship that a weather man later figured a sailor could have jumped and swum into dead calm only a few feet away.

Life aboard the LST became a nightmare. The crew watched in amazement as a succession of objects were carried out into the Gulf: a church organ, a Ford pickup truck, a motorboat riding on top of a car.

In addition to its anchor, the LST was secured by a line to a huge tree on shore. Then the wind and waves hit the ship with such force that it dragged its anchor and pulled the tree over. The ship was propelled backwards out into the Gulf.

Then the LST was hit with a barrage. "The wind is blowing rocks—rocks!" a crewman shouted. The stout steel mast started to bend. When the portholes began blowing out, the captain thought he would cut the anchor, start the engines and try to run the ship ashore. The trouble was he couldn't see shore. He couldn't even see his ship's rail. He decided against it.

The scream of wind rose. Now came the snakes: rattlers and cottonmouth moccasins, not swimming or crawling *but flying through the air*. They'd been blown from the swamps. Five landed squirming, fighting, on the bridge. Others fell on deck. One slithered below decks, where a crewman killed it. Then came the collision. The LST was hit by two unseen ocean freighters, and all three ships drifted off together.

Ashore in the powerhouse behind

Biloxi's Broadwater Beach resort, the hotel engineer watched costly lobby furniture float out of the back doors. Three big ships came up on land, their long steel keels screaming on the sand and concrete. At Pascagoula, the tanker *Mormacsun* climbed out like a great sea animal seeking land.

The alarm to man the rescue boats reached the Biloxi National Guardsmen when the wind suddenly reversed itself toward 8:00 p.m. and the tide came rushing in. The men sloshed through knee-deep water to board six landing craft called LARCs. They rumbled toward town. The wind was 80 mph and growing stronger.

It was about 9:00 p.m. when screams rose above the noise of the wind at the Towne House Motel. Owner Bill Hood knew the couple in Room 16 were in trouble. But to get outside would be tough. U.S. 90 was deep in ocean. The Amoco station up the street was gone. So were surrounding houses. Lightning flashed—a sign of tornadoes.

And then Hood *heard* the tornadoes. "I've heard them before and I know the sound," he says. The west sky turned red with electrical fire. The big Pontiac garage next door exploded. Hood saw the Biloxi Yacht Club spin around. Then it blew away like paper before an electric fan. A yacht whirled ashore. "If that hits us we're gone," he said. When he looked again the whole east wing of his motel—built of heavy concrete block—was missing.

Screams still came from Room 16, and there were thuds—furniture floating against the ceilings downstairs. Hood said: "We've got to get to those kids."

"I'll go with you," said the Air Force lieutenant. It was almost impossible to open the door against the wind. When the men got out on the porch it was like being on a ship's deck in a storm.

Waves crashed over the railing and smashed them against the wall. They crept from door to door. It took 20 minutes to reach No. 16—the fourth

(Please turn to page 218)

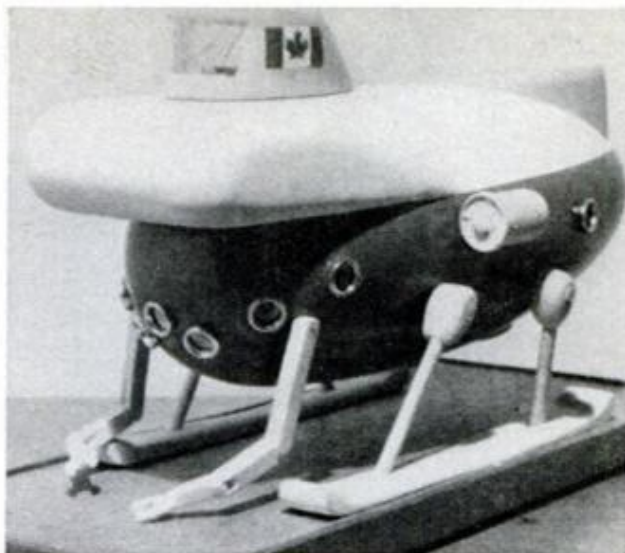

Canadian submersible

Shown as a scale model, this new submersible will be used by Canadian armed forces for underwater searches, submarine rescue and research. The 25-foot sub will carry two.



Low-slung, high-speed Lotus

Unusual features of the new 200-mph Lotus 72 include amidships radiators and extremely low build. The racer, powered by a Ford Cosworth DFV V8, is in Grand Prix competition.



Supersonic lollipop

Newest French confection is the 24-inch Concorde lollipop, named for the SST.

PM OWNERS REPORT
BUICK RIVIERA

A Nationwide Survey Based on
1,200,000 Owner-Driven Miles



OWNERS SAY:

'Fantastic Styling, but How About a Little Trunk?'

By **MICHAEL LAMM**, West Coast Editor / Photos by the Author

RIVIERA DEVOTEES bask more than a little in their own good taste. Styling ranks as the main reason for purchase. Says a Texas bookkeeper, "I like the ooohs and aaaahs of passersby and the is-that-*your*-car, and the sideways glances from owners of older Rivieras!"

But as always, lush styling brings concessions. Eventually these come to the surface, though usually not until owners live with their cars a while. The Riviera's small trunk came in for most criticism, with pinched rear-seat legroom next on the list.

An Indiana engineer complains, "Fat vinyl side moldings can be yanked off by brushes in a car wash." An Ohio retiree, "Lousy visibility out slanted rear window and past high bucket seat-backs." "I would like to see them take

the rear skirts off the car, or at least make it look okay without them." "I liked the '67 grille treatment better—concealed headlights." "Wish Buick would restyle the Riviera to make it more distinctive from other GM lines." "Bring back hidden headlights." "Trunk certainly needs to be much larger; also could use less plastic."

Not everyone bought his Riviera for looks alone. Here are other reasons:

"Typifies *nouveau riche* look," is the unusual admission of a New York distributor. And, "Good resale value" was listed by a number of owners, though an equal number complained of low resale value. One gent mentioned his previous Gran Sport had gone down \$4500 in three years.

"I buy a new car every three years. This is my fifth Buick, second Riviera,



ABSOLUTELY NO NEGATIVE WORD on handling—Riviera owners give cars rave reviews in this area

was well pleased with my 1967." Lots of repeat buyers: "Good experience with my 1963, 1966, and now my 1970 Riviera." And a 75-year-old Missouri engraver sighs, "Was driving a 1955 Roadmaster since 1955, couldn't wear it out, but it was too much out of style." So styling even got to him.

As mentioned, the Riviera's least-liked feature is its tight trunk. "My only major complaint," says a TV station manager, "is that the trunk is very shallow, most of it being taken up by the spare." Similarly, "Not enough room for suitcases." There's relatively little legroom in the rear seat, and a few owners went so far as to suggest making the Riviera a two-passenger car. None, though, wanted a wider selection of body styles (as did Toronado owners, some of whom would have preferred sedans and wagons).

People expect expensive cars to be put together better than cheap ones, a reasonable demand that's not always observed by assembly-line workers. Representative comments on quality and workmanship: "My Riviera is well put together, but the paint job is terrible. I'll never understand why they build a \$7000 car and finish it off with a two-bit paint job." Another owner says, "The dealer had to repaint the car because it came in two different shades of dark gold." Or, "I wanted a car that wasn't cheaply put together. The

SEPTEMBER 1970



MANY COMPLAINTS, though, on trunk. Too small and shallow, even with spare hidden under floor

RIVIERA FUEL MILEAGE CHART

455-cu.-in. V8

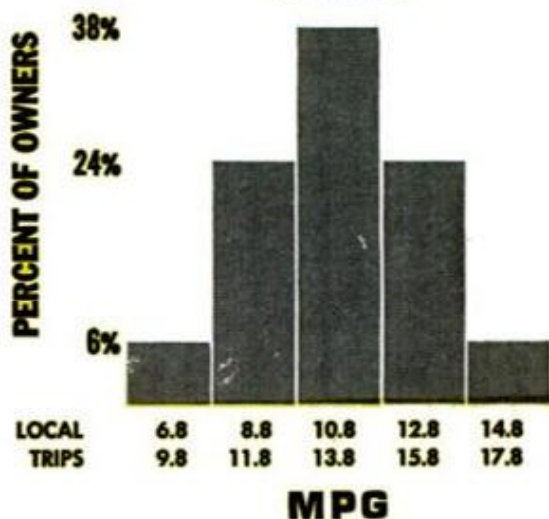



COCKPIT COMES OFF okay except for idiot lights and gripes that it's hard to tell where hood ends



QUITE A SQUEEZE back here for big feet; also it's a long stretch for rear riders to reach door handles

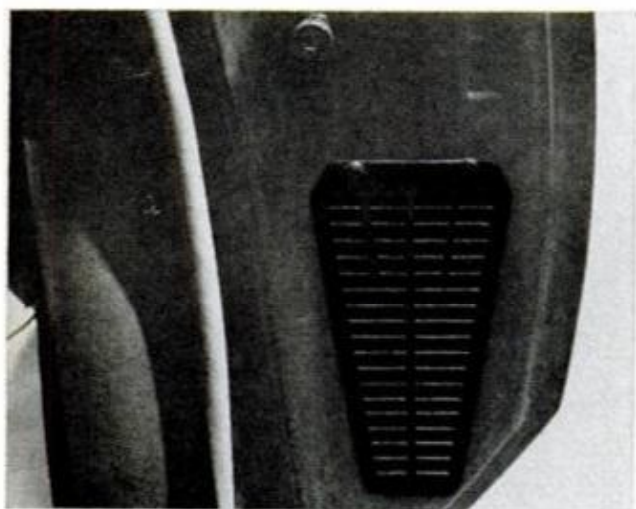

FLOW-THROUGH VENT SYSTEM lets air out here and below backlight. Many would prefer windwings

workmanship is very, very poor. There are screws missing, loose clips, paint scratches, defroster installed improperly." "Workmanship excellent, considering the way they make cars today." (But why "considering"? Have we become so inured to poor workmanship that we're willing to excuse it simply because other cars are also poorly put together?) "I can see that *some* pride was taken in the workmanship of my Riviera anyway." "Quality is generally very well done—no complaints."

Of specific mechanical ills, and there were very few, the most surprising was: "My Riviera burns oil—about a quart every 400-600 miles." Not many owners mentioned it, but enough did to form a pattern. Another owner echoed, "So far I'm getting 800 miles per quart." Again, "Seven quarts in 4000 miles." And, "While mileage is

still low (3100), oil consumption seems excessive. Compared to my 1965 GS and 1968 Riviera, I have used three times as much oil. I'll have to wait to see whether oil consumption is the fault of design or low mileage. Dealer couldn't find anything wrong and claims it will improve with miles, but to date I'm not happy about it."

Concerning handling, these jottings: "Best all-around handling car I've ever owned." "I appreciate the ease with which the car can be handled under all road conditions. Also smooth acceleration and ease of braking." "Handles well at high speeds; corners well in town."

But conversely, "No complaints except road tramp. Requested wheel balance at 6000-mile check; still rough at 65-80 mph. May be out-of-round tires or weak suspension." "Glass-belted tires are terrible—can't be balanced." "Belted tires are absolutely awful. I had to *replace* three of them at my own cost!"

About the Riviera's ride and general comfort: "Very nice. Just like sitting in my easy chair. Can drive all day and feel good at the end of the trip." "Comfortable front seat, rear a little tight on legroom." "Suspension could be better—ride is not up to my expectations." "My 1970 Riviera rides considerably harder than my 1967, although not objectionable. It handles better, however." "When driving, one feels part of the car." "Overheard one passenger who had ridden 200 miles in the back

Summary of 1970 Riviera Owners Reports*

Total miles driven 1,200,053

Average miles per gallon:

455-cu.-in. V8,
local driving .. 10.8
long distance .. 13.8

Why the Riviera?

Styling 40.1%
Past experience 29.7
Handling 8.9
Size 8.9
Performance 6.9
Comfort 5.9

Specific likes:

Style 50.0%
Handling 47.5
Ride 38.0
Comfort 29.5
Performance 18.0
Power 13.5
Roadability 7.5

Specific dislikes:

Trunk too small 16.8%
Poor workmanship 14.8
Poor gas mileage 7.1
Poor paint/finish 6.6
Rattles 5.1

What changes would you like to see?

More trunk space 26.0%

Better styling 15.8
Concealed headlights 7.3
Better workmanship 5.1
More legroom 5.1
Mudguards 4.5
Lower seatbacks 4.5

Had any mechanical troubles?

No 71.6%
Yes 28.4

What kind of trouble?

Electrical 20.0%
Oil leaks 10.0
Transmission 6.7
Battery 5.0

Did you repair it yourself?

No 98.1%
Yes 1.9

Dealer repairs satisfactory?

Yes 66.0%
No 34.0

Is the Riviera your only car?

No 59.6%
Yes 40.4

Other cars owned:

Chevrolet products 33.6%
Buick 23.2
Ford products 17.6

Pontiac 9.6
Volkswagen 8.0
Cadillac 5.6

Accessories/power options:

Airconditioning 65.9%
Power windows 63.1
Radio 54.7
Power seats 45.4
Stereo tape 40.0
Rear defroster 28.8
Vinyl top 21.2
Cruise control 20.0
Tinted glass 19.4
Tilt steering wheel 14.1
Lighting group 13.5
Power door locks 5.9

What accessories/options would you order next time?

The same 83.1%
Stereo tape 6.2
Rear defroster 3.6
Cruise control 3.1
Power windows 2.1

Age distribution of owners:

15-29 years 21.5%
39-49 years 43.0
50-plus 35.5

Would you buy another Riviera?

Yes 84.4%
No 15.6

*Percentages might not equal 100% due to rounding and/or insufficient data.

seat. He cussed like hell." "Too much wind noise and motor sound, more than my Delta 88." "Front seats seem to angle back too far." "Smooth ride." "Very hard ride not present in my 1968 Riviera."

Running through our I'd-like-to-see-them-change notes: "When I open the trunk, water runs inside." "Doors are very heavy, makes opening them when the car stands at an angle difficult." "Put back hideaway lights, eliminate fender skirts." "More trunk." "I miss the side vent windows." "Can't replace tail or signal lights unless I drop the bumper." "Cannot replace dash

lights unless you take it to the dealer. They charge you \$23 labor to change a 39-cent bulb." "Go back to an instrument panel with gauges instead of idiot lights."

To sum up, these random parting shots: "I trade every year and can trade for less money on Rivieras than any other car." "Prestige, handling, looks." "It's a high-performance car with comfort." "Have had a fair and pleasant relationship with my Buick dealer for 10 years." "I rarely carry passengers in the rear seat or make long trips where I'd need more trunk space, so for me the Riviera is the greatest." ★ ★ ★

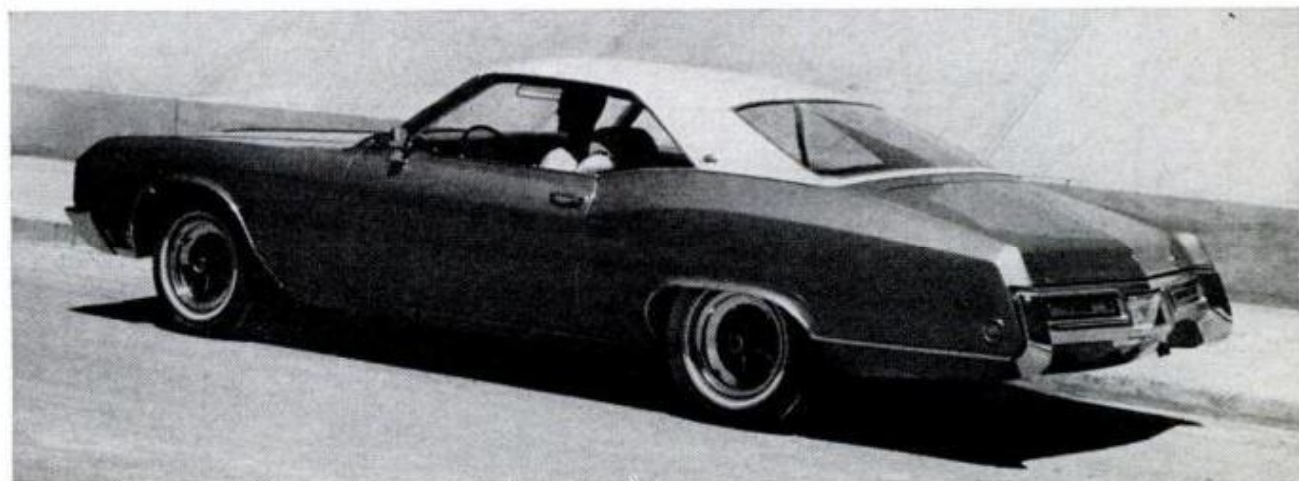

Just patented

PM'S PICK OF THE NEW INVENTIONS

Prepared in cooperation with Roger S. Shashoua, Director, International Inventors Assn., Inc.



1. A DISABLED AIRLINER making a wheels-up landing would come down on a series of padded rollers in this unique invention. The rollers, built into a special emergency runway, are concave to keep the plane centered and are motor-driven to match its speed. A trough of water cools the rollers and

prevents sparks. Two adjustable outboard supports riding in tracks rise up to grip the wings and gradually brake the liner to a safe stop. The system is designed to eliminate the friction in belly landings that often causes fires and to save the time normally required to spray the runway with foam

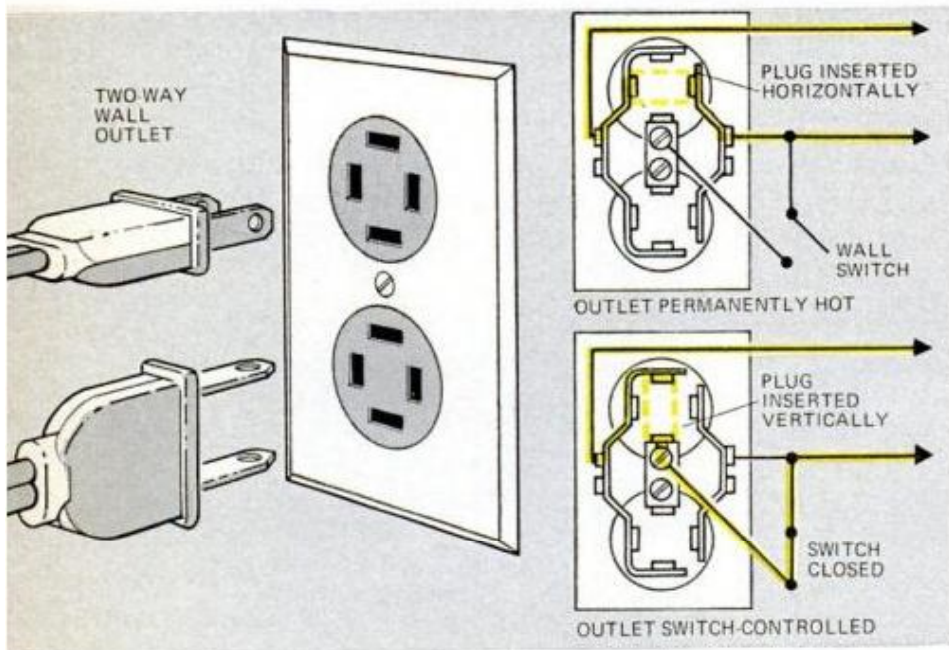

2. TWO-WAY WALL OUTLET serves as either a switched receptacle or a permanently hot one depending on how you insert the plug. Each receptacle has four terminals instead of the usual two, as shown at left. With the plug horizontal, it contacts the two terminals at the sides. These are wired directly to power so the outlet is permanently hot. When the plug is turned vertically, it contacts the top and bottom terminals. These are wired through a wall switch so the outlet is hot only when the switch is turned on. Thus, when you plug a lamp in this way, it can be controlled from a distance. In conventional house wiring, switched outlets often end up in the wrong place for convenient use. With this two-way type, you could have them wherever you want

Inventors of the items shown on these pages are as follows: 1. Karl-Heinz Schnarr, Hannoversche Strasse 82, Bremen-Hemelingen, Germany, and Walter Kucken, Braahlandsweg 26, Bremen-Huchting, Germany (No. 3,490,722); 2. Glenn D. Smith and Robert G. Cook Sr., Dayton, Ohio

(No. 3,426,216); 3. H. Schneebeli and Co., Schaffhuserstrasse 307, Zurich, Switzerland; 4. Albert F. Abbott and Bruce J. Haskin, Seattle, and Marshall E. Klopich, Renton, Wash. (No. 3,444,811); 5. Gerhard Wagner and Walter Kinzel, Mainz, Germany (No. 3,492,683).



4. BLASTING TREES DOWN with explosive charges may soon replace the woodsman's ax in the fast, simple method for felling timber shown above. A straight-in cut is first made at the base of a tree with a chain saw to produce a long, shallow pocket. A thin plastic envelope is then slipped into the



3. YOU CAN PEDAL UP A POLE or tree the way you ride a bicycle with this unusual climbing aid for linemen and tree surgeons. You just pump your legs up and down and you automatically go upward. Attached to each foot is a pivoted lever connected to a metal collar. As you press one leg down, its collar wedges tightly around the pole or tree, giving you a firm foothold. This frees the other leg so its collar can be slid upward. The action is repeated, one leg after another, until you reach the top

pocket and filled with a liquid explosive (top photo at left). A detonator is inserted in a hole in the mouth of the plastic envelope and fired electrically. The force of the shaped charge spreads sideways in a narrow path, severing the tree cleanly near the ground without endangering the trunk

5. INSTANT BRIDGES for soldiers crossing streams and gorges are possible with this special bridge-building vehicle. It carries a pair of prefabricated ramp sections on top over a telescoping boom. As the boom is extended, the sections are pulled apart and joined end to end, forming a rigid span. The boom continues until it reaches the opposite side and the span is slid across it, bridging the gap. The boom is then retracted, leaving the bridge in position, ready for use

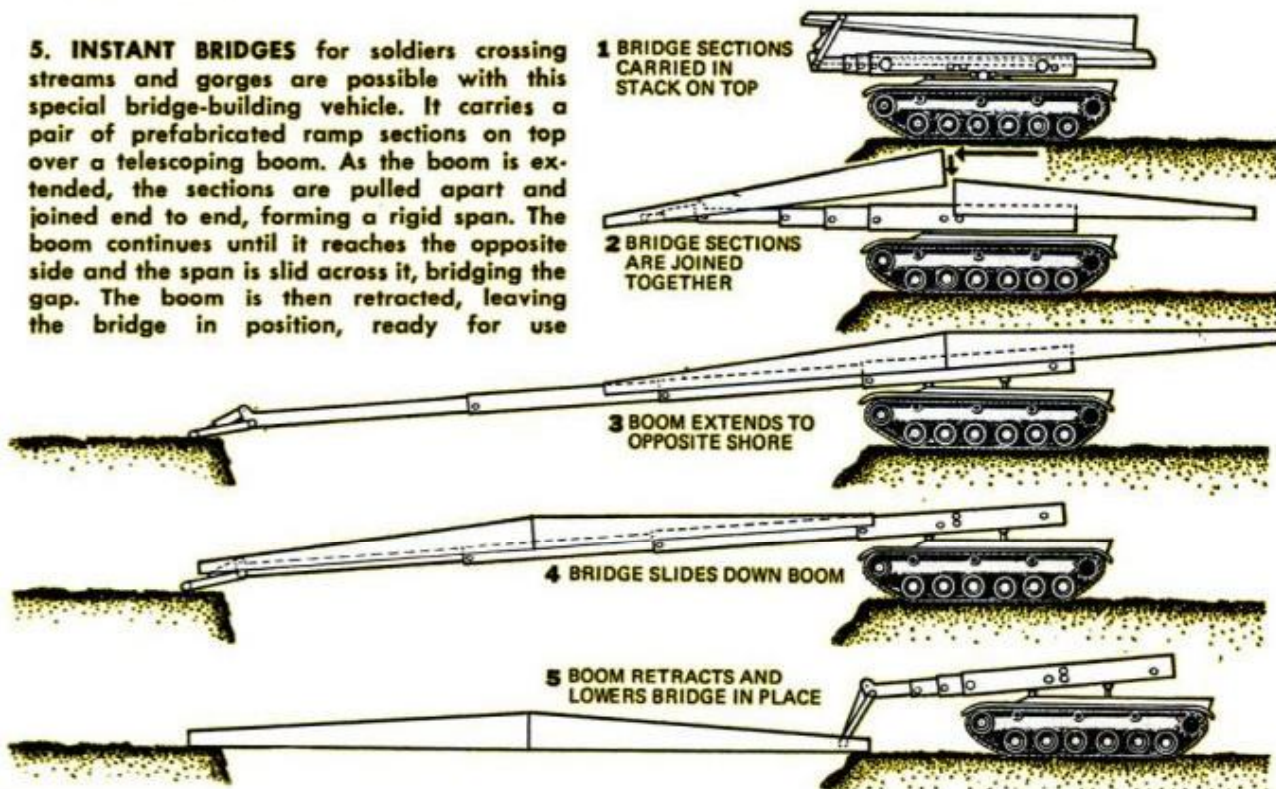

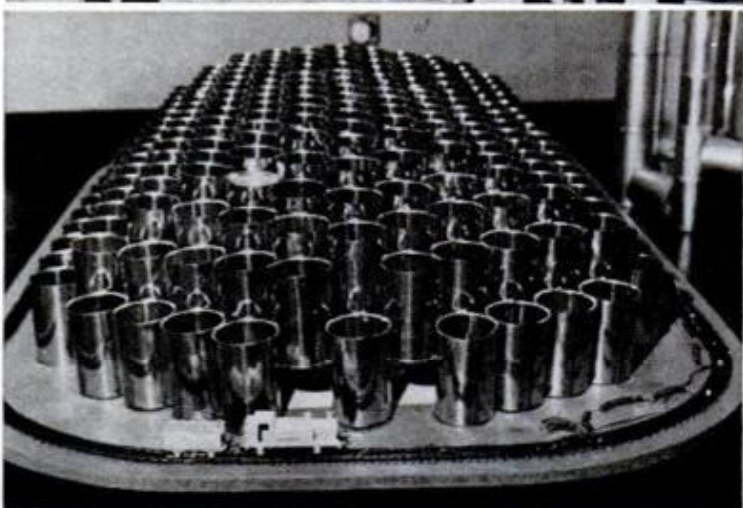

London sound from Tin-Can Alley

To publicize its canned rice pudding, a British firm offered prizes for "unconventional musical instruments" made from cans. Entries included a tuba (upper left), an organ (left), which blew up during the demonstration, and an array of cans (lower right) that "bleeped" as a toy train passed over electrical contacts. Bandsmen (upper right) drew curious stares.



Not really topless—it's a see-through car

Drivers can enjoy the effect of an open-top car without the wind and the rain in their hair when the vehicle is fitted with a custom glass top that a London firm offers. Triplex Safety Glass Co. can put the see-through top on virtually any make of car. The toughened glass is tinted so that it blocks about 40 percent of the sun's heat. In particularly hot weather, the driver can use a zip-in lining to block the sunlight.



Glass carillon

Brandeis University has a "glass" carillon that sounds like the best of the metal ones, but weighs only 40 pounds. The electro-mechanical device, made by G. Finkenbeiner, Inc., of Waltham, Mass., contains 35 "glass" bells made of fused quartz manufactured by General Electric. The sound source in each glass bell is a thin, hollow thread of fused quartz tubing drawn into a foot-long, elongated-bell shape. Each bell is sealed in an evacuated glass tube with a tiny glass-tipped hammer that strikes the bell. The mechanical vibrations are electronically amplified 100,000 times and fed to loudspeakers.



Scores from 50-yard line

It took a football field to dramatize the 150-foot reach of the Lorain Moto-Tower, a crane used in building construction. The truck-mounted tower is also 150 feet high.



Land-and-water houseboat

Powered by a 90-hp stern-drive engine, the Combo-Cruiser zips along at 20 mph in the water. Loaded onto its low-slung trailer for towing, the 23-foot houseboat is a travel trailer, complete with bathroom, kitchen (including a refrigerator) and sleeping space for five adults and one child. The maker is Ship-A-Shore Corp., Mishawaka, Ind.



Tent-trailer that floats

NaviCamper, the boating-camping-trailer sports rig, now comes in Mark II and Mark III versions. The luxurious Mark III includes such features as running lights, compass, LP-gas stove, water tank and sink. The retractable pontoons on all three versions of the 18-foot-long unit are made of fiberglass.

Now: Atomic Power to

To eliminate battery failure in heart

By **ARTHUR S. FREESE**

Illustration by Peter Trojan

ABOUT 100,000 PEOPLE owe their lives day-by-day to an electronic marvel smaller than a deck of cards and powered by tiny batteries implanted under their skin. Since its development 12 years ago, the heart pacemaker has made normal living possible for those who suffer from a malfunction of the nerves controlling the heartbeat, a rather common ailment.

Though tiny, the mercury cells that deliver a slight electric shock to the coronary muscles are relatively bulky and must be replaced about every two years. Scientists in the United States, France and Britain have been seeking a smaller, more permanent power source. In May, 1969, the first atomic pacemaker was implanted in a dog, a foxhound named Brunhilde, by National Heart and Lung Institute (NHLI) researchers. Nine days later

Nuclear-Powered Cardiac Pacemaker

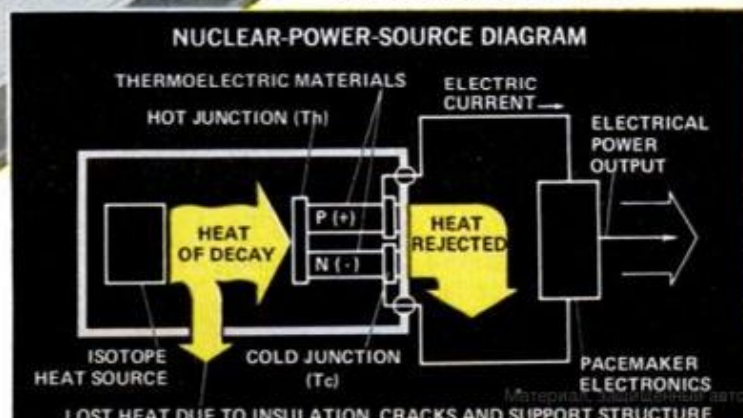
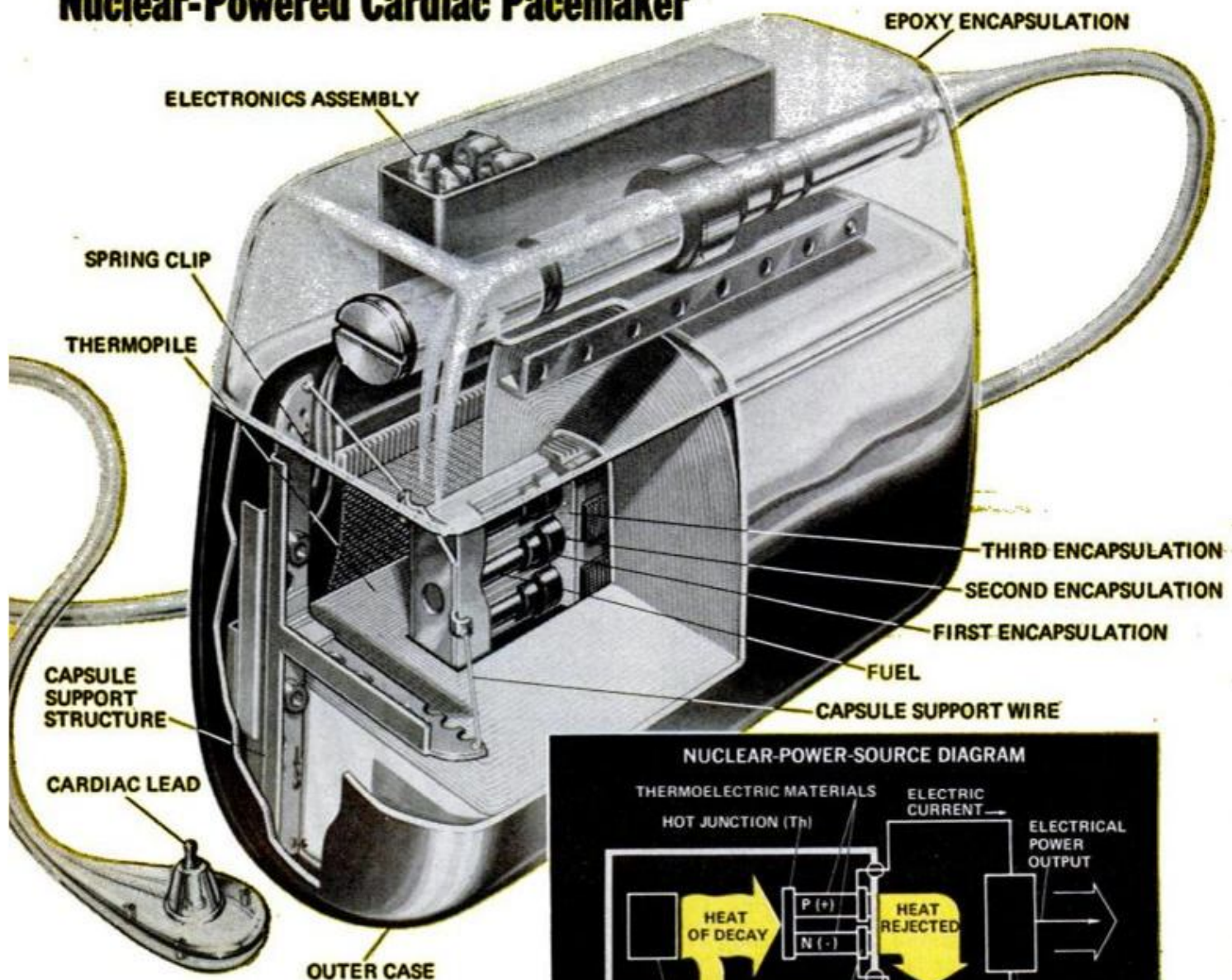

Keep Your Heart Beating

pacemakers, a tiny amount of plutonium may be the answer

the French placed one in a deerhound. While NHLI trials with animals were still under way, the French made the first human implantation of a nuclear-powered pacemaker on April 28 of this year. The device was inserted in the chest of a 58-year-old woman. Dr. Paul Laurens, its developer, estimates that it should function without refueling for a minimum of 10 years.

The atom provides pacer power by thermoelectricity, the direct conver-

sion of heat into electricity. In the NHLI atomic power source, three tiny rods of plutonium 238 (each triply encapsulated in tantalum-tungsten alloy, Hastelloy "C," and titanium-palladium) are the source of the heat. The plutonium gives off alpha particles, but their penetrating power is so slight that they can be stopped by a piece of paper. About 500 milligrams (less than $\frac{1}{50}$ of an ounce) of plutonium is used.

According to Stanley Seiken, chief of the Atomic Energy Commission's Isotope Power Branch, the nuclear device is at present "a handmade laboratory system. We know it works. It's now a matter of adapting the design so it can be manufactured."

Dr. Sidney Levitsky, NHLI heart surgeon responsible for implanting the nuclear pacemaker in animals, estimates the life of the device as a mini-

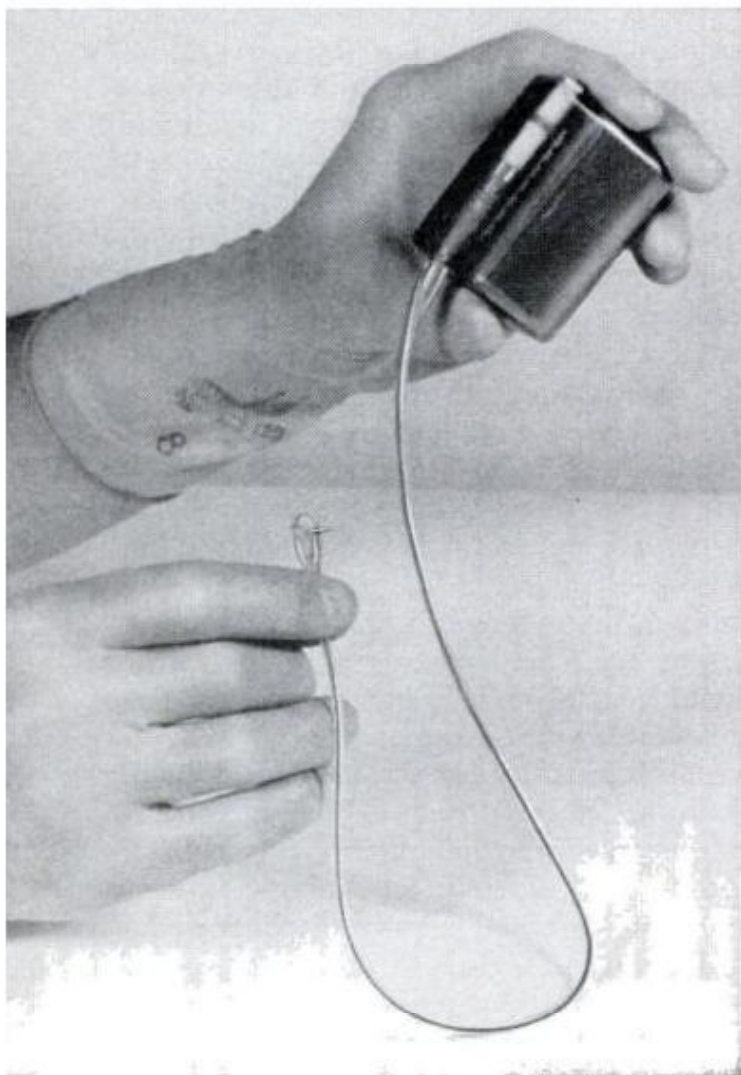

FIRST NUCLEAR-POWERED PACEMAKER (left) generates electricity from a tiny amount of plutonium 238. Heart lead (above) is normally in contact with left ventricle of the heart. The thermocouple consists of eight metallic ribbons, each containing 88 hairlike wires (right) that surround the radioisotope fuel

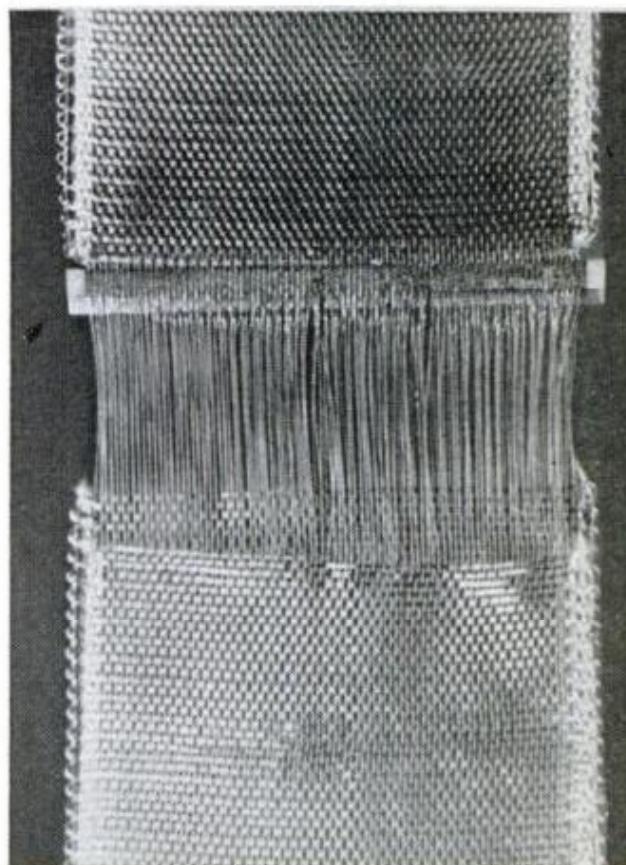

SEPTEMBER 1970

105

imum of 10 years and most probably 20. Seiken foresees the cost as probably \$3000 to \$5000 as compared to the \$750 to \$1000 for today's battery pacers. (Each set of batteries costs about \$250.) But the nuclear pacer will last as long as five or more battery replacements. Each replacement also means hospitalization surgery costs and the inconvenience and risk accompanying the operation.

The American atomic pacer is about two-thirds the size of a cigaret pack and weighs only three ounces—at this stage. Its stray radiation is "no greater than that from the radium dial of some wristwatches," according to NHLI. Surrounding the plutonium rods is a copper strap with six sets of ceramic tabs, each containing 88 thermocouples. These are nine inches long, 2/1000 of an inch thick (barely thicker than a human hair). The thermocouple is made of a copper and nickel alloy wire brazed to a copper and chromium alloy wire. The thermocouples are heated at one end by the decay of the plutonium and the resultant electricity is drawn off and fed into a conventional pulse generator to operate the electronics—the same as any other pacer's.

While the French seem to have stolen the lead by having made the first human implantation, their nuclear pacemaker is, according to Medtronic, the American company that supplied the electronic components, "still in the research stage." Nevertheless, the company insists that the device is "quite superior to the AEC's and quite a bit smaller." The French pacer is an inch and a half in diameter and an inch thick. It uses 150 milligrams of plutonium, less than a third of that used in the American pacer. Its thermocouples are made of a bismuth-tellurium compound, and it's claimed that this is superior to other compounds.

Meanwhile, several institutions are pursuing research on fuel cells that would create electricity to power a pacemaker—or possibly a complete artificial heart—from human body fluids.



POWER FOR PRESENT-DAY PACEMAKERS comes from mercury cells; six cells form a battery that lasts an average of 18 months. Nuclear pacer implanted in dog (right) in May, 1969, is still working perfectly

Scientists have already produced small amounts of electricity by using the hydrogen from glucose and the oxygen from air. Glucose is a form of sugar found in blood serum. In one experiment a transistor radio played for three hours on the electricity produced from a pinch of sugar in a water solution. The power source consisted of two catalytic electrodes separated by a plastic membrane. Hydrogen atoms are freed from the glucose by one electrode and oxygen from the air is supplied by the other. When the hydrogen and oxygen combine, water is produced and releases electricity. In the human body such a fuel cell would draw oxygen and water from body fluids and the water would be absorbed harmlessly by the circulatory system.

At Emory University Medical School, Atlanta, Hal Warner, a biomedical engineer, has operated such a fuel cell on water and glucose and plans experiments with blood serum, the best probable source of glucose if such a device were implanted in an animal or human.

Biological fuel cells are still in the experimental stage. So, for that matter, is the nuclear pacer. Meanwhile battery-powered pacers are saving lives every day.

These electronic marvels are inserted

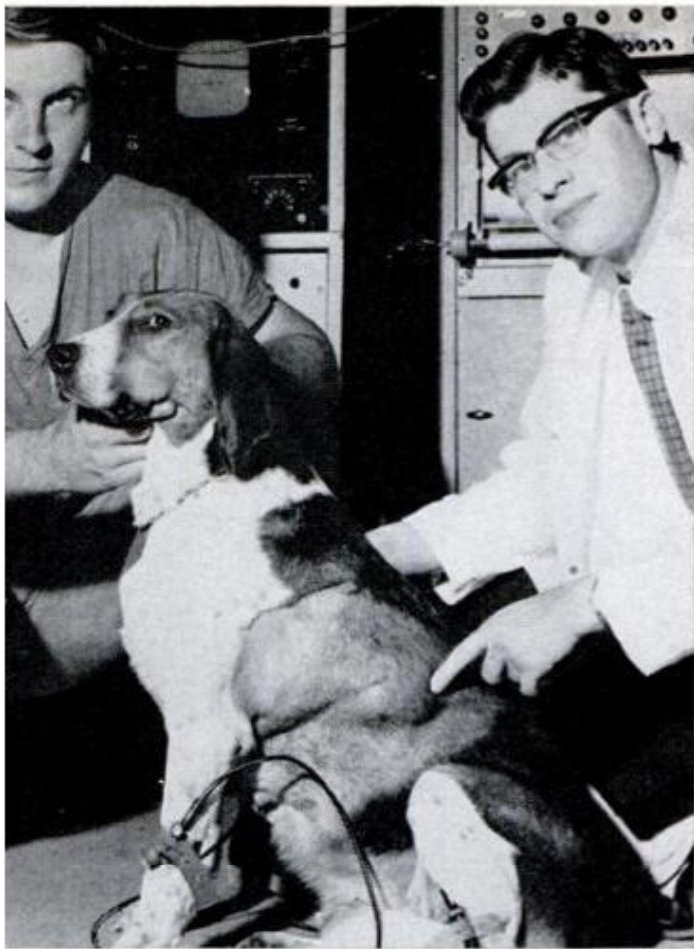

by a sort of life-and-death plumbing. Cardiac pacemakers sense when the heart beats normally and shut themselves off, to protect the heart and to preserve their own batteries. Yet they will promptly cut in should the heart miss even one of its 100,800 daily beats.

Your heart is essentially a hollow muscle, about the size of your clenched fist and weighs less than three-quarters of a pound. Its two upper chambers are called "atria" (plural of atrium) and its two lower—and larger—ones, "ventricles." Your blood is driven through your heart by a flowing muscular contraction (like squeezing fluid out of a balloon), starting with the topmost muscles and sweeping through at some 70 times a minute (nearly 40 million heartbeats a year).

Your heart is kept beating—and its rate determined—by a tiny lump of modified muscle at the back of the right atrium and close to its top. This is the sinoatrial node, your heart's *natural* pacemaker. It has been compared to an electric condenser which steadily builds up a charge, then periodically dis-

charges. This electrical impulse spreads through the atria, reaching another bit of modified muscular tissue, the atrio-ventricular node, which passes the impulse on to the ventricular muscles. It is this electric current which your doctor records on an electrocardiogram.

Disease or surgery of the heart can damage these vital nodes, or the conduction of their signals. The ventricles may then be slowed ("heart-block") to half their normal rate, or even less, and perhaps occasionally stop. This produces faintness, dizziness, unconsciousness and even death. These fainting spells are called Adams-Stokes disease.

To get disorganized hearts back on the beam, work began on artificial pacemakers in the 1950s. First used on a temporary basis, the common early ones had their electrodes implanted directly on the heart. Dr. Seymour Furman, attending cardiothoracic surgeon at New York City's Montefiore Medical Center, recalls that in 1958 "we had reached the point where we felt that in a desperate-enough case we could try it." That year, a Montefiore patient whose life depended on cancer surgery also had Adams-Stokes disease, which seriously reduced his chances of surviving the surgery. Furman tried his pacemaker—and it worked!

Furman and his team were the first to use a transvenous pacer, one whose electrode passes through the veins to lie in a heart chamber. But as soon as the surgery was over, surgeons removed this appliance. They next succeeded with a patient desperately ill with Adams-Stokes disease. But here the Furman team found they had a tiger by the tail—they were afraid to hang on and they couldn't let go. Every time they tried to cut off the device, the heart lost its rhythm. For three months they had to use the pacemaker. But then they knew—permanent pacing was possible.

The principle of the artificial pacemaker is simple—a painless electric shock of 3 to 6 volts can stir a heart

(Please turn to page 214)

How to Talk to Vietnam -Free



You can phone any serviceman almost anywhere in the world via MARS and a network of volunteer ham-radio operators

By ALBERT LEE

YOU CAN ARRANGE a personal telephone conversation with any GI in Vietnam—absolutely free—thanks to a little-known organization with the unlikely name MARS. Using the free MARS service is only slightly more complicated than placing a commercial person-to-person call through to Vietnam—if you know a few of the ground rules about how the organization works.

MARS (Military Affiliated Radio System) has a prime objective to act as an alternate network should regular

lines of communication be blacked out during a national emergency. But since hurricanes, earthquakes and similar tragedies are infrequent, MARS members keep in practice by handling the emergencies and commonplace chatter of everyday life between servicemen and their families and friends.

MARS is a joint venture of the Armed Forces with more than 22,000 civilian ham radio operators. To be a member, a civilian must be an FCC-licensed amateur radio operator with several thousand dollars already invested in sophisticated electronic equipment.

Short of occasional government grants of surplus radio equipment, civilian members receive no compensation for their efforts. The number of calls made by members varies widely, from a New York City lawyer who places a half-dozen calls a week, to Sen. Barry Goldwater of Phoenix, Ariz., whose round-the-clock radio station completes more than 100 calls daily.

Calls are transmitted by a method known as "telephone patching." More

ARRANGING CALL from Phan Rang, Vietnam, to Jacksonville, Fla., is USAF MARS Sgt. Ted Trojanowski



than 641,000 such patches went through from Vietnam alone last year.

Here is how a MARS telephone patch works: A soldier in Vietnam contacts his radio station on base and supplies your U.S. telephone number and address. The station puts through a short-wave radio call to the MARS civilian radio operator nearest your home.

The local MARS operator plugs his short-wave receiver into a commercial telephone (the actual patch); then he calls the telephone company and has them place a station-to-station call to you.

When you answer the phone, the hook-up is complete, and you're ready to talk to the soldier in Vietnam.

The MARS service is free, but you may have to pay a dollar or two for the commercial telephone call portion of the patch from the MARS civilian operator to you. A few MARS stations even pay this charge for you. A group of businessmen in Omaha, Neb., for example, pick up the tab for 70 percent of the calls transmitted through that city. Their bill runs around \$1500 a month.

You can generally tell how much a call will cost you by your location. Short-wave propagation from Vietnam is best west of the Mississippi River. Therefore, if you live on the Eastern Seaboard, you can expect to pay as much as \$1.35 from California or as little as 50 cents from Kansas. If you live in the West, you might pay only a dime for a local call.

The advantages of using MARS over commercial telephone lines to Vietnam are numerous. An AT&T call to Saigon costs you \$12 for three minutes person-to-person. Even if money is no object—an unlikely circumstance for most soldiers' wives—it is often impossible to contact a Vietnam serviceman over commercial lines.

There are just six commercial telephone locations in Vietnam, all clustered around Saigon. MARS has 78 stations spread evenly across the country. In many locations, MARS service is the

only communication available. Only 10 conventional telephone circuits are available for Southeast Asian use, and these are open approximately 12 to 15 hours a day.

But while MARS is by far the best way to contact a GI, it too has its complications. Most perplexing is the MARS regulation which requires that all patch calls originate from the serviceman rather than from you.

The reason: Soldiers are constantly being shuffled around the countryside in Vietnam. Sometimes entire platoons are simply listed as "in the field." To get a serviceman to the telephone, if you called, would be virtually impossible. And even if the soldier is stationed on a fixed base and can be pinpointed to a specific office, your call would undoubtedly tie up the phone lines for several minutes while he was paged.

The waiting list for calls is long. The rule of one-way communication exists to insure every GI a chance to call home. Even commercial telephone company executives ask that you arrange to have the serviceman call you instead of attempting to contact him yourself.

The easiest way to accomplish this is to write and ask the soldier to call you via MARS. However, it could take upwards of a week before the soldier could receive your letter and respond.

If you are in a hurry to arrange a call, a faster approach is available through another free MARS service—teletype messages. By contacting any

RETIRED TEACHER, James Cotter, Dearborn, Mich., uses ham equipment to patch servicemen's calls



local MARS member, you can send a 25-word message to any serviceman. The message goes by short-wave radio teletype and, according to a recent Navy poll, usually reaches the serviceman within 12 to 48 hours.

Here a problem lies in ferreting out a local MARS member who can send the message. It is possible that you may have trouble finding a nearby MARS station. Why? Because MARS, as large and efficient as it is in operation, is highly disjointed on the civilian volunteer level.

There is not one MARS organization but three: Army, Air Force and Navy-Marine Corps. If you want to send a message to a Navy man, you have to find a local Navy MARS member.

The three separate MARS headquarters in Washington, D.C., have no listings of members in specific areas which

MARS volunteers furnish time, skills and equipment to keep communications open

they are willing to release to the public. They will give you names of regional MARS directors, but finding a local member this way is like trying to get the name of your postman by writing to the U.S. Postmaster General—it's just not worth the effort.

MARS volunteers are usually well-known in their communities. A call to the reference library of your town newspaper will usually turn one up. If that fails, call the nearest amateur radio operators' club and you'll end up with a long list of MARS members. The Red Cross and city hall are also sources of information.

Once you have arranged your first patch call, the second and third will be easy. A Detroit wife talks to her husband via MARS every week. She maintains a list of things to tell him and keeps it next to her telephone so that she can rattle it all off before her three-minute limit is up.

A Chicago wife doesn't like the fact

that a radio operator must listen in on every call to know when to switch channels. She and her Air Force husband devised their own code. When he calls from Vietnam, they talk in their own private language.

Wives have also learned to remind their distant husbands that Vietnam is 13 hours ahead of Eastern Standard time. A couple of half-conscious conversations at 3:00 a.m. are generally adequate to get this across.

Though Southeast Asia demands the lion's share of the MARS service—over a million and a half calls since 1965—much of their phone patching is in other directions. You can use MARS to call any American fighting man, almost anywhere around the globe. There are a couple of noteworthy exceptions, such as England, where British regulations forbid U.S. ham radio operations in their frequencies. Egypt and most communist countries also outlaw MARS service.

No location is too inaccessible for MARS service. Navy MARS, for example, puts through about 10,000 calls to Antarctica during the four-month-long freeze-over each year.

MARS welcomes messages and calls for any reason. But it suggests that you go directly to a military recruiter or Red Cross chapter if a real emergency should occur. News of serious injuries or deaths in the family can best be handled by military or Red Cross emergency communication networks.

MARS volunteers furnish time, skills and tie up millions of dollars in equipment to keep communications open between you and servicemen. They do not care whether you use their free service or choose to call commercially—as long as you call.

As one radio operator in Da Nang put it: "When a soldier gets a letter from home he's happy. When he sets down the MARS telephone receiver after talking to someone special back home, he's ready to scale 10-foot walls."

MARS is morale building on both ends of the line. ★★★



Honda's three-wheeler

Snow, sand and mud are not obstacles to Honda's new US90, a three-wheeled vehicle powered by a 4-cycle, 89-cc engine. The US90 comes apart for carrying in a car.



Probe heart with sound

A camera can photograph ultrasonic echoes of sonar impulses bounced off the heart's interior walls to record heartbeat and blood circulation data. This use of sonar is by Stanford physicians and scientists.

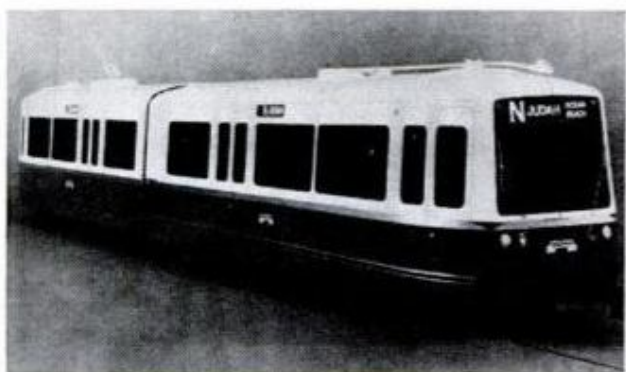

Articulated trolley cars planned for San Francisco

A fleet of 78 two-unit articulated cars may be operating on San Francisco's municipal railway by 1972. The airconditioned, electric cars will run on the surface and in subways.



Both French and German pilots may train in Alpha-Jets

Proposed as a training plane for French and German flyers, the Alpha-Jet will be built in both countries. First flying prototype of the near-sonic craft can be ready in 1972.

The Minis Are Out to Rule the Road



PM crosses the Rockies with Chevrolet engineers in a Vega 2300, drives a Pinto on Ford's proving grounds and revisits Lincoln-Mercury's hot-selling little Capri

By **MICHAEL LAMM**, West Coast Auto Editor

Photos by the Author

LAST MAY, Chevrolet invited *PM* to ride shotgun with six engineers putting final shakedown mileage on three preproduction Vegas. The route: Denver to Phoenix—high Rockies to desert lowlands. Travel time: two days. Our hosts: the six men mostly responsible for the Vega's design and development. The three cars were a Vega 2300 sedan with the 90-hp ohc Four and standard three-speed manual trans, a 90-hp Vega wagon with Powerglide, and a high-performance 110-hp Vega coupe with four-speed. All cars were hand-built prototypes, since assembly-line production had not started.

We had CB radio contact between all cars at all times. In addition to the Vegas, we also had for comparison a new VW, a Toyota Corona and a Maverick.

By June, it would be too late to make major changes in the Vega, but, for example, one engineer considered the accelerator spring too strong, so he ordered a different stretch rate. Another engineer was testing to see whether the Vega really needed a vibration damper on its driveline. Without it, the

(Please turn to page 114)

By **BILL HARTFORD**, Auto Editor

Photos by Bruce Moss

PREPRODUCTION PINTOS were corraled in the Romeo, Mich., Proving Grounds of the Ford Motor Co. for test driving early last June. On the way there, before even seeing the new model, I thought about a lead to kick off a story about the new minis . . . "They'll sell themselves. That's for sure. It's been a long wait for these American 'Volkswagens' which—like their German rival—will keep the same styling for years to come. At last, with Pinto and Vega joining Gremlin, there will be a choice of domestic cars to break the status habit, that will be really economical to own and operate, that, with tender, loving care, should be as 'new' and as satisfying to own four years from now as today . . ."

Right on the money. There's been a steadily growing market for cars of this description, and I was sure, as Ford promised, that the Pinto would be one of them. It was only late '68 when Ford engineers got the go-ahead to start with a 94-inch wheelbase and build a 'better Volkswagen.' Between that time and Feb., 1969, when the final design was approved, the amazing bug was prob-

(Please turn to page 115)

JOINING THE GREMLIN (center left) in booming mini-car market is Ford's sleek Pinto (top), lowest of the minis. Vega hatchback coupe (center right) and station wagon are additional body styles to sedan on cover. Selling faster than it's made is Capri, offered by Linc-Merc dealers and built by Ford of England



PINTO



GREMLIN



VEGA



CAPRI



HATCHBACK VEGA, officially called the coupe, combines fastback styling with station-wagon convenience. Test car is equipped with optional custom interior: includes woodgrain accent, passenger-assist handle

VEGA (Continued from page 112)

four-cylinder engine set up a barely perceptible hum at 2600 rpm and a related, more noticeable buzz at 4000 rpm. The damper happened to be intricate and costly, so if the car could do without it, the saving might be used elsewhere.

Of the Vegas on the trip, the 90-hp sedan, with its 2.53 axle, equaled the fuel mileage of the VW—24.6 mpg at high speeds in flat country. Average Vega consumption is about 28 mpg in normal driving. Acceleration of the 3.36:1-axled, 110-hp coupe beat the Maverick up hills. And cornering ability with the coupe's H-D suspension and front and rear antiroll bars put the Vega far ahead of its competition on mountain curves. Even the plain-Jane wagon felt more stable to me in fast maneuvering than the three compari-

son cars. Yet all Vegas have what amounts to a big-car ride—very smooth, quiet and unchoppy.

Both the coupe and the wagon have surprising amounts of cargo space. The rear seats of both cars fold flat, giving the coupe a lot extra storage volume and the wagon a whopping 50.2 cu. ft. The sedan carries 9.1 cu. ft. of luggage by virtue of its deep trunk shape. And for a change, trunk space is *usable*, not all chopped up by the spare tire and gas filler.

Front seats in the three body styles are full-sized and comfortable, adjustable for rake. There's no fender-well encroachment on legroom. Rear legroom tends to be short—33.8 inches, but that's five inches more than the Mustang fastback.

The all-new engine is an in-line,

(Please turn to page 220)

THE '71 MINIS—HOW THEY COMPARE

Car	Body Style	Wheel- base (in.)	Overall Length (in.)	Overall Width (in.)	Overall Height (in.)	Track (f/r., in.)	Engines (Displacement—4 cyl. except as noted—ohv except as noted—carburetion)
American Motors Gremlin	2-dr. sedan,	96.0	161.3	70.6	51.8	57.5/57.0	232 cu.in. (3800 cc)-6-1bbl. 258 cu.in. (4200 cc)-6-1bbl.
Chevrolet Vega 2300	2-dr. sedan 2-dr. coupe, wagon, sedan deliv.	97.0	169.7	65.4	51.2	54.6/54.1	2300 cc (140 cu.in.)-ohc-1&2bbl.
Ford Pinto	2-dr. sedan	94.0	163.0	69.4	50.0	55.0/55.0	1600 cc (97 cu.in.)-1bbl. 2000 cc (122 cu.in.)-ohc-2bbl.
Lincoln-Mercury Capri	2-dr. sports coupe	100.8	167.8	64.8	50.9	53.0/52.0	1600 cc (97 cu.in.)-1bbl.

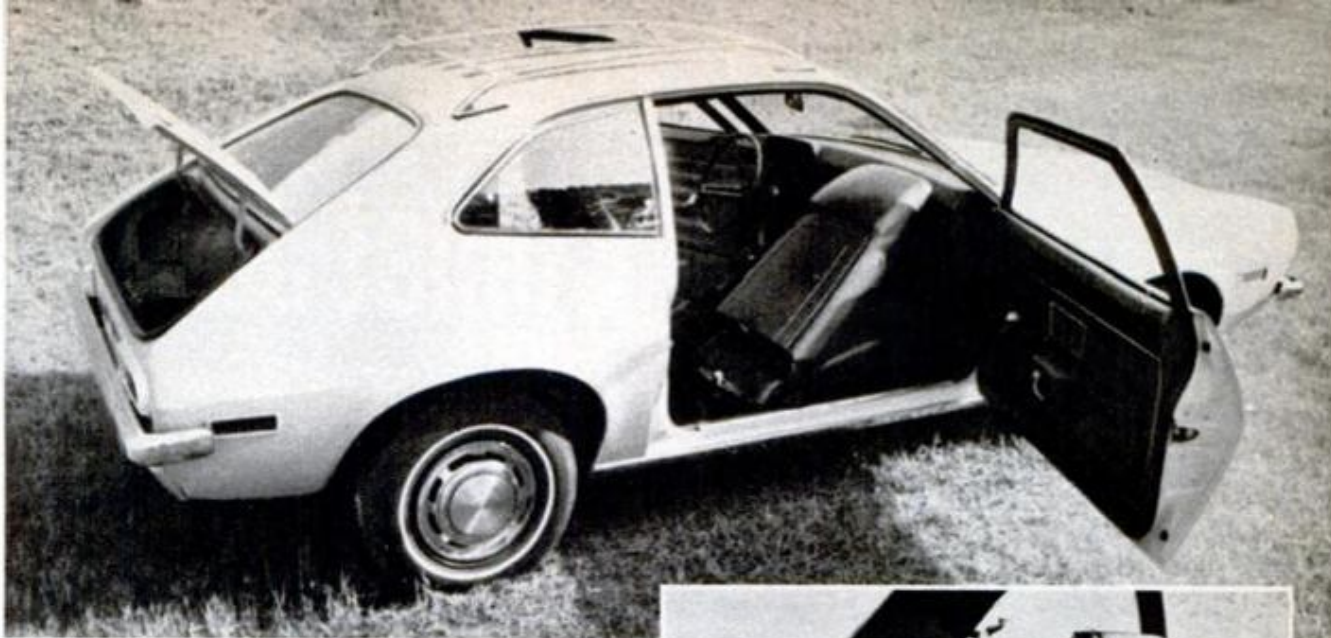

PINTO OPENS UP for easy access to rear seat which folds down, becomes platform, goes through to trunk

PINTO *(Continued from page 112)*

ably more discussed in Dearborn than in Wolfsburg. Meeting VW "head-on" was the rallying cry.

Here was the result! I scrutinized the Pinto and I drove it. And I'm sure that the people responsible for it—having spent all-too-short months designing a new car within dimensional limitations and price range of a VW, and striving to better VW's comfort, convenience, performance and appearance—would take it as the most flattering indication of their success that it was well after I first saw and drove the Pinto that I remembered this was a VW-sized automobile!

Ford rearranged VW dimensions inside and out to come up with a car that's nothing like a Beetle, yet competitive in almost every respect. True, the Pinto design sneaks in a .5-inch longer wheelbase, four inches more length and about eight inches more width, but it's over a half-foot lower, of conventional front-engine design and styling, and one-up on VW in all people-packaging dimensions except headroom. Add to that "comparable" initial cost, economy, performance and simplicity of design, an even smaller turning radius than VW and similar versatility, like the fold-down rear seat (giving 38.1 cu. ft. cargo space, but, alas, it's an extra-cost option), and

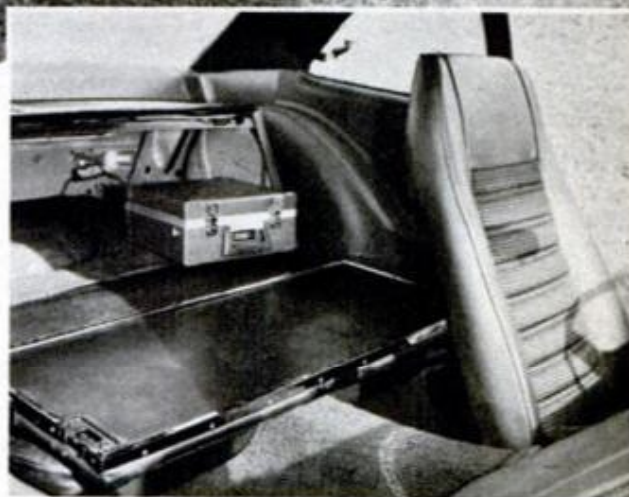

the result is an automobile that makes all the sense that VW has been making since its 1949 U.S. introduction.

I drove two Pintos—one with the standard, 1600-cc, British-built engine and all-synchro, four-speed, floor-mounted manual transmission, and the other with the optional, German-built, 2000-cc overhead-cam engine and three-speed floor-mounted automatic (four-speed stick will be available with this engine soon).

Axle ratio with all engine-transmission combinations is 3.55. The engines, with compression ratios of 8:1 and 8.6:1, use regular fuel and are rated at 75 hp at 5000 and 95 hp at 5700 rpm, respectively. While I didn't make timed performance runs, it was obvious the stronger, higher-revving two-liter ohc is a desirable option for this 2013-pound car. It gives the little extra performance that can be used to beat VWs away from traffic lights. Overall impression is that the Pinto should appeal

(Please turn to page 220)

FORD



The Ford, Lincoln-Mercury

Comet Joins the



COUGAR



THUNDERBIRD



MONTEGO

COMET

FORDSPORT DAY at Brands Hatch in Merry England is an annual motoring spectacular where you can see Fords that you never see here. Owners of little passenger cars—Cortinas, Anglias, Escorts, Capris, and somewhat larger Zephyrs, Corsairs and Zodiacs—go out to thrill to a full day of fanfare and Ford-powered competition: Formula Fords, twin-overhead-cam Escorts, 3-liter Capris and other FoMoCo performance machines—even an F1 car with the extraordinary Cosworth-Ford—the winningest engine on the Grand Prix circuit.

All this may sound like a lot of British ballyhoo over scaled-down kiddie cars. Why, even the GP engine (183 cu. in.) is only a little "larger" than Maverick's 170 Six! And the Maverick—smallest of

FORD CONVERTIBLES, in XL series last year, are LTD models for '71

COUGAR CONVERTIBLES and hardtops are restyled, longer, wider

THUNDERBIRD HARDTOPS and Landau roof models have redone grille

MONTEGO here is Cyclone Spoiler model. Comet is L-M's new compact

Lineup

Big Stars

By **BILL HARTFORD**,
Auto Editor

Photos by Bruce Moss

Ford's cars (until Pinto and Capri)—is about as big as the English deluxe sedans or saloons as they are called. But as the waiting list for Gremlins and Capris grows and as lines start forming to see the Pinto and Vega, it's obvious that Americans are getting a new perspective on size this year. The imports, and the new domestic minis with their nimble handling and zippy four-cylinder engines may also give us a new perspective on the meaning of performance.

There's no Fordsport Day, U.S.A., but last June was the press introduction of Ford and Linc-Merc's '71s—parading hot performers like the Mach 1, Torino Cobra and...sssnarl.... Cyclone Spoiler. Again, "wider stance, greater length and more rakish angle of the windshield," describe even the tamer models. The day of the small car may be dawning, but there is still a strong demand for larger, higher-pow-

TORINO COBRA, one of 14 mild to wild intermediates, comes only as SportsRoof

MUSTANG MACH 1, longer and wider for '71, has an all-new "flatback" SportsRoof

MERCURY continues family-size Marquis, Monterey; discontinues Marauder models

MAVERICK is back with four-door sedan that's 7 inches longer than two-doors



TORINO



MUSTANG



MERCURY

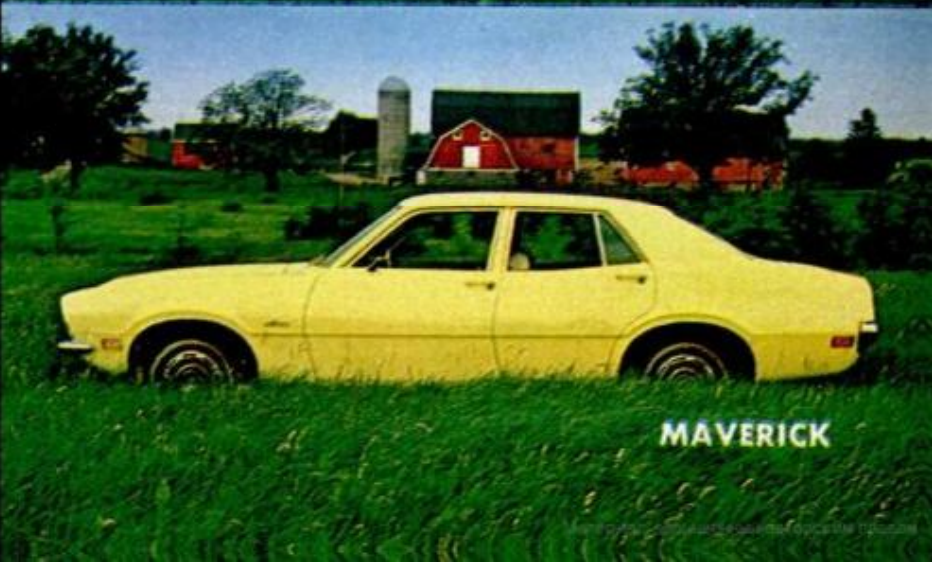

MAVERICK



LINCOLN CONTINENTAL, slightly changed outside, gets side impact beams, standard Michelin radials



CONTINENTAL MARK III, unchanged in sheet metal, offers longer list of standard, optional features

ered luxury cars (yup, even "compacts" among them are available with options like V8s, air and power steering). Ford's "bigger" cars certainly meet this demand—while still, by the way, incorporating more safety features for '71 and controlling exhaust emissions within the currently defined limits.

Maverick and Comet are essentially the same car. Maverick has a four-door model—thoughtfully placed on a longer wheelbase—that's in addition to last year's two-door sedan and the superbly executed '70½ "Grabber" Sports Sedan. The same three-model approach holds for L-M's Comet, the sporty two-door being a "GT." Traditionally offering what buyers regard as a "step-up" from Ford, L-M has in the Comet more trim, appointments, power options and 302-cu.-in. V8 power. Still more options for the '71 Maverick—such things as electric clock, rear-window defogger, convenience and accent groups, high-back buckets, just to start the list—should put the average selling price of the car well above that for the more austere Pinto and hence out of price, as well as size competition—in case you were wondering about Maverick's low-price tag *vis-a-vis* Pinto's only slightly lower predicted price.

Torino and Montego, intermediate-size car lines of Ford and L-M, respectively, share the same wheelbase and offer a plethora of body styles. Torino is a couple up on Montego with a convertible and SportsRoof hardtop models.

Both lines—running with a good thing—are little changed from last year. Look for only the predictable changes in a facelift year: new or revised grilles, new ornamentation—also a lot of new paint colors. Inside and under the skin of all the cars—from the base models through Cobra, GT and Brougham and the Cyclone, GT and Spoiler—are new design and technical features, and new options and power team features. Electric rear-window defroster (or heated backlight as it's called by L-M) is an option as is a really sharp-looking two-tone vinyl-knit upholstery. The simple addition of a return spring integral with throttle control cable (on all car lines) gives a smooth pedal feel. On hardtops and convertible (and on Mustang and Ford) door glass is mechanically held to prevent slip, simplify replacement.

Ford and Mercury, the so-called "full size" cars, have been extensively redesigned and the best word to describe them is . . . smooth. Hide the wipers, eliminate the vent panes, recess the door handles, do a little wraparound and French curve treatment on the bumpers and the result is a "family car" conceived more in fine modelers' clay than Play-Doh. Ford's got 19 models spread out among the Custom, Custom 500, Galaxie 500, LTD and LTD Brougham lines. XL has been discontinued. Mercury has 15 models in its Monterey, Monterey Custom, Marquis and Marquis Brougham lines. Convertibles and Marauders are no more. Both FoMoCo

divisions have more "sedan/hardtop" models this year. The term refers to a car with four-door hardtop roof style, using thinner pillars than a sedan and frameless window glass. Side impact beams are in the doors of all models (as well as those of Mustangs, Cougars, Mercurys and Continentals). A 400-cu.-in. V8 (derived from the 351 Cleveland engine) is all new. The regular-fuel powerplant has a compression ratio of 9.1 and, at 4.0x4.0 in., a perfectly square bore and stroke.

Mustang, while retaining enough vestigial design elements to identify it immediately, is most changed since its introduction in '65. Wheelbase is up one inch, overall length up 2.1 inches, width up 2.4 inches. All models have wider track and are lower, but, most significantly, the flatback is flatter than ever for '71! The line is severe, but I'm sure Mustang has correctly monitored the

pulse of the sporty car buyer again. The SportsRoof comes in base model, Mach I and Boss 351. The convertible, hardtop and Grande hardtop complete the line and give the option of rear visibility! Hidden wipers, 60° windshield angle and flush door handles are other styling snares or aerodynamic design elements, depending on your orientation. Power windows are among many new options and a new top linkage in the convertible model looks and works better and gives more rear seat room. The 250-cu.-in. Six replaces the 200 as base engine for the line, and standard in the Boss 351 Mustang is the 351 HO high-performance V8 set up by Holman & Moody. The 429 CJ and CJ-R replace last year's 428s.

Cougar, too, gets its most extensive changes since it first hit the road with the '67 model. Changes parallel those for Mustang—longer wheelbase, longer,

(Please turn to page 222)

1971 FORD AND LINCOLN-MERCURY SPECIFICATIONS

Car	Body Style	Wheel-base (in.)	Overall Length (in.)	Overall Width (in.)	Track (f/r in.)	Engines in Model(s) Series* (Displacement, cu. in.—V8 except as noted—carburetion)
Maverick	2-dr. sedan, 4-dr. sedan	103.0 109.9 ¹	179.4 186.3 ¹	70.6 70.7 ¹	56.5/56.5	170-6-1bbl., 200-6-1bbl., 250-6-1bbl.
Comet	2-dr. sedan, 4-dr. sedan	103.0 109.9 ¹	181.7 188.6 ¹	70.6 70.7 ¹	56.5/56.5	200-6-1bbl., 250-6-1bbl., 302-2bbl.
Mustang	2-dr. hdt., SportsRoof, convertible	109.0	189.5	74.1	61.5/61.0	250-6-1bbl., 302-2bbl., 351-2&4bbl., 429-4bbl.
Cougar	2-dr. hdt., convert.	112.1	196.9	75.1	61.5/61.0	351-2&4bbl., 429-4bbl.
Thunderbird	2-dr. hdt., 2&4-dr. landau	115.0 117.0 ²	212.5 215.0 ²	78.0 77.4 ²	62.3/62.3	429-4bbl.
Torino	2-dr. hdt., 2-dr. SportsRoof, convert., 4-dr. hdt., sedan, wagon	117.0 114.0 ³	206.2 209.0 ³	76.8 ⁶ 75.4 ³	60.5/60.0	250-6-1bbl., 302-2bbl., 351-2&4bbl., 429-4bbl.
Montego	2-dr. hdt., 4-dr. hdt., sedan, wagon	117.0 114.0 ³	209.9 211.8 ³	77.3 75.4 ³	60.5/60.0	250-6-1bbl., 302-2bbl., 351-2&4bbl., 429-4bbl.
Continental Mark III	luxury coupe	117.2	216.1	79.4	62.34/62.34	460-4bbl.
Ford	2-dr. hdt., convert., 4-dr. hdt., sdn., sdn./hdt., wagon	121.0	216.2 219.0 ⁴ 219.2 ⁵	79.2	63.0/64.0 63.3/64.3 ⁴	240-6-1bbl. ⁷ , 302-2bbl., 351-2bbl., 390-2bbl. ⁷ , 400-2bbl., 429-2&4bbl.
Mercury	2-dr. hdt., 4-dr. hdt., sdn./hdt., wagon	124.0	224.7	79.3	63.0/64.0	351-2bbl., 400-2bbl., 429-2&4bbl.
Lincoln Continental	4-dr. sedan, coupe	121.0 ³ 127.0	220.5 ³ 225.0	79.4 ³ 79.6	64.3/64.3	460-4bbl.

1, 4-dr. models; 2, 4-dr. landau; 3, 4-dr. wagon; 4, 6-passenger wagon; 5, dual-facing rear-seat wagon; 6, 2-dr. models, 76.4 for 4-drs. and 76.7 for convert.; 7, not available in California

*Not all engines available in all models

BOATING

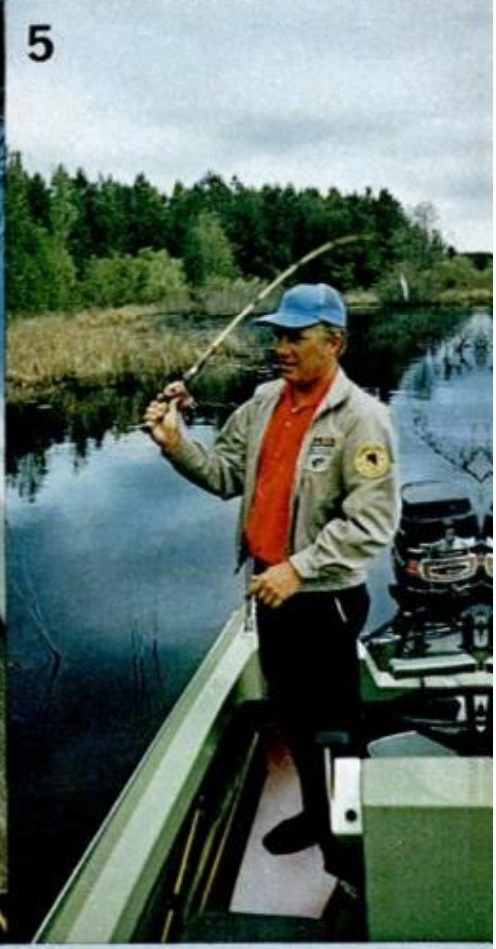
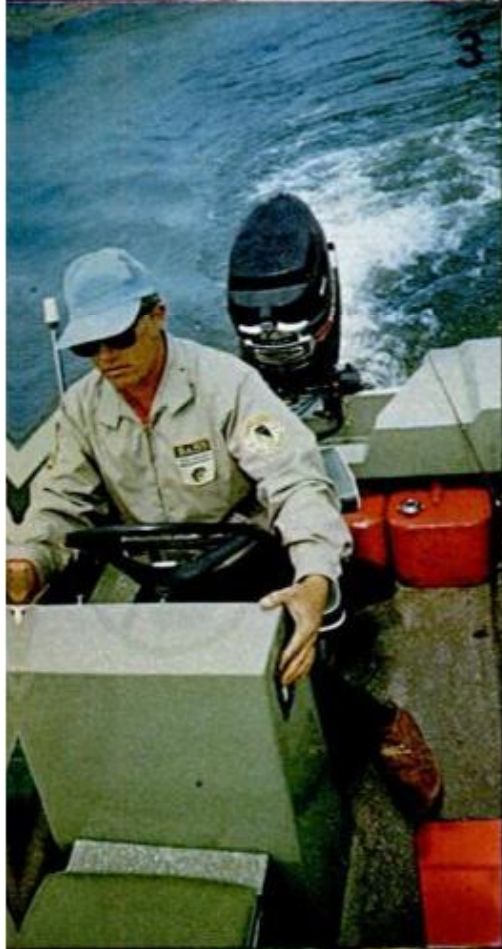
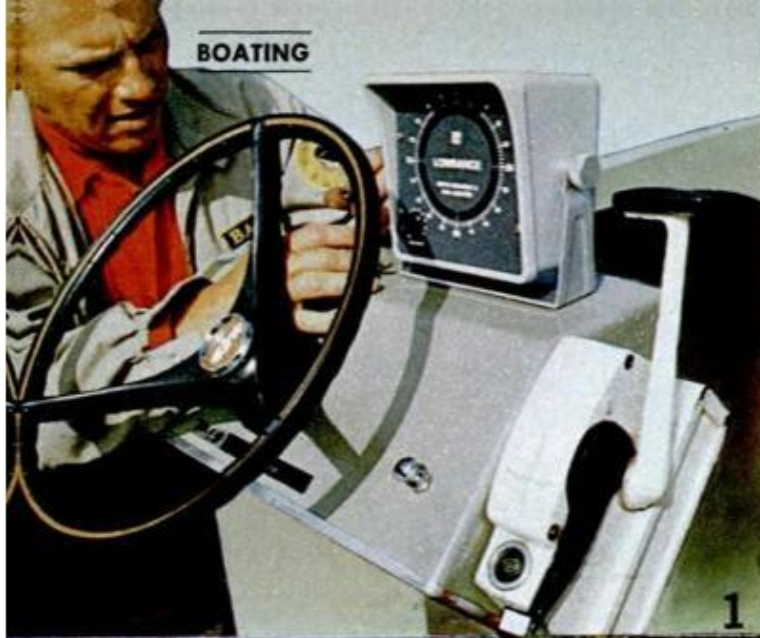

FISHING WITH A GYPSY

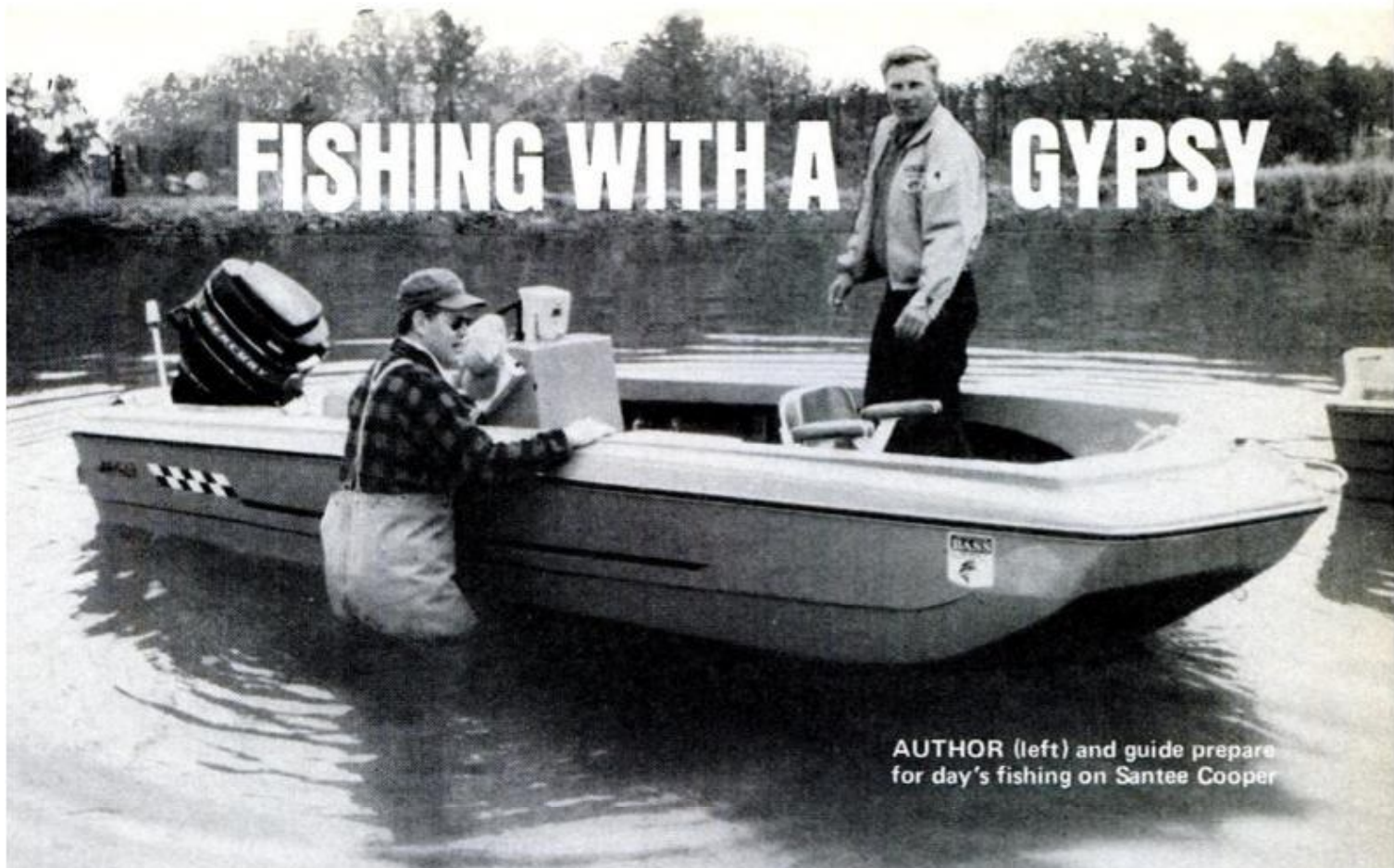

AUTHOR (left) and guide prepare for day's fishing on Santee Cooper

PM took MFG's new Fishin' Gypsy into South Carolina with another fishin' gypsy, 30-year-old Roland Martin, as guide.

By GEORGE REIGER, Boating and Outdoors Editor

A FORMER U.S. ARMY OFFICER who taught school in Brazil and then drifted through a dozen different states before settling in South Carolina is currently one of the hottest anglers on the BASS (Bass Anglers Sportsman Society) Masters competition circuit. Just last year Roland Martin joined BASS and promptly took second place in the first fishing contest he entered, at Toledo Bend Reservoir on the Texas-Louisiana border. In March he took top honors in the \$6500 Lake Seminole Tournament held on that famous lake along the Georgia-Florida line. In between tournaments and guiding assignments, PM persuaded him to help us test the merits of MFG's Gypsy.

Built primarily with anglers in mind, the Fishin' Gypsy can double as a family ski boat. In fact, the newness of this boat is actually in its interior layout—not in its hull design—and MFG fanciers will recognize the familiar Gypsy 15 cathedral-Vee hull, a bow rider with forward sponsons. Its manufacturer claims more square footage capacity than other similar designs of equal length, and we can attest to the ample casting room for two men—even three, if necessary.

It's rated for an 85-hp outboard; we used an 80-hp Merc—a remark-

1) Martin finds ample room atop MFG console for installation of Lowrance depth indicator. 2) Forward storage space is best for bundled items that won't slip out lower opening. 3) Mercury power tilt lets Martin run with fingertip control around stumps, over shallows. 4) Storage area for rods is adequate but needs lock for rods left overnight. 5) Stern has plenty of casting room. 6) Gypsy really moves with 80-hp engine. 7) Displacement caused by author's weight on bow is hardly noticed in horizontal line of boat

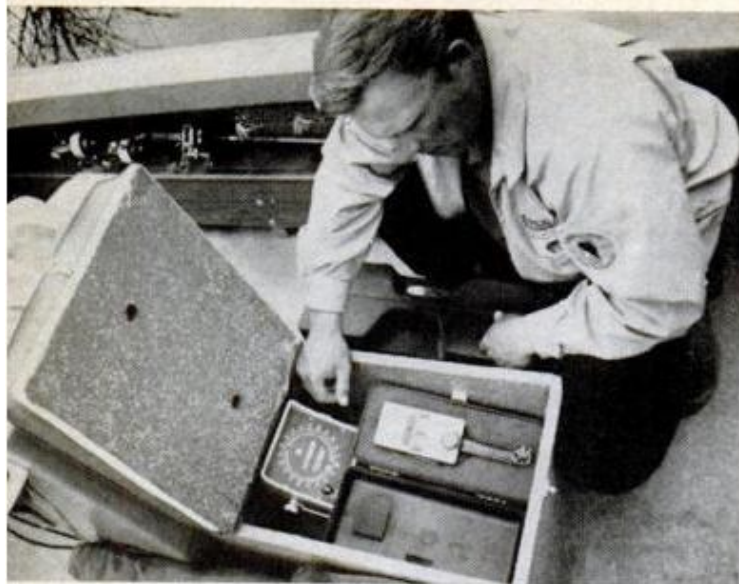

IF YOU FISH with artificials, live baitwell doubles as a storage box; padded top also makes it a seat



CENTER CONSOLE SEATING offers best balance and visibility on speed runs through watery outback



NOT ALL OUR TIME was spent in testing the MFG hull; that big bass on the right weighed 8¾ pounds

ably economical engine in this power rating. We found the boat extremely quick on takeoffs but with a tendency to rear up while accelerating to plane with just one man aboard. The hull is stable and corners well, but it will skid in too sharp or fast a turn.

Lakes Moultrie and Marion—the two major components of the Santee-Cooper reservoir and drainage system—are perfect for testing boats as well as catching lunker largemouths. With a stiff breeze, the 170,000 acres of water make for good test runs over choppy to downright stormy seas. The 7½-mile-long Diversion Canal connecting the lakes provides a fine straightaway.

During our three-day test, which included some terrifically rough runs across Lake Moultrie, we found little to complain about in the hull's ability to take punishment. In addition, the high freeboard kept us relatively dry.

But I herewith submit a plea to all small-craft engineers—not merely MFG's—to consider carefully the *durability* of every piece of interior hardware they install. Just because a lid will open and close without jamming at the factory, or wood screws seem as strong as nuts and bolts for attaching a seat top, this does not mean these items will hold up under real-life use—or should I say, abuse? In three days of riding rough seas, I bent the arms off the front seat, pulled it loose from the floor and broke the hinges off the baitwell cover. Now I don't fancy myself a Joe Btfsplk or even King Kong—just a big guy holding on for dear life while riding over some vicious water! If you're putting your Gypsy through a tough season, you might consider some interior reinforcing.

The boat has a load capacity of 1420 pounds and, with mechanical steering, swivel seats and live baitwell as standard items, sells for \$899 f.o.b. Union City, Pa. If you'd like to contact Roland Martin for fishing the Santee-Cooper, write c/o Jones Boat Landing, Box 319, Cross, S.C. If he doesn't answer right away, he's probably out fishing! ★★

POPULAR MECHANICS

BOATING TIPS

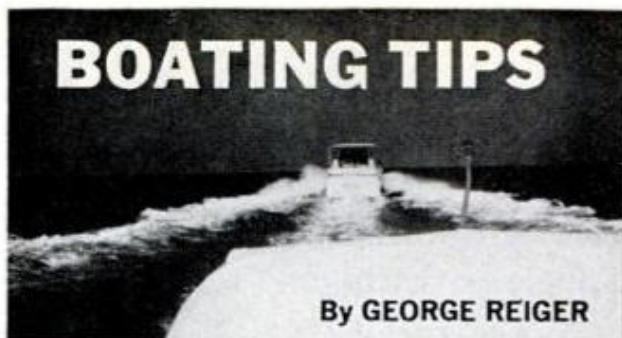

By GEORGE REIGER

DROP A LINE HERE, cross a line there, and you're all set for the night. Then while you're ashore, a wind comes up and makes a mockery of your jury-rig docking arrangement. The boat at right was rigged this way. Poor owner! Secure your boat for the night as though doing it for the summer. Rig lines for a hurricane; not merely for the halcyon days of summer boating.

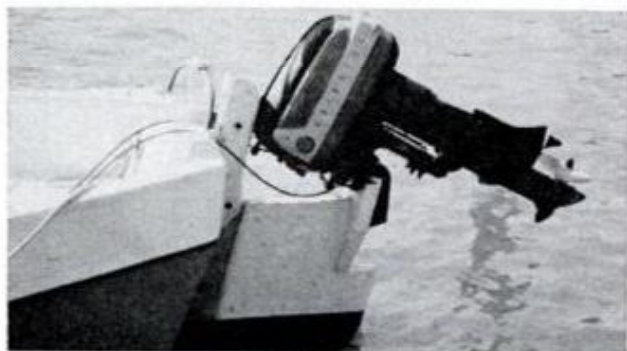

DOWN SOUTH (bottom left) you'll sometimes see a pair of bamboo or fiberglass outrigger-type poles with tension-spring lines being used to hold a boat away from the dock and thereby protect it from unwanted piling bumps and barnacle scratches. Lines tied directly to the dock pull the boat in; the straining poles keep the boat out. The poles also help absorb the shock of wakes if your boat is docked on a frequently traveled waterway, and can be easily installed on any dock.



SEPTEMBER 1970

YOU CAN'T ALWAYS DEPEND on it, but running in behind a large boat may be a lifesaver when the wind comes up while you're far offshore. Though dangerous to ride too close to the leader, two or three "swells" back from a sizable yacht will go a long way toward "laying down" the wind and waves of choppy seas.



SAILBOAT AUXILIARY a nuisance to carry? Dr. S. T. Brown of St. Petersburg, Fla., has the "insurance power" storage and ease-of-handling problems licked. He mounted his auxiliary directly on the rudder, out of the cockpit, high and dry for normal sailing, but readily accessible and easily steered with the tiller. Imitators, anyone?

A GREASE SUCTION GUN, says Harvey Shepardson of Lilliwaup, Wash., will remove gummy residues from outboard motor tanks before storage. Benton S. Clark of Colorado Springs says your trailer hitch ball can be protected with an old tennis ball with a hole slightly smaller than the hitch ball diameter.

MAN IN SEARCH of a concussion? A snag will flip him out; running aground will hurl him into the bow. Helmetless and standing, he courts disaster.



123

PM OWNERS REPORT
AMC HORNET

Economy

A Nationwide Survey Based on
1,507,000 Owner-Driven Miles

By **MICHAEL LAMM**
West Coast Auto Editor



and Handling Tops But, Oh, Those Workmanship Blues

REASONS people buy small cars tend to be more rational than reasons for buying big ones. Example: Riviera owners (see page 96) agreed that styling was their main buying motive—not a particularly sensible or functional reason.

On the other hand, Hornet owners, perhaps because they put a greater value on their money, gave these reasons for buying the AMC compact:

"An economical car with most of the features of a big luxury job." Or, from a Kentucky merchant, "I chose the Hornet for 'charisma'—a combination of performance, price, good looks, and sane balance." Too, several echoed this Pennsylvania factory worker: "I traded in my Volks because I wanted a roomier car." Or, "I wanted a compact. This was the lowest-priced I could find."

"The Hornet is a big little car," wrote a New York railway conductor. "Best damned car I ever owned." "Beautiful car—love it more all the time." "Good, inexpensive transportation." Lower price than Nova, better handling and feel than Maverick." "Economy, and U.S. parts as opposed to foreign." This last statement cropped up a number of times.

Still, when we asked what owners thought about their Hornet's quality

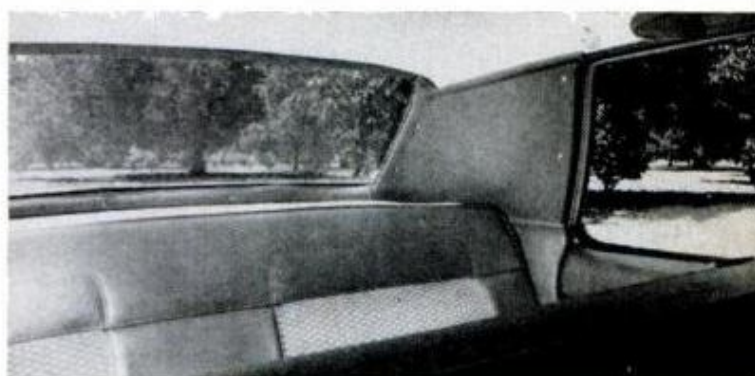

OWNERS LIKE ROOMY INTERIOR but not rear pillars. Only 17.8 percent ordered power steering; while it's not needed, it does give a faster steering ratio

HORNET FUEL MILEAGE CHART

199-cu.-in. Six

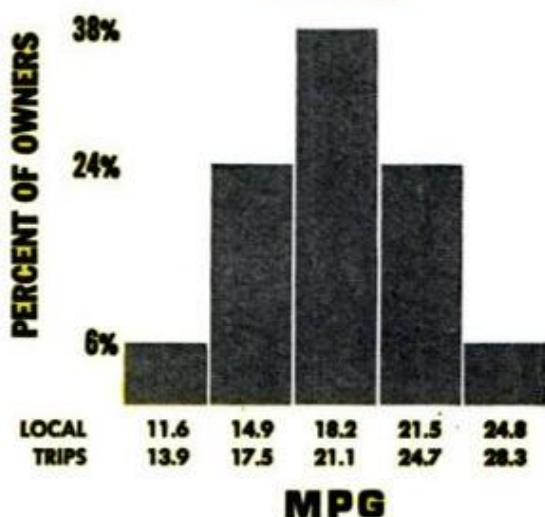

Summary of 1970 Hornet Owners Reports*

Total miles driven	1,507,531
Average miles per gallon:	
199-cu.-in. 6,	
local driving ..	18.2
long trips	21.1
232-cu.-in. 6,	
local driving ..	18.4
long trips	21.3
304-cu.-in. V8,	
local driving ..	14.8
long trips	15.9
Engines:	
199-cu.-in. 6	55.1%
232-cu.-in. 6	39.0
304-cu.-in. V8	5.9
Transmissions:	
Automatic	72.0%
3-speed manual	28.0
Body styles:	
2-door sedan	67.8%
4-door sedan	32.2
Series:	
Hornet (base)	61.2%
Hornet SST	38.8
Why the Hornet?	
Economy	44.2%
Styling	30.8
Size	23.4
Past AMC experience ..	15.7
Price	13.7
Handling	3.1
Specific likes:	
Economy	48.0%
Handling	47.7
Style	35.5

Size	16.3
Comfort	15.7
Power	9.6
Ride	8.7
Performance	6.7
Specific dislikes:	
Workmanship	25.1%
Rattles	8.4
Gas mileage	6.0
Finish	5.5
Brakes	4.6
Visibility	4.3
Ride	3.2
What changes would you like?	
Better workmanship ..	11.3%
Better rear vision	6.9
Styling	6.5
Better vent system	6.2
Quality of materials ..	5.8
More headroom	5.8
Better seat style	4.5
Had any mechanical troubles?	
No	68.3%
Yes	31.7
What kind of trouble?	
Carburetor	24.6%
Electrical	10.9
Brakes	10.0
Transmission	7.3
Gas gauge	5.5
Did you repair it yourself?	
No	98.1%
Yes	1.9
Dealer repairs satisfactory?	
Yes	53.5%
No	46.5

Is the Hornet your only car?	
No	55.9%
Yes	43.1
Other cars owned:	
AMC products	21.4%
Chevrolet	19.4
Buick	11.4
Ford	11.4
Volkswagen	8.5
Dodge	8.5
Oldsmobile	8.0
Pontiac	7.5
Accessories/power options:	
Automatic transmission ..	72.0%
Radio	63.7
Power steering	17.8
Light group	10.3
Belted tires	10.3
Airconditioning	9.7
Tinted glass	4.1
Power brakes	1.2
What accessories/options would you order next time?	
The same	54.6%
Power steering	12.2
Airconditioning	11.9
Power brakes	7.8
Radio	5.0
Bigger engine	4.1
Age distribution of owners:	
15-29 years	24.1%
30-49 years	37.2
50-plus	38.6
Would you buy another Hornet?	
Yes	75.1%
No	23.9

*Percentages might not equal 100% due to rounding and/or insufficient data.

of workmanship, we got these answers: "Rather poor. Floor mat loose and sagging, rough edges under dash, clutch pedal wobbles, doors leak, windows don't work easily." "Terrible even compared to the 1969 Rambler I owned. Problems may be due to first of model run." "Looks like the factory overdid mass production—too much mass and not enough production." "Technically a fine car, but small details just not done right." Yet, we also did get answers like this: "After comparing the Hornet with two other

major U.S. autos in the same price, I found workmanship to surpass both."

Owners are well pleased with fuel economy, and surprisingly enough, the larger 232-cu.-in. Six gets a trifle better gas mileage than the 199. Reason might be that it takes a heavier pedal foot to keep the smaller version up with traffic. What makes our findings more surprising, though, is that buyers order automatic transmission much more often with the 232 than with the 199, and theoretically the automatic should bring down mpg. However, the 232 au-



HORNET'S HANDLING rates right behind economy as a specific like. Roadability, ease of parking, and stability through corners all get good marks. "It fits into $\frac{1}{2}$ to $\frac{2}{3}$ of a parking space," says one owner. The 232-CID Six gets better gas mileage than the 199-incher, which will be dropped for 1971. Relatively few buyers order the 304-CID V8

tomatic comes with a 2.37 rear axle, while either engine with manual trans has a 3.08 rear-end ratio, so that helps account for the 232's better mileage.

As for ride and handling, owners said: "Handles very well in traffic and is steady on the road for a small car." "Good stability on curves at high speeds." "The 232 engine with automatic makes a good, snappy combination—easy steering and fine roadability." "Will move right around other cars stuck in the snow." Still, "Needs better shocks." "Rather hard ride on bumpy roads." "Rear springs seem weak when carrying passengers."

We always ask what owners would like to see changed or improved about their cars. Answers are significant, give good clues to what drivers consider weaknesses. "A fully synchronized manual transmission would be nice. Other AMC cars using the same 232-in. engine have all-synchro, so why not the Hornet?" "Front wheelwells should be closed to stop water and salt from hitting the front door hinges." "Make V8 standard." "Bring back overdrive," said a few old-timers. "Can't lock right front door from driver's seat without breaking my arm reaching around headrest."

About comfort: "Driving slowly on

concrete, it rides a little stiff, but after 60 mph, it goes along like a whisper jet." "Road noise is high, but this is not a complaint. If I'd wanted a smoother ride and less noise, I would have had to pay a premium." "Excellent air circulation." "Gives a hard ride." "I am 6-6 and not uncomfortable." "Rate comfort next to Mercedes formerly owned." "My passengers like the surprising room in the rear but dislike solid windows and having no ashtray." A Pennsylvania carpenter digresses, "My honey loves it—she says it feels just like the seat opens its arms and gathers her right in."

The Hornet's styling gets good marks, although owners rate it second behind economy as a reason for buying (and third behind economy and handling under "specific likes"). A retired Minnesotan sums up many owners' feelings about concessions to styling: "Needs a larger trunk, not so much rake to windshield (glare), and bottoms of fenders should be flared so wheels don't toss gravel onto lower body, because this chips the paint."

Dealer opinions run the gamut; most owners feeling they're getting fair shakes. Some report parts hard to get. Lots of repeat buyers, though, as with the Rebel and Ambassador. ★★

CONSIDERING OVERALL CAR SIZE, that's a whale of a trunk. Gas filler on early Hornets tended to gurgle due to misalignment of the connecting hose

"IT'S A BIG LITTLE CAR," wrote one owner; easier to get into and out of than most. Curved windows let water from roof drip onto exiting passengers' legs



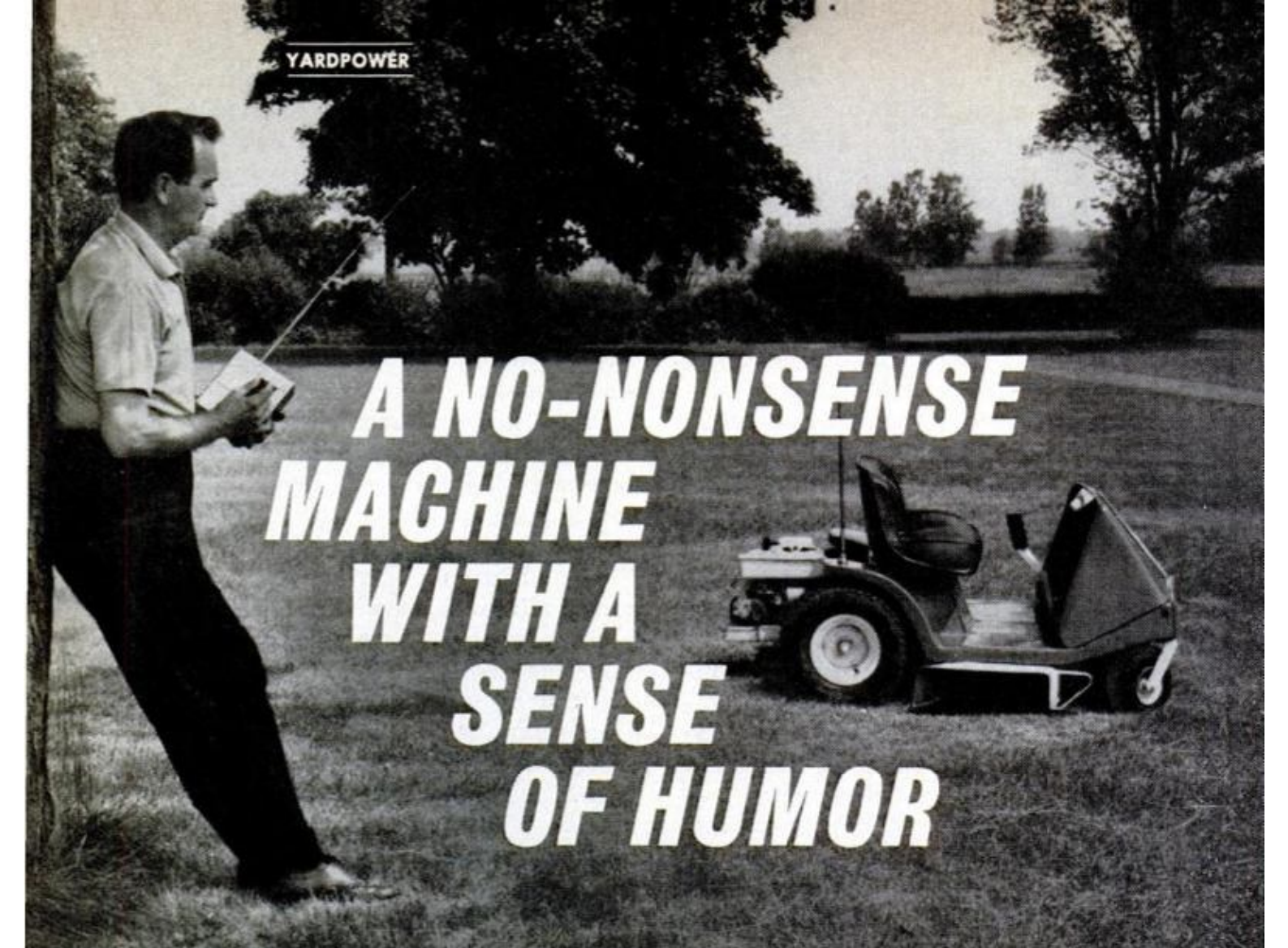

A NO-NONSENSE MACHINE WITH A SENSE OF HUMOR

If you want to astound your neighbors, this rugged little lawnmobile will go along with the gag, doing a beautiful job of mowing—or throwing snow—while you take it easy

By JAMES M. LISTON, Executive Editor

RADIO RECEIVER under dash operates push rods to control levers. Switches on the transmitter correspond to the control levers. Floor lever engages the mower

MAN'S MIDSUMMER DREAM of a mower that runs itself while he sips a cool one is now a \$1195 reality—on a par with a 10-hp tractor.

Equipped with a 42-inch rotary mower, the Remote-A-Matic lawnmobile can be operated by radio remote control so precisely that the operator—sitting on his patio—can edge flower beds, trim around trees, return the machine to the garage and shut it off without leaving his chair.

In winter, the "Mighty Mo" can be equipped with a snow blade or snow blower. You can clear your walks and driveway and enjoy it all from your

picture window or the shelter of your garage. The fun doesn't end there. The mower unit is easily detached and you have a golf cart or an all-terrain vehicle. (Well, *almost* all-terrain). When equipped with the bogie wheels and track used for snow—but without the skis—Mighty Mo will really go.

The utility cart (four feet wide, six feet long) is big enough to carry the Mighty Mo. Attach the cart to a hitch on your car and you can transport the lawnmobile to the golf course—or take it with you on camping, hunting or fishing trips. With optional large pulley, the vehicle will do 20 mph.

More fun can be had by equipping the unit with a second set of rear wheels, cleated rubber tracks, and skis for the front wheels (all available from the manufacturer). Then you have a highly maneuverable snow machine. It's not designed to compete with snowmobiles, but it's fun as well as transportation.

The unique mechanical feature of the lawnmobile is a cone-drive transaxle that combines transmission, clutch and differential. Forward, reverse and steering are controlled by two levers. Push forward on both to move ahead; pull back to reverse. Move one lever forward and the other back and the vehicle turns in its own radius. Steering is done by the rear wheels; front wheels serve as casters.

This transmission, called a Triple Action Transaxle, was used two years ago by *PM* editors to design *PM's Mini-Mover* (page 140, Aug. '68 *PM*). Remote-A-Matic chose the cone-drive transaxle because:

- It operates with the throttle at one set position; ground speed can be slowed to a crawl while full tip speed is sent to mower blade or snow thrower;
- It's efficient, steals little horsepower;
- Steering, acceleration and braking are controlled by only two levers; thus the vehicle requires only a two-channel system for radio remote control. A conventional tractor would require five channels.

SEPTEMBER 1970

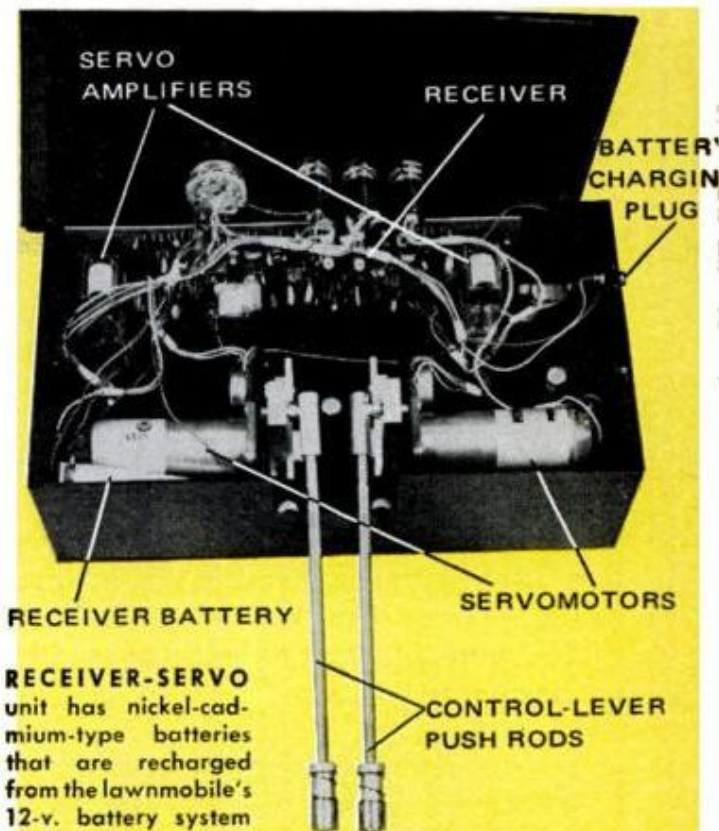

The electronic controls were developed by Harry Sampe, the company's chief engineer, who for years has been a R/C model plane hobbyist. The two-channel system operates on the 11-meter (Citizens Band) radio frequency at 100 milliwatts—a wattage requiring no license. The range is about 1000 feet. A six-foot-long wire under the dash serves as the antenna.

The transmitter is about the size and weight of a paperback book. The re-

"MIGHTY MO" sports a mighty three-blade, 42-inch mower that's easily disconnected: Remove six pins

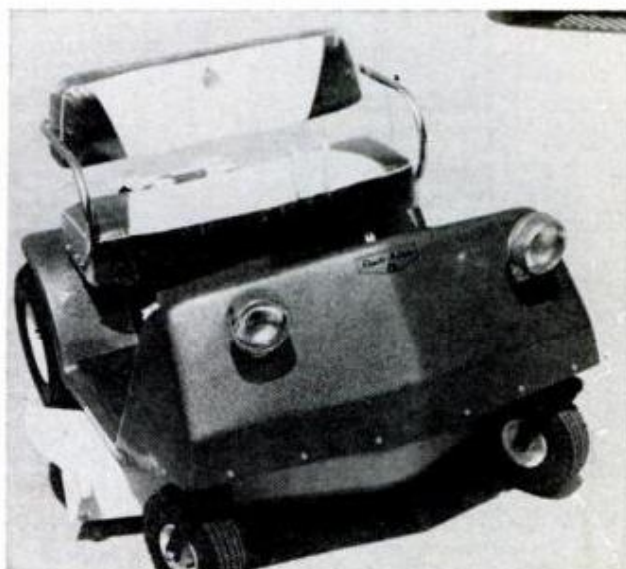

ceiver, with two servo amplifiers and electric motors—the type used in aircraft auto-pilots—is mounted on the dash just forward of the control levers. (Quick-disconnect ball joints on the levers can be snapped off for manual operation of the machine.) The system is digital proportional: for every degree of movement demanded on the radio control, the servo will respond proportionately.

Batteries in the transmitter are nickel cadmium and they are recharged from the vehicle's 12-volt system simply by connecting an adapter cable between the transmitter and receiver and placing a selector switch in the charge position.

Anything that operates on remote control needs safeguards against getting out of control. The lawnmobile has a "fail safe" system—a special circuit that "looks" at the total signal out of the transmitter. If the receiver is not looking at this signal, a relay drops out and kills the engine. Or if the signal to the receiver is lost—if, for example, the vehicle travels out of range (beyond 1000 feet) of the transmitter—the engine is killed. The range can be extended to over a mile by adding a whip-type auto antenna.

Since steering is done off the rear wheels and there are 360° casters on the front, there is no tendency to dig in and rut on sharp turns. Also, with

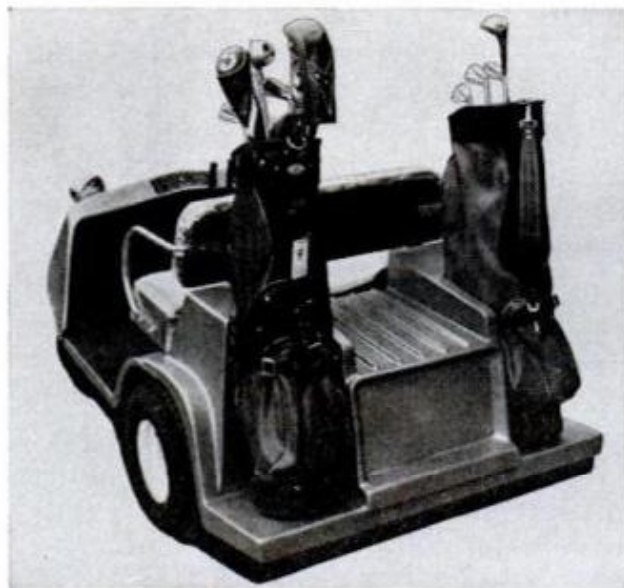
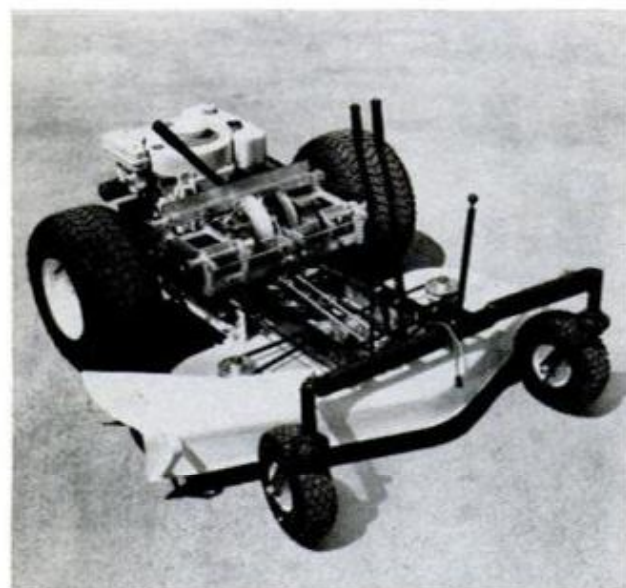
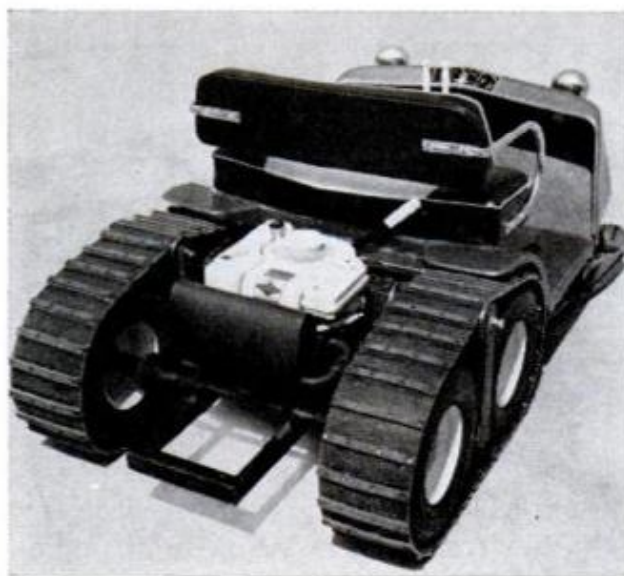
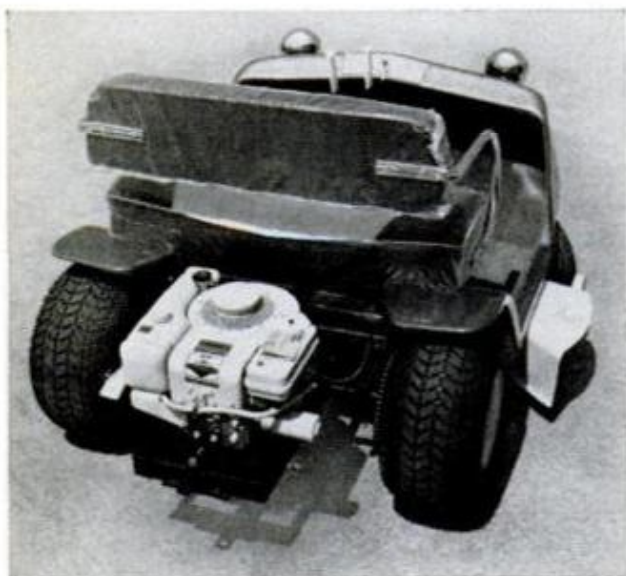

REAR-MOUNTED ENGINE is 8-hp synchro-balanced Briggs & Stratton with solid-state ignition. With fiberglass body off (four bolts), adjustment is easy

GOLF-CART CONVERSION is optional, includes a high-speed pulley and big muffler. Skimobile conversion includes front skis, track and bogie wheels

POPULAR MECHANICS

its center of gravity low over the rear wheels, the vehicle is virtually tip-proof. The tractor itself weighs 300 pounds—with the mower, 350—as compared with about 700 pounds for most garden tractors. Since nearly all this weight, plus the operator's is over the drive wheels, the company claims ideal traction for the vehicle.

A golf-cart attachment kit consists of a fiberglass rear deck (shaped to take two sets of clubs) that conceals the engine and is simply attached with two pins; a special quiet muffler, and a large sheave for increased speed. The advantages of a radio-controlled golf

cart become more apparent with use. Walking back to retrieve the cart or driving it to the next tee isn't necessary; it can be summoned by radio.

The radio controls and mower are optional equipment. For those who want a tractor, an in-plant vehicle, or an all-terrain-type vehicle for fishing and hunting, the base price is \$799, including running lights, starter and 12-volt system. The company expects the greatest demand from the mower market because of the machine's maneuverability and simple operation. Practically all units sold to date have been radio-controlled. ★ ★ ★

SPECIFICATIONS—MODEL X-150 LAWNMOBILE

Engine: Four-cycle, synchro-balanced 8-hp Briggs & Stratton, 19:44 cu. in., solid-state ignition.

Electrical system: 12-v. key start with starter, generator, solenoid, heavy-duty battery, sealed beam running lights.

Transaxle: Two levers give infinite speeds in forward or reverse on either wheel; control braking, clutching, turning, acceleration.

Tires: Rear: 18-9; front: 50-8 on 360° casters.

Mower: Full-floating 42-inch, three-blade with adjustable cutting heights.

Frame: Welded 1x2-inch rectangular tubing.

Drive: Independent rear-wheel drive, two live axles, chain drive.

Body: Two-piece molded fiberglass, red gold, blue or green in metal fleck finish.

Speed: Up to 10 mph for mowing; up to 20 mph with optional larger pulley.

Weight: 325 pounds without mower.

Overall dimensions: Length: 65 inches; width: 44 inches (less mower deck); height: 30 inches.

Turning radius: Zero (machine turns in its own radius).

Price: Lawnmobile: \$799; mower (3-blade, 42-inch cut) \$196.

Accessories: remote control (transmitter, receiver, power train): \$199.88; golf-cart attachment: \$178.25; snow blower (38-inch): \$179.88; heavy-duty trailer (4 by 6 feet): \$178.22; dozer blade: \$49.88; skis (fit front tires): \$37.50; bogie wheels, track, idler pulleys: \$199.

Address inquiries to Remote-A-Matic, Inc., 1012 Commerce Tower, Kansas City, Mo. 64199.

HOW CONE-DRIVE TRANSMISSION FUNCTIONS

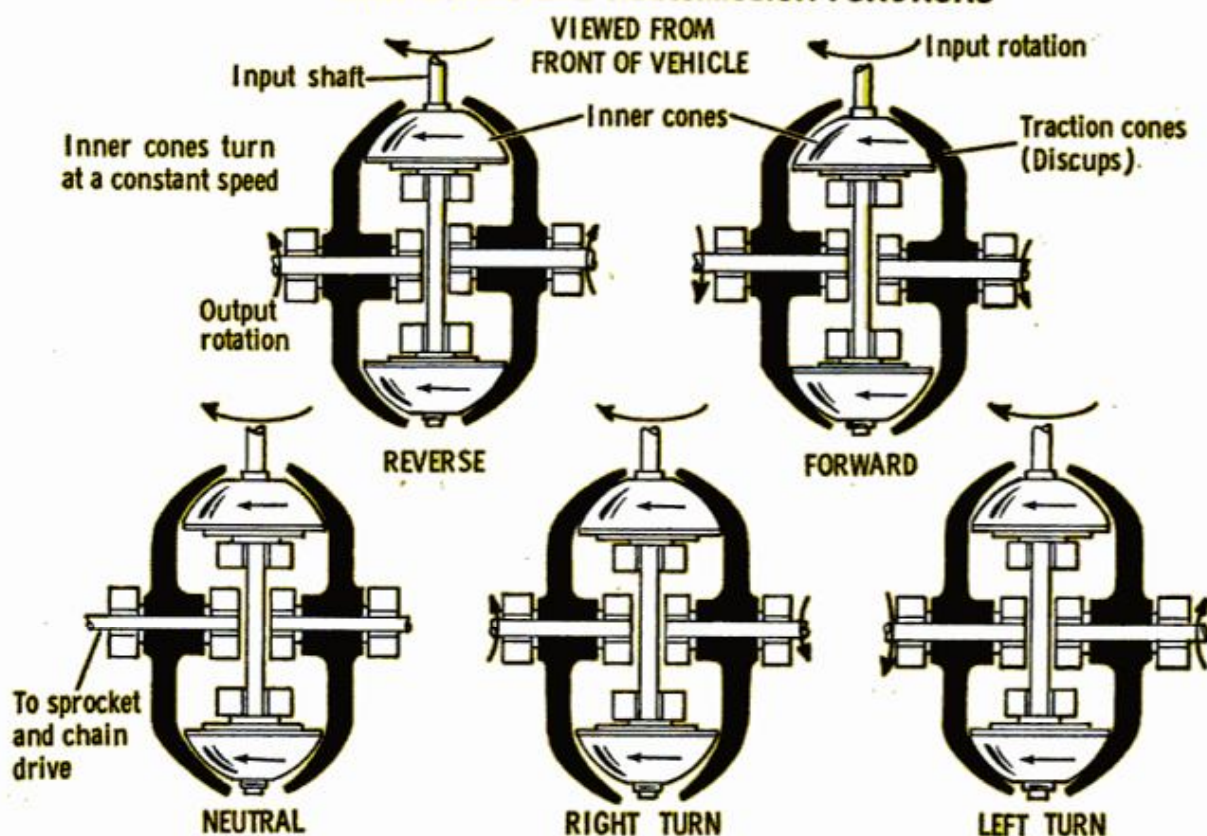

How to Sight-In A Rifle



If you haven't been varmint hunting all summer, it's time to get your rifle from the closet for your preseason 'tune-up'

By **RAYMOND SCHUESSLER**

Illustrations by Roy Grinnell

OPEN SIGHTS ON RIFLES are carefully adjusted before they leave the factory. If your eyes are normal and you hold in the proper manner, you'll find most rifles shoot true to their sights. It's advisable, however, for every purchaser of a new rifle to test it before going on a hunting trip to be sure the sights are just right for his eyes, and also to make sure the sights have not been jarred out of line during transportation.

Because of individual peculiarities of eyesight, gun manufacturers do not mark range graduations on the rear sight of high-power rifles. You'll have to fire the rifle yourself and mark the sight for the ranges you expect to use in your own shooting.

Choose a spot where you can see the bullets strike. A bank of earth is excellent. Never shoot over water where bullets may ricochet and fly long distances. Many rifle clubs make their ranges available to hunters. Ask around.

Shooting should be done with a bench rest or in a prone position using sandbags or a log to brace comfortably your arms, and *not the rifle's barrel*.

First, bore-sight the rifle (Figure 1).

Remove the bolt and secure the rifle with its bore aligned on a distant aiming point. Look through the bore and adjust the sights at the same time; in this way you make the sight line parallel to the bore.

Replace bolt and fire three shots with front end of the rifle rested. The shots should form a small group. Adjust the center of this group to the aiming point. To do so, move the rear sight in the direction you wish the bullet to go, both vertically and laterally.

Memorize the following rule so you won't be confused as to proper sight alignment: *Always move the rear sight in the direction in which you want the point of impact to move.* If you want a rifle to shoot to the left, move the rear sight to the left. Conversely, the front

Figure 1



sight should be moved in the opposite direction for the same result.

The sight can best be moved in its notch with a hammer and a drift rod of brass or hard fiber about four inches long and at least $\frac{1}{4}$ -inch in diameter (Figure 2). The barrel should be supported by a block of wood, and the sight should be moved the smallest possible amount. A pencil or crayon mark on the sight and barrel will serve as a guide.

Telescopic sights offer even fewer problems. Telescope mounts must be tightened very securely since their short spacing multiplies the effect of any looseness. First make sure the screws fastening the base or bases to the rifle are tight (Figure 3).

Telescopic sights are adjusted vertically and laterally by knobs on the

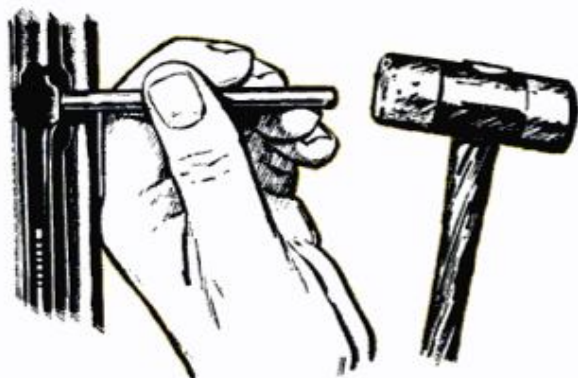

Figure 2

telescopic tube, protected with screw caps (Figure 4). These knobs are usually marked with arrows to indicate the change in direction of bullet impact. Graduations are in minutes or fractions of minutes. When adjustment is in the mounts instead of the telescopic tube, move the rear mount the way you wish the shot to go.

If the sights are graduated in minutes of angle, remember that a minute of angle corresponds about to 1 inch at 100 yards. At the short range of a sighting-in target, this will be proportionately less.

After adjusting, verify with three shots. If the sight adjustment was correct, these should group precisely on the aiming point. If not, readjust and check-fire until they do. Take a fresh

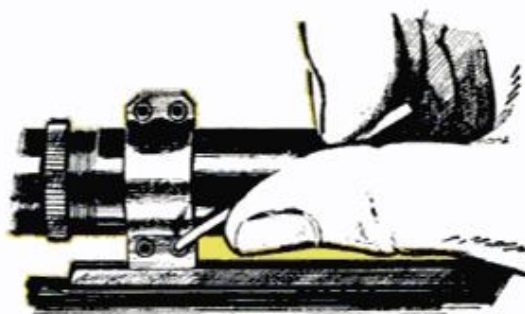

Figure 3

aiming point for each firing to make sure you can identify the groups.

Hunters, unlike match shooters who know the exact range of their targets at all times, most often shoot quickly at moving targets and at a variety of vaguely estimated ranges. This is a real test of a marksman. But he must be prepared with some technical knowledge of the bullets he uses and how they will affect his aim. For example, if you zero in 30-30 and 30-06 cartridges, both with 150-grain bullets, at 100 yards, the former will strike about 5 inches lower than the latter when firing at live targets 200 yards away.

Some hunters attempt to solve this problem by marking their sight settings for various ranges, but wary game won't always wait for them to make a field adjustment. There is, however, a rule of thumb that can be applied to any caliber, bullet weight or type of bullet. All you need do is determine the bullet velocity of your cartridge at 100 yards. Such information is often included in the manufacturer's ammunition catalog. If you don't have one, write for either the catalog or information. Here's how it works.

With slight variations, any cartridge

(Please turn to page 224)

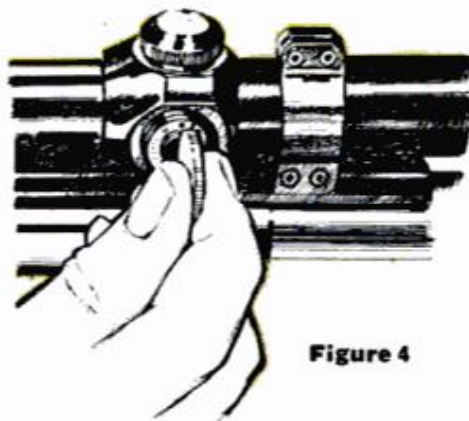

Figure 4

Take a look at a long lineup of functionally sized, stylish and attractively priced wagons—more than just the Simca, Volvo, Fiat and VW, below—that make a lot of sense

By ALEX MARKOVICH

ALL BUT TWO ARE IMPORTS. People who've never driven an imported station wagon may wonder why anybody would buy one. After all, most of them hold only four passengers, maybe five in a pinch—not nine, as do the biggest U.S. wagons. Four-by-eight plywood sheets? The imports will haul them in a diagonal position—if you don't mind having a third of your load hanging out the tailgate.

So why buy an imported wagon?

For one thing, they don't cost much more than imported sedans. Many of the models listed in our chart sell for under \$2500. The small wagons also save you money at the gas station. Expect to average well over 20 mpg with any of these models, including the two new small U.S. wagons—Hornet and Vega.

But perhaps the most appealing feature of these wagons is their small overall size. They'll fit inside garages already overflowing with bikes and garden tools. You can nose them into parking spots that full-size cars have to pass up.

They're handy for grocery shopping and other light-duty hauling. But most will also handle your weekend camping gear or nine or ten sacks of cement.

Although our chart lists 20 models, we actually test-drove 10. The German Audi, British Cortina, French Peugeot, Japanese

Subaru and Mazda, American Motors Hornet and Chevy Vega weren't available in time for our deadline. (The new Vegas are discussed in *The Minis Are Out to Rule the Road*, page 112.) And of the three Japanese Toyota wagons, we tested one: the Corona Mark II, Toyota's newest and mechanically most interesting model.

All our test cars have swing-up tailgates, and all are about equal in loading ease. If load capacity is your prime interest, compare load-area specifications in our chart. The brief road-test reports that follow will tell you what it's like to live with and drive each model.

SIMCA 1204

The French-made, Chrysler-owned Simca 1204 was fun to drive. But we had to make compensations: Our car showed only seven miles on its odometer when we took delivery. Even worse, we couldn't adjust the engine for proper idle (the carburetor later had to be replaced). Luckily, we also had a chance to drive a well-turned 1204 sedan, which showed us what the little Four is really capable of.

In spite of the ailing carb and a drastically accelerated break-in (300 miles), we managed 0-60 mph in 18.5 seconds, which is adequate if not exciting. Above 60, performance drags; our 50-70-mph run required a tedious 16.8 seconds. Fuel mile-



THOSE 'SENSIBLE'

age is exceptional; maintaining a 65-mph average on a long trip, we recorded 27.0 mpg. The optimistic speedometer was two mph off at 30, five mph off at 80 (which we attained on a downhill slope).

The Simca has independent, adjustable-for-height torsion-bar suspension front and rear. This setup gives excellent ride control over the worst bumps. In spite of its noticeable lean, the car is stable and predictable during the most violent maneuvers. We never noted an extreme transition from understeer to oversteer when letting up on the throttle in a hard corner, as we have in many other front-wheel-drive cars.

The disc-front, drum-rear brakes are powerful and fade-resistant, the rack-and-pinion steering is fast and precise. The four-speed, floor-mounted gearshift feels vague and spongy, but the well-synchronized gearbox allows the fastest shifts without protest.

The reclining front bucket seats are extremely comfortable. Legroom front and rear is just adequate for average-size people, but headroom is generous. The instrument panel is covered with strips of phony wood veneer which look better than they sound; the round gauges are well-placed for quick scanning. With the three-point belts (a real bundle of worms) fastened, reaching the radio or the window cranks is almost impossible.

DATSUN 510

Several sophisticated features usually found only on expensive imports are included in the Datsun 510. Among them are independent suspension front and rear and an overhead-cam Four.

Here again our test car came to us brand-new, and our tests were run after only 300 miles of break-in. Even so, the Datsun, with an optional automatic transmission, managed 0-60 in 16.3 seconds, 50-70 in 11.6. We couldn't shave these times by shifting manually.

Fuel economy on our 65-mph-average trip measured 24.4 mpg—and a broken-in engine should do even better. Our speedometer proved dead accurate from 30 mph on up.

The Datsun instrument panel is one of the handsomest and best-laid-out, regardless of price. It's glareproof and well-padded, and the round gauges are easy to read. Ball-socket vents swivel on either side to let you aim incoming air where you want it.

The skimpy front buckets were the only ones among our test cars not to adjust for rake. And the steering wheel is too close for comfort. Front and rear legroom is adequate, no more. But the seat belts are unusually convenient.

The Datsun handles predictably on smooth roads, but on bumpy corners the independent rear suspension feels like a live axle and the tail end of the car occasionally gets a bit out of shape. Steering is fairly fast, but transmits little road feel. Brakes (disc front, drum rear) are quite powerful and practically fade-free.

OPEL KADETT

The Opel Kadett has a small Four developing a scant 55 hp. But we had an optional larger engine that turned out 102 hp, also a smooth, crisp automatic transmission.

The engine was rough and noisy, but it



STATION WAGONS



VOLKSWAGEN SQUAREBACK is only wagon with front trunk. Louvers help cool engine under floor in rear



CITROËN D-21, largest and most expensive, has plush features; lacks carpet or mat in rear, however

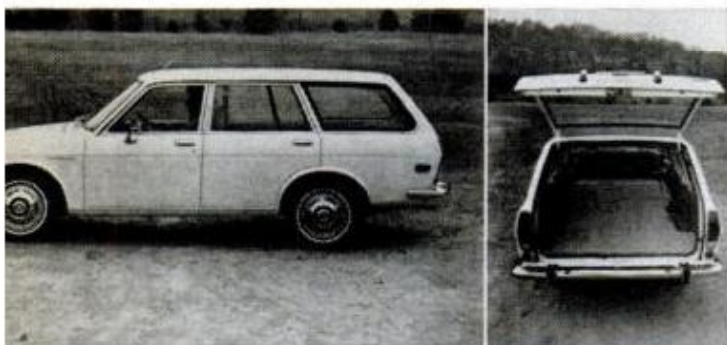

DATSUN 510, sophisticated wagon for economy price, features an overhead-cam engine, good instruments



TOYOTA CORONA MARK II has luxurious interior with feel of domestic automobile; features ohc Four

FIAT 124 SPECIAL, with real sports-car feel, is most fun to drive, but instrument panel is nondescript



pushed the car to 60 mph in a quick 12.1 seconds, and from 50 to 70 in 8.1 seconds. Shifting manually failed to improve these times. On our 65-mph trip we recorded 24.9 mpg. Our speedometer read three mph fast from 30 mph on up.

The Opel is finished neatly inside and out. The instrument panel is attractive and laid out with the driver in mind. The front bucket seats, though comfortable, offer no side support, and legroom front and rear is just adequate. But the steering wheel is well-placed, almost at arm's length.

The Opel's ride is unimpressive. With just the driver aboard, it's harsh and bouncy. Adding three passengers and 350 pounds of sand changes the ride, but doesn't improve it. Handling is ho-hum on smooth roads and unpredictable in rough corners (rear-axle hop being the primary problem). But the disc-and-drum brakes are excellent in every respect.

FIAT 124 SPECIAL

If you want sports-car handling, consider the Fiat 124 Special. It gobbles up corners at the highest speeds; on rough roads the well-located live rear axle may hop, but it never gets badly out of hand.

Normal ride is firm and well-controlled, though with a little more pitching than we'd like. A full load, however, causes excessive bottoming of the suspension.

The plain-Jane instrument panel obviously is derived from a farm tractor. There's a beetle-browed, rectangular speedometer that's not too easy to read, and an immense, nonlocking glovebox with an ugly cable cutting right through its middle. But the Fiat also has those swiveling fresh-air ducts, full horn ring and near-perfect visibility in all directions.

The front bucket seats are comfortable, and legroom is okay front and rear. But rear headroom is cramped. The steering wheel, well away from the driver, invites an Italian-style, arms-straight, let-it-all-hang-out style of driving. Controls are well-placed except for the headlight dimmer stalk, which makes it easy to shut off the headlights accidentally.

The slick, fast four-speed floor shift can't be faulted. Steering is fast, pleasantly light, and responsive. And the four-wheel disc brakes stop the car right now. Our well-tuned engine covered 0-60 in 12.8 seconds, 50-70 in 7.9. The speedometer was just one mph fast at 30 and 40 and

two mph fast from 50 up. We netted 27.4 mpg on our mileage trip.

RENAULT 16

The Renault 16 stranded us early in our driving test: We ran out of gas, although the gauge didn't show "empty."

The Renault 16 "sedan-wagon" basically is a four-door sedan. But it has a unique tailgate that hinges open station-wagon style, and its rear seat can be folded into more different positions than you'd believe possible. For extra-large loads the rear seat can be removed (if you don't mind working up a sweat).

Those sensuously padded front and rear seats are the most comfortable we've ever settled into, bar none! And rear legroom is especially impressive. But the stalk-actuated horn takes some getting used to, and the foot-operated dimmer switch is confusingly close to the foot-operated windshield squirter.

Thanks largely to its front-wheel drive, the Renault feels stable at turnpike speeds, but soft springing and poor shock control make handling somewhat unpredictable in high-speed corners. We wished for an optional heavy-duty suspension.

Ride is comfortable over most road surfaces under lightly loaded conditions; a full load produces longer, floating ride motions that aren't objectionable.

Speedometer error ranged from two mph fast at 30 to three mph fast at 80. We managed 0-60 in 19.3 seconds; shifting manually, we got a still-lethargic 19.0. And 50-70 took 14.8 seconds. Fuel mileage on our 65-mph trip, however, averaged 29.9 mpg, the best we recorded.

TOYOTA CORONA MARK II

Seating comfort is the forte of the Toyota Corona Mark II. For its compact size, the car has a surprising amount of legroom front and rear. The front-seat rake adjustment makes it easy to find a comfortable driving position.

Under both light and heavy load the ride feels harsh over small irregularities and poorly controlled over large bumps. Handling generally is predictable, but cornering power is modest and rough corners start the live rear axle a-bouncing. Steering is slowish, heavy and none too sensitive. But the disc and drum brakes display very mild fade, fast recovery and excellent stability. Visibility is excellent.

Our test car, equipped with the optional automatic transmission, reached 60 mph in



OPEL KADETT has fine lines, attractive instrument panel. Bucket seats only adequate, ride a bit bouncy



VOLVO 145 is solid, fast, extremely comfortable and luxurious. Steering is a bit slow; stick a bit stiff

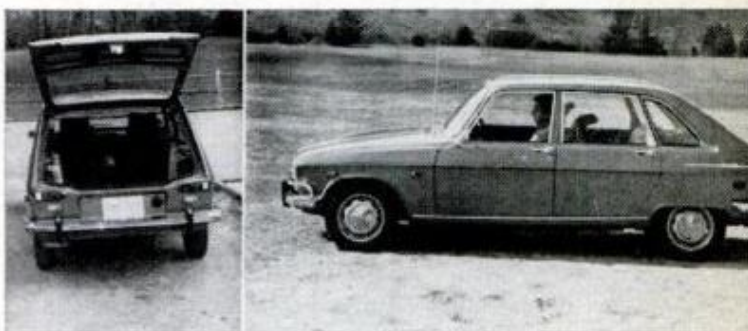

RENAULT 16 SEDAN-WAGON has versatile layout; rear seat can be folded in various ways or removed

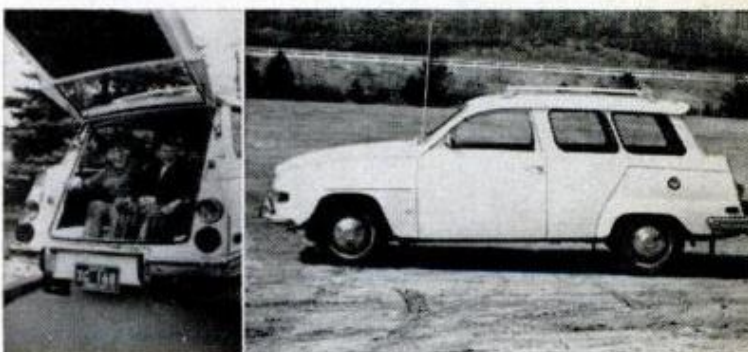

SAAB WAGON has four-stroke V4 engine, front-wheel drive. Jump seat can be folded out of way

SIMCA 1204 has a transverse four-cylinder engine, front-wheel drive, adjustable torsion-bar suspension

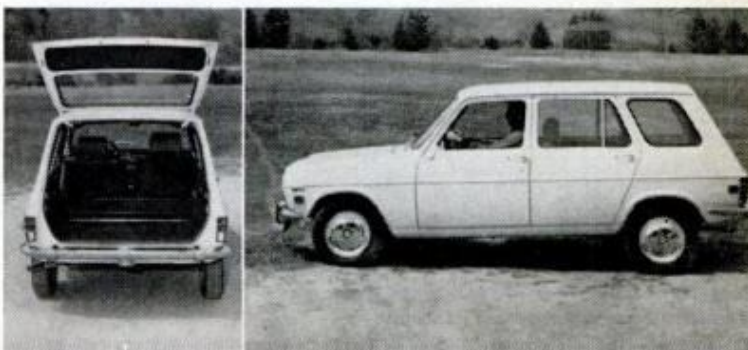

SMALL STATION WAGONS—SPECIFICATIONS AND BASE PRICES

Model	Overall Length	Overall Width	Overall Height	Wheelbase	Engine Cu.-in. Displacement	Engine HP/RPM	Tailgate Opening, Max. Height/Width	Load Area Length (rear seat folded)	Load Area Length (rear seat up)	Load Area, Max. Floor Width	Load Area Maximum Height	Max. Load Space (cu. ft.)	Load Capacity (lbs.)	Base Dollar Price, East Coast P.O.E.	Warranty, Months/Mileage	Dealers in U.S.A.
AMC Sportabout	179.3	70.6	52.9	108.0	232 (6-cyl.)	145/4300	N.A.	N.A.	N.A.	N.A.	N.A.	58.3	N.A.	N.A.	N.A.	2400
Audi Super 90	173.8	64.0	57.2	98	107.5	100/5200	29.0/46.6	64.0	41.0	52.0	33.0	56.5	950	3245	24/24000	115
Chevrolet Vega	169.7	65.4	51.2	97	140.0	80/4400	26.1/42.1	67.4	N.A.	42.6	28.9	50.2	N.A.	N.A.	N.A.	6300
Citroen D-21	196.5	70.5	60.25	123.0	132.7	115/5750	42.25/41.75	84	48.5	38.25	39.5	69.0	1340	4900	12/unlim.	131
Cortina	168.0	63.8	54.8	98	97.5	71/5000	30.0/47.3	76.0	43.3	53.0	34.0	70.5	904	2304	12/12000	859
Datsun 510	163.2	61.4	56.5	95.3	87.3	96/5600	30.6/43.6	60.9	34.3	50.0	32.0	57.4	750	2226	12/12000	739
Fiat 124 Special	156.75	64.0	53.75	95.25	87.75	76/5400	33.0/44.0	58.0	38.0	50.0	33.5	59.0	949	2273	12/12000	560
Mazda 1200	145.0	58.3	55.3	88.9	71.3	64/6000	33.4/47.4	52.1	29.0	47.4	32.0	47.0	800	1930* (2-dr.)	12/12000	18
Mazda 1800	172.0	64.2	56.3	98.4	109.6	98/5500	32.0/51.0	63.0	35.0	51.0	33.4	59.0	1050	2450	12/12000	18
Opel Kadett	164.4	61.9	58.8	95.1	115.8	102/5400	28.9/48.0	61.9	38.5	49.0	32.5	55.6	963	2155	12/12000	2000
Peugeot 404	180.0	64.0	58.8	111.8	110.0	90/5500	22.0/43.0	75.0	51.0	40.5	37.0	81.2	1100	2995	12/unlim.	275
Renault 16	168.4	64.9	57.3	104.3	95.5	70/5200	37.0/47.0	72.5	38.5	49.0	41.0	42.0	900	2395	12/unlim.	400
Saab	168.3	62.2	58.6	98.3	91.4	73/5000	29.6/44.0	63.8	43.4	47.3	35.45	49.2	1150	2799	12/unlim.	375
Simca 1204	154.7	62.5	55.8	99.2	73.47	62/5800	35.0/45.0	67.5	34.5	42.0	35.75	41.0	1000	2145	12/12000	548
Subaru	152.8	58.3	55.7	95.2	66.4	62/6000	40.6/56.0	57.0	N.A.	47.5	N.A.	N.A.	N.A.	1899	6/6000	391
Toyota Corolla	154.3	58.7	55.1	90.0	71.1	73/5500	32.0/46.0	56.0	34.0	47.0	32.0	49.0	770	1876	12/12000	800
Toyota Mark II	171.5	63.2	56.1	98.8	113.4	108/5500	31.0/46.0	72.0	37.0	50.0	30.0	62.0	800	2400	12/12000	800
Toyota Crown	184.6	66.5	57.7	105.9	137.5	115/5200	32.0/43.0	78.0	43.0	47.0	32.0	68.0	900	3149	12/12000	800
Volkswagen Squareback	170.9	63.2	57.9	94.5	96.66	65/4600	27.5/48.0	66.0	42.75	48.0	31.0	42.4†	992	2499	24/24000	1000
Volvo 145	182.7	68.3	57.1	102.4	121.0	118/5800	31.5/46.0	74.0	44.5	52.4	33.0	67.0‡	1100	3495	6/unlim	360

* Two-door model; four-door, \$2030.

† Plus 8.1-cu.-ft. trunk in front

‡ Plus 3.5 cu. in. extra storage under floor

a creditable 14.2 seconds; shifting manually, we shaved another 0.6 second off this time. Our 50-70 runs averaged 8.9 seconds (8.7 shifting manually). Our 18.8-mpg trip mileage disappointed us, since our experience with other samples of this make convinces us that our test car wasn't properly tuned. We estimate about 23 mpg for a representative sample. Our speedometer was two mph fast at lower speeds, three mph fast at 60 and above.

The instrument panel is nicely laid out except for the rectangular speedometer (we're biased in favor of round ones). The headlight dimmer is conveniently combined with the directionals.

VOLKSWAGEN SQUAREBACK

The rear-mounted engine may usurp some rear load space in the Volkswagen Squareback, but a roomy front trunk

makes up for the loss. Normally you never feel that rear engine; the VW actually understeers right up to maximum cornering speeds, when it changes (fairly abruptly) to oversteer.

The car leans hard in the turns, and ride motions are long and abrupt. With a full load the ride actually improves slightly. The front bucket seats are comfortable, but the built-in headrests reduce rearward vision. Front legroom is skimpy, even for an average-size driver. Rear seating room is adequate for two.

The instrument panel styling is functional; round gauges offer good visibility.

Ventilation controls are complicated and hard to reach, and we'd prefer an old-style center horn button to a hard-to-find partial horn ring. The heater, usually a problem in air-cooled cars, is efficient, and a

rear-window defogger makes a useful addition.

Our car came equipped with the optional automatic transmission, which proved smooth and positive-shifting. Allowing the box to shift for itself netted a 0-60 time of 19.1 seconds; manual shifting brought this down to 18.8. Our 50-70 runs took a leisurely 16.8 or 15.8 seconds, depending on whether the transmission was left alone or shifted by hand. Trip fuel mileage averaged a decent 23.2 mpg. The speedometer read two mph high throughout most of its range.

Steering in the VW is fast, but heavy, even at speed. The disc and drum brakes do their job well in every respect.

SAAB

That old free-wheeling device—necessary to prevent oil starvation in Saab's old two-cycle engine—has been retained on the newer V4-powered Saab. We wish it hadn't been.

This diabolical mechanism disengages the engine from the transmission whenever you let up on the accelerator. Sure, this saves gas by allowing you to coast with the engine idling. And sure, it lets you upshift without using the clutch, if that turns you on. But the lack of engine braking made us feel queazy, especially when cornering. Also, coasting puts greater demands on the disc and drum brakes which, happily, are up to the job. The Saab brakes, though not the most powerful, are directionally stable and fade-resistant. Incidentally, the free-wheeling can be locked out with a lever under the instrument panel—and that's what we did.

As is true with most front-wheel-drive cars, the Saab's handling is stable at high speeds, even in strong crosswinds. On a corner the front end plows strongly unless you let up on the accelerator; then the front end abruptly tucks into an oversteering condition. Such behavior may frighten the novice driver, but it's great fun once you get used to it. Steering is heavy, particularly when accelerating in a corner; but it's precise and fairly fast. Ride is firm and reasonably comfortable for a car of this size; even under full load it remains acceptable.

The column-mounted four-speed shift lever is sloppy, but the transmission synchronizers do their job well. Our 0-60 times averaged 17.3 seconds, and 50-70 took 12 seconds flat. Fuel mileage, 29.1 mpg, was a close second to the Renault's. Speedometer error ranged from plus 1.5 mph at 30 to plus four mph at 80.

The interior made us feel claustrophobic; the windshield slants back sharply, and the high cowl and window sills give passengers the impression of sitting in a bathtub. But actually, visibility all around is fine.

The instrument panel is neither modern nor

(Please turn to page 216)



SUBARU STAR has horizontally opposed, four-cylinder, water-cooled engine, top speed of 90



AUDI SUPER 90 is clean, smartly styled, has front-wheel drive from water-cooled Four



CHEVROLET VEGA is long-awaited domestic wagon of compact and handsome proportions



PEUGEOT 404 has a 1.8-liter engine, dual carburetion, ZF automatic transmission option

CORTINA from Ford of Britain has a 1600-cc engine with 71 hp, economy close to 30 mpg



Switch Your Stereo Speakers

This easily built selector automatically maintains a proper impedance load as you turn speakers on and off. It lets you choose three stereo pairs and one monaural extension

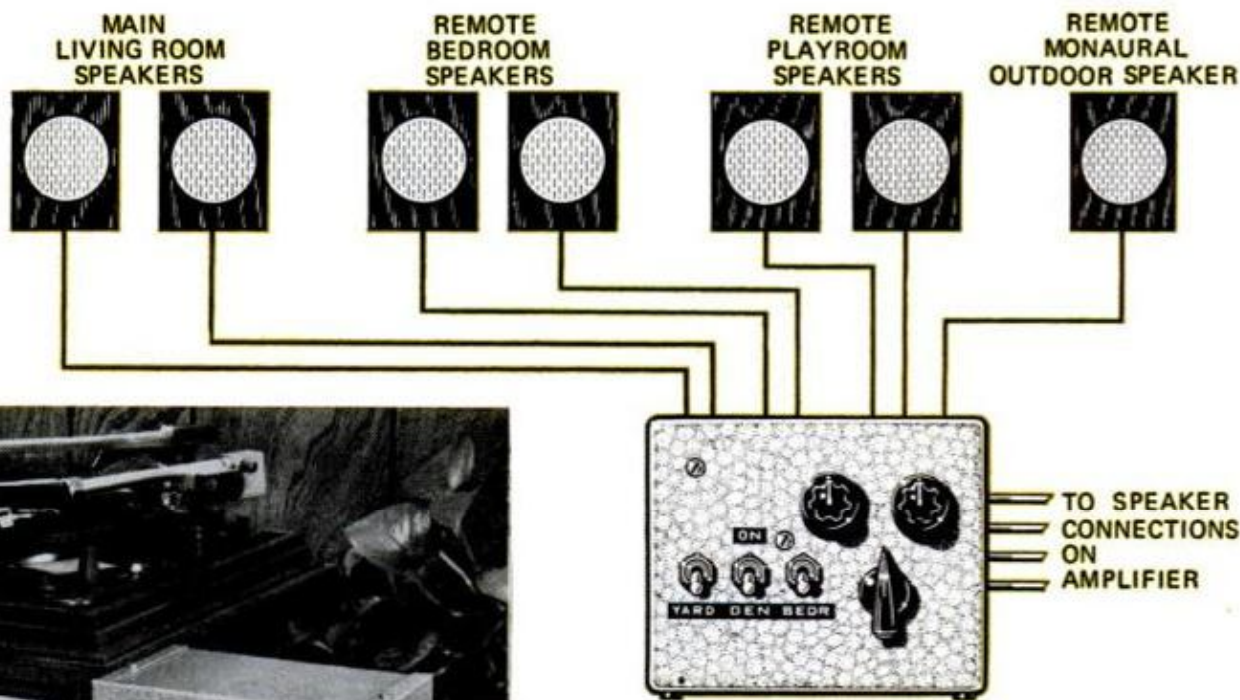

A HANDY COMPANION to a hi-fi set, this master selector makes it easy to switch speakers on and off without changing the load on the circuit. It handles up to three pairs of stereo speakers and one monaural extension and also offers individual volume control on main speakers. It makes no difference which or how many speakers are on at a time—the load is always kept the same automatically

By **WALTER G. SALM**

Photos by Robert D. Borst

SOONER OR LATER, most hi-fi owners dream of adding extra speakers throughout the house—a second stereo pair in a playroom or den and maybe another set in the bedroom. The trouble is, most amplifiers provide for hooking up, at most, only one or two sets of speakers.

If you simply attach additional speakers to the same terminals, wiring them in parallel, you decrease the resistance in the circuit and create a serious impedance mismatch. This drastically reduces the amplifier's effective power, and, on transistor models, can cause an overload that may damage the set or blow the speaker fuses. Most of today's amplifiers are lim-

ited to a safe impedance range of 4 to 8 ohms. If total speaker resistance falls much below 4 ohms, you're in for trouble.

The handy control shown here lets you switch on up to three pairs of stereo speakers, plus a fourth, monaural speaker, without affecting the impedance match to the amplifier. It does this with a clever combination of series-parallel wiring and dummy loading resistors to keep the total impedance the same, no matter how many speakers are switched on or off.

Here's how the system works: Wiring two 8-ohm speakers in parallel cuts their resistance in half to 4 ohms. The formula for determining this is to multiply the two

With This Self-Balancing Control

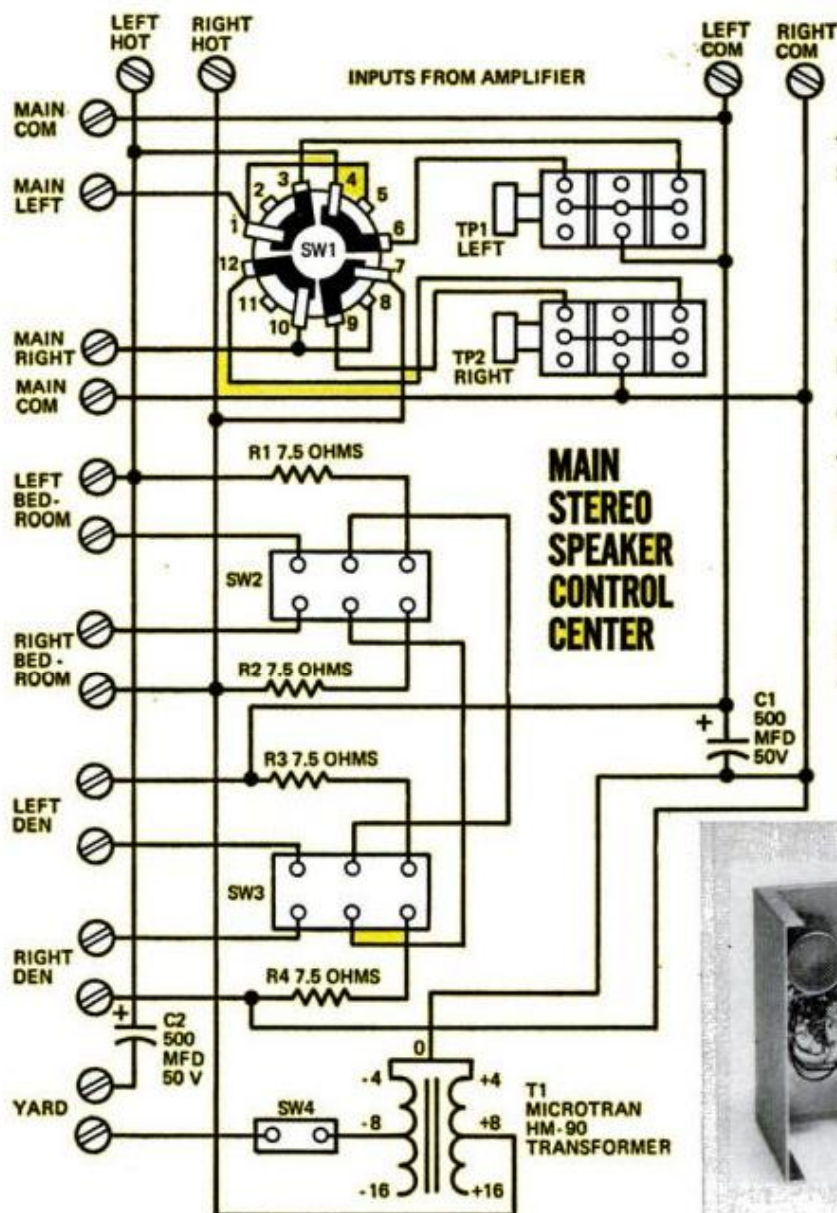

PARTS LIST

- TP1, TP2—8-ohm T-pads (46F3116)
 SW1—4-pole, 2-position rotary wafer switch (56A4306) or use alternate 4-pole, double-throw miniature toggle switch (56A3204)
 SW2, SW3—D.p.d.t. miniature toggle switches (56A3202)
 SW4—S.p.s.t. miniature toggle switch (56A3201)
 R1, R2, R3, R4—7.5-ohm, 20-w. wire-wound resistors (45F7196C)
 C1, C2—500-mfd., 50-v. electrolytic capacitors (43A9269)
 T1—Microtran HM-90 transformer
 Case—6x5x4" minibox (42A7623)
 Misc.—4-lug terminal strips (package of 10, 47A4335), 8-terminal barrier strip, 10-terminal barrier strip, 3/8" rubber grommet, hookup wire, mounting hardware
 (Part numbers in parentheses from Allied Radio, 100 N. Western Ave., Chicago, Ill. 60680.)

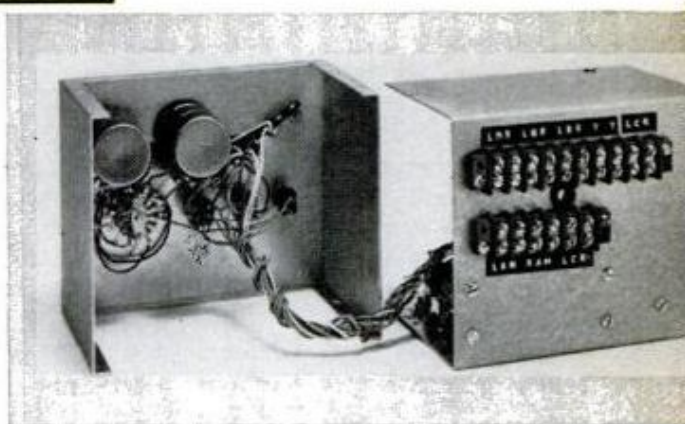

WIRING DIAGRAM shows how loading resistors are switched into circuit as speakers are turned off to maintain a constant impedance. Switches and T-

resistances together, then divide the product by the sum of the resistances. Thus, you multiply 8 times 8, divide the product, 64, by the sum, 16, and get an impedance of 4 ohms. This is within the safe limit, but when you add a third 8-ohm speaker in parallel, you multiply 4 times 8, divide the product, 32, by the sum, 12, and get 2.67 ohms—well below the danger point.

Now if you connect two 8-ohm speakers in series instead of parallel, you double their resistance, producing an impedance of 16 ohms. But you can't wire all of your speakers in series or the total would get too high. The trick is to arrange some in

pads are mounted on inside of front panel, as shown in photo at right, above. Other components are wired between lug-type terminal strips on rear panel series and some in parallel in such a way that their total impedance falls within the safe range.

This is what the control does. The two remote pairs of stereo speakers are wired in series, then this combination is wired in parallel with the main living room speakers. The result is a 16-ohm load for the series speakers added in parallel to the 8-ohm load for the main speakers. You multiply 8 times 16, divide the product, 128, by the sum, 24, and get a total impedance of 5.3 ohms—well within the allowable range.

This is fine if all your speakers are

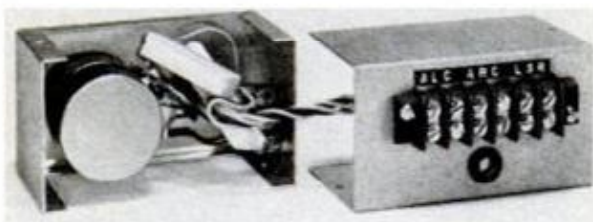
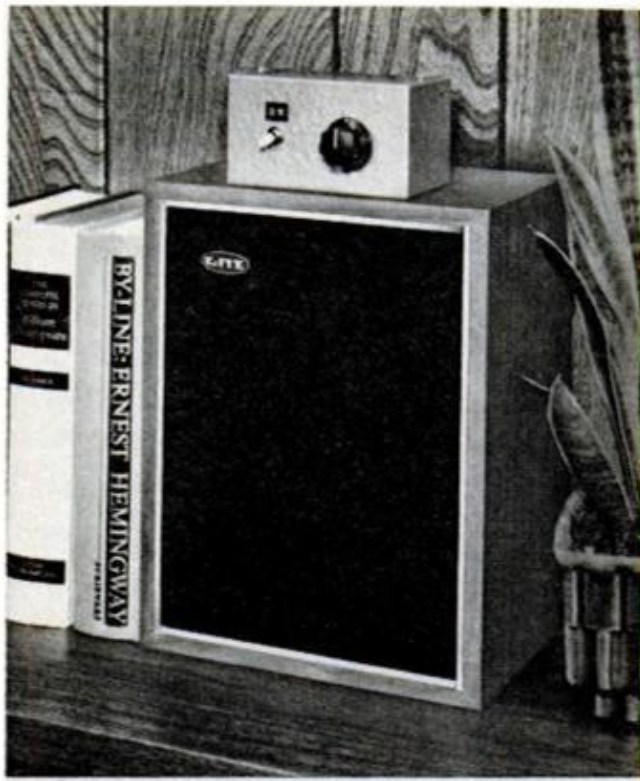

REMOTE CONTROL is not part of basic circuit, but can be added if you want to switch speakers on and off at each location independently of the main control. It uses a stereo L-pad to vary the volume

playing at once, but obviously you'll want to select only certain ones at a time. The control automatically provides for this, too. As each pair of remote speakers is turned off, its switch cuts in a pair of loading resistors of the equivalent value. Thus, the speakers always present the same total impedance to the amplifier, no matter whether they're playing or not.

The main speakers are wired through a switch to two T-pads that function as volume controls. To get sufficient volume from your remote speakers, it's sometimes necessary to turn up your main speakers louder than you want for comfortable listening. The T-pads let you reduce the volume on your main speakers while keeping the remote ones at an adequate level. The switch is a two-position, four-pole rotary. In one position, the T-pads are in the circuit; in the other, they're switched out and the main volume control

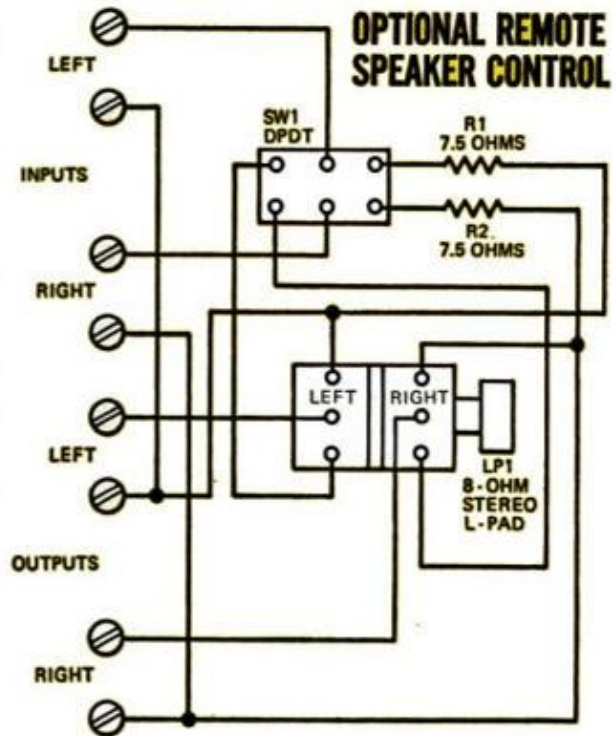

PARTS LIST

LP1—8-ohm stereo L-pad (46D3097)
SW1—D.p.d.t. miniature toggle switch (56A3202)
R1, R2—7.5-ohm, 20-w. wire-wound resistors (45F7196C)
Case—2¼x2¼x4" minibox (42A7619)
Misc.—4-lug terminal strip, 8-terminal barrier strip, 3/8" rubber grommet, hookup wire (Part numbers in parentheses from Allied Radio, 100 N. Western Ave., Chicago, Ill. 60680.)

simultaneously on paired speakers. It also incorporates loading resistors so the circuit will remain balanced if speakers are switched off remotely while they're still turned on at the main control

on the amplifier takes over. You can cut out the T-pads whenever you're using only your main speakers.

If you want only your remote speakers on, turn the T-pads down to the point where your main speakers can't be heard. This, in effect, turns them off without removing their resistance load from the circuit. If you prefer, you can substitute a four-pole, double-throw toggle switch for the rotary type, but this is usually more expensive and harder to find. The other switches shown are all miniature toggles, but standard toggles of the same pole arrangement would do just as well.

The extra monaural speaker is added in case you want a single extension for use outdoors on a porch or patio. The monaural signal is derived by using a matrixing transformer, a Microtran HM-90 type, bridged across the right and left stereo channels. Capacitors isolate the two

channels so they will not become grounded together. This is necessary because many of today's transistor amplifiers do not have a common ground and the two channels must be kept separated.

If you don't need the monaural extension, you can eliminate the transformer and the two capacitors. In this case, be sure also to omit the connection that bridges the right and left common bus wires together at capacitor C1 as the two commons must remain isolated if the capacitors aren't used. If your amplifier does have a common ground, you needn't worry about this isolation and you can connect your single ground lead to both the right and left common input terminals on the control.

When you shop for the loading resistors, you'll discover that there are no wire-wound types at exactly 8 ohms to match your speakers' impedance. The nearest that are commonly available are 7.5 ohms, but this is close enough. Heavy-duty wire-wound resistors of 20 to 25 watts capacity are necessary because the simple carbon type will burn out quickly under power surges.

In addition to the master selector, it's often handy to be able to control your speakers from each location. For this, an optional remote control is shown that incorporates a stereo L-pad, a pair of 7.5-ohm loading resistors and a double-pole, double-throw switch. The L-pad serves as a volume control and has two sections ganged on one shaft so it adjusts the level of both stereo speakers simultaneously. The switch works in the same way as those in the main selector—in one position, the speakers are on; in the other, the speakers are cut out and the loading resistors are switched in. This way, the circuit is kept balanced even if you turn off your speakers at the remote control while they're still turned on at the main control.

Connections are made on the back of both the main selector and the remote control by means of barrier-type terminal strips. The main control requires 18 connections so you'll need one 10-terminal strip and one 8-terminal type. The remote control requires eight connections, but you'll note that the inputs and outputs are electrically common on one side of each channel. Each of these pairs can be connected together on one terminal if you

wish, reducing the total number of terminals to six. However, it's probably easier to keep track of the wiring if you set up separate terminals, as shown in the diagram, using an 8-terminal strip.

Except for the matrixing transformer, all parts can be obtained from Allied Radio, 100 N. Western Ave., Chicago, Ill. 60680. The Microtran HM-90 transformer is available from Arrow Electronics, 900 Broadhollow Rd., Farmingdale, L. I., N.Y.

Once your speakers are hooked up, it's a good idea to check to see if they're properly phased. Switch your amplifier to the monaural mode or play a monaural record so both channels are mixed together. Crank up the bass control so you're getting a lot of deep, throaty low frequencies. Now stand in front of the speakers between them and listen carefully. If they're properly phased, the sound should be rich and full-bodied. If it seems weak and flat, reverse the connections to one speaker (it doesn't matter which one, but only do it to one of the two).

Try reversing the connections several times until you can be sure of a noticeable difference. The hookup that gives the best sound will be the one that indicates correct phasing. Do this for each pair of stereo speakers separately. ★★★

PRINCIPLE OF SELF-BALANCING CONTROL

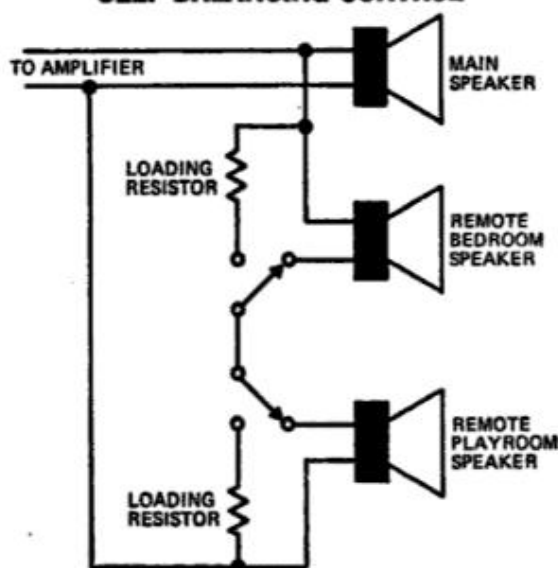

BASIC THEORY of self-balancing circuit is shown in simplified diagram above. As each speaker is turned off, a loading resistor is switched into the circuit to maintain a constant impedance load. Remote speakers are wired in series with each other, then in parallel with main speaker to keep impedance from falling too low. Diagram shows only one stereo channel. Other channel is identically wired

Now: Home TV Films in



SLIP A REEL OF FILM into a small player about the size of a phonograph and you can watch movies in full color right on your TV screen. Based on the EVR (Electronic Video Recording) process developed by CBS, the player connects to your TV's antenna terminals and works like a miniature TV transmitter. It feeds electronic signals into the set just as if they were broadcast over the air. The pictures appear in color on color sets and in black-and-white on noncolor sets.

Unlike magnetically recorded video tape—too costly at present for home viewing in color—the new EVR system uses ordinary movie film. The film is divided into three tracks—one for sound, one for visual images in black-and-white, and one for a series of squiggles representing coded information on

4-Channel



Stereo From Cartridge Tapes

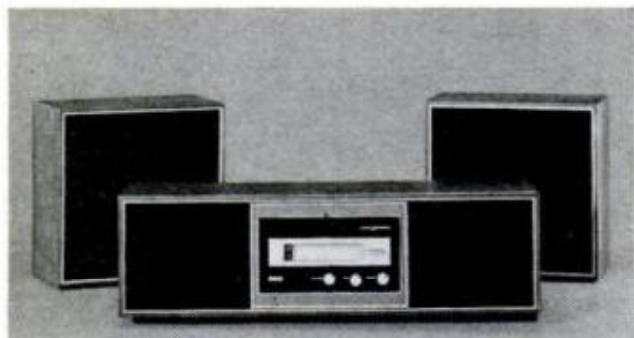

NEW 4-CHANNEL PLAYER has two built-in front speakers and two remote rear speakers. You can also attach two more front speakers to replace the built-in ones if you want wider stereo separation

144

FOUR-CHANNEL STEREO, an exciting new concept in hi-fi listening, is here at last in a convenient, relatively inexpensive system for use in any home. Developed by RCA, it provides 4-channel sound from ordinary 8-track cartridge tapes and will sell for under \$200—considerably less than previous quadrasonic systems based on large open-reel tapes.

The three-piece system consists of a main unit containing a cartridge tape player and a pair of built-in speakers plus two separate plug-in speakers. The built-

POPULAR MECHANICS

Full Color

what colors to add to each picture. In the player, the images are electronically scanned and converted into TV signals along with the color information and the sound track. These are transmitted to the TV set and the picture is recreated on the screen in full color.

Each 7-inch film reel holds 25 minutes of program material. To assure that there will be plenty of films for home viewing, 20th Century-Fox plans to release popular movies for use in the EVR system after they have appeared in theaters. Other companies are producing special programs like travelogues, sports events, historical documentaries and instructional hobby films. The players will be manufactured for CBS by Motorola and will sell initially for \$795. Future, more simplified models are expected to cost less as production increases. ★★★

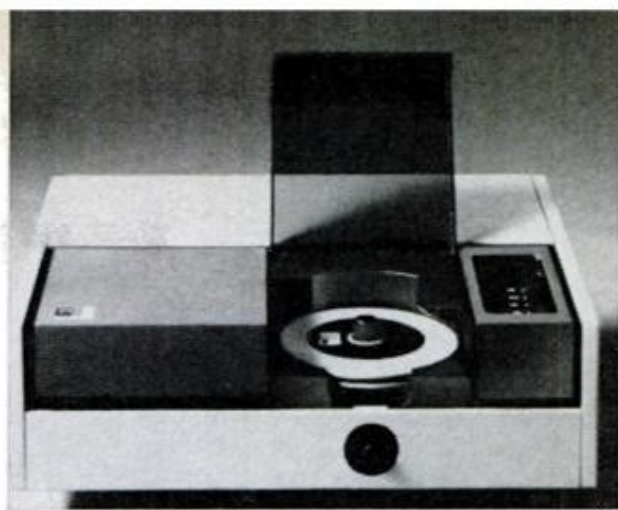

CLOSE-UP OF COLOR PLAYER shows lift-up plastic lid and spindle that holds the reel of film. Reel is simply slipped onto spindle, like a record on a phonograph, and threads automatically into the mechanism. At end of program, film is rewound onto reel and removed for storage. It can be stopped at any point for single-frame viewing or backed up. Plastic reel, shown below, is 7 inches in diameter



in speakers produce conventional 2-channel stereo. The two remote speakers are placed at the rear of your listening area to add a rich, reverberant background effect. The result is a spacious, room-filling sound similar to live music heard in a huge concert hall.

The tapes are identical to 8-track cartridges used in car players except that four channels are recorded simultaneously instead of the usual two. A 4-track playback head feeds the signals to four separate amplifiers, each connected to one of the four speakers. The head shifts sideways, playing tracks 1, 3, 5 and 7 in one position and tracks 2, 4, 6 and 8 in the other position. This alternate-track arrangement provides two sets of musical selections on each tape and also enables the machine to play conventional 2-channel cartridges interchangeably.

Recording companies are already producing 4-channel tapes and expect to have an extensive collection available soon. Motorola is planning to introduce a 4-channel car tape player, similar to the RCA home system, that will also play the new cartridges. ★★★

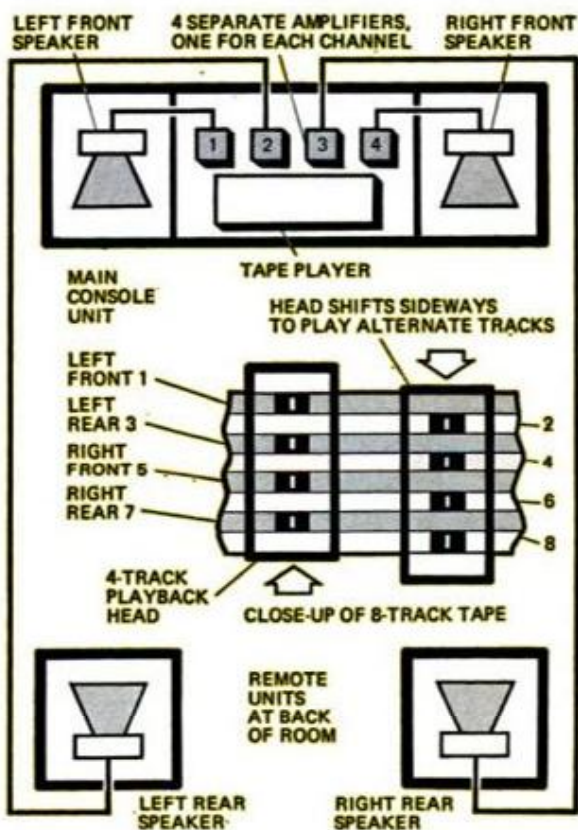

WALL-TO-WALL SOUND: Two built-in speakers at front and two added speakers at rear give rich, room-filling effect. Diagram at center shows how tape head shifts to play alternate sets of tracks

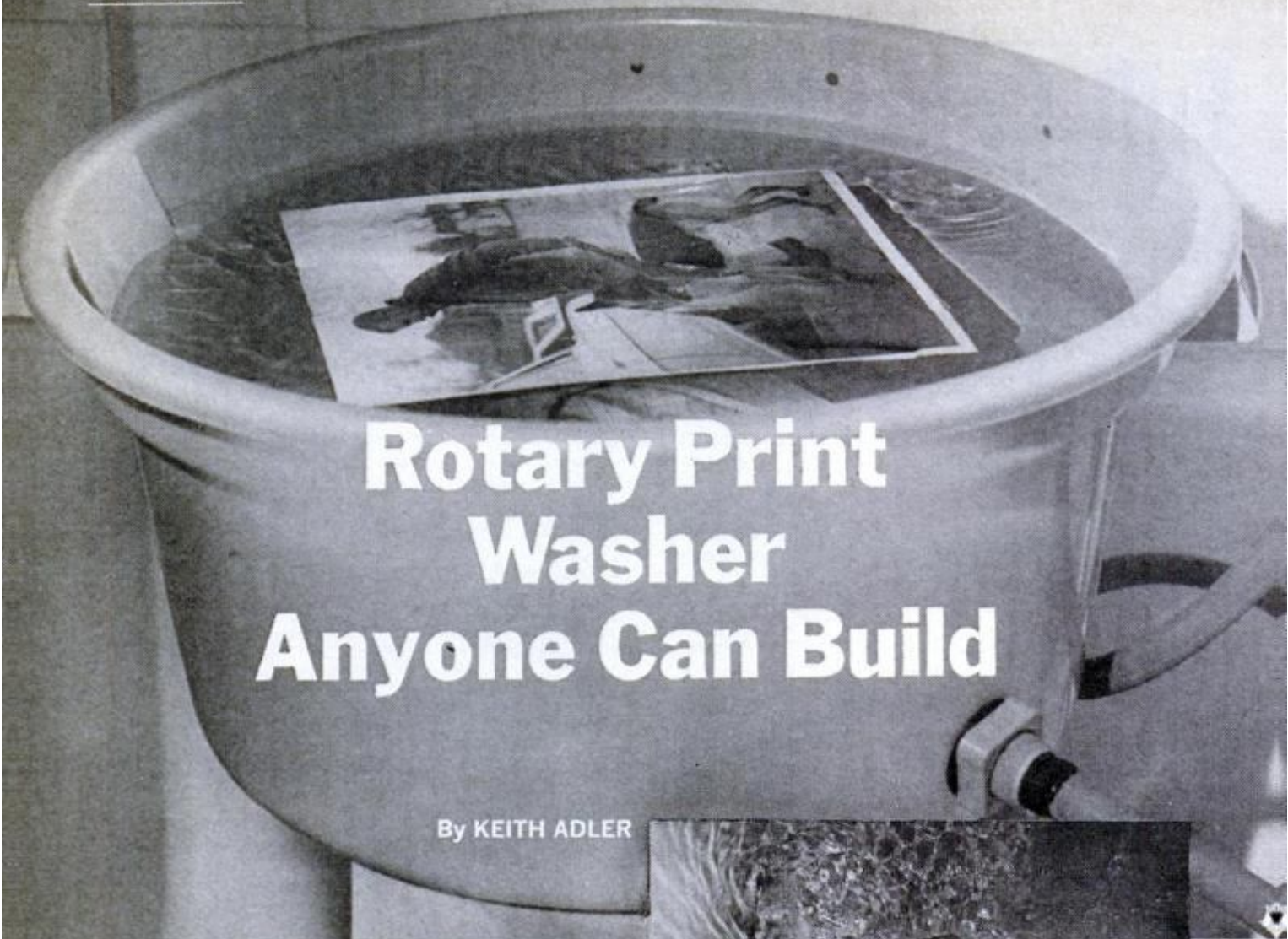

Rotary Print Washer Anyone Can Build

By KEITH ADLER

A plastic laundry tub and some hose fittings can give you a professional-type, swirling-action washing tank for \$5 worth of parts.

ROTARY PRINT WASHERS are too expensive for most home darkrooms, but you can make one like this from a plastic washtub. Water is forced in through a right-angle inlet pipe, creating a circular flow to keep your prints swirling and tumbling for a good washing action. Dirty water drains off at the top.

A \$3 plastic bulkhead fitting, sold at plumbing shops for use with plastic pipe, is the key to making a neat inlet. Cut a hole in the side of the tub near the bottom and clamp the bulkhead over it. Locate the threaded end of the bulkhead on the outside and screw in a $\frac{3}{8}$ -in. reducing adapter to take $\frac{3}{8}$ -in. rubber hose. On



the inside, cement in a plastic elbow using epoxy or similar adhesive.

Slip rubber tubing over the outside fitting and run it to any nearby source of water. I connect my washer to a bathroom shower by removing the shower head and using the adapter shown on the opposite page. You can hook up to a threaded faucet with a garden-hose adapter or to an unthreaded faucet with a rubber laundry connector.

Drill $\frac{1}{4}$ -in. drain holes around the tub's rim. The washer's agitation can be varied by adjusting the angle of the inlet. Pointing the end upward increases turbulence and downward decreases it. ★★★

PHOTO HINTS



PLASTIC BULKHEAD FITTING makes it easy to feed water into the washtub. Reducing adapter is screwed into outer half for attaching $\frac{3}{8}$ -in. hose, and the plastic elbow is cemented into the fitting's inner half

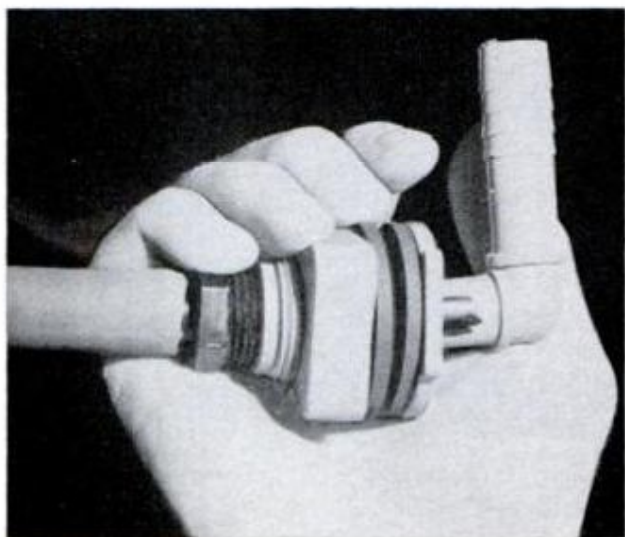

COMPLETED INLET shows elbow on inside of bulkhead fitting and rubber hose attached to outside. Bulkhead is now taken apart and clamped together on either side of the hole in the plastic washtub



WASHER CAN BE FED from a bathroom shower with an arrangement like this. Shower head is removed and a pipe coupling screwed on. Reducing adapter for $\frac{3}{8}$ -in. hose then lets you run tubing to tub

SEPTEMBER 1970



AN ORDINARY SCREWDRIVER with a $\frac{1}{4}$ -in. shank makes a perfect replacement for a lost or damaged tripod handle. Pick an inexpensive variety-store type since its metal is not as hard as that in higher-quality drivers and will be easier to work. Hacksaw off the blade tip and thread the end to match the threads in the tripod head. It's sometimes necessary to grind a shoulder near the end to serve as a stop before threading.—Arthur L. Ramos

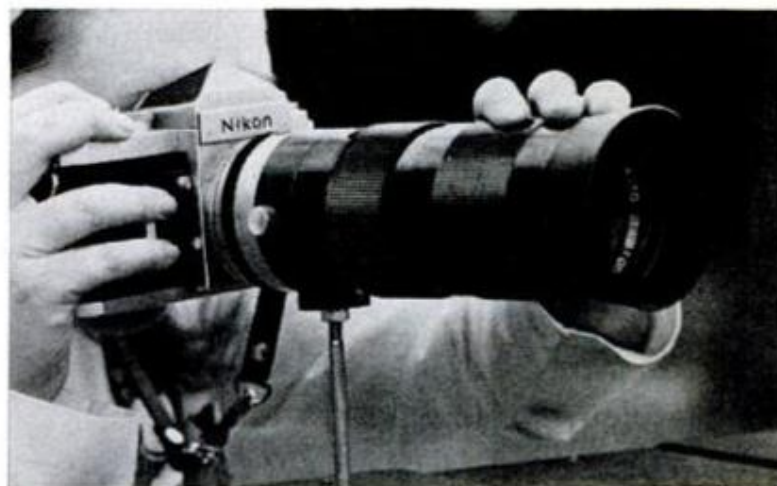

A HANDY MINIPOD for steadying long telephoto lenses can be made from a standard $\frac{1}{4}$ -in. bolt 4 or 5 inches long. Screw the bolt into the tripod socket found under the barrel on many long lenses. Run a nut up tight against the barrel to prevent any looseness. With the lens resting on the minipod, your left hand is free to concentrate on focusing. The bolt can also be used as a pistol grip for steadier hand-held shooting.—James Tallon

147

HOW TO SOLVE



JIGGLING a loose or defective ignition switch may put enough life back into it to get engine restarted

A logical, step-by-step approach to the possible causes of a stalled engine makes it easy to get back on the road and on your way again

HAVING A CAR STALL is no fun, especially when it strands you in the boondocks. But straight-line thinking from the minute the engine quits will help you cope with the situation if it happens to you.

Aside from an empty gas tank and a few other problems (bad fuel pump and bad coil are the primary ones), roadside repairs are easy to make. A good troubleshooter knows that the most likely causes of stalling are in the fuel or ignition systems, and wastes no time before investigating the major trouble spots. Let's look at a hypothetical situation and see just how it's done.

Suppose you're driving along a stretch of freeway that generally has little traffic and even fewer service areas. At this moment, you and the cars behind you are zipping along when your engine suddenly quits.

Getting safely off the road is your first consideration. If your car is equipped with emergency warning flashers, as all late models must be, push the button to let those behind know that you are in trouble. If this signal isn't available, wave off other cars by putting on your turn signal and motioning with your hand (arm out, palm facing to the rear) that you are stopping. Put the transmission into neutral to give yourself maximum maneuvering movement, and, with light taps on the brake pedal, smoothly glide off the road onto the right-hand shoulder. Try to stay off the left-hand median; it's a more dangerous spot. Hopefully you will have some warning device (flares or light) that you

SUDDEN STALL

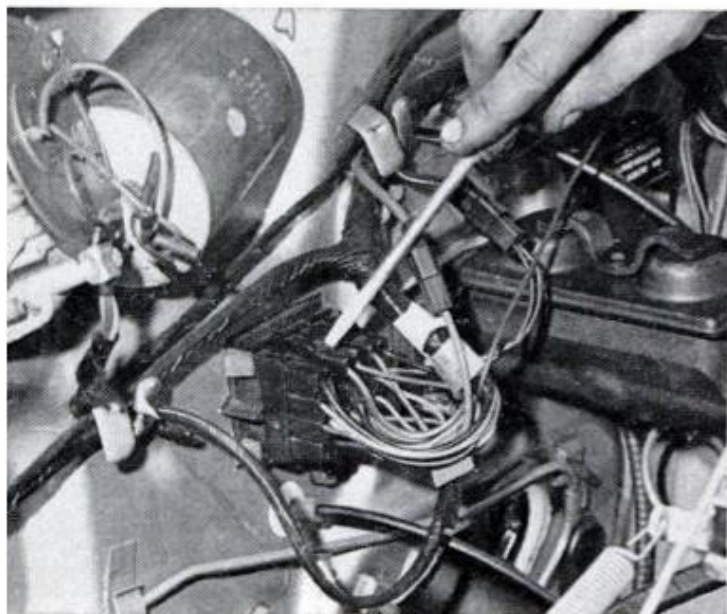

THE BULKHEAD CONNECTOR located on the firewall of today's cars looks like this. Make sure all the ignition wires coming into it are pushed on tight

CORRODED BATTERY TERMINALS could be your problem. Scrape clean with penknife or battery tool. Wipe off battery posts and connect terminals tightly



can place well aft of the car to warn approaching motorists.

Okay, go to work. Are you out of gas? Start hiking.

If fuel is okay, consider how the engine stalled. Did it sputter and jerk before it died? The trouble is probably a fuel failure. Did it just cut out? That signifies ignition trouble.

SEPTEMBER 1970

Before getting under the hood, what about climatic conditions? If the weather is hot, the problem could be vapor lock. If you have a jug of cold water, pour it on the fuel pump and fuel line. This will cause vapor to liquify and allow gas to flow again. Otherwise you will have to sit for half an hour or so until the engine cools down to the point where the vapor dissipates by itself.

Is it winter? Perhaps a sliver of ice is blocking fuel. Try the same method as for summer, this time pouring hot water or hot coffee over the carburetor and fuel line. If you don't have a hot liquid with you, you will have to try to clear ice by removing the fuel filter, clearing the needle valve, or blowing out the fuel line, which we'll explain below.

Did you splash through a deep puddle? Ignition parts could have gotten wet. Wipe off the distributor cap, coil and sparkplugs.

Another thing you should do immediately is jiggle the ignition switch under the dash. The switch may be defective, and shaking it could put enough life back into it to get the engine started.

Another place an ignition failure often occurs is at the bulkhead connector on the firewall, where ignition wires connect. One of the connections may have worked loose and just needs to be pushed back in.

One other place to check is the battery cables. If terminals have worked loose from battery posts, tighten them. If they are badly corroded, take them off the posts and scrape them clean. A regular battery tool is good to have and costs only \$1.50.

If the way the engine died suggests a fuel-system problem, remove the carburetor air cleaner. Is the choke plate closed? Maybe a malfunctioning choke control piston caused the plate to shut, and the engine has flooded. Wedge the plate open with a block of wood or a book of matches folded in half.

Although it rarely happens, the filter in the carburetor air cleaner may be so clogged with dirt that it cut off air to the carburetor, causing the engine to flood. In

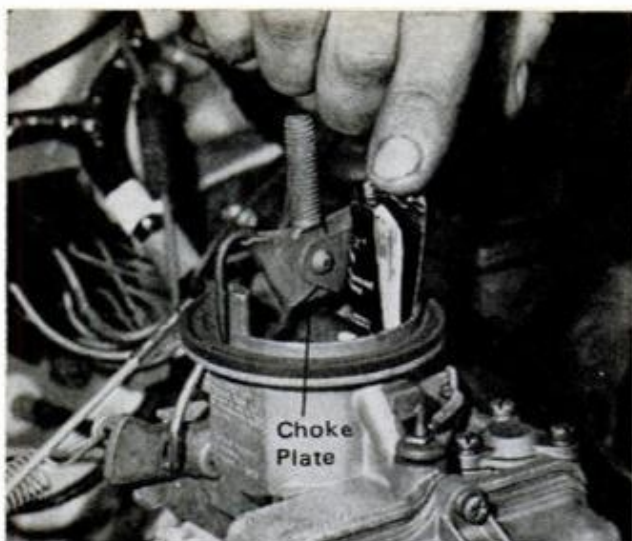

KEEP FAULTY CHOKE PLATE open by wedging an emergency device between choke plate and carburetor

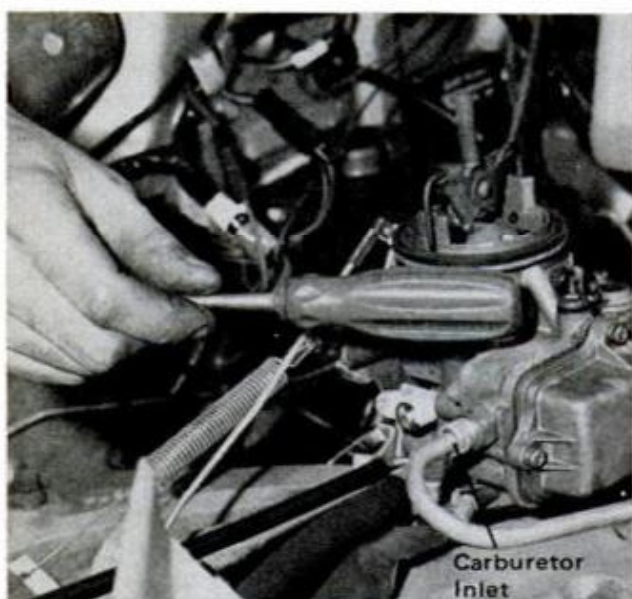

TO FREE NEEDLE VALVE of dirt, tap carburetor inlet. Remove fuel line here to reach the internal fuel filter

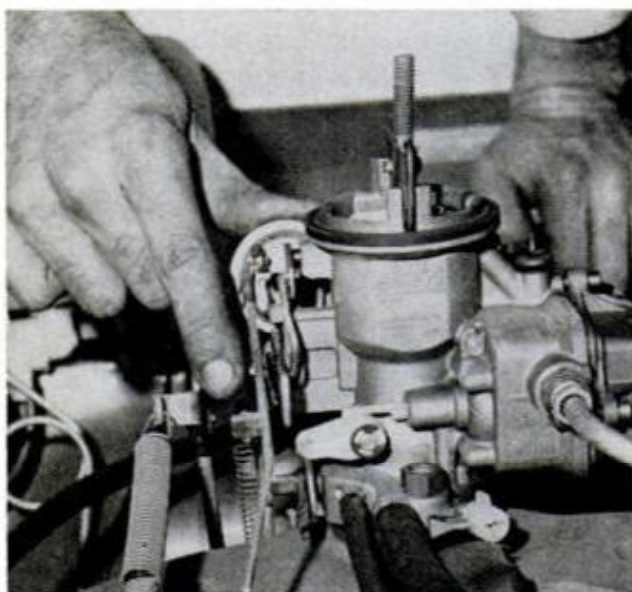

CHECK TO SEE if gas is getting to cylinders by operating throttle as you look down the carburetor throat

this case, throw away the air cleaner and run the car without it until you can get a new one at a service area.

Another cause of engine flooding can be a piece of dirt (or ice) wedged between the needle valve and seat. Tap the carburetor bowl with a screwdriver handle to try to loosen the dirt.

If the engine has flooded, you will have to clear the cylinders before it will restart. With the accelerator pedal to the floor, crank the starter, allowing the influx of air to deflood the engine.

If flooding is not the problem, maybe lack of fuel is. To see if gas is getting to the carburetor, look into the carburetor throat as you open and close the throttle manually.

No fuel? Disconnect the fuel line from the carburetor side of the fuel pump. Crank the engine for a moment. If gas comes out, the blockage is between this spot and the carburetor throat, probably in the fuel filter (either an external type located on the fuel pump-to-carburetor fuel line or an internal type in the carburetor inlet).

If you have an external filter, take it off and replace it with a length of 5/16-inch hose. If you have an internal filter, remove it from the carburetor inlet and hook the fuel line back up. In either case, you can run the engine without a fuel filter until you get to a service station, but don't forget to install a new filter as soon as possible.

Rarely will the fuel pump-to-carburetor fuel line get clogged, but if there is no other explanation for lack of fuel at the carburetor, remove the line and blow it out by mouth.

If you get no gas at the outlet side of the fuel pump, make sure the fuel line coming to the pump from the gas tank is tight. If an air-sucking loose connection is not the trouble, the fuel pump has no doubt gone bad.

Is an ignition failure indicated? Remove a sparkplug cable, insert a screwdriver into the boot so it contacts the terminal, hold the screwdriver about 1/4 inch from ground and crank the engine. If spark jumps, the ignition system is okay.

Plugs bad? Not likely under these circumstances, since it is almost impossible for all plugs to go out simultaneously and cause a moving car to stall. If there is no spark, however, make sure all electrical

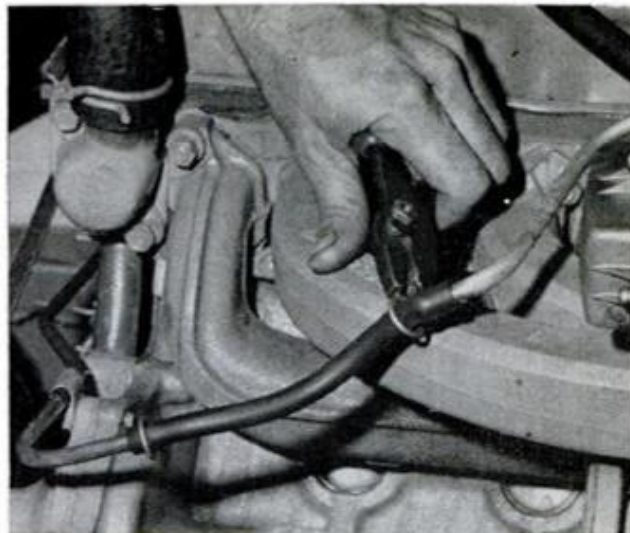
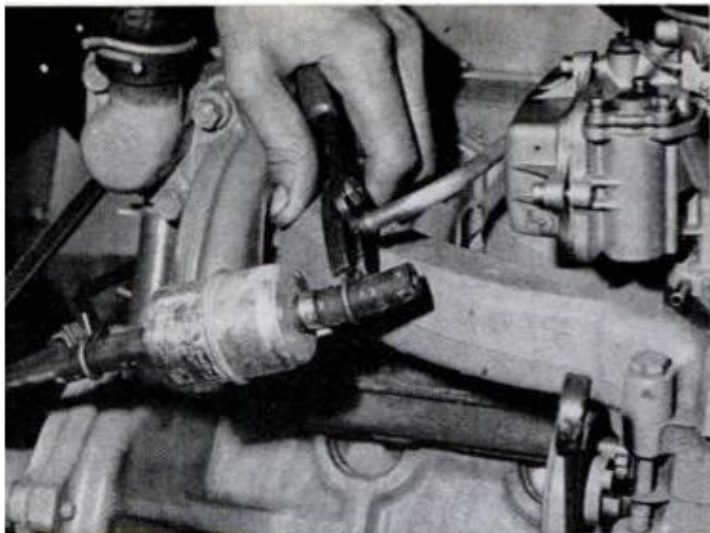

CLOGGED FUEL FILTER will stop an engine dead. A length of $\frac{3}{16}$ -inch hose will serve as substitute bypass to get car started. If original filter was attached by holders, hose must be held in place by clamps

connections are tight. Push all sparkplug cables firmly onto plugs. Do the same for all cable terminals at the distributor cap. Pay particular attention to the cable from the coil tower to the distributor tower. If this one comes loose, it will stop you dead in your tracks. Tighten up on the primary wire between the coil and the distributor. This wire is usually connected at the distributor points so you will have to remove the distributor cap.

Also make sure the wire on the ignition switch side of the coil hasn't worked loose and that the connections at the ballast resistor are in place. (The ballast resistor, if you have one, is a white ceramic resistor on the firewall.)

If none of this gets you going, the distributor points may be fouled. Clean them off with an ignition point file if you have one. If not, give the points a pass or two with the striking part of a book of matches.

Finally, it could boil down to either a bad condenser or coil. In either case, there isn't much you can do unless you are carrying spares.

To find out which is at fault, disconnect the condenser and place it so it isn't grounded on the distributor plate, turn on the ignition key and open and close the points with a screwdriver. If a spark jumps the point gap, the condenser is bad. If there's no spark, the coil is the probable bottleneck.

There is one other possibility, although it's not too likely—a rotor spring clip that suddenly breaks off. You can check this when the distributor is open. A new rotor is the only help. ★★★

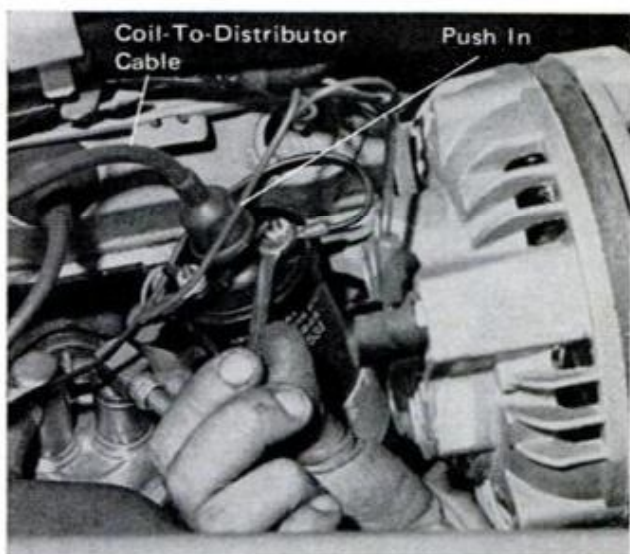

LOOSE ELECTRICAL CONNECTION may cause stall. Check connections, including coil-to-distributor cable

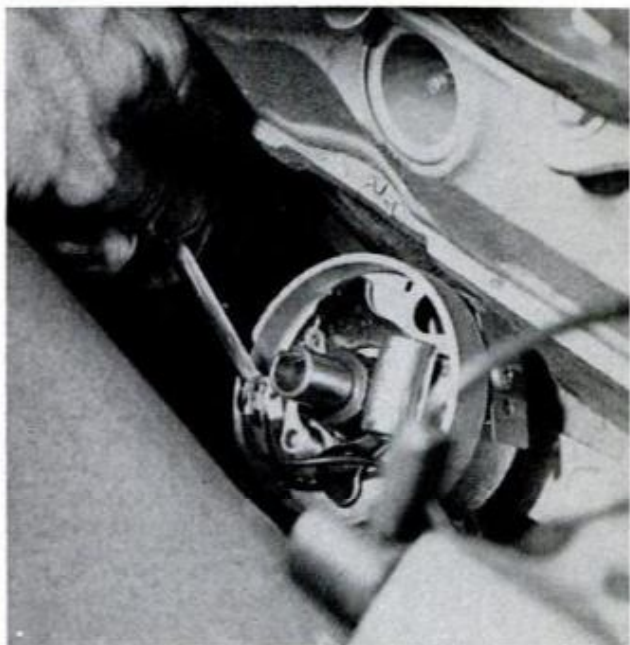

REMOVE DISTRIBUTOR CAP to make sure primary wire, usually connected at distributor points, is tight

Evinrude's Portable Diving Unit

Model AH-101E

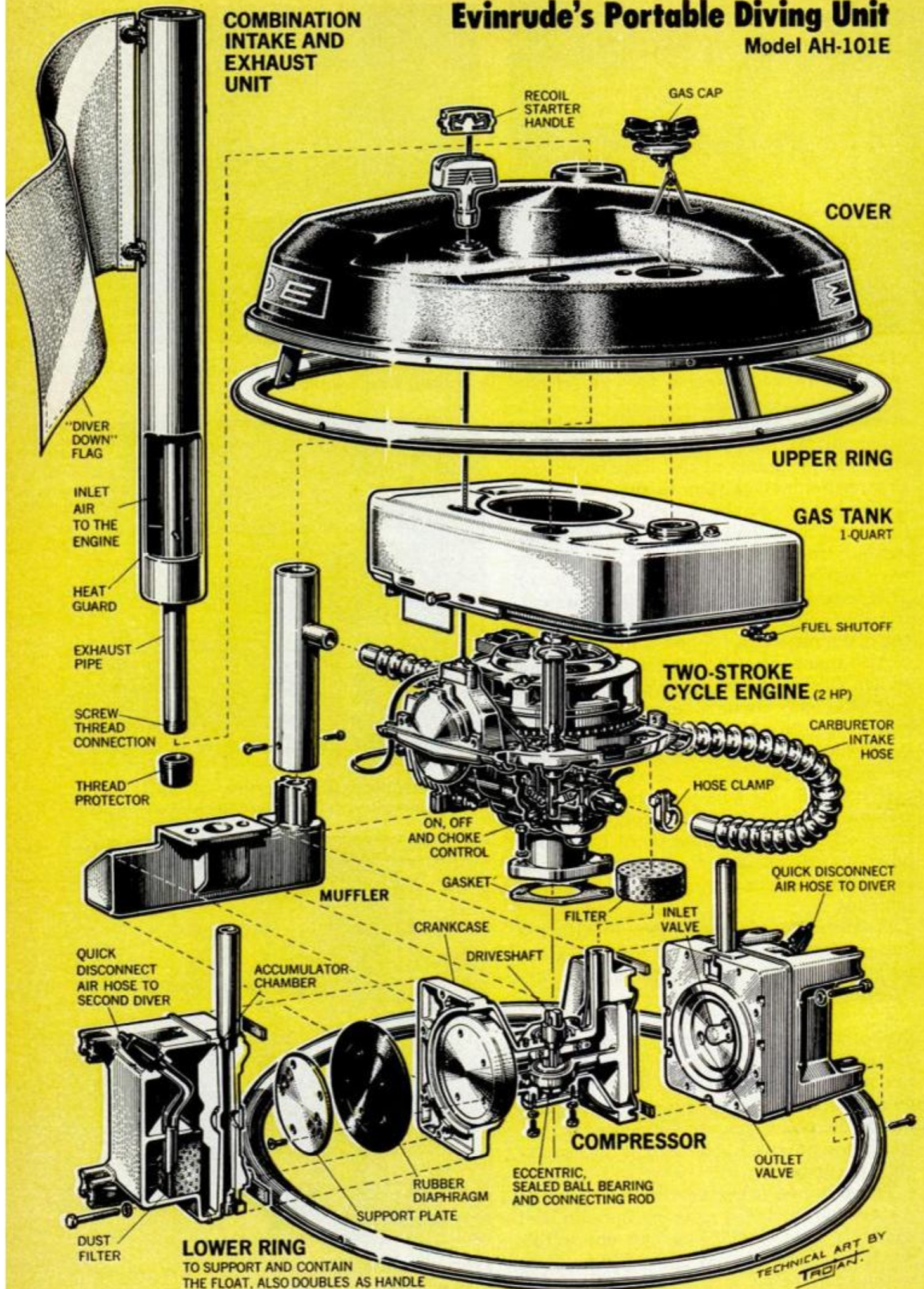

LOWER RING
TO SUPPORT AND CONTAIN THE FLOAT, ALSO DOUBLES AS HANDLE

TECHNICAL ART BY
TRIGAN

OUTDOOR RECREATION

Aquanaut Makes Diving Easy

By DAN FALES



Now you can get into sport diving with this simple device



IF YOU HAVE NEVER CRUISED at the bottom of a state park, it's high time you tried. And it takes absolutely no experience. Just strap on a face mask, crank up a little two-cycle compressor and head for the bottom of John Pennekamp Coral Reef State Park in the Florida Keys. There are no tanks to harness on your back, no hours of costly lessons to learn how to use the equipment—there's just the freedom of exploring the undersea world.

This freedom is available through use of Evinrude's ingenious "Aquanaut." It's a floating air compressor operated by a two-hp motor. The whole 40-pound unit rides on a life-preserver ring on the sur-

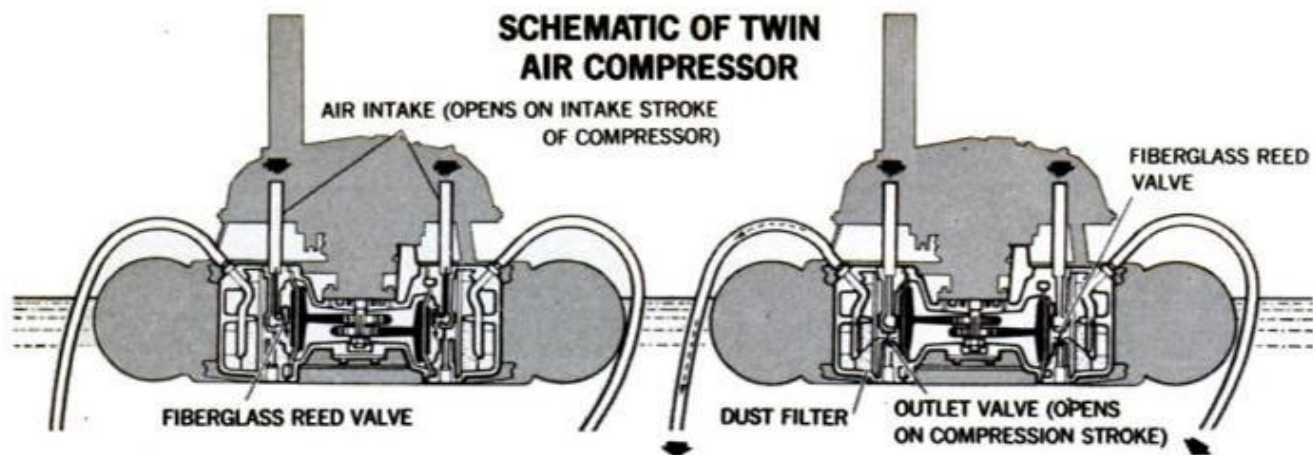

face. Two air hoses lead from the compressor and attach to individual harnesses. Each hose is a different color so that a diver can keep track of his line. Hose length is limited to 25 feet—for a good reason.

Any scuba diver knows that if he swims below 30 feet he must figure on decompression time during his ascent. If a diver doesn't go below that 30-foot level he doesn't have to decompress. So the hose length is your limiting factor in determining your dive depth.

There's another reason for eliminating the need to decompress. When under water you always hear the drone of the two-cycle motor running above. During my tests, I suddenly noticed the drone from topside had stopped. This happened at the same time I became aware of a distinct lack of air in my face mask. It was an anxious moment and I surfaced immediately. What had happened?

The motor had simply run out of gas, a common occurrence that happens about every 20 minutes. All you need to correct this insecure feeling is climb aboard your boat, refill Aquanaut's one-quart tank with a mixture of one part outboard motor oil to 24 parts of regular automotive gasoline. Then, with the tank full, pull the starter cord, refit your face mask and dive back into the water. You can repeat this operation all day long.

Though there's little chance of anyone getting into trouble, it's always best to dive with a buddy. That's the reason for the two air hoses.

Even with the hoses dangling from the compressor, everything is so arranged that you can swim underwater while gently tugging the surface unit behind like a buoy.

Actually, this is a buoy with a diving flag flying from the exhaust pipe. But remember not to get too far from your boat. It's tough to swim a long distance on the surface after spending much time below. Also, currents can play tricks on you by moving you farther from your boat than you realize.

I can see where this unit would be great fun at resorts, camps, summer homes and aboard cruising boats. It's good for your guests if they haven't done much underwater swimming or do not have any equipment with them. The Aquanaut is great for shallow-water diving, but if you are inclined to go deeper, or if you wish to join a group of adventurous wreck divers or treasure hunters, it's not for you. What you want then is the sophisticated equipment used by the varsity: tanks, regulators, depth gauges and underwater watches.

Actually, for the price of the Aquanaut you can get a good scuba rig. The Aquanaut costs \$259; for an expenditure of about \$300 you can do very well in the scuba department.

But if you are like me and find the 30-foot level quite nice, thank you, then the Aquanaut is for you and a buddy. However, I do wish the maker would develop a harness with straps that didn't rub the skin off my sides, and also develop a face mask that doesn't leak around the fleshy cheek area. Still, these are only minor complaints.

The Aquanaut is an easy-to-manage device for getting two people at a time into the beautiful underwater world. And they can do this without the rigamarole required in scuba diving. Given that design reason, you'll find that the Aquanaut is perfect. ★ ★ ★

HINTS FROM READERS

Junction-box receptacle

To improve the lighting over my workbench, I found that it isn't necessary to go to the trouble of installing an additional outlet box. Instead, I used a nylon knock-out socket-fuse holder. Having a junction box at about the right location, I simply pried out a knockout and installed the holder as shown.—*Joseph Braunstein*

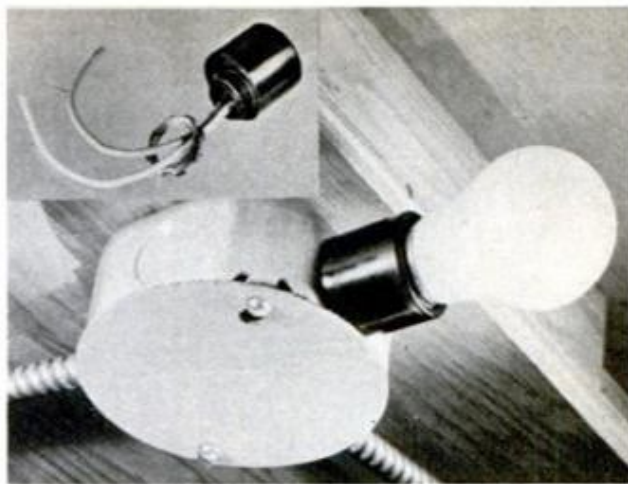

Lengthen life of fiberglass mix

If you make a double container from two different-size containers, you can use the device to keep mixed fiberglass and hardener from setting up too fast. Fill the larger can half full with a slush-mix of ice and water, then, after mixing the fiberglass in the smaller can, set it into the ice water. I've found this works even at high temperatures.—*Ivan Mowry*



Bandsaw wheel replacement

When the rubber facing on my bandsaw wheels deteriorated to the point that the blade slipped, I made "new" ones by cutting large bands from an old truck inner tube. After stretching them around the wheels, I started the motor and trimmed the excess by holding a linoleum knife against wheel's edge.—*Wilbur R. Gradin*



Small parts keeper

You can keep small parts, such as those you have on hand when doing electrical work, from rolling off a stepladder shelf if you do this stunt. It's nothing more than a strip of wide adhesive tape applied around the edge. It makes a simple and effective fence and, of course, can be easily removed when it's no longer needed.

—*William Swallow*

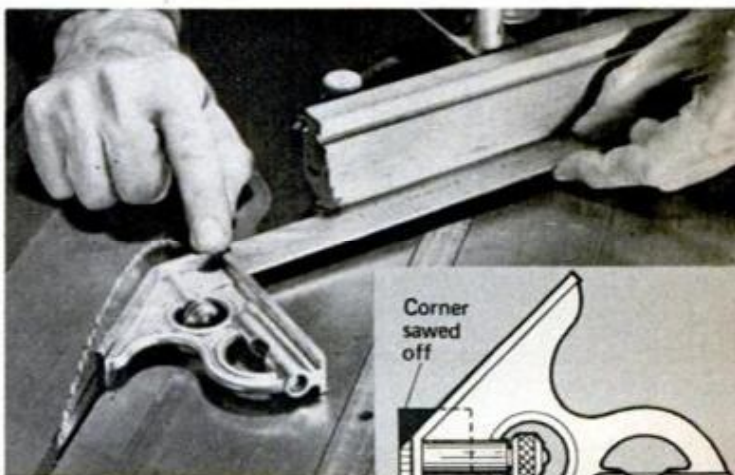

Modified combination square

By making a simple change on my combination square, I've greatly increased the tool's versatility. All I did was saw off the corner of the blade—45° by about 5/8 in.—so that I can use the tool to accurately set my bench-saw miter gauge to the blade. An added bonus is that the square can also be used to check 135° angles.

—*Robert F. Finch*

DO-IT-YOURSELF



HOME IMPROVEMENT

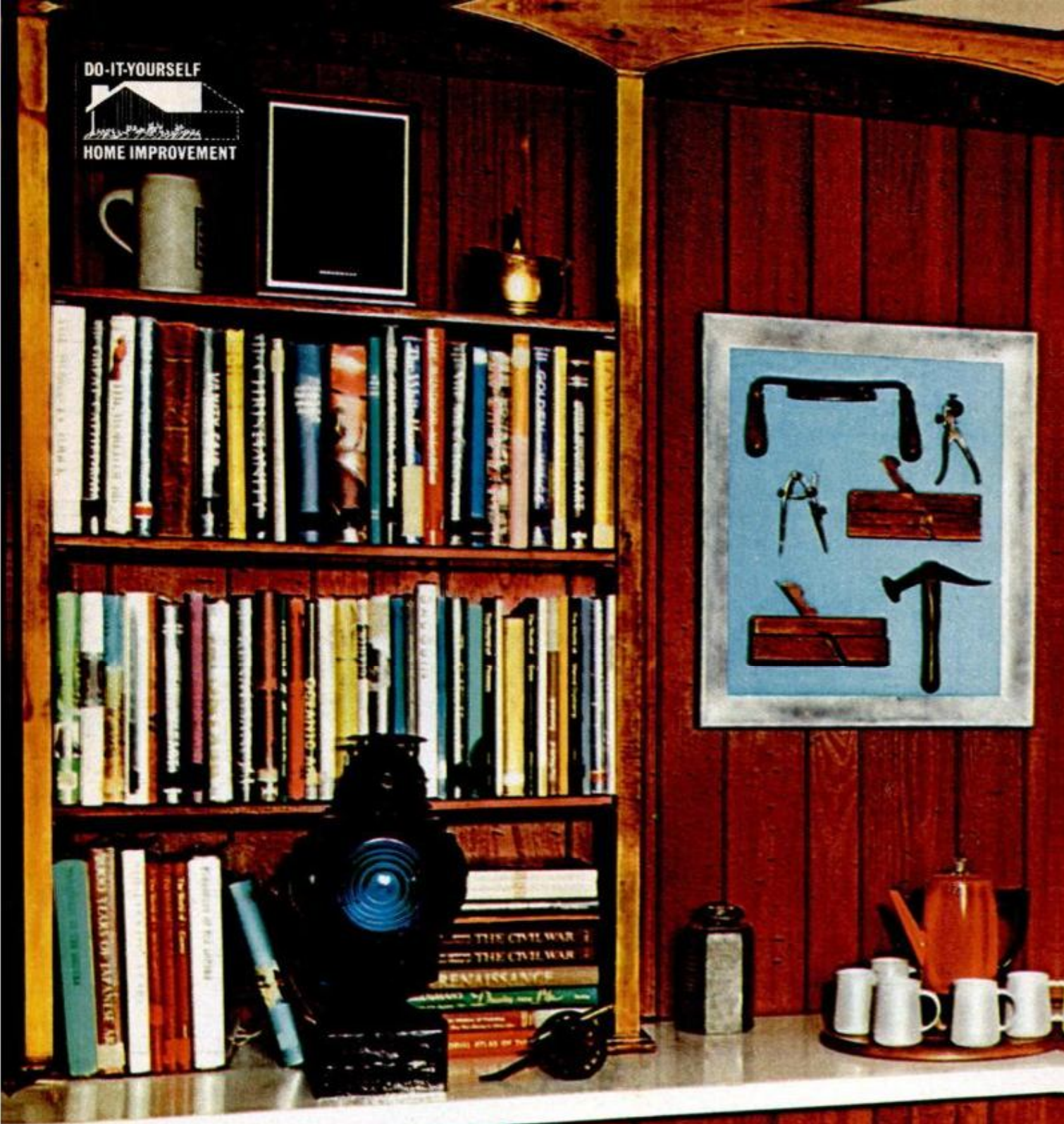

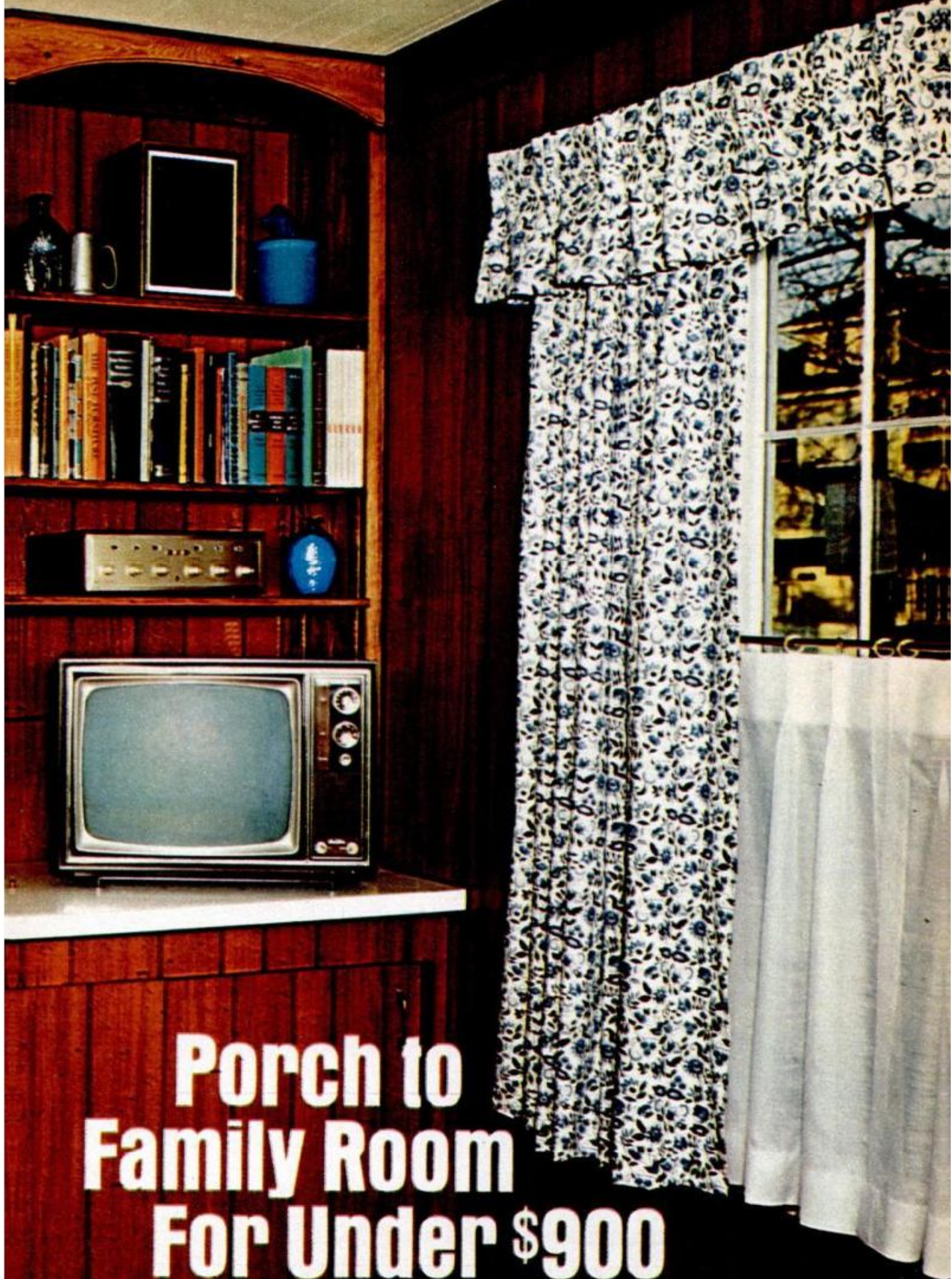

Porch to Family Room For Under \$900

PLEASE TURN PAGE 

Материал, защищенный авторским правом

More room for better living may already be well begun in an area now used only as a porch

By HARRY WICKS, Workshop Editor

Color Photo by Bill Aller, Styling by Robert Lotgren

THERE ARE REAL ADVANTAGES in buying an older home but there are also some points on the minus side. The biggest liability, as far as my wife and I were concerned, was a front sun porch that seemed more like a greenhouse than a room. It had nine windows and a pair of French doors. This made it just about impossible to arrange furniture sensibly and get full use of the room.

The room required a lot of curtain and window-washing, plus twice-a-year storm and screen-changing chores. This—and our real need for a family room—prompted the project you see on these pages. By doing it myself, I was able to keep total construction costs to about

\$810. I'd guess that in my area (Long Island) the same job by a contractor would have run close to \$2500.

Windows. The project was started by closing in the windows as shown. The double-mullion window installed in front is sized to satisfy FHA requirements—5 percent of floor space for ventilation, 10 percent for light. Vinyl clad on the exterior, the windows won't need painting for at least 10 years. And the muntins are removable. When the glass needs washing, it's a simple four-pane job. The windows come finished on the exterior; you, of course, supply the interior trim.

(Please turn to page 210)



BEFORE: Over-windowed porch on front of older home was of little use—lots of work inside and out



AFTER: Double window meets FHA minimum requirements; rebuilt room functions for everyday living

158

Technical Art by Fred L. Wolff

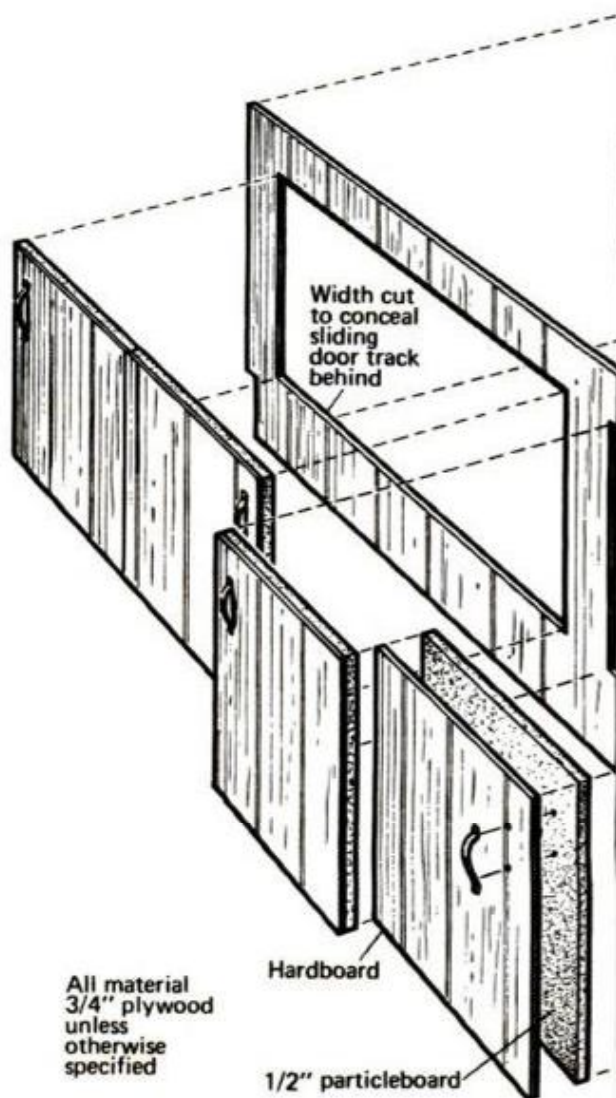

BUILT-IN ENTERTAINMENT CENTER

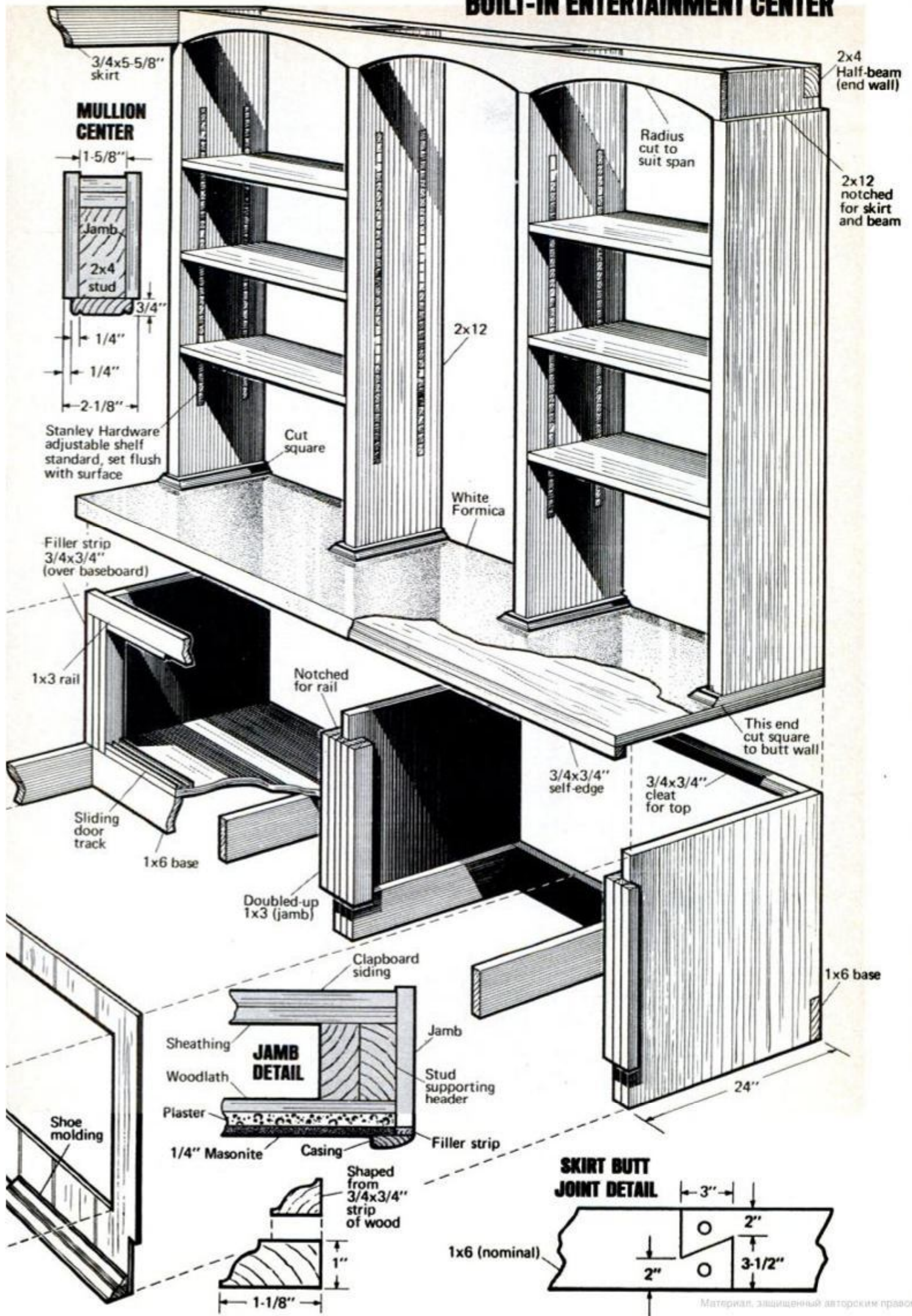

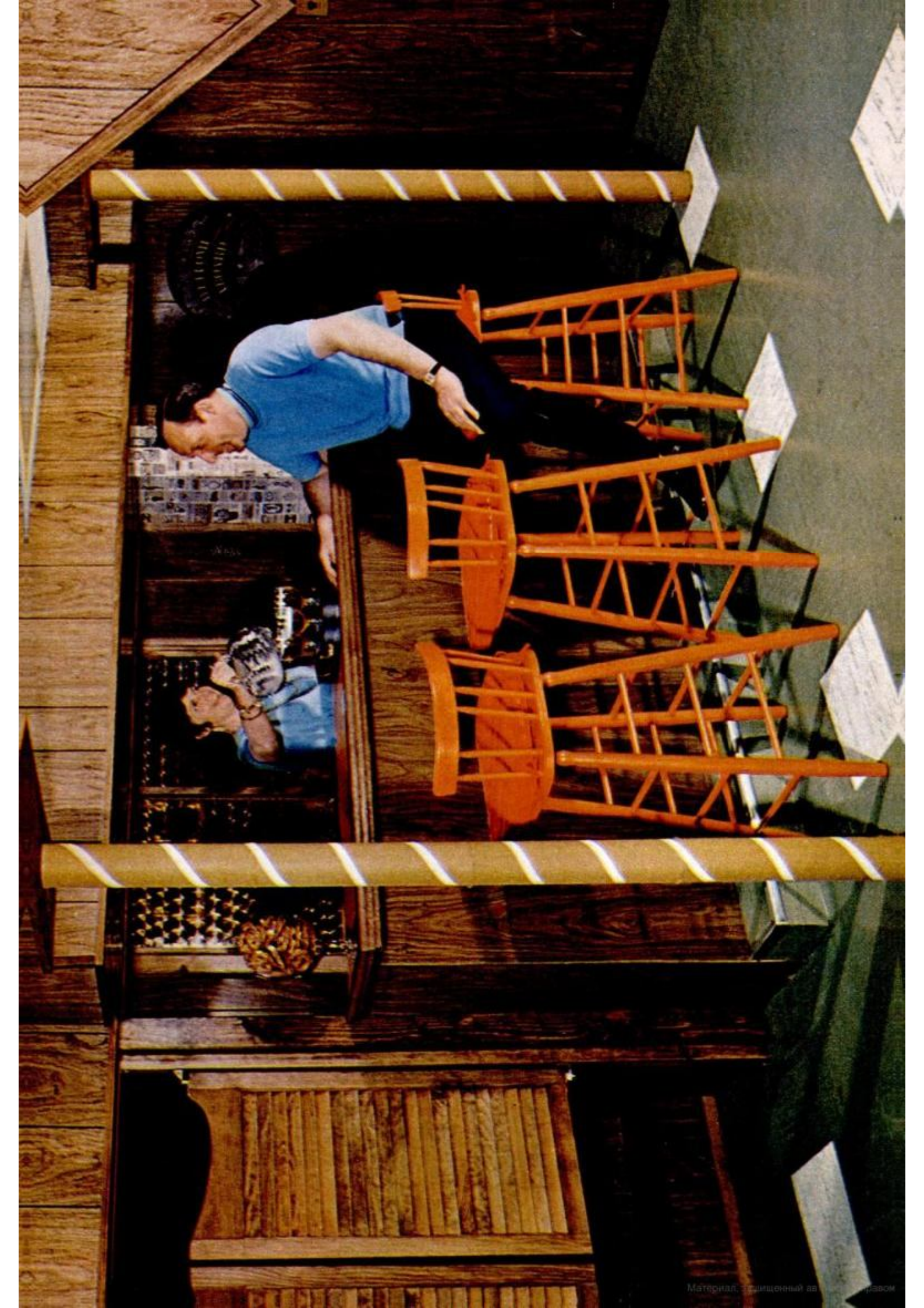



A Handsome Space-Saving Bar

With the bar located under low-hanging, boxed-in heat pipes, this finished basement uses 'wasted' floor space to best advantage.

By HARRY WICKS, Workshop Editor

Color Photo by Bill Aller. Styling by Robert Lofgren

WHEN YOU DECIDE to refinish your basement, the first, and wisest, step you can take is to draw up a floor plan. On it, besides the overall room dimensions, indicate floor-to-ceiling height, locations of pipes hanging from joists, meters, electric panels and any other apparatus that might require an access panel.

The Eugene P. Southers of Bellerose, N.Y. approached their basement project in just such a manner. Then, armed with this information, they determined how the entire room would be treated logically and attractively. Since they do considerable entertaining (and the family includes six active youngsters) they felt there was a need for a "wet" bar (a bar with a sink).

There's no arguing that a bar takes an inordinate amount of floor space. So, where to place it is of considerable con-

cern. In their layout (below) they located the bar directly beneath several low-hanging heat pipes. (There is also a water line and shutoff valve in the cluster hanging below the joists but for clarity's sake, they are not shown in the art.) This location is space that would otherwise have been wasted because of the drop ceiling. As can be seen in the drawings, there is plenty of headroom for the bartender behind the bar.

The bar is built to architectural standards. The dimensions shown give a comfortable working area, and you will notice that most of them are variable. The variables, of course, are for customizing the bar to suit the person who will use it.

The sink was no problem because in this house the drain-waste line exits from the cellar floor. But if your line is hung

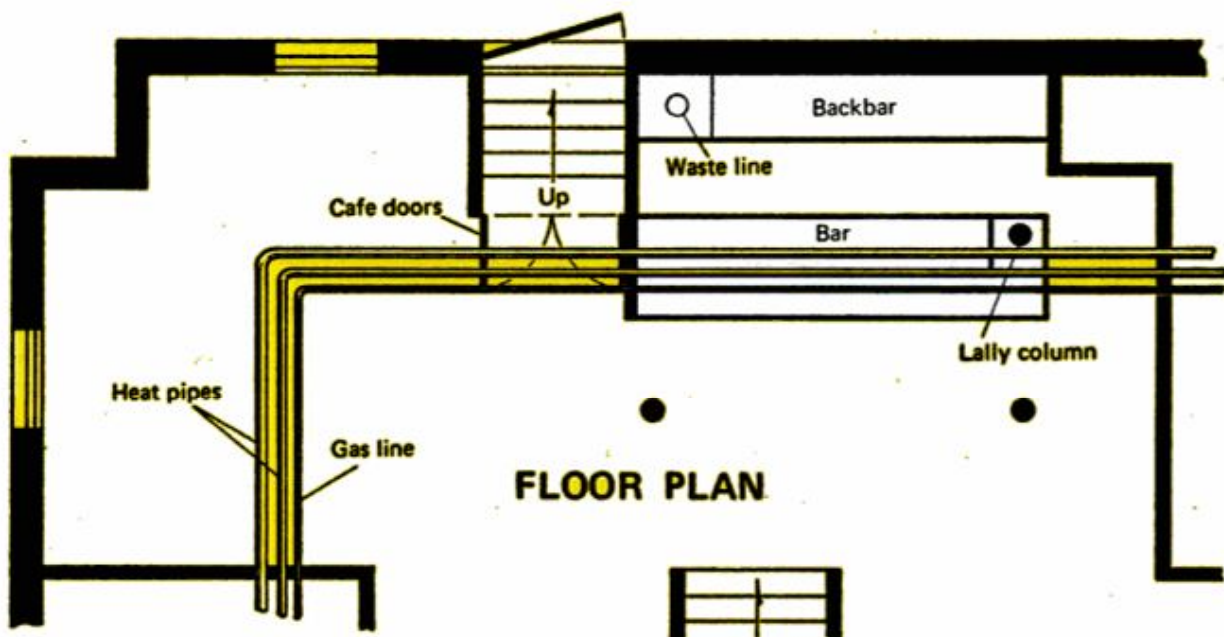

BACKBAR

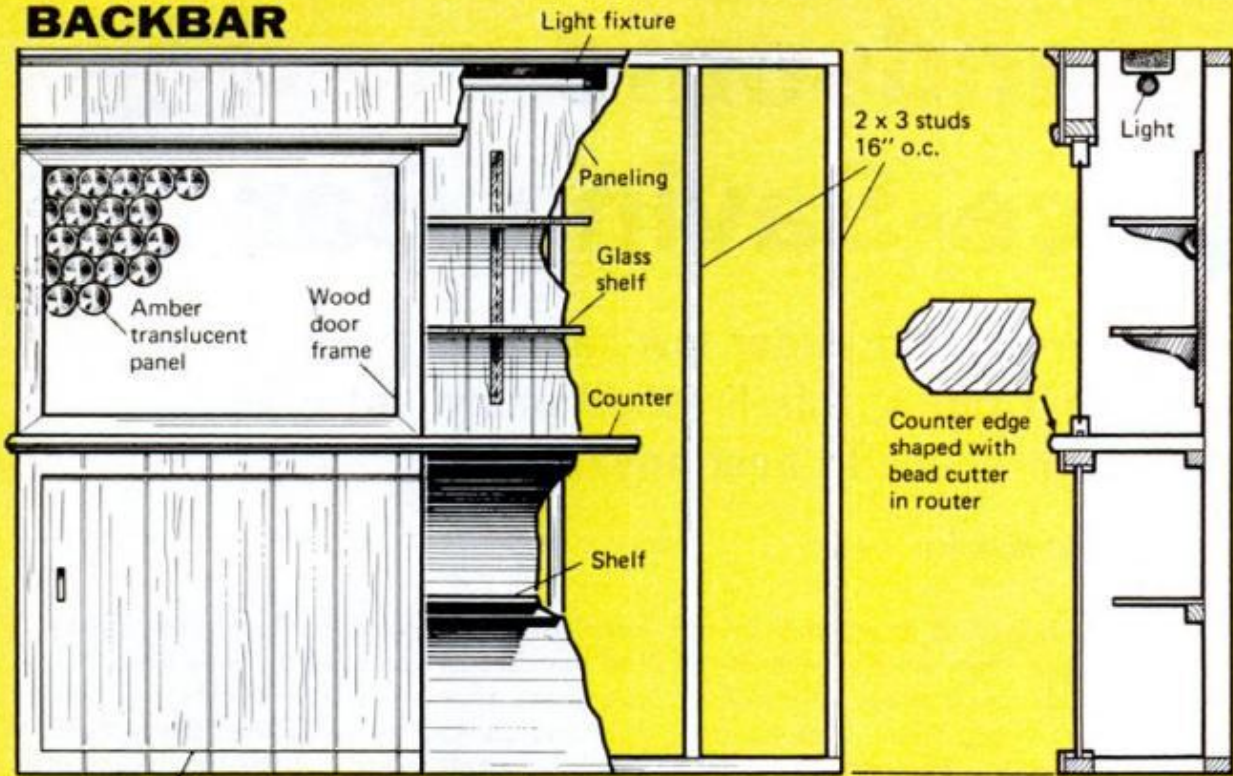

Sliding door, 1/4" paneling over 1/2" particleboard

ELEVATION

SECTION

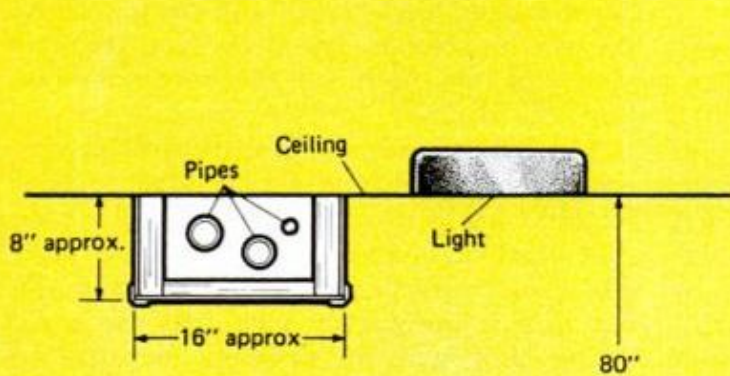

BAR

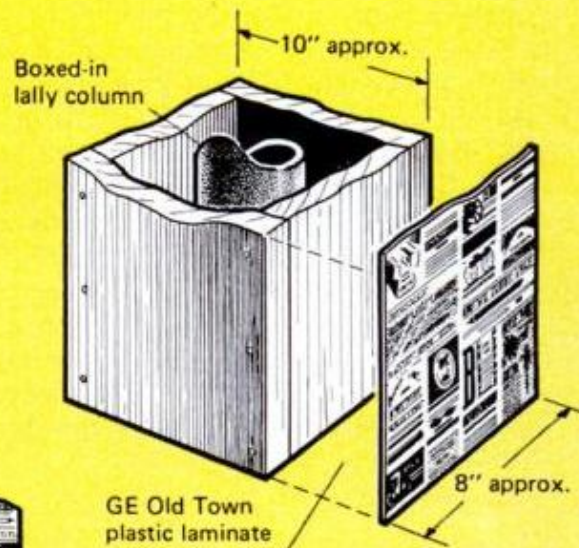

GE Old Town plastic laminate

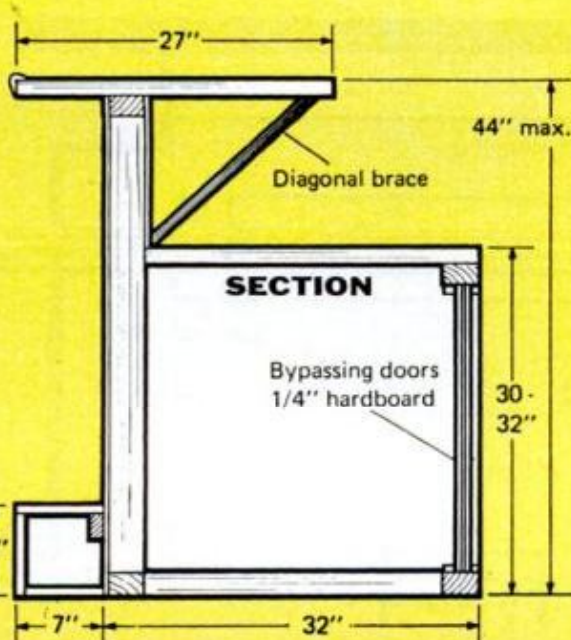

SECTION

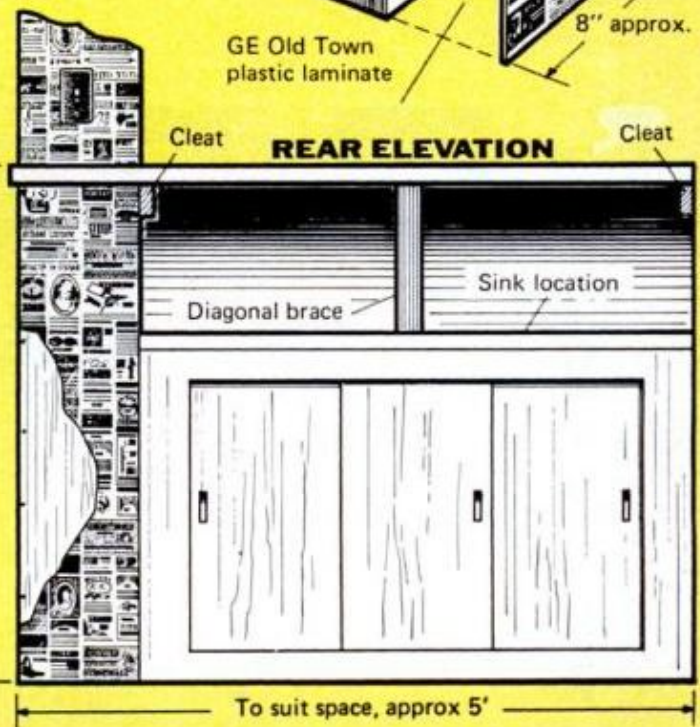

REAR ELEVATION

To suit space, approx 5'

from the joists, you can install a pump to handle water discharge.

As a matter of convenience and to reduce maintenance, Souther used plastic laminate on the work-counter surface behind the bar. And he went all the way by installing a laminated backsplash. In the final analysis, his decision was a sound one.

The lally column at one end of the bar was slightly out of plumb; thus, as can be seen in the drawings, it took considerable material to box it in. And the look was not good. So it was decided to make a strong point out of a weak one by making it decorative. Since the bar top was laminated with Formica's Persimmon (suede finish), the laminate applied to the boxed-in lally was selected to heighten the festive air that a party room should have. GE's Textolite Oldtown 6000 pattern was the choice.

Another factor in selecting this particular location for the bar was the "nook" that existed in the foundation wall. It was a natural for a back bar. Fitted below with sliding doors that can be locked with a standard sliding-door lock, the space behind provides storage for party potables and the like.

For appearance's sake, the deck (the counter separating the upper and lower sections of the cabinet) was made of 5/4-in. (nominal) stock. The top and bottom edges were shaped with a bead cutter in the router to create an architectural shadowline. The deck was stained to match the paneling and treated with two coats of semigloss varnish.

To help eliminate the dark, cavelike look that is common in many finished basements, the upper part of the cabinet was fitted with a pair of sliding doors made of translucent, amber panels of "bottle" design. Then, with a light installed overhead and glass used for shelving, the effect is much the same as if it were a first-floor window.

Though not obvious in the photo on page 160, there is an access panel fitted under the dropped ceiling for quick access to that water shutoff valve mentioned earlier. Souther chose to use the type illustrated on page 155, Dec. '69 *PM*. All in all, his planning paid off; the room provides an area for the youngsters, another for adult gatherings and the handsome bar to serve as a focal point. ★★★

SEPTEMBER 1970

HINTS FROM READERS



Eyeglass case 'toolbox'

An ordinary eyeglass case provides a fine container for drill bits and other small workshop tools or parts. The cases are felt-lined and have a strong spring hinge that keeps the cover tightly closed. If you decide to use several cases for small-parts storage, label each of them for quick identification of the contents.

—Edward L. Fisher

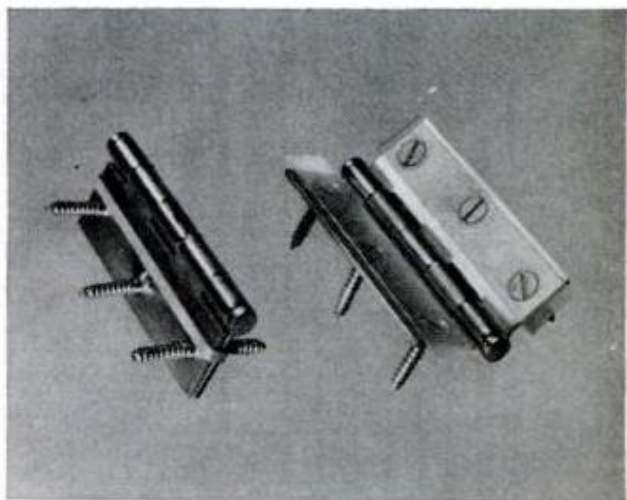

Store screws with hinges

Often when you store hinges for future use, the screws get mislaid. To be sure that you will have a complete set of screws for each hinge, here are two ways for storing the screws right with the hinge. One way is to insert the screws, close the hinge leaves and clamp them with a rubber band. The second method is to merely stick a strip of cellulose or masking tape over the screwheads and leaves.

163



Pretty, Use-Full Walls

**There's no reason to let walls just stand there.
Make them see-throughs with a storage-space bonus**

AS YOUR FAMILY GROWS, so does the accumulation of personal possessions. It becomes increasingly clear that the more square feet of living space in your home you can utilize efficiently, the greater your family comfort will be. A logical, and frequently the most economical, place to turn to for desperately needed storage space is a wall. The three wall ideas shown on these pages, in addition to satisfying particular family storage needs, have something else in common: Each is well-designed and adds to the looks and the value of the home.

The long see-through wall shown above

is framed to give a deck (or counter) at a height of approximately 36 in. The deck and post enclosures are of nominal 1-in. clear pine. The cabinet on the living room side was paneled; on the opposite side narrow pine shelves were installed to hold a collection of knickknacks.

Above the deck, large dowels (closet poles) were installed to give the illusion of greater room height and size. Thus, several advantages were gained by converting a flat, run-of-the-mill wall into a customized "room divider."

The unit shown at the top of the facing page was designed by a pro. The

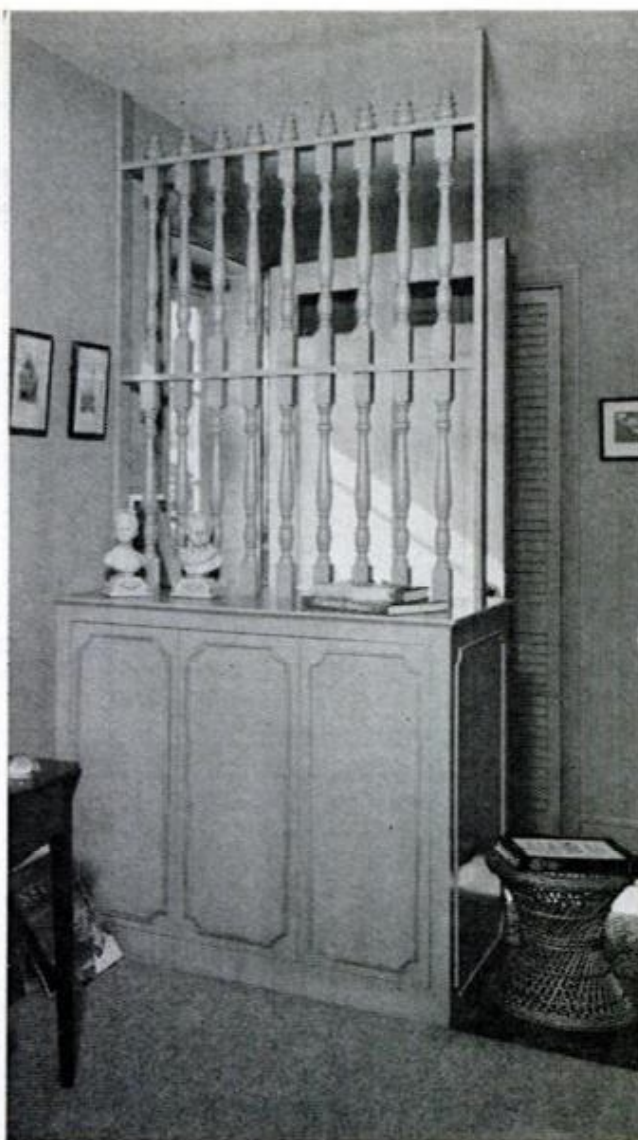
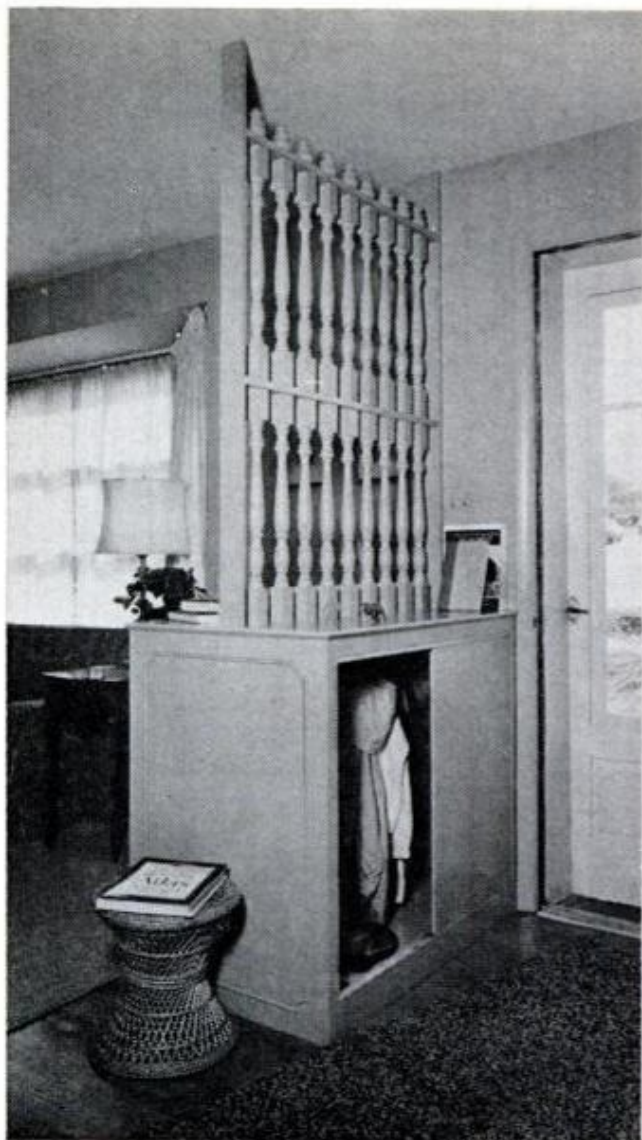

PHOTO BY MARK BLAIR

ENTRY WALL, viewed above from both sides, provides storage area for stereo components, closet for children's wardrobe and attractive foyer at the front door. This handsome divider was created by Top Recker, A.I.D.

homeowners required a built-in that could be used for stereo equipment and a convenient closet for their children to store boots, mittens and so forth. Additionally, they wanted it placed near the front entrance to create an entry way. The design accomplishes all three aims.

The cabinet is 27 in. wide, 39 in. high and 42 in. long. In turn, it is topped by a double-deck set of 18 hand-turned balusters (nine per row). The folding doors on the living-room side are trimmed with factory-made moldings for a decorator touch and fitted with friction catches for easy access. The interior shelves are removable; thus, should storage needs ever change, there is a built-in flexibility to meet them.

The children's side of the cabinet, by the front door, is fitted with sliding doors for quick use. Inside, there is an accor-

dion-type wood hanger with peg hooks for small-fry clothes plus the storage for boots and the like. To match the existing decor in the room, the entire cabinet-divider unit was painted a Wedgwood blue shade.

The third unit shown was designed expressly to handle the storage needs in a playroom next to a kitchen. It's a built-in along a wall, 15 feet long, that has been divided into five equal sections. Each of the five youngsters in the family, from toddler to teen-ager, has his own personal storage area.

Horizontal members are spaced so as to create 13 sections (plus a pass-through to the kitchen for snack serving). Six of the sections are fitted with doors to protect the older children's more valuable games and possessions from the little ones' inquisitive hands. The remaining lower

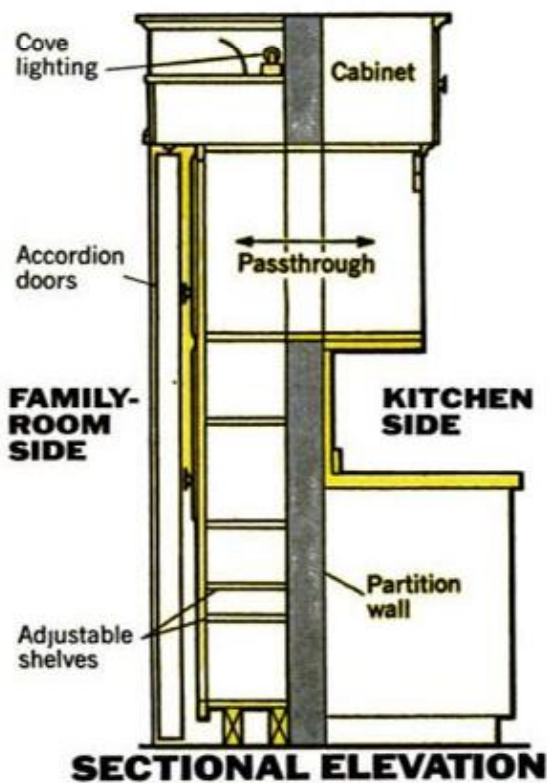
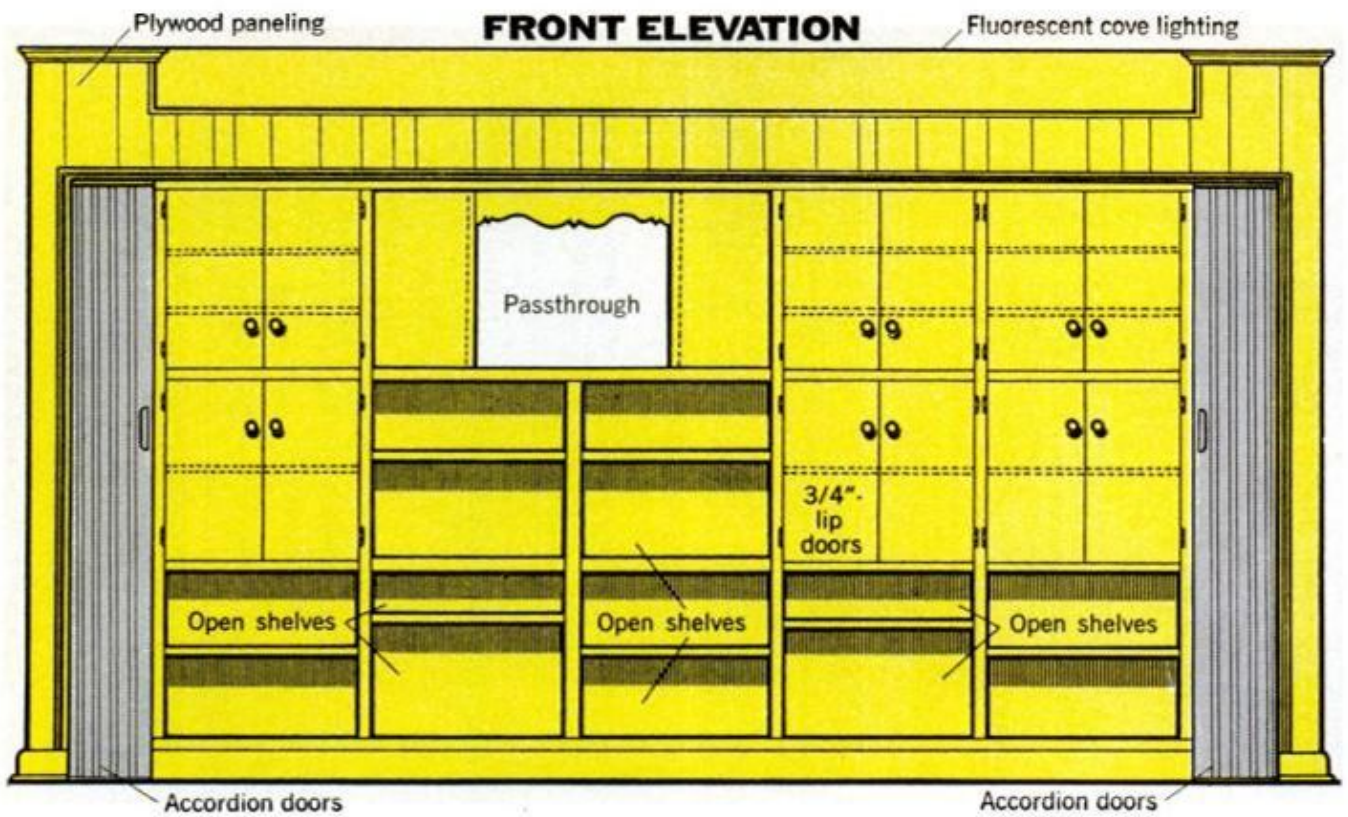

FULL-DEPTH WALL gives that ample storage so much appreciated by a large family. Accordion doors hide it all when desired

sections are fitted with 18-in. adjustable shelves.

The unit shown was constructed entirely of $\frac{3}{4}$ -in. plywood (except for cleats, nailers and the like). To withstand abuse, the unit was finished, inside and out, with a primer and semigloss paint.

To hide the unavoidable clutter of toys that always seems to be present on the toddler's open shelves, accordion doors were installed in front. Then, when the

room is used for adult parties, the paraphernalia behind can be quickly removed from view.

If the wall is to be used primarily by adults or teen-agers, the face of the unit could be built of cabinet-grade plywood and stained for a natural finish. Another method would be to treat the facing with either $\frac{1}{2}$ -in. plywood or particleboard, and then glue and nail prefinished paneling over. ★★★

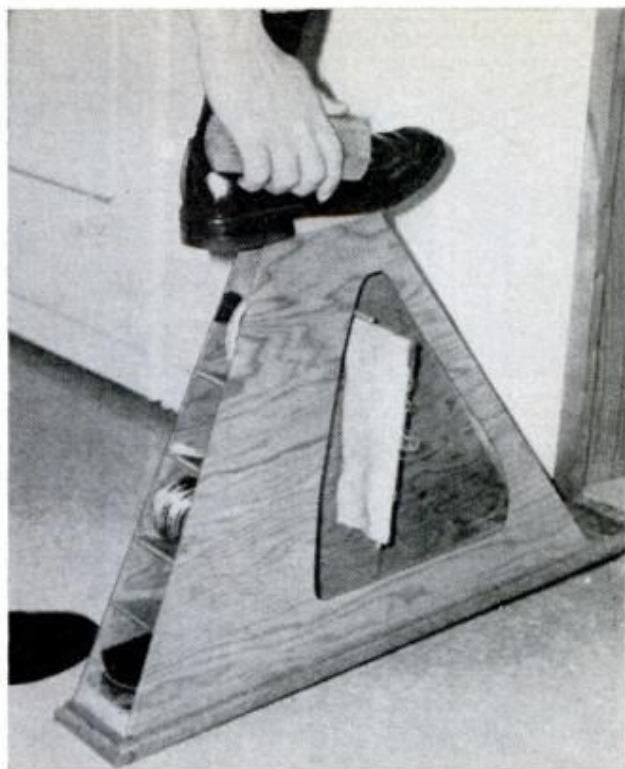

Narrow cabinet space in laundry saved from going to waste

If you are planning to build new, or remodel existing, cabinets in your laundry area, here's one good way to make use of that leftover narrow space that always seems to exist. It's a built-in storage unit that holds all of your shoe-shining needs—polish, rags and brushes. The one shown occupies a scant 4 in. of space and is installed with hinges so that it swings down to provide a comfortable footrest for shin-

ing your shoes. For sturdiness, build the entire unit of $\frac{3}{4}$ -in. plywood. And, since the unit will be exposed to almost daily use, make certain it is well put together; use an ample amount of glue and brads. If you put prefinished factory-made cabinets in the laundry you can take the completed stand to a local cabinet shop (along with a drawer front) in order to match the cabinet finish.—*R.S. Tupper*

Back of basement partition can be handsome, too

Generally, when a basement or recreation room is remodeled, the side of the wall in the unfinished area is left untreated. Though that space may be used for nothing more than seasonal storage, it can still be made attractive with a minimum investment of time and money. Our solution was to first stain the framing members a dark brown and then apply a coat of white paint to the back of the paneling. The result is a resemblance to the half-timber English Tudor style. For color accent, we then applied several travel posters between studs with wallpaper paste. For easy cleaning, the paper was coated with shellac.—*Edward G. Gold*



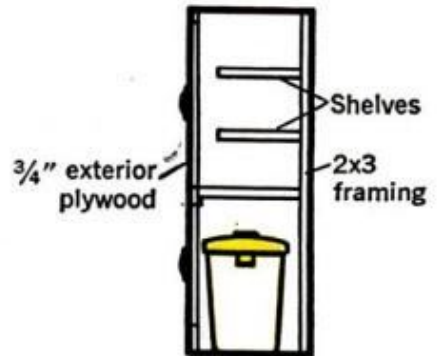
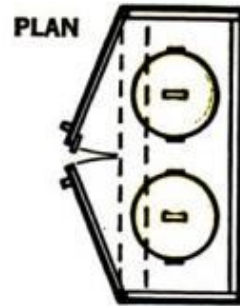
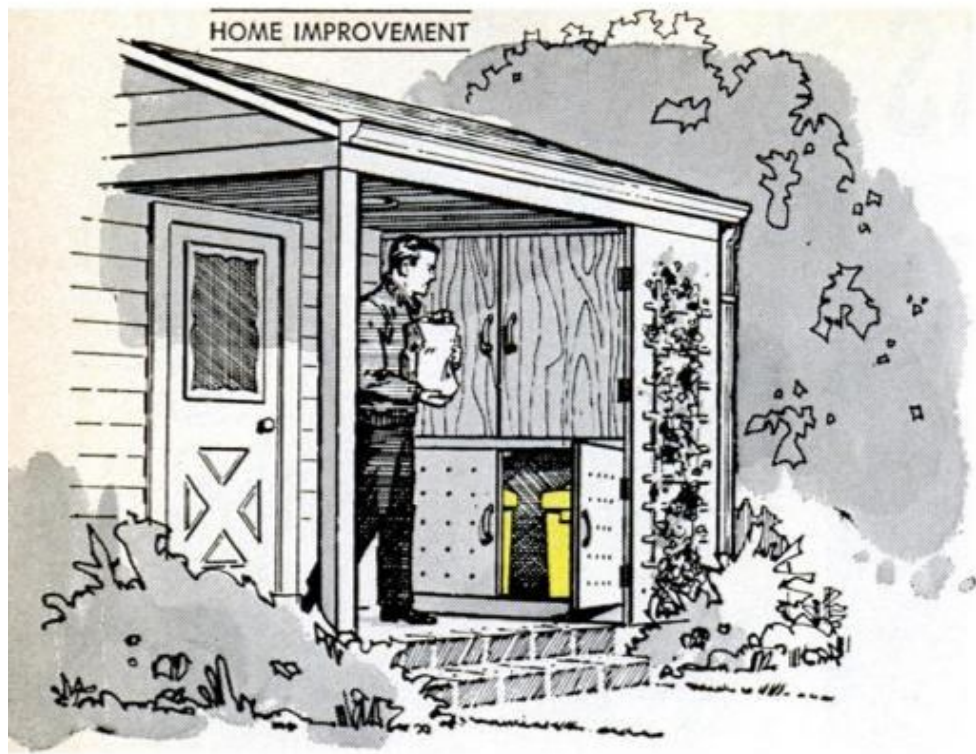

SIDE ELEVATION

ROOF OVERHANG on a rear porch makes the latter an ideal spot for a trash-can hide-away. Doors to the trash-can space are of perforated hard-board, provide ventilation. Space above can be used for seasonal storage after installation of several adjustable shelves

FOUR WAYS TO HIDE

WHAT CAN BE DONE to hide that back-yard eyesore—the cluster of needed, but unaesthetic, trash cans—from view? We asked Gerald Geerlings, A.I.A. to tackle the problem. It's interesting to note that all four of his practical solutions have two good design ideas in common:

● **Location:** Each is convenient to the service entrance, keeping trash-hauling steps at a minimum.

ROOFLESS PORCH can also be used for small structure, but top of enclosure should be pitched to provide positive water runoff. Though board and batten construction is shown here, exterior of bin can be sheathed with materials that complement the house

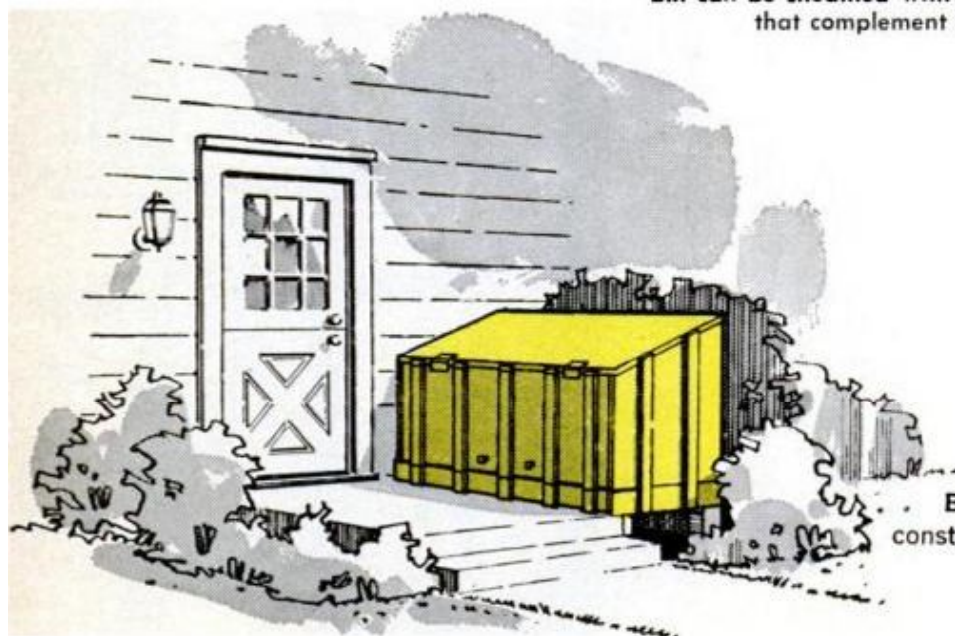

SIDE ELEVATION

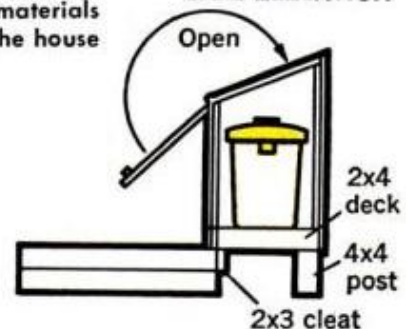

PLAN

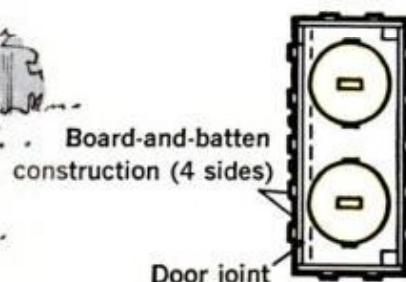

POPULAR MECHANICS

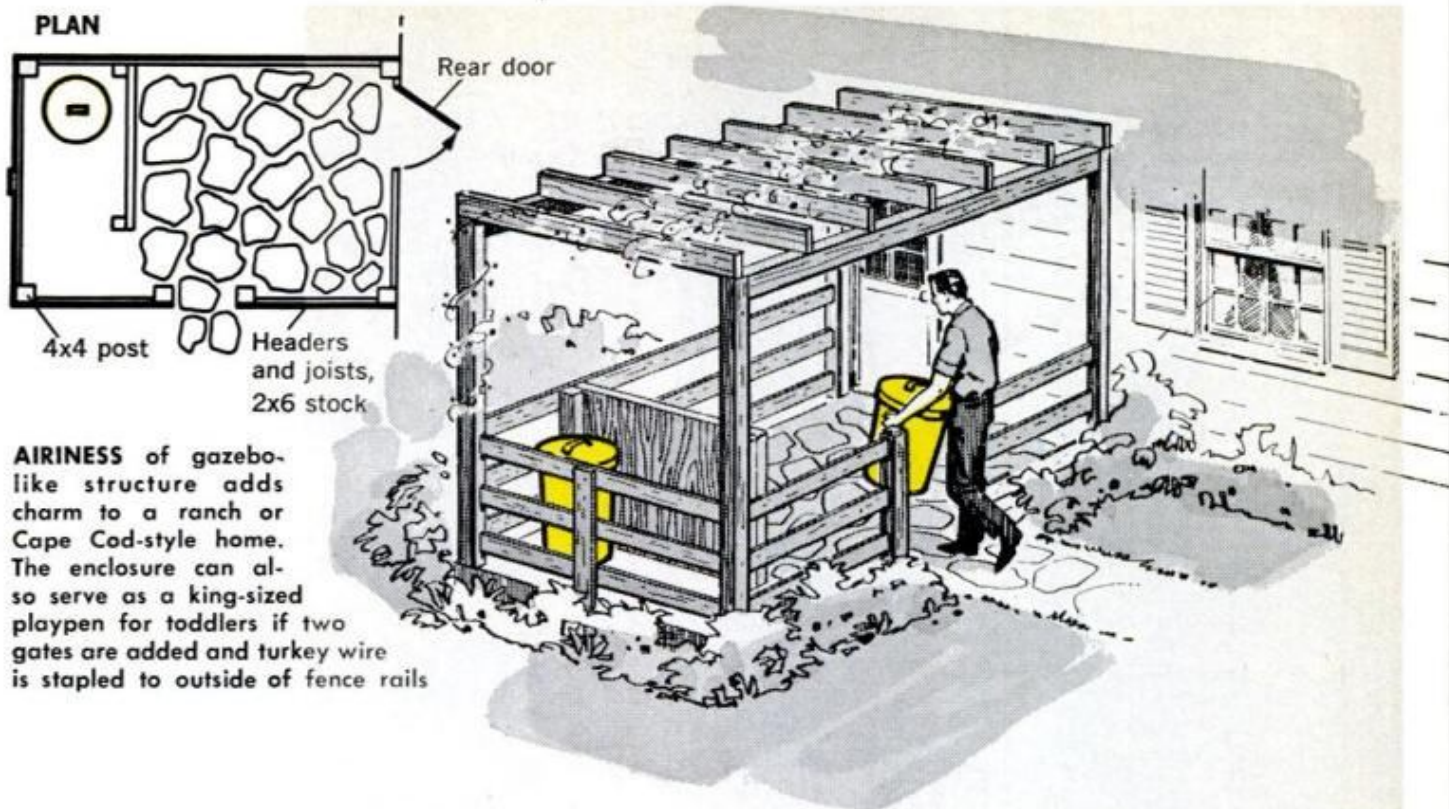

AIRINESS of gazebo-like structure adds charm to a ranch or Cape Cod-style home. The enclosure can also serve as a king-sized playpen for toddlers if two gates are added and turkey wire is stapled to outside of fence rails

TRASH CANS

A portfolio of good ideas for keeping those unsightly necessities concealed, yet very accessible for everyday use

- **Design flexibility:** Each allows for a custom exterior that suits the house design. Though the four types shown are attached to the house, they can be built as free-standing units if property lines and location make this solution more desirable. Bearing corner posts are of cedar, treated with wood preservative, plywood is exterior grade and if you add wood members such as battens, redwood is recommended. Use galvanized nails or brass screws for all assembly to avoid beauty-marring rust stains on the paint finish.—*Harry Wicks, Workshop Editor*



IF GARBAGE ROUTE in your locale includes a back-yard pickup, this built-in should keep collector happy. To ease hinge strain, drop door used by the collector can be equipped with two sturdy chains

Benches You'll Want to Build for Your Deck

HAIL, HAIL the gang's all here for the cookout, but where do they park when their legs get weary?

From spring through fall, outdoor entertaining is a real part of the American scene. But when there's a big party group in your back yard, you may have a problem finding seats for everybody.

If you are a bit short in back-yard seat-

ing, you may want to build one or both of the beauties shown on these two pages. These benches are very good-looking, sturdy and, best of all, they will last for years. The movable bench (on this page) is constructed of eight standard-size pieces of fir. Thus, it is simply a hammer-and-saw project. You just cut the pieces to length and assemble them.

MOVABLE BENCH

A PRACTICAL APPROACH to extra seating on the patio is this simply designed, but handsome, movable bench. It was created by Western Wood Products Assn., Yeon Building, Portland, Ore. Though easy to build, bench is extremely sturdy

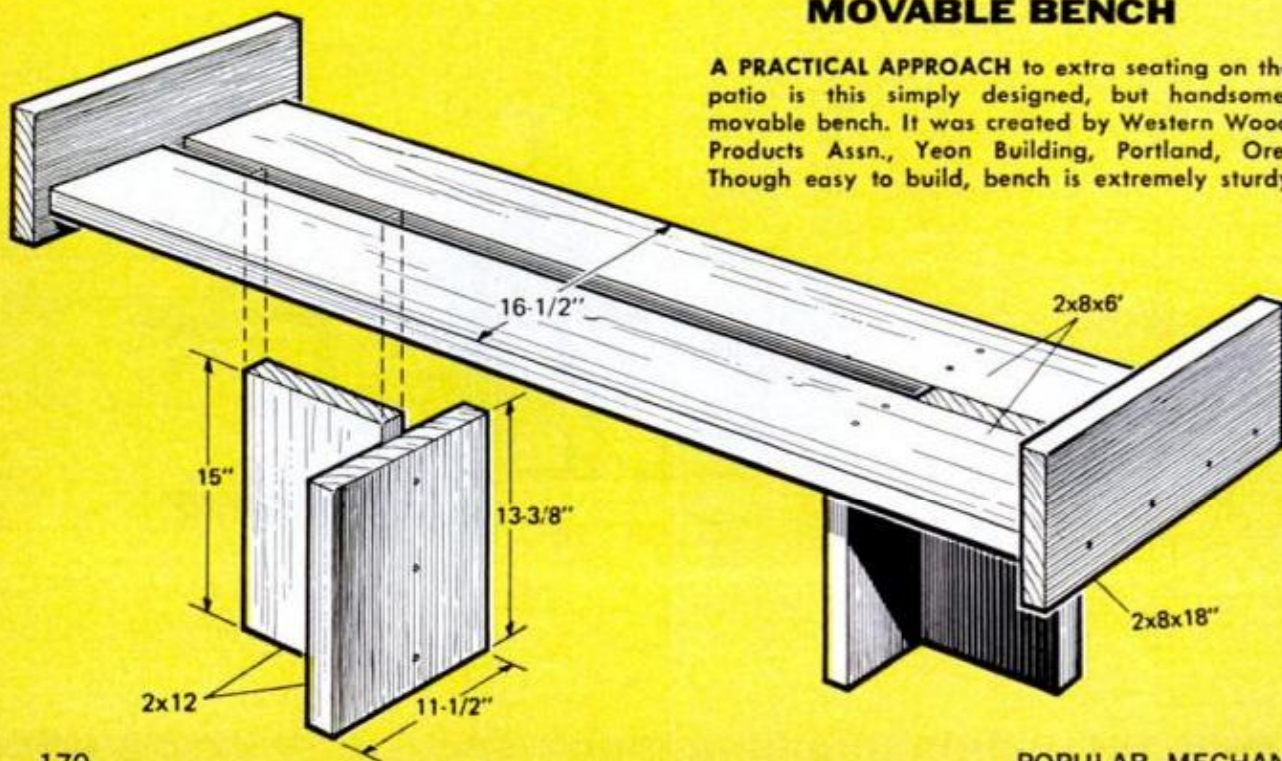

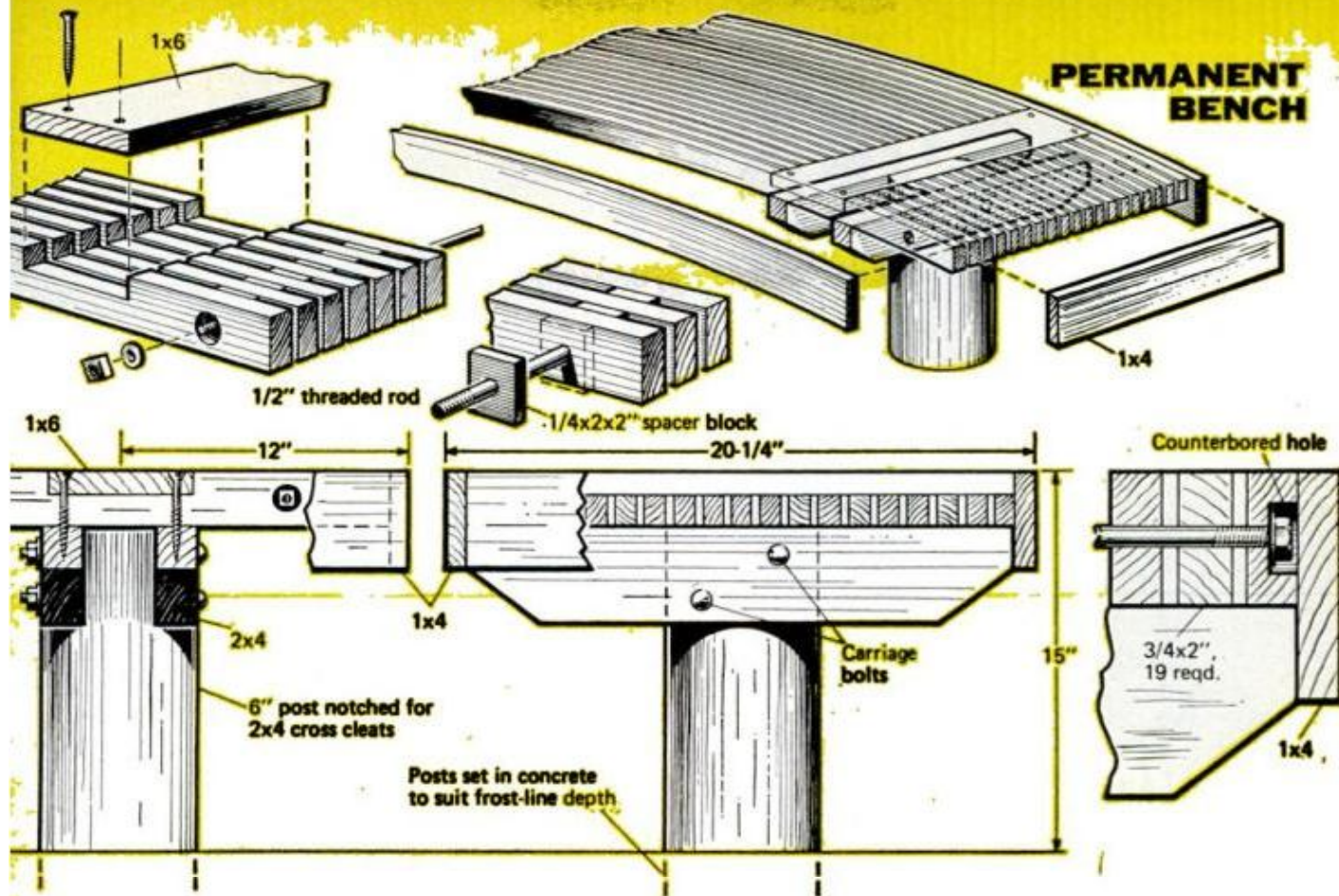

The curved bench shown below is a little more involved to build and is generously dimensioned, but, if your patio is modestly scaled, simply adjust the bench's length proportionately to suit. This bench is permanently installed and is fastened to posts which in turn are embedded in concrete. Designed for the California Redwood Assn., 617 Montgomery St., San

Francisco, Calif., by landscape architect John Staley, the bench, like the privacy screen, is of redwood. Notice how gaps between slats are assured by use of spacers where the threaded rod goes through. These gaps are necessary—they permit water to drain.

For a finish, sand and then apply two coats of clear exterior sealer. ★★★





PLASTIC PIPING

Makes You an 'Instant Plumber'

It's rigid, lightweight, heat-toughened and, best of all, easy to fabricate and install

By RICHARD DAY

THE BEST THING that's happened to plumbing since it moved indoors is CPVC. If your local plumbing code doesn't prohibit its use, this recently available pipe is the best for do-it-yourself plumbers when remodeling or installing new plumbing. Just about every fitting you could want is available, and the solvent-welded joints quickly harden as strong as the pipe itself.

CPVC was developed from PVC (polyvinyl chloride), which has a long history of success in cold-water and drain-wastewater runs, but which softens too much when heated and doesn't withstand house hot-water pressures. Chemists found that by hypoing another chlorine atom into the PVC formulation they could get added resistance to heat-softening. They first called the improved vinyl *polyvinyl dichloride* (PVDC), reflecting that extra atom. But recently its name was changed to CPVC.

Some advantages of CPVC pipe:

- It can be cut with any saw.
- Its heat-insulating qualities reduce

172

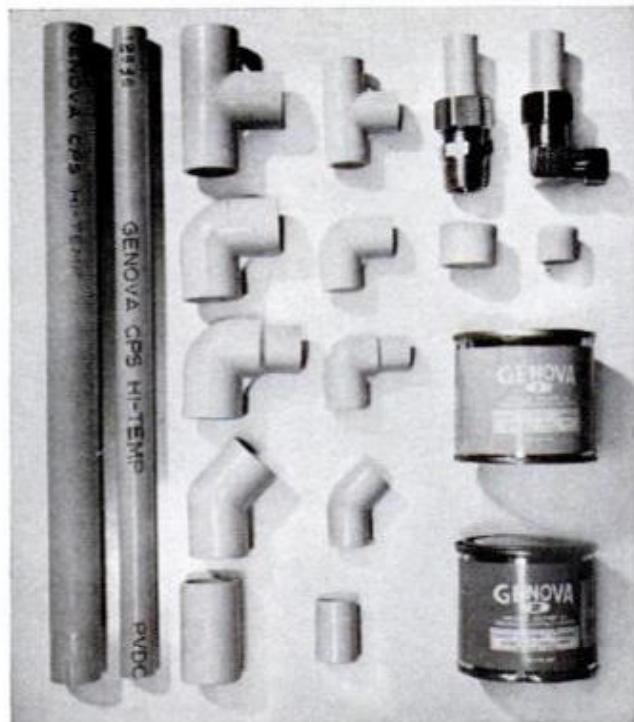

PIPES AND FITTINGS (left to right, top to bottom): $\frac{3}{4}$ and $\frac{1}{2}$ -in. pipe, $\frac{1}{2}$ and $\frac{3}{4}$ -in. tees, 90° elbows and street ells, 45° elbows and couplings, two types of transition fittings for connecting other kinds of pipe, two cap sizes and No. 1 and No. 2 solvents for joining

POPULAR MECHANICS

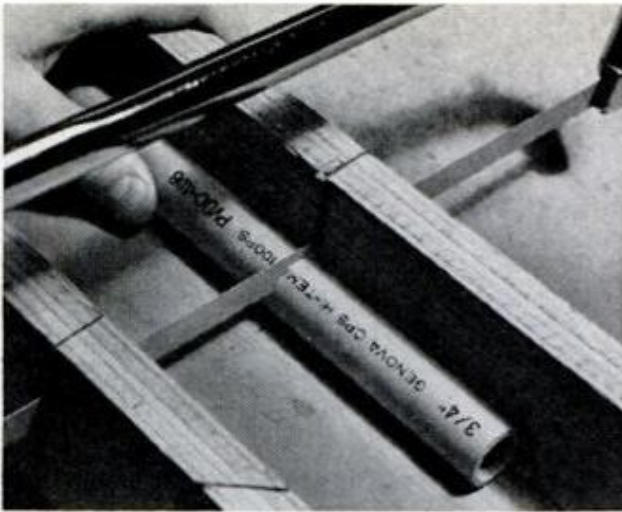

USE MITERBOX and a hacksaw or wood saw to cut plastic pipe, or use a conventional tubing cutter

sweating of cold-water pipes and heat loss from hot-water pipes.

- Its smooth inside walls give little friction to water flow.
- It does not corrode inside or out. Bi-metallic corrosion has no effect on it and scale does not build up in it.
- It is resistant to rodent and termite attack, will not support combustion, has no odor or taste to impart to the water, and resists denting.

CPVC pipe and fittings are available in two colors from one manufacturer. There is no difference in the pipe other than the color, but this allows you to color-code your lines—green for cold water, orange for hot—if you wish, for instant identification.

As with anything, there is a drawback. CPVC is touchy about high temperature and pressure in *combination*. It is rated to withstand 180° F. at a working pressure of 100 pounds p.s.i., so you must install and maintain your plumbing system to stay below these maximums. This will be no problem if you follow the tips given later.

One other thing: You *can't* use plastic pipe for an electrical ground.

The pipe comes in 1/2 and 3/4-in. diameters. Use 3/4-in. pipe for main hot and cold runs, 1/2-in. for branch runs to fixtures.

The greatest thing I found about plastic pipe is the speed and ease of working it. Tools are minimum. For cutting it, I prefer a hacksaw. And you'll need a knife, sandpaper or tapered reamer for removing burrs left inside the pipe after sawing. You should have two cheap 3/8-in. coarse-bristle brushes for applying the



BRUSH SOLVENT No. 1, then solvent No. 2 on the end of the pipe and on the inside of the fitting



WITHIN A MINUTE of starting to dope the joint, insert the pipe into the fitting with a slight turn

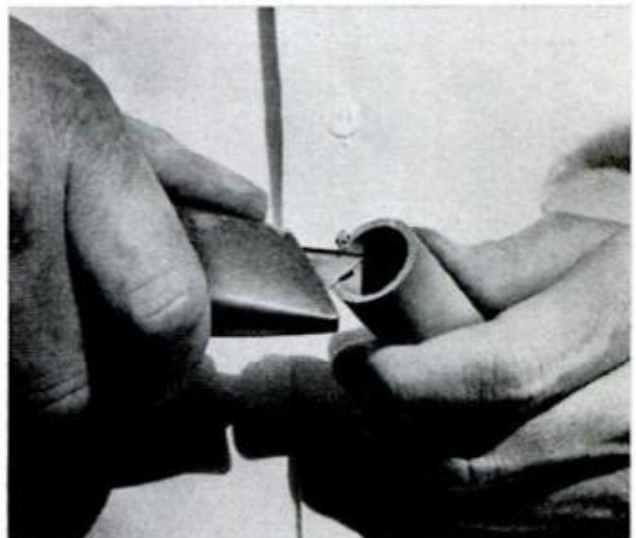

ANY BURRS or rough spots should be removed with a knife, file or sandpaper before you make joint

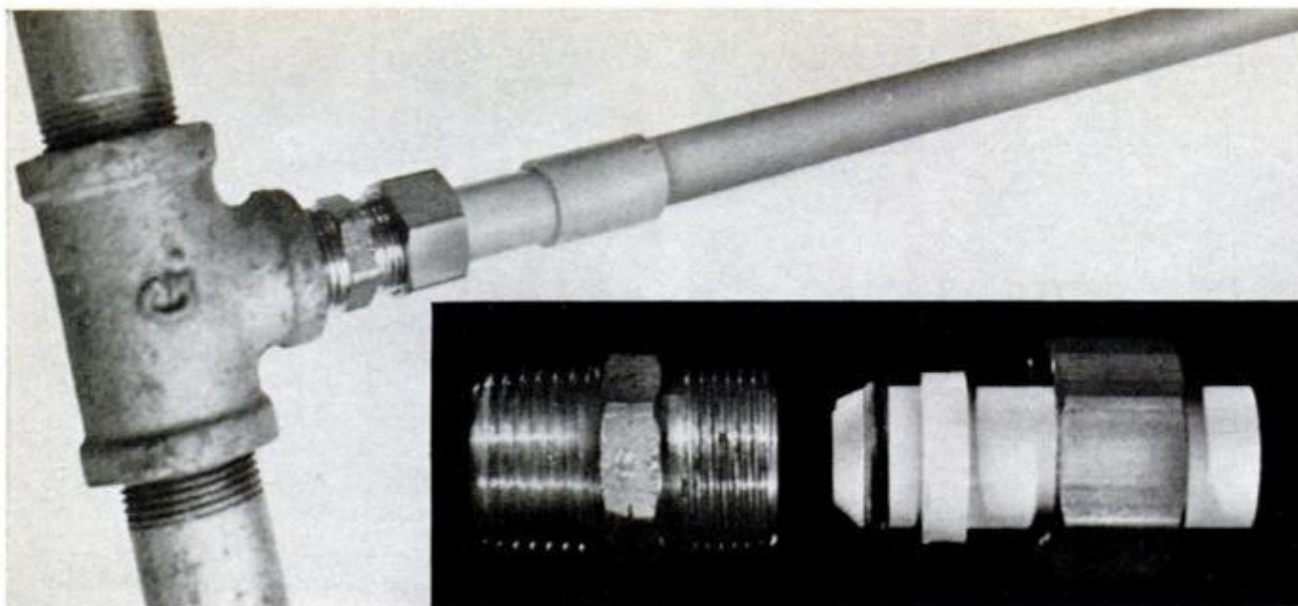

TRANSITION ADAPTER with gasketed plastic bayonet acts as a union to let you connect section of plastic pipe to other types of pipe. To make a joint with steel (above), the adapter is solvent-welded to the coupling

joint-welding solvents. You will also need a rule for measuring, a pencil for marking the pipes and a hammer for fastening pipe straps.

Fabricating plastic pipe: If you cut the pipe with a saw, you can get square cuts by using a miterbox, although this isn't necessary. After cutting, remove the burr around the inside edge of the pipe. When you cut a pipe, be sure to allow for what is called *make-up*; that's the amount the pipe ends slide into each fitting. Allow as much in extra length as the pipe diameter; for instance, $\frac{1}{2}$ -in. pipe should be cut a half-inch longer on each end, $\frac{3}{4}$ -in. pipe needs $\frac{3}{4}$ -in. per end for make-up.

Now check the pipe in the fitting before you go any further. CPVC pipes and fittings are designed for an *interference fit*; that is, they should be tight enough to touch when the pipe is one-third to two-thirds of the way into the fitting. If they are too loose, the joint might not seal tightly.

It's a good practice when fabricating plastic pipe to dry-assemble the whole system, or at least a sizable part of it, before welding any joints. This way you'll know whether you have all the parts and if everything fits.

Joints to be solvent-welded should be clean and free of oil or grease. Solvent-welded joints in CPVC pipe are made by using the two liquids shown. Get these where you buy the pipe. No. 1 is a cleaner, No. 2 a solvent. Never get them mixed and always use separate brushes for application. The ideal brush size is half as wide

as the diameter of the pipe you're working on. Shelf life of the solvents is limited to several months. If they thicken or discolor, throw them out and get fresh stock. Work in a ventilated area and avoid breathing the vapors.

To make a joint, first brush No. 1 cleaner on the end of the pipe to socket depth and on the inside of the fitting socket. Apply enough No. 1 to cut the shiny skin of both the pipe and the fitting. A definite lightening in color should be apparent. Follow immediately by flowing No. 2 solvent onto both, giving the pipe a liberal coat and the fitting a light one. Coat the surface completely but don't brush out either of the solvents. You'll get best results by brushing in the direction of the pipe at a temperature above 40° F.

Do one joint at a time, and don't dally. Push pipe and fitting together until the pipe bottoms against the fitting's flange. Quickly give a quarter turn to distribute the dissolved plastic and align the fitting. You don't have much time until the joint becomes immovable, so align it fast. Then leave it to set. It is ready for pressure within a few minutes. A good joint will have a bead of softened plastic (fillet) all around the fitting.

Once assembled, a fitting cannot be removed and used again. If you should goof on a joint, don't give up. Saw the bad fitting off and use a coupling and short length of new pipe to replace the ill-fated joint.

Pressure-test any plumbing job before

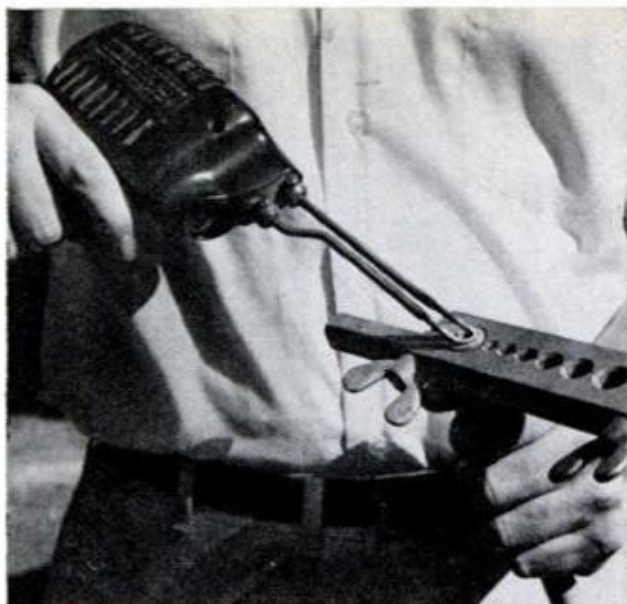

SUREST METHOD for successful flaring of plastic piping is to heat the end first with a soldering gun



FLARING is frequently useful in water-heater hook-ups; connection is made using standard flare nut

you close-in the piping, while repairs are still easy. To pressure-test the system, plug or cap all openings and turn on the water. Examine each fitting carefully for leaks. Check again after four hours. A leaky joint is rare. If you do find one, cut out the bad joint and replace it with short lengths of pipe and couplings, all solvent-welded. Some joints will have to be installed without twisting. You can do it successfully if you're careful to get full distribution of solvent.

Make all your capped stub-outs (leads to faucets and other fixtures) from wall or floor long enough to permit cutting off the caps and hooking up fixtures to them later.

Adapting to other pipes. Fittings come in both pipe sizes. You can get elbows, tees, wyes, couplings, reducers, caps and adapters for connecting to pipes other than plastic.

When adding to existing plumbing, and at every fixture and at the water heater, softener and other plumbing appliances, you'll find it necessary to connect plastic piping into steel or copper pipe or into threaded fittings. Using a CPVC transition adapter makes this a simple chore. The adapter has a gasketed plastic bayonet that solvent-welds to the plastic pipe system and assembles finger-tight to a leakproof permanent joint with the non-plastic system.

The transition adapter can serve as a union, connection to a fixture stop valve, connection to a fixture compression union

(Please turn to page 192)

SEPTEMBER 1970

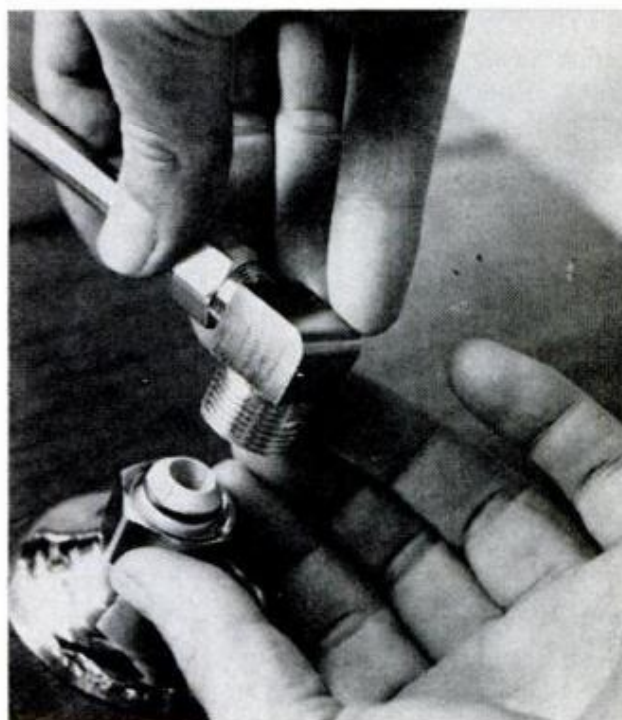

TRANSITION ADAPTER is solvent-welded to wall stub-out; angle compression fitting is then attached



USE SMOOTH PLASTIC HANGERS to hang pipe. This type lets pipe slide without damage as it expands

175

New Products for

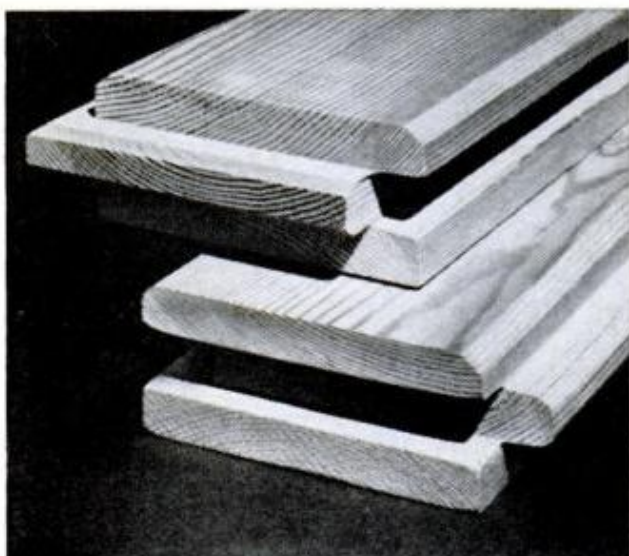

LAMINATED DECKING is manufactured with a face layer of ponderosa pine, Engelmann spruce, Douglas fir or larch bonded to two layers of softwood. It's said to maintain a relatively constant moisture content to reduce chance of cupping. Boise-Cascade, Box 7727, Boise, Idaho 83707.

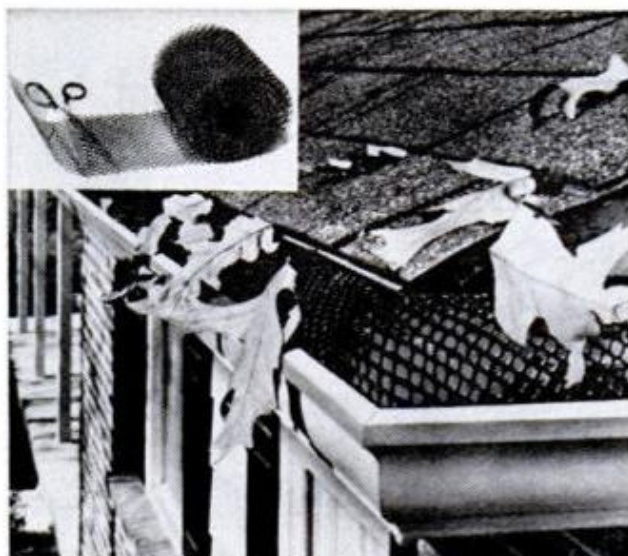

NONRUSTING PLASTIC GUTTER GUARD labeled Vexar installs quickly because you simply insert one edge under the shingles and tuck the other edge into the front slot on the gutter. In 25-ft. rolls, plastic material can be cut with scissors, will not rust. DuPont, 3301 N. Market St., Wilmington, Del. 19802.

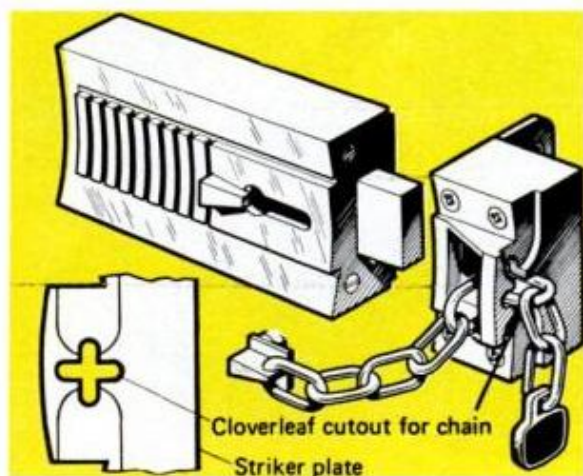

LATEST IN LOCKS introduced by 3M Co., St. Paul, Minn., is made for use on all nonglass doors. The Lock Alarm consists of a dead-bolt lock and chain coupled to a highly sensitive, battery-powered, solid-state electronic alarm. In operation, the bolt is moved conventionally by a knob or key. Price: \$79.95.

DESIGNED FOR USE on masonry surfaces above or below grade, Kwal-Chek is a self-contained waterproofing compound designed to stand up to 4.5 p.s.i. hydrostatic pressure. It will cover 75 to 100 sq. ft. per gallon depending on masonry porosity. Kwal Paints, Inc., 800 Water St., Denver, Colo. 80217.

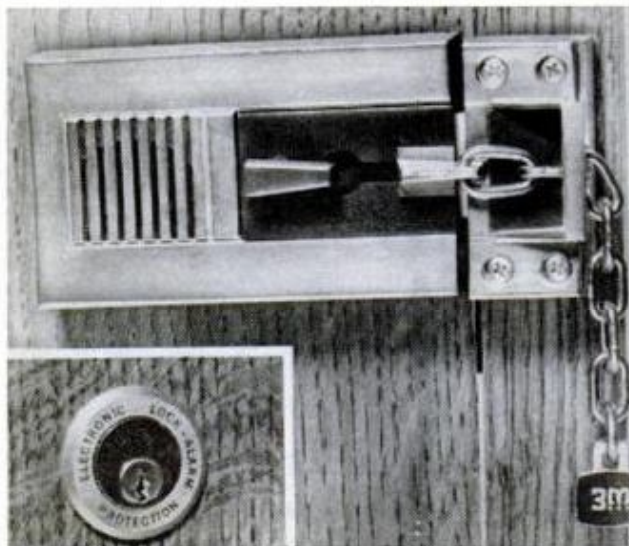

Home Improvement

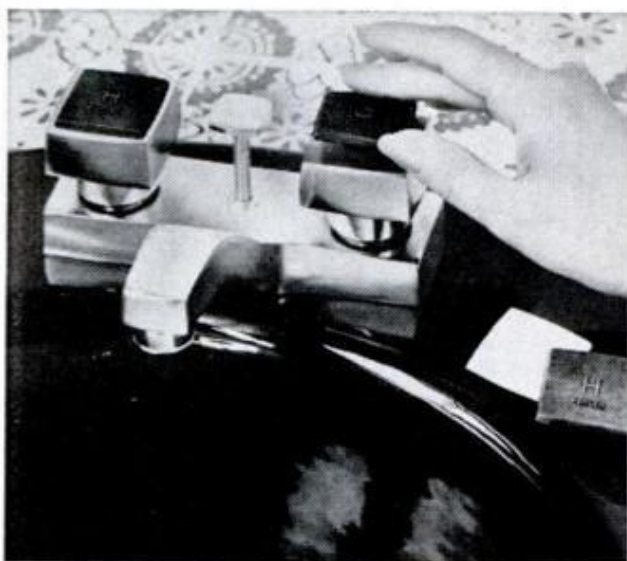

ADD A TOUCH of decorator color to your bathroom with Alterna lavatory and bathtub fittings. Inserts with embossed H or C come in teak, walnut, ebony and white to mix or match with fittings of brushed chrome and gold electroplate. At plumbing supply dealers. Kohler Co., Kohler, Wis. 53044.

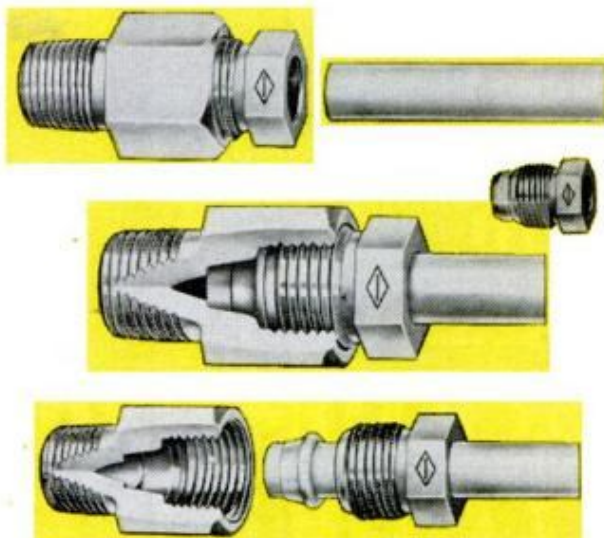

NEW TUBE FITTINGS are claimed to be easier to install than flare or compression-type fittings. To make a joint, push tube into the fitting and tighten the nut. The sleeve shears off and attaches to the tube in the assembly. For information, write Imperial-Eastman, 6300 W. Howard St., Chicago, Ill. 60648.

GAS-FIRED FIREPLACE boasts a 28-in. opening and a remote-control pushbutton operation. Unit, only 13 in. deep, is installed behind built-up wall (far right), vented with standard 5-in., type-B gas vent or existing approved flue. Labeled Gasilator GF-28, it's sold by building supply dealers and department stores. For the nearest source, write Majestic Co., Huntington, Ind. 46750.

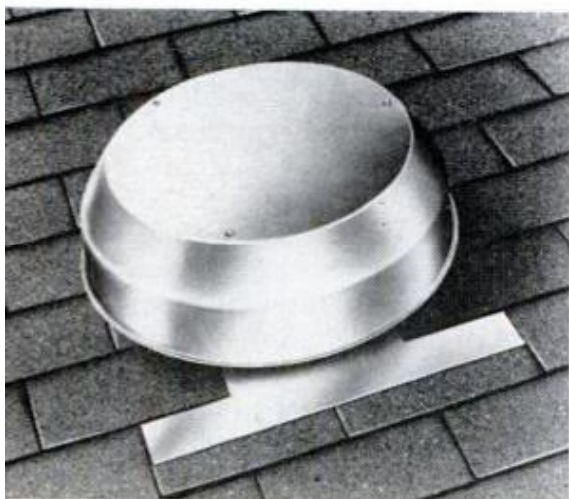
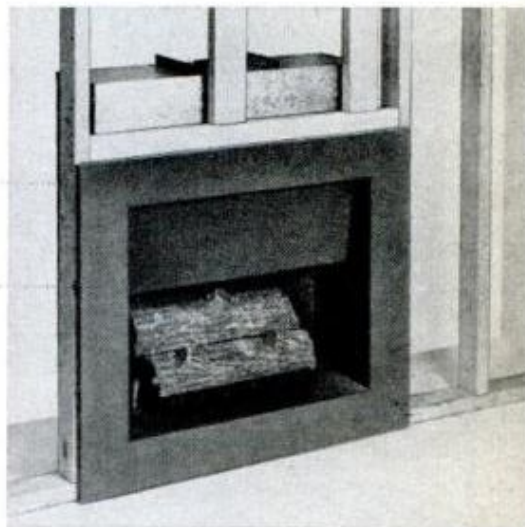
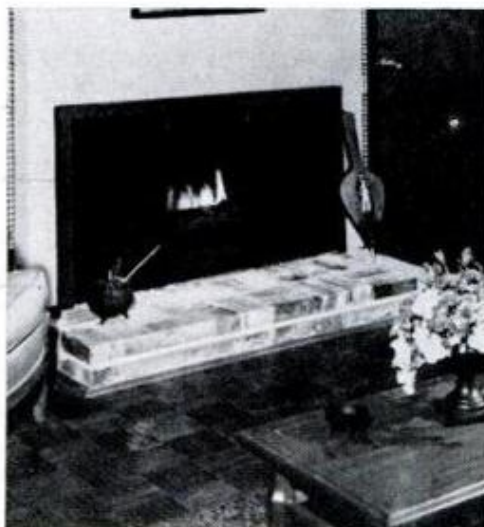

KEEP YOUR COOL by sucking hot attic air out with this exterior-mounted roof fan with thermostat designed for flat or pitched roofs. Nutone, Madison and Red Bank, Cincinnati, Ohio 45227.

YOU CAN PRODUCE exposed aggregate patio blocks using a chemically treated paper set in the mold. After concrete sets, simply brush or spray off excess. Jewel-Tex Corp., 55 Skyline Dr., Plainview, N.Y. 11893, makes it.





HOW TO MAKE A BLACKTOP DRIVE LOOK LIKE NEW



EXAMINE DRIVEWAY, then fill large holes with stone and complete patching with a suitable patching mix



SMALL CRACKS and holes can be treated with a crack filler. Let the cracks cure for at least one week

ASPHALT DRIVEWAYS require periodic care to extend their life, save costly repairs and improve their appearance. Even a new driveway should be covered with a tar-emulsion driveway coating and sealer after it has aged one to three months (to allow all solvents to evaporate). This protects it from oxidation, seals hairline cracks and keeps it from softening as a result of gasoline and oil that may drip on it. And, happily, it's a do-it-yourself job.

All the necessary materials for maintenance of an average home driveway can be purchased for around \$20 to \$35. They should include the compound to fill in driveway cracks; smoothing paste to prepare the surface for application of the coating-sealer (if the driveway is rougher than desired); two or three five-gallon cans of coating (usually enough for an average driveway), and a two-way applicator tool, which is a combination brush and squeegee. All the materials used on the job shown were purchased from Sears, Roebuck.

Check the labels when you buy to make sure you're getting tar-emulsion coating and sealer; some labels don't specify. Sears claims that a coating with tar-emulsion properties will not dissolve when the dried film is wiped with a rag soaked in gasoline, kerosene or paint thinner. That test, hopefully, your driveway will not have to endure.—*Harry Wicks, Workshop Editor*



IF YOUR DRIVEWAY SURFACE looks this good it is ready for a final sealing with Sears Tar Emulsion



SWEEP OUT PUDDLES and low spots. If available, use jet of air to blow dirt and water out of cracks



SMOOTHING PASTE is poured on damp surface in continuous ribbons to cover area about 20 to 40 sq. ft.



USING APPLICATOR sold for the purpose, spread the ribbons with firm pressure to get uniform coverage

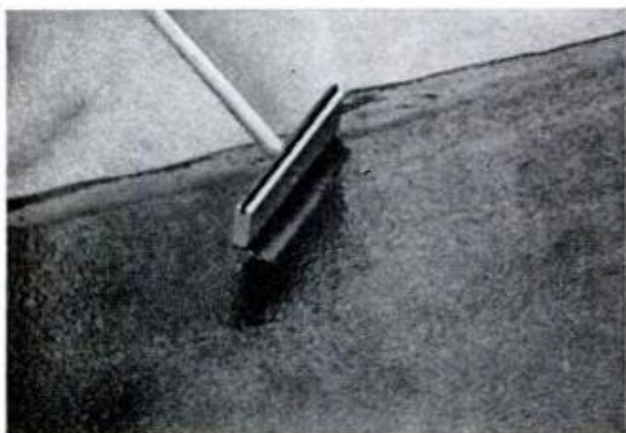

DO NOT APPLY the paste too thickly, never over $\frac{1}{4}$ in. For big depressions, two coats are better than one



IF NECESSARY, smoothing paste can be mixed with just enough water to obtain good flow consistency



WHEN COLOR changes from brown to black, drive can be walked upon. On rough areas, apply a second coat
SEPTEMBER 1970



APPLY THE FINAL coat to give a smooth surface, but don't get it so smooth that it's slippery when wet

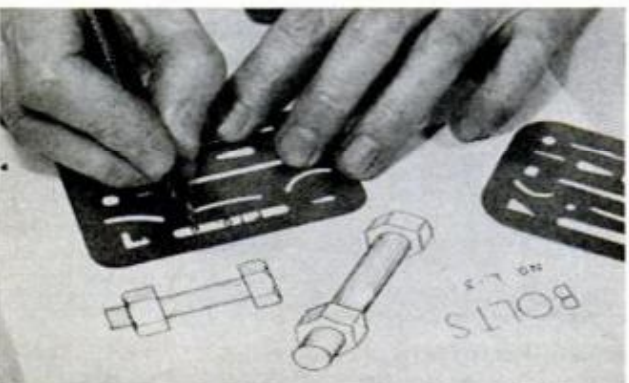
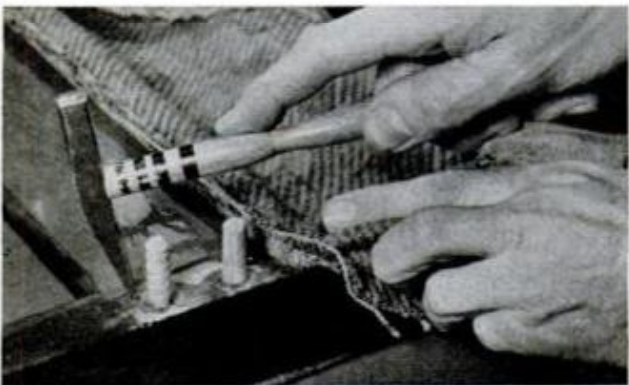
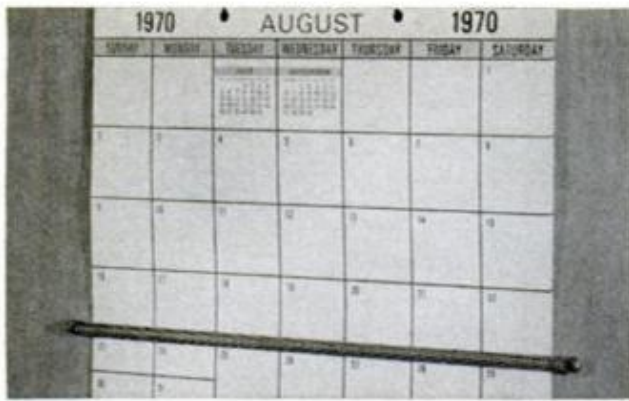

HINTS FROM READERS

Year-round 'spring' for calendar

I have a large wall calendar in my shop which flutters annoyingly whenever the door is opened. To eliminate this, I stretched a screen-door spring across the lower portion of the calendar and fastened it to the wall at both ends with screws. Now the pages stay put, yet it is still easy to change the page each month.

—Clarence N. Breitenfeldt

Painter's mitt saves cleanup

When you're painting small articles, such as drawer knobs, a mitt made from cardboard holds the work steady while keeping the paint off your hands. Bend, but do not crease, the cardboard and attach the knobs with screws, as shown. Position the fingers between screws and wear the sleeve like a glove. Leave parts on the mitt until completely dry.

—A. J. Stephenson

Hammer serves as gluing aid

A tack hammer with one end shaped much like the cutting end of a cold chisel provides an effective method of removing thick deposits of old glue from any old furniture you might be repairing. Use the hammer like a metal-chipping hammer (or miniature adz) then finish cleaning the glued area with a conventional wood scraper.—B. W. Ervin

Fast way to cut plastic foam

Next time you have a project that involves using a plastic foam such as Styrofoam, try my trick for cutting the stuff. I've found that a serrated kitchen knife or fine-toothed hacksaw blade—ground to a bevel on both sides—works perfectly. For soft foam, blade thickness doesn't seem to matter, but for rigid foams a thin blade is best.—David W. May

Eraser-shield lettering guide

An erasing shield can be used as an aid when you do small-size lettering with a pencil or ballpoint pen. Guide openings make it easy to keep the letter height uniform with the tops and bottoms of the various characters. Photo shows shield being used to do small lettering to supplement large lettering done with another scale.—Walter Burton

New tools you should know about



PORTABLE CUTOFF TABLE and miterbox can be set up in minutes as an on-the-job workshop for production building. Designed to accept any full-shoe portable circular saw, Trim-A-Table features a built-in precision tape measure and an adjustable sliding butt stop with quick lock that can be used anywhere along the back fence. Light in weight, table can be folded and carried by one man. Cost: \$110. Van Mark Products Corp., 18235 Weaver, Detroit, Mich. 48228.

JET BATH FOR PAINT ROLLERS does a thorough cleaning job in two minutes. Designed to accommodate seven and nine-inch rollers, it rinses latex paint out of the roller by spinning it with nine 30° angle jets. It will also clean out oil-base paint after the roller has been dipped in emulsion. The power source is your laundry-tub faucet or outside hose bib. RinSpin is made of styrene plastic, self-cleaning and comes with a satisfaction or money-back guarantee. \$2.95 postpaid. For information, write Busch Enterprises, Dept. M, 1622 Polk St., Minneapolis, Minn. 55413.

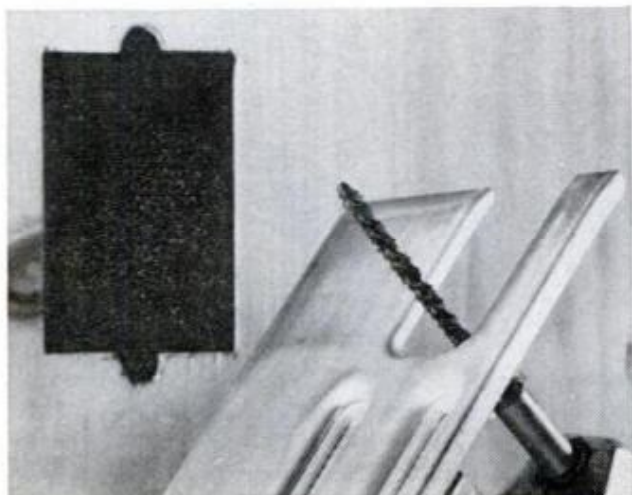

TIGHT TURNS and small-radii scrollwork are easily cut in wood or plasterboard with a Stickle-Dickle because the blade diameter is only 3/16 in. Manufactured by Coastal Abrasive & Tool Co., Box 337, Trumbull, Conn. 06611, the blade fits most popular sabre saws and gives an exceptionally smooth finish cut that requires little or no sanding. At hardware and department stores.



SOLVING



THE BEST METHOD for wiping a paintbrush that I've found is to halve an old cover and use it while painting. Bonus: The rim stays even cleaner than one that is punched with several holes.—*Walter Griffin*

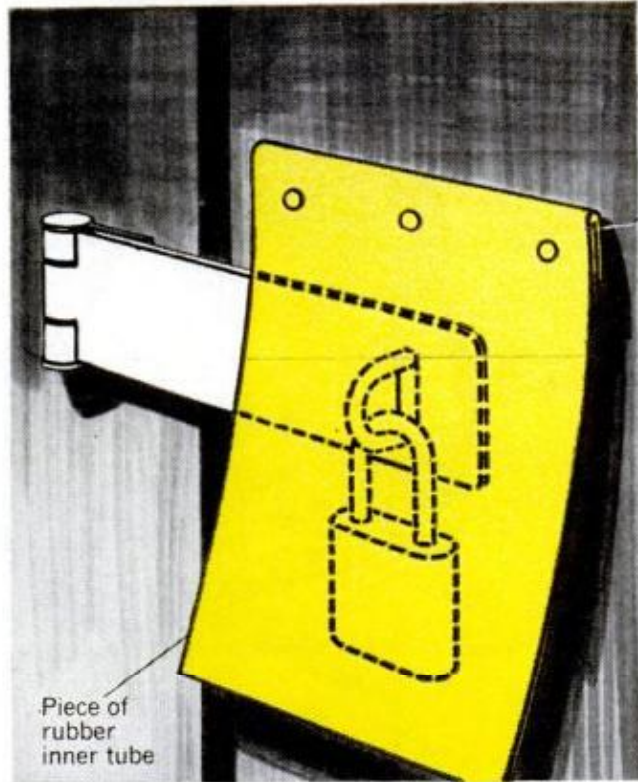

PROTECT AN OUTSIDE PADLOCK from foul weather by covering it with a small section cut from an old inner tube. Make the flap so that it is about 2 in. wider than the lock it covers.—*Blanche Campbell*



MOUNT SNAPSHOTS in an album without glue-on corners by slitting hold-down corners with this simple tool. Make it of a short piece of thin wood with two razor blades bolted to one end.—*William Swallow*

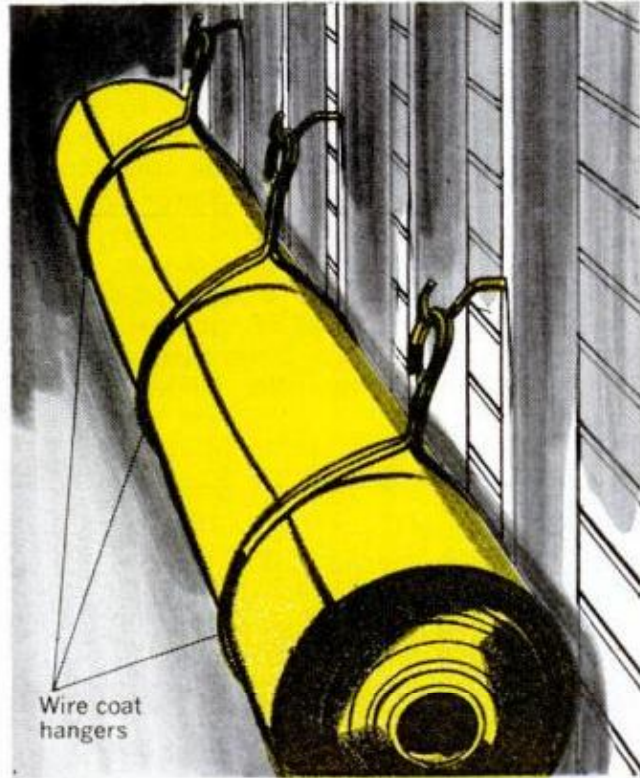

STORE A CARPET easily by spotting three clothes-line hooks on your garage wall about 4 ft. apart. Then, using two shaped wire hangers per hook, hang the rolled-up carpet from the hooks.—*Allen Wilks*

HOME PROBLEMS

Illustrations by Adolph Brotman, Worman Associates

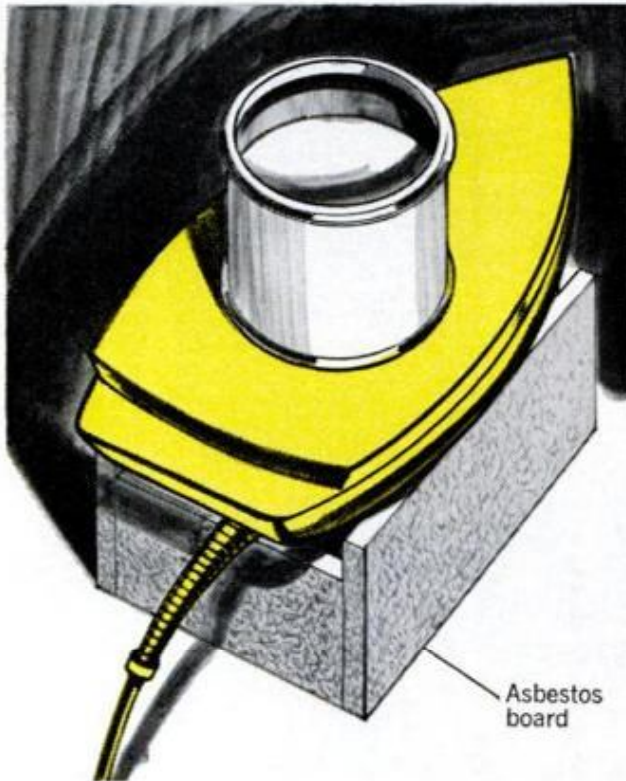

A DANDY SMALL "STOVE" for your shop can be made from an old iron. I rescued one about to be thrown out, removed the handle and placed it on an asbestos stand to heat coffee and warm glue.—*Frank Shore*

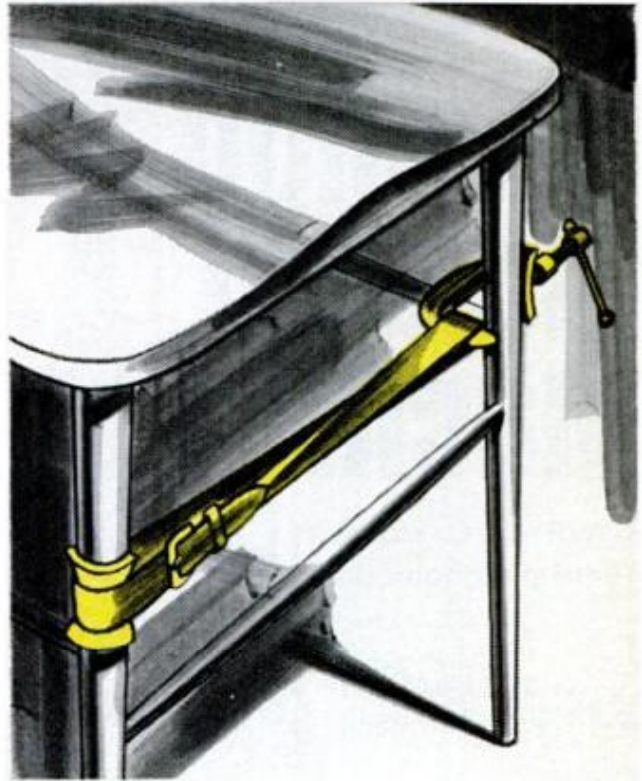

LACKING AN ADJUSTABLE BAR CLAMP of the right size for a gluing job recently, I made a substitute using a buckled belt and C-clamp. Padding under belt and handle protects surface.—*William Kuester*



PERFORATED-BOARD HOLES that enlarge due to continual use can be kept in service simply by placing a piece of tape over the wire hook shank. Nylon filament tape seems to work the best.—*Bob Olson*



NEXT TIME YOU NEED LIGHT but can't find a candle, try wrapping a tuft of cotton around a toothpick. Coat the cotton "wick" with petroleum jelly, then insert it in the jar and light it.—*William Swallow*

What You Can Do With an Injection Molding Machine

By WAYNE C. LECKEY,
Home and Shop Editor

Photos by Robert Borst

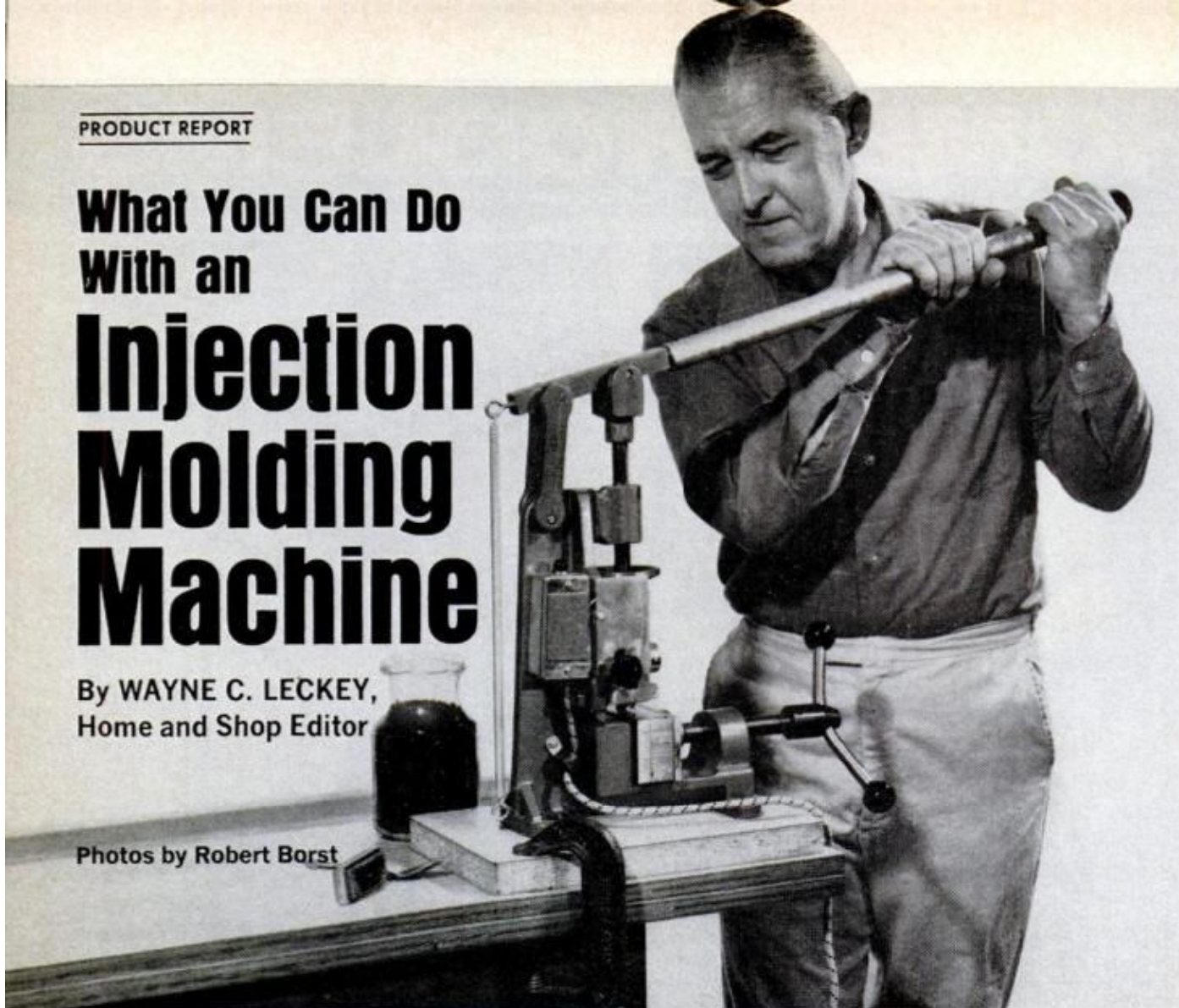

MOLD IS FILLED by pulling lever down with steady motion and holding for a few seconds at end of stroke

Molten plastic forced under pressure into aluminum molds lets you mass-produce salable items at home

IF YOU HAVEN'T HAD the fun of using an injection molding machine, get ready for a fascinating new hobby—one that could put you in business.

Injection molding is a process by which plastic objects can be produced in quantity by first heating resin pellets until they become viscous liquid and then forcing the molten plastic into a ready-made mold. Since the plastic solidifies instantly in the mold, you can produce one molded part after another just as fast as you can operate the machine. I found the whole procedure extremely interesting.

What can you make with a hand-operated molder like the bench model shown here? Dozens of things, and for pennies. You can mold three-dimensional letters of the alphabet for making signs and nameplates. You can make rubber stamps

which require no vulcanizing. You can mold plugs on the ends of lamp cords, produce all kinds of specialty items such as bottle cappers, telephone dialers, golf tees, fishing lures, screwdriver handles, corncob holders, key chains—you name it. The many different molds available give you a wide choice of things to make for fun or profit.

The machine is operated by a pipe-handle lever which exerts a pressure of some 2000 pounds per square inch on a vertical ram which, in turn, forces the molten plastic into the mold's cavity. All it takes to fill the molds is a steady, uninterrupted pull on the lever.

Once the mold is filled, the ram is returned to the top of its stroke, the two-part mold is unlocked, opened and the finished part is removed. Then the cylinder

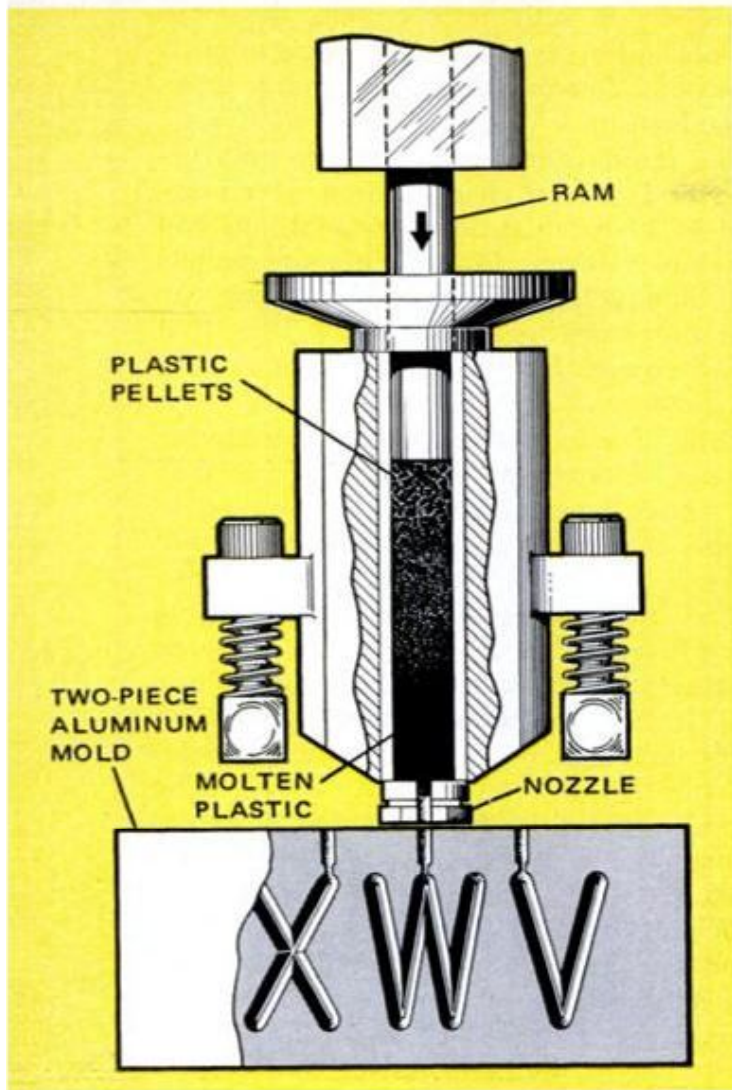

CUTAWAY DIAGRAM (above) shows how ram forces molten plastic in cylinder through the nozzle and into the mold. Each letter in set of three-letter molds has own sprue hole for casting letters individually

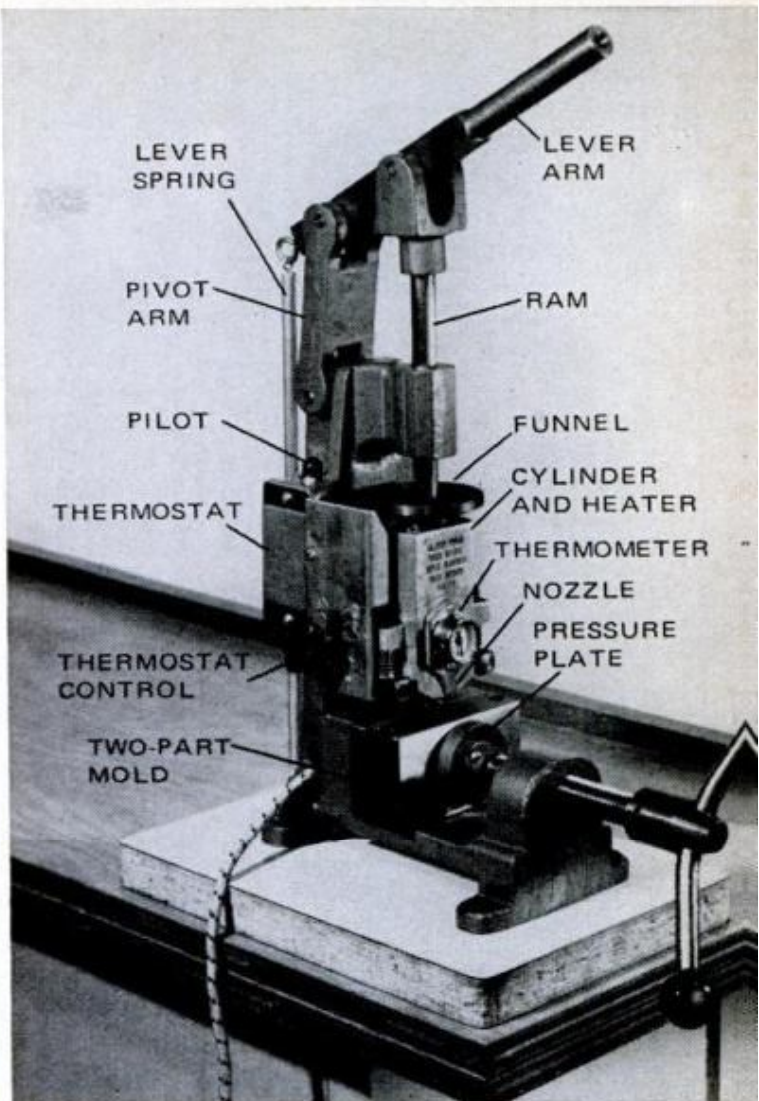

BECAUSE LEVER OPERATES RAM, machine must be bolted solidly to sturdy benchtop so it won't flip up. Pipe extension slips over the lever arm to provide the necessary leverage to force plastic into mold



MOLDED LETTERS AND NUMERALS are lifted from mold either singly or in groups, depending on size. Sets of alphabet molds come in $\frac{3}{8}$ and $1\frac{1}{2}$ -in. letters
SEPTEMBER 1970

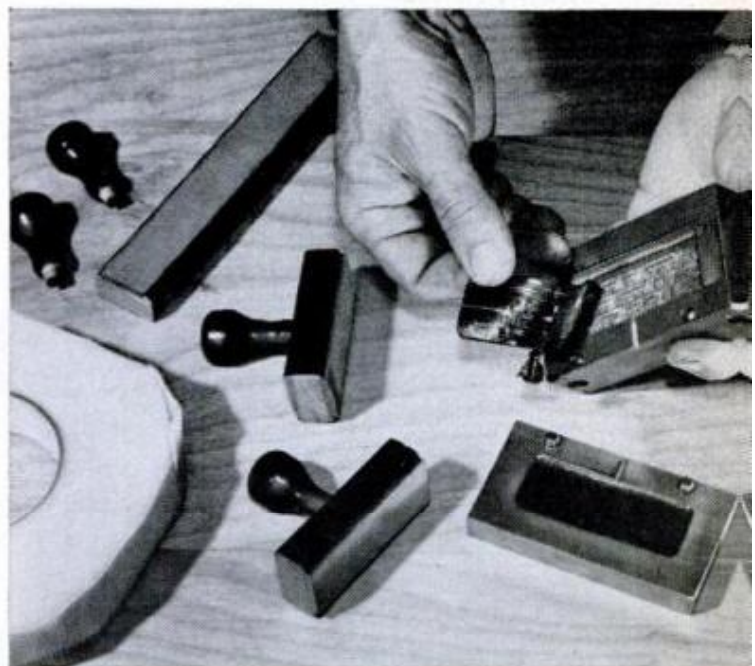

SPECIAL FONTS of recessed type let you mold raised letters for hand stamps in one operation. Here rubberlike molded part is being peeled from mold

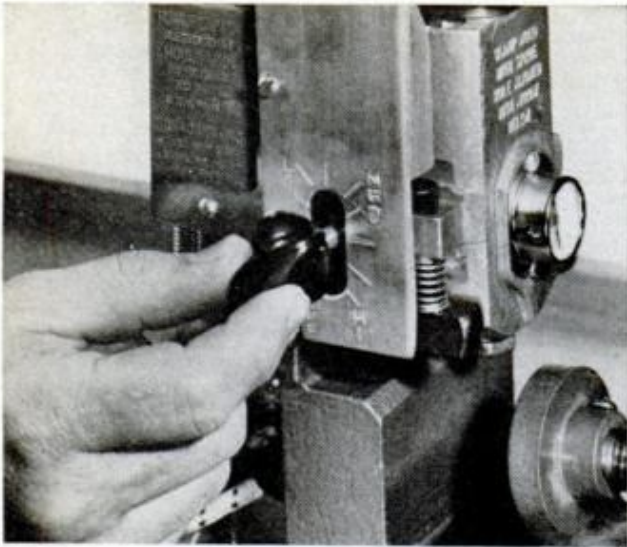

AFTER PLUGGING IN MACHINE, set thermostat at medium and preheat for two to three minutes. Machine is ready for molding when thermometer reads 300°F.

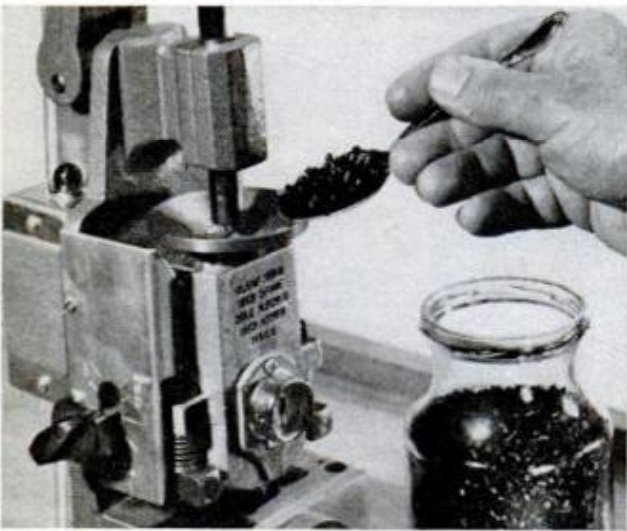

USE SPOON TO FILL CYLINDER each time with plastic pellets. Pack even with top by tamping slightly with end of ram. Don't overfill cylinder with pellets

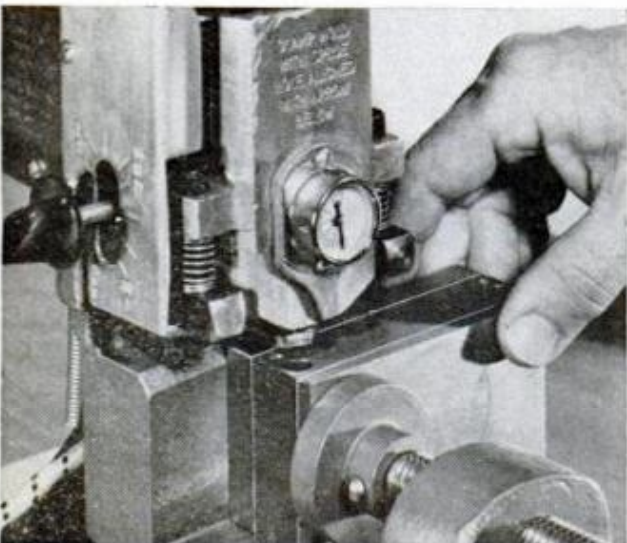

ALIGN SPRUE HOLE in two-part mold with machine's nozzle; lock the mold by tightening pressure plate. See that tightening does not cause mold to shift

is recharged with more pellets, the mold is relocked in its vise and the operation is repeated. You can do this as many times as you wish.

The molding materials include polystyrene and polyethylene pellets which are sold in 10-lb. quantities. In addition, you can buy colorant for coloring the pellets red, blue, yellow, green or black. You can also purchase special plastic pellets that are designed for use in molding rubber hand stamps.

Best of all, there's no waste material. Sprues, flashing and rejected parts may be reused and molded again and again simply by cutting up the plastic into small pieces.

The machine is designed to plug into any 110-v. outlet. To ready it for use, you first set the thermostat knob to medium and let the machine warm up two or three minutes, or until the thermometer at the front reads about 300°F. The proper operating temperature is determined by the nature of the plastic being used.

When you find that the molten plastic cannot be injected by normal pressure, increase the temperature a little. If the finished part shows signs of excessive shrinkage in the mold, lower the temperature a bit.

The important thing in the making of a perfect part is to remember that the lever must be brought down with one deliberate motion. Any hesitation during the full stroke will cause the plastic to "freeze" in the mold and will result in an incomplete shot. It is important, too, that the ram be held a few seconds under pressure at the end of the stroke before withdrawing it from the cylinder.

To change from one color to another, or to change from one type plastic to another, you purge the cylinder while it is hot. This is done by supporting the nozzle with just a corner of the mold so the plastic can run free. Then, after adding the new plastic on top of the old (or the new color) you gently squeeze the multicolor plastic from the cylinder and out the nozzle like spaghetti. This is done several times, or until the plastic finally emerges in its true color.

For further information about this fascinating money-making machine, write to Honacast, Inc., 131 E. 169th St., Bronx, N.Y. 10452. ★★★

HINTS FROM READERS

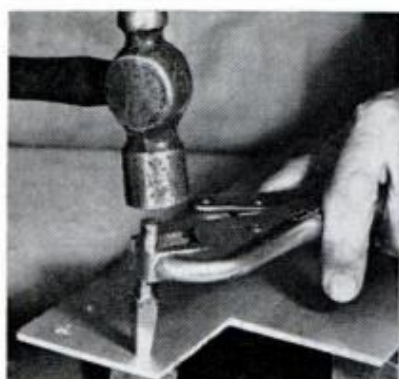

Punching square holes

Recently, I had to machine several holes that were to receive square, taper-shank bolts. To do it, I cut the shank end from an old auger and used it as a punch to broach the holes. Using a torch, I heated the hole surface, held the shank with a pliers and gave a few raps with a hammer.—*Robert J. D. Hill*



Curing sick clocks

Clock failure is usually due to friction in the power train. Often, you can re-oil the clock without disassembling it. Dissolve gummed oil first with kerosene and a small brush, then put a drop of light mineral oil in each bearing. While you're at it, oil the mainspring to minimize rubbing as it unwinds.

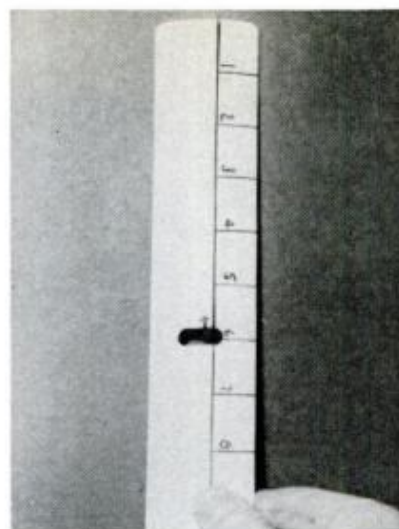

Durable 'yardstick'

The next time your wife throws out a venetian blind, hoard a couple of the slats for use as rulers; their straight edges beat using a yardstick. Simply mark off desired increments using nail polish or indelible ink. If you make several rulers, calibrate each for special jobs.

—*William Swallow*

BX cable makes handy snake for cleaning clogged downspouts

Cleaning gutters and downspouts is just one item on the annual spring cleaning schedule. A trick that I have used, when I have been unable to flush the downspouts out with the garden hose, is to use a length of old BX cable as a snake. It easily loosens twigs, leaves and an occasional tennis ball. Feed the BX up from the bottom, and then flush from the top with the hose.—*E. M. Woodbury*

NEXT MONTH IN SHOP AND CRAFTS

LOOK WHAT YOU CAN DO WITH A SWIVEL-BLADE SABER SAW. They're the latest in portable jigsaws, and three makers are now offering them at retail. With one you can do cutting tricks that were once impossible. And if you already own a conventional saw, you can steal some of the tricks and get more mileage from your present tool. Look for it in October *PM*.

HOW TO PAINT WITH SPRAY CANS. They're a good way to get small jobs out of the way in a hurry, but, if they're used improperly, the results can be a lot less than satisfying. Read October *PM* and you'll be able to avoid the spray can pitfalls that have trapped so many others.

BUILD THIS ELECTRONIC BANJO. You're sure to make a hit with your youngsters—and all their friends—if you tackle this project. You can make the instrument practically from scrap and, the effort will pay off at your next get-together. Complete plans in *PM* next month.

A WORKBENCH FIT FOR A PRO. Besides being handsome, this workbench is exceptionally rugged and has a top with a density that equals rock maple. You'll find complete plans for building it in next month's *PM*.

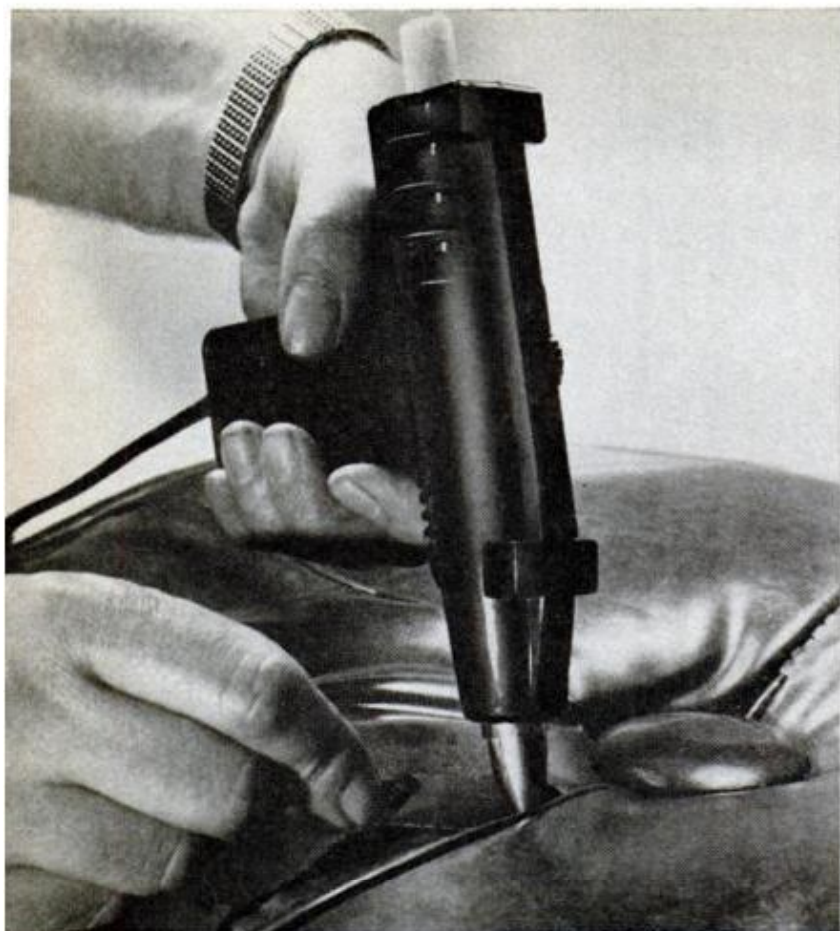

Hot Tips For Using Glue Guns

By JOHN BURROUGHS

Hot-melt glue gives you a flexible bond in a hurry. Here are some of its uses that you may never have thought of

ANYONE using a glue gun for the first time discovers that the polyethylene-base, hot-melt adhesive applied with electric guns differs completely from other common glues. For example, it's not like the hide glue that cabinetmakers cooked up in glue pots or the white glue that comes in squeeze bottles.

A glue-gun glue's special advantage—besides fast-method application—is its flexibility, which is a key property for any adhesive. The lack of brittleness in a layer of glue is a factor as important as adhesion in determining the strength of a glued joint.

Like hide glue, which is flexible, most synthetic-resin base glues are also hard-drying and must also be applied in thin glue lines to prevent cracking and glue failure.

White glue, which is polyvinyl acetate emulsion, is more pliable. Since even a thick glue line won't harden enough to become brittle, this glue holds tenaciously. Aside from its lack of water resistance, the only serious disadvantage (for anyone in a hurry) when using white glue is its dry-

ing time. It takes an hour or more to dry out.

Polyethylene-base, hot-melt glue was developed to supply a flexible, waterproof adhesive suitable for fast production-line bonding procedures, especially those in use by the shoe manufacturing and packaging industries.

The adhesive is simply ordinary linear polyethylene—the familiar flexible white plastic used to make squeeze-bottles—with sticky plasticizer added. It comes in slugs, or sticks, about $\frac{1}{2} \times 1\frac{3}{4}$ in. The sticks can be stored indefinitely without deterioration.

When heated to around 300° in an electric gun, the solid adhesive becomes quite fluid—about like maple syrup—and can be squirted readily through the gun's nozzle. A bead of hot glue from the nozzle, applied to wood, stays hot enough to remain workable for about half a minute, which is time enough to permit pressing together whatever you're gluing.

Since the adhesive sets by cooling rather than by drying out, the bond develops some 90 percent of its ultimate strength



SQUIRT OF HOT-MELT GLUE permanently repairs shoes, leather goods such as chair seat (opposite)

in about one minute. As it cools, the glue layer becomes a gummy solid that adheres particularly well to wood, ceramic, glass, plastic, leather, fabrics, paperboard and similar materials. It also adheres fairly well to steel if the metal is first preheated to prevent the glue from chilling as it is applied. The adhesive does not shrink appreciably, it's nontoxic and it's nonflammable. Squeezed-out glue can be trimmed away with a sharp knife after it has cooled.

The three most popular guns for applying hot-melt glue are operationally quite similar.

The top-of-the-line version is USM's Professional Model 250, pictured on page 190. Built with a die-cast aluminum melting chamber and nozzle, the tool has a 285-watt, ceramic-cartridge heating element with an adjustable thermostat regulating heat—and therefore rate of melt—from approximately 250 to 450°F. Glue sticks are inserted in a silicone rubber inlet tube, four sticks filling the gun; the sticks are fed by pressing with the thumb. Pulling the gun's trigger opens a valve in the nozzle and permits the molten adhesive to squirt out.

Though this model is priced several dollars more than the others, it's the only gun available with the capacity for large gluing jobs. Its 3/32-in.-dia. nozzle hole can discharge a large quantity of liquified glue

SEPTEMBER 1970

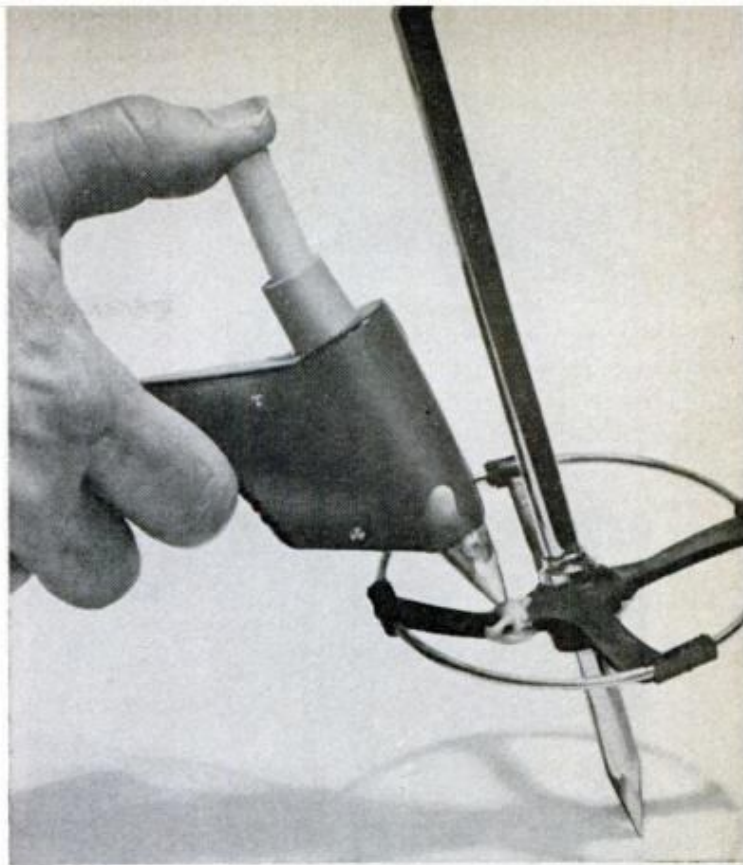

GLUE IS WEATHERPROOF, thus ideal for repairing outdoor sporting equipment such as broken ski pole

over a large area rapidly. Nozzles are interchangeable, with special-purpose nozzles also available. USM has also marketed a lighter-duty glue gun at approximately \$8.

The low-wattage, single heat-element unit offered by Sears has an aluminum nozzle with a 1/16-in.-dia. hole. The nozzle has a ball-check valve that opens automatically when thumb pressure is applied and closes to stop melted glue from drooling out when thumb pressure is released. Glue is delivered at 300-400°F., and the nozzle's rate of flow is entirely adequate for the making of ordinary repairs and the hot-gluing of small-area joints in woodwork.

Swingline's automatic-feed gun, which uses a special glue stick having a molded-in ratchet along the bottom, is equipped with a high-medium-low thermostat. The low setting is used when the gun is set aside for short periods to reduce reheating time. The gun's nozzle can be turned with a plastic box-end wrench supplied with the gun to either *open* or *closed* position. When the gun has heated you open the valve, and when you're through, you close it.

The real secret of success when using any of these guns is to work fast. Squirt the hot glue on the joint liberally and press the glued parts together with firm hand pressure in the shortest possible

189

Материал, защищенный авторским правом



YOU'LL SAVE MONEY if you buy the glue sticks in large quantities. Box with 60 sticks costs \$2.65



SPECIAL GLUE STICK for Swingline's Auto-Feed has a built-in ratchet; pawl mechanism feeds the sticks

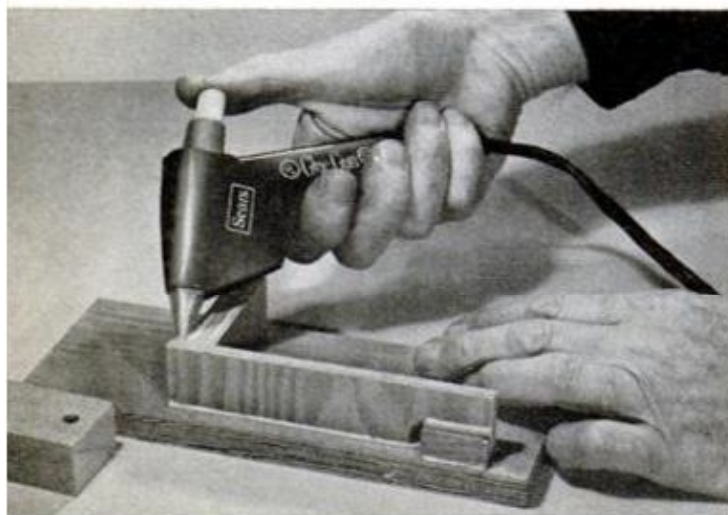

MODELS OFFERED by three leading makers vary in size and price. From left to right, Auto-Swingline, \$9.95; Sears, \$7.95 and USM's "Zap" gun, \$22.95

time. For best results, you should have all parts ready before you start the gluing operation.

Ordinarily, hot glue is applied to only one face of the joint. A little practice will show just how much is required. Pressing the joint together while the glue is still fluid distributes the adhesive evenly throughout the joint. Thereafter the parts should be held firmly in position for at least 20 seconds. In one minute the joint will have cooled enough for it to be put to use.

No surface preparation is required on most materials, although the work should be clean. When gluing to a gloss paint or other smooth surface, roughening the parts with an abrasive cloth improves the bond. Avoid using the gun before it has become fully heated, since any joints made with lukewarm glue can't be squeezed tightly together.

A word of caution. When fully hot, the gun will inflict burns if you should touch it near the nozzle. And the glue itself will burn like fury if you should get it on your skin.

In addition to glue, sticks of hot-melt polyethylene caulking sealant are also available. These are fed through the gun in the same way as the glue. Applied in a hot bead, the clean, bright-white sealant can be forced into cracks with a heated putty knife, wiped into joints while still hot with a rag, or tooled to a neat fillet with the hot tip of the gun. The sealant isn't quite as adherent as the glue, but it sticks satisfactorily to nearly all common materials. Flash can be removed fair-

LOWEST-PRICED VERSION has 60-w. ceramic element, heats to 400° operating temperature in three minutes

POPULAR MECHANICS

ly readily with a knife. The sealer is fully waterproof.

In general, the three guns shown have the same advantages and disadvantages. A glue gun shines when you want to bond a number of small parts in a hurry. It's also very handy for joining roughly-fitted, quick-and-dirty woodwork. A framework of 1x4 lumber, for example, will have considerably more strength and rigidity when assembled with hot-melt glue than when joined with nails. And using the glue gun will take no more time than the nailing operation.

But glue guns do have disadvantages. For one, joints joined with hot-melt glue can't withstand heat above 135°. Thus, it's unwise to use a glue gun, say, to glue in automobile headliners. Since the temperature inside a closed car can soar as high as 200°F. on a hot summer day, the glue would fail.

Occasionally, the fact that the glue can be remelted can be used as an advantage. For example, hot-melt adhesive can be used to bond metal parts to a machine table for machining, and later melted off with a propane torch.

Probably a glue gun's most serious drawback is the difficulty of making large-area joints. Joints larger than roughly one foot square and requiring more than one stick of glue usually must be made a section at a time. If you attempt to glue the full area, you'll find that the glue congeals before you can join the parts together. Generally, when making broad-area bonds, it is recommended that you use some kind of cold glue or cement.

If you think of a glue gun as primarily a line-gluer and spot-gluer, rather than an area-gluer, you'll enjoy the tool's advantages and not be bothered by its disadvantages. Speed of application with flexibility and shock-resistance are polyethylene-base, hot-melt glue's real virtues. If you stick to using the gun on jobs for which it's formulated, the glue is simply great.

When you've become used to handling a glue gun you'll find more than enough hot-melt gluing jobs turning up to justify the tool's purchase price. How else would you glue a tip back on a pool cue? Or fill nicks in a white-plastic-covered ski? And, for bonding polyethylene or repairing rips in plastic upholstery material, it's certain to be the glue you'll turn to. ★★★

SEPTEMBER 1970

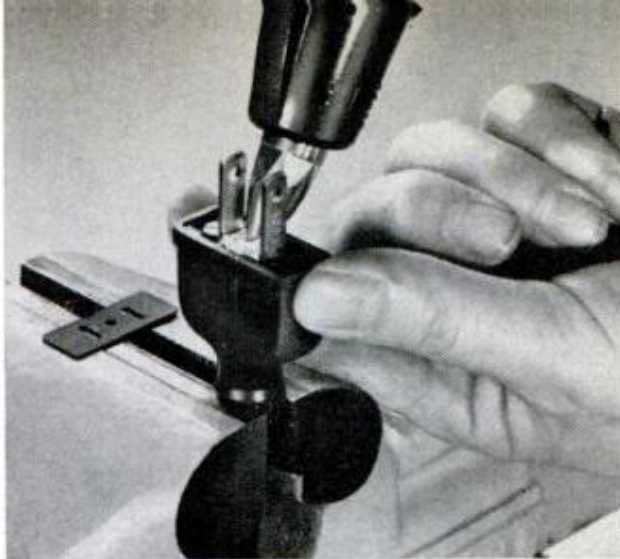

GOOD INSULATING PROPERTIES make hot-melt glue a great agent for anchoring wayward cords in plugs



FAST WAY to make strong joints: Apply beads of hot glue and press the parts together within 20 seconds

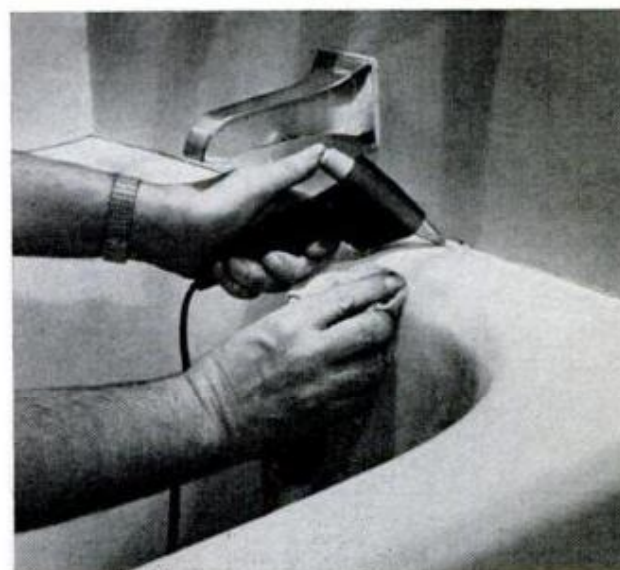

POLYETHYLENE-BASE SEALANT applied with gun around tubs or windows provides a lasting caulking

PLASTIC PIPING

(Continued from page 175)

or connection into any threaded pipe or fitting. It also hooks up with almost any compression fitting of the same size. As a union it can be assembled and taken apart as many times as necessary.

To connect to a nonplastic piping system, merely install an elbow, tee or coupling or other fitting with inside or outside pipe threads available. Then thread on the brass end of the transition fitting. Use pipe dope or wrap a Teflon tape on the outside threads. The plastic bayonet then can be solvent-welded to begin the plastic piping system.

In addition to adapters, you can connect to nonplastic systems with flare fittings. Plastic pipe can be flared if you're careful. The main hang-up is trying to flare a pipe with a nicked end. It tends to break. To avoid this, cut the end with a tubing cutter or file it smooth after sawing. Heating the pipe end also helps.

Precautions. Because the temperature-

Plastic pipe must be installed so that it is not restrained

pressure threshold of CPVC pipe is lower than that of steel or copper pipe, it requires proper installation to prevent damage from expansion and contraction, as well as from overheating and overpressure.

In general, installation of plastic pipe is no different from any other. All materials expand and contract with variations in temperature. Plastics, however, change more than copper or steel. For this reason, plastic pipe must be installed so that it is not restrained. Always use smooth-face plastic strap hangers so that the pipe can slide back and forth on these hangers and not have any clamps digging into it.

Heated from 60° to 160°, a 10-foot length of CPVC pipe will expand ½ in. Provide for this expansion throughout your plastic system. Be sure the ends of the pipe runs aren't blocked in. Branches leading away from long, straight pipe runs should have sufficient length (at least 20 pipe diameters) to bend with the movement. Keep pipe hangers at least 2 ft. away from fittings to allow for sufficient free movement.

Support the pipes at least every 3 ft.; every other joist is better. Vertical runs of pipe can rest on the sill or on a header in-

stalled to support them. Install metal strips where plastic pipes are run through studs as a safeguard to keep nails from puncturing pipes.

Your water heater can be a source of temperatures too high for plastic pipe. As in any water-heater installation, there should be a temperature-pressure relief valve in a galvanized steel tee so that its temperature-sensing probe reaches down into the water storage tank. The temperature-relief setting may be as high as 210° but no higher. For the best job, run 10-in. metal nipples off the top of the water heater to dissipate conducted heat from the burner. Fit your plastic pipe to them using threaded CPVC adapters.

The recommended water-heater setting for use with plastic pipe is 140°. This is hotter than your hands can stand. However, you can set the heater dial as high as 180° and still be within the design limitations of CPVC pipe.

Eliminating overpressures: When water flow is shut off quickly, overpressures can reach many times the normal working pressure of CPVC pipe. The resulting water hammer can wreck any kind of pipe if bad enough, but it's deadly to a hot plastic system. Every plumbing system must be designed to prevent water hammer. Automatic washers with fast-operating solenoid fill valves are especially bad actors. Your plumbing system should have air chambers at every outlet to cushion water hammer. Such chambers are formed by capping a 12-in. length of ½-in. pipe and extending it up from the tee behind the wall stub-out to the fixture. Air chambers for automatic washers should be made from 18-in. lengths of ¾-in. pipe.

In time air chambers may become waterlogged. Whenever this happens, turn off the water, open all of the faucets and drain the system enough to let air in again.

Never use CPVC pipe in a hot-water heating system—and don't use it for piping to or from a hot-water coil immersed in a boiler. Temperatures here often skyrocket to 200° plus.

Where to find. CPVC pipe still is not widely distributed. B.F. Goodrich and other manufacturers make the materials which specialized manufacturers turn into the pipe and fittings. If you have trouble finding CPVC pipe in your area, contact Genova Products Co., 300 Rising St., Davison, Mich. 48423. This firm is the largest marketer of CPVC pipe and fittings and can advise you where to find its nearest dealer.

In 10-ft. lengths, the ½-in. pipe sells for about 25 cents a foot and the ¾-in. costs about double that. ★★★



This is one Cat you can treat like a dog.

Climb over hidden obstacles with it. Flash across soft powder snow with it. Slip it around tight turns. Ride it hours on end. It's an Arctic Cat. And that means there are no welds to break. Instead, Arctic's riveted all-aluminum aircraft-type chassis distributes and absorbs the stress. And Arctic's patented torsion spring slide rail suspension gives-and-takes to keep you running smooth.

So choose one of the four exciting new Arctic Cats for 1971. Especially if you're going to treat your snowmobile "like a dog." Then, next season and the season after, when another make of snowmobile might need bogey wheel replacement or extensive rust removal, your Arctic Cat will still be rarin' to go. And begging for more.

It's good to know your Arctic Cat is precision engineered and built for durability. Even if you want to treat it nice. **ARCTIC CAT**

**this
is the
year
of
the
Cat**

REVISED EDITION

Popular Mechanics Catalog Plans, Publications, Projects

Want to build a boat, garage, sidewalk classic, plane or a clock, kayak, fireplace, kite, patio, coffee table aquarium, kitchen cabinet, organ, swimming pool, telescope, children's play furniture, camping trailer, science project, electronic project?

Send for the NEW Popular Mechanics illustrated catalog! 32 pages crammed full of fascinating and useful projects you can build yourself!

For more than 67 years, Popular Mechanics has been the world's leading authority on how-to information. In this **h e l p f u l** catalog you'll find the very best of Popular Mechanics plans and publications. In step-by-step text, photos and drawings, these plans show you how to build something for everyone in the family.



Above are shown a runabout boat you can build for less than \$75; a four-place plane you can construct yourself; a patio-garage and the famous sidewalk classic for youngsters that rolls along at 5 m.p.h.

For information on scores of other exciting projects, order the new catalog today! Send only 25c to cover postage and handling.

Enclose 25c in coin, no stamps please, to cover postage and handling.

Mail to: **Popular Mechanics Dept. JR**
224 West 57 Street
New York, New York 10019

Please Print:

Name _____

Address _____

City _____ State _____

Zip _____

Join "THE TROUBLESHOOTERS"

who get paid top salaries for keeping today's electronic world running

Suddenly the whole world is going electronic! And behind the microwave towers, push-button phones, computers, mobile radio, television equipment, guided missiles, etc., stand THE TROUBLESHOOTERS—the men urgently needed to inspect, install, and service these modern miracles. They enjoy their work, and get well paid for it. Here's how you can join their privileged ranks—without having to quit your job or go to college to get the necessary training.

JUST THINK how much in demand you would be if you could prevent a TV station from going off the air by repairing a transmitter...keep a whole assembly line moving by fixing automated production controls...prevent a bank, an airline, or your government from making serious mistakes by servicing a computer.

Today, whole industries depend on electronics. When breakdowns or emergencies occur, someone has got to move in, take over, keep things

running. That calls for a new breed of technicians—The Troubleshooters.

Because they prevent expensive mistakes or delays, they get top pay—and a title to match. At Xerox and Philco, they're called Technical Representatives. At IBM they're Customer Engineers. In radio or TV, they're the Broadcast Engineers.

What do you need to break into the ranks of The Troubleshooters? You might think you need a college degree, but you don't. What you need is know-how—the kind a good TV service technician has—only lots more.

What You Need to Know

As one of The Troubleshooters, you'll have to be ready to tackle a wide variety of electronic problems. You may not be able to dismantle what you're working on—you must be able to take it apart "in your head." You'll have to know enough electronics to understand the engineering specs, read the wiring diagrams, and calculate how the circuits should test at any point.

Learning all this can be much simpler than you think. In fact, you can master it without setting foot in a classroom or giving up your job!

For over 30 years, the Cleveland Institute of Electronics has specialized in teaching electronics at home.

We've developed special techniques that make learning easy, even if you've had trouble studying before. Our AUTO-PROGRAMMED® lessons build your knowledge as easily and solidly as you'd build a brick wall—one brick at a time. And our instruction is personal. Your teacher not only grades your work, he analyzes it to make sure you are thinking correctly. And he returns it the same day received.

Get FCC License or Money Back

Two-way mobile work and many other types of troubleshooting call for a Government FCC License. Even if your work doesn't require a license, it's a good idea to get one. It will be accepted anywhere as proof of good electronics training.

The licensing exam is so tough that two out of three non-CIE men who take it fail. But 9 out of 10 CIE graduates pass. That's why we can offer this warranty. If you complete one of our license preparation courses, you will be able to get your FCC License—or your money back.

Mail Card for 2 Free Books

Want to know more? Mail bound-in postpaid card for our 44-page catalog on CIE courses, and book on how to get an FCC License. If card is missing, use coupon below.

ENROLL UNDER NEW G.I. BILL

All CIE courses are available under the new G.I. Bill. If you served on active duty since Jan. 31, 1955, or are in service now, check box in card for G.I. Bill information.



CIE Cleveland Institute of Electronics
1776 East 17th Street, Cleveland, Ohio 44114

Cleveland Institute of Electronics

1776 E. 17th St., Cleveland, Ohio 44114

Please send me without cost or obligation:

1. Your 44-page book "How To Succeed In Electronics" describing the job opportunities in electronics today, and how your courses can prepare me for them.
2. Your book on "How To Get A Commercial FCC License."

Name _____ (Please Print)

Address _____

City _____

State _____ Zip _____

Occupation _____ Age _____

Check here for G.I. Bill information

Accredited Member National Home Study Council PM43

HOMEOWNERS' CLINIC

BY W. CLYDE LAMMEY

Rotary mower 'gases' lawn?

I've been told that rotary mowers with two-cycle engines—in which lubricant is mixed with fuel—damage lawns by exhausting gases and particles of unburned oil. I have noticed that many lawns have a yellowish-gray color a few days after mowing. Is this caused by the mower?—L.W., Ohio.

Could be, if the engine is in poor condition or the exhaust system is misdirected or damaged so that exhaust gases are directed downward onto the turf. I don't know that any tests have been run to determine if lawn damage results from engine exhaust. Offhand, I'd say this does not cause the condition you describe. Other possibilities are: mower set to cut too low, resulting in "scalping" the entire lawn or areas that may be slightly rolling or undulating; turf allowed to grow abnormally high between mowings; a dull blade which doesn't cut the grass cleanly.

... it's the humidity!

What's the meaning of relative humidity? What's it got to do with condensation on windows, walls and elsewhere in the house? So far, no explanations mean much to me. Can you clarify?—W.W. Tex.

To simplify the explanation, it might be put something like this: Relative humidity is the ratio between actual vapor content of the atmosphere at a given time and place and vapor (or moisture) content of air that's saturated with vapor. If air temperature rises and there is no change in the amount of vapor the air contains, the relative humidity is lowered—that is, the ratio changes. Conversely, a drop in temperature increases relative humidity. Thus, relative humidity can reach 100 percent—the dew point—at which the water vapor condenses as droplets on any surface, such as on grass in summer or window panes in colder months.

In winter, warm, moist air inside the house tends to seek the colder, drier air outside the walls. Since the walls are generally at a lower temperature than the air they contact on the room side, this sometimes causes moisture to condense on the walls—more often on the window

panes which, unlike most common building materials, are impervious to passage of air from inside to outside.

Louvers in storm sash

All last winter our storm sashes sweat badly—so much that water dripped down and damaged the frames, causing the paint to peel and the wood to turn a soggy, brownish color. Moreover, the frames swelled so much, they were difficult to remove last spring. I've been told to cut louvers in the lower rails of the sashes. Will this prevent sweating?—M.S., Minn.

No. In fact, louvers or holes in the lower rails will only enlarge the problem and defeat the basic purpose of the storms which is to entrap air between the sashes to serve as "insulation" and prevent condensate from forming. However, both inner and outer sashes should fit quite tightly, or the inner sashes should be weatherstripped to prevent leakage of warm, moist air from the room side and leakage of cold air from outside. In the latter case, the storms should be sealed with strips of adhesive weatherstripping or felt about 1/2 in. wide. They should be held tightly in place with turnbuttons.

For ventilation during warm periods in winter you can cut an elongated opening in the lower rail of each storm sash but this should be fitted with a pivoted cover which closes the opening tightly when dropped to a horizontal position.

Shingles 'washing' away

My home is only a year old and recently I noted that the gutters contain a quarter to a half inch of the fine particles with which the shingles are coated. The roofing is supposed to be good quality, but I'm wondering what's happening. Is my roof washing down the drainpipe?—G.S., Tenn.

I'd put this "problem" out of mind for the next 15 or 20 years. It's quite normal for asphalt roof shingles to shed the particles of slate with which they are coated. Some are loosened just in handling and applying. Others, not too solidly embedded, are loosened by rainfall, snow and sleet. Just clean them out of the gutters so that rainwater will flow freely. ★ ★ ★

Now on Your Newsstand

The all-new 1971 edition of *Better Ways to Do It*, filled with hundreds of ideas, suggestions and shortcut hints for your home, yard and workshop, is now on sale. Look for it at your favorite newsstand.

A lot of people who aren't impressed by the price of our cigars are impressed by our cigars.

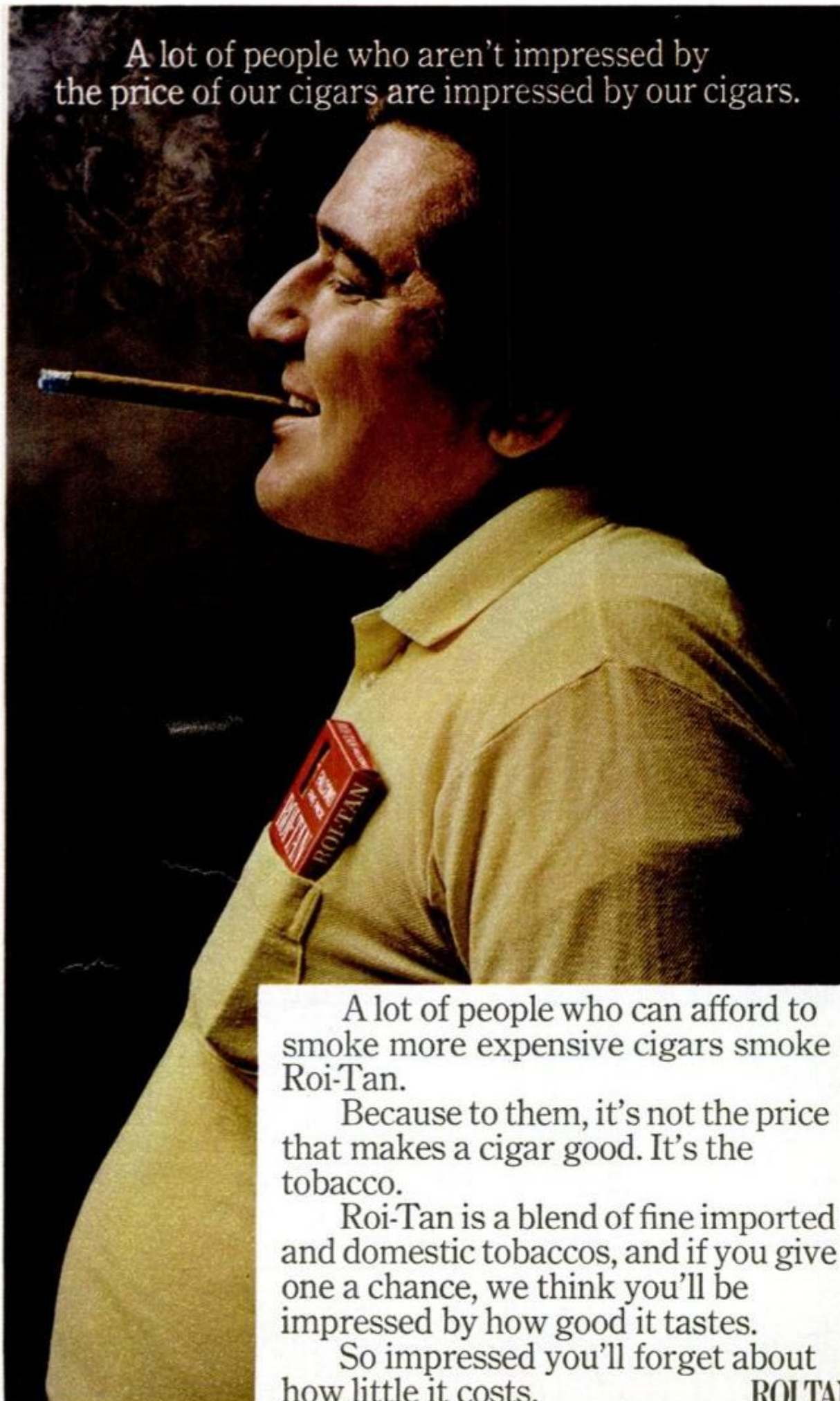

A lot of people who can afford to smoke more expensive cigars smoke Roi-Tan.

Because to them, it's not the price that makes a cigar good. It's the tobacco.

Roi-Tan is a blend of fine imported and domestic tobaccos, and if you give one a chance, we think you'll be impressed by how good it tastes.

So impressed you'll forget about how little it costs.

ROI TAN *Falcon*

New Tabletop Viewer Shows Color Prints

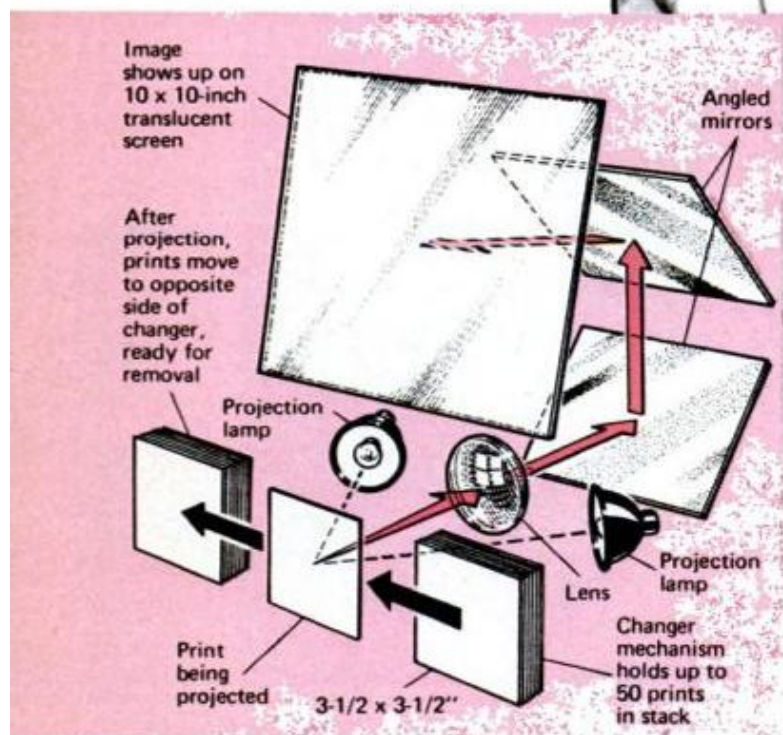

HINGED DOOR on front of viewer swings out for easy loading of prints into changer mechanism. Changer holds stack of 50 prints and moves them, one by one, in front of projection lens

OLD PHOTO PRINTS usually get stored away in shoeboxes or seldom-looked-at albums. But not anymore. Now you can project your prints just like slides and movies. The answer is a trim tabletop viewer—first of its kind—that shows black-and-white or color prints on a 10-inch-square screen so you can easily put on picture shows for your family or friends.

Made by GE, the portable, plug-in viewer holds up to 50 prints in a changer. To switch from one picture to the next, you just slide a knob across the front. The prints feed, one at a time, from a loading chamber on the right to a collection chamber on the left. After viewing, they can be removed and stored neatly in an accessory file box for future use.

The optical system is similar to that found in old-time opaque projectors except that the modern version uses a rear-projection setup. As each print is moved into position for viewing, it's illuminated by two bright lights, and the image is reflected through a system of lenses and mirrors onto a translucent screen. The changer is designed to take the familiar 3½-inch-square print size made from 126 instant-load film cartridges. It will also take 3½-inch prints made from 620, 120 and 127 film or any other prints that can be trimmed to the 3½-inch size.

The GE viewer sells for \$69.95. The accessory file box, which stores up to 600 prints along with their negatives, is priced at \$5.95.—*Sheldon M. Gallager*

You'll see better ideas clear through Ford's Econoline

Small wonder it outsells all other vans



Twin-I-Beam ride. The independent front suspension made famous by Ford pickups: Twin-I-Beam. Two I-beam axles for strength... big coil springs for easy ride. Twin-I-Beam gives you greater stability, less wind wander, and a better ride. Only Ford has it.

"Walk-thru" to rear. Because the engine is forward out of the way, the driver can step from his seat into the load area and exit through side or rear doors. The loadspace is not only bigger than in older vans, it's easier to reach. See all the better ideas in the best selling van at your Ford dealer's.

Outside service center. Just raise the hood, and all these service points are at hand: oil, water, battery, windshield-washer water, wiper motor, brake master cylinder, voltage regulator. Ford's better idea vans make everything you do easier to do.

Greater payload than ever before. Now Ford vans can take on loads that vans never before were designed to take. Choose from three Econoline series and two body lengths. Power choices include two economical Sixes and a top-performance 302-cu. in. V-8.

FORD ECONOLINE VANS



ON-THE-GO

CAMPING

BY WADE MITCHELL

IF YOU'RE TIRED OF MOTOR-HOME BARGAINS that don't include all the essentials, Winnebago is producing a new economy model to suit your needs—and pocket-book. The F-17 (Ford chassis—17-ft.) Renegade at \$5995 includes furnace, 36-gallon holding tank, gas/electric refrigeration, stove with oven, and sleeping for four with optional room for six. In addition, Marketing Manager John V. Hanson promises no skimping on ventilation, doors, mattresses or armrests! Now that is a bargain!

CAN YOU NAME 10 MOST POPULAR NATIONAL PARK AREAS? Surprise! Yellowstone National Park isn't listed in the top 10. In order of daily attendance, the top 10 parks for 1969 were Blue Ridge Parkway, Natchez Trace Parkway, Colonial National Historical Park, Great Smoky Mountains National Park, Lake Mead (Nevada), George Washington Memorial Parkway, Cape Cod National Seashore, Lincoln Memorial, Gettysburg National Cemetery and Grand Teton National Park. Notice that eight of the parks are east of the Mississippi River.

WORLD SPEED RECORD SET FOR MOTOR HOMES. A Toronado-engined Tra-Voy, California-built motor home, was officially clocked at 97.613 miles per hour on El Mirage Dry Lake. The big fiberglass front-drive Tra-Voy, weighing about 9000 pounds, was equipped for actual camping duty with all beds, galley and bathroom facilities intact. Just what we need barreling down a two-lane mountain road!

NEW GMC LUXURY VAN ANNOUNCED. They call it the Rally STX and it comes in half, three-quarter and one-ton sizes. Completely restyled, the new GMC vans will offer wheelbases of 110 or 125 inches for all models, with larger bodies all around. A sliding right-side door and choice of three engines are available. Largest engine for the STX is the 350-cu.-ft. V8.

USED COACHES HOLDING TOP RESALE VALUE. One California dealer reports he can get up to 85 percent of new-unit cost out of used motor homes, up to 75 percent out of used travel trailers and tent-trailers, and up to 70 percent out of van-conversions and pickup campers. Toughest to find: clean, used luxury motor homes. A used 22-foot Winnebago that sold new for about \$10,000 two years ago recently resold in used condition for \$8500! All coach dealers contacted indicated trouble finding enough clean *used* trailers, campers and motor homes to satisfy the demand.

RECREATIONAL-VEHICLE CONDOMINIUMS SPREADING. Typical model is in Waterville Valley in New Hampshire's White Mountains. Instead of renting a site by the night, you can *buy* your space. Owners collectively pay for maintenance. The advantages include instant availability of campsite at all times—and you can *rent out* your space during periods of nonuse. Neither public nor private, such condominium campgrounds will be operated much like country clubs. But instead of luxury hotel bungalows, you bring your own camping vehicle.

PARK RANGERS PACKING GUNS? Yes, that's the status in some national parks during hours of darkness. Tremendous crowds of campers packed together cause many frictions and, to preserve tranquility, a show of force is sometimes necessary. The old one-man park is a thing of the past. Rangers are considering adding full-time security men to patrol duty. As one ranger put it: "It isn't so much the campers we worry about—but the *punks* who cruise through the perimeter after dark looking for easy pickings."
★★★



"I Earn Two Incomes Now"

Says **JOHN BENNIE, Pittsburgh, Pennsylvania**
"Thanks to your wonderful training, I have been able to earn \$20 to \$25 extra each and every week doing little locksmith jobs at home and after work at my regular job. This is the best trade a man can take up."

Be a LOCKSMITH

Train at HOME—Earn While You Learn. Add 50%-100% to YOUR INCOME with easy spare time earnings. Cash in on the nation-wide shortage—trained locksmiths in great demand! Quickly step into a big pay opportunity job or start a high-profit shop of your own.

Earn Extra Money RIGHT AWAY! All Master Locksmiths Special Tools, Equipment and Supplies Furnished FREE for use with course.

Age, education, minor physical handicaps don't matter in this growing trade. You can quickly qualify as a skilled locksmith. It's like a fascinating hobby. Study at home as little as one hour a week. Gain practical experience through complete well-illustrated lessons. Do real jobs on car locks, house locks, padlocks and safe locks, under the guidance of experts. FREE Illustrated Book, write NOW.

LOCKSMITHING INSTITUTE,

(Div. of Singer Communications Corp.)

Dept. 1110-090 • Little Falls, New Jersey 07424

MAIL
COUPON
for FREE
ILLUSTRATED
BOOK

For a future as your own boss or in a high-pay job, write now for FREE Illustrated Book. Only school of its kind. Licensed by State of New Jersey. Approved for Veterans.

306
pieces of professional equipment
FREE
for use with course.

Professional Equipment includes
LOCKS—PICKS—PARTS—KEYS
SPECIAL TOOLS & SUPPLIES
all FREE for use with course.

Accredited, Nat'l Home Study Council.

MAIL COUPON NOW

LOCKSMITHING INSTITUTE, Dept. 1110-090
Little Falls, New Jersey 07424

Please send FREE Illustrated Book—"Your Big Opportunities in Locksmithing," complete Equipment folder and sample lesson pages—FREE of all obligation—(no salesman will call).

Name _____

Address _____

City _____ State _____ Zip _____

AFTER ONE HOUR'S WORK

Your Typewriter is now like new! I'll send a bill for the \$25.



This Can Be YOU Sooner Than You Think!

BECOME A TYPEWRITER MAINTENANCE EXPERT

Quickly—Easily—At Home without risk!

Earn \$50 for 2 hours in your spare time, get a big pay position with a future or, start your own business.

There is a critical shortage of technicians to keep America's 30 million typewriters in repair. Now, regardless of age, education, or present job, you can enter this big-paying field by training in the Office Equipment Industry's only Approved Home Study Course.

Learn fast, and earn money while learning. Diagrams, photos, clear lessons, professional tools, plus benchwork assignments on actual typewriter that we give you, make learning easy.

Send name today for FREE BOOKLET telling of your opportunities in this profitable vocation. Full information, no obligation. No salesman will call. (VA Approved.)

Royal Typewriter for practice given you



PLUS ALL YOUR PROFESSIONAL TOOLS FREE!



MAIL COUPON FOR FREE BOOKLET

Typewriter Repair School, Dept. 3110-090
Little Falls, N. J. 07424

Please rush Booklet entirely FREE. No obligation. No salesman is to call.

Name _____

Address _____

City _____ State _____ Zip _____

Big Profits in UPHOLSTERY Get Your Share... FAST!

EARN BIG MONEY 3 NEW EASY WAYS

FREE Deluxe Illustrated Book and Sample Lesson Pages

1. Be your own boss, make up to 85% profit.
2. Start earning right away at home in spare-time—keep furniture you make, or sell for hundreds of dollars.
3. Today's home and office upholstery, re-upholstery, slipcover boom make it easy to take your pick of big-pay jobs.

LEARN FAST—EARN FAST

You get expert instructions, plus all tools, new wooden frames, materials, fabrics, business tips, wholesale privileges, decorating magic AT NO EXTRA CHARGE. FREE Book, sample lesson pages show you how—no obligation—no salesman. Write TODAY.

UPHOLSTERY TRADES SCHOOL

Division of Singer Communications Corporation
Dept. 5110-090 Little Falls, New Jersey 07424
(N. J. State Approved. Accredited Member National Home Study Council. Vet Approved.)

Tools, Equip., Frames, Materials, Fabrics, Supplies yours with course.

MAIL COUPON TODAY

Upholstery Trades School, Dept 5110-090
Division of Singer Communications Corporation
Little Falls, New Jersey 07424

ESTABLISHED 1939

Please send me FREE book, "Your New Way to a Successful Career," and FREE sample lesson pages. No obligation—no salesman will call.

Name _____

Address _____

City _____ State _____ Zip _____

Does your car need a good laxative?



GO GUM, the laxative for cars.

GO GUM works while you drive to remove sludge from carburetor and fuel system. Keeps engines "regular." Quality guaranteed; only 99¢.

GO GUM... from the makers of HEET gas line anti-freeze. **DeMert**

DeMERT & DOUGHERTY, INC./5000 W. 41st Street/Chicago, Illinois 60650

THIS IS IT!!!

Now you can give permanent new beauty to any sound floor (tile, wood, concrete) . . . in one day or less! Roll-on amazing 1-2-3-Floor for a long-lasting gloss finish that never needs waxing, won't scuff or dent. Apply it wall-to-wall seamlessly . . . choose from wide range of colors to match your decor. Perfect for counter tops, tables, walls, too. 1-2-3-Floor goes on easy as 1-2-3:

1. Apply base coat on pre-cleaned floor with roller (or brush).
2. Apply clear plastic, sprinkle on decorator chips and seal with another coat of clear plastic.
3. Lightly sand, then finish with final coat of clear plastic.



Ask your hardware dealer or write **TOP LINE DIV. OF DATEY CO.** Cleveland, Ohio 44135



TUNGSTEN CARBIDE ARMORED

Guaranteed to cut at least a half mile of 2 in. construction lumber before dulling.

New concept—Swedish saw steel with thin layer of tungsten carbide electronically alloyed to teeth—can't chip off. May be resharpened if necessary. Crosscut and rip comb. 1/2 and 3/8 arbor.

6 1/2"	\$3.49 ppd
7"	\$3.65 ppd
8"	\$3.95 ppd

EM/TEK TOOLS Dept. A B
4181 N. 124th St., Brookfield, Wis. 53005

TREASURE & COIN DETECTOR

MONEY BACK GUARANTEE

New electronic detector penetrates deep into earth to locate gold, silver, coins, minerals. More penetrating power than ever before. Sensitive enough to locate a single coin or small nugget. Works through earth, wood, vegetation, water, rock, etc. Not a "probe" type but a fully electronic detector that is guaranteed to have at least twice the detection ability of any detector in this price range or return in 10 days for refund. Uses inexpensive 9V battery. Fully transistorized. Weighs only 2 pounds. Loudspeaker signals when object is detected. Has plug-in earphone for treasure hunting in privacy. **NOTHING ELSE TO BUY!**



29⁹⁵
per unit

Comes complete, ready for operation. Shipping container has compartments for detector and all accessories, serves as a carrying case. Send only \$29.95 check, cash or M.O. for postpaid shipment or \$2.00 and pay \$27.95 plus small C.O.D. when delivered. Viking Detectors, Dept. V-2, Box 10880, Houston, Texas 77016

BUILD REFINISH RESTORE

... anything of wood

LET Constantine's picture-packed Catalog-Manual help you build new furniture—help you restore and refinish beat-up cabinets, chairs, chests, tables. Find instantly whatever you need. Newest materials plus plans, instructions. Largest selection of beautiful woods. Specialty tools. Products not found in stores or by mail elsewhere. *Unsurpassed values.* Send for vast, illus. catalog NOW!



2,000

Tear out ad. Mail with 25¢ for vast new CATALOG Plus New "101 Project Ideas"



CONSTANTINE
2051 Eastchester Rd., Bronx, N.Y. 10461

CRAFTSMAN PRODUCTS
Woods—Veneers—Inlays
Newest Workshop Tools
Wood Finishes—Moldings
Carving Woods & Patterns
Cane Kits—Lamp Parts
Hard-to-find Hardware

WHAT'S HE DOING?

Making a Concrete Flower Pot! . . . and **SO CAN YOU!**

Make and sell your own Ornamental Concrete items. Rush \$2.00 for book about Aluminum Molds with prices and production trade secrets direct from world's largest mold manufacturer. Over 350 designs to select from.



Send **\$2.00** **CONCRETE MACHINERY COMPANY**
Today To ➔ P. O. BOX 99 • HICKORY 2, N. C. 28601

You can become part owner in a portfolio of more than 120 U.S. Corporations for \$20 a month.

Investors Stock Fund is a mutual fund that owns securities in more than 120 U.S. corporations.

It is designed to give you both long-term capital gain possibilities and reasonable income consistent with capital gain objectives.

By using our Investors Accumulation Plan, you can now buy Investors Stock Fund for \$20 a month.

This fund is distrib-

uted only by IDS® (Investors Diversified Services).

IDS is also the exclusive distributor of five other mutual funds and Face Amount Certificates. For free prospectuses (information booklets) mail the prepaid coupon today.

Your IDS man also offers Self Employed Retirement Plans-Keogh Act. Life insurance plans also available.



Investors Diversified Services, Inc.

Investors Building, Minneapolis, Minn.

MOD I snowmobile kit \$379

Here it is! A sporty family snowmobile in easy-to-assemble kit form for only \$379 complete. MOD I is safe for any member of the family to ride, yet zips along at speeds up to 30 m.p.h. Great fun to build in your spare time. Enjoy the fun of snowmobiling for less than half the cost of other machines.

Freight Prepaid

Mail to:

Snow Kits
P.O. Box 8169
St. Paul, Minn.
55113



Please send me complete information on the MOD I snowmobile kit.

PM-9

Name _____

Address _____

City _____ State _____ Zip _____

"LISTEN IN" TO POLICE-FIRE RADIO CALLS IN YOUR CAR!

WORKS with ANY CAR—Portable or HOME RADIO! Just PLUGS In—No wiring—3 minute hookup! Switch instantly from regular to ALL POLICE-FIRE-EMERGENCY-COMMERCIAL-TAXICAB-STATE-CITY-GOV'T 2 way Radio calls in YOUR AREA. DUAL-HI-LOW BANDS—OVER A MILLION Radio Cars/stations. USE Everywhere—anytime—always works!

SEND ONLY \$2.00 (cash, Ck., M.O.) and pay post-man \$7.99 plus COD postg or send \$9.99 for ppd Del in USA. COMPLETE, ready to use with instructions. One Year service Warranty—10 DAY MONEY BACK TRIAL (if retnd). AMAZING OFFER good only by mail—WESTERN RADIO Dept. BPM-9 KEARNEY, NEBR. 68847



You can make money in

WATCH REPAIR

Learn at home the low cost Sweazey Way

Watch repairing pays up to \$6 an hour, part time watch makers report on survey. Unique and modern Sweazey home study System starts you making repairs right away on Swiss and American watches. Professionally prepared training. No previous experience needed. Special tools provided for practice. Diploma Awarded. Free sample lesson and opportunity book give all facts. Write today. No obligation.

CHICAGO SCHOOL OF WATCHMAKING
Dept. 190 Fox River Grove, Illinois 60021

FREE BOOK and SAMPLE LESSON

CHICAGO SCHOOL OF WATCHMAKING
Dept. 190 Fox River Grove, Illinois 60021
Please rush FREE BOOK and Sample Home Study Lesson.

Name _____ Age _____

Address _____

City _____ State _____ Zip _____

MADE IN OHIO BY ROBOTS

(Continued from page 83)

system. Five separate articulations provide up-down, in-out and rotary motion from a central pivot point and, at the outer arm, a bending and swiveling motion. The arm can pick up an 80-pound item and move it anywhere within a 350-cu.-ft. working area with an accuracy of 0.050 inches. It can reach from three-and-a-half to seven-and-a-half feet and rotate 220°.

"Unimate is taught a job by leading it manually through the required motions, establishing the work program in the machine's memory. The work program can also be fed into the machine via paper tape. Up to 180 sequential commands can be employed in a program. The memory receives information from machinery as it works and makes limited decisions based on incoming information. It can also issue commands and control operation of other machines."

There's more. Unlike some "dummy" equipment used by automakers, Unimate is not a single-purpose robot. It can be fitted with a practically endless variety of hands, fingers and gripping surfaces for grasping and holding objects. Power tools can be substituted for fingers without dismantling the unit's "hand."

Unimate is a quick learner and equally quick at forgetting. An old program can be erased instantly by pressing a button and leading the machine through a new series of motions—and so be able to work on any number of models or body styles.

The GM robots are incapable of turning out an inferior job. There's no chance for error as there is with humans. If something goes awry, the machine will send out an SOS or shut-down the line. It will not allow a botched job to slip through.

The slave machines can work 24 hours a day, seven days a week. No coffee breaks, no lunch hour, no vacations. GM says it doesn't know how long the equipment will hold up under a nonstop schedule, but it intends to find out. The company that makes the robots says they will average 600 hours mean time between failures.

Lordstown will be getting into full swing just about the time you read this, hence GM doesn't have any solid figures on how many cars can be turned out using the new equipment. Preliminary studies indicate a production capability of at least 100 cars an hour. GM normally considers a run of 50 to 60 cars an hour absolute tops. But PM believes GM is understating the case again in forecasting maximum output of 100 vehicles an hour. Our information is

(Please turn to page 206)



Let's Do LEATHERCRAFT!

HERE'S A GENUINE LEATHER BILLFOLD KIT AS A STARTER

WORTH \$5.00 AFTER YOU ASSEMBLE AND LACE!

ONLY

50¢

with coupon below

ONLY 50c IF YOU ACT NOW!

3 1/2" x 9 1/4"

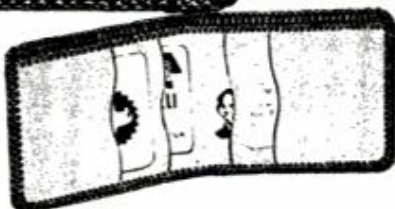

Get all the features of expensive billfolds! Handsome design already embossed . . . has 4 roomy pockets. Kit complete. Easy n' fun to assemble and lace. You'll also receive a big full-color Leathercraft Idea Catalog and Instruction Manual showing other valuable things you can make from genuine leather.



1001 Foch, Dept. MB, Fort Worth, Texas 76107

Yes, send me your embossed billfold kit and big Idea Catalog and Instruction Manual. I'm sending 50¢ as full payment. (Limit one per family.)

NAME _____

ADDRESS _____

CITY _____ STATE _____ ZIP _____

ENROLL—EARN YOUR DEGREE

of Bachelor of Bible Philosophy (B.Ph.B.), Master of Bible Philosophy (M.Ph.B.), Graduate of Bible Philosophy (G.Ph.B.), Doctor of Metaphysics (Ms.D.), or Doctor of Divinity (D.D.). Chartered by State, Correspondence Courses only. Please write for FREE BOOKLET.

AMERICAN BIBLE INSTITUTE

Dept. PM, Post Office Box 8748, Kansas City, Missouri 64114

FREE BOOK

THE MILLIONAIRE BOOK of Businesses, Plans and Know-how sent free of cost to you. Get case histories of how 999 other men and women have broken out of their ruts—found success—became independent—many found wealth.

SEND NO MONEY—GET FREE BOOK

Send me only your name and address. I'll prove you can set up your business in sparetime at home. Invest under \$10.00 on a money-back guarantee. Let us take all the risk. Write me today.

SMALL BUSINESS Consultant
DIV. 20, KERRVILLE, TEXAS 78028

"\$7,108.50 First Year SERVICING RADIATORS!"

— Hank Konter, Newcastle, Wyo.

Make good money servicing auto-truck-tractor radiators with new Inland 1-Piece Radiator Shop. Easy to test-clean-repair radiators. Inland, world's largest radiator equip. mfr., trains you free. Small down payment starts you. Easy-pay plan lets you pay from profits. Proved merchandising assures volume. Profitable dept. for garage or service station. WRITE for Free Book. INLAND MFG. CO., Dept. PM91108 Jackson St., Omaha 2, Nebr.



NEW!

At Last a New Amazingly Simple

GAS TURBINE JET ENGINE

Build from easy to follow plans. Length 15", Dia. 8 1/2", Wt. 15 lbs. Fuel: Gasoline or Kero.

"Screamin Demon" develops 20 H.P. Ideal project for serious-minded hobbyists, students; scientific and industrial arts classes. Make on 9" metal cutting lathe with milling attachment. For use on small racing boats, midget cars, etc. Full size assembly drawings with critical dimensions, bill of materials and photos. Price \$5.00. No C.O.D.

SAVOY SCIENTIFIC, BOX 1398, SANTA MONICA, CALIF. 90406



Wedgewood

one of the world's fine pipe tobaccos imported . . . fresh from Canada . . . ask for it



Whether you prefer an English Mixture blended with Latakia and Perique or a Full Aromatic Caven-dish blend, you'll discover Wedgewood to be a supreme quality pipe tobacco. Available wherever fine tobaccos are sold . . . ask for it!

Send for free sample PM-9-70

To: Orens Universal Inc., P.O. Box 5835, Sherman Oaks, California 91413

English Mixture Aromatic

Name _____

Address _____

City _____

State _____ (Zip) _____

think mailboxes

personalized FREE

Series 700 is made of heavy-gauged aluminum and comes in a variety of gold, black, and natural combinations. See display at your Hardware or Building Supply Dealer.



MACKLANBURG-DUNCAN CO.

BOX 25188

Our 50th year. Oklahoma City, Okla. 73125 U.S.A.



ALVA ALLEN Power Punch Presses

1 to 100 Ton Capacity

Complete line of Punch Presses in hundreds of different style and model combinations. Write for FREE literature on presses and complete line of punch Press accessories as—Feeds, Punch Units, Dies, etc.
Alva Allen Industries, Dept. PM, Clinton, Mo. 64735

\$156.40
fob less
Motor

This Is THE Lock



If You LIKE it . . . LOCK it!
Remember THE Name . . .

Slaymaker

LOCK CO. LANCASTER, PA. 17604

MADE IN OHIO BY ROBOTS

(Continued from page 204)

that Lordstown rev up to 110 to 115 cars an hour—almost two a minute—without straining either men or machines.

One reason GM is proceeding so cautiously in the use of Unimates—aside from not wanting to step on the toes of the union—is that it has no bank of experience with industrial robots. The handbook GM executives live by requires that every angle, every contingency, every plus, minus and maybe be weighed before making a decision. And GM still has a lot of questions about robots.

Although Fisher Body has had experience with robot welders at another Ohio plant, in Norwood, many of the decisions GM has had to make at Lordstown have been based on information obtained from the company that created Unimate. GM doesn't question the accuracy of this information. But it believes there's no substitute for firsthand experience.

Despite the questions dangling in the air, GM is committed to the concept of robotizing more operations in more of its plants. Months before the first Vega came off the line at Lordstown, Fisher Body had already developed a second-generation version of Unimate.

Fisher calls its offspring "SAM"—short for Six-Axis-Manipulator. SAM is a one-arm automatic welder. It can maneuver a welding gun or other tool through extremely complex motions and find its way into relatively inaccessible areas with what Fisher describes as "great accuracy and speed."

SAM can move in six directions—longitudinal up-down, in-out, bend, swivel and rotate. The machine has a logic panel consisting of a magnetic core for storing program information and integrated circuitry to pass and compare command and encoder information. It can store 510 commands over 10 different programs.

SAM learns the same way Unimate is programmed—by inching the machine through the movements of the work program. SAM can tell the difference between different body styles—a four-door and a two-door, for example. Switches brushing the surface of the car body as it comes down the line alert the robot to what the next vehicle will be and SAM automatically changes the welding sequence to match up with the car.

Fisher has a working model of SAM and is building 14 more. The division won't say where they'll be used except that they will go in GM plants.

SAM's edge over Unimate in I.Q. may

(Please turn to page 208)

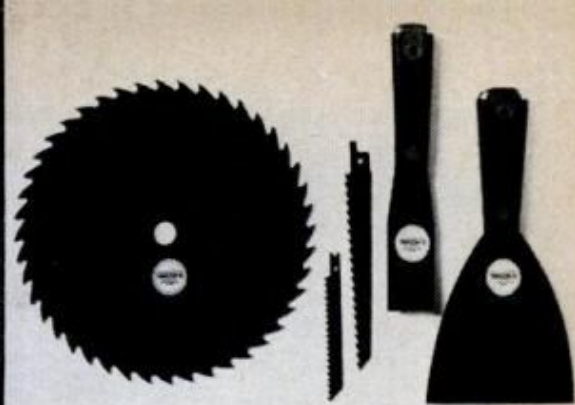

What you'll like about tools coated with TEFLON-S* is the sharp cut—in your work.

Any saw, hand or power, that's coated with no-stick TEFLON-S glides so smoothly through green wood, wet spots, knots or bad runs of grain—you'll swear it was just sharpened. Industrial strength TEFLON-S makes the blade friction-free and abrasion-resistant. There's no grab, no bind. Nothing sticks to it. You can feel a hand saw gain momentum in your hand. And power saws last longer, because TEFLON-S reduces the drag on motors. TEFLON-S is self-lubricating too. Rust can't get a grip because moisture runs off.

You can also get wood planes, wall scrapers, putty knives, linoleum knives, taping knives and other tools—all coated with TEFLON-S. They save you work, and time. And tool maintenance.

Look for the TEFLON-S quality seal at your store. It's on the best tools you can buy.

*Reg. U.S. Pat. Off. for Du Pont's non-stick finishes.



Better things for better living
...through chemistry



MOST FLYING FUN — AT LOWEST COST!

Get in the pilot's seat of your own personal Bensen Gyrocopter and go aloft when you like—high and fast or low and slow. Pros and beginners alike praise it as the greatest thrill in flying. Wheels interchange with floats or snow skis for extra fun. Costs no more to operate than a car. Designed for building with ordinary hobbyshop tools. Make your first move now—send \$5 for Copter (\$3 for Glider) colorful "Info Packet", with 3-View Drawings; General Specifications; Design and Piloting Information; Construction Hints; in-flight photo; 6-page "Bulletin" with numerous pictures plus descriptions of Plans, Kits, Engines; Condensed Price List . . . and a Certificate for \$5 (or \$3) toward the purchase of Construction Plans.

SEND **BENSEN AIRCRAFT CORP., Dept. PM-90**
 \$5 RDU Airport, P. O. Box 2746, Raleigh, N. C. 27602
 OR NAME _____
 \$3 ADDRESS _____



GI APPROVED
 For Home study or Resident School!

Be a Dental Technician

LEARN AT HOME! Course Includes Tools, Supplies and Materials

- Spare time home study leads to high pay profession!
- Work for dental laboratory, dentist or open own shop!

Since 1925 we have trained thousands of young men and women to make and repair dental plates, crowns, bridges, etc. Lack of high school education no barrier . . . shortage of skilled workers opens door to fabulous opportunity!

Mail Coupon Now For Illustrated Brochure

McCARRIE SCHOOL OF MECHANICAL DENTISTRY
 132 N. 12th Street, Philadelphia, Pa. 19107

I would like to be a Dental Technician. Please send me full information without obligation.

Name _____
 Address _____
 City _____ State _____ Zip _____

5-in-1 MINIATURE MACHINE SHOP

UNIMAT

VERSATILE UNIMAT converts from precision lathe to vertical mill, drill press, grinder or polisher. Easy to use. Make all small precision parts—for models, guns, cameras. Inventions \$149.50, ready-to-use. Send for free details (Available in Canada.)



AMERICAN EDELSTAAL, INC DEPT BI-0, 1 ATWOOD AVE., TENAFLY, N J 07670

MADE IN OHIO BY ROBOTS

(Continued from page 206)

be short-lived. Unimation, Inc., is already at work on an anything-you-can-do-I-can-do-better version of its machine—a robot with eyes! Up to now, the part a robot picks up and the area where the piece is to be placed has to be locked in a fairly rigid position, so the machine can find its work. Unimation has a big brother to Unimate under development that will come with a TV scanning device, enabling the machine to "see" its work.

Will there be more Lordstowns? More robots taking over from men? Or will the Auto Workers Union force the car companies to make an antirobot reassessment of plans?

The UAW's position is not antirobot. The union is against its members being thrown out of work as a result of machines taking over. But if workers can be shifted to other jobs at the same pay, the union has no objection. The late Walter Reuther, long-time president of the UAW, went so far as to say that certain jobs in the auto factories are so arduous, mentally enervating and degrading to humans that they should be robotized.

A don't-quote-me-by-name source at GM notes that in every instance where GM has introduced automatic equipment into its plants, the company still has the same number of employees on the payroll as it had premechanization. Workers have been absorbed in other jobs, frequently at higher pay.

Another pro-labor source, an economist for the AFL-CIO, predicts that if the nation's robot population climbs to 50,000 by 1975—that's 50,000 for all the industries, not just the auto firms—the machines would constitute only two-tenths of one per cent of the country's total labor force. The people who make robots forecast a machine labor crew of 5000 by 1974. They don't see robots reaching the 40,000 to 50,000-unit level before 1980.

Finally, an official of Unimation points out the rate at which robots are entering industry is substantially lower than the normal attrition rate for humans.

The auto companies are always too occupied with now and tomorrow to reflect on yesterday or the day before. They lack a sense of the historical importance of day-to-day developments and seldom put up plaques or markers as reminders of events and achievements scored along the way. But if the industry ever pauses long enough to put up a tablet marking the site where the robot served his apprenticeship in auto-making, it will be at GM's plants in Lordstown. ★★★

POPULAR MECHANICS

How to get rich

How can you get rich some day? Make a hit record . . . a killing on the stock market . . . or invent a gadget like the hula hoop?

For most of us, these are just dreams. But have you ever stopped to think that there is a way to get rich—possibly only one sure way? Most fortunes, as you know, are made by people who own their own business.

Perhaps you've thought of starting a small business of your own . . . a franchised drive-in, or maybe a service business. Trouble is, you need \$10,000 to \$15,000 to get started and even then it's a gamble—with slim chances of ever making really big money.

But there is *one* business which could make you rich—almost overnight! And the beauty of it is, you can start on a shoestring during your spare time, even while holding your regular job.

Cash by Mail

The business is Mail Order—and it's fabulous! Come up with a 'hot' new item . . . and WHAM!

It strikes like a bolt of lightning! Suddenly, you are deluged with cash orders from all over the country . . . MORE MONEY than you could ever make in a lifetime!

Like the Vermont dealer who ran one ad in Sports Afield Magazine. His ad pulled 22,000 orders—over A HALF MILLION DOLLARS IN CASH!

There is no other business where you can make a fortune so quickly!

● A beginner from Newark, N.J., ran his first small ad in House Beautiful—offering an auto clothes rack. Business Week reported that his ad brought in \$5,000 in orders. By the end of his first year in Mail Order, he had grossed over \$100,000!

● Another beginner—a lawyer from the midwest, sold an idea by mail to fishermen. Specialty Salesman Magazine reveals, "he made \$70,000 the first three months!"

Proof

It's a fascinating business! Running ads in newspapers and magazines . . . mailing gift catalogs . . . getting cash orders in your daily mail—steady as clockwork.

There is no other business where you can start on a shoestring and pyramid your profits—without investing in merchandise! One husband and wife mail order team took in \$40,000 selling one item. They obtained FREE ads in national magazines . . . didn't invest a cent in merchandise, and even got the supplier to ship all orders for them!

These exceptional cases are absolute proof that you can get rich in your own Mail Order business. Very rich. Even a U.S. Gov. Report stated: "A number of

one-man Mail Order enterprises make up to \$50,000!"

Pick up any magazine. Notice how the same mail order ads are repeated . . . month after month? That's concrete proof! You know those ads wouldn't be repeated over and over again—unless they were bringing in big cash profits to their owners.

The Secret

The secret of getting rich in Mail Order lies in *financial leverage*. It's a little-known, almost secret method—using other people's capital to make money for you!

You can get thousands of dollars worth of advertising in big national magazines—without investing your own money! And you don't have to write a single ad. Tested and proven ads are prepared for you by experts. Reinvest the profits from your first successful ad—to get more, larger ads, and the profits begin to snowball! It's like building a chain of stores . . . each new store puts more money in your pocket.

You mail out beautiful catalogs which offer hundreds of dollars worth of fine, quality gifts—yet you don't invest one



The thrill of receiving money in your mail is one you'll never tire off!

cent of your own money in merchandise! Your catalogs are printed with your name and address, so all orders come to you. Everything is "drop-shipped" for you, and there's up to 100% mark-up! You pocket the cash profits immediately—even before the orders are shipped to your customers!

Repeat orders alone, just from mailing catalogs, could bring you a steady income for the rest of your life!

Yes, Mail Order is the fastest-growing, most profitable business in America! And now, with more people moving to the suburbs . . . the population explosion . . . and the expanding teenage market . . . we are on the verge of the BIGGEST BOOM in Mail Order history!

Now, with the help and backing of Mail Order Associates, Inc., of Montvale, N.J., you can follow the same proven steps to Mail Order success—using the 'secret' of financial leverage!

Start Now

We supply you with beautiful gift catalogs throughout the year. All products are dropshipped for you, with up to 100% mark-up! You get free samples of top-selling mail order items, plus monthly trade reports on 'hot' new products . . . tested, successful ads are sent to you monthly. You get advertising directories, postal laws, complete courses, expert guidance—EVERYTHING you need to practically guarantee YOUR SUCCESS. Why? Because *our* business depends upon your success. It's mutually profitable!

A recent feature article in Income Opportunities Magazine stated, "Mail Order Associates Inc., offers the most comprehensive Mail Order program ever offered to beginners." They go on to say, "This could be the opportunity you've been looking for. A chance to get in on the ground floor in a little-known business which we believe is on the verge of a new boom."

Free

We are now accepting a limited number of charter members in our new Mail Order Program. No previous experience is required but you must be over 21.

If you are sincerely interested in starting a profitable business of your own . . . if you can see the tremendous advantages which Mail Order offers . . . then ACT NOW!

Mail the coupon today, or simply send your name and address on a postcard. No salesman will call. We will send you a free book—gift catalog, reprints of feature articles, plus complete facts about our program. Write to:

Mail Order Associates, Inc., Dept. 285
Montvale, New Jersey 07645

Rush Coupon for
FREE BOOK!

plus reprints of
Mail Order
articles

Mail Order Associates, Inc., Dept. 285
Montvale, New Jersey 07645

Please rush complete details on your Mail Order Program. I understand everything is free and there is absolutely no obligation. I am over 21.

Name

Address

City..... State..... Zip.....

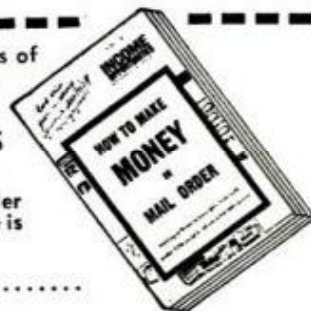



WITH A FRIEND HELPING, author knocked out windows in one day and had the room closed in by sundown. Opening was stripped down to the wall studs before any rebuilding was started. For safety, keep the work area free of debris



ROUGH OPENING is measured for new framing (left); exterior sheathing is applied next. Small opening in background (right) is framed for windows, which go in next. Windows here were installed with one stud between them



WINDOW INSTALLATION is simple; plastic "fins" that you insert into the side jambs are provided with holes for use in nailing to sheathing. To prevent leaks, felt is stapled over the fins. Clapboard, which follows, finishes exterior

PORCH TO FAMILY ROOM

(Continued from page 158)

mullion was covered with a shop-made molding.

All framing for windows and the recessed radiator was accomplished in one day with the help of a friend. I completed the balance of the job over four weekends.

Walls. The original plaster walls were left intact. In the holes created by the new framing, insulation was installed between studs and then plasterboard was applied. To bring the plasterboard flush with the existing walls, it was necessary to shim the face of the studs about $\frac{3}{8}$ in. As shown in photos of the exterior, the holes were covered with $\frac{3}{4}$ -in. sheathing, 15-lb. felt and clapboard. Finally, in the crawlspace below, insulation was installed between joists. This completed the rough construction.

The wall finish selected was Cambridge Red Antique hardboard paneling, which sells for about \$10 per sheet. The material is also available in four other colors, each toned to match one of the popular antiquing kits on the market. (This makes it simple to finish the trim to a perfect match).

Since room height was just about $8\frac{1}{2}$ ft., I left the 1x6 baseboard in place and rested the panels atop. As they were cut, scraps were carefully placed aside for use on other parts of the job. All paneling was applied using a generous amount of adhesive and color-matched nails. Any mars or nail holes were filled with PanelTouch, a Masonite product that comes in tube rather than stick form.

The ceiling. This was in terrible shape, so I added furring strips and covered it with paneling. I picked up the cheapest V-groove plywood available (about \$3 per 4x8 sheet). After installing the panels, I sealed, primed and painted them white. The beams that cover the joints are 4x4 cedar that I "antiqued" (roughed with an adz). Beams are held in place by countersunk screws which are concealed by short lengths of doweling. To create a "half beam" look, 2x4s were used at both ends of the room.

Along both sides (length) of the room, I installed a 1x6 skirt (or apron) at the ceiling. Where it was necessary to butt two boards end-

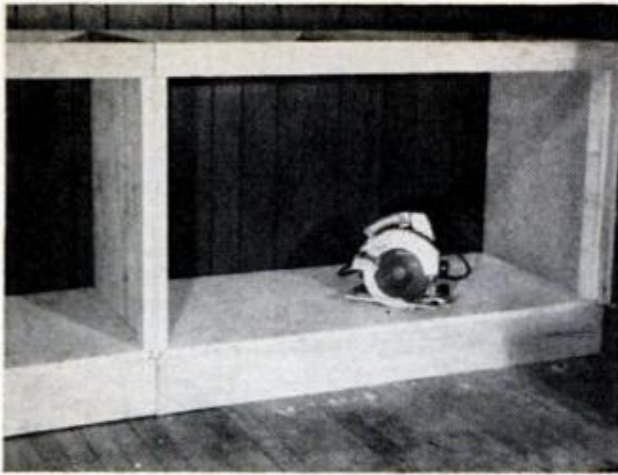

ENTERTAINMENT CENTER, framed almost entirely with $\frac{3}{4}$ -in. plywood, is built to suit width of room

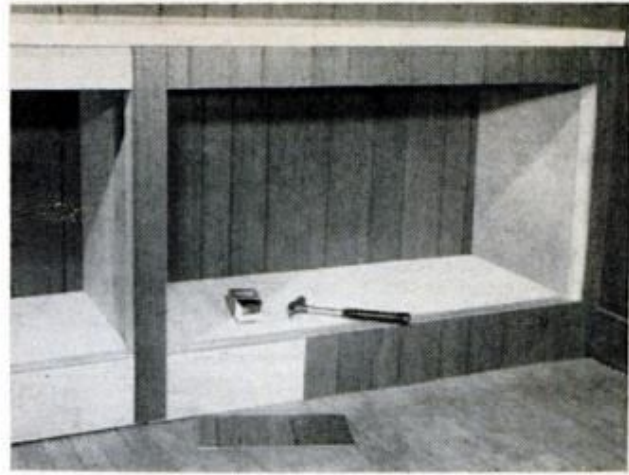

FACE OF UNIT was skinned with scrap paneling obtained from cutouts and applied with glue and brads

to-end, I invented a joint that would give an [Early American feeling](#) (see [skirt butt joint detail, page 159](#)). Dowels at these joints heighten the effect. Skirts were notched for the beam ends to rest on. To make the job go faster, all materials used for beams and skirts were stained and antiqued before installation.

Entertainment center. Now the busiest corner of the house, this built-in was challenging, but fun, to build. It is built in place and permanently fastened to the wall. The counter height is a standard 36 in. The deck and shelves below give ample storage for items such as records, games and photography gear. Sliding doors were used for a practical reason; swingers would have required clearance in the room, thus restricting furniture placement. Above the deck, four 2x12s (for economy, structural grade was used) were installed vertically to create shelf space. These were placed to give three

bays of equal width. At bottom, they rest on shop-made plates that were cut from exterior, 5/4-in. casing that was saved when the old windows were torn out. For appearance, their edges were shaped with an ogee cutter in the router. The verticals were simply toenailed at top into the ceiling, at bottom into the counter and at several points along the back edges into the wall. Before installing them, the grooves for the flush-type wall standards were routed. ★ ★ ★

CREDITS

Perma-Shield windows, Andersen Corp., Bayport, Minn.
 Recessed radiator, American-Standard, 40 W. 40th, New York.
 Hardboard paneling, Masonite Corp., 29 N. Wacker Dr., Chicago, Ill. 60606.
 Chateau doors, General Products Corp., Box 887, Fredericksburg, Va. 22401.
 Carpet, Ozite Corp., 1755 Butterfield Rd., Libertyville, Ill. 60048.
 Adjustable shelf hardware, Stanley Hardware, New Britain, Conn.
 Exterior nylon shutters, DuPont, 3301 N. Market St., Wilmington, Del. 19802.

ADJUSTABLE SHELF HARDWARE is let into routed grooves for a snug shelf fit. The bifold doors were actually designed for a closet, had unfinished backs. Strips of pine were cut to force-fit into channels, then the paneling was cut to suit, glued and nailed in place. Metal frame was finished with antiquing kit

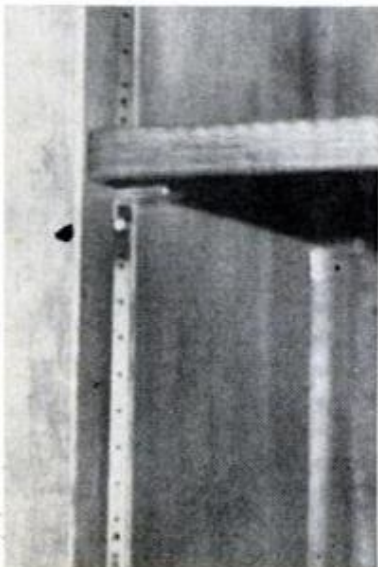

TOO FAST IN FOG

(Continued from page 89)

center steel guard rail. It now faced backward toward the home he had left not long before.

Trooper Winkler, helped by a few others, began searching cars near the propane truck, hoping firemen would arrive to cool it. He was afraid it would explode. He attempted to reach those in the burning cars but found it impossible to get close because of the fire. There was no hope of getting to the man and woman trapped in their cars.

Winkler knew they must be dead. As the fire rose he watched the truck cab become a skeleton of red-hot steel. Then the huge van's metal sides actually began melting away, revealing its cargo: three new diesel engines in big wooden crates. The crates were on fire.

Back in the fog a fourth truck, a big Mack tractor pulling a long rental trailer, shuddered to a safe stop in the right lane,

There was a shuddering collision . . . the car was rammed ahead far under the trailer.

air brakes whistling. Behind it came another truck, a White tractor from Maryland pulling a long van. Then a big Cabrini moving van pulled off on the shoulder and stopped.

Then through the fog came a sound like an explosion, and then another. Other collisions were happening . . .

Earlier, when the Blake family had come to a stop on the right shoulder, the young husband shouted: "Get out and run—quick! Get across the ditch and on the other side!" It was good advice. His family fled safely.

But when he opened his own door to get out, he was hit and hurled against his fender. Though injured, he ran to join his family. All hurried northward off the road.

"We were just trying to get away," he said later. They had gone some distance when the three trucks—the fourth, fifth and sixth to come along—made safe stops. Then, dimly in the fog, Blake made out a "long low vehicle" that was approaching and seemed about to stop, too. It looked like a truck, but actually it was the Pontiac Tempest from New Jersey with its U-Haul trailer. In the Tempest, an elderly couple named Matos were heading south.

Driver Matos stopped safely behind the fifth truck, the big White from Maryland. He sat in the car, as if wondering what to

do next when a seventh truck came along. The truck's brakes went on hard. Then there was a shuddering collision and the U-Haul trailer was hurled high into the air. The Tempest, with both occupants in it, was rammed ahead far under the trailer of the White truck from Maryland. Young Blake ran to help. When he reached the car he could see Mr. and Mrs. Matos hopelessly trapped in the crushed metal. Then fire broke out, fed by gasoline from the car itself, and soon the Matos couple was dead.

The truck that had hit the Matos car and trailer continued rolling. (A big gasoline tanker, badly damaged, was later found stopped just ahead on the left shoulder, but whether this was the truck is not known.)

Next came the young mother from Maryland driving a Pontiac station wagon carrying several children. She managed a safe stop on the left shoulder.

A couple from Georgia, also riding in a '66 Pontiac station wagon, approached in the left lane. When the husband saw the burning Tempest and U-Haul he started to pass, but his wife was afraid to go farther. He stopped. Then his car was rammed by a '66 Ford Fairlane from New Jersey. A fourth pileup had begun.

Now came a tractor-trailer from Massachusetts. It swerved left, probably in an attempt to miss the two cars that had just collided. It ran on the shoulder and stopped inches from the Maryland station wagon with the children in it. In making this maneuver, the Massachusetts truck may have partly run over still a third Pontiac, a '68 Bonneville from Connecticut. The Bonneville, squeezed off the road, was found jammed against the steel guard rail and part way under the Massachusetts trailer. This, as counted by U.S. Highway Safety Bureau investigators, was the nineteenth collision in 20 minutes.

And suddenly it was all over. The fog, heated by fires in several vehicles, was thinning. Troopers had stopped all traffic at last. Firemen had arrived and were pouring water on the hot propane truck to keep it from exploding.

And a shaken Trooper Winkler now surveyed 380 feet of highway devastation. Six persons were dead. Four motorists had been trapped under trucks and burned to death. A fifth had burned to death in a fiery collision to the right of the propane tanker. The sixth death was that of the propane tanker's driver. Twenty cars were demolished, six trucks destroyed or damaged. The pavement was so badly damaged that it would have to be repaved.

Winkler looked at the trail of wreckage;

(Please turn to page 214)

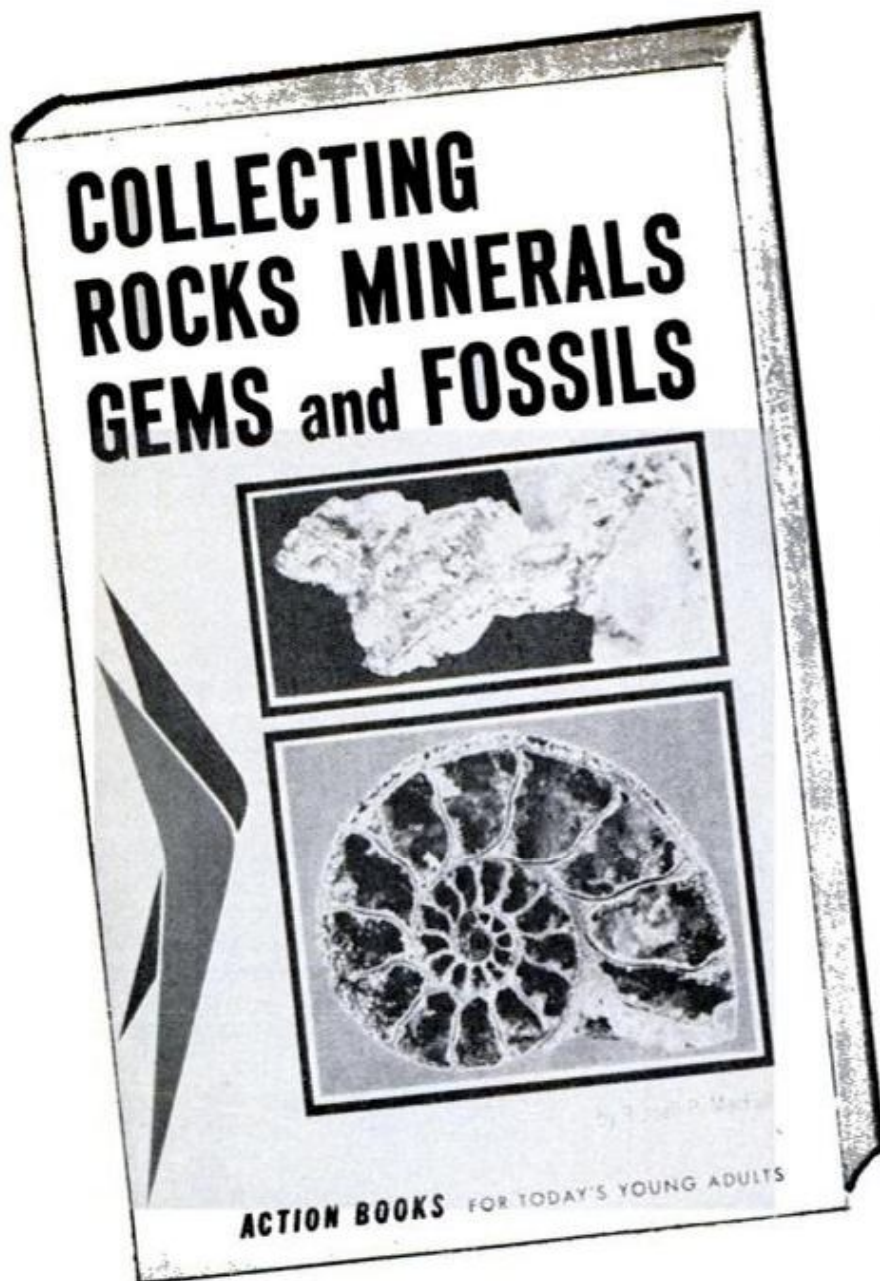

**A MUST . . .
AT ONLY \$4.95**

**. . . FOR THOSE WHO HAVE
BEEN CAUGHT UP IN THE
FASCINATING HOBBY OF
COLLECTING ROCKS, MIN-
ERALS, GEMS AND FOSSILS.**

- This 156-page book not only investigates the science of geology, but how the rockhound can apply this knowledge to more specific areas of the field.
- Here the reader will find where to look for certain specimens; how to identify and classify them; and how to display them to best advantage.
- The many identification charts and tables will give the reader a clear picture of the scientific approach to rock collecting.
- This wonderful book offer from POPULAR MECHANICS will introduce you to a new and interesting hobby which becomes more intriguing as you go along. SO, DON'T WASTE ANY TIME . . . ENCLOSE YOUR CHECK OR MONEY ORDER WITH THE COUPON BELOW AND MAIL TODAY.

Mail to Books, Department HSM, POPULAR MECHANICS, 224 W. 57th St., New York, N.Y. 10019 HSM

Please send me () copies of COLLECTING ROCKS, MINERALS, GEMS AND FOSSILS postpaid at a price of only \$4.95 each. My check () money order () is enclosed.

Name.....

Street Address.....

City..... State..... Zip Code.....

TOO FAST IN FOG

(Continued from page 212)

it was a monument to the folly of driving in superhighway fog. And it was something more: *A warning of tremendous disasters to come unless drivers, officials and truckers work together to find a solution.* Ironically, the Turnpike disaster came at a time when the trucking industry was pressing hard in Washington for permission to run wider and longer trucks on the highways.

As the fog cleared, Dr. Jaffee recovered consciousness. He found himself stumbling in the grass far beyond the northbound side of the Turnpike. He saw the wreckage, the smoke and fire, the people running. He heard the screams. It was last year all over again, but this time he was in it and hurt. He slowly found his way back to the lump of metal that had been his new blue car. He probed in it, found the small box with the denture, and carefully tucked it into a pocket. Its recovery, oddly, gave him comfort. ★★★

ATOMIC POWER FOR YOUR HEART

(Continued from page 107)

to a normal "beat." Electric pulses produce the necessary 70 or so heartbeats a minute by adding a pulse generator to a power source—truly a miracle in a battery.

There are two types of pacers—myocardial and transvenous. The *myocardial*, rapidly losing favor, requires major chest surgery to expose the heart so the surgeon can sew the electrodes to its surface. Power source and pulse generator are buried under the skin nearby. This pacer is particularly useful in children whose growth will stretch and strain the electrode.

Often using only a local anesthetic and working at the bedside, the heart surgeon can insert a *transvenous* pacer by making an incision in the armpit, neck or abdomen. He then locates a large vein and snakes the pacer's electrode through the veins to the heart. The power source most commonly used today is a set of five or six mercury batteries (each little more than a half-inch in diameter and less than a half-ounce), connected in series.

Pacers work essentially in two ways—at a fixed rate or "on demand." The fixed-rate pacer, also losing favor, delivers its pulse automatically at a set rate (usually about 70 a minute). However if the heart should suddenly beat by itself at the exact moment of the pacer's shock, the double impulse can throw the heart muscles into

runaway disorganized contractions and lead to major problems. For this reason "demand" pacers were developed.

The demand pacer is designed to utilize the heart electrode as both the stimulating and the sensing device. If the heart has a normal beat, the electrical impulse in the muscle is sufficient to inhibit the pulse generators and the pacer will rest until the normal heartbeat stops. Even a single missed beat, however, will bring the pacer back into action!

The pulse generators emit a 3 to 6-volt impulse lasting for 1 to 2 milliseconds (thousandths of a second) and taking a tenth to a thousandth of a millisecond to reach full intensity. The heart electrodes may be helical coils of metal covered with silastic: platinum-iridium, stainless steel, gold or platinum-plated stainless steel, or even Elgiloy (chromium, nickel, iron and other metals) at a thickness of about two human hairs (0.006 inches) are all used.

What effect has the wearing of a pacemaker on its owner? How much does it limit his activity? At what ages can it be used? U.S. Supreme Court Justice William O. Douglas—whose pacemaker is almost always mentioned in stories about him—is past 70 and is an avid mountain climber. At the opposite extreme, is Elliott Wilson: Only a few hours after birth, his electrocardiogram showed heart-block. By his tenth day he was receiving digitalis for congestive heart failure, a condition more often found in the aged.

At four months, Elliott had a temporary pacer and shortly thereafter a permanent junior-size one. There are a considerable number of children like Elliott who attend regular school, enjoy unrestricted activities, even go to camp. At Yale University, doctors have successfully implanted an extra six or eight inches of electrode coil enclosed in a Teflon envelope—it pays out as the child grows.

There is Will Gray, an active 40-year-old executive who works and travels at high speed. His first pacer was an early, and relatively primitive, myocardial one installed in 1961. It failed, and Furman replaced it with a transvenous model. When the batteries recently ran down, Gray entered the hospital on a Thursday afternoon. His battery was replaced on Friday, and he was home catching up on work by Saturday. Incidentally, Will is not a guy to tangle with—he takes jujitsu lessons!

While you're certainly better off if you never need a pacer, if you do, this marvelous electronic device can save your life! And when the atomic pacemaker is perfected and available, you may never have to give it another thought. ★★★



IT'S ALMOST LIKE PRINTING YOUR OWN MONEY!

9¢ WORTH OF RAW MATERIAL becomes **\$125** in less than 60 seconds—and ANYONE can LEARN to do it in a FEW SHORT HOURS!

Since 1922, Warner has enabled thousands of men and women to establish a business of their own—to reap the benefits of their own labor and have the personal satisfaction, and independence, that comes with operating a business of their own.

Now, a revolutionary new machine makes it possible for an Independent Business Man with no "PULL" . . . No Big Money to Invest . . . and, No Experience — to start a business of his own, at home in his spare time. Here's what J. H. of Pennsylvania says:

Now you can get into this highly lucrative business, and use your own home as headquarters. No experience needed because we supply everything. The new Warner Success Program, "Engraving as a Profitable Business," is now ready for you. We will send you a FREE illustrated brochure and no salesman will call. Send no money — just your name and address on the coupon or on a postcard. Be the first in your locality to cash in on this ground floor opportunity.

**Warner Electric Co., Dept. E-2-K
1512 Jarvis Ave., Chicago, Ill. 60626**

\$7,280.00 for 1 to 1½ hours work an evening in my spare time—and without advertising. When I start to advertise I will have my own full-time business. Right now I am using the extra income to give my family the luxuries my present job does not afford.

Engraving Division, Dept. E-2-K **SEND NO MONEY**
1512 Jarvis Ave., Chicago, Ill. 60626

Please rush your free illustrated brochure to:

Name _____

Address _____

City, State, Zip _____



CAN A SHOOTER WHO IS OUT TO SCORE BULL'S-EYES FIND HAPPINESS with the New BENJAMIN AIR RIFLE?

We think so. Indeed, shooters have told us that the accuracy and performance of our new Super Single Shot are next to fantastic! And just what makes the new Benjamin something all by itself? It's probably the retention of things the owners of its famous predecessor used to brag about. And the painstaking way we build them. For example, it has the same dependable, time-tested action. And the same adjustable firing power. It even has the same bronze barrels, machined brass and steel parts that gave our older model an amazing wallop.

Of course, there are certain new features about the rifle which further enhance shooting pleasure. For one thing, it has a thumb operated top safety for more efficient fire control. And a ramp-type front sight plus adjustable stepped leaf rear sight to help bring out the full accuracy potential of the new gun. Safe. Quiet. Odorless. Shoot indoors or out. Model 340 BB. Model 342 Cal. 22 Pellet. Model 347 Cal. 177 Pellet. Find happiness at your dealer's.

Use Benjamin H-C Pellets—Sized and Lubricated for Greater Accuracy.

BENJAMIN AIR RIFLE COMPANY
896 Marion St., St. Louis, Mo. 63104

FREE CATALOG WRITE

You Can **DEPEND** on **BENJAMIN**



ROTARY FILES

U.S. Surplus High Speed Milling Files going fast. New, in G.I. Packs. Hardened steel, for filing, milling, routing, drilling—any work in light metal or wood. Use in ¼ in. drill, etc. Range in size from ¼ to 1 inch wide. Get these most useful tools now.

16 tool set—government cost \$109. **\$ 9.00 to you!**
36 tool set—government cost \$265. **\$15.00 to you!**
100% GUARANTEED. WE PAY POSTAGE. A LIFETIME BUY!!

THE SURPLUS CENTER
LANCASTER, TEXAS 75146



BE A MAN—GET A MAN'S JOB OPERATING HEAVY EQUIPMENT

- HYDRAULIC BACKHOES
- CRANES
- DRAGLINES
- CLAMSHELLS
- SCRAPERS
- BULLDOZERS
- GRADERS
- TRENCHERS

The Construction Industry is Booming! Earn top money in this fast moving, action-packed field. Keep present job and train at home in spare time followed by practical training on our machines under project conditions at our facilities. Nationwide placement assistance. For FREE information fill out and mail coupon today!

Member American Road Builders' Assn.

VA APPROVED FOR VETERANS AND INSERVICE PERSONNEL UNDER NEW GI BILL

UNIVERSAL HEAVY CONSTRUCTION SCHOOLS, Dept. P M
1901 N.W. 7 STREET, MIAMI, FLORIDA 33125

Please Print

Name

Address

City State Zip

Age Phone



MAZDA 1200, from Japan, is two or four-door model

'SENSIBLE' STATION WAGONS

(Continued from page 139)

particularly attractive, but it houses round, easy-to-read gauges and sensibly placed controls. A thermostat modulates the heater output—a nice touch. But two hard-to-find, one-inch-square buttons on the steering wheel actuate the horn. Why?

Front bucket seats provide good comfort along with a fantastically generous amount of fore-and-aft adjustment. The rear seat is roomy enough for two adults, and a collapsible rear jump seat holds a couple of small children or two desperate adults.

VOLVO 145

If you like a big-car feel, check out the Volvo 145. Its ride, interior accommodations and all-around performance resemble those of a domestic compact or even an intermediate-size wagon.

Padding in each individual front seat adjusts with a knob for lower-back support—very comfortable. The rear bench seat holds three without crowding, and rear jump seats are optional. The rear window has a wiper (gosh) and a defroster. Controls, most of them massive, are well-placed on the instrument panel.

The steering wheel is large, set a bit too close to the driver and its slow gearing limits maneuverability. Otherwise, handling is pleasant and predictable, with lots of tire squeal and mild oversteer coming in near the Volvo's respectably high limit of adhesion. The four-speed floor shift is precise, but stiff, and the clutch pedal is rather heavy, especially for women.

The Volvo engine gave the best performance in our group of test cars; it pushed the 2860-pound wagon to 60 mph in 11.7 seconds, and from 50 to 70 in 8.1 seconds. During the latter runs it didn't seem to matter whether we used third and fourth gears or third alone. Volvo's fuel economy, though lowest of all our wagons except the Toyota, was a decent 21.9 mpg.

CITROEN

It's not really an economy wagon, but the Citroen is so unique mechanically that we included it in our group.

The oddest feature of the Citroen is its hydropneumatic suspension, which auto-



HORNET SPORTABOUT, new in AMC's '71 lineup

matically levels the car regardless of load or incline of the road surface. It also gives a fantastically comfortable ride (better than Cadillac's) over all road surfaces and regardless of load. But when stopped at traffic lights, Citroen occupants need a sense of humor to shrug off the stares of other motorists as the car, sighing contentedly, alternately rises and sinks.

The suspension has no metal springs; countless feet of hydraulic spaghetti carry a "special green fluid" (to quote the owner's manual). A lever under the instrument panel raises the suspension for greater clearance over rough roads. To change a flat tire, simply raise the suspension, prop up the car with a jack stand, and push the lever to the lowest suspension setting. The wheel tucks up into its well without any jacking.

The interior is absolutely splendid. Well contoured, thickly-padded bucket seats provide superlative comfort, and the equally comfortable rear bench seat cradles three adults if necessary. Legroom is good in front, exceptional in back, and the front-wheel drive allows a perfectly flat floor. Headroom is ample all around. And for occasional extra passengers, jump seats unfold in the load area. Wall-to-wall carpeting over thick foam padding adds to the feeling of luxury. But the inside door handles are abominations; Houdini would have had trouble escaping from inside.

The instrument panel design could have been lifted from a captured World War II Japanese submarine. We suppose the controls make sense once you've memorized the layout, but we never quite managed this during our five days with the car. Gauges, including a tachometer, are large, round, and legible, but we'd be happier without that Mickey Mouse rotating band on the speedometer telling you how many feet you need to stop at various speeds.

The finish inside and out was flawless. But the load area—plain painted metal—should have at least a rubber mat to prevent scratching.

The weird, single-spoke steering wheel takes lots of effort in spite of power assist. The disc and drum brakes stop fast

(Please turn to page 218)

Dr. Grabow VIKING



A dozen pipes in one! Interchangeable bowls make Dr. Grabow's Viking an entire collection of fine pipes. Extra bowls are only \$1.95 and available everywhere.

LOOKS COOLER... SMOKES COOLER

\$3⁹⁵
DeLuxe

INTERCHANGEABLE
BRIAR BOWLS



NICOTINE TRAP

For FREE informative booklet, write VIKING PIPES, P. O. Box 21888, Greensboro, N. C. 27420

HEAVY DUTY BALL-BEARING PUMP



IRRIGATE-DRAIN-SPRAY-CIRCULATE. All-metal, rust-proof, Type XB. Stainless shaft. Use 1/4 HP or larger. 1 HP 1,200 GPH 60' high or 3,000 GPH 25' well. 5,200 GPH max. 1 1/4" in; 1" out. Belt or direct drive \$12.95
Type P won't rust or clog. Bronze bearing. Hundreds of thousands in use. Up to 2,400 GPH. 1" inlet. 3/4" outlet. Free coupling..... \$8.95
P'pd. cash with order **MONEY BACK GUARANTEE**

LABAWCO. Box 40, Belle Mead, N. J. 08502

locksmithing and key making

PRACTICAL UP-TO-DATE COURSE — ONLY \$7.95



Teaches you how to pick locks, de-code, make master keys, repair, install, service, etc. New self-instruction lessons for every handyman, homeowner, carpenter, mechanic, service station operator, fix-it shop, hardware dealer, gunsmith. 53 easy illustrated lessons. Full price only \$7.95 post-paid. Satisfaction or refund guaranteed. Mail order today!

NELSON-HALL CO., Dept. JP-2
325 W. Jackson Blvd., Chicago 60606

2 for 1 WAREHOUSE CLEARANCE SALE



TWO FOR \$1⁹⁸ \$3.96 VALUE 10 Year Guarantee
FOR TWO FOR THE PRICE OF ONE

Razor sharp blade opens with flick of finger and automatically locks in place. PUSH-BUTTON release. Tough, razor steel blade honed and polished to mirror-like finish. Balanced for target throwing. Blade GUARANTEED 10 YEARS. If blade breaks we replace free. 30-day MONEY BACK GUARANTEE. A favorite with sportsmen. Priced for quick sale of 200,000 knives. Makes excellent gift for any man or boy. Two for \$1.98 plus 50c shipping. Send cash, ck. or M.O. to VIKING KNIVES, Dept. K-3, Box 10880, Houston, Tex. 77018.

WRIST ROCKET

AMERICA'S Pat. HARDEST U.S. HITTING SLING
Range 225 yd. - 232 fps
Matched spare rubbers and pouch assembly, \$1.00.
Write:



WRIST ROCKET P. O. BOX 21-B
Columbus, Nebraska 68601 **\$3.00 Post Pd.**
No C.O.D.'s

FREE! CAMPER & TRAILER KITS catalog

Save 1/2 over factory built. Anyone can assemble. No experience required. Save \$500 to \$2000 over cost of factory built. Only household tools needed. Everything furnished—nothing else to buy! Just put factory pre-assembled parts together. 12 models—8', 8 1/2', 10 1/2' Pickup Truck Campers, 24', 31', 36' Pickup Truck Covers, 16', 19' Travel Trailers and 4 Soft & Hard Top Tent Trailer Models. Money back guarantee. Rush name, address for 24 page color catalog, FREE!

LUGER CAMPER & TRAILER KITS 10% dn, E-Z terms
Dept. TA90, 1300 E. Cliff Road, Burnsville, Minnesota 55378



"G. I. BILL APPROVED"

Excitement! Security! Good Pay!

CRIME DETECTION

LEARN AT HOME IN SPARE TIME—START NOW!

Crime everywhere is on the rise! Learn now, in your own home, the profitable profession that enables you to track down criminals and bring them to justice! Hundreds of Identification Bureaus employ I. A. S. graduates... trained in finger printing, police photography, handwriting identification, firearms and investigation. Our 44th year! FREE "Blue Book of Crime"... packed with crime facts and the full story of famous I. A. S. training. State exact age. No salesman will call. Rush Coupon!

A Correspondence School Founded in 1916.

FREE

Blue Book of Crime

MAIL COUPON

INSTITUTE OF APPLIED SCIENCE, Dept. 1359
1920 Sunnyside Avenue, Chicago, Ill. 60640
Rush Blue Book of Crime... FREE!

NAME Age.....
ADDRESS
STATE..... ZIP.....

EVERLITE*

World's THRIFTIEST Light Plants



THE CHAMPION \$149.50

The Champion—1200 watts
115 volts AC for only \$149.50

Unbelievable but true—Brand new production methods now make possible world's finest design in a service free alternator light plant at this unprecedented price. Plant puts out a steady 1200 watts of 115 volt AC power to run power tools, oil burners, pumps, TV, or anything that requires up to 1200 watts. Powered by a rugged 3 HP, 4 cycle, easy start gas engine with 1 year factory warranty. Complete with carry handle and shock mounts. Why fool with short life 2 cycle plants when you can buy this rugged top quality machine at our factory price.

Item # 1265 wt. 65 lbs. \$149.50

MASTER MECHANIC MFG. CO., Dept. A-90, Burlington, Wis.
Southern Customers write Dept. A-90, Box 65, Sarasota, Florida

EARN \$20.00/HOUR



Assemble the MINI-DOZER & MINI-BEEP for resale at big profit. Unique easy-to-assemble kits. Full-line of attachments. "Build-it-yourself" Plans—either machine \$5.00, both \$7.50; 16-page Catalog—50¢ each, both 75¢.
C. F. STRUCK CORP., Dept. PM-90, Cedarburg, Wis. 53012

'SENSIBLE' STATION WAGONS

(Continued from page 216)

and straight, with little fade. Clutch action is smooth and progressive, and the four-speed column shift, though vague, allows reasonably fast gear changes.

By exceeding the 6000-rpm redline slightly to avoid a two-three shift, we covered 0-60 in 13.9 seconds. With third gear only, 50-70 runs averaged 8.7 seconds. On our fuel economy tests the Citroen recorded 23.9 mpg. The speedometer was two mph fast at 30, three mph fast at higher speeds.

Specifications of the wagons that were not available in time to test are in the chart. All in all, 20 attractive alternatives to large, domestic land cruisers. ★★★

HURRICANE CAMILLE

(Continued from page 95)

room down. When the door wouldn't yield they smashed a window and climbed in.

The girl was hysterical. Her husband, hands bloodied, was trying to smash a hole through the wall. Hood and the lieutenant grabbed them and led them, one at a time, back to the other rooms.

Through it all, incredibly, the young guardsmen in the LARCs kept going. They bumped submerged cars, tangled with wires, got blown toward the Gulf and struggled back to tie up to rooftops. They saved hundreds of people.

Back in Pass Christian, a group of men and boys were rescuing people from treetops in a DUCK borrowed from the National Guard. A boy standing in the bow lifted fallen wires and passed them back over the heads of the passengers, not knowing for sure whether the wires were live or dead.

At 10:00 p.m. the DUCK got a frightening radio message: The Episcopal Church had blown away with 14 people in it. Soon afterward, Civil Defense Director McKay also got a call: Randolph School gym had just collapsed. McKay knew that some buildings strong enough to take the battering of wind and sea were exploding as air pressure dropped sharply outside their walls. In one parking lot, it was later learned, 180 cars exploded.

Luckily no one was in the gym at Randolph, an elementary school. McKay now was concerned about the 700 people in the public high school gym. If one gym had gone, another might go, too.

He wasn't worried about the strongly built Catholic school gym. But he flashed a radio order to the high school: "Get those people out of the gym—quick!"

They came out, wading, stumbling, gasping in the wind. The last stragglers had just reached the main schoolhouse when, with a roar, the gym walls blew and the massive roof caved in. As many as 500 lives may have been saved by McKay's quick thinking.

A huge tide came at 11:00 p.m. Forty-five minutes later there was an attack from the rear. A second tidal wave, a backlash, came rushing toward Pass Christian from the north. It swept down from the forests, which now were treetop deep in water. It crested and knocked down houses in its way.

This second wave peaked out at 12:30 a.m. At that time Director McKay waded out of the firehouse, trying to find what was left of his town. Chest deep, he got into a factory building, helped by an aide. "We've got to see if anybody else is alive," McKay said. But finally they had to turn back. The sea was too deep, the night too black.

By 2:00 a.m., Monday, the worst was over. A total of 136 people had been killed along the Mississippi coast—over 100 in Gulfport, Long Beach and Pass Christian, and at least 15 in Biloxi. (Three days later Camille, swinging northeast as it petered out, unleashed furious rains over Virginia, killing over 100 more people.) Property damage in Mississippi totaled nearly \$1 billion. Over 36,000 homes and nearly 600 mobile homes had been destroyed or damaged. The Towne House Motel—or at least a good part of it—remained standing. But not a trace remained of the Richelieu apartments.

The oil company LST miraculously survived. The pirated ship *Wade Klein* had been hurled high over the island where it had anchored, and landed ashore in full view of police. But there was no sign of its crew.

The yacht with the old man and the boy had been swept right over the closed Biloxi drawbridge, smashing against a bridge lamppost. The boy, in a desperate leap, grabbed the post. But the yacht and the man vanished. Next day the boy was found, still alive, clinging to the post.

If the horror that hit Mississippi should ever strike a big city, say Miami or New Orleans, experts warn that a quarter of a million people could die. May it never happen. As for the Weather Bureau, though it did a good job of warning residents, it was so shaken by the death and destruction that it has wiped the name Camille off its lists forever—"retired" it like Babe Ruth's famous No. 3. Other names may be reused on future hurricanes. But never again will a storm be called Camille. ★★★

2-in-1 FOLD-DOWN PICKUP CAMPER



- Assemble in 5 hrs. (6 sections in one box)
- Welded steel tubing frame . . . paneled . . . insulated
- Will support your boat on top
- Converts easily to pickup cover
- Has 3 jacks for quick loading and unloading

SAVE ... FACTORY TO YOU

6' 6" High — Fits Into Garage

\$875 Base Price

Plus freight and local taxes.

Send \$3.00 for brochure, Assembly Plan, Floor Plan and Equipment Catalog. Refunded on first order.



SCANDIA CAMPERS, INC.

P.O. Box 22638
Robbinsdale, Minn.



New 2-Way Revolving Record Table at Half Price! Only \$12.95

Plus 80¢ Postage

Use as a Table or flip top over for double record space.

The practically indestructible trays spin on smooth nylon bearings. They come in three colors: Avocado Green, Harvest Gold, or Jet Black.

Send order to:
Bob's Gift House
243 Corry St.

Madison, Wisconsin 53704

Wis. Res. 4% Sales Tax

I-N-V-E-N-T-O-R-S WE NEED INVENTIONS

Sell your invention for cash—need money for Patent?—Are technical problems holding you back? Universal Inventions has helped inventors all over the world—just like yourself—why not you? Inventions provide the magic spring-board to sudden riches. REMEMBER, we either sell your invention or pay you a cash bonus. Write for details. UNIVERSAL INVENTIONS, Dept. 13, Marion, Ohio

REAL ESTATE BE A BROKER

PAYS BIG! SEND FOR BIG FREE CATALOG NOW! Graduates report making substantial incomes. Operate your own business quickly. Men, Women, all ages, learn easily. Course covers Sales, Appraising, Loans, Mortgages, & related subjects. **STUDY AT HOME** or in classrooms in leading cities. **Diploma Awarded. Write Today for FREE Book!** Accredited Member National Home Study Council. (Est. 1936) G. I. Approved.

FREE
BOOK
TELLS
HOW

WEAVER SCHOOL OF REAL ESTATE
3521-P Broadway Kansas City, Mo. 64111

1¢ SALE
GUARANTEED
10 YEARS



The knife for hunting, fishing and all around use. Mirror polished, imported stainless steel blade honed to a razor's edge. Rugged. Opens with flick of finger. Locks into position. Blade will not close when in use. Press button in hand to close. Safety finger guard. Sure-grip handle. Balanced for target throwing.

IF BROKEN WITHIN 10 YEARS WE WILL REPLACE AT NO CHARGE! Use 30 days. Money back if not pleased. Special 1¢ sale. REG. PRICE \$1.98. Send \$1.99 & receive 2 knives. Add 49¢ postage, handling. Remit TOTAL \$2.48 for 2 knives

ORDER NOW! Midwest Knife Co., 9043 S. Western Ave. Dept. DD-2208, Chicago, Ill. 60620. Est. 1936.

SEPTEMBER 1970

BULLDOZE, PLOW SNOW, MOW BIG LAWN FAST with man-size Economy Tractor



No weekend toy — this garden tractor gives you real workpower. Doze with 4-ft. angling blade. Mow up to 3 acres per hour. Landscape, plow, roto-till, cultivate, haul, load. 14 hp plus extra size, weight and traction. No fluid-drive loss . . . geared drive converts horsepower to more pull and push power. Most for your money. Send for catalog, prices, name of your dealer.

NAME _____

ADDRESS _____

CITY, STATE, ZIP _____

C-21

SEND TO

ECONOMY TRACTOR

1005 K-9 Anoka Ave., Waukesha, Wisconsin 53186

GET INTO ELECTRONICS

V.T.I. training leads to success as technicians, field engineers, specialists in communications, guided missiles, computers, radar, automation. Basic & advanced courses. Electronic Engineering Technology and Electronic Technology curricula both available. Assoc. degree in 29 mos. B.S. obtainable. G.I. approved. Start Sept., Feb. Dorms, campus. High School Graduate or equivalent. Catalog.

VALPARAISO TECHNICAL INSTITUTE
DEPARTMENT D, VALPARAISO, INDIANA 46383



New Table Top Invention Puts You In... PROFITABLE RUBBER STAMP BUSINESS

Home Operators now make
\$16.50 AN HOUR in Business
once monopolized by
a few big companies

Special rubber stamps bring high prices—cost only pennies to make on new, low-cost table top machine. Take 27 cents worth of material, make perfect stamps, the kind businesses and offices now buy by the dozen at \$2.75 each. Make up to \$16.50 an hour. Start in spare time in your own home. Run machine on kitchen table using ordinary electrical outlet. Make any kind of stamp. We'll send you free information without obligation about this established, highly profitable business. **We'll even help finance your start.** For free information send name and address today on a postcard to: Rubber Stamp Div., 1512 Jarvis, Dept. R-2-K, Chicago, Ill. 60616



219

INVENTORS

**INVENTIONS—NEW PRODUCTS—IDEAS
DEVELOPED & PREPARED**

For Commercial Appeal & Sales

DESIGN—MARKETING—PATENT RESEARCH—DRAWINGS

DIRECTOR: *United States Patent Office former Patent Examiner*

United States Dept. of Army former Patent Adviser

Member: *United States Council Int'l Chamber Commerce*

Second Decade of Reliable Service to

INVENTORS—MANUFACTURERS—ATTORNEYS

FREE CONSULTATION

THE RAYMOND LEE ORGANIZATION

230-Z Park Ave., New York 10017 (212-MU 6-8500)

SEND FREE "INVENTION RECORD" Form & "PRODUCT MARKETING" BROCHURE

Name _____

Address _____

City _____ State _____ Zip _____

BUILD YOUR OWN CAMPER SAVE UP TO 50%



Complete, easy to follow plans, instructions, materials list.

Camper Plans	\$3.95
Travel Trailer	\$3.95
Pickup Cover	\$2.00
CONVERSION PLANS:	
Econoline Type Van	\$2.95
Passenger Bus or Delivery Van	\$2.95
Satisfaction Guaranteed	

EQUIPMENT CATALOG \$1.00

Refundable on First Order. Send Dime for Details. Save 50% on Camper Kit. All items from catalog to build \$1,795. Camper, 8', 10', 10'6" or Chassis Unit.

VIKING

VIKING CAMPER SUPPLY, INC.
99-8P Glenwood Ave.,
Minneapolis, Minn. 55403
Please send _____ for
which I enclose \$ _____
NAME _____
ADDRESS _____
CITY _____
STATE _____ ZIP _____

LAW FREE BOOK THE LAW TRAINED MAN

Write today for a FREE copy of illustrated law book, "THE LAW TRAINED MAN," which shows how to earn the professional Bachelor of Laws (LL.B.) degree through home study of the famous Blackstone Law Course. All necessary books and lessons provided. Moderate cost; convenient monthly terms. Write for FREE law training book today.

Blackstone School of Law, 307 N. Michigan Ave.
Founded 1890 Dept. 56, Chicago, Illinois 60601

FIND BURIED TREASURE

Powerful electronic detector finds buried gold, silver, coins, etc. 5 new models. Write for free catalog.



RELCO, Dept. D-3 19.95

BOX 10839, HOUSTON, TEX. 77018



Free Catalog!

GERSTNER CHESTS
are for the
FEW TRUE Craftsmen

GERSTNER TOOL CHESTS
Dept. D-0 20 Cincinnati Street
Dayton, Ohio 45407

VEGA

(Continued from page 114)

overhead-cam four. The aluminum-alloy block is die cast and weighs a mere 36 pounds. What makes it even more unusual is that the engine uses no cast-iron cylinder liners. Instead, the aluminum alloy carries a 17-percent silicon content. Cylinders are bored and then an electrochemical etch eats away a tiny bit of the aluminum. This leaves the silicon exposed for the pistons to ride up and down on.

To match the hard silicon cylinder surfaces, GM Research came up with electroplated pistons. Theirs is a four-layer process over a basic aluminum piston. The first flash is zincate, followed by a very thin film of copper. The third and primary coating is hard iron. A final flash of tin keeps the iron rust-free during handling.

Up top, the block has an open deck; that is, you can look right down into the water jackets as well as into the bores. Cylinders are siamesed (webbed together), with water jackets along both sides. Ordinarily, this open-deck arrangement would make the block relatively weak, but Chevy uses the cast-iron (not aluminum) head as a strengthening member.

Major differences between the 90 and 110-bhp engines are one and two-barrel carburetors, respectively, and different cam grinds. Transmission choices for the Vega include all-synchro three and four-speed manual, Powerglide two-speed automatic and semiautomatic Torque-Drive.

Disc brakes are standard up front, and they give excellent stopping. I could feel no fade from 80-mph stops on the flat nor during normal driving in the mountains. The brakes have no power assist and don't need any. It was safe going all the way to Phoenix. ★★★

PINTO

(Continued from page 115)

to the driver who wants familiar look, feel and handling in his car. One code name was, appropriately, Special Maverick.

Options, by the way, are numerous. Many more, as Ford boasts, than competitive imports. Is this good or bad? Tailor the car to your taste, goes one argument. On the other hand, when a potential buyer realizes that the cost of his Pinto will soar over \$2000 to set it up the way he wants it, he'll take a closer look at features imports may offer as standard equipment. Options include: airconditioning, manual front discs, tunnel console with electric clock, roof rack, whitewalls,

(Please turn to page 222)

MAGIC MAIL PLAN

that comes with this Little Machine
CAN MAKE YOU \$12⁰⁰ AN HOUR

The machine is turning out a job that will bring operator \$2.58, by mail. Material cost, only 11c



Write today for free facts about the newest and most fascinating of all new home operated businesses. For the first time, a simplified machine brings the fabulous profits of Plastic Sealing and Plastic Laminating within reach of the small operator. Anyone can learn to operate it with a few minutes practice. Then—with our MAGIC MAIL PLAN—can get mail orders pouring in daily with cash in every envelope.

No Canvassing or Selling
Fill orders at home in spare time to start. Then expand to full time business. We even supply circulars to bring back cash and orders. Rush name for all the facts you need to start. A postcard will do. No charge.

WARNER ELECTRIC CO., Dept. L-2-K
1512 Jarvis, Chicago, Ill. 60626

HEARING AIDS

Huge savings on tiny, all-in-the-ear, behind the ear, eyeglass and body models. New space age models are so tiny and well concealed your closest friends may never even notice. **FREE HOME TRIAL.** No down payment. Low as \$10 monthly. Money back guarantee. Order direct and save. Write today for free catalog and confidential booklet. **PRESTIGE, Dept. D-34.** Box 10947, Houston, Tex. 77018.



LIFETIME "SPIN-ON" OIL CLEANER



Cleans motor oil 100 times cleaner than any other "spin-on" filter. Never drain oil again. Never buy another spin-on filter. Change 15 cent element every 3000 miles, available everywhere. Doubles engine life. Oil is 100% clean 100% of the time. Guaranteed 5 years. \$25.95 post paid. Write for the facts. Save \$8.00 every 3000 miles.

VIRDEN PERMA-BILT
Box 7066 PM, Amarillo, Texas 79109

HEAVY DUTY WELDER



10-DAY FREE TRIAL
Lifetime Guarantee

Brand New **1895**
1970 Model **1895** POST PAID

Fits ordinary 110V outlet
Not one • but 3 welding heats

Weld, braze, solder or cut most anything made of metal. No experience necessary. Follow simple instructions to make repairs on cars, trailers, farm and lawn equipment, bicycles, appliances, etc. Make campers, boats, furniture, hundreds of valuable items. **NOTHING ELSE TO BUY!** Comes complete with full face shield, \$2.00 pack of welding and brazing rods, heavy duty power cables, special electric torch attachment, ground clamp, flux, easy-to-follow illustrated instructions, rod holder, etc. Uses standard 1/8" rods and 1/4" carbons to weld iron, steel, brass, bronze, aluminum, other metals. New improved HEAVY DUTY circuit gives more welding power. Gives 4 times the heat needed to melt toughest iron. Plugs into ordinary 110V outlet. **3 WELDING HEATS** . . . Not just one as with other low cost models. Use "high" for tough jobs, "medium" or "regular" for lighter work. This important feature saves you money and time. Makes it possible for even beginners to start welding professionally the very first day. Pays for itself quickly. 10 day MONEY BACK GUARANTEE. You must be satisfied or return for refund.

FREE automatic arc striker. Now weld with push-button ease.
SEND ONLY \$2.00. Pay postman \$16.95 plus postage when delivered, or send \$18.95 cash, c.k., M.O., for fast postpaid shipment.

WEL-DEX MFG. CO., Dept. W-10, Box 10776, Houston, Texas 77018

BASEMENT TOILET FLUSHES UP



TO OVERHEAD SEWER OR SEPTIC TANK.
NO DIGGING UP FLOORS. INSTALLS EASY. Write

McPHERSON, INC., BOX 15133, TAMPA, FLORIDA 33614

GOVT. SURPLUS AND OTHER BARGAINS SAVE UP TO 90%



DC FAN Set in its own 8 1/2" x 8 1/2" housing with 3 adjustable deflectors & closable door to prevent draft when not in use. Mount in boat, bus trailer, mobile home to circulate air in or out. Runs on 12 or 24 VDC. Produces up to 150 CFM. Approx. GOVT. COST \$125. Tested prior to shipment. Shp. wt. 11 lbs. \$12.50 (Stk. #2645)

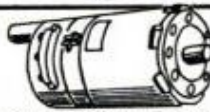

D. C. JET GENERATOR Mfg. by G.E. Rated 400 amp., 3700 RPM. Continuous duty @ 30 VDC. Does up to 600 amps intermittent duty. Exc. arc welder. Can use as is with no internal rewiring. Complete with wiring diagram. 16 1/2" L x 7" dia. Govt. overhauled cond. GOVT COST \$464. Shpg. wt. 98 lbs. \$59.50 (Stk. #1795)



SCAVENGE PUMP Miniature pump unit. 7 1/2" L x 2 3/4" W x 2 5/8" H. Positive displacement, rotary vane-type pump. 27 V.D.C. motor, continuous duty, explosion-proof. Pumps up to 165 GPH @ 6 PSI. Self-priming. Exc. for transfer of gas, diesel fuel, crankcase oil, etc. Pump ports 3/8" tube. Shpg. wt. 5 lbs. Govt. overhauled condition. Approx. GOVT COST \$231. Now \$14.95 (Stk. #2026)



SILVER ANNIVERSARY EDITION

Send 35c for amazing catalog with 1000's of bargains in hydraulics; electrical, marine, automotive items, etc. 90 day guarantee. Order from ad. All prices FOB Culver City. 50% deposit for COD. Cal. res. add 5 1/2% sales tax. Include zip. Satisfying world-wide customers since 1945.

AIRBORNE SALES CO. Dept. PM970
8501 Stellar Dr., Box 2727 • Culver City, Calif. 90230

be a TAX CONSULTANT

Income unlimited in ever growing profession. Our students are earning lucrative fees in dignified full or part time home-office business preparing income tax returns during busy tax season. Many operate profitable Business Tax Service with steady monthly fees of \$10-\$50. No bookkeeping experience necessary. We train you at home and help you start. Licensed by N.Y. Education Dep't. No agent will call. Write for free literature. Accredited Member NHTC. Approved For Veterans.
NATIONAL TAX TRAINING SCHOOL, Monsey, 20YC, N. Y. 10952

FREE PLAN

Be Your Own Boss

New Business Opportunity

FILING SAWS



Start a steady repeat CASH business in your basement or garage. Earn \$3 to \$6 an hour in your spare-time! Excellent profits in saw sharpening business! Automatic Foley Saw Filer, easy to operate, files combination saws, hand, band, and circular saws. No experience needed. H. C. Delbert wrote us: "Since I got my Foley Filer 5 years ago, I have averaged 4 1/2 saws each day since I started."

Every saw you sharpen brings you more customers. "I rented a two-car garage and have all the work I can do," writes Charles H. Smith.

FREE BOOK Shows How to Start

Fact filled booklet tells you how to start a sparetime business immediately; how to get new business, how to advertise. Rush coupon now; get "Money Making Facts" and details on Easy Payment Plan. No Salesman will call.

Send Coupon for **FREE BOOK Money Making Facts**

- FOLEY MANUFACTURING CO.
916-0 Foley Bldg. Minneapolis, Minn. 55418
- Send **FREE BOOK**—"Money Making Facts", and Time Payment Plan.

Name _____

Address _____



Bean's Free Fall Catalog

Just Off the Press



Hunters, Campers and Fishermen will find many practical items in our fully illustrated Fall Catalog. Shows hunting footwear, clothing and other specialties of interest to both men and women. Many items are of our own manufacture.

Send Free Catalog

Name _____

Address _____

Zip _____

L. L. Bean, Inc.

627 Main St., Freeport, Maine 04032

Hunting, Fishing and Camping Specialties

22 CAL. PELLET FIRING "STINGER AUTOMATIC"



\$1.00

50 22 CAL. PELLETS FREE
Looks and Feels Like Real Pocket Automatic — Loads 15 Shots

Fires 22 cal. pellets just as fast as you can pull the trigger. Great for fast action combat-type target practice. 50 reusable 22 cal. pellets free. Free supply of targets. Money back if not satisfied. Just send \$1.00 plus 25¢ postage and handling to:

HONOR HOUSE, Dept. 96RA69, Lynbrook, N. Y. 11563



Regardless of your age, size or strength, in just 15 minutes, I'll have you using my TERROR-FIGHTING secrets. **TEN TIMES MORE EFFECTIVE than KARATE and JUDO Combined.** They will turn you into a destructive MARINE TOUGH fighter able to protect yourself and loved ones from any hoodlum twice your size without working up a sweat — anytime — anywhere — in any and all situations.

If you really want self defense mastery and confidence, send now for amazing free booklet, revealing for the first time 5000 years of trip-hammer political, military and religious fighting orders, including Judo, Karate, Boxing, Wrestling and Rough & Tumble fighting secrets that will quickly turn you into a Terror-Fighter. You will never again get "weak in the knees" and run but stand and successfully defend yourself against even two or three attackers. Yes! from this day on YOU need never FEAR ANY MAN.

Mail NOW for self defense fighting secrets.

ABSOLUTELY FREE

Send only 50¢ to cover Postage and handling to

JOE WEIDER, Dept. 38-90SD3
531 - 32nd St., Union City, N.J. 07087



PINTO

(Continued from page 220)

pivoting rear-quarter window, tinted glass, rear-window defogger, vinyl roof, AM radio. There are no less than five "groups"—protection, convenience, accent, luxury decor and sports appearance—including rubber-insert bumpers, various moldings, carpet . . . you name it.

Pinto—still to be tested in the marketplace—joins the Capri which got off to an auspicious start last April. The highly-acclaimed, European-built Ford has been a sellout to the delight of Lincoln-Mercury dealers who indicate they come through so well made they do nothing but wash them. The '71 model is the same as the '70½—same standard equipment: power front discs, radials, carpeting, bumper guards and so on. For such a sporty coupe, it's a bit underpowered with the 1600-cc engine (European version offers engines up to three liters).

Pinto and Capri are different—the American and European design approaches are quite evident—but will be very alike in their market impact. ★★

'71 FORD, LINCOLN-MERCURY

(Continued from page 119)

lower, wider, wider track, sheet metal shaped to hide wipers, recessed door handles, the same new convertible top linkage and a host of interior and exterior changes that are small but not insignificant. Four-way power seat is among the new options for five two-door hardtop and convertible models in the base, Cougar XR-7 and GT series. The 429 engines are now optional for all models.

Thunderbird's story for '71—after the design refinements inside and outside have been appraised—is, as usual, mostly about the standard and optional features that go even further in transforming this automobile into one of the most extraordinary personal domiciles on wheels. New weatherstripping better seals the interior where are found switches and controls for everything from new electric deck-lid release to electrically operated sunroof (now available on all models.).

Lincoln Continental and Mark III are slightly refined and unchanged "following the tradition of timeless automobiles," respectively. Both now offer as standard equipment airconditioning with automatic temperature control, Michelin white-side-wall radials, tinted glass, side impact beams, AM/FM stereo radio using integrated circuits, and more . . . better see the dealer nearest you! ★★



How to get good water.

You can get sparkling clean, spring-like water by the thousands of gallons for less than \$35.

That's exactly what we offer with two types of Aqua-Pure home water filters. One removes dirt, rust, other solid matter. The other removes chlorine, sulphur, other bad tastes and odors.

Aqua-Pure water filters are now in use in over a million homes. They work. Year after year. They're sold by leading hardware, plumbing and farm supply dealers nationwide. They're the sure cure for almost every "bad water" problem.

For a free copy of AMF Cuno's informative booklet, "How To Get Good Water" write: Consumer Products Dept. PM-1, AMF Cuno Division, American Machine & Foundry Company, Meriden, Conn. 06450.



Aqua-Pure
WATER FILTERS

AMF
CUNO

LICKITY SPLITTER

Splits Big Profits from toughest woods — Ends Splitting Drudgery with 18 ton hydraulic power!

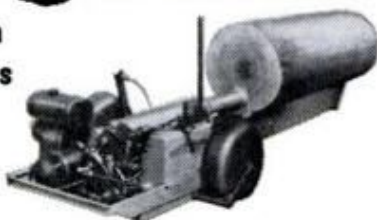

7 H.P. trailer unit squats under power to load logs without dead lift. Has 2 speeds, auto-shift, auto-stroke. 26" ram travel splits logs up to 34", any diameter — with extended frame and adjustable wedge splits up to 60". **NEW LOW COST** Economy model for farmers and small wood lots. Also ask about the 60L Series for logs up to 8½ ft. long—Details free.

Piqua Engineering Inc., Dept. P, Box 605, Piqua, Ohio

A BUSINESS OF YOUR OWN REPAIR HYDRAULIC JACKS



Earn while you learn at home. Millions of jacks in gas and auto service stations, trucking firms, body shops, riggers, factories and farms need servicing . . . most of which you can learn to repair. We show you HOW. Start spare time in your basement or garage. Big opportunity for mechanics. **ACT NOW!** Write for folder: **PM-9**, and free bonus offer

HYDRAULIC JACK REPAIR MANUAL CO., INC.

G.P.O. BOX 3 • STATEN ISLAND, N.Y. 10314

Two or four-wheel drive
JEEP OR SCOUT
owners

REPOWER with a 6 or V-8. H.D. ADAPTORS for using Car, Compact and some Truck engines. "State year & model, Jeep or Scout." Want fast action? Give us **FULL INFORMATION**. Send \$25.00 Dep. and we will ship correct kit, bal. COD. Send full amount for prepaid shipment. Wire, phone or write today. Details **FREE**

HOOSIER MACHINE PRODUCTS CO.

312 S. E. 6th St., Phone 276-3442. Pendleton, Oregon 97801

FREE!

Learn how you can buy used engines \$15 up, new engines \$30 with **FREE** confidential list and coupons when you order your plans

• **BUILD THIS MINI-BIKE!**

Plans reveal step by step details!

• **BUILD A RACING KART!**

Build frame for less than \$10!



KUSH \$2 for plans (Indicate type) or send 25¢ for circular describing plans **PLANS**, Box 517, Omaha, Nebr. 68101



LEARN MEAT CUTTING

Train quickly in 8 short weeks at Toledo for a bright future with security in vital meat business. Big pay, full-time jobs — **HAVE A PROFITABLE MARKET OF YOUR OWN!** Time payment plan available. Diploma given. Job help. Thousands of successful graduates. **OUR 47th YEAR!** Send now for big new illustrated **FREE** catalog. No obligation. **G.I. Approved.**

NATIONAL SCHOOL OF MEAT CUTTING
Dept. 50-L, Toledo, Ohio 43604

TELLS HOW TO SELL YOUR INVENTION

If you have an invention that you believe has merit, write us at once for copy of copyrighted booklet "How to Go About Selling Your Invention." We work with manufacturers, and booklet reveals present markets, qualities of a saleable invention, current royalty rates being paid by manufacturers. Booklet is **FREE**, is offered to encourage new ideas we might submit to manufacturers. Just send name (no drawings, please) to **Kessler Sales Corp., Dept. D-519, Fremont, Ohio 43420**

Free



WORLD'S LARGEST ELECTRONIC KIT CATALOG!

The latest edition . . . with more kits and more color. Includes over 300 kits for unique creative fun at 50% savings. You can build your own solid-state color TV, stereo system, electronic organ, home protection system, portable and shortwave radios, ham equipment, marine electronics, metal locator and many more. No special skills or knowledge needed. Millions of others have done it already — you can too! Mail the coupon today and see how easy it is.



HEATH COMPANY, Dept. 17-9 a Schlumberger Company
Benton Harbor, Michigan 49022 **CL-388**
Please send **FREE** Heathkit Catalog

Name _____

Address _____

City _____ State _____ Zip _____



BUILD THESE BEAUTIFUL CLOCKS



NOW AT BIG SAVINGS!

Send just \$1 for plans & instructions to build choice of: (A) Grandfather, (B) Steeple, (C) Grandmother—plus information-packed catalog of movements, dials, parts & kits to build these & 16 other fine clocks. All 3 plans—\$2.50. Catalog alone—25¢.

MASON & SULLIVAN COMPANY
Dept. PM, Osterville, Mass. 02655



DEFENDER OF WOMEN!

Instantly Stops Attacker

Assailants run screaming when sprayed in face with DEFENDER. When you're in danger, simply press top. Temporarily leaves attackers helpless. Dyes skin identifi-

ing attacker for police. Effective up to 15 ft. Lip-Stick size—hides easily in palm of hand. Women buy on sight. Amazing profit! **SAMPLES for TRIAL** Sample offer sent to all who send name at once. Postcard will do. **SEND NO MONEY.** Just your name.

KRISTEE CO. Dept. 681, Akron, Ohio 44308

BIG PROFITS FOR YOU!!

In your own spare-time **PRINTING BUSINESS**



Since 1872 thousands from high school to retirement ages have made important extra money with Kelsey hand presses, supplies, paper and how-to-do-it printing and business management help. Have your own printing business and your present job too. Send 25c (credited against your first order) for big catalog and details. **ACT NOW!! KELSEY PRESSES, Dept. 70T, Meriden, Conn. 06450**

DIESEL TRUCK DRIVER SCHOOL

Send for a free brochure on our four week course located in Rosemead (Los Angeles). The only school recommended by the California Trucking Association.

CTA'S TRUCK DRIVER SCHOOL

1240 Bayshore, Dept. 4 Burlingame, California 94010



\$151 WIN A RACE DAY \$2 WITH 2 STAKES

ONE GUY said he couldn't win whatever way he tried. Another said he couldn't win whatever way he tried, until he had PENCILIFF world's top race computer and got up to \$151 profit a day with \$2 stakes.

SENSATIONAL—space age—scientific, yet so easy to operate, wonderful Penciliff on sale since 1965, has a master director and 6 predictors. You simply FEED in previous form, weights, etc. **FABULOUS** results U.S.A., Canada, U.K., etc. We supply **FACTS**—over 4,000 latest U.S.A. **CHECKABLE** big win PENCILIFF predictions. **BIG \$2** payoff's incl. \$66, \$70, \$82, \$90, \$96, \$104, etc., and **BIG** track wins—\$2 stakes on all predictions in all races incl. \$113, \$118, \$121, \$134, \$141, \$151, etc. **CLEAR PROFIT ON THE DAY.** Money refund guarantee. Learn how an accident on the inventor's yacht, his 25 years racing experience, aid of 12 other experts, and a giant I.B.M. Computer, all led to the invention of amazing PENCILIFF. **R.H.P. Co., Box 5715 PME-12, Carmel, Calif. 93921.** Tear out this ad NOW and mail with name, address, and zip.

HOW TO SIGHT-IN A RIFLE

(Continued from page 133)

with a 100-yard bullet velocity between 2500 and 2800 feet per second can be zeroed in to hit 2 inches high at 100 yards. Aimed directly at the target, it will then strike just 1 inch high at 50 yards and be right on the money at 200 yards. Longer-range cartridges with 100-yard bullet velocities between 2900 and 3300 f.p.s., when zeroed in 2 inches high at 100 yards, will also be about 1 inch high at 50 yards and exactly on target at 250 yards.

It's not really as complicated as it sounds. All you have to do is determine that 100-yard bullet velocity figure.

With a correctly sighted-in rifle, you can virtually forget about elevation adjustment for most game out to 200 or 250 yards and concentrate on a steady hold.

Some scope manufacturers offer a convenient, silent way to check their products for accuracy. An item such as Marlin's V70 Veri-Fine Columnator enables gunners to make a quick check of sight alignment in the store before you buy, on the range, or in the field just before a hunt.

A word about wind deflection. First, a formula we hope won't intimidate the beginner: $D = V (T_a - T_v)$. Translated, this means deflection in inches is found by multiplying the crosswind velocity in inches per second by the time of flight for the bullet in air minus its time of flight in a vacuum, both over the same distance. Our problem: How do we determine the crosswind velocity throughout the distance the bullet will travel (remember, it varies up and down the range)—all while the eight-point buck we're after is quickly moving out of sight?! In brief, the match shooter has half a chance to bring this formula into play; the hunter must rely on experience and instinct when determining wind deflection.

Something must be said about lateral drift arising from the bullet's spin. Up to 600 yards, drift is almost imperceptible. It increases rapidly with range, but at 1000 yards is still only about a foot.

Since most whitetail deer are shot well within 100 yards, zero your open sights dead on for that range and hold some 8 inches high on a buck across a 200-yard pasture.

If you're using a telescopic sight and a high-powered bullet and you're hunting mule deer in the West, you'd be unwise to adjust the sights for only 100 yards.

Know your rifle and where it will hit with regular ammunition. Once you have learned to sight-in accurately, you can put venison on the table instead of chicken-dinner alibis.

★★★

Next Month in Popular Mechanics

More on the 1971 Cars

Starting on page 112 in this issue, you can read about—and see in color—the Chevy Vega and the full Ford lineup. In October, PM's auto editors continue with American Motors, Chrysler ("four-wheel, antiskid system, headlamp washers . . .") all General Motors divisions ("each has its own surprises . . .") and add a kind word for the auto industry.

New Outboards and Snowmobiles for 1971

In two separate reports, Outdoors Editor George Reiger sizes up the new machines. For snowmobiles, he says: "New companies, new designs and better machines." For outboards: "Minor modifications, not major changes."

They Said I Was Crazy to Drive in Japan!

"But it was fun and easier than we expected in Datsun's snazzy little 1200," reports PM Editor Robert Crossley, who just got back from a visit to Japan's Expo '70.

What's Watt in Choosing a Hi-Fi?

Like a car's horsepower, the number of watts an amplifier puts out is an important key to good performance. Here's how to determine the amount of power you need and how to unscramble the various output rating systems manufacturers use.

Will You Lose Your Right to Fly?

Misleading "scare stories" about congested airspace and mid-air collisions may bring laws that will virtually eliminate private flying. Here's the truth—and the real solution—as seen by a professional pilot.

Build This Electronic Banjo

You can make it from scrap that you probably have lying about your shop, and you'll end up with an instrument that's sure to pep up your get-togethers.

A Workbench Fit for a Pro

The smooth, durable work surface of this basic piece of shop equipment is sure to make any project go better.

The Truth About Pet Foods

You can kill your pet with 'kindness'—by feeding him all-meat canned foods that were never intended to be his sole diet.

Electronic Football Lets You Play Like the Pros

This home-built game, based on an intriguing random-chance circuit, will give you hours of fun long after the football season has ended.

Look What You Can Do With a Swivel-Blade Sabre Saw

You can make cuts that once were impossible. And you can steal a couple of tricks to use with an ordinary portable jigsaw.

HOW CAN AN 8" TILT ARBOR SAW WITH \$80. PERFORMANCE SELL FOR \$19⁹⁵?

HERE ARE THE 7 IMPORTANT REASONS

1. Simplified design, sound engineering and several basic patents make possible important savings in materials and production costs.
2. You don't pay for fancy chrome plated gimmicks. (They don't help you cut wood.)
3. The perforated ground cast iron table saves metal and grinding time.
4. You buy direct from the factory at factory prices.
5. Castings are made in our own foundry, parts are processed in our own factory, machines are assembled, tested, packed and shipped directly to you from our own two assembly plants.
6. Washers, bolts, nuts, fasteners, etc. are standard hardware items, not expensive designer dreams.
7. More AMCO bench-type power tools are sold each year than any other single make in America. Savings made possible by our large buying power and mass production methods are reflected in the low prices you pay.

WHEN YOU BUY AN AMCO POWER TOOL DIRECT FROM OUR FACTORY, YOU **SAVE AS MUCH AS 80%**

8" TILT ARBOR POWER SAW DOES WORK OF \$75 BENCH SAWS, AS IS

... Includes completely assembled cast iron and steel 8" saw with ground cast iron table, less blade. RIP FENCE, if desired, for easier work alignment: standard size (for bench saw) \$3.50, larger fence (for cabinet base as ill'd below) \$4.50. PRECISION BALL BEARING SPINDLE for commercial service, \$5 add'l.

\$19⁹⁵
f.o.b. factory
Wt. 25 lbs.

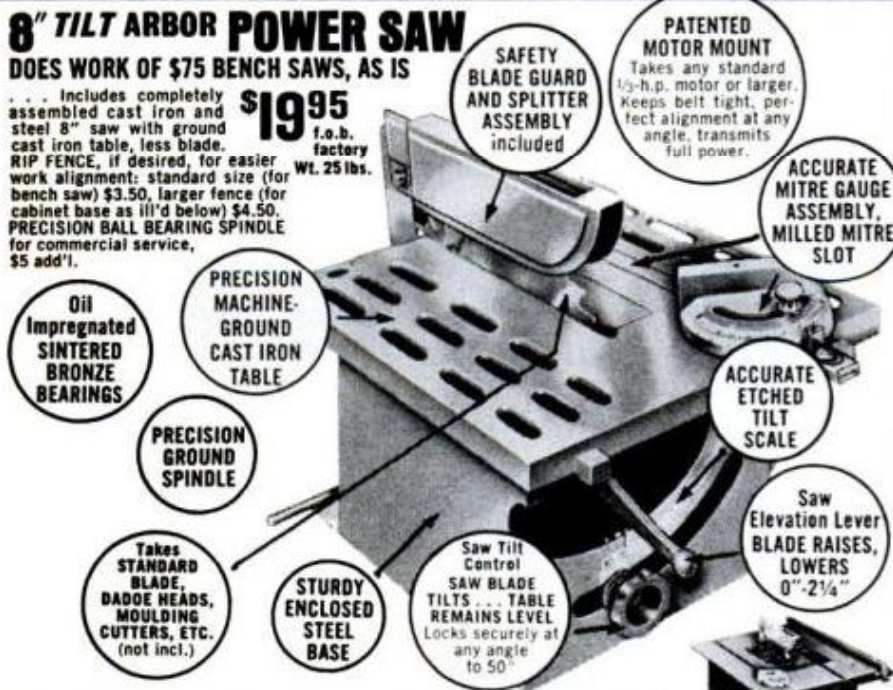

**SAFETY
BLADE GUARD
AND SPLITTER
ASSEMBLY**
included

**PATENTED
MOTOR MOUNT**
Takes any standard
1/2-h.p. motor or larger.
Keeps belt tight, perfect
alignment at any
angle, transmits
full power.

**ACCURATE
MITRE GAUGE
ASSEMBLY,
MILLED MITRE
SLOT**

**ACCURATE
ETCHED
TILT
SCALE**

**Saw
Elevation Lever
BLADE RAISES,
LOWERS
0"-2 1/4"**

**Saw Tilt
Control
SAW BLADE
TILTS... TABLE
REMAINS LEVEL**
Locks securely at
any angle
to 50°

**STURDY
ENCLOSED
STEEL
BASE**

**Takes
STANDARD
BLADE,
DADOE HEADS,
MOULDING
CUTTERS, ETC.**
(not incl.)

**PRECISION
GROUND
SPINDLE**

**PRECISION
MACHINE-
GROUND
CAST IRON
TABLE**

**Oil
Impregnated
SINTERED
BRONZE
BEARINGS**

• CROSSCUTS • RIPS • MITRES • CUTS COMPOUND ANGLES • DADOES • MAKES COVES, MOULDINGS

— These machines will do everything those selling for 4 or 5 times the price will do... as accurately, as easily, as quickly—and for at least as long. Granted, they don't have the sparkling good looks of the high priced brands. But if you are a once-in-a-while woodworker, these mini-priced full-function machines make sense. They will provide you with all the muscle, accuracy, versatility and speed you'll ever need to do the job, and do it well. How can you be sure? There are 2 no-nonsense guarantees that say so. And you have the say-so of the country's most sophisticated woodworking authorities.

OVER 1 1/2 MILLION AMCO USERS CAN'T BE WRONG

— Our files are filled with letters of praise. Articles by the nation's top feature writers and editors, reporting on their personal experience with AMCO tools, have been appearing regularly in such authoritative national publications as POPULAR MECHANICS, POPULAR SCIENCE, WORKBENCH, FAMILY HANDYMAN, FURNITURE DESIGN & MFG., INDUSTRIAL WOODWORKING. Typical of their objective evaluation is this uninhibited report by Popular Science: "... (the tools) were put through the same demanding jobs expected of other (far more expensive) shop tools. No gleaming chrome, no fancy extras, sturdy but plain... a good bit of sound, imaginative engineering... The company is justified in giving an unconditional 10-year guarantee". These same AMCO tools were recently awarded the coveted Workbench Magazine WORKSHOP TESTED SEAL. All are in full agreement that they are, indeed,

FREE CABINET BASE PLANS

Use as a portable bench saw as received, or transform easily and inexpensively into floor model (as shown) guaranteed to do work of floor models costing \$300. FREE plans... all you'll need are a sheet of 3/4" plywood and 3-4 hours. Use your AMCO saw for cutting. Plans provide 27" x 24" work surface, 33" height, tool storage compartment.

AMERICA'S GREATEST VALUES IN DEPENDABLE POWER TOOLS

GUARANTEES

10-DAY MONEY BACK GUARANTEE

Put it through its paces. Give it any valid test you can think of for accuracy, speed and ruggedness. Compare its performance with any similar machine at any price. Not satisfied? Return it—freight collect—for prompt, no-questions-asked refund.

10-YEAR FULL SERVICE GUARANTEE

Any part or parts of any AMCO power tool which may become inoperative for any reason within ten years after purchase date will be repaired or replaced by factory without cost to purchaser. Your only cost: for postage.

*Except motors and motorized power tools, to which the same terms for a one-year guarantee will apply.

AMERICAN MACHINE & TOOL CO., Dept. PM-90
Royersford, Penna. 19468

Please send me the units checked. Payment in full enclosed \$..... or \$3. deposit each item, bal. C.O.D. I MUST BE FULLY SATISFIED OR WILL RETURN WITHIN 10 DAYS FOR FULL REFUND, no questions asked.

8" Power Saw at \$19.95 • Standard rip fence at \$3.50 • Long rip fence at \$4.50 • Precision ball bearing spindle at \$5 • G.E. Motor \$19.90 (with other item) — \$24.85 (purchased separately) • Send FREE Catalog of America's Greatest Power Tool Values

NAME _____
ADDRESS _____
CITY _____ STATE _____ ZIP _____
(please print)

ENJOY THE SAME FANTASTIC SAVINGS ON THESE FULL PERFORMANCE AMCO TOOLS. SAME 2 GUARANTEES.

- 3-ft. 6" Swing Wood Lathe \$14.95
- 4-ft. 12" Swing Wood Lathe \$29.95
- Optional (for either lathe):
- Face Plate \$2.50
- Turning Chisels \$4.95
- Hi-Speed Wood Shaper Kit.... \$19.95
- 22" long 4 1/2" Jointer-Planer \$24.95
- 6" Ball Bearing Bench Grinder \$14.95
- 32" Radial Drill Press \$34.95
- 4"x36" Precision Belt Sander ...\$14.95
- Optional:
- Mitre Gauge \$1.95
- Disc Sander Attach..... \$7.95

All Prices F.O.B. Factory. ORDER NOW.
FREE CATALOG ON REQUEST

MAIL
QUICK
ACTION
COUPON
TODAY

BRAND NEW MOTOR DEVELOPING FULL 1 HP \$19.90 f.o.b. factory / For any of these machines. Wt.: 17 lbs. Purchased Separately, \$24.85

Pump guns don't have to be ugly.

Our Model 870 "Wingmaster" proves it.

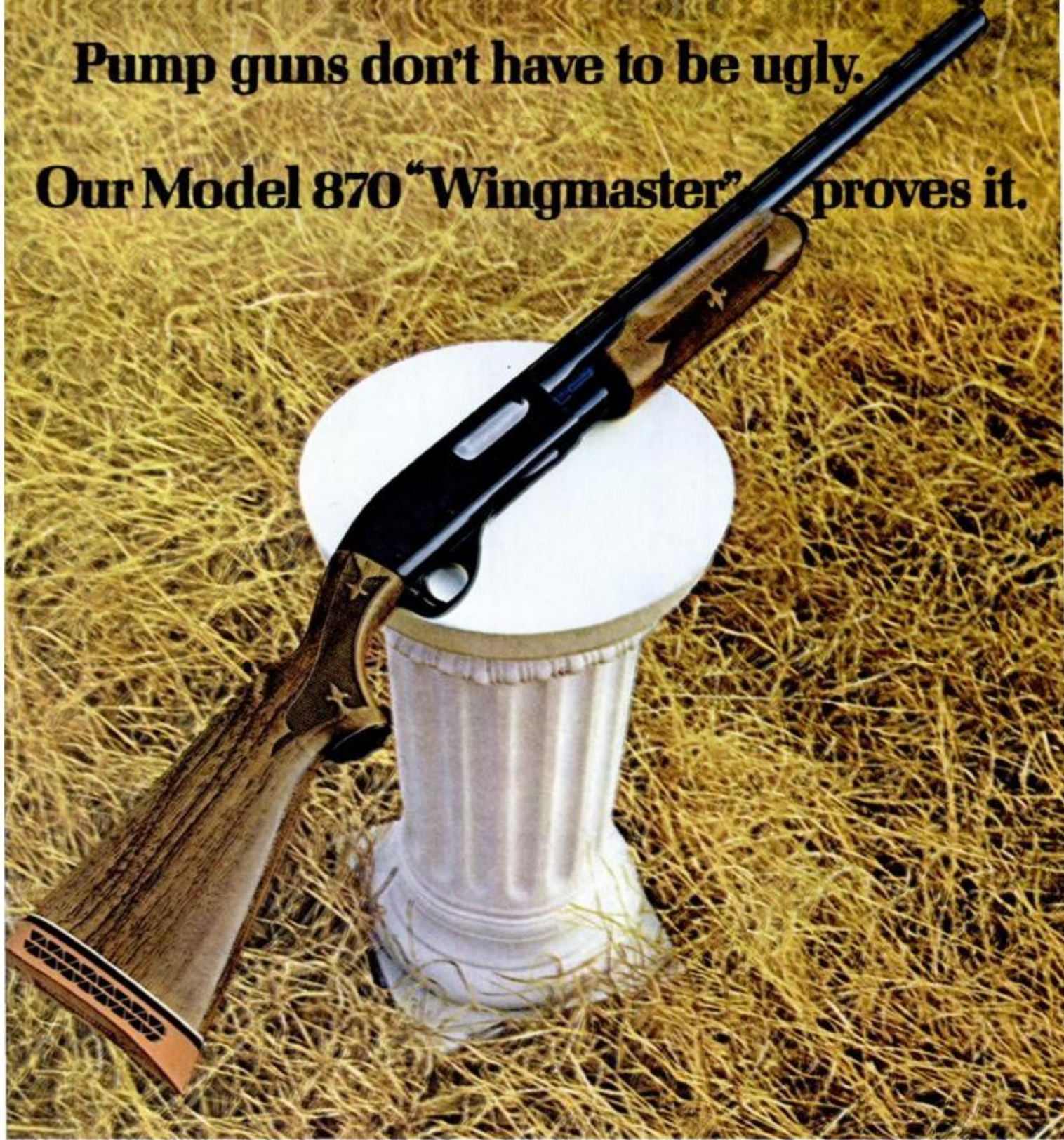

There's no doubt that pump shotguns offer more solid value than any other type. They're reliable, fast-shooting and rugged. But if you think they're all ugly, you've been looking at the wrong catalogue.

We think the 870 "Wingmaster" is great-looking. We may be biased, but take a look at its clean, classic lines. And the way the stock and fore-end gleam under our exclusive RK-W finish. The metal has a deep, lustrous blueing. And the 870 has all the little luxuries you want: ventilated rib, Monte Carlo stock, recoil pad and white line spacers.

But the 870 is built to fill the practical eye, too. Twin action bars prevent binding and sticking. The

receiver is solid steel—no soft alloys are used. And there just isn't a shotgun easier to take down. Push out two pins, and the entire trigger assembly slips out. Unscrew one knob, and the barrel comes off. (Which means that changing barrels in the field is a snap. Shoot a few early-morning geese with a 30" full choke . . . then twist the knob and change to a 26" improved cylinder barrel for afternoon quail. Extra barrels cost as little as \$35.70.*)

The 870 "Wingmaster" comes in a wide range of gauges, chokes and barrel lengths from a 410 to the thunderous 12 gauge 3" magnum. They're all described in our big, full-color catalogue. It's something

you should have . . . and it's free. Just write: Remington Arms Company, Inc., Bridgeport, Conn. 06602—Dept. 9E

Remington® **DU PONT**

**Remington builds
thousands of firearms a year.**

One at a time.

"Wingmaster" is a registered trademark of the Remington Arms Co., Inc.
*Manufacturer's suggested retail price.

Guess what?

You can't take
the country
out of Salem

