

Build PM's Back-Yard Beauty – All-Purpose Toolshed

Page 110

POPULAR MECHANICS

MAY 1970
50 CENTS

ELECTROLUNG

– 1000-Foot Scuba?

Page 114

INDIANAPOLIS

500

PREVIEW

Can the Can-Am
Kings Blitz the
Brickyard?

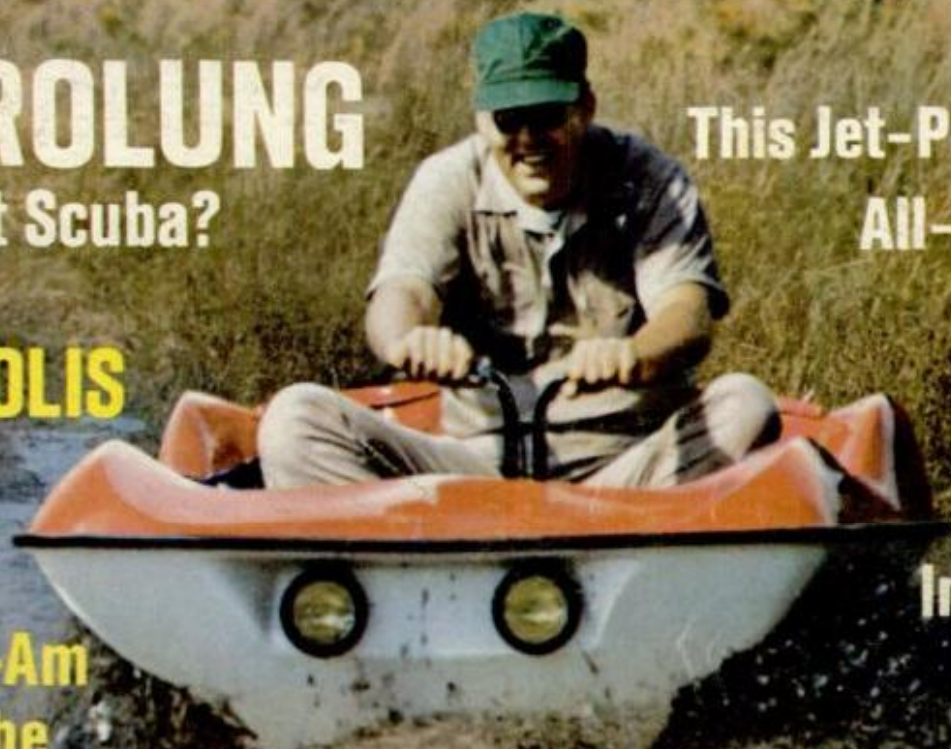

This Jet-Powered

All-Terrain

Vehicle

Really

Moves

In Water

Page 98

CAMPING '70

IDEAS • TIPS • EQUIPMENT

SPECIAL
32-Page Keep-It
SECTION

- New Mini-Cameras
- Stay-Hot Serving Cart
- Four Exciting Weekend Projects
- Saturday Mechanic • 4-Channel Stereo

Owners Reports: Mustang, Barracuda • Boat-Test Tips

Chrysler Fastbacks

Once upon a time an outboard was a putt-putt on the back of a rowboat. 1970! Wham! Enter the Chrysler Fastbacks.

Now, as powerful as the ocean-splitting Chrysler 120 or as mini as the Chrysler Swinger 3.6 hp. . . . with 41 more models in between. All hp.'s OBC certified. Add sports-car-type "racing stripes" . . . in fire orange or racing blue.

Now, hang one of these on your kind of '70 Chrysler Boat. An armada of choice, from fishers to cruisers, 8 to 24 footers, all shaped to *live* in water.

Chrysler Makes It Happen, Captain! Call for the name of your Chrysler Crew Dealer at 800-243-6000, free. (In Connecticut, 800-942-0655.) He's where it all happens.

MARINE PRODUCTS



CHRYSLER CORPORATION



Tireless.

This Atlas fiberglass belted tire keeps on rolling along. It rolls up more mileage than you thought possible.

If you want to keep on rolling get the new Atlas Plycron 2 plus 2*. This new kind of tire was subjected to one of the industry's toughest testing programs. Results proved it will deliver really outstanding mileage.

New construction puts Atlas ahead. Two fiberglass belts are bonded onto a tough Vicron polyester cord body. And for traction, the unique wide tread design literally puts

hundreds of gripping edges on the road at all times. These features add up to less tread squirm, extra mileage.

Buy a set of Atlas Plycron 2 plus 2 tires today. You'll never get tired of the money you save with every extra mile.

And remember, Atlas tires, batteries and accessories are sold at over 50,000 leading service stations.



**BELTED
FOR
MILEAGE**

This One



8UBP-3R4-NDS9

ATLAS
PLYCRON 2 PLUS 2

Trademarks "Atlas," "Plycron," "Vicron," Reg. U.S. Pat. Off.
*Trademark. © 1970 Atlas Supply Company



AN **AC** ACTION ADVENTURE

WILD RIVER RUN



When you guide a raft full of green-horns through the Colorado River Rapids, you've got to have equipment as rugged as the wild river run.

That's why professional guide Tony Sparks uses reliable AC Marine Spark Plugs in his outboards. Tony knows AC's hot tip resists fouling. So when he needs power to battle the rapids, he gets it.

You may never ride the Colorado River Rapids . . . but the same hot tip that's built into AC Marine Spark Plugs is built into the AC Fire-Ring Spark Plugs that go into your car. They fire hotter, burn cleaner. Next tune-up, insist on reliable AC Fire-Ring Spark Plugs. They're original equipment on all GM Cars. AC keeps your car in action.



MARK OF EXCELLENCE

AC SPARK PLUG DIVISION OF GENERAL MOTORS

AC BUILDS MORE PARTS FOR MORE CARS THAN ANYONE ELSE IN THE WORLD. AC FIRE-RING SPARK PLUGS • AC OIL FILTERS • AC AIR FILTERS • AC GASOLINE FILTERS • AC PCV VALVES • AC RADIATOR CAPS • AC GAS CAPS • AC CRANKCASE BREATHING CAPS • AC FUEL PUMPS



Dodge introduces two great new ways to work and play!

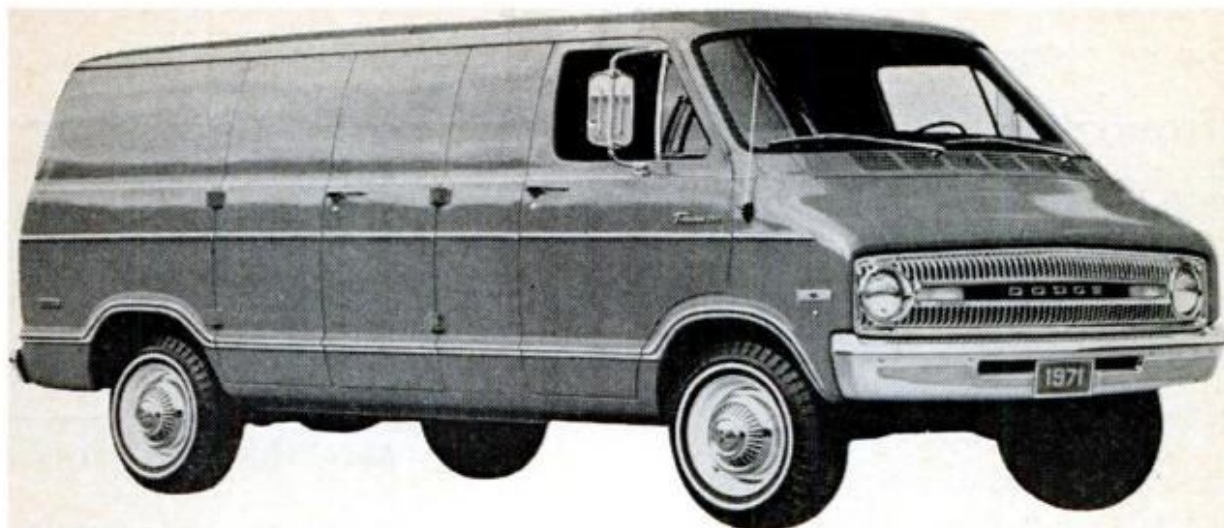

Tradesman van...for the man on the job.



Sportsman camper...for the man on the go.

Both with 31 significant advantages the better idea people can't match. See your nearby Dodge Dealer. He'll be happy to point them all out to you. Or send us the coupon for more information.

*Conversion shown is the Family Wagon Royale by Travco.

Dodge



TO: Dodge Division, P.O. Box 2088, Detroit, Michigan 48231.
Please send me more information on: (Check one)

Dodge Tradesman vans _____ Dodge Sportsman wagons _____

Name _____

Address _____

City _____ State _____ Zip Code _____

POPULAR MECHANICS®

INTERNATIONAL EDITIONS: AUSTRALIA, BRAZIL, CARIBBEAN, DENMARK, FRANCE, MEXICO, SOUTHERN HEMISPHERE, SWEDEN

AUTOMOBILES AND DRIVING

- [22 Detroit Listening Post](#)
- [36 Drivin' With Dan](#)
- [74 Automobile Clinic](#)
- [79 He Earns \\$30,000 a Year](#)
Behind the Wheel
- [90 Can the Can-Am Kings Blitz the](#)
Brickyard?
- [102 PM Owners Report: Plymouth](#)
Barracuda
- [122 Why Winnebago Is Number One](#)
- [128 PM Owners Report: Ford Mustang](#)
- [146 Saturday Mechanic: Troubleshooting](#)
Some of Those 'Newfangled Gadgets'

BOATING, OUTDOOR RECREATION

- [30 What's New Outdoors](#)
- [98 The Hustler: A New Breed of](#)
Arkansas Traveler
- [140 Be Your Own Boat Tester—](#)
Part 3: On the Water

HOME AND YARD

- [72 Homeowners' Clinic](#)
- [110 Build This Back-Yard Beauty](#)
- [118 Build This Electric Serving Cart](#)
- [154 Exciting New Products](#)
- [156 What You Should Know About Garbage](#)
Disposers Before You Buy One
- [162 18 Great Tools That Make](#)
Yardwork Easier
- [166 Super Scooper Saves Your Back](#)
- [170 Solving Home Problems](#)

ELECTRONICS, RADIO AND TV

- [134 Now It's 4-Channel Stereo!](#)
- [138 New in Electronics](#)

REGULAR FEATURES

- [6 Letters](#)

CAMPING '70

32-page tear-out section (*inside the front cover*) tells about public and private campgrounds, rigging your new RV, new first-aid techniques, use of bottled gas, camp security and what equipment you should have.

SPACE, AVIATION, MILITARY

- [14 Was Apollo Too Successful?](#)
- [83 How the Airlines Hope to Stop](#)
the Hijackers
- [87 A 'P-38' From Piper?](#)

SHOP AND CRAFTS

- [48 New Jointer Attachment for](#)
Your Unimat
- [150 Workshop Projects You Can Build](#)
in a Weekend
- [159 Hints From Readers](#)
- [160 A Puzzle to Stump You](#)
- [161 Hints From Readers](#)
- [169 Hints From Readers](#)
- [172 Black & Decker's New Low-Cost Radial](#)
- [174 Make This Split-Ring Lathe Dog](#)
- [176 You Can Improve Your Lathe Work](#)
With Indicators
- [179 New Tools You Should Know About](#)
- [180 Cabinetmaker Scrapers](#)

SCIENCE AND INVENTIONS

- [20 Science Worldwide](#)
- [96 Just Patented: PM's Pick of the](#)
New Inventions
- [114 Coming: the Safe 1000-Foot Dive](#)

PHOTOGRAPHY

- [106 Biggest Little Cameras in the World](#)
- [144 New in Photography](#)

Cover Photo by Burton McNeely
This Jet-Powered All-Terrain Vehicle Really Moves in Water

NEXT MONTH IN POPULAR MECHANICS

Jet That Goes Straight Up. Britain's amazing Harrier will join the U.S. Marines.
'71 Cars: Something New at Last? Sneak preview of Detroit's upcoming offerings.
New Tools for Treasure Hunters. Diver tells secrets of world's most successful finders.
PM Owners Reports. Buyers rate their Olds Toronados and Dodge Chargers.

ROBERT P. CROSSLEY

Editor

JAMES M. LISTON
Executive Editor

JOHN A. LINKLETTER
Managing Editor

WAYNE C. LECKEY
Home and Shop
Editor

SHELDON M. GALLAGER
Assistant Executive
Editor

THOMAS G. DAUER
Art Director

Published by The Hearst Corporation
RICHARD E. BERLIN, PRESIDENT

RICHARD E. DEEMS
President, Magazines Division

JOSEPH F. KERN
Publisher

BILL HARTFORD _____ Automotive
JOHN F. PEARSON _____ Science and Aerospace
GEORGE W. REIGER _____ Boating and Outdoors
SHELDON GALLAGER _____ Electronics and Photography
HARRY WICKS _____ Home Workshop
MICHAEL LAMM _____ West Coast Automotive
ROBERT LUND _____ Detroit Automotive
GARRY WINTER _____ Copy and Production
RICHARD H. FUNK _____ Associate Copy and Production
JOHN ADKINS _____ Assistant Copy and Production
ALVIN KIETZ _____ Assistant Art Director
DON EVANS _____ Assistant Art Director
FRED A. LEERS _____ Assistant Art Director
GEORGE W. BLOW _____ Technical Art Director
CLIFFORD B. HICKS _____ Special Projects
SOPHIE GRONOWICZ _____ Director, Bureau of Information
EVERETT JOHNSON _____ Cabinetmaker

ADDRESS ALL EDITORIAL COMMUNICATIONS TO: 224 West 57th St., New York, N.Y. 10019. For additional sources of information on the articles and products in this issue, write to Bureau of Information, Popular Mechanics, for free "Where-to-Find-It" list.

DANIEL J. COLEMAN
Director of Advertising

ADVERTISING OFFICES: New York: 224 West 57th St., 765-6850; Chicago: 520 N. Michigan Ave., 527-2400; Detroit: General Motors Bldg., TRinity 5-8711; Cleveland: 20310 Chagrin Blvd., Shaker Heights, 283-7788; Los Angeles: 601 North Vermont Ave., 666-6263.

SUBSCRIPTION SERVICE: Mail all subscription orders, changes of address, correspondence concerning subscriptions, and Postmaster notices of undeliverable copies to Popular Mechanics, Box 646, New York, N.Y. 10019. Please enclose your latest address label for quickest service when writing about your subscription.

POPULAR MECHANICS IS PUBLISHED MONTHLY by The Hearst Corporation, 37th St. at 8th Ave., New York, N.Y. 10019, U.S.A. Richard E. Berlin, President; George Hearst, V-Pres.; Richard E. Deems, President of Magazines; John R. Miller, Executive V-Pres. of Magazines; Raymond J. Petersen, Senior V-Pres. of Magazines; William S. Campbell, V-Pres. of Magazines; Albert A. Rachoi, V-Pres. and Director of Circulation; Joseph F. Kern, V-Pres. for Popular Mechanics; Frank Massi, Executive V-Pres. and Treasurer; Harvey L. Lipton, Secy. Single copy in the United States and Canada, 50 cents. Subscription prices: United States and Possessions \$5.00 for one year; \$9.00 for two years; \$12.00 for three years. Canada, add \$0.75 for each year. Pan American Postal Union countries, add \$1.00 for each year. All other countries, add \$2.00 for each year. When changing address, give old address as well as the new, with postal-zone number, if any, and allow six weeks for change to become effective. Second-class postage paid at New York, N.Y., and at additional mailing offices. Authorized as second-class mail by the Post Office Department, Ottawa, and for payment of postage in cash. Registered as second-class matter at the Post Office at Mexico D.F., Mexico, June 20, 1950. © 1970 by The Hearst Corporation. All rights reserved. Printed in U.S.A.

*Offer valid only where legal—for a limited time only



86 PROOF — EARLY TIMES DISTILLERY CO., LOUISVILLE, KY. © 1970

What's new Pussycat?

We hereby declare 1970 The Year of the Pussycat. Our national prize-winning drink has become a great success. No wonder. This sunny,



orange-sweet sour makes you want to purr. And mixes up quick as a cat. Just combine a packet of "Instant Pussycat Mix," water and Early Times. Ask for Instant Pussycat Mix at your favorite food or liquor store.

To get a set of 4-10½ oz. Pussycat glasses and 4 packets of Instant Pussycat Mix*, send \$2.95 to:
EARLY TIMES PUSSYCAT GLASSES,
P.O. BOX 378, MAPLE PLAIN, MINN. 55395

If your wife says she
doesn't go for the
great autumn day
aroma of Field
& Stream...

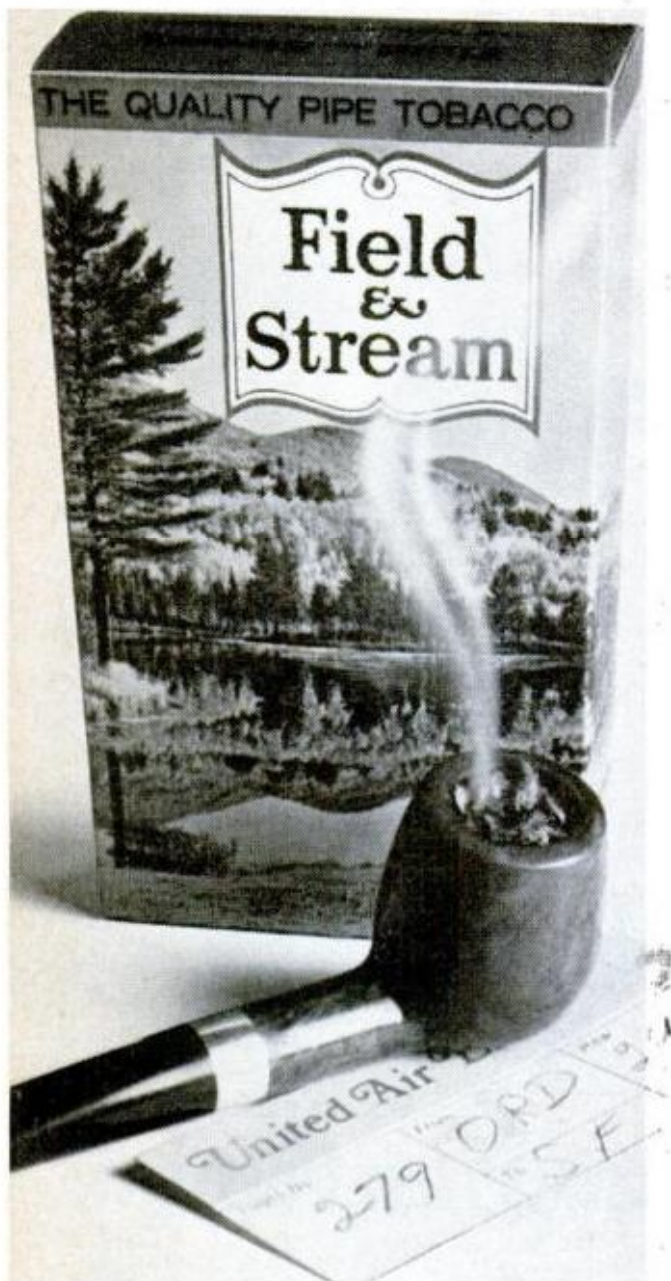

send her
home to
Mother.

A quality product of Philip Morris U.S.A.

LETTERS TO THE EDITOR

Uncannily timely

I can hesitate no longer to express my appreciation for your publication. In the two years that we have been receiving the magazine, hardly a month has passed that we have not found some item of immediate interest in the current issue.

A year ago we had a fire in our home. The very next issue of *PM* had an article on fire-detection systems that prompted the purchase of the system we have since installed. This past summer an article on paths and walkways helped with the construction of a brick patio and walks in our back yard. This winter, following the frustrations of many hard starts on cold Minnesota mornings, your article on automatic chokes was a lifesaver.

These are only a few examples. Timeliness of the articles has been uncanny.
NEW HOPE, MINN. THOMAS F. CARROLL

Thimbleful of power

I enjoyed the News Brief about the fellow who puts sailboats in light bulbs (*Mini-Mini-Boats*, page 112, Feb. *PM*). However, I am more interested in things

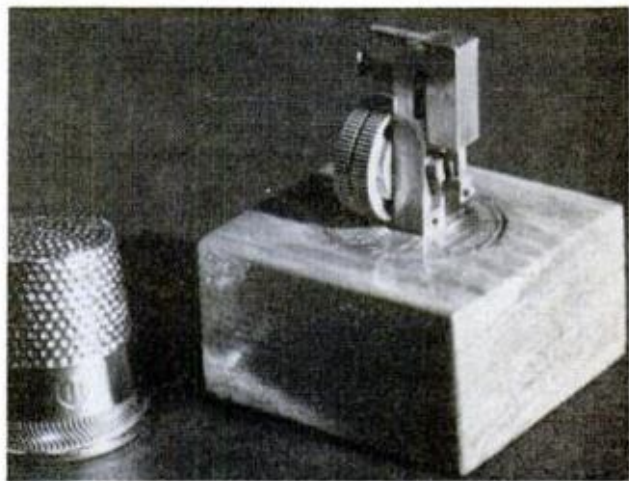

that move. Enclosed is a snapshot of one of a number of model steam engines I build in my spare moments. This one will fit in a thimble and is actually a high-speed engine.

NEW YORK

ANDREW SPRAGUE

End that muskrat ramble

There's a serious flaw in the plans for *Pontoon Fun Raft* (page 138, March *PM*). Apparently raw, or possibly painted, Styrofoam in the floats is exposed to the water. Styrofoam should be covered by hard-

(Please turn to page 8)

POPULAR MECHANICS

“ Our biggest task today is finding trained personnel to fill the executive and supervisory openings generated by our company's continued expansion. And this problem exists throughout the industry. Few careers offer so many positions with excellent salaries, fringe benefits and opportunities for advancement. To help meet our ever-growing need for trained executives, we strongly recommend such courses as the Food & Beverage Management Courses of the Educational Institute of the AH&MA to our own employees, and to all newcomers in the field. ”

—James E. Durbin,
Executive Vice President, Marriott Motor Hotels.



Now you can train at home for an executive career in the booming restaurant industry

More than 50,000 managers and supervisors are needed each year!

Here's your big chance to step up to man-sized earnings, executive status and a career with a future in one of the nation's largest industries.

America's exciting Restaurant/Club and Food Service industry has grown so big and fast it needs 50,000 more managers to help "run the show." At salaries of \$10,000, \$12,000, \$15,000 a year. And even more.

Food and beverage managers are professionals who enjoy prestigious careers that others envy. In restaurants and smart country clubs. In hotels and resorts. In big college and company cafeterias. At airports and on cruiseships. And in all the other places where millions eat away from home. Now *you* can take the step that will get you into this lucrative field with both feet!

Now—authorized "at-home"
training for you

Because there just aren't enough trained people around to fill all the new executive openings each year, the Restaurant/Club industry opens its doors wide to newcomers willing to train. The Educational Institute of the American Hotel & Motel Association is now offering its executive training courses to you through LaSalle, a leader in correspondence study. You learn in your spare time at home without a day lost from your present job.



Supervisory positions are open in top restaurants, clubs, lounges, resorts, travel lines, company and college cafeterias.

These are the same courses endorsed by top officials of such famous chains as Howard Johnson's, Hilton, Sheraton, Marriott, Ramada and many others.

When you have the LaSalle diploma and the AH&MA's Certificate in Food & Beverage Management—the Institute's placement assistance will be available to you.

Who may qualify for this training? Anyone who enjoys interesting work with above average pay and many fringe benefits, a life in congenial, often glamorous surroundings, the opportunity to meet people.

Get all the facts, without obligation. Mail the coupon today for free illustrated booklet "Rewarding Careers in Restaurant/Club & Food Management." LaSalle, 417 S. Dearborn Street, Chicago, Illinois 60605.

Send for FREE
career
booklet



LA SALLE EXTENSION UNIVERSITY
A Correspondence Institution

417 S. Dearborn Street, Dept. 53-095, Chicago, Illinois 60605

Please send me your free illustrated booklet
"Rewarding Careers in Restaurant/Club &
Food Management." No obligation, of course.

Print Name..... Age.....
Apt.....
Address..... No.....
City & State..... Zip.....

© 1970 LaSalle Extension University

Go ahead, have a picnic.



Have a ball with your outdoor furniture. Perk it up. Paint it up new. With Krylon® Spray Paints. They're fun to use. Fast to dry. And come in 49 colors. Mustard anyone?

You'll find Mystik® Tape, Krylon® Spray Paints, and Elmer's® Adhesives at Borden's "Love Thy Neighborhood" displays at your local store.



LETTERS

(Continued from page 6)

board (or even wire netting) because muskrats love to burrow in this stuff and will ruin a good float in short order. These animals live all over America.
NOPEMING, MINN. B. J. TERRELL, MD

Rocks, shoals—and now muskrats! That's a hazard they didn't tell us about in Power Squadron.

Not so new

Congratulations to the party who made the *Flip-Over Ladder-Chair* (page 175, Feb. PM). I have one that was manufactured in the early 1900s. It has dowels in the chair back and a wire locking device.
SIOUX FALLS, S.D. J. E. MARRION

We published it because we figured a lot of those old chairs would be wearing out about now.

Doesn't prove a thing

Easy-to-Fix Cars (page 83, Feb. PM) doesn't prove anything.
I am owner of a Ford, and those easy-

to-fix parts don't help because the biggest problems occur in the engine and the transmission. If the manufacturers would worry more about quality and craftsmanship in the mechanical parts, they might be able to sell somewhat better.
PALO ALTO, CALIF. PAT KENNEALLY

Liters or not, he likes us

Why do you quote and write in liters, meters and cc? Have you gone high hat? Put on the dog?

This is the U.S.A. I'm not buying a foreign subscription.

Young and old of several families read (or try to read) my magazine. You should realize this!

Even so, in spite of it, well, hell, I like PM.

BROOKSVILLE, FLA. C. B. BARNHILL

Shucks, we're just plain folks. Thanks a bushel (35.238 liters) fer writin'.

Uptight in Colorado

I've just finished reading *To the Summit by ATV* (page 102, March PM). First off, he should not have done it. People doing
(Please turn to page 10)

Save up to \$200 or more on auto air conditioning!



Super Unit.

Quick 'n easy to install, Comfy-Kit air conditioners give you cooling power that's unsurpassed — yet cost less than half the price of many units. This means you can earn up to \$50 an hour for installation time.

Comfy-Kit is available in three superbly engineered units: Supreme, Super Air and Standard. All give you famous Comfy-Kit durability and performance — plus trim

good looks that rival any unit on the market.

Let someone else pay the high prices for auto air conditioning. You'll have a better unit — save lots of money to boot. Comfy-Kit comes complete — including the loan of tools if you need them.

So, mail in your coupon right away. Enjoy windows-up comfort all year.

COMFY-KIT®

P. O. Box 8585, Dept. PM-5 • Dallas, Texas 75216

- Enclosed is \$133* for Standard Unit.
- Enclosed is \$148* for Super Unit.
- Enclosed is \$165* for Supreme Unit.
- Enclosed is \$30 deposit on a Super Standard Supreme Unit. I will pay the balance, plus C.O.D. charges when delivered.
- Enclosed is \$8.00 deposit for a set of four tools, which will be returned to me when I return the tools.
- I would like to see the instruction book before I order. I enclose \$1.00 for the instruction book only. I understand this will apply on any future Comfy-Kit order.

Name

Address

City State Zip

My car is a (year) (model)

Engine displacement Horsepower

Power Steering yes no

Floor shift Steering column shift

Smog pump yes no

*plus state tax where applicable

End squeaks in children's swings and play equipment.

When your children's backyard play equipment, swings and seesaws squeak, save your nerves—with 3-IN-ONE HOUSEHOLD OIL SPRAY in the aerosol can. It sprays deep into rust spots to end annoying squeaks. Lubricates and cleans, to prevent rust and tarnish. Get 3-IN-ONE HOUSEHOLD OIL in the aerosol can or squeeze can. In hardware stores and supermarkets.

3-IN-ONE[®]
HOUSEHOLD OIL



Lock loose casters into chair legs for keeps

When casters come loose, fill the leg hole like professional repairmen do—with GENUINE PLASTIC WOOD. Handles like putty—hardens like wood. Insert caster while PLASTIC WOOD is wet. It holds tight to both metal and wood. Get GENUINE PLASTIC WOOD Cellulose Fiber Filler in tube or can. In hardware stores or supermarkets.

GENUINE
PLASTIC WOOD[®]
CELLULOSE FIBRE FILLER



LETTERS

(Continued from page 8)

dumb things like that will just get all off-road vehicles banned. Wheels start erosion, tearing up tundra that takes 100 years to grow. There are other places that are just as challenging to drive without destroying the ecology. Second, you should not have printed the article because everybody will go do it just to prove he can. A lot of people in Colorado are already uptight over this situation and you didn't help a bit.

DENVER

FRED HENKE

Best project yet

When Mr. Clyde Lammey's plans for a hall clock came out (*PM's Handsome Hall Clock*, page 124, Oct. '69 *PM*), I knew at once that this was the one I had been waiting for.

I used black walnut, some of which had lain in my workshop for several years, but had to buy the longer pieces for the waist portion of the cabinet. My total outlay for materials was just under \$30.

I completed the clock just in time to present it to my wife for Christmas.

The enclosed photo does not do justice to the clock, but it does prove to me how well the plans were presented by Mr.

Lammey.

I read *PM* regularly and make many projects but this is the best yet.

KINGSPORT, TENN.

CECIL H. DAVIS

Any readers who want to build the clock but missed the two-part (Oct.-Nov.) article can get Xerox copies of the pages for \$1.40. (In fact, any past articles can be obtained the same way. Figure 20 cents per page plus 15 cents for mailing.) *PM* also has a revised catalog of plans, publications and projects available for 25 cents for postage and handling.

Order any of them from Popular Mechanics Service Bureau, Dept. JL, 224 West 57th St., New York, N.Y. 10019.

Instant inflation

The *Shelv-A-Grill* indoor barbecue grills (Exciting New Products, page 180, March *PM*) were tagged with amazingly low—and, unfortunately, erroneous—prices. A spokesman for Jenn-Air Corp., the maker, reports that the single and twin units sell for \$360.75 and \$419, respectively. ★ ★ ★



Vista[®] gives your car a shine like sterling.

Get real deep-down, hard-wax kind of shine—a dazzling shine like sterling with Simoniz[®] Vista.

Vista is a special paste-wax blend of jeweler's polish and high gloss silicones. You clean and wax in one easy step...for a dazzling shine that lasts.

Get Simoniz Vista. Paste, Liquid, or new Soft and Easy formula. Give your car a shine like sterling.



**NEW! Soft and Easy Vista
with handy applicator.**

SIMONIZ is a registered Trade Mark of Texize Chemicals, Inc.

EARN BIG MONEY IN AIR CONDITIONING REFRIGERATION & HEATING

25 KITS SENT TO BUILD THIS
COMPLETE REFRIGERATION SYSTEM



APPROVED FOR GI TRAINING
If you served since January 31, 1955 or are
in service, check GI line in coupon

A better job, top pay and steady work are easily within your reach. Learn to repair and install air conditioning systems, refrigerators and freezers. Air conditioning is one of America's fastest-growing industries. Millions of autos and homes are being air-conditioned. The need for trained men is immediate and great.

Make Home Your Training Center—Learn by practicing. CTI sends 25 kits of tools and parts to build a complete refrigeration system—which you later convert into a refrigerator or freezer. The course is easy!

Earn Money As You Train—Since the CTI course includes training with real equipment, many students earn money repairing units soon after enrolling. On completing training they go into top pay jobs. Many get started in their own business.

Mail Coupon Today for FREE book. No obligation. Prove to yourself that the air conditioning, refrigeration and heating field is best for you—the easiest training to master and loaded with top pay opportunities.

Commercial Trades Institute, Chicago, Ill. 60626

COMMERCIAL TRADES INSTITUTE
1400 Greenleaf Avenue
Chicago, Illinois 60626 Dept. PM570



Send book, Be a Success in Air Conditioning,
Refrigeration & Heating. No obligation.

Name _____ Age _____

Address _____ Zip _____

City _____ County _____ State _____

Check for facts on GI Bill

Accredited Member National Home Study Council

New Improved HEAVY DUTY FOUR-WAY AMERICA'S ORIGINAL LOW-COST ARC WELDER AND ELECTRIC TORCH

10 DAY
TRIAL

LIFETIME
GUARANTEE

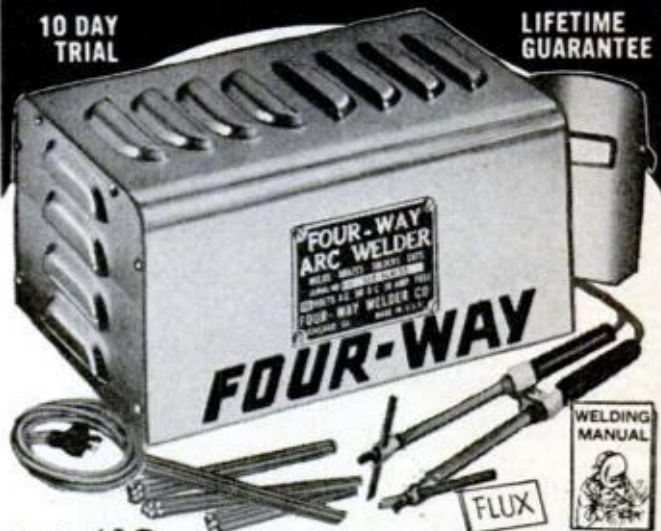

Only \$18.95 Prepaid Complete Ready To Use
\$20.95 VALUE. WITH EXTRA \$2 PACK OF SUPPLIES
WELD, BRAZE, SOLDER, CUT

Every home, shop and hobbyist needs this quality metal working machine. Use up to 1/8" welding rods and 1/4" carbons. Follow simple instructions to make or repair 1001 items including furniture, toys, auto bodies, fenders, trailers, boats, farm and garden tools and equipment. Operates on 110 V. 30A. for pennies—Adjustable Twin Carbon Arc Torch easily REGULATES HEAT FOR EACH JOB. Eliminates changing cables—replaces gas torches—no tanks or refills to buy—produces to 1,000° heat. YOU CAN PAY MORE BUT YOU CAN'T GET A BETTER LOW COST WELDER. Over 500,000 in use. Manufacturers of welders for over 30 years. LIFETIME GUARANTEE. Simply return prepaid. We will repair and reship FREE of charge. YOU GET: heavy duty welder in rugged metal cabinet, ground clamp, cables, combination torch and rod holder, welding manual and helmet, plus Free \$2.00 pack "TOUCH WELD" rods for instant automatic arc, brazing rods, 1/4" carbons, solder and flux. Complete ready to use. Nothing else to buy.

FREE Only 4-Way Gives You an Extra \$2.00 Pack
Welding & Brazing Rods, Carbons, Flux and
Solder. 2 Packs With Order.

Order Today on Money Back Trial. If Not Completely Satisfied, Return in 10 Days and We Will Refund Purchase Price. SEND ONLY \$2.00 and pay \$16.95 plus C.O.D. and delivery charges, or send only \$18.95 for postpaid shipment in Continental U.S.A. Four-Way Welder Co., 1810 Federal St., Dept. R2-E, Chicago, Ill. 60616

I-N-V-E-N-T-O-R-S WE NEED INVENTIONS

Sell your invention for cash—need money for Patent?—Are technical problems holding you back? Universal Inventions has helped inventors all over the world—just like yourself—why not you? Inventions provide the magic spring-board to sudden riches. REMEMBER, we either sell your invention or pay you a cash bonus. Write for details. UNIVERSAL INVENTIONS, Dept. 13, Marion, Ohio

FREE!

Learn how you
can buy used
engines \$15 up,
new engines \$30
with FREE confidential list and
coupons when you
order your plans

BUILD THIS MINI-BIKE!

Plans reveal step by step details!

BUILD A RACING KART!

Build frame for less than \$10!



RUSH \$2 for plans (indicate type) or
send 25¢ for circular describing plans
PLANS, Box 517, Omaha, Nebr. 68101

The Ronson Varaflame Butane Torch.

For people who take their fun seriously.

Torch with 150 gr. Multi-Fill Injector and idea book. Only

\$6.95

- Lightweight, compact, safe, easy to handle.
- Adjusts from pinpoint to blowtorch flame.
- Burns for hours on economical butane gas.
- Multi-Fill fuel injectors available everywhere.
- Cleans itself, never clogs.

Meet the hottest, handiest, sturdiest little torch that's ever crossed your palm. It's a fixer of pipes and tubing. A drain-patching, paint-removing, putty-softening, jewelry-making, ice-melting, toy-mending, tool-repairing, go-everywhere, do-anything whiz of a tool.

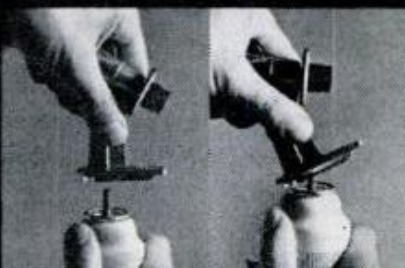

A SNAP TO FUEL: Place Ronson Varaflame® Torch in position over Ronson butane Multi-Fill® fuel injector and SNAP...you're set for hours of hobby-making fun, or serious professional work.



DIAL YOUR FLAME: Turn calibrated dial to precisely adjust from pinpoint to blowtorch flame to meet exacting demands of the most critical job.



STANDS ITSELF: Place torch on flat working surface. Tripod formed by torch head and Multi-Fill provides firm three-point stand, leaving both hands free for holding, bending and turning operations.



VERSATILE: 7- and 10-piece Ronson Varaflame Torch kits include three flame head attachments: Soldering Tip, Blowtorch Tip and Flame Spreader.

7-PIECE TORCH KIT with torch, 3 head attachments, 250 gr. Multi-Fill and idea book, \$11.95



10-PIECE TORCH KIT in plastic carrying case, 3 head attachments, 250 gr. Multi-Fill and idea book, \$13.95



RONSON

DIFFERENT BY DESIGN AND BETTER BECAUSE OF IT.

Ronson Corp., Woodbridge, N. J., U. S. A. Available in Canada. All prices suggested retail.

Материал, защищенный авторскими правами.

Was Apollo Too Successful?

Nine months after the whole world watched Neil Armstrong climb down that ladder on the moon some Americans are "bored" with space, and we're breaking up the scientific team and mothballing the engineering complexes that produced what President Nixon called "the greatest event since Creation." What was the name of that movie last year? *Goodbye, Columbus?*

The President put his name on the plaque Armstrong and Aldrin left on the moon and he telephoned them while they were there, but he cut America's space budget to the smallest total since John Glenn orbited the Earth. The Vice-President says on to Mars by 1985, but we won't make it by "stretching out" our effort. Perhaps NASA was *too* successful with Apollo. It violated the "Catt Concept," enunciated by Britisher Ivor Catt. According to Catt, the most secure project is the unsuccessful one, because it lasts the longest. Since most layoffs follow completion of a project, only a fool or a brave man completes one unless he is already entangled in its successor.



Seven thousand people, we read the other day, rode snowmobiles into Yellowstone Park last winter. It was only three years ago we sent Dan Fales on the *first* snowmobile safari through the park. If you've been wondering what has happened to Dan, we suggest you plunk down a dollar for a copy of our new sister publication (*Sports Afield's* offspring, to be precise), *Rod & Gun*. It's the handsomest, slickest, most exciting outdoor magazine we've ever seen. Because of the great job he did as Boating and Outdoors Editor of *PM*, Dan was "drafted" to be Executive Editor of *R&G*.

Dan's successor on *PM*, as you've no doubt discovered, is George Reiger, a 30-year-old, 6-foot 3-inch fishing nut, naval officer and Princeton graduate who joined us last summer after two tours of duty in Vietnam, two years of teaching Vietnamese and small-boat handling at the Naval Academy and six months as language officer at the Paris Peace Talks. A bachelor when we hired him, George disappeared one Friday in January. When he showed up on Monday, he had a bride, secretary to Alabama Congressman, Jack Edwards. On a delayed honeymoon in March, George and Barbara explored the new Arkansas River waterway in a houseboat. You'll read about it in a couple of months.



Editor

ARROW
All-Purpose
STAPLE GUN
T-50

SHOOTS A STAPLE

Uses 6 Staple Sizes 1/4" to 9/16" including Ceiltile.

WHEREVER YOU'D DRIVE A NAIL!

At Hardware, Lumber & Building Supply, Stationery, Variety and other retail outlets.

ARROW FASTENER COMPANY, INC.
271 Mayhill Street, Saddle Brook, N. J. 07663

FREE CATALOG OF WATERFRONT EQUIPMENT

Docks, pontoon boats, ladders, mooring bars and other Perma-D products.

WRITE: PERMA-D MARINE PRODUCTS DIV.
DEPT. 50, CENTRAL MACHINE CORP.
P.O. Box 4243, Minneapolis, Minn. 55418

HOLD IT!
the glue that never lets go!

write for FREE glue and caulk selector guides

WILHOLD

WILHOLD GLUES, INC.
8707 Millergrove Dr., Santa Fe Springs, Cal. 90670



Learn at Home to Fix APPLIANCES

Plus Air Cond. & Refrigeration

MAKE \$5 TO \$7 AN HOUR



It's a fact — there are a billion appliances in U.S. homes. You can profit from this growing, demanding field. Learn at home quickly to fix small and large appliances, air conditioners, refrigeration units, farm and commercial appliances, power tools, small gasoline engines. Earn extra money in spare time, have a full-time business or get a good job. Low-cost training includes professional Appliance Tester. Mail coupon for FREE CATALOG. No obligation. No salesman will call. NRI APPLIANCES TRAINING, Washington, D.C. 20016.

NATIONAL RADIO INSTITUTE 600-050
Appliance Division, Check for facts on GI Bill
Washington, D.C. 20016

Name _____ Age _____

Address _____

City _____ State _____ Zip _____

If you can solve this "problem" you could become a computer programmer!

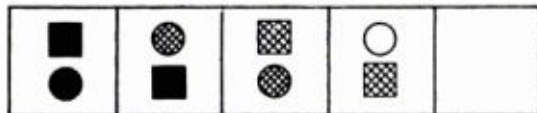

INSTRUCTIONS FOR COMPLETING THE LOGIC SERIES TEST

- (1) The problem shows a series of 4 figures and a blank answer box.
- (2) Note VERY CAREFULLY exactly HOW the figure changes from box to box.
- (3) In the blank answer box, draw the figure which you logically believe would be next in the series.

Do you enjoy unscrambling problems? Like the one illustrated above? Then it's likely you have a logical mind—which is really what it takes to become a successful computer programmer.

Programmers are in Demand—Even though 300,000 men and women work as computer programmers, thousands more are still needed. Now, through a remarkable home-study course, you could qualify for a high paying job as a Computer Programmer.

No Math Required—You'll use IBM's official course material. Learn by methods which actually enable you to
MAY 1970

progress at your own pace. You don't need math. You don't have to know how to operate a computer (that's another field). All you really need is a logical mind.

Without interfering with your present job, you can prepare yourself for a fascinating, rewarding future.

Academy Guarantee! Computer Programming Academy™ guarantees that if after successful completion of your home study course, you have been unable to secure employment in this field and have furnished documented proof of a sincere effort to do so, Computer Programming Academy will at its option either refund to you the full tuition paid or permit you to repeat the course at no additional cost.

Free Brochure: An Exciting Age—Mail coupon for a FREE Copy of "An Exciting Age." Plus full details on your course of study and an aptitude exam. There's no obligation.

COMPUTER PROGRAMMING ACADEMY, Box # PM-5
640 Palisades Ave.
Englewood Cliffs, N.J. 07632

Please mail to me the free illustrated booklet "An Exciting Age."

Name _____ Age _____

Address _____

City _____ State _____ Zip _____

Occupation _____

the glass fixer

T.M.

glazing compound

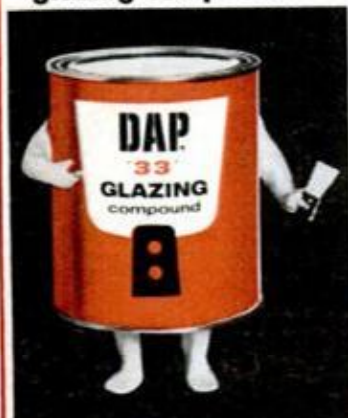

DAP '33' Elastic Glazing Compound. Easy to use and the best way to replace broken window glass. Stays flexible for airtight, watertight seals. Outlasts ordinary putty by years.

DAP

DAP Inc., Dayton, Ohio 45401/Subsidiary of *Plough, Inc.*
Also available in Canada

GO GUM carburetor cleaner keeps engines regular. GO GUM—removes gum, varnish and sludge in carburetor and fuel system. Regular use of GO GUM prevents sluggish performance, rough idling, stalling and fuel waste. Works while you drive.



The laxative for your car.

Another dependable from **DeMert**

DeMERT & DOUGHERTY, INC./5000 West 41st Street/Chicago, Illinois 60650

HIT KIT FOR THE DO-IT-YOURSELF DAD



All those little jobs that need doing around the house or summer place? Those loose shingles and screening? That chair that needs rewebbing? The shelf that should be re-lined? The shade that ripped away from its roller? Dad can fix 'em all – in no time at all – with our T-5 Stapler Gun Tacker. (Our T-5 can even drive heavy duty staples through hardwood or metal.)

T-5 Kit includes Stapler Gun Tacker, 3000 assorted staples – all in handy case that Dad can carry around the house, the yard, the summer place. Sold at hardware and building supply counters everywhere. Bostitch, Briggs Drive, East Greenwich, R.I. 02818.

BOSTITCH
A **textron** COMPANY

A POWER PACKED PERFORMER



- with Non-Breakable Fiber-Glass handle guaranteed not to break, bend or collapse in normal use.
- and PermaBond—keeps handle tight for added safety and service.

FA57
NAIL HAMMER
\$7.29



MR. SAFETY SEZ:
Nail and ripping hammers are made to drive or withdraw common nails. Any other use may be hazardous.
SO . . . Be a safe driver. Hit common nails and nothing else.

PLUMB

FAYETTE R. PLUMB, INC. • PHILADELPHIA, PA. 19137

PUBLICATIONS **WORTH WRITING FOR** BY CATHERINE BILSKI

FROM PM'S LIBRARY come two exciting and educational wall charts. These full-color reproductions of *U.S. Warplanes in Vietnam* and *U.S. Helicopters in Vietnam* are printed on heavyweight stock, measure 19x25 inches and are suitable for framing. You can get both of the charts for only \$1. Send your remittance to Popular Mechanics, Dept. VB, 224 West 57th St., New York, N.Y. 10019.

PLANNING YOUR VACATION? Well

here's a book that will help you select the tour which will best suit your budget and holiday duration. Called *The World Travel and Vacation Almanac*, it lists 2744 separate travel tours with brief description of each, a 100-page guide to countries and cities and lots more. \$2.50 from Enterprise Press, 230 Park Ave., New York, N.Y. 10017.

IF YOU HAVE BOUGHT a radial-arm saw and want to know how to get the most out of it, Black and Decker's new radial-saw manual leaves nothing out. Written by Howard Silken, an expert in the use of the radial saw, the book deals specifically with the DeWalt R-1450, but the many tricks and jigs given can be applied to any make saw. Send \$3.95 to Home Industry Tool Distributors, Inc., 2 Merle Ave., Ocean-side, N.Y. 11572. ★★★

A new supersmall electromagnetic device for taking precise measurements of heart performance and blood flow has been developed by Dr. Alexander Kolin, professor of biophysics at the UCLA School of Medicine. The wire-like detector is inserted into an artery by means of a hypodermic passed through the skin. A magnetic field generated outside the patient creates a voltage in the blood streaming through the artery. Made up of two tiny electrodes spaced about an inch apart inside a thin tube, the meter senses the voltage and thus measures flow rate. The device, says Dr. Kolin, can be as small in diameter as 20/1000ths of an inch, only a bit larger than a human hair. The smallest instruments of this type now used are too large for introduction into the bloodstream without surgery.

Those old tires, beer bottles and plastic containers that litter many roads could be used in the construction of new highways. That's the idea of Texas A&M's Dr. Douglas Bynum, an engineer, who says that ground-up glass, rubber and plastic are useful pavement additives. Rubber tires make a good binder for asphalt, and crushed glass is an outstanding aggregate. Powdered plastics improve the pliability of asphaltic concrete and plastic chips can be used as an aggregate.

A clean bill of health for DDT is given by James W. Wright, an official of the World Health Organization. He says that no toxic effects from DDT were reported in over 20 years by the estimated 200,000 spraymen working on antimalaria campaigns around the world nor by the 600 to 1000 million people living in homes that have been sprayed repeatedly. Millions of lives have been saved by the insecticide, according to the official, who asserts that limiting its use in malaria-threatened countries could result in a major disaster. In addition to malaria, DDT is used to fight insect-transmitted diseases such as dengue, plague and sleeping sickness.

One of the world's tiniest engines—smaller than an ordinary paper clip—is made by North American Rockwell's Rocketdyne Div. The mini-engine develops a scant 1/100th of a pound thrust and is designed to be used to change the attitude of an interplanetary spacecraft. Two of these engines firing together for a fraction of a second could move a spacecraft a quarter turn in about 15 or 20 minutes, according to a Rocketdyne engineer. Because fabrication involves working with tolerances of 1/10,000th of an inch, some components are made by a jewelry concern.

A computer reads your electric, water or gas meter automatically through your telephone line—and without ringing your phone or perceptibly tying up the line. Bell Telephone has developed such a system, which it plans to test in 150 homes at Holmdel, N.J. Here's how it works: After an attendant establishes a connection between the utility's computer and special equipment at the phone company's central office, the computer calls the subscriber's number. The call automatically goes to the meter, traveling over special circuits so that the bell is not rung. Gadgets at the meter convert mechanical dial readings into electrical pulses that are sent back to the utility's information collection center.

An electronic collar and NASA's Nimbus 3 weather satellite may combine to tell scientists about the migratory habits of elk. The 23-pound collar contains an antenna, transmitter, receiver, batteries and solar cells for recharging. It's sealed against water and can withstand temperatures of minus 40°F. It will be fitted around the neck of an elk among the 7000 on a refuge in Wyoming. A system aboard the Nimbus 3 will interrogate the collar twice daily from orbit, obtaining info on air and animal skin temperatures, altitude above sea level, light intensity and location. In addition to NASA, the experiment is sponsored by Smithsonian Institution and Department of the Interior. ★★

KEEP PACE WITH SPACE AGE! SEE MOON SHOTS—LANDINGS, SPACE FLIGHTS, CLOSE-UP!

AMAZING SCIENCE BUYS

for FUN, STUDY or PROFIT



WOODEN SOLID PUZZLES



Here's a fascinating assortment of 12 different puzzles to provide hours of pleasure and stimulate ability to think and reason. Animals and geometric forms. Take them apart and reassemble them. Lots of fun for the whole family—Young and old. Will test skill, patience and ability to solve problems. Order yours now.

Stock No. 70,205H \$5.00 Ppd.

SCIENCE FAIR HEADQUARTERS

GIANT WEATHER BALLOONS

"Balls of fun" for kids, traffic stoppers for stores, terrific for amateur meteorologists. Create a neighborhood sensation. Great backyard fun. Exciting beach attraction. Amateur meteorologists use to measure cloud heights, wind speed and temp. Made of heavy duty neoprene. Inflate with vacuum cleaner or auto air hose; or locally available helium for high rise.

Stock No. 60,568H (8 Ft. diameter) \$2.00 Ppd.
Stock No. 60,632H (16 Ft. diameter) \$7.00 P. d.



AMERICAN MADE OPAQUE PROJECTOR



Projects illustrations up to 3" x 3 1/2" —enlarges them to 35" x 30" if screen is 6 1/2 ft. from projector, larger pictures if screen is farther away. No film or negatives needed. Projects charts, diagrams, color or black-and-white. Operates on 115 volts A.C. current . . . 6 ft. extension cord and plug included. Size 12" x 8" x 4 1/2" wide. Weight 1 lb. 2 ozs. Plastic case.

Stock No. 70,199H \$8.75 Ppd.

ROTATING MULTI-COLORED LIGHT



Dazzling colors stream endlessly from constantly rotating light. Faceted, transparent globe has lowered drum inside with red, green, blue & yellow stars. Bulb heat rotates drum which projects flickering star points on walls, ceilings, etc. while individual globe facets present constantly changing array of brilliant colors. 11 1/4" star—approx. 12" high on bell-shaped base. Surprisingly light. Easily placed on table, TV, fireplace, or Xmas tree top.

Stock No. 71,000H \$6.00 Ppd.

PLASTIC MODEL V-8 ENGINE

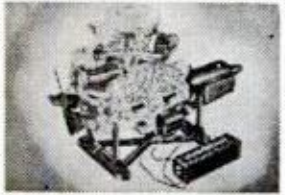

Hours of fun! Get thrill of building your own easily assembled engine from over 350 parts. Then push starter and watch it run. Crankshaft revolves, pistons move, valves open and close in sequence with spark plugs. Does everything but burn oil. 1 1/4 scale, molded in 4 colors. Used in many auto-mechanic courses. Excellent, easy-to-understand "tech manual."

Stock No. 70,448H \$12.95 Ppd.

HOT-AIR FLYING SAUCER KIT



Giant 9 ft. model rises to amazing heights. Easy to assemble and launch. Use over and over. Low cost. Lots of fun. Can carry 1 1/2 lb. objects with string tether. Fly school colors at games, use for advertising, attach mirror—play "spy in the sky." Includes complete instructions, 16 pre-cut 2 1/2 white model paper gores, 8 red panels for portholes, wire, cord. Easily repaired if damaged.

Stock No. 71,175H \$3.00 Ppd.
9 Ft. Hot-Air Balloon Kit

Stock No. 60,691H \$2.00 Ppd.

WAR SURPLUS ELECTRIC GENERATOR



Brand new Signal Corps Electric Generator. Generates up to 90 volts by turning crank. Use in high impedance relays. Charge ground & bring up night crawlers for bait or study. 2 Alnico Magnets alone now worth more than original gov't cost of \$15. Wt. 2 lbs.

Stock No. 50,225H \$ 6.95 Ppd.

MOUNTED WITH LIGHT, TO DEMONSTRATE ELECTRICITY.

Stock No. 50,365H \$11.95 Ppd.

3" ASTRONOMICAL TELESCOPE



See moon shots, orbits—stars, phases of Venus, planets close up. 60 to 180 power. Aluminized and overcoated 3" diam. f 10 primary mirror, ventilated cell. Equatorial mount with locks on both axes, 60X eyepiece and mounted Harlow lens. 3X finder telescope, hardwood tripod. FREE: "STAR CHART"; "HANDBOOK OF HEAVENS".

Stock No. 85,050H \$29.95 Ppd.

Stock No. 85,105H 4 1/4" \$94.50 FOB

Stock No. 85,086H 6" \$239.50 FOB

BATTERY POWERED GYROSCOPE

Have the fun & enjoyment of a gyro without bother of constant string winding & pulling. 5" diam. flying-saucer shaped. Spins on its edge, upside-down, on your head, hanging from a string, drives rocket car, races around ring . . . you'll be amazed at its performance. Accessories incl. rocket car, pedestal, 19" diam. orbit ring, ring pedestal, cap, chain, loop, instruct. Operates on 2 "C" batt. (not incl.).

Stock No. 71,161H \$6.00 Ppd.



DIAGNOSE MECHANICAL TROUBLE

Professional Stethoscope. Designed for use by physicians, this super-sensitive Stethoscope is ideally suited for detecting faults in machines and engines, and in fluid, air and gas leakage. Dozens of uses in auto repair shops, labs and for hobby and educational applications.

Stock No. 50,270H \$7.50 Ppd.

BARGAIN PRICE STETHOSCOPE

Stock No. 50,223H \$3.25 Ppd.

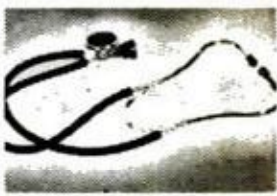

AMAZING "TRICK" PHOTOGRAPHY KIT

Now any amateur can produce all kinds of weird, wild, way-out photo effects. No special knowledge, or equipment required. Unique kit enables you to turn friends into monsters, show house with water to 2nd floor, make psychedelic slides, kaleidoscopic photos, impressionistic photo-art . . . unlimited possibilities. Complete instructions reveal the secrets . . . includes all accessories needed.

Stock No. 71,229H \$10.50 Ppd.



"FISH" WITH A MAGNET

Go treasure hunting on the bottom! Fascinating fun & sometimes profitable! Tie a line to our 5-lb. Magnet—drop it overboard in bay, river, lake or ocean. Troll it along bottom—your "treasure" haul can be outboard motors, anchors, other metal valuables. 5-lb. Magnet is war surplus—Alnico V Type—Gov't cost \$50. Lifts over 150 lbs. on land—greater weights under water.

Stock No. 70,571H \$14.00 Ppd.

Stock No. 70,570H 31 1/2 lbs. (lifts 40 lbs.) \$ 8.75 Ppd.

Stock No. 70,572H 71 1/2 lbs. (lifts 175 lbs.) \$18.75 Ppd.

Stock No. 85,152H 153 1/4 lbs. (lifts 350 lbs.) \$33.60 FOB



NEW MODEL DIGITAL COMPUTER

Solve problems, teach logic, play games with miniature version of giant electronic brains! Adds, subtracts, multiplies, shifts, complements, carries, memorizes. Colored plastic parts—easily assembled. 12" x 3 1/2" x 4 1/4". Incl. step-by-step assembly diagrams, 32-p. instruction book covering operation computer language (binary system) programming, problems & 15 experiments.

Stock No. 70,683H \$5.98 Ppd.

ANALOG COMPUTER KIT

Stock No. 70,341H \$18.95 Ppd.

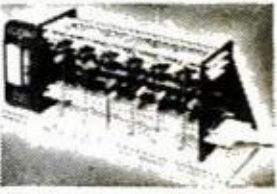

MAIL COUPON FOR GIANT FREE CATALOG

148 PAGES! MORE THAN 4,000 UNUSUAL BARGAINS.

Completely new Catalog. Packed with huge selection of telescopes, microscopes, binoculars, magnets, magnifiers, prisms, photo components, parts, kits, accessories—many hard-to-get surplus bargains, 100's of charts, illustrations. For hobbyists, experimenters, schools, industry.

EDMUND SCIENTIFIC CO.
300 Edscorp Building, Barrington, N. J. 08007

Please rush Free Giant 1970 Catalog "11"

Name

Address

City

State

Zip



ORDER BY STOCK NUMBER • SEND CHECK OR MONEY ORDER • MONEY-BACK GUARANTEE

EDMUND SCIENTIFIC CO. 300 EDSCORP BUILDING

BARRINGTON, NEW JERSEY 08007

DETROIT

LISTENING POST

BY ROBERT LUND

WHAT NEXT, AFTER THE MINIS are launched? There's nothing nailed down on this, but the next trend could be two-in-one automobiles—cars that could be used for conventional purposes or as recreational vehicles. The long-range thinkers who rough out the basic package three to five years ahead of production are looking at the idea. The concept may sound like old stuff to those of you wheeling around in Broncos, Blazers, Scouts and Jeeps. But those are basically work vehicles that can also be used as passenger cars. The new type of car under consideration would be a switch on the utility car in that it would be an everyday automobile first with features built in so it could double as a recreational vehicle. If it comes off, much of the credit will go to Borg-Warner, which has developed a four-wheel-drive system for nonutility cars—meaning standard passenger cars.

HOW ABOUT A REMAKE of Chevy's small car under the Pontiac label, say next spring, after Chevy has popped the cork? The Tempest followed Corvair, remember? Chevrolet brought out Corvair in October, 1959, and Tempest followed in November, 1960. Pontiac general manager Jim McDonald answered the question *comme ci, comme ca* at a press conference. "We've traditionally served GM a notch above Chevrolet," he replied, "so if the market is sliding that way, we have to look in that direction." That may sound like a strong maybe, but don't bet on it. Talking to McDonald privately, *PM* asked if the division has ordered tooling or asked for bids on tooling to produce a small car. McDonald says, "Positively not." So if Pontiac has a small car in the oven, it's a long way from being served up. At the same bash, *PM* asked Steve Malone, Pontiac's chief engineer, if the industry is coming to the bumperless car. There have been a couple of no-front-bumper jobs in recent months. It started with Plymouth's Superbird and then Pontiac's Firebird showed up minus a front bumper. Malone says he can't see the idea spreading to many cars. "You have to consider the entire vehicle," he explains. "You can carry it off on an intermediate or a specialty car, but I don't think you'll see the bumper—front or rear—done away with on the big cars." The nose section of Firebird is made of polyurethane plastic—Pontiac calls it "Endura"—a material that has a retention characteristic causing it to return to its original shape under minor impact.

GM AND FORD have apparently decided to steer separate courses in a couple of areas where they've been traveling tandem. GM has never liked the idea of going along with the long-hood, short-deck look in cars popularized by Ford. Not that GM is anti the tight-rear, elongated-hood shape. But the leader in sales figures it ought to lead in styling too, rather than follow a theme pioneered by a rival. Starting this fall, GM will begin to break out of the Mustang mold by stretching out the aft end of its big cars. The change won't hit you as a new shape, because the transformation will be made gradually, over a period of several years. But GM is going to a more balanced distribution of metal—less hood, more rear. In another area, there's evidence GM and Ford don't see eye-to-eye on ways of improving service features of their respective cars. Ford is all for making parts easier to get at and easier to repair. GM goes along on the accessibility angle, but believes emphasis should be on reducing the need for service and the chances of something going wrong, rather than on making parts easier to repair.

WITH THE INDY 500 COMING UP, it seemed like a good time to put a couple of questions to old never-say-die, Andy Granatelli, winner of last year's contest. Here's how it went. *Listening Post*: "Are we reaching a peak on speed at Indianapolis?" *Andy*: "Hell, no! You have to have one constant factor in racing—the track. Cars and drivers improve against that constant. We'll see a 175-mph qualifying lap at Indy this year or

(Please turn to page 24)

Will we have to put this label on our package?



Caution:

**The Spoiler®
is habit-forming.**

The miracle plastic coating on these super stainless blades gives such comfortable shaves that you may be unable to stop using them.

10 BLAD

Gillette Super Stainless: The Spoiler®

DETROIT LISTENING POST

(Continued from page 22)

next. If USAC had really let us innovate, you'd see safe speeds in the 180-mph bracket right now." LP: "What's Detroit's emphasis on safety going to do to racing?" Andy: "Nothing. Racing's survival and progress have always depended on ongoing safety developments. We have the fly-apart chassis now and fuel cells that are nearly fireproof. Next, you'll see water-filled crash walls, speedway walls, a continuous ribbon of safety lights and all kinds of new safety ideas. Racing will always get faster—and safer." LP: "Suppose there were no strings, no financial restrictions, anything goes. What kind of car would you build?" Andy: "That's easy. It'd be an all-new STP-Turbocar, an improvement on No. 40 [Granatelli's Indy entry of 1967 that stopped five miles short of victory]. It would make the hair stand straight up on every racing fan in the world. You couldn't build seats fast enough to handle the audience."

IT'S A LONG WAY from Andy Granatelli and Indy 1970 to Rene Thomas and Indy 1914. It's a long way from Indianapolis, U.S.A., to Villa Indianapolis, 15 Rue de la Paix, Colombes, France. That's Rene Thomas's address. Who's Rene Thomas? He participated in the 500 four times: 1914, 1919, 1920 and 1921. He won the race in 1914 in a Delage, average speed 82.47 mph. That was the only time he finished in the money. Thomas is now 84 years old. He still drives his own car and takes in the races at Le Mans, Rouen and Reims. He has raced everything except trains and horses. Bicycles, motorcycles, cars, planes, you name it. He fell out of a plane while stunt flying in 1910, breaking his shoulder in three places and acquiring a nickname he has carried for 60 years. He is known in France as "The Death Deceiver." Thomas raced cars for eight companies—LaCoste & Batman, Prima, Delage, Le Gui, Peugeot, Sneider, Talbot and Sunbeam. If you want to know anything about those makes, drop him a line. He doesn't read or write English, so you'll have to translate into French. (It says at the beginning that this space is supposed to stick to stuff on Detroit. This detour just once, with your indulgence, please, for an old champion.)

THERE'S BEEN TALK about early introductions of the '71 cars. The theory is that sales of the current cars have been so disappointing to Detroit that the auto companies would like to push the off button as soon as possible and move in with a fresh batch of cars in the hope of signing you up

for a '71. Yes and no. Each company sets a minimum production target at the beginning of the model year and these goals are used to order a certain number of door handles, instrument panels and other components that can't be carried over to the next model year. Good times or bad, the minimum "buy" on these items must be used up before a new model goes into production. It will be July or August before parts inventories are used up, so the new cars won't be out any earlier this year than last. That means you'll see most of them between the final week of August and the first week of October.

MID-ENGINE FORD isn't a Ford at all. The company won't be making such a car but it will be instrumental in importing one. Ford's year-old working arrangement with Alejandro de Tomaso has resulted in a Ford-powered, midship-engine car that will be in select Lincoln-Mercury dealer showrooms in the autumn. The name is "Pantera," Italian for panther. De Tomaso of America is already promoting the machine and Linc-Merc dealers are preparing prominent display areas for the



foreign car they'll be selling and servicing. It's powered by Ford's 351 V8, weighs 2860 pounds, has a wheelbase of 98.4 inches and a length of 167 inches. It has monocoque chassis and independent suspension front and rear. Other technical features of the car, which will be priced under \$10,000, include ventilated disc brakes front and rear with 464-sq.-in. swept area. Transmission is a Zed-F five-speed. Cast magnesium wheels and low-profile radial tires are standard.

The Italian car, first seen here at last month's New York Auto Show, gives Ford the jump on other U.S. makes (namely Corvette) in getting a mid-engine car to market.—B.H.

AN AGENT at American Motors says *Listening Post's* prediction that AMC will be the second (to Ford) U.S. carmaker to bring out a mid-engine vehicle and the first domestic car manufacturer to produce a mid-engine in the United States is half-safe, half-cocked. It's definite that AMC

(Please turn to page 26)

Tell someone you like about Lark's Gas-Trap™ filter...



...he may stay in the game.

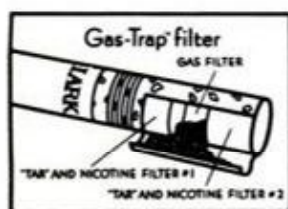

Bet him that almost 90% of cigarette smoke is made up of gases. (You'll win.)

Now tell him only Lark has the patented Gas-Trap™ filter. A filter with amazing charcoal granules. One that reduces certain harsh gases in cigarette smoke as well as "tar" and nicotine.

No need to bluff. Offer him a Lark. He can taste the difference Lark's Gas-Trap™ filter makes, himself.



Soup for nuts

Car nuts, that is.
It's 100% Pure Pennsylvania
with ZDP.

Tough. Heat-resistant.
Cools the hot ones for the
track or traffic. Buy your oil
the way you bought
your car. Carefully.

Wolf's Head Oil Refining Co.,
Oil City, Pa. 16301.

WOLF'S HEAD

RACING
MOTOR OIL
with
ZDP

NET CONTENTS 1 U.S. QUART

the uncommon motor oil
Exceeds car makers'
warranty requirements.

DETROIT LISTENING POST

(Continued from page 24)

has a mid-engine upcoming, probably next spring. But according to the Man Who Knows, it will be built in Italy. It will be a limited-production job with about 36 to be built the first year. At least one exists now. It's called AMX/3 and is powered by AMC's 390-cu.-in. V8.

1971 CHEVY VANS number 36 models in $\frac{1}{2}$, $\frac{3}{4}$ and, for the first time, 1-ton ratings. Two basic body styles are the side-windowless Chevy-Van and Sportvan wagons. The luxury Beauville, shown here, is the top of the Sportvan line. Most prominent change is the extended front end. The engine has been moved forward, resulting in more usable floor space, easier access to the rear, greater passenger protection in a collision and outside engine servicing through a conventional front hood. Front-seat entry is easier, too, since wheels are



ahead of the doors. The side-loading door is of the sliding type and conceals an inside step. Short and long-wheelbase models are 110 and 125 inches, respectively; overall lengths are 176.9 and 200.9 inches, both are 79.9 inches wide. Vans in the new line are bigger in all dimensions than previous models. Standard powerplant in six-cylinder models is 250 cu. in. putting out 155 hp. Standard V8 is 307 cu. in. in half-ton vans, and 350 in $\frac{3}{4}$ and one-ton models.

—B. H.

GROOVY HIGHWAYS might be the bane of motorcyclists, and many drivers of cars have also cursed and wondered about their effectiveness. Many states began grooving curves on new freeways and turnpikes after NASA tests showed that grooving dramatically cut down hydroplaning and skidding on wet pavement. (See *Farewell to Wet-Weather Skids*, page 124, March '67 PM.) Now the National Safety Council reports accidents on grooved surfaces have dropped 30 to 60 percent compared to the same curves ungrooved. ★★★



Build A Better Dream

with
Dremel
Creative
Power Tools

Dremel's dream tool . . . the compact, portable power shop.

The Moto Shop weighs only 12 pounds. It operates on a table top and stores on a shelf. It is basically a jigsaw with a 15-inch throat. It has a power takeoff for a grinding wheel, sanding disc, or buffing wheel. And there's a flexible shaft attachment, too, for carving, polishing, drilling, etc.

When an idea takes shape, Dremel Moto Shop shapes the idea. Build a better dream. Dream priced at \$37.95 to \$54.95.



Dremel Moto Tool—the most versatile tool you can own . . . grinds, carves, drills, polishes, deburrs, sharpens, engraves, routs! Fastest, most powerful tool of its kind. Permanent magnet, 30,000 RPM constant torque motor defies stalling. Complete kits with storage case and 34 accessories from \$34.95 to \$49.95.

Years from now, you'll be glad you got a Dremel creative power tool today. Not just because its superior quality makes it outlast and outperform them all . . . but also because years from now your grown-up children will be closer to you, cherishing the memories of when your family had the fun of *Building A Better Dream* together.

Creating with a Dremel is a Family Affair!



Make Room for Mamma. She goes creative with Dremel Moto Shop, a complete power shop in one compact, portable unit with attachments. Many women are creating their own gifts, knick-knacks, toys, household items. Some are even making money by selling their creations as gift items.



Bringing up Junior. Encourage his natural creative instincts with the Dremel Moto Tool. It makes child's play of any job, because it works so efficiently. Even Junior can hold this compact power tool in one hand, just as he would a pencil. You build a better man when your boy enjoys building a better dream.



For Handy Hubbies and Hobbyists. He'll get professional results with his Dremel Moto Tool. It handles any job with precision; makes it fun to do home projects, make household repairs. Gives you the "feel" you like for delicate, precision work—muscle, too, when it's needed.

WRITE for free literature or see your dealer for a demonstration. Send \$1.45 for 160-page "Dremel Handbook of Hobbies, Crafts and Projects." It's jam-packed with fun-filled projects for the whole family.



CREATIVE POWER TOOLS

Dremel Mfg. Co.

Dept. 1160-E • Racine, Wisconsin 53401

BUY THIS HOMELITE[®] CHAIN SAW



Get \$20 worth of accessories FREE

Buy a new Homelite XL-12 or Super XL Automatic (with 16" bar and chain) at the regular price from your participating Homelite dealer and take home these handy accessories absolutely FREE –

- Molded Carry Case
- Flat File, Round File
- Ampol File Handle
- Oregon Depth Gauge
- Bar and Chain Oil – pint
- Engine Oil – 1/2 pint
- Plastic Wedge
- Accessory Compartment – fits inside Carry Case

With one of these time-tested, money-saving Homelite chain saws you can take care of any outdoor woodcutting job – from cutting firewood, pruning and limbing, clearing brush and saplings, felling trees up to 3-foot diameter ... even to making a rustic picnic table or log shelter.

See your nearest participating Homelite dealer and take advantage of this spectacular offer while promotional supply lasts. Homelite dealers are listed in the Yellow Pages.

HOMELITE

10205 RIVERDALE AVE., PORT CHESTER, N.Y.

A **Textron**
DIVISION



Don't waste your life in a dead-end job!

Become a well-paid computer programmer—this free McGraw-Hill booklet tells you how.

Now you can train at home, in your spare time, for a career in this new, exciting field.

More than 50,000 programmers are needed now; many more will be needed within the next few years.

No college or technical background required. All you need is a logical mind and proper training. People from virtually every walk of life have found success in computer programming.

This new course has been developed by experts. CREI/McGraw-Hill has trained thousands of men and women for better jobs through home study and has an unmatched reputation in educational circles.



JUST OFF THE PRESS!

For **FREE** booklet, mail coupon or write: CREI, Dept. P1105A, 3224 16th Street, N.W., Washington, D.C. 20010

Founded 1927



Accredited Member of the National Home Study Council

APPROVED FOR TRAINING UNDER NEW G.I. BILL

CREI, Home Study Division, McGraw-Hill Book Company
Dept. P1105A, 3224 Sixteenth St., N.W., Wash., D.C. 20010

Please mail me **FREE** booklet with complete information on how I can learn computer programming at home. I have a high school diploma or the equivalent.

Name _____ Age _____

Address _____

City _____ State _____ Zip _____

WHAT'S NEW OUTDOORS

BY GEORGE REIGER

BASS AND BREAM are on their spawning beds this month, and new products are on the market to aid anglers in catching, keeping and "recording" them. From Commerce-Pacific comes the Depth/Range Finder Reel RF-70 (right) with its patented Memory-Lok. Later in the season when bass school in deep water, this device will enable you to set the reel so your lure will return to the same depth automatically. Ideal for still fishermen and trollers, the reel is also claimed to be an aid to casters who set it so that their lures always shoot out the same distance. But what angler wants to make more than a few casts to precisely the same spot? For more information, write Commerce-Pacific, 161 W. 24th St., Los Angeles, Calif. 90007.

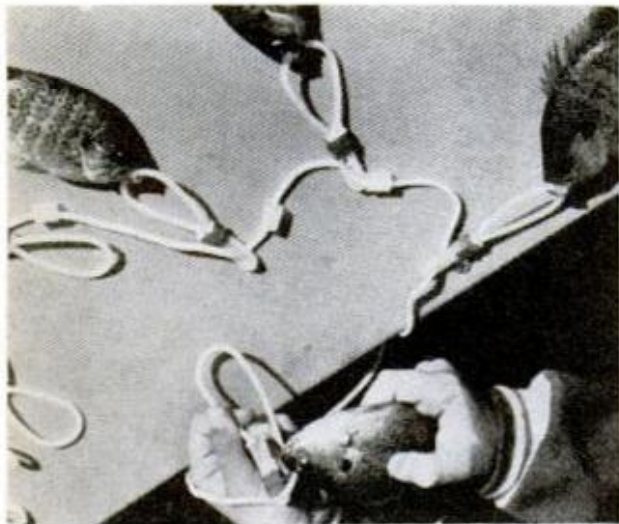

ALL-NYLON FISH STRINGER (left) has been developed by DeWitt Plastics (26 Aurelius Ave., Auburn, N. Y. 13021). It will neither corrode nor rot, and once the fish is hooked on the stringer (both lips should be hooked so the fish can breathe properly and live longer) and the lock slid into place over its plastic socket, a positive locking action is created that eliminates sprung clips—and escaped fish! Free-sliding clip means fish can be attached and spaced up or down the cord without lifting the entire stringer from the water. In 6, 10 and 15-foot lengths, each stringer sells for \$1.35. ★★★

WHILE GYOTAKU (ichthyography) has been fairly popular in Japan for years, only recently has a kit for this process been made available to Americans. India ink and rice paper are the essential components used in making a silhouette (right) of any fish that you would like to record without actually mounting it. An unfortunate feature of the system is that unless you fillet one side before you make the print, you'll be unable to eat any part of your catch because the fish is washed in soap and water before copying, and the ink solution itself is poisonous. While I had some difficulty in coming up with a decent facsimile of our experimental sunnies, I may just lack the proper knack. The kit is great for kids who want to keep a record of their first fish. For more information, write Anglecraft Inc., R2, Gardiner, Me. 04345.

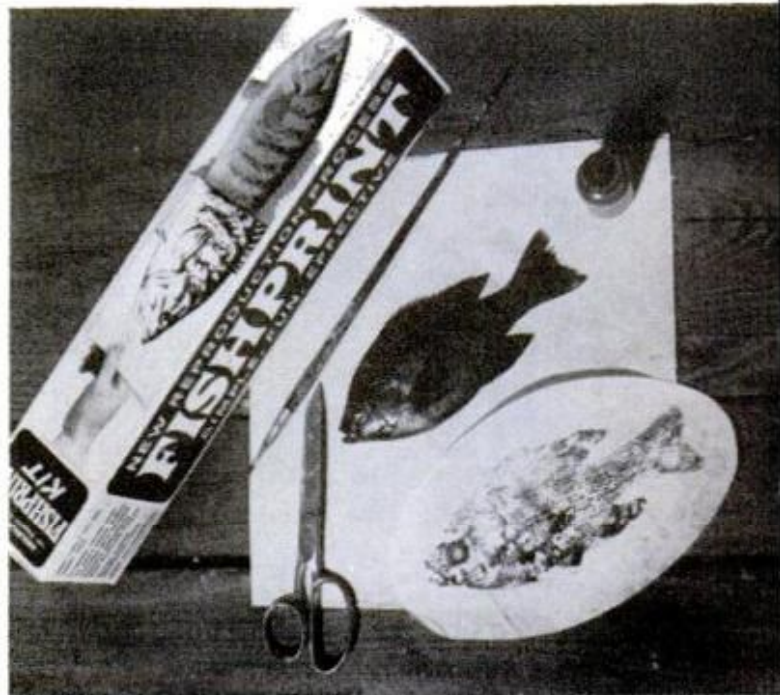

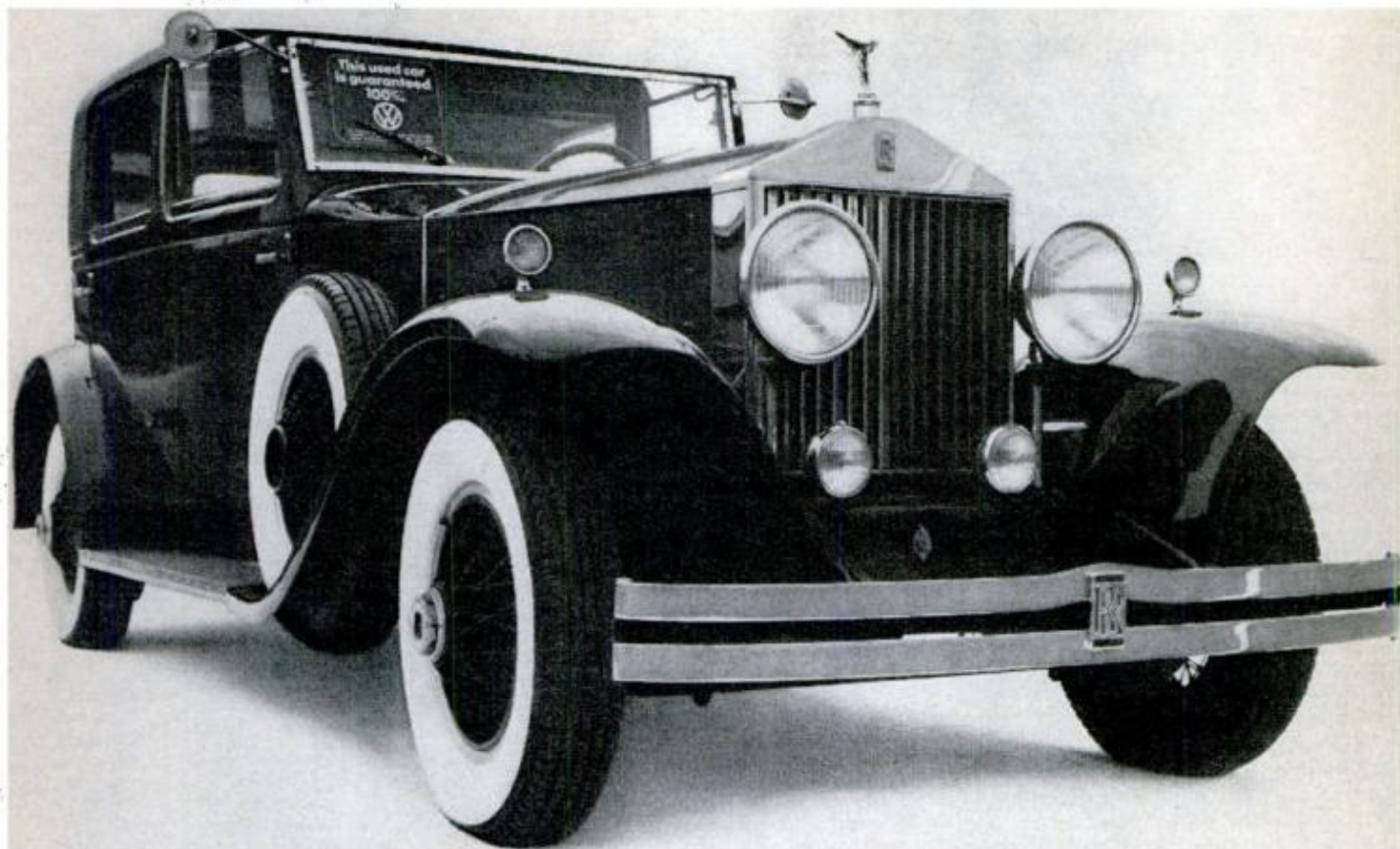

Pick up a good second car from Volkswagen.

Somebody traded in a Rolls-Royce for a Volkswagen?

Yes, somebody traded in a Rolls-Royce for a Volkswagen.

It happened in Texas, of course.

But even in average states some pretty fancy cars show up on a VW dealer's used car lot.

And some not so fancy cars. And some quite practical cars. Like Volkswagens.

But no car, Rolls or VW, gets that guarantee on the windshield automatically.

First it goes through a rigorous 16-point in-

spection.

If anything needs fixing, it gets fixed.

Only then does the dealer guarantee the free repair or replacement of every major working part* for thirty days or a thousand miles.

Whichever comes first.

So when a Volkswagen dealer says that a used car is as good on the inside as it looks on the outside, you don't have to trust him.

He'll put it all down in writing for you.

This
used car is
guaranteed
100%.



*engine, transmission, rear axle, front axle assemblies, brake system, electrical system.

Turn any car into the toughest car in town

Whether your baby is a 'Vette or a VW, you can have her humming like a little atom-smasher, every part doing its job with laser-beam cleanness. Just grab onto the giant 1970 MOTOR's AUTO REPAIR MANUAL.

Brand New 1970 Edition Now Available

Shrewd racing mechanics bank on MOTOR's AUTO REPAIR MANUAL to give them every last fact about the cars they're handling and to make the most of their car sense. Whatever it takes to get top performance, from a simple carb adjustment to a complete tune-up, MOTOR's 1970 Manual gives you the know-how of a pit pro.

225,000 Repair Facts for 2,300 Car Models

The big 1970 Edition has more than 1,000 double-size pages featuring 55,000 specs and 365 quick-check spec charts, 225,000 service and repair facts, and over 3,000 "this-is-how" photos and diagrams. They get you into the guts of 2,300 domestic models—Standards, Compacts, and Intermediates—including all the hot '70's, plus the Volkswagen.

Detailed Trouble-Shooter Section, plus trouble-shooting information throughout, helps you to pinpoint 4,200 car troubles. Then you're shown exactly how to quickly fix almost any part of these cars made in America from 1964 to 1970: Toronado, Mustang, Barracuda, Bronco, Jeep,



Chevy II, Pontiac, Thunderbird, Buick, Imperial, Cadillac, Continental, Dart, Ford, Mercury, Chevelle, Chevrolet, Chrysler, Plymouth, Rambler, Dodge, Oldsmobile, Buick Special, Comet, Corvair, American, Olds F-85, Falcon, Ford Fairlane, Lancer, Tempest, Corvette, New Front-Drive Cadillac, Lincoln, Mark III, AMX, Camaro, Valiant, Cougar, Scout—even Montego, Javelin, Torino, Blazer, Challenger, Hornet, Rebel, etc. They're all included—plus Volkswagen. And you get tune-up and front-end alignment specifications for all cars built from 1946 thru 1963.

And all this information is authoritative. It comes from the car manufacturers themselves. MOTOR's editors distill more than 300 official factory manuals and hundreds of service bulletins to make sure your auto repair questions are answered, your service problems are solved. That's why over 5 million copies have been sold—to auto buffs, beginner and professional mechanics, students—making MOTOR's AUTO REPAIR MANUAL the all-time best seller in the field.

If you really want to keep your machine mean, we'd like you to make a test run with the big '70 MOTOR's AUTO REPAIR MANUAL.

10-Day Free Home Trial

Just fill in and mail the coupon on this page, and we'll send you a copy of the '70 MOTOR's Manual to look over and use, free, for ten days. Then, if you're satisfied, simply pay \$9.95 plus a few cents handling. Otherwise, return the book and owe nothing. MOTOR Book Dept., 250 West 55th Street, New York, N. Y. 10019.

SAME 10-DAY FREE TRIAL ON MOTOR's Auto Engines & Electrical Systems.

Ideal basic book for enthusiasts, students, engineers, mechanics. Explains engines and electrical systems thoroughly, showing exactly how and why they work. Over 700 pages, 1,300 illustrations. Only \$10.00.



MOTOR BOOK DEPT., Desk 0015 250 W. 55th St., N.Y., N.Y. 10019

Please send me the book(s) checked below, for 10-day free examination. If I decide to keep them, I will remit payment as indicated.

MOTOR's Auto Repair Manual, \$9.95, for which I will remit \$2.00 in ten days, \$3.00 monthly for two months, and a final payment of \$1.95 (plus delivery charges and sales tax, if any).

MOTOR's Auto Engines & Electrical Systems, \$10.00, for which I will remit \$2.50 in ten days and \$2.50 monthly for 3 months plus delivery charges and sales tax, if any.

Print Name _____ Age _____

Address _____

City _____ State _____ Zip Code _____

SAVE MONEY! Check here if you are including payment in full for book(s) ordered, in which case we pay postage. Same 10-day trial applies; you can return book(s) for prompt, full refund.

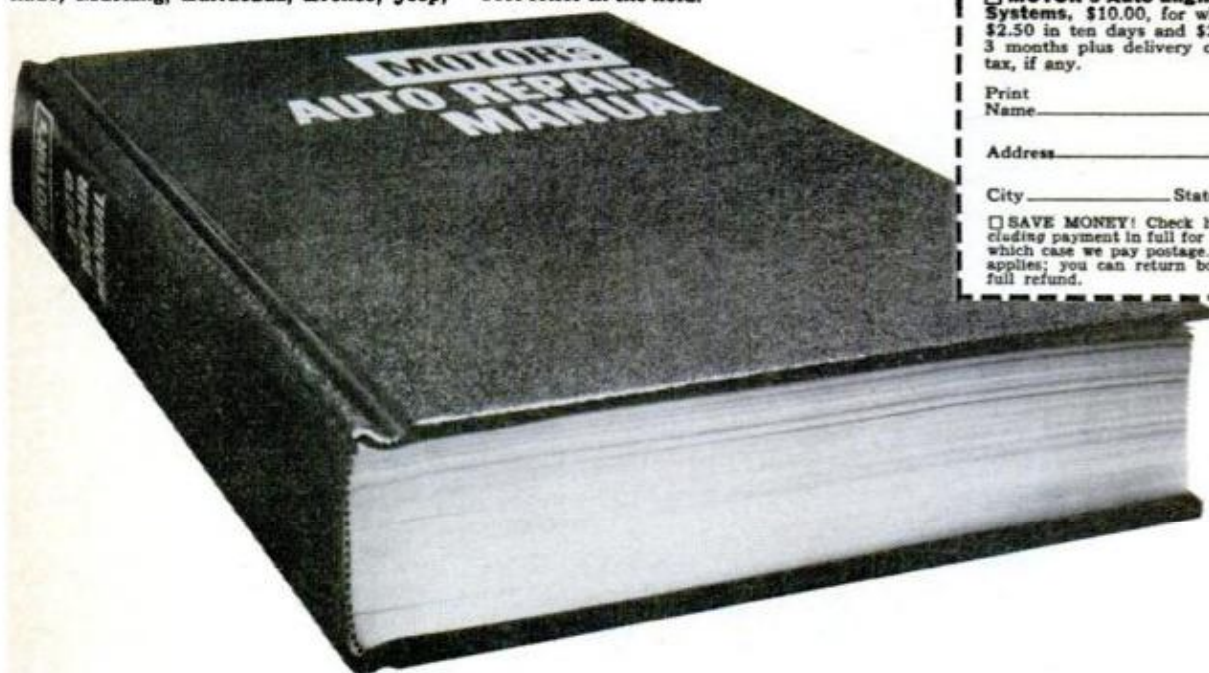

Owens-Corning explains the high cost of not enough insulation.

Fiberglas 6&3 insulation could save over \$3,000 toward your mortgage

6" of Fiberglas* insulation in ceilings and 3" in walls can cut heating and cooling costs as much as 30% a year.

Fiberglas 6&3 insulates so well, it could save a homeowner more than \$3,000 toward payments over the term of a 25-year mortgage. Yet it costs only around \$200 more than requirements of FHA minimum property standards.

How much you might save depends on size and location of your house. To find out, locate your zone on the map — then estimate your savings on the charts.

Free booklet tells you more. It's called The Full Story of Full Insulation. Write Owens-Corning Fiberglas Corporation for it today, Attn: P.M. Meeks, Box 901, Toledo, Ohio 43601. Then ask your dealer or builder for Fiberglas 6&3.

*T. M. Reg. O-C. F.

Calculate possible savings in your area — add heating and cooling savings for total.

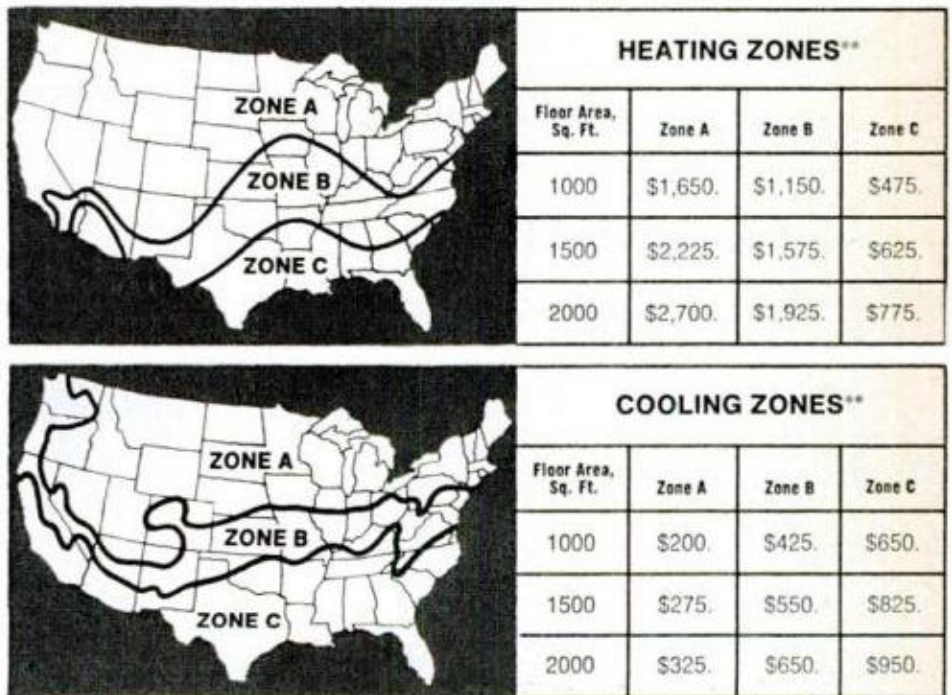

**Estimated savings: Ranch house on slab, 15% glass area, over 25-year term of mortgage. Heating costs, 10¢ per therm, cooling costs 0.02¢ per KWH. 6" & 3" versus FHA minimum property standards.

Owens-Corning is Fiberglas



We've taken the "bite" out of pipe smoking



Your favorite blend never had it so smooth, right from the very first puff because: the world's only pre-smoked pipe needs no breaking-in! What curing does for tobacco, pre-smoking does for your Dr. Grabow.

WORLD'S FINEST IMPORTED BRIAR

Starfire.....\$5.95
Viscount.....\$6.95
Commodore...\$7.95
Eldorado.....\$10.00

For FREE informative booklet, write Dr. Grabow pre-smoked pipes Box 21888, Greensboro, N. C. 27420

Dr. Grabow

the World's Only Pre-Smoked Pipes

ACCORDION PLAYERS ARE HAPPIER...

when they save 1/2 or more dealing direct with America's leading accordion importer. You save at least 50% off prices you'd expect to pay for comparable accordions. Save on accordion amplifiers, too. Over 40 standard, electronic and button models of world's most famous makes. All with newest features. Get 5 day home trial. Small down payment delivers. Easy terms. Trade-ins welcomed. Money back guarantee. Write today for catalogs and discount price list.

ACCORDION CORPORATION of AMERICA, Dept. R-50
5535 West Belmont Ave., Chicago, Illinois 60641

TUNE UP ELECTRONICALLY ANY CAR EVER MADE!



- ✓ COMPACT or LIMOUSINE
- ✓ DOMESTIC or FOREIGN
- ✓ POSITIVE or NEGATIVE GROUND
- ✓ 4, 6 or 8 CYLINDER
- ✓ 6 VOLT or 12 VOLT

With New Improved Model BT-162

DWELL TACHOMETER

ASSURE EASY STARTS, OPTIMUM PERFORMANCE and MAXIMUM GAS ECONOMY with MODEL BT-162

MADE ORIGINALLY FOR THE PROFESSIONAL AUTOMOTIVE TECHNICIAN, MODEL BT-162 WILL PAY FOR ITSELF MANY TIMES OVER FOR THE AUTOMOTIVE HOBBYIST AND EXPERIMENTER.

The Model BT-162 will perform the services specified below in addition to many other tasks too numerous to mention.

It is no longer necessary to file points to smoothness when using the Model BT-162. The instrument will automatically make allowance for any existing "pitting" or "wear." • Indicate the most effective point setting without removing the distributor cap. • Indicate the correct settings for external adjustment type distributors. • Car manufacturers' dwell angle recommendations are included in the manual provided with the Model BT-162. • To adjust for mathematically correct carburetor adjustment and thus insure maximum gas economy and quiet engine running, simply use

the Tachometer section of the Model BT-162. • To locate a "miss" you need only disconnect or "short" the spark plugs one at a time with the Model BT-162 switched to the Tachometer position. You will be able to instantly identify which particular plug (or frequently its wire lead) is responsible for the malfunction. • Cars with automatic transmissions function efficiently if the fluid pressures are correctly maintained. Since manufacturer's instructions always refer to RPM when making such adjustments, the 5,000 RPM range of the Model BT-162 is ideal for this purpose

Operating manual includes manufacturer's dwell angle recommendations for all cars. The manual is yours to keep even if you decide to return the instrument. **\$29.95**

**SEND NO MONEY WITH ORDER
PAY POSTMAN NOTHING ON DELIVERY**

Pay Cash or in EASY MONTHLY PAYMENTS AFTER 15 Day Trial!

Try it for 15 days before you buy. If completely satisfied remit \$29.95 plus postage and handling charge. (If you prefer you may PAY MONTHLY ON OUR EASY PAYMENT PLAN.) If not completely satisfied, return to us, no explanation necessary.

ACCURATE INSTRUMENT CO., INC.
2435 White Plains Road, Bronx, N. Y. 10467

Dept. 745

Please rush me one Model BT-162. If satisfactory I agree to pay at the terms specified at left. If not satisfactory, I may return for cancellation of account.

Name _____

Address _____

City _____ State _____

Save money! Check here and enclose \$29.95 with coupon and we will pay all shipping and handling charges. You still retain privilege of returning after 15-day trial for full refund.

MOW AN ACRE IN 30 MINUTES!



MAN SIZE!

Handles 48" and 60" mowers . . . bigger implements for gardening, dozing, removing snow. Here's why: Big 14 hp . . . extra size and traction . . . all-gear-drive with automotive clutch, transmission and differential. More for your money! Send for free catalog.

ECONOMY TRACTOR

1005 K-5 Anoka Ave.
Waukesha, Wis. 53186

Start A Profitable BUSINESS On A Shoestring!



You don't need big money to make big money. A small investment in the complete saw sharpening equipment from Foley gives you the right start. Includes the remarkable Foley Automatic Saw Filer that sharpens hand saws, band saws, and circular saws. No Experience Needed. Earn up to \$8 an hour — even in your spare time! Work out of your home to start.

FREE Plan Tells All

Write for our FREE PLAN that tells you how to get going in a going business of your own. No big investment needed. No salesman will call. We assist with financing. Send for exciting information today!



FOLEY Manufacturing Company

Dept. 516-0 Foley Bldg, Minneapolis, Minn. 55418



RON RIEDER, PRESIDENT OF AMERICAN UNIFAX, SAYS:

“If you can give me just 10 hours per week of your spare time, I’ll show you how to add as much as \$300.00 to your present income.”

DOES an extra \$300.00 per week sound “just too good to be true”? If you’re willing to invest about 10 hours per week in your own future. I assure you that profits like this are very definitely within reach. Let me give you some real-life examples.

A Florida housewife, with no selling experience whatsoever, spent “maybe 5 minutes” talking to the Purchasing Agent of her local newspaper and left him a sample of a revolutionary new product. The result: a \$785 sale—including a \$215 commission for the housewife! The manager of a Connecticut bank, helped only by his teenage daughter, spends a few hours evenings and weekends mailing out samples of this same product. The orders that pour in a few days later net them an average of over \$275 a week. And a California businessman reports that the sales volume of his 14-year-old company has quadrupled since he started handling this product.

The product that makes success stories like these possible is called COPYFAX. This unique, patented “break-through” is rapidly replacing old-fashioned carbon paper—and carbon paper is a big, big, multi-million-dollar business

COPYFAX resembles carbon paper only in that it does the same job as carbon paper—although it does that job more effectively. Carbon paper is a flimsy grade of tissue paper coated with a mixture of grease and carbon particles. COPYFAX contains neither carbon nor paper.

COPYFAX is made from incredibly tough DuPont Mylar®, with a microscopic “honeycomb” surface impregnated with liquid ink similar to that used by printers.

COPYFAX won’t curl, crease, or wrinkle like carbon paper. It won’t smear or smudge. Try to tear a sheet of COPYFAX. You can’t; it actually has one-third the structural strength of steel. A sheet of carbon paper is ready for the wastebasket after 5 to 10 uses. A sheet of COPYFAX is still giving sharp, crisp copies after 100 . . . 150 . . . even 200 uses. In terms of cost, COPYFAX outperforms carbon paper by at least 500%.

COPYFAX is available exclusively through distributors appointed by American Unifax. As shown by the house-

wife, the banker, and the businessman mentioned above, our distributors come from all walks of life. No special experience or big cash investment is required to become a COPYFAX Distributor. By acting now, YOU can cash in on this unusual opportunity to turn spare-time hours into dollars.

Within a few miles of your home, there are thousands of offices, industries, banks, stores, doctors, lawyers, schools, churches. They all use carbon paper—and they all hate it!

Show them COPYFAX . . . challenge them to try to tear it or smudge it . . . invite them to type with it. You’ll make sales so fast it’ll take your breath away! Not just small sales, either—even relatively small business offices are accustomed to ordering hundreds of dollars worth of carbon paper at a time. And these initial sales are just the beginning. As an American Unifax Distributor, your repeat-order business is automatic, fully protected, and fantastically profitable. Once a customer has tried COPYFAX, they’ll never again be satisfied with carbon paper. It’s as simple as that.

If you’re of average intelligence, if you’re ambitious, and if you’ll give me just 10 hours per week of your time, I’ll show you how to make more money than you ever dreamed possible. To get started, just fill out the coupon and drop it in the mail. There’s no obligation and no one will call on you, so mail the coupon today, before some other wide-awake person in your area beats you to it!

AMERICAN UNIFAX, INC. Dept. P-57
95 Madison Ave., New York, N. Y. 10016

YES! I want to get in on the ground floor with COPYFAX! Rush the order checked below:

- RUSH FREE SAMPLE AND MONEY-MAKING DETAILS.
- \$3.50 enclosed. Rush sample demonstrator pack of COPYFAX (worth \$4.50 retail) and all details.
- \$15.00 enclosed. Rush limited introductory Wholesale Offer of 5 packs of COPYFAX (worth \$22.50 retail) and all details.
- \$47.00 enclosed. Rush special complete sales kit: 15 packs of COPYFAX (worth \$68.85 retail), plus free samplers, brochures, business cards and invoices (worth over \$5.00).

NAME

ADDRESS

CITY STATE ZIP



95 MADISON AVE.
NEW YORK, N.Y. 10016

Drivin' with Dan

Will pollution problems with engines affect racing? Does an airfoil add speed or just improve handling? How does an AAR Cuda differ from standard Cuda? Dan Gurney answers these and other automotive questions

PEDAL POWER gets Dan around Daytona's pits during practice for the 24-hour endurance race. Dan co-piloted a Ferrari 512 with Chuck Parsons. Their car, entered by Luigi Chinetti's North American Racing Team, needed a last-minute improvised bubble in the roof to make a little rattling-around room for the top of big Dan's helmet. Running 116.434 mph, the 5-liter Ferrari qualified in seventh place. The car was running in the top five until midnight of the first day, when, racing in the dark on the road portion of the circuit, Dan nudged the rear of a slower car and had to stop for repairs. After dawn of the next day, the transmission seized and the race was over for the team. Pedro Rodriguez and Leo Kinnunen won in a Porsche at a record 114.866 mph



Q. Do you think motor racing will be affected by the pollution criticism being directed at the internal combustion engine?—R.T. Sargeant, Los Angeles.

A. To a certain extent, yes. Racing and racing engine efficiency should help lead the way toward smaller engines that get more miles per gallon of fuel. It stands to reason that if we double our miles per gallon, we should do the same work for half the pollution. I feel that smaller cars make more sense on the highway, anyway. Good performance means agility and safety to me.

Q. Why hasn't the Chevy V8, which powered every winner in the Continental Championship and won every Can-Am in 1969, been campaigned in Formula 1 where every race last year was won by a Ford V8?—Gary Maugle, Quakertown, Pa.

A. The Chevy is too large for Formula 1 rules (430-CID Chevy vs. 183-CID Ford Cosworth). The "Ford" that you mention was designed and built in England for Ford of Great Britain by Cosworth Engineering.

Q. Is a car faster with an airfoil, or does it just handle better?—David Smith, Duncan, Okla.

A. Usually it just handles better. Often it enables the car to achieve better lap times. Basically the tires are pressed down on the road harder with an airfoil (they don't spin as easily) but there is very little added weight to cause more centrifugal force. Acceleration and deceleration are increased where wheel spin was the limiting factor before adding a wing.

Q. I see Plymouth has an AAR Cuda now, presumably named for your racing team. What is the difference in the AAR Cuda and standard Cuda,

(Please turn to page 38)

one quart of your new oil change will be dirty oil... unless you change your filter, too.

Think about it next time you ask the guy to change your oil. Think about how there's a full quart of yccch-y, dirty oil lurking in your oil filter just waiting to dirty up the fresh, clean oil you're putting in.

And the way we see it, if your oil's only partly changed, your oil's not changed at all.

Change it all. By making a filter change next oil change. And make it a Fram. It'll be a change for the best.



Fram
Automotive Division
Providence,
Rhode Island 02916



Announcing the Popular Mechanics

DO-IT-YOURSELF YEARBOOK—1970

Just off the press—**Popular Mechanics New Yearbook** gives you the newest do-it-yourself advances that save time, work and money for the home handyman and hobbyist!

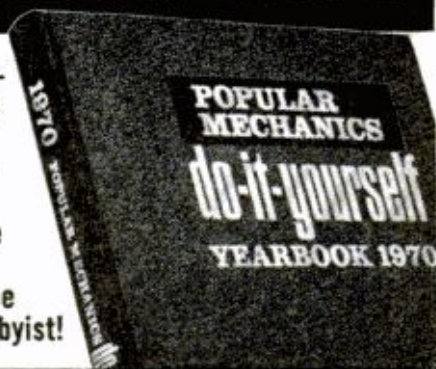

• 14 Big "How-To" Classifications, 63 Section Topics • Over 500 "Show-How" Photos and Illustrations • Printed 2-Colors Throughout • Washable, Permanent Hardbound Cover, 196 Big 8½" x 11" Pages • Quick Reference Index

Here at last—a new, ideal way to keep up with the how-to field! The most up-to-date guidebook and workshop companion available: **POPULAR MECHANICS DO-IT-YOURSELF YEARBOOK—1970!**

Whether you're a beginner or an experienced handyman, a hobbyist or sportsman, here are illustrated easy-to-follow, step-by-step instructions on new projects and news of new products sure to increase enjoyment and save money for you and your family this year and every year.

You'll be able to do things that weren't even possible a year ago. Tape your own TV show. Build a whole aquarium in a coffee table. Make a stereo balance meter. Install an inexpensive automatic lawn sprinkling system. Put together your own brush buggy for a few hundred dollars. Put in an alarm system built from a kit. Construct a no-hands telephone amplifier. Select the right gun for the game you seek. Create a child's sidewalk car that looks like a Grand-Prix racer.

You'll be brought up-to-date on the year's new products: building materials, tools, electronic devices, fishing gadgets, boats, recreation vehicles, the 1970 cars, photography equipment. Whatever job you tackle, you'll know about the newest materials and tools to make-it or fix-it better.

Examine 14 Days On Approval

Available Now Only Through Popular Mechanics

As a Popular Mechanics reader you can have your copy of the Do-It-Yourself Yearbook—1970 sent to your home by return mail for 14-days no-risk examination. It is not available in stores or from any other source. For hundreds of the best time and money-saving ideas of the year, detach and mail the coupon now. This is a limited edition. So please order promptly before supply is exhausted.

Mail for On Approval Examination

Popular Mechanics Book Division, Dept. 0015
250 West 55th Street, New York, N.Y. 10019

Please rush me my copy of POPULAR MECHANICS DO-IT-YOURSELF YEARBOOK—1970. I enclose a check or money order for \$4.95. You will pay all postage and handling. I must be completely satisfied or I may return the Yearbook within 14 days for full refund.

Print Name _____

Address _____

City _____

State _____ Zip Code _____

DRIVIN' WITH DAN

(Continued from page 36)

and did you or will you have anything to do with this car?—Ben Calloway, Memphis.

A. The "AAR Cuda" is a road version of our Trans-Am racing Cuda. It has a special tape stripe on the side, a high-performance but light 340 engine with six-barrel carburetion and special shocks and sway bars. As we continue racing the AAR Cuda, we expect to incorporate the results of lessons learned in the races into the road version.

Q. I am a 15-year-old girl whose dream is racing cars. I have tried drag racing but wonder if you think I have a chance of getting involved in other kinds of racing such as Indy?—Catherine Haas, Staten Island, N. Y.

A. I don't doubt that it might happen some day, but at the moment, they don't allow girls in the pits at Indy, much less in a racing car on the track. There are quite a few girls in SCCA road racing. If you are a real winner with natural ability, you'd be a sensation. It's a long, hard road to the top.

Q. Do you know if a crankshaft can be cut and rewelded to make two pistons fire at the same time?—W. J. Hull, Clyde, Ohio.

A. It can be, of course, but it would be a vibrator. I think you can change the cam and ignition and do the same thing.

Q. How do you feel about airconditioning and power steering on high-performance cars like the 428 Mach I Mustang? Do these accessories slow down a car much or hurt its handling?—Mike Cibor, Detroit.

A. It all depends on the purpose of the car. Unfortunately you just can't have everything in the same vehicle. You must sacrifice performance for comfort as a rule. The extra weight does hurt the handling under above-average cornering demands. These items also rob horsepower and impede acceleration.

Q. I am building a soap-box derby car and wonder if you think a wedge design or regular soap-box design would be better aerodynamically.—Gary Alexander, Sweetser, Ind.

A. I would say the regular soap-box design
(Please turn to page 40)

'SWEET 16' BRIDGES THE GENERATION GAP

Old-fashioned virtues wrapped up in styling more modern than tomorrow make the Lufkin Mezurlok® 16 the power tape for all reasons. And all generations. The best materials, finest workmanship and dependable accuracy make this power tape right for the most painstaking, traditional carpenter or hobbyist. Trend-setting design, lightweight and impact-resistant Cyclocac* case, natural-action toggle lock and exclusive rubber bumper give it everything the "now" generation could ask for—and more. Close the generation gap today—visit your favorite dealer and buy a Mezurlok power tape.

*Cyclocac is a Registered Trade Mark of Borg-Warner Corp.

- Automatic blade return
- Lock holds blade at any reading
- Bold, jet-black numerals on snow-white blade for easy reading
- Rigid 3/4-inch blade
- Available in 12 and 16-foot lengths

LUFKIN

A division of  COOPER INDUSTRIES, INC.
P.O. Box 728, Apex, North Carolina 27502



WHEN YOU NEED IT... RENT IT!

YOUR UNITED RENT-ALL Dealer has it! Power Tools (all kinds), Spray Guns, Ladders, Dropcloths, Finishing Tools, and that's just for starters. ■ Actually, your UNITED RENT-ALL Dealer is the handyman's (pro and amateur) rental center, for the most up-to-date equipment of every description. ■ If, "To Buy Or Not To Buy" is your question, then your UNITED RENT-ALL Dealer has the answer. He says:

"When You Need It...Rent It!"...because:

- Purchasing equipment is costly
 - Break-down and maintenance expenses are budget-shattering
 - Infrequently used items take up valuable storage space
- Need additional "convincers?" See your friendly (he likes people) UNITED RENT-ALL Dealer.

The UNITED RENT-ALL Store In Your Community Is Listed In The "Yellow Pages".

United Rent-All

An International Industries Company

Send coupon for FREE Home Project Plans.

UNITED RENT-ALL
10131 National Boulevard, Dept. PM570
Los Angeles, California 90034

Please send me the FREE easy-to-do Home Project Plans that I have checked below:

- | | |
|--|--|
| <input type="checkbox"/> Decorator Coffee Table | <input type="checkbox"/> Perfect Patio Floor |
| <input type="checkbox"/> Versatile Patio Bar-B-Que | <input type="checkbox"/> Landscaping Made Easy |
| <input type="checkbox"/> Colorful Bookcase | <input type="checkbox"/> Mosaic Mural Designing |
| <input type="checkbox"/> Simplified Wall Papering | <input type="checkbox"/> Refinishing Hardwood Floors |
| <input type="checkbox"/> English Window Planter | <input type="checkbox"/> Christmas Tree Decorating |

Name _____

Address _____

City _____ State _____ Zip _____



RIDGID Tools

make pipe and conduit installation easy!

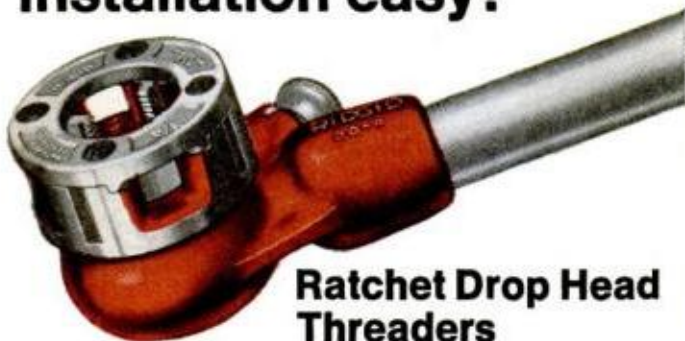

Ratchet Drop Head Threaders

Capacities: 1/8" through 2", 5 models

Easiest-to-operate hand threader around! Every threader and set of dies work-tested at our factory. Dies reverse for close-to-wall threading. Interchangeable die heads lock in; release easily. All RIDGID threaders cut perfect threads every time. And be sure to use RIDGID Thread Cutting Oil.

Heavy Duty Pipe Cutters



Capacities: 1/8" through 2", 2 models

Perfectly balanced professional design. Smooth tracking, specially tempered cutter wheel gives straight, burr-less cuts every time — even on rough surfaces. Factory tested for perfect tracking. For close-quarter work, convert to 3-wheel cutter by replacing rollers with cutter wheels.



No. 2-S Spiral Ratchet Pipe Reamer

Capacity: 1/8" through 2"

Self-feeding spiral design and razor sharp cutting edges make reaming fast and smooth. No chatter . . . even on sheet metal conduit box outlets. Reamer Unit, available separately, fits No. 00-R Drop Head Threader ratchet and handle.

Buy these RIDGID Tools at your quality Hardware Store. And be sure to see the other RIDGID Work Saver Tools from The Ridge Tool Company, Elyria, Ohio 44035, U.S.A.

RIDGID®

Ridge Tool Subsidiary
Emerson Electric Co.
EMERSON

DRIVIN' WITH DAN

(Continued from page 38)

is better. The idea of the wedge is to give increased down force as the car goes through the air. This down force adds cornering power, but the wedge actually creates more air drag than the soap-box shape.

Q. I'm not especially strong but I find I can place my hand against the side of just about any make car and make it bow inward as if it were so much plastic. Can you confirm my suspicions that manufacturers are using thinner, cheaper body metals? —Karl Wolfshohl, McAllen, Tex.

A. I suspect they are using thinner body metal, but doubt that it's cheaper. The shape of various panels has a lot to do with ability to resist deflection or bowing in. The egg is an example of a strong, thin shape. Curved panels are usually stronger than flat. Remember the old-fashioned oil can?

Q. Is the Plymouth Superbird legal for street use? —Gregg Rafter, Winnipeg, Can.

A. Yes, it certainly is. It is a real eye-catcher and a conversation piece as well as being a fine road car.

Q. I understand that accelerating on a curve will help in making the turn. Is this true, and what are the physical principles involved?—Emmett Henley, Bakersfield, Calif.

A. This is not necessarily so. Really, you have four patches of rubber in contact with the road and the more evenly you can divide or spread the loads involved in negotiating the curve at the highest speed possible, the better off you will be. I know this doesn't answer your question, but it certainly contains the seed of something you could write a book on. And such a book doesn't seem to be in the library, either.

Q. Did you ever drive the Baja 100? Why or why not?—Chris Neri, Plymouth, Mass.

A. No, I haven't had a car nor the time, thus far.

If you have questions on racing, high-performance and everyday driving techniques, send them to "Drivin' with Dan," c/o Popular Mechanics, 224 West 57th St., New York, N.Y. 10019. Questions cannot be answered by individual letters. Questions on maintenance and repair should be addressed to the Auto Clinic (see page 74).

One of a kind



No other distiller makes his whiskey the same way we make Seagram's 7 Crown.

So no other whiskey has the same smooth taste.

Or the same consistently fine quality.

And guess what.

No other brand of whiskey is asked for as often as 7 Crown.

It figures, doesn't it?

Say Seagram's and Be Sure.

Seagram Distillers Co., N.Y.C.
Blended Whiskey. 86 Proof.
65% Grain Neutral Spirits.

LEARN UPHOLSTERY AT HOME!
Men & Women All Ages! Send for free book on learning to reupholster chairs, divans, footstools, all furniture for **BIG MONEY** in spare or full time. No experience needed, no age or educational limits. We show you how and provide **EVERYTHING** needed to start: (1) Home training covering all phases, (2) all tools and 6 big furniture kits for practice, (3) free supplies, frames & materials to build \$300 worth of furniture, yours to keep or sell. Write **TODAY** for big free upholstery career book. No obligation, no salesman will call! Veteran Approved. **Modern Upholstery Institute**, Box 899-DBB, Orange, Calif. 92669

FREE BOOK!

HOME-IMPORT BUSINESS - Make Big Profits

New Drop Ship Plan offers you first day profits! Deal direct with overseas sources at prices shown. Dazzling bargains with no investment. Full or spare time. Write for **FREE BOOK** today to...

Transistor Radio with Battery \$1.70
Calendar Watch \$2.44
Derringer Pistol \$5.99

MELLINGER, Dept. D2255, 1554 S. Sepulveda, Los Angeles, Calif. 90025

ENROLL—EARN YOUR DEGREE

of Bachelor of Bible Philosophy (B.Ph.B.), Master of Bible Philosophy (M.Ph.B.), Graduate of Bible Philosophy (G.Ph.B.), Doctor of Metaphysics (Ms.D.), or Doctor of Divinity (D.D.). Chartered by State, Correspondence Courses only. Please write for **FREE BOOKLET**.

AMERICAN BIBLE INSTITUTE
Dept. PM, Post Office Box 8748, Kansas City, Missouri 64114

LEARN SURVEYING AT HOME

U.S. Bureau of Labor Statistics predicts shortage of 50,000 civil engineering technicians (Surveyors, etc.) by 1975. Send for **FREE "SURVEYING CAREER KIT."** No salesman will call.

NAME _____ AGE _____
ADDRESS _____
CITY _____ STATE _____ ZIP _____

NORTH AMERICAN SCHOOL OF SURVEYING & MAPPING
4500 Campus Drive • Dept. 04175, Newport, Calif. 92660

ALL 3 FREE!

POWERFUL yet gentle, safe

Heathkit Screw-Drive Radio Controlled Garage Door Opener Kit

- giant 8½' screw
- ¼ hp motor — clutched
- safety switch reverses door when obstructed
- positive locking of door
- easy assembly — no soldering

NEW LOWER PRICE
GD-209A System Shown **\$139.95**

Solid-State Assembled & Tested UHF Transmitter & Receiver Operates Up To 150' Away

components available separately

Send for **FREE** Catalog, Heath Company, Dept. 17-5, Benton Harbor, Michigan 49022

DART[®] ELECTRONICS ANNOUNCES THE ALL NEW GOLDSEYE[®] SERIES

COPYRIGHT 1969 DART ELECTRONICS U. S. PAT. PEND.

NEW PROFESSIONAL METAL LOCATOR OUTPERFORMS OTHER MODELS

GUARANTEED • Easily detects buried coins, relics, gold, silver, copper and all other metals. Works through dirt, sand, rock, wood, water, etc. New solid state circuit assures maximum performance.



MODEL XL

ONLY **\$29⁹⁵** POSTPAID

Comes complete, ready to use. New powerful circuit for maximum sensitivity. Has both loudspeaker and ear-phone, uses inexpensive 9 volt battery. Lightweight: Only 2 pounds.



Fully Transistorized 1970 MODEL



VIEW-METER MODEL XXL
New View-Meter model detects objects on the fringe of detectable depths, means more sensitivity.

VIEW-METER MODEL ONLY \$39⁹⁵ POSTPAID

NEW POWER-COIL AVAILABLE



Order one now or add it on later. Why buy a detector without this valuable feature?

The all new Dart power-coil will effectively double the penetration depth of the XL and XXL Goldseye Models on larger objects that are buried deeper.

POWER-COIL, ONLY \$12⁹⁵ POSTPAID

ORDER NOW FOR IMMEDIATE SHIPMENT!

TO: DART ELECTRONICS P. O. BOX 361 PM HUNTSVILLE, TEXAS 77340
ENCLOSED THE SUM OF \$ _____ FOR THE ITEMS CHECKED BELOW.

CASH CHECK MONEY ORDER

DART MODEL XL \$29.95
 DART MODEL XXL, WITH VIEW-METER ... \$39.95
 POWER-COIL \$12.95

NAME _____
ADDRESS _____
CITY _____ STATE _____ ZIP _____



EARN HIGH WAGES
as a **HEAVY EQUIPMENT OPERATOR**

Train your way to high pay in the booming construction industry! Learn the skills you need to qualify, by actual field training on machines like the ones used by the industry. Huge training grounds in North Carolina, a million dollars worth of school-owned diesel-engined machines, experienced instructors, full 220-hour and 440-hour courses. National, the original school of heavy equipment operation, is a recognized leader. Member American Road Builders Assn., Services and Supply Division. Associate Member A.G.C. Full-time Job Advisory and Counseling Director on staff. VA approved. For men ages 17 to 56. Train Now-Pay Later plan . . . other payment plans also available. Write TODAY for FREE catalog and FREE copy of school newspaper reporting news of National School graduates. Accredited member NATTS.

NATIONAL SCHOOL OF HEAVY EQUIPMENT OPERATION, Dept. D-39 P. O. Box 8529, Moores Chapel Road, Charlotte, N. C. 28201

Please send me FREE illustrated school catalog and complete information. I understand there's no obligation.

Name _____ Age _____

Address _____ Phone _____

City _____ State _____ Zip Code _____



110-120 VOLT A.C. LIGHT PLANTS—60 CYCLES

Fanbelt driven from pickup or small gas engine. Operates saws, drills, pumps, freezers, T.V. X1000 Watts—Needs No Battery. Now \$70.00. 1500 Watts—6 and 12 volt vehicles. Now \$60.00. 3000 Watts—12 volt vehicles only. Now \$99.50. Guaranteed. Check or Money Order.

VIRDEN PERMA-BILT, Box 7066 P.M., Amarillo, Texas 79109

Career in ELECTRONICS?

Career training at home the new easy way with RCA Institutes. Lab work with first lesson. Easy payment plans. Send for free 64-page book.

RCA Institutes, Dept. 699-005-0 320 W. 31 St., N.Y., N.Y. 10001



LEARN TO BE A SKILLED LOCKSMITH

Professional Key Machine yours to keep!

Be your own boss. Earn steady, year-around income in your spare time at home. BELSAW INSTITUTE lessons show you how to make keys, open and repair locks on homes, cars, business buildings. Accredited Member NHSC. Approved for Veterans. All tools and supplies furnished including the \$125 Key Machine. Write for FREE BOOK. No salesman will call.

BELSAW INSTITUTE / 100B Field Bldg.
Kansas City, Mo. 64111



"Changed My Life"

"My CIE course and new job have changed my life completely. Before getting into electronics, I drove a cab, repaired washers, rebuilt electric motors and was stuck at \$1.50 an hour. Now that I'm an electronics technician, I work eight hours a week less and earn \$228 a month more. We have a new home and two good cars. We also have color TV. My CIE training was worth every minute and every dollar I spent on it."

EUGENE W. FROST
Columbus, Ohio

Chief Radio Technician Now



"CIE training enabled me to pass my 1st and 2nd Class FCC License exams on my first attempt...even though I'd had no other electronics training. Now I'm in charge of Division Communications...an interesting, challenging and extremely rewarding job [which] I got through CIE's Job Placement Service."

CHUCK HAWKINS
Div. 12,
Ohio Dept.
of Highways



His Own 2-Way Radio Business

"Prior to my CIE course, my only professional skill was as a crop dusting pilot. Today I own my own 2-way radio service business. I manufacture radio equipment and employ seven men. I found the training thorough and easy to understand. My CIE course is undoubtedly the best investment I've ever made."

EDWARD DULANEY, Scottsbluff, Nebraska

**Who else wants to
make big money
in electronics?**

**CIE's home training helped
these men change their lives
—it can help you too**

**"You Make
Electronics
Easy"**



"I give CIE credit for my Government FCC (Federal Communications Commission) License. Even though I had only six weeks of high school algebra, your lessons make electronics easy. I now have a good job... enjoy my work and am on my way up."

MATT STUCZYNSKI
Senior Transmitter
Operator
Radio Station WBOE

WANT TO CHANGE YOUR LIFE like the men shown here? Get into electronics! Trained men are in big demand everywhere. No high school diploma necessary. You'll need to get a good grasp of basic electronics, but we can teach you that, at home in your spare time. Even if you know nothing about electronics today, our home study courses make it easy to prepare for the high-pay job of your choice. Find out more. Mail the coupon for two FREE books.

If coupon has been removed, write to Cleveland Institute of Electronics
1776 E. 17th St., Cleveland, Ohio 44114

ENROLL UNDER NEW G.I. BILL

All CIE courses are available under the new G.I. Bill. If you served on active duty since January 31, 1955, or are in service now, check box in coupon for G.I. Bill information.

CIE **Cleveland Institute of Electronics**
1776 East 17th Street • Cleveland, Ohio 44114

Please send me without cost or obligation:

1. Your 40-page book "How To Succeed In Electronics" describing the job opportunities in Electronics today, and how your courses can prepare me for them.
2. Your book on "How To Get A Commercial FCC License."

Name _____ Age _____
(Please Print)

Address _____

City _____ State _____ Zip _____

Check here for G.I. Bill information

Accredited Member National Home Study Council

PM-39



I'd like to give this to my fellow men...

while I am still able to help!

I was young once, as you may be—today I am older. Not too old to enjoy the fruits of my work, but older in the sense of being wiser. And once I was poor, desperately poor. Today almost any man can stretch his income to make ends meet. Today, there are few who hunger for bread and shelter. But in my youth I knew the pinch of poverty; the emptiness of hunger; the cold stare of the creditor who would not take excuses for money. Today, all that is past. And behind my city house, my

summer home, my Cadillacs, my winter-long vacations and my sense of independence—behind all the wealth of cash and deep inner satisfaction that I enjoy—there is one simple secret. It is this secret that I would like to impart to you. If you are satisfied with a humdrum life of service to another master, turn this page now—read no more. If you are interested in a fuller life, free from bosses, free from worries, free from fears, read further. This message may be meant for you.

By Victor B. Mason

I am printing my message in a magazine. It may come to the attention of thousands of eyes. But of all those thousands, only a few will have the vision to understand. Many may read; but of a thousand only you may have the intuition, the sensitivity, to understand that what I am writing may be intended for you—may be the tide that shapes your destiny, which, taken at the crest, carries you to levels of independence beyond the dreams of avarice.

Don't misunderstand me. There is no mysticism in this. I am not speaking of occult things, of innumerable laws of nature that will sweep you to success without effort on your part. That sort of talk is *rubbish!* And anyone who tries to tell you that you can *think* your way to riches without effort is a false friend. I am too much of a realist for that. And I hope you are.

I hope you are the kind of man—if you have read this far—who knows that anything worthwhile has to be *earned!* I hope you have learned that there is no reward without effort. If you have learned this, then you may be ready to take the next step in the development of your karma—you may be ready to learn and use the secret I have to impart.

I Have All The Money I Need

In my own life I have gone beyond the need of money. I have it. I have gone beyond the need of gain. I have two businesses that pay me an income well above any amount I have need for. And, in addition, I have the satisfaction—the deep satisfaction—of knowing that I have put more than three hundred other men in businesses of their own. Since I have no need for money, the greatest satisfaction I get from life is sharing my secret of personal independence with others—seeing them achieve the same heights of happiness that have come into my own life.

Please don't misunderstand this statement. I am not a philanthropist. I believe that charity is something that no proud man will accept. I have never seen a man who was worth his salt who would accept something for nothing. I have never met a highly successful man whom the world respected who did not sacrifice something to

gain his position. And, unless you are willing to make at least half the effort, I'm not interested in giving you a "leg up" to the achievement of your goal. Frankly, I'm going to charge you something for the secret I give you. Not a lot—but enough to make me believe that you are a little above the fellows who merely "wish" for success and are not willing to sacrifice something to get it.

A Fascinating and Peculiar Business

I have a business that is peculiar—one of my businesses. The unusual thing about it is that it is needed in every little community throughout this country. But it is a business that will never be invaded by the "big fellows." It has to be handled on a local basis. No giant octopus can ever gobble up the whole thing. No big combine is ever going to destroy it. It is essentially a "one man" business that can be operated without outside help. It is a business that is good summer and winter. It is a business that is growing each year. And, it is a business that can be started on an investment so small that it is within the reach of anyone who has a television set. But it has nothing to do with television.

This business has another peculiarity. It can be started at home in spare time. No risk to present job. No risk to present income. And no need to let anyone else know you are "on your own." It can be run as a spare time business for extra money. Or, as it grows to the point where it is paying more than your present salary, it can be expanded into a full time business—overnight. It can give you a sense of personal independence that will free you forever from the fear of lay-off, loss of job, depressions, or economic reverses.

Are You Mechanically Inclined?

While the operation of this business is partly automatic, it won't run itself. If you are to use it as a stepping stone to independence, you must be able to work with your hands, use such tools as hammer and screw driver, and enjoy getting into a pair of blue jeans and rolling up your sleeves. But two hours a day of manual work will keep your "factory" running 24 hours turning out a product that has a steady and

ready sale in every community. A half dollar spent for raw materials can bring you six dollars in cash—six times a day.

In this message I'm not going to try to tell you the entire story. There is not enough space on this page. And I am not going to ask you to spend a penny now to learn the secret. I'll send you all the information, free. If you are interested in becoming independent, in becoming your own boss, in knowing the sweet fruits of success as I know them, send me your name. That's all. Just your name. I won't ask you for a penny. I'll send you all the information about one of the most fascinating businesses you can imagine. With these facts, you will make your own investigation. You will check up on conditions in your neighborhood. You will weigh and analyze the whole proposition. Then, and then only, if you decide to take the next step, I'll allow you to invest \$15.00. And even then, if you decide that your fifteen dollars has been badly invested I'll return it to you. Don't hesitate to send your name. I have no salesmen. I will merely write you a long letter and send you complete facts about the business I have found to be so successful. After that, you make the decisions.

Does Happiness Hang on Your Decision?

Don't put this off. It may be a coincidence that you are reading these words right now. Or, it may be a matter that is more deeply connected with your destiny than either of us can say. There is only one thing certain: If you have read this far you are interested in the kind of independence I enjoy. And if that is true, then you must take the next step. No coupon on this advertisement. If you don't think enough of your future happiness and prosperity to write your name on a postcard and mail it to me, forget the whole thing. But if you think there is a destiny that shapes men's lives, send your name now. What I send you may convince you of the truth of this proverb. And what I send you will not cost a penny, now or at any other time.

VICTOR B. MASON
1512 Jarvis Ave., Suite M-2-E
CHICAGO, ILLINOIS 60626

3 WAYS to a profitable business of your own

— and only —

VON SCHRADER HAS ALL 3

Von Schrader is the oldest and largest company making Detergers of this type. For over 30 years our FREE ENTERPRISE PLAN has been fashioned with your future in mind. Start with the Deterger that most appeals to you. We have thousands of Associates who have built successful businesses with just one Deterger. Naturally, bigger and more profitable businesses can be built when you are able to offer two or all three cleaning services.

For example, let's say you start with the

VON SCHRADER WALL DETERGER

(LOWEST PRICE OF ALL THREE)

1 • Associate G. H. Jones made \$1200.00 on one job. Associate R. G. Fullmer says contracts this year will gross about \$18,000.00. And no wonder...this machine washes walls 6 times faster than by hand...with no mess...no drop cloths needed. Washing is so easy...no tiresome scrubbing...special glider wipes walls clean with little effort. You can start part-time and by working week-ends add hundreds of dollars to your income while still employed.

Then you can double your profit by adding the

VON SCHRADER UPHOLSTERY DETERGER

2 • Associate Charles Lemmin averaged \$100.00 a day during his first year. Associate Peter Young took in \$960.00 last week. You clean upholstered furniture on customers' premises—homes, hotels, motels, etc....even auto upholstery. No hauling...operate from your home. Watch business grow as customers tell their friends.

And, finally, you can more than triple your profits by adding the

VON SCHRADER RUG DETERGER

because each service helps to sell the other two

3 • Associate C. E. Nevin reports he averaged \$1000.00 a month for 12 months. An Associate father-son team grossed \$33,000.00 their first year. Von Schrader's FREE ENTERPRISE PLAN is not a lease arrangement. You sign no contract. You own the equipment. You pay no fees, dues or royalties to anyone. Every dollar you take in is yours to keep.

Full Operating Instructions come with each Deterger... you need no special skill or training. And our Business Manual tells everything you need to know about getting business, suggested sales letters, tips on keeping books and tax records, suggested ads and radio announcements, etc. Our assistance is always at your service. Training and consulting with experts is also available...and without charge.

Don't Delay...it costs nothing to get the details. Return the coupon TODAY for informative FREE booklet. Be sure to check the Deterger you are most interested in starting with.

VON SCHRADER MFG. CO.

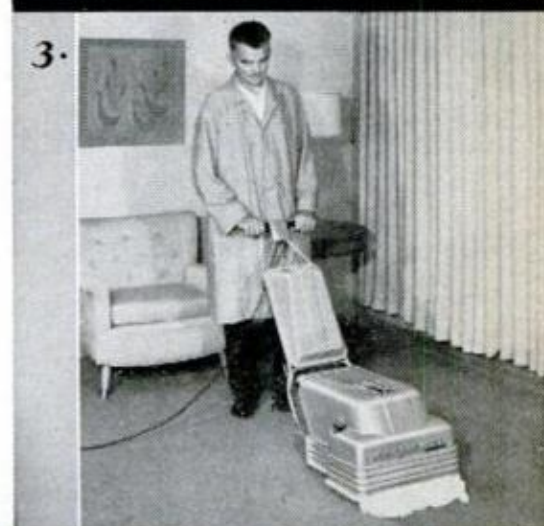
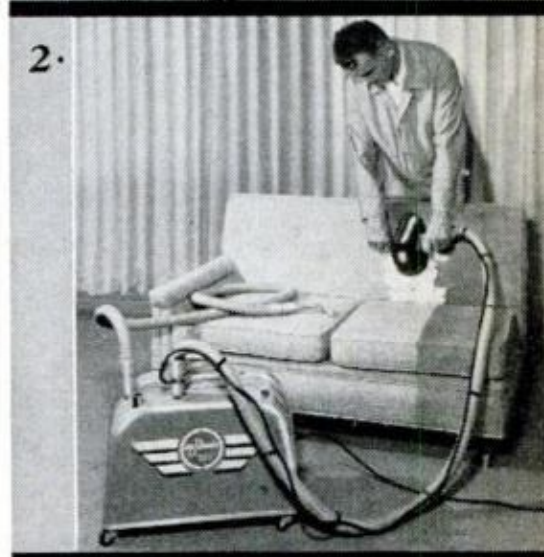

SEND FOR THE FACTS TODAY

VON SCHRADER MFG. CO.
1057 Place, Racine, Wis. 53403

Please rush information about your

_____ DETERGER(S)

(Write in name of detergent(s))
and how I can start my own profitable business.

Name _____

Address _____

City _____ State _____ Zip _____

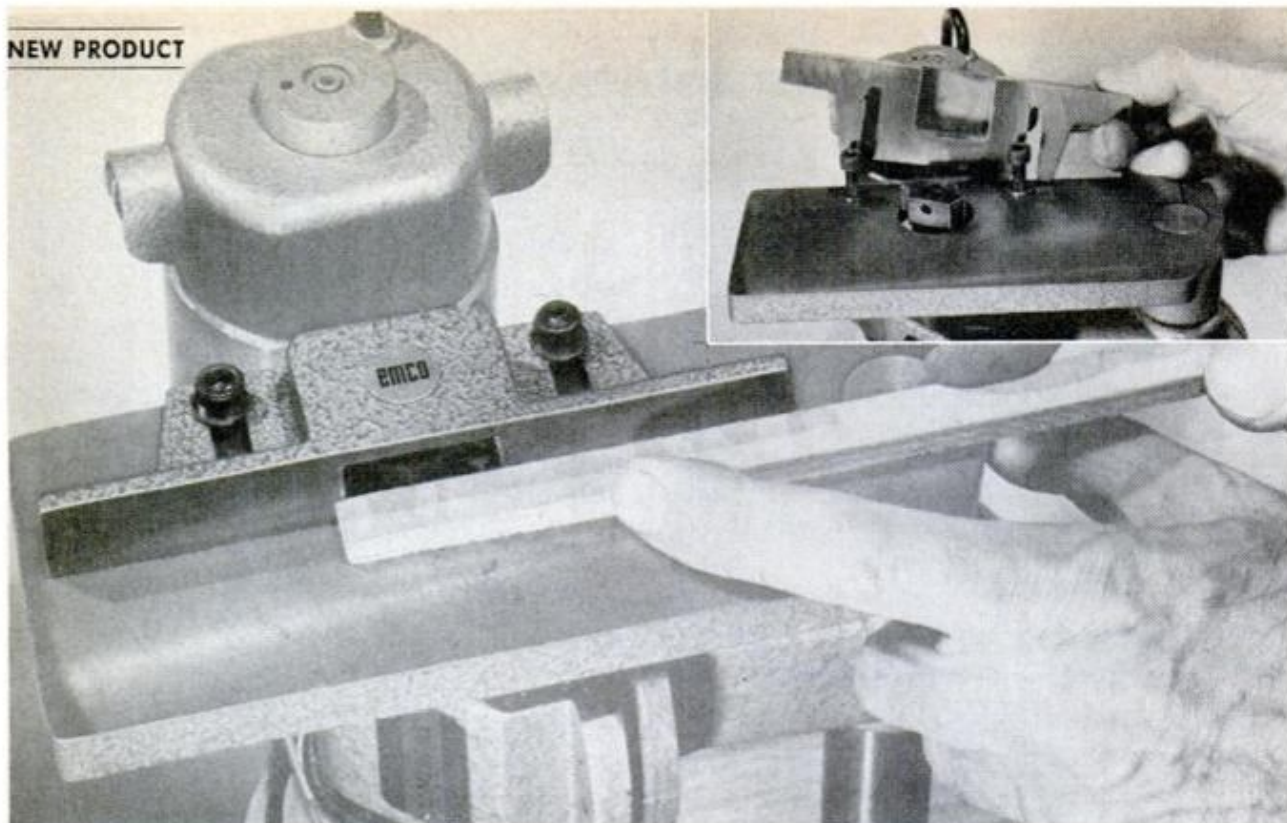

USING JOINTER to smooth edge of fir plywood strip. Care must be exercised when workpiece end is reached

New Jointer Attachment for Your Unimat

By WALTER E. BURTON

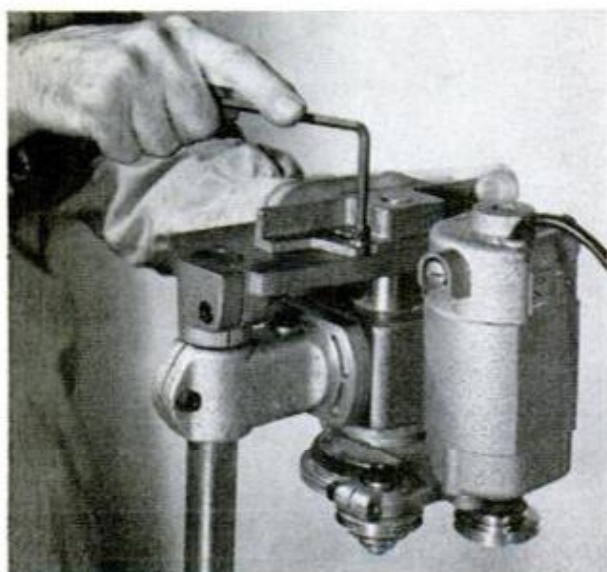

GUIDE FENCE is secured to table by two bolts. To change depth of cut, loosen bolts and move the fence

IF YOU OWN a Unimat, you'll be interested to know there's a new attachment which converts it into a jointer capable of producing a very smooth finish on the edges of wood, hardboard and similar materials.

To mount the jointer, the Unimat headstock assembly is transferred from the machine base to the vertical column—much as if the machine were being converted into a drill press, except that the spindle is positioned with its threaded nose up. The attachment table, clamped above the assembly, and the arm on the vertical column are swung so their clamping screws are toward the machine base. The $3\frac{1}{8} \times 7\frac{3}{4}$ -in. jointer table is a casting having two holes, one fitting over the vertical column and the other over the two-edged, $1\frac{1}{8}$ -in.-diameter cutter screwed on the spindle nose.

The setup illustrated required a spacing block almost $\frac{1}{2}$ in. thick between the spindle head and vertical-column arm, plus a clamping bolt or pin of appropriate length, to align the cutter with its table hole.

I tested the jointer on edge-smoothing, rabbeting and beveling wood and hardboard. It handled all chores effortlessly but, since the fence does not adjust independently like the tables on a real jointer, care must be taken at the end of each pass to prevent the workpiece from biting in. The Emco jointer attachment sells for \$19.95 from American-Edelstaal, Inc., 350 Broadway, New York City 10013. ★★

Inventors,



N.Y. Coliseum

strike paydirt!

Announcing PATEXPO 70, INTERNATIONAL PATENT LICENSING EXPOSITION, N.Y. COLISEUM, OCT. 1-5

Do you really believe in your idea? If so, your new products, new ideas, unsold patents can make you a fortune by their outright sale or on a royalty basis.

However, to achieve that goal, they first should be shown. More precisely, they must be *exhibited*. Not to just anyone, but to the proper business audience. In an ideal environment created especially for this purpose. At the only patent licensing—new product marketing showcase of its kind in the world.

Now you can reach over 30,000 new products managers, licensing executives, top representatives of major national U.S. and foreign companies—the people who are *looking for* new ideas and technology to expand and diversify, who are anxiously seeking new products to license, manufacture and distribute.

By reserving your space before June 1st, 1970, you can also enjoy numerous benefits of early registration. For example, free advance publicity and promotion for your invention. So don't

miss out, send for your free PATEXPO '70 brochure and application form.

Last year, over \$10 million in licenses, joint venture transactions and new product sales were reported by exhibitors. Creators of new ideas and products became internationally known. And made their fortunes! Is your idea worth a million dollars? Now you can find out!

Act now. Space is limited and is assigned on a first-come-first-served basis. So write, or call today.

Companies that attended PATEXPO 69 include: Alcoa • American Cyanamid • AT&T • Bendix • Black & Decker • Borg Warner • Bristol Myers • Bulova Watch • Burlington • Celanese • Clairrol • Coca Cola • E. I. DuPont • Ford Motor • General Electric • General Foods • General Motors • IBM • International Paper • Johnson & Johnson • Lever Brothers • Litton Industries • 3M Company • RCA • Sears Roebuck • Singer • Sperry Rand • Sunbeam • TWA • Uniroyal • Westinghouse • Xerox

Mail coupon or call: (212) 581-7616 or 581-7617

Managing Director, Dept. F, International New Products Center
680 Fifth Avenue, New York, N.Y. 10019

I have a new product, new invention, unsold patent. Please send me an application to exhibit. I am interested in advertising in the Official Catalog.

Name _____

Address _____

City _____

State _____ Zip code _____

PATEXPO 70

A service of PATENTS INTERNATIONAL AFFILIATES, LTD.—a public corporation (OTC)

NOTE:

If you are unable to attend, we will set up, sell and license on your behalf.

The bargain hunter

Fantastic Swiss Measuring Tools

Model 70-D

NEW



Dial Caliper 5 1/2" RANGE

Measures inside, outside, depth & step readings. Dial graduated in .001" unbreakable, rust proof, patented construction.

ONLY \$ 8.95 3 for \$ 26.00 | 12 for \$100.00 | postpaid

Includes metal case, catalog & shipping



CALIPER MODEL 60P

3 vernier scales .001"-1/10 mm 1/128" on each caliper. Depth and step, inside & outside measuring ability - parallax-free, unbreakable Cyclocac® precision construction.

ONLY \$ 3.00 3 for \$ 9.00 | 12 for \$35.00 | postpaid + postage

Send 25¢ for Money Saving Catalog of hundreds of tools

SCHLESINGERS FOR TOOLS LTD.
1020 East 54th Street, Brooklyn, N.Y.
TEL: (212) 241-7482



Bartlett Flying Saucer ultra-light hovercraft powered by ordinary lawn mower engine—easy to build—fun to fly—complete plans, kit brochure, photos and supply sources \$4.00. All orders returned via airmail. Write:

HERB BARTLETT
Box 3339-M, Scottsdale, Arizona 85257

BILLS PRESSING?

WE CAN HELP YOU NOW!

- Bad Credit No Problem
- Not a Loan Company
- Nobody Refused

UP TO \$10,000

Write Nearest Office for FREE Application

INTERNATIONAL ACCEPTANCE, dept. M-36
3003 N. Central Ave., Phoenix, Ariz. 85012
1000 N. Madison Ave., Greenwood, Ind. 46142
507 Carondelet St., New Orleans, La. 70130
1825 Conn. Ave. N.W. Rm. 428 Wash. D.C. 20009

NEW SAFARI JUNGLE BLOWGUN

HUNTING - TARGET DEFENSE

SILENT... POWERFUL... DEADLY... SHOOTS LIKE A RIFLE—KILLS RABBITS, SQUIRRELS, BIRDS, PESTS: PENETRATES 1/2" PLYWOOD, tires, tin cans, 200' range. Kills without poison. Not a toy! Improved version of most accurate, lethal, feared native weapon ever devised—Malaysia's hunting blowgun. Scientifically researched, engineered, steel-barreled, acrylic-lined, 4 1/2' length, 10 5/8" steel darts, instructions. Extra darts 10 for 50¢! Add 95¢ shipping. Moneyback guarantee! UNAVAILABLE ELSEWHERE.

SPORTSMAN'S, Box 262-P ONLY \$4.98
Tustin, CA 92680 **2 FOR \$3.98 ea.!**



NEW SLIM-GARD Trims inches off your middle, waist, hips & lower back without dieting—without exercising! All you do is wear it. Stretches approx. 6". Made of finest, most resistant neoprene rubber. Easy to slip off & on. Sizes: S, M, L. \$9.98, Slim-Gard Co., 531-32nd St., Dept. 38-50D2, Union City, N.J. 07087.

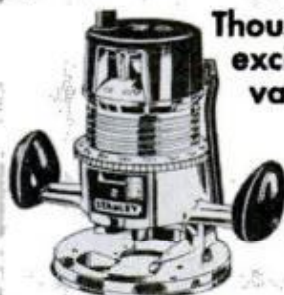

Thousands of exciting tool values!

SILVO (BRAND NAME) TOOL CATALOG

Thousands of Exciting Tool Values! Stanley, Millers Falls, Skil, Thor, Wen, Dession, Wiss, Wellsaw, Dremel, Speedy, Sprayers, Plumb, Huot, Kennedy, Channellock, Porter-Cable, Rockwell, Helios, Vise-Grip, Crescent, Ridgid, Pony Clamps, Unimat, Foredom and many other Nationally Advertised brands of Tools & Supplies. We ship Coast to Coast at prices Hard to Beat. Send 50¢ for our big 148 page tool catalog, today. Silvo Hardware Co., PM-5, 107 Walnut St., Philadelphia, Pa. 19106.

Which of these 14 musical instruments would you like to play?

- | | | |
|--------------------------------------|---------------------------------------|-----------------------------------|
| <input type="checkbox"/> Piano | <input type="checkbox"/> Steel Guitar | <input type="checkbox"/> Trumpet |
| <input type="checkbox"/> Guitar | <input type="checkbox"/> Saxophone | <input type="checkbox"/> Cornet |
| <input type="checkbox"/> Accordion | <input type="checkbox"/> Violin | <input type="checkbox"/> Clarinet |
| <input type="checkbox"/> Organ-pipe, | <input type="checkbox"/> Tenor Banjo | <input type="checkbox"/> Ukulele |
| electronic, reed | <input type="checkbox"/> Mandolin | <input type="checkbox"/> Trombone |

Now you can learn with lessons we send you by mail

Thousands have learned this way—you can, too. Practice at home in spare time. Clear word-and-picture instructions teach you to read notes, play regular sheet music. And the cost is only about \$1 a lesson. For free booklet, check instrument you want to learn, then mail this ad with your name, address and zip to U.S. School of Music, Studio 305, Port Washington, N. Y. 11050.

KLEEN-A-ROLL Original

paint roller cleaning device
\$4.74 A FANTASTIC TOOL
This TERRIFIC electric drill attachment SELF-PUMPS clean solvent as it quickly SCRUBS fresh oil or water paint from a 7" or 9" cover. KLEEN-A-ROLL makes it EASY. See offer includes DIME Cover on plastic core (N.J. Residents plus 6% tax.) ORDER THIS AMAZING TOOL BY CHECK OR M.O. TODAY. KLEENAROLL P.O. Box 72, SUMMIT, N. J. 07901

FREE FEL-PRO GASKET MANUAL

... for top performance in all gasket applications

Learn about the latest gasket materials and trouble-free gasket installation techniques from Fel-Pro... for 50 years a leader in gasketing improvements. Improve engine... transmission... and rear end performance with these helpful tips. 36 fact-filled pages.

Write: **FEL-PRO, INC.**
7452 N. McCormick Blvd. Dept. PM5
Skokie, Illinois 60076



HOW MANY HANDY DANDYS CAN YOU USE?

Handy Dandys are plastic caps that hook onto 1/4" pegboard and hold quarter-twist glass jars, such as used for baby food. Suggestions for getting FREE JARS in every package. Nothing better for storing supplies, parts and small tools. Keeps workshop neat. Sample pack 10 for \$1 ** 36 for \$3.50 ** 72 for \$6 ** 144 for \$11.50. Caps only. No jars. Postpaid U.S.A. No C.O.D.'s. WICKLIFFE INDUSTRIES, Box 286-PM-5, Wickliffe, Ohio 44092

BEER LOVERS

LEARN THE ART OF BREWING BEER
IT'S EASY—IT'S FUN—IT'S CHEAP

The cost is less than 10¢ a quart. For complete instructions send only \$2.00 to

Kraft Supplies, 4078 Kraft Avenue, Studio City, California 91604

CLASSIFIED ADVERTISEMENTS

Rate: \$1.85 per word payable in advance each insertion. Capitalized words—75¢ per word additional. Minimum insertion ten words. To be inserted under the proper classification, copy must be in our office by the 15th of the second month preceding date of issue. The next available issue to place an advertisement in America's No. 1 Classified Section is July. The closing date is May 15th. Send remittance and order to C. A. Martin, Popular Mechanics, 224 West 57th Street, New York, New York 10019. Please make remittance payable to Popular Mechanics.

POPULAR MECHANICS

AUTOMOBILES

CAR VALUE increased up to \$300 when you sell. Booklet, Send \$1.00 to Automobile, Box 10773, Pittsburgh, Pa. 15203.

BOOST ignition without cost. Unique method. Instructions \$1.00. Leon's Electronics, Box 1512, Muskogee, Okla. 74401.

"NEW or used car owners. Stop being swindled by Highway Robbery. Details free. Gestan, P.O. Box 882, Lima, Ohio 45802."

GROSE-JET two ball CARBURETOR needle and seat replacement. PERFECT fuel control, mileage, performance and idle. Decals 50¢ each. Free Catalog. Herbert C. Grose, 8 Mt. Vernon St., Stoneham, Mass. 02180.

MIDGET CARS

YOUR Ad in Popular Mechanics will be seen by more than 5,000,000 active buyers for your products and services. It costs only \$1.85 per word. And, if you wish to run all or part of your ad in capital letters—you can do so for as little as 75¢ per word additional. Act now! Place your Classified ad in Popular Mechanics today.

AUTO SUPPLIES AND EQUIPMENT

BURGLAR-Proof your automobile ignition (or any device) electronically! Illustrated plans including PC, \$5. Information, 25¢. Logan, 403 Lakewood Circle, Virginia Beach, Virginia 23451.

VOLKSWAGENS, Mercedes. Below wholesale prices. New/used. Direct from Germany. Details, \$1.00. Darlingco, Box 456, Richmond, Cal. 94807.

BRASS DASHPLAQUES—This (car) built especially for (John Doe) \$2.00. Ringmasters, 627M Nissen Building, Winston-Salem, N.C. 27101.

VOLKSWAGEN and Dune Buggy Accessories. Catalog 50¢. Gem Products, Box 845P, Carol Stream, Ill. 60187.

PARTS: Army jeep and truck parts. Spare Parts & Equipment Co., P.O. Box 751, Lexington, Ky. 40502.

CROSLEY, Foreign, American, Parts. Discounts Accessory Catalog 616 Burnside, Inwood, New York 11696.

UNBELIEVABLE Huge Savings!! (Repairs, Gas, Oil) with Ring-Valve Job while driving. \$6.50 postpaid. Lasts 100,000 miles! Nothing Compares! Motaloy, Grantham, Penna. 17027.

VOLKSWAGEN Replacement Parts. Save 20% to 50% on VW mechanical parts and accessories. Send 25¢ for catalog. Western Distributors, Box 316 E. Cedar Crest, New Mexico 87008.

AUTO Parts for old and new Cars. All makes. Catalogue \$1.10. Antique Auto, Milwaukee, Wisconsin 53204.

CAPACITOR Discharge Ignition System, automobiles, motorcycles, snowmobiles, under \$25.00. Sydmar: Midwood Station, Brooklyn 11230.

PARK Guide—New invention—park on "target" in garage, carport or parking stall. Eliminates guess work. \$1.00 Postpaid. Star-Mount Gifts, 60 Mountain Avenue, Paterson, New Jersey 07501.

ELIMINATE CAR THEFTS. Revolutionary new solid state auto alarm, eliminates costly and time consuming installations by detecting flow of current from car batteries to electrical devices in cars, such as all lights, starters, etc. Extra loud siren and round key control lock can be installed in half hour. No need for hood, trunk and door switches. Send \$49.95 to Serv-A-Larm, 1627-29 W. Lawrence, Chicago, Ill. 60640.

REVITALIZE—Save your transmission. \$2.50 postpaid. Guaranteed. Profitable for salesmen. Weldtite, 120 N. Fourth St., North Wales, Pennsylvania 19454.

HYDRAULIC Jack repair kits, parts and supplies. Catalog 50¢ (in coin). Hydraulic Jack Packing & Tool Co., Inc., General, P.O. Box 3, Staten Island, N.Y. 10314.

LIFETIME Carburetor air filter; more mileage, cleaner engine; \$3.95. State height, diameter of your filter. Fidelity Corp., Box 45324, Dallas, Texas 75235.

AUTO ALARM, complete with 10 year manufacturer's guarantee. \$10. T.P.A. Outlet, 393 Belmont Ave., Springfield, Mass. 01108.

SAVE \$\$\$\$\$ Steam from Manifold to Carburetor cleans out carbon—Doubles Engine Life, Gas burns slower creating 20% more Horsepower. 60% less pollution. Possible to gain up to 10 miles per gallon. Write for free literature or send \$10 check or money order for easy to install gas saver. Money back guarantee within 30 days. Berger Engineering, Erskine, Minnesota 56535.

SPARKPLUGS—CHAMPION, A.C. Autolite only 69¢ each, set of 8. We pay postage! Give plug number or year, model, motor information. Glen Distributors, 875 Widener Rd., Elkins Park, Pa. 19117.

MAVERICK Owners: Custom glove compartment kit eliminates open tray. Beautiful walnut finish matches any interior. \$10.95. Easy installation. Specify if Air Conditioned. Instructions. K. Harrison, 900 Maple Ave., Laurel, Md. 20810.

IGNITION Wire Sets. Custom Made to your Car or Truck. Send Make, Engine, \$9.95. Motive Systems, Box 9763, Cleveland, Ohio 44140.

BE your own ignition expert. Free details. Q-arc, Box 47876, Los Angeles, Calif. 90047.

JEEP Owners—V8 conversions. Read Jeep Owners' ad, page 217

AUTO TRAILERS

BUILD Your Pickup Camper. Precut Kits. Blueprints. Supplies. Literature 25¢. Comstock Trailers, Dept. 664, Parsons, Kansas 67357.

PICKUP Camper, Trailer or Pickup—Cover. Build yourself. Save! Complete plans \$3.95 each cover plans \$2.00. Conversion Plans—econoline type van \$2.95; passenger bus or delivery van \$2.95. Satisfaction Guaranteed. Equipment catalog \$1.00 (refundable). Details 10¢. Viking Camper Supply, 99-F Glenwood, Minneapolis, Minn. 55403

CAMPING Trailer, sleeps 6. 15 photos, complete plans \$3.50. Canvas top and kits available. Circulars 15¢. Stratford Trailers, Stony Creek, Conn. 06405.

CAMPER & Trailer Kits—Assemble yourself, save 1/2 over factory built. 12 models: Pickup Truck Campers, Pickup Covers, Travel Trailers, Folding Tent Trailers. Big line of accessories. E-Z terms, money-back guarantee. Free 24 page color catalog. Luger, Dept. TW-70, 1300 East Cliff Road, Burnsville, Minnesota 55378.

CAMPER plans and full sized patterns. The most detailed available with written and pictorial instructions. Various models and accessory kits offered. Send for literature—Glen L. 9152—PM5—Rosecrans, Bellflower, California 90706.

BUILD Truck Campers Trailers Bus Conversions. Blueprints plans parts catalog \$2.00 catalog .50 Kamcraft, Box 1153, Milwaukee, Wis. 53201.

MOTORCYCLES, BICYCLES, MOTORSCOOTERS AND SUPPLIES

ELECTRIC Bicycle. Ride All Day For Nickel. Complete Plans \$3.00. Electro, Box 27203P, Indianapolis, Indiana 46227.

BUILD "Popular Mechanics" MINIBIKE featured June 1967 issue. Detail plans, photographs \$2.50 refundable. Kits, parts, engines; factory discount prices. Catalog 25¢. Gilliom Mfg.; PMC; St. Charles, Missouri 63301.

SNOW VEHICLE & KART Hop up accessory CATALOG. Speed and performance equipment—manifolds, engine mounts, exhaust systems. Send 25¢. G.E.M. PRODUCTS, Box 845, Carol Stream, Ill. 60187.

ILLUSTRATED Catalog 25¢. Parts, Accessories. Custom Stock, most makes, models. Cycle Supply, Box 192M, Fairbury, Ill. 61739.

BARGAIN PRICES. Every part, Kart or Mini-bike. Giant Catalog \$1.00. New, "how-to" plans \$1.00. Both, \$2.00. Brown's Motorsports, 19P Central St., Worcester, Mass. 01608.

INDIAN PARTS. Rebuilding. Accessories. Indian Motorcycle Sales, Kansas City, Missouri 64127.

(Continued on next page)

MOTORCYCLES, BICYCLES, MOTORSCOOTERS AND SUPPLIES

(Continued from preceding page)

MOTORCYCLE Turn Signals. Accessories Catalog 35¢. Houston PM Lockport, Illinois 60441.

MINI-BIKES. Chain Saws. Wholesale Catalog 25¢. Loren Products, Danville, Illinois 61832.

CONVERT Your bicycle to electric drive. Using old auto starter for motor. Plans, photos and instructions \$1.00. Jager, 115 West 37th St., Long Beach, Calif. 90807.

REVOLUTIONARY! Auto battery motorizes your bike. Simply built . . . Inexpensively operated. Choice of two models. **SPEEDSTER—\$2.00** . . . **COMMUTER—\$2.00.** Both \$3.00. Bat-Re-Bike, Box 504-M-5, Cherry Hill, N.J. 08034.

PLANS: Cycle Trailer and Car Trailer \$2.00 each. AROS, 379 N. Johnson, El Cajon, Cal. 92020.

SPACE, ROCKETS AND ASTRONAUTS

MODEL ROCKETRY Magazine: Designs, Instrumentation, Scale, more! Sample 25¢, 12 issues \$5.00. MRM, Box 214E, Boston, Massachusetts 02123.

ROCKETS!! Real flying models—2500 feet altitude with powerful motors. Terrific Science Projects. Tubes—Cones—Parachutes—Launchers—Igniters. Gigantic catalog—rocket data—diagrams—25¢. Fast Delivery. Centuri Rockets, Box 1988, Phoenix, Arizona 55001.

ROCKETS: Real flying models—flights up to 2500 ft. New illustrated catalog 25¢: Singles and multistage kit, cones, engines, launchers, trackers, rocket aerial cameras, technical information. Fast service. Estes Industries, Penrose 7, Colorado 81240.

ROCKETEERS: Chrome plated mylar parachute material, 1,000 square inches \$1.00 Chromylar, Box 173, Sylvania, Ohio 43560.

MOON landing pictures, slides, maps, other space unusuals. Free pricelist. Box 234-PM Merritt Island, Florida 32952.



AVIATION

PRIVATE Pilots license. New half price plan includes everything. Details \$2.00. Electro. Box 27203P, Indianapolis, Indiana 46227.

BE A Government licensed aviation mechanic. Practical training. Free information. Aero Mechanics School, Municipal Airport, Kansas City, Missouri 64116.

AIRBOAT. Propellers, Engines, Plans, Kits, Supplies. Complete Airboats Outboard Airdrives. Catalog \$1.00. Banks-Maxwell, Box 3301E, Ft. Worth, Texas 76105.

AVIATION Surplus Big Catalogue 50¢ (Refundable). Box 1TFPM, Spring Grove, Penna. 17362.

AERO-CAR. Amazing Hovercraft built easily with ordinary tools. Lawnmower engine power. Carries one man plus. Hovers, flies forward, backward, sideways over land/snow/water. Complete construction plans and brochure. \$5.25. Aero-Projects, Box 5118PM, Clinton, N.J. 08809.

HOME BUILT. Real enclosed helicopter. 24 pages ideas, information. \$2.50. Build "executive" helicopter, drawing, specifications. \$2.00. Helicopter Development, Box PM147, Washington, New Jersey 07882.

HOME BUILT helicopter, gyroplane and airplanes **PLANS and KITS.** Complete literature \$3.00 (refundable). Genet Aircraft (PM), 6200 Iberville, Montreal 331, Q.ébec, Canada.

HELICOPTER, SNOWMOBILE, HOVER-CRAFT, AIRBOAT. Bubble canopy, One-Man, Portable, Kits, Plans, Information 20¢ each. Photos and three-view drawings \$1.00 each. COMPCOP, Box 1267, Redwood City, California 94064.

FREE Catalog. Aviation Space Books. Aero Publishers, 329 Aviation, Fallbrook, Calif. 92028.

HI-INTENSITY STROBE. Aircraft Beacon. Complete kit \$89.50. Plans and pictures \$4.50 refundable. Ewes, 1286 St. Paul, Rochester, N.Y. 14621.



BOATS AND TRAILERS

AMATEUR Boat Building Magazine. Plans, Discounts, books, instructions. 3183 Merrill, Royal Oak, Michigan 48072.

CANOE! Kayaks! Factory-direct quality kits, from \$25.00. Many different models. Canvas hulls. Strongest construction materials. Free literature. Sportscraft, Box 8393-PM, Columbus, Ohio 43201.

BOAT PLANS, FRAME KITS, BOAT KITS. World's largest catalog—Over 200 top design for the amateur builders. New catalog includes Cruisers, Runabouts, Deep vee's, Catamarans, Trimarans, Houseboats, Sailboats from small sail fish to 34 ft. motor sailers, large selection of inboard and outboard Hydroplanes. Send \$1.00 for large new plan & kit catalog or \$2.00 for catalog plus Boat Builder's Guide. Clark Craft Boat Company, 16-P Aqua Lane, Tonawanda, New York 14150.

BUILD Your own boat from our large-scale blueprints. Books of plans give how-to-build help. Hundreds of professional designs—motor, sail or auxiliary—for amateur builders. Free catalog. MoToR Boating, 959 Eighth Ave., Dept. PM-RS, New York, N.Y. 10019.

FIBERGLASS Cloth and resin. World's finest cloth and non-run resin, at direct mill prices flotation foam. Complete line of plastics, silicon bronze and brass screws, save 60%. No sales tax. Boat Plans, Catalog 25¢. Freight prepaid. Stiles Boat Supply, Box 11P, Linden Ave., Mantua Hts., N.J. 08051.

BOAT maintenance information. **LIFE-CALK, "GIT"-ROT, LIFE-GLAS.** Finishes & Cleaners. Send for "How to do-where to do" literature. **FREE.** Boatlife, 5-45 49th Av., L.I.C., N.Y. 11101.

BOAT Kits. Molded Fiberglass. Save money—assemble yourself. Factory molded sections bond into one-piece craft. 20 models—14' to 32'. Cruisers, Runabouts, Houseboats, Sailboats. Big line accessories, motors, trailers. Easy terms. Free 80 page catalog. Luger, Dept. BC-70, 1300 East Cliff Road, Burnsville, Minnesota 55378.

KAYAK Kits, inexpensive professional models. Exclusive Nylon hull, aluminum trim. One day assembly. S-T Kayaks, Stony Creek, Conn. 06405.

250 PLANS. Some kits. Catalogs: Powerboat \$1.25, sailboat 50¢. Marinecraft, Box 161-M, Brighton, Mass. 02135.

CONVERTIBLE TOPS. Side Curtains. Folding Frames. Save 80%. make your own. Free information. Product Engineering, 1900 Thunderbird, Florissant, Mo. 63033.

NEW 1969 McCulloch and other Outboards. 4 H.P. \$116 . . . 9 Electric \$288 . . . 18 \$358 . . . 25 \$399 . . . 55 Electric \$818 . . . 85 Electric \$978 . . . All sizes. Literature 50¢. Electra Marine, 1427 Broadway, Brooklyn, New York 11221.

FIBERGLASS Canoes, Kayaks, and Duckboats. Many exciting models. Easily assembled kits. \$39.95 up. Free Literature. Riverside Canoes, Box 5595P, Riverside, Calif. 92507.

PLANS, FULL-SIZE PATTERNS, FRAME KITS with step-by-step instructions specially for amateurs. Send \$1.00 for new 96 page catalog of over 80 designs: 8' to 36' Sail, Jets, Inboards, Outboards, Cruisers, Houseboats, Hot Boats, Catamarans, Hydros, Glen Designs. 9152 Rosecrans, Bellflower, Calif. 90706.

SAIL BOAT KITS. Molded fiberglass and wood for Snipe, Lightning, Penguin, and many others. Free catalogue on sail boats, canoes, ice boats, and fiberglass and sail making supplies. Taft Marine Corp. 636 1/4 39th Avenue, Minneapolis, Minnesota 55421.

BOAT BAILER: AUTOMATIC: Small Craft. A Check ball does it; and it won't forget! Only \$5.95. Write: De Persia **AUTOMATIC BAILER, INC.,** Grand Haven, Michigan 49417.

BUILD AQUA CYCLE, a hydroplane you ride and control like a motorcycle. Illustrated brochure 25¢, plans \$5.00. Sprint Marine, Box 7732, Spokane, Washington 99208.

CANOEES, Kayaks, kits, plans, Sailing Rigs, accessories. Free catalogue. Quicksilver, 115 McGavock Pike, Nashville, Tennessee 37214.

RACE Boat Plans, Kits, Hardware. Hydro's, SK's, Runabouts. Inboard and Outboard. 24 model catalog 50¢ stamps or check. Champion Boats, 816A Schley, Wilmington, California 90744.

MARINE EQUIPMENT AND SERVICES

CONVERT Auto engines to marine. 68 Page Catalog, 50¢. Lehman Manufacturing Company, 800 Elizabeth Avenue, Linden 4, New Jersey 07036.

ATHLETIC AND BODY BUILDING COURSES

WEIGHTLIFTING!!! "How to develop SPEED TIMING CO-ORDINATION." Beginners to Olympics \$2.00. Connecticut State Champ, 127 1/2 West Broad, Pawcatuck, Connecticut 02891.

CATALOGUE—\$1.00—KungFu, GungFu, Karate, Weapons, Equipment, Books. Orient East Suppliers, 3577 West Lyndale, Chicago, Illinois 60647.

FEAR No Bully! Master Authentic Chinese Kungfu Unbeatable Techniques! Defeat Within Seconds Any Attacker Including Giant Judo-Karate Experts. Free Details By Air Write Asia's Greatest Master. Leongfu (M1/44) 119 Anderson Road, Ipoh, Malaysia.

"GIANT Arms." Dr. Young's, D.C. revolutionary discovery. \$2. Satisfaction or refund. Gaucho. Box 9309-S7, Chicago 60690.

POWERFUL Muscles fast! Free brochure! Universal Bodybuilding, Box 4327-C, Dearborn, Michigan 48126.

MIGHTY muscles fast! No weights. Complete illustrated course only \$4.00. Free details. Avron, 9315 Avenue "A", Brooklyn, New York 11236.

ZAKAL, Modern Russian toughening system. \$2.00. Eastview Book Service, P.O. Box 7053, Ottawa 7, Ontario, Canada.

NEW! PUSH-UP BARS for arms, shoulders, chest. Set, \$4.95 (postpaid). Satisfaction or refund. Push-up Bars, Box 262, Portage, Mich. 49081.

SPORTING GOODS AND EQUIPMENT

FREE . . . Wholesale Catalog. Arrow Shafts, Broadheads, Fletchings Fisharrow Parts, Tools, Bows, Finnyports. (22G). Toledo, Ohio 43614.

FREE 1970 Catalog. Guaranteed Lowest Prices! Rods Reels, Lures, Accessories—Thousands of Item. Cabela's Inc., Dept. S. Sidney, Nebraska 69162.

AMAZING Portable Grill Charbroils Steak with newspapers. Free Literature. Arrington, 216 W. Alfred, Tavareas, Fla. 32778.

AMAZING! Indestructible dynaflyte golf balls, lifetime guarantee, 4—\$5.00. Wildwood House, 1236 Wildwood Lane, Binghamton, N.Y. 13903.



FISHING, TACKLE, LURES

FAMOUS SPARKLE TAIL FISHING LURE \$1.95. Swhear & Elliott, 4018 Alsace Place, Indianapolis, Indiana 46226.

(Continued on next page)

FISHING, TACKLE, LURES

(Continued from preceding page)

SEND for FREE Wholesale Catalog. The most complete and fully illustrated catalog of reels, rods, beads, spinners, jigs, bodies and parts, sinker molds, feathers, tools, hooks, rod blanks, rod parts, swivels, wire, etc. FINNYSPOITS, ME Sports Bldg., Toledo, Ohio 43614.

MOLDS—For casting your own fishing sinkers. Free illustrated booklet. Reading Instrument Co., Box P78, Reading, Pa. 19603.

EARTHWORMS, LIVE BAIT

BLACK Widow Ranchers!! Big Guaranteed Market! Free Stock! NBWC, P.O. 260-XPM-1, Brigham City, Utah 84302.

EARN Money raising fishworms for us! Exciting details free! Oakhaven—56, Cedar Hill, Texas 75104.

SUCCESS for you! Raise red wigglers, crickets, mealworms, 6 inch garden wigglers, 12 inch African worms. We teach you to raise and sell. Make money fast! Free Literature. Carter Redworms, Plains, Georgia 31780.

GROW FISHWORMS. Outstanding New Breed produces great profits! Free Literature. Fain's Hatchery-31, Edison, Ga. 31746.

HYBRID Redworms 5000 \$10.00, 20,000 \$20.00 Postpaid with Raising Instructions, Worms, Route 9, Waco, Texas 76705.

FROGS, FISH, REPTILES

YOUNG Frogs and Giant Breeders. Stock your lakes and ponds. Nu-Tex Frog Farm, Box 4601, Corpus Christi, Texas 78408.

REPTILES, Snake sticks, traps. List 10¢. Dealers welcome. Remle Enterprises, Box 611, Palmdale, Calif. 93550.

THREE Praying Mantis Egg Cases \$2.50. Insect eaters. Bernard, Trevilians, Va. 23170.



HUNTING, GUNS, DECOYS

RANGEMATIC rangefinders measure distances to 1000 yards; convert distances into trajectories, M.P.H. etc. Free literature. Ranging, Box 9106H, Rochester, N.Y. 14625.



DOGS AND KENNELS

GUARANTEED Hunting hounds. Picture Catalog \$25. Clayco Kennels, Henrietta, Texas 76365.



POULTRY & GAME BIRDS

QUAILS, Incubators, cages, supplies catalog. Marsh, 14216 Brookhurst, Garden Grove, Calif. 92640.

BABY Chicks, Ducklings, Goslings, Turkeys, Guineas. Free Catalogue. Hockmans, Box 7187K, San Diego, Calif. 92107.

GAME BIRDS . . . Eggs or chicks. Pheasants, Chukars, Ducks, Quail. Write for free price list. Northwest Farms, Inc., Box 3003PM, Portland, Oregon 97208. 503/233-4659.

RABBITS—FUR BEARING ANIMALS

RAISE Rabbits successfully by knowing facts. 48 page illustrated book describing 25 breeds. Housing, breeding, feeding, markets, marketing etc. 25 cents. American Rabbit Association, 36 Arba Building, Pittsburgh, Penn. 15217.

\$500—\$800 MONTHLY Raise small Laboratory-breeding stock for us. We supply equipment, breeders, and instructions. Illinois Research Farms, Dept. MPB-5, Barrington, Illinois 60010.

MAKE Big Money raising chinchillas, rabbits, guinea pigs for us. Catalog—25¢. Keeney Brothers, New Freedom, Pa. 17349.

RAISE Rabbits for us on \$500 month plans. Free details. White's Rabbitry, Mt. Vernon, Ohio 43050.

AMAZING PROFITS! \$10,000 Yearly Raising Rabbits for Wool and Breeding. Details 25¢ coin. American Angora, Malta 12, Montana 59538.

PETS—BIRDS, CATS, HAMSTERS, ETC.

SALAMANDERS Pets or eliminate mosquitoes without spraying. \$1.00 each or \$1.50 pair. Bodewig, Box 381, Coos Bay, Ore. 97420.

LIVE Traps, all sizes, mouse to dog. Collapsible or rigid. Carrying Cages. Free literature. National Live Traps, Tomahawk, Wisconsin 54487.

LIVE SEAHORSES, Marine Specimens, aquarium supplies. Illustrated catalog 20¢. Marine, Box 248-310, Dania, Florida 33004.

HAWKS, Reptiles, raccoons, skunks, squirrels. Catalogue 25¢. Trails End Zoo, St. Stephens, S.C. 29479.

SEAHORSES, Animals, Aquariums and Pet Supplies Catalog 25¢. Aqualand, Box 130, M-5, Miami, Fla. 33145.

BUY DIRECT: Save—Monkeys, Ocelots, Birds, Reptiles, Wildlife, Dog Books. List 10¢ Exotic Animal Importers, Inc. Box 3069-30 Hialeah, Florida 33013.

FANCY guppies, live seahorses, aquarium supplies. Aquarius Ranch, Box 6506, Ft. Myers, Fla. 33902.

SKUNKS wholesale. Monkeys, Animals, Birds, Snakes. Catalogue 25¢. The Bazar, Box 3173, Ft. Worth, Texas 76105.

HORSES, LIVESTOCK

"HOW To Train Horses"—Everyone who likes horses or ponies should have this book; Free. Write Beery School, 1105 Pleasant Hill, Ohio 45359.

VETERINARY Guide to Farmers. The only book of its kind. Send \$6.95 to POPULAR MECHANICS, Dept. VG, 224 West 57 Street, New York, N.Y. 10019.

REGISTERED Polled Herefords with guaranteed market with high percentages returns. Land nor experience needed. Free booklet, write: Wilson Stock Farm, Phone 615-893-8927, Murfreesboro, Tennessee 37130.

CAMPING EQUIPMENT AND TENTS

ELECTRIFY Your cottage with wind generated power. Photos, drawings, complete set of plans, the package \$3.00. Woodlawn, 365½ Bank Street, Ottawa, Canada.

SWEET-JON Deodorant, the new Toilet Deodorant that really works. Kills odors in all kinds of portable and self-contained toilets. Easy, Pleasant and Economical to use. Won't harm tanks or automatic toilets. Based on formula used by U.S. Forest Service for Years. Send \$1.25 for generous 8-oz. supply. Money back if not Satisfied. Olsen Supply Company, 1783 Cahoon Street, P.O. Box 1636, Ogden, Utah 84402. Dealer Inquiries Invited.

JUMBO 1970 Catalog, 132 pages latest camping equipment, clothing, surplus, at lowest prices. Send 25¢, I. Goldberg, Dept. PM5, 902 Chestnut St., Phila., Pa. 19107.

CAMPING

SAVINGS Plus dividends! Campers-fishermen-outdoorsmen cooperative. Free 68-page catalog. Recreational Equipment, Inc., 1525-P 11th, Seattle, Washington 98122.

TRAVEL AND RESORTS

VACATION BARGAINS. Know-Your-World Club, 733 N. LaBrea, Hollywood, Calif. 90038.

"AMERICA BY CAR" tells you what to see and where to go in every corner of the United States. Lists scenic roads, important sights, best places to eat and stay. This big book 170,000 words is as large as 3 novels! Discover this great country by car. Only \$3.50 to CLEMENT ANDREW, 11459 Beach Blvd., Jacksonville, Florida 32216.

DISCOVER "America by Car." Where to go, what to see, scenic roads, best places to eat and stay, places of interest. Large as 3 novels, 170,000 words. Order now. Be prepared by vacation time. Send only \$2.95 to HOLLIS HOUSE, 220-03 Kingsbury, Flushing, N.Y. 11364.

AMERICA BY CAR. Names best places to eat and stay. Scenic Routes, Parks, Historic Sights. 170,000 word book only \$3.50. Know before you go. Peter Athans, 10 Aldrich Drive, P.M., Howell, New Jersey 07727.

WILDERNESS Canoe Trips—Outpost Cabins. Write Bill Rom, Ely, Minnesota 55731.

ELECTRICAL SUPPLIES

METERS—Surplus, new, used, panel and portable. Send for list. Hanchett, Box 5577, Riverside, Calif. 92507.

LAMP Parts. Catalog, prices, wiring instructions. 50¢. Refunded first order. Gyro, 5218P N.W. 35 Ave., Miami 42, Fla. 33142.

LAMP Parts for building, repairing converting. Catalog 40 cents. Refunded first order. Brown Lamp Co., Box 12511, Creve Coeur, Mo. 63141.

LO-VOLT Circuit Tester. Handiest ever! Guaranteed, \$1.75. Mathco, 4256-1 Minnor, Cincinnati 45217.

BATTERIES, GENERATORS

BATTERY Reconditioning Kit, includes molds, material, instructions. Battery Shop, Route 1-188D, Blythe, Calif. 92225.

ENGINES, MOTORS, MAGNETS

WINDING Data, 275 motors. \$1.20. Data Company, 512 Kensington, Kansas City, Mo. 64124.

LIVE Steam powered backyard railroads! All sizes. Complete "bolt-together kits," and rough castings. Excellent drawings. 100 page catalog \$1.00. Little Engines, Lomita, Calif. 90717.

PROJECT PLANS! Motors! Generators! Batteries! Electroplaters! Modequip, Box 7266, Kansas City, Missouri 64113.

STEAM Engine Kits, Automotive, Marine. Catalog-Handbook, \$1.00. Reliable Industries, New Baltimore, Michigan 48047.

MACHINERY, TOOLS AND SUPPLIES

SMALL Foundry furnaces, Supplies. Free literature. Pyramid Products, 3736 South 7th Avenue, Phoenix, Arizona 85041.

"FREE Catalog. Imported Micrometers and Precision Measuring Tools. Savings up to 50%. Raimike's, Springfield, N.J. 07081.

GRANITE Toolmaker's flat, \$18.95 postpaid. Precision Granite, 11550 Larch, Minneapolis, Minn. 55433.

FREE Catalog—Micrometers, Dial Calipers, Indicators, Lathe—R. Leung, Rm. 136, 664 King's Road, Hong Kong.

REVOLUTIONARY NEW TOOL DOLLY FOR CONSTRUCTION CRAFTSMEN. Rugged, compact design. Turns on a dime. Easily maneuvered over cords, hoses, and in crowds. Detailed plans, \$1.95 postpaid. Paneling Specialties, Box 11764 Station A, Palo Alto, Calif. 94306.

LATHE OWNERS: Build your own Tool Post Grinder for less than \$30.00 (purchased parts, 10" Lathe) Patented design. Complete detailed blueprint with instructions, etc., \$2.00. General Devices, 861 West 66th Street, Hialeah, Fla. 33012.

(Continued on next page)

MACHINERY, TOOLS AND SUPPLIES

(Continued from preceding page)

IMPROVE SHOP SAFETY, EFFICIENCY! New electronic brake instantly stops lathes, saws, drill presses, grinders, etc. For motors to 5Amps, \$14.95; to 10Amps, \$19.95. NOT for motors having brushes. AMPITECH, Box 34302, Bethesda, Maryland 20034.

MICROMETERS — Indicators — Steel — Aluminum — Brass, Maximat, Unimat Lathes, Accessories. Lists free: Complete mailing—50¢. Campbell, 1424 Barclay, Springfield, Ohio 45505.

BE A PANELING EXPERT Take the guesswork out of marking corner panels with our kit of rugged aluminum jigs and gauges. For plywood, 1/4" or less. Satisfaction guaranteed. \$9.95 postpaid. Paneling Specialties, Box 11764, Station A, Palo Alto, Calif. 94306.

40 FOOT SQUARE For Staking out Excavations, Footings, Foundations, Etc. Large enough to do the job Small enough to fit into your tool box. \$15.95. QUICK SQUARE, 8 Mechanic St., Pawcatuck, Conn. 02891.

BIG 170 Page Tool and Hardware Catalog \$1.00. Refunded. Elwick, Dept. 124, 230 Woods Lane, Somerdale, N.J. 08083.

WELDING, SOLDERING, PLATING

WELDERS—110/220, 150 Amperes, \$53.50. Morris, 1070 Inner, Schenectady, New York 12303.

CHROME Plating equipment, supplies. All other finishes. Home workshop and production sizes. Send \$2.00 (refundable) for formulas, operating data, equipment guide and catalog. HBS Equipment Division L50, 3543 East 16th, Los Angeles, Calif. 90023.

LINCOLN ARC WELDER. Great Dad's Day gift. 225 amps AC. Less than \$100 list. Includes holder, helmet, cables. Lincoln Electric, Dept. C3, Cleveland, Ohio 44117.

GOVERNMENT SURPLUS

GOV'T Surplus. How and where to buy in your area. Send \$1.00. Surplus information, Headquarters Building, P.M., Washington, D.C. 20036.

JEEPS Typically From \$53.90 . . . Trucks From \$78.40 . . . Airplanes, Typewriters, Boats, Clothing, Camping, Sporting, Photographic, Electronics Equipment, Wide Variety, Condition, 100,000 Bid Bargains Direct From Government Nationwide. Complete Sales Directory and Surplus Catalog \$1.00 (Deductible First \$10.00 Order). Surplus Service, Box 820-A, Holland, Michigan 49423.

JEEP and Gov't. Surplus Buying Manual (Jeeps Pictured) 50¢. Surplus Bargain Catalogue 50¢. Both \$1. Surplus Bargains, Box 789PM, York, Penna. 17405.

1970 SURPLUS Army, Navy store illustrated catalog. Send 25¢ (refundable with first \$5.00 order). Ruvel, 3037 North Clark, Dept. 9-J, Chicago, Illinois 60614.

JEEPS From—\$52.50; Typewriters from—\$4.15; Cars from—\$31.50. Walkie-talkies, motorcycles, airplanes, boats. Typical "As Is" bid bargains from Uncle Sam. Tremendous variety. Exciting free list. Write: Enterprises, Box 402X58, Jamaica, New York 11430.

ALASKAN Army Surplus Clothing, Equipment, Wilderness Survival Gear, Catalog 10¢. Yerger's Supplies, Box 8138, Anchorage, Alaska 99504.

NEW REPORT: How To Buy Government Surplus from U.S. Post Office, U.S. Customs, U.S. Marshal, Defense Department, And General Services Administration. Send \$1.00. Franklin, Box 532, Owosso, Mich. 48867.

HOBBIES AND COLLECTIONS

SHOULDER PATCHES—Collectors items: Official Apollo 11 patch \$3.00 postpaid. U. S. Army and Air Corps patches. Special patches made to order. 10 assorted patches, price list and catalog \$2.50. Catalog only, 25¢. SPRINGER'S, Box 577-PM, El Paso, Texas 79944.

COLLECT Regimental Crests: 3 samples and 32 page military catalog, send 50¢ postage, handling, insignia. Box 71-M, Rockaway, N.Y. 11694.

50 GORGEOUS Jungle butterflies \$2.50. Collectors Wonderland, Box 1170, New York 10008.

APOLLO 8 Iron Moon Bank \$6.50 Postpaid. Trojan Horse, 117 North Central, Paris, Illinois 61944.



STAMP COLLECTING

INDONESIA 50 different 10¢, cataloguing \$2.50. Approvals. Hijop Box 505, Norristown, Pa. 19404.

FREE—Mint British Colonials from Sabah, Seychelles, Tristan Cunha, Sarawak, Negri Sembilan, Caymans, South Georgia. Free with approvals. Viking, Great Neck 8, N.Y.

SQUAREDEAL Bargains. Illustrated Discount Catalog. 10¢. 199 Circuit, Waterbury, Conn. 06708.

"WHOLESALE" U.S.—Foreign Pricelist and catalog Free! Everything Guaranteed. Schneider, Box 1240, Grand Rapids, Michigan 49501.

FREE! 55 Different, including triangles, Space, Others! Nice low-cost approvals. L. Baird, PM-25, Box 8128, Portland, Oregon 97207.

ISRAEL 10 Pictorials 10¢. Approvals. Gouge, Box 88-MM, Elizabethton, Tennessee 37643.

GIANT Apollo Moonlanding Issue free with exciting approvals. Postmark, Great Neck 3, N.Y.

I PAY \$250 EACH for 1924 1¢ green Franklin stamps rotary perforated eleven (\$2,500 unused). Send 25¢ for illustrated folders showing amazing prices paid for old stamps, coins, collections. Vincent, 85PM, Bronx, New York 10458.

POSTMARKED MOON! Valuable Moon Landing First Day Cover postmarked from die taken to Moon and back by Apollo 11 Astronauts. This unique Cover features century-old wood cut from Jules Verne's 1869 novel predicting 3 Americans would be first to land on Moon! We'll give you one Free of extra cost to introduce our famous Approval Service. Buy \$1 worth and get extra bonus of 110 stamps including spectacular Space Issues, plus Illustrated Album—or buy nothing, return stamps and album, cancel service anytime. Moon Cover is yours to keep in any case! Send 25¢ for postage and handling today. Kenmore, MC-534, Milford, New Hampshire 03055.

RUSSIAN Space collection 10¢. Russian Approvals. Snedco, Box 68-P, Waldwick, N.J. 07463.

"UNUSUAL" Set 10¢, with approvals. Gorliz, Box 1915PM, Naples, Florida 33940.

FAR East Assortment—Viet Nam, Japan, Korea, Formosa and others only 10¢ with world-wide approvals. Clark Stamps, Dept. 57 V, Muskegon, Mich. 49444.

ONE CENT a Stamp. Write for a jumbo book of Foreign stamps at 1¢ each, mounted in Scott order, PP, Bullot, 6815 Bay Parkway, Bklyn., N.Y. 11204.

DEFECTIVE Old U.S. Approvals. Karl Swartz, Box 373, Venice, Fla. 33595.

PAKISTAN 25 Different 10¢ approvals. Lansdowne Stamp Co., Box 257, Lansdowne, Pa. 19050.

PENNY! Approvals! Regardless catalogue! Kloster, 4164 52nd St., San Diego 5, Calif. 92105.

50 YEARS Old, fifteen different United States, over fifty years old—10¢ with approvals. Jaxon, Box 145-P, Brooklyn, New York 11230.

FREE 50 Worldwide. Approvals. University Stamps, P.O. Box 1471, Lake Worth, Florida 33460.

GIANT Stamp Collection including: Astronauts, Satellites, Moonrockets, Boy Scout issue. Complete U.N. Set, recent Olympic and Sport issues from many countries, etc., Plus Big Stamp Dictionary and approvals. Everything 10¢! Stampex, Box 47-RR, White Plains, N.Y.

ABSOLUTELY FREE 25 different United States Commemoratives when requesting United States Approvals. K & B, Box 70, Brooklyn, N.Y. 11223.

FREE! Big Bargain Catalog—New Edition listing thousands of bargains including U.S. & B.N.A. stamps, packets, albums, accessories and supplies. Also, fine stamps from our approval service which you may return without purchases and cancel service at any time. Jamestown Stamp, Dept. E50PM, Jamestown, N.Y. 14701.

WOW! 110 All Different Germany 10¢. Commemoratives, Airmails, High Values. Big catalog, bargain lists. Also, fine stamps from our approval service, which you may return without purchases and cancel service at any time. Jamestown Stamp, Dept. A50PM, Jamestown, N.Y. 14701.

U.S. Mint specials! Flag set, complete \$1.00. 1¢, 2¢, 3¢ famous Americans (21 different) \$1.00. Free list. Brooks, 2601 Avenue "U", Brooklyn, N.Y. 11229.

100 OLD United States between 1861 and 1935. \$1.00. Roush Stamps, 51 Chestnut, Mansfield, Ohio 44903.

50 DIFFERENT United States Commemoratives only 10¢. Approvals Included. Sheiron, Box 547 C, North Miami, Florida 33161.

1500 FOREIGN \$1.00; 5000 \$3.00; 9000 \$5.00; 5000 USA. Contains airs, dues, 19th Century, presidentials, revenues, high values, etc. \$3.00, 300 pre-1939 USA commemoratives \$2.00, 200 pre-1926 USA \$1.00; 700 \$3.00; 3000 \$12.00. No approvals. Meyers, 5321 Fleming, Richmond, Calif. 94804.

"GORGEOUS" Sets Free. Request Approvals, Martell, Box 421, Westerly, Rhode Island 02891.

UNITED STATES commemorative collection containing 33 different—10¢. Approvals. White, 516-A Avenue L, Brooklyn 30, New York.

ONE Pound value Geo. VI Bermuda. p' s 100 worldwide 10¢, approvals. Stevens, Box 105A, Homecrest Sta., Brooklyn, N.Y. 11229.

PICTORIAL BONANZA! 10¢ Brings gorgeous collection. Includes sports, space, paintings, animals. Also, other stamps to examine. Buy any or none, return balance. Romar Stamps, Box 8642, Kansas City, Missouri 64114.

RYUKYU Turtles complete set 15¢ approvals. Herman Mills, 237 Ashworth Avenue, Toronto 4, Ontario, Canada.

U.S. Bargain, 50 different 10¢, with beautiful worldwide, approvals. Stamp Center, Kennebunk, Maine 04043.

14,000 DIFFERENT! AMAZING new plan builds your collection systematically, country by country. Only 50¢ weekly. Ware, Monroe Conn. 06468.

CANADA Sports complete, 10¢. Canada approvals. Valley Stamps, Little Valley, New York 14755.

225 STAMPS for only 10¢! Airmails, Pictorials; stamps from strange countries cataloging up to 25¢ each! Plus unusual stamps to examine. Buy any or none return balance, cancel service anytime. Mystic Stamp Co., Camden 80, New York 13316.

(Continued on next page)

STAMP COLLECTING

(Continued from preceding page)

QUALITY AND LOW PRICE. EXCELLENT For advanced or beginner. Mounted approvals 2¢ up, all countries in Scott's Order. Preview Stamps, P.O. Box 9809M, San Diego, California 92109.

"INVERTED ERROR" Dag Hammarskjöld. 6¢ with approvals. Belmont Stamps, Washington, D.C. 20015.

WOW! \$25.00 VALUE! 1000 Different Worldwide \$1.50 with PROFIT SHARING APPROVALS. Universal, Box 6-A, Kenosha, Wisconsin 53141.

RUSSIA High-Value Collection. 32 different Russia—some over 50 years old! Commemoratives, Czarist Issues, Airmails. Catalog price \$2.50. Special Get Acquainted Offer—all for only 10¢! H. E. Harris, Dept. GG 49, Boston, Mass. 02117.

U.S. Approvals Low prices. Eagle, 2221 Romine Ave., Pittsburgh, Pa. 15226.

50 DIFFERENT Old U.S. Revenue stamps 50¢. Winchester Stamps, Box 1592, Mansfield, Ohio 44907.

FREE duplicate exchange. Details 10¢ approvals. Belden, Box 4175b, Dearborn, Michigan 48126.

UNBELIEVABLE Low Prices: Generous Lot 30 cts., Large Assortment \$1. High Value Packet \$2.—Persile, 436 N.Y. Ave., Brooklyn, N.Y. 11225.

NEW Issues—Free weekly illustrated list. Brooks, 2601N Avenue "U," Brooklyn, N.Y. 11229.

FREE Surprise collection sent with approvals. Gould, 1784 Union, San Francisco 94123.

MILLIONS Foreign Stamps! 2¢ each! Send for gigantic approvals! ABC, Box 6000-MB, San Francisco, California 94101.

IRELAND! 25 different 10¢. Approvals. John Mullins, 10321 Muskegon, Chicago, Illinois 60617.

255 DIFFERENT Worldwide: 15¢. Approvals. Tibbets, 8675 Meadow, Downey, Calif. 90242.

FREE Stamp Wallet with approvals. Wide choice collections by Countries. Clark, Box 428, Northbrook, Illinois 60062.

FREE!! Two Beautiful Multi-Colored Complete Mint Sets. Approvals. Hamilton, 1246 Pratt, Chicago OE-5, Illinois 60626.

HITLER—Mussolini 1941 Axis Commemorative Mint Set \$1.00. Satisfaction Guaranteed. Approvals. Iannuzzi, Box 76241-A, Los Angeles 90005.

NOW Rockets, Paintings, Giant beauties, others, 10¢. Approvals. Tiquet, Box 1496, Denver, Colorado 80201.

APPROVALS: Plus collections by year. Martus, Box 158, Centuck, Yonkers, New York 10710.

FREE Large Worldwide Collection with Approvals. W. Lamkin, Farmington, Maine 04938.

PAINTINGS—Multicolored set 10¢. Approvals. Philatelics, Box 2061, South Bend, Indiana 46615.

300 BRITISH EMPIRE \$2.00! F. Ross, 320 Rockland Road, Wayne, Penna. 19087.

MINT. 25 Different British 25¢. Approvals. Box 10146, Norfolk, Va. 23513.

FREE mint set. Approvals accompany. Stamps, Box 22092, Memphis, Tenn. 38122.

RARE Stamp Free! Also new packet Aden to Urundi, with Kennedy, Triangles, Space, Sports, Ships, Dogs, Cats, Reptiles, Plus Others. All Free. Send 10¢ for mailing. Empire Stamp Co. Dept. 1, Toronto, Canada.

FREE! Colonial collection—beauties! Approvals accompany. Gains, 716 South Sixteenth, Mattoon, Illinois 61938.

UNIQUE APPROVAL SERVICE with valuable free packet included. State preference. Cost Reduction Company, Box 10192, Raleigh, North Carolina 27605.

"MONA LISA" painting stamp free with approvals! Roger Williams Stamp Co., Box 1281-P3, Pawtucket, R.I. 02862.

25 LARGE Australian Pictorials 20¢. Approvals? Penniston, 5510 Lee, Arlington, Va. 22207.

MOON, SPACE Collection 20¢—Approvals, Bonuses. Fisk, Box 35, Elmhurst-A, N.Y. 11373.

STAMP SHOW. We invite you to attend the ASDA Show, May 15-17, 1970, Hilton Hotel, Los Angeles, California.

UNITED NATIONS. Four pictorials. Free to approval applicants. Morrell, 161 No. Whitney St., Hartford, Conn. 06105.

SCANDINAVIAN 70 different only 30¢. Kimber, Box 40, 14011 Vairby, Sweden.

HISTORIC MAN on MOON First Day Cover. Addressed to you on special cacheted envelope picturing 3 Astronauts. Has official July 20 "Moon Landing USA" postmark. 50¢ each. K. M. Walsh, Box 308M, Tuckahoe, New York 10707.

ANTIQUE Motorcars, Gigantic Bicolored 1970 Hungary Commemoratives—Free! Approvals plus 101 Bonus Sets. William Deems, 226 Race, Ravenswood, West Virginia 26164.

FREE! 25 Stamps with approvals. Chapman Stamps, Box 633, Galesburg, Michigan 49053.

500 DIFFERENT Stamps, \$1.00. Smith, 508-A Brooks, College Station, Texas 77840.

TEN Different Nudes: 20¢. Approvals. Stamp Farm, 2M18, Oxford, Wis. 53952.

CANADA. 100 different, 25¢. Approvals. Continental, 174 Lakeshore E., Oakville, Ontario, Canada.

PENNY Stamps! 1000 Mounted in book at 1¢ each! Trast Stamp Company, P.O. Box 100-P, Jamaica, New York 11435.

FREE: 100 British Empire. Request unmounted approvals. Ohlsen, Box 103, Fairfield, Illinois 62837.

VIETNAM 25 Different 10¢ approval. Sam Chazen, Box 95, Ozone Park, N.Y. 11417.

COINS, TOKENS, CURRENCY

BARREL of Pennies found on ranch! All before 1956 (mostly "S")—includes Indianheads! 50 mixed \$1.75. Huge Wholesale Listings 25¢. HARRIS 2373P Prunridge, Santa Clara, California 95050.

BUYING? SELLING? "MAILORDER AUCTIONS MONTHLY." \$1.00. Traders, 322 N13, San Jose, California 95112.

INDIANHEAD Cents, V-Nickels 8 different \$1.98. Bargain Pricelists Free. Edel's, Carlyle, Illinois 62231.

TRUNKFUL 25,000 Indian—Lincoln cents from the 1920's & older, mixed 'grab-bag' style. 150—\$10; sample bag of 20—\$2. Mrs. Terry Fischer, Box 1778, Encino, Cal. 91316.

COMPLETE United States Coin List. Coin Stamp Supplies Plus 70S Lincoln Cent 25¢. Schultheis, Box 151M, New Hyde Park, New York 11040.

50 DIFFERENT Lincoln Cents. Beginning with 1909VDB. Nothing later than 1939. Graded Good-Extrafine, \$8.75 postpaid. Free Catalog. Monterey Coins, 311-PM Homeland Northwest, Albuquerque, New Mexico 87114.

49S LINCOLN Cent and Price list 10¢. Rich, Box 34133, San Francisco, California 94134.

ROOSEVELT Dime Specials. All Very Good Or Better. 1949S-80¢, 1955-\$1.50, 1955D-65¢, 1955S-40¢. All Other Dates Are 25¢ Each. Complete Set Of 55 Different With Album For \$14.50. Satisfaction Guaranteed. Bryson Inc., 612 A White, Toledo, Ohio 43605.

WE'LL PAY \$125 each for certain Lincoln Pennies! Nickels \$200! Dimes \$2250. We buy all U.S. coins before 1939. All Foreign. 32 page Buyingbook 25¢. BONANZA, 3962P Ross, San Jose, California 95124.

SILVER Dollars, three different uncirculated \$10.00 or 4 different used \$10.00. Illustrated Catalogue 50¢. Shultz, Salt Lake City, Utah 84110.

COIN-BARGAINS Galore! 10¢ brings large price-list. Premiere Coins—Dept. PM—P.O. Box 7776, Spokane, Washington 99208.

GOLD COINS of the World. Beautiful low prices. Plus thousands of United States Coins. Free price list. Please send long, airmail envelope, self-addressed, stamped. Silver Center, Box 22171-M, San Francisco, California 94122.

ILLUSTRATED Coin Catalog—\$1.00 Post-paid! "How." Box 276-PM, Noble, Oklahoma 73068.

1909-VDB LINCOLN \$1.25. Price list 25¢. Village Coins Shop, Dept. P, Plaistow, N.H. 03865.

BARGAINS—Latest coin price list. 10¢. Ron Farley, Metamora, Ill. 61548.

1970S CENT, Wooden Nickel, and coin list. all 10¢. Lawrence, Anamosa, Iowa 52205.

SCARCE \$2.20 Catalog Price coin set from Laos yours for only 25¢! Offer made to introduce "Coins on Approval" Service. You may return without purchases and stop service at any time. Littleton Stamp & Coin Company, Inc., Dept. L1, Littleton, New Hampshire 03561.

25 NEW Coins. 25 Different Countries \$1.00. Satisfaction Guaranteed. Worldwide Coins, Box 339P, Shelter Island, New York 11964.

GERMAN Coins wanted. Ship insured or write for offer. Graham, Box 39083, Solon, Ohio 44139.

RARE Coins Wholesale! Complete Catalog 25¢. Roger's, Box 26524-AM, Minneapolis, Minnesota 55426.

PROOF Sets 1968-S \$9.95 1969-S \$7.95 1970-S \$7.95. 50 diff. cents before 1941 plus 1909VDB \$4.95, 12 diff. V-Nickels \$3.00, 12 diff. Buffalos \$1.90, 16 diff. "S" Jefferson nickels plus 1950P & 1955P \$2.95, 30 diff. Mercury dimes \$4.95, Warnickel Set \$2.75, 10 diff. "S" Roosevelt dimes plus 1955D \$2.95, 12 diff. "S" Quarters \$4.95, 5 diff. "S" Franklin halves \$4.50, 20 diff. Indian cents \$5.95, 20 diff. Walking Liberty Halves \$15.95. Cash Coins, Dept. PM, 309 Hyde St., San Francisco, Calif. 94109.

3 DIFFERENT Wartime Nickels, only 25¢. Stevens, Box 546F, North Miami, Florida 33161.

SCARCE 1955-S Mint Error Cent 25¢. Bargain lists free. Sayers, 1000 Unaka, Johnson City, Tennessee 37601.

MONTHLY Coin Approval Service. Merlo, 1527 Anderson Ave., Fort Lee, New Jersey 07024.

BRILLIANT Proof sets. 1954-\$17.95, 1955-\$24.95, 1956-\$12.75, 1957-\$6.95, 1958-\$16.75, 1959-\$8.45, 1960-\$6.95, 1961-1962-1963- each \$4.95, 1964-\$8.25, 1968-\$8.95, 1969-\$7.95. List other bargains 15¢. Beebes Inc., Omaha, Neb. 68111

\$2.00 BILLS For Sale. Circulated and Uncirculated. Limited Supply. \$8.00 each. Send Cash or Money Order. Dept. C, P.O. Box 1101, Topeka, Kansas 66601.

ANTIQUES, RELICS, INDIAN GOODS & CURIOS

SECRETS of professional refinishing and restoring in 190 page instructions that tells all for \$1.00. Lyndale Enterprises, Box 18833, 223 East Gowen Ave., Phila., Penna. 19119.

LIST Indian relics. 10 Arrowheads \$3.00. Hyde's, Box 2304, Santa Fe, New Mexico 87501.

INDIAN relic list. Birdpoints \$7.50, doz. Folsom, \$5.00 each. C. Sechrist, Muscatine, Iowa 52761.

10 BEAUTIFUL Arrowheads \$2.00. Guajardo's, 8713 Shaver, El Paso, Texas 79925.

(Continued on next page)

ANTIQUES, RELICS, INDIAN GOODS AND CURIOS

(Continued from preceding page)

FREE List Three Collections Purchased, George Smith, 9825 Conway Drive, Indianapolis, Indiana 46236.

TONS Of antique gun parts and supplies. All reproduction muzzle loading guns. Send \$1.00 for enlarged illustrated catalog No. 119A. Dixie Gun Works, Union City 12, Tennessee. Everybody likes Dixie Gun Works.

MODELS—CARS, SHIPS, TRAINS, PLANES ETC.

STUART Steam engines, castings, catalog 75¢. Carolus Models, 1131 Wilson Avenue, Salt Lake City, Utah 84105.

"HAND-Printed authentic color reproductions of North-American STEAM LOCOMOTIVES. Collectors item. For free information write to Mika Studio, Belleville, Ontario, Canada."

SCALE Building materials, 1/4" & 1/8" scale. Windows, doors, siding, roofing, lumber and structural shapes. Send 50¢ for catalog. Small Sales Co., P.O. Box 177, Shawnee Mission, Kansas 66201.

SHIP And yacht model fittings: Pine construction hull kits; blueprints. Send 50¢ for illustrated catalog. A. J. Fisher, Inc., 1002 Etowah Avenue, Royal Oak, Michigan 48067.

SHIP Model kits and fittings: clippers, frigates, etc. Catalog paint-tool list, 1969 catalog 50¢. Models Shipways, Box 65, Bogota, N.J. 07603.

SHIP Models catalog 25¢. Scientific, Inc., 100 Monroe, Newark, N.J. 07105.

ROCKETS: Real flying models—flights up to 2500 ft. New illustrated catalog 25¢. Single and multistage kits, cones, engines, launchers, trackers, rocket aerial cameras, technical information. Fast service. Estes Industries, Dept. 2, Penrose, Colorado 81240.

SHIP Models, Kits, fittings, plans, books, tools, engines, motors. Big illustrated catalog 50¢. Mass. residents add 3% tax. James Bliss & Co., Dept. SM, Route 128, Dedham, Mass. 02026.

MODEL Airplanes—Big 220 Page Catalog 50¢. Sig Company, Montezuma, Iowa 50171.

AUTOS—World's greatest Kits! Big Scale \$12.95—\$139.95! Plus 500 assembled models \$1.50—\$500.00. Catalog 25¢. Sinclair's, (A-19), Box 8068, Erie, Penna. 16505.

GAMES, TOYS, PUZZLES, NOVELTIES

SATELLITE Build your own. Flies mile high under control. Kit form. All parts included, precut. Easy assembly. 28" size \$3.98. Airtoy 1855 Industrial, Los Angeles, California 90021.

PEACE Buttons, 300 Novelty Buttons. Bumper Stickers, Dealers Inquire, Catalogue 10¢. Harrison, Box 233m, Bethpage, New York 11714.

"ROULETTE DICE" . . . with a unique, "easy-to-learn" Roulette system. only \$1.00. D.E. Products & Co. Box 488, Worcester, Mass. 01601.

PITCH (Setback or Hi-Lo-Jack). Tips for beginners and strategy for serious players \$2.00. McHorney, 127 1/2 West Broad, Westerly, Rhode Island 02891.

STOP!!!! Send quarter for 1970 discount catalog—sample!!! Smoke cartridges!!! Blank Guns!!! Etc.!!! M & M Novelty, Box 17-2373PM Bishop's Corner, Conn. 06117.

MAGIC TRICKS, JOKES, VENTRILOQUISM

MAGIC Trick and 500 item Catalog Both 35¢. Mystic Magic Company, Box 2824, Plainfield, New Jersey 07062.

COMPLETELY Illustrated catalog. 84 pages, 25¢. Manhattan Magic, Box 334-M, N.Y.C. 10011.

HOUDINI'S Greatest Magic Tricks!! You can do them! Giant Illustrated Catalog and Free Secret Trick. 25¢ House of 1000 Mysteries, Dept. PM70C, Ft. Lauderdale, Florida 33308.

500 TRICKS. Douglas famous Magic Catalog, only 10¢. Better Magic for pocket, club, stage. Fastest mail service. Douglas Magicland, Dept. 11, Dallas, Texas 75221.

BE A Magician! Two booklets explaining sixty-eight tricks plus large professional catalog. \$1.00. Magic Inc., 5082 Lincoln, Chicago, Illinois 60625.

WORLD'S Finest professional magic tricks. Joker's Novelties. Giant illustrated catalog 10¢. Top Hat, Evanston, Illinois.

MAGIC Catalog. World's finest 3000 tricks. (340) pages \$2.50. Beginners, amateurs, professionals. Kanter's, A-200 South 13th St., Philadelphia, Pa. 19107.

FABULOUS MAGICS new 1970 catalogue 25¢. Our specialty orders shipped same day no substitutes. Fabulous Magic, 3319 East Charleston, Las Vegas, Nevada 89104.

MAGIC MAGAZINE—Monthly since 1936. 44 pages. All phases. 3 month trial \$1.00. Genii, P.O. Box 36068, Los Angeles, Calif. 90036.

"VENTRILOQUISM! Unique "listen-and-learn" method. Write, Show-Biz, 1735-P East 26th Street, Brooklyn, N.Y. 11229.

FREE Trick, Magic Magazine and Catalog 25¢. Magic & Fun, Box 9-PM, New York, N.Y. 10022.

VENTRILOQUISM! Information free! Dummy catalog 25¢. State age. Maher, Studio E, Box 9037, Denver, Colorado 80209.

MAGIC BUFFS—Learn to do magic. Receive free monthly 140 page magazine with active memberships now available to those 18 years or older. Write INTERNATIONAL BROTHERHOOD OF MAGICIANS, Box 227A, Kenton, Ohio 43326.

BOOKS, CATALOGS, NEWSPAPER

REMEMBER The Scopes Trial, \$1.00. Christian Evidence League, Malverne, N.Y. 11565.

PAPERBACK Catalogue, 15,000 titles, \$1.00. Free Listings Publishers' Overstocks, Hardbounds, L.Ps, Savings to 84%. New York Book, 4 P West 43rd Street, N.Y.C. 10036.

FREE BOOK. Prophet Elijah Coming Before Christ. Megiddo Mission, Dept. 63, 481 Thurston Road, Rochester, N.Y. 14619.

NATIONAL Geographic Magazines, 1888-1967, any issue. Buxbaum, Box 465-PM, Wilmington, Delaware 19899.

CATALOGUE 500 "How-To-Do-It" Books, 52 Subjects, 35¢. Arthur Kill Publishing, Box 158M, Staten Island, New York 10309.

COLLECTORS! HOBBYISTS! Books you need. Write: free catalog, Cleveland, Box 888H3, San Angelo, Texas 76901.

SELF-Development, autosuggestion books. Free literature. Collinse, B67, Appalachia, Virginia 24216.

BOOK Sale. Free List. Hillsdale Gifts, Box 144, Hillsdale, New Jersey 07642.

INTELLECTUAL Atheist Periodical and Catalog 25¢. Truthseekers, Box 2832, San Diego, California 92112.

PUBLISH Your book! Join our successful authors: All subjects invited. Send for free appraisal and detailed booklet. Carlton Press, Dept. PME, 84 Fifth Avenue, New York 10011.

WAS JESUS A JEW? Day Jesus Died, Burial of Jesus. 3 booklets, catalog \$1.00. Edify Associates, Box 341, Urbana, Ohio 43078.

FREE Brochures. TRAVEL, CAMPING, Hobbies—Self Improvement, INCOME, BUSINESS Opportunities. Indicate interest. Val-U-House, 17-Y Wilton Terrace, Verona, New Jersey 07044.

"BOOK DISCOUNTS. Send needs. Most publishers. JMS Box 891-PM 570, Clifton, N.J. 07013."

EARN EXTRA CASH! Homemaker Manual reveals 55 moneymaking plans, tips, ideas. Only \$3.00 Postpaid. Piqua Supply —Dept. 312-PM—Piqua, Ohio 45356.

YOU CAN enjoy the best books in the world. Increased knowledge; health; entertainment; hobbies etc. Large selection; many categories. Write for free list now. Kenneth Masiarchin, 2616 W. Lloyd, Milwaukee, Wis. 53205.

BOOKS and catalogs for every need in home business laboratory or hobby ISIS, Box 622, Ogdensburg, N.Y. 13669.

315 FREE MAGAZINES Covering 65 SUBJECTS Every Month. E & T, 11720 So. Harding Alsip, Ill. 60658.

UNUSUAL book HOW TO GET WHAT YOU WANT. Stimulating Reading. \$5.00 postpaid. Richard Allen Sales, 110 Birch Street, Midland Park, N.J. 07432.

FREE! ILLUSTRATED CATALOG, tremendous savings, satisfaction guaranteed. Kinderman Assoc., 3515 West Market, Louisville, Ky. 40212.

FREE Popular Mechanics NEW illustrated 32 page catalog of plans, publications and projects. Crammed full of fascinating ideas. Plans for boats, patio furniture, camping trailers, swimming pools. Projects for the home and shop. Special sections covering electronics and science. For information on hundreds of other exciting projects send for your catalog today. Enclose only 25¢ to cover postage & handling to: POPULAR MECHANICS, Dept. HE, 224 West 57th Street, New York, New York 10019.

PLAYS, SONGS, MANUSCRIPTS

FREE! "Song-poems Tested Before Investing!" Castle's, 203-M West 46th, New York City 10036.

WANT Your book published? Learn how we publish advertise, promote, distribute. Many successes. Free booklet PM. Vantage, 120 West 31, New York City.

BUSINESS OPPORTUNITIES

MAKE Gorgeous original candles for all holidays and special occasions. Learn expert Candle decorating, candlemaking, use of professional molds. Free details on home instruction method. Candle Institute, Dept. A11, 1600 Cabrillo, Torrance, Calif. 90501.

MOLDING Rubber Liquid Plastic, Hobby Supplies. Details 10¢. Chaney's, 5415-L San Jose Blvd., Jacksonville, Fla. 32207.

400% PROFIT—300 "Unusual" relative items!!! Details! Garen's, Xenia, Ohio 45385.

BECOME Tax consultant. Our students earn \$1,000-\$3,000 every tax season preparing returns evenings. State approved. National Tax School, Monsey 2TB, New York 10952.

SECRETS! Mail Order Success. Internationally famous expert reveals how to make business fortunes. Beginners: Get free copy "Make Money By Mail." Discloses free advertising, profitable products. Mailco, 1554 Sepulveda, Dept. D2705, Los Angeles 90025.

BOOK Sent "999 Little-Known, Successful Businesses." \$25 day plan. Small Business Institute, Dept. 7, Kerrville, Texas 78028.

MAKE Big Money Growing Ginseng! \$3,000-\$30,000 annually. We buy your Crop. Send \$2 for seed sample and information. Glass' Ginseng Exchange, Box 336, Rochdale Station, Jamaica, N.Y. 11434.

OPEN "Deluxe" Clothing Consignment Shop Duplicate my success by purchasing my autobiography. Free information. Ana's Consignment Shop, 7334 Carroll Avenue, Takoma Park, Maryland 20012.

(Continued on next page)

BUSINESS OPPORTUNITIES

(Continued from preceding page)

OPERATE Restaurant. Free booklet reveals profitable plan. Write Restaurant Business School, Dept. EC-50, 1920 Sunnyside, Chicago, Illinois 60640.

BIG Profit in mail order. Hilltop, Dept. 26, Clive, Iowa 50053.

IMPORT-Export opportunity, profitable world-wide mailorder business from home, without capital; or travel abroad. We ship proven plan for no risk examination. Experience unnecessary. Free details. Melinger, Dept. D2705, Los Angeles 90025.

START A profitable mail order business immediately. Follow this expert's advice. Let Alfred Stern's latest, greatest book "How Mail Order Fortunes Are Made" be your guide. Well-illustrated, hard-cover book, chock full of down-to-earth information. Free Details. Write today to Shipstead, Box 231-P, Glenville, Greenwich, Connecticut 06830.

HOW And Where To Get Capital. Get \$500 to \$2,000,000. Free proof. Counselor-17, Kerrville, Texas 78028.

AT LAST a part-time income that does not require selling a product. Our profit-making project can be operated at home with an investment under \$100. Complete illustrated manual \$5.00 postpaid. Check, money order, stamps. Write Moneymaker Co., Box 24122, Ft. Lauderdale, Florida 33307.

MAKE MONEY IN MAIL ORDER. Sell popular mail order aids. We drop-ship, supply your selling needs. Details free. Martyn, 475 Fifth Avenue, Dept. PM75, New York 10017.

INSTALL Burglar Alarm Systems. Big profit home business. Beginners start spare time, without mechanical experience or costly equipment. Free starter plan. Nasco, Dept. D2705, 11071 Massachusetts, Los Angeles 90025.

AMAZING \$1,000.00 Profit Possible every 1,000 mailings! Complete free details; write today, West, Box 447E, Falls Church, Virginia 22046.

START Big-Pay Business at home in spare time. No experience needed to operate little table-top machine for bronzing baby shoes. Make \$7.32 profit on every pair. Full particulars free. Send postcard to: Mason, 1512 Jarvis, Room CM-2-F, Chicago, Ill. 60626.

BE YOUR OWN BOSS. Our instructional manuals show you how. Thousands of business opportunities. Free catalog. Informative Publications, Box 187, Painted Post, New York 14870.

\$15.00 HOURLY Profit—Own Business with one serviceman. Quickly learned. Easy to do. Operate from home. Few hundred dollars builds your own nationally advertised business while continuing present job. Investigate immediately before your territory is taken. Free booklet explains everything. Send today. Then decide. Duraclean, CO-163 Duraclean Building, Deerfield, Illinois 60015.

MAILORDER Book publisher wants dealers. Wonderful "drop-ship" proposition. Sample imprint circulars free. Neil H. Tasker, Shamokin, Pennsylvania 17872.

HUGE Profits! Mail order importing. Free information. ITIS, PM-5, Boy 454, Hollywood, Calif. 90028.

\$400.00 MONTHLY Raising giant fishworms. Soilless method. Charlie Morgan, Bushnell, Florida 33513.

EARN Money raising fishworms for us! Write: Oakhaven-38, Cedar Hill, Texas 75104.

400,000 BARGAINS Below wholesale! Many free. Liquidations . . . closeouts . . . job lots . . . single samples. Free details. Bargainhunters Opportunities, Box 730A, Holland, Michigan 49423.

ESTABLISH Profitable Catalog Mailorder Business! Vikari's, Box 1312-PM-E, Salt Lake City, Utah 84110.

STOP Throwing Away Those Boxtops! They're worth money, some 25¢ each! Write: Boxtops—80, Cedar Hill, Texas 75104.

ADVERTISING BUSINESS—YOU own it. \$350 First Week or Money Back. Electric Neon Action Ad Clock, 229 W. Illinois, Chicago 60610.

JOIN "MONEY GETTER'S GUILD". Receive hundreds money-making. Business Building Propositions. Year's membership only 25¢. Write: Fourstars, Box 839, Long Beach, New York 11561.

I MADE \$40,000.00 Year by Mailorder! Helped others make money! Start with \$10.00—Free proof! Torrey, Box 318-Y, Ypsilanti, Michigan 48197.

MAIL Baby Catalogs imprinted with your address to New Mothers for Big Profits! Details 25¢. Volz-PM, Ypsilanti, Michigan 48197.

CLIP Newspaper items, \$1.60-\$5.00 each. Details free. Walter, Box 1360-PA Erie, Pa. 16512.

WANT To make big money at home? \$10.00 profit in an hour possible with invisible mending. Make tears, holes disappear from clothing, fabrics. Steady year-round demand from cleaners, laundries, homes. Details free. Fabricon, 1585 Howard, Chicago 60626.

SELL Lifetime, Metal, Social Security Plates. Big Profits! Sample and Sales Kit Free. Russell, Box 286-PM, Pulaski, Tennessee 38478.

SPARE Time Cash—Sell Advertising Book Matches—every business a prospect—no investment—no experience needed to build steady repeat business. Daily Cash commission in advance. Write today—We'll send your sure-fire selling kit by return mail. Dept. MX-570, Superior Match Co., 7530 S. Greenwood, Chicago, Illinois 60619.

COPUBLISH "Mail Sale Advertiser," leading mailorder paper. Copy and details 25¢; U.S.A. only. Vanroy Shirk, Lebanon, Pa. 17042.

\$200.00 DAILY in your mailbox! Your opportunity to do what mailorder experts do. Free details. Associates, Box 136-A, Holland, Michigan 49423.

\$75.00 THOUSAND. Home Addressing! Longhand, Typewriter. Information, send stamped self-addressed envelope. Brewster, Box 1348-TF, Clearwater, Florida 33517.

DRAFTSMEN! Operate own DRAFTING SERVICE! Full, Part Time; Experience unnecessary; Details: Roberts Drafting, 1741 Circle Road, Baltimore, Maryland 21204.

JEWELRYCRAFT—It's easy! Big profits! Catalog, 25¢. Modern Craft, 12790 US 19; Clearwater, Florida 33516.

RAISE Rabbits for us on \$500 month plan. Free details. White's Rabbitry, Mt. Vernon, Ohio 43050.

EARN \$60.00 DAILY manufacturing Concrete Fence Posts. Practically no investment. Free information. Send stamp. American, Excelsior Springs, Mo. 64024.

VACUUM Plastic Molding & Liquid Plastic Casting—At Home! Make Hundreds of full 3-D plastic products. Big profit in spare time. Facts, Nationwide Plastics, Dept. OC, 4140 Eagle Rock Blvd., L.A., Calif. 90065.

56 ACTIVE Franchise opportunities available all over USA. Brochure details 56 franchise chances for you to have your own business tied with successful national companies. Send name, address to P. Stewart, 1085 Walnut, Des Plaines, Illinois 60016.

MAILORDER Records help get increased business! Complete 32 Page Record Book shows your inquiries, orders, advertising, expense, etc. Only \$1.00. C. A. Martin, Popular Mechanics, Dept. PM, 224 West 57 Street, New York, N.Y. 10019.

\$500—\$800 MONTHLY Raise small Laboratory-breeding stock for us. We supply equipment, breeders, and instructions. Illinois Research Farms, Dept. MPD-5, Barrington, Illinois 60010.

TREMENDOUS \$1,000.00 Profit From 1,000 Mailings! Free Proof! George-PM, Box 2188, Cypress, California 90630.

MAILORDER—Profitable products; drop-shipped. No merchandise investment. Everything supplied—catalogs, ads, mailing lists. Gif-Guide, 1137½ Crenshaw, Dept. 185, Los Angeles 90019.

BOOKKEEPERS Earn \$500.00 week. Operate Bookkeeping Tax Service. Details free. Universal, Box 664-M, Springfield, Missouri 65801.

MAIL ORDER Sell books. Fascinating, profitable, details. Jobre, Box 27, Great Neck, N.Y. 11023.

WORLD'S Largest supply. Merchandise 25% to 40% under wholesale. Bankrupts. Closeouts 10¢ on dollar. Imports. Hongkong clothes. Automobile discounts. Free details. International Buyers, Box 16386-MM Portland, Oregon 97233.

HOLLYWOOD CEMENTCRAFT: Offers Highly Profitable Home Business. Experience Unnecessary. Unlimited Unique Pottery Designs Easily Made Without Moulds. Bird-baths, Fountains, Washing-Weirs, Waterfalls, etc. Chemical Coloring Formulas, Marble-glazing. FREE Illustrated Brochure. CONCRETE FACTS, 602 Athens Street, Altadena, California 91001.

SELL Books by mail. 400% profit. Royal, Box 450-X Cleveland, Ohio 44127.

FREE "Franchise Profit Letter" tells how unique NR Service is helping thousands seeking profitable businesses. Write today. National Franchise Reports, W-528, 333 North Michigan, Chicago 60601.

QUICK Income with Mail Order Collection Agency. \$1000 monthly and more. We show you how. Continental, Box 2023-A, Des Moines, Iowa 50310.

MAKE Money from old tires. Operators clearing \$800, weekly. Equipment costs \$1500. Get facts. S & S Patents, Inc., 3752 N. Damen, Chicago 60618.

GROW FISHWORMS. Outstanding NewBreed produces great profits! Free Literature. Fain's Hatchery-26, Edison, Ga. 31746.

FREE Catalogs. Repair air conditioning refrigeration. Tools, supplies, full instructions. Doolin, 2016 Canton, Dallas, Texas 75201.

CALIFORNIA MANUFACTURER NEEDS man to assemble our product and be local agent, experience unnecessary. May start while presently employed. Five-figure income for responsible applicant. S.K.R.M. Manufacturers, 2347 West 238 Street, Torrance, California 90501.

VENDING Machines. No selling. Routes earn amazing profits. Big catalogue Free. Parkway Corporation, 715PBM Ensor Street, Baltimore, Maryland 21202.

ADDRESSERS And mailers needed. Send stamp for information. Lindbloom, 3636 West Peterson, Chicago 60645.

BECOME PROFESSIONAL DRIVING INSTRUCTOR. Earn \$10.00 Hour, \$400 Week. Part-Full Time. Business Yourself. Free Details. Howard David, 1818 Evarts, Phila., Pa. 19152.

SELL Beautifully colored Social Security Plates. Big Profits! Free Sample. Pop Wright, 1075 Ringwood Avenue, Pompton Lakes, N.J. 07442.

AMAZING PROFITS! Sell by mail quality self-improvement books. Drop-shipped by reliable publisher. GRAPHIC, 1033-PM S.W. 53rd, Oklahoma City, Oklahoma 73109.

SIMPLE, EASY way to enter mail order. Earn \$12,000 year up. Stamp for details. Emptage, 1033-PM S. W. 53rd, Oklahoma City, Oklahoma 73109.

UNBELIEVABLE extra money can be YOURS through amazingly easy Mail Order method. No inventory. No boss. Work at home YOU can START NOW. Free information. Thank you, River Shores, Box 577-504 Fifth, Crystal River, Florida 32629.

FREE FRANCHISE JOURNAL magazine with over 100 franchise opportunities in every issue. Franchise Journal, Dept. G, Box 1790, Newport Beach, Calif. 92663.

(Continued on next page)

BUSINESS OPPORTUNITIES

(Continued from preceding page)

MAKE \$46 from square foot plywood: jigsaw or bandsaw necessary. Free details. Woodar, Bridgewater, Mass. 02324.

1000% PROFIT Bronzing Shoes. Free Literature—N.B.C. Box 11069-PM, Kansas City 64119.

\$70.00 WEEKLY—home, spare time. Simplified mail bookkeeping. Immediate income easy. Auditax, 34741A, Los Angeles 90034.

MAILORDER success plan! "How to Get Rich by Mail." Free copy reveals millionaire's secrets! Executive (1005), 333 North Michigan, Chicago 60601.

MAKE Magnetic car signs. Write Route 1, Box PM-49A, Bardstown, Ky. 40004.

BLACK Widow Ranchers!! Big Guaranteed Market! Free Stock! NBWC, P.O. 260-XPM-1, Brigham City, Utah 84302.

\$25.00 HUNDRED Addressing. Possible! Year 'round. Special information included. Send 25¢ postage, handling, Cove, Box 1348-BE, Clearwater, Florida 33517.

BUY Diamonds from friends, sell us! Free instructions. Send \$2.00 for professional equipment. Olympic, Box 4398, Tyler, Texas 75701.

MAIL Galore! Money-making offers. Name on national mailing lists. 25¢. Box 2065-M, Forsyth, Georgia 31029.

CLIP Short newspaper items. To \$10.00 each. Details free. Foster, 272-M5, Brooklyn 11235.

MAKE Durable building plastic easily. Waterproof, fireproof, economical. Bays Laboratory, Cedaredge, Colorado 81413.

MAKE A Year's Income in 8 weeks. No capital investment, no selling, no land ownership necessary. 9 different ways. Write Edru's, Route 5, Box 5733, Gig Harbor, Wash. 98335.

\$60.00 DAY. Manufacturing concrete Posts. Blocks. Mold Equipment Catalog \$1.00 refundable. Carlayne, Route One, Box 106T, Rapid City, South Dakota 57701.

SELL Magnetic Car Truck Signs. Easy sold part time. Dean's, 224 South Kenwood, Casper, Wyo. 82601.

CLASSIFIED ADVERTISING SUCCESS Manual. Free details. Bonus offer. Koltun's, 60 Willowgreen Drive, Tonawanda, New York 14150.

EXCITING new Jewelry! Sensational tested profit plan free! Libra, 1368-P Pacific, Santa Cruz, Calif. 95060.

SELL ART! Outstanding opportunity to represent booming artists at home. Apply to: A.T.I. Division Arquitectura, apartado 32083, Mexico City.

FREE! I'll give you your own home business. Details 25¢ Jackson's Imports, Rt. 2, Roseboro, N.C. 28382.

SUCCESSFUL Money-making Opportunities. Thousands. Butler, Box 1521, Anniston, Alabama 36201.

NEW! How to Succeed in the Second-hand Business. Manual of hard facts for every businessman. Free brochure. Merit House, 1810 Cabrillo, Oxnard, California 93030.

'TEXAS RANCHER found OIL. Needs help test four sands. GOOD Geology. References. Full Information. R. M. Cooksey, 318 N. 14th St., Corsicana, Texas 75110.'

WHOLESALE BARGAIN DIRECTORY 50,000 low cost items. \$2.00 postpaid. Free catalog. Winchester Enterprises, 2807 Hargrave Street, Philadelphia, Penna. 19136.

MAGNETIC SIGNS. Vacuum Machine. Complete Shop. Investment \$1,295.00. Interested? Call or write Nova Mfg. Co., 727 14th St., Bessemer, Ala. Phone 205-426-2411.

MAILORDER! How to prepare your own catalog for pennies... without merchandise investment! Free Catalog—proof! Obie, 5711-MKE—14th, Brooklyn, New York 11219.

YOUR Name Listed with 1650 Foreign and Domestic Mailers, Importers, Manufacturers, Wholesalers, Publishers, etc. Year \$1.00 Our offers included. International Listing Service, Middleton, Tennessee 38052.

MAILORDER IMPORTS. Report reveals foreign dropship sources. Ideal mailorder items. \$1.00. Tedders, 5061 Amnest, San Diego, California 92117.

MAILORDER Business. Free sample. Andrews, Box 485, New York, New York 10013.

DATING Service—Fantastic Business. Write Blandco, 328 S. Main, Ann Arbor, Mich. 48108.

\$200 WEEKLY Without investment or purchases. New plastic Laminating services franchise in your area. Send \$5.00 for complete portfolio and contract: VMF Company, 371 E. 5th Street, Chuluota, Florida 32766.

DRAFTSMEN! All classifications. I earned over \$17,000 year. So can you. Details \$2.00. Earn More, 2449 Mobile Drive, Huntsville, Alabama 35805.

LEARN Money-making Methods. Monthly newsletter. Moneymaker, Box 1835-DE, Philadelphia, Pennsylvania 19105.

BUILD Custom Cases at home for profit. Get orders by mail. We supply materials, instruction—everything. Free home business details. Custom Case Supply Co., 6961 CPE, Hayvenhurst Avenue, Van Nuys, California 91406.

PROFITABLE WATCH REPAIR. Free information. Watchmaking, YEB, Fox River Grove, Illinois 60021.

INSIDE Secrets of marketing your home-manufactured product profitably. New manual reveals know-how for rapid growth from small beginning. Free details. Flexipress-PM5, 10918 South Western, Chicago, Illinois 60643.

50% OFF Possible on engraved signs, nameplates, plaques. Your personal nameplate a \$2.50 value only \$1.00 postpaid. Two \$1.75. Free catalog. Forsberg, 61 Friendly Lane, Levittown, Pa. 19055.

HOW to Make Money in Mail Order Imports. Fabulous new method of starting your own Mail Order Business from home. You don't invest one cent in merchandise. U.S. Government will help you! How to get free 'ads' in national magazines! Includes Directory of drop-ship import mail order items. Booklet #MO-521 A only \$1.00. All Seasons, 422 South Western, Los Angeles, Calif. 90005.

TAKE Catalog orders. We drop-ship 1001 best selling specialty products. Guaranteed lowest below wholesale prices. Fantastic spare-full time home business. Free book shows you how. SMC 6963 SPE, Hayvenhurst Avenue, Van Nuys, California 91406.

VENDING Machine big catalog. Rake, 523 A Spring Garden, Philadelphia, Pa. 19123.

PIANO Tuning Learned Quickly At Home! Tremendous field! Musical knowledge unnecessary. GI Approved. Information free. Empire School, Box 327, Miami, Florida 33145.

\$300.00 WEEKLY Possible!! Successful mailorder yours!!—easily!! Proof Free!!! Williams, POB44646XA, Los Angeles 90044.

HOMEWORKERS Envelope Addressers WANTED. Perrone, Box 203, Bronx, New York 10458.

MAILORDER Books. Free Lists. Earl's, 121-PM East Melrose Findlay, Ohio 45840.

FANTASTIC Opportunity—Your Own Gift Catalog Business. No merchandise investment! Free Sample Catalog! Mail Marketing Services, Benton, Illinois 62812.

DEALERS, BARGAINHUNTERS: Import, Dropship, Wholesale, Government Surplus directories. Write, Malone, Box 111, New Baltimore, Michigan 48047.

NEW Easy—learn how to earn more. 25¢ for handling. Sides, 3511 Link Valley A-27, Houston, Texas 77025.

MONEYMAKING OPPORTUNITIES

SWEEPSTAKES Contests. How to Win. Write for free particulars. General Contests, 1609-18 East Fifth, Duluth, Minnesota 55812.

RESEARCH At Home. One-man business. Big demand. Learn in 7 days. Start with \$15. Free proof. Datacraft-7, Kerrville, Texas 78028.

WE BUY Bottles, Coins, Antiques, Books, Stamps, Magazines (Anything!) Fruit Jars. Send \$1.00 (refundable) for huge Buying Lists. Schroeders, Paducah, Ky. 42001.

MAIL Letters featuring real merchandise. Everything furnished. Big profits. Write: Woodcrest, Box 235-PM, South Easton Massachusetts 02375.

MAKE Money—Ghostwriting! Free details. Mailord Company, (PM-470), Bedford Hills, New York 10507.

AMAZINGLY Profitable! Make one-way mirrors from ordinary glass. Complete formula and instructions 25¢. Cameo, 826 South Hobart, Los Angeles, Calif. 90005.

INSTANT Money! Plastics are the wave of the future. Big profits now! At home! Spare time! Materials costing 11¢ bring \$2.58 profits immediately! Free information! Rush name on postcard to: Warner, 1512 Jarvis, Dept. CL-2-F, Chicago, Ill. 60626.

\$80.00 TO \$100.00 weekly profit Part time sign-business. Magnetic Signs, 306 East Sunrise, Fort Lauderdale, Florida 33304.

WRITE To Sell. Details Free. Novak, 18720 Hatteras, Tarzana, California 91356.

'WRITE Persuading Letters. Profitable! Samples. Eljay, 603-B Navarro, San Antonio, Texas 78205.

LYRIC WRITERS write songs with writers who write hits for top Nashville artists. Globe, 420 Broad, Dept. PM, Nashville, Tenn. 37203.

\$15.00 HOURLY Profit—Own Business with one serviceman. Quickly learned. Easy to do. Operate from home. Few hundred dollars builds your own nationally advertised business while continuing present job. Investigate immediately before your territory is taken. Free booklet explains everything. Send today. Then decide. Duraclean, CO-163B Duraclean Building, Deerfield, Illinois 60015.

CIGARETTES 12¢ a pack. Improved roller makes 20 filtertip, plain, king or regular for 12¢. Facts free. Moberly, Box 953, Owensboro, Kentucky 42301.

EARN \$240.00 a month at home, spare time, doing only two \$5.00 invisible mending jobs a day. Big money paid for service that makes cuts, tears disappear from fabrics. Steady demand. Details free. Fabricon, 1532 Howard, Chicago 60626.

MAKE Statuettes, novelties, imitation marble. Sell to stores or start gift shop. Free details. Marbleizing, 41 Waverton, St. Louis, Mo. 63124.

HOW To Make money writing short paragraphs. Information free. Barrett, Dept. C-27-D1, 6216 N. Clark, Chicago 60626.

FREE Copy of world's leading contest magazine! Write Prizewinner, Box 11569, St. Petersburg, Fla. 33733.

FREE. 206 Easy Ways to make money taking orders for exciting new products—spare time. Send name, age for 5 months free subscription. Opportunity Magazine, 1460 Hancock Center, Dept. 17-EM, Chicago 60611.

HOMEWORK. Mailing circulars. Free details! Cam Company, Dept. 155-KP, Verona, N.J. 07044.

(Continued on next page)

MONEYMAKING OPPORTUNITIES

(Continued from preceding page)

SCIENTIFIC Massages: Big Earnings uncrowded profession. Learn spare time at home. Diploma awarded. Free catalog. Write Anderson School, Dept. E-1C, Princeton, Illinois 61356.

CLIP Newspaper items. \$1.00-\$5.00 each. Details free. Walter, Box 1360-P, Erie, Pa. 16512.

MAKE: \$12.00 Profit each dozen assembling Belts. Details Free. (Stamp appreciated.) Redikut's-40, Richland Center, Wis.

HOW TO GET RICH!! Free "Money-making Brochure"! Success International, Box 2447-C, Livonia, Mich. 48151.

\$200.00 FROM Sheet 1/4" plywood (scrap). Details 25¢. Novelties, 610 So. 24th, Elwood, Indiana 46036.

\$500-\$800 MONTHLY Raise small Laboratory-breeding stock for us. We supply equipment, breeders, and instructions. Illinois Research Farms, Dept. MP-5, Barrington, Illinois 60010.

FREE Details. "990 Successful, Little-Known Businesses." Conn. Box 1274-A, Fort Wayne, Indiana 46801.

\$2.40 HOURLY Making simple wood novelties. Free details! Gene's, 55 Boxwood, Falmouth, Mass. 02540.

SELL Lifetime Social Security plates. Free sample. Lady P. McGuire, Rt. #6, Anderson, S.C. 29621.

VENDING Machines. No selling. Routes earn amazing profits. Big catalogue Free. Parkway Corporation, 715PMM Ensor Street Baltimore, Maryland 21202.

YOUR Fortune can be photographing beautiful models. Maybe importing, possibly real estate. Free information. Write: PM-5 Distributors, Box 83, Verdun, Quebec.

SELL Foolproof! Fire-Burglar Alarms. Inexpensive. Write: WATCHDOG, #4U, Williamsburg, Ohio 45176.

"MONEY—111 Select Ways For Making It!" plus "Free Item Sources." Guaranteed. \$1.00. Premier Enterprises, Postbox 10597-PM, Pittsburgh, Penna. 15235.

WATCH REPAIRING builds spare time income fast. Free details. Sweazey, YEA, Fox River Grove, Illinois 60021.

BECOME Notary Public! Free particulars. Stationers, 405-PM Richardt, Evansville, Indiana 47711.

LEARN The secrets of repairing junk batteries "Fabulous Profits" at home. Battery Shop, Route 1-188 D, Blythe, Calif. 92225.

WE Buy newspaper clippings for 50¢ each. Details \$1.00. Clippings, Box 53, Chalmette, Louisiana 70043.

"START Moneymaking Mail Order Business Today!" Roban's, Box 3124, Industry, California 91744.

HOW TO GET RICH! Amazing plan revealed! \$2.00 Refundable. Seco, Box 144, Walkerton, Indiana 46574.

\$2000.00 MONTHLY. Easily done with my new business. Free details. Send stamp to Ropchan, Box 5341, Sherman Oaks, California 91413.

INVEST IN STAMPS FOR PROFIT! Details of systematic investment program free. Jeffrey Needleman, 2367P East 18th Street, Brooklyn, New York 11229.

MONEY BY MAIL. Mailtrade magazine been telling 40 years. Tips, ideas. Sample 50¢. Year \$4 with bonus offer. Mailtrade, Sheboygan, Wisc. 53082.

SPECIALTY Merchandise Wholesale, gifts, premiums, etc. for catalogues, send \$2.00. M. Zinn, Box 89, Elmwood Park, Ill. 60635.

FREE Details: "101 Ways To Make Money". Park Enterprises, Box 198PM, Palisades Park, 07650.

"CLIPPING Services, Potter, 11 S. Fenwick, Arlington, Va. 22204."

INCREASE INCOME, no Experience needed. Details free. ACT NOW. Write, LAKEVIEW SALES, A-111 Volusia Ave., Lake Helen, Florida 32744.

\$52.00 WEEKLY! Sparetime! Addressing. Details, Application—10¢. Troy Co., Dept. 206PM, Bayonne, New Jersey 07002.

EARN Big money drawing cartoons for Advertisers, Bulletins, others. Manual shows how. \$3.95. Satisfaction Guaranteed. Hart, 3240-D Hennepin, Minneapolis, Minnesota 55408.

MONEYMAKING electronic projects you can start in your garage. Experience unnecessary. Manual 25¢. Barta, PMA Box 15083, San Francisco, California 94115.

ALL NEW IDEA! Turn scrap lumber into cash. Information free. Taywa Craftwork, Rt. 1, Box 1, Sylva, N.C. 28779.

FABULOUS Prize opportunities. Sample "sweepstakes bulletin" 25¢. Benro Enterprises, Box 6656-PM, Philadelphia, Pa. 19149.

YOU CAN make money in mail-order. Advanced book reveals how. Mail-order is simple and profitable. Send for free information now. Kenneth Masiarchin, 2616 W. Lloyd, Milwaukee, Wis. 53205.

REAL MONEY MAKING Spare Time Opportunity. Men and Women. Details Free. SIDENSTICK, 1230 Purcell Ave. Cincinnati, Ohio 45205.

BIG PROFITS GUARANTEED! 1970's Top home operated mailorder offer! Details Free! Minnesota Specialties, Box 1186-M, Minneapolis, Minn. 55440.

AMAZING BOOK! Skyrocket your income, gain financial security, send \$2.00 today. Kinderman Assoc., 3515 West Market, Louisville, Ky. 40212.

HANDY MEN assemble new sportarticle. Send \$1 (refundable) for detailed plans, instructions. HJ Skibike, Box 402, Sunland, Calif. 91040.

TAKE Printing orders. Big profit. Allstate Press, Dept. PM, 120 So. LaSalle, Chicago 60603.

"FLESH Eating Moon Plants!!!" Raise Astronomical Profits!!! 3 living plants, tremendous guaranteed program!! \$1.25 (refundable). Biowitics, P.O. 260 BPM4, Brigham City, Utah 84302.

UNUSUAL, Spare Time, Successful Business can be yours. Free details. Deagle, 171-A Ranch Drive, Pocatello, Idaho 83201.

NEED EXTRA CASH? Six excellent opportunities! Free catalog! MGR Studios, Box 15036, Fort Worth, Texas 76119.

ATTENTION: Build Cuesticks for fun and PROFIT. Send \$1.00 for complete information. Billard Supply Co., 3149 Lassen, Oxnard, Calif. 93030.

YOU Can earn up to \$50 per paragraph. Experience unnecessary. Send \$3.00. DeJorio, 25 Vineyard, Highland, N.Y. 12528.

RECEIVE \$100 Orders. Set others up in Mailorder selling your own Mailorder Dealerships. Everything Dropshipped. Free Details. Marnel, Box 485-C, Framingham, Massachusetts 01701.

ZAPART SAWFIER Special Sale now. Free details write: Zapart, 360 South Seventh Street, Lindenhurst, N.Y. 11757.

NEED MONEY??? Hundreds of dollars—56 ways to make it fast. Push 50¢. James Paulman, Dept. AM-5, 70 Argyll, New Rochelle, New York 10804.

FROM BUM to millionaire, from poor to rich. Amazing way to become millionaire. For information \$1.00 cash or m.o. Z.S., P.O. Box 68, Victoria, B.C. Canada.

MAKE more money—Take orders for Book Matches. Prospects everywhere—every day is payday—no experience needed—no investment. We'll send you power house selling kit with new complete catalog so you can make quick sales and big cash commissions. Superior Match. Dept. MA570, 7528 S. Greenwood, Chicago 60619.

MANUSCRIPT: Raise Capital. Free Circular. Gene Chiasson, 507 West 8th Street Thibodaux, Louisiana 70301.

WORLD'S Biggest Wholesale Import Merchandise Catalog. Unbelievable Bargains! Single, quantity purchases. Details free. Northwest-E, Medina, Washington 98039.

WIN Valuable oil leases—government lottery. Complete information 50¢. Professional Filing Service, Department M, Patterson Building, Denver, Colorado 80202.

PROFITS FROM CLASSIFIED ADVERTISING! Booklet shows you how to start your own business with Classified Advertising. Only \$1.00 (Refundable with first order.) C. A. Martin, Popular Mechanics, Dept. PM, 224 West 57 Street, New York, N.Y. 10019.

CHANCE OF A LIFETIME—Scoop the wholesale Market. Free Sample Catalog; Samples Available; Imports; Electric Shavers; Wigs; Watches; Hosiery; Gift Items—Many Many More!!! Send 25¢ for details today. UNI-WAY ENTERPRISES, Dept. PM2, P.O. Box 29132, CLEVELAND, OHIO 44129.

CAMERA OWNERS! Sell your photos. Report tells How, Where. Color Slide Markets. Only \$1.00. Sumax Sales, 4453 Howard, Skokie, Ill. 60076.

\$1,000 MONTHLY, Booklet, 10¢. Homecraft, 2350 W47 AP, Denver, Colo. 80211.

PROFITABLE OCCUPATIONS

CULTURED MARBLE vanity tops with lavatory bowls cast into one unit. Manufacture in your basement or garage. Big profits. Marco, P.O. Box 2733, Augusta, Georgia 30904.

FREE Book "990 Successful, Little-Known Businesses." Work Home! Plymouth 47-Y, Brooklyn, New York 11218.

EARN \$240.00 A month at home, spare time, doing only two \$5.00 invisible mending jobs a day. Big money paid for service that makes cuts, tears disappear from fabrics. Steady demand. Details free. Fabricon, 1586 Howard, Chicago 60026.

CHROME Plating Instructions, equipment and supplies. Platers' Supply, P.O. Box 565, Lugo Station, Los Angeles, Calif. 90023.

FT. SMITH Auction School. Ft. Smith, Ark. Residents & Home study. Veteran approved.

BECOME A mortgage broker, earn \$10,000 to \$50,000 a year. Details free. United, Box 6284A, Marietta, Georgia 30060.

\$500-\$800 MONTHLY Raise small Laboratory-breeding stock for us. We supply equipment, breeders, and instructions. Illinois Research Farms, Dept. MPA-5, Barrington, Illinois 60010.

SHARPEN Scissors, Pinkers. Inexpensive equipment, tools, supplies. Blackhawk's, Sheldahl, Iowa 50243.

LOCKSMITHING—Fifty Page Automotive Lock Manual—\$4.95. Glenstone, Box 3127, Springfield, Missouri 65804.

PHOTOGRAPHERS—Sell your pictures. 1970 Markets Directory. Send 20¢ for sample list or \$4.95 for complete book: PHOTO MARKETS, Box 956, Bellevue, Washington 98004.

MAKE \$300 CLEAR MONTH few hours from 10 customers, representing us in your community. No individual selling. Repeats forever. Customers waiting. \$1 for sample, details. Our 40th year. Progressive, Box 1302, Springfield, Ill. 62705.

MECHANICALLY inclined? Little money all profit home business fiberforming bird houses etc. from newspaper. \$5.00 Kinney Machine, 105 Filmore Ave., Endicott, New York 13760.

COMPUTERS—Amazing opportunities in four high income careers—no college degree necessary! "Computer Technical Jobs," Box 34010, Bethesda, Maryland 20034. \$3.00 Satisfaction guaranteed!

(Continued on next page)

PROFITABLE OCCUPATIONS

(Continued from preceding page)

HOW To Make Money writing short Paragraphs. Information Free. Barrett, Dept. C-27-D2, 6216 N. Clark, Chicago 60626.

SALESMEN—DISTRIBUTORS

MAKE Extra \$25 to \$75 spare time! Take orders for double air cushion Bronson Shoes. Men's, women's line for dress, work, play. Highest commissions. Shoes for yourself. Outfit Free. Bronson, Dept. 205, Minneapolis, Minnesota 55408.

HOUSEHOLD Products Route. Earn \$25.00 or more daily. Larger repeat orders. Man, woman. Full, part time. McNess, Freeport 2650, Illinois 61032.

SELL Hertel Bibles—Part Time. Finest reference Bible available. Demonstrator and supplies furnished. Excellent commissions. Write International Book, Dept. PM, Box 118, Wichita, Kansas 67201.

WANTED: Man contact service stations. Huge profits. Write Cyclo, 3816 Dahlia, Dept. 138, Denver, Colo. 80201.

THERE'S Money in selling office supplies and equipment, full or part time. Steady repeat commissions. Free selling outfit. Write Oseco, 15-PM North Jefferson, Chicago 60606.

EARN Big Commission Full or Part Time. Show America's largest line Low Priced Business Printing and Advertising Specialties Plus calendars in season. No experience. No investment. No collections or deliveries. On-the-spot commissions. Big Free Sales Kit samples hundred items used daily by businessmen. Merchandise bonuses for you. Build profitable repeat business. Start now. National Press, Dept. 01D, North Chicago, Ill. 60064.

DO You wish to use or sell a plant food that is field proven, shows the greatest results at lowest cost? Something different in sales and use. Big monthly income or get your fertilizer FREE. Campbell's Gro-Green, 414 Dewey, Rochelle, Illinois.

FREE. 206 Easy Ways to make money taking orders for exciting new products—spare time. Send name, age for 5 months free subscription. Opportunity Magazine, 1460 Hancock Center, Dept. 17-ES, Chicago 60611.

EARN big money calling on business-professional men. Send us their delinquent accounts for collection. General Finance, Dept. PM-11, Columbia Bank Bldg., Kansas City, Mo. 64106.

100% PROFIT—Sweet Georgia Brown Cosmetics sell fast. Write for Sample Case offer. Valmor, Dept. H, 2411 Prairie, Chicago 60616.

SELL High Profit service station items. Free list. Inka, 2401 Crocker, Houston, Texas 77006.

AGENTS WANTED

EVERY Man a prospect. Refundable sales kit offer showing line belt buckles, tie clasps, money clips, cuff links, lapels, identification badges, individualized with customer's name and emblems. Cap badges for trucking, bus, taxi, police, firemen, also postal, letter carriers and heavy construction emblems. Choice 3000 emblems. Hook-Fast, Box 1088PM, Providence, R.I. 02901.

PRINTING. Advertising Salesmen—Excellent moneymaking sideline selling Decalcomania Name Plates, small quantities. Advertising Specialties, sign letters. Free Samples, Balco XL, Boston, Mass. 02119.

PROFITABLE! FULL OR PART TIME. Represent largest manufacturer of removable magnetic signs for cars and trucks. Trimetric, 2640 Saddle, Oxnard, California 93030.

FREE. 206 Easy Ways to make money taking orders for exciting new products—spare time. Send name, age for 5 months free subscription. Opportunity Magazine, 1460 Hancock Center, Dept. 17-EA, Chicago 60611.

LIFETIME Income. Business Loan Representative Write: Financial, 28 E. Jackson, Suite 1204-X3, Chicago 60604.

ESTABLISH Your own business. Low prices on used clothing, shoes, household goods. Unlimited profits. Free catalog. Northwestern Distributors, 2129 No. Western Avenue, Chicago, Illinois 60647.

WANT TO MAKE UP TO \$100 A WEEK spare time, and get free shoes for life, too? No investment. Rush card for free details. Mason Shoes, K-768, Chippewa Falls, Wisconsin 54729.

YOUR own business—Used Suits \$1.50; Overcoats 65¢; Mackinaws 35¢; Shoes 12½¢; Ladies' Coats 30¢; Dresses 15¢. Enormous profits. Catalog Free. Nathan Portnoy Assoc., 2109-AA Roosevelt Road, Chicago, Illinois 60608.

AMAZING Profits! Sell Personalized Lifetime Metal Social Security Cards. Free Sample, Starting Kit. Myers, 928-B Crescenthill, Nashville, Tennessee 37206.

EMPLOYMENT INFORMATION

AUSTRALIA WANTS YOU! Government Assisted Passage. 50,000 Jobs. Latest Government Information and Forms \$1.00. Special Reports on Employment, Business, Taxes, Housing, Education, Ranching, Farming, Teaching, Maps, Etc. AUSTCO, Box 3623-E, Long Beach, California 90803.

HIGH Paying overseas jobs. Construction, other projects. Bonuses. Travel Expenses. Extras. International Information, 124, Cortez, Florida 33522.

ALASKA. High pay jobs, many with room and board furnished. Send \$3.00 for brochure. H-W ENTERPRISES, Box 4-406, Anchorage, Alaska 99503.

FOREIGN And USA job opportunities available now. Construction, all trades. Earnings to \$3,000.00 monthly. Paid overtime, travel bonuses. Write, Universal Employment, Woodbridge, Conn. 06525

JOBS! JOBS! and more Jobs! OVERSEAS. U.S.A. Year-round and Summer Jobs. Jobs with Money. Challenge. Opportunity. Travel. All occupations and trades. For Information, write: "JOBS," Box 475, (PM-3), Lodi, California 95240.

ALASKA! Due to the interest in the oil industry and construction projects in Alaska, our Research Department has made public their annual report; showing how to obtain employment, cost of living, wages paid, etc. For a copy, send \$3.00 to B & J Surveys, Box 265, Lost Hills, California 93249.

BOOMING Australia wants You—Application forms and new 1970 Australian Handbook describing Australian assisted passage, family and housing allowances, jobs, business, ranching, teaching, hunting, fishing, etc. \$1.00. Buckeye, Box 1032ML, Fairborn, Ohio 45324.

AUSTRALIA!! AUSTRALIA!! Government Assisted Transportation. Latest Handbook. Free Details! Write: Associated, Box 17-850 Lafayette, California 94549.

AUSTRALIAN EMPLOYMENT INFORMATION listing over 600 American Firms employing personnel in Australia. All occupations! \$3.00 Ambrose Publications, Box 2446, Newport News, Va. 23602.

TEMPORARY And Permanent Foreign Travel Correspondent Opportunities. Earnings Unlimited. Details \$2.00. Suggs, 1213 Summit, Barrington, Illinois 60010.

APPLY for employment in Australia. Send \$5.00 for list of 496 US firms doing business down under. REBCO, 10478 Rosehill, Rancho Cordova, California 95670.

THE Building of Modern Mexico needs People. Send \$3.00 for Employment Information. Infomex, PM, Box 366, Berea, Ohio 44017.

WHY pay more? Latest Overseas Job Guide. Company names, addresses, countries. \$1.00 NiVar, Box 100, Lakeview, Wash. 98491.

HELP WANTED

OVERSEAS Jobs—Europe, South America, Australia, Far East, etc. 2000 openings all trades. Construction, Office, Engineering Sales, etc. \$700 to \$3,000 month. Expenses paid. Free Information. Write Overseas Jobs, International Airport, Box 536-M, Miami, Florida 33148.

OVERSEAS Jobs—Australia, Europe, South America, Far East, Etc. Openings in all trades and professions. \$400 to \$2,500 monthly, free information write Foreign Employment Mart, Box 2235 A.M.F., Miami, Florida 33159.

WORLDWIDE . . . U.S.A. jobs now!! \$600.00 to \$3,000.00 monthly. Travel Allowance, Paid Overtime. Write: Global Employment Box 706CA50, Orinda, Calif. 94563.

REAL ESTATE & FARMS

FLORIDA CAMPSITES. Hunt, fish, boat, ski, swim or loaf. For a second home or investment. Warranty Deed. Free Maps and Photos. (Unavailable in states requiring separate registration) (Florida AD69-LB634E) Howard Vernor, Deland, Florida 32720.

FREE COPY! New spring listings, Arkansas property Journal! Statewide Realty Co., 507-AE Pyramid Bldg., Little Rock, Ark. 72201.

ARIZONA mountain retreat acreage, near Prescott National Forest. 2½ acres, \$1,295, low terms. Mrs. Young, Glenarm Co., 2233 North 7th St., Phoenix 85006.

CANADIAN Lands, seized and sold for taxes. Our 53rd annual series of lists, describe many choice properties, situated from coast to coast, acquired by us through Tax Sale. Priced as low as six dollars per acre, guaranteed perfect title, small monthly payments, no mortgage. Beautifully situated hunting and fishing camps, where there is real sport; summer cottage sites, heavily wooded acreages. Now is the time to invest in Canada's minerals, forests and farms. Write to-day for free booklet with full explanation. Tax Sale Service, Room 301-D, 85 Bloor St., East, Toronto 5, Canada.

CANADIAN Vacation lands: Full price \$385.00. 40 acres, \$10 month. Suitable cottage sites, hunting, fishing, investment. Free information. Land Corporation, 3768-C Bathurst, Downsview, Ontario, Canada.

\$1 ACRE—Canadian Border—hundreds campsites, islands, farmlands, directly from tax authorities. (Non-profit). Lists, photographs mailed. Register, Room 10, 110 Church Street, Toronto 1, Canada.

CENTRAL Ontario—Choice 640 acre Sportsmen's paradises still available—\$20.00 plus \$6.50 taxes yearly. Maps, pictures, \$2.00 (Refundable). Information Bureau, Norval 4, Ontario, Canada.

GOVERNMENT LANDS . . . Low as \$1.00 acre. Millions acres. For exclusive copyrighted report . . . plus "Land Opportunity Digest" listing land available throughout U.S., send \$1.00. Satisfaction guaranteed. Land Disposal, Box 9091-PE, Washington, D.C. 20003.

BUY CANADA \$10—10 ACRES. Thousands of Tax Sale properties direct from government authorities. Atlantic to Pacific. Good roads. Near border. Sensational investment gains. Lake frontage. Cottages. Hunting. Fishing. Unique researched lists. Maps, Photos. "BUREAU," 16 Quinby Court, Thistleton, Ontario, Canada.

\$1 ACRE—U.S.A.—CANADA Millions Acres. Direct from Government Agencies. No middlemen. . . . Family vacationing. Fishing. Hunting. Homesteading. Investing. . . . For amazing "where" and "how" "ALL STATES—ALL CANADA GOV'T LANDS DIGEST" . . . plus invaluable Canadian maps. Rush \$1.00 (Guaranteed): Can-Am-Lands, P.O. Box 1147, Buffalo, New York 14240.

(Continued on next page)

REAL ESTATE & FARMS

(Continued from preceding page)

LAKE FRONTAGE. Canadian Shoreline Properties with well wooded acreage on Lakes teeming with fish. Suitable for Hunting, Fishing, and investment. Small monthly payments. Free booklet. Northern Land—Department P, 33 Rosehill Avenue, Suite 2507, Toronto 270, Canada.

FREE CATALOG! Giant SUMMER edition! Over 4,000 properties described, pictured—Land, Farms Homes, Businesses—Recreation, Retirement. Selected Best thru-out the U.S.! 70 Years' service, 518 Offices, 40 states Coast to Coast. Mailed FREE from the World's Largest! **STROUT REALTY**, 60-RX E. 42nd St., N.Y., N.Y. 10017; 7-RX S. Dearborn, Chicago, Ill. 60603; 521-RX E. Green, Pasadena, Cal. 90013.

CANADIAN LAND INVESTMENT, from \$9.00 an acre. Choice properties available across Canada. Acquired through estate liquidations. Low monthly payments. Ideal farming, timber, minerals, cottages, hunting fishing. Write for free catalogue. Canadian Estate Land, Department 65B, 194 Wilson Ave., Suite 101, Toronto 12, Canada.

10 TO 80 Acres—Lake Superior, Marquette, Michigan area. \$99 acre. Only \$19 down, only \$19 month. Write Hiawatha Forest Lake Acres, 1301 E. 6 Mile, Detroit 6, Michigan 48203.

NEW: Canadian oil leases. \$1.00 acre. Free information. Northern, Box 560-F, Westmount, Montreal 215.

BUY with confidence for Retirement, Vacation, or Investment—under America's only "No-Risk Land Purchase Plan"—in Carolina Coast multi-million dollar 14,000-acre development. 10 year money-back guarantee. 1/3-acre homesites as low as \$700.00 cash price; \$8.00 down, \$7.70 monthly for 120 months, including interest at an annual percentage rate of 6%. Motel, hunting, fishing, golf, country club, right on property. Private ocean beach, 50 fresh water lakes. Write for free literature. Dept. 1-Z, Boiling Spring Lakes, North Carolina 28461. (Not offered to residents of California, Florida, New York.)

FREE! Real Estate Catalog! Farms, Ranches, Business, Recreational and Investment Property. 18 States, pictures galore. Note State Desired. **BANNER Adv.**, Box 3333, 19-A, Springfield, Mo. 65804 "Real Estate Our Specialty."

FREE CATALOG Bargains in Real Estate! Actual property photos! Write today! **SAFE-BUY Real Estate**, Box 589-PM, Little Rock, Ark. 72203.

FARMS, Land lake frontage. Free brochures. Coldbrook Real Estate, Box 117, Skowhegan, Maine 04976.

A LAST FRONTIER—Michigan's Upper Peninsula. Worthwhile tax, state lots and acreage available for building or speculating. Little as \$5.00. Guaranteed official Plat descriptions and locations, \$1.00 (refundable). Also details once in a lifetime opportunity near Cedarville, Les Cheneaux Islands. Mich-On Corporation, Dept. 101, Croswell, Mich. 48422.

FREE GOVERNMENT LAND. Also Lease or Purchase Throughout U.S.A. and Canada. Millions of acres Available. Agricultural Vacation. Developmental. 1970 Listing and Report \$1.00. Homesteads, Swan Lake, Montana 59911.

FREE . . . NEW 224-page SUMMER catalog. All types real estate coast to coast! **UNITED FARM AGENCY**, 612-PM West 47th St., Kansas City, Mo. 64112.

GOVERNMENT Land—450,000,000 acres, U.S.A.-ALASKA, \$1.25 acre, up. Buy: Homestead: Vacation, Cabin, Ranch Sites. Copyrighted guide, guaranteed!! Rush \$1.00 today. Surplus Land Bureau, Box 80 HM, Las Vegas, Nevada 89101.

LAND! EASY TERMS LESS THAN BANK RATES. NORTHWEST TIMBERED ACREAGES as low as \$950 Total Price. 5-10-20-40 Acres. For people who love the land—A tract of Recreation Land to have for your very own! In Northern Idaho, Northeastern Washington, and Western Montana. In the heart of lakes and big game country. All covered with growing timber. Access and Title insurance with each tract. This is select land with natural beauty, recreational and investment values. Plan for the future and retirement recreation. We have tracts of many types and sizes from which to choose, including beautiful Northwest Waterfront property. Your inspection is welcomed. Write us for free list, maps, and complete information. Write to: Dept. PC Reforestation, Inc. P.O. Box 106, Opportunity Station, Spokane, Wash. 99214.

FARM & GARDEN EQUIPMENT

MAILORDER Records help get increased business! Complete 32 Page Record Book shows your inquiries orders, advertising, expense, etc. Only \$1.00. C. A. Martin, Popular Mechanics, Dept. PM, 224 West 57 Street, New York, N.Y. 10019.



FLOWERS, PLANTS & NURSERY SUPPLIES

SICK Trees, Plants? Free Information! Vitaspike, 3527 Aquilla, St. Louis Park, Minnesota 55426.

LEARN Landscaping and the growing of plants. Start a profitable business part or full time. Free information without obligation. Lifetime Career Schools, Dept. A-753, 2251 Barry Avenue, Los Angeles, California 90064.

GINSENG Bringing \$18 Pound. Have Seeds Roots. Goldenseal. Full Information. K. Collins, Viola, Iowa 52350.

SAGEBRUSH, Guaranteed Live, \$3.00. Plants, Box 292, Chino, Calif. 91710.

COMFREY For your nutritional garden. Free literature. North Central Comfrey Producers 195L, Glidden, Wisc. 54527.

CONSTRUCTION PLANS, BLUEPRINTS

HOBBYISTS, EXPERIMENTERS, amateur scientists, students . . . Construction Plans—All complete including drawings, schematics, parts list with prices and sources . . . Laser—Build your own coherent-light optical laser. Operates in the visible light range, pulsed mode—\$6.00 . . . Radar—Build your own ultrasonic doppler radar. Detect motion of people, automobiles, even falling rain drops Transistorized, uses standard small 9-volt battery—\$4.00 . . . Long Range "Sound Telescope"—This amazing device can enable you to hear conversations, birds, other sounds hundreds of feet away. Very directional. Transistorized, uses 9-volt battery—\$3.00 . . . Or send 25¢ coin (no stamps) for complete catalogue . . . Wide range of other plans, including psychedelic lights, color organs, robot man, etc. . . . 38 different plans . . . Technical Writers Group, Box 5994, State College Station, Raleigh, N.C. 27607.

MONEY MAKER-SAVER!! LOW COST HIGH PRESSURE SPRAY CLEANER & CHEMICAL PUMP—500 PSI—2 gal./min. Wash houses—cars—trucks—boats—airplanes furniture—etc. Spray trees—shrubs—lawns—fertilizer or weed killer—rid property of insects etc. Easy assembly—no special tools—portable—115 volts—hot or cold water outlet \$2.00—complete plans—bill material instructions—ideas. "Systems." P.O. Box 18242, Louisville, Kentucky 40218.

HOME CRAFTSMEN

INSTALL An extra bathroom for next to nothing. Drawings, photos, all the how-to you'll need. Complete set of plans, the package \$3.00. Woodlawn, 365½ Bank, Ottawa, Canada.

BUILD Stairs instructions \$2.00. Don Haskins, Union Street, R.F.D., Whitman, Massachusetts 02382.

MAKE your own fine picture frames with our beautiful moldings and amazing Clamless Assembly Method. Terrific savings! We show how. Free proof, particulars. Japs, 126-PM Seventh North, Hopkins, Minnesota 55343.

CABINETMAKING MADE EASY and "How to Make Formica Counter Tops," two excellent guides let you build kitchen cabinets and counter tops like professionals. Extraordinary guides bring master craftsmen's shortcut methods. Satisfaction guaranteed. Write: Japs, 126-P Seventh North, Hopkins, Minn. 55343.

SKIL-CRAFTS new 200 page catalog with world's largest, finest selections of hobby-craft, leather-craft, artist supplies. Send 50¢ (refunded plus free gift with first \$5 minimum catalog order). Skil-Crafts, Box 105-P, Joplin, Mo. 64801.

PLANS, Bird houses. Send 15¢ for brochure and free feeder plan. Yeager, 1665 Linden, Homewood, Ill. 60430.

WALNUT And Cherry tapered legs, lumber, gunstock blanks, picture frame moulding. Midland Lumber Company, Box 262, Savannah, Missouri 64485.

REPAIR Book, 1000 Subjects. Free Details. Ronloe, 13432 No. County Branch, St. Louis, Missouri 63138.

BE SELF sufficient, develop skills, confidence, with hammer and saw projects—footstool, child's chair, bench, bookcase, table. Detailed plans, instructions. Send \$3.00 to A. E. Wright, Dept-S, Box 8641, Richmond, Va. 23226, Va. residents add 4%.

FULL SIZE FURNITURE PLANS, Traditional, Early American, Danish Modern. Catalog 50¢. Furniture Designs, Dept. P-50 1425 Sherman, Evanston, Illinois 60201.

DO-IT-YOURSELF

LEAKY Basement? Solve it 1-2-3. X-Pando, 43-15 36th Street, Long Island City, N.Y. 11101.

DO-IT-YOURSELF simplified Central Air Conditioning. Approximately \$450 for homes with forced air furnaces. Write for step-by-step brochure. McGraw-Edison Company, 705D N. Clark St., Albion, Michigan 49224.

REFRIGERATOR Door gaskets—Electric Range and Washer Parts. Send Make and model for cost. Box 5465, Hamden, Conn. 06518.

AIR Compressors made from Mower Engines. Write: Showalter, Box 409, Abilene, Kansas 67410.

EXERCISE At home on build-it-yourself physical fitness equipment, including bicycle exerciser, rowing machine, belt massager, and abdominal board. Send \$3.00 for blueprints B1208 and instructions. Popular Mechanics Service Bureau, 224 West 57th St., New York, New York 10019.

CRIB-Youth bed detailed plans, send \$3.00. R.A.S. Designs, 62 Fairview Avenue, Binghamton, New York 13904.

POPULAR MECHANICS MASTER SHOP GUIDE. Greatest product offered to a man with a workshop. All information printed on heavy boards, punched and ready to hang above his workbench. Covers wall fasteners, nails, screws, bolts, twist drills, abrasives, lumber, moulding patterns, plywood grades, hardboard, drywall, plumbing supplies, electrical supplies. Plus information on scores of other subjects. Send \$3.95 to: **POPULAR MECHANICS**, 224 West 57th Street, New York, New York 10019.

CRACKED Heads, blocks, casings? Repair without special tools. Complete instructions, supplies list \$1.00 refundable. X-L Weld, Box 5184, Fullerton, California 92632.

(Continued on next page)

DO-IT-YOURSELF*(Continued from preceding page)*

FREE List! 120 Do-It-Yourself Books. Shiffers, 2412 Boissevaon, Richmond, Virginia 23229.

"KIT Or unfinished, handcrafted colonial furniture. Send 25¢ for fully illustrated catalogue. TOMMIJOHN of N. E. P.O. Box 421, Franklin, Mass. 02034."

BURGLAR-Fire Alarm Supplies and information. Free Catalog. Protecto Alarm Sales, Box 357, Birch Run, Michigan 48145.

FLUORESCENT Tubes rejuvenated at no cost. Instructions \$1.00. Rejuvenators, 172 Bolton St., Portland, Me. 04102.

MAGNETIZE SCREWDRIVERS YOURSELF—Apparatus with magnetism manual \$1.50. Vista Products, Box 39723, Solon, Ohio 39273.

ARTS AND CRAFTS

MAKE Figurines, plaques, lawn ornaments, Molds, plastercraft kits, liquid rubber. Sample and catalogue 10¢. Wooley Company, Box 29-B, Peoria, Illinois 61601.

FREE: New 136 page handicraft catalog. Supreme Handicrafts, Box 395-PM, Sioux Falls, South Dakota 57101.

200 MOLDS For Ornamental Concrete—Catalog 25¢—Plycrete Molds, Elk Rapids, Mich. 49629.

"GETTING Started in Stained Glass" 25¢. Whittemore, Box 2065Y, Hanover, Mass. 02339.

GLASS SWAN novelty. Mailed anywhere in U.S.A. for \$1. Swan, Box 9207, Akron, Ohio 44305.

BINOCULARS, TELESCOPES, MICROSCOPES, MAGNIFIERS

SCIENCE Bargains! Lenses, telescopes, binoculars, microscopes, kits, parts, war surplus. Send \$1.50 for beginner's 10-lens kit with instruction booklet. Order Stock 2-CH. Request free 148 page Catalog CH. Edmund Scientific Co., 300 Edscorp Bldg., Barrington, New Jersey 08007.

BINOCULAR Specialists. Repairs And Sales. Free Catalog. Tele-Optics, 5514 Lawrence, Chicago, Ill. 60630.

BINOCULARS Direct from manufacturer. Finest quality, tremendous savings! catalogue 25¢. Koyu, 3860 Crenshaw Blvd., Los Angeles, Calif. 90008.

BINOCULAR Sale! Free color catalog 100 models \$9.95-\$250.00. Write, United, 9043 So. Western, BCAT-1608, Chicago 60620.

**CAMERAS AND EQUIPMENT**

48 PAGE ILLUSTRATED CATALOG with the low Central Discount price. Send 50¢. get 75¢ CREDIT on order of \$7.50 or more. **CENTRAL CAMERA CO.**, Photographic headquarters for the Amateur and Professional SINCE 1899. Central Camera, Dept. 11M, 230 S. Wabash Ave., Chicago, Ill. 60604.

NEW! SAVE MONEY flash gun for all flash cube cameras \$2.85 postpaid. The Budovec Co., 10951 Canelo Road, Whittier California 90604.

PHOTO SUPPLIES

NEW Film Catalog. Write Chai Photo Supply Co., 14-03 Berdan Avenue, Fair Lawn, New Jersey 07410.

PROFITS FROM CLASSIFIED ADVERTISING! Booklet shows you how to start your own business with Classified Advertising. Only \$1.00 (Refundable with first order.) C. A. Martin, Popular Mechanics, Dept. PM, 224 West 57 Street, New York, N.Y. 10019.

PHOTO FINISHING

CAMERA FANS! Expert photofinishing by one of Country's largest labs at lowest prices. Fast service and free "Foto-Fan" Stamps you quickly redeem for valuable Photo Supplies. 8MM Kodachrome \$1.29; 8 Exp. Kodacolor \$1.79; 35MM Kodachrome. 20 Slides \$1.39; 8 Exp. Black White 69¢. Satisfaction guaranteed. Send exposed film or request free mailers, complete Price List and Gift Catalog. Direct Mail Photo. Box 8352-PM, Pittsburgh, Pa. 15218.

TRIAL OFFER. Twelve prints from roll 60¢. Eight enlarged color prints from Kodacolor roll \$1.39; twelve \$1.79; twenty \$2.69. Young Photo Service, 45C, Schenectady, N.Y. 12301.

COLOR SLIDES

OLDTIME Silent Movie "Coming Attractions" Theatre slides in beautiful 35mm. Slides. Also Currier-Ives. Lists Free. WICP, Box 392, Elmira New York 14902.

MARDI GRAS (1970). 5/\$1.00; 25/4.85; 50/9.25. Lawson, Box 14701, Baton Rouge, Louisiana 70808.

MOTION PICTURES AND SOUND EQUIPMENT

16MM, 35MM FEATURES Shorts. Distributors Wanted. Lists Free. Minot Films, Milbridge, Maine 04658.

FREE! 64-page catalog. 8-16mm film, supplies, processing equipment. Superior. 448 N. Wells. Chicago 60610.

8MM-16MM BARGAINS! Free Catalog! Cinema Eight, Box 245-PM, NYC. 10028.

UNUSUAL Movie supplies. Free circular. Esor, 47th Holly, Kansas City, Missouri 64112.

16MM SOUND Features, Shorts, New, used for Sale. Free Catalog. National Cinema, 333 W 57th St.—N.Y.C., N.Y. 10019.

SUPER 8 Titles! De Luxe Sample "1970" \$1.00. Vega, Bx 14172, Las Vegas, Nevada 89114.

RADIO, TELEVISION AND HAM EQUIPMENT

CONVERT Car radio to two way CB Transceiver with Pace Auto-Mate \$19.95, regularly \$69.00. American Comset Inc., 1638 W. 135th, Gardena, Calif. 90249.

TUBES—Lowest world prices. Foreign—American. Obsolete, current, receiving, special purpose, transmitting tubes. Send for tube and parts catalog. United Radio Company, 56-PM Ferry St., Newark, N.J. 01705.

33¢ RADIO & TV tubes. Free list. Cornell, 4213-17 University, San Diego, California 92105.

GOVERNMENT Surplus receivers, transmitters, snooperscopes, parts. Catalog. 25¢. Meshna, Nahant, Mass. 01908.

POLICE-FIRE Radio Dispatcher Directories! Exclusive official confidential listings; call signs, frequencies. Catalog; send stamp. CRB Research, Box 56-PM, Compack, New York 11725.

HOME Radio-Television Course. Free Literature. Progressive Edu., Department 725 B. Hewlett, New York 11557.

TV-FM Antennas all channels. Easy construction. Complete instructions \$3.00. GCS, 12226 Gibson Rd., Everett, Washington 98201.

FIRE Police Monitors, Details, Griffin, 322 West State, Ithaca, N.Y. 14850.

HIFI, TAPES, RECORDS AND ELECTRONICS

FREE Catalogues, 2000 hard to find unusual records. Rose's Records, 300 Chelsea Louisville, Ky. 40207.

FREE Circular—Country Western Records and Tape Cartridges—Fiddle Tunes—Waltzes—Blue Grass. Uncle Jim O'Neal, Box A-PM, Arcadia, Calif. 91006.

RECORDS! Discounts on all LP's. Free details. Citadel Record Club, Symphonette Sq., Dept. 2, Larchmont, N.Y. 10538.

STEREO TAPES! 33% discount! Unavailable elsewhere. Cartridges, cassettes, reels. Latest hits . . . Oldies . . . Professionally recorded. 25¢—catalogs, free offer. Star Recordings—PM, Box 1055, El Paso, Texas 79946.

**MUSIC AND MUSICAL INSTRUMENTS**

GUITAR MAKING Books, Imported Woods, Supplies, Accessories. Catalog 25¢. Guitar Center, Box 15444, Tulsa, Okla. 74115.

POEMS And Songs wanted by America's most popular studio. Recording bonus for select material. Tin Pan Alley, Broadway Productions Division PM, Lake Grove, New York 11755.

78 GUITAR Lessons. \$3.00. Richard's Studio, Box 5024, Borger, Texas 79007.

ACCORDIONS and Amplifiers! Save to 50%. Famous makes. Easiest terms. Trade accepted. Free home trial. Free discount catalog. Accordion Corporation, 5535-R West Belmont, Chicago 60641.

VIOLIN and Guitar makers—send for latest Free Catalogue of woods & accessories. International Violin, PMO, 414 East Baltimore St., Baltimore, Md. 21202.

POEMS, Songs, wanted for new songs and immediate recordings. Contracts, royalties. Weiss Music Company, 1472-PM Broadway, New York, New York 10036.

ACCORDION Manufacturing. 6846-P North Avenue, Chicago, Illinois 60635. Concertinas, Hohners, Chromatics, Guitars, Drums, New, Used, Tuning, Repairing. Wholesale Catalogs Free.

PLAYER Piano Rebuilding—get details from: Vestal Press, Vestal 11, N.Y. 13850.

GUITARS, MANDOLINS, BANJOS, Complete stock of Gibson Martin guitars. Free 100 page catalog, parts and accessories. Big Savings. New York discount prices. Send 50¢ postage handling. Eddie Bell Guitar, Dept. PM, 201 West 49, New York 10019.

SONGWRITERS! London Company now in USA needs poems for new songs. All types wanted. Details free. Musical Services, 715/P. West Knoll, Hollywood, California 90069.

GET Discounts, Save Money. 426 page catalogue only \$5.00, deductible from first order over Fifty Dollars. Globe Music, 3522 Church Avenue, Brooklyn, N.Y. 11203.

ELECTRIFY Player Pianos, Pump Organs Quickly, Inexpensively with Lee Silent Suction Units. Write Lee Music, 525F Venezia Avenue, Venice, California 90291.

LEARN Banjo. 5-String Bluegrass. No music. Makes learning easy. Free details. Blaylock, Box 25-M, Marietta, Georgia 30060.

PROFESSIONAL 674 Watt Amplifiers. Guitars. Free Wholesale Catalog. Carvin PM70. Escondido, Calif. 92025.

DOBRO Type guitar—world's best acoustical. The Guitar, 4668 Hollywood Blvd., Hollywood 90027.

FORTY Music flash cards to learn note reading. \$2.00. Nu-Wa Music, Bybee, Kentucky 40412.

LYRIC WRITERS write songs with writers who write hits for top Nashville artists. Globe, 420 Broad, Dept. PM, Nashville, Tenn. 37203.

30% DISCOUNT Any Name Brand Musical Instrument. Free Catalog. Freeport Music, 127 E. Sunrise Highway, Freeport, New York 11520.

POEMS Wanted for new songs, records. FIVE STAR MUSIC, 6M Beacon, Boston, Mass. 02108.

(Continued on next page)

MUSIC AND MUSICAL INSTRUMENTS

(Continued from preceding page)

FORTY Music flash cards to learn note reading. \$2.00. Nu-Wa Music, Bybee, Kentucky 40412.

SONGS, Poems wanted! Accepted songs published, recorded at our expense! Talent, 17-PM, Longwood Road, Quincy, Mass. 02169.

LEARN SONGWRITING FAST! Co-operative Music Publishers, 2005 St. Anne, Santa Ana, California 92704.

SONGWRITERS; Need good demo-tapes to promote material? Save money. Write: T&S, 2420 E. 20th, Farmington, N.M. 87401.

SONGS, Poems Offer, Newark Publications, Box 693 Syracuse, N.Y. 13201.

GUITAR, Banjo Making books, Plans, woods, necks, tools. List 25¢. Satinwood, 510 East 11th Street, New York, N.Y. 10009.

ACCORDION Top brands. Buy direct. Tremendous discounts. Trade accepted. Free brochure PM. Accordion-O-Rama, 874 Broadway, N.Y.C. 10003.

MOTEL-HOTEL MANAGEMENT TRAINING

MOTEL MANAGERS Wanted by leading chains, resorts, motels-hotels everywhere! Men, women, couples enjoy free rent, plenty of free time. Easy home-study plan. Free! "Motel Career Kit." No salesman will call, North American School of Motel-Hotel Management-AZS, Newport, California 92660.

EDUCATION AND INSTRUCTION

"BECOME Ordained Minister. Free Information, Church, Box 191, Auburn, N.Y. 13021."

EXCELSIOR Accordions and Amplifiers. Save 50%. Buy Direct. Factory Distributor. Terms, Trades. Free Catalog. Excelsior, 3147 North Luna, Chicago 60641.

AIRLINE CAREER—Airlines want men for good-paying positions in ticketing, operations, passenger and air freight service. G. I. Approved. High School graduates, 17 to 38, see if you can qualify. Write Weaver Airline Personnel School, Dept. PM-5, 3521 Broadway, Kansas City, Missouri 64111.

FINGERPRINTING—Investigation. Exciting. Secure career. Learn at home. Free book. State age. Institute of Applied Science, 1920 Sunnyside, Dept. 165, Chicago, Illinois 60640.

SELF-Improvement books! Catalog 10¢. Write Jack Butler, 1384-B Monroe Drive, N.E., Atlanta, Georgia 30324.

BE A Real Estate Broker. Big earnings. Prepare quickly, easily. GI approved. Free Catalog. Weaver School, 3519-P Broadway, Kansas City, Missouri 64111.

USED CORRESPONDENCE Courses and Books sold and rented. Money back guarantee. Catalog free. (Courses bought.) Lee Mountain, Pisgah, Alabama 35765.

LEARN Auctioneering. Term soon. Free catalog. Reisch Auction College, Box 850, Mason City, Iowa 50401.

PIANO Tuning quickly learned with home study course. Diploma granted. American Tuning School, Gilroy, Calif. 95020.

OWN Collection agency. "Little Gold Mine!" Franklin Credit, Roanoke, Virginia 24004.

EARN \$125 A week and up. Learn a trade with a future. Learn auto diesel mechanics in our shops. You learn with tools on real equipment. Earn while you learn. Many of our graduates earn \$125 a week and up. Write for free bulletin: Dept. 256, Auto Diesel College, Nashville, Tennessee 37219.

MISSOURI Auction School. GI Approved. Free Catalog! 424-03 Nichols Road, Kansas City, Mo. 64112.

USED Courses! Books! List 10¢. Smith's, 124 Marlborough, Salem, Mass. 01970.

HIGHLY EFFECTIVE home study courses in Electronics Engineering Technology and Electronics Engineering Mathematics. Earn your Degree. Write for Free Descriptive Literature. Cook's Institute of Electronics Engineering, (Dept. 10), P.O. Box 10634, Jackson, Miss. 39209. (Established 1945).

SUPERIOR Auction School. Nation's top Auctioneers own and instruct. Box 1281, Decatur, Ill. 62523.

AUCTIONEERING Resident or Home Study Course Free Catalog. Nashville Auction School, 2004 West End, Nashville, Tennessee 37203.

DETECTIVE Course. Free information. Universal Detectives, Box 8180-F, Universal City, California 91608.

PROFITABLE Camera service training at home. National Camera, Dept. PM, Englewood, Colo. 80110.

PENMANSHIP Corrector. Improve Poor penmanship quickly. Details free. Ozment, Box 2344-34, St. Louis, Mo. 63114.

EXTENSION And Post-Graduate Awards in Philosophy, Arts, Sciences, Botanic Medicine, Homeopathy, Radionics and others. 30 subjects. Curricular free (air-mail \$1.00 refundable). Registrar, Sussex College of Technology, Highfield, DaneHill, Sussex, England.

WATCH REPAIRING. Learn to repair American and Swiss watches in spare time at home. Diploma awarded. Free sample lesson. No obligation. Chicago School, Dept. YE, Fox River Grove, Illinois 60021.

PENMANSHIP Improver. Improve penmanship quickly, easily. Write: Tevis, Chillicothe, Mo. 64601.

FREE Bible course! Degree! Request information! 708 Bragg, Monroe, North Carolina 28110.

PIANO Technology—Electronic organ servicing, learned easily at home. G.I. Approved. Free booklet. Niles Bryant School, Dept. P, 3631 Stockton, Sacramento, California 95820.

HIGH SCHOOL diploma at home. Licensed teachers. Send age, highest grade completed for free details. No salesman will call. Southern States Academy, 5300 W. Belfort, Dept. 16-E, Houston, Texas 77035.

LEARN Asleep or awake! Records, tapes, equipment! Free catalog! Drawer PM-400, Ruidoso, New Mexico 88345.

GET A British Degree. Divinity, Philosophy, Radionics. 35 Courses. Prospectus free. Brantridge Forest School, Highfield, Dane Hill, Sussex, England.

PIANO Tuning pays. Big money in spare time. Learn at home. No musical knowledge necessary. Phonograph, records, tools and instructions furnished. Electronic tuning also taught. Free catalog. Capital Tuning School, 3160 S.W. 16th Court, Ft. Lauderdale, Fla. 33312.

LEARN Massage. Home study course. Free details. Massage, Box 190-PM, Quincy, Mass. 02169.

BECOME Real Estate Broker quickly. Economical Homestudy. Prospectus Free. Howard Schools, Box 8585-A, Kansas City, Missouri 64114.

BE A TECHNICIAN Investigate opportunities. 2 year Associate Degree programs in Numerical Control Programming; Power Technology (Small Engine) Food Manufacturing Technology—Canning and Freezing or Dairy. Accredited. Free information available. Fond du Lac Technical Institute, 805 E. Johnson Street, Fond Du Lac, Wisconsin 54935.

PERFECT Husband-wife business. Learn Upholstery at home. Make \$10 in an hour. Buy-repair-sell for even bigger profits. Kits, tools included. Free Booklet. Upholstery Institute, Dept. 5310-050, Little Falls, New Jersey 07424.

LEARN Handwriting analysis. International, Dept. 700, 11749 Eldridge, Lake View Terrace, Calif. 91342.

LEARN To Fix Typewriters. Desperate shortage trained men. Hundreds needed. Make up to \$25 in one hour. Learn at home in spare time. Industry Approved course. Facts free. Send name. Typewriter Repair School, Dept. 3310-050, Little Falls, New Jersey 07424.

UNLOCK Your Future. Become professional Locksmithing by spare time home-study. Make up to \$6 per hour. All tools, equipment incl. Facts Free. Send name. Locksmithing Inst. Dept. 1310-050, Little Falls, New Jersey 07424.

SIMPLIFIED Space Age Ordinations. Details 10¢. Astro Science Church, 431 Cedarhill, Wyckoff, N.J. 07481.

IMPROVE Yourself!!! Bargain priced books!! Free Catalog! Wainer, 739 East 82nd, Brooklyn, New York 11236.

EARN College degrees at home. Many subjects. Florida State Christian College, Post Office Box 1674, Fort Lauderdale, Florida 33302.

MAKE MONEY in real estate! Complete home study course designed to start you on new career. Opportunities waiting! Write: Career School of Real Estate Studies, 1825PM E. Seminole, Springfield, Mo. 65804.

DRIVING—Paralleled Parking Simplified. Easy to follow. Illustrated instructions. Send \$1.00, to R. E. Angioletti Driving School, RD 2, Belle Vernon, Pennsylvania 15012.

LIFETIME ORDINATIONS. Send stamp for information. Church, 2207 Cardinal, Rolling Meadows, Ill. 60008.

SLIDE RULE—Learn by LECTURE TAPE—An instructor in your home. Brochure. Creighton Tutoring Institute, Box 841, Findlay, Ohio 45840.

MINISTERIAL Courses. School of Ministerial Studies, 887 West Spruce, Ravenna, Ohio 44266.

EARN University degrees through experience—All subjects . . . details \$1.00 . . . St. Matthew University. . . . Box 9734 . . . Columbus, Ohio 43206

LEARN COMPUTER PROGRAMMING Self-instruction books. Free catalog. Computers, Box 471, Rosemount, Minn. 55068.

FCC First Class License in six weeks—Nations highest success rate—Approved for Veteran's Training. Schools in Dallas, Atlanta, Chicago, New Orleans, Minneapolis and Houston. Write Elkins Institute, 2603D Inwood Road, Dallas, Texas 75235.

ATTEND College at home. Free catalog. North American, 306-364 99th Avenue SE, Calgary 30, Alberta.

AUTOSUGGESTION. Sleep-learning headquarters! Tapes, records, books. Gigantic catalog free. Research Association, Box 24PM, Olympia, Washington.

FOR INVENTORS

PATENT Searches complete and thorough. Related copies Air Mailed with maximum speed \$6.00. Free "Protection Forms" and "Patent Information." Write American Patent Search Company, Dept. 27, 711 14th St., N.W. Washington, D.C. 20008.

PATENT Application Financing. Free patent search plan. Global Patent Division, 2420 77th, Oakland, Calif. 94605.

U.S. Patent Office Searches. 234 Broadway, Room 3615, New York. Free invention certificates.

PATENT And invention development by licensed professional patent engineer and U.S. Patent Office former examiner, and engineering specialists. Your inventions and ideas engineered for patent protection and commercial value. Inventions developed by us negotiated for cash or royalties with our nationwide contacts. Send for free protection "Invention Certificates" and further interesting, valuable patent information. George Spector, Licensed Professional Patent Engineer, Woolworth Building, New York.

(Continued on next page)

FOR INVENTORS

(Continued from preceding page)

PATENT Searches, including copies of related U.S. patents. Inventors attorneys, manufacturers use our "worldwide" airmail service! "Invention Record" form and "Information Every Inventor Needs." Sent free! Hayward Company, 1029P Vermont, Washington 5, D.C.

FREE PAMPHLET: "Tips on Safeguarding Your Invention." Write: United States Inventors Service Company, 501P Thirteenth Street N.W., Washington, D.C. 20004.

INVENTORS: Your ideas and inventions (patented; unpatented) expertly searched, developed for commercial appeal and cash/royalty sales to manufacturers by professional Invention Developer with excellent record of experience. B.S. Industrial Engineering; United States Patent Office former Patent Examiner, United States Government former Patent Advisor. Second decade reliable service! Member: United States Chamber Commerce. Free "Invention Record" and "Recommended Protection Procedure." Airmailed! Write: Raymond Lee, Invention Developer 230P-Park Ave., New York City 10017.

MANUFACTURERS NEED New Products! FREE Literature explains "How to Submit Your Invention." Congress Invention Company, 911-C Warner Building, Washington, D.C. 20004.

IMMEDIATE Cash, for patent applications. Free patent searches. Write for details. Universal Patents, 184-D, Marion, Ohio 45750.

INVENTIONS wanted immediately for promoting on cash or royalty. Patented, Un-Patented. Free booklet outlines royalty rates, requirements. Write Kessler Corporation, C-55-F1 Fremont, Ohio 43420.

CAN'T PATENT YOUR INVENTION?—Book written for engineers explains what's wrong with the patent laws and what should be done. "THE GREAT COTTAGE INDUSTRY," hardcover, 320 pages, \$8.95. Order from Vincent L. Carney, Box 1882, Chicago, Illinois 60690.

PROTECT Salable, Unpatentable Ideas Without Lawyer's Expense. Complete Details \$1. Great Expectations, 990 Ocean Front, Laguna Beach, Calif. 92651.

PROFESSIONAL Society for Inventors!!! Details, application form upon request. Write: "Inventors," Membership Department, Box 247-B, Webster, New York 14580.

INVENTIONS WANTED

INVENTIONS Wanted. Patented: unpatented. Tremendous manufacturers lists. Global Marketing Service, 2420G 77th, Oakland, California 94605.

INVENTORS! Sell your invention for cash or royalties! Our client manufacturers eagerly seek new items. Patented. Unpatented. Financial assistance if needed. 25 years proven performance. For free information, write Dept. 15, Gilbert Adams, Invention Broker, 80 Wall St., New York, N.Y. 10005.

INVENTORS! We will develop, sell your idea or invention patented or unpatented. Our national manufacturer-clients are urgently seeking new items for highest outright cash sale or royalties. Financial assistance available. 10 years proven performance. For free information write Dept. 47, Wall Street Invention Brokerage, 79 Wall Street, New York, N.Y. 10005.

INVENTORS! Don't sell your invention, patented or unpatented, until you receive our offer. Eagle Development Company, Dept. H, 79 Wall Street, New York 5, N.Y.

FREE "Directory of 500 Corporations Seeking new Products." For information regarding development, sale, licensing of your patented/unpatented invention. Write: Raymond Lee Organization, 230-N Park Avenue, New York City 10017.

INVENTORS! Protect your ideas! Free "Recommended Procedures." Washington Inventors Service, 422F, Washington Building, District of Columbia 20005.

WE Either sell your invention or pay cash bonus. Write for details. Universal Inventions, 28-E, Marion, Ohio.

INVENTIONS wanted immediately for promoting on cash or royalty. Patented, Un-Patented. Free booklet outlines royalty rates, requirements. Write Kessler Corporation, C-55-IW, Fremont, Ohio 43420.

PATENTS FOR SALE

REVOLUTIONARY Music Box That Plays Any Tune. Musical Instrument or Toy. Edward F. Fedoryszyn, Golden Hill Road, East Durham, New York 12423.

MANUFACTURING

INVENTORS Ideas developed. Research. Models. Manufacturing. Sales. Free brochure. William Parker, 32 Westminster, Worcester, Mass. 01605.

BUY IT WHOLESALE

BARGAINS! Buy wholesale and below. Name brands. Appliances, furniture, sports equipment, televisions, cameras, watches, jewelry, thousands more. Huge discounts to \$1,000.00 on new automobiles. All makes. Free details. Write today: Worldwide Bargainhunters, Box 730-A, Holland, Michigan 49423.

800,000 BARGAINS! Tremendous Discounts Available! Wholesalers, 1265-MR Broadway, New York, N.Y. 10001.

HEARING Aids, Batteries, Wholesale. Catalog 25c. Fiston, Box 1444, New Preston, Conn. 06777.

WORLD'S Largest wholesale dropship sources. U.S., foreign. Factory suppliers dropship direct to you or customers. Now!, have your own catalog for pennies. Free details. International Buyers, Box 16386-M, Portland, Oregon 97233.

WHOLESALE—Buy 40% To 50% Off Retail—same prices retailers pay! Thousands of name brands! Watches, cameras, jewelry, radios, phonographs, tape recorders, etc. Buy for yourself or resell at fat profit. Big wholesale catalog. Confidential Wholesale Price List. Free details. Wholesale Merchandise Club of America, Dept. 401, 154 Jericho Turnpike, Floral Park, N.Y. 11001.

WATER SOFTENERS, 5 cycle, Lifetime Warranty, \$140. Information \$1.00, refundable. Jerred, RT2WA, Pardeeville, Wisconsin 53954.

1969 FORDS, Dodges, \$799. 1968 cars only \$599. For free catalog, Associated Dealers, 50 Swalm, Dept. L, Westbury, N.Y. 11590.

EXPORT-IMPORT

IMPORT and Save 1000 overseas exporters. Many drop ship and most send free or low cost samples. Directory \$2. Shields Enterprises, 147 Georgetown Road, Annapolis, Md. 21403.

JAPAN: 1200 Products Directory. Illustrated Manufacturers' names, addresses. \$3.00. Send cash. Yamagata Office, 814 Togin Bldg., Marunouchi, Tokyo.

FOR THE HOME

"WILL Weather" 3X10 Mailbox nameplate. P. O. Box 1990, Milwaukee, Wisconsin 53201. Trademark registration applied for—Patent applied For.

SLEEPING PARTNERS—Dual control simply installed in center of headboard allows either partner to operate either nightstand lamp without rising. \$3.95. Neno, 7025 N.W. 20th Court, Ft. Lauderdale, Fla. 33313.

FOR PARENTS

FOOD Costs got you down? Write for the answer. Capitol Gifts, Box 19304, Washington, D.C. 20036.

DADS, worldwide organization dedicated to restoration of your lost rights and privileges is expanding. For application and exciting details send \$1.00 deposit. Comptroller, Box 705, Port Orange, Fla 32019.

OF INTEREST TO WOMEN

EARN Money Painting Novelties at home. N. Roland 10-V Lakeview, Hammonton, N.J. 08037.

MOODY? SPIRIT LOW? Get uplift, only 29¢! Be exotic, mysterious, contented! One package, 30 Joss sticks incense 29¢ (regular 49¢) plus 11¢ postage and handling. 4 packages \$1.00 plus 25¢. 24 assorted cones 59¢ (regular \$1.00) plus 11¢. Best offer from Orient! Ming Tree House, P.O. Box 1057-A, Merritt Island, Florida 32952.

HOMEWORKERS Directory! 262 national firms seeking help. Information free. Economy, Box 1348-AD, Clearwater, Florida 33517.

WOMEN! Make big money at home. \$10.00 profit in an hour possible with invisible mending. Make holes, tears disappear from clothing fabrics. Steady year-round demand from cleaners, laundries, homes. Details free. Fabricon, 1533 Howard, Chicago 60626.

WOMEN: BIG MONEY! Studio Girl Cosmetics needs women in all states including Hawaii, Alaska, Puerto Rico and American Samoa. Full or part time. No experience required. No territory restrictions. Take orders anywhere. Highest profits. 300 Good Housekeeping approved cosmetics, wigs, wiglets and falls. Everything furnished. Credit extended. No stock to carry. No franchise fees. No stock investment. For full information by mail, plus 2 free beauty samples, write HARRY TAYLOR, Chairman, Studio Girl Cosmetics, Dept. BC-459, 11461 Hart Street, No. Hollywood, Calif. 91605. Also immediate big profit earnings for experienced city and state managers and for party plan operators. Former Studio Girls please write.

HOW To make money writing short paragraphs. Information free. Barrett, Dept. C-27-D3, 6216 N. Clark, Chicago 60626.

DRIVE New car, wear new clothes, buy color TV. Get daily cash income. Put spare hours to work. Write for 5 months free subscription Opportunity Magazine, see hundreds easy ways to make money. Opportunity, 1460 Hancock Center, Dept. 17-E0, Chicago 60611.

\$75.00 THOUSAND. Home addressing! Longhand, typewriter. Information, send stamped self-addressed envelope. Brewster, Box 1348-YL, Clearwater, Florida 33517.

\$100 WEEKLY Possible addressing mailing circulars. Send self address stamped envelope. Details Free! Ayers Opportunities, Box 1591PM, Denton, Texas 76201.

\$100 WEEKLY Possible—Home Typing Immediate earnings! Employers list, complete instructions. Details 25 cents. Typing, Box 593, PM-5, Bettendorf, Iowa 52722.

\$25.00 HUNDRED Addressing. Possible! Year 'round. Special Information included. Send 25¢ postage, handling. Cove, Box 1348-B, Clearwater, Florida 33517.

HOMEWORKERS! Earn \$100 weekly typing, addressing. Begin immediately. Details free. Hamilton, 272-TM5, Brooklyn 11235.

HOME Newspaper clippers needed. \$500 monthly possible. Details free. Foster, 272-MA5, Brooklyn 11235.

EARN Up To \$6.00 per dozen lacing beautiful Baby Boots! Cowboy, Warsaw 9, Indiana 46580.

HOMEWORKERS! \$85 weekly possible addressing envelopes for firms. Start immediately! Information: send stamped, self addressed envelope. Enterprises, Box 16143-PM, Phoenix, Arizona 85011.

(Continued on next page)

OF INTEREST TO WOMEN

(Continued from preceding page)

\$100.00 WEEKLY Possible addressing Mail for Firms. Start Now. Send stamped self addressed envelope. Davis, Box 6992-PM Phoenix, Arizona 85005.

\$500.00 MONTHLY Possible—clippings news at home. No experience. Send stamped-addressed envelope. American, Excelsior Springs, Mo. 64024.

GIFT SHOPPING

DISTINCTIVE Gift Catalogue. Send 50¢. International, Box 208, Wendell, North Carolina 27591.

FREE Catalog. Latest Gift Ideas for everyone. Lakeside Gifts, Dept. 1, Box 69, Lakeport, N. H. 03246.

FREE! Distinctive Gifts catalog. Brownes, 3604—Guthrie, Pasadena, Texas 77503.

WATCH Fobs and belt buckles featuring Caterpillar products. Collector's item; 1970 date imprinted on back. For more information and prices, write Dept. PM-5, Today's Merchandising, Inc., 1909 E. Cornell Street, Peoria, Illinois 61614.

FREE Catalog, write Wood and Company—Box 2705—St. Paul, Minn. 55112.

WATCHES, OLD GOLD, JEWELRY

HIGHEST CASH For Gold, Jewelry, Gold Teeth, Rings, Diamonds, Watches, Silver, Platinum. Mail Articles Today. Free gift with information. Chicago Gold & Precious Metals, 6 E. Monroe Dept. 958, Chicago 60603.

WATCH And clock repairing books. Free catalog. North American, Box 77-AS, Fox River Grove, Illinois 60021.

WANTED—gold, silver, platinum (any form), mercury. Information free. Wilmot's, 1067 Bridge Street, Grand Rapids, Michigan 49504.

CASH Immediately for old gold, jewelry, gold teeth, watches, diamonds, silverware, spectacles, platinum, mercury. Free information. Rose Industries, 29-A East Madison, Chicago 60602.

WATCHMAKERS' — Jewelers' Catalog: Surprise: \$1.00. Watchmaking Course; Tools; \$35.00. Bengal's, 17942 Ventura, Encino, California 91316.

WEARING APPAREL

PROFITS FROM CLASSIFIED ADVERTISING! Booklet shows you how to start your own business with Classified Advertising. Only \$1.00 (Refundable with first order.) C. A. Martin, Popular Mechanics, Dept. PM, 224 West 57 Street, New York, N.Y. 10019.

HEARING AIDS

HEARING AIDS—Batteries Wholesale! Brochure—Hearing Center, Box 211, St. Petersburg, Florida.

HEARING Aids below wholesale. Regular, eyeglass, completely hidden models. Smallest, most powerful. Free home trial. No Salesman will call. Free details. Write Prestige-C6, Box 10880, Houston, Texas 77018

All Type hearing Aids \$89.00, Rhodes, 333 North 9th, Paducah, Ky. 42001.



SCIENCE AND CHEMISTRY

FREE Periodic classification of elements and conversion tables with catalog 35¢. Chemicals, apparatus, biology. Mid-States Scientific, 7053 N. Clark, Chicago, Ill. 60626.

ILLUSTRATED Catalog: Chemistry, mineralogy, biology 25¢. Tracey Laboratories, Evanston, Illinois 60204.

CHEMICALS And apparatus for industrial, analytical, and private laboratories. Catalog 50¢. Dept. M-50. Biological Supply Co., 1176 Mt. Hope Ave., Rochester, N.Y. 14620.

LABORATORY Supplies At Discount Prices. Catalog—35¢. De'uxe Scientific, Manitowoc, Wisconsin 54220.

SEARCHING For Economically Priced Laboratory Supplies? Elements Charts And Catalogue—35¢. Hagenow Laboratories, Manitowoc, Wisconsin 54220.

SEARCHING For Economically Priced Chemicals and Apparatus? Conversion Charts with Catalogue—35¢. Starr Scientific, Manitowoc, Wisconsin 54220.

BUILD HOT-AIR BALLOONS From household items. SEND \$1.00 for plans. DEREK INDUSTRIES, BOX 31442, AURORA, COLORADO 80010.

"CHEM-CUPS": Won't slip, slide, spill, crack or leak! Holds powders, liquids—everything. Hundred uses. 5—\$1.00, 13—\$2.00 + Free Catalogue Kenrus-K, Box 158M, Staten Island, New York 10309.

CHEMICALS, Apparatus, Biological Supplies, Microscopes, etc. Catalog 50¢. Sheard Science, Dept. PM, Columbus, Wisconsin 53925.

CATALOGUE Of ver-ry interesting products. 35¢. Things that go zoom, also Books—all about them. Kenrus-C, Box 158M, Staten Island, New York 10309.

LASER PISTOL—\$1.00. How to build PHASER PISTOL—\$1.00. MOON MAN (ROBOT). Build now. Complete plans \$2.00. (add 25¢ postage.) New catalogue—25¢. Roy Davis Laboratories, Dept. PM, 118 West Adams Street, Jacksonville, Florida 32202.

FORMULAS, PLANS, ETC.

FOR Proof of what you can do in specialty manufacturing get our literature. It's free! Miller, Chemist, 1517-P, Tampa, Florida 33601.

ANY Formula \$3.00. Catalog—Treatise 10¢. Belfort, 192 N. Clark, Chicago 60601.

MAKE CASTING PLASTICS AT HOME WITH MATERIALS FROM DRUG AND GROCERY STORES. SIMPLE, GUARANTEED FORMULA, \$3.00. NO CHECKS UNLESS CERTIFIED. STARMOUNT, 3306 NORTH BOULEVARD, RALEIGH, NORTH CAROLINA 27604.

PLASTICS

PLASTIC Embedders, jewelry workers. We have everything. Findings, moulds. New Catalog 25¢. David Co., 861 Broad St., Dept. M, Providence, R.I. 02907.

CRAFT Kits—Supplies. Casting Resin, Molds, Cookin' Crystals, Dippity-Glas, etc. New enlarged catalog—50¢ (refundable). Specialty Products, Dept. 7, 731 Brooks Road, Muskegon, Michigan 49442.

CASTOLITE pours like water and hardens like glass at room temperature. Embed natural flowers, coins, special collections. Also new molding and casting resins for reproducing originals. Manual 25¢. CASTOLITE, 70/101E, Woodstock, Ill. 60098.

MOTHER of Pearl Chips wholesale. Used for plastic imbedment used in making beautiful table-tops, wall panelling and decorative novelties. Send 25¢ for price list. Apco, Post Office Box 282, Metropolis, Illinois 62960.

TREASURE FINDERS

FREE 128 Page detector catalog. General Electronic Detection Co., Box 67, Bellflower, California 90706.

TREASURE LOCATORS MOST COMPLETE LINE. FREE INFORMATION. TESOROS, APARTADO 7-948, MEXICO 7, MEXICO.

FREE TREASURE GUIDE! Fact-filled collectors edition: send 50¢ for postage. Also request free literature on ultrasonic, professional Fisher Detectors. FISHER RESEARCH, Dept. PM-5, Palo Alto, California 94303.

POWERFUL Metrotech locator detect gold, silver, coins, relics. Moneyback guarantee, terms. Free information. Underground Explorations, Dept. A, Box 793, Menlo Park, California 94025.

ULTRA-SENSITIVE AND POWERFUL METAL DETECTORS—join the many who are finding buried coins, minerals, relics and artifacts. Don't buy till you see our FREE catalog of new models. Write Jetco—Box 132, PM, Huntsville, Texas 77340.

TREASUREPROBES. Patented transistorized detector signals "dig" by earphone "beeping." 5" search head, PC boards, two coilpit oscillators improve stability. Kit \$13.95, assembled \$18.88, with speaker \$24.88. 60 day guarantee. Send for Free bibliography. "Treasure Maps and Books of U.S.", Treasurehouse, PA50, Tennent, N.J. 07763.

FIND Buried treasure with new revolutionary analytical metal detector. Features push button tuning, automatic tuning, loudspeaker, negligible ground pickup greatest range. Free catalog. Gardiner Electronics, Dept. 9, 4729 N. 7th Ave., Phoenix, Ariz. 85013.

TREASURE. Gold, silver, relics. New 1970 detectors now available. Free Information. Excelsior Electronics Company, 7448 Deering Avenue, Canoga Park, California 91303.

"TREASURE BOOKLET. Excellent information on treasure hunting and metal detectors. Send 25¢. BOOKLET, Dept.—PM-5, Box 243, San Gabriel, California 91778.

TREASURE Hunters! Prospectors! Relco's new instruments detect buried gold, silver, coins, minerals, historical relics. Transistorized. Weighs 3 pound. \$19.95 up. Free catalog. Relco-A40, Box 10839, Houston, Texas 77018.

NEW: Canadian oil leases. \$1.00 acre. Free information. Northern Box 560-F, Westmount, Montreal 215.

GOLDAK Treasure Locators—Pleasure and profit in a hobby you'll enjoy. Find coins, relics, gold, silver. Charge on BankAmericard. GOLDAK, Dept. PM 1101-A Air Way, Glendale, California 91201.

PRECIOUS STONES AND MINERALS

EARTH Science Rockhound Magazine. Subscription \$2.50. Sample 35¢. Box-550-PM, Downers Grove, Ill. 60515.

100 COLORFUL, Polished gemstones \$1.00. Tumblecraft, 5401 James North, Minneapolis, Minnesota 55431.

GET Free catalog no serious rockhound, gem cutter, jewelry maker, hobbyist or craftsman can be without. Full of bargains, exclusive items, low prices from largest suppliers and authorities in the field. Free new catalog just off the press, yours for the asking. Write Grieger's, Dept. C-12, 1633 E. Walnut, Pasadena, California 91106.

12 POLISH-Gem-Stones-Of-The-World. Names-And-Locations. — Educational — \$1.00. Empire Gem's, Trinidad, Calif. 95570.

500 BEAUTIFUL POLISHED GEMSTONES \$1.50. Floodstones, P.O. 1673 Fremont, California 94538.

SILVER, Dendritic crystals, several in plastic box for \$1.00. Free lists. Prospectors Shop, 201 San Francisco, Santa Fe, New Mexico 87501.

CARTOONING, COMMERCIAL ARTS, SHOWCARD & SIGN PAINTING

TRICK Chalk Stunts. Catalog 10¢. Balda The Cartoonist, Oshkosh, Wis. 54901.

COMPACT 23 lesson Cartoon Course and Cartoonist's Magazine, \$2.00. Hartman, Box 30367, Lincoln, Nebraska 68510.

LEARN sign painting at home. Free talent test. Ben Kerns, Box 812-PM, Greenville, S.C. 29601.

SIGN Painting. Fascinating System—Straley, 410 So. Western, Springfield, Ohio 45506.

(Continued on next page)

(Continued from preceding page)

SIGN Painting Matthews' big new 18 lesson course \$5.00 postpaid, Circulars free. Sign Book Co., 470 Oak Street, St. Louis, Mo. 63119.

"HOW TO MAKE MONEY WITH SIMPLE CARTOONS"—Everyone who likes to draw should have this book; FREE. Write Cartoonists' Exchange, 95 Pleasant Hill, Ohio 45359.

SIGN Painting—Latest methods. Free catalogue explains everything. Kaufmann Supply, Centertown, Missouri 65023.

\$200.00 MONTHLY Sparetime possible making signs, posters, silkscreen printing. Learn quickly—easy instruction. Information free! Hampton, 102-PM, 8 Warren Place, Brooklyn, New York 11201.

ADVERTISING AGENCIES, ADV. SERVICE, MAILING LISTS

ADVERTISING Ratebook leading newspapers, magazines, 25¢. Chicago Advertising Agency, 28-E Jackson, Chicago 60604.

MAILING Lists most all kinds 1000 \$5.00. Free folder Your circulars mailed \$4.00 1000. Dixie Mailers, King, N.C. 27021.

EXCLUSIVE! HIGH INCOME LISTS. One thousand names, \$3.00. R.&D., Box 8045-M, Salt Lake City, Utah 84108.

TYPEWRITERS, DUPLICATORS, OFFICE EQUIPMENT

FREE Plan. Start printing, lettershop. Offset Presses. Mimeograph Copy machines. DixieGraph, King, N. Car. 27021.

RUBBER STAMPS AND OFFICE SUPPLIES

ADDRESS Stamp with Handle. Four lines \$1.25. House Tom Henry, Bensenville, Illinois 60106.

FREE 40 Page catalog. Rubber stamps, office supplies. Youngers Stamp Shop, Princeton, Iowa 52768.

ADDRESS Stamp 85¢. Signature \$2.80. Catalog, Carol's, McCloud, Okla. 74851.

RUBBER Stamps. Any Copy, 4 lines \$1.00. Phillips, Box 164, Staten Island, New York 10314.

ADDRESS Stamps any 4 lines \$2.00. Peter Dokus, 101 Main Street, Newark, New Jersey 07105.

FREE Illustrated rubber stamp booklet. Beckley's, 430 South Avery Avenue, Syracuse 3, New York 13219.

RUBBER Stamps, new free brochure, Willman's Stamp Works, Guttenberg, Iowa 52052.

PRINTING PRESSES, RUBBER STAMP OUTFITS

RUBBER Stamp Manufacturers Supplies. Presses, starting outfits. Best Prices, Service. Catalog. Jackson Supply, Box 443-A Franklin Park, Ill. 60131.

PRINTING—8 HOUR SERVICE. Any quantity. Lowest prices. Allstate Press, 120-PM South LaSalle, Chicago 60603.

SIMPLE-X RUBBER STAMP PRESSES, hydraulic operated, electrically heated. Sizes 5"x8", 8"x12", 10"x15". Starting outfits. Orders for presses, supplies shipped day received. Free catalog low supply prices. Custom Manufacturers, 406-P East Elm, Springfield, Mo. 65801.

PRINTING Presses, type, supplies. Lists. 5¢. Turnbaugh Service, Mechanicsburg, Pennsylvania 17055.

TYPE Catalog No. 12, 120 pages. Send One Dollar. Deductible First Order. Acme Type, 732 Federal, Chicago, Illinois 60605.

SAME Day shipment on rubber stamp supplies. Revised wholesale price list No. 6 free. Star Stamp Supply, 732 Federal, Chicago, Ill. 60605.

MAKE your own self-molding rubber stamps and printing cuts. Plexirubber. Argyle 1, Wisconsin.

RUBBER Stamp outfits, supplies. Kiewiet, 2025 Barney Road, Kalamazoo, Michigan 49007.

DEEP Face Hard Type for better rubber stamps and printing. Complete Line, stamp presses and supplies. Buy direct. Barco Type Manufacturing, 237 Evergreen, Bensenville, Illinois 60106.

PRINTING AND SUPPLIES

AMAZING business printing values. Quotations. Print Shop, Box 576, Greenville, R.I. 02828.

8 HOUR PRINTING—Free Booklet "Secrets of Cutting Printing Cost" Nationwide Printing, Atlanta, Ill. 61723.

FREE Literature. Address Labels, Business Cards, Printing, Rubber Stamps: Jordan's, 552 West O'Connor, Lima, Ohio 45801.

PRINTED Business Forms—all kinds—Free Illustrated Catalog. Sound Mechanics, Box 1, Bronx, N.Y. 10472.

OFFSET PRINTING—100 Copies \$3.95. Send copy with money order to Lamar Printing Co., P. O. Box 52395 Houston, Texas 77052.

QUALITY Business Forms, Envelopes, Labels, Samples. Burnfin, Weaubleau, Missouri 65774.

1,000 EMBOSSED Business Cards \$4.75 Postpaid. Robert Gersh, Box 105, Allston, Massachusetts 02134.

MULTIGRAPH, MIMEOGRAPH

PROFITS FROM CLASSIFIED ADVERTISING! Booklet shows you how to start your own business with Classified Advertising. Only \$1.00 (Refundable with first order.) C. A. Martin, Popular Mechanics, Dept. PM, 224 West 57 Street, New York, N.Y. 10019.

MIMEOGRAPH Machines—Brand new—Complete with supplies. Only \$29.95. Free details. Custom, 3816 Butler St., Pgh. 15201.

GUMMED LABELS

1,000 GUMMED address labels \$1.00. Fabrico, PE-1, 1512 N.E. 29th Street, Ocala, Florida 32670.

1000 GUMMED Address Labels \$1.00. Walt's, Box 966A, South Bend, Indiana 46624.

REMAILING SERVICE

CONFIDENTIAL 25¢ Special Services. Write Treasure, Box 9255, San Diego, Calif. 92109.

LOUISIANA 25¢ each, \$3.00 month. CROCKETT, P.O. Box 3714, Shreveport, La. 71109.

CONFIDENTIAL Remails 25¢ each. 3.00 Monthly. Bodewig, Box 381, Coos Bay, Ore. 97420.

FORT WAYNE Remails. Receiving Re-mailing. Confidential. 25¢ Single, \$3.00 Monthly. Adams, Box 500, Auburn, Indiana 46706.

INSTANT Remail. 25¢. \$3.00/Month. John, Box M 2032; Sunnyvale, California 94087.

RECEIVING-Forwarding, Confidential Services. Remails 25¢ single. P. O. Box 3511, Toledo, Ohio 43608.

MOTOR CITY Remails Special Services Available. M.C.R.S., Drawer 890, Dearborn, Michigan 48121.

MIAMI Remails 25¢. Monthly rates. Marie, Box 1266, Coral Gables, Fla. 33134.

CONFIDENTIAL New York City mail address \$3.00 month. Remails 25¢. Details Free. Birnhan, 152 W. 42, New York City 10036.

SECRET. Receiving-forwarding. Discreet and confidential. Remail 25¢ single. Mail Forwarding Service, 8050 S. Main, Houston, Texas 77025.

HAWAII Remails 35¢—Fox, 1642 Kewalo, Honolulu, Hawaii 96822.

REMAILS. Individual-Business. \$3.00 monthly, 25¢ singles. Gregory, 1121 Palomas, Southeast, #25, Albuquerque, New Mexico 87108.

RECEIVING—Forwarding. Monthly Rates. Hedgpeth, 406-M, South Second, Alhambra, Calif. 91802.

LLOYD'S Anchorage Remails 25¢, air-mails 40¢. 1701 Twining, Anchorage, Alaska 99504.

RECEIVING—Forwarding \$4.00 monthly. Wright House, Box 2112-M, Asheville, N.C. 28802.

MAY'S NEW YORK CITY Remails, Confidential, 25¢ each, \$3.00 Monthly. 370 East 76th, New York, New York 10021.

PRIVATE. Receiving—Forwarding, re-mails 25¢. Wellington, 3227 Kearny Villa, San Diego, California 92123.

DETROIT! 1/25¢. Letters composed Special Order! YB-Lemke's, 3476 Balfour, Detroit 48224.

MEXICO—Re-airmailing \$1.00 each, monthly \$3.00. Postcards 5 for \$1.00. Alex Mercado, Apartado 29-085, Mexico 1, D. F.

JOLIET Remails 25¢ monthly \$3.00 Kor, Box 712A, Joliet, Ill. 60434.

EVERETT, WASHINGTON Remails 25¢, \$3 Mo. Confidential Services, 12226 Gibson, 98201.

NATION'S CAPITAL Remails 50¢. Capitol Gifts, Box 19304, Washington, D.C. 20036.

SO. AMERICA REGISTERED RE-AIRMAILS \$1.00. Confidential. Genaro, Box 360, Guayaquil, Ecuador.

SAN FRANCISCO Remails. Fast. Confidential. 25¢. Communicator, Box 31043, San Francisco 94131.

CANADA Remails 50¢ each. Reliable. Confidential, Box 2066, Burnaby, 2, British Columbia.

SAN DIEGO 25¢ single. Stephens, Box 22083, San Diego, Calif. 92122.

NATIONWIDE (any city) 25¢. Complete services. Box 283, Vienna, Virginia 22180.

KENTUCKY Remails 25¢. \$3.00 Monthly rates. Smile, Box 203, LaGrange, Ky. 40031.

NEW YORK CITY 1/25¢; 6/\$1.25. Additional Services. Snow-M, 458 Vermont, Brooklyn 11207.

GEORGIA Remails 25¢ Confidential, \$3.00 Monthly. Don, Box 737, Tucker, Georgia 30084.

REPAIRS AND SERVICING

PROFITS FROM CLASSIFIED ADVERTISING! Booklet shows you how to start your own business with Classified Advertising. Only \$1.00 (Refundable with first order.) C. A. Martin, Popular Mechanics, Dept. PM, 224 West 57 Street, New York, N.Y. 10019.

SPECIAL SERVICES

INFORMATION On anything. Ferguson Research Specialists, 83-45 Vietor Ave., Elmhurst, N.Y. 11373.

COMPUTERIZED Lifetime Listing; Fantastic Mailings—\$1.00! Details, 25¢. Fabian's, Box 154-G, Montreal 130, Canada.

THE HANDICAPPER will answer any speculative questions. Brad Goff, P.O. Box 951, Johnstown, Pa. 15907.

AUTHORITATIVE information direct from Australia lavishly color illustrated including beautifully detailed maps. Free forms for free material. We are not kidding! We will IMMEDIATELY air mail you complete accurate information enabling you to obtain your passport/visa in least possible time—absolutely without charge. AUSTRALIAN OPPORTUNITIES NEWSLETTER, Box 6428, Torrance, California 90504.

(Continued on next page)

SPECIAL SERVICES

(Continued from preceding page)

AUTHORITATIVE Information On Anything! \$2.00 (deductible). Metzler Research, Box 2206PR, Long Island City, New York 11102.

TOBACCO

CIGARETTES FREE one carton when you send \$3.00 for information "Where to buy wholesale." United Wholesale, Box 807, Roanoke Rapids, N.C. 27870.

RAZORS

YOUR Ad in Popular Mechanics will be seen by more than 5,000,000 active buyers for your products and services. It costs only \$1.85 per word. And, if you wish to run all or part of your ad in capital letters—you can do so for as little as 75¢ per word additional. Act now! Place your Classified ad in Popular Mechanics today.

PERSONAL

YOUR Lucky Number. Send Birthdate \$3.00. Trowbridge, 35-PM Woodcrest, Dayton, Ohio 45405.

INFORMATION On any subject—satisfied clients worldwide. Research-4, Box 286, Biloxi, Mississippi 39533.

BORROW Up To \$1,000 By Mail. Money on your signature for any purpose. Write: Budget Finance Company Dept. EB-0135, City National Bank Bldg., Omaha, Nebraska 68102.

BORROW up to \$1500 by mail on convenient terms! State licensed. Postal Finance, Dept. 17-E, 200 Keeline Building, Omaha, Nebraska 68102.

SECRET Law Wipes Out All Debts to \$25,000. Immediate relief. Free details. Capital-7, Kerrville, Texas 78028.

SECRET LOANS BY MAIL. Borrow \$100 to \$1500 for any good reason in absolute privacy. No interviews, no endorsers, no co-signers. Fast service. Write Dial Finance Co., Dept. E-214, 410 Kilpatrick Bldg., Omaha, Nebraska 68102.

SUBCONSCIOUS Conditioning remakes personality while you sleep. Free details. Sleep-Learning, Box 24N, Olympia, Washington 98551.

BEAUTIFUL Girls. Free Information "International Introductions." Apartado 950, Guadalajara, Mexico.

INVESTIGATORS. Latest electronic Aids. Free literature. Clifton, 11500-P NW 7th Ave., Miami, Florida 33168.

RUPTURED. Relief and comfort. No understraps, elastic or steel. Write Hand-Lock Products, Preston 4, Ont., Canada.

BIBLE Questions answered. Stamped envelope. Bylon, 17167 Bentler, Detroit, Michigan 48219.

HYPNOTISM SECRETS. Lowest prices. Free information. Merlin Enterprises, P.O. Box 613, Los Gatos, Calif. 95030.

MAKE NEW FRIENDS Worldwide. Meet Marriage minded Girls through our illustrated Catalog. 1200 Ladies' Fotos and Descriptions \$2.00. I. C. B., Box 12, Sta. O Toronto, 375, Ont. Canada.

MAKE YOUR WILL. Get 4 Will Forms and attorney's informative book. \$1.00. Legal Forms Company, Department 124, 1830 Guardian Building, Detroit, Michigan 48226.

ARE YOU REALLY SINCERE about wanting to find a marriage partner? **SOCIAL INTRODUCTION SERVICE,** P.O. Box 1547, Eugene, Oregon 97401.

GET OUT OF DEBT in 90 minutes, legally without borrowing or bankruptcy. facts so explosive, credit syndicate tried suppressing, free details. Anderson, 5818-E Hamilton, Cincinnati, Ohio 45224.

BIRTH, Marriage, Certificates, Diplomas, Three Blank Forms \$1.00. Free Samples. Form Distributors, Box 893, League City, Texas 77573.

FREE! List of Low Cost Popular Books. Success, Happiness, Personality, Wealth, Personal Problems. Write Lori Ann Gifts, 901 Pierpont Road, Richmond, Virginia 23225.

ELECTRONIC listening devices. Free catalog. SSC, 27597P Bahama, Hayward, Ca. 94545.

SIMPLE pleasant way to Health and Vitality. Details free. THORNGREN'S 4515-D 23rd Avenue, Moline, Illinois 61265.

VOCATION to aid underprivileged. Little Brothers of the Good Shepherd, Box 217, Orangeville, Ont., or Box 389, Albuquerque, N. Mex. 87103.

EXCHANGE Ideas write to new friends everywhere. . . Long list \$1.00. Lee's Penpal, Box 326G, Queen City, Texas 75572.

LOSING HAIR? DON'T GIVE UP HOPE! CELLOBION WITH BIOSTIMULINS—Unique, new scientific formulation from London Biocosmetic Laboratories, containing 20 active ingredients helps regenerate scalp, curb hair loss, stimulate new hair growth. This one works. Write for free folder! American International, 1875 Massachusetts Ave., Cambridge, Mass. 02140.

U.S. Government gives many benefits not known by the General Public. They're yours for the asking. Free Details. Markwell Enterprises, Box 2933-PM, Little Rock, Arkansas 72201.

CONFIDENTIAL Receiving Forwarding \$3.00. Monthly. Registered re-airmails \$1.00. Colorful Postcards 4/\$1.00. Femor PM, Apartado 5-131, Old Mexico 5, D.F.

TATTOO Removing. Do-It-Yourself Kit \$14.00. Information Free: Atlanta Co., 907 Lakecrest, Fairport Beach, Ontario.

WANTED—MISCELLANEOUS

MERCURY. Gold, Silver, Platinum: Ores assayed. Wholesale Terminal, Norwood, Mass. 02062.

MERCURY. Immediate Payment. Free information. Mercury Supply, PM-52, Fairfield, Ohio 45014.

MISCELLANEOUS

FILL Your mail box with interesting mail—\$1.00. Bodewig, Box 381, Coos Bay, Ore. 97420.

HERBS—FOR BETTER HEALTH—Free STARTLING Report. Specialty—103, Belleville, Pa. 17004.

WINEMAKERS Yeast, Recipes & Catalog 25¢; Kraus, Box 451-L, Nevada, Missouri 64772.

WANT Greatest Cash Crop working for you? Write Ginseng, Asheville 53, N.C.

YOUR Name sent to 1000 importers, publishers, mailers, wholesalers, etc. on our mailing list. Year \$1.00. Dixie Mailers, King, N. Car. 27021.

CIGARETTES 12¢ a pack. Improved roller makes 20 filtertip, plain, king or regular for 12¢. Facts Free. Moberly, Box 954, Owensboro, Kentucky 42301.

BIRTH Certificates, Marriage Certificates, Diplomas! 2 blank forms \$1.00. Sample 10¢. Standard Forms, Box 482-M, Washington, D.C. 20044.

WINEMAKING . . . Grape, Elderberry, Dandelion, Frozen Juices, etc. Brewmasters' secrets revealed! Powerful Methods! Instructions, Recipes, and Supplies Catalog. \$1.00. Continental, Box 11071 PE, Indianapolis, Indiana 46201.

BOOKS On antiques and their prices. Free circular!! P. Warner Publishers, Uniontown, Penna. 15401.

POLYETHYLENE Bags. Top quality, low-cost prices. 10¢ brings price list with 200 stock sizes. Milvan, 7055B Rich Ave., Newark, Calif. 94560.

ORNAMENTAL Iron designs. Book of 1600 beautiful, practical designs for railings, columns, etc. Free literature. Cunningham, 3881 South 3200 West, Salt Lake City, Utah 84119.

WINEMAKERS. Free illustrated catalog of yeasts, equipment. Semplex, Box 12276, Minneapolis, Minn. 55412.

HEARING Aid batteries wholesale. Free list. Habs, Box 51, York, Penna. 17405.

PSYCHEDELIC Catalog of Posters, Lighting, Jewelry, Etc. Send 25¢. Hole, 6055 Lankershim, N. Hollywood, Calif. 91606.

YOUR Name placed with 1295 mailers, distributors, wholesalers, importers for mailings all year \$1.00. Tayco Mailers, 528-C Sharon, Stockton, Calif. 95205.

WINEMAKING Kit—\$4.98 Free Catalog and recipes. JIMDANDY, Box 30230M, Cincinnati, Ohio 45230.

BIRTH Certificate, Driver's License, H.S. Diploma, College Diploma, Marriage License—Blank Forms—Highest quality. \$2.00 each; any four—\$5.00. Glennco, Box 834-PA, Warren, Mich. 48090.

IDENTIFICATION CARDS—Send stamped self-addressed envelope for free samples & details to: E.C.S.M., P.O. Box 12117, Las Vegas, Nevada 89112.

FABULOUS ORIENTAL Zodiac horoscope booklet. \$1.00. Shopper's Fair, 1025B Bristow, Belleville, Illinois 62221.

VIETNAM Color photos 10 photo album \$1.00. Photos, Box 669, Bremerton, Washington 98310.

SEE Singapore—Exotic East postcards booklet \$4.00 airmail Box 1913, Singapore.

MENS Mod watch band. Genuine leather, 2¼ inches wide, with gold or silver ornamentations. The in thing for teenagers and adults. \$2.95 Prepaid. Enter-space, Box 36, Saugus, Calif. 91350.

LATEST Type MAGNETOC CRANK PHONES used by telephone Companies before dial conversion. Excellent condition. Rugged, compact dependable for all intercom use—Ring and talk room to room or several miles—Wall and desk models. Two phones with 50 feet wire \$35.00—Single phones \$17.50. Check or money order. Postage collect—Money back guarantee. Lake Intercom, Shell Lake, Wisconsin 54871.

MYSTERY PACKAGE Surprise yourself. Novelties, necessities, gifts, tricks. Could be anything. Take a chance. \$1.00 or \$2.00 package. Ernest Albert, Box 15677, New Orleans, Louisiana 70115.

BALLOON Wine—Make inexpensive wine with toy balloon and gallon jug. Illustrated \$1.00 EMS Co., Box 3965, St. Louis, Mo. 63136.

"LOVE AMERICA or Leave It"—Bumper Stickers. 50¢. 3 for \$1. Enterprise, Box 7, Greenwich, Ohio 44837.

WINEMAKING . . . Grape, Apple, Cherry, Blackberry. Powerful home-tested recipes without expensive equipment! \$1.00. Bates, 5806 Lemay, Detroit, Michigan 48203.

MAGNETS. All types. Specials—20 disc magnets, or 2 stick magnets, or 10 small bar magnets, or 8 assorted magnets. \$1.00. Maryland Magnet Company, 5412-A Gist, Baltimore, Maryland 21215.

FABULOUS Grape Wine year round, slick trick. \$1.00. Edwards, RD #2 Box 51, LEWES, Dela. 19958.

YOU Don't have to be a Connoisseur to make wine at home. Arborhouse makes it easy and fun for you. Send for illustrated FREE catalog. Arborhouse, Dept. AO, 8007 Douglas Ave., Racine, Wisc. 53402.

WINEMAKING at home, instructions and recipes \$1.00. The Finest, Box 10032, Station V, Cincinnati, Ohio 45210.

SLOT Machine banks \$5.95. Catalog 35¢. Refundable. Coffco, P.O. Box 522, Lake Zurich, Illinois 60047.

FIFTY Nature Verses \$1.00 prepaid. Also secret mailing place. Everitt Rosenberg, 511 Oxford Rd., Morrisville, Pennsylvania 19067.

The 1970 GRAVELY Riding Tractor.

We'd sell even more of them if the old Gravelys didn't last so long.



That old tractor is 15 years old and still going strong. Which should come as no surprise to you, if you've ever talked to a Gravelly owner. We sell many of our new tractors because of word-of-mouth praise by owners who know how long their old Gravelys last.

As good as our old tractors are, the new Gravelly Riding Tractors are even better. You get an all-gear-drive, with no belts to slip or break ...instant forward, neutral or reverse at the flip of a lever. A unique rear-mounted engine for extra traction

when the going's tough. Center or front-mounted mower to suit your needs. Choose from a variety of front, rear or center-mounted attachments—for mowing, gardening, snow removal and many other jobs —on a 10, 12, 14 or 16.5 H.P. tractor that's built better than it has to be.

Please let us send you a new catalog on Gravelly Riding and Convertible Tractors, and the name of your Gravelly dealer. Write: Gravelly Corporation, 5804 Gravelly Lane, Clemmons, N.C. 27012.



GRAVELLY
CORPORATION
A SUBSIDIARY OF STUDEBAKER-WORTHINGTON INC.

HOMEOWNERS' CLINIC

BY W. CLYDE LAMMEY

Low heat

I live in a recently acquired, older home, equipped with hot-water heating. Originally coal-fired, the boiler is now fitted with an oil burner and room thermostat controls, but I don't keep warm in cold weather. I'd like to do something about it before another winter. But what?—A.E., N.D.

The answers to two questions may provide a solution or at least point the way. Is your heating system controlled by one or more than one room thermostat and where are they located? And are you reasonably sure the system is of adequate capacity to provide comfortable room temperatures in your locality?

Assuming that your system has adequate capacity, and also that the pipe lines and radiators are in good condition, the remedy could prove to be the relocation of the thermostat, or 'stats. Often, and especially in older converted installations, thermostatic controls are placed where there is inadequate air circulation or they may be affected by a nearby radiator. This possibility should be checked by someone who is acquainted with your particular heating system.

Streaky ceiling

I built my own home, a small ranch type, only a couple years ago. I was then told (erroneously, I know now) to apply creosote to the framing to preserve it. Now there are brownish streaks in the ceiling plaster directly under each attic joist. Fresh applications of paint just don't conceal the streaks. What can I do now?—G.H., Tenn.

As a stain, creosote will penetrate almost anything other than metals. There just isn't any simple solution. I can suggest, for example, that you cover the streaks with wooden box beams, but with joists on 16-inch centers that's a lot of beams, even in a small room. Or, I can tell you to take off the paint down to the plaster—and the stains—and coat the ceiling with white shellac. That's right, white shellac. It's available, but you may have to shop around to find it. One brand is B.I.N., made by William Zinsser & Co.

As a rule, white shellac will seal the

bleeding creosote. It can do no harm and it's worth a trial. You can paint over it, of course, but I wouldn't apply any other coating for a while, just to make sure that the shellac will seal out the stains completely.

While I can't conscientiously recommend that you box-beam the ceiling, this could be done and it might not be too far-out a solution in some rooms if the beams were, say, painted the same color as the ceiling.

Wet attic

Last winter, my attic was dripping water. I've checked for roof leaks and have been told the water comes from sleet blown in the vents—that it may work in under shingles during a driving rain. But the shingles have sealed tabs. I've even watched during the rain and no leaks are visible. Where can the water come from?—W.H., Miss.

The water comes from inside the house, not through the roof or in the vents. Every time you or other family members exhale, shower, prepare food, boil the teakettle or do the laundry you contribute to moisture in the room air. This can build up to several gallons in a 24-hour period. Warm, moist air seeks the colder, dryer air outside the house and forces its way through common building materials and insulation by what is known as vapor pressure. Unless your attic vents are of ample size, this moisture-laden air is trapped in the attic. It condenses on any material—rafters, roof boards and nail tips, mainly because these areas are at a lower temperature.

Attic vents or louvers should provide at least one square foot of free area for each 100 square feet of attic floor space. This is minimum, especially where there are low pitched roofs. Enlarge the louvers, if necessary, and do everything else possible to lower the moisture content of air in rooms. Don't let the teakettle boil; install a fan in your bath or shower stall; air the house after laundering, and if you have a clothes dryer or your house is heated by a gas floor furnace, be sure they are properly vented to the outside.

Leaky water pipe

How can I stop a slow leak in a water pipe?—J.J., Utah.

It's best to replace the leaking pipe or have your plumber do it. Should replacement be delayed for some reason, there is a device that can be clamped around a pipe for stopping a leak temporarily. ★★★

A touch of Turkish
turns on taste.
Turns it on smooth.
Camel's got it.
Get it.
Start walking.

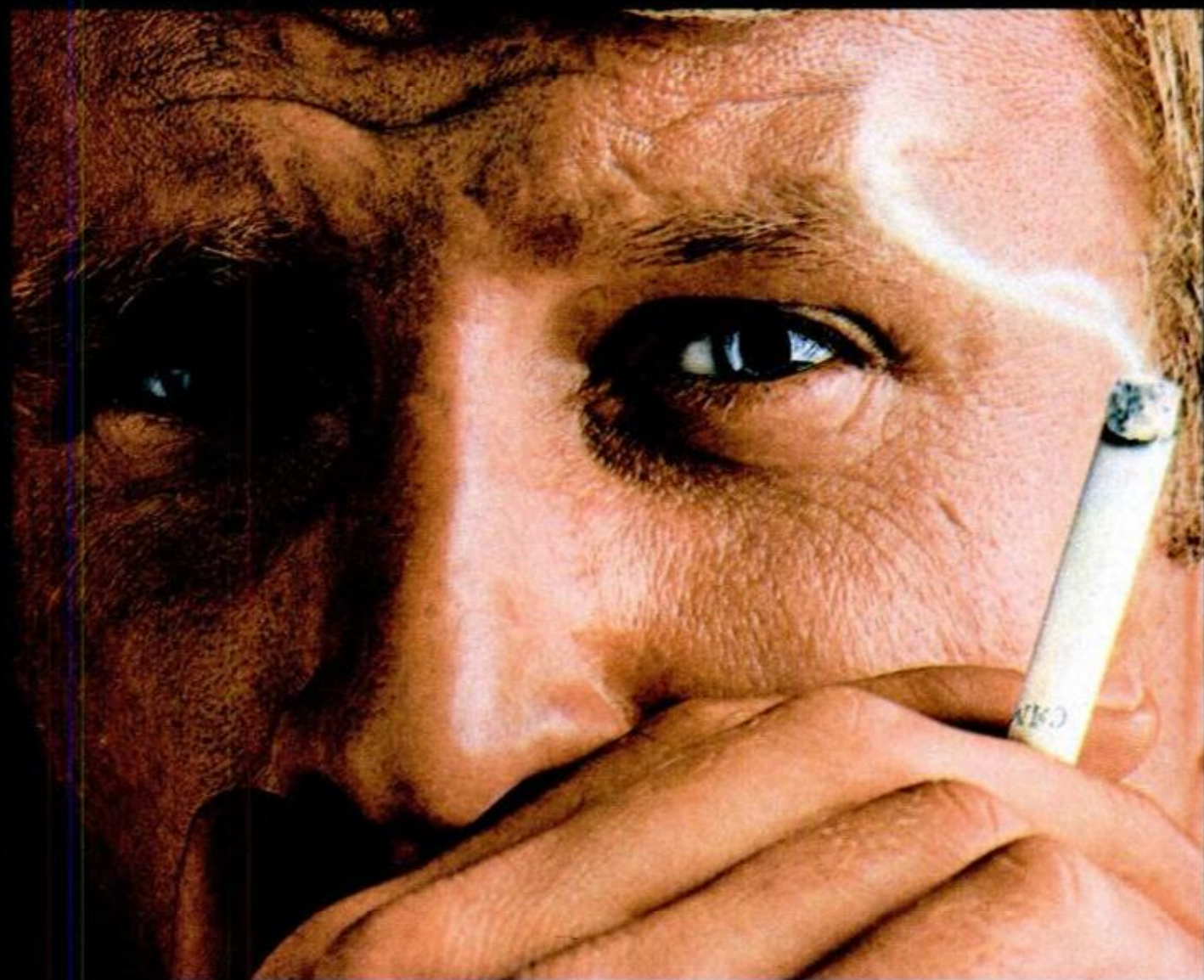

“I'd walk a mile for a Camel.”

© 1970 R. J. Reynolds Tobacco Company, Winston-Salem, N. C.

Материал, защищенный авторским правом

SOLUTIONS FOR MECHANICAL HEADACHES

AUTOMOBILE CLINIC

BY MORT SCHULTZ

All washed up

The windshield washers of my 1969 Buick won't work unless they are primed. What's wrong?—W. S. Goodlett, Big Spring, Tex.

The trouble is most likely a dirty pump intake or exhaust valves which are not sealing. Remove the check-valve assembly, which is held by four screws, and clean it. After cleaning, check the operation of the valves by attaching a hose to the assembly's intake pipe (that's the large one). You should be able to blow through it, but not draw through it. Attach a hose to each exhaust outlet (there are two—they're the small ones). You should be able to draw through them, but not blow back the other way.

Jumping around

I've been told that you should never try to start a car with a d.c. generator by jumping over from the battery of a car that has an a.c. generator (alternator). If so, why not? Is the reverse true?—Robert Clark, Cincinnati.

You can jump a battery in a generator-equipped car with one in an alternator-equipped car, and vice versa, but you better make sure you don't cross polarity—only then will you have problems, like burned-out diodes in the alternator. Make sure you connect the positive of one battery to positive of the other, and negative to negative.

Gassed

When my 1969 ½-ton Dodge pickup (318-cu.-in. engine) was new, I was getting 15 miles to the gallon but used 8 quarts of oil in 2000 miles. At 4300 miles, the dealer replaced rings and valve stem seals to solve the oil problem. Now I'm getting 10 miles to the gallon. The dealer says the rings are of a different type, and that I'll have to be content with this gas mileage. I would appreciate your opinion.—James O. Walker, Indianapolis.

It sounds to me as if the mechanic did a good ring job, but upset one of the engine's basic settings. The type of ring would have no effect on gas consumption. I would make sure that basic specifica-

tions are on the button, especially ignition timing, distributor breaker-point gap and, of course, carburetor settings.

By the book

The coolant in the radiator of my 1969 Pontiac Catalina checks out 1½ inches below the mark when cold. This is 1½ inches lower than the book calls for. A pressure test reveals no leaks and I get no flash of the warning light. What's wrong?—John J. Drumm, Oswego, N. Y.

Nothing. I don't know what book you checked or what mark you're speaking of, John, but the owner's manual for your car says that the coolant level with a cold engine should be about 3 inches below the bottom of the filler neck. You might even be too high.

Foul-up

My 1969 Corvette fouls plugs as fast as I put them in. I'm on my fourth set in 17,000 miles. The dealer can't find the trouble. He just keeps replacing the R44s with the same kind. That's the plug that came with the car. Help!—L. L. Runion, Black Mountain, N. C.

Did you say Black Mountain? I've got a hunch that this is your problem, L.L. The R44 is a normal-heat-range plug for average driving conditions. It's probably too hot for your driving if it is, as I suspect, over hill and dale. I'd switch to an R43 or R42S, which are colder plugs.

Gearing for work

I have a 1969 Jeep Wagoneer with 327-cu.-in engine that has 28,000 miles on it. The dealer says I should replace the fiber-toothed timing gear with a steel one as all fiber gears break on these engines between 30,000 and 35,000 miles. Is this correct?—Philip Subry, Denver.

He's got the right idea, but the wrong facts. Yes, fiber gears are known to break, but why do the job until it's necessary? Your gear may last for 60,000 miles or the life of the car. But if it does break, replace it with an aluminum gear—not steel. A steel gear will give steel-to-steel contact since the timing chain is of steel. This

(Please turn to page 76)

**if you've been
eyeballing
stern drives**

**get the
inside
story**

Before you buy that new boat, look into this:

Of all the stern drives made, only one gives you a choice of nine power packages. 90, 120, 140, 160, 165, 215, 270, 325 and 390 hp.

Only one gives you Power Trim that lets you adjust the angle of your drive with just a push of the button and at any speed.

Only one gives you Jet-Prop exhaust which increases performance while burying noise and fumes.

Only one offers breakerless Thunderbolt ignition which delivers up to 40,000 volts for sure, fast starts and continuing peak performance.

Only one offers matched engines, drive units, props, instrumentation, controls and steering— all engineered to work as a system.

Only one has a network of over 2,000 trained service dealers across North America.

Only one gives you all this and more—MerCruiser. That's why more boats are powered with MerCruiser than all other stern drives combined.

Get the Inside Story from your dealer. He's got a lot to show you.

MERCUISER
STERN DRIVES



Kiekhaefer Mercury, Fond du Lac, Wisconsin; Canada, Ltd.; Australia Pty. Ltd.

AUTOMOBILE CLINIC

(Continued from page 74)

will make one hell of a racket. An aluminum gear in contact with the steel chain won't make noise.

Cougar siesta

My 1969 Cougar is very hard to start when it's hot. The dealer has tried to correct the problem, but has failed. Can you tell me if he's missed something?—Lester P. Walsh, San Diego, Calif.

There has been a problem of this sort with these cars which the company has tried to correct in steps. First of all, if the car is equipped with a 351-cu.-in. V8 engine, have the dealer apply the provisions of Service Letter 41 (8/4/69). He should replace the six-gauge battery cables with four-gauge. If this doesn't work, he should relube the armature shaft at the nose of the starter. Finally, new starters have been issued if all else fails. The new starter for a Cougar (and Montego, which also has the trouble) with automatic transmission is C20Z-11002-B. The one for a car with standard transmission is C5TZ-11002-D.

Brake hang-up

I've had no end of trouble keeping brake shoes on the right front wheel of my 1965 Pontiac. A set of shoes wears out in 10,000 miles, while I get 25,000 miles or so from the other wheels. A mechanic told me to remove the self-adjusting mechanism, but I can't believe this is the cause. Do you agree?—J. Dunbar, Cleveland.

With you—yes. A self-adjuster works or it doesn't, it just won't adjust. It will never overadjust. Your problem, obviously, is a set of shoes that is hanging up. Look for a weak retracting spring or a sticking wheel cylinder.

Exhaust pipe revisited

Having followed your column and having found its accuracy amazing, I felt upon reading your answer to Neil Walton (see Auto Clinic, page 68, Dec. '69 PM) that I must write that you may have oversimplified his problem. International Harvester has been having troubles with the exhaust pipes on its 196-cu.-in. Four since 1967 and the solution might involve as many as five different problems:

1. Manifold flange warpage as mentioned.

2. The pipe from the small Four is being used by mistake.

3. An original-equipment pipe or another brand is being used. There's a new pipe made by IHC to correct the trouble that's available only at IHC dealers. It is aluminized and won't discolor after being run.

4. The installation procedure is critical and the manifold flange bolts must be tight and double-nutted before the tail-pipe is installed.

5. On some Scouts the wrong spring package was installed at the factory. This spring can hit the exhaust pipe, cracking the flange.

If Mr. Walton will contact IHC in Chicago the company will correct the problem—no charge. I know all about this, because IHC put 14 exhaust pipes, two exhaust manifolds and a leaf in the front springs on my 1969 Scout until the problem was cured.—Peter Gilbert, Henniker, N.H.

Thanks for the valuable information, Pete.

Service Tips

● Chevrolet says that some of its 1970 models with the Quadrajet carburetor may have a slow engine idle, because the fast-idle speed was incorrectly adjusted in production. The fix is simply to turn the fast-idle speed screw one full turn to provide an engine speed of 1800 rpm when the fast-idle cam is at the second step position and the engine is hot.

● Ford and Mercury warn that some 1969 models with the 302-2V engine may have been built with a 302-4V mechanical lifter camshaft. If your 302-2V engine has a rough idle that no amount of fixing can correct, tell your dealer to check the shaft—it should be marked "UA." The shaft for the 302-4V carries a "VE-B" or "VE-D" identification, which is located between the last lobe and bearing journal.

● Chrysler says that some early production 1970 Barracudas and Challengers may be leaking water from the airconditioner evaporator housing into the passenger compartment. The cause is a missing bracket that's supposed to stiffen the lower flanges of the housing. The correction is provided by service bulletin 70-24-2. ★ ★ ★

GOT A PROBLEM WITH YOUR CAR? Ask Mort about it. Send your question to Auto Clinic, Popular Mechanics, 224 West 57th St., New York, N.Y. 10019. Letters cannot be answered individually, but problems of general interest will be published in the column.

Get a new riding sensation

Pleasurizers help smooth out an older car's ride. Make driving a pleasure again. The Delco Pleasurizer features a "Genetron® Gas Filled Cushion". . . a GM engineering development that replaces air in the hydraulic reservoir.

Delco's "Genetron Gas Filled Cushion" eliminates aeration and foaming of the fluid as it takes the place of air inside the reservoir. This smooths out the action and the ride.



Low Pressure Multi-Lip seal keeps hydraulic fluid in, dirt out. Assures quiet low-friction action.



Nylon-skirted piston travels freely along the mirror-finished cylinder wall. Eliminates metal-to-metal contact and provides more positive compression.

Super-finished piston rod resists corrosion for long life and smooth operation. Induction-hardened carbon steel for ramrod toughness.

The Delco Pleasurizer — available wherever you see the United Delco Service sign.



MARK OF EXCELLENCE

Delco Pleasurizer

with Genetron Gas Filled Cushion

A 5¢ Bargain right under your nose.

Our full-sized Roi-Tan has such great taste it's the best selling 10¢ cigar. So now we'd like to tell you about a 5¢ bargain that tastes every bit as good.

It's the Roi-Tan Tip. It costs the same as a lot of other tipped cigars, but that's where the similarity ends.

And, we make two other 5¢ cigars, besides. Trumps and Cigarillos and a 4¢ cigar called Golfers. They all have that great Roi-Tan taste. And they all cost a nickel or less.

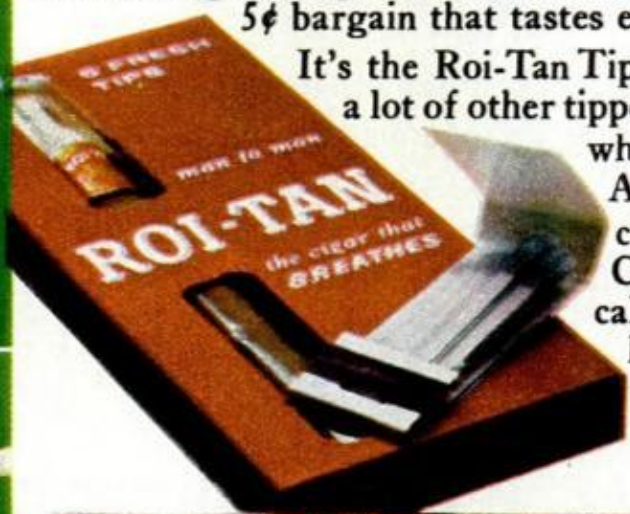

Roi-Tan The Crowd Pleaser.





HE EARNS \$30,000 A YEAR BEHIND THE WHEEL

His 'office' is a \$25,000 tractor. From it last year he handled an \$80,000 business. He's one of a new breed—the 'contract driver.'

By E. D. FALES Jr.

AT 2:00 P.M. THE OTHER DAY, J. A. Selman, a California businessman and flier, put away his golf clubs, spent a few minutes looking at plans for his new \$35,000 hunting lodge in Oregon, then kissed his wife goodbye.

When next he saw his modern hilltop home in Los Angeles he had visited 19 states, enjoyed some scenery that he likes, caught a mess of fish in Florida and earned \$5000—not bad for three weeks driving a truck.

Selman is a new breed of driver, the "contract truckman." He owns his own "tug"—a spick-and-span \$25,000 International trac-



MAYFLOWER VAN 3829, dodging blizzard on Loveland Pass, heads south for Colorado Springs. Selman (below) readies New Jersey shipment for California

tor—and runs 60,000 miles a year hauling household goods for Aero Mayflower. He does very well. His gross income this year will be \$80,000. He splits 52-48 percent with Mayflower, which means he keeps about \$41,600. He must make his own payments for fuel, tires, repairs and taxes, and hire loaders in each city. This leaves him a handsome clear profit: close to \$30,000.

When *PM* assigned me to ride with Selman recently, I wanted to know two things: What's a contract trucker's life like? How do you get such a job? A few other drivers like Selman gross \$60,000 and even \$95,000, among them a retired colonel and an airline pilot. This means clear earnings of about \$20,000-\$32,000.

I joined Selman in the Colorado Rockies as he headed for California with two big shipments: one the furniture of an East Orange, N.J., family bound for Van Nuys; the other belonging to a Wilmington, Del., family moving to San Diego.

It was 10 a.m. Standing in Clear Creek Canyon, I heard the air horn. Then came a sound like a jet climbing out of mile-high Denver, and the yellow Mayflower rig came soaring up out of a tunnel. I flagged it.

Fourteen wheels (tires, \$100 each) and 24,000 pounds of freight came to a grumbling stop. Selman waved down

SUPERVISING LOADING, Selman checks number and condition of cartons. Like ship's captain, he has full responsibility. He hires and pays his helpers



from the sparkling cab. I hiked up the ladder. There was a loud explosion of air and I thought a tire had blown. But it was just Selman releasing the brakes. His hand played over the 13-speed gearshift-and-progressive-splitter lever and we began to roll.

"Hi!" Selman shouted. Full of western friendliness, he reached across the cab and gave me a rock-crusher handshake. The windshield was huge. There were business-like files, a red radio telephone and a dispatch board. Behind green curtains: a roomy bunk and a TV. The cab was quieter than many, although the new smokeless Detroit Diesel under us packed 318 hp. Selman was an agreeable, no-nonsense type; I sensed that he could make quick decisions.

He was about to make one. He frowned at the 13,000-foot peaks. Black clouds swept down, with long white trails. "I hate snow," Selman said. Then, as if to reassure himself, "It isn't supposed to snow up there today."

Selman lifted his phone: "This is Mayflower van 3829 calling Denver." The radio operator patched him by phone to Mayflower's Denver dispatcher at Buhler Transfer Co. "I'd like to get a quick report on the Loveland—and Colorado Springs," said Selman.

The Loveland lay due west. But Colorado Springs was 60 miles south. The dispatcher came back: "A snow-

RADIO-TELEPHONE REPAIR is made by technician at all-night truck stop. Efficient use of the radio has played a big part in increasing Selman's earnings

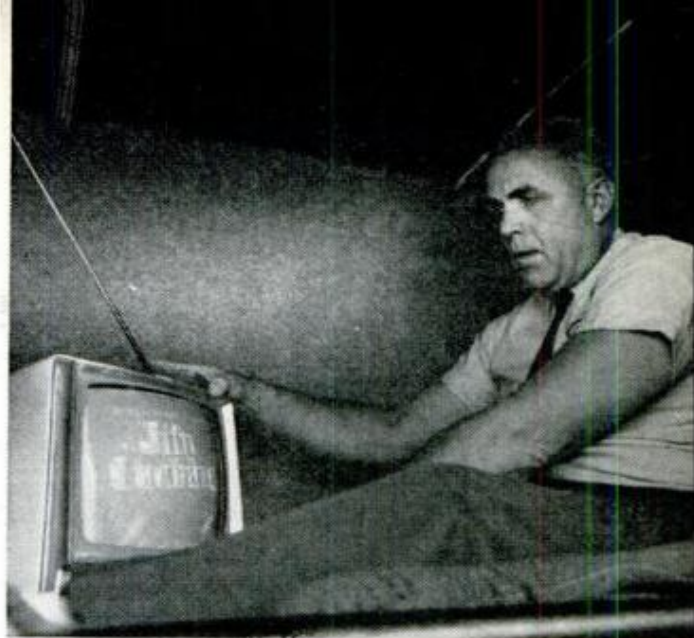

PORTABLE TV in the bunk behind driver's seat in his big tractor helps Selman get to sleep. Cabin bunk saves motel bills and time hunting a truck stop



SELMAN'S HAND ON THE WHEEL is ready on the trailer emergency brake. He has logged 600,000 accident-free miles. Below: The author interviews Selman



storm has just hit the Pass. But Colorado Springs is clear."

"That settles it," Selman said. He swung his 55-foot rig in a U-turn. Then he headed back 30 miles to get on I-25. And away we went on our new course, roaring south toward Colorado Springs and New Mexico.

Selman was trying to go around the storm. I began to see how he makes big money: by thinking ahead—and using that radio to the limit. Our lights showed a clear road. Selman drove like a man who loves the road. "You like the work, don't you?" I said.

"Love it. Nothing like it," he said.

"How did you get to be a contract truckman?"

He downshifted for a grade. "Six years ago I was making \$10,000 commission driving a bakery truck. I saw an ad: Mayflower wanted a driver. They would train me, but I'd have to buy my tractor. I decided to risk it."

Selman knew that some freight drivers were getting \$275 a week mileage pay. But Mayflower had a better idea: he could keep *half the revenue from everything he could haul*, a 50-50 split,

and Mayflower would drum up the business. He learned it costs the average family about \$1500 to move and a van can hold from two to four shipments. He flew to Indianapolis to the Mayflower school.

"When I graduated I invested in my first tractor, a little gas job," he said. (Mayflower assigned him a small van to match.) "You can't make big money that way but after all I was new, and my tractor couldn't pull a big van. I decided to try to work up to a big tractor and some seniority. And I saw I could do a lot more business with a radio telephone."

On his first night Mayflower sent him to Chicago. "I was scared," he said. "My light trailer kept skittering on ice. I *couldn't* have a wreck on my maiden run. That night I learned to hate snow."

But he learned something else. The Chicago load was for Florida. "Two days later," he said, "I drove into balmy sunshine. It was great! I felt wonderful and I'd made \$500. I knew I'd made the right decision."

He didn't get rich that year or the

(Please turn to page 186)

BIG WELCOME HOME by wife Margie Ann at Corona, Calif., makes up for many days Selman spends on the road. Though he often works without weekend breaks, his reward is plenty of accumulated time for fishing



How the Airlines Hope to



BOARDING PASSENGERS pass between poles of gradiometer, unaware that light arrow (arrow) can signal warning

Stop the Hijackers

A magnetized gateway that can detect a gun or knife now screens passengers boarding jet planes. If it doesn't spot a skyjacker, the airlines hope a 'behavioral profile' will

By MORT SCHULTZ/Photos by Irv Dolin

HE FLASHED THE BADGE as I was about to board the Miami-bound Eastern Airlines jet at Washington National Airport.

"Keep your hands where I can see them and come with me," he ordered.

His hand was in his coat pocket. So, undoubtedly, was his gun. I obeyed.

A minute later he identified himself as a member of the Federal Aviation Administration, frisked me, and said:

"That's how the gradiometer works. If you were really a hijacker, you would now be facing a jail term."

It was a game, of course, but I

wanted a first-hand feeling of how airports are now set up to catch hijackers. The instrument referred to is a unique weapons detector that is the heart of the system. Its purpose is to keep people armed with guns and knives off planes.

The gradiometer measures disturbances (or deviations) in the earth's magnetic field. These are created when ferrous-metal objects pass nearby. The increase in magnetic force is recorded on a meter or other signaling device. An airline attendant is thus warned that the passenger who just walked by

HOW THE GRADIOMETER DETECTS WEAPONS

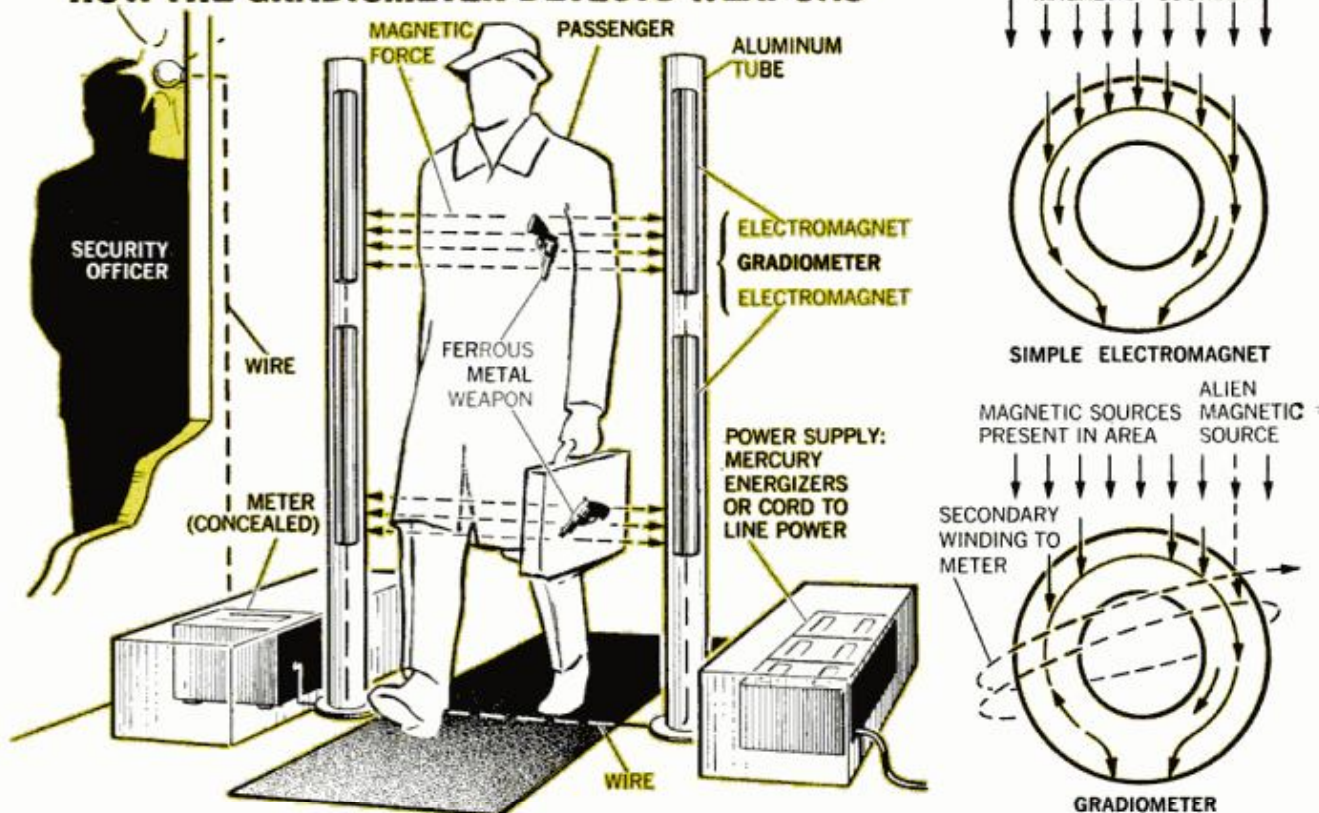

HOW IT WORKS: A simple electromagnet senses a magnetic force in a nonmagnetic environment. Two electromagnets are used in each sensor of gradiometer so magnetic forces in an area (desks, girders) can be accounted for and read-out meter zeroed. When an alien force (dotted arrow) is introduced, gradiometer detects it. Secondary winding measures it to determine if it's equivalent to the force of a potential weapon

may be carrying a concealed weapon.

The gradiometer went into regular use last October following some seven months of testing by FAA engineers to determine the degree of magnetic field disturbance created by weapons of different sizes. Now weapons can be distinguished from other ferrous-metal objects that people often carry on board a plane, such as keys and golf clubs.

The comparatively long test period was used to develop a "behavioral profile" of a typical hijacker. This was needed to assist airline personnel in picking a possible hijacker from a crowd rushing to board an airliner.

This "profile of a hijacker" is based on behavioral traits of known sky pirates. Passengers who exhibit such traits get a careful screening as they pass through the gradiometer's "force field."

The gradiometer is hidden so every boarding passenger must pass it. An ideal location would force them to walk slowly in single file or two abreast.

Unlike X-ray, the gradiometer doesn't "look" beneath garments or into bags. A passive device that emits no energy, it is, in essence, a measuring instrument. It is an outgrowth of the magnetometer, developed more than 50 years ago by the Navy for detecting sea mines. A magnetometer contains an electromagnet, the strength of which depends on how much current is passed through a wire coil surrounding a metal core.

The magnetometer can detect the presence of metal in a nonmetal environment, such as beneath the sea. However, it can't tell the difference between a cigaret lighter and a gun, or keys and a knife—in other words, between an innocent metal object and the weapon a hijacker normally carries.

The gradiometer can make the distinction. Its electromagnets employ a second winding around the metal core capable of picking up and measuring magnetic force in much the same way as a voltmeter measures volts. This

force, shown on a meter, allows an operator to determine if it's equivalent to that given off by a mass of metal the size of a pistol.

Metal emits a force proportional to its mass. Disturbances created by a gun, then, are greater than those created by keys. An operator who sees a reading of, say, 1 to 4 on the gradiometer would know that the passenger who just passed through the "field" was not carrying a gun. However, he'd be suspicious if the reading was 5 to 9.

Naturally, the gradiometer is not foolproof. No one can say for sure that a disturbance is being created by a gun or an innocent object of equal size. However, the airline can ask that the person submit to search, especially if he falls into the pattern of the behavioral profile. If he refuses, as is his right, the airline can refuse him passage, which is its right.

Why has it taken this long to develop the gradiometer? Why wasn't it done some 60 hijackings ago in 1961? Malcolm Schwartz, president of Infinetics, Inc., of Wilmington, Del., says the gradiometer was in existence in 1960, but was too expensive to produce.

"Advancements in the state of the art to allow us to manufacture the electronic circuitry with greater efficiency now permit a reduction in price," Schwartz says.

The man developing the antihijacking program for the FAA is Dr. Homer L. Reighard, deputy air surgeon in the office of aviation medicine. Dr. John T. Dailey, psychologist member of the medical-engineering task force, developed the behavioral profile of a hijacker.

Which airports and airlines are being protected by the gradiometer are classified data. However, Dr. Dailey told me that several FAA teams are now roaming from airport to airport with gradiometers.

"These teams act like traffic cops who are equipped with radar," he says. "A hijacker won't know whether an airport is under surveillance, just as a

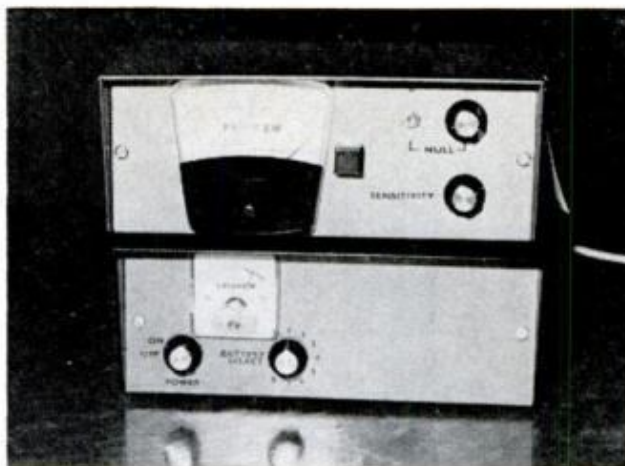

GRADIOMETER PEDESTAL hides power supply (bottom)—eight 6-volt mercury energizers—and meter (top) with null control to zero out any local magnetism

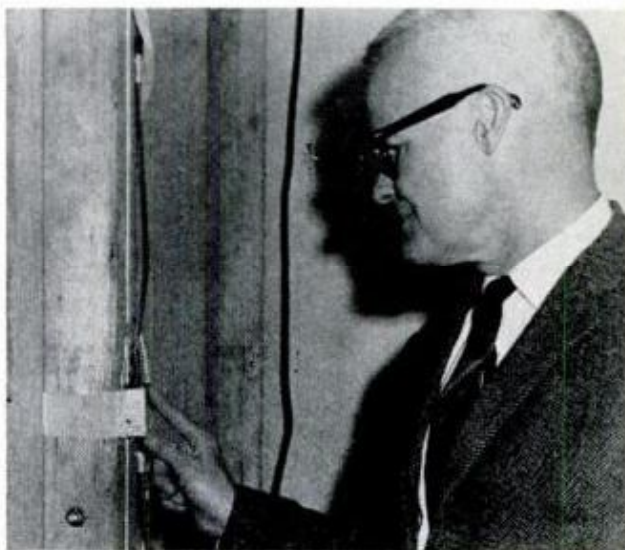

WARNING LIGHT connected to meter flashes if a "hot" reading is registered. It's concealed behind a partition and monitored by a security officer

speeder doesn't know if there's a radar-equipped patrol car behind a clump of bushes. We're hoping that the threat of being caught will deter him."

Another job is to train airline personnel in the use of the gradiometer and familiarize them with the behavioral profile. Screening of flights will eventually be their job.

It's safe to assume that airports the size of JFK in New York, O'Hare in Chicago and Miami International will have gradiometers. Equally certain is that carriers with routes to Florida and the Caribbean will have immediate protection.

"That doesn't mean that other airports and airlines won't eventually be protected," Dr. Reighard says. "In time, we hope that all will." ★ ★ ★

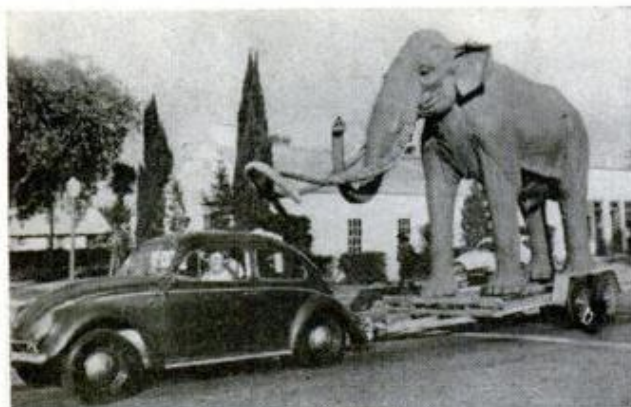

Prehistoric beasts are back again in Los Angeles

Strange animals that, some 40,000 years ago, roamed the area that is now Los Angeles are reappearing in that city's Hancock Park. This time, though, the mastodons, saber-toothed tigers, ground sloths and camels are molded of fiberglass and toted to the site behind a Volkswagen (upper left) by sculptor Howard Ball. The scene at lower left is of the animals in place. At right, Ball makes one of the clay models he uses as a mold for the fiberglass.

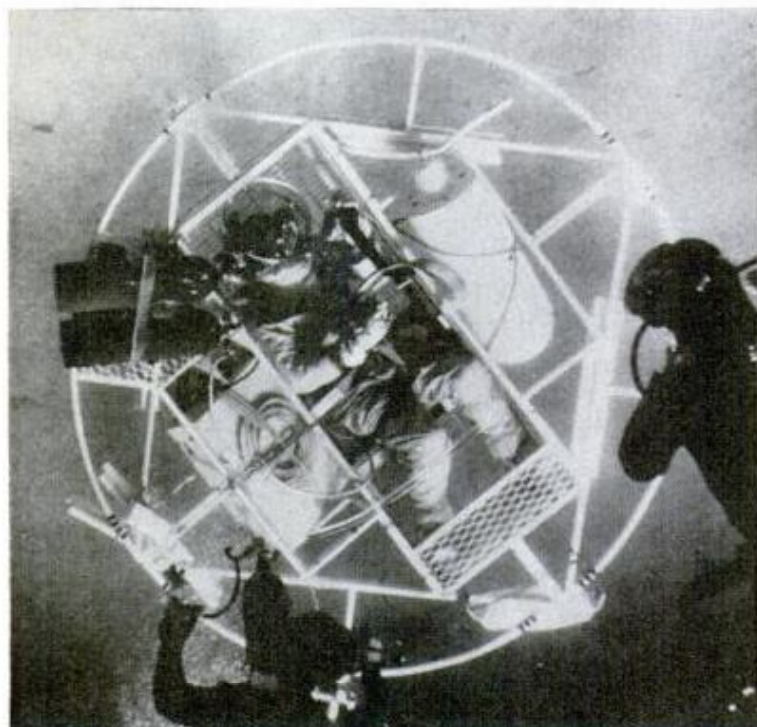

Underwater tests for space 'lifeboat'

Shown in underwater tests is a space rescue system called MOOSE (for Manned Orbital Operations Safety Equipment). If a spacecraft were damaged, the astronaut would climb into a frame (left) and activate foam plastic to form a heat shield (right). Aided by a rocket motor, he'd re-enter the atmosphere and parachute to the earth.



A 'P-38' From Piper?

Well, not exactly. But the Twin Comanche's counterrotating props are the first since World War II's famous fighter. Result: a safer, easier-to-fly small airplane



By **BEN KOCIVAR**

AS THE MAN SAID, the more things change the more they stay the same. Or here we come again around full circle. Historically, and with a propeller idea. All of which is by way of introducing the fact that one of the world's most popular manufacturers of the small twin-engine airplane has reached back to the days of the Wright Brothers and made its two propellers rotate in different directions. It's Piper, and the company is introducing the idea once again in its newest PA-39 Twin Comanche.

I was the first aviation reporter allowed to fly the PA-39 late this winter. I can report that it is as close to being a "feet on the floor" airplane as anything since the original Ercoupe, which had no rudder pedals because the rudder and ailerons were interconnected.

On takeoff and landing, the new Twin Comanche C/R (for counterrotating) rolled straight down the runway as power was applied and reduced.

The only corrections that had to be made were in response to the strong winter gusts that hit the strip.

In the air, I experienced stalls both power-on and power-off. There was lots of warning of the impending stall, and when it happened the plane just gently lowered its nose and recovered level flight with little loss of altitude.

Counterrotation sounds logical, of course. In our well-balanced world, wouldn't you think everything should be symmetrical?

Well, that's not the way it worked out. In the years since the Wright Brothers, plane builders decided it was cheaper and simpler to have all engines turn the same way. It saved on the number of spare parts, made for quicker interchanges and smaller inventories for dealers. But it also created a bit of a problem. The rudder had to be used to correct for the yaw brought on by having both propellers go the same way.

As the Wright Brothers found out,

the fast-moving propeller has a gyroscopic action that tends to hold an airplane on a fixed axis and resists steering. This was why the Wrights used two propellers, turning in different directions to balance each other out. In order to do this, they connected the propeller shaft to the engines with a chain. To make one propeller turn in the opposite direction from the other, its chain was crossed in a figure eight.

Piper's solution is more sophisticated. It involved a few changes in the air-cooled 160-hp Lycoming engine. They reversed the direction of the propeller in the right engine by changing the firing order of its cylinders from 1-3-2-4 to 1-4-2-3. Several engine components had to be modified, and the prop is different, too, with blades pitched the opposite way from the left one.

But more interesting than the engine changes are the aerodynamic reasons for making them.

Possibly one of the most misunderstood and erroneously named factors involving airplane engines and propellers is "torque." Thousands of pilots still think that, because the propeller turns to the right or clockwise, the resulting force in the other direction is

RIGHT ENGINE FAILURE in situation illustrated would cause a slight pull to the right. This holds for both conventional and counterrotating planes

what makes the plane try to turn to the left. This force exists, but is negligible.

The real reason the plane tries to go to the left is the result of side-wash and direct propeller yawing moment. This is commonly known as the "P" effect, and you counteract it by changing the angle of the rudder to maintain directional control. The trouble with this is that it sets up needless air drag. At slow flying speeds, particularly with one engine not operating, this extra drag can slow a plane down to the point where it can no longer climb.

But let's get back to the "P" effect. The side-wash part of this is the swirl or corkscrewing of the propeller slipstream against the fuselage. This swirl, according to Piper, can be compared to a large coil spring. At slow speed and high power setting, such as on takeoff, this "spring" is compressed and the swirls of air are close together. This causes the air to hit the tail surfaces and fuselage at a sharp angle, and

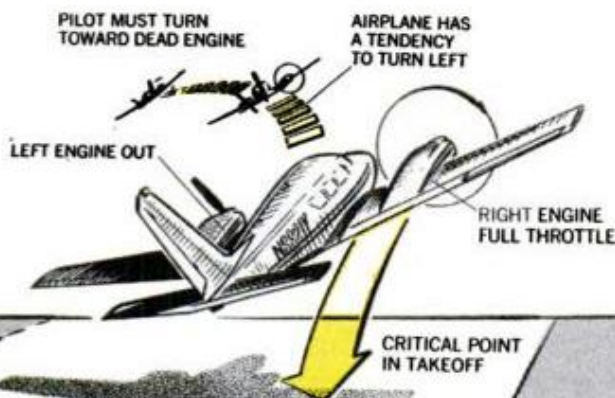

Technical Art by Fred Wolff

LEFT ENGINE THRUST VECTOR LINE INBOARD CLOSE TO FUSELAGE

CONVENTIONAL PROPELLER ROTATION

RIGHT ENGINE THRUST VECTOR OUTBOARD

PIPER TWIN COMANCHE

BOTH ENGINES CREATE SLIPSTREAM IN SAME DIRECTION: TENDS TO MAKE PLANE TURN TO LEFT

PROPELLER WASH

LEFT ENGINE FAILURE ON TAKEOFF WITH CONVENTIONAL PROPELLERS

it takes lots of right rudder to overcome the tendency to turn left.

As airspeed is increased, however, the swirl lengthens like a spring that is stretched. Then the angle at which the side-wash hits the plane surfaces is decreased and it takes less right rudder to correct direction.

But the most significant effect on directional control, according to Piper, is the direct propeller yawing moments. These come from the difference in thrust produced by the blade of the propeller going up while the other blade is going down. The amount of this difference depends on the attitude of the plane, that is, the angle at which it is pointed—called the angle of attack.

When the plane is in a climbing attitude and the nose is pointed up higher than the flight path it makes, the down-going side of the propeller is providing more thrust than the upgoing blade. But when the plane is pointed down

and flying at a reduced angle of attack, the upgoing blade has more thrust.

Thus, if you were to draw a line showing the resulting thrust of both blades of the propeller, the line would not line up with the center of the propeller but with the blade providing more thrust.

On takeoff, when speed is low, the engine is at full throttle and the angle of attack is high, you need lots of right rudder to keep the plane going straight.

During World War II, many single-engine fighters swerved off the runway when power was applied too abruptly or if not enough rudder was applied. One of the hottest fighters, the Lockheed P-38 Lightning, as a matter of fact, was the last twin-engine plane to use counterrotating props to compensate for this.

This effect is noticeable, not only at takeoff and landing, but any time power settings are changed on a plane; the pilot must compensate by slight pressures

(Please turn to page 204)

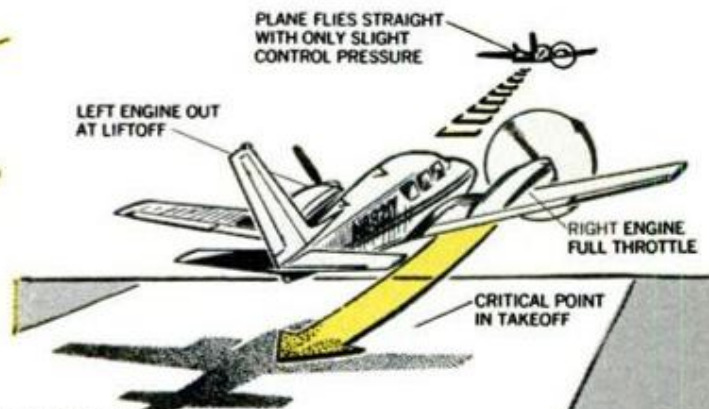
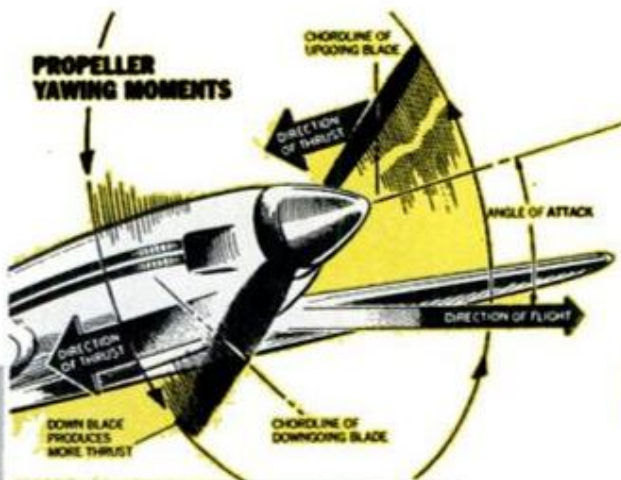

LEFT ENGINE THRUST VECTOR INBOARD CLOSE TO FUSELAGE

COUNTERROTATING PROPELLERS

PIPER TWIN COMANCHE C/R

RIGHT ENGINE THRUST VECTOR INBOARD CLOSE TO FUSELAGE

BOTH ENGINES CREATE SLIPSTREAM THAT IS BALANCED— AIR FLOWS EVENLY OVER FUSELAGE AND TAIL SURFACES

PROPELLER WASH

LEFT ENGINE FAILURE ON TAKEOFF WITH COUNTERROTATING PROPELLERS

Can the Can-Am Kings



McLAREN M15 cools down in pit lane. The boss, in cockpit of this the prototype of three cars entered, talks to Denis Hulme and team manager Ted Mayer. Test laps over 168 mph took place before '69 season was even over! That kind of preparation should make the team a hard one to beat

Blitz the Brickyard?

When the 1970 Indy 500 field roars down the front straight to take the green, it will be streaked with the orange of machines McLaren running to win—just like in the Can-Am

By BILL HARTFORD, Auto Editor

THE RACE REALLY STARTS on May 1. That's when an expected eighty cars can start practice. The Memorial Day spectacle of speed is just the last heat in a month of eliminations at the Indianapolis Motor Speedway. It's a climactic run for the money by the top thirty-three cars and drivers who have already competed—negotiating for the best ride, outwitting mechanical gremlins and running against the clock—to win the honor of starting.

It's impossible at this writing, three months before the gentlemen start their engines, to pick the starters. Late in May of last year, for example, Colin Chapman withdrew his four-wheel-drive Lotus after Andretti went into a wall because a lightweight wheel hub failed in the Hoosier sun. No second chance for 4wd designs this year. The United States Auto Club has turned thumbs down on putting power to all four: A successful design would outclass the field.

The field this year will again see some imported cars—by no means economy models—challenging the famous American marques. Easily able to afford a fuel consumption of two mpg from the turbo-Offy in its new

M15 Indy car will be Bruce McLaren Motor Racing Ltd. The McLaren team is backed by both Goodyear and Reynolds Aluminum, but the real payoff is that they put as much hard work and long hours as money into their racing efforts. It has paid off well. The immaculate preparation of the M8Bs and the driving of McLaren and Hulme have made the Canadian-American Challenge Cup theirs for coffee breaks.

McLaren and Gordon Coppuck designed the semimonocoque M15 as a single-seat version of the Can-Am car. They're powering it with the tried and true 2.6-liter, 650-hp, four-in-line, \$25,000 Offy. The 475-pound powerplant bolts to engine-bearer plates on the rearmost bulkhead that terminates the monocoque—nothing radical in this design. The engine in the test car, or mule, at left is exposed but will be covered for qualifying.

Three cars are scheduled for Indy but as of this writing only two drivers have been named: Denis Hulme and Chris Amon. McLaren himself has indicated that he does not plan to drive. Hulme, with a fourth-place finish in both '67 and '68, is no stranger to Indy.

The 1967 World Driving Champion

DUE



LEONARD

McCLUSKEY

OVERDUE



GURNEY

RUBY

COULD DO



YARBROUGH

AL UNSER

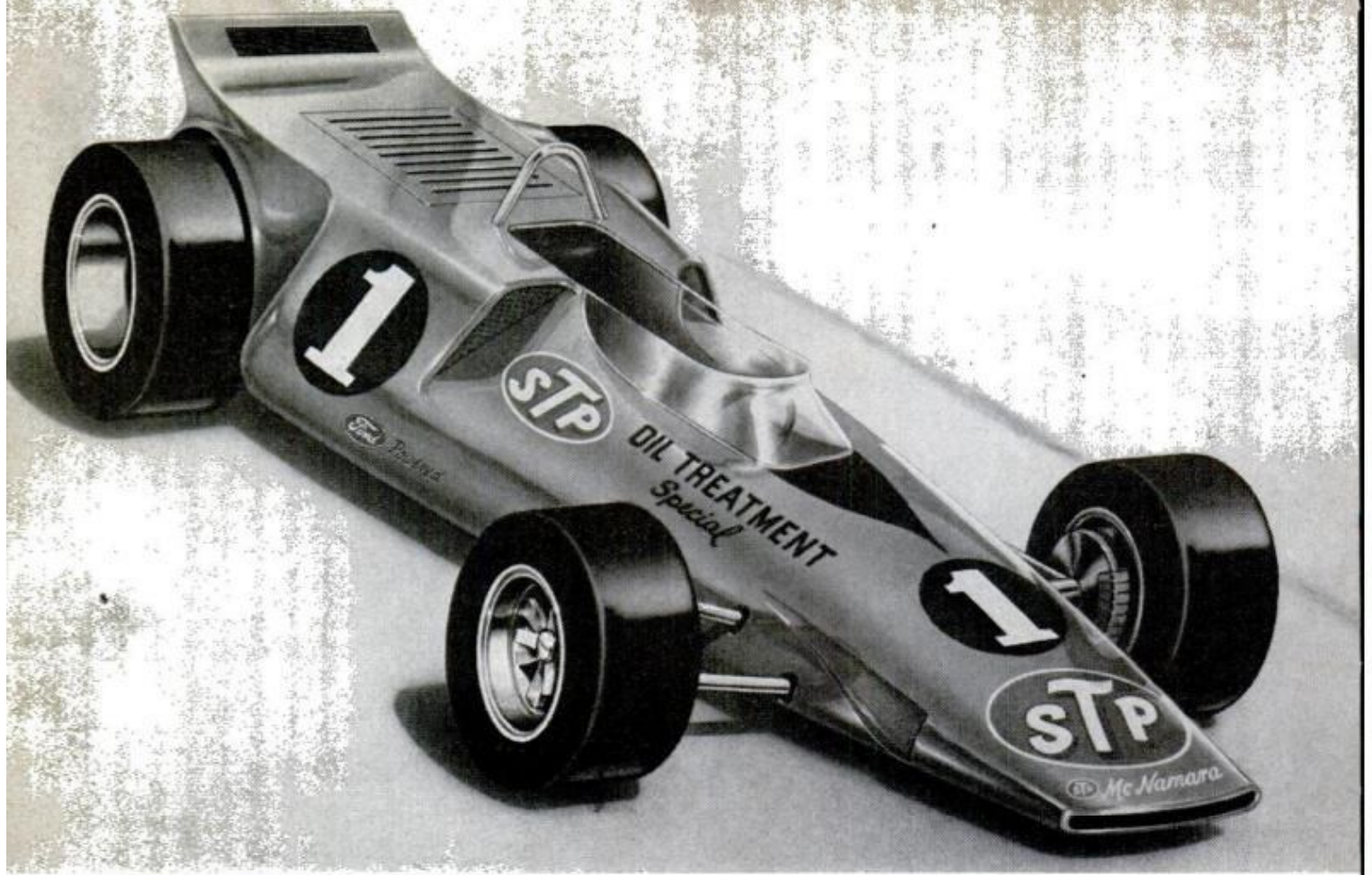

CAR OWNER ANDY GRANATELLI and champion driver Mario Andretti—last year's dynamic duo—are back with a new car. The STP-McNamara T-500, which will be running turbocharged DOHC Ford V8, is built in Germany

was running second to Andretti last year when clutch trouble grounded him with 55 laps to go. Grand Prix driver Amon has never started at the Brickyard but has run enough practice for a good driver to feel and master the humps and ripples of a circuit.

The McLaren team and car is a strong one, but with an historical disadvantage: "New cars rarely win the first time out." This is Andy Granatelli speaking to *PM* not about the McLaren but about his own new car, the STP-

McNamara. Francis McNamara, who has been building Formula Vee, Ford, III and II cars at his factory in Lengries, Germany, contracted four cars for Granatelli's 1970 racing effort: the Indy machine, a "supercar" for the USAC 500-miler at the new Ontario (Calif.) Speedway in September, plus cars for USAC mile oval tracks and road courses, respectively. All but the Ontario car are expected to be at Indy. In addition, last year's winning Brawn-Hawk will be a backup. So far, only Andretti has been signed to drive.

The T-500 Indy car is a two-thirds monocoque chassis with a DOHC, turbocharged Ford V8 supplying the power. Visible in the drawing above is one of the outboard-mounted Airheart ventilated discs that Mario will be riding hard—not so much for stopping, but for more go. The '69 champion is a master at working throttle and binders at the same time for the flying start and then for the four turns per lap—

1970 EAGLE from All American Racers sprouts rear spoiler that's part of chassis and within the rules

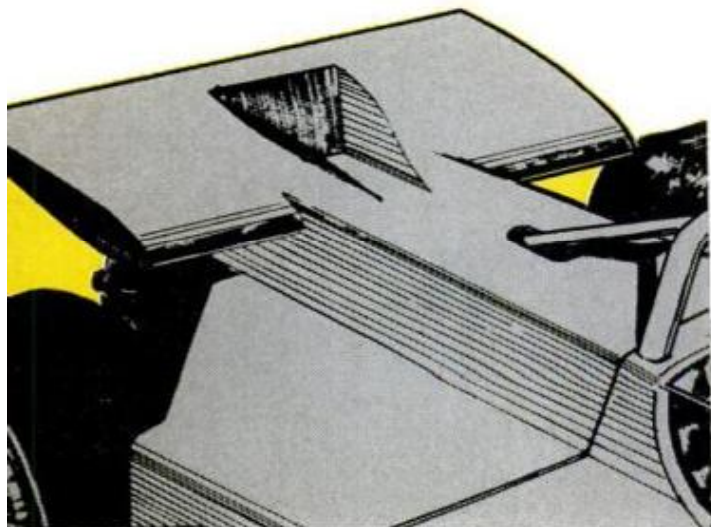

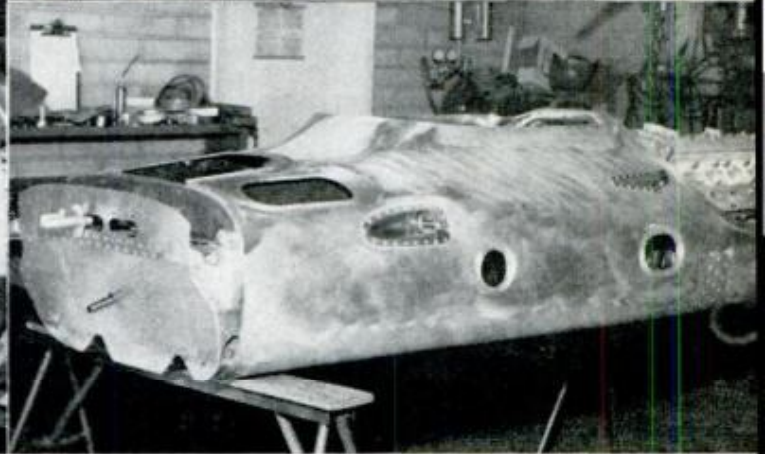
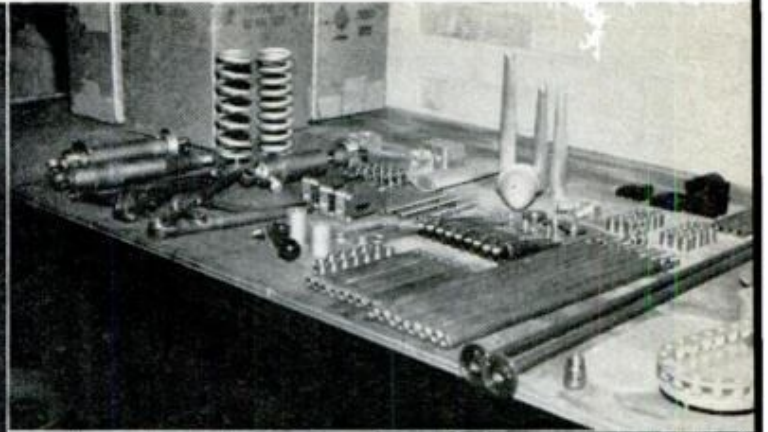

CAR BUILDER CLINT BRAWNER positions steering gear assembled from some of machined parts on workbench. Brawner built the '69 winner, was this far along on new monocoque chassis or "tub" earlier this year

this way he's always got lots of pressure in the turbocharger system for instant acceleration. It's something a driver has to do and do well to overcome the acceleration lag inherent to the turbos.

Granatelli is quick to claim that he has the best driver in the business, but he also knows the competition and, among others, considers Roger McCluskey overdue for the big win. It could well be McCluskey's year: He's got a ride in a car that is little more than a chassis in the photos above, but is now a strong, fast (turbocharged Ford), Clint Brawner and Jim McGee-designed championship car—son of last year's winning wheels. McCluskey, champion of USAC's stock car division in '69, and sprint car champ in '63 and '66, has been driving Indy since '61 with a lot of those mechanical gremlins along for the rides. This year he'll be looking for everything to hold together for all 200 laps.

Last year, as the year before, Dan Gurney placed second in the one race

he'd like to win more than any other. He's been driving his own Eagles since 1965, with 1968 a triumphant year for the machines: Bobby Unser first, Dan second and Denny Hulme fourth.

This year overdue Dan's entry is a new 1970 Eagle powered by a turbo-Offy—an engine he's never run at Indy. The car differs from previous Eagles in details of suspension geometry, fuel capacity and, visibly, in its aerodynamics. Sketched at left is what Dan refers to as a "growth"—a spoiler that beats USAC's no-spoiler-wings regulation by its dimensions and being integral to the engine cover. This is how it appeared on the blueprints earlier this year. Less prominent on the car are aerodynamic "fences"—two folds in the skin that run back from the nose on either side of the chassis to prevent the airstream from spilling off. Wasting no space, AAR has designed them to shroud cooling water lines that run back to the engine. Top view of the monocoque reveals its spear-point

(Please turn to page 201)

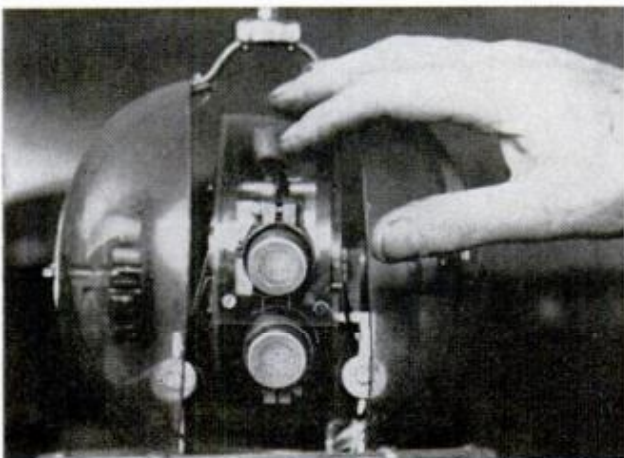
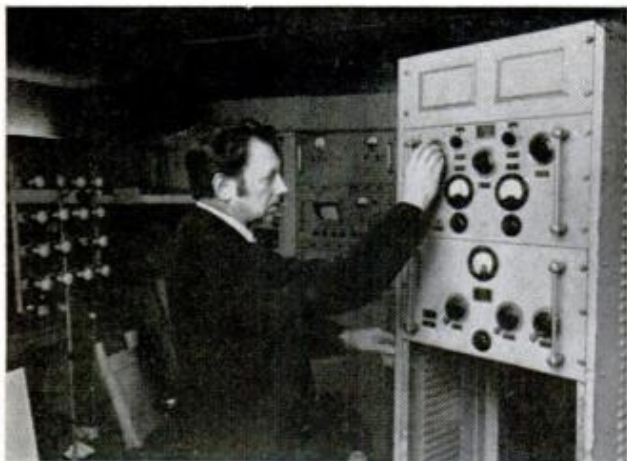

Inventor controls his robots up to two miles away

One of England's most ingenious robot inventors is Dennis Weston of Leeds. His best-known creation is Tinker, a six-foot-tall robot that can be programmed for such tasks as washing a car (upper right). Tinker is activated by some 430 motors and can be controlled up to two miles away via Weston's control panel (upper left). A TV camera in the robot's head even transmits a picture to the operator. In the two lower photos, Weston is shown at work on a new creation, Percy. Electronic sensors in the head (right) receive high-frequency signals that enable Percy to calculate the best route past objects in his path.

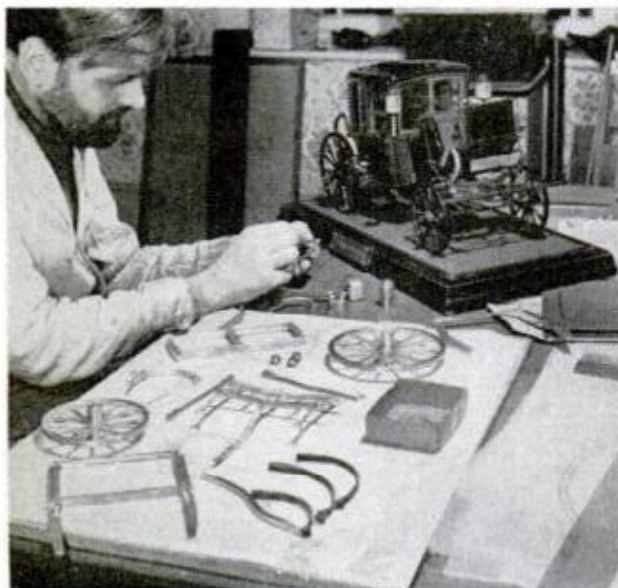

Carriage builder thinks small to make it big

A job of restoring old carriages led Eric Homewood of England to a new vocation of making one-inch-scale models. They sell for about \$1000 each and back orders total \$190,000.



Fast train for Expo

A "21st Century Train" will be shown by Japan National Railways at Expo 70 in Japan. Driven by linear motors over a magnetized rail, it will be designed to travel 300 mph.

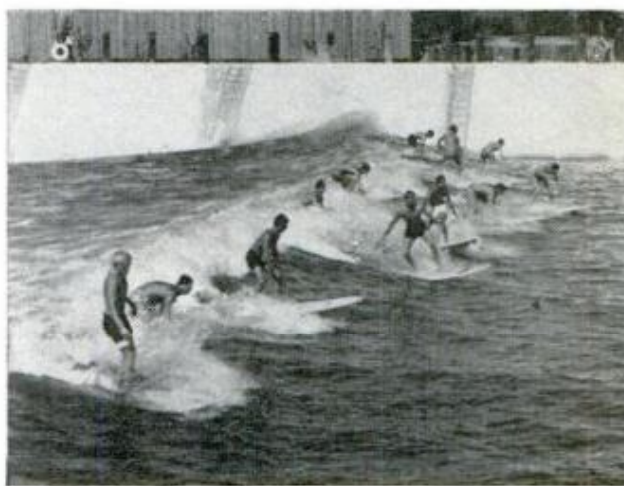

Surf's up in the desert

Every 40 seconds, a five-foot wave carries surfboard riders the 400-foot length of a man-made lagoon at Tempe, Ariz. The waves are created when water, pumped into a huge concrete reservoir, is suddenly released (left-hand photo) through submerged gates.

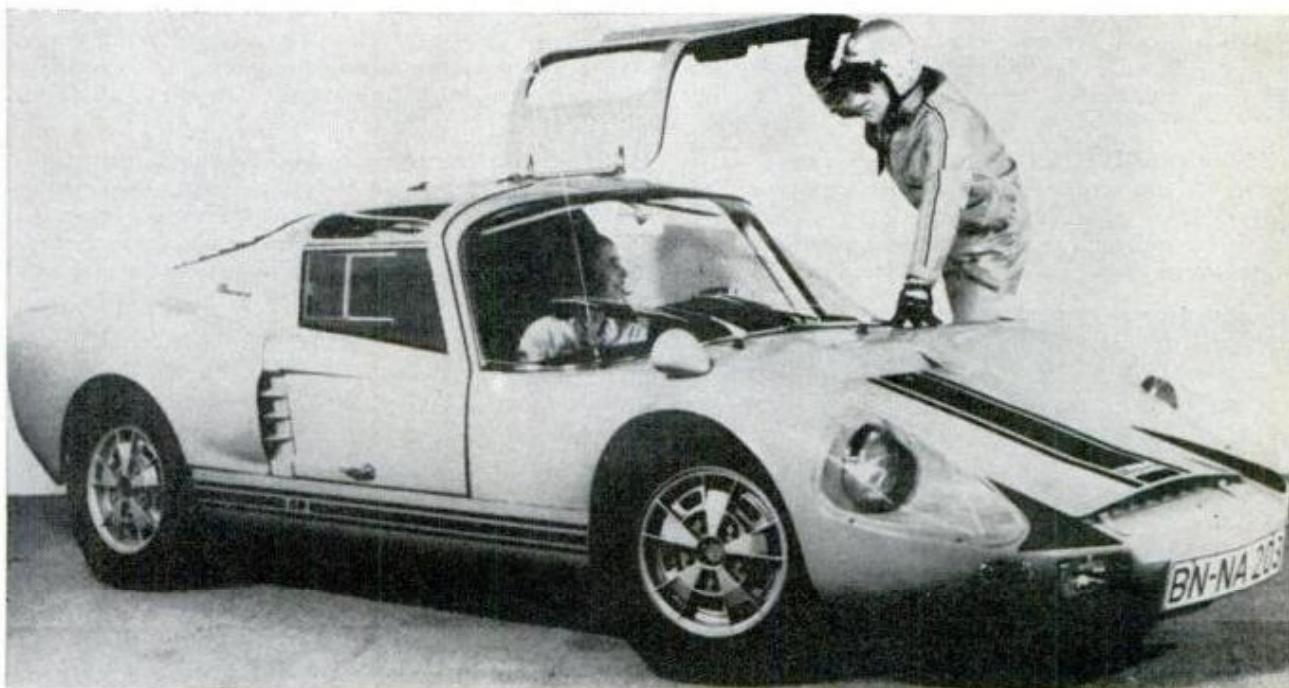

Sleek German sports car gets lots of speed from 75 hp

The low-slung Gepard, shown recently in Germany, will do 125 mph with its 75-hp NSU 1200 engine. The body is formed from the lightweight and tough plastic, Leguval, developed by the Bayer Co.

Just patented

PM'S PICK OF THE NEW INVENTIONS

Prepared in cooperation with Roger S. Shashoua, Director, International Inventors Assn., Inc.

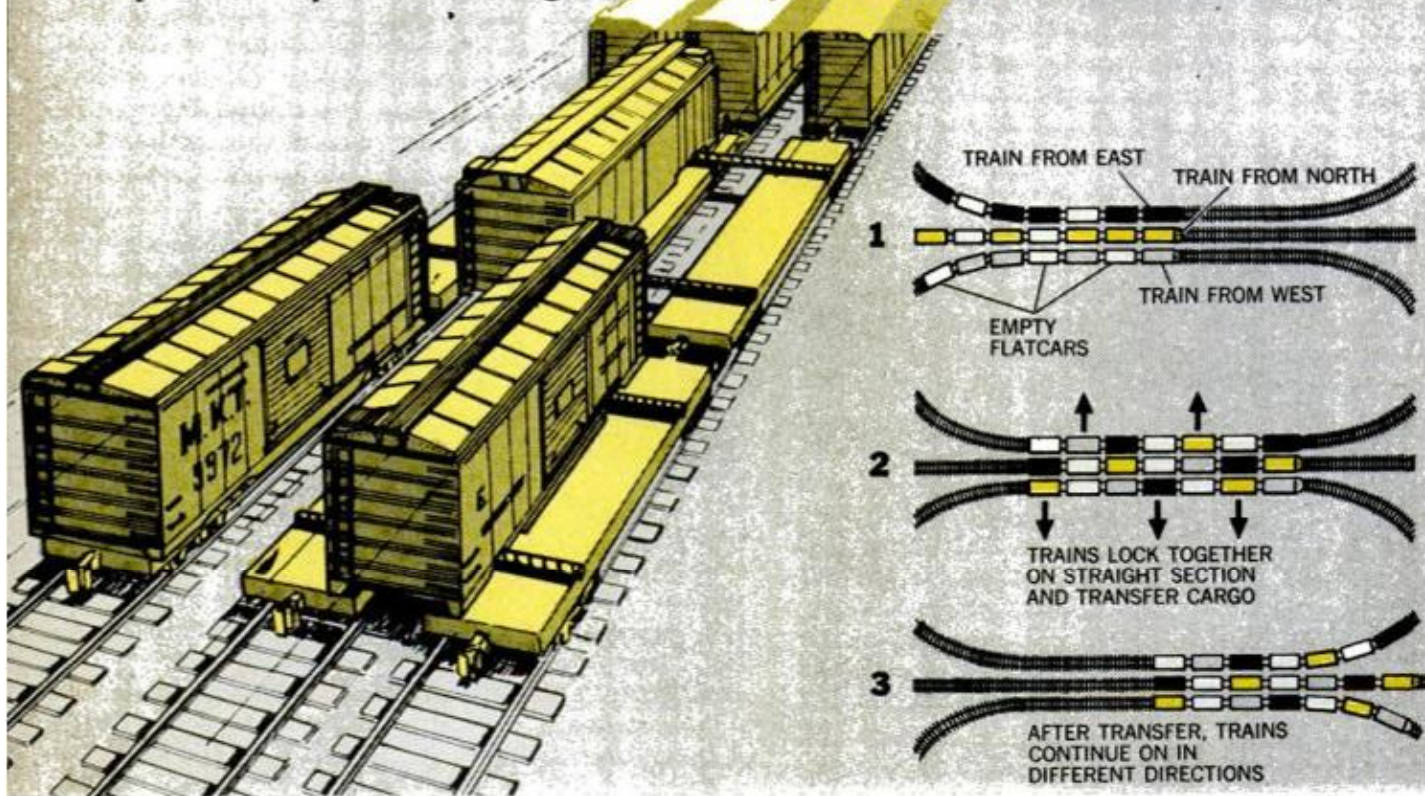

1. TRAINS SWITCH CARGOES without even stopping in this ingenious plan to speed freight handling. The idea is to have trains from different parts of the country come together on parallel tracks. While on this straight section, they are adjusted to the same speed and locked together. Cargo compartments are then transferred from one train to another

across worm-type conveyors extended out from the sides of the cars. At the end of the exchange, the trains swing off in different directions, each carrying only cargo bound for its particular destination. The fast, on-the-run transfer system is designed to eliminate the tedious process of switching the cars around in freight yards to make up trains

2. YOU WOULDN'T FORGET to have your car greased or the oil changed with this handy dashboard reminder. Rows of numbered wheels in windows let you preset mileages at which filter changes and other servicing jobs should be performed. Starting

with the current mileage, you just dial the appropriate number for each future check, then watch your speedometer's mileage counter to see when the number comes up. There's also a place for recording trip mileages so you can remember them easily

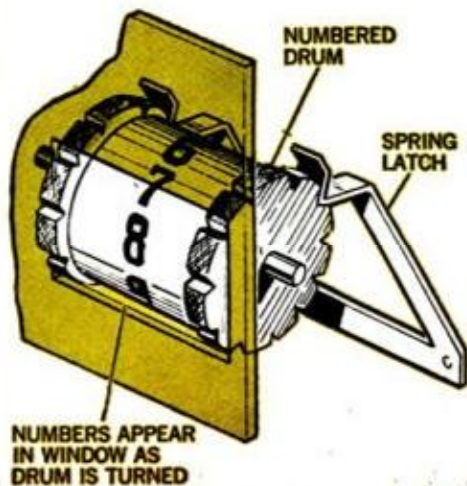

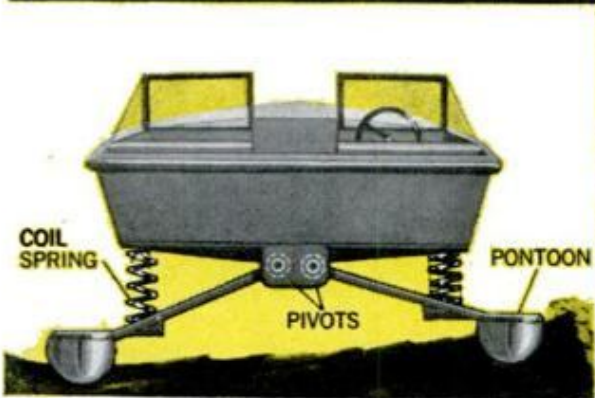

3. KNEE-ACTION SPEEDBOAT skims over waves as smoothly as a car takes bumps in the road. It's supported on four independently sprung pontoon floats that ride up and down to absorb shocks and keep the boat level. Since the hull itself never touches the water, it can maintain high speeds even through rough seas. The system is also intended for stabilizing aircraft carriers, military pontoon bridges, marina docks and various other floating structures that must remain level

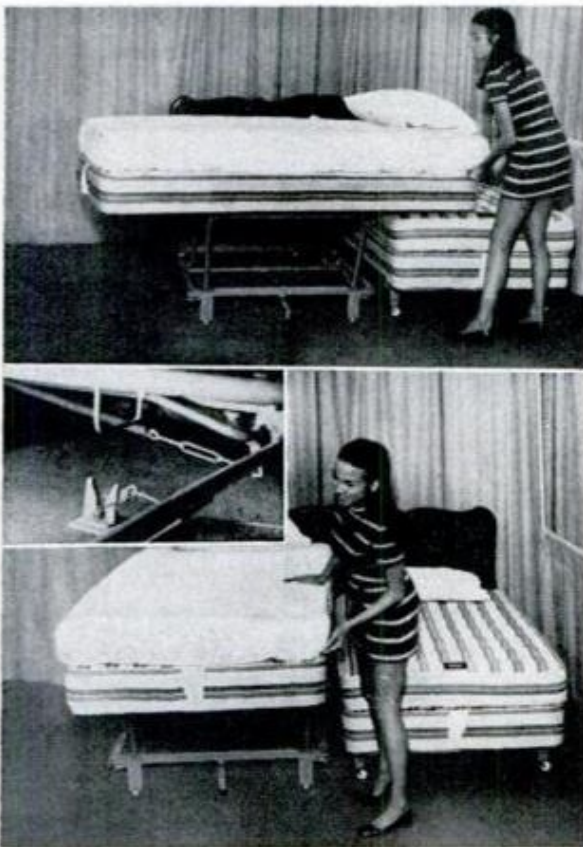

4. REVOLVING BED springs up to waist-level height, then rotates in any direction to ease the job of bedmaking. The mattress rests on a spring-loaded frame held down by a latch underneath (inset photo above). Releasing the latch allows the mattress to pop up, clearing the bed next to it. The mattress can then be turned on a central pivot so that all sides are reached easily from one position without leaning over

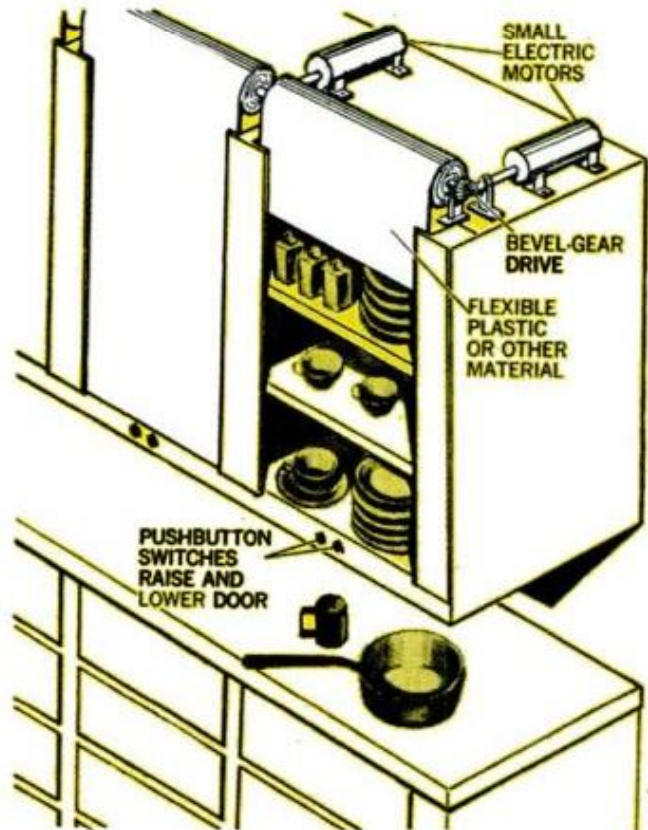

5. YOU CAN'T BUMP YOUR HEAD on these motorized kitchen-cabinet doors. Instead of swinging outward, the flexible panels slide in tracks and roll up like window shades. Each door is powered by a small reversible electric motor at the top of the cabinet. The motor is controlled by two pushbuttons. One button sends the door up and the other brings it down. The motors and roller mechanisms can be hidden from view behind a decorative edging strip along the ceiling

Inventors of the items shown on these pages are as follows: 1. Leonard Schoonman, P.O. Box 8075, Greensboro, N. C.; 2. Russell Forrest Egner, 621 Sheridan St., Chillum, Md. (No. 3,310,025); 3. George Levinson, Brooklyn, N. Y. (No. 2,952,234); 4. Robert Angus Associates, 1835 Vauxhall Rd., Union, N. J.; 5. Samuel S. Otis, 516 Walnut St., Winnetka, Ill. Readers wishing to bring new inventions to the attention of Roger S. Shashoua can reach him at the International Inventors Assn., Inc., 608 Fifth Ave., New York, N. Y. 10019.

THE HUSTLER: A New Breed Of Arkansas Traveler

At last someone has come up with an all-terrain vehicle that really moves in water

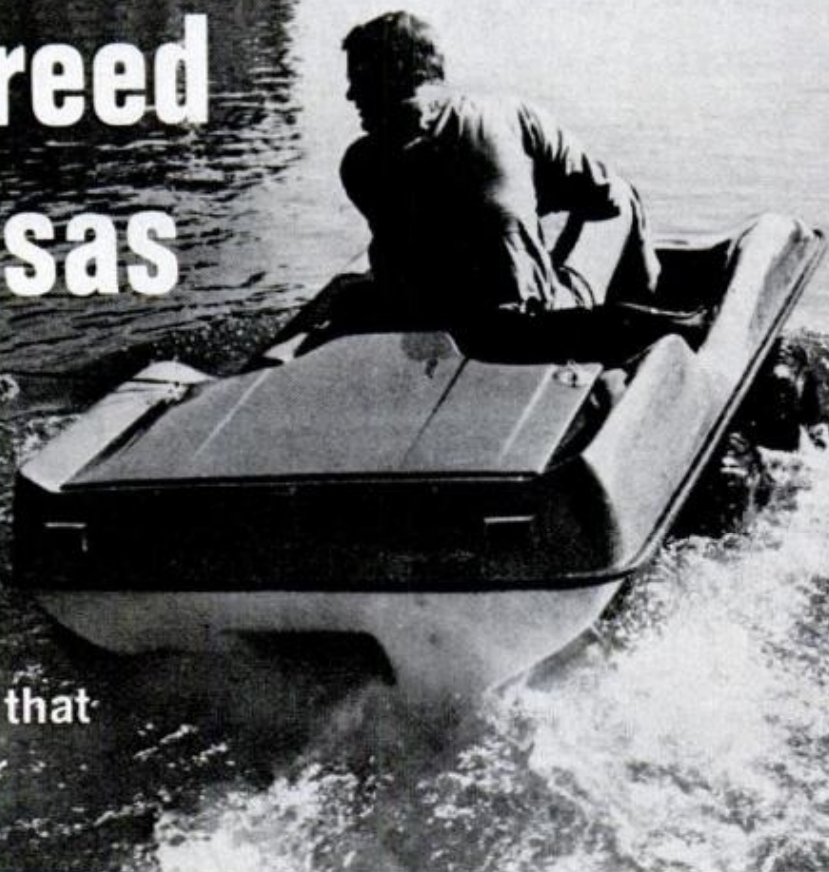

By **GEORGE REIGER**, Boating and Outdoors Editor

Photos by Burton McNeely



WHAT MAKES THE DIFFERENCE is Jacuzzi 8-inch marine jet. Nozzle is in recess between rear tires

FOR TWO AND A HALF DAYS I drove the Hustler through soupy muck and smashed through thick palmetto so high I couldn't see over it, leaped ditches at speeds only a suicidal maniac (or a *PM* tester) would attempt, and raced through water and plowed up 50° embankments at speeds no conventional ATV could take.

After thoroughly wringing out the vehicle on River Ranch Acres in Central Florida, I can list results: one headlight jolted from its socket, a damaged drive belt on the jet pump, some leaking at the midriff seam after long driving in water—and one mighty impressed (and mildly bruised) outdoors editor.

All all-terrain vehicles claim water as one of their elements. But most



STEERING REVERSE enables you to drive off trailer and continue journey when end of road is reached



BALLOON TIRES with 1½ pounds air pressure never suffered a puncture in scrambling over rocks and logs



LEAPS FROM DITCH BANKS soaked driver and sometimes flooded interior, but the engine never quit



IMAGINE TRYING TO RUN this bank from deep water with family car! Note water draining from jet

splash along at two and three mph when their churning wheels are immersed in water. Then one day three boys from Arkansas dropped an eight-inch Jacuzzi marine jet propulsion unit into a fiberglass and steel-frame body with a 20-hp Kohler engine. The result: An ATV that did better than 8 mph in water during our test and might have added another 4 mph had not my man-handling damaged the drive belt.

The jet pump is a \$250 option that's controlled from the front seat. Ride into the water, throw the jackshaft into neutral (lever under the front seat), put the jet pump into gear and—roar—away you go! All controls are hand operated (put your feet where they'll be most comfortable), and water steering is the same as that used on land, though

you may have to lean a little into turns to get your "boat" around corners.

Other features of the Hustler include neoprene motor mounts for easy engine installation and removal (just 10 minutes for takeout!) as well as the best vibration isolation in the industry. A five-inch duct hose takes hot air from the block, and the outside dual power-tuned muffler gives a 15 percent greater hp rating over straight-pipe designs, enabling the 309-cc, two-cycle Kohler to get itself and driver up to 35 mph—in reverse as well as forward!

Roger Hurt, the 25-year-old engineer responsible for so many of the Hustler's features, is especially proud of the quality of workmanship in *his* ATV. There are only two bronze bushings used anywhere in the machine, he pointed out,

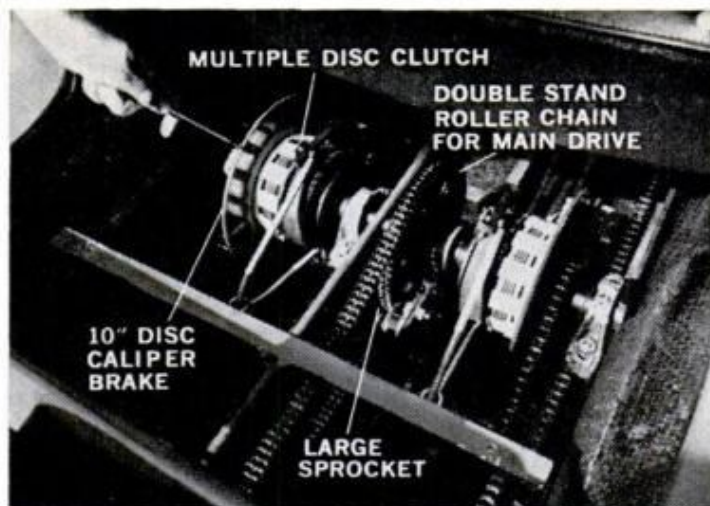
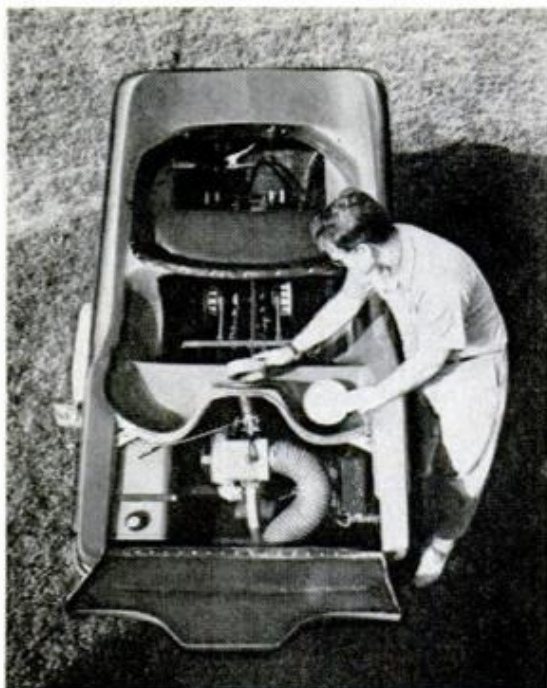

DISC BRAKES are 10-inch caliper type. Adjustable chains run on the largest sprockets possible to avoid slippage

OVERSIZE PAPER AIR FILTER (left) is convenient between two back seats, provides fresh, cool air to carburetor

and they're at two low-pressure points in the steering mechanism. "Elsewhere we use a total of 44 ball, roller and needle bearings," he added.

"We're also the only manufacturer combining a steel frame with a fiberglass hull. Some give you A.B.S. plastic with everything bolted on, but our system not only provides greater damage resistance, but even if you do bust up the body, your frame keeps things in line so you can limp home for repairs."

Another happy feature of this ATV has to do with its origin. Jacuzzi Jet Pumps are made in Little Rock. Not all of the other components come from Arkansas, but at least Roger, his broth-

er, Bill, and partner, Lowell Chrisco, chose 100-percent American parts. Even if you're not moved by this patriotism, it means you should have little difficulty obtaining parts and service.

Sorry I didn't give the Hustler a snow, sand or mountain test, but anyone familiar with Florida's interior (during the wet season) can vouch for the strenuousness of our workout.

The machine weighs 644 pounds and can carry its own weight in gear and passengers. Price with the pump is \$1945. For more information, write Bill Hurt Jr., Hustler Corp., Box 1283, Jonesboro, Ark. 72401. And try to keep all six wheels on the ground! ★★



WITHOUT JET PUMP, Hustler in deep water churns up a mighty froth while I sit and wait for a tailwind

WITH JET UNIT'S THRUST we even make a little wake on our way out for an afternoon's angling along shoreline



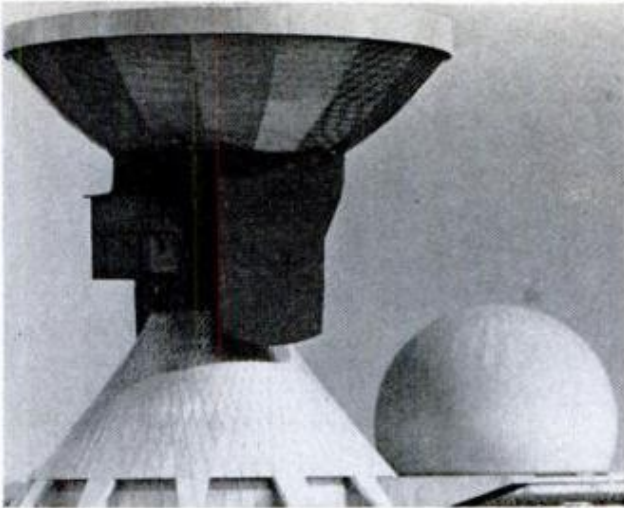

New ear in Bavaria

A new antenna for satellite communications with North America is in operation at Raisting, Bavaria. An earlier antenna (rear) is now used for communications with East Asia.



Big noise in the cornfield

Firing every 2½ minutes, this noisy, but harmless, propane-gas cannon scares birds from test plots of corn. Thus, no grain is lost to birds and yields can be accurately checked.



He steers his car with his feet

Paralyzed in his arms, Nigel Harvey of Ealing, England, steers his car with a foot-operated disc that he turns. He selects gears with his knee, operates a hand brake by shoulder.

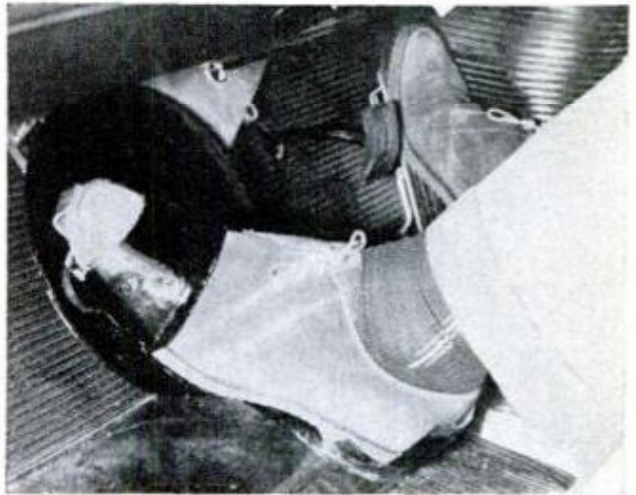

Hovertrailer carries seven tons on air

Seven-ton loads can be carried over rough or soft ground by the Hovertrailer, an air-cushion transporter that gets its lift from fans powered by two 95-hp engines.

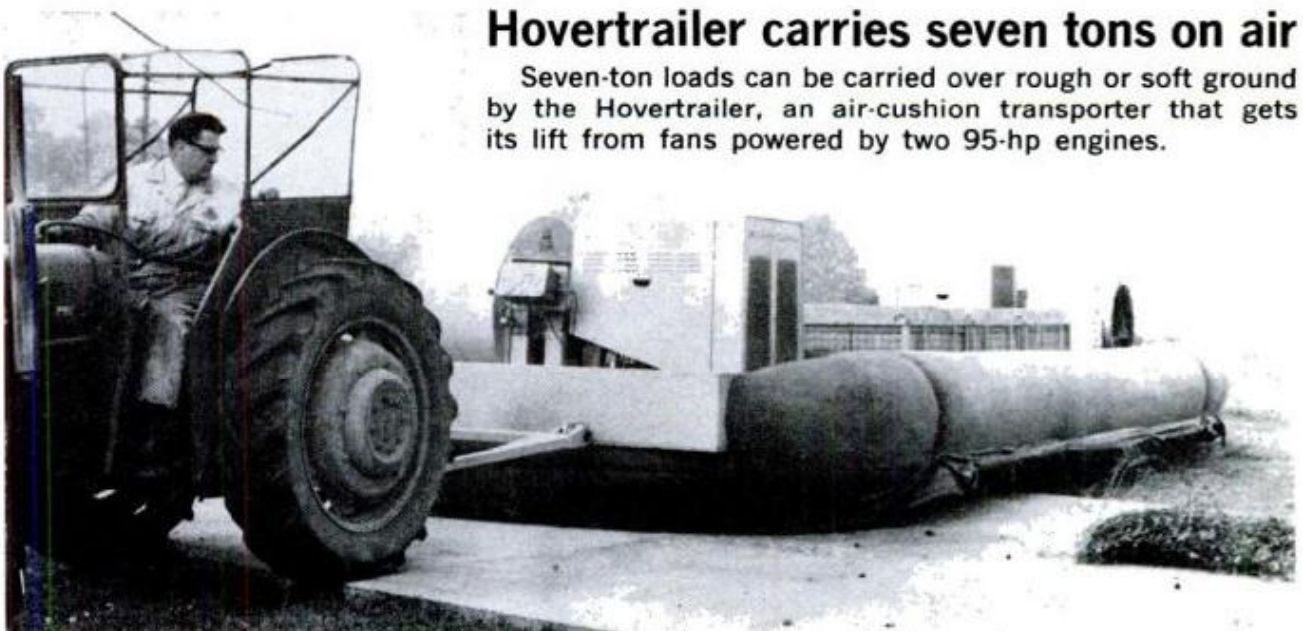



**PM OWNERS REPORT
PLYMOUTH BARRACUDA**

A Nationwide Survey Based on
1,052,499 Owner-Driven Miles

Sizzling and Sexy, but Too Much Concession To Styling

By **MICHAEL LAMM**
West Coast Auto Editor

Photos by Irv Dolin

STYLING SOLD most buyers on the Barracuda initially, but now that they've had a chance to live with it, styling is what they grumble about most.

The long-snout, bobbed-tail treatment might look bosso, baby, but it sure cuts into interior space. Several owners in our survey aren't too happy with front legroom; absolutely no one raved about the rear. There's two inches less front legroom in the '70 Barracuda than in the '69, and rear-seat abbreviation has several owners spontaneously suggesting Barracuda be made a two-passenger car so there'd at least be some trunk.

Well, no pony car has much trunk, but the 'Cuda seems to take it one step beyond by planting the spare tire dead center in what little room is left. Here are a few random owner comments: "Trunk? What trunk?"—New York teacher. "Won't hold golf clubs."—California chemist. "I'd like more back seat, seeing as how they forgot the trunk. How about going back to the fastback with

'CUDA'S STYLING spurred most sales; later, owners cry out for more trunk and legroom, less tuck-under





SEAT BELTS retract cleverly through slots by hinge arms, can't catch in door or between seat sections



DARN LITTLE space in rear seat and 2 in. less up front than in '69, yet drivers rate comfort high

its lay-down rear seat?"—Texas salesman. Or "Move tire from middle to wheel well." Easily said. An optional collapsible spare costs only \$13, but what salesman will tell you it's available?

Which brings up another common complaint: door pox—dings, the parking-lot disease. "Dings?" writes a California lab tech, "Need some? I got 'em." And an Illinois bookkeeper says: "Need chrome down sides to avoid parking nicks." Here again, a good salesman could have saved these people a lot of grief by suggesting the optional vinyl belt molding strips. These are standard on Gran Coupes and 'Cudas, cost \$14 more on Barracuda models.

A more minor styling irk came from the radical tuck-under of the lower body edges. This causes the body to get dirty more quickly, and small stones chip paint near wheel wells.

Generally, though, owners like their Barracuda's looks more than a little. "Real eyeball appeal."—Louisville engineer. "It's only 186 inches long and very sporting."—Brooklyn lawyer. "I got tired of Ford's better idea," says a department store manager. An Indiana wholesaler took his teen-agers' advice: "Have girl 18 and boy 16 who dig the body style. Now so do I." The Barracuda draws from the young. In our sample, 55.2 percent are 20-29 years old.

In the go department, nothing but

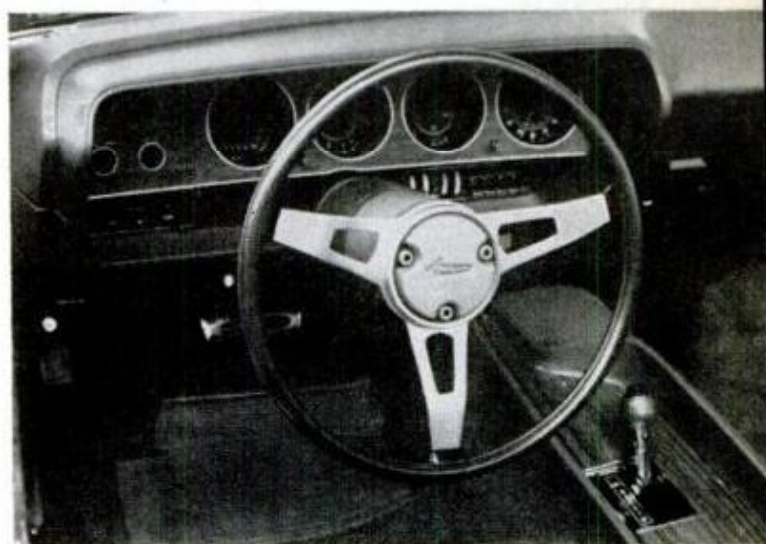

BARRACUDA shares dash with Dodge Challenger. Radio hides at steering column, heater controls at left



NO TRUNK, moan most owners—a situation not aided by spare being mid-mounted. Lip stands very high

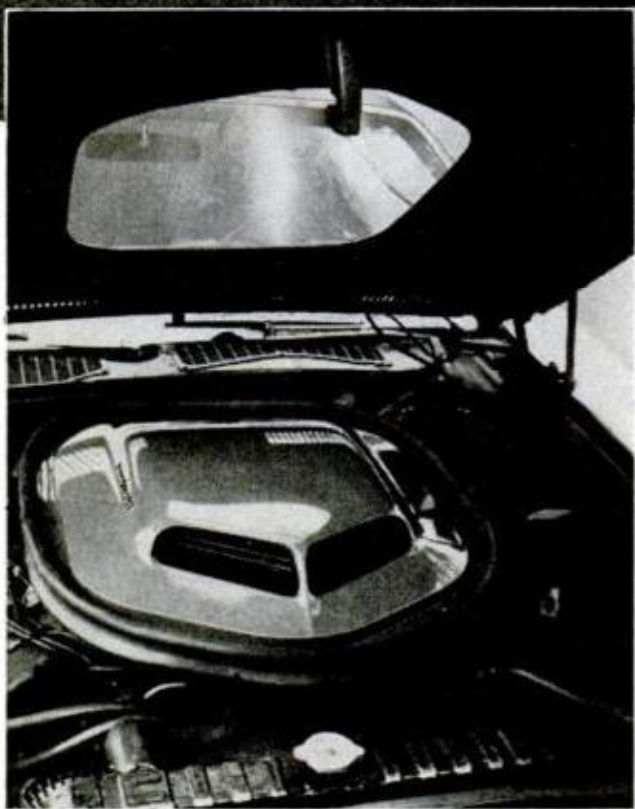

SUPERLONG SNOOT houses \$98 Shaker air cleaner on 440 6-bbl. V8. One owner says it merely serves as excuse for poor idle adjustment. Shaker picks up cooler outside air so oxygen-richer charge reaches cylinders, giving milliseconds better acceleration

rhapsodizing. "Poor man's Corvette," says one Kentuckian. Michigan business exec: "Fantastic pickup and go." The owner of a 440 six-barrel: "Very good acceleration in quarter mile," but then he wrings his hands about gas mileage. A Michigan beauty operator purrs, "When I step on it, it moves." She's talking about the 340 four-barrel V8, an optional, very good engine Chrysler tends to sweep under the rug.

As for handling, a Staten Island draftsman notes, "Being a previous Corvair owner, I find handling surprisingly good. Cornering without body lean is excellent." Says a Minnesota gymnast, "It reacts!" A Nebraska trailer manufacturer adds, "Handles well without power steering or power brakes."

Most Barracuda owners feel their cars are put together well enough, with only 16 percent fingering bad workmanship specifically. Of these, predominant complaints center on rattles (big windows, especially), leaks (windshield, rear glass, trunk), engine not starting because trans selector won't close the switch in Park, and window alignment. On the more serious side, one owner

BARRACUDA FUEL MILEAGE CHART
318-cu.-in. V8

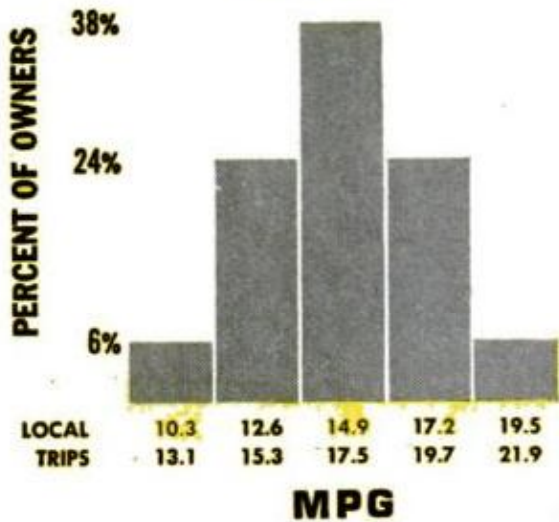

Summary of 1970 Barracuda Owners Reports*

Total miles driven.....1,052,499

Average miles per gallon:

225-cu.-in. 6, local driving	17.0
long trips	19.8
318-cu.-in. V8, local driving	14.9
long trips	17.5
340-cu.-in. V8, local driving	12.3
long trips	14.8
383-cu.-in. V8, local driving	11.4
long trips	14.6
426-cu.-in. V8	n.a.
440-cu.-in. V8, local driving	8.7
long trips	n.a.

Engines:

225-cu.-in. 6	14.8%
318-cu.-in. V8	53.1
340-cu.-in. V8	5.9
383-cu.-in. V8	20.7
426-cu.-in. V8	1.5
440-cu.-in. V8	4.1

Transmissions:

Automatic	73.7%
4-speed manual	13.5
3-speed manual	12.8

Why the Barracuda?

Style	70.2%
Past experience	11.7
Size	10.6
Performance	9.1
Economy	6.8
Price	5.7
Handling	5.7

Specific likes:

Styling	64.9%
Handling	49.4
Performance	22.4
Comfort	20.1
Economy	17.0

Power	13.5
Ride	12.7

Specific dislikes:

Trunk space	23.8%
Workmanship	16.1
Wind noise	11.9
Rattles	10.3
Rear legroom	10.0
Dealer service	8.9
Fuel economy	5.8

What changes would you like?

Transmission	19.0%
Workmanship	13.5
Legroom	13.1
Rear vision	10.1
Seat style	9.3
Quality of materials	5.5

Had any mechanical troubles?

Yes	43.5%
No	56.5

What kind of trouble?

Carburetor	12.2%
Transmission	11.3
Windshield wipers	9.6
Electrical	8.7
Brakes	7.8
Power-steering leak	7.0
Cold starting	6.1

Did you repair it yourself?

Yes	7.3%
No	92.7

Dealer repairs satisfactory?

Yes	69.9%
No	30.1

Is the Barracuda your only car?

Yes	43.9%
No	56.1

Other cars owned:

Plymouth	39.9%
Chevrolet	22.4
Chrysler	18.4
Dodge	11.2
Oldsmobile	8.6
Volkswagen	7.2
Barracuda	6.6
Ford	6.6
Valiant	6.6
Pontiac	6.6

Power options/accessories:

No power options	26.4%
Automatic transmission	73.7
Power steering	45.7
Radio	45.6
Power brakes	27.9
Airconditioning	21.0
Console	17.9
Vinyl top	17.9
Light group	14.7
Stereo tape	13.1
Whitewall tires	11.1

What options/accessories would you order next time?

The same	55.7%
Airconditioning	9.4
Rear defroster	9.0
Power steering	8.6
Stereo tape	6.7
Power brakes	5.5

Age distribution of owners:

15-29 years	61.9%
30-49 years	24.2
50-plus	13.9

Would you buy another Barracuda?

Yes	65.9%
No	34.1

*Percentages may not equal 100% due to rounding and/or insufficient data.

had an engine burn up at 1100 miles, but the dealer replaced it without question. One woman reports the factory left off a front shock absorber.

In the area of misengineering, here's another quick rundown: "Heater controls on wrong (left) side, unlighted." "High front seatbacks block vision." "Please put vents back in windows!" "Tach scale all wrong." "Car too low for our area—won't clear snowbanks."

There were a few complaints, too, about materials. "More metal and less plastic," pleaded a number of owners. However, those who paid the \$82-\$137 extra for Elastomeric bumpers said they were glad they did.

Owner/dealer relations run hot and cold, as always. Fair numbers said they had long waits for parts. Typically, "Parts not available. Dealer service poor, doesn't seem to care, only interested in selling new cars." But on the other side, "When I do have trouble, I take mine to my dealer. His work is al-

ways satisfactory." Or, "My transmission went out. Warranty covered everything. No complaints."

Summing up, these words from a Massachusetts modelmaker who's owned 12 Plymouths since 1945: "Was sold on looks, expected durability and performance, got all these and more. My next car will be another Plymouth product." ★★★



HANDLING RANKS second as reason for buying. Hard cornering makes driver press power-window buttons

The Biggest Little Cameras

Ultraminiature cameras, once a curiosity, are now loaded with almost as many convenience features as their bigger brothers. Here's a look at what these versatile, pocket-sized performers can do and how to shop for one

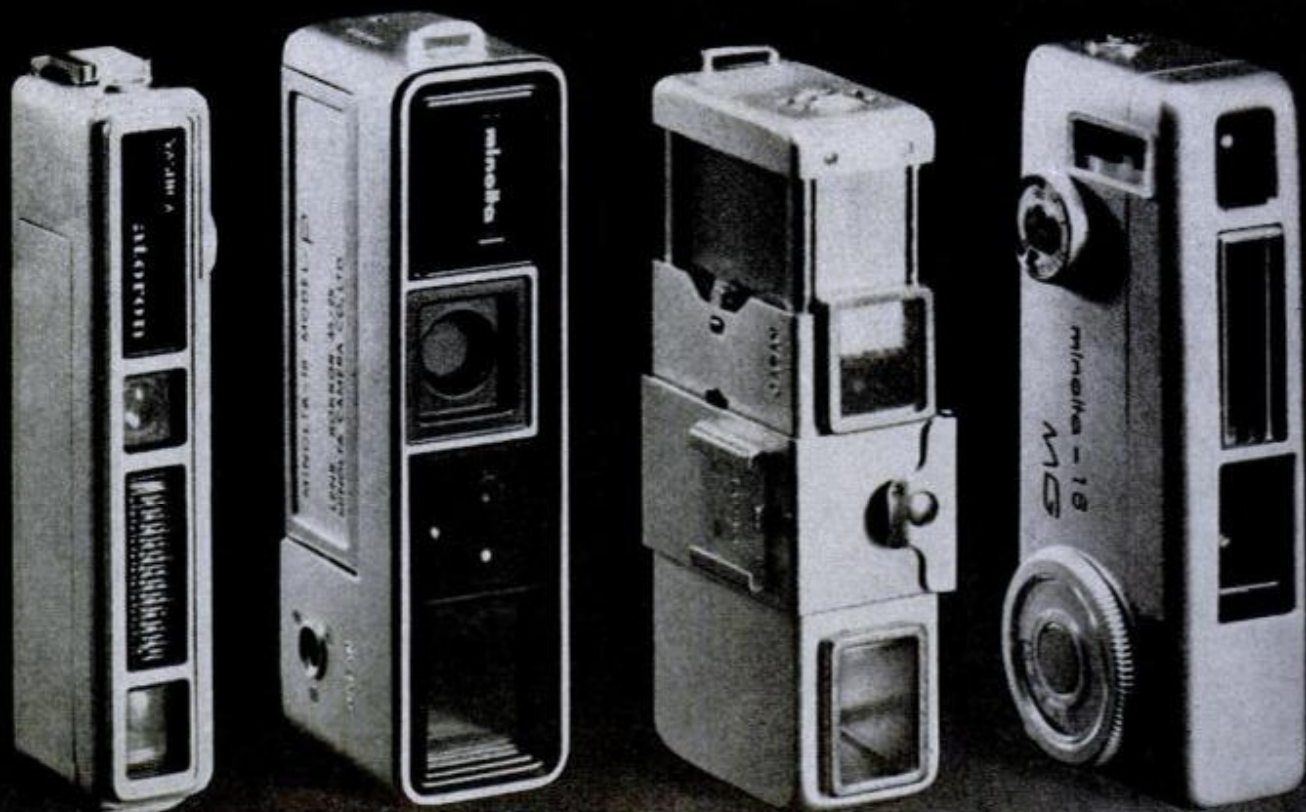

YASHICA ATORON
\$110

MINOLTA 16 PS
\$29.95

MINOLTA 16 II
\$39.95

MINOLTA 16 MG
\$79.50

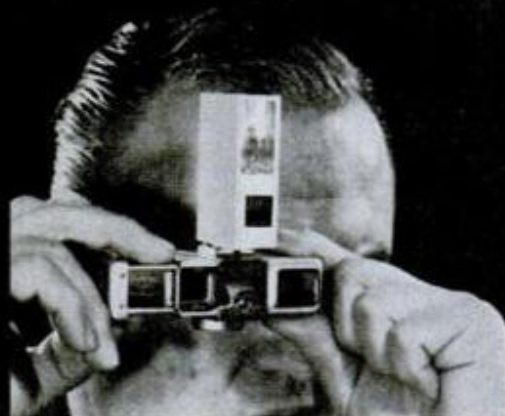

HANDY CLIP-ON FLASHGUNS are now available for all mini-cameras. This battery-powered Minolta gun takes tiny AG-1 flashbulbs

MINI-CAMERAS are growing bigger every day—not in size but in the features they offer and the jobs they'll do. Physically, they're still slim, watch-like jewels half the size of a pack of cigarets—a whole photographic system small enough to slip into a shirt pocket.

Over the years, these finely crafted mechanical marvels have been refined and advanced to the point where there's practically nothing big cameras do that an ultraminiature can't do almost as well. Several models now have built-in automatic exposure controls. All offer accessory flash units for photography in poor light and at night. At least one, the new

Minox, even gives you high-speed electronic flash.

Ultraminiatures have also grown in number. In addition to the original Minox, first of the pocket cameras, there are now five other mini-models on the market. Rollei, famous for its long-popular twin-lens reflex, has introduced a tiny new Rollei 16S. Yashica, a maker of 35-mm cameras, has added an ultra-

in the World

By BURT MURPHY

PHOTOGRAPHY

Photos by Robert D. Borst



MINOX C
\$199.50

ROLLEI 16S
\$199.50

PUSH



PULL



CLICK



LATEST MINOX, the Model C, has the familiar telescoping body featured on earlier models. The two halves slide apart to reveal the lens in the center. A quick push-pull of the mechanism advances the film and cocks the shutter for the next picture, permitting rapid-fire shooting. Newest feature to be added is high-speed electronic flash

miniature called the Atoron. Minolta offers a choice of three different models, the 16 II, the 16 PS and the 16 MG. Prices range from a modest \$29.95 for the least expensive Minolta, the 16 PS, up to \$199.50 for the latest Minox, the Model C.

Mini-cameras do have their limitations and aren't designed to replace other photographic equipment completely. They're more like having a second car just for fun—a flashy two-seater sports model in addition to the family sedan. You can slip one in a pocket and carry it wherever you go without packing along a lot of bulky gear. A mini is handy to have on trips and outings where photography is not the main objective, but where you might want to take some spur-of-the-moment snapshots. It can be inconspicuous in situations where you don't want to make your picture-taking obvious. It can also be helpful in business for recording documents, displays, construction progress at building sites, accident damage and so forth. With the aid of automatic exposure controls and supplementary flash, you can shoot under almost any photographic condition without having to stop and figure out complicated adjustments.

Two different film sizes are used in the minis. The Minox C and Yashica Atoron take 8-mm film, similar to 8-mm movie stock. The Rollei 16S and the three Minoltas have adopted the larger 16-mm format. There are advantages and disadvantages on both sides. The 8-mm models are noticeably slimmer, lighter and hand-

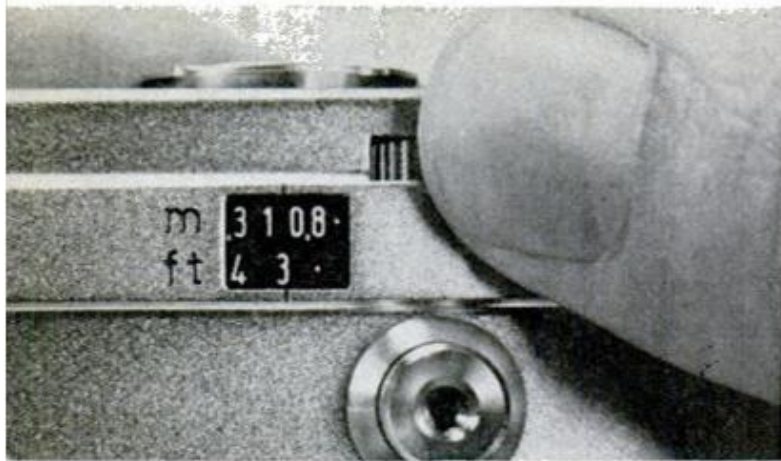

TURNING A THUMB KNOB on the Rollei 16 above focuses the lens and simultaneously shows distance on a scale in a small window. Button below and to right of the scale is the shutter release. Photo at right shows miniature battery in the Minox C that powers the automatic exposure system. Battery lasts about a year, is easily reached by sliding out the camera's end cap



ier if you're concerned with size alone. On the other hand, the 16-mm models, while somewhat bulkier, have an edge in increased image size, theoretically making sharp prints easier to produce.

Neither the 8-mm nor 16-mm film size, however, is designed to provide jumbo enlargements. They yield small, wallet-size prints of acceptable snapshot quality, and these are what you usually get back from the processor. Somewhat larger prints, up to about 3½x5 inches, are available on special

order in some cases. Bigger blowups from the tiny negatives are possible, but they require high-quality custom processing and must usually be made in a two or three-step operation involving intermediate copy negatives.

Most mini-camera makers supply their own film and processing. In general, a processing envelope comes with the film when you buy it and you use this to return the exposed roll for developing and printing. Several types of color and black-and-white films are

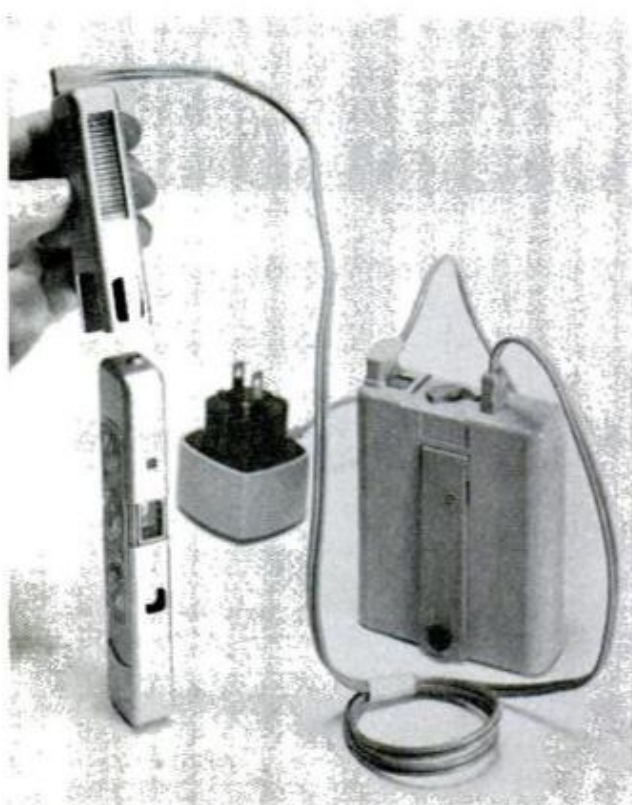

NEW ELECTRONIC FLASH, just introduced for the Minox C at left, slips onto the camera, automatically making contact with the flash-trip mechanism. Flash is powered by a pocket-sized battery pack that can be recharged from an a.c. outlet. Below, a tiny crank on the Rollei 16 rewinds exposed film back into the supply container so it can be removed



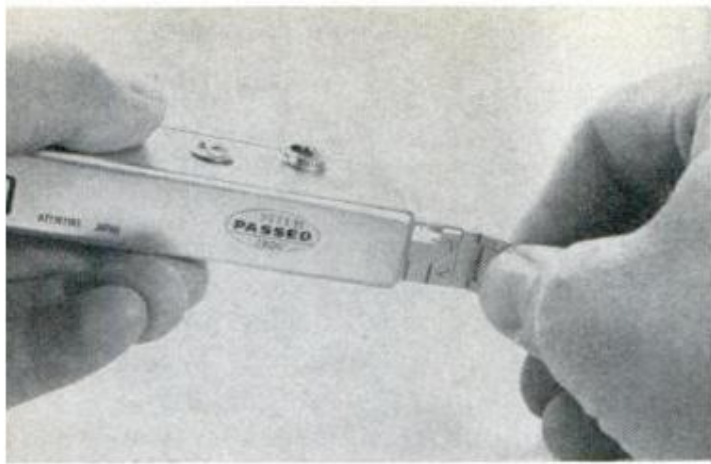

NOVEL PULL-OUT TAB advances the film and cocks the shutter on the Yashica Atoron above. Like the Minox, the Atoron uses tiny 8-mm film, permitting an exceptionally slim body. At right, drop-in film cassette, used in most mini-cameras, makes loading and unloading easy. This Minolta cassette is a one-piece, sealed container, requiring no threading



available, providing a reasonably wide selection. Typical costs are \$1.10 to \$1.60 for a 20-exposure roll of film, with processing running to an additional \$2 for transparencies and up to \$6 for color prints.

All of the ultraminiatures except the Rollei use sealed film cassettes that just pop in and out without requiring any threading. With the Rollei, the film must be threaded manually into a take-up compartment, then rewound into the original container after exposure.

The familiar push-pull film advance long used on the Minox is now found on two other models, the Minolta 16 II and the Rollei 16S. The telescoping mechanism advances the film and cocks the shutter in one quick, easy motion, making fast shooting a breeze. The other two Minoltas use less-fancy wheel advances, and the Yashica Atoron features a pull-tab advance.

Focusing is fixed on the Minoltas but adjustable on the Minox, Rollei and the

(Please turn to page 208)

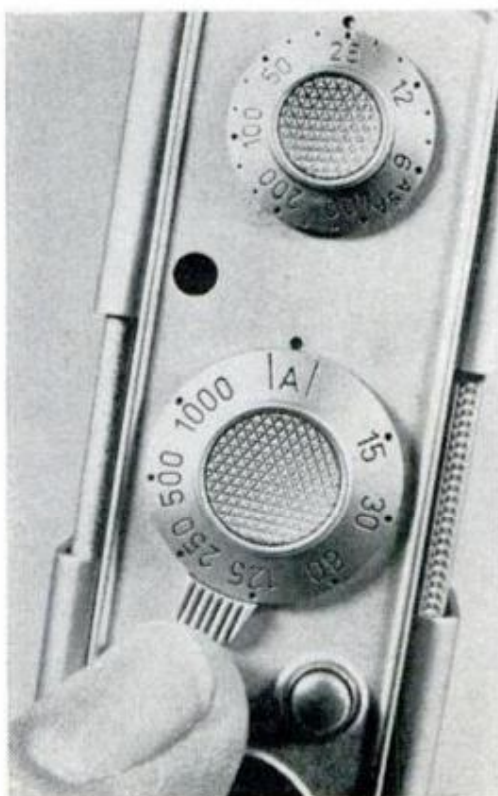

WARNING INDICATOR on the Minox C at left tells you if exposure will be longer than 1/30th of a second. If small round window between the two dials lights up, it means you'll need flash or a tripod to assure a sharp picture. Lower dial sets shutter speed, upper one ASA film speed. Most minis can be mounted on a tripod for steadiness. A removable clip provides tripod socket and flash shoe for Minolta 16 II below



Build This Back-Yard Beauty

Its western styling makes it a handsome playhouse for youngsters, and when they outgrow it, you'll have roomy storage for all your garden and yard tools

By BRAD SNYDER

WHETHER YOU NEED a playhouse for the youngsters, a summer office, pool cabana or more storage space for yard equipment, a lawn building lets you make greater use of your property.

Once we decided to build one, the next step was to decide its architectural style. This was solved by selecting the Western-style model shown which matched our home exterior. Elevations for it (and the alternate Western Side Door) are shown on these pages. Complete building plans for both versions are available at \$2 per set from PM's Reader Service Dept., 224 W. 57th St., New York, N.Y. 10019. To order plans for one of four other styles—Cape Cod, Barn, Swiss Modern or Vermonter—write to the plan designers, Alpine Enterprises, Box 9332, Colorado Springs, Colo. 80909.

Though the house could have been

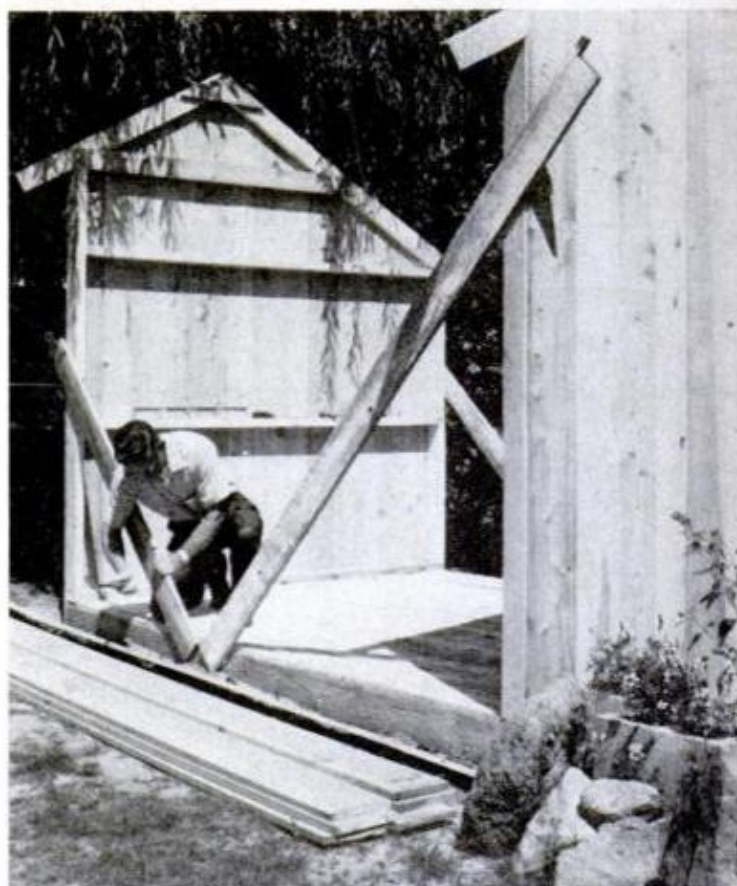
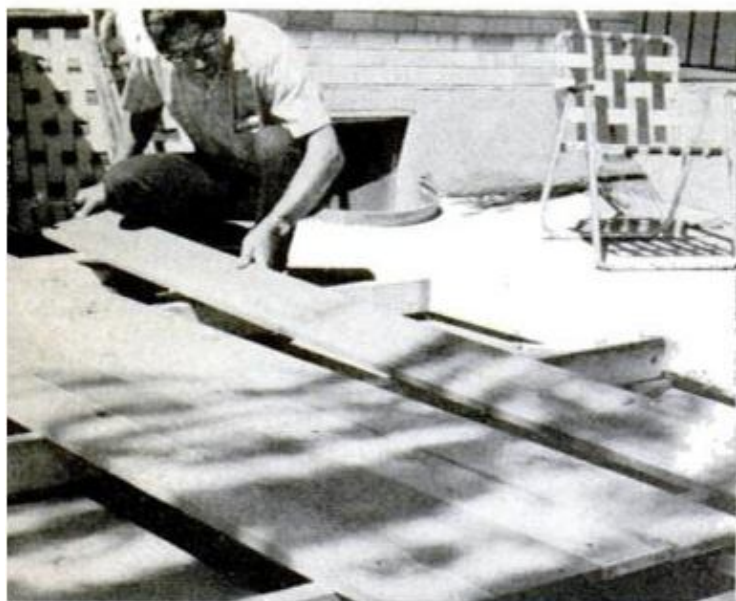

SHED FRAMING rests on four piers (upper left); flooring is then nailed to joists and trimmed in place

TO SPEED CONSTRUCTION, each wall is assembled on the ground (left), then hoisted into place as a unit

END WALLS ARE PLACED (above) and temporarily held with diagonal bracing. Ends equal width of platform



ELEVATIONS

LEFT END
(both ends alike)

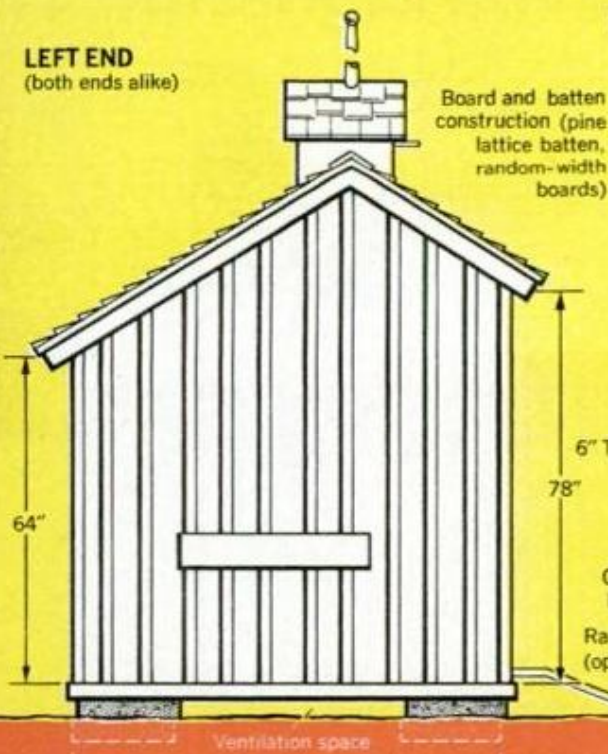

Board and batten construction (pine lattice batten, random-width boards)

FRONT

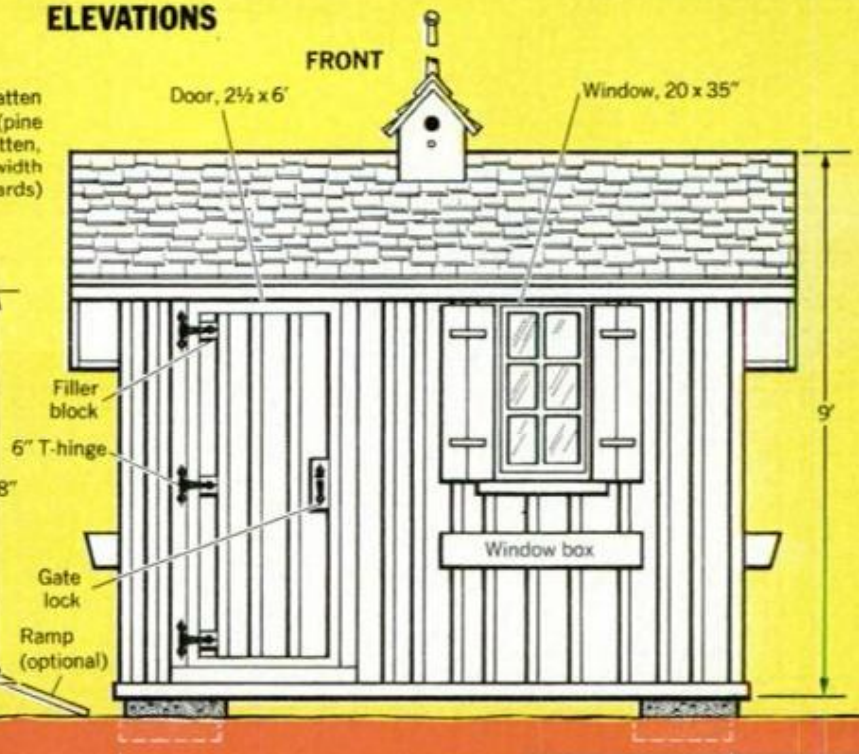

Filler block

6" T-hinge

Gate lock

Ramp (optional)

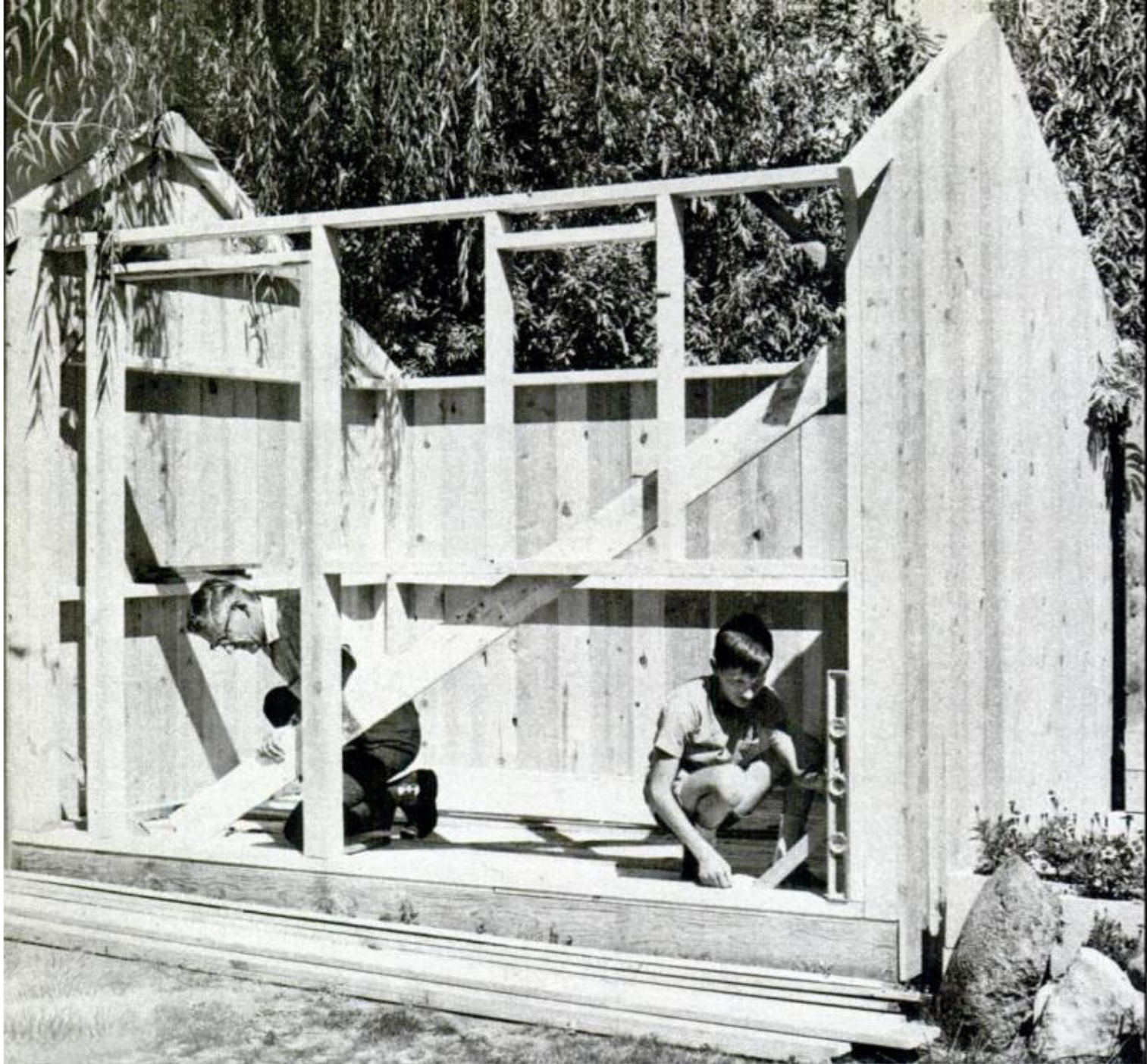

ALTERNATE CONSTRUCTION

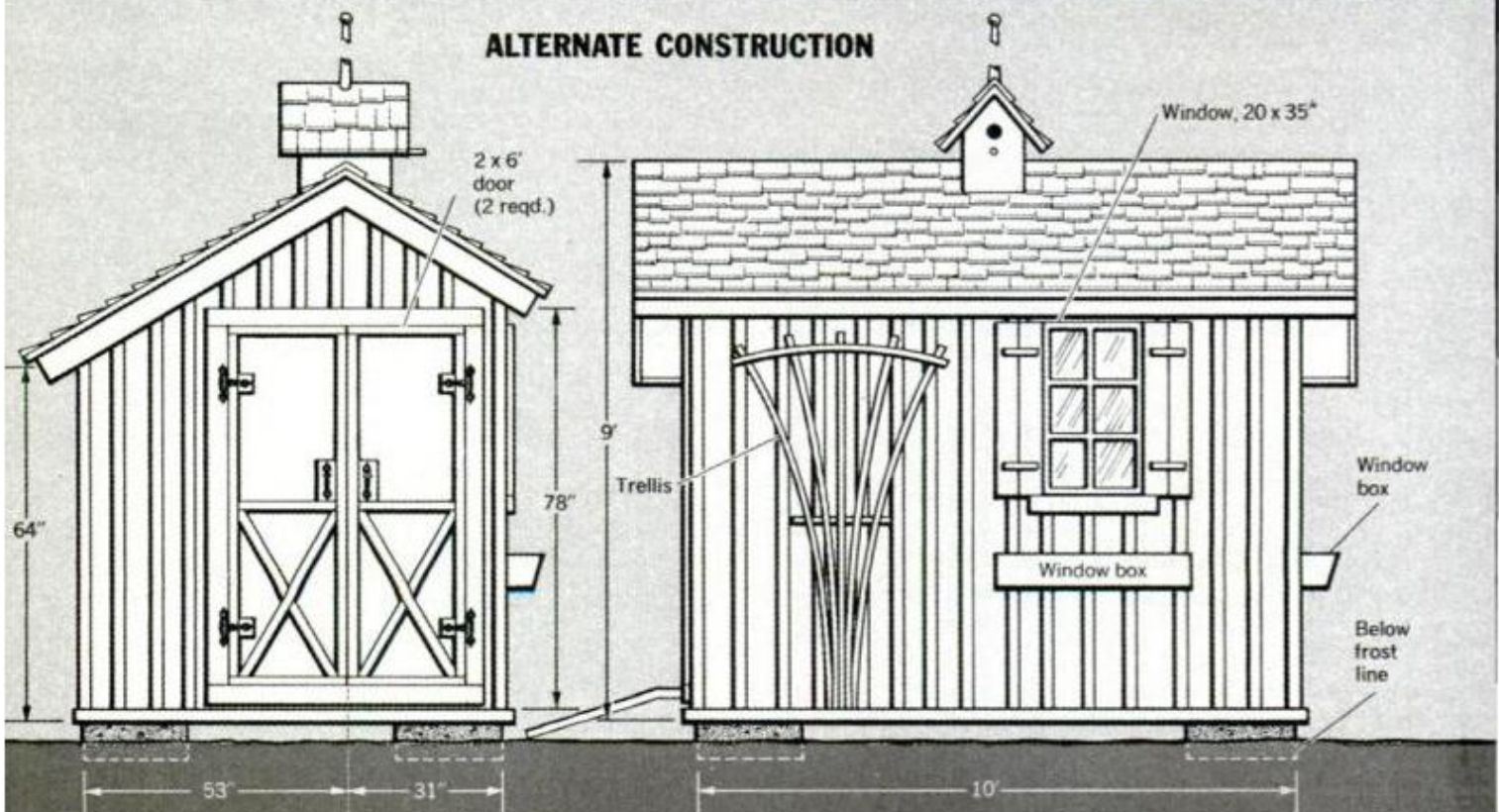

HINTS FROM READERS



PREASSEMBLED ROOF FRAMING is hoisted into place and fastened to 1x6 ridge board installed at the peak

built on a slab, I elected to construct it on four concrete-block piers (in my area, exempt from tax assessment). After evaluating exactly what would be stored in the shed, I actually built it slightly larger than shown on the plans. Extra attention to details—window boxes, cupola birdhouse and ornamental hardware—yields the touches that elevate this little house from the construction-shanty look frequently found in home-built yard structures. I kept complete labor and materials records while building the house; they added up to about 35 hours of labor and \$228.19. (This is a 1969 materials' cost; I'd recommend a slightly higher budget this year). ★★★



ROOF SHINGLES are laid 5 in. exposed to weather; 3/4-in. exterior-plywood door is hung with T-hinges

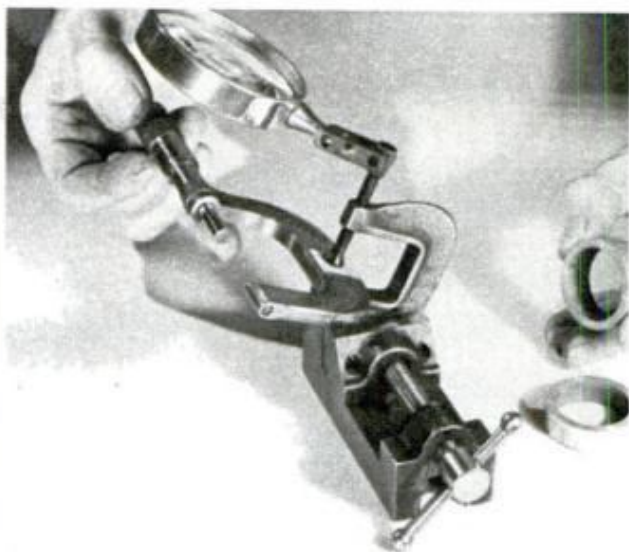

Improvised bench micrometer

A conventional micrometer can be temporarily converted into a bench-type tool by mounting it in a small drill-press vise which serves as a base. Since most micrometers have the index line on the side, it's best to tilt the tool for easy reading by grasping it in a C-clamp held by the vise as shown. (Check the micrometer to see if clamp pressure affects zero setting.) For easier reading, mount a magnifying glass on the C-clamp.—Walter E. Burton

Camper's 'washboard'

A washboard improvised from a corrugated fruit juice or vegetable can will serve nicely for scrubbing socks, hankies and other small items when you're camping. Though the can may be used in its conventional shape, you'll have a wider working area if you cut out both ends and flatten the can.



COMING: THE SAFE 1000-

This new electronically regulated breathing rig may revolutionize skin diving. It's over 100 times more efficient than standard scuba, permitting a diver to go deeper than ever before and stay down longer.

By JOHN F. PEARSON, Science Editor

WALTER STARCK KEPT AN ANXIOUS EYE on his buddy Bill Schwicker. They were down better than 200 feet, a depth uncomfortably close to the safe maximum for the standard scuba Bill wore. Though prettier than many other waters, the luminous, magically blue Caribbean can be just as deadly.

The divers had released a chemical in the area and were scooping stunned fishes from the bottom and popping them into specimen nets for later study. Bill was in trouble. His movements were uncoordinated and his hands trembled. As a result, with each fish he would also bring up a handful of sand.

Even when not watching his buddy, Walter was keenly aware of Bill's presence. There was a loud rasp and gurgle each time Bill sucked air through his regulator and expelled it into the water.

Finally Walter signaled Bill that he'd been down long enough. Bill waved and swam off, trailing bubbles as he ascended. Soon the gurgle of the scuba grew faint.

In contrast, Walter's rig was virtually silent. Every minute or so it emitted a low, three-second *ssst* as additional oxygen was injected into the system. This was a test dive with the Electrolung, an electronically regulated, closed-circuit, mixed-gas unit that he had helped develop.

The two divers had been working a ledge along the face of a cliff that angled to meet the ocean floor hundreds of feet below. Walter descended to the 250-foot level, inspecting giant sponges and black coral trees projecting from the cliff face. He glided past schools of small fish that paid him little attention. That was one of the things the Electrolung was designed to do—permit a diver to become an unobtrusive invader of the world below the surface of the sea.

Even though his oxygen partial-pressure gauges showed he could stay down for five more hours, Walter decided to surface. At 40 feet he made his first decompression stop. Above, he could see Bill clinging to their boat's anchor line while continuing to decompress. Walter went up to 30 feet, where he switched to pure oxygen to speed the process. After brief stops at 20 and 10 feet, Walter surfaced alongside Bill.

"How'd it go, Bill?" The question came from another member of the party after the two divers had boarded.

"Fine," Bill said. "No problems."

Walter grinned. "That's not the way it looked from where I was sitting."

Bill was surprised to learn that at the deepest part of his dive he'd become

FOOT DIVE

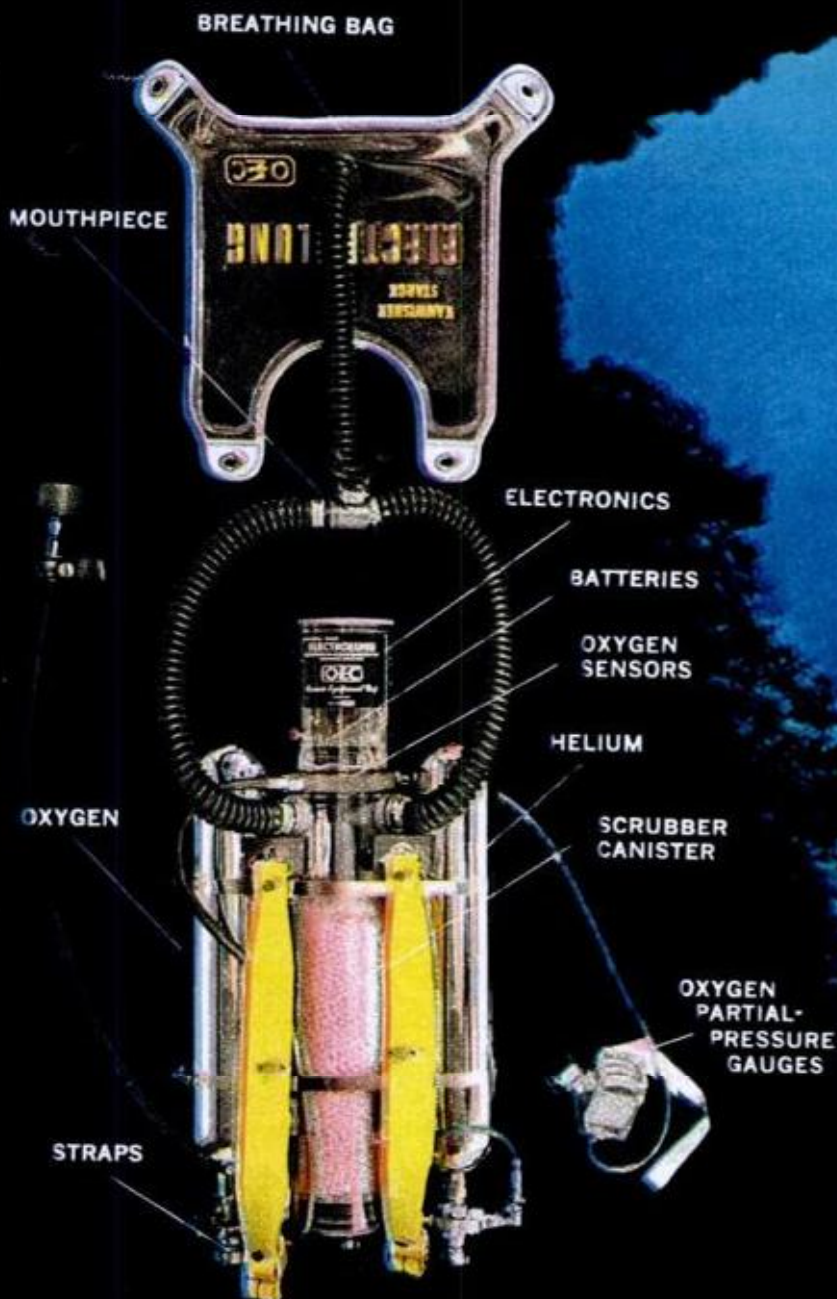

CORAL REEF IN CARIBBEAN is explored by diver wearing Electrolung. There are no bubbles as no gas is exhaled into water

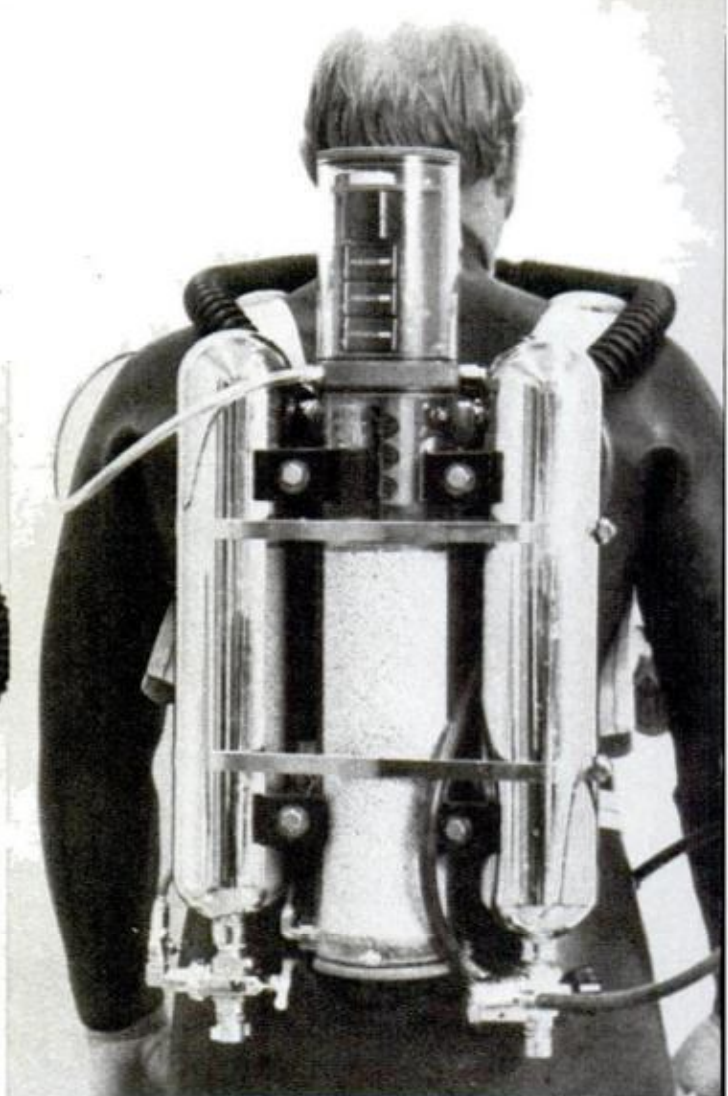

COMPACT, 35-POUND ELECTROLUNG uses gases very efficiently, permits six-hour dives regardless of depth

clumsy and uncoordinated. But the proof lay in his specimen bag, which contained as much sand as fish.

Bill's experience illustrates one of the shortcomings of the standard compressed-air breathing apparatus. On deep dives nitrogen in the bloodstream causes the effect called "nitrogen narcosis." The result is like that of having had one too many. Though the diver thinks he is in good shape, in reality he is incapable of handling any problem calling for quick or involved thinking.

In addition, the density of the nitrogen increases so greatly with depth that it inhibits ventilation of the lungs, resulting in a CO_2 buildup in the lungs. As a result, any extra effort required of the diver will cause him to struggle for breath even though there is plenty of oxygen available.

Conventional scuba is an open-circuit system: The diver breathes compressed air through a mouthpiece and exhales

into the water. Though reliable, it is a very inefficient system. Each exhalation wastes large volumes of gas. Thus, a twin-tank unit weighing close to 100 pounds will last two hours at 30 feet and about 30 minutes at 200 feet.

A step-up in efficiency was achieved with the semiclosed-circuit units, in which an oxygen-rich mixture is continually added at a slow rate. Part of the gases are rebreathed and part expelled. This type of unit permits a diver to stay down significantly longer, but it's cumbersome and has depth limitations.

The semiclosed units are an improvement over standard apparatus, but still not good enough. Walter A. Starck II (to use his full name) had specific objectives in mind in seeking an improved scuba. He wanted an apparatus that would enable him to go deeper, stay down longer and that would be free of fish-frightening noise and bubbles. The tall, soft-spoken Ph.D. is a

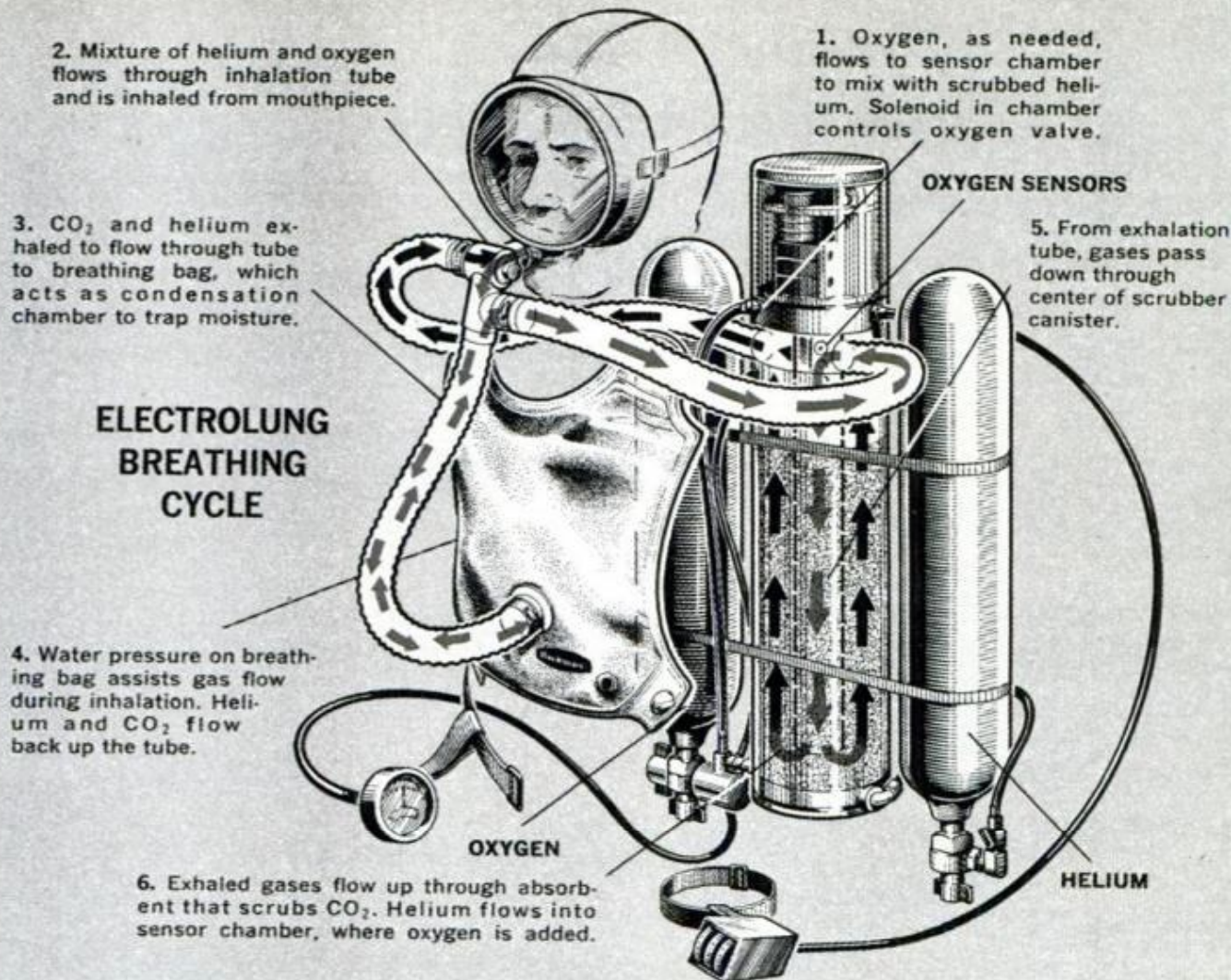

HEART OF SYSTEM ARE ELECTRODES that "read" oxygen level, trigger valve to maintain proper gas mixture

marine biologist at the University of Miami and specializes in the study of fauna found around coral reefs. A veteran diver, he has spent much of his life exploring off the Florida Keys and coral reefs in many parts of the world.

Starck felt certain that a closed-circuit apparatus would meet his needs. He was mulling over its design when, in February, 1968, he met Dr. John Kanwisher on a Bahaman expedition.

Kanwisher, it turned out, had built a crude working model of a closed-circuit unit some years before. A biophysicist at the Woods Hole (Mass.) Oceanographic Institution, he has made a close study of the physiological aspects of diving, has done research with porpoises and is credited with having taken the first electrocardiogram of a whale. Dr. Kanwisher also is an expert in electronics and has invented a special electrode used in breathing systems.

The two scientists put their heads to-

gether and produced, in less than two months, a prototype of a closed-circuit unit that they named the Electrolung.

"The problem," says Dr. Starck, "was not in building a working system. John and others had done that. The problem was to build a completely *reliable* system."

The Electrolung has two tanks. One contains oxygen; the other, helium (or some other inert gas). A clear plastic canister contains a chemical that absorbs carbon dioxide, permitting the helium to be breathed again.

Scrubbing of the CO_2 is continuous, and the helium is used over and over. Oxygen is injected into the system at intervals in response to the diver's physiological requirements. If he's working hard, he'll burn up oxygen faster and will need more frequent "doses."

At 200 feet, the lung is said to be 100 times better in gas utilization than

(Continued on page 210)

Build This Handsome



Electric Serving Cart

Plug-in food warmer under a lift-up top keeps side dishes piping hot and flavor perfect when you entertain.

By WAYNE C. LECKEY, Home and Shop Editor

IF YOU MAKE the mistake of showing your wife this elegant Early American serving cart, you might just as well start building it. She won't give you a moment's peace until you do.

That's how much she'll love its rich fruitwood finish, its built-in electric warming tray, its retractable cord, its felt-lined silver and linen drawer and its easy-rolling ball casters.

You'll need such special tools as a wood lathe and router, but don't worry about being an expert at finishing. Its

slick finish is a decorative laminate—you just cement it on and that's it. (See *How to Work With Plastic Laminates*, page 154, March PM.)

We covered the original cart with Consoweld's Colonial cherry and used solid cherry for the turned legs and exposed edges of the top, drop leaves, drawer fronts, lower shelf and front crossrails. These surfaces were later stained and finished to closely match the cherry laminate.

First turn the four legs from 1 $\frac{7}{8}$ -in.

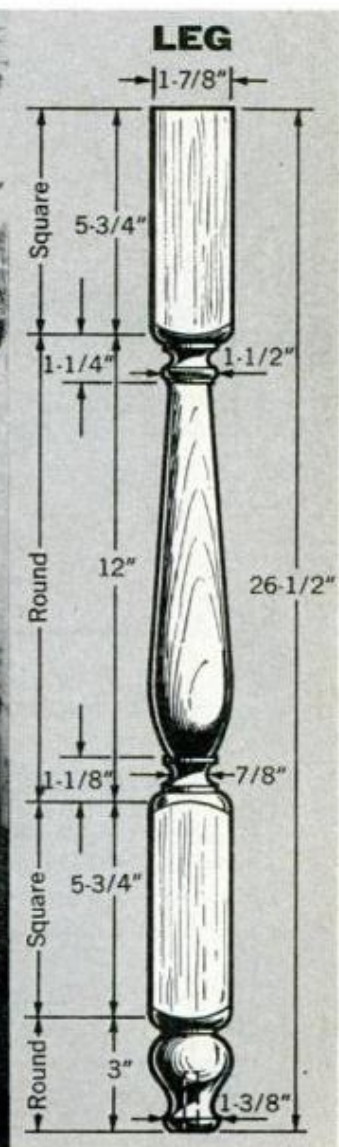

SERVING CART

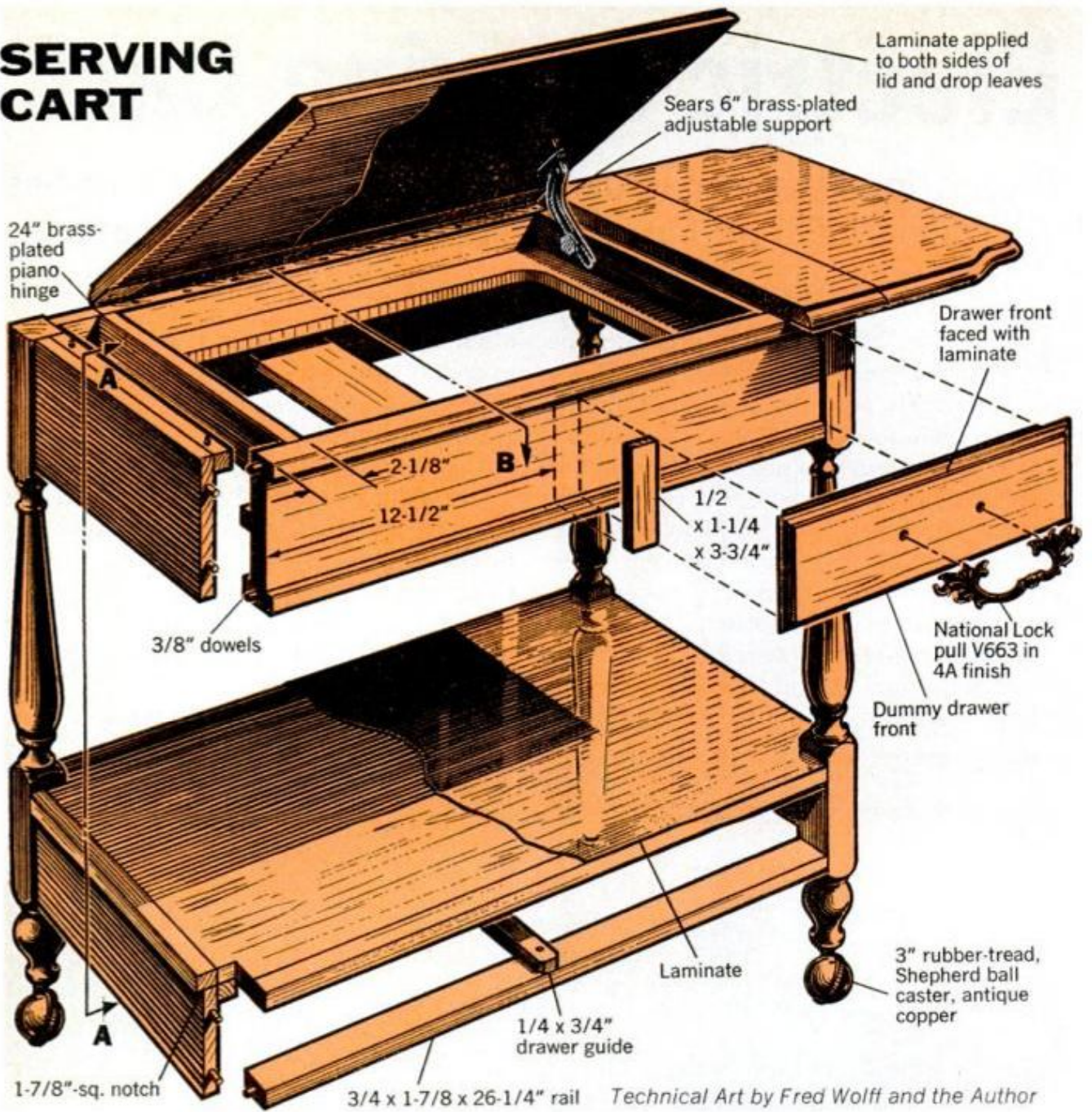

Technical Art by Fred Wolff and the Author

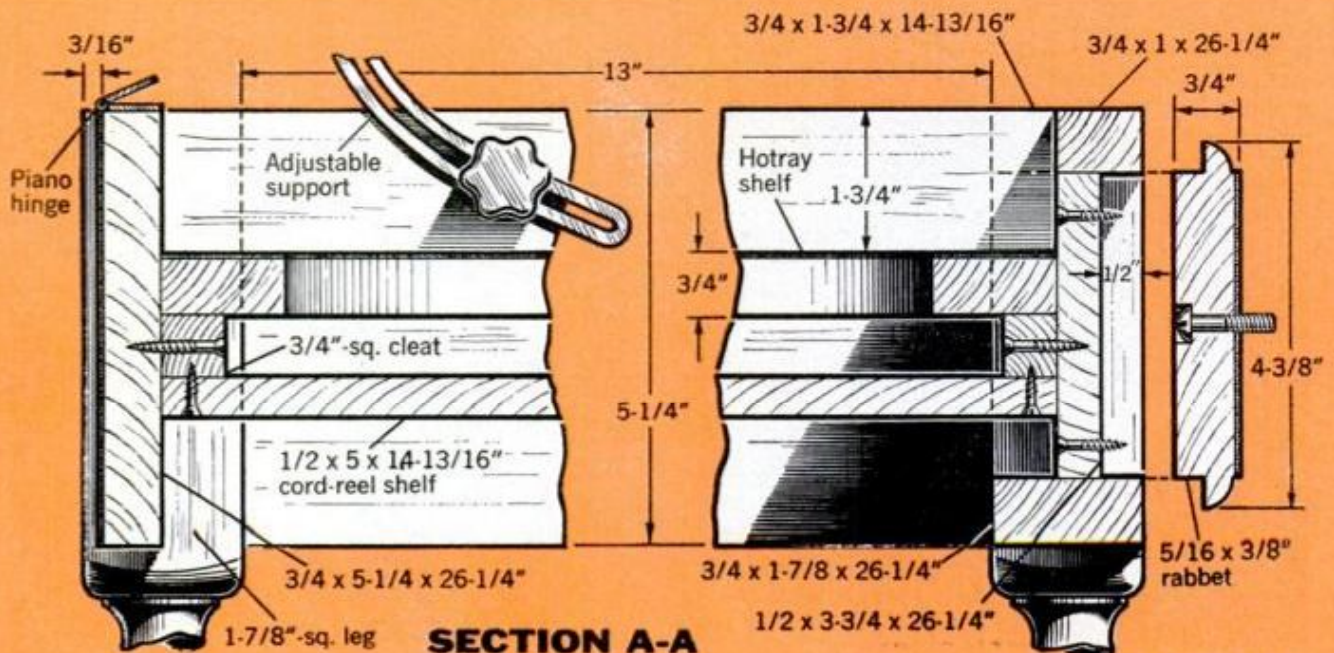

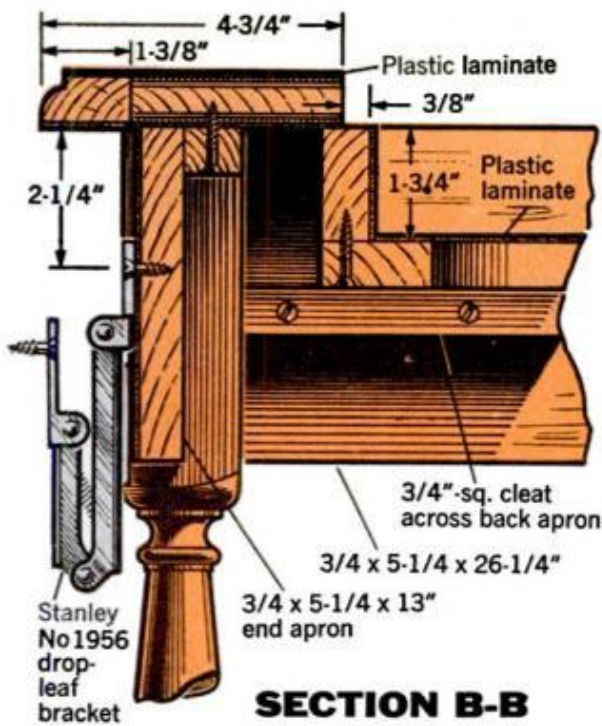

SECTION B-B

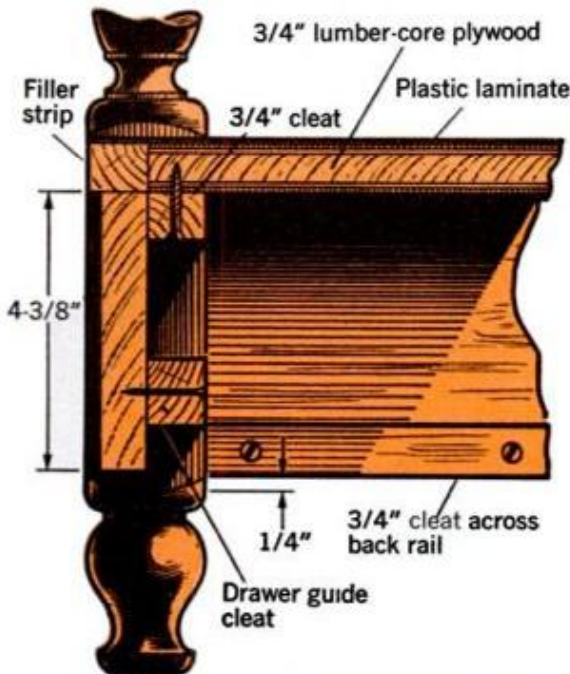

turning squares. To turn all four alike, make a full-size cardboard template to mark off the round and square sections of the leg. Mount each turning between centers so the top of the leg is at the headstock end of the lathe. This way, with a bit in the tailstock, you'll be able to bore holes dead-center in the ends of the legs for casters. Take caliper readings directly from the template.

Next cut the four end aprons. The two top ones are 5 1/4 in. wide; the two bottom ones are 4 3/8 in. Cover the aprons with laminate before you trim them to size and bore the dowel holes. The upper aprons are kept even with the tops of the legs and 3/16 in. in from the face. The lower aprons are 3/4 in. from being centered on the square portion of the leg to allow for the bottom shelf which rests on them. Now dowel and glue the aprons to the legs. Cover and cut the top and bottom back aprons to size and bore for dowels. They're 26 1/4 in. long and the same widths as the end aprons, set in the same amount and cut from fir plywood.

The recessed front apron is built up as shown in section A-A. Top and bottom rails of cherry are glued and nailed to a center piece of 1/2-in. fir plywood. Then a filler block of cherry is glued to the front to divide the recessed apron exactly in half. The ends are bored for dowels as before to align with holes in the legs. The top surface of the top rail is later covered with laminate so the lid will be flush with the rest when closed.

Cut the lower crossrail 26 1/4 in. long from cherry and bore for dowels. Now glue the parts to the end assemblies. Do this at one time, preferably with clamps. Keep the assembly square.

While the glue is drying, make the recessed

(Please turn to page 182)

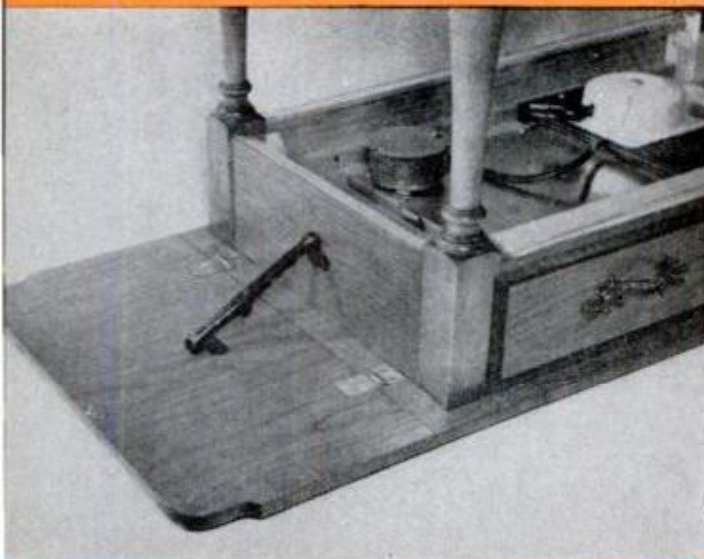

UNDERSIDE VIEW of drop leaf shows bracket which holds leaf up. It's surface-mounted with four screws

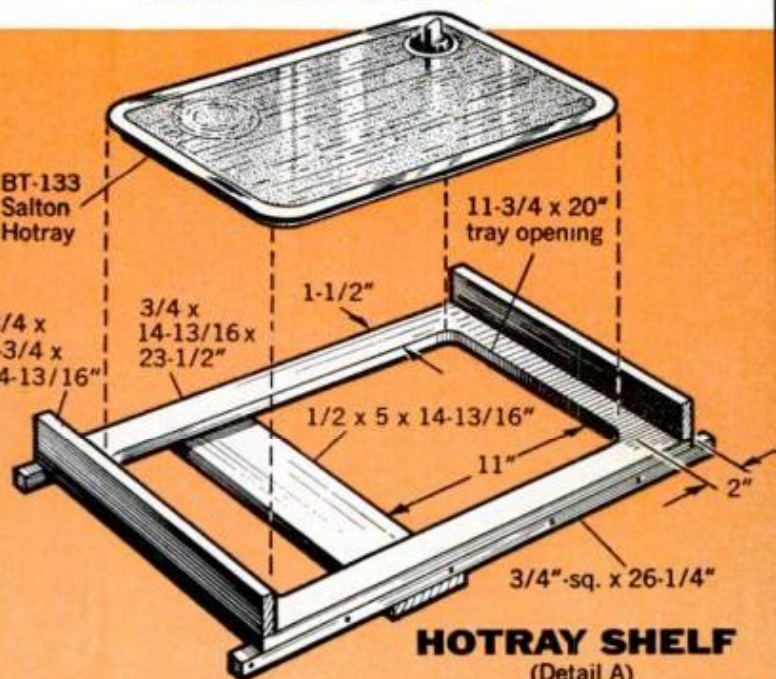

HOTRAY SHELF
(Detail A)



AUTOMOTIVE

Why Winnebago Is Number One

'Giving people what they want at a price they can afford' made Winnebago the leader in motor homes. We chose the 18-footer to test both motto and motor home

By JAMES M. LISTON, Executive Editor / Photos by Jerome Drown

WINNEBAGO INDUSTRIES, the company the little town of Forest City, Iowa, built to keep the town from folding, builds more motor homes than any of its competitors—and sells four times as many.

I had often wondered why. The Winnebago is anything but streamlined. It makes no secret of its trailer origin. It's boxy and angular and—it would seem to any user of Detroit products—overdue for a redesign that would turn its sharp corners into graceful curves.

"Why is the Winnebago number one?" I asked president John V. Hanson, the former furniture-store proprietor who got Winnebago started when it was stalled.

"Would you like the one-hour talk or the one-minute explanation?"

"One sentence, if possible."

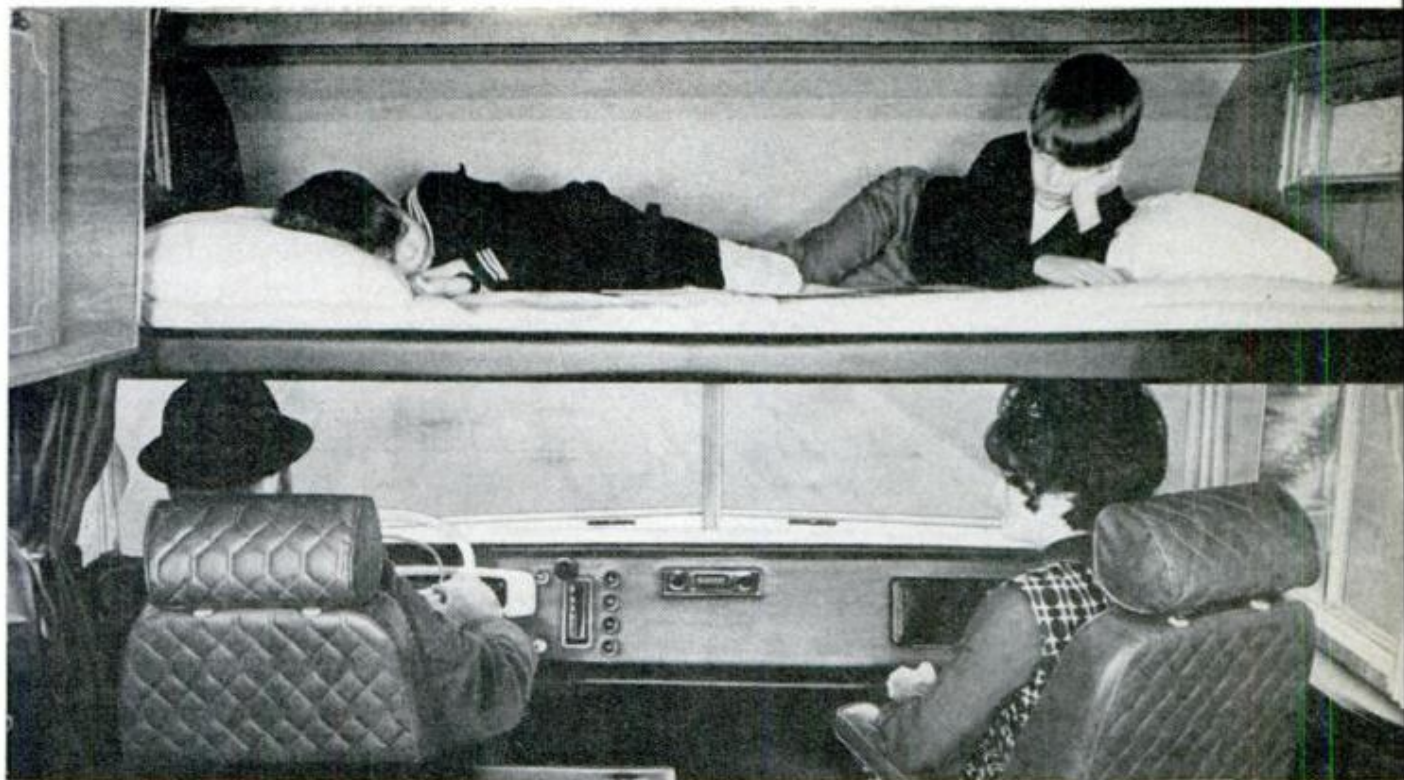

FOLDING BUNK OVER DRIVER'S COMPARTMENT is favored by kids, holds two adults, has screened, swing-out windows at head and foot. Driver and co-pilot have swivel seats with armrests. Full power and automatic transmission encourage women to do relief driving. Blackout curtain (left) shields the driver at night

"The key to our success is knowing what people want and producing it at a price they can afford."

What people want—when they can afford it—is a vacation home they can drive. Like a good motel, it needn't be plush, but it must have all the conveniences people now consider essential: good beds, a bathroom with shower, storage, a modern kitchen, and heat, light and airconditioning.

Like others, Winnebago offered all this in its trailers. But many people shy away from towing. It's illegal to carry passengers in a trailer. And most people like to enjoy the roominess of a home on wheels while they're rolling, not just when stopped. Winnebago recognized this three years ago and switched its main effort to motor homes. Vacation homes—not overstuffed land yachts—that are mass-produced.

The company builds all its vehicles in Forest City; the economies offset freight charges. Winnebago manufactures its own windows, cushions, seats, and mattresses, fiberglass lavatories, holding tanks and showers. It laminates its own Thermo-Panel materials (a

sandwich of aluminum, Styrofoam and plywood used for walls, roof and floors) and builds all its cabinets.

Winnebago now turns out 150 vehicles a week, will soon be capable of turning out 400. Because of mass production efficiency, the company claims that it offers as standard equipment much that its competitors have on their option lists.

The Winnebago motor home comes in five models, from the F-17 (F for Ford chassis, 170 hp) which is 17 feet, 4 inches long, 7 feet wide, and sells for \$6500, to the D-27 (D for Dodge chassis, 212 hp) which is 27½ feet long, 7½ feet wide and sells for \$11,210. The F-17 is about the size of a compact station wagon. The D-18, no longer than a standard wagon, with 104-inch wheelbase, sells for \$8500 and has the same engine, dual rear wheels, and most of the conveniences of the best-selling D-22. I chose to test the D-18, between the bottom-of-the-line model and the big seller.

The \$8500 price tag is downright reasonable for a vacation home with automatic heat. At that price a completely



SIDE LOUNGE has colorful, stain-resistant fabric covering 5 inches of foam rubber. Bath has shower with an automatic water heater, marine-type toilet



FULL DOUBLE BED, 49 by 73 inches, is made of back and seat of lounge. Dinette also converts to double bed. Lavatory is concealed in cabinet at the right



GENEROUS OVERHEAD STORAGE explains angular exterior design. If wall curved to roof line, half of storage would be lost. Magnetic catches hold doors

furnished cottage—with beds for six, range, oven, refrigerator, and wall-to-wall carpeting—would be a real steal. Still better, at the drop of a hint this vacation home can move itself from Maine to California.

The D-18 I picked at the factory had accumulated 22,000 miles and over a year of use by outdoorsmen and Winnebago employees and their families. It hadn't had tender, one-owner care; it would give me a good idea of what the vehicle was like after the "new" had worn off. Some optional equipment had been added: A 2500-watt Onan power plant (\$751), a 10,000-B.T.U. roof-mounted air conditioner, radio and trailer hitch—total, \$1289.

You don't test a motor home on a track. You take it out on the road and live with it for a while. With my wife in the co-pilot's seat, I headed the Winnebago south on Interstate 35 on the first leg of a circuit that would swing through Kansas to Denver, eastern Wyoming and South Dakota's Black Hills and return to Forest City.

It was dusk when we set out, and we passed several motels displaying "no vacancy" signs. As darkness came on and we bored into it, Dorothy said it seemed strange to be starting a trip so late—and with no idea of where we were going to stop for the night.

We had nothing to worry about. We could park this vehicle anywhere overnight parking was not prohibited because we were—as the industry terms it—"self-contained." (Primarily this means the vehicle has a holding tank for waste water and sewage; it's not necessary to have a sewer hookup at a campground to use the plumbing.) We were also self-sufficient; we didn't need an electric hookup. We could operate off twin batteries or use the gasoline powerplant. We also had 36 gallons of water aboard. If necessary, we could pull into any suitable off-the-road parking area, draw the curtains, and enjoy complete privacy.

Not having to hunt a motel—or a restaurant—we covered 120 miles be-

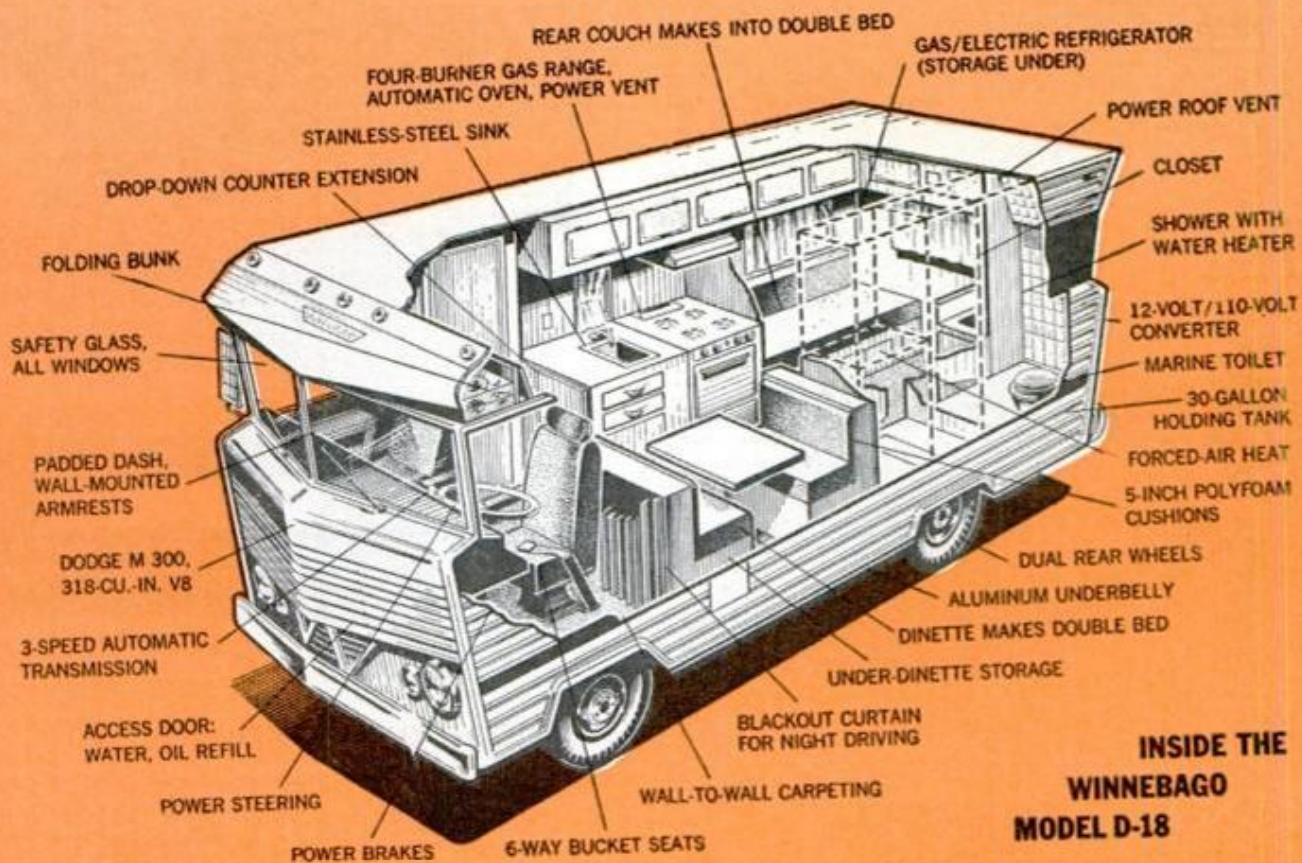

**INSIDE THE
WINNEBAGO
MODEL D-18**

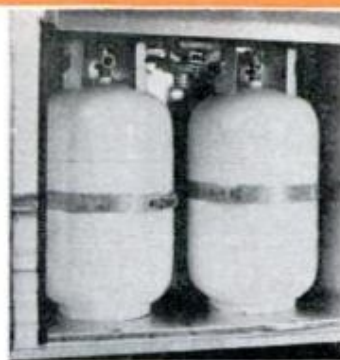

DOUBLE 20-POUND LP TANKS are standard equipment. Gas is used for cooking, heating—and for gas-electric refrigerator when camped

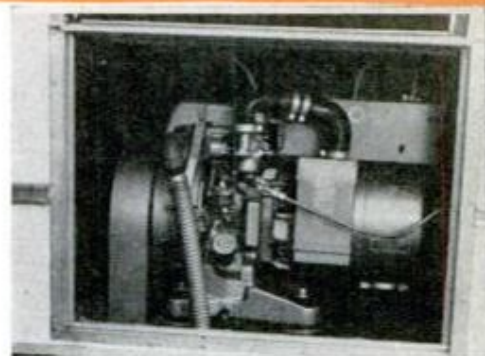

POWERPLANT is optional equipment. The 2500-watt generator runs the roof-mounted airconditioner, powers all electrical equipment when electric hookup is not available

fore bedtime and swung into one of those new private campgrounds that are the perfect answer for anyone with a trailer, camper or motor home. For \$2.50 we had water, electric and sewer hookups, and the use of a swimming pool, hot showers, a Laundromat, and a general store for provisions.

We converted the rear couch and were bedded down in less time than it takes to carry your bags into a motel. In the morning it was chilly. I flipped the thermostat to 72, and the forced-air furnace clicked on. Almost immediately the vehicle was comfortable. I started frying bacon on the range, turned on the power vent above it and there was no smoke, no cooking odor. The fan is more effective than those found in most kitchens. There was

plenty of hot water for washing dishes. The extension on the end of the counter gave the dishwasher a place to set things. We had the whole place ship-shape in less time than it would have taken to be served in a restaurant.

Driving a motor home on a four-lane divided highway is a breeze; driving on a narrow, two-lane road with trucks coming toward you a high speed is work and demands your best. The Winnebago is 7½ feet wide, 9 feet, 3 inches high. The closer you are to trucks, the more their blast buffets you. If you have a strong, steady crosswind, a passing truck can cause you to wander dangerously close to the center line. The solution, of course, is to slow down. Winds that don't affect the average car

(Please turn to page 185)



Self-propelled trailer

Starting with a second-hand 28-foot Air-float travel trailer, Californian Paul Prigg added the front end of a wrecked Chevrolet truck to turn the vehicle into a motor home. Prigg says that he spent a total of \$3500 for the rig—\$1600 for the trailer, \$1100 for the truck and another \$800 to put the two together and add the wide windshield. He also salvaged and utilized the front-wheel drive from the truck, so his unique vehicle has hydraulic brakes on the front wheels and electric brakes on the rear. Prigg recently drove the camper from California to Florida and back. Mileage at 45 mph was 12 mpg.



Gadget warns speeders

Drivers needn't take their eyes off the road to see if they're exceeding a speed limit when they use the British "Speedset." The device sounds a warning if, for example, the "30" button has been pushed for a 30-mph zone and the car goes faster than that.



Sees with sound

New Zealander Ivan Pivac, who is blind, can walk crowded streets with unique sonar spectacles that took 10 years to develop. Tiny receivers in the bridge pick up signals from objects and transmit them to his ears, enabling him to avoid collisions.

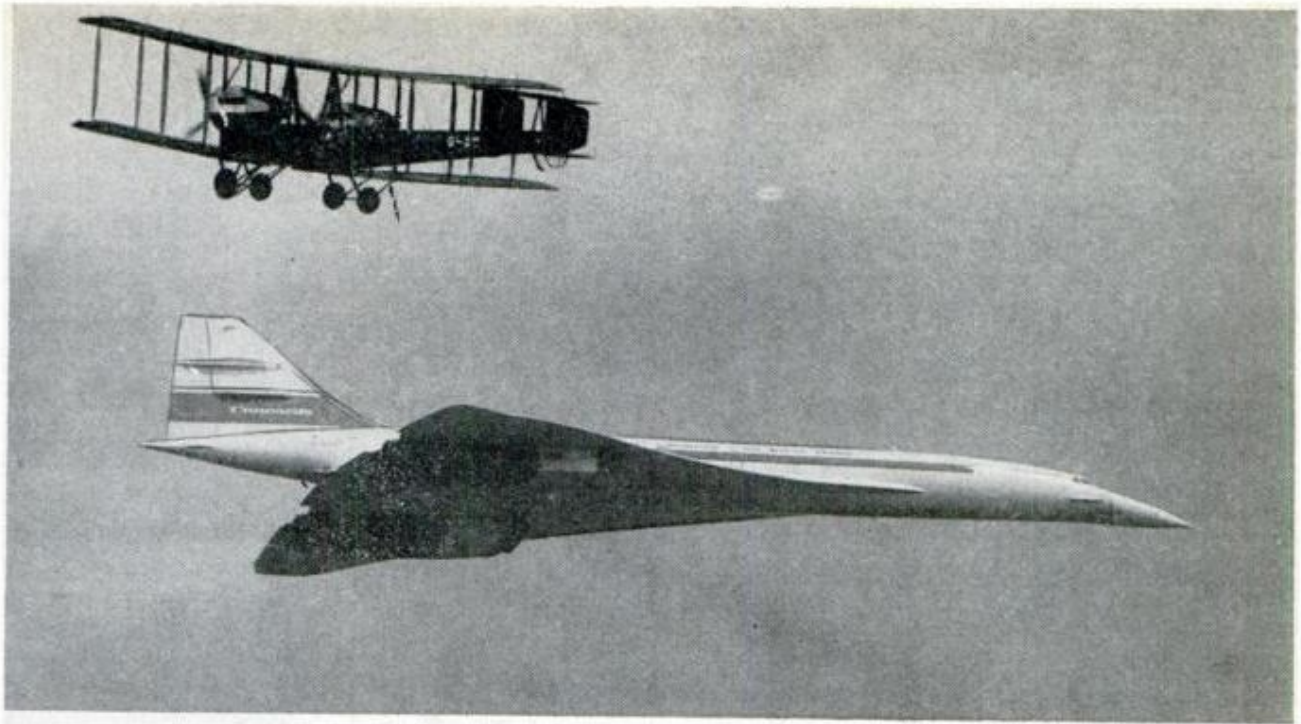

Half a century of aviation progress

Some 50 years of aircraft development are illustrated in this photo of a Vickers-Vimy bomber and a Concorde supersonic transport during a flyby near Paris, France.



Antique firearm disguised as a walking stick

A London antique dealer is the owner of an unusual firearm that was used by an 18th century bandit in Bavaria. Shaped like an alpenstock (walking stick), the weapon consisted of a hollow metal tube over which a flintlock fitted to fire a lead ball from the barrel.

Once You've Beat The World, What Do You Do For an Encore?



The owners get all choked up when they talk about their Mustangs. Most feel a touching tenderness, but a few fly into uncontrollable rages. Here's a small sampling

By **MICHAEL LAMM**
West Coast Auto Editor

Photos by the Author

MUSTANG ALREADY HOLDS a special place in American car-dom. As *the* pioneer ponycar, it became *the* industry determiner of the 1960s. Had it not been for Mustang, the Camaro, Barracuda, Javelin, Firebird, Challenger and the rest most likely wouldn't exist today. Nor would the vogueish long-hood, short-deck look.

Good or bad, the Mustang's influence remains strong. It also strongly affects owners' feelings. No one can remain ho-hum or even especially objective about his Mustang.

So rather than follow our usual format of lumping together owner opinions into categories, we've decided to let five representative Mustang owners air complete sets of praises and gripes. These are set down as they came in on our questionnaires. Before we jump in, though, remember that most owners,

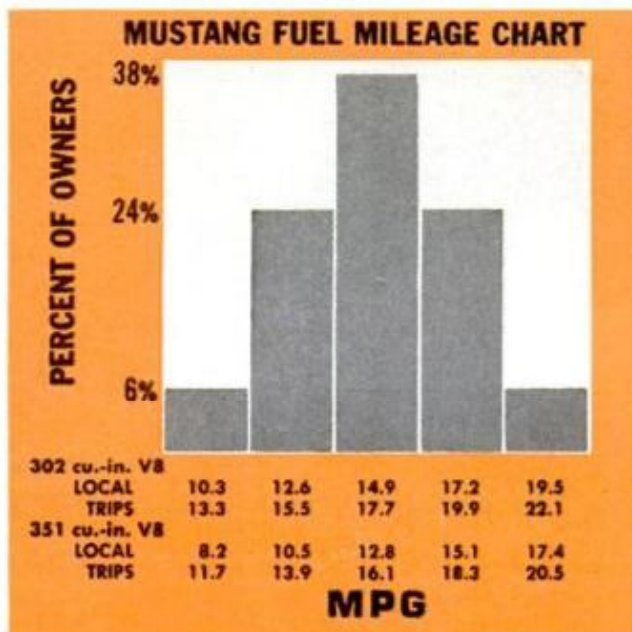

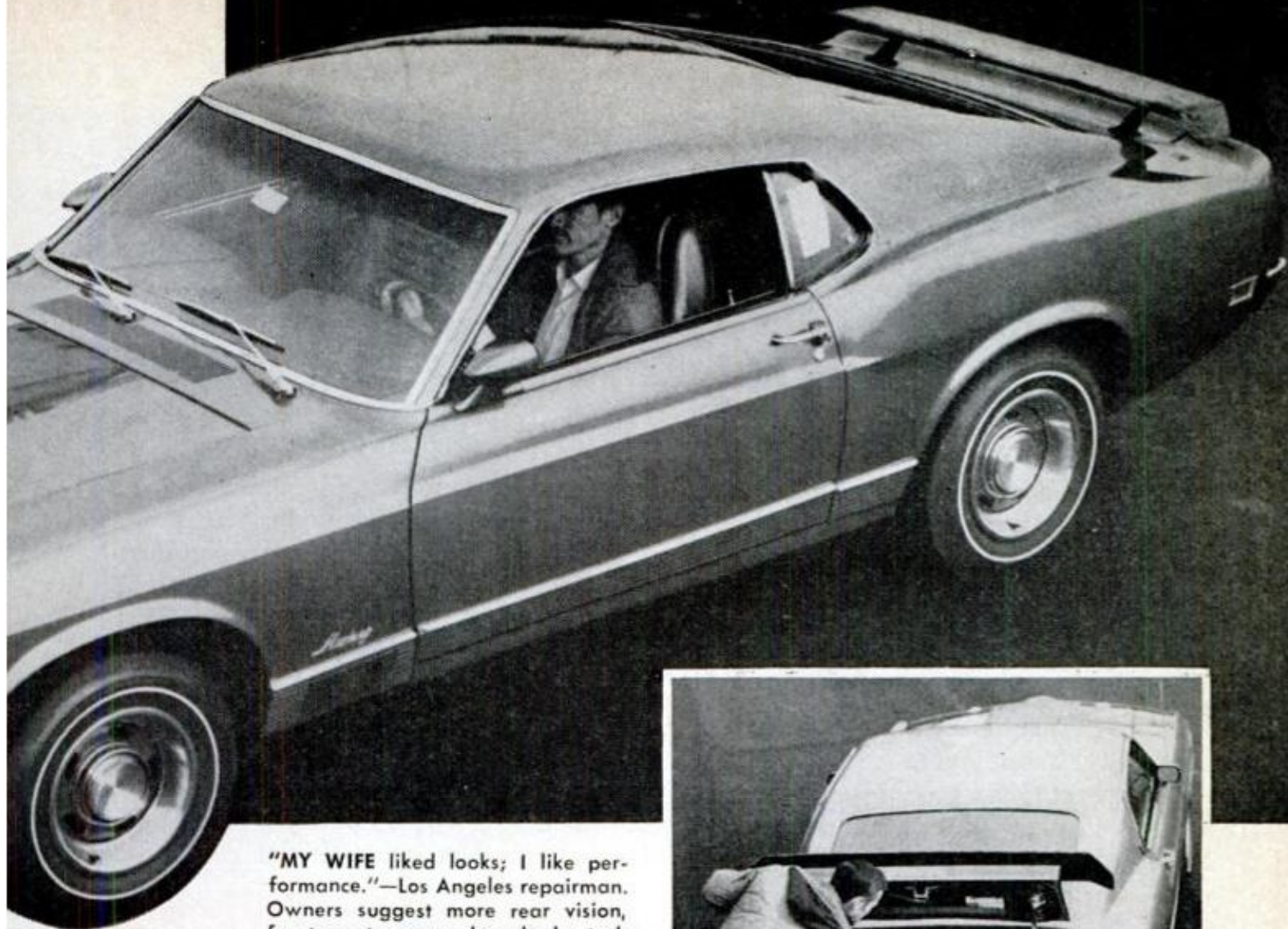

"MY WIFE liked looks; I like performance."—Los Angeles repairman. Owners suggest more rear vision, front vent panes, less body tuck

given the chance to put down *any* opinion, tend toward extremes. If they've been handled roughly by dealer or factory, here's where they get back. Conversely, people basically happy with their cars tend to overlook even gross flaws. When we at *PM* write up our *Owners Reports*, we try to sift out or balance these extremes. But in this case, that's very hard to do.

A Minnesota adman filled out his questionnaire like this:

Any mechanical troubles? "Yes. Both windows fell out. Brake fluid leaked onto linings. Brakes had to be relined." Dealer repairs satisfactory? "Dealer couldn't get replacement windows." Why did you buy your Mustang? "Was trading a miserable Maverick that I couldn't stand after 3 months." How's workmanship? "Motor's great. Body and interior crappy. Everything's glued on." What about comfort? "Front okay. Back seat horrendous." Praises? "The go of the thing. It moves like a blue bat. And it's great looking." Com-



SPOILER makes deck lid heavier than coil springs can hold, so it takes one hand to keep trunk open



DRIVER can't see clock, and glovebox won't hold beans. Otherwise, cockpit layout rates very high

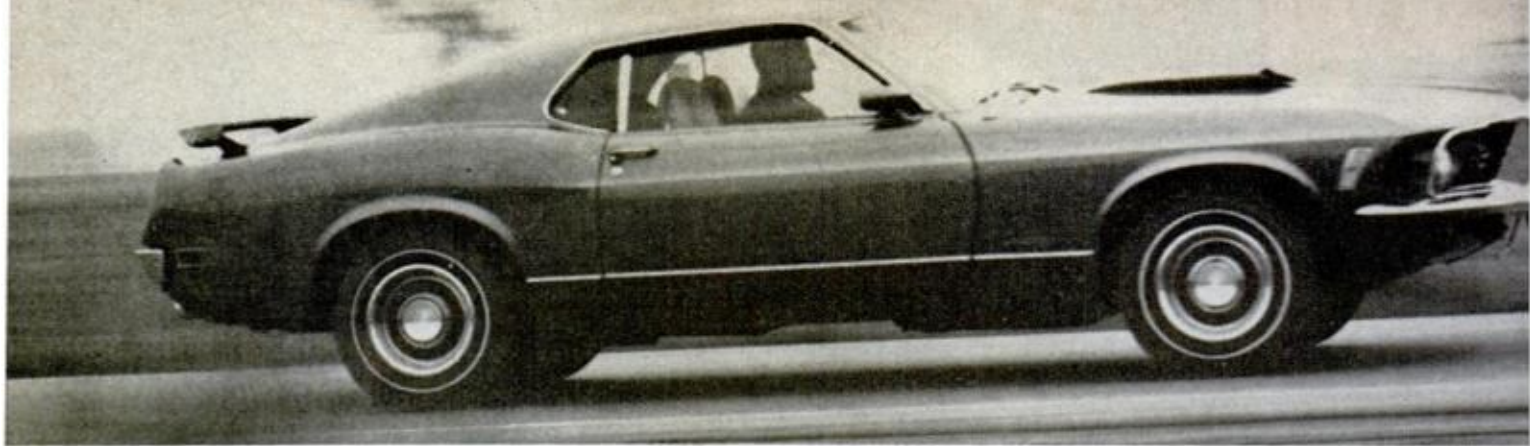

MUSTANG'S A GOER even with Six. One owner boasted clipping quarter mile in 12.56 with new 351-in. V8

"Cut-corner bodywork. Hood overrides bumper. Cramped inside."

Next, comments from an Alabama architect: Mechanical problems? "None." Dealer policies? "Excellent." Why did you buy? "Pleased with our 1965 Mustang at 80,000 miles; also 1959 Ford at 130,000." Workmanship? "Excellent." Comfort? "Front seats very comfortable but seatbacks too high. Rear seat all right for small car." Complaints? "None." Praises? "You can't buy bet-

ter for the money. No repairs, good mileage, excellent styling."

A New York telephone installer: Mechanical trouble? "Minor." Dealer? "Bad. Quoted price of \$3178 one day; when I picked up the car it was \$3378. I accepted only because I had no other transportation." Why the Mustang? "Wanted 1970 Camaro. When told they wouldn't come till after January, went to Mach I." Workmanship? "Not bad. But a crumpled rear fender cost \$598

Summary of 1970 Mustang Owners Reports*

Total miles driven 947,619

Average miles per gallon (samples too small to tabulate 200, 428, and 429-cu.-in. engines):

250-cu.-in. Six, local driving 16.6
long distance 20.8
302-cu.-in. V8, local driving 14.9
long distance 17.7
351-cu.-in. V8, local driving 12.8
long distance 16.1

Engines:

200-cu.-in. Six 3.1%
250-cu.-in. Six 7.1
302-cu.-in. V8 41.1
351-cu.-in. V8 44.4
428-cu.-in. V8 3.5
429-cu.-in. V8 0.0

Transmissions:

Automatic 72.6%
3-speed manual 15.2
4-speed manual 12.2

Body styles:

Coupe 64.2%
Fastback 33.0
Convertible 2.8

Series:

Mustang (std.) 55.7%
Mach I 32.5
Grande 10.5
Boss Mustang 1.3

Why the Mustang?

Style 46.3%
Past experience 27.5
Size 16.1
Economy 8.7
Handling 7.3
Performance 6.9

Specific likes:

Styling 56.1%
Handling 49.1
Comfort 26.6
Economy 17.8
Performance 16.4
Ride 12.2
Power 9.8
Size 7.9

Specific dislikes:

Rattles 9.3%
Rear vision 8.9
Light weight 7.4
Ride 7.4
Workmanship 7.4
Trunk too small 7.0
Rear seat too small 7.0

What changes would you like?

More rear legroom 12.8%
Ashtray location 7.8
Snot style 7.8
Rear vision 6.7
Workmanship 6.1
More trunk space 5.6

Had any mechanical troubles?

Yes 36.4%
No 63.6

What kind of trouble?

Carburetor 21.2%
Ignition 16.3
Electrical 8.8
Clutch 6.3

Did you repair it yourself?

Yes 4.2%
No 95.8

Dealer repairs satisfactory?

Yes 70.2%
No 29.9

Is the Mustang your only car?

Yes 44.5%
No 55.5

Other cars owned:

Ford products 50.0%
Chevrolet 10.9
Buick 9.4
Pontiac 7.8
Oldsmobile 6.2
Volkswagen 5.5

Accessories/power options:

Automatic transmission 72.6%
Radio 61.4
Power brakes 40.0
Power Steering 32.4
Airconditioning 25.6
No power options 24.0
Stereo tape 12.6
Whitewall tires 12.1
Vinyl top 8.2
Racing mirrors 7.3

What accessories/options would you order next time?

The same 51.0%
Airconditioning 10.9
Power steering 7.5
Stereo tape 8.1
Power brakes 7.1
FM radio 5.2
Traction-Lok 4.7

Age distribution of owners:

15-29 years 49.8%
30-49 years 31.8
50-plus 18.3

Would you buy another Mustang?

Yes 73.1%
No 26.9

*Percentages might not equal 100% due to rounding and/or insufficient data.



"RIDE, ROAD CONTROL GREAT. Feels solid. Acceleration takes getting used to."—New York designer

to straighten." Comfort? "Back seat useless." Complaints? "Dealer service, warranty, rattles." Praises? "Handles great, also like stereo, looks, gas mileage with 351 V8."

A claims coordinator from East Orange, N. J.: Mechanical trouble? "Yes. Radio suppression capacitor in alternator came loose, threw rotor out of balance, ruined unit." Dealer? "Very fast service, and they had the parts in stock." Why the Mustang? "Fast, agile, impressive car to drive. I enjoy driving it." Workmanship? "Above average." Comfort? "Front fine. Never have folded up the rear seat." Praises? "With a 780-cfm Holley it turns 12.56 in the quarter. Not bad for a 351 with four-speed. Very comfortable on trips. Good-looking car." Complaints? "Noise. I glued \$24 worth of foam inside body panels to stop outside noise coming in. Still working on squeaks, rattles."

A California college student had this to say: "Starter broke right away—Bendix." Dealer fix it? "Yes, but service is generally horrible, abysmal." What do you think of dealer? "He's a charlatan. Once sold, you're systematically ignored." Workmanship? "Good as any." Comfort? "Very comfortable front; rear is a lesson in masochism. Trunk is about the size of a glovebox, and glovebox won't hold owner's manual unfolded." Complaints? "Too expensive. Gas mileage absurd. Service a laugh." Praises? "Great looks, great power, ability to lure pretty girls." ★ ★ ★

MAY 1970



CLIMBING out of rear seat takes contortionist, but doors are big and open wide for loading groceries



MUSTANG'S 28.8-in. REAR LEGROOM sets industry record for tightness. Most riders also bump heads



"SATISFIES ME as it is. Very economical and easy to handle. It's a fine little car and I love it"

131



Three-legged 'clam'

Suspended on three metal legs, this lightweight, clam-shaped plastic "caravan house" is the invention of a French architect.



Inner-tube art

Large inner tubes that are tied together form a "Body Ball"—a work of art and also a plaything, says the sculptor who did it.

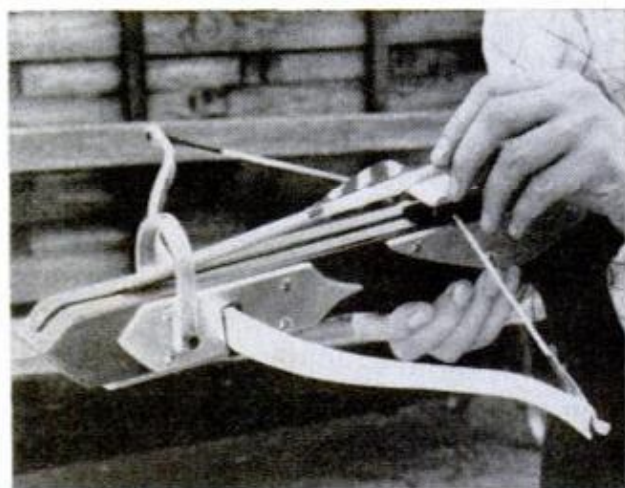
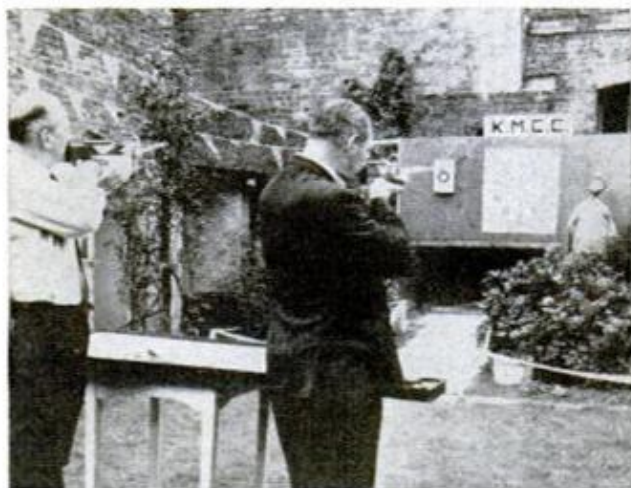

Darts too dull, so pubkeeper installs crossbow range

The traditional game of darts wasn't exciting enough for one pub owner near London, so he installed a crossbow range at his establishment. The 17-inch bows fire 9-inch bolts.



Former racing driver now builds 15-mph models

Able to zip along at 15 mph, this little gas-powered racer was built by former racing driver Tom Barnard. He plans to set up an assembly line and sell the cars for about \$500.

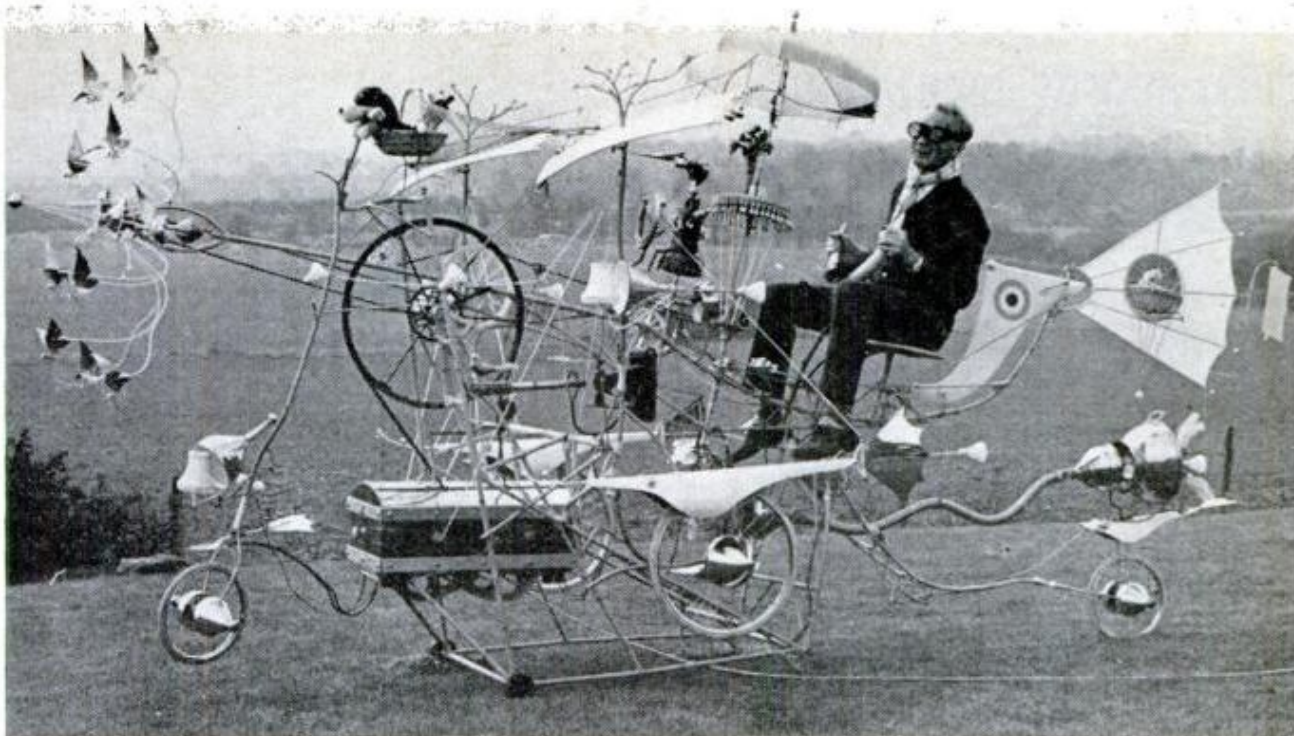

Gentleman's plane

The "Featherstone Kite Open Basket-Weave Gentleman's Flying Machine" might, at first glance, appear to be incapable of flying. In this case, as with many of inventor Rowland Emmett's other creations, the first impression is correct. It won't fly. Fortunately, Emmett's genius has enabled him to incorporate enough never-before-seen details on the flying machine that no one really cares if it doesn't hit Mach 1. Emmett's in the cockpit (above); the regular pilot appears at far right. Tail assembly appears at right.

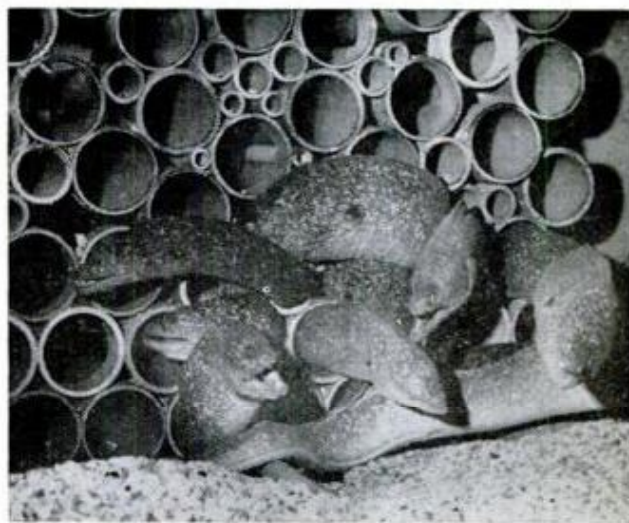
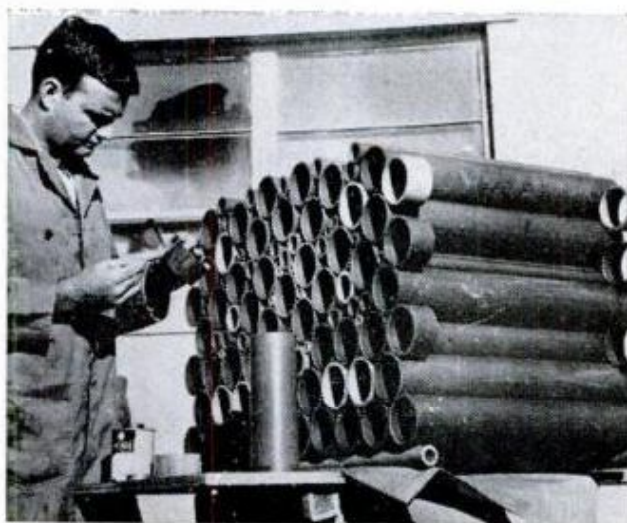

Plastic pipe—a home away from home

To simulate the natural home of moray eels (who like dark crevices) yet display them for visitors, Marineland of the Pacific, Los Angeles, created an "apartment" of plastic pipes.

Newest improvement in hi-fi listening: NOW IT'S 4-CHANNEL STEREO!

Quadrasonic sound uses four separate speakers to literally surround you with music for a realistic concert-hall effect. Here's how the system works and what you'll need to add to your present gear.

By WALTER SALM

Technical Art by Peter Trojan

THERE'S AN EXCITING new kind of hi-fi listening looming on the horizon. It's known by several names—"Surround Sound," "Quadrasonic Stereo" and "4-Channel Stereo." Whatever the name, what it amounts to is the use of four separate channels to deliver music to your ears instead of the usual two in conventional stereo. The idea is to recreate in your living room the full richness of sound as you would hear it live in a concert hall.

Proponents of the system claim that four-channel stereo is as much of an advance over two-channel stereo as the latter was over early single-channel monaural listening. The reason is this: When you listen to live sound in a concert hall or any other large room, you hear it

from many different directions. Part of it is beamed directly at you from the source in front. But a lot of it bounces around the room and is reflected off the walls, floor and ceiling, surrounding and engulfing you with sound. A good bit of it caroms off the rear of the room and is actually heard from *behind* you, although you may not be aware of it.

Conventional stereo brings you essentially the direct sound from in front, but omits the subtle side and rear reflections that enrich and reinforce the music. Surround sound is designed to increase the realism of home listening by using two additional channels to bring you the missed reflections from the rear of the room. In recording four-channel stereo, microphones are placed at the rear of the

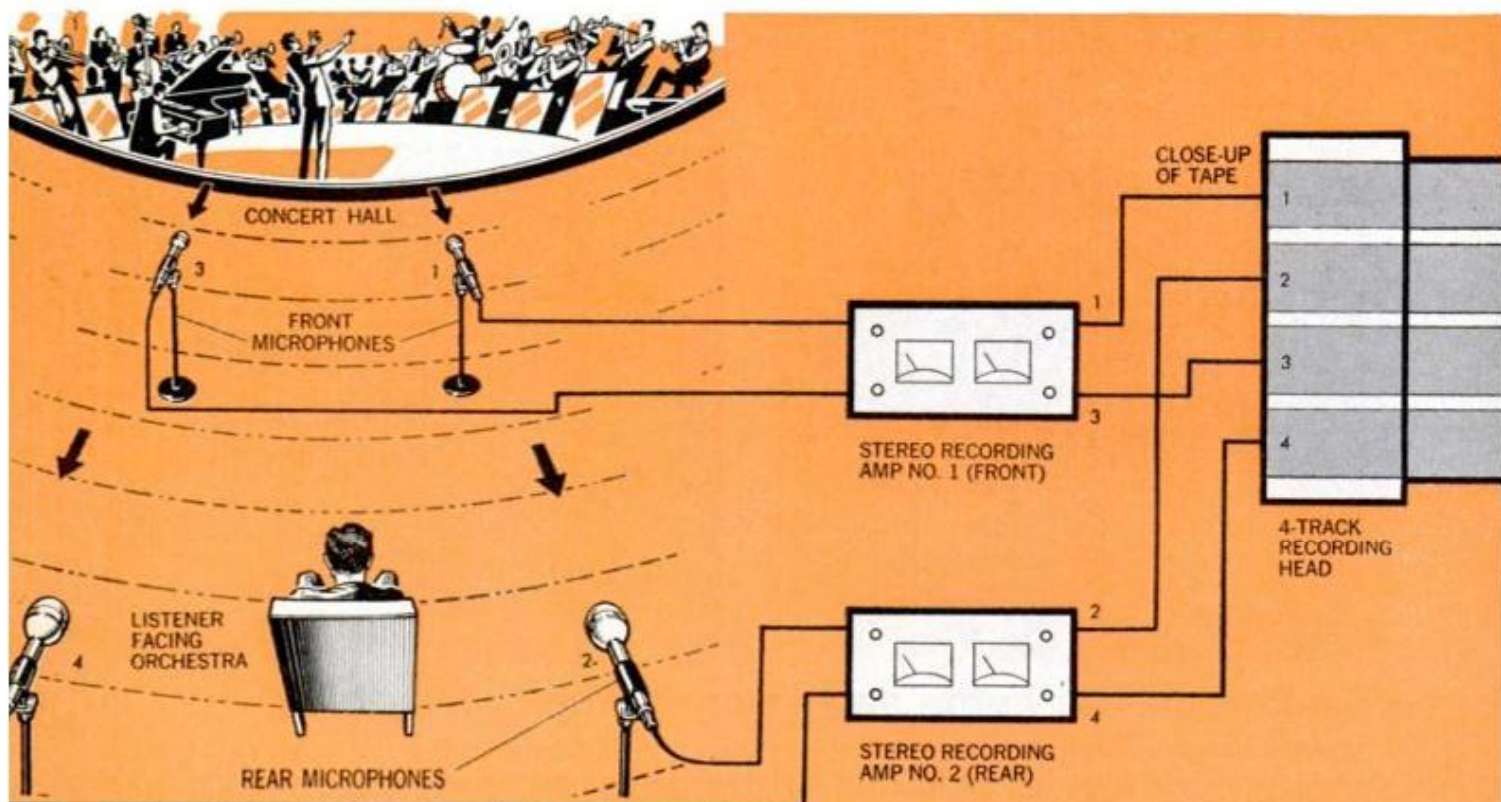

SCOTT'S NEW 4-CHANNEL STEREO AMPLIFIER

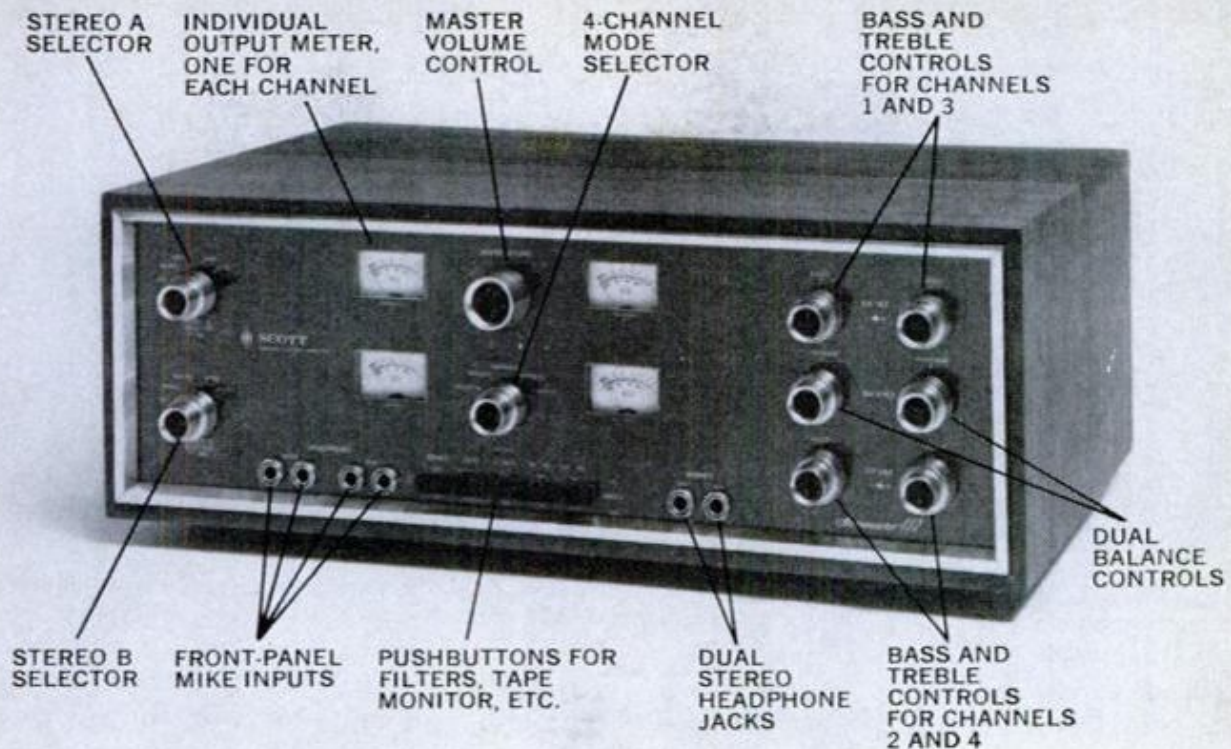

FIRST OF ITS KIND, Scott's new four-channel Quadrant amplifier combines two complete stereo systems

in one unit. It has four mike inputs and individual controls for each channel. Price is \$599.95

concert hall in addition to those up front near the orchestra. The rear microphones pick up the reflected sound a fraction of a second later, creating a rich, reverberant effect.

To listen to four-channel stereo in your home, you need a second stereo amplifier feeding an additional pair of stereo speak-

ers placed at the back of the room. Sound from the forward microphones reaches you through your regular stereo amplifier and front speakers. The added sound from the rear microphones is fed to the second amplifier and rear speakers so you hear it from behind you just as you would in a concert hall. You are literally surrounded

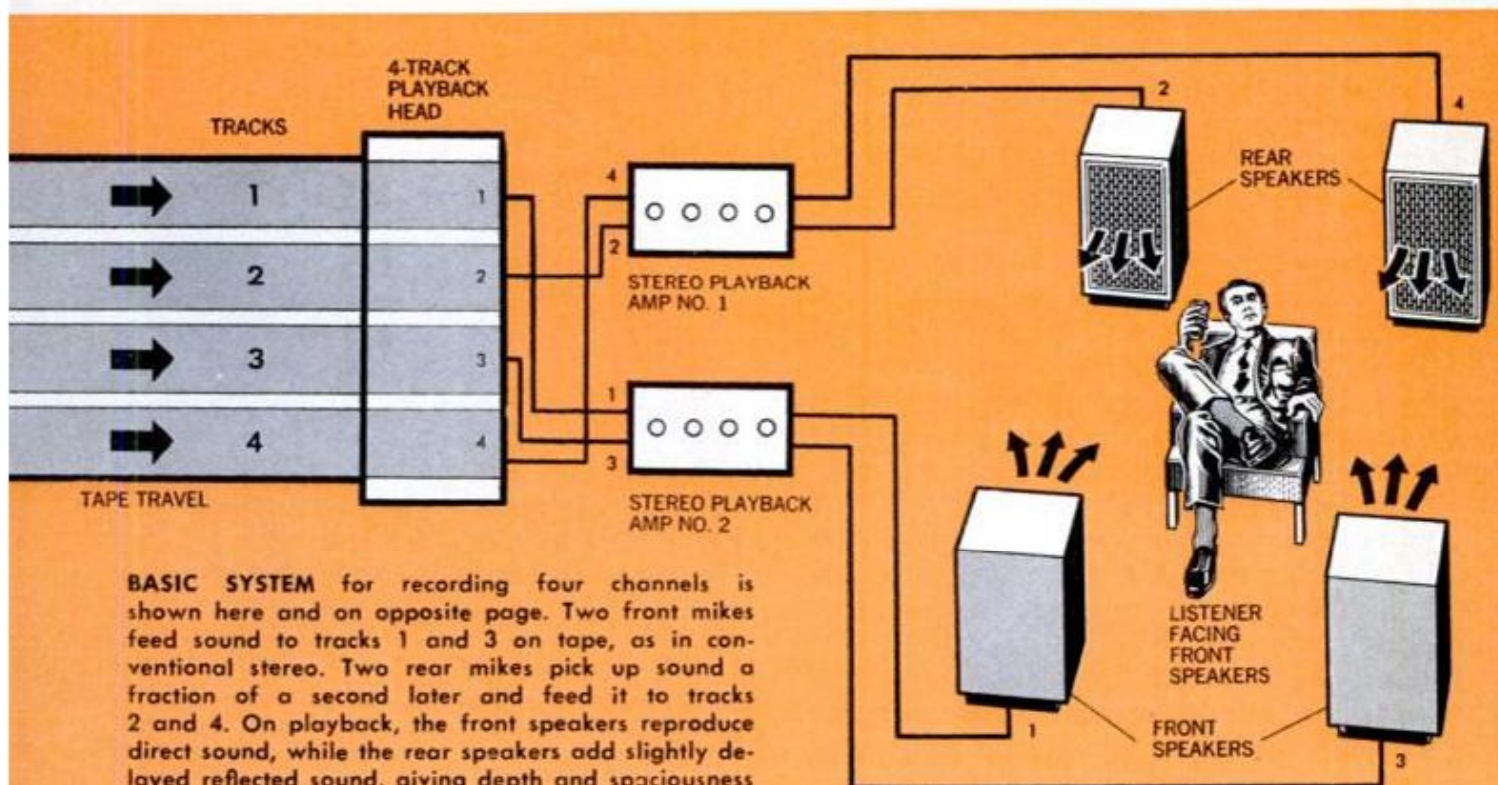

BASIC SYSTEM for recording four channels is shown here and on opposite page. Two front mikes feed sound to tracks 1 and 3 on tape, as in conventional stereo. Two rear mikes pick up sound a fraction of a second later and feed it to tracks 2 and 4. On playback, the front speakers reproduce direct sound, while the rear speakers add slightly delayed reflected sound, giving depth and spaciousness



USING TWO SEPARATE stereo amplifiers stacked together, Teac's tape system both plays and records

on four channels simultaneously. Current model is \$799.50 but will soon be replaced with newer units

by sound, producing a sense of depth and spaciousness similar to that experienced when listening to live music.

Eventually, you'll be able to listen to four-channel stereo from records and FM radio broadcasts. Both of these are still in the future, however. For the present, tape recordings offer the easiest way of bringing quadrasonic sound into the home. The basic two-track, alternate-direction tape system currently in use for regular stereo can, with relatively minor modifications, be adapted to record and play four-channel stereo. Instead of recording two pairs of tracks in opposite directions, all four tracks are recorded simultaneously in the same direction. Tracks 1 and 3 carry sound from the right and left front microphones, as in conventional two-channel stereo. Tracks 2 and 4 add sound picked up by the right and left rear microphones.

Several tape recorder manufacturers already have four-channel reel-to-reel machines on the market. These include Telex, Teac, Crown and 3M Wollensak. In addition, Scott has just introduced a basic four-channel amplifier that can be used with any quadrasonic program source—tape, records or FM radio. These first units are expensive, running around \$500 to \$600 or more, but prices are expected to drop as interest grows and the machines go into mass production.

Vanguard already has a few four-channel tapes on the market, and more are expected to be available soon. Columbia Records has a large library of tape masters

originally recorded with four channels but released with only two for conventional stereo play. Now Columbia plans to re-release these tapes using all four channels. By sticking to the 1-3, 2-4 alternate track system, quadrasonic recordings remain compatible with many current two-channel tapes and tape machines. You could play four-channel tapes on an existing two-track machine and get conventional stereo. Later, when you switch over to new four-channel equipment, you could play the same tapes and get the full four-track effect.

The fact that quadrasonic stereo doubles everything required for conventional stereo doesn't necessarily mean it has to cost twice as much. In fact, the second



COMPACT AND PORTABLE, this 3M Wollensak model plays four-channel quadrasonic tapes, but records only conventional two-channel stereo. It's \$599.95 with 60-watt amplifier, \$499.95 without the amplifier

FOUR-CHANNEL FM STEREO

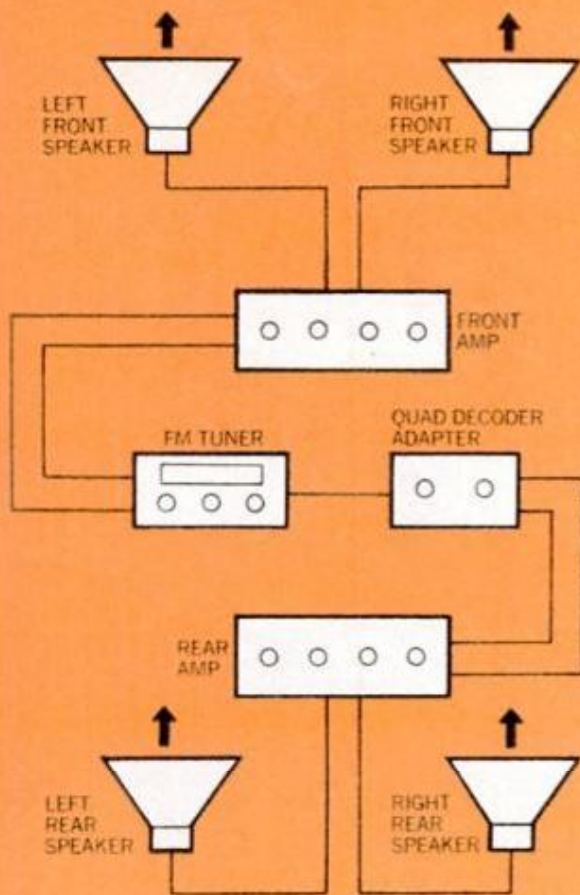

FUTURE SYSTEM for receiving four-channel FM broadcasts will require a special decoder adapter hooked to your regular FM set. This will split off two additional FM signals to feed speakers at the rear of the room. You'll also need a second stereo amplifier to power the speakers, as in diagram above

SIMULATED FOUR-CHANNEL STEREO

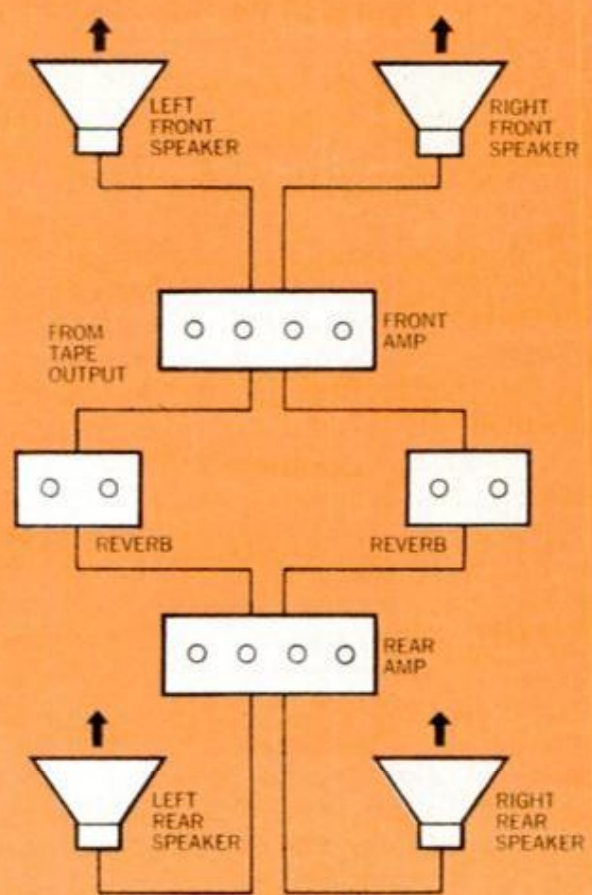

YOU CAN SIMULATE the sound of four-channel stereo with two low-cost guitar-type reverb units connected to your amplifier's tape output jacks. Feeding their signals through a second stereo amplifier to the two rear speakers produces a slight delay or echo effect, adding depth and richness to the sound

half of the system can cost relatively little. This is because the two rear channels require much less power than the front ones and can have a substantially narrower frequency range, probably not more than about 8000 cycles. Almost any low-cost stereo amplifier and a pair of \$10 or \$20 economy speakers will serve nicely.

Exactly how four-channel stereo will be broadcast has not yet been decided. Several systems have been proposed and it will be up to the FCC to determine which one gets the nod. Experimental quadrasonic broadcasts have been tried using two separate FM stations, one to transmit the front two channels and one the rear two. These are similar to early

AVAILABLE IN FOUR MODELS, the Telex four-channel tape machine at right ranges in price from \$500 for a playback-only deck without recording amplifiers to \$1544 for a complete record-playback unit

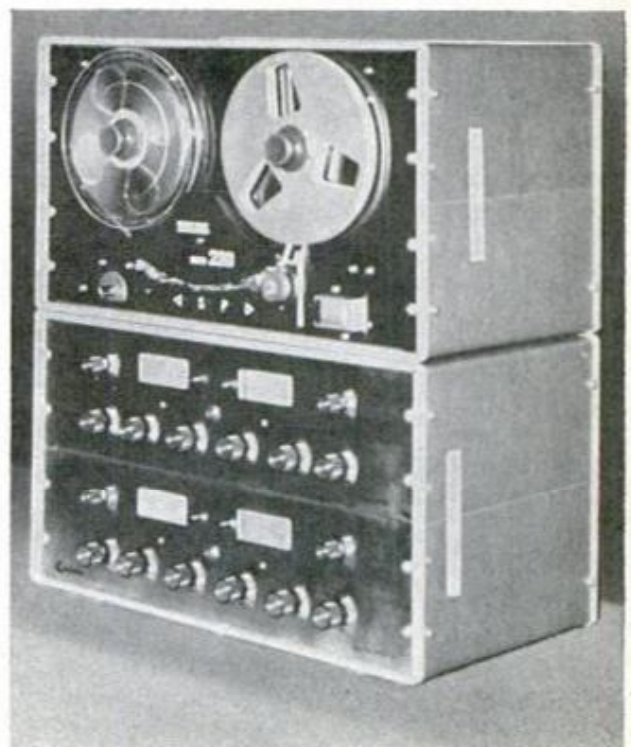

experiments with conventional stereo where an FM and AM station teamed up to make simultaneous broadcasts.

Eventually, you'll be able to receive four-channel FM stereo simply by hooking a small decoder adapter to your present FM tuner or receiver. As in conventional FM multiplexing, the method is based on the use of subcarrier frequencies to transmit the additional channels over the main broadcast band. In the Halstead/Feldman system, one of the leading contenders for FCC approval, the two front channels are transmitted over the main band and a subcarrier frequency of 38 kilohertz. The rear channels are transmitted over two additional subcarrier frequencies of 72 and 92 kilohertz. The 8-kilohertz channel band-width brings the total FM station deviation to 100 kilohertz on either side of the main carrier—the extreme limit allowed by the FCC. The problem is that this leaves no margin of safety at the edges of the band, and it's possible that one station's signal could spill over into an adjacent station's band, causing interference. Whether this objection can be overcome is still not certain.

Bringing up the rear in quadrasonic developments are four-channel disc recordings. These pose even greater difficulties. It's hard to imagine how a stylus could handle four channels simultaneously from a single record groove. Several companies, however, are working on the problem. One outfit, the Audio Data Co. in New York, claims to have developed an encoder-decoder system something like FM multiplexing that can add two extra channels to a regular stereo record groove. The discs can be played on present equipment and will require only a decoder adapter attached to your amplifier.

In the meantime, for those who like to experiment, a kind of simulated four-channel stereo can be rigged up with a couple of inexpensive reverb units of the type sold for use with electric guitars. These reverbs produce a slight time delay or echo effect similar to that supplied by the two rear channels in quadrasonic stereo. You can connect the units to the tape output terminals on any conventional stereo amplifier, one for the left channel and one for the right. The outputs from the reverbs are then fed through a second stereo amplifier to an extra pair of speakers at the back of the room. ★★

NEW IN

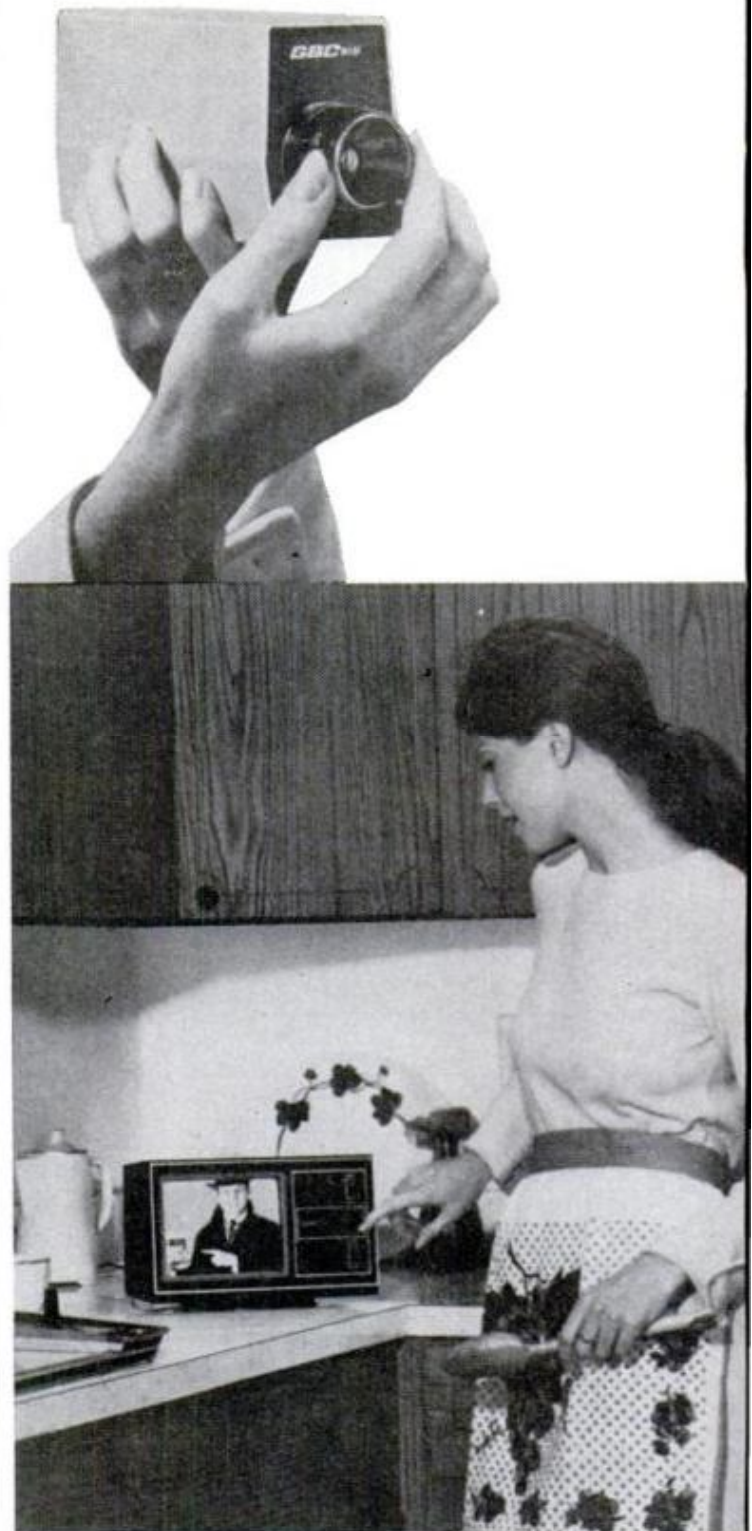

YOU CAN HAVE YOUR OWN closed-circuit TV with this low-cost system for home use. Priced at \$350, it consists of a small TV camera (top photo) and a 7-inch monitor set joined by a cable. Watching the monitor screen, you can check callers at the front door, keep tabs on children playing out in the yard or put on family TV shows for amusement. Called the Mini-CCTV, the system also includes an intercom so you can carry on a two-way conversation between camera and monitor. GBC Closed Circuit TV Corp., 74 Fifth Ave., New York, N.Y.

ELECTRONICS

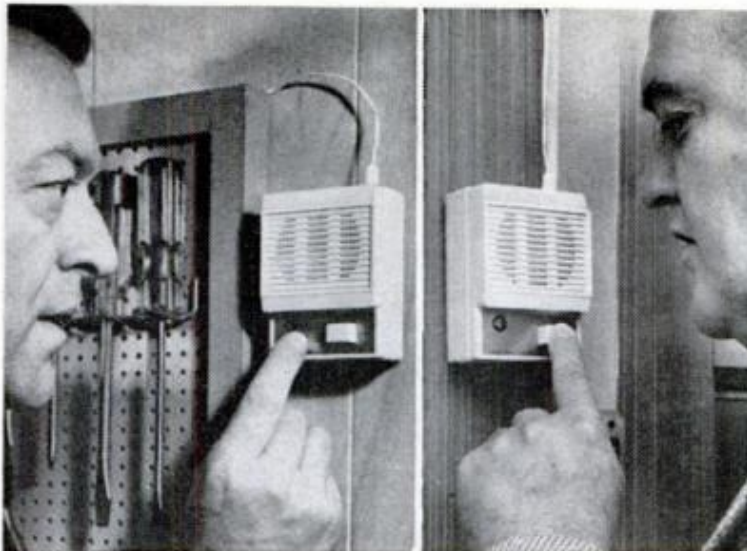

INEXPENSIVE INTERCOMS let you talk between any two locations in your home up to 66 feet apart. One unit can be mounted outside the house at the front door so callers can announce themselves without your having to open the door first. It can also be used for listening, such as for checking on a baby sleeping in another room. The battery-powered transistorized units are said to be sensitive enough to pick up sounds from as far as 8 feet away. Each station can call the other, even when power is not turned on. Price, about \$10, includes wire. Telco, 3710 E. 10th Court, Hialeah, Fla.



THERE ARE 14 SPEAKERS in this unusual console designed for fine hi-fi reproduction. It contains four 15-inch woofers, four 8-inch mid-base, four 6-inch mid-range and two 5-inch horn tweeters. Special controls permit the system to be adjusted to suit different room acoustics. Prices are \$950 finished and \$725 for a semi-finished kit. LWE Div., Acoustron Corp., 2418 Bartlett St., Houston, Tex.

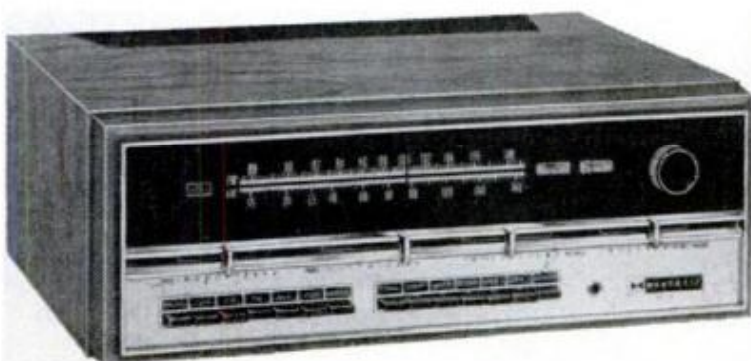

NEW KIT-BUILT STEREO RECEIVER from Heath is an outgrowth of the famous AR-15 introduced several years ago. The latest version, the AR-29, is rated at 100 watts with a frequency range of 5 to 30,000 cycles. Harmonic and IM distortion are less than .25 percent, even at full power. Assembly is simplified by modular plug-in parts boards, self-test circuitry. AM/FM/FM stereo kit is \$285. Heath Co., Benton Harbor, Mich.

BE YOUR OWN BOAT TESTER

PART 3: ON THE WATER

By BOB WHITTIER

DOES YOUR BOAT handle well on high-speed turns? Is its power rated to hull shape, length and weight?

MANY FORCES start working on a boat when you open its throttle, but there's no need to drag a computer aboard to sort them all out. It's enough to have an appreciation of these forces that cause things to happen during acceleration.

The propeller-thrust line of an outboard or stern drive is an appreciable distance below the keel; thrust is therefore applied that far below the hull's line of resistance in the water. When the throttle is shoved forward the boat's bow rises in the air. While the weight of the rig remains unchanged, it is now supported by fewer square feet of bottom area.

Bottom loading temporarily increases at a time when speed is still relatively low, and acceleration is slowed. Since modern hulls tend to be short and wide, a lot of drag exists at this stage. That's why boats with marginal horsepower tend to plow along for some distance before they gradually get up onto plane. That's also why powerful motors are common.

Now, take any handy propeller and put it on a stick to resemble the propeller shaft. Hold this in front of you with the stick angled like a propeller shaft will be when a boat is in bow-high attitude during acceleration. Pick one blade to watch and rotate the prop slowly, remembering that in an actual boat, water will be flowing

into the propeller at an angle. You can readily see how the *actual angle* at which your chosen blade *meets the oncoming water* will vary in the course of each revolution. This makes the stern of the boat "walk" to one side. It isn't a serious problem but when you open the throttle of a light and powerful boat and feel the sideways movement of its stern, it can be a puzzling matter if you don't understand the cause.

The spinning crankshaft and flywheel make an outboard motor want to turn the other way in its steering pivot. The flywheel of an inboard engine and the twist it imparts to the propeller shaft make the boat want to roll in the other direction. Some pre-World War I speedboats rolled right over from propeller torque when their throttles were opened quickly!

While a boat is getting up onto plane watch what happens to your forward vision in various speed ranges. Momentary blocking of forward vision by the bow during quick takeoffs is of little consequence. But if you have to travel a long distance within a speed limit, you may not want a boat that puts its nose up so much at low and intermediate speeds that vision is impaired.

Once you get onto plane and are mov-



BIG WAKE AND WAVE under tug's stern creates suction on the hull that limits the boat's maximum speed



DESPITE ENGINE WEIGHT AFT, most houseboats carry enough weight forward to plane at flat angle

ing swiftly, release the steering wheel cautiously to see if the boat will stay on course. Sometimes you find one that'll slam over into a turn immediately when the wheel is released and this is not good; it is tiring to hold pressure on the wheel to stay on course, and if you should impulsively happen to let go of the wheel to grab a windblown cap the boat could get away from you.

On a test drive, make sure that any tendency to veer off course is something that can be corrected with appropriate adjustments—friction adjustments, trim tabs or an exhaust snout placed at an angle on the motor to compensate. Otherwise, no sale.

How well a boat accelerates and what its cruising and top speeds are depend not only on the power and weight, but on the propeller installed. Typically, a two-blade, high-pitch, small-diameter prop will give high speed with a light load, but will produce sluggish acceleration. A four-blade, low-pitch propeller of larger diameter will push a heavy load onto plane easily but top speed will be limited. In between these extremes may be several three-blade propellers, each tailored for a particular gross weight for the whole rig. In test-driving a boat always ask what propeller is installed and judge acceleration and speed accordingly.

The tilt of an outboard or stern drive lower unit can be altered by means of a pin-and-hole arrangement. In general the prop shaft should be parallel to the keel line of the boat but you often may find it worthwhile to experiment with other settings.

It's a little known fact that there is a horizontal fin called the cavitation plate just above the propeller of an outboard or stern drive that keeps air from being sucked down into the propeller. It is large enough to create a surprising amount of

upward or downward pressure when speeding through the water at some angle of tilt.

You may encounter cases in which a forward-tilted lower unit produces so much uplift on the cavitation plate that steering friction is considerably reduced, making for light, "wild" handling. There are other cases in which a lower unit tilted too far aft has so much download on its cavitation plate that it tends to pull down the stern of a boat in sharp turns. So don't forget the possibility that water pressure on a cavitation plate is not parallel to water flow.

While running straight en route to a test area, observe the attitude of the boat in the water and the riding qualities. It's normal for conventional boats to list slightly due to propeller torque. Usually the weight of the driver on one side when running solo will counter this adequately, and sometimes an additional correction is made by locating the battery or a gas tank on the high side. If the boat still lists, there might be a defect such as a warped bottom.

Conventionally shaped planing boats in the runabout class normally tend to list *into* the wind when running crosswind, so don't worry if you notice this.

The aspect of ratio of length to width of the bottom's planing surface also affects riding attitude. Typically, a short, wide hull will plane at a higher angle than will a long, narrow one. If the angle is too high or too low, it will cause drag.

You'll hear much patter around boat clubs about the smooth wake of this or that boat, the inference being that somehow a particular designer has waved a magic wand, uttered incantations and come up with a hull that has a smooth wake and therefore is somehow better. A large wake does not indicate a poorly de-

signed boat, just one that is heavier, or less powerful in proportion to its weight, than another boat.

Around boating men, you hear references to "wet" and "dry" boats. This is nautical lingo for spray-throwing qualities. A wet boat is one that drenches you with its own spray!

Things like how deep in the water or high on the surface a boat runs, the location and size of spray rails, the shape of the bottom and wave size determine spray-throwing characteristics. If there's a touchstone to the spray matter, it is this. Take a boat of any length. *The wider you make it, the blunter must be its bow*, and the more it will butt into waves and throw spray forward. It's the spray thrown ahead of a boat that is picked up by the wind and dumped back on you. Other things being equal, a boat whose bow throws spray out to each side is

. . . put a new boat through a series of figure-eight turns of gradually decreasing size.

likely to be dryer than one which throws it forward.

Riding and handling qualities on waves are important, for every boat meets its share of rough going. You can try running over the wakes of other boats to simulate rough water, but if it's a comfortable rough-water boat you want, only a test run on genuine wind-driven waves will tell the true story.

The real key to riding quality is the relation between the length of the boat and the distance between the wave crests. Whether it's a pram or an ocean liner, any boat will give you a rough ride when the distance from wave crest to wave crest is nearly the same as the hull's waterlength line because of hull pitching action.

For use on large lakes and coastal waters, a boat with a long hull that will straddle the crests of two or more waves at once will keep pitching action at a minimum.

It's wise to put a new boat through a series of figure-eight turns of gradually

decreasing size. This reveals how a boat will act in right and left turns and when going at all angles to the waves. How a boat goes into these turns depends on how easily the bottom shape lets it lean into a bank.

The purpose of banking is to resist centrifugal force. The deflected propeller thrust encourages banking. In fact, it produces such a powerful banking force it can easily overturn a boat if you swing the steerer over too abruptly. As your turns become sharper, you will feel more reaction.

A boat that is banking too little for its speed and the sharpness of the turn tells you so by a feeling in the seat of your pants of sliding across the seat to the outside of the turn under the influence of centrifugal force. One that banks too much or too abruptly feels as if it were giving you an unpleasant up-and-down seesaw ride as you go from a left turn into a right one and vice versa. One that banks just right makes you feel secure in the seat, regardless of the tightness of the turn.

As your turns get really tight, be on the lookout for signs of "spinning out"—the stern is swinging so far out that there's danger of the boat turning end-for-end. To test for this, drop a wad of paper on the water, go some distance away, bear down on the paper and see how well the boat responds to a quick, slight avoiding motion of the wheel.

Another sensible test is to pick out a buoy or other fixed object on the water to use as a reference point and pass somewhat to one side of it. As you pass it, turn and watch to see how much the boat drifts to the outside of the turn. A boat that drifts to the outside (through inadequate banking or inadequate keel area) is a dangerous one, for some day when operating on a winding river or in a busy channel you might make a fast turn and find



AUTHOR TESTING A BOAT with a relatively long, narrow hull designed to reduce pitching in choppy seas

yourself drifting helplessly to the outside of the turn—right into the shore or another boat.

Light, fast boats sometimes “porpoise”; they gallop up and down rhythmically as they move along. Porpoising usually results from an improper relationship between the boat’s center of lift and center of gravity. As it goes faster it rises out of the water more and rides on the aftermost part of its bottom. Then the center of lift is too far back. The bow drops, bounces up, drops again, and this continues indefinitely.

True porpoising can take place even on calm water; don’t confuse it with an occasional up-and-down bouncing of the bow caused when you meeting a stray wave from some other boat’s wake. Porpoising can usually be stopped by moving weight forward in the hull. Rarely, at least in new boats, porpoising is caused by a hump, hollow or hook in the planing bottom as a result of bad workmanship or hull distortion.

One last thing. Sometime during your test run, throttle back to the engine’s normal cruising rpm and get a good idea of the boat’s cruising speed. Modern motors are so smooth it is often hard to throttle back to proper cruising rpm without the aid of a tachometer. If there’s no tach, a good salesman will know his motor well enough to help you pick out cruising rpm by sound.

Most outboard motors have an “economizer linkage” built into their throttles and spark advance mechanisms. These linkages are designed to adjust the throttle and spark settings to the most economical positions when the motor is throttled to cruising rpm, hence you can see how important it is to know what kind of speed the boat delivers at this particular engine setting.

A smaller motor that has to be run nearly wide open in order to maintain a satisfying speed will often burn more gas and wear out faster than a larger motor that is able to give the same speed while just loafing along at its designed cruising rpm.

This ends my third and last installment in the boat-testing series. If you follow my suggestions you should have no trouble picking out a boat that will give you all the comfort and performance you desire. ★★★

MAY 1970



Largest walking dragline

Able to lift 195 tons (130 cubic yards) in its huge bucket, the American-made Marion 8900 is shown at work in an Australian coal mine. It can travel 800 feet per hour.

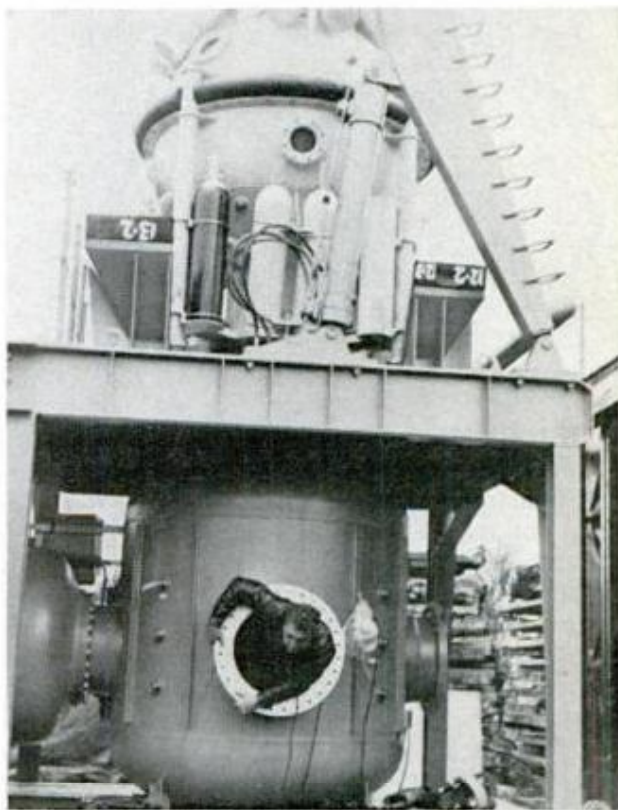

Deep-sea bell

A new system by Strongwork Diving of England has a 6-foot diving bell (top) that clamps to a decompression chamber and frame on deck. The pressurized bell can descend to a depth of 600 feet.

NEW IN

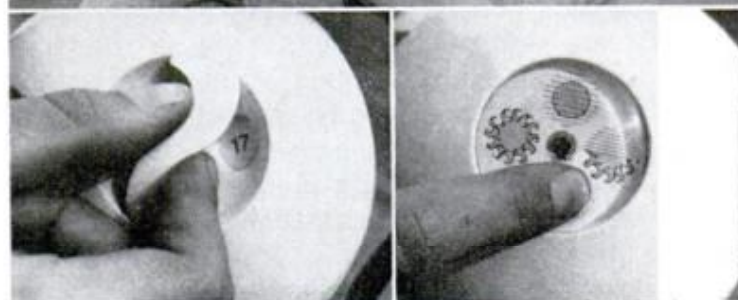
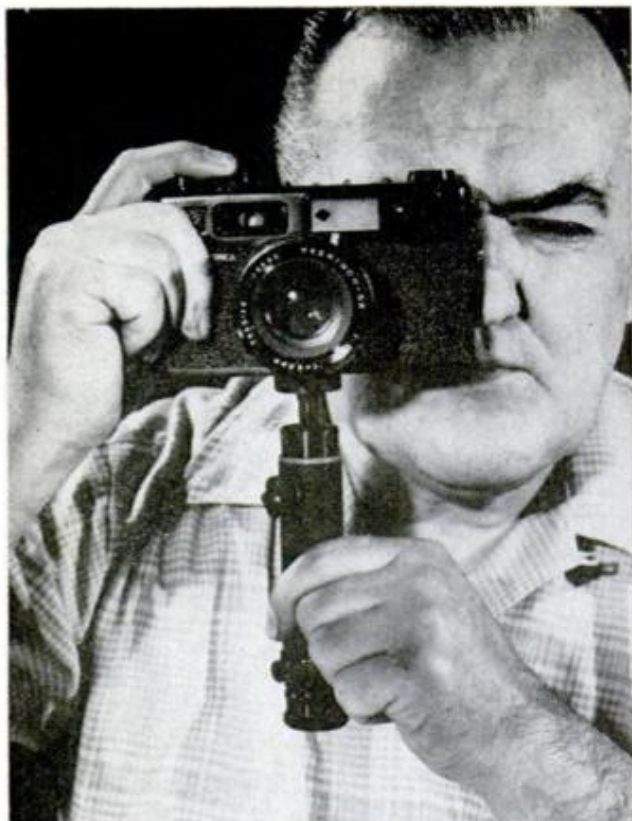

A DETACHABLE HANDGRIP that turns into a tripod is a feature of the newest 35-mm Yashica (above). As a handle, the grip screws into the tripod socket to help you hold the camera (top photo). Folded up inside is a three-legged attachment that slides out and screws onto the lower end of the handle (left, above). This forms a shorty tripod to support the camera for tabletop photography or long time exposures. It can also be used as a chest pod for steadier freehand shooting. Called the Electro 35GT, the new model has a built-in exposure system that automatically sets the speed from 1/500th of a second to 30 seconds depending on light conditions. While it has a fixed lens, supplementary telephoto and wide-angle lens attachments are available. There's also provision for adding flash. Price, about \$142. Yashica, Inc., 50-17 Queens Blvd., Woodside, N. Y.

THIS STRANGE-LOOKING BALL is actually a camera—a far-out design conceived by students at London's Royal College of Art. Its object: to simplify picture-taking and get rid of projecting controls that stick out around conventional cameras. A recessed knob (lower photo at left) advances the film and cocks the shutter. To set the correct exposure, you turn another recessed control to the appropriate weather symbol (lower right).



LOW-COST RAPID-FIRE CAMERA has a spring-motor drive that lets you shoot as fast as you can press the shutter release. The wind-up motor automatically advances the film and cocks the shutter after each shot so you're ready for the next one. Called the Ricoh Compact Hi-Color 35, the 35-mm camera has a built-in exposure system, f/2.8 lens, speeds up to 1/300th second. Price is \$75. Lenco Photo Products, 2414 W. Devon, Chicago, Ill.

PHOTOGRAPHY



BORDERLESS PRINTS are easy to make with this vacuum-operated enlarging easel. The device connects to any standard household vacuum cleaner and draws air through tiny perforations in the top. This holds printing paper flat and wrinkle-free and eliminates the usual hold-down clips that produce borders. Two sizes take prints up to 11x14 inches for \$29.95, to 16x20 for \$49.95. Hudson Photographic Ind., 2 S. Buckout St., Irvington, N.Y.



QUICK-CHARGING ELECTRONIC FLASH takes only three hours to restore its batteries to full power—about half the time usually required. The Capro FL-7 strobe, shown with its accessory charger above, gives 50 flashes per charge, recycles in seven seconds. Price for gun and charger, \$49.95. Ehrenreich Photo-Optical, 623 Stewart Ave., Garden City, N.Y.

MAY 1970



ONE-LEGGED CAMERA SUPPORT has a stirrup-like fitting at the bottom. You just slip your foot into the stirrup to anchor it firmly to the ground. A swivel allows the telescoping leg to tilt in any direction for easy positioning of the camera. Called the Stirrupod, the device was invented by New York photographer Bill Tetlow who hopes to market it soon.



GUNSTOCK CAMERA MOUNT gives you a steady support when you're working with long telephoto lenses. The lens platform slides along a rail so you can adjust the camera to any desired position. Squeezing a trigger in the pistol grip actuates a cable to trip shutter. Price of Soligor mount is \$29.95. Allied Impex, 168 Glen Cove Rd., Carle Place, N.Y.

145

Материал, защищенный авторским правом

HOW to Troubleshoot Some of Those 'NEWFANGLED GADGETS'

Hidden headlights, antennas, electronic voltage regulators—some are gimmicks, some advancements, but all might need fixing

By MORT SCHULTZ

IN RECENT YEARS, car owners have had many new devices offered as options or provided as standard equipment. If you know something about them your chances of accurately troubleshooting a problem will be much better.

Windshield radio antennas have been offered as an option for a couple of years. However, the trend seems to be to provide the antenna as standard equipment.

The antenna placed inside the windshield has little effect on FM reception. The only adverse reaction may be a faint "swishing"

sound on weaker FM stations as wipers pass over the windshield antenna elements. This is normal. There's nothing you can do about it.

AM reception, on the other hand, can present a problem if the AM antenna trimmer isn't set carefully. This adjustment is supposed to be done by the dealer. It must also be made whenever the radio is removed from the car for repair.

If your radio doesn't receive distant stations that other AM car radios get or if a relatively strong AM station fades in and

EACH HEADLIGHT ASSEMBLY on '69 Riviera has its own vacuum tank. Disconnect it to actuate manually

MECHANICAL LINKAGE connects vacuum tank to headlight assembly. Check for smooth operation

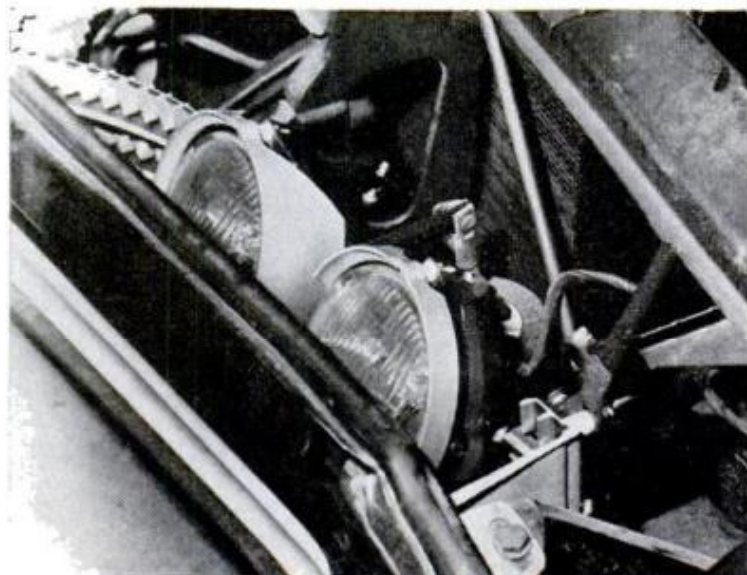
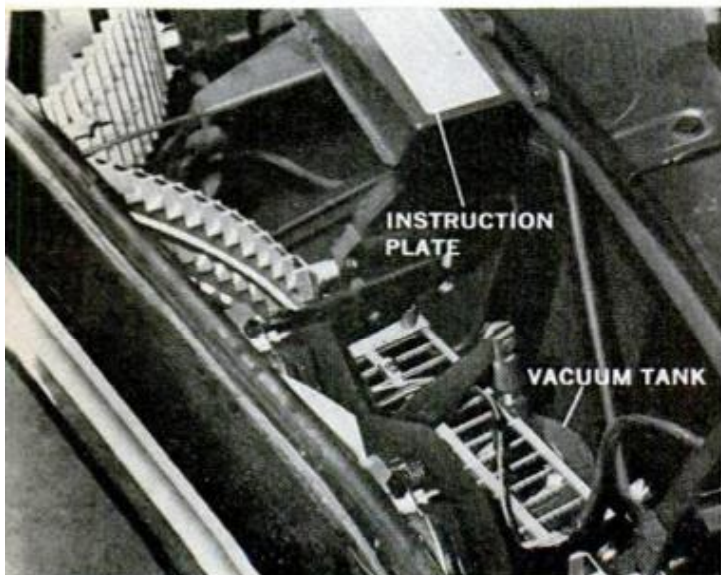



HEADLIGHT COVERS on Toronado are actuated by vacuum. If vacuum fails, remove hoses to lift cover by hand

out, the trimmer adjustment is not set right. To adjust it, set the volume control full and tune in a weak station at about 1400 kc. and turn the antenna trimmer-adjustment screw until you receive maximum volume. The screw is usually found just above the tuning shaft. Peak volume normally occurs when the screw is about one-quarter turn from clockwise position.

Transistorized voltage regulators have been offered by some manufacturers as an option since 1963. Others have them as standard equipment. Here's the line-up:

CHECK FOR SUCTION by hand if no vacuum gauge is available. Also make sure check valve is working

Ford Motor Co. provides transistorized voltage regulators on the 1968-70 Mark III, 1969-70 T-Bird and 1970 Continental.

Chrysler Corp. has transistorized regulators as standard equipment on the 1969 Imperial and on all 1970 models.

GM has treated transistorized regulators pretty much as an option although they're standard on the 1969 (but not the 1970) Pontiac Grand Prix and the Olds 4-4-2.

AMC adopted the unit as standard equipment in 1963.

There are differences in units from

ELECTRIC MOTOR on '70 Dodge Charger operates bar-linkage to each headlight cover. Check connections

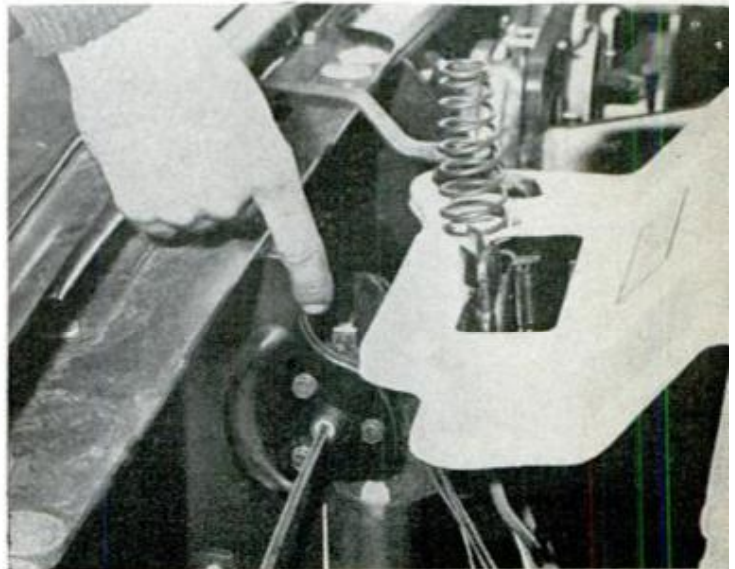

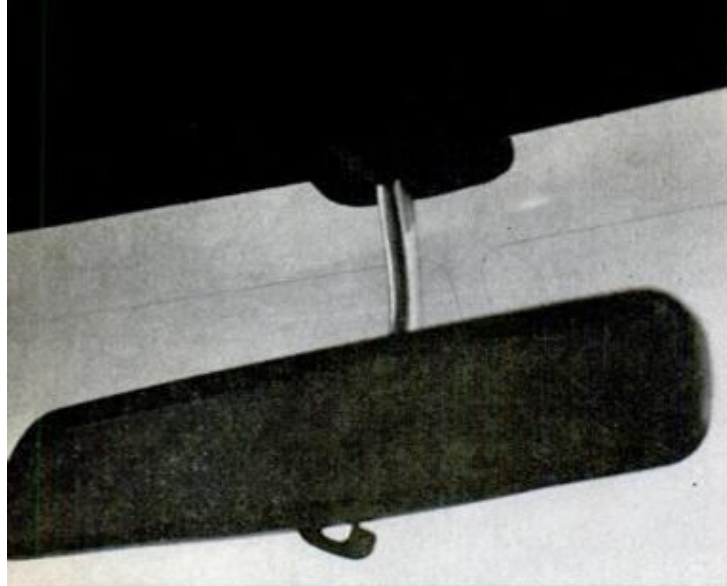

WINDSHIELD ANTENNA, barely visible above, is fast becoming standard equipment. The trimmer adjustment screw is in the radio. On the '70 Olds, it's behind the dial knob. See text for tuning procedure



model to model. For example, on Ford products, the Grand Prix, the Olds 4-4-2 and some other late-model GM cars there are integral microelectronic units that are fitted right to the alternator. That's how you'll recognize one. There are no interconnecting wires to connect the separately mounted regulator to the alternator.

Two tests are required to check on integral voltage-regulator performance. First check the voltage-limiter range. If the voltage-limiter test doesn't provide a reading of 13.5 to 14.5 volts (engine at operating temperature), test the supply voltage before replacing the unit. Otherwise you could throw away a good regulator while keeping your problem.

This regulator is switched on by applying battery voltage from the ignition switch. A resistor wire is in series with

the supply circuit. If the circuit is disconnected or defective, there will be no regulator action and no alternator output.

Supply voltage is tested by connecting a 12-volt test light or voltmeter between the regulator or supply lead and ground. Turn on the ignition. If the light doesn't glow or the meter shows no voltage, the supply circuit is disconnected or broken.

An electronic voltage regulator used on some GM cars from 1963 to 1969 can be recognized by the deep fins of its case. This unit is distinguished from all other transistorized regulators because it can be adjusted. Others aren't adjustable, and if a malfunction occurs, the unit must be replaced.

The GM regulator has a removable plug in its case. The slotted adjusting screw beneath the plug allows an increase or decrease of 0.3 volts for each notch the screw is turned. If a voltage reading of 13.5 to 14.5 (engine at operating temperature) can't be obtained, replace the unit.

The 1969 Imperial has an insulated brush alternator that has both brushes insulated from the alternator frame. It's identified by the short metal strap that connects the positive brush to the heat sink. This alternator has one field terminal, and its transistorized voltage regulator has three terminal posts.

All 1970 Chrysler Corp. cars have an isolated field terminal alternator that has two field terminals. Its transistorized voltage regulator has two terminal posts. It cannot be interchanged with the regulator used in the 1969 Imperial.

If the transistorized voltage regulators of either the '69 Imperial or the '70 models don't meet the following test results, replace the unit:

Ambient Temperature Near Regulator	Voltage Range
80° F.	13.8—14.4
140° F.	13.3—14.0
Above 140° F.	Less than 13.8

The voltage output of the transistorized voltage regulator in AMC models is tested by connecting a 1/4-ohm resistor into the circuit. If a voltmeter doesn't show the following, replace the unit:

Ambient Temperature Near Regulator	Voltage Range
40° F.	14.3—15.0
80° F.	14.0—14.8

Most disappearing headlight covers op-

erate by vacuum. Some function by electricity, such as pre-1968 Dodge Chargers, Corvettes and Buick Rivieras.

If disappearing headlights of the vacuum type fail to work, first check vacuum hoses from manifold to the cover control motor, from the control motor to the distribution valve, from the valve to the headlight switch, and from the vacuum reservoir. These hoses are color-coded for easy identification. Replace those that are split, pinched or kinked.

Now, test each section for adequate vacuum. If you have a gauge, vacuum should be 18-21 inches at the manifold and no less than 14 inches at other outlets. If you do not have a gauge, place your finger over each outlet. You should feel a strong pull.

If vacuum is okay, the problem is in front of the hookup, probably inside the control motor, or with a jammed linkage or binding cover. If you get adequate vacuum at the manifold but not at other points, the problem is a damaged vacuum reservoir, distribution valve or check valve. Most times, the fault lies with the check valve.

Retractable headlights having electric motors function when current is sent to the electric motor. A failure could be caused by a bad switch, faulty wiring or a malfunction in the motor.

Before tearing things down, however, check the linkage that controls the covers. It could be jammed by dirt, so clean it off and lubricate. Another quickie repair is to rap the motor housing with a hammer. (Electric motors sometimes stop because brushes are stuck.) If this fails to free the brushes, repair or replace the motor.

Keep in mind that if you allow a vacuum-operated headlamp system to remain inoperative for a time, the covers open as vacuum escapes. As soon as the engine is started and vacuum builds up, the covers close unless you turn on the lights.

Cars with disappearing headlights built after 1968 have a safety factor. Should vacuum fail, covers are automatically opened by springs inside the control motor.

Rear-window defrosters have been available to new-car buyers for about five years. Up until now, they have been blower motors that direct warm air on the rear window. Chrysler and Ford still use them. GM and VW, however, have switched to an electric element in the window that's

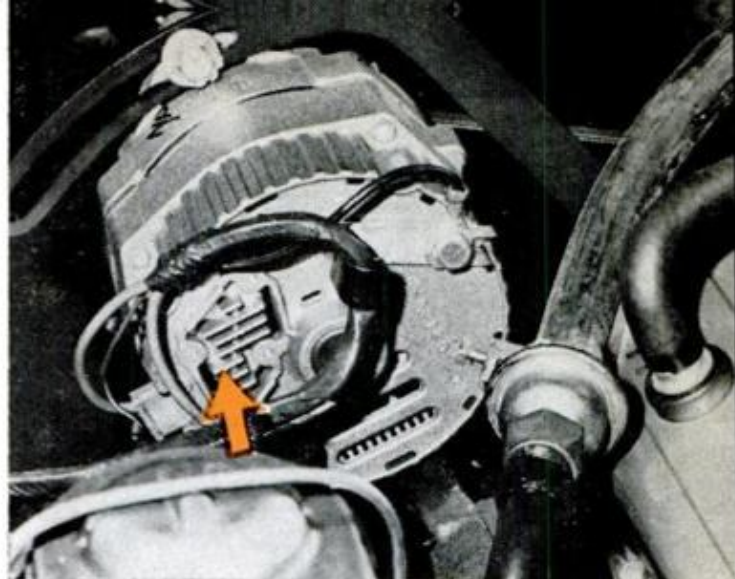

ELECTRONIC VOLTAGE REGULATOR, integral to alternator in '70 Corvette, has no adjustment points. Electronic unit below, in 1970 Chrysler cars, is tested by checking the voltage at Ignition 1 terminal

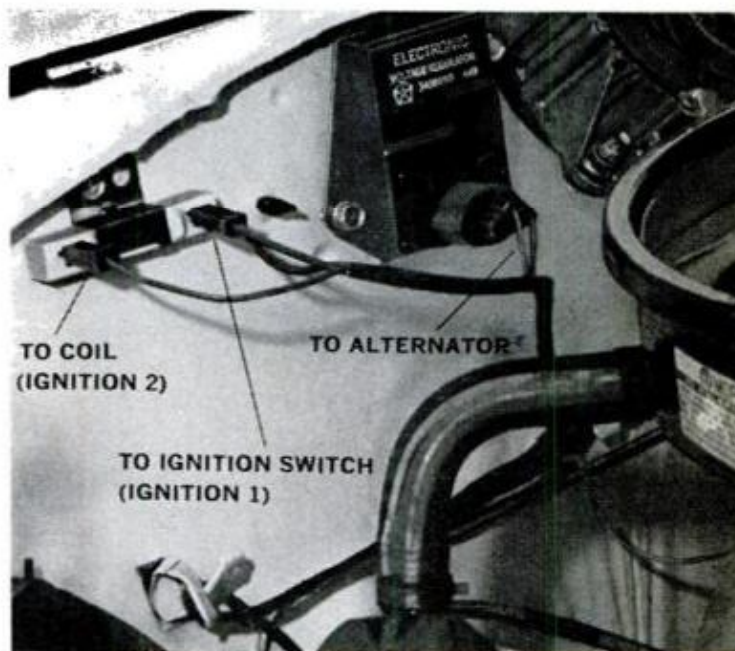

optional on most models. If it's not working, check the fuse first. If blown, there's a short in the circuit that has to be traced. If the fuse is okay, then the cause of the trouble is an open wire, a bad relay or switch, or a faulty ground.

The unit that prevents the rear wheels from locking during a panic stop is, as of now, relatively rare. It's an option on the 1969 and 1970 Mark III and T-Bird, and 1970 Continental and El Dorado.

Troubleshooting consists of listening for an audible click when you turn on the ignition, and testing brakes with rear wheels off the floor. Put transmission into drive, accelerate to about 30 mph, and apply brakes hard. Rear wheels should cycle (stop and go) about five or six times. If not, trouble can be with control module, solenoid or sensors. ★ ★ ★

Workshop Projects You

Decanter Cabinet

Fancy decanter bottles are meant to be displayed, not tucked away in a cupboard. This little wall cabinet will let you show off two of your favorite bottles and still keep their contents under lock and key.

I made this cabinet from $\frac{3}{4}$ -in. fir; pine, cherry and walnut are other fine choices. You may find it necessary to alter the dimensions to suit your bottles. Both side members are alike except for being made right and left-hand to receive the $9\frac{3}{4}$ -in. shelves and plywood back. Run the shelf dadoes before bandsawing side members.

Front pieces, including doors, lap the side members. Make the rabbets on your table saw before bandsawing. Make gains for the hinge leaves so they are flush with the surface. Since there is no room for screws, attach hinges to the doors with epoxy cement. Leave about $\frac{1}{16}$ -in. clearance where doors meet. Sand parts well, stain and finish, and add padlock and hasp last.—*Bob Corley*

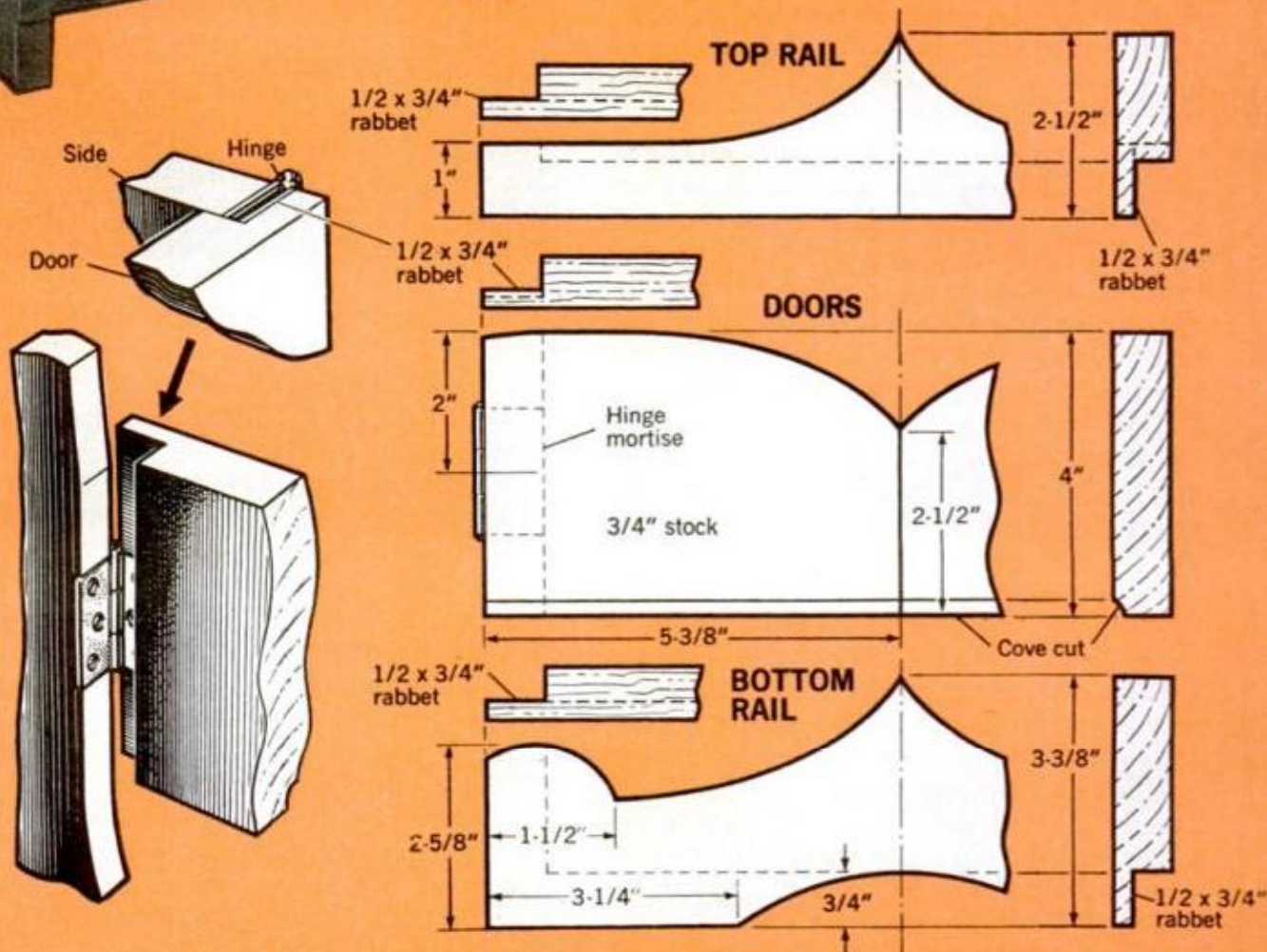
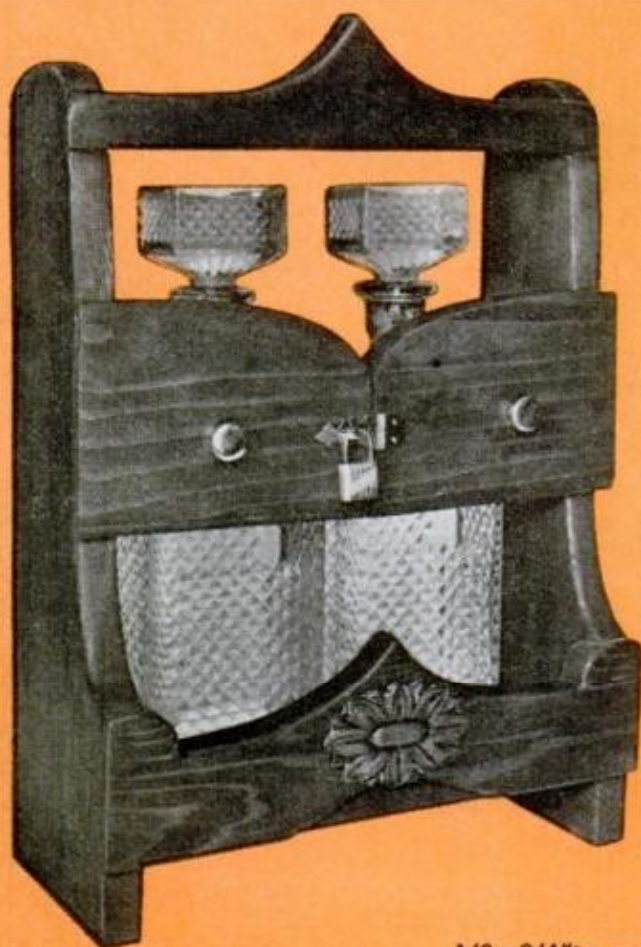

Can Build in a Weekend

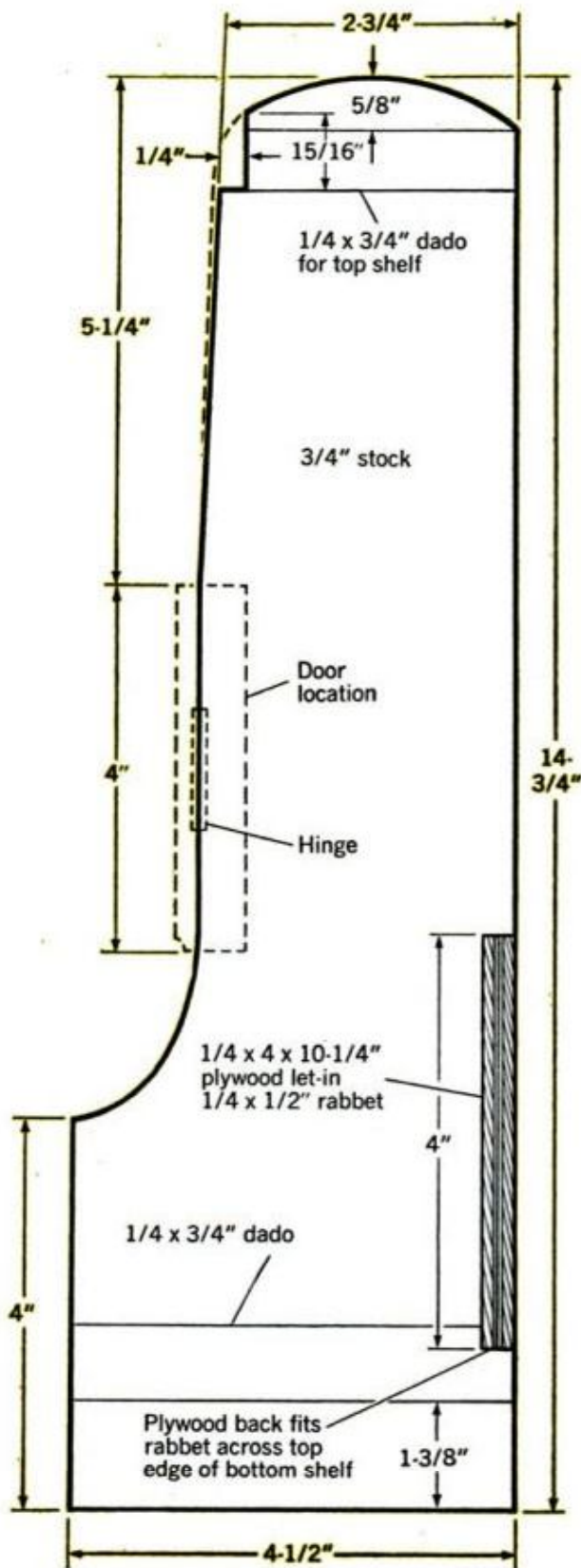

Technical Art by Peter Trojan

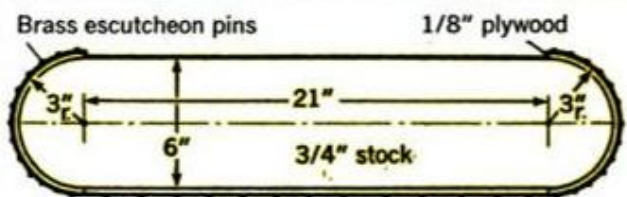
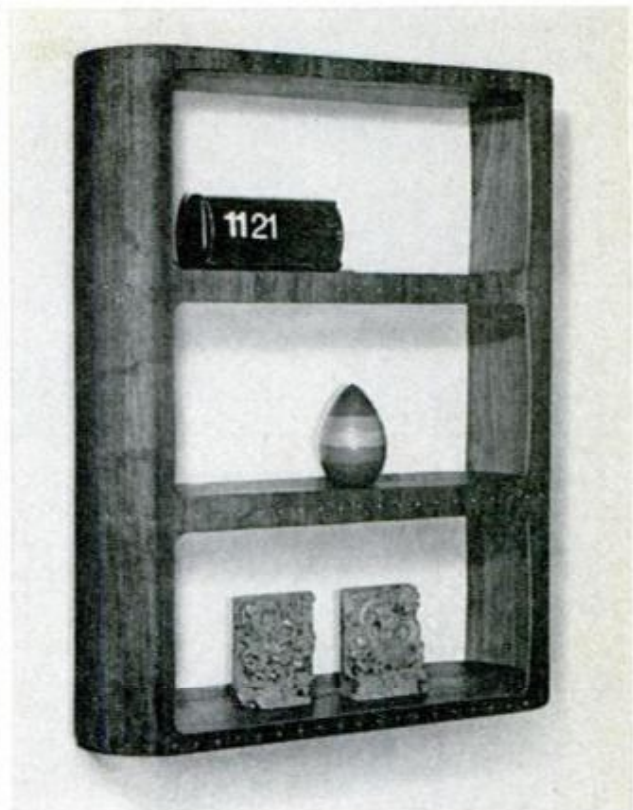

Wraparound Shadow Box

Handsome simple in design, this wrap-around curio shelf is equally as simple to make. It consists of three identical shelves of hardwood "wrapped" with a 1/8-in.-thick panel of marine plywood.

Overall size is a matter of choice, but make sure the cutout panel is large enough to go around the rounded ends of the shelves. Cut and sand the rounded ends of all three shelves while they're tacked together to assure identical pieces.

To wrap the shelves, first soak the ends of the plywood in hot water. Then stand shelves on edge, center the panel over them and start nailing across the front of the shelves. Drive 1/2-in. brass escutcheon nails 1/2 in. apart in straight rows. Then, nail by nail, start wrapping the soaked ends. An extra hand will help to bend the panel and hold it as you drive nails. Leather, plastic and even cardboard can be used as a covering.—Paul Airomi



Handsome Carrying Case

With sides of fancy-grain plywood and the rest covered with simulated vinyl leather, this classy carrying case has anything but a home-made look. It's a fully enclosed box sawed through around its perimeter to form a cover, hinged, covered with vinyl, which is slit with a razor blade, and fitted with luggage hardware.

Fasten the hardwood-plywood top and bottom with glue and hold them with C-clamps, then round all edges slightly. Before applying the vinyl with contact cement, finish exposed plywood surfaces with two coats of clear sealer.

—Kenneth Wells

FITTED with standard luggage hardware, this smart-looking attaché case can be used for school, business or your hobbies

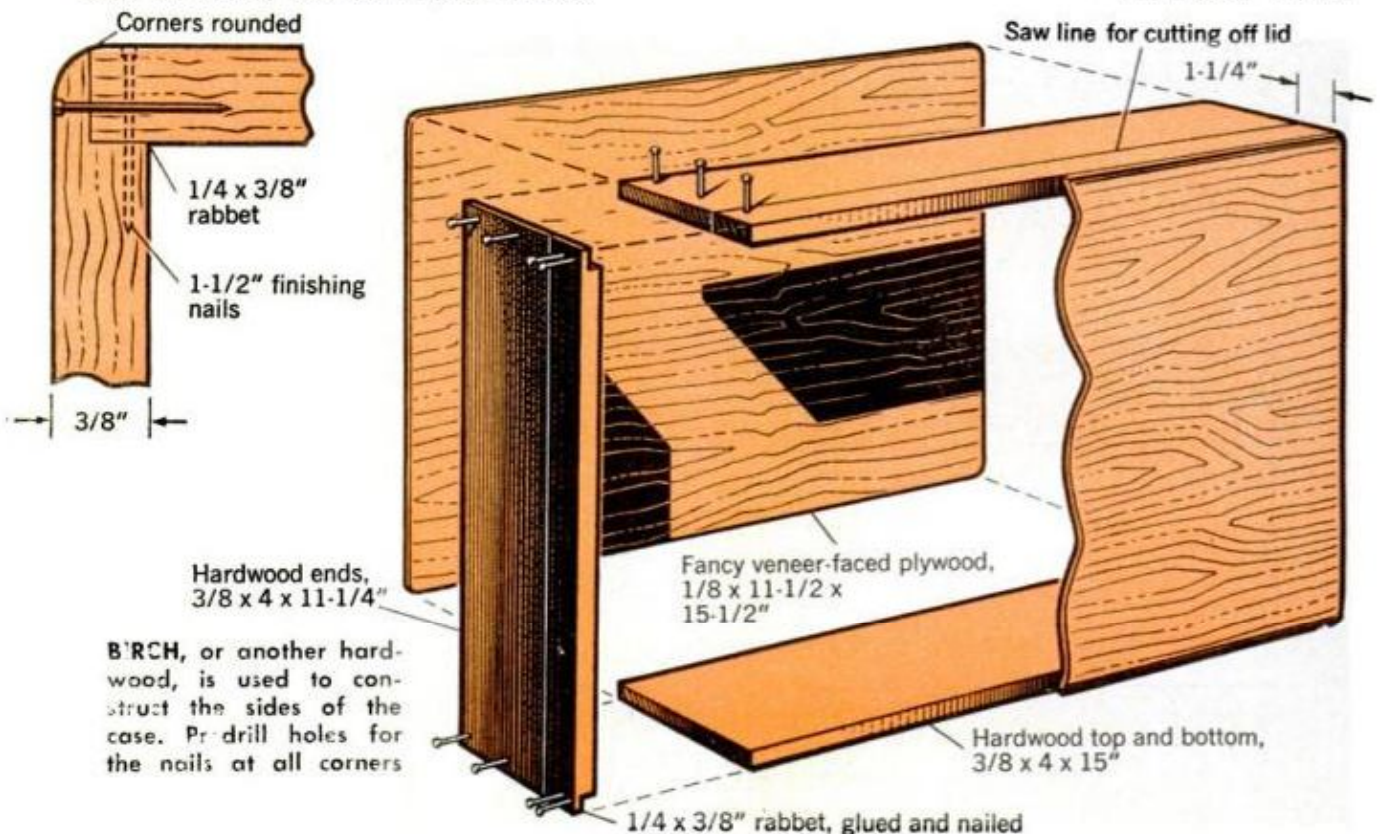

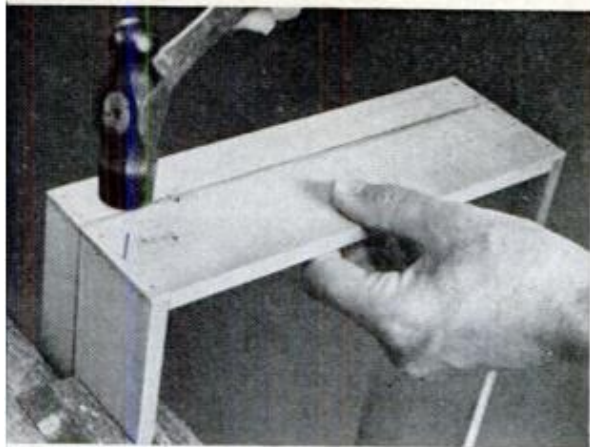

RABBETED CORNERS are glued and nailed. Next, mark sawing line on sides



BOX IS CUT, then plywood sides only are given two coats of a clear sealer

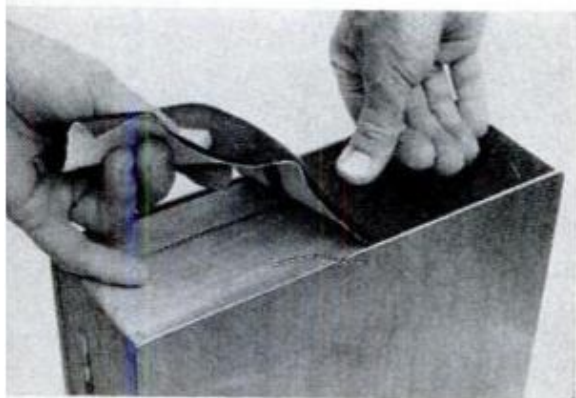

USE CONTACT CEMENT to bond vinyl to box perimeter, put joint at bottom

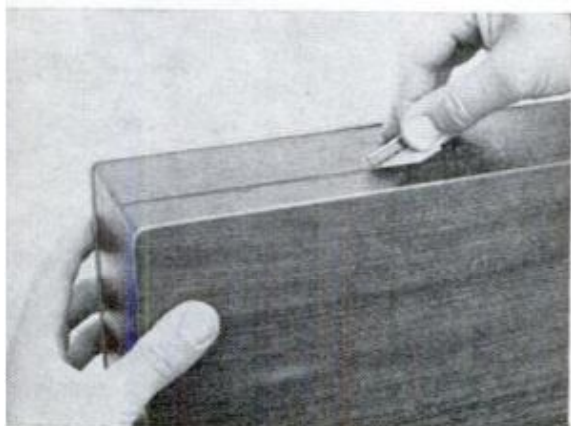

CUT VINYL carefully along the cover line using a single-edge razor blade

MAY 1970



Park Bench for Your Yard

Supported by two or more 1½-in. steel posts set in concrete, this permanent park-type bench is solid as a rock and will last for years. The 2x4 seat slats and back rails are screwed to curved pieces of channel iron which are welded to the tops of the pipe posts. When a slat or rail needs replacing, it's easy to back out the screws.

While it's possible to bend the steel channels cold, they'll bend easier if heated. This can be done with charcoal in the brazier of your patio grill. Chalk a pattern on your concrete driveway and bend the channels to match. Use pliers to grip the hot metal and heat it only at the point of bend. Heap the charcoal over the metal and let it get white hot. For a 6-ft. bench, set the posts 54 in. apart so the 2x4s overhang the channels about 6 in.—Hal Kelly

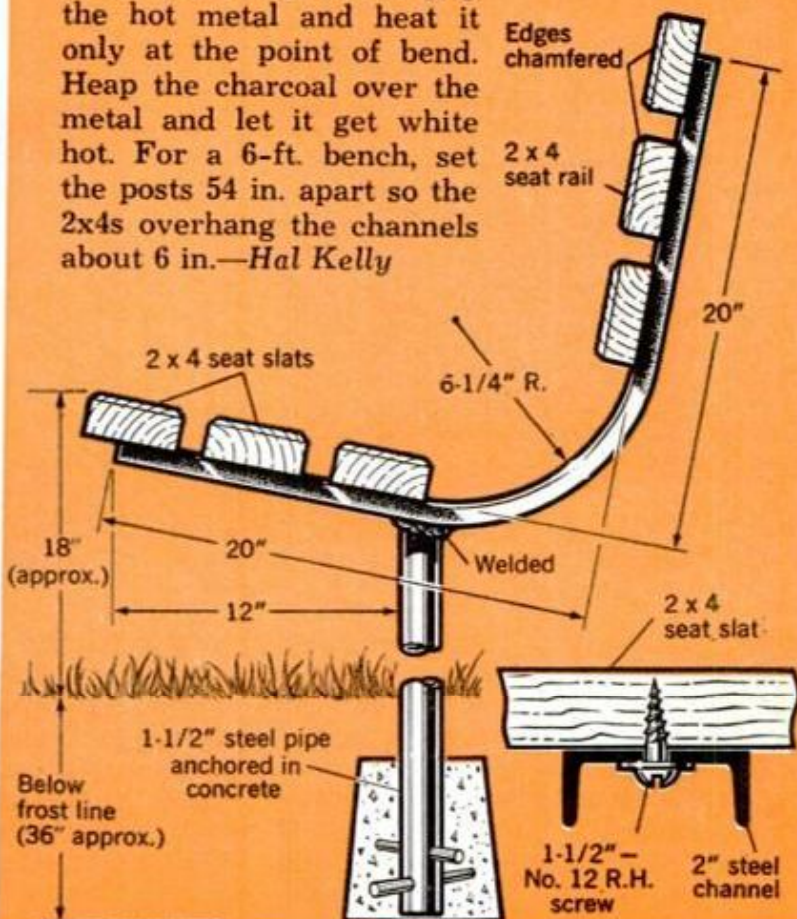

EXCITING NEW PRODUCTS

By CATHERINE BILSKI

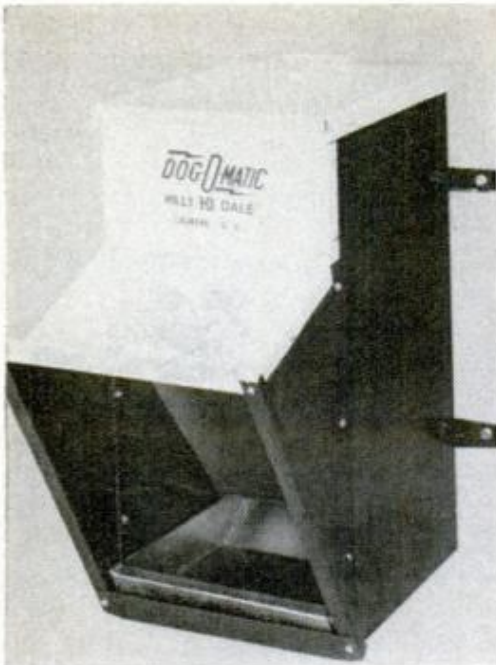

DON'T WORRY ABOUT YOUR DOG not being fed while you're away on vacation. Food will be available to him at all times with the Dog-O-Matic feeder. Just fill the tray, press food injector all the way down and lock into place. The tray holds up to 25 pounds of dog food and keeps it fresh and dry. For limited feeding just fill the tray with desired amount of food. If your dog likes wet food, just add water. Priced at \$24.95 from Saunders & Sons, 14590 Hubbell St., Detroit, Mich. 48227.

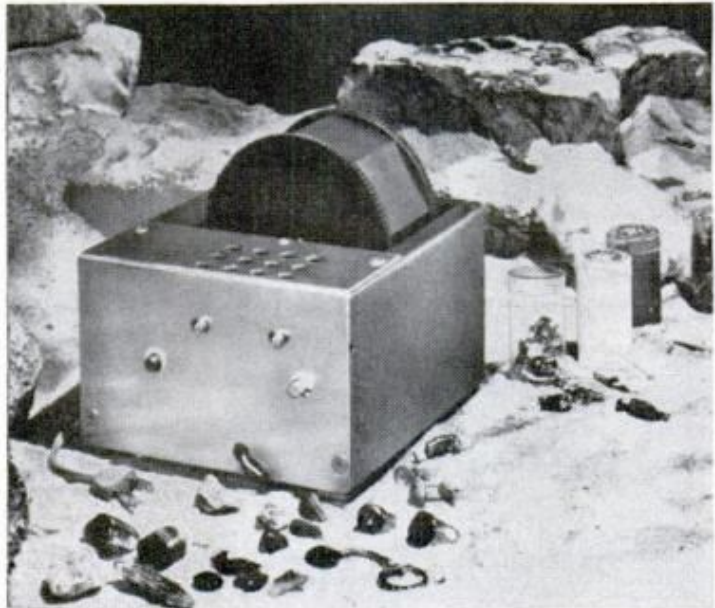

CONVERT ROUGH ROCKS into sparkling gemstones for rings, tieclasps, pins and other jewelry with the Electric Rock Tumbler set. In addition to the tumbler, the set includes a basic rock polisher, four types of gemstones, three grades of grit, jewelry settings, glue for mounting and complete instructions. The deluxe model is priced at about \$30 from Skil Craft Corp., 325 West Huron, Chicago, Ill. 60610. It's great fun for the entire family.

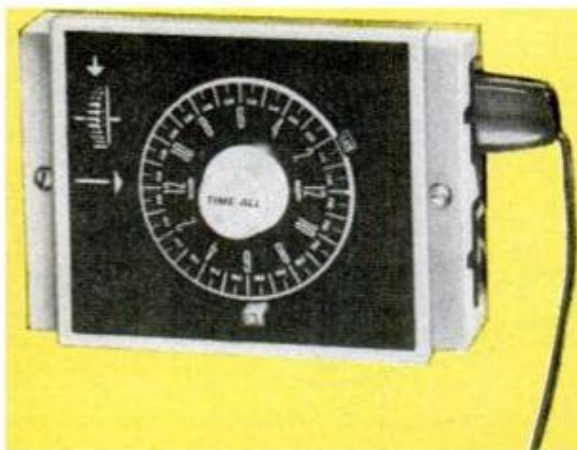

GIVE YOUR HOME that "lived-in" look and discourage burglars with the Intermatic Time-All. This high-capacity unit allows you to turn on (or off) automatically the lamps in your home when you're away. It can also be used to control fans, heaters, TV programs, whatever. Model E-911 retails for \$12.95 and is made by International Register Co., 4700 W. Montrose Ave., Chicago, Ill. 60641.

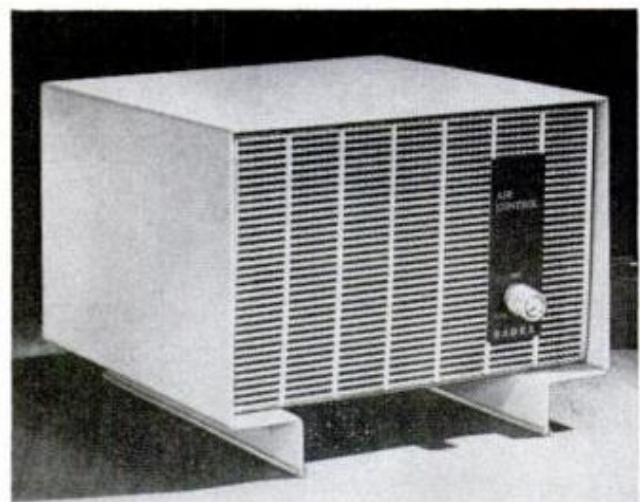

PURIFY THE AIR in your home by eliminating odors with the Radex Air-Control. This small, portable, electronic device employs the principle of adsorption by activated charcoal, which collects odors much like a sponge soaks up liquids. The disposable charcoal filter can be replaced for \$3 postpaid. The unit sells for \$39.95 and is made by Envair Corp., 2201 Oakton St., Evanston, Ill. 60202.



FOR A WEEKEND OF CAMPING or just an afternoon picnic, the Swinger cooler, will keep beverages frosty cold. In addition, it's also great for carrying wet swimsuits, icing down fish or for use as a tackle or toolbox. Available in colors, the cooler sells for \$8.95 from Covey Corp., 8101 Carpenter Freeway, Dallas, Tex. 75247.



A LOT OF TRASH can be compacted neatly in a bag by a new major appliance called the Trash Masher Compactor, recently introduced by the Whirlpool Corp., Benton Harbor, Mich. You simply put in paper, bottles and cans, turn a safety key switch and push a button. Contents are compacted under approximately 2000 pounds of pressure. Price, \$225.

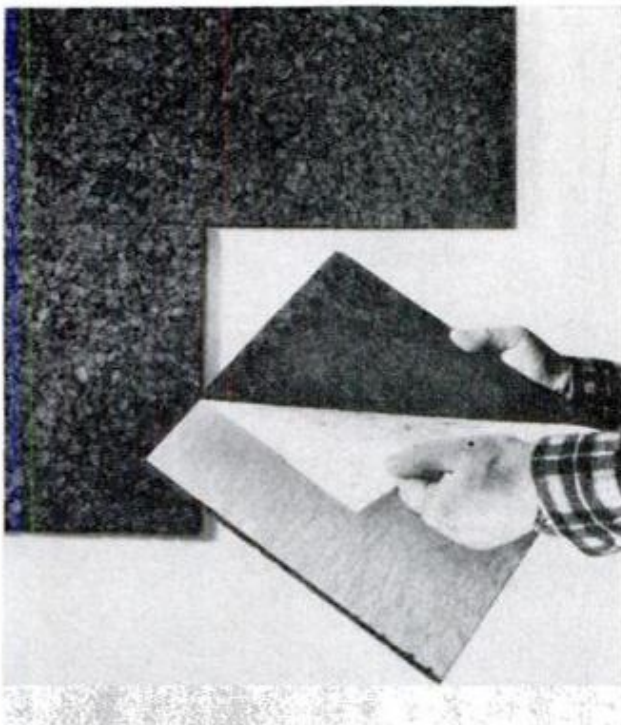

ACCENT YOUR WALLS with self-sticking, natural cork wall panels. Easily applied by peeling off the backing paper and pressing them on the wall, they're ideal for any room or for use as a bulletin board. A box of four 1/2 x12x12-inch panels sell for around \$3.50 from Decro-Wall Corp., Executive Blvd., Elmsford, N.Y. 10523.

MAY 1970



PLUG-IN, THERMAL JIGSAW called the Marvel Maker cuts through a 6-in. block of Styrofoam like butter. Low-voltage transformer provides low or high heat for the blade. Exciting as a toy and handy for modelmakers, designers and florists, it sells for \$12.95, with foam, extra cutter. Lancer Industries Inc., 5782 Thornwood Dr., Goleta, Calif. 93017.

155

What You Should Know About Garbage Disposers

By STEVEN J. HOWARD

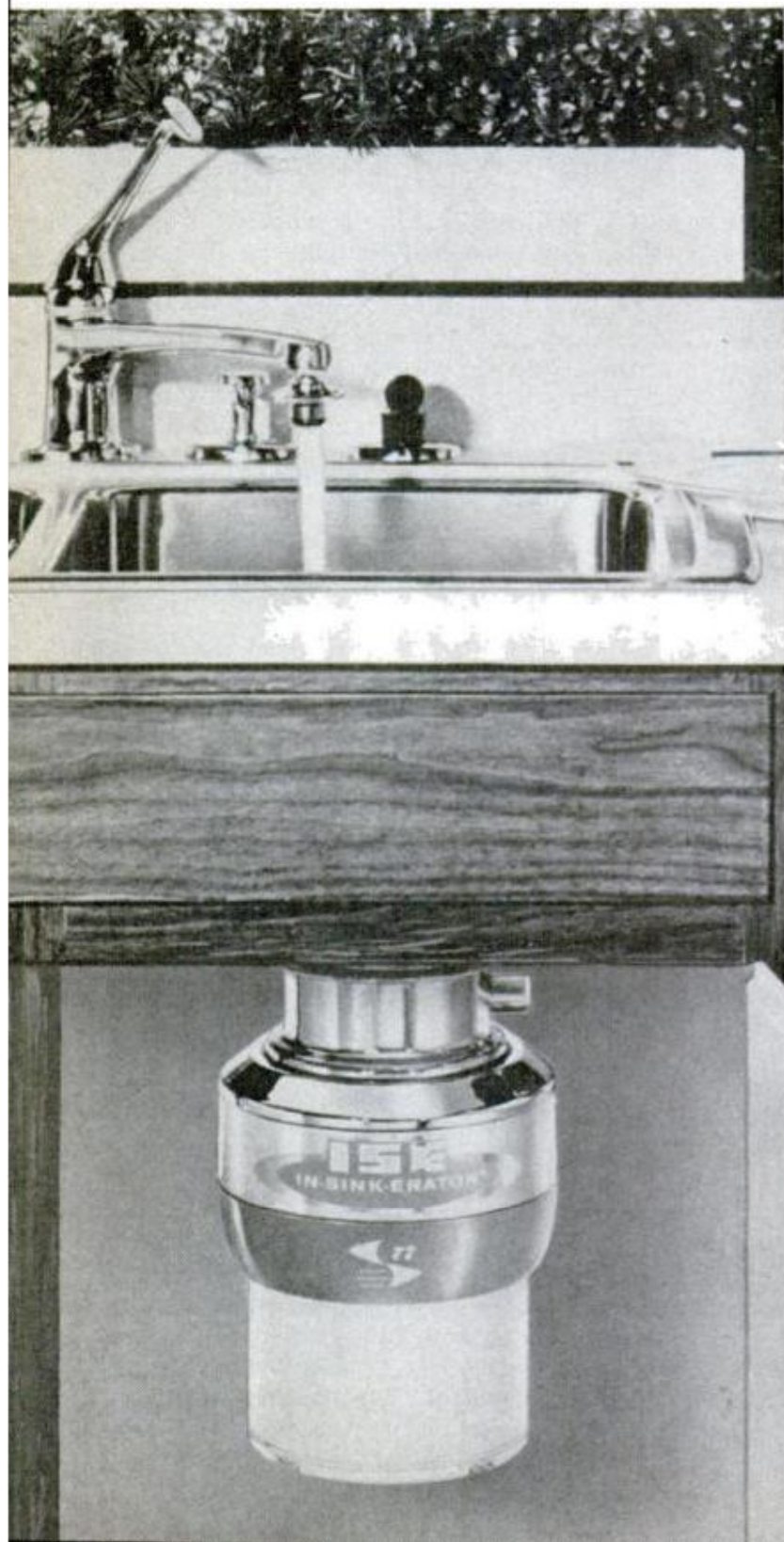

FEW CAN ARGUE with the advantages of a garbage disposer. It creates a more healthful condition by quickly ridding a home of food wastes and, from a practical viewpoint, it cuts down considerably the number of trips to the trash can.

In simple terms, garbage pushed into a disposer is whirled around (about 1725 rpm) and flung against shredders. The shredders have dull edges that pulverize garbage into tiny particles which drop through discharge holes in the drain so they can flow into the sewerage waste line.

Of the two types, continuous and batch feed, the first lets you deposit garbage into the unit while the unit is running. It is operated by an off-on wall switch.

A batch-feed unit does one load

BEFORE STARTING DISPOSER, cold water is turned on to provide continual flow during grinding. With the grinding complete, turn off and flush the unit

When you are ready to plunk down the cash for one, you'll probably wonder how they work, which is best and why the price difference. Here are the answers

Before You Buy One

of garbage at a time. This unit runs only when a cover is placed over its opening and is turned to the lock position. When the cover is turned in the opposite direction the unit shuts off automatically.

Generally, a batch-feed unit costs about \$15 more than a continuous feed. However, if there is any chance of a youngster turning on a continuous-feed system and poking inquisitive hands through the opening, the smartest move is to buy a batch-feed unit. The cover protects those precious fingers.

Not all disposers can handle all kinds of waste, so check the manufacturer's literature before deciding on a model. Most expensive models will easily dispose of bone, corncobs and seafood shells, but some units aren't geared for this type of heavy-duty operation.

No disposer is designed to shred metal objects such as bottle tops and cans, or glass, crockery, rags, string, paper cartons,

REVERSE ACTION in this disposer is possible by flipping the switch at the bottom. On some models, the reverse action is automatic if jamming occurs

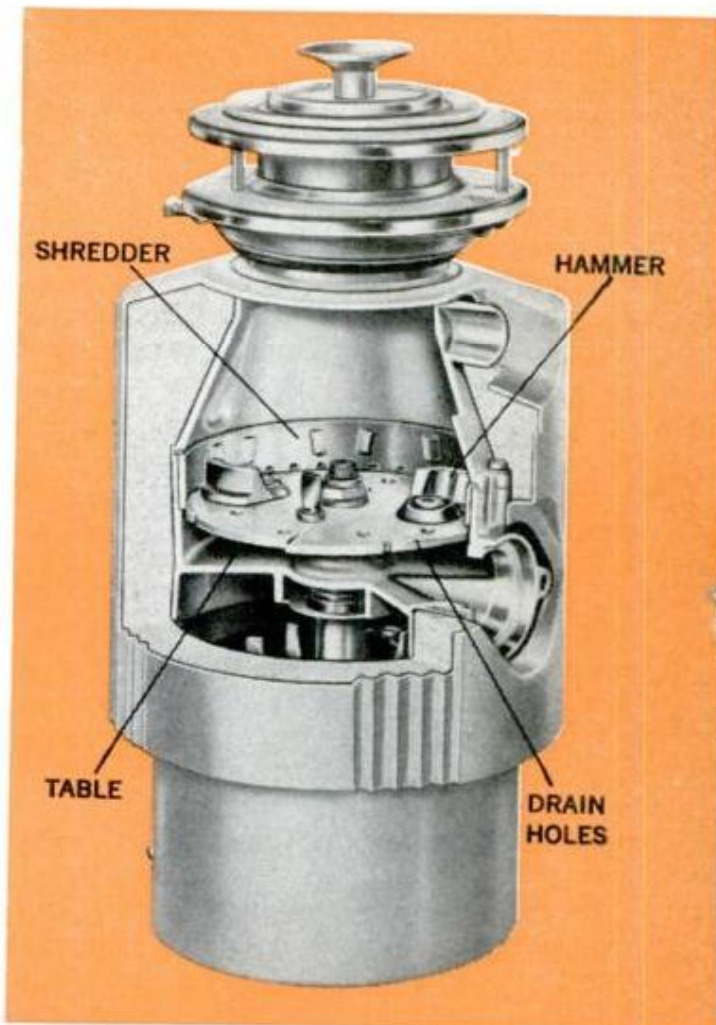

HOW IT WORKS. Revolving table starts when motor is turned on, hammers fling waste against shredders which pulverize garbage into small particles

rubber, plastic or cigaret filters. These materials can damage the disposer and clog drain lines.

A garbage disposer will not cause the absorption field of a septic system to flood. The average field handles about 50 gallons of water a day per person. The average disposer uses 6 gallons of water a day, which is about equivalent to an 80-second shower. Inexpensive to operate, a disposer

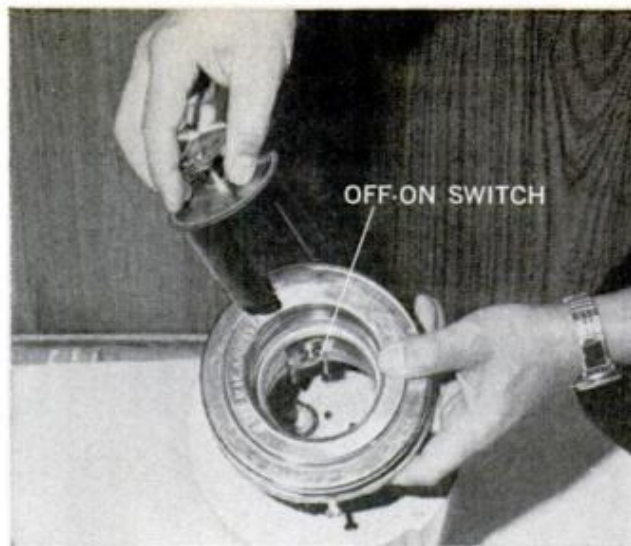

TO DISTINGUISH a continuous-feed disposer from a batch-feed unit, look into its throat. The continuous-feed models have a rubber baffle covering the opening. The batch-feed type comes with a cover that is manually placed in position to trip the on-off switch. If there are children around, the latter type is advisable

consumes about 3 cents worth of electricity a month.

If you have a septic tank, the U.S. Public Health Service advises that you can safely use a garbage disposer if your septic system meets the following standards:

House Occupants	Min. Tank Capacity
4	750 gallons
6	900 gallons
8	1000 gallons
10	1250 gallons

Price range

The least expensive models are equipped with a low-capacity ($\frac{1}{3}$ hp) motor which doesn't produce sufficient torque to handle the heavier types of food waste (melon rinds, corncobs, fruit skins). Furthermore, they generally handle only one quart of garbage at a time. Prices begin around \$25.

Better quality disposers boast $\frac{1}{2}$ -hp heavy-duty motors. These will accommodate two quarts of garbage at a clip. Price difference between the latter and the highest quality models is about \$30 because the most expensive units have extra features such as noise-reducing insulation and automatic unjamming.

Disposer dos and don'ts

- The most important operating tip to remember is to make sure that the cold water is running when the disposer is turned on and left running for a few seconds after the unit has been turned off. This flushes out any residue that may remain, thus eliminating chance of odors.
- Never operate a disposer with hot wa-

ter running. Tests have shown that cold water causes grease and fat to congeal into tiny globules that flow easily. Hot water melts grease which can then coat a drain line and eventually cause a stoppage.

- Although garbage disposers are self-cleaning, fill the sink with cold water frequently and let it drain out all at once to flush the drain line. This gets rid of waste and detergent scum. Since some detergents are caustic, periodic flushing will get rid of them before they damage the disposer.

- Never pour a chemical or solvent compound down the drain of a garbage disposer. This stuff will damage the unit. You can, if necessary, pour a drain cleaner down the drain of the other bowl of a double-bowl sink.

- Don't let food scraps remain in a unit for any length of time. "Stored" waste leads to odors and could cause the unit to jam.

- If you have a dishwasher hooked up so it drains through the garbage disposer, run the disposer for several seconds before starting the dishwasher, then turn it off. This flushes away wastes that could cause a backup of discharge water from the dishwasher. After the dishwasher has finished, run the disposer again for several seconds to flush away particles that may have been discharged into the disposer by the dishwasher. Never feed (or run) a garbage disposer while the dishwasher is running.

- To prevent objects from accidentally falling in, always keep the cover in place when the disposer is not in use.

If you operate a disposer properly, and

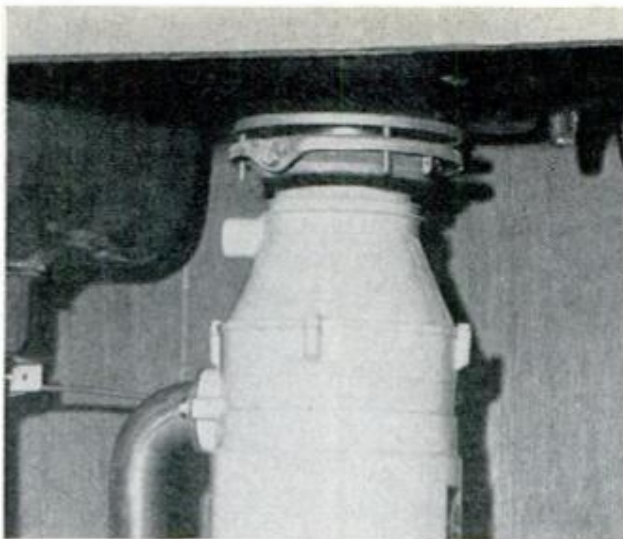

BEFORE INSTALLING a disposer, be certain that the warranty covers do-it-yourself installation; also that the sink has a standard 4-in. drain opening

don't overload it, it should not jam. However if a foreign object accidentally drops through the drain and causes clogging, follow these steps:

Clearing a jammed unit

More expensive units usually have an automatic reverse action switch which kicks in when the disposer is overloaded by a jam.

Unjamming a less expensive model must be done manually by flipping the reverse-action switch.

If a jam is stubborn, and won't loosen with reverse-action, turn off the disposer and fish out the jamming object with pliers or ice tongs. *Never* poke your hands in to do the unjamming.

Most garbage disposers today have built-in overload protection. If such a disposer jams for more than 30 seconds an overload switch will automatically cut off the current to keep the motor from burning up.

When you notice that the overload protection has been activated, turn off the unit and free the jam. Some models automatically reset themselves when the overload switch cools. With the others, wait five minutes to let the switch cool; then press the reset button.

Most disposer manufacturers require that their units be installed according to the local code, and many codes stipulate that the work must be done by licensed plumbers and electricians. Since it is possible that a do-it-yourself hookup will void the warranty, check this point out before starting the job. ★★ ★

HINTS FROM READERS

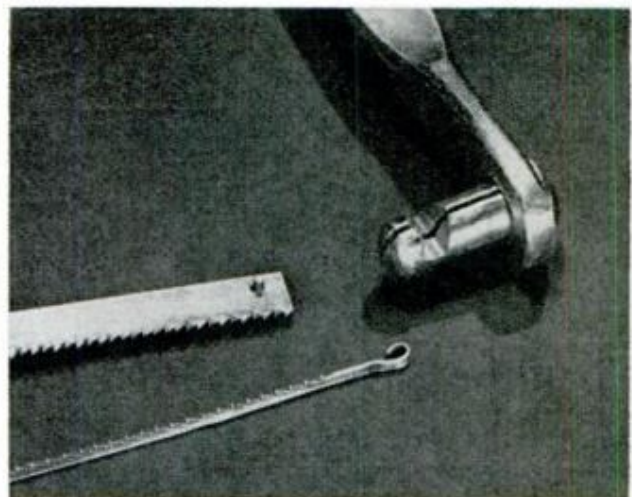

Using coping-saw blades

You can adapt saw frames (designed to accept pin-end metalcutting blades) to hold coping saw blades of the same length. Simply file a notch in the blade-holding part at each end to accommodate the coping blade loop; the blade slit is probably already wide enough for the new blade. Photo shows blades positioned to cut on the pull stroke. They could, of course, be reversed in the frame so they cut on the push stroke.—*Walter E. Burton*

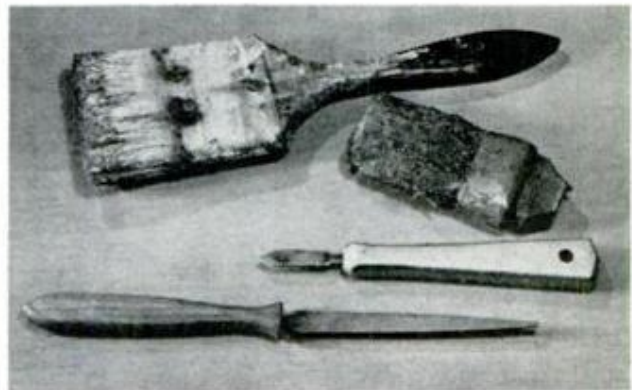

Handles from old paintbrushes

Don't throw away an old paintbrush just because it no longer is useful for painting purposes. If the handle is sound, it can be sawed off and put to use as a handle for a file, scribe, punch or other small tool. After cutting the handle, clean off all of the old dirt, then paint and refinish if necessary. Finally bore a longitudinal hole to receive the tool tang. If a ferrule is desired to discourage splitting, cut a groove or shoulder around the handle near the end and make a couple of turns with small wire.—*Norbert Walters*



A PUZZLE TO STUMP YOU

If you are a whiz at puzzles, you may solve this one in less than five minutes. More than likely, however, it will take much longer. In fact, you may simply have to give up.

All you have to do to solve it is to arrange the 10 pieces in a perfect square. Sounds easy, but wait until you try it. If you finally run out of patience, you'll find the solution on page 169.

The parts of the puzzle can be made any size as long as you make five identical pieces of both shapes. You can cut them from cardboard or $\frac{1}{8}$ -in. hardwood or plywood. This type of puzzle can be quickly mass-produced on your table saw, nicely finished, then boxed as gifts or for sale.

—Kenneth Wells

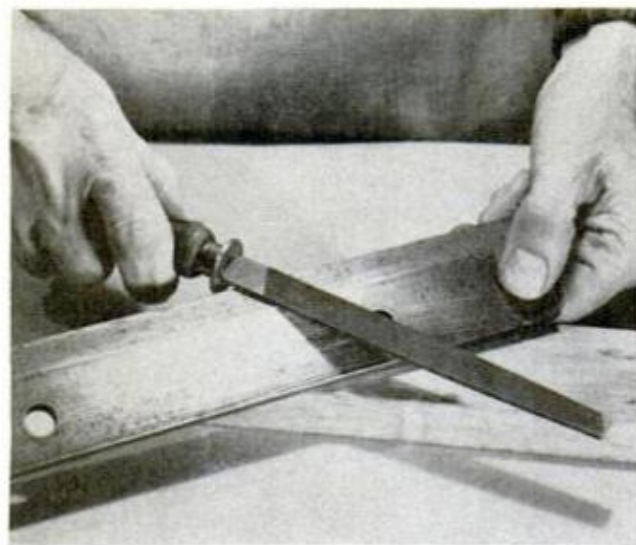

Washer protects knuckles

When you file an ax or knife blade, the correct way is to file toward the cutting edge, but if you are not careful, a slip of the file can cause a nicked finger. To prevent such an accident, slip a large flat washer over the file so that it will keep your knuckle away from the cutting edge. The washer should have a hole large enough so that it will rest against the file handle. While the washer provides a safeguard, ax filing is always done with short strokes where only the outer end of the file contacts the blade. Thus your fingers are a safe distance from the cutting edge.

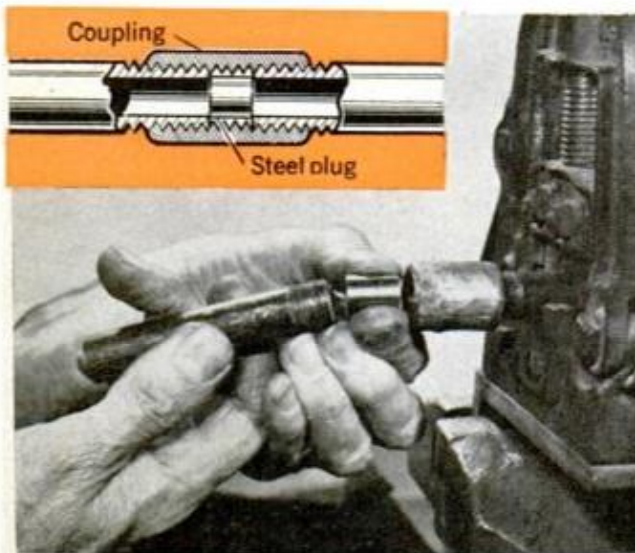

Holding pipe nipples

Short lengths of pipe threaded at one end are often held in a "nipple chuck" for threading the opposite end. Usually the chuck consists of a length of pipe clamped in a vise and fitted with a straight coupling. However, because of the thread taper, the workpiece can become overly tight in the coupling and be difficult to back out without damage. You can solve this problem by inserting a steel plug in the coupling. This way the workpiece cannot become "frozen" in the coupling since the plug will prevent the pipe ends from coming close together.

Sawbuck Does Double Duty as Table



Like most fireplace owners, I spend considerable time every fall cutting up a winter's supply of logs. Tiring of using a makeshift sawhorse, I built this versatile sawbuck. It takes little space to store; I simply fold and hang it on the garage wall. And, by adding the third pair of legs, it's possible to cut short logs without having the saw bind. The extra length also makes the buck a solid outside work table.—*George O. Guesmer*

Quick reference to PM projects

I have many years of *PM* in my workshop library. Locating a particular project was frequently a time-consuming task until I "cataloged" the projects by cutting out the monthly tables of contents and filing them in a folder. Now it's a snap to find what I want.—*Dick Scalone*

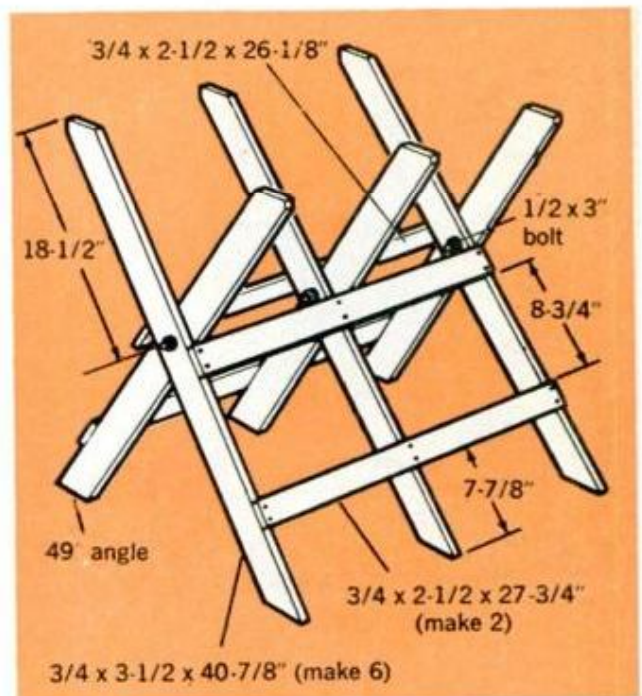

Quickie tool trough for sawhorse

When working on a sawhorse, I used to have my tools strewn about the ground. Thus, it was a necessary nuisance to do a lot of bending. To save my back, I've attached a length of gutter, complete with end pieces and dividers, to provide a handy tool tray.—*Ken Patterson*

Neater way to bleed radiator

Next time you have to bleed a hot-water radiator, use a plastic bag over the valve to catch the water and spray. I find that the bag is easier to handle than a small metal container and does a fine job of protecting floor and furniture.

—*R. M. Woodbury*

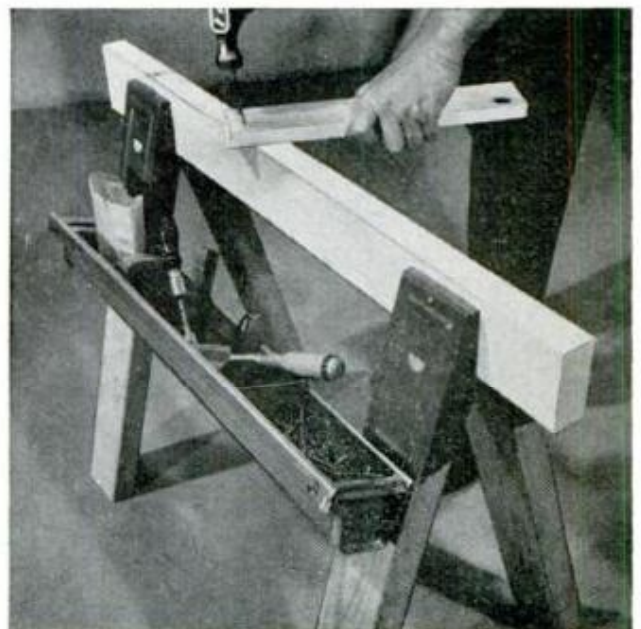

18 Great Tools That Make Yardwork Easier

Four pages of new and improved garden and yard tools that do the job better in less time



HOSE REEL with front, rather than side, discharge has been introduced by True Temper Corp. Of heavy-gauge steel, reel neatly coils 200 ft. of $\frac{5}{8}$ -in. o.d. hose and may be mounted on house. Price: \$21.

ELECTRIC TRIMMER, which operates off tractor battery (above), is now also offered as an independent tool with a battery mounted in the handle. Key-Lectric Trimmer, \$45. Toro Manufacturing Corp., Minneapolis, Minn.



NONKINK COILING is the boast made for Flatline garden hose by Amerace Esna Corp., 436 E. Mansfield St., Bucyrus, Ohio. With water turned on, hose opens to $\frac{5}{8}$ -in. i.d.; when water is turned off hose assumes easy-to-handle flat shape. Sold at hardware stores, a 50-ft. length costs \$10.

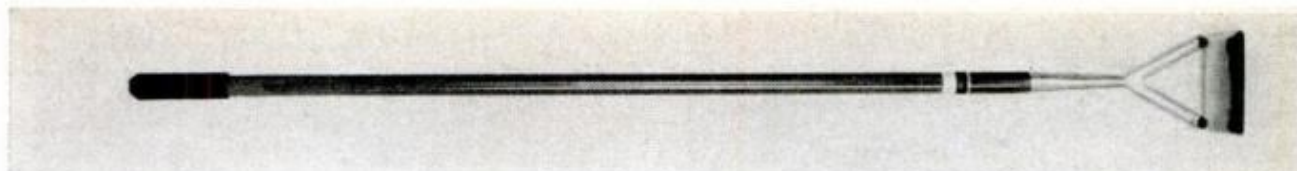

DUTCH HOE features rustproof stainless-steel blade and durable PVC-covered handle. Price: \$20. Wilkinson Sword, Inc.



TREE PRUNER adjusts to any height between 6 and 12 ft., is made of lightweight aluminum. Dual-leverage pulley system triples cutting power. Priced at \$15. Seymour Smith & Son, Inc., Oakville, Conn.

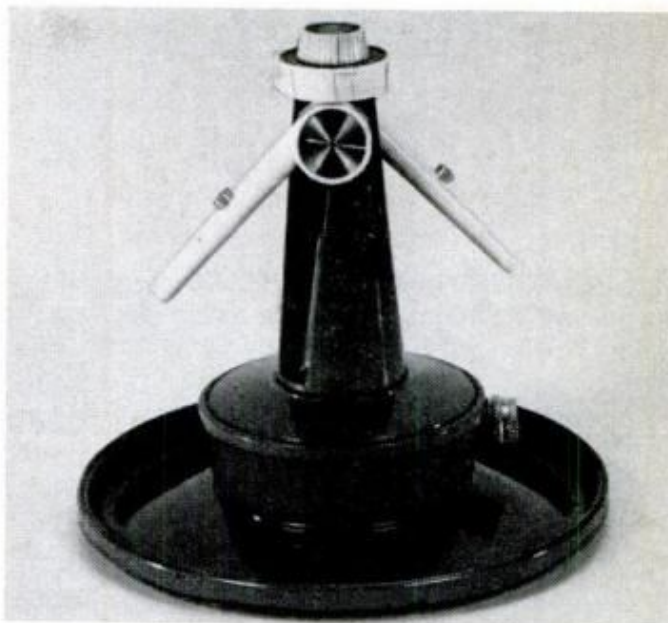

ROTARY SPRINKLER coverage adjusts from a 5 to 50-ft. dia. by twist of a knob to raise arms vertically from 0 to 90°. Price: \$10. Burgess Vibrocrafters, Grayslake, Ill. 60030 makes it.

POST-HOLE DIGGER claimed to be the first coated with Teflon-S has 13-ga. steel blade and handle in 4, 6 or 8-ft. length. Costs about \$12. Union Fork & Hoe Co., 500 Dublin Ave., Columbus, Ohio.



BROADCAST SPREADER has an 8-ft.-wide distribution pattern, a vibration anticlog agitator and a fingertip calibrated setting control. It's priced at \$27 by True Temper Corp.



POINTED SHAPE of this trowel makes it the ideal tool for thinning small seedlings or dibbling holes up to 8 in. deep. Fine Point trowel, priced at \$4, is manufactured by the Wilkinson Sword Co., Mountainside, N.J. 07092.

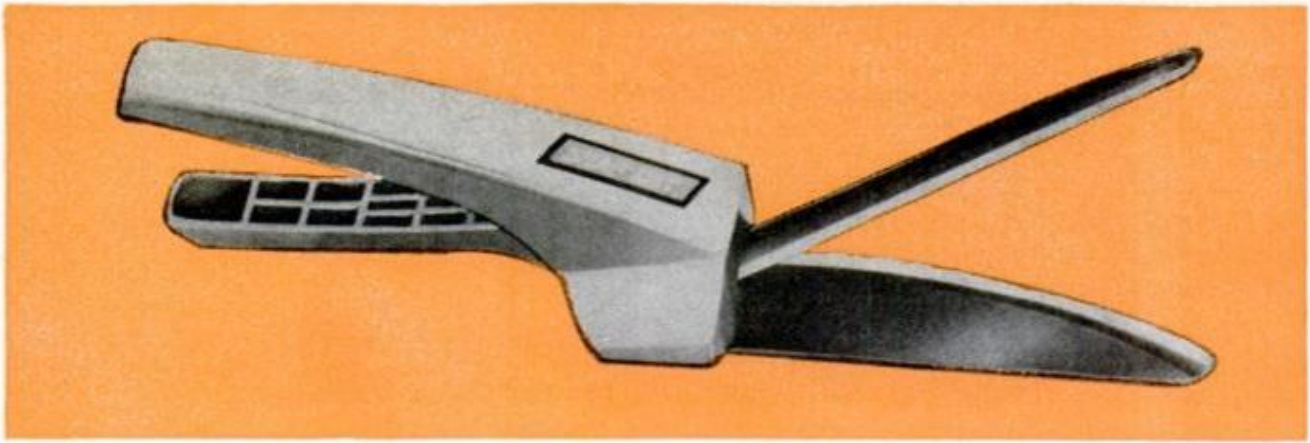

SELF-SHARPENING GRASS SHEARS are designed to cut like a mower. The sweep blade slices across the stationary bed-knife to cut all types of grass. Designed to maintain correct tension, shears are priced at \$2.49. Seymour Smith & Son, Inc., Oakville, Conn. 06779, is the maker.



CORDLESS ELECTRIC GRASS SHEARS never need lubricating, come with charger that brings batteries back to full power with an overnight charge. Self-sharpening blades are coated with Teflon-S. \$35. Made by Disston, H. K. Porter Co. Inc.



JUMBO EARTH AUGER drills big holes fast, is sold in two sizes and three lengths. The 1 $\frac{3}{4}$ x 24-in. drill shown costs \$6.50. Johnson's Industrial Supply Co., 1941 Karlin Dr., St. Louis, Mo.



AUGER can "pin" slope: pea gravel in the holes slows fertilizer runoff

IMPROVED VERSION of the world's lightest chain saw, Power Mac 6A has built-in automatic chain oiling and a longer, 16-in., bar and chain. An updated manual oiling system operates independently for additional oiling in rugged cutting operations. \$200. McCulloch Corp., 6101 W. Century Blvd., Los Angeles, Calif. 90045.

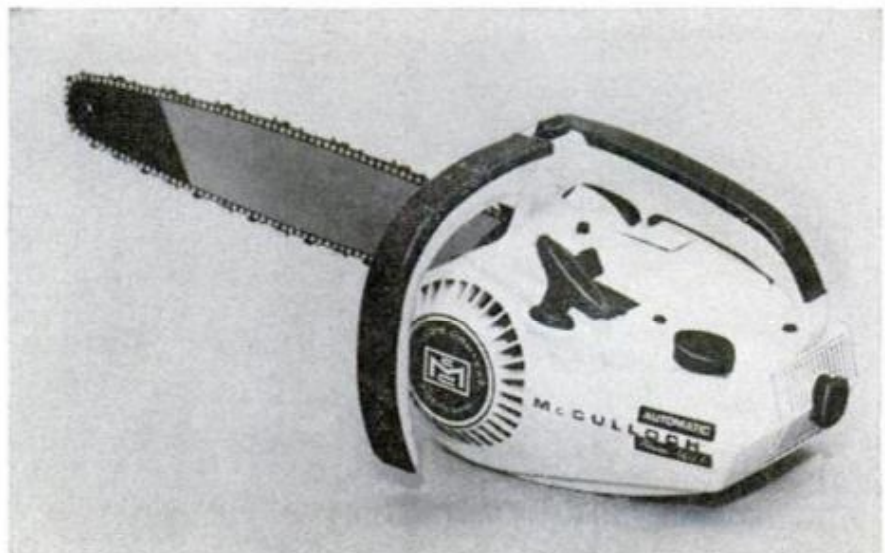



NOTCHED V-BLADE DESIGN lets the ESC Scuffle Hoe from True Temper Corp., Cleveland, Ohio, 44115, cut weeds off below the surface where it counts. \$5.

NEW LAWN COMB RAKE features 20 flexible dogleg tines, is available with a 19-in. head width and a 54-in. handle. \$4. Union Fork and Hoe Co. makes it.

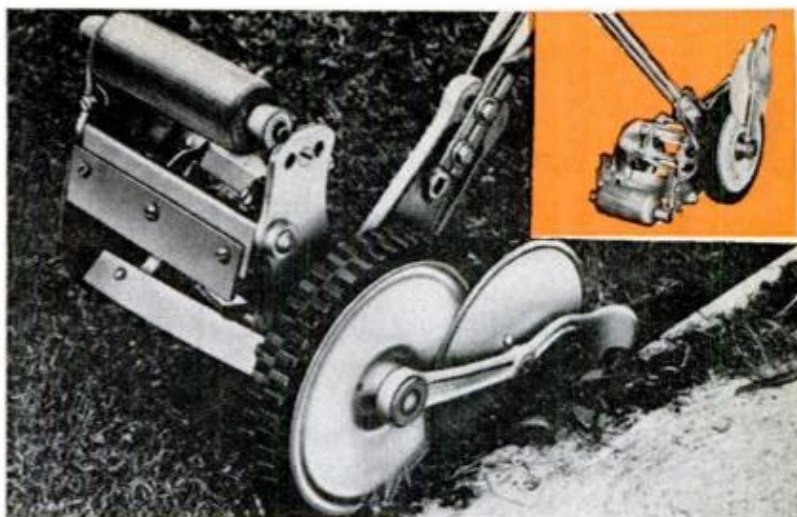

HANDY YARD TOOL gets where other cutting equipment won't. The 6-in. mower does the trimming (inset); for edging you simply 'flip' it over. Model 1706, \$26. Pennsylvania Lawn Products, Inc., Waynesboro, Va., makes it.

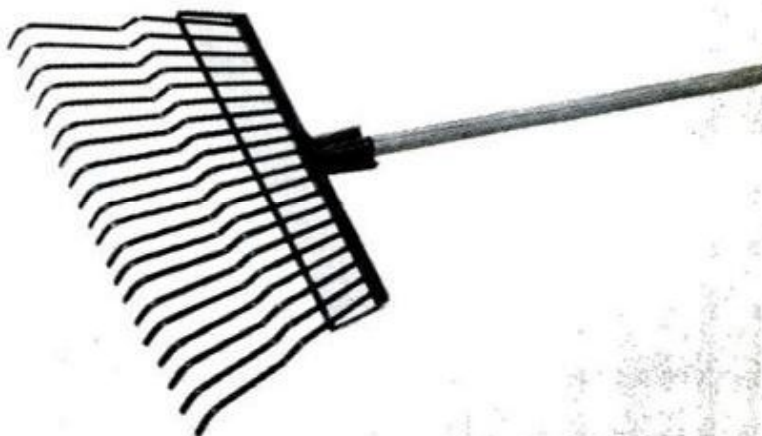

GARDEN SPRAYER dubbed Ladybug has one-gal. capacity, comes complete for \$25. H. D. Hudson Manufacturing, 154 E. Erie St., Chicago, Ill. 60611.



ROSE CHIMNEY over newly planted rose produces superior plant when filled with Soil-Aid mixture. For information, write Boise-Cascade Bark Products, Box 2885, Portland, Ore. 97208.

SUPER SCOOPER SAVES

Faced with a king-size digging chore? Let this conveyor do the heavy lifting for you.

By SVEN CORSAK as told to HARRY WICKS

Technical Art by Fred Wolff

WHEN MY WIFE AND I decided to build our own swimming pool (it's the one shown in the photos of *Build This Poolhouse*, page 124, April PM), the thought of digging a 20x40-ft. excavation 10½ ft. deep didn't fill me with enthusiasm. After one session of hand-digging, I figured I could save a lot of backache by building a "trencher" somewhat like those used in heavy construction. Industrial versions are self-loading and require a hefty power

source for digging; my version is intended simply to carry soil that's pushed into its buckets up out of the hole. A small electric motor provides ample power. Basically, my scooper is easy to build and has no critical dimensions. It took me about a week and a half's spare time to build. I purchased all parts from a junkyard for about \$15. The buckets travel on approximately 32 ft. of Morse No. 50 chain. Since the conveyor



Push dirt to scooper

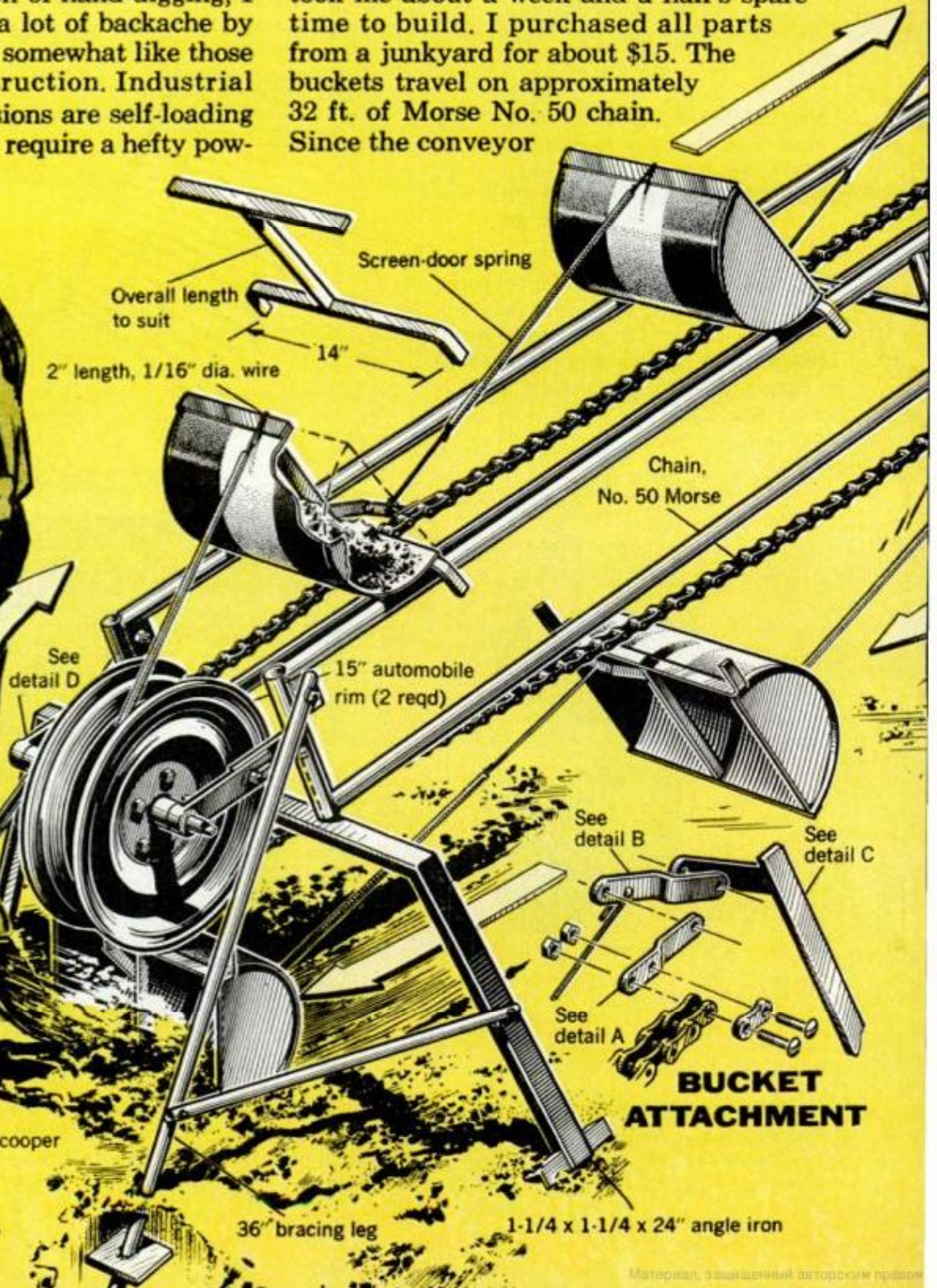

BUCKET ATTACHMENT

YOUR BACK

CONNECTOR DETAIL

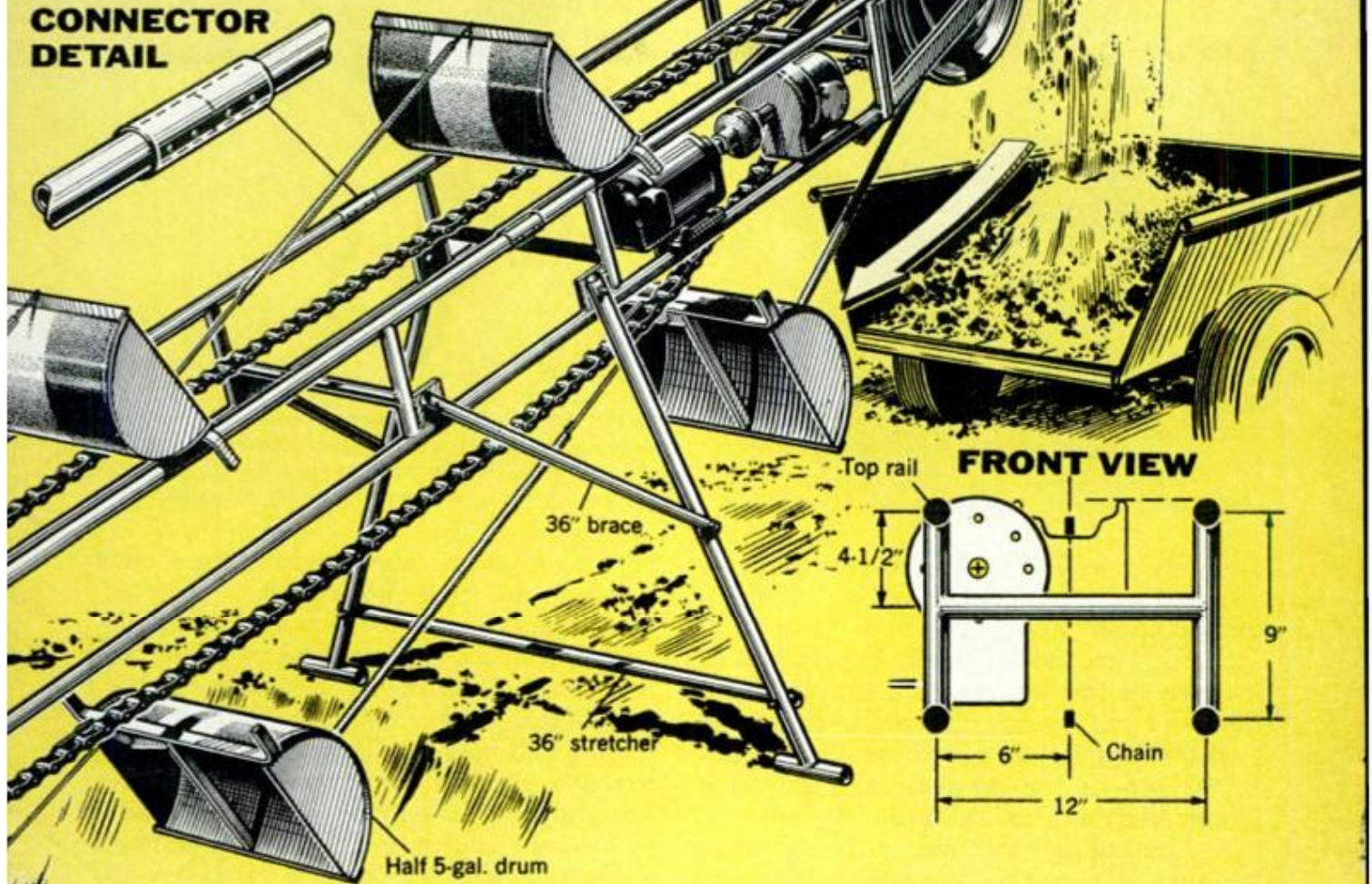

FRONT VIEW

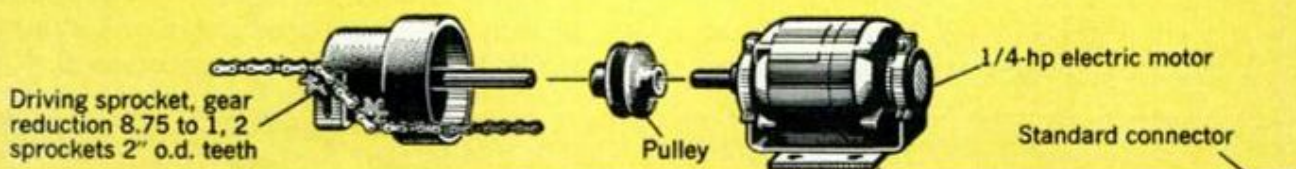
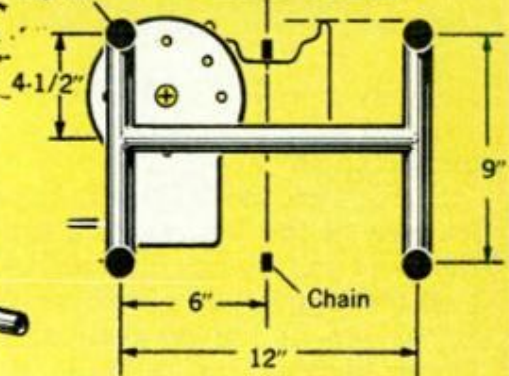

TOP FRAME AND DRIVE UNIT

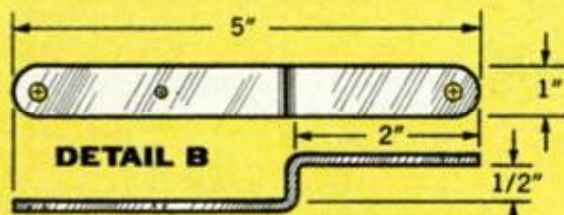
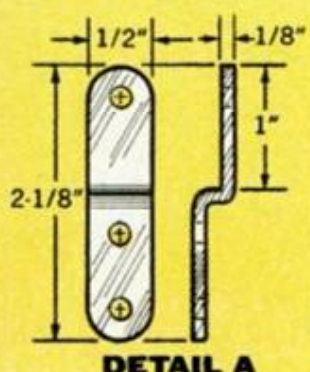
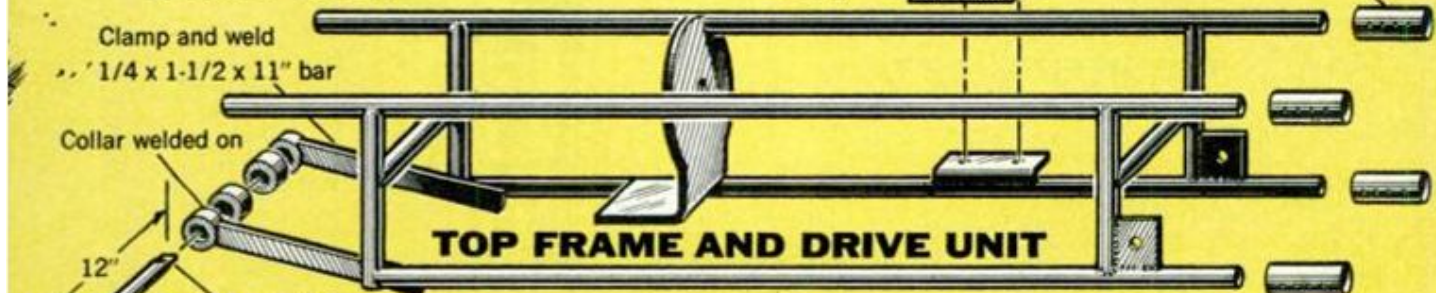

Entire frame of 1-1/2" o.d. thinwall conduit except verticals at ends

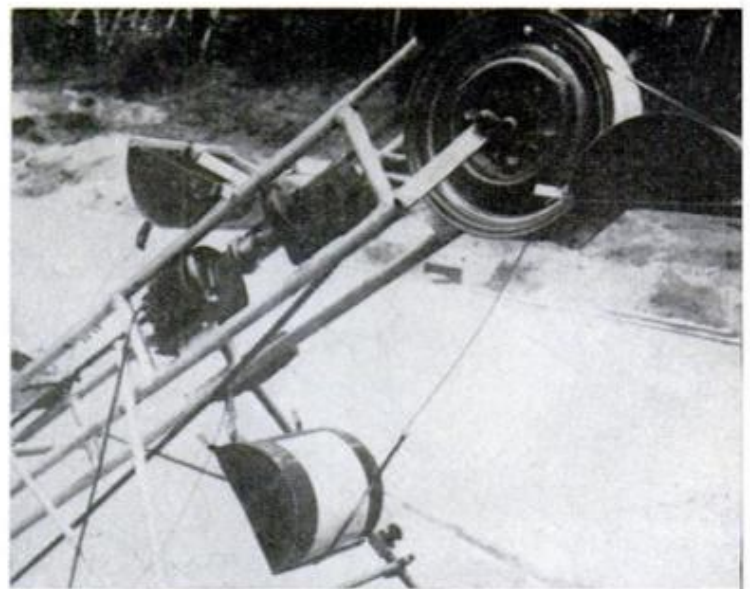
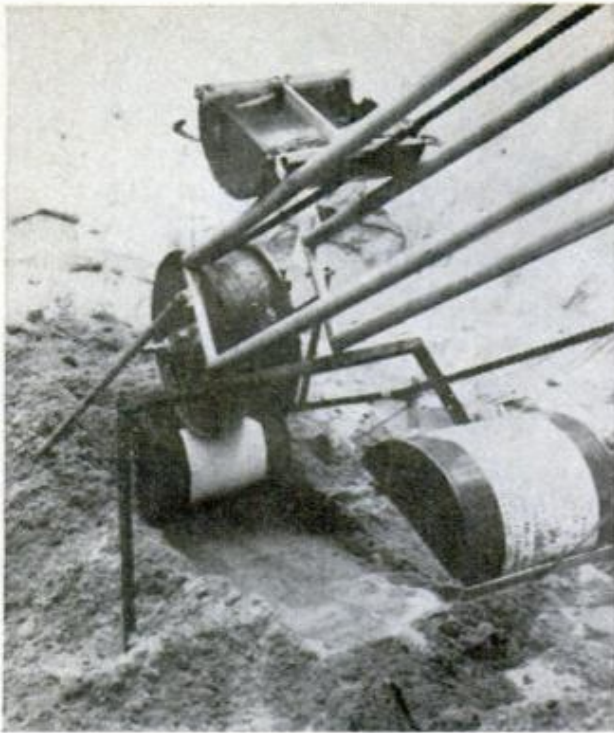

LOOSE SAND in excavation is pushed into each bucket as it makes turn. Owner solved the problem of holding the buckets back as they discharge soil at top by adding a screen-door spring to each bucket

has only four loaded buckets to move at a time, I suspect I could have used a much lighter chain.

Buckets are hand-loaded. As each makes its turn at the bottom, you simply scoop the sand in. About 10 seconds later, the load is dropped into a small trailer parked at the top of the excavation. The frame length shown was designed to suit the hole I had to dig; this can be shortened or lengthened to satisfy your particular job. (Editor's note: The Scooper in the drawing on pages 166-167 is shown in an exaggerated near-horizontal position for

layout reasons. In use, the machine stands closer to 60° from horizontal.)

Besides the chain, the major parts obtained from the junkyard were 8:1 reduction gear, 1/4-hp motor, two auto wheels, five 5-gal. drums and six 10-ft. lengths of thinwall conduit. The time the scooper saved is obvious when production figures are compared. Digging by hand I was able to produce approximately 30 trailer loads a day (about 15 cu. yds.). With the scooper in operation, this figure was upped to a healthy 70. Thus, production was doubled while necessary effort was decreased. ★ ★ ★

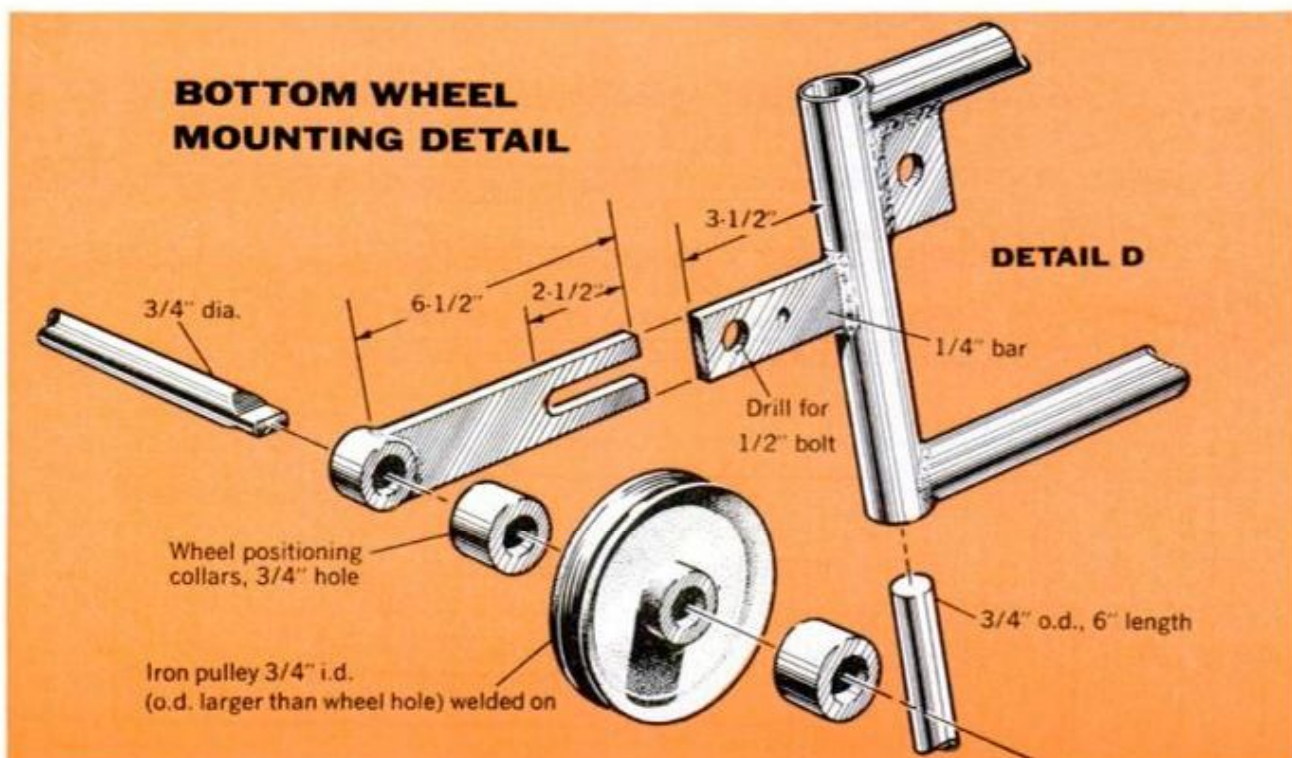

HINTS FROM READERS

Mirror warns of hazard

Until a hazard can be permanently corrected, a mirror placed at floor level and tilted to reflect light upward can serve as an effective warning. Because of constantly changing reflections, the mirror attracts the eye as one approaches, particularly if the mirror is placed to reflect light from a window or lamp. The photo shows how a mirror placed in front of an air compressor will warn passersby to keep ankles clear of the moving pulley.

—John Menke



Carpet-and-plastic work pad

For a soft pad on which to handle optical equipment or other delicate items, slip a scrap of carpeting into a plastic bag and staple or seal the end shut. The plastic covering prevents the carpet from absorbing dirt, keeps carpet lint out of the parts handled and is easily cleaned with soap and water. Carpet samples are perfect for such pads and can usually be obtained for little or nothing from the rug department of a furniture store. A rug with deep pile makes the best pad.—Walter E. Burton



Neat knobs by the dozen

Needing a knob to replace one on an appliance, I found that a solderless connector of the type used in electrical work makes the neatest knob you ever saw. Threaded on the inside, these connectors can be turned onto threaded studs, or you can attach them to drawers with stovebolts from the inside. You can even fit them with threaded shanks by turning screws tightly in the connectors and then sawing off the screw heads. They come in black or white.—Nello Suffredini

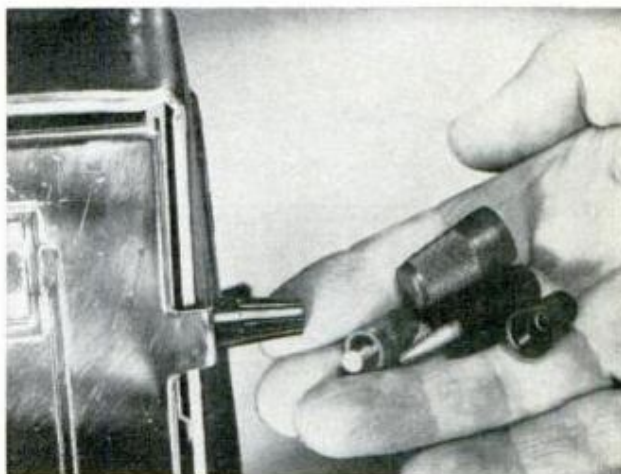

Solution to puzzle on page 160

Like any puzzle, once you know how to work it there's nothing to it. But this one can be a real teaser. If you solved it right off the bat, you are above average. If you have had to peek at the solution, you are one of many who have failed to figure out that the key to the puzzle is the triangular piece which forms the center square. This is a great party game when the pieces are made 12 in. square from 1/4-in. plywood or hardboard and played on the floor. Pieces can be painted different colors if you wish.

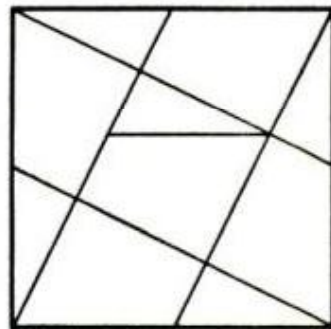



SOLVING



GYPSUM BOARD EDGES can be quickly smoothed or chamfered with the use of a discarded vegetable grater. The type shown has different degrees of coarseness and can be used to best suit the job.—Victor H. Lamoy

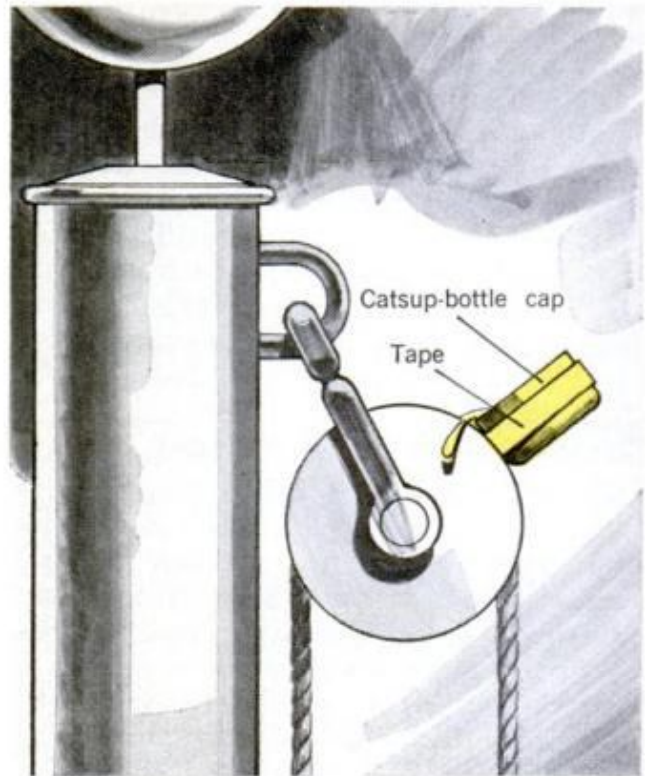

A FLAGPOLE PULLEY can be oiled by taping a catsup bottle cap to the rope. Just fill the cap with light oil and pull it to the top. Then jerk the rope slightly and oil will flow on pulley.—Ed McGinley

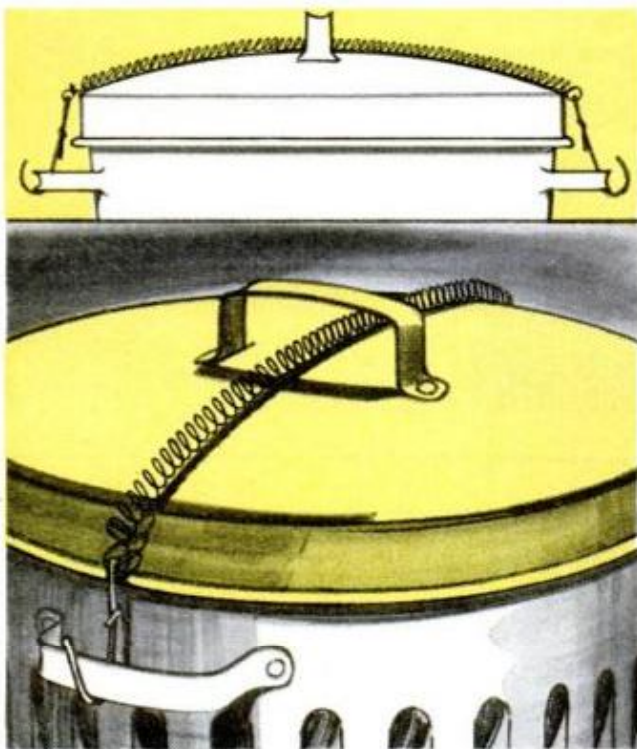

STOP SCATTERED GARBAGE by dogproofing the cover of your refuse can. To do this, simply pass a screen-door spring through the handle and attach a wire hook at each end with cord.—Joseph W. Gorrell

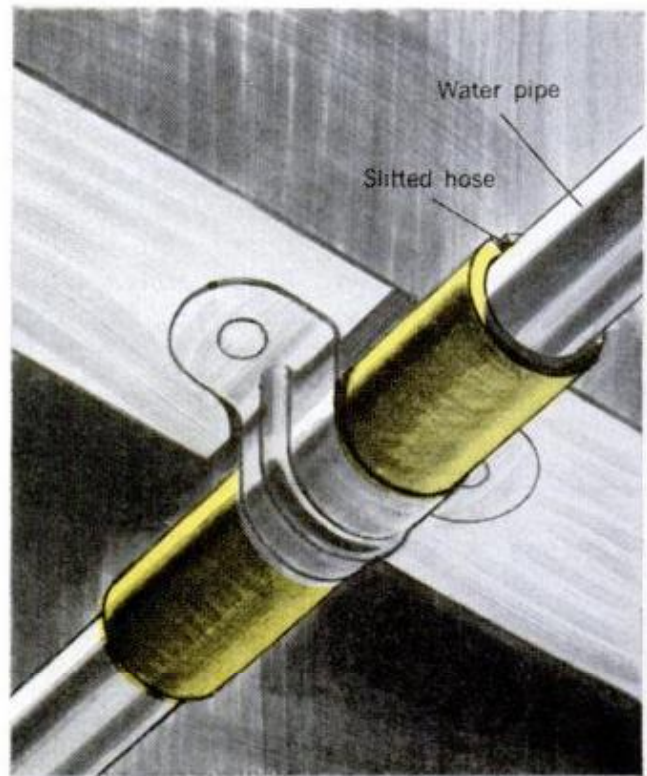

ELIMINATE CLANKING PIPES by using a short, split section of garden hose as a cushion between the pipe and each pipe strap. You'll find that this procedure will stop both side and end play.—Albert T. Pippi

HOME PROBLEMS

Illustrations by Adolph Brotman, Worman Associates

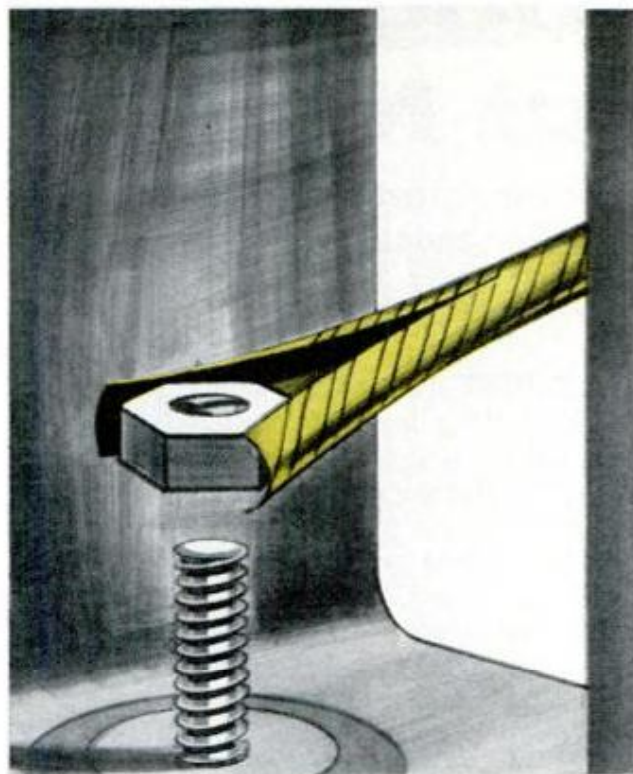

HARD-TO-PLACE NUTS AND SCREWS can be carried to position and then started through the use of an ordinary sipping straw. Just slit one end to hold the part snugly until threads are caught.—R. T. Stewart

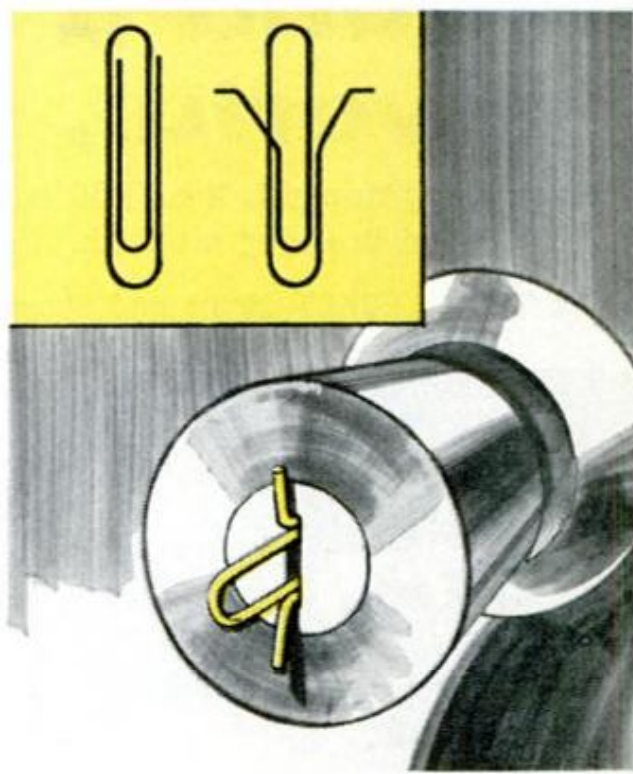

WHEN A CHILD LOCKS HIMSELF in the bathroom and can't remember how to unlock the door, don't panic. A bent paper clip will operate the lock from outside in absence of the emergency key.—Mike McNeilly

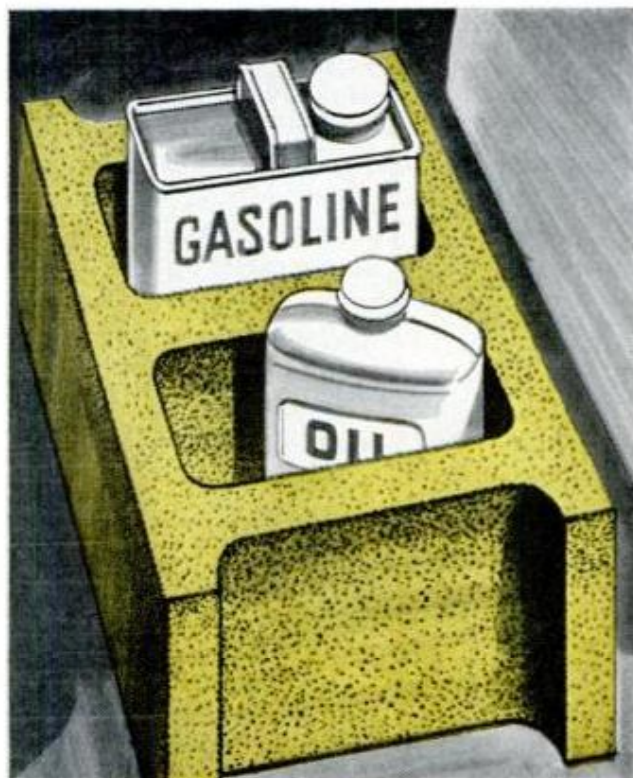

GASOLINE CANS and other vertical containers that are usually stashed in an automobile trunk won't tip over and leak if you park them in a concrete block. Use a 12-in.-size block for a gas can.—P. E. Fiechter



A DROP AT A TIME can be dispensed from a plastic bottle if you back off the top slightly and drill a hole through both cap and bottle. To use, line up holes; to close opening, tighten the cap.—Joseph Braunstein

Black & Decker's new low-cost radial:

I Found It Rugged, Powerful, but Noisy

A 58-pound lightweight, the 7700 is a saw the carpenter can tote to the job without breaking his back. It produces 'sandpaper-smooth' cut

By WAYNE C. LECKEY, Home and Shop Editor

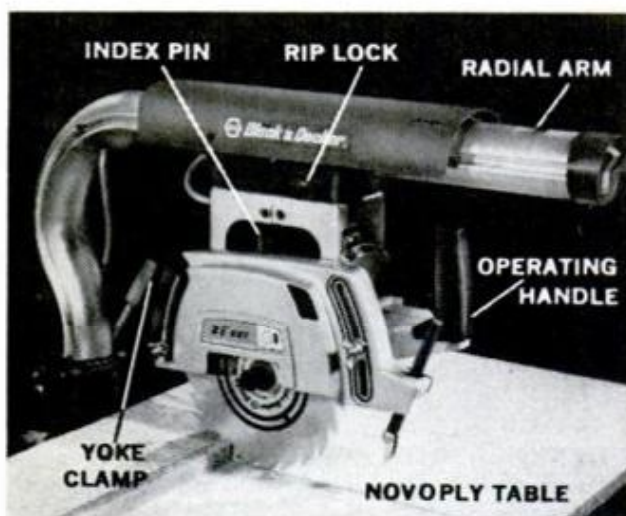

CONTROLS, as well as major parts of machine are shown and identified here. Table rests on steel frame

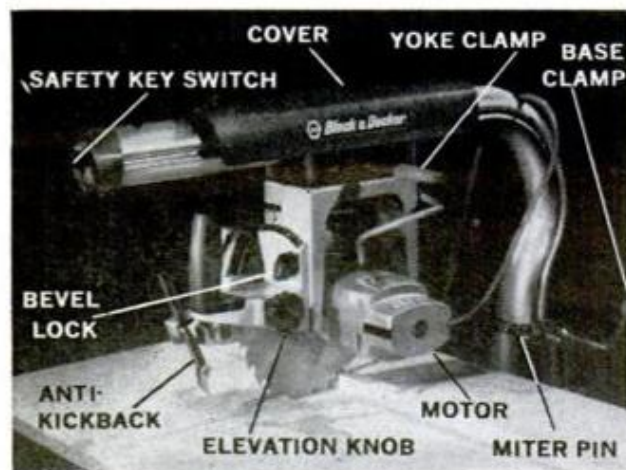

I'VE JUST ASSEMBLED and put Black & Decker's new \$99.95 radial-arm saw through its paces and, believe me, it's a honey for the money.

I found it has just one fault—it's overly noisy. Its blade spins at a top speed of 5200 rpm, which is 1750 rpm faster than conventional saws. And while this extra speed adds more cutting power, the two-hp, ball-bearing universal motor produces a whine that can be ear-splitting in a small home shop. For on-the-job contracting, that wouldn't mean a thing.

Unique in design, this low-cost beauty performs all the basic cuts in woodworking with accuracy and smoothness. It will crosscut, rip, miter, bevel-miter, bevel-rip, dado and plough. Its 8-in. blade cuts to a depth of 2 $\frac{7}{8}$ in. and crosscuts a 1-in. board up to 10 $\frac{1}{2}$ in. wide.

The machine has all the safety features of its deluxe big brothers—antikickback protection, blade guard and key-controlled switch. The one thing it doesn't have is a sawdust discharge spout.

The tool is a unique piece of engineering, from its sturdy one-piece extruded arm to its clever depth-of-cut adjustment. The conventional arm-raising-and-lowering crank found on most radial saws has given way to a rack-and-pinion adjust-

SPECIFICATIONS

Motor	120-v. universal	Spindle dado capacity—width	13/16 in.
No-load rpm	5200	Ripping capacity—width	19 $\frac{1}{2}$ in.
Rated amps.	10	Bevel adjustment	0 to 45°
Max. hp	2	Miter locating pin	0 to 45° R or L
Max. watts output	1680	Scales	Bevel, miter
Standard guard	8 in.	Column diameter	2 $\frac{1}{2}$ in.
Standard blade	8 in.	Worktable size (Novoply)	22 x 32 in.
Arbor size	5/8 x 15/16 in. long	Machine height	19-3/8 in.
Max. depth of cut	2-7/8 in.	Machine width	32 in.
Max. depth of cut at 45° bevel	1-7/8 in.	Machine depth	28-13/16 in.
Crosscut capacity	10 $\frac{1}{2}$ in.	Net weight	58 lbs.

SAFETY-GUARD EXTENSION COVER offers maximum protection at rear of blade. Wingnut permits setting to clear work



ment. Here the motor and blade are raised and lowered by an elevation knob that's located on the saw assembly itself. With your right hand on the knob you loosen the locking wingnut and turn the knob back or forward to regulate the depth of cut. The nut locks the setting.

The saw comes knocked down in nine basic parts, along with a bag of bolts and an exceptionally clear book of instructions.

You can see this precision tool at your local B&D dealer. For more information write Black & Decker Mfg. Co., Towson, Md. 21204. ★★ ★



TO ROTATE SAW in switching from crosscut to rip and back again, you depress index pin with finger



TO SWING SAW for mitering, you release clamp handle, pull miter pin and move arm to suit desired angle

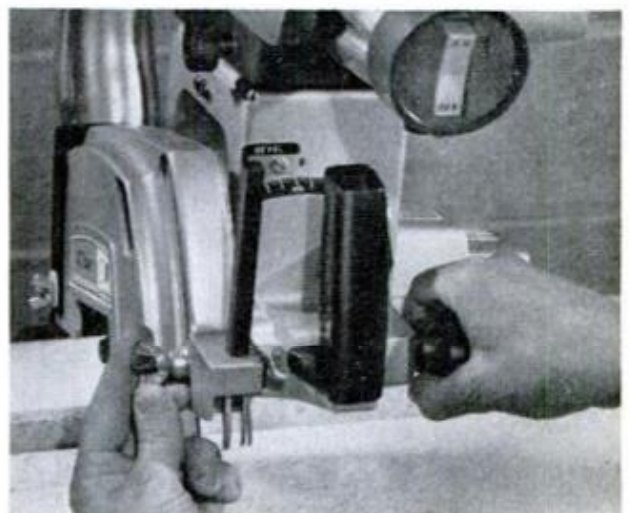

SAW RATHER THAN ARM raises and lowers as you turn knob with right hand after loosening wingnut

MAKE THIS SPLIT-RING LATHE DOG

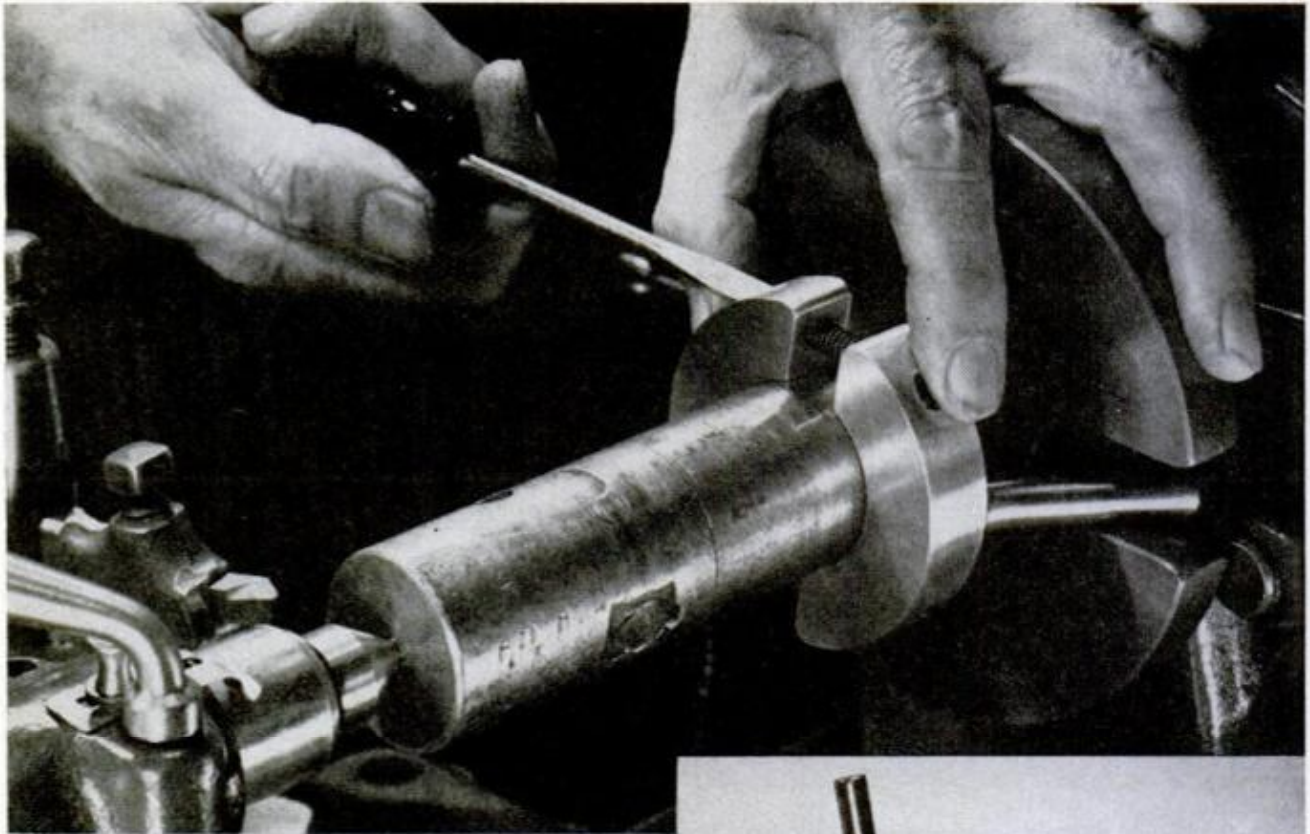

THIS SPLIT-RING lathe dog utilizes the gripping power of two concave surfaces—drawn toward one another by two cap-screws—to hold a workpiece without marring. Although the split ring could be of steel or cast iron, I used aluminum because it is easy to machine.

The dimensions given provide a work-diameter range of about $1\frac{5}{16}$ to $1\frac{1}{2}$ in. By using longer bolts or shims you can stretch these limits even further. Several such dogs, made up in sizes to cover a considerable range of workpiece diameters, are sure to make a useful addition to the conventional types of lathe dogs you already may have.

To make the split-ring dog, cut the blank from aluminum, mount it in a chuck and surface both faces. Then drill a $\frac{3}{4}$ -in. centerhole and bore to a $1\frac{7}{16}$ -in. diameter. Next rechunk the piece so the jaws grip the i.d. of the work and machine the rim smooth. The two clamping-bolt holes are blanked-in with a No. 7 bit and counter-bored with an end mill to bring the bolt heads below the ring's surface. The tail of the dog is a $\frac{3}{8}$ -in. steel rod (projecting 2 in.), which engages the faceplate slot. Install the dog so that the clamping screws, in normal forward rotation, travel head-

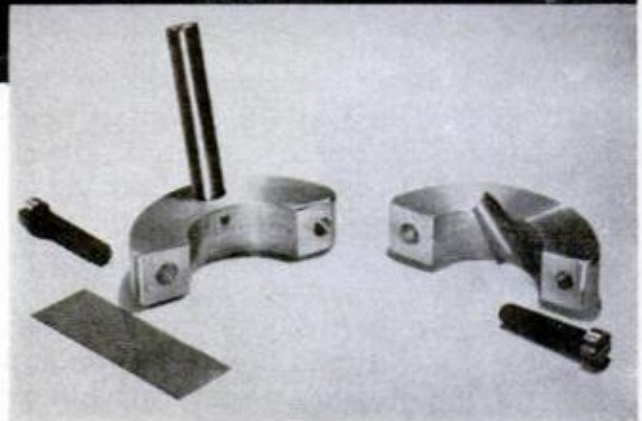

PLASTIC TAPE, shown partly applied to dog segment (right, above), protects the workpiece from marring

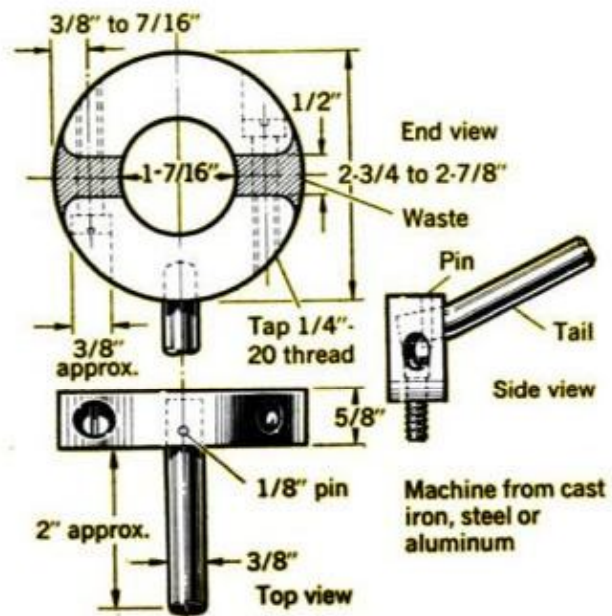

Machine from cast iron, steel or aluminum

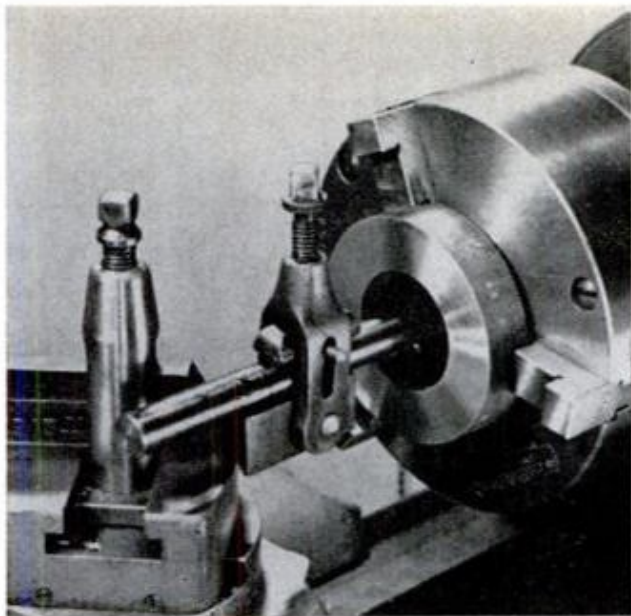

RING-SHAPED BODY BLANK is set up on the lathe as shown above for boring the ring's inside diameter

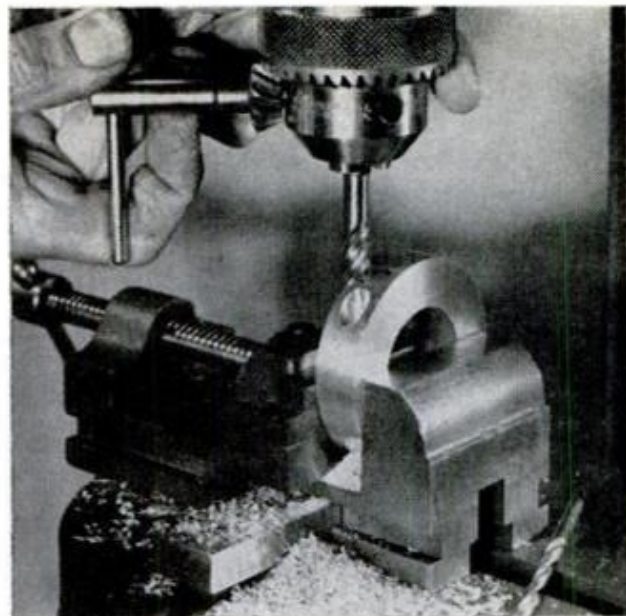

END MILL is preferable for counterboring clamp- ing screw holes because of the sloping hole edges

first; otherwise a screw tip could form a hazardous hook.

To cushion the concave surfaces of the segments, strips of self-adhering plastic tape, ordinary friction tape, or other thin material can be applied. Trials will indi-

cate whether a particular lining material has a tendency to creep under heavy or prolonged torque action. By making the screws tight, much can be done to eliminate any creep that might exist.

—Walter E. Burton

Emergency file handle

To protect your hands from the sharp point of a file tang, simply screw on a solderless wire connector (type used in electrical work). They're available in a wide range of sizes.—W. G. Greenwood

Repel insects when painting

If you plan to paint your house with oil-base paint during the hot months, part of the job is to keep bugs out of the wet paint. Just add two tablespoonfuls of citronella oil to the gallon.—L. Rueff

NEXT MONTH IN SHOP AND CRAFTS

IS THIS THE WORLD'S BEST WORKSHOP? When photos of this fabulous workshop were first brought to our attention, we could hardly believe what we saw—a shop that appeared to have everything that a woodworker dreams about. To confirm that it was for real, we sent Workshop Editor Harry Wicks to Minneapolis. You'll learn what he found in June *PM*.

FOUR WAYS TO HIDE TRASH CANS. What can be done to hide the cluster of trash cans in the back yard? Since that's a frequent query from *PM* readers we commissioned designer Gerald Geerlings, A.I.A., to create four out-of-the-ordinary enclosures to shield this eyesore from view. There's sure to be one that will blend with the architectural style of your home. You'll find them in the June issue of *PM*.

FIVE WEEKEND WORKSHOP PROJECTS. Each of these useful items can be built over a single weekend and, for the most part, scraps lying about your shop will probably fill the bill for materials. Pick up the June *PM* and get complete plans for building a wheelbarrow planter, pipe rack, wall caddy, chairside table and electric shoeshine stand.

DECKS YOU CAN BUILD. With summer close at hand, thoughts turn to outdoor living—cookouts, parties and just plain sitting and relaxing. Here's a roundup of the latest design ideas for insuring maximum outdoor comfort while investing minimum effort. You'll find the ideas in *PM* next month.

You Can Improve Your Lathe Work With Indicators

By WALTER E. BURTON

A TEST INDICATOR not only greatly improves lathe accuracy, but frequently saves you time to boot. This versatile instrument, which measures or compares movement and dimensions in thousandths of an inch (or as little as 0.0005 in.), can be used to check tapers, help center work on a faceplate, determine the degree of trueness of centers, help position holes accurately and let you know quickly whether chucked work runs true.

There are two general indicator types of interest to a lathe user. One consists of a

system of levers that terminates in a pointer which moves over a rather short, curved scale having a total range of perhaps 0.030 in. This is often called a universal test indicator or universal indicator. The second type has a gear system that moves a pointer around a circular scale; appropriately it is called a dial indicator. A well-made dial indicator is likely to be more sensitive than the simpler, usually less costly, lever type. Dial indicators sell for \$20 and up.

A lathe test indicator is generally

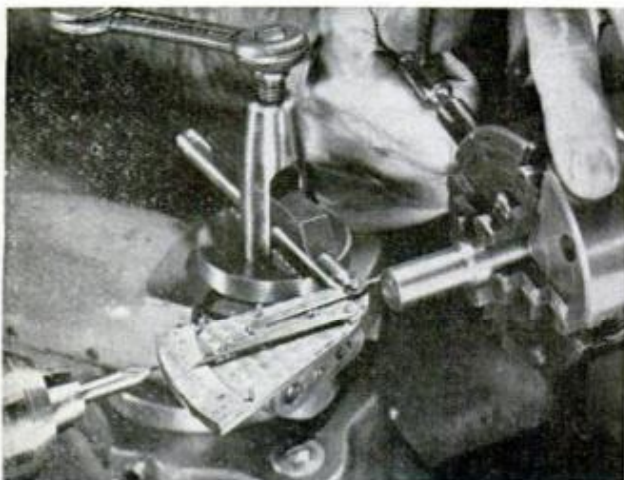

CENTERING TURNED PIECE in four-jaw chuck before drilling. Indicator point engages the circumference

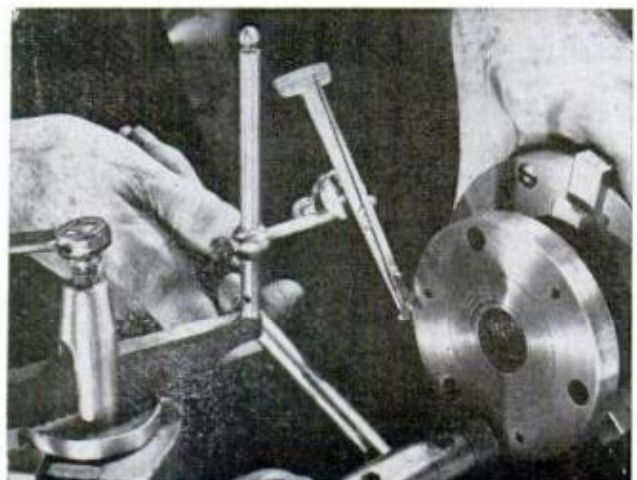

ADJUSTING CHUCK PLATE before making face cut. If hammer blows must be struck, move the indicator

TYPICAL INDICATORS at right, accumulated over the years in a home workshop, include: A. dial indicator, B. Starrett's test indicator and its three-piece stand, C. shop-made indicator and D. Federal dial indicator. Most hardware stores and retail power-tool outlets stock a variety of these indicators; several mail-order sources are listed at end of the text

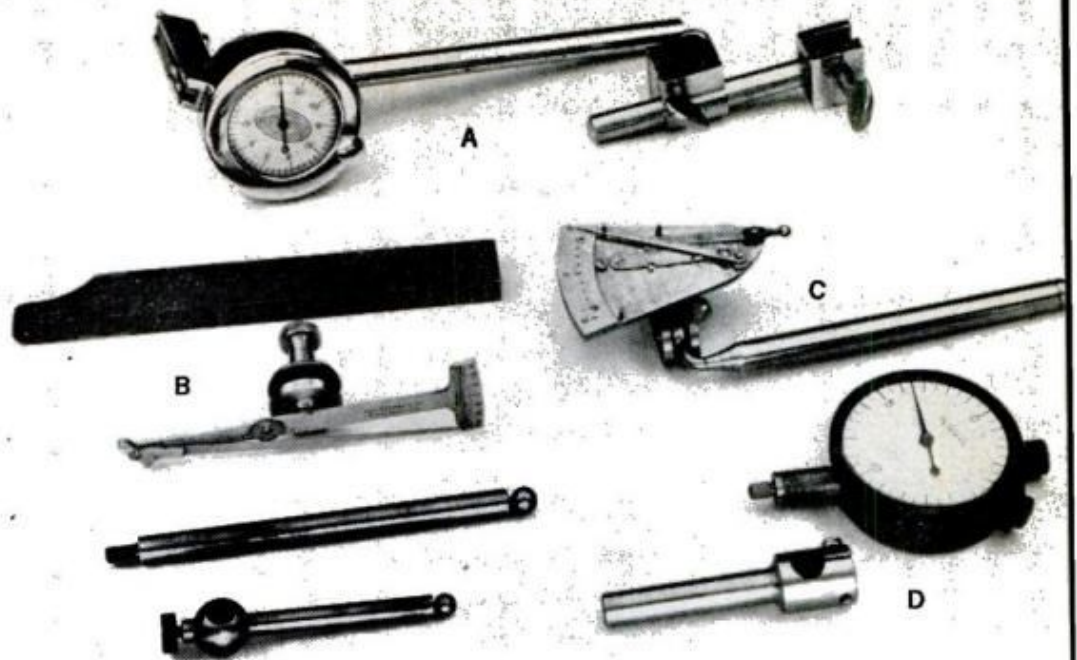

mounted firmly on the top slide or other part so its sensitive contact point (feeler) presses against the surface to be checked for roundness, movement, taper or other quality. Various combinations of bars, shafts, swivels and clamps, which can often be shop-made, position the indicator. Available attachments can adapt indicators for easy measuring of holes, checking internal surfaces, and measuring at a 90° angle to the indicator spindle. Some manufacturers offer contact points in quite a variety of shapes.

A dial-indicator stem (typically of 3/8-in. diameter) is the portion through which the movable spindle operates, and which provides a means to mount the instrument. You can make holders to fit your needs. For example, the short rod near D in the photo above was machined from a steel bar to fit the 3/8-in. hole in the clamping sleeve that came with the indicator in the background. The large end was drilled to accept the 3/8-in. indicator stem, slotted and provided with a 6-32 clamping screw.

Indicators should be handled with about the same care you give your watch. Protect them against dropping, bumps, excessive dust and other foreign material; dust seals are available for some models. When the contact point of an indicator slides over a surface, as in testing the trueness

DIAL INDICATOR contact point (right, above) presses against flexible shaft whose tip engages punch mark that is being centered. Dial indicators are sensitive, show slightest side movement of rod. Indicator holder (sketch) is shop-made, does job adequately. Lower photos show toolmaker's button being centered and circular saw arbor tested for trueness

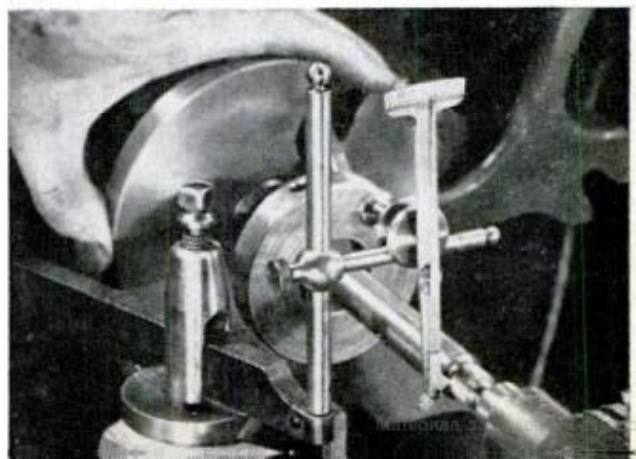
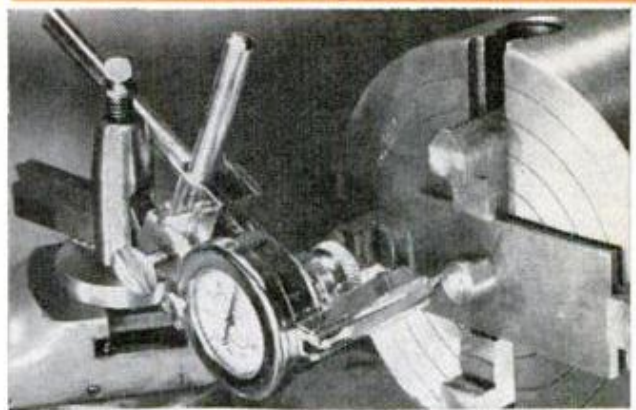
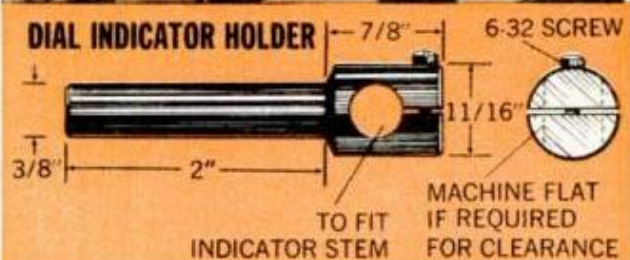
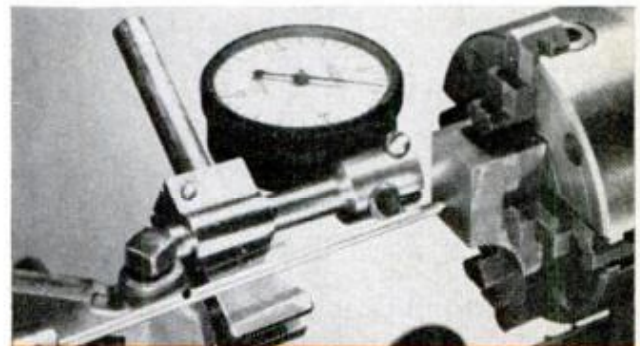

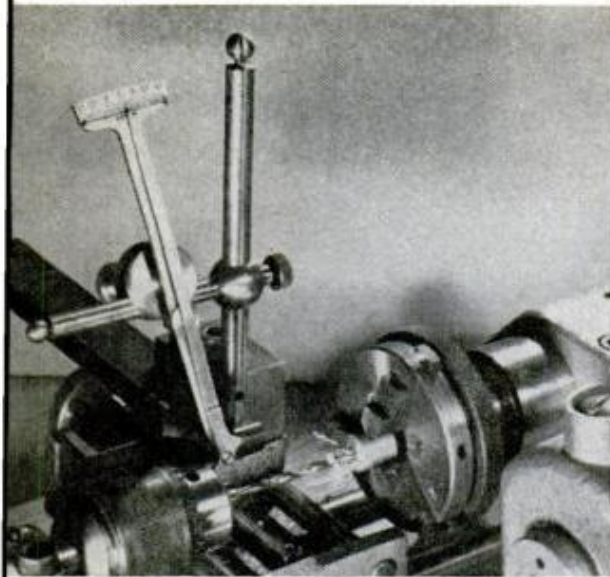

INDICATOR FEELER is used to test for depth of hole. O indicates the stopping point

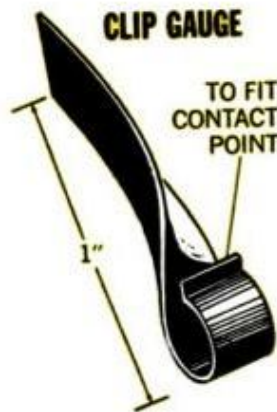

TO MEASURE FOR THICKNESS, contact point is equipped with a shop-made retractor clip made of tin-can material



of a cylindrical piece in a chuck, be sure that surface is clean. A very thin oil film will contribute to smoother sliding and help reduce point wear. When testing work where lathe-spindle movement is involved, the spindle customarily is rotated by hand.

In some applications of an indicator to lathe operation, it is not necessary to determine how much a dimension varies or something moves, unless the point of minimum movement or variation has been reached. Thus, when centering cylindrical work in an independent-jaw check, the piece is shifted until the indicator pointer stands still or shows movement within acceptable limits. In other applications, the indicator scale is used to determine how much a movement or dimension varies. For example, when measuring a taper between centers, the indicator is used to show radius changes at points 1 in. apart.

Other ways you can use indicators to improve accuracy or save time:

- *Centering work in an independent-jaw chuck.* The work generally is either a piece machined to a reasonably true cylinder, or has several points that can be positioned on the same circle. Mount the indicator on a toolpost or fasten it to the top slide (as with a magnetic base). Position the contact point to bear against the important circumference—outside or inside. Rotate the chuck by hand and note run-out before you actually touch the indicator to the work. Adjust the chuck jaws so that run-out seems to be within limits of the indicator's contact-point movement.

Then bring the point against the work until it touches the high spots but not necessarily the low ones. Rotate the workpiece slowly and note the pointer movement; take care not to jam the work so tightly against the indicator that the instrument may be damaged. Adjust the chuck jaws until the indicator shows little or no run-out.

When some work, such as a ring of rather thin section, is in a chuck, jaw pressure tends to distort it. Then the indicator might show four high spots where the jaws engage it. It might also show other spots where jaw pressure affected previous machining. When centering such work with the aid of an indicator, avoid excessive jaw pressure.

- *Chucking work for drilling of center holes.* Sometimes a piece that has been machined in a chuck or is otherwise reasonably uniform is to be provided with center holes. Simply use a test indicator to determine when, by adjustment of chuck jaws, the outside surface is running true. Then use a center drill in a tailstock chuck. If necessary, first face off the end of the piece so the drill won't be deflected. The indicator can also help you center an existing hole for reboring or reaming.

- *Aligning chucked work for facing.* Clamp the piece lightly, mount the indicator so its contact point bears against the surface to be machined, and use a soft hammer to tap the piece until this surface shows reasonably true rotation. Tighten the jaws. Retest to determine whether

(Please turn to page 188)

New tools you should know about



Durable roof brush

All roof coatings can be applied with its No. 4515 roof brush, claims Wright-Bernet, Inc., 1524 Bender Ave., Hamilton, Ohio. About \$2.50.

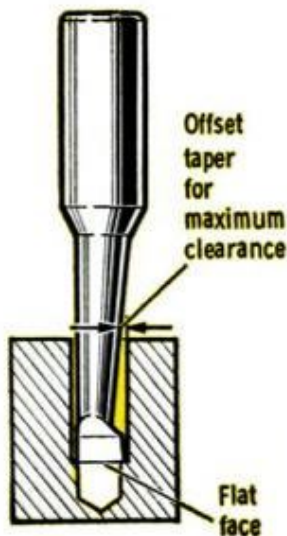

Boring bars with longer tool life

High-speed boring bars made in five sizes by Enco Manufacturing Co., 4520 W. Fullerton, Chicago, Ill. 60639, have carbide tips, are claimed to last up to twice as long as conventional bars. Half-inchers shown, \$59.



Sander hugs the work

Low center-of-gravity design of Black & Decker's professional belt sander No. 836 eliminates tilt-gouge action found in high-profile tools. At builder supply houses, \$60.



Tool removes sheared-off screws

Broken screws, bolts and studs are easily removed with these extractors. Simply drill hole in buried screw and pound correct-size extractor into hole. Flutes grip stud as extractor is turned with wrench. Set 70007, \$6.50, Vaco Products, 510 N. Dearborn, Chicago, Ill.

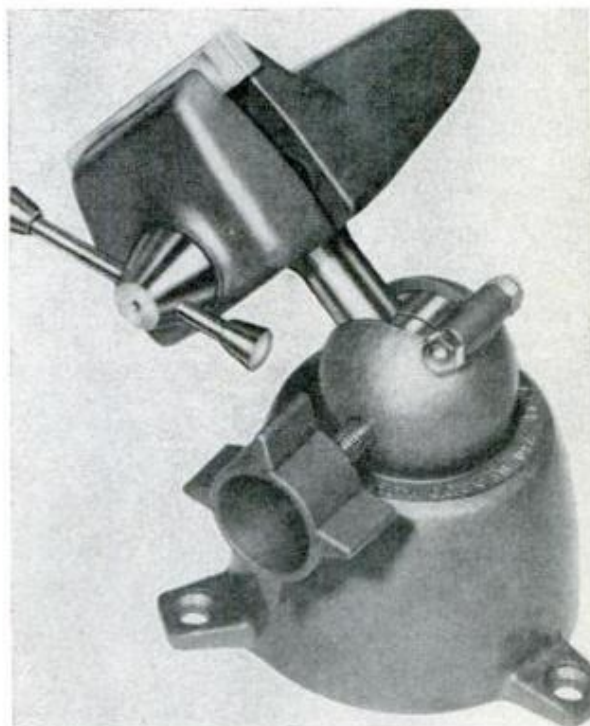

Workholder tilts and rotates

This workholder features a vise-head that turns a full-circle within the $\frac{5}{8}$ -in. throat of locking unit in base. Dubbed PanaVise, it also tilts vise jaw 90° either way. Model 301, \$19, is made by Colbert Industries, 10107 Adella Ave., South Gate, Calif. 90280.

The Forgotten Handtools:

Cabinetmaker Scrapers

By JOHN BURROUGHS

BEFORE SANDPAPER became widely available, the scraper was one of the cabinetmaker's more important tools. It was used primarily to smooth off blade marks left by hand-planing. Today, since most woodwork is now machine-cut and power-sanded, the scraper, unfortunately, has fallen into near oblivion.

But not complete oblivion, for there are some jobs that scraping does better than sanding. Scraping is preferable, for example, if the surface you're smoothing isn't all of equal hardness—such as when

you're finishing glue-joints flush or finishing repairs made with wood filler. Carefully scraped hardwood acquires a smooth gleam that's hard (if not impossible) to match with sanding. Scraping is sometimes the fastest, cleanest way to remove old paint or varnish from furniture you plan to refinish.

The scraper itself is simply a thin spring-tempered steel blade having either a straight or curved edge. (The rectangular scraper measures 2¼x6 in.). The edge is first filed and oilstoned perfectly

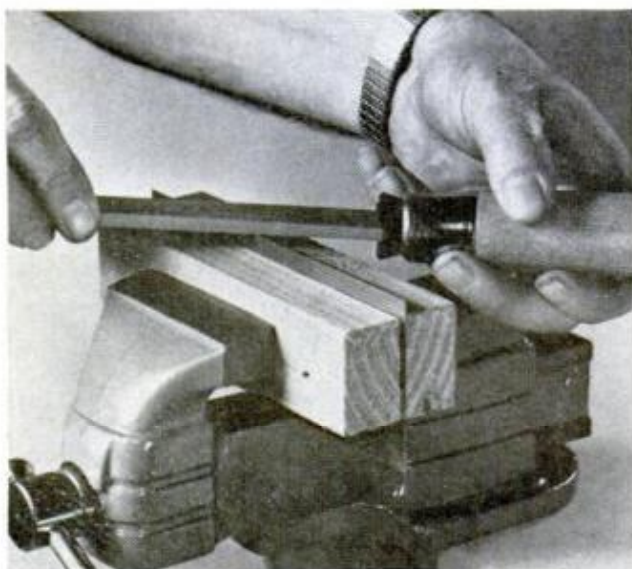

UNFINISHED EDGES of new scraper are draw-filed with single-cut file to prepare blade for sharpening

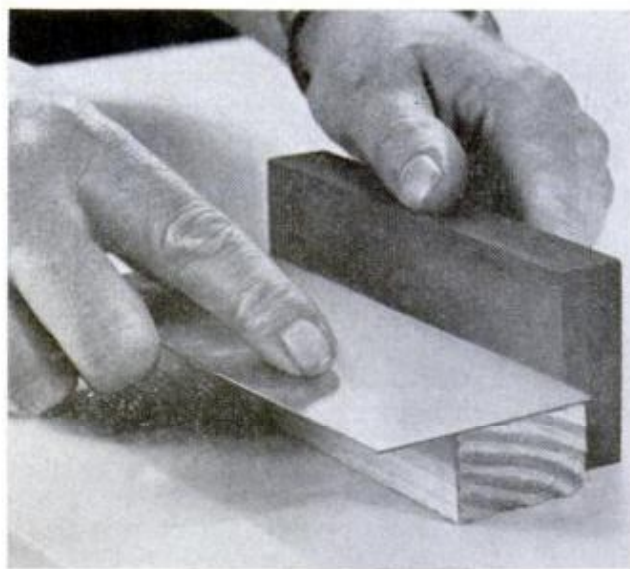

TO TRUE THE EDGE, slide the scraper back and forth on a wood block against an oilstone set on edge

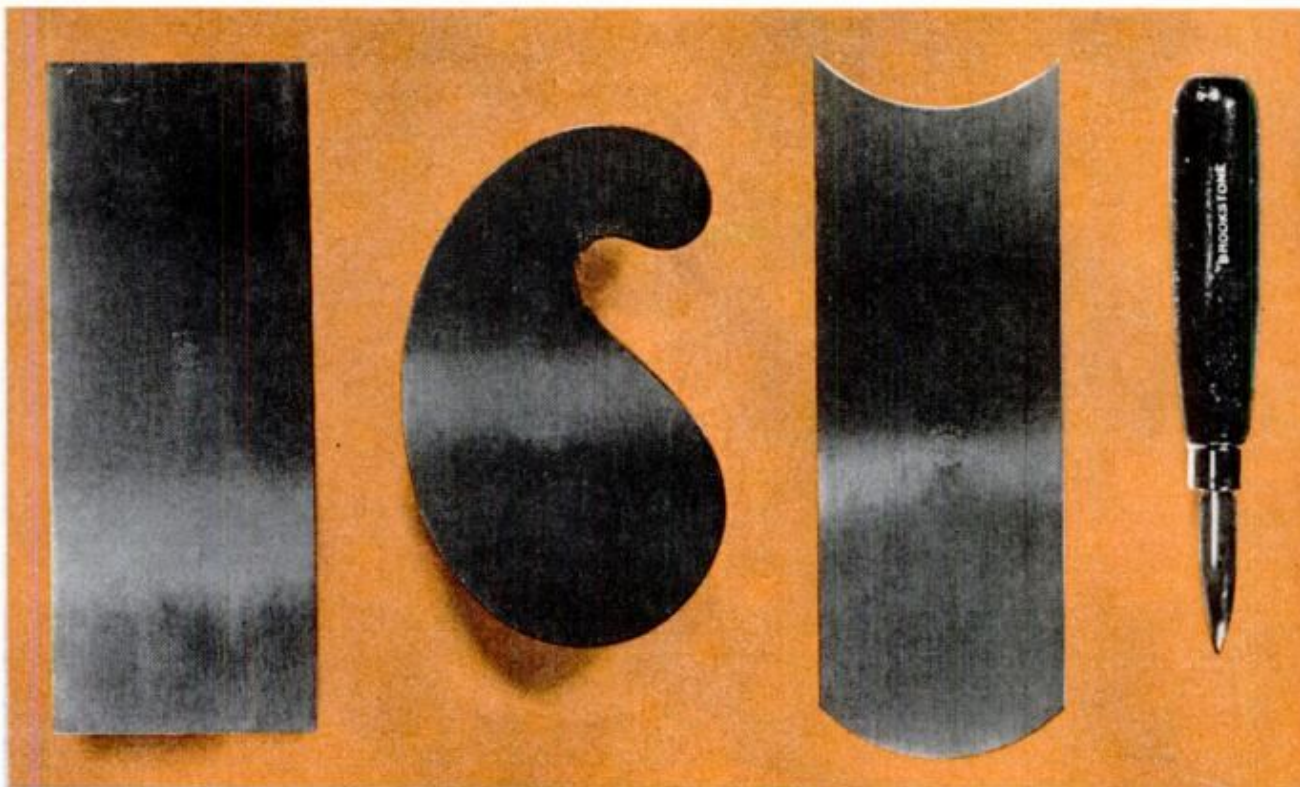

SET OF THREE cabinet scrapers, plus burnishing tool, sells for less than \$5. Text tells where to buy it. Complete instructions for using the burnisher (far right in photo) are furnished with the tools

square. It is then "turned" with a burnisher—burnished over to form a hooked cutting edge. The burnisher, which is file-hard steel polished glass-smooth, is stroked several times with firm pressure along the square edge of the scraper at gradually increased angles until it has a turned-over sharp, even burr.

While a scraper can be pulled toward you, experienced cabinetmakers, when scraping a flat surface, ordinarily push the tool. The blade is grasped with both hands and sprung into a shallow arc with the thumbs. Then it's tilted forward until the

cutting edge cuts and it is canted slightly for shearing action. Scraping with the grain of the wood leaves the smoothest finish; scraping across the grain at an angle removes wood more rapidly. The scraper's cutting edge can be reformed with the burnisher several times before re-oilstoning is necessary.

The set of three alloy-steel scrapers, pictured together with the burnisher, is available by mail from the Brookstone Co., 10924 River Rd., Worthington, Mass. 01098 for \$4.60 plus 70 cents mailing charge. ★★★

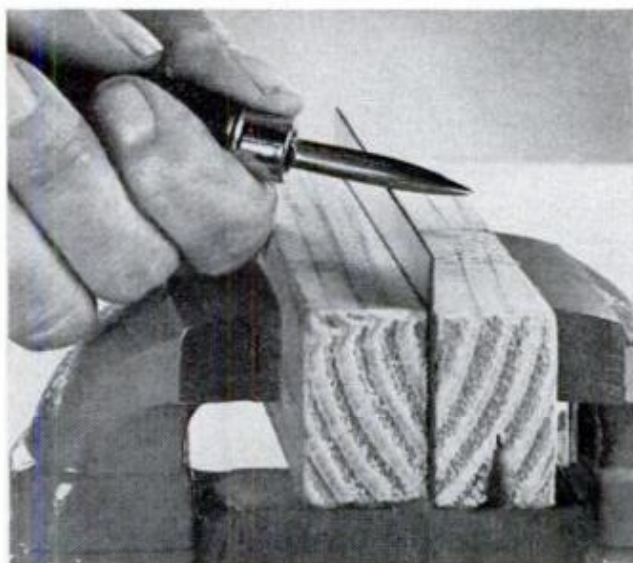

TO "TURN" SCRAPER'S EDGE, burnisher is stroked at angle with pressure to burnish hooked cutting edge

MAY 1970



FRENCH-CURVE SCRAPER does a great job of removing paint or varnish from furniture to be refinished

181

ELECTRIC SERVING CART

(Continued from page 121)

shelf for the Salton warming tray (Detail A, page 121). It consists of a $\frac{3}{4}$ -in. fir-plywood panel with a hole in it to fit the flanged tray. Two $\frac{3}{4}$ -in.-square cleats are glued to the front and back edges, and two $\frac{3}{4} \times 1\frac{3}{4}$ -in. members are glued on edge at the ends. (Here it's wise to check the $14\frac{13}{16}$ -in. dimension against the actual inside width of the cart.)

Since the tray shelf is also faced with laminate, it's easier to cover it before it's installed. We covered the shelf top and inside surfaces of the ends with yellow

(Please turn to page 184)

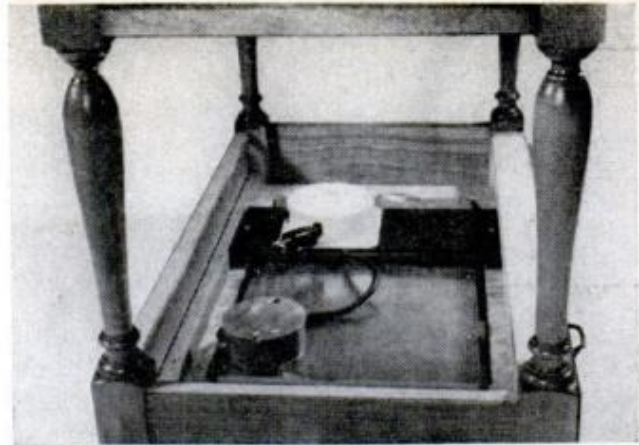

RETRACTABLE REEL, which holds 6 ft. of electric cord, is wired to junction box that comes with tray

BOTTOM-DRAWER CONSTRUCTION

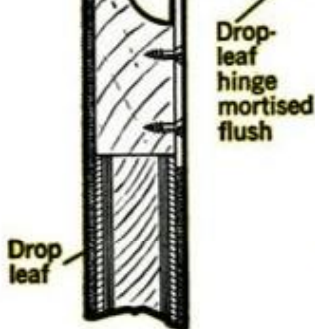
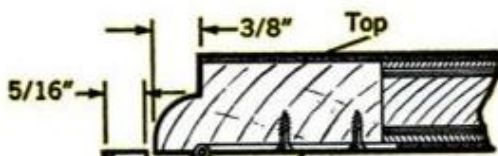
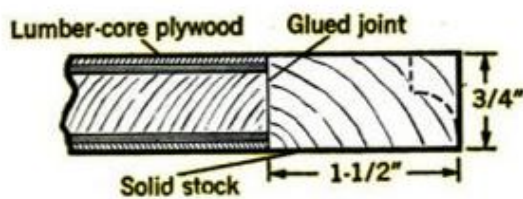
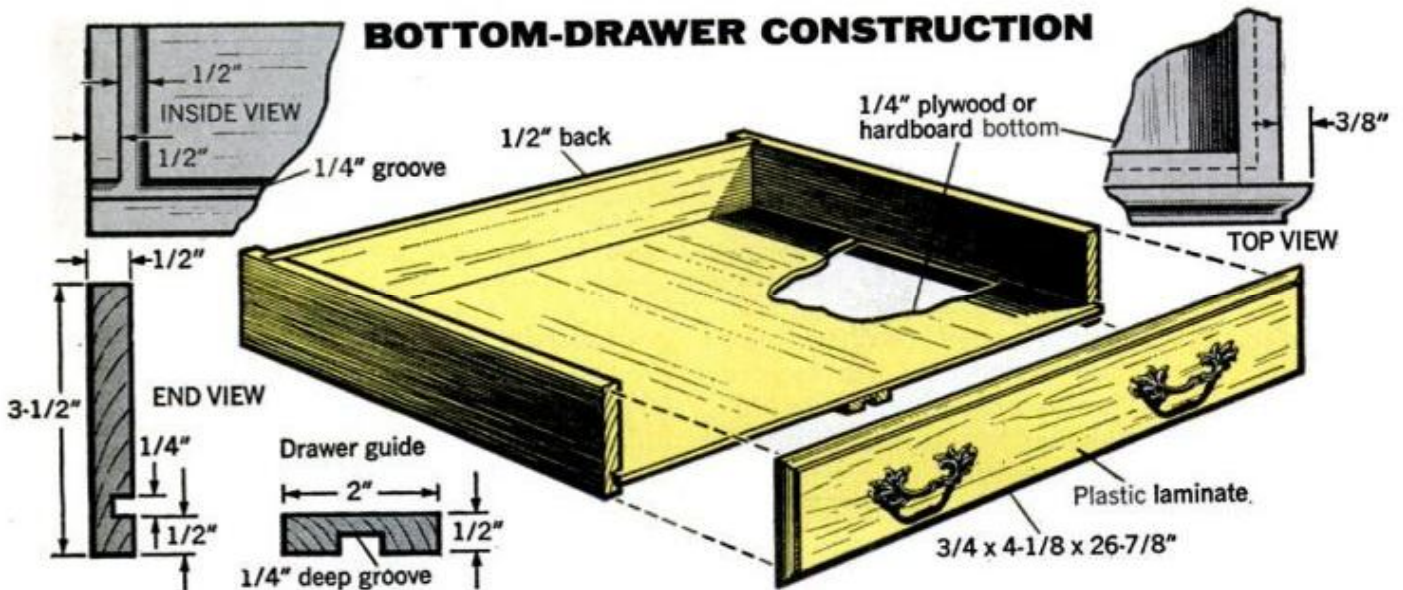

LID AND LEAF CONSTRUCTION

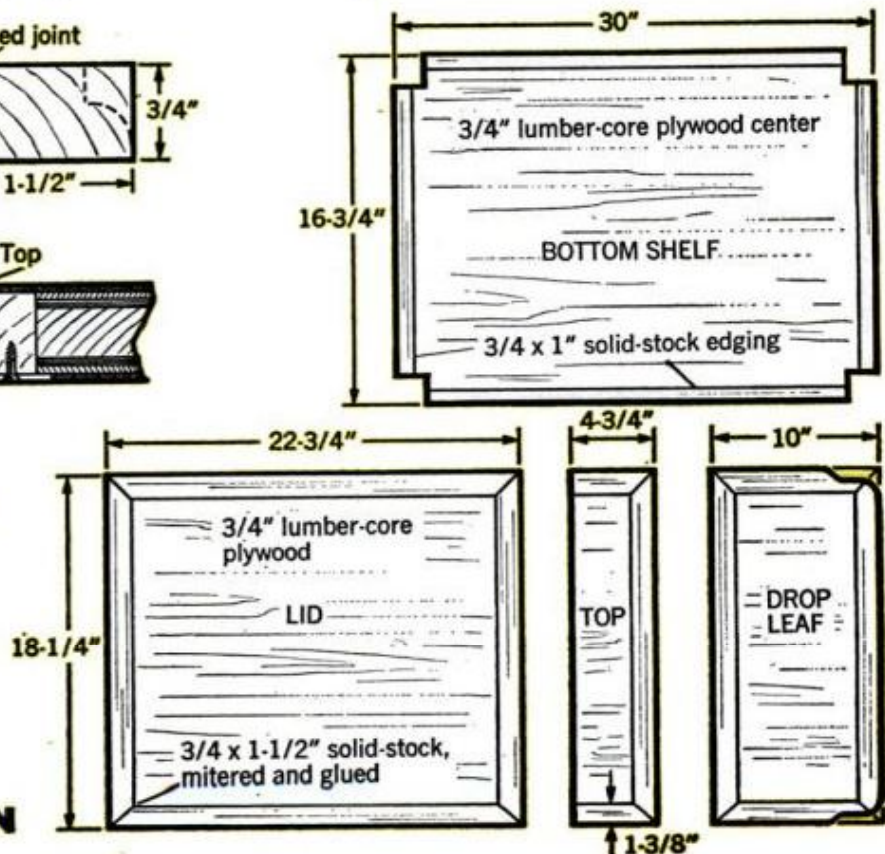

That's a comment made by one off-road magazine editor. And what he's talking about is the new SCOUT® 800A ... the vehicle that's drawing enthusiastic response from off-road editors everywhere.

Here's why:

More Under The Hood. A SCOUT's new 304 cu. in. V-8 churns out 193 horsepower ... and brings the hilliest horizons closer than ever before. And in independent tests, the SCOUT 800A beat the wheels off of every competitor in mileage runs — in spite of all that new muscle.

More Behind The Engine. There's a shifttable 3-speed automatic. So you can use it like a manual ... or notch it into "Drive" and get the advantages automatically. Greater torque multiplication, smoother take-offs, better towability and gas mileage make this transmission the one that's getting more popular every day.

For an all-wheel drive, there's a single-lever transfer case. So you get out and going faster than ever. Easier, too.

More Underneath. Front axle rating for the big V-8 is a burly 2500 lbs. And that's attached to a frame bred from INTERNATIONAL's big trucks. There's an improved rear suspension that lets you plow through the rough without getting roughed.

There's more. As another editor said, "... has to be reported as even

better than the best SCOUT ever built." If you won't take their word for it, see for yourself. Your INTERNATIONAL® dealer has a test drive waiting.



The Scout®

**"If you haven't driven it since its early four-banger days...
you won't believe it's the same rig!"**



INTERNATIONAL HARVESTER COMPANY
CHICAGO, ILLINOIS 60611

The rule

New! extra-long 20-ft Stanley Powerlock® • lightweight • non slip lock, power return • 3/4" x 20' blade clad in Mylar® • about \$6.98

STANLEY
helps you do things right

P.S. Made by the same Stanley that makes the finest power tools

ELECTRIC SERVING CART

(Continued from page 182)

laminate. After installing it, we added 1 3/4-in.-wide strips of the laminate to exposed parts of the aprons. The 1/2 x 5-in. crossmember, screwed to the shelf cleats, supports the self-winding cord reel.

To make the bottom shelf, glue 3/4 x 1-in. strips of cherry to the edges of a plywood center panel, notch the corners for legs and cover the top with laminate. Attach the completed shelf to the cart with screws through cleats glued to the end aprons. (Study section B-B.)

Make the lid, top and drop-leaf parts essentially the same way, but make the edge pieces 1 1/2 in. wide and miter the corners. Note that the narrow top sections are banded only on three edges. Both top and bottom surfaces of the five top parts are covered with laminate, then the edges are shaped. Use a standard drop-leaf cutter and its mate to shape the hinged edges. The other edges can be shaped with less of a shoulder or even with a different-shaped cutter. Mortise the drop-leaf table hinges flush with the laminate. Be sure the barrels of the hinges are centered exactly on the shoulder of the shaped edge.

Attach the narrow top sections to the

cart with cleats and screws from below and let them overhang the ends 1 3/8 in. The lid should fit between the two with 1/16-in. clearance at each side. It's hinged at the back with a piano hinge mortised flush with the laminate. The lid should overhang front and back 3/4 in. Adding an adjustable support like the one shown completes the lid. Fit the drop leaves with surface-mounted, spring-loaded brackets.

The drawers complete the job. The two upper ones are dummies, of course; they're actually made and attached before laminate is applied to the inside of the tray shelf. The fronts are pieces of cherry, rabbeted around the back, faced with laminate and shaped. Attach the pulls before you screw the fronts in place.

Make the front of the bottom drawer as just described, and the rest is typical drawer assembly (see construction details, page 182). Attach a grooved guide to the bottom to ride on a rail screwed to the front crossrail and to a cleat added to the back apron. Note in section B-B (page 121) how drawer rubrails are nailed to the end aprons.

Wire the plug-in Acopian cord reel to a junction box mounted on the tray bottom. Use wire suited for 167° F., and be sure the tray is properly grounded. ★★★

WHY WINNEBAGO IS NO. 1

(Continued from page 125)

can be a problem for motor homes; you must learn to live with them. In this respect I found the Winnebago no better or worse than other motor homes I have driven. Headwinds at turnpike speeds make for conspicuous gas consumption. Holding 70 mph all day against a stiff Kansas breeze, we got only 4.4 mpg. At a steady 50, with little or no wind we registered a 7.1 average.

The eyes of the driver—and co-pilot—of a Winnebago are 6 feet 10 inches above the road. From this vantage point you can see over the roofs of cars ahead. You can spot trouble ahead and anticipate your moves. Because the view is great, it makes even traffic jams bearable. But rear visibility depends on side mirrors. On multilane expressways, where drivers overtake you in the right lane, cars can be lost in the blind spot between your right rear bumper and the mirror. This is the only visibility fault of the Winnebago. It could be easily remedied with the addition of a convex wide-angle mirror to give "panoramic" rear vision.

A weekend stopover with relatives pointed up another advantage of the mo-

tor home: People are glad to see you when you bring your own guest room. At this time we took inventory of the toll a year's hard use had taken of the vehicle. All appliances were in good working order with the exception of a leaking broiler connection. Plastic countertops, paneling, cushions, drapes and upholstery were still like new; maintaining a neat home was easy. A screen at the driver's window needed replacement. A small leak had developed at a union near the toilet bowl. It needed tightening. The engine needed a new alternator belt and a tune-up. Taking into account all the equipment aboard, the Winnebago passed her one-year, hard-use test better than most homes I've owned.

Who can afford a \$9000 motor home? A lot of retired people apparently. Father-son partnerships let Dad winter in the South and give the young family a summer home. Five to 10-year financing is common.

The motor home is fast becoming the equivalent of the vacation home, but there is a difference. Owners find that a motor home is the only vacation cottage that gives you a complete change of scenery and really lets you get away—from uninvited weekend guests. ★★★

and new pal

Utility pull-push
tape rule 6' model,
about \$1.45

Utility tape rules come in
6', 8', 10' and 12' lengths
with replaceable blades

Lifeguard™ blade
clad in Mylar® resists
oil, acid, abrasion

Simulated leather
case of extra strong
Cyclac®

Lightweight taper
design fits palm
or pocket

STANLEY
helps you do things right

\$30,000 BEHIND THE WHEEL

(Continued from page 82)

next. "After expenses I cleared about \$6300," he said. But he did buy a better tractor so the company gave him a bigger van. His seniority began to help. He got more and better assignments. Result: in his third year his gross jumped to \$40,000. After expenses he cleared about \$18,000, of which \$3000 went toward a new gas tractor.

We were pulling into old Santa Fe, N.M. I spotted a good motel. "Where will you go?" I asked Selman. He patted the curtains.

"Here's my home," he said. "Not many motels like trucks because we break up driveways, so I use my bunk." (It also saves him \$10-\$20 a night.)

The big van headed down the road toward a bright new truck stop where it would be checked while he slept. It was his 19th night away from home this trip.

Any good job has its disadvantages, too. Selman's is no exception. One price he

"I try to make Monday deliveries and keep busy on weekends . . ."

must pay is loneliness—long stretches away from his wife, Margie Ann. Another is a fantastic amount of paper work. He's always buried in receipts and record-keeping. Luckily, Margie helps with this at home.

Next morning we were whistling toward California. Selman whooped, "Isn't that great? Look at all those mountains!"

The whole bright morning was rushing toward us. "Been in 48 states this year," Selman said. "I never get tired."

"How do you get started? Can anybody gross \$80,000?" I asked.

"Well, like any business, it depends on how hard you work. Mayflower has several hundred drivers. I judge 15 percent earn big money. You've got to be strong. It takes a good man to drive three days and then help carry pianos upstairs."

We pulled into an Albuquerque truck stop. A man flagged us.

While they worked the rig over, we went into the trucker's restaurant. Over coffee I asked, "But how does a beginner get the money to start?"

"You start small—a little gas truck. My first cost \$7500. You can get one for \$3500. If you want to be a contract truckman, you apply to any Mayflower driver—like me. I size you up. If I think you're the

type I give you a green card. You fill it in. A recruiter comes to see you.

"You've got to have a good driving record. Legally, you've got to be perfect, no crimes. You take a lie test. Then Mayflower sends you to the Indianapolis school for 30 days. You get paid a salary plus your hotel bills. When you graduate, you go on a student trip with an old hand. And you buy your tractor."

With full diesel tanks we thrummed west on I-40.

"I'd recommend Indianapolis for truck bargains," he said. "Mayflower won't sign your note. But they'll take out monthly payments for you. As soon as you can, you should go to diesel. There's no comparison. I made it three years ago. My first International cost \$15,000. I had only 238 hp but this, plus the radio, was enough to put me in the big money."

Next year Selman will graduate to a still better International, with automatic transmission, and an automatic antiskid device—for ice. "And I'll get another smokeless diesel," he said. "People are beginning to dislike trucks putting out trails of smoke. A smokeless engine makes us look better. And it doesn't mess up that purty name Mayflower on the van."

I asked why a big diesel was so important. "Two reasons," he said. "No plugs, points, pumps, tune-ups, carburetors. I used to spend \$1750 a year on repairs. The 'down time' cost me lots of money."

"With the big diesel I can roll. It used to take 10 minutes to crawl over a bad hill. Now I'm over in a minute. And I can accelerate. You save a lot of time and money by fast acceleration after any slowdown."

As much as his diesel, Selman depends on his radio. He uses a new type. "You just lift it and talk," he said. Radio service costs him only \$16 a month plus 30 cents a minute for air time. He really keeps the radio hot.

"You've got to keep planning ahead," he said. "I try to make Monday deliveries and keep busy on weekends when everybody is sleeping," he said. He often turns a weekend into an extra \$800 or more.

He tossed me a directory. "Where's the nearest radio control? I thumbed the pages. "Grants, N.M.," I said. Grants was 35 miles ahead.

He began calling. "Mayflower to Grants. Grants, give me a land patch, please, to Los Angeles code 213 number 666-1593."

After a while, Mayflower Los Angeles said hello. "I am van 3829," Selman said. "Westbound on I-40 in New Mexico with two loads. ETA San Diego tomorrow noon. Please hire two helpers. I will be at Van Nuys, Calif., at 8 a.m. next day with the

(Please turn to page 188)

Our new fishing motors, the 9½, 6, 4 and 1½ hp, all have the same Johnson dependability as Mr. Chenoweth's 1938 Sea-Horse. They also have the benefit of 32 more years of improvements in engine performance, hydro-dynamic design, fuel economy and corrosion resistance. We're so sure of them, we back every Sea-Horse from the 1½ up to the 115 hp with an exclusive 2 year war-

ranty*. That's a lot of warranty. But then, a Johnson is a lot of outboard. Right, Mr. Chenoweth?

Visit your Johnson dealer. Or write for a free catalog. Johnson Motors, Waukegan, Ill. 60085, Dept. PM-75.

*For 24 months after purchase. Johnson Motors will replace or repair without cost to the original purchaser any part of its manufacture which, upon inspection, proves to have failed in normal pleasure use due to faulty material or workmanship.

Johnson is the way to go!
FIRST IN DEPENDABILITY • Div. Outboard Marine Corporation



Sea-Horse
9½

JAY CHENOWETH
PAINTING AND DECORATING
LICENSED CONTRACTOR

FEATHER RIVER DRIVE • CHESTER, CALIFORNIA
BOX 611 92020

Johnson Outboard Motor Co.
Waukegan Ill.

Dear Sirs:

Enclosed are two snapshots of a Johnson MS-38; wired together, welded together, mended with epoxy, thirty one years old and still catching fish.

It is phenomenal the dependability of a Johnson regardless of age. I have been using outboard motors for thirty eight years and have owned nothing but Johnsons..I have never had to row in because of motor failure.

I hope that a great part of the outboard world appreciates as I do the fine product you have been manufacturing all these years..

Very truly yours,

Jay Chenoweth

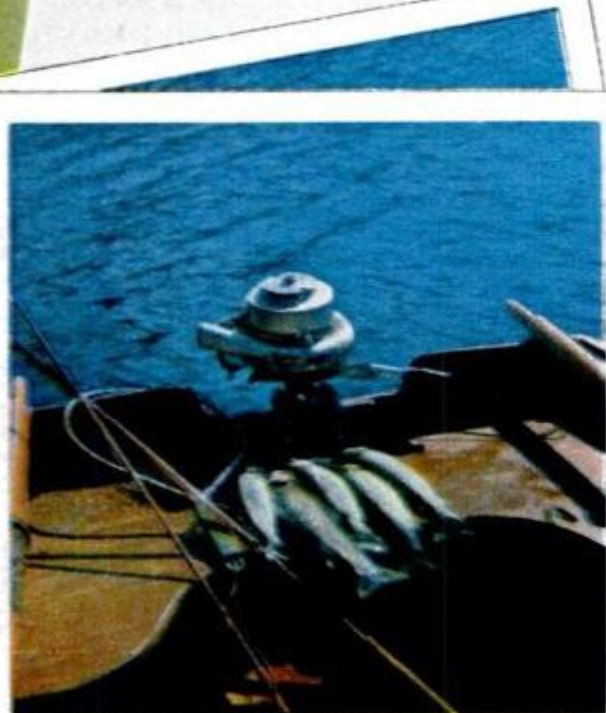

\$30,000 BEHIND THE WHEEL

(Continued from page 186)

second shipment. At Van Nuys, I'll need only one helper."

"Roger," said Mayflower LA.

"And," Selman said, "please line up new shipments for a week from tomorrow."

He stopped that night at Kingman, Ariz. Next noon he rolled up to a home in San Diego. The customer was waiting with \$2500. So were two helpers. At 6 a.m. next day he arrived at Van Nuys to deliver furniture to the handsome home of Ed McGrath, an IT&T executive. Selman collected \$2800 more.

Time: 3 p.m. Selman worked his radio one last time. His wife's voice came on the speaker. "Hello, Margie Ann," he said, tired now. "I'll be home at 4. And I've decided to take a week off. Let's get out the plane and fly up to the lodge in Oregon for a little fishin'." ★★

LATHE WORK WITH INDICATORS

(Continued from page 178)

something shifted during tightening. While you tap the piece into alignment, be careful not to transmit damaging shock to the indicator; move it out of contact first.

● *Centering a punch mark.* A punch mark used to denote the location of a future hole in a chuck or faceplate-mounted piece can be centered precisely with an indicator. On a slender, rather flexible rod (say $\frac{1}{8}$ to $\frac{3}{16}$ in. in diameter and 10 in. long), form a sharp point. Clamp the other end in a tailstock chuck, and bring the rod against the workpiece until its point rests in the punch mark. As you hand-rotate the lathe spindle, adjust the rod until there seems to be little sidewise movement. Then bring the indicator contact point against the rod close to the work, and make further adjustments until the indicator pointer stays in one place as you turn the spindle through a full revolution.

● *Using button to position work for drilling.* Clamp a toolmaker's button to the workpiece and, by customary measurements from edges, position it precisely with respect to desired hole location. Mount workpiece in chuck or on faceplate and (with indicator) check to be sure it's held so that axis of the proposed hole is parallel to lathe axis. Place indicator point against the button circumference (with indicator mounted on toolpost), and adjust workpiece until this surface runs true. Remove indicator and button, and machine hole to diameter.

● *Testing live centers.* Mount the indicator to bear against sloping surface of the

center, rotate spindle by hand, and note degree of run-out, if any. The center should, of course, be smooth—not scarred from wear or rough handling. If it is not true, machine or grind it to the proper angle, and retest.

● *Checking arbors, mandrels.* Such pieces customarily are machined between centers, so they can be mounted the same way for testing. Bring the indicator feeler against the portion to be checked, then rotate spindle by hand (if dog and faceplate are used), or rotate arbor or mandrel on the stationary centers (which may be lightly oiled). Center holes must be clean.

● *Measuring taper on a piece mounted between centers.* Clamp indicator on the toolpost, with the top slide positioned to move parallel to the lathe axis. Using a reference, a bar of known straightness and uniformity of diameter between centers, adjust the slide until it moves truly parallel to the bar. Substitute the tapered piece to be measured, and bring indicator point against its surface. Using micrometer collar on the top slide, move the indicator exactly one inch (or some multiple thereof) along the lathe axis. Difference in readings at the two positions will correspond to one-half of the difference in diameters at these positions. As in other tests of work between centers, the centers must be in alignment.

● *Checking straightness of tubing or rods mounted between centers.* Use indicator on the toolpost to check surface of a bar or tubing for straightness. This can be done either by rotating the piece or moving the carriage along the bed. In the case of tubing or pipe, ends must be carefully trued or they are not likely to rotate uniformly on centers. When the piece checked does not have a precisely machined surface, this method can be used only for a relatively rough test. Although a piece such as a length of soft aluminum tubing can be straightened by tapping it with a hammer while it is mounted in a lathe, it is not recommended that a lathe employed for precision work be used as a straightener. Hammering on shafting mounted in the lathe could cause serious damage.

You can undoubtedly find many more uses for these indicators. You don't have to buy one if your toolbox lacks such an aid: The shop-made lathe indicator in the photo on page 177 is the custom-built instrument described in *Make This Handy Indicator for Your Shop* (page 196, Jan. '68 PM). Commercial versions are available by mail order from Sears and Edmund Scientific Co., Barrington, N.J. Indicators made by L. S. Starrett Co., Lufkin Rule Co. and others are available at most well-stocked hardware stores. ★★

What makes it work like a truck, ride like a car?



Twin-I-Beam Only Ford has it!



It's a fact that forged steel I-beams make the strongest front axles. That's why all the big trucks use them. It's a fact, too, that independent wheel suspensions with coil springs make the smoothest ride. That's why nearly all passenger cars use them. And when you combine two I-beam axles and coil springs in an independent suspension, as in Twin-I-Beam front suspension, you have what only a Ford can deliver: big-truck toughness *and* a car-smooth ride. If

you like, add Flex-O-Matic rear suspension and the ride stays smooth, with or without a load. Inside Ford's cab—the roomiest and quietest of them all—is comfort unlimited. All the options you may want: power front disc brakes, power steering, air conditioning, sliding rear cab window and a choice of five great engines, up to a 390-cu. in. V-8. Test-drive a Ford soon. It's the only pickup that gives you big-truck toughness with a car-like ride. And that's a fact.

FORD PICKUPS





*It's a giant 6x3 foot,
\$2.00 put-up—*

It's Champion's giant racing poster—and it's yours to put up for just two bucks! And with it you'll get a pair of official Champion racing decals—yours to put on FREE! Order as many posters as you want—for yourself and for friends.

*—and FREE
put-ons too!*



Please send me _____ Champion Racing Poster(s) @ \$2.00 each, postpaid. Enclosed is my check or money order, payable to Champion Racing Poster, for \$_____. (Offer good in U.S.A. only.)

NAME _____
(PLEASE PRINT)

ADDRESS _____

CITY _____ STATE _____ ZIP _____

CHAMPION RACING POSTER
MAIL TO: P.O. BOX 225
BIRMINGHAM, MICHIGAN 48012

- 3/8" DRILL
- SCREWDRIVER
- NUTRUNNER
- SANDER • GRINDER
- POLISHER • HOLE SAW
- ACCEPTS OVER 100 ACCESSORIES.



FULL TORQUE, VARIABLE SPEED,
WITH SPEED LOCK AND REVERSE.

Grab a handful of this NEW power package.

1/2 HP motor with 0-1000 RPM variable speed trigger control. Full-torque circuit senses load and automatically adds power at all speeds. Speed lock pre-sets variable speeds from 400-1000 RPM. Thumb-tip reverse for backing out bits, taps, and screws. Model 1832.

From **\$24⁹⁹**



Full-Torque — Variable Speed Sabre Saw. Same control circuits as drill above. Adjustable bevel and rip. Model 1818.

From \$29.99



7 1/2" Circular Saw. 1 1/2 HP Motor. Bevel and depth of cut adjustment. Cuts 2" lumber at all angles. Model 1875.

From \$29.99



Dual-Motion Sander. Gear driven orbital or straightline motion. For rough or finish sanding. Model 1805.

From \$23.99

SHOPMATE tools make your jobs easier, more professional.

All have FULL TOOL LIFE WARRANTY.

SHOPMATE

**POWER
TOOLS**



GW MURPHY INDUSTRIES
Portable Electric Tools Division

It's Here! The handiest "tool" you'll ever own!

- 12 handy hang-up boards!
- 56 charts—scores of illustrations!
- Wipe-clean-plastic laminated to last for years!
- Authoritative answers to 1001 shop questions!

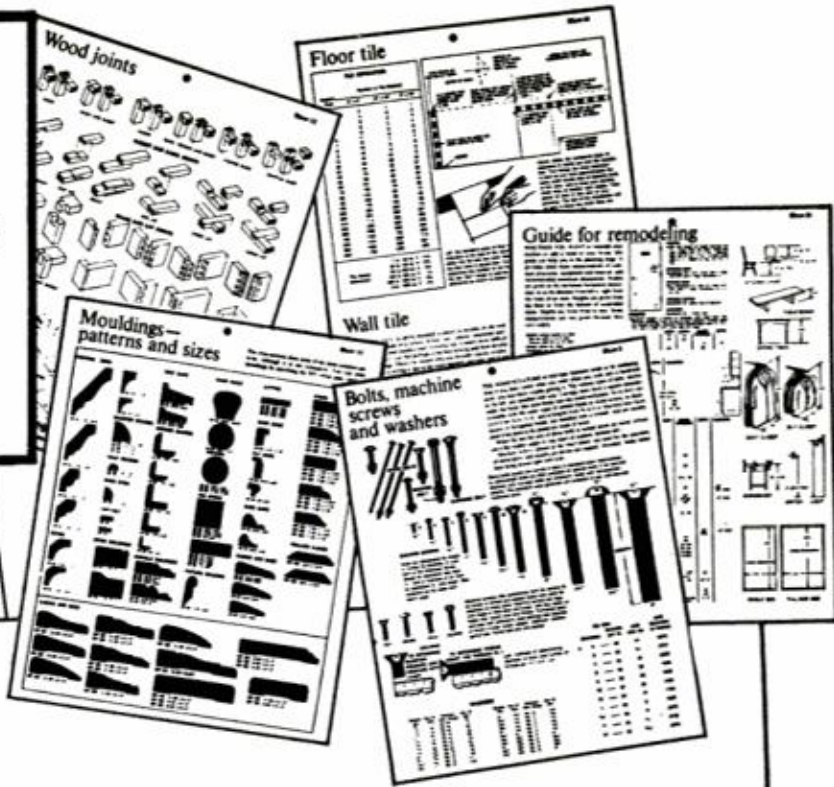

NEW!

POPULAR MECHANICS

MASTER SHOP GUIDE

Save hundreds of dollars! Save hours of time!

Everything you need to know about: what nails, screws, bolts, wall-fasteners, drills, abrasives to use and why. How to order and use lumber, hardwoods, moldings, plywood, hardboard, gypsum, adhesives, plumbing, electrical work, floor and wall tile, glass. Plus the facts on remodeling measurements, gutters and downspouts, concrete work, lawn and garden chemicals! Plus—all on one "take-right-to-the-job" board—a ruler, centimeter rule, protractor, 45-degree triangle, and a compass for accurate circles up to 19½" diameter.

You'll reach for the MASTER SHOP GUIDE for every job you tackle!

What nail should you use for underlayment? What's the diameter of a No. 12 screw? What types and sizes of sheet-metal screws are available? How many pounds will a ¼-in. toggle bolt hold? How can you save money ordering lumber? What size quarter-rounds are available? How do you bleach close-grained hardwoods? What glue is best for cementing metal to wood?

All the answers on repairs, too! Illustrations of most-used plumbing and electrical fittings. How to fix dripping faucets, how to lay out a room for floor or wall tile, how to cut and apply plastic laminates, how to replace a pane of glass. Remodeling? All the basic dimensions you'll need to plan the job. Leaking gutters? Best way to patch them. What chemical controls which weeds and diseases? Best mixing ratio for concrete work? Just look it up.

One sheet even shows how to solve those puzzling math problems you often encounter in shop work.

By the editors of *Popular Mechanics*—order yours now—you'll use it the rest of your life!

\$3.95 complete set of 12 8½" x 11" boards!

PARTIAL LIST OF CONTENTS

Nail and screw sizes and uses	Bolts, machine screws, washers	Plumbing guidance
Useful mathematics	Wallpaper	Lumber sizes
Masonry	Wall fasteners	Mouldings—patterns and sizes
Lawn and garden chemicals	Plastic laminates	Properties of common woods
Stair construction	Glass	Glues and adhesives
Gutters and downspouts	Floor and wall tile	Wood joints
Guide for remodeling	Drill sizes	Plywood grades and uses
	Electrical work	Wood finishes
	Abrasives	

Popular Mechanics, Dept. SG
224 West 57th St., N.Y., N.Y. 10019

Rush me ___ sets of MASTER SHOP GUIDE.

I enclose check or money order for \$3.95 for each set ordered.

Name _____

Address _____

City _____ State _____ Zip _____

MAIL COUPON TODAY!

The tough one.

Hard paste wax protection, long-lasting paste wax shine—that's how Kit earned its reputation for toughness. But Kit's the paste wax that's been pre-softened, so it slides on easily. Deep cleans as it waxes. Kit—the one that started it all. No wonder it's the best selling pre-softened paste wax in the world.

J/WAX Kit:
everything you'd expect
from Johnson Wax.

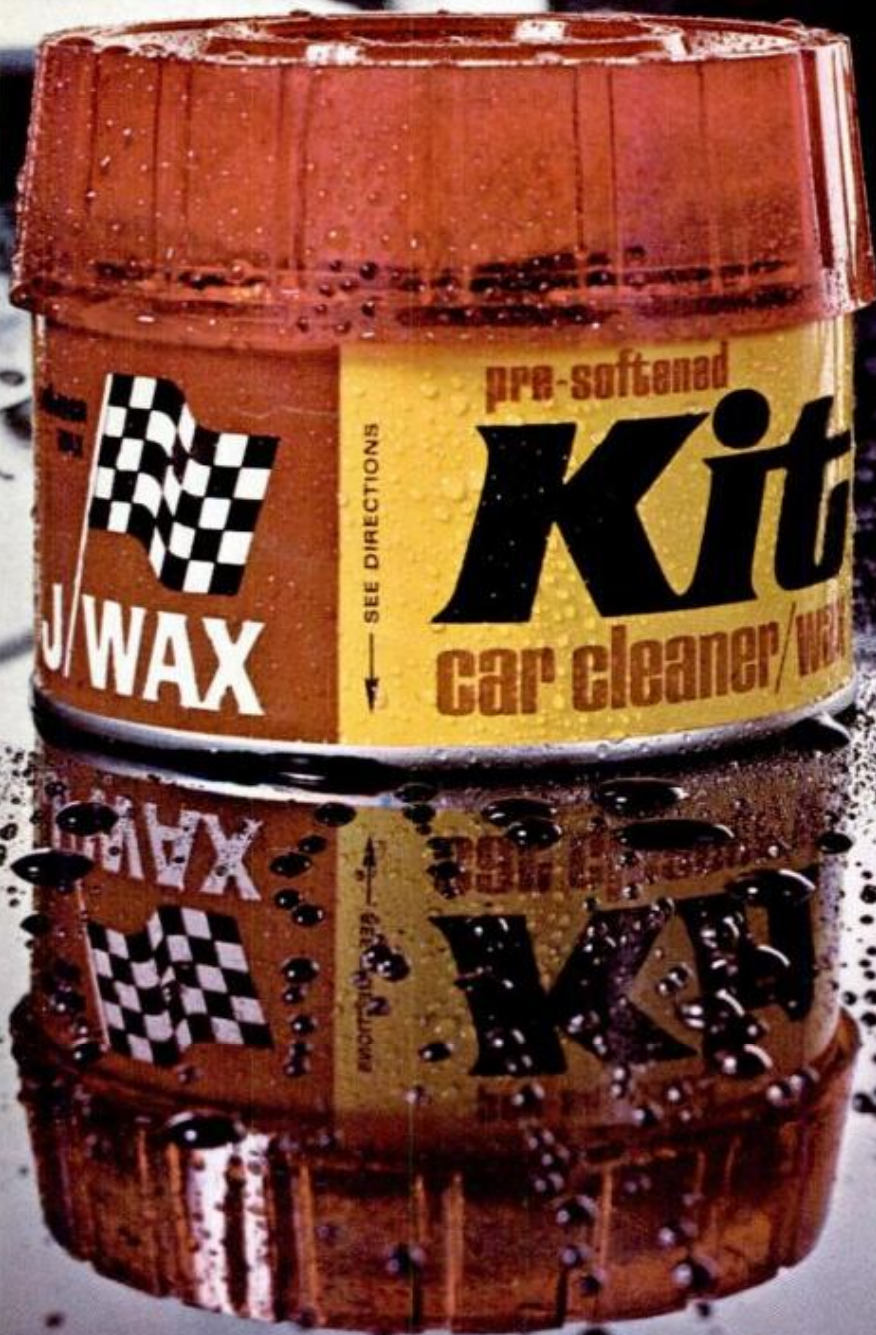

There's a
new power structure
in the middle power class



Evinrude's loop-charged "60"
leads the power revolution

This is the mid-range motor with the *inside* advantage. The one with efficient, economical, *legitimate* loop charging.

Instead of conventional ports in the cylinder walls, Triumph gets its fuel through *aimed* fuel passages that loop the fuel charge *upward*, from three directions, swirling it *directly into the top* of the combustion chamber.

Piston deflector humps aren't needed

— so the combustion chamber doesn't have to be shaped to accommodate them.

The result is more efficient combustion — more power from less fuel — without overheating the pistons or the engine.

New self-cleaning pressure-backed piston rings add another power bonus — by improving the combustion seal and reducing friction. Power-tuning adds still another. And the computer-

designed lower unit converts maximum power into thrust.

And the final pleasant surprise: The push-button new Triumph "60" is as elegant and quiet as it is efficient and quick and strong.

Just because it leads a revolution doesn't mean it has to look the part.

Write for catalog, Evinrude Motors, 4217 N. 27th St., Milwaukee, Wis. 53216

power for the performance generation **EVINRUDE** **first in outboards**
Div. of Outboard Marine Corporation

SPECIAL SECTION

POPULAR MECHANICS

CAMPING '70

**Campgrounds
Controversy:
Public vs.
Private**

- Rigging Your New RV
- Camping Security
- New First-Aid Techniques
- Equipment You Should Have
- All About Bottled Gas

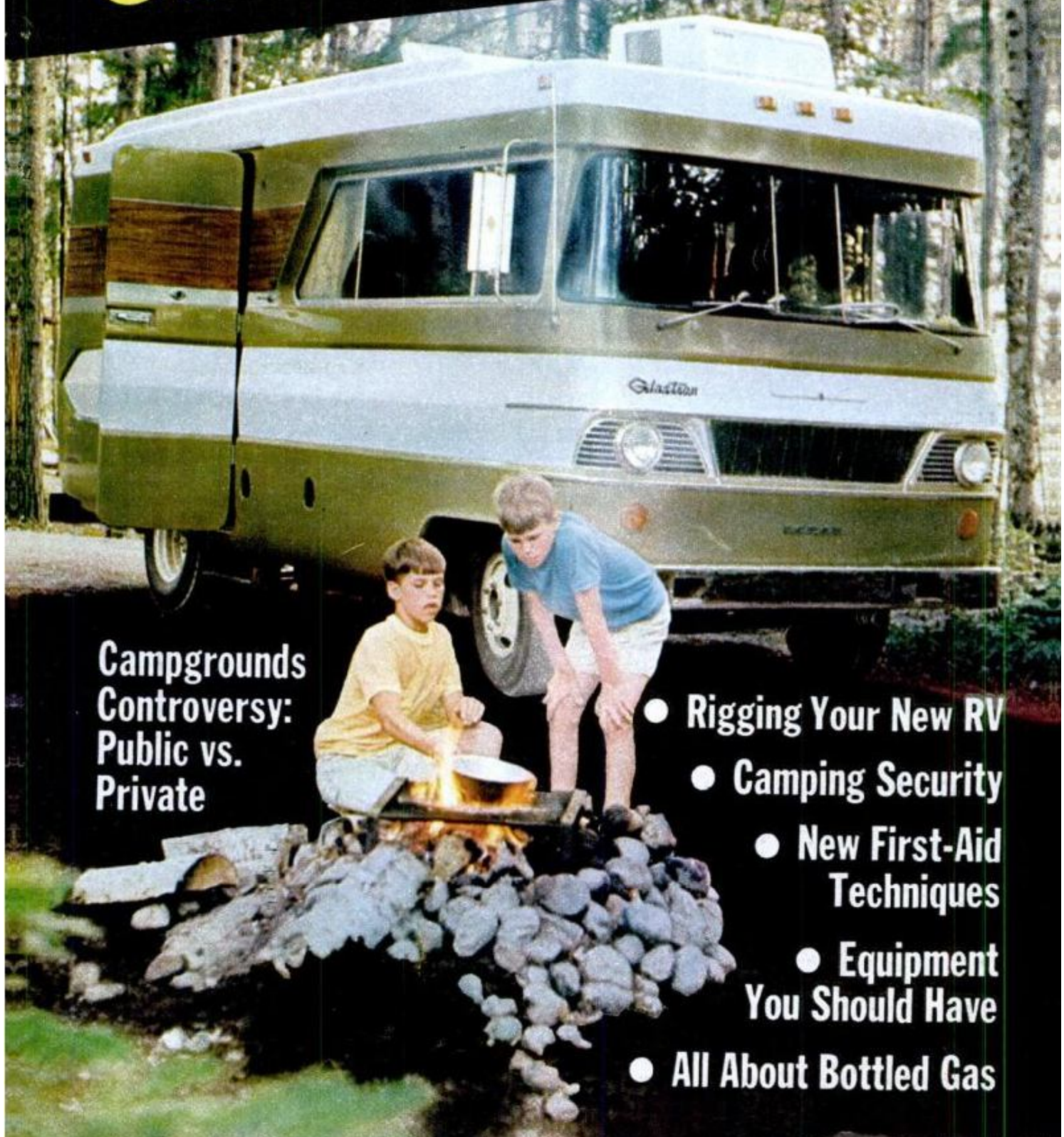



How much do you have riding on your camper's tires?

A lot. In pounds and in people.

So you need a lot of tire. Firestone recommends nylon-cord truck tires with Triple-Strength Construction. For example:

The new Transport 500 Wide Oval truck tire, now original equipment on new pickup campers. This all-wheel tire puts more rubber on the road for more stability and less sway in crosswinds, and a smoother ride.

The new Traction All Season Wide Oval truck tire for rear wheels. Runs smooth and silent on the highway. But get off in the roughest country and this one pulls you through mud, loose gravel or snow.

Both of these tires are Wide Oval truck tires. They'll carry heavy loads. And stop faster. But, most important, they are made with Firestone's exclusive Triple-Strength Construction. That's the special way Firestone bonds the tread to the body, reinforces the sidewalls and insulates every cord.

Get them at your Firestone Dealer or Store. Or specify them on your new camper.

Because you have a lot riding on your camper's tires.



The new Transport 500 Wide Oval truck tire.

The new Traction All Season Wide Oval truck tire.

Transport 500 Wide Oval,
Traction All Season Wide Oval—Firestone T.M.'s. Transport®

Firestone

The Only Way to Go

The first motorized camping trip we ever took was in a 1921 Nash. We pitched a tent in dusty school yards and small town parks and took three days to get from Omaha to Colorado Springs. Fifteen years ago we were the travel editor of a national magazine. We plugged family vacations in the family car and told our readers to be sure to allow \$8 a night for a motel room for four.

Those days, like free camping in the school yard, are gone forever. Now you get color TV in every room and a swimming pool you pay for whether you use it or not. The \$20 motel room is as responsible as anything else for the boom in travel trailers, tent trailers, pickup campers and motor homes. Increasingly they're the *only* way to see America and to experience the refreshing solace, if not solitude, of wild places.

The camping vacation is still the *best* vacation—the biggest change, the most renewing in spirit, the most productive of memories and the least expensive. In this special section, *Camping '70*, which we hope you'll tear out and save, we've packed ideas, suggestions and new equipment to make it easy, simple, comfortable and safe.



Editor



GEORGE W. REIGER

Outdoors Editor

JAMES M. LISTON

Executive Editor

This One



Z9BX-A4X-P03H

Cover Photograph: JOHN A. LINKLETTER

Camping Equipment Photo (Page S20): TOP VALUE ENTERPRISES, INC.

Popular Mechanics is published monthly by The Hearst Corporation, 57th St. at 8th Ave., New York, N. Y. 10019, U.S.A. Richard E. Berlin, President; George Hearst, V-Pres.; Richard E. Deems, President of Magazines; John R. Miller, Executive V-Pres. of Magazines; Raymond J. Petersen, Senior V-Pres. of Magazines; William S. Campbell, V-Pres. of Magazines; Albert A. Rachol, V-Pres. and Director of Circulation; Joseph F. Kern, V-Pres. for Popular Mechanics; Frank Massi, Executive V-Pres. and Treasurer; Harvey L. Lipton, Secy. Single copy in the United States and Canada, 50 cents. Subscription prices: United States and Possessions, \$5.00 for one year; \$9.00 for two years; \$12.00 for three years. Canada, add \$0.75 for each year. Pan American Postal Union countries, add \$1.00 for each year. All other countries, add \$2.00 for each year. When changing address, give old address as well as the new, with postal-zone number, if any, and allow six weeks for change to become effective. Second-class postage paid at New York, N.Y., and at additional mailing offices. Authorized as second-class mail by the Post Office Department, Ottawa, and for payment of postage in cash. Registered as second-class matter at the Post Office at Mexico D.F., Mexico, June 20, 1950. © 1970 by The Hearst Corporation. All rights reserved. Printed in U.S.A. VOL. 133, NO. 5

MAY 1970

S3

Материал защищенный авторским правом



The New Look in Campgrounds

By V. LEE OERTLE

SOMEWHERE BETWEEN 40 MILLION AND 50 MILLION PEOPLE will attempt to use approximately 600,000 campsites during the season just ahead. That's a little like stuffing five pounds of cheese into a two-pound bag! Last year as many as 60,000 persons tried to jam into Yosemite Valley in a single day. The time when national park, monument and state park campsites were always available has gone forever.

The trouble is that too many American families think only of well-known parks at vacation time. Names of parks like Yellowstone, Grand Canyon and Great Smoky Mountains tumble easily out of every camper's bag. But the truth is that a world of freedom and relaxation can be found in areas outside these heavily visited parks.



Hundreds of new **privately operated** campgrounds have opened just this year. Considering the growing crush of humanity on the one hand and the luxury and varied facilities at these new campgrounds on the other, it might make sense to plan your overnight stops **between** the popular areas and then drive into them for your daily fun.

With their (1) clean restrooms (2) uncrowded laundries, and (3) well-managed general stores, private campgrounds offer new hope for the American camper. Campers desire spaciousness and comfort, quiet and cleanliness—and franchised campgrounds are trying to take the strain off public sites.

On the following pages we show how private grounds are a definite part of the new look for camping '70.

The Case for Public Campgrounds

By V. LEE OERTLE



WARM-WATER SWIMMING HOLE by a chilly trout stream, Bridger National Park, Wyoming



BUDDING CAMPERS learn ropes from a friendly ranger in Florida's Everglades National Park



THE HIGHLIGHT of all national parks, as well as most national forests and state parks, is scenery. No private campground can compete with Yellowstone's geysers, Haleakala's crater or the great gorge of the Grand Canyon.

And there are these other advantages in the public parks:

1. Regular rangers (not summer help) are generally experts in their field. They can provide information about natural wonders, where the best fishing is, and how to find Indian petroglyphs, as well as assist the new camper. In the face of summer crowds which threaten to engulf our best parks with choking dust and the shrieks of unwatched children, the patience and eternal friendliness of the rangers is a miracle in itself.

2. Individual campsites in a state or national park are generally to be found in a natural setting which will add to your camping enjoyment. Shade trees, cold-water trout streams, deep mountain lakes and spectacular backdrops are routine at the Cascades or Yosemite. Camping in the best national parks provides a true outdoor experience.

3. Rates are generally lower at state and national parks, except at overvisited areas such as Yosemite or Yellowstone. Even then, rates are generally on a par with private campgrounds in the area or slightly below their average fee.

4. Some state and national parks remain open throughout the autumn, winter and early spring seasons. During those slack periods, camping is ideal. Crowds disappear, except in a popular desert region such as Death Valley. Few private campgrounds can compete with public parks when it comes to providing both scenic beauty and readily available sites.

5. Public parks are generally designed for stays of one to three weeks (unless long stays are prohibited, as they are in a few busy locations). Private campgrounds, by contrast, seem to cater to the overnighter. Many campers feel that the mode of life in a public campground is much more relaxed, casual and enjoyable.

6. If you're a backpacker or a man who really wants to explore nature, the public parks cater to you more specifically than to the man with a motor home. You can obtain a fire permit and get off the beaten path. Private campgrounds discourage such adventure. ★★★

FOAMING FALLS serve as fitting backdrop for spectacular Genesee Gorge in New York's Letchworth State Park, a bit southwest of Rochester

BigHorn. The only machine you can adjust 19 ways to fit you.



- A. Hatta forks adjust 3 ways at axle base.
- B. Hatta forks adjust 3 ways on spring tension.
- C. Hatta forks adjust to any length you desire.
- D. 350cc, 33 horsepower engine. (with PowerPack, 45 hp)
- E. Foot brake control and shift lever are reversible.
- F. Cables protected by rubber boots.
- G. Footpegs rotate 180°.
- H. Sprocket changes without oil loss.
- I. Exclusive water-free rear hub.
- J. Alloy rims.
- K. Alloy fenders.
- L. Alloy rear sprockets.

- M. Reversible trip-meter in 10ths of a mile.
- N. Handle bars rotate in 7-inch arc.
- O. 7" fork travel.
- P. Total weight 265 lbs. light.
- Q. Vacuum-fuel cock.
- R. Altitude compensating carburetor with main jet removable from outside.
- S. Magneto type CDI. Not dependent on battery.
- T. Air-cleaner is under seat. Can be replaced in less than 30 seconds.
- U. Rear shocks with 5-way position and 4-inch travel.

12,000/12 month warranty.



Kawasaki Motors Corporation
1062 McGaw Ave., Santa Ana, Calif. 92705



The Case for Private Campgrounds

BASIC ADVANTAGE of privately owned and operated campgrounds is all-year availability. In addition:

1. Only privately operated campground franchises offer a cross-country reservation system. If you're a good planner you can set up an entire trip across many states well ahead of departure and have reservations confirmed at each stop for specific upcoming dates. Uncertainty about overnight sites is eliminated.

2. Physical facilities of most new private campgrounds outclass those of the older public parks. The new franchised campgrounds have set a higher standard—much as the motel industry outclassed the cabin court.

3. A certain standardization exists in all private campgrounds. In franchised units such as Safari Camps or Kampgrounds of America (KOA), a family quickly accepts the familiar layout of playgrounds, restrooms, camp store and other facilities.

4. Cross-country camping trips can be budgeted closely with reasonable accuracy. Advance estimates of overnight fees can be more accurate than is possible with public-park camping. (When space can't be located in a public campground three or four nights in a two-week vacation, motel bills will wreck the budget!)

5. Private campground operators erect better highway signs directing you to their sites. They're easier to find at night. Most are on good roads near major routes.

6. Virtually all privately operated campgrounds have a manager-in-residence. In



MANY KOAs have swimming pools or are near lakes or rivers. All offer free hot showers



COMFORTABLE LOUNGE adjoins laundry. (Below) Kids unwind after long day on the road



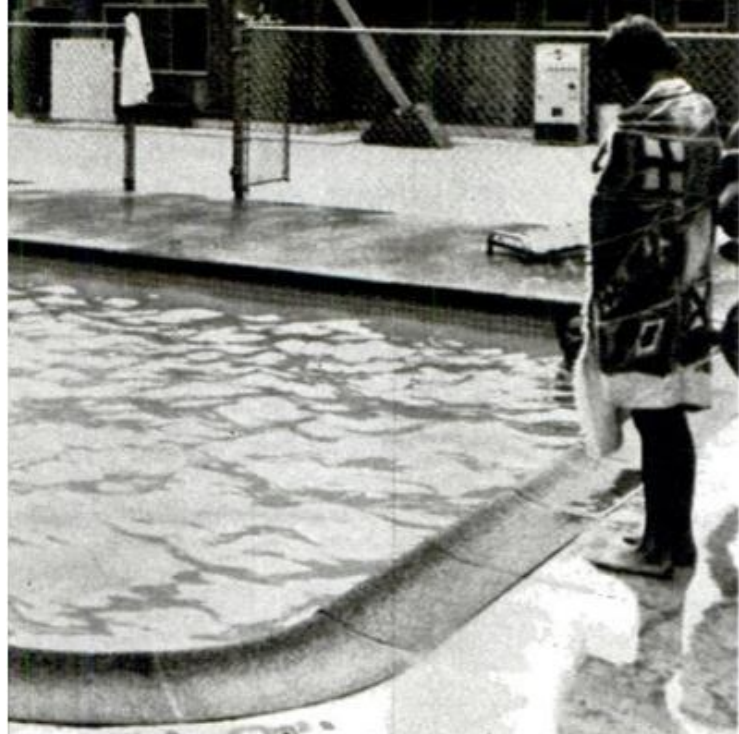

case of a late-night arrival, or in an emergency requiring medical or mechanical services, most campground operators can steer you to quick assistance.

7. Knowing where you will stay each night during a two-week vacation is a plus when it's important to keep in touch with home. Businessmen can take calls at specific times and campgrounds, if desired. And, most private campgrounds keep a bulletin board for easier friend-finding.

8. Most private campgrounds offer coin-operated washers and dryers, a camp store, hot showers and ice—conveniences that save you time seeking them out in towns during the day. A central recreation hall provides a great place for teen-agers to relax in the evenings, friends to get together and travelers to swap experiences. On rainy days, it's a real kid-saver.

9. In hot weather, electric power is highly desirable when you consider the growing number of coaches with rooftop airconditioning. Virtually all private parks furnish electrical outlets at camping sites. Most self-contained coaches have refrigerators operating on electric power (which is cheaper) or LP-gas. (Portable generators are sometimes limited to specific operating hours in public campgrounds.)

10. Pet lovers find their animals are barred from many public grounds. Virtually all private areas allow pets on a leash.

11. Most private areas provide sanitary dumping facilities or sewer hookups.

12. Nearly every private campground is designed to accommodate recreational vehicles. In national parks and most state parks, campgrounds are developed for tents only and RVs merely tolerated. Strong sentiment exists in some quarters to bar recreational vehicles from public campgrounds and allow tents only. ★★

Ranch Camps



By JAMES M. LISTON

KAMPGROUNDS OF AMERICA (KOA), with over 300 franchises the largest privately-owned system in the United States, is fast becoming the camper's Holiday Inn. Soon it may be every man's home on the range.

A new venture—Ranch Kamps of America—which lets you camp overnight or vacation at a ranch, promises to be the greatest idea since ranchers discovered dudes. You can now stay at a dude ranch on a camper's budget. Most guest ranchers don't accept overnights and the cost of a one-week stay is out of reach of many families. But RKO daily rates are only slightly more than those of KOAs and you are charged only for the facilities you use. These range from Saturday-night barn dances to horses (by the hour) and trout (by the pound) from well-stocked lakes and streams. Rates are \$4-\$5 per car. (KOAs are generally \$2.50-\$3.50 per car for two, plus 25 cents for each additional person.)

This year RKOAs at Chugwater, Wyo.; Swan Valley, Mont.; North Palm Springs, Calif.; and Nephi, Utah, will take campers—and more RKOAs are being planned. Last summer, the writer camped at the historic Diamond Ranch, a 75,000-acre working cattle ranch 42 miles north of Cheyenne and 13 miles west of Chugwater. Campsites, showers, laundry, heated swimming pool and other features are (spelled backwards) AOK, but the big barn for evening fun and square dancing, and the tremendous horizon (100 miles around the fence) of this spread are alone worth driving in to see. The kids can ride trails, hike, rock-hunt, fish—really feel the West on an RKO. The only problem: getting them to leave. The 1970 KOA *Kampground Directory* has full information on the RKOAs. Write: Kampgrounds of America, Inc., Box 1138, Billings, Mont., 59103. ★★

How to Rig Your New Recreation Vehicle

By V. LEE OERTLE

IT MAY BE A DISAPPOINTMENT to learn that the window-sticker price doesn't cover all those flashy accessories you want for your new camper, trailer or motor home. The advertised price just about covers the bare necessities. But if the salesman insists that *everything* is a necessity, don't believe it!

Although it's possible to drive away in a showroom-fresh RV without 10 cents' worth of extra hardware, you wouldn't enjoy it. In fact, in some states your rig might not even pass legal muster without some accessory equipment. For example, California RV owners must use outside mirrors on both sides of their rig.

So how does an eager new camper owner know what he really needs for safe, legal and convenient travel? We've boiled away the sales pitch to arrive at the three classes of RV rigging: *Must Have*, *Nice to Have* and *Luxury Equipment*.

CARS towing trailers *must have* special equipment:

1. Load-equalizing hitch (\$60 to \$150) for trailers weighing over 2000 pounds.
2. Frame-mounted hitch (\$30 to \$40) for light tent-trailers and travel trailers.
3. Set of high-quality clamp-on side-view mirrors (about \$15).
4. Electrical coupler installation (about \$15) tying in the lights and electric brakes of the trailer to the car.

Nice-to-have options would include such things as heavy-duty shock absorbers (from \$40 to \$60 extra), a transmission cooler for towing large trailers (\$57 up), fiberglass variable-pitch radiator fan (less than \$20), hill-holding brake device such as an Almico (about \$50), wheel chocks (\$5 to \$15), folding front-window awning

for the coach (metal, about \$20 to \$45), an extra five-gallon LP-gas tank (\$15 up), and an outside roll-up awning (\$35 up).

If you're considering a **VAN** or **PICKUP CAMPER**, there are two general divisions: equipment for the truck and accessories for the camper. Let's start with the truck.

If you order a Camper Special, your problems are simplified. But if you start with a bare truck, you *must have* the following items:

Heavy-duty tires, preferably flotation type in sizes 8.00x16.5, 8.75x16.5, 9.50x16.5 or 10x16.5 (\$65 to \$90 per tire and \$35 per wheel). The greater the tire's width, the better stability, traction and flotation you get. I'd consider an 8.00x16.5 an absolute minimum for carrying a camper. Greater safety and satisfaction result from each step up in tire size.

Heavy-duty springs front and rear are mandatory. Just make sure that the truck is rigged for maximum GVW rating. This simply means installing springs and tires (and axles) that match the highest legal rating for the particular vehicle.

Electrical equipment should include a 72-ampere-hour (or larger) battery, heavy-duty alternator, heavy-duty flasher unit.

Side-view mirrors, large and husky, are a must (\$20 to \$40 a pair). A large rear bumper should also be classed as a necessity even though truckmakers still call the rear bumper optional. The total cost of the options listed to this point run from \$200 to \$300 more than the standard pickup truck. Without them no pickup can be considered an efficient coach carrier.

Nice-to-have equipment includes power steering and power brakes (particularly disc brakes) because they reduce the ef-

COUPLER PLUG (left) is a must for trailer lights, brakes (\$10 to \$25). Stabilizer jacks (center) steady parked trailer (\$9 to \$20 for four). Large mirrors are recommended for trucks, motor homes

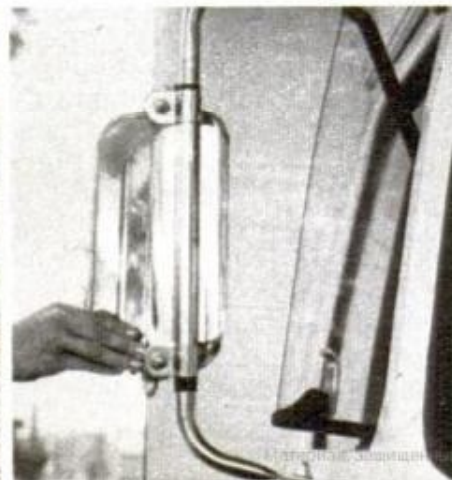

DURACELL® THE STRONG VS. THE WEAK.

DURACELL keeps going strong when an ordinary battery is long gone. DURACELL costs a little more, but winds up costing far less in the long run.

DURACELL has the strength to last weeks, even months longer. Its improved design is the first big change in batteries in years.

DURACELL—steel jacket protects against leakage, insures freshness for up to 2 years when not in use.

DURACELL—exclusive molded seal end locks long-lasting power in.



The ordinary battery hasn't basically changed since 1888.

Old-style batteries may leak, cause corrosion.

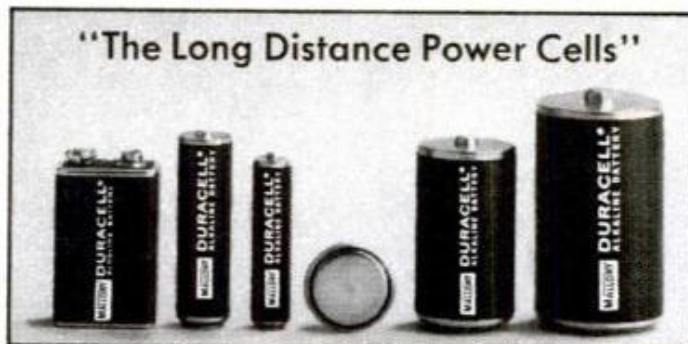

**DURACELL. STILL GOING STRONG...
LONG AFTER ORDINARY BATTERIES ARE DEAD.**
IN RADIOS—CAMERAS—RECORDERS—FLASHLIGHTS—TOYS.

MALLORY

® Registered trademark of P. R. Mallory & Co. Inc.



EXTRA VENT WINDOWS are bargain at any price. They freshen atmosphere, release trapped heat

fort of driving. The average camper spends as much time behind the steering wheel as at the campsite. Power steering could run from \$80 to \$200, plus another \$65 to \$100 for power brakes. They're both worth the price. Electric windshield wipers and washers are great for off-road trips. Custom cab options, such as quality seats and padded armrests (from \$75 to \$150 extra), make life more pleasant.

Luxury equipment includes airconditioners (\$275 to \$400), chrome bumpers (\$25 to \$50), stereo tape recorders, cruise-control and light-dimming electronic devices.

If you're considering a **TENT-TRAILER**, you'll find deluxe units are generally well-equipped. However, all models under the top-line designation need extra equipment for ultimate convenience. For example, many tent-trailers still need a water tank (\$20 to \$50), 12-volt light fixtures (\$5 to \$15 each), ice chest (\$10 to \$25) or a campstove (\$15 to \$35). A spare tire and wheel (\$30 to \$60) make a good addition. Plastic windows (\$15 to \$50) help keep out rain and allow light to enter the trailer.

Any self-propelled **MOTOR HOME**, be it a \$5000 van-bus or \$20,000 luxury coach, comes pretty well equipped for normal camper operation. Yet there are options the motor-home owner would find appealing: a roof-mounted, low-silhouette airconditioner, for example, (\$200 to \$500); a portable electric powerplant to handle it (\$350 to \$650); big truck-type side-view mirrors that give a better view (\$20 to \$40); and plush carpeting in place of floor mats. (Carpeting is warmer, but debatable because it collects dirt.)

Instead of a standard wall heater, luxury motor homes often have a forced-air furnace as an option. If you're planning winter trips, that extra \$250 to \$300 is probably well spent.

Another concern of RV buyers is a well-balanced **POWER TRAIN**. Some tips:

1. Heavy loads require a large engine. Remember that a big engine loafing will outlast a small one straining to move a load. In many cases, the large one will yield better fuel economy.

2. Three-speed automatic transmissions are still the best bet for most RV owners. An automatic unit can be handled by anyone, so all car and truckmakers recommend them for recreational use.

3. Too much gear reduction is worse than not enough. Don't overdo it! Exces-

BEDROOM EXTENSIONS are sometimes optional, make sense for big families, increase living area

TRAILER-BRAKE CONTROLLERS come in variety of styles, electric and hydraulic (\$15 to \$25)



BIG RUBBER is key to good stability, flotation and traction on RV. Well worth any extra cost

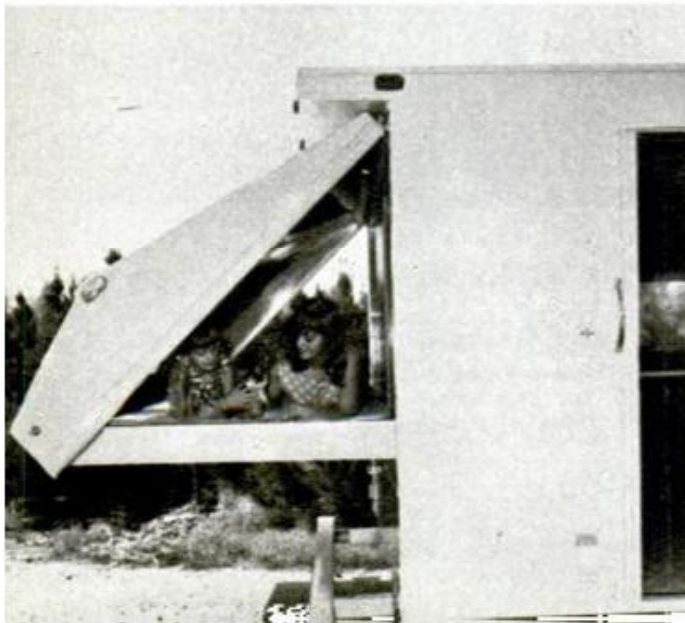



The difference between a great turn and an ordinary one is maybe 1/10 of a second... and you'll remember it all day.

That's what the CS-3C is all about. It's a 200-twin mounted on a lightweight frame. Give it a blast of throttle and put some pavement behind you. Autolube oil injection lubricates automatically,

crisp 5-speed gearbox makes beautiful music, and you...you discover the difference between a great turn and an ordinary one. Try a CS-3C like the one below and on the left, above. Or, a DS-6B 250, a slightly bigger twin, also shown above.

Yamaha International Corporation
P.O. Box 54540, Los Angeles, California 90054
In Canada: Fred Deeley, Ltd., Vancouver, B.C.



YAMAHA
It's a better machine

A high-contrast, black and white close-up photograph of a Goodyear tire tread. The tread pattern is a classic zig-zag or chevron design, with the ridges and grooves creating a strong geometric pattern. The lighting is dramatic, highlighting the texture and depth of the tread.

THE TRACKER

GOODYEAR

NEW FIBERGLASS BELTED TIRE FOR CAMPERS

You've heard a lot about fiberglass belted passenger car tires, and the long mileage they deliver. Most 1970 cars come equipped with them.

Now here's a belted tire for campers. From Goodyear, the leader in belted tires.

The Tracker. A tire that runs with the tread firm against the road. Two strong fiberglass belts circle the tire, like hoops, under the tread. They hold the tread grooves open as the tire rolls to fight squirm.

That's why The Tracker tire wears more evenly, and delivers 40% or more mileage than our best non-belted tires for light trucks. Better wet traction, braking and cornering ability too.

See your Goodyear Dealer or Goodyear Service Store for The Tracker. Hi-Miler Wide Tred Nyloglas tire (shown) or Custom Xtra Grip Wide Tred Nyloglas tire for mud and snow. Available in the following sizes: 8.00-16.5, 8.75-16.5, 9.50-16.5.

Hi-Miler, Nyloglas, Tracker—T.M.'s The Goodyear Tire & Rubber Company, Akron, Ohio



Nyloglas tire: Four nylon cord body plies and two fiberglass belts that extend around the tire to help hold the tread firm and fight squirm.



IT COULD SAVE YOUR VACATION

FREE! New Travel Guide to New York State.



96 pages.
204 color photos.
Road map.
890 resorts and attractions.
Send for it today.

Mail coupon to the New York State
Department of Commerce "Vacationlands"
Distribution Center at address shown.

New York State Dept. of Commerce
"Vacationlands"
PO Box 490-732
Latham, N.Y. 12110

Gentlemen: Please send free, 96-page, full-color
"Vacationlands" guide, listing attractions,
visiting hours, admission fees (if any), etc.

Name _____

Address _____

City _____ State _____

Zip _____



TOWING HITCH, of 1-inch steel bars arc-welded together and bolted to frame, is best type

sive gear reduction in the axle ratio results in high engine rpm at cruising speeds. Higher rpm raises operating temperature, hence the rate of wear. So select higher axle ratios cautiously, a step at a time.

ALL COACHES, whether motor home, truck camper or travel trailer, have the basic function of providing sleeping, dining and sanitary facilities. Among the universal options:

You can replace the standard manual water pump with a 12-volt electrically pumped water system for \$30 to \$125. A larger capacity water tank (\$20 to \$50 extra) which holds 40 to 70 gallons of water is worthwhile for long trips, belongs in the *nice-to-have* category.

A portable powerplant falls into the *luxury* category. It serves two functions: operating a 110-volt air conditioner and powering a large electric refrigerator.

Sanitary systems fall into three main categories: (1) The recirculating toilet (from \$195) in which a basic charge of about four gallons of water is repeatedly used and refiltered; (2) a flush-type marine toilet in which a standard flushing unit is connected to a waste-holding tank (from \$200 to \$500), and (3) an incinerating toilet (from \$395 to \$600). ★★★

TRAILER DOLLY (shown) or load-equalizer hitch is required for safe towing of large trailers



After you conquer the backwoods, enjoy it.



Where would you rather camp? Elbow-to-elbow in some crowded park—or off with your family enjoying your own private place in the sun? Meet the perfect get-away combination: a classy new 'Jeep' Wagoneer and the Starcraft Astro Star. Just flip into 'Jeep' 4-wheel drive, you own the back country. And with options like V-8, automatic or 4-speed manual transmission, power brakes and steering, air conditioning—you're roughing it in style. So leave the crowds behind. Your Starcraft 23' Astro Star gives you all the comforts of home. More standard equipment than any other trailer of its kind. See the 'Jeep' Wagoneer, the Starcraft Astro Star today. A rugged twosome. Then call the backwoods your own!

'Jeep'
4 WHEEL DRIVE
**The 2-Car
Car.**

The 
STARCRAFT
Wide World of Recreation

Write 'Jeep' Brochure, Box 903, Toledo, Ohio 43601 and Starcraft Company, OPM 5, Goshen, Indiana 46526.

Bring Your First Aid Up-to-Date

By WILLIAM W. CONNER, M.D.

VACATIONERS are frequently far from medical help when an injury occurs—so it's important to know alternate first-aid methods for some common ills:

Fishhook penetration: The old recommended method for removing a fishhook



was to force the point out through the skin and cut off the eye so it would pass through the hole thus made.

An equally good, and often less damaging to the victim, method employs an 18-inch length of string which is looped around the bend of the hook and held slack. With your other hand grasp the eye of the hook and press the shank down in the direction of the point. At the same time the shank is depressed, give the string a sharp jerk—and out snaps the hook. A little disinfectant over the wound, and you're ready to bait up again.

Snake bites: America has only four types of truly venomous snakes: rattlesnake, copperhead, moccasin and coral snake. Other snakes may bite when alarmed, but they lack venom and fangs.

A new method used by doctors in handling snake bites is to remove a patch of skin from the site of the bite about the size of a half dollar, along with the underlying tissue. The venom usually collects here in large quantities, and removing the tissue rids the victim of most danger. The limb is then treated with antivenom injected into an artery, and a new piece of skin is later placed over the wound. Most of this is obviously best left to the doctor. What, then, can be done in the way of first aid?

First, allow the victim to expend as little energy as possible. This helps slow down circulation and delays absorption into the system. Second, apply a snug tourniquet about two inches above the bite. That is, between the bite and the heart. It is a good rule of thumb that if you cannot eas-

ily push your finger under the tourniquet, it is too tight. A greater danger results from applying it too tightly than too loosely; a leg can be lost if the blood supply is cut off for too long. Third, transport the victim to a hospital or a doctor.

Note that no mention is made of cutting or sucking on the bite area! However, if the accident occurs where it may take many hours to reach a doctor, and the bite was from a moccasin, a snake whose venom is particularly destructive to injected tissue, your first aid should be more extensive. The area of the bite should be cut out. All that is necessary is a clean, sharp knife. The venom itself provides good anesthesia. Make a circular incision about two inches in diameter with the fang marks in the center. Cut deep enough to include the fat that lies under the skin. The venom may have blackened the fat, and by picking out all of the blackened tissue visible, you can remove much of the stored venom. A careful cleaning of the wound with a good disinfectant before and after the operation and a sterile or clean pressure-dressing will suffice to ward off infection until you get medical help.

More complications can arise from an infected wound than from the snake bite itself! So avoid making any cuts in the skin unless a long delay in reaching the doctor is unavoidable.

Bleeding: Bleeding from any cause can usually be treated most effectively by applying firm pressure with a clean cloth directly on the wound. Forget tourniquets and pressure points unless the bleeding is from a severed limb.

Burns: Perhaps the most common vacation mishap is a burn—sunburn, campfire burn, lantern burn and others. The treatment is similar for all. The prime consideration is to stop tissue damage as quickly as possible, and the best counteractant for heat is cold. So plunge the burned area into cold water immediately—a cold stream, a pail of drinking water, or over the side of a boat. Hold it in the water until the pain subsides. Many otherwise serious burns treated in this simple manner can be reduced to not much more than a moderate sunburn. A clean and dry dressing or a small amount of antibiotic ointment can then be used to cover the area. Avoid the age-old "goo treatment" or butter, baking soda and the like. These applications often make matters worse. ★★★





Get more fun
from your
recreational
vehicle

Be sure it's equipped with a
Dometic
refrigerator

In LP gas or electric refrigeration, Dometic is known and trusted world wide by leading makers and millions of owners of Travel Trailers, Motor Homes, Tent and Truck Campers. There is a reason.

Can you trust your trailer to go along with every move you make?

You can if it's Timken® bearing equipped. Timken tapered roller bearings are the most reliable you can have on your trailer, in the first place. Made of Timken fine alloy steel. Case-hardened for super strength outside. Extra resilience to shock inside. And with proper installation and preventive maintenance, they'll continue to handle long hauls, bad weather, heavy loads—even those off-the-beaten-track kind of roads mile after mile, year after year.

So before you make a move with your trailer, make your move to Timken bearings. Insist on them!

The Timken Roller Bearing Company, Canton, Ohio.

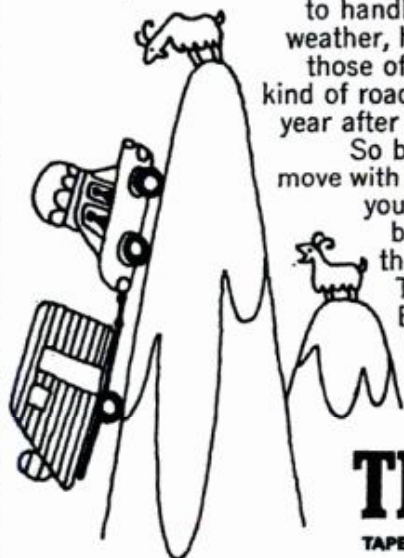

TIMKEN
TAPERED ROLLER BEARINGS

GIVE A TRAILER TIMKEN BEARINGS AND IT'LL FOLLOW YOU ANYWHERE.

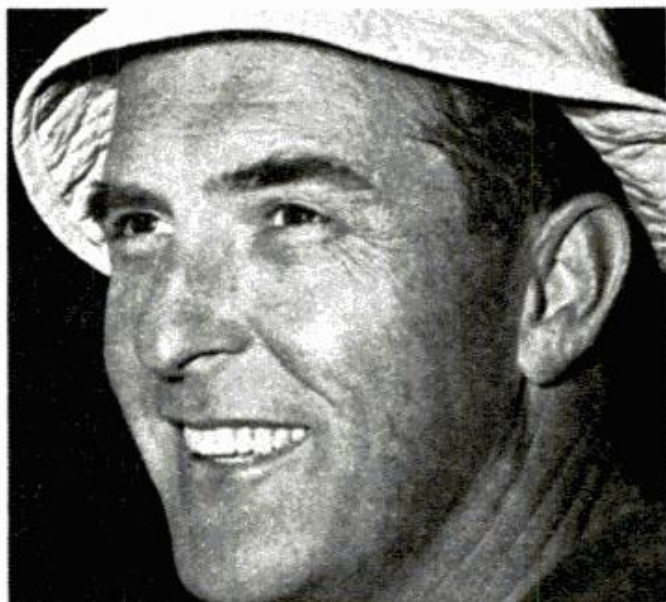

“As Angling Editor for Sports Afield magazine and a charter member of the Safari Camping Council, I do a lot of traveling. On many occasions I have ‘angled’ into a Safari Campground. I have always found them clean, comfortable and down right congenial... with all the creature comforts a family needs for a week or a weekend. I suggest you give Safari a try.”

Homer Circle
Angling Editor
Sports Afield Magazine

Rush me my FREE 1970 Safari Camps Directory.

Some selected and protected franchises still available.

For information write:

**Safari Camps
Dept. 2012
Eastgate Plaza
Columbia, Mo. 65201**



A sure sign of comfortable camping

Name _____

Street _____

City _____ State _____ Zip _____

'70 Camping Equipment

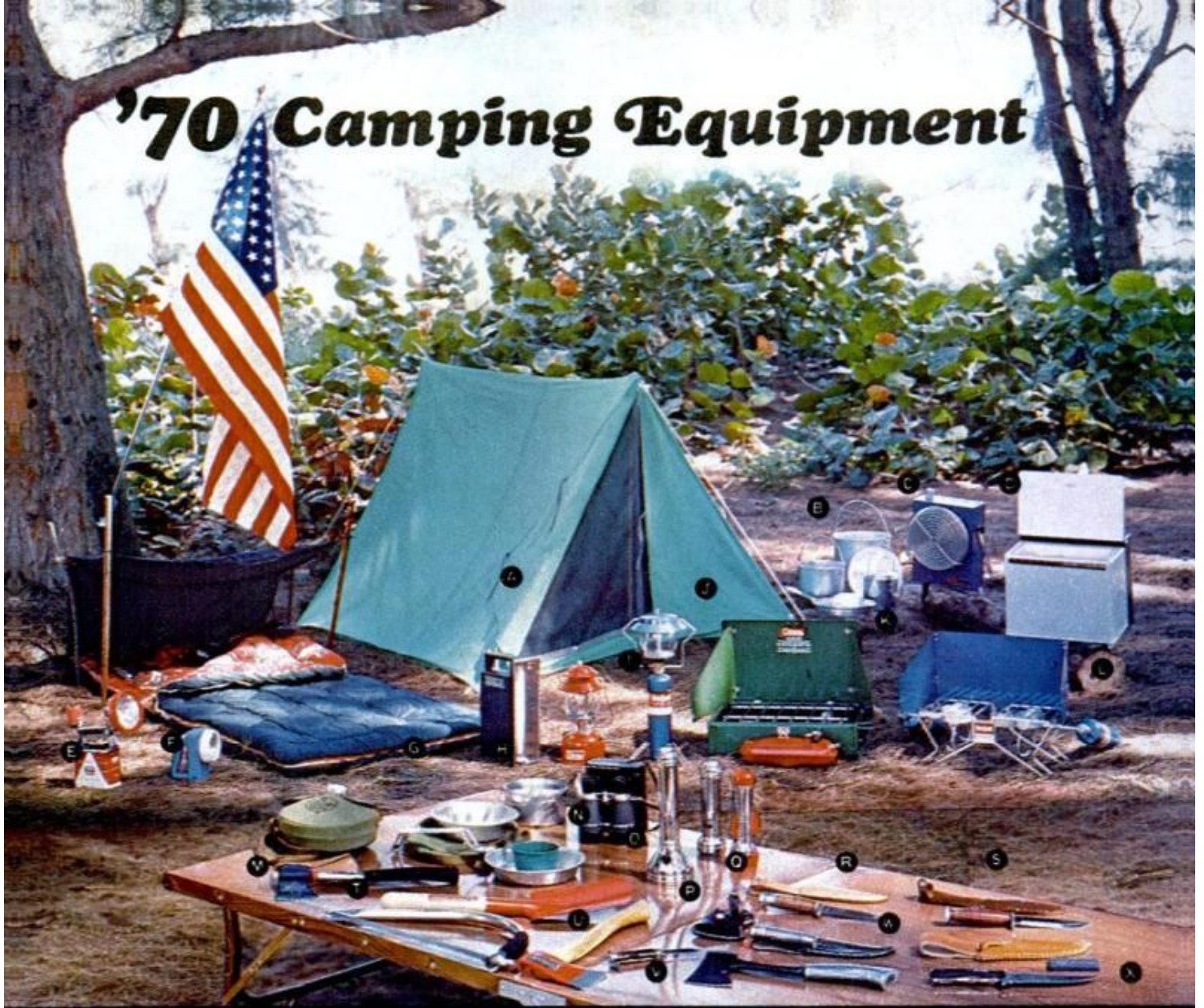

WHETHER YOU PICK a giant 12-man canvas cover or a 5-pound plastic pup, you need a tent to keep the rain off your sleeping face. And whether you tote a single-cell flashlight or a large gasoline burner, you'll want some kind of portable illumination around the campfire at night. Even if you only camp as a means to the best fishing and hunting, you'll need some, if not all, of these items:

- A** Tent, here an adult pup, 5x7x3½ feet.
- B** Twelve-piece camp set for four people.
- C** Adjustable catalytic propane heater.
- D** Portable electric icebox for 110 a.c. or 12-volt power.
- E** Powerhead lantern with six-position arm.
- F** Pistol-grip spotlight lantern, rustproof.
- G** Sleeping bag: Make it water resistant.
- H** Fluorescent lantern, 100-hour battery.
- I** Gasoline lantern, single mantle model.
- J** Instant-lighting propane lantern.
- K** Folding campstove, two-burner model.
- L** Propane campstove.
- M** Two-quart aluminum canteen for hikers.
- N** Lightweight aluminum five-piece mess kit.
- O** Field glasses for spotting birds, game.
- P** Adjustable three-cell searchlight (dim to bright).
- Q** Pair of flashlights (always a spare).
- R S** Six-inch-bladed hunting knives are handy for a variety of camping tasks.
- T** Belt ax, also can be used as hammer.
- U** Camper's kit of saw, ax and shovel.
- V W X** Utility knife and knife-ax combination can be used as spear, can opener, screwdriver, cap-lifter and punch.



Discover Yourself!

CAMP IDAHO

Here, it's all worth while.

The planning. The waiting. The travel.
You've found something special in the early
morning mist rising from a thousand lakes.

The freshness of a million pine trees and
clean mountain air invites you to breathe deeply.

You're happy with the sounds of children running, laughing
and new-found friends sharing campfire conversation.

And the pageantry of the sunset
introducing a star-spangled night
puts you at peace.

Discover yourself! For complete information send this coupon to CAMP IDAHO, 108 Capitol Building, Boise, Idaho 83702.

NAME _____

ADDRESS _____

CITY _____

STATE _____ ZIP _____

MAY 1970

S21

Материал, защищенный авторским правом

Camper's Guide to Butane/Propane

NO MATTER WHOM YOU ASK about LP-gas, the reaction is never mild. Almost all campers hold it in awe, view it with suspicion or regard it as mysterious. It seems strange in view of the fact that LP-gas, better known as butane-propane, fires virtually all appliances in recreational vehicles. It's the handiest fuel you can get outside of an electric wire, yet it's the least understood. Because it's so versatile and popular in the outdoor world, *PM* has gathered these easy-to-remember rules about handling butane and propane.

LP-gas stands for *liquified petroleum* gases. It might be either butane or propane, or a mixture of both. Some other gases may be mixed with them, but only in minute quantities.

One of the strange advantages of butane-propane is that it can exist as either a gas or a liquid. That makes it easy to package in those familiar lemon-shaped bottles bolted to every coach and camper. The second characteristic is that LP-gas is compressible. By altering either the temperature or the pressure it can be changed to liquid or gas. A single five-gallon tank may contain up to 270 times more LP-gas as a liquid than as a gas, so it is transported as a liquid, then burned off as a gas in coach appliances.

Butane-propane burns clean and leaves no sooty deposits on cooking utensils. It's odorless, too, producing no unpleasant fumes. (That strong odor is an added chemical to warn you of a leak.) And butane and propane gases are *not* poisonous. If inhaled, either gas would make you sleepy, but under ordinary circumstances with a proper amount of oxygen,

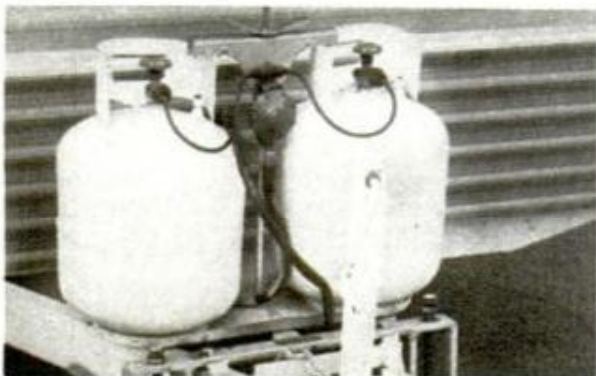

TWIN LP-GAS TANKS double the range. When one tank is emptied, you simply change to the second by shutting one valve, opening another



VALUE OF LP-GAS lies in portability. Taken anywhere, it offers quick, clean-burning fuel

breathing in small amounts is harmless.

As for those tired tales about LP-gas being "extremely unstable and explosive," that's sheer poppycock! When handled with only routine caution it's safer than gasoline. Because LP-gases are heavier than air, they flow to the lowest point when released in the atmosphere. Naturally, a spark can set it off just as a spark can set off fumes hovering over spilled gasoline. Realistically, any fuel is dangerous when leaking into a closed area with a flame nearby.

The effects of temperature on LP-fuels show why a mixture of butane and propane is best.

In warm climates *butane* is the best choice because it has a higher boiling point: It converts from a liquid to a gas at temperatures over 32° F. Below this, butane will not function as a gas fuel. In cold climates *propane* is more logical because the boiling point is minus 44° F. That means propane functions normally at very low temperatures, while butane cannot.

But that isn't the whole story. As the temperature rises in propane fuels, so does the pressure. This creates some problems, since high-pressure storage affects leakage, container strength and sealing. That's why the best LP-gas fuel is a mixture of butane and propane. The exact chemical composition determines the temperature range, and it is the local LP-gas distributors who give you the proper mixture for local temperature and atmospheric conditions.

All LP-gas tanks must have relief valves. When the internal pressure exceeds a certain point the valve pops and LP-gas escapes into the atmosphere, which reduces

In Utah there are 23 National Parks, Forests, Monuments & 36 State Parks.

Help yourself to their beauty and their unsurpassed camping right now. Mail this ad (yep, the whole thing) for your Free Utah Travel Kit that includes a 120-page Fact Book, a brochure and a highway map. The kit itself is free. Utah is priceless.

UTAH!

NAME.....
 ADDRESS.....
 CITY.....
 STATE.....ZIP.....

Send to: Utah Travel Council, Dept. PM-10, (please)
 Salt Lake City, Utah 84114



FAMILY VACATIONS • CAMPING OUTINGS • HUNTING TRIPS



TRAVEL RIGHT! TRAVEL LIGHT!

SERRO SCOTTY TRAVEL TRAILERS

Prices From

More fun for
less money.

\$845*

Write for
Free Catalog!

*Standard Model, F.O.B. factory

SERRO TRAVEL TRAILER CO.

DEPT: Arona Road, Irwin, Pa. 15642
 AM Scotty Drive, Bristow, Okla. 74010
 Route #2, Ashburn, Ga. 31714

TRAVELPOD—CARTOP CAMPER PLANS

It's a boat, it's a camper, it's an equipment carrier all in one. Closes up like a capsule for high-speed highway travel. Complete plans, plus a step-by-step construction booklet all for \$5.00. Add 50 cents for full-color decal emblems. Plans for fitting out the Pod as a boat are an additional \$2.00. Send remittance to: **POPULAR MECHANICS**, Dept. TP 224 W. 57 St., New York, N.Y. 10019.

HOW BURNER FLAME SHOWS PROPER GAS/AIR SETTING

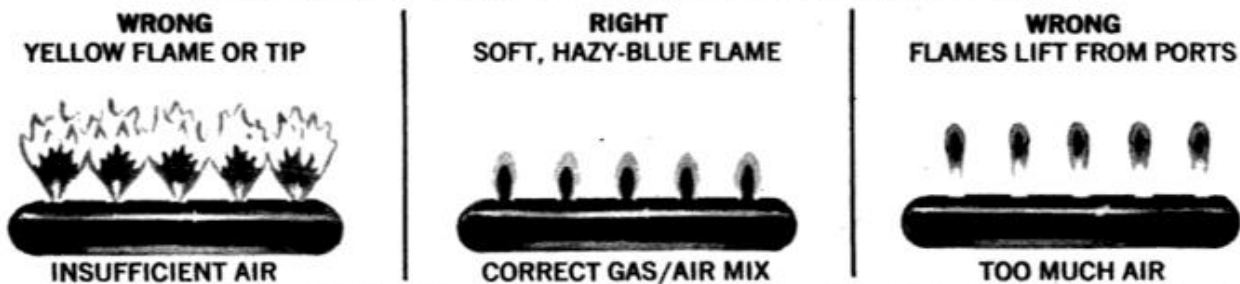

internal pressure. Rapid temperature increases usually cause the valve to pop off whenever the tank pressure rises past 375 psi.

Many beginners, when attempting to change their first tank of butane-propane, place a large wrench on the tank fitting and proceed to twist it off. It should be remembered that all LP-gas tanks have left-hand-threaded fittings! Turn the wrench *clockwise* to loosen the line for refilling; *counterclockwise* for tightening. A loose-fitting wrench should never be used on brass fittings. Carry one of the right size in your coach toolkit. Don't depend on the serviceman at LP-gas stops to have the size you need.

Incidentally, it may be illegal in some areas to ask an LP-gas attendant to refill your tank while it's in the coach. If you must remove the tank for him, all that's necessary to do is to shut off the main tank valve, then loosen the main tank fitting (remember, turn it clockwise). In hidden compartments LP bottles are usually held in place with metal straps and wing-nut restrainers.

All LP bottles are marked for vertical or horizontal mounting. *Never install an LP bottle until you check that rating.* Vertical bottles mounted horizontally will result in the relief-valve freezing (from contact with liquid butane-propane) which could spew gas into the atmosphere. Even where such a condition was not dangerous it would bring about a terrible waste of fuel.

How to adjust burners: Range burners are the cause of most complaints. But in about 95 percent of the cases the problems are related to the air-shutter adjustment. Considering the fact that roughly 20 to 30 cu. ft. of air is consumed with every cubic foot of LP-gas, you can readily understand the importance of air-shutter settings!

Here's a simple method of adjusting burners according to the flame-tip. First, check the *color* of the flame. Sick yellow flame indicates lack of air, so increase air-shutter setting. Second, check the *shape* of the flame. Hard, sharply defined flame indicates too much air, so reduce air-shutter setting. The ideal flame is a soft hazy

blue. Third, watch the height of the flame. If it appears to be hovering over the burner orifices there's too much air. Reduce the air setting until you have a hazy blue flame that extends all the way down to the burner.

There shouldn't be any problem with noxious fumes from butane or propane because they burn clean and soot-free. However, eye-stinging fumes can occasionally be traced to a burner operating in a draft, a restriction in the air shutter or dust in the burner ports. Thoroughly vacuum-clean all range and oven burner orifices after a few trips, and give them a periodic cleaning thereafter.

LP-gas refrigerators make ice in 20 minutes—or else make no ice at all! Even a few degrees off *true level* will affect the efficiency of the gas box. Since self-levelers are not standard in all gas refrigerators, it is still necessary to make the coach exactly level. Carry stabilizer jacks; you'll need them.

On LP-gas lamps, the new mantle is tied over the nose of the burner after removing the globe. Light the mantle and let it burn completely out, leaving a chemical ash coating. Open the gas valve and hold a match below the mantle; in a few seconds the mantle will become incandescent. When an old mantle shows signs of cracks or punctures you must replace it or it will crack the globe. Keep insects out of the globe; they cause blackening of the mantle and a weak yellow flame. Adjust the air shutter if blackening is a problem after a new mantle is attached.

Never test for leaks with a lighted match! Instead, brush a wet, soapy solution onto all line fittings. Where you find gas bubbles, shut off the main tank valve and take these steps: Shut off all LP-gas equipment in the coach, including the gas lamp. Test the tank fittings first, then open the tank valve and follow the lines back through the coach. Starting with the regulator itself, brush your soapy solution onto all trees, elbows, sweat fittings, pilot valves, burner orifices and range manifolds. If simple repairs don't stop the leak, shut off the gas at the tank again and call a trained serviceman. Keep the coach aired until the leak is repaired. ★★★



Sears sized up the weather and discovered two new ways to camp dry and sleep tight.

Nothing ruins camping trips like cold, wet weather.

Sears didn't want anyone to suffer through it. So they worked out new ways to beat the weather.

This new tent is one of them. It has a 100% waterproof floor that runs 6 inches up the tent's sides. Even if the tent sits in a puddle, not a drop gets in.

For the tent fabric, Sears chose a rugged cotton drill with a special finish that sheds water like a duck. So whatever the weather, your family camps dry.

Sleeps well, too, because Sears had a great idea for sleeping bags. They went to the U.S. Weather Bureau to find out the tem-

peratures you could expect across the country. Then had bags made to match them. Warm, cool and cold night bags. In three sizes, too, including king.

Tomorrow, see the great new camping equipment at the Sears Sports Center in a Sears, Roebuck and Co. store. Or the Catalog.

Sears 
SPORTS CENTER
 where the new ideas are

APPROVED BY SIR EDMUND HILLARY
 MEMBER, SEARS SPORTS ADVISORY STAFF

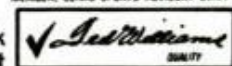

This check mark certifies this tent and sleeping bag met the standards set by Ted Williams, Chairman, Sears Sports Advisory Staff, and were personally tested and approved by Sir Edmund Hillary, Staff Advisor.

This Cool Night Bag looks as good as it sleeps. It's made with light new fabrics in bright new colors.

Zip in, zip up tight. These new nylon zippers have gaskets that seal drafts out.



Camping Security and Common Sense



NEAR YUMA, ARIZ., a 68-year-old man, asleep in the back of his pickup camper coach, was awakened by the sound of his truck engine starting. Puzzled, he sat up on his cot and peered through the coach window into the truck cab. Two dark figures huddled there, evidently unaware of his presence. The keys had been left in the ignition. Now the truck started slowly across the hardpan of the area. The truck-owner fumbled under the cot and grabbed a 12-gauge shotgun he kept there. There was a loud blast, a shattering of glass, and the truck veered to a stop with the driver-thief slumped wounded over the steering wheel. His passenger bolted out the door and disappeared. It might have ended differently.

Camping is no longer an exclusive activity of outdoor lovers, and security has greatly deteriorated in the past decade. In California's beautiful Jedediah Smith State Park last season campers reported equipment worth over \$1000 stolen in a single weekend, a park ranger told me.

Astonished, I asked him for specific information. What types of equipment? His list included cameras (a favorite), fishing tackle, outboard motors, portable camping stoves and lanterns, sleeping bags, binoculars, axes and a score of other commonly toted items.

"Campers presume that all visitors to a park are, like themselves, recreational campers," another ranger told me. "But, in actual fact, a great many potential

thieves drift through our campgrounds. We can't possibly police every campsite, nor watch all the gear that visitors carelessly strew about."

Is the situation really this grim? That's a tough question. My family has traveled hundreds of thousands of road-test miles in all kinds of campers, trailers and motor homes. We've stayed in campgrounds fenced and nightlighted. Yet I'd have to say that most of our overnight stops have been along deserted highways where no campgrounds existed. In all that time we've never been molested. Yet the fact remains that robberies and even occasional assaults on people camping in remote areas seem to be on the increase.

This means all campers should know that while probably 99 percent of all campers are honest, law-abiding outdoor lovers, a tiny percentage of them are out for trouble and special caution should be exercised nowadays.

Preventing theft

The solution is not better police work. What's needed is more theft-prevention work by campers. To this end, *Popular Mechanics* suggests:

1. Keep valuables out of sight! Along your route to camping areas, keep cameras, binoculars, purses and expensive tools hidden. Don't leave your favorite driving gloves, flashlight or movie camera on dashboard or rear window ledges while you enter a restaurant or purchase groceries. At the campsite, lock your car and camper before hiking away on side trips.
2. Eliminate the easy pickings. Lanterns, ice chests, sleeping bags and other compact camping equipment should be covered, set inside the tent, or at least placed out of sight of roadways. Most campground thieves cruise roadways looking for unprotected gear at open campsites.
3. Where camping areas are adjacent to lakes and rivers, lock your boat and outboard motor at night. Remove ignition





keys and run a chain and padlock through the boat trailer winch-stand to some solid object.

4. The simple act of parking with the tongue of a trailer facing into the campsite is enough to discourage a lot of impulsive thievery. If your family takes an overnight backpack trip, keep everything locked in the coach during your absence. For trailer-towers, trailer stores carry locking-ball devices that can be inserted into the trailer coupler to prevent theft.

5. When you temporarily abandon a campsite with your camping vehicle, there are several ways to post your intent to return. Make or purchase a small sign bearing your name and on which you can write the time you'll return. Some campers leave a pair of camp chairs (which might disappear), or notify a park ranger. Several campgrounds have firm rules that limit absence to one overnight trip. It depends on the park policy.

6. If you unload your pickup camper coach at a campsite, take the precaution of running a length of chain through one of the coach tie-down eyebolts to a nearby tree, camp table or other solid object.

Picking an overnight site

The old saying about "safety in numbers" is certainly true when you stop along open highways. Where you find a wide clearing during the travel season, two or three camping vehicles will con-



The FordTM minihome:



second car, second home

The mountains. The beach. Wherever you want to go, the Minihome will get you there in comfort. And keep you there in style. It's the vacation home that doesn't tie you down.

The Minihome is a conversion of the Ford Super Econoline. It has a full-length, full-height fiber glass roof. The kitchen is complete with stainless sink, water system, stove, ice box and built-in storage.

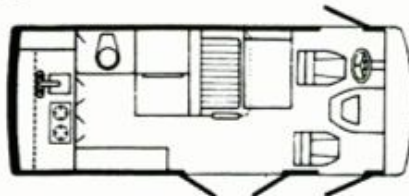

The dinette/passenger lounge converts to a double bed. Add three bunks if you like. There are draperies, a full-length wardrobe, screens, even an optional toilet.

And when you're *not* on vacation and long weekends, the Minihome serves as a second car and station wagon. For a brochure see your Ford dealer or send us the coupon below.

Motor Homes, Inc.
Dept. PM, 3709 West Erie Ave., Lorain, Ohio 44053
Please send complete information about the Minihome and the name of my nearest Ford dealer.

Name _____

Address _____

City _____ State _____ Zip _____

motor homes inc.
SUBSIDIARY OF PRF INDUSTRIES INC.

Camping '70 Shopping Guide

KLEPPER 3 Boats-in-1 Foldaway

Easy to Carry . . .
(bags fit any car)
Speedy Assembly
(no tools, no strain)
Most Economical
(low upkeep)
Unsinkable
(perfect family boat)
Many New Models
(kayaks to sloops)
FREE Catalog PM 75

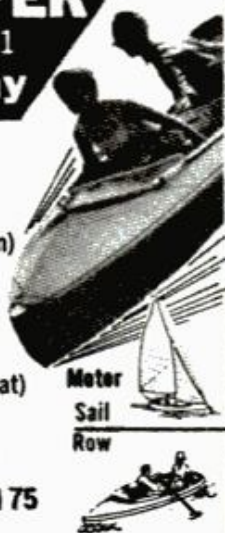

KLEPPER, 35 Union Sq. W. • N.Y.C. 10003

WHITE'S is #1 CHOICE

with over 25 models of Metal Detectors to select from! Detects GOLD—SILVER—COPPER NUGGETS—COINS—RINGS—JEWELRY, etc. GUARANTEED!! from \$9.50 up



FREE LITERATURE

WHITE'S ELECTRONICS, INC.
1011 Pleasant Valley Rd., Rm. #481
Sweet Home, Ore. 97386

APPLEBY Camping Trailer



Sturdily built. All-Aluminum hard top. Tent 10.10 pro-shrunk army duck. Easy to pull.

329.50 Retail List

Write for FREE Catalog
Dealer Inquiries Invited

Appleby Mfg. Co., Box 831, Lebanon, Mo. 65536
Telephone—417 532-4191

STOP AUTO THEFT FOR ONLY \$5.00

AUTO-TRONIC THEFT GUARD—ELECTRONIC IGNITION DEACTIVATOR
Installs in minutes, without drilling or wire splicing. Electronically deactivates the ignition system so the car absolutely can't be started by master keys, jumping and other methods. Can be used on trucks and boats too. If you're concerned about car theft—And who isn't?—You'll be glad you invested in this reliable protective device. Send \$5.00 Refund guarantee (regular \$8.95). Dealers, \$3.50 each, minimum 10.



AUTO-TRONIC THEFT GUARD
P.O. Box 44115-PM5, 6200 Biddulph Rd.,
Cleveland, Ohio 44144

CAMPERS SPORTSMEN GOLFERS PERMANENT METAL MATCH NEVER FAILS!
Lights Thousands of times, rain or shine. Only 98¢ plus 30¢ postage and handling. **GOLF SCOREKEEPER**—Wear it on your wrist like a watch. This push-button scorekeeper will tally your strokes on each hole or a running total of your game. Only \$1.49 plus 30¢ postage and handling.

Free Below-Discount Catalog With Each Order!
C.B.T. Enterprises, SPECIALTY SALES,
516 West Broadway, P.O. Box 406,
Maryville, Tennessee 37801

THE PERFECT FISHERMAN'S PLIERS

A must for every Sportsman. 15 tools in 1 with 1001 uses. Made of Solingen forged magnetized steel to last a lifetime. Shipped prepaid with cowhide leather belt holster. Only \$6.95 from



ROYCE AGENCY
Dept. 101F, 6528 Oneida, Wichita, Kan. 67206

DEALERS NEEDED

for new U.S. POSTAL ZIP CODE DIRECTORY. The most complete Directory with Maps on the market today. Over 100,000 listings, \$62 pages, 1 inch thick. Multiple codes for large City Branches and stations. A complete Guide for all Mailings. Sample Copy \$1.25, including DEALER DETAILS.
O'Brien P.O. Box 27, Great Neck, N.Y. 11023

G-100 "MERCURY" MEN'S JET PLANE CALENDAR WATCH

Precise, Durable, Elegant . . . unbelievable low price. Years of service. Gives date and time. Invisible second hand makes jet plane appear flying suspended in space. Fine features expected only in expensive watches. Water resistant and anti-magnetic. Complete with expandable metal watch band.



P.P. \$14.95. THE BENTON CO.
114 Carrier St., Liberty, N.Y. 12754

Watch for this mark on retailers shelves. It will help you recognize the products advertised in Popular Mechanics.

POPULAR MECHANICS PRODUCT FEATURE

UTOPIA IS AN ISLAND—

50 Island paradises you can drive to, plus 100 others. \$2.

OFF THE BEATEN PATH—Guide to America's Bargain Paradises. \$2.

AMERICA BY CAR—Planned routings to all that's worth seeing in U.S.A., Canada and Mexico. \$3.50.

Money back guarantee.
HORIZON HOUSE, Drawer 2109, Dept. C5,
Lake Havasu City, Ariz. 86403

—SEARCH—Metal Detector

Locates coins, gold, metal objects. Solid state electronics.

10 Day free trial. For free literature write:

SEARCH ELECTRONICS
P.O. Box 8396 Dept. C
St. Petersburg, Florida 33738



BARBED WIRE

CASH IN ON A FAST GROWING HOBBY! RARE BARBED WIRE BRINGS UP TO \$100.00 per 18" piece.

THE BARBED WIRE BOOK. Showing hundreds of illustrations. Also includes price guide. Where and how to sell your wire. \$2.95 postpaid.

THE BARBED WIRE BOOK
P.O. Box 176P
Edison, Calif. 93220

ENJOY THE OUTDOORS

START BLAZING LOG FIRES INSTANTLY!

Handy, reusable Log-Liter generates intense long lasting starting flame. Reliably ignites stubborn logs, damp wood, etc. Operates on kerosene or other low cost fuel. Just think, never again a problem starting fireplaces, barbecues, campfires! Very compact and light weight. Only \$1.50 ea. or 4 for \$5.00 PPD. No C.O.D. Refund Guarantee.



LOG-LITER

P.O. Box 44115-PM5; 6200 Biddulph Rd.;
Cleve., Ohio 44144



MIRACLE-LIGHT
Fits any key.

Powered by self-charging silver cell. No bulbs or batteries to buy—ever! Guaranteed. **MOA-0012 \$3.95 & 25¢ PP. HOUSE OF HANKES**, Dept. PMC, 2060 California St. Mtn. View, CA 94040

MARVELLOUS OLD MEXICO

Registered re-airmails \$1.00 each. Colorful Postcards 4 for \$1.00. Receiving, Forwarding \$3.00 Monthly. Confidential. **FEMOR, PM, Apartado 5-131, Mexico 5, D.F.**

Truck Mechanic Stand

Stand slips firmly on all size truck tires. Safety grip tread provides an anti-skid surface for safe footing in all directions.

Hudson T. Marsden Co., 40 Genesee Pk. Blvd., Rochester, N. Y.

\$14.95

each
Special Offer \$25.00 for pair. Freight prepaid.



SKIN DIVER'S WATCH

This Swiss made precision watch is pressure sealed to operate 350 feet deep! It's an automatic calendar watch! Movable bezel shows how long you've been under water! Shock protected, unbreakable mainspring, luminous dial, anti magnetic, sweep second hand, electronically timed, under water strap . . . features not found in watches costing twice this price! Only \$15.95 + 25¢ postage. N.J. residents add 5% sales tax. Please send check or money order, no COD's. Satisfaction guaranteed or your money back.



MALORD SALES 31-B West Main St., Columbus, N.J. 08022

NORTH AMERICAN RADIO-TV STATION GUIDE

1970 edition 160 p. by Vane A. Jones

Lists Frequencies, call letters, locations, etc. for all AM, FM & TV stations in United States, Canada, Mexico and West Indies. Most accurate up-to-date guide available. No. 20779. Send check or M.O. for \$2.95 ppd. (In Canada \$3.75) to Dept. P.S.

HOWARD W. SAMS & CO., INC.
4300 West 52nd Street • Indianapolis, Indiana 46268





Send dime for full color oversize post-card of this Dogteam and Mt. McKinley tapestry, and complete list of woven wildlife tapestries in stock, ready to mail. \$4.50 to \$22.50 (none higher) HEGGENS-ALASKA TAPESTRIES, 540 E. 5th Ave. Anchorage, Alaska 99501.



QUICKLITE CHAR-COAL STARTER

Satisfaction guaranteed for picnics quick starting charcoal burner \$4.98 plus 50¢ handling.

Write Quicklite, P. Hughes, 218 N B'way Schuylerville, N.Y.

SWISS-MADE Pilot's Chronograph



Features: 1—tachometer for mph; 2—telemeter for distance; 3—two push button stops for races; 4—minute counter dial for football; 5—hour counter for trips; 6—precision movement for time. Send \$13.75 to:

"JACOB'S GIFTS BY MAIL"
407 Azalea Street,
Fairhope, Alabama 36532
Please add 4% sales tax in Alabama.



New PORTABLE

"Shuro" SLUICE

\$\$\$ GOLD \$\$\$

Vacation prospecting can be exciting family fun and profitable with this simple & unique equipment so easy to build. Materials, available everywhere, usually cost less than \$10. Amazing method of recovery, recently developed by old California gold miner, works where others fail. GOLD is where you find it—and it has been found in nearly every state! Some "week-enders" have struck it rich with a lucky find. . . . These plans & method have been selling for \$10. Now PM readers can get this complete package (drawings, parts list, and method instructions) at fantastic savings with this Special Offer! Send only \$2., to:

JAYBEN ENTERPRISES COMPANY,
Dept. GM-1, 2500 W. Almond;
Orange, California 92668

EASY RELEASE COAST-OUT UNDER SLUNG TIRE CARRIER

Remove spare tire without having to crawl under vehicle. No nuts—No soiled clothes. Safe—No worry about being trapped under vehicle. Fast—Seconds to remove or replace spare tire. Easy installation.

HUSKY PRODUCTS order today \$19.95

P.O. BOX 474 LONGMONT, COLO. 80501

ARIZONA

Walden Village, at edge of Prescott National Forest. Mile-high ranch land, will sell on low terms. 2½ acres priced at \$1295. Also, investment acreage near Big Sandy River. \$200 per acre.
Mrs. A. Young, 2233 N. 7th Street
Phoenix 85006

WATER!

"How to Drill Your Own Water Well & Save 75%"

Please write for a FREE copy.

DeepRock Drilling Co.
2006 Poplar Ave., Opelika, Ala. 36801

Unique Chuck Wagon Gong

Call your family with attractive chuck wagon gong. Hanger, Iron Triangle and Klanger. Attach to Porch, Patio, Post, etc. 10"X10"X1½".—\$3.98 P. PD. Money Back Guarantee —Makes Nice Gift.

SAME DAY SHIPMENT
BIG SKY TREASURES
Box 149, Rapid City, S.D. 57701
"Dress Up Your Cabin"

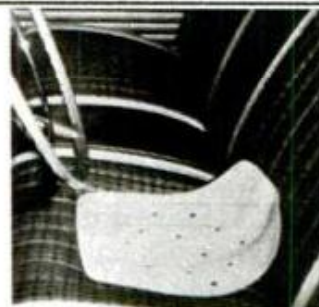

REDUCE RIDING FATIGUE

Relaxo-Bak might be just what the doctor ordered for cross country traveling. It is a thin, form-fitting auxiliary seat contoured for weight distribution and comfort. It provides a firmer support in cases where the car seat is too soft. Also may be used in home or office chairs, or in planes, buses or trucks. Price 4.75. Order from Hartwell Associates, Dept. PM, RD 1, Middletown, New York 10940.



HAND TIED FISHING FLIES
25 Superb Specimens. Send Only \$2.50 to
THE POST MART
8141-A Falmouth Drive,
Huntington Beach, California 92646
Calif. Residents add 5% Tax

DUALAMATIC PROTECTOR

Deflects bugs, snow, gravel. Protects windshield and front hood. Easy installation • Custom designed \$17.45 see your NAPA Retail Jobber

Made of heavy duty clear plastic • Order by make and model car

DUALAMATIC PRODUCTS
P.O. BOX 419 • LONGMONT, COLO. 80501



Watch for this mark on retailers shelves. It will help you recognize the products advertised in Popular Mechanics.

— Home — Campers — Boats — TV X-RADIATION INDICATOR Test Kit.

Check for possible x-radiation from your T.V. receiver. Send only \$2.98 + 35¢ postage for your kit to:

EARLY WARNING ELECTRONIC SYSTEMS, INC.,
1286 St. Paul Street, Rochester, N.Y. 14521

SEE AMERICA FIRST!

Discover this great country by car. This big book, "AMERICA BY CAR", tells you what to see and where to go in every corner of the U.S.A. It lists scenic roads, important sights, best places to eat and stay. Contains 170,000 words. As large as 3 novels! Only \$2.95. Send to: S. J. Huss Co., 505 Penrhyn Place, East Chicago, Indiana 46312

NEW! for OUTDOORSMEN all purpose SOLID FUEL



INSTANT CAMPFIRE STICKS

10 Large sticks \$2.00 postpaid. The Fast, Safe, non-explosive fuel made especially for campers.

HOUSE OF WINFIELD
P.O. Box 590, Burbank, Calif. 91503
Guaranteed as advertised or money refunded.

VERSA-LITE For People On the Go!

Amazing, new, lightweight, rechargeable on 12 volt car battery (through cigarette lighter) or 110 volt house current. Safe. Provides up to 30 HOURS FLUORESCENT LIGHT on a single charge. No dangerous fuels or fumes. Dim and bright positions. GUARANTEED SATISFACTION. \$37.50.

Mountain Mart (Dept. M1-2), 230 S. Sierra Madre St., Colorado Springs, Colo. 80903



TREASURE
\$\$\$\$\$

New revolutionary analytical transistorized metal detector will distinguish a gold bar from a tin can. No more unnecessary digging for tin cans, nails, bottle caps, etc. Also features push button tuning, automatic tuning, loudspeaker. Negligible ground pickup. Greatest detection range, etc. Many models—free catalog.

GARDINER ELECTRONICS CO.
Dept. 8, 4729 No. 7th Ave., Phoenix, Ariz. 85013



REST IN A HAND MADE HAMMOCK of multi-colored sisal. Only \$4.98. Ideal for camping and your own back yard. Order early. Check or money order.

CASA INTERNACIONAL
Mission Sta., Box 2701, Santa Clara, Ca. 95051



CAF-7 (FISHERMAN'S COMBO)

Features Deluxe filleting and cleaning board, stainless steel filleting knife with sheath. Filleting board is sturdy 6" x 24" woodgrained styrene with powerful clamp to hold fish firmly in place during cleaning and filleting operations. 6" curved flexible knife blade, tapered to resist dulling. Combo is neatly packaged, a terrific gift for all fishermen. \$7.95 Ppd. Money back guarantee. Florida residents add 4% sales tax. S. M. MANOR, Rt. 1, Box 371, Hernando, Florida 32642

KODACOLOR

12 ex roll developed and printed plus free album for \$2.59. Offer for limited time only; 40 years of satisfied customers.

GRAND HAVEN PHOTO SERVICE
Dept. A
Grand Haven, Mich. 49417

BUILD THIS MOTOR HOME FOR LESS THAN \$3900 INCLUDING CHASSIS!



You can own this lovely 19 ft. motor home for less than half the cost of a comparable manufactured unit. To keep the cost down so the average family can now make this dream come true, we suggest you build on a used Ford, Econoline, Dodge, GMC or Chev panel-type van. Completely self contained, sleeps 6, 17 ft. upper cabinets, double sink, 6 cu. ft. refrig, furnace and all the features of an expensive rig. Write today for step by step instructions with numerous photos, 14 sheets of detailed blueprints, 14 x 24, and list of materials needed. All for \$35.00. Many items for above coach available through us at a great savings.

LariDel Enterprises

Rt. 2, Box 123, Gaston, Oregon 97119

**When you
see this mark
you've seen
the product in
Popular Mechanics.**



gregate. If you're forced to park where traffic is light and no other parked campers are found, try to get far enough off the highway to hide your vehicle. Sometimes all that's necessary is to turn in behind a signboard or grove of trees, or drive a short way up a country lane.

Many all-night service stations allow recreational vehicles to park on the apron behind their main building. If you find a friendly station don't abuse your host by demanding water, electricity or sewer outlets. Usually farmers are tolerant of over-night campers if they observe a few common sense rules. For example, parking in farm lanes and blocking gates will infuriate your host. Fields of stubble or cleared fields are generally a safe bet, but don't drive out across them. Park as close to the fence as possible. Just one discarded paper cup, cigaret wrapper or bean can *should* get you ousted. If you arrive before dark, ask permission politely. Leave without an argument if turned down. Personally, I like to offer a modest payment when a farmer is kind enough to allow us over-night space on his ranch. Three to five dollars is not too much to pay when other space is virtually impossible to find.

Rural towns sometimes let visitors park in market shopping plazas, adjacent to a city park or on a fairgrounds. The key is courtesy. Leave promptly at sunup. City parks are not campgrounds.

Roadside rest areas

One of the pleasant surprises of the 1970s will be the increased availability of highway rest areas. However, such areas are designed primarily to give weary motorists a chance to grab a few hours needed sleep. They're not campgrounds! Some states limit the stay to a few hours, with frequent police checks. A sure way to get roused is to get out a tent, scatter litter, or appear to make a permanent camp. Grab your rest, and at sunup leave things as you found them and make way for the next family. ★ ★ ★

Johnny Crawford finds that customers who use Stren® line have the best luck. Only he doesn't call it luck.

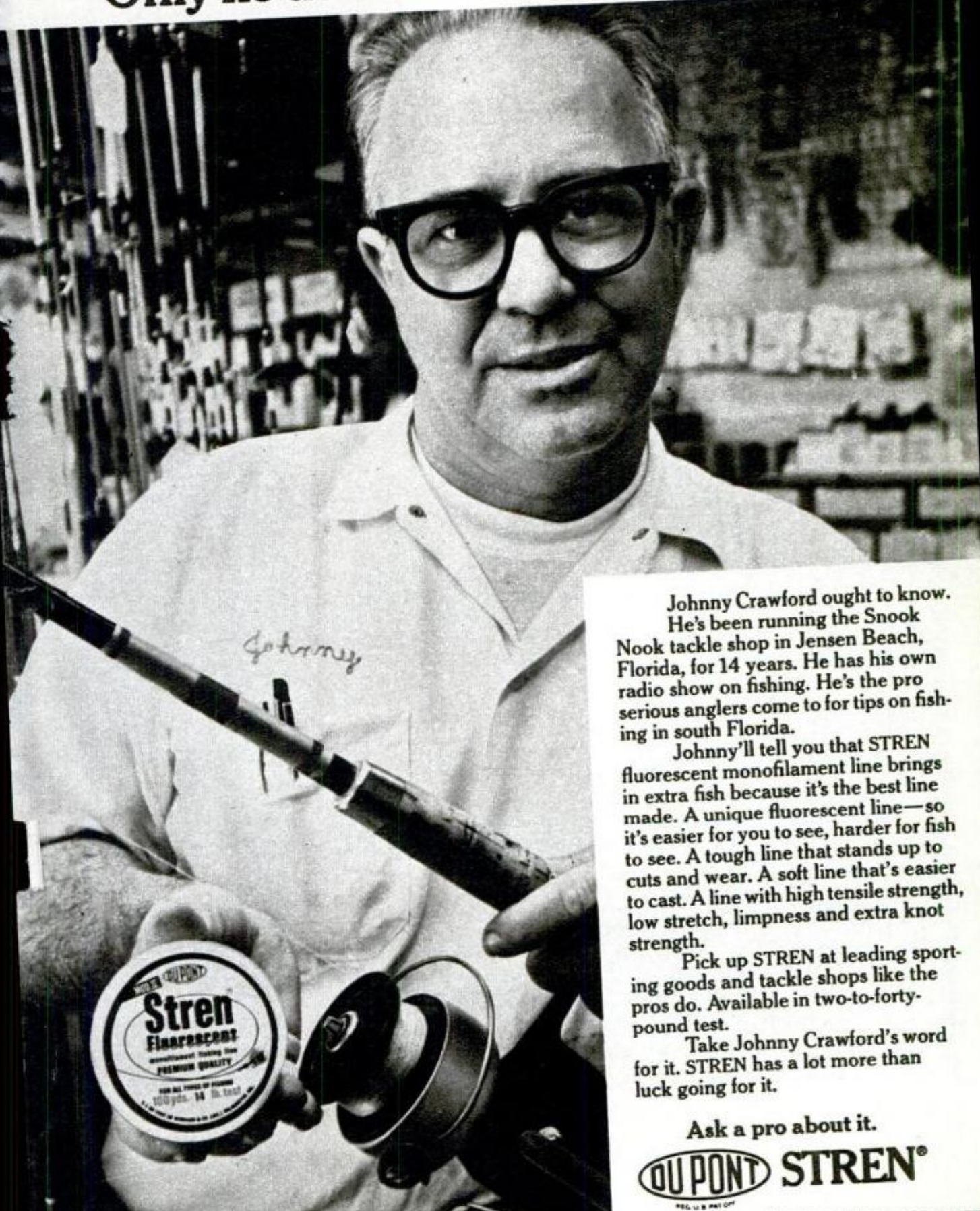

Johnny Crawford ought to know. He's been running the Snook Nook tackle shop in Jensen Beach, Florida, for 14 years. He has his own radio show on fishing. He's the pro serious anglers come to for tips on fishing in south Florida.

Johnny'll tell you that STREN fluorescent monofilament line brings in extra fish because it's the best line made. A unique fluorescent line—so it's easier for you to see, harder for fish to see. A tough line that stands up to cuts and wear. A soft line that's easier to cast. A line with high tensile strength, low stretch, limpness and extra knot strength.

Pick up STREN at leading sporting goods and tackle shops like the pros do. Available in two-to-forty-pound test.

Take Johnny Crawford's word for it. STREN has a lot more than luck going for it.

Ask a pro about it.

DU PONT STREN®

REG. U.S. PAT. OFF.

When your home's on wheels, you'd better put a good foundation under it.

A Chevrolet.

Our Independent Front Suspension, with coil springs, lets each wheel react separately. So road shock isn't passed back and forth between the wheels.

Or up to the cab.

Rear springs matched to the load give you firm-but-comfortable support while carrying your home away from home.

What else makes Chevrolet the camper's pickup? Our tough double-walled build. A rugged chassis. And special

camping conveniences you can order.

But during a long day's drive, what you'll savor most is that Chevrolet ride. And sweet it is.



Putting you first, keeps us first.

Home, sweet-riding home.

