

Giant Foldout: Boeing's Huge New 747

POPULAR MECHANICS

DEC. 1969
50 CENTS

What Owners Think Of Maverick Page 92

ORBIS—New Automatic Speed Detector That Takes Your Picture

30 Smart Ideas For Getting More Living Out of the Space You've Got

Choosing The Right Varmint Gun

Paul Goldsmith Tests Dodge's Hot New Challenger

Automobiles Through Minnesota's Winter Wilderness

Steps to Give Your Basement That Professional Touch

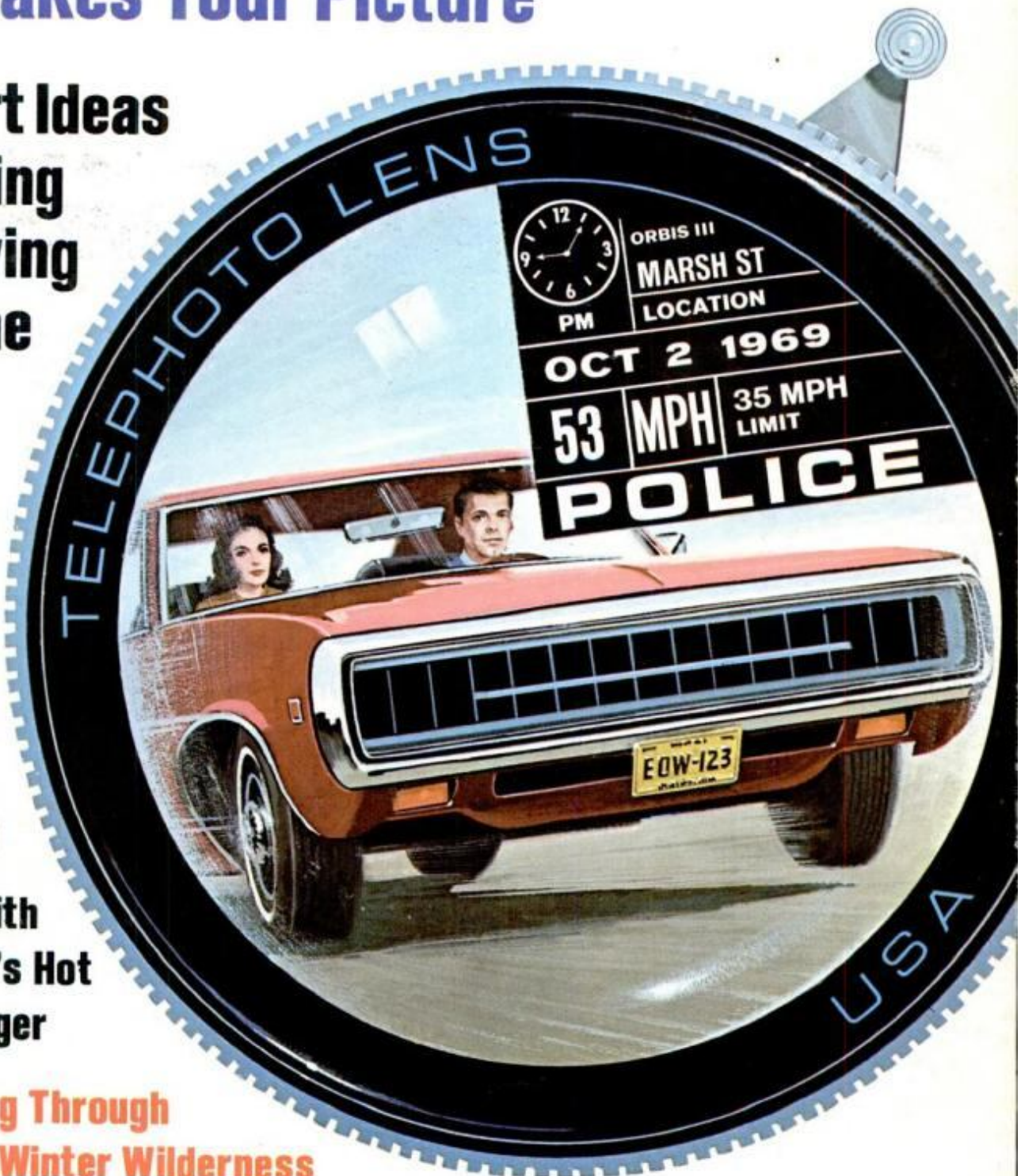



Photographed at Bradenton, Florida



MILLER MAKES IT RIGHT!

Miller makes it hearty and robust
and deep-down good.

That's why more and more men
are making the move
to Miller High Life –
The Champagne of Beers.

“MAKE YOUR MOVE TO MILLER”

Noelco!



Shaped just for a woman. Shaves legs and underarms closely, gently. The Lady Norelco 15L.



Manicures, buffs, and files nails, massages, shaves legs and underarms beautifully. The Home Beauty Salon 25LS.



Two floating heads give fast, clean, comfortable shaves. Famous Norelco rotary action. Handsomely priced. The Speedshaver[®] 20.



As gentle on the purse as it is on the person. Two sides for close shaves on legs and underarms. The Ladyshave 10L.



Completely self-sufficient! Shaves anywhere. For up to 30 days. On just 4 penlight batteries. The Cordless 20B.



Shaves the toughest beards as close or closer than a blade. Pop-out trimmer. Everything you could want in a shaver. The Tripleheader 35T.



Shaves the toughest beards. Anywhere. For up to 3 weeks on a single charge. More than twice the shaves of any other rechargeable. The Rechargeable Tripleheader 45CT.

This One



20RZ-D1K-UF85

Norelco[®]
The Perfect Gift

©1969 North American Philips Corporation, 100 East 42nd Street, New York, N. Y. 10017

Christmas might just be your chance for a Homelite® E-Z™ chain saw

Here's what to tell your wife

Tell her it's the lightest chain saw Homelite ever built. Just eight and one half pounds* Tell her the E-Z tackles any woodcutting job she can dream up, even building her a rustic planter box or picnic bench and table! Cut up enough firewood in an afternoon to keep you warm through next winter. You can fell a tree three feet in diameter – if you ever need to. You can save enough money by cutting firewood, clearing brush and doing your own tree pruning to pay for the saw several times over.

And tell her about the special Christmas offer. The Homelite E-Z chain saw comes pre-assembled with 16" bar and chain in a special custom-molded carry case. Carry case is free with the purchase of a new E-Z chain saw. Tell her she doesn't even have to gift wrap it – it's in its own decorative carton ready to go under your Christmas tree.



Gently grasp the starting handle with two fingers and lift. Vvvvroom!



Saw an 8" hardwood log in 8 seconds. Softwood in 3½. The rest is up to you.



Prune a 2" limb in less than 1 second. Clear storm damage.



Christmas Special! Custom-molded case for safe carrying – FREE with purchase of an E-Z.

HOMELITE

10212 RIVERDALE AVE., PORT CHESTER, N. Y.

Alextron
DIVISION

* Minus cutting attachments



If you're not working with tools coated with TEFLON-S*



you're working much too hard.

The friction-free magic of TEFLON-S means handsaws don't bind, putty knives don't drag, pruning shears don't gum up, snow shovels don't let ice and snow build up and power saw blades last longer and cut cleaner. They all clean up like a snap, and resist rusting.

TEFLON-S lends the same ease to grass clippers, anvil pruners, hedge trimmers, wall scrapers—and who knows what next?

When you see the TEFLON-S Quality Seal on a tool you know that the coating definitely contributes to its performance, and that the coating meets Du Pont's tough standards. You can have confidence in it even before you use it.

Look for the TEFLON-S seal on tools in your hardware store.

*Reg. U.S. Pat. Off. for Du Pont's non-stick finishes.



Better things for better living... through chemistry

POPULAR MECHANICS®

INTERNATIONAL EDITIONS: AUSTRALIA, BRAZIL, CARIBBEAN, DENMARK, FRANCE, MEXICO, SOUTHERN HEMISPHERE, SWEDEN

AUTOMOBILES AND DRIVING

- 12 Detroit Listening Post
- 32 Drivin' With Dan
- 66 Automobile Clinic
- 73 Smile! You Just Got a Ticket
- 88 PM Owners Report: Ford Maverick
- 96 Track-Testing Dodge's New Pony Car: the Challenger
- 132 Saturday Mechanic: How to Check Ball Joints
- 208 Canada Joins the Rotary Club: Mazda Car Test

SHOP AND CRAFTS

- 124 Electronic Music-Makers You Can Build From Kits
- 160 A Jigsaw for a Dime
- 161 New Tools You Should Know About
- 166 New Toothless Blades Cut the 'Uncuttables'
- 168 Look What You Can Do With a Belt Sander
- 172 Hints From Readers
- 178 How to Anneal, Harden and Temper Steel
- 182 Hints From Readers

SCIENCE AND INVENTIONS

- 22 Science Worldwide
- 78 'I'm Not Stuffed—I'm Freeze-Dried!'
- 82 Four-Mile Train With a Mind in the Middle
- 102 Just Patented: PM's Pick of the New Inventions

REGULAR FEATURES

- 6 Letters

HOME AND YARD

- 70 Homeowners' Clinic
- 120 Care and Feeding of Snow Throwers
- 136 Exciting New Products
- 138 30 Smart Ideas for Putting Space to Work
- 154 Finish Your Basement Like a Pro
- 158 Solving Home Problems
- 168 Look What You Can Do With a Belt Sander
- 173 The Right Way to Replace Furnace Filters
- 174 New Building Products You Should Know About

BOATING, OUTDOOR RECREATION

- 11 What's New Outdoors
- 42 On-the-Go Camping
- 116 Use What the Varmint Shooters Use
- 150 Conquering Minnesota's Wilderness by Snowmobile
- 163 Outboard-Motor Service Guide No. 3: How to Check Out Your Lower Unit

PHOTOGRAPHY

- 127 New in Photography
- 128 New Mini-Strobes: Flashguns You Can Slip in a Pocket

ELECTRONICS, RADIO AND TV

- 112 New in Electronics
- 124 Electronic Music-Makers You Can Build From Kits

SPACE, AVIATION, MILITARY

- 94 Fastest Prop in the World
- 104 Boeing's 747: First of a Great New Breed

Cover Illustration by Ed Valigursky
Orbis: New automatic speed detector that takes your picture

NEXT MONTH IN POPULAR MECHANICS

Special 64-Page Tear-Out Section: Auto Racing Guide for 1970: The cars (in color), the drivers, the tracks, the races, the rules . . . plus "argument settlers." This special section was prepared especially for PM's auto-racing fans by our automotive editors.

How We Raised the Alvin From 5000 Feet. Veteran skipper tells of deepest rescue.

Great Things to Build: Bumper-pool table, gun cabinet, mini-bike, spiral stairway.

ROBERT P. CROSSLEY

Editor

JAMES M. LISTON

Executive Editor

JOHN A. LINKLETTER

Managing Editor

WAYNE C. LECKEY

Home and Shop

Editor

SHELDON M. GALLAGER

Assistant Executive

Editor

THOMAS G. DAUER

Art Director

Published by The Hearst Corporation

RICHARD E. BERLIN, PRESIDENT

RICHARD E. DEEMS

President, Magazines Division

JOSEPH F. KERN

Publisher

WILLIAM KILPATRICK _____ Automotive

JOHN F. PEARSON _____ Science

GEORGE W. REIGER _____ Boating and Outdoors

SHELDON GALLAGER _____ Electronics and Photography

BILL HARTFORD _____ Technical Automotive

HARRY WICKS _____ Home Workshop

GARRY WINTER _____ Copy and Production

RICHARD H. FUNK _____ Associate Copy and Production

JOHN ADKINS _____ Assistant Copy and Production

ALVIN KIETZ _____ Assistant Art Director

DON EVANS _____ Assistant Art Director

FRED A. LEERS _____ Assistant Art Director

GEORGE W. BLOW _____ Technical Art Director

CLIFFORD B. HICKS _____ Special Projects

SOPHIE GRONOWICZ _____ Director, Bureau of Information

EVERETT JOHNSON _____ Cabinetmaker

ADDRESS ALL EDITORIAL COMMUNICATIONS TO: 224 West 57th St., New York, N.Y. 10019. For additional sources of information on the articles and products in this issue, write to Bureau of Information, Popular Mechanics, for free "Where-to-Find-It" list.

DANIEL J. COLEMAN

Director of Advertising

ADVERTISING OFFICES: New York: 224 West 57th St., 765-6850; Chicago: 520 N. Michigan Ave., 527-2400; Detroit: General Motors Bldg., TRinity 5-8711; Cleveland: 20310 Chagrin Blvd., Shaker Heights, 283-7788; Los Angeles: 601 North Vermont Ave., 666-6263.

SUBSCRIPTION SERVICE: Mail all subscription orders, changes of address, correspondence concerning subscriptions, and Postmaster notices of undeliverable copies to Popular Mechanics, Box 646, New York, N.Y. 10019. Please enclose your latest address label for quickest service when writing about your subscription.

POPULAR MECHANICS IS PUBLISHED MONTHLY by The Hearst Corporation, 57th St. at 8th Ave., New York, N.Y. 10019, U.S.A. Richard E. Berlin, President; George Hearst, V-Pres.; Richard E. Deems, President of Magazines; John R. Miller, Executive V-Pres. of Magazines; Raymond J. Petersen, Senior V-Pres. of Magazines; William S. Campbell, V-Pres. of Magazines; Albert A. Rachol, V-Pres. and Director of Circulation; Joseph F. Kern, V-Pres. for Popular Mechanics; Frank Massi, Executive V-Pres. and Treasurer; Harvey L. Lipton, Secy. Single copy in the United States and Canada, 50 cents. Subscription prices: United States and Possessions, \$5.00 for one year; \$9.00 for two years; \$12.00 for three years. Canada, add \$0.75 for each year. Pan American Postal Union countries, add \$1.00 for each year. All other countries, add \$2.00 for each year. When changing address, give old address as well as the new, with postal-zone number, if any, and allow six weeks for change to become effective. Second-class postage paid at New York, N.Y., and at additional mailing offices. Authorized as second-class mail by the Post Office Department, Ottawa, and for payment of postage in cash. Registered as second-class matter at the Post Office at Mexico D.F., Mexico, June 20, 1950. © 1969 by The Hearst Corporation. All rights reserved. Printed in U.S.A.

DECEMBER 1969



Frees Sticking Chokes—Squirt on both ends of choke valve shaft, remove choke cover, flood vacuum cylinder while engine runs. It's fast!



Cleans Carburetor Linkage—Dirty, oily linkage can badly foul up carburetor performance. Clean it in seconds!

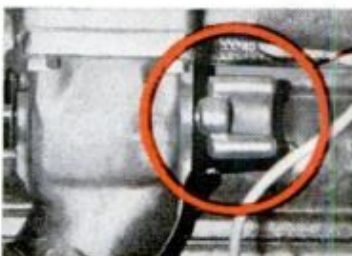

Loosens Manifold Heat Controls—Quickly penetrates and frees heat controls frozen by rust and carbon. Leaves no oily residue to cause further sticking.

Available at leading auto supply stores.

GUMOUT

Pennsylvania Refining Co., Cleveland, Ohio 44104

IN CANADA: 8677 Delmeade Road, Montreal 307, PQ

The Lazy Pipe Tobacco

When you have some relaxing to do, here's the pipe tobacco to do it with. Bond Street's never in a hurry. It's a rich-tasting combination of plugs and flakes, brought together to smoke slow and easy. Look at it this way: one pipeful will last long enough to give the little woman a good workout and you one of the best rides you've had since you were a kid. We know you'll like the Bond Street taste. And if anyone gets within sniffing distance, be prepared for some compliments about the aroma.



Lights easy—
takes its own good
time about burning



LETTERS TO THE EDITOR

Lesson 2: Birds and bees

In *Secrets of the Animal World* (page 84, Sept. PM) reference is made to the worker bee as "he" and "him" on page 85. Please be advised that there are male bees, but they are only drones and do no work. The worker bee is an underdeveloped female, while the queen is a fully developed female and lays the eggs.

CANTON, MISS.

LESTER M. JAMES

Guess our bias showed. We don't mind having females (preferably developed) around to do the work, but how can a men's magazine label any gang of guys—even bees—a bunch of drones?

Not out of steam

I read *Speaking of Steam* in the *Detroit Listening Post* (page 36, Sept. PM) with considerable amusement and some sorrow for your publication. It seems the author has an uncanny ability to guess wrong.

As for my steam-car plans having evaporated, about the only thing that has evaporated so far is \$5,500,000 of well-spent money in finding out all the problems and most of the solutions.

I never professed to have a fleet of steam-powered buses at any time. However, strange as it may seem, we may have a couple pretty well along the way toward completion.

The race car was not my idea, but Ken Wallis's screwball dream on which I spent a lot of money, only to find there were no rules for racing it at Indianapolis.

The California Highway Patrol car is progressing nicely, and we are not at all chagrined over the time it takes to make something worthwhile, nor the money it costs. We went into this thing with our eyes wide open; we knew it would be a difficult objective and at the proper time we will make a creditable showing.

The author's reference to the "rock" of designing and building a suitable boiler is just too ridiculous to discuss. As a matter of fact, we have spent over \$1 million on boilers and have something to really crow about, but it is too early to do that.

Now, the funny one is the statement that I am no longer president of the company. You have no idea how important this is to me, especially in view of the fact that I own 100 percent of the company. I personally appointed Mr. Joseph Walsh,

(Please turn to page 8)

"Look who's smiling now!"

"The department head's job had just been left vacant. When the boys in the office learned I was gunning for it, they gave me their widest grins. One thing they didn't know: I had made up my mind sometime back to take LaSalle training that would qualify me for a better job. My study paid off so fast it surprised even me—I was picked for that shiny promotion over everyone's head. Who wouldn't be smiling with a neat new \$1,500 increase!"

LaSalle's files are filled with letters with this kind of story from LaSalle graduates who have rapidly climbed the ladder of success. You, too, can qualify for the career opportunity of your choice through LaSalle home study—without interfering with your present work—and by devoting only a little of your spare time.

LaSalle has been an acknowledged leader in home education for over sixty years. It has enrolled more than 1,500,000 ambitious men and women in its many types of training courses. LaSalle's distinguished faculty includes some of the country's foremost practicing specialists and instructors. That's why your training is in good, experienced hands... why your LaSalle diploma will be respected by employers.

Mailing the LaSalle coupon below may be the first step in getting a better job, higher pay, and all of the good things that go with success. Simply check the program in which you are most interested, and we will send you a valuable free booklet describing the opportunities in that field. Mail the coupon to LaSalle, 417 S. Dearborn Street, Chicago, Illinois 60605.



LA SALLE EXTENSION UNIVERSITY

A Correspondence Institution • 417 S. Dearborn Street, Dept. 96-100, Chicago, Illinois 60605

Please send me, without cost or obligation, FREE booklet and full information on the field I have checked below:

ACCOUNTING

- Complete Accounting
- Income Tax
- Accounting Fundamentals
- CPA Training
- Modern Bookkeeping

BUSINESS MANAGEMENT

- Complete Business Management
- Credit and Collections
- Office Management
- Personnel Management
- Sales Management

REAL ESTATE

- Complete Real Estate
- Real Estate Brokerage
- Real Estate Management

Interested in a career not listed? Write here: _____

COMPUTER PROGRAMMING

- Complete Training

LAW COURSES

- Bachelor of Laws Degree
- Business Law
- Insurance Law
- Claim Adjusting Law
- Law for Police Officers

STENOTYPE

- Machine Shorthand

TECHNICAL COURSES

- Air Conditioning, Refrigeration, Heating
- Diesel

TRAFFIC & TRANSPORTATION

- Complete Traffic Mgt. Truck, Air, Rail, Sea

DRAFTING

- Complete Drafting

INTERIOR DECORATION

- Professional Training

ART TRAINING

- Commercial Art
- Oil, Water Color Painting
- Complete Training

Mr.

Mrs.

Miss

HIGH SCHOOL

- High School Diploma

LANGUAGE INSTRUCTION

- French
- Spanish

HOTEL/MOTEL MANAGEMENT

- Executive Training

CAREERS FOR WOMEN

- Accounting
- Bookkeeping
- Commercial Art
- Computer Programming
- Dental Assistant
- Hotel/Motel Mgmt.
- Interior Decorator
- Real Estate
- Secretarial
- Stenotype

Age....

(Circle title and please print)

Address..... Apt.No.....

City & State..... Zip No.....

TAX SEASON IS COMING!

LEARN TAX PREPARATION
WITH H&R BLOCK

EARN UP TO
\$700
PER MONTH

Here's your opportunity to learn tax preparation in your spare time from H & R Block, America's largest tax service. Join the ranks of successful H & R Block graduates who occupy a respected position in the tax preparation field. Earn up to \$700 a month as a tax preparer during tax season. No previous training or education required. Ideal for retired people and/or men and women seeking full or part time income. Job opportunities available for qualified graduates. Low tuition costs includes all supplies you need for this complete home study course. Send for free information today. No salesman will call.

H-R BLOCK INC.

301-129

TAX TRAINING INSTITUTE

4410 Main Street Kansas City, Mo. 64111

Yes, please send me without obligation full details on your home study course for income tax preparation.

Name _____

Address _____

City _____ State _____ Zip _____

LETTERS

(Continued from page 6)

one of the most capable individuals of my acquaintance, as president. The author failed to mention that Bill Lear is still chairman of the board, chief executive officer and sole owner of Lear Motors Corp.

I guess the author was trying to belittle me in this article.

RENO, NEV.

WILLIAM P. LEAR

Belittling? Gee, Bill, have you forgotten already that in April we printed a major story on your steam-car developments along with the first full-color painting of your racer to be published anywhere?

Better to learn again

The artificial larynx (*Mechanics of Medicine*, page 138, Oct. PM) is generally considered to be a good "last resort."

Most laryngectomees can, with proper training and patience, learn esophageal speech. It is far superior to the electro-larynx because it is almost like the natural voice, having no mechanism to detract from it.

The patient should not be given the electro-larynx because he will then lack motivation to give it up to learn esophageal speech. Writing is preferable.

CHATTANOOGA, TENN.

LYNN DANIEL, M.A.
SPEECH PATHOLOGIST

Three perfect rounders

Bob Bitner shot his perfect 300 round in 1967, not last year as was stated in *Look What's Happened to Bows and Arrows* (page 120, Sept. PM). And his "strange-looking bow" is the Golden Eagle, a take-apart bow with a die-cast aluminum handle. There were two others who shot perfect 300 rounds in that 1967 competition: Lester Gervais (whom you mentioned) and Bob Brewer.

BIG RAPIDS, MICH.

CHARLES ALLEN

PM collector

I am in the process of collecting old *Popular Mechanics* magazines. I intend to collect as many as possible. As you can guess, I am having trouble finding the older issues. I would appreciate any helpful information you or your readers can give.

CHICO, CALIF.

FRED M. ALEXIS

To keep from inundating Mr. Alexis under a pile of paper, we'd suggest that readers who have old magazines to spare query him first: Rt. 1, Box 744A, Chico, Calif. 95926.

★★★

UNIMAT

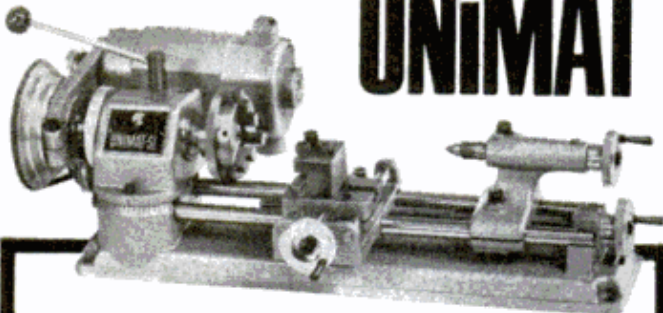

MULTI-JOB MINIATURE LATHE

makes it easy for modelmakers, inventors, craftsmen to turn their own precision parts from metal, plastic, wood. Mounting headstock on auxiliary post converts tool to drill press, vertical milling machine or surface grinder. 17" overall, quality-built with precision bearings, universal motor, 11-speed belt drive. Outfit comes complete in wood chest. Lifetime investment that saves its cost. Write today for free Unimat folder or send \$1 for informative 40-page "Miniature Machining Techniques" handbook.

AMERICAN EDELSTAAL, INC.,

Dept. BL9,
350 Broadway, New York, N.Y. 10013

only
\$139⁵⁰

available in Canada

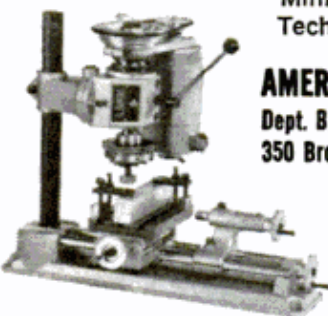

If you never think about your car battery, these facts can save you from an ugly surprise

How good was your battery the day you bought it? Chances are the last battery you bought was a "standard." Good enough for a couple of years, but after that you're pushing your luck.

Here's how good it is now. If your battery is two years old, you have a 50-50 chance of making it through the next twelve months without buying a replacement. If your battery is three years old, the odds are against you. Better plan on a new one.

Two ways to avoid ugly surprises. (1) Next time you need a replacement, buy the better battery. GO* will give you more life—more starting power—than batteries that come in brand new cars. Twice the power of some. Instant power for fast, sure starts. Reserve power for tough-weather starts. (2) Insist on a GO* battery in your next new car. It will be one item you'll never pay to replace. (For proof, read on.)

Your guarantee is dying along with your battery. Because almost all battery guarantees are prorated by the month. Say you have a \$30 battery with a 24-month guarantee. It quits at 20 months. You get four twenty-fourths, or one-sixth, of the \$30 toward a new one. A big \$5. Not much of a guarantee by then, is it?

But this guarantee never dies. The GO* guarantee is different. Lifetime free replacement means no prorating, no time limit, no arguments. No kidding. If a GO* battery ever dies, we replace it. It's that simple.

Lifetime Free-Replacement Guarantee.

If this battery becomes unserviceable in noncommercial passenger car use, it will be replaced with a battery of like quality at no cost, subject to the following conditions: The guarantee is not transferable, applies only so long as the battery remains in the car in which it is installed and only if the battery cannot accept and hold a charge. This guarantee will be honored by all Exide and Willard dealers.

Call the GO* Line number 800/243-1890 free of charge (in Connecticut call 853-3600 collect) for your nearest Exide or Willard dealer. ESB BRANDS, INC., A Subsidiary of ESB Incorporated, Box 6949, Cleveland, Ohio 44101.

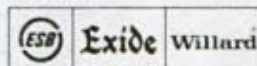

Willard

Exide

more life for the life of your car

The Yule Tool

Bernzomatic's Jet Torch with the double guarantee.

When his first truck bites the dust on Christmas morning, you can solder it whole again with your new Jet Torch. After that, you can do your own do-it-yourself thing—peel paint, sweat pipes, thaw almost anything—with the hottest torch under the sun. Bernzomatic's Jet Torch is the only torch made that gives you a double guarantee: 1. A lifetime guarantee on the torch. Anything happens to our torch head, your fault or ours, we fix it free. For life.* 2. A quality/quantity guarantee on the cylinder. Pure filtered propane with no impurities. Sealed cylinder to make sure you get all the gas you're paying for. Bernzomatic torch kits run from as little as \$7.29. This Christmas, give one. Or get one. Your Bernzomatic Jet Torch will pay for itself in smiles as you fix your kids' Christmas toys. Another gift of warmth... from Bernzomatic.



***Lifetime Guarantee:**
The Bernzomatic torch burner is guaranteed for the life of the owner. When returned to our factory it will be put in first class mechanical condition. It doesn't matter how the burner was damaged. We will either fix it or send you a new one free of charge.

BERNZOMATIC®

BERNZOMATIC CORP., ROCHESTER, N.Y. IN CANADA, BERNZOMATIC LTD., TORONTO

WHAT'S NEW **OUTDOORS** BY GEORGE REIGER

BAND-AIDS FOR SNAKE BITES? If a vaccine being developed by Drs. Clifford C. Snyder and Gary R. Hunter is successful, outdoorsmen may one day have no more fear of rattler, cottonmouth and copperhead snake bites than we now have of bee stings. These vipers presently account for between six and seven thousand snake bites reported annually in the United States, of which 15 to 20 are fatal. The two University of Utah researchers have thus far developed a vaccine that protects dogs from timber rattlers, but Dr. Snyder is at work on a polyvalent rattler vaccine that will protect people against sidewinders, diamondback and Mojave rattlers. And he foresees a day when even the dread king cobra of India may threaten man with no more than a little fright and soreness!

A NEW FLASHING SAFETY LIGHT for hunters doubles as an emergency light for snowmobilers, ice fishermen and other outdoorsmen. Bird shooters will particu-

larly appreciate its value during the deer season. The flashing red Safe Lite can be attached to the top of your cap to warn other hunters of your presence up to half a mile away. The light can be worn during the critical faint-light hours of dusk and



dawn and on dark, overcast days. Its small size and light weight make it no more bulky than a pack of cigarets—and far less hazardous to your health! Also good for boats, kids on bikes, and people walking along highways at night. Manufactured by B & G Industries, Hanover, N.H., the suggested retail price is \$3.50.

One of a kind



No other distiller makes his whiskey the same way we make Seagram's 7 Crown.

So no other whiskey has the same smooth taste.

Or the same consistently fine quality.

And guess what.

No other brand of whiskey is asked for as often as 7 Crown.

It figures, doesn't it?

Say Seagram's and Be Sure.

Seagram Distillers Co., N.Y.C.
Blended Whiskey. 86 Proof.
65% Grain Neutral Spirits.

DETROIT

LISTENING POST

BY BILL KILPATRICK

A FORD GAS TURBINE ENGINE prototype has been installed in a Continental Trailways bus and right now is undergoing final tests before being placed in regularly scheduled passenger service. Installation of the engine—dubbed the 707—was completed last month at Ford's Engineering and Research Center. Following a number of "shake-down" cruises between various Michigan points, the bus was driven to Trailways' Dallas headquarters. It will be placed in long-haul service—probably between Dallas and Los Angeles—after a period of further testing and exhibition. Insiders report the most notable features of the new turbine bus from a passenger's point of view are its quietness and lack of vibration.

USED CAR AND TRUCK TIRES, long a blight on the American landscape—so much so that archaeologists of the future could understandably consider them the principal artifact of the 20th century—have been proven a valuable source of such raw materials as oil liquids, gasses and tar. Joint research by Firestone and the U.S. Bureau of Mines has developed a "destructive distillation" process found to be a "technically feasible method of disposing of, and obtaining potentially valuable products from, scrap automobile and truck tires." The "distillation" is accomplished by heating scrapped tires in a reactor normally used to test the coking properties of coal. Shredded, the tires are fed into a closed reactor where, as they are heated, they break down into various chemical compounds. The Bureau of Mines reported that the highest yield of liquid products resulting from the process was obtained at about 500° Centigrade (930° F.), whereas the highest yield of solid and gaseous products was obtained at about 900° C. (1650° F.). In one test, a ton of used tires resulted in as much as 140 gallons of liquid oils, in another, 1500 cu. ft. of gas. Ultimate goal of the project, according to Firestone's Dr. J. A. Beckman, would be to have such reclaim facilities set up all over the country. Big effort right now, says Dr. Beckman, is to make the process and facilities economically feasible.

THE BATTLE OVER AIR POLLUTION caused by cars is far from over, despite statements issued by auto-industry public relations departments. Research at Ohio State University indicates that present automobile engines spew about 29 pounds of deadly carbon monoxide into the atmosphere for each ten gallons of gasoline burned. OSU's studies, sponsored by the National Air Pollution Control Administration of the U.S. Public Health Service, are aimed at determining the chemical reactions and rates of removal of carbon monoxide, sulphur dioxide and other common pollutants from the atmosphere.

"Right now," says OSU chemistry professor Jack G. Calvert, "we don't know exactly how or how fast carbon monoxide removes itself from the air. We're trying to find out what happens." Calvert says monoxide's potential threat comes from the length of time it stays in the atmosphere and the toxicity of the transition products occurring as it passes into a harmless substance. "Naturally occurring reactions in the atmosphere remove most pollutants," Calvert points out, "but if they are dumped in faster than they are taken out, they can build to toxic levels." And Calvert thinks carbon monoxide—to mention just one pollutant—is being dumped in the air faster than it's being taken out, with the main culprit being internal combustion auto and truck engines.

His contention contrasts sharply with that advanced earlier this year by Charles M. Heinen, Chrysler's chief engineer for emissions control and chemical development. Heinen claims the main battle against car-caused air pollution has been won, that if there were no cars on the road except 1969-70 models, "we would—overnight—breathe the same clean air we had in 1940 as far as the automobile contribution is concerned." But Calvert says a perfectly-tuned test car, regardless of model year, has little relation

(Please turn to page 20)

They're here. The all-new BMW's. Hottest, sportiest BMW's ever. 500, 600 and 750 cc's!

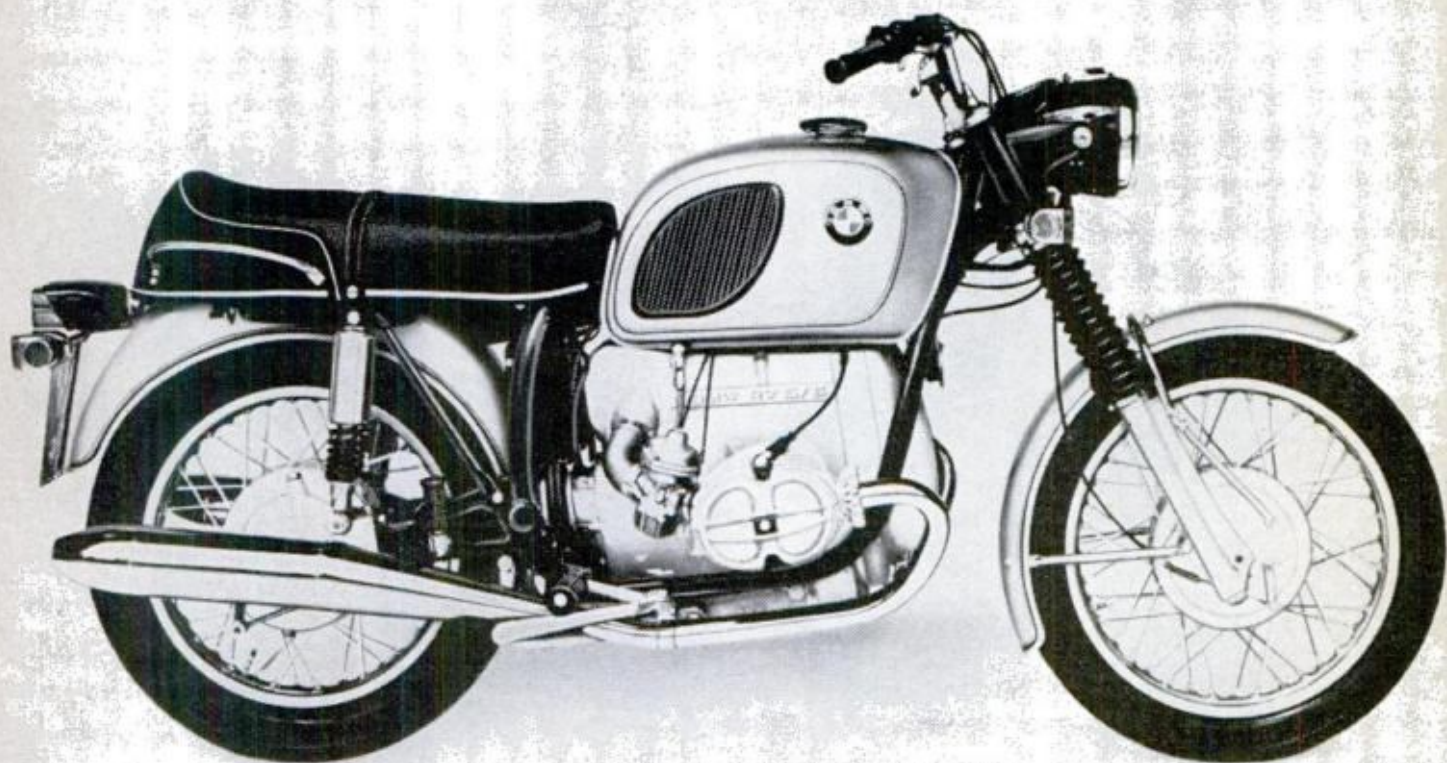

This is the most exciting motorcycle news in years. These BMW's are totally new, in everything but BMW craftsmanship and our famed horizontally-opposed cylinder layout.

For one thing, these new ones are all sport. All go. Lighter and faster. With more muscle and more speed. With greater acceleration and greater agility. With displacement all the way up to 750 cc's.

In fact, they're so full of tech-

nical advances they set a new standard for the motorcycle world. And with it all, there's the quality of design and construction that only BMW could give you.

Over the past 45 years, we've come up with more motorcycle firsts than anybody else. Which is why it's no surprise that our white-and-blue insignia again marks the machine that's way out front.

So if you're ready for a real

man's motorcycle, check out the new BMW's. One look and you'll know what we mean when we say, here comes the new king of the road.

See your nearest authorized BMW dealer, or for information write to: East: Butler & Smith, Inc., Walnut Street and Hudson Avenue, Norwood, N.J. 07648. West: Flanders Company, 340 S. Fair Oaks Avenue, Pasadena, California 91101. Canada: BMW Motorcycle Distributors, Ontario.

Bavarian Motor Works





A.
Model 2478



B.
Model 25162



C.
Model 4295

Dear _____,

(Fill in name)

If you're wondering what I'd like to have for Christmas...

Check one. Or why think small?

Check more than one. Then leave this magazine, opened to this page, on the dinner table.

A. This 10-inch hobby jig saw is for grownups, and for kids, the future Craftsmen of America. It's designed with safety in mind. It's almost impossible to get even a tiny scratch because the stroke is so short and fast. The fast stroke also means very few saw marks, and that means little or no sanding. It will cut soft woods, plywood, plastics, even thin aluminum, brass, or copper. There's no oiling, no belts or pulleys, a minimum of moving parts.

The tempered spring steel blade holder maintains correct cutting tension. Rubber feet absorb vibration. And the table has a 1/2 in. grid pattern to help in guiding and layout. This is the kind of tool that can help a kid become a Craftsman.

B. The Lil Crafty® rotary electric tool kit comes complete with accessories to handle all kinds of jobs. It has cutters, saws, brushes, polishing wheels, buffs, and extra shafts. It's a high speed rotary tool for use with wood, plastic, or non-ferrous metals. The Lexan® housing is sturdy, yet lightweight. The Lil Crafty can be used for carving wood, plastics or metal, as well as etching glass or metal, and finishing wood. It's the kind of tool that makes you look like a Craftsman when you're putting on those fine touches that mean so much.

C. This electric engraving tool requires no special skill. You can inscribe names, numbers, codes, sizes . . . anything . . . on glass, wood, plastic, copper, brass, steel, any hard surface. And whatever you write, on whatever you write it, stays there permanently. It can't be erased, ripped off, or rubbed off. This tool has a tungsten carbide tip and develops 7200 strokes per minute. Protect your property; brand it forever.

All of these tools are available at most Sears, Roebuck and Co. stores, or through the catalog.

Sears

Buy a Craftsman® and be one.

**SAVE
AS MUCH AS
66%
WITH THIS
COUPON**

FABULOUS DIRECT-FACTORY LATHE OFFER!

AMERICAN MACHINE & TOOL CO., Dept. PMDL, Royersford, Pa. 19468

Please send me the unit(s) checked, plus the FREE 16 Page booklet, "The ABC's Of Lathe Turning". Payment in full enclosed \$ or \$3 deposit each item enclosed, balance C.O.D. I MUST BE FULLY SATISFIED OR WILL RETURN WITHIN 10 DAYS FOR FULL REFUND No questions asked. And the lathe booklet remains mine to keep

6" Swing Lathes @ \$14.95 12" Swing Lathes @ \$24.95
 Faceplates @ \$2.50 Sets of turning chisels @ \$4.95
 GE Motors: @ \$18.80 (with lathe) @ \$24.85 (purchased separately)

Name _____
 Address _____
 City _____ State _____ Zip _____

**SAVE
AS MUCH AS
66%
WITH THIS
COUPON**

World's greatest fun tool—Makes woodworking a delight

\$14⁹⁵ f.o.b. factory **6" SWING 3-FT. WOOD LATHE**

Shipping wt.: 15 lbs.
 Faceplate (optional) for turning bowls, lamp bases, etc. \$2.95
 Set of 3 high speed turning chisels: \$4.95 add'l



The wood turning lathe was the first of all power tools. And it is still the most fun, the easiest for an amateur to master. Also converts easily for use as a disc sander, drum sander, horizontal drill press, a jig to hold work to be reeded or fluted.

MOST VERSATILE! EASIEST TO LEARN! EASIEST TO USE!

MAKE THESE AND 100's OF OTHER FUN ITEMS



INDUSTRIAL SIZE 12" SWING 4-FT. WOOD LATHE



\$24⁹⁵ f.o.b. factory

Comparable in speed, precision and durability to units selling for \$75.00 and more. Full 36" between centers. For wood and plastics. Special tubular steel bed rails with dual point suspension increase accuracy, ease of operation, virtually eliminate vibration. Precision ball thrust cup center. Large graduated T-rest. Screw action tail stock. 3-Speed pulley for different work diameters. SAME DUAL GUARANTY APPLIES

Shipping Wt.: 30 lbs.
 Faceplate (optional) for turning bowls, lamp bases, etc. \$2.95
 Set of 3 high speed turning chisels: \$4.95 additional

- ALL CAST IRON AND STEEL PRECISION CONSTRUCTION
- DOES WORK OF MACHINES SELLING FOR 3 TIMES THE PRICE
- TURNS WOOD AND PLASTICS TO 23" LONG
- MADE BY AMERICA'S LARGEST DIRECT SALES POWER TOOL FACTORY
- ENDORSED BY EDITORS OF THE NATION'S TOP MAGAZINES

Professionals, industrial users, home hobbyists . . . over one million satisfied owners . . . attest to the precision, versatility and rugged performance of AMCO power tools. Praise heaped on them by America's top shop and crafts editors. *Popular Science*: "A good bit of sound, imaginative engineering." *Popular Mechanics*: "Amazingly versatile." *Workbench*: ". . . particularly delighted with the lathe . . . did everything we demanded of it." Sturdy cast iron and steel construction with tubular steel bed. Complete with ball thrust cup center, T-rest assembly, lever action tail stock, 2-speed pulley. Takes any standard motor ¼ hp or larger.

UNCONDITIONAL 10-DAY GUARANTEE

You must be fully satisfied. If not, return in ten days, shipping charges collect for prompt, full refund.

10-YEAR FULL SERVICE GUARANTEE

Any parts which may become inoperative for any reason within ten years after purchase date will be replaced or repaired without charge. Your only cost: for postage.



FREE 16 PAGE BOOKLET "ABC'S OF LATHE TURNING"

Fully illustrated step by step instructions in articles by the nation's leading hobby writers. Shows how easily and quickly you can reap the benefits of this most rewarding of hobbies. Included FREE with your purchase.

BRAND NEW MOTOR DEVELOPING FULL 1 HP . . . **\$18⁸⁰** F.O.B. FACTORY / FOR ANY OF ABOVE MACHINES. WT. 17 LBS. PURCHASED SEPARATELY, \$24.85

Cast your ballot for a successful future!

266 ICS COURSES



You get the widest choice from ICS —oldest, largest home study school. Check the list. (Also available, programs tailored to your special needs.) You receive individual instruction, plus success-proved facts

and theory you can apply immediately. Mastery of subject is assured. No skimping. You earn your diploma.

Why mark time when you can mark the coupon and get a fast, sure fix on your best course to success.



ACCOUNTING
Accounting (U.S.A.)
Accounting (Canadian)
Accounting for Business Programmers
Accounting for Man'g'm't Decisions
Auditing
Business Law (U.S.A.)
Canadian Business Courses
Cost Accounting
CPA Review (U.S.A.)
General Accounting
Income Tax (U.S.A.)
Industrial Accounting
Junior Accounting
Office Accounting
Practical Accounting
Public Accounting
Small Business
Accounting (U.S.A.)
Starting and Managing a Small Bookkeeping Service (U.S.A.)

ARCHITECTURE AND BUILDING
Architectural Drawing and Designing
Architecture
Building Contractor
Building Estimator
Building Inspector
Building Maintenance
Carpenter-Builder
Carpentry and Millwork
Fundamentals of Urban Planning
House Planning and Interior Design
Mason
Painting Contractor
Reading Arch. Blueprints
Review in Architectural Design and Practice
Review of Mechanical Systems in Buildings

ART
Amateur Artist
Commercial Art
Commercial Cartooning
Illustrating with Options: —Magazine —Advertising Layout and Illustration
Interior Decorating
Oil Painting for Pleasure
Show Card and Sign Prod.
Show Card Writing
Sign Painting & Designing
Sketching and Painting
AUTOMOTIVE
Automatic Trans. Spec.

Automobile Air Conditioning Specialist
Automobile Body Rebuilding & Refinishing
Automobile Engine Tune-Up
Automobile Mechanic
Automobile Technician
Diesel-Gas Motor Vehicle Engines

BUSINESS
Advertising
Business Administration
Business Practice (Cond.)
Canadian Business Course
Condensed Marketing
Direct Mail and Mail Order
Advertising
Industrial Psychology
Inventory Control
Magazine & Newspaper
Advertising
Managing a Retail Business
Managing a Small Store
Marketing Management
Marketing Research
Modern Exec. Management
Office Automation
Office Management
Production Management
Purchasing Agent
Retail & Local Advertising
Retail Bus. Management
Retail Merchandising
Retail Selling
Systems and Procedures
Analysis

BUSINESS: SALES
Creative Salesmanship
Real Estate Salesmanship
Salesmanship
Sales Management

BUSINESS: SUPERVISION
Basic Supervision
Industrial Foremanship
Industrial Supervision
Management, Salesmanship and Sales
Modern Woman as a Supervisor
Personality Development
Personnel-Labor Relations (U.S.A.)
Supervision

CHEMICAL
Analytical Chemistry
Chemical Engineering
Chemical Laboratory Tech.
Chemical Process Equip.
Design & Operation

Chemical Process Operator
Elements of Nuclear Energy
General Chemistry
Instrumental Laboratory Analysis

CIVIL ENGINEERING
Civil Engineering
Construction Eng'r'g Tech.
Highway Engineering Tech.
Principles of Surveying
Reading Highway Bl'pr'ts
Reading Structural Blueprints
Sanitary Engineering Tech.
Sewage Plant Operator
Structural Eng'r'g Tech.
Surveying and Mapping
Water Works Operator

COLLEGE COURSES
American History
Calculus Economics

COMPUTERS
COBOL Programming
Fortran Programming for Engineers
Programming for Digital Computers
Programming the IBM 1401 Computer
Programming the IBM System/360 Computer, Introduction

DRAFTING
Aircraft Drafting
Architectural Drafting
Design Drafting
Drafting Technology
Electrical Drafting
Electrical Eng'r'g Drafting
Electronic Drafting
Introductory Mech. Draft.
Mechanical Drafting
Pressure-Vessel and Tank Print Reading
Sheet Metal Layout for Air Conditioning
Structural Drafting

ELECTRICAL
Electrical Engineering —Electronics Option —Power Option
Electrical Appliance Ser. with Equipment Training
Electrical Contractor
Electrical Engineering Tech.
Electrical Home Maint.
Electrical Home Maint. with Equipment Training

APPROVED FOR VETERANS
Accredited member, National Home Study Council.
Convenient payment plan.
Special rates to members U.S. Armed Forces

Electrical Instrument Tech.
Electric Motor Repairman
Industrial Electrical Tech.
Power-Line Design and Construction
Power Plant Operator —Hydro Option —Steam Option
Practical Electrician
Practical Electrician with Equipment Training
Practical Lineman
Reading Elec. Blueprints

ENGINEERING (Refresher Courses for Graduate Engineers)
Chemical Civil Electrical
Industrial Mechanical
Sanitary Structural

ENGLISH AND WRITING
Better Business Writing
English for Spanish (U.S.A.)
Free Lance Writing for Fun and Profit
Introductory Tech. Writing
Modern Letter Writing
Practical English
Short Story Writing

HIGH SCHOOL
High School Business
High School (Canadian)
High School General
High School Mathematics
High School Secretarial
High School Vocational
High School College Preparatory—Arts
High School College Prep—Engineering and Science
Preparatory Course for High School Equivalency Test

MACHINE SHOP PRACTICE
Grinder Operator
Industrial Metallurgy
Lathe Operator

Machine Shop Inspection
Machine Shop Practice
Metallurgical Eng'r'g Tech.
Multicraft Maintenance Mechanic
Practical Millwrighting
Reading Shop Prints
Rigging
Tool & Die Making
Tool Engineering Tech.
Welding Engineering Tech.
Welding Process

MATHEMATICS
Advanced Mathematics
Math and Mechanics for Engineering Technicians
Math and Physics for Engineering Technicians

MECHANICAL
Mechanical Engineering
Aircraft and Power Plant Mechanic
Hydraulic and Pneumatic Power
Industrial Engineering
Industrial Eng'r'g Tech.
Industrial Instrumentation
Machine Design
Quality Control
Safety Engineering Tech.
Tool Design
Vibration Analysis and Control

PETROLEUM
Natural Gas Production and Transmission
Oil Well Technology
Petroleum Production
Petroleum Production Engineering Technology
Petroleum Refinery Oper.

PLASTICS
Design of Plastic Products
Plastics Technician

PLUMBING, HEATING AND AIR CONDITIONING
Air Conditioning
Air Conditioning Maint.
Domestic Heating with Gas and Oil
Heating
Heating & Air Conditioning with Drawing
Industrial Air Conditioning
Pipe Fitting Plumbing
Plumbing and Heating Est.
Practical Plumbing
Refrigeration and Air Conditioning Servicing

PULP AND PAPER
Paper Machine Operator
Paper Making Pulp Making
Pulp & Paper Eng'r'g Tech.

SECRETARIAL
Clerk-Typist Commercial
Secretary, Engineering
Sec'y, Legal Sec'y, Medical
Secretary, Professional
Shorthand Stenographic
Typewriting

STEAM AND DIESEL POWER
Boiler Inspector
Industrial Building Eng'r
Power Plant Engineering
Stationary Diesel Engines
Stationary Fireman
Stationary Steam Eng'r'g

TEXTILES
Carding
Carding and Spinning
Dyeing and Finishing
Loom Fixing Spinning
Textile Mill Supervision
Textile Technology
Warping and Weaving

TRAFFIC
Motor Traffic Management
Traffic Management

TV-RADIO-ELECTRONICS
Color Television Principles and Servicing
Electronics Instrumentation
Electronics and Servo Fundamentals
Electronics Technician
First Class Radio Telephone License
Fundamentals of Electronic Computers
General Electronics with Equipment Training
Hi-Fi Stereo and Sound System Servicing
Industrial Electronics Tech.
Numerical Control
Electronics & Maint.
Practical Telephony
Principles of Semiconductor
Radio & TV Servicing
Radio & TV Servicing with Equipment Training
Second Class Radio
Telephone License
Sound Systems Specialist
Telephony, Electronics, and Radio Communications

ICS[®]
International
Correspondence
Schools
Division of Intext

ICS, Scranton, Pa. 18515
Canadian residents use this address for service from ICS Canadian, Ltd.
In Hawaii: P.O. Box 418, Honolulu.

TAKE YOUR FIRST STEP... MAIL THIS COUPON TODAY—ICS, SCRANTON, PA. 18515. N4569L

I'm interested in a program of independent study. Send me, without cost, your booklet on the principles of success, sample text demonstrating famous ICS method, and your catalog for _____ (Print name of course. See list.)

Miss _____ Age _____
Mrs. _____
Mr. _____

Address _____

City _____ State _____ Zip Code _____

Occupation _____ Employed by _____ Working Hours _____ A.M. to _____ P.M.

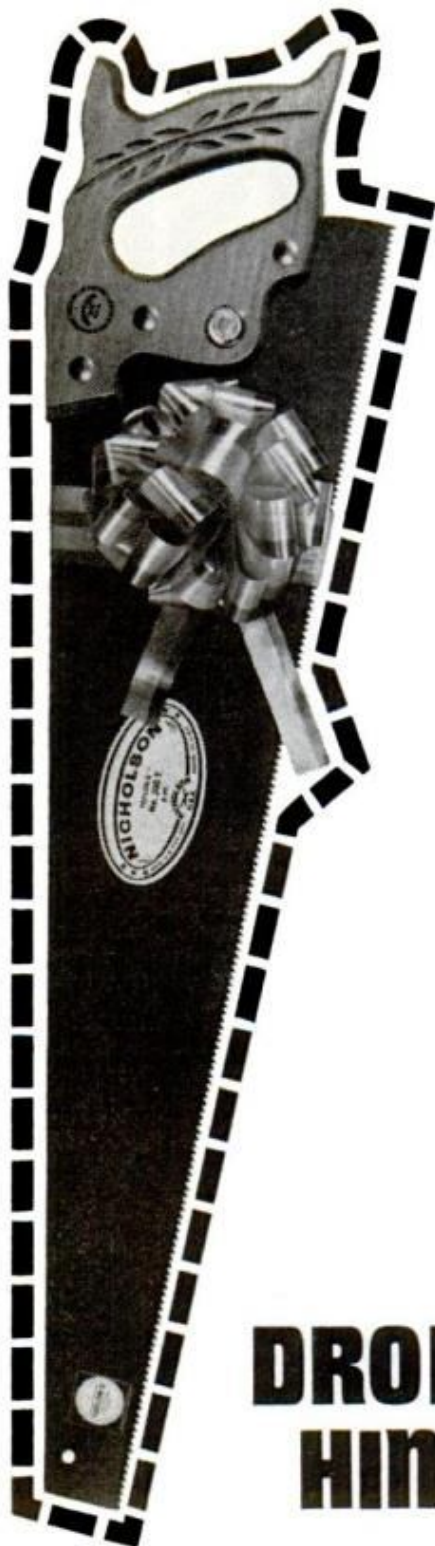

DROP A HINT.

Don't take it for granted your family knows you'd like a new Nicholson handsaw with rustless, self-lubricating DuPont Teflon-S® coating on the blade. Cut out the picture and leave it where they'll get the Christmas message. Your hardware dealer will take it from there.

There's never a dull moment with

Nicholson 
Nicholson File Co., Providence, R.I.

DETROIT LISTENING POST

(Continued from page 12)

to the average vehicle on the road. So, despite the government's recent and apparent go-easy attitude on carmakers regarding air pollution, the issue is far from dead and you can look forward to the exchange of some hot charges and counter-charges. One possible upshot? The end of leaded gasolines.

THAT BELL you hear tolling ominously in the background could be for the automobile and driving as we know them. An ever-increasing number of individuals and organizations are expressing alarm over the proliferation of cars. No less an august group than the National Geographic Society is on record as saying the end of the road for the automobile—one big traffic jam—may be just ahead. The Society cites a number of "trouble spots" in various cities throughout the world (including Agana, the capital of Guam, which each day goes through the agonies of rush-hour traffic), quotes the head traffic man of Washington, D.C., as saying, "By 1975 every single center city area of every big city will be absolutely choked with automobiles." The "traffic mess" is being bounced off the walls of Congress these days, a possible result being that manufacturers may one day be restricted to producing only as many cars as are junked in a given year.

LOOK FOR DODGE to bow with a new van in the next couple of months. The new vehicle, as opposed to the present '68 series of vans, will feature a longer wheelbase, bigger cargo capacity, increased passenger space. As yet unnamed, it'll join the industry's new spate of so-called "super-vans."

AUTO BUFFS, car nuts—whatever you want to call them (and us)—can spend many happy hours these cold winter nights poring over the pages of Leo Levine's great book, *Ford: The Dust of the Glory, A Racing History*. Over 600 pages of delightful, informative reading, plus many, many illustrations, some appearing for the first time, the book traces the story of auto racing from its earliest days on frozen Michigan lakes to modern super speedways. Although concentrating primarily on Ford, the man and the company, the book covers just about all the men and machines that have roared through racing's history. I found it fascinating, often funny, and so might someone on your Christmas list. It's in bookshops, published by Macmillan. ★ ★ ★

START YOUR NEW CAREER NOW! WITHOUT OVERHEAD! ANY PLACE! ANY AGE!

UPHOLSTERING JUST ONE

CHAIR can pay you as much as your present weekly paycheck!

you don't even have to quit your present job!!!

Start learning now. At home, or in the garage, in your spare time — no outside classes to attend. If you can tie a knot and drive a tack, you can learn this business, quickly, easily. You start learning the basics right away through the proven MUI Home Training Plan. And before you're barely into it, you can start doing the simple upholstery jobs that are all around you waiting to be done. Chairs, cushions, seats, footstools. Even before MUI students finish their training, people start bringing upholstery jobs to them, and remember—the world is full of furniture that needs fixing and re-upholstering and more is wearing out all the time!



"What started as a hobby, now pays me \$10 an hour"

Yes, many MUI graduates make better than \$10 an hour turning old wornout furniture into bright new decorator pieces! **Stack it up against what you're doing now!** Are you making \$150 a week? \$200? \$250? Do you put in long hours of dull work, with small raises? Is that the way you want to spend the rest of your life? Just imagine, you can make \$150, \$200, \$250 upholstering just one chair or sofa these days! And if you're the kind of person who likes to work and earn, you can sometimes finish a job like this in a day. That's pay, ... and it beats what most college graduates make!

AS YOU LEARN, YOU JUST SLIP INTO THE IMMENSE FLOW OF UPHOLSTERY WORK! Think of all there is! . . . Sofas, lounging chairs finished in beautiful fabrics, which MUI tells you how to get at the right price — even leather and all the new vinyls. And then you have built-ins and breakfast nooks, boats, trailers and all the millions of automobiles in America. Yes, you learn all this and more! When we finish teaching you, (in your own home in your spare time) and when you get our California state approved diploma, you know this business . . . as a real professional! You will then have one of the most fantastic moneymaking skills in America built into your head and hands! No one can ever take this skill away from you . . . and no one can ever fire you, because you're the boss of a business that you can take with you . . . You can make big money from then on . . . any time, anyplace you want to put out your shingle!

When you read the papers you see there's a strike here, a lockout there. Detroit lays off 150,000 men. A plant is shut down and moved out of state. A new automated machine eliminates 5,000 jobs. They talk about dislocated workers and try to do something about it. What pays the bills if you get caught up in one of these situations? When you know upholstering, life gets very simple and lots of fun. It's simple because where there are people, there are upholstery jobs and lots of them. It's fun because life is fun when the bills are paid and there's money in the bank, even enough to buy those things you've always wanted for yourself.

YOU GET SIX BIG FURNITURE KITS FREE



YOU GET THIS AUTHORIZED DIPLOMA WHEN YOU GRADUATE

WORK THE HOURS YOU LIKE TO WORK!!

If you favor a regular 35 hours a week, upholstery lets you do it and make a really fine living. On the other hand, if you're really ambitious and want to work 60 or 70 hours a week, you are starting to talk about some big, big money! The important thing is that the choice is yours, not somebody else's! (Not like when you're working for someone else.) Many students of retirement age just do a few pieces now and then just to keep things nice and comfortable.

TO GET STARTED, JUST GET THE COUPON IN THE MAIL... TODAY!

It costs you nothing to get the information and there's no obligation. No salesman is going to call you. This much and this much only, every successful MUI graduate must do for himself — send the coupon today!

YOU'LL GET A BIG ILLUSTRATED 32 PAGE BOOK ON UPHOLSTERY

and the upholstery business, and an actual free sample lesson showing how the fabulously successful MUI system is taught. For your sake and the sake of your future, do it now. Cut out the coupon, fill it out, put it in an envelope and mail it now. Air mail reaches MUI about two days sooner!

ALL THE SPECIAL "TOOLS OF THE TRADE" ARE YOURS... FREE

THIS FREE UPHOLSTERY BOOK may be the most important information you ever read.

MAIL COUPON NOW!

MODERN UPHOLSTERY INSTITUTE, Box 899-CFD, Orange, Calif. 92669

Please send the FREE UPHOLSTERY CAREER BOOK, the FREE SAMPLE LESSON. I understand I am under no obligation whatever and am just sending for the free facts on job and career opportunities in Upholstering and the MUI home training program. I understand that no salesman will call.



APPROVED FOR VETERANS

MUI IS APPROVED BY THE CALIFORNIA SUPER-INTENDENT OF PUBLIC INSTRUCTION AND IS AUTHORIZED TO ISSUE A DIPLOMA IN UPHOLSTERY.

**MODERN UPHOLSTERY INSTITUTE
Box 899-CFD, Orange, Calif. 92669**

Name _____ Age _____
Address _____
City _____ State _____ Zip _____

A soft landing on Mars by an unmanned Viking spacecraft is planned for 1973, according to NASA. Upon arrival at Mars, the spacecraft will go into orbit to search for a good landing area. Following release of the landing module, the orbiter portion of the spacecraft will continue to gather scientific data. The Viking project will benefit from information gathered in the Mariner 6 and 7 Mars missions, and from the Mariner '71 orbiter flights currently being developed. The Langley Research Center, Hampton, Va., has management responsibility for Viking.

Do smart people live longer? They tend to, according to a 12-year study of 47 men at the Philadelphia Geriatric Center. Those still alive at the age of 80 have higher IQs than those who died, says the center's psychologist, Samuel Granick. The men showed no apparent differences in physical health when they were examined at the start of the study in 1956. Nutritional differences also were ruled out. Intelligence may be a factor in longevity, thinks Dr. Granick, because it may be related to the strength of the nervous system.

Construction of a 440-foot fully steerable radio telescope is called for in a report recently released by the National Science Foundation. Prepared by a special panel, the report warns that if the construction of the telescope and other modern instruments is not started immediately, the momentum of the U.S. effort in radio astronomy will be lost. This loss would affect the fields of chemistry and physics, too, because many discoveries in astronomy—the pulsars, for one—add to our understanding of the fundamental nature of matter. The panel notes that there has been no significant construction of major new radio telescopes in the United States in recent years, but that several large telescopes are being built in Great Britain, the Netherlands, West Germany and India.

A breakthrough in gumdrop and jelly-bean production is on the horizon as a result of the work of Prof. Thomas J. Schoch of New York's Cornell University. In the standard method, a starch-sugar syrup is cooked, injected into molds and stored at 95°F. for two days until it has jelled. Since fatty acids in the cornstarch slow the jelling process, Prof. Schoch has devised a way to remove them before the starch is mixed with the sugar syrup. Result: gum drops and jelly beans become firm within 30 minutes, ready for sugar-coating and packaging.

Mount Rainier is exhibiting signs of geologic restlessness. That report comes from U.S. Geological Survey scientists who cite as evidence a new warm spot on the summit cone of the 14,410-foot volcanic mountain. Detected by an infrared-sensing plane, the warm spot could indicate steam emissions, capable of melting glacier ice and causing the flashflooding of streams. "The current signs of increased restlessness do not necessarily mean that another eruption is likely to occur in the near future," says Dr. Dallas Peck, the Survey's assistant chief geologist, "but they do require close watching." Since the Ice Age, which ended about 10,000 years ago, Mount Rainier has had long quiet periods punctuated by brief episodes of activity. The last one—an eruption of clouds of ash—occurred about 75 years ago.

A chemical that makes male rats permanently sterile has been developed by the Upjohn Co., Kalamazoo, Mich. A member of a family of chemicals called the chlorohydrins, the drug causes lesions in the rat's reproductive tract, resulting in the blockage of sperm. But this doesn't affect the animal's health. He continues to compete for territory, food, social order and sexual partners. After mating with a sterile rat, females have false pregnancies, precluding for a while sexual activity with other males. Upjohn scientists say the drug, which can be mixed with food or dissolved in water, may have the potential of controlling rat populations the way sterilization of males has successfully limited the growth of screwworm fly populations.

★★★

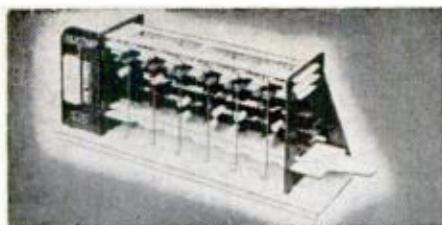

MODEL DIGITAL COMPUTER

Solve problems, teach logic, play games with miniature version of giant electronic brains! Adds, subtracts, multiplies, shifts, complements, carries, memorizes, counts, compares, sequences. Colored plastic parts easily assembled. 12" x 3 1/2" x 4 3/4". Incl. step-by-step assembly diagrams, 32-page instruction book covering operation, computer language (binary system) programming, problems and 15 experiments.

Stock No. 70,683H \$5.98 Ppd.
ANALOG COMPUTER KIT
 Stock No. 70,341H \$18.95 Ppd.



AMER. MADE OPAQUE PROJECTOR

Projects illustrations up to 3" x 3 1/2"—enlarges them to 35" x 30" if screen is 6 1/2 ft. from projector, larger if screen farther away. No film or negatives needed. Projects charts, diagrams, color, black-and-white. 115 V A.C. Operates on 60 W bulb, not incl. 12" x 8" x 4 1/2". 1 lb. 2 ozs.
 Stock No. 70,199H \$8.75 Ppd.



"FISH" WITH A MAGNET

Now go treasure hunting on the bottom! Great idea! Fascinating fun and sometimes tremendously profitable! Tie a line to our 5-lb. Magnet—drop it overboard in bay, river, lake or ocean. Troll it along the bottom—your "treasure" haul can be out-board motors, anchors, fishing tackle, all kinds of metal valuables. 5-lb. Magnet is war surplus—Alnico V Type—Gov't cost \$50. Lifts over 150 lbs. on land—much greater weights under water.

Stock No. 70,571H... 5 lb. .. \$14.00 Ppd.
 Stock No. 70,570H... 3 1/2 lb. .. \$ 8.75 Ppd.
 Stock No. 70,572H... 7 1/2 lb. .. \$18.75 Ppd.



FLY 9-FT. HOT AIR BALLOON

9 Ft. tall. Rises to amazing heights on just hot air. Tether attached, can be used repeatedly. Easy to make, launch, fly, loads of fun. Great for celebrations, science fairs, plain fun. Will lift model gliders, parachutes, instruments, etc.—anything up to 1/2 lb. Approx. 5 ft. diam. when fully inflated. Kit contains 10 pre-cut red & white gores (No. 1 model paper), 6 ft. 14-gage wire for bottom ring, top, "tie-off" cord, complete instructions.

Stock No. 60,691H..... \$2.00 Ppd.

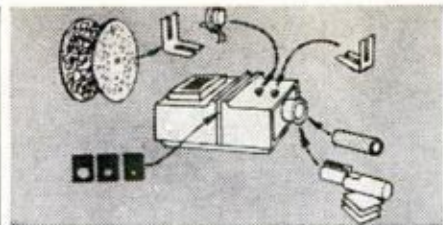

VISUAL EFFECTS PROJECTOR SET

Dazzling, avant-garde visual effects. Fantastic variety. Incredibly beautiful. Special package offer contains all necessary apparatus. Create floating, exploding, fiery bursts of color like "Symphony of Spheres," "Chromatic Starbursts," "Crystal Starburst." Features 35mm 500 W. fan cooled projector—produces big image at short distance. Accepts two 9" diam. wheels (Dry Kaleidoscope & Hexidoscope), 2 cylindrical accessories (6" Colored Cloud & 5" Hexidoscope w/six internal mirrored walls). Perfect for entertaining, parties, photography. Complete instructions.
 Stock No. 71, 212H \$79.50 Ppd.



**UNUSUAL GIFTS
FOR CHRISTMAS**

AMAZING BARGAINS

for Fun • Study • Profit
from
EDMUND SCIENTIFIC CO.
300 Edscorp Building
Barrington, N. J. 08007



DIAGNOSE MECHANICAL TROUBLE

Professional Stethoscope. Designed for use by physicians, this super-sensitive Stethoscope is ideally suited for detecting faults in machines and engines, and in fluid, air and gas leakage. Dozens of uses in auto repair shops, labs and for hobby and educational applications.

Stock No. 50,270H \$7.50 Ppd.
BARGAIN PRICE STETHOSCOPE
 Stock No. 50,223H \$3.25 Ppd.

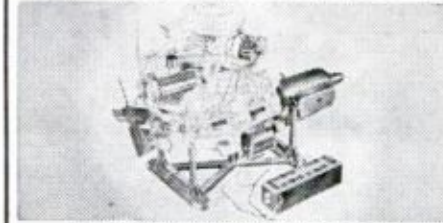

PLASTIC MODEL V-8 ENGINE

Hours of fun! Get thrill of building your own easily assembled engine from over 350 parts. Then push starter and watch it run. Crankshaft revolves, pistons move, valves open and close in sequence with spark plugs. Does everything but burn oil. 1/4 scale molded in 4 colors. Same motor used in many auto-mechanic courses. Excellent, easy-to-understand "tech manual".

Stock No. 70,448H \$12.95 Ppd.



3" ASTRONOMICAL TELESCOPE

See moon shots, orbits—stars, phases of Venus, planets close up. 60 to 180 power. Aluminized and overcoated 3" diameter f/10 primary mirror, ventilated cell. Equatorial mount with locks on both axes. Equipped with 60X eyepiece and mounted Barlow lens. 3X finder telescope, hardwood tripod. Included FREE: "STAR CHART"; 272-page "HANDBOOK OF HEAVENS"; "HOW TO USE YOUR TELESCOPE" book.
 Stock No. 85,050H \$29.95 Ppd.
 Stock No. 85,105H... 4 1/4" ... \$94.50 f.o.b.
 Stock No. 85,086H... 6" ... \$239.50 f.o.b.



GIANT WEATHER BALLOONS

"Balls of fun" for kids, traffic stoppers for stores, terrific for amateur meteorologists. Create a neighborhood sensation. Great backyard fun. Exciting beach attraction. Amateur meteorologists use to measure cloud heights, wind speed and temp. Heavy duty neoprene. Inflate with vacuum cleaner or auto air hose; or locally available helium for high rise.

Stock No. 60,568H... 8' \$2.00 Ppd.
 Stock No. 60,632H... 16' \$7.00 Ppd.



WOODEN SOLID PUZZLES

Here's a fascinating assortment of 12 different puzzles to provide hours of pleasure and stimulate ability to think and reason. Animals and geometric forms. Take them apart and reassemble them. Lots of fun for the whole family—young and old. Will test skill, patience and ability to solve problems. Order yours now.

Stock No. 70,205H \$5.00 Ppd.

MONEY-BACK GUARANTEE

Order by Stock No.—Send Check or M.O.

GIANT FREE CATALOG

148 Pages! More than 4,000

UNUSUAL BARGAINS

Completely new Catalog. Packed with huge selection of telescopes, microscopes, binoculars, magnifiers, prisms, photo components, parts, kits, accessories—many hard-to-get surplus bargains. 100's of charts, illustrations. For hobbyists, experimenters, schools, industry. Mail coupon for FREE Catalog "H".



EDMUND SCIENTIFIC CO., 300 Edscorp Building, Barrington, N. J. 08007.

NAME _____
 ADDRESS _____
 CITY _____
 STATE _____ ZIP _____

POPULAR MECHANICS

HOLIDAY SHOPPING GUIDE

AMERICA'S ORIGINAL LOW-COST ARC WELDER AND ELECTRIC TORCH

10 DAY
TRIAL

LIFETIME
GUARANTEE



MAIL THIS ORDER COUPON NOW!

Four-Way Welder Co., Dept. R2-N,
1810 S. Federal St., Chicago, 60616

Please send welder and 2 FREE gifts as indicated below.

- Wrench Kit. Wire Tool. Welding Rod Pack.
 Enclosed \$18.95. Ship Enclosed \$2.00. I will pay \$16.95
 postpaid in U.S.A. plus C.O.D. and delivery charges.

NAME _____

ADDRESS _____

CITY _____ STATE _____ ZIP _____

New Improved HEAVY DUTY FOUR-WAY

Only \$18.95 Prepaid Complete Ready To Use
 \$22.95 VALUE WITH 2 EXTRA FREE GIFTS
WELD, BRAZE, SOLDER, CUT

Every home, shop, and hobbyist needs this quality metal working machine. Use up to 1/8" welding rods and 1/4" carbons. Follow simple instructions to make or repair 1001 items including furniture, toys, auto bodies, fenders, trailers, boats, farm and garden tools and equipment. Operates on 110 V. 30A. for pennies—Adjustable Twin Carbon Arc Torch easily REGULATES HEAT FOR EACH JOB. Eliminates changing cables—replaces gas torches—no tanks or refills to buy—produces to 11,000° heat. YOU CAN PAY MORE BUT YOU CAN'T GET A BETTER LOW COST WELDER. Over 500,000 in use. Manufacturers of welders for over 30 years. LIFETIME GUARANTEE. Simply return prepaid. We will repair and reship FREE of charge. YOU GET: heavy duty welder in rugged metal cabinet, ground clamp, cables, combination torch and rod holder, welding manual and helmet, including \$2.00 pack "TOUCH WELD" rods for instant and automatic arc, brazing rods, 1/4" carbons, solder, flux. Complete ready to use. Nothing else to buy.

FREE

CHOICE OF 2 BONUS GIFTS
 WITH ORDER—\$4.00 VALUE

ORDER TODAY ON MONEY BACK TRIAL. If not completely satisfied, return in 10 days and we will refund purchase price.

1. 10-piece wrench, plier and screw driver kit in case.
 2. Wire forming tool. Forms wire to weld valuable items.
 3. Big pack welding & brazing rods, carbons, flux & solder.

SEND ONLY \$2.00 and pay \$16.95 plus C.O.D. and delivery charges. Or send only \$18.95 for postpaid shipment in Continental U.S.A.

FOUR-WAY WELDER CO.

1810 S. Federal St., Dept. R2-N, Chicago, 60616



HENLEY'S

20th Century Book of
 10,000 Recipes, Formulas & Processes

Here is a wealth of practical, accurate and clear information and instruction that can save you thousands, or make you a fortune! Housewives, manufacturers, farmers, handymen, home experimenters, electricians, chemists, people in every walk of life, refer to Henley's daily. In this gold-mine of a book, you too will find formulas and recipes for almost everything used in the

home, farm, workshop or industry. Discover the trade secrets of thousands of commercial products—learn new money-saving and exciting ways of doing things. As indispensable as a dictionary. Satisfaction guaranteed. 900 pages hard cover—cloth binding. Only 85.95 postpaid.

EMBASSY SALES, Dept. PM-8
 Box 67, East Elmhurst, N.Y. 11369



Lean 'way back, reach for those chromed riser handlebars, get that feel of being in command. That's the Minichopper! ■ Hot performance combined with a "far out" look. Chromed extended fork and riser handlebars, sissy bar, iridescent paint, big engine. ■ Send 25¢ for brochure or \$1 (refundable) for packet on entire line. Dept. P119 1775 South First Street, San Jose, California 95112.

SCOUT

Div. of Bonanza Inds.

PER-FEC DRILL SHARP-NER

GUARANTEED TO BE THE
 FASTEST & EASIEST DRILL
 SHARPENER IN THE
 MARKET. POSITIVE
 RESULTS



SIMPLE &
 EASY TO USE

ORDER NOW \$

4.95
 PPD

GRINDING WHEEL NOT INCLUDED. DEALERS WANTED

◆◆ T. W. SIMPKINS CO. ◆◆
 4510-B MONTANA / EL PASO, TEXAS 79903



THESE 3 BIG DRAFTING KITS* GIVEN TO YOU!

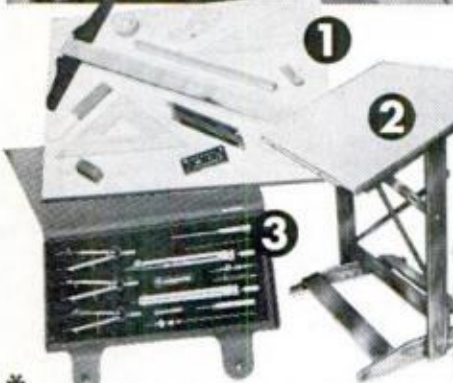

* Precision Drawing Instrument Set, Professional Drafting Board Outfit and Fingertip Tilting Drafting Table are given to you with your complete North American Course in Drafting.

U. S. LABOR DEPT. REPORTS SERIOUS SHORTAGE OF DRAFTSMEN

(The following quotes from U. S. Labor Dept. point out nationwide shortage for Draftsmen.)

"The dearth of qualified applicants has resulted in increasing calls for trainees, as employers in many areas relaxed hiring specifications. Experience requirements have been virtually eliminated, along with age barriers."

"Steadily growing employer requirements... were accompanied by marked reductions in the supply of draftsmen available."

TOP AMERICAN EMPLOYERS WELCOME NASD GRADUATES

"We would be interested in interviewing your grads as potential employees." **REMINGTON**

"At the present time we have several openings available for qualified Draftsmen. I look forward to considering graduates of your institution." **WESTINGHOUSE**

"We have immediate openings for designers and Draftsmen and have a definite interest in interviewing candidates immediately." **AMERICAN MACHINE & FOUNDRY**

...when you train at home with NASD for a HIGH PAY JOB IN DRAFTING!

Coast-to-Coast Shortage of Trained Draftsmen Opens Thousands Big Salary Jobs for Beginners!

Now you can take your pick of thousands of big salary jobs open to Draftsmen (see "help wanted" sections of metropolitan newspapers). Huge nationwide demand... U.S. Dept. of Labor reports "42% more Draftsmen needed in next 10 years—not enough applicants to fill drafting jobs available now!" Our easy "Quick-Learn" Method has helped hundreds toward good income, security and prestige as Draftsmen. Why not you?

You Need No Drawing Skill—No Technical Ability

NASD's staff of Professional Draftsmen guide you step-by-step. With our spare time home-study plan you work on actual projects. Makes learning fun—easy to remember, too. Many graduates have succeeded with only grade school training. Others report good earnings drafting part time while still learning. Rush coupon today sure... get **FREE "DRAFTING CAREER KIT," Sample Lesson, Drafting Aptitude Test** including intriguing new **5-Way Drafting Instrument** and **20 page Book "Your Future in Drafting"**—jam-packed with revealing facts on your opportunity to win top pay and job security in Drafting. Everything mailed to you **FREE** and **WITHOUT OBLIGATION**. No salesman will call.

Take Your Pick of 2 EXCITING FIELDS

1 Architectural Drafting

Today's population explosion guarantees boom in building of homes, churches, schools, factories, office buildings & warehouses is just starting. Thousands Architectural Draftsmen needed NOW because drawings must be made of every part of every building before ground can be broken.

2 Mechanical Drafting

Skyrocketing U.S. mass production requires millions of drawings & thousands of Mechanical Draftsmen all along the way. Drawings must be made of every PART of every product used in the U.S. (as well as of the machines that make these parts) before production can be started.

(3) High School Draftsmen
\$80-\$120 FREE NO EXPERIENCE

NO EXPERIENCE REQUIRED!

Trainers who satisfactorily pass a basic quiz and accept employment will receive **100% FULL SALARY UPON AUTOMATIC SALARY ADJUSTMENTS** UP TO 41% EMPLOYEE BENEFITS. Let immediately to arrange interview appointment.

JOE PASCHORZ
3014712

THE FLUOR
Corporation, Ltd.
INTERNATIONAL
ENGINEERING CONSTRUCTORS
2100 S. Atlantic Blvd.
Los Angeles, Calif. 90022

Design Draftsmen
Require experience in design and drafting of small mechanical devices.

CALL OR APPLY
ADOLPH-GENTRAL CORP.
11711 Woodhull Ave.
DRAFTSMAN
Architectural
WESTERN GEAR

HERE'S WHAT STUDENTS SAY

Earns \$820 Month!
"My first position after completing your course jumped my income from \$350 to \$820 per month."
—G. W., Tenn.

Big Promotion!
"I was promoted from the production line ahead of 4 others and got a good pay raise."
—W. A., Wisc.

Gets 50% Raise!
"Shortly after I completed your course I was made shop foreman. My pay was increased by half."
—W. R., New York

No Layoffs!
"Strikes and layoffs are nightmares of the past. Your training has opened the door to a wonderful future for me."
—H. O., Ohio

Authorized to issue diplomas by California Superintendent of Public Instruction.
Accredited Member, National Home Study Council.

APPROVED FOR VETERANS

Veterans, Servicemen you may be eligible for Gov't education benefits. A home-study program in association with Cleveland Engineering Institute.

ALL 4 FREE!
Rush Coupon Today!

Your FUTURE in DRAFTING

APTITUDE TEST

SAMPLE LESSON

- 5-Way Drafting Instrument—yours to keep as a FREE GIFT without obligation.
- 20-Pg. Drafting Career Fact Book — packed with details about career opportunities.
- Self-Scoring Drafting Aptitude Test — tells if you are suited for high-pay Drafting Career.
- Sample Lesson — a "sneak preview" of things to come.

NORTH AMERICAN SCHOOL OF DRAFTING, Dept. 417C
4500 Campus Dr., University Plaza, Newport, Calif. 92660

Rush "DRAFTING CAREER KIT" including Book, Sample Lesson, Aptitude Test & Drafting Instrument — ALL FREE! No salesman will call.

NAME _____ AGE _____

ADDRESS _____

CITY _____ STATE _____ ZIP _____

NORTH AMERICAN SCHOOL OF DRAFTING
4500 Campus Dr., Dept. 417C University Plaza, Newport, Calif. 92660

TWO FREE GIFTS

reserved for PUZZLE LOVERS only



If you are over 18 and have the kind of lively mind that loves to solve puzzles, mail this entire ad to us today and we'll send you a new ballpoint pen plus a big copy of our *Puzzle Lovers Newspaper*, both FREE to new inquirers. You'll discover how to cash in on the thousands of dollars awarded every month to our members. They compete for our cash prizes by solving puzzles in the quiet of their own homes. There is no obligation. Send this ad only if you believe you have the talent to solve puzzles and win cash prizes.

PUZZLE LOVERS

Box 2, Prince Street Station, New York City, N.Y. 10012

NAME _____

ADDRESS _____

CITY _____ STATE _____ ZIP _____

OFFER EXPIRES DECEMBER 31, 1969 • MAIL TODAY



FREE!!! POWERFUL MUSCLES FAST!
 Fantastic New Discoveries in the science of bodybuilding. Now, in the privacy of your bedroom, our method will add inches of powerful muscles to arms, chest, shoulders & legs. Learn secrets on trimming the waist with ultra-modern methods—fast! Results Guaranteed! Send for free brochure, Universal Bodybuilding, Box 485-MI, Dearborn, Mich. 48121.

Lift off to a new world of discovery

ESTES ROCKETS

LEARN SPACE AGE PRINCIPLES
 44 challenging space science kits to build and fly. Launch electrically. Easy to build starter kits . . . to scale models of the mighty Saturn V, shown left. All good for many flights, and packed with space age excitement for all the family. Ideal father-son activity.

SAFE EDUCATIONAL GIFT TO GUIDE EXPLORING YOUNG MINDS
SPECIAL STARTER OFFERS

DSK 20 - Includes Alpha rocket, 2 engines, instructions, design manual \$2.00

DSK-70 - Above, plus electric launcher w/batteries \$7.00

128 page color catalog . . 25¢ (free with kit order)

ESTES INDUSTRIES, Dept. 15
 Penrose, Colo. 81240

TRUE SCALE only \$9.95

100 STYLES FOR
WIDE FEET
 and HIGH INSTEPS
 EE to EEEEE Only
 Sizes 5 to 13

Men only Casual, dress, work shoes that really fit. Top quality, popular prices. Money-back guarantee.

Not sold in stores

Write Today for FREE CATALOG
 HITCHCOCK SHOES, INC.
 Hingham 28-K, Mass. 02043

SOMETHING OLD & SOMETHING NEW



SOMETHING ELSE!

Good luck for the Bride is a "shoe-in" when she wears a genuine British silver sixpence in her shoe. Give her a keepsake to cherish forever . . . a rolled-out sixpence engraved with the old adage . . . "something old, something new, something borrowed, something blue and a lucky sixpence in her shoe!"

ATTRACTIVELY GIFT BOXED
 ONLY \$2.75 POSTPAID
 Send check or money order to
NOVELTY COINS
 Dept. #P • P. O. Box 111
 Painesville, Ohio 44077

EARN A STEADY INCOME SHARPEN CIRCULAR SAWS



Professional circular saw sharpener sharpens saws 5" to 60", rip, cross-cut, combination, dado. Easy to operate—accurate—fast—safe. Bevels 45°, joints, gums. You can profit from this machine.

Thousands of Circular saws need sharpening every month.

Write for details

BURR MANUFACTURING CO.
 8933 W. VENICE BLVD.
 LOS ANGELES, CALIF. 90034

Cat stamps

Set of 8 for only 10¢ while the supply lasts



Cats? You bet. And they make some pretty wild looking stamps for your collection, with their big wide eyes and bright feline colors. From Rumania and Poland. All 8 are yours for only 10¢. Because we want to introduce you to the attractive offerings of our unique "Stamps on Approval" Service. Buy any or none. Cancel service any time. We will also include a catalog. Send 10¢, name, address to:
Littleton Stamp & Coin Co., Inc.
 Dept. CS-15, Littleton, N.H. 03561

WHAM-O \$150

HITS LIKE A RIFLE — KILLS RABBITS, SQUIRRELS
 Powerful, silent, accurate. For hunting, target, routing pests.
 Sportsman's choice sold world over!

NEW! surgical quality pure gum rubber
 40 heavy extra steel balls 20¢

HUNTING SLINGSHOT
 Heavy duty 7" ash stock.
 40 heavy steel balls, extra rubber, adapter for shooting arrows.
 GUARANTEED Professional model of Nat'l Slingshot Assn. At dealers, or write
WHAM-O MFG. CO., P.O. Box W-15 San Gabriel, Calif. 91778

GYROCOPTER

Spectacular rotating high flying kite having aero-dynamic airfoil that is gyroscopically stabilized (will not dive). Great kite flying sport for young and adults—either for fun or profit. Ideal for eye-catching advertising, etc. Ready to fly in seconds, or disassembles for easy storage. Made of light, durable styrofoam with a printed spiral. ONLY \$1 plus 25¢ for postage & handling. Dealer inquiries invited. Order yours TODAY from **S. P. PRODUCTS CO., Box 14011, Dept. PM120, San Diego, Calif. 92114**

WHEN ANSWERING ADS GIVE YOUR ZIP CODE

POPULAR MECHANICS

TOM McCAHILL SAYS:

"There's COLD CASH In Repairing These Things!"



Each time a buddy of mine moans about the lousy repair job he got on his refrigerator or toaster or washing machine, I'm reminded of the fact that a good Appliance repairman is a mighty rare breed these days.

This neighbor of mine had refrigerator trouble just last month, and needed some speedy repair service. After phoning half a dozen repairmen who were booked solid for days, he finally had to settle for a bum job from a guy who had no business calling himself an Appliance repairman. This brings me to an important point. No one who wants to earn money in Appliance repair needs to learn by trial and error. There's a great, low-cost home study plan on the market that covers every type of Appliance repair in detail. The course was prepared by the Appliance Division of the National Radio Institute, one of the biggest and best schools in the field. Thousands of guys like yourself have studied with NRI, and many of them have more than paid for the low tuition fee within their first couple months servicing Electric Appliances.

If you want to make money (and who doesn't) in a field that's crying for good talent, make certain you send for a free NRI catalog. Get the details on the well-illustrated lessons that teach you how to repair home, farm and commercial Appliances, and small gasoline engines. You'll be amazed at how little the training costs. And you'll even get a professional Appliance Tester without extra cost.

NRI has been in the home study field since 1914, and they have a staff of 150 experts in Washington, D.C., who guide you through the course with more personal attention than you'd find in some classrooms. If you're really out to learn, they can furnish a

special course in air-conditioning and refrigeration repair, too.

Even if you've never tried to put a toaster in working order, even if your schooling never went beyond the tenth grade, I'm as certain as my name is McCahill that you can make money in the Appliance repair field with the help of this NRI course.

Do yourself a favor right now. Send off the coupon below and NRI will send you a free catalog. If you don't like the looks of this material, you can forget the entire deal, and you'll be out only one postage stamp. But remember, the Appliance repair field needs qualified men *now*. And you can qualify with NRI training.

Tom McCahill

P. S. NRI won't send a representative to call on you. They've never needed any with this great course!

APPLIANCE DIVISION, NATIONAL RADIO INSTITUTE
3939 Wisconsin Avenue, Washington, D. C. 20016

AVAILABLE UNDER NEW GI BILL.
If you served since January 31, 1955
or are in service, check GI line below.

600-129

OK—I want to see for myself. Send me the free book on Professional Appliance Servicing. No salesman will call.

Name _____ Age _____

Address _____

City _____ State _____ Zip Code _____

Accredited Member National Home Study Council.

Check for facts on new GI Bill.

Trail and Snow



the **Big Wheel** outdoors is the **Heathkit® "Boonie-Bike"** Only \$214.95 — **Free Ski Included**

- Rugged, versatile transportation • 5 HP, 4 cycle Briggs & Stratton engine • 2 speed chain drive transmission • Giant 18 x 8.50 x 8 rear tire for amazing traction • Hand operated Bendix rear brake • Strong tubular steel frame with spring front suspension • Accessory Horn & Lights and Spark Arresting Muffler also available • Free ski offer good to December 31, 1969 • Heath Company, Dept. 17-69, Benton Harbor, Mich. 49022



COMPLETE SPECIAL INVESTIGATOR KIT
★ BADGE ★ CARRYING CASE \$275
★ SPECIAL I. D. CARD ONLY
First time ever offered! Professional type detective badge kit and case. Includes professionally styled silver badge of extra heavy nickel for use by private and special investigators PLUS authentic type carrying case AND I. D. Card. Limited Supply. Order Now. Satisfaction Guaranteed or immed. refund. Only \$2.75 plus 25¢ to cover post. & handling. **WESTBURY SALES CO., D. D. Dept. SK-5-C** P. O. Box 434, Westbury, N. Y. 11590

WESTERN HAIG

.12 CALIBER
SPECIAL FACTORY
OFFER!



\$300
post-paid

USES POWDER CHARGE

This small bore gun shoots .12 cal. steel bullets fired by small 4.4 mg. powder charge. Not a CO₂ gun. You'll like the handsome lines, grip, and balance. Western in style, but patented ball and cap action allows this low price. 9 3/4" steel barrel cased in knurled styrene stock, overall 13 1/2". Develop pistol form, accuracy at a fraction of cost of large cal. pistols. Comes with 50 steel bullets. Satisfaction guaranteed. Send \$3.00 to: **HAIG MFG. CO., P.O. Box 8-26 Alhambra, Calif. 91802**

**LESS THAN 15¢ PER OIL
FILTER CHANGE WITH
AMAZING**

STILKO



ETERNAL OIL CLEANER

Full-flow oil filtering system uses the best-known filtering material available anywhere—toilet tissue—already proven in thousands of automobiles. Recommended for all types of cars and trucks. Keeps oil cleaner sludge-free and carbon-free. No costly installation or maintenance—simply spins on in place of regular throw-away filter! Each filter change costs less than 15¢ and oil lasts longer (some users report never changing oil). Fully guaranteed. Send check or MO for \$24.95. Or send \$5.00 and pay balance COD. Include Make, Model & Year of car, engine type and no. of cylinders.

DEALER INQUIRIES INVITED
STILKO ETERNAL OIL CLEANER
7445 Convoy Court
San Diego, Calif. 92111

HANDBOOK OF

Knots & Splices

By Charles E. Gibson . . . Now tie knots for every purpose—useful, ornamental, fun-to-make! Book gives complete "1-2-3" sketches and instructions for every hitch, splice, bend, lashing, sling on whipping you'll ever need for boating, camping, climbing, fishing, hunting . . . for patio awnings, swings, hammocks, rope fences, "welcome" mats . . . ornamental lamps, vases, bell ropes, key chains, buggy whips, cat-o-nine tails, rope handcuffs, play quoits, etc. They're all here . . . over 100 kinds of knots and ropework! From the simple square knot to such fancy numbers as the Manrope, Stopper, Shroud, Crown, Turk's Head and Pineapple knots. Also covers plaiting, braiding, much more. "Highly recommended." *Library Journal*. Profusely Illustrated. **ORDER NOW!** \$4.95 Postpaid • 10-Day Money-Back Guar.



EMERSON BOOKS, Inc., Dept. 398-S
251 W. 19th Street, New York, N.Y. 10011

CUT METAL FINISHING COST

WITH **Schaffner's**
COMPLETE METAL FINISHING



STARTER KIT #10

SCHAFFNER'S COMPLETE METAL FINISHING STARTER KIT enables you to experiment at your shop or home with various grits and sizes with both flapwheels and buffs—including our own compound for perfect finishing on flat, curved or irregular surfaces. WOOD, PLASTIC, METAL—GRIND, ING, BLENDING, POLISHING, SATIN FINISHING—ALL IN ONE OUTFIT!

Schaffner Manufacturing Co., Schaffner Center, Dept. P-12, Pittsburgh, Pa. 15202
STARTER KIT-10 includes 3 assorted flapwheels, 2 satin finishing wheels, 2 buffing wheels & 4 bars of buffing compound.
LIST VALUE . . . \$32.36
INTRODUCTORY PRICE . . . \$20.25
ENTER my order for Starter Kit #10
(attach this coupon to your purchase order)
Ship Schaffner's new, illustrated data & metal finishing manual FREE WITH MY ORDER
Name of my coated Abrasive Distributor _____

REVOLUTIONARY NEW ANTI-FREEZE TESTER

Fast! Accurate! Easy to Use!
Stores in Your Glove
Compartment!

NOW you can check the experts. SIMPLY insert tester into car radiator; draw up enough fluid to fill tester 3/4 full, COUNT the number of floating BALLS and a quick glance at the self-storing package tells the story.



JUST \$1.89 ppd

Send check or money order, No COD's.

Harvey-Westbury Corp.

P.O. Box 484 Dept. 2-B
Westbury, N.Y. 11590

SAVE! INSTALL IT YOURSELF



Remote control
Garage Door Opener
ONLY \$99.50

Easy to install. Garage door opener with solid state transmitter and receiver. Built by Crane, manufacturers of quality door operators for over half a century. Guaranteed for one year. Save by buying direct and installing yourself (selling nationally for \$165.00 installed). F.O.B. Factory. Send check or money order. Deposit of \$10.00 required on COD orders. Ill. residents add 5% sales tax.

Additional transmitters \$18.00 ea.
F & A SALES 9810 W. Lawrence Ave.
Schiller Park, Ill. 60176

S



MINTS

Now near impossible to find in circulation. We offer popular packets with "S" on coins. 22 different "S" cents including rare 1955s, \$1.60. 10 different "S" Jefferson nickels, \$1.60. 10 diff. "S" Roosevelt dimes (1946S-1955S comp.), \$3.25. 26 diff. 1¢ before 1940 (P1-D-S) + 1960D sm. date, \$1.60. 30 diff. Unc. (new) coins—30 diff. countries, \$1.95. Buy 4 or more packets, we'll toss in a scarce old Indian-head cent! Wholesale price list (has startling silver info.) included with order, otherwise 25¢.

ROBT. HARRIS, 2373P Pruneridge,
Santa Clara, Calif. 95050

It only tastes expensive

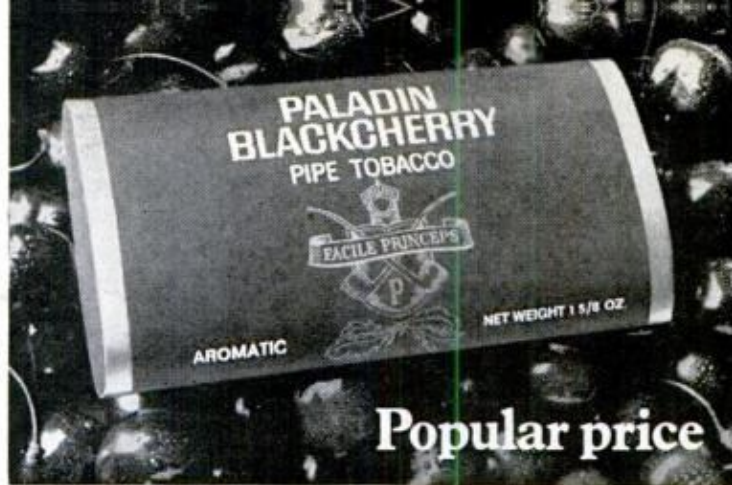

Popular price

ENJOY YOUR OWN BUSINESS

Start earning at once—No special experience required

A SHOP
IN ITSELF
AUTOMATIC
FOOLPROOF

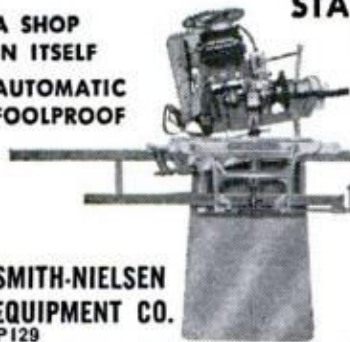

SMITH-NIELSEN
EQUIPMENT CO.
P129

Mfg. of Saw Grinders—Distributor of Complete Saw Shop Equip.
Box 2505 Terminal Annex, Spokane, Washington 99220 FA 8-6680

STAND-ALL Model 7

Sharpens & Retoots Hand Saws 3 point through 16 point. SHARPENS—BAND SAWS—HACK SAWS—WOOD AND METAL CUTTING SAWS with straight back and identical tooth profile.

CROWNS—adjusts to any standard crown.

HOOKS—5° to 21°

BEVELS—0° to 30°

ARROW
All-Purpose
STAPLE GUN
T-50

SHOOTS A STAPLE

Uses 6 Staple Sizes 1/4" to 9/16" including Ceiltile.

WHEREVER YOU'D DRIVE A NAIL!

At Hardware, Lumber & Building Supply, Stationery, Variety and other retail outlets.

ARROW FASTENER COMPANY, INC.
271 Mayhill Street, Saddle Brook, N. J. 07663



"I Earn Two Incomes Now"

Says JOHN BENNIE, Pittsburgh, Pennsylvania

"Thanks to your wonderful training, I have been able to earn \$20 to \$25 extra each and every week doing little locksmith jobs at home and after work at my regular job. This is the best trade a man can take up."

Be a LOCKSMITH

Train at HOME—Earn While You Learn. Add 50%-100% to YOUR INCOME with easy spare time earnings. Cash in on the nation-wide shortage—trained locksmiths in great demand! Quickly step into a big pay opportunity job or start a high-profit shop of your own.

Earn Extra Money RIGHT AWAY! All Master Locksmiths Special Tools, Equipment and Supplies Furnished FREE for use with course.

Age, education, minor physical handicaps don't matter in this growing trade. You can quickly qualify as a skilled locksmith. It's like a fascinating hobby. Study at home as little as one hour a week. Gain practical experience through complete well-illustrated lessons. Do real jobs on car locks, house locks, padlocks and safe locks, under the guidance of experts. FREE Illustrated Book, write now.

LOCKSMITHING INSTITUTE,

(Div. of Singer Communications Corp.)

Dept. 1110-129 • Little Falls, New Jersey 07424

MAIL
COUPON
for FREE
ILLUSTRATED
BOOK

For a future as your own boss or in a high-pay job, write now for FREE Illustrated Book. Only school of its kind. Licensed by State of New Jersey. Approved for Veterans.

306
pieces of professional equipment
FREE
for use with course.

Professional Equipment includes
**LOCKS—PICKS—PARTS—KEYS
SPECIAL TOOLS & SUPPLIES**
all FREE for use with course.

Accredited, Nat'l Home Study Council.

MAIL COUPON NOW

**LOCKSMITHING INSTITUTE, Dept. 1110-129
Little Falls, New Jersey 07424**

Please send FREE Illustrated Book—"Your Big Opportunities in Locksmithing," complete Equipment folder and sample lesson pages—FREE of all obligation—(no salesman will call).

Name _____

Address _____

City _____ State _____ Zip _____



Stamp Your Name PERMANENTLY



\$4.50
ppd.

EVERSTAMP

DIE TOOL

Hardened tool steel. Lasts a lifetime. Comparable to a \$10 die tool, still available at this special price. Stamps almost anything you own with a single blow. Made only by the Henry A. Evers Co., Inc., makers of quality marking devices since 1898.

HENRY A. EVERS CO., INC.

Dept. PM, 72 Oxford St., Prov., R. I. 02905

Enclosed is payment for die tool:

Reg. size 1/16". 15 letters max.
@ \$4.50 ppd.

Large size 3/32". 10 letters max.
@ \$5.75 ppd.

NAME.....

Please Print

STREET.....

CITY..... STATE..... ZIP.....

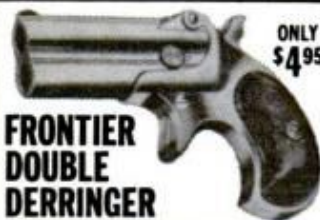

ONLY
\$4.95

FRONTIER DOUBLE DERRINGER

SOLID METAL NOT A PLASTIC IMITATION
• EUROPEAN MADE

• FIRES POWERFUL 22 CAL. CRIMPED BLANKS

Looks and feels like the original Remington Derringer
—The Hide-Out Gun of Wild Bill Hickock.

Now this beauty can be yours at this amazing low price. Positive reliable European Made—it fires two quick shots from its double barrels. Perfect for dog training, stage use, sporting events, personal defense. No bulky cylinder, it lays flat in the pocket ready for instant action. Purchaser must be over 21. Just send \$4.95 plus 30 cents postage and handling. State age when ordering. Not sold in New York City or California. Money back guarantee if not satisfied.

WESTBURY SALES CO., DEPT. DR-53-D
P.O. BOX 434, WESTBURY, N.Y. 11590

**THIS
IS
IT!**



Popular Mechanics said in July, 1969 (p. 166):

**"Handiest Tool
You Can Have
in Your Shop"**

It sands, grinds, polishes, sharpens. It's portable. Take it on the job. Use with any 1/4 hp motor. Model 165. Factory direct special.

\$19.95 less motor

ARCO MFG. CO.

P.O. Box 817, Grand Forks, N. Dak. 58201

Write to POPULAR MECHANICS and request their FREE 32 page catalog. Include 25¢ for postage and handling.

"\$7,108.50 First Year

WITH INLAND
3-IN-1
RADIATOR
SHOP"

NEW!



—John Burns, Sr.,
Fredericksburg, Va.

Inland shop owners make good money testing, cleaning, repairing auto-truck-tractor radiators. You can too! Compact shop only 11"7"x16". Inland, world's largest radiator equip. mfr., trails you free in 2 weeks or less. Pay-As-You-Profit purchase plan. Proved merchandising assures volume. Write for FREE BOOK, owner letters, details on program. Profitable dept. for garage or gas station.

INLAND MFG. CO., Dept. PM12
1108 Jackson, Omaha, Neb., 68102

NEW Fantastic Swiss Measuring Tool



CALIPER

MODEL 60P

3 vernier scales.001"-1/10 mm 1/128" on each caliper. Depth and step, inside & outside measuring ability - parallax-free, unbreakable Cyclocac® precision construction.

ONLY **2.89** + 25¢ POSTAGE 3 for \$ 8.50
12 for \$33.00 p.p.

Send 25¢ for Money Saving Catalog of hundreds of tools

SCHLESINGERS FOR TOOLS LTD.

1020 East 54th Street, Brooklyn, N.Y.
TEL.: (212) 241-7482



FREE MUSCLE COURSE!

Want a new Jet-Charged body? In 15 minutes I'll prove you can slap on 4" of muscles to your chest—3" to each arm—give you life-guard shoulders, trim your waist to athletic size—give you speedy athletic legs. I don't care if you're short or tall (skinny or fat) young or not so young, expect a muscle building miracle when you send for my free course. Send only 25¢ to cover postage and handling to Joe Weider, Dept. 38-129D2, 531 32nd St., Union City, N.J.

**When you see
this mark**



**you've seen
the product in
Popular
Mechanics**

FIRST STRUCK IN 13 YEARS



FIRST COINS MINTED SINCE 1955 at fabulous SAN FRANCISCO mint. Collectors prized set of 10 bright uncirculated coins as illust. 3.95 - 25¢ p.p. FREE \$1 luxurious velvet lined presentation case embossed in 24 KT. gold. SAVE 10 double sets 37.50 - \$1 p.p. 20 sets \$70 p.p. 50 sets \$165 p.p. COLLECTORS SPECIAL—Last silver coins minted. Five coins bright uncirculated 1964 sets from Phila. or Denver mint. Cent to scarce J.F.K. all silver 1/2 dollar 2.95 - 25¢ p.p. FREE 50¢ gift case. Double set both mints 10 coins 5.50 - 25¢ p.p. FREE \$1 presentation case. SAVE—10 double sets \$49.50 p.p. Twenty sets \$95 p.p. 50 sets \$225 p.p. Money back guarantee. Write for FREE catalog. Member Retail Coin Dealers Assn.—Amer. Numis. Assn. Est. 1947. Novel Numismatics Dept. A5031-2nd Ave., N.Y.C., N.Y. 10003

"FLIP"



YOU FOR IT"

**You Can't Lose With This
Two-Headed Magic Coin!**

This half dollar looks real because it is real . . . except for the fact that it's the same on both sides. Made from two actual coins. . . it defies detection. Great lucky piece and conversation piece. Order either "Heads" or "Tails" and you're headed for fun.

ONLY **\$3.95** POSTPAID
Send check or money order to

NOVELTY COINS
Dept. #P • P. O. Box 111
Painesville, Ohio 44077

**AMERICA'S NO. 1
CLASSIFIED SECTION
CAN BE FOUND
ON PAGE 47
IN THIS ISSUE**



Bartlett Flying Saucer ultra-light hovercraft powered by ordinary lawn mower engine—easy to build—fun to fly—complete plans, kit brochure, photos and supply sources \$4.00. All orders returned via airmail. Write:

HERB BARTLETT
Box 3234-M, Scottsdale, Arizona 85257

Here's what
VON SCHRADER
 has to offer YOU...

if you would like to go into
 a profitable business
 of your own (full or part-time)

1 • **VON SCHRADER** offers you these 3 money-making businesses: **RUG CLEANING, UPHOLSTERY CLEANING, WALL WASHING.**

2 • **ALL DETERGERS** are reasonably priced. Many **VON SCHRADER** Associates make more than the price they paid in the first month and from the original supplies that come with the Deterger.

3 • **SOME VON SCHRADER** Associates start spare-time . . . and later on change to full time.

4 • **NO SHOP** is needed . . . all work is done in customers' homes or on their premises.

5 • **NO COSTLY OVERHEAD** . . . you work from your own home and hire helpers only when your business justifies.

6 • **YOU ALWAYS OWN** your Detergers . . . no one can ever take them from you.

7 • **ALL THE MONEY** you take in is yours alone . . . you never pay any fees, or dues, or royalties to anyone; you are truly **YOUR OWN** boss in **YOUR OWN** business.

8 • **YOU WORK WHEN** and where you care to . . . you have no quotas to meet, no extensive forms to keep, no reports to make.

9 • **FULL OPERATING INSTRUCTIONS** come with the detergers. They are easy to read and to follow; anyone can operate; you need no special skill or training.

10 • **VON SCHRADER BUSINESS MANUAL** is complete; it tells everything you need know to make a success out of your venture, including how to go about getting business, suggested sales letters, who to call on, tips on keeping your books and tax records, suggested telephone book and newspaper advertisements, radio announcements, etc. Handout literature is also included.

11 • **VON SCHRADER** cooperation and assistance is always at your service. We continue to help you solve unusual problems regardless of nature. Training and consulting with experts is also available at no extra cost.

12 • **VON SCHRADER** perfected the first **RUG DETERGER** and we are by far the oldest and largest company manufacturing machines of this type.

VON SCHRADER MFG. CO.



• Read below what a few of our many Associates have to say about the success of **VON SCHRADER'S FREE ENTERPRISE PLAN.** Then return the coupon or write **TODAY.** It costs nothing to get the details.

HOMER KENDALL, Indiana • "Your business helps and training are really wonderful. How could anyone fail?"

LESTER VERNON, Wisconsin • "Have had my Rug Deterger almost two weeks, have earned 2/3 its cost already."

J. M. ROGERS, Pennsylvania • "Worked 7 hours yesterday, earned \$85.56. Part-time last week netted \$103.70."

ROY NELSON, No. Carolina • "I am doing real well with the Upholstery Deterger. I grossed \$204 in four days last week and have plenty more work. Everyone is very well satisfied."

BOB GREENBERG, California • "First month I made over \$800; now 80% to 90% are old customers."

EMMET FREMONT, Colorado • "It's amazing what the Wall Deterger will do. I'm more than satisfied."

SEND FOR THE FACTS TODAY

VON SCHRADER MFG. CO.
 DW10"A" Place, Racine, Wis. 53403
 Please rush information about your

DETERGER(S)

(Write in name of detergent(s))

and how I can start my own profitable business.

Name _____

Address _____

City _____ State _____ Zip _____

Drivin' with Dan

Will McLaren-car domination hurt Can-Am? If better, why are disc brakes used only on front wheels? Are dune buggies practical for use on the street? Dan Gurney answers these and other automotive questions

Q. Do you feel the McLaren domination of the Can-Am series the last two years has hurt this type of racing?—Dottie Dickenson, Irvine, Calif.

A. Frankly, no. For the same reason I don't think the New York Yankees' domination in baseball, or the Boston Celtics' domination in basketball hurt those sports. On the contrary, I believe it has a lot of pull for Can-Am racing and that people are keenly interested to see who will be the one to finally knock them off. I'm sort of interested to find out myself.

Q. Why are six-cylinder engines always "economy" engines? Can't Detroit make them perform like V8s?—Ben Abernathy, Lakeland, Fla.

A. Apparently the V8 is a more compact (lighter) package. The crank is lighter and stronger in proportion to a six. The V8 seems to be a better compromise. Of course, a Six is less expensive to build. There are always exceptions. LeMans and Indy have been won by Sixes. Some great Honda G.P. motorcycles were six-cylinder jobs.

Q. If disc brakes are better, why do cars just have

them on the front wheels, with drums on the back?—Fred Little, Dover, Del.

A. I'm not sure, but I've been told that it involves the difficulty of designing and building an inexpensive parking brake utilizing a disc in the rear. Most racers use them all the way around. It is interesting that Nascar Grand National stock cars have not changed over to them yet. Apparently the available drums are superior in that particular case.

Q. What have you done with your Formula 1 Eagle in which you won the Belgian Grand Prix in 1967?—R. C. Reece, Philadelphia, Pa.

A. She sits in a special place of honor in Briggs Cunningham's Auto Museum in Costa Mesa, Calif. The curators of this outstanding museum maintain her in tip-top, ready-to-battle condition, and every once in a while she is rolled out to grace a press conference or a special automotive show. She is still very beautiful, and looks as though she could sit on the pole today without many changes.

Q. Are dune buggies practical for street use or (Please turn to page 36A)



OUR DAN in his "McLeagle" (McLaren/Eagle) Can-Am car, powered by a 427-CID Chevy engine. The switch marks first time in seven years of much varied competition Dan has used anything but Fords

The blade turns but the saw doesn't.

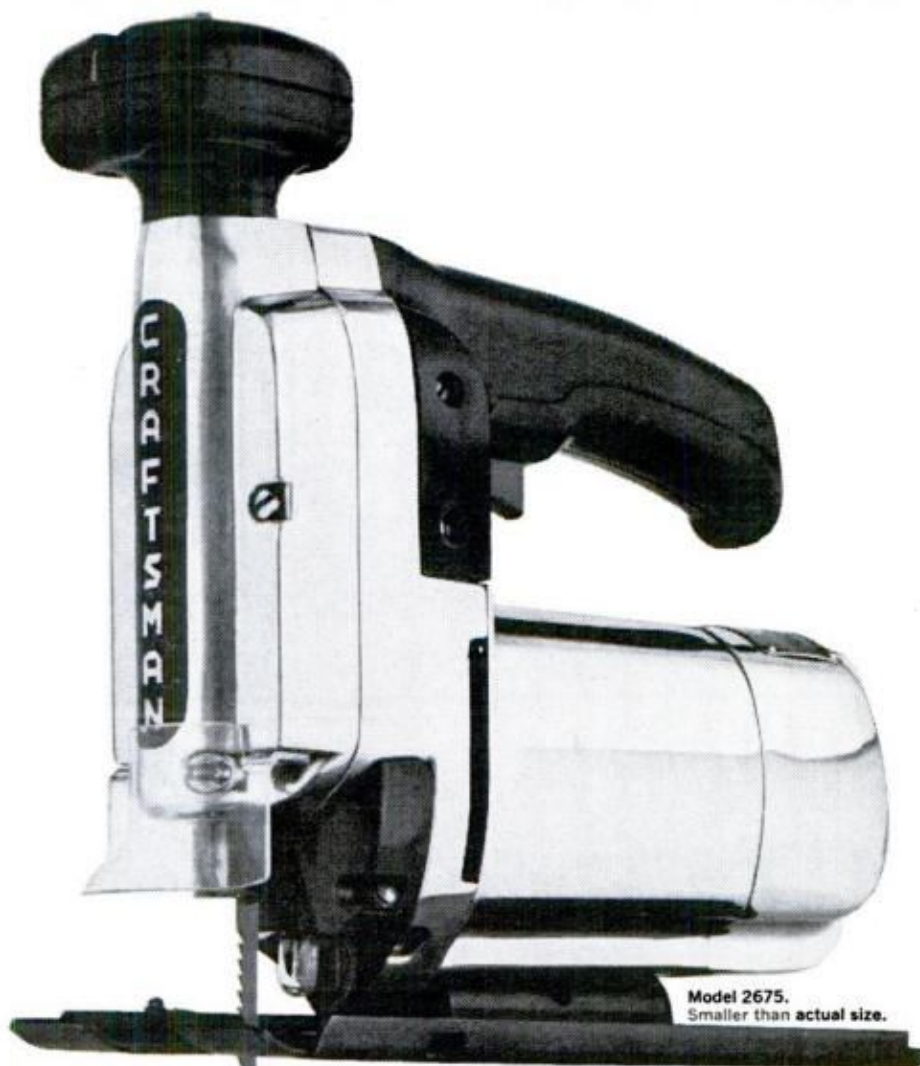

Model 2675.
Smaller than actual size.

This Craftsman® 12-speed scroller sabre saw does something no other saw in the world can do. The turning blade turns and follows the direction of your cut without your having to turn the saw. The side pressure you apply in following a curved line, zig zag or circle, is enough to make it turn.

Or, if you'd rather, turn the blade by hand with the knob on top. Either way, Sears new turning-blade sabre saw turns a full 360°. And it will lock in any 90° position in case you want to cut a straight line. Then it acts just like a conventional sabre saw. And, as we said, no other saw in the

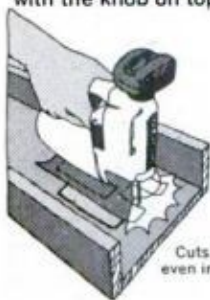

Cuts corners and circles even in tight spots.

world will do all that.

In fact, with this one tool you can do the work of a rip, crosscut, coping, jig, scroll, band, keyhole, and hacksaw. It has a full ½ HP motor for smoother cutting, a 1-inch stroke for faster cutting. The base plate is adjustable, 0 to 45°. Those 12 speeds give you the right speed for every job, from delicate wood veneer to steel pipe. That also means up to four times longer blade life.

This new saw even has a light for dark work areas. And a blower to keep sawdust out of the way. The solid state speed regulator automatically boosts power to maintain speed for heavy loads. It cuts the same through thick and thin, and it's UL listed.

In short, there's so much precision built into this saw, and it can do so many things, it can make a craftsman out of almost anyone.

So, if you're already a craftsman, you're way ahead of the game. This saw comes with a circle-cutting edge-guide attachment, 8 blades, splinter-free guide and an 8-ft. cord.

If you need just about any power tool or accessory, you can find it at most Sears, Roebuck and Co. stores or through the catalog. And, it will be every bit as good as the new scroller sabre saw. Just come in and try one out for yourself.



Pick a speed, 1-12.

Sears

Buy a Craftsman and be one.

Exclusive fun products by mail



**AUTOMATIC
100 SHOT
PELLET STINGER**

The pellet is harmless but STINGS. Holds and fires 100 pellets automatically, fully guaranteed. Keeps dogs and animal pests off your property—is more humane than kicking or hitting. Send \$1.98 in cash, cheque or money order plus 27c to cover handling. 50 pellets included. Not sold in N.Y.C. or if under 16 (State age on order). (100 pellets \$1) (250 pellets \$2) (1000 pellets \$5). Regency Mail-Order Dept. PM-V12 Box 826, Niagara Falls, N.Y. 14302



IMPORTED LOCK-BLADE KNIFE

OPENS quickly, easily locks into position. Blade can't shut when in use. PUSH BUTTON release. Handy pocket size, yet rugged. Fine quality, polished stainless steel razor-sharp blade. PIERCES METAL. Fine outdoor knife for sportsmen. Comfortable handle. Safety guards. \$1.88. Regency Mail-Order Dept. PM-V12 Box 826, Niagara Falls, N.Y. 14302



**SECRET
BOOK SAFE**

The Secret Book Safe looks like a real book. Even if found, people can't open it because of secret combination . . . only YOU can. Store your valuables, treasures, etc. Tough understructure is covered in simulated leather binding. Only \$1.00. Regency Mail-Order Dept. PM-V12 Box 826, Niagara Falls, N.Y. 14302



GIANT 6FT. BALLOON

Have a ball! These huge surplus weather balloons are great at the beach, pool, or backyard. Inflate with air pump, vacuum cleaner or helium. Terrific for out-door displays and advertising sales, grand openings, fund drives, etc. \$1.98. Regency Mail-Order Dept. PM-V12 Box 826, Niagara Falls, N.Y. 14302



**'BIG BOOM'
CARBIDE CANNON**

A sound as LOUD as DYNAMITE! A brilliant FLASH! Echoes for blocks—yet safe to use, has no recoil. Made of heavy cast iron. 9" cannon \$4.95; Big 17" cannon \$9.95; Mammoth 25" cannon \$13.95. Ammo 39c tube (500 shots) — 3 tubes for \$1.25. Regency Mail-Order Dept. PM-V12 Box 826, Niagara Falls, N.Y. 14302



LOW PRICED JET ENGINE

Hell cat takes off all by itself or powers model autos, plane, boat, train, etc. Operates on ram jet principle. Fast starting. No Moving Parts. Operates on solid fuel. Only \$1.49 each and 50c for fuel. \$1.49. Regency Mail-Order Dept. PM-V12 Box 826, Niagara Falls, N.Y. 14302



Metal Piercing Throwing Knife

FAST, EASY TO THROW. Use for self defense, hunting, thrills, targets. Razor sharp cutlery steel. 10" long—Double edge. Wrapped leather handle. 99c (2 for \$1.85) (3 for \$2.75). Knife-throwing instructions FREE. Order Now. Regency Mail-Order Dept. PM-V12 Box 826, Niagara Falls, N.Y. 14302

RADIAL ARM SAW KIT—for under \$100...

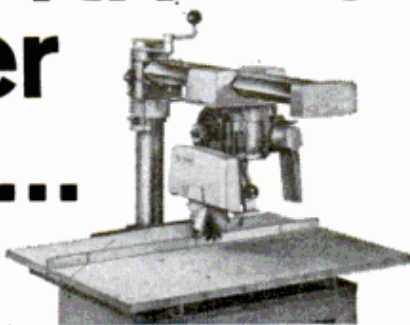

Buy direct from factory, assemble yourself. Incl. 1/2 h.p. G.E. motor, easy to follow instructions, all parts, nuts and bolts. Guar. for life pat. pend. radial arm track; twice the usual bearings for extra rigidity, greater precision. Rips 24", crosscuts 12"; belt brake. \$99. complete, freight col. Kit less motor (any standard 1/2 h.p. or larger will do) \$ 84.85. With opt'l G.E. motor developing 1 h.p. \$108.65. Money back guaranteed by one of world's largest manufacturers of bench power tools.

MAIL COUPON FOR ILLUSTRATED BROCHURE

American Machine & Tool Co.

Dept. PMDR, Royersford, Pennsylvania 19468

Please send me without obligation your free illustrated brochure containing full information on the PermaTrak radial arm saw kit. Also send free reprints of feature articles by editors of Popular Mechanics, Workbench and Family Handyman. NO SALESMAN IS TO CALL.

NAME _____

ADDRESS _____

CITY _____ STATE _____ ZIP _____

AFTER ONE HOUR'S WORK

Your Typewriter
is now like new!
I'll send a bill
for the \$25.



This Can Be YOU Sooner Than You Think!

BECOME A TYPEWRITER MAINTENANCE EXPERT

Quickly—Easily—At Home without risk!

Earn \$50 for 2 hours in your spare time, get a big pay position with a future or, start your own business.

There is a critical shortage of technicians to keep America's 30 million typewriters in repair. Now, regardless of age, education, or present job, you can enter this big-paying field by training in the Office Equipment Industry's only Approved Home Study Course.

Learn fast, and earn money while learning. Diagrams, photos, clear lessons, professional tools, plus benchwork assignments on actual typewriter that we give you, make learning easy.

Send name today for FREE BOOKLET telling of your opportunities in this profitable vocation. Full information, no obligation. No salesman will call. (VA Approved.)

Royal Typewriter
for practice
given you



PLUS ALL YOUR
PROFESSIONAL
TOOLS FREE!



MAIL COUPON FOR FREE BOOKLET

Typewriter Repair School, Dept. 3110-129
Little Falls, N. J. 07424

Please rush Booklet entirely FREE. No obligation. No salesman is to call.

Name _____

Address _____

City _____ State _____ Zip _____

DRIVIN' WITH DAN

(Continued from page 32)

in the cold weather areas?—Bart Floyd, Sioux City, Iowa.

A. I don't see why not. I see a lot of them on the road in California. I should think they would be great fun in the snow. They can be heated easily.

Q. *After studying results of the major NASCAR races it looks like Ford's best record is at the Riverside 500, where they have never been beaten. Is that as good as it sounds, or does anyone else try hard?—Roger Robertson, Atlanta.*

A. It's a good record. Everyone tries hard in racing. A Pontiac won a 300-mile USAC race on the same circuit after the winning Chevy (mine) was disqualified due to a political squabble. The Chrysler-Plymouth-Dodge cars have the best chance of snapping the Ford win streak in 1970.

Q. *Do you think the Plymouth Barracuda you are going to race in Trans-Am will be competitive against the Camaro, Mustang and Javelin teams which have much more experience?—Ronald Cox, Los Angeles.*

A. Although the teams you name, plus the Pontiac Firebird, do have a big edge in experience, I definitely feel the Barracuda has the potential to give them all a run for their money before the 1970 season is finished. I think the 'Cuda is the best thing to come along since sliced bread. The car makes a lot of sense, and it has a lot of built-in heritage from both engineering and styling standpoints.

Q. *How many kinds of Eagles have you built, and do you ever plan on making a street version?—Charles Walter, Spartanburg, S. C.*

A. Thus far at our All American Racers facilities in Santa Ana, Calif., we have manufactured Formula 1 Grand Prix Eagles, USAC Championship (Indianapolis) Eagles, and Formula A Eagles. And we are very proud of the success each has achieved. You may well see a Group 7 or Can-Am Eagle by 1970, but we have no plans at present for a street version, thank you.

Q. *I read where Bruce McLaren said the preparations of Can-Am cars, with the exception of Roger*
(Please turn to page 36D)

Versamatic®

Reversible Speed Reducer turns your power drill into a power drive!

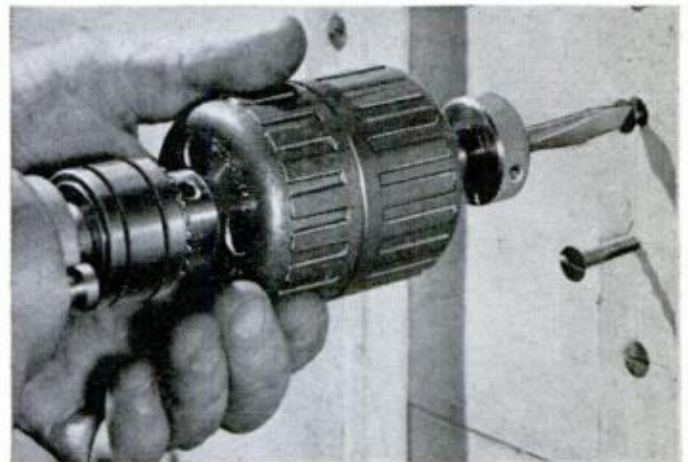

Versamatic increases your drill's power 7 times — power-drives and removes screws and nuts — and helps drill into steel, concrete, masonry, and ceramic tile. Next to your power drill, Versamatic is the most versatile tool you can own!

The Versamatic No. 4100 comes with a medium-duty screw driver bit, a No. 2 Phillips-type bit, $\frac{1}{4}$ " square drive adapter, and a wrench pin. Optional screw driver bits, $\frac{3}{8}$ " square drive adapter, and $\frac{1}{2}$ " RIDGID/Supreme Chuck and Key also available.

See the Versamatic at your nearest quality Hardware Store. And be sure to ask about other RIDGID Pre-Tested Work Saver Tools and parts from The Ridge Tool Company, Elyria, Ohio 44035, U.S.A.

RIDGID

Supreme

 Ridge Tool Subsidiary Emerson Electric Co.

Sure, you can buy welders for less money
... and even more money... but...

YOU CAN'T GET A BETTER VALUE THAN A LINCOLN!

AC 225 AMP WELDER



Lincoln Electric, the world's largest manufacturer of arc welding equipment, builds welders to industrial quality standards in high volume.

Powerful . . . enough heat for $\frac{3}{16}$ " electrodes.

Versatile . . . welds even with low hydrogen and stainless steel rods. For cast iron and hardsurfacing, too. Cuts, solders, brazes.

Easy to operate . . . simple, one-switch control. Easy to start. No spit or sputter.

Safe . . . built to conservative, industrial ratings. UL approved.

Perfect gift for the man with a well-equipped shop.

Only \$93* including holder, ground clamp, power cord, plug, electrode kit, instruction booklet.

*Zone 1 list price . . . subject to change without notice.

MAIL COUPON FOR FREE LITERATURE

The Lincoln Electric Company
Cleveland, Ohio 44117

I am interested in the 225 AC
shop welder.

Send full details without obligation.

Name _____

Address _____

City _____ State _____ Zip _____

**LINCOLN
ELECTRIC**

NEW!

HOTSPARK™

Attention:
Snowmobile
and
Outboard Motor
Operators

Compact spark plug cleaner consisting of aluminum tube containing special alloy scouring wires and solvent.



T Rapid shaking causes scouring wires and solvent to gently remove carbon and other conducting deposits from tip as well as deep inside plug cavity in a matter of seconds. No abrasive particles to damage plug or engine. One end is for 14mm. plugs and the other for 18mm.—the two standard sizes. May be used with any good quality non-flammable dry cleaning solvent. One charge of solvent cleans dozens of plugs. Rugged leakproof construction allows it to be carried in pocket or tool box. A safety device for snowmobile and outboard motor operators. \$4.95 complete postpaid with initial charge of solvent. Check or Money Order only. Satisfaction guaranteed.

PAT. PEND.

Auto Mechanics: Clean the plugs when you re-gap for better performance.

HENDERSON MFG. CO. INC.
P.O. BOX 503, DEPT. A
NARBERTH, PA. 19072

Big Profits in UPHOLSTERY Get Your Share . . . FAST!

EARN BIG MONEY 3 NEW EASY WAYS

FREE
Deluxe Illustrated
Book and Sample
Lesson Pages

1. Be your own boss, make up to 85% profit.
2. Start earning right away at home in spare-time—keep furniture you make, or sell for hundreds of dollars.
3. Today's home and office upholstery, re-upholstery, slipcover boom make it easy to take your pick of big-pay jobs.

LEARN FAST—EARN FAST

You get expert instructions, plus all tools, new wooden frames, materials, fabrics, business tips, wholesale privileges, decorating magic AT NO EXTRA CHARGE. FREE Book, sample lesson pages show you how—no obligation—no salesman. Write TODAY.

UPHOLSTERY TRADES SCHOOL

Division of Singer Communications Corporation
Dept. 5110-129 Little Falls, New Jersey 07424
(N. J. State Approved. Accredited Member National Home Study Council. Vet Approved.)

Tools, Equip.,
Frames, Mate-
rials, Fabrics.
Supplies yours
with course.

MAIL COUPON TODAY

Upholstery Trades School, Dept 5110-129
Division of Singer Communications Corporation
Little Falls, New Jersey 07424

ESTABLISHED
1939

Please send me FREE book, "Your New Way to a Successful Career," and FREE sample lesson pages. No obligation—no salesman will call.

Name _____

Address _____

City _____ State _____ Zip _____

MOLDS

for making
Ornamental Concrete
Items...



Book about Aluminum
Molds with prices and
production trade secrets
direct from world's larg-
est mold manufacturer.

SEND
\$2.00

CONCRETE MACHINERY COMPANY,

INC.

P. O. BOX 99 • HICKORY 2, N. C. 28601

Most automatic automatic.

Kodak

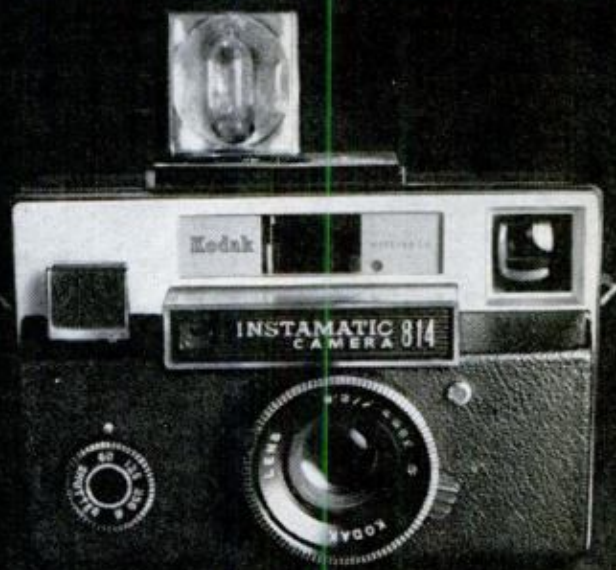

If there's one thing you want when
you travel — around the block or
around the world — it's a camera that's
fast and easy.

This is it. The Kodak Instamatic 814
camera. The most automatic automatic.
Just drop in the film cartridge. The "814"
accepts any 126-size film, for snapshots
or slides; adjusts itself to the speed of the
film; computes the exposure; tells you
when to use flash; adjusts automatically
for flash exposure as you focus. It's so
automatic, it even advances both film and
flashcube for the next picture after
you've clicked the shutter!

You could hardly make a mistake even
if you tried.

Complete and self-contained, this
traveler's aid comes with a
precision rangefinder and
a superb 4-element f/2.8
Ektar lens. Travel right.
It's less than \$145 at your
photo dealer's.



Kodak Instamatic® 814 camera.

Price subject to change without notice.

BELSAW PLANER · MOLDER · SAW!

BELSAW

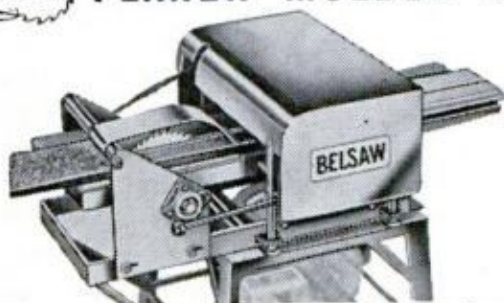

Now you can use this ONE power-feed shop to turn rough lum-
ber into moldings, trim, flooring, furniture... ALL popular pat-
terns. RIP... PLANE... MOLD... separately or all at once
with a one HP motor. Use 3 to 5 HP for high speed output. Low
Cost... You can own this power tool for only \$30.00 down.

Send Postcard Today... No Salesman Will Call

BELSAW POWER TOOLS, 900Z Field Bldg., Kansas City, Mo. 64111

LAW FREE BOOK THE LAW TRAINED MAN

Write today for a FREE copy of illustrated law book, "THE LAW-
TRAINED MAN," which shows how to earn the professional Bachelor
of Laws (LL.B.) degree through home study of the famous Blackstone
Law Course. All necessary books and lessons provided. Moderate cost;
convenient monthly terms. Write for FREE law training book today.

Blackstone School of Law, 307 N. Michigan Ave.

Founded 1890 Dept. 59, Chicago, Illinois 60601

BASEMENT TOILET FLUSHES UP



TO OVERHEAD SEWER OR SEPTIC TANK.
NO DIGGING UP FLOORS. INSTALLS EASY. Write
McPHERSON, INC., BOX 15133, TAMPA, FLORIDA 33614

TREASURE

Find buried gold, silver,
coins, treasures.

5 Powerful models.

Write for free catalog



RELCO DEPT. D-3 \$19⁹⁵
BOX 10839, HOUSTON, TEX. 77018 UP



The Death Valley Test.

Some of the guys at our advertising agency wanted to find out for themselves if our *Better Pouch* is as good as we say. So they buried one—in the middle of the desert. Then five months later they dug it up. And smoked the still-fresh pipe tobacco inside! How did it stay fresh so long? The pouch is *sealed*. Air-tight. Nothing gets in or out. But don't you take our word for it either. Get a **FREE** pouch of Kentucky Club Mixture and see for yourself. Just send us the coupon, and an empty pouch of what you're now smoking (any brand but ours). And get a fresh start with our *Better Pouch*.

FREE OFFER TO PIPE SMOKERS

Mail to: Fresh Tobacco, Box H
Wheeling, W. Va. 26003

Gentlemen: Here's my ordinary pouch. Now I'd like to try a full-size package of Kentucky Club Mixture with that *sealed-in freshness* you promise.

Name _____

Address _____

City _____

State _____ Zip _____



Offer good in U.S.A. only, and expires January 31, 1970. Sorry, only one to a customer.

DRIVIN' WITH DAN

(Continued from page 36A)

Penske's, was pretty sloppy. He also said that American mechanics thought they knew it all, but ought to take lessons from European F-1 mechanics. Do you agree?—Tom Baxter, Birmingham, Mich.

A. No! First-class racing mechanics are a very rare breed. You will find them wherever you find consistent race winners. They exist in America as well as in other parts of the world.

Q. Do you think A. J. Foyt is a tough competitor in the Indy 500? If so, why?—Tony Nestor, Willowdale, Ont.

A. A.J. is a very tough competitor. Anyone who has won as many races as he has, has got to be plenty tough. He is very experienced and wise. He understands a great deal about what makes a car tick, and he is a superstrong competitor with lots of drive and instinctive driving talent. He hates to lose and has always gathered top people for his team.

Q. I've always been interested in what the favorite leisure pastimes of athletes are. What do you do for relaxation, hobby, and so forth?—Sara Singleton, Denver.

A. I'm a motorcycle enthusiast. I love cow trailing and exploring and riding dirt fire roads in the California hills. Swimming, skiing (I'm very new at it), the movies, books, music, television, food, and, last but not least, my business, All American Racers.

Q. Do you need a state driver's license to become a competition driver?—Joe Bartle, Louisville, Ky.

A. Most of the top sanctioning bodies in the U.S. make that stipulation or reference to it. However, there are many cases when drivers have competed professionally before actually receiving a state license. You are talking about two very different types of driving, and owning a competition license does not necessarily make you a qualified highway driver, and vice versa. ★ ★ ★

If you have questions on racing, high-performance and everyday driving techniques, send them to "Drivin' with Dan," c/o Popular Mechanics, 224 West 57th St., New York, N.Y. 10019. Questions cannot be answered by individual letters. Questions on maintenance and repair should be addressed to the Auto Clinic (see page 66).

Introducing: Elmer's improvements on the nail and screw.



Elmer's® new Heavy Grip® Cement does what nails and screws can't.

It installs things like towel bars and brackets to tile, metal, concrete, brick, plastic. Just about anything.

And it's so strong that parts need no support while Heavy Grip is setting.

Elmer's Panel Fast® eliminates nails and screws. You can install any kind of paneling with it. You can even reposition a panel while Panel Fast is setting.

And, if a stud or furring strip is set back too far, Panel Fast will fill in the gap.

These improvements are brought to you by the makers of Elmer's® Glue-All, America's favorite glue.

Free. A guide to gluing, taping and spray painting. Mail a stamped, self-addressed envelope to: Borden Inc/Chemical Division, Dept. B-2, 350 Madison Ave., N.Y., N.Y. 10017.



Give the "Yule Tool" from Bostitch

Looking for that "different but practical" gift?

You'll find it in the versatile, easy-to-use Bostitch T5 Stapling Tacker Kit.

The rugged T5 Tacker is designed for hundreds of fastening jobs in the home, office or camp, wherever you drive a tack or light nail. The T5's high penetrating power drives even heavy-duty staples through hardwoods and light metals.

Each T5 Kit includes 3,000 assorted staples and a lightweight, durable plastic carry case with removable tray.

You'll find T5 kits wherever you see the "Great New Gift Idea from Bostitch" display. And when you buy those T5's as gifts, don't forget yourself.

BOSTITCH
A **textron** COMPANY



As featured in Nov. 1969 issue—

Build Popular Mechanics' \$7500 House!

**1457 sq. ft.! 3 bedrooms!
2 Full Baths! 29-Foot Living
Room with Fireplace!
Air Conditioned!**

Sound impossible? The Robert R. Hunts—man, wife and 15-year old son—did it in about 600 man-hours and figure their savings at over \$30,000 at current mortgage rates. They told all about it in our November 1969 issue. Now—as a service to Popular Mechanics readers—complete do-it-yourself instructions are available.

Complete Plans Only \$25.00

You get everything you need—11 sheets of detailed blueprints, complete instruction booklet, and materials list. If you're a skilled craftsman and can follow instructions, you can do it all. If you're a handyman, you can hire skilled help for some jobs and save a bundle by doing the rest. Even if you plan to hire a builder, you'll still get a lot of house for your money (you'll need 4 sets of plans for a contractor—special price \$35.00). Allow 2 weeks for delivery.



Popular Mechanics, Dept. HP12
224 West 57th St., N. Y. 10019

Please rush me complete plans for the \$7500 house.

I enclose \$_____ (Single set \$25.00—
4 sets \$35.00).

NAME _____

STREET _____

CITY _____ STATE _____ ZIP _____



Campground cooler

A new campground refrigerator, made in France, has 24 compartments where campers can store food. Another model has 36 spaces.



Tabletop workshop

Four miniature, battery-powered tools—a drill, sabre saw, circular saw and orbital sander—enable youngsters to work with balsa wood and Styrofoam without danger of injury. Ideal Toy Corp.'s new Power Mite Workshop also includes workbench and hand tools.



**Great gift
to trim a tree with.**

Why not? It's McCulloch's Power Mac 6, the best selling chain saw in America. The only one in the 6-pound class! More power than some saws twice its size. And more features than most saws any size. Zips through an 8-inch log in 6 seconds. Cuts a winter's worth of firewood quick and easy. And now the world's lightest chain saw comes with automatic oiling too. Just ask for new Power Mac 6 Automatic. Either way you get a special lightweight bar and fast cutting McCulloch chain. So let your McCulloch dealer play Santa Claus. He's not at the North Pole. You'll find him in the Yellow Pages under "saws".

*less cutting attachments

McCulloch

6101 W. Century Blvd., Dept. CD
Los Angeles, Calif. 90045



FREE!

McCulloch "Six Pac" carrying case special Christmas bonus!

This easy way to carry and store your new Power Mac 6 also has room for files, wedge, extra spark-plug and chain oil. A regular \$14.95 value, free when you buy a new Power Mac 6 or Power Mac 6 Automatic. At participating McCulloch dealers while promotional quantities last.

FANTASTIC VALUES WITH THIS COUPON

AMERICAN MACHINE & TOOL CO., Dept. PMD9 Royersford, Pa. 19468
Please send me the units checked. Payment in full enclosed \$.....
or \$3 deposit each item enclosed, balance C.O.D. I MUST BE FULLY
SATISFIED OR WILL RETURN UNIT WITHIN 10 DAYS FOR FULL REFUND.
No questions asked.

8" Power Saw at \$14.95
 Standard Rip Fence at \$3.50
 Long Rip Fence at \$4.50
 Precision Ball Bearing Spindle at \$5.00
 Jointer Planer at \$19.95
 Drill Press at \$29.95

Belt Sander at \$14.95
 Disc sander attach. at \$7.95
 Mitre Gauge for sander at \$1.95
 Woodshaper Kit at \$14.95
 Hold Down Assembly at \$2.75

G.E. Motor \$18.80 (with other item) \$24.85 (purchased separately)

NAME

ADDRESS

CITY STATE ZIP

SAVE AS MUCH AS...
80% WITH
QUALITY **Amco**
POWER TOOLS

DIRECT FACTORY OFFER AND REVOLUTIONARY PATENTS decrease costs, increase efficiency. Full scale power tools of heavy duty 100% cast iron and steel. Streamlined design reduces weight, cuts material and production costs. Special patents provide added efficiency, accuracy, savings. Parts made, assembled, tested, packed right in our own factories shipped direct... save store profits.

ENDORSED BY AMERICA'S TOP MAGAZINES... Here is what the editors say:

"A good bit of sound—imaginative—engineering." Popular Science; "(saw) boasts many features of bigger brothers." Popular Mechanics; "Amazingly versatile." Workbench; "Highly substantial construction, sturdy enough for production line use."

Industrial Woodworking. And Workbench awarded these tools their coveted "Work Tested" Seal.

OVER A MILLION USERS confirm their precision, versatility and rugged performance.

***10-YEAR FULL SERVICE GUARANTEE...** Any part or parts of any AMCO power tool (except motor) which may become inoperative for any reason within ten years after the purchase date will be repaired or replaced by the factory without cost to the purchaser. Your only cost: for postage.

**UNCONDITIONAL
10-DAY
MONEY BACK
GUARANTEE**

You must be fully satisfied. If not, return in 10 days, freight collect. Money promptly refunded in full.

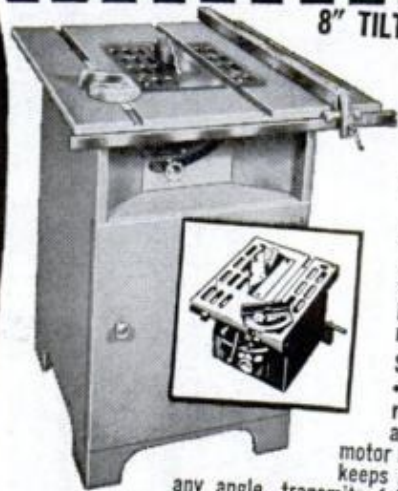

8" TILT ARBOR POWER SAW

DOES WORK OF \$75 BENCH SAW as is. Converts easily to equal any \$300 floor model cabinet units! Crosscuts, rips, mitres, cuts compound angles, dadoes, makes coves and moldings.

\$1495 f.o.b. factory. Wt. 25 lbs. Includes completely assembled cast iron and steel 8" saw with ground cast iron table... less blade. RIP FENCE, if desired, for easier work alignment, \$3.50 add'l.

PRECISION BALL BEARING SPINDLE for Commercial Service, \$5.00 add'l.

SAW BLADE TILTS... TABLE STAYS LEVEL

Locks securely at any angle up to 50°, raises, lowers 0"-2 1/4". Patented tilt mechanism, accurate etched scale. Patented

motor mount takes std. 1/4 h.p. or larger motor, keeps belt tight, assures perfect alignment at

any angle, transmits full power. Takes std. blade, saw insert removes to take dadoe heads, cutters, etc. (not incl.). Accurate mitre gauge assembly. Ground spindle. Enclosed steel base. "Compo" bearings. Access.

Std. size (for bench saw) \$3.50; larger fence (for cabinet base, as ill'd.) \$4.50.

FREE CABINET BASE PLANS Use as portable bench saw as received (inset photo) ... or transform easily and inexpensively into floor model (as shown) guar. to do work of floor models costing \$300. FREE plans ... all you'll need are a sheet of 3/4" plywood and 3-4 hours. Use your AMCO saw for cutting. Plans provide 27" x 24" work surface, 33" height, tool storage compartment.

10-YEAR FULL SERVICE GUARANTEE*

HIGH SPEED WOOD SHAPER KIT

\$1495 f.o.b. factory. Wt. 15 lbs. Compl. less wood parts, motor.

Optional hold-down assembly \$2.75 add'l.

DOES WORK OF \$100 UNITS... Makes beads, coves, moldings, tongue-and-groove joints, etc. Easy assembly plans. Has sealed greased-for-life ball bearings, adjustable height control, fence assembly. Makes smooth, accurate cuts at high speed. Takes 1/4 h.p. or larger motor, standard cutters.

10-YEAR FULL SERVICE GUARANTEE*



FULL 22" LONG, 4 1/8" JOINTER-PLANER

\$1995

f.o.b. factory. Wt.: 19 lbs. Complete as shown.

100% precision ground cast iron and steel.

DOES THE WORK OF \$60 UNITS... Professional power planing at a hand tool price. Make faster, more accurate joints, rabbets, bevels for windows, doors, drawers, square tapered legs—Adjustable precision ground cast iron tables. Patent-pending design holds knife to table clearances at any depth. Rabbet depth 3/8". Fence adjustable 0°-50°. Hardened, ground hi-speed steel knives. Dual cutter guards. Balanced cutter head.

10-YEAR FULL SERVICE GUARANTEE*



PRECISION 4" x 36" BELT SANDER

f.o.b. factory. Wt. 15 lbs.

\$1495 †Disc Sander attachment incl. disc bracket, ground cast table (tilts 0-45°): \$7.95 add'l.

DOES WORK OF \$50 SANDERS... The world's most talented belt sander. Heavy cast sander incl. 4" x 36" sanding belt, V-pulley drive, multi-purpose drive spindle. Changes from horizontal to vertical sanding in secs. Uses 1/2 hp or larger motor.

10-YEAR FULL SERVICE GUARANTEE*



Mitre gauge: \$1.95 add'l.

32" RADIAL DRILL PRESS

All cast iron and steel f.o.b. factory Wt. 30 lbs. **\$2995**

1/2" cap. Jacob's chuck incl.

DOES WORK OF \$90 UNITS... and much more. Industrial quality precision unit with all standard features, many extras. Head raises, lowers. Depth of throat up to 16". Pre-set to any angle for on-or-off table drilling, even horizontal drilling. **10-YEAR FULL SERVICE GUARANTEE.***

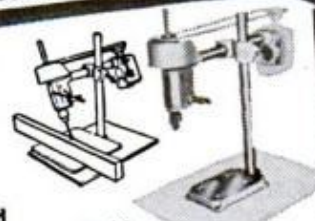

BRAND NEW MOTOR DEVELOPING FULL 1 HP... **\$18.80** F.O.B. FACTORY / FOR ANY OF ABOVE MACHINES. WT. 17 LBS. PURCHASED SEPARATELY, \$24.85

You're a pretty important guy

...when you know Electronics. And now you can learn enough to break into this exciting field right at home in your spare time.

How would you like to be the kind of guy other men come to for advice and "know-how"?

The kind of guy businessmen and scientists lean on—and listen to?

With a salary that can bring a guy respect? And an impressive title like Communications Officer, or Customer Engineer?

People admire a man like that. His success shows in his bearing. He doesn't have to be timid in business or social situations any more...he's important!

And you can be that man!

How? By cashing in on one of the hottest growth fields of all time: Electronics.

Today, whole industries are built upon Electronics. It's Electronics that makes computers and automated production lines and modern aerospace developments possible. And to keep all these electronic miracles running—to see that problems don't occur, and to solve them when they do—the world depends on a new breed of professional: the Electronics specialist.

But there just aren't enough trained Electronics specialists to go around! By 1975, the booming Electronics industry will need an estimated 4 million of these men.

With this kind of demand for

qualified people, you can earn the kind of salary you've always dreamed about. Once you have some experience, you can make up to \$5, \$6, \$7 an hour. \$200, \$225, \$250 a week. \$8,000, \$10,000, \$12,000 a year—doing work you'll really enjoy!

You might think you need college to break into this great field. But you don't. You don't even have to leave home to go to technical school.

The Cleveland Institute of Electronics can teach you all you need to know in your spare time at home.

CIE is the largest school in the country specializing exclusively in Electronics home training. The Institute's methods make learning Electronics easy, even for men who once had trouble studying.

It's all spelled out in two informative books that CIE will send you FREE. To get them, just mail the bound-in card. If card is missing, use the coupon below or write Cleveland Institute of Electronics, 1776 E. 17th St., Cleveland, Ohio 44114.

It could be your first step toward becoming a mighty important guy in this world.

ENROLL UNDER NEW G.I. BILL
All CIE courses are available under the new G.I. Bill. If you served on active duty since January 31, 1955, or are in service now, check box on card for G.I. Bill information.

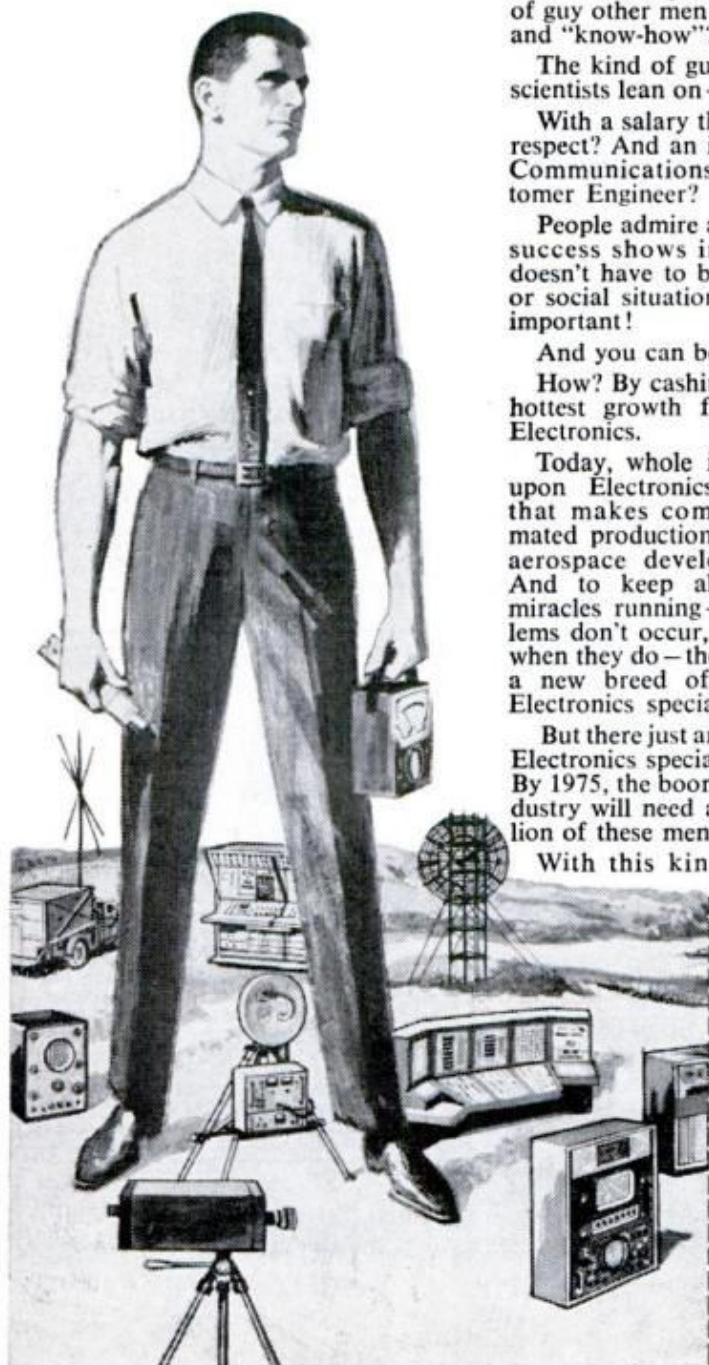

CIE Cleveland Institute of Electronics
1776 East 17th Street, Cleveland Ohio 44114

Please send me 2 FREE books describing opportunities in Electronics and how to prepare for them.

Name _____ Age _____
(Please print)

Address _____

City _____ State _____ Zip _____

Check here for G.I. Bill information.

Accredited Member National Home Study Council
A Leader in Electronics Training... Since 1934



PM-32

The bargain hunter



HOW MANY HANDY DANDYS CAN YOU USE?

Handy Dandys are plastic caps that hook onto pegboard and hold quarter-twist glass jars, such as used for baby food. Suggestions for getting **FREE JARS** in every package. Nothing better for storing supplies, parts and small tools. Keeps workshop neat. Sample pack 10 for \$1 ** 36 for \$3.50 ** 72 for \$6 ** 144 for \$11.50. Caps only. No jars. Postpaid U.S.A. No C.O.D.'s. **WICKLIFFE INDUSTRIES**, Box 286-PM-12, Wickliffe, Ohio 44092

NOW! GET 5 REAL OLD LINCOLN CENTS
--for only **10¢**



Only 10¢ brings you 5 old Lincoln pennies issued before 1927—America's most sought-after coins. (One set to a customer.) For all 5 Lincoln coins sent with Free Catalog plus selections of coins to examine. Buy any or none, return balance. Cancel service anytime. Send 10¢ to Littleton Coin Co. Dept. C-13, Littleton, New Hampshire 03561.

PLAY GUITAR IN 7 DAYS OR MONEY BACK

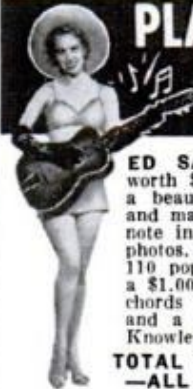

ED SALE'S 66 page system worth \$3.00 teaches you to play a beautiful song the first day and many more songs by ear or note in seven days! Contains 52 photos, 87 finger placing charts, 110 popular and western songs; a \$1.00 Chord Finder of all the chords used in popular music; and a \$3.00 Guitarist Book of Knowledge.

TOTAL VALUE \$7.00 **\$2.98**
—ALL FOR ONLY

SEND NO MONEY! Pay postman \$2.98 plus C.O.D. postage. Or send \$3.00 with order and I pay postage. (Sorry, no C.O.D. outside Continental U.S.A.—please remit with order). **Unconditional Money-Back Guarantee.** **ED SALE, Studio 153-R, Avon by the Sea, N.J.**

BULL FIGHTER Lock Blade STILETTO KNIFE

5 1/4" Overall Length
3" Blade

ONLY \$1.25

- Tough and Sharp
- Opens Instantly
- Stainless Steel
- Folding Finger Guard
- Blade Locks

Flips open instantly and locks automatically to prevent accidental closing. Razor sharp tough stainless steel blade for reliable use and hard, long service. Money back in 5 days if not satisfied. Send \$1.25 plus 25¢ to cover postage & handling. Please state age.

WESTBURY SALES CO., DEPT. B M 54 D
P. O. BOX 415, WESTBURY, N. Y.

FREE Catalog 2000 Jokes & Novelties



World famous catalog of novelties, live animals, scientific supplies, hobbies, fun-makers, planes & boats, looms, magic tricks, joke articles, unusual seeds, gadget time-savers, cameras, optical goods, projectors, movies, lucky jewelry, religious novelties, disguises, musical instruments, stamps, coins, puzzles, fortune tellers, radios, auto & bike accessories, telescopes, magnifiers, compasses, banks, smokers' gadgets, artists supplies, printing sets, engines, motors, shockers, knives, billfolds, books, games, etc. Send postcard or this ad. No letter needed!

Yes—I want **FREE** Catalog. My Name & Address Attached or on Envelope

Johnson-Smith, Dep. C1012, Detroit 48224



Thousands of exciting tool values!

SILVO (BRAND NAME) TOOL CATALOG

Thousands of Exciting Tool Values! Stanley, Millers Falls, Skil, Thor, Wen, Disston, Wiss, Wollswaw, Dremel, Speedy Sprayers, Plumb, Huot, Kennedy, Channellock, Porter-Cable, Rockwell, Helios, Vise-Grip, Crescent, Ridgid, Pony Clamps, Unimat, Foredom and many other Nationally Advertised brands of Tools & Supplies. We ship Coast to Coast at prices Hard to Beat. Send 25¢ for our big 132-page tool catalog, today. Silvo Hardware Co., PM-12, 107 Walnut St., Philadelphia, Pa. 19106.

500 RETURN ADDRESS LABELS



50¢

USE YOUR "ZIP" CODE

RICH GOLD TRIM
FREE HANDY BOX

Quick and easy way to put your name and return address on letters, checks, books, records, etc. ANY name, address and Zip code up to 4 lines, beautifully printed in black on white gummed labels with rich gold trim. 2" long. Free decorative box for purse or desk. Set of 500 labels just 50¢ postpaid. Shipped within 48 hrs. Money back if not pleased. Don't know the Zip Code? Add 10¢ per set and we will look it up.

Send for free catalog.

Walter Drake & Sons
345-C Drake Building
Colorado Springs, Colo. 80901

WIN UP TO \$3,000 MONTHLY WORKING PUZZLES

Join a club with regular monthly puzzles—competitions in which you can win up to \$3,000.00.

NO EXPERIENCE NECESSARY

Simple puzzles, only common logic needed. Mail this ad, your name and address **TODAY**. We send you a Free Puzzle Magazine and membership details. First, try your skill free and find out if you can win. Yes! you may win \$3,000 in less than 45 days.

MUCH TO GAIN—NOTHING TO LOSE INTERNATIONAL CONTEST CLUB

Dep't PM, Westport Station
Kansas City, Missouri 64111

MOMENTOS of the infamous 3rd REICH East NAZI Eagle-Wall Plaque 7"x20" Wide. Bronze finish. While they last \$5.00 postpaid.



Our fully illustrated collector's **CATALOG** of... Helmets, Hats, Medals, Pins, Badges, Books, Photos, Posters, Manuals, Stamps, Flags, Decals, Arm Bands & other hard-to-find items. **CATALOG** free with order or Air Mailed to you for \$1.00. W.W. #2-M Ltd., Box 2063, St. Louis, Mo. 63158

KNOW ANTIQUE PRICES!



Latest 400 Page Illustrated Book puts prices of antiques and collectors' items at your fingertips. Covers practically every group found in America, such as: pattern glass, art and fine glass, banks, dolls, toys, chinaware, pottery, furniture, clocks, lamps, silverware and more than 250 other groups of items.

Book is widely used by dealers and collectors—now available to the public! Know the value of your antiques—also be price wise if you buy or sell! You could make or save more than cost of book on one transaction. Order Now!

Only \$7.95 postpaid.
E. G. Warman Publishing Co., Dept. P., 8 Frankhooover St., Uniontown, Pa. 15401

WHEN ANSWERING ADS GIVE YOUR ZIP CODE

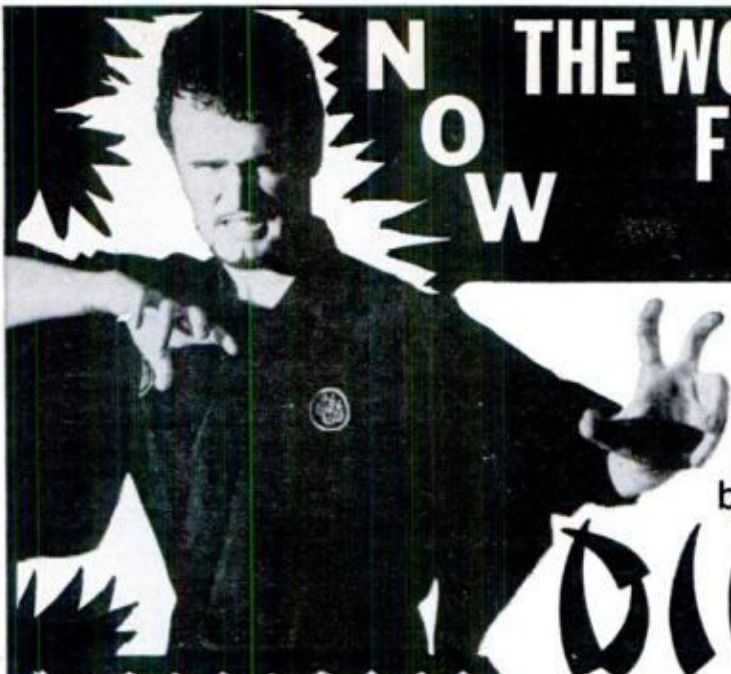

N O W THE WORLD'S DEADLIEST FIGHTING SECRETS CAN BE YOURS...

THE SUPREME GRAND MASTER OF THE
BLACK DRAGON FIGHTING SOCIETY
brings you the forbidden secrets of

DIM MAK "The Death Touch" in this exclusive book!

"THE DEADLIEST MAN ALIVE!"

Bringing to you these forbidden and secret fighting arts is the Supreme Grand Master of all the fighting arts — Count Dante who won the World overall Fighting Arts championship (Master & Expert Divisions) after defeating the top Judo, Boxing, Wrestling, Karate, Gung Fu, Aikido, etc. masters in 'Death Matches'. On Aug. 1, 1967 the World Federation of Fighting Arts crowned the Count — "The World's Deadliest Fighting Master."

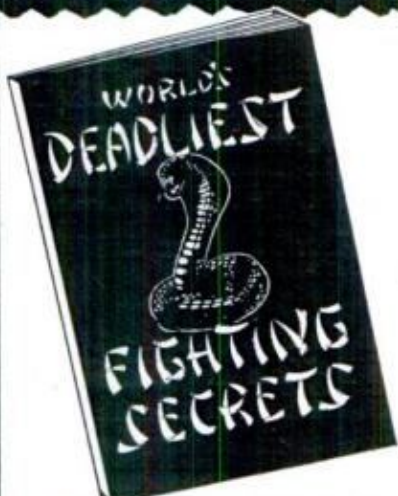

THIS BOOK CAN SAVE YOUR LIFE

The FORBIDDEN and SECRET training manual of the BLACK DRAGON FIGHTING SOCIETY has never before been available to anyone outside of the Society. Recent attempts for regular publication and public exposure have been rejected as the contents were considered HORRIFYINGLY DANGEROUS and BRUTALLY VICIOUS.

Yes, this is the DEADLIEST and most TERRIFYING fighting art known to man — and WITHOUT EQUAL, its MAIMING, MUTILATING, DISFIGURING, PARALYZING and CRIPPLING techniques are known by only a few people in the world. An expert at DIM MAK could easily kill many Judo, Karate, Aikido and Gung Fu experts at one time with only finger tip pressure using his murderous POISON HAND WEAPONS. Instructing you step by step thru each move in this manual is none other than COUNT DANTE — THE DEADLIEST MAN WHO EVER LIVED.

BLACK DRAGON FIGHTING SOCIETY

The BLACK DRAGON FIGHTING SOCIETY is the WORLD'S DEADLIEST FIGHTING ORGANIZATION which has included in its closed membership the top fighting experts of the DREADED CHINESE TONG SOCIETY — the oriental, and more vicious counterpart of the Mafia. Its members, who are the world's top Masters in the oriental fistic and grappling arts, train in the most SECRET and FORBIDDEN aspects of the DEADLY Chinese fighting arts of GUNG FU, TAI CHI CHUAN, CHUAN-FA, KEMPO, HSING YI, PA-KUA, SHAOLIN BOXING and DIM MAK.

Until recently the forbidden training secrets of the society have been closely guarded by the members who were sworn to secrecy and joined together thru their initiation ceremony of blood. Breaking of the oath to secrecy meant death by torture to the offender.

Now for the first time their FORBIDDEN SECRETS OF TERROR can be shared with you.

BREAK A BRICK

Included in the manual is a GUARANTEED method of brick and board breaking enabling anyone to break a brick or board after only minutes of training. THIS IS NO EXAGGERATION. THERE IS NO TRICK OR GIMMICK. There is nothing to be held in the hand, or any hand brace needed; and no special stunt bricks or boards are needed. This is the same method that many famous Karate Masters use.

POISON HAND

Considered by many as evil and cruel; the lethally savage ripping, tearing, slashing, clawing and gouging techniques which comprise

the POISON HAND ARSENAL are used to attack (by strike, touch or pressure) the nerve centers, pressure points, major blood vessels and vital organs of the body. You will learn the original 77 "POISON HAND" techniques of ancient China in actual photographs showing them in application. These are not photos of drawings, but actual photos of COUNT DANTE applying these torturing techniques which are meant to maim, disfigure, cripple or kill and have been used by oriental terrorists and assassins to MURDER!

OUR \$10,000 GUARANTEE

We cannot guarantee to make you a Fighting Arts Master or even an expert, as this is up to you; but we can make a \$10,000 GUARANTEE that this book is DEADLIER than any other book, manual or course ever printed anywhere, at any cost and that it was, as mentioned before, refused for past publication due to its extremely FEROCIOUS nature. We also guarantee that the "WORLD'S DEADLIEST FIGHTING SECRETS" contains the most SECRET and FORBIDDEN attack and defense methods ever devised by man and that the DIM MAK and POISON HAND techniques are completely authentic and the WORLD'S DEADLIEST FIGHTING FORMS. Last we guarantee that you can break a real, authentic brick or board WITH NO GIMMICK — just your hand, using our method AFTER ONLY MINUTES OF TRAINING. If you are not satisfied; return the book in good condition and you will receive a refund. MAIL COUPON NOW! AIR MAIL, REACHES US OVERNIGHT.

FREE BLACK DRAGON FIGHTING SOCIETY MEMBERSHIP

as a special bonus for ordering early!
Your own authentic identification card will be rushed to you absolutely free!



MAIL GUARANTEED NO-RISK COUPON NOW!

**BLACK DRAGON FIGHTING SOCIETY, Dept. 38-129DM4
Box 423, Union City, New Jersey 07087**

Rush my copy of "The World's Deadliest Fighting Secrets" in plain wrapper immediately. I enclose full payment of \$4.98 and there will be nothing to pay on delivery. If for any reason I am not satisfied, I may return the book in 7 days for a full refund. I pledge never to use the deadly techniques of the manual as an aggressor (only to defend myself) and will never abuse the trust placed in me.

Name _____
Address _____
City _____ State _____ Zip _____

As a special bonus for those ordering early an authentic I. D. card (silver thermographed on black) of the Black Dragon Fighting Society will be sent — while they last.

ON-THE-GO

CAMPING

BY WADE MITCHELL

DODGE DIV. FROWNS WHEN WE ASK . . . but coach manufacturers insist that Dodge field representatives have contacted them about a *front-drive* van! Rumors have circulated for over 12 months. This reporter is convinced such a van is in the works, regardless of half-hearted official denials. Big advantages afforded by a front-drive van are a lower silhouette and a flat cargo floor, made possible by elimination of a driveline tunnel.

WORLD'S LARGEST RV SERVICE CENTER UNDERWAY. Frank Lee, of Kent, Wash., is reportedly building a huge recreational vehicle service center that will entail an investment of roughly \$750,000 and contain six large "bays" where all types of RV service, repairs and maintenance can be handled. Called the Valley Garage, this new RV service center is being closely watched by all segments of the RV industry. Frank Lee is a Winnebago dealer, but reportedly will handle all makes of motor homes, trailers and campers in his service clinic. We have long anticipated such a venture and predict a booming future.

NEW ELECTRONIC SAFEGUARDS FOR RV POWER SYSTEMS. Unless great care is exercised, a new RV owner can forget to switch over from 12-volt to 110-volt operation when connecting to park sources. The result is instant battery and wire burn-out. Now new systems are available whereby the owner can switch from 12-volt to 110-volt operation with full automatic protection. Sensors immediately change circuits when the voltage changes. This burn-out protection is long overdue.

THIS TENT TRAILER FLOATS! The NaviCamper is a new amphibious fold-out trailer. The owner can tow it like any trailer-camper, but at the water's edge, he simply cranks down pontoons and it becomes a boat. Motors as large as 55 hp can be used to water-ski, fish or cruise. The NaviCamper has an aluminum roof, roll-down canvas back and front, and sleeping space for up to six people. Amphibious units may solve some of the problems fishermen face where waterside campsites are scarce. (NaviCamper, 5518 S. Country Rd. 18, Minnetonka, Minn. 55343).

NEW RANCH CAMPS COMING. Some of the new private campground chains are planning dude-ranch-style camping for 1970. Their campgrounds will resemble western cattle ranches, with wagons, riding stables, hay rides, barns and growing crops on the property. Overnight side trips by horseback with ranch-hand guides, western pit barbecue, square dancing, and other Western pastimes will be offered as regular fare. As one campground planner emphasizes: "A modern campground should be a *way of life*, not merely a place to park the family overnight."

BEVY OF NEW RV PUBLICATIONS. The Trail-R-Club of America has published three informative books for the RV owner or would-be owner: *How to Buy Recreational Vehicles and How to Select a Car or Truck for Trailer Towing*, both by Jack Kneass, and *Trailer Owners Handbook* by Jesse Dipboye. For prices and details write the Trail-R-Club, Box 1376, Beverly Hills, Calif. 90213.

WATCH FOR NEW SUPER-LUXURY OPTION PACKAGES ON RVs. The word is that 1970 will see the first general offering of flashy-trim options for campers, trailers and motor homes. Such packages will range from about \$125 to \$1000 or more per recreational vehicle—but strictly at the buyer's request. Such luxuries as larger refrigerators, deep-pile carpeting, higher-quality drapes, and stereo-music systems are only a few of the possible extras. ★★ ★

Tools you should get your hands on.

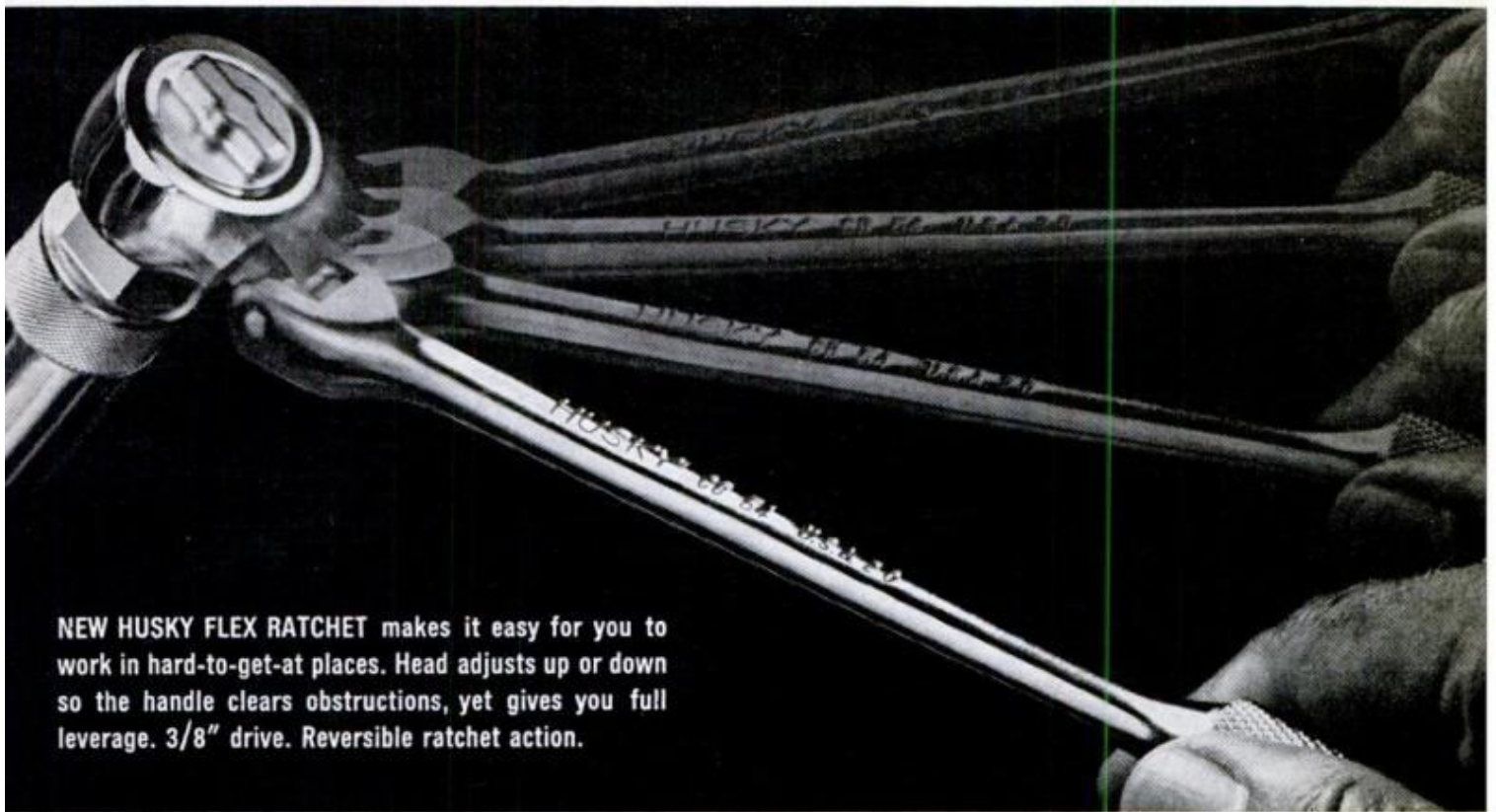

NEW HUSKY FLEX RATCHET makes it easy for you to work in hard-to-get-at places. Head adjusts up or down so the handle clears obstructions, yet gives you full leverage. 3/8" drive. Reversible ratchet action.

Get your hands on a Husky Tool and you'll never settle for the ordinary. Husky is professional mechanic quality. Made of special steel... forged, heat treated, precision machined. The 45-tooth ratchet action gives you remarkable smoothness and power. Four-way ball grooved sockets attach quickly, fit like a glove. Husky Tools are built to give you a

lifetime of satisfaction. And priced to give you a lifetime of value. Get your hands on them. You'll like what you get! Husky Tools, New Britain, Conn.

Husky



WHY FUMBLE? When you choose from Husky's Matched Socket Wrench Sets, you're sure to have the right tool to work on anything — car, truck, plane, boat, lawnmower, garden tractor or snowmobile. Choice of 1/4", 3/8", 1/2" and 3/4" drives... in sets ranging from 9 to 104 pieces.



The bargain hunter



BUILD YOUR OWN GUITAR

Here's your chance to make your own Spanish guitar for as little as \$20.00 — an electric guitar for \$28.50 — or a two-pickup electric guitar for only \$33.50. Kits are shipped postage paid, complete with all materials and easy-to-follow instructions. Nothing else to buy. No special tools needed. Send check or money order. Or send 25c for free literature.

SPANISH GUITARS LTD.

Box 1377, San Antonio, Texas 78206

CUTS HAIR

... as You **COMB!**

SAVE \$50 and more yearly with the MIDAS QUICKTRIM. Anyone can automatically trim, taper, shape hair evenly, smoothly, on head, neck, temples, legs. Perfect for Mom, Dad, Junior's hair. Hold in either hand. Completely safe! No blade refills to re-order! FREE carrying case. 7" long. COSTS LESS THAN ONE HAIRCUT! Satisfaction or money back. **\$1.59** PPD. (2 for \$2.98; 3 for \$4.17)

ROSE-LEE, INC.

Dept. AG-3, 5 East 4th St. Wilmington, Del. 19801



REDUCIBLE

RUPTURE

AGONY Removed (or trial COSTS YOU NOTHING)



WHEN you slip into a low-cost, contour-designed Brooks Patented Air Cushion Appliance! Your reducible rupture will be held in securely yet gently—or the trial costs you nothing! This invention has made millions of sufferers happy. You can enjoy heavenly comfort night and day at work and play—or the Appliance costs you NOTHING. Isn't this worth a no-risk trial by you? If interested, write for free facts now. **BROOKS CO., BOX 346-H, MARSHALL, MICH. 49068**



THIRD HAND SPECIALTY CLAMP

IDEAL GIFT. Made of fine steel, it holds awkward jobs and leaves both hands free for cutting, welding, etc.

NOTHING ELSE LIKE IT. The standard G holds 1 piece while the right angle holds the second to the first. Throat opens 1 3/4" to 2 3/8" and is 1 1/4" deep.

NO WORKSHOP OR HANDYMAN SHOULD BE WITHOUT THEM

\$4.00 each \$6.50 for 2 \$12.00 for 4

Post Paid U.S. Prices

SORRY NO COD'S.

obtainable exclusively from

E. S. BOWEN 41 Yonge St. N. Richmond Hill, Ont. Canada

RARE 1955S NEW 1968S



Included in collection 33 diff. Uncirculated (new) Lincoln Cents: 1954 to 1963 plain-D-S complete (Regularly \$6.25)—**SPECIAL ONLY \$2.95** (Limit 2 sets). 35 tough "S" cents mixed (used) only \$1.00. 30 Uncirculated coins—30 countries, Bargain—\$1.95. Buy all 3 packets we'll toss in an old Indianhead Cent! Include 20¢ Insurance. Silver Dollars \$2.45 ea. Huge bargain coin lists with year sets, silver dollars, accessories, etc., included with order, otherwise 25¢. We buy coins—huge premium book 50¢.

BONANZA, Box 820P Cupertino, Calif. 95014

One Sharpening Machine Does All This—

Start your sharpening business with Treycos 6-in-1 grinder. No need to buy separate machines for every job. You can hollow-grind scissors, pinking shears, knives, tools, garden tools, rotary mower blades, hand and circular saws—all with **ONE SIX-IN-ONE** Treycos Sharpener at low price of one machine. Safeguard your future—build your own spare or full time sharpening business. Take in as much as \$6.00 an hour—no lay-offs, no cut-backs, no forced retirement—enjoy independence and security! **ACT NOW—write for FREE CATALOG and LOW FACTORY-TO-YOU 6-in-1 prices.**



TREYCO Products, Inc.

332-A Niagara St. N. Tonawanda, N.Y. 14120

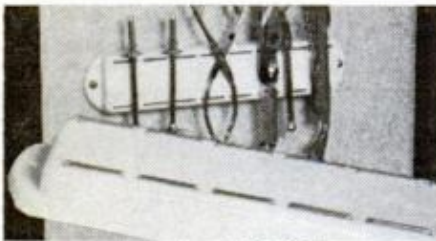

Perfect Gift!

Magnagrip Mark X. Homemakers love it. Holds all metal kitchen or shop tools magnetically in sight, safely, orderly. Handy, compact. Mounts easily on any surface. Styled in white. Gift boxed. For camp, garage, shop, kitchen, trailer.

\$3.95 p.p. Money-Back guarantee. Ck. or M.O. to Dept. E

PHELON MAGNAGRIP COMPANY, INC. East Longmeadow, Mass. 01028

Stop Slipping On Ice!



NEW ARMY

ICE

CREEPERS

\$2.00 pair plus 50¢ postg.

Adjustable to any size foot. Wear them on any shoe or boot, sharp cleats cut through ice or sleet to give you sure footing. A must for ice fishermen, hunters, outdoor workers, etc. They cost Gov't \$3.45 pair. You pay only \$2.00 plus 50¢ postage! Write for unusual **FREE Catalog**

BankAmericard Charges Welcome!

P & S SALES Dept. P-12 P.O. Box 155 Tulsa, Okla. 74102



22 CAL.

PELLET

FIRING

"STINGER AUTOMATIC"

50 22 CAL. PELLETS FREE

Looks and Feels Like Real

Pocket Automatic—

Loads 15 Shots

Fires 22 cal. pellets just as

fast as you can pull the trigger.

Great for fast action combat-type target practice.

50 reusable 22 cal. pellets free.

Free supply of targets. Money

back if not satisfied. Just send

\$1.00 plus 25¢ for postage and handling to:

Honor House, Dept. 96RA60, Lynbrook,

N. Y. 11563



Write to **POPULAR MECHANICS**

and request their **FREE 32 page catalog.**

Include **25¢** to cover postage and handling.

HEAVY DUTY WELDER

Does work of \$85.00 welder
yet costs only **1895**
POST PAID
Fits ordinary 110V outlet
Not one • but 3 welding heats

Weld, braze, solder or cut most anything made of metal. No experience necessary. Follow simple instructions. Uses standard 1/4" rods to weld iron, steel, brass, bronze, aluminum, other metals. Repair cars, farm implements, appliances, toys. Make campers, trailers boats. Pays for itself quickly. Comes complete with mask, \$2.00 pack of rods, flux, etc. **NOTHING ELSE TO BUY.**

3 WELDING HEATS . . . Not just one as with other low cost models. "High" for tough jobs, "Medium" or "Regular" for lighter work. 3 heat feature saves you money. New **HEAVY DUTY** circuit gives more welding potential than ever before. Approved for homes, garages, factories, shops. Has power boost circuit for industrial uses. Raises heat to 4 TIMES that needed to melt toughest iron. No other welder has all three fine features.

FREE! Automatic arc striker now makes welding easy, even for beginners. Just plug welder into ordinary 110V outlet, touch automatic arc striker and start welding. You can't buy this important new Wel-Dex invention but it's yours free if you order from this ad.

10 day MONEY BACK TRIAL. Guaranteed against burnout. SEND \$2.00 and pay \$16.95 plus small C.O.D. when delivered or \$18.95 for postpaid shipment. Phone (713) 682-5811 for C.O.D.

WEL-DEX MFG. CO., Dept. W-10, Box 10776, Houston, Texas 77018

\$\$ TREASURE \$\$



New revolutionary analytical transistorized metal detector will distinguish a gold bar from a tin can. No more unnecessary digging for tin cans, nails, bottle caps, etc. Also features push button tuning, automatic tuning, loud-speaker. Negligible ground pickup. Greatest detection range, etc. Many models — free catalog.

GARDINER ELECTRONICS CO.

Dept. 8, 4729 No. 7th Ave., Phoenix, Ariz. 85013

POLICE - FIRE - EMERGENCY - CAR RADIO \$9.99

Works with regular CAR RADIO and ANTENNA! NO special wiring or installation. Mounts UNDER DASH in 5 minutes in ANY CAR OR TRUCK. Panel switches INSTANTLY from REGULAR to POLICE-FIRE-EMERGENCY radio CALLS—Receives ALL stations in your AREA within range. Works with ALL HOME RADIOS TOO!

SEND ONLY \$2.00 (Cash, Ck, M.O.) and pay postman \$7.95 plus COD note or send \$9.99 for post paid in USA. **COMPLETE** ready to clip in your CAR with all parts and instructions. One year parts and service Warranty—10 day money back trial (if retrnd). **AMAZING OFFER** good only by mail and from: **WESTERN RADIO Dept. BPM-12 Kearney, Nebr. 68847**



OUTDOORSMEN wanted for 500,000 exciting new jobs!



FREE Career Kit shows how to qualify at home in spare time for big-pay jobs now open as Forest Ranger, Park Officer, Fish-Wildlife Mgr., Game Warden. Lifetime security. Many other benefits. H.S. diploma not required. Approved under GI Bill. Write Conservation, 2000 P St., N.W., Washington, D.C. 20036, Dept. 2112 N.

FREE!

Learn how you can buy used engines \$15 up, new engines \$30 with **FREE** confidential list and coupons when you order your plans

- **BUILD THIS MINI-BIKE!**
Plans reveal step by step details!
- **BUILD A RACING KART!**
Build frame for less than \$10!



RUSH \$2 for plans (indicate type) or send 25c for circular describing plans **PLANS, Box 517, Omaha, Nebr. 68101**

HOW YOU CAN BECOME RICH!

FREE!

Revolutionary New wealth-building secrets! You can become a Money-Making Success . . . **FAST!** Write today for your free copy of "How To Become Rich"!

Success International, Box 2447-C3, Livonia, Mich. 48151

LEARN TO BE A SKILLED LOCKSMITH



Change combination of pin tumbler cylinder
EARN \$1.50 in 15 MIN.

Owner loses key; pick car trunk—
EARN \$5.50 in 10 or 20 MIN.

TYPICAL JOBS EARN YOU \$271 PART TIME (in only 53 hours!)



Install new knob door lock—**EARN \$15.00** in 30 MIN.

After-hour emergency opening—**EARN \$2.50** to \$5.50 in 20 MIN.

Hundreds have succeeded like these Belsaw Graduates:

R. W. Davis, St. Louis, Mo.: "I am doing a wonderful business thanks to your course in locksmithing. Last Saturday I took in \$110.00."

Pierson Crook, Los Angeles, Calif.: "I am making \$200 a month extra income with the Belsaw Locksmith Course. I would recommend your course to anyone."

Big demand for skilled Locksmiths! Earn big money spare time in your own home. Be your own boss. No layoffs. Steady year 'round income. Age and schooling are no handicap.

BELSAW INSTITUTE training... approved by master locksmiths... helps you start faster with easy picture lessons guided by your own mail instructor.

Get thorough job training on all types of locks. We supply tools, equipment and business help: how to start, how to charge, how to get jobs, how to earn while you learn and build a lifetime cash-profit business. Accredited Member National Home Study Council. Approved by State Board of Education. Approved for Veterans.



This \$125 key machine is yours to keep!

MAIL COUPON—NO SALESMAN WILL CALL

BELSAW INSTITUTE, 1002 Field Bldg. Kansas City, Mo. 64111

Send **FREE** book, "Keys To Your Future!"



Name _____

Address _____

City _____ State _____ Zip _____

We'll Help
You Start A

BUSINESS of YOUR OWN

No Money Down

Here's an unusual opportunity to start a business of your own without investing any money to get started... that's because we know that any person who wants to succeed in a profitable saw sharpening operation can make money. Thousands are already doing it but every neighborhood can use this service. No need to quit your present job—Start in sparetime and build it into a money-making full-time business of your own.

No Experience! No Selling

The easy-to-operate Foley Saw Filer is automatic—it does the job for you. You can be doing business the day after you receive your machine. And with a saw filing business customers will come to you. No door to door selling! You are supplying a much needed service. If you'd like more information about this unique business opportunity, return coupon (no salesman will call) and we'll send you our fact-filled

MONEY-MAKING BOOKLET FREE!

Foley Manufacturing Co.
1216-9 Foley Bldg., Minneapolis, Minn. 55418
Send for FREE book on Money-Making facts about the sharpening business.

NAME _____
ADDRESS _____
CITY _____ STATE _____ ZIP CODE _____



Tiller Users!



TORTURE!



JOY!

If the tiller you've been using has its revolving blades in **FRONT** and **NO** power to the wheels (See 'Torture!' at left), you won't ever be happy with it again once you try the **TROY-BILT**® which has its revolving blades in the **REAR** and **POWER DRIVEN WHEELS**—and is **SO EASY** to use you guide it with just **ONE HAND!** (See 'JOY' at left). You do **NOT** have to walk behind it, leaving footprints! It does **NOT** shake you half to death! It leaves **NO** wheelmarks! The **TROY-BILT**® is now in its 9th great year. **SO**, if you want tilling to be a **JOY** instead of **TORTURE**

from now on, please clip this ad now and send today for the whole story of this wonderfully **different** and **better** design in tillers! We'll send complete details, including prices and **OFF-SEASON SAVINGS** now in effect for a limited time! Just ask for **FREE BOOKLET**. Write now to —

TROY-BILT® Roto Tillers, Dept. 1962
102nd St. & 9th Ave., Troy, N.Y. 12182

HEARING AIDS

2/3 OFF DEALER PRICES

LARGEST SELECTION of tiny, all-in-the-ear, behind the ear, eyeglass and pocket models. **FREE HOME TRIAL**. No obligation. Money back guarantee. No down payment. Easy terms. No salesmen or dealers. Order direct, save 65%. Write for free catalog. **PRESTIGE**, Dept. D-34 Box 10947, Houston, Tex. 77018.



DART® ELECTRONICS ANNOUNCES THE ALL NEW GOLDSEYE® SERIES

COPYRIGHT 1969 DART ELECTRONICS U. S. PAT. PEND.

NEW PROFESSIONAL METAL LOCATOR OUTPERFORMS OTHER MODELS

GUARANTEED • Easily detects buried coins, relics, gold, silver, copper and all other metals. Works through dirt, sand, rock, wood, water, etc. New solid state circuit assures maximum performance.



MODEL XL

Fully Transistorized
1970 MODEL

ONLY \$29⁹⁵ POSTPAID

Comes complete, ready to use. New powerful circuit for maximum sensitivity. Has both loudspeaker and earphone, uses inexpensive 9 volt battery. Lightweight: Only 2 pounds.



VIEW-METER MODEL XXL
New View-Meter model detects objects on the fringe of detectable depths, means more sensitivity.

VIEW-METER MODEL ONLY \$39⁹⁵ POSTPAID



NEW
POWER-COIL
AVAILABLE

Order one now or add it on later. Why buy a detector without this valuable feature?

The all new Dart power-coil will effectively double the penetration depth of the XL and XXL Goldseye Models on larger objects that are buried deeper.

POWER-COIL, ONLY \$12⁹⁵ POSTPAID

ORDER NOW FOR IMMEDIATE SHIPMENT!

TO: DART ELECTRONICS P. O. BOX 361 PM
HUNTSVILLE, TEXAS 77340
ENCLOSED THE SUM OF \$_____ FOR THE ITEMS CHECKED BELOW.

CASH CHECK MONEY ORDER

DART MODEL XL \$29.95
 DART MODEL XXL, WITH VIEW-METER \$39.95
 POWER-COIL \$12.95

NAME _____
ADDRESS _____
CITY _____ STATE _____ ZIP _____

CLASSIFIED ADVERTISEMENTS

Rate: \$1.85 per word payable in advance each insertion. Capitalized words—75¢ per word additional. Minimum insertion ten words. To be inserted under the proper classification, copy must be in our office by the 15th of the second month preceding date of issue. The next available issue to place an advertisement in America's No. 1 Classified Section is February. The closing date is December 15th. Send remittance and order to C. A. Martin, Popular Mechanics, 224 West 57th Street, New York, New York 10019. Please make remittance payable to Popular Mechanics.

POPULAR MECHANICS

CHRISTMAS GIFT SHOPPING

UNIQUE, Distinctive Gifts for Everyone. Write: Novak, 18720 Hatteras, Tarzana, California 91356.

GIFTS! Lowest Prices! Everything Supplied! Mandarin, 214 Shaws Building, Hong Kong.

SPANISH MAJA Soaps and Perfume. \$4.00 set. Exquisite! Roque, 2256 Division, Chicago, Illinois 60622.

GIFTS FOR MEN & BOYS FROM 9 to 90. Steam Engines, Toy & Model, ready to run. Binoculars, Telescopes, Air Rifles, Safari Grills, Handcrafted Hunting Knives. Free Catalog. Safari Outfitters, Baker, Ore. 97814.

ATTRACTIVE Gifts for all Occasions. Free Catalog. Harvard House, 1691 Davidson, Bronx, New York 10453.

NEW! MAGNETIC KEY CARRIER—amazingly thin! Eliminates bulges—pocket wear. Handsome leather. Holds 4-5 keys (any type). Satisfaction guaranteed—send only \$2.50: "MAGNA-THIN", 6422 Olde Stage, Boulder, Colorado, 80302.

LIFETIME GIFT! Engraved Golden Aluminum Social Security Plate. Carrying case. Send name, number and \$2. Fast Service! MGR Studios, 4445 Berke, Ft. Worth, Texas 76115.

"FUN MONEY" \$100 bill your picture's on it. © Send \$8.00 and photo to W. Freeman, 5062 23rd Detroit, Michigan 48208.

PRACTICAL gift! Amazing new GT solid state electronic ignition. Fits all cars, motor boats! Eliminate Tune-ups! Instantly connectable! One \$9.95; Two \$18.95; Three \$26.95 postpaid. Bunda, Box 29, Cedar Grove, New Jersey 07009.

FREE Gift catalog. Mountain Mart, 1123K West Eighth, Cedar Falls, Iowa 50613.

INSTANT Fish. Live pet toy. Add water, watch them hatch. 1,000 eggs, food, instructions \$1.49. Guaranteed Products, Box 7225, Kansas City, Missouri 64113.

GERMAN Clocks, free folder. Del Marsh Co., P.O. Box 767 Lompoc, Calif. 93436.

"QUALITY Christmas Gifts. Free catalogue. Woodland House, 2437C Tortugas, Ft. Lauderdale, Fla. 33312."

MIDGET CARS

YOUR Ad in Popular Mechanics will be seen by more than 5,000,000 active buyers for your products and services. It costs only \$1.85 per word. And, if you wish to run all or part of your ad in capital letters—you can do so for as little as 75¢ per word additional. Act now! Place your Classified ad in Popular Mechanics today.

AUTOMOBILES

GERMAN hand and special TOOLS. VW and others. Werner Import, Box 84, Redondo Beach 90277.

FREE BOOKLET—"101 Ways To Save Money On Your Car". Send 35¢ in coins for postage-handling to: National Auto Club, Box 368, Elmont, N.Y. 11003.

AUTO SUPPLIES AND EQUIPMENT

VOLKSWAGEN and Dune Buggy Accessories. Catalog 50¢. Gem Products, Box 845P, Carol Stream, Ill. 60187.

PARTS: Army jeep and truck parts. Spare Parts & Equipment Co., P.O. Box 751, Lexington, Ky. 40502.

VOLKSWAGEN Replacement parts at 20% to 50% discounts. Free Catalog. Western Distributors, Box 316 D, Cedar Crest, New Mexico 87008.

CROSLEY. Foreign, American. Parts. Discounts Accessory Catalog 616 Burnside, Inwood, New York 11696.

AUTO Parts for old and new Cars. All makes. Catalogue \$1.10. Antique Auto, Milwaukee, Wisconsin 53204.

DOUBLE Your battery's life, save money, recondition old or dead batteries for profit. Information \$1.00 Re + Charg. Box 1083, Station 'A', Toronto 116, Canada.

VX-6 PREVENTS battery killing sulphation, increases capacity. Guaranteed! \$2.98. Herford, 2729-E Midvale Ave., Los Angeles, Calif. 90064.

STOP CAR THIEVES: DO IT YOURSELF plan discloses six inexpensive, highly effective, common-sense ways to stop theft and pilfering. Complete plan \$3.00 Check or M.O. Verdi-systems, P.O. Box 186, Belle, Missouri 65013.

REVITALIZE—Save your transmission. \$2.50 postpaid. Profitable for salesmen. Weldtite, 120 N. Fourth St., North Wales, Pa. 19454.

(PREVENT AUTO THEFT!) Protect your Cars for years. Send \$2.95 C.C. Products, Box 96, Rialto, Calif. 92376.

INEXPENSIVE automotive electronic test equipment free information Auto-Test, P.O. Box 1133, Walnut Creek, Calif. 94597.

BE Your own ignition expert. Free details. Q-arc, Box 47876, Los Angeles, Calif. 90047.

INGRAHAM PORTABLE CAR CLOCKS. Instant Installation. Guaranteed. Write Pompa Industries, Box 8544, Rochester, N.Y. 14619.

BUILD This ELECTRONIC IGNITION for fun or profit. Part time-Full time Comparable to \$40 systems. Resonant charging design gives magneto-like racing performance. Complete plans \$1.00 and self-addressed stamped envelope. L & M Enterprises, P.O. Box 937 PN, Slidell, La. 70458.

JEOP Owners—V8 conversions. Read Jeep Owners' ad, page 206.

BIGGEST \$\$\$\$\$ Saver in Automotive History!! Motaloy Ring-Valve Job. \$6.50 postpaid. Lasts 100,000 miles! (New engines too) 18 years proven results! Motaloy, Grantham, Penna. 17027.

SNOWMOBILES

SNOWMOBILE KITS \$25. Plans and photos \$1.00. Information 10¢. Compco, Box 1267, Redwood City, California 94064.

SNOWMOBILES—Factory Direct Prices. Save 20%. 7 latest 1970 models. 18-30 HP. Free Inspection. Money back guarantee. Easy terms. Free catalog. Luger, Dept. SB-69, 1300 East Cliff Road, Burnsville, Minnesota 55378.

AUTO TRAILERS

MOTORCYCLE carriers and 12 volt fluorescent, savings! Moon, Box 252-P, Covina, Calif. 91722.

PICK UP CAMPER WITH KING SIZE BED + Storage for Outboard—Guns—Tackle—more. 10½' SPECIAL—Plan \$4.95—8'—\$3.95—W & R Custom's, P.O. Box. 11382, Memphis, Tennessee 38111. SAVE 40%.

PICKUP Camper, Trailer or Pickup—Cover . . . Build yourself. Save! Complete plans \$3.95 each cover plans \$2.00. Conversion Plans—economy type van \$2.95; passenger bus or delivery van \$2.95. Satisfaction Guaranteed. Equipment catalog \$1.00 (refundable). Details 10¢. Viking Camper Supply, 99-F Glenwood, Minneapolis, Minn. 55403

BUILD Your Pickup Camper. Precut Kits. Blueprints. Supplies. Literature 25¢. Comstock Trailers, Dept. 664, Parsons, Kansas 67357.

LOWEST Prices! Catalog of 19 pre-cut Camper Kits, send 25¢. Trailer and Camper Parts and Accessories Catalog, send \$1.00 (refundable). Snowy Mountain Campers, Dept. PMC, Lewistown, Montana 59457.

MOTORCYCLES, BICYCLES, MOTORSCOOTERS AND SUPPLIES

BUILD "Popular Mechanics" MINIBIKE featured June 1967 issue. Detail plans, photographs \$2.50 refundable. Kits, parts, engines; factory discount prices. Catalog 25¢. Gilliom Mfg.: PMC; St. Charles, Missouri 63301.

EVERY PART for Kart or Mini-bike. Bargain prices. Giant catalog \$1.00. Brown's Motorsports, 19 Central St., Worcester, Mass 01608.

MINI-BIKES \$49.95. Motorcycles supplies. Catalogs 25¢. Loren Products, Danville, Illinois 61832.

BUILD Your Own MINI-BIKE NO WELDING OR BRAZING REQUIRED. 24 Pages of Detailed Step by Step Instructions and Diagrams. Money-Back Guarantee. Only \$2.00. Mini-Brute Industries Inc., Dept. PM-L, P.O. Box 1083, West Caldwell, New Jersey 07006.

HONDA. \$25, other bargains. Send 50¢. Motorscooter, P443, Bend, Oregon 97701.

(Continued on next page)

MOTORCYCLES, BICYCLES, MOTORSCOOTERS AND SUPPLIES

(Continued from preceding page)

BUILD Motorbike From Bicycle! Plans \$2. Go-Cart Plans \$2. Snowmobile Plans \$3. Go-Byk Industries, Rothsay, Minn. 56579.

MOTORCYCLE TURN SIGNALS Accessories. Catalog 25c. Houston, PM Lockport, Illinois 60441.

SNOW VEHICLE & KART Hop up accessory CATALOG. Speed and performance equipment—manifolds, engine mounts, exhaust systems. Send 25c. G.E.M. PRODUCTS, Box 845, Carol Stream, Ill. 60187.

SPACE, ROCKETS AND ASTRONAUTS

ROCKETS!! Real flying models—2500 feet altitude with powerful motors. Terrific Science Projects. Tubes—Cones—Parachutes—Launchers—Igniters. Gigantic catalog—rocket data—diagrams—25c. Fast Delivery. Centuri Rockets, Box 1988, Phoenix, Arizona 55001.

MOON GLOBE. Exciting new 6-inch diameter moon globe illustrating moon's craters, "seas" and mountains in detail. Ideal for following future explorations! Including descriptive 16-page moon book. \$3.50 plus 40c postage. Michigan residents 4% sales tax. Graylines Express, 4465-C Janice Lee Dr., Okemos, Mich. 48864.

ROCKETS: Real flying models—flights up to 2500 ft. New illustrated catalog 25c. Singles and multistage kit, cones, engines, launchers, trackers, rocket aerial cameras, technical information. Fast service. Estes Industries, Penrose 7, Colorado 81240.

OUR FIRST 19 IN SPACE. This limited edition lithograph has been created as a tribute to America's Gallant Astronauts. 12 X 18 inch chart ready for framing. Only 75 cents. Popular Mechanics, Dept. GWP, 224 West 57 Street, New York, New York 10019.

ROCKET. Launching Material, Flying Saucers, Hot Air Balloons, Cannons, Books, Taxidermy, More. Free Catalog. Zeller, Box 71, Hudson, Mich. 49247.



AVIATION

BE A Government licensed aviation mechanic. Practical training. Free information. Aero Mechanics School. Municipal Airport, Kansas City, Missouri 64116.

AIRBOAT. Propellers, Engines, Plans, Kits, Supplies. Complete Airboats Outboard Airdrives. Catalog \$1.00. Banks-Maxwell, Box 3301E, Ft. Worth, Texas 76105.

HELICOPTER. One-Man. Portable Kits, Plans, Information 10c. Photos and three-view drawings \$1.00 Compcop, Box 1267, Redwood City, California 94064.

AVIATION Surplus Big Catalogue 50c (Refundable). Box 1TFPM, Spring Grove, Penna. 17362.

FREE Catalog. Aviation Space Books. Aero Publishers, 329 Aviation, Fallbrook, Calif. 92028.

AIR CUSHION VEHICLE. acv-oox, easy to build, up to 50 mph over water, land, snow. Hovers any direction. Two air cooled engines. Will carry 4 people. Easy to read construction plans \$10.00. Physics Phenomena Research, Box 43, Newport, Indiana 47966.

AIRBOAT. Snowsled. Hovercraft. Gyroplane Plans \$3.00 Each. Catalog of supplies \$1.00. Esco-A, Box 3379, Sarasota, Florida 33578.

AERO-CAR. Amazing Hovercraft built easily with ordinary tools. Lawnmower engine power. Carries one man plus. Hovers, flies forward, backward, sideways over land/snow/water. Complete construction plans and brochure. \$5.25. Aero-Projects, Box 5118PM, Clinton, N.J. 08809.

HOMEBUILT. Real enclosed helicopter, 24 pages ideas, information, \$2.50. Build "executive" helicopter, drawing, specifications, \$2.00. Helicopter Development, Box PM147, Washington, New Jersey 07882.



BOATS AND TRAILERS

FREE Catalog! Camping, Boating, Sailing Supplies; Gadgets, Hardware and Gifts, Laacke and Joys, 1439 N. Water St., Milwaukee, Wisconsin 53202.

NEW 1969 McCulloch And Other outboards 4 H.P. \$114 . . . 9 electric \$288 . . . 18 \$338 . . . 25 \$388 . . . 40 electric \$558 . . . 55 electric \$768 . . . all sizes. Literature 50c. Electra Marine 1427 Broadway Brooklyn, N. Y. 11221.

CANOE! Kayaks! Factory-direct quality kits, from \$25.00. Many different models. Canvas hulls. Strongest construction materials. Free literature. Sportsraft, Box 8393-PM, Columbus, Ohio 43201.

BOAT PLANS, FRAME KITS, BOAT KITS. World's largest catalog—Over 200 top design for the amateur builders. New catalog includes Cruisers, Runabouts, Deep vee's, Catamarans, Trimarans, Houseboats, Sailboats from small sail fish to 34 ft. motor sailers, large selection of inboard and outboard Hydroplanes. Send \$1.00 for large new plan & kit catalog or \$2.00 for catalog plus Boat Builder's Guide. Clark Craft Boat Company, 16-P Aqua Lane, Tonawanda, New York 14150.

BUILD Your own boat from our large-scale blueprints. Books of plans give how-to-build help. Hundreds of professional designs—motor, sail or auxiliary—for amateur builders. Free catalog. MoToR Boating, 959 Eighth Ave., Dept. PM-RS, New York, N.Y. 10019.

FIBERGLASS Cloth and resin. World's finest cloth and non-run resin, at direct mill prices Flotation foam. Complete line of plastics, silicon bronze and brass screws, save 60%. No sales tax. Boat Plans, Catalog 25c. Freight prepaid. Stiles Boat Supply, Box 11P, Linden Ave., Mantua Hts., N.J. 08051.

PLANS, FULL-SIZE PATTERNS, FRAME KITS with step-by-step instructions specially for amateurs. Send \$1.00 for new 96 page catalog of over 80 designs: 8' to 36' Sail, Jets, Inboards, Outboards, Cruisers, Houseboats, Hot Boats, Catamarans, Hydros "plus" boat trailers. New "How To Build Boat Trailers" book \$4.00 ppd. Glen Designs 9152 Rosecrans, Bellflower, Calif. 90706.

FIBERGLASS CANOES. Four Exciting Models. Easily Assembled Kits. \$39.95 up. Factory Direct. Free Literature. Riverside Canoes, Box 5595-B, Riverside, California 92507.

BOAT Kits. Molded Fiberglass. Save money—assemble yourself. Factory molded sections bond into one-piece craft. 30 models—14' to 32'. Cruisers, Runabouts, Houseboats, Sailboats. Big line accessories, motors, trailers. Easy terms. Free 80 page catalog. Luger, Dept. BC-69, 1300 East Cliff Road, Burnsville, Minnesota 55378.

BOAT maintenance information. LIFE-CALK. "GIT"-ROT, RUB-R-COTE, Finishes & Cleaners. Send for "How to do-Where to do" literature. FREE. Boatlife, 5-45 49th Av., L.I.C., N.Y. 11101.

SAILMAKING Step by step Instructions \$3.00. 12' Dinghy plans FREE with order for its sails. Mainsail \$65 Jib \$18. Bowen, 41 Yongen, Richmond Hill, Ontario, Canada.

FREE Catalogue—plans for canoes, kayaks, accessories. Quicksilver, 115 McGavock, Nashville, Tenn. 32714.

200 BOAT Plans, some kits. Catalogs: Powerboat \$1.25, condensed 60c. Sailboat 50c. Marinecraft, Box 161M, Brighton, Mass. 02135.

AMATEUR Boat Building Magazine, plans, discounts, books, instruction. 1001-B Beveridge, Richmond, Va 23226.

MARINE EQUIPMENT AND SERVICES

MOTORS Brand New Outboard Motors. 1 1/2 HP through 115 HP. WHOLESALE. Write Motors, P. O. Box 34, Wetumpka, Alabama 36092.

CONVERT Auto engines to marine. 68 Page Catalog, 50c. Lehman Manufacturing Company, 800 Elizabeth Avenue, Linden 4, New Jersey 07036.

NEW, Used, rebuilt marine motors. Marine conversions, fittings Free catalog. Stokes Marine Supply, Dept. 24, Coldwater, Michigan 49036.

FREE Catalog—Gary inboard, inboard-outboard marine engines—gasoline, diesel. Graymarine Corporation, Coldwater, Michigan 49036 or Berkeley, California 94710.

BIG Discounts—Conversion Kits—Marine Engines—Manifolds—Transmissions—Outdrives—Free Brochure. Star Marine, Berkeley, California 94710.

MARINE Or Travel Trailer supplies discounted. Walters Marine Supply: 2620 Deepwood Drive, Wilmington, Delaware 19803.

ATHLETIC AND BODY BUILDING COURSES

"GIANT Arms." Dr. Young's, D.C. revolutionary discovery. \$2. Satisfaction or refund. Gaucho, Box 9309-S7, Chicago 60690.

POWERFUL Muscles fast! Free brochure! Universal Bodybuilding, Box 4327-C, Dearborn, Michigan 48126.

KARATE, KungFu, Weapons equipment, supplies Catalogue—\$1.00. Orient East Imports, 3577 West Lyndale, Chicago, Ill. 60647

SPORTING GOODS AND EQUIPMENT

SILENCER! Pistol, Rifle details. Simpler, Cheaper! New design for .22s included: \$1.00 SLINGBOW: Powerful slingshot shoots arrows accurately with simple adapter easier than bow. Complete plans: \$1.00. Both plans: \$1.75. Box 192, Dunellen, N.J. 08812.

FREE Wholesale Catalog. Arrow Shafts, Broadheads, Fletchings Fisharrow Parts, Tools, Bows, Finnyports. (22G), Toledo, Ohio 43614.

FREE 1969 Catalog. Guaranteed Lowest Prices! Rods Reels, Lures, Accessories—Thousands of Items. Cabela's Inc., Dept. S, Sidney, Nebraska 69162.

WATER PROOFING LEATHER BOOTS Lustrous black space age application 100% waterproofs leather and seams. Brushes on. Retains original flexibility. Surpasses hours boiling water test. Plenty for pair 99c. Kurt Meyer, 1819 Victoria Park Rd., Fort Lauderdale, Florida 33305.

FLASHLIGHT HOLSTER!, for regular flashlights. PERSONALIZED!, with your Initials. Snaps, Conveniently, Securely, over Belt. Western Styling. Genuine Leather! Send \$3.00, postpaid. Joseph's PM, 754 Southwest 37th, San Antonio, Texas, 78237.



FISHING TACKLE, LURES

SEND for FREE Wholesale Catalog. The most complete and fully illustrated catalog of reels, rods, beads, spinners, jigs, bodies and parts, sinker molds, feathers, tools, hooks, rod blanks, rod parts, swivels, wire, etc. FINNYSPORTS, ME Sports Bldg., Toledo, Ohio 43614.

Molds—For casting your own fishing sinkers. Free illustrated booklet. Reading Instrument Co., Box P78, Reading, Pa. 19603.

JAPAN'S Fishing equipment. Details, \$1.00, refundable. OHGA, PM-54, Sigakenkusatu, Japan-525.

MOLDS For fisherman's sinkers, jigs, squids, casting and spinning lures. Free catalog. Sweets Molds, Tonawanda 1, New York 14150.

EARTHWORMS, LIVE BAIT

EARN Money raising fishworms for us! Exciting details free! Oakhaven—56. Cedar Hill, Texas 75104.

HYBRID Redworms—3,000—\$5.75. 5,000—\$8.00. 10,000—\$14.00. Bedruns 20,000—\$18. postpaid with raising instructions. Brazos Bait Farms, R-9, Waco, Tex. 76705.

MAKE Money growing Fishworms. Outstanding new breed. Large size, tough, hardy. Plenty of action. They sell on sight. Free information. Fain's Hatchery-31, Edison, Georgia 31746.

RAISE Worms. Soilless Method. Garage, Basement. Three Oaks, Dresden, Tenn. 38225.

FROGS, FISH, REPTILES

MAILORDER Records help get increased business! Complete 32 Page Record Book shows your inquiries orders, advertising, expense, etc. Only \$1.00 C. A. Martin. Popular Mechanics, Dept. PM, 224 West 57 Street, New York, N.Y. 10019.

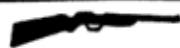

HUNTING, GUNS, DECOYS

PROFITS FROM CLASSIFIED ADVERTISING! Booklet shows you how to start your own business with Classified Advertising. Only \$1.00 (Refundable with first order.) C. A. Martin, Popular Mechanics, Dept. PM, 224 West 57 Street, New York, N.Y. 10019.



GAME BIRDS

QUAILS, Incubators, cages, supplies catalog. Marsh, 14216 Brookhurst, Garden Grove, Calif. 92640.

RABBITS—FUR BEARING ANIMALS

RAISE Rabbits successfully by knowing facts. 48 page illustrated book describing 25 breeds. Housing, breeding, feeding, markets, marketing etc. 25 cents. American Rabbit Association, 36 Arba Building, Pittsburgh, Penn. 15217.

MAKE Big Money raising chinchillas, rabbits, guinea pigs for us. Catalog—25¢. Keeney Brothers, New Freedom, Pa. 17349.

EARN \$10,000 Yearly raising angora rabbit wool, and breeding stock for us. Information 25¢ coin. American Angora Company, Malta 12, Montana 59538.

RAISE Rabbits for us on \$500 month plans. Free details. White's Rabbitry, Mt. Vernon, Ohio 43050.

\$500—\$800 MONTHLY Raise small Laboratory-breeding stock for us. We supply equipment, breeders, and instructions. Illinois Research Farms, Dept. MPB-12, Barrington, Illinois 60010.

TAXIDERMY

TAXIDERMY Success Training sure, easy way into Taxidermy. Complete training. No skimping. All steps illustrated. Request information and free samples. Box 5815E, Bossier City, Louisiana 71010.

PETS—BIRDS, CATS, HAMSTERS, ETC.

HAWKS, Reptiles, raccoons, skunks, squirrels. Catalogue 25¢. Trails End Zoo, St. Stephens, S.C. 29479.

LIVE SEAHORSES, Marine Specimens, aquarium supplies. Illustrated catalog 20¢. Marine, Box 248-310 Dania, Florida 33004.

FLYING Squirrels, Chipmunks. Wonderful Pets. Literature 25¢. Pets, Neches, Texas, 75779.

HORSES, LIVESTOCK

"HOW To Train Horses"—Everyone who likes horses or ponies should have this book: Free. Write Beery School, 11012 Pleasant Hill, Ohio 45359.

CAMPING EQUIPMENT AND TENTS

SAVINGS Plus dividends! Campers-fishermen-outdoorsmen cooperative. Free 68-page catalog. Recreational Equipment, Inc., 1525-P 11th, Seattle, Washington 98122.

TRAVEL AND RESORTS

YOUR Ad in Popular Mechanics will be seen by more than 5,000,000 active buyers for your products and services. It costs only \$1.85 per word. And, if you wish to run all or part of your ad in capital letters—you can do so for as little as 75¢ per word additional. Act now! Place your Classified ad in Popular Mechanics today.

ELECTRICAL SUPPLIES

METERS—Surplus, new, used, panel and portable. Send for list. Hanchett, Box 5577, Riverside, Calif. 92507.

LAMP Parts for building, repairing converting. Catalog 40 cents. Refunded first order. Brown Lamp Co., Box 12511, Creve Coeur, Mo. 63141.

LAMP Parts. Catalog, prices, wiring instructions. 50¢. Refunded first order. Gyro, 5218P N.W. 35 Ave., Miami 42, Fla. 33142.

LO-VOLT Circuit Tester. Handiest ever! Free catalog: Mathco, 4256-1 Minmor, Cincinnati 45217.

APPLIANCE-LAMP parts. Wholesale catalogue 25¢. SECO, 109 South 20th Street, Birmingham, Alabama 35233.

BATTERIES, GENERATORS

ELECTRIC power units—5-KW to 45-KW, gasoline and diesel. K. A. Weimer, 1300 Richard Road, Decatur, Ga. 30032.

BATTERY Reconditioning Kit, includes molds, material, instructions. Battery Shop, Route 1-188D, Blythe, Calif. 92225.

ENGINES, MOTORS, MAGNETS

WINDING Data, 275 motors. \$1.20. Data Company, 512 Kensington, Kansas City, Mo. 64124.

STEAM Engine Kits—automotive. Marine. Catalog 50¢. Reliable Industries, New Baltimore, Michigan 48047.

LIVE Steam powered backyard railroads! All sizes, Complete "bolt-together kits," and rough castings. Excellent drawings. 100 page catalog \$1.00. Little Engines, Lomita, Calif. 90717.

OPERATE Three phase motors from single phase. Plans \$2.00. Donald Howell, Barnesville, Ohio 43713.

SUPERCHARGER; Pep up your Snowmobile Engine with the Cyclone. Free brochure. Power Systems, Minneapolis, Minnesota 55412.

REWINDING DATA, 300 Motors. \$1.00. Modequip, Box 7266, Kansas City, Missouri, 04113.

MACHINERY, TOOLS AND SUPPLIES

BIG 170 page tool and hardware catalog \$1.00. Refundable. Elwick, Dept. 114, 230 Woods Lane, Somerdale, N.J. 08083.

SMALL Foundry furnaces. Supplies. Free literature. Pyramid Products, 3736 South 7th Avenue, Phoenix, Arizona 85041.

MICROMETERS — Indicators — Rods — Lathes — Accessories. Campbell, 1424 Barclay, Springfield, Ohio 45505.

WELDING, SOLDERING, PLATING

CHROME Plating equipment, supplies. All other finishes. Home workshop and production sizes. Send \$2.00 (refundable) for formulas, operating data, equipment guide and catalog. HBS Equipment Division L50, 3543 East 16th, Los Angeles, Calif. 90023.

WELDERS—110/220, 150 Amperes. \$53.50. Morris, 1070 Inner, Schenectady, New York 12303.

GOVERNMENT SURPLUS

GOV'T Surplus. How and where to buy in your area. Send \$1.00. Surplus information, Headquarters Building, P.M., Washington, D.C. 20036.

JEeps Typically From \$53.90 . . . Trucks From \$78.40 . . . Airplanes, Typewriters, Boats, Clothing, Camping, Sporting, Photographic, Electronics Equipment. Wide Variety, Condition, 100,000 Bid Bargains Direct From Government Nationwide. Complete Sales Directory and Surplus Catalog \$1.00 (Deductible First \$10.00 Order). Surplus Service, Box 820-A, Holland, Michigan 49423.

JEOP and Gov't. Surplus Buying Manual (Jeeps Pictured) 50¢. Surplus Bargain Catalogue 50¢. Both \$1. Bargain Surplus, Box 789PM, York, Penna. 17405.

SURPLUS BARGAINS—War, Government. Industrial surplus at savings to 80%! Clothes, boots, cots, tents—Bargains for farm, home, outdoor. SEND FOR FREE CATALOG—must give zip code. Surplus Store, Sioux Falls, S.D. 57102.

1969 SURPLUS Army, Navy store illustrated catalog. Send 25¢ (refundable with first \$5.00 order). Ruvel, 707 Junior Terrace, Dept. 9-J, Chicago, Illinois 60613.

FREE Jeep buying information when you send 50¢ for 1970 Gov't. Surplus Bargain Catalogue. Surplus, Box 1PMTF, Spring Grove, Penna. 17362.

JEeps From—\$52.50; Typewriters from—\$4.15; Cars from—\$31.50. Walkie-talkies, motorcycles, airplanes, boats. Typical "As Is" bid bargains from Uncle Sam. Tremendous variety. Exciting free list. Write: Enterprises, Box 402X53, Jamaica, New York 11430.

HOBBIES AND COLLECTIONS

"SAMPLE 20 pocket plastic albumet for FDC's or post cards, 50¢, or ten for \$3.00, prepaid and guaranteed. State whether for FDC's or cards. Tepabco, Box 198P, Gallatin, Tennessee 37066."

50 GORGEOUS Jungle butterflies \$2.50. Collectors Wonderland, Box 1170, New York 10008.

FREE German Regulation Medal! Send 50¢ postage, handling, get catalog. Iron Cross with Ribbon \$1.50. S. S. Collar Device 50¢. Insignias, Box 71-M Rockaway, N.Y. 11694.

MODEL RAILROADING—The finest hobby 25¢ brings packet informative material NMRA, Box 1328(B), Sta. C. Canton, Ohio 44708.

SURPLUS Arctic clothing special survival gear and trail equipment. Catalog 10¢. Yerger's Supplies, Box 8138, Anchorage, Alaska 99504.



STAMP COLLECTING

SENSATIONAL Clearance. Forty Different Packets \$1.00. No approvals. Norge, Ho-Ho-Kus, New Jersey 07423.

25 DIFFERENT U.S. Airmails 25¢. 45 Different \$1.00. Free pricelist. Eberling, 105 Franklin Avenue, Staten Island, New York 10301.

500 DIFFERENT Worldwide \$1.00! Ross, 320 Rockland Road, Wayne, Penna. 19087.

SPACEPHOBIA? Monaco nudes plus 50 different, 10¢ with approvals. BKJ, Boston, Mass. 02123.

STAMPS Free! New issues—New Countries—Triangles—Rockets—Olympics—Scouts—Birds—Flowers—Animals—Also old Canadian and U. S. Stamps. Plus complete illustrated Canadian Stamp Catalog. Send 10¢ for mailing. Gray Stamp Co., Dept. A, Toronto, Canada.

(Continued on next page)

STAMP COLLECTING

(Continued from preceding page)

NEW African Stamp Collection—including Burundi, Guinea, Mali, Rwanda, Toga, and others, 10¢ with approvals. Clark Stamps, Dept. No. 57B, Muskegon, Michigan 49444.

CANADA 25 Different 5¢ Approvals. Hijop, Box 505, Norristown, Pa. 19404.

SURPRISE COLLECTION! Exotic mint British Colonials, absolutely free with approvals. VIKING, Great Neck 8, N.Y.

DEFECTIVE Old U.S. Approvals. Karl Swartz, Box 373, Venice, Fla. 33595.

PAKISTAN 25 Different 10¢ Approvals. Lansdowne Stamp Co., Box 257, Lansdowne, Pa. 19050.

500 STAMPS 25¢ Approvals. Eric's, Box 1444, Kitchener, Ont., Canada.

PENNY! Approvals! Regardless catalogue! Kloster, 4164 52nd St., San Diego 5, Calif. 92105.

500 DIFFERENT Stamps, \$1.00. Smith, 508-A Brooks, College Station, Texas 77840.

50 YEARS Old, fifteen different United States, over fifty years old—10¢ with approvals. Jaxon, Box 145-P, Brooklyn, New York 11230.

"AFRICA," 25 beauties, 10¢ Approvals. Gorliz, Box 1915PM, Naples, Florida 33940.

FREE Surprise collection sent with approvals. Gould, 1784 Union, San Francisco 94123.

50 DIFFERENT Old U.S. Revenue stamps 50¢. Winchester Stamps, Box 1592, Mansfield, Ohio 44907.

FREE!! Two Beautiful Multi-Colored Complete Mint Sets. Approvals. Hamilton, 1246 Pratt, Chicago OE-12, Illinois 60626.

FREE 50 Worldwide. Approvals. University Stamps, P.O. Box 1471, Lake Worth, Florida 33460.

WORLDWIDE Approvals. Humphrey, 805 24th Ave., Santa Cruz, Calif. 95060.

GIANT Stamp Collection including: Astronauts, Satellites, Moonrocks, Boy Scout issue. Complete U.N. Set, recent Olympic and Sport issues from many countries, etc., Plus Big Stamp Dictionary and approvals, Everything 10¢! Stampex, Box 47-RM, White Plains, N.Y.

ABSOLUTELY FREE 25 different United States Commemoratives when requesting United States Approvals. K & B, Box 70, Brooklyn, N.Y. 11223.

EXCHANGE Send 100-200 Different stamps with 25¢. Receive different. Patterson, Lancaster, New York 14086.

FREE! Big Bargain Catalog—New Edition listing thousands of bargains including U.S. & B.N.A. stamps, packets, albums, accessories and supplies. Also, fine stamps from our approval service which you may return without purchases and cancel service at any time. Jamestown Stamp, Dept. E129PM, Jamestown, N.Y. 14701.

WOW! 110 All Different Germany 10¢ Commemoratives. Airmails, High Values, Big catalog, bargain lists. Also, fine stamps from our approval service, which you may return without purchases and cancel service at any time. Jamestown Stamp, Dept. A129PM, Jamestown, N.Y. 14701.

U.S. Mint specials! Flag set, complete \$1.00. 1¢, 2¢, 3¢ famous Americans (21 different) \$1.00. Free list. Brooks, 2601 Avenue "U," Brooklyn, N.Y. 11229.

50 GREAT BRITAIN from 1881 to date. Catalog price \$2.60—Introductory offer—only 10¢ with approvals. Roger Williams Stamp Co., Box 1281-P2 Pawtucket, R.I. 02862.

100 OLD United States between 1861 and 1935, \$1.00. Roush Stamps, 51 Chestnut, Mansfield, Ohio 44903.

RUSSIAN Space sets 10¢. Russian approvals, Snedco, Box 68-P, Waldwick, N.J.

225 STAMPS for only 10¢! Airmails, Pictorials; stamps from strange countries cataloging up to 25¢ each! Plus unusual stamps to examine. Buy any or none return balance, cancel service anytime. Mystic Stamp Co., Camden 80, New York 13316.

RUSSIA High-Value Collection. 32 different Russia—some over 50 years old! Commemoratives, Czarist Issues, Airmails, Catalog price \$2.50. Special Get Acquainted Offer—all for only 10¢! H. E. Harris, Dept. GG-49, Boston, Mass. 02117.

FREE Stamp Wallet with approvals. Wide choice collections by Countries. Clark, Box 428, Northbrook, Illinois 60062.

WEST GERMAN Commems, recent, large. 50—\$1.00, 120—\$2.00. Langheinrich, D 8000—Muenchen, 23 Stury Strasse.

555 WORLDWIDE Different—\$1.00 With Foreign Approvals—Klondike, Harrisburg, Illinois 62946.

50 DIFFERENT United States Commemoratives only 10¢. Approvals Included. Shelron, Box 547 C, North Miami, Florida 33161.

"WHOLESALE" U.S.—Foreign Pricelist and catalog Free! Everything Guaranteed. Schneider, Box 1240, Grand Rapids, Michigan 49501.

FREE PACKET LIST. Kucher, 167 Cleveland Ave., Colonia, N.J. 07067.

GOLD Proof Coin Stamps \$1.00. Bick, Box 46695, Los Angeles, California 90046.

QUALITY AND LOW PRICE. EXCELLENT For advanced or beginner. Mounted approvals 2¢ up, all countries in Scott's Order. Preview Stamps, P.O. Box 9809M, San Diego, California 92109.

NUDE Painting set. Amazing Trade-In Exchange Plan. Approvals, 25¢. Stamp Club Unlimited, Box 5332-PM-4, Inglewood, Calif. 90310.

VATICAN Xmas Set 60¢ Approvals. Baricks, POB 7154, Detroit, Mich. 48202.

EUROPE, BRITISH EMPIRE. United States packets, sets, singles. Wide variety! Lists sent free! Faville, Box 4164, Brookwood, Madison, Wis. 53711.

OVER 5000 Grab Bags—Worldwide Stamps—\$1.00 Each—Big Mail Also. Superior Stamps, Avon Lake, Ohio 44012.

14,000 DIFFERENT! AMAZING new plan builds your collection systematically, country by country. Only 50¢ weekly. Ware, Monroe, Conn. 06468.

5,000 GRAB Bags! Dollar each. Stamp Service 1498/22 Huntsville, Ontario, Canada.

1500 FOREIGN \$1.00; 5000 \$3.00; 9000 \$5.00; 5000 USA. Contains airs, dues, 19th Century, presidentials, revenues, high values, etc. \$3.00, 300 pre-1939 USA commemoratives \$2.00, 200 pre-1926 USA \$1.00; 700 \$3.00; 3000 \$12.00. No approvals. Meyers, 5321 Fleming, Richmond, Calif.

U.S. Bargain, 50 different 10¢. with beautiful worldwide approvals. Stamp Center, Kennebunk, Maine 04043.

VATICAN, 10 Large Pictorials 30¢. Lists. Approvals? Penniston, Suite 302, 6000 Stevenson, Alexandria, Va. 22304.

25 LARGE Poland stamps, 15¢. No approvals. Jack Field, 2109 N. Argonaut, Stockton, Calif. 95204.

"GORGEOUS" Sets Free, Request Approvals. Martell, Box 421, Westerly, Rhode Island 02891.

30 RARE Stamps!!! \$1.00. Rare Stamp—\$2.50!!! Approval!!! MIKE PARNELL, MAMMOTH SPRING, ARKANSAS 72554.

EIGHTEEN Different Ceylon, 10¢ handling. With approvals. Camelot, Evensville, Tennessee 37332.

"ASTRONAUTS—Space stamps, 25 all different 25¢. Approvals. George Bell, 1115 Barnes, Milton, Florida 32570"

FREE DOLLAR GIFT And 1,000 Different. \$3.00. Gold Star, Box 7066P, Commerce, California 90022.

FREE Mint Set. Approvals accompany. Stamps, Box 22092, Memphis, Tenn. 38122.

500 DIFFERENT Worldwide Beauties 25¢. Approvals. Stamps, Box 4155M, Tulsa, Oklahoma 74104.

50 DIFFERENT Space-Rockets 50¢. Approvals. GJC, P. O. Sub 28, Saskatoon, Canada.

UNITED STATES commemorative collection containing 33 different—10¢. Approvals. White, 516-A Avenue L, Brooklyn 30, New York.

2,000,000 STAMPS 150 Countries 2¢ each. Beiden, Box 4175, Dearborn, Mich. 48126.

NEW ZEALAND 1969 Christmas "Nativity Paintings" Commemorative—Free! Approvals plus 101 Bonus Sets, William Deems, 226x Race, Ravenswood, West Virginia 26164.

50 DIFFERENT U.S. Commemoratives, 10¢. Approvals. Cambridge, Box 2311, Heath, Ohio 43055.

FREE: Triangles, Scout, 25 others. Approvals. Cambridge, Box 2311, Heath, Ohio 43055.

112 WORLDWIDE only 10¢. Extraordinary collection. Exotic pictorials, famous people; unique shapes. Includes Fujeira butterfly, Qatar coin Cook Islands Boy Scout, Nicaragua space flight, Bhutan abominable snowman, Bulgaria skiers, 106 other fascinating foreigners. Plus outstanding approval selections. Select those you like, return balance. Mail dime today. Douglas Cook, Box N-510, Fort Lee, N.J. 07024.

WORLDWIDE Collection .10 to introduce lowest prices and discount credit plan. W. Lamkin, Farmington, Maine 04938.

255 DIFFERENT Worldwide: 15¢. Approvals. Tibbets, 8675 Meadow, Downey, Calif. 90242.

MILLIONS Foreign Stamps! 2¢ each! Send for gigantic approvals! ABC, Box 6000-MB, San Francisco, California 94101.

ONE Pound value Geo. VI Bermuda, plus 100 worldwide 10¢. approvals. Stevens, Box 105A, Homecrest Sta., Brooklyn, N.Y. 11229.

ABSOLUTELY Free—100 Different Worldwide. Approvals Iannuzzi, Box 76241-PM Los Angeles 90005.

"50 DIFFERENT Canada 10¢ with approvals. Oroszky, P.O. Box 1-C, Sarnia, Ontario, Canada."

U.S. Approvals Low prices. Eagle, 2221 Romine Ave., Pittsburgh, Pa. 15226

PENNY Stamps! 1000 Mounted in book at 1¢ each. Trust Stamp Company, P.O.B. 132-P, Jamaica, N.Y. 11435.

TOPICALS—Three Colorful Sets, 10¢. Approvals. COLE, Box 223A, Buffalo, N.Y. 14221.

CANADIAN CENTENNIAL \$1.00 plus 30 others, approvals, 15¢. Lewis, 360 Fundy Drive, Saint John B, New Brunswick.

SPECIAL Sale: 500 stamps 40 cts. High value packet \$2. Persile, 436 N.Y. Ave., Brooklyn, N.Y. 11225.

HISTORIC MAN on MOON First Day Cover. Addressed to you on special cacheted envelope picturing 3 Astronauts. Has official July 20 "Moon Landing USA" postmark. 50¢ each. K. M. Walsh, Box 308M, Tuckahoe, New York 10707.

VIETNAM 25 Different 10¢ approval. Sam Chazen, Box 95, Ozone Park, N.Y. 11417.

"INVERTED ERROR" Dag Hammarskjold. 6¢ with approvals. Belmont Stamps, Washington, D.C. 20015.

TEN Different Nudes: 20¢. Approvals. Stamp Farm, 2M13, Oxford, Wis. 53952.

"SPACE" Pictorials, others, 110 Different—10¢! Approvals. Shaw, Drawer E-64, Montealio, Alabama 35115.

ONE CENT a Stamp. Write for a jumbo book of Foreign stamps at 1¢ each, mounted in Scott order. M. Bullot, 6815 Bay Parkway, Bklyn., N.Y. 11204.

COINS, TOKENS, CURRENCY

GERMAN coins wanted, top prices. Graham, Box 39083, Solon, Ohio 44139.

TRUNKFUL 25,000 Indian-Lincoln cents from the 1920's & older, mixed 'grab-bag' style. 150—\$10; sample bag of 20—\$2. Mrs. Ora Fischer, Box 743—Encino, Calif. 91316.

UNITED STATES Coins Cheap! Retail Catalog, 25¢. Buying (prices paid) Catalog, 50¢. Currency Valuation Catalog, \$1.50. Max's, Box 11055BR Minneapolis, Minnesota 55411.

UNCIRCULATED Dollars, 1880-81-82 S, 1883-84-85-1889-1900 01-02 O mint, \$3.50 ea. Catalogue 50¢. Shultz, Salt Lake City, Utah 84110.

20 UNCIRCULATED Foreign Coins \$1.00. Coins, Box 35041, Minneapolis Minnesota 55435.

100 INDIAN And Lincoln Cents 1930's And Older \$5.00. 40 Well mixed buffalo nickels \$5.00. 100 mixed 1943 steel cents \$5.00. Wesly Rood, West Union, 4. Iowa 52175.

COMPLETE U.S. Coin List!—Cents To Silver Dollars, 69 ESS 10¢ with 69S Nickel 25¢. Schultheis, Box 151M, New Hyde Park, N.Y. 11040.

SCARCE Date Jefferson nickels. All V.G. Satisfaction Guaranteed. 1942D—1949S—1950—50¢ each. 1943D—1951S—1955—75¢ each. 1939S—\$1.25. 1938D—\$1.65. 1938S—\$3.25. 1939D—\$5.00. 1950D—\$14.50. Dates not listed 20¢ each. Bryson Inc., 612A White, Toledo, Ohio 43605.

FREE Bargain Lists—35 Different brilliant uncirculated Lincolns plus 2 Free Albums (\$6.95 Value) Special \$3.50; Ten Indianheads \$2.75; Five V-Nickels \$1.50; Silver Dollars \$2.25 Each. Pacificoin, Box 274-M, Downey, California 90240.

WHOLESALE Lots of U.S. Coins. We will sell you \$50.00 catalogue value, U.S. coins of our choice, containing Large Cents thru Silver Dollars dating back as far as the 1800's for just \$19.95. \$100.00 value, just \$38.95. \$500.00 value, \$177.95. Each lot contains: 100 to 300 coins, many UNCIRCULATED coins, a PROOF coin And an ANCIENT coin over 1,000 years old. The perfect Christmas Gift. Guaranteed or your money refunded. Free pricelist. Kennedy's, 18474Z Prospect, Saratoga, Calif. 95070.

50 MIXED "S" cents, includes uncirculated 1955S, new 1968S, 1969S. Only \$1.95 BONANZA, Box 820P, Cupertino, Calif. 95014.

40 GENUINE Coins from 40 countries. Mostly uncirculated. Beautiful, \$2.00. Hindley, Box 708, Aurora, Illinois 60507.

BUY Coins cheap! List 10¢ (Refundable). Economy Sales, Mansfield, Mass. 02048.

"MOON LANDING COMMEMORATIVE A Genuine Collector's Item, Ideal Gift \$1—MERCURY Dimes 6 Different \$1—Moon Landing First Day Cover \$2.00. Free Gift With Each Order. Save, All 3 Items \$3—Dean Lawrence, Drawer 309, Monticello, N.Y. 12701."

ILLUSTRATED Coin Catalog—\$1.00 Postpaid! How, Box 276-A, Noble, Oklahoma 73068.

FIVE different Buffaloes, 40¢. Sellout list, 10¢. Jim's, Capitol Hotel, Louisville, Ky. 40202.

ORDER NOW FOR CHRISTMAS! WEST GERMAN eight coin type set uncirculated, in sealed vinyl mint-type envelope, \$4.00 including airmail postage. Robert McKinney, 6916th Scty Sqdn, Box 2347, APO New York 09057.

SCARCE JEFFERSON Nickels, All V.G. 100% Satisfaction Guaranteed. 1942-D, 1949-S, 1950—50¢ each. 1943-D—1951-S—1955 75¢. 1939-S \$1.00. 1938-D \$1.50. 1938-S \$2.95. 1939-D \$4.95. 1950-D \$13.95. Dates not listed 19¢. Free coins with order. Premiere Coins—Box 7776, Spokane, Washington 99208.

PRICE list. Send 25¢. Village Coin Shop, Dept. P, Plaistow, N.H. 03865.

LINCOLNS: 21 Different uncirculated \$1.00. Nayko, 174-01D Jewel, Flushing, New York 11365.

BRILLIANT Proof Sets: 1957. 1960. each \$6.97. 1968 \$10.97. 1969 \$8.97. Bargain Lists 25¢. Bebee's Incorp., Omaha, Nebraska 68111.

FREE "S" coin price list. Dickson, Box 34133, San Francisco, Calif. 94134.

LINCOLN'S: 10 Different Before 1930, only 25¢. Stevens, Box 546F, North Miami, Florida 33161.

BRILLIANT Uncirculated silver dollar key chains. Excellent Christmas gift \$4.95. 3/\$14.50. Rod Smith, West Lynn, Mass. 01905.

40-PAGE Illustrated United States and Canadian coin list 10¢. Stoney, 260 Washington, Boston 8, Mass.

ANTIQUES, RELICS, INDIAN GOODS AND CURIOS

SAVE! Old Time Car Radio \$16.95 Prepaid. SMITH ENTERPRISES-101 N. Richman, VILLA GROVE, ILLINOIS 61956.

INDIAN relic list. Birdpoints \$7.50, doz. Folsom, \$5.00 each. C. Secrist, Muscatine, Iowa 52761.

DOZEN Beautiful notched arrowheads \$2.00. Guajardo's, 8713 Shaver, El Paso, Texas 79925.

TONS Of antique gun parts and supplies. All reproduction muzzle loading guns. Send \$1.00 for enlarged illustrated catalog No. 119. Dixie Gun Works, Union City 12, Tennessee.

LIST Indian relics. 10 Arrowheads \$3.00. Hyde's, Box 2304, Santa Fe, New Mexico 87501.

10 PERFECT Arrowheads \$4.00. George Smith, 9825 Conway Drive, Indianapolis, Indiana 46236.

COLLECTOR'S ITEM. 1908 Sears catalog. Perfect replica. 20,000 items. Ideal Christmas gift. Only \$6.95. Shopper's Fair, 1025 Bristow, Belleville, Illinois 62221.

MODELS—SHIPS, TRAINS, PLANES, ETC.

SHIP And yacht model fittings: Pine construction hull kits; blueprints. Send 50¢ for illustrated catalog. A. J. Fisher, Inc., 1002 Etowah Avenue, Royal Oak, Michigan 48067.

SHIP Model kits and fittings; clippers, frigates, etc. Catalog paint-tool list, 1969 catalog 50¢. Models Shipways, Box 65, Bogota, N.J. 07603.

SHIP Models catalog 25¢. Scientific, Inc., 100 Monroe, Newark, N.J. 07105.

SHIP Models, Kits, fittings, plans, books, tools, engines, motors. Big illustrated catalog 50¢. Mass. residents add 3% tax. James Bliss & Co., Dept. SM, Route 128, Dedham, Mass. 02026.

SCALE Building materials, 1/4" & 1/8" scale. Windows, doors, siding, roofing, lumber and structural shapes. Send 50¢ for catalog. Small Sales Co., P.O. Box 177, Shawnee Mission, Kansas 66201.

ROCKETS: Real flying models—flights up to 2500 ft. New illustrated catalog 25¢. Single and multistage kits, cones, engines, launchers, trackers, rocket aerial cameras, technical information. Fast service. Estes Industries, Dept. 2, Penrose, Colorado 81240.

MODEL Stirling type hot air engines. Plans—kits information, send stamped envelope. Engines, Box 9221, Lansing, Michigan 48909.

MODEL Airplanes—Big 220 Page Catalog 50¢. Sig Company, Montezuma, Iowa 50171.

LIVE Steam Engine Kits. Fascinating hobby for model mechanics. Boilers, Fittings, Accessories. Pictured Catalog \$1.00. H.P.K. Models, Centuck 34, Yonkers, S. New York 10710.

MODELS. Kits, Wood Sailing Ships, Antique Wagons, Hobbies. Catalog 25¢. Astro, Box 202D, Maplewood, N.J. 07040.

GAMES, TOYS, PUZZLES, NOVELTIES

HUMOROUS, Colorful Credit Cards 12 Different \$1.00. HALL'S, 5153 W. 58th Pl., Los Angeles. 90056.

"ROULETTE DICE" . . . dice that have a range of 36 numbers. Only \$1.00, write D.E. Products & CO. Box 488, Worcester, Mass. 01601.

CARIBBEAN Checker games \$2.00 color \$3. C. Ljohn, 5118 South Dorchester, Chicago, Ill. 60615.

BASEBALL Fanatics! The Perfect Table Baseball Game. Same averages as Big Leagues. Not a toy. Organize Championships with friends. \$3.00 Postpaid. Davar, Box 236, Forest Hills, New York 11375.

KITES, Kits, Plans. Delightful Booklet, 25¢. Kyte Tales, Box 145C, Richardson, Texas 75080.

MAGIC TRICKS, JOKES, VENTRILOQUISM

500 TRICKS, Douglas famous Magic Catalog, only 10¢. Better Magic for pocket, club, stage. Fastest mail service. Douglas Magicland, Dept. 11, Dallas, Texas 75221.

HOUDINI Magic Catalog!! Giant Professional Deluxe Edition!! 1000 World's Greatest Tricks!! 25¢ with Free Gift Certificate!! House of 1000 Mysteries, Dept. PM9C, Northeast Fifth Ave., Ft. Lauderdale, Florida 33308.

BE A Magician! Two booklets explaining sixty-eight tricks plus large professional catalog. \$1.00. Magic Inc., 5082 Lincoln, Chicago, Illinois 60625.

COMPLETELY Illustrated catalog, 84 pages, 25¢. Manhattan Magic, Box 334-M, N.Y.C. 10011.

WORLD'S Finest professional magic tricks. Joker's Novelties. Giant illustrated catalog 10¢. Top Hat, Evanston, Illinois.

CATALOG \$26. 175 pages, 25¢ (1,500-399 tricks, jokes, novelties). Elbee, 7408-P, San Antonio, Texas 78207.

MAGIC Catalog. World's finest 3000 tricks. (340) pages \$2.50. Beginners, amateurs, professionals. Kanter's, A-200 South 13th St., Philadelphia, Pa. 19107.

FREE! World's Leading Catalog 2000 Novelties, Jokes, Tricks, Scientific Gadgets, Hobbies. Johnson-Smith, D-191, Detroit, Michigan 48224.

VENTRILOQUISM! Information free! Dummy catalog 25¢. State age. Maher, Studio L, Box 9037, Denver, Colorado 80209

FABULOUS MAGICS new 1970 catalogue 25¢. Our specialty orders shipped same day no substitutes. Fabulous Magic 3319 East Charleston. Las Vegas, Nevada 89104.

VENTRILOQUISM! Unique "listen-and-learn" method. Write. Show-Biz, 1735-P East 26th Street, Brooklyn, N.Y. 11229.

HOUDINI'S Original Magic Shop. Established 1856. Send 25 cents for Illustrated Catalog containing 5000 Tricks, Mindreading, Puzzles, Hypnotism and Jokes. Flosshornmann, 304 West 34th St., N.Y. 10001.

MAGIC MAGAZINE—Monthly since 1936. 44 pages. All phases. 3 month trial \$1.00. Genii, P.O. Box 36068, Los Angeles, Calif. 90036.

MINDREADING Trick Cards Plus Catalog. Send 25¢. Ace Magic, Box 329, Evanston, Illinois 60204.

BOOKS, CATALOGS, NEWSPAPERS

NATIONAL Geographic Magazines, 1888-1967, any issue. Buxbaum, Box 465-PM, Wilmington, Delaware 19899.

PROPHET Elijah coming before Christ. Wonderful book free. E. Megiddo Mission, 481 Thurston Rd., Rochester, New York 14619.

FREE Brochure, Interesting Books. True Value Products, Box 903, Salt Lake City, Utah 84110.

NEW 1970 booklet on computer oriented facts and techniques covering dice, blackjack, roulette. Send \$2.95 check or money order to: FACTS & TECHNIQUES ASSOC., P.O. Box 1677, Glendale, Arizona 85301.

(Continued on next page)

BOOKS, CATALOGS, NEWSPAPERS

(Continued from preceding page)

FREE List! Personal Self Improvement. Books, L. Cricket, Box 527, Ardmore, Penna. 19003.

SEND \$1.00 For a FASCINATING List of OCCULT Books to the Aquarian Age, Dept. 7, 74 Winthrop Street, Cambridge, Massachusetts 02138.

315 FREE MAGAZINES! Details 25c. Leo Fiddes, 238 South Loudon, Baltimore, Maryland 21229.

SELF-DEVELOPMENT, Autosuggestion books. Free Catalog. Collinse, Box 67 Appalachia, Virginia 24216.

PAPERBACK Catalogue, 270 pages, 15,000 titles, subject indexed. \$1.00, credited toward order. New York Book. 4 P West 43 Street, N.Y.C. 10036.

SMOKEHOUSE COOKERY: Methods, Recipes, and simple construction plans. \$2.00. Jolie Acres, P.O. Box 147-M, Agnew Station, Santa Clara, Cal. 95054.

FREE List of low cost interesting practical Books. McAllister Sales, PM10, Box 13128, St. Louis, Mo. 63119.

FREE Popular Mechanics NEW illustrated 32 page catalog of plans, publications and projects. Crammed full of fascinating ideas. Plans for boats, patio furniture, campin' trailers, swimming pools. Projects for the home and shop. Special sections covering electronics and science. For information on hundreds of other exciting projects send for your catalog today. Enclose only 25c to cover postage & handling to: POPULAR MECHANICS, Dept. HE, 224 West 57th Street, New York, New York 10019.

315 FREE Magazines. Free Information Bilmar, Box 20142, Minneapolis, Minn. 55420.

"END Of World prophecies explained. 46,000 word book \$2.00. Box 94173, Oklahoma City, 73109."

SEND 50c for Giant New Color Navy Arms Catalog Reference Book featuring America's largest selection of Muzzle Loading Replica Firearms & Accessories, which can be purchased by mail. Complete instruction on how to handle a Muzzle Loader and kits to build your own. Address: Navy Arms Company, 689 Bergen Blvd., Ridgefield, New Jersey 07657.

PLAYS, STORIES, MANUSCRIPTS

WANT Your book published? Learn how we publish advertise, promote, distribute. Many successes. Free booklet PM. Vantage, 120 West 31, New York City.

"HOW to Sell Every Word You Write! Aubrey, Box 3124 Industry, California 91744."

\$10 DAILY Writing Short Articles. Report Reveals How, Where. Send \$1.00. Banner Gifts, 124 Sunset Blvd., Biloxi, Miss. 39531.

BUSINESS OPPORTUNITIES

PREPARE TAX Returns—Policeman Albert Myers made \$2000 his very first season. Train at home. VA Approved. National Tax School, Monsey, 2MB, N.Y. 10952.

HOW To Prepare Your Own Mailorder Catalog for pennies . . . without merchandise investment! Free Catalog! Obie, 5711-MD—14th, Brooklyn, New York 11219.

MAILORDER Book publisher wants dealers. Wonderful "drop-ship" proposition. Sample imprint circulars free. Neil H. Tasker, Shamokin, Pennsylvania 17872.

SECRETS! Mail Order Success. Internationally famous expert reveals how to make home business fortunes. Beginners: Get free copy "Make Money By Mail." Discloses free advertising, profitable products. Mailco, 1554 Sepulveda, Dept. C270C, Los Angeles 90025.

I GROSSED OVER ONE MILLION DOLLARS year selling by mail. So can you, at home! Send \$2 for success book #PM. Wayne Johnson, 880 SW 60th Avenue, Ft. Lauderdale, Florida 33314.

MAILORDER Business. Free Literature. Harry Andrews, Box 485, New York, N.Y. 10013.

BURGLAR Alarms. 200% Profits. Easy! Free Particulars. Alarms, Uleta, Florida 33164.

"BUILDERS Trade Secrets" Become Rich!! Builder, Box 99, Uleta, Florida 33164.

INSTALL Burglar alarms without previous experience or costly equipment. Big profit. Free details. Nasco, 11071 Massachusetts, Dept. C270C, Los Angeles 90025.

REPAIR WATCHES. Step up income. Unique home course. Watchmaking. YZB, Fox River Grove, Illinois 60021.

BUILD Custom Cases at home for profit. Get orders by mail. We supply materials, instruction—everything. Free home business details. Custom Case Supply Co., 6961 CPM Hayvenhurst Avenue, Van Nuys, California 91406.

TAKE Catalog orders. We drop-ship 1001 best selling specialty products. Guaranteed lowest below wholesale prices. Fantastic spare-full time home business. Free book shows you how. SMC 6963 SPL Hayvenhurst Avenue, Van Nuys, California 91406.

MAKE Big Money on income tax by helping others prepare their forms. New home training puts you in your own full time or spare time business or a high paying job with tax companies. Full information by mail. No salesman. Federated Tax Service, 1561 Howard, Chicago 60626.

HUNDREDS fantastic buys. Toys, carded specialties, close-outs. Guaranteed lowest prices. New samples monthly. Proved home business plan. Write Specialty Products, 11136A Chandler, North Hollywood 91601.

OPERATE Restaurant or diner. Free booklet reveals profitable plan. Write Restaurant Business School, Dept. EC-129 1920 Sunnyside, Chicago, Illinois 60640.

IMPORT Export opportunity, profitable world-wide, mail-order business from home, without capital, or travel abroad. We ship proven plan, for no risk examination. Experience unnecessary. Free details. Mellinger, Dept. C270C, Los Angeles 90025.

\$2000.00 MONTHLY can be yours! Build own chemical business starting part time. Interviews arranged. Enterprises, Box 274, Danville, California 94526.

\$200 WEEKLY Mailing Catalogs. Free catalog—Proof! Tayco, 528-PM Sharon, Stockton, Calif. 95205.

MAILORDER Selling; what, where how. Details: Doorbar-PM, 3364 North West 35th Street, Fort Lauderdale, Florida 33309.

BOOKS on mailorder. Free literature. Earl's, 121-PM Melrose, Findlay, Ohio 45840.

NEW! \$250.00 weekly. My success passed on to you. Sparetime mailorder program. Write-DeLang, Box 16037-M, Portland, Oregon 97233.

HUGE Profits! Mail order importing. Free information, ITIS, PM-12, Box 454, Hollywood, Calif. 90028.

CONCRETE FACTS: Highly profitable home business. Experience unnecessary. Unlimited unique pottery designs easily made without moulds. Birdbaths, fountains, wishing-wells, benches, etc. Chemical coloring formulas, marbled glazing FREE illustrated brochure. Hollywood Cement-craft, 602 Athens Street, Altadena, California 91001.

\$400.00 MONTHLY Raising giant fishworms. Soilless method. Charlie Morgan, Bushnell, Florida 33513.

EARN Money raising fishworms for us! Write: Oakhaven-38, Cedar Hill, Texas 75104.

FREE "franchise Profit Letter" tells how unique NR service is helping thousands seeking profitable businesses. Write today. National Franchise Reports, W-528, 333 North Michigan, Chicago 60601.

400,000 BARGAINS Below wholesale! Many free. Liquidations . . . closeouts . . . job lots . . . single samples. Free details. Bargainhunters Opportunities, Box 730A Holland, Michigan 49423.

ADDRESSERS And mailers needed. Send stamp for information Lindbloom, 3636 West Peterson, Chicago 60645.

MAKE \$75.00 daily distributing tools to service stations. Free Plan. INKA, 2401 Crocker, Houston, Texas 77006.

ESTABLISH Profitable Catalog Mailorder Business! Vikari's, Box 1312-PM-L, Salt Lake City, Utah 84110.

STOP Throwing Away Those Bixtops! They're worth money, some 25c each! Write: Bixtops—80, Cedar Hill, Texas 75104.

ADVERTISING BUSINESS—YOU own it. \$350 First Week or Money Back. Electric Neon Action Ad Clock, 229 W. Illinois, Chicago 60610.

JOIN "MONEY GETTER'S GUILD". Receive hundreds money-making. Business Building Propositions. Year's membership only 25c. Write: Fourstars, Box 839, Long Beach, New York 11561.

I MADE \$40,000.00 Year by Mailorder! Helped others make money! Start with \$10.00—Free proof! Torrey, Box 318-Y, Ypsilanti, Michigan 48197.

MAIL Baby Catalogs imprinted with your address to New Mothers for Big Profits! Details 25c. Volz-PM, Ypsilanti, Michigan 48197.

READ Progressive Mailtrade, the magazine that tells how to make money by mail. Quarter brings sample and special offer. Mailtrade, P.O. Box 357, Sheboygan, Wis. 53082.

FREE Catalogs. Repair air conditioning refrigeration. Tools, supplies, full instructions. Doolin, 2016 Canton, Dallas, Texas 75201.

VENDING Machine big catalog. Rake, 523 A Spring Garden, Philadelphia, Pa. 19123.

CLIP Newspaper items, \$1.60-\$5.00 each. Details free. Walter, Box 1360-PA Erie, Pa. 16512.

SELL Lifetime, Metal, Social Security Plates. Big Profits! Sample and Sales Kit Free. Russell, Box 286-PM, Pulaski, Tennessee 38478.

SPARE Time Cash—Sell Advertising Book Matches—every business a prospect—no investment—no experience needed to build steady repeat business. Daily Cash commission in advance. Write today—We'll send your sure-fire selling kit by return mail. Dept. MX1269, Superior Match Co., 7530 S. Greenwood, Chicago, Illinois 60619.

COPUBLISH "Mail Sale Advertiser." leading mailorder paper. Copy and details 25c: U.S.A. only. Vanroy Shirk, Lebanon, Pa. 17042.

\$200.00 DAILY in your mailbox! Your opportunity to do what mailorder experts do. Free details. Associates, Box 136-A, Holland, Michigan 49423.

BOOKKEEPERS Earn \$1000.00 month. Operate simplified Bookkeeping tax service. Universal, Box 664-M, Springfield, Missouri 65801.

BIG Money-making new greaseless donuts in kitchen. Everything furnished. Sell stores. Free recipes. Montgomery Ray, Waseca, Minnesota 56093.

MAILORDER Program for Beginners. Write to Winco, 3905-M Mannerdale, Louisville, Kentucky 40220.

\$75.00 THOUSAND. Home Addressing! Longhand, Typewriter. Information, send stamped self-addressed envelope. Brewster, Box 1348-TF, Clearwater, Florida 33517.

(Continued on next page)

BUSINESS OPPORTUNITIES

(Continued from preceding page)

FREE Selling Outfit, Office Supplies, Furniture & Equipment. Oseco, 15-PM North Jefferson, Chicago 60606.

QUICK Income with Mail Order Collection Agency. \$1000 monthly and more. We show you how. Continental, Box 2023-A, Des Moines, Iowa 50310.

UNLOCK Your Future. Become professional Locksmith with spare time home-study. Make up to \$6 per hour. All tools, equipment incl. Facts free. Send name. Locksmithing Inst., Dept. 1310-129, Little Fall, New Jersey 07424.

DRAFTSMEN! Operate own DRAFTING SERVICE! Full, Part Time; Experience unnecessary; Details: Roberts Drafting, 1741 Circle Road, Baltimore, Maryland 21204.

MAKE \$46 from square foot plywood; jigsaw or bandsaw necessary. Free details. Woodar, Bridgewater, Mass. 02324.

JEWELRYCRAFT—It's easy! Big profits! Catalog, 25¢, Modern Craft, 12790 US 19, Clearwater, Florida 33516.

MAILORDER . . . No merchandise investment. Profitable! Tested! Dynamics, 1430P Wells, Milwaukee, Wisconsin 53233.

MAIL ORDER Sell books. Fascinating, profitable, details. Jobre, Box 27, Great Neck, N.Y. 11023.

MAIL Baby Catalogs, Imprint, to new Mothers. Big Profits! Details \$1.00. Krefski, 609 Lee, Plymouth, Pa. 18651.

WANT To make big money at home? \$10.00 profit in an hour possible with invisible mending. Make tears, holes disappear from clothing, fabrics. Steady year-round demand from cleaners, laundries, homes. Details free. Fabricon, 1585 Howard, Chicago 60626.

IF YOU can do simple, grammar school arithmetic, you can easily become prosperous Income Tax Consultant. Free details. Paramount-A, 119 W. Avenue 33, Los Angeles, California 90031.

RAISE Rabbits for us on \$500 month plan. Free details. White's Rabbitry, Mt. Vernon, Ohio 43050.

PERFECT husband-wife business. Learn Upholstery at home. Make \$10 in an hour. Buy-repair-sell for even bigger profits. Kits, tools included. Free Booklet. Upholstery Institute, Dept. 5310-129, Little Falls, New Jersey 07424.

\$300.00 WEEKLY Possible. Mailorder. Others do; you can with our help. Free proof. Williams, Box 44646M, Los Angeles 90044.

MAKE, Sell magnetic car signs. Write PM-1834 Edgeland, Louisville, Ky. 40204.

PLASTERCRAFT Molds, liquid rubber, plasters, flock, candle supplies. Catalog and manual free. Blue Rapids Supply, Blue Rapids, Kansas 66411.

SELL Books by mail, 400% profit. Royal, Box 450-X Cleveland, Ohio 44127.

CLIP Short newspaper paragraphs. Up to \$10 each. Details free. Foster, Box 272-M12, Brooklyn, New York 11235.

"FREE Book 'MoneyMoneyMoney—How to Make it in Mail Order.'" Plymouth—P472, Brooklyn, N.Y. 11218.

VENDING Machines. No selling. Operate a route of coin machines and earn amazing profits. 32-page catalogue free. Parkway Machine Corporation, 715 PMB Ensor Street, Baltimore, Maryland 21202.

MAIL ORDER. No Inventory Needed. Free Catalog. Your Name Imprinted. 125FD Mailing Methods, Lafayette Hill, Pennsylvania 19444.

START Profitable mail order business. Book explaining how plus extensive wholesale directory just \$2.00. Satisfaction guaranteed. Bac Sales, LaPlata, Mo. 63549.

YOUR Own business for \$75.00. No additional money necessary. Includes franchise, supplies equipment instructions. Earn \$1000, a month with ten sales a week. Guaranteed Program. Send \$1.00 for details. ARC ADJ., INC. 1 N.Y. Ave. Atlantic City, N.J. 08404.

AMAZING Profits! Start your own successful business. Details free. Musgrove, 1404-B Camp Gifford Road, Bellevue, Nebraska 68005.

EARN \$60.00 DAILY manufacturing Concrete Fence Posts. Practically no investment. Free information. Send stamp. American, Excelsior Springs, Mo. 64024.

PIANO TUNING learned quickly at home. Tremendous field! Musical knowledge unnecessary. GI approved. Information Free. Empire School, Box 327, Miami, Florida 33145.

SUPPLY Fried chicken dinners on \$500 week home plan. No franchise fee! No royalty fee! Free information. White's Chicken Dinners-PM, Mt. Vernon, Ohio 43050.

\$2.00 PER Dozen Cash Profits. Assemble New Art Foam Products. All Supplies Furnished. Showcase Box 55392D, Indianapolis, Indiana 46205.

WORK Home! Mail Baby Catalogs, with your address, to new Mothers, for Big Profits! Samples, Details—10¢. Troy Company, Dept. 896 PM, Bayonne, N.J. 07002.

SELL engraved Lifetime Social Security colored metal plates with case. Profitable! Personalized! Your card \$1.00. Details. Rogue, 2256 Division, Chicago, Illinois 60622.

BALDING? Get Relief. Send 25¢. Moran, Box 602, Ben Lomond, California 95005.

BE YOUR OWN BOSS Our instructional manuals show you how. Thousands of business opportunities. Free catalog. Informative Publications, Box 187, Painted Post, N.Y. 14870.

"MONEY! MAKE More. Details. Total Research, Box 6866-A, Seattle, Wash. 98116".

WORLD'S Largest supply. Merchandise 25% to 40% under wholesale. Bankrupts. Closeouts 10¢ on dollar. Imports. Hongkong clothes. Automobile discounts. Free details. International Buyers, Box 16386-MM Portland, Oregon 97233.

"LEARN Moneymaking Methods. Monthly Newsletter. Moneymaker Reports, 1405 Locust, EB-0512, Philadelphia, Pennsylvania 19102.

"HOW to Sell Books by Mail", and Source Directory. \$3.00. Burkart, 10723-S Farallone, Cupertino, Calif. 95014.

SELL books by mail. Good profits! Catalog, details, 20¢. Sullins, Box 20611-M, Forsyth, Georgia 31029.

VACUUM Plastic Molding & Liquid Plastic Casting—At Home! Make Hundreds of full 3-D plastic products. Big profit in spare time. Facts. Nationwide Plastics, Dept. LF, 4140 Eagle Rock Blvd., L.A., Calif. 90065.

56 ACTIVE Franchise opportunities available all over USA. Brochure details 56 franchise chances for you to have your own business tied with successful national companies. Send name, address to P. Stewart, 1085 Walnut, Des Plaines, Illinois 60016.

MONEY-making small business of your own. Write: Lehman Tyndall Rte 2 Tarboro, N.C. 27886.

250% PLUS Profit! Sell America's lowest cost fire, burglar alarms. No installation required. 10 second demonstration clinches sales fast, easy. Write today; free details. Watchdog Alarms-DS, Williamsburg, Ohio 45176.

SELL Books by Mail. 450% Profit. Midwest-PM. 4209 Esch, Madison, Wisconsin 53704.

START Own Mailorder Business! Amazing. Proven Profit Plan. Everything furnished! Success assured! Write: Wallace, Box 288-PM Gladstone, Oregon 97027.

PROFIT With Popular Mechanics' subscription plan No investment, no experience needed. Earnings begin immediately when you obtain subscription for Popular Mechanics. Good Housekeeping and others. High commissions, bonus. No experience needed. Deal directly with the publishers. Write Popular Mechanics, Room 12B, 250 West 55th St., New York 19, N.Y.

MAKE money at home spare time. Details for self-addressed stamped envelope. R1-Allen, 2418 Lori, Santa Ana, Cal. 92706.

TREMENDOUS \$1,000.00 Profit From 1,000 Mailings! Free Proof! George-PM, Box 2188, Cypress, California 90630.

MAILORDER Records help get increased business! Complete 32 Page Record Book shows your inquiries, orders, advertising, expense, etc. Only \$1.00. C. A. Martin, Popular Mechanics, Dept. PM, 224 West 57 Street, New York, N.Y. 10019.

MAGNETIC SIGN BUSINESS. Vacuum Machine and everything you need to go into the Magnetic Sign Business. Only \$1295.00 interested? Call or Write Nova Manufacturing Company, 727—14 Street, Bessemer, Alabama 35020. Phone (205) 426-2411.

\$70.00 WEEKLY—home, spare time. Simplified mail bookkeeping. Immediate income easy. Auditax, 34741A, Los Angeles 90034.

\$60.00 DAY. Manufacturing concrete Posts, Blocks, Mold Equipment Catalog \$1.00 refundable. Carlayne, Route One, Box 106T, Rapid City, South Dakota 57701.

INSTANT Mail Order Catalog Business—All you need is a mailbox. Details \$1 refundable. Mail Marketing Services, Benton, Illinois 62812.

\$500—\$800 MONTHLY Raise small Laboratory-breeding stock for us We supply equipment, breeders, and instructions. Illinois Research Farms, Dept. MPD-12, Barrington, Illinois 60010.

1000% PROFIT Bronzing Shoes. Free Literature—N.B.C. Box 11069-PM Kansas City 64119.

FREE Book "996 Successful, Little-Known Businesses." Work Home. SBI-7, Kerrville, Texas 78028.

MEXICO! Investments and/or Retirement! Comprehensive, Informative, Basic Source Data Send \$2.00. Villa-9, Box 1228, Cuernavaca, Mexico.

LIQUID Molding rubber also liquid plastics. Free information. Chaney's, 5415-A San Jose Blvd., Jacksonville, Fla. 32207.

AMAZING PROFITS! Sell by mail quality self-improvement books. Drop-shipped by reliable publisher. GRAPHIC, 1033-PM S.W. 53rd, Oklahoma City, Oklahoma 73109.

LEARN The secrets of repairing junk batteries "Fabulous Profits" at home. Batteryman, Route 1-188 D, Blythe, Calif. 92225.

MAKE Money from old tires. Operators clearing \$800, weekly. Equipment costs \$1500. Get facts. S & S Patents, Inc., 3752 N. Damen, Chicago 60618.

SIMPLE, EASY way to enter mail order. Earn \$12,000 year up. Stamp for details. Emptage, 1033-PM S. W. 53rd, Oklahoma City, Oklahoma 73109.

HOW & Where To Get Finance Capital. \$500 to \$2 million—clear credit. Free details. Counselor-17, Kerrville, Texas 78028.

MONEYMAKING OPPORTUNITIES

HIGHER INCOME, Security. Book reveals secrets of Riches. \$2.00. EL Gifts, Dept. PM1 900-4 Baychester Avenue, Bronx, New York 10475.

PROFIT from mail order with a concrete program based on real value plus merchandise we have know how and capital to back a successful program for those who qualify request details . . . Carboni Multi Mail, Box 115, Garner Road, Lilburn, Ga. 30247.

WOMEN BUY ON SIGHT! Protection against rapist, mugger. Big profits. Write: DEFENDER, Box 307, Lorain, Ohio 44052.

MAKE \$5,000 yearly, sparetime, raising mink, chinchilla, nutria, etc. Free booklet reveals proven plan. Write: Furs, Dept. R, Bewdley, Ont., Canada.

(Continued on next page)

MONEYMAKING OPPORTUNITIES

(Continued from preceding page)

\$52.00 WEEKLY! Sparetime! Addressing! Details, Application 10¢. Tory Company, Dept. 424PM, Bayonne, New Jersey 07002.

WATCH REPAIRING multiplies earnings. Free information and sample lesson. Watchmaking, YZA, Fox River Grove, Illinois 60021.

CIGARETTES 12¢ a pack. Improved roller n.acks 20 filtertip, plain, king or regular for 12¢. Facts free. Moberly, Box 953, Owensboro, Kentucky 42301.

PROFITABLE Mail Order Opportunities. Trial subscription 25¢. Mail Sale Advertiser, Box 1750-P, Seattle 98111.

EARN \$240.00 a month at home, spare time, doing only two \$5.00 invisible mending jobs a day. Big money paid for service that makes cuts, tears disappear from fabrics. Steady demand. Details free. Fabricon. 1532 Howard, Chicago 60626.

MAKE Statuettes, novelties, imitation marble. Sell to stores or start gift shop. Free details. Marbleizing, 41 Waverton, St. Louis, Mo. 63124.

HOW To Make money writing short paragraphs. Information free. Barrett, Dept. C-27-X1, 6216 N. Clark, Chicago 60626.

FREE Copy of world's leading contest magazine! Write Prizewinner, Box 11569, St. Petersburg, Fla. 33733.

HOMEWORK. Mailing circulars. Free details! Cam Company, Dept. 155-KP, Verona, N.J. 07044.

FREE. 206 Easy Ways to make money taking orders for exciting new products—spare time. Send name, age for 5 months free subscription. Opportunity Magazine, 1460 Hancock Center, Dept. 17-MN, Chicago 60611.

SCIENTIFIC Massage: Big Earnings uncrowded profession. Learn spare time at home. Diploma awarded. Free catalog. Write Anderson School, Dept. M-1C, Princeton, Illinois 61356.

CLIP Newspaper items. \$1.00-\$5.00 each. Details free. Walter, Box 1360-P, Erie, Pa. 16512.

MAKE: \$12.00 Profit each dozen assembling Belts. Details Free. (Stamp appreciated.) Redikut's-40, Richland Center, Wis.

HOW TO GET RICH!! Free "Money-making Brochure"! Success International, Box 2447-C, Livonia, Mich. 48151.

\$2.40 HOURLY Making simple wood novelties. Free details! Gene's, 55 Boxwood, Falmouth, Mass. 02540.

ART Talent? Be your own boss. Earn \$200 weekly freelancing. Free Brochure. Famous American Studios, P6, Spring Park, Minnesota 55384.

FREE Unique Moneymakers Digest True Histories. Shugart, Box 566-W, South Pasadena, California 91030.

INSTANT Money! Plastics are the wave of the future. Big Profits now! At Home! Spare Time! Materials costing 11¢ bring \$2.58 profits immediately! Free information! Rush name on postcard to: Warner, 1512 Jarvis, Dept. CL-2-D, Chicago 60626.

\$200.00 FROM Sheet 1/4" plywood (scrap). Details 25¢. Novelties, 610 So. 24th, Elwood, Indiana 46036.

EASY-To-start rubber stamp business at home in spare time. Make up to \$16.50 an hour without experience. Facts free. Write to: Roberts, 1512 Jarvis, Room CR-2-D, Chicago, Ill. 60626.

INTERESTED In mailorder? Write to: Advancement, Box 24, La Grange, Illinois 60525.

LEARN To Fix Typewriters. Desperate shortage trained men. Hundreds needed. Make up to \$25 in one hour. Learn at home in spare time. Industry Approved course. Facts free. Send name. Typewriter Repair School, Dept. 3310-129, Little Falls, New Jersey 07424.

SWEEPSTAKES Contests How to Win. Write for free particulars. General Contests, 1609-18 East Fifth, Duluth, Minnesota 55812.

DEALERS, Beginners and Professionals "100 MAIL ORDER SUCCESS SECRETS." will make money for you. Hall's Mail Order Supplies, Box-72146, Los Angeles, California 90002.

\$400.00 MONTHLY Possible in your home woodwork shop. Experience unnecessary. Free information—send stamp. Mission Industries, Box 755, Shawnee Mission, Kansas 66201.

HOMEWORKERS! 200 companies—48 page Directory. FREE details. Quest-112, Box 6029, San Jose, California 95150.

MAKE more money—Take orders for Book Matches. Prospects everywhere—every day is payday—no experience needed—no investment. We'll send you power house selling kit with new complete catalog so you can make quick sales and big cash commissions. Superior Match. Dept. MA1269, 7528 S. Greenwood, Chicago 60619.

FREE Book "MoneyMoneyMoney—How to Make it in Mail Order." Plymouth-P47, Brooklyn, N.Y. 11218.

SELL What You Write, Instantly! Beginners Market List tells where, how, and what to write. Send stamped, self-addressed envelope, free proof. Economy, Box 1348-G, Clearwater, Florida 33517.

VENDING Machines. No selling. Operate a route of coin machines and earn amazing profits 32-page catalogue free. Parkway Machine Corporation, 715 P.M. Ensor Street, Baltimore, Maryland 21202.

SELL Your photos. Report tells how, where. \$1.00. Gilco, A 7695 Torrem, LaMesa, Calif. 92041.

HOMEWORKERS! Money making brochure. Scores of companies. \$1.00. Speller, Box 8215-P, C. H. Station, Newark, New Jersey 07108.

MAKE MORE MONEY Than you Dreamed possible! We buy anything old: Fruit Jars, Bottles, Books, Magazines, Antiques, Coins, what have you? Send \$1.00 (refundable) for huge buying lists. Shroeders, Paducah, Kentucky 42001.

MAKE GOOD MONEY—Homeworker's needed! Free details. Gibson, 1465 Luning Drive, San Jose, Cal. 95118.

CAMERA PROFITS. Up to \$400.00 for your photos. Free details. Enterprise Books (PM12), Box 188, Seabrook, Texas 77586.

SHARP \$\$\$ opportunity! One low-cost machine sharpens, serrates knives, scissors, pinking shears. Earn \$6-\$9 hourly in spare time. Professional results without experience. Free details. Beaver Grinder, 3129 Nielsen Building, Eugene, Oregon 97402.

"CLIP Newspaper Items for Cash. Details Davan, Box 269DX, Holden, Massachusetts 01520."

MAKE \$8.00 Profit on \$12.00 Merchandise orders received by mail. Everything furnished. Write J & B Sales, 411 West Orange Street, Duluth, Minn. 55811.

EARN \$1000. A month and more. Send \$1.00 for complete details. ARC Adj., Inc. 1 N.Y. Ave., Atlantic City, New Jersey 08404.

WRITE for Television. Will establish. Bolticus, 22841 Calabash, Woodland Hills, Calif. 91364.

PLASTERCRAFT HANDBOOK Illustrated, instructions statuary pouring, finishing, selling and mold making. Also where to obtain all materials. Only \$3.00 postpaid. Guaranteed. Wolfe, Box 561GB, Melbourne Beach, Florida 32951.

\$500—\$800 MONTHLY Raise small Laboratory-breeding stock for us. We supply equipment, breeders, and instructions. Illinois Research Farms, Dept. MP-12, Barrington, Illinois 60010.

YOU May Win A Fortune. Read "Sweepstakes Can Be Reapstakes." \$1.00. Benro Enterprises, Box 6656-PM, Philadelphia, Pa. 19149.

HOW to ACQUIRE ADEQUATE INCOME for life. Free details. Specialties, 520 West Cypress, Redlands, California 92373.

OPPORTUNITIES, Bargains Galore. Free Information. Bilmar, Box 20142, Minneapolis, Minn. 55420.

MAKE Money Quick with our New Sign Making Discovery. Learn in one day. No Talent or Experience required. We show how to make Beautiful Show Card and Display Signs in minutes instead of hours. No expensive Brushes, Paints or Equipment needed. Start business with only \$1.50 invested and earn money now. Send Name, Address And only \$1.00 for complete set of Instructions to Simplex Signs, P.O. Box 3059, Hamilton, Ohio 45013.

"GET Rich selling comic books. Unbelievable Profits. Free details. Ross, 2307 Nesmith Lake, Akron, Ohio 44314."

LYRIC WRITERS write songs with writers who write hits for top Nashville artists. Globe, 420 Broad, Dept. PM, Nashville, Tenn. 37203.

DAILY INCOME, mailing commission circulars, advertising. Complete program. Details, 12¢ stamps, Box 953-PM, Newark, N.J. 07101.

PROFITABLE OCCUPATIONS

MORTGAGE Brokerage. Lucrative! Huge Commissions. Free Particulars. Chase, Uleta, Florida 33164.

HOW To Make Money writing short Paragraphs. Information Free. Barrett, Dept. C-27-X2, 6216 N. Clark, Chicago 60626.

CHROME Plating Instructions, equipment and supplies. Platers' Supply, P.O. Box 565, Lugo Station, Los Angeles, Calif. 90023.

FT. SMITH Auction School. Ft. Smith, Ark. Residents & Home study. Veteran approved.

BAKE New greaseless doughnuts in kitchen. Sell stores. Free recipes. Michael Ray, Waseca, Minnesota 56093.

FREE Book "999 Successful, Little-Known Businesses." Work Home! Plymouth-37-P, Brooklyn, New York 11218.

JANITORS—Cleaners—Custodians Get a Better Job—Make More Money. Become a Maintenance Supervisor. Homestudy Details Free: Maintenance Training, 907 Beachpoint, Ajax, Ontario.

NEW Idea! Part. Full time. \$75.00. \$150.00 week up! Details, \$1.00. Martin, Rt. 2, Box 5286E, Issaquah, Washington 98027.

LEARN TERMITE INSPECTION. Unlimited Demand Plus FHA Mandatory. Repeat Customer Business. Certificate By Examination. Complete Course \$4.95. Refund Guaranteed. Chicago School of Termite Inspection, 735 Junior Terrace, Chicago, Illinois 60613.

BECOME A mortgage broker, earn \$10,000 to \$50,000 a year. Details free. United, Box 6284A, Marietta, Georgia 30060.

PAINT FOR PROFIT! New Method oil painting. Results first try. Not available elsewhere. Free details. Money back guarantee. David Press, Box 278, Capitola, Calif. 95010.

EARN big money. Computer programming job guide \$1 Couto, Box 615, Eatontown, N.J. 07724.

SHARPEN Scissors, Pinkers. Inexpensive equipment, tools, supplies. Blackhawk's, Sheldahl, Iowa 50243.

\$500—\$800 MONTHLY Raise small Laboratory-breeding stock for us. We supply equipment, breeders, and instructions. Illinois Research Farms, Dept. MPA-12, Barrington, Illinois 60010.

LOCKSMITHING—Ten Lessons—Tools—Practice Locks—Glenstone, Box 3127, Springfield, Missouri 65804.

YOUR Own Sign shop. Signs, 410-S, So. Western, Springfield, Ohio 45506.

(Continued on next page)

PROFITABLE OCCUPATIONS

(Continued from preceding page)

LOCKSMITHING—Ten Lessons—Tools—Practice Locks—Glenstone, Box 3127, Springfield, Missouri 65804.

SALESMEN—DISTRIBUTORS

BIG earnings selling Hertel Bibles. New 3-dimension cover, finest reference edition sells fast. Demonstrator furnished. Big commission. International Book, Dept. PM, Box 118, Wichita, Kansas 67201.

MAKE extra \$25 to \$75 spare time! Take orders for double air cushion Bronson Shoes. Amazing comfort. Terrific men's, women's line for dress, work, play. Highest commissions. Shoes for yourself. Big outfit free. Write Bronson, Dept. 171, Minneapolis, Minnesota 55408.

DO You wish to use or sell a plant food that is field proven, shows the greatest results at lowest cost? Something different in sales and use. Big monthly income or get your fertilizer FREE. Campbell's Gro-Green, 414 Dewey, Rochelle, Illinois.

MAKE Your Own Drop Ship Catalog. Get direct manufacturers listings who supply catalog merchandise. Write-DeLang, Box 16037-MM Portland, Oregon 97233.

FREE. 206 Easy Ways to make money taking orders for exciting new products—spare time. Send name, age for 5 months free subscription. Opportunity Magazine, 1460 Hancock Center, Dept. 17-MS, Chicago 60611.

EARN big money calling on business-professional men. Send us their delinquent accounts for collection. General Finance, Dept. PM-11 Columbia Bank Bldg., Kansas City, Mo. 64106.

100% PROFIT—Sweet Georgia Brown Cosmetics sell fast. Write for Sample Case offer. Valmor, Dept. H, 2411 Prairie, Chicago 60616.

SELL Advertising book matches. Write us today. We put you in business by return mail, handling complete line ad book matches in demand by every business right in your town! No investment; everything furnished free! Top commissions daily: Superior Match, Dept. M1269, 7530 S. Greenwood, Chicago, Illinois 60619.

FREE! Money Making Opportunities! Your Own Business! Write name, address, zip, today, Bradley, Box 509-D, Mt. Kisco, New York 10549.

FREE Selling Outfit Office Supplies. Furniture & Equipment. Oseco, 15-PM North Jefferson, Chicago 60606.

\$40 COMMISSION each sale—cash in on jogging craze—S. A. LeBuda, 12560W Oxnard, N. Hollywood, Cal. 91606.

SELL Advertising Ball Pens, Calendars, Ad-Specialties—Build Own Repeat Business—Free Kit—Fleming, Dept. A, 6535 Cottage Grove, Chicago 60637.

AGENTS WANTED

OWN Your own business! Local training possible. Small investment required. Write! Training, Box 331, Sheboygan, Wisconsin 53082.

YOUR Own business—Used suits \$1.50; overcoats 65c; mackinaws 35c; shoes 12½c ladies' coats 30c; dresses 15c. Enormous profits. Catalog free. Nathan Portnoy Associates, 2109-AA Roosevelt Road, Chicago, Ill. 60608.

EVERY Man a prospect. Refundable sales kit offer showing line belt buckles, tie clasps, money clips, cuff links, lapels, identification badges, individualized with customer's name and emblems. Cap badges for trucking, bus, taxi, police, firemen, also postal, letter carriers and heavy construction emblems. Choice 3000 emblems. Hook-Fast, Box 1088PM, Providence, R.I. 02901.

PRINTING. Advertising Salesmen—Excellent moneymaking sideline selling Decalcomania Name Plates, small quantities. Advertising Specialties, sign letters. Free Samples, Raico XL, Boston, Mass. 02119.

LIFETIME Income. Business Loan Representative Write: Financial, 28 E. Jackson, Suite 1204-X3, Chicago 60604.

OPPORTUNITY knocks 25c refundable. Clayton, 1415 Jefferson Heights, Pittsburg, Pennsylvania 15235.

ITEMS Needed by Everyone. 50% Profit. Popular Dollar price. 3 saleable samples, complete details \$1.00. Daufeldt-PM, Atalissa, Iowa 52720.

EMPLOYMENT INFORMATION

AUSTRALIA 1970 Directory! Biggest! 65,000 Jobs in Construction, Mechanics, Sales, More! Guaranteed, \$1.00. Austrajobs, Box 5157-E, Fort Wayne, Indiana 46805.

AUSTRALIA WANTS YOU! Government Assisted Passage. 50,000 Jobs. Latest Government Information and Forms \$1.00. Special Reports on Employment, Business, Taxes, Housing, Education, Ranching, Farming, Teaching, Maps, Etc. AUSTCO, Box 3623-E, Long Beach, California 90803.

HIGH Paying overseas jobs. Construction, other projects. Bonuses, Travel Expenses. Extras. International information, 124, Cortez, Florida 33522.

ALASKA. . . Jobs, Land, Business Opportunities, Living. For information write: Alcan Research, Box M5-811, College, Alaska 99701.

AUSTRALIA!! AUSTRALIA!! (1969) handbook and forms describes Government assisted transportation, high living standard, climate, entry requirements, employment opportunities, Jobs Galore! Send \$1.00. Other reports on Employment, Ranching, Housing, Taxes, etc. ASSOCIATED, Box 17-B129, Lafayette, California.

COMING TO WASHINGTON D.C. Check jobs, Rentals First, Complete Vicinity Classified Section. \$1.00. Waddells, 9317 Telegraph Rd., Seabrook, Md. 20801. Free Map.

ALASKA, High pay jobs, many with room and board furnished. Send \$2.00 for brochure. H-W ENTERPRISES, Box 4-406 Anchorage, Alaska 99503.

FOREIGN And USA job opportunities available now. Construction, all trades. Earnings to \$3,000.00 monthly. Paid overtime, travel bonuses. Write, Universal Employment, Woodbridge, Conn. 06525

HELP WANTED

WORLD-WIDE . . . U.S.A. jobs now!! Earnings to \$3,000.00 monthly. Travel allowances, paid overtime. Write: Global Employment, Box 706-CA12, Orinda, California.

OVERSEAS Jobs—Europe, South America, Australia, Far East, etc. 2000 openings all trades. Construction, Office, Engineering Sales, etc. \$700 to \$3,000 month. Expenses paid. Free Information. Write Overseas Jobs, International Airport, Box 536-M, Miami, Florida 33148.

OVERSEAS Jobs—Australia, Europe, South America, Far East, etc. Openings in all trades and professions. \$400 to \$2,500 monthly. free information write Foreign Employment Mart, Box 2235, A.M.F., Miami, Florida 33159.

REAL ESTATE & FARMS

THE Only "No-Risk Land Purchase Plan" in America—10 year money-back guarantee on any Vacation, Retirement or Investment homesite in Boiling Spring Lakes—the multi-million dollar, 14,000-acre development on the Carolina Coast. All facilities, electricity, roads, motel, golf course, country club, already in. Private ocean beach, 50 fresh water lakes. ½ acre homesites as low as \$700.00 cash price; \$8.00-down, \$7.00 monthly for 120 months, including interest at an annual percentage rate of 6%. Write for free literature, Dept. 1-S, Boiling Spring Lakes, North Carolina 28461. (Not offered to residents of California, Florida, New York.)

GET YOUR FREE COPY of NEW SPRING catalog; late Real Estate bargains. Just Off The Press! SAFE-BUY REAL ESTATE, P.O. Box 589-PM, Little Rock, Ark. 72203.

\$ PROFITS FROM CHARTING CAN BE FABULOUS! If making really big money from raw land is your goal, charting is the best way. It's original; it's copyrighted. Don't be without this surest way yet. Only \$5. Order today. Land Investor's Profit Charts, Box 1070 Dept. 1, Arcadia, Calif. 91006.

232-page FALL-WINTER real estate catalog. All types property, coast to coast! UNITED FARM AGENCY, 612-PM West 47th St., Kansas City, Mo. 64112.

HOW to make money from Florida real estate. How to live rent free. Where land is still cheap. Where property values are bound to increase. Send for booklet HP-382 only \$2.00. Zeman's Gifts, 47-29 44 Street, Woodside, New York 11377.

LESS Than 1 mile to Disney property. Lake living, ¼ acre. Private ramp, beach. 11 mi. to Orlando. \$24 mo., \$50 down. BLOCH BROS., 1 North Rosalind, Orlando 26, Florida. AD65LS169-L.

CANADIAN Vacation lands: Full price \$385.00. 40 acres, \$10 month. Suitable cottage sites, hunting, fishing, investment. Free information. Land Corporation, 3768-C Bathurst, Downsview, Ontario, Canada.

\$1 ACRE—Canadian Border—hundreds campsites, islands, farmlands, directly from tax authorities. (Non-profit). Lists, photographs mailed. Register, Room 10, 110 Church Street, Toronto 1, Canada.

CENTRAL Ontario—Choice 640 acre Sportsmen's paradises still available—\$20.00 plus \$6.50 taxes yearly. Maps, pictures. \$2.00 (Refundable). Information Bureau, Norval 4, Ontario, Canada.

GOVERNMENT LANDS . . . Low as \$1.00 acre. Millions acres. For exclusive copyrighted report . . . plus "Land Opportunity Digest" listing land available throughout U.S., send \$1.00. Satisfaction guaranteed. Land Disposal, Box 9091-PL, Washington, D.C. 20003.

CANADA'S Finest lands. \$4.00 an acre and up. Acquired through Estate liquidations. Suitable for hunting, fishing, camps, cottages, farming, timber, minerals, investment. Small monthly payments. Free descriptive booklet. Canadian Estate Land, Dept. PMC, 194 Wilson Ave., Suite 101, Toronto, 12, Canada.

FREE CATALOG! Giant Fall-Holidays edition! Over 4,000 properties described, pictured—Land, Farms, Homes, Businesses—Recreation, Retirement, Selected Best thruout the U.S.! 69 Years' service. 515 Offices. 40 states Coast to Coast. Mailed FREE from the World's Largest! STROUT REALTY, 60-RX E. 42nd St., NY, NY 10017; 7-RX S, Dearborn, Chicago, Ill. 60603; 521-RX E. Green, Pasadena, Cal. 90013.

HOW To buy a retirement home or lot. Send \$1.00. Satisfaction guaranteed. Armon T. Mays, 2036-C Travis Street, Amarillo, Texas 79109.

LAND! Easy terms less than bank rates. Northwest Timbered Acreages as low as \$950 Total Price. 5-10-20-40-acres. For people who love the land—A tract of Recreation Land to have for your very own! In Northern Idaho and Northeastern Washington, and Western Montana. In the heart of lakes and big game country. All covered with growing timber. Access and Title insurance with each tract. This is select land with natural beauty, recreational and investment values. Plan for the future and retirement recreation. We have tracts of many types and sizes from which you can choose, including beautiful Northwest Waterfront property. Your inspection is welcomed. Write us for free list, maps and complete information. Write to: Dept: PC, Reforestation, Inc., P.O. Box 8146, Spokane, Wash. 99203.

FREE! Real Estate Catalog! Farms, Ranches, Business, Recreational and Investment Property. 18 States. Pictures Galore. Note State desired. BANNER Adv., Box 3333, 19-A, Springfield, Mo. 65804. "Real Estate Our Specialty."

(Continued on next page)

REAL ESTATE & FARMS

(Continued from preceding page)

BUY CANADA \$10—10 ACRES. Thousands of Tax Sale properties direct from government authorities. Atlantic to Pacific. Good roads. Near border. Sensational investment gains. Lake frontage. Cottages. Hunting. Fishing. Unique researched lists. Maps. Photos. "BUREAU," 16 Quinby Court, Thistleton, Ontario, Canada.

ARIZONA. Great investment opportunity. North of Lake Havasu City! Level 2½ acres \$895, low terms. Mrs. Anne Young, Glenarm Land Co., 2233 North 7th St., Phoenix, 85006.

VACATION Lands: Canada: \$1.00 acre. Free information. Tax Corp. Box 560-F Westmount, Montreal 215.

10 TO 80 Acres Lake Superior, Marquette, Michigan area \$99 Acre—Low, Low, Terms A-OK. Write H & H Bloch 1301 E. 6 Mile, Detroit 6, Michigan 48203.

FISHING Boat and Motor included with our beautiful wooded 1 acre Ranchette located in Florida's lake and citrus area. Full price only \$1995. Easy terms available. Will send plat and color photos. Write Gary Morse, Rainbow Acres, P.O. Box 369, Miami, Florida 33162. (AD0555B).

BARGAIN Bonanza! New listings, Arkansas properties! Statewide Realty Co., 507-AE Pyramid Bldg., Little Rock, Ark. 72201.

FLORIDA CAMPSITES—Deep in the heart of the great Ocala National Forest—Good fishing, hunting, Warranty Deed. Free maps and photos. (Unavailable in states requiring separate registration) (AD 66 LS 149) Howard Vernor, Deland, Florida 32720.



DRINKING WATER—PURIFIER

A WATER PURIFIER That fits on ANY kitchen faucet. No installation Necessary. Replaces Bottled Water. Lasts 3-4 Months. Performance Guaranteed. Only \$4.25 Prepaid. Free Information, Bal-Park Distributors, Box 700, Baldwin Park, California 91706.

CONSTRUCTION PLANS

HOBBYISTS, EXPERIMENTERS, amateur scientists, students Construction Plans—All complete including drawings, schematics, parts list with prices and sources . . . Laser—Build your own coherent-light optical laser. Operates in the visible light range, pulsed mode—\$6.00 . . . Radar—Build your own ultrasonic doppler radar. Detect motion of people, automobiles, even falling rain drops Transistorized, uses standard small 9-volt battery—\$4.00 . . . Long Range "Sound Telescope"—This amazing device can enable you to hear conversations, birds, other sounds hundreds of feet away. Very directional. Transistorized, uses 9-volt battery—\$3.00 . . . Or send 25¢ coin (no stamps) for complete catalogue . . . Wide range of other plans, including psychedelic lights, color organs, robot man, etc. . . . 38 different plans . . . Technical Writers Group, Box 5994, State College Station, Raleigh, N.C. 27607.

HOME CRAFTSMEN

BUILD unique new speaker enclosure! Versatile! Economical! Complete plans and instructions \$2.00. Midwest Specialty Company, Box 217, Dayton View Station, Dayton, Ohio 45406.

PLANS, Bird houses, feeders \$1.00. Custom Cabinet, Box 1355, Englewood, Colo. 80110.

MAKE your own fine picture frames with our beautiful mouldings and amazing Clamless Assembly Method. Terrific savings! We show how. Free proof, particulars. Japs, 126-PM Seventh North, Hopkins, Minnesota 55343.

101 PATTERNS of Smart Gifts, Novelties, Shelves, Action Windmills, plus "Make Money Jig Sawing." \$1.00. Mastercraft, 125M, 7041 Olcott, Chicago 60631.

\$21.00 HOUR Profit—From Home Picture Framing Business. (Clamless Assembly Method) Write: Japs, 126-PM Seventh North, Hopkins, Minnesota 55343.

CABINETMAKING MADE EASY and "How to Make Formica Counter Tops," two excellent guides let you build kitchen cabinets and counter tops like professionals. Extraordinary guides bring master craftsman's shortcut methods. Satisfaction guaranteed. Write: Japs, 126-P Seventh North, Hopkins, Minn. 55343.

WOODWORKING Catalog and Manual 25¢ Plus free "101 Project Ideas." World's most beautiful veneers, lumber, plywood! Wood finishing, upholstery supplies, Cane Lamp parts. Furniture hardware. Animal whittling blocks, 2,000 workshop products. Constantine, 2051-T Eastchester Road, Bronx 10461.

"GETTING Started in Stained Glass" 25¢. Whittemore, Box 2065Y, Hanover, Mass. 02339.

FULL SIZE FURNITURE PLANS. Traditional, Early American, Danish Modern. Catalog 50¢. Furniture Designs, Dept. P-129, 1425 Sherman, Evanston, Illinois 60201.

WALNUT And Cherry tapered legs, lumber, gunstock blanks, picture frame moulding. Midland Lumber Company, Box 262, Savannah, Missouri 64485.

PLANS, Bird houses. Send 15¢ for brochure and free feeder plan. Yeager, 1665 Linden, Homewood, Ill. 60430.

UNIQUE Tool Grips any size Pulley, Wheel, Shaft, etc. without marring finishes. HUNDREDS of uses. \$3.00 each. Postpaid. W. Staples, Box 252, Nazareth, Pa. 18064.

SKIL-CRAFTS new 200 page catalog with world's largest, finest selections of hobby-craft, leather-craft, artist supplies. Send 50¢ (refunded plus free gift with first \$5 minimum catalog order). Skil-Crafts, Box 105-P, Joplin, Mo. 64801.

HEADQUARTERS for Swiss Musical Movements. Catalog, Tune Lists 50¢. Walters, 207-P French, Utica, New York 13502.

DO-IT-YOURSELF

WATER? Drill Your Own Well with Amazing New \$179 Machine. Easy! Economical! Free Information, DeepRock Drilling Company, Opelika, Alabama 36801.

FINDING ANCESTORS—fascinating hobby. Send \$1.00 for helpful pamphlet "Searching for Your Family Tree"—including free chart. Genealogical Publishers, established thirty years. Box 307, Danboro, Pa. 18916.

REFRIGERATOR Door gaskets—Electric Range and Washer Parts. Send Make and model for cost. Box 5465, Hamden, Conn. 06518.

AIR Compressors made from Mower Engines. Write: Showalter, Box 409, Abilene, Kansas 67410.

STEAM Engines. Make from twin cylinder air conditioner, compressors easy to find engines fire tube boilers, flash boiler, gas burners, steam powered lawn mower, send \$2.00 for pictures descriptions. Travis Tools Co., Sidney, Iowa 51652.

BURGLAR-Fire Alarm Supplies and information. Free Catalog. Protecto Alarm Sales, Box 357, Birch Run, Michigan 48145.

HOW I MADE MY SKIL SAW INTO A RADIAL SAW out of spare parts. Send \$1.00 for blueprints and SELF STAMPED ADDRESS ENVELOPE to: Saw, P.O. Box 2303, Grand Rapids, Michigan 49501.

FLUORESCENT Tubes rejuvenated at no cost. Instructions \$1.00. Rejuvenators, 172 Bolton St., Portland, Me. 04102.

SMOKEHOUSE. Venison, Fish, Beef. Genuine Frontier Recipe and plans for inexpensive backyard smokehouse. \$2.00 . . . Smokehouse, Box 1113, Pendleton, Oregon 97801.

EXERCISE At home on build-it-yourself physical fitness equipment, including bicycle exerciser, rowing machine, belt massager, and abdominal board. Send \$3.00 for blueprints B1208 and instructions. Popular Mechanics Service Bureau, 224 West 57th St., New York, New York 10019.

MEN. Women double chin, flabby arms, wear 5 oz reducer. \$2.00. Petersen, 1786 East 23rd, Brooklyn 11204.

WATER—Free! Drill your own well. Easy illustrated instructions. \$2.00. Butler, Box 67AA, East Longmeadow, Mass. 01028.

ARTS AND CRAFTS

JEWELRY Metalcrafting Handbook \$4.95 postpaid. Craft Training Institute, 7438A 40th, Mercer Island, Wash. 98040.

MAKE Figurines, plaques, lawn ornaments. Molds, plastercraft kits, liquid rubber. Sample and catalogue 10¢. Wooley Company, Box 29-B, Peoria, Illinois 61601.

BINOCULARS, TELESCOPES, MICROSCOPES, MAGNIFIERS

BINOCULARS Direct from manufacturer. Finest quality, tremendous savings! Request catalog. Koyu, 3860 Crenshaw Blvd., Los Angeles, Calif. 90008.

SCIENCE Bargains! Lenses, telescopes, binoculars, microscopes, kits, parts, war surplus. Send \$1.50 for beginner's 10-lens kit with instruction booklet. Order Stock 2-CH. Request free 148 page Catalog CH. Edmund Scientific Co., 300 Edscorp Bldg., Barrington, New Jersey 08007.

BINOCULAR Specialists. Repairs And Sales. Free Catalog. Tele-Optics, 5514 Lawrence, Chicago, Ill. 60630.

TELESCOPES (Reflectors) complete kits, other accessories, request free literature. Criterion Manufacturing, Dept. PM-2, Hartford, Conn.



CAMERAS AND EQUIPMENT

48 PAGE ILLUSTRATED CATALOG with the low Central Discount price. Send 50¢. 75¢ CREDIT on order of \$7.50 or more. Central Camera Co., Headquarters for the Amateur and Professional since 1899. Central Camera, Dept. 1AN, 230 S. Wabash Ave., Chicago, Ill. 60604.

WORLD'S Largest Buying Guide—800 Illustrations—50¢—Deductible With Your Order—Olden Camera—1265 Broadway, New York, N.Y. 10001.

POLAROID Owners. Now at Photo Dealers. Rhedan Instant Copier \$8.95. Duplex Photo Adaptor \$2.00 Saves Film. Rhedan, P.O. Box 42, Bridgeport, Conn. 06601.

FREE! FREE!—Photographic and optical bargain book. Jimco, Dept. 1AD, 9006 Waukegan Road, Morton Grove, Ill. 60053.

PHOTO SUPPLIES

ANSCOCHROME—DYNACHROME—FILM—save by mail—free price lists. Hillis Products, Dept. M Box 1182, Kokomo, Indiana 46901.

PHOTO FINISHING

LOOK—Save Money on Pictures! Jumbo Size Prints from your Kodacolor Rolls, \$1.98. Black & White, 69¢. Huge Discounts on Supplies. Enclose Advertisement. Wisconsin Film Service, Dept. 33, La Crosse, Wisconsin 54601.

50% DISCOUNT "get-acquainted" offer to 126 Instamatic Camera owners for one month only . . . \$1.50 for 12 exposure (regular \$3.00). We develop, print ONLY 126 Instamatic film . . . no black and white. Send \$1.50 today. I/T/K CO., Dept. B. Ishpeming, Mich. 49849.

SPECIAL: BLACK-White, 8-45¢; 12-55¢. Kodacolor 8-\$1.89; 12-\$2.09. Astro Photo Service, Box 530, Waterloo, New York 13165.

SPECIAL WITH THIS AD—Kodacolor developed 12 prints \$2.25. Black & White developed 2 prints each Jumbo size—12 exposure 70¢. LENS PHOTOS, Dept. J-4, Janesville, Wis. 53545.

(Continued on next page)

PHOTO FINISHING

(Continued from preceding page)

RECEIVE 4 BEAUTIFUL 8X10 ENLARGEMENTS Of picture or negative, originals returned \$1.95. GIANT PHOTOS, Camden, Ala. 36726

CAMERA FANS! Expert photofinishing by one of Country's largest labs at lowest prices. Fast service and free "Foto-Fan" Stamps you quickly redeem for valuable Photo Supplies. 8MM Kodachrome \$1.29; 8 Exp. Kodachrome \$1.79; 35MM Kodachrome. 20 Slides \$1.39; 8 Exp. Black White 69¢. Satisfaction guaranteed. Send exposed film or request free mailers, complete Price List and Gift Catalog. Direct Mail Photo, Box 8352-PM, Pittsburgh, Pa. 15218.

TRIAL OFFER. Twelve prints from roll 60¢. Eight enlarged color prints from Kodachrome roll \$1.39; twelve \$1.79; twenty \$2.69. Young Photo Service, 45C, Schenectady, N.Y. 12301.

COLOR SLIDES

MAILORDER Records help get increased business! Complete 32 Page Record Book shows your inquiries orders, advertising, expense, etc. Only \$1.00. C. A. Martin, Popular Mechanics, Dept. PM, 224 West 57 Street, New York, N.Y. 10019.

MOTION PICTURES AND SOUND EQUIPMENT

FREE! 64-page catalog. 8-16mm film, supplies, processing equipment. Superior, 448 N. Wells, Chicago 60610.

UNUSUAL Movie supplies. Free circular. Esor, 47th Holly, Kansas City, Missouri 64112.

16MM SOUND Features. Shorts. New, used for Sale. Free Catalog. National Cinema, 333 W. 57th St.—N.Y.C., N.Y. 10019.

16MM. FILM Lists: 12¢: Gordon—28-53 Steinway Street, Astoria, L.I. N.Y. 11103.

5,000 8-16MM MOVIE Films. Free catalogues. International. Greenvale, L.I., N.Y. 11548

RADIO, TELEVISION AND HAM EQUIPMENT

TUBES—Lowest world prices. Foreign—American. Obsolete, current, receiving, special purpose, transmitting tubes. Send for tube and parts catalog. United Radio Company, 56-PM Market St., Newark, N.J. 07105.

HOME Radio-Television Course. Free literature. Progressive Edu., Department 720B, Hewlett, New York 11557.

33¢ RADIO & TV tubes. Free list. Cornell, 4213-17 University, San Diego, California 92105.

GOVERNMENT Surplus receivers, transmitters, snooperscopes, parts. Catalog. 25¢. Meshna, Nahant, Mass. 01908.

HIFI, RECORDS AND ELECTRONICS

FREE—FREE—FREE—FREE—FREE—FREE—FREE. Send in for your FREE one year subscription to Olson Electronics' fantastic value packed catalog—unheard of low, low prices on brand name speakers, changers, tubes, tools, stereo amplifiers, tuners, CB and other values. Credit plan available. If you have a friend interested in electronics, send his name and address for a FREE subscription also. Olson Electronics, 527 S. Forge St., Akron, Ohio 44308.

TAPE Recorders, hi-fi components. Sleep learning equipment, tapes. Unusual values. Free catalog. Dressner, 1523C Jericho Tpke., New Hyde Park, N.Y. 11040.

CASSETTE, 8-track cartridge-blanks, language, classical, special accessories, recorders. Quality, low prices, Box 13119M, Pittsburgh, Penna. 15243

FREE Catalogues, 2000 hard to find unusual records. Rose's Records, 300 Chelsea, Louisville, Ky. 40207.

RECORDS! Discounts on all LP's. Free details. Citadel Record Club, Symphonette So., Dept. 2, Larchmont, N.Y. 10538.

STEREO TAPES Cassettes 4-8 Track Encyclopedia of Stereo Tapes just off Press. Over 9000 Selections. Send 25¢ (if it's on tape we have it). Stereo Tapes Unlimited, 2318 Sheffield, Chicago, Ill. 60614.



MUSIC AND MUSICAL INSTRUMENTS

FORTY Music Flash Cards Quickly Learn note reading. \$2.00. Nu-Wa Music, Bybee, Kentucky 40412.

WE Pay All Recording Costs on accepted material! Need new Song Material for immediate recording! Grand Recording, 1354-PM Hancock St., Quincy, Mass. 02169.

ACCORDIONS and Amplifiers! Save to 50%. Famous makes. Easiest terms. Trades accepted. Free home trial. Free discount catalog. Accordion Corporation, 5535—R West Belmont, Chicago 60641.

EXCELSIOR Accordions and Amplifiers. Save 50%. Buy Direct. Factory Distributor. Terms. Trades. Free Catalog. Excelsior, 3147 North Luna, Chicago 60641.

WHOLESALE Musical Instruments Catalog. Allied, 406 East 189, Bronx, N.Y. 10458.

PLAYER Piano Rebuilding—get details from: Vestal Press, Vestal 11, N.Y. 13850.

ACCORDION Manufacturing, 6846-P North Avenue, Chicago, Illinois 60635. Concertinas, Hohners, Chromatics, Guitars, Drums. New, Used. Tuning, Repairing. Wholesale Catalogs Free.

VIOLIN and Guitar makers—send for latest Free Catalogue of woods & accessories. International Violin, PM8, 414 East Baltimore St., Baltimore, Md. 21202.

POEMS Wanted for new songs and records by America's largest song studio. Send poems. Free examination. Five Star Music, 6M Beacon, Boston, Mass. 02108.

GUITAR, Banjo Making books Plans, woods, necks, tools. List 25¢. Satinwood, 510 East 11th Street, New York, N.Y. 10009.

ELECTRIFY Player Pianos, Pump Organs quickly, inexpensively with Lee Silent Suction Units. Write Lee Music, 525 Venezia Avenue, Venice, California 90291.

GUITAR MAKING Books, Imported Woods, Supplies, Accessories. Catalog 25¢. Guitar Center, Box 15444, Tulsa, Okla. 74115.

SWISS Musical Movements Mechanical-Electrical. Spielman, 131 West 42nd, New York 10036.

DRUMS, Electric guitars, amps, organs. Free catalog M: A.L.A.S. Import Company, 31 East 18th Street, NYC. 10003.

GUITARS, MANDOLINS, BANJOS, Complete stock of Gibson Martin guitars. Free 100 page catalog, parts and accessories. Big Savings. New York discount prices. Send 50¢ postage handling. Eddie Bell Guitar, Dept. PM, 201 West 49, New York 10019.

HANDMADE Guitars—classical, flamenco. Dobro type. Martin, Gibson. Wood, tools, books. The Guitar, 4668 Hollywood Blvd., Hollywood 90027.

30% TO 50% DISCOUNT. Any Guitars, Amps, Drums. You name brand, model. Fast. Warehouse P5, Box 9352, Fort Worth, Texas 76107.

PROFESSIONAL 674 Watt Amplifiers, Guitars. Free Wholesale Catalog. Carvin PM70, Escondido, Calif. 92025.

POEMS, Songs wanted for new song hits and recordings by America's most popular studio. Tin Pan Alley, Dept. PM, Lake Grove, New York 11755.

ACCORDION Top brands. Buy direct. Tremendous discounts. Trade accepted. Free brochure PM. Accordion-O-Rama, 874 Broadway, N.Y.C. 10003.

POEMS, Songs Wanted for new songs and immediate recording, contracts. Royalties. Weiss Music Company, 1472PM Broadway, New York, New York 10036.

LEARN Banjo. 5-String Bluegrass. No Music. Makes Learning Easy. Free Details. Blaylock, Box 25-M, Marietta, Georgia 30060.

FLUTES, play music in your home. \$2.00. J. L. Gardner Co., 120 Liberty St., N.Y., N.Y. 10006.

PLAY GUITAR IN 7 DAYS! Guaranteed! \$7 Value, Now \$2.98. MGR Studios, 4445 Berke, Ft. Worth, Texas 76115.

POEMS, Songs wanted for Commercial Records. Contacts with Publishers. Golden Planet Music, Box 3416 Anaheim, Calif. 90823.

SONGS, Poems, Offer. Newart Pubs, Box 693, Syracuse, New York 13201.

SONGPOET'S "Jiffy" pocket Rhyme-Finder! \$1. Ardbox, 85-X, Trumbull, Conn. 06611.

PLAY ORGAN EASILY! AMAZING METHOD! FREE INFORMATION! Kegley, 1016 Kelly, Joliet, Illinois 60435.

30% DISCOUNT Any Name Brand musical instruments. Write for low price. Freeport Music, 127 W. Sunrise Highway, Freeport, New York 11520.

EDUCATION AND INSTRUCTION

LEARN ACCIDENT INVESTIGATION. Train at home to earn \$750 to \$1,000 monthly. Car Furnished. Expenses paid. No selling. No college needed. Full or spare time. Men urgently needed. Free placement service. Write for FREE information. No obligation. Universal Schools, CPM 12, 6801 Hillcrest, Dallas, Texas 75205.

LEARN Civil and criminal investigation at home. Earn steady, good pay. State age. Institute Applied Science, 1920 Sunnyside, Department 16C, Chicago, Illinois 60640.

EXTERMINATING: BE YOUR OWN BOSS! High Pay: full or part time. Earn as you learn, inside information. Instruction pamphlet only \$3.95 (full price). Money back guarantee, Exterminating Institute, P.O. Box #98, Guttenberg, New Jersey 07093.

DRAFTING (Electronic, Mechanical, Architectural). Home Courses \$25.00. Send \$2.00 first lesson. Prior, Inc., 23-09 169 Street, Whitestone, New York 11357.

HAVE Holy Ghost, Virtue, Avoid Hell. Romans, Peter, Acts, Tracts, Box 233, Newport News, Virginia 23607.

POLICEMAN Correspondence Course and Diploma. — \$10.00 — Free Information. Southern Police Academy, Box #306, Fairfield, Alabama 35064.

WATCH REPAIRING. Learn to repair American and Swiss watches in spare time at home. Diploma awarded. Free sample lesson. No obligation. Chicago School, Dept. YZ, Fox River Grove, Illinois 60021.

EARN College degree at home. Many subjects. Ohio Christian College, 1156 Striebel Road, Columbus, Ohio 43227.

LEARN Auctioneering. Term soon. Free catalog. Reisch Auction College, Box 850, Mason City, Iowa 50401.

PIANO Tuning quickly learned with home study course. Diploma granted. American Tuning School, Gilroy, Calif. 95020.

BOOKKEEPERS. Operate your own "Dollar-A-Week" system. Ellis, Box 200, Cedar Grove, North Carolina.

OWN Collection agency. "Little Gold Mine!" Franklin Credit, Roanoke, Virginia 24004.

EARN \$125 A week and up. Learn a trade with a future. Learn auto diesel mechanics in our shops. You learn with tools on real equipment. Earn while you learn. Many of our graduates earn \$125 a week and up. Write for free bulletin: Dept. 256, Auto Diesel College, Nashville, Tennessee 37219.

USED CORRESPONDENCE Courses and Books sold and rented. Money back guarantee. Catalog free (Courses bought). Lee Mountain, Pisgah, Alabama 35765.

MISSOURI Auction School. GI Approved. Free Catalog! 424-03 Nichols Road, Kansas City, Mo. 64112.

(Continued on next page)

EDUCATION AND INSTRUCTION

(Continued from preceding page)

FCC First Class License in six weeks—Nations highest success rate—Approved for Veteran's Training. Schools in Dallas, Atlanta, Chicago, New Orleans, Minneapolis and Houston. Write Elkins Institute, 2603D Inwood Road, Dallas, Texas 75235.

HIGHLY EFFECTIVE home study courses in Electronics Engineering Technology and Electronics Engineering Mathematics. Earn your Degree. Write for Free Descriptive Literature. Cook's Institute of Electronics Engineering, (Dept. 10), P.O. Box 10634, Jackson, Miss. 39209. (Established 1945).

USED Courses! Books! List 10¢. Smith's. 124 Marlborough, Salem, Mass. 01970.

GET A British Degree, Divinity, Philosophy, Radionics. 35 Courses, Prospectus free. Brantridge Forest School, Highfield, Dane Hill, Sussex, England.

LEARN Asleep or awake! Records! tapes, equipment! Free Catalog! Drawer. PM-400, Ruidoso, New Mexico 88345.

INSTANT Spanish. Free lesson Mayco. Dept. M-1, 257 Chloride Star, Kingman, Ariz. 86401.

LEARN Handwriting analysis. International. Dept. 700, 11749 Eldridge, Lake View Terrace, Calif. 91342.

PENMANSHIP Improver: Correct poor penmanship, plus ornamental. Tevis, Chillicothe, Mo. 64601.

AUTOSUGGESTION, Sleep-learning headquarters! Tapes, records, books. Gigantic catalog free. Research Association, Box 24PM, Olympia, Washington.

SUPERIOR Auction School. Nation's top Auctioneers own and instruct. Box 1281, Decatur, Ill. 62523.

DETECTIVE Course Details. Write P.S., 4425-B W. Irving Park, Chicago, Ill. 60641.

AUCTIONEERING Resident or Home Study Course Free Catalog. Nashville Auction School, 2004 West End, Nashville, Tennessee 37203.

COMPLETE YOUR HIGH SCHOOL at home in spare time with 72-year-old school. Texts furnished. No classes. Diploma. Information brochure free. American School, Dept. X945, Drexel at 58th, Chicago, Illinois 60637.

DETECTIVE Course. Free information. Universal Detectives, Box 8180-F, Universal City, California 91608.

HIGH SCHOOL diploma at home. Licensed teachers. Send age, highest grade completed for free details. No salesman will call. Southern States Academy, Westbury Square Professional Bldg., Dept. 16, Houston, Texas 77035.

HIGH SCHOOL DIPLOMA FAST! Free information. Educational Service, Box 514, Dept. PM, Jackson Heights, N.Y. 11372.

FREE Bible course! Degree! Request information! 708 South Bragg, Monroe, North Carolina 28110.

BECOME real estate broker quickly. Economical homestudy. Prospectus free. Howard Schools, Box 8585-A, Kansas City, Missouri 64114.

SIMPLIFIED New Age ordaining procedure. Stamp brings info. Church, 2207 Cardinal, Rolling Meadows, Ill. 60008.

PIANO Tuning pays. Big money in spare time. Learn at home. No musical knowledge necessary. Phonograph, records, tools and instructions furnished. Electronic tuning also taught. Free catalog. Capital Tuning School, 3160 S.W. 16th Court, Ft. Lauderdale, Fla. 33312.

REAL ESTATE BROKER TRAINING Simplified course. train at home. Write: RETA, Box 713, Elkhart, Ind. 46514.

FREE! Catalog of low cost popular self-improvement books. Write Jack Butler, 1384-B Monroe Drive, N.E., Atlanta, Georgia 30324.

BE A Real Estate Broker. Free Details. Moran School, Ben Lomond, California 95005.

LEARN To prepare income tax returns. It's easy and profitable. Act today! Write American Tax Training Institute, Dept. PM, Box 4845, Chicago, Ill 60680.

PROFITABLE Camera service training at home. National Camera, Dept. PM, Englewood, Colo. 80110.

LAW Degree at home. Easy tuition plan! Williams College, 138-PM South Second East, Salt Lake City, Utah.

MINISTERIAL Bible College. Christian Education. Ordination and Degree Courses. Write: Soms, 887 West Spruce, Ravenna, Ohio 44266.

EARN College degree at home. All subjects. Florida State Christian College, 4307 North Andrews Avenue, Fort Lauderdale, Florida 33309.

HOME STUDY COURSES in WATCH-MAKING, ENGRAVING, DIAMOND SETTING and CLOCK REPAIRING. For information write: KANSAS CITY SCHOOL OF WATCH-MAKING Dept. PM3, 101 West 11th Street, Kansas City, Missouri 64105.

LEARN Bookkeeping: Excellent pay; Full, spare time. Simplified Technique for home study. Inexpensive. Free Details. Business Research, Box 745E, Wilmington, Delaware 19899.

PENMANSHIP Corrector. Improve Poor penmanship quickly. Details free. Ozment, Box 2344-34, St. Louis, Mo. 63114.

ART Production. Study this profitable occupation at home Drawing ability unnecessary. Free information. Box 122, New Canaan, Connecticut 06840.

GOD Speaks to twentieth century. Free lessons. Home Bible Studies, Box 370PM, Elkhart, Indiana 46514.

EARN University degrees through experience—All subjects . . . details \$1.00 . . . Ohio St. Matthew University . . . Box 9734 . . . Columbus, Ohio 43206.

EXTENSION And Post-Graduate Awards in Philosophy, Arts, Sciences, Botanic Medicine, Homeopathy, Radionics and others. 30 subjects. Curricular free (air-mail \$1.00 refundable). Registrar, Sussex College of Technology, Highfield, Dane Hill, Sussex, England.

PIANO Technology—Electronic organ servicing, learned easily at home. G.I. Approved. Free booklet. Niles Bryant School, Dept. P, 3631 Stockton, Sacramento, California 95820.

FOR INVENTORS

INVENTORS Wanted immediately for promoting on cash or royalty. Patented, unpatented. Free booklet outlines royalty rates, requirements. Write Kessler Corporation, C-512-F1, Fremont, Ohio.

PATENT Searches complete and thorough. Related copies Air Mailed with maximum speed \$6.00. Free "Protection Forms" and "Patent Information." Write American Patent Search Company, Dept. 27, 711 14th St., N.W. Washington, D.C. 20008.

PATENT Application Financing. Free patent search plan. Global Patent Division, 2420 77th, Oakland, Calif. 94605.

PATENT And invention development by licensed professional patent engineer and U.S. Patent Office former examiner, and engineering specialists. Your inventions and ideas engineered for patent protection and commercial value. Inventions developed by us negotiated for cash or royalties with our nationwide contacts. Send for free protection "Invention Certificates" and further interesting, valuable patent information. George Spector, Licensed Professional Patent Engineer, Woolworth Building, New York.

U.S. Patent Office Searches, 234 Broadway, Room 3615, New York. Free invention certificates.

MANUFACTURERS NEED New Products! FREE Literature explains "How to Submit Your Invention." Congress Invention Company, 911-C Warner Building, Washington, D.C. 20004.

IMMEDIATE Cash, for patent applications. Free patent searches. Write for details. Universal Patents, 184-D, Marion, Ohio.

PATENT Searches, including copies of related U.S. patents. Inventors attorneys, manufacturers use our "worldwide" air-mail service! "Invention Record" form and "Information Every Inventor Needs." Sent free! Hayward Company, 1029P Vermont, Washington 5, D.C.

INVENTORS: Your ideas and inventions (patented; unpatented) expertly searched, developed for commercial appeal and cash/royalty sales to manufacturers by professional Invention Developer with excellent record of experience. B.S. Industrial Engineering; United States Patent Office former Patent Examiner, United States Government former Patent Advisor. Second decade reliable service! Member: United States Chamber Commerce. Free "Invention Record" and "Recommended Protection Procedure." Airmailed! Write: Raymond Lee, Invention Developer 230P-Park Ave., New York City 10017.

FREE PAMPHLET: "Tips on Safeguarding Your Invention." Write: United States Inventors Service Company, 501P Thirteenth Street N.W., Washington, D.C. 20004.

INVENTORS. PROTECT YOUR IDEAS. Simple. 4-way Do-It-Yourself Method. Details \$1.00. Kish-Burke, 915½ Jones Street, Martinez, California 94553.

FILE YOUR OWN PATENT. \$5.00. Complete instructions, forms. Satisfaction guaranteed or \$4.00 refunded if returned ten days. Risk \$1.00. Nielsen, 2020 APS, Santa Barbara, Cal. 93103.

INVENTIONS WANTED

INVENTIONS Wanted immediately for promoting on cash or royalty. Patented, unpatented. Free booklet outlines royalty rates, requirements. Write Kessler Corporation, C-512-IW, Fremont, Ohio.

INVENTIONS Wanted. Patented: unpatented. Tremendous manufacturers lists. Global Marketing Service, 2420G 77th, Oakland, California 94605.

INVENTORS! Sell your invention for cash or royalties! Our client manufacturers eagerly seek new items. Patented. Unpatented. Financial assistance if needed. 25 years proven performance. For free information, write Dept. 15, Gilbert Adams, Invention Broker, 80 Wall St., New York, N.Y. 10005.

INVENTORS! We will develop, sell your idea or invention patented or unpatented. Our national manufacturer-clients are urgently seeking new items for highest outright cash sale or royalties. Financial assistance available. 10 years proven performance. For free information write Dept. 47, Wall Street Invention Brokerage, 79 Wall Street, New York, N.Y. 10005.

INVENTORS! Don't sell your invention, patented or unpatented, until you receive our offer. Eagle Development Company, Dept. H, 79 Wall Street, New York 5, N.Y.

WE Either sell your invention or pay cash bonus. Write for details. Universal Inventions, 298-E, Marion, Ohio.

INVENTORS! Protect your ideas! Free "Recommended Procedures." Washington Inventors Service, 422F, Washington Building, District of Columbia 5.

FREE "Directory of 500 Corporations Seeking new Products." For information regarding development, sale, licensing of your patented/unpatented invention. Write: Raymond Lee Organization, 230-N Park Avenue, New York City 10017.

PROCORP Is an international organization assisting inventors of technical products all over the world in obtaining for them the best return from their invention efforts at no outlay of cash. Write Pro International Corporation, 111 E. 4th, Dayton, Ohio 45402.

MANUFACTURING

INVENTORS Ideas developed. Research. Models. Manufacturing. Sales. Free brochure. William Parker, 32 Westminster, Worcester, Mass. 01605.

BUY IT WHOLESALE

ELECTRIC Toothbrush, four brushes, carrying case. Only \$4.95. Paul Guertin, 20 Grotto Avenue, Warwick, Rhode Island 02888.

BARGAINS! Buy wholesale and below. Name brands. Appliances, furniture, sports equipment, televisions, cameras, watches, jewelry thousands more. Huge discounts to \$1,000.00 on new automobiles. All makes. Free details. Write today: Worldwide Bargainhunters, Box 730-A, Holland, Michigan 49423.

FANTASTIC Free catalog—watches, general merchandise. Department Forty, 100 North Greene Street, Baltimore, Md. 21201.

WORLD'S Largest Dropship Sources. U.S. & Foreign. 7853 Suppliers. Hongkong clothes. Automobile discounts. Save 10¢ on dollar bankrupts, closeouts. Free details. International Buyers, Box 16386-M, Portland, Oregon 97233.

HEARING Aids, Batteries, Wholesale. Catalog 25¢. Fiston, Box 1444, New Preston, Conn. 06777.

GIANT Illustrated Tool—hardware—automotive catalog. \$1.00, refundable. Lithco, Box 51, Canoga Park, Calif. 91305

EXPORT-IMPORT

JAPAN: 1200 Products Directory. Illustrated Manufacturers' names, addresses. \$3.00. Send cash. Yamagata Office, 814 Togin Bldg., Marunouchi, Tokyo.

REAL ALLIGATOR HEAD Letter Opener. South American Import. Limited Supply! Send \$7.25. CASA IMPORTADORA, P.O. Box 15067, Denver, Colorado 80215

HUNDREDS of manufactures names, addresses: Send \$2.00. Scientific, 8886 Melvin, Livonia, Michigan 48154.

FOR THE HOME

COMPLETE Home BURGLAR And FIRE ALARM SYSTEM, \$44.95. Satisfaction Guaranteed. MRP Inc. Dept. B., 215 Mill Street, N.E. Vienna, Va. 22180.

OF INTEREST TO WOMEN

WOMEN! Make big money at home. \$10.00 profit in an hour possible with invisible mending. Make holes, tears disappear from clothing fabrics. Steady year-round demand from cleaners, laundries, homes. Details free. Fabricon, 1533 Howard, Chicago 60626.

HOW To make money writing short paragraphs. Information free. Barrett, Dept. C-27-X3, 6216 N. Clark, Chicago 60626.

DRIVE New car, wear new clothes, buy color TV. Get daily cash income. Put spare hours to work. Write for 5 months free subscription Opportunity Magazine, see hundreds easy ways to make money. Opportunity, 1460 Hancock Center, Dept. 17-MO, Chicago 60611.

\$75.00 THOUSAND. Home addressing! Longhand, typewriter. Information, send stamped self-addressed envelope. Brewster, Box 1348-YL, Clearwater, Florida 33517.

\$500 MONTHLY POSSIBLE—Clipping news at home. No experience. Free information—send stamp. American, Excelsior Springs, Mo. 64024.

\$25.00 HUNDRED Addressing, Possible! Year 'round. Complete instructions 25¢ for registration, postage, Cove, Box 1348-B, Clearwater, Florida 33517.

\$100 WEEKLY Possible addressing mailing circulars. Send self address stamped envelope. Details Free! Ayers Opportunities, Box 1591PM, Denton, Texas 76201.

EARN Up to \$2.00 Hour Lacing Baby Boots! Cowboy. Warsaw 9, Indiana 46580.

HAVE Won over 650 sweepstakes. Secrets \$1.00. Sweepstakes, Box 304, Columbia City, Ind. 46725.

\$100 WEEKLY Possible—Home Typing Immediate earnings! Employers list, complete instructions. Details 25 cents. Typing, Box 593, PM-12, Bettendorf, Iowa 52722.

ADDRESS Envelopes, home, from lists. \$100.00 Thousand. Longhand, Typewriter. Proven method \$1.00. Economy, Box 1348-V, Clearwater, Florida 33517.

WANTED! Addressers—Commission Mailers. Stamp required. Ooton Distributors, 4120-P Duke Drive, Portsmouth, Virginia 23703.

WOMEN: BIG MONEY! Studio Girl Cosmetics needs women in all states including Hawaii, Alaska, Puerto Rico and American Samoa. Full or part time. No experience required. No territory restrictions. Take orders anywhere. Highest profits. 500 Good Housekeeping cosmetics, wigs, wiglets and falls. Everything furnished. Credit extended. No stock to carry. No franchise fees. No stock investment. For full information by mail, plus 2 free beauty samples, write HARRY TAYLOR, Chairman, Studio Girl Cosmetics, Dept. BC 414, 11461 Hart Street, No. Hollywood, Calif. 91605. Also immediate big profit earnings for experienced city and state managers and former party plan operators. Former Studio Girls please write.

HOUSEWIVES, Teachers, students, office workers. If you need extra cash each week but household or other duties prevent you from taking a part-time job learn how you can earn by accepting orders to Popular Mechanics. Good Housekeeping and all other magazines. No experience needed. Write Popular Mechanics, Room 12W, 250 West 55th St., New York 19, New York.

HOMEWORKERS! \$85 Weekly addressing mail for firms. Start immediately! Details: Send stamped self addressed envelope. Enterprises, Box 16143-PM, Phoenix, Arizona 85011.

WOMEN! Start your own fabric shop. Details free. Fabrics Unlimited, 7738 Springdale Dr., St. Louis, Missouri 63121.

EARN Money Painting Novelties at home. N. Roland, 10-V Lakeview, Hammonton, N.J. 08037.

GIFT SHOPPING

WRITE For: "Free Gift Catalog" 1506 Indiana Avenue, Sheboygan, Wisconsin 53082.

FREE Outstanding Gift Catalog. Harry Haines, Route 1, Box 151, Mill Hall, Pennsylvania 17751.

JEWELRY and HANDICRAFT—Catalogue #10 M 25¢ (refunded with first order) EVE'S GIFTS, Box 132 Tallman, New York 10982.

INDIAN HEAD Letter Opener. South American Import. Elegantly Hand Carved by Indians of Andes. Send \$4.85. Limited Supply. CASA IMPORTADORA, P.O. Box 15067, Denver, Colorado 80215.

FREE Distinctive Gift Catalog. Over 100 useful and practical gifts. Bruce Sheppard Ltd., 1 Continental Avenue, Forest Hills, New York 11375.

WATCHES, OLD GOLD, JEWELRY

HIGHEST CASH For Gold, Jewelry, Gold Teeth, Rings, Diamonds, Watches, Silver, Platinum. Mail Articles Today. Free gift with information. Chicago Gold & Precious Metals, 6 E. Monroe, Dept. 458, Chicago 60603.

WATCH And clock repairing books. Free catalog. North American, Box 77-AN, Fox River Grove, Illinois 60021.

USED Wrist, pocket watches—\$3.00 up. Free list. Southern Watches, 5-PM South Wabash, Chicago 60603.

WANTED—gold, silver, platinum (any form), mercury. Information free. Wilmot's, 1067 Bridge Street, Grand Rapids, Michigan 49504.

CASH Immediately for old gold, jewelry, gold teeth, watches, diamonds, silverware, spectacles, platinum, mercury. Free information, Rose Industries, 29-A East Madison, Chicago 60602.

WEARING APPAREL

MEN—Buy your outerwear Coats and Jackets **WHOLESALE** directly from manufacturer. Write now for free illustrated booklet showing styles for Fall 1969. Sharob Corp., Carbondale, Penna. 18407.

HEARING AIDS

HEARING AIDS—Batteries Wholesale! Brochure—Hearing Center, Box 211, St. Petersburg, Florida.

HEARING Aids below wholesale. Regular, eyeglass, completely hidden models. Smallest, most powerful. Free home trial. No Salesman will call. Free details. Write Prestige-C6, Box 10880, Houston, Texas 77018.



SCIENCE AND CHEMISTRY

AMAZING New Book of Science Experiments, formulas and Catalogue of Laboratory Supplies. Only 50¢. National Scientific Co., 9 S. Park Avenue, Lombard, Illinois 60148.

CHEMICALS, Apparatus for Schools, Private Labs, etc. 40 Page Catalog 35¢. Sheard, Columbus, Wisconsin 53925.

FREE Periodic classification of elements and conversion tables with catalog 35¢. Chemicals, apparatus, biology. Mid-States Scientific, 7053 N. Clark, Chicago, Ill. 60626.

CHEMICALS And apparatus for industrial, analytical, and private laboratories. Catalog 50¢. Dept. M-50. Biological Supply Co., 1176 Mt. Hope Ave., Rochester, N.Y. 14620.

LABORATORY Supplies At Discount Prices. Catalog—35¢. Deluxe Scientific: Manitowoc, Wisconsin 54220.

ILLUSTRATED Catalog: Chemistry, mineralogy, biology 25¢. Tracey Laboratories, Evanston, Illinois 60204.

GET Smart. Science, Chemistry, Technology Books. Many fields. Catalog 45¢. See our interesting ads in back issues of PM. Bilton, Box 28, River Edge, N.J. 07661

BOOMERANGS! So unique you can't throw it away. Of laminated Birch imported from Finland \$2.95. Arwel, Box 236PM, Hasbrouck Heights, New Jersey 07604.

FLYING Saucer Detector. Inexpensive to make. Send \$2.00 for Plans and Instructions to: Mosser, P.O. Box 163, Minnesota Lake, Minnesota 56068.

LASER PISTOL—\$1.00. How to build. **PHASER PISTOL**—\$1.00. (Add 25¢ postage.) New catalogue—25¢. Roy Davis Laboratories, Dept. PM, 118 West Adams St., Jacksonville, Florida 32202.

FREE Rocket sent with catalog. 50¢. Scientific, 8886 Melvin, Livonia, Michigan 48154.

NEW! Low Priced Science Courses. Send 35¢ for Catalog. M—Bergeron, Suite 2, 515 Park Drive, Boston, Mass. 01550.

SEARCHING For Economically Priced Chemicals and Apparatus? Conversion Charts with Catalogue—35¢. Starr Scientific, Manitowoc, Wisconsin 54220.

COMPLETE catalog, 20¢ postpaid. Laboratory Sales, Box 161-A, Brighton, Mass. 02135.

CATALOGUE of ver-ry interesting products 25¢. Things that go boom, things that go zoom, and things that make money! Kenrus-C, Box 158M, Staten Island, New York 10309.

PSEUDO MOON DUST. Dollar a daub, Phillips, Box 8528, Honolulu, Hawaii 96815.

(Continued on next page)

SCIENCE AND CHEMISTRY

(Continued from preceding page)

100 ONE Minute time delay fuses! \$1.00 240—\$2.00. 700—\$5.00. Use with rockets, experiments, etc. Kenrus-F, Box 158M, Staten Island, New York 10309.

SEARCHING For Economically Priced Laboratory Supplies? Elements Charts And Catalogue—35c. Hagenow Laboratories, Manitowoc, Wisconsin 54220.

TREMENDOUS OPPORTUNITIES IN AVIATION. Learn Aerosciences at home: Navigation, Aerodynamics, Communications, Weather. Free information: United Aerosciences, P.O. Box 4106, Torrance, California 90503.

FORMULAS, PLANS, ETC.

FOR Proof of what you can do in specialty manufacturing get our literature. It's free! Miller, Chemist, 1517-P, Tampa, Florida 33601.

PERFUME Oils, Formulas, Private Label Perfumes. Sample plus complete information \$1.00. House Of Edouard, Box 229, Covina, Cal. 91722.

ANY Formula \$3.00. Catalog—Treatise 10c. Belfort, 192 N. Clark, Chicago 60601.

PLASTICS

PLASTIC Craft Kits—Supplies. New, Enlarged Catalog 50c. (Refundable). Specialty Products, Dept. 7, 731 Brooks Road, Muskegon, Michigan 49442.

CASTOLITE Liquid Plastic pours like water and hardens like glass without heat. Clear. Colors. Embed real flowers, butterflies, photos, coins. Also new molding formulas for perfect reproductions. Illustrated booklet shows HOW. Send 25c—Dept. 9/101P, CASTOLITE, Woodstock, Ill. 60058.

PLASTIC Embedders, jewelry workers. We have everything. Findings, moulds. New Catalog 25c. David Co., 861 Broad St., Dept. M, Providence, R. I. 02907.

TREASURE FINDERS

TREASURE Hunters! Prospectors! Relco's new instruments detect buried gold, silver, coins, minerals, historical relics. Transistorized. Weighs 3 pounds, \$19.95 up. Free catalog. Relco-A40, Box 10839, Houston, Texas 77018.

TREASURE LOCATORS MOST COMPLETE LINE. FREE INFORMATION. TESOROS, APARTADO 7-948, MEXICO 7, MEXICO.

POWERFUL Metrotech locator detect gold, silver, coins, relics. Moneyback guarantee, terms. Free information. Underground Explorations, Dept. A, Box 793, Menlo Park, California 94025.

FIND Buried treasure with new revolutionary analytical metal detector. Features push button tuning, automatic tuning, loudspeaker, negligible ground pick-up, greatest range. Free catalog, Gardiner Electronics, Dept. 9, 4729 N. 7th Ave., Phoenix, Ariz. 85013.

TREASURE BOOKLET. Excellent information on treasure hunting and metal detectors. Send 25c. BOOKLET, Dept. 12-PM, Box 243, San Gabriel, California 91778.

TREASURE, Gold, silver, relics. New 1970 detectors now available. Free information. Rayscope, Box 715, North Hollywood, California 91603.

FREE 128 Page detector catalog. General Electronic Detection Co., Box 67, Bellflower, California 90706.

FREE TREASURE GUIDE! Fact-filled collectors edition; send 50c for postage. Also request free literature on ultrasensitive, professional Fisher Detectors. FISHER RESEARCH, Dept. PM-12, Palo Alto, California 94303.

MAKE Money: Oil leases: \$4.00 acre: Others have. Free proof. Northern, Box 560-F Westmount, Montreal 215, Canada.

GOLDAK Treasure Locators—New for '69! A hobby you'll enjoy for fun and profit. Find coins, gold, silver. Goldak, Dept. PMC, 1101A Airway, Glendale, California 91201.

ULTRA-SENSITIVE AND POWERFUL METAL DETECTORS—join the many who are finding buried coins, minerals, relics and artifacts. Don't buy till you see our FREE catalog of new models. Write Jetco—Box 132, PM-10, Huntsville, Texas 77340.

PRECIOUS STONES AND MINERALS

EARTH Science Rockhound Magazine. Subscription \$2.50. Sample 35c. Box-550-PM, Downers Grove, Ill. 60515.

100 COLORFUL, Polished gemstones \$1.00. Tumblecraft, 5401 James North, Minneapolis, Minnesota 55431.

SEMI-Precious uncut gems. Ten different for \$1.00. Request list #35. Prospectors Shop, 201 San Francisco, Santa Fe, New Mexico 87501.

GET Free catalog no serious rockhound, gem cutter, jewelry maker, hobbyist or craftsman can be without. Full of bargains, exclusive items, low prices from largest suppliers and authorities in the field. Free new catalog just off the press, yours for the asking. Write Grieger's, Dept. C-12, 1633 E. Walnut, Pasadena, California 91106.

12 POLISH-Gem-Stones-Of-The-World. Names-And-Locations. — Educational — \$1.00. Empire Gem's, Trinidad, Calif. 95570.

GOLD—10 Small Nuggets Panned from Oregon Streams, \$1.00. Robert Brandt, Sweet Home, Oregon 97386.

LARGE POLISHED GEMSTONES. 15 different \$1.00. Colorful crystal specimens, 3 different \$1.00. Lists with order. Sering, 1705 E. Michigan, Indianapolis, Indiana.

500 BEAUTIFUL POLISHED GEMSTONES \$1.50. Floodstones, P.O. 1673 Fremont, California 94538.

CARTOONING, COMMERCIAL ARTS, SHOWCARD & SIGN PAINTING

COMPACT 23 lesson Cartoon Course and Cartoonist's Magazine. \$2.00. Hartman, Box 30367, Lincoln, Nebraska 68510.

LEARN sign painting at home. Free talent test. Ben Kerns, Box 812-PM, Greenville, S.C. 29601.

"HOW TO MAKE MONEY WITH SIMPLE CARTOONS"—Everyone who likes to draw should have this book FREE. Write Cartoonist's Exchange, 912 Pleasant Hill, Ohio 45359.

SIGN Painting, Fascinating System—Straley, 410 So. Western, Springfield, Ohio 45506.

LEARN Profitable tattooing. Illustrated information and instruction \$3.00. Zeis, 2220-P Delcy Dr., Rockford, Illinois 61107.

MODERN Cartooning taught by mail. Write for free brochure. Cartoonorama—Box 263-Q Branford, Conn. 06405.

SIGN Painting—Free Catalogue, Instructions, Equipment. Kaufmann Signs, Centertown, Missouri 65023.

ART Talent? Make money right away. Course may not be necessary. Free brochure. Famous American Studios, P5, Spring Park, Minn. 55384.

LEARN CARTOONING at home. Free book. "Key To A Cartoon Career." Write: Cartooning, Box 0-3176, Colorado Springs, Colo. 80907.

ADVERTISING AGENCIES. ADV. SERVICE, MAILING LISTS

ADVERTISING Ratebook leading newspapers, magazines, 25c. Chicago Advertising Agency, 28-E Jackson, Chicago 60604.

"LIST O'Trades and How to Reach 'Em". Over 3,000 Businesses. Send \$1.00. Ponton, 248 Long Lane, Upper Darby, Pa. 19082.

HOW To Develop a Mailing List. Send \$1.00. Ponton, 248 Long Lane, Upper Darby, Pa. 19082.

MAILING Lists most all kinds 1000 \$5.00. Free folder Your circulars mailed \$4.00 1000. Dixie Mailers, King, N.C. 27021.

TYPEWRITERS, DUPLICATORS, OFFICE EQUIPMENT

FREE Plan. Start printing, lettershop. Offset Presses. Mimeograph Copy machines. DixieGraph, King, N. Car. 27021.

RUBBER STAMPS AND OFFICE SUPPLIES

RUBBER Dies for making stock rubber stamps. Many styles. You mount for extra profits. Free chart. Complete rubber stamp supplies. Barco, 237A S. Evergreen Bensenville, Ill. 60106.

FREE 40 Page catalog. Rubber stamps, office supplies. Youngers Stamp Shop, Princeton, Iowa 52768.

RUBBER STAMPS wood mount \$1.00 plus 10c per word. Ross, Box 152, Wayne, Pa. 19087.

ADDRESS Stamp 85c. Signature \$2.80. Carol's, McCloud, Okla. 74851.

CHRISTMAS Stamps, 2/\$1., 5/\$2. Plus 25c postage. Wendell's, Dept. 3D, Box 2284, Everett, Wash. 98201.

QUALITY Stamps, \$1.50. Butler, Box 67AB, East Longmeadow, Mass. 01028.

ADDRESS Stamp with handle \$1.25. Brookfield Stamps, Box 121, Brookfield, Wis. 53005.

PRINTING PRESSES, RUBBER STAMP OUTFITS

PRINTING Presses, type, supplies. Lists, 5c. Turnbaugh Service, Mechanicsburg, Pennsylvania 17055.

TYPE Catalog No. 12, 120 pages. Send One Dollar. Deductible First Order. Acme Type, 732 Federal, Chicago, Illinois 60605.

SAME Day shipment on rubber stamp supplies. Revised wholesale price list No. 6 free. Star Stamp Supply, 732 Federal, Chicago, Ill. 60605.

RUBBER Stamp outfits, supplies, Kiewiet, 2025 Barney Road, Kalamazoo, Michigan 49007.

MAKE your own self-molding rubber stamps and printing cuts. Plexirubber, Argyle-1, Wisconsin.

RUBBER Stamp Manufacturers Supplies. Presses, starting outfits. Best Prices, Service. Catalog. Jackson Supply, Box 443-A Franklin Park, Ill. 60131.

PRINTING AND SUPPLIES

1,000 QUALITY Business cards up to seven lines, raised letter printing \$4.75. Robert Gersh, Stetson Street, Hyannis, Massachusetts 02601.

PRINTING Starter Package—250 business cards; letterheads; envelopes, statements, \$15.95. Send copy with check or money order to Atlas Printing Co., 234 Long Lane, Upper Darby, Pa. 19082.

8 HOUR PRINTING-Free Booklet "Secrets of Cutting Printing Cost" Nationwide Printing, Atlanta, Ill. 61723.

AMAZING business printing values. Quotations. Print Shop, Box 576, Greenville, R.I. 02828.

QUALITY Printing, discount prices, free catalog. Gables—405A Clifton—Glenshaw, Pa. 15116.

100 TWO Colors Porcelain Business Cards \$1.50. Eslick's Craft Studio, Delavan, Wisconsin 53115.

FREE Literature. Address Labels, Business Cards, Printing, Rubber Stamps: Jordan's, 552 West O'Connor, Lima, Ohio 45801.

1000 EMBOSSED Business Cards \$4.95 Postpaid. Free samples. Joseph Winters, Box 333, Pleasantville, New Jersey 08232.

(Continued on next page)

PRINTING AND SUPPLIES

(Continued from preceding page)

QUALITY Printing, cards, letterheads, Etc. Samples, price list. Printer, Box 659, Venice, Calif. 90291.

MULTIGRAPH, MIMEOGRAPH

UNIQUE Attractive Letterheads. Small Quantities, Samples, Edgewood Industries, Box 751, Kernersville, N.C. 27284.

GUMMED LABELS

1,000 GUMMED Address labels \$1.00. Walt's, Box 966A, South Bend, Indiana 46624.

REMAILING SERVICE

OSLO—LONDON Remails \$1.00. Confidential. Europe, Box 96, Lambertseter, Oslo 11, Norway.

CANADA Remails, 50¢ each. Confidential, Dependable, Box 61, Whitehorse, Yukon Territory.

MILE-HI Remail 25¢; Monthly \$3.00 Confidential. Colorful postcards 6/\$1.00. Box 11265-B, Denver, Colorado 80211.

SINGAPORE Receiving/Re-Airmailing \$1.00 Discreet. Confidential. Tan S. Hee, 8 Cairnhill Road, Singapore.

DETROIT! Holiday Special!—25¢—Five \$1.00! DA-Lemke's, 3476 Balfour, Michigan 48224.

REMAIL \$1.- other services \$2.- up. Trafimex, Box 9068, Amsterdam, Holland.

CONVENTION City Remails 25¢. Colorful Postcards. Schoen, Box 1963-P, Chicago, Illinois 60690.

MIAMI Remails 25¢. Monthly rates. Marle, Box 1266, Coral Gables, Fla. 33134.

RECEIVING—Forwarding. \$4 Monthly. Hedgpath, 406-M South Second, Alhambra, Calif. 91802.

PHOENIX. Receiving, forwarding, remailing. Confidential. Troen, Box 2386, Phoenix, Arizona 85002.

HOUSTON. Secret receiving and remailing. Discreet and confidential. Remail 25¢ single. Permanent address. Bonded Notary. Mail Forwarding Service, 8080 S. Main, Houston, Texas 77025.

PENNSYLVANIA Remails 25¢. J. Dougherty, Box 17611, Philadelphia, Pa. 19135.

SACRAMENTO Remails 25¢ Singles. \$3.00 monthly. Box 19123, Sacramento, Calif. 95819.

MIAMI BEACH Individual and Business. Confidential Reliable. Weyant, Box 245, Miami, Florida 33165.

10,000 LAKES 25¢. \$3.00 month. Stanley, Box 23094, Minneapolis, Minnesota 55423.

MONTHLY \$3.00 Singles \$.25 Details McDermott, Box 870, Saranac Lake, New York 12983.

CONFIDENTIAL New York City mail address \$3.00 month. Remails 25¢. Details Free. Birnhan, 152 W. 42, New York City 10036.

DYNAMIC DALLAS—Remailing Service. 25¢ singles. Frank and Son, Box 34443, Dallas, Texas 75234.

YOUR Letter Stamped and Remailed From CANADA 25¢. Rix, 1028 Bridgeport, Richmond, British Columbia.

ART'S, 25¢ Each, \$3.00 Monthly. Box 4589, Lincoln, Nebraska 68504.

NYC—DAILY. Singles 25¢. Monthly rates. P. Rolab, Box 362, Bergenfield, N.J. 07621.

TORONTO, Canada Remails 50¢. Ellis, 12-14 John, Orangeville, Ontario, Canada.

FORT WAYNE Remails. Receiving Remailing. Confidential 25¢ Single. \$3.00 Monthly. Adams, Box 500, Auburn, Indiana 46706.

MARYLAND Remails—25¢. Prompt, Dependable. MarMar, Box 2114, Wheaton, Maryland 20902.

DENVER COLORADO Confidential, dependable remail, 25¢. Dept. A, Box 9145, South Denver Station, Denver, Colorado 80209.

ORLANDO—Booming Action Center of Florida. Remails 25¢. Monthly \$3.00. Eight colorful postcards \$1.00. Confidential, prompt. Two consecutive Orlando Sunday newspapers (includes map of Greater Orlando N/C with order) \$3.00. Raymond White, 5831 Hornet, Orlando, Florida 32808.

NEW YORK City; United Nations 25¢. Additional Services. Snow-M, 458 Vermont, Brooklyn 11207.

CALIFORNIA Remails 25¢. Receiving, Forwarding \$3.00 monthly. Colorful Postcards 10 for \$1.00. Confidential, Prompt. Mickens, 773 Mar Vista, Pasadena, Calif. 91104.

REMAILS \$1.50 from following countries: Hong Kong, Vietnam, Japan, Australia, Ireland, England, Germany, France, Mexico, Switzerland, Poland, Holland, Streamwood, remailing 25¢. \$3.00 monthly. Unlimited domestic receiving, forwarding. Sullivan, Box 14A, Streamwood, Illinois 60103.

JACKSON Singles—25¢—Monthly \$3.00 unlimited. Jones, 1606 Floral, Jackson, Michigan 49202.

REPAIRS AND SERVICING

REPAIR TV TUNERS; FREE TRICKS, Bocek, Box 832, Redding, California 96001.

SPECIAL SERVICES

BUSINESS Card, Tie Clasps, New, Sensational! Free Literature. W. A. Willis, 2513 Santa Ana Street, Huntington Park, California 90255.

INFORMATION On anything. Ferguson Research Specialists, 83-45 Vietor Ave., Elmhurst, N.Y. 11373.

ALASKA? for background information on a new job or business, new house, new future. \$2.00 ALASKA-UN, Ltd. Box 10-028, Klatt Station, Anchorage, Alaska 99502.

AUTHORITATIVE INFORMATION On Anything! \$2.00 (deductible). Metzler Research, P.O. Box 2206PL, Long Island City, New York 11102.

RAZORS

RAZOR GUARD. Patented snap on cover for head of Gillette razor. Saves blades, protects fingers and travel Kit, 50¢. 3 for \$1.00 postpaid. Camero Products, 7924 Olson Highway, Minneapolis, Minn. 55427.

PERSONAL

THINK BIG! Skyrocket your income and gain financial security, prestige and power. Learn the secrets that make men rich. "The Magic of Thinking Big" is a must, for anyone who wants to get ahead. 256 Pages of inside facts, case histories, and secrets of riches. Book #WB-123, only \$2.00. Golden Thought Enterprise, 216 E. Smith Street, Milwaukee, Wisconsin 53207.

BORROW Up To \$1,000 By Mail. Money on your signature for any purpose. Write: American Loan Plan, Dept. RA-0135, City National Bank Bldg., Omaha, Nebraska 68102.

BORROW \$1,205 Airmail! Repay \$47 for 36 months. State licensed. Postal Finance, Dept. 17-T, 200 Keeline Building, Omaha, Nebraska 68102.

INVESTIGATORS. Latest electronic Aids. Free Literature. Clifton, 11500-P NW 7th Ave., Miami, Florida 33168.

RUPTURED. Relief and comfort. No understraps, elastic or steel. Write Hand-Lock Products, Preston 4, Ont., Canada.

BIBLE Questions answered. Stamped envelope. Bylon, 17167 Bentler, Detroit, Michigan 48219.

SUBCONSCIOUS Conditioning remakes personality while you sleep. Free details. Sleep-Learning, Box 24N, Olympia, Washington 98551.

ARE YOU REALLY SINCERE about wanting to find a marriage partner? SOCIAL INTRODUCTION SERVICE, 1760 Wilamette, Eugene, Oregon 97401.

SECRET LOANS BY MAIL. Borrow \$100 to \$1500 for any good reason in absolute privacy. No interviews, no endorsers, no co-signers. Fast service. Write Dial Finance Co., Dept. M-214, 410 Kilpatrick Bldg., Omaha, Nebraska 68102.

HYPNOTISM SECRETS. Lowest prices. Free information. Merlin Enterprises, P.O. Box 613, Los Gatos, Calif. 95030.

MAKE NEW FRIENDS Worldwide. Meet Marriage minded Girls through our illustrated Catalog. 1200 Ladies' Fotos and Descriptions \$2.00. I. C. B., Box 12, Sta. O Toronto, 375, Ont. Canada.

"INVESTIGATORS, Latest electronic equipment free brochure. Dehart Electronics, P.O. Box 5232, Sarasota, Fla. 33579."

MAKE your will. Four approved forms: Attorneys instructions, \$1.00. Willforms, Box 8585-A, Kansas City, Missouri 64114.

MAKE YOUR WILL. Get 4 Will Forms and attorney's informative book. \$1.00. Legal Forms Company, Department 124, 1967 Guardian Building, Detroit, Michigan 48226.

TATTOO Removing—Do-It-Yourself Kit \$14.00 Information Free: Atlanta Co., 907 Lakecrest, Fairport Beach, Ontario.

GET OUT OF DEBT in 90 minutes, legally without borrowing or bankruptcy. Anderson, 5818 E. Hamilton Avenue, Cincinnati, Ohio 45242.

SMOKERS! Stop within weeks! "Count-Down" holder dials to inhale less. Thoughtful gift! \$4.95. 35¢ postage, handling. Chaparral House, Box 807, Tucson, Arizona 85702.

"PROTECT YOUR HOME. Information on Burglar, Fire, Lightning devices. How to make your own simple devices at home. \$1.00. Home World, 337 22nd Ave. No., St. Petersburg, Florida 33704."

FREE DETAILS. \$2000.00 Puzzle Contest. Send stamped, self-addressed envelope. Prizes Unlimited, Box 2124P, Culver City, California 90230.

MAKE Big Money With Real Estate. Send 50¢. Moran, Ben Lomond, California 95005.

COMBAT BALDNESS! Grow thicker healthier Hair; stimulate dormant hair follicles. Newly published information permits you to apply Knowledge in privacy of your Home. Send \$2.00 to: Box 9145, South Denver Station, Denver, Colorado 80209.

SUB-MINIATURE LISTENING DEVICES. Low Priced, High performance, direct from Manufacturer. Dealers Welcome. Audiotronics, PM-12, 156 5th Avenue, New York, New York 10010.

SECRET Law Wipes Out All Debts. Immediate relief—clear credit. Free details. Counselor-7, Kerrville, Texas 78028.

WANTED—MISCELLANEOUS

MERCURY. Gold, Silver, Platinum; Ores assayed. Wholesale Terminal, Norwood, Mass. 02062.

MERCURY. Immediate Payment. Free Information. Mercury Supply, PM-28, Fairfield, Ohio 45014.

MISCELLANEOUS

PEACH Brandy, Wines, Etc. Strongest Formulas, \$2.25. (hydrometers list and supplies catalog included)—Research Enterprises, 29-SN35 Samoset, Woburn, Mass. 01801

"HOW TO BUILD A STILL." Humorous, Factual, Illustrated, 50 Pages. Includes distillation, Fermentation, Wines, Taxes, etc. Over 25 Recipes. Send \$2.50. Buze, Box 252 W-1, Oklahoma City, Okla. 73132.

YOUR Name sent to 1000 importers, publishers, mailers, wholesalers, etc. on our mailing list. Year \$1.00. Dixie Mailers, King, N. Car. 27021.

(Continued on next page)

MISCELLANEOUS

(Continued from preceding page)

WINE recipes, 15 different kinds. \$1.00 Automail, Box 802, Burlington, Iowa 52601.

FIND A Fortune In Your Pocket! Dollar bill worth \$75! Coins, stamps worth many dollars! Order 3-volume set Official Collector's Guides. Send \$2.98 to Richards', New Cumberland, W. Va. 26047.

ORNAMENTAL Iron designs. Book of 1600 beautiful, practical designs for railings, columns, etc. Free literature. Cunningham, 3881 South 3200 West, Salt Lake City, Utah 84119.

SILENCERS For pistols and rifles. Complete details for construction and operation. \$1.00. Gunsmith, Box 185, Fairfield, Alabama 35064.

WINEMAKERS—Free catalog and recipes. Kraus, Box 451-L, Nevada, Missouri 64772.

CIGARETTES 12c a pack. Improved roller makes 20 filtertip, plain, king or regular for 12c. Facts Free. Moberly, Box 954, Owensboro, Kentucky 42301.

BIRTH Certificates, Marriage Certificates, Diplomas! 2 blank forms \$1.00. Sample 10c. Standard Forms, Box 482-M, Washington, D.C. 20044.

WANT Greatest Cash Crop working for you? Write, Ginseng, Asheville 53, N.C.

WINEMAKING . . . Grape, Elderberry, Dandelion, Frozen Juices, etc. Brewmasters' secrets revealed! Powerful Methods! Instructions, Recipes, and Supplies Catalog, \$1.00. Continental, Box 11071-PL, Indianapolis, Indiana 46201.

BOOKS On antiques and their prices. Free circular! P. Warman Publishers, Uniontown, Penna. 15401.

WINEMAKERS. Free illustrated catalog of yeasts, equipment. Semplex, Box 12276, Minneapolis, Minn. 55412.

WINEMAKING Kit—\$4.95 Postpaid. Free Catalog—Jim Dandy Wine Supplies, Box 30230M, Cincinnati, Ohio 45230.

HEARING Aid batteries wholesale. Free list. Habs. Box 51 York, Penna. 17405.

MONTRACHET Wine Yeast makes superb wines. Three yeast packets with 101 recipes \$1.00. Nichols, 1190 North, Albany, Oregon 97321.

FIVE-YEAR CALENDAR and HOLIDAY BOOKLET. Beautiful, excellent gifts. \$1.25 including tax. Ellis, P.O. Box 726, Fresno, Calif. 93712.

HOME HAIRCUTTER—pocket size; easy to use; cuts as it combs; guaranteed . . . (\$1.00). Marco Polo Enterprises, Dept. 6, 150 Broadway, New York, N.Y. 10038.

FAMILY HEIRLOOM—Do It Yourself Family Tree. Big 21" X 34" Genealogy Chart on Quality Antique Parchment. Comes in Heavy Storage Tube. Ideal Gift \$2.00. FORMCO, Box 3828-X, Long Beach, California 90803.

PSYCHEDELIC Catalog send 25c. Hole, 6055 Lankershim, North Hollywood, Calif. 91606.

UNUSUAL RACING PROFITS From Simplified Handicapping Methods. Gil Howard, Box 507 PM, Carroll, Iowa 51401.

UP To \$151 Daily track Wins With Scientific Computer. \$2 Stakes. Proof Supplied. Free Details: RH-P10, 5715, Carmel, Calif. 93921.

GENUINE 23K GOLD in pan \$1—Phillips, Box 8528, Waikiki, Hawaii 96815.

"ORIGINAL OLD FASHIONED GINGER-BEER. Instructions \$1.00. S. A. LeBuda, 12560 Oxnard, N. Hollywood, Cal. 91606."

HIGHER INCOME. Security and Power. 256 page Book "Thinking Big" reveals secrets that make men Rich! Send \$2.00 to Al Berry Enterprises, 456 North Country Club Drive, #1, Mesa, Arizona 85201.

FLOATING igneous ROCKS could be similar to MOON ROCKS \$1.35. Floating Rocks, Box 5493, Eugene, Oregon 97405.

YOUR Address placed with hundreds of distributors, wholesalers, publishers, importers. Year \$1.00 California Listing, Box 1114, Saugus, California 91350.

SOCIAL SECURITY Identification Plates. Engraved Brass. \$1.35 Postpaid. Garson Advertising, Box 306, Patton, Calif. 92369.

HORSE Race Handicapping Systems Newly researched. \$5.00 T. Freske, Box 174, Hales Corners, Wisc. 53130.

SAMPLE CINNT Today. Only \$1.00. Stoker, Peddie School, Hightstown, New Jersey 08520.

SLOT & PINBALL machines, etc. Catalog 35c, refunded with order, COFFCO, Dept. B, P.O. Box 522, Lake Zurich, Ill. 60047.

KEEP Birds, Animals out of Orchards. Vegetable Farms. \$15.00 Patent. 5522 Norwich Avenue, Los Angeles, California 90032.

YOUR Name Send to thousands of Importers, Publishers, mailers, Wholesalers, Etc. \$1.00 per year. Golden Planet Advertiser Box 3416 Anaheim, California 90823.

PATRIOTIC Bumper stickers, 3 different, \$1.00. P & P Novelities, Box 4642, Springdale, Conn.

MONEY For old bottles! Illustrated handbook lists 1850 bottles, 17 categories. Gives identification, prices, markets. \$3.95 Ppd., satisfaction guaranteed. Request free gift brochure. GRANCO, PM1 Beech Hill Road, Granville, Massachusetts 01034.

DO You have coins or stamps? New Service gets you top market. 6c stamp for particulars. Dryz, P. O. Box 9209, Treasure Island, Florida 33740.

1001 VALUABLE THINGS FREE. Details free. Giftown, Box 8224, Fort Worth, Texas 76112.



EARN HIGH WAGES as a HEAVY EQUIPMENT OPERATOR

Train your way to high pay in the booming construction industry! Learn the skills you need to qualify, by actual field training on machines like the ones used by the industry. Huge training grounds in North Carolina, a million dollars worth of school-owned diesel-engined machines, experienced instructors, full 220-hour and 440-hour courses. National, the original school of heavy equipment operation, is a recognized leader. Member American Road Builders Assn., Services and Supply Division. Associate Member A.G.C. Full-time Job Advisory and Counseling Director on staff. VA approved. For men ages 17 to 56. Train Now-Pay Later plan . . . other payment plans also available. Write TODAY for FREE catalog and FREE copy of school newspaper reporting news of National School graduates. Accredited member NATTS.

NATIONAL SCHOOL OF HEAVY EQUIPMENT OPERATION, Dept. D-34
P. O. Box 8529, Moores Chapel Road, Charlotte, N. C. 28201
Please send me FREE illustrated school catalog and complete information. I understand there's no obligation.

Name _____ Age _____
Address _____ Phone _____
City _____ State _____ Zip Code _____

Men Wanted NOW TO TRAIN AS CLAIMS ADJUSTERS

Former U.S. Army mechanic and service station attendant EDWARD D. PAIGE is now employed as staff adjuster by Free State Adjusters, in Virginia. "Your I.A.S. Home Study Course, in my opinion, is the best that can be obtained. Also, the Resident Training I received, gave me a good working knowledge and understanding of the claim adjusting business."



You can earn top money in this fast moving, action packed field. Insurance Investigators are urgently needed to settle claims worth billions of dollars annually. The tremendous increase of auto accidents alone have doubled the need of qualified adjusters. INSURANCE ADJUSTERS SCHOOLS lets you train at home in your spare time, followed by Resident Training at school owned facilities at MIAMI BEACH, FLA. or LAS VEGAS, NEVADA. Nationwide employment assistance. Don't Delay! Write for FREE information today!

Accredited Member N.H.S.C.

APPROVED FOR VETERANS UNDER NEW GI BILL

INSURANCE ADJUSTERS SCHOOLS DEPT. PM5
1901 N.W. 7 Street, Miami, Fla. 33125

Please Print

Name.....
Address.....
City.....State.....Zip.....
Age.....Phone.....

Let us prove that you can become a good artist, at home and in your spare time.

Mail the bound-in postpaid card and we'll send you our helpful booklet, *Art for Pleasure and Profit*.

We'll send you two valuable art lessons free.

We make this offer to demonstrate how easily you can develop professional skill in drawing and painting . . . through the Washington School of Art, America's oldest home-study art school.

As a WSA student, you learn from lessons prepared by 11 master artists, including internationally famous Prof. Otto Dix, the German Expressionist, and Mario Cooper, N.A., President of the American Watercolor Society, who share with you the skills and know-how they use themselves.

Your course covers all these branches of art: oil and watercolor painting, advertising art and layout, illustrating, cartooning, fashion illustration, figure drawing, fine art, television art.

You get individual appraisals of your work from highly qualified instructors who treat you as a class of one. Their personal encouragement and corrections on transparent overlays, show exactly where you went wrong and how to improve your art.

As your skill increases, you can start to earn money—full- or part-time—by exhibiting your paintings or in one of the exciting and profitable fields of commercial art. There are 370,000 American firms who buy such art: advertising agencies, commercial art studios, corporations, department stores, newspapers, magazines, TV graphics departments. Most employ full-time artists at jobs that pay \$150, \$300, or

more a week. Most of them also buy artwork from freelance artists who work at home.

Hundreds of WSA students and graduates are now earning money with their artwork. Richard White of Zelienople, Pa., was promoted from the welding department to the art department in his company. Alicia Jane Bailey of Miami Beach, Fla., opened her own art and decorating shop with some friends. Mrs. Wallace T. Ahlborn of Munising, Mich., reports she has sold over \$2000 worth of paintings in just two summers alone. Ben Blackson of Pittsburgh, Pa., is now a successful muralist, and has sold his work to General Electric. And there are many other success stories like these.

If you really want to expand your horizons . . . and if you'd enjoy the sense of fulfillment that comes from earning an extra income at work you love to do . . . mail the card today. If card is missing, send us your name, address and zip on a postcard or in an ordinary envelope.

Washington School of Art

Studio 24-012, Port Washington, New York 11050



**If you do this sort of thing,
and would like to go further...
we'll send you 2 art lessons free**

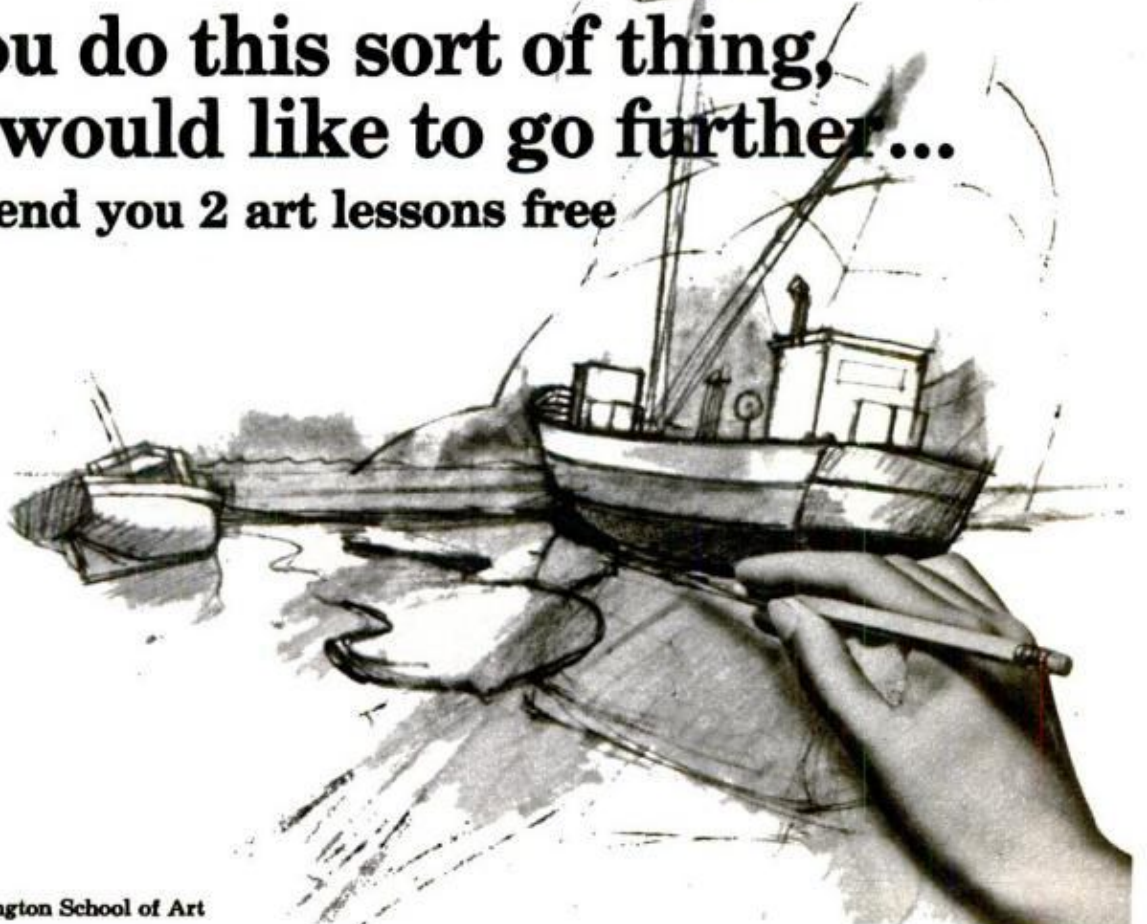

SOLUTIONS FOR MECHANICAL HEADACHES

AUTOMOBILE CLINIC

BY MORT SCHULTZ

Double check

The owner's manual says the crankcase oil capacity of my 1967 250 Ford pickup with 352-cu.-in. engine is five quarts without a filter change and six quarts with. The dipstick reads one quart over the full mark. Which is wrong, specs or dipstick?—R. J. Andrlich, Omaha, Neb.

Keep in mind that before you check the oil level you should allow the engine to run a few minutes to fill the oil filter. That's where the "extra" quart goes. However, if this doesn't give you the correct dipstick reading, compare the height of the dipstick tube as it extends from the sump with that of a dipstick in another 352-cu.-in. engine. In some cases, the tube is pushed down too far during assembly, which allows the dipstick to be overinserted.

Expensive economy

My Volvo P1800S needs an overdrive and rear end. The overdrive is sealed to the transmission and will probably be very expensive to repair. I think overdrives are ridiculous, anyway. Could I put a different transmission and rear end on this car and save myself money?

—Brian Benwick, Tampa, Fla.

I think the first thing you'd better do is get some prices. Replacing the transmission-rear end setup with a new one without overdrive is going to cost about \$800. You can get what you now have fixed for about \$300. It's your choice.

Fickle freeze plugs

I bought a 1967 Dodge Monaco 500 about 1½ years ago. I've had three different freeze plugs rust out and now a fourth is starting to leak. The dealer says it's due to a rusting condition in the cooling system, despite the fact that the best grade of permanent antifreeze with rust inhibitor is always used, and the cooling system is cleaned out and refilled twice a year. The engine doesn't overheat except when I plug leaks and I lose coolant. The dealer says this is common with new cars. What can I do?

—Mrs. Joan Samler, Huntington, N.Y.

First, don't believe the dealer. This is

certainly not a common problem with new cars or otherwise. In fact, it's one of the strangest I've run across in some time. I doubt if the plugs are rusting out because of a mechanical malfunction. If, for example, the problem was a combustion leak, the engine would be overheating. The only reason I can see for the condition is that the inside of the engine may have been coated with rust to begin with. I think you should demand that your dealer get in touch with the manufacturer. You may have a claim here for a new engine under your five-year, 50,000-mile warranty.

Roll out the barrels

Performance of my 1968 Buick LeSabre becomes rough as the back two barrels of the four-barrel carburetor start to open. Speed falls off slightly. When the back barrels are about half open, performance smooths out. Tune-ups haven't helped.

—D. F. Arnold, Sunnyside, Wash.

This sounds like there's dirt in the secondary. If I'm right, performance will eventually get so bad you'll have to do a complete carburetor cleaning.

Choked off

I've had a dangerous problem with my 1966 Pontiac with two-barrel carburetor since the day it was new. There's a period between closed choke and open choke when, upon acceleration, the engine bogs down and actually dies. Tune-ups and a carburetor overhaul haven't helped. Do you know what's causing this?

—Nick Strelchuk, Chicago

Yes: inability of your present automatic choke control to open fast enough to prevent a mild flooding condition as the engine warms up. A choke kit was issued to cure the trouble, and I'm surprised that your dealer hasn't said anything about it. Maybe you had better remind him that there's a new thermostatic spring, choke piston and choke arm that have to be installed.

Chatterbox

I get a chatter from the antispin rear end of my 1968 Oldsmobile, especially when I go around a curve or corner. I



SUPERMISTLETOE

Let's face it. Mistletoe might make a nice shrub and all, but a 100 proof lady-killer it's not. That's why men should ask Santa for Hai Karate® After Shave and Cologne. Hai Karate really works. Sometimes too well. That's why we include instructions on self-defense in every package. Hai Karate. Available in regular, oriental lime and oriental spice. And in attractive gift sets. They're all like supermistletoe in a bottle. **Hai Karate—be careful how you use it.**



After Shave and Cologne Gift Sets in regular, oriental lime and oriental spice. Also, regular after shave with soap on a rope.

want the dealer to call an Olds representative, but he says this is normal. What should I do?—Cal Felton, Peoria, Ill.

This is not unusual, but it isn't exactly normal. In breaking in this car, something caused an excessive temperature increase in the differential, resulting in a breakdown of the axle lubricant. Did you, for example, haul a trailer? In any event, here's what to do: Drain all the old lube. Clean the assembly with mineral spirits or kerosene, using an air liquid siphon gun. Air-dry the assembly to remove all the cleaning solvent. Now apply new anti-spin differential lubricant and drive the car for 50-75 miles to let the lube work through the unit. By this time, the chatter will have disappeared.

Horizontal filter

When I take the oil filter off my 1968 Corvair, oil spills on the engine shroud, and it smells awful until it finally evaporates. Is there a way to avoid this?

—George Lincroft, Kansas City, Mo.

The trouble, of course, is that the filter is mounted horizontally, rather than vertically. To avoid this, remove the adapter with the filter and make sure that the assembly (filter and adapter) is kept level. The drawback is that you'll have to replace both adapter gaskets every time you replace the filter. The part number for the inner gasket is 5575514, while that for the outer gasket is 3838401.

Heads up

My car is a 1968 International Scout. I've had to replace the header pipe and exhaust more times than I'd care to tell because they start to leak fumes. What do you think is causing the damage?

—Neil Walton, Glenville, Minn.

Have you checked the exhaust manifold flange (header) for warpage? You'd better pull the exhaust manifold to do this; I'm almost sure you'll find this to be the trouble. If so, replace the manifold.

Under pressure

I have a 1966 Volkswagen 1600, bought used, with 65,000 miles now on it. I overhauled the engine at 38,000 for bearing troubles. My oil-pressure gauge shows 40

pounds per square inch cold and 23-25 at 55 mph in fourth gear. However, under heavy load, such as a fast run on an interstate or full-throttle mountain climbing, pressure drops to 17-20 p.s.i. Is this okay or should I expect trouble?

—Eugene Ramsey, Waynesboro, Va.

VW oil-pressure specifications call for 28 p.s.i. at 3000 rpm with the engine warmed to an operating temperature of 185° F. This puts you just on the short end of things, but slightly, and I think you can live with it. There are no specs provided for mountain climbing, but 17-20 p.s.i. would appear adequate to me. I'd say not to worry unless things get worse.

Service Tips

● **Mercury** warns about a false low oil reading on the 1969 Montego and Cougar with 428-cu.-in. Cobra Jet engine. Watch how that dipstick is put back into the tube after the oil level has been read. If the end of the stick is bent accidentally or if the stick is inserted backward into the tube, you'll get a wrong reading the next time you check the oil. The curl of the handle must be toward the front of the engine and the blade must be kept straight.

● **Chrysler Corp.** cars (Dodge, Plymouth, Chrysler and Imperial) have been having problems with their three-speed windshield wipers. Two repair kits have now been issued to clear up short-circuit, binding and failure-to-park difficulties. They carry part Nos. 3420870 and 3420871.

● **American Motors** has issued a notice to keep in mind if you ever need to have an automatic transmission overhauled. After transmission bands and clutches have been washed in solvent, make sure they are allowed to dry only by plain old, ordinary, atmospheric air. Compressed air causes protective material on those clutch parts to separate. This material protects these parts against the high temperature generated in a transmission.

● **Chevrolet** recommends that the Powerglide transmission throttle-valve override linkage of 1967, 1968 and 1969 Sixes now be lubricated, so add this tip to your lube chart. The job's to be done every 6000 miles or four months with water-resistant EP chassis lubricant. This linkage has caused some binding problems that lubricating will prevent. ★ ★ ★

GOT A PROBLEM WITH YOUR CAR? Ask Mort about it. Send your question to Auto Clinic, Popular Mechanics, 224 West 57th St., New York, N.Y. 10019. Letters cannot be answered individually, but problems of general interest will be published in the column.



Waltham's Swiss wardrobe. Merry Christmas, indeed!

If you really like to pick and choose, here are sport and dress watches at prices that won't wreck your holiday budget.

Pick a handsome man's day/date calendar or the spectacular skin diver-day/date for a surprisingly low price. These new Waltham watches all have Swiss movements. This accounts for their great dependability.

Consider, too, the elegant ladies diamond watch for an extra special gift. And for that certain man who demands that his watch have every modern convenience feature as well as sharp styling, we have many more to choose from.

Or better still, take the entire glittering collection and your list or eight favorite people is complete.

See how easy Christmas shopping can be?

Most Waltham watches are from \$24.95 to \$150.00.

WALTHAM®

an international product of Waltham of Chicago

CHICAGO • NEW YORK • LOS ANGELES • GENEVA

Look for Waltham decorator wall clocks, too.

For more information, contact your nearest Waltham store.

HOMEOWNERS' CLINIC

BY W. CLYDE LAMMEY

Painter's bane

I'm going to paint my house. The old paint is blistered and I'm told to sand down the edges of the blistered areas—"feather" them. Okay, I do this until the paint film is thin. Then it breaks off, and I have an unsightly square "shoulder"—the same scabby look as before, even under two coats of new paint. Just how is this trick done?—R. E., Mass.

Blisters are the bane of house painters, both pros and amateurs. They scrape, sand, chip and sand again and some finally give up, knock off the loose pieces and paint right over what's left. I've found that a small sanding block of $\frac{3}{4}$ -in. stock cut to about 2 in. long and $1\frac{1}{4}$ in. wide, with one end cut at an angle, and a sandpaper strip thumbtacked to the block, does the best job of feathering those unsightly edges. With it, you can sand a minimum area and get the edge sufficiently thin to prevent it from casting the shadow which causes the unsightly appearance.

There's another way: Remove all the loose paint film and coat the edges with a paint remover. As soon as the old paint has been softened, work outward from the center of the blister with a putty knife. If you're careful you can peel off the paint at the edges to a film so very thin that it will not cast a shadow when painted over. Use a thick-paste, wash-off remover, rinse the surface immediately and wait until it's thoroughly dry before applying new paint.

Dewaxing linoleum

The linoleum kitchen floor at my new address is covered with something that's a dirty, brownish color I simply can't live with. Washing and scouring seems to have no effect. What can I try next?

—M. R., Mont.

I'd guess right away that the coating must be either multiple coats of wax or a linoleum varnish that has been neglected, so that the dirt is literally embedded in the coating. This is impossible to remove by ordinary means. What to do next depends on the condition of the linoleum. If it is still good, you may find an at-

tempt to salvage it worthwhile. If the coating is linoleum wax, turpentine applied liberally will remove it. But remember, when using turpentine there's both a health and fire hazard. Have the windows and doors open and, if necessary, place a fan to provide air circulation. As a rule, the turps will soften the wax within a few minutes so that it can be wiped off readily. Treat only a small area at a time. On the other hand, if the coating is linoleum varnish, it will be more satisfactory in the end to replace the old linoleum.

Whitening 'rock roof'

My home has what is referred to locally as a "rock roof"—that is, white crushed stone over layers of roll roofing. It's now discolored by dirt, dust and other debris. I'd like to wash, paint or otherwise whiten it to its original color. What do I use and how do I go about it?—L. B., Miss.

A strong spray from the garden hose should get rid of most of the dust accumulation and possibly lighten the covering. Otherwise I would use a stucco paint or any water-soluble white paint. Perhaps the stucco paint would be best. Ask your building materials dealer to tell you what is used locally. Very likely you could use your knapsack sprayer for application, but with only $3\frac{1}{2}$ -gal. capacity this would be a rather slow process. You also would have to thin the paint to a sprayable consistency and possibly use a nozzle with a larger opening than normally supplied with such units. Were I doing this job myself I would spray one coat, then turn the loose material with a rake and apply another coat, just to make sure all surfaces of the individual particles were covered. Most stucco and water-soluble paints require that the surface be wet or at least damp immediately before application. Follow instructions on the container.

Wintertime green thumb

I want to grow tuberous begonias next season but I don't know when to start them for the earliest blooms. Some say midwinter, others say later on, some plant directly in open ground after frost. Can you suggest a procedure?—O. L., Ind.

I've only limited experience with these plants, but I've learned that the blooms will be much later in season unless you give the plants an early start indoors. If the season breaks right with an early spring, you should do all right by planting directly in open ground. ★★★



Works like
a truck
Rides like a car

Getting toughness and comfort on the same four wheels takes some doing. Like Twin-I-Beam front suspension, Ford's better idea for smooth riding. Two I-beam axles give it strength. Coil springs cushion the ride. Inside Ford's roomy cab is comfort many cars might envy. Customize it with SelectAire conditioning, power steering, power front disc brakes and any of five great engines, including an economy 302-cu. in. V8. See how easy-riding a truck can be—at your Ford dealer's.



FORD PICKUPS



A 5¢ Bargain right under your nose.

Our full-sized Roi-Tan has such great taste it's the best selling 10¢ cigar. So now we'd like to tell you about a 5¢ bargain that tastes every bit as good.

It's the Roi-Tan Tip. It costs the same as a lot of other tipped cigars, but that's where the similarity ends.

And, we make two other 5¢ cigars, besides. Trumps and Cigarillos and a 4¢ cigar called Golfers. They all have that great Roi-Tan taste. And they all cost a nickel or less.



Roi-Tan The Crowd Pleaser.

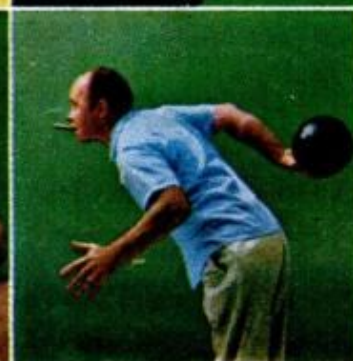

Next Month in Popular Mechanics

How We Raised the Alvin From 5000 Feet

In an exclusive report, William O. Rainnie describes how the *Alvin*, deep-diving submersible, was recovered from the ocean bottom after being submerged nearly a year following an accidental sinking. Rainnie, deep-diving expert at the Woods Hole Oceanographic Institution, tells how the Navy, Woods Hole personnel and other civilian organizations recovered the largest object ever brought up from such a depth.

A Hot New Fighter for the Navy

The F-14 is designed to roll and turn at supersonic speeds and outshoot planes threatening our fleet. It's the Navy's substitute for the controversial F-111.

An Old Pro Tries Out the World's Most Advanced Car

John Fitch, the only American to race for Mercedes-Benz in the glorious days of Fangio and Moss, takes some fast laps at Hockenheim in their new experimental, mid-engine sports car.

How to Catch a Hippopotamus

. . . or an elephant or a zebra or a buffalo. Game wardens in South Africa's Kruger National Park do it every day. All you need is a helicopter or a bulldozer, a crossbow, a quiver of tranquilizing darts and a steady aim. It also helps to take a tranquilizer yourself.

Fantastic Farm Machinery

New machines plant seed with a roll of plastic tape, pick tomatoes, select only ripe heads of lettuce—and drop two tons of blueberries an hour into crates.

Shoot Glareless Pictures With Polarized Light

Those annoying reflections you get off glass and other shiny surfaces can be eliminated with easy-to-make filters over your photofloods.

Special Roundup: Great New Ideas from the Hardware Show

PM editors scouted the National Hardware Show to see what new—and updated—items would be available for the home, yard and shop in 1970. The January issue tells what they found.

Put a Speed Control on Your Windshield Wipers

Slowing down your blades' sweep rate gives you a clearer, safer view in light rain or muddy road spatter. This easy-to-make device will work on any car with electric wipers.

Rotary Print Washer Anyone Can Build

A plastic laundry tub and some hose fittings can give you a professional-type, swirling-action washer for \$5.

The Boeing 747

WORLD'S LARGEST AIRLINER

THE 747 is the first of a new breed—the giant jets. Though it is designed to carry up to 490 passengers, Pan Am's seating configuration calls for 362. The craft cruises at 625 mph and has a range of more than 5000 miles. It is 231 feet, 4 inches long, has a wingspan of 195 feet, 8 inches, and weighs up to 712,000 pounds at takeoff.

(For more information on the 747 see reverse side.)

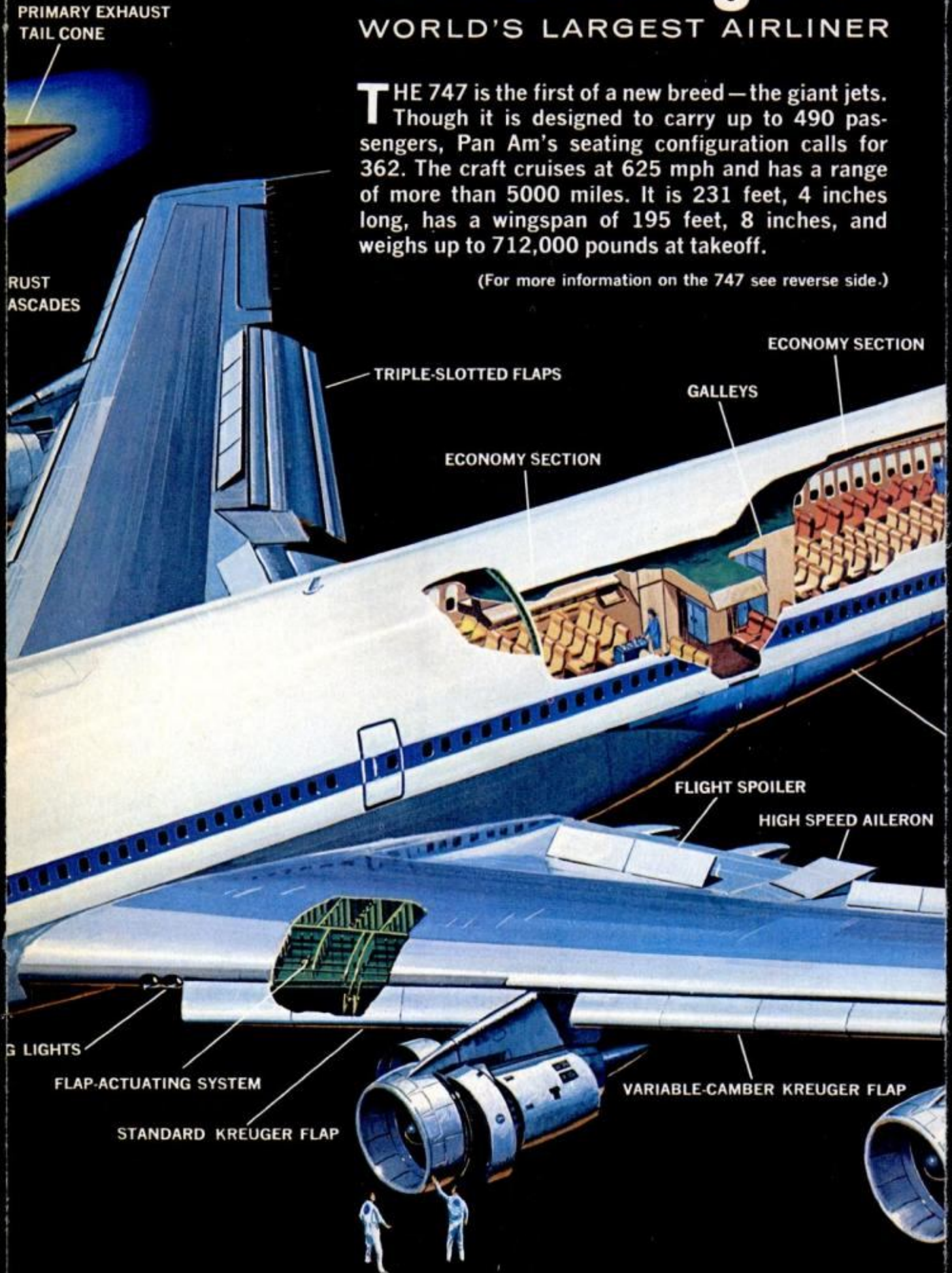

AIRESEARCH GT-CP 660 AUXILIARY POWER UNIT

Equivalent to 2000 HP

On ground, it provides power
for all airplane systems.

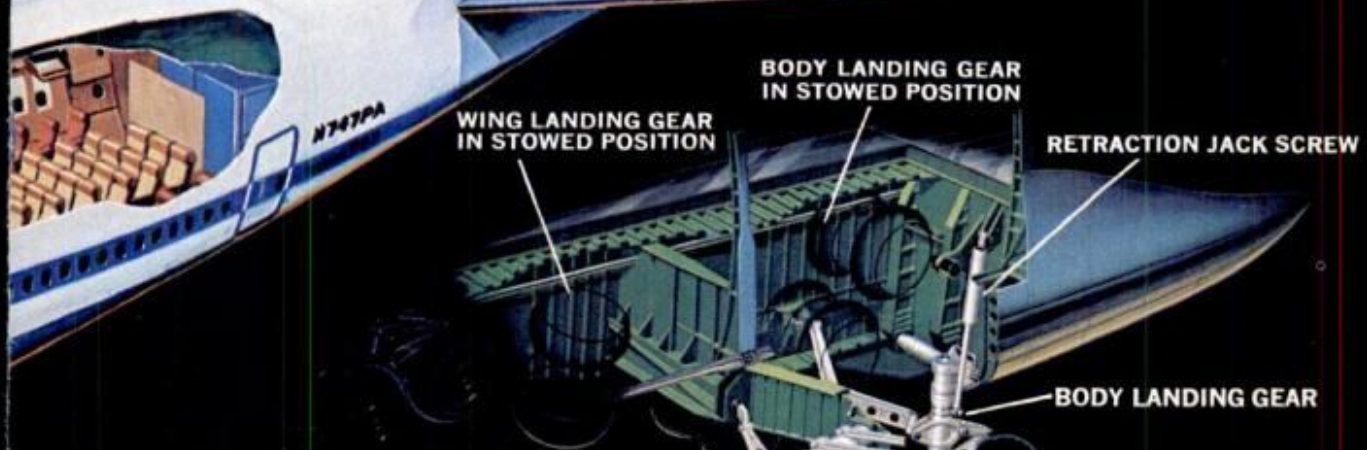
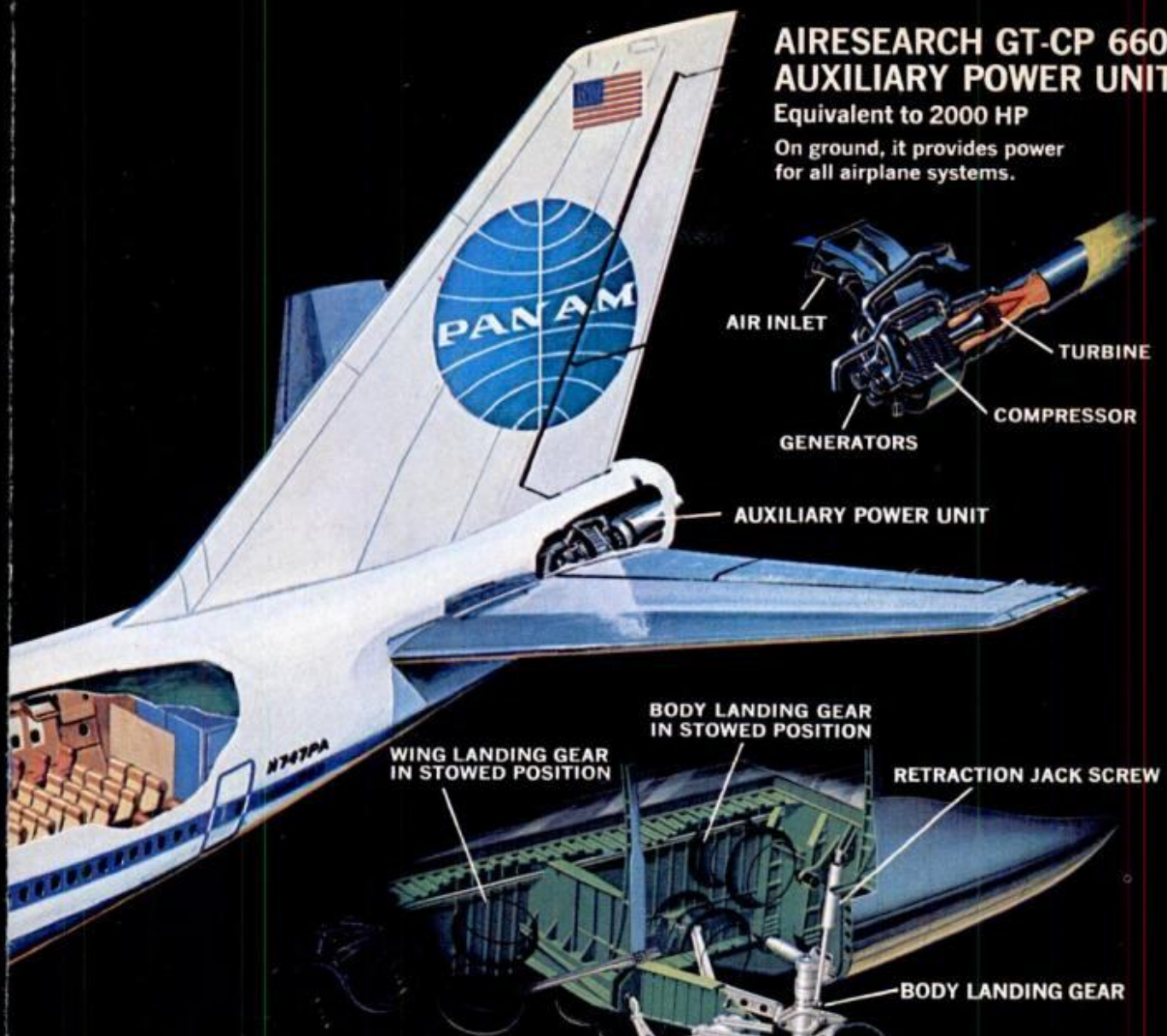

LANDING GEAR

A total of 18 wheels: 2 sets of 4-wheel bogies are attached to fuselage, 1 set is affixed to each wing, and 2 wheels support nose.



PAN AM FLIGHT INSIGNIA
All 747 Command
Captains will wear these wings.

New Era in Air Travel

By JOHN F. PEARSON



AIR TRAVEL WAS REVOLUTIONIZED when the jets replaced piston craft. Now another new era is at hand: the era of the giant jet. Boeing's 747 is the first of the big birds and promises to be a workhorse in long-range travel for years to come. Among its enthusiastic supporters is Najeeb E. Halaby, president of Pan American World Airways, who predicts that there will be three times as many passengers flying by the late 1970s as there are today. Since Pan Am is an international carrier, it needs large-capacity planes. The company helped to make the 747 a reality by placing a substantial initial order for the big plane.

How big is big? The photo at the top of this page shows a 747 next to a Boeing 707, one of today's most widely used long-haul jets. Almost 80 feet shorter than the 747, the 707 can carry a maximum of 187 passengers in an all-economy configuration. The 747's capacity is 490. But Pan Am, the first airline to put the plane into service, has no intention of "packing 'em in." Pan Am's planes will normally carry 362 passengers: 58 in first class and 304 in economy. The cabin, nearly 20 feet wide (7 feet wider than the 707) and 186 feet long, is partitioned into five sections to give passengers the feeling of being seated in something resembling a small theater rather than the customary tubular cabin. Economy seating is nine abreast, as shown in drawing at right. Two aisles, each 20 inches wide, permit passengers to move about relatively freely and make food-dispensing chores easier for the 14 stewardesses. There are six galleys and 12 lavatories.

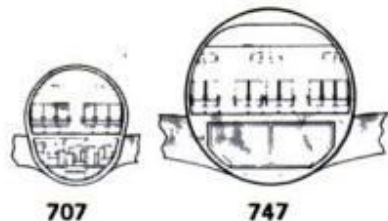

Economy seats on Pan Am's 747 are 10 percent wider—19 inches in all—than on current Pan Am jets. Entertainment facilities have been upgraded, too. Each passenger has a choice of 10 audio channels, carrying everything from travel tips to classical music, that he can listen to on his headphones. In addition, movies are shown on six separate screens on the plane's main deck.

The 747 has 10 doors, five on each side, but Pan Am plans to use only three for boarding. Doors are huge by airliner standards—42 inches wide and 76 high—allowing two passengers to board at the same time. It's estimated that boarding will be accomplished in 17 minutes, about the same time required by current jets. Bridges (shown in drawing) or mobile covered ramps will be used.



Plans call for splitting some terminal waiting rooms into two or three lounges, each serving a different door of the plane.

On the standard 747, baggage is carried in 16 color-coded containers in the forward hold. Containerized cargo is carried in the aft hold and bulk cargo in a rear compartment. Total payload, including passengers, hits about 124,000 pounds.

The plane also comes in freighter or convertible (passengers and/or freight) versions. These models have a nose that swings up to allow cargo pallets or 8-by-8-foot containers, in lengths up to 40 feet, to be loaded straight in. Loading systems for both the main deck and lower hold are mechanized, the freight moving in on powered wheels and tracks containing casters. Only two men, one at the nose and one inside, are needed to load and unload the main deck. The freighter can carry a payload of 260,000 pounds, more than twice that of current jets, for a distance of about 2900 miles. It will carry more than 200,000 pounds nearly 4000 miles.

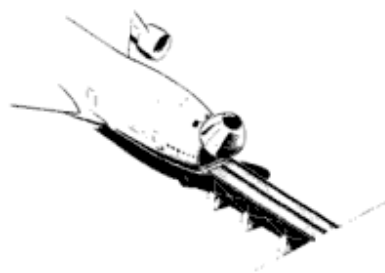

The 747 requires extensive ground support. Pan Am mechanics and other ground personnel will work with some of the most sophisticated servicing equipment ever devised.

A four-wheel-drive tractor weighing 108,000 pounds—some 1000 pounds heavier than the maximum gross weight of a DC-6B airliner—is used to tow the 713,000-pound giant from the terminal to taxiways. Through the use of a ballast system, the weight of the tractor can be boosted to 155,000 pounds to increase traction on slick taxiways.

Pan Am uses prepacked galley modules to handle the food and drink for the 747. The modules, some of them over seven feet wide and nearly three feet deep, are packed at a ground commissary and transported by scissor-lift trucks to the aircraft. Once aboard, the modules are simply “plugged” into the six galleys.

At a major airport like Kennedy International, servicing for an originating flight requires about two hours. Some 64,000 pounds of containerized baggage and cargo is placed aboard the aircraft and 46,770 gallons of fuel pumped into its huge tanks.

Noticeably absent from the array of supporting equipment are the familiar air compressor “start cart,” the airconditioning truck and the electrical power truck. These functions are handled by the 747’s auxiliary power unit (APU), located in the tail.

Many innovations and technical improvements help to make the 747 what it is. It is the first airliner, for example, to have an inertial navigation system (INS) as standard equipment. Similar to the guidance system used on the Apollo moon rockets, the INS needs no outside signals in guiding the plane. Tests have shown the system to be five times more accurate than the standard method of navigation.

Shaded areas in drawing (above) indicate fiberglass honeycomb panel-

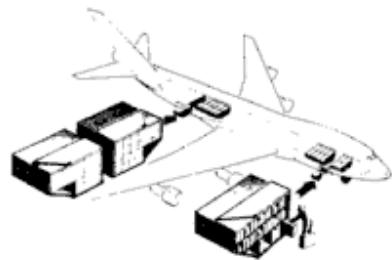

**We've made it
even harder
to choose.**



Let Christmas be the occasion. And decide which of these four tools you need the most. The dual motion sander that offers a choice of straight line or orbital sanding motions for smoother finishes; the precision-cutting sabre saw; the variable speed $\frac{3}{8}$ " drill that lets you match the speed to the job; or the compact $\frac{1}{2}$ " drill for the tough jobs. Get the tool you need the most. Look for SHOPMATE.

**No. 1805
Dual Motion Sander**



No. 1850 $\frac{1}{2}$ " Drill



No. 1810 Sabre Saw



No. 1836 $\frac{3}{8}$ " Drill

from
\$23.99
each

SHOPMATE®

**POWER
TOOLS**



GW MURPHY INDUSTRIES
Portable Electric Tools Division

P15172A

Материал, защищенный авторским правом



SMILE! You Just Got a Ticket

A computerized camera provides the evidence: a picture of the speeder, his car, license, speed at which he was clocked, time, place and speed limit. No muss and no fuzz; he gets the ticket in the mail

By MICHAEL LAMM

START CHECKING YOUR MAILBOX for speeding tickets. Evidence will be a picture of you and your car high-tailing it past a computerized roadside camera.

True, it'll take all the fun out of speeding, but look at the bright side. There'll be no patrolman to yessir, no reprimands, no excuses to think up—just a clean, straightforward, automatic, unfixable ticket.

If the Orbis speed monitoring system comes off as planned, speeding will be a thing of the past. The system's computer gauges speed in a flash. The photo shows: 1) an identifiable mug shot of the driver, 2) license plate, 3) make and type of car, 4) your speed in mph, 5) the legal, posted speed limit, 6) date and time, and 7) location. That's it, man—you've had it.

Shattering as it might seem, Orbis (Latin for circle or orb, secondarily meaning eyeball) can and will save lives. It'll also save money and manpower. *PM* flew me to Dallas to see the thing work. It's being developed by LTV Aerospace Corp.'s Missiles and Space Div. in Grand Prairie, Tex. There was only one Orbis unit in



MOBILE DEMONSTRATION UNIT of Orbis has its own power, can be used in school zones, suburban areas

existence at the time, but two more were being assembled, and production versions will be very similar—more refined, yet identical in all essentials.

I must say the Orbis works with marvelous efficiency. It's unemotional, unbiased, direct and completely accurate. In fact, I now hold the dubious distinction of being among the first of its victims. To see how it worked, I flashed past the Orbis truck in my rented VW. A little red light winked at me as I streaked through a 35-mph zone at 53 mph. That wink was about as bright as someone blipping his brake light for an instant. It meant I'd been zapped and my speed and picture had been recorded. The result is shown on the previous page.

Two types of Orbis installations are planned for production: mobile and stationary. The stationary unit will stand beside a highway, permanently encased in a bulletproof, practically in-

destructible fixture. Electromagnetic sensors will be buried in the pavement, one set under each lane. The reason everything will be concealed and armored is because some people will feel less than friendly toward these little snapshooters. But about the only way to kill a permanent Orbis installation will be to ram it briskly with your car, shearing the breakaway mount. Otherwise, there's nothing much you can do to jam it or outfox the system.

The existing mobile prototype carries the Orbis camera, computer, illuminators, a self-contained darkroom, plus such accessories as two-way radio and airconditioning. Its projected price with this equipment comes to \$13,000-\$15,000 complete (1970 Chevy Custom 10 wagon with 350 V8 and all extras). Fixed installations will sell between \$4500 and \$6000.

To set up the Orbis mobile unit, LTV technicians first placed two pressure

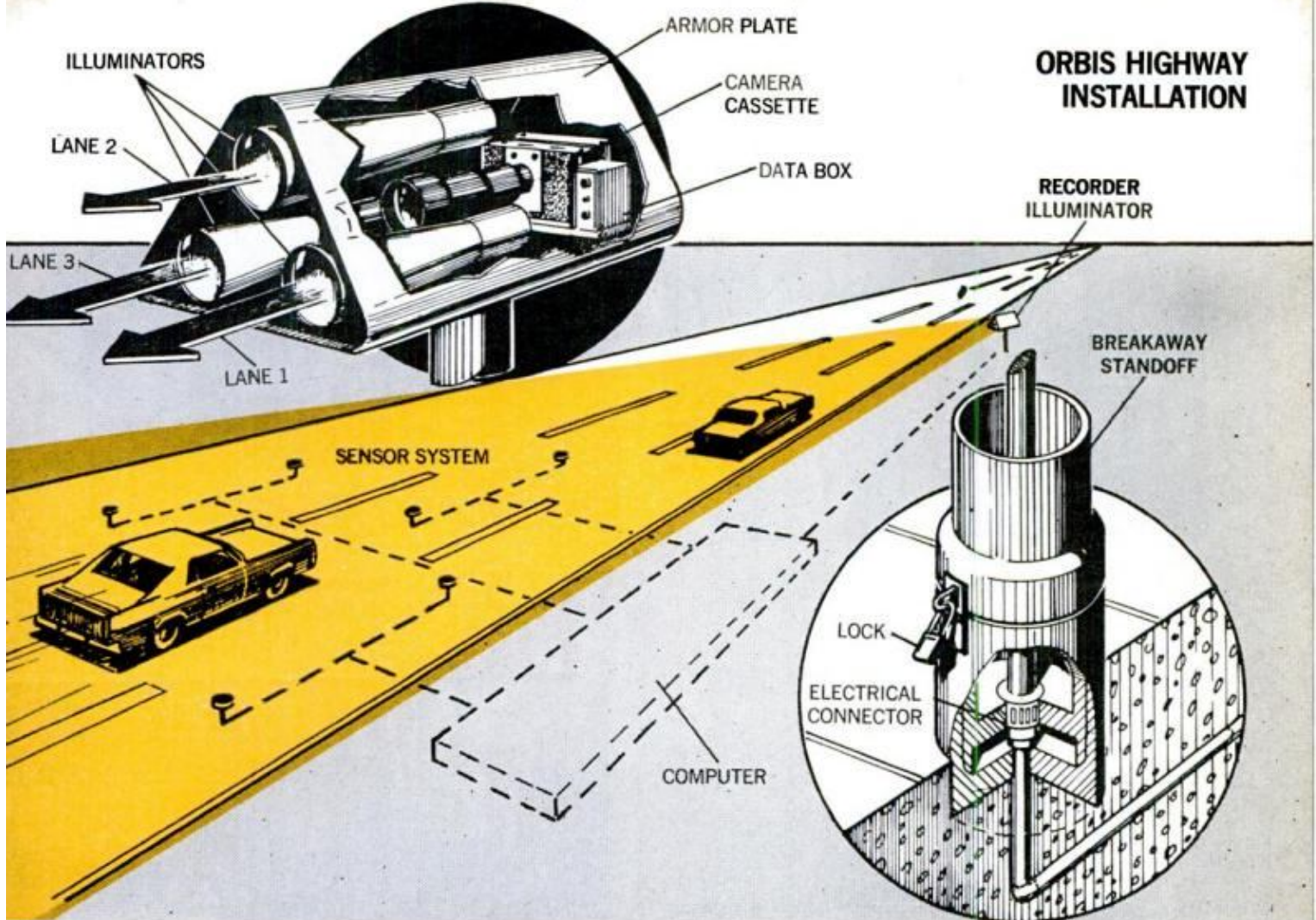

ORBIS HIGHWAY INSTALLATION

HIGHWAY INSTALLATION will have sensors in roadway, camera protected from vandals by armor plate

sensor strips across one lane of Route 303 southeast of Dallas. These sensors are unlike those to be buried with the fixed installation. They're more like the hoses stretched across gas-station driveways. In either case, sensors are spaced 14 feet apart and stand about 117 feet in front of the Orbis camera.

Inside the truck, there's a little computer mounted right beside the camera. This measures the time it takes a car's front wheels to roll from one sensor strip to the next—14 feet. Like similar systems used to time drag races, the computer translates this time span into mph. If car speed is more than the posted limit, the computer automatically trips the camera shutter, at the same instant flashing the two powerful (yet nearly invisible) red illuminators.

Now here's the astute part. If the computer notes that the car *isn't* speeding, nothing happens. Orbis is interested only in speeders. The officer can

dial the posted speed limit with a simple knob on the computer. If he wants to, he can also set another knob to give a minimum speed limit. The computer has a little window that shows the exact speed of each passing car, whether it's speeding or not. If this is above (or below) the posted limit, though, the computer read-out (the number that shows in the little window) is carried via a system of small mirrors into a secondary lens of the camera so its image passes into the camera itself. Here it's captured on the same film frame as the speeding car. Now that's pretty clever, you've got to admit.

The Orbis illuminators are interesting, too. They act as strobes. Their light tends toward the red end of the visible spectrum, as does the camera's sensitivity. The camera uses a commercially available 35-mm film, but filters inside the lens make it partial to red light. The red beam works well in daytime,

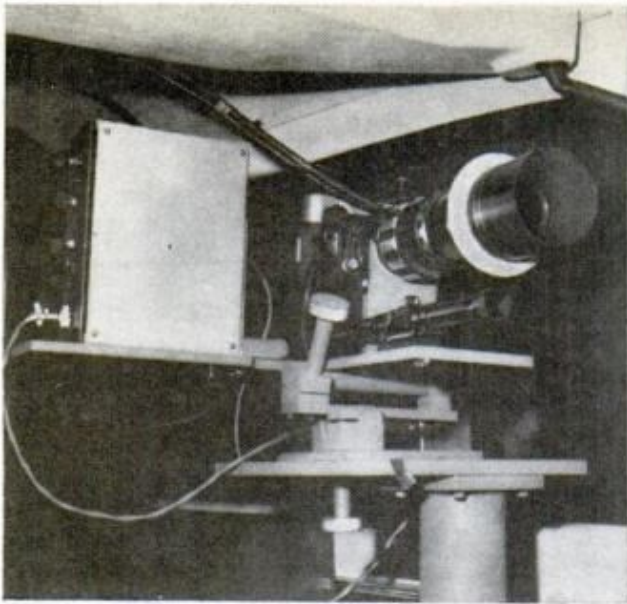

REWORKED 35-MM CAMERA has separate lens on side next to computer (left) to record mph, violation data

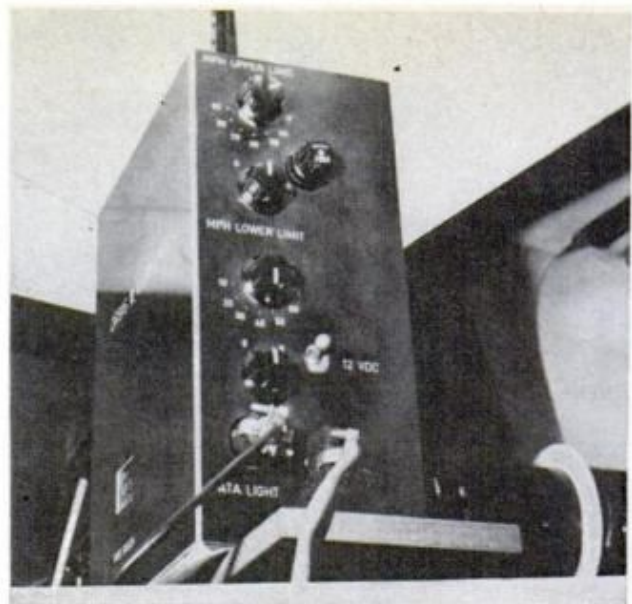

BRAIN OF SYSTEM is computer, with dials to set upper and lower limits. It trips camera, illuminators

but it's even more effective at night. It penetrates beyond the glare of headlights and easily pierces windshield reflections and tints. All the speeder sees in passing is that brief blip of red, not bright enough to dazzle, yet noticeable. In addition to illuminating, the red becomes a warning. When Orbis installations become common, dummy units with only the red blipper might be just as effective as the real thing.

LTV's manager of technology applications, Dave Lee, told me that during an early demonstration given for law-enforcement agencies, Orbis photographed 276 speeders during one three-hour period. This was along the same fairly deserted stretch of highway where they set up the demo for me. Mostly, Dave said, speeders were going only two or three mph over the limit, but the system as now set up has the capability of recording any speed up to 199 mph. Film and camera can also capture clear images at that speed. The winner, so far, of the Orbis Speed Award, goes to a driver who registered 132 mph in a 70 zone.

As first planned, LTV engineers had hoped a film cassette of 1500 frames would have enough capacity to monitor an average three-lane highway for eight hours. Along some routes, though, speeders are so common that 1500

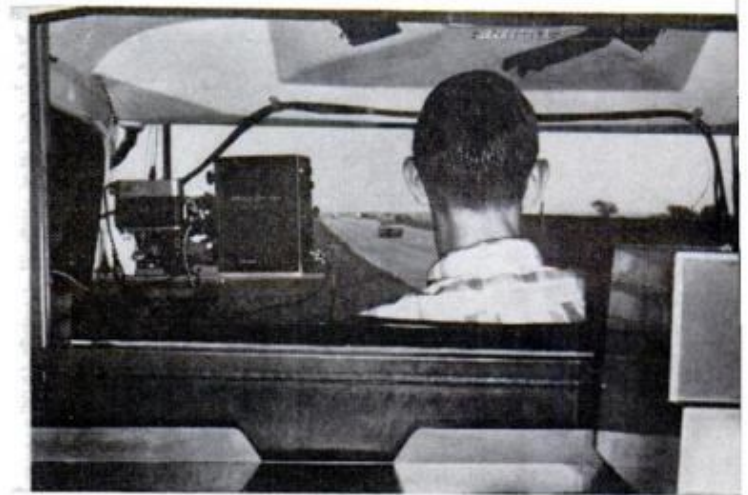

VIEW FROM DARKROOM of mobile unit shows camera and computer ready as speeder nears sensor system

frames would last only about three hours. Of course, once the Orbis system becomes known, traffic will probably slow to meet cassette capacity.

Most state vehicle bureaus are now in the process of computerizing their auto registration records. When that's finished a few years from now, it'll be a simple matter to match photo-recorded license numbers with car owners' names and addresses. And that's how speeding tickets will be passed out by mail. Still, law enforcement agencies might not want to cite all violators shot by Orbis. Depending on circumstances, perhaps they'll want to ticket only drivers caught speeding again and again—the

(Please turn to page 194)

Robot sailboat

A unique robot sailboat developed by RCA can navigate itself unmanned to any point on the seas of the world and keep its station without a mooring. It can remain in one position for as much as a year and return home on a command sent by radio. While in position, it could carry out such scientific chores as monitoring weather or such military tasks as detecting submarines. Named SKAMP (for Station Keeping and Mobile Platform), the 16-foot-tall prototype navigates over water guided by a computer that acts as an automatic "helmsman." The computer sends signals that cause the rigid sail to rotate at its base and the craft's two rudders to move to maneuver the vessel so it takes best advantage of the wind. Spokesmen for RCA's Astro-Electronics Div. say they plan to test a self-contained navigation system that receives signals from Navy satellites.

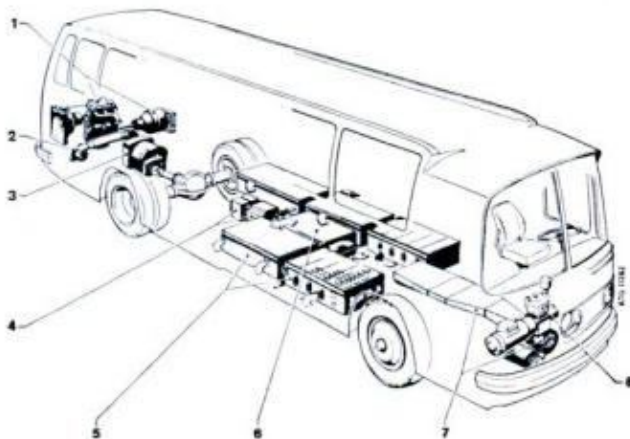
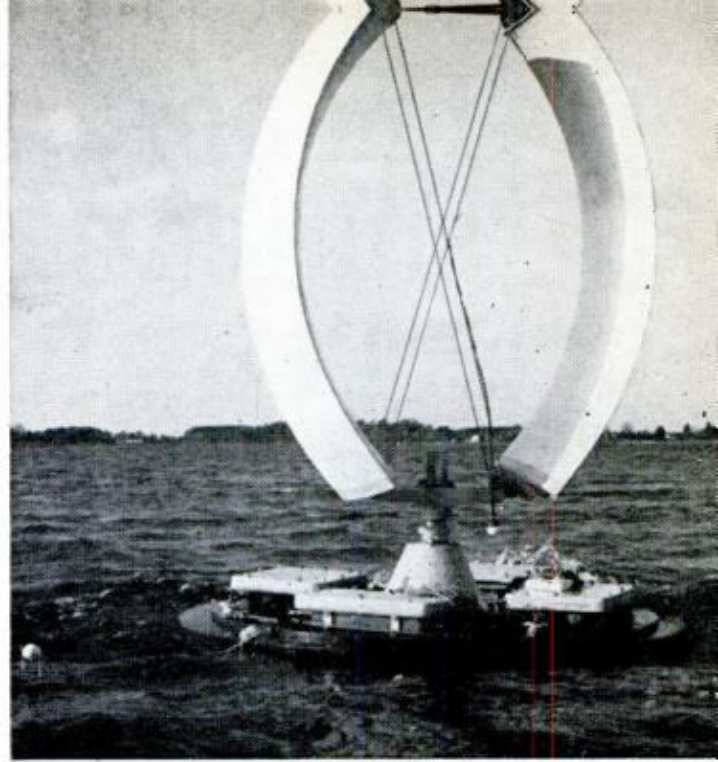

1. OM 314 engine with generator.
2. Cooling blower for traction engine.
3. Electrical traction engine with reduction gear.
4. High-tension section.
5. Five lead batteries.
6. Electronic control.
7. Cooling blower for batteries.
8. Air compressor and servo steering pump.

'Hybrid drive' electric bus

"A city bus with a hybrid drive" is the way Daimler-Benz describes its new Mercedes-Benz OE 302 electrically powered bus. Carrying 3½ tons of lead batteries, the 66 passenger experimental vehicle can reach a top speed of 43½ mph. There are two principal reasons for developing an electric bus, says the firm: Electric drive is quiet and is free from exhaust-gas emission. While operating within city limits, the vehicle gets its energy from the storage batteries; while in intercity travel, a large share of the energy is supplied by a diesel engine and generator combination that is insulated to cut down noise and vibration. Daimler-Benz has developed an electronic control that minimizes the energy losses common to electric-drive vehicles in the past. The firm has announced no plans yet for manufacturing the electric buses for commercial use.

'I'm not stuffed— I'm freeze-dried!'



SHINER MINNOW is about to become meal for belted kingfisher. Exhibit was made by freeze-drying method

The lifelike, frozen-in-action poses of the new wildlife specimens in the Smithsonian Institution are the result of freeze-drying, a process that leaves animals and birds perfectly preserved

By **WILLIAM O'NEILL**

Photos by James Pickerell

IF YOU HAVE EVER VISITED your local natural history museum, you probably were impressed by the lifelike appearance of the wildlife displayed there. But if you gave the credit to the taxidermist, you may have been wrong. More museums today are experimenting with freeze-drying to keep animals permanently in true-to-life poses without all the trouble of cutting them open, eviscerating them and mounting their skins.

Hunters in Alaska are familiar with freeze-drying. Ducks hung outside overnight in winter will be completely dehydrated by morning. The liquids in the birds will have frozen, then been drawn off as vapor by the cold wind blowing across them. Blood plasma and antibiotics are freeze-dried for preservation, storage and shipment. Campers and hikers appreciate packaged, freeze-dried foods because of their lighter weight and smaller size.

Credit for adapting the process for museum use goes to Rolland Hower, 40, an exhibits specialist at the Smithsonian Institution in Washington, D.C. Hower was introduced to freeze-drying by Dr. Harold T. Merryman of the U.S. Navy Medical Research Institute's Biophysics Div., and has been working with it at the Smithsonian since 1960, modifying and improving the procedure as he goes along.

The Smithsonian's freeze-drying equipment consists of a specimen chamber, a condenser chamber and a vacuum pump. The refrigerated, airtight

specimen chamber is nine feet long and five feet in diameter, and can hold up to 100 specimens at a time. When a specimen—which can be an animal, reptile, fish, bird or insect—is received by the museum for exhibit, Hower puts it into one of the two large deep-freezers that occupy one wall of his laboratory. To prepare it for display, Hower's assistant, Bob Winkelman, 21, thaws out the specimen and fixes it in the desired pose. He will run wires into the feet of a bird or raccoon, for example, so that it can be attached to a tree branch. Winkelman also replaces the eyes with artificial ones.

He then places the specimens inside the chamber, seals the chamber and drops the temperature in it to minus 4° F. Water freezes at 32° F. but the lower temperature is necessary to insure that every drop of body fluids in the museum specimens turns to solid ice. After this subfreezing temperature is reached, air is pumped out of the chamber until its atmospheric pressure is .039 pounds per square inch, compared with a normal pressure at sea level of 14.7 pounds. In this near-vacuum, the ice inside the specimens "boils" and evaporates.

The boiling point of a liquid is the point at which it changes into a vapor. Water changes into steam at 212° F. under normal atmospheric pressure at sea level. But on top of Mount Everest, 29,028 feet above sea level, the atmospheric pressure is considerably lighter and water will boil at only 162° F. Decreasing the pressure still further will take the boiling point so low that a frozen liquid will go right from the ice to the vapor state. This is the key to freeze-drying.

In the Smithsonian's refrigerated vacuum chamber, the liquids in the bodies of the specimens—now frozen into ice crystals—are given off as vapor, starting at the surface of the skin and gradually working in to the center. Since they change directly from ice to vapor, bypassing the liquid stage, there is no chance for blood vessels and tis-

DECEMBER 1969



READY FOR DISPLAY, a yellow-shafted flicker has his back feathers smoothed by laboratory assistant

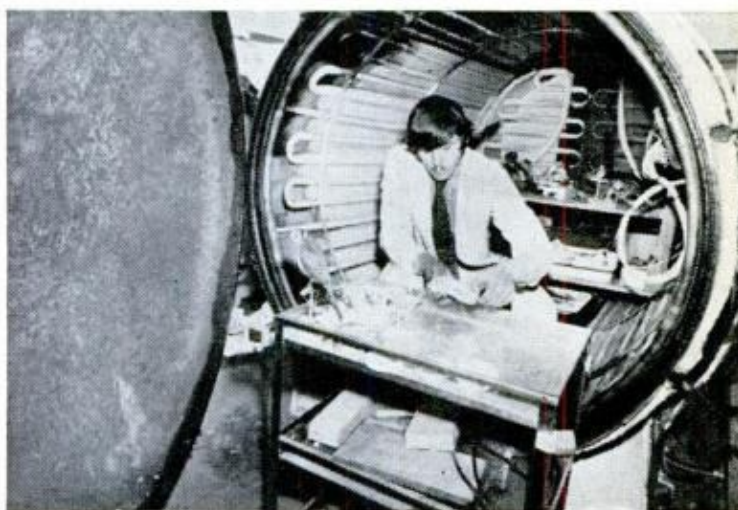

FOR GREATER EFFICIENCY, the specimens are processed in batches. Loaded trays go into chamber



RED SHOULDERED HAWK alights on branch—pose in which the bird was placed before being freeze-dried

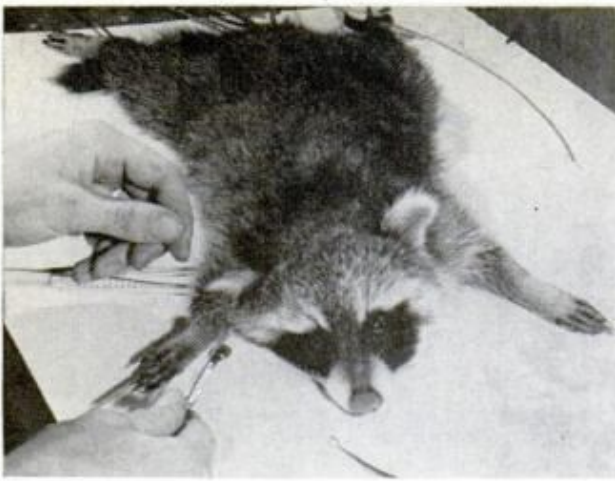

TWEEZERS GRIP artificial eye about to be placed in empty socket. Eyes are inserted before freezing



HOLES IN BOARD permit insertion of wires used to hold the specimen in pose during freeze-drying

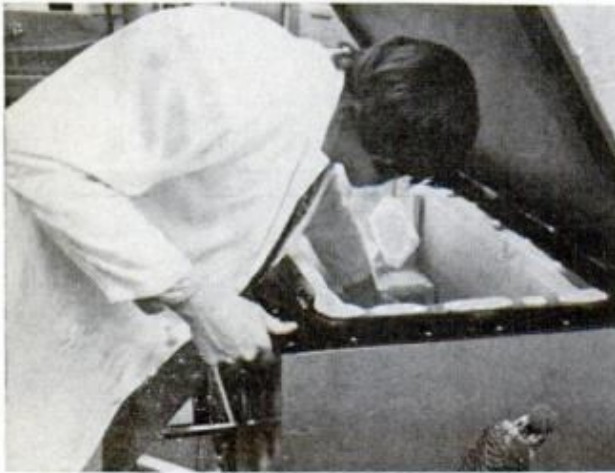

FREEZERS HOLD mammals, reptiles, birds, fish, insects—specimens awaiting mounting and processing



SPECIMENS DRY OUT in chilled vacuum chamber, a key step in process. Drying takes about two weeks

sues to collapse, shrink and change shape, as would normally occur during dehydration. Such reduced size may be ideal for the frozen-food maker, but the distortion would be disastrous in a specimen to be displayed in a museum.

If the vapor given off by all the specimens were allowed to accumulate in the chamber, it would build up the atmospheric pressure until the process slowed down and finally stopped. In the heavier atmosphere, no more vapor would escape from the specimens, even though ice crystals still remained in their bodies. To keep the process moving, a condenser chamber is attached to the specimen chamber and is kept at about minus 58° F.

The vapor is attracted to the colder chamber, where it forms ice around the condenser coil. By the time the freeze-dry process is complete, the temperature in the two connected chambers

will have about averaged out, but will still have been adequate to completely dry out the frozen specimens. Since outward appearance of the specimens remains unchanged during the process, Hower and Winkelmann enter the freeze-dry chamber at intervals of from one to two weeks and bring specimens out to be weighed. The specimens become lighter as dehydration progresses. When a specimen shows no further weight loss, it has been completely freeze-dried and is ready for exhibit. Another specimen replaces it in the chamber and the process continues.

It takes about 10 days to freeze-dry an insect, two to three weeks for a robin, and about twice that long for a fox. The finished specimens are rigid, lightweight and perfectly preserved against decay. Because fewer man-hours are required to prepare specimens by freeze-drying, as compared



WEIGHT LOSS indicates evaporation of body fluids. Freeze-drying is completed when weight loss stops



FINISHED EXHIBIT is a lifelike raccoon. Success of the method has prompted other museums to try it

with taxidermy, the process represents a financial saving to museums.

A skilled taxidermist can mount from 50 to 100 animals in a year. Winkelman can produce more than 400 finished specimens in that time by freeze-drying, and Hower estimates that more than 3000 specimens have been freeze-dried for Smithsonian exhibits in the past eight years.

The lighter weight, greater realism and fewer man-hours involved are not the only advantages museums derive from freeze-drying. Insects and small, soft-bodied specimens that formerly had to be preserved in jars of alcohol, now can be shown in their natural surroundings. Snakes in museum exhibits previously were painted plaster casts, but freeze-drying enables curators to put the real thing on display.

The largest specimen Hower has freeze-dried was a six-foot-long alliga-

tor, but he sees no size limitations. Given enough time, a larger vacuum chamber and the necessary block and tackle, Hower would be willing to freeze-dry an elephant if the Smithsonian requested it. The specimens that continue to give him trouble are fish. While some fish freeze-dry perfectly, others change the color of their scales, and Hower and his assistants are still checking ways to prevent this.

Museums frequently contact Hower for advice on setting up freeze-dry laboratories. The Smithsonian Press has published a paper in which he gives a detailed description of the equipment required. A museum in London now freeze-dries its specimens, as do some museums in the United States, and the Australian Museum is preparing to construct a freeze-dry chamber.

Last year, Hower began working with the George Washington University School of Medicine, Washington, D.C., freeze-drying hearts, stomachs, livers and other pathological specimens for use in classroom instruction. Previously, medical students learned from studying human organs kept in alcohol jars or from plaster and plastic replicas. Now, freeze-dried specimens will help train new generations of doctors. ★ ★ ★

DEVELOPER of Smithsonian process, exhibits officer Rolland Hower, holds freeze-dried human organs



Four-Mile Train With

More than two miles behind the locomotive, a string of diesels responds instantly to engineer's throttle and brake. UHF, VHF slaves are now working on the railroad

By HENRY COMSTOCK / Illustrations by the Author

PICTURE A COAL TRAIN four miles long. Stowed in its 500 hopper and gondola cars is enough bituminous coal to generate all the electricity a city the size of Boston uses in a month. The gross weight is close to 50,000 tons.

Up front, a single engineer holds the reins on six diesel locomotive units cranking out 21,600 hp. At the train's originating yard in Iaeger, W. Va., he spends four minutes picking up the slack in a thousand couplers, and he is 480 feet on his way to Portsmouth, Ohio, before the cabooses begins to roll.

This is no crystal-ball glimpse into the future. The run actually took place on the Norfolk & Western Railway over a year ago. Admittedly it was an experiment, and the regular operation of such land monsters must wait until terminals and block-signal systems are revamped. Nevertheless, superfreight trains almost as impressive are now being tested, and in some cases routinely dispatched, on a score of U.S. and Canadian lines.

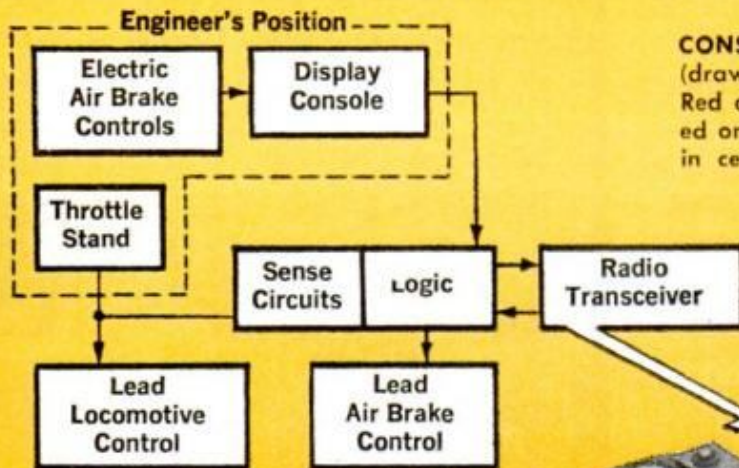

CONSOLE IN FRONT CAB of Locotrol-equipped train (drawing, opposite page) controls all operations. Red and green lights keep the engineer posted on slave locomotive. Selector switch in center is the throttle

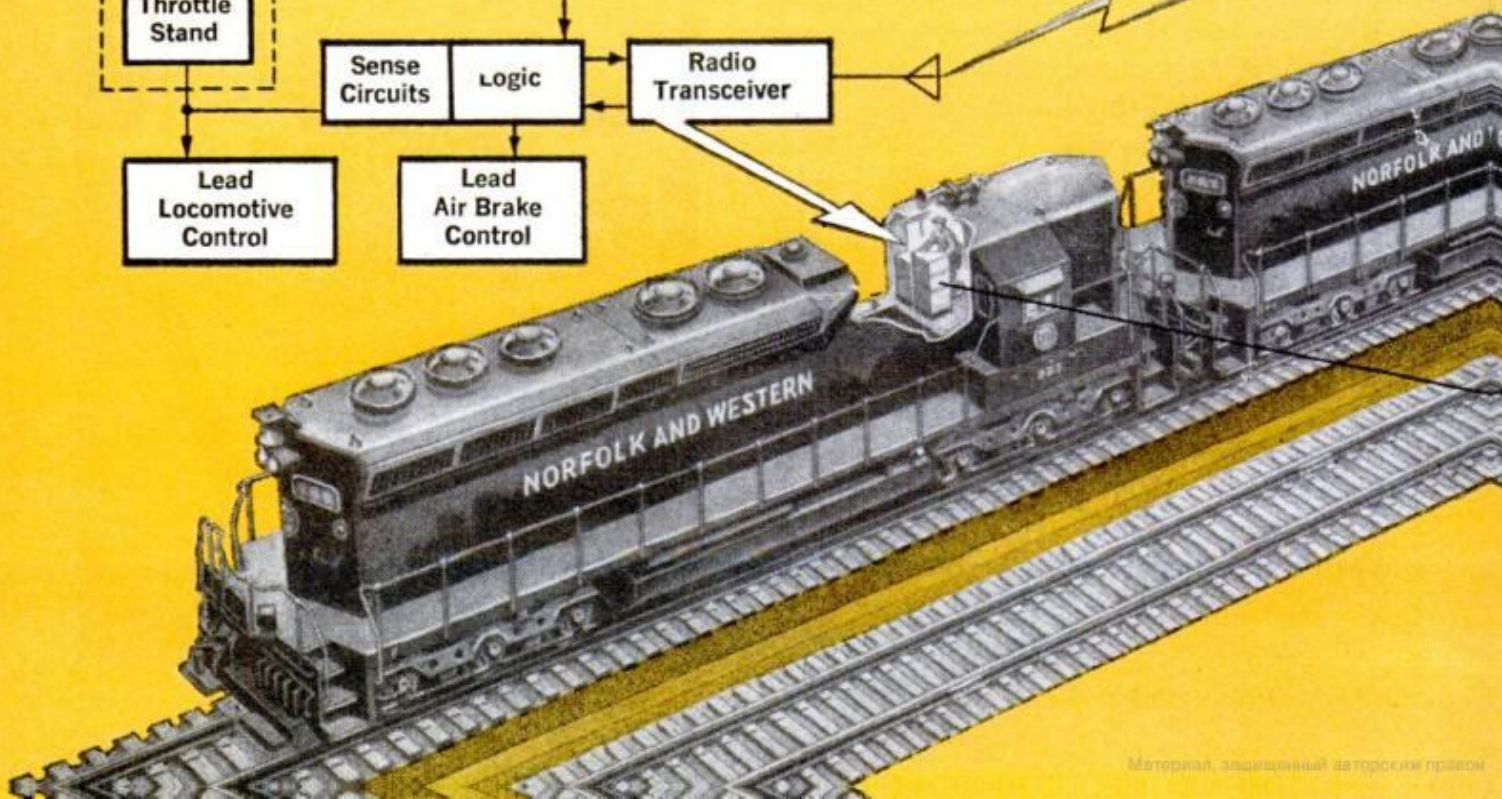

a Mind in the Middle

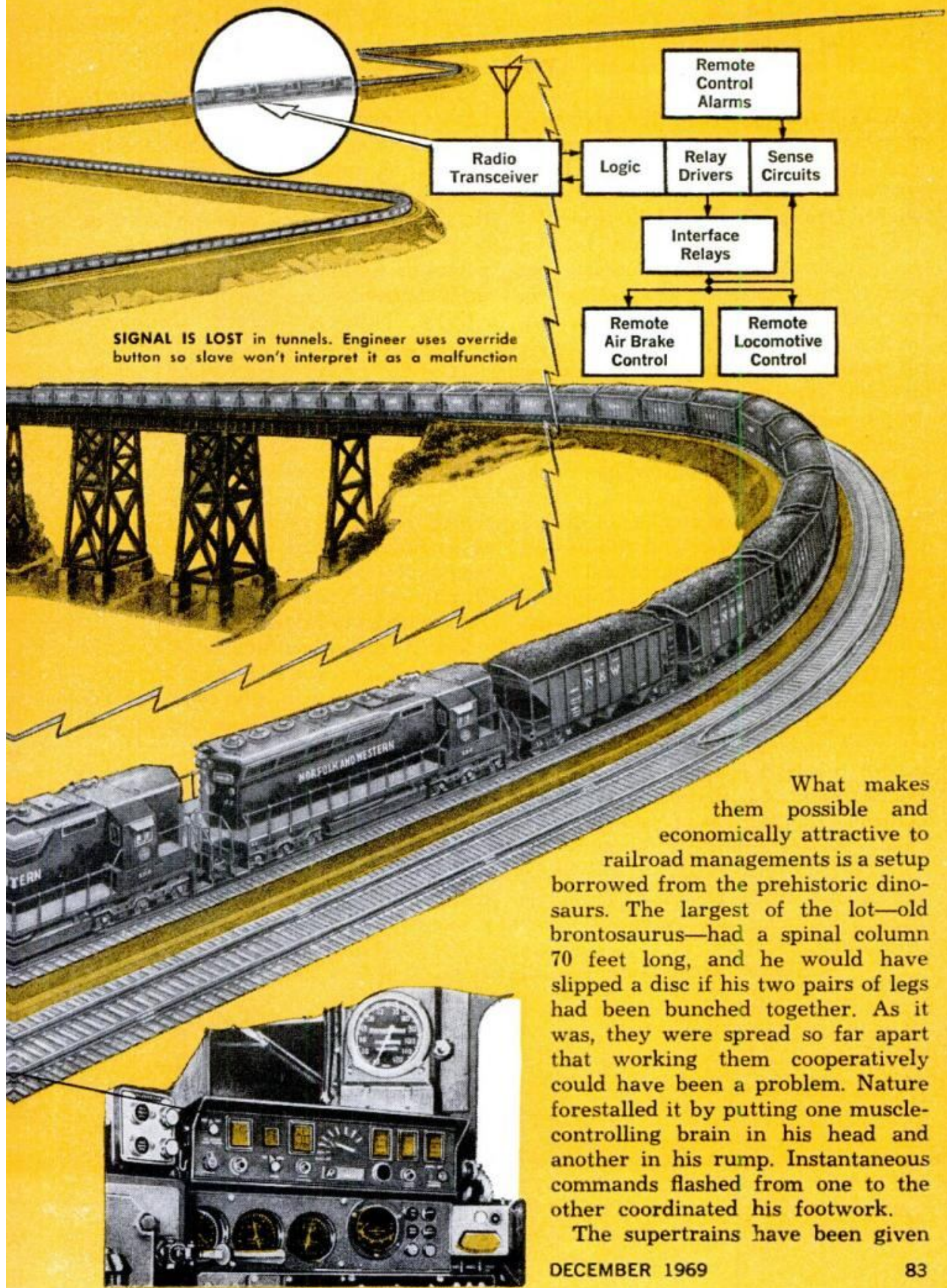

SIGNAL IS LOST in tunnels. Engineer uses override button so slave won't interpret it as a malfunction

What makes them possible and economically attractive to railroad managements is a setup borrowed from the prehistoric dinosaurs. The largest of the lot—old brontosaurus—had a spinal column 70 feet long, and he would have slipped a disc if his two pairs of legs had been bunched together. As it was, they were spread so far apart that working them cooperatively could have been a problem. Nature forestalled it by putting one muscle-controlling brain in his head and another in his rump. Instantaneous commands flashed from one to the other coordinated his footwork.

The supertrains have been given

the same arrangement, brought up to date with electronic think boxes developed by two manufacturers. The pioneering outfit—Radiation Inc.—calls its bundles of solid-state circuitry *Locotrol*. The competition—Westinghouse Communications—counters with *RMU*, short for Remote Multiple Unit.

With either product, the string of diesels assigned to a miles-long train is split into two groups, or locomotives. One is placed up front; the other, sandwiched into the cars far to the rear.

That part of the dinosaur hookup isn't new; conventional tonnage has been tooled over heavy grades this way for years; not of choice, but as a concession to railroad couplers. Knuckle all of the horses to the head end and the drawbar directly behind them would be plucked from its pocket like a baby tooth.

Spreading out the power has never brought cheer to the top brass, however. For, while any number of diesels can be linked together and run as one, until now it has been impractical to extend multiple-unit operation from one locomotive back over a train to another. Each has called for its own engineer.

Locotrol and RMU change the picture. A cluster of consoles, or a "master station group," is placed in the forward cab of the lead engine, where it supplements and in part replaces the usual controls. Another set of cabinets, or a "slave station group," is linked to the throttle and brake valves governing the second batch of units. There no human hand ever flips levers.

Instead, whenever the lone engineer 100 or more cars ahead readjusts his controller switch, the master station takes note and snaps the information by VHF or UHF radio to the slaves. Within milliseconds they duplicate the setting.

The same thing happens during air-brake applications and releases. Here the layman might question the need for railroading robots to get into the act, because today's sophisticated pneumatic systems do a first-rate job of tying down conventional consists. But the supertrains are more than a match for the most ingenious pipe circuitry and sensitively balanced valves. Responses would be slow at the rear, with the last cars either giving their forward mates the battering-ram treatment or dragging their shoes and causing pull-in-twos.

The only solution is to apply or kick off the brakes simultaneously at two widely separated control stands. A pair of engineers often out of sight and sound of one another couldn't do it. But the electronic equipment collaborates with hair-trigger speed.

There's a dividend unrelated to radio control. Every diesel has an air compressor, and collectively these pumps can charge the train line and storage reservoirs of all of the cars a parade of units can haul. The farther back the air must be pushed, however, the slower the chore becomes, due to leakage at hose connections.

For example, in a recent Penn Central test it took 20 minutes to build up pressure in 75 cars, and a full hour to

CANADIAN PACIFIC can quickly convert any diesel units on its roster into automated locomotives by coupling them to an unpowered robot car equipped with an electronic-slave station



charge 150. In both cases, all of the power was at the head end. Then half of the engine units were moved two-thirds of the way to the rear of the longer train. With that setup the first locomotive's compressors rammed air a bit more than a third of the distance to the caboose. At the same time, the pumps in the second locomotive shoved their output in both directions. The freight was ready to roll in 15 minutes.

Both Locotrol and RMU meet every other demand of dual-station control. On locomotives whose traction motors can be converted into reluctantly turning dynamos for frictionless braking, a selector switch offers whatever retarding force is needed, front and rear.

A more vital safeguard prevents two passing trains from scrambling their signals with spectacular results. A pre-wired selector card in each master station sends out an address code unlike any other. Only a slave locomotive whose transceiver has been properly dialed will respond to its commands.

This dialing feature permits a convenient interchange of trailing power. But for even greater flexibility, more and more roads are placing slave-station groups in "idler" or "robot" cars. Jumper-cable-connected to any diesels on the roster, these units convert them into automated locomotives.

What about radio blackouts in tunnels? Under normal conditions, a master station repeats its last instructions at frequent intervals to maintain continuity. But when a malfunction or physical obstruction interrupts the signals for more than 47 seconds the slaves advise the engineer. Alerted by a red light and a pinging bell, he knows they are about to cut the second locomotive's big combustion engines back to idling speed and turn the entire braking system over to him. If, as in the case of a tunnel, he sees no need for such drastic action, he thumbs an override button and maintains the status quo.

Finally, there is the matter of undu-

(Please turn to page 194)

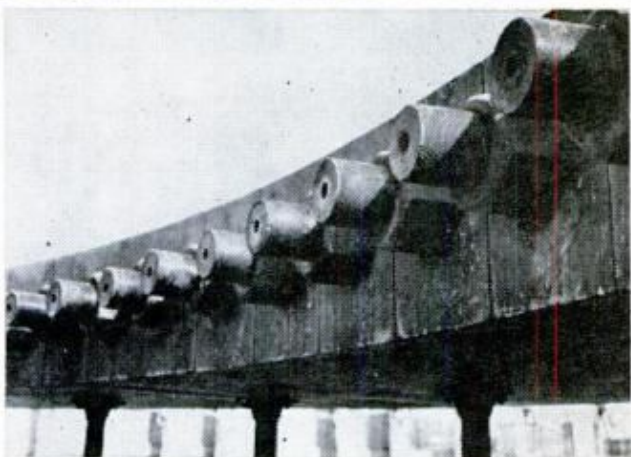
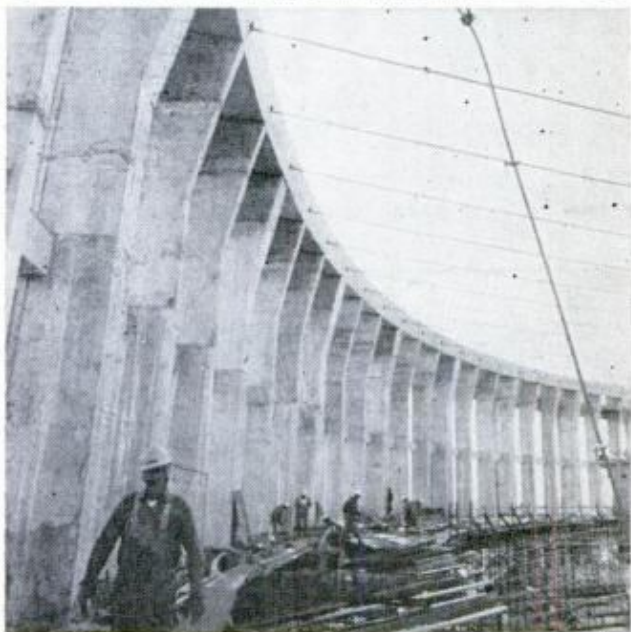
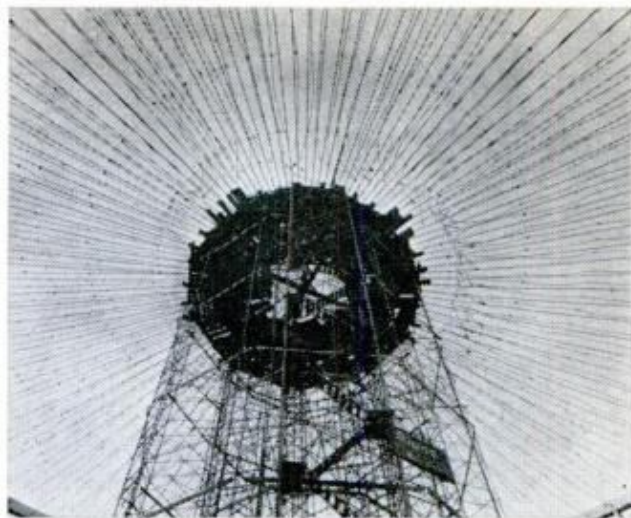

Cables support palace roof

The roof of Salt Lake City's new convention hall, the Salt Palace, is held up by 216 thick steel cables, strung like the spokes of a bicycle wheel (top photo). Two huge outer compression rings of reinforced concrete, 385 feet in diameter, form the rims of this wheel; they're mounted on concrete columns (center photo). Tension is applied to the cables by turning huge nuts inside the wheel hub—a concrete ring 45 feet in diameter (lower photo).



Supermarket for automobile parts

An enterprising New Yorker has turned his scrapped-car lot into a supermarket for car parts. Customers push carts through the lot, selecting parts from the display racks much



Pitching machine

By varying the speed of one of the two counterrotating wheels on the Curvemaster pitching machine, a baseball can be made to curve right or left. The machine also throws knuckle-balls for batting practice.



Identification in minutes

Case records, fingerprints and photos filed on videotape will be available for immediate viewing in 15 facilities of the Los Angeles County Sheriff's Dept. when the Ampex Videofile system is installed next year. Here an officer studies suspect's photo on screen; printer (background) can print photo.



Lone oarsman rows Atlantic

Rowing this specially outfitted boat, John Fairfax, British big-game hunter, crossed the Atlantic in six months. He traveled from the Canary Islands to Florida, to become the first man to row across alone.



the way they would do in a grocery store. The owner, James Lodato, says he gets cars from several sources: auctions of abandoned cars held by the Sanitation Dept., insurance companies selling stolen and wrecked vehicles and the like. Lodato adds that no matter how badly wrecked the car, there's usually some part he can salvage—and put up for sale.



Airy Aero is the first open Opel

First open version of the Opel GT is the Aero GT, shown at the Frankfurt auto show. The removable roof can be stored in the trunk; the portion that remains in place serves as a rollbar. Other features include an electrically operated rear window and wider wheel track.



Gas mask for a discotheque

The operator of an English discotheque offers free oxygen to overly tired dancers to revitalize them. He calls it "moon gas."



One-horse Volks

Well, it's about the only way to go when you're missing the engine and steering wheel. A Dutch farmer did the "conversion."

PM OWNERS REPORT FORD MAVERICK

A Nationwide Survey Based on
1,260,000 Owner-Driven Miles

By **BILL HARTFORD**, Technical Auto Editor



FAMILIAR, FALCON-LIKE HANDLING is liked second to economy

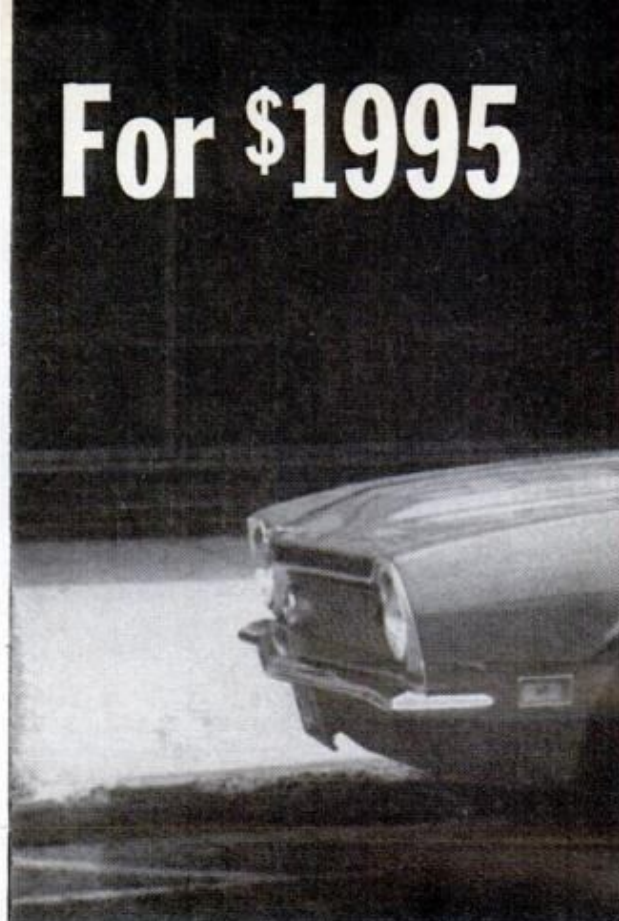

Photos by Irv Dolin

IF YOU'VE BEEN LOOKING for a used Volkswagen, you might find one at your local Ford dealer. You can see a good recent-model-year Bug on a dealer's lot in Oakland: "I had a 1968 VW before I traded it in on the Maverick," says the previous owner, a California iron-worker. He's got 2700 miles on his new subcompact, gets from 24 to 26 mpg and has no complaints.

Back East, a Maryland analyst with a growing family refers to the fact that he "owned a VW before." He finds the Maverick workmanship not up to that of the VW but prefers the size, luggage space and ride.

Down South, a Florida superintendent says his dealer couldn't have been more generous: "Good trade-in for my 1968 VW."

In the Midwest, an Iowa engineering technician explains: "I wanted a bigger car with more engine than my VW had." A safety and security officer from the same state traded in his Karmann-Ghia for a Maverick. And another Iowan couldn't be more emphatic about his preference: "Believe me I wouldn't

trade in my Maverick for two VWs!"

The reasons given by owners who switched to a Maverick fall into three categories. Some are emotional: "I got sick of shifting," says a Michigan student. Other decisions were based more on product evaluation: "I had a very good Volkswagen," says an Illinois student, "but after seeing the Maverick I felt I had found a 'better Volkswagen,' so to speak, in terms of gas mileage, parking ease, engine, etc." An Illinois airline pilot didn't own a VW to begin with, but came close to buying one. He finally decided on the Maverick, how-



FULL-WIDTH SHELF is no substitute for real glove box which is sorely missed by many Maverick owners

You Want a Glove Box, Too?



SUPERSAVINGS in price, operation and maintenance is the promise of Maverick; so far so good, say owners

ever: "We wanted VW economy all around. The Maverick is as close as a U.S. manufacturer has come. We felt the better ride and additional hp offset the additional cost."

A third reason given by ex-VW owners and other Maverick owners who wouldn't even look at an imported car is the fact that the Maverick is, as an Illinois truck driver emphasizes, "American-made." "I like its being American," confesses a Louisiana student. And a California stock clerk says, "I wanted a U.S.-made economy car."

It's economy, coming and going, that

owners tout. High advertised fuel mileage, a tantalizing price tag of \$1995 (although a good percentage of owners paid upward of \$2800 with all the options they specified), and the promise of simple maintenance and repair of an uncluttered domestic vehicle all add up to overall economy in the eyes of the prospective buyer.

All the promises are borne out on the road, owners tell us. Averages of 21.5 and 24.5 mpg are reported for the 170-cu.-in. Six that over three quarters of Maverick owners are fueling. A California naval officer likes "the simplic-



EASY DO-IT-YOURSELF MAINTENANCE on six-cylinder engines is liked. Rod in front keeps up hood



REAR-SEAT ROOM, for the type of car, is praised. Few comfort complaints are for inadequate padding

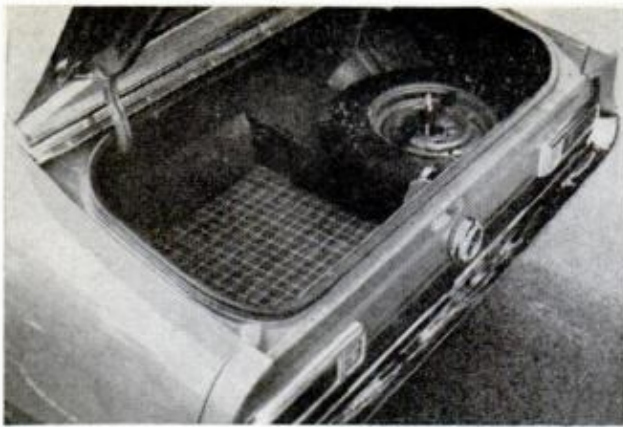

TRUNK SPACE is sufficient but use of fuel tank as floor for trunk drew many complaints from owners

ity of it." And that says a lot. As the first "subcompact" among the half dozen or so that will have been introduced between 1969 and 1971, the Maverick, with its excellent sales kickoff and acceptance, portends nothing but success for the concept. It's a "return to rationality" for a Minnesota inspector who also likes the "common-sense arrangement of components under the hood."

A California carpentry foreman who, in fact, bought a Maverick so he might do his own work, says he's "disgusted with service cost at garages." A Kentucky lab inspector couldn't get satisfactory repair of a sticking carburetor float at his dealer; he says he'll fix it himself. In fact, he'll do almost all of his future maintenance and service because of "the high cost of service at the dealer's shop." A Delaware barber



DRIVING POSITION and three-speed stick are okay, but bucket seats, four-on-floor are desired options

wraps it up with a statement that he bought his Maverick hoping it would be "the answer to all our car problems."

Not too many owners would be so hopeful, yet with the Maverick they might have a chance this would actually be the case. Four of five owners report having had no mechanical problems whatsoever. The percentage—81.6—is actually a little better than that of the Cadillac Eldorado owners report (page 125, July '69 PM).

Any complaints that owners do have refer mostly to the design of the car and occasionally to the production techniques that enable the Maverick to be sold for the low price they bought it for in the first place. The lack of a glove box, for example, is the biggest sore point with the owners. They expect every car to have a glove box, right? Wrong! In Detroit, economy car means just that. It costs money for all those hinges, catches and plastic pieces. If you want a Maverick for less than \$2000, you'll have to live with a shelf that runs along the underside of the dash and along which your flashlight, maps, large bulbs, fuses and other

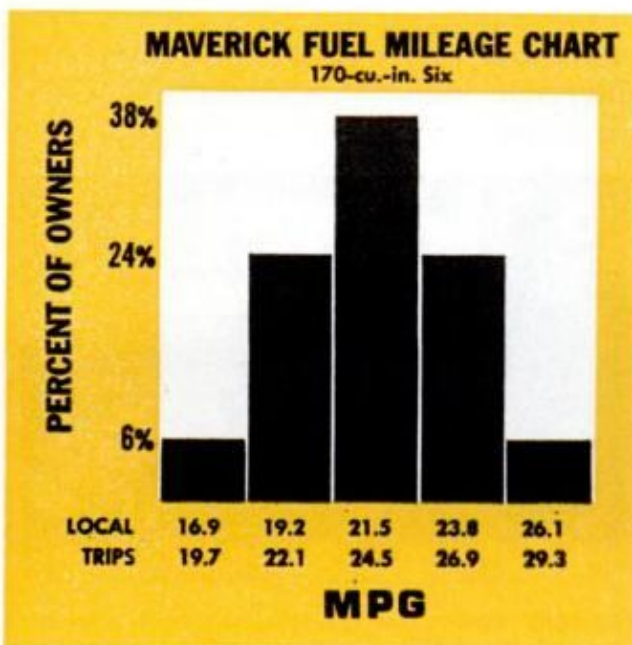



REAR VISIBILITY is limited due to rear deck and backlight styling; head restraints don't help

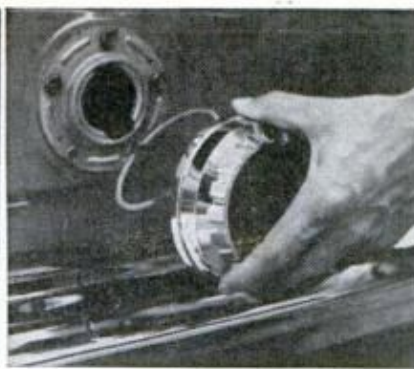

GAS-CAP LANYARD is optional. Some owners weren't told of this, other options they could order



REAR WINDOW hinges out slightly for very little ventilation; catch and window rattle when open

glove-box gear will slide in every turn. And how about the air vents over the shelf on either side of the car: Things blow off the shelf whenever the vents are open!

Counterbalanced hinges for the Maverick's engine bonnet also cost money, so they're not used. Instead, a support rod is swung into place to hold up the hood. It saves money and only a few owners complain. A Colorado secretary, though, says: "Gas-station men almost drop it on their heads every time they open it!"

There's nothing else about the car itself that really upsets owners. "Next

time I take a lawyer to the dealer's with me!" says an Illinois engineer. And "all salesman lie a lot," observes a Minnesota housewife.

A tree and lawn serviceman does want a spoiler on his Maverick, however. At sixteen, he's one of the youngest owners, many of whom are students. For getting a haircut and shaving his beard, a New York college student got a loaded Maverick a year early as a graduation present. Then there's a 17-year-old Michigan girl whose Maverick is also a present: graduation from high school! Imagine. Whatever happened to the wristwatch? ★★★

Summary of 1969 Ford Maverick Owners Reports*

Total miles driven1,260,821

Average miles per gallon:

170-cu.-in. Six,
local driving 21.5
long trips... 24.5

200-cu.-in. Six,
local driving 20.0
long trips... 22.6

Specific likes:

Economy 62.0%
Handling 48.2
Style 40.4
Ride 16.8
Comfort 13.8
Size 10.5
Price 8.7
Performance 8.1

Specific dislikes:

Rattles 9.0%
No glove compartment 8.0
Rear visibility 7.4
Vent system 6.5
Workmanship 5.2
Finish 3.1
Trunk space 3.1
Gas mileage 3.1

What changes would you like?

Glove compartment added 20.2%
Rear visibility 9.6

Bigger engine 7.9
Better vent system 6.8
Ashtray location 5.5
Bucket seats 5.1
Styling 4.4

Engine:

170-cu.-in. Six 77.2%
200-cu.-in. Six 22.8

Transmission:

3-speed manual 70.6
Automatic 29.4

Had any mechanical trouble?

No 81.6%
Yes 18.4

What kind of trouble?

Heater 20.0%
Carburetor 14.6
Transmission 10.9
Electrical 9.1
Shift 7.3
Clutch 7.3

Dealer repair satisfactory?

Yes 78.9%
No 21.1

Why the Maverick?

Economy 72.8%
Style 27.2

Size 18.1
Price 5.6
Handling 3.2
Comfort 2.0

Is the Maverick your only car?

No 60.0
Yes 40.0

Other cars owned:

Ford 32.8%
Chevrolet 24.2
Pontiac 11.1
Oldsmobile 6.8
Buick 6.8
Mercury 5.8
Plymouth 5.3
Volkswagen 5.3
Mustang 4.8

What options/accessories?

Radio 71.2%
Whitewall tires 33.7
Oversize tires 22.7
Accent group 11.3
Floor shift 10.0
Cigaret lighter 7.8
Carpet 7.8

Age distribution of owners:

15-29 46.7%
30-49 35.0
50 plus 18.3

*Where applicable, percentages may not equal 100 percent due to rounding and/or insufficient sample.

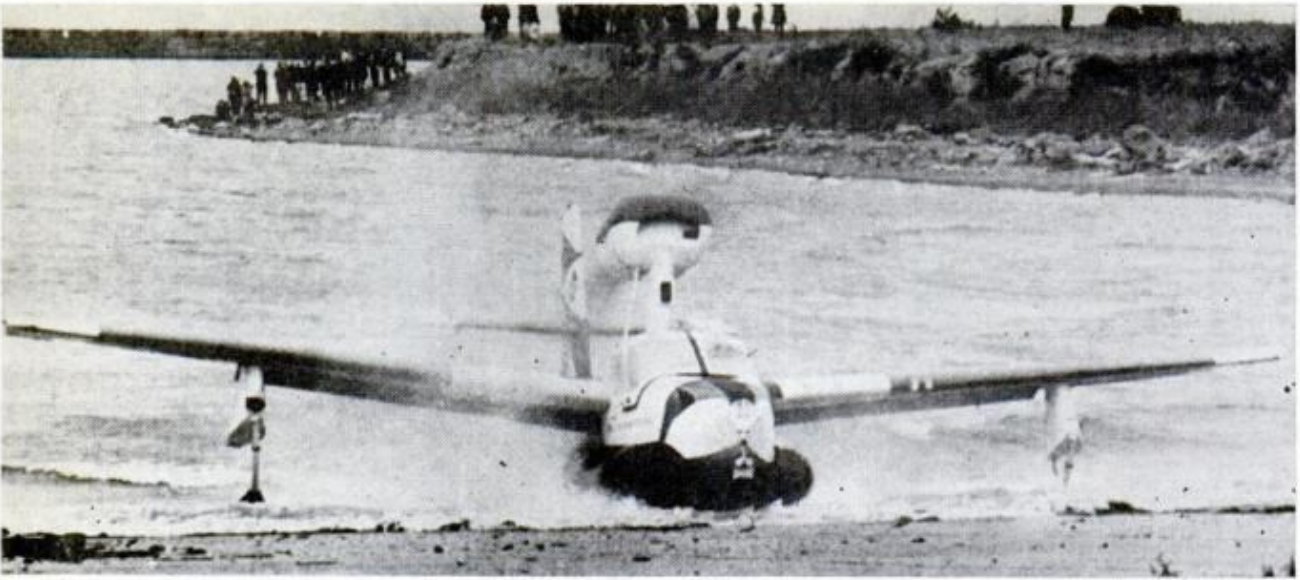

Air-cushion plane operates successfully from water

A Lake amphibian, redesigned with an air-cushion "landing gear," took off and landed in the choppy waters of Buffalo harbor in a recent demonstration. Developed by Bell Aero-systems Co., the air-cushion device consists of a large rubber bag under the plane's belly. A separate engine and fan force air into the bag; the air then shoots out through thousands of jet nozzles, providing the cushion of air. Earlier tests were on land, ice, snow and mud.

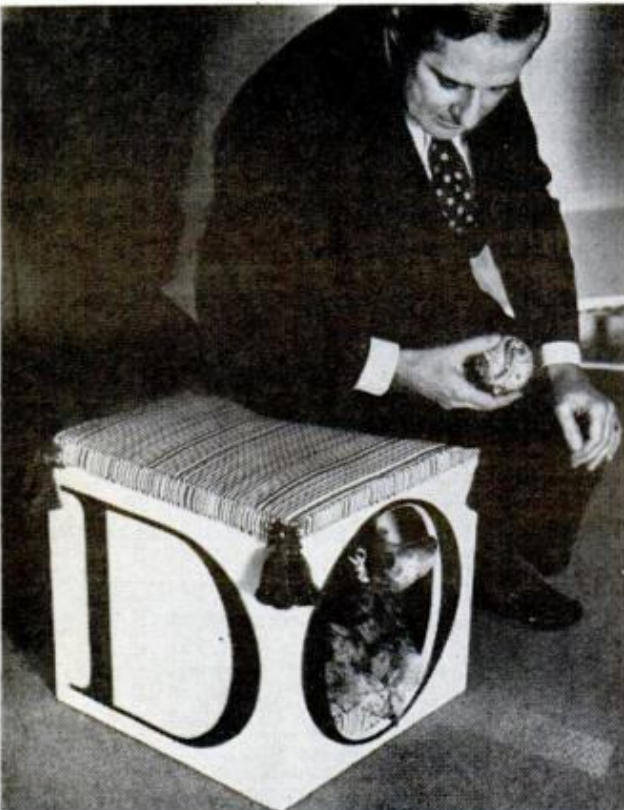

Poshest doghouses in town

Dogs should be housed indoors—and in fancy doghouses that match the decor. That's the contention of James De Vries who operates a New York furnishings shop. He cautions, however, that the dogs should be cocker spaniel size or smaller. Among his creations are a modern one (above) for \$264; a lacquered Ming Dynasty table bed (upper right), \$670; and a wicker one for \$330.



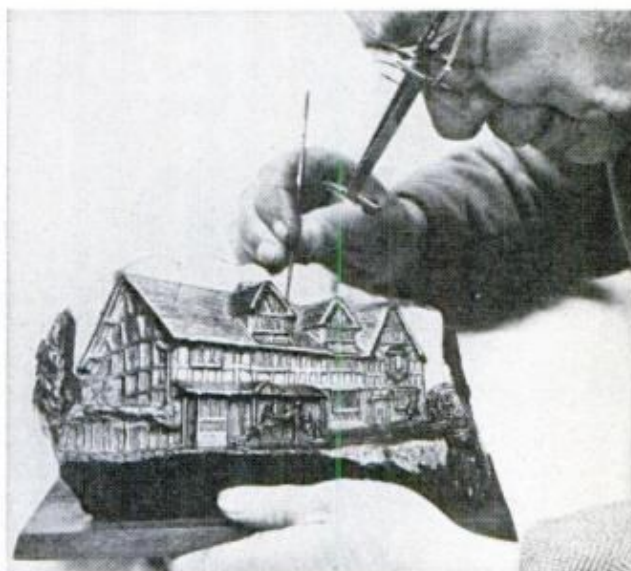

Coal sculptor practices an ancient art

Sculpting in coal, or coal carving as it was called, was a popular art form in northern England in the 17th and 18th centuries. Now, however, there's only one known exponent who has the necessary patience and skill. He's Ernest Holder of Portslade in Sussex. Coal is a difficult medium since it's full of veins and splits, so Holder must select pieces carefully (upper left-hand photo). At upper right, he makes the first cut with a touch that's as skilled as a diamond cutter's. Final polishing is done with emery dust to give the porcelainlike finish apparent in the Napoleon bust and the lion and Tudor cottage carvings.



FASTEST PROP IN THE WORLD

By RALPH L. EMERSON



DARRYL GREENAMYER, 33-year-old Lockheed test pilot, flies such exotic craft as the SR-71 and YF-12A at speeds of 2000 mph and altitudes of 80,000 feet.

But his favorite kind of flying is a few feet off the ground in an obsolete Grumman F8F-2 Bearcat, a 24-year-old fighter developed by the Navy to operate from a carrier. It was in his highly modified Bearcat, the *Conquest 1*, that he set a new world's piston-engine air-speed record of 483.041 mph at Edwards Air Force Base, Calif., in August.

Streaking through the shimmering heat above a dry lake bed at an altitude of about 50 feet while baking in a cockpit that warmed up to 140° and more during runs, Greenamyer made four passes over the three-kilometer (1.86 miles) course—at 510.236 mph, 458.849 mph, 508.458 mph and 454.622 mph—to set the record.

The new speed mark is the result of several years' effort by Greenamyer to crack the long-standing record of 469.22 mph set in 1939 by Luftwaffe pilot Fritz Wendel in a modified Messerschmitt 109R.

Greenamyer's *Conquest 1* is considerably different from the Navy version. For one thing, the entire hydraulic system has been removed except for cylinder rams on the landing gear. At take-off, high-pressure nitrogen blows the gear into raised position; the pilot must yaw the plane to get wheels locked down for landing.

The new 13½-foot propeller—12 inches longer than the original—sweeps so close to the ground that the pilot must take off and land in a three-point position.

When special low-drag wingtips were added (mainly for pylon racing), the wings were cut back 3½ feet on each end. This modification left only 21 inches of aileron. Another set of controls, the landing flaps and related gear,

CONQUEST 1 streaked as low as 50 feet (photo, top left) at speeds up to 510 mph as Darryl Greenamyer set piston-engine speed record. At left, Greenamyer adjusts special, tiny canopy on his converted Bearcat

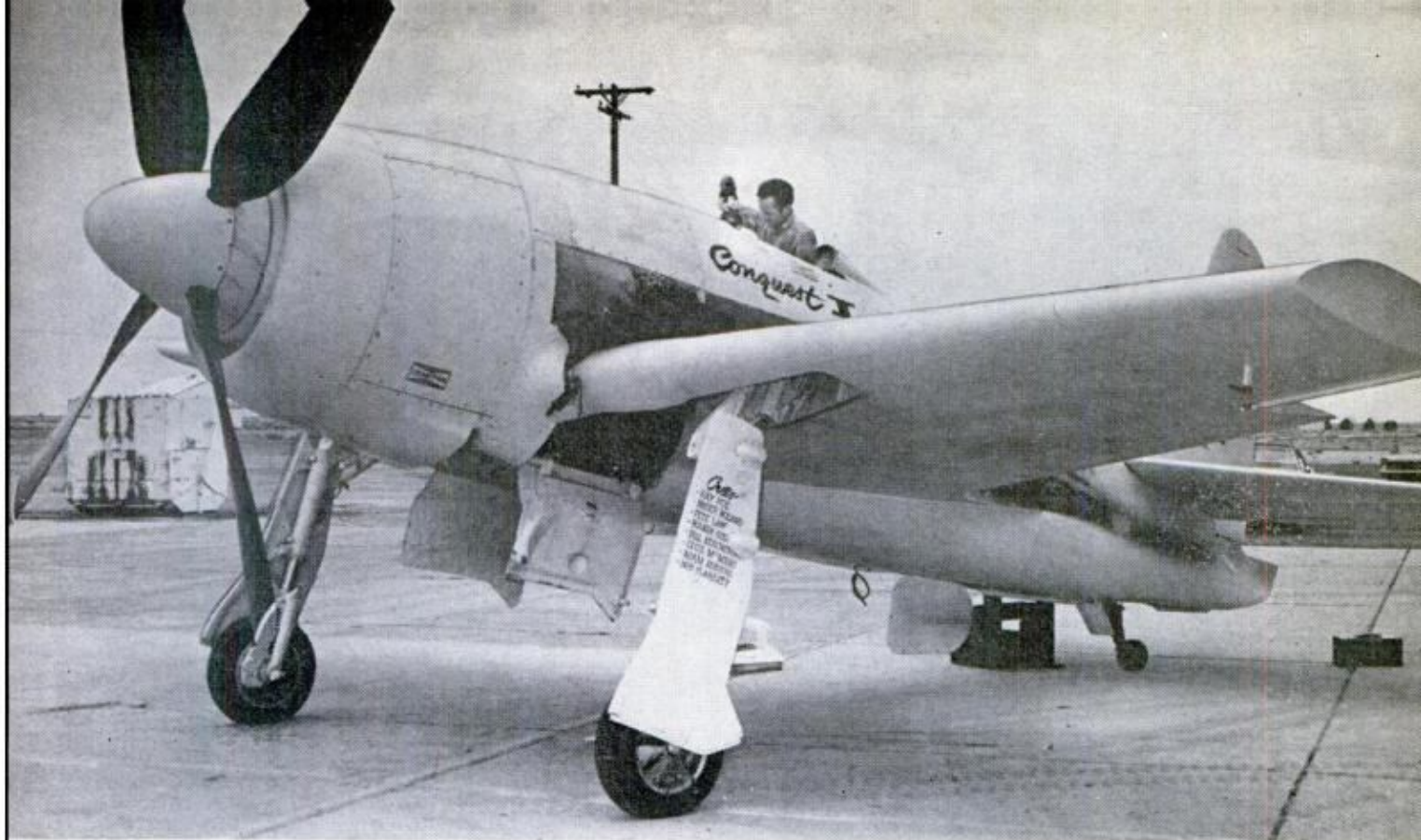

GREENAMYER'S BEARCAT, once a carrier-based Navy fighter, underwent many modifications, including addition of larger propeller and spinner, cutting back of wingtips, closing of air inlets and gunports

were removed to cut the plane's weight.

Other modifications that help reduce drag include the addition of a spinner from a P-51 ahead of the propeller plus an inner spinner from a Lockheed Constellation in front of the engine. The gunports of the fighter were covered, as were the oil-cooler inlets. Now there's a heat exchanger located behind the cockpit to cool the oil.

The engine is a Pratt & Whitney R-2800 Wasp. Fuel is 145-octane aviation gas with a combustion improver raising the effective octane to 180. ★ ★ ★

PRETTY GROUND 'CREWMAN', Sue Johnson, scrubbed plane before it was waxed for speed attempt. Paint here was burned away by extreme heat of exhaust

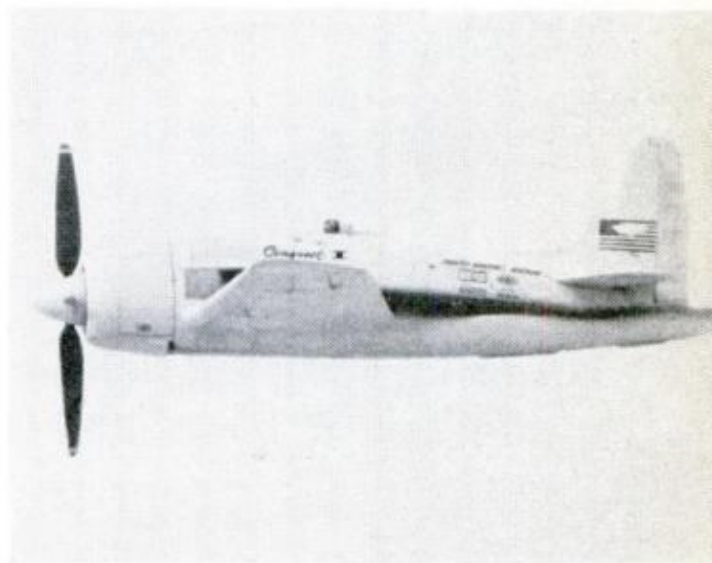

HUGE PROP appears to stand still in high-speed photo (above). It barely cleared ground (below) as crew turned engine to make sure cylinders were clear



TRACK-TESTING DODGE'S NEW PONY CAR

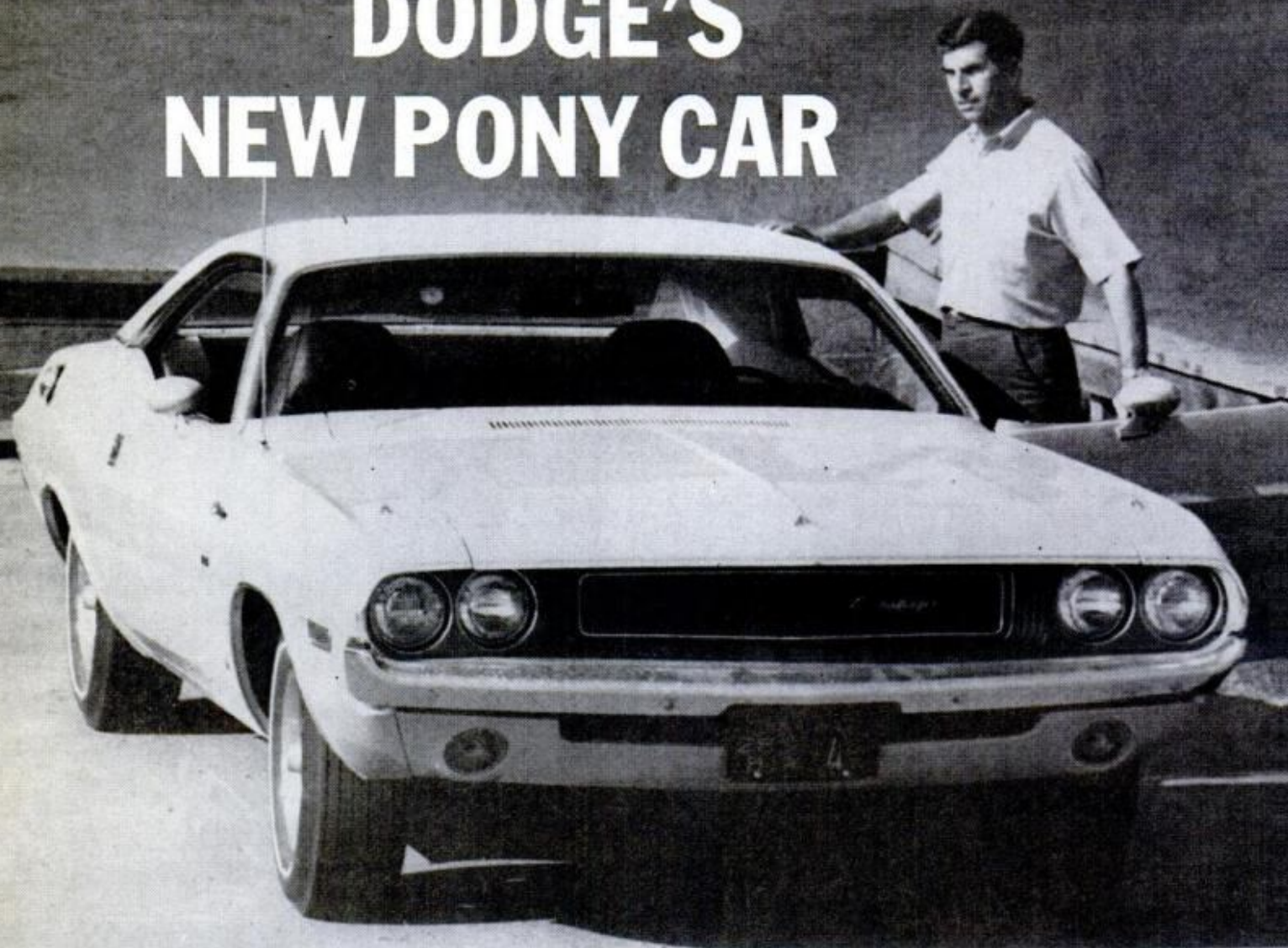

Racing star Paul Goldsmith puts the new Challenger through its paces and reports there's a lot to like

By PAUL GOLDSMITH

ACTUALLY, I'm new at this road-test business. But on the other hand, I subconsciously test every car I drive. Whether it's a rental from the airport in a strange town, or my own Grand National stocker, I just naturally pick out little things I like or dislike every time I fire up and head out.

I had to join the jet set to test the Challenger because the only one suited for the purpose was in Southern California. You can bet I didn't mind that, so the day after Richard Brickhouse brought my new Daytona Charger home the winner in the inaugural Talladega 500, there I was in Los Angeles, sampling a brand-new car.

My first reaction to climbing behind the steering wheel of this 340-CID V8-engined car was that it just didn't seem like a so-called "pony car." The hood length was just too much, or so I thought. One reason for this is that the hood comes back and over the windshield wiper arms. Those wipers are really hidden. The rear lip of the hood sweeps up an inch or two and the gap for the wipers to move through isn't great, meaning there shouldn't be a lot of snow caught there. This, of course, is a guess on my part, but I'm no stranger to snow and the troubles



THE CHALLENGER proved quick off the dime, my 0-60-mph times being respectable at under seven seconds

that it can whip up in a hurry on the highway.

Once out and moving on the roads of southern California, the car impressed me with its unusual quietness. Later I discovered why. It's all due to some very interesting engineering. That wiper-hiding hood is one contributor. Air hits the steeply angled windshield without contacting any chrome trim or other obstacle that could set up buffeting. The chrome trim around the top and sides of the front glass is flush, eliminating any catch spots. The car I tested had a vinyl roof cover that fills in the front "A" pillar, making it a flush panel from windshield to drip rail. There just isn't a rough spot anywhere along the way. These are wind-cheating tricks we've used for many years in stock-car racing, and it's obvious Chrysler designers have been doing more than just watching races when they come to the track. In fact, the Challenger is pretty slippery all the way to the rear end—side glass is smooth and curved inward at the top, door handles are flush and the tail is chopped off clean with a minimum of overhang.

The only offender to the good wind shape is the grille—the worst possible spot for a poor air shape. At the center, it is seven inches inset and all the frontal air is caught under the nose of the hood. At very, very high speeds this can cause lift. The front valance panel (below the bumper) is angled rearward, which isn't in good race-car tradition. It should be more blunt, or, better yet, angled forward at the bottom to keep air from passing beneath the car. But then I'm looking at this from a racer's viewpoint. As a passenger car, this front end isn't about to cause any trouble. The Challenger's present good

DECEMBER 1969



FLUSH-MOUNTED WINDSHIELD is one of several wind-cheaters on the Challenger



FUEL-FILL PIPE on Challenger offers optional lock, is located on right side



TRUNK surprised me with its roominess, thanks mainly to collapsible spare tire



GOT IT HUNG OUT a little bit here, a condition I had to induce as the Challenger tends to stick well



I REALLY SLAMMED Challenger around, became convinced it's at home on open road or in switchbacks

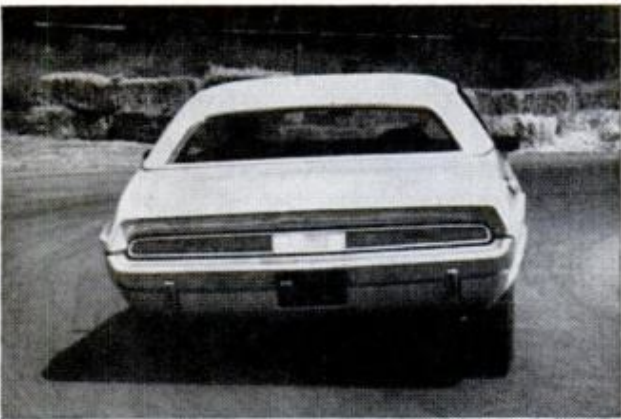

BODY LEAN is at a minimum in hard cornering, yet stiffer springs don't give a feeling of a rough ride



ONLY OFFENDER to overall fine wind shape is grille, inset of which catches frontal air under hood nose

front-end appearance would probably look pretty bad if they made it the way I wanted them to.

If you've ever ridden in short-wheelbase cars, you're aware of how choppy the ride can be sometimes. I expected a bit of this from the 110-inch-wheelbase Challenger, but found none. My test car had rallye suspension, wide-rim wheels and F70-14 tires (which look like they're for a much bigger car). I found it one of the smoothest driving and riding cars I've ever experienced. I don't like really soft riding cars, but the other extreme isn't any better. This one showed no up-and-down action over washboard surfaces, no airborne tricks when crossing railroad tracks, no kidney-jarring shocks, and never a trace of a too-firm ride. Some carmakers make the mistake of putting high-rate springs on their cars so they can call them performance models. That's not the real answer. It takes a correct combination of firm

springing and good shock absorbers as well as a firm front-stabilizer bar. I'm sure the suspension I tested could be made race-ready with just stiffer front torsion bars added. A sturdy rear-stabilizer bar and adjustable shock absorbers would guarantee the car a spot on most starting grids.

This may sound a little far out, I know, but I had a chance to really drive the car. I pushed it so hard through some of the turns at Orange County International Raceway, I was sure the California landscape was going to bear my tire tracks, but the car never left the pattern I set. The result of my race-like driving is a solid endorsement of this Challenger model as an outstanding highway and twisting road car. It's highly predictable, very stable and sure handling.

I've noticed in most Chrysler-made cars over the years that the front wheels don't always care to stay in a



MY TEST CHALLENGER caught admiring looks wherever I went with it. I think it's a sleek, sporty-looking car

straight line ahead without the driver keeping his mind and hands concentrated on the wheel. This isn't necessarily bad, but the Challenger is a bit easier to handle in this respect. It seems as though Dodge has added more caster to the front wheels, allowing them to run straight without too much action in the steering department. Caster is the degree of king-pin inclination in relation to a vertical line perpendicular to the ground. The more caster, the more easily the wheels will run in a straight set course. The less caster, the easier it is for the wheels to move "off-center." Dragsters, for example, have a great deal of caster so the driver doesn't have to make too many corrections. But they have so much caster that the front wheels won't return to a straight-ahead attitude without a lot of struggling. The Challenger setup is a happy medium—no effort with wheel control in any position.

The test car was built with a relatively low rear-axle ratio of 3.90 to 1, which is a good choice for in-town driving or for weekend use at a drag strip. However, mileage suffers because engine speed is rather high at expressway speeds. Constant high-speed running calls for something less, like a 3.23 or 3.50 to 1 ratio. With a four-speed transmission linked to the potent 340 engine, my test car cut 0-60-mph times in less than 7 seconds, and quarter-mile

elapsed times in the 14-second bracket, both very respectable. If you want good performance, make sure such a car has a Sure-Grip differential. It also makes for safer driving in bad weather.

After a couple of hours of wringing it out, I took particular note of the Challenger's interior room. There's lots, especially up front. The back seat is a bit tight for six-footers, but I wouldn't object to riding there providing it wasn't for a long time. The front bucket seats are very comfortable, with head restraints being a part of the seat backs. They reminded me somewhat of a jet aircraft pilot's seat. I'm not sure what they call the six-way adjustable seat setup my test car had, but my helmet's off to the man who dreamed it up. It's a manual adjuster that allows up, down, tilt forward or rearward positioning, plus the regular fore and aft adjustments. It doesn't cost much, and it'll very definitely be in my next car. If it happens you run out of front leg-room, chances are you should be playing for the New York Knicks.

Steering-wheel position is low, which I like, because the top of the rim doesn't interfere with forward vision. The wood-rimmed wheel in this particular Challenger had a rim-blow horn. The horn ring is buried inside the inner rim and can be operated at any point around the wheel. Neat idea,

(Please turn to page 196)



Add-on shipbuilding produces unusual vessel

When you want a bigger ship, you simply graft two smaller ones together. At least that was the technique employed by a shipyard in Slikerveer, Holland, when it produced this unusual "coaster" with three prows and two sterns. Starting with two 15-year-old coasters (shallow-draft vessels capable of carrying heavy loads), the firm welded them together and then added further cargo space in the center, plus a third prow.



Quiet motorbike

A battery and starter motor added to a standard bicycle by Edward Roy, Largo, Fla., turned the vehicle into a silent, smooth-operating motorbike. Power from the 9-volt starter motor is transmitted to the front wheel by a spool-shaped fiberglass roller that is lowered onto the front tire.



High-speed office

A British designer has turned this car's interior into an office on wheels. Equipment includes a radiotelephone, TV, dictaphone, typing desk, file cabinet and food cabinet.



WATER JETS (above) spaced on slope make "snow" more slippery. Lift (below) takes skiers to the top



EXPERT SKIERS can reach speeds of 50 mph on the 180-meter slope. There are also slopes for beginners



BATHING SUITS are standard attire in the 90° heat, and there's a pool at the foot of the slope (below)

Skiing without snow

It's white, powdery, slippery and great for skiing. It looks like snow and feels somewhat like snow—but it's not. It's quartz sand, and that explains the appearance of bikini-clad skiers on the slopes under a hot summer sun. A large china factory at Hirschau, West Germany, produces 1000 tons of the sand daily as a waste product. Now the "dump"—formerly an eyesore—has become the center of a ski resort. The sand mountain, made up of some 10 million tons of the stuff, stands over 350 feet high.



Just patented

PM'S PICK OF THE NEW INVENTIONS

Prepared in cooperation with Roger S. Shashoua, Director, International Inventors Assn., Inc.

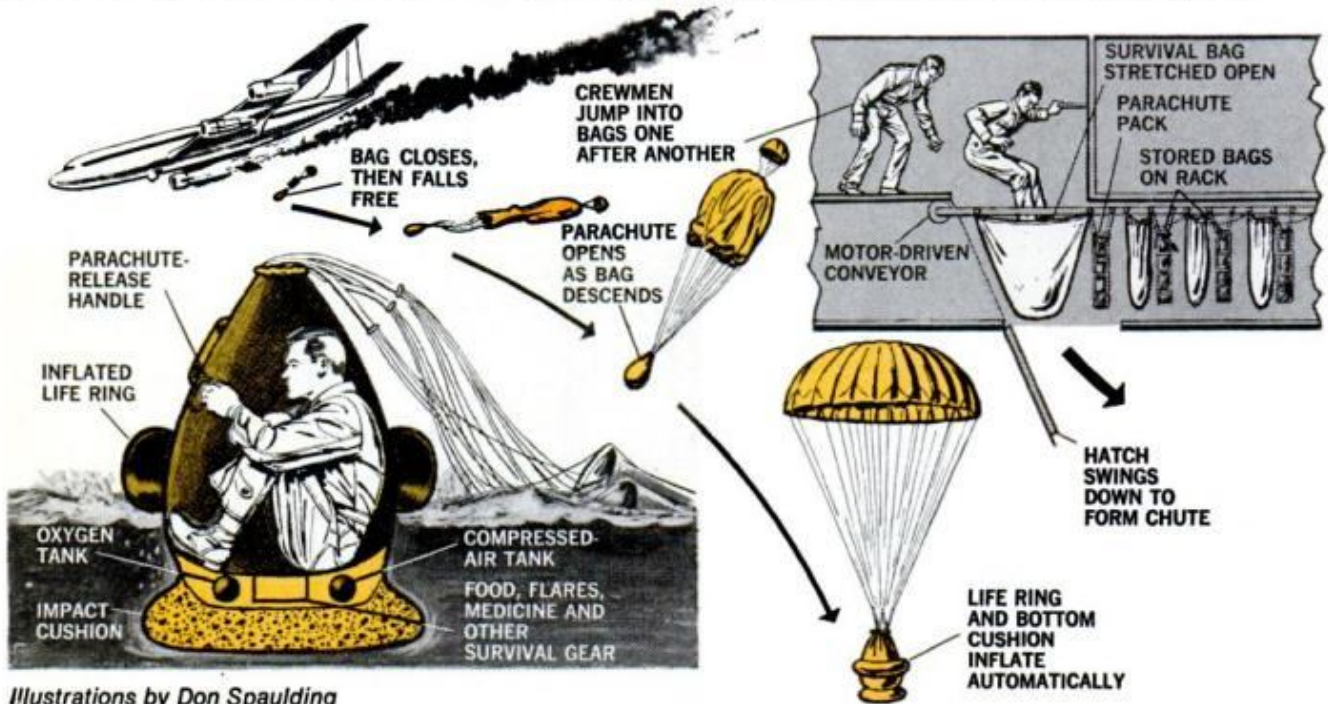

Illustrations by Don Spaulding

1. INSTANT ESCAPE SYSTEM for crewmen bailing out of a disabled aircraft eliminates the need to wear or put on cumbersome parachute packs and other survival gear. In an emergency, a trap door opens and each man merely jumps into a bag stretched across the opening. This trips a release, causing the bag to drop clear of the plane. As it falls, the top is drawn closed over the airman's head and a

parachute pops out. On the way down, a buoyant life ring and an air cushion on the bottom inflate automatically. The cushion softens the impact if the bag comes down on land and the life ring supports it in water. Once down, the bag also serves as an emergency shelter until rescuers arrive. Food, medicine, chemical heaters, flares and a radio are stored in a compartment in the bag's floor

2. AUTOMATIC FOCUSING for cameras is the object of the ingenious invention below. A tiny, high-intensity light is aimed at the subject and reflected back to the camera. A pivoted photocell linked to a motor-driven eccentric swings rapidly back and forth, scanning the scene for the reflected light. At the same time, the eccentric also racks the lens elements in and out, constantly changing the

focus. At the point where the photocell picks up the strongest reflections from the subject, it triggers a solenoid switch, stopping the motor. Since the angle of reflected light depends on how far away the subject is, this stops the lens at the point of correct focus for a subject at that distance. The light goes out as you snap the picture, then it comes on again, ready for the next shot

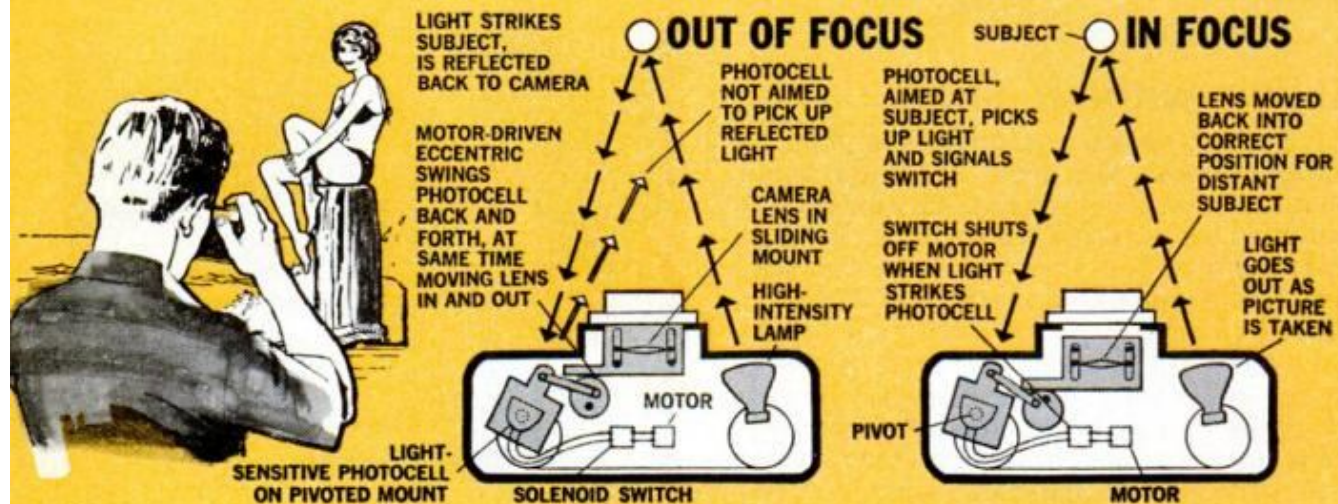

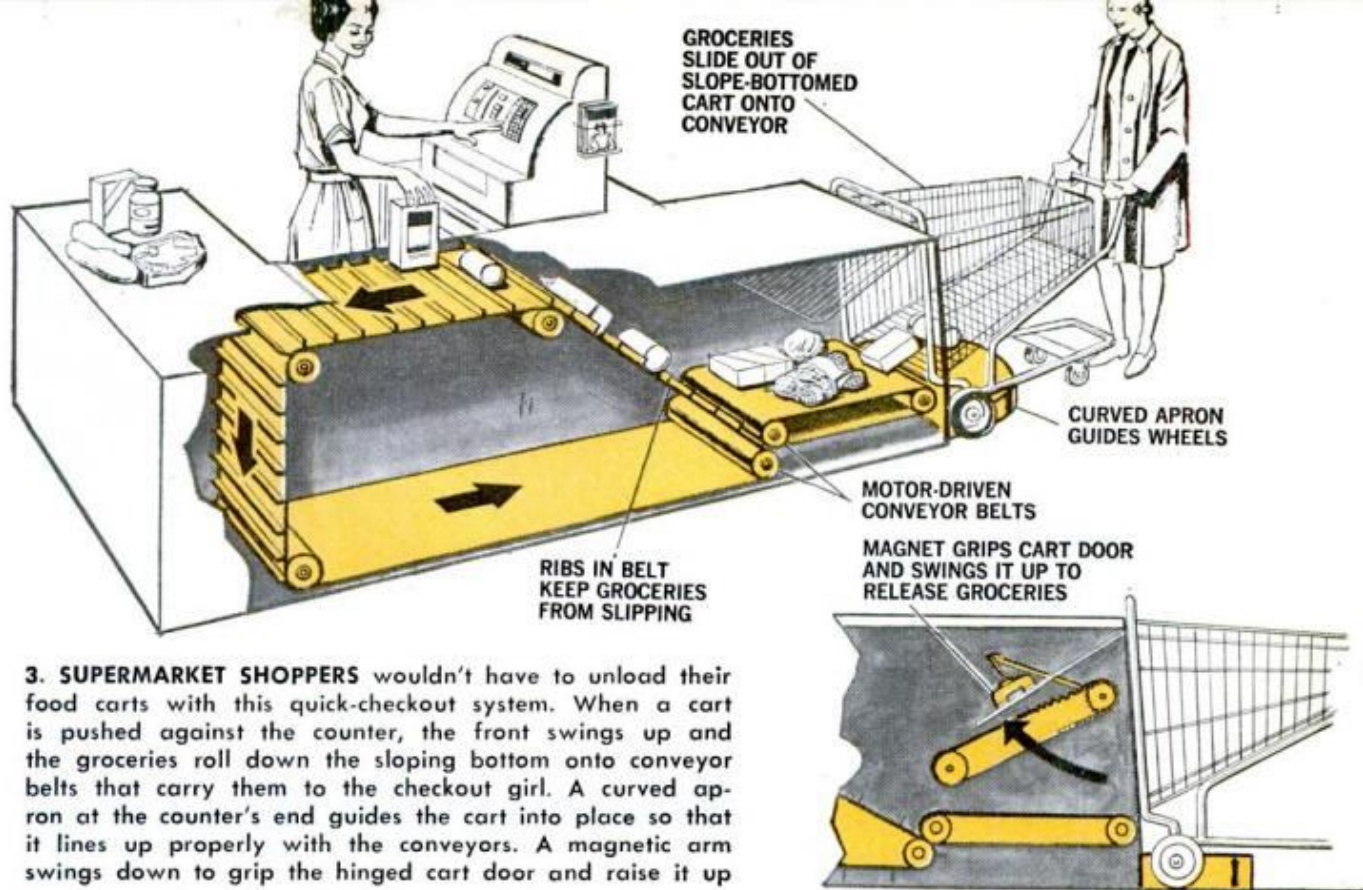

3. SUPERMARKET SHOPPERS wouldn't have to unload their food carts with this quick-checkout system. When a cart is pushed against the counter, the front swings up and the groceries roll down the sloping bottom onto conveyor belts that carry them to the checkout girl. A curved apron at the counter's end guides the cart into place so that it lines up properly with the conveyors. A magnetic arm swings down to grip the hinged cart door and raise it up



4. ONE LEG DOES THE JOB OF TWO in this interlocking arrangement for sectional furniture. One half of the leg slips into a groove in one section and the other half locks into a similar groove in an adjacent section, joining the two firmly together. The single leg looks trim, keeps the sections from slipping apart and permits shipping furniture without the legs attached, eliminating the chance of their breaking off

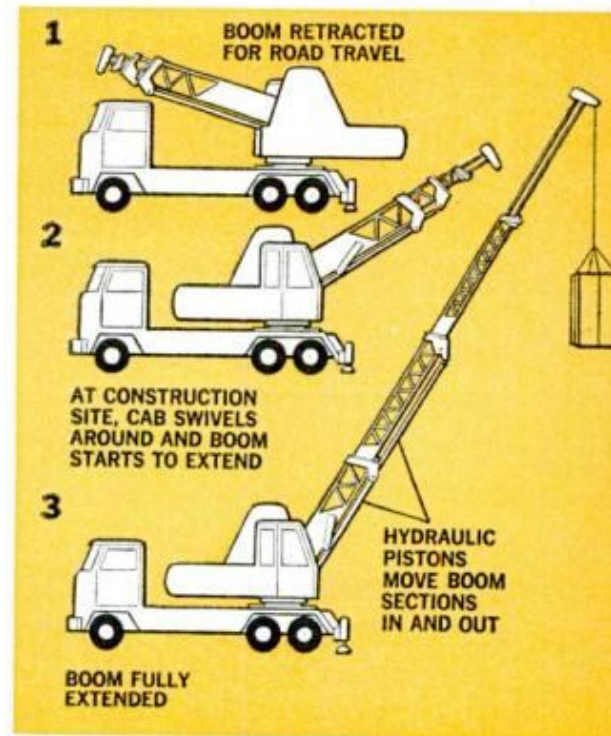

5. TELESCOPING BOOM on the crane above can place a load more precisely because it can vary its length as well as its angle of tilt. It's also safer than long fixed booms since it can be shortened for unusually heavy loads to avoid buckling. For road travel, the boom is simply retracted and it need not be folded or dismantled as with conventional booms

Inventors of the items shown on these pages are as follows 1. Robert G. McIntyre, Manhattan Beach, Calif. (No. 3,438,601); 2. Armin B. Pagel, Janesville, Wis. (No. 3,442,193); 3. Harold J. Ruttenberg, Pittsburgh, Pa., and Garth Close, Lubbock, Tex. (No. 3,437,176); 4. Henry P. Glass,

666 Lake Shore Drive, Chicago, Ill. (No. 3,033,635); 5. Lyle D. Grider, New Berlin, Wis., and Gottfried Reuter and George W. Mark, South Milwaukee, Wis. Roger Shashoua can be reached at the International Inventors Assn., Inc., 680 Fifth Ave., New York, N.Y. 10019



First of a Great New Breed

Slated to start service this winter, Boeing's giant jet will carry more passengers — up to 490 in all — and more cargo than any airliner in history.

By JOHN F. PEARSON, Science Editor

EARLY NEXT YEAR A NEW PLANE WILL ANGLE across the busy sky over Kennedy International Airport. It shouldn't be hard to spot, for it's sure to be the single biggest object cutting through the New York smog. The plane is the Boeing 747, newest and largest airliner in the world, capable of carrying as many as 490 passengers. Sporting the blue and white livery of Pan American, it will be configured to carry 362 and be bound for London and Frankfurt on its first commercial flight.

The 747 is the first of a new breed. It is *not* America's answer to the French-English Concorde or Russia's TU-144, needle-nosed supersonic darts now being tested. Rather, it is a bigger, faster, more stable, more comfortable version of today's subsonic jets.

But that ho-hum description doesn't do the 747 justice. It's an exciting plane, even awesome and majestic. That's the impression I came away with after two days of examining test planes and those in various stages of completion at Boeing's huge facility north of Seattle. Stand toward the rear of a 747 and you have to bend your head back to see the top of its tail, which juts as high as a five-story building. You walk under wings that stretch almost 200 feet from tip to tip, and look into engine intakes eight feet in diameter, more than big enough to permit Wilt Chamberlain to stand inside wearing a top hat. The craft is so big and solid-looking that you wonder how it can be supported by anything as insubstantial as air.

But fly it does, and very well. On takeoff you notice that it is quieter than current jets and that the engines are almost smokeless. Despite its bulk, the 747 requires even less takeoff runway—about (*Text continues on page 111*)

PRATT & WHITNEY AIRCRAFT JT9D TURBOFAN ENGINE

Thrust: 43,500 pounds

This high-bypass engine is more than twice as powerful as its predecessor, the JT3D. Advanced design concepts make it virtually smokeless and quieter than current engines.

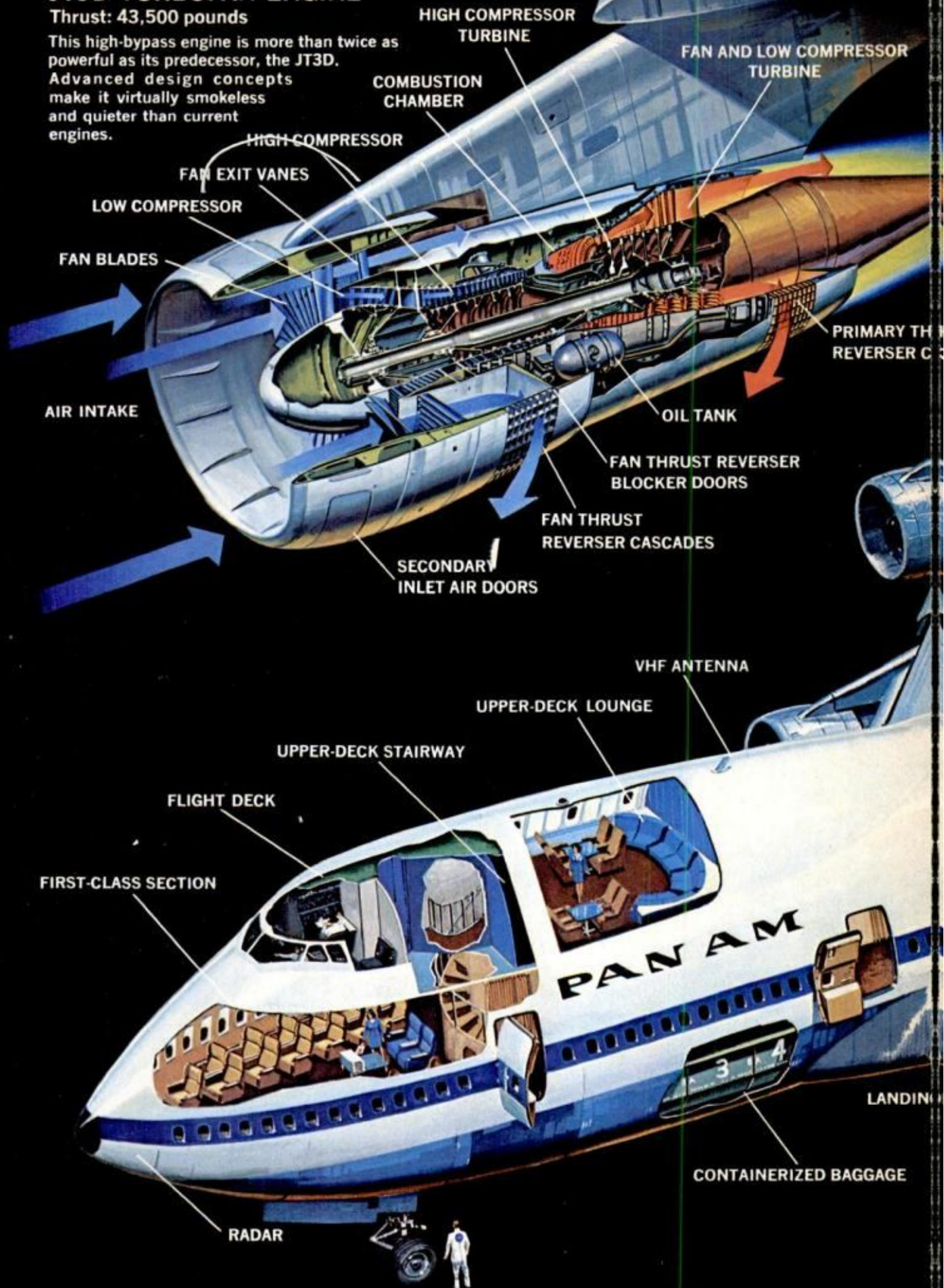

Art Concept Created for Popular Mechanics by Ed Valigursky, Fred Wolff, Howard Schafer, Roger Metcalf and Peter Trojan.

Материал, защищенный авторским правом

ing, used in a greater proportion in the 747 than in any previous airliner. Aluminum honeycomb is also used.

The 747 can operate from runways used by the 707 and the DC-8. This capability is due, partly, to high-lift devices in the wings. Flaps on leading and trailing edges add to wing area and direct the flow of air so as to give the plane increased lift as it speeds down the runway.

The engines also do their share. The big bird has four Pratt & Whitney JT9D turbofan units that are each capable of producing 43,500 pounds

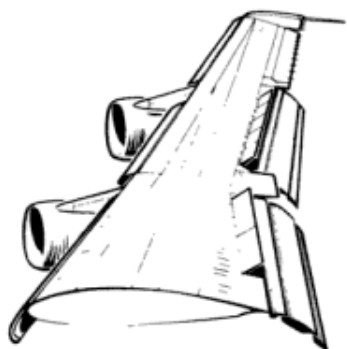

thrust, more than double that of the JT3D on the 707. Though the JT9D has an intake almost twice the diameter of the JT3D, it is six inches shorter than the latter and more efficient. Design advances in the combustion and compressor sections make the difference. Because individual compressor stages, for example, produce higher pressures than achieved in earlier models, fewer such stages are needed. Growth versions of the engine, with thrusts up

to 47,000 pounds, are in the works.

Research also has achieved a quieter engine. By lowering jet-exhaust velocity, engine roar was lessened; the elimination of inlet guide vanes (stationary inlet struts) and a reduction in the speed of the fan at the front of the engine minimized the ear-splitting siren sound that is characteristic of turbofan engines. In addition, sound absorbent material was installed in the engine cowling, ahead of and behind the fan.

The 747's maximum cruise speed is 625 mph, a 10 percent increase over the 575 mph of the 707. Thus, flight time from New York to London will be reduced to 5 hours and 45 minutes, slicing 30 minutes from current schedules. The 747 is rated for flying at 45,000 feet.

When Pan Am's first 747 leaves Kennedy for London, passengers can rest assured that they are aboard the most thoroughly tested plane in the history of commercial aviation.

In addition to laboratory tests of separate parts and components, two complete airframes were used for static and fatigue tests. In the static tests the airframe was subjected to stresses and loads far in excess of those experienced in airline service. In the fatigue testing program, the airframe was subjected to repeated operation of its flight controls and cabin pressurization systems. The equivalent of years of operation was compressed into months. The goal of these programs was to prove an airframe life of 60,000 hours for the 747—the equivalent of 15 years of normal operation.

In another major phase of the test program, Boeing built a full-scale operating replica of the plane's flight control systems. This "iron bird" precisely duplicated the operation and responses of the 747's controls, enabling engineers to refine the systems well ahead of installation in the first plane and giving test pilots a chance to get the "feel" of the controls. Finally, five of the big jets were flight-tested for some 1400 hours. ★★★



First of a Great New Breed *(Continued)*

10,000 feet—than some current craft. It will be able to operate from runways now used by 707s and DC-8s. This capability derives from high-lift devices built into the 747's wings and from turbofan engines that individually develop a thrust of 43,500 pounds, more than twice that of the turbofans on the 707. (For more technical information, please see the accompanying foldout.)

"It would have been impossible to build this plane 15 or even 10 years ago," says Brien Wygle, Boeing's assistant director of flight operations. "We now know more about stability and how to attain it without excessive structural weight and complexity. And we know much more about how to control a plane."

The 747 is simply too big to control manually. Since there are no manual controls to fall back on in the event of a power-assist system failure, Boeing has put in four independent hydraulic systems to actuate primary controls. In test flights, the plane has been flown with three of the systems shut off.

After his first flight, Jack Waddell, 747 project pilot, commented: "The plane is ridiculously easy to fly. It almost lands itself."

But before that fact was established, there had been concern expressed by officials of airlines, the Federal Aviation Administration and Boeing. "The question was," says Wygle, "whether a pilot could manage a plane this big with the same margins that he has had in past airplanes. Well, the evidence that we have gained from flying the 747—and this includes not only our experience but that of FAA, military and other non-Boeing pilots—is that it is as easy to operate as other planes. We've had nothing but good landings out of people on the very first try."

The plane exhibits exceptional stability in flight, say test pilots. Its weight and aerodynamic qualities made it less sensitive to gusts and turbulences than smaller jets.

The cockpit, which occupies part of a short top deck, bristles with electronic gear, about \$1 million worth. (A complete plane, if you're in the market, costs about \$20 million.) In addition to such more familiar equipment as radar scope, radio compass, autopilot, altimeter and so on, the 747 is the first plane to have an inertial guidance system (INS) as standard equipment.

The INS is similar to that used for navigation on Polaris submarines and the Saturn moon rockets. One of its main advantages is that it needs no outside signals. Key elements in the system, a piece of hardware no larger than

The cockpit . . . bristles with electronic gear, about \$1 million worth

a standard file drawer, are a precision inertial reference unit and a digital computer.

In the reference unit, gyros and accelerometers are mounted on a platform set within gimbals that allow it to turn in any direction. Spinning at 24,000 rpm, the gyros stabilize the platform to a known, fixed reference, such as the latitude and longitude of an airport. Whenever the plane strays off course, the gyros give off an error signal.

The starting point and a series of waypoints are fed into the INS before takeoff. The system's computer calculates the shortest course from waypoint to waypoint, and finally to the destination. When connected to the autopilot, the INS actually flies the plane, leaving the pilot free to monitor a continuously updated control and display unit.

Boeing pilots and engineers stress the fact that the 747 is the end result of a steady evolution, incorporating all the technical improvements initially used in the 707, 727 and 737, plus some new ones. Boeing first started thinking "big"

(Please turn to page 188)

NEW IN ELECTRONICS

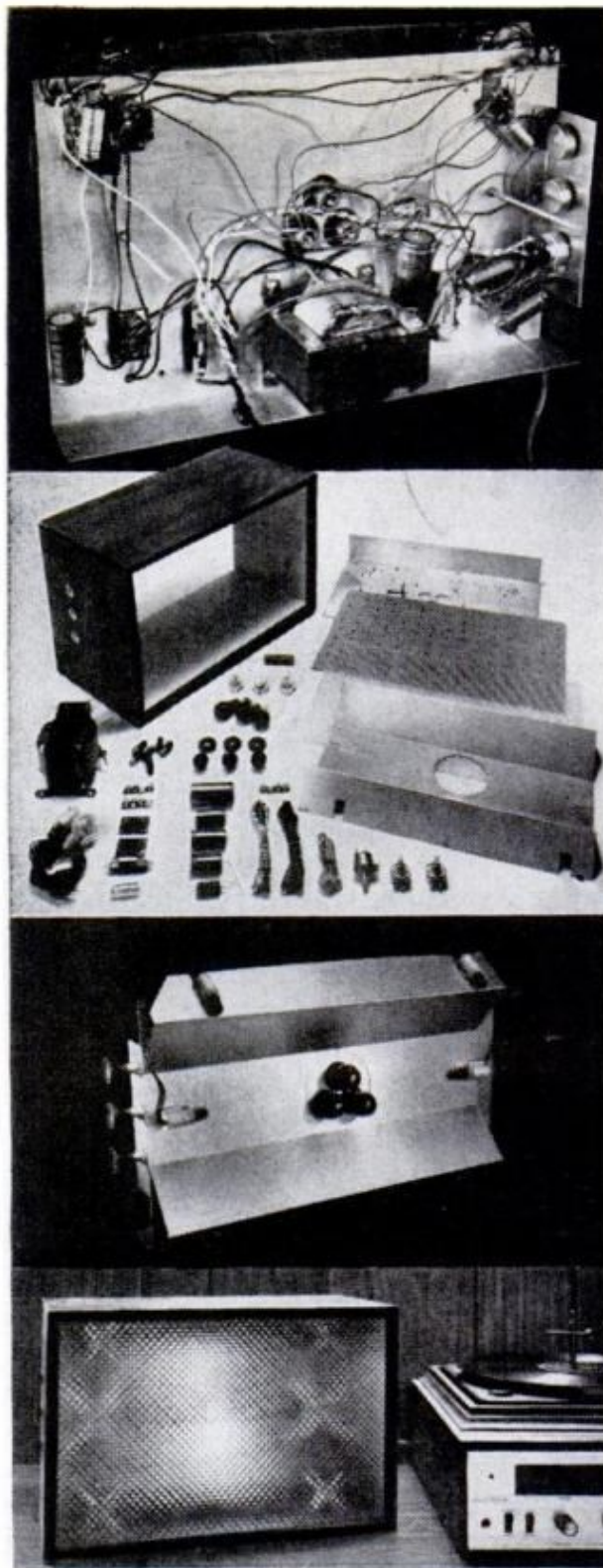
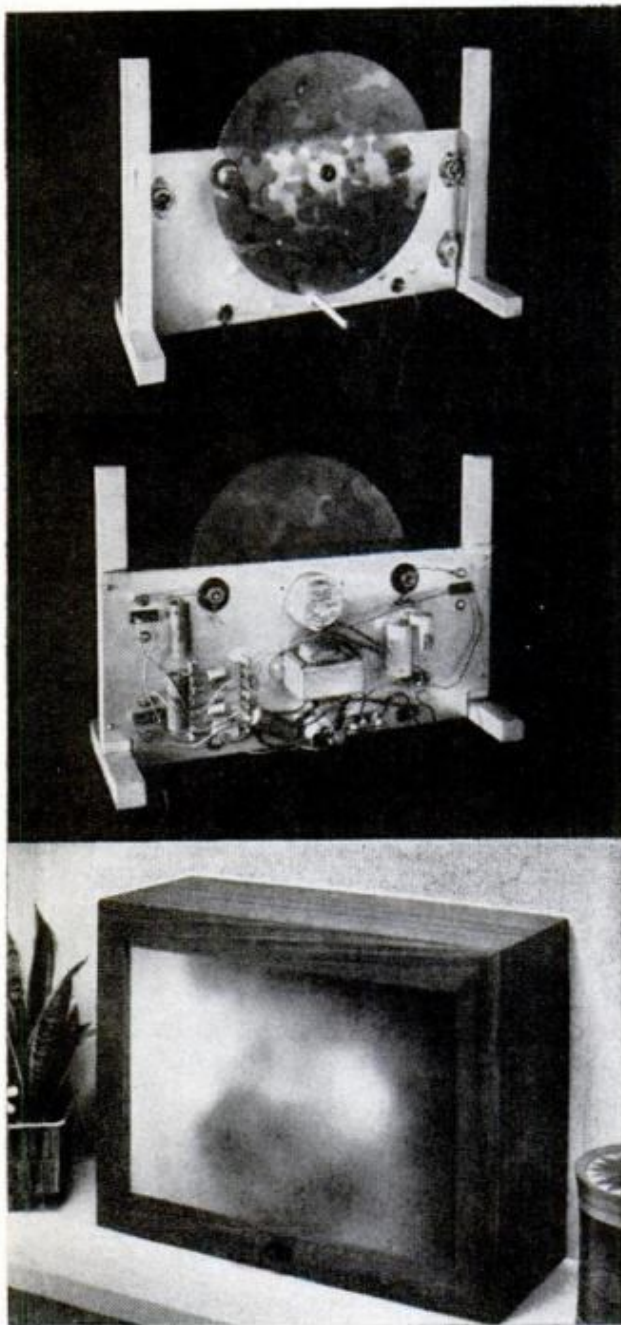

Two Psychedelic Lights You Can Build From Kits

If you've been intrigued by those wild colored lights that dance in time to music, here are two you can assemble yourself. They work on different principles, but produce similar effects. The Conar model at left uses a rotating color wheel backed by two white lights that pulse on and off with the music's beat. The flashing lights and turning wheel give the appearance of changing colors on a translucent screen. The Eico model at right has no moving wheel, but uses different-colored lights in a metal reflector. The lights not only

flicker in time to the music, but different colors flash on and off depending on the frequencies of the notes played. The result is an eerie, ever-changing pattern of pulsing colors. The Conar unit sells for \$44.95 in kit form and \$54.95 assembled. Conar, 3939 Wisconsin Ave., Washington, D. C. The Eico is \$49.95 in kit form and \$79.95 assembled. Eico Electronic Instrument Co., 283 Malta St., Brooklyn, N. Y. Each runs on house current and needs but a simple connection to the speaker terminals on any radio or phonograph.

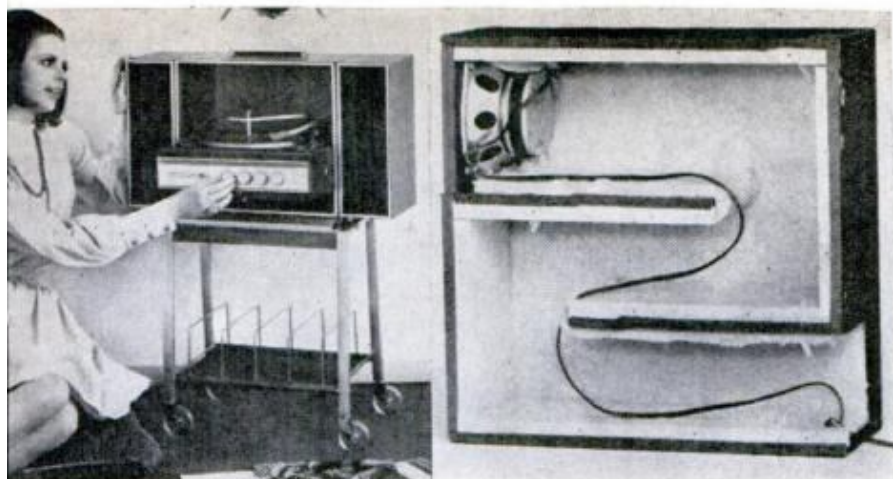

BIG SOUND from small speakers is the object of a new speaker enclosure developed by Admiral for its 1970 line of radios and phonographs. The speaker is mounted in a tall, thin box with a labyrinth of baffles forming a long, resonant tunnel. This reinforces low frequencies, providing a deep, rich base. With a 4-in. speaker, frequency response is from 15,000 cycles down to 30. The result is better sound for portable and table models that, due to size, are limited to tiny speakers.

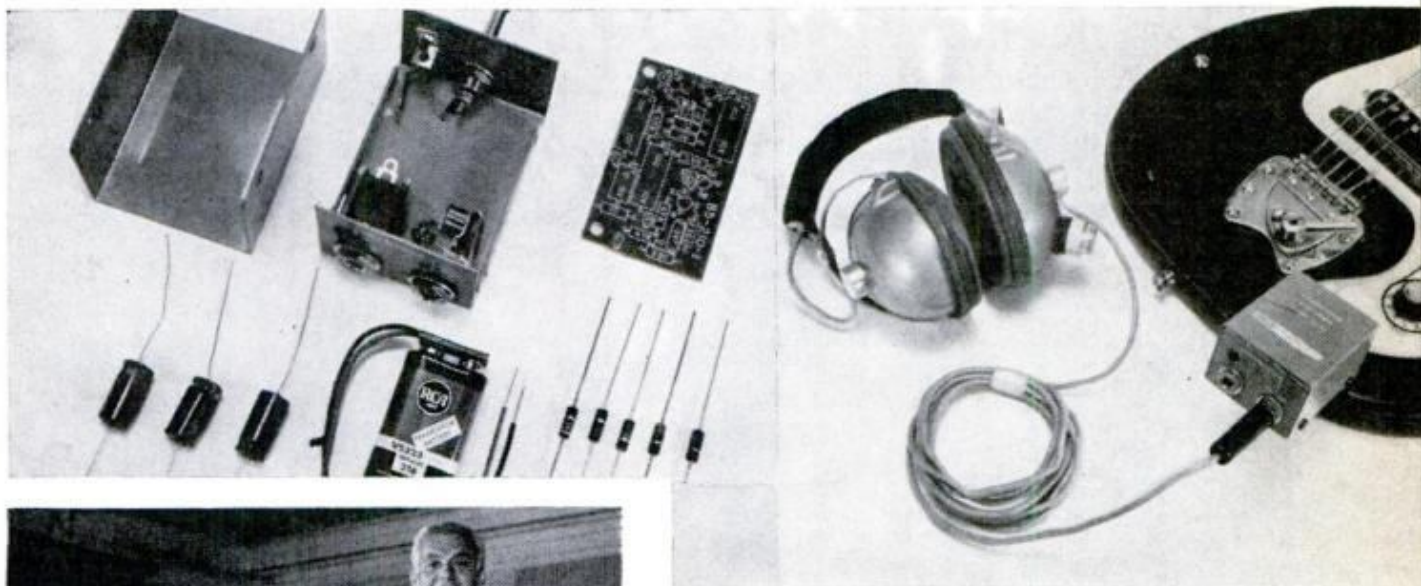

YOU CAN HEAR YOURSELF play an electric guitar with this tiny amplifier and a pair of headphones. The idea is to permit quiet practice sessions that won't disturb others. The battery-powered device plugs into the guitar's input and has two phone jacks. It's \$9.95 in kit form from Heath Co., Benton Harbor, Mich.



YOU DON'T GO ANYWHERE, but you can tell how fast and far you're traveling with this electronic jog meter. As you jog in place on a mat, the rate shows on a dial so you can maintain a steady pace. Device permits indoor jogging in bad weather or city apartments. \$120. Central Quality Industries, Polo, Ill.

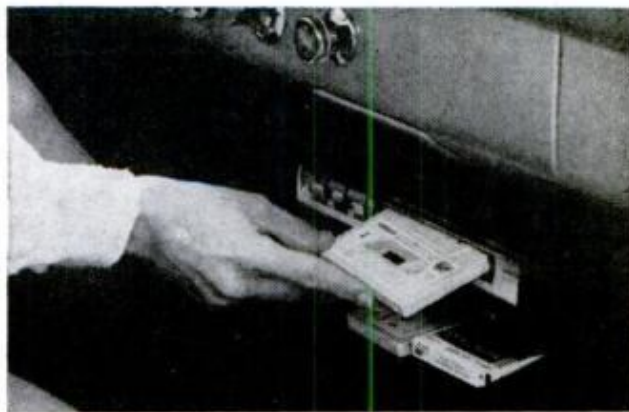

ADDING TAPED MUSIC to your car is easy with this cassette unit designed to mount under the dash. It plays stereo, records monaurally and has a handy lower shelf for extra cassettes. Price is \$119.95. A similar playback-only model is available for \$99.95. Ampex Corp., 2201 Estes Ave., Elk Grove Village, Ill.

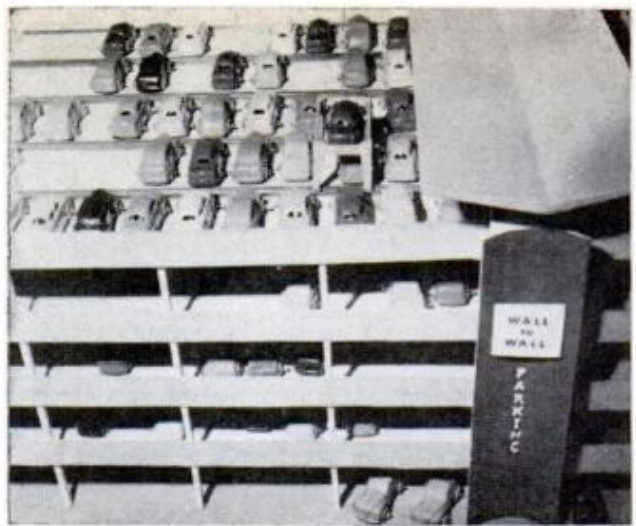
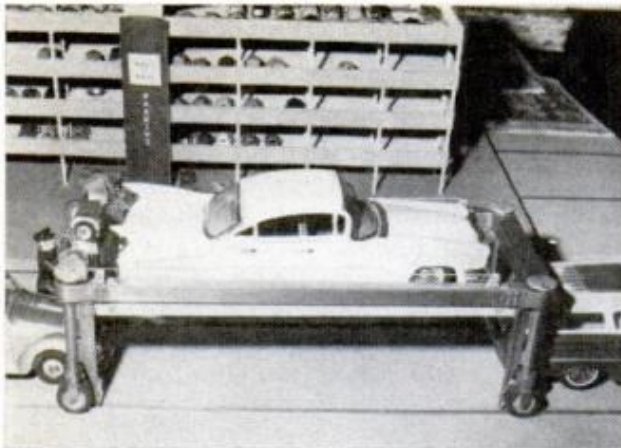

Parking machine would pack cars 'wall to wall'

This model illustrates engineer Glen Diehl's "wall-to-wall" parking machine that utilizes almost 100 percent of a building's parking space. The machine, on rails, picks up cars to take them to parking spaces and return them. Elevators lift the carrier to upper floors.



Beach and yard shelter

This plastic shelter was built by a German inventor to protect occupants against cool breezes at the beach or in a back yard.

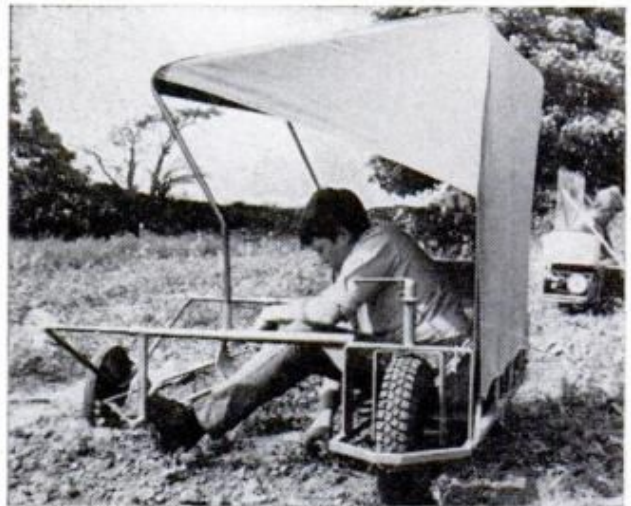

Gardener's go-cart

The battery-powered Horticar enables English nursery employees to do weeding and planting without bending over all day.



'Cigar' for world cruise

This is the hull of a 36-foot, cigar-shaped boat that Californian William Bonner is building to sail around the world.



Four-engine homebuilt

Four go-cart engines, totaling 35 hp, power the metal-tubing-and-fiberglass plane built by Vernon and Verlon Weber of Cuba City, Wis.

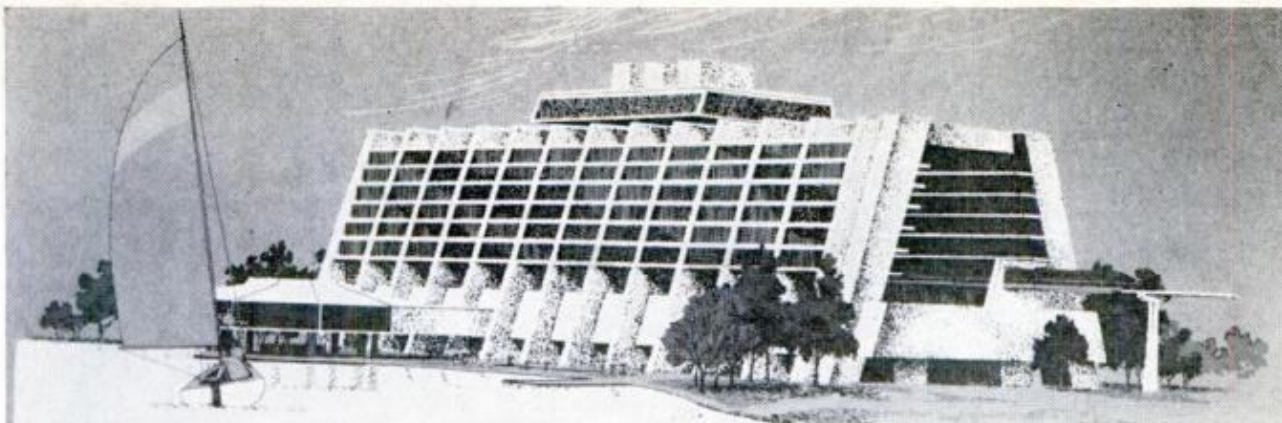

Steel modules for Disney hotel

The first two "theme resort hotels" to be built in Walt Disney World at Orlando, Fla., will utilize the world's first major use of steel-framed modular construction. Shown in the drawing above is the Contemporary theme resort; at right is a model of modular hotel room that has been developed by United States Steel for this project. Some 1450 hotel rooms of this type will be built at an on-site facility and lifted into place in the first two hotels. The Contemporary resort shown here will have 750 rooms, rise 10 stories and feature an open-mall lobby longer than a football field and 80 feet high. Monorail trains linking this hotel and others at Walt Disney World with the theme park will travel directly through the lobby.

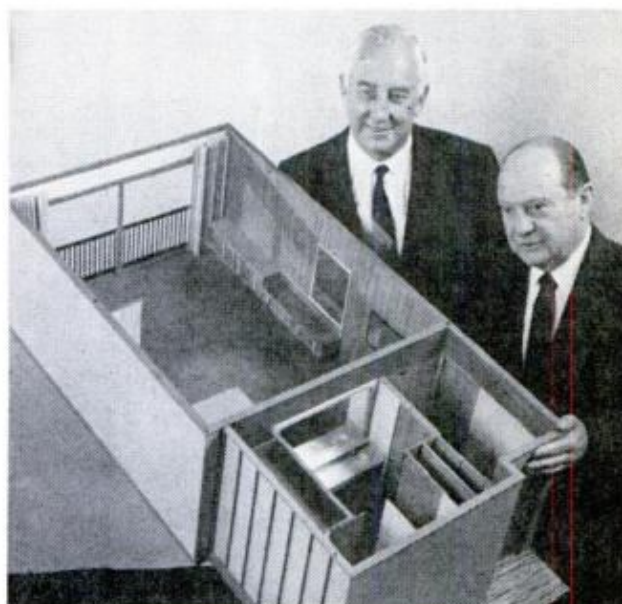

Bentley in fiberglass

An English manufacturer has introduced an electrically powered fiberglass model of the 1929 Bentley for young motorists.

DECEMBER 1969

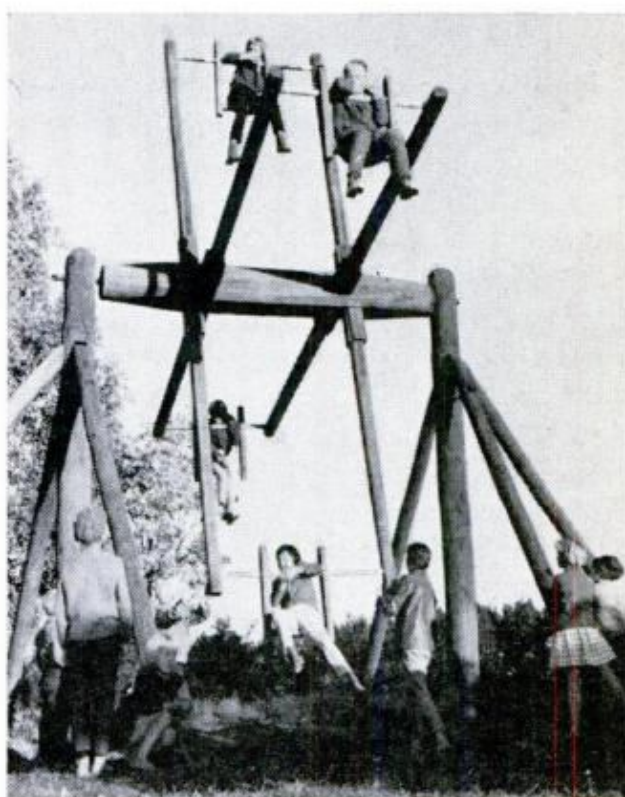

Playground in Finland

Youngsters in a Finnish rural community don't need city parks; they have this home-built "Ferris wheel" for thrills.

Varmint hunting is now a big-time sport with special rifles for special jobs. Here's what you should know about them

THERE WAS A TIME when a hunter shot varmints only when nothing else was in season. If he couldn't shoot deer or bear, he might keep in practice by knocking off an occasional woodchuck with his 30-30. But now the varmint specialist is usually a more expert rifleman than the average big-game hunter. Varmints are small targets compared to moose and elk, and you must often hit them at long range with a small bullet sensitive to wind deflection.

Favorite target of the varmint shooter is the woodchuck or groundhog. In the West, he's called the rock chuck due to the type of terrain he frequents. Western varminters have two additional targets to shoot at in the jackrabbit and coyote.

The Northwest has the little ground squirrel. He's small and hard to hit. But the guns and marksmanship required are identical to those needed for woodchuck.

Crow shooting with rifles is also popular, but sometimes hazardous to other people. Since crows are often fired at when perched in a tree, a miss may send your bullet into the next county. Obviously, you must examine what's behind your target with great care.

If you're like most other hunters, the fun begins when you go shopping for a rifle. First choice you'll make is caliber, and a good rifle for the beginner is the .22 rimfire. Most hunters who tote a sophisticated custom model started with the .22. And it kills varmints. But its trajectory (arched line of flight) is

not flat enough for reliability at much beyond 75 yards. In addition, it simply hasn't got the punch needed to kill a woodchuck instantly unless you put a long-rifle, hollow-point slug directly into a vital spot. A more likely choice for the novice varminter is the .22 Winchester rimfire magnum, which will hit reliably at 100 yards or more. Its

copper-jacket 40-grain bullet, made specifically for varminting, has a muzzle velocity of 2000 feet per second, 635 f.p.s. faster than the .22 hollow point. Available in several fine guns costing little more than the inexpensive .22s, the Winchester rimfire magnum packs a substantial wallop.

Incidentally, when the name of a manufacturer is used as part of a caliber designation, it simply indicates the company that developed the cartridge. Usually, all manufacturers will produce the cartridge, no matter which one developed it.

From this point on, we are talking to the man who is, or wants to become, an expert at long-range shooting. The smallest cartridge he will choose is the .222 Remington. This round sends out a 50-grain bullet at 3200 feet per second and is one of the most accurate ever developed. Its light recoil makes it a pleasure to shoot, and its low cost per round is easy on your pocketbook. It hits reliably and kills cleanly out to well over 200 yards.

A slight step-up in power is represented by two cartridges which have almost identical ballistics—the .223 and

USE WHAT THE VARMINT SHOOTERS USE

By ART MAHER

FIVE TOPNOTCH VARMINT RIFLES (from left to right): Remington Model 700 BDL .222, Browning Safari Grade .243, Mossberg Model 800BV .22-250, Winchester .225, Savage Model 65-M .22 Rimfire Magnum.

SCOPES (at top, left to right): Redfield 2X to 7X variable, Weaver 4X to 12X variable, Savage 4X, Tasco 10X



the .222 Remington magnum. The former is a civilian version of the military's M16 round; the latter a .222 with elongated case. Both fire 55-grain bullets at 3300 f.p.s. The extra five grains of weight enables the bullet to retain its velocity better than the plain .222 and it increases resistance to wind drift. Some say these two cartridges provide 50 yards more range than the .222.

With the next larger caliber—the .225 Winchester—we're definitely in a high-velocity class. Its 55-grain bullets take off at 3650 f.p.s., making 300 yards a reasonable range. Then there's the .22-250 Varminter which fires the same weight bullet at 3810 f.p.s. You should use these cartridges only in sparsely

Broad fore end of a varmint stock provides for steady holds on far-off targets.

populated areas where a loud report won't bring the townspeople down on you or frighten the cows out of a week's milk!

For ranges exceeding 300 yards, you'll have to step up from the .22-type calibers. While the faster bullets have trajectories sufficiently flat to simplify aiming, wind drift becomes increasingly significant at long ranges. The little .22 slugs don't have the weight or shape to resist deflection by air currents.

A 6-mm cartridge is your best bet for distances over 350 yards. There are two on the market—the .243 Winchester and the 6-mm Remington. They fire 80-grain varmint bullets at speeds of 3500 and 3450 f.p.s., respectively. Their greater mass and weight give you increased resistance to wind drift.

An added advantage of the 6-mm cartridge is that it comes in heavier loads for hunting deer and other large animals. Thus, either the .243 or the 6-mm Remington makes a good choice for the man who wants one gun for both varmints and medium-sized game. But, never use 100-grain medium-game

loadings for varmint shooting. Varmint slugs need light jackets, which have an explosive effect when they hit a small animal and will shatter if they miss and hit the ground. Bullets for large game have heavier jackets and will often ricochet off hard surfaces, making them unsafe for pasturelands.

As you shop around, you may run into some second-hand rifles in discontinued varmint calibers. The .218 Bee (fine in populous, noise-sensitive areas) the .219 Zipper, .220 Swift, .250-3000 and .257 Roberts are all excellent rifles. The latter two, especially the .257, are good substitutes for the 6-mm.

Of course, some larger calibers such as the .270 Winchester, .280 Remington, .264 Winchester Magnum and 6.5-mm Remington Magnum are widely used for varmint shooting. But these rifles were created with larger game in mind.

When you get up into .30-cal. varmint loadings, you approach the realm of overkill. In addition, 110-grain .30-cal. slugs are not good wind buckers, nor is their shape particularly accurate. The .30s will do for varmints, but they're hardly your best choice.

Your best bet in an action is the bolt type. An exception is a custom-grade single-shot which might have a lever or falling-block-type action. Another is the pump-action or semi-automatic action favored by jackrabbit and coyote gunners. These animals often require a quick-firing gun, and are seldom shot at ranges beyond 150 yards. The bolt-action's improved accuracy serves little advantage in hunting these fleet-footed targets which are often killed within 150 yards only after several rounds have been sent after them.

The stock of your varmint rifle is important. The specialist usually chooses a varmint stock, a cross between a medium-weight hunting stock and a hefty target stock. One important feature is the broad, or beavertail fore end that provides a substantial wood grip for steady holds on far-off targets. Another is its high comb (top edge of the butt). When you aim a high-combed

rifle, the comb supports your head so you can align your eye comfortably with the rear end of a telescopic sight.

Don't forget a sling. Besides helping to carry the gun, it assists you with your aim, especially when prone.

Finally, you'll need a good scope. Open sights and peeps won't do the job.

The .22 rimfire or rimfire magnum is easily outfitted with an inexpensive 4X or 6X scope in 3/4-inch diameter with a tip-off mount to fit the parallel grooves you'll find in the receiver of the rifle. The 4X is probably the better choice, as the 6X has a smaller field of view and lacks its visibility.

For 6-mms and .22 centerfires to be used on varmints only, the connoisseur's choice would be a target-type scope. These range in power from 8X to 30X, and offer very accurate adjustments. They help you get every bit of potential out of your rifle. Your next best choice is a regular hunting scope in 8X to 12X. Anything less powerful would handicap the difficult long-range sniping you'll often encounter with varmints.

Incidentally, don't believe anyone who tells you that low-light visibility is better with a low-power scope than with one of higher power. A powerful scope will help you see better in any light. The only time a varmint hunter wants a lower-power scope—say, about 4X—is when he's hunting jackrabbits or coyotes. He's got to line up fast on these two, and a low-power scope will help him do that.

The scope to buy for the rifle that shoots both varmints and big game is a variable of 3X or 4X at the low end of its range and at least 7X at the high end. Use low power in deep woods where your glimpses of game are brief; use high power for varmints.

There's a lot more to buying a good varmint rifle than going into a store and saying, "Gimmee." But the time spent in finding out which rifle and scope are best suited for you will more than pay for itself in the great enjoyment found in this growing sport. ★★

DECEMBER 1969



Fast sub hunter

Scheduled to go into service in 1972 is Navy's new carrier-based antisubmarine warfare plane, the S-3A. Top speed will be over 400 knots and range, 2000 miles. This illustration is an artist's concept.



New undersea craft

The Vickers-Pisces, a British two-man submersible, will be able to work at depths down to 3500 feet. It's shown here during tests.



Monster hunter

The most recent entrant in the perennial search for the Loch Ness monster is Dan Taylor with his 20-foot fibreglass submarine. At last report, there were no sightings.

119



Care and Feeding Of Snow Throwers

Now's the time to make sure your snow thrower is ready to go to work—and keep working through the snows ahead. Here's a simple checkout for that most vital part—the engine—plus a handy troubleshooting guide

By MORT SCHULTZ

MOST MANUFACTURERS of snow throwers do a fine job of telling you how to take care of the auger, the chute control and the other snow-handling parts of your machine. But what about the engine? Most manuals merely advise you to take the rig to a repair shop if the engine needs service.

Actually, working on the engine is usually no more difficult than maintaining the other parts, and obviously it's the engine that has to go if you're going to throw snow in the coming winter. Here,

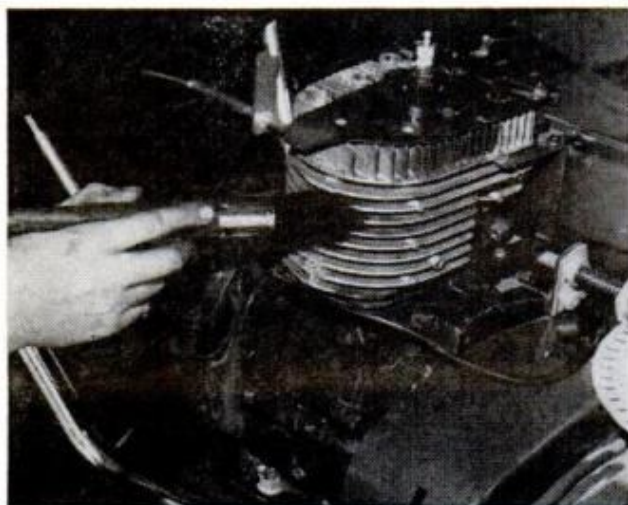

CLEAN COOLING FINS with a stiff-bristle brush. Despite frigid winter weather, the engine can overheat dangerously if fins are clogged with debris

120



COVER OVER CARBURETOR is found on most snow throwers to keep moisture from getting in and freezing. Remove cover if carburetor needs an adjustment

POPULAR MECHANICS

then, are some helpful pointers on getting an engine in shape and troubleshooting tips if a failure should occur.

If you stored your equipment properly last year, you should have no trouble getting it started now. Prestorage preparation involves draining fuel, replacing crankcase oil in four-cycle engines and lubricating the upper cylinder by pouring some SAE 10W oil in through the spark-plug port. If you should have difficulty waking up a sleeping engine, check the accompanying troubleshooting guide for possible causes.

Even if the engine starts easily, there are several maintenance steps that must be taken to be sure it will give trouble-free service all winter long. Start by checking the sparkplug for damage and correct gap adjustment. Bad plugs are the second major reason why two and four-cycle gasoline engines refuse to start. (The first reason, ironically, is an empty tank.)

Discard the plug if the insulator is cracked or the electrodes are broken or badly worn. If the plug looks usable, clean the electrodes with a wire brush and file the center one bright with an ignition point file. Only one or two passes are necessary.

Gap the plug to .030-.035 inches. Before reinstalling it, apply a little graph-grease to the threads to keep the plug from sticking in the engine in cold weather. Screw the plug in finger-tight, then give it an additional half turn with a wrench.

Remove the fuel line, fuel tank and

gas filter if there is one. Wash them in kerosene. Make sure the vent hole in the fuel-tank cap is unclogged. While you have the fuel tank off, clean debris from the cylinder's cooling fins with a stiff-bristle brush to guard against engine overheating.

Fill the machine with the correct lubricant and fuel. Keep in mind that the recommendations on the viscosity of oil to use are important if you want the engine to start easily throughout the winter. One of the main reasons why engines fail to start is that some owners substitute heavier oil than the grade called for. This puts a drag on engine parts.

If your machine has a two-cycle engine, oil and gasoline must be mixed together before they are put into the fuel tank. Use an SAE 30 outboard motor oil or a two-cycle engine oil. Don't use a multi-viscosity automobile oil such as SAE5W-30. It contains additives that leave carbon inside two-cycle engines.

The gasoline should be regular grade and fresh. Never use gas that's been stored. Gum forms in stored gas and will plug the carburetor. Also, be sure the gas you buy is a winter grade. Gasoline sold for warm-weather use is less volatile and will make starting difficult.

Mix the oil and gas in a clean container and shake thoroughly. Mixing should be done at room temperature. Generally, a half pint of oil to a gallon of gas is the correct ratio. Check your manual.

If your engine is a four-cycle, fill the crankcase with SAE 5W-30 or SAE 10W motor oil that's designated for MS ser-

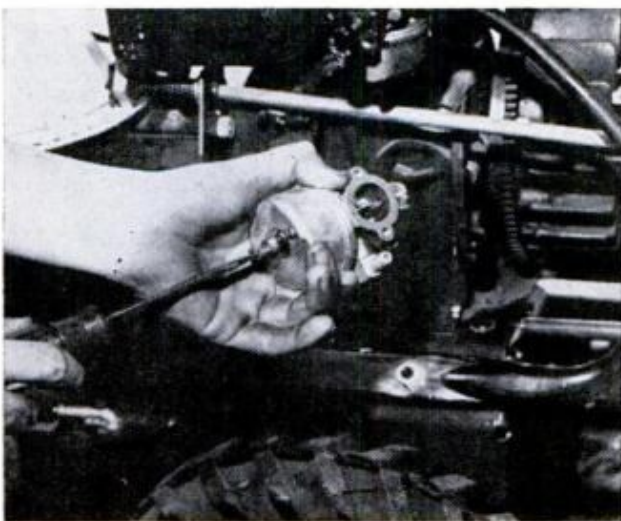

HIGH-SPEED ADJUSTING SCREW is sometimes under the carburetor in the bowl. If you remove the bowl to replace needle and seat, remove this screw, too

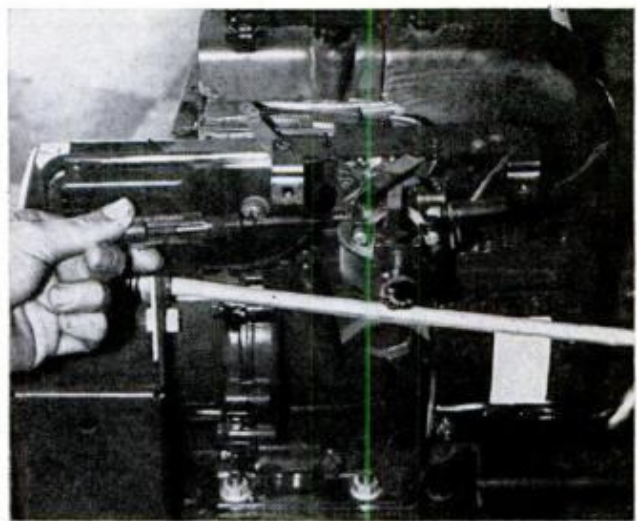

AFTER MAKING the high-speed adjustment, set the idle by turning the idle-speed adjusting screw until you get the smoothest possible engine idling

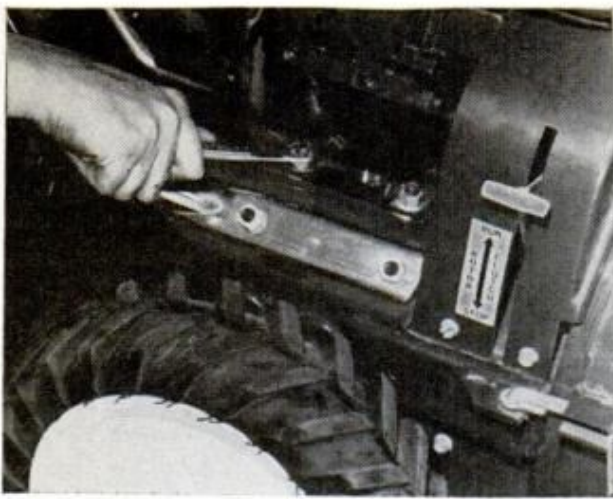

EXCESSIVE VIBRATION can actually damage an engine. Tighten all bolts to prevent looseness. Handiest tool for this is an open-end or socket wrench

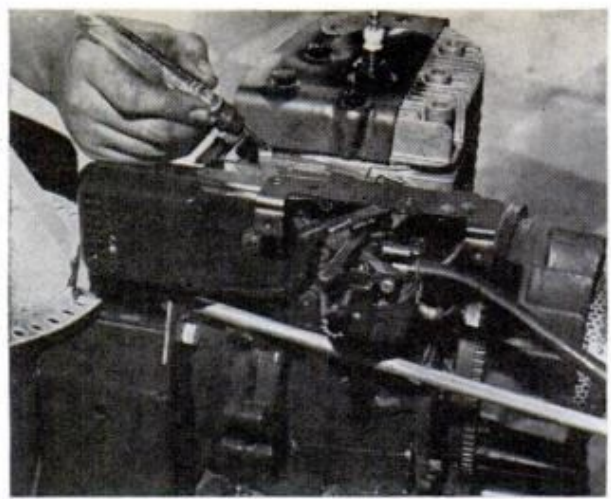

USE LIGHT MACHINE OIL on governor, throttle and choke-linkage pivot points. Don't put on too much, though. A drop at each point of movement is plenty

vice. This means that the oil is for engines that are used under severe operating conditions.

In starting your engine for the first time, let it warm up, then run it through its various speed ranges. If it starts and runs without stalling or faltering, leave it alone. If not, readjust the carburetor. If you have a two-cycle engine, allow it to run at top speed and turn the high-speed mixture screw to the closed position. Then open it one full turn. Now turn the idle-speed mixture screw to the closed position, then open it $1\frac{1}{8}$ to $1\frac{1}{4}$ of a turn. Hold the throttle closed and turn the idle-speed regulating screw clockwise until the engine idles smoothly. When you use the machine at the first snowfall, a slight readjustment may be necessary if the engine stalls.

To adjust the carburetor of a four-

cycle engine, run the engine at top rpm and close the high-speed adjusting screw until the engine just starts to lose speed. Slowly open the screw past the point of smoothest operation until the engine just begins to run unevenly. Set the engine speed to idle and turn the idle-speed adjusting screw until a smooth idle is obtained.

This should be the correct carburetor adjustment for a four-cycle engine, but you'll have to test it during the first snowfall with the engine under load just as with a two-cycle engine. If the engine stalls, the mixture is too lean, so open up the high-speed adjusting screw slightly even though you will probably get an uneven idle.

Tighten all fasteners, especially mounting bolts. A part that vibrates excessively

(Please turn to page 198)



FLYWHEEL PULLER uses leverage to pry flywheel off the engine shaft so you can reach the magneto. Never use hammer; you may wreck entire assembly



COMPRESSION TEST can tell you if engine needs major work, such as on valves and rings. Pressure shows on a gauge as engine is turned over by hand

TROUBLESHOOTING GUIDE FOR SNOW-THROWER ENGINES

Cause

Remedy

ENGINE FAILS TO START OR IS HARD TO START

- | | |
|------------------------------------|--|
| 1. No fuel in tank | Fill it up. |
| 2. Shutoff valve closed | Some engines have a shutoff valve between the fuel tank and carburetor. Be sure it's open. |
| 3. Grounding clip shorted | This allows stopping of the engine. Be sure it's not in the "stop" position. |
| 4. Engine overchoked | Engine might be flooded, especially if you smell gas. Shut fuel shutoff valve and turn engine over several times, or let it sit for a while. |
| 5. Fuel-tank cap vent plugged | Use a bristle from a wire brush to ream dirt out of vent hole. |
| 6. Sparkplug lead loose | Be sure high-tension lead is firmly connected to the plug. |
| 7. Water in fuel | Hold a few drops of fuel in your hand. If water remains after fuel evaporates, drain and clean the tank. Refill. |
| 8. Sparkplug loose | Tighten finger-tight, then give half turn with wrench. |
| 9. Sparkplug cracked | Replace. |
| 10. Sparkplug fouled | Clean and regap. |
| 11. Improper carburetor adjustment | Readjust. |
| 12. Obstructed carburetor | Wash in kerosene. Replace needle, seat and gaskets. |
| 13. Faulty magneto | Points and condenser give the most trouble. Replace, gap points and set timing. |
| 14. Poor compression | Overhaul engine. |

ENGINE KNOCKS

- | | |
|---------------------------------|---|
| 1. Bad fuel | Dump and refill with fresh gas. |
| 2. Incorrect magneto timing | Time magneto to specification. |
| 3. Loose flywheel | Check flywheel key and keyway and replace parts if worn. Be sure flywheel nut is tight. |
| 4. Carbon in combustion chamber | Remove cylinder head and clean carbon from head and piston. |
| 5. Worn connecting rod | Replace. |
| 6. Worn cylinder | Have cylinder rebored and replace piston with one that's properly oversize. |

ENGINE MISSES UNDER LOAD

- | | |
|--|-----------------------------------|
| 1. Sparkplug cracked | Replace. |
| 2. Sparkplug fouled or improperly gapped | Clean and regap. |
| 3. Improper carburetor adjustment | Readjust. |
| 4. Faulty magneto breaker points | Replace (replace condenser, too). |
| 5. Faulty condenser | Replace. |
| 6. Improper valve clearance | Adjust. |
| 7. Weak valve spring | Replace. |

ENGINE LACKS POWER

- | | |
|---|---------------------------------------|
| 1. Improper amount of oil in fuel mixture (2-cycle) | Mix new batch in correct proportions. |
| 2. Lack of lubrication (4-cycle) | Fill crankcase to correct level. |
| 3. Choke partially closed | Make sure choke opens freely. |
| 4. Improper carburetor adjustment | Readjust. |
| 5. Magneto improperly timed | Time to specification. |
| 6. Leaky valves | Grind valves. |
| 7. Worn pistons or rings | Replace faulty parts. |

ENGINE OVERHEATS

- | | |
|-----------------------------------|--|
| 1. Lack of lubrication | Fill crankcase to proper level (4-cycle); be sure oil-to-gas ratio is correct (2-cycle). |
| 2. Clogged cooling fins | Clean debris from cooling fins. |
| 3. Carburetor improperly adjusted | Readjust. |
| 4. Incorrect timing | Time magneto. |
| 5. Carbon in combustion chamber | Remove cylinder head and clean carbon from head and piston. |

ENGINE SURGES OR RUNS UNEVENLY

- | | |
|---|---|
| 1. Fuel-tank cap vent plugged | Use a bristle from a wire brush to ream dirt out of vent hole. |
| 2. Governor parts sticking | Clean. If parts are damaged, replace. |
| 3. Carburetor throttle linkage or throttle shaft and/or butterfly binds or sticks | Clean, lubricate or adjust. Deburr throttle shaft or butterfly. |

ENGINE VIBRATES EXCESSIVELY

- | | |
|---|---|
| 1. Engine not securely mounted | Tighten loose mounting bolts. |
| 2. Snow-handling equipment out of balance | Readjust in accordance with instructions in owner's manual. |
| 3. Bent crankshaft | Replace. |

Electronic Music-Makers You Can Build From Kits

By SHELDON M. GALLAGER

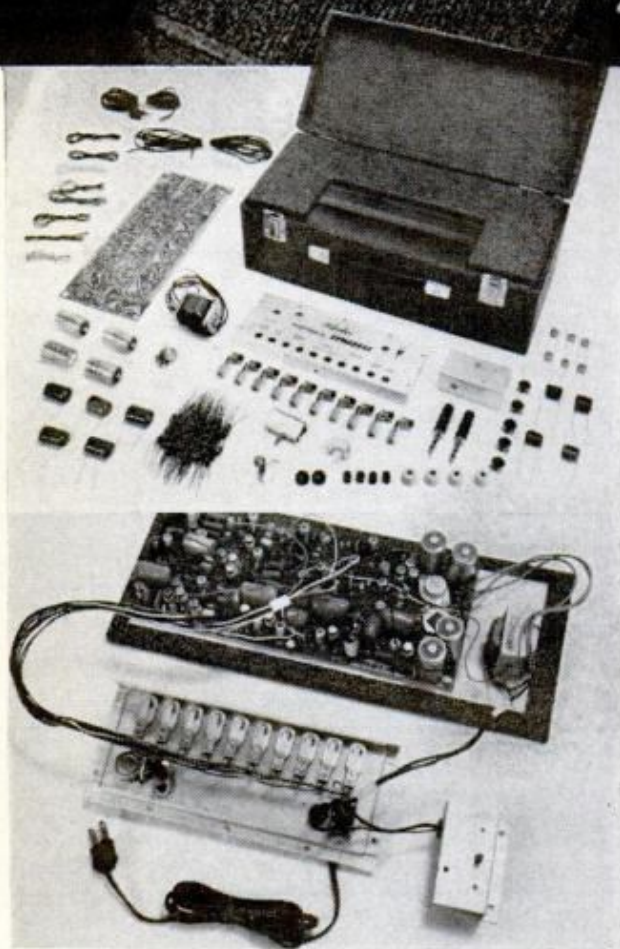

DYNABEAT KIT, most complicated of the three, is shown completed at top of page and in parts in lower views. Photo immediately above shows printed-circuit board and underside of 10-switch keyboard

Press a button and you can beat out a drum rhythm like a pro or create notes that sound like an organ. Here are three fun-to-build, fun-to-play instruments that let you join in the merrymaking whether you're a musician or not.

DO-IT-YOURSELF MUSIC is rapidly becoming a major form of adult recreation and relaxation for people who never made it past sixth-grade lessons on the violin or tuba. All over, grownups are gathering at parties and family get-togethers to sing songs around a piano or record player, beating out simple rhythms



DRUMBEATS are produced electronically by Knight-Kit's Combo Sideman. Knobs control rhythm, tempo and volume. Kit comes with pre-wired circuit board, takes only an hour or so to assemble. Accessory foot switch is also included. Instrument is shown connected to a Knight-Kit guitar amplifier, one of the many types of amplifiers that you can use

on a pair of bongos or an old washtub.

Here are three kit-built electronic instruments that can add a lot of fun at such sessions without requiring either musical or electrical know-how. They're not only easy to play, but offer the satisfaction of putting something together yourself. All three produce musical sounds through the use of ingenious solid-state circuits. Two are percussion rhythm instruments that provide realistic drum, cymbal, brush and bongo sounds at the touch of a button. The third has a simplified piano keyboard that produces rich, vibrant organlike tones.

The instruments are ideal for adding your own accompaniment to a phonograph, piano, guitar or accordion. All three can be played through any hi-fi amplifier or receiver that has external inputs for mike, phono, tape or similar equipment. All you do is run a standard mike or phono connector cable from the instrument to the input jack on the amplifier.

Simplest of the three kits is Allied's Knight-Kit Model KG-392 Combo Sideman. This produces three percussion sounds—bass drum, snare drum and

cymbal—in any of six rhythm patterns. You don't have to keep the beat yourself. You just select the rhythm you want, press a button and out it comes. The clever part is that you can adjust the speed of the beat so it exactly matches the tempo of the music you're singing or playing. The result is that it sounds as if someone is playing the drums right along with you.

You can also play the instrument manually by tapping a button with your finger. This provides a single drumbeat or a continuous roll depending on how long you hold the button down. Both the manual and automatic functions can be controlled by foot switches, leaving your hands free to play another instrument.

The Combo Sideman comes partially assembled to speed the work. You merely solder connections between a prewired circuit board and the controls. The job can easily be done in an evening. Kit price is \$49.95 from Allied Radio Corp., 100 N. Western Ave., Chicago, Ill. 60680.

A more advanced electronic percussion instrument is the Dynabeat developed by Schober, famous maker of electronic organs. In this case, you provide the rhythm

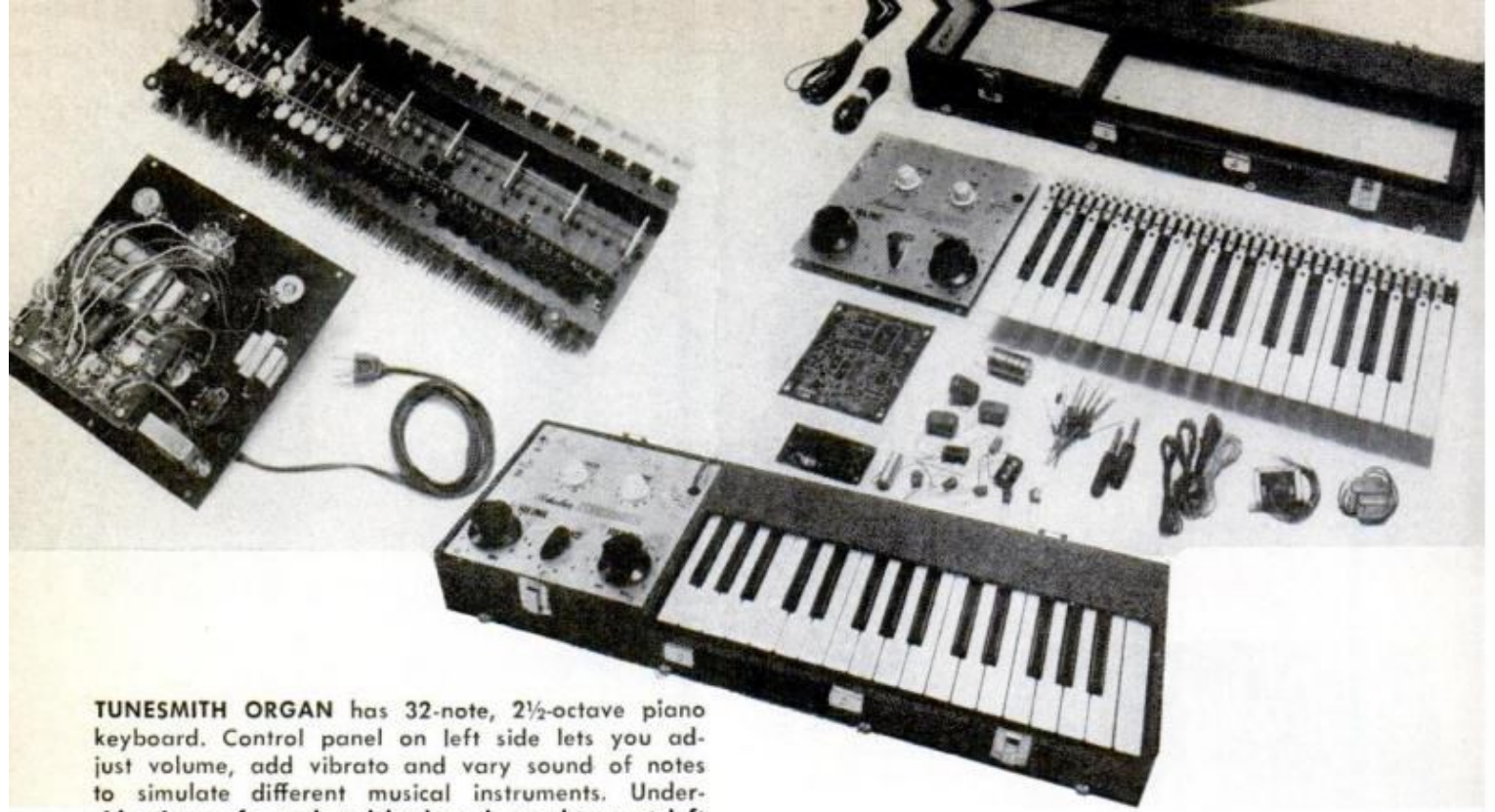

TUNESMITH ORGAN has 32-note, 2½-octave piano keyboard. Control panel on left side lets you adjust volume, add vibrato and vary sound of notes to simulate different musical instruments. Under-side views of panel and keyboard are shown at left

and tempo yourself, and you have a wider range of percussion sounds. A 10-button keyboard gives you a choice of bass drum, snare drum, tom-tom, brush cymbal, crash cymbal, castanets, two types of wood block sounds and two bongo sounds.

By playing the buttons with several fingers at a time, you can produce different combinations of sounds in rapid succession. Some of the buttons, such as the bass drum and tom-tom, provide a single beat with each tap. With others, you can hold the button down and get a continuous series of sounds, such as a dramatic drum roll or repetitive cymbal crashes. The tempo is determined by how fast you tap the buttons. You can provide a professional-like accompaniment merely by flicking the buttons in time with the music.

The Dynabeat is a highly sophisticated instrument and consequently a fairly hefty kitbuilding job. You can't rush it. There are, for instance, 145 resistors alone to install along with a number of other parts. A printed-circuit board speeds the wiring, however, and makes for a neat, trim job. Assembly time was found to be about 35 hours—comparable, say, to a small radio chassis.

The Dynabeat's sounds are produced by phase-shift oscillators, in some cases combined with multivibrators and diodes. They are extremely lifelike and make anyone who has ever dreamed of being a

drummer really sound like one. Price for the Dynabeat kit is \$139.50 from the Schober Organ Corp., 43 W. 61st St., New York, N. Y. 10023. A ready-built version is available for \$169.50.

Anyone who can tap out simple tunes with one finger on the piano can play the Tunesmith, also made by Schober. Although not a full-fledged electronic organ, it produces organlike tones from a 32-note, 2½-octave keyboard. The only limitation is that you must play the notes singly, one at a time. You can't press several keys simultaneously to create chords.

A control panel on the Tunesmith, operated with your left hand, lets you vary the character of the notes as you play them. One knob gives you a choice of different organ voices like trumpet, flute, oboe, violin and cello. Another allows you to add a mellow vibrato effect. You can also tune the organ to match any other instrument you're playing it with.

The Tunesmith is a relatively easy assembly job, simpler than the Dynabeat. Working steadily, you can complete it over a weekend. It's price is \$149.50 in kit form and \$189.50 assembled. Both the Tunesmith and Dynabeat include handsome, simulated-leather carrying cases with removable covers. They operate on 115-volt a.c. In the case of the Combo Sideman, no external power is required as it runs on a built-in battery. ★★★

NEW IN PHOTOGRAPHY



PORTABLE MOVIE LIGHT operates on rechargeable batteries, enabling you to shoot night or other scenes away from a power source. The Sylvania SG77 Sun Gun comes with a shoulder pack that can be recharged in an hour from either 115-v. house current or 12-v. d.c. from a car's cigaret-lighter socket. The lamp runs 10 minutes on a charge—enough for two 50-foot rolls of film. \$119.95.



HORIZONTAL HAND GRIP is an unusual feature on a new line of Anscomatic Super-8 movie cameras. Designed to be grasped with your wrist in a vertical position, it has a built-in shutter trigger, is said to permit easier, steadier holding. Prices range from \$44.50 for fixed-focus model above to \$249.50 for an advanced version with electric zoom and fading control. GAF, New York.



POLAROID OWNERS can now use electronic flash with models not originally equipped for such units. This GE strobe is designed to fit all 100, 200 and 300-series folding Polaroid pack cameras except the 360, which has its own flash. A novel two-level light control gives you full power for distant shots or half power for close-ups. Flash comes with special mounting bracket and shutter cord. \$50.95.

DECEMBER 1969

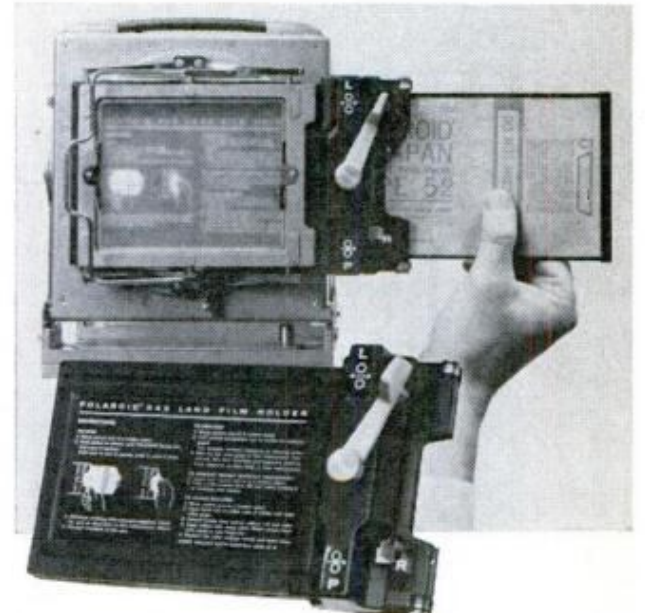

NEW ADAPTER HOLDER for using instant Polaroid film in 4x5 press and view cameras is said to be simpler and easier to use than earlier models. The load process mechanism is enclosed to prevent its being touched accidentally and spoiling the results during removal of the film. A new clip holder eliminates the chance of clip jamming, and a safety catch prevents premature film withdrawal.

127

PHOTOGRAPHY



New Mini-Strobes: Flashguns

By BURT MURPHY



MINI-STROBES like the Bauer E-160 (above) clip easily onto your camera and weigh only a few ounces

THE FIRST electronic flashguns were bulky affairs with a battery pack slung over your shoulder that felt like a bucket of lead. Now they weigh only a few ounces and are slim enough to slip into a shirt pocket. The batteries are built-in and can be recharged in a few hours with a small accessory charger that plugs into any 115-volt wall outlet. The result is a new freedom and convenience in flash photography not possible before.

These new-generation mini-strobes are ideal for the casual vacation or party-bound snaphooter who doesn't want to carry or invest in a lot of expensive gear. They do, however, have their limitations and it's important to be aware of these. As a class, pocket strobes are not as powerful as full-size electronic flashguns, and can't be expected to be. Their light won't reach as far or cover as broad an area. To compensate for this lower level of illumination, you have to use larger lens openings, thus sacrificing some sharpness and depth of field.

Mini-strobes also vary widely among themselves in capacity, as their prices indicate. You can pay

PM MINI
MITE
\$24.95

METZ 184
\$74.95

BRAUN
F-280
\$79.50

MINOLTA
\$34.95

BROOKS
BLITZ
\$49.95

HONEYWELL
STROBONAR 330
\$89.50



LINE-UP OF POPULAR MINI-STROBES shows the wide variety of models available, ranging in price from

as little as \$20 to more than four times that. Guide numbers, an indication of light output, also vary con-

Not much bigger than a pack of cigarettes, they're easy to carry, handy to use and moderately priced. Here are helpful pointers on buying and using one

You Can Slip in a Pocket

anywhere from \$20 to nearly \$90 for one. What you get in the higher-price units are greater light output and, usually, such things as more flashes per charge, faster recycling time and special convenience features. On the average, prices for most of the minis fall in the \$50 to \$60 range.

The exposure guide numbers supplied with each strobe are one helpful indication of available power. The higher the number, the greater the light output. For the units shown here, the guide numbers range all the way from 30 to 69 for ASA 25, the film speed for Kodachrome II color film. The average is between 35 and 45 for ASA 25. By comparison, the guide number for a typical standard-size strobe gun (Honeywell's Strobonar 880) is 80 for ASA 25. At 10 feet, a common shooting distance for small groups, the big

strobe would provide a lens opening of $f/8$, while the minis would need larger openings of $f/4$ or $f/3.5$.

What the minis lack in capacity, however, they make up for in convenience. They not only let you take pictures indoors and at night, but they're perfect for carrying along on daytime outings when you wouldn't normally think of needing flash equipment. They'll add sparkle to shots when the weather turns dreary and cloudy or provide fill-in light to soften harsh shadows. You can compensate for their limited output by taking advantage of today's high-speed films. These, by requiring less light, will enable you to shoot at smaller lens openings for sharper pictures and greater depth of field.

Flash duration—in effect, the speed at which the picture is taken—is im-

PM POWER
MITE
\$49.95



CAPRO FL4
\$20

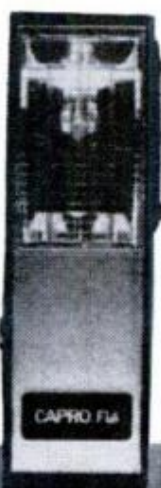

BRAUN
F-210
\$59.95



BRAUN
F-110
\$39.95



BAUER
E-160
\$59.95



REGULA
VARIANT FM
\$59.95

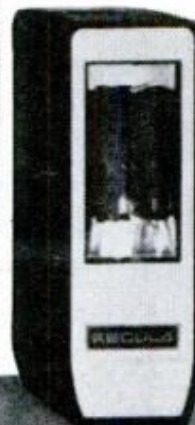

METZ
180
\$49.95



siderably from 30 to 69. Recycle time—the number of seconds you have to wait between flashes—is

another important factor to check on when you select a unit. Prices shown above are approximate



ACCESSORY CHARGER plugs into wall outlet, rejuvenates strobe batteries overnight. In most cases, same charger can also be used to run strobe on 115-volt a.c. to save batteries when shooting indoors

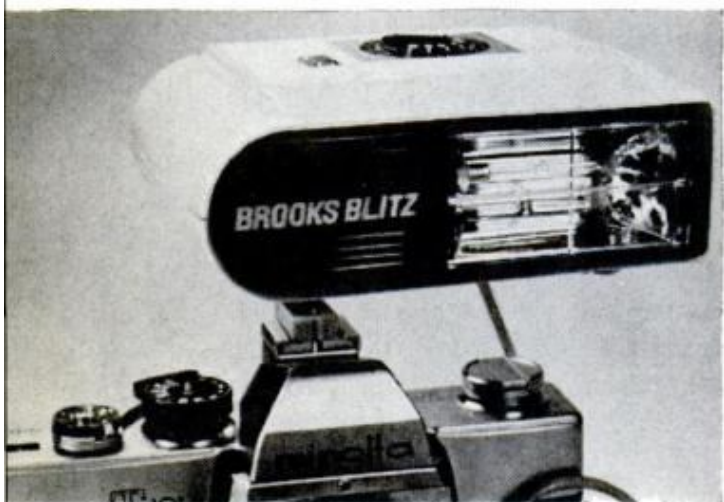

REVOLVING SHOE on some models, like this Brooks Blitz, lets you turn strobe vertically or horizontally. In horizontal position, light coverage is slightly broader, which is useful when shooting wide scenes



LIGHT-SENSING STROBE, Honeywell's Auto-Strobonar 330, automatically provides the right amount of flash for any scene from 2 to 14 feet. A switch on the front (above) also permits manual operation

portant to consider if you're going to be shooting fast-moving subjects. Most pocket strobes range from 1/500th of a second to 1/2000th in duration. A speed of 1/500th will stop average action, but 1/1000th or better will give greater assurance of freezing very fast motion.

Flashes per charge run from about 40 to 60, with a few manufacturers claiming up to 150. At the minimum of 40, you're covered for at least one 36-exposure roll of 35-mm film—in most cases, probably all you'd want to shoot at one session anyway. Also, you can extend your shooting time and save your batteries by operating on 115-volt a.c. whenever you're near a wall outlet. The same accessory charger unit that's used to restore the batteries can be plugged in to give you unlimited flashes on house current. Recharging with the unit takes anywhere from a few hours to overnight.

Recycle time—the period you have to wait between flashes—varies from about 3 to 10 seconds on batteries and usually a little less on 115-volt current. You want fast recycling if you're trying to catch action that can't be repeated, such as sports events or possibly a wedding ceremony. Ten seconds can seem like an eternity if you're in a hurry. But for most around-the-home and party shooting, this factor is not too critical.

Most mini-strobes have a handy exposure calculator that gives you the proper lens opening without your having to do any mental arithmetic. You turn a dial to the film speed you're using and simply read the appropriate lens opening opposite the lens-to-subject distance.

Beyond these basic characteristics, mini-strobes differ mainly in the added conveniences they offer. One unusually slick model, Honeywell's Auto-Strobonar 330, provides automatic exposure. A scaled-down version of Honeywell's bigger automatic guns, it measures the amount of flash illumination reflected from a subject and regu-

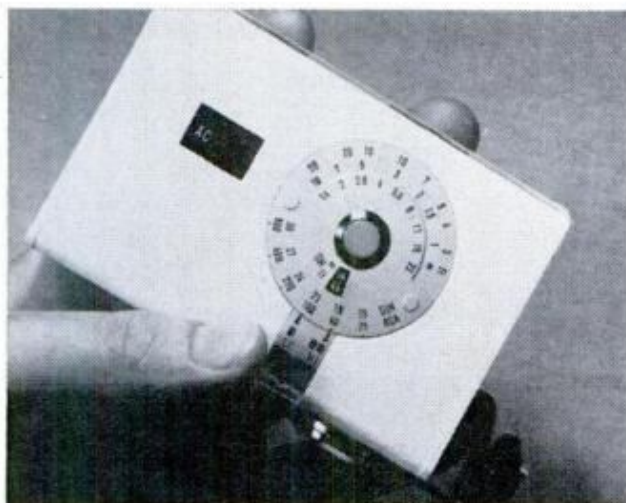
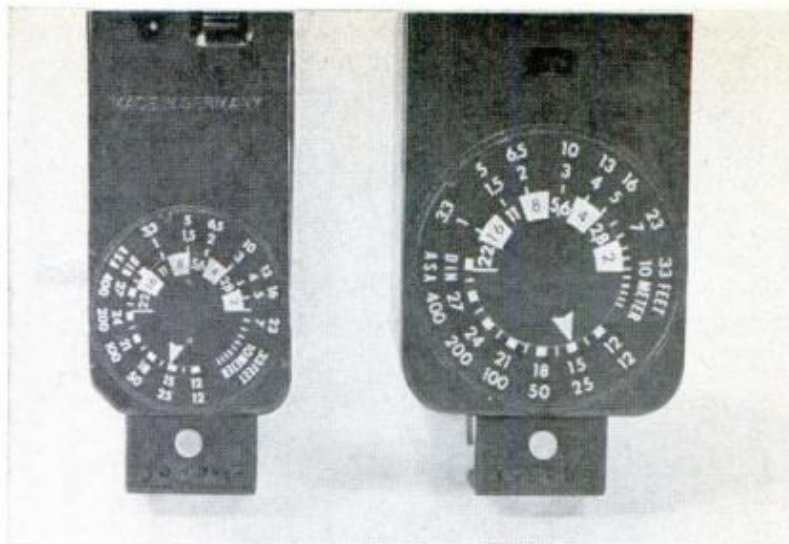

HANDY EXPOSURE CALCULATOR is found on back or side of most mini-strobes. You set dial to your film speed, then read proper lens opening opposite the distance to your subject in feet. Dial on side of Minolta Electroflash at left has added feature—a Hi-Lo indicator that lets you compensate for weak batteries. If unit is fully charged, Hi setting lights up and you turn dial pointer to it. If batteries are running down, Lo setting lights up and you switch dial to it, giving one stop extra exposure. How similar strobes can differ in light output is shown by two Metz units above. Both are set to a film speed of ASA 25, yet larger 184 model on the right indicates a lens opening of f/4 at 13 feet, while smaller 180 model on the left reads f/2.8 for same distance. Thus the larger strobe model has a greater light output since it gets by with smaller lens openings

lates its own duration to produce the correct exposure for any given film speed and subject distance. Naturally, this extra feature puts the 330 at the top of the price pile at \$89.50.

All of the minis are equipped with a standard attachment shoe that slips into a matching clip on many cameras. If your camera doesn't have such a clip, the flash can be attached with an L-shaped accessory bracket of which many types are readily available. For added convenience, some of the Minis have a so-called "hot" shoe—the current that triggers the flash travels right through an electrical contact in the shoe itself, eliminating the need for a separate tripper cord. This cordless arrangement is clean and neat, but obviously is useful only if your camera is equipped with a corresponding hot clip. If it isn't, the strobe can be controlled in the conventional way with a tripper cord. All of the hot-shoe mod-

els have provision for cord operation as well.

Because mini-strobes are typically tall and thin, their angle of flash coverage varies somewhat depending on whether a unit is turned vertically or horizontally. The coverage averages about 50° in the normal vertical position and 60 to 65° when the flash is tilted sideways. Some units come with a swiveling shoe that lets you use the flash in either position. You can flip the flash over on its side for a broader coverage on wide scenes or turn the camera sideways and still have the flash in an upright position.

One disadvantage of mini-strobes is that they can't easily be removed for off-camera flash as can a regular gun with a quick-release bracket. This limits you to the more static, flat-lighted shots typical of on-camera flash. You can, however, use a pocket strobe off

(Please turn to page 188)

How to Check

Upper and Lower:
Tension Loaded
(Coil Spring Suspension)

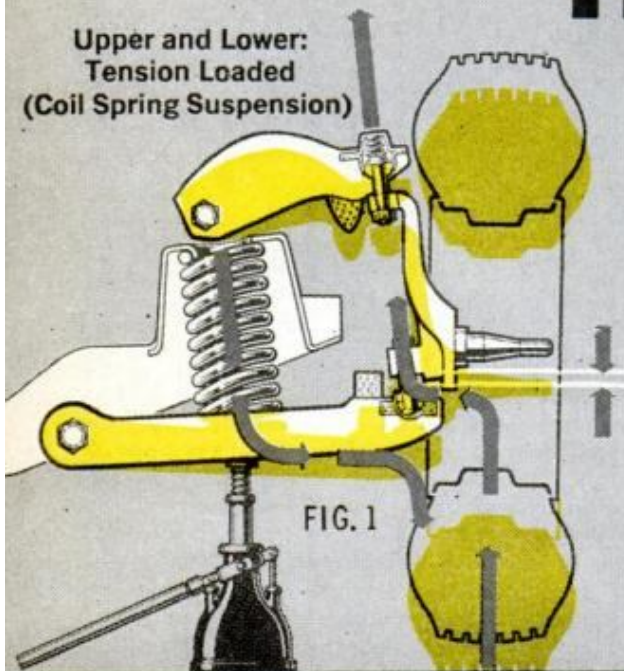

Upper: Tension Loaded
Lower: Compression Loaded
(Coil Spring Suspension)

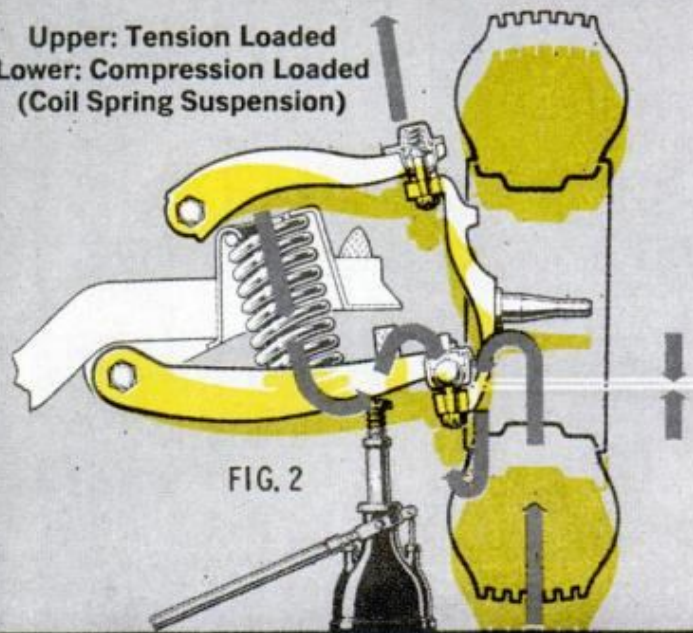

FOUR TYPES OF SUSPENSIONS are shown in Figs. 1-4. In each illustration, the suspension appears both

in the jacked-up position and with the weight of car on the suspension (shown in yellow). Gray ar-

A SERIOUS ARGUMENT is still taking place between some independent garages and the automobile manufacturers. Although ball-joint front suspensions are over a dozen years old, much controversy rages over what constitutes a bad ball joint.

And the car owner winds up coping with the difference of opinion: "A garage told me I needed new ball joints. The dealer said I didn't. Who do I believe?"

Recently, I noticed a manufacturer's service bulletin that pulled no punches in warning against the expensive approach—that of indiscriminately replacing ball joints:

"... dealers are often confronted by a customer who has been 'sold' new ball joints by an independent garage; yet the removed ball joints are perfectly good in every respect."

The other side of the story is voiced by representatives of some independent front-end shops I contacted. They caution that car manufacturers provide too much latitude in ball-joint looseness before the part is condemned and replaced.

"Loose ball joints are extremely hazardous and have led to serious accidents," one man told me. "I frankly don't want to

be the cause of someone's death simply because I didn't recommend replacing a ball joint."

I'm jumping into the middle of this squabble, because replacing is expensive. Conversely, not replacing ball joints when they need replacing is dangerous.

The problem boils down to getting answers to these two questions:

1. How do you tell when your ball joints are loose?
2. How loose is too loose?

Forces on ball joints

Ball joints are loaded in two ways: compression and tension. In a compression-loaded ball joint, forces push the stud head against the top of the housing. In a tension-loaded ball joint, forces try to pull the stud out of the housing.

When a ball joint is new, the stud is fitted closely to the housing. There is hardly any (if any) play. In time, wear takes place—and it will be hastened if water gets into the joint housing and dilutes the grease.

You can't check a ball joint for looseness when it is loaded. The load must be removed. Depending upon the type of ball joint and suspension you have in your car,

Ball Joints

By MORT SCHULTZ

Upper: Tension Loaded
Lower: Compression Loaded
(Torsion Bar Suspension)

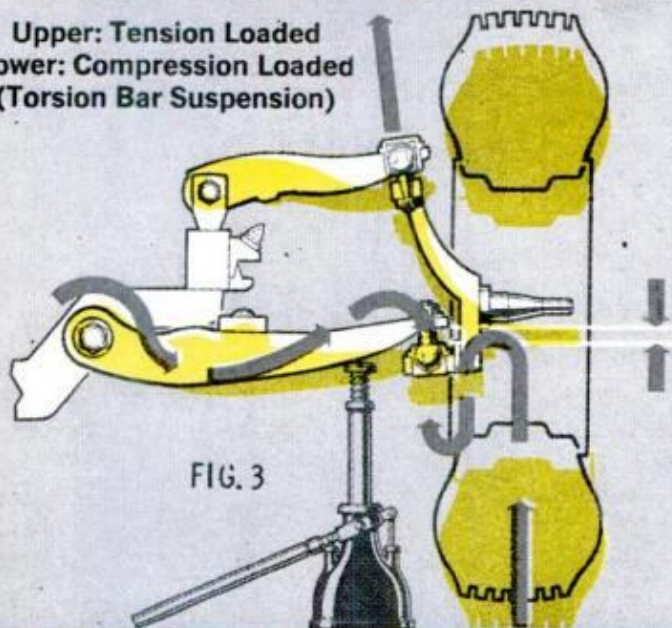

FIG. 3

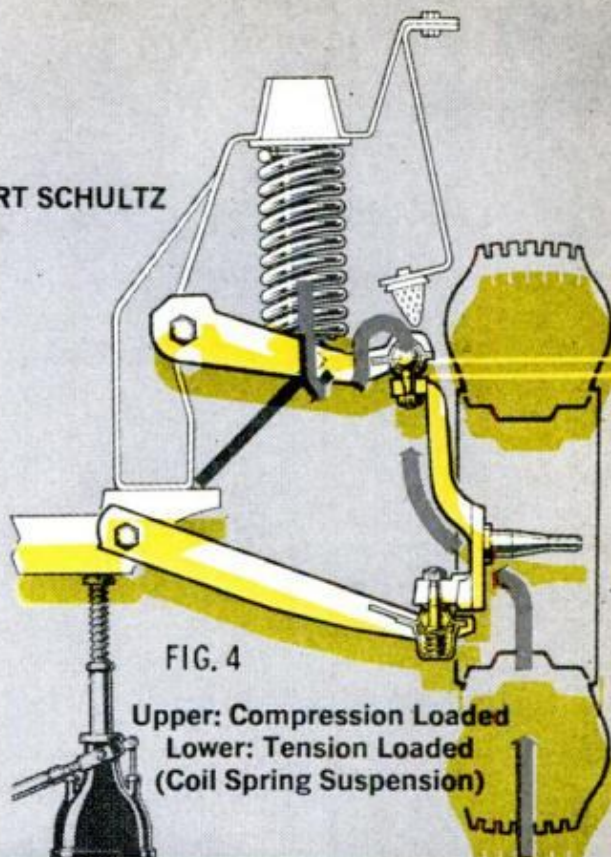

FIG. 4

Upper: Compression Loaded
Lower: Tension Loaded
(Coil Spring Suspension)

rows indicate the force (compression or tension) acting on the ball joints when the car is on the ground.

Axial movement or looseness of the load-carrying ball joint is measured with jack positioned as shown

the load is taken off a joint in one of three ways. By comparing the illustrations here with the underside of your car, you will be able to determine which unloading method you have to use.

tems and will be discussed after all four are described.

Upper, lower joints tension-loaded

Upper ball joint tension-loaded

In one system (Fig. 1) the coil spring is positioned on top of the lower control arm, and both upper and lower ball joints are tension-loaded. To test for ball-joint looseness, the load must be removed from the lower ball joint, which is the prime load-carrying member.

The second and third systems, with the upper ball joint tension-loaded and the lower compression-loaded, are checked for ball joint looseness in the same manner even though one system uses coil spring suspension (Fig. 2) and the other uses torsion bar suspension (Fig. 3).

The prime load-carrying ball joint is the one that takes practically all of the punishment and fails first. The other ball joint—in this assembly, the upper joint—is the follower or guiding member. It's checked and replaced, if necessary, only when the prime load-carrying joint is removed from the car for replacement.

With coil-spring suspension, the spring is positioned on top of the lower control arm. With torsion-bar suspension, the bar is fixed to the lower control arm. In both instances, the lower ball joint is compression loaded and the upper ball joint is tension loaded. To check the lower ball joint, which is the prime load-carrying member, raise the wheel by positioning a jack as close to the wheel as possible.

To check the lower ball joint of this setup, raise the wheel by placing a jack beneath the lower control arm as close as possible to the center line of the spring, as shown. This unloads the joint to permit checking of stud-end play or axial movement. Measuring axial movement is done the same for all front-end suspension sys-

Upper ball joint compression-loaded

In the fourth system (Fig. 4), the coil spring is positioned on top of the upper control arm. The upper ball joint is compression loaded and is the prime load-carrying member. The lower ball joint is tension loaded and is the follower member.

Since the coil spring is mounted on the

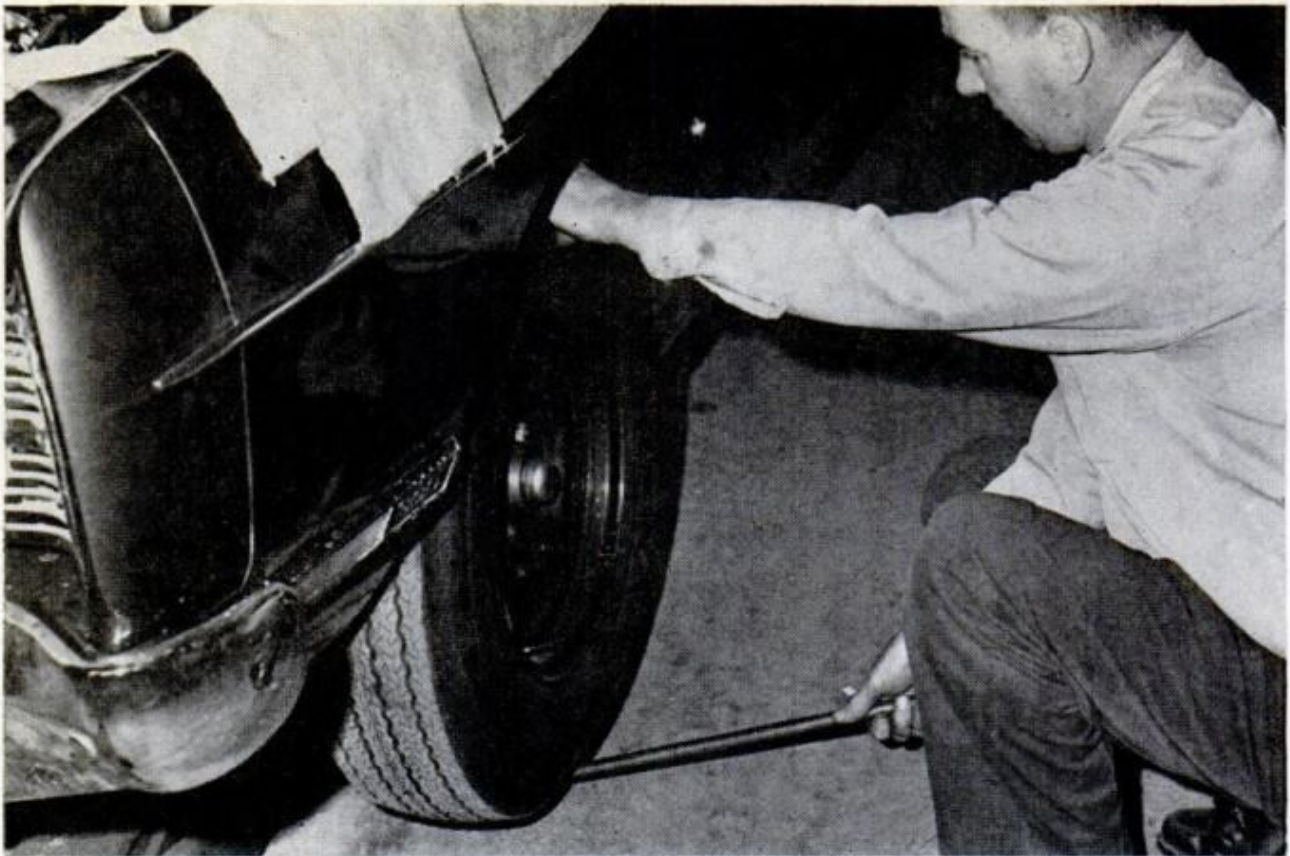

UP-AND-DOWN MOVEMENT of ball joint is checked using a pry bar beneath tire to force wheel up and down

upper control arm, you have to lock out the force of the spring against the control arm to unload the upper ball joint. Place a support wedge between the upper control arm and the front cross member. The wheel is raised by placing a jack beneath the front cross member.

Checking for looseness

Whichever assembly your car possesses, the procedure for checking looseness is the same. The wheel and tire must be off the ground, and the car must be raised high enough to provide clearance for the rubber rebound bumpers.

Rubber rebound bumpers are shock-absorbing elements that are mounted to the frame. If they remain in contact, they place a load on the ball joint, and an inaccurate measurement results.

Place a pry bar beneath the wheel and tire, and force the assembly upward. Note the amount of axial (up-and-down) movement. To get the most accurate measurement, it's best to use a dial indicator that you mount to the wheel. You can buy one at an auto supply store for about \$5.

Allowable axial movement

Now for that most important question:

How much looseness should you permit in a ball joint before replacing it?

I'm of the opinion that some looseness has to be expected as a ball joint does its job over a period of time. If you replaced joints as soon as they started to show some end play, you'd have to have a fat bankroll. Still, you don't want to approach that area of looseness where a ball joint is liable to collapse and leave you without control of your car.

I compromise at .050 inch. If ball joints show more than a .050-inch axial movement, I replace them.

A ball joint that demonstrates .050 inch axial play is not one that's in a critically dangerous stage. However, if a joint gets much looser than this, not only does it start to become a hazard, but steering problems develop.

Some mechanics recommend that ball-joint looseness be checked by measuring side-to-side (radial) movement. I don't agree, because this method of measuring looseness is just not as reliable as measuring axial play. For one thing, axial movement is the true direction in which a ball-joint stud moves within the housing. Furthermore, wheel-bearing looseness has no effect on the measurement as it does when you check radial play.

To sum up the answers to the two questions:

1. To check ball-joint looseness, the ball

joint must be unloaded as described for your setup. (Keep in mind that this is true only when checking ball joints. When inspecting the steering and rest of the suspension system, a load can be maintained on the ball joints.)

2. If axial play exceeds .050 inch, replace the joints.

To round out this discussion, there are two other questions that we should cover. How often should you check ball joints for looseness and should you get involved in replacing bad ball joints?

Periodic inspection

Ball joints should be visually inspected when the car is on a lift for whatever purpose, and whenever you change the oil. Make sure that no grease is oozing from the joint, which would signify a ruptured seal and necessitate replacement of the joint.

The task of checking for looseness can be done whenever you desire. I make it a point to check joints before I lubricate the suspension.

Certainly, you should check them as soon as the car demonstrates symptoms of bad ball joints. These symptoms include excessive play in the steering, scuffed or cupped tires, front-wheel shimmy and wander.

I personally replace ball joints, but I have the tools to do it. Those tools you need depend on how your joints are mounted and fastened. Ball joints are bolted, riveted, screwed or pressed into position.

Joints that are screwed into place require large sockets (1 $\frac{1}{16}$ to 1 $\frac{5}{8}$ in.) for replacement. Those that are pressed into position are removed with special pullers and drive sleeves. Riveted ball joints usually require center punching and hollow drilling.

Since there are several variations and I don't have space to cover them all, I can only advise that you get the service manual for your car and consult that if you're interested in replacing ball joints. In most cases, you shouldn't have trouble if you follow manual instructions.

Once new ball joints have been installed, immediately apply grease to them with a low-pressure hand gun. That done, the front end should then be checked for proper alignment, and the wheels should be balanced.

★★★

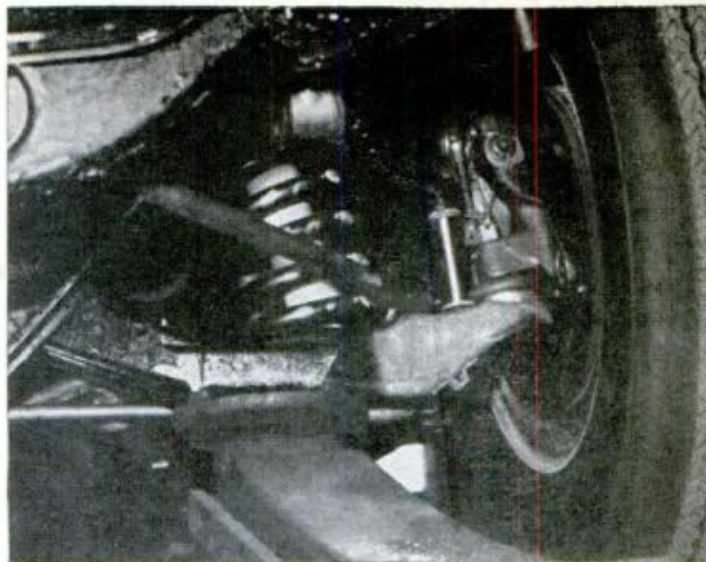

JACK IS PLACED as close as possible to center line of spring to check lower tension-loaded ball joint. Coil spring is on lower control arm. Car is '69 Ford

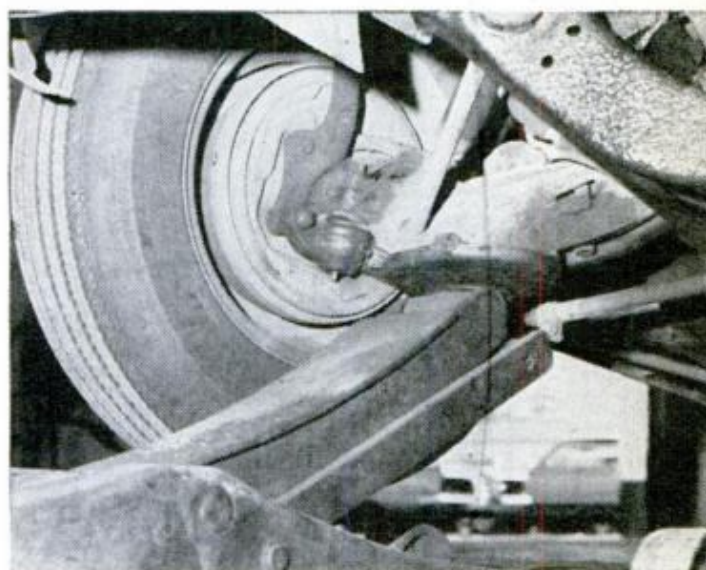

TO CHECK lower compression-loaded ball joint of this 1965 Dodge (which has torsion-bar suspension), jack is placed as close as possible to the wheel

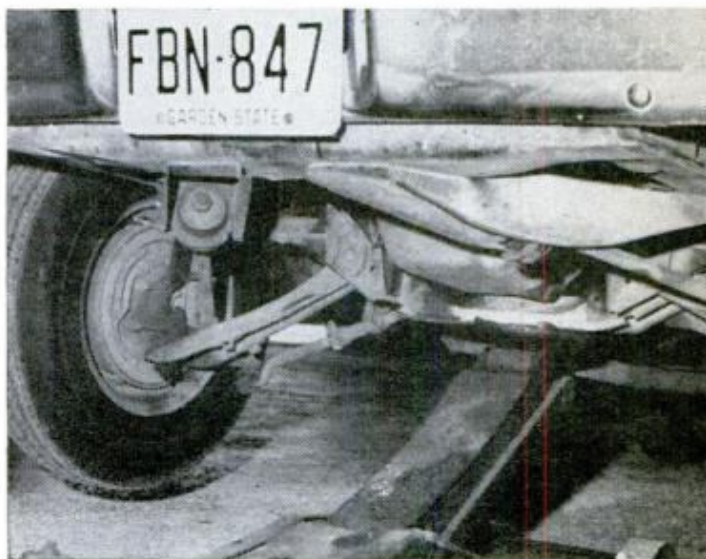

JACK IS PLACED beneath the front cross member to check upper compression-loaded ball joint on this 1967 Falcon. Coil spring is on the upper control arm

EXCITING NEW PRODUCTS

By CATHERINE BILSKI

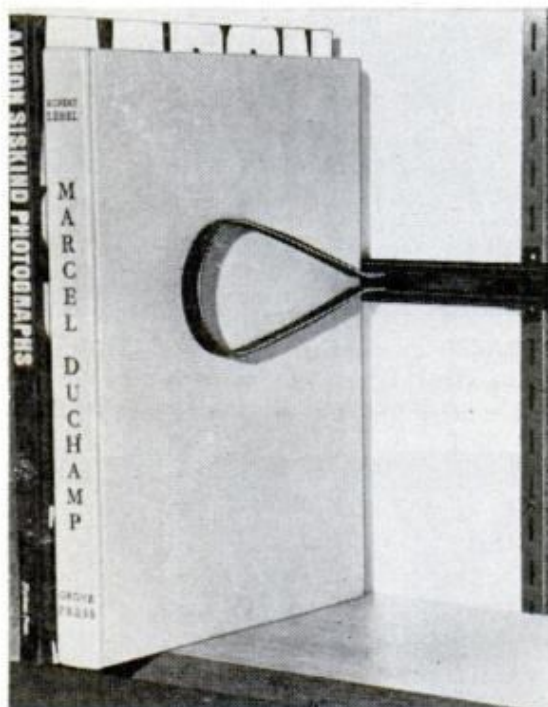

STOP FALLING BOOKS! Unlike ordinary bookends, Protect-A-Book offers two anodized aluminum loops that "squeeze" the books, never let them slip. When compressed slightly, the end loop moves, making possible the addition or removal of books. Prices range from \$3.03 to \$4.78 from Wylde and Co., 333 N. Michigan Ave., Chicago, Ill. 60601.

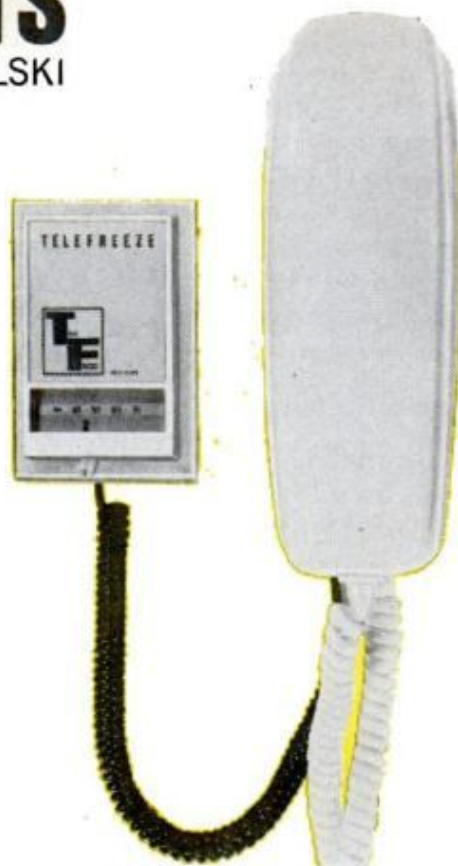

PREVENT PLUMBING FREEZE-UP with a warning system called Telefreeze. The unit enables someone away from home to check if his house-heating system is working. He calls home; if the phone rings, the system is working. If it doesn't ring, his oil supplier should be alerted. The no-heat signal is about \$19.95, the signal with a thermostat about \$35. both from Telefreeze Div. of Ema, Inc., 200 Park Ave., New York.

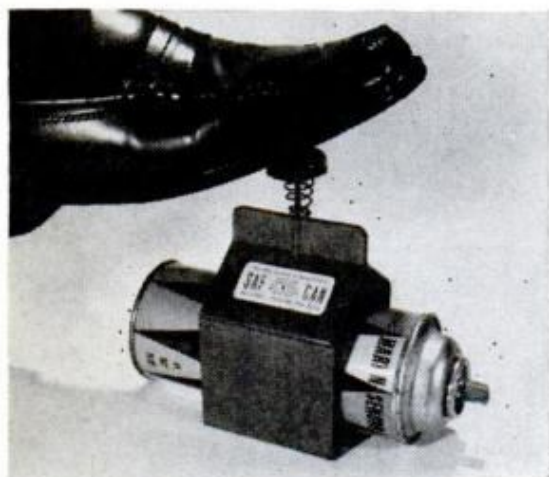

DISPOSE OF AEROSOL CANS the safe way with Saf-Can. Just insert the empty can in the holder and step on a spring plunger. Pierced hole in side of can releases gas, prevents explosion when can is accidentally tossed in incinerator. Unit sells for \$1.75 postpaid from Saf-Can Sales, 8405 Holser Rd., Grabill, Ind. 46741.



AN ANTI-FREEZE that not only guards against cooling-system freeze-ups and corrosion, but also seals radiator leaks (and keeps them sealed), is Du Pont's new Anti-Leak "Zerex" Anti-Freeze. Other products to help winterize your car are Windshield Washer Anti-Freeze and Cleaner, Windshield De-Icer, and Gas Line Anti-Freeze. All are made by E. I. du Pont de Nemours & Co., Inc., Consumer Products Div., Wilmington, Del. 19898.

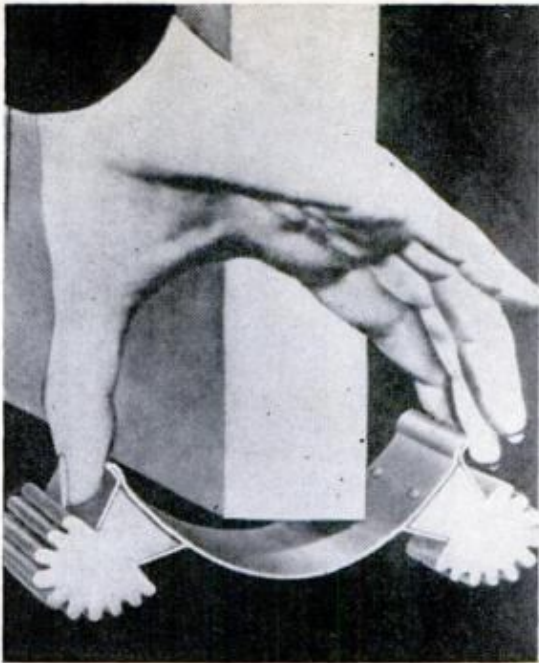

HOLD DOORS OPEN at any desired position with this simple, flexible device. Made of spring steel with non-marring rubber grippers, it can't scratch floors or hurt carpets. Sells for \$1.25 from Craft-Mark Products, Station A, Box 113, Flushing, N.Y. 11358.



YOUR CHRISTMAS TREE can be kept fresh and green throughout the holiday season with a preservative made from regular chlorinated bleach, light corn syrup and a horticultural micronized iron called Green Garde. The latter is available at garden-supply, florist, hardware and variety stores. Made by Encap Products Co., Box 425, Park Ridge, Ill.



AVOID COSTLY FREEZE-UP DAMAGE to outside faucets or hydrants with Little Dropper, a thermostatic unit that lets an open faucet drip water whenever the temperature drops to the freezing point. Sold for \$5.10 postpaid by Del-Mar Products, Box 26663, Houston, Tex. 77032.

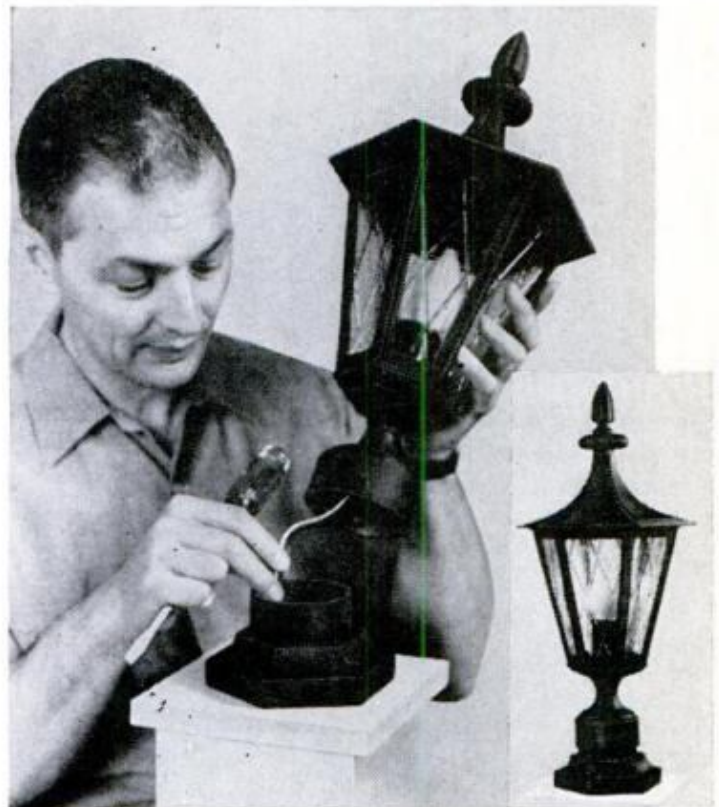

A SIMPLE BASE for mounting post lanterns is being marketed by Artolier Div. of Emerson Electric. The attractive base, constructed of rugged, durable cast aluminum, is ideal for gateposts and wall installation. It's available in six finishes to match that of your lantern. For more information, write to Artolier Lighting Div., Emerson Electric Co., 141 Lanza Ave., Garfield, N.J.



**Special 12-Page
SAVE-IT SECTION**

Garage-Wall Storage With a Place to Fix Things, Too

DOUBLE-DUTY BUILT-IN provides both work and storage space, takes only two feet off the end of a garage. Long benchtop is handy for car and yard-tool fix-it jobs. Detailed plans (No. AE-101) are available from Masonite Corp.

30 SMART IDEAS FOR PUTTING SPACE TO WORK

Looking for more storage room? Today, the answer isn't just another trunk in the attic. In the modern equipment-packed home, you need to hide things away and still have them at your fingertips, ready for instant use. There's the movie projector, the hi-fi rig, your prized fishing, hunting and photographic gear, countless tools and toys, games and hobby supplies, skis and tennis rackets and baseball bats, kitchen and laundry appliances, a model train or road-race set—all must have their place yet be kept handy if you're going to use and enjoy them. Here, PM brings you 12 pages of versatile, space-saving storage arrangements that can make living more efficient and more fun.

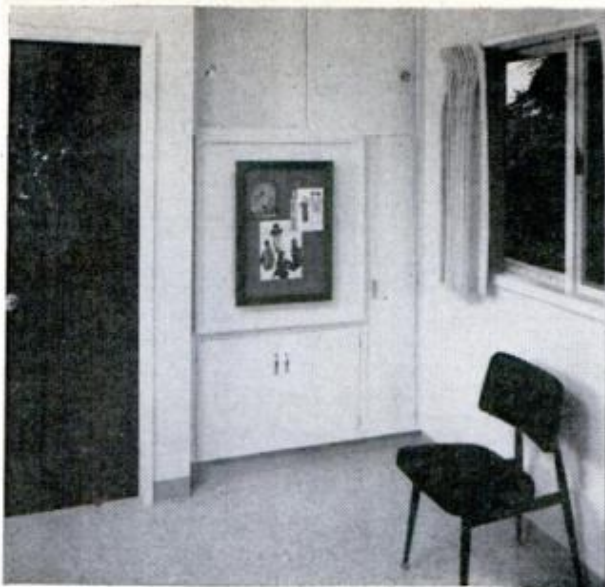

A Work or Hobby Center With a Drop-Down Table

HIDDEN NEATLY in the wall, this fold-out work center is ready in an instant for Mom's sewing or family hobbies. Shelves and drawers behind the drop-down worktable store supplies. Tall cupboard at right-hand end is big enough to take an ironing board or guns and fishing rods. Hinged leg, designed to look like a decorative wall panel, swings out to support the table's outer end.

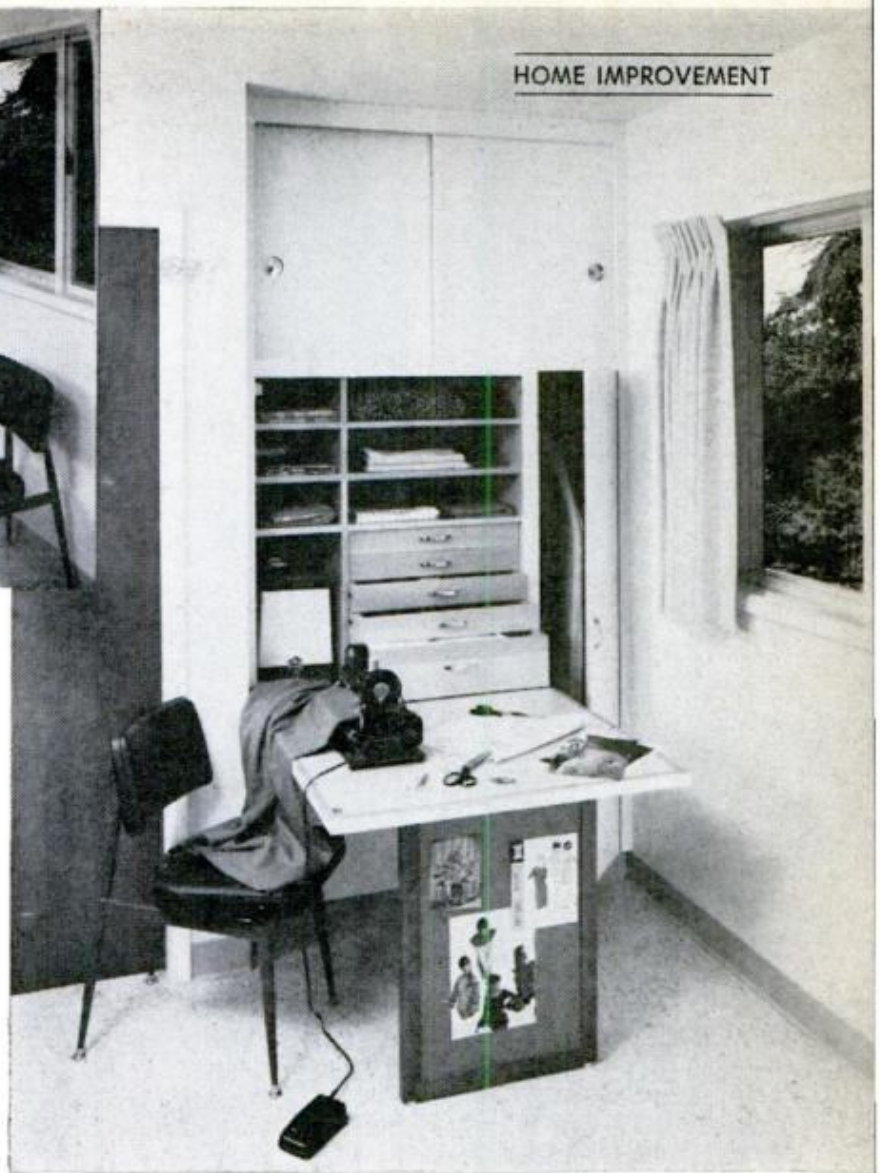

Make Use of the Space Over a Car

DESIGNED TO HANG over the hood of a car, this L-shaped storage unit takes advantage of normally wasted garage space. It's perfect for garden supplies, extra tires, folding patio chairs and similar items. Side panels of Masonite perforated hardboard (Pegboard) provide additional space on the outside for hanging tools. If ceiling is low enough, you can fasten the unit directly to it. If not, suspend the outer end on chains or cables anchored to the ceiling with screw hooks. Inner end of unit is fastened to wall, either with screws into studs or expansion anchors into masonry. Complete construction plans for this project are available from Masonite Corp., 29 N. Wacker Dr., Chicago, Ill. 60606.

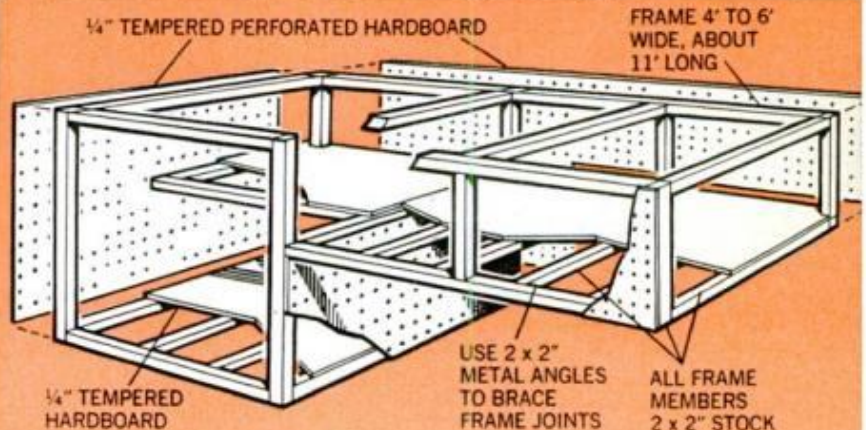
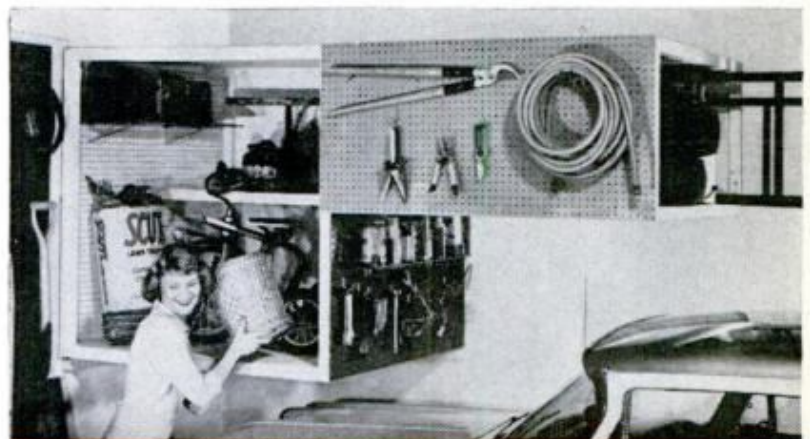



Two Slick Tricks for Building Storage Walls

INTERCHANGEABLE STORAGE UNITS slide in and out on tracks in two clever walls above. At left, strips of grooved Texture 1-11 plywood provide ready-made slots. Get plans for 10 cents from American Plywood Assn., 1119 A St., Tacoma, Wash. Right, bevel siding nailed upside down forms support ledges. Plans are 10 cents, Western Wood Products, Yeon Bldg., Portland, Ore.

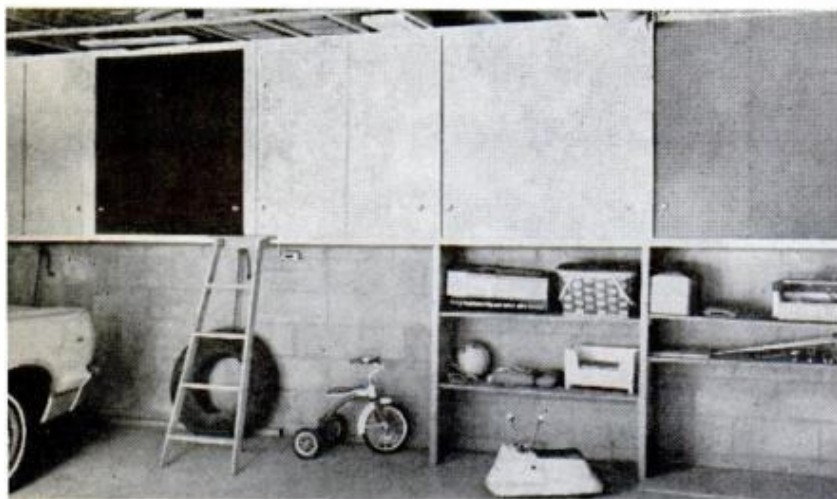
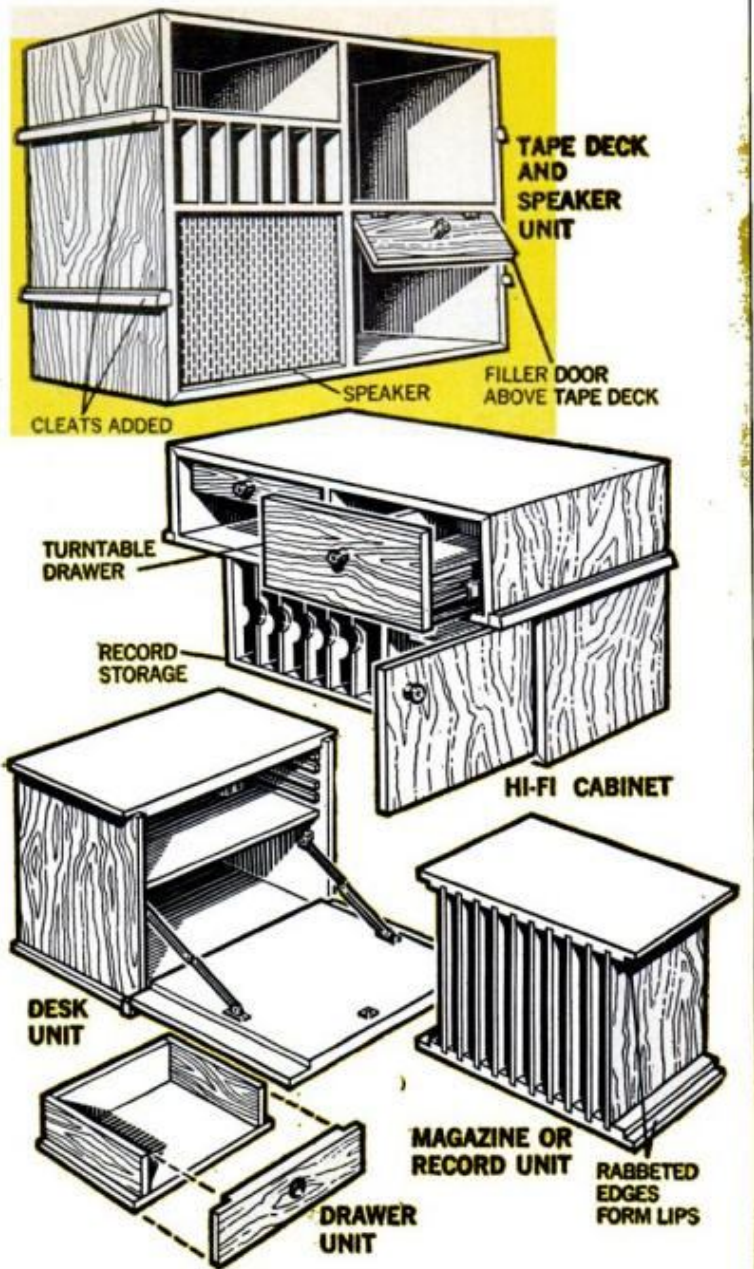

Overhead Cabinets Hide Clutter Along a Garage Wall

HIGH OFF THE FLOOR, wall-hung cupboards don't block car, leave parking space underneath for bikes and other bulky gear. Each 3-foot-wide section is a different color for a gay appearance. Doors of perforated hard-

board cost little and provide ventilation to prevent mildew inside. Front half of an old stepladder rested against cabinets is handy for reaching upper shelves. For added storage, full-length cabinets (right) can line side walls.



30 SMART STORAGE IDEAS



Two Ways to Use Wasted Attic Space

LOW-HEADROOM NOOKS under the eaves can be put to good use for storage. Scallop-topped "fence" at left, above conceals a row of shelves and clothes poles. Leaving top part open to the ceiling makes room seem larger than if it were closed in. Tree branches painted on wall behind give illusion of a distant garden scene to increase feeling of space.

SLOPING BUILT-IN at right packs a lot of storage in a little space, even has a drop-down desk. Side doors give access to rear compartments. Plans are available from American Plywood Assn.

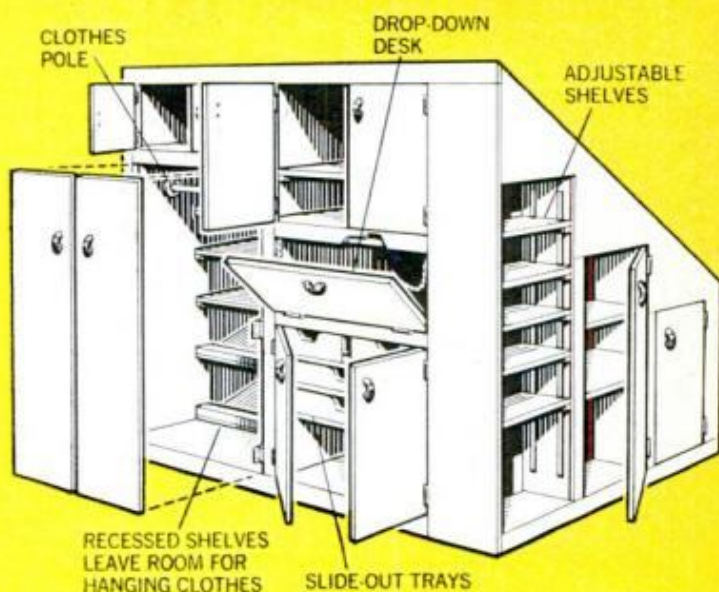

Three Ways to Make Kitchen Cupboards More Efficient

SLANTED SHELVES in cupboard at left work like supermarket racks. Cans, stored on their sides, roll down to you as you lift front ones out. In center photo, shallow shelves are used in place of conventional overhead cabinets.

Cans and jars are easy to see, can be reached without having to move items in front to get at others in back. In cupboard at right, closely spaced shelves and vertical dividers keep trays, platters and flat pans neatly sorted

An Appliance Center That's Also a Convenient Snack Bar

THIS MODERN HUTCH stores appliances and lets you use them at the same time. Outlets at the back enable you to keep toaster, percolator, food blender and other electrical appliances plugged in, ready for use. A hinged panel swings up to form a serving counter. Doors and sides are a clever sandwich of $\frac{3}{8}$ -in. plywood with two kinds of Marlite paneling cemented to it—wood-grained outside, solid color inside. Get plans from Marlite Paneling, Dover, Ohio 44622, or West Bend Co., West Bend, Wis. 53095.

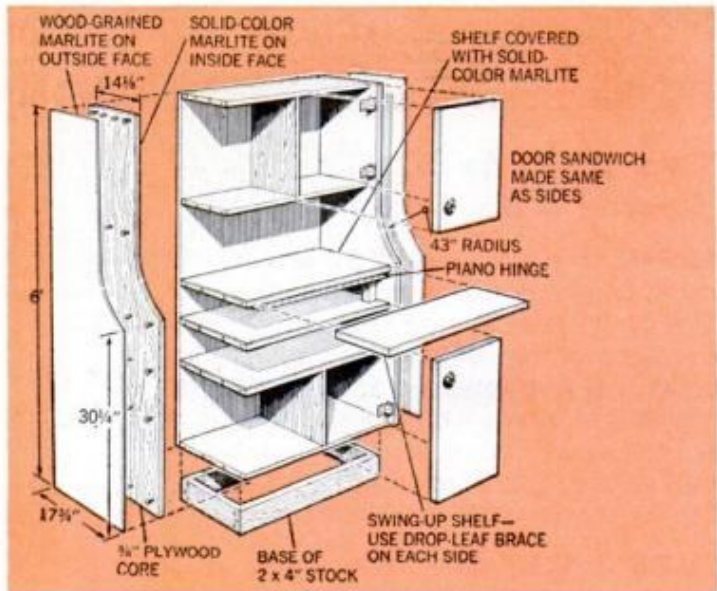

HOLLOW SPACES behind false walls can hide hard-to-store items like the Ping-Pong table at right, below. If you're paneling a wall, especially in a basement, it's often a good idea to locate your framing so it leaves a few inches between it and the old wall. This will provide room for recessed shelves, built-in hi-fi equipment or storage compartments such as the one here. In the wall shown, one four-foot-wide sheet of hardboard paneling is removable, creating a big opening so the Ping-Pong table can easily be slipped in and out. Magnetized catches hold the paneling so there's nothing to show from outside.

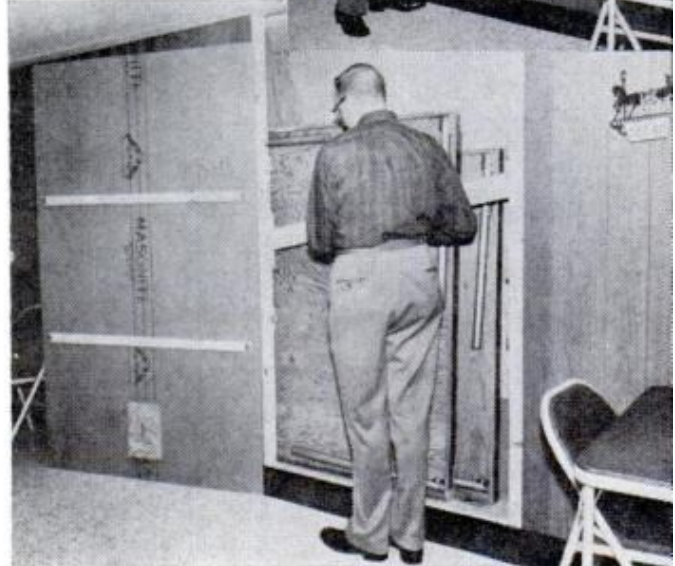

STORAGE CAN BE HANDSOME as well as functional. These open shelves at the foot of a stairway display decorative objects, while the larger base cabinet conceals less-showy items behind louvered doors. Such a unit not only adds storage space, but can also serve as an attractive room divider, in this case helping to screen off the stairway from an adjoining living room.

Entertainment Wall With a Handy Work and Study Counter

MULTIPURPOSE BUILT-IN is room divider, storage wall, hi-fi center and worktable all rolled into one. Front panels house tape deck, amplifier, stereo speakers, TV set. Surrounding counter adds workspace for editing tapes, doing school homework and similar chores. Wood-grained Celotex panels give wall handsome appearance, yet are inexpensive.

30
SMART
STORAGE
IDEAS

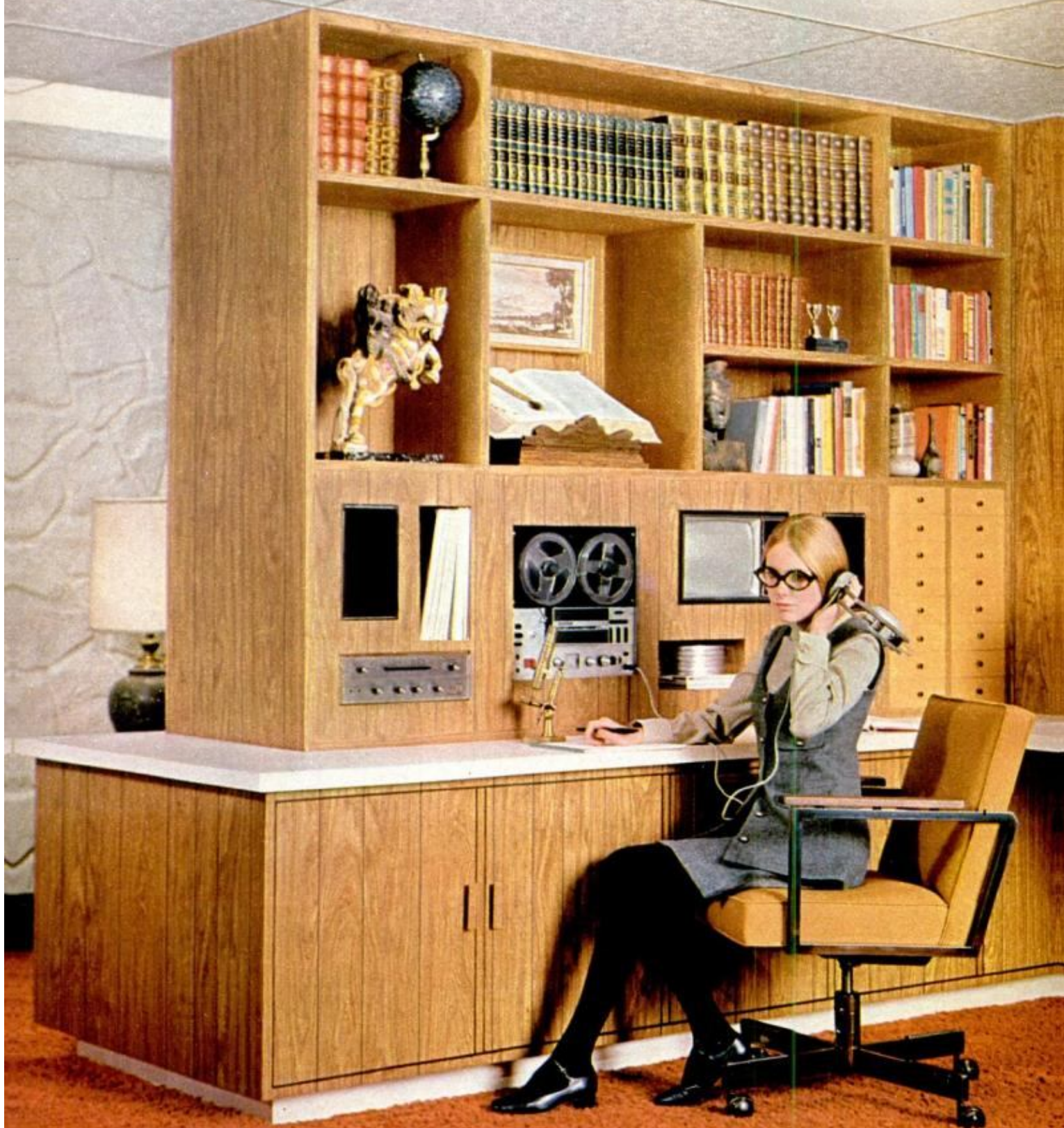

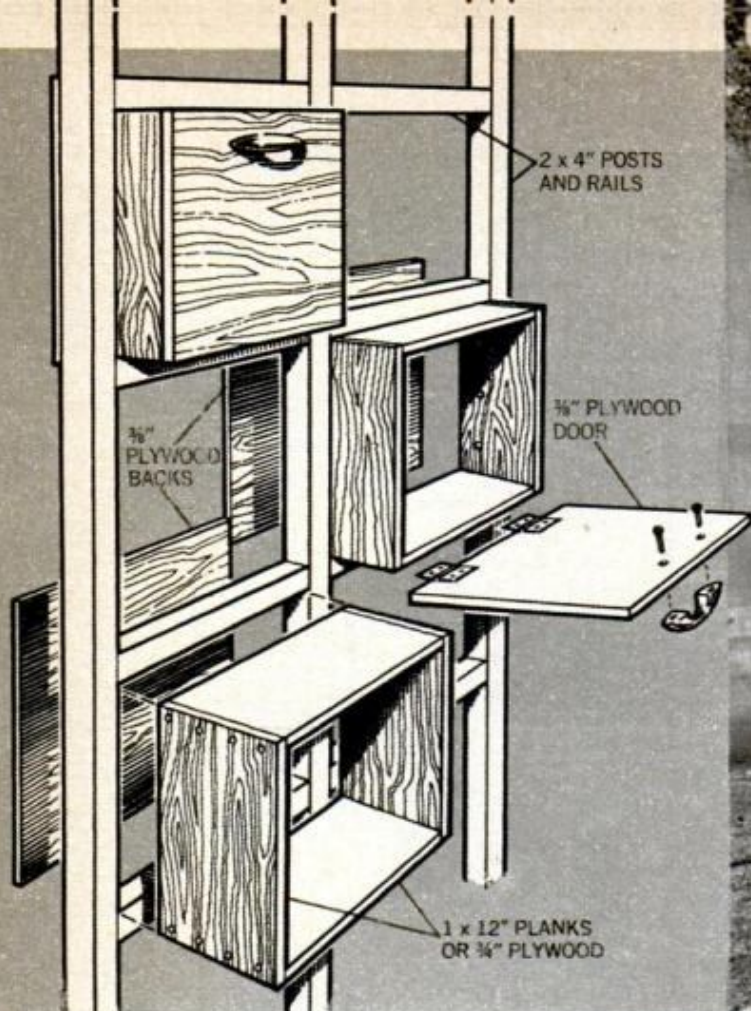

30
SMART
STORAGE
IDEAS

A Privacy Wall That Stores Things, Too

WALL OF CABINETS in a pleasing staggered arrangement gives shade and privacy and at the same time stores garden supplies, barbecue utensils and other outdoor items. Cabinets can be built under an existing structure, such as along the open side of a carport or porch, or they can be part of a garden shelter, as here. If wall is load-bearing, use four-by-four posts instead of two-by-fours shown in drawing. Note that backs of cabinets are extended to overlap posts and cross rails. This adds extra bracing and helps strengthen wall. Simpson Timber Co., Seattle, Wash., designed the storage fence around use of redwood planks and posts for good resistance to rot and weathering.

Build Your Own Home Movie Theater

MINIATURE PROJECTION BOOTH—actually an unused cellar alcove closed in with pine paneling—not only stores photo equipment out of the way, but lets you leave it set up for quick use. Swiveling projector platform at right holds a Kodak Instamatic Super-8 machine alongside a 16-mm model so either can be run without disturbing other. A slide and movie projector could be paired in the same way. Left-hand photo on opposite page shows projection window and smaller viewing port for operator to see. Screen is mounted behind doors at far end of cellar (photo, far right).



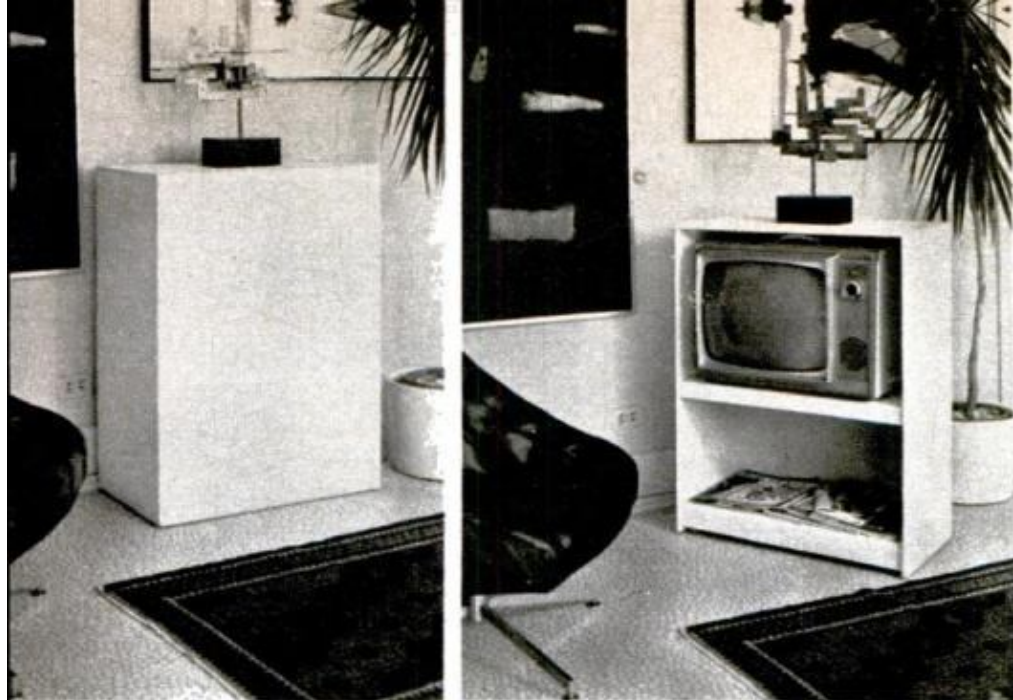

TV Caddy Puts Best Face Forward

MOUNTED ON CASTERS, this mobile cart for a TV set can be turned to give the best viewing angle, depending on where watchers are seated, or even rolled from room to room. When not in use, TV can be turned to face the wall, as at far left, to conceal its blank screen. Casters, mounted underneath a recessed bottom, are fixed in front and swivel at back for easy maneuvering. Cart of plywood is covered with painted burlap.



HOME LAUNDRY CENTER like one at left designed by Maytag combines washer and dryer with shelves and a work counter for easing washday chores and storing supplies attractively. Wall of perforated hardboard at back supports shelf brackets and other hook-in fixtures. Three-section tilt-out bin under counter makes it easy to sort soiled clothes.



HANDY BOOT CUPBOARD at right keeps wet and muddy overshoes out of sight, lets them drain harmlessly into bottom drip pan. Boots rest on slide-out rack of perforated hardboard; removable baking tin below catches drips.





Double-Decker Bunk Is Also Room Divider

FACING OPPOSITE WAYS, these over-under bunkbeds help to divide a room for youngsters of different ages and interests. On one side, lower bunk doubles as couch when area is used for teenage get-togethers. On other side, a train board drops down. Study desk swings out from end. Celotex V-grooved panels cover bunks and walls.



SLIDE-OUT TRAIN BOARD goes to bed along with its owner, storing neatly away underneath. Its sloping design lets it fill the opening under the bed when pushed in for a trim appearance, while leaving the sides and back unobstructed for reaching the trains easily. Extra train equipment is kept in cupboard that forms bed's headboard. For plans, write to American Plywood Assn., 1119 A St., Tacoma, Wash. 98401.

Under-Bed Hideaway for Model Trains

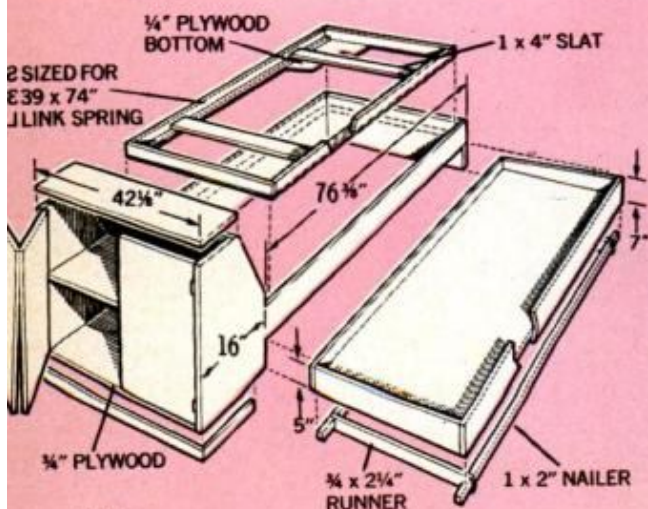

30 SMART STORAGE IDEAS

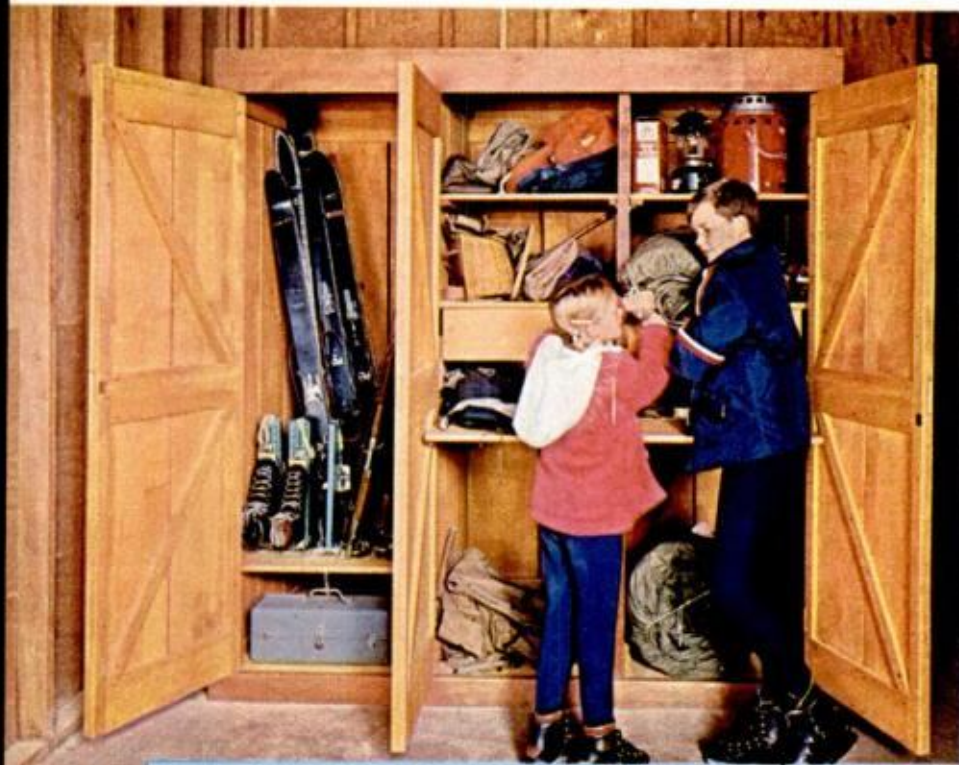

Sportsman's Catchall For Hard-to-Store Outdoor Equipment

SPECIAL COMPARTMENTS in this roomy storage unit take all the bulky things that never seem to fit anywhere—campstoves, sleeping bags, fishing-tackle boxes, ski boots, life jackets and similar outdoor gear. The tall section on the left side lets you slip skis, fishing poles, boat oars and other long items down behind a shelf where they're kept out of the way at the back. A hinged shelf swings out to provide space for working on equipment. Above this are two drawers for small items like fishing reels and ski goggles. Plans for the closet are available for 25 cents from Western Wood Products Assn., 535 American Bank Bldg., Portland, Ore. 97205.

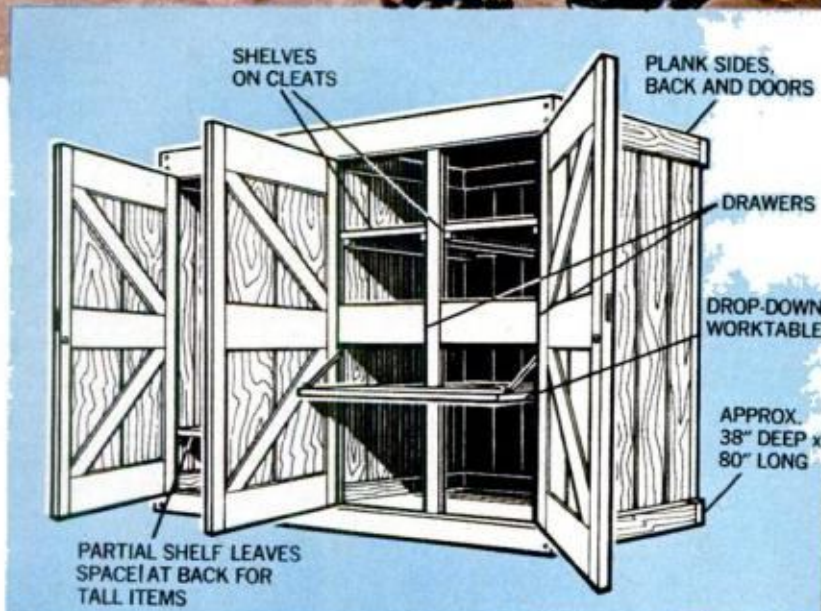

Easy Way to Put A Wall to Work

A COMBINATION of perforated paneling and floor-to-ceiling poles creates this unusual storage arrangement for a playroom, den or boy's bedroom. The square two-by-two poles, spaced about a foot away from the wall, support the front edges of shelves, while the rear edges rest on shelf brackets hooked into the paneling's holes. A small desk is also suspended between the poles. Special Georgia-Pacific V-grooved hardboard paneling has perforations in upper two-thirds and is solid at bottom for a trim wainscot look.

DECEMBER 1969

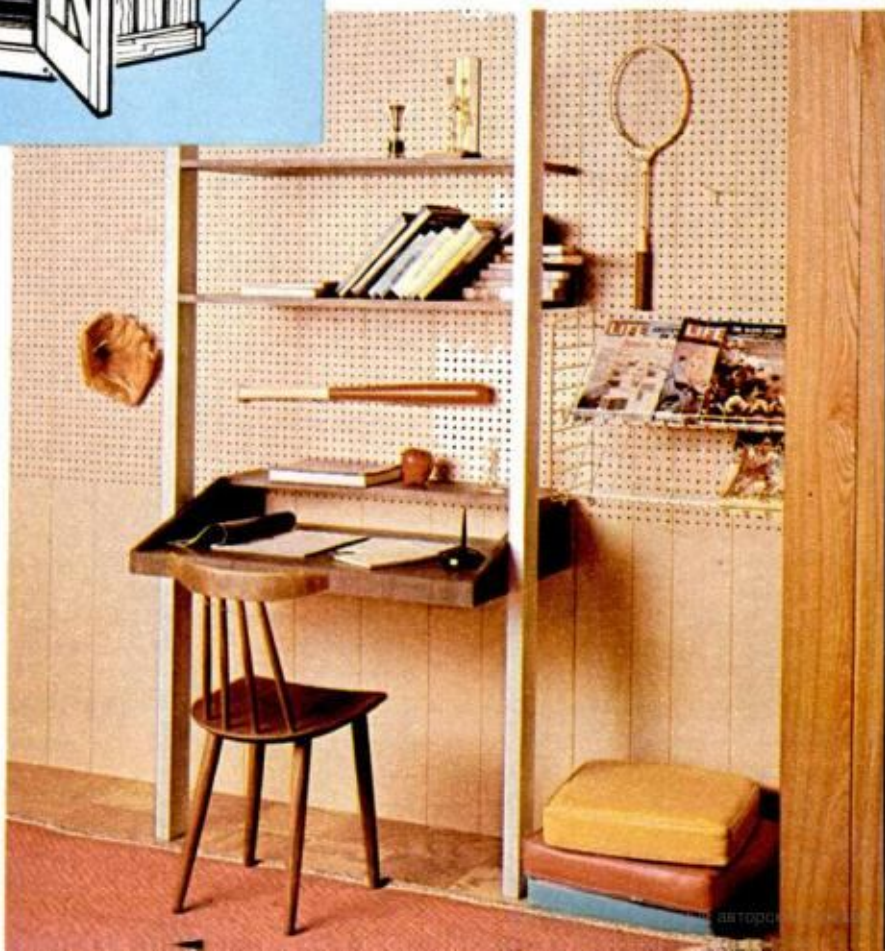

Three Ways to Turn a Closet Into Added Living Space

AN UNUSED DOUBLE CLOSET becomes a small home office at left. Lined with a bright checkered wallpaper pattern, it provides enough room for a typing table and file cabinet. With doors closed, it's quickly hidden from view.

A similar closet is converted into an attractive vanity alcove in left-hand photo on opposite page. Shallow shelves and drawers at back hold toiletries, yet still leave space for hanging clothes. Inset photo shows handy sloping shoe rack under drawers. Makeup mirror is indirectly lighted from recessed fixture above. At far right, single closet with doors removed becomes a bookcase, helping to make small room seem bigger.

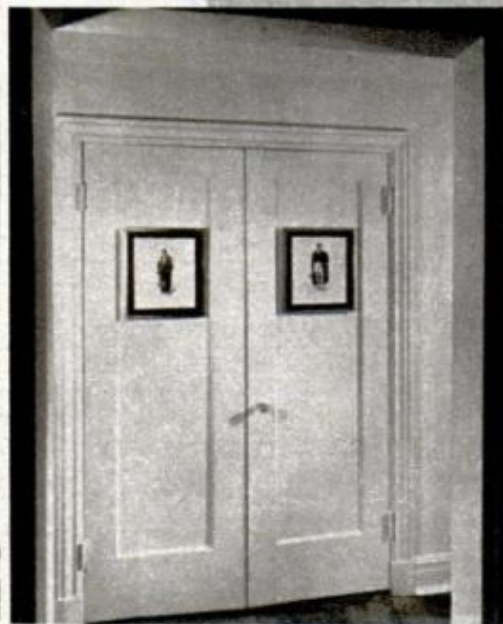

PADDED BENCHES along a wall are an easy way to gain extra seating space and at the same time add storage room inside. Bench at right makes use of space at one end as a bin for fireplace logs. Additional compartments along the bench hide assorted household items behind cupboard doors. Lift-up seat-tops are another good way to get at space inside a bench and save the framing and fitting required for doors. Such under-bench bins are ideal for holding a slide or movie projector, musical instruments, record collections and stacks of sheet music or old magazines. Slide-out drawers can also house a phonograph and other hi-fi equipment. Bench can be sized to take stock cushions, usually available in 18, 20 and 24-inch squares.

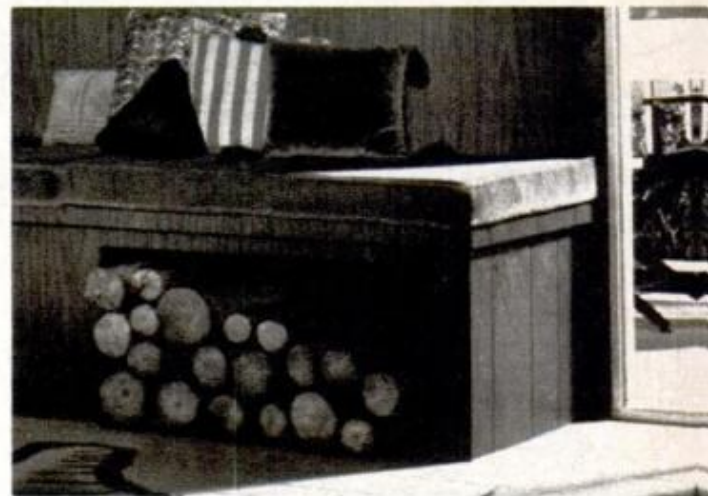

SWING-UP TOP on this versatile hobby bench opens to provide a convenient work area underneath for building models, electronic kits and other small projects. With the top closed, delicate parts and partially assembled projects are protected from damage between sessions. Upper surface also serves as a desktop for doing homework. The design permits quick cleanup since tools and parts don't have to be put away—you just close the lid down over them. Sides around the work area keep tiny pieces from getting lost. Adjustable shelf standards on the walls store supplies and display completed projects handsomely. They can be put up in various irregular arrangements, as here.



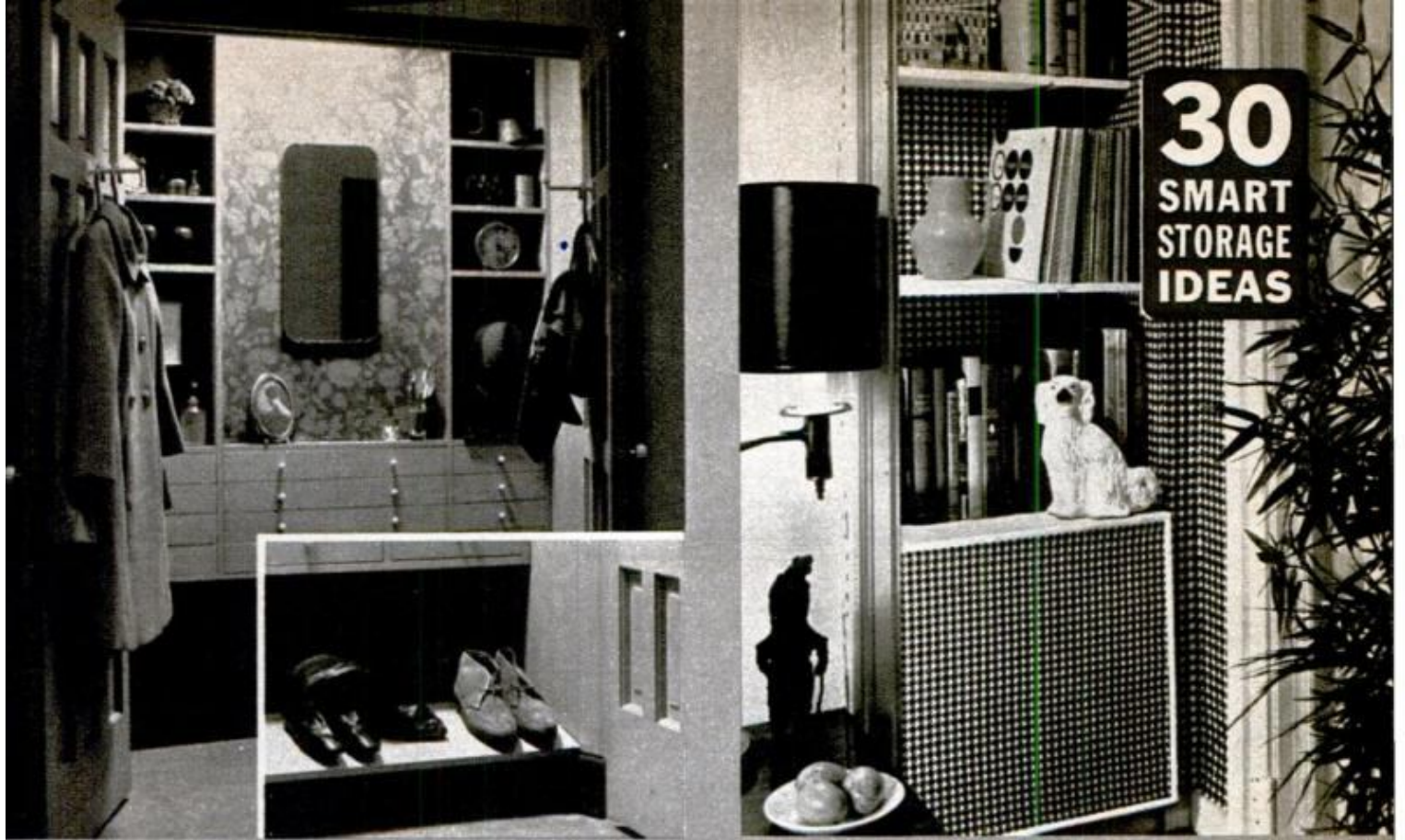

**30
SMART
STORAGE
IDEAS**

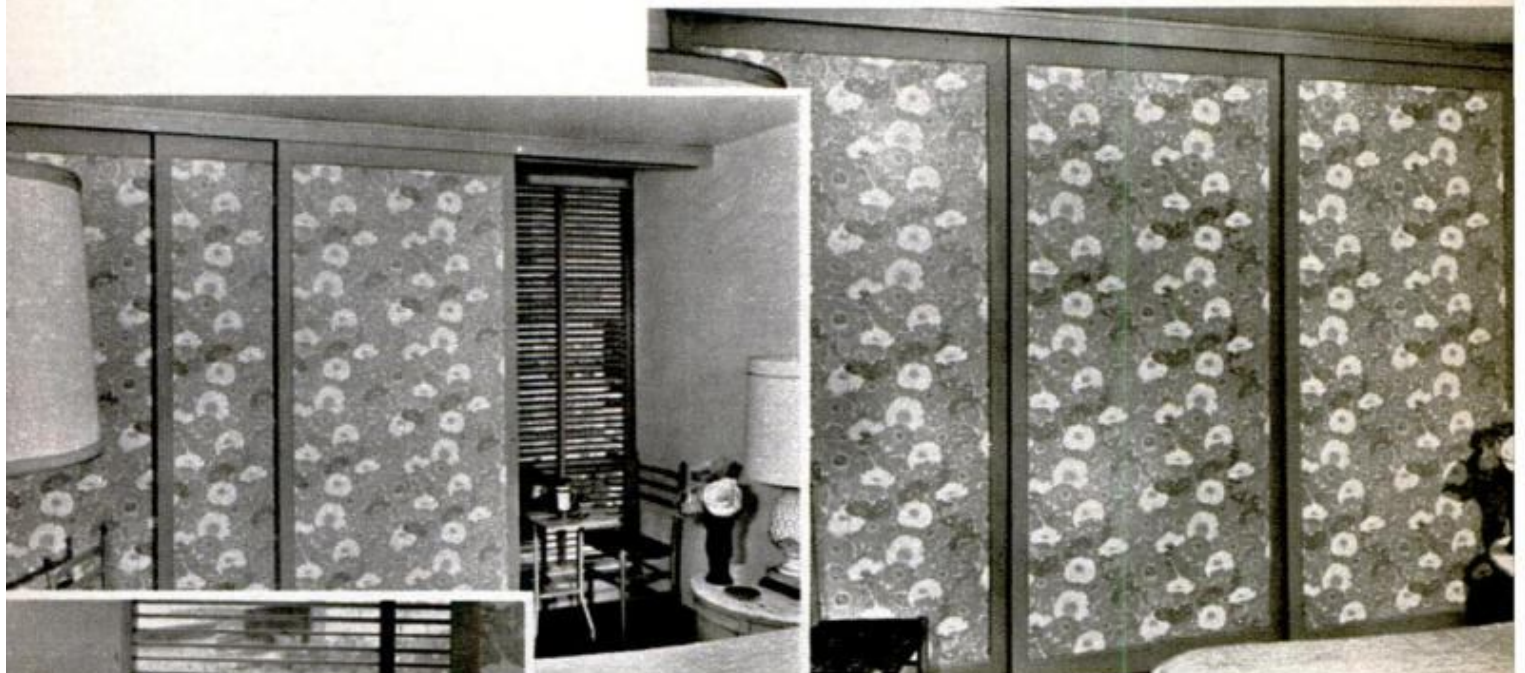

**Can't Find a Place for It?
Put It Behind a Sliding Wall**

STEALING A SMALL SLICE off an existing room can often give you needed space for special activities. A sliding partition like one above can hide a sewing nook for Mom, a hobby bench for Dad, a bar for parties and similar equipment that must be readily available without sticking out like a sore thumb. It's also useful for screening off a TV set or airconditioner, as at left. Wall shown here is made of framed plywood panels wallpapered and sliding in floor and ceiling tracks.

Conquering Minnesota's

Few travel this route in summer, let alone in winter. But now you can penetrate this tough, deep-freeze paradise



CHARGING from the smooth surface of a frozen lake to the tough terrain of a snow-covered portage is a real test of men and equipment. Our wilderness trail, a canoe route in the summer, took us over several such portages

AT DUSK you start a campfire, tell a few stories, then head for sleeping bags as temperature drops

THE SNO-CRUISER is like a tent-trailer. The tent folds down into a low-profile sled for towing

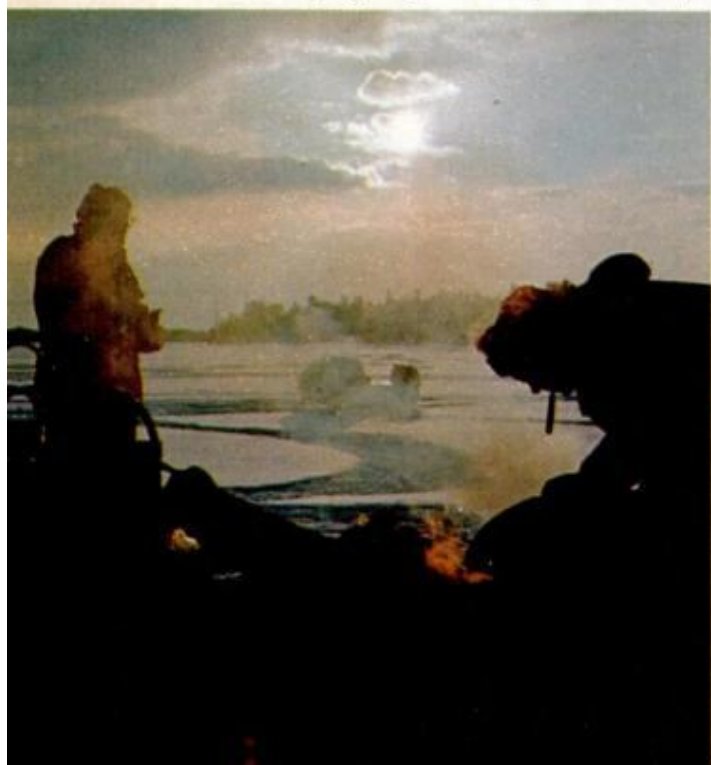

Wilderness by Snowmobile

By DAN FALES

Photos by Rohn Eng

WOLVES, NORTHERN LIGHTS, lake trout, frosty trees and freezing cold are all part of any snowmobile trip into the wild, wild Minnesota wilderness.

By penetrating the Boundary Waters Canoe Area in winter, you can enter a silent world that's seldom seen even in summer. The canoe wilderness is a mammoth section along the Minnesota-Canada border. Protected by law from motors, most of the "park" is accessible only to canoeists or snowshoers. But there are several trails open to motorized vehicles—outboards in summer, snowmobiles in winter. The portages in both seasons are tough. But in winter, "portaging" (as the local guides call it) with a snowmobile really tests your skill and equipment, even though you don't physically carry the snowmobile over your head like a canoe to get from one lake to another.

If your machines are good, if the weather holds, if you want to go deep into the wilderness in winter, this is the place to come, be it weekend or longer. However, traveling this country is no cakewalk. Things go wrong. Experts Curley Kruger and Dick Marsh make my trip possible.

Dick is general manager of Canadian Waters, an outfitting company in Ely,

SPEEDING over the flat lake ice is the easiest part of the trip. We make good time on these stretches



ON PORTAGES the moguls and hills can make it tough. We found we had to push a lot to get through





A TIMBER WOLF is carted out of the wilderness on a snowmobile by a game warden we meet during trip

MAP shows section of the Boundary Waters Canoe Area that we traveled. This is not the only route for snowmobiles; several others are open to machines

Minn., owned by energetic brothers Dan and Jon Waters. Curley is an old-time bosun's mate who's found "home" surrounded by the land of the United States and Canada, plus hundreds of freshwater lakes. He's chief "doer" for the Waters.

It's with these two as guides and with Rohn Eng as photographer that I enter the wilderness on frozen Moose Lake about 20 miles northeast of Ely. From here we will travel over seven lakes and six land bridges to our base on Knife Lake.

Speeding over the flat lake ice is easy. Our four snowmobiles pull two supply sleds and a Sno-Cruiser—a fold-up tent that's easy to tow on snowmobile runners.

Trouble hits on the first portage. After a mile of traveling over unbelievable, six-foot-high snow mounds, called moguls, a sled hitch breaks. We quickly bring up the free snowmobile, hook up the sled and travel on. Before we get back home, we will have overcome three broken hitches, a broken sparkplug wire, a sheared transmission pin, a broken windshield due to a roll-over on a portage, a pulled-out starter rope, a frozen carburetor, a frozen tool-pouch zipper—and abandoned one supply sled because of hitch trouble. Given the tough weather and tough terrain, it's amazing that our trip goes so smoothly.

Six hours after starting, we set up camp on Knife Lake. We now jig for lake trout through holes in the ice; have dinner of trout and stew; feel the temperature drop to 15 below, and watch the sky in awe as the northern lights play tricks after dark.

By 9:00 p.m. I'm bedded down, having made a foolish mistake as the temperature

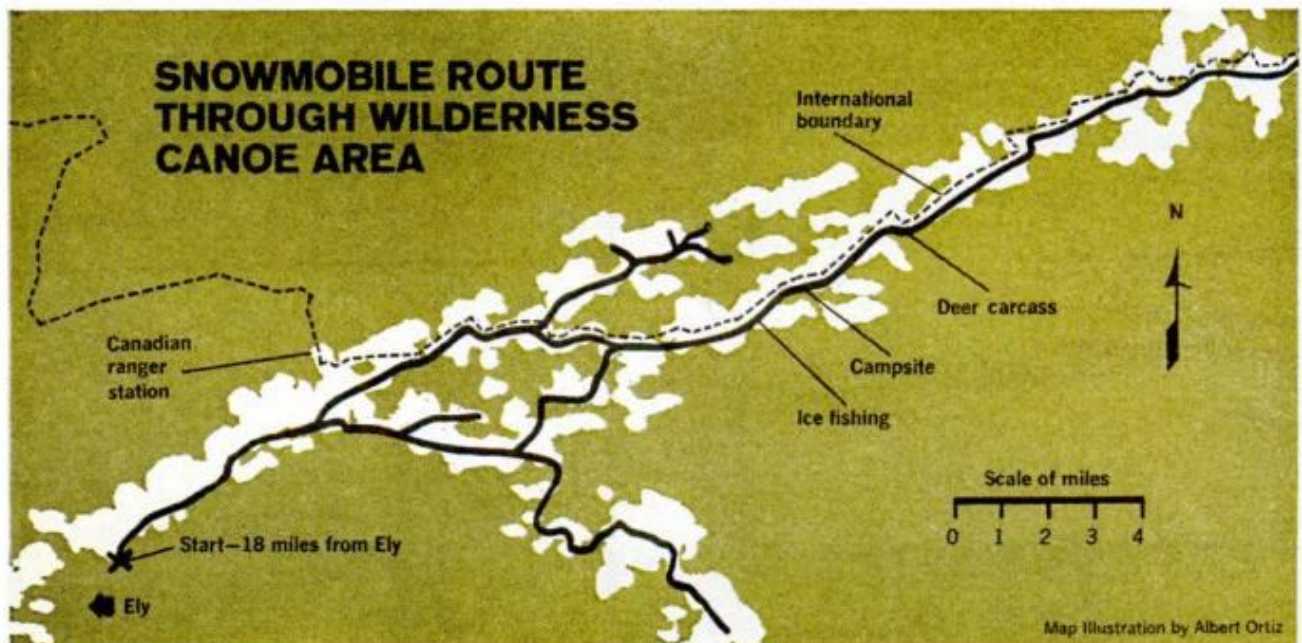



DEER CARCASSES are evidence of continuing struggle in the wilderness. This one was apparently cornered by wolves and then attacked. You can follow tracks of deer and wolves on all the frozen lakes of the area

goes to 25 below. Though I wisely removed all but my long johns before piling into my sleeping bag, I left my socks on. They're damp from use. By midnight my feet are freezing. My socks are still not dry, so I yank them off. I put them under my back along with the inner felts of my snowmobile boots. Boot felts, I am wise enough to know, need nighttime placement in a sleeping bag. If they're left in your boots, you'll never get the frozen forms on your feet come morning.

The other item that should be carefully put in sleeping bags at night is spark-plugs. Nonfrozen plugs are needed to start frozen snowmobile engines in the morning. I must admit I didn't do that the first night. Even so, my Mercury started without much trouble the next day, though for some unknown reason I could only start it in reverse.

The next day I roam out looking for wildlife. And do I find it!

It's only an hour after breakfast that a game warden zips by with a dead timber wolf strapped to his snowmobile. And an hour after that I spot the carcass of a deer recently felled by a pack of wolves.

Soon we reach our destination in the wilderness and turn back over the portages and the lake ice. Finally, we push the machines into pickup trucks.

Now, at a typewriter months later, I realize I miss this wilderness in winter.

If you are the kind who likes a wilderness trip sprinkled with a little adventure and a little work, then you should tackle the Canoe Area this winter. But I strongly suggest that you take along a guide who knows the North, who knows the cold, who knows how to handle a blizzard. Be prepared, for it's all worth it. ★★★



TAKING NOTES is part of my daily routine in camp. Snowshoes (by tent) are a must for a wilderness trip



RELAXING in the "warm" winter sun and listening to the wilderness sounds is also part of my routine

Swipe a few ideas from the trades and solve your tricky basement problems easily. Here's how you can . . .

Finish Your

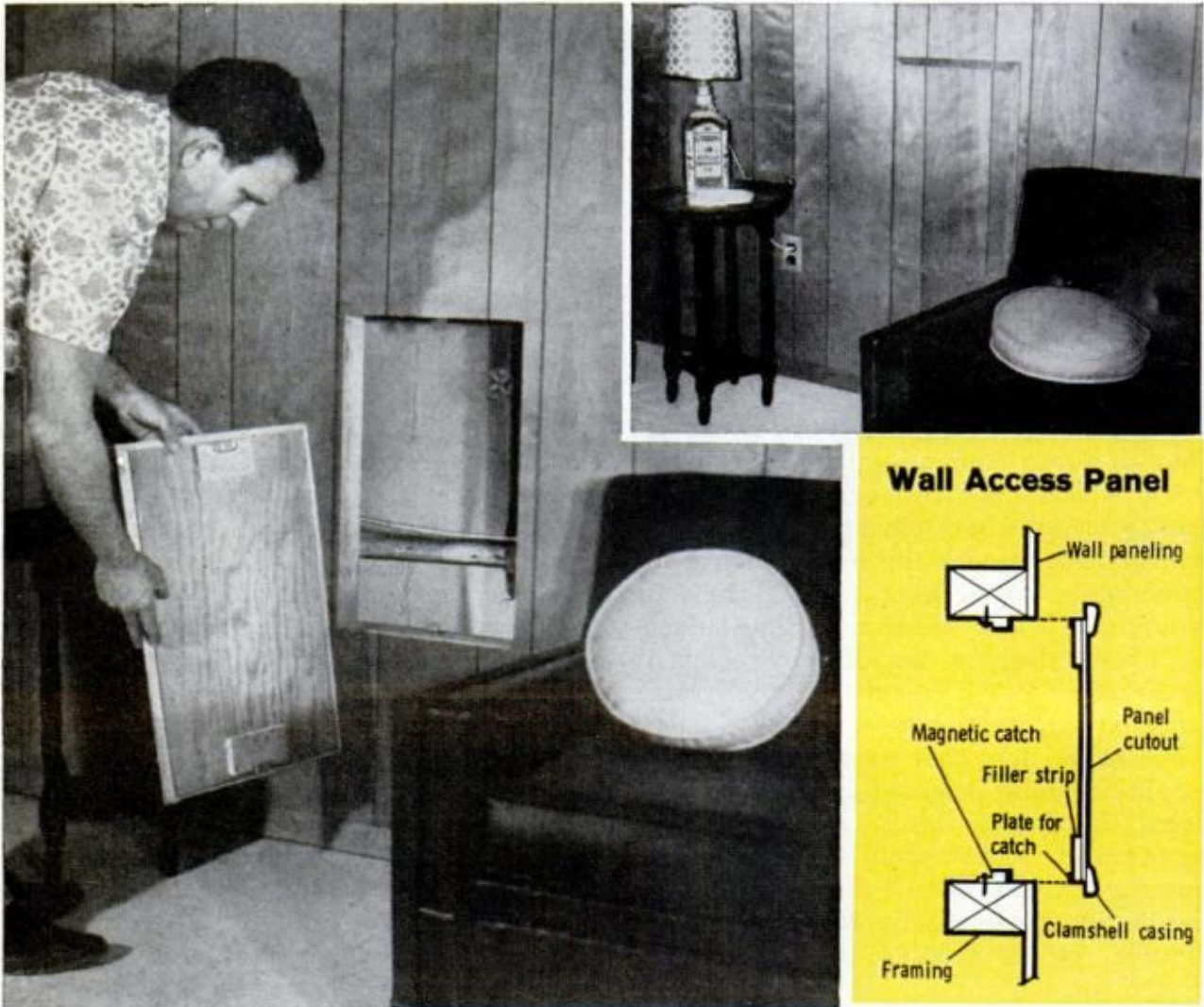

WATER SHUTOFF VALVE is hidden by panel that is practically invisible because there is no exterior hardware. The "door" removes quickly—a feature that is a must in an emergency; two magnetic catches hold it in place and cost only pennies to install. To minimize the chance of $\frac{1}{4}$ -in. paneling warping in a warm basement, use contact cement to glue cutout to $\frac{1}{2}$ -in. particleboard before fitting magnetic catches

By **JOHN GAYNOR** and **HARRY WICKS**

THOUGH MANY do-it-yourself magazine articles make it seem that finishing a basement is a snap, it's not all that easy. It takes hard work and, more important, thorough planning before the job ever starts. Framing and paneling the walls are probably the easiest parts of the job; how to handle finish details attractively is what usually stumps the average man remodeling his first basement.

In most basements (particularly in older homes), many access doors and some

intricate framing around pipes and stairs are called for. This sets up a good rule of thumb: Wherever possible, keep eye and dust-catching hardware to a minimum. The ideas on these pages—used by the professionals—accomplish just that.

The three "door" treatments shown can solve just about any concealment problem, yet they boast a flexibility that lets you adapt to suit a particular problem. There are two important points to remember: First, make sure that all access openings are framed large enough so that it will not be necessary to rip out a wall if

Basement Like a Pro

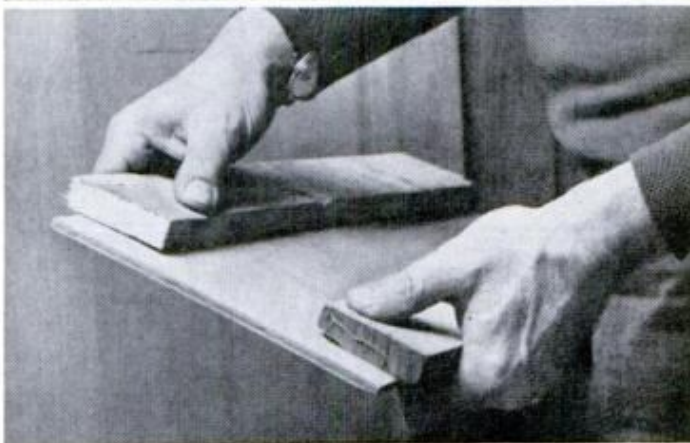

Soffit Access Panel

Access panel viewed from above (size of cutout to suit)

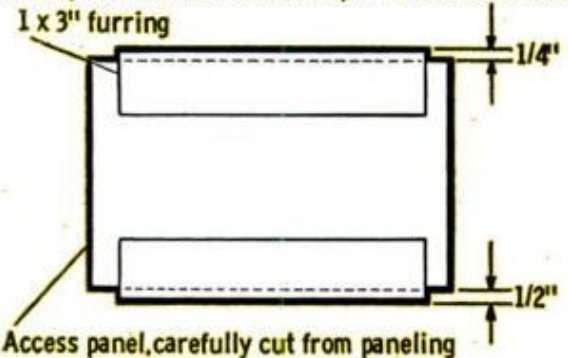

In place (from above)

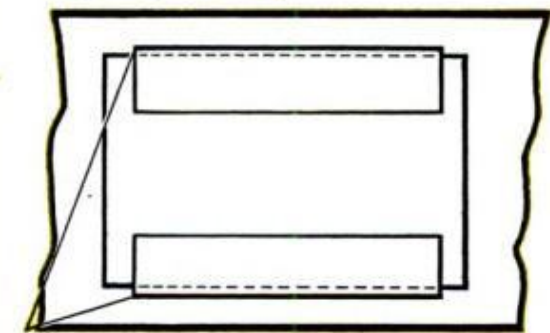

Furring rests on soffit paneling

HARD-TO-SPOT ACCESS PANEL in box around heat pipes is simply pushed up, then lowered for removal. Here, since the joint is not concealed by molding, the panel should be cut from the drop ceiling to insure a splinterfree straightedge. Size of panel is determined by opening requirements; furring strips are fastened with glue and brads. Access panels shown are cut to insure V-groove alignment between panel and cutout

Paneling a Beam

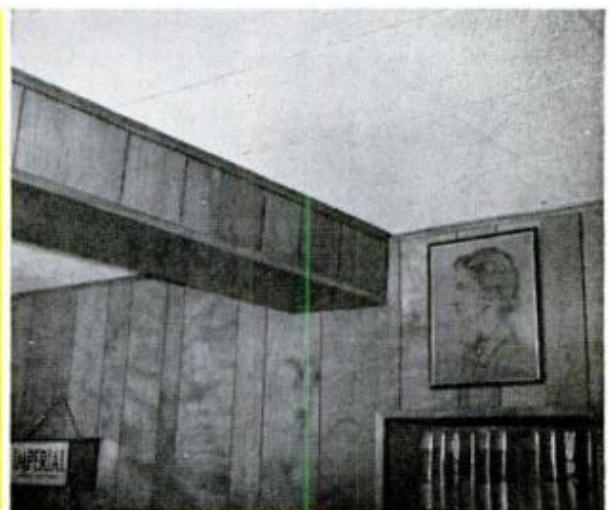
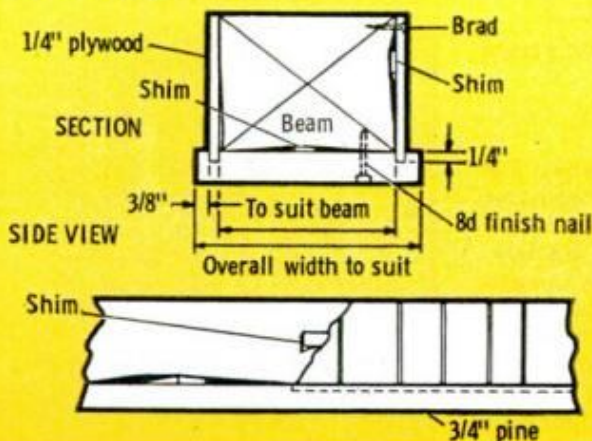

GOOD-LOOKING WAY TO BOX IN A BEAM eliminates time-consuming framing, costs less to do. Tack the clear pine temporarily to the beam's underside, level it with shims and drop the plywood panels into the grooves. Then, using undercourse shingles as shims, plumb the paneling, tack it at top and nail the pine in place. For best results, panel both sides of the beam completely before you drive nails home in the pine

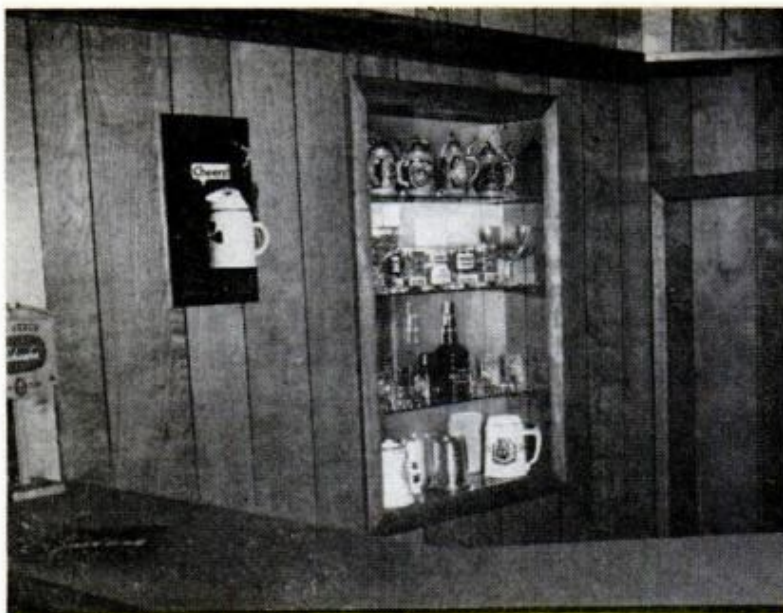

Backbar Access Panel

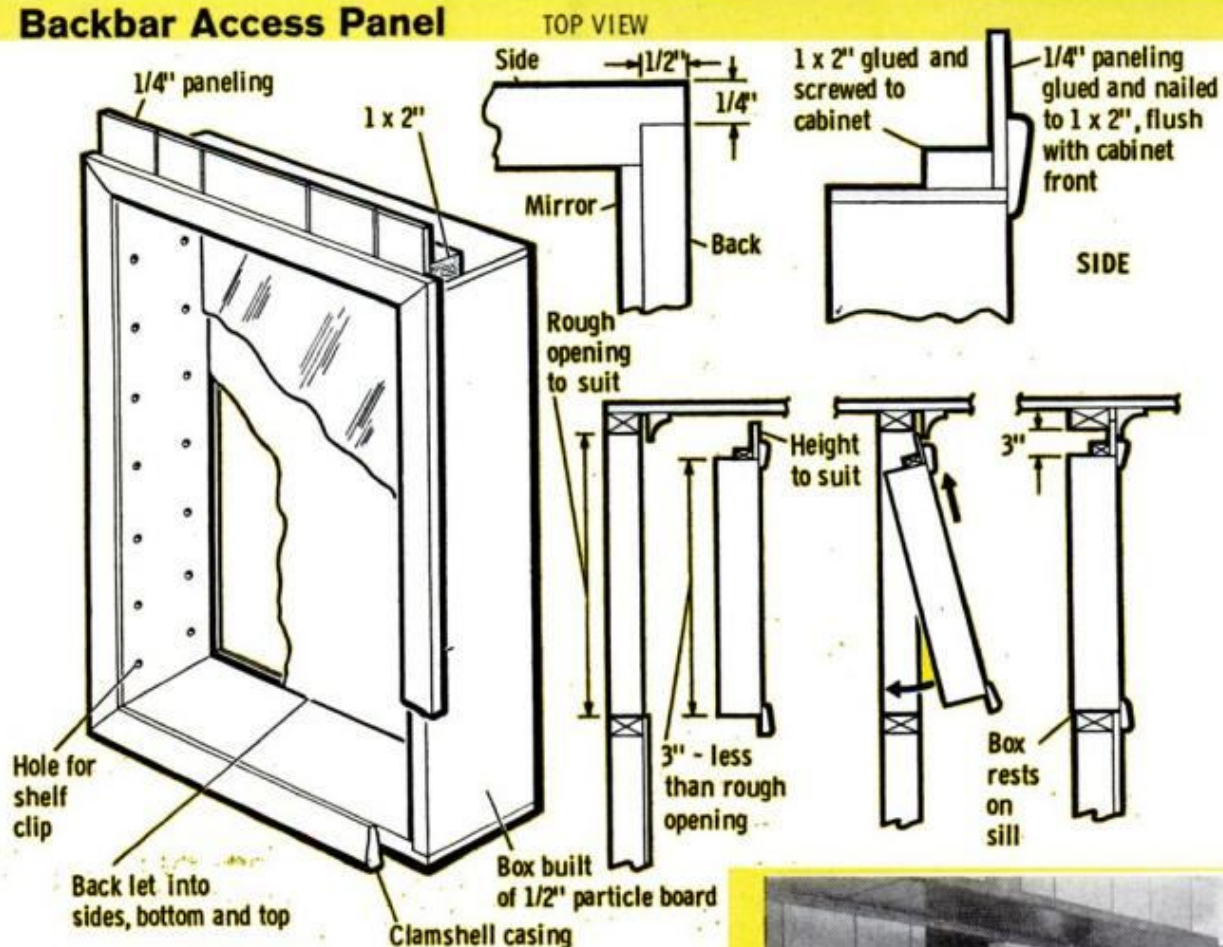

ACCESS TO CRAWLSPACE and cleanout plug in waste line doesn't have to be an ordinary hinged door. Handsome backbar at top left holds bar supplies, stands double duty. No tools are needed to remove or replace this box-like built-in. Once it's removed, the rough opening remaining (right) affords ample clearance for swinging a wrench or manipulating a snake to clean out a waste line. Use this method of construction where fast or frequent removal is not of prime concern. Though a mirror was installed on the cabinet back here, you could use paneling or, for a touch of decorator color, a painted hardboard. If a larger opening is called for, you could build the backbar in sections to lighten the load during removal

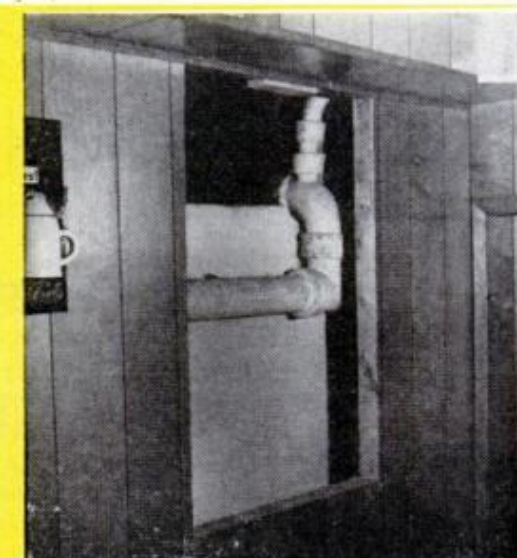

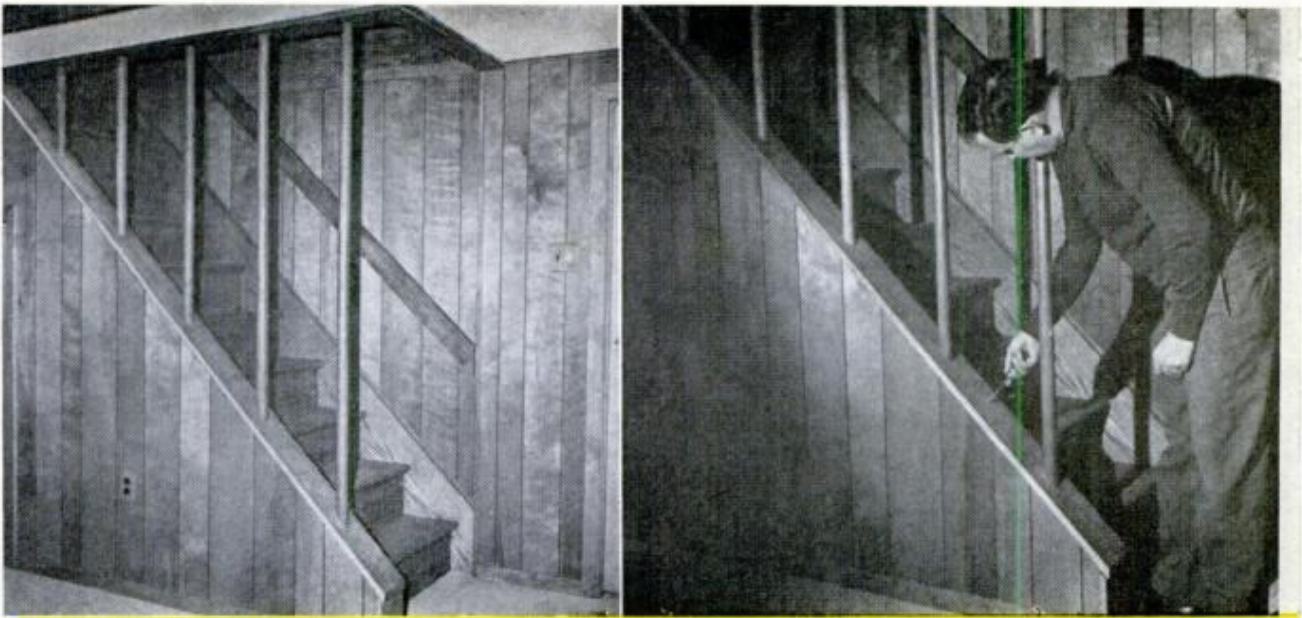

Stairwall

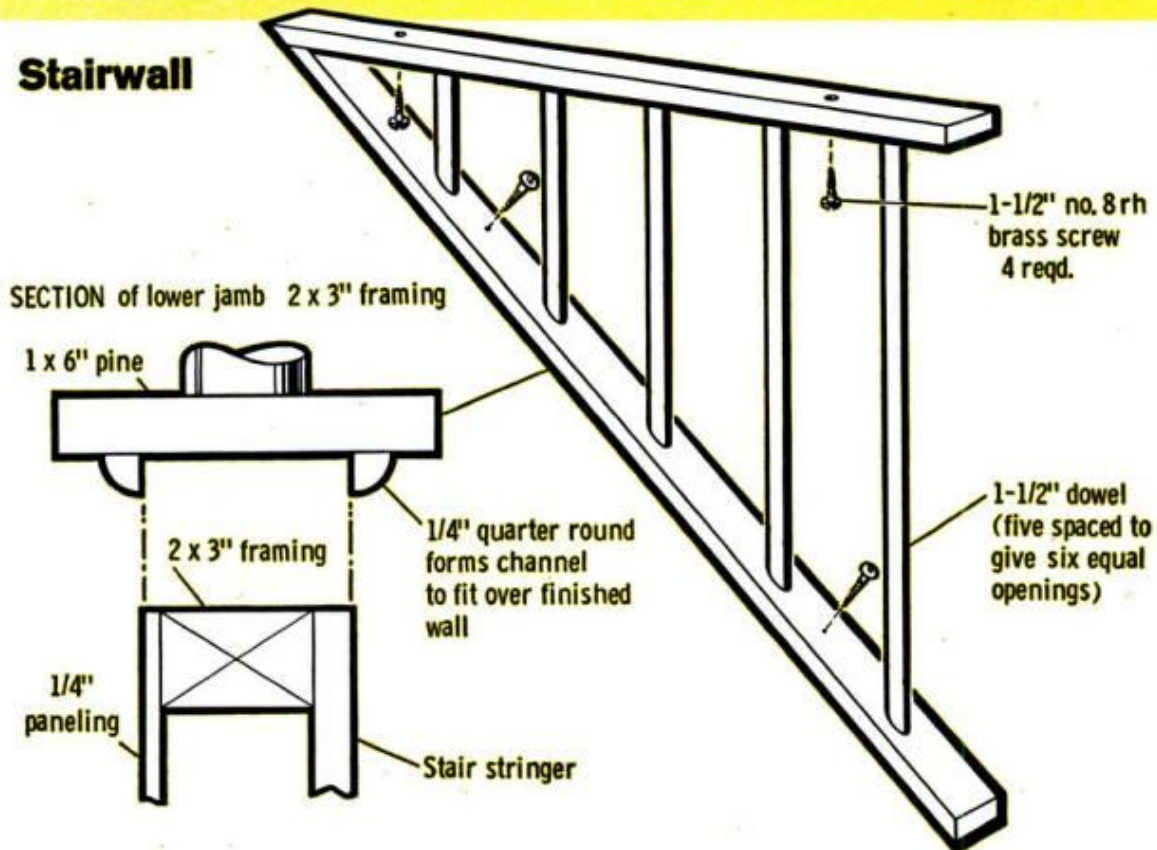

DOWEL TREATMENT along one stairwall permits light to enter from above, eliminates dark, cave-like look found in many basements. To remove the "wall," the lowest screw through the pine frame into stringer is last removed (above right). Stairwall should be framed and paneled first, then removable section built to fit. Quarter-round molding (above) brackets stringer and wall, guides unit when removing or replacing

plumbing or electrical repairs are ever needed. Second, after the framing in front of foundation walls is up, walk around the room and double-check to insure that all valves, cutoffs and the like have been provided with an adequate rough opening.

Though there are several methods for boxing-in a girder (ladderlike framing is perhaps the most common), the technique on page 155 is far simpler and saves materials. To insure a good-looking job, the

pine on the underside should be clear.

Finally, it's a mistake to close-in both sides of the cellar stairs permanently, since this restricts the size of furniture you can move in or out. Instead, finish the room side up to the top of the stringer only and build a removable frame with four or five heavy dowels (such as closet poles). If your basement has a center stairway, consider making both sides removable. ★★★

Solving home problems

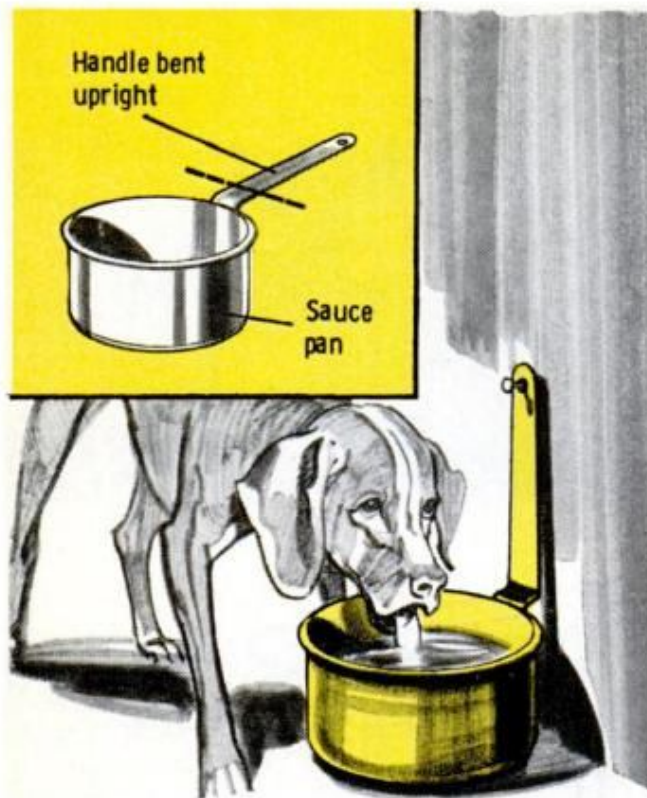

A SAUCE PAN makes the best nontip dog dish. Heat the handle near the rim of the pan and make a sharp 90° bend. Use the hole in the end of the handle to hang the pan on a nail. It can't upset.—Ray Beck

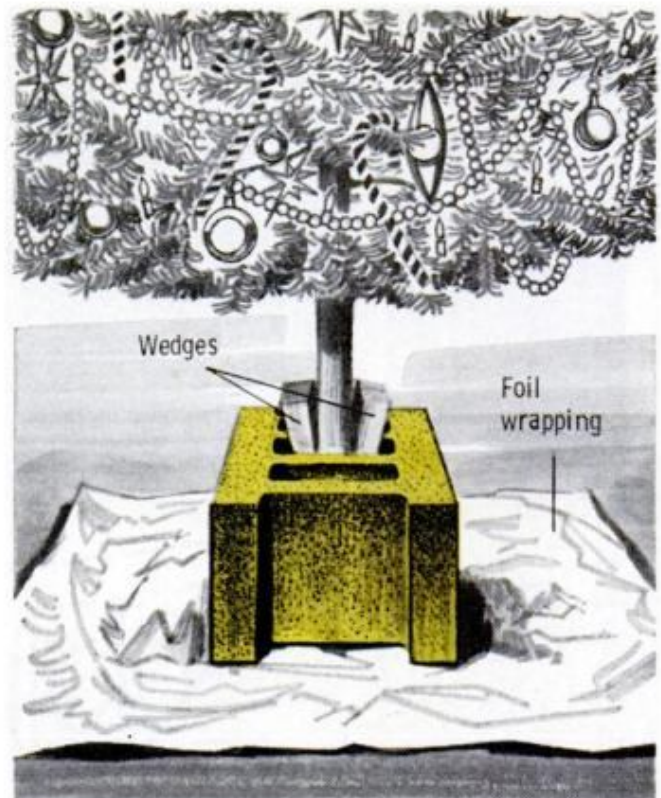

WHEN IT COMES TO HOLDING a Christmas tree, you can't beat a concrete block. Whittle down the trunk to fit the center core hole and secure with wedges. Wrap entire block in a colorful foil.—Victor H. Lamoy



IF YOU ARE ON THE ROAD and get caught without a bottle opener, remember to look in your car trunk. There's a slot in the base of most all bumper jacks which will fit a bottle cap perfectly.—P. F. Atwood

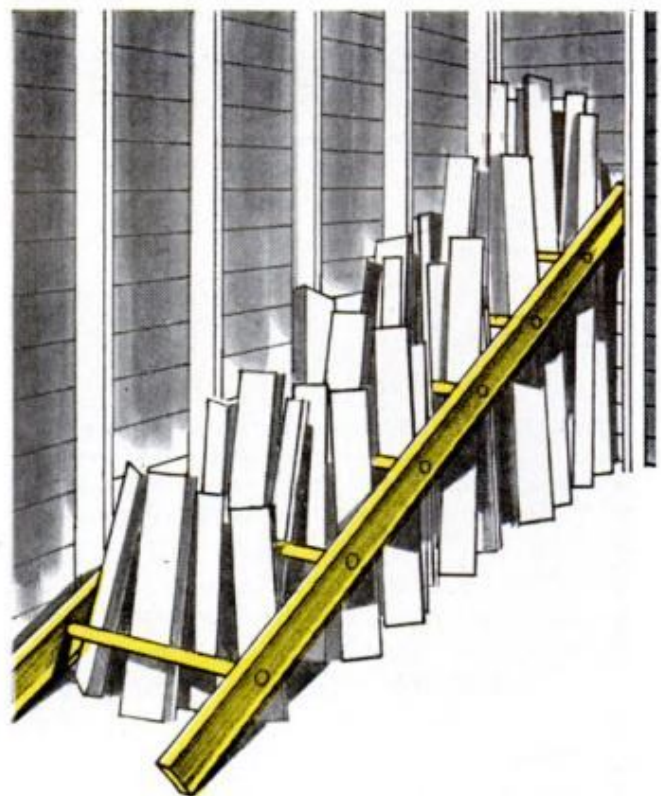

LOOKING FOR A WAY to store short lengths of lumber in an orderly manner? Lean and anchor a ladder against garage wall and stand pieces between the rungs. It will hold a lot of scraps.—Victor H. Lamoy

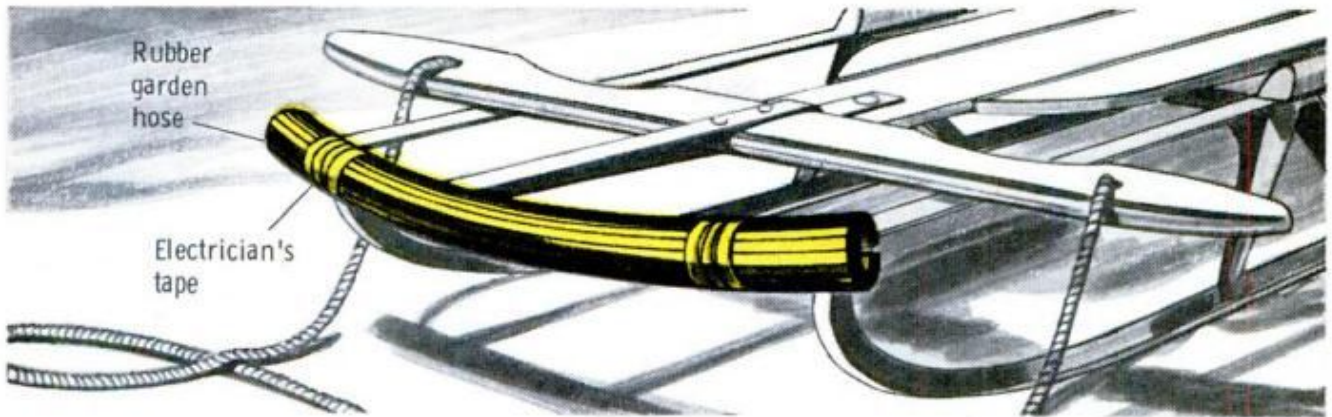

TAKE TIME TO PAD the steel bumper on your kid's sled with rubber and it will cushion a shin should he run into a playmate. Slit a piece of garden hose to fit over the bumper and bind it with tape.—*Harley L. Sachs*

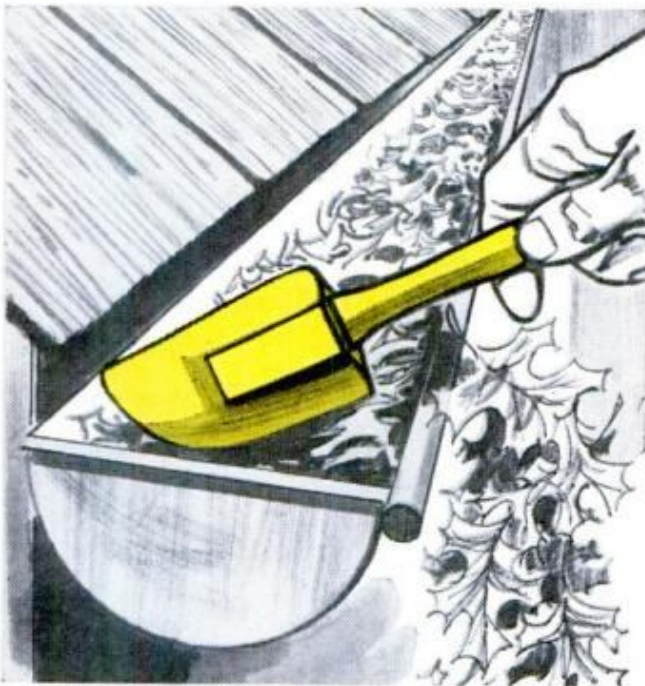

PERFECT TOOL FOR CLEANING leaves and muck from half-round gutters is a kitchen plate scraper. Made of rubber it won't scratch the paint lining and its rounded shape fits the gutter.—*A. E. Davidson*

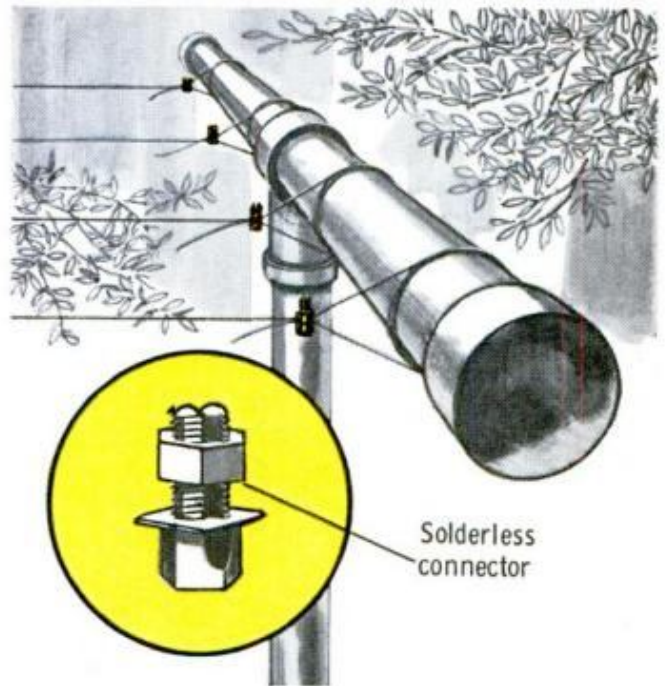

GOOD WAY TO ANCHOR wire clothesline to a post is with solderless connectors. Electricians use them to join wires. They can't rust because they're made of Bakelite. Use the large size.—*Clarence Breitenfeldt*

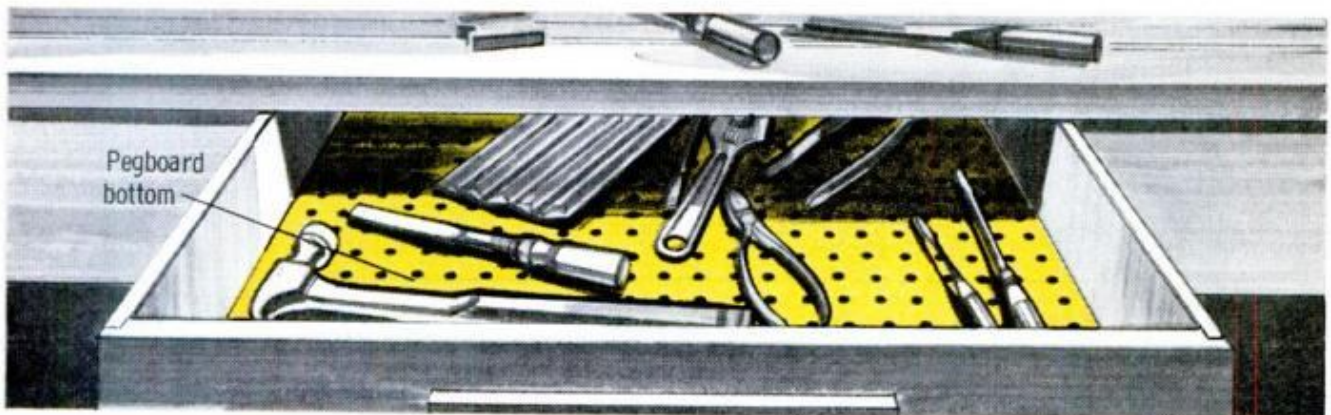

WORKBENCH DRAWERS have a way of collecting sawdust, but not if they have bottoms of perforated hardboard. Dust falls right through holes to shop floor; hand tools stay bright and dust free.—*C. Wayne Close*

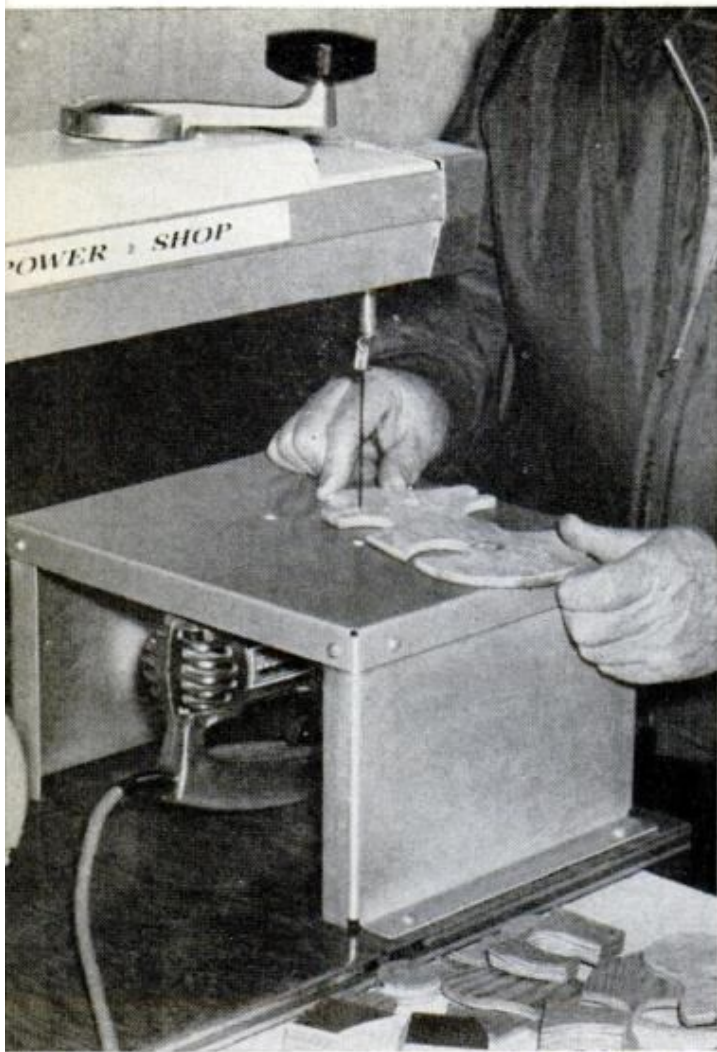

A JIGSAW FOR A DIME

WHEN YOUR PROJECT involves intricate work and tight, curved cuts, a jigsaw is the only tool for the job. For the price of a coil-spring you can adapt equipment you already have—the radial arm saw and a stand-mounted sabre saw—to fashion a jigsaw for your shop. The setup shown uses an ordinary coping-saw blade with the bottom end snipped off so that it can be held in the sabre-saw chuck. To hold the coping blade secure, simply break off the end of a worn sabre-saw blade and leave it in the chuck.

Use a block of $\frac{3}{4}$ -in. plywood to fasten the spring underneath, and inside, the arm of your radial saw. Then rabbet as shown for the hardwood dowels. The block carries the spring that returns the blade to its original position after each stroke.

—William G. Waggoner

PLYWOOD BASE is fitted with strip that rides in saw-table groove. Turnbuttons hold it at the front

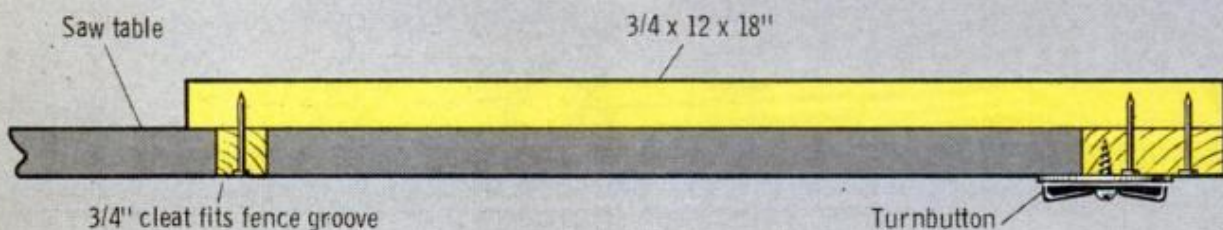
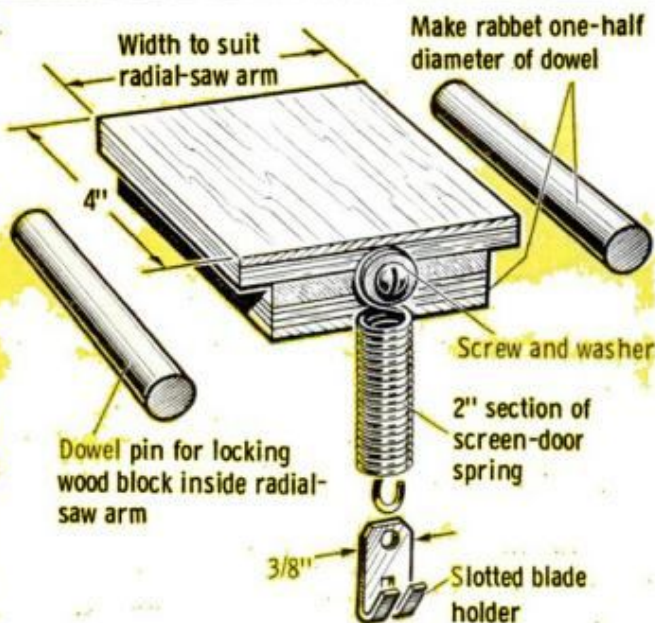
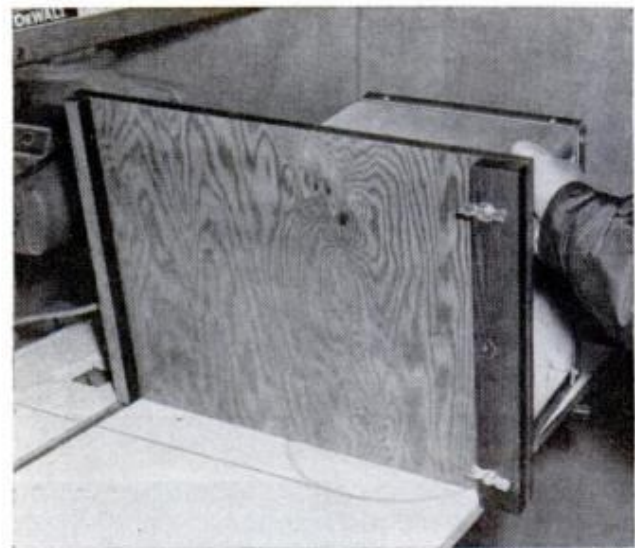

New tools you should know about

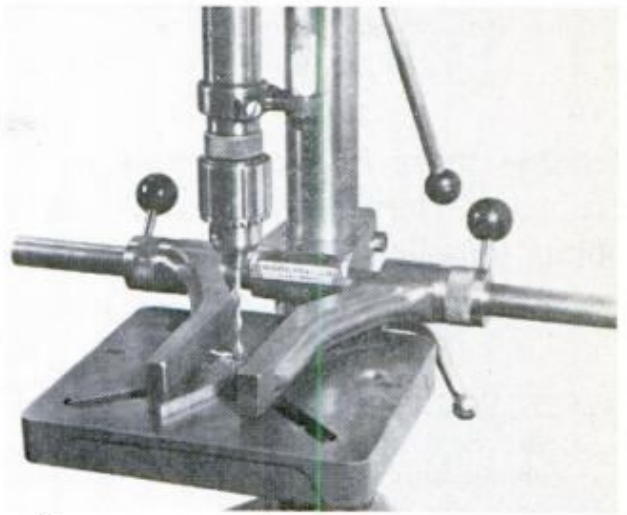

Drill-press workholder increases safety, fits most equipment

Instantly adjustable because a mere quarter-turn of the handles locks the arms, the drill-press workholder above holds any shape workpiece securely. Featuring a split collar, it can be installed without disturbing the machine. Prices start at \$67 for a unit to fit 1 $\frac{5}{8}$ -in. round column; six other sizes are offered. Universal Vise and Tool Co., Parma, Mich. 49269.

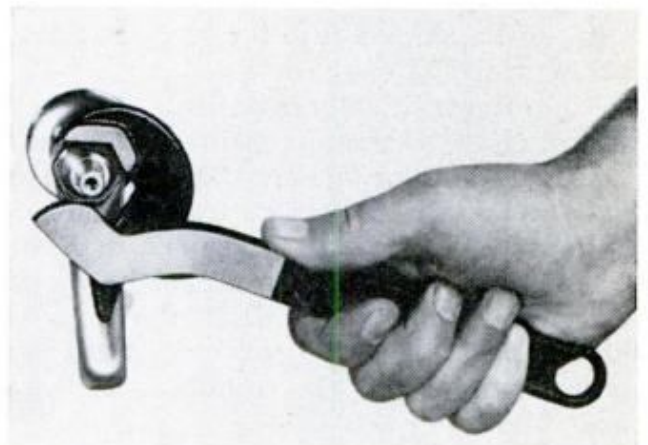
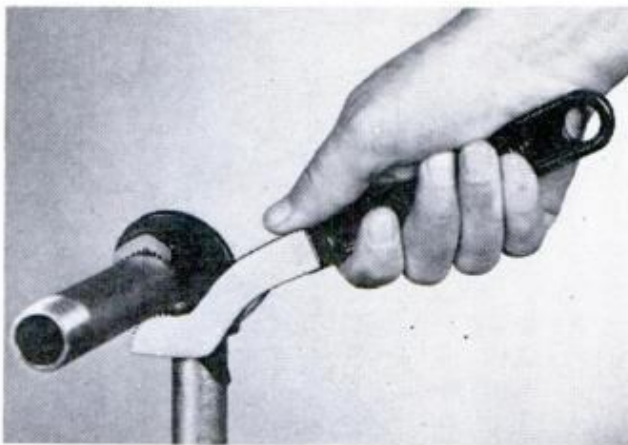

Wrench that lets you do it with one hand, even under wash basins

Claimed to be the fastest wrenches for pipe or nuts, Witherby's One-Hander self-adjusting ratchet wrenches are available with serrated or smooth jaws in sizes to fit pipes $\frac{1}{8}$ to 2 $\frac{1}{4}$ in. and nuts $\frac{3}{16}$ to 1 $\frac{5}{8}$ in. Simply slip wrench on the part, grip and turn. Available from 6 to 20 in. long, with prices starting at \$3.25. Witherby Tool Co., Inc., Trumbull, Conn. 06611.

Vac features unique dolly

Two deluxe shop vacuum cleaners have been added to Shop-Vac's 5 and 10-gallon vac line. Ease of handling is provided by a dolly dubbed Two-Way Four-Wheel Dolly by the maker. Swivel casters, plus two 4-in. fixed wheels, let you use vac vertically or horizontally. Offered in three colors—cocoa brown, orange and beige—deluxe versions sell for \$40 and \$45, respectively including \$15 worth of accessories; standard models cost \$5 less. For nearest dealer, write Shop-Vac Corp., 1 Industrial Rd. Wood-Ridge, N.J. 07075

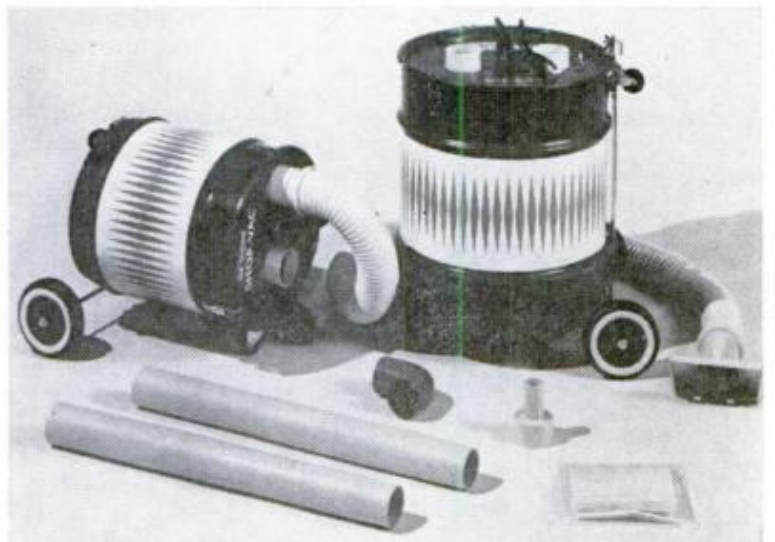

How to Check Out

Trouble there is second only to ignition problems. Here's how to deal with water-pump impeller, gears and the propeller

By HENRY B. NOTROM
 Technical Art by Fred L. Wolff

ENEMY NUMBER ONE of a lower unit is lack of proper maintenance. Failure to use the correct lubricant as recommended by the manufacturer is a greater cause of damage to your lower unit than those occasional under-water obstructions you may bump over.

Lower-unit trouble can be detected in one of three ways:

1. The engine won't shift into forward and/or reverse.
2. It can be shifted into forward, but not back into neutral.
3. It jumps continually in and out of gear.

Do you have a remote-control shifting arrangement? Before tearing into that gearcase, better make certain the remote control mechanism isn't the cause of your problem. To test it, disconnect the remote-control unit cable at the motor and shift the motor by hand. If the engine now shifts properly, the problem is the remote control unit. If not, the trouble is in the gearcase.

You need no special tools to disassemble a mechanically operated lower unit. But you do need patience, a go-slow approach and a keen eye, especially in your first attempt at lower-unit work. If you observe the following guidelines, you should have little trouble:

- As you disassemble, make notes and diagrams of what you've done so that reassembly will be easier.
- As you take down each part, examine it

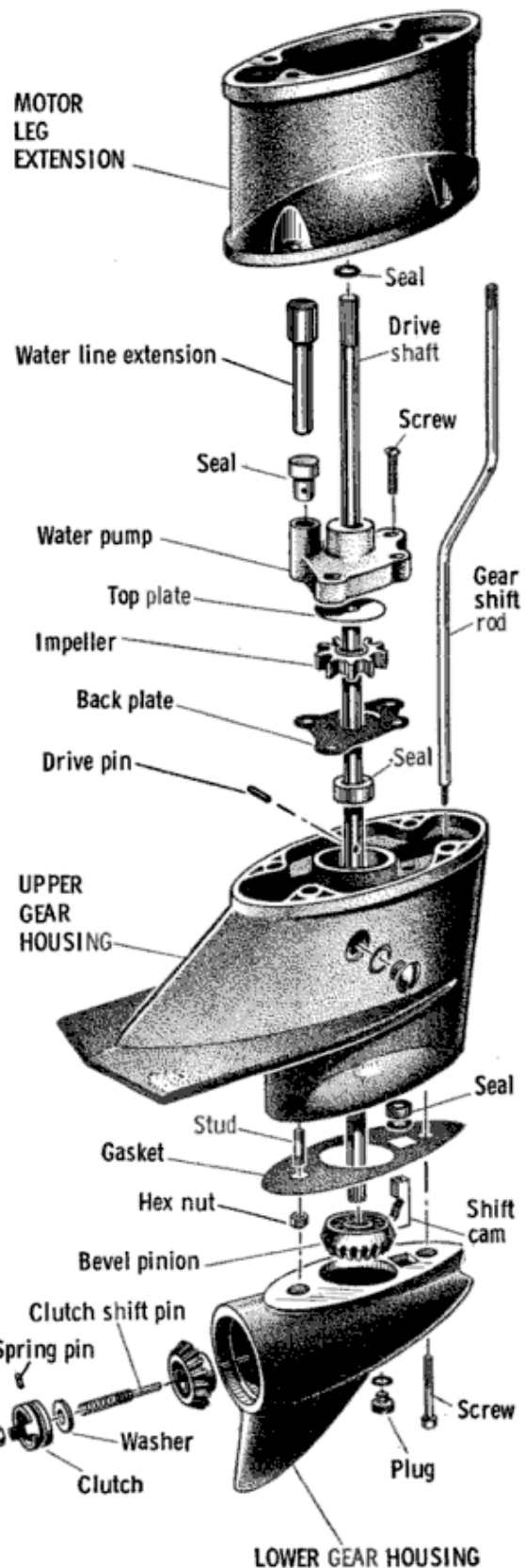

TYPICAL LOWER UNIT

POPULAR MECHANICS

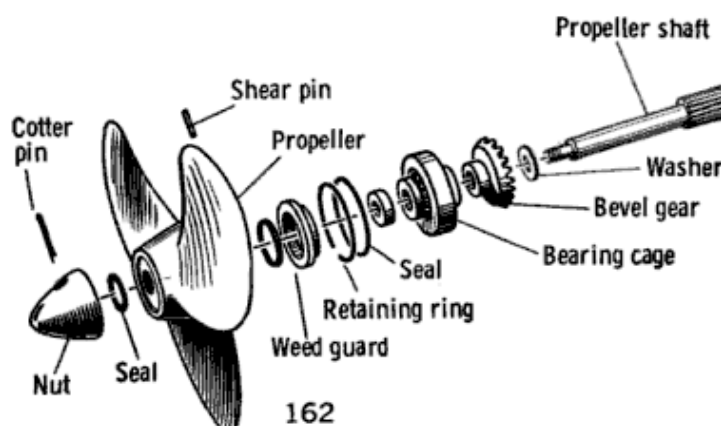

Your Lower Unit



1. EXAMINE EACH PART CAREFULLY on disassembly so you'll be better prepared to reassemble it right

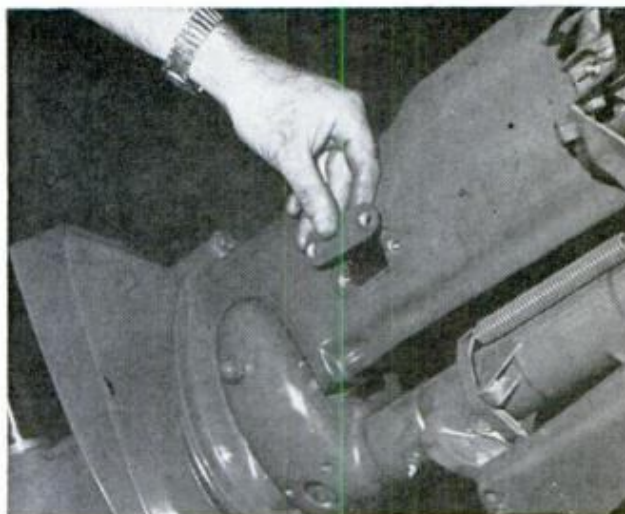

2. THIS INSPECTION PLATE is found primarily on Chrysler, Johnson and Evinrude outboard motors



3. BEGIN LOWER-UNIT REPAIR WORK by removing the propeller and draining the gearcase of lubricant

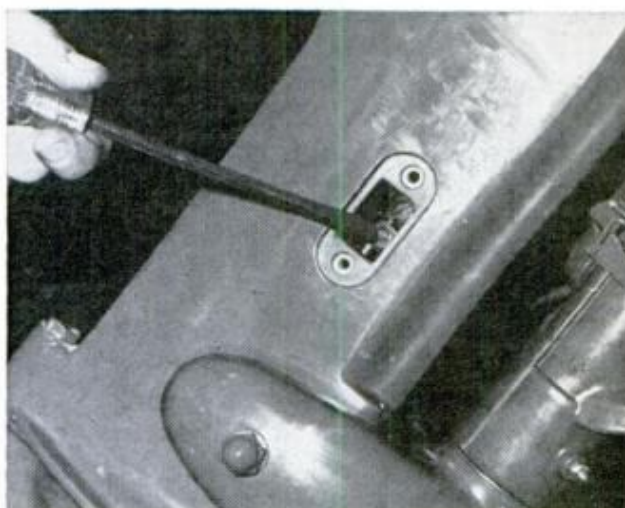

4. IF YOUR UNIT IS THIS TYPE, remove inspection cover and unscrew lower pin to disengage shift rod



5. REMOVE FASTENERS that hold gearcase to the exhaust housing; place in handy place for reassembly

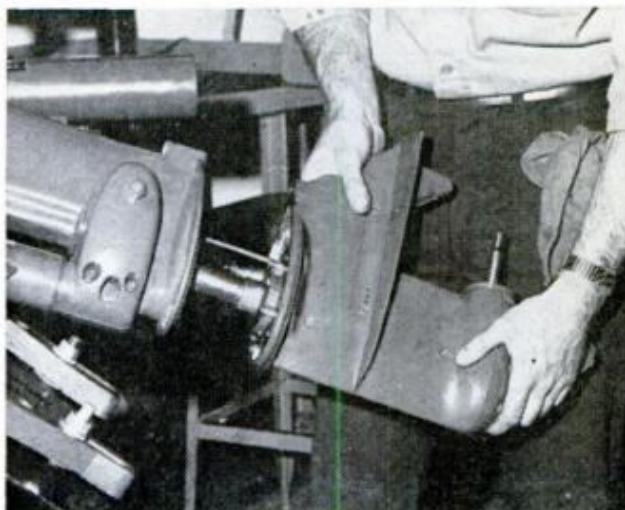

6. PULL GEARCASE FREE of exhaust housing. Let a pro inspect the machined surfaces of each for nicks

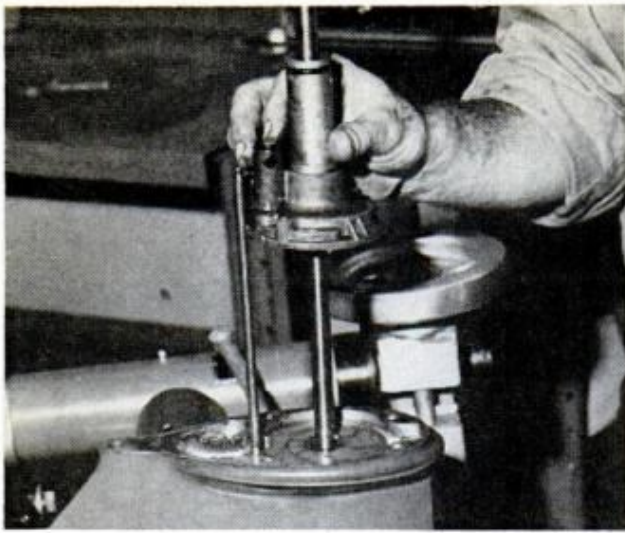

7. DETACH WATER-PUMP HOUSING, slide off shaft

carefully to determine if there's anything special about the way it goes together. For example, in the 18-hp Evinrude used in the illustrations, there's a slot in the front roller bearing that has to fit into a small dowel pin in the gearcase. Otherwise the entire gear train is thrown out of line!

- Keep everything clean, especially when reassembling. If dirt gets on the gears, they will grind themselves to pieces.

- Discard all old seals, O-rings and gaskets for new ones. Most manufacturers issue these in kit form, and you can get them from a dealer of marine supplies.

- If any component, such as a water-pump impeller, is bad, buy it separately.

Basically, there are two types of lower units. One employs a spring-loaded ratchet-type shift dog in forward gear. Mercury makes wide use of it. The other type has a nonspring-loaded, ratchet-type shift dog in forward gear. You'll find

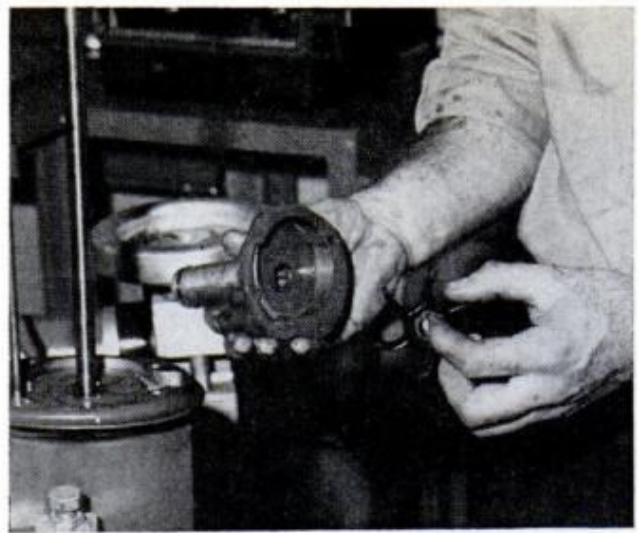

8. REMOVE IMPELLER from the water-pump housing

it primarily on OMC and Chrysler motors. Its shift rod has to be disconnected before you can drop the lower unit.

To tell which setup you have, examine the lower-unit case. If you find a little inspection cover, your unit is a nonspring-loaded type (Fig. 2).

Follow the step-by-step plan of our illustrations to take your lower unit apart. Clean all parts in a solvent—kerosene is okay—and let dry. Compressed-air drying is best, but normal air will do. Inspect all parts carefully. If you're not sure whether a part is damaged, don't take a chance. Get rid of it.

Here are a few tips for inspecting lower-unit parts:

- Inspect the driveshaft splines for wear and replace the shaft if it's bent.

- Inspect the gearcase. If it's nicked on any machined surface, the damage must be repaired and the case face resurfaced. The same applies to the surface of the

9. REMOVE PIVOT PIN and screws to free the skeg



10. EXPOSED GEAR TRAIN, after removal of the skeg



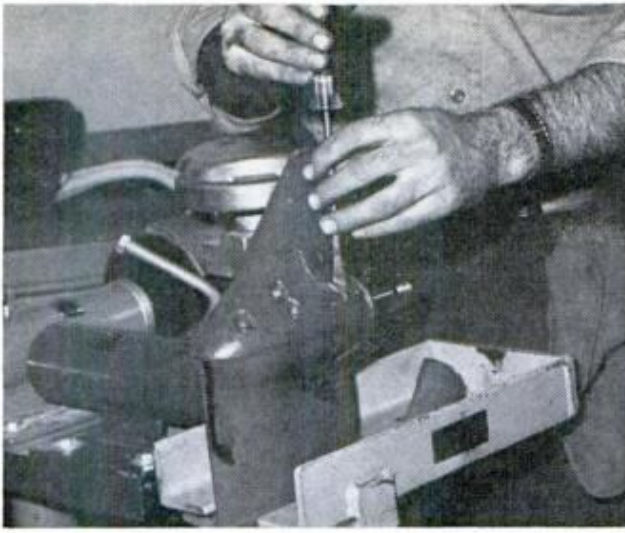

11. LIFT GEAR TRAIN carefully from the gearcase

exhaust housing. Let a professional do this. He has the surface plate, surface gauge and scribe needed for such work. If the gearcase is bent, replace it.

- Inspect water tube for obstructions.
- Inspect the water-pump impeller and replace it if vanes are damaged or worn.
- Inspect water-pump housing, drive gears, clutch dog, pinion gear, bearings, brushings and thrust washers for wear. Replace all damaged parts.
- Don't forget the propeller. Minor nicks can be removed with a file. But a broken or cracked blade means that the propeller should be replaced. It's also a good idea to check the prop pitch on a pitch block.

When reassembling remember that machined surfaces between two parts, primarily between skeg and gearcase, and gearcase and exhaust housing, must be sealed with a marine sealer. Also be sure that screws holding these components are sealed. Dip them in a sealer, such as Per-

13. REMOVE DRIVESHAFT and, if bent, replace it



DECEMBER 1969



12. REMOVE PINION GEAR, then the thrust washer

fect Seal No. 4, before they're run up tight.

When the lower unit is reassembled, refill it with gearcase lubricant. It's wise to lubricate all other parts relating to the unit, such as clamp screws, swivel-bracket fittings, throttle-shaft bushings and gears. See the owners' manual lube chart.

Finally, outboard-engine manufacturers stress two basic rules for proper handling of the gearshift. If observed, the chances of a lower unit being damaged will be greatly reduced.

1. Shift at recommended idle speed only. (Consult your owner's manual—it's usually 600 rpm, plus or minus 100.)

2. Shift smartly with a quick motion of the gearshift lever. Don't ease into gear, and don't wrench your control over.

If you follow these guidelines and the manufacturer's suggestions, your take-down of an outboard motor's lower unit should be limited to a once-in-a-lifetime experience. ★★★

14. CHECK WATER TUBE fit in water-pump housing

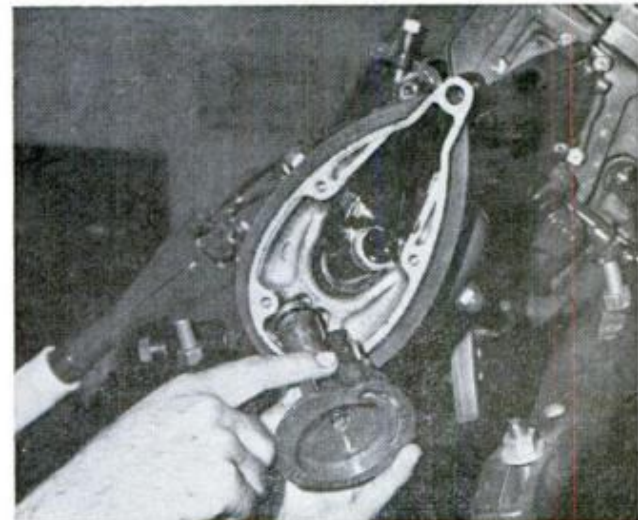

165

New Toothless Blades



1/4" SHANK, 2 7/8" STANDARD

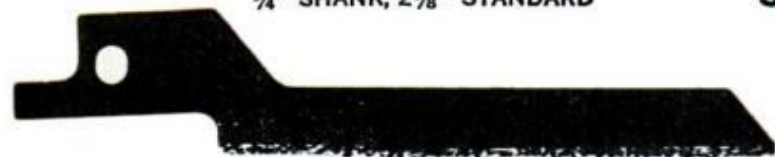

1/2" SHANK, 3 1/2" SCROLL



1/4" SHANK, 4" FLUSH CUT

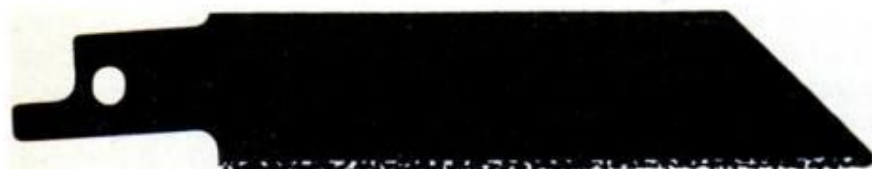

1/2" SHANK, 4" STANDARD



1/2" SHANK, 6" STANDARD

Really tough-to-cut stuff, such as laminate, ceramic tile, asbestos cement, slate and fiberglass, is easy prey for the amazing sabre-saw blades that cut just like diamonds

YOU'VE NEVER SEEN a sabre-saw blade like this, nor the way it cuts. In place of teeth it has a cutting edge that's coated with hundreds of tungsten-carbide particles, a man-made substance of diamond hardness, which multiplies tenfold the cutting power of any sabre saw.

Developed by Remington Arms, Inc., of Bridgeport, Conn. 06602, the same people who make the tungsten-carbide rod saw, this new blade will cut its way through tough, hard abrasive materials that break

and blunt ordinary tooth blades. Not only does it wade through hardwood like butter, but, since it cuts on both reverse and forward strokes, the abrasive coated blade actually sands as it cuts to produce a smooth, chipfree edge. Of the five shapes shown, blades A and B are available to the do-it-yourselfer at most hardware stores. The others are available industrially. The 1/4-in. blades fit most sabre saws; blade A sells for \$2; blade B, \$2.40.—*Wayne C. Leckey, Home and Shop Editor*

ONCE THE HARDEST PART of adding a new soap dish or towel bar, cutting a hole in ceramic-tile wall is now plain easy. Toothless blade is started by holding saw at angle and easing blade into the hard tile

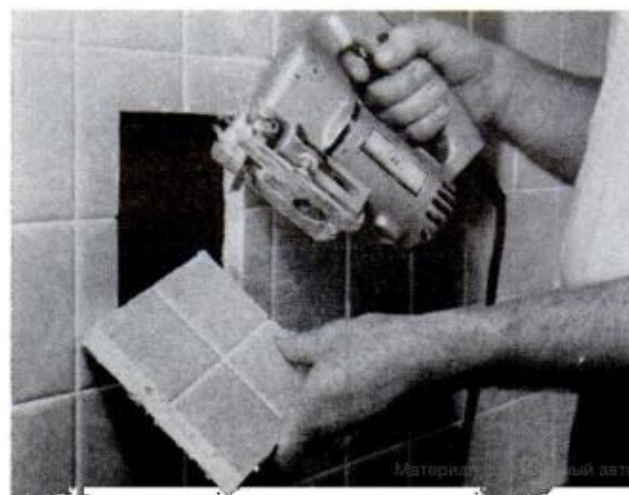

Cut the 'Uncuttables'

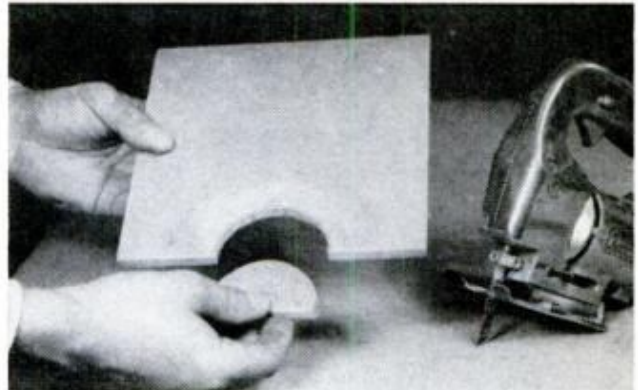
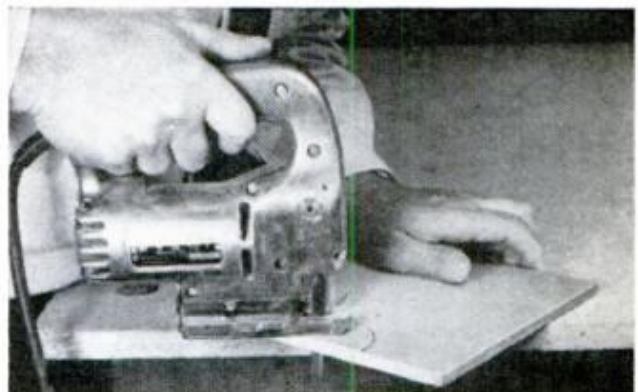
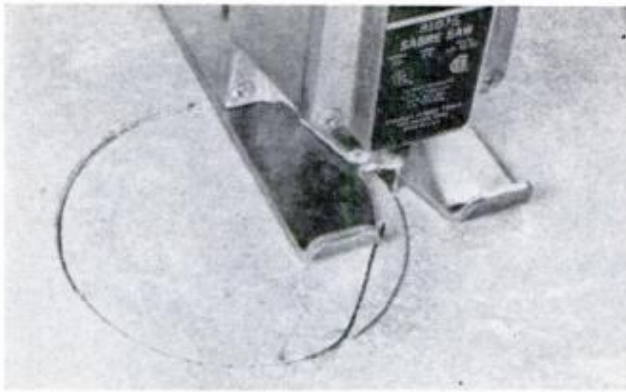

CUTTING A PIPE HOLE through "pane" of asbestos cement when venting a dryer through a basement window is a cinch by making plunge cut in material

SAWING QUARRY TILE when fitting it around floor pipes and other obstructions is no problem. Here abrasive-coated blade works best at a slow speed

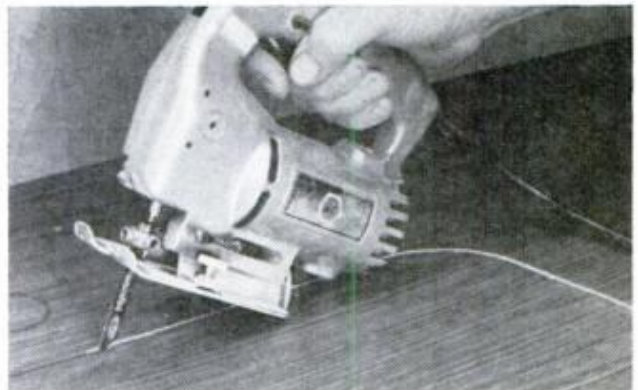
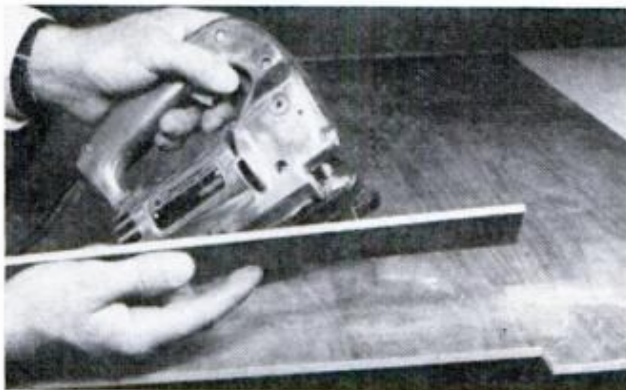

SINCE BLADE CUTS on both forward and reverse strokes, kerf in plywood is sand-smooth, splinter-free

FINE-GRIT BLADE cuts brittle countertop material without chipping, leaving a relatively smooth edge

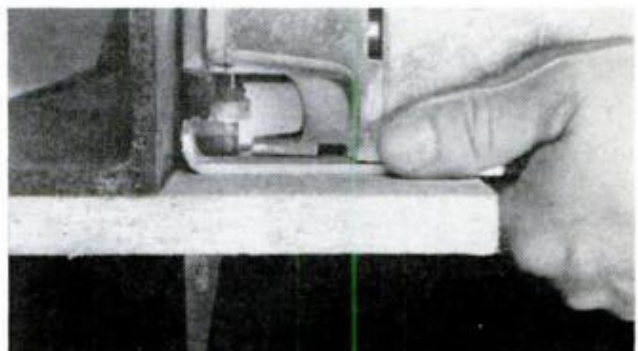
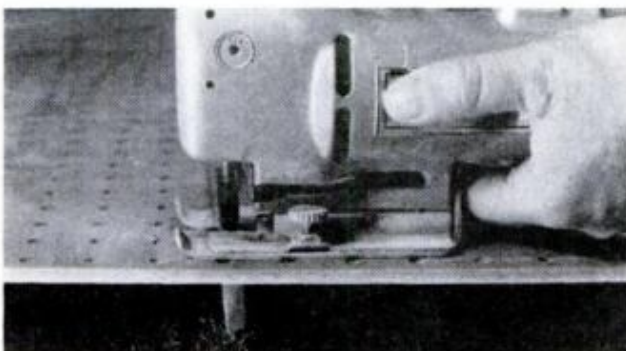

ABRASIVE PARTICLES used in banding perforated hardboard soon dull regular blade, not Remington's

SHAPE OF FLUSH-CUT BLADE lets you cut right up to a vertical surface without saw interference

Look What You Can Do With a BELT SANDER

It's a rugged tool you can use for rough or finishing chores



By BURT MURPHY

THE BELT SANDER is a workhorse of a tool. Faced with a job that would be dirty and tedious by hand, a belt sander will literally chew its way through the chore effortlessly. Actually, once you own one, you'll wonder how you ever got along without it.

Using a belt sander, you will find that with a little practice you'll spend a lot less time on such tasks as:

- Sanding rough stock smooth.
- Removing an old finish.
- Putting a bevel on a door.
- Reducing stock thickness.
- Back-cutting miter cuts for neater joints (casings, for example).
- Dressing up a poor saw cut.
- Polishing and buffing.

If you have never used a belt sander before, take the time to familiarize yourself with it when you first get one. Since a belt sander is larger, livelier and heavier than a pad sander or drill-disc combination, it does take some getting used to. Hefting, changing belts, adjusting belt tracking and the pull as the sanding belt digs into the workpiece will all be new to you. To gain this experience, use the tool on various materials: hard and soft woods, metals, plastic laminate and any others that you usually work with.

The belt sander should always be turned on before contact is made with the workpiece and turned off after it is lifted off. When lowering the sander to the material, you should keep the flat platen parallel to

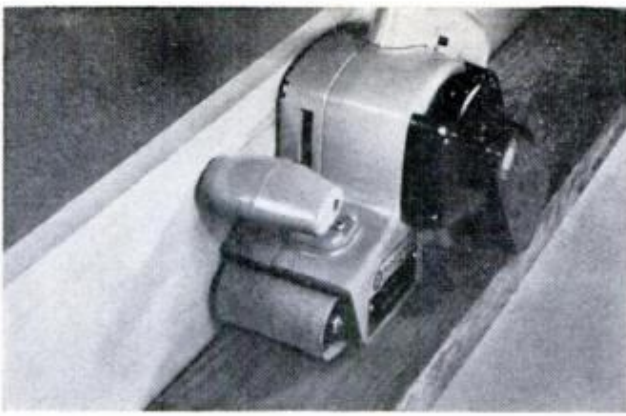

LATEST DESIGN TREND by most makers lets you use power for flush sanding next to a vertical surface

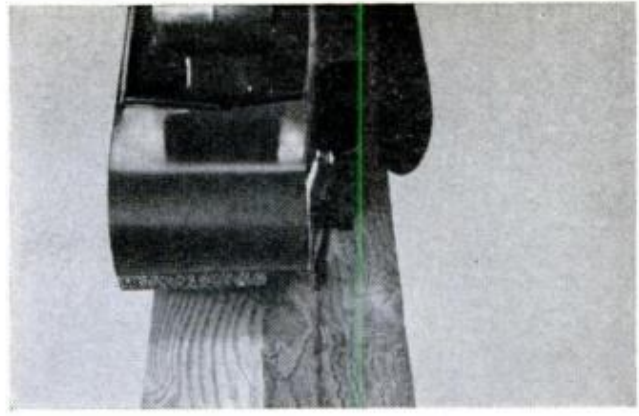

COARSE-GRIT BELT sands rough stock smooth in few minutes. Finer-grit belts are used to finish the job

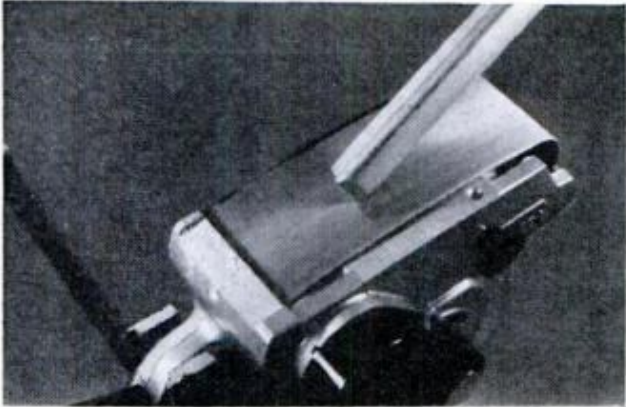

TO WORK SMALL PIECES, sander can be clamped upside down on the workbench to free both hands

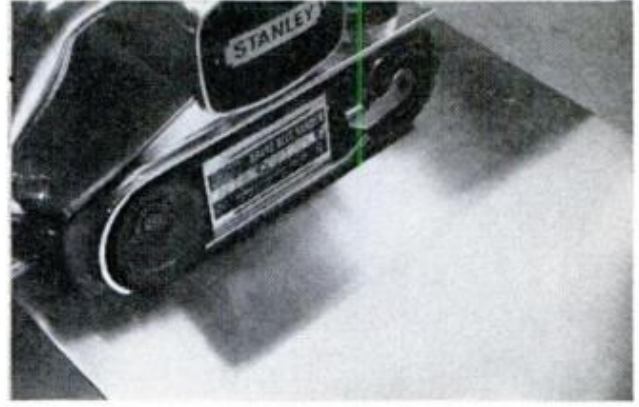

EVENLY POLISHED FINISHES on metal are possible in home workshop using special belts and lubricant

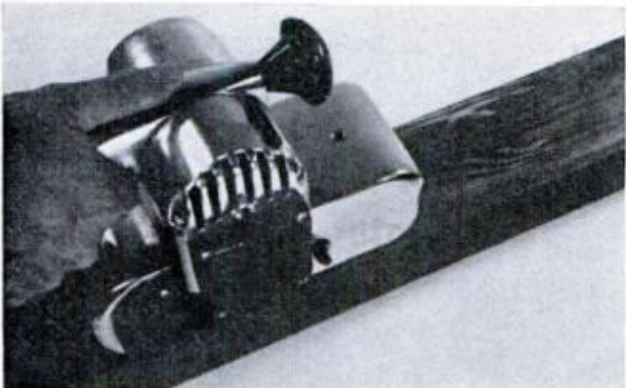

TO STRIP PAINT, use a coarse, open paper to start, then complete the job with finer, closed-coat belt

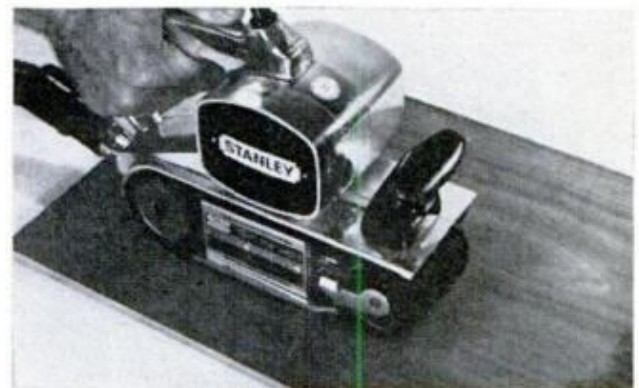

NYLON WEB BELT and small amount of cutting oil clean dirty-plywood surface, produce even tones

the work. Once it contacts the workpiece, keep the sander moving to prevent "dishing out." The weight of the sander itself provides adequate pressure; all you need do is guide the machine. Bearing down on the sander can, in fact, cause damage. When working with wood, move the sander with the grain of the wood, never across. Work the entire surface, overlapping each succeeding pass. If you attempt to complete a 3-in. strip and then move over for successive strips, you will end up with a wavy surface.

The sanders shown on these pages are all

basically the same, with slight design variations. Most manufacturers offer at least one model equipped with a dust collector. It's a good feature and it adds little to the total cost. If you do a lot of sanding or, if your wife hasn't been too happy with the dust settling in the laundry room, the extra couple of dollars that a collector costs will be money well spent.

In addition to on-the-job uses, a sander can also be rigged with clamps for use as a bench-type power sander. Small-size workpieces can then be brought to the sander and, since you are saved the task



CONCRETE FLOOR STAINS can be cleaned with a belt sander. Tool's not limited to wood and metal chores

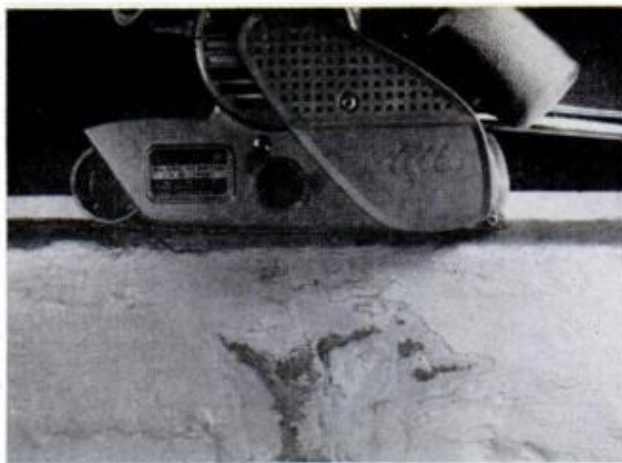

LUMPY CONCRETE on basement window sill is removed using coarse grit. Here dust collector pays off

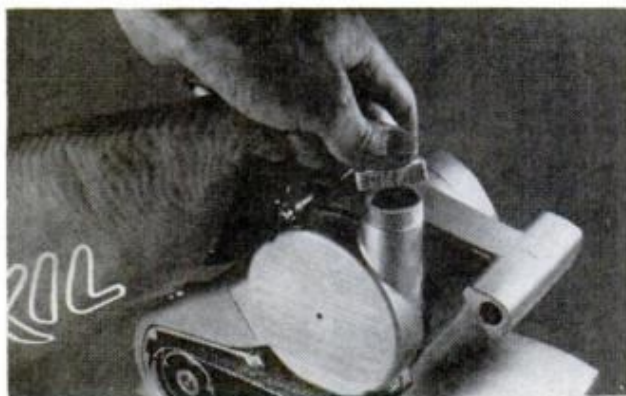

DUST COLLECTOR on Skil's sander is a tube and bag connected to unit with a threaded, knurled ring

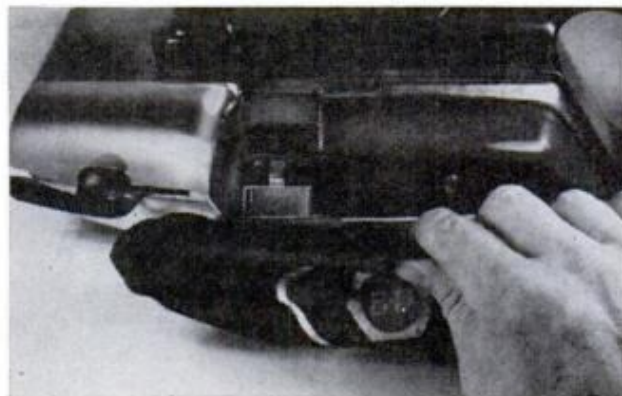

A SPRING-TENSIONED SLIP-IN NOZZLE is connected to the collection bag on the Black & Decker model



HOSE AND NOZZLE serve as dust collector on the Stanley sander—they're attached to vacuum cleaner

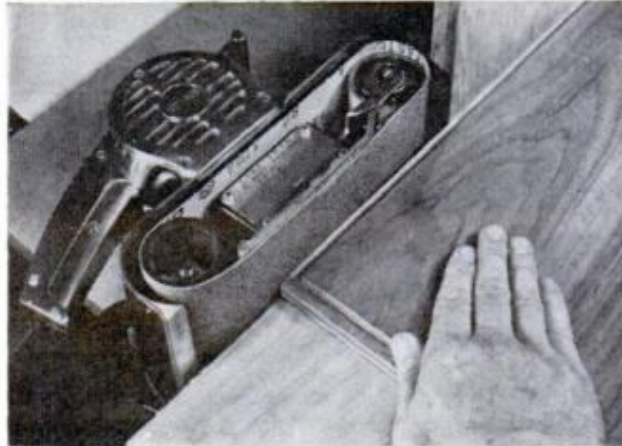

CLAMPED ON ITS SIDE, the belt sander can be used for "planing" jobs. Vertical board serves as a fence

of hefting the tool, both hands are free to guide the work against the belt.

Both general and special-purpose abrasive papers are manufactured for use with belt sanders. For a roundup of abrasives, see *What You Should Know About Choosing and Using Abrasives*, page 186, April PM. Aluminum oxide, manufactured in a wide variety of grits, is the type you will use most often. Or, you can use special-purpose belts to convert the belt sander for use as a cleaner, buffer and polisher

for metals, woods, plastics and laminates.

Belt sanding facts you should know:

- *Wood finishing.* For final finishing of furniture or cabinetry, use as many progressively finer grits as possible. The object here is to remove any marks left by the coarser belt that preceded the one being used.

- *Metal finishing.* Beeswax or tallow are recommended for use as lubricants for metal sanding, polishing or stain finishing. Several manufacturers market commer-



LEFT IN ONE SPOT TOO LONG, belt sander will plow a deep groove (shown across the grain here)

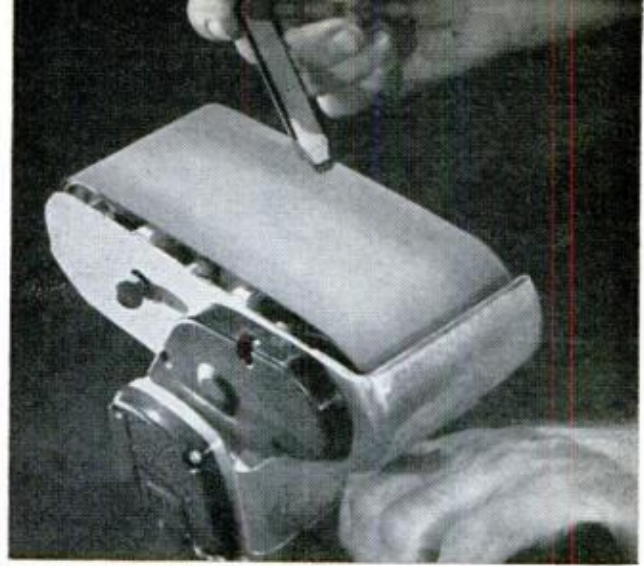

CARPENTERS on construction jobs find that sander offers a fast way to sharpen pencil to a keen point

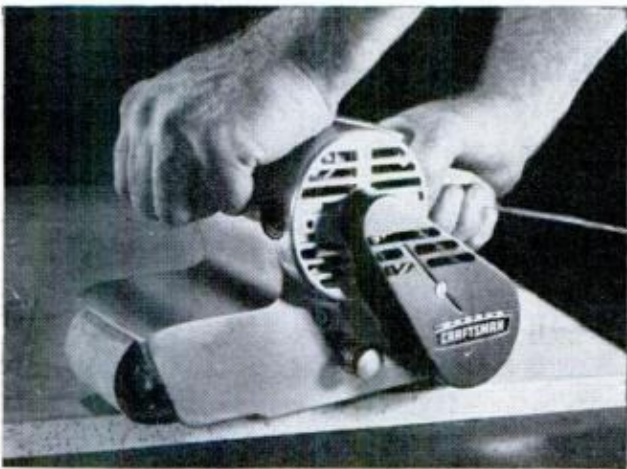

USING AN 80-GRIT BELT, plastic laminate self-edge is quickly and easily smoothed flush with plywood



WORKBENCH STAND comes with accurate miter gauge, secures sander. The one shown is by Rockwell

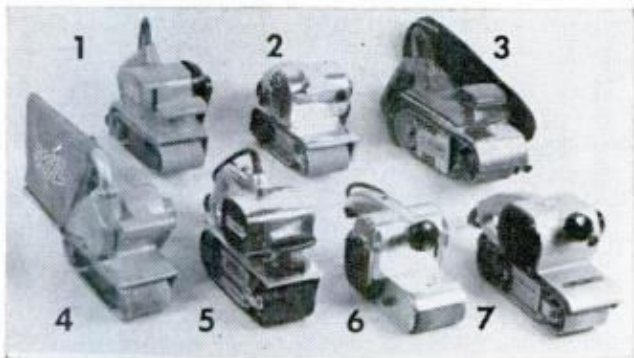

cial lubricants for metal sanding. Black & Decker, for example, offers Luster-lube belt lubricant and the Stanley Works markets two products, Tripoli and Greastick, for use with its Stanbrite belts.

● *Refinishing*: When removing paint, varnish or lacquer, use a coarse grade, open-coat belt for the initial stripping. Then change to closed-coat belts as the material shows through the coating. Use short, light strokes to avoid burning the coating and for longer belt life. ★★★

DECEMBER 1969

ALL MAJOR MANUFACTURERS listed offer quality manufactured, rugged belt sanders. If you can't locate the brand you want locally, write the maker for buying information.

- 1 Rockwell Mfg. Co., Model 91, type 1
411 N. Lexington Ave.
Pittsburgh, Pa. 15200
- 2 Sears, Roebuck and Co., Model 315-22420
925 So. Homan Ave.
Chicago, Ill. 60607
- 3 Black & Decker Mfg. Co., Model U-244
Towson, Md. 21204
- 4 Skil Corp., Model 595
5033 Elston Ave.
Chicago, Ill. 60630
- 5 The Stanley Works, Model 80493
195 Lake St.
New Britain, Conn. 06050
- 6 Wen Pdts. Corp., Model 910
5812 N.W. Hwy.
Chicago, Ill. 60631
- 7 Millers-Falls Company, 830 Model C
Greenfield, Mass. 01301

HINTS FROM READERS



Wire mesh aids spray painting

Ordinarily, when you spray-paint small parts, the final step of the job is prying them loose from the work surface after they have dried. But, if you lay them on a platform made from hardware cloth, the problem is eliminated. The wire screen should be bent or supported to keep it 1 in. above paper spread below to catch overspray.—*Walter E. Burton*

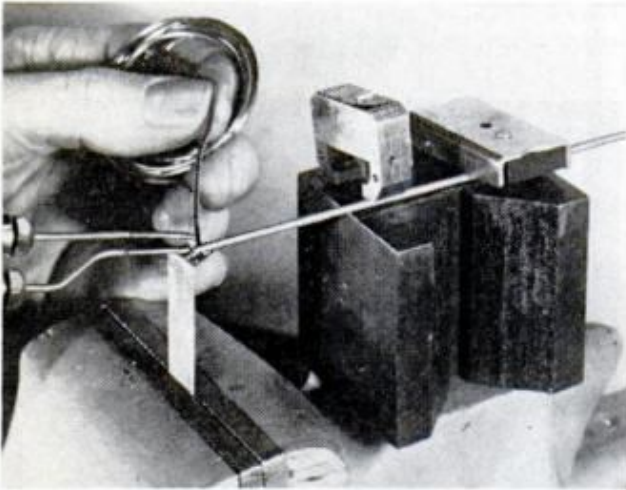

Magnets serve as third 'hand'

It's a waste to throw away an old permanent magnet; it can be used in the shop for holding various things. The photo at left shows how two magnets—one a horseshoe type, the other a unit from a cabinet catch—were used to steady a rod being soldered to a metal strip. The magnets are clamped to a V-block that rests on the vise anvil.—*Walter E. Burton*



Faster kickback-guard adjustment

Before turning on your radial saw you normally have to heft a large piece of lumber to be cut onto the table so you can adjust the kickback guard. Instead, cut a set of 2x3-in. scraps of the material you usually work with. Fitted with screw eyes, they can be hung near the saw for speedy, easy to handle changes.—*Sidney J. Riskin*

Stencils made from photo film

Discarded photographic film can be used as practical erasing shields or stencils simply by cutting appropriate openings in it. Round openings can be formed with punches, other shapes with a pointed knife. The erasing shield on the right is being used to correct a drawing; on the left is a punched-hole stencil and a sample of work done with it.—*Walter E. Burton*

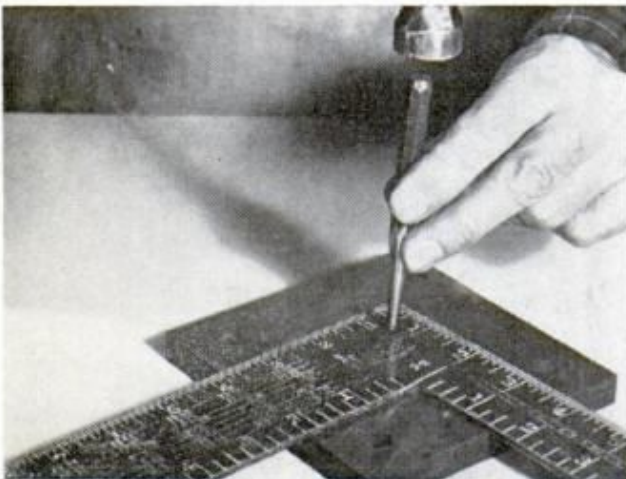

Resquaring a framing square

Since a framing square occasionally goes out-of-square, it should be checked periodically with a second square. If not true, it can be corrected by placing the square on an anvil and peening it with a punch. To close the legs, strike the back of the corner as shown; to spread them, punch the inside edge. Check for square after each blow.—*Lloyd L. Long*

The Right Way to Replace Furnace Filters

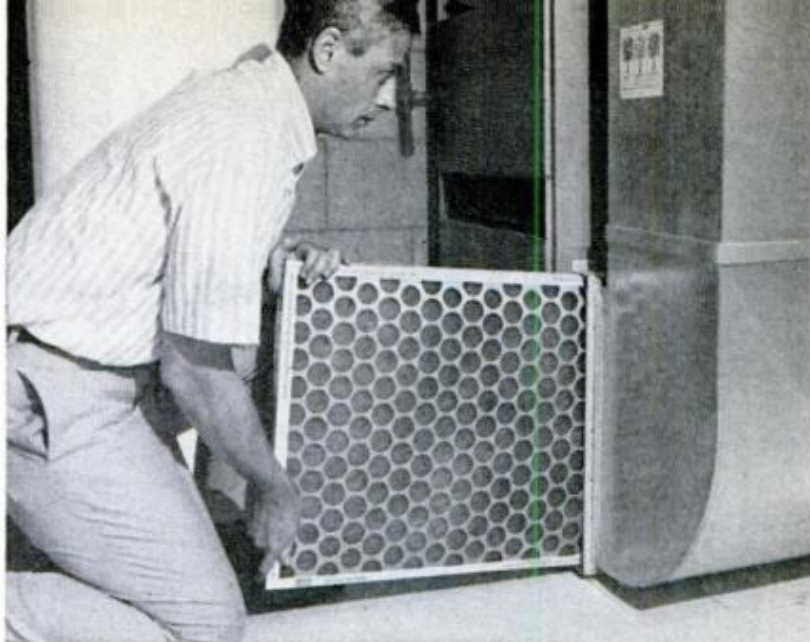

HOMEOWNERS with forced warm-air furnaces and airconditioning systems know the importance of replacing air filters frequently. However, there's a right and a wrong way to put them in. Improperly installed, a filter does only half the job and lasts only half as long.

What difference does it make how an air filter is installed? In the case of fiberglass disposable air filters of the common type shown above, a dust-catching adhesive, "Corsol" is applied to only one side of the filter media. If the adhesive-treated side is installed incorrectly, dust will quickly accumulate on the face of the filter and greatly reduce air flow. Thus, the air filter will become useless in a very short time.

When the air filter is properly installed, dust will be carried through the entire thickness of the filter media. The dust will then start building up from the rear to the front of the filter, holding more dust and providing longer, more efficient life. An air-flow arrow is printed on the frame of all dust-stop air filters which instruct the user as to the proper insertion in heating and cooling equipment. This arrow should always point in the same direction as the flow of cold air into the furnace.

Tests conducted by the world's largest disposable air-filter manufacturer, Owens-Corning Fiberglas Corp., indicate that air filters should be changed at least three times a year and about once a month during peak heating and cooling periods. A dirty, clogged air filter will restrict air flow and cut down equipment efficiency.

In the case of a furnace which uses a hammock-style filter (the blower being

cradled in a blanket of fiberglass) the throwaway filter media comes tinted blue on one side. Here it is important to see that the filter material is installed with the tinted side on the outside so the air will enter the tinted side. Such filtering material comes in 20-ft. rolls and is cut off as needed when the filter is renewed. ★ ★ ★

DIAGRAMS BELOW show how dust-laden cold air is pulled through the filter by the blower and then forced up through the furnace's heat exchanger

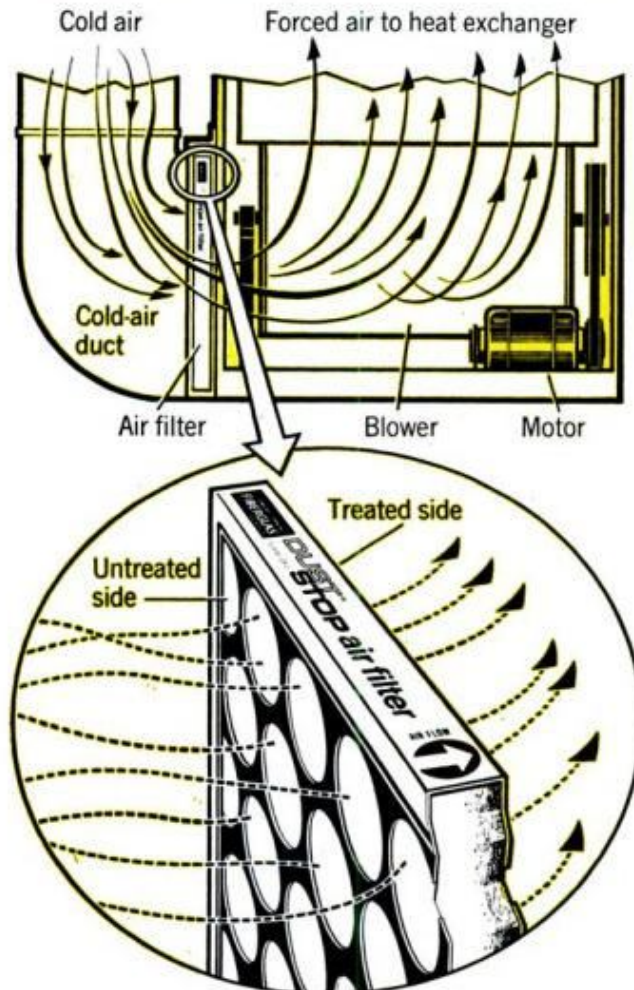

New Building Products You Should Know About

SPECIAL ROUNDUP

Four pages of new building materials for updating old homes and making new homes better

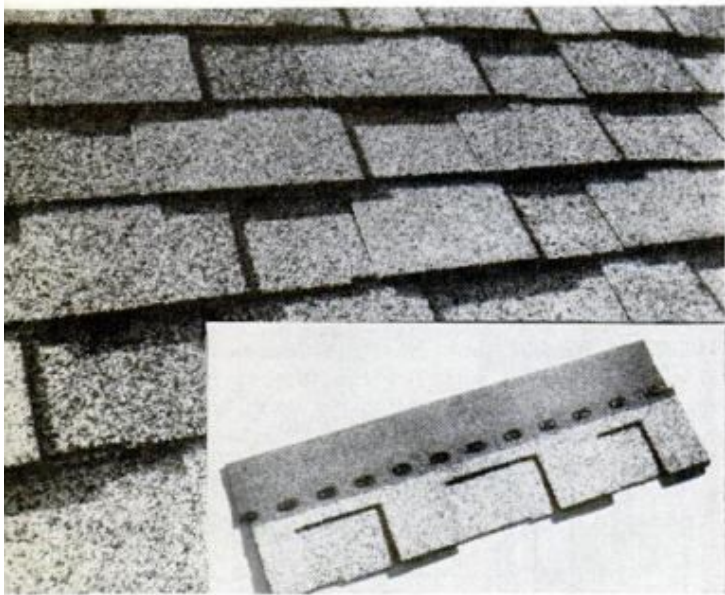

LATEST MANUFACTURER to hop on the "looks-like-wood-shakes-but-isn't" bandwagon is Bird & Son, Inc., East Walpole, Mass. Its asphalt shingles closely resemble wood, boast sturdy double-strip construction and self-sealing adhesive spots for maximum lift resistance. Labeled Architect 70, shingles carry UL class C ratings for wind and fire resistance. Sold with a 25-year warranty against imperfection, shingles weigh 345 lbs. per square, have 5-in. exposed surface and 2-in. headlap.

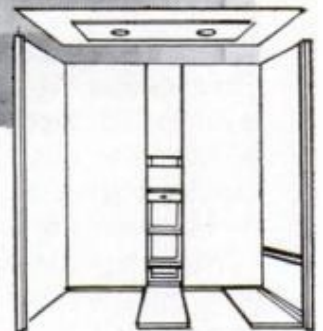
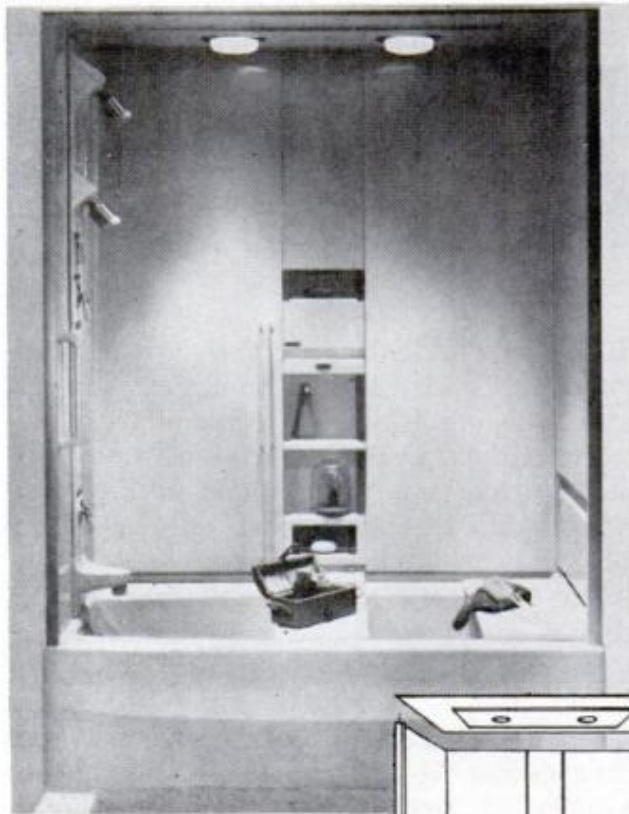
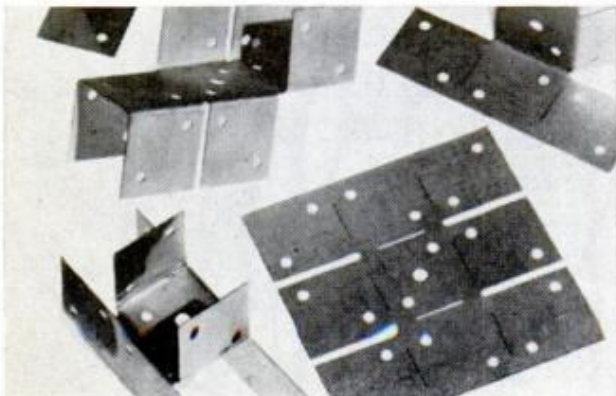

HERE'S A TUB that does everything but take your bath for you. Dubbed Spectra 70 by American Standard, the tub add-on unit (see sketch) fits any 32x60-in. bathtub. Of reinforced fiberglass, the Triwall Surround has two lighting fixtures in the ceiling, two safety bars, drop-down seat and counter. The Shower Tower boasts twin adjustable showerheads, hide-away body spray and the usual bath spout. Complete setup sold through plumbing dealers is about \$825 (in white) or \$900 (in color).

DEVELOPED FOR USE on practically any structural wood joint, this steel plate replaces clumsy, and time-consuming, wood braces. Called Quickform, it is made as a flat plate divided into nine segments. The resulting flaps, and the center section, are dotted with nail holes; thus, the flaps can be bent independently and nailed as needed. Of 20-ga. galvanized steel, the plate can be used for shelf and table-leg braces, joining studs to plates, and headers to joists. Wood Connector Products, 240 W. Colfax St., Palatine, Ill. 60067.



IF YOU LIKE THE LOOK, but not the twist, of bi-fold doors you might consider a pair of nonwarping steel doors. Called Chateau, the doors at left are designed to operate on a top track only. They come complete with hardware and a factory baked-on enamel which can be used as is or as a prime coat when matching decor. Prices start at about \$35. General Products Co., Inc., Box 887, Fredericksburg, Va.

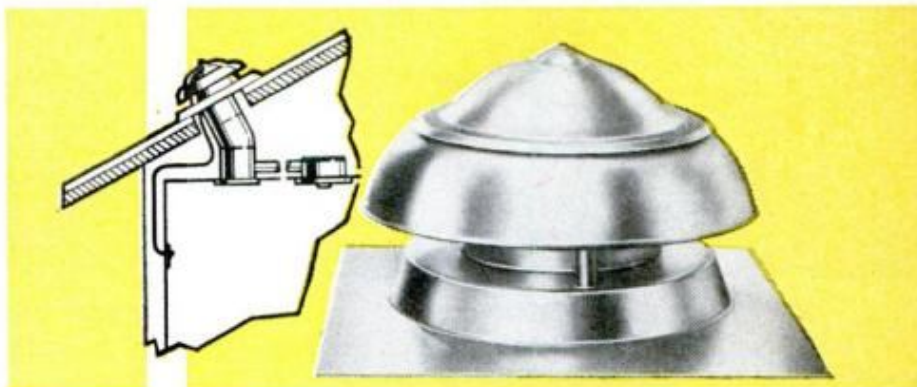

EXTERIOR-MOUNTED ROOF BLOWER FAN is quieter because all motor sound is outside the home. Ideal for central systems that ventilate two or more areas, Model RF-IN moves 632 c.f.m. of air, can be installed on flat or pitched roofs with 10-in. duct. Optional extra, a solid-state speed control (Model VS-65), adjusts air-delivery to venting needs. Nutone, Madison and Red Bank Rds., Cincinnati, Ohio 45227.

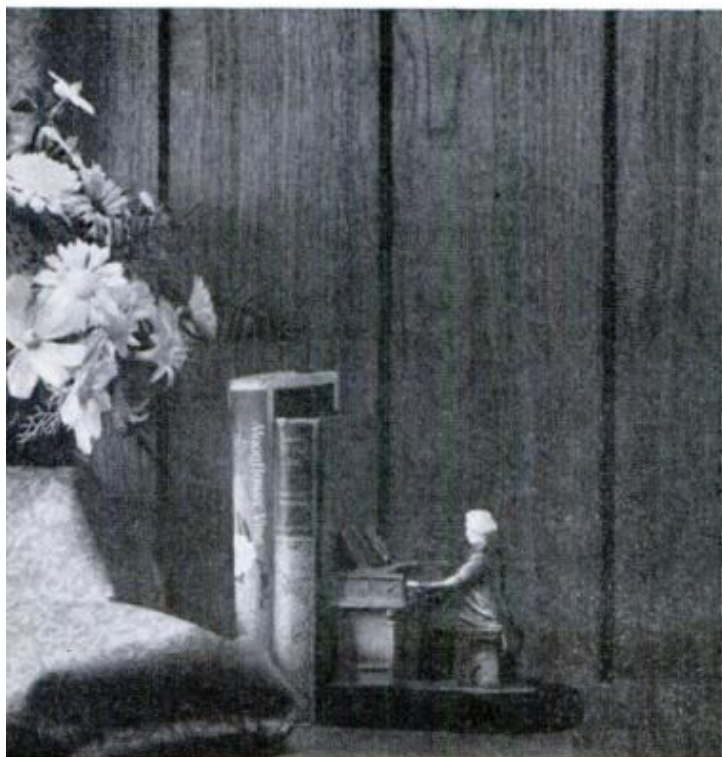

NOW YOU CAN "PANEL" A WALL without driving a nail or squirting a gun. The wall shown above is covered with styrene panels, called Wood Tone Paneling, measuring 6x24 in. each. You simply peel off the paper backing and stick the panel in place. In Spanish oak, Indian teak, white oak, rosewood, traditional and contemporary walnut—with simulated grain and grooves. Six panels, \$4. Decro-Wall, Executive Blvd., Elmsford, N.Y.

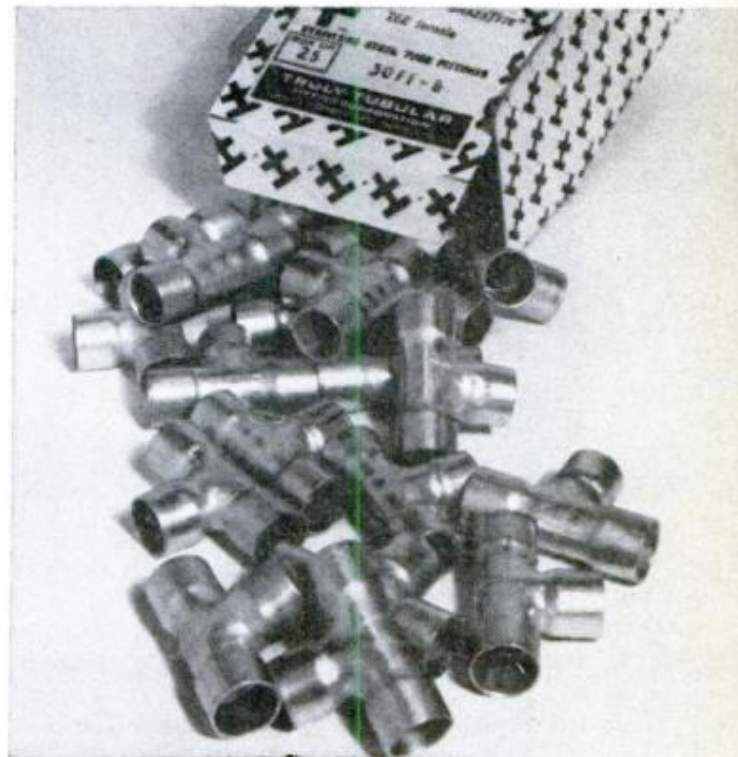

PLASTIC SEWER AND DRAIN FITTINGS molded for 6-in. drain and waste lines have been developed by Olin Evanite Plastics, Carrollton, Ohio, with a versatility to enable homeowner and plumber to handle any sewer drain installation. Fittings include 1/16, 1/8 and 1/4-in. bends in hub-by-hub, hub-by-spigot and spigot-by-spigot combinations, also tees, wyes, couplings and O-ring bell adapters. Now made of ABS, fittings will be offered in PVC in 1970.

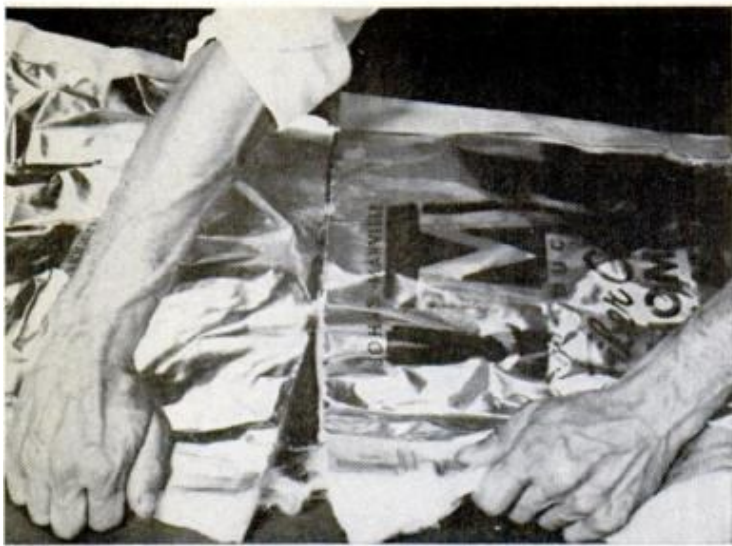

NO KNIFE IS NEEDED to cut this insulation. Johns-Manville's new Snap/Pak fiberglass insulation comes in rolls perforated so they may be snapped apart into batt lengths. Faced with either foil or kraft paper, packages are labeled to show the R (resistance) value for specific part of room insulated. At building supply dealers and lumberyards.

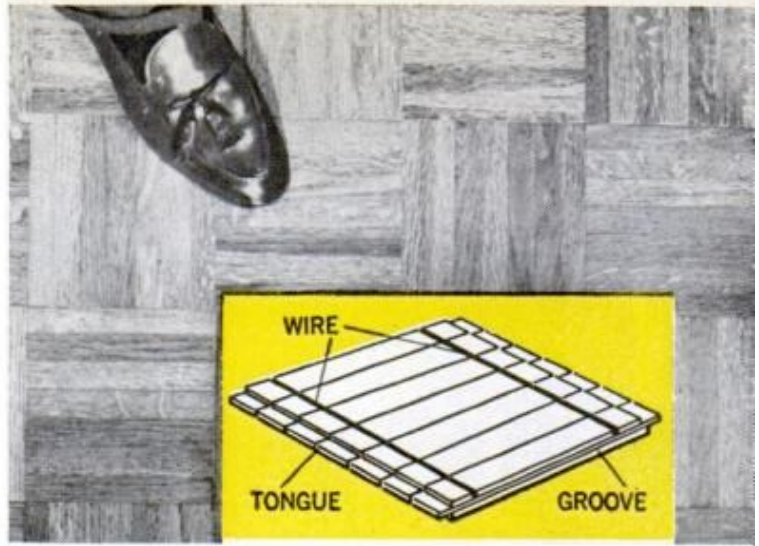

WEAR RESISTANCE superior even to marble is the boast made for this space-age parquet flooring. Called Gammite, the irradiated wood has natural beauty of a fine hardwood floor, requires no waxing or varnishing. Each flexible square contains seven narrow strips held by wires set in dadoes in bottom. Radiation Machinery Corp., Route 46, Parsippany, N.J.

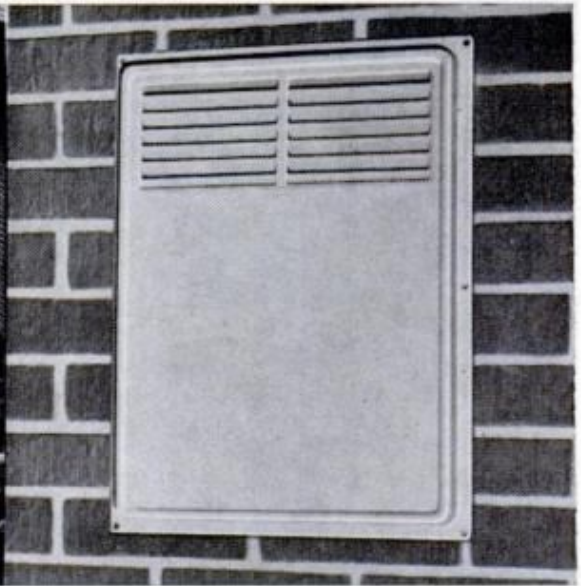

WOULD YOU BELIEVE it's a wall fan? Flush-mounted on the inside, Model 8150 projects outside less than an inch. The smooth aluminum center panel can be left as is or finished to match room decor. Fan is concealed in walls 5 to 10 in. thick; outside louvers deflect air from wall. Nutone Div., Scovill, Madison and Red Bank Rds., Cincinnati, Ohio 45227.

FOUR SOFFIT COMPONENTS—angle molding, drip edge, flashing and plain and louvered soffit supports—made of heavy-gauge aluminum, provide a complete soffit system when used with Vinyl-Bond, rough-sawn Philippine mahogany or other Insulite siding. In factory-finish white, guaranteed for 10 years. Available at building materials suppliers. For illustrated brochure, write Boise Cascade Building Products, Box 7727, Boise, Idaho 83707.

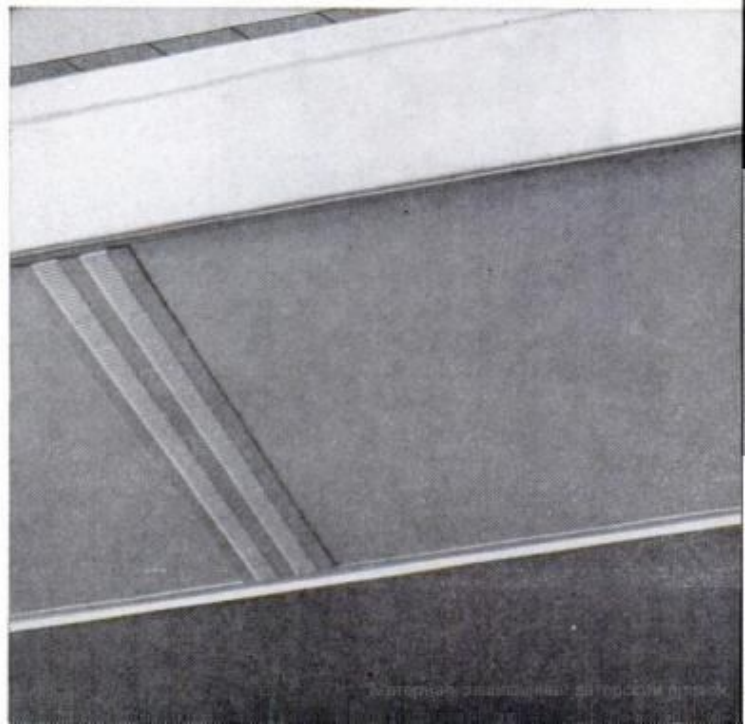



STAINLESS STEEL TUBULAR FITTINGS now come in 28 different styles. Sizes range from $\frac{1}{4}$ in. o.d. with an .025-in. wall thickness up to $1\frac{1}{2}$ in. o.d. in an .049 thickness. Styles include both male and female endings, a combination of the two, and special swivel endings for use with the flare-type union. Truly Tubular Fitting Corp., Mount Vernon, N.Y.

RADCLIFFE WATER CLOSET features a ventilating device installed in tank and operated by lifting the flush handle. This starts water flowing through a venturi tube and negative pressure created draws air from bowl, through rim punching and vents, into outlet of bowl. Venting stops when toilet is flushed. Crane Co., 4100 S. Kedzie Ave., Chicago, Ill.



AN ATTIC SCUTTLE can now do more than provide access to the attic. A new light fixture from Emerson Electric Co., Box 22179, 6263 Randolph St., Los Angeles 90037, lets you retain easy access while providing two-way illumination plus a convenience outlet in the attic. Fixture uses three 60-watt lamps to light attic when you remove diffusing panel and flip top scuttle over into the attic. Cost: about \$30.

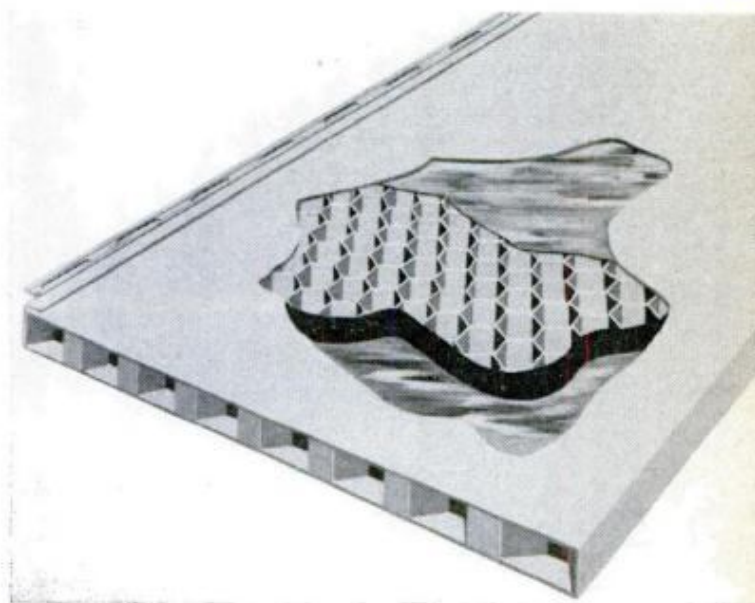

CUTAWAY DIAGRAM shows the construction of what is claimed to be the first pure vinyl siding with a honeycomb backer. Noncorrosive (the backer is like that used in space-capsule bulkheads), the siding also provides thermal and soundproofing. With color through plastic, material has high dent and fire resistance, eliminates painting. U.S. Aluminum Corp., 11440 W. Addison St., Franklin Park, Ill.

How to Anneal, Harden and

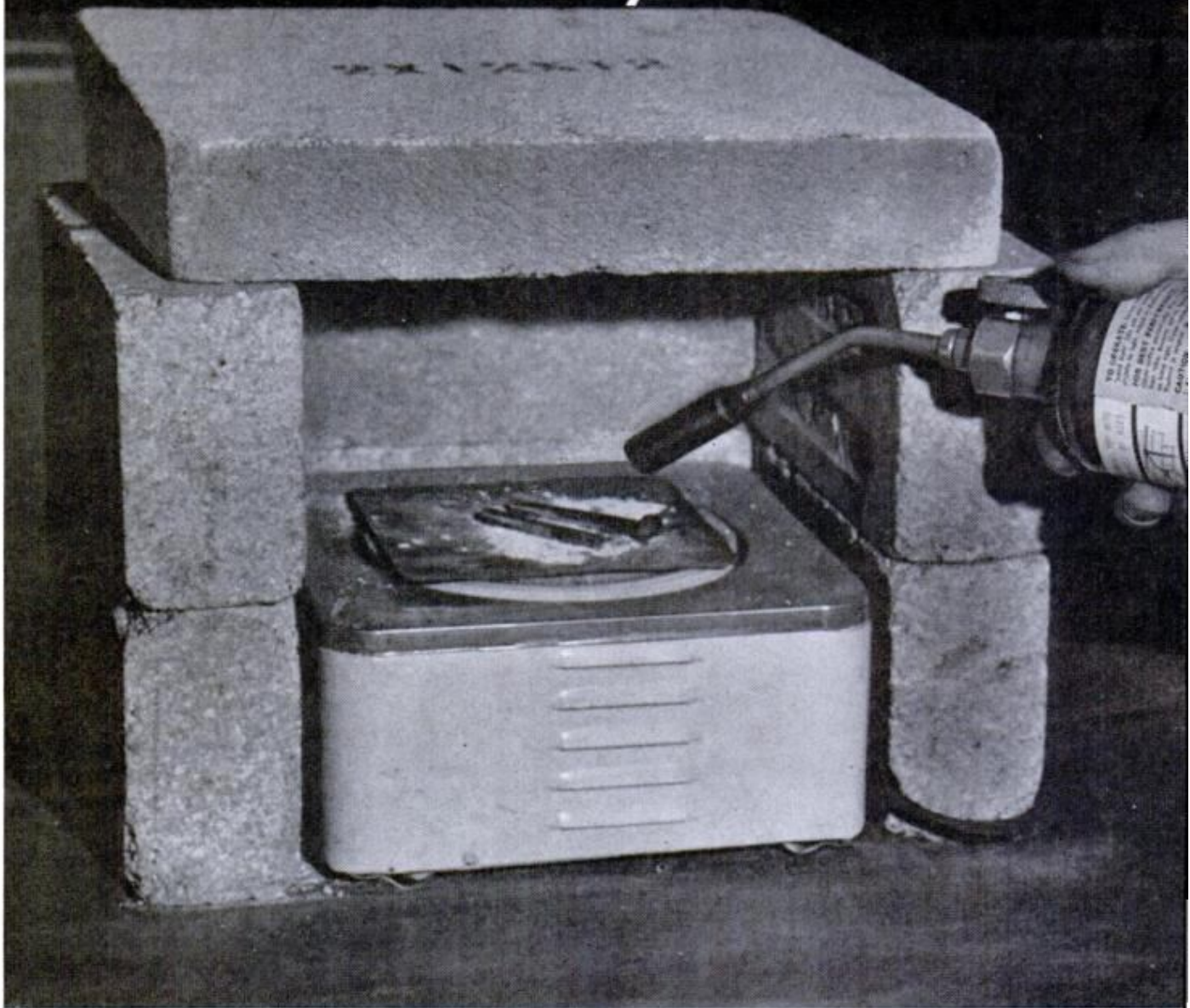

ANNEALING AND HARDENING TOOLS are furnace, torch, oil, dehydrated lime and pair of tongs. Asbestos can be substituted for the oven bricks if necessary

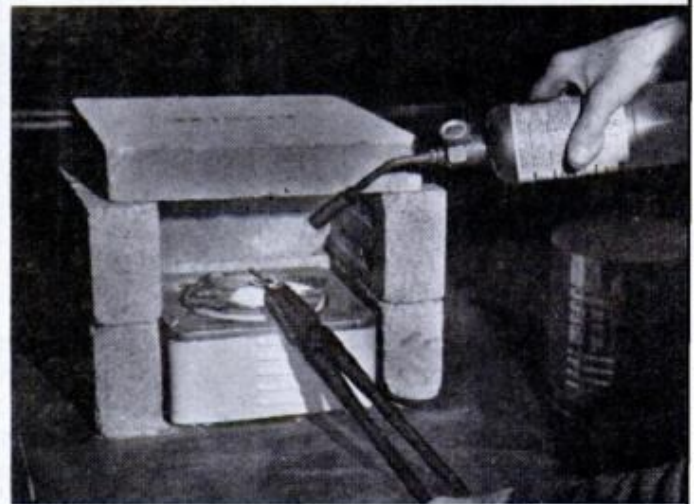

FLAME IS PLAYED back and forth until parts are cherry red, then parts are immersed immediately. Here, flame regains the heat loss caused by tongs

Temper Steel

It's no great mystery.
Using a simple furnace
you can do all
three in your shop.

By **FREDERICK W. SCHLUETER**
Master Machinist, Stevens
Institute of Technology

H EAT TREATING, the process of annealing, hardening and tempering steel, is actually a comparatively simple operation. All three steps can be done in your workshop. Since these procedures are not hazardous and do not create obnoxious odors, there's no reason why your shop shouldn't have a heat-treating setup.

The basic needs are few and, from the investment angle, the small cash outlay will serve your needs for years.

There are many annealing applications. You not only can soften steel but you can also relieve it of strains and stresses attributed to a variety of materials. Technically, the latter is a tempering process, but it is loosely defined here as annealing. For our purpose, annealing will mean just that: to make soft the metals you, as a home craftsman, will most often encounter. These metals could be working parts of locks, guns, screws, bolts, chisels and so on. By annealing, you make them workable; then by hardening, you put them back into their previous state.

To do it you need a furnace. You can improvise one from an old single-burner gas or electric stove by surrounding it with yellow firebricks to make an enclosure. And, since the heat requirements for both annealing and hardening are about 1450° F. you'll also need a small torch. A propane-gas torch will do nicely.

To insure an even heat from the burner and a spot to rest your work on, cut a small piece of sheet steel to rest on the burner. This can be square or round, but drill a couple of small holes to encircle the part placed on it. This part prevents burning of the steel, causing a loss of carbon.

If you lack a thermometer, you can rely on color sequences as a guide to temperatures. If you observe closely, after placing a piece of steel on the furnace plate, you will see an array of colors developing.

Since the colors are important guides, you should know them. Though there are

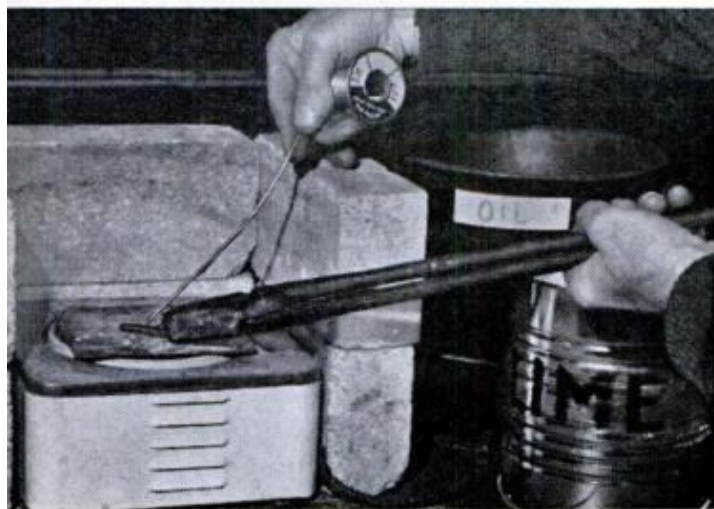

TEMPERING TECHNIQUE. Punch is tested with piece of solder for correct drawing of heat. Solder begins melting and starts flowing at approximately 400° F.

a number of specified colors (see chart) you need only to memorize three that apply to annealing, hardening and tempering. They are light cherry red—both for annealing and hardening; straw color for tempering and cherry red. The latter occurs at 1450° while light cherry red is about 1500° —the limit for proper carbonization. The reading for straw yellow is 460° which is the correct temperature for drawing (this reduces the brittleness caused by hardening). Variations from slate-gray to deep-blue cover a range of about 200° ($400-600^{\circ}$) and each indicates a 10° difference.

For annealing you'll need some dehydrated lime in which you immerse a treated part for cooling. A 5-lb. bag, obtainable at hardware stores, should be adequate to serve all your future needs.

Slowly heat the piece, shifting and turning it to prevent burning, then grip it with the tongs and play the flame of your torch back and forth to reach the critical moment of light cherry red. Then, quickly submerge it in the lime. Make sure it is well covered on all sides and do not dis-

turb it until it is fully cooled (at least five or six hours). The annealing process is completed.

The art of hardening, developed centuries ago, was a closely guarded secret of the skilled, ancient practitioners—and passed on only to their heirs. The technique is common knowledge today. And, if instructions are carefully followed, it is failureproof.

Have on hand about 1 gal. of quenching oil, enough to cool your metal without undue overheating of the oil. The procedures for hardening are much the same as for softening (the same degree of heat is required) except that instead of lime, the part is immersed in the oil and constantly agitated. Swishing it in a figure-eight motion will cool it evenly and in about five minutes the part can be removed.

Here are a few points to remember. Grip the steel only at those points where hardness is not critical—the spalling end of a chisel, for example. And, to insure the hardness of the critical parts, quickly immerse those sections first. If both ends are important, grip the middle and dunk the

ANNEALED PARTS are immersed in lime mixture after heating to required color. A part should be fully covered with lime, left to cool for five or six hours

TEMPERED PARTS are plunged in quenching oil, take less time to cool. Heated part should be swished around in figure-eight fashion until completely cooled

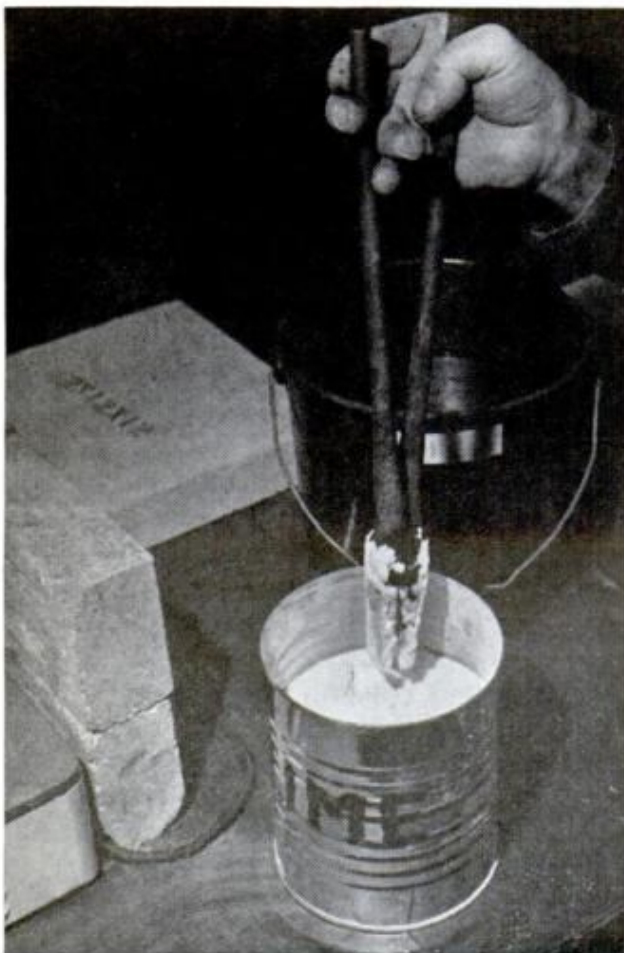

part horizontally. *Speedy immersing is important.*

Done properly, the piece will look like mottled slate—indicating scale. This is good but it has to be polished-off before tempering. To test its hardness, run a three-cornered file over the edge. If it sings, you know it is hard, and your file will not scratch it.

Tempering is the final step. As it is now, the part is *too hard and brittle* and will break under the slightest strain. It therefore requires tempering.

For this, the furnace serves again, but without the bricks that roofed it for the first two steps. First, polish the piece to a

whiteness, using emery cloth; this lets you distinguish the color changes. Next, place it on the burner plate without disturbing it further. Unroll a safe length of solder and play it back and forth on the piece. (No torch is needed if the part is small). Watch the color as the piece changes from gray to yellow. Be prepared to grip the piece with the tongs when the solder starts melting. The moment it reaches straw-yellow, quickly immerse it in oil.

Again, speed is important to prevent heat loss. Though somewhat less time is needed for cooling, follow the procedure of constant agitation when cooling. ★★★

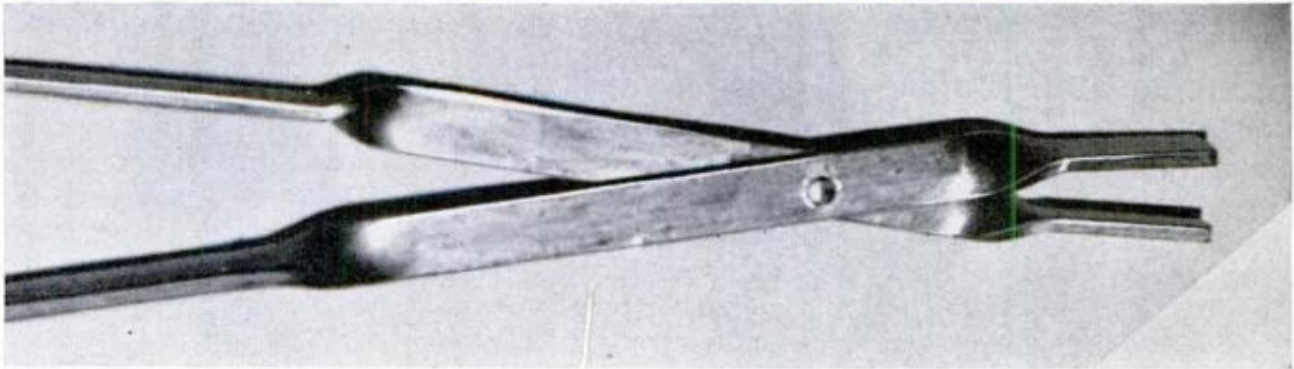

TO MAKE TONGS, scribe both pieces of metal for bending and drill the rivet holes. Clamp the metal in a vise and bend the jaws and handles, using a wrench. After riveting the pieces together, vise the jaws and adjust the handle spread to suit. For protection from heat, the tongs should be at least 12 in. long

HOW TO MAKE TONGS

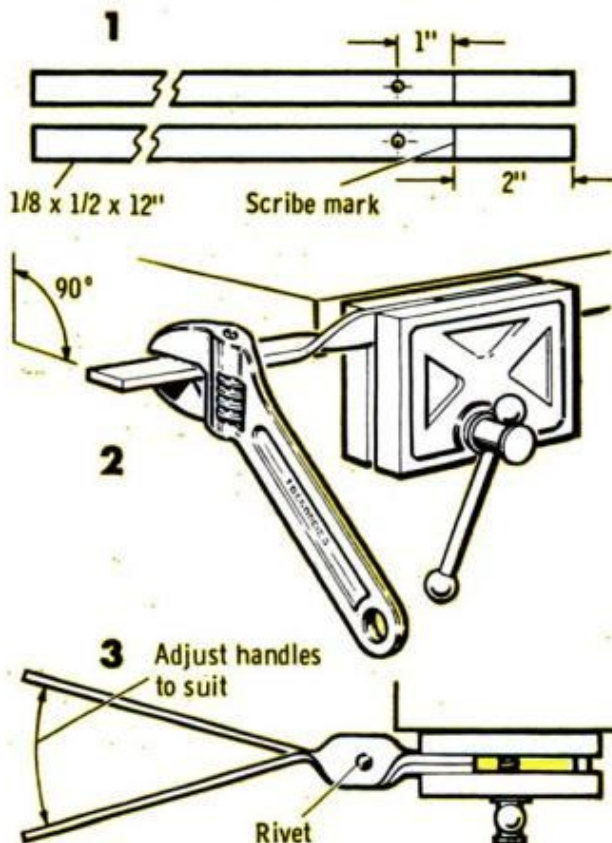

COLOR HEAT SCALE

COLOR	DEGREES
Dark Gray	400
Medium Gray	410
Light Gray	420
Very Pale Yellow	430
Light Yellow	440
Pale Straw Yellow	450
Straw Yellow	460
Deep Straw Yellow	470
Dark Straw Yellow	480
Yellow Brown	490
Brown Yellow	500
Spotted Red Brown	510
Brown Purple	520
Light Purple	530
Full Purple	540
Dark Purple	550
Full Blue	560
Dark Blue	570
Very Dark Blue	600
Cherry Red	1450
Light Cherry Red	1500
White Hot	1700

HINTS FROM READERS



Accurate straightedge

The next time you have to trim a few inches off the long edge of a piece of plasterboard, don't throw the scrap away. Kept handy in the workshop, it can be used whenever you need a straightedge for laying out a job. The sheets are factory-formed with a finished edge that can be used for any carpentry job. If used to cut plasterboard, move the knife carefully.

—Herbert Y. Moon

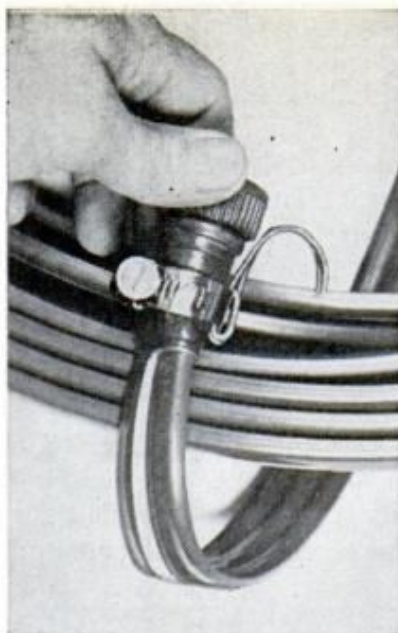

Anchor for soaker hose

To correctly position a soaker hose with its perforations topside where they ought to be, you have to walk the length of the hose, bending frequently. But, if you attach a hook as shown with a hose-clamp, you can anchor one end then simply tug on the other end, twisting the hose as necessary, to align the holes. The anchor holds firmly and allows easy repositioning.

—C. W. Gaston



Discharge extension

Recently, when my wife threw away her worn-out hair dryer, I salvaged the hose for use in my shop. Fastened to the elbow discharge on my radial-arm saw, it directs sawdust away from the workpiece and my face. Use either plastic or electrician's tape on the fitting and guard to hold the hose securely out of the path of the traveling saw and blade.

—Arthur L. Ramos

NEXT MONTH IN SHOP AND CRAFTS

TINY TRAINS HAVE MADE THE GRADE. Needing only one-fourth the space of HO, the new microgauge trains have taken model railroaders by storm. Being so small, they let you build and operate a complete railroad empire in a minimum of space. A two-part story beginning in January shows you how to start setting up an N-gauge system by first building a space-saving, swing-up train board.

A SPIRAL STAIRWAY YOU CAN BUILD. Though circular stairways have always been popular, high cost has kept them out of most homes. Ingeniously designed, here's our version which can be built by a do-it-yourselfer for less than \$60. Pick up a copy of the January *PM* and see for yourself.

A CABINET FOR YOUR GUNS. This beautiful glass-front, oak cabinet in Mediterranean styling will hold up to six guns with plenty of storage below for ammunition, scopes and cleaning tools. If guns are not your cup of tea, the cabinet can be fitted with shelves and used to display your prized china, trophies or bound volumes. Complete details for building the cabinet are in the January issue.

BUILD A BUMPER-POOL TABLE. Playing bumper pool is just plain fun. And, since the entire family can share in the enjoyment, the game has taken the country by storm. To get *PM* readers in on the fun, we've designed and built a table that's easy to copy. It's in next month's *PM*.

PLUS: A Mini-Motor Bike, Lathe Angle Post, and more, much more.

new breed of scat

The Bobcat, from Evinrude



Evinrude driver takes the Bobcat over a test jump. (Leave this to the "pros" — it's tricky.)

the performance-plus snowmobile

Most "performance" snowmobiles are stripped-down, single-purpose speed machines.

The Evinrude Bobcat is a high performance *trail* machine. A world of difference.

Bobcat is designed for speed — *plus*. 50 mph speed in flat country. With

power in reserve for hill climbing and high altitude running; and for powering through deep powder and soft, sticky snow.

The secret is the Bobcat engine — a 25 hp Evinrude twin with enormous 437 cc displacement.

An engine big and powerful enough

so the whole machine can be made as strong and tough as it needs to be for high speed cross-country running.

With enough performance left over to take a little luxury along.

Man can't live on speed alone.

Write for catalog. Evinrude Motors, 4077 N. 27th St., Milwaukee, Wis. 53216

the trailblazers, from **EVINRUDE**  **first in outboards**
Div. of Outboard Marine Corporation

Next Month in Popular Mechanics



STOCK CAR



FUEL DRAGSTER



CHAMPIONSHIP CAR

Special! 64-Page Tear-Out Section: Auto Racing Guide for 1970

This colorful, information-packed special section is a must for every fan of auto racing, the "greatest sport in the world." Major types of racing cars are shown in full color, along with photos and biographies of top drivers. There are also layouts of top tracks, racing schedules, current records, racing rules, argument settlers . . . even a glossary of racing terms. It's in next month's PM.



HELP!

...Yours When You Reach For Tools By CHANNELLOCK

Whenever you want to hold, cut, strip, drive, grip, bend, pull, twist, straighten, tighten or loosen . . . man, you need help! The kind of help that not only gets the job done faster *now* but year after year as well. The kind of help you get only from hand tools by Channellock. Doubt it? Take hold of a Channellock tool.

See and feel the fine-polished drop-forged steel . . . the precision-machined, smooth-working moving parts . . . the skillfully hand-honed cutting edges. You'll know then why Channellock is the favorite brand with men who know good tools and won't tolerate less. Men like you.

TOOLS BY
CHAN NEL LOCK[®]
MEADVILLE, PA.

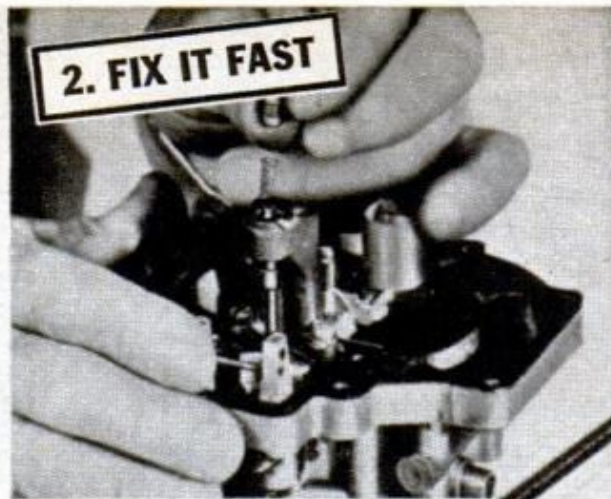

MOTOR'S easy "2-step" repair method helps you

Fix almost any part of any car...FAST

So clear, you'll breeze through tune-ups, air conditioning, brake jobs, engine overhauls — practically any repairs on cars listed.

You just can't make mistakes with the "2-step" method in MOTOR'S New 1969 AUTO REPAIR MANUAL. First, the special "Trouble Shooter" section helps pinpoint in a flash the cause of trouble. Next, 3,000 "How-To-Fix-It" close-up pictures (and plain-talk directions) show how to lick repair problems — fast and right! Even green beginner mechanics find the Manual so clear and easy to follow, they speed through the toughest jobs like real pros!

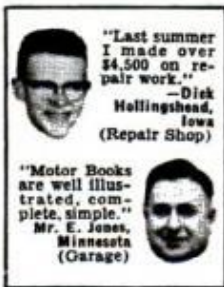

the auto repairman's indispensable "Bible." It's no wonder that more than 5,000,000 copies of the manual have been purchased by repairmen, service station operators, the U.S. Armed Forces, schools and students all over the world. Here is the help every beginner or "pro" needs to fix almost any part of any car right the very first time. And save time, work, money!

SEND NO MONEY

The Manual costs \$9.95, but we'll send it to you for 10 days FREE trial, so you can see for yourself how it makes auto repairs go quick and easy. Use it for 10 days. If it doesn't give you complete satisfaction, return it and owe nothing. Mail the coupon today.

Auto Repairman's "Bible"

Here's the real "meat" of facts and data distilled from over 300 official factory manuals and hundreds of service bulletins. Every job, from installing distributor points to front end jobs, is covered in minute detail for 2,300 car models of 45 series of American-made cars plus Volkswagen, from 1963 through 1969. There are over 1,100 oversize pages in this giant Manual containing 55,000 essential service specifications and adjustments. It's no wonder MOTOR'S is called

ALSO! FREE 10-DAY TRIAL on AUTO ENGINES & ELECTRICAL SYSTEMS



1,300 big pictures. Clear text explains how parts work; principles involved; design; construction; maintenance. Covers all parts of engines & entire electrical system. For FREE trial, check box in coupon.

Mail coupon now for

FREE 10-DAY TRIAL

MOTOR BOOK DEPT., Desk O1Y
250 W. 55th St., New York, N. Y. 10019

Rush to me at once (check appropriate box):
 MOTOR'S NEW COMPLETE 1969 AUTO REPAIR MANUAL. It's mine by paying \$2.00 in 10 days, \$3.00 a month for 2 months, and a final payment of \$1.95 plus delivery charge and sales tax, if any. Otherwise, I will return book postpaid in 10 days.

MOTOR'S NEW REVISED AUTO ENGINES & ELECTRICAL SYSTEMS. It's mine by paying \$8.95 plus delivery charge and sales tax, if any, in 10 days. Otherwise, I will return book postpaid in 10 days.

Print Name.....Age.....

Address.....

City & State..... Zip.....

I WANT TO SAVE DELIVERY CHARGE by enclosing \$8.95 for AUTO MANUAL and/or \$8.95 for AUTO ENGINES, plus sales tax if any). 10-day return-for-refund guaranteed.

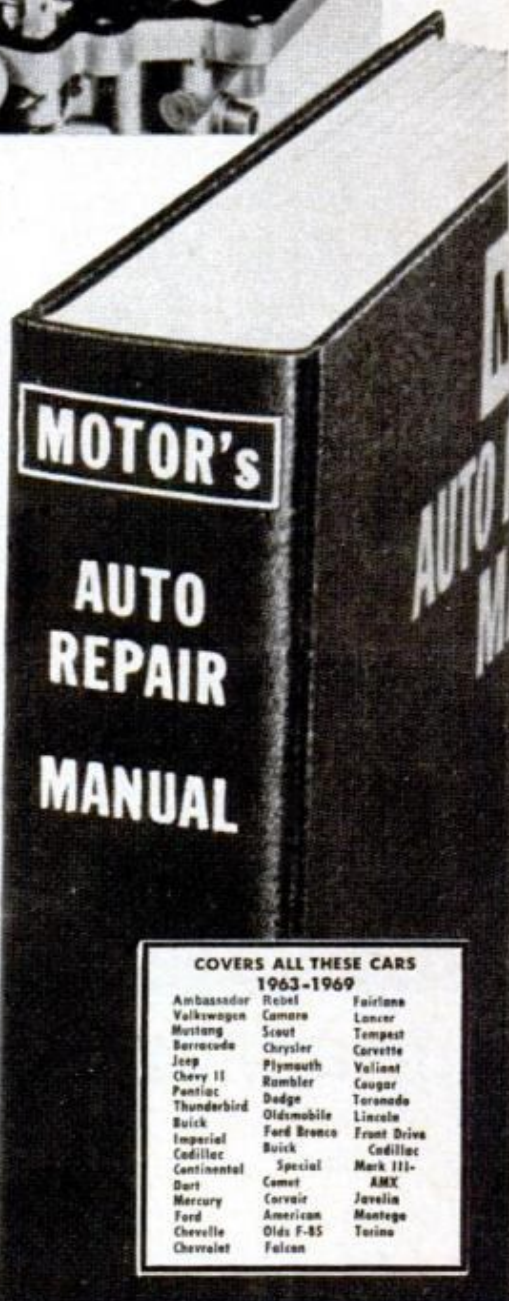

COVERS ALL THESE CARS 1963-1969

Ambassador	Rebel	Fairlane
Volkswagen	Camaro	Lancer
Mustang	Scout	Tempest
Barracuda	Chrysler	Corvette
Jeep	Plymouth	Valiant
Chevy II	Rambler	Cougar
Pontiac	Dodge	Toronado
Thunderbird	Oldsmobile	Lincoln
Buick	Ford Bronco	Front Drive
Imperial	Buick	Cadillac
Cadillac	Special	Mark III-
Continental	Comet	AMX
Dart	Corvaire	Javelin
Mercury	American	Montego
Ford	Olds F-85	Torino
Chevelle	Falcon	



No telling what you might find behind the doors of a Chevy-Van these days. It keeps working its way into more and more businesses.

Why Chevy-Van? Low price, for one thing. And the most powerful standard engines in its field. And low price. And outstanding maneuver-

ability. And low price. The fact is, you just can't find a popular van that costs less. Or does more. Chevy-Van is built to put in long, productive hours. Like we say, putting you first, keeps us first.



Busy body.

Would everybody
taste the difference
if we stopped
Beechwood Ageing
Bud tomorrow?



Shown above: beech wood ... the kind used in
Beechwood Ageing, the exclusive process that
gives Bud the taste, smoothness and drinkability
you find in no other beer of any price.

(Well . . . maybe not everybody.)

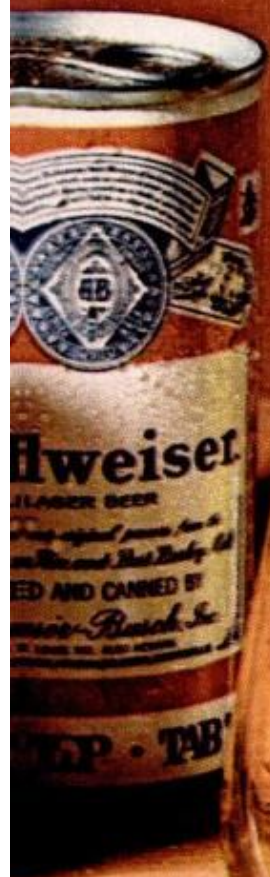

FIRST OF A GREAT NEW BREED

(Continued from page 111)

back in the early '60s when it competed with Lockheed for an Air Force contract to produce a long-range, big-capacity transport. Lockheed won the competition, and its huge C-5A is a reality today.

Boeing then turned its thoughts to the passenger-plane market, hoping to make use of the expensive research and development already carried out. The manufacturer became convinced that there was a need for a big subsonic craft in the long-haul market and that the plane would still be needed when the SSTs came into service in the '70s. The first Concorde models are designed to carry only 132 passengers, compared with the 490 maximum capacity of the 747. (Pan Am's seating configuration allows for 362 passengers.) Boeing also thought in terms of the big bird functioning as a cargo ship, another reason for its size.

With a go-ahead decision made, the 747 reached formal project status in March,

Laser beams make sure that long parts go in straight into jumbo freight cars

1966. A month later Pan Am announced the purchase of 25 of the superjets.

The history of the 747 is also a history of meeting and solving big problems. One hurdle had to be faced immediately: where to build the monsters. Boeing bought 780 acres in Everett, 30 miles north of Seattle, and built a \$200-million manufacturing facility that includes the world's largest building, even more spacious than the huge Saturn assembly building at Kennedy Space Center. Used as a manufacturing and assembly facility, the building encloses 160 million cubic feet. It is so vast that some workers use bikes to get around.

But before the plant could be put up, Boeing had to build a three-mile rail spur to the site. The spur climbs a 5.6 percent grade, making it the second steepest stretch of standard-gauge track in the country.

Structural parts of the plane are manufactured in many sections of the country and shipped to Seattle for assembly. This operation was hampered in the beginning because the parts were so huge. Standard-sized freight cars could not carry the larger parts, so special oversized cars had to be made. And even loading these jumbo cars is tricky. Tolerances are so fine that

laser beams are used to make sure that long parts go in straight. Crooked loading could result in damage.

Boeing's decision to build the 747 has stood up. At this writing, over 180 orders from the world's major airlines are on the books. With 33 of the big birds on order, Pan Am is by far the biggest buyer.

Though almost all the orders are for the passenger plane, a few have come in for the convertible (passengers and/or cargo) and the freighter versions, models that are sure to grow in importance as more goods are shipped by air. The freighter will be able to carry a maximum payload of 260,000 pounds for a distance of about 2900 miles, or 200,000 pounds nearly 4000 miles.

The convertible can be changed over from freight to passengers, or vice versa, in about 10 hours. Because special weight-adding equipment is needed to provide the versatility, the convertible will carry a somewhat smaller payload than the pure freighter. As a passenger plane, it will be able to carry 374 passengers, plus baggage and 40,000 pounds of cargo, for better than 5000 miles. These alternate versions will have engines with slightly more thrust than the first 747s off the line.

The potential of the 747 doesn't end there. If the future passenger market really booms, the big plane could possibly be expanded by stretching the fuselage 50 feet or by running the second deck—now long enough to contain only a lounge in addition to the cockpit—almost all the way back to the tail. The expanded plane could carry as many as 700 passengers.

But even if that never comes to pass, one thing is certain: While the bugs are being worked out of the SSTs, the 747s and other big subsonic birds will be busy carrying record numbers of people all over the world. ★★★

NEW MINI-STROBES

(Continued from page 131)

the camera for open-flash pictures. In this case, there is no connection to the camera at all. You open the shutter, flash the strobe by pressing a separate button on the unit itself, then close the shutter. Most minis have a flash-test button on the back that can be used for this purpose. While the technique is limited mainly to still-life scenes, it can produce some interesting effects. You can, for instance, flash the strobe several times in succession with the shutter open to "paint" a scene with light that's too large to be covered by a single flash. ★★★



400 watts can drown out the roar of Niagara Falls. A Delco Energizer can produce nine times that power to start your car.

We stationed a group of musicians right at the base of Niagara Falls. All nine of their amplifiers were powered by a single R-71S 12-volt Delco Energizer. Their music came through loud and clear, despite the roar of the falls.



The Energizer used is the same type that can produce, at zero degrees, up to 3600 watts of cranking power in the first few seconds of starting. To give you the biggest, fastest burst of starting power Delco's ever

developed for your car.

When you replace your old battery, ask for the Delco Energizer with the Peak Watts Rating molded right in the case. That way you'll know the exact cranking power you're getting.

See your United Delco Serviceman. He's a real Care-taker. To locate him fast, Dial Delco: 800-243-0355*. Free. Or just look for this sign.

*Dial as for long distance. In Conn., call collect 325-4336.



See the Care-taker.

Материал, защищенный авторским правом

FREE

Popular Mechanics Catalog Plans, Publications, Projects

Want to build a boat, garage, sidewalk classic, plane or a clock, kayak, fireplace, kite, patio, coffee table aquarium, kitchen cabinet, organ, swimming pool, telescope, children's play furniture, camping trailer, science project, electronic project?

Send for the NEW Popular Mechanics illustrated catalog! 32 pages crammed full of fascinating and useful projects you can build yourself!

For more than 67 years, Popular Mechanics has been the world's leading authority on how-to information. In this brand new catalog you'll find the very best of Popular Mechanics plans and publications. In step-by-step text, photos and drawings, these plans show you how to build something for everyone in the family.



Above are shown a runabout boat you can build for less than \$75; a four-place plane you can construct yourself; a patio-garage and the famous sidewalk classic for youngsters that rolls along at 5 m.p.h.

For information on scores of other exciting projects, order the new catalog today! Send only 25c to cover postage and handling.

Enclose 25c in coin, no stamps please, to cover postage and handling.

Mail to: **Popular Mechanics Service Bureau Dept. B**
224 West 57 Street
New York, New York 10019

Please Print:

Name _____

Address _____

City _____ State _____

Zip _____



**Before you buy
any snowmobile...**

back up a moment!

You can with the new Skee-Horse Wide-Trac snowmobile. Back up, that is.

Off your trailer.

Away from a tree.

Out of any trouble spot. This new Wide-Trac has reverse. Most other snowmobiles don't. They don't have neutral either. The Wide-Trac does. You can warm up the engine without having to tip over or prop up the snowmobile. And you can start up without lunging.

If reverse and neutral don't turn you on, forward gear will. Powered by a brawny 25-horse engine, this Skee-Horse really flies. It accelerates quickly and cruises effortlessly. And the wide stance contributes good stability and over-

the-snow flotation at any speeds. All Skee-Horse models feature the rugged reliability of two cylinder engines. Our engines are American made, so parts and service are close and fast. The engine on the Wide-Trac is completely enclosed. Very quiet and very clean. And it has a compression relief valve to assure easy cold weather starts. As easy as turning a key if you like.

The new Skee-Horse Wide-Trac makes snowmobiling a sport instead of an ordeal. It's the one you can back up. One we can back up, too, with a 90-day warranty*. Get the full story from your Johnson dealer. Or write for a free catalog. Johnson Motors, Waukegan, Illinois 60085, Dept. PM-S912

*For 90 days after purchase, Johnson Motors will replace or repair without cost to the original purchaser any part of its manufacture which upon inspection proves to have failed in normal use due to faulty material or workmanship.

 **FIRST IN DEPENDABILITY**
Johnson is the way to go!
Division Outboard Marine Corporation



**Take it
from people
who know,
Ski-Doo is the one
with the
winning
personality!**



Last winter, Ski-Doo won more races than all other snowmobiles combined. And set a world speed record doing it!

If a snowmobile can take on all competitors in every class and win race after race, it has to be good. But being good on the track isn't good enough. Once again, we've gone all out, so you can go one better on the trail, too.

Better performance. Ski-Doo has more dependable power for climbing, towing, funning around. Better ride. Smoother over the bumps. More stable in the turns. And no snowmobile is so light-footed — over deep, deep snow.

Better selection. For 1970, we offer five Ski-Doo series, each with a totally different personality. If it's luxury you're after, we have it. If it's economy, we have a Ski-Doo so low-priced, many people are buying two.

If you want the number one choice in snowmobiles, in high fashion winter sportswear and accessories, see your Ski-Doo dealer. He'll show you the 1970 reasons why you go one better when you go Ski-Doo.

go one better
go Ski-Doo
North America's number one snowmobile



*T.M. Bombardier Ltd.

Take this \$3.49 book FREE!

Let these 257 experts show you how to attain the skills of a real pro!

You get this giant 8¼" x 11" illustrated volume of exciting "how-to" projects for your family, home, garden, car, boat, vacation—as an outright gift—nothing to buy. It is crammed with reliable shop-tested, do-it-yourself techniques and practical show-how pictures. Use these hundreds of do-it-yourself plans, projects, tips and hints to polish your own shopwork and hobby skills! Here is a brief glimpse of all your FREE Volume brings:

 • Having car engine trouble? Fix 8 common problems quickly without having to pay a garage mechanic anything he chooses to charge you.

• Professional tips for expert sanding show how to bring out the best finish in woods and metals with power and hand tools.

• Complete plans help you build an inexpensive 3 x 4 foot plywood table to give any small band saw big-machine capacity and flexibility.

• Need extra space? Turn an unfinished attic or basement into handsome, usable areas with practical, money-saving plans.

• Save on band saw blade costs. Build brazing fixture to make your own blades.

• Do your own auto body repair expertly with simple tools and methods.

• Build a boat designed just for fun. Step-by-step plans and materials list included.

• Home too hot for comfort? Follow complete directions for air conditioning your home.



• Bothered by a wet basement? Cure it yourself and save \$200 to \$2,000 under what professionals charge.

• Need better burglar protection? Build effective power alarm for a safer home.

• Refinish furniture perfectly. Hands-at-work pictures show you how.

• You'll wonder how you ever got along without an air supply in your shop once you've built and used the "foot-bellows" system.

• Build a gas-fired barbecue for more back-yard fun.

• New soundproofing techniques enable you to relax in quiet.

• Anyone can hand-letter signs with the "Project-A-Plan" method.

• Special trouble-shooting chart pin points malfunctions in an auto electrical system so you can fix it quickly.

• Target practice in the living room? Believe it or not you can blast away indoors without harming anything.

• Build your children model planes that fly higher than any others.

• Special tricks-of-the-trade save you time and effort in handling power tools.

• Save hundreds of dollars on buying and servicing appliances.

Plus hundreds of other exciting plans and do-it-yourself ideas to save you big money and add thousands of hours of pleasure to your hobby, sport and vacation projects.

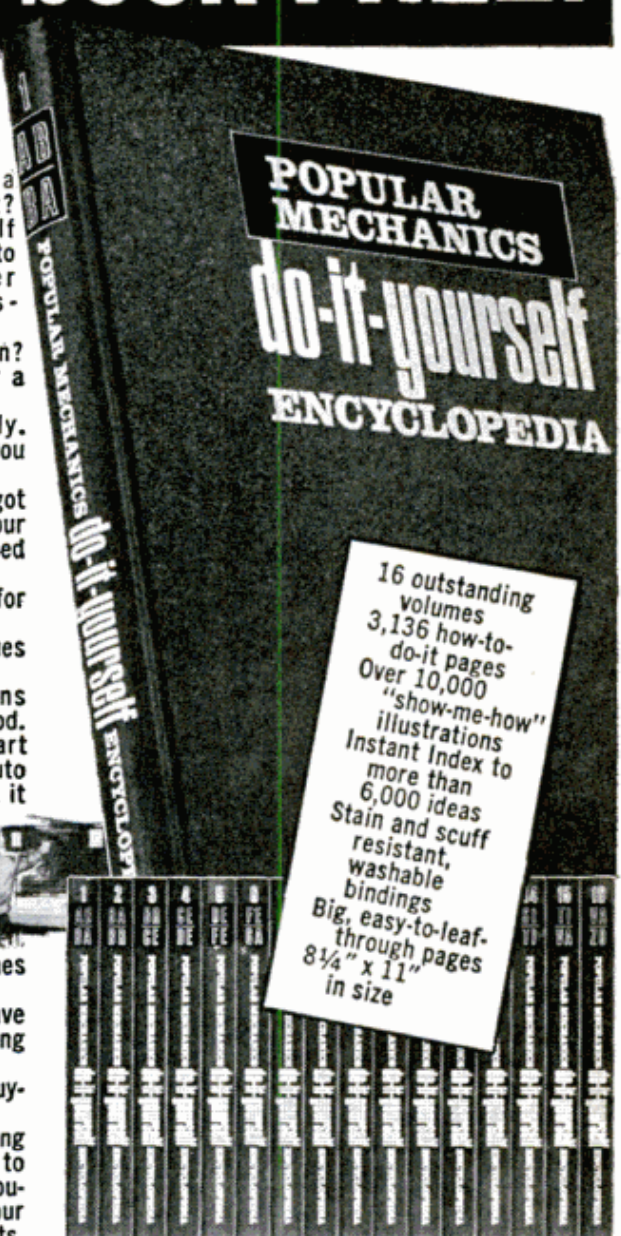

16 outstanding volumes
3,136 how-to-do-it pages
Over 10,000 "show-me-how" illustrations
Instant Index to more than 6,000 ideas
Stain and scuff resistant, washable bindings
Big, easy-to-leaf-through pages
8¼" x 11" in size

Why you receive this practical do-it-yourself handbook ABSOLUTELY FREE!

The reason you get this brand-new \$3.49 book as an outright gift is simple. This gold mine of "how-to" projects and money-saving plans is the first volume in POPULAR MECHANICS DO-IT-YOURSELF ENCYCLOPEDIA—an amazingly useful guide created by the editors of *Popular Mechanics*—experts in do-it-yourself techniques for over 65 years. The Encyclopedia gives you over 6,000 projects, repairs and improvements you can do by yourself to save hundreds of dollars on labor and materials. 257 experts lead you through every step of every project you select. They give you thousands of practical pointers to sharpen your skills in carpentry, car repair, metalwork, plumbing, masonry, electrical work, electronics, hi-fi, stereo, painting and decorating.

We believe that if you browse through the first volume—select a plan or project—use it at your workbench—try some of the money-saving shortcuts, shop-tested methods—you will be anxious to receive the others. Therefore, you may enjoy future volumes as they are published for 14 days' FREE EXAMINATION. You may buy one, two, the whole set, or none at all. But the first volume is yours to keep without obligation, no matter what you decide. Mail coupon today, to be sure of getting your FREE Volume.

FREE GIFT CERTIFICATE

Popular Mechanics Book Division, Dept. 91Y
250 West 55th Street, New York, N.Y. 10019

Please send me, ENTIRELY FREE of any charge, my complimentary copy of Volume One of the all-new, illustrated POPULAR MECHANICS DO-IT-YOURSELF ENCYCLOPEDIA. I am not obligated to buy anything—now or later.

I understand I will be entitled to receive additional volumes for my FREE EXAMINATION as they are published each month. After examining each volume FREE for 14 days, I will either return it and owe nothing—or keep it and remit low subscriber price of only \$3.49 a volume, plus a few cents for shipping.

I reserve the right to cancel any time I wish—even immediately after receiving my FREE Volume 1—without obligation. Whatever I decide, Volume 1 is mine to keep FREE.

Name _____
(Please Print)

Address _____

City _____

State _____ Zip

Signature _____



HEART-BREAKERS



Mark I and Mark II target pistols for .22 Pellets or .177 Pellets and BBs. They feel, look, handle like—and are—fine match target pistols. The most accurate Crosman has ever designed for Pellet and BB shooting. Fully adjustable sights, trigger adjustment for conventional or fine shooting. Up to 60 shots per single CO₂ Powerlet. Single shot action for accuracy. About \$28.



Model 38-C Combat "38" CO₂ Pelgun Revolver. Here's a pistol that's easily mistaken for a .38 caliber firearm. It offers single and double action and revolving cylinder which holds six .22 caliber Crosman Super Pells® for slow or rapid firing. About \$35.

Gift idea: all pistol models available in pistol guard case with complete shooting supplies. Send for free booklet, "More Shooting Fun." Write Dept. PM129.

Crosman/Going Great Guns
 Crosman Arms Co., Inc., Fairport, N. Y. 14450
 Crosman Arms (Canada) Ltd., Dunnville, Ont.

SMILE! YOU JUST GOT A TICKET

(Continued from page 76)

habitual leadfoot. Maybe they'll ignore the guy who's doing only a few mph above the limit. In any event, Orbis won't be accused of favoritism, inaccuracy, or bad manners. Whether Orbis photos will be admissible in court as valid evidence remains to be seen, but there's no reason to doubt it. There's been no trouble with radar, and radar doesn't include a picture—only the officer's word.

Several other uses for Orbis have already come to mind. Businessmen hope it can tell them where to locate new shopping centers, billboards, filling stations, motels and the like. Also, by evaluating types of traffic, not just numbers, Orbis will aid in highway planning, traffic control, border patrol, surface maintenance, and even help spot stolen vehicles.

Surveys via Orbis might even bring about higher speed limits. As Dave Lee mentioned, "If by constant surveillance of a particular stretch of highway we find everybody is speeding, yet there aren't more accidents than normal, that might be good justification for changing the speed limit." So it isn't total gloom after all. ★★

FOUR-MILE TRAIN

(Continued from page 85)

lating trackage, which calls for one locomotive to pour on power while the other pinches down the wheels. To take care of that, both Locotrol and RMU offer the engineer independent control of the master and slave stations. But here he and his Brotherhood draw the line, maintaining that it is both hazardous and unreasonable to add this responsibility to his one-man-band routine.

There is a likely solution. Prior to radio control, experiments were made with less versatile slave locomotives in which a stress-sensing device measured the tug or slack at the forward coupler and actuated the throttle and brake valve accordingly. Diplomatically, a similar triggering mechanism could and probably will be tied into future slave-station setups.

Sad to say, that will only hasten the day of the fully-automated freight train. Then who will acknowledge a small boy's trackside wave? ★★★

COMING NEXT MONTH

Auto Racing Guide for 1970: 64-page section.
Hot New Fighter for Navy: Grumman's F-14.
How We Raised the Alvin: Deepest rescue.
Build a Bumper-Pool Table: Complete plans.

Master Mechanic Everlite Battery Charger

DON'T BUY BATTERIES SAVE \$ - RECHARGE THEM

Over and over up to 15 times or more

- By far the best
 - Charges 6 batteries at once
 - Charges 3 times faster
 - Charges all types of batteries.
- Only Everlite charges tiny hearing aid batteries as well as big lantern batteries.

Only Everlite charges flashlight, toys, radio, telephone, hearing aid, cameras—yes, even mercury cells. Save money and have the convenience of fresh batteries. Simple, safe, foolproof and unbelievably efficient. Plugs into any 115 volt outlet. Free battery tester included. Guaranteed for one year.

2 MODELS—The Everlite #75 for all Dry Cell Batteries up to 12 volts.Send

\$6.95
plus \$.65
for shipping.

The Everlite #76 for all Dry Cell Batteries plus a special charge for Car Batteries to assure fast starts on cold mornings.Send

\$8.95
plus \$.75
for shipping.



"Copy any Contour Instantly"

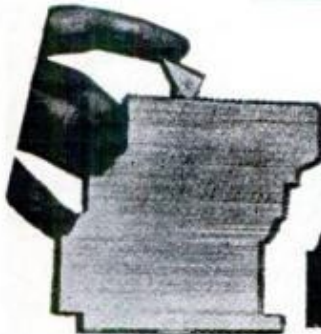

**NEW IMPROVED
Contour
Copy**
Copies exact outline
of any object!

Save dollars—save material. Can pay for itself on one job. The perfect tool for fitting in against door casings, bath fixtures, moldings, pipes, sinks, masonry, etc. A real boon to pattern makers, sheet metal mechanics, tool makers, body men, linoleum and floor tile men, etc. **EASY TO USE**—Just push the gauge leaves against any contour and lock. A perfect template every time. Works against any surface or material.



TEMPLATES

DOOR CASINGS



Made of hardened aluminum alloy.

Size 1#—4 1/4" x 4 1/4" **\$6.90**

plus \$.65
for shipping.

Will retain its accuracy forever.

Size #2—7 1/2" x 4 1/4" **\$9.90**

plus \$.75
for shipping.

EVERLITE * World's THRIFFIEST Light Plants



THE CHAMPION \$149.50

The Champion—1200 watts
115 volts AC for only \$149.50

Unbelievable but true—Brand new production methods now make possible world's finest design in a service free alternator light plant at this unprecedented price. Plant puts out a steady 1200 watts of 115 volt AC power to run power tools, oil burners, pumps, TV, or anything that requires up to 1200 watts. Powered by a rugged 3 HP, 4 cycle, easy start gas engine with 1 year factory warranty. Complete with carry handle and shock mounts. Why fool with short life 2 cycle plants when you can buy this rugged top quality machine at our factory price.

Item # 1265 \$149.50
wt. 65 lbs.

2 3/4 h.p. Clinton—39.95

Model 400, rugged 4 cycle model. Alum. Block, castiron cylinder Rope start—3/8" std. shaft.

Item 1107 **39.95**
2 for **78.95**

3 1/2 h.p. Clinton—44.50

A big engine with big power. Model 404, 4 cycle, rope start, 3/4" std. shaft, industrial ball bearing engine.

Item 404 **44.50**
2 for **87.50**

Remember these engines are absolutely perfect and standard and under factory warranty. Money back guarantee. Order now while stocks are complete. Factories—we buy new engines.

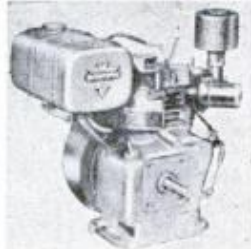

STANDARD DIAL PHONES WITH BELL

Bell System late model dial phones same as used by all telephone companies. Ideal as extensions on any system. Easy to connect. Several may be connected on one line. Easily modified for private inter-com system. Cost \$40.00 new—guaranteed excellent condition.

ITEM 855 NC. Wt. 8 lbs. **\$8.95**



All Prices FOB Factory—10 Day Money-Back Guarantee

Briggs & Stratton — Clinton New Gas Engine Sale



Clinton 2 1/2 hp. Mdl. 500—Re-coil starter Std. 3/8 shaft w. keyway—ready to go. Reg. price \$59.50
Special (item 1002)

\$39.95

2 for **\$78.95**
6 for ... **\$229.50**



Briggs & Stratton 2 3/4 hp. Mdl. 81106 ratchet start. 3/4 shaft. Sturdy 4 cycle engine. Reg. price \$69.50
Spec Item # 1518

\$39.50

2 for **\$78.95**
6 for ... **\$229.50**

\$74.50

5 3/4 hp.

Briggs

&

Stratton



Same engine with 12 v. elec. start and battery charging. (Item # 1571)

\$99.50

Remember these engines are absolutely perfect and standard and under factory warranty. Money back guarantee. Order now while stocks are complete. Factories—we buy new engines.

TRUCK OR BOAT WINCH 2000#

A powerful, compact winch which installs easily even in limited space. Works with any 12, 24 or 32 volt system. Reverses under power—positive brake holds load. Drip proof cover. Remote control if desired. Drum holds 100 ft. of 3/4" cable. Speed 30 ft. per minute. A terrific winch at an economy price. Item 1263

Wt. 55# **\$69.50**

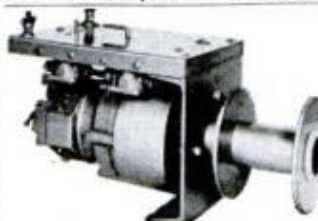

MASTER MECHANICS MFG. CO.

Dept. A-129

Box A, Burlington, Wis.

Box 65, Sarasota, Fla.

Send orders to nearest office.

'I go for the top!'



**Refinish it yourself for only \$9⁹⁵
with NEW**

FINISH-R

AUTO TOP REVINYLIZER

Now you can do something *fast* and *easy* about your dull, discolored or beat up vinyl top... without spending a small fortune at the repair shop. FINISH-R, the new miracle polymer acrylic coating, renews and recolors vinyl surfaces better than new. Only luxury cars (like the Caddy) leave the factory with a hard gloss finish just like FINISH-R. You'll like the way FINISH-R *bonds perfectly to any vinyl, goes on easy, dries fast, lasts up to one year or longer and adds resale value.* Complete kit only \$9.95 includes: FINISH-R Auto Top Revinylizer, FINISH-R Cleaner Conditioner, non-scratch scrubber and Patented 'Immie' Applicator. Here's all you do... wash down your top with FINISH-R Cleaner Conditioner, let dry, apply FINISH-R... that's it. *You're ready for action!*



FREE! ACT NOW and we'll send you your choice of a handy carry-all tool chest or unbreakable tackle box. Hurry! Supply is limited.

P.C.A. Sales, P.O. Box 29
Staten Island, N.Y. 10314

**POPULAR
MECHANICS
PRODUCT FEATURE**

Please send me _____ FINISH-R Kits @ \$9.95 each. Enclosed is my check or money order for \$_____ (Check one) FREE Tool Chest FREE Tackle Box

My car top color is: _____

NAME _____

ADDRESS _____

CITY _____ STATE _____ ZIP _____

11/9

N.Y. State residents please include local tax—we pay postage and handling

DODGE'S NEW PONY CAR

(Continued from page 99)

though it can cause a surprise until you get used to it. I honked it several times—at the wrong time.

Dashboard instruments and controls are fine, all logically placed. You can have full instrumentation with the rallye cluster or go with the standard setup. I'd like to see a combination of gauges and warning lights, however. That way the light would signal trouble and the gauges would let a driver know just exactly how everything was going under the hood.

The four-speed transmission control sports a handgrip rather than the usual knob. It's close at hand to the driver, and I really like the new grip coupled to the Hurst linkage.

Noise level within the car is moderate. What noise there is is a combination of exhaust and air-cleaner sounds. The 340 V8 has a low restriction filter and a pair of low restriction mufflers. But I sure wouldn't call it an offensive sound. Personally, I enjoy hearing a bit of "music" from a thoroughbred powerplant.

Trunk room is surprising. A collapsible spare is used and it takes up very little room. The bumper jack is held in place with a spring to keep it from rattling. The fuel fill pipe, which can and should (I think) have the optional lock, barely intrudes in the trunk area. That right-side gas fill will be appreciated by anyone who's ever run out of gas and had to tip a gallon can into a left-side filler while traffic rushed by. Taillight bulbs are replaced from underneath the pods inside the trunk. They're put there to keep from being smashed by anything in the trunk.

You don't have to read between the lines to know I'm impressed with the Challenger. I like a lot of cars, and now here's another to add to my list. I can't get over how well this one handles. The small-block 340, combined with a decent suspension, really gave me a good ride. The Challenger seems to have a great deal of personality. It can have a lot of different ones, since every engine from the small six-cylinder to the big 440-CID V8 can be put in the car. You can even install the racing Hemi 426.

Everybody looked at my test car while I was driving it, partly—I suppose—because of its good looks, and partly because of its brilliant Lime-Fire paint. Most of the people who really took a close look weren't old, but they weren't real young either. That's probably a good sign. It made me feel sort of "in." At least it made me very sure this car is no retirement-village special. It's everything but that. ★★

BIG

YACHT-SMART
Sail Rig
DACRON
from
\$112



FALL SAVINGS NOW FOLBOT

TRAVEL CRAFT
fits in every
home or car

FOR YOUR SPORT AND FAMILY FUN

and
RECORD
FISHING

GENUINE Folbot RECREATION for just ONE small investment, WITHOUT the continuous burdens of complicated 'big rig' operation. You GO CAREFREE anytime with COMPACT Folbot . . . rocky streams, lakes, marsh, surf & open sea. Superior non-sinkable designs provide SAFEST low gravity center, balanced low & high seating, substantial construction, protective decks & EXCLUSIVE swivel-back COMFORT. ALL within your reach. In handy Folbot YOU GLIDE smoother, faster & NOISELESS with paddles, oars, or sails and ride softly w. 1 to 10 HP. motors. Many styles & sizes from 1 to 4 seaters, FOLDING or rigid PORTABLE come in PREFAB KIT, or expertly FACTORY BUILT

Just a few Dollars start
YOU right away. From

ONLY \$19 NOW

for BASIC KIT

16 feet long

'CAYAT'
car top
YACHT.

NEW
Fabulous
16 foot
\$115

Factory BUILT

FREE
ACTION CATALOG

**STARTLING
FACTS & FIGURES**
Mail coupon or address

to: FOLBOT CORP.
Dept. PM1269, Charleston, S. C. 29405

Name _____

Address _____

City _____ State _____



"Sta-Trim" WAIST BELT!!!

Designed for the person desiring a trimmer waistline appearance. Ruggedly constructed non-porous belt covers the entire waist area, and causes it to perspire with the slightest exertion. Exercise program and instructions included. Send waist size and \$3.98 to "STA-TRIM," Suite 1204-PM-6 28 E. Jackson Blvd., Chicago, Ill. 60604

75 POWER TELESCOPE \$498

NEW 3 in one telescopes, 3 variable 25X 45X-75X magnification. Brass bound. 25 power for ultra bright images 45 & 75 power for long range. Guaranteed to bring distant stars, moons, objects, sports 75 times closer.

Most powerful scope anywhere at this amazing-low price. 5 sections. Opens 36" closes 1 ft.; contains 4 ground & polished lenses. Can also be used as powerful microscope. American made. Mass production enables us to offer telescope complete including case \$4.98 post paid. Money back guarantee.

CRITERION CO., Dept. PBM-56, 331 Church St., Hartford, Conn. 06101

INVENTORS

INVENTIONS—NEW PRODUCTS—IDEAS
DEVELOPED & PREPARED

For Commercial Appeal & Sales

DESIGN—MARKETING—PATENT RESEARCH—DRAWINGS

DIRECTOR: United States Patent Office former Patent Examiner
United States Dept. of Army former Patent Adviser
Member: United States Council Int'l Chamber Commerce
Second Decade of Reliable Service to

INVENTORS—MANUFACTURERS—ATTORNEYS

FREE CONSULTATION

THE RAYMOND LEE ORGANIZATION

230-Z Park Ave., New York 10017 (212-MU 6-8500)

SEND FREE "INVENTION RECORD" Form & "IMPORTANT PATENT INFORMATION"

Name _____

Address _____

City _____ State _____ Zip _____

DECEMBER 1969

This Dremel Electric Engraver Permanently Marks Any Material—



metals, glass, wood, plastic. Ideal for identifying tools, engraving jewelry, coding industrial tooling. Weighs only 7 oz. Calibrated stroke regulates depth of engraving. Only \$14.95 with solid carbide point and storage case. Diamond points available. See your dealer or write for literature.

DREMEL MFG. CO.
Dept. 89-M, Racine, Wis. 53401

197

HOLIDAY SPECIAL

SAVE UP TO \$200
ON AUTO AIR-CONDITIONING
PLUS — EXTRA SAVINGS
DURING THE
HOLIDAY SEASON



COMFY-KIT®

Supreme Kit. . . . \$150
regular price \$165



COMFY-KIT®

Super Kit. \$133
regular price \$148

Comfy-Kit has saved thousands of people up to \$200 or more, compared with the cost of "factory" air. And now . . . you can save even more by ordering before December 31.

Like the long, lean look of the Supreme Kit? It's reduced to just \$150 from regular price of \$165. Super Kit is down to \$133 from the regular price of \$148. (Reduced prices apply to 64 thru 70 model cars only).

Comfy-Kit is easy to install. Takes just a few hours. It's just like being paid up to \$50.00 an hour for your time. And you get a good-looking, high performance unit with all the cooling power you'll ever need.

Complete, easy-to-follow instructions are included - even the loan of special tools if you need them. Just fill out the coupon and send it in. Get extra savings now . . . and be ready for hot weather when it arrives next summer. Hurry, offer expires December 31, 1969.

MAIL HOLIDAY SPECIAL COUPON TODAY

COMFY-KIT®

P.O. Box 8585
Dept. PM12
Dallas, Texas 75216

- Enclosed is \$150. for Supreme
- Enclosed is \$133. for Super
- Enclosed is \$30. deposit for Supreme for Super I will pay balance, plus C.O.D. charges when delivered.*
- Please ship immediately.
- Ship so I will receive unit about.....
- Enclosed is \$8.00 deposit on set of four tools, which will be returned to me when I return the tools.
- I would like to see the instruction book before I order. I enclose \$1.00 for instruction book only. I understand this will apply against a future Comfy-Kit order.

Name.....

Address.....

City.....State.....Zip.....

My car is a.....(year).....(model).....

Engine displacement.....Horsepower.....

Power Steering.....yes.....no

Floor shift.....Steering column shift.....

Smog pump.....yes.....no

* plus state tax where applicable

CARE OF SNOW THROWERS

(Continued from page 122)

because of looseness can easily be damaged. Finally, place a drop of lightweight machine oil on the governor, throttle and choke linkage pivot points to keep them working free and easy, despite the cold weather.

The chart on page 123 will help you troubleshoot typical engine problems. Usually, the cause is minor and easily corrected.

Sometimes, however, a major component, such as the carburetor or magneto needs repair or replacement. How can you tell which one is the culprit? If none of the simple cures proves successful, remove the sparkplug after priming the carburetor and see if the tip of the plug is wet with gas. If it isn't, the hangup is somewhere in the fuel system, probably the carburetor. This should be disassembled and soaked in kerosene. Replace the needle, seat and gaskets with new parts.

If the tip of the plug is wet with gas, the problem is probably in the ignition. To make sure, hold the plug 1/4 inch away from the side of the cylinder or other grounded part and pull the starter rope. If a spark doesn't jump the gap, the magneto needs attention.

Magneto needs special tools

Magneto work requires some special tools, such as a flywheel puller so you can remove the flywheel and get at the magneto inside. Such pullers usually cost about \$10, but you may be able to rent or borrow one for a day.

If you can reach the magneto, you can replace the points and condenser—the two most likely sources of trouble. These parts can be obtained from a dealer who stocks replacements for your make of engine or thrower. Gap the points according to the manufacturer's specification. You'll also have to set the timing. Instructions for doing this are usually included in the owner's manual.

If you don't want to bother trying to remove the flywheel, this is the time to make a trip to the repair shop. You will at least have saved some of the repairman's time by localizing the problem for him. If you should find that both the fuel and ignition systems are okay and the engine still won't run, the cause is probably inside the engine itself. Have it compression-tested to determine if it meets the specs for your engine. If it doesn't, an engine overhaul is in order. This may involve new piston rings, valve grinding and possibly a reboring job on your cylinder.

★★★

The smokeless tobaccos.

They aren't lit, puffed or inhaled. They're too good to smoke.



Put a pinch between gum and cheek, and enjoy it. Without even chewing. The smokeless tobaccos are too good to smoke. You get all the satisfaction of prime aged tobaccos. They cost less, too. Sure beats smoking!



Straight



Raspberry

For information on how to use smokeless tobaccos, please write:
United States Tobacco Company, Dept. PM, 630 Fifth Ave., New York, N.Y. 10020.

HOW TO FIND OUT IF YOUR IDEA CAN BE PATENTED . . . FREE!

Take Advantage of The Services Offered by U.S. Patent Office!

At Last! New easy-to-follow manual—written for the amateur—clears up the mysteries about obtaining a patent. Protect your ideas! In complete secrecy—from your home—and at no cost whatever—you can check to see if your idea has been previously patented, and look over patents of a similar nature.

Did you know that your Patent Office issues about 100 patents each day, and that about 40% go to independent inventors from all walks of life? The basic requirements for a patent are "it must be new—it must be useful—and it must work."

This manual shows how to seek financial assistance if required—how you can list your patent for sale in the Department's "Official Gazette" which is read by the big corporations who pay millions in Royalties for new inventions—gives lists of publications and services available to inventors, for pennies from the Government Printing Office.

Crammed with facts, years of research have gone into this Manual!

Just off the press, it is available by mail for \$3.00 from Independent Inventors Assn., 234 5th Avenue, New York 10001.

GUARANTEE: Your money back immediately and without question, if not delighted!

Bore 35 standard holes with just one tool

New IRWIN Expansive Bit

lets you dial your size

Just turn the dial and you're set to go with this new Irwin Expansive bit. No hunting for the size you need. Fits all hand bit braces. Clean, fast, accurate boring action from $\frac{7}{8}$ " to 3"—35 standard hole sizes in all!

And what a really fine precision tool to own. It's drop-forged from special bit steel, heat treated full length, machined for accuracy and sharpness, highly polished, too. Two cutters supplied with each bit. Model No. 21 with $\frac{5}{8}$ " to $1\frac{3}{4}$ " boring range also available. Ideal for home handyman, professional woodworker, or farm. See your independent hardware or building supply dealer soon.



**No. 22
Micro
Dial
only
\$5.00**

$\frac{7}{8}$ " to 3"
boring
range

IRWIN every bit as good
as the name

at Wilmington, Ohio, since 1885

NEW **DYNAMIC** MARK 88
80 AMP INDUSTRIAL TRANSFORMER ARC WELDER

IDEAL GIFT — EDUCATIONAL, ENJOYABLE, PROFITABLE

WELD, BRAZE,
CUT, SOLDER, HEAT
STEEL, BRASS, ALUMINUM,
AND MOST OTHER METALS.

Build and repair anything of metal. Save time & money with this **BRAND NEW, PROFESSIONAL ARC WELDER!** Rugged metal cabinet, baked Hammerloid finish. Ideal for home, shop, farm and industrial use. **POWERFUL** glass insulated transformer welds most metals up to 1/2" thickness with multi-pass weld, with 1/8" rods. 4 heat settings 20 to 80 amps. Operates on 110 Volt AC line fused for 30 amps. Complete with fibre glass helmet, electrode holder, ground clamp and cables, solder, assorted rods and simplified welding manual. **DOUBLE PROTECTION GUARANTEE.** 10 day money back trial plus full 5-yr. warranty. If inoperative return prepaid, we will repair or replace without charge & reship collect. **ORDER TODAY.** Complete ready to weld. Only \$59.50 F.O.B. **SEND ONLY \$6.00.** Pay balance plus C.O.D. & delivery charges or write for easy "PAY AS YOU WELD" Low Down Payment Plan. Welder details FREE.



1808 S. FEDERAL ST.
Dept. D2-N
CHICAGO, ILL. 60616

DYNAMIC WELDER CO.

\$2,000

WOOD
CATALOG & MANUAL

Hard-to-find PRODUCTS for easier...better woodworking!

Discover! Enjoy! Benefit from newest products and ideas in Constantine's big picture-packed Manual. Wood headquarters since 1812. Largest selection of world's most beautiful cabinet lumber, veneers, plywood, inlays, moldings. Woods in natural color. Tool bargains. Furn. hdwe. Finishing & upholstery supplies. *Fabulous glue that needs no clamps!* Instructions. Everything. Unsurpassed values. Send 25¢ now for your copy. **TEAR OUT AD.**



ALBERT CONSTANTINE AND SON, INC.
2050 Eastchester Rd., Bronx N.Y. 10461 Dept. T-5

Enclosed 25¢ for new Constantine Catalog-Manual

MAIL AD

NAME.....
ADDRESS.....



ACCORIONS and AMPLIFIERS

BIG SAVINGS up to 1/2 or more on famous make accordions. Over 40 models. Standard and new electronic models. Buy direct at low discount prices. Get five-day home trial. Small down payment, easy terms. Free gifts. Trade in allowance. Money back guarantee. Rush coupon for color catalogs, discount price list. Accordion Corp. of America, Dept. R-129, 5535 W. Belmont Ave., Chicago, Illinois 60641

COUPON BRINGS FREE COLOR CATALOG & DISCOUNT PRICES	ACCORDION CORP. of AMERICA—Dept. R-129 5535 W. Belmont Ave., Chicago, Illinois 60641 Send FREE Color catalogs and discount prices. Include special information checked:	
	<input type="checkbox"/> Accordion Amplifiers	<input type="checkbox"/> Button Type Accordions
	Name _____	
	Address _____	
City _____ State _____ Zip _____		

FANTASTIC BUY
direct from factory



17 Jewel Swiss Day-Date Calendar Watch, Mod 4340 manual wound \$19.50, self wound \$29.50, manufactured and assembled in Switzerland under strict quality control. Antimagnetic, shock-resistant, big sweep second hand, rugged movement, luminous dial and hands, with matching expansion metal band. Make excellent X-mas gifts. For free catalog send 50¢ postage. Order direct from Switzerland and save. Send money order, Bank check or personal check for registered airmail delivery, (No C.O.D's)
PROTEL WATCH SA, Dept. PM-1269
Gartenstr. 10, 8002 Zurich, Switzerland

ARCO TWIST DRILL SHARPENER



NEW IMPROVED!
Fits ANY Electric Drill. Includes 3" Aluminum Oxide Grinding Wheel with 3/4" shank and Guard, Twist Drill Holder for sharpening any bit up to 1/2" diameter and Adjustable Tool Rest for sharpening chisels, knives, scissors, plane blades, etc. No. 220—a "Best Buy" at.....
ONLY \$298

Order today on our 20-day Money Back Guarantee
Send check, M.O.—we pay post. (No COD's)

ARCO ARCO TOOLS, INC.
Dept. PM-12, 421 W. 203 St., N.Y., N.Y. 10034

HEAVY DUTY BALL-BEARING PUMP



IRRIGATE • DRAIN • SPRAY • CIRCULATE • All-metal, rust-proof XB. Stainless shaft. Use 1/4 HP or larger. 1 HP for up to 5,200 GPH 60' high or 3,000 GPH from 25' well. 1 1/4" inlet. 1" outlet. For belt or direct drives.....\$12.95
Type P won't rust or clog. Bronze bearing. Hundreds of thousands in use. Up to 2,400 GPH. 1" inlet. 3/4" outlet.....\$8.95
P'pd. cash with order. **MONEY BACK GUARANTEE.**
LABAWCO, Box 2, Belle Mead, N.J. 08502

BIG DEMAND FOR SURVEYORS!

• LEARN AT HOME IN SPARE TIME!
FREE "Surveying Career Kit" shows how you can step into big pay prestige career as Surveyor. Big Demand! U.S. Bureau of Labor Statistics predicts shortage of 50,000 civil engineering technicians (Surveyors, etc.) by 1975. Rush name for FREE KIT. No salesman will call. Vet. approved. **NORTH AMERICAN SCHOOL OF SURVEYING**
4500 Campus Drive, Dept. 417C, Newport, Calif. 92660

BUILD THESE BEAUTIFUL CLOCKS

NOW AT BIG SAVINGS!

Send just \$1 for plans & instructions to build choice of: (A) Grandfather, (B) Steeple, (C) Grandmother—plus information-packed catalog of movements, dials, parts & kits to build these & 16 other fine clocks. All 3 plans—\$2.50. Catalog alone—25¢.

MASON & SULLIVAN COMPANY
Dept. PM, Osterville, Mass. 02655



ELECTRIC ARC WELDER \$9.99!



NATIONALLY ADVERTISED \$18.95 VALUE!—NOW 1/2 PRICE! WELDS—BRAZES—SOLDERS—CUTS—ALL METALS! Plugs into ANY 110 volt socket. MAKE—REPAIR 1001 items for CAR—HOME—BUSINESS. Lifetime BURNOUT GUARANTEE 10 day money back trial (if retnd). HEAVY DUTY Design—Does \$85.00 welder work. No experience needed—FREE WELDING LESSONS!

SEND ONLY \$2.00 (cash, ck, M.O.) and pay postman \$7.99 COD postage or send \$4.99 plus \$1.00 postage for paid del. in U.S.A. COMPLETE READY TO USE—Includes BIG pack steel, Brazing, Solder, Carbon "touch" rods. **ELECTROFLAME ARC TORCH! OFFER LIMITED—Order TODAY!** MIDWAY WELDER Dept. EPM-12 Kearney, Nebr. 68847

Travel the SHORT way

avoid wrong turns—save time, money and frustration with



AIRWAY COMPASS, Mexico, Indiana 46958



... at leading stores everywhere!

IS THERE A CHEMIST IN THE HOUSE???

Only \$4.00 Plus \$1.00 p.p. Will bring 49 "PLUS" individual, assorted, items of standard quality laboratory apparatus: glassware, porcelain, rubber, plastic, etc., etc. Value? 2 to 3 times our offer. None dangerous. No junk. One surprise item. Pyrex Advanced Student Assort. @ \$10 plus \$2 p.p.



HARRY ROSS Scientific & Lab. Projects
61-0 Reade St., N.Y. 7, N.Y.

ROTARY FILES

U.S. Surplus High Speed Milling Files going fast. New, in G.I. Packs. Hardened steel, for filing, milling, routing, drilling—any work in light metal or wood. Use in 1/4 in. drill, etc. Range in size from 1/4 to 1 inch wide. Get these most useful tools now.
16 tool set—government cost \$109.....\$ 9.00 to you!
36 tool set—government cost \$265.....\$15.00 to you!
100% GUARANTEED, WE PAY POSTAGE. A LIFETIME BUY!!

THE SURPLUS CENTER
LANCASTER, TEXAS 75146

Career in ELECTRONICS?

Career training at home the new easy way with RCA Institutes. Lab work with first lesson. Easy payment plans. Send for free 64-page book.

RCA Institutes, Inc. Dept. PM-D9
320 W. 31 St., N.Y., N.Y. 10001



ALL FAMOUS BRANDS! **FARM TRUCK AUTO** **AT LESS THAN WHOLESALE**

TIRES! SAVINGS NEVER LESS THAN 50% up to 70% OFF REG. PRICE!

HEADQUARTERS for ALL SPORT CAR TIRE SIZES
FREE - SEND FOR YOUR FREE CATALOG - FREE!

RELIABLE TIRE DIST., 1111 Chestnut St., Camden, N. J.

Print Your Own



Cards, Stationery, Advertising, Circulars, labels, photo and movie titles, church work, tags, greeting, sympathy, prayer cards, etc. Save money. Pays for itself in a short time.

Own a Printing Business

Good Profit. Raised printing like engraving too. Have home shop. We supply everything. Direct from factory, only. Easily followed rules. Write now for free details. **KELSEY PRESSES E-37 Meriden, Conn. 06450**

DECEMBER 1969

THE GLUE FIXER

DURATITE WHITE GLUE MAKES A QUICK, PERMANENT BOND STRONGER THAN THE WOOD ITSELF. SETS FAST. DRIES CLEAR. DOES HUNDREDS OF HOME, HOBBY AND SHOP FIX-UP JOBS. GET HANDY SQUEEZE BOTTLE.



DAP Inc., Dayton, Ohio 45401 / SUBSIDIARY OF Pileough, Inc.
Also available in Canada

MY SPARE TIME HOBBY MAKES ME \$500 an hour CASH PROFIT

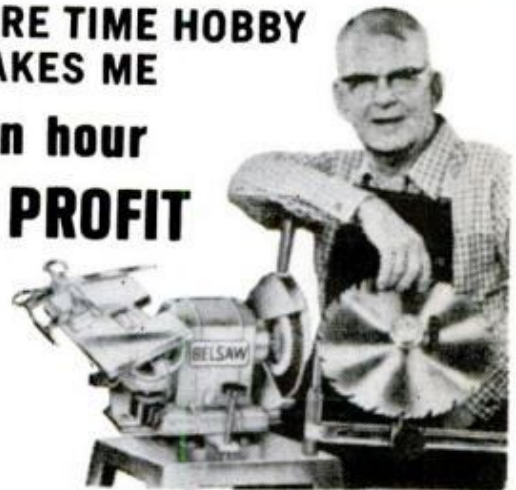

START YOUR OWN SPARE TIME BUSINESS

You can turn your spare time into Big Cash Profits with your own COMPLETE SHARPENING SHOP... Grind saws, knives, scissors, skates, lawn mower blades... all cutting edges. Your Own Cash Business with no inventory... right at home... no experience needed.

FREE BOOK tells how you can start your own spare time business while you are still working at your regular job. Low Cost—time payments.

Just Mail Coupon—No Salesman Will Call

FREE BOOK

BELSAW SHARP-ALL CO., 7102 Field Bldg., Kansas City, Mo. 64111
Send Free Book, "LIFETIME SECURITY." No obligation.

Name _____
Address _____
City _____ State _____ Zip _____



**Northwest Timbered
ACREAGES as low as
\$950 Total Price**

5 - 10 - 20 - 40 - ACRES

For people who love the land—A tract
of Recreation Land for YOUR Own!

In Northern Idaho, Northeastern Wash-
ington, and Western Montana. In the heart
of lakes and big game country. All covered
with growing timber. Access, Title insurance
with each tract. This is select land with
natural beauty, recreational and investment
values. We have tracts of many types and
sizes from which to choose, including beau-
tiful Northwest Waterfront property. Your
inspection welcomed. Write us for free list,
maps and complete information. Write to:
Dept. P.



P.O. Box 8146, Spokane, Wash. 99203

**TO YOUR OWN DOCTOR'S PRESCRIPTION
EYEGLASSES
BY MAIL AT
GREAT SAVINGS!**



Mail orders filled by **\$10⁹⁵**
licensed optician from

(Including single vision lenses, frame and case).

Doctor's prescription will be filled by a skilled, approved and licensed optician
or your own prescription duplicated. Lenses are ground and manufactured to
U. S. optical standards. Choose from complete catalog of men's, women's and
children's glasses. Bifocals, trifocals, sunglasses or SAFETY HARDENED LENSES
at low additional cost. We guarantee accuracy, perfect fit.

SEND FOR YOUR FREE CATALOG TODAY
PRISM OPTICAL INC.

Dept. PM, 136 Liberty St., New York, N. Y. 10006

**MAKE
EXTRA
MONEY
IN YOUR
SPARE
TIME**

**LEARN PROFESSIONAL
"PLEXIGLAS"
SIGN
MAKING!**

\$13.75 brings you over 120
ACRYLIC LETTERS AND FREE
INSTRUCTIONS. Send your re-
mittance to:

DAYTONA PLASTIX

Box 6161, Daytona Beach, Florida 32022.

LIFETIME "SPIN-ON" OIL CLEANER



Cleans motor oil 100 times cleaner than any other
"spin-on" filter. Never drain oil again. Never
buy another spin-on filter. Change 15 cent element
every 3000 miles, available everywhere. Doubles
engine life. Oil is 100% clean 100% of the time.
Guaranteed 5 years. \$25.95 post paid. Write for
the facts. Save \$8.00 every 3000 miles.

VIRIDEN PERMA-BILT

Box 7066 PM, Amarillo, Texas 79109

**Don't change
your address
without notifying us!**

To insure uninterrupted service on
your **Popular Mechanics** subscription,
please notify us at least six weeks be-
fore you move.

1. Attach your address label from a recent issue in
the space provided below... (If label not available, be
sure to give us your old address, including Zip Code)
2. Print your name and new address below (be sure
to include your Zip Code).

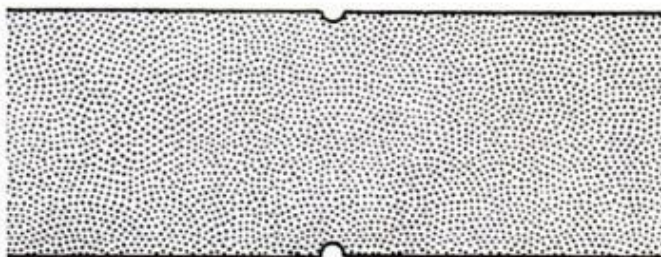

3. Mail entire notice to: **Subscription Service Dept.
Box No. 646
New York, N. Y. 10019**

Name _____

Please Print

New Address _____

City _____

State _____ Zip
Code _____



BUILD THESE BEAUTIFUL CLOCKS



NOW AT BIG SAVINGS!

Send just \$1 for plans & instructions to build choice of: (A) Grandfather, (B) Steeple, (C) Grandmother—plus information-packed catalog of movements, dials, parts & kits to build these & 16 other fine clocks. All 3 plans—\$2.50. Catalog alone—25¢.

MASON & SULLIVAN COMPANY
Dept. PM, Osterville, Mass. 02655

WOOD EVERYTHING FOR THE WOODSHOP TOOLS-SUPPLIES



World's Largest Selection of Finest Domestic and Imported Hardwoods, Veneers, Hardware—
at MONEY SAVING PRICES

Over 2000 items! Your money saving hardwood and woodshop buying guide. We've added new Clock kits, wood picture kits, musical instrument kits, many more. Complete selection of hard-to-find hardware, lamp and upholstery supplies, etc. Big savings on name brand power tools. Send name, address and 35¢ for handling and postage to:

CRAFTSMAN WOOD SERVICE CO.
DEPT. A-129
2729 S. Mary St., Chicago, Illinois 60608

New Catalog!
Write Today!...

BUILD THE POPULAR MECHANICS MINI-BIKE FROM 26-IN. BICYCLE FRAME

—with **VARIABLE SPEED TRANSMISSION**, as featured in June '67 issue. Step-by-Step plans, photos show you how. **PLANS, \$2.50**, refundable with order for wheels, engines, clutches, kits at **Discount Prices**. Order Plans, or send 25¢ for Catalog, today!

SAVE \$50 to \$150
GILLIOM MFG. CO. Dept. PM-12 St. Charles, Mo. 63301

EARN MONEY FAST! REPAIR HYDRAULIC JACKS

Earn while you learn at home. Millions of jacks in gas and auto service stations, trucking firms, body shops, riggers, factories and farms need servicing... most of which you can learn to repair. We show you HOW. Start spare time in your basement or garage. Big opportunity for mechanics. **ACT NOW!**
Write for folder PM12 and free bonus offer



HYDRAULIC JACK REPAIR MANUAL CO., INC.
G. P. O. BOX 3 • STATEN ISLAND, N. Y. 10314

REAL ESTATE BE A BROKER

PAYS BIG! SEND FOR BIG FREE CATALOG NOW! Graduates report making substantial incomes. Operate your own business quickly. Men, Women, all ages, learn easily. Course covers Sales, Appraising, Loans, Mortgages, & related subjects. **STUDY AT HOME** or in class-rooms in leading cities. **Diploma Awarded. Write Today for FREE Book!** Accredited Member National Home Study Council. (Est. 1936) G. I. Approved.
WEAVER SCHOOL OF REAL ESTATE
3521-P Broadway Kansas City, Mo. 64111



DECEMBER 1969

from the fix 'n' fasten people

2 Great Gifts for Santa to give ... or get!

THERMOGRIP® Electric Glue Gun Kit

Solid glue sticks melt to bond almost any material... permanently... in a minute! Thermogrip gun, metal work-stand, glue and sealer sticks included in a durable plastic case.

Regular price,
\$11.95



"POP"® Rivetool Kit

This amazing "POP" Rivetool sets rivets from one side of the work... fastens many materials in a minute! Kit includes tool and assorted "POP" Rivets in a durable plastic case.



Regular price,
\$9.95

AT HARDWARE AND DEPARTMENT STORES
Or write **USM Corporation**, Consumer Products Division, P.O. Box 1139, Reading, Pa. 19603.



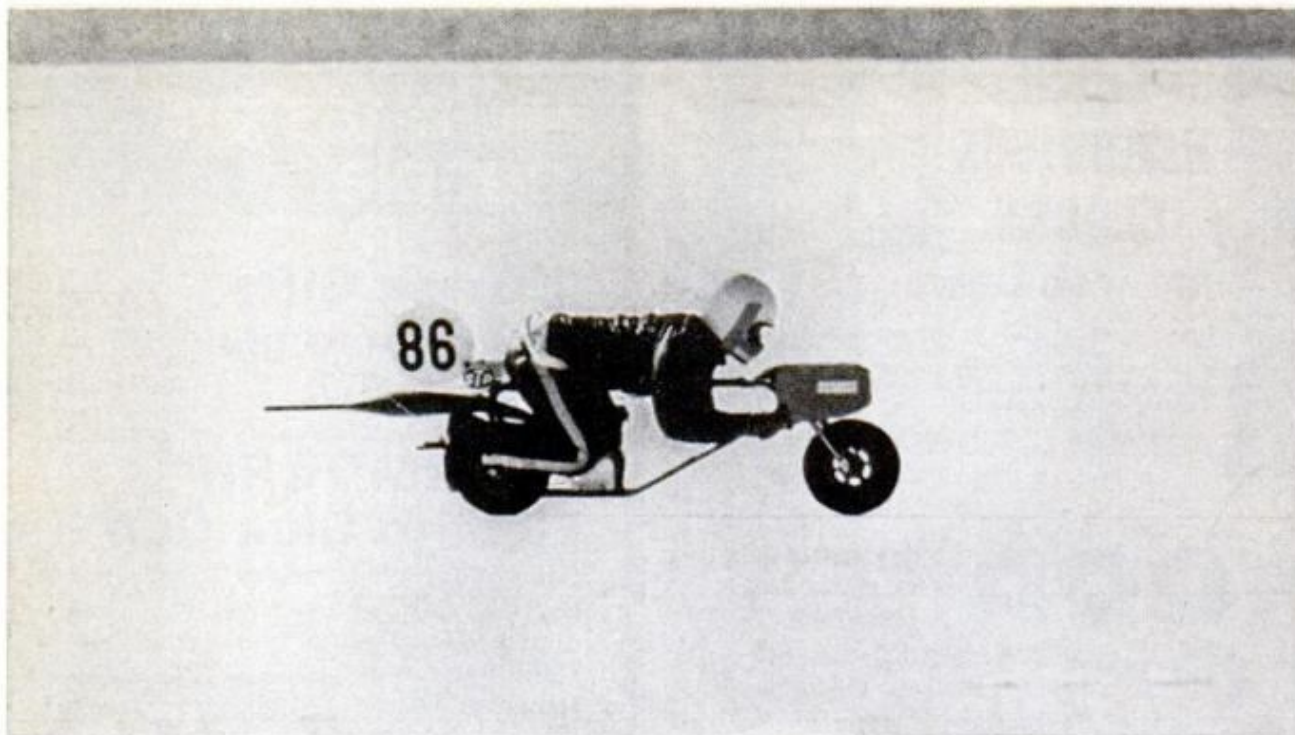

Mini-bikes set records on the salt flats

Unofficially clocked at speeds as high as 120 mph, tiny mini-bikes running on the salt flats in recent Bonneville Speed Trials set a couple of motorcycle speed records. The bikes, made mostly of stock parts built by Bonanza Industries, set the PSA-AG-175 record at 92.561 mph and the A-AG-100 record at 79.774 mph.

Own a camera?

Here's a complete enlarger/darkroom outfit for under \$50.

Includes everything you need to make your own big prints at home: famous, ultra-compact Durst J35 enlarger for 126 and 35mm negatives with lens, easel, trays, tongs, paper, chemicals — the works — even instructions.

Takes only minutes to set up for use in kitchen, bathroom, closet — anywhere. Knocks down for storage in as little space as a bureau drawer.

Mail coupon for FREE Illustrated "how-to" Booklet

DURST (USA) INC.*
 623 Stewart Ave., Garden City, N.Y. 11530
 Rush FREE illustrated booklet, prices and other information about the new Durst J35 Enlarger and Enlarger/Darkroom Outfit.

NAME _____ (Please print)
 ADDRESS _____
 CITY _____ STATE _____ ZIP _____

* Subsidiary of Ehrenreich Photo-Optical Industries, Inc.



POPULAR MECHANICS

Fox Mini Bike

DO IT
YOURSELF
OR FULLY
ASSEMBLED

from
\$99⁵⁰



SEND \$1 FOR BIG CATALOG Shows new line of the world's finest MINI-BIKES (street and trail models), plus Go Kart ®, parts, accessories and plans. Amazingly low prices! There's a Fox MINI-BIKE for everyone from age 10 to adults.

EXTRA BONUS Catalog shows radios, watches, walki-talkies, cameras, musical instruments, tools, appliances and many other items you can buy at practically wholesale prices. Free \$1 coupon.

FOX CORP., Box 797PM, Janesville, Wis. 53545

MEN/WOMEN...



Buy Below Wholesale

BIG PROFIT HOME IMPORT BUSINESS. My plan starts you fast. Deal direct with overseas sources at prices shown. Thousands other dazzling bargains with no investment. Any age or location. Full or part time. You keep all profits. Write for FREE BOOK to...

MELLINGER, Dept. C225C, 1554 S. Sepulveda, Los Angeles, CA 90025



You can make money in

**WATCH
REPAIR**

Learn at home the low cost Sweazey Way

Watch repairing pays up to \$6 an hour, part time watch makers report on survey. Unique and modern Sweazey home study System starts you making repairs right away on Swiss and American watches. Professionally prepared training. No previous experience needed. Special tools provided for practice. Diploma Awarded. Free sample lesson and opportunity book give all facts. Write today. No obligation.

CHICAGO SCHOOL OF WATCHMAKING

Dept. 1129 Fox River Grove, Illinois 60021

FREE BOOK and SAMPLE LESSON

CHICAGO SCHOOL OF WATCHMAKING
Dept. 1129, Fox River Grove, Illinois 60021
Please rush FREE BOOK and Sample Home Study Lesson.

Name _____ Age _____
Address _____
City _____ State _____ Zip _____

DECEMBER 1969

See what happens

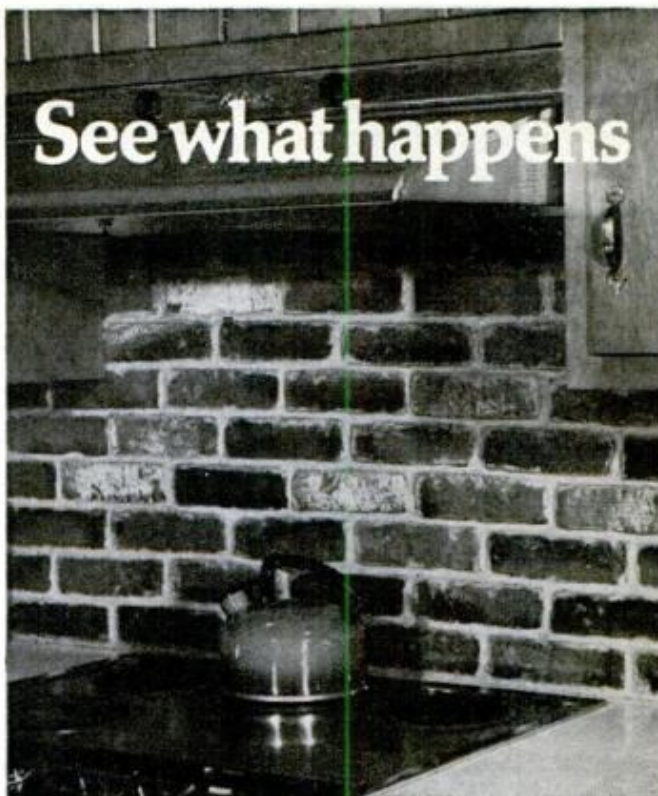

when you put up

**DACOR
Miracle Bricks!**

Here's one of the *easiest* home beautifying projects you can take on. No special skills, tools, foundation work or extra support. Yet look at the results you get! Dacor Miracle Bricks reproduce the look, even the feel, of real bricks. But they're actually 1/4" facings of light, tough, high-density polyester - and simplicity itself to apply with the ready-to-use Dacor Mastic. Take your pick of six handsome, authentic styles - Used Brick, Antique Klinker, White Roman, Colonial White, Red Oak Bark or White Oak Bark - and transform a kitchen, a den, any room, in a few hours. *Dacor Miracle Bricks let you work wonders.*



At leading building supply and do-it-yourself centers.

Or write to us.

Dacor Manufacturing Co., Inc.
Worcester, Mass. 01601

205

PRACTICAL PICTORIAL GUIDE TO MECHANISMS AND MACHINES

By S. S. Palestrant

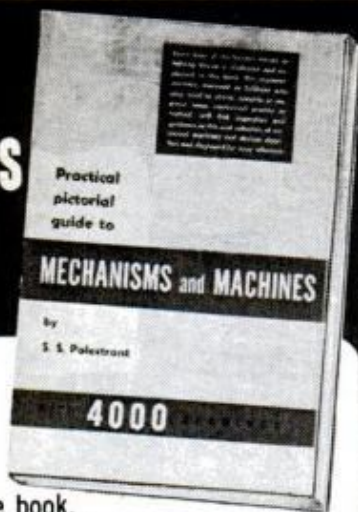

Every kind of mechanical motion or holding device is fully illustrated and explained.

A complete reference book. Contains 4000 photos and illustrations.

#502 \$5.95

PARTIAL CONTENTS —

Electrical System

Magnetic Fields
Electron Theory of Electricity
Amperage and Voltage
Resistance
Circuit Breaker
Regulators
Wiring Circuit for Regulators
Wiring Diagram — Voltage Regulator
Single-Loop DC Motor
Generator System
Vacuum Switch Control — Solenoid
Two-Circuit Distributor
Two-Circuit System, V-12 Engine
Wiring Diagram

Electrical Wiring and Equipment

Demand Loads for Household Ranges
Overcurrent Problems
Overhead Electrical Service
Fire Protection Equipment
Fire Alarm Systems
Fire Detecting Systems

Gears, Bearings and Joints

Meshing Gears
Ball Bearings
Tapered Roller Bearing
Three-Speed Selective Gear System
Universal Joints
Final Drive Gears
Spring Shackles

Braking Devices

External Contracting Brake
Internal Expanding Brake
Disk Brake
Braking Devices — Braking Action

Air Conditioning and Refrigeration

Electrical Ratings
Condensation
Compressed Air Temperature Chart
Voltage Amplification Principles
Heat Pump Operation

Power Sources

Internal Combustion Engine
External Combustion Engine
Fuel Injection Principles
The Two-Cylinder Engine
Piston Pin Arrangements
Fuel-Air Ratio
Metering Rod Circuit
Power Jet
Carburetor
Vacuum Stepup Circuit
Accelerator Circuit
View of Four-Cylinder Engine
Radial Engine Gear Trains
Diesel Engines
Atomic Power Plants
Fuel Injector
Governors
Rotor Pump
Gear-Type Oil Pump

More Great Reference & Self-Improvement Books:

500	Key To A Successful Business.....	\$2.95
501	The Engineers' Illustrated Thesaurus.....	5.95
503	Electrical Engineer.....	7.95
511	The Key To Basic Electronics.....	4.00
512	The Key To Advanced Electronics.....	4.00
513	Engineer's Handbook.....	5.95
1512	Be Your Own Carpenter.....	2.95
1514	Be Your Own Plumber.....	2.95
3118	Mechanical Drawing Self Taught.....	2.00
3148	Inventor's Guidebook.....	2.00
3161	Motorboat Owner's Handbook.....	2.00
3162	How To Repair Your Car.....	2.00
3164	Home Repairs Made Easy.....	2.00

ORDER BOOKS BY NUMBER • MONEY-BACK GUARANTEE—No C.O.D.'s

KEY PUBLISHING CO. | 817 Broadway
New York, N.Y. 10003

Please rush books checked below, I enclose \$_____ in payment.

500 501 502 503 511 512 513
 1512 1514 3118 3148 3161 3162 3164

Name _____

Address _____

City _____ State _____ Zip _____

Dept. PM-1269

More Comfort Wearing FALSE TEETH

To help relieve discomfort when dentures slip down and come loose, just sprinkle FASTEETH on your plates. FASTEETH holds dentures firmer longer. You can bite harder, eat faster, feel more comfortable. FASTEETH is alkaline—won't sour. No gummy, gooey, pasty taste or feeling. Dentures that fit are essential to health. See your dentist regularly. Get FASTEETH today at all drug counters.

make your own Gems 39.50 F.O.B.

The Gem Maker comes complete with all necessary equipment, including a super-charged diamond blade for sawing, and all the wheels for grinding, shaping and polishing; also complete instructions. The complete equipment as shown, less motor and belt for only \$39.50, f.o.b., Burlington, Wisconsin. Write today for information and literature.

B&I MANUFACTURING CO.
Dept. P, Burlington, Wis. 53105

Two or four-wheel drive
JEEP OR SCOUT owners

REPOWER with a 6 or V-8. H.D. ADAPTORS for using Car, Compact and some Truck engines. "State year & model, Jeep or Scout." Want fast action? Give us **FULL INFORMATION**. Send \$25.00 Dep. and we will ship correct kit, bal. COD. Send full amount for prepaid shipment. Wire, phone or write today. Details **FREE**

HOOSIER MACHINE PRODUCTS CO.
312 S. E. 6th St., Phone 276-3442, Pendleton, Oregon 97801

HOLD IT!

the glue that never lets go!

write for **FREE** glue and caulk selector guides

WILHOLD

WILHOLD GLUES, INC.
8707 Millergrove Dr., Santa Fe Springs, Cal. 90670

This is TOP GUN

A new kind of hunting garment that gives you the kind of comfort and convenience you've dreamed about... available only from **AMERICAN FIELD** dealers. We'll send your dealer's name and valuable booklet, "Camping Tents & Tips"... send 10¢ to

HETRICK, Dept. PM-C, Statesville, N. C. 28677

LOCK-BLADE POCKET KNIFE

\$1.98 Postpaid **10-Year Guarantee**

Blade opens instantly and automatically locks in place. Ruggedly built for reliable use and long, hard service. Tough steel blade honed and polished to a mirror-like finish. Safety grip handle with finger guard. Balanced for target throwing. Guaranteed 10 years. If blade breaks we replace free. Send \$1.98 check, cash, M.O. to **VIKING KNIVES, Dept. Z-7, Box 10880, Houston, Texas 77018.**

locksmithing and key making

PRACTICAL UP-TO-DATE COURSE — ONLY \$6.95

Teaches you how to pick locks, de-code, make master keys, repair, install, service, etc. New self-instruction lessons for every handyman, homeowner, carpenter, mechanic, service station operator, fix-it shop, hardware dealer, gunsmith. 53 easy illustrated lessons. Full price only \$6.95, postpaid. Satisfaction or refund guaranteed. Mail order today!

NELSON-HALL CO., Dept. MR-2
325 W. Jackson Blvd., Chicago 60606

RIFLE WALL RACKS

For displaying valuable rifles — over-under and double barrel shotguns. Plastic — will not rust or corrode metal parts / Lock 2 or more sets together for multiple rack.

At your favorite sporting goods counter or order direct — enclosing correct amount for each set plus 25¢ additional to cover cost of handling.

\$2.00 (Set of 2)
PYRO PLASTICS CORP., PYRO PARK, UNION, N. J. 07083



\$5.95

less bell

DIAL TELEPHONES

With bell \$8.95. If plug is required add \$2.00. Factory reconditioned, Guaranteed. Many other phones available, write for free list.

All shipments FOB Waymart, Pa.

SURPLUS SAVING CENTER

Dept. PM-869, Waymart, Penna. 18472



Free Catalog!

TOOL CHESTS
of the
HIGHEST QUALITY
for your
PRECISION TOOLS..
GERSTNER TOOL CHESTS
Dept. E-9, 20 Cincinnati Street
Dayton, Ohio 45407

I-N-V-E-N-T-O-R-S

WE NEED INVENTIONS

Sell your invention for cash—need money for Patent?—Are technical problems holding you back? Universal Inventions has helped inventors all over the world—just like yourself—why not you? Inventions provide the magic spring-board to sudden riches. REMEMBER, we either sell your invention or pay you a cash bonus. Write for details. **UNIVERSAL INVENTIONS, Dept. 13, Marion, Ohio**



LEARN MEAT CUTTING

Train quickly in 8 short weeks at Toledo for a bright future with security in vital meat business. Big pay full-time jobs — HAVE A PROFITABLE MARKET OF YOUR OWN! Time payment plan available. Diploma given. Job help. Thousands of successful graduates. OUR 46th YEAR! Send now for big new illustrated FREE

catalog. No obligation. G.I. Approved.
NATIONAL SCHOOL OF MEAT CUTTING
Dept. 50B, Toledo, Ohio 43604

HEARING AIDS

2/3 OFF DEALER PRICES

LARGEST SELECTION of tiny, all-in-the-ear, behind the ear, eyeglass and pocket models. FREE HOME TRIAL. No obligation. Money back guarantee. No down payment. Easy terms. No salesmen or dealers. Order direct, save 65%. Write for free catalog. **PRESTIGE**, Dept. D-166, Box 10947, Houston, Tex. 77018.



HOW TO GET RICH

Secret Mail Order business brings cash by mail. Pyramid profits. No investment. Start at home in spare time. Write for full details and Free Book.

MAIL ORDER ASSOCIATES, INC.

Dept. 2, Montvale, New Jersey 07645

LEARN TAX PREPARATION NOW WITH H&R BLOCK

GET READY TO EARN UP TO

\$700
PER MONTH

Learn tax preparation in your spare time at home with H & R Block, America's largest tax service. Get ready now to make up to \$700 a month next tax season as a tax preparer. Join the ranks of successful H & R Block graduates who occupy a respected position in the tax preparation field. No previous training or education required. Ideal for retired people and/or men and women seeking full or part time income. Job opportunities available for qualified graduates. Low tuition cost includes all supplies you need for this complete home study course. Write for free information. No salesman will call.

H&R BLOCK Inc.

301F-129

TAX TRAINING INSTITUTE

4410 Main Street Kansas City, Mo. 64111

Yes, please send me without obligation full details on your home study course for income tax preparation.

Name _____

Address _____

City _____ State _____ Zip _____

BE YOUR OWN MAN— OPERATE HEAVY EQUIPMENT



- BULLDOZERS
- DRAG LINES
- SCRAPERS
- CLAM SHELLS
- BACK HOES
- GRADERS

Train NOW to operate earth-moving equipment. The Construction Business is Booming! Earn top money in this fast moving, action-packed field! Keep present job and train at home in your spare time followed by Resident Training in the actual operation of heavy earth-moving equipment under project conditions at our facilities near MIAMI, FLA. Excellent employment assistance.

Member American Road Builders' Assn.

CONTRACTORS: Information about our trained Operators available upon request

UNIVERSAL HEAVY CONSTRUCTION SCHOOLS

Dept. PM2- 1901 N.W. 7 STREET, MIAMI, FLORIDA 33125

Name.....

Address.....

City.....State.....Zip.....

Age.....Phone.....



CANADA JOINS THE ROTARY CLUB

By MICHAEL LAMM

Photos by the Author

PM tests the first Wankel engine production car to reach North America and finds it smooth, quiet and economical

I FLEW UP TO VANCOUVER this fall to drive Mazda's new R-100 coupe—the first twin-rotary production car ever to reach the Western Hemisphere.

The Wankel-powered Mazda R-100 is just starting to enter Canada. Mazda hopes to begin selling rotaries in the States soon. It remains for its engineers to bring emission levels down to U.S. standards.

The R-100 coupe weighs only 1775 pounds and its 110 horses give it plenty of kick. The engine idles with such extreme

smoothness and silence, it's hard to tell when it's running. Blipping the throttle makes the rotary give out with a purring sound, like a well muffled two-stroke but without annoying back-popping.

The first generation of Wankel-engined cars, represented by the NSU Prinz of 1961, wouldn't idle worth a darn. One reason the Mazda rotary idles so smoothly is that it has twin ignition. The engine uses two distributors and two sparkplugs

(Please turn to page 210)

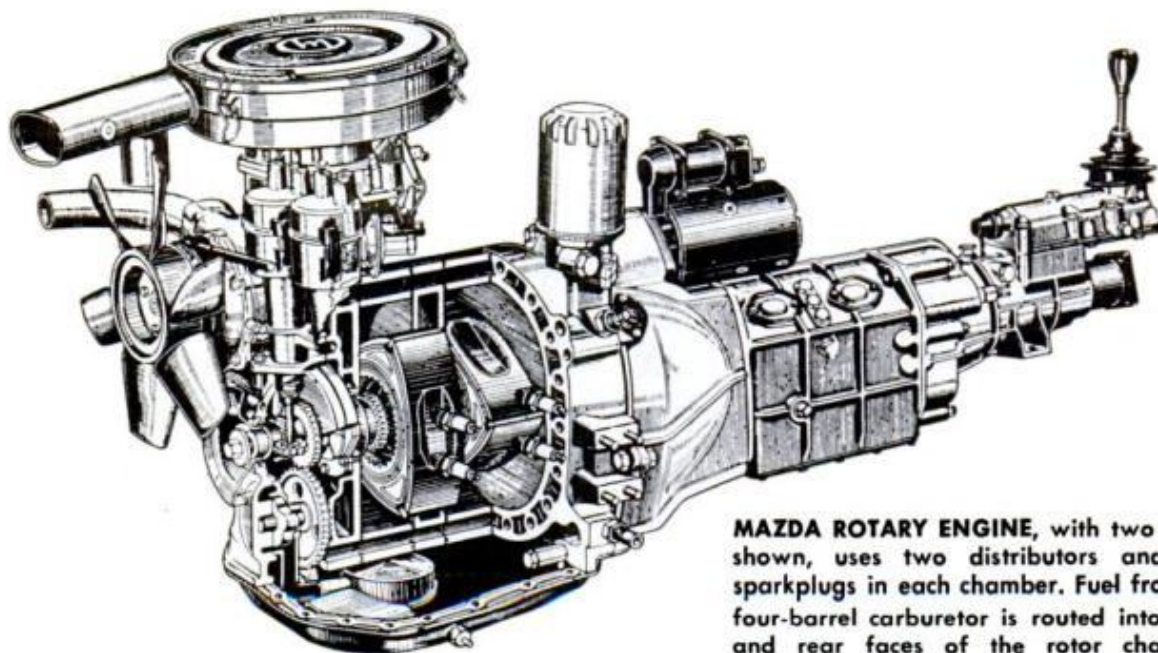

MAZDA ROTARY ENGINE, with two rotors shown, uses two distributors and two sparkplugs in each chamber. Fuel from the four-barrel carburetor is routed into front and rear faces of the rotor chambers

NEW!

PROFESSIONAL-TYPE HEAVY DUTY PAINT SPRAYER

**SPRAYS SMOOTH, EVEN COAT
AUTOMATICALLY
AT ANY ANGLE!**

ONLY \$12⁹⁸



**New jet propulsion pump
powers any pourable liquid!**

**Adjustable jewel nozzle prevents
clogging, skipping... lets you spray
up, down, or sideways
—without tilting jar!**

**FREE viscometer attachment holds
consistency even—adjusts for
thick, medium, or thin spray!**

**Slip-proof trigger provides
simple one-finger operation!**

Now...save yourself a bundle of time and money on any painting or spraying job around the house! Just plug in the cord, squeeze the trigger, and paint walls, ceilings, doors...house exterior, garage...car—*anything!*—*automatically!* Works on any liquid that pours—even varnish or polyurethane! Revolutionary new viscometer lets you adjust any brand or type of paint (enamel, flat...latex, PVC—or what have you) for proper consistency—and holds it! Foolproof electromagnetic motor never needs oiling or adjustment. Completely rustproof. **LIFETIME SERVICE GUARANTEE!**

**You must get professional results
—or money refunded!**

MAIL NO-RISK COUPON TODAY!

**JAY NORRIS CORP., Dept. ME-6
31 Hanse Ave., Freeport, N. Y. 11520**

Please rush me the following:

—“Heavy Duty Paint Sprayers” @ \$12.98, 2 for \$25.00
plus 10% for postage and handling.

TOTAL \$ _____

Enclosed is check money order.
Charge to my American Express Diners Club
 Master Charge BankAmericard.

Account # _____

(Signature) _____

Name _____
(please print)

Address _____

City _____

State _____ Zip _____

CANADA JOINS ROTARY CLUB

(Continued from page 208)

in each combustion chamber. This is because, as rpm increases, the actual position of the combustion chamber inside the rotary engine *moves*. So there's a leading and a trailing plug to catch up with this movement. Both fire simultaneously, one for low rpm and one for high.

The rpm characteristics of this engine take some getting used to. The Mazda rotary's power surge starts coming in strongly at about 2000 rpm and keeps climbing to red-line at 6500. If you tromp the gas and hold it there, power increases as speed increases. The R-100 goes from 70 to 90 mph in 15.1 seconds. Yet 80-90 takes only 5.8 seconds, so you can see where the surge comes in.

Since this engine has no valves, therefore no valve float, it would keep revving higher and higher until it blew itself apart. At least it would if there weren't a safety system built into it. A warning buzzer sounds at 7000 rpm, and at the same time the secondary barrels of the four-barrel carb automatically shut themselves.

This brings us to one more reason for the R-100's smooth idling and general engine flexibility: The intake ports are routed into the front and rear faces of the rotor chambers, not into the edge as in the old NSU. NSU's Prinz was plagued with rough idle and lack of power at low rpm; Mazda's R-100 isn't.

Oil consumption is no problem with the R-100. Sealing technology has advanced considerably since the Prinz's day, and normal consumption for the Mazda is about a pint every 1200 miles. However, the sump, oil cooler and filter hold only 5.5 quarts and recommended oil changes

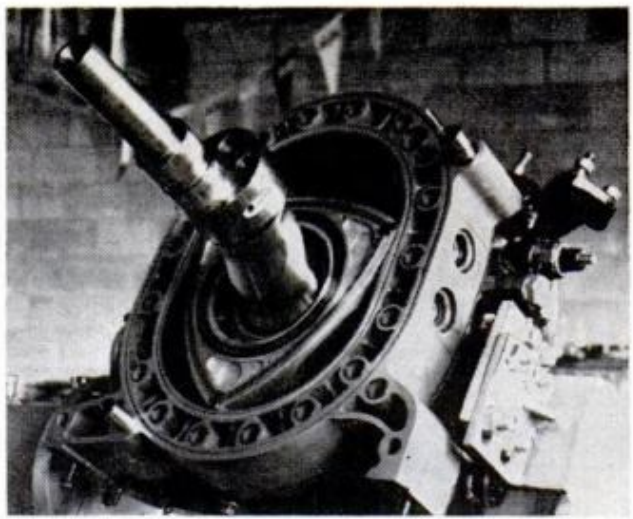

ONE CHAMBER OF TWIN ROTARY (second is mounted in front of this) showing surrounding water jacket. Water passages are between round holes for studs

are every 2000 miles. The R-100 has a separate oil cooler just below the radiator.

The Mazda coupe, with its engine up front, uses a conventional and very smooth wide-ratio, all-synchro four-speed gearbox. This transmission proved relatively quick-shifting and unquirksome. The small amount of stick sloppiness came from indirect linkage, but you notice this only in full-bore acceleration.

My acceleration figures are fairly representative of the R-100 in normal tune, with street equipment, some cargo, and on a typical road. At that, 0-30 mph came up in low gear alone in 4.6 seconds, while 0-60 demanded two shifts and a very respectable 12.2 seconds.

The R-100's ride is amazingly gentle and quiet. There's the usual choppy rock and roll that any short-wheelbase car suffers. The R-100 hangs into long, sweeping curves

(Please turn to page 212)



COCKPIT LAYOUT has 8000-rpm tachometer left of speedometer. All other gauges, switches, radio and shift lever are in central pod. Wheel is real wood



BOTH FRONT SEATS recline and move on long tracks. Legroom is comfortable for driver of any size. Rear seat is well padded but cramped for adults

LOOSENS RUSTED NUTS, BOLTS, PARTS



LIQUID WRENCH

AT HARDWARE & AUTO STORES

ENROLL—EARN YOUR DEGREE

of Bachelor of Bible Philosophy (B.Ph.B.), Master of Bible Philosophy (M.Ph.B.), Graduate of Bible Philosophy (G.Ph.B.), Doctor of Metaphysics (Ms.D.), or Doctor of Divinity (D.D.). Chartered by State, Correspondence Courses only. Please write for FREE BOOKLET.

AMERICAN BIBLE INSTITUTE

Dept. PM, Post Office Box 8748, Kansas City, Missouri 64114

MAKE UP TO \$12 AN HOUR AT HOME

Let Me Prove It To You FREE!

I'll show you how Plastic Sealing and Laminating at home, spare time, can give you as much as \$12 each hour you operate. Table-top machine sets up anywhere. Easy. Fun. No experience needed. We furnish everything. We'll even help finance you. No house-to-house selling. Orders come by mail. Write for facts FREE. No salesman will call.



WARNER ELECTRIC, 1512 Jarvis, Dept. L-2-PS, Chgo, Ill. 60626

SNOWMOBILES / SAVE 20%

Buy DIRECT at FACTORY PRICES—Save dealer profit. Have fun this winter! 6 Models from 20-30 HP in 15" and 18" track widths. '70 styling, performance. Welded steel chassis, Fiberglass body. Low Down Payment, E-Z terms. Free inspection. Money back guarantee. Free delivery, Free color catalog. Write:



LUGER INDUSTRIES, Dept. BS-129

1300 East Cliff Road
Burnsville, Minnesota 55378

E-Z TERMS

BE A SUCCESS

Have Money, Prestige & Happiness. Noted psychologist offers Guideline with IDEAS that give basic principles you can learn in a few moments. Apply them & have the success you want. Mail \$1.00.

RESEARCH & METHODS CO.

Box 8623, Detroit, Mich. 48224

WRIST ROCKET
AMERICA'S Pat.
HARDEST U.S.
HITTING SLING

Range 225 yd. - 232 fps

Matched spare rubbers
and pouch assembly, \$1.00.

Write WRIST ROCKET® \$3.00 Post Pd.
2654 44th Ave. No C.O.D.'s
Columbus, Nebr. 68601



110-120 VOLT A.C. LIGHT PLANTS—60 CYCLES

Fanbelt driven from pickup or small gas engine. Operates saws, drills, pumps, freezers, T.V. X1000 Watts—Needs No Battery. Now \$70.00. 1500 Watts—8 and 12 volt vehicles. Now \$80.00. 3000 Watts—12 volt vehicles only. Now \$99.50. Guaranteed. Check or Money Order.

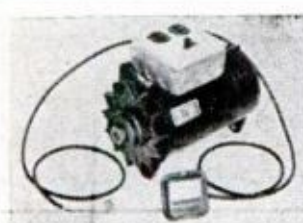

VIRDEN PERMA-BILT, Box 7066 P.M., Amarillo, Texas 79109



Chances are that pickup cover ahead of you is a Winnebago.

One out of every four on the road is.

Winnebago dealers sell more pickup covers than any other company in the world. Here's why they're so popular.

Selection: Winnebago has 90 versatile models to fit most any pickup.

Comfort: Fully foam insulated and lined with prefinished plywood.

Strength: Exclusive Winnebago Thermo-Panel® construction combines insulation with strength and light weight.

Safety: Safety glass windows all around that comply with all federal regulations.

Price: From less than \$200 to \$700.

Service: Over 140 assembler-dealers from coast to coast and Canada.

Chances are this is the kind of pickup cover you're looking for.

WINNEBAGO

Designed from the inside out

Send for a free catalog and the name of your nearest dealer!

Winnebago Industries, Inc. PM12
Thermo-Panel Div. Box 152
Forest City, Iowa 50436

NAME _____

ADDRESS _____

CITY _____

STATE _____ ZIP _____

CANADA JOINS ROTARY CLUB

(Continued from page 210)

and the standard Dunlop radial tires help quite a bit. They squeal a lot but absolutely refuse to slideslip on dry pavement. Cornering remains flat, very neutral and completely predictable.

Suspension uses MacPherson struts up front. The entire shock assembly becomes a kingpin and rotates with the steering knuckle (as well as doing up-and-down chores). There's a heavy stabilizer bar up front, and that helps keep body roll to a minimum. Around back, springing is conventional, by leaves.

The R-100 uses disc brakes in front, with drums in back. I wasn't able to fade them, even on repeated downhill stops. My only objection in the brake department was that the pedal pad is too near its suspending arm.

The rotary engine offers several advantages:

1. *Lightness*—the R-100 Wankel weighs only 269 pounds complete, comparing favorably with, say, the Datsun ohc Four, which puts out 96 bhp and weighs 421 pounds.

2. *Compactness*—generally speaking, a rotary engine takes up about half as much cubic volume as a piston engine.

3. *Simplicity*—there's half the number of internal working parts (comparing a single-rotor Wankel with a one-cylinder overhead-valve piston engine—less than half with multi-cylinder engines).

Now, transcribing directly from my drive-test notes: "Instrumentation complete, readable. Seats comfortable, tiltable, almost infinitely adjustable. Fit and finish inside and out first-rate. Decor sporting a

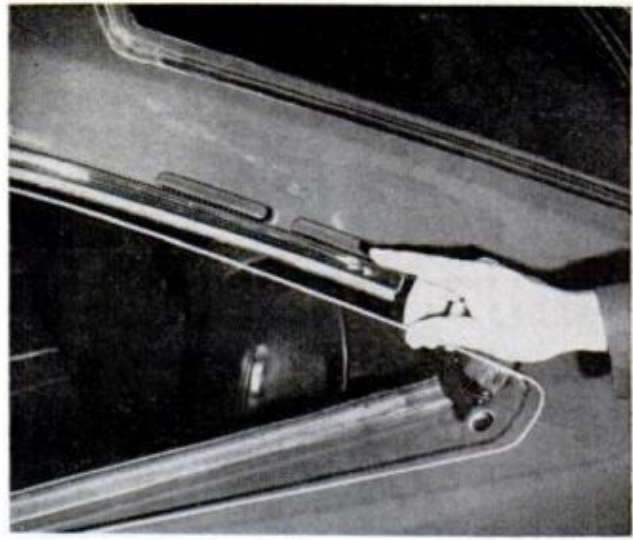

AIR EXITS THROUGH SLOTS behind rear side windows. Ventilation system lets you drive on cool days with windows shut. Rear windows open out slightly

real wood wheel. And at last, a flow-through ventilation system that ventilates; two positions for air intake, vents really blow you out of car at high speed. Solid car, no thumpy noises on bumps, no rattles. Back seat too small for anything but penguins."

Overall fuel consumption came to 24.8 mpg, for which, considering that my driving included city, freeway, acceleration and braking tests, repositioning the car for photo-taking, and a good deal of just plain idling, I give the R-100 top marks in fuel economy. With a light foot, the conscientious driver should get 30-34 mpg easily.

The R-100 coupe sells for \$2929 p.o.e. Vancouver. I view this as a very fair price. In U.S. dollars, that comes to \$2709—even fairer. ★★★

SPECIFICATIONS AND PERFORMANCE

1970 Mazda R-100 coupe, Toyo Kogyo Co., Ltd., Hiroshima, Japan. Price: \$2929 (\$2709 U.S.) p.o.e. Vancouver, B.C.

ENGINE—Type: Wankel 2-rotor, in-line, water-cooled.

Bore and stroke: none.

Displacement: 59.6 cu.in. (491 cc each chamber).

Horsepower: 110 bhp @ 7000 rpm.

Torque: 100 ft.-lb. @ 4000 rpm.

Compression ratio: 9.4:1.

Valves: none.

Carburetion: Hitachi KCB-306 4-bbl., two-stage.

Fuel pump: Electric pulse-type.

Electrical system: 12-v. battery/coil, two complete ignition systems.

CLUTCH—Type: single dry plate.

Outside diameter: 7.874 in.

Actuation: hydraulic, pedal activated.

TRANSMISSION—Type: four-speed manual, floor shift.

Ratios: 1st, 3.737:1; 2nd, 2.202:1; 3rd, 1.435:1; 4th, 1.000:1; reverse, 4.024:1.

DIFFERENTIAL—Type: spiral-bevel, hypoid.

Final drive ratio: 3.7:1.

Drive axles: semifloating.

STEERING—Type: recirculating ball and nut.

Turns lock to lock: 2.25. Turning diameter: 27.2 ft.

BRAKES—Hydraulic, disc and drum, tandem master cylinders; disc dia. (front), 9.6 in.; drum dia. (rear), 7.9 in.

CHASSIS—Front suspension: independent by MacPherson strut with high-mounted coil spring, hydraulic shock absorber, single lower suspension arm with lower ball joint.

Rear suspension: longitudinal semi-elliptic leaf springs, hydraulic tubular shock absorbers.

DIMENSIONS—Wheelbase, 89.0 in.; overall length, 149.0 in.; front/rear track, 47.0/46.0 in.; width, 58.2 in.; height loaded, 54.0 in.; ground clearance, 6.0 in.

WEIGHTS—Curb weight, 1775 lbs.; engine, 269 lbs. Total test weight, 1925 lbs.

CAPACITIES—Crankcase, oil cooler, filter, 5.5 qts. Cooling system, 14.7 pts.; gas tank, 15.85 gal.

PERFORMANCE—Acceleration: 0-30 mph, 4.6 sec.; 0-40, 8.3 sec.; 0-50, 10.1 sec.; 0-60, 12.2 sec.; 0-70, 16.8. Max. mph in gears: 1st, 27; 2nd, 54; 3rd, 83; 4th, 112.

FUEL CONSUMPTION—Test, 24.8 mpg; range, 22-34 mpg.

Now! Use your Bank Americard



5000° OXYGEN WELDING TORCH
\$34.95 New portable SOLIDOX welding torch goes anywhere. Only 4 lbs. Burns amazing solid oxygen pellets & propane. Flame exceeds 5000°F. Braze weld, silver solder, melt 1/4" steel. Complete kit: torch, pellets, propane, glasses, braze rods, lighter, etc. Ideal for shops, hobby, metal repair. Professional results. Low-cost SOLIDOX pellets available by mail. SOLIDOX is simple and safe. Money-back guarantee. Only \$34.95 ppd.

Easy assemble thrift kit, no propane \$24.95

SEND ONLY \$5.00

pay postman \$29.95 plus postage on delivery.

Cleanweld Products Co., PM12 Box 1061, South Gate, Calif. 90280

TREASURE & COIN DETECTOR

MONEY BACK GUARANTEE



New electronic detector penetrates deep into earth to locate gold, silver, coins, minerals. More penetrating power than ever before. Sensitive enough to locate a single coin or small nugget. Works through earth, wood, vegetation, water, rock, etc. Not a "probe" type but a fully electronic detector that is guaranteed to have at least twice the detection ability of any detector in this price range or return in 10 days for refund. Uses inexpensive 9V battery. Fully transistorized. Weighs only 2 pounds. Loudspeaker signals when object is detected. Has plug-in earphone for treasure hunting in privacy. **NOTHING ELSE TO BUY!**

29.95
POST PAID

Comes complete, ready for operation. Shipping container has compartments for detector and all accessories, serves as a carrying case. Send only \$29.95 check, cash or M.O. for postpaid shipment or \$2.00 and pay \$27.95 plus small C.O.D. when delivered. Viking Detectors, Dept. V-2, Box 10880, Houston, Texas 77018

BUILD YOUR OWN POWER TOOLS



METAL PARTS KITS AT LOW FACTORY DISCOUNT PRICES FOR:

- 10-IN. TILT/ARBOR SAW
- COMB. DRILL PRESS-LATHE
- 12-IN. BAND SAW
- 18-IN. BAND SAW
- 6-IN. BELT SANDER
- SPINDLE SHAPER

SAVE \$50 OR MORE

PLANS \$1.00 EACH
Full Size Patterns DEDUCTIBLE

Kits from \$16.99 to \$43.99. Satisfaction guaranteed. Built and sold for 23 years. 50,000 units in use. Send \$1.00 for Plans, or 25¢ for Catalog!

GILLIOM MFG. CO. Dept. PMT-12 St. Charles, Mo. 63301

The Grabber



... the tool that allows you to truly do-it-yourself! The GRABBER allows you to hold, position, and line up just about everything. No handyman should be without one. Tough, versatile, self adjusting made of high tensile alloys.

- 101 uses
- Repair walls
- Hold paneling
- Furniture Clamps
- Automotive repairs

LIMITED OFFER
only **\$3.95**

Please send me (no.) — GILSON GRABBERS at \$3.95 each. Money back guarantee.

GILSON PRODUCTS
3888 Vly Road, Schenectady, New York 12309

GOVT. SURPLUS AND OTHER BARGAINS SAVE UP TO 90%



HEAVY DUTY GEAR MOTOR All ball bearing construction. Rated approx. 3.5 HP @ 24 V.D.C. Turns 400 RPM, no load, on 12 V.D.C. & 800 RPM on 24 V.D.C. Contains instant start-stop magnetic clutch. Reversible. Has 12 tooth, 5/8" shaft, 18 1/2" L x 7" dia. GOVT. COST \$454. Shpg. Wt. 35 lbs. **\$27.50** Stk. #2463



MOTORIZED TRANSFER PUMP High volume. Delivers up to 700 GPH @ 35 PSI. 1 1/2" pipe ports. Exc. for pumping water & oil base insecticides, transferring diesel fuels, gas, kerosene & solvents. 1/4 HP motor will operate 24 or 12V DC. Tested prior to shipment. Shpg. wt. 17 lbs. Approx GOVT COST \$135, NOW **\$24.50** (Stk. #1243).



ELECTRIC UTILITY PUMP Output up to 360 gal. per hr. @ 18 PSI. Exc. for water, fuel, insecticides, etc. Aluminum construction. Runs on 12 or 24 V.D.C. Explosion-proof motor. Inlet & outlet ports are 1/2" pipe. Draws 5.2 amps, 9 3/4" H x 6" W. Approx. GOVT COST \$150. Shpg. wt. 8 lbs. **\$14.50** (Stk. #2486A).

NEW! BIG! 1969 CATALOG

Send 25¢ for amazing catalog with 1000's of bargains in hydraulics; electrical, marine, automotive items, etc. Order from ad. All prices FOB Culver City, 50% deposit required for COD. Cal. res. add 5% sales tax. Include zip. Satisfying world-wide customers since 1945.

AIRBORNE SALES CO. Dept. PM1269
8501 Stellar Dr., Box 2727 - Culver City, Calif. 90230

ARCTIC REINDEER SKINS!

Excellent for wall decor. Order direct from Lapland at fantastic savings! Fully-finished, fluffy, 1" thick furs, approximately 12 sq. ft. Only \$29.00 postpaid world-wide (U.S. 8% duty not included). Add \$6.00 for speedy airmail delivery. Certified cheque or money order only—COD not possible. Other Arctic skins also available: elk, bear, polar bear, wolf, arctic fox etc. Full details on request—please enclose International Reply Coupon.

LAMAR, Kirkkokatu 7, Oulu, Finland

TUNE UP ELECTRONICALLY

ANY CAR EVER MADE!

- ✓ COMPACT or LIMOUSINE
- ✓ DOMESTIC or FOREIGN
- ✓ 4, 6 or 8 CYLINDER
- ✓ 6 VOLT or 12 VOLT
- ✓ POSITIVE or NEGATIVE GROUND

With New Improved Model BT-162

DWELL TACHOMETER

ASSURE EASY STARTS, OPTIMUM PERFORMANCE and MAXIMUM GAS ECONOMY with MODEL BT-162

MADE ORIGINALLY FOR THE PROFESSIONAL AUTOMOTIVE TECHNICIAN, MODEL BT-162 WILL PAY FOR ITSELF MANY TIMES OVER FOR THE AUTOMOTIVE HOBBYIST AND EXPERIMENTER.

The Model BT-162 will perform the services specified below in addition to many other tasks too numerous to mention:

It is no longer necessary to file points to smoothness when using the Model BT-162. The instrument will automatically make allowance for any existing "pitting" or "wear." • Indicate the most effective point setting without removing the distributor cap. • Indicate the correct settings for external adjustment type distributors. • Car manufacturers' dwell angle recommendations are included in the manual provided with the Model BT-162. • To adjust for mathematically correct carburetor adjustment and thus insure maximum gas economy and quiet engine running, simply use the Tachometer section of the Model BT-162. • To locate a "miss" you need only disconnect or "short" the spark plugs one at a time with the Model BT-162 switched to the Tachometer position. You will be able to instantly identify which particular plug (or frequently its wire lead) is responsible for the malfunction. • Cars with automatic transmissions function efficiently if the fluid pressures are correctly maintained. Since manufacturer's instructions always refer to RPM when making such adjustments, the 5,000 RPM range of the Model BT-162 is ideal for this purpose.

Operating manual includes manufacturer's dwell angle recommendations for all cars. The manual is yours to keep even if you decide to return the instrument. **\$29.95**

SEND NO MONEY WITH ORDER
PAY POSTMAN NOTHING ON DELIVERY

Try it for 10 days before you buy. If completely satisfied remit \$29.95 plus postage and handling charge. (If you prefer you may **PAY MONTHLY ON OUR EASY PAYMENT PLAN**) If not completely satisfied, return to us, no explanation necessary.

ACCURATE INSTRUMENT CO., INC. DEPT. 709
2425 White Plains Road, Bronx, N. Y. 10467

Please rush me one Model BT-162, if satisfactory I agree to pay at the terms specified at left. If not satisfactory, I may return for cancellation of account.

Name: _____
Address: _____
City: _____ Zone: _____ State: _____

Save money! Check here and enclose \$29.95 with coupon and we will pay all shipping and handling charges. You still retain privilege of returning after 10 day trial for full refund.

LAFAYETTE RADIO ELECTRONICS

FREE!

1970 CATALOG 700

496 Pages

BETTER THAN EVER

Stereo Hi-Fi • Citizens Band • Ham Gear • Tape Recorders • Test Equipment • TV and Radio Tubes and Parts • Cameras • Auto Accessories • Musical Instruments • Tools • Books

LAFAYETTE Radio ELECTRONICS
Dept. 15129 • P.O. Box 10
Syosset, L.I., N.Y. 11791

Send me the FREE 1970 catalog 700 15129

Name
Address
City
State Zip

BUILD YOUR OWN CAMPER
SAVE UP TO 50%



Complete, easy to follow plans, instructions, materials list.

Camper Plans \$3.95
Travel Trailer \$3.95
Pickup Cover \$2.00

CONVERSION PLANS:
Econoline Type Van... \$2.95
Passenger Bus or Delivery Van..... \$2.95
Satisfaction Guaranteed

EQUIPMENT CATALOG \$1.90

Refundable on First Order. Send Dime for Details. Save 50% on Camper Kit. All items from catalog to build \$1,795. Camper, 8' 10", 10'6" or Chassis Unit.

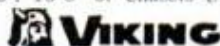

VIKING CAMPER SUPPLY, INC.
99-BP Glenwood Ave.,
Minneapolis, Minn. 55403
Please send for
which I enclose \$.....
NAME
ADDRESS
CITY
STATE ZIP

So easy to handle
you guide it with
Just ONE HAND!



Tiller users, for heaven's sake, please don't buy nor put up any longer with any other make of Tiller without giving yourself a chance to find out about our wonderfully different & better kind of Tillers — with POWER DRIVEN WHEELS and with tines in the REAR instead of the FRONT!

No Footprints!
No Wheelmarks!
No Struggle!

Please let us send you complete details, prices, OFF-SEASON SAVINGS, etc. Ask for FREE BOOKLET. Clip this ad and write now to —

TROY-BILT® Roto Tillers, Dept. 1972
102nd St. & 9th Ave., Troy, N.Y. 12182

Doctors Find Way To Shrink Hemorrhoids

And Promptly Stop Itching, Relieve Pain In Most Cases.

Science has found a medication with the ability, in most cases — to stop burning itch, relieve pain and actually shrink hemorrhoids.

In case after case doctors proved, while gently relieving pain and itching, actual reduction (shrinkage) took place.

The answer is *Preparation H®* — there is no other formula like it for hemorrhoids. Preparation H also soothes inflamed, irritated tissues and helps prevent further infection. In ointment or suppository form.

LUCK! GET UP TO **\$151** WIN A RACE DAY **\$2**

SENSATIONAL—space age—scientific, yet so easy to use. All purchasers get facts. Over 4 years checkable Big Win Pencliff results. Over THREE THOUSAND Big Win Pencliff Payoffs to \$2 stakes incl. \$89, \$105, \$169. Big Pencliff Track Wins—\$2 on all predictions in the 9 races incl. \$87, \$108, \$151 clear net profit on the day. Obviously payoffs and profits every day are not ALL BIG, but PENCLIFF shows a magnificent 28% aver. approx. win with a GRAND percent of real big 'uns. 30 day money back guarantee. Learn how an accident on the inventor's yacht, his 25 years horse race knowledge, the aid of 12 other expert handicappers, and a giant I. B. M. computer all led to the invention of amazing PENCLIFF.

R.H.P. CO. Box 5715-PME3, Carmel, Calif. 93921.
Tear out this ad NOW and mail with name, address, & zip.

\$\$ TREASURE \$\$



New revolutionary analytical transistorized metal detector will distinguish a gold bar from a tin can. No more unnecessary digging for tin cans, nails, bottle caps, etc. Also features push button tuning, automatic tuning, loud-speaker. Negligible ground pickup. Greatest detection range, etc. Many models — free catalog.

GARDINER ELECTRONICS CO.
Dept. 8, 4729 No. 7th Ave., Phoenix, Ariz. 85013

WORLD'S FINEST CORED SOLDER

ERSIN MULTICORE 5-CORE SOLDER

BUY IT AT RADIO-TV PARTS STORES

EASY DISPENSER ONLY 59¢

**BUILD THIS MINI-BRUTE
NO WELDING OR BRAZING!
NEW SIMPLIFIED METHOD.**

Just follow the 24 pages of detailed instructions and diagrams step by step—from start to finish. **FREE!** Confidential list of parts, wheels, frame, brake, etc. **SPECIAL BONUS**—learn where & how you can buy used engines from \$10.00 up—**Money Back Guarantee.**



Send only \$2 to **MINI-BRUTE INDUSTRIES, INC.**
Dept. PM-2, P.O. Box 1083, West Caldwell, N.J. 07006

BE YOUR OWN BOSS!

**A SPACE AS SMALL AS 10" X 13" CAN
MAKE YOU INDEPENDENT**

in the high profit (low investment) rubber stamp field. Increase your income; full or part time basis. Deal direct with manufacturer offering lowest prices on professional **SIMPLE-X** presses & supplies, plus valuable aid. For **FREE** full facts write

CUSTOM MFRS.

406PM E. Elm, Springfield, Mo. 65801



STATEMENT OF OWNERSHIP, MANAGEMENT AND CIRCULATION (Act of October 23, 1962; Section 4369, Title 39, United States Code). 1. Date of filing: October 1, 1969. 2. Title of publication: *Popular Mechanics*. 3. Frequency of issue: Monthly. 4. Location of known office of publication: 224 West 57th Street, New York, N. Y. 10019. 5. Location of the headquarters or general business offices of the publishers: 959 Eighth Avenue, New York, N. Y. 10019. 6. Names and addresses of publisher, editor, and managing editor. Publisher: The Hearst Corporation, 959 Eighth Avenue, New York, N. Y. 10019. Editor: Robert P. Crossley, 224 West 57th Street, New York, N. Y. 10019. Business manager: Joseph F. Kern, 224 West 57th Street, New York, N. Y. 10019. 7. Owner: The Hearst Corporation, principal office, 100 West Tenth Street, Wilmington, Delaware 19899—Stockholders owning or holding 1 percent or more of total amount of stock of The Hearst Corporation are: William Randolph Hearst, Jr., Randolph Apperson Hearst, David Whitmire Hearst, George Hearst, The Hearst Foundation, Inc., and the Trustees of Trusts created under the Will of William Randolph Hearst. Deceased, namely: Richard E. Berlin, Herbert W. Beyea, Richard E. Deems, David Whitmire Hearst, George Hearst, Sr., George Hearst, Jr., Randolph Apperson Hearst, William Randolph Hearst, Jr., Harold G. Kern, Frank Massi, John R. Miller, Raymond J. Petersen, J. Kingsbury Smith, the address for all of the foregoing being 959 Eighth Avenue, New York, New York 10019, and the William Randolph Hearst Foundation, 626 Wilshire Boulevard, Los Angeles, California 90017. Those having a beneficial interest in the Trusts mentioned above are: William Randolph Hearst, Jr., George Hearst, Randolph Apperson Hearst, David Whitmire Hearst, John Randolph Hearst, Jr., William Randolph Hearst, II, Deborah Anne Hearst, Joanne Hearst Tarafa and The Hearst Corporation. 8. Known bondholders, mortgagees, and other security holders owning or holding 1 percent or more of total amount of bonds, mortgages or other securities: None. 9. For completion by nonprofit organizations authorized to mail at special rates (Section 132.122, Postal Manual) (Check one)—The purpose, function, and nonprofit status of this organization and the exempt status for Federal income tax purposes: Have not changed during preceding 12 months; Have changed during preceding 12 months. (If changed, publisher must submit explanation of change with this statement.) 10. Extent and nature of circulation. A. Total no. copies printed (Net Press Run): Average no. copies each issue during preceding 12 months, 1,884,333; actual number of copies of single issue published nearest to filing date, 1,780,000. B. Paid Circulation: 1. Sales through dealers and carriers, street vendors and counter sales: Average no. copies each issue during preceding 12 months, 423,718; actual number of copies of single issue published nearest to filing date, 375,100. 2. Mail subscriptions: Average no. copies each issue during preceding 12 months, 1,296,703; actual number of copies of single issue published nearest to filing date, 1,248,897. C. Total paid circulation: Average no. copies each issue during preceding 12 months, 1,720,421; actual number of copies of single issue published nearest to filing date, 1,623,797. D. Free distribution (including samples) by mail, carrier or other means: Average no. copies each issue during preceding 12 months, 10,956; actual number of copies of single issue published nearest to filing date, 9,647. E. Total distribution (Sum of C and D): Average no. copies each issue during preceding 12 months, 1,731,377; actual number of copies of single issue published nearest to filing date, 1,633,444. F. Office use, left-over, unaccounted, spoiled after printing: Average no. copies each issue during preceding 12 months, 152,956; actual number of copies of single issue published nearest to filing date, 146,556. G. Total (Sum of E & F—should equal net press run shown in A): Average no. copies each issue during preceding 12 months, 1,884,333; actual number of copies of single issue published nearest to filing date 1,780,000. I certify that the statements made by me above are correct and complete. Joseph F. Kern. (Signature of business manager).

It's Here! Handiest "tool" you'll ever own! ■ 12 handy hang-up boards! ■ 56 charts ■ Wipe-clean-plastic laminated to last for years! ■ Answers to 1001 shop questions!

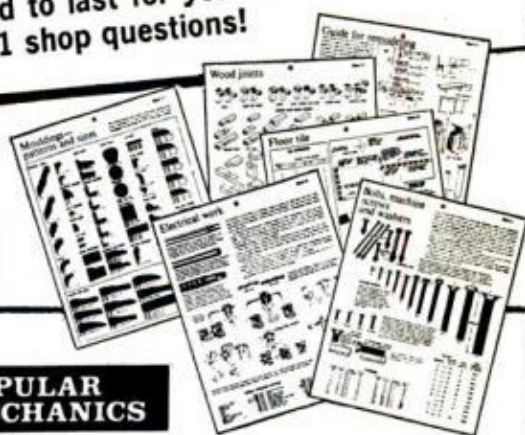

NEW!

POPULAR MECHANICS

MASTER SHOP GUIDE

Everything you need to know about: nails, screws, bolts, wall-fasteners, drills, abrasives. Lumber, hardwoods, moldings, plywood, hardboard, gypsum, adhesives, plumbing, electrical work, floor and wall tile, glass. Facts on remodeling measurements, gutters, concrete, garden chemicals. Plus—all on one board—a ruler, protractor, 45-degree triangle, and compass for accurate circles!

You'll reach for the MASTER SHOP GUIDE for every job you tackle! What nail should you use? How many pounds will a 1/4-in. toggle bolt hold? How can you save money ordering? What size quarter-rounds are available? How do you bleach close-grained hardwoods?

By the editors of **Popular Mechanics**—order yours now—you'll use it the rest of your life!

- PARTIAL LIST OF CONTENTS**
- Nail and screw sizes and uses
 - Lawn and garden chemicals
 - Guide for remodeling
 - Plumbing guidance
 - Lumber sizes
 - Bolts, machine screws, washers
 - Wood joints
 - Wood finishes
 - Plastic laminates
 - Glass
 - Floor and wall tile
 - Drill sizes
 - Electrical work
 - Abrasives
 - Wallpaper

\$3.95
complete set
of 12
8 1/2" x 11"
boards!

MAIL COUPON TODAY!

Popular Mechanics, Dept. SG
224 West 57th Street, N.Y., N.Y. 10019
Rush me ___ sets of MASTER SHOP GUIDE.
 I enclose check or money order for \$3.95 for each set ordered.

Name _____

Address _____

City _____ State _____ Zip _____

WHEN YOU JOIN THE
POPULAR SCIENCE
BOOK CLUB

THIS 8-BOOK SKILL LIBRARY IS

(Regular Price \$15.60)

YOURS FREE

These 8 fact-packed, illustrated manuals help you do every job like a pro!

Big 6½ x 9¼ format • 1540 pages • hard-gloss paper covers • 1724 how-to pictures • indexed • thousands of tips, techniques, shortcuts.

"PS Skill Books turn you and your tools into star performers."
—Independent Press

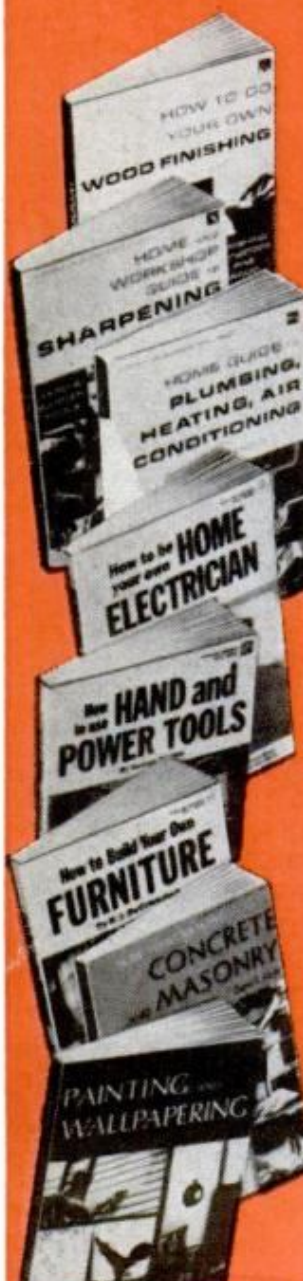

HOW TO DO YOUR OWN WOOD FINISHING by Jackson Hand. Finish new wood, restore surfaces, antiques, refinish floors. Covers wood fillers, bleaches, shellac, varnish, enamel.

HOME AND WORKSHOP GUIDE TO SHARPENING by Harry Walton. How to sharpen every cutting tool, utensil in your workshop, yard and kitchen.

HOW TO WORK WITH CONCRETE AND MASONRY by Darrell Huff. From patio or barbecue to foundation. How to pour, reinforce, cure, trowel, texture, color concrete. Lay bricks, block, stone, flagstones; top and waterproof a wall.

HOW TO BE YOUR OWN HOME ELECTRICIAN by George Daniels. Make simple repairs, even re-wire your house. Covers tools, codes, wire types, house and service wiring, outlets, plugs, switches, fixtures, fuses, motors.

HOW TO USE HAND AND POWER TOOLS by George Daniels. Choose, use, take care of all hand, power tools. How to set up a power shop, safety practices, money-saving ideas, shortcuts.

HOME GUIDE TO PLUMBING, HEATING AND AIR CONDITIONING by George Daniels. Step-by-step instructions on maintenance, repairs, installation.

HOW TO BUILD YOUR OWN FURNITURE by R. J. DeCristoforo. Use just three basic elements—slabs, rails and legs—and build tables, chairs, cabinets, desks. Construction, new component adaptations, tools, wood hardware, fasteners, fixtures.

HOW TO DO YOUR OWN PAINTING AND WALLPAPERING by Jackson Hand. Acquire the ease and skill of a pro. Use color effectively. Choose brushes, applicators, sanders, primers, paints, wallpaper.

And you get your first Club selection at a big 48% discount . . .

THE HOW AND WHY OF MECHANICAL MOVEMENTS by Harry Walton

Can you name the six simple principles which operate every machine ever invented? This amazing book gives you the whole history of machines and mechanics, with emphasis on the machines of today and tomorrow. Whether it's your car's transmission, sabre saw or turbo jet engine, this book tells and shows exactly how it works. You learn how the terms horsepower, thrust, torque originated and what they mean. And a brilliant series of over 300 drawings, carefully integrated with the concise text, make every principle and development absolutely clear. This giant \$7.95 book is yours for just \$4.10, as your first PSBC selection. Enroll in the Popular Science Book Club now! Mail the attached card to get your 8-BOOK SKILL LIBRARY free and THE HOW AND WHY OF MECHANICAL MOVEMENTS (a \$23.55 value) for only \$4.10 plus postage.



*ANSWERS 1. lever 2. pulley 3. wheel-and-axle 4. inclined plane 5. wedge 6. screw

CHECK THESE UNIQUE ADVANTAGES OF PSBC MEMBERSHIP

- You choose from the broadest range of titles on practical and technical subjects. The finest books on home workshops, mechanics, cars, science, mathematics, history of science, how things work, engineering, electronics, astronomy, home improvements.
- You save up to 50% and more on every Club selection. PSBC books are priced way below regular prices for identical editions.
- With every selection you accept from the Club, you'll receive an exciting free surprise gift. This handy, practical item will be something your whole family will look forward to and enjoy. It's always a delightful surprise and it's always absolutely free.

- You buy as many or as few books as you please. Each month you receive a Club bulletin fully describing the current selection, which you may accept or reject. To retain full membership privileges, you need purchase only one more Club selection (after your first selection) for the entire year.
- Free 10-day trial examination for every book you choose. If, after you receive a book, you wish to return it for any reason, you may do so at absolutely no obligation.

MAIL THE ATTACHED CARD TODAY!

POPULAR SCIENCE BOOK CLUB 44 Hillside Avenue, Manhasset, New York 11030

© 1995 JAMES EARLY COMPANY, LONDON, ENGLAND. ALL RIGHTS RESERVED. PHOTOGRAPHY BY JAMES EARLY COMPANY.



**...and to all
a good
nightcap**

THE TRUE OLD-STYLE KENTUCKY BOURBON



“We and our Winstons”

we got a
real good thing...
a real good
taste.



KING SIZE

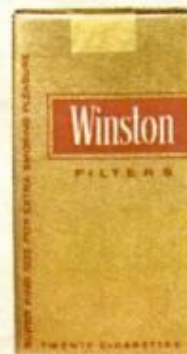

SUPER KING SIZE

© 1969
R. J. REYNOLDS
TOBACCO COMPANY,
WINSTON-SALEM, N. C.

Материал, защищенный авторским правом