

Sun or Ski Vacation Homes Page 176

Great Ideas
From the
World's Biggest
Inventors
Show

POPULAR MECHANICS

OCT. 1969
50 CENTS

In Color! '70 Cars

Amazing New Instantaneous Fire Extinguisher

For Your Car, Boat
Or Home



Build
PM's Graceful
Grandfather's Clock Page 124

What's New
In Snowmobiles
And Outboards

Insulating Your Home: What to Use and How to Use It

Dan Gurney Answers Your Questions on Racing and Driving

Oneida...the boot that took Antarctic punishment in stride



Glacier-hopping on perilous Heard Island, this explorer wears Oneida for warmth, safety, comfort.

You probably won't ever sail a small vessel through sub-antarctic waters to a treacherous, weather-blasted island and climb to the summit of a storm-swept volcano.

But it's nice to know Red Ball Oneidas can take that kind of punishment!

That's why Oneida, the fully insulated boot that conquered cold, repelled water, resisted wear, required no maintenance and gave solid comfort to members of an Antarctic expedition—is the best boot for you.

Buy a pair and do your own exploring!

 **Red Ball Oneida**

Look for the Red Ball by Ball-Band, Mishawaka, Indiana

For dealer in your area call 800-243-6000 at no cost. In Connecticut, call free, 800-942-0655



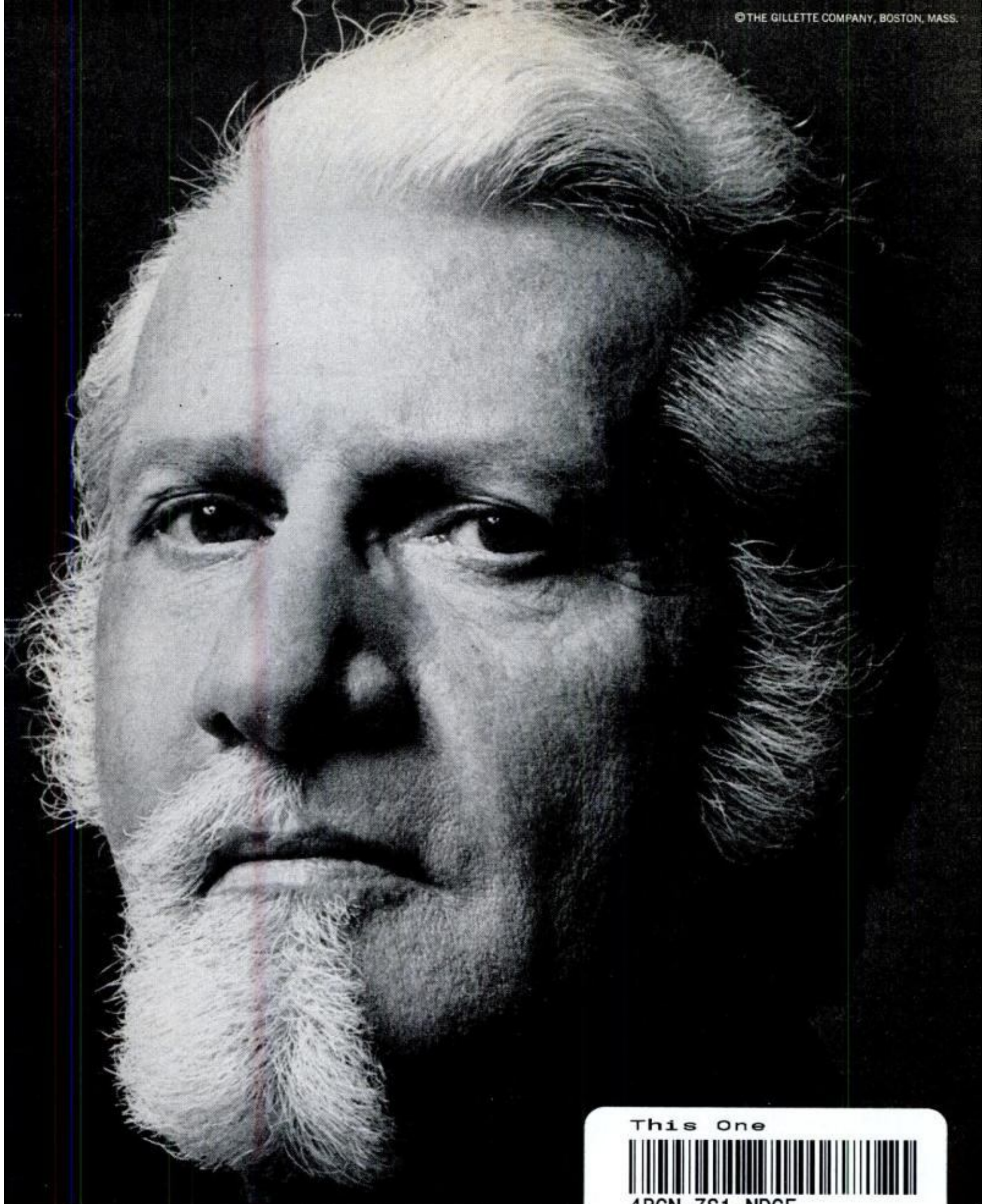

This One



4RCN-7S1-NDGF

Once you start using Gillette Super Stainless Injector Blades it's very hard to stop.



(Coated with the miracle plastic that reduces pull.)



A typical Dodge "Job-Mated" van interior for general service, showing some of the equipment available to make your job easier. Choose the equipment to do your job right, from a wide selection of shelves, drawers, bins, baskets, and many others.

It all started with the hot-selling Dodge compact van. And now, its versatility has been extended to eighteen "Job-Mated" units like the one shown below, outfitted to handle the needs of just about any trade. And you can order your Dodge Tradesman Van with options such as air conditioning, power steering, or automatic transmission. Only Dodge offers power steering on compact vans. Proof again that Dodge Truck is first with the most.

RACK UP ANOTHER FIRST FOR DODGE.

Dodge Tradesman Van is here with specially installed interiors to meet your business needs. If you're in a business requiring a compact truck built for general service duty, there's a Dodge "Job-Mated" Tradesman equipped to make your job easier, more efficient. See the Dodge "Job-Mated" Tradesman, the hottest idea in trucks since the compact van.

DODGE TRADESMAN PUTS YOUR BUSINESS ON WHEELS

TO: Advertising Department, Dodge Truck Operations, P.O. Box 2088, Detroit, Michigan 48231

Please rush me a copy of your new Dodge Tradesman Van catalog. I want to know more about them.

Name _____

Address _____

City _____

State _____

Zip _____

Dodge



**“I didn’t know what
a blitz was until
I splashed on
your after shave.”**



Even your beefiest blockers can't protect you if you're not careful how you use Hai Karate® After Shave and Cologne. It's like being gang tackled by eleven love-starved linebackers. So make sure you read the instructions on self-defense which we include in every package. And don't oversplash. Or you might lose a lot more than yardage.

Hai Karate-be careful how you use it.



POPULAR MECHANICS®

INTERNATIONAL EDITIONS: AUSTRALIA, BRAZIL, CARIBBEAN, DENMARK, FRANCE, MEXICO, SOUTHERN HEMISPHERE, SWEDEN

AUTOMOBILES AND DRIVING

- [22 Drivin' With Dan](#)
- [44 Detroit Listening Post](#)
- [72 New Mercedes Sports Car](#)
- [92B Automobile Clinic](#)
- [93 Amazing New Instantaneous Fire Extinguisher](#)
- [104 The '70 Cars: What's New Depends Upon Your Point of View](#)
- [107 The Really New Ones](#)
- [110 The Compacts](#)
- [112 The Intermediate Cars](#)
- [115 The Personal Cars](#)
- [119 The Favorite Family Cars](#)
- [123 The Luxury Cars](#)
- [154 Saturday Mechanic: How to Stop a Dieseling Engine](#)
- [260 The Man Who Made Bentleys](#)

HOME AND YARD

- [92F Homeowners' Clinic](#)
- [124 PM's Handsome Hall Clock \(Part 1\)](#)
- [164 Weekend 'Thinwall' Projects](#)
- [168 Instant Cement Fills Cracks for Good](#)
- [170 Which Insulation Should You Use?](#)
- [176 All-Season 'Ski Lodges'](#)
- [181 Now: A Vacation Home in Three Hours](#)
- [182 Exciting New Products](#)
- [184 How to Install a Wall Safe](#)
- [188 Solving Home Problems](#)
- [190 Update Your Heating System](#)

BOATING, OUTDOOR RECREATION

- [14 New Starcraft Coach](#)
- [41 What's New Outdoors](#)
- [52 On-the-Go Camping](#)
- [100 '70: A Fine-Tuning Year for Outboards](#)
- [142 '70: A Sensational Year Coming Up for Snowmobiles](#)

REGULAR FEATURES

- [6 Letters](#)

SHOP AND CRAFTS

- [124 PM's Handsome Hall Clock \(Part 1\)](#)
- [164 Weekend 'Thinwall' Projects](#)
- [169 Hints From Readers](#)
- [175 Hints From Readers](#)
- [187 Make This Hinged Fixture for Your Radial Saw](#)
- [192 New Tools You Should Know About](#)
- [193 Hints From Readers](#)
- [194 How to 'Plane' on a Lathe](#)
- [198 Dent Puller From Pipe Parts](#)
- [199 Hints From Readers](#)
- [200 You Can Build a Lightweight Press for Heavyweight Jobs](#)
- [204 The Handiest Tool in Your Shop! PM's Master Shop Guide](#)

SCIENCE AND INVENTIONS

- [20 Science Worldwide](#)
- [93 Amazing New Instantaneous Fire Extinguisher](#)
- [130 Patexpo '69: PM's Exclusive Preview of World's Biggest Inventors Show](#)
- [138 Mechanics of Medicine: A 200-mph Surgical Drill, Steady Beep of a Heart Monitor, Electronic Voice Box](#)

ELECTRONICS, RADIO AND TV

- [146 For Tops in Hi-Fi Listening: Now It's Back to Earphones Yet!](#)
- [248 New in Electronics](#)

PHOTOGRAPHY

- [158 New in Photography](#)
- [160 Zoom Your Way to Bigger, Better Pictures](#)

SPACE, AVIATION, MILITARY

- [96 Now: 'Hands Off' Landings on a Carrier](#)

NEXT MONTH IN POPULAR MECHANICS

Build a 3-Bedroom, 2-Bath Airconditioned House for \$7500. An Indiana family did!
How to Buy the Right Oil for the Way You Drive. A complete guide.
'Read' Your Tires for Wear. Saturday Mechanic shows how tires reveal car faults.
How to Winterize a Camper. One of several features to get you ready for winter.

ROBERT P. CROSSLEY

Editor

JAMES M. LISTON
Executive Editor

JOHN A. LINKLETTER
Managing Editor

WAYNE C. LECKEY
Home and Shop
Editor

SHELDON M. GALLAGER
Assistant Executive
Editor

THOMAS G. DAUER
Art Director

Published by The Hearst Corporation
RICHARD E. BERLIN, PRESIDENT

RICHARD E. DEEMS
President, Magazines Division

JOSEPH F. KERN
Publisher

WILLIAM KILPATRICK _____ Automotive
JOHN F. PEARSON _____ Science
GEORGE W. REIGER _____ Boating and Outdoors
SHELDON GALLAGER _____ Electronics and Photography
BILL HARTFORD _____ Technical Automotive
HARRY WICKS _____ Home Workshop
GARRY WINTER _____ Copy and Production
RICHARD H. FUNK _____ Associate Copy and Production
JOHN ADKINS _____ Assistant Copy and Production
ALVIN KIETZ _____ Assistant Art Director
DON EVANS _____ Assistant Art Director
FRED A. LEERS _____ Assistant Art Director
GEORGE W. BLOW _____ Technical Art Director
CLIFFORD B. HICKS _____ Special Projects
SOPHIE GRONOWICZ _____ Director, Bureau of Information
EVERETT JOHNSON _____ Cabinetmaker

ADDRESS ALL EDITORIAL COMMUNICATIONS TO: 575 Lexington Ave., New York, N.Y. 10022. For additional sources of information on the articles and products in this issue, write to Bureau of Information, Popular Mechanics, for free "Where-to-Find-It" list.

DANIEL J. COLEMAN
Director of Advertising

ADVERTISING OFFICES: New York: 575 Lexington Ave., Murray Hill 8-8500; Chicago: 520 N. Michigan Ave., 527-2400; Detroit: General Motors Bldg., TRinity 5-8711; Cleveland: 20310 Chagrin Blvd., Shaker Heights, 283-7788; Los Angeles: 601 North Vermont Ave., 666-6263.

SUBSCRIPTION SERVICE: Mail all subscription orders, changes of address, correspondence concerning subscriptions, and Postmaster notices of undeliverable copies to Popular Mechanics, Box 646, New York, N.Y. 10019. Please enclose your latest address label for quickest service when writing about your subscription.

POPULAR MECHANICS IS PUBLISHED MONTHLY by The Hearst Corporation, 57th St. at 8th Ave., New York, N.Y. 10019, U.S.A. Richard E. Berlin, President; George Hearst, V-Pres.; Richard E. Deems, President of Magazines; John R. Miller, Executive V-Pres. of Magazines; Raymond J. Petersen, Senior V-Pres. of Magazines; William S. Campbell, V-Pres. of Magazines; Albert A. Rachol, V-Pres. and Director of Circulation; Joseph F. Kern, V-Pres. for Popular Mechanics; Frank Massi, Executive V-Pres. and Treasurer; Harvey L. Lipton, Secy. Single copy in the United States and Canada, 50 cents. Subscription prices: United States and Possessions, \$4.00 for one year; \$7.00 for two years; \$10.00 for three years. Canada, add \$0.75 for each year. Pan American Postal Union countries, add \$1.00 for each year. All other countries, add \$2.00 for each year. When changing address, give old address as well as the new, with postal-zone number, if any, and allow six weeks for change to become effective. Second-class postage paid at New York, N.Y., and at additional mailing offices. Authorized as second-class mail by the Post Office Department, Ottawa, and for payment of postage in cash. Registered as second-class matter at the Post Office at Mexico D.F., Mexico, June 20, 1950. © 1969 by The Hearst Corporation. All rights reserved. Printed in U.S.A.

OCTOBER 1969

86 Proof Early Times Distillery Co., Louisville, Ky. ©1968



let's make it

Make yourself the greatest home bartender in town. Just send \$3.50 to Early Times Glass Offer*—P. O. Box 1080, Louisville, Kentucky 40201. We'll send you a set of 6 Giant 15 oz. Early Times Jiggers. Or send \$3.00, for a set of 8 Early Times 10½ oz. Highball Glasses. They're beautiful, so get both sets while they last. Do it now.

*offer valid only where legal

THE TRUE OLD-STYLE KENTUCKY BOURBON

5



Revelation hasn't changed since Gramps helped make "The Perils of Pauline."

Revelation's not made of sugar and spice, boys. Just tobacco: 5 great tobaccos. Revelation's for the experienced pipe smoker.



A quality product of Philip Morris U.S.A.

LETTERS

TO THE EDITOR

Versus Maverick

In Bill Kilpatrick's article, *Maverick Versus the Mob* (page 73, Aug. PM), Ford's Maverick is seen as posing very little threat to the economy imports because it lacks their *uniqueness*.

As a happy Volkswagen owner, I've been following Detroit's concern and breast-beating over import sales with amusement. What most American cars lack tragically and what cars such as Volkswagen enjoy in abundance is quality of workmanship. Economy, price, maneuverability—these are all icing on the cake.

Workmanship is not a luxury. It is an essential mark of quality merchandise.
CLIFTON, N.J. REV. JOHN MAIORANA

You stated: "Maverick offers more room, more power, a bigger trunk . . ." I'm sure that if you'd look again, you'd find that the Renault 10 has a bigger trunk than the Maverick, more front headroom and more front-seat legroom. As for Maverick's higher power—seems to me buying a more powerful car defeats the purpose of buying economy.

5TH SPECIAL FORCES SGT. D. K. KRETZINGER
VIETNAM.

Cannon builder

I have just completed the scale model of the 24-pounder from the main battery of the U.S. frigate *Constitution* (*Model This 24-Pounder*, page 134, Feb. PM). I found this a challenging project.

I thoroughly enjoy reading your maga-

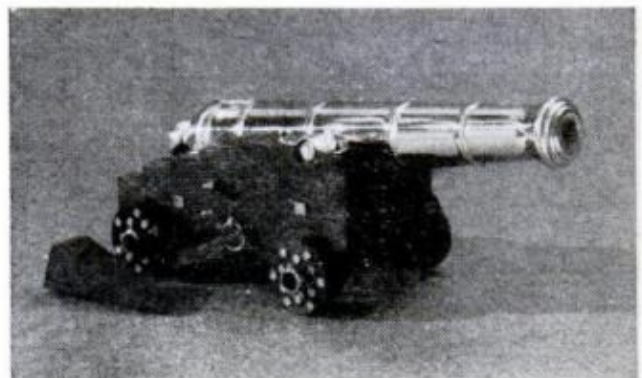

zine and think it is a tremendous inspiration to die-hard model builders.

OTTAWA, ONT. JOHN F. BRYDGES

No bars in Fort Worth, either

In *Zoo With Invisible Bars* (page 111, Aug. PM), you stated that in the Antwerp
(Please turn to page 8)

Are you still working for peanuts while others are making it big?

Why put up with a dead-end job and low pay while other men forge ahead to exciting promotions and big incomes?

There are more key positions waiting around today than there are people to fill them. Do you know how easily you can train for one of these positions? You can do it without giving up your present job, or going back to class.

LaSalle training at home will give you the specialized skills that lead to the best-paid positions in the business world. So that you'll have enough money for the good things in life—and plenty left over for your savings account.

Many LaSalle graduates report increases of two and three times

their former salaries. Frequently students report big increases during the first year of training. You can do the same.

LaSalle has been an acknowledged leader in home study for over 60 years. More than 2,000,000 ambitious men and women have enrolled in its many courses. Your

training is in experienced hands. Your LaSalle diploma is a credential you can be proud of.

Check the subject you are interested in—then send the coupon below for FREE booklet. No obligation, of course. Mail to LaSalle, 417 S. Dearborn Street, Chicago, Illinois 60605.



© 1969 LaSalle Extension University

LA SALLE EXTENSION UNIVERSITY

A Correspondence Institution • 417 S. Dearborn Street, Dept. 94-134, Chicago, Illinois 60605

Please send me, without cost or obligation, FREE booklet and full information on the field I have checked below:

ACCOUNTING

- Complete Accounting
- Income Tax
- Accounting Fundamentals
- CPA Training
- Modern Bookkeeping

BUSINESS MANAGEMENT

- Complete Business Management
- Credit and Collections
- Office Management
- Personnel Management
- Sales Management

REAL ESTATE

- Complete Real Estate
- Real Estate Brokerage
- Real Estate Management

Interested in a career not listed? Write here: _____

COMPUTER PROGRAMMING

- Complete Training

LAW COURSES

- Bachelor of Laws Degree
- Business Law
- Insurance Law
- Claim Adjusting Law
- Law for Police Officers

STENOTYPE

- Machine Shorthand

TECHNICAL COURSES

- Air Conditioning, Refrigeration, Heating
- Diesel

TRAFFIC & TRANSPORTATION

- Complete Traffic Mgt. Truck, Air, Rail, Sea

DRAFTING

- Complete Drafting

INTERIOR DECORATION

- Professional Training

ART TRAINING

- Commercial Art
- Oil, Water Color Painting
- Complete Training

Mr.

Mrs.

Miss

HIGH SCHOOL

- High School Diploma

LANGUAGE INSTRUCTION

- French German
- Spanish Italian
- Other _____

HOTEL/MOTEL MANAGEMENT

- Executive Training

CAREERS FOR WOMEN

- Accounting
- Bookkeeping
- Commercial Art
- Computer Programming
- Dental Assistant
- Hotel/Motel Mgmt.
- Interior Decorator
- Real Estate
- Secretarial
- Stenotype

..... Age.....

(Circle title and please print)

Address..... Apt.No.....

City & State..... Zip No.....

Winegard announces everything you need to make color tv sharp and clear!

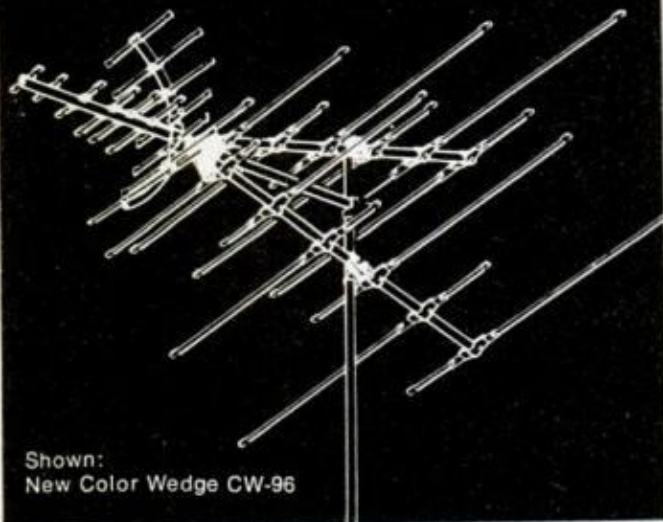

Shown:
New Color Wedge CW-96

Maybe all you need is a special made-for-color Winegard antenna. Like, say, one of our totally new Color Wedge models.

As you can see, the Color Wedge looks different than other antennas. It has a new electronic design that makes it work better on all channels. And it has a new mechanical design that makes it last years longer regardless of rain, ice, high winds and the like.

The unique "wedge" design provides greatly increased vertical capture area in a much shorter, more compact antenna. This means your TV set receives increased signal for sharper, clearer color reception. Even on those weak, hard-to-get channels. And it means that ghosts, snow and other TV interferences are drastically reduced or eliminated.

New truss construction makes Winegard Color Wedge the strongest antenna around. It's permanently weather-protected by the genuine gold anodized finish. Just like the TV wire connections are protected by the exclusive built-in cartridge housing.

In addition, Winegard supplies fine quality antenna mounts, TV cable, and everything you need for a convenient, plug-in home TV antenna system.

For sharpest, clearest TV—no matter what kind of set you own—see your Winegard dealer. Or write for our giant new catalog. It's free!

Solid state
home TV
system
amplifier.



 **Winegard**
ANTENNA SYSTEMS

WINEGARD COMPANY • 3020-4 KIRKWOOD STREET
BURLINGTON, IOWA 52601

LETTERS

(Continued from page 6)

Zoo, birds stay in their unbarred cages because the area outside, where the visitors stand, is dark, and the birds won't leave their lighted cages.

There is the very same type of cage at the Forest Park Zoo in Fort Worth, but in a larger display. It has been here for several years.

FORT WORTH, TEX.

KENT RAY

His cup of tea

I have sailed my version of the *Teacup* (*A Basic-Basic Sailboat*, page 146, Jan. 1966 PM) on Jackson Lake, Wyo., on lakes here and across San Francisco Bay and have never turned it over.

I used the recommended sail and added a jib. I intend to purchase a larger main later on. I used a different seating ar-

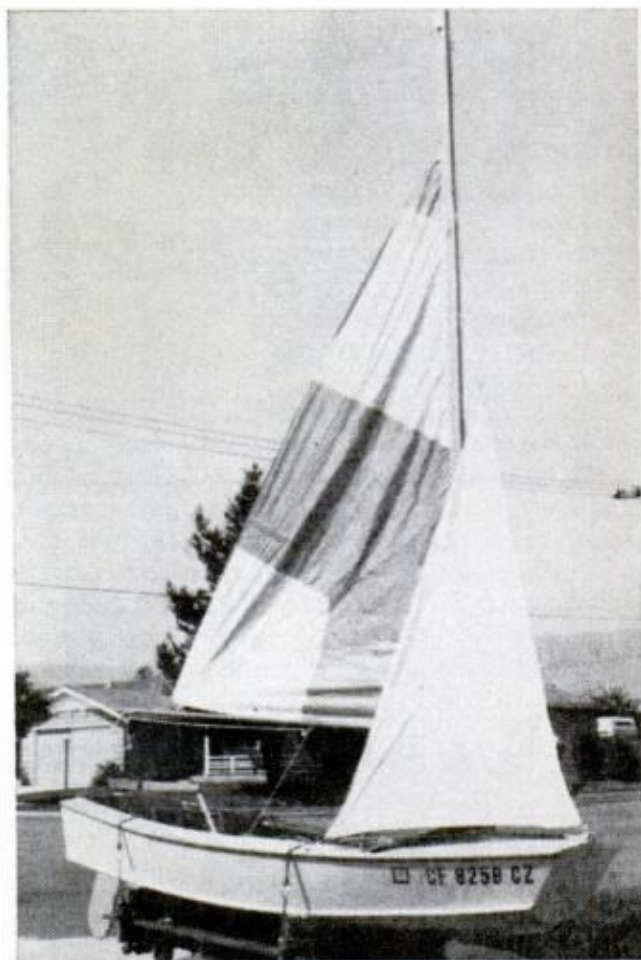

angement than you showed, made the stem and stern of double thickness, added more bracing and fiberglassed the hull.

SUNNYVALE, CALIF. KENNETH S. FERRIN

Outboard tune-up

In your Outboard Service Guide No. 2: *How to Check Out Your Starting System* (page 132, Aug. PM) you show that special tools are needed to insert the spring in the

(Please turn to page 10)

Krylon spray chart: something to keep at your fingertips.

Krylon® Spray	Description	Uses
Decorator Spray Paints	sprays on evenly; baked-enamel finish; contains Rust Magic®; comes in over 45 colors.	can be used indoors or outdoors. On wood. Rust Magic makes it especially good for metal.
High-Heat Resistant Spray Paint	withstands temperatures up to 1200°F; comes in 4 colors: Aluminum, Black, White, Red.	for painting anything exposed to high heat—steam pipes, boilers, furnaces, ovens, radiators, motors, etc. Also can be used on barbecues.
Car Colors	special formula for auto body painting; comes in wide variety of standard auto colors.	for touch-up work on scratches, covers larger areas after collision repair too. Also good for small home decorating jobs where the wide variety of car colors is desirable.
Automotive Trunk Paint	long lasting and scuff-resistant; covers scratches, scars, soil; gray/white spatter finish.	makes trunk interiors factory-fresh.
Engine Spray Paint	heat and oil resistant; prevents rust; comes in 12 colors.	for refinishing engines and transmissions; also good on steam pipes, radiators, boilers, etc.
All-Purpose Primer	sprays on smoothly to hard finish; may be topcoated with or without sanding; can be covered with almost any finish; colors: white or gray.	a primer for plastics, ceramics, metals, rivets and bolts. Also good on wood.
Rust Magic Metal Primer	penetrates to prevent further rust corrosion; flexible—permits expansion and contraction of metal; recoatable with most finishes.	for general indoor or outdoor use.
Zinc Chromate Primer	hard finish; inhibits rust; can be topcoated with or without sanding; colors: yellow, green.	best for outdoor structural or ornamental work—for galvanized and other white metal surfaces.
Hot Rod Primer	special formula automotive primer; hard, smooth finish is lacquer resistant; can be covered with almost any finish.	best for automotive refinishing; can be used as regular auto body undercoater; also good on sheet metal and cast-iron surfaces, on wood, plastic, ceramic or masonry.
Auto Body Undercoater	tough coating resists rust, road salts, alkali, acids; won't chip or crack; deadens sound.	also good for sealing rain gutters and roof cracks.
Crystal-Clear	a non-yellowing acrylic spray coating; long-lasting; water-resistant; won't crack or dry; high dielectric strength.	electronics: keeps lead-in connections tight; prevents corona in high-voltage sections. general use: protects blue-prints, drawings, etc. Also prevents tarnishing of brass, copper and other metals.



Free. A guide to gluing, taping and spray painting. Mail a stamped, self-addressed envelope to: Borden Inc./Chemical Division, Dept. B-2, 350 Madison Ave., N.Y., N.Y. 10017.





The Death Valley Test.

Some of the guys at our advertising agency wanted to find out for themselves if our *Better Pouch* is as good as we say. So they buried one—in the middle of the desert. Then five months later they dug it up. And smoked the still-fresh pipe tobacco inside! How did it stay fresh so long? The pouch is sealed. Air-tight. Nothing gets in or out. But don't you take our word for it either. Get a FREE pouch of Kentucky Club Mixture and see for yourself. Just send us the coupon, and an empty pouch of what you're now smoking (any brand but ours). And get a fresh start with our *Better Pouch*.

FREE OFFER TO PIPE SMOKERS

Mail to: Fresh Tobacco, Box H
Wheeling, W. Va. 26003

Gentlemen: Here's my ordinary pouch. Now I'd like to try a full-size package of Kentucky Club Mixture with that sealed-in freshness you promise.

Name _____

Address _____

City _____

State _____ Zip _____



Offer good in U.S.A. only, and expires January 31, 1970. Sorry, only one to a customer.

LETTERS

(Continued from page 8)

housing on manual starters. Actually, it is far easier to put the hook of the spring on the pin of the housing and wind it in the housing. Then bend the spring slightly to allow the pulley to go in. It is then simple to rewind the pulley to the necessary tension.

BROOKLYN, N.Y.

BRUCE CAVANAGH

After reading *Outboard Service Guide No. 1: How to Check Out Your Ignition System* (page 138, July PM), my advice to readers is to scrap the outboard causing the trouble and buy a brand-new one. Why?

Well, Henry Notrom advises the purchase of a \$15 flywheel puller and a \$120 magneto analyzer. When you get your old motor all tuned up, you scrap the equipment purchased to tune it up and what have you got?

WATERBURY, CONN.

JAMES B. WALKER

Well, you've got a motor that's running again plus equipment to tune it up the next time (why scrap it?). You've also got an idea that it will cost some money to do the job right.

Brush Buggy builder

Here's a picture of the Brush Buggy (*Build a Brush Buggy*, page 132, Nov. '68

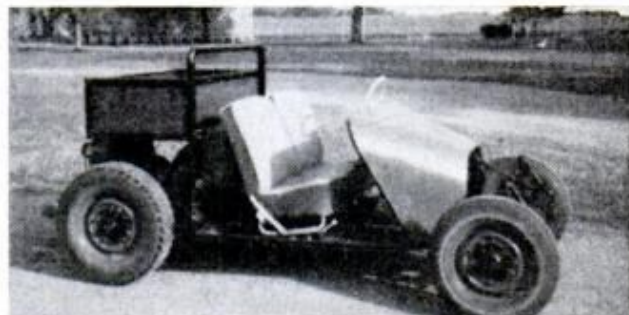

PM) I built with the help of my dad. It was a lot of fun making it, and its performance is something else! Thanks for a fine magazine; keep the great articles coming. SILVER LAKE, MINN.

JOHN MALLAK

Any other readers who yearn to zoom off into the brush—and who don't have the November issue on hand—can order Xerox copies of the Buggy article for \$1.20. (Or the cannon on page 6 for \$1.40 and the sailboat on page 8 for \$1.80.) In fact, we'll Xerox any past article for 20 cents a page.

PM also has lots of books and large-size plans for projects; we'll send a catalog of them for 25 cents for handling and mailing.

Order from: Bureau of Information, Popular Mechanics, 575 Lexington Ave., New York, N.Y. 10022. ★★

100%

more mileage on this new Atlas tire.

**Proven against complete sets
of two-ply tires that came on
most '69 cars.**

Results of these tests against two-ply original equipment tires for most 1969 cars showed that you'll get twice the mileage with the new Atlas Plycron 2 plus 2*.

Polyester/Fiberglass Construction

This rugged "tread-saver" construction helps reduce scuff and squirm. Just one of the many reasons why the tread lasts and lasts — twice as long.

Extra resistance to cuts and punctures

Our combination of fiberglass belts and blended chlorobutyl liner gives you extra resistance to cuts and punctures. See your Atlas dealer soon. And get 100% more mileage on the new Atlas Plycron 2 plus 2.

ATLAS PLYCRON 2 plus 2

Atlas Tires • Batteries • Accessories
Sold at over 50,000 leading service stations.



Trademarks "Atlas," "Plycron,"
Reg. U.S. Pat. Off.
*Trademark
© 1969 Atlas Supply Company

“With a 16-to-1 ratio, the pressure on the pistons is enough to shatter bricks. We’re tough on spark plugs.”

Clint Brawner and Jim McGee were co-chief mechanics for Mario Andretti’s record-busting 1969 Indy 500 championship car. When these experts talk, it pays to listen.

“The heat and compression in our turbocharged Ford engine is tremendous,” says Clint Brawner. **“Our Autolite plugs have to survive 37,000**

brick-busting ignitions a minute. Yet I’ve never seen one fail.”

Autolite spark plugs have a special hermetic seal that prevents compression loss under all operating conditions. They stay sealed despite extremes in heat and pressure.

“Racing may be hell on spark plugs. But you’re tougher,” says:



Co-chief mechanics Jim McGee, left, and Clint Brawner beside Mario Andretti’s turbocharged Ford 1969 Indy winner.

Autolite plugs in our Indy winner was enough But you're tougher on yours."

Jim McGee. "When you crawl in traffic, ash deposits build up in the cylinders. Then you speed up, and those deposits splash around and heat bakes them onto the plug tips. You get shorts. Lose power. Waste gas."

With Autolite, no problem. Autolite originated spark plugs that clean

themselves. Their extended Power Tips reach down into the hottest engine gasses. Fouling deposits are burned off before they get a chance to build up.

"You got clean plugs, buddy, you got max power."

Next time ask for Autolite spark plugs. They pass the toughest test in racing. And the toughest test there is. Your kind of driving.



Autolite 



We pass the toughest test.

EARN BIG MONEY IN AIR CONDITIONING REFRIGERATION & HEATING

25 KITS SENT TO BUILD THIS
COMPLETE REFRIGERATION SYSTEM

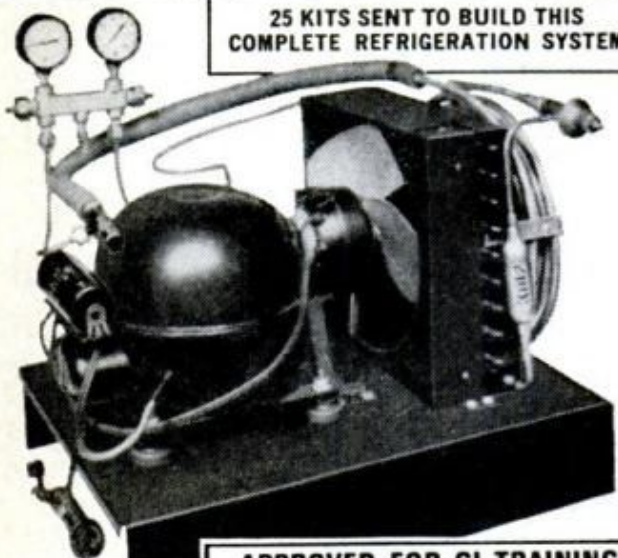

APPROVED FOR GI TRAINING

If you served since January 31, 1955 or are
in service, check GI line in coupon

A better job, top pay and steady work are easily within your reach. Learn to repair and install air conditioning systems, refrigerators and freezers. Air conditioning is one of America's fastest-growing industries. Millions of autos and homes are being air-conditioned. The need for trained men is immediate and great.

Make Home Your Training Center—Learn by practicing. CTI sends 25 kits of tools and parts to build a complete refrigeration system—which you later convert into a refrigerator or freezer. The course is easy!

Earn Money As You Train—Since the CTI course includes training with real equipment, many students earn money repairing units soon after enrolling. On completing training they go into top pay jobs. Many get started in their own business.

Mail Coupon Today for FREE book. No obligation. Prove to yourself that the air conditioning, refrigeration and heating field is best for you—the easiest training to master and loaded with top pay opportunities.

Commercial Trades Institute, Chicago, Ill. 60626

COMMERCIAL TRADES INSTITUTE
1400 Greenleaf Avenue
Chicago, Illinois 60626 Dept. PM-1069



Send book, Be a Success in Air Conditioning,
Refrigeration & Heating. No obligation.

Name _____ Age _____

Address _____ Zip _____

City _____ County _____ State _____

Check for facts on GI Bill

Accredited Member National Home Study Council

New Starcraft Coach



THERE IS A DEFINITE TREND toward fiberglass in RV housing. Starcraft is the most recent company to announce production of a luxury liner molded from this material. Still being tested and refined at the Goshen, Ind., headquarters, the Starcraft 19-foot motor coach comes equipped with wall-to-wall carpeting, wood-grain cabinetry and wardrobe, gas-electric refrigerator, range and oven, all-fiberglass-molded marine head with shower and dinette seats which can be faced forward for traveling or folded down for a double bed. The gaucho can also be converted into a second double bed. The base price of \$9995 does not include such comfort options as airconditioning and an AM-FM stereo with tape deck. ★★★



START YOUR NEW CAREER NOW! WITHOUT OVERHEAD! ANY PLACE! ANY AGE!

UPHOLSTERING JUST ONE

you don't even have to quit your present job!!!

CHAIR can pay you as much as your present weekly paycheck!

Start learning now. At home, or in the garage, in your spare time — no outside classes to attend. If you can tie a knot and drive a tack, you can learn this business, quickly, easily. You start learning the basics right away through the proven MUI Home Training Plan. And before you're barely into it, you can start doing the simple upholstery jobs that are all around you waiting to be done. Chairs, cushions, seats, footstools. Even before MUI students finish their training, people start bringing upholstery jobs to them, and remember—the world is full of furniture that needs fixing and re-upholstering and more is wearing out all the time!



"What started as a hobby, now pays me \$10 an hour"

Yes, many MUI graduates make better than \$10 an hour turning old wornout furniture into bright new decorator pieces! **Stack it up against what you're doing now!** Are you making \$150 a week? \$200? \$250? Do you put in long hours of dull work, with small raises? Is that the way you want to spend the rest of your life? Just imagine, you can make \$150, \$200, \$250 upholstering just one chair or sofa these days! And if you're the kind of person who likes to work and earn, you can sometimes finish a job like this in a day. That's pay, ... and it beats what most college graduates make!

AS YOU LEARN, YOU JUST SLIP INTO THE IMMENSE FLOW OF UPHOLSTERY WORK!

Think of all there is! . . . Sofas, lounging chairs finished in beautiful fabrics, which MUI tells you how to get at the right price — even leather and all the new vinyls. And then you have built-ins and breakfast nooks, boats, trailers and all the millions of automobiles in America. Yes, you learn all this and more! When we finish teaching you, (in your own home in your spare time) and when you get our California state approved diploma, you know this business . . . as a real professional! You will then have one of the most fantastic moneymaking skills in America built into your head and hands! No one can ever take this skill away from you . . . and no one can ever fire you, because you're the boss of a business that you can take with you . . . You can make big money from then on . . . any time, anyplace you want to put out your shingle!

When you read the papers you see there's a strike here, a lockout there. Detroit lays off 150,000 men. A plant is shut down and moved out of state. A new automated machine eliminates 5,000 jobs. They talk about dislocated workers and try to do something about it. What pays the bills if you get caught up in one of these situations? When you know upholstering, life gets very simple and lots of fun. It's simple because where there are people, there are upholstery jobs and lots of them. It's fun because life is fun when the bills are paid and there's money in the bank, even enough to buy those things you've always wanted for yourself.

MUI IS APPROVED BY THE CALIFORNIA SUPER-INTENDENT OF PUBLIC INSTRUCTION AND IS AUTHORIZED TO ISSUE A DIPLOMA IN UPHOLSTERY.

MODERN UPHOLSTERY INSTITUTE
Box 899-CDT, Orange, Calif. 92669



YOU GET SIX BIG FURNITURE KITS FREE



YOU GET THIS AUTHORIZED DIPLOMA WHEN YOU GRADUATE



WORK THE HOURS YOU LIKE TO WORK!

If you favor a regular 35 hours a week, upholstery lets you do it and make a really fine living. On the other hand, if you're really ambitious and want to work 60 or 70 hours a week, you are starting to talk about some big, big money! The important thing is that the choice is yours, not somebody else's! (Not like when you're working for someone else.) Many students of retirement age just do a few pieces now and then just to keep things nice and comfortable.

TO GET STARTED, JUST GET THE COUPON IN THE MAIL . . . TODAY!

It costs you nothing to get the information and there's no obligation. No salesman is going to call you. This much and this much only, every successful MUI graduate must do for himself — send the coupon today!

YOU'LL GET A BIG ILLUSTRATED 32 PAGE BOOK ON UPHOLSTERY

and the upholstery business, and an actual free sample lesson showing how the fabulously successful MUI system is taught. For your sake and the sake of your future, do it now. Cut out the coupon, fill it out, put it in an envelope and mail it now. Air mail reaches MUI about two days sooner!

ALL THE SPECIAL "TOOLS OF THE TRADE" ARE YOURS . . . FREE

THIS FREE UPHOLSTERY BOOK may be the most important information you ever read.

MAIL COUPON NOW!

MODERN UPHOLSTERY INSTITUTE, Box 899-CDT Orange, Calif. 92669

Please send the FREE UPHOLSTERY CAREER BOOK, the FREE SAMPLE LESSON. I understand I am under no obligation whatever and am just sending for the free facts on job and career opportunities in Upholstering and the MUI home training program. I understand that no salesman will call.



APPROVED FOR VETERANS

Name _____ Age _____
Address _____
City _____ State _____ Zip _____



I'd like to give this to my fellow men... while I am still able to help!

I was young once, as you may be—today I am older. Not too old to enjoy the fruits of my work, but older in the sense of being wiser. And once I was poor, desperately poor. Today almost any man can stretch his income to make ends meet. Today, there are few who hunger for bread and shelter. But in my youth I knew the pinch of poverty; the emptiness of hunger; the cold stare of the creditor who would not take excuses for money. Today, all that is past. And behind my city house, my

summer home, my Cadillacs, my winter-long vacations and my sense of independence—behind all the wealth of cash and deep inner satisfaction that I enjoy—there is one simple secret. It is this secret that I would like to impart to you. If you are satisfied with a humdrum life of service to another master, turn this page now—read no more. If you are interested in a fuller life, free from bosses, free from worries, free from fears, read further. This message may be meant for you.

By Victor B. Mason

I am printing my message in a magazine. It may come to the attention of thousands of eyes. But of all those thousands, only a few will have the vision to understand. Many may read; but of a thousand only you may have the intuition, the sensitivity, to understand that what I am writing may be intended for you—may be the tide that shapes your destiny, which, taken at the crest, carries you to levels of independence beyond the dreams of avarice.

Don't misunderstand me. There is no mysticism in this. I am not speaking of occult things, of innumerable laws of nature that will sweep you to success without effort on your part. That sort of talk is *rubbish!* And anyone who tries to tell you that you can *think* your way to riches without effort is a false friend. I am too much of a realist for that. And I hope you are.

I hope you are the kind of man—if you have read this far—who knows that anything worthwhile has to be *earned!* I hope you have learned that there is no reward without effort. If you have learned this, then you may be ready to take the next step in the development of your karma—you may be ready to learn and use the secret I have to impart.

I Have All The Money I Need

In my own life I have gone beyond the need of money. I have it. I have gone beyond the need of gain. I have two businesses that pay me an income well above any amount I have need for. And, in addition, I have the satisfaction—the deep satisfaction—of knowing that I have put more than three hundred other men in businesses of their own. Since I have no need for money, the greatest satisfaction I get from life is sharing my secret of personal independence with others—seeing them achieve the same heights of happiness that have come into my own life.

Please don't misunderstand this statement. I am not a philanthropist. I believe that charity is something that no proud man will accept. I have never seen a man who was worth his salt who would accept something for nothing. I have never met a highly successful man whom the world respected who did not sacrifice something to

gain his position. And, unless you are willing to make at least half the effort, I'm not interested in giving you a "leg up" to the achievement of your goal. Frankly, I'm going to charge you something for the secret I give you. Not a lot—but enough to make me believe that you are a little above the fellows who merely "wish" for success and are not willing to sacrifice something to get it.

A Fascinating and Peculiar Business

I have a business that is peculiar—one of my businesses. The unusual thing about it is that it is needed in every little community throughout this country. But it is a business that will never be invaded by the "big fellows." It has to be handled on a local basis. No giant octopus can ever gobble up the whole thing. No big combine is ever going to destroy it. It is essentially a "one man" business that can be operated without outside help. It is a business that is good summer and winter. It is a business that is growing each year. And, it is a business that can be started on an investment so small that it is within the reach of anyone who has a television set. But it has nothing to do with television.

This business has another peculiarity. It can be started at home in spare time. No risk to present job. No risk to present income. And no need to let anyone else know you are "on your own." It can be run as a spare time business for extra money. Or, as it grows to the point where it is paying more than your present salary, it can be expanded into a full time business—overnight. It can give you a sense of personal independence that will free you forever from the fear of lay-off, loss of job, depressions, or economic reverses.

Are You Mechanically Inclined?

While the operation of this business is partly automatic, it won't run itself. If you are to use it as a stepping stone to independence, you must be able to work with your hands, use such tools as hammer and screw driver, and enjoy getting into a pair of blue jeans and rolling up your sleeves. But two hours a day of manual work will keep your "factory" running 24 hours turning out a product that has a steady and

ready sale in every community. A half dollar spent for raw materials can bring you six dollars in cash—six times a day.

In this message I'm not going to try to tell you the entire story. There is not enough space on this page. And, I am not going to ask you to spend a penny now to learn the secret. I'll send you all the information, free. If you are interested in becoming independent, in becoming your own boss, in knowing the sweet fruits of success as I know them, send me your name. That's all. Just your name. I won't ask you for a penny. I'll send you all the information about one of the most fascinating businesses you can imagine. With these facts, you will make your own investigation. You will check up on conditions in your neighborhood. You will weigh and analyze the whole proposition. Then, and then only, if you decide to take the next step, I'll allow you to invest \$15.00. And even then, if you decide that your fifteen dollars has been badly invested I'll return it to you. Don't hesitate to send your name. I have no salesmen. I will merely write you a long letter and send you complete facts about the business I have found to be so successful. After that, you make the decisions.

Does Happiness Hang on Your Decision?

Don't put this off. It may be a coincidence that you are reading these words right now. Or, it may be a matter that is more deeply connected with your destiny than either of us can say. There is only one thing certain: If you have read this far you are interested in the kind of independence I enjoy. And if that is true, then you must take the next step. No coupon on this advertisement. If you don't think enough of your future happiness and prosperity to write your name on a postcard and mail it to me, forget the whole thing. But if you think there is a destiny that shapes men's lives, send your name now. What I send you may convince you of the truth of this proverb. And what I send you will not cost a penny, now or at any other time.

VICTOR B. MASON
1512 Jarvis Ave., Suite M-2-LS
CHICAGO, ILLINOIS 60626

Take command of your future...now!

Choose the job you want from 266 ICS Courses

Dozens of new careers are open to you with ICS training. Oldest, largest correspondence institution. 8,000,000 students since 1890. Learn facts, theories, practical applications. Instructors guide

you, answer your questions. Texts, written by authorities, are yours to keep. Famed ICS diploma to graduates. Convenient payment plan. Send our coupon for three FREE booklets.

ACCOUNTING

Accounting (U.S.A.)
Accounting (Canadian)
Accounting for Business Programmers
Accounting for Man'g'm't Decisions
Auditing
Business Law (U.S.A.)
Canadian Business Courses
Cost Accounting
CPA Review (U.S.A.)
General Accounting
Income Tax (U.S.A.)
Industrial Accounting
Junior Accounting
Office Accounting
Practical Accounting
Public Accounting
Small Business
Accounting (U.S.A.)
Starting and Managing a Small Bookkeeping Service (U.S.A.)

ARCHITECTURE AND BUILDING

Architectural Drawing and Designing
Architecture
Building Contractor
Building Estimator
Building Inspector
Building Maintenance
Carpenter-Building
Carpentry and Millwork
Fundamentals of Urban Planning
House Planning and Interior Design
Mason
Painting Contractor
Reading Arch. Blueprints
Review in Architectural Design and Practice
Review of Mechanical Systems in Buildings

ART

Amateur Artist
Commercial Art
Commercial Cartooning
Illustrating with Options:
—Magazine
—Advertising Layout and Illustration
Interior Decorating
Oil Painting for Pleasure
Show Card and Sign Prod.
Show Card Writing
Sign Painting & Designing
Sketching and Painting

AUTOMOTIVE

Automatic Trans. Spec.

Automobile Air Conditioning Specialist
Automobile Body Rebuilding & Refinishing
Automobile Engine Tune-Up
Automobile Mechanic
Automobile Technician
Diesel-Gas Motor Vehicle Engines

BUSINESS

Advertising
Business Administration
Business Practice (Cond.)
Canadian Business Course
Condensed Marketing
Direct Mail and Mail Order Advertising
Industrial Psychology
Inventory Control
Magazine & Newspaper Advertising
Managing a Retail Business
Managing a Small Store
Marketing Management
Marketing Research
Modern Exec. Management
Office Automation
Office Management
Production Management
Purchasing Agent
Retail & Local Advertising
Retail Bus. Management
Retail Merchandising
Retail Selling
Systems and Procedures Analysis

BUSINESS: SALES

Creative Salesmanship
Real Estate Salesmanship
Salesmanship
Sales Management

BUSINESS: SUPERVISION

Basic Supervision
Industrial Foremanship
Industrial Supervision
Management, Salesmanship and Sales
Modern Woman as a Supervisor
Personality Development
Personnel-Labor Relations (U.S.A.)
Supervision

CHEMICAL

Analytical Chemistry
Chemical Engineering
Chemical Laboratory Techn.
Chemical Process Equip. Design & Operation

Chemical Process Operator
Elements of Nuclear Energy
General Chemistry
Instrumental Laboratory Analysis

CIVIL ENGINEERING

Civil Engineering
Construction Eng'r'g Tech.
Highway Engineering Tech.
Principles of Surveying
Reading Highway Bl'pr'ts
Reading Structural Blueprints
Sanitary Engineering Tech.
Sewage Plant Operator
Structural Eng'r'g Tech.
Surveying and Mapping
Water Works Operator

COLLEGE COURSES

American History Economics
Calculus

COMPUTERS

COBOL Programming
Fortran Programming for Engineers
Programming for Digital Computers
Programming the IBM 1401 Computer
Programming the IBM System/360 Computer, Introduction

DRAFTING

Aircraft Drafting
Architectural Drafting
Design Drafting
Drafting Technology
Electrical Drafting
Electrical Eng'r'g Drafting
Electronic Drafting
Introductory Mech. Draft.
Mechanical Drafting
Pressure-Vessel and Tank Print Reading
Sheet Metal Layout for Air Conditioning
Structural Drafting

ELECTRICAL

Electrical Engineering
—Electronics Option
—Power Option
Electrical Appliance Ser. with Equipment Training
Electrical Contractor
Electrical Engineering Tech.
Electrical Home Maint.
Electrical Home Maint. with Equipment Training

APPROVED FOR VETERANS

Accredited member, National Home Study Council.
Convenient payment plan.
Special rates to members U.S. Armed Forces

Electrical Instrument Tech.
Electric Motor Repairman
Industrial Electrical Tech.
Power-Line Design and Construction
Power Plant Operator
—Hydro Option
—Steam Option
Practical Electrician
Practical Electrician with Equipment Training
Practical Lineman
Reading Elec. Blueprints

ENGINEERING (Refresher Courses for Graduate Engineers)

Chemical Civil Electrical
Industrial Mechanical
Sanitary Structural

ENGLISH AND WRITING

Better Business Writing
English for Spanish (U.S.A.)
Free Lance Writing for Fun and Profit
Introductory Tech. Writing
Modern Letter Writing
Practical English
Short Story Writing

HIGH SCHOOL

High School Business
High School (Canadian)
High School General
High School Mathematics
High School Secretarial
High School Vocational
High School College Preparatory—Arts
High School College Prep—Engineering and Science
Preparatory Course for High School Equivalency Test

MACHINE SHOP PRACTICE

Grinder Operator
Industrial Metallurgy
Lathe Operator

Machine Shop Inspection
Machine Shop Practice
Metallurgical Eng'r'g Tech.
Multicraft Maintenance Mechanic
Practical Millwrighting
Reading Shop Prints
Rigging
Tool & Die Making
Tool Engineering Tech.
Welding Engineering Tech.
Welding Process

MATHEMATICS

Advanced Mathematics
Math and Mechanics for Engineering Technicians
Math and Physics for Engineering Technicians

MECHANICAL

Mechanical Engineering
Aircraft and Power Plant Mechanic
Hydraulic and Pneumatic Power
Industrial Engineering
Industrial Eng'r'g Tech.
Industrial Instrumentation
Machine Design
Quality Control
Safety Engineering Tech.
Tool Design
Vibration Analysis and Control

PETROLEUM

Natural Gas Production and Transmission
Oil Well Technology
Petroleum Production
Petroleum Production Engineering Technology
Petroleum Refinery Oper.

PLASTICS

Design of Plastic Products
Plastics Technician

PLUMBING, HEATING AND AIR CONDITIONING

Air Conditioning
Air Conditioning Maint.
Domestic Heating with Gas and Oil
Heating
Heating & Air Conditioning with Drawing
Industrial Air Conditioning
Pipe Fitting Plumbing
Plumbing and Heating
Plumbing & Heating Est.
Practical Plumbing
Refrigeration and Air Conditioning Servicing

PULP AND PAPER

Paper Machine Operator
Paper Making Pulp Making
Pulp & Paper Eng'r'g Tech.

SECRETARIAL

Clerk-Typist Commercial Secretary, Engineering Sec'y, Legal Sec'y, Medical Secretary, Professional Shorthand Stenographic Typewriting

STEAM AND DIESEL POWER

Boiler Inspector
Industrial Building Eng'r
Power Plant Engineering
Stationary Diesel Engines
Stationary Fireman
Stationary Steam Eng'r'g

TEXTILES

Carding
Carding and Spinning
Dyeing and Finishing
Loom Fixing Spinning
Textile Mill Supervision
Textile Technology
Warping and Weaving

TRAFFIC

Motor Traffic Management
Traffic Management

TV-RADIO-ELECTRONICS

Color Television Principles and Servicing
Electronics Instrumentation and Servo Fundamentals
Electronics Technician
First Class Radio Telephone License
Fundamentals of Electronic Computers
General Electronics with Equipment Training
Hi-Fi Stereo and Sound System Servicing
Industrial Electronics Tech.
Numerical Control Electronics & Maint.
Practical Telephony
Principles of Semiconductor Radio & TV Servicing
Radio & TV Servicing with Equipment Training
Second Class Radio Telephone License
Sound Systems Specialist
Telephony, Electronics, and Radio Communications

ICS[®]

International
Correspondence
Schools
Division of Intext

ICS, Scranton, Pa. 18515

Canadian residents use this address for service from ICS Canadian, Ltd.
In Hawaii: P.O. Box 418, Honolulu.

TAKE YOUR FIRST STEP... MAIL THIS COUPON TODAY—ICS, SCRANTON, PA. 18515. N1569J

I'm interested in a program of independent study.
Send me, without cost, your booklet on the principles of success,
sample text demonstrating famous ICS method, and your catalog for _____
(Print name of course. See list.)

Miss _____
Mrs. _____
Mr. _____ Age _____

Address _____

City _____ State _____ Zip Code _____

Occupation _____ Employed by _____ Working Hours _____ A.M. to _____ P.M.

Science Worldwide

BY JOHN F. PEARSON

The deaf can "see" messages and the blind can "feel" them on the Code-Com, a new instrument developed by Bell Telephone Laboratories for people who are totally deaf, deaf and blind, or deaf and mute. The device, which connects with a conventional phone, converts messages into flashes of light and into vibrations that can be felt when the user puts his fingertips on a small disc. A sending key, worked like a telegraph key, permits mute users to send messages. Calls from conventional phones can be received if the caller talks in Morse code: "dit" for each dot, "dah" for each dash. After some practice with Morse code, handicapped users of the Code-Com were able to attain sending and receiving speeds of about 10 words per minute, according to Bell Laboratories. Field trials are still in progress.

Wallaba is "one of the most rot-resistant woods ever examined" at the U.S. Forest Products Laboratory, Madison, Wis. In the event you've never heard of it, wallaba comes from French Guiana. It was tested along with 14 other exotic species by researchers who were looking for woods that can provide long outdoor service where the decay hazard is high. The scientists also gave high ratings to ekki, a tropical African hardwood, and jarrah, an Australian hardwood. The rot evaluations are part of a program of determining the strength, machineability and other properties of foreign woods to establish those best suited for importation here.

Sound waves provide an assist in unloading powdery cargoes—grains, chalk, iron ore—from large containers. The usual unloading method is to blow the powders out with a powerful stream of compressed air. But this frequently creates the formation of powdery arches that have to be broken up, stalling the process. A Swedish company reports that sound waves, projected into the container, quickly knock down the troublesome arches.

Air pollution accounts for that beautiful blue haze associated with the Smoky Mountains in Tennessee and North Carolina. So says Dr. Paul Story, a professor of chemistry at the University of Georgia, who explains that pine trees are the cause. During growth, the pines exude volatile hydrocarbons that react in sunlight to form other substances. Many of these compounds mix with water droplets to create the small particles of matter that comprise the smoke of the Smokies.

A "spin off" of Apollo 11's success last July was the \$1000 reportedly won by Dr. Fred L. Whipple, director of the Smithsonian Astrophysical Observatory, Cambridge, Mass. In 1960 Dr. Whipple bet a Viennese physicist that before 1970 man would set foot on the moon and make a safe return to Earth. Dr. Whipple's interest in and enthusiasm for a moon-landing project predates his big bet by many years. In 1952 he contributed to a series of articles in *Collier's* telling how man could achieve such a feat. If you want to know how that '52 blueprint (drawn by Dr. Wernher von Braun and Willy Ley in addition to Dr. Whipple) stacks up against actuality in '69, read *The Dream Comes True* (page 80, July PM).

Creation of a new, tamperproof computer is the goal of a project at Case Western Reserve University, Cleveland. Such a computer is needed, according to Prof. Edward Glaser, project director, because more and more government secrets and data about private individuals are being stored in computers, which can possibly be "tapped" by unauthorized persons. The new computer will incorporate safeguards that signal if the machine has been tampered with. A key member of his design team, says Prof. Glaser, is another computer.

An instrument for spotting mineralized rocks on the sea floor is now being lab-tested by scientists of the U.S. Geological Survey. The "finder" is a pipelike cylinder that contains radioactive californium-252. Lowered into a tank of seawater, the finder irradiates rock samples, "exciting" minerals in the rocks. The minerals begin to emit gamma rays, which are analyzed and identified. Different minerals have different gamma "signatures." The finder, which could be used in prospecting, is slated for deep-sea tests in about a year. ★ ★ ★



DECORATIVE "3-D" STAR CHART

Quickly, easily locate stars in your sky—anytime, anywhere. Handsome 10" high Sky and Earth Globe has fixed transparent 7" diam. outer celestial sphere with equator calibrated in months. 4" diam. inner earth sphere (in relief) revolves on inclined axis—includes long. & lat. markings. Correlate location on earth globe with current month—outer globe shows stars visible in your sky. Incl: Free Star Finder, Atlas, Instr.

Stock No. 70,984H\$13.95 Ppd.

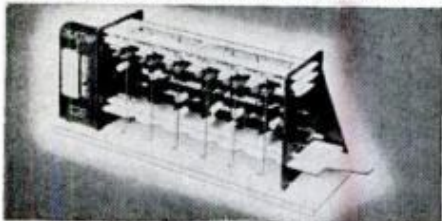

MODEL DIGITAL COMPUTER

Solve problems, teach logic, play games with miniature version of giant electronic brains! Adds, subtracts, multiplies, shifts, complements, carries, memorizes, counts, compares, sequences. Colored plastic parts easily assembled. 12" x 3 1/2" x 4 3/4". Incl. step-by-step assembly diagrams, 32-page instruction book covering operation, computer language (binary system) programming, problems and 15 experiments.

Stock No. 70,683H\$5.98 Ppd.

ANALOG COMPUTER KIT

Stock No. 70,341H\$18.95



"FISH" WITH A MAGNET

Now go treasure hunting on the bottom! Great idea! Fascinating fun and sometimes tremendously profitable! Tie a line to our 5-lb. Magnet—drop it overboard in bay, river, lake or ocean. Troll it along the bottom—your "treasure" haul can be outboard motors, anchors, fishing tackle, all kinds of metal valuables. 5-lb. Magnet is war surplus—Alnico V Type—Gov't cost \$50. Lifts over 150 lbs. on land—much greater weights under water.

Stock No. 70,571H... 5 lb. ..\$14.00 Ppd.

Stock No. 70,570H... 3 1/2 lb. ..\$ 8.75 Ppd.

Stock No. 70,572H... 7 1/2 lb. ..\$18.75 Ppd.

Stock No. 85,152H... 15 1/4 lb. ..\$33.50 FOB



AMER. MADE OPAQUE PROJECTOR

Projects illustrations up to 3" x 3 1/2"—enlarges them to 35" x 30" if screen is 6 1/2 ft. from projector, larger if screen farther away. No film or negatives needed. Projects charts, diagrams, color, black-and-white. 115 V A.C. Operates on 60 W bulb, not incl. 12" x 8" x 4 1/2". 1 lb. 2 ozs.

Stock No. 70,199H\$8.75 Ppd.



SUPER 6" SPACE CONQUEROR

Share the wonders of space exploration. Features aluminized & overcoated 6" f/8 ground and polished pyrex parabolic mirror accurate to 1/4 wave, 48 F.L. 6X achromatic finder scope, 4 eyepieces—48X Kellner, 1/2" 96X & 1/4" 192X Ramsdens, Barlow to double or triple power—rack & pinion focusing mount. 47 3/4" aluminum tube, Electric clock drive w/manual slow-motion control. Setting circles. Heavy-duty equatorial mount. Pedestal base. Compares to \$295—\$350 models.

Stock No. 85,086H\$239.50 FOB

4 1/4" REFLECTOR TELESCOPE

Stock No. 85,105H\$94.50 FOB

Stock No. 85,050H ...3"....\$29.95 Ppd.

KEEP PACE WITH THE SPACE AGE!

AMAZING BARGAINS

for Fun • Study • Profit
from
EDMUND SCIENTIFIC CO.
300 Edscorp Building
Barrington, N. J. 08007

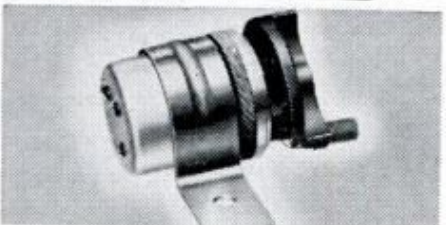

WAR SURPLUS ELECTRIC GENERATOR

Brand new Signal Corps Electric Generator. Generates up to 90 volts by turning crank. Use in high impedance relays. Charge ground and bring up night crawlers for bait or study. 2 Alnico Magnets alone worth more than original gov't cost of \$15. Wt. 2 lbs.

Stock No. 50,225H\$6.95 Ppd.

MOUNTED WITH LIGHT TO DEMONSTRATE ELECTRICITY

Stock No. 50,365H\$11.95 Ppd.

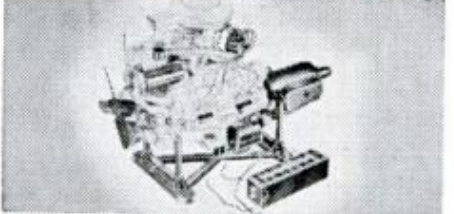

PLASTIC MODEL V-8 ENGINE

Hours of fun! Get thrill of building your own easily assembled engine from over 350 parts. Then push starter and watch it run. Crankshaft revolves, pistons move, valves open and close in sequence with spark plugs. Does everything but burn oil. 1/4 scale molded in 4 colors. Same motor used in many auto-mechanic courses. Excellent, easy-to-understand "tech manual".

Stock No. 70,448H\$12.95 Ppd.

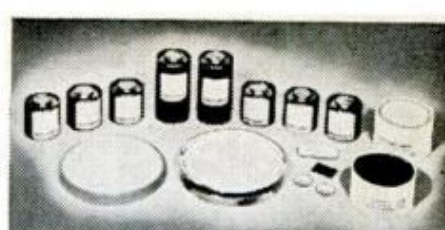

ASTRONOMICAL TELESCOPE KITS

Grind your own mirror for powerful telescope. Kit contains fine annealed pyrex mirror blank, tool, abrasives, diagonal mirror, and eyepiece lenses. You build instruments valued from \$75.00 up.

Stock No.	Diam.	Thickness	Price
70,003H	4 1/4"	3/4"	\$9.75 Ppd.
70,004H	6"	1"	12.95 Ppd.
70,005H	8"	1 3/8"	21.00 Ppd.
70,006H	10"	1 3/4"	34.25 FOB
70,007H	12 1/2"	2 1/8"	65.85 FOB



GIANT WEATHER BALLOONS

"Balls of fun" for kids, traffic stoppers for stores, terrific for amateur meteorologists. Create a neighborhood sensation. Great backyard fun. Exciting beach attraction. Amateur meteorologists use to measure cloud heights, wind speed and temp. Heavy duty neoprene. Inflate with vacuum cleaner or auto air hose; or locally available helium for high rise.

Stock No. 60,568H....8'.....\$2.00 Ppd.

Stock No. 60,632H....16'.....\$7.00 Ppd.



WOODEN SOLID PUZZLES

Here's a fascinating assortment of 12 different puzzles to provide hours of pleasure and stimulate ability to think and reason. Animals and geometric forms. Take them apart and reassemble them. Lots of fun for the whole family—young and old. Will test skill, patience and ability to solve problems. Order yours now.

Stock No. 70,205H\$5.00 Ppd.

MONEY-BACK GUARANTEE

Order by Stock No.—Send Check or M.O.

GIANT FREE CATALOG

148 Pages! More than 4,000

UNUSUAL BARGAINS

Completely new Catalog. Packed with huge selection of telescopes, microscopes, binoculars, magnifiers, prisms, photo components, parts, kits, accessories—many hard-to-get surplus bargains. 100's of charts, illustrations. For hobbyists, experimenters, schools, industry. Mail coupon for FREE Catalog "H".

EDMUND SCIENTIFIC CO., 300 Edscorp Building, Barrington, N. J. 08007.

NAME _____
 ADDRESS _____
 CITY _____
 STATE _____ ZIP _____

Drivin' with Dan

What make of car has won the most NASCAR Grand National races? Should a 16-year-old drive a street motorcycle? Does airconditioning cut engine power? Dan Gurney answers these and other automotive questions



MOON MEN have nothing on race drivers when it comes to protective outfitting. Here Dan dons flame-proof gloves before test lap at this year's Indy 500

Q. Now that wings have been banned from Formula 1 Grand Prix racing, is there any type of racing where they are still allowed?—Dan Wilson, Cleveland.

A. The full-fledged wings to which you refer are still eligible in Can-Am Group 7 racing and in the Formula A Continental Championship, both sanctioned by SCCA. In addition, spoilers of considerable size continue to be used in most other types of racing.

Q. What make of car has won the most NASCAR Grand National races?—Bobby Catlin, Charleston, S.C.

A. According to NASCAR records from 1949,

the first year of Grand National racing, through the last event in 1968 Ford is the runaway leader with 237 victories. Then come Plymouth, with 139; Chevy, 114; Oldsmobile, 87; Hudson, 79; Pontiac, 69; Dodge, 64; Chrysler, 59; Mercury, 25; Thunderbird, 6; Lincoln, 4; Studebaker, 3; Buick, 2, and Nash, 1. Biggest single year for any make was Ford's 1965 season when it won 48 of 55. Next biggest years were Plymouth's 1967, with 31 wins in 49 races, and Pontiac's 1961, with 30 victories in 52 events. And, would you believe that Hudson won 27 of 34 in 1952?

Q. Is the new track at College Station, Tex., supposed to be a drag strip or Indianapolis-type layout?—Leroy Roberts, El Paso, Tex.

A. The College Station plant—Texas International Speedway—is to be a major racing facility based on a two-mile oval, but including a road course. Its first event is scheduled for Nov. 9 and plans call for major stock-car, USAC championship, and sports-car races. Although I imagine TIS will also stage some drag-racing events, I believe you may be thinking of a new drag-racing facility in the Dallas area.

Q. Since you run both types of racing, can you tell me the basic difference between Can-Am cars and Indianapolis cars?—Aaron Hollander, Stamford, Conn.

A. You can run any kind or size of internal-combustion reciprocating engine in Can-Am, but you must run on gasoline. At Indy, about the only thing you have freedom on is fuel. Any kind is okay. Can-Am cars have bodies which envelop the wheels. Indy cars don't. Can-Am has no minimum weight or maxi-

(Please turn to page 37)

Ed Crouch Never Dreamed He'd Earn Up To \$2,000 A Month When He Mailed The Coupon



But he does . . . And his car and business expenses are paid, too. Read how he moved up fast to an exciting, top pay career

For 10 long years Ed Crouch worked in a drive-in theater in California. He saw a lot of movies, but he didn't see much in the pay envelope. A bright future just wasn't in the coming attractions.

So Ed became dissatisfied, restless for change. He wanted a fresh start in a real pay-off business. But what do you do when you've got 10 years of your life invested in one job?

If you're at all like Ed Crouch, you start looking around for a better opportunity. And that's what Ed was doing when he mailed the coupon that changed his life.

That coupon, the same one that's on this page you're reading right now, brought Ed a free book of facts on the booming Accident Investigation field. And it was an eye-opener!

30 MINUTES THAT CHANGED THE FUTURE FOR ED CROUCH

Ed learned that Accident Investigation is part of the *biggest business in the world today* — a \$20 billion industry of wide-open opportunities.

He learned that more than 22 million accidents and losses must be investigated and settled every year in this country. He learned that more and more trained men are urgently needed now, everywhere, to handle this huge workload — in cities, towns and rural areas.

It took Ed Crouch just 30 minutes to skim through that free book of facts. But that half-hour changed everything. He knew he had found the opportunity of a lifetime.

EARNS UP TO \$2,000 A MONTH, EXPENSES PAID

Today Ed is a professional Accident Investigator with an independent firm in California. His income ranges from \$1,200 a month up to \$2,000 a month! He has car and all business expenses paid. He's on top and set for life.

Ed Crouch has the kind of life and income now that he never even dreamed of when he mailed the coupon on this page. But how did he do it? How did he make such a success when he had absolutely no experience in the field?

It was simple. Ed just followed the path hundreds of others have taken to new careers in Accident Investigation.

He trained at home in his spare time. He read lessons-by-mail from Universal Schools of Dallas, Texas.

HE DIDN'T MISS A PAYCHECK

Ed learned that Universal is the oldest, largest, most successful correspondence training school in the field. He learned that Universal has trained and placed more men in Accident Investigation careers than any other organization — 80% of them men with no experience, no college.

So Ed enrolled. He studied Universal's famous 50-lesson course in his spare time at home. He kept right on with his old job while he trained. He didn't miss a single paycheck.

In brief, clear, interesting lessons, Ed learned exactly how to step in and start making money quickly in Accident Investigation. And that's what he did.

"The training I received from Universal Schools put me where I am today," Ed writes. "There are not words to thank them enough. Universal is the top school in the field."

Ed Crouch's income is unusually high and not typical of the field. But it shows what an inexperienced man can do with the help of Universal training and placement service.

Here, for example are just a few reports from other recent Universal graduates:

"My income has more than doubled." — James T. Woodruff, Louisiana.

"An immediate 40% increase in wages." — Bill Ruhnke, Missouri.

"A raise every three months for the next two years, plus new car and expense account." — Oscar Singletary, Georgia.

"My salary has increased by 63%." — Marcel Roy, Canada.

SEND FOR FREE BOOK TODAY

Send for your free book of facts on this remarkable field — the same book that put Ed Crouch and so many others on the road to bigger opportunities.

Remember, more trained men are urgently needed right now, everywhere — in cities, towns and rural areas. There's opportunity wherever you live or wherever you want to live.

Simply mail the coupon below and we'll send your free book immediately. Or, write to Universal Schools, 6801 Hillcrest Ave., Dallas, Texas 75205.

When Ed Crouch mailed this coupon, he didn't dream he'd someday be making up to \$2,000 a month. But he does!

APPROVED FOR VETERANS' TRAINING

FREE PLACEMENT SERVICE

Universal Schools provides prompt, effective job placement help in any part of the United States and Canada. More than 1,000 companies have requested and receive our monthly list of graduates. Universal trains and places more men in the Accident Investigation field than any other school. Or, if you would prefer to start your own full or part time business, we will show you exactly how to do it.

SEND FOR YOUR FREE BOOK OF FACTS

UNIVERSAL SCHOOLS, Dept. PMA-10
6801 Hillcrest, Dallas, Texas 75205

Gentlemen: Please rush free book on opportunities and earnings in the booming Accident Investigation field. No obligation. No salesman will call.

Name _____ Age _____
Address _____
City _____ State _____ Zip Code _____



From the Bavarian Motor Works.

The hottest, sportiest BMW's ever

They're BMW's, all right. With all the quality of design and superb engineering we're famous for. But these new ones have something else, too. It's a spirit, a boldness of concept that sets these brilliant machines apart from any others built anywhere in the world. Faster, lighter, more powerful than their famed ancestors, the new generation are all sport, all go. With speed and acceleration that will astonish you. With fantastic handling and maneuverability. And with a big, brawny look that says, make way—here comes the new king of the road.

First off, these extraordinary machines are completely new from the ground up.

They give you more horses than ever: 36, 46, and 57 respectively. Top speed? 110 mph. Acceleration? Terrific. 0 to 60 mph in 6.1 seconds.

Those famed horizontally-opposed cylinders now utilize a unique new casting process that results in less engine weight and optimum heat dissipation. The one-piece, forged crankshaft has even greater strength to permit the higher power output.

The entirely new oval-tube cradle frame is

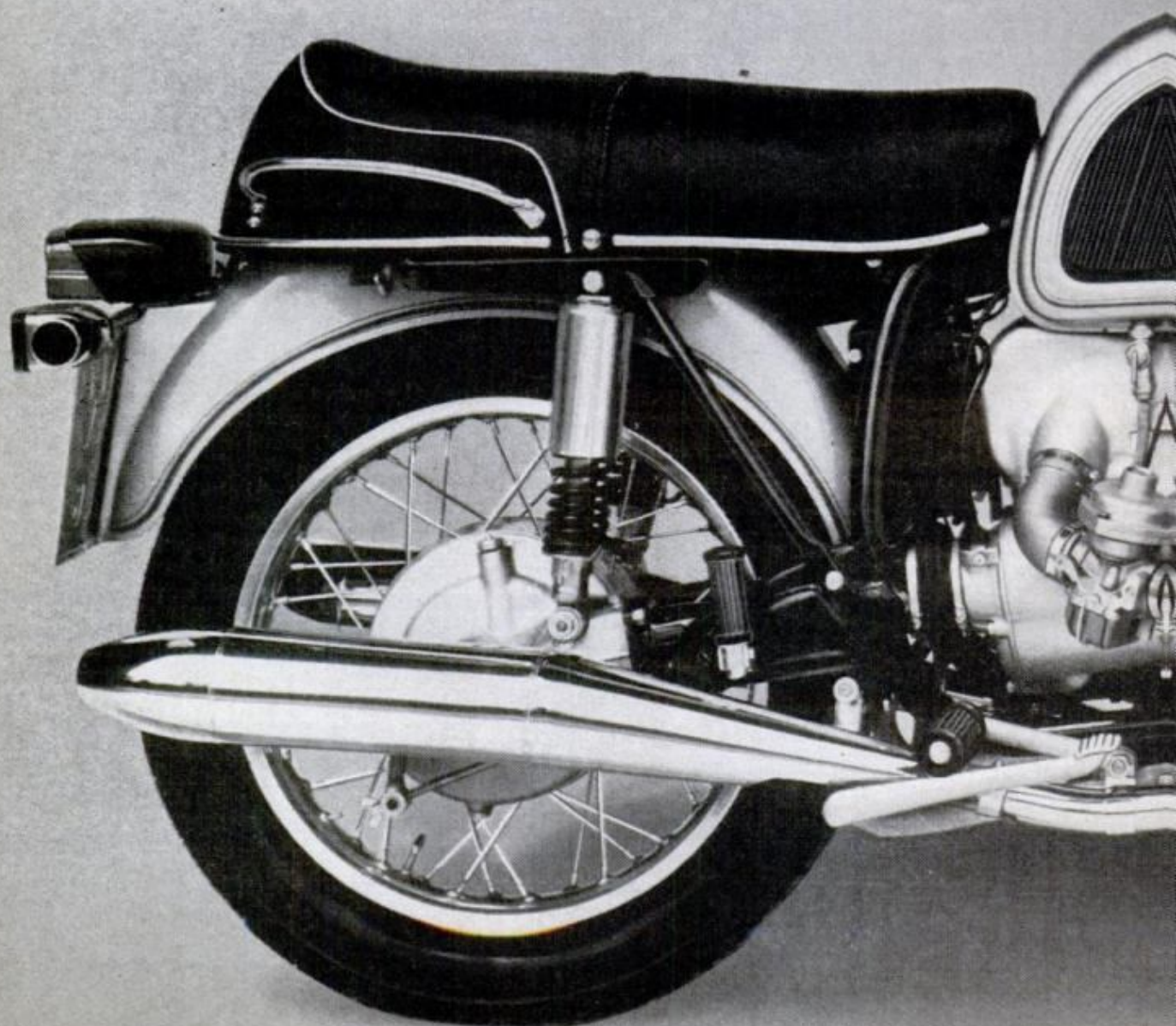

The all-new BMW motorcycles. built. 500, 600 and 750 cc's!

capable of taking enormous stress, and the 8-inch travel of the new telescopic front fork is matched by almost 5 inches of rear wheel travel.

Electric power is provided by a 12-volt, 3-phase alternator, and for the first time, the electric starter is standard equipment (optional on the R50/5).

There is more. A lot more. Not to mention factory-approved accessories. We could fill a book. But why not go to your nearest dealer and see the real thing? White, black or Polaris silver, the all-new BMW's have to be ridden to be believed.

See your nearest authorized BMW dealer, or for information write to: East: Butler & Smith, Inc., Walnut Street and Hudson Avenue, Norwood, N.J. 07648
West: Flanders Company, 340 S. Fair Oaks Avenue, Pasadena, California 91101
Canada: BMW Motorcycle Distributors, Ontario.

Bavarian Motor Works

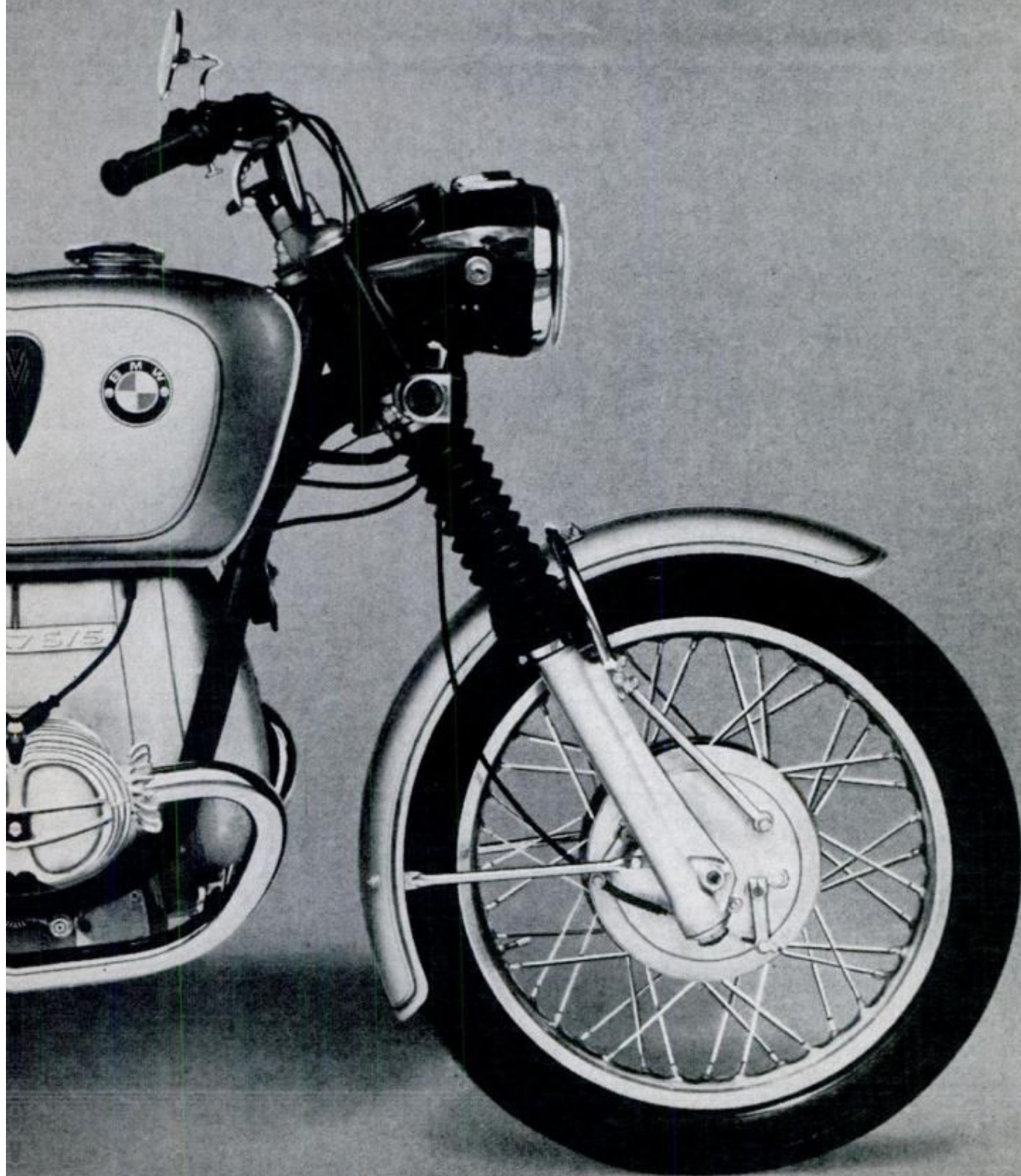

POPULAR MECHANICS

HOLIDAY SHOPPING GUIDE

AMERICA'S ORIGINAL LOW-COST ARC WELDER AND ELECTRIC TORCH

10 DAY
TRIAL

LIFETIME
GUARANTEE

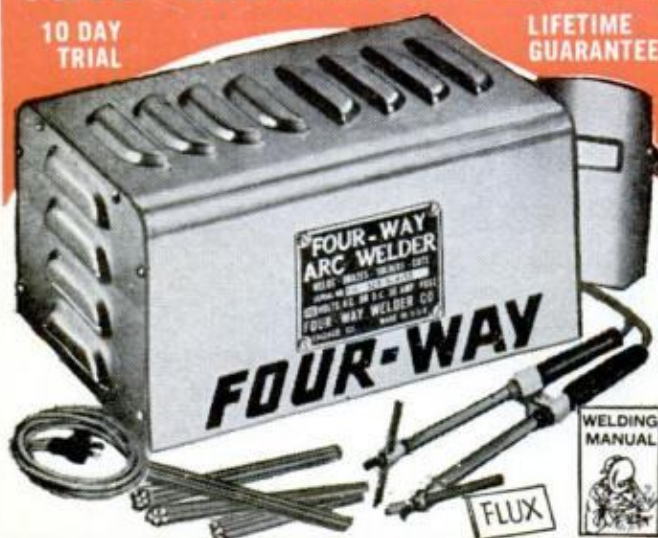

MAIL THIS ORDER COUPON NOW!

Four-Way Welder Co., Dept. R2-K,
1810 S. Federal St., Chicago, 60616
Please send welder as indicated below and include FREE
gift of Welding Rod Pack.

Enclosed \$18.95. Ship postpaid in U.S.A. Enclosed \$2.00. I will pay \$16.95 plus C.O.D. and delivery charges.

NAME _____

ADDRESS _____

CITY _____ STATE _____ ZIP _____

New Improved HEAVY DUTY **FOUR-WAY**

Only \$18.95 Prepaid Complete Ready To Use
WELD, BRAZE, SOLDER, CUT
Most Metals Including Aluminum

\$20.95 VALUE. WITH EXTRA \$2 PACK OF SUPPLIES

Every home, shop, and hobbyist needs this quality metal working machine. Use up to 1/8" welding rods and 1/4" carbons. Follow simple instructions to make or repair 1001 items including furniture, toys, auto bodies, fenders, trailers, boats, farm and garden tools and equipment. Operates on 110 V. 30A. for pennies—Adjustable Twin Carbon Arc Torch easily REGULATES HEAT FOR EACH JOB. Eliminates changing cables—replaces gas torches—no tanks or refills to buy—produces to 11,000° heat. YOU CAN PAY MORE BUT YOU CAN'T GET A BETTER LOW COST WELDER. Over 500,000 in use. Manufacturers of welders for over 30 years. LIFETIME GUARANTEE. Simply return prepaid. We will repair and reship FREE of charge. YOU GET: heavy duty welder in rugged metal cabinet, ground clamp, cables, combination torch and rod holder, welding manual and helmet, plus Free \$2.00 pack "TOUCH WELD" rods for instant and automatic arc, brazing rods, 1/4" carbons, solder and flux. Complete ready to use. Nothing else to buy.

FREE

Only 4-WAY gives you an Extra \$2.00 pack welding & brazing rods, carbons, flux and solder. 2 packs with order.

ORDER TODAY ON MONEY BACK TRIAL. If not completely satisfied, return in 10 days and we will refund purchase price.

SEND ONLY \$2.00 and pay \$16.95 plus C.O.D. and delivery charges. Or send only \$18.95 for postpaid shipment in Continental U.S.A.

FOUR-WAY WELDER CO.

1810 S. Federal St., Dept. R2-K, Chicago, 60616

S MINTS



Now near impossible to find in circulation. We offer popular packets with "S" on coins. 22 different "S" cents including rare 1955s, \$1.60. 10 different "S" Jefferson nickels, \$1.60. 10 diff. "S" Roosevelt dimes (1946S-1955S comp.), \$3.25. 26 diff. 1¢ before 1940 (P1-D-S) + 1960D sm. date, \$1.60. 30 diff. Unc. (new) coins—30 diff. countries, \$1.95. Buy 4 or more packets, we'll toss in a scarce old Indian-head cent! Wholesale price list (has startling silver info.) included with order, otherwise 25¢.

ROBT. HARRIS, 2373P Pruneridge,
Santa Clara, Calif. 95050

Free Catalog 2000 Jokes & Novelties



World famous catalog of novelties, live animals, scientific supplies, hobbies, fun-makers, planes & boats, looms, magic tricks, joke articles, unusual seeds, gadget time-savers, cameras, optical goods, projectors, movies, lucky jewelry, religious novelties, disguises, musical instruments, stamps, coins, puzzles, fortune tellers, radios, auto & bike accessories, telescopes, magnifiers, compasses, banks, smokers' gadgets, artists supplies, printing sets, engines, motors, shockers, knives, billfolds, fireworks, guns, rifles, sports, books, games, plants, etc. Send postcard or this ad. No letter needed!

Yes—I want FREE Catalog. My Name & Address Attached or on Envelope

Johnson-Smith, Dep. C1010, Detroit 48124

FIX CLOCKS, WATCHES

FOR FUN & PROFIT! Fascinating new Handbook by master craftsman H. Harris gives you the knowledge skilled watch-makers learn.

OVER 200 ILLUSTRATIONS show how to install hands, dials, crystals, mainsprings, stems—rehouse old movements in modern cases—clean timepieces, etc.

INSTRUCTIONS COVER every popular watch and clock, chimes, grandfather's, cuckoo, everyday alarm and electric clocks. Handbook tells you where to buy parts . . . where to send "overflow" work for repairs at wholesale prices as business expands!

Friends gladly pay \$5 to \$50 for restoring cherished timepieces. Try the HANDBOOK OF WATCH AND CLOCK REPAIRS seven days! Rush only \$4.95, on money-back guarantee. EMERSON BOOKS, Inc., Dept. 301-S, 251 West 19 St., New York, N. Y. 10011.



How About Joining in the Fun!



Playing the accordion does it every time! Maybe you have an accordion and would like to trade it on one of the fabulous "New Sound" electronic models. Beginner or professional . . . we can save you big money and put a fine accordion in your hands! Save 50% or even more! We are America's largest direct-importer-to-you dealer in accordions. We buy for

much less and we sell for much less. AND we back up every accordion with a positive money back guarantee and liberal 5 day home trial. We'll gladly send our newest color catalogs and low discount prices telling about newest models just arrived from Italy's most famous craftsmen. Mail the coupon . . . no obligation!

I GUARANTEE TO

Save You 1/2

OFF RETAIL PRICES OF ANY COMPARABLE
"NEW SOUND" ELECTRONIC OR STANDARD

ACCORDION!



DAVE BIASCO
President,
Import Director
Accordion
Corporation
of America

TRY BEFORE YOU BUY!

5 DAY HOME TRIAL

FREE Bonus Gifts -

E-Z LESSONS • MUSIC PORTFOLIO
• MUSIC STAND • DELUXE CASE
YEAR'S SUPPLY OF MUSIC and other
valuable awards!

TRADES ACCEPTED...

We'll accept anything of value in trade
... cameras, encyclopedias, radios,
musical instruments. Tell us what you
have . . . get bigger than ever trade-in
allowance!

EASY TERMS - LOW DOWN PAYMENT

In all America you have your largest accordion selection at A.C.A.! Choose from over 40 "New Sound" accordion models. Accordions for the student . . . the advanced hobby player . . . and the skilled professional artist. Make your selection from the finest makes and greatest names . . . created for you by the Italian masters. *Yet you save at least half of what you'd expect to pay.* If you are interested in an Electronic Accordion amplifier, we offer you amazing savings. Why pay more when you can get so much more for your money buying *direct!* You buy just as the dealers do . . . and you can save yourself as much as several hundred dollars on advanced models. We make it easy to enjoy your new accordion. Convenient terms with a low down payment. NO RISK PLAN . . . 5 day home trial before you decide! Lifetime performance guarantee. Satisfaction guaranteed or your money refunded. Trade-ins welcomed.

FREE Color Catalogs, Selection Guide, Discount Prices, Color Swatches

Let us prove how much you save . . . how much more you get for your music dollar! We'll send you complete details, color pictures, lowest discount prices . . . plus big savings on amplifiers and accessories. No obligation. Just mail the coupon.

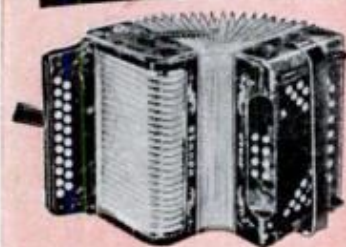

POPULAR "BUTTON" ACCORDIONS

Full line now available
at low discount prices.
Check coupon.

ACCORDION AMPLIFIERS

and reverb units. Custom designed for accordions. Finest makes at low money saving prices. Check coupon for details.



FREE COLOR CATALOGS - DISCOUNT PRICES

Accordion Corp. of America Dept. R-109
5535 W. Belmont Ave., Chicago, Illinois 60641

Send FREE Color Catalogs and Discount Prices. Also include special information I have checked:

Accordion Amplifiers Button Accordions

NAME _____

ADDRESS _____

CITY _____

STATE _____

ZIP _____

ZIP NUMBER SAVES THREE DAYS

Rush coupon at right to:

Accordion Corp. of America, Dept. R-109
5535 W. Belmont Ave., Chicago, Illinois 60641



HENLEY'S
20th Century Book of
10,000 Recipes, Formulas & Processes

Here is a wealth of practical, accurate and clear information and instruction that can save you thousands, or make you a fortune! Housewives, manufacturers, farmers, handymen, home experimenters, electricians, chemists, people in every walk of life, refer to Henley's daily. In this gold-mine of a book, you too will find formulas and recipes for almost everything used in the home, farm, workshop or industry. Discover the trade secrets of thousands of commercial products—learn new money-saving and exciting ways of doing things. As indispensable as a dictionary. Satisfaction guaranteed. 900 pages hard cover—cloth binding. Only \$5.95 postpaid.

home, farm, workshop or industry. Discover the trade secrets of thousands of commercial products—learn new money-saving and exciting ways of doing things. As indispensable as a dictionary. Satisfaction guaranteed. 900 pages hard cover—cloth binding. Only \$5.95 postpaid.

EMBASSY SALES, Dept. PM-6
Box 67, East Elmhurst, N.Y. 11369

100 STYLES FOR
WIDE FEET

and HIGH INSTEPS
EE to EEEEE Only
Sizes 5 to 13

Men only Casual, dress, work shoes that really fit. Top quality, popular prices. Money-back guarantee.



Not sold in stores

Write Today for FREE CATALOG
HITCHCOCK SHOES, INC.
Hingham 28-H, Mass. 02043



AIR LIFT AUTO LEVELERS

These tough, inflatable butyl cylinders raise the rear of your vacation-loaded car to safe, normal riding level. Air Lift Auto Levelers literally lift excess weight from overworked springs... also minimize sway on turns and absorb impact of bumps. Simple to install—no parts to remove from car. Ideal for camping, a "must" for trailering. Low as \$33.95 per set—tell us model of car. Free literature.

AIR LIFT COMPANY
Dept. PM, 2710 Snow Road, Lansing, Mich.

RARE
1955
NEW
1968S



Included in collection 33 diff. Uncirculated (new) Lincoln Cents: 1954 to 1969 plain-D-S complete (Regularly \$6.25)—**SPECIAL ONLY \$2.95 (Limit 2 sets)**. 35 tough "S" cents mixed (used) only \$1.00. 30 Uncirculated coins—30 countries. Bargain—\$1.95. Buy all 3 packets we'll toss in an old Indianhead Cent! Include 20¢ Insurance. Silver Dollars \$2.45 ea. Huge bargain coin lists with year sets, silver dollars, accessories, etc., included with order, otherwise 25¢. We buy coins—huge premium book 50¢.

BONANZA, Box 820P
Cupertino, Calif. 95014



BUILD YOUR OWN GUITAR

Here's your chance to make your own Spanish guitar for as little as \$20.00 — an electric guitar for \$28.50 — or a two-pickup electric guitar for only \$33.50. Kits are shipped postage paid, complete with all materials and easy-to-follow instructions. Nothing else to buy. No special tools needed. Send check or money order. Or send 25c for free literature.

SPANISH GUITARS LTD.
Box 1377, San Antonio, Texas 78206

One Sharpening Machine Does All This—

Start your sharpening business with Treycos 6-in-1 grinder. No need to buy separate machines for every job. You can hollow-grind scissors, pinking shears, knives, tools, garden tools, rotary mower blades, hand and circular saws—all with ONE **SIX-IN-ONE** Treycos Sharpener at low price of one machine. Safeguard your future—build your own spare or full time sharpening business. Take in as much as \$6.00 an hour—no lay-offs, no cut-backs, no forced retirement—enjoy independence and security! **ACT NOW—write for FREE CATALOG and LOW FACTORY-TO-YOU 6-in-1 prices.**



TREYCO
Products, Inc.

332-A Niagara St.
N. Tonawanda,
N.Y. 14120



FREE MUSCLE COURSE!

Want a new Jet-Charged body? In 15 minutes I'll prove you can slap on 4" of muscle to your chest—3" to each arm—give you life-guard shoulders, trim your waist to athletic size—give you speedy athletic legs. I don't care if you're short or tall (skinny or fat) young or not so young, expect a muscle building miracle when you send for my free course. Send only 25¢ to cover postage and handling to Joe Weider, Dept. 38-109D2, 531 32nd St., Union City, N.J.

WIN UP TO \$3,000 MONTHLY WORKING PUZZLES

Join a club with regular monthly puzzles—competitions in which you can win up to \$3,000.00.

NO EXPERIENCE NECESSARY

Simple puzzles, only common logic needed. Mail this ad, your name and address **TO-DAY**. We send you a Free Puzzle Magazine and membership details. First, try your skill free and find out if you can win. Yes! you may win \$3,000 in less than 45 days.

MUCH TO GAIN—NOTHING TO LOSE INTERNATIONAL CONTEST CLUB

Dep't PM, Westport Station
Kansas City, Missouri 64111

When you see this mark



you've seen the product in Popular Mechanics



Free Catalog!

GERSTNER CHESTS
are for the
FEW TRUE Craftsmen

GERSTNER TOOL CHESTS
Dept. D-9 20 Cincinnati Street
Dayton, Ohio 45407

BURGLARS BEWARE!!!

Wouldn't you feel safer knowing that a lamp in your home was turned on at dusk and off at dawn *automatically*? No controls to set, self contained. 115V-UL approved. Specify indoor or outdoor type. Send \$4.50, check or money order to:

SAFEGUARD, Box 262, Bellflower, Calif. 90706



THESE 3 BIG DRAFTING KITS* GIVEN TO YOU!

Coast-to-Coast Shortage of Trained Draftsmen Opens Thousands Big Salary Jobs for Beginners!

Now you can take your pick of thousands of big salary jobs open to Draftsmen (see "help wanted" sections of metropolitan newspapers). Huge nationwide demand... U.S. Dept. of Labor reports "42% more Draftsmen needed in next 10 years—not enough applicants to fill drafting jobs available now!" Our easy "Quick-Learn" Method has helped hundreds toward good income, security and prestige as Draftsmen. Why not you?

You Need No Drawing Skill—No Technical Ability

NASD's staff of Professional Draftsmen guide you step-by-step. With our spare time home-study plan you work on actual projects. Makes learning fun—easy to remember, too. Many graduates have succeeded with only grade school training. Others report good earnings drafting part time while still learning. Rush coupon today sure... get **FREE "DRAFTING CAREER KIT," Sample Lesson, Drafting Aptitude Test** including intriguing new **5-Way Drafting Instrument** and **20 page Book "Your Future in Drafting"**—jam-packed with revealing facts on your opportunity to win top pay and job security in Drafting. Everything mailed to you **FREE** and **WITHOUT OBLIGATION. No salesman will call.**

...when you train at home with NASD for a

HIGH PAY JOB IN DRAFTING!

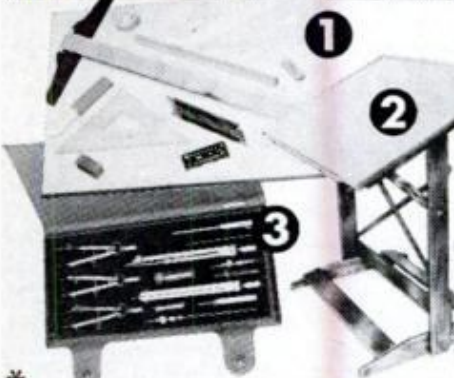

* Precision Drawing Instrument Set, Professional Drafting Board Outfit and Fingertip Tilting Drafting Table are given to you with your complete North American Course in Drafting.

U. S. LABOR DEPT. REPORTS SERIOUS SHORTAGE OF DRAFTSMEN

(The following quotes from U. S. Labor Dept. point out nationwide shortage for Draftsmen):

"The dearth of qualified applicants has resulted in increasing calls for trainees, as employers in many areas relaxed hiring specifications. Experience requirements have been virtually eliminated, along with age barriers."

"Steadily growing employer requirements...were accompanied by marked reductions in the supply of draftsmen available."

TOP AMERICAN EMPLOYERS WELCOME NASD GRADUATES

"We would be interested in interviewing your grads as potential employees." **REMINGTON**

"At the present time we have several openings available for qualified Draftsmen. I look forward to considering graduates of your institution." **WESTINGHOUSE**

"We have immediate openings for designers and Draftsmen and have a definite interest in interviewing candidates immediately." **AMERICAN MACHINE & FOUNDRY**

(3) High School Draftsmen

\$90-\$120 PER MONTH
NO EXPERIENCE
Start with a basic course and average employment well income

NO EXPERIENCE REQUIRED!

Trainers who satisfactorily give a basic course and average employment well income
✓ FULL SALARY
✓ AUTOMATIC SALARY INCREASES
✓ FULL EMPLOYEE BENEFITS
Get immediately to average income
✓ PASSPORT
JOE PASQUARE
2674111

The **FLUOR** Corporation, Ltd.
INTERNATIONAL ENGINEERS CONSTRUCTORS
2300 S. Atlantic Blvd.
Los Angeles, Calif. 90022

Design Draftsmen

Requires experience in design and drafting of most mechanical devices.

CALL OR APPLY
AERQUIET-GENERAL CORP.
11711 Woodhull Ave.

DRAFTSMAN
Architectural
WESTERN GEAR

Take Your Pick of 2 EXCITING FIELDS

1 Architectural Drafting

Today's population explosion guarantees boom in building of homes, churches, schools, factories, office buildings & warehouses is just starting. Thousands Architectural Draftsmen needed NOW because drawings must be made of every part of every building before ground can be broken.



2 Mechanical Drafting

Skyrocketing U.S. mass production requires millions of drawings & thousands of Mechanical Draftsmen all along the way. Drawings must be made of every PART of every product used in the U. S. (as well as of the machines that make these parts) before production can be started.



HERE'S WHAT STUDENTS SAY

Earns \$820 Month!

"My first position after completing your course jumped my income from \$350 to \$820 per month." —G. W., Tenn.

Big Promotion!

"I was promoted from the production line ahead of 4 others and got a good pay raise." —W. A., Wisc.

Gets 50% Raise!

"Shortly after I completed your course I was made shop foreman. My pay was increased by half." —W. R., New York

No Layoffs!

"Strikes and layoffs are nightmares of the past. Your training has opened the door to a wonderful future for me." —H. O., Ohio

Authorized to issue diplomas of California Superintendent of Public Instruction.

Accredited Member, National Home Study Council.



Veterans, Servicemen you may be eligible for Gov't education benefits

A home-study program in association with Cleveland Engineering Institute.

ALL 4 FREE!
Rush Coupon Today!

Your FUTURE in DRAFTING

APTITUDE TEST

SAMPLE LESSON

- 1 5-Way Drafting Instrument—yours to keep as a FREE GIFT without obligation.
- 2 20-Pg. Drafting Career Fact Book — packed with details about career opportunities.
- 3 Self-Scoring Drafting Aptitude Test — tells if you are suited for high-pay Drafting Career.
- 4 Sample Lesson — a "sneak preview" of things to come.

NORTH AMERICAN SCHOOL OF DRAFTING, Dept. 4170
4500 Campus Dr., University Plaza, Newport, Calif. 92660

Rush "DRAFTING CAREER KIT" including Book, Sample Lesson, Aptitude Test & Drafting Instrument — ALL FREE! No salesman will call.

NAME _____ AGE _____

ADDRESS _____

CITY _____ STATE _____ ZIP _____

NORTH AMERICAN SCHOOL OF DRAFTING
4500 Campus Dr., Dept. 4170 University Plaza, Newport, Calif. 92660

TWO FREE GIFTS

reserved for **PUZZLE LOVERS** only



If you are over 18 and have the kind of lively mind that loves to solve puzzles, mail this entire ad to us today and we'll send you a new ballpoint pen plus a big copy of our *Puzzle Lovers Newspaper*, both FREE to new inquirers. You'll discover how to cash in on the thousands of dollars awarded every month to our members. They compete for our cash prizes by solving puzzles in the quiet of their own homes. There is no obligation. Send this ad only if you believe you have the talent to solve puzzles and win cash prizes.

PUZZLE LOVERS

Box 2, Prince Street Station, New York City, N.Y. 10012

NAME _____

ADDRESS _____

CITY _____ STATE _____ ZIP _____

OFFER EXPIRES DECEMBER 31, 1969 • MAIL TODAY

ESTES

FLYING SPACE-AGE MODELS

Rockets

- 47 MODELS TO BUILD AND FLY
- PARACHUTE RECOVERY
- FLIGHTS TO 2500 FT.

STARTER SPECIAL

Includes Alpha rocket, 2 engines, instructions, design manual.

No. DSK-20.....\$2.00

DSK-70 - with Electro-Launch and batteries \$7.00

128-page color catalog (free with order) . 25¢

ESTES INDUSTRIES
Dept. 15
Box 227, Penrose, Colorado 81240

REVOLUTIONARY NEW ANTI-FREEZE TESTER

Fast! Accurate! Easy to Use!
Stores in Your Glove Compartment!

NOW you can check the experts. **SIMPLY** insert tester into car radiator; draw up enough fluid to fill tester $\frac{3}{4}$ full, **COUNT** the number of floating **BALLS** and a quick glance at the self-storing package tells the story.

JUST \$189 ppd

Send check or money order, No COD's.

Harvey-Westbury Corp.
P.O. Box 484 Dept. 2-B
Westbury, N.Y. 11590

EARN A STEADY INCOME SHARPEN CIRCULAR SAWS

Professional circular saw sharpener sharpens saws 5" to 60", rip, cross-cut, combination, dado. Easy to operate—accurate—fast—safe. Bevels 45°, joints, gums. You can profit from this machine.

Thousands of Circular saws need sharpening every month.

Write for details

BURR MANUFACTURING CO.
8933 W. VENICE BLVD.
LOS ANGELES, CALIF. 90034

THIS IS IT!

Popular Mechanics said in July, 1969 (p. 166):

"Handiest Tool You Can Have in Your Shop"

It sands, grinds, polishes, sharpens. It's portable. Take it on the job. Use with any $\frac{1}{4}$ hp motor. Model 165. Factory direct special.

\$19.95 less motor

ARCO MFG. CO.
P.O. Box 817, Grand Forks, N. Dak. 58201

PER-FEC DRILL SHARP-NER

GUARANTEED TO BE THE FASTEST & EASIEST DRILL SHARPENER IN THE MARKET. POSITIVE RESULTS

SIMPLE & EASY TO USE

ORDER NOW \$4.95 ppd

GRINDING WHEEL NOT INCLUDED. DEALERS WANTED

◆◆ T. W. SIMPKINS CO. ◆◆
4510-B MONTANA / EL PASO, TEXAS 79903

REDUCIBLE RUPTURE

AGONY Removed
(or trial COSTS YOU NOTHING)

WHEN you slip into a low-cost, contour-designed Brooks Patented Air Cushion Appliance! Your reducible rupture will be held in securely yet gently—or the trial costs you nothing! This invention has made millions of sufferers happy. You can enjoy heavenly comfort night and day at work and play—or the Appliance costs you NOTHING. Isn't this worth a no-risk trial by you? If interested, write for free facts now. **BROOKS CO., BOX 346-H, MARSHALL, MICH. 49068**

FIRST STRUCK IN 13 YEARS

1968 YEAR SET

PHILADELPHIA MINT SAN FRANCISCO MINT
DENVER MINT

FIRST COINS MINTED SINCE 1955 at fabulous SAN FRANCISCO mint. Collectors prized set of 10 bright uncirculated coins as illust. 3.95 25¢ p.p. FREE \$1 luxurious velvet lined presentation case embossed in 24 KT. gold. SAVE 10 double sets 37.50 - \$1 p.p. 20 sets \$70 p.p. 50 sets \$165 p.p. d. COLLECTORS SPECIAL—Last silver coins minted. Five coins bright uncirculated 1964 sets from Phila. or Denver mint. Cent to scarce J.F.K. all silver $\frac{1}{2}$ dollar 2.95 - 25¢ p.p. FREE 50¢ gift case. Double set both mints 10 coins 5.50 - 25¢ p.p. FREE \$1 presentation case. SAVE—10 double sets \$49.50 p.p. Twenty sets \$95 p.p. 50 sets \$225 p.p. d. Money back guarantee. Write for FREE catalog. Member Retail Coin Dealers Assn.—Amer. Numis. Assn. Est. 1947. Novel Numismatics Dept. 2A 31-2nd Ave., N.Y.C., N.Y. 10003

KNOW ANTIQUE PRICES!

Latest 400 Page illustrated Book puts prices of antiques and collectors' items at your fingertips. Covers practically every group found in America such as: pattern glass, art and fine glass, banks, dolls, toys, chinaware, pottery, furniture, clocks, lamps, silverware and more than 250 other groups of items.

Book is widely used by dealers and collectors—now available to the public! Know the value of your antiques—also be price wise if you buy or sell! You could make or save more than cost of book on one transaction. Order Now!

Only \$7.95 postpaid.

E. G. Warman Publishing Co., Dept. P.,
8 Frank Hoover St., Unicomb, Pa. 15401



TUNE UP ELECTRONICALLY ANY CAR EVER MADE!

- ✓ COMPACT or LIMOUSINE
- ✓ DOMESTIC or FOREIGN
- ✓ 4, 6 or 8 CYLINDER
- ✓ 6 VOLT or 12 VOLT
- ✓ POSITIVE or NEGATIVE GROUND

With New Improved Model BT-162

DWELL TACHOMETER

ASSURE - EASY STARTS, OPTIMUM PERFORMANCE and
MAXIMUM GAS ECONOMY with MODEL BT-162

MADE ORIGINALLY FOR THE PROFESSIONAL AUTOMOTIVE TECHNICIAN, MODEL BT-162 WILL PAY FOR ITSELF MANY TIMES OVER FOR THE AUTOMOTIVE HOBBYIST AND EXPERIMENTER.

The Model BT-162 will perform the services specified below in addition to many other tasks too numerous to mention:

- ✓ Assure precise adjustment of points that are slightly worn or pitted.
- ✓ Indicate the most effective point setting without removing the distributor cap.
- ✓ Read the average dwell of dual breaker points as well as individual dwell of each individual set of points.
- ✓ Indicate the correct settings for external adjustment type distributors.
- ✓ Car manufacturers' dwell angle recommendations are included in the manual provided with the Model BT-162 for all cars including the external adjustment type distributors specified above.
- ✓ It is no longer necessary to file points to smoothness when using the Model BT-162. The instrument will automatically make allowance for any existing "pitting" or "wear."
- ✓ To adjust for mathematically correct carburetor adjustment and thus insure maximum gas economy and quiet engine running, simply use the Tachometer section of the Model BT-162. Read the exact RPM while the engine is in neutral position. Then adjust the carburetor in conformity with the car manufacturer's recommendations as specified in the manual provided with the Model BT-162.
- ✓ To locate a "miss" you need only disconnect or "short" the spark plugs one at a time with the Model BT-162 switched to the Tachometer position. You will be able to instantly identify which particular plug (or frequently its wire lead) is responsible for the malfunction.
- ✓ Cars with automatic transmissions function efficiently only if the fluid pressures are correctly maintained and since manufacturer's instructions always refer to RPM the Model BT-162 (or an equivalent tachometer) is required to properly service automatic transmissions. Incidentally, the 5,000 RPM maximum range of the Model BT-162 is adequate for all car engines without any exceptions.

Comes complete, ready to use. Operating manual includes manufacturer's dwell angle recommendations for all cars. The manual is yours to keep even if you decide to return the instrument.

\$29⁹⁵

SEND NO MONEY WITH ORDER PAY POSTMAN NOTHING ON DELIVERY

Try it for 10 days before you buy. If completely satisfied remit \$29.95 plus postage and handling charge. (If you prefer you may **PAY MONTHLY ON OUR EASY PAYMENT PLAN.**) If not completely satisfied, return to us, no explanation necessary.

ACCURATE INSTRUMENT CO., INC. Dept. 693
2435 White Plains Road, Bronx, N. Y. 10467

Please rush me one Model BT-162. If satisfactory I agree to pay at the terms specified at left. If not satisfactory, I may return for cancellation of account.

Name _____

Address _____

City _____ Zone _____ State _____

Save Money! Check here and enclose \$29.95 with coupon and we will pay all shipping and handling charges. You still retain privilege of returning after 10 day trial for full refund.

STIHL American, Inc.

194 Greenwood Avenue,
Midland Park, N. J. 07432,
Code 201-445-0890 .

23962 Clawiter Road,
Hayward California 94541,
Code 415-785-9100

7364 Lee Industrial Boulevard,
Mableton (Atlanta), Georgia 30059,
Code 404-941-1730 .



We've added Solid State Ignition to the World's most advanced chain saw!

Our engineers and designers are a very dedicated and conscientious group and not at all inclined to rest on past laurels. Consequently, although the new Stihl 041AV was recognized all over the World, as being far ahead of its field in design, engineering and performance . . . our people still were not satisfied. How could we improve upon the World's first and only chain saw with build-in shock absor-

bers to eliminate vibration?

We added Solid State Ignition!

Now, you have such Stihl "firsts" as automatic chain oiling and an anti-vibration system for smoother cutting with less fatigue . . . plus the addition of a molded solid state ignition system. Now our technical people are happy with the Stihl 041AV Electronic. We think you will be too!



3 WAYS

TO A PROFITABLE BUSINESS of your own with small investment

**YOU CAN START WITH ONE DETERGER...
ANY TWO... OR ALL THREE
FULL OR PART TIME!**



■ Von Schrader offers you these three tried and proven money-making businesses. You can start with one Deterger and, by working week-ends, add hundreds of dollars to your monthly income while still employed.

■ Or, you can start your business with any two, or all three Detergers, and build rapidly to a point where helpers and even additional Detergers are necessary. All three Detergers are reasonably priced...and many Associates make more than the price they paid in the first few weeks and from the supplies that came with their original order.

■ You need no shop because all work is done in customers' homes or on their premises. And you have no overhead because you work out of your own home.

■ Full operating instructions come with the Detergers and you need no special skill or training. You can grow as fast as you want to with the assurance that Von Schrader will help you every step of the way. Our Business Manual tells everything you need know, including how to go about getting business, suggested sales letters, tips on keeping books and tax records, suggested ads and radio announcements, etc. Von Schrader assistance is always at your service. Training and consulting with experts is also available... and without charge.

■ Von Schrader is the oldest and largest company manufacturing machines of this type and we are keenly interested in the success of each of our Associates. Our FREE ENTERPRISE PLAN has been developed and fashioned with your future in mind. Your business always belongs to you...no one can ever take it away. You pay no dues or fees or royalties to anyone. All the money you take in belongs to you...you are truly your own boss in your own business.

VON SCHRADER MFG. CO.

READ BELOW what a few of our many Associates have to say about the success of Von Schrader's FREE ENTERPRISE PLAN. Then return the coupon or write today. It costs nothing to get the details. Be sure to check the Deterger you are most interested in starting with.

E. L. McLAINE • New York • Wall—"I'm over 60 years old. In my spare time I make \$125 to \$175 per week."

F. LOTMAN • Canada • Wall—"Our machines have grossed us over \$50,000 for the past 12 months."

R. MORTON • Michigan • Wall—"This last month just working Saturdays and occasional evenings I cleared around \$600."

G. WINTER • Wyoming • Upholstery—"Last year I did \$10,000. This is a one-man operation. Many weeks are now \$250-\$300."

E. ACTON • Oregon • Upholstery—"I don't work very hard at this but in one day my boy and I made \$170."

S. RALLINGS • California • Upholstery—"I'm averaging about \$200 a week... one month went up to \$1000."

T. NORTHRUP • New Jersey • Rug—"I'm averaging \$2000 in two weeks... several weeks over \$1000"

J. THORNTON • Illinois • Rug—"\$90 and \$100 a day is common with your wonderful detergent."

C. LEONARD • Ohio • Rug—"My largest week so far brought me \$1568."

SEND FOR THE FACTS TODAY

VON SCHRADER MFG. CO.
DN10 "A" Place, Racine, Wis. 53403
Please rush information about your

_____ DETERGER(S)
(Write in name of detergent(s))
and how I can start my own profitable business.

Name _____

Address _____

City _____ State _____ Zip _____

Now! New J-M Insulations give you more for your dollar than ever before.



**This much
J-M Foil-Faced
insulation...**

Our new smaller package makes home insulation easier to take home than ever before.

J-M Foil-Faced Fiber Glass insulation always was lighter, more compact and easier to use. Now we've gone even further. A unique new process gives you four rolls of insulation to cover the same area as before—in a 25% smaller package.

And you can now buy J-M Foil-Faced insulation in a handy new Uni/Pak, one roll in a polyethylene bag. So you get the exact amount you need. Without carrying home messy, unprotected single rolls.

J-M Fiber Glass insulation is avail-

able in the new perforated Snap/Pak, which lets you snap off pre-measured batts with no cutting (leave it in the roll for ceilings.) Or in the Quad/Pak in continuous roll lengths.

What's more, type for type, dollar for dollar, the new J-M Fiber Glass insulations are thicker and have higher "R" values (for greater insulating effect) than ever before.

Your nearest J-M dealer has Foil-Faced insulation in its new form right now. Look for the special Uni/Pak display next time you're there. If you want more details, write Johns-Manville, Box 290-BA, N.Y., N.Y. 10016.

Johns-Manville

Good things come in smaller packages.

DRIVIN' WITH DAN

(Continued from page 22)

mum fuel capacity. Indy has both. Can-Am cars are two-seaters; Indy cars, one-seaters. Wheel sizes are restricted at Indy, but not in Can-Am.

Q. *What is the top speed of a Ford Mach 1 powered by a ram-air 428?—Jim Applegate, Queen City, Mo.*

A. I would guess that most of them can go over 125 mph just about anytime. Some might go over 150 mph, a few top 170. With a lot of work, one could probably top 200. The supercharged drag versions can do over 200 mph in a standing quarter mile. In other words, it depends.

Q. *Why isn't Ford, which seems to think so much of racing as a sales tool, any more effective in Can-Am racing? I don't see how it can afford to take such a beating from Chevrolet in a major series.—Robert J. Beckwith, Houston.*

A. Ford doesn't build and sell a suitable engine at the moment. Chevrolet has an aluminum 427 which is the basic ingredient for all the winning Can-Am engines this year. Chevy isn't in stock-car racing, but Ford is. Chevy apparently prefers to spend money making parts readily available to customers who want to go racing on their own.

Q. *I'm told that Ford's three-speed automatic is better for high-performance cars than the four-speed synchromesh because the gears shift faster. I don't agree. What do you think?—Arnold Schmidt, Jr., Raleigh, N.C.*

A. I don't agree either, but they are mighty good, and also very close on performance. I drive an automatic mostly, but for road racing, I believe the old four-speed is still best.

Q. *When we refused to buy our 16-year-old son a motorcycle for street use, he suggested that we write you for your opinion. He says he thinks they're safer than a car; we are frankly scared of them. What do you think?—Mrs. L.L. Benfield, Norfolk, Va.*

A. In the first place, I must warn you by telling you I love motorcycles. If your son

(Please turn to page 38)

**Sure, you can buy welders for less money
... and for even more money ... but ...**

YOU CAN'T GET A BETTER WELDER VALUE THAN A LINCOLN!

Lincoln Electric, the world's largest manufacturer of arc welding equipment, builds welders to industrial quality standards in high volume. You get these unbeatable values:

- **Longer life** ... some Lincolns over 50 years old are still going strong.
- **Rugged, reliable** ... just push the button and get the job done, fast, every time!
- **Easy to operate** ... no spit, no sputter. Easy to start, easy to set controls.
- **Versatile** ... weld all metals, cut, solder, braze. Ample amps.
- **Safe** ... built to conservative, industrial ratings. Underwriters approved standards.

Compare these values ...

(Prices subject to change without notice.)

Only \$93 (Zone 1 list) for this 225-amp shop welder. Complete with accessories, electrode kit, power cord, instruction books. ▼



Air-cooled engine-driven Weldanpower®. Goes anywhere, welds anything. 130 amps AC for welding, plus auxiliary power for tools. Zone 1 list price \$375.



Versatile, heavy-duty Idealarc® AC or AC/DC welder. Range 30-300 amps. Single phase. Zone 1 list price (AC/DC) \$287.

MAIL COUPON FOR FREE LITERATURE

The Lincoln Electric Company
Cleveland, Ohio 44117

**LINCOLN
ELECTRIC**

I am interested in Weldanpower 130
 225 AC shop welder Idealarc 250

Send full details without obligation.

Name _____

Address _____

City _____ State _____ Zip _____

RIDGID the toughest pipe wrench in the joint.

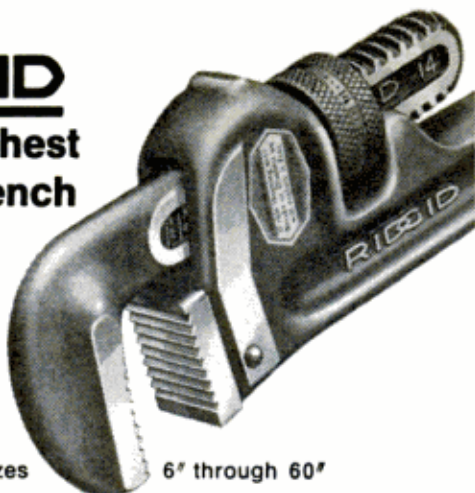

Choice of 10 sizes 6" through 60"

Certainly RIDGID Heavy-Duty Pipe Wrenches are tough. That's the way we build them. Then we work test them just to be doubly sure that they'll outperform and outlast all others.

Tool steel hook jaw has patented spring suspension that gives instant, slip-proof grip. Jaws can't lock . . . always release fast. Handy pipe scale, always easy adjustment and comfort-grip I-beam handle all help make a genuine RIDGID your best pipe wrench buy. Try one.

Buy a time-saving RIDGID Pipe Wrench at your Dealer's. He has a complete stock of RIDGID Work Saver Tools from The Ridge Tool Company, Elyria, Ohio 44035.

RIDGID

This great **RIDGID** Tube Cutter gives you 3 tools for the price of 1.

It's the RIDGID No. 15 tube cutter, and it's one of the handiest tools ever invented!

One. It's the smoothest little tube cutter available for all $\frac{3}{16}$ " through $1\frac{1}{8}$ " copper, brass and aluminum tube, also thin-wall conduit.

Two. Our tool is also a reamer. The blade folds into the frame where it's out of the way but always handy.

Three. The No. 15 is also a gas cylinder wrench. The key is cut right into the blade . . . it can't get lost.

So get 3 tools for the price of 1. Get a RIDGID No. 15 Tube Cutter at your Dealer's. He carries a complete stock of Work Saver Tools from The Ridge Tool Company, Elyria, Ohio 44035.

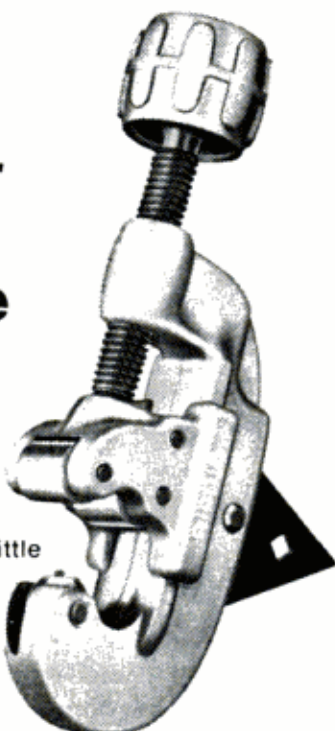

RIDGID

DRIVIN' WITH DAN

(Continued from page 37)

has excellent judgment and thinks defensively all the time, I think he should be allowed to own one. I don't think they are safer than cars. But on the other hand, they need not be more dangerous. I feel that a machine, whether it is a car or a motorcycle, does what the driver or rider makes it do. How good is your son's judgment and ability? If you can rely on your son in this respect, I believe you can rely on a motorcycle.

Q. *I'm not interested in precise figures, but wonder by how much airconditioning reduces the efficiency of a car's engine. What is your opinion?*—Dr. H.K. Summerville, Houston.

A. *If you're going along at a steady neutral throttle, and switch on the airconditioning, you can feel the slow-down. My guess would be that it knocks three to five percent off acceleration and mileage.*

Q. *How does Ford's new small block compare with your Gurney-Eagle version of this engine? And do you expect more Ford engines in Formula A racing next year?*—Tim Anderson, Browns Mills, N.J.

A. *I am prejudiced, of course, but I feel that it is not as good. However, it is less expensive. I do expect more F-A Fords in racing next year. The 305-CID Trans-Am Mustang Ford engines are pulling more than 500 hp now.*

Q. *Could I step out of a pro race-driving school into professional competition? Do you think I could support myself or should I keep a job?*—Judd Cadwell, Grand Rapids, Mich.

A. *It really depends how good you are. It could be done, but you would probably be the first man to do it if you did succeed. I suggest you keep a job until you get a good idea of how you stack up against competition.* ★ ★ ★

If you have questions on racing, high-performance and everyday driving techniques, send them to "Drivin' with Dan," c/o Popular Mechanics, 575 Lexington Ave., New York, N.Y. 10022. Questions cannot be answered by individual letters. Questions on maintenance and repair should be addressed to the Auto Clinic (see page 92B).

A real professional hand tool for the do-it-yourselfer!

ARROW®

HEAVY DUTY T-50

STAPLE GUN TACKER

SHOOTS A STAPLE
wherever you'd
drive a nail!



Model T-50
\$12.95
Others
priced
from
\$5.95

**FASTER!
EASIER! BETTER!**
for 1001 fastening jobs
ALL-AROUND the house!

- Powerful compression spring action drives staples into hardest woods, plywood, composition board, plastics even soft metals!
- Rugged all-steel construction with lasting lustrous chrome finish.
- Absolutely jam-proof with patented mechanism!
- Takes 6 different staple sizes from 1/4" to 9/16" leg, including Ceiltile.

\$14.93 VALUE
for only
\$12.95

The perfect
Christmas gift.

\$1.98 VALUE FREE!
WITH PURCHASE OF T-50 GUN TACKER
YOU GET ARROW'S M-25 STAPLER and
1,000 S-25 STAPLES FREE!



Available at HARDWARE • LUMBER • BUILDING MATERIAL • STATIONERY • VARIETY and Other Retail Outlets
ARROW FASTENER CO., INC. 271 Mayhill Street, Saddle Brook, New Jersey 07663

No other
super lightweight chain saw
starts as easy
as the new Homelite® E-Z™



Pull it... Prove it

Homelite's exclusive Simplex Starting System insures fast, easy starts . . . every time, any time.

No kidding. Prove it to yourself, go to any participating Homelite dealer and try it. Gently grasp the starting handle between thumb and index finger and lift . . . the super high performance engine spins over with unbelievable ease.

But, easy starting is only one of many unique features found on the new Homelite E-Z chain saw. It has power to spare to cut

* Less cutting attachments

Your participating Homelite dealer has a free gift for you when you come in and try it for yourself.

trees 3 feet in diameter, saw 8 inches of hardwood in 6 seconds (softwood in less than 4), yet weighs only 8½ pounds*. So, come try the only super lightweight chain saw that delivers like a pro.

HOMELITE®

10210 RIVERDALE AVE., PORT CHESTER, N.Y. 10573

**A textron
DIVISION**

POPULAR MECHANICS

WHAT'S NEW OUTDOORS

BY DAN FALES

SNOW POLO is the newest of the active snowmobile games. It's played with three machines to a side, and one person to a machine. A shortened polo mallet is used to hit a leather or hard-rubber ball with a circumference of 14 to 16 inches.

There are four 15-minute quarters in the game with 10-minute breaks after the first and third periods, and a 20-minute intermission at half time.

Snow polo is played on a rather large field—300 yards long by 165 yards wide. The goal posts—usually 55-gallon drums set 20 feet apart—are located at each end.

To hit the ball, each player must use only the mallet and must be on his machine. Several right-of-way rules are observed to eliminate collisions at times when a number of snowmobiles are chasing the ball.

As in regular polo, it's the maneuverability of your "mount," not its speed, that counts. This means that the high-powered snowmobiles are not good for this game. Most of the players feel that machines



having 300 to 350-cc engines are tops.

If you're interested in the rules, send 75 cents to Thomas Lynch, 1000 Oak Brook Road, Oak Brook, Ill. 60521, for his *Sno-Polo Guide*. Lynch also has information on obtaining mallets and other materials for playing the game.

Snow-polo teams have popped up in more than a dozen cities and towns across the country. And, there's even an unofficial national championship which is held every year at the Chanticleer Inn in Eagle River, Wis. ★★★

One of a kind



No other distiller makes his whiskey the same way we make Seagram's 7 Crown.

So no other whiskey has the same smooth taste.

Or the same consistently fine quality.

And guess what.

No other brand of whiskey is asked for as often as 7 Crown.

It figures, doesn't it?

Say Seagram's and Be Sure.

Seagram Distillers Co., N.Y.C.
Blended Whiskey. 86 Proof.
65% Grain Neutral Spirits.

NEW FINCO®

HOME ENTERTAINMENT
DISTRIBUTION WIRING SYSTEM
FOR DO-IT-YOURSELFERS



Everything needed to wire your home for multiple set reception — in easy-to-handle kit form.

MODELS:
HWK-75
75 ohm
HWK-300
300 ohm

- FM/FM Stereo
- For Color TV — UHF/VHF

Turn your whole house into a home entertainment center. Operate up to four sets, or be able to move your entertainment equipment from room to room. Kit includes all necessary parts, fittings and instructions.



THE FINNEY COMPANY

34 W. Interstate St., Dept. PM-10
Bedford, Ohio 44146

Please send free brochure 20-520 on FINCO HOME TV DISTRIBUTION KIT.

Name _____

Address _____

City _____ State _____ Zip _____

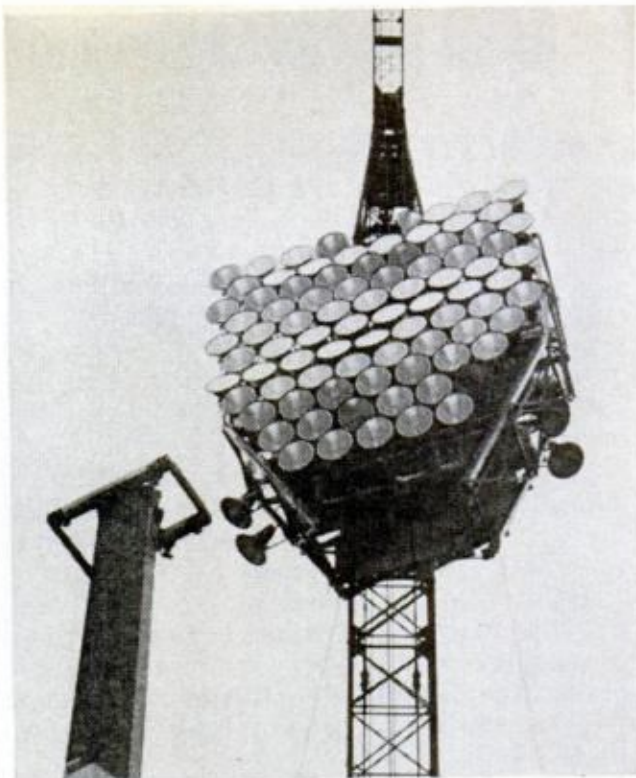

Bright lights for stadium

Four banks of floodlights in the new Neckar Stadium in Stuttgart, Germany, will give enough light to allow the televising of sports in color.



Aluminum softball bat

The bright colors and metallic gleam of new aluminum bats now dress up many softball diamonds. Approved for league play, the metal bat is the same weight as a wood one; it has a wood tip epoxied into the handle plus a rubber plug in the end. The maker, True-Cue Co., Pittsburgh, has also developed an aluminum baseball bat that's being tested.

POPULAR MECHANICS

SPERRY RAND®

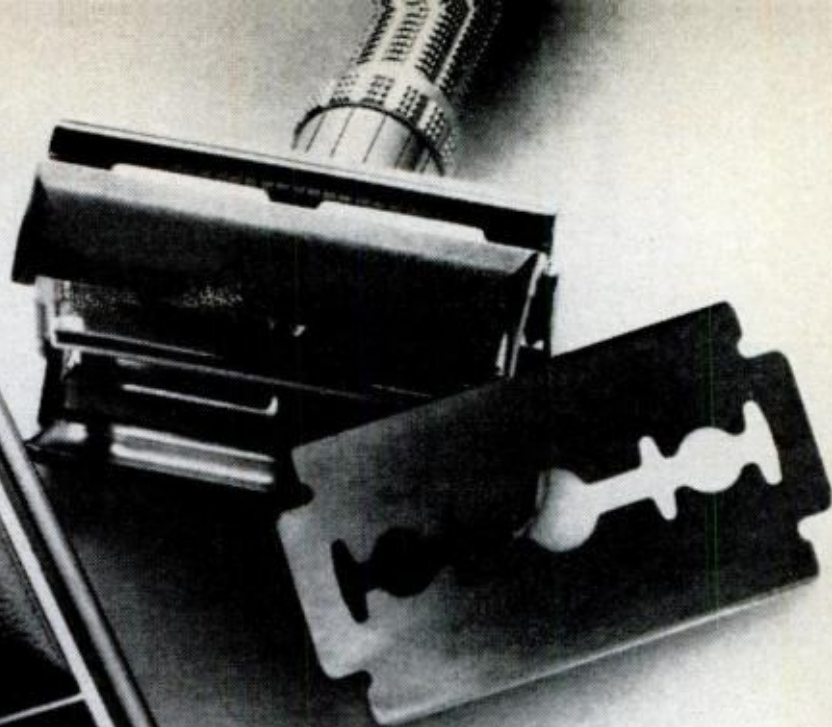

Remington announces
the greatest idea in close,
comfortable shaves since
disposable blades.

Disposable blades.

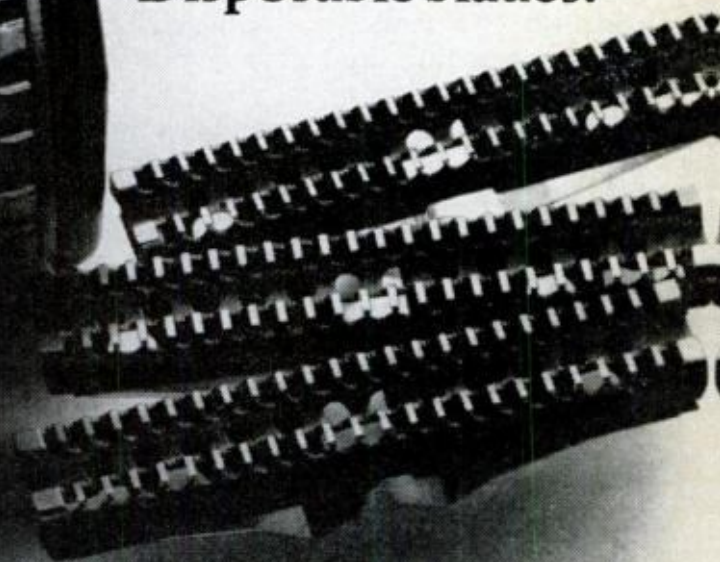

The safety razor uses extremely sharp disposable blades. And when they get dull, they simply get replaced.

"Great idea," said Remington.

So our new *Lektro Blade™* shaver has disposable blades—honed *four times* sharper than ever before.

That sharpness means the closest electric shaves possible—and unusual comfort.

That sharpness lasts up to six months, then you change blades. (Blades also fit our

previous *Selectro* shavers. See dealer or write Box 435, Bridgeport, Conn. 06602. Enclose \$1.95 and we'll mail new blades.)

Our shavers with disposable blades might just make other shavers—disposable.

THE NEW
REMINGTON®
LEKTROBLADE™ SHAVER



REMINGTON ELECTRIC SHAVER DIVISION/BRIDGEPORT, CONN. SELECTRO, LEKTRO BLADE. TRADEMARKS OF SPERRY RAND CORP. ©1969 S.R.C.

Материал защищен авторским правом

DETROIT

LISTENING POST

BY BILL KILPATRICK

THE REAL EYE-POPPERS from General Motors in '71 will probably be Buick's Riviera, Oldsmobile's Toronado, Cadillac's Eldorado, all three even now not exactly exercises in modesty and restraint. As now, all will be built around the same body shell, but will be even more distinctive. One source told us the cars will have a decidedly European GT flavor, the accents being definitely Italian. If—hopefully—the cars duplicate (or even attempt) Italian GT handling and braking, GM could find itself in a whole new world.

ALL STOPS ARE OUT AT FORD to make its forthcoming small car—to date called Phoenix—a VW-beater in every respect. The car, which might debut as early as next spring, has as its goal outstripping "The Bug" on looks (*that* shouldn't be too hard), power, economy, handling, ease of service. Particular emphasis is being given to the latter. Right now the ubiquitous Bug is the closest thing the auto world has to Henry's marvelous T, meaning parts and VW-tailored gadgets are readily available, that an owner needn't be more than average brave to risk doing his own repair work. So, to beat VW at what has become its own game, the word at Ford is to make the Phoenix "the most serviceable car ever built." Considering Model T history, that's a real order.

IF YOU OWN a Camaro or Firebird convertible, hold onto it, it may be the last of the breed. Same if you own a notchback. Talk around town has it that when all-new versions of the two cars bow after the first of the year (February's a good bet) they'll be offered as fastbacks, period. Decision to make the cars available in only one body style may portend the rumored and long-awaited (at least by dealers) cutback by manufacturers in model proliferation. The same sort of reasoning is said to be in vogue at Ford regarding the radically restyled Mustang now in the works.

FUEL ADDITIVES, denounced by some as one of the great put-ons of our time, may provide at least one way to go in the battle against car-caused air pollution. A Long Beach, Calif., outfit—AnPol Chemical Corp.—has come up with an additive which it claims will reduce harmful exhaust emissions as much as 50 percent. If true, a lot of auto-industry headaches will be at least partially relieved; right now, the clean-air problem has Detroit working feverishly to further improve on the solutions (e.g., PCV, evaporative control systems) it has already evolved. An effective additive would make the job just that much easier. AnPol said its "wonder drug," called (appropriately) *AnPol*, not only reduces emissions, but also boosts horsepower. West Coast engine whiz Bill Stroppe, no stranger on auto-racing circuits, is reported so impressed with the stuff he's working out a deal with the manufacturers to peddle it through speed shops under the label FAST. Tests of the additive on Stroppe's dynamometer reportedly indicated hp boosts of as much as 20 percent. All this and cleaner air, too!

AN INFLATABLE JACK will hit the market later this year. Developed by B. F. Goodrich, the rubber jack looks like a king-sized hockey puck when deflated, a small keg when blown up via a pressure bottle containing either compressed air or gas. Reusable, the jack will lift a tire three inches off a level surface, can be inflated in less than a minute. Jack is one piece, weighs only 2½ pounds, measures 3 inches thick, 13 in diameter when deflated, 21 high, 8½ wide at the top, 9½ at the bottom when blown up. Goodrich says the jack will take pressures up to 70 lbs. p.s.i., will safely lift any car. Automakers are said to be interested in the jack as possible OE.

AMERICAN MOTORS will field yet another Hornet next year. The car will not be [\(Please turn to page 47\)](#)

This can be your "BIG BREAK" if you're a man who's ever said

"I'm sick and tired of my job!"

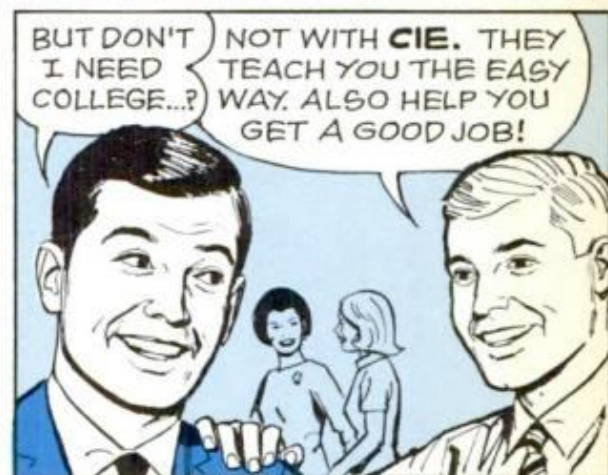

How about you?
Want a great job
in Electronics
too? Detach
and mail this
postpaid card for

TWO FREE BOOKS

 **CIE** Cleveland Institute of Electronics
1776 East 17th Street, Cleveland, Ohio 44114

Please send me 2 FREE books describing the opportunities in Electronics and how to prepare for them.

Print Name _____

Address _____

City _____

State _____ Zip _____ Age _____

PM-30

Veterans and Servicemen: Check here for G.I. Bill information.

Accredited Member National Home Study Council

Материал, защищенный авторским правом

"Prior to my CIE course, my only professional skill was as a crop dusting pilot. Today I own my own 2-way radio service business. I manufacture radio equipment and employ seven men. My CIE course is the best investment I ever made."

Edward Dulaney,
Scottsbluff, Nebraska



"Before I enrolled with CIE, my pay was approaching the maximum for a person with my limited training. But since then, I've had two pay increases—and I'm getting to be known as a theory man around work instead of one of the screwdriver mechanics."

Harry J. Remmert,
Groton, Conn.



"If someone had told me four years ago that I would now have a beautiful home, two cars, and be making what I am today, I would never have believed it. But after completing my CIE course, I got my present job as an electronics technician. And this is only the beginning, as the future looks brighter than I could have ever hoped."

Dennis J. Stout,
Ogden, Utah



"Even though I had only six weeks of high school algebra, CIE's lessons made Electronics easy. I now have a good job as Senior Transmitter Operator at Radio Station WBOE. I enjoy my work, and am on my way up."

Matt Stuczynski,
Cleveland, Ohio



"Since completing my electronics course with CIE, I've opened my own 2-way mobile radio business. We have one of the best-equipped shops in northern Oklahoma and have a real fine business and income."

Donald E. Breidenbach,
Ponca City, Okla.



"I was stuck in low-pay TV repair work before studying electronics with CIE. Now I work eight hours a week less, and earn \$228 a month more. I have a new home, 2 good cars, and a color TV. My CIE electronics course has really paid off."

Eugene Frost,
Columbus, Ohio



Sick and tired of your job? Do what these men did.

FIRST CLASS
PERMIT NO. 8685
CLEVELAND, OHIO

BUSINESS REPLY MAIL

No Postage Stamp Necessary if mailed in the United States

POSTAGE WILL BE PAID BY

**Cleveland Institute
of Electronics**

**1776 East 17th Street
Cleveland, Ohio 44114**

**Mail card
at left for
TWO FREE BOOKS
that can change
your life**

Trapped in a job with no future? Follow the lead of the men above. Just mail the postpaid card and we'll send you, FREE, two books that can start you on the road to a rewarding new career in America's hottest growth industry—Electronics.

If reply portion of this card has been detached, just write Cleveland Institute of Electronics, Dept.PM-30,1776 East 17 St., Cleveland, Ohio 44114.

Материал, защищенный авторским правом

DETROIT LISTENING POST

(continued from page 44)

tabbed a '71, but rather another version of the recently-introduced 1970 Hornet. The new one will be more stark than the present Hornet, will not carry a V8 option, will sell in the \$1800 range. Look for it in late February, early March. About this time—or a little later—look for an all-new small car (no name yet) from AMC.

ON THE MARKET along about now should be a new version of duPont's Zerex antifreeze. Key to the new brew is the presence of polystyrene balls ranging in size from one micron to 500 microns, their purpose being to pack together and plug small cooling-system leaks such as solder seam cracks, gasket leaks, the slow-drip-drip leaks that tend to open around hose clamps. The material won't plug big hose breaks or breakdowns of or in cooling system components (the water pump, for example). In normal operation, the polystyrene balls float along in the regular ethylene glycol antifreeze solution, accumulate and pack together only in the event of a leak.

MICHELIN, French tire manufacturer, will build two new plants in Nova Scotia, the company's first manufacturing venture in North America. Plants will be located near Bridgewater and in Pictou County, will represent an investment of \$75-\$100 million when completed next spring. Tires made in the new plants will be sold mainly in Canada and the U.S., but will also be exported throughout the world.

NOSES LIKE SHIP PROWS are on the way out in industry styling studios, partly through a need for a fresh look, partly to get the safety people off the industry's back. The projecting grille will still be around for a few years, but the protruding center section will be curved (Pontiac's Grand Prix, for example) rather than pointed. Safety people, who've scorned sharp snouts for years, apparently can get results if they holler long and loud enough.

BRITISH AUSTIN reports its Austin America, an economy import designed as a so-called "second car" for the U.S. market, broke all Austin sales records for this country in its first full year over here. Austin sold 16,628 units as opposed to the 11,811 record chalked up by the old Austin Devon in its peak year of 1948. The America offers either a manual or automatic transmission and sells both versions for under \$2000. ★★★

If your car's burning oil, it's time to trade it in.

Or read this.

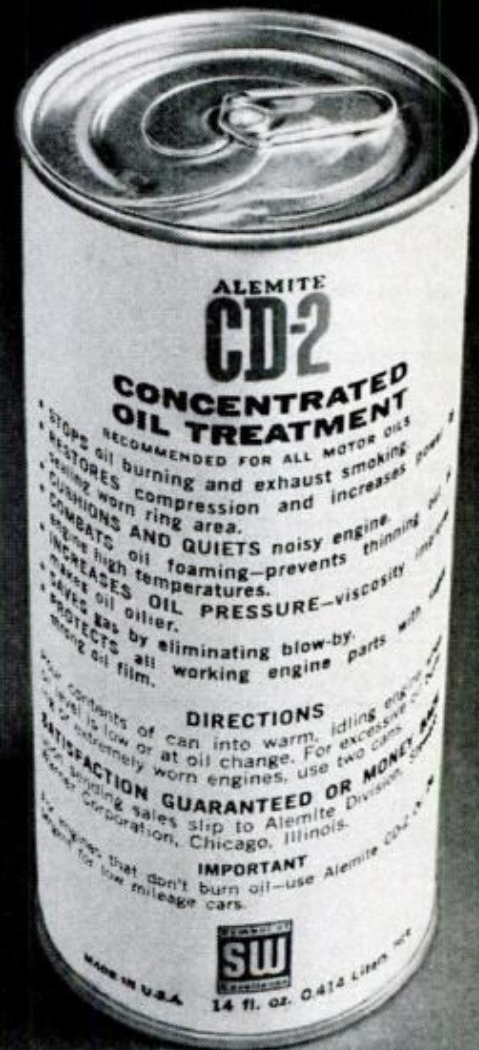

The back of a can of CD-2 tells how you might get another ten or twenty thousand miles out of a car that's burning oil and losing power. If you use what's inside.

The other CD-2. Don't get mixed up. There's a different CD-2 for low-mileage cars that don't burn oil. If we only made one kind, it couldn't do either job as well.

Two more great products by Stewart-Warner.



The bargain hunter

Get your full share of the multi-million \$ radiator repair business . . . start now or expand your own radiator repair shop



Invest as little as \$1500 to \$3000

. . . make handsome profits

with

BARBEE

radiator repair equipment and supplies

- ✓ Two weeks of free schooling
- ✓ Small down payment
- ✓ Extended terms

Without obligation please send me free literature on how to get into the Radiator Repair Business.

The BARBEE CO., Inc.

P. O. Box 323 PM Louisville, Ky. 40201



HOW MANY HANDY DANDYS CAN YOU USE?

Handy Dandys are plastic caps that hook onto pegboard and hold quarter-twist glass jars, such as used for baby food. Suggestions for getting **FREE JARS** in every package. Nothing better for storing supplies, parts and small tools. Keeps workshop neat. Sample pack 10 for \$1.00 36 for \$3.50 72 for \$6.00 144 for \$11.50. Caps only. No jars. Postpaid U.S.A. No C.O.D.'s. **WICKLIFFE INDUSTRIES**, Box 286-PM-10, Wickliffe, Ohio 44092



COMPLETE SPECIAL INVESTIGATOR KIT

★ **BADGE** ★ **CARRYING CASE**
★ **SPECIAL I. D. CARD ONLY \$275**
First time ever offered! Professional type detective badge kit and case. Includes professionally styled silver badge of extra heavy nickel for use by private and special investigators PLUS authentic type carrying case AND I. D. Card. Limited Supply, Order Now. Satisfaction Guaranteed or immed. refund. Only \$2.75 plus 25¢ to cover post. & handling. **WESTBURY SALES CO., D. D. Dept. GK-5-B**
P. O. Box 434, Westbury, N. Y. 11590

"\$7,108⁵⁰" First Year **NEW!**

WITH INLAND 3-IN-1 RADIATOR SHOP"



—John Burns, Sr., Fredericksburg, Va.

Inland shop owners make good money testing, cleaning, repairing auto-truck-tractor radiators. You can too! Compact shop only 11"7"x3'6". Inland, world's largest radiator equip. mfr., **trains you free** in 2 weeks or less. Pay-As-You-Profit purchase plan. Proved merchandising assures volume. Write for **FREE BOOK**, owner letters, details on program. Profitable dept. for garage or gas station.

INLAND MFG. CO., Dept. PM10
1108 Jackson, Omaha, Neb., 68102



FREE!!! POWERFUL MUSCLES FAST!
Fantastic New Discoveries in the science of bodybuilding. Now, in the privacy of your bedroom, our method will add inches of powerful muscles to arms, chest, shoulders & legs. Learn secrets on trimming the waist with ultra-modern methods—fast! Results Guaranteed! Send for free brochure. Universal Bodybuilding, Box 5327, M-20, Northeastern, Dearborn, Mich. 48126.

For split Second Reliability!

SEBRING 500 STOP WATCH



Only \$5.49

+ 50¢ postage

NY residents add tax. Send check or MO, no COD's. 21-Day Money Back Guarantee.

This is the watch used by sports officials everywhere for thoroughly accurate timing up to a full 60 minutes. Perfect for track meets, swimming meets, races of all kinds including horse, bicycle, model planes, cars, Go Kart, skate, ski, etc. and for any sport where precise timing is essential. 2" diameter, dustproof metal case with gleaming chrome finish. Easy-to-work stop button, black minute hand and bright red sweeping second hand.

send for your free gift catalog:

BARCLAY Dept. 59-L,
170-30 Jamaica Ave, Jamaica NY



THIRD HAND SPECIALTY CLAMP

IDEAL GIFT. Made of fine steel, it holds awkward jobs and leaves both hands free for cutting, welding, etc.

NOTHING ELSE LIKE IT. The standard G holds 1 piece while the right angle holds the second to the first. Throat opens 1 3/4" to 2 3/4" and is 1 1/4" deep.

NO WORKSHOP OR HANDYMAN SHOULD BE WITHOUT THEM

\$4.00 each \$6.50 for 2 \$12.00 for 4

Post Paid U.S. Prices

SORRY NO COD'S.

obtainable exclusively from

E. S. BOWEN 41 Yonge St. N., Richmond Hill, Ont. Canada



22 CAL. PELLET FIRING

"STINGER AUTOMATIC"

50 22 CAL. PELLETS FREE
Looks and Feels Like Real
Pocket Automatic—
Loads 15 Shots

Fires 22 cal. pellets just as fast as you can pull the trigger. Great for fast action combat-type target practice. 50 reusable 22 cal. pellets free. Free supply of targets. Money back if not satisfied. Just send \$1.00 plus 25¢ for postage and handling to: **Honor House, Dept. 96RA58** Lynbrook, N. Y. 11563



\$5.95

less bell



DIAL TELEPHONES

With bell \$8.95. If plug is required add \$2.00. Factory reconditioned, Guaranteed. Many other phones available, write for free list.

All shipments FOB Waymart, Pa.

SURPLUS SAVING CENTER

Dept. PM-869, Waymart, Penna. 18472

**PRECISION TOOL HANDLE
FOR INJECTOR TYPE
RAZOR BLADES**



\$1.89
P.P.

RAZOSHARP

Pat. Pend.

IDEAL POCKET KNIFE—EXCELLENT HOUSEHOLD UTILITY TOOL—Only holder to use standard injector type razor blades. Only holder allowing for varying blade length exposure. Only holder allowing blade to be completely sheathed, protected. Only razor blade holder to give precision tool feel.

ALWAYS RAZOR SHARP—When blade dulls—pop in new blade. Re-use injector type razor blades. **SHAVE and SAVE.** Inexpensive injector type razor blades always available. To expose new sharp edge—reverse blade or clip dull edge. Excellent for cutting clippings, cardboard, trimming. Ideal for opening packages, cartons, boxes. Use for carving, whitening, sharpening, erasing, etc. Shape blade to suit use—snip edge, grind or break with pliers. Nothing to break or wear out.

**RAZOSHARP 421 Stockholm Street,
Brooklyn, New York 11237**

CUTS HAIR

.. as You COMB!

SAVE \$50 and more yearly with the **MIDAS QUICKTRIM.** Anyone can automatically trim, taper, shape hair evenly, smoothly, on head, neck, temples, legs. Perfect for Mom, Dad, Junior's hair. Hold in either hand. Completely safe! No blade refills to re-order! **FREE** carrying case. 7" long. **COSTS LESS THAN ONE HAIRCUT!** Satisfaction or money back. **\$1.59** PPD. (2 for \$2.98; 3 for \$4.17)



ROSE-LEE, INC.
Dept. AG, 5 East 4th St.
Wilmington, Del. 19801

**IMPORTED
LOCK BLADE
STILETTO**

- ONLY \$2.75 Ea.**
- 9" Overall Length
5" When Closed
 - Opens instantly
 - Sharp and Tough
 - Stainless Steel Blade



WESTBURY SALES CO.
P.O. BOX 415 WESTBURY, N.Y. 11591
DEPT. L-2-B

**NEW
Heathkit Radio-Controlled
Screw-Drive Garage Door Opener
Semi-Kit . . . Only \$149.95***

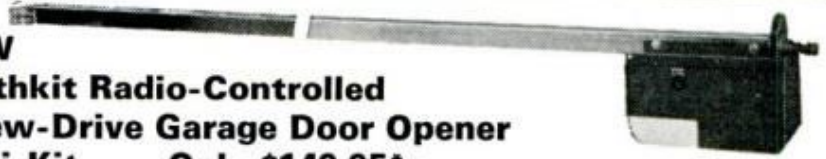

The next best thing to a personal doorman. "Wireless" factory assembled transmitter operates up to 150 feet away. Push the button & your garage door opens & the light turns on . . . stays on until you're safely inside. The giant 7 ft. screw mechanism & 1/4 HP motor mean real power & reliability & the adjustable spring-tension clutch automatically reverses the door when it meets any obstruction . . . extra safety for kids, pets, bikes, car tops. Assembles without soldering in just one evening. Easy fast installation on any 7' overhead track (and jamb & pivot doors with accessory adapter). Order model GD-209A (includes mechanism, transmitter, receiver) 66 lbs. **\$149.95***

Heath Co., Dept. 17-67, Benton Harbor, Mich. 49022
*Mail order prices F.O.B. factory.

**Reversible
FLIGHT
JACKET**

Sage Green on one side, International Orange the other!

\$13.95
plus 75¢ pstg.



Same type used by Air Force. Sage Green outer shell made of hard finished sateen. International Orange inner shell made of 100% nylon, quilted stitched. Warm 50% wool interlining. Rib-knitted neck, cuffs and waist. Heavy duty double-pull zippered front. Zip cigarette and pencil pocket on sleeve. Two slash pockets. Sizes: S-M-L (XL Size, \$15.50 plus 75¢ pstg.)

Write for unusual **FREE** Catalog

**P & S SALES, P-10, 115 W. 1st
P. O. Box 155 Tulsa, Okla. 74102**

**Stamp Your Name
PERMANENTLY**

\$4.50
ppd.



EVERSTAMP

DIE TOOL

Hardened tool steel. Lasts a lifetime. Comparable to a \$10 die tool, still available at this special price. Stamps almost anything you own with a single blow. Made only by the Henry A. Evers Co., Inc., makers of quality marking devices since 1898.

HENRY A. EVERS CO., INC.
Dept. PM, 72 Oxford St., Prov., R. I. 02905

- Enclosed is payment for die tool:
- Reg. size 1/16". 15 letters max. @ \$4.50 ppd.
 - Large size 3/32". 10 letters max. @ \$5.75 ppd.

NAME.....
STREET..... Please Print
CITY..... STATE..... ZIP.....

**NOW
ROTARY SHAVERS \$2.98
SHARPENER** ppd.

Smoother, faster, cleaner shaves!



Good news for owners of Norelco and other make rotary electric shavers. This new scientifically designed sharpener gives rotary blades the sharpest possible cutting edge—**IN JUST 1 MINUTE!** Use it just once a month to keep your razor operating at peak efficiency. Works fast, safely, surely.

NY residents add tax. Send check or money order. 21-Day Money Back Guarantee.

send for your free gift catalog:

**BARCLAY Dept. 59-L,
170-30 Jamaica Ave., Jamaica, N.Y. 11432**

WHAM-O \$150

HITS LIKE A RIFLE—KILLS RABBITS, SQUIRRELS
Powerful, silent, accurate. For hunting, target, routing pests. Sportsman's choice sold world over!

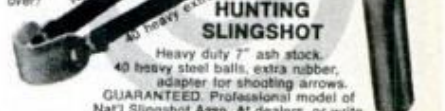

**HUNTING
SLINGSHOT**

NEW! surgical quality pure gum rubber
40 heavy extra steel balls for
Heavy duty 7" ash stock,
40 heavy steel balls, extra rubber,
adapter for shooting arrows.
GUARANTEED. Professional model of
Nat'l Slingshot Assn. At dealers, or write
WHAM-O MFG. CO., P.O. Box R-15 San Gabriel, Calif. 91775

**WHEN
ANSWERING ADS
GIVE YOUR
ZIP CODE**

The bargain hunter

500 RETURN ADDRESS LABELS



50¢

USE YOUR
"ZIP" CODE

RICH GOLD TRIM
FREE HANDY BOX

Quick and easy way to put your name and return address on letters, checks, books, records, etc. ANY name, address and Zip code up to 4 lines, beautifully printed in black on white gummed labels with rich gold trim. 2" long. Free decorative box for purse or desk. Set of 500 labels just 50¢ postpaid. Shipped within 48 hrs. Money back if not pleased. Don't know the Zip Code? Add 10¢ per set and we will look it up.

Send for free catalog.

Walter Drake & Sons
3450 Drake Building
Colorado Springs, Colo. 80901

**IMAGINE! A Powerful
FM WIRELESS
MICROPHONE**



Half the
Length of
a Cigarette!

\$19.95

+\$1.00
postage
& handling

Latest micro-
miniaturization
miracle—
one of the
world's smallest, complete-
ly self-contained

micro units. Performs
with perfect fidelity without wires.
Broadcast through blank spot on any
FM tuner, table model, portable or
car FM and you come thru loud and
clear up to 200 ft. away.

NY residents add tax. Send check or MO.
no COD's. 21-Day Money back guarantee

BARCLAY Dept. 59-L,
170-30 Jamaica Av., Jamaica, N.Y. 11432

**MOMENTOS of the infamous 3rd
REICH.** 10" x 12" x 1 1/2". Cast
HEER Wall plaque, Bronze
finish with wood grain
frame. While they last
\$6.00 Postpaid.

Our fully illustrated relief
collectors **CATALOG** of . . .
Helmets, Hats, Medals, Pins,
Badges, Books, Photos, Post-
ers, Manuals, Stamps, Flags,
Decals, Arm Bands & other
hard-to-find items. **CATALOG** free with order
or Air Mailed to you for **\$1.00.** W.W. #2-M
Ltd., Box 2063, St. Louis, Mo. 63158



**LESS THAN 15¢ PER OIL
FILTER CHANGE WITH
AMAZING**

STILKO



**ETERNAL
OIL CLEANER**

Full-flow oil filtering system uses the
best-known filtering material available
anywhere—toilet tissue—already proven
in thousands of automobiles. Recommended
for all types of cars and trucks. Keeps
oil cleaner sludge-free and carbon-free.
No costly installation or maintenance—
simply spins on in place of regular
throw-away filter! Each filter change
costs less than 15¢ and oil lasts longer
(some users report never changing oil).
Fully guaranteed. Send check or MO for
\$24.95. Or send \$5.00 and pay balance
COD. Include Make, Model & Year of car,
engine type and no. of cylinders.

DEALER INQUIRIES INVITED
STILKO ETERNAL OIL CLEANER
7445 Convoy Court
San Diego, Calif. 92111

SAVE! INSTALL IT YOURSELF

Remote control
Garage Door Opener
ONLY \$99.50

Easy to install. Garage door opener with
solid state transmitter and receiver. Built
by Crane, manufacturers of quality door
operators for over half a century. Guaranteed
for one year. Save by buying direct and
installing yourself (selling nationally for
\$165.00 installed). Postpaid.

Send check or money order. Deposit of
\$10.00 required on COD orders. Ill. residents
add 5% sales tax.

Additional transmitters **\$18.00 ea.**
F & A SALES 9810 W. Lawrence Ave.
Schiller Park, Ill. 60176

WESTERN HAIG

**.12 CALIBER
SPECIAL FACTORY
OFFER!**



\$300
post-
paid

USES POWDER CHARGE

This small bore gun shoots .12 cal.
steel bullets fired by small 4.4 mg.
powder charge. Not a CO₂ gun. You'll
like the handsome lines, grip, and balance.
Western in style, but patented ball and cap
action allows this low price. 9 1/2" steel barrel
cased in knurled styrene stock, overall 13 1/2".
Develop pistol form, accuracy at a fraction of
cost of large cal. pistols. Comes with 50 steel
bullets. Satisfaction guaranteed. Send \$3.00 to:
HAIG MFG. CO., P.O. Box A-26 Alhambra, Calif. 91802

**WHEN
ANSWERING ADS
GIVE YOUR
ZIP CODE**

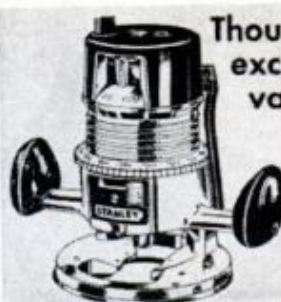

Thousands of
exciting tool
values!

SILVO (BRAND NAME) TOOL CATALOG

Thousands of Exciting Tool Values! Stanley,
Millers Falls, Skil, Thor, Wen, Disston, Wiss
Wellsaw, Dremel, Speedy Sprayers, Plumb,
Huot, Kennedy, Channellock, Porter-Cable,
Rockwell, Helios, Vise-Grip, Crescent, Ridgid,
Pony Clamps, Unimat, Foredom and many other
Nationally Advertised brands of Tools & Sup-
plies. We ship Coast to Coast at prices Hard
to Beat. Send 25¢ for our big 132-page tool
catalog, today. Silvo Hardware Co., PM-10,
107 Walnut St., Philadelphia, Pa. 19106.

BULL FIGHTER

Lock Blade

**STILETTO
KNIFE**

5 1/4" Overall Length
3" Blade

ONLY
\$1.25

- Tough and Sharp
- Opens Instantly
- Stainless Steel
- Folding Finger Guard
- Blade Locks



Flips open in-
stantly and
locks automatically
to prevent accidental
closing. Razor sharp
tough stainless steel
blade for reliable use
and hard, long service.
Money back in 5 days
if not satisfied. Send
\$1.25 plus 25¢ to cover
postage & handling. Please state age.
WESTBURY SALES CO., DEPT. B M 54C
P. O. BOX 415, WESTBURY, N. Y.

**PLAY GUITAR
IN 7 DAYS
OR MONEY BACK**



ED SALE'S 66 page system
worth \$3.00 teaches you to play
a beautiful song the first day
and many more songs by ear or
note in seven days! Contains 52
photos, 87 finger placing charts,
110 popular and western songs;
a \$1.00 Chord Finder of all the
chords used in popular music;
and a \$3.00 Guitarist Book of
Knowledge.

TOTAL VALUE \$7.00
—ALL FOR ONLY **\$2.98**

SEND NO MONEY! Pay postman \$2.98 plus
C.O.D. postage. Or send \$3.00 with order and
I pay postage. (Sorry, no C.O.D. outside Con-
tinental U.S.A.—please remit with order).
Unconditional Money-Back Guarantee.
ED SALE, Studio 153N, Avon by the Sea, N.J.

Write to
POPULAR MECHANICS
and request their
FREE 32 page catalog.
Include 25¢ to cover
postage and handling.

**SOLID CRASH
WEIGHT GAIN
FORMULA #7 PLAN**

available at the following stores

- ALABAMA**
Birmingham: Foods for Health
- ARIZONA**
Phoenix: Health Foods
- ARKANSAS**
Ft. Smith: Olde Fashioned Foods
- CALIFORNIA**
Beverly Hills: Jones Modern Foods
Burbank: Burbank Health Food Store
Hollywood: Hollywood Natural Foods
Los Angeles: Jay's Health Foods
Sacramento: Elliot Health Foods
San Diego: A-1 Vital Health Foods
San Francisco: Gianetti Natural Foods
Santa Monica: Weider Health Foods
- COLORADO**
Denver: General Nutrition Centers
- CONNECTICUT**
Bridgeport: General Nutrition Ctr.
Hartford: Nature Food Centres
- DISTRICT OF COLUMBIA**
Washington: Good Diet Shop
- FLORIDA**
Miami: Hale's Health Foods
Tallahassee: General Nutrition Centers
Tampa: Keppel Nutrition Center
- GEORGIA**
Atlanta: Helen's Health Food Shop
- IDAHO**
Pocatello: Gate City Health Food Ctr.
- ILLINOIS**
Chicago: Eaton's Dietary Foods
Chicago: Nature Food Centres
- INDIANA**
Indianapolis: Brown's Health Foods
- IOWA**
Dubuque: General Nutrition Centers
Cedar Rapids: The Kam Co.
- KANSAS**
Kansas City: Central Health Foods
- LOUISIANA**
New Orleans: Fine Foods
- KENTUCKY**
Bowling Green: General Nutrition Ctr.
- MAINE**
Portland: Mitchell's of Portland
- MASSACHUSETTS**
Boston: Nature Food Centres
Cambridge: Nature Food Centres
Springfield: General Nutrition Ctr.
Worcester: Nature Food Centres
- MICHIGAN**
Battle Creek: The Health Food Center
Detroit: Detroit Vital Foods
Lansing: Randall Health Foods
- MINNESOTA**
Minneapolis: Health Harmony, Inc.
- MISSOURI**
Clayton: Clayton Natural Foods
Kansas City: Nature Food Centres
- NEW JERSEY**
Atlantic City: Artman's Health Foods
Bergenfield: The Health Shoppe
Cherry Hill: General Nutrition Centers
Edison: Health House
Jersey City: Advanced Health Foods
Moorestown: General Nutrition Ctr.
Newark: Zinn's Health Food Store
Summit: Summit Health Food Center
Wayne: General Nutrition Centers
- NEW YORK**
Albany: Nature Food Centres
Bethpage: Long Island Health Gym
Bronx: Health Aid Center
Brooklyn: Nature Food Centres
East Syracuse: Diet & Health Shoppe
Flushing: Flushing Health Foods
Jackson Hts: Jackson Hts. Health Foods
New York: All Diet Foods
New York: Brownie's
New York: Mid-City Health Club
New York: Nature Food Centres
Rochester: Nature Food Centres
White Plains: White Plains Health Foods
- NORTH CAROLINA**
Asheville: General Nutrition Centers
Raleigh: Natural Health Foods
- OHIO**
Akron: General Nutrition Centers
Cincinnati: Spatz Health Foods
Dayton: General Nutrition Centers
Marietta: General Nutrition Centers
Toldeo: Dietrich's Health Foods
Youngstown: Health Food Center
- OKLAHOMA**
Oklahoma City: Nutritional Food Center
Tulsa: A Nutritional Food Center
- PENNSYLVANIA**
Allentown: General Nutrition Centers
Bally: Merril Food Co.
Erie: General Nutrition Centers
Philadelphia: Lahr's Nutritional Center
Philadelphia: Nature Food Centres
Pittsburgh: General Nutrition Centers
- RHODE ISLAND**
Providence: Nature Food Centres
- SOUTH CAROLINA**
Columbia: Barkoot's Karate School
- TENNESSEE**
Chattanooga: Foods for Life Center
- TEXAS**
Beaumont: American Health Foods
Houston: General Nutrition Centers
San Antonio: Harmon's Health Service
- UTAH**
Ogden: Nutrition Center
- VIRGINIA**
Norfolk: Health Food Center
- WASHINGTON**
Seattle: Randi's Pure Food
- WEST VIRGINIA**
Fairmont: Johnny's Sport Shop
- WISCONSIN**
Milwaukee: Nature Food Centres
- PUERTO RICO**
San Juan: Malta Corona Gym



Joe Weider, Trainer of Champions Since 1936,
Produces Another Breakthrough!

**THIS DELICIOUS
ZESTFUL DRINK PUTS AN
END TO THE
SKINNY BODY!**

**You Drink on Up to
A-Pound-A-Day...
14 Pounds in 14 Days
or Every Penny Back!**

GUARANTEED
TO MAKE YOU
**COME
ON
STRONG!**
by putting an end to
your skinny body—
IN JUST 14 DAYS!



No Dieting. No Exercise. It's the new kinky, lazy way to "drink on" figure-shaping pounds. It's an instant body-shaper! You become a totally new breed of wildcat! New life, new loves! Power-packed pounds enhance your whole way of life! You look better, feel better. You become a new, fresh, exciting personality! So easy! You "drink on" weight secretly, discreetly. And weight stays on!

NOBODY LIKES A BAG OF BONES!

Joe Weider, trainer of champions, has discovered the way to a healthier, happier, more virile you in just 14 days! This totally new and nutritional drink is absolutely guaranteed to put an end to your hungry-looking body, to fill out your narrow, shallow chest, your skinny arms and spindly legs—fast! JUST DRINK 4 ZESTFUL GLASSES DAILY, with your regular meals, and you take in up to 3,500 extra calories a day! Crash Weight Gain Formula #7 does all the work for you—making you a handsomer, more exciting take-charge guy who can perform like a tiger from morning to night! It's the only crash weight program tested and proved through university research. Complete documented report available on request. It really works!

FREE!



**FOR MEN OF ALL AGES
WHO WANT TO "SHAPE UP" FAST!**
Turn your weight-gains into solid muscle. This 48-page illustrated guide filled with latest ideas on how you can "Muscle up" to a handsome muscular body. Guaranteed to add 3" to your arms, 6" to your chest, 3" to your legs—fast!

FOR WOMEN OF ALL AGES WHO NEED TO RESHAPE THEIR FIGURE FAST!
Here's a Mini-Course that transforms you from a scrawny "No-Body" to a curvy caressable Some-Body! Reshape your figure—chest blossoms, thighs, arms, legs, lose their bony, ugly look. You become a whole new Happy Happening in 14 days! Choice of One Course Free With Every Purchase!

If No One
is Complimenting
Your Appearance—
Feed it Solid
"Crash-Weight Gain"
Formula #7



SHAPE UP FAST! OR IT COSTS YOU NOTHING!

JOE WEIDER, Trainer of Champions Since 1936,
with over 2,000,000 successful students
531 - 32nd St. Dept. 38-109K11
Union City, N.J. 07087

Dear Mr. Weider. YES! I want to put an end to my skinny body—and fast! Please rush me the order of solid CRASH-WEIGHT GAIN Formula #7, which I've checked below—PLUS my FREE Mini-Course. Enclosed please find \$..... for

7-Day Supply of CW #7 \$ 8.00
 14-Day Supply of CW #7 \$14.98

Check Flavor Desired Vanilla Chocolate
Check Free Course Needed For Men For Women

NAME..... AGE.....
ADDRESS.....
CITY..... STATE..... ZIP.....

ON-THE-GO

CAMPING

BY WADE MITCHELL

SECRETLY A NEW MOTOR HOME is being prepared by Grumman Allied Industries—masters of riveted aluminum air-frame construction. Speculative reports indicate that their contribution will be a luxury item. Insiders claim that Grumman's vast aircraft and boat-building experience will give them a great advantage in the motor coach field, but only time will tell.

MORE WARRANTY PROTECTION FOR RV BUYERS. A new interpretation from the Federal Trade Commission indicates that verbal assurances from a salesman may be construed in courts of law to represent a guarantee. If a salesman describes an RV as being good for a certain purpose, he is, in effect, warranting it for that purpose, according to the new definition. Carry a notebook with you when you shop for a new trailer, camper or motor home. Jot down any unusual claims that the dealer or his salesman makes for a product. Before signing the contract of sale, show your notes to the dealer and ask him if he agrees with his salesman's comments. You'll either get a fast approval or an embarrassed apology. Either way, it's bound to be interesting!

WORLD'S FIRST SPLIT-LEVEL CAMPING VEHICLE! Link-up coaches are on the way! Advanced design privately shown to *PM* functions like this:

1. Cabover pickup camper has absolutely flat and vertical rear wall, but has studs which mate with second vehicle.
2. Trailer (towed behind pickup) is cranked forward into mating grooves on back of camper coach to present one long coach at campsite.
3. Difference in floor height between coaches is handled with fold-up step in trailer.

FACING SOME REPAIRS? Make sure you get several estimates. There is no standard pricing in the coach-repair business. One shop might quote \$375 to repair a crushed three-way corner, while another would do the same job for \$250 or less. Repairs involving more than one panel cost the most, such as damage to intersecting sidewalls, sidewall-to-roof, or roof-to-front wall. Because of the ultraspecialized nature of coach repairs, the state of the art is roughly comparable to the television industry in 1950: too new to set price standards.

NO-SLIP DIFFERENTIAL CONTINUES TO DRIVE WITH BROKEN AXLE. They call it the Hy-Torq model, and the maker claims that even with one axle broken or removed, it continues to deliver power to the other wheel. No spider gears, cams or friction clutches are used. The Hy-Torq unit employs rollers to differentiate the axles. This new model is made by Hy-Torq Corp., 8609 S.W. Barbur Blvd., Portland, Ore. 97219.

DON'T FILL WATER TANKS FROM STRANGE HOSES! Many campers have cut short vacations because of nausea, cramps or fever. Eliminate this potential problem with any one of three easy solutions: First, fill tanks *only* from known sources of fresh water. Second, carry bottled water for drinking purposes where water is suspect. Third, install a quality water purifier in your coach. Prices range from a few dollars to about \$100 for a top-brand water purifier of generous capacity. That's a lot less expensive than a ruined vacation, medical bills, and discomfort.

NEXT YEAR'S TRAVEL TRAILERS WILL COST ROUGHLY \$250 MORE per unit, says one manufacturer. Greater labor and material costs and increased taxation account for most of the price rise. If you're considering the purchase of a luxury trailer, you'd better hurry. Within a few months, prices will be upped. ★★ ★

The Ronson Varaflame Butane Torch.

For people who take their fun seriously.

Torch with 150 gr. Multi-Fill Injector and idea book only.

\$5.95*

- Lightweight, compact, safe, easy to handle.
- Adjusts from pinpoint to blowtorch flame.
- Burns for hours on economical butane gas.
- Multi-Fill fuel injectors available everywhere.
- Cleans itself, never clogs.

Meet the hottest, handiest, sturdiest little torch that's ever crossed your palm. It's a fixer of pipes and tubing. A drain-patching, paint-removing, putty-softening, jewelry-making, ice-melting, toy-mending, tool-repairing, go-everywhere, do-anything whiz of a tool.

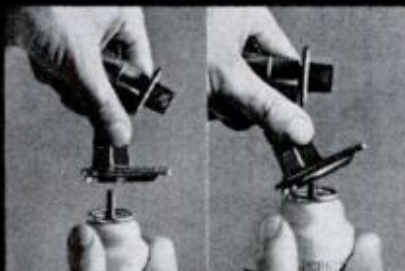

A SNAP TO FUEL: Place Ronson Varaflame® Torch in position over Ronson butane Multi-Fill® fuel injector and SNAP...you're set for hours of hobby-making fun, or serious professional work.

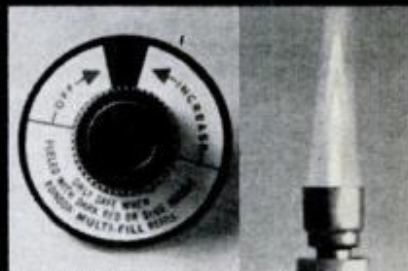

DIAL YOUR FLAME: Turn calibrated dial to precisely adjust from pinpoint to blowtorch flame to meet exacting demands of the most critical job.



STANDS ITSELF: Place torch on flat working surface. Tripod formed by torch head and Multi-Fill provides firm three-point stand, leaving both hands free for holding, bending and turning operations.



VERSATILE: 7- and 10-piece Ronson Varaflame Torch kits include three flame head attachments: Soldering Tip, Blowtorch Tip and Flame Spreader.

7-PIECE TORCH KIT with torch, 3 head attachments, 250 gr. Multi-Fill and idea book, \$9.95.*



10-PIECE TORCH KIT in plastic carrying case, 3 head attachments, 250 gr. Multi-Fill and idea book, \$11.95.*



RONSON®

The people who keep improving flame.

TALL or BIG MEN



FAMOUS BRANDS GO KING-SIZE ARROW • MCGREGOR • JANTZEN

We specialize in sizes for tall and big men. Popular, ARROW, MCGREGOR, JANTZEN Sweaters, No-Iron Shirts and Jackets. 4" longer bodies, sleeves to 38". Slacks with longer inseams, higher rise, waists to 60". 200 SHOE STYLES in Hard-to-Find Sizes 10-16, AAA-EEE.

THE FAMOUS KING-SIZE GUARANTEE
"You Must Be Completely Satisfied Both Before and After Wearing."

Send for FREE 128 Page Color Catalog

Please rush the new 128 Page Full-Color KING-SIZE Catalog of Apparel and Footwear for Tall and Big Men Exclusively.

Name _____

Address _____

City _____ State _____ Zip _____

The KING-SIZE Co. 4859 KING-SIZE BLDG
BROCKTON, MASS.

"RECREATION CAREER KIT" **FREE!**



... shows how men, women all ages can win good pay job as Playground-Camp-Sports Leader, Crafts-Nature-Social Director or one of 100's other "Fun Careers" in Recreation.

Big Demand! U. S. Labor Department predicts "750,000 new jobs by 1980!" Easy home-study plan. Send for big "RECREATION CAREER KIT"—**ALL FREE!** State your age.

Tom Harmon, NORTH AMERICAN SCHOOL OF RECREATION
4500 Campus Drive, Dept. 4170, Newport, Calif. 92660



Electric Razor
1.70

Calendar Watch 2.44

Auto \$954

START IMPORTING IN 10 MINUTES

MEN/WOMEN—BIG MONEY AT HOME First day profits! Make your first import transaction order 10 minutes after you get my plan. Thousands more dazzling products from overseas. Deal direct—below whole-sale prices. No product investment. Full or part time. Write for FREE BOOK today to...

MELLINGER, Dept. C225A, 1554 S. Sepulveda, Los Angeles, CA 90025

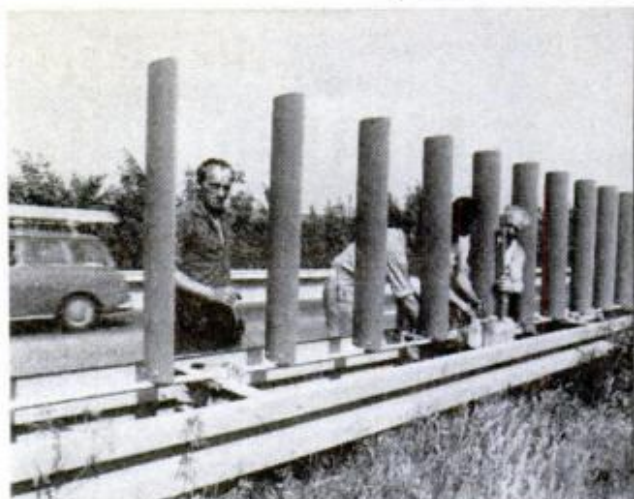

New barrier near Frankfurt

Posts that will give way if they're struck by an automobile are being erected on a highway barrier near Frankfurt. Added to the old barrier, the new posts give additional protection to motorists.



It's a tree, he says

Flowers and bushes he had—but no trees. So London sculptor Robert Simon created a 20-foot "tree" of galvanized gray metal, plastic, wire and a bright red bowl. However, a number of Simon's neighbors objected that it wasn't a tree at all, but an eyesore. Beautiful or not, Simon says the metal tree gives him superb television reception.

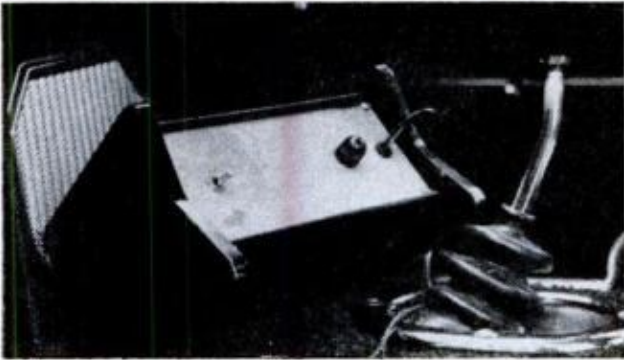
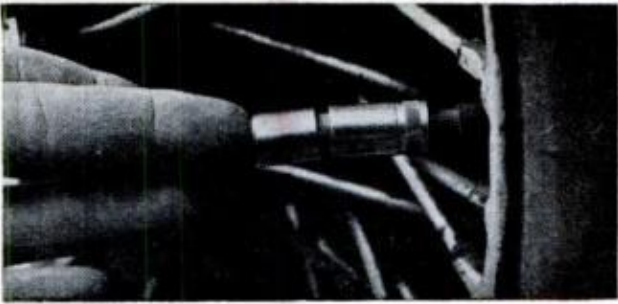

Early warning for flat tires

A tiny radio transmitter that fits on the valve of a car tire (top photo) is activated if tire pressure drops. It sets off a warning light on a receiver (bottom photo) in front of the driver. The experimental system is a British development.

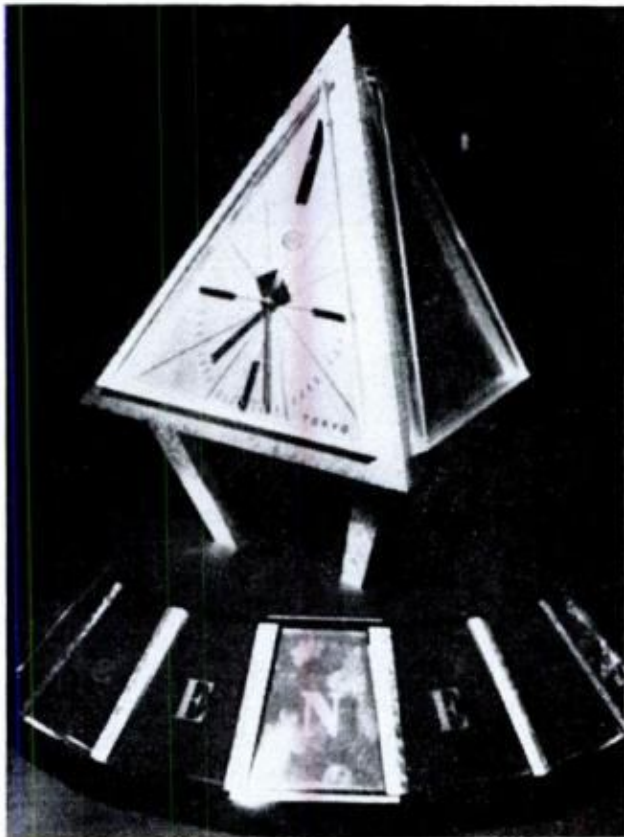

Plutonium power

Power for this Swiss clock is supplied by 150 milligrams of plutonium 238. The prototype is the first to use such a power source.

**Soup up
your engine.**

**Here's the
soup.**



GUMOUT. A canful in the tank does the job. Cleans your carburetor as you drive. Dissolves gum and varnish in the fuel system on contact. You'll start faster. Idle smoother. Get more power on less gas.

A can of GUMOUT in the tank three or four times a year will keep your engine humming a happy tune.

GUMOUT

Pennsylvania Refining Co., Cleveland, Ohio 44104

SWINGS EASY



PLUMB® FA57

A "Proven Performer"
for more than 14 years
Fiber-Glass handle
guaranteed not to break,
bend or collapse in normal use.
Dura-Cushion grip absorbs shock.

Advertised
Price
\$6.95

FAYETTE R. PLUMB, INC. • PHILADELPHIA, PA. 19137

HITS HARD

PUBLICATIONS **WORTH WRITING FOR** BY CATHERINE BILSKI

A NEW EDITION of the *Guide to Record Retention Requirements*—an 86-page reference tool that's fully indexed and easy to use—has over 2000 items listing the categories of persons, companies and products affected by Federal record retention requirements. Send 75 cents to the Superintendent of Documents, Government Printing Office, Washington, D.C. 20402.

MELAMITE DECORATIVE LAMINATES is the title of a brochure containing de-

tailed step-by-step instructions and line drawings showing how Melamite surfacing should be applied. It covers all the elements in a typical application ranging from the material and tools needed to the cutting and applying of the Melamite to countertops and backsplash areas or walls. Free by writing Johns-Manville, Advertising Dept., 22 East 40th St., New York, N.Y. 10016.

HOW TO WIN SUCCESS in *Your Own Secondhand Business* is the name of a manual that shows how to start and operate a secondhand business. Subjects covered include: picking a location, sources of merchandise, how to buy, sell, specialize and advertise, plus advice on all phases of the business. Price is \$3 postpaid. Order from Empire Publishing Co., Dept. 215, 13292 Euclid St., Garden Grove, Calif. 92640.



Duck hunters are tough customers. We like 'em.

Ask a diehard duck hunter why he shoots a Browning A-5. He might surprise you with his answer.

Probably, he won't even mention the sharp checkering and hand engraving. Or the select French walnut and handsome bluing. More likely, he'll tell of days when cold rain turned to stinging sleet. Or days when the snow blew so thick you could hear their wings whistlin' before you saw 'em.

And what he'll tell is how that Browning seemed to enjoy bad weather. Because the mechanism's

design is not complex — fewer working parts to get out of adjustment. Because the gunmaker gave the same attention to detail on the inside as he obviously did on the outside — no shallow heat treatments, no loose fit, machined steel parts.

Your duck hunter friend might surprise you when he says his Browning is the most inexpensive gun he's ever owned. He measures expense by the time his shotgun lasts . . . and he knows a Browning won't jam on a flight of greenheads . . . *no matter how fowl the weather.*



From \$184.75

12, 16, 20 ga. & 12 & 20 ga. Mag.

BROWNING
Finest in Sporting Arms®

Write for
FREE
CATALOG

Detailed information on all Browning guns and accessories plus special illustrated section of practical shooting information.

Copyright® Browning Arms Company 1969

Browning Arms Company, Dept. 229, P.O. Box 500, Morgan, Utah 84050
In Canada — Browning Arms Company of Canada, Ltd.



DISSTON

You can't get a better saw at a better price

When it comes to quality, nobody argues with the Disston name. Since 1840, Disston has been a leader in saw developments—like coating blades with industrial tough Teflon-S* for smoother, slicker cutting. Ask any carpenter about Disston—it's the saw they use. Other Disston tools including Teflon-S coated handsaws on Fall Sale at your hardware store. H. K. Porter Company, Inc. *T.M. Du Pont



For the craftsman—220SS—
now \$6.95. Save \$2.20



For the professional—D-230SS—now \$9.95. Save \$3.27

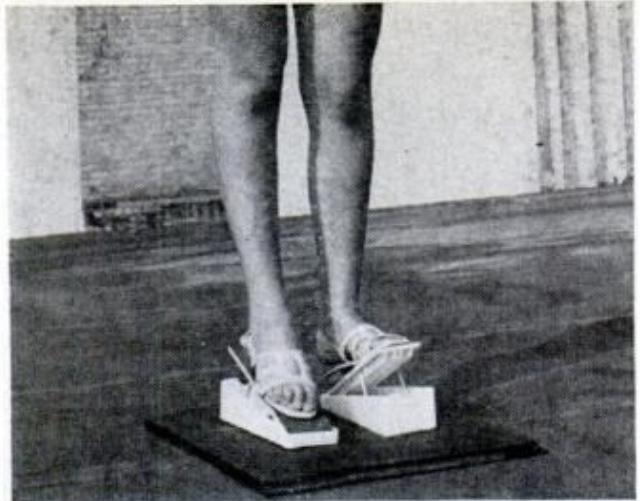

New angle on exercise

Plastic wedge-shaped blocks, upon which the user stands to do a series of exercises, are one of the newest "in-place" methods of keeping fit. The "Rela-Wedgies" are adjustable so that the user can increase the angle and thus get more benefit from them.



Moving day

A three-story stone house that had to be moved to make way for a filling station in France involved quite a bit of engineering. It was raised hydraulically, placed on railroad wheels and moved on special rails installed for that purpose.



**When we teach a skill,
the career comes with it.**

Grab a handful of opportunity. Set yourself up in a technical, administrative or industrial job with a secure future. Right now there are over 300 job training courses you can pick from.

And when you finish our training, you've got a job. The rest is up to you. That's what we mean by a career. We supply training and jobs. You supply the initiative.

So get the skill you need. The chance to make it on your own. Get in touch with your Army Recruiter. Who else?

Your future, your decision . . . choose **ARMY**.

Army Opportunities
Department 200
Hampton, Va. 23369

2PM 10-69

Send me more information on jobs with a future.

Name _____ Age _____

Address _____

City _____ County _____

State _____ Zip _____

Education _____



STRIKING INTERIOR is at once all function and all luxury. The seats have turnbuckle adjustable rake and extraordinary lateral support

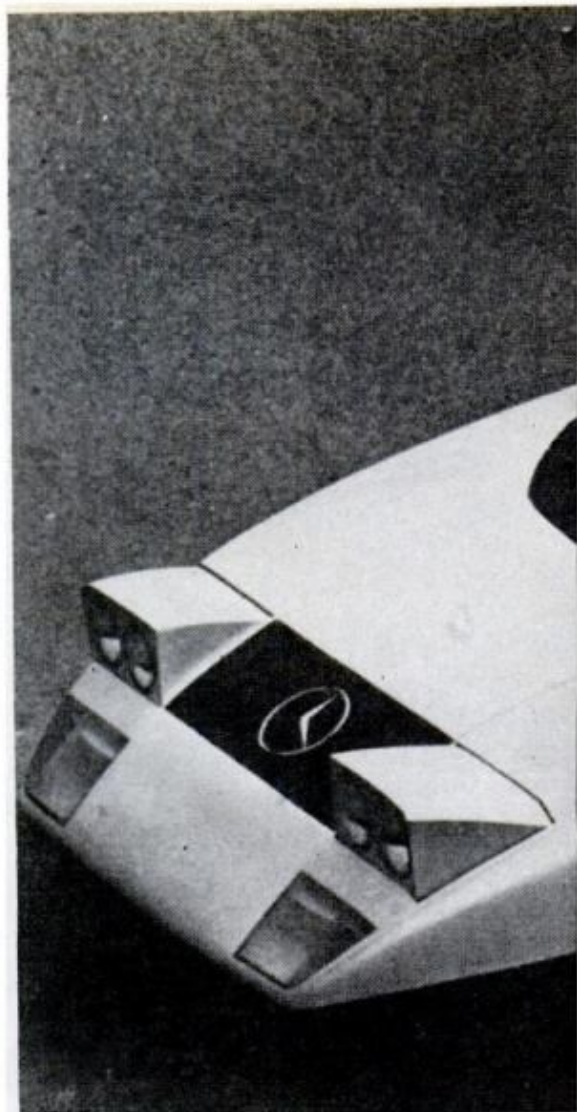
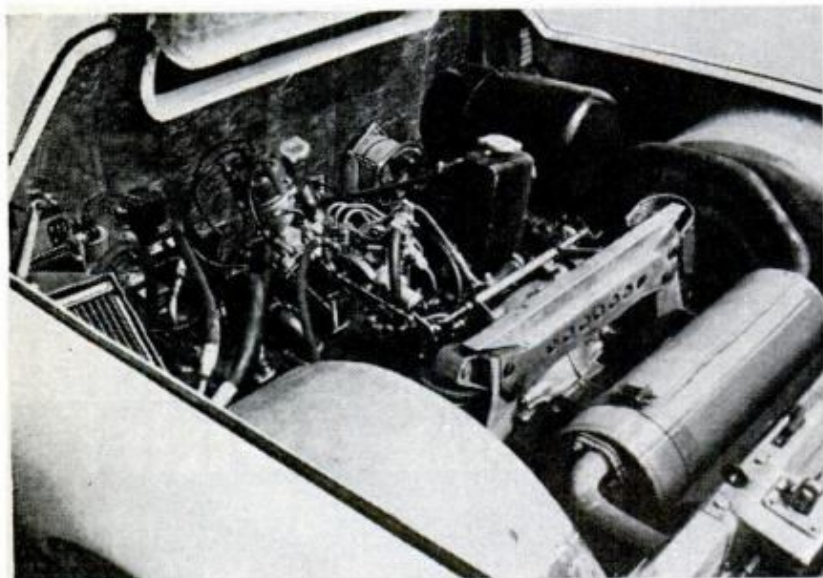

WANKEL POWERPLANT is a three-chamber design that puts out 280 hp geared through a box that gives the car an amazing acceleration

Mercedes Places Triple Rotor Amidships In New Limited-Production Sports Car

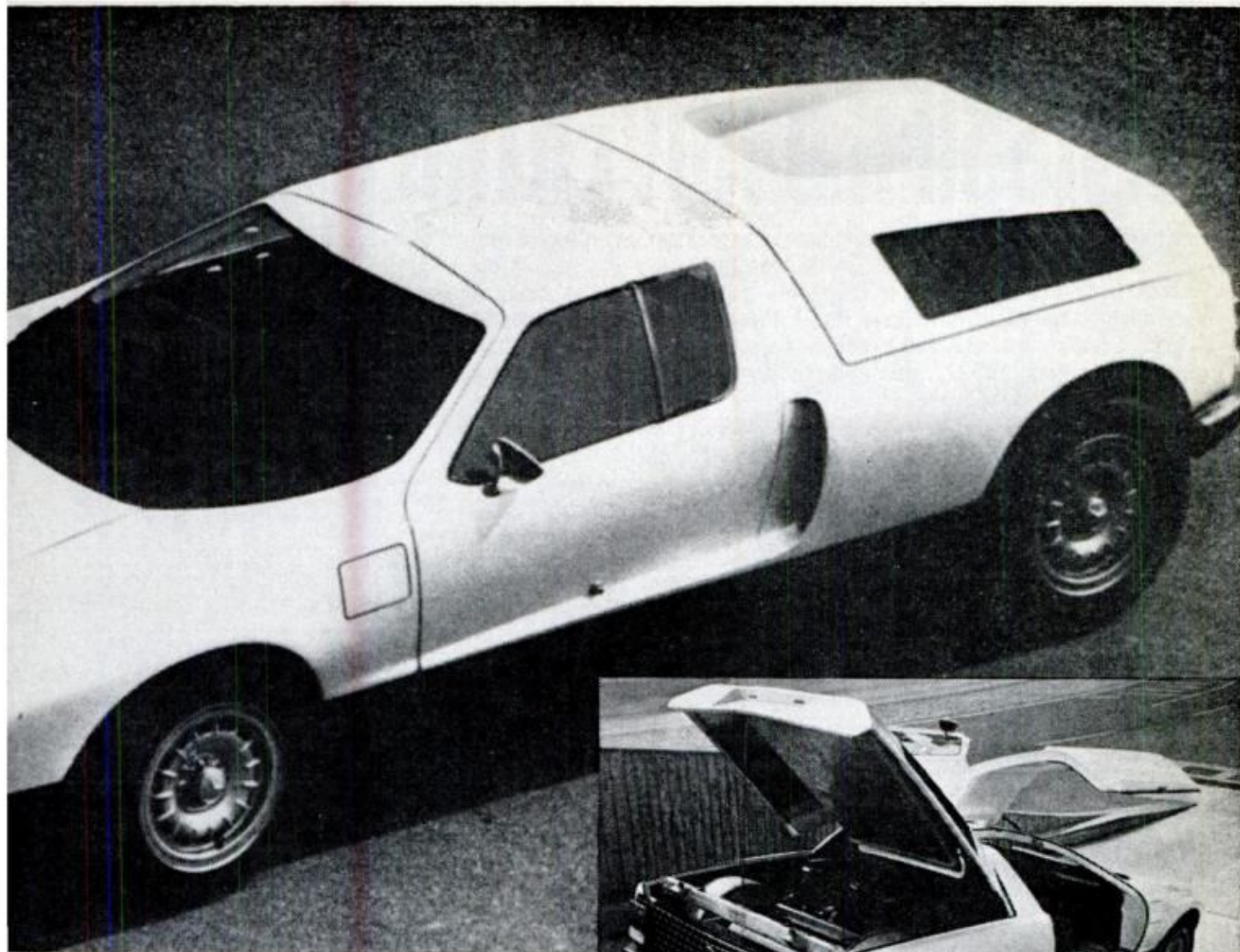

SLEEK SHOW STOPPER has low, aerodynamic profile for high maximum speed, retractable headlights, large disc brakes, weight distribution for superb handling



FLIP-TOP BONNET reveals placement of the three-chamber rotary combustion engine. Weight is just ahead of the rear axle

**Gull-winged,
Wankel-engined
C-111, just
unveiled at the
International
Auto Show in
Frankfurt, is
one of a kind**

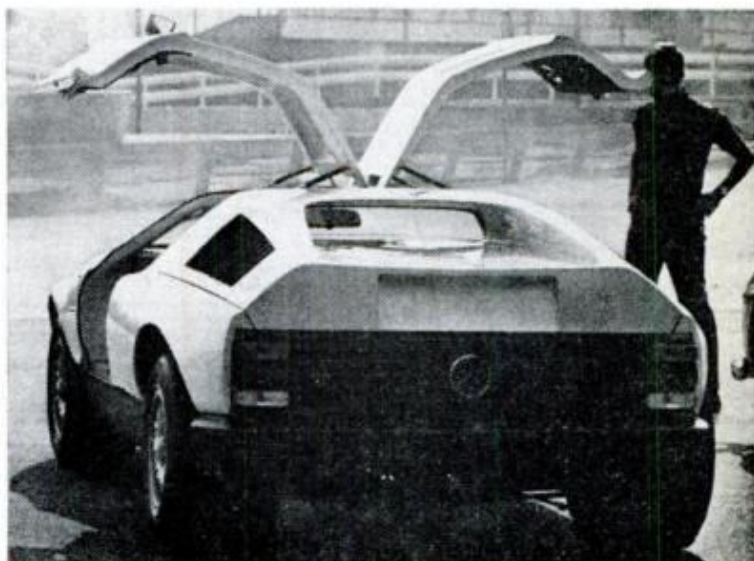

GULL WINGS SPREAD OPEN for driver and single passenger. Backlight arrangement is characteristic of mid-engine machines

CLASSIFIED ADVERTISEMENTS

Rate: \$1.85 per word payable in advance each insertion. Capitalized words—75¢ per word additional. Minimum insertion ten words. To be inserted under the proper classification, copy must be in our office by the 15th of the second month preceding date of issue. The next available issue to place an advertisement in America's No. 1 Classified Section is December. The closing date is October 15th. Send remittance and order to C. A. Martin, Popular Mechanics, 575 Lexington Avenue, New York, New York 10022. Please make remittance payable to Popular Mechanics.

POPULAR MECHANICS

CHRISTMAS GIFT SHOPPING

FREE Gift Catalog Quality Merchandise. E & T, 11720 So. Harding, Alsip, Ill. 60658.

BARGAINS! BARGAINS! SAVE \$50, \$100 or more on Nationally Advertised Products. APPLIANCES, TOOLS, STEREOS, CAMERAS, WATCHES, SPORT EQUIPMENTS, JEWELRY, CASSETTES and many many more. Credit Plan Available. FREE Information. Boston Shop, Dept. PM-109, 17 Etna Street, Brighton, Mass. 02135.

"QUALITY Gifts never out of season. Christmas, Birthdays, Anniversaries. Send for catalogue. Stamp appreciated. Woodland House, 2437A Tortugas Lane Ft. Lauderdale, Florida 33312."

MONOGRAMMED PLAYING CARDS. 2 decks \$2.95. Free catalog. The Shirley Shoppe, 17 Rundel Park, Rochester, New York 14607.

UNIQUE. Distinctive Gifts for Everyone. Write: Novak, 18720 Hatteras, Tarzana California 91356.

FREE Gift Catalog. Mountain Mart, 1123 G West Eighth, Cedar Falls, Iowa 56613.

GERMAN Clocks, free folder, Del Marsh Co., P.O. Box 767 Lompoc, Calif. 93436.

AUTOMOBILES

BUY almost any car for 10% to 15% less than wholesale. Send \$1.25 for full instructions. S. Smyth, 6 Blanchard Ave., Uxbridge, Mass. 01569.

MIDGET CARS

NEW Mini/Commuter \$800 complete. Information \$1. Shemorry's, Williston, North Dakota 58801.

AUTO SUPPLIES AND EQUIPMENT

PARTS: Army jeep and truck parts. Share Parts & Equipment Co., P. O. Box 751, Lexington, Ky. 40502.

NEW heavy duty CD ignition system. Details free. Kits \$28.95. Assembled \$39.95. Dealers invited. Delta International Ltd., Box 1946PM, Grand Junction, Colo 81501.

VOLKSWAGEN Replacement parts at 20% to 50% discounts. Free Catalog. Western Distributors, Box 316 D, Cedar Crest, New Mexico 87008.

CROSLEY. Foreign. American. Parts. Discounts. Accessory Catalog 616 Burnside, Inwood, New York 11696.

GAS-OIL HOG??? . . . Smoking ?? . . . No Pep?? . . . Hard Starting?? (Save \$150-\$250) with Motaloy Ring Valve Job While driving (\$6.50 postpaid) Advertised here every month for years! Continues saving money on repairs, gas, oil for 100,000 miles! Absolutely true! (new engines too) Nothing compares! . . . Money-back guarantee. You can't lose! Motaloy, Grantham, Penn. 17027.

BE Your own ignition expert. Free details. Q-arc, Box 47876, Los Angeles, Calif. 90047.

PROFESSIONAL MECHANICS needed as dealer/agents for unique stud wrench. Technical Imports, Box 242, Jackson, Mississippi 39205.

VX-6 PREVENTS battery killing sulphation, increases capacity. \$2.98 Rudolf Herford, 2729-B Midvale Ave., Los Angeles, Calif. 90064.

NEW INGRAHAM PORTABLE CAR CLOCKS. Instant installation. Fully guaranteed. Only \$4.95 ppd. Literature 25¢. Pompa Industries, Box 8544, Rochester, N.Y. 14619.

AMAZING INVENTION Automatically ejects car key into hand when ignition is turned off. Prevents locking keys inside auto. Discourages theft. Send \$1.50. Satisfaction guaranteed. Richmar, Dept. PM-1069, 144-08 32 Ave, New York, N. Y. 11354.

SIMPLIFIED Method to PAINT CAR with professional look. Send \$1.00. Castle Co., 45 Oxford Ave., Jersey City, N.J. 07306.

BEST CAPACITIVE DISCHARGE IGNITION Available. More Power. Better mileage and acceleration. Saves tune-ups. Free details, or order now, special \$29.95 offer (Refundable). Complete, not a kit! **ADVANCED ELECTRONICS.** 9004 Quintana Drive, Bethesda, Md. 20034.

AUTO Parts for old and new Cars. All makes. Catalogue \$1.10. Antique Auto, Milwaukee, Wisconsin 53204.

JEEP Owners—V8 conversions. Read Jeep Owners, ad. page 252.

SNOWMOBILES

SNOWMOBILE KITS \$25. Plans and photos \$1.00. Information 10¢. Compco, Box 1267, Redwood City, California 94064.

AUTO TRAILERS

PICKUP Camper, Trailer or Pickup—Cover . . . Build yourself. Save! Complete plans \$3.95 each Cover plans \$2.00. Conversion Plans—econoline type van \$2.95; passenger bus or delivery van \$2.95. Satisfaction Guaranteed. Equipment catalog \$1.00 (refundable). Details 10¢. Viking Camper Supply, 99-F Glenwood, Minneapolis, Minn. 55403.

BUILD Your Pickup Camper. Precut Kits. Blueprints. Supplies. Literature 25¢. Comstock Trailers, Dept. 664, Parsons, Kansas 67357

CAMPER Plans. Compact buses, Vans—Volkswagens, Econoliner, Dodges. Build yourself—Save! Details—Dot Campers, Box 2115M, Culver City, California 90230.

MOTORCYCLES, BICYCLES, MOTORSCOOTERS AND SUPPLIES

MOTORCYCLE TURN SIGNALS. Accessories. Catalog 25¢. Houston, PM Lockport, Illinois 60441.

HONDA 50-90-160 Speed Equipment. Cams—Big-Bore-Stroker. Columbia Engineering, 2105 E. 37 St., Los Angeles, Calif. 90058.

BUILD "Popular Mechanics" MINI-BIKE featured June 1967 issue. Detail plans, photographs \$2.50 refundable. Kits, parts, engines; factory discount prices. Catalog 25¢. Gilliom Mfg.; PMC; St. Charles, Missouri 63301.

SNOW VEHICLE & KART Hop up accessory CATALOG. Speed and performance equipment—manifolds, engine mounts, exhaust systems. Send 25¢. G.E.M. PRODUCTION, Box 845, Carol Stream, Ill. 60187.

BUILD Motorbike From Bicycle! Plans . . . \$2: Go-Cart Plans . . . \$2: Snowmobile Plans . . . \$3: Go-Byk Industries, Rothsay, Minn. 56579.

MINI-BIKES. Wheels, Chain Saws. Catalog 25¢. Loren Products, Danville, Illinois 61832.

INDIAN Engine & Parts service. Myles Indian Co., Sloansville, N.Y. 12160.

SPACE, ROCKETS AND ASTRONAUTS

SATURN V Apollo Flight Configuration. cutaway rocket 13 inches. 25¢. Astra, Box 234, Merritt Island, Florida 32952.

OUR FIRST 19 IN SPACE. This limited edition lithograph has been created as a tribute to Americas Gallant Astronauts. 12 X 18 inch chart ready for framing. Only 75 cents. Popular Mechanics, Dept. GWP, 575 Lexington Avenue, New York, New York 10022.



AVIATION

BE A Government licensed aviation mechanic. Practical training. Free information. Aero Mechanics School, Municipal Airport, Kansas City, Missouri 64116.

TREMENDOUS OPPORTUNITIES IN AVIATION. Learn Aeresciences at home: Navigation, Aerodynamics, Communications, Weather. Free Information: United Aeresciences, P.O. Box 4106, Torrance, California 90503

BARTLETT FLYING SAUCER. Amazing machine hovers 200 lb. man over land/water, powered by ordinary lawn mower engine. Easy to build. Fun to fly. Complete Plans, Kit Brochure and Photo Review \$3.00. Write: Herb Bartlett, Box 3234-C, Scottsdale, Arizona 85257.

AIRBOAT. Propellers, Engines, Plans, Kits, Supplies. Complete Airboats Outboard Airdrives. Catalog \$1.00. Banks-Maxwell, Box 3301E, Ft. Worth, Texas 76105.

HELICOPTER. One-Man. Portable. Kits, Plans, Information 10¢. Photos and three-view drawings \$1.00 Compco, Box 1267, Redwood City, California 94064.

FREE Catalog. Aviation Space Books. Aero Publishers, 329 Aviation, Fallbrook, Calif. 92028.

50TH ANNIVERSARY Specials and Traders (What have you?) List 20¢. 500 Museum-Quality Flying aircraft plans, Engineering Reference Library, parts, some kits! #4 Catalog 50¢. CleveModels, 10307 PM, Detroit, Cleveland, Ohio 44102.

AERO-CAR. Amazing Hovercraft built easily with ordinary tools. Lawnmower engine power. Carries one man plus. Hovers, flies forward, backward, sideways over land/snow/water. Complete construction plans and brochure, \$5.25. Aero-Projects, Box 5118PM, Clinton, N.J. 08809.

HOMEBUILT. Real enclosed helicopter, 24 pages ideas, information, \$2.50. Build "executive" helicopter, drawings, specifications, \$2.00. Helicopter Development, Box PM147, Washington, New Jersey 07882.

ANYONE Can build and fly amazing Bat-Glider. Plans, photos, flying instructions, \$5.00. Photos, information 50¢. Bat-Glider, Box 7115, Amarillo, Texas 79109.



BOATS

CANOES! Kayaks! Factory-direct quality kits, from \$25.00. Many different models. Canvas hulls. Strongest construction materials. Free literature Sportscraft, Box 8393-PM, Columbus, Ohio 43201.

BOAT PLANS, FRAME KITS, BOAT KITS. World's largest catalog—Over 200 top design for the amateur builders. New catalog includes Cruisers, Runabouts, Deep vee's, Catamarans, Trimarans, Houseboats, Sailboats from small sail fish to 34 ft. motor sailers, large selection of inboard and outboard Hydroplanes. Send \$1.00 for large new plan & kit catalog or \$2.00 for catalog plus Boat Builder's Guide. Clark Craft Boat Company, 16-P Aqua Lane, Tonawanda, New York 14150

BUILD Your own boat from our large-scale blueprints. Books of plans give how-to-build help. Hundreds of professional designs—motor, sail or auxiliary—for amateur builders. Free catalog. MoToR Boating, 959 Eight Ave., Dept. PM-RS, New York, N.Y. 10019.

FIBERGLASS Cloth and resin. World's finest cloth and non-run resin, at direct mill prices. Flotation foam. Complete line of plastics, silicon bronze and brass screws, save 60%. No sales tax. Boat Plans, Catalog 25¢. Freight prepaid. Stiles Boat Supply, Box 11P, Linden Ave., Mantua Hts., N.J. 08051.

PLANS, FULL-SIZE PATTERNS FRAME KITS with step-by-step instructions specially for amateurs. Send \$1.00 for new 95 page catalog of over 80 designs: 8' to 36' Sail, Jets, Inboards, Outboards, Cruisers, Houseboats, Hot Boats, Catamarans, Hydros "plus" boat trailers. New "How To Build Boat Trailers" book \$4.00 ppd. Glen Designs 9152 Rosecrans, Bellflower, Calif. 90706.

FIBERGLASS CANOES. Four Exciting Models. Easily Assembled Kits. \$39.95 up. Factory Direct. Free Literature. Riverside Canoes, Box 5595-B, Riverside, California 92507.

BOAT maintenance information, LIFE-CALK, "GIT"-ROT, RUB-R-COTE. Finishes & Cleaners. Send for "How to do Where to do" literature. FREE. Boatlife, 5-45 49th Av., L.I.C., N.Y. 11101.

FREE CATALOG from manufacturer of nylon and Dacron rope. Direct to you at dealer cost. Other important accessories. Write: West Products, Dept. 20, Box 707, Newark, New Jersey 07101.

New 1969 McCulloch And Other Outboards. 4 H.P. \$112 . . . 9 Electric \$288
18 \$338 . . . 25 \$378 . . . 40 Electric \$548
. . . 55 Electric \$748 . . . All Sizes Literature 50¢ Electra Marine, 1427 Broadway, Brooklyn, NY. 11221.

BOAT KITS. Molded Fiberglass. Save money—assemble yourself. Factory molded sections bond into one-piece craft. 30 models—14' to 33'. Cruisers, Runabouts, Houseboats, Sailboats. Big line accessories, motors, trailers. Easy terms. Free 88 page catalog. Luger, Dept. BC-69, 9200 Interstate 35W South, Minneapolis, Minnesota 55431.

AMATEUR Boat Building Magazine, plans, discounts, books, instruction. 1001-B Bevrige, Richmond, Va. 23226.

FREE Catalog! Camping, Boating, Sailing Supplies; Gadgets, Hardware and Gifts, Laacke and Joys, 1439 N. Water St., Milwaukee, Wisconsin 53202.

FREE Catalogue—plans for canoes, kayaks, accessories. Quicksilver, 115 McGavock, Nashville, Tenn. 37214.

200 BOAT Plans, some kits. Catalogs: Powerboat \$1.25, condensed 60¢. Sailboat 50¢. Marinecraft, Box 161M, Brighton, Mass. 02135.

MARINE EQUIPMENT AND SERVICES

CONVERT Auto engines to marine. 68 Page Catalog, 50¢. Lehman Manufacturing Company, 800 Elizabeth Avenue, Linden 4, New Jersey 07036.

NEW. Used, rebuilt marine motors. Marine conversions, fittings Free catalog. Stokes Marine Supply, Dept. 24, Coldwater, Michigan 49036.

FREE Catalog—Gary inboard, inboard-outboard marine engines—gasoline, diesel. Graymarine Corporation, Coldwater, Michigan 49036 or Berkeley, California 94710.

COMPETITION Marine Equipment. Over 300 items for complete auto conversions and installations in high performance SK and ski boats. Mail \$1.00 for new 72 page catalog complete with photos, specifications and prices. Glenwood Marine, Dept. PM, 1627 W. El Segundo Blvd., Gardena, Calif 90249.

FREE Ponton Boat Catalog. Dock Brackets, Float Brackets, Mooring Bars, Deck Ladders. Perma-D Marine Products, Dept. 35, 2308 Central Ave., Minneapolis, Minn. 55418.

BIG Discounts—Conversion Kits—Marine Engines—Manifolds—Transmissions—Outdrives—Free Brochure. Star Marine, Berkeley, California 94710.

RESTORE Tents, sails. Five specialized needles. Assortment quality crafted. \$1.00. State Service, Box 7923, Pittsburgh, Pa. 15216.

ATHLETIC AND BODY BUILDING COURSES

"GIANT Arms." Dr. Young's, D.C. revolutionary discovery. \$2. Satisfaction or refund. Gaucho, Box 9309-S7, Chicago 60690.

POWERFUL Muscles fast! Free brochure! Universal Bodybuilding. Box 427-C, Dearborn, Michigan 48126.

BEAUTIFUL MUSCLES FOREVER. ORDER TODAY—COMPLETE COURSE RUSHED WITHIN ONE WEEK—APPLY ENTHUSIASTICALLY FOR 150 DAYS—HAVE FAITH, NEVER GIVE UP. IT'S EASY, FABULOUS BUILD MUST RESULT, FAILURE IMPOSSIBLE. SUCCESS \$3.00 A109, Box 1434, MUSKOGEE, OKLAHOMA 74401.

WEIGHT Exercising equipment. Free literature. Box 662, Holyoke, Mass. 01043.

CATALOGUE—\$1.00 (no C.O.D.s) Every Book, Movie, Chart, Costume, Toughening Machine, Death-Touch, Poison-Hand in Gung Fu Where men, act, think, fight like Animals, Karate, Judo, Tai Chi, Persian, Indian Secret Weapons, fighting chains, Battle-Axes, Spears, Macs, Combat Knives, Teargas-Areosols: Single Purchase of KungFu Brick Crushing Iron Palm, Chinese Kickboxing Arts Books, Oriental Paralysis Stick, Cantonese twin fighting rods against three antagonists, gets catalogue, Instructions Free (tax we pay) 1/\$5.95, 2/\$10.95, 3/\$13.95 any combination; Orient East Imports, 3577 West Lyndale, Chicago, Illinois 60647.

SPORTING GOODS AND EQUIPMENT

FREE . . . Wholesale Catalog. Arrow Shafts, Broadheads Fletchings Fisharrow Parts, Tools, Bows, FinnySports, (22G), Toledo, Ohio 43614.

FREE 1969 Catalog. Guaranteed Lowest Prices! Rods Reels, Lures, Accessories—Thousands of Items. Cabela's Inc., Dept S, Sidney, Nebraska 69162.



FISHING, TACKLE, LURES

SEND for FREE Wholesale Catalog. The most complete and fully illustrated catalog of reels, rods, beads, spinners, jigs, bodies and parts, sinker molds, feathers, tools, hooks, rod blanks, rod parts, swivels, wire, etc. FINNYSPORTS, ME Sports Bldg., Toledo, Ohio 43614.

Molds—For casting your own fishing sinkers. Free illustrated booklet. Reading Instrument Co., Box P78, Reading, Pa. 19603.

MOLDS For fisherman's sinkers, jigs, squids, casting and spinning lures. Free catalog. Sweets Molds, Tonawanda 1, New York 14150.

NEW De-hooker a must for fishermen. Flips fish off hook with flip of wrist. \$1.00. House of McCall, 432 Avalon Drive, Danville, Virginia 24541.

EARTHWORMS, LIVE BAIT

EARN Money raising fishworms for us! Exciting details free! Oakhaven—56, Cedar Hill, Texas 75104.

BLACK Widow Spider Ranchers wanted!! Tremendous profits! Complete program \$1 (refundable). NBWC, Box 260-PM3A, Brigham City, Utah 84302.

HYBRID Redworms—3,000—\$5.75, 5,000—\$8.00, 10,000—\$14.00, Bedruns 20,000—\$18., postpaid with raising instructions. Brazos Bait Farms, R-9, Waco, Tex. 76705.

MAKE Money growing Fishworms. Outstanding new breed. Large size, tough, hardy. Plenty of action. They sell on sight. Free information. Fain's Hatchery-31, Edison, Georgia 31746.

FROGS, FISH, REPTILES

PROFITS FROM CLASSIFIED ADVERTISING!! Booklet shows you how to start your own business with Classified Advertising. Only \$1.00 (Refundable with first order.) C. A. Martin, Popular Mechanics, Dept. PM, 515 Lexington Avenue, New York 10022.



HUNTING, GUNS, DECOYS

YOUR Ad in Popular Mechanics will be seen by more than 5,000,000 active buyers for your products and services. It costs only \$1.85 per word. And, if you wish to run all or part of your ad in capital letters—you can do so for as little as 75¢ per word additional. Act now! Place your classified ad in Popular Mechanics today.



DOGS AND KENNELS

PROFITS FROM CLASSIFIED ADVERTISING!! Booklet shows you how to start your own business with Classified Advertising. Only \$1.00 (Refundable with first order.) C. A. Martin, Popular Mechanics, Dept. PM, 575 Lexington Avenue, New York 10022.



GAME BIRDS

QUAILS, Incubators, cages, supplies catalog. Marsh, 14216 Brookhurst, Garden Grove, Calif. 92640.

RABBITS—FUR BEARING ANIMALS

RAISE Rabbits successfully by knowing facts, 48 page illustrated book describing 25 breeds, Housing, breeding, feeding, markets, marketing etc. 25 cents. American Rabbit Association, 36 Arba Building, Pittsburgh, Penn. 15217.

MAKE Big Money raising chinchillas, rabbits, guinea pigs for us. Catalog—25¢. Keeney Brothers, New Freedom, Pa. 17349.

EARN \$10,000 Yearly raising angora rabbit wool, and breeding stock for us. Information 25¢ coin. American Angora Company, Malta 12, Montana 59538.

\$500—\$800 MONTHLY Raise small laboratory-breeding stock for us. We supply equipment, breeders, and instructions. Illinois Research Farms, Dept. MPB-10, McHenry, Illinois 60050.

RAISE Rabbits for us on \$500 month plans. Free details. White's Rabbitry, Mt. Vernon, Ohio 43050.

TAXIDERMY

PROFITS FROM CLASSIFIED ADVERTISING!! Booklet shows you how to start your own business with Classified Advertising. Only \$1.00 (Refundable with first order.) C. A. Martin, Popular Mechanics, Dept. PM, 575 Lexington Avenue, New York 10022.

PETS—BIRDS, CATS, HAMSTERS, ETC.

LIVE Traps, all sizes, mouse to dog. Collapsible or rigid. Carrying Cages. Free literature. National Live Traps, Tomahawk, Wisconsin 54487.

HAWKS, Reptiles, raccoons, skunks, squirrels. Catalogue 25¢. Trails End Zoo, St. Stephens, S.C. 29479.

LIVE SEAHORSES, Marine Specimens, aquarium supplies. Illustrated catalog 20¢. Marine, Box 248-310 Dania, Florida 33004.

WILDLIFE Pets—Catalog 10¢. Ray Singleton, Interbay Station, Tampa, Fla. 33611.

"AMAZINGLY PRESERVED SEA-HORSES. Secret process saves life-like color and appearance. Exciting fact sheet with each specimen. Send \$1.25 each. Send TODAY. Excellent teaching aid or collectors item. Other varieties available. Woodland House, 2437B Tortugas Lane, Ft. Lauderdale, Florida 33312."

BUY DIRECT—SAVE! Monkeys, Ocelots, Birds, Reptiles, Pet Books. List 10¢. Exotic Animal Importers Inc., Box 3069, Hialeah, Florida 33013.

HORSES, LIVESTOCK

"HOW To Train Horses"—Everyone who likes horses or ponies should have this book; Free. Write Beery School, 11010 Pleasant Hill, Ohio 45359.

CAMPING EQUIPMENT AND TENTS

SAVINGS Plus dividends! Campers-fishermen-outdoorsmen cooperative. Free 68-page catalog. Recreational Equipment, Inc., 1525-P 11th, Seattle, Washington 98122.

CAMPING

LATEST Camping Maps of United States and Canada. Complete trip planning information. Send stamp. Lightco, Rapids City, Illinois 61278.

SURPLUS Arctic clothing special survival gear and trail equipment. Catalog 10¢. Yeager's Supplies, Box 8138, Anchorage, Alaska 99504.

TRAVEL AND RESORTS

Your Ad in Popular Mechanics will be seen by more than 5,000,000 active buyers for your products and services. It costs only \$1.85 per word. And, if you wish to run all or part of your ad in capital letters—you can do so for as little as 75¢ per word additional. Act now! Place your classified ad in Popular Mechanics today.

ELECTRICAL SUPPLIES

I MADE Over \$100,000.00 year selling by mail. IRS proof available. Success story, book form \$2.00. Wayne Johnson, 880 SW 60th Avenue, Ft. Lauderdale, Florida 33314.

METERS—Surplus, new, used, panel and portable. Send for list. Hanchett, Box 5577, Riverside, Calif. 92507.

LAMP Parts. Catalog, prices, wiring instructions. 50¢. Refunded first order. Gyro, 5218P N.W. 35 Ave., Miami 42, Fla. 33133.

Lamp Parts for building, repairing converting. Catalog 40 cents. Refunded first order. Brown Lamp Co., Box 12511, Creve Cœur, Mo. 63141.

LO-VOLT Circuit Tester. Handiest! Free brochure; Mathco, 4256-1 Minmor, Cincinnati 45217.

PORTABLE LIGHT PLANTS 110-120 volt AC light plants. 60 cycle, fan belt driven from pickup or small gas engine. Operates: saws, drills, pumps, freezers, T.V. C1000watts, needs no battery. NOW \$59.50. 1500watts, 6 or 12 volt vehicles, NOW \$52.50. 3000watts, 6 or 12 volt vehicles, NOW \$89.50 Guaranteed. Check or money order. Mini-power, Box 328, PM Hallock, Minnesota 56728.

APPLIANCE-LAMP Parts. Wholesale catalogue 25¢. SECO, 109 South 20th Street, Birmingham, Alabama 35233.

BATTERIES, GENERATORS

BATTERY Reconditioning Kit, includes molds, material, instructions. Battery Shop, Route 1-188D, Blythe, Calif. 92225.

ENGINES, MOTORS, MAGNETS

WINDING Data, 275 motors, \$1.20. Data Company, 512 Kensington, Kansas City, Mo. 64124.

STEAM Engine Kits—automotive. Marine. Catalog 50¢. Reliable Industries, New Baltimore, Michigan 48047.

LIVE Steam powered backyard railroads! All sizes. Complete "bolt-together kits," and rough castings. Excellent drawings. 100 page catalog \$1.00. Little Engines, Lomita, Calif. 90717.

ELECTRICAL PROJECTS! Motors! Generators! Batteries! Electroplaters! "Mod-equip," Box 10025, Kansas City, Mo. 64111.

MAGNETS, Powerful Alnico—1"x1 7/16" diameter, weight 6¾ ounces, \$1.00 each. 3 for \$2.50. Mail Sales, Box 8497, St. Louis Park, Minnesota 55426.

MACHINERY, TOOLS AND SUPPLIES

I MADE Over \$100,000.00 year selling by mail. IRS proof available. Success story, book form \$2.00. Wayne Johnson, 880 SW 60th Avenue, Ft. Lauderdale, Florida 33314.

SMALL Foundry furnaces, Supplies. Free literature. Pyramid Products, 3736 South 7th Avenue, Phoenix, Arizona 85041.

HORIZONTAL MILLING MACHINE, Terrific Shop project—cut gears, keyways, slots—blueprints \$2.00 Microm, Box 2313-L, Santa Ana, Calif. 92707.

SURPLUS H.S. Cutters, Counterbores, Taps, and Taper Reamers plus Carbide Tools, only \$10.50 Dozen. Send stamp for list. Salme Enterprises, 15 Briarcliff Lane, Holden, Mass. 01520.

WELLER 8200 Sold. Iron Reg. \$7.95. Send \$5.25 plus \$1.00 for postage and handling. Tool Sales, P.O. Box 2272, San Leandro, Calif. 94577.

BANDSAWS—12" to 24"—Paul Kornau, 6503 Hamilton Ave., Cincinnati, Ohio 45224.

ROUTER Bits, 1/4" shank, high speed, used; excellent condition, \$2.50 dozen postpaid. Lillian's, Box 17165, Chicago, Illinois 60617.

MICROMETERS — Indicators — Rods — Lathes — Accessories, Campbell, 1424 Barclay, Springfield, Ohio 45505.

"HOPPY" Split Image Transit: For homeowners, contractors. Finely engineered to indicate level and incline accurately! With handsome leatherette case. \$14.95-PP, Money-Back Guarantee! Glen-Bel Enterprises, Rt. 5, Crossville, Tenn. 38555.

WELDING, SOLDERING, PLATING

CHROME Plating equipment, supplies. All other finishes. Home workshop and production sizes. Send \$2.00 (refundable) for formulas, operating data, equipment guide and catalog. HBS Equipment Division L50, 3543 East 16th, Los Angeles, Calif. 90023.

WELDERS—110/220, 150 Amperes, \$53.50. Morris, 1070 Inner, Schenectady, New York, 12303.

WELDER'S TEST GUIDE. Free information. Everett Smith, Box 191PM, New Castle, Delaware 19720.

GOVERNMENT SURPLUS

I MADE Over \$100,000.00 year selling by mail. IRS proof available. Success story, book form \$2.00. Wayne Johnson, 880 SW 60th Avenue, Ft. Lauderdale, Florida 33314.

GOV'T Surplus. How and where to buy in your area. Send \$1.00. Surplus information. Headquarters Building, P.M., Washington, D.C. 20036.

JEeps Typically From \$53.90 . . . Trucks From \$78.40 . . . Airplanes, Typewriters, Boats, Clothing, Camping, Sporting, Photographic, Electronics Equipment. Wide Variety, Condition. 100,000 Bid Bargains Direct From Government Nationwide. Complete Sales Directory and Surplus Catalog \$1.00 (Deductible First \$10.00 Order). Surplus Service, Box 820-A, Holland, Michigan 49423.

JEep and Gov't. Surplus Buying Manual (Jeeps Pictured) 50¢. Surplus Bargain Catalogue 50¢. Both \$1. Bargain Surplus, Box 789PM, York, Penna. 17405.

CASH IN ON GOVERNMENT SURPLUSES. Eliminate middle men. Complete new Government Agency Directory, 187 addresses, zipcodes, and telephone numbers. Over 2000 free publications, \$2.98 Cover Box, 283-B, Kent, Ohio 44240.

JEeps From—\$52.50; Typewriters from—\$4.15; Cars from—\$31.50. Walkie-talkies, motorcycles, airplanes, boats, Typical "As Is" bid bargains from Uncle Sam. Tremendous variety. Exciting free list. Write: Enterprises, Box 402X51, Jamaica, New York 11430.

SURPLUS BARGAINS—War, Government, Industrial surplus at savings to 80%! Clothes, boots, cots, tents—Bargains for farm, home, outdoors. **SEND FOR FREE CATALOG**—must give zip code. Surplus Store, Sioux Falls, S.D. 57102.

GOVERNMENT Sales depots listed nationwide. Copyrighted booklet gives all details for buying surplus. \$1.00. Crawfords, PM-109, 363 Poppy, Long Beach, California 90805.

1969 SURPLUS Army, Navy store illustrated catalog. Send 25¢ (refundable with first \$5.00 order). Ruvel, 707 Junior Terrace, Dept. 9-J, Chicago, Illinois 60613.

HOBBIES AND COLLECTIONS

Our first 19 IN SPACE. This limited edition lithograph has been created as a tribute to Americas Gallant Astronauts. 12 X 18 inch chart ready for framing. Only 75 cents. Popular Mechanics, Dept. GWP, 575 Lexington Avenue, New York, New York 10022.

PRESIDENTIAL Campaign buttons. Free list. Bristow, Box 1460-P, Los Gatos, Calif. 95030.

SHOULDER PATCHES—Official U.S. Army and Air Corps. Special patches made to order. 10 assorted patches, price list and catalog, \$2.00. Catalog only, 25¢. SPRINGER'S, Box 577, El Paso, Texas 79944.

COLLECT COINS For Profit! How To Start, Where To Sell. Lists of valuable coins. Check your change! Send \$1.00 Graylines Express, 4465A Janice Lee Dr., Okemos, Mich. 48864.

50 GORGEOUS Jungle butterflies \$2.50. Collectors Wonderland, Box 1170, New York, 10008.

CARS FOR COLLECTORS! Hard to find 1/43 die casts—not kits. Catalog 30¢ coin/stamps. Sinclair's Box 8068 (PM-2) Erie, Pa. 16505.

JAPANESE Suicide Emblem 25¢; Iron Cross with ribbon \$1.50; Illustrated catalog 25¢. Insignias, Box 71-M, Rockaway, New York 11694.

POSTCARDS. Navy ships, 35 for \$2.00. Marine Photos, P.O. Box 425, Spring Valley, Cal. 92077.

REINDEER Antlers full rack \$17.50. Whale Baleen silver to jet-black \$4.75 lb. Whale vertebrae \$1.95 lb. Maruskiya's, Nome, Alaska 99762



STAMP COLLECTING

PENNY! Approvals! Regardless catalogue! Kloster, 4164 52nd St., San Diego 5, Calif. 92105.

500 DIFFERENT Stamps, \$1.00. Smith, 508-A Brooks, College Station, Texas 77840

50 YEARS Old, fifteen different United States, over fifty years old—10¢ with approvals. Jaxon, Box 145-P, Brooklyn, New York 11230.

"AFRICA." 25 beauties, 10¢. Approvals. Gorliz, Box 1915PM, Naples, Florida 33940.

MILLIONS Foreign Stamps! 2¢ each! Send for gigantic approvals! ABC, Box 6000-MB, San Francisco, California 94101.

FREE Surprise collection sent with approvals. Gould, 1784 Union, San Francisco 94123.

50 DIFFERENT Old U.S. Revenue stamps 50¢. Winchester Stamps, Box 1592, Mansfield, Ohio 44907

FREE!! Two Beautiful Multi-Colored Complete Mint Sets. Approvals. Hamilton, 1246 Pratt, Chicago OE-10, Illinois 60626.

FREE 50 Worldwide. Approvals. University Stamps, P.O. Box 1471, Lake Worth, Florida 33460.

WORLDWIDE Approvals. Humphrey, 805 24th Ave., Santa Cruz, Calif. 95060.

UNITED States commemorative collection containing 33 different—10¢ Approvals. White, 516-A Avenue L, Brooklyn 30, New York.

GIANT Stamp Collection including: Astronauts, Satellites, Moonrockets, Boy Scout issue, Complete U.N. Set, recent Olympic and Sport issues from many countries, etc., Plus Big Stamp Dictionary and approvals. Everything, 10¢! Stampex, Box 47-RM, White Plains, N.Y.

ABSOLUTELY Free 25 different United States Commemoratives when requesting United States Approvals. K & B, Box 70, Brooklyn, N.Y. 11223.

EXCHANGE Send 100-200 Different stamps with 25¢. Receive different. Patterson, Lancaster, New York 14086.

FREE! Big Bargain Catalog—New Edition listing thousands of bargains including U.S. & B.N.A. stamps, packets, albums, accessories and supplies. Also, fine stamps from our approval service which you may return without purchases and cancel service at any time. Jamestown Stamp, Dept. E109PM, Jamestown, N.Y. 14701.

WOW! 110 All Different Germany 10¢. Commemoratives, Airmails, High Values, Big catalog, bargain lists. Also, fine stamps from our approval service, which you may return without purchases and cancel service at any time. Jamestown Stamp, Dept. A109PM, Jamestown, N.Y. 14701.

COUNTRY Collections: Free List. High Value Packet \$2. Persile 436 New York Ave., Brooklyn, N.Y. 11225.

U.S. Mint specials! Flag set, complete \$1.00. 1¢, 2¢, 3¢ famous Americans (21 different) \$1.00. Free list. Brooks, 2601 Avenue "U," Brooklyn, N.Y. 11229.

ONE Pound value Geo. VI Bermuda, plus 100 worldwide 10¢ approvals, Stevens, Box 105A, Homecrest Sta., Brooklyn, N.Y. 11229.

"INVERTED ERROR" Dag Hammarskjöld, 6¢ with approvals. Belmont Stamps, Washington, D. C. 20015.

14,000 DIFFERENT! AMAZING new plan builds your collection systematically, country by country. Only 50¢ weekly. Ware, Monroe, Conn. 06468

2,000,000 STAMPS 150 Countries 2¢ each. Belden, Box 4175, Dearborn, Mich. 48126.

AFRICAN TRIANGLES! Plus Van Dyck Art, Kennedy Memorial, Sport Championships, Colorful Insects. Plus big bonus collection of 25 exotic Persia. All only 10¢! Approvals included. Yukon, Dept. K, Box 834, Church Station, New York, N.Y. 10008

50 GREAT BRITAIN from 1881 to date. Catalog price \$2.60—Introductory offer—only 10¢ with approvals. Roger Williams Stamp Co., Box 1281-P2 Pawtucket, R.I. 02862.

FREE Large Colorful Pictorials with Approvals. W. Lamkin, Farmington, Maine 04938.

DWIGHT EISENHOWER Memorial stamp on special cacheted envelope addressed to you. Will have official Oct. 14 First day postal marking from Abilene, Kansas 35¢ each or 3 for \$1. K. M. Walsh, Box 308 Tuckahoe, N.Y. 10707.

PENNY Stamps! 1000 Mounted in book at 1¢ each. Trust Stamp Company, P.O.B. 132-P, Jamaica, N.Y. 11435.

100 OLD United States between 1861 and 1935. \$1.00. Roush Stamps, 51 Chestnut, Mansfield, Ohio 44903.

FREE! Triangles, Scout, 25 others. Approvals. Cambridge, Box 411, Cambridge, Ohio 43725.

RUSSIAN Space set 10¢. Russian approvals. Snedco, Box 68-P, Waldwick, N.J.

TOPICALS—Three Colorful Sets, 10¢! Approvals. COLE, Box 223A, Buffalo, N.Y. 14221.

U.S. Approvals Low prices. Eagle, 2221 Romine Ave., Pittsburgh, Pa. 15226.

225 STAMPS for only 10¢! Airmails, Pictorials; stamps from strange countries cataloging up to 25¢ each! Plus unusual stamps to examine. Buy any or none return balance, cancel service anytime. Mystic Stamp Co., Camden 80, New York 13316.

RUSSIA High-Value Collection. 32 different Russia—some over 50 years old! Commemoratives, Czarist Issues, Airmails. Catalog price \$2.50. Special Get Acquainted Offer—all for only 10¢! H. E. Harris, Dept. GG-49, Boston, Mass. 02117.

FREE Stamp Wallet with approvals. Wide choice collections by Countries. Clark, Box 428, Northbrook, Illinois 60062.

VIETNAM 25 Different 10¢ approval. Sam Chazen, Box 95, Ozone Park, N.Y. 11417.

RUSSIAN Colorful Topical Set Free! Approvals. Iannuzzi, Box 76241-PM, Los Angeles 90005.

FREE Surprise Bonus with Approvals. Collier, Box 755, Folkston, Ga. 31537.

INDONESIA 50 Different 10¢. Catalogues \$2.75. Approvals, Hijop Box 505, Norristown, Pa. 19404.

FAR East Assortment—Stamps from Viet Nam, Japan, Korea, Formosa and others only 10¢ with world-wide approvals. Clark Stamps, Dept. 57V, Muskegon, Mich. 49444.

STAMPS Free! New issues—New Countries—Triangles—Rockets—Olympics—Scouts—Birds—Flowers—Animals—Also old Canadian and U. S. Stamps. Plus complete illustrated Canadian Stamp Catalog. Send 10¢ for mailing. Gray Stamp Co., Dept. A, Toronto, Canada.

500 DIFFERENT Worldwide Beauties 25¢. Approvals. Treasure, Box 4155M, Tulsa, Oklahoma 74104.

SWITZERLAND 25 Different 10¢ approvals. Gouge, Box 88, Elizabethton, Tennessee 37643.

WORLD AIR MAILS \$1. Pkt. Eagle-Kiwi Stamps, Box 108, Sag Harbor, New York 11963.

PAINTINGS 25 Different 25¢ with approvals. Rudner, Box 2462, Hialeah, Florida 33012.

50 DIFFERENT Canadian Stamps, 10¢ with approvals. Oroszky, P.O. Box 1-C, Sarnia, Ontario, Canada.

WEST GERMAN Commems, recent, large, 50—\$1.00, 120—\$2.00. Langheinrich, D 8000—Muenchen, 23 Stury Strasse.

555 WORLDWIDE Different—\$1.00 With Foreign Approvals—Klondike, Harrisburg, Illinois 62946.

50 DIFFERENT United States Commemoratives only 10¢. Approvals Included. Shelton, Box 547 C, North Miami, Florida 33161.

\$1.00 FOR 25¢. Take stamps worth \$1.00 from first approval selection. Send quarter today. Valley Oak Stamps, Box 3101, Visalia, Calif. 93277.

"WHOLESALE" U.S.—Foreign Pricelist and catalog Free! Everything Guaranteed. Schneider, Box 1240, Grand Rapids, Michigan 49501.

50 PAINTINGS \$1.00! 50 Space \$1.00! No approvals. Ross, Box 152, Wayne, Pa. 19087.

FREE PACKET LIST. Kucher, 167 Cleveland Ave., Colonia, N.J. 07067.

25 LARGE Poland stamps, 15¢. No approvals. Jack Field, 2109 N. Argonaut, Strickton, Calif. 95204.

GOLD Proof Coin Stamps \$1.00. Bick, Box 46695, Los Angeles, California 90046.

FREE 50 Different Stamps to approval Applicants. Write I. J. Stamps, Box 644, Bloomington, Ill. 61701.

BARGAINS In Old Used U.S. Seconds. Karl Swartz, Mountain Home, No. Car. 28758.

QUALITY AND LOW PRICE. EXCELLENT For advanced or beginner. Mounted approvals 2¢ up, all countries in Scott's Order. Preview Stamps, P.O. Box 9809M, San Diego, California 92109.

HIGHEST PRICES paid for collections or odd stamps. U.S. & Foreign Stamp Exchange, 1232 Neil Ave., PM1, Columbus, Ohio, 43201.

1500 WORLDWIDE \$1.00 off paper. No approvals. Regency Stamps, Box 8854, Pittsburgh, Pa. 15221.

PICTORIALS—Large Beauties! Terrific collection includes exciting outer space issues plus many others—10¢ Approvals. Shaw, Drawer E-54, Montevallo, Alabama 35115.

RUSSIA 25 Different 5¢. Approvals, Iwasaki, Box 599, Chicago, Ill. 60690.

SEND 12¢ For special sale list. Penniston, Room 302, 6000 Stevenson, Alexandria, Va. 22304.

PINEAPPLE Mangces Triangles, Greenland Gorilla, 25 others 10¢ Approvals, Lichvar, 11806 Princeton, Cleveland, Ohio 44105.

FREE—Mint British Colonials from Sabah, Seychelles, Tristan Cunha, Sarawak, Negri Sembilan, Caymans, South Georgia. Free with approvals. Viking, Great Neck, 8, N.Y.

500 CANADA Mixed 25¢. Approvals. Continental, 271M Pinecove, Burlington, Ontario, Canada.

PICTORIALS! 50 Different large only 10¢, with colorful worldwide approvals. Gordon McCoy, Box 887-P, Chicago, Ill. 60690.

EXTRAORDINARILY Beautiful! 31 Magnificent Painting Masterpieces 25¢ with unmounted pictorial approvals 2¢ and up. Blue Chips, 1806PM Metzertott, Adelphi, Maryland 20783.

RUMMAGE Sale Penny Approvals. Stamp Mart, Box 272, Mesick, Mich. 49668.

NUDE Painting set. Amazing Trade-In Exchange Plan. Approvals. 25¢ Stamp Club Unlimited, Box 5332-PM2, Inglewood, Calif. 90310.

FREE!! 25 US Commemoratives, 2" diameter Magnifier. Postage—10¢. Approvals. Mixdrak, 5630 West Wilson, Chicago 60630.

U.S. APPROVALS. Postage paid both ways. Cross, 1212 Lynch, St. Louis, Mo. 63118.

115 DIFFERENT Including Ceylon, Canada, South America and pictorials for 25¢ with approvals. Camelot, Evensville, Tennessee 37332.

MOON Stamp. Valuable first day cover. Colorful astronaut envelope. \$1.00. Stout, Drawer J, Cape Canaveral, Florida 32920.

GIGANTIC List, 200 different stamps, approvals. 15¢. Valley, Box 5061, Evansville, Indiana 47715.

FREE Mint set. Approvals accompany. Stamps, Box 22092, Memphis, Tenn. 38122.

ASTRONAUTS—Space stamps, 100 all different \$1.00. Approvals. George Bell, 1115 Barnes, Milton, Florida 32570.

100 WORLD wide, includes Space Set. 10¢ with approvals. Stampede, Box 2772, Culver City, Cal. 90230.

SPACE ACHIEVEMENTS interesting set 10¢ with approvals. M.B. Stamps, Box 27366, San Francisco, California 94127.

50 DIFFERENT Indonesia. 20¢. Approvals. GJC, P. O. SUB 28, Saskatoon, Canada.

INCREASE Your Collection! 200 different China many topicals \$1.-. 400 different **MAINLAND CHINA** \$2.- Postpaid. Request special mixture-pricelist. Rolf Gummesson AB, Kungsgatan 55, 11122 Stockholm.

SPAIN 25 beauties, 10¢ approvals. Herman Mills, 237 Ashworth Avenue, Toronto 4, Ontario, Canada.

1000 DIFFERENT Stamps \$2.00. Dale, 1959 Clays Mill Road, Lexington, Ky. 40503.

"RUSSIAN Bear in Berlin Set. Only 10¢. Approvals. Ken Zielski, Box 364-M, Morton Grove, Illinois 60053."

VATICAN Xmas Set 60¢ Approvals. Barricks, POB 7154, Detroit, Mich. 48202.

1500 FOREIGN \$1.00; 5000 \$3.00; 9000 \$5.00, 5000 USA \$3.00, contains airs, dues, 19th Century, presidentials, revenues, high values, etc. 200 large size only (your choice of USA or foreign) pictorials and commemoratives \$1.00; 700 \$3.00; 3000 \$12.00. No approvals. Meyers, 5321 Fleming, Richmond, Calif.

FRENCH Art, "Saint Savin" 25¢. Request worldwide approvals. C. & F. Stamps, 655 Forbes St., East Hartford, Conn. 06118.

125—WONDERLAND Collection. Paintings, Rockets, Triangles, 10¢ With approvals, Dealing, Box 185, Long Lake, Minnesota 55356.

EUROPE, BRITISH EMPIRE. United States, packets, sets, singles. Wide variety! Lists sent free! Faville, Box 4164 Brookwood, Madison, Wis. 53711.

10 CANAL ZONE 25¢. Approvals! Merkel 30 Grandview, South Hadley Falls, Mass. 01075.

FREE 121 Flag Stamps with approvals. W-B Stamps, Wilkes-Barre, Penna. 18703.

704 U.S.A. (Plenty Commemoratives)—25¢. Approvals. Horace Gatewood, Winston-Salem, North Carolina 27102.

PAINTINGS, 25 Different 20¢. Approvals. Boyd, Box 423, Delevan, N.Y. 14042.

AFRICAN Witch Doctors, Tribel Chief's Headdress. Rwanda's Latest Commemoratives—Free! Approvals plus 101 Bonus Sets. William Deems, 226A Race, Ravenswood, West Virginia 26164.

FREE! Giant First Moon Landing, with approvals. Postmark, Great Neck 9, N.Y.

U.S. Bargain, 50 different 10¢, with beautiful worldwide approvals. Stamp Center, Kennebunk, Maine 04043.

50 DIFFERENT U.S. Commemoratives, 10¢. Approvals. Cambridge, Box 411, Cambridge, Ohio 43725.

NEW Countries, New Issues. Free gift with approvals. Ernest, 1784 Union, San Francisco 94123.

TEN Different Nudes: 20¢. Approvals. Stamp Farm, 2M11, Oxford, Wis. 53952.

TWO Cent Approvals. The Best. Scotty Stamp Co., Box 155, Staten Island, New York 10301.

COINS, TOKENS, CURRENCY

PRICE List. Send 10¢. Village Coin Shop, Dept. P. Plaistow, N.H. 03865.

UNITED STATES Specials: Half Dime before 1873, \$3.00; Large Cent before 1857, \$3.00; 1893 Columbian World's Fair Half Dollar, \$3.00; Old style Large \$5.00 bill, \$12.00; All four offers \$20.00. Moneyback Guarantee. Raroca, 31-A, North Clark, Chicago 60602.

UNCIRCULATED Dollars, 1880-81-82 S, 1883-84-85-1889-1900 01-02 O mint. \$3.50 ea. Catalogue 50¢. Shultz, Salt Lake City, Utah 84110.

FREE Bargain Lists—35 Different brilliant uncirculated Lincolns plus 2 Free Albums (\$6.95 Value) Special \$3.50; Ten Indianheads \$2.75; Five V-Nickels \$1.50; Silver Dollars \$225 Each. Pacificoin, Box 274-M, Downey, California 90240.

SIX Different Mercury Dimes \$1.00. Bargain Lists Free. Sayers, 1000 Unaka, Johnson City, Tennessee 37601.

HARD To find "S" mint cents 1940-S thru 1969-S \$1.50. Kennedy-Lincoln strange but true set in holder \$1.75. Scenner, Box 5049C, Sherman Oaks, Calif. 91413.

1852-1858 "50¢ CALIFORNIA Gold Pieces". All seven different mounted in gift box presentation. With framable parchment map of old California. \$4.50. Heritage Society of America, 422 Washington Building, Washington, D.C. 20005. Scuenirs Guaranteed!

SCARCE Date Jefferson nickels. All V.G. Satisfaction Guaranteed. 1942D—1949S—1950—50¢ each. 1943D—1951S—1955—75¢ each. 1939S—\$1.25. 1938D—\$1.65. 1938S—\$3.25. 1939D—\$5.00. 1950D—\$14.50. Dates not listed 20¢ each. Bryson Inc., 612A White, Toledo, Ohio 43605.

50 MIXED "S" cents, includes uncirculated 1955S, new 1968S, 1969S. Only \$1.95. BONANZA, Box 820P, Cupertino, Calif. 95014.

UNITED STATES Coins Cheap! Retail Catalog, 25¢. Buying (prices paid) Catalog, 50¢. Currency Valuation Catalog, \$1.50. Max's, Box 7055—BN, Minneapolis, Minnesota 55411.

TRUNKFUL 25,000 Indian-Lincoln cents from the 1920's & older, mixed 'grab-bag' style. 150-\$10; sample bag of 20-\$2. Mrs. Nan Fischer, Box 743, Encino, Calif. 91316.

LINCOLNS, 140 Different 11.95. Free List. Jewelry City Coin, 5 Angell, Attleboro, Mass. 02703.

LINCOLN'S "S" Mints, 3 Different Only 5¢. Stevens, Box 546F, North Miami, Florida 33161.

FREE Album with EACH order. 95 different **WORLD MINT SETS** \$69.95. Starter kit, 40 sets with **FREE** album \$29.95. The perfect **CHRISTMAS GIFT**. Satisfaction or money refunded within 7 days. **THE COIN EXCHANGE**, P.O.B. 85Y, Greenbelt, Maryland 20770.

BRILLIANT Uncirculated Silver Dollars: 1881-O, 1882-O, 1883-O, 1884-O, 1885-O, 1886, 1887, 1889, 1899-O, 1900-O, 1901-O, 1902-O each \$3.50. Any Ten Different \$33.75. Bargain Lists 25¢. Bebee's, Incorp., Omana, Nebraska 68111.

SILVER War nickel. Coin list, 25¢. Economy Sales, Mansfield, Mass. 02048.

20 UNCIRCULATED Foreign Coins \$1.00. Coins, Box 35041, Minneapolis Minnesota 55435.

COIN Supplies: wholesale, retail; free catalog. Special: dozen plastic mint set holders \$1.95. Tonka Hobby, Box 166, Wayzata, Minnesota 55391.

100 INDIAN And Lincoln Cents 1930'S And Older \$5.00. 40 Well mixed buffalo nickels \$5.00. 100 mixed 1943 steel cents \$5.00. Wesly Rood, West Union, 4, Iowa 52175.

INDIANHEAD Cents, V-Nickels, Eight different \$1.98. Pricelists. Edel's, Carlyle, Illinois 62231.

RARE 1969S Uncirculated Cent. Wooden Nickel and pricelist 10¢. Lawrence, Anamosa, Iowa 52205.

CENTENNIAL tokens, Sample and list \$1.00. Nick Myszuk, Wildwood, Alberta, Canada.

49s LINCOLN and price list 10¢. Rich, Box 34133, San Francisco Cal. 94134.

INDIANHEAD, V-Nickel and Morgan Dime \$1.35; Terrific List! Nelson, 346-P, Rye, New York 10580.

SPECIAL! Eagle Cent \$2.75! Bargain List! Coins Wanted! Fairway 121-P, Rye, New York 10580.

"COMPARE And Save!" Lincolns: 25 "S" including 1955S, \$1.50, 30 1909-1939, \$1.50. 33 Uncirculated (New), 1954-1969P, D. S. complete! (Regularly \$6.60) just \$2.75. 12 "S" Jeffersons, \$1.50. 23 Mercury Dimes, \$3.95. 10 "S" Roosevelts (1946-1955s complete), \$2.95. All different Silver Dollars, \$2.35 each. 60 MIXED "S" cents, includes Uncirculated 1955S, new 1968S, 1969S, \$1.90. "Special!" 50 Buffalo Nickels—all FULL dates! \$6.95. Free gift and pricelist with order! Kennedy's 18488 Dept. D Saratoga, Calif. 95070.

5,000 PENNIES GUARANTEED unpicked from our vending machines, 55.00 First Vending Company, Box PM, 5322 Belmont, Chicago, Illinois 60641.

RARE Lincolns: 1909VDB, 1915PD, 1916PDS, 1917PDS, etc. to 1943PDS Inclusive, SIXTY Different \$7.95. Catalog 20¢. Roger's, 3531-M West 29th, Minneapolis, Minnesota 55416.

GOLD COINS of the World. Beautiful low prices. Plus thousands of United States Coins. Free price list. Please send long, airmail envelope, self-addressed, stamped, Silver Center, Box 22171-M, San Francisco, California 94122.

(SCARCE) Jefferson's 1942D 50¢, 1938S \$3.25, 1939D \$5.00, 1950D \$14.50. Lacheen, Box 1073, Phila., Pa. 19105.

40-PAGE Illustrated United States and Canadian coin list 10¢. Stoney, 260 Washington, Boston 8, Mass.

ANTIQUES, RELICS, INDIAN GOODS AND CURIOS

TONS Of antique gun parts and supplies. All reproduction muzzle loading guns. Send \$1.00 for enlarged illustrated catalog No. 118-A. Dixie Gun Works, Union City 12, Tennessee.

LIST Indian relics, 10 Arrowheads \$3.00. Hyde's, Box 2304, Santa Fe, New Mexico 87501.

10 PERFECT Arrowheads \$4.00. George Smith, 9825 Conway Drive, Indianapolis, Indiana 46236.

SAVE money with ANTIQUE DEALER'S HANDBOOK, for more information write to: Coldstream Sales, P.O. Box 9891, South Town Branch, Dept. PM 1069, Rochester, New York 14623.

MODELS—SHIPS, TRAINS, PLANES, ETC.

ROCKETS: Real flying models—flights up to 2500 ft. New illustrated catalog 25¢. Single and multistage kits, cones, engines, launchers, trackers, rocket aerial cameras, technical information. Fast service, Estes Industries, Penrose 2, Colorado 81240.

SHIP And yacht model fittings: Pine construction hull kits: blueprints. Send 50¢ for illustrated catalog. A. J. Fisher, Inc., 1002 Etowah Avenue, Royal Oak, Michigan 48067.

SHIP Model kits and fittings; clippers, frigates, etc. Catalog paint-tool list. 1969 catalog 50¢. Models Shipways, Box 65, Bogota, N.J. 07603.

SHIP Models, Kits, fittings, plans, books, tools, engines, motors. Big illustrated catalog 50¢. Mass. residents add 3% tax. James Bliss & Co., Dept. SM, Route 128, Dedham, Mass. 02026.

SHIP Models catalog 25¢. Scientific, Inc., 100 Monroe, Newark, N.J. 07105.

MODEL Airplanes—Big 220 Page Catalog 50¢. Sig Company, Montezuma, Iowa 50171.

SUPER CAR & CANNON KITS! \$12.95 to \$85.00. Catalog 30¢ coin/stamps Sinclair's—Box 8068 (PM-1) Erie, Pa. 16505.

LIVE Steam engine kits. Fascinating hobby for Model Mechanics, Boilers, Fittings, Accessories. Pictured catalog \$1.00. H.P.K. Models, Centuck 34, Yonkers, Q. New York 10710.

STUART Steam Engines. Castings, Catalog 75¢. Carolus Models, 1131 Wilson Avenue, Salt Lake City Utah 84105.

GAMES, TOYS, PUZZLES, NOVELTIES

KITES, Kits, Plans, Delightful Booklet, 25¢. Kite Tales, Box 145C, Richardson, Texas 75080.

"**ROULETTE DICE**" . . . a novel way to play Roulette. \$2.00 a pair. System free. D. E. Products & Co., Box 488, Worcester, Mass. 01601.

BASEBALL Fanatics! The Perfect Table Baseball Game. Same averages as Big Leagues. Not a toy. Organize Championships with friends. \$3.00 Postpaid. Davar, Box 236, Forest Hills, New York 11375.

MAGIC TRICKS, JOKES, VENTRILOQUISM

HOUDINI'S Original Magic Shop. Established 1856. Send 25 cents for Illustrated Catalog containing 5000 Tricks, Mindreading, Puzzles, Hypnotism and Jokes. Flcso-Hornmann, 304 West 34th St., N.Y. 10001.

HOUDINI Magic Catalog!! Giant Professional Deluxe Edition!! 1000 World's Greatest Tricks!! 25¢ with Free Gift Certificate!! House of 1000 Mysteries, Dept. PM9C, Northeast Fifth Ave., Ft. Lauderdale, Florida 33308.

500 TRICKS Catalog. 1969 Edition, showing latest magic for pocket, parlor, stage. Only 10¢. Fastest mail service for 45 years. Douglas Magicland, Dept. 11, Dallas, Texas 75221.

BE A Magician! Two booklets explaining sixty-eight tricks plus large professional catalog. \$1.00. Magic Inc., 5082 Lincoln, Chicago, Illinois 60625.

COMPLETELY Illustrated catalog, 84 pages, 25¢. Manhattan Magic, Box 334-M, N.Y.C. 10011.

WORLD'S Finest professional magic tricks. Joker's Novelties. Giant illustrated catalog 10¢. Top Hat, Evanston, Illinois.

CATALOG \$26. 175 pages, 25¢ (1,500.-399 tricks, jokes, novelties). Elbee. 7408-P, San Antonio, Texas 78207.

MAGIC Catalog. World's finest 3000 tricks, (340) pages \$2.50. Beginners, amateurs, professionals. Kanter's, A-200 South 13th St., Philadelphia, Pa. 19107.

FREE! World's Leading Catalog 2000 Novelties, Jokes, Tricks, Scientific Gadgets, Hobbies, Johnson-Smith, D-191, Detroit, Michigan 48224.

FREE Ventriloquism Information on Dummy's—Books—Records—Mouthpiece 25¢—Stavdry—Whitestone, New York.

CARD Tricks—Get 10 of the world's easiest and most amazing card tricks for party or parlor. \$1.00. Trix, Box 2929, Milwaukee, Wisconsin 53218.

MAGIC MAGAZINE—Monthly since 1936. 44 pages. All phases. 3 month trial \$1.00. Genli, P.O. Box 36068, Los Angeles, CA 90036.

AMATEUR and **PROFESSIONAL** MAGICIANS all new magic tricks and gags catalog 25¢. Our specialty same day service. Fabukus Trick and Magic, 3319 E. Charleston, Las Vegas, Nevada 89104.

MINDREADING Trick Cards Plus Catalog. Send 25¢. Ace Magic, Box 329, Evanston, Illinois 60204.

RUSH 25¢ (refunded) big catalog. Circulars free. Dohn-39R-Marks Company, Broadview, Illinois 60153.

VENTRILOQUISM! Information free! Dummy catalog 25¢. State age. Maher, Studio J, Box 9037, Denver, Colorado 80209.

VENTRILOQUISM! Working man's price! Information free! JHD Enterprises, Box 7, Savannah, Tennessee 38372.

PROFESSIONAL Catalog, 175 pages 25¢. Williams, 900 Plymouth, Ellwood City, Pa. 16117.

BOOKS, CATALOGS, NEWSPAPERS

NATIONAL Geographic Magazines, 1888-1967, any issue Buxbaum, Box 465-PM, Wilmington, Delaware 19899.

PROPHET Elijah coming before Christ. Wonderful book free. E. Megiddo Mission, 481 Thurston Rd., Rochester, New York 14619.

PAPERBACK Catalogue, 270 pages, 15,000 titles, subject indexed. \$1.00 credited toward order. New York Book, 4 P West 43 Street, N.Y.C. 10036.

FREE Brochure, Interesting Books. True Value Products, Box 903, Salt Lake City, Utah 84110.

BOOKS. Free catalog on every subject, Courtesy Service, Box 15307, Las Vegas, Nevada 89114.

BOOK Sale. Write Modern Gift House, Dept PMA, 177 Granite Street, Mexico, Maine 04257.

BACK Date Magazines! Send needs. Midtown, Box 917-PM, Maywood, N.J. 07607.

FREE List! Personal Self Improvement. Books, L. Cricket, Box 527, Ardmore, Penna 19003.

MAILORDER Books. Free Literature. Earl's, 121 East Melrose, Findlay, Ohio 45840.

SEND \$1.00 For a FASCINATING List of OCCULT Books to the Aquarian Age. Dept. 7, 74 Winthrop Street, Cambridge, Massachusetts 02138.

"**FREE** Catalogue on hard-to-get books of unusual topics. Send 25¢ for postage handling to Byron Products, 4520 North Clarendon, Chicago, Illinois 60640."

SENSATIONAL Book HOW TO GET WHAT YOU WANT. Free Brochures Describe This And 112 others. Richard Allen Sales, 110 Birch Street, Midland Park, N.J. 07432.

LOSE Weight. Gain Health, Confidence and Happiness. Medically approved book "Mind Over Platter" shows how. \$2.00. Morganhouse, C-1147, Presque Isle, Maine 04769.

FREE Catalog—Guerrilla Warfare. Guns, Related Subjects, 10¢ Postage. Variety, Box 395PM, McDonald, Ohio 44437.

THINK BIG! Skyrocket income, gain financial security, prestige, power. Learn secrets that make men rich. "The Magic of Thinking Big!" A must to get ahead. 256 Pages of inside facts, case histories. Box =WB-123, only \$2.00. Grix, 1877-24th Street, Ogden, Utah 84401.

PLANT MANAGER: The ABC's of Lubrication booklet for training personnel. \$2.00. Jess Carpenter, 1001 Usher St., Ft. Worth, Texas 76126.

ANTIQUING SOMETHING? Learn how experts do it! Send \$1.50 for book "Successful Methods of Antiquing" Pilot Publishing Co., Box 15044, Winston-Salem, North Carolina 27103.

ASTONISHING Self-Development Book Sale. Many new Success Secrets to open your door to Power, Riches, Health, Happiness. Free Catalog—Bonuses. Don Lenzi, Box Z-8A11, Beverly Hills, Calif. 90213.

FREE List of low cost interesting practical books. McAllister Sales, PM10, Box 13128, St. Louis, Mo. 63119.

CLASSIFIED Sections from U.S. Sunday newspapers. Mail \$1.00 Customart, Box 10380, Santa Ana, Calif. 92711.

BOWLING STRIKES. Key to more strikes, higher scores. Unique book tells secret of strike ball. Easily understood. \$2.00. Payne, 1269 "B" Street, Arcata, California 95521.

UNUSUAL Books, three for \$2.00. P&P Novelties, Box 929, Darien, Connecticut.

PLAYS, STORIES, MANUSCRIPTS

WANT Your book published? Learn how we publish advertise, promote, distribute. Many successes. Free booklet PM. Vantage, 120 West 31, New York City.

BUSINESS OPPORTUNITIES

I MADE Over \$100,000.00 year selling by mail. IRS proof available. Success story, book form \$2.00. Wayne Johns n. 880 SW 60th Avenue, Ft. Lauderdale, Florida 33314.

HUGE Profits! Mail order importing. Free information, ITIS, PM-10, Box 454, Hollywood, Calif. 90028.

CONCRETE FACTS: Highly profitable home business. Experience unnecessary. Unlimited unique pottery designs easily made without moulds, Birdbaths, fountains, wishing-wells, benches, etc. Chemical coloring formulas, marblingglazing. FREE illustrated brochure. Hollywood Cementcraft, 602 Athens Street, Altadena, California 91001.

FREE "franchise Profit Letter" tells how unique NR service is helping thousands seeking profitable businesses. Write today. National Franchise Reports, W-528, 333 North Michigan, Chicago 60601.

\$400.00 MONTHLY Raising giant fishworms. Soilless method. Charlie Morgan, Bushnell, Florida 33513.

EARN Money raising fishworms for us! Write: Oakhaven-38, Cedar Hill, Texas 75104.

400,000 BARGAINS Below wholesale! Many free. Liquidations . . . closeouts . . . job lots . . . single samples. Free details. Bargainhunters Opportunities, Box 730A Holland, Michigan 49423.

VENDING Machines. No selling. Operate a route of coin machines and earn amazing profits. 32-page catalogue free. Parkway Machine Corporation, 715 PMB Ensor Street, Baltimore, Maryland 21202.

ADDRESSERS And mailers needed. Send stamp for information Lindbloom, 3636 West Peterson, Chicago 60645.

FREE Book "990 Successful, Little-Known Businesses." Work Home! Plymouth-372-M, Brooklyn, New York 11218.

MAKE \$75.00 daily distributing tools to service stations. Free Plan. INKA, 2401 Crocker, Houston, Texas 77006.

ESTABLISH Profitable Catalog Mailorder Business! Vikari's, Box 1312-PM-J, Salt Lake City, Utah 84110.

STOP Throwing Away Those Bostops! They're worth money, some 25¢ each! Write: Bostops—BO, Cedar Hill, Texas 75104.

ADVERTISING BUSINESS—YOU own it. \$350 First Week or Money Back. Electric Neon Action Ad Clock, 229 W. Illinois, Chicago 60610.

JOIN "MONEY GETTER'S GUILD". Receive hundreds money-making, Business Building Propositions. Year's membership only 25¢. Write: Fourstars, Box 839, Long Beach, New York 11561.

\$21.00 HOUR Profit—From Home Picture Framing Business. (Clampless Assembly Method) Write: Japs, 126-PM Seventh North, Hopkins, Minnesota 55343.

I MADE \$40,000.00 Year by Mailorder! Helped others make money! Start with \$10.00—Free prof! Torrey, Box 318-Y, Ypsilanti, Michigan 48197.

MAIL Baby Catalogs imprinted with your address to New Mothers for Big Profits! Details 25¢. Volz-PM, Ypsilanti, Michigan 48197.

MAKE Big money growing ginseng! \$3.-000-\$30,000 annually. We buy your crop. Send \$2 for seed sample and information. Glass' Ginseng Exchange, Box 1969, Springfield, Mass. 01101.

READ Progressive Mailtrade, the magazine that tells how to make money by mail. Quarter brings sample and special offer. Mailtrade, P.O. Box 357, Sheboygan, Wis. 53082.

FREE Catalogs. Repair air conditioning refrigeration. Tools, supplies, full instructions. Doolin, 2016 Canton, Dallas, Texas 75201.

VENDING Machine big catalog. Rake, 523 A Spring Garden, Philadelphia, Pa. 19123.

56 ACTIVE Franchise opportunities available all over USA. Brochure details 56 franchise chances for you to have your own business tied with successful national companies. Send name, address to P. Stewart, 1085 Walnut, Des Plaines, Illinois 60016.

CLIP Newspaper items, \$1.60-\$5.00 each. Details free. Walter, Box 1360-PA Erie, Pa. 16512.

SELL Lifetime, Metal, Social Security Plates. Big Profits! Sample and Sales Kit Free. Russell, Box 286-PM, Pulaski, Tennessee 38478.

SPARE Time Cash—Sell Advertising Book Matches—every business a prospect—no investment—no experience needed to build steady repeat business. Daily Cash commission in advance. Write today—We'll send your sure-fire selling kit by return mail. Dept. MX 1069, Superior Match Co., 7530 S. Greenwood, Chicago, Illinois 60619.

COPUBLISH "Mail Sale Advertiser," leading mailorder paper. Copy and details 25¢: U.S.A. only. Vanroy Shirk, Lebanon, Pa. 17042.

MAILORDER Records help get Increased Business! Complete 32 page Record Book shows your inquiries, orders, advertising expense, etc. Only \$1.00. Martin, Popular Mechanics, Dept. PM, 575 Lexington, New York 10022.

I MAKE \$1,200 MONTH IN ACCOUNTING. You start, train fast. Only 10 lessons. Certificate awarded. Work from home or office. Mail \$2, first lesson. Jenkins, Box 571, Taft, California 93268.

\$200.00 DAILY in your mailbox! Your opportunity to do what mailorder experts do. Free details. Associates, Box 136-A, Holland, Michigan 49423.

TAKE Catalog orders. We drop-ship 1001 best selling specialty products. Guaranteed lowest below wholesale prices. Fantastic spare-full time home business. Free book shows you how. SMC 7630 SPJ, Gloria Avenue, Van Nuys, California 91406.

BOOKKEEPERS Earn \$1000.00 month. Operate simplified Bookkeeping tax service. Universal, Box 664-M, Springfield, Missouri 65801.

\$70.00 WEEKLY—home, spare time. Simplified mail bookkeeping. Immediate income easy. Auditax, 34741A, Los Angeles 90034.

UP To \$5.00 each for newspaper clippings! Free details. Philip, Box 368-S, Southfield, Michigan 48075.

BIG Money-making new greaseless donuts in kitchen. Everything furnished. Sell stores. Free recipes. Montgomery Ray, Waseca, Minnesota 56093.

MAKE Gorgeous original candles for all holidays and special occasions. Learn expert Candle decorating, candlemaking, use of professional molds. Free details on home instruction method. Candle Institute, Dept. WP, 1600 Cabrillo, Torrance, Calif. 90501.

EARN \$60.00 DAILY manufacturing Concrete Fence Posts. Practically no investment. Free information. Send stamp. American, Excelsior Springs, Mo. 64024.

MAILORDER Book publisher wants dealers. Wonderful "drop-ship" proposition. Sample imprint circulars free. Neil H. Tasker, Shamokin, Pennsylvania 17872.

MAILORDER Program for Beginners. Write to Winco, 3905-M Mannerdale, Louisville, Kentucky 40220.

AMAZING Profits! Start your own successful business. Details free. Musgrove, 1404-A Camp Gifford Road, Bellevue, Nebraska 68005.

MAILORDER—Profitable products; drop-shipped. No merchandise investment. Everything supplied—catalogs ads, mailing lists. Gif-Guide, 1137 Crenshaw, Dept. 161, Los Angeles 90019.

ESTABLISH Profitable CONCERT MANAGEMENT. Your community. Details free. CONCERTS, 905 Fox Bldg., Detroit, Mich. 48201.

MAKE Money: Oil leases: \$4.00 acre: Others have. Free prof. Northern, Box 560-F Westmount, Montreal 215, Canada.

FREE Selling Outfit Office Supplies, Furniture & Equipment, Osco, 15-PM North Jefferson, Chicago 60606.

QUICK Income with Mail Order Collection Agency. \$1000 monthly and more. We show you how. Continental, Box 2023-A, Des Moines, Iowa 50310.

MAILORDER Selling has made others successful, why not you. Free information about my plan. Millor, Box 185-PM Tonasket 98855.

FANTASTIC Profits—Your Own Advertising Specialty Business. Buy direct and have hundreds of salesmen working for you. Dynamic, 509-P Fifth, New York 10017.

SAW SHARPENER. Build your own Saw Grinder. Own your own business. Plans and instructions. Free information. Grind Rite, Box 2115 Dept. K, Montclair, Calif. 91763.

FREE Advertising? 500 Publications. Write: Dee, 10639-PM Riverside, North Hollywood, Calif. 91602.

\$75.00 THOUSAND. Home Addressing! Longhand, Typewriter. Information, send stamped self-addressed envelope. Brewster, Box 1348-TF, Clearwater, Florida 33517.

UNLOCK Your Future. Become professional Locksmith by spare time home-study. Make up to \$6 per hour. All tools, equipment incl. Facts free. Send name. Locksmithing Inst., Dept. 1310-109, Little Fall, New Jersey 07424.

DRAFTSMEN! Operate own DRAFTING SERVICE! Full, Part Time; Experience unnecessary; Details: Roberts Drafting, 1741 Circle Road, Baltimore, Maryland 21204.

SELL Books by mail. 400% profit. Royal, Box 450-X, Cleveland, Ohio 44127.

MAKE Money Operating Home Mailorder Business. No Inventory. Write Purple Enterprises, Box 16291-AK, Jacksonville, Fla. 32216.

MAKE Money from old tires. Operators clearing \$800, weekly. Equipment costs \$1500. Get facts, S & S Patents, Inc., 3752 N. Damen, Chicago 60618.

CALIFORNIA MANUFACTURER NEEDS man to assemble cur product and be local agent, experience unnecessary. May start while presently employed. Five-figure income for responsible applicant. S.K.R.M. Manufacturers, 2540 Olive Avenue, Long Beach, California 90806.

MAKE \$46 from square foot plywood: jigsaw or bandsaw necessary. Free details. Woodar, Bridgewater, Mass. 02324.

\$60.00 DAY. Manufacturing concrete Posts, Blocks, Mold Equipment Catalog \$1.00 refundable. Carlayne, Route One, Box 106T, Rapid City, South Dakota 57701.

MAKE, Sell magnetic car signs. Write PM-1834 Edgeland, Louisville, Ky. 40204.

JEWELRYCRAFT—It's easy! Big profits! Catalog, 25¢. Modern Craft, 12790 US 19, Clearwater, Florida 33516.

\$6 CAN START YOU IN BUSINESS. Investigate 100 business opportunities in every monthly issue of Franchise Journal. Get the facts, figures, company histories, profit potential, investment requirements, etc. Send \$6 for 12 exciting copies to Franchise Journal, 892-G W. 16 St., Newport Beach, Calif. 92660.

MAILORDER . . . No merchandise investment. Profitable! Tested! Dynamics, 1430P Wells, Milwaukee, Wisconsin 53233.

BECOME PROFESSIONAL DRIVING INSTRUCTOR. Earn \$10.00 hour. \$300 week. Part time. Full time. Business for yourself. Free details. Howard David, 1818 Everts St., Phila., Pa. 19152.

PROFITS FROM CLASSIFIED ADVERTISING!! Booklet shows you how to start your own business with Classified Advertising. Only \$1.00 (Refundable with first order.) C. A. Martin, Popular Mechanics, Dept. PM, 575 Lexington Avenue, New York 10022.

MAILORDER Business. Free circulars. Andrews, P. O. Box 485, New York, New York 10013.

INSTALL Burglar alarms without previous experience or costly equipment. Big profit. Free details. Nasco, 11071 Massachusetts, Dept. C270A, Los Angeles 90025.

FREE Book "999 Successful, Little-Known Businesses" by writing: Small Business Institute, Dept. 7, Kerrville, Texas 78028.

OPERATE Restaurant or diner. Free booklet reveals profitable plan. Write Restaurant Business School, Dept. EC-109, 1920 Sunnyside, Chicago, Illinois 60640.

NEW Plan! Pays up to \$25.00 an hour! Little as 4 hours weekly. Place Thriftee self-service displays in stores. No cost to merchants. No experience needed. Free details. Lux Company Incorporated, Dept. 1227, Elkhart, Indiana 46514.

WATCH REPAIRING piles up extra cash fast. Free sample lesson. Watchmaking YXB, Fox River Grove, Illinois 60021.

IMPORT Export opportunity, profitable world-wide, mail-order business from home, without capital; or travel abroad. We ship proven plan, for no risk examination. Experience unnecessary. Free details. Mellinger, Dept. C270A, Los Angeles 90025.

\$500-\$800 MONTHLY Raise small Laboratory-breeding stock for us. We supply equipment, breeders, and instructions. Illinois Research Farms, Dept. MPD-10, McHenry, Illinois 60050.

MAKE Durable building plastic easily. Waterproof, Fireproof, Economical. Bays Laboratory, Cedaredge, Colorado 81413.

HOW To Finance Your Own Business. \$500 to \$200,000. Helped many others. Free details. Capital-17, Kerrville, Texas 78028.

VACUUM Plastic Molding & Liquid Casting—At Home! Make Hundreds of full 3-D plastic products. Big profit in spare time. Facts, Nationwide Plastics, Dept. HH, 4140 Eagle Rock Blvd., L.A., Calif. 90065.

MAILORDER! HOW TO PREPARE YOUR OWN CATALOG for pennies... including popular products... without merchandise investment! Free Catalog—Proof! OBIE, 5711-MO—14th, Brooklyn, New York 11219.

SECRETS! Mail Order Success. Internationally famous expert reveals how to make home business fortunes. Beginners: Get free copy "Make Money By Mail." Discloses free advertising, profitable products. Mailco, 1554 Sepulveda, Dept. C270A, Los Angeles 90025.

EARN Extra cash! At home; full, spare time. Proven, no-investment productive business. Write today; free details. McLemore, 262A Westoak, San Antonio, Texas 78227.

NOW! Beginners tired of worthless schemes can learn mailorder facts at a LOW price! Details free. Falk, 91-F Myles, Levittown, New York 11756.

MONEYMAKING From Oil Leases!—\$1.00. "How". Box 276-A, Noble, Oklahoma 73068.

NEW! \$250.00 Weekly. My success passed on to you. Sparetime mailorder program. Write, Delang, Box 4612-M, Colorado Springs, Colorado 80909.

MAIL ORDER Sell books. Fascinating, profitable, details. Jobre, Box 27, Great Neck, N.Y. 11023.

EARN \$60.00 DAILY manufacturing Concrete Fence Posts. Practically no investment. Free information. Send stamp. American, Excelsior Springs, Mo. 64024.

\$50,000 YEAR Very possible in Mail Order Imports. Cash in advance business. Booklet reveals Foreign drop ship method, World-Traders Digest. Start business day instructions arrive. Satisfaction guaranteed. Send \$1.00, nothing else. The Oakton House, A Gillespie Enterprise, 741 Elmhurst Road, Des Plaines, Illinois 60016.

PIANO TUNING learned quickly at home. Tremendous field! Musical knowledge unnecessary. GI approved. Information free. Empire School, Box 327, Miami 33145.

PREPARE Tax Returns—Housewife Jo Ann Netzey made \$5,500 last season. Train at home. VA Approved. National Tax School, Monsey 2KB, New York 10952.

START Own Profitable Mailorder Business! Everything furnished. Success assured. Write today; free details. Wallace House, Box 288PM10, Gladstone, Oregon 97027.

SENSATIONAL New kitchen remodeling franchise. Proven successful—24 profitable franchises in operation. \$1500 investment. Homewood Industries Inc., Homewood, Illinois 60430.

WORLD'S Largest supply. Merchandise 25% to 40% under wholesale. Bankrupts. Closeouts 10¢ on dollar. Imports, Hongkong clothes. Automobile discounts. Free details. International Buyers, Box 16386-MM Portland, Oregon 97233.

\$2.00 PER Dozen Cash Profits. Assemble New Art Foam Products. All Supplies Furnished. Showcase, Box 55392D, Indianapolis, Indiana 46205.

BUILD Custom Cases at home for profit. Get orders by mail. We supply materials, instruction—everything. Free home business details. Custom Case Supply Co., 7630-CPK Gloria Ave., Van Nuys, Calif. 91406.

WANTED!! People interested in making money at home in spare time. For details send stamped self-addressed envelope: RL-Allen, 2418 Lori Lane, Santa Ana, Calif. 92706.

PROFITABLE. Low cost. Easy. Manufacture specialties. Mamfa, 2050 Hutchinscn, Chicago 60618.

PLASTERCRAFT Molds, liquid rubber, plasters, flocks, candle supplies. Catalog and manual free. Blue Rapids Supply, Blue Rapids, Kansas 66411.

MAILORDER Advertising. learn how, where, what and costs. Details. Doorbar 3364 North West 35 Street, Fort Lauderdale Florida PM 33309.

SQUABS—raise moneymaking baby PI-GEONS. Guaranteed market. 3055PM-10P9 Kincaid, Eugene, Oregon 97405.

\$200.00 WEEKLY Possible! Make Statuary. Figurines, Plaques. Materials cost pennies per pound. Small work space required. "Plastercraft Handbook" reveals detailed, illustrated mold-making, pouring, finishing, selling instructions. Only \$3.00 postpaid. Guaranteed. Wolfe, Box 561M, Melbourne Beach, Florida 32951.

HOW to start your own typewriting service. Wonderful profits. Free details. Coach House, Box 834D, Bangor, Maine 04401.

FREE information. Start your own SECRETARIAL SERVICE at home! Private Secretary, P.O. Box 6773, Long Beach, California 90815.

OPERATE C-lection Agency; high returns. Globe, Box 814-P, Macon, Georgia 31202.

FREE details, own, operate small successful business Paulsen, Box 303, Temple City, Cal. 91781.

STEADY INCOME from your own PR/U Bureau. Furnish 50-word photo reports, extraordinary market. Reliable, 6544 Friends, Whittier, Calif. 90601.

THERE'S MONEY FOR YOU in Pizzas. Chef's secrets. Details free. D. Allard, P. O. Box 578, Baldwin Park, Calif. 91706.

NOW! Your word = 1 "MONEY." \$1.25 How to make yours today. Ron Leppert, Box 1086, Dania, Florida 33004.

SELL Books by mail. Big profits! Catalog details, 20¢. Sullins, Box 206-M, Forsyth, Georgia 31029.

MAKE Full time wages on part time, with my new advertising method. No investment. Send \$3.00 Geo Ropchan, 6846 Texhoma, Van Nuys, Calif. 91406.

FOR THOSE Who dare be your own boss, write your own paycheck. Opportunities unlimited. Information 25¢ R. S. Weslake Agency, 259 McKay, Winnipeg 16, Manitoba, Canada.

MORE Sales, Profits! 88 Ways to Promote. Build Your Business. Free details. Write today. Graybow, Box 141, Brampton, Ontario, Canada.

MAIL Baby Catalogs, Imprint, to new Mothers. Big Profits! Details \$1.00. Krefski, 609 Lee, Plymouth, Pa. 18651.

RAISE Rabbits for us on \$500 month plan. Free details. White's Rabbitry, Mt. Vernon, Ohio 43050.

WANT To make big money at home? \$10.00 profit in an hour possible with invisible mending. Make tears, holes disappear from clothing, fabrics. Steady year-round demand from cleaners, laundries, homes. Details free. Fabricon, 1585 Howard, Chicago 60626.

START Mail Order. No Middleman. Fantastic—do it yourself plan. Make your own catalogues, \$10 or less. No investment, products dropshipped. Free details. New York Research Service, Suite 1002, 509-5th Avenue, N.Y. 10017.

TREMENDOUS \$1,000.00 Profit From 1,000 Mailings! Free Proof! George-PM, Cypress, California 90630.

FREE PROOF. Home mailorder riches Photos-Facts. National. Box 1531-E St. Petersburg, Florida 33731.

IF YOU can do simple, grammar school arithmetic, you can easily become prosperous Income Tax Consultant. Free details. Param unt-A, 119 West Avenue 33, Los Angeles, California 90031.

PERFECT husband-wife business. Learn Upholstery at home. Make \$10 in an hour. Buy-repair-sell for even bigger profits. Kits, tools included. Free Booklet. Upholstery Institute, Dept. 5310-109, Little Falls, New Jersey 07424.

MAIL ORDER Dealers wanted. Earn outstanding profits using tested promotions! Executive type business. Openings limited. Details 25¢ (refundable) Unicis, Box 735-PM, Norwalk, Conn. 06852.

MAIL ORDER. No Inventory Needed. Free Catalog. Your Name imprinted. 123-FD Mailing Methods, Lafayette Hill, Pennsylvania 19444.

\$300.00 WEEKLY Possible. Mailorder. Others do; you can with our help. Free proof. Williams, Box 44646M, Los Angeles 90044.

EXCLUSIVE DISTRIBUTORSHIPS AVAILABLE. Four Complete Lines—Call on Retailers—Contractors—Truckers—Schools. Unlimited Earnings. Send \$3.00 (Refundable) Unitek Corp., 815 So. Nixon Avenue, Lima, Ohio 45805.

NEWEST . . . Biggest moneymaker since mailorder!!! Gift Showcase, Box 513-M, Carlisle, Pennsylvania 17013.

BURGLAR-FIRE Alarms and kits. Build for profit. Brochure 25¢. The Securitrronics Co. P.O. Box 371, Frankfort, Indiana 46041.

INSTANT Mail Order Catalog Business—All you need is a mailbox. Details \$1 refundable. Mail Marketing Services, Benton, Illinois 62812.

SIMPLE, EASY way to enter mail order. Earn \$12,000 year up. Stamp for details. Emptage, 1033-PM S. W. 53rd, Oklahoma City, Oklahoma 73109.

AMAZING PROFITS! Sell by mail quality self-improvement books. Drop-shipped by reliable publisher. GRAPHIC, 1033-PM S.W. 53rd, Oklahoma City, Oklahoma 73109.

FAST Money. \$1000 sample and instructions 25¢. Kay, 4004, Baypines, Fla. 33504.

1000% PROFIT Bronzing Shoes. Free Literature—N.B.C. Box 11069-PM Kansas City 64119.

STEADY Income Daily! Address, mail our commission circulars. Details, 10¢. Box 953-PM, Newark, N.J. 07101.

MONEYMAKING OPPORTUNITIES

I MADE Over \$100,000.00 year selling by mail. IRS proof available. Success story, book form \$2.00. Wayne Johnson, 880 SW 60th Avenue, Ft. Lauderdale, Florida 33314.

EARN \$240.00 a month at home, spare time, doing only two \$5.00 invisible mending jobs a day. Big money paid for service that makes cuts, tears disappear from fabrics. Steady demand. Details free. Fabricon, 1532 Howard, Chicago 60626.

MAKE Statuettes, novelties, imitation marble. Sell to stores or start gift shop. Free details. Marbleizing, 41 Waverton, St. Louis, Mo. 63124.

HOW To Make money writing short paragraphs. Information free. Barrett, Dept. C-27-X1, 6216 N. Clark, Chicago 60626.

VENDING Machines. No selling. Operate a route of coin machines and earn amazing profits 32-page catalogue free. Parkway Machine Corporation, 715 PMM Ensor Street, Baltimore, Maryland 21202.

FREE Copy of world's leading contest magazine! Write Prizewinner, Box 11569, St. Petersburg, Fla. 33733.

HOMEWORK. Mailing circulars. Free details! Cam Company, Dept. 155-KP, Verona, N.J. 07044.

FREE. 206 Easy Ways to make money taking orders for exciting new products—spare time. Send name, age for 5 months free subscription. Opportunity Magazine, 1460 Hancock Center, Dept. 17-KM, Chicago 60611.

SCIENTIFIC Massage: Big Earnings uncrowded profession. Learn spare time at home. Diploma awarded. Free catalog. Write Anderson School, Dept. K-1C, Princeton, Illinois 61356.

CLIP Newspaper items. \$1.00-\$5.00 each. Details free. Walter, Box 1360-P, Erie, Pa. 16512.

SPARE Time Cash—Sell Advertising Book Matches—every business a prospect—no investment—no experience needed to build steady repeat business. Daily Cash commission in advance. Write today—We'll send your sure-fire selling kit by return mail. Dept. MA-1069, Superior Match Co., 7530 S. Greenwood, Chicago, Illinois 60619.

MAKE: \$12.00 Profit each dozen assembling Belts. Details Free. (Stamp appreciated.) Redikut's-40, Richland Center, Wisc.

HOW TO GET RICH!! Free "Money-making Brochure"! Success International, Box 2447-C, Livonia, Mich. 48151.

LEARN The secrets of repairing junk batteries "Fabulous Profits" at home. Batteryman, Route 1-188 D, Blythe Calif. 92225.

TEAR OUT THIS AD AND MAIL WITH NAME, address for big box of home needs and cosmetics for Free Trial, to test in your home. Tell your friends, make money. Rush name, Blair, Dept. 31HP, Lynchburg, Va. 24505.

INVEST IN STAMPS! Free details. Needleman, 2367P East 18th, Brooklyn, N.Y. 11229.

BIG Money with PROPERLY PLANNED school band concerts. Proven effective! Details FREE, CONCERTS, 905 Fox Bldg., Detroit, Mich. 48201.

MAKE Money clipping newspaper items. Book reveals many ways. \$1.00 postpaid. LEUNG S, 38-48 Rutgers 5F, New York City 10002.

\$2.40 HOURLY Making simple wood novelties. Free details! Gene's, 55 Boxwood, Falmouth, Mass. 02540.

BLACK Widow Spider Ranchers wanted!! Tremendous profits! Complete program \$1 (refundable). NBWC, Box 260-PM3, Brigham City, Utah 84302.

SPARE Time cash. Sell Famous Hanover Shoes. Actual samples and sales kit Free. No experience needed. No age limit. Lowest prices for high quality makes selling easy. Every man a prospect. Big daily commissions. For full details. Write Hanover Shoe, 492 Carlisle, Hanover, Penna. 17331.

MONEY—SPARETIME OPPORTUNITY PANELISTS AT HOME WANTED BY NEW YORK RESEARCHER. Leading research firm seeking people to furnish honest opinions by mail from home. Pays cash for all opinions rendered. Clients' products supplied at no cost. For information write: Research 669 Mineola, N.Y. 11501, Dept. PM-24.

HOMEWORKERS! 200 companies—48 page Directory. FREE details. Quest, Box 6029, Dept. 110, San Jose, California 95150.

OPPORTUNITIES. Bargains Galore. Free Information. Write Bargains, 10024 Oxborough, Minneapolis, Minnesota 55431.

PROFITS FROM CLASSIFIED ADVERTISING!! Booklet shows you how to start your own business with Classified Advertising. Only \$1.00 (Refundable with first order.) C. A. Martin, Popular Mechanics, Dept. PM, 575 Lexington Avenue, New York 10022.

\$500—\$800 MONTHLY Raise small laboratory-breeding stock for us. We supply equipment, breeders, and instructions. Illinois Research Farms, Dept. MP-10, McHenry, Illinois 60050.

ART Talent? Be your own boss. Earn \$200 weekly freelancing. Free Brochure. Famous American Studios, P6, Spring Park, Minnesota 55384.

WRITE Persuading Letters. Profitable! Samples. Eljay, 603-B Navarro, San Antonio, Texas 78205.

WATCH REPAIRING makes every day a payday. Learn at home. Free details. Watchmaking, YXA, Fox River Grove, Illinois 60021.

FREE Unique Money-makers Digest True Histories. Shugart, Box 566-W, South Pasadena, California 91030.

CLIP Newspaper Items. \$1.00 \$5.00 each. Details Free. Andersen's, Box 4468, San Jose, California 95126.

AMAZING Profit potential with Swiss precision electric razor, guaranteed one year. Sample \$6.00. low quantity price \$2.60 each. Wholesale catalog \$1.00. details free. Robert P. Bales, 63 Giessen Amselweg 8, W. Germany.

MEXICAN HANDCRAFTED LEATHER. Purses, Billfolds, Golf bags, Bowling bags, others. 10 day delivery. Free Gifts. Free information. Quantity Discounts, P.O. Box 584, Lemon Grove, California, 92045.

INSTANT Money! Plastics are the wave of the future. Big Profits now! At Home! Spare Time! Materials costing 11¢ bring \$2.58 profits immediately! Free information! Rush name on postcard to: Warner, 1512 Jarvis, Dept. CL-2-D, Chicago 60626.

COMPLETE New program. Mail order. No inventory. Details. IFL, Box 441, Clarksdale, Miss. 38614.

SWEEPSTAKES Contests. How to Win. Write for free particulars. General Contests, 1609-18 East Fifth, Duluth, Minnesota 55812.

EASY-To-start rubber stamp business at home in spare time. Make up to \$16.50 an hour without experience. Facts free. Write to: Roberts, 1512 Jarvis, Room CR-2-D, Chicago, Ill. 60626.

SELL Your Photos. Report tells How. Where. Let your Camera provide a second income for you. Booklet MO-54P only \$1.00. San Anne Co., PM-611, I-40, Pine Ridge Exit, Kingston, Tennessee 37763.

GOOD Money spare time, writing fillers. Programmed 10 lesson course tells how. Many receive checks before completing lesson 3. Only \$4.95. Satisfaction guaranteed. Oviatt Enterprises, Mystic, Connecticut 06355.

START Your own wholesale or mailorder business with imports. Make a killing with unusual new products before others do with New York Importers Directory. \$2.00 Granato, 4601 Tyson Ave., Philadelphia, Penna. 19135.

IF YOU want to start making money IMMEDIATELY writing short paragraphs, try our way. Send \$1.00. Pacific Exclusive, 117 Huckleberry Lane, North Bend, Oregon 97459.

FANTASTIC Profits selling new 69¢ self-closing coin purses. Eliminates holes in pockets. Sample 25¢ Hartsel, P.O. Box 386, King of Prussia, Penna. 19406.

HIGHER INCOME. Security and Power. 256 Page Book "Thinking Big" reveals secrets that make men Rich! Send \$2.00. Rainbow Mailorder Products, 605H Oak Street, Fort Atkinson, Wisconsin 53538.

"THERE'S a fortune for you in photography. Plus an opportunity to work with glamorous models. No experience required. Details 10¢. Var-Co Distributors, Box 83, Verdun, Quebec."

OVER \$2,500.00 Weekly average income in mailorder by originator of guaranteed program. Free details, Enterprise Books (PM10), Box 188, Seabrook, Texas 77586.

INTERESTED In mailorder? Write to: Advancement, Box 24, La Grange, Illinois 60525.

HOW to ACQUIRE ADEQUATE INCOME for life. Free details. Specialties, 520 West Cypress, Redlands, California 92373.

START, operate profitable business. Information 10¢. Lehman Tyndall, Rte 2, Tarboro, North Carolina 27886.

MIMEOGRAPH And ruler can make you financially independent for life. Further sensational details 25¢. The Graphic Garret, Box 1105, Washington, D.C. 20013.

MAIL ORDER Opportunity Booklet 25¢. Snells, Box 682-A, Bath, New York 14810.

MAKE \$5,000 yearly, sparetime, raising mink, chinchilla, nutria, etc. Free booklet reveals proven plan. Write: Furs, Dept. R, Bewdley, Ont., Canada.

\$200.00 FROM Sheet 1/4" plywood (scrap) Details 25¢. Novelties, 610 So. 24th, Elwood, Indiana 46036.

POWERFUL shortcuts to lucrative mail-order enterprises. Proof. Literature. Eddie's, 4809-MG North Montclare, Chicago, Illinois 60656.

MAKE Big Easy Profits making costume jewelry at home. Spare time. Quick, easy to make; easier to sell! Details Free! Donbar, 2934 Fullerton, Dept. J-209, Chicago, Illinois 60647.

\$80.00 DAY selling Information Manuals by Mail. Write: Beach House, 3716 Gresham, Virginia Beach, Virginia 23452.

UNUSUAL RACING PROFITS From Simplified Handicapping Methods. Gil Howard, Box 507, PM, Carroll, Iowa, 51401.

HOME Moneymaking Mailorder Programs Catalog. Only 25¢. Fitz, Freeville, New York 13068.

LEARN To Fix Typewriters. Desperate shortage trained men. Hundreds needed. Make up to \$25 in one hour. Learn at home in spare time. Industry Approved course. Facts free. Send name. Typewriter Repair School, Dept. 3310-109, Little Falls, New Jersey 07424.

SELL sensational Auto Burglar Alarm. Write NORTHWEST ELECTRIC, Ave. 556, Mitchell, S. Dak. 57301.

ADDRESSERS Needed Now. Setup \$2.25. Trowbridge, 35-11 Woodcrest, Dayton, Ohio 45405.

\$10,000 SWEEPSTAKES Contest Winner Shares Winning Secrets. \$1.00. Benro Enterprises, Box 6656-PM, Philadelphia, Pa. 19149.

MAKE Money operating home mailorder business. No inventory. Write Purple Enterprises, Box 16291-AKO, Jacksonville, Fla. 32216.

MAKE Money in today's highest profit industry. Fantastic returns—\$12,000 to \$42,000 per year. Send \$2.00 to Universal Recreations for information. West 1523 Providence, Spokane, Wash. 99208.

BIG Profits mailing letters featuring real merchandise. Everything furnished. Details 25¢. Robert's, Box 252, Grafield, Wash. 99130.

PROFITABLE OCCUPATIONS

I MADE Over \$100,000.00 year selling by mail. IRS proof available. Success story, book form \$2.00. Wayne Johnson, 880 SW 60th Avenue, Ft. Lauderdale, Florida 33314.

BECOME A mortgage broker, earn \$10,000 to \$50,000 a year. Details free. United, Box 6284A, Marietta, Georgia 30060.

HOW To Make Money Writing Short Paragraphs. Information Free. Barrett, Dept. C-27-X2, 6216 N. Clark, Chicago 60626.

CHROME Plating Instructions, equipment and supplies. Platers' Supply, P.O. Box 565, Lugo Station, Los Angeles, Calif. 90023.

FT. SMITH Auction School, Ft. Smith, Ark. Residents & Home study. Veteran approved.

SHARPEN Scissors, Pinkers, Inexpensive equipment, tools, supplies. Blackhawk's, Sheldahl, Iowa 50243.

YOUR Own Sign shop. Signs, 410-S, So. Western, Springfield, Ohio 45506.

BAKE New greaseless doughnuts in kitchen. Sell stores. Free recipes. Michael Ray, Waseca, Minnesota 56093.

"RESEARCH AS A PROFESSION": Informative Manuscript reveals Home earning methods, without experience; write now; free details. Merkle, Forestville, Pennsylvania 16035.

SELL Your photos. Report Tells How. Where. Color Slide Market. Send \$1.00. July Gifts, P.M. 10, 132 Arlington Ave., Cliffwood, New Jersey 07721.

\$500—\$800 MONTHLY Raise small laboratory-breeding stock for us. We supply equipment, breeders, and instructions. Illinois Research Farms, Dept. MPA-10, McHenry, Illinois 60050.

PIANO Tuning for fun or profit. Sure-fire method if you can handle a tuning hammer—a special wrench—and can match piano tones with those on a phonograph record. Priced under \$25. Stamm Industries, Dept. PM, Oregon, Illinois 61061.

BRAND New Idea! Parttime work! \$100: \$200 month up. Details 25¢. Martin, Route 2, Box 5286E, Issaquah, Washington 98027.

PAINT FOR PROFIT! New Method oil painting. Results first try. Not available elsewhere. Free details. Money back guarantee. David Press, Box 278, Capitola, Calif. 95010.

LOCKSMITHING—Ten Lessons—Tools—Practice Locks—Glenstone, Box 3127, Springfield, Missouri 65804.

EARN \$240.00 A month at home, spare time, doing only two \$5.00 invisible mending jobs a day. Big money paid for service that makes cuts, tears disappear from fabrics. Steady demand. Details free. Fabricon, 1586 Howard, Chicago 60026.

FREE Book "990 Successful, Little-Known Businesses." Work Home! Plymouth-37-M, Brooklyn, New York 11218

EARN Money Writing Short Paragraphs for Magazines. 10 Complete Lessons. Send \$4.95, plus \$1.40 postage. Lillian Smith, 53 Downing Ave., Haverhill, Mass. 01830.

LEARN Yearly trade, install aluminum storm windows, doors, jalousies, etc. Complete instruction book \$2.00. Stoloff, Box 100, Inwood, New York 11696.

SALESMEN—DISTRIBUTORS

I MADE Over \$100,000.00 year selling by mail. IRS proof available. Success story. book form \$2.00. Wayne Johnson, 880 SW 60th Avenue, Ft. Lauderdale, Florida 33314.

FREE. 206 Easy Ways to make money taking orders for exciting new products—spare time. Send name, age for 5 months free subscription. Opportunity Magazine, 1460 Hancock Center, Dept. 17-KS, Chicago 60611.

100% PROFIT—Sweet Georgia Brown Cosmetics sell fast. Write for Sample Case offer. Valmor, Dept. H, 2411 Prairie, Chicago 60616.

SELL Advertising book matches. Write us today. We put you in business by return mail, handling complete line ad book matches in demand by every business right in your town! No investment; everything furnished free! Top commissions daily. Superior Match, Dept. M1069, 7530 S. Greenwood, Chicago, Illinois 60619.

FREE! Money Making Opportunities! Your Own Business! Write name, address, zip, today. Bradley, Box 509-D, Mt. Kisco, New York 10549.

EARN big money calling on business-professional men. Send us their delinquent accounts for collection. General Finance, Dept. PM-11 Columbia Bank Bldg., Kansas City, Mo. 64106.

FREE Selling Outfit Office Supplies, Furniture & Equipment. Oseco, 15-PM North Jefferson, Chicago 60606.

LONG Needed invention. Man contact service stations. Huge profits. Write Cyclo Mfg., 3816 Dahlia, Dept. 190, Denver, Colorado 80201.

BIG Earnings selling Hertel Bibles. New 3-dimension cover, finest reference edition sells fast. Demonstrator furnished. Big commission. International Book, Dept. PM, Box 118, Wichita, Kansas 67201.

SELL Advertising Ball Pens, Calendars, Ad-Specialties—Build Own Repeat Business—Free Kit—Fleming, Dept. A, 6535 Cottage Grove, Chicago 60637.

MAKE Your Own Drop Ship Catalog. Get direct manufacturers listings who supply catalog merchandise. Write, Delang, Box 4612-MM, Colorado Springs, Colorado 80909.

MAKE Extra \$25 to \$75 spare time! Take orders for double air cushion Bronson Shoes. Amazing comfort. Terrific men's women's line for dress, work, play. Highest commissions. Shoes for yourself. Big outfit Free. Write Bronson, Dept. 169, Minneapolis, Minnesota 55408.

NEW Year's Party Goods For Hotels, Clubs, Taverns. Complete Assortments. Top Commissions. Sperry Goods, Horseheads, N.Y. 14845.

BIG profits selling new type magnetic signs. Nothing like it on market. Sells on sight. Velco; Box 4416-C, Tampa, Fla. 33607.

AGENTS WANTED

I MADE Over \$100,000.00 year selling by mail. IRS proof available. Success story. book form \$2.00. Wayne Johnson, 880 SW 60th Avenue, Ft. Lauderdale, Florida 33314.

YOUR Own business—Used suits \$1.50; overcoats 65¢; mackinaws 35¢; shoes 12½¢; ladies' coats 30¢; dresses 15¢. Enormous profits. Catalog free. Nathan Portnoy Associates, 2109-AA Roosevelt Road, Chicago Ill. 60608.

EVERY Man a prospect. Refundable sales kit offer showing line belt buckles, tie clasps, money clips, cuff links, lapels, identification badges, individualized with customer's name and emblems. Cap badges for trucking, bus, taxi, police, firemen, also postal, letter carriers and heavy construction emblems. Choice 3000 emblems. Hook-Fast, Box 1088PM, Providence, R.I. 02901.

PRINTING, Advertising Salesmen—Excellent moneymaking sideline selling Decalcomania Name Plates, small quantities. Advertising Specialties, sign letters. Free Samples. Raico XL, Boston, Mass. 02119.

CHRISTMAS CARDS—Business and Personal. Customer's name imprinted. Earn unusually high commissions from this medium—and high-priced line. No investment. No inventory. Free Sample Album. Process Corp. (our 48th year), 3436 S. 54th Ave., Chicago, Ill. 60650.

SENSATIONAL "Defender of Women!" Stops attackers instantly! Effective to 15 feet. Lipstick size. Samples for trial, Rush name. Kristee, 161, Akron, Ohio 44308.

BE The Popular Mechanics representative in your neighborhood and earn big profits in your spare time. Write Popular Mechanics, Room 10A, 250 West 55th St. New York 19, N.Y.

25 PEOPLE needed, 25 hours per month, \$25 per week profit. Write Box 603, Sheboygan Wisconsin 53082.

ESTABLISH Your own business. Low prices on used clothing, shoes, household goods. Unlimited profits. Free catalog. Northwestern Distributors, 2129 No. Western Avenue, Chicago, Illinois 60647.

LIFETIME Income. Business Loan Representative Write: Financial 28 E. Jackson, Suite 1204-X3, Chicago 60604.

EMPLOYMENT INFORMATION

FOREIGN And USA job opportunities available now. Construction, all trades. Earnings to \$3,000.00 monthly. Paid overtime, travel bonuses. Write, Universal Employment, Woodbridge, Conn. 06525.

AUSTRALIA WANTS YOU! Government Assisted Passage, 50,000 Jobs. Latest Government Information and Forms \$1.00. Special Reports on Employment, Business, Taxes, Housing, Education, Ranching, Farming, Teaching, Maps, Etc. AUSTCO, Box 3623-E, Long Beach, California 90803.

HIGH Paying overseas jobs. Construction, other projects. Bonuses, Travel Expenses, Extras. International Information, 124, Cortez, Florida 33522.

"HOW To Get Overseas Jobs"—Worldwide—Lists Hiring Organizations—143 pages—\$3.98—Refundable. Staydryp—Whitestone, New York.

BOOMING Australia wants You! Good jobs. Adventure. Forms and Australian Handbook (1969) describing Australian assisted passage, passport-visa, advantages, opportunities \$1.00. Buckeye, Box 1032MS, Fairborn, Ohio 45324.

CANADA. Employment guide to Montreal, Toronto, Vancouver. Send \$1.00. Personnel Publications, Suite 101, 30 Bloor Street, West, Toronto 189.

ALASKA. High Paying Jobs, many with room and board furnished. Send \$2.00 for directory. H-W Enterprises, Box 4-406, Anchorage, Alaska 99503.

AUSTRALIA!! AUSTRALIA!! Jobs Galore, Government assisted transportation, 1969 Handbook \$1.00. Guaranteed!! Associated, Box 17-B910, Lafayette, California.

LISTING Of 1500 Florida Job Opportunities. Statewide. All Categories. \$2.00. Southern Publishing, P.O. Box 20-M, Holly Hill, Florida 32017.

HELP WANTED

OVERSEAS Jobs—Europe, South America, Australia, Far East, etc. 2000 openings all trades. Construction, Office, Engineering Sales, etc. \$400 to \$2,500 month. Expenses paid. Free Information. Write Overseas Jobs, International Airport, Box 536-M, Miami, Florida 33148.

OVERSEAS Jobs—Australia, Europe, South America, Far East, etc. Openings in all trades and professions. \$400 to \$2,500 monthly, free information write Foreign Employment Mart, Box 2235 A.M.F. Miami, Florida 33159.

MALE Or FEMALE. No experience necessary. \$100.00 per Week. Plus Expense Account. Drivers License required. No selling. For complete information and application blank send \$3.00 plus large stamped envelope to: RJC, Box 537, Duluth, Minnesota 55801.

REAL ESTATE & FARMS

CANADIAN Vacation lands: Full price \$385.00, 40 acres, \$10 month. Suitable cottage sites, hunting, fishing, investment. Free information. Land Corporation, 3768-C Bathurst, Downsview, Ontario, Canada.

\$1 ACRE—Canadian Border—hundreds campsites, islands, farmlands, directly from tax authorities. (Non-profit). Lists, photographs mailed. Register, Room 10, 110 Church Street, Toronto 1, Canada.

CENTRAL Ontario—Choice 640 acre Sportsmen's paradises still available—\$20.00 plus \$6.50 taxes yearly. Maps, pictures. \$2.00 (Refundable). Information Bureau, Norval 4, Ontario, Canada.

GOVERNMENT LANDS . . . Low as \$1.00 acre. Millions acres. For exclusive copyrighted report . . . plus "Land Opportunity Digest" listing land available throughout U.S., send \$1.00. Satisfaction guaranteed. Land Disposal, Box 9091-PJ, Washington, D.C. 20003.

CANADA'S Finest lands, \$4.00 an acre and up. Acquired through Estate liquidations. Suitable for hunting, fishing, camps, cottages, farming, timber, minerals, investment. Small monthly payments. Free descriptive booklet. Canadian Estate Land, Dept. PMC, 194 Wilson Ave., Suite 101, Toronto, 12, Canada.

NORTHWEST TIMBERED ACREAGES AS LOW AS \$950. TOTAL PRICE \$50 DOWN \$25 MONTH. 5-10-20-40 acres for people who love the land—A tract of Recreation Land to have for YOUR own! In Northern Idaho, Northeastern Washington, and Western Montana. In the heart of lakes and big game country. All covered with growing timber. Access. Title insurance with each tract. This is select land with natural beauty, recreational and investment values. We have tracts of many types and sizes from which to choose, including beautiful Northwest Waterfront property on the Pend Oreille, Priest and Kettle Rivers; and property on Pend Oreille Lake. Your inspection welcomed. Write us for free list, maps and complete information. Write to: Dept. PJC, Reforestation, Inc., P.O. Box 8146, Spokane Wash. 99203.

10 to 40 ACRE Tracts. Lake Superior, Marquette, Michigan area. \$99.00 acre. \$2.00 month. Write Hiawatha Lake Acres, 17129 Chrysler Drive, Detroit, Michigan 48203.

FREE CATALOG! Giant Fall-Holidays edition! Over 4,000 properties described, pictured—Land, Farms, Homes, Businesses—Recreation, Retirement. Selected Best thru. ut the U.S.! 69 Years' service, 515 Offices, 40 states Coast to Coast. Mailed FREE from the World's Largest! **STROUT REALTY**, 60-RX E. 42nd St. NY, NY 10017; 7-RX S. Dearborn, Chicago, Ill. 60603; 521-RX E. Green, Pasadena, Cal. 90013.

VACATION Lands; Canada: \$4.00 acre. Free information. Tax Corp., Box 560-P Westmount, Montreal 215.

BUY CANADA \$10.00—10 ACRES. Thousands of Tax Sale properties direct from govt. authorities, Atlantic to Pacific. Easy driving distance. Lakeshore cottages. Hunting. Fishing. Investing. Researched lists published every few weeks. Particulars mailed. Write: **BUREAU**, 16 Quinby Court Thistleton, Ontario, Canada.

JUST OFF THE PRESS! Write for YOUR FREE copy of our NEW Fall/Winter Catalog. Latest real estate bargains, actual property photos. Yours for the asking! **SAFE-BUY REAL ESTATE**, P.O. Box 589-PM, Little Rock, Ark. 72203.

NEWEST Issue! FREE Journal! Latest Arkansas bargains! Statewide Realty Co., 507-AE Pyramid Bldg., Little Rock, Ark. 72201.

THE Only "No-Risk Land Purchase Plan" in America—10 year money-back guarantee on any Vacation, Retirement or Investment homestead in Boiling Spring Lakes—the multi-million dollar, 14,000-acre development on the Carolina Coast. All facilities, electricity, roads, motel, golf course, country club, already in. Private ocean beach, 50 fresh water lakes, 1/3-acre homesteads as low as \$700.00 cash price; \$8.00 down, \$7.70 monthly for 120 months, including interest at an annual percentage rate of 6%. Write for free literature, Dept. 1-P, Boiling Spring Lakes, North Carolina 28461. (Not offered to residents of California, Florida, New York.)

FREE . . . NEW 232-page FALL-WINTER real estate catalog. ALL types property, coast to coast! UNITED FARM AGENCY, 612-PM West 47th St., Kansas City, Mo. 64112.

FREE! Real Estate Catalog! Farms, Ranches, Business, Recreational and Investment Property, 18 States, Pictures Galore. Note State desired. **BANNER Adv.**, Box 3333, 19-A Springfield, Mo. 65804. "Real Estate Our Specialty."

ARIZONA: Secluded mountain retreat acreage near Prescott National Forest, 2 1/2 acres, \$995. Low terms. Mrs. Young, Glenarm Co., 2233 North 7th St., Phoenix, 85006.

TAX Savings through real estate—For analysis on real estate tax savings send \$1.00 to Stephanie Enterprises, Inc., Post Office Box 101, Wadsworth, Ohio 44281.

FARM & GARDEN EQUIPMENT

WATER? Drill your own well with amazing new \$179 Machine. Easy! Economical! Free information. **DeepRock Drilling Company**, Opelika, Alabama 36801.

FLOWERS, PLANTS & NURSERY SUPPLIES

LEARN Landscaping and the growing of plants. Start a profitable business part or full time. Free information without obligation. Lifetime Career Schools, Dept. A-649, 2251 Barry Avenue, Los Angeles, California 90064.

GINSENG Bringing \$18 Pound. Have Seeds Roots, Goldenseal. Full Information. K. Collins, Viola, Iowa 52350.

DRINKING WATER—PURIFIER

PROFITS FROM CLASSIFIED ADVERTISING!! Booklet shows you how to start your own business with Classified Advertising. Only \$1.00 (Refundable with first order.) C. A. Martin, Popular Mechanics, Dept. PM, 575 Lexington Avenue, New York 10022.

HOME CRAFTSMEN

CABINETMAKING MADE EASY and "How to Make Formica Counter Tops," two excellent guides let you build kitchen cabinets and counter tops like professionals. Extraordinary guides bring master craftsmen's shortcut methods. Satisfaction guaranteed. Write: **Japs**, 126-P Seventh North, Hopkins, Minn. 55343.

FREE Popular Mechanics 16 page illustrated catalog of publications, plans and projects. Booklet covers an extremely wide variety of do-it-yourself data on home remodeling, shop tools and machines, car repair, hobbies, crafts, boating, games, lawn and garden and hundreds of others. For your free copy write to **Service Bureau**, Dept. PE, Popular Mechanics, 575 Lexington Ave., New York, N.Y. 10022.

PLANS For pool table with extra two-face top for table tennis and model railroad. Blueprints B1209 and building instructions \$3.50. **Popular Mechanics Service Bureau**, 575-M Lexington Ave., New York, N.Y. 10022.

WOODWORKING Catalog and Manual 25¢ Plus free "101 Project Ideas." World's most beautiful veneers, lumber, plywood! Wood finishing, upholstery supplies, Cane Lamp parts, Furniture hardware, Animal whittling blocks, 2,000 workshop products. **Constantine**, 2051-P Eastchester Road, Bronx 10461.

FOUNDRYETTE 2400 F. 1 1/2 to 48 lb. capacity. Circular 10¢. **Kansas City Specialties**, Box 193-P-10, Middleton, Wisconsin 53562.

"GETTING Started In Stained Glass" 25¢. **Whittemore**, Box 2065Y, Hanover, Mass. 02339.

FULL SIZE FURNITURE PLANS. Traditional, Early American, Danish Modern. Catalog 50¢. **Furniture Designs**, Dept. P-109, 1425 Sherman, Evanston, Illinois 60201.

BATHROOM Vanities. Assemble yourself, save 50%. Provincial style plastic laminated, complete details, \$1.00. **Refundable Vanities**, Box 234, Babbitt, Minnesota 55706.

WALNUT And Cherry tapered legs, lumber, gunstock blanks, picture frame moulding. **Midland Lumber Company**, Box 262, Savannah, Missouri 64485.

101 PATTERNS of smart Gifts, Novelties, Shelves, Action Windmills, plus "Make Money Jig Sawing" \$1.00. **Mastercraft**, 105M, 7041 Olcott, Chicago 60631.

PLANS. Bird houses. Send 15¢ for brochure and free feeder plan. **Yeager**, 1665 Linden, Homewood, Ill. 60430.

MOUNT A Delta Rip Fence and bars on your Craftsman 10" Table Saw. Instructions with Pictures \$1.00. Write: **Saws**, Box 1282, Canton, N.C. 28716.

UNIQUE Tool Grips any size Pulley, Wheel, Shaft, etc. without marring finishes. **HUNDREDS** of uses, \$3.00 each. **Postpaid**, W. Staples, Box 252, Nazareth, PA. 18064.

UPHOLSTERY

MAILORDER Records help get increased Business! Complete 32 Page Record Book shows your inquiries, orders, advertising expense, etc. Only \$1.00. **C. A. Martin**, Popular Mechanics, Dept. PM, 575 Lexington Ave., New York 10002.

DO-IT-YOURSELF

EXERCISE At home on build-it-yourself physical fitness equipment, including bicycle exerciser, rowing machine, belt massager, and abdominal board. Send \$2.50 for blueprints B1208 and instructions. **Popular Mechanics Service Bureau**, 575-K Lexington Ave., New York, N.Y. 10022.

BURGLAR-FIRE ALARM Systems and Supplies. Free Catalog. **Informer Alarm Mfg.**, 715B Ensor Street, Baltimore, Maryland 21202.

AIR Compressors made from Mower Engines. Write: **Showalter**, Box 409, Abilene, Kansas 67410.

BURGLAR-Fire Alarm Supplies and information. Free Catalog. **Protecto Alarm Sales**, Box 357, Birch Run, Michigan 48145.

MAKE Your own wall plaques for fun or profit. Easy to do. Catalog 10¢. **Arts Magic** Box 6232, West Palm Beach, Fla. 33405.

BURGLAR-Fire Alarms, Automatic Police Telephoning, Gas, Bells, Supplies. Free Catalog. Specify: business-residence. **Alarm/Supply**, 7294 Glenview, Fort Worth, Texas 76118.

A-FRAME And cabin building plans. Catalog, \$1.00. Kits available. **Leisure Homes**, 11623 Tescord, St. Louis, Missouri 63128.

WATER!! Drill your own well the easy, economical way with Amazing New Invention. Save 75%. Free information. **DeepRock Drilling Company**, Opelika, Alabama 36801.

BUILD Your own clocks; modernize old clocks. Movements complete with hands & instructions, cordless \$5.95; electric \$3.95 p.p.d. Send 10¢ for catalog. **Morse Products**, Box 38930-A, Hollywood, California 90038.

STEAM Engines. Make from twin cylinder air conditioner, compressors easy to find engines fire tube boilers, flash boiler, gas burners, steam powered lawn mower, send \$2.00 for pictures descriptions. **Travis Tools Co.**, Sidney, Iowa 51652.

WATER? Drill your own well with amazing new \$179 Machine. Easy! Economical! Free information. **DeepRock Drilling Company**, Opelika, Alabama 36801.

FLUORESCENT Tubes rejuvenated at no cost. Instructions \$1.00. **Rejuvenators**, 172 Bolton St., Portland, Me. 04102.

ON-GUARD Car Alarm with Pick-proof lock \$26.50, plus postage. **Selwee Merchandising**, 83-29 159 Street, Jamaica, N.Y., 11432.

ARTS AND CRAFTS

MAKE Figurines, plaques, lawn ornaments. Molds, plastercraft kits, liquid rubber. Sample and catalogue 10¢. **Wooley Company**, Box 29-B, Peoria, Illinois 61601.

BINOCULARS, TELESCOPES, MICROSCOPES, MAGNIFIERS

BINOCULARS Direct from manufacturer. Finest quality, tremendous savings! Request catalog. **Koyu**, 3860 Crenshaw Blvd., Los Angeles, Calif. 90008.

SCIENCE Bargains! Lenses, telescopes, binoculars, microscopes, kits, parts, war surplus. Send \$1.50 for beginner's 10-lens kit with instruction booklet. Order Stock 2-CH. Request free 148 page Catalog CH. **Edmund Scientific Co.**, 300 Edscorp Bldg., Barrington, New Jersey 08007.

WORLD Famous "Dynascope" Telescope. Build your own reflector telescope, mirrors, eyepieces, tripods, accessories. Request free brochures. **Criterion Manufacturing**, Dept. PP 36 Hartford, Connecticut 16101.

TELESCOPE, 30X, \$6.95. See Moon, Planets. Among quality items in free, illustrated catalog. **Winston Roberts**, Dept. PM9, 41695 Paseo Padre, Fremont, Calif. 94538.

CAMERAS AND EQUIPMENT

WORLD'S Largest Buying Guide—800 Illustrations—50¢—Deductible With Your Order—Olden Camera—1265 Broadway, New York, N.Y. 10001.

SELL Your photos. Report tells how, where. Only \$1.00. **Hilltop House**, Dept. 22, Clive, Iowa 50053.

SELL Your Photos. Report tells how, where. Color slide markets. Only \$1.00. **Flair Products**, 1050 West Avenue, Eureka, Calif. 95501.

35MM CAMERA lens F. 40, 1:8 Fixed Focus Takes 9"X12" pictures. Send \$14.95 to Camera, Box 717, Pontiac, Michigan 48056.

FREE! FREE!—Photographic and optical bargain book, Jimco, Dept. 1A0, 9006 Waukegan Road, Morton Grove, Ill. 60053.

48 PAGE ILLUSTRATED CATALOG with the low Central Discount price. Send 50¢. 75¢ CREDIT on order of \$7.50 or more. Central Camera Co., Headquarters for the amateur and professional since 1899. Central Camera, Dept. 1A0, 230 S. Wabash Ave., Chicago, Ill. 60604.

PHOTO SUPPLIES

ANSCOCHROME—DYNACHROME—FILM—save by mail-free price list. Hillis Products, Dept. M Box 1182, Kokomo, Indiana, 46901.

YOUR Ad in Popular Mechanics will be seen by more than 5,000,000 active buyers for your products and services. It costs only \$1.85 per word. And, if you wish to run all or part of your ad in capital letters—you can do so for as little as 75¢ per word additional. Act now! Place your classified ad in Popular Mechanics today.

PHOTO FINISHING

CAMERA FANS! Expert photofinishing by one of Country's largest labs at lowest prices. Fast service and free "Foto-Fan" Stamps you quickly redeem for valuable Photo Supplies. 8MM Kodachrome \$1.29; 8 Exp. Kodacolor \$1.79; 35MM Kodachrome, 20 Slides \$1.39; 8 Exp. Black White 69¢. Satisfaction guaranteed. Send exposed film or request free mailers, complete Price List and Gift Catalog. Direct Mail Photo, Box 8352-PM, Pittsburgh, Pa. 15218.

LOOK—Save Money on Pictures! Jumbo Size Prints from your Kodacolor Rolls, \$1.98. Black & White, 69¢. Huge Discounts on Supplies. Enclose Advertisement. Wisconsin Film Service, Dept. 33, La Crosse, Wisconsin 54601.

50% DISCOUNT "get-acquainted" offer to 126 Instamatic Camera owners for one month only . . . \$1.50 for 12 exposure (regular \$3.00). We develop, print ONLY 126 Instamatic film . . . no black and white. Send \$1.50 today. I/T/K CO., Dept. B. Ishpeming, Mich. 49849.

SPECIAL: BLACK-White, 8-45¢; 12-55¢. Kodacolor, 8-\$1.89; 12-\$2.09. Astro Photo Service Box 530, Waterloo, New York 13165.

KODACOLOR, 20¢/Print. Free Developing. Keaton's, 3540 N. 6th, Abilene, Texas 79603.

SPECIAL WITH THIS AD—Kodacolor developed 12 prints \$2.25. Black & White developed 2 prints each Jumbo size—14 exposure 70¢. LENS PHOTOS, Dept. J-4, Janesville, Wis. 53545.

INTRODUCTORY Special—12-Exposure Kodacolor Developed For \$2.00 With This Ad. FREE GIFT. Expires April 1, 1970. Paul Bunyan Photo, Box 309Q30, Brainerd, Minnesota 56401.

RECEIVE 4 BEAUTIFUL 8X10 ENLARGEMENTS Of picture or negative, originals returned \$1.95. GIANT PHOTOS, Camden, Ala. 36726.

COLOR SLIDES

PROFITS FROM CLASSIFIED ADVERTISING!! Booklet shows you how to start your own business with Classified Advertising. Only \$1.00 (Refundable with first order.) C. A. Martin, Popular Mechanics, Dept. PM, 575 Lexington Avenue, New York 10022.

MOTION PICTURES AND SOUND EQUIPMENT

16MM Sound Features, Shorts, New used for Sale. Free Catalog National Cinema, 333 W. 57th St.-N.Y.C., N.Y. 10019.

FREE! 64-page catalog. 8-16mm film, supplies, processing equipment. Superior, 448 N. Wells, Chicago 60610.

UNUSUAL Movie supplies. Free circular. Esor, 47th Holly, Kansas City, Missouri 64112.

5,000 8-16MM MOVIE Films. Free catalogues. International, Greenvale, L.I., N.Y. 11548.

RADIO, TELEVISION AND HAM EQUIPMENT

33¢ RADIO & TV tubes. Free list. Cornell, 4213-17 University, San Diego, California 92105.

TUBES—Lowest prices in the world. Hard to get British, German, Foreign and American obsolete and present day special purpose transmitting tubes. Send for giant tube and parts catalog. United Radio Company, Dept. Z-56 Ferry St., Newark, N.J. 07105.

GOVERNMENT Surplus receivers, transmitters, scopes, parts. Catalog. 25¢. Meshna, Nahant, Mass. 09108.

HOME Radio—Television Course. Free Brochure. Progressive Edu., Department 718B, Hewlett, New York 11557.

FREE Brochure MONITOR Fire, Police RADIOS with MINIVERTER II, full SQUELCH. Easy installation. Scientific Associates, Box 276(MX), South Glastonbury, Conn. 06073.

HIFI, RECORDS AND ELECTRONICS

TAPE Recorders, hi-fi components. Sleep learning equipment, tapes. Unusual values. Free catalog. Dressner, 1523C Jericho Tpke., New Hyde Park, N.Y. 11040.

RECORDS! Discounts on all LP's. Free details. Citadel Record Club, Symphonette Sq., Dept. 2, Larchmont, N.Y. 10538.

CASSETTE, 8-track cartridge-blanks, language, classical, special accessories, recorders. Quality, low prices. Box 13119M, Pittsburgh, Penna. 15243.

FREE Catalogues, 2000 hard to find unusual records. Rose's Records, 300 Chelsea, Louisville, Ky. 40207.

TAPES . . . blank recording . . . pre-recorded music. Catalog 10¢. Tower, Lafayette Hill, Pa. 19444.

FREE - FREE - FREE - FREE - FREE - FREE Send in for your FREE one year subscription to Olson Electronics' fantastic value packed catalog—unheard of low, low prices on brand name speakers, changers, tubes, tools, stereo amplifiers, tuners, CB and other values. Credit plan available. If you have a friend interested in electronics, send his name and address for a FREE subscription also. Olson Electronics, 487 S. Forge St., Akron, Ohio—44308.

STEREO TAPES Cassettes 4-8 Track Encyclopedia of Stereo Tapes just off Press. Over 9000 Selections. Send 25¢ (If it's on Tape we have it). Stereo Tapes Unlimited, 2318 Sheffield, Chicago, Ill. 60614.

SEE Electric Sounds! Variety of mind-blowing lighting effects. KITS KITS KITS or assembled. Catalog \$1. Trans-Lites, Box 207, Lenox Hill Sta., N.Y.C. 10021.

MUSIC AND MUSICAL INSTRUMENTS

PLAYER Piano Rebuilding—get details from: Vestal Press, Vestal 11, N.Y. 13850.

ACCORDION Manufacturing, 6846-P North Avenue, Chicago, Illinois 60635. Concertinas, Hohners, Chromatics, Guitars, Drums, New, Used, Tuning, Repairing. Wholesale Catalogs Free.

POEMS Songs wanted for new song hits and recordings by America's most popular studio. Tin Pan Alley, 1650-PM Broadway, New York 10019.

VIOLIN and Guitar makers—send for latest Free Catalogue of woods & accessories. International Violin, PM8, 414 East Baltimore St., Baltimore, Md. 21202.

POEMS Wanted for new songs and records by America's largest song studio. Send poems. Free examination. Five Star Music, 6M Beacon, Boston, Mass. 02108.

GUITAR, Banjo Making books Plans, woods, necks, tools. List 25¢. Satinwood, 510 East 11th Street, New York, N.Y. 10009.

30% DISCOUNT Any Name Brand musical instruments. Write for low price. Freeport Music, 127 W. Sunrise Highway, Freeport, New York 11520.

ELECTRIFY Player Pianos, Pump Organs quickly, inexpensively with Lee Silent Suction Units. Write Lee Music, 525 Venezia Avenue, Venice, California 90291.

GUITAR MAKING Books. Imported Woods, Supplies, Accessories. Catalog 25¢. Guitar Center, Box 15444, Tulsa, Okla. 74115.

SWISS Musical Movements, Mechanical-Electrical. Spielman, 131 West 42nd, New York 10036.

ACCORDION Top brands. Buy direct. Tremendous discounts. Trade accepted. Free brochure PM. Accordion-O-Rama, 874 Broadway, N.Y.C. 10003.

DRUMS, Electric guitars, amps, organs. Free catalog M: A.L.A.S. Import Company, 31 East 18th Street, NYC. 10003.

EXCELSIOR Accordions and Amplifiers. Save 50%. Buy Direct. Factory Distributor. Terms, Trades. Free Catalog. Excelsior, 3147 North Luna, Chicago 60641.

LEARN 5-String Banjo. Play Bluegrass the first week. \$4.95 Postpaid. Satisfaction guaranteed. Blaylock, Box 25-M, Marietta, Georgia 30060.

ACCORDIONS And Amplifiers! Save to 50%. Famous makes. Easiest terms. Trades accepted. Free home trial. Free discount catalog. Accordion Corporation, 5535—R West Belmont, Chicago 60641.

FREE Song Selling Information. Peerless Publications, Box 193-A, Bloomfield, Conn. 06002.

GUITARS, MANDOLINS, BANJOS, Complete stock of Gibson Martin guitars. Free 100 page catalog, parts and accessories. Big Savings. New York discount prices. Send 50¢ postage handling. Eddie Bell Guitar, Dept. PM, 201 West 49, New York 10019.

HANDMADE Guitars—classical, flamenco, Dobro type, Martin, Gibson, Wood tools, books. The Guitar, 4668 Hollywood Blvd., Hollywood 90027.

SONGPOET'S "Jiffy" pocket Rhyme-Finder! \$1. Ardbox, 85-X, Trumbull, Conn. 06611.

FORTY Music flash cards quickly learn note reading. \$2.00. Nu-Wa Music, Bybee, Kentucky 40412.

SONGPOEMS Wanted. Top composer with publisher contacts. Share royalties. Midsouth, 10623F Westland, Jackson, Mississippi 39209.

POEMS, Songs Wanted for new songs and immediate recording contracts. Royalties. Weiss Music Company, 1472PM Broadway, New York, New York 10036.

30% TO 50% DISCOUNT. Any Guitars, Amps, Drums. You name brand, model. Fast. Warehouse P3, Box 9352, Fort Worth, Texas 76107.

SONGWRITING SECRETS and SELLING. Free publishing information. 3055-PM-10S9 Kincaid, Eugene, Oregon 97405.

WE Pay All Recording Costs on accepted material! Need new Song Material for immediate recording! Grand Recording, 1354-PM Hancock St., Quincy, Mass. 02169.

TEACH Yourself guitar, piano, accordion privately! Details. Bigben, 26-1211 Court, Brooklyn 11201.

EDUCATION AND INSTRUCTION

LEARN Auctioneering. Term soon. Free catalog. Reich Auction College, Box 850, Mason City, Iowa 50401.

PIANO Tuning quickly learned with home study course. Diploma granted. American Tuning School, Gilroy, Calif. 95020.

BOOKKEEPERS. Operate your own "Dollar-A-Week" system. Ellis, Box 200, Cedar Grove, North Carolina.

OWN Collection agency. "Little Gold Mine!" Franklin Credit, Roanoke, Virginia 24004.

EARN \$125 A week and up. Learn a trade with a future. Learn auto diesel mechanics in our shops. You learn with tools on real equipment. Earn while you learn. Many of our graduates earn \$125 a week and up. Write for free bulletin: Dept. 256, Auto Diesel College, Nashville, Tennessee 37219.

SWEDISH Massage and physical culture pays big profits. Learn at home. Diploma. Free catalog. National Institute, Dept. E-109, 307 North Michigan, Chicago 60601.

USED CORRESPONDENCE Courses and Books sold and rented. Money back guarantee. Catalog free (Courses bought). Lee Mountain, Pisgah, Alabama 35765.

MISSOURI Auction School. GI Approved. Free Catalog! 424-03 Nichols Road, Kansas City, Mo. 64112.

BE A POLICEMAN. Complete Course and Diploma, only \$10.00. Southern Police Academy, P.O. Box #306 Fairfield, Alabama 35064.

FCC First Class License in six weeks—Nations highest success rate—Approved for Veteran's Training. Schools in Dallas, Atlanta, Chicago, New Orleans, Minneapolis and Houston. Write Elkins Institute, 2603D Inwood Road, Dallas, Texas 75235.

HIGHLY EFFECTIVE home study courses in Electronics Engineering Technology and Electronics Engineering Mathematics. Earn your Degree. Write for Free Descriptive Literature. Cook's Institute of Electronics Engineering, (Dept. 10), P.O. Box 10634, Jackson, Miss. 39209. (Established 1945).

EARN College degree at home. All subjects. Ohio Christian College, 1156 Striebel Road, Columbus, Ohio 43227.

USED Courses! Books! List 10¢. Smith's, 124 Marlborough, Salem, Mass. 01970.

BE A REAL Estate Broker. Big earnings. Prepare quickly, easily. GI approved. Free Catalog. Weaver School, 3519-P Broadway, Kansas City, Missouri 64111.

GET A British Degree. Divinity, Philosophy, Radionics. 35 Courses. Prospectus free. Brantridge Forest School, Highfield, Dane Hill, Sussex, England.

LEARN Asleep or awake! Records, tapes, equipment! Free catalog! Drawer, PM-400, Ruidoso, New Mexico 88345.

PIANO Tuning pays. Big money in spare time. Learn at home. No musical knowledge necessary. Phonograph, records, tools and instructions furnished. Electronic tuning also taught. Free catalog. Capital Tuning School, 3160 S.W. 16th Court, Ft. Lauderdale, Fla.

INSTANT Spanish. Free lesson. Mayco, Dept. K-1, 257 Chloride Star, Kingman, Ariz. 86401.

REAL ESTATE BROKER TRAINING Simplified course, train at home. Write: RETA, Box 713, Elkhart, Ind. 46514.

FAMOUS HOME FIX-IT GUIDE. Other Self-Improvement books. Free list. Harry Haines, R. 1, Box 151, Mill Hall, Pennsylvania 17751.

LEARN Handwriting analysis. International, Dept. 700, 11749 Eldridge, Lake View Terrace, Calif. 91342.

PENMANSHIP Improver: Correct poor penmanship, plus ornamental. Tevis, Chillicothe, Mo. 64601.

PROFITABLE National Camera Repair School training at home! PM-10, Englewood, Colorado.

PIANO Technology—Electronic organ servicing, learned easily at home. G.I. Approved. Free booklet. Niles Bryant School, Dept. P, 3631 Stockton, Sacramento, California 95820.

PHOTO RETOUCHING. Interesting, profitable career at home; full or part-time. Easily learned. Hamilton Studios, Dept. PR-39, Claymont, Del. 19703.

AUTOSUGGESTION. Sleep-learning headquarters! Tapes, records, books. Gigantic catalog free. Research Association, Box 24PM, Olympia, Washington.

LEARN ACCIDENT INVESTIGATION. Train at home to earn \$750 to \$1,000 monthly. Car furnished. Expenses paid. No selling. No college needed. Full or spare time. Men urgently needed. Free placement service. Write for FREE information. No obligation. Universal Schools, CPM-10, 6801 Hillcrest, Dallas, Texas 75205.

TEN LESSON WRITING COURSE Secret of Success. What to write. How to write it. Where to send it. \$4.95. Nolan Enterprises, 10280 Vicksburg, Cupertino, Calif. 95014.

COMPLETE Home training in lucrative Watch Repair. Free sample lesson. Chicago School, YX, Fox River Grove, Illinois 60021.

LEARN Civil and criminal investigation at home. Earn steady, good pay. State age. Institute Applied Science, 1920 Sunnyside, Department 16A, Chicago, Illinois 60640.

SIMPLIFIED NEW AGE ordaining procedure. Stamp brings info. Church, 2207 Cardinal, Rolling Meadows, Ill. 60008.

COLLEGE-LEVEL COURSES at home in your spare time—for college credit, advancement in business, self-satisfaction. Low monthly tuition includes textbooks. One of world's largest home study schools. Our 72nd year. Accredited Member, National Home Study Council. Free Brochure. Write today! American School, Dept. CX745, Drexel and 58th, Chicago, Illinois 60637.

HOME STUDY COURSES in WATCHMAKING, ENGRAVING, DIAMOND SETTING, and CLOCK REPAIRING. For information write: KANSAS CITY SCHOOL OF WATCHMAKING Dept. PM3, 101 West 11th Street, Kansas City, Missouri 64105.

LEARN Bartending. Bartenders Correspondence School. P. O. Box 6253, Tucson, Ariz. 85716.

SUPERIOR Auction School. Nation's top Auctioneers own and instruct. Box 1281, Decatur, Ill. 62523.

CONVERT Your leisure reading, hobby, work experience to certified educational credentials. Quality for better employment. Advance faster. Educational Merit System, Box 253, Plymouth, Mass. 02360.

BANJO Instructions, easiest plectrum method published \$2.95. P.O. Box 38371, Hollywood, Calif. 90038.

AUCTIONEER School. The greatest methods ever developed. Recorded step by step. Even children become Auctioneers at home. Satisfaction Guaranteed. Send \$9.95. P.O. Box 4801, Charleston Heights, South Carolina 29405.

CONQUER AUTOMATION—Acquire profitable skill Motor Carrier Transportation Tariff Rates. . . . Your future potential earnings unlimited. . . . Write . . . Macord Enterprises, 254-PM, Southaven, Mississippi 38671.

READ COMPUTER CARDS! Easy decoder kit deciphers bills, checks, etc. Send \$1—R&L Associates, Box 366, Villanova, Penna. 19085.

PENMANSHIP Corrector. Improve poor penmanship quickly. Details free. Ozment, Box 2344-34, St. Louis, Mo. 63114.

DETECTIVE Course Details. Write P.S., 4425-B W. Irving Park, Chicago, Ill. 60641.

SAVE! Immediate Bid Your Book Needs. Hawkins, 24146 Naranjas, South Laguna, California 92677.

AUCTIONEERING Resident or Home Study Course Free Catalog, Nashville Auction School, 2004 West End, Nashville, Tennessee 37203.

COMPLETE YOUR HIGH SCHOOL At home in spare time with 72-year-old school. Texts furnished. No classes. Diploma. Information brochure free. American School, Dept. X745, Drexel at 58th, Chicago, Illinois 60637.

DETECTIVE Course. Free information. Universal Detectives, Box 8180-F, Universal City, California 91608.

HIGH SCHOOL diploma at home. Licensed teachers. Send age, highest grade completed for free details. No salesman will call. Southern States Academy, Westbury Square Professional Bldg., Dept. 16, Houston, Texas 77035.

ORDAINED? Free credentials! Request information! NSU, 708 South Bragg, Monroe, North Carolina 28110.

FREE! Catalog of low cost popular self-improvement books. Write Jack Butler, 1384-B Monroe Drive, N.E., Atlanta, Georgia 30324.

BECOME real estate broker quickly. Economical homestudy. Prospectus free. Howard Schools, Box 8585-A, Kansas City, Missouri 64114.

MILLIONS OF SEWING MACHINES NEED REPAIR. New book shows how. \$7.95. Sincere Press, Box 10422, Phoenix, Arizona 85018.

SELF-STUDY Material, all subjects, any purpose. Aural, Allenhurst, New Jersey 07711.

FOR INVENTORS

PATENT Searches complete and thorough. Related copies Air Mailed with maximum speed \$6.00. Free "Protection Forms" and "Patent Information." Write American Patent Search Company, Dept. 27, 711 14th St., N.W. Washington, D.C. 20008.

PATENT Application Financing. Free patent search plan. Global Patent Division, 2420 77th, Oakland, Calif. 94605.

PATENT And invention development by licensed professional patent engineer and U.S. Patent Office former examiner, and engineering specialists. Your inventions and ideas engineered for patent protection and commercial value. Inventions developed by us negotiated for cash or royalties with our nationwide contacts. Send for free protection "Invention Certificates" and further interesting, valuable patent information. George Spector, Licensed Professional Patent Engineer, Woolworth Building, New York.

U.S. Patent Office Searches, 234 Broadway, Room 3615, New York. Free invention certificates.

IMMEDIATE Cash, for patent applications. Free patent searches. Write for details. Universal Patents, 184-D, Marlon, Ohio.

SELL Your Invention Now! Inventor's Guide for Marketing Inventions only \$1.00. Invention Marketing Research, 3138R Wilson, Chicago, Ill. 60625.

MANUFACTURERS NEED New Products! FREE Literature explains "How To Submit Your Invention," Congress Invention Company, 911-C Warner Building, Washington, D.C. 20004.

PATENT Searches, including copies of related U.S. patents. Inventors attorneys, manufacturers use our "worldwide" airmail service! "Invention Record" form and "Information Every Inventor Needs," sent free! Hayward Company, 1029P Vermont, Washington 5, D.C.

INVENTORS: Your ideas and inventions (patented; unpatented) expertly searched, developed for commercial appeal and cash/royalty sales to manufacturers by professional Invention Developer with excellent record of experience. B.S. Industrial Engineering; United States Patent Office former Patent Examiner, United States Government former Patent Advisor, Second decade reliable service! Member: United States Chamber Commerce. Free "Invention Record" and "Recommended Protection Procedure." Airmailed! Write: Raymond Lee, Invention Developer, 230P-Park Ave., New York City 10017.

INVENTIONS Needed immediately for manufacturers. For additional information write Kessler Corporation, C510-F1, Fremont, Ohio.

"SELLING YOUR INVENTION." Booklet describes several methods of marketing your invention. \$1.00 Postpaid. Litke Products, 219 E. Blair, Lyons, Kansas 67554.

NEEDING ASSISTANCE? INVENTION DEVELOPMENT FOUNDATION, 1823 Jefferson Place, N.W., Washington, D.C. 20036. CANADIAN OFFICE: 155 Kent, Ottawa 4, Ontario.

FREE PAMPHLET: "Tips on Safeguarding Your Invention." Write: United States Inventors Service Company, 501P Thirteenth Street N.W., Washington, D.C. 20004.

INVENTIONS WANTED

INVENTIONS Wanted, Patented: unpatented, Tremendous manufacturers lists, Global Marketing Service, 2420G 77th, Oakland, California 94605.

INVENTORS! Sell your invention for cash or royalties! Our client manufacturers eagerly seek new items. Patented. Unpatented. Financial assistance if needed. 25 Years proven performance. For free information, write Dept. 15, Gilbert Adams, Invention Broker, 80 Wall St., New York, N.Y. 10005.

INVENTORS! We will develop, sell your idea or invention patented or unpatented. Our national manufacturer-clients are urgently seeking new items for highest outright cash sale or royalties. Financial assistance available. 10 years proven performance. For free information write Dept. 47, Wall Street Invention Brokerage, 79 Wall Street, New York, N.Y. 10005.

INVENTORS! Don't sell your invention, patented or unpatented, until you receive our offer. Eagle Development Company, Dept. H, 79 Wall Street, New York 5, N.Y.

WE Either sell your invention or pay cash bonus. Write for details, Universal Inventions, 298-E, Marion, Ohio.

INVENTORS! Protect your ideas! Free "Recommended Procedures." Washington Inventors Service, 422F, Washington Building, District of Columbia 5.

FREE "Directory of 500 Corporations Seeking new Products." For information regarding development, sale, licensing of your patented/unpatented invention. Write: Raymond Lee Organization, 230-N Park Avenue, New York City 10017.

INVENTORS—If you have an invention for sale, patented or unpatented. Wire for free brochure outlining manufacturer's requirements. Royalty rates. Kessler Corporation, C-510-IW, Fremont, Ohio.

YOUR Metal-Plastic products made in Japan. Low cost. Information 10¢. P.O. Box 487M, Miami, Florida 33156.

PATENTS FOR SALE

YOUR Ad in Popular Mechanics will be seen by more than 5,000,000 active buyers for your products and services. It costs only \$1.85 per word. And, if you wish to run all or part of your ad in capital letters—you can do so for as little as 75¢ per word additional. Act now! Place your classified ad in Popular Mechanics today.

MANUFACTURING

INVENTORS Ideas developed. Research. Models. Manufacturing. Sales. Free brochure. William Parker, 32 Westminster, Worcester, Mass. 01605.

MODELS—Small lot manufacturing—Reasonable—Reliable. Frigan Precision, Oil City, Pennsylvania (16301)

EXPERIENCED CONSULTANT solves technical, management problems—reduces costs. Mr. Parker, Box 1071, Springfield, Va. 22151.

BUY IT WHOLESALE

I MADE Over \$100,000.00 year selling by mail. IRS proof available. Success story, book form \$2.00. Wayne Johnson, 880 SW 60th Avenue, Ft. Lauderdale, Florida 33314.

BARGAINS! Buy wholesale and below. Name brands. Appliances, furniture, sports equipment, televisions, cameras, watches, jewelry, thousands more. Huge discounts to \$1,000.00 on new automobiles. All makes. Free details. Write today: Worldwide Bargainhunters, Box 730-A, Holland, Michigan 49423.

DRAFTING Equipment Slide Rules Catalog 30¢/Stamps. Amtech Inc., Box M-122, Mt. Holly, N.J. 08060.

BUTANE LIGHTERS \$3.75. Smith Enterprises, 101 N Richman, Villa Grove, Illinois 61956.

FANTASTIC Free catalog—watches, general merchandise. Department Forty, 100 North Greene Street, Baltimore, Md. 21201.

BARGAINS! SAVE \$50, \$100 or more. See Christmas Gift Shopping Classifieds. Boston Shcp.

WORLD'S Largest Dropship Sources. U.S. & Foreign. 7853 Suppliers, Hongkong clothes. Automobile discounts. Save 10¢ on dollar bankrupts, closeouts. Free details. International Buyers, Box 16386-M, Portland, Oregon 97233.

HEARING Aids, Batteries, Wholesale. Catalog 25¢. Fiston, Box 1444, New Preston, Conn. 06777.

800,000 BARGAINS! Tremendous Discounts Available! Wholesalers 1265-MR Broadway, New York, N.Y. 10001.

EXPORT-IMPORT

I made Over \$100,000.00 year selling by mail. IRS proof available. Success story, book form \$2.00. Wayne Johnson, 880 SW 60th Avenue, Ft. Lauderdale, Florida 33314.

JAPAN: 1200 Products Directory, Illustrated Manufacturers' names, addresses. \$3.00. Send cash. Yamagata Office, 814 Tegin Bldg., Marunouchi, Tokyo.

BE INDEPENDENT! Import-Export without capital. World's largest trade organization helps you succeed. For Official Journal, valuable information send \$2.00 (Creditable): International Export Association, Columbia, Maryland 21043.

MEXICAN Imports, Aztek calanders, etc. Inquiries. Hanson, Box 3561. HAFB, New Mexico 88330.

FOR THE HOME

BURGLARY-FIRE Protection. Everyone can afford. No wiring, installation. Free details. Watchdog Alarms. P492M. Williamsburg, Ohio 45176.

SAVE \$\$\$\$ Sensational new Device prevents Theft or use of Electrical Appliances; Workshop Tools, easily attached. \$2.50 Postpaid. Guaranteed. Details 25¢ refundable with order. Home Aids, Post Office Box 2216, Naranja, Florida 33030.

PROTECT YOURSELF! Amazing peephole device gives expanded view out through door, no one sees in. \$2.98. Siren Burglar Alarm, requires no installation. \$6.95. Details 10¢. Lightco, Rapids City, Illinois 61278.

COMPLETELY NEW-Weatherproof House numbers. Perfect room numbers Etc., Three color combinations. Rust-proof, Fadeproof, Wholesale or Dropship. Fields Co., 708 Peter, Garrett, Ind. 46738.

FOR PARENTS

PROFITS FROM CLASSIFIED ADVERTISING. Only \$1.00 Refundable with first order.) C. A. Martin, Popular Mechanics, Dept. PM, 575 Lexington Avenue, New York 10022.

OF INTEREST TO WOMEN

WOMEN! Make big money at home. \$10.00 profit in an hour possible with invisible mending. Make holes, tears disappear from clothing, fabrics. Steady year-round demand from cleaners, laundries, homes. Details free. Fabricon, 1533 Howard, Chicago 60626.

HOW To make money writing short paragraphs. Information free. Barrett, Dept. C-27-X3, 6216 N. Clark, Chicago 60626.

DRIVE New car, wear new clothes, buy color TV. Get daily cash income. Put spare hours to work. Write for 5 months free subscription Opportunity Magazine, see hundreds easy ways to make money. Opportunity, 1460 Hancock Center, Dept. 17-KO, Chicago 60611.

WANTED! Addressers — Commission Mailers. Stamp required. Ooton Distributors, 4120P Duke Drive, Portsmouth, Virginia 23703.

\$75.00 THOUSAND. Home addressing! Longhand, typewriter. Information, send stamped self-addressed envelope. Brewster, Box 1348-YL Clearwater, Florida 33517.

WOMEN: Big Money! Studio Girl Cosmetics needs women in all States including Hawaii, Alaska, Puerto Rico and American Samoa. Full or part time. No experience required. No territory restrictions. Take orders anywhere. Highest profits. 500 Good Housekeeping approved cosmetics. Everything furnished. Credit extended. No stock to carry. No franchise fees. No stock investment. For full information by mail, plus 3 free samples, write Harry Taylor, Chairman, Studio Girl Cosmetics, Dept. BC-400, 11461 Hart Street, No. Hollywood, Calif. 91605. Also immediate big profit earnings for experienced City and State managers and former party plan operators.

\$500 MONTHLY POSSIBLE—Clipping news at home. No experience. Free information—send stamp. American, Excelsior Springs, Mo. 64024.

\$100 WEEKLY Possible—Home Typing Immediate earnings! Employers list, complete instructions. Details 25 cents. Typing, Box 593, PM-10, Bettendorf, Iowa 52722.

HOMEWORK, Mailing circulars! Free details! Cam Company Dept. 155-XM, Verona, N.J. 07044.

SOURDOUGH SECRETS — Complete starter instructions, plus 7 delicious recipes. \$1.00. Box 127H, Martin City, Montana 59926.

HOMEWORKERS! \$85 Weekly addressing mail for firms. Start immediately! Details, send stamped self addressed envelope. Enterprises, Box 16143-PM, Phoenix, Arizona 85011.

\$25.00 HUNDRED Addressing, Possible! Year 'round. Complete instructions 25¢ for registration, postage. Cove, Box 1348-B, Clearwater, Florida 33517.

HELPLESS? DON'T BE! YOU'RE NOT ALONE ANYMORE. FOR POSITIVE PROTECTION CARRY PROTECT-HER! "T.M." CONCEAL THIS PATENTED LIFESAVER IN YOUR HAND. NO TOY. DEFEND AGAINST MOLESTERS EASILY THUMB DEPRESSABLE SPIKE RETURNS SAFELY INTO SHEATH WHEN IDLE. CONFIDENCE CAN BE RESTORED. SEND \$1.65 EACH TO: LEBERS, INC., BOX 9521-P, RAYTOWN, MISSOURI 64133.

UNIQUE Full Length Mirror \$1.00! Ross, Box 152, Wayne, Pa. 19087.

\$100 WEEKLY Possible addressing mailing circulars. Send self address stamped envelope. Details Free! Ayers Opportunites, Box 1591PM, Denton, Texas 76201.

BUY WHOLESALE—Nylons—Rush \$1.00—Receive guaranteed lifetime membership. Genie, Department F, 3725½ Whittier Blvd., Los Angeles, California 90023.

FOR educational, Home, Job, Self and Money-Saving Improvements. Write now! Particulars—25¢. Lotto's Distributing, 507 Fifth Ave., New York, N.Y. 10017.

EARN Up to \$2.00 Hour Lacing Baby Boots!! Cowboy, Warsaw 9, Indiana 46580.

GIFT SHOPPING

GET FREE GIFTS Send for new catalog. Harry Haines, Route 1, Mill Hall, Pennsylvania 17751.

FREE Distinctive Gifts Catalog. Send Name Address. Elmo, 2136A 71 Street, Brooklyn, New York 11204.

DISTINCTIVE Catalog Free! Chen, PM-919, 244 West 99, Rm-302, New York 10025.

FREE Gift Catalogs. Holidays are coming, get a Head Start. Specify Domestic or Import. R. J. Renn Co., 16 Wellington Rd., Elmont, N.Y. 11003.

NEW—UNUSUAL GIFTS and NOVELTIES from many Foreign Lands, direct to you—low prices through our Worldwide Mailorder Service. Send \$1.00 cash for Catalogs: H. Hjaltason, Box 412, Akureyri, Iceland.

FREE Catalog. Useful Gift for everyone. Write: Krull, 211 Oak Ave. La Plata, Md. 20646.

BARGAINS! SAVE \$50, \$100 or more. See Christmas Gift Shopping Classifieds, Boston Shop.

GIFTS of Distinction. Write for free brochure. Raymond Fuson, Drawer 1188, New Bern, North Carolina 28560.

SOUVENIR OF FREEDOM Authentic Replica 1776 Continental Dollar, \$1.00 Dixie-Gary, Rt. 5, Box 485, Tallahassee, Florida 32301.

WATCHES, OLD GOLD, JEWELRY

WATCH And clock repairing books. Free catalog. North American, Box 77-AL, Fox River Grove, Illinois 60021.

USED Wrist, pocket watches—\$3.00 up. Free list. Southern Watches, 5-PM South Wabash, Chicago 60603.

WANTED—gold, silver, platinum (any form), mercury. Information free. Wilmoth's, 1067 Bridge Street, Grand Rapids, Michigan 49504.

HIGHEST CASH For Gold, Jewelry, Gold Teeth, Rings, Diamonds, Watches, Silver, Platinum. Mail Articles Today. Free gift with information. Chicago Gold & Precious Metals, 6 E. Monroe, Dept. 268, Chicago 60603.

CASH Immediately for old gold, jewelry, gold teeth, watches, diamonds, silverware, spectacles, platinum, mercury. Free information. Rose Industries, 29-A East Madison, Chicago 60602.

WEARING APPAREL

PROFITS FROM CLASSIFIED ADVERTISING!! Booklet shows you how to start your own business with Classified Advertising. Only \$1.00 (Refundable with first order.) C. A. Martin, Popular Mechanics, Dept. PM, 575 Lexington Avenue, New York 10022.

HEARING AIDS

HEARING Aids below wholesale. Regular, eyeglass, completely hidden models. Smallest, most powerful. Free home trial. No salesman will call. Free details. Write Prestige-C6, Box 10880, Houston, Texas 77018.

HEARING AIDS—Batteries Wholesale! Brochures—Hearing Center, Box 211, St. Petersburg, Florida.

BIG Hearing aid battery savings. Free details—P. Reid, 11600 Wayne, Romulus, Michigan 48174.



SCIENCE AND CHEMISTRY

ROCKETS: Real flying models—flights up to 2500 ft. New illustrated catalog 25¢. Singles and multistage kit, cones, engines, launchers, trackers, rocket aerial cameras, technical information. Fast service. Estes Industries, Penrose 7, Colorado 81240.

FREE Periodic classification of elements and conversion tables with catalog 35¢. Chemicals, apparatus, biology. Mid-States Scientific, 7053 N. Clark, Chicago, Ill. 60626.

35,000 VOLT CONTINUOUS Spark Generator, cheaply made in minutes. Plans, \$1.00 and self-addressed, stamped envelope. Lawrence Engineering, Box 18366, Phila., Pa 19120.

ROCKETS! Flying models, engines, igniters. Send 25¢ for News-A-Log, Rocket Development Corporation, Route 3-M, Seymour, Ind. 47274.

ROCKETS!! Real flying models—2500 feet altitude with powerful motors. Terrific Science Projects. Tubes—Cones—Parachutes—Launchers—Igniters. Gigantic catalog—rocket data—diagrams—25¢. Fast Delivery, Centuri Rockets, Box 1988 Phoenix, Arizona 55001.

ROCKETS, Launching Materials, Flying Saucers, Hot Air Balloons, Cannons, etc. Free Catalog, Zeller, Box 70, Hudson, Mich. 49247.

SAVE! Quality Scientific Supplies—Chemistry, Physics, Biology, Mineralogy (Money Back Guaranteed)—Catalog 35¢ (Refundable)—Dale Hawkins, 24146 Naranjas, South Laguna, California 92677.

CHEMICALS And apparatus for industrial, analytical, and private laboratories. Catalog 50¢. Dept. M-50, Biological Supply Co., 1176 Mt. Hope Ave., Rochester, N.Y. 14620.

SEARCHING For economically priced Laboratory Supplies? Gifts with catalogue—25¢. Hagenow Laboratories; Manitowoc, Wisconsin 54220.

SEARCHING For Economically priced Chemicals And Apparatus? Gifts With Catalogue 35¢. Starr Scientific Manitowoc, Wisconsin 54220.

LABORATORY Supplies At Discount Prices. Catalog—35¢. Deluxe Scientific; Manitowoc, Wisconsin 54220.

GET Smart. Science Chemistry, Technology Books. Many fields. Catalog 45¢. See our interesting ads in back issues of PM. Bilton, Box 28, River Edge, N.J. 07661.

CATALOG Of Ver-ry Interesting Products—25¢ (Free with any purchase—see our other Kenrus ad) Kenrus, Box 158M, Staten Island, New York 10309.

100 ONE Minute time delay fuses! \$1.00. 240—\$2.00. 700—\$5.00. Use with rockets, experiments, etc. Kenrus, Box 158M, Staten Island, New York 10309.

AMAZING New Book of Science Experiments, formulas and Catalogue of Laboratory Supplies. Only 50¢. National Scientific Co., 9 S. Park Avenue, Lombard, Illinois 60148.

UFO PHOTOS Books, Magazines, Catalog 25¢. Paradise-M 290 Washington, Vidor, Texas 77662.

ILLUSTRATED Catalog: Chemistry, mineralogy, biology 25¢. Tracey Laboratories, Evanston, Illinois 60204.

LASER COURSE, personal instruction. \$10.00. 3436 Cuesta Dr., San Jose, Calif. 95122.

NATURAL RUBBER TUBING! 1/8" I.D. 1/32" Wall, Amber, 50 ft. \$2.00; 100 ft. \$3.00. Flexo-Line, Sidney, Ohio 45365.

FORMULAS, PLANS, ETC.

ANY Formula \$3.00. Catalog—Treatise 10¢. Belfort, 192 N. Clark, Chicago 60601.

FORMULAS — Secrets — Remedies — Information. Catalog—10¢ Goodkin, Box 19G, Clifton, N.J. 07015.

PLASTIC, DECALS

CASTOLITE Liquid Plastic pours like water and hardens like glass without heat. Clear. Colors. Embed real flowers, butterflies, photos, coins. Also new molding formulas for perfect reproductions. Illustrated booklet shows HOW. Send 25¢—Dept. 9/101L, CASTOLITE, Woodstock, Ill. 60098.

PLASTIC Craft Kits—Supplies. New. Enlarged Catalog 50¢. (Refundable). Specialty Products, Dept. 7, 731 Brocks Road, Muskegon, Michigan 49442.

PLASTICS

3-D MOLDS FOR VACUUM FORMING—Over 100 nat'l trademarks, logos, pictures, great for magnetic and display signs. "ready-to-use" Brochure 25¢ Samples (2) \$5.00 with order. Kimball Plastics, 2602 Whitaker, Savannah, Ga. 31401.

TREASURE FINDERS

TREASURE Hunters! Prospectors! Relco's new instruments detect buried gold silver, coins, minerals, historical relics. Transistorized. Weighs 3 pounds. \$19.95 up. Free catalog. Relco-A40, Box 10839, Houston, Texas 77018.

TREASURE LOCATORS, MOST COMPLETE LINE, FREE INFORMATION. TESOROS, APARTADO 7-948, MEXICO 7, MEXICO.

FISHER DETECTORS! Treasure fun and profit with new professional quality solid-state models. Unsurpassed sensitivity, reliability. Guaranteed. Free literature. FISHER RESEARCH, Dept. PM-10, Palo Alto, California 94303.

POWERFUL Metrotech locator detect gold, silver, coins, relics. Moneyback guarantee, terms. Free information. Underground Explorations, Dept. A, Box 793, Menlo Park, California 94025.

ULTRA-SENSITIVE AND POWERFUL METAL DETECTORS—join the many who are finding buried coins, minerals, relics and artifacts. Don't buy till you see our FREE catalog of new models. Write Jetco—Box 132, PM-8, Huntsville, Texas 77340.

FIND Buried treasure with new revolutionary analytical metal detector. Features push button tuning, automatic tuning, loudspeaker, negligible ground pickup, greatest range. Free catalog. Gardiner Electronics, Dept. 9, 4729 N. 7th Ave., Phoenix, Ariz. 85013.

TREASURE BOOKLET. Excellent information on treasure hunting and metal detectors. Send 25¢. BOOKLET, Dept. 10-PM, Box 243, San Gabriel, California 91778.

TREASURE, Gold, silver, relics. New 1970 detectors now available. Free information. Rayscope, Box 715, North Hollywood, California 91603.

GOLDAK Treasure Locators—New for '69! A hobby you'll enjoy for fun and profit. Find coins, gold, silver. Goldak, Dept. PMC, 1101A Airway, Glendale, California 91201.

FREE 128 Page detector catalog. General Electronic Detection Co., Box 67, Bellflower, California 90706.

PRECIOUS STONES AND MINERALS

EARTH Science Rockhound Magazine. Subscription \$2.50. Sample 35¢. Box-550-PM, Downers Grove, Ill. 60515.

100 COLORFUL, Polished gemstones. \$1.00. Tumblecraft, 5401 James North, Minneapolis, Minnesota 55431.

SEMI-Precious uncut gems. Ten different for \$1.00. Request list = 35. Prospectors Shop, 201 San Francisco, Santa Fe, New Mexico 87501.

GET Free catalog no serious rockhound, gem cutter, jewelry maker, hobbyist or craftsman can be without. Full of bargains, exclusive items, low prices from largest suppliers and authorities in the field. Free new catalog just off the press, yours for the asking. Write Grieger's, Dept. C-12, 1633 E. Walnut, Pasadena, California 91106.

THREE Ounces of pure silver in a beautiful mini bar. Stamped with the emblem of a still active Idaho mine. \$9.95 each postpaid. Foster Inc., Box 795M, Walla Walla, Wash. 99362.

TEKTITE From Thailand. 1 inch \$1.00. Larger \$2.00. Plummer's, 4720 Point Loma Ave., San Diego, Calif. 92107.

12 POLISH-Gem-Stones-Of-The-World. Names-And-Locations.—Educational—\$1.00 Empire Gem's, Trinidad, Calif. 95570.

CARTOONING, COMMERCIAL ARTS, SHOWCARD & SIGN PAINTING

COMPACT 23 lesson Cartoon Course and Cartoonist's Magazine. \$2.00. Hartman, Box 30367, Lincoln, Nebraska 68510.

LEARN sign painting at home. Free talent test. Ben Kerns, Box 812-PM, Greenville, S.C. 29601.

"HOW TO MAKE MONEY WITH SIMPLE CARTOONS"—Everyone who likes to draw should have this book, FREE. Write Cartoonists' Exchange, 910, Pleasant Hill, Ohio 45359.

SIGN Painting. Fascinating System—Straley, 410 So. Western, Springfield, Ohio 45506.

LEARN Profitable tattooing. Illustrated information and instruction \$3.00. Zeis, 2220-P Delcy Dr., Rockford, Illinois 61107.

LEARN CARTOONING at home. Free book "Key To A Cartoon Career". Write: Cartooning, Box O3176, Colorado Springs, Colorado 80907.

MODERN Cartooning taught by mail. Write for free brochure. Cartoonorama—Box 263-K, Branford, Conn. 06405.

SIGN Painting—Free Catalogue. Instructions, Equipment, Kaufmann Signs, Centertown, Missouri 65023.

ART Talent? Make money right away. Course may not be necessary. Free brochure. Famous American Studios, P5, Spring Park, Minn. 55384.

INTERESTED In art? Write Midwest Arts, Box 95E, Hamilton, Michigan 49419.

YOU Can entertain with chalk talks. Catalog 10¢. Balda the Cartoonist, Oshkosh, Wis. 54901.

ADVERTISING AGENCIES, ADV. SERVICE, MAILING LISTS

MAILING Lists most all kinds 1000 \$5.00. Free folder. Your circulars mailed \$4.00 1000. Dixie Mailers, King, N.C. 27021.

ADVERTISING Ratebook leading newspapers, magazines, 25¢. Chicago Advertising Agency, 28-E Jackson, Chicago 60604.

TYPEWRITERS, DUPLICATORS, OFFICE EQUIPMENT

FREE Plan. Start printing, lettershop. Offset Presses, Mimeograph Copy machines. DixieGraph, King, N. Car. 27021.

RUBBER STAMPS AND OFFICE SUPPLIES

FREE 40 Page catalog. Rubber stamps, office supplies. Youngers Stamp Shop, Princeton, Iowa 52768.

RUBBER Stamps. Any copy. 4 lines \$1.00. Phillips, Box 164A, Staten Island, New York 10314.

CATALOG. Address Stamp \$1.50. Signature \$2.80. Carol's, McLoud, Okla. 74851.

ADDRESS Rubber stamp. \$1.25. Wendell's, Dept. 30, Box 2284, Everett, Wash. 98201.

ADDRESS Stamp with handle \$1.25. Brookfield Stamps, Box 121, Brookfield, Wis. 53005.

ENGRAVED Metal, Plastic Nameplates. Doorplates, Deskplates, Social Security Plates. \$1.00. Brochure. Morris, 410 West Oaklane, Lake Charles, Louisiana 70601.

PRINTING PRESSES, RUBBER STAMP OUTFITS

PRINTING Presses, type, supplies. Lists, 5¢. Turnbaugh Service, Mechanicsburg, Pennsylvania 17055.

TYPE Catalog No. 12, 120 pages. Send One Dollar. Deductible First Order. Acme Type, 732 Federal, Chicago, Illinois 60605.

SAME Day shipment on rubber stamp supplies. Revised wholesale price list No. 6 free. Star Stamp Supply, 732 Federal, Chicago, Ill. 60605.

MAKE Your own self-molding rubber stamps and printing cuts. Plexirubber, Argyle-1-, Wisconsin.

RUBBER Stamp Manufacturers Supplies. Presses, starting outfits. Best Prices. Service. Catalog. Jackson Supply. Box 443-A Franklin Park, Ill. 60131.

PRINTING AND SUPPLIES

8 HOUR PRINTING-Free Booklet "Secrets of Cutting Printing Cost" Nationwide Printing, Atlanta, Ill. 61723.

FREE Literature. Address Labels, Business Cards, Printing, Rubber Stamps: Jordan's, 552 West O'Connor, Lima, Ohio 45801.

AMAZING business printing values. Quotations. Print Shop, Box 576, Greenville, R.I. 02828.

FREE Information: Business Cards, Beautifully Embossed, 3 Colors. Spartan, 8210 170th Ave., Stanwood, Mich. 49346.

EMBOSS Business cards! 1000 \$4.50. Parcel post labels! Three lines imprinted, 1000 \$3.95! Fairway, 138 James, Athens, Ohio 45701.

100 8 1/2 x 11 LETTERHEADS, 100 No. 10 Envelopes, your 3 line copy, \$3.95. Jack Armstrong, 52724 Francis Road, South Bend, Indiana 46637.

QUALITY Printing, discount prices, free catalog. Gables—405A Clifton—Glenshaw, Pa. 15116.

IMPRINTED envelopes—all kinds! Information: Ross, Box 152, Wayne, Pa. 19087.

MULTIGRAPH, MIMEOGRAPH

PROFITS FROM CLASSIFIED ADVERTISING!! Booklet shows you how to start your own business with Classified Advertising. Only \$1.00 (Refundable with first order.) C. A. Martin, Popular Mechanics, Dept. PM, 575 Lexington Avenue, New York 10022.

GUMMED LABELS

1,000 GUMMED Address labels \$1.00. Walt's, Box 966A, South Bend, Indiana 46624.

1000 ADDRESS Labels. Finest quality gummed paper. 75¢ Fletcher House, 6745 Sunny Brae Drive, San Diego, California 92119.

1000 PERSONALIZED name and address labels 50¢. Specialties, Ora, Indiana 46968.

GUARANTEED Gummed Address Labels, \$1.00/1000. ECway, Drawer 9037PM, San Jose, California 95117.

REMAILING SERVICE

CONVENTION City Remails 25¢. Colorful Postcards. Schoen, Box 1963-P, Chicago, Illinois 60690.

MIAMI Remails 25¢. Monthly rates. Marle, Box 1266, Coral Gables, Fla. 33134.

KANSAS CITY Remails 25¢. Receiving—Forwarding. Midway 3115-F South 45th, Kansas City, Kansas 66106.

RECEIVING—Forwarding. \$4 Monthly. Hedgpeh, 406-M South Second, Alhambra, Calif. 91802.

PHOENIX, Receiving, forwarding, remailing, Confidential. Troen, Box 2386, Phoenix, Arizona 85002.

FROM Fabulous Las Vegas. Unexcelled, fast, dependable, confidential service. Remails 25¢. Monthly rates. Colorful cards. Ruthie, 558 Oakey Boulevard, Las Vegas Nevada 89105.

JAY'S Remails 25¢. \$3.00 Monthly. Box 28574, Atlanta, Ga. 30328.

HOLLYWOOD Remails 25¢. Receiving, forwarding. George, Box 38638, Hollywood, California 90038.

NORTHWEST REMAILS 25¢ each. Box 3365TA, Spokane, Washington 99220.

BOSTON—Singles—25¢—Monthly \$3.00 unlimited. P-Dad, Box 651, Waltham, Massachusetts 02154.

ADDRESS—CANADA 35¢. Confidential. Airmail \$1.00*. Monthly \$3.00 Plus 10¢ item. Stamp*included. Postcards 6/\$1.00. Jumbo 3/\$1.00. Rix, 1028 Bridgeport, Richmond, British Columbia.

HOUSTON. Secret receiving and remailing. Discreet and confidential. Remail 25¢ single. Permanent address. Bonded Notary. Mail Forwarding Service, 8080 S. Main, Houston, Texas 77025.

PENNSYLVANIA Remails 25¢. J. Dougherty, Box 17611, Philadelphia, Pa. 19135.

CHICAGO. Milwaukee. Wausau prompt reliable free information. Jay's, P.O. Box 1301, Wausau, Wis. 54401.

REMAILING \$1.00 Monthly. No limit personal. Jones, Box 563—B, Silverado Canyon, Calif. 92676.

SACRAMENTO Remails 25¢ Singles. \$3.00 monthly. Box 19123, Sacramento, Calif. 95819.

MOTOR CITY REMAILING SERVICE Singles 35¢. Request Rates. Write: M.C.R.S., Drawer 890, Dearborn, Michigan 48121.

SO. AMERICA Registered re-airmails \$1.00. Confidential. Genaro, Box 360, Guayaquil, Ecuador.

MIAMI BEACH Individual and Business. Confidential Reliable. Weyant, Box 245, Miami, Florida 33165.

SAFE Remails DAILY confidential 25¢ cards. Free information. Mars, Box 4787, Philadelphia, Pa. 19134.

SAN FRANCISCO Remails 25¢ Suremail. P.O. Box 469, San Francisco, California 94101.

PANAMA Or Balboa, Canal Zone. Airmail 50¢. Box 9963, Panama 4, Panama.

DYNAMIC Detroit!—Grosse Pointe: 25¢—\$3.00 Monthly. Lemke's, 3476-TM Balfour, Detroit 48224.

10,000 LAKES 25¢. \$3.00 month. Stanley, Box 23094, Minneapolis, Minnesota 55423.

LAKELAND, CYPRESS GARDENS. Remails 25¢. Monthly \$3.00! Jackson, Box 1535, Bartow, Florida 33830.

AIRMAILS 50¢. Anywhere. Louis Freedman, 240 Major Street, Toronto, Canada.

MONTHLY \$3.00 Singles \$2.25 Details McDermott, Box 870, Saranac Lake, New York 12983.

WASHINGTON, D. C., daily, confidential 20¢ each. 9 gorgeous postcards \$1.00. Sunday Classified \$1.50. Box 1105, Washington, D.C. 20013.

CALIFORNIA Remails 25¢. Receiving, Forwarding \$3.00 monthly. Colorful Postcards 10 for \$1.00. Confidential. Prompt. Mickens, 773 Mar Vista, Pasadena, Calif. 91104.

TIMES Square Mail Address. \$3.00 Month. Remails 25¢. Details Free. Birnhan, 152 West 42 St., New York 10036.

REPAIRS AND SERVICING

REPAIR TV TUNERS; FREE TRICKS. Bocek, Box 832, Redding, California 96001.

SPECIAL SERVICES

INFORMATION On anything. Ferguson Research Specialists, 83-45 Viotor Ave. Elmhurst, N.Y. 11373.

RETAIL Appliance Dealers. Want Increased Sales? Proven Copy-righted System. \$5.00. Speaver's, Drawer C, New Sarpy, Louisiana 70078.

HIDDEN TALENTS. Inventiveness? For creative analysis, send 1/2 page handwriting. \$2. Anton, Box 494, Findlay, Ohio 45840.

AUTHORITATIVE INFORMATION On Anything! \$2.00 (deductible). Metzler Research, P.O. Box 2206PJ, Long Island City, New York 11102.

TOBACCO

LARGE Samples Smoking—Chewing 10¢.
Jolley Farms, Dresden, Tenn. 38225.

RAZORS

PROFITS FROM CLASSIFIED ADVERTISING!! Booklet shows you how to start your own business with Classified Advertising. Only \$1.00 (Refundable with first order.) C. A. Martin, Popular Mechanics, Dept. PM, 575 Lexington Avenue, New York 10022.

PERSONAL

INVESTIGATORS, Latest electronic Aids, Free Literature, Clifton, 11500-P NW 7th Ave., Miami, Florida 33168.

RUPTURED. Relief and comfort. No understraps, elastic or steel. Write Hand-Lock Products, Preston 4, Ont., Canada.

MAKE YOUR WILL. Get 4 Will Forms and attorney's informative book, \$1.00. Legal Forms Company, Department 124, 1967 Guardian Building, Detroit, Michigan 48226.

UNUSUAL Domestic, foreign items. Free catalog. Bohey Sales, Dept. 3710P, Santa Monica, Calif. 90403.

BIBLE Questions answered. Stamped envelope. Bylon, 17167 Bentler, Detroit, Michigan 48219.

LIFE DULL, UNINTERESTING?? Send \$1.00 to Sanada Enterprises, 15728 Pintura Drive, Hacienda Heights, Calif. 91745, and receive ten sizzling sure ways to add "New Life"!!!

ESCAPE—daily grind. Retire without money. Details free. McAllister's International, 1111 Las Vegas Blvd. So., Suite 317-M, Las Vegas, Nevada 89104.

TATTOO Removing, Do-It-Yourself Kit \$14.00. Information Free: Atlanta Co., 907 Lakecrest, Fairport Beach, Ontario.

GET OUT OF DEBT in 90 minutes, legally without borrowing or bankruptcy. Anderson, 8873E Kenwood, Cincinnati, Ohio 45242.

SUBCONSCIOUS Conditioning remakes personality while you sleep. Free details. Sleep-Learning, Box 24N, Olympia, Washington 9851.

SUB-MINIATURE LISTENING DEVICES. Low Priced, High performance, direct from manufacturer. Dealers Welcome. Audiometrics, PM-10, 156 5th Avenue, New York, New York 10010.

ARE YOU REALLY SINCERE about wanting to find a marriage partner? SOCIAL INTRODUCTION SERVICE, 1760 Willamette, Eugene, Oregon 97401.

HOW To Borrow Any Amount Of Money. \$500 to \$200,000. Helped many others. Free details. Counselor-7, Kerrville, Texas 78028.

BORROW Up To \$1,000 By Mail. Money on your signature for any purpose. Write: American Loan Plan, Dept. OA-0135, City National Bank Bldg., Omaha, Nebraska 68102.

BORROW \$1,205 Airmail! Repay \$47 for 36 months. State licensed. Postal Finance, Dept. 17-T, 200 Keeline Building, Omaha, Nebraska 68102.

STOP SMOKING! New book presents Medical and Psychological step by step method. Money back guarantee. Send \$1.00. C. E. Evans, 3028 Treefern, Duarte, Calif. 91010.

STOP Smoking through Self-Hypnosis. Book \$2.00. Herrick Enterprises, R 1 B 552, Coos Bay, Oregon 97420.

STOP SMOKING! New Book presents Medical and Psychological Step-By-Step Method. Money Back Guarantee. Send \$2.00 Newcastle House, 2522-A Newcastle Ave., Cardiff, California 92007.

SECRET LOANS BY MAIL. Borrow \$100 to \$1500 for any good reason in absolute privacy. No interviews, no endorsers, no co-signers. Fast service. Write Dial Finance Co., Dept. K-214, 410 Kilpatrick Bldg., Omaha, Nebraska 68102.

HYPNOTISM SECRETS. Lowest prices. Free information. Merlin Enterprises, P.O. Box 613, Los Gatos, Calif. 95030.

THE "MUSKETEERS FOR MUSKIE" ABOUT TO ORGANIZE. SEND YOUR NAME AND ADDRESS FOR COMPLETE INFORMATION TO P.O. BOX 143, RED BANK, N.J. 07701.

LIVE Better on less money. 200 ways, \$1.00. Stanton Service, Box 892-H, Binghamton, N. Y. 13902.

GAIN! Success, Wealth, Happiness, Health, Personality. Post Card brings free list. Elston House, 35 Stonecliff Road, Centerville, Mass. 02632.

THE SEARCHERS. Professionals in finding fast confidential answers. Free brochure. Research-1, Box 286, Bloxi, Miss. 39533.

HOW to ask for, and get, that raise: 100% successful. \$3.50 cash. B. Phillips, 10034 Timberoak, Houston 77055.

IMPROVE YOUR PERSONALITY! 110 Page Book "Dynamic Thinking" shows How. Send \$1.00 HUSS, 505 Penrhyn Place, East Chicago, Indiana 46312

DP—DYNAMIC MANAGEMENT Tool for increased income. Sample, instructions \$1.00. Box 150, James Park, N.B., Canada.

BE PREPARED. Make your own will. Four will forms with authoritative legal instructions. Only \$1.00. FORMCO, Box 123-M, Milwaukee, Wisconsin, 53201.

MAKE your will. Four approved forms; Attorneys instructions, \$1.00. Willforms, Box 8585-A, Kansas City, Missouri 64114.

MAKE NEW FRIENDS Worldwide. Meet Marriage minded Girls through our illustrated Catalog. 1200 Ladies' Fotos and Descriptions \$2.00. I. C. B., Box 12, Sta. O Toronto, 375, Ont. Canada.

PERSONAL! Your photo or art copied on gummed glossies, postage size stamps. 100—\$3.00. Large 50—\$3.00. Chapman Photo to Stamps, Box 631, Hurst, Texas 76053.

BE POPULAR! Lead the conversation. Develop a better speaking voice. 124 page book tells how. Send \$1.00. Kay's Enterprises, 226 No. Santa Rita, Los Banos, Calif. 93635.

"INVESTIGATORS, Latest electronic equipment free brochure. Dehart Electronics, P.O. Box 5232, Sarasota, Fla. 33579."

WANTED—MISCELLANEOUS

MERCURY, Gold, Silver, Platinum; Ores assayed. Wholesale Terminal, Norwood, Mass. 02062.

YOUR Ad in Popular Mechanics will be seen by more than 5,000,000 active buyers for your products and services. It costs only \$1.85 per word. And, if you wish to run all or part of your ad in capital letters—you can do so for as little as 75¢ per word additional. Act now! Place your classified ad in Popular Mechanics today.

MISCELLANEOUS

I MADE Over \$100,000.00 Year selling by mail. IRS proof available. Success story, book form \$2.00. Wayne Johnson, 880 SW 60th Avenue, Ft. Lauderdale, Florida 33314.

ORNAMENTAL Iron designs. Book of 1600 beautiful, practical designs for railings, columns, etc. Free literature. Cunningham, 3881 South 3200 West, Salt Lake City, Utah 84119.

SILENCERS For pistols and rifles. Complete details for construction and operation, \$1.00. Gunsmith, Box 185, Fairfield, Alabama 35064.

YOUR Name sent to 1000 importers, publishers, mailers, wholesalers, etc. on our mailing list. Year \$1.00. Dixie Mailers, King, N. Car. 27021.

WINEMAKERS—Free catalog and recipes. Kraus, Box 451-L, Nevada, Missouri 64772.

CIGARETTES 12¢ a pack. Improved roller makes 20 filtertip, plain, king or regular for 12¢. Facts Free. Moberly, Box 954, Owensboro, Kentucky 42301.

BIRTH Certificates, Marriage Certificates, Diplomas! 2 blank forms \$1.00. Sample 10¢. Standard Forms, Box 482-M, Washington, D.C. 20044.

WANT Greatest Cash Crop working for you? Write, Ginseng, Asheville 53, N.C.

WINEMAKING . . . Grape, Elderberry, Dandelion, Frozen Juices, etc. Brewmasters' secrets revealed! Powerful Methods! Instructions, Recipes, and Supplies Catalog, \$1.00. Continental, Box 11071-PJ, Indianapolis, Indiana 46201.

BOOKS On antiques and their prices. Free circular!! P. Warman Publishers, Uniontown, Penna. 15401.

WINEMAKERS. Free illustrated catalog of yeasts, equipment. Semplex, Box 12276, Minneapolis, Minn. 55412.

SLOT & PINBALL machines, etc. Catalog 35¢, refunded with order. COFFCO, Dept. B, P.O. Box 522, Lake Zurich, Ill. 60047.

WINEMAKING Kit—\$4.95 Postpaid. Free Catalog—Jim Dandy Wine Supplies, Box 30230M, Cincinnati, Ohio 45230.

HEARING Aid batteries wholesale. Free list. Habs, Box 51, York, Penna. 17405.

PSYCHEDELIC Catalog send 25¢. Hole, 6055 Lankershim, North Hollywood, Calif. 91606.

KILL Mosquitoes, Insects, electrically. Free information. Insect Control, Box P374, Royal Oak, Michigan 48068.

AMAZING Books, jewelry-sweaters-watches. Lynn's, Box 1573, Waco, Texas 76703.

TIRED Of Taxes—Contemporary Cards \$1.00. Lynori, Box 752, Manitowoc, Wisconsin 54220.

BUY—SELL—TRADE. Need something? Want to sell? Trade? Tell us about it. Anything of value. Your listing 25¢. Mailers' Exchange Agency, Box 132-PM, Chicago Heights, Illinois 60411.

FLOATING ROCKS, amazing natural rocks will float in water, coffee, etc. \$1.35 Floating Rocks, Box 5493, Eugene, Oregon 97406.

MONTRACHET Wine Yeast makes superb wines. Three yeast packets with 101 recipes \$1.00. Nichols, 1190 North, Albany, Oregon 97321.

WINEMAKING Recipes—also Brandies, Whiskies—Plus over one hundred other exotic Recipes for all fruits, Vegetables—complete Instructions, Supply source and Bartender's Guide—all for \$2.00. FISHER'S, 2735-D Mission, San Francisco, California 94110.

RADIOSUNGLASSES catalog 25¢ (refundable). Carlton, P.O. Box 12005T, Houston, Texas 77017.

1001 VALUABLE THINGS FREE. Details free. Giftown, Box 8224, Fort Worth, Texas 76112.

STOP Buying Batteries for your transistor Radio! 9v ELIMINATOR lasts forever! \$2.50 Ppd. Energy Labs, 3605-D Parkview, Baltimore, Maryland 21207.

SAVE BROKERAGES FEE'S Exception list seventy addresses and information of No-Load Funds. \$2.00. V.J.B. Enterprises, Box 1862PM, Binghamton, N.Y. 13902.

SECRETS of Life and Ideal Living! Send no money. Write today. Dr. Lane Williams, 111-P West College Street, Covina, California 91722.

COCKTAIL Lovers! A whisk of Twist o Lemon across your cocktail gives it that gourmet touch. Choicest blends of Lemon Oils not Lemon Juice. Approximately 2,800 cocktails. Send check or m.o. \$4.95. Thomas Gifts, 5555 Schofield Rd., College Park, Ga. 30337.

FREE! World's Largest Electronic Kit Catalog

New 1970 Edition... Over 300 Kits For Every Interest, Save Up To 50%

• **Deluxe Color TV** ... The sets you've heard and read about that give better performance yet cost no more; six models: 295, 227, & 180 sq. in. rectangular; with or without AFT; all with exclusive built-in self-servicing aids for best pictures always; custom, wall or cabinet installation; optional wireless remote controls. Also new Heathkit antennas, towers, and deluxe 12" B & W portable TV.

• **Stereo/Hi-Fi Components** ... Transistor stereo receivers (including the world famous Heathkit AR-15), amplifiers, tuners, speakers, turntables, cartridges, furniture.

• **Transistor Organs** ... Deluxe 19-voice "Paramount" and low cost 10-voice Thomas models in kit form with instant-play "Color-Glo" keys — save up to \$500. Also Percussion and Rhythm accessories.

• **Music Instrument Amplifiers** ... 20, 25 & 120 watt amplifiers for lead and bass instruments; distortion boosters, headphone amps, plus mikes and stands.

• **Home Equipment** ... Intercoms, table radios, garage door openers, portable radios and phonographs, home protection systems.

• **Shortwave Radios** ... Multi-band shortwave receivers, solid-state and tube-type, portable and AC operated.

• **Amateur Radio Equipment** ... World's most complete line of SSB transceivers, transmitters, receivers, and accessories.

• **Citizen's Band Radio** ... 5-watt fixed and mobile transceivers, kit or assembled.

• **Test and Lab Instruments** ... A complete line of meters, generators and testers for shop, school, industrial and hobby use.

• **Scientific Instruments** ... Including Berkeley Physics Lab, Malmstadt-Enke instrumentation for spectroscopy, analog/digital equipment, pH meters, recorders.

• **Home Study Courses** ... Basic kit-courses in electronics, radio, and transistor theory. Application kit-courses on how to use meters, generators, and oscilloscopes.

• **Photographic Aids** ... Darkroom computers for B & W and Color printing; electronic timer; color developing trays.

• **Radio Control Electronics** ... For modelers, NEW Heathkit R/C gear including transmitters and receivers (choice of 3 bands) servos, tachometer.

• **Trail Bikes** ... For off-street use, the Heathkit Trail & Snow Bike; outstanding performance at low cost.

• **Marine Electronics** ... For safety and pleasure; radio-telephones, direction finders, depth sounders, weather monitors, and accessories.

• **Automotive Electronics** ... For hobbyist and professional, new Heathkit 3-in-1 Tune-up Meter, Ignition Analyzer Scope, Tachometer, accessories.



Learn how you can build sophisticated electronics at 50% savings ... no special skills needed, famous Heathkit instructions show you how, free technical consultation available ... enjoy the fun and satisfaction of building the best ...

**MAIL
COUPON
NOW!**

HEATHKIT
a Schlumberger subsidiary

HEATH COMPANY, Dept. 17-67
 Benton Harbor, Michigan 49022
 Please send FREE Heathkit Catalog

Name _____
(please print)

Address _____

City _____ State _____ Zip _____

CL-366

SOLUTIONS FOR MECHANICAL HEADACHES

AUTOMOBILE CLINIC

BY MORT SCHULTZ

Cougar cuts out

My 1968 Cougar acts like a cold fish in the morning. The engine cuts out and has to be re cranked three or four times before it finally takes hold. Then it runs like a tiger the rest of the day. What's the remedy for this morning sickness?—Alfred Greer, San Antonio, Tex.

Give it the automatic-choke, fast-idle treatment. Make sure the choke's closing fully for the start—it could be out of adjustment or have a bad part, such as a weak thermostatic spring. Then make sure the fast-idle cam is set properly to provide the fast-idle speed needed for morning get-up-and-go.

The ultimate test

If you can solve this one, you're a genius. No one else can and they've driven the car—a 1967 Plymouth Fury III. When I drive along with my foot on the gas pedal, everything's fine. However, the minute I release my foot from that pedal, there's a terrible rumbling sound from beneath the car. It's been like this for 21,000 miles, and every Plymouth mechanic who's tried his hand at stopping the racket has failed. Good luck.—Charles P. Reichardt, Mays Landing, N.J.

There are a few things that can cause this, Charlie, such as a loose baffle in the muffler that's sounding off on deceleration. When you decelerate, a vacuum is created inside the muffler which could be rocking the baffle. Have someone get his ear close to the muffler as you accelerate and decelerate. Other conditions that can create a rumble include exhaust-pipe interference on deceleration, a loose engine-mounting bracket, and faulty drive-line angularity. A sharp mechanic would run the car on a dynamometer to duplicate the condition.

Obstreperous speedometer

Do you know why the speedometer of my 1968 Chevy II Nova should make noise? My dealer has replaced the cable with a new one.—Miss Marie Pannone, North Haven, Conn.

I know of nine reasons why a speedom-

eter can make noise, so replacing the cable isn't always the answer. Here they are as outlined for Chevy shops (remind your dealer) in the Chevrolet Service News for Nov., 1968: (1) loose cable coupling nut at the speedometer head; (2) tip of cable is bent at the speedometer head; (3) cable extends too far into the transmission; (4) there's an extra or a missing thrust washer on the cable at the speedometer head; (5) speedometer cable and/or the casing is kinked; (6) cable isn't properly lubricated; (7) maybe the noise isn't in the speedometer system at all—perhaps the driven or drive gears at the transmission are at fault; (8) speedometer cable is whipping; (9) a bad speedometer head.

Baby talk

A couple of months ago I drove my 1962 200B Mercedes-Benz to the point of seizure because of a leaky radiator hose. The head was pulled and milled to the maximum of 20 thousandths, valves were replaced, and the head was reinstalled using two gaskets. Now I'm getting water in a cylinder. A friend says to pour evaporated milk into the cooling system—that it will cure the problem. Will it?—Harry E. Dieckman, Harvey, La.

No, it won't. You'd better replace that aluminum head, which probably warped badly because of your unfortunate experience. It will pay to look around for a used one, because a new head costs about \$160. Try some agencies that sell foreign cars. Occasionally, they take in badly beat-up cars which they can't restore, but can cannibalize for parts.

Tired Tempest

My 1966 Pontiac Tempest V8, demonstrates a perceptible lag on acceleration, causing the engine to die out on occasion. This happens after a stop or when rounding a slow corner. A "cold stumble" kit was put in. It hasn't helped. Neither have endless carburetor adjustments.—Byron Mackay, San Antonio, Tex.

It's possible that the kit put in your car was kept in storage for some time. This delay will cause the neoprene cup of the accelerator pump to become hard, affect

Take the fun of driving seriously.)

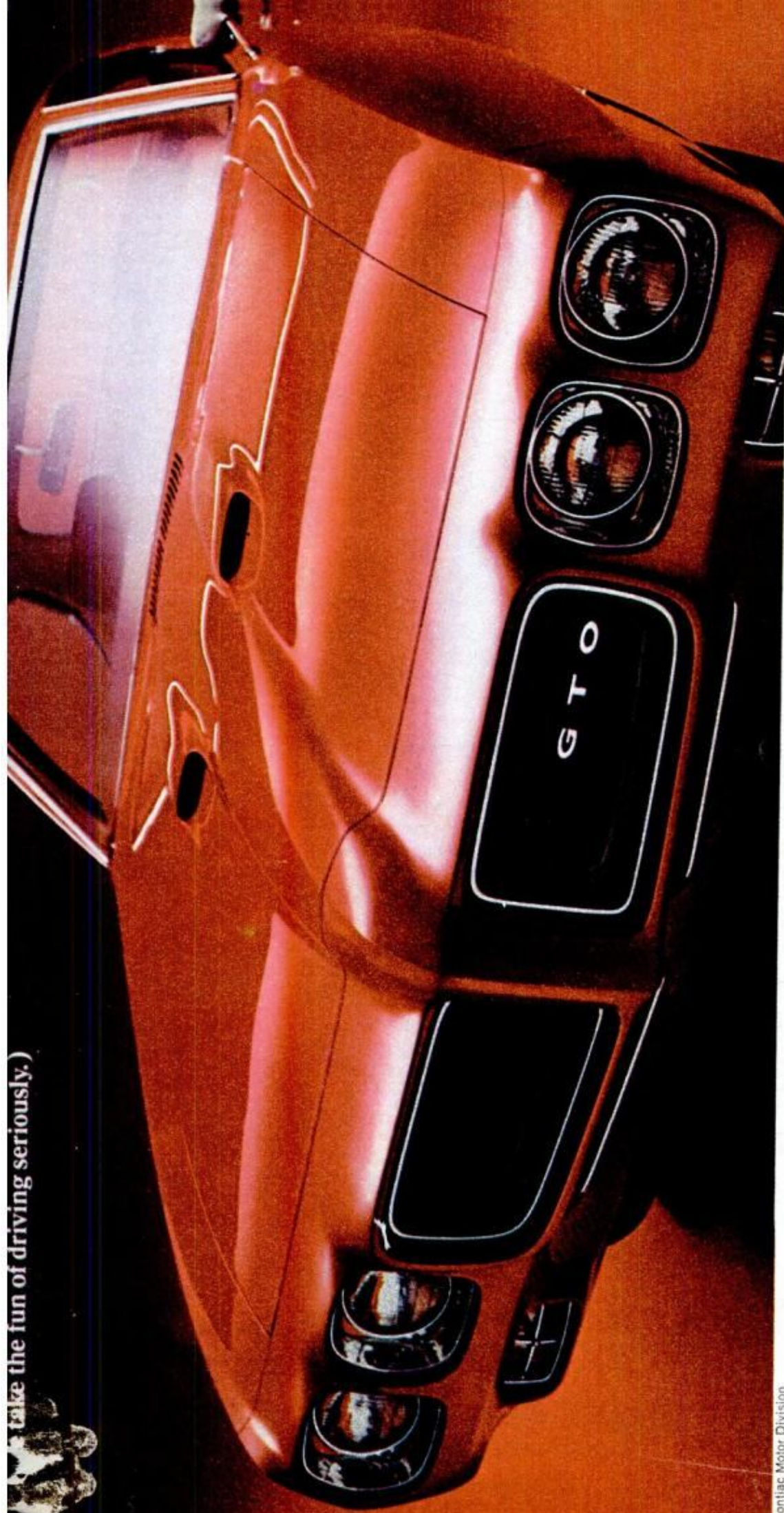

Pontiac Motor Division

Материал, защищенный авторским правом

The Humbler.

1970 Pontiac GTO. So dazzling we've dubbed it "The Humbler."
Listen up. You'll catch on. The basso burble comes from a new performance exhaust you can order.

Of course, pipes can't do it alone. Standard Humbler is a 400 V-8. But you can order a new 455 V-8. Or one of the Ram Air engines.

You can also specify the Hurst-stirred 4-speed, instead of the standard 3-speed.

About now, a lot of pseudo performers are wishing they could slither off to a nice, quiet garage.



MARK OF EXCELLENCE

3 individual color pictures of Pontiac performance cars, specs, book jackets and decals are yours for 40¢ (60¢ outside U.S.A.). Write to: '70 Wide-Tracks, P.O. Box 888, 196 Wide-Track Blvd., Pontiac, Mich. 4800

ing its performance on acceleration. I'd replace the pump with a new one. If that doesn't work, look for the cause of the problem in the ignition system, such as faulty timing or distributor-point dwell.

Bouncy brakes

I have a 1965 Mercury. When I apply the brakes, the foot pedal jumps up and down. I've had it to a brake repair shop, but it still does the same thing. The repair man told me to get rid of the car. What should I do?—James D. Maxwell, Yates City, Ill.

Keep the car—get rid of the repair man. It sounds like a drum (or drums) out of round. Maybe it can be machined—maybe not. But it's a lot cheaper buying new drums than a new car.

Bum steer

I hear and feel a "groaning" vibration when I turn the steering wheel of my 1969 Buick LeSabre with power. It occurs especially at slow speed, and I can't detect it when going over 35 mph. The service manager tells me it's a normal thing. Do you agree?—Ralph H. Caldwell, Greensboro, N.C.

I wouldn't regard this as a normal condition until I replaced the drive belt and power-steering valve on the chance that they were bad.

Stopping a leak

The car is a 1967 Chrysler Newport Custom. The problem: I've gone through three power-steering hoses in the last two years. They all start to spout at the metal connection halfway up the hose. Can you put a finger in this dike?—L.V. Laurie, Woodland Hills, Calif.

Try this. If your car is equipped with airconditioning, are you using a Hypalon power-steering pressure hose (part No. 2537613)? The standard neoprene hose (part No. 2537612) won't withstand the higher temperature of the power-steering fluid on an airconditioner-equipped car.

Hot stalling

I have a 1964 Corvair that runs smooth-

ly while the engine's cold but stalls at every stop I make when the engine is warm. Mechanics who tune it up swear my trouble is over. Not yet it isn't. Can you help?—Noble St. Clair, Ann Arbor, Mich.

There are several reasons why a car stalls when it's hot and not when cold or warming up. First, carburetor idle speed may be out of adjustment, causing an improper or unbalanced fuel-air mixture. Perhaps the engine is flooding at hot idle because of a high carburetor float level, a leaky carburetor needle and seat, or excessive fuel-pump pressure. Maybe the choke plate is sticking in a partially closed position. Also check for a dirty carburetor air-cleaner filter that can give the same effect as a partially closed choke. Maybe heat is causing a mild vapor lock condition. These are things to look into that a mechanic who simply does a tune-up won't consider.

Service Tips

● **1968 and 1969 Plymouths, Chryslers, Imperials and Dodges** with 383 and 440 cu.-in. engines and 4-barrel Holley carburetors have been failing to start when the engine's cold. Why? Blame a sticking choke. Chrysler-Plymouth service bulletin 69-14-2 (1/22/69) and Dodge service bulletin D69-14-2 (2/12/69) tells your dealer how to fix it. Briefly, the solution calls for filing a bevel on the rear side of the raised lip on the choke-coil cover.

● **Chevrolet's 1969 Corvette** with 427 cu.-in. engine and power steering should sport a new upper radiator hose if the one you now have on the car is rubbing against the Delcotron pulley. The new hose (part No. 3967433) provides adequate clearance. Until you can get it, make sure the hose now on the car is positioned so it doesn't interfere with that pulley.

● **1969 Fords and Mercurys** with rim-blow horn systems may experience no blow in cold weather. Plastic at the horn terminal connection shrinks, creating poor electrical contact and erratic horn operation. Your dealer should remove the steering-wheel crash pad, torque the three horn-terminal screws to assure a tight contact and reinstall the crash pad. ★★★

GOT A PROBLEM WITH YOUR CAR? Ask Mort about it. Send your question to Auto Clinic, Popular Mechanics, 575 Lexington Ave., New York, N.Y. 10022. Letters cannot be answered individually, but problems of general interest will be published in the column.

The makings of a winner:

DUAL WIDE TRACK HEADS
cover more ground—
shave you closer, cleaner.

8000 R.P.M.'S
set a fast shaving pace.

CUSTOM PADDED GRIP
for the look and feel
of racing glove comfort.

SPEED SLOTS hug
the surface for quick
long hair pick-up.

SIX REAL BLADES
race your beard
at a better angle.

SIDEBURN TRIMMER
for a perfect finish.

**CURVED BODY
DESIGN** makes
fast, smooth
handling a breeze.

© 1969 SUNBEAM CORPORATION, CHICAGO, ILLINOIS

SUNBEAM[®] **FASTBACK[™]**

TEST SHAVE A FASTBACK SHAVER. NEWEST SLANT ON SHAVING!

built with integrity - backed by service



HOMEOWNERS' CLINIC

BY W. CLYDE LAMMEY

In-and-out home repairs

By necessity I must become a lady "handyman" and I need some elementary "how-tos," such as patching small cracks in walls and ceilings—what patcher to use and what kind of paint? Outside trim needs painting; what kind of paint do I use? Heating is a forced warm-air system; how often should filters be changed? There are small leaks in basement walls; how do I patch them? Screens have some whitish spots; how can these be removed? With kerosene?—A.V., Ind.

Small cracks in plastered walls and ceilings are usually filled with spackling compound, applied with a wide putty knife and sanded smooth after it dries.

Use a water-soluble interior paint on walls and ceilings; color, your choice. Apply it with a roller a narrow strip at a time and usually across the width—so that you can roll to a wet edge when rolling on the second strip.

On outdoor trim, brush or scrape off all loose material and "feather" the edges of blisters flush so that they will not show under new paint. Use a paint especially compounded for outside trim. If "trim" includes sash frames, be careful not to "paint them in." After painting loosen each sash to break the seal. Be sure to lower the upper sash and raise the lower one so you can paint the exposed outer edge of the upper rail of the latter. Do this work only during the warmer months.

Hold an unused furnace filter up to good light and note its clarity; when this "see-through" has been reduced 50 percent, or less, used filters should be replaced.

As a rule, small cracks in basement walls can be filled with a masonry waterproof paint. Apply paint to cracks first; then do the whole wall.

Whitish spots that usually appear on aluminum screening can be removed with a detergent. Don't use kerosene; it's a fire hazard.

Replace wooden gutters?

My old house has wooden gutters. Although they still don't leak they are "un-modern" and unsightly. What kind of guttering should I use as a replacement—aluminum, steel or plastic?—S.L., Mass.

If the wooden gutters still "turn water" why replace them? Why not just freshen them with a new coat of paint or two and let well enough alone? But if replacement is a must, you have a wide choice of types and materials. If I had to do the job myself I'd select ordinary aluminum guttering with those handy slip-connectors. Such an installation can be a fairly neat job if done with care, and is likely to be the cheapest of all. But if I were to contract the work I think I would order galvanized-steel guttering. It's neat and durable if the work is done properly. Pre-finished metal and plastic guttering also are widely used. You have no painting problems with these types, but such installations are relatively expensive.

Finishing 'raw-wood' turnings

I obtained four cherrywood squares from a sawmill, dried them in my attic for two years and then turned them into "cannonball" bedposts. Rather huge cracks have appeared in all four turnings. What can I do now to salvage them?—W.T., Ky.

Well, you've learned that the attic is no place to cure "green" wood. It can be done, of course, but not in the average attic. Salvage? Other cracks could turn up as the seasoning process continues and those existing may widen. Then again, maybe not. I'd fill the cracks with wood putty colored to match the wood as nearly as possible. Then, when I was sure the putty was thoroughly dry, I would remount in the lathe and cut down the turned parts very slightly, and sand them until the patches were as smooth as the wood, or as nearly so as possible.

For a finish, I would use artist's color direct from the tube, rubbing it on with a finger. In this way you can control the color and conceal the patchings. After this "stain" dries at least a week, cover it with a semigloss clear lacquer or other clear finish. Rub the final coat with fine steel wool. While new cracks may appear, the chances are this treatment will work.

Wintering roses

Do those big plastic cones give adequate winter protection to rose plants? If so, how are they placed and anchored?—Y.L., S.D.

Yes, if you don't remove the protectors until all danger of frost has ended. You simply slip the cones carefully over the plants and anchor with stones, bricks, or other weighting material such as earth or short length of heavy planking. ★★



7:22. Good morning.

Your eggs are getting cold.

If it says 7:22, believe it. Because it's a **Waltham**. With a Swiss movement. The **Auto-Cal Courier**. Thoroughly male. Designed to get you through the day on time. Even if you're off to a late start right now.

Notice the calendar? Now you know what day it is. That's a significant start, Sleepyhead.

Consider: self-winding. Luminous hands. Luminous hour dots. Wow, that moon is bright! Sweep second. And a heavy, no-nonsense expansion band.

It won't wreck your budget, either. You can pick it up tonight, after work.

Don't gulp.

WALTHAM®

an international product of Waltham of Chicago

CHICAGO • NEW YORK • LOS ANGELES • GENEVA

Waltham watches are available in Canada, too.

Waltham clocks: everywhere!

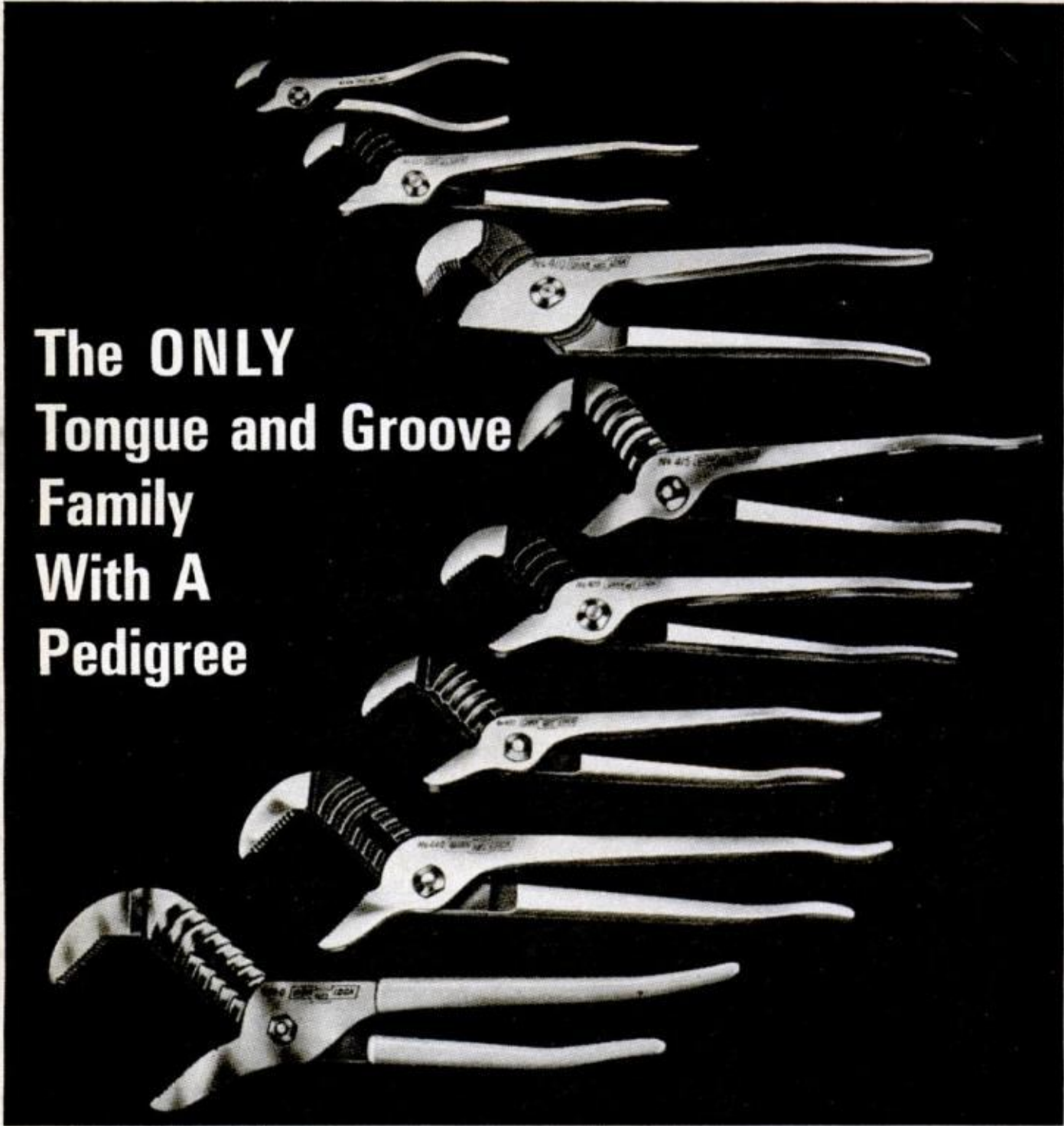

The **ONLY**
Tongue and Groove
Family
With A
Pedigree

Channellock *originated* the tongue and groove plier more than 30 years ago.

Channellock *improved* its original design with patented features available in none of its imitators.

Channellock *precision machines* the mating parts to ensure smooth-working action.

In short, Channellock has been imitated but

never equalled...ask mechanics who own them. How do you make sure you're getting a genuine Channellock? Look for the trademark on the handle. If it isn't there, tell the man "No thanks" and go elsewhere. You'll be glad you did.

Let us introduce you to the entire family. Send for our catalog, no charge.

TOOLS BY
CHAN NEL LOCK
MEADVILLE, PA.



© VOLKSWAGEN OF AMERICA, INC.

A Volkswagen dealer will gladly sell you one.

Obviously.

What's not so obvious, however, is why you would gladly buy one.

So we'll give you a little clue:

See that sign by the windshield? That's what you get for buying that thing.

A 100% guarantee.*

Don't laugh. It's a beautiful thing in itself. Because it covers the big things that can plague you in a used car:

Engine. Transmission. Brakes. Axles. And electrical system.

So if anything goes wrong with any of those parts within 30 days or 1000 miles (whichever comes first), worry not.

The VW dealer guarantees 100% to repair or replace it. And it doesn't cost you a cent.

Not every car he gets in trade gets that guarantee, either. Only those that pass a tough 16-point inspection earn his guarantee sign.

Which is your sign. Of a car that's really beautiful.

This
used car is
guaranteed
100%.



Volkswagen of America, Inc. 1977. All rights reserved. Volkswagen is a registered trademark of Volkswagen of America, Inc. in the U.S. and other countries. *The dealer guarantees 100% to repair or replace the engine, transmission, rear axle, front axle assemblies, brake system and electrical system, for 30 days or 1000 miles, whichever comes first.

*The dealer guarantees 100% to repair or replace the engine, transmission, rear axle, front axle assemblies, brake system and electrical system, for 30 days or 1000 miles, whichever comes first.

style

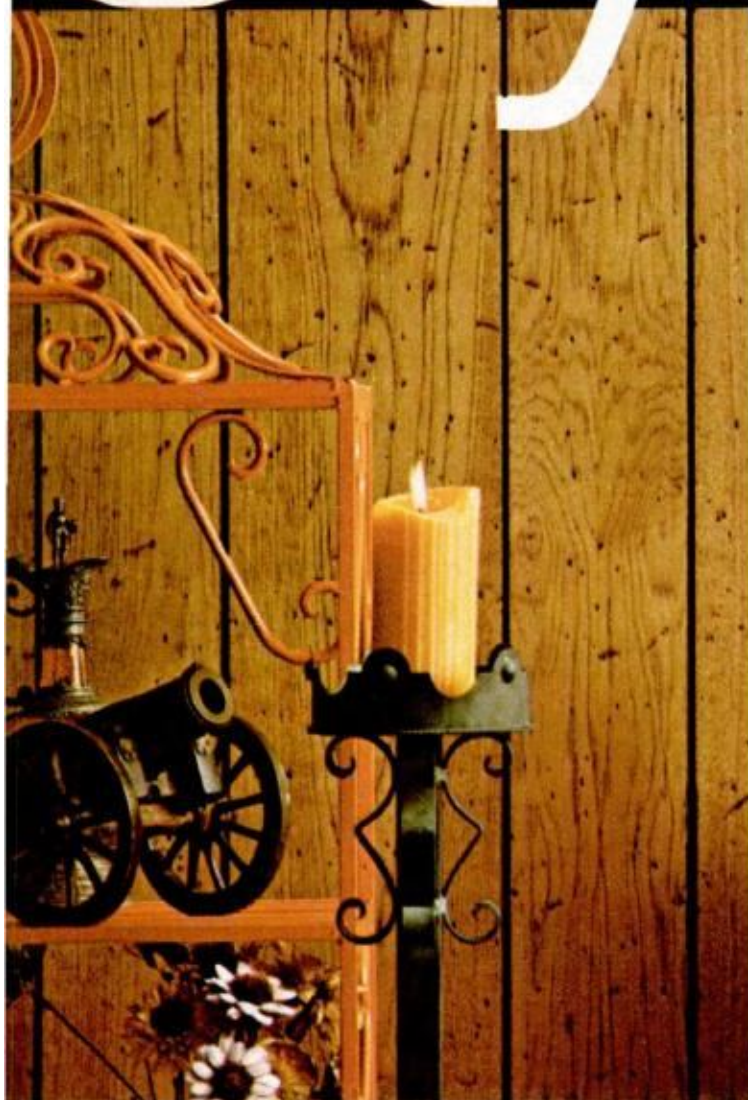

OLD WORLD™ CHATEAU™ PECAN



RIVIERA™ NUTMEG ELM



CHATEAU™ OAK



VINYL SHIELD®

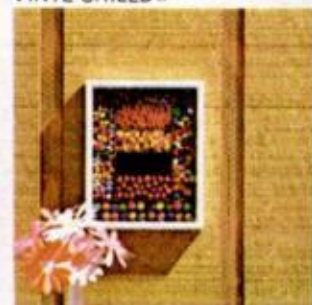

ROUGH SAWN SIDING

**Georgia-Pacific paneling has it!
In the species, wood grains, and colors you're looking for!**

Each Georgia-Pacific panel has something unique. A certain style. But which one fits *your* style? Which species or wood grain would be best in your rec room? Your kitchen? Your living room or bedroom? G-P now offers a free STYLE KIT that illustrates the world's finest line of prefinished paneling. It also offers suggestions

on what paneling to use, where to use it, how to use it. Send the coupon on the opposite page for your free kit. You don't have to look any further for paneling. If it's got style, your G-P dealer's got it!



GEORGIA-PACIFIC
THE GROWTH COMPANY



Ready for the road

The foam-padded headrest, padded guard rail around the middle and nylon mesh restraint vest of the Stroeel "Safety Cradle" keep this lad safely packaged for car travel.



One man, two jets

Sud Aviation has started testing a one-man, jet-powered "helicopter" that will be used by the French army. First flight of the Ludion took place at a test center near Paris.

OCTOBER 1969

free

Georgia-Pacific Style Kit

Paneling ideas for every room in your home. Ideas on new uses for paneling. Plus plans, pictures, do-it-yourself diagrams. Much more. Send the coupon today.



Georgia-Pacific Corporation
Dept. PS10
Portland, Oregon 97204

Please send me your free STYLE KIT with new uses for wall paneling, plus suggestions for using it in kitchens, basements, attics—every room in my home!
(Please Print)

Name _____

Address _____

City _____ State _____ Zip _____

 **GEORGIA-PACIFIC**
THE GROWTH COMPANY

A man's world. Shiny wood, smoke, pretzels,
good conversation, and best of all, the best of all,
Miller High Life. For over six generations,
the great premium beer.

Miller makes it right!



Next Month in Popular Mechanics

How We Built a House for \$7500

A 29-foot living room with fireplace and glass doors to the patio; three bedrooms, two complete baths, 90 square feet of closet space and airconditioning—how do you get all that for \$7500 today? You build it yourself. The Robert Hunt family of Cicero, Ind., did—and they have the receipts to prove that you can do it, too.

How to Catch a Hippopotamus

. . . or an elephant or a zebra or a buffalo. Game wardens in South Africa's Kruger National Park do it every day. All you need is a helicopter or a bulldozer, a crossbow, a quiver of tranquilizing darts and a steady aim. It also helps to take a tranquilizer yourself.

Build a Christmas Greeting for Your Lawn

Designed especially for *PM* readers, this Christmas greeter is motorized and decorated with Disney characters. Complete plans, including Project-a-Plan slides (which make it a snap to copy the art), are in the November issue.

Oceangoing Drive-In

There's a new type of cargo vessel—the roll on/roll off container ship—that handles almost anything that can be pushed, pulled or driven aboard. The odd-shaped and oversized cargo that won't fit in containers (buses, bulldozers, steamshovels and the like) is rolled aboard over stern ramps while overhead cranes load the container cargo.

Jetting Down Montana's Mighty Missouri

Shallows, rapids and steamboats were all part of *PM*'s test of Glastron's new 17-foot Berkeley jet boat.

Bring Life to Those Forgotten Snapshots: Make a Montage

Mounting a whole collection of prints on a background panel is a handsome way to display photos that usually get stored away in a bureau drawer.

Tune In Shortwave on That Transistor Portable

This handy, home-built antenna selector can pull in shortwave on a small transistor portable as well as improve reception on expensive multiband receivers. It also lets you control a tape recorder and external speaker.



Come ride

Scorpion '70

... the snomobile that tops 'em all for family fun, personal enjoyment



Take your family where the fun is . . .

. . . travel comfortably, dependably, safely on Scorpion '70 to the thousands of beautiful sights and fun-filled moments awaiting you over each new hill, in each new valley. Cruise leisurely, with unmatched stability . . .

or light the fuse and . . .

And how! Sleek new Scorpion '70 bombshells are loaded! Light the fuse under one and see for yourself. Scorpion's range of power plant options will rocket you as fast and as far as you want to go!

Tame or wild . . .

. . . it's your choice with Scorpion '70! Five great models to choose—with engine options up to 800cc's. And remember, Scorpion snomobiling is 24-hour-a-day fun. Scorpion's one snomobile that's not afraid of the dark. Because when day is done, Scorpion isn't. It's ready to take you there and back in grand style. So shoot the works! See your Scorpion dealer now and make the scene with Scorpion '70.

The proven snomobile that never lets you down—

manufactured by



Crosby, Minn. 56441
Phone: 546-5125
(Area Code 218)



... FIREWORKS!



Amazing New Instantaneous Fire Extinguisher

**Popular
Mechanics**

By ARTHUR FREESE

An electronic device that can put out a fire faster than you can blink an eye now saves racing drivers from their most dreaded enemy. You could have one, too, in your family car or boat

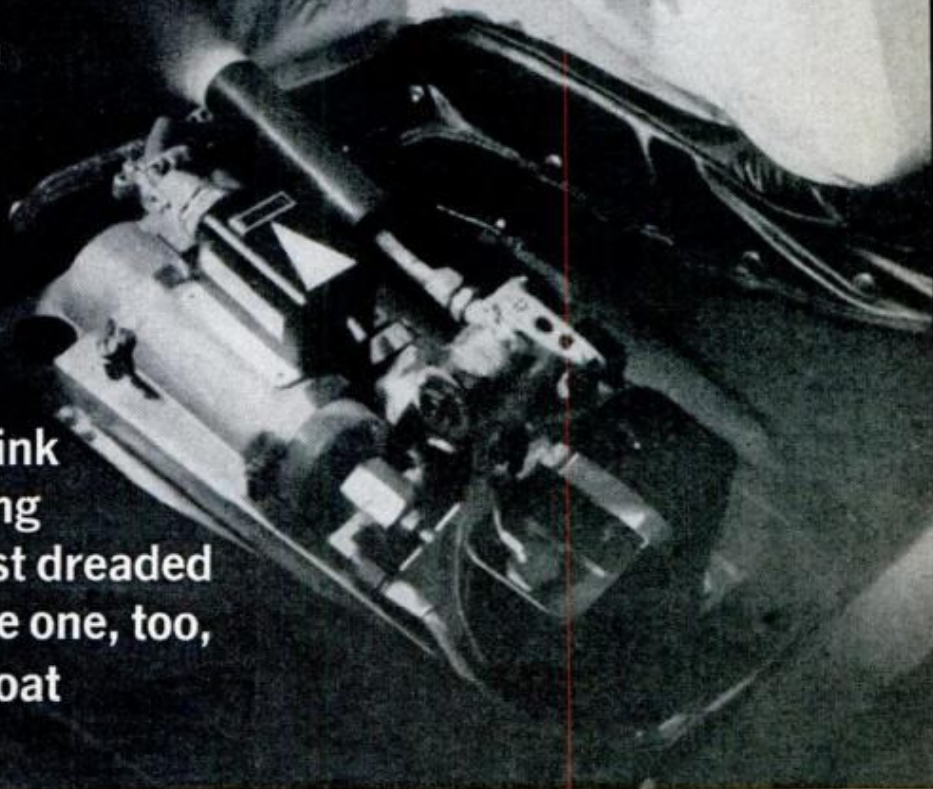

A NEW FIRE-EXTINGUISHING SYSTEM works so fast that you can soak a \$100 bill in gasoline, hold a match to it, and see the flame go out before the paper is even scorched. This recently developed solid state optical detection system can put out a fire in 50 milliseconds—50 thousandths of a second—about one-thirtieth the time it takes to blink an eye.

The system protects racing drivers (Bruce McLaren, Bobby Unser, Sam Posey, Joe Bonnier, Ronnie Bucknum, Denny Hulme, Tony DeLorenzo, Tony Adamowicz, among others) by automatically detecting flame and releasing in the cockpit a nontoxic gas that immediately breaks the chain reaction needed for combustion. The system is also used for military helicopters and planes, computers and bank vaults, radioactive "glove boxes," and on one of our new aircraft carriers. The new extinguisher protects many private pleasure boats, and recent tests indicate the system will soon protect our troops in Vietnam as well.

This fire detector and extinguisher uses an optical infrared-sensing device and Freon gas. (Freon is DuPont's brand name; there are others.) Discovered in the late 1930s, this colorless, odorless gas, a member of the fluorocarbon family, was soon used as a refrigerant because its nontoxicity and nonflammability are truly amazing. Freon 1301 (or Halon 1301, the generic name) is able to put out all common types of fires. The infrequent fires for which this gas can't be used are those involving chemicals such as cellulose nitrate that contain their own oxygen supply; reactive metals, such as sodium or magnesium; and the metal hydrides.

Where the conventional extinguishing agents take considerable time to kill a

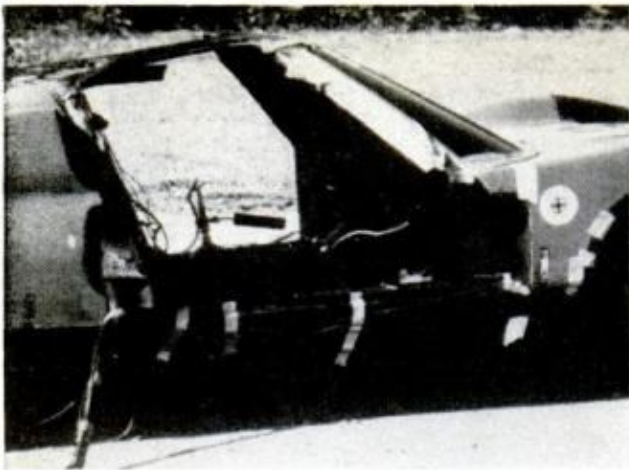

FIRE IS STARTING to break out in this wrecked sports car used in test of new Freon extinguisher

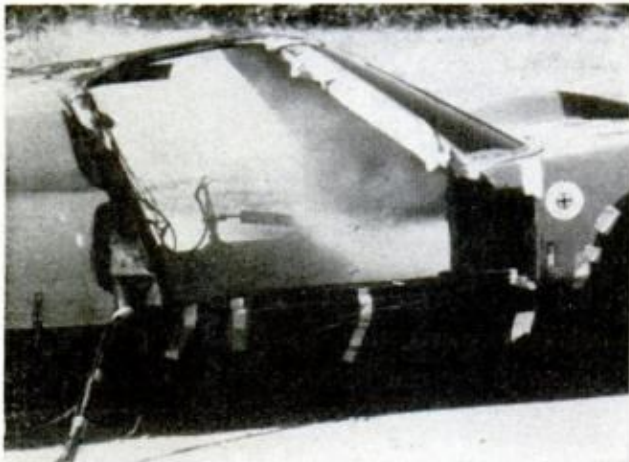

IN LESS THAN AN EYE BLINK, Freon floods cockpit to snuff out fire before you even see a flame



fire by smothering or cooling it, Freon 1301 works almost instantaneously by chemically breaking the chain reaction that keeps a fire going. Scientists are not certain exactly what the process is, but they know it works many times faster than ordinary extinguishing agents.

Originally developed by Pyrotector, Inc., of Hingham, Mass., the new instantaneous fire-detection system is now sold by Formula 1 Enterprises, Inc., in New York City. Its most dramatic use to date has been in auto racing where drivers' greatest concern is fire. Jim Patterson, deputy competition director for the Sports Car Club of America, calls fire "auto-racing's greatest safety problem, because—with seat belts, shoulder harnesses, roll bars and other devices—drivers are now relatively well protected against the impact of an accident." There have been three successive fire deaths connected with auto races at Le Mans, France, North Italy's Monza course, and the Monaco Grand Prix. Charles Ford of DuPont's Freon Products Div. heard that Champion driver A. J. Foyt had been badly burned and quoted as saying he would not race again without an automatic fire extinguishing system.

Ford called A. J. to say "I think I've got something to keep you out of trouble." The driver welcomed the idea and DuPont's expert on firefighting turned to Pyrotector, which custom-made a system for both of Foyt's cars for the Indianapolis race. After seeing it, the Ford Motor Co. had similar systems installed in its seven cars to be driven at Le Mans.

Charles Ford sees the racing car as "virtually a gas tank on wheels. The entire front is all gas tank except for the radiator and an area, the size of a basketball, through which air passes; gas tanks extend along both sides of the driver who is practically lying on

RACING CHAMPION A. J. Foyt (at center in photo at left) confers with the inventor of the Freon extinguisher, DuPont's C. L. Ford at right. Foyt was first driver to adopt the system for his cars. At left is Foyt's father, Tony, his chief mechanic

HOW A FREON EXTINGUISHER PROTECTS A SMALL CRUISER

TYPICAL ARRANGEMENT for safeguarding a boat's critical engine compartment is shown at right. Optical sensors aimed at engine trigger discharge nozzles that flood compartment instantly with Freon.

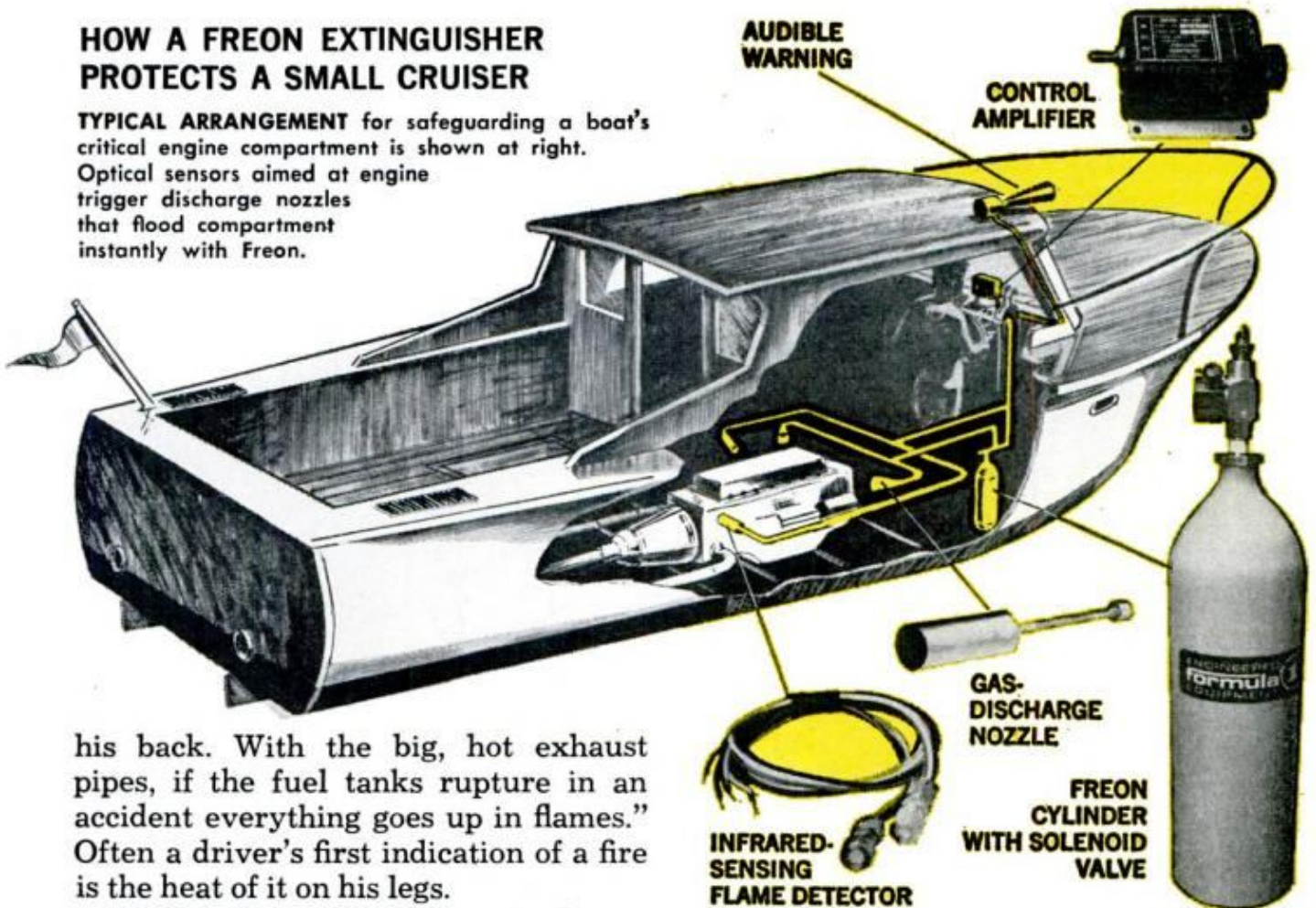

his back. With the big, hot exhaust pipes, if the fuel tanks rupture in an accident everything goes up in flames." Often a driver's first indication of a fire is the heat of it on his legs.

In the new system, the optical sensors "see" the cockpit and release the Freon at the first sign of flame. Even in the inferno of burning gasoline all over the track, an "extinguishing atmosphere" can be established around the driver for 15 to 20 seconds with a small Freon system. This, hopefully, will protect the driver long enough for him to unbuckle and escape or for track people to pull him free or reach him with major firefighting equipment.

The value of an optical detection system lies in its speed, for the light of a fire occurs simultaneously with the flame whereas heat takes time to build up sufficiently to affect a detector some distance away. However, an optical detector must be placed so that nothing will block its view of the area to be protected. Several sensors are often used to "watch" from different angles.

To make certain that the system reacts only to flame and not to ordinary light, it uses a clever triggering device sensitive to infrared radiation, found to a much greater degree in fire than in

daylight. This is done with two infrared-sensitive photocells connected together by a center tap. One cell is covered with a red filter and the other with a green filter. Under ordinary light, the electrical resistance of the two cells is equal. Electricity flowing through the circuit passes through the red cell, across the center tap connection and out the green cell to ground.

As soon as a fire breaks out, the increased infrared radiation passes through the red filter on the first photocell and lowers the cell's resistance sharply. Most of the infrared is blocked by the green filter, however, so that the resistance of the second photocell remains virtually unchanged. Electricity flowing through the red photocell is suddenly faced with a higher resistance in the green photocell. Instead of passing through the green cell to ground, it takes the path of least resistance and flows down the center tap. This triggers an amplifier that, in turn, opens a

(Please turn to page 244)

Now: 'Hands Off'

When it comes to making tricky—and dangerous—deck landings, the computer is surer than the human pilot. The Navy's new automatic system proves that.

By JOHN D. BURLAGE and H. RAY HENDLEY

Illustration by Fred L. Wolff



- | | |
|---|----------------|
| 6 | WAVE-OFF |
| 5 | 10 SECONDS |
| 4 | COMMAND CONT. |
| 3 | COUPLER AVAIL. |
| 2 | ALS LOCK-ON |
| 1 | CHECK-OFF |

Landings on a Carrier

DROPPING to under 1000 feet, the Navy pilot jockeys his jet into the approach path for landing aboard the USS *Forrestal*. Big as she is, the 70,000-ton carrier looks almost like a toy from four miles away, a pitching, rolling toy

in an angry Atlantic. Landing a jet on the flight deck of a carrier is never a picnic, even under the best conditions. But when the weather is bad, with the deck rising and falling as much as 20 feet, it can be a nightmare. A miscue means, at

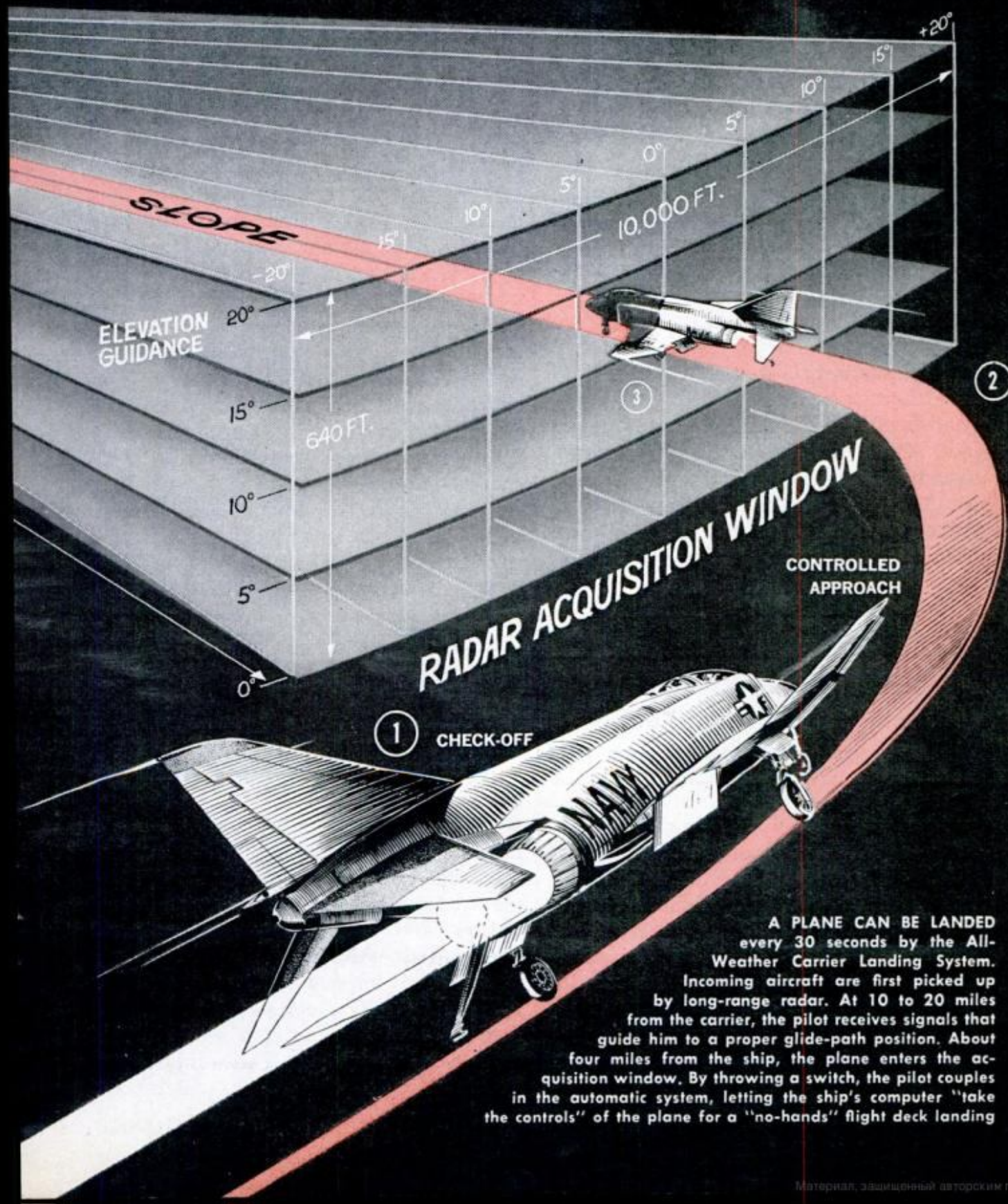

A PLANE CAN BE LANDED every 30 seconds by the All-Weather Carrier Landing System. Incoming aircraft are first picked up by long-range radar. At 10 to 20 miles from the carrier, the pilot receives signals that guide him to a proper glide-path position. About four miles from the ship, the plane enters the acquisition window. By throwing a switch, the pilot couples in the automatic system, letting the ship's computer "take the controls" of the plane for a "no-hands" flight deck landing

best, a wave-off that sends the pilot around for another try; at worst, an accident, perhaps injury or death.

The pilot heading for the *Forrestal* has hundreds of carrier landings under his belt. Yet he wonders how this one will work out. Responding to a signal from the carrier, he throws a switch on the instrument panel. Soon the plane begins to buffet, slightly but steadily. This is a new experience for the pilot, but he has been told to expect it.

Now he does an unusual thing: He removes his hands and feet from the flight controls. Yet the plane continues to sweep in toward the carrier, right on the proper glide path. The touchdown is smooth, and the plane's tailhook grabs the No. 3 arresting cable for a good landing. The pilot grins and gives a "thumbs up" signal to show his approval of the Navy's new automatic landing system.

This landing is typical of more than 1000 made since 1967, when the Navy started evaluating its All-Weather Carrier Landing System (AWCLS). Today, "hands off" landings are an established fact. One carrier and two aircraft squadrons are equipped and qualified for AWCLS operation. Within the next three years, 11 other carriers and over 2000 naval aircraft will be provided with the same capability.

It took more than two decades of ex-

He removes hands and feet from flight controls. The plane continues to sweep in

perimentation and trial-and-error efforts to develop a reliable system. In 1963, for example, the USS *Midway* put to sea to test the AN/SPN-10 system, forerunner of today's AWCLS. Twelve F-4 Phantoms, rigged for automatic landings, were used. The results were later reported as follows:

"The object was technical and operational evaluation. The results were almost catastrophic. Equipment relia-

bility was so poor that a large team of engineers and technicians was hard pressed to obtain any flights."

The AWCLS system was developed by Navy and civilian personnel assigned to the Navy Air Control and Identification Systems (NACIS) Project Office, Washington, D.C. The two top men in NACIS are Capt. Frederick R. Fearnow and his civilian deputy, John L. Loeb, an engineer widely recognized for his work on the Tactical Air Navigation System (TACAN), an operational instrument guidance system.

In 1964 Capt. Fearnow was given the job of developing a reliable system. He explains that automatic landings are needed in normal sea-air operations, not just in bad weather.

"I've read too often about aircraft going into the drink when weather was not even a factor," he says. "Or of a plane hitting the ramp and taking the ship out of action temporarily. These are the kinds of incidents we hope the system will eliminate."

Weather, of course, increases the hazards. Conditions of reduced visibility, absence of exterior visual references, and the presence of turbulent air coupled with the roll, pitch and heave of a carrier deck add to the danger of making a carrier landing.

NACIS engineers tackled the problem by adding refinements to the AN/SPN-10 hardware, making full use of new advances in electronics and computer technology. A digital computer is at the heart of the new system.

AWCLS is composed of three major systems:

- A shipboard complex of solid-state hardware that includes precision tracking radar units, data stabilization equipment, tracking and navigation computers and display/control consoles. Designated AN/SPN-42, this complex is an improved version of the AN/SPN-10. The computer is fed information relative to ship and aircraft motions and attitudes. These inputs are processed by the computer, which then

sends command signals to the aircraft. In this way, the plane is "aimed" at a rectangle 20 feet wide and 120 long, where it touches down and catches an arresting cable.

● The AN/ASW-25A—the airborne part of the system—is a microelectronic data link about the size and shape of a cigar box. It receives the signals from the AN/SPN-42 and triggers proper responses by the aircraft.

● The AN/SPN-41. Also called C-SCAN (Carrier System for Controlled Approach of Naval Aircraft), it is completely independent of the other AWCLS components. It was designed to provide the pilot with a method of monitoring exactly how his aircraft was reacting during an automated landing. It worked so well in its own right, however, that it is also to be installed in older carriers and aircraft (those not receiving the AWCLS components) for use as a primary instrument-landing-aid system. C-SCAN consists of two shipboard transmitters that send coded microwave signals to the aircraft, and airborne equipment that receives the signals, decodes them and presents the information on cockpit display indicators that can be easily monitored by the pilot.

The AWCLS system also enables pilots to make carrier landings in two other modes besides the fully automatic. If the system reacts improperly because of partial component failure, for instance, an aviator may override it by taking over the flight controls and using the SPN-41 monitor information to make his own landing. Or he may permit an air traffic controller manning the carrier's SPN-42 console to "talk" him down by radio-transmitted instructions.

In operational use, the AWCLS will be the final stage of a carrier-landing system that will begin functioning while an incoming plane is still many miles from its carrier.

First, the aircraft will be picked up by long-range search radar and TACAN. These aids will vector the

pilot onto a final approach course. At 10 to 20 miles from the carrier, he will begin to receive SPN-41 signals to guide him both in line-up and glide-path position until he couples into the automatic landing system 4 to 8 miles from the ship.

Once he has thrown the switch coupling in the automatic system, the pilot can sit back and monitor the sys-

No more than a foot deviation between what radar "sees" and plane's actual position

tem. His plane is firmly in the grasp of the SPN-42 data-link combination. With a retractable corner reflector near the nose of the plane as a focusing point, the SPN-42 radar obtains data on elevation angle, azimuth angle and range. The information obtained is so accurate that there is no more than a foot deviation between what the radar "sees" and the plane's actual position in space.

The SPN-42 radar data is fed to the system's data stabilization unit, which also receives inputs from ship's motion sensors—gyros and accelerometers that acquire information on pitch, roll, yaw and vertical motion of the touchdown point.

The data stabilization unit also provides outputs of the aircraft's actual horizontal and vertical position to the navigation computer, which determines the plane's position to the left or right of a center line and its deviation in elevation from a selected glide slope.

Coupling what it receives with known performance limits for the type of aircraft being controlled, the "nav" computer issues pitch and roll commands to the aircraft through the data link transmitter. The data link transmits the commands to the plane's autopilot.

The aircraft responds, pitching up or

(Please turn to page 238)

'70

A Fine-Tuning Year for Outboards

By DAN FALES

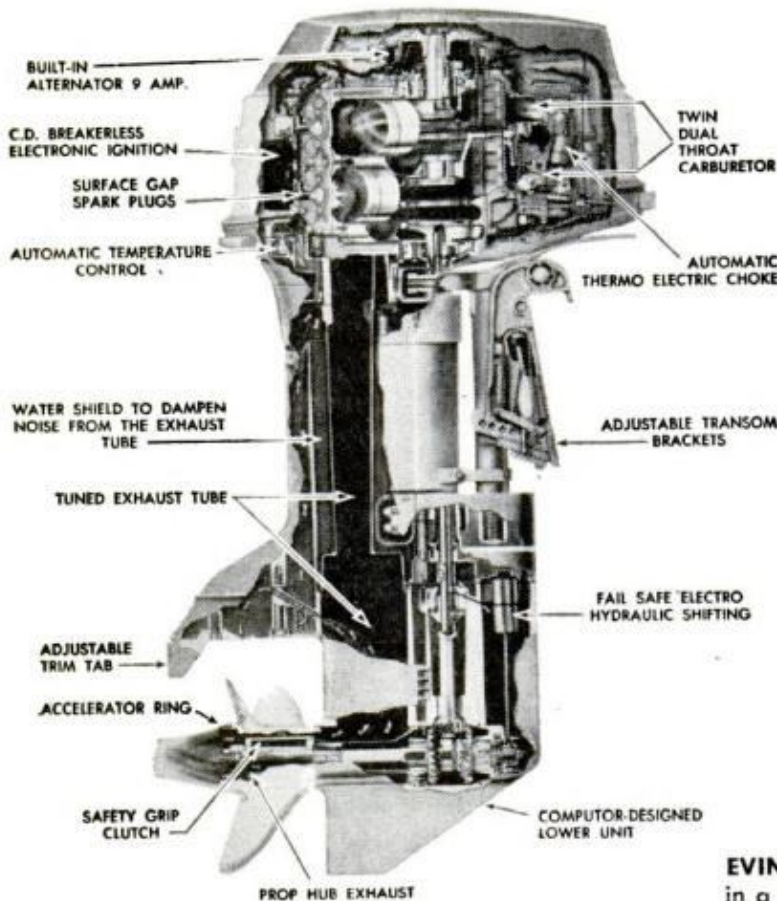
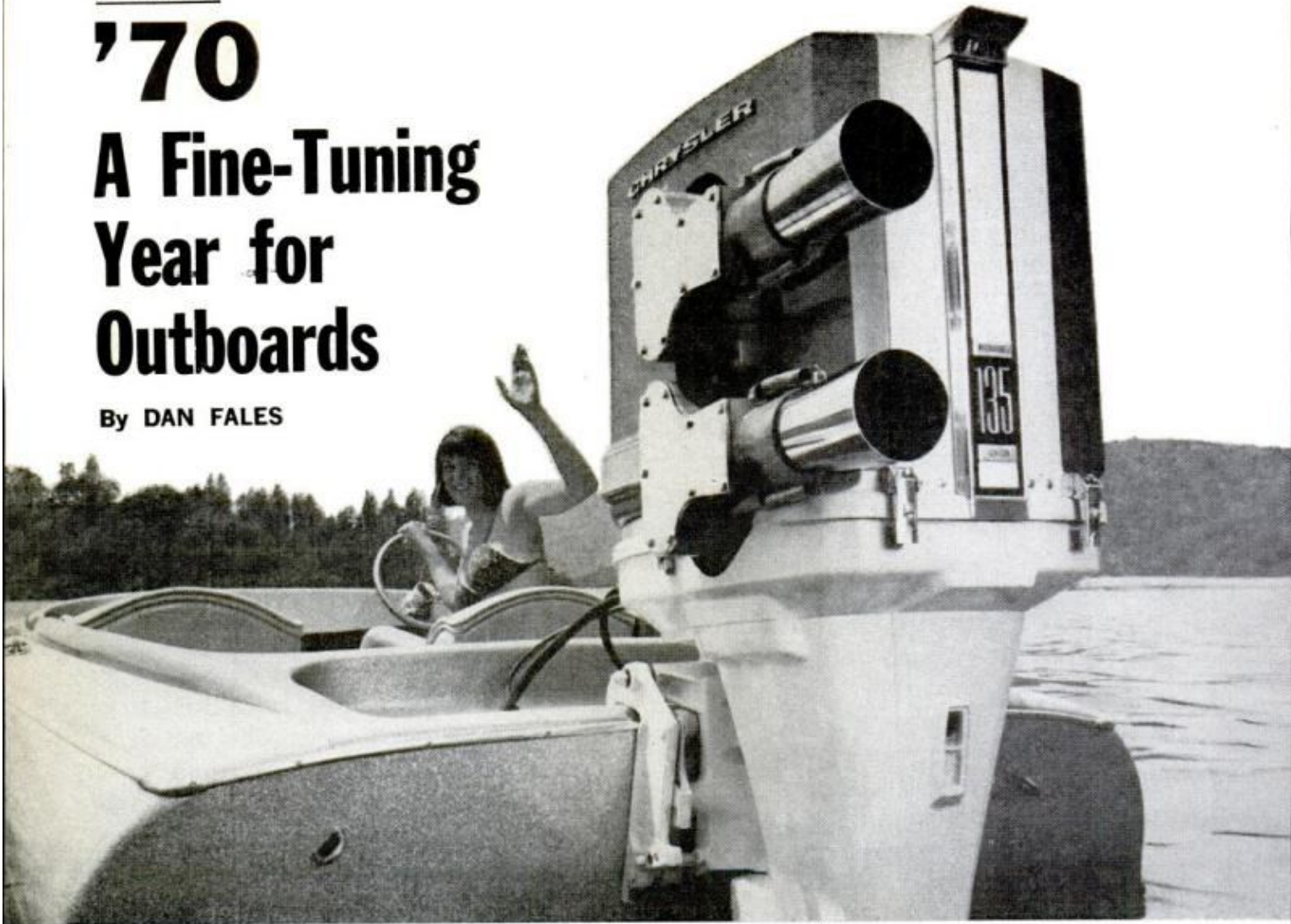

More horsepower, major technical changes, name changing—all are part of the new lines of outboard motors.

THERE'S BIG NEWS in the outboard-motor field. But what's important to you is that just about every manufacturer is improving and fine-tuning his product from last year.

The big news is that McCulloch is out of the outboard-motor business entirely. Aeroceanic of California bought the McCulloch outboard division lock, stock and barrel. More big news is that Yamaha is regrouping in the outboard field and will introduce big changes in model designs. Yamaha isn't saying just when.

Kiekhaefer Mercury still leads the

EVINRUDE'S 115-hp Starflite is shown at the left in a full cutaway rendering. Evinrude has 15 models

outboard horsepower race. Merc has a 135-hp production model with a 140-hp racing motor. But Chrysler is right behind it with a 135-hp racing motor.

Johnson and Evinrude, right in there fighting, have announced a new 60-hp model with loop scavenging.

Seagull is staying with its popular Century and Silver Century lines. The Silver Century packs 25 percent more power than the same size Century.

Sears is cutting back, sticking to low-power motors—3.6, 5, 7.5 and 9 hp.

Ward, too, is staying in the popular ranges with 3.5, 6 and 9.3-hp. models.

Though there was a rumor last year that Fisher-Pierce might come out with a smaller motor, the present word is that only the popular 55-hp Bearcat will be available.

Mercury's big news this year is that the direct-charging system announced last year for the 80-hp model is now being used in the 135, 115 and 40-hp

JOHNSON is bringing out the 60-hp Sea Horse, a much improved version of last year's 55-hp model. It features a new porting system in the cylinders

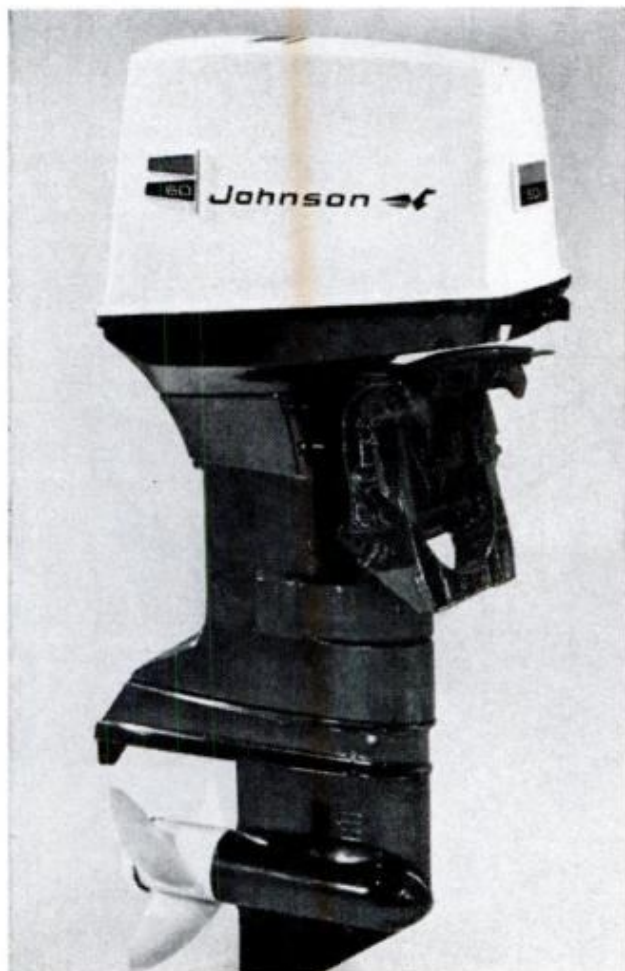

OCTOBER 1969



MERCURY'S 135-hp outboard (above) is largest of 10 power ratings being offered in 1970. Company is introducing the Merc 400 with direct charging

motors. Using this type of cylinder-scavenging in the 40-hp Merc 400 is news, as is the fact that Merc has dropped its old 35-hp model in favor of the 40.

Merc is also adding Perma-Gap spark-plugs which it claims will last for the lifetime of the engine under normal operating conditions. This new plug will be in all models, as will be Merc's Thunderbolt ignition. Breakerless igni-

101

tion will be on models ranging from 40 to 135 hp; Maker-Point Thunderbolt on the 4 through 20-hp motors.

Chrysler has a 135-hp motor which is classed as a limited-production model used for racing. But the 120-hp Chrysler is a full-production motor. It's at the top of a 43-model line that boasts models from 3.6 to 120 hp.

The new 120-hp unit is a four-cylinder, high-compression engine boasting a new exhaust system, Molybdenum-filled piston rings and Chrysler's Magnapower—a capacitor-discharge ignition system.

Chrysler has introduced an all-new molded plastic ignition switch which is water and corrosion-proof, plus a new concentric-float carburetor that prevents spilling of fuel when the engine is tilted up. It also offers a new accessory called Capac—an anticorrosion kit that protects outboards and stern drives.

Johnson Motors has redone its 55-hp loop-scavenging motor of last year to come up with a 60-hp version. This new three-cylinder, loop-scavenging powerplant has the same bore and stroke as last year's 55. Increasing the horsepower was accomplished by adding a third intake passage in the cylinder sleeve called a power port. The motor has increased compression ratio and easier breathing through a carburetor silencer. A new pressure-back piston ring also helped develop more horsepower. Technical improvements in other Johnson motors give quieter operation and better performance.

Evinrude Motors has 15 models in 11 power ratings ranging from 1.5 to 115 hp. The newest motor, the three-cylinder, 60-hp Triumph, has a loop-scavenging system. Electro-hydraulic gear shifting is a feature of the 115 and 85-hp models. This system eliminates the danger of being stranded in your boat if the shift mechanism fails.

On Evinrude's 18 and 25-hp models, starter interlock has been added. And on the 4-hp motor there's 360° pivoting and an "up" operating position. ★★★



FISHER-PIERCE Bearcat is still the only four-cycle outboard among U.S. makes, has four cylinders and carries a power rating of 55 hp

WARD'S Sea Kings this year are designed for fishermen rather than the high-horsepower speedsters



ALL THE OUTBOARDS FOR 1970

Hp	Cylinders	Weight	Bore & Stroke	Displacement	Starting
CHRYSLER					
135	4	235 lbs.	3.312" x 2.800"	96.55 cu. in.	electric
120	4	248 lbs.	3.312" x 2.800"	96.55 cu. in.	electric
105	4	248 lbs.	3.312" x 2.800"	96.55 cu. in.	electric
85	3	221 lbs.	3.312" x 2.800"	72.39 cu. in.	electric
70	3	221 lbs.	3.312" x 2.800"	72.39 cu. in.	electric
55	2	140 lbs.	3.187" x 2.800"	44.7 cu. in.	electric
45	2	127 lbs.	3.125" x 2.750"	42.18 cu. in.	manual*
35	2	127 lbs.	3.000" x 2.540"	35.9 cu. in.	manual*
20	2	79 lbs.	2.437" x 2.140"	19.96 cu. in.	manual*
9.9	2	56 lbs.	2.187" x 1.750"	13.15 cu. in.	manual**
7	2	49 lbs.	2.000" x 1.625"	10.2 cu. in.	manual
5	2	47 lbs.	1.875" x 1.625"	8.99 cu. in.	manual
3.6	1	29 lbs.	2.062" x 1.562"	5.18 cu. in.	manual

*Electric model available

**Autoelectric model available

EVINRUDE					
115	4	252 lbs.	3.438" x 2.588"	96.1 cu. in.	electric
85	4	252 lbs.	3.375" x 2.588"	92.6 cu. in.	electric
60	3	207 lbs.	3" x 2-11/32"	49.7 cu. in.	electric
40	2	156 lbs.	3-3/16" x 2-3/4"	43.9 cu. in.	electric*
33	2	140 lbs.	3-1/16" x 2-3/4"	40.5 cu. in.	electric*
25	2	81 lbs.	2 1/2" x 2 1/4"	22.0 cu. in.	manual**
18	2	80 lbs.	2 1/2" x 2 1/4"	22.0 cu. in.	manual**
9 1/2	2	60 lbs.	2-5/16" x 1-13/16"	15.2 cu. in.	manual
6	2	51 lbs.	1-15/16" x 1 1/2"	8.84 cu. in.	manual
4	2	35 lbs.	1-9/16" x 1 3/8"	5.28 cu. in.	manual
1 1/2	1	20 lbs.	1-9/16" x 1 3/8"	2.64 cu. in.	manual

*Also available with manual starting

**Also available with electric starting

FISHER-PIERCE					
55*	4	239 lbs.	2.75" x 2.50"	59.4 cu. in.	electric

*Four-cycle engine, the only such outboard available in the United States today

JOHNSON					
115	4	252 lbs.	3.438" x 2.588"	96.1 cu. in.	electric
85	4	252 lbs.	3.375" x 2.588"	92.6 cu. in.	electric
60	3	207 lbs.	3" x 2-11/32"	49.7 cu. in.	electric
40	2	156 lbs.	3-3/16" x 2-3/4"	43.9 cu. in.	electric*
33	2	140 lbs.	3-1/16" x 2-3/4"	40.5 cu. in.	electric*
25	2	81 lbs.	2 1/2" x 2 1/4"	22.0 cu. in.	manual**
20	2	80 lbs.	2 1/2" x 2 1/4"	22.0 cu. in.	manual**
9 1/2	2	60 lbs.	2-5/16" x 1-13/16"	15.2 cu. in.	manual
6	2	51 lbs.	1-15/16" x 1 1/2"	8.84 cu. in.	manual
4	2	35 lbs.	1-9/16" x 1 3/8"	5.28 cu. in.	manual
1 1/2	1	20 lbs.	1-9/16" x 1 3/8"	2.64 cu. in.	manual

*Manual starting also available

**Electric starting also available

AEROMARINE					
7 1/2	2	48 lbs.	1-15/16" x 1-45/64"	10 cu. in.	manual*
5	2	39 lbs.	1-15/16" x 1-45/64"	10 cu. in.	manual*
4	1	37 lbs.	2 1/8" x 1 1/2"	5.3 cu. in.	manual

*Electric model also available

MERCURY					
135	6	—	27/8" x 2-9/16"	99.812 cu. in.	electric
115	6	—	27/8" x 2-3/10"	89.587 cu. in.	electric
80	4	—	27/8" x 2-9/16"	66.6 cu. in.	electric
65	4	—	2-15/16" x 2-3/10"	62.35 cu. in.	electric*
50	4	—	2-9/16" x 2 1/8"	43.837 cu. in.	electric*
40	2	—	3" x 2-3/10"	33.3 cu. in.	manual**
20	2	—	2-9/16" x 2 1/8"	21.918 cu. in.	manual**
9.8	2	—	2" x 1-3/4"	11.000 cu. in.	manual
7.5	2	—	2" x 1-3/4"	11.000 cu. in.	manual
4	1	—	2" x 1-3/4"	5.5 cu. in.	manual

*Manual starting also available

**Electric starting also available

MONTGOMERY WARD					
9.6	2	56 lbs.	2 1/8" x 1-11/16"	11.97 cu. in.	manual
6	2	55 lbs.	2" x 1-11/16"	10.6 cu. in.	manual
3 1/2	1	29 lbs.	2-1/16" x 1-9/16"	5.18 cu. in.	manual

SEAGULL					
6 1/2*	1	37 lbs.	2.244" x 1.575"	6.1 cu. in.	manual
5*	1	37 lbs.	2.244" x 1.575"	6.1 cu. in.	manual
4**	1	34 lbs.	2.244" x 1.575"	6.1 cu. in.	manual
3**	1	28 lbs.	1.772" x 1.575"	3.8 cu. in.	manual
2**	1	26 lbs.	1.772" x 1.575"	3.8 cu. in.	manual

*Clutch

**Available in Silver Century model which is 25% more powerful

SEARS					
9	2	49 lbs.	1-15/16" x 1-45/64"	10 cu. in.	manual*
7.5	2	42 lbs.	1-15/16" x 1-45/64"	10 cu. in.	manual*
5	1	37 lbs.	2.125" x 1.5"	5.2 cu. in.	manual
3.6	1	37 lbs.	2.125" x 1.5"	5.2 cu. in.	manual

*Electric model also available

THE 70 CARS

What's New Depends Upon Your Point Of View

By **BILL KILPATRICK**
Auto Editor

Photography by Jeannie Weaver

**Five new cars
highlight the
year's offerings,
but 'new' is not
necessarily
'new-new'**

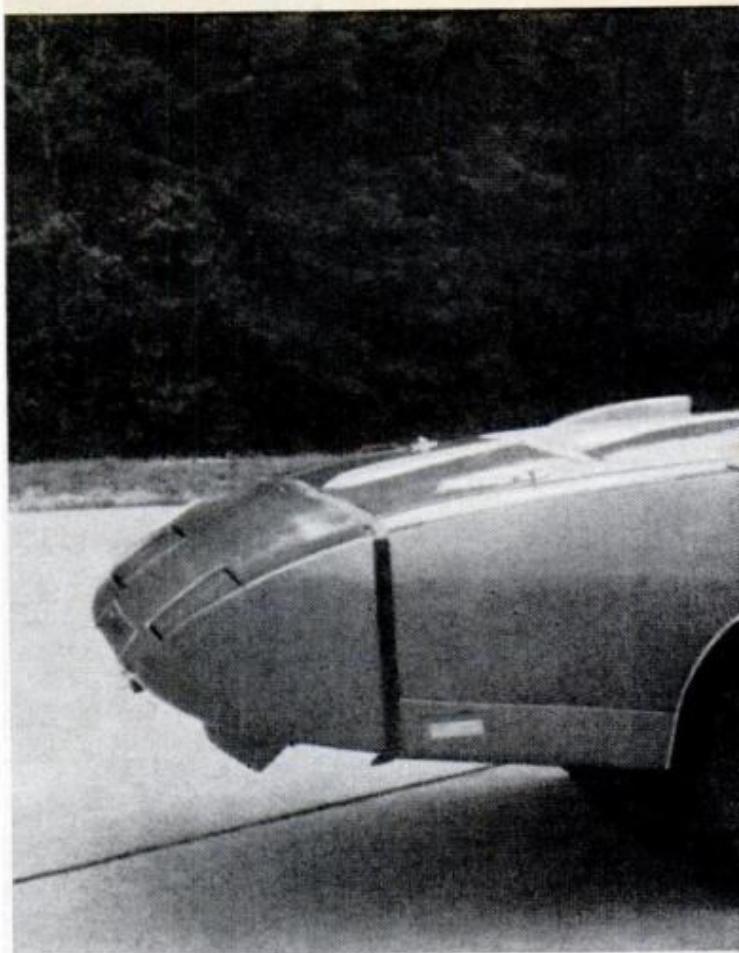

DODGE CHARGER DAYTONA was designed to win races,

TOM KLEENE is a big, gentle man who smokes a million cigars a day and writes for the business and financial pages of the *Detroit Free Press*. I call on him whenever I can; his affectionate cynicism and great good humor never fail to help knit up "the ravell'd sleeve of care."

"Well, William," he said on a particular day, "what brings you to our fair city this time?"

"The new-car previews," I said.

"Lots of 'bold, new sculptured lines,' I suppose."

"Yep."

"A couple of 'industry breakthroughs,' no doubt."

"The very same."

"Plenty of 'clean, uncluttered styling,' I dare say. 'Exciting, youth-oriented.'"

"Yeah. That, too."

"Everything with a 'long, low, sporty look' and 'all interiors color-keyed with optional accent groups.'"

"Oh, sure. The usual."

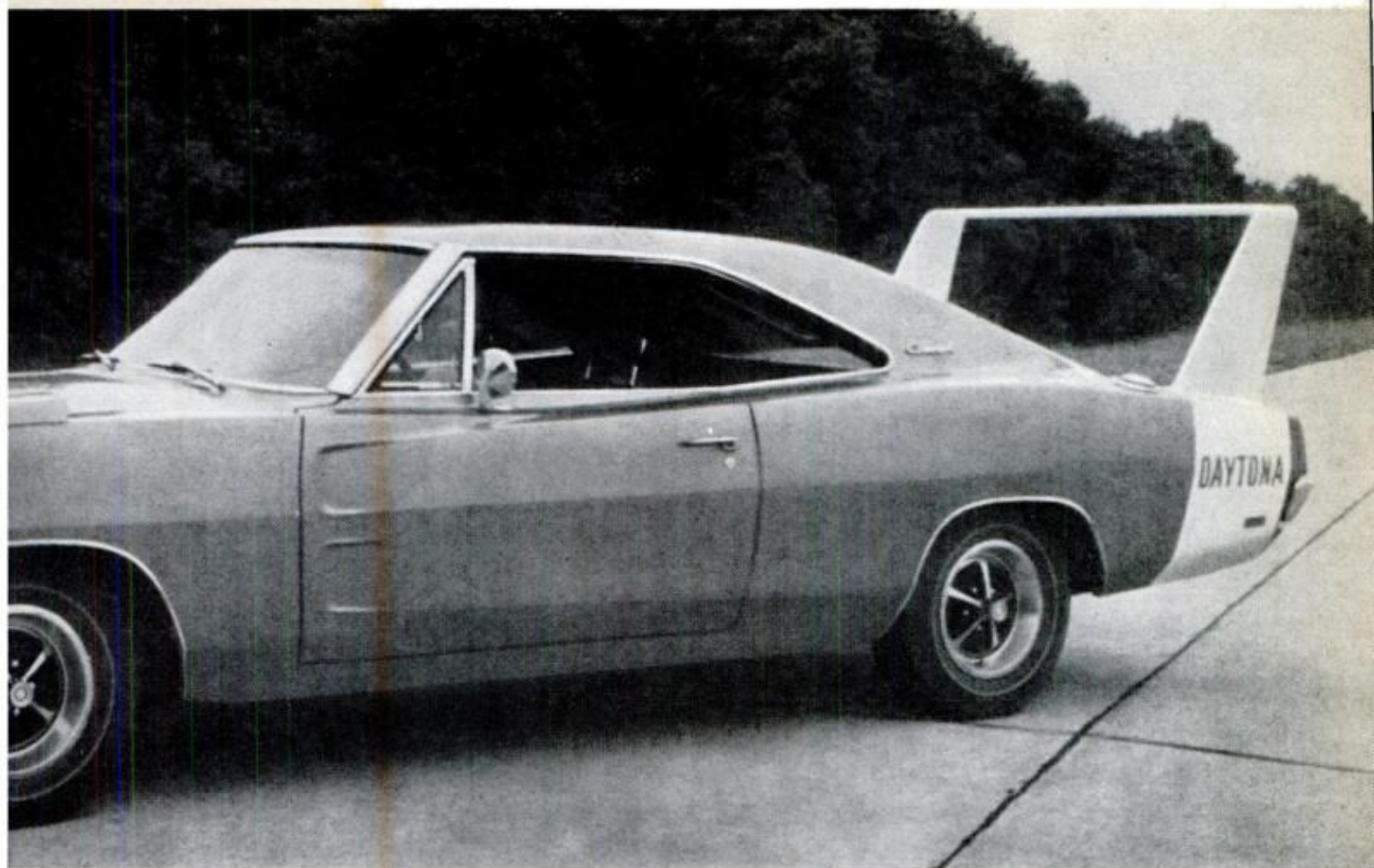

period. It typifies Detroit's dedication to speed, come hell or high water. Anyone can walk in off street and buy it

We stopped our game abruptly, both a bit sobered by the thought we were so immersed in the auto industry's clichés they rolled off our tongues like small talk. Somehow it wasn't funny.

So I told Tom about the fellow out at Ford who had just finished a press presentation of the company's 1970 car-engineering highlights. During a question-and-answer period following the presentation, he was fielding reporters' queries about the new 351-CID "Cleveland" V8 engine. He seemed to be having considerable trouble making his point.

"Look," he said finally, a touch of exasperation in his voice, "I hope you guys realize this is a new-new engine, not the new you usually hear about around here."

The poor guy had unwittingly laid bare the skeleton in Detroit's closet, the real essence of the 1970 (or any) model year—the usual "new," but not much that's "new-new."

I left Tom and dove for the elevator,

my mind pondering what in the world it is that separates the auto industry from the rest of us. I decided that fundamentally it was a matter of words, what they mean to us and what they mean to the industry. Their "bold, new sculptured line" looks to me like last year's "bold, new sculptured line." But they see it as a revelation, an "exciting new concept." This is okay, I guess, but I just wish auto men weren't so hurt when an outsider points out that the Emperor has no clothes.

Here we have a model year in which, at the very beginning, five new cars are being introduced. Here we have long-wearing, low-profile, bias-belted tires across the board, steering column locks throughout, evaporative emission-control systems, and such engineering exotica as rotating valves, plus a lot of unique, even possibly interesting stuff. But, despite the glowing adjectives, is any of this *really* new? You know better.

The trouble, it seems to me, is that

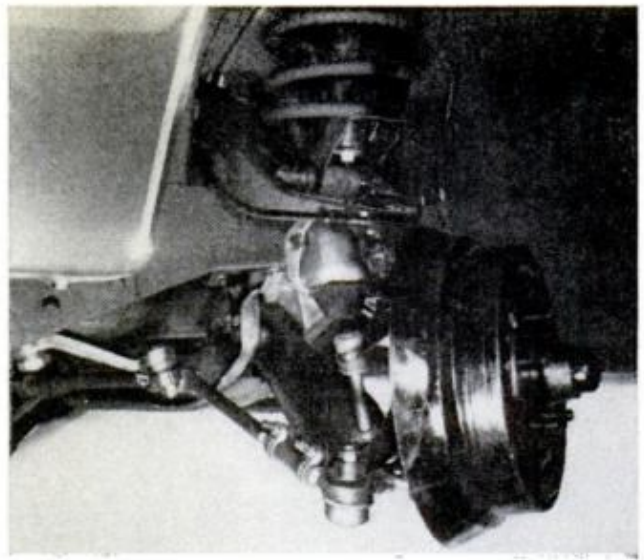

AMC cars for 1970 offer new twin-ball-joint front suspension. System features antinosedive braking

PONTIAC, on limited basis, will offer a new plastic gas tank on full-size wagons for sale in California

the auto industry is guilty of a sort of ultimate sin—the sin of excess. It's an industry that decides something is good (or at the very least, profitable) and then punches it, kicks it, pummels it, expands it and drives it into the ground, all to excess. Thus we have cars that are too fast and too powerful, cars that are too long, too fat, too complex, too expensive to own and operate. Pinned to the wall on any of these or similar charges, the industry pleads it is merely "giving the public what it wants." That won't march.

The public doesn't want, for exam-

ple, front ends that tend to go out of alignment every time a curb is bumped. It doesn't want erratically aimed headlights. It doesn't want shoddy workmanship, or recall campaigns, or cars that spend too much time in the shop being serviced.

This sort of thing, of course, hasn't gone unnoticed. The federal government in particular is hip-deep in both general and specific inquiries as to how the auto industry conducts its affairs. The Federal Trade Commission, for example, recently began poking

(Please turn to page 217)

AMC HORNET features a straightforward, uncluttered dash panel with easily readable instrumentation





**THE
70
CARS**

The Really New Ones

New, sure, but out of the ordinary, no

ANY NEW MODEL YEAR that opens with the introduction of five cars never seen by the public before *ought* to be an exciting year, a year that should—at least for the first month or so—see both buyers and just plain buffs storming dealer showrooms to dream and have a look.

Such a year is this one, but my guess is that showroom traffic won't break any records simply because the "show" is about as exciting as two weeks in your back yard. Why? A key, I think, is in defining the word "new."

There are five new cars this year—AMC's Hornet, Chevrolet's Monte Carlo, Dodge's Challenger, Plymouth's Barracuda and Duster. Later on in the model year there'll be even more—a new Camaro, a new Firebird, possibly a surprise or two from Ford. But how *new* are and will these cars be? Based on those covered here (and I've seen and driven all of them), I'd have to answer, "Not very."

Speaking of the five at hand, all are Detroiters in concept, execution and

feel, all feature stuff you've seen, 10, these many moons, and all commit in varying degrees sins universal to the Motown breed—mushy suspensions, something less than exact steering, power that's either a stone or wildly overdone, adventurous braking, slapdash workmanship. And again all—with the *possible* exception of the Hornet, maybe the Duster—are exercises in wish fulfillment rather than the very best cars that can be made for the money.

Does this mean they're bad? Of course not. It simply means they are disappointing. I had hoped for more, cars that somehow in total would reflect that we've put men on the moon, not cars that are a collective rehash of old ideas—good, nicely done, but still cliches.

Here's a closer look:

AMERICAN MOTORS: The Hornet (see photo above) is the entry here. It's offered as either a two or four-door sedan in either a base or SST version. A handsome little car, it features ade-



SPOILER on Dodge Charger Daytona is engineered to help hold car's rear end down at 200-plus mph racing speeds. It's also great for drying wet bathing suits

quate power, better-than-average handling, several little touches missing from comparably-priced (about \$2000) offerings. You'll like the interior room, particularly if you have to ride in back. Oddly enough, there's nothing Spartan about the car; it gives the impression of being a lot more than it really is. Standard engine is a 199-CID Six, the options a 1 or 2-bbl. 232-CID Six, a 304-CID V8. Transmissions, both column-mounted, include a three-speed manual and an automatic. In all, the car is a worthy successor to the Rambler series it replaces and should—if there's any such thing as buyer prudence—prove a winner in the marketplace.

CHEVROLET: Here we have the Monte Carlo, a five-passenger (four with the optional bucket seats) hardtop coupe somewhat scaled down in opulence from the similarly-bodied Pontiac Grand

Prix. It's a so-called "personal" car designed to offer buyers elegance and prestige. Whether or not it succeeds depends upon how far you're willing to let Chevrolet go with a Cadillac vocabulary. It is a nice car—powerful, quiet, good-looking in a middle-of-the-road way, tastefully done inside and out. But it's a Chevy. It *looks* like a Chevy and it *feels* like a Chevy. Still, you ask, is this bad? No, but I find myself wishing the Monte Carlo had proved in its own way to be as radical a departure for Chevrolet as was, say, the Corvette. Then again, I was 30 before I realized "Alice In Wonderland" was fiction. Anyway, you can get the Monte Carlo powered by a 2 or 4-bbl. 350-CID or 400-CID V8. There's a three or four-speed manual transmission or a choice of two automatics. Chevy'll sell 'em by the bushel.

DODGE: What Dodge will be challenging with its new Challenger are the well-entrenched, medium-priced Mercury Cougar and Pontiac Firebird, plus the more posh versions of the Mustang and Camaro. And, happily for Dodge, the battle is being joined with a formidable weapon. The Challenger, particularly in the Special Edition (SE) versions, is an outstanding example of the genre. It's low, sporty, sleek, offers both power and "comfort and convenience" options up to here. You can get the car as either a two-door hardtop or a convertible in both the base and R/T versions plus, in either price range,

(Please turn to page 217)

THE REALLY NEW ONES

Car	Wheel-base (in.)	Track (f/r. in.)	Overall Length (in.)	Overall Width (in.)	Engines in Model(s) Series* (Displacement, cu. in.—V8 except as noted—carburetion)
American Motors (Hornet)	108	57.5/57.0 57.2/56.6 (V8 models)	179.3	71.1	199-6-1bbl., 232-1&2bbl., 304-2bbl.
Chevrolet (Monte Carlo)	116.0	60.3/59.3	205.8	75.6	350-2&4bbl., 400-2&4bbl., 454-4bbl.
Dodge (Challenger, R/T)	110	59.7/60.7	191.3	76.1	225-6-1bbl., 318-2bbl., 340-4bbl., 383-2&4bbl., 426-(2)4bbl., 440-(3)2&4bbl.
Plymouth (Valiant, Duster, 340)	108	57.4/55.6	188.4	71.6 71.1 (4dr.)	198-6-1bbl., 225-6-1bbl., 318-2bbl., 340-4bbl.
(Barracuda, Gran Coupe, 'Cuda)	108	59.7/60.7	186.7	74.9	225-6-1bbl., 318-2bbl., 340-4bbl., 383-2&4bbl., 426-(2)4bbl., 440-(3)2&4bbl.

*Not all engines available in all models

THE 70 CARS

The Really New Ones



DODGE CHALLENGER is offered as either two-door hardtop or convertible with a wide range of engine options. Car also offers such safety innovations as door guard rails, a beefed-up roof structure



PLYMOUTH DUSTER tops Valiant line, is offered only as two-door coupe in high performance, standard versions. Car is very good-looking outside, neatly done inside, may be surprise car of the year

CHEVROLET MONTE CARLO is new entry in personal luxury-car field, is available only as five-passenger two-door hardtop coupe. Car offers long list of built-in luxury features, broad array of options

PLYMOUTH BARRACUDA offers distinctive front-end styling featuring unique fog lamps, turn signals recessed in grille in 'Cuda series. Available as either a two-door hardtop coupe or a convertible



THE 70 CARS

The Compacts



FORD MAVERICK remains the same as when introduced last spring—a two-door fastback powered by either the standard 170-CID Six or optional 200-CID Six

IF OUR CRYSTAL BALL has the right sheen and is properly wired and tuned in, and if straws in the wind are anything other than flying debris, the 1970 model year should be a dandy for compacts. Why?

For one thing, the classification offers two new cars (perhaps three if we include Ford's Maverick, tabbed a '70 when it was introduced last spring)—AMC's Hornet and Plymouth's Valiant Duster, both described under "Really New" (see page 107) and both certain to build traffic in dealer showrooms.

For another, tight money coupled with a growing awareness by buyers that Detroit's compacts add up to attractive buys should focus attention on the smaller cars. If, for example, money-in-hand dictates a choice between, say, a full-sized Chevy Biscayne without airconditioning and a Nova

with air, a lot of buyers are going to opt for the latter.

And with good reason. Compacts, as we've pointed out before, are excellent value. True, they're subject to the same vagaries of assembly and operation as their bigger and higher-priced kin, but for some reason such nonsense doesn't seem as painful with a smaller car; as if a stalled compact isn't quite as useless as a stalled Cadillac.

The big rub with compacts—apart from size limitations and somewhat prosaic appearance—has been trade-in value; dealers just didn't want to see 'em on their used-car lots. But now demand for used compacts is (and presumably will continue to be) up. So if there's a new car in your immediate future, give 'em a look. Here's what you'll find:

CHEVROLET: Offered here is a sin-

COMPACTS—HOW THEY COMPARE

Car	Wheel-base (in.)	Track (f/r, in.)	Overall Length (in.)	Overall Width (in.)	Engines in Model(s) Series* (Displacement, cu. in.—V8 except as noted—carburetion)
Chevrolet (Nova, SS)	111.0	59.0/58.9	189.4	72.4	153-4-1bbl., 230-6-1bbl., 250-6-1bbl., 307-2bbl., 350-2&4bbl.
Dodge (Dart, Custom, Swinger, 340)	111	57.4/55.6	196.2	69.7	198-6-1bbl., 225-6-1bbl., 318-2bbl., 340-4bbl.
Ford (Maverick) (Falcon)	103.0 111.0	55.5/55.5 58.8/58.5	179.3 184.3	70.6 73.2	170-6-1bbl., 200-6-1bbl. 200-6-1bbl., 302-2bbl.

*Not all engines available in all models

gle series—the Nova, available as a two-door five-passenger coupe or a six-passenger four-door sedan. A sporty SS option, which includes a lot of go-go gimmickry, is available only on V8-powered coupes with either a manual four-speed or automatic transmission. Don't look for styling changes; there aren't any. There's some new trim styling and color choices, what Chevy calls "refined exterior details," and—ready? —"new slimline sparkplugs for six-cylinder engines" (only 27 calories per plug!). There are three standard engines—a 153-CID Four, a 230-CID Six, a 307-CID V8. The options are a 250-CID Six and, in the SS package, a 350-CID V8. Transmissions include manual three and four-speeds and three automatics.

DODGE: Three series here—the Dart, the Swinger 340 and the Dart Custom. All feature new grilles, longer hoods, new bumpers fore and aft, new interior trim schemes. The base Dart is available as a four-door sedan only, the Swinger and Swinger 340 as a two-door hardtop, the Dart Custom as a two-door hardtop and a four-door sedan. Engines include a 198-CID Six, a 225-CID Six, a 318 or 340-CID V8. Transmissions offered are manual three and four-speed and an automatic. Dodge says the Dart was its most successful car last year. No surprise here; it's nifty.

FORD: For the moment, there are two Ford entries: Falcon and Maverick. Falcon may be dropped after the first of the year. For now, the base Falcon and Falcon Futura are available as two and four-door sedans and wagons with no significant style changes. Engines are a 200-CID Six and a 302-CID V8, transmissions a three-speed manual and an automatic. Maverick remains the Maverick—a trim two-door fastback powered by a 170-CID Six or an optional 200-CID Six. Transmissions are a three-speed manual and an automatic. ★ ★ ★

OCTOBER 1969



CHEVROLET NOVA offers few, if any, styling changes, is available as a two-door coupe, a four-door sedan. In SS version (coupe only), car adds up to a brisk performer



DODGE DART features a new grille, longer hood, minor trim changes inside and out, new front, rear bumpers. Car is available as base Dart, Custom, Swinger and 340



FORD FALCON is carried over from '69, may in fact be dropped after first of the year. Car is available as a two-door or four-door sedan, a four-door station wagon



PLYMOUTH GTX leads an intermediate line that features restyled grilles, fenders, hoods. Also offered is new power option



BUICK GS features restyled grille, rear-end treatment, new functional air scoops in hood. GS combines muscle with luxury

THE 70 CARS The



CHEVROLET CHEVELLE offers new rear styling with taillights, backup lights recessed in bumper. Front has been face-lifted



A CLASSIC EXAMPLE of something referred to earlier—words losing their meanings in the Never-Never Land of the auto industry—can be found in Detroit's description of the 1970 intermediates. The manufacturers tend to say something along the lines of the cars being "all-new from the ground up." But between us, I'm hard-pressed to see how.

Moving a decal from here to there, making almost microscopic changes in a grille, or lengthening or shortening of things fractions of an inch do not, to my mind, an all-new car make, certainly not one "all-new from the ground up." Yet this is what "they" would have us believe.

Still, my sour grapes and low-baloney threshold can't detract

PONTIAC GTO tops line that includes the Tempest, LeMans, LeMans Sport. Concealed windshield radio antenna will be standard



MERCURY CYCLONE GT offers new grille, a longer wheelbase, more overall length, wider front, rear tread, redone rear end

Intermediate Cars

from the 1970 intermediates as being good cars, cars well-suited to the job(s) for which they were designed; i.e., plain or exotic transportation at a reasonable size and a reasonable price.

Apparently, buyers agree with the concept. Intermediates this past year grabbed off a larger share of the overall auto market than did any other type of car. This year they could make even deeper market inroads, probably at the expense



OLDSMOBILE 4-4-2 continues as muscular head of Olds mid-size line. Others in series are the F-85, Cutlass and Cutlass Supreme



AMC REBEL is offered as two-door hardtop, four-door sedan, wagon in both the base and SST series. There's no convertible

DODGE CORONET features new double-loop bumpers, split grille, revamped hood, rear-deck lid

FORD TORINO series ranges from Fairlane 500 to posh Torino Brougham, offers new grilles, long, lower look



INTERMEDIATES—HOW THEY COMPARE

Car	Wheel-base (in.)	Track (f/r, in.)	Overall Length (in.)	Overall Width (in.)	Engines in Model(s) Series* (Displacement, cu. in.—V8 except as noted—carburetion)
American Motors (Rebel)	114.0	59.9/60.0 59.7/60.0 (V8 models)	199.0	72.2	232-6-1&2bbl., 304-2bbl., 360-2&4bbl., 390-4bbl.
Buick (Skylark, 350, GS, GS 455)	112 116 (4dr.)	59.0/59.0 59.4/59.0 (GS 455)	200.7 204.7 (4dr.)	75.6	250-6-1bbl., 350-2&4bbl., 455-4bbl.
Chevrolet (Chevelle Malibu, SS 396)	112.0 116.0 (4dr.)	59.0/59.0	197.2 201.2 (4dr.)	76.0	250-6-1bbl., 307-2bbl., 350-2&4bbl., 396-4bbl., 400-4bbl. 454-4bbl.
Dodge (Coronet Deluxe, 440, 500, R/T, SuperBee)	117	59.7/58.7 59.7/59.2 (V8 models)	209.7	76.72	225-6-1bbl., 318-2bbl., 383-2&4bbl., 426-(2)4bbl., 440-(3)2bbl. & 4bbl.
Ford (Fairlane 500, Torino, GT, Brougham, Cobra)	117	60.5/60.0	206.2	76.7 76.8 (Sports Roof) 76.4 (4dr.)	250-6-1bbl., 302-2bbl., 351-2&4bbl., 429-4bbl., 429-4bbl. in "C", CobraJet & Cobra Jet HO performance versions
Mercury (Montego, MX, Cyclone, GT, Spoiler)	117.0	60.5/60.0	209.9	77.3	250-6-1bbl., 302-2bbl., 351-2&4bbl., 429-4bbl., 429-4bbl. in CJ, Ram Air & NASCAR performance versions
Oldsmobile (F-85, Cutlass, Supreme, 4-4-2)	112.0 116.0 (4dr.)	59.0/59.0	203.2 207.2 (4dr.)	76.2 76.8 (4dr.)	250-6-1bbl., 350-2&4bbl., 455-4bbl.
Plymouth (Belvedere, Satellite, Sport Satellite, Road Runner, GTX)	116	59.7/58.7 59.7/59.2 (V8 models)	204.0	76.36	225-6-1bbl., 318-2bbl., 383-2&4bbl., 426-(2)4bbl., 440-(3)2bbl. & 4bbl.
Pontiac (Tempest, LeMans, LeMans Sport, GTO)	112 116 (4dr.)	61/60	202.5 206.5 (4dr.)	76.7	250-6-1bbl., 350-2bbl., 400-2&4bbl., 455-4bbl. *Not all engines available in all models

of the traditional full-sized offerings.

On tap for '70:

AMERICAN MOTORS: The entry here is the Rebel, a car that comes in either the base or SST series and is offered as a two-door hardtop, a four-door station wagon. AMC has reworked the roof panels, rear fenders, sedan rear door panels, bumpers and the grille-headlamp arrangement—all only slightly. Standard engine is the 232-CID Six with 304, 360 and—in the SST—390-CID V8s being the options. Transmissions include a standard three-speed manual and an automatic for either steering column or console.

The Rebel has a "no nonsense" air about it I find appealing.

BUICK: These handsome intermediates are offered as the Skylark, Skylark 350, Skylark Custom, Sportwagon, GS and GS 455. The Skylark and GS series each has its own distinctive grille, with the GS offering functional air scoops in the hood. A new "Stage 1"

performance package is available in the GS 455 series. Styling changes are minor, the highlight being a side panel character line that begins along the front fender, fades, then reappears along the rear fender. Cars are available as two-door coupes, two-door hardtops, four-door sedans, convertibles, four-door wagons. Engines include a 250-CID Six, a 350-CID 2 or 4-bbl. V8, and a 455-CID 4-bbl. V8, transmissions a three-speed manual and an automatic.

This is a handsome line of cars, among the best-looking Buick has ever produced.

CHEVROLET: Offered here is the Chevelle Malibu as a two-door hardtop coupe, a four-door hardtop sedan, a four-door sedan and a convertible. Featured throughout are a new grille, hood and fenders, plus new front and rear bumpers and minor ornamentation changes. There's also new interior

(Please turn to page 220)



FORD THUNDERBIRD styling this year is all-new up front, features longer, lower hood, bulging grille

**THE
70
CARS**

The Personal Cars

Lots of flash, but few real changes

STRIP AWAY everyone's rationale for buying, say, a four-door sedan, and underneath we'll probably find a heart that secretly beats for one of these lithe, sleek beauties—the so-called “personal” car.

Even Dad, the Little Woman and kids in tow and determined to buy a “sensible” car, will cast a longing eye at a flashy low-slung little job over in a showroom corner. The cars in this classification are so blatant in their appeal to the blythe spirit within us all it's almost depressing; *no* one should know *that* much about us.

But the auto industry's styling and

marketing wizards have us perfectly pegged. They know we're all hung up on exotica and, being first, last and always businessmen, can't crank out these gratifying, self-aggrandizing symbols fast enough. Symbols of what? Oh, of youth, of freedom, of never having to pay the piper. In the “personal” car is distilled everything—every nuance—of America's never-ending love affair with the automobile.

On tap for '70:

AMERICAN MOTORS: Two cars here—the Javelin and the AMX, both a bit longer but changed very little from their immediate model-year predeces-



BUICK RIVIERA gets a major facelifting this year. There's a new grille, longer hood, new bumpers fore and aft, new body molding, new wider rear window



OLDS TORONADO features a new grille, new front-rear bumpers, new deck lid and taillight setup, new dash layout, and—praise be!—a pushbutton ashtray



CHEVROLET CAMARO is carried over as is for the time being. There'll be an all-new, completely restyled Camaro introduction early in 1970

DODGE CHARGER this year features new loop bumper, new front fenders. Also new is a lower-priced version—called, simply, Charger—featuring bench seats and a more modest trim package



THE **70** CARS

The Personals



AMC JAVELIN gets minor facelifting, features refinements both inside and out. Car is slightly longer than last year, a shade lower. New for '70 is a special safety windshield designed to reduce possibility of cuts in a crash



PONTIAC FIREBIRD, also a carryover, will debut as an all-new car after the first of the year. Car is offered as a convertible, a hardtop coupe in versions from mild to very warm, including the Trans-Am with racy spoiler

MERCURY COUGAR is up more than two inches in overall length, features restyled grille, headlamp covers. Models in series include basic Cougar, posh XR-7, high-performance Eliminator



AMC AMX is a bit longer, a bit lower for '70, features new power, performance options including new hood with ram-air power blister. Car remains two-seater, is offered only as coupe. As with Javelin, AMX features special safety windshield



FORD MUSTANG is revamped front and rear, features a number of interior and exterior styling refinements. Car is offered as hardtop, convertible, sports roof in versions ranging from the base model to all-out Boss 302, Boss 429, Mach 1, and the posh Grande hardtop



CHEVROLET CORVETTE, carried over intact from '69, is still industry's only stab at a true sports car



PONTIAC GRAND PRIX for new model year is the same Grand Prix we've all come to know and love

sors. The Javelin is again offered as a two-door coupe in base and SST versions. There's a new hood featuring simulated air scoops, new trim and decorative options inside and out. Standard Javelin power is a 232-CID Six with 304-CID, 360-CID (2 and 4-bbl.), and 390-CID (4-bbl.) V8s the options. Transmissions include three and four-speed manuals and an automatic.

In the AMX—still a two-seat, two-door coupe—standard power is the 360-CID V8 with the 390-CID V8 the option. AMX transmissions include a floor-mounted four-speed manual and an optional console-mounted automatic. Inside the AMX (the Javelin, too)

you'll find new high-back bucket seats, a new instrument panel layout, a new (and welcome) glove box arrangement.

In all, not much new with either the Javelin or the AMX, but both are stylish, very much "with it" cars.

BUICK: Riviera is the name of the game here and—by Detroit standards—the car has been extensively restyled. Up front you'll notice a new, uncluttered grille, a longer hood, a new bumper. Along the sides you'll see a new twin-stripe molding and new rear-wheel-opening covers. There's a new rear bumper, a wider rear window. In-

(Please turn to page 223)

PERSONAL CARS—HOW THEY COMPARE

Car	Wheel-		Overall Length (in.)	Overall Width (in.)	Engines in Model(s) Series* (Displacement, cu. in.—V8 except as noted—carburetion)
	base (in)	Track (f/r, in.)			
American Motors (AMX) (Javelin)	97.0	59.1/56.6	179.0	71.6	232-6-1bbl., 304-2bbl., 360-2&4bbl., 390-4bbl.
	109.9	59.3/57.0	191.0	71.9	
		59.1/56.6			
		(V8 Models)			
Buick (Riviera)	119.0	63.44/63.00	215.5	79.30	455-4bbl.
Chevrolet (Corvette) (Camaro)	98.0	58.7/59.4	182.5	69.0	350-4bbl., 427-(3)2bbl. & 4 bbl. 230-6-1bbl., 250-6-1bbl., 307-2bbl., 350-2&4bbl., 396-4bbl.
	108.0	59.6/59.5	186.0	74.0	
Dodge (Charger, 500, R/T)	117	59.7/59.2	208.5	76.6	255-6-1bbl., 318-2bbl., 383-2&4bbl., 426-(2)4bbl., 440-(3)2bbl. & 4bbl.
Ford (Mustang) (Thunderbird)	108.0	58.5/58.5	187.4	71.7	200-6-1bbl., 250-6-1bbl., 302-2&4bbl., 351-2&4bbl., 428-4bbl. & 4bbl. with Ram Air, 429-4bbl. with Ram Air 429-4bbl.
		(6-in. rims)			
		59.5/59.5			
		(7-in. rims)			
	115.0	62.0/62.0	212.5	78.0	
	117.0		215.0	77.4	
	(4dr.)		(4dr.)	(4dr.)	
Mercury (Cougar)	111.1	58.5/58.5	196.1	74.3	302-4bbl., 351-2&4bbl., 428-4bbl., 429-4bbl.
Oldsmobile (Toronado)	119.0	63.5/63.0	214.3	78.8	455-4bbl.
Pontiac (Firebird, Trans-Am) (Grand Prix)	108	60/60	191.1	73.9	250-6-1bbl., 350-2&4bbl. 400-2&4bbl., 428-4bbl. 400-2&4bbl., 455-4bbl.
	118	62.0/60.0	210.2	75.7	

*Not all engines available in all models



PLYMOUTH FURY has been restyled up front via new bumper, grille. Car's longer, the rear track wider

The Favorite Family Cars

EACH YEAR, it seems, I shuffle out here on stage and gloomily tell anyone who will listen that the full-size, so-called "family" car is a dead duck in the marketplace. So what happens? Each year it rolls merrily along, selling in the millions, its makers wearing big smiles at annual stockholder meetings. Maybe I need a new crystal ball.

Yet (he said, going under for the third time), the concept is doomed. Buyers are paying more attention to the intermediates, the hotshots, the personal cars, the out-and-out luxury jobs. It is, I'm convinced, only a matter of time before sales of the family car drop out of sight.

(Either that or automakers will be reduced to the absurdity of promoting, say, "the biggest intermediate in the industry." Don't laugh. It already happened. Two years ago one outfit was hustling what it called the industry's "biggest compact.")

But until the knell for the family car is sounded, here they are at least one more time:

AMERICAN MOTORS: The Ambassador is a bit longer this year, thanks

mainly to a revamped rear end featuring new fenders, new bumper, new taillight arrangement. Otherwise, things are pretty much carried over as is from '69. There are seven models in the line—a base four-door sedan, and a two-door hardtop, a four-door sedan and a wagon in the DPL and SST series. Air-conditioning is again standard in all Ambassador models. Reclining front seats are available on all SST models. There are five engines, three transmissions. The 232-CID Six is standard on the base line, the 304-CID V8 standard on DPLs and SSTs. Other engines include the 360-CID V8 2-bbl. and 4-bbl., and the 390-CID V8 4-bbl. Transmissions are a column-mounted three-speed manual and an automatic, available for console mounting on SST hardtops.

It's hard to fault the Ambassador, if only because AMC has the good sense not to claim for it virtues just shy of a moonshot. Actually, it's good value in a pretty good car.

BUICK: The LeSabre and Wildcat are the entries here, both featuring new grilles and minor styling refinements

THE 70 CARS

Family Cars



DODGE MONACO, longer in front, shorter in rear, is an inch shorter overall. Rear track is wider. New loop bumpers appear fore and aft. Car is offered as two or four-door hardtop, four-door sedan, wagon



PONTIAC VENTURA, fancy version of the Catalina, features all-new grille, new hood, new fenders, new headlight arrangement and new bumper. Other cars in model line include Executive and Bonneville



BUICK WILDCAT features a new front end highlighting grille, bumper, repositioned headlights, parking lights; plus new two-piece rear wraparound bumper design for tail, turn signal, backup lights

AMC AMBASSADOR is a shade longer overall this year, due mainly to revised rear-end styling. New are the rear bumper, tail-lamp arrangement, rear fenders, roof panel for station wagons





OLDS DELTA 88 is offered as base, Custom and Royale models in two and four-door hardtops, four-door sedan, base convertible



FORD XL series is priced midway in full-sized Ford line, and offered as a two-door hardtop, the line's only big convertible



CHEVROLET CAPRICE tops line that includes Impala, Bel Air and Biscayne. New grille, fenders, bumpers highlight 1970 styling



for 1970. If you look closely, you'll also note a new hood, new front fender caps and a new front bumper. There are some minor styling touches along the sides and around back, but that's about it. There's a base LeSabre, a LeSabre Custom, a LeSabre Custom 455 (in honor of a 455-CID 4-bbl. V8). In the Wildcat there's the Wildcat Custom, period. There is also a separate wagon. In the LeSabre you can get a two-door hardtop, a four-door hardtop, a plush four-door sedan. Same thing in the 455. Only the Custom offers a convertible. Engines are either the 350-CID or 455-CID V8s. Transmissions are a three-speed manual and a three-speed automatic.

These cars—the entire Buick line, in fact—looked good to me this year.

CHEVROLET: The hand of the stylist has been stayed at Chevy for '70. There's a slight grille change, new bumpers front and rear, new headlight framing, new side marker lights, a new hood, 12 new colors. There's also new interior trim styling. The car is offered in four series—top-rated Caprice, Impala, Bel Air and base Biscayne. You can get a hardtop coupe or sedan in the Caprice (V8 power only), a hardtop coupe, sport coupe, sport sedan, convertible or four-door sedan in the Impala. The only Six you can get in the Impala series is on either the sport coupe or the four-door sedan; the others are all V8s. The Bel Air and Biscayne are offered only as four-door sedans with either Six or V8 power. The Six is 250-CID, the V8s 350

MERCURY MARAUDER is available only as two-door hardtop, comes in either base or X-100 versions, the latter being powered by 429 CID 4-bbl. Car is a real marcher

(2 and 4-bbl.) and 400-CID. Transmissions are a three-speed manual and two automatics.

CHRYSLER: The Chrysler was extensively restyled last year, so there's not much new to report other than new grilles on all series, plus a new sound and vibration isolation system said to result in a significant reduction in road noise. Offered are five series of cars—Newport, Newport Custom, 300, New Yorker and a Town & Country wagon. There are two V8s—a 383-CID 2-bbl. and a 440-CID unit that comes with either single or dual exhaust or a potent high-performance package. You can get a three-speed manual transmission in the base Newport, but everything else is automatic. The Newport comes as a two and four-door hardtop, a convertible and a four-door sedan. Same with the Custom, only there's no convertible. The 300 comes as a two



CHRYSLER NEWPORT offers new grille, minor changes. Chrysler claims new sound-vibration system results in noticeable reduction of all road noise

and four-door hardtop and a convertible, the New Yorker as a two and four-door hardtop and a four-door sedan. The wagon is a two or three-seater.

DODGE: New proportions are the big news here. The front end has been

(Please turn to page 230)

FAMILY CARS—HOW THEY COMPARE

Car	Wheel-base (in.)	Track (f/r in.)	Overall Length (in.)	Overall Width (in.)	Engines in Model(s) Series* (Displacement, cu. in.—V8 except as noted—carburetion)
American Motors (Ambassador)	122.0	59.9/60.0, 59.7/60.0 (V8 models)	208.0	77.2	232-6-2bbl., 304-2bbl., 360-2&4bbl., 390-4bbl.
Buick (Le Sabre, Wildcat, "455")	124.0	63.0/63.0, 63.5/63.0 ("455")	219.4	80.0	350-2&4bbl., 455-4bbl.
Chevrolet (Biscayne, Bel Air, Impala, Caprice)	119.0	62.5/62.5	215.9	79.8	250-6-1bbl., 350-2&4bbl., 400-2bbl., 454-4bbl.
Chrysler (Newport, Custom, 300, New Yorker)	124	62.1/62.0	225.1	79.0, 79.1 (4dr.)	383-2&4bbl., 440-4bbl.
Dodge (Polara, Custom, Monaco)	122	62.1/63.4	220.4	79.3, 79.2 (4dr.)	318-2bbl., 383-2bbl., 440-4bbl.
Ford (Custom, 500, Galaxie, 500, XL, LTD, LTD Brougham)	121.0	63.0/64.0	213.9, 216.0 (4dr.)	79.7, 79.8 (4dr.)	240-6-1bbl., 302-2bbl., 351-2bbl., 390-2bbl., 429-2&4bbl.
Mercury (Monterey, Custom, Marauder, X-100, Marquis, Brougham)	121.0, 124.0 (4dr.)	63.0/64.0	219.1, 221.8 (Monterey 4dr.), 224.3 (Marquis 4dr.)	79.6, 79.8 (4dr.)	390-2bbl. (reg. or prem. fuel), 429-2&4bbl.
Oldsmobile (Delta 88, Custom, Royale)	124.	62.5/63.0	219.1	79.9	350-2bbl., 455-2&4bbl.
Plymouth (Fury I, II, III, Sport Fury, GT)	120	62.1/62.0	215.3	79.5	225-6-1bbl., 318-2bbl., 383-2&4bbl., 440-(3)2bbl. & 4bbl.
Pontiac (Catalina, Executive, Bonneville)	122, 125 (Executive, Bonneville)	64/64	217.9, 223.9 (Executive), 224.6 (Bonneville)	79.8	350-2bbl., 400-2bbl. (reg. or prem. fuel), 400-4bbl., 455-4bbl.

*Not all engines available in all models

THE 70 CARS

The Luxury Cars

BIG NEWS in the luxury-car field for 1970 centers around a restyled Lincoln and a 500-CID (!) engine for Cadillac's Eldorado. Otherwise, in the best traditions of cars in the luxury category, changes are at a tasteful minimum.

The Lincoln is all-new, and I can't make up my mind whether the Mercury is being upgraded to look like the Lincoln or the Lincoln is being downgraded to look like the Mercury. In any event, there's a definite resemblance, particularly up front.

Cadillac's 500-CID engine is, of course, "the largest passenger-car engine in the world." Cadillac would have it no other way. As usual, unfortunately, we didn't get either pictures or specifications of the new Cadillacs in time to make this issue's deadline, so please pardon the void. But regarding the new engine, we do know horsepower is rated at 400 . . . and this, loafing.

Anyway, here's what the big spenders are being offered for '70.

BUICK: The Electra 225 offers an all-
(Please turn to page 234)

OLDS 98 features a new grille, new hood sheet metal, new bumpers front and back, a side and deck-lid paint-stripe option. The taillights are new



IMPERIAL by Chrysler underwent major restyling in '69, is carried over only slightly changed for the new year



LINCOLN CONTINENTAL is all new, has longer wheel-base, a wider front, rear track, new front, rear suspension



LUXURY CARS—HOW THEY COMPARE

Car	Wheel-base (in.)	Track (f/r, in.)	Overall Length (in.)	Overall Width (in.)	Engines in Model(s) Series* (Displacement, cu. in.—V8 except as noted—carburetion)
Buick (Electra 225)	127.0	63.5/63.0	225.0	80.0	455-4bbl.
Cadillac (Eldorado)	120.0	63.5/63.0	221.0	79.9	500-4bbl.
(Calais, DeVille)	129.5	63.0/63.0	225.0	79.8	472-4bbl.
(Brougham, Sixty-Spec.)	133.0		228.5		
(Seventy-five)	149.8		245.5		
Chrysler (Imperial)	127	62.4/62.0	230.2	79.0 79.1 (4 dr.)	440-4bbl.
Lincoln (Mark III)	117.2	62.0/62.0	216.1	79.4	460-4bbl.
(Continental)	127.0	64.3/64.3	225.0	79.6	460-4bbl.
Oldsmobile ("98")	127.0	62.5/63.0	225.2	80.0	455-4bbl.

*Not all engines available in all models



PM's Handsome Hall Clock

Creating this family heirloom is easier than it looks. Presented in two installments. Part 1 lets you get started on the housing and next month's details finish the job

PART I

By W. CLYDE LAMMEY

Technical Art by Fred Wolff

GREAT GRANDFATHER referred to his timekeeper in the hall as a "tall" clock, never as a "grandfather" clock. Both terms referred to the case, of course. Some early cases were huge and ornate—up to nine feet high and two feet or more wide. PM's version is scaled to suit today's tastes; it's a clock that blends with any decor.

Though the case pictured is sometimes called a three-quarter case, it is more commonly known as "grandmother" size. Such cases usually varied from about 50 to 72 in. (or slightly more) in height with other details in proportion. Our version is 17 $\frac{3}{8}$ in. wide and about 77 in. high overall.

The movement features visible weights with polished brass shells and chains. It chimes the quarter hours and strikes the hour on rods. The "moon" dial (ordered separately) will keep track of the moon phases, provided it is correctly adjusted and the clock runs constantly. Movement and dial (Model U-10) were purchased from Craft Prod-

ucts, Elmhurst, Ill. 60126, for \$77.

Woods to use are your choice. The case pictured was made from selected curly maple. Mahogany or black cherry are also good choices. Cash outlay for wood was about \$30 from Craftsman Wood Service, 2727 S. Mary St., Chicago, Ill. 60608.

Actually, the clock enclosure is simply three boxes stacked one atop the other. The parts are built using simple construction techniques. Bracket feet, for example, *look* difficult to make, but aren't. The two parts are bandsawed to rough shape and ends are spline-mitered as detailed. After joining with glue, the triangular filler piece is added and each foot rasped to rough shape.

Next, you make the base frames. The lower one has a plywood panel framed in; the upper one is an open frame to allow the weights to pass through. If you don't have a molding knife of the proper size for shaping the frames, do this by hand (or this could be the project that justifies treating yourself to a

BRACKET FOOT is assembled, shaped to contour with a rasp and file. Finish the smoothing with sandpaper

FEET ARE ATTACHED to base frame with screws and glue. Position the feet with long arms at the front

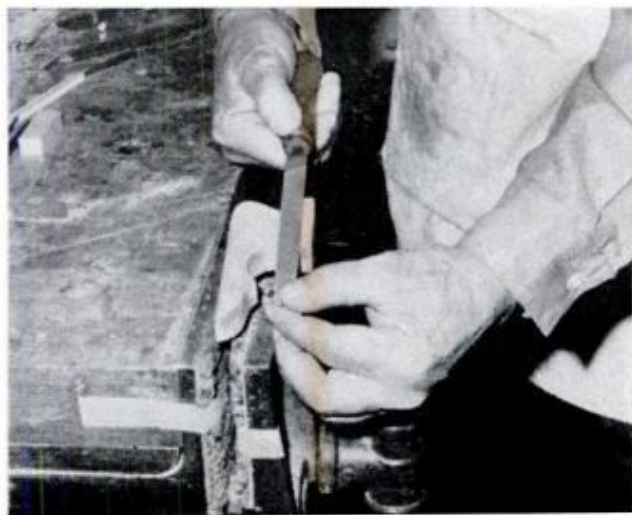

molding head and cutter set). If you do the frame moldings by hand, duplicate the bead (right angle) portion of the shape by ripping a 1/4-in. groove about 1/8 in. deep. Then, using a hand plane, round the edge to shape. Grooves in the mitered corners for the splines are

stopped just before cutting through into the molded edges.

The front member of the three-sided base will require edge-gluing two or more pieces to obtain the necessary width. Select stock so that the boards are well matched for attractive grain

Housing Components

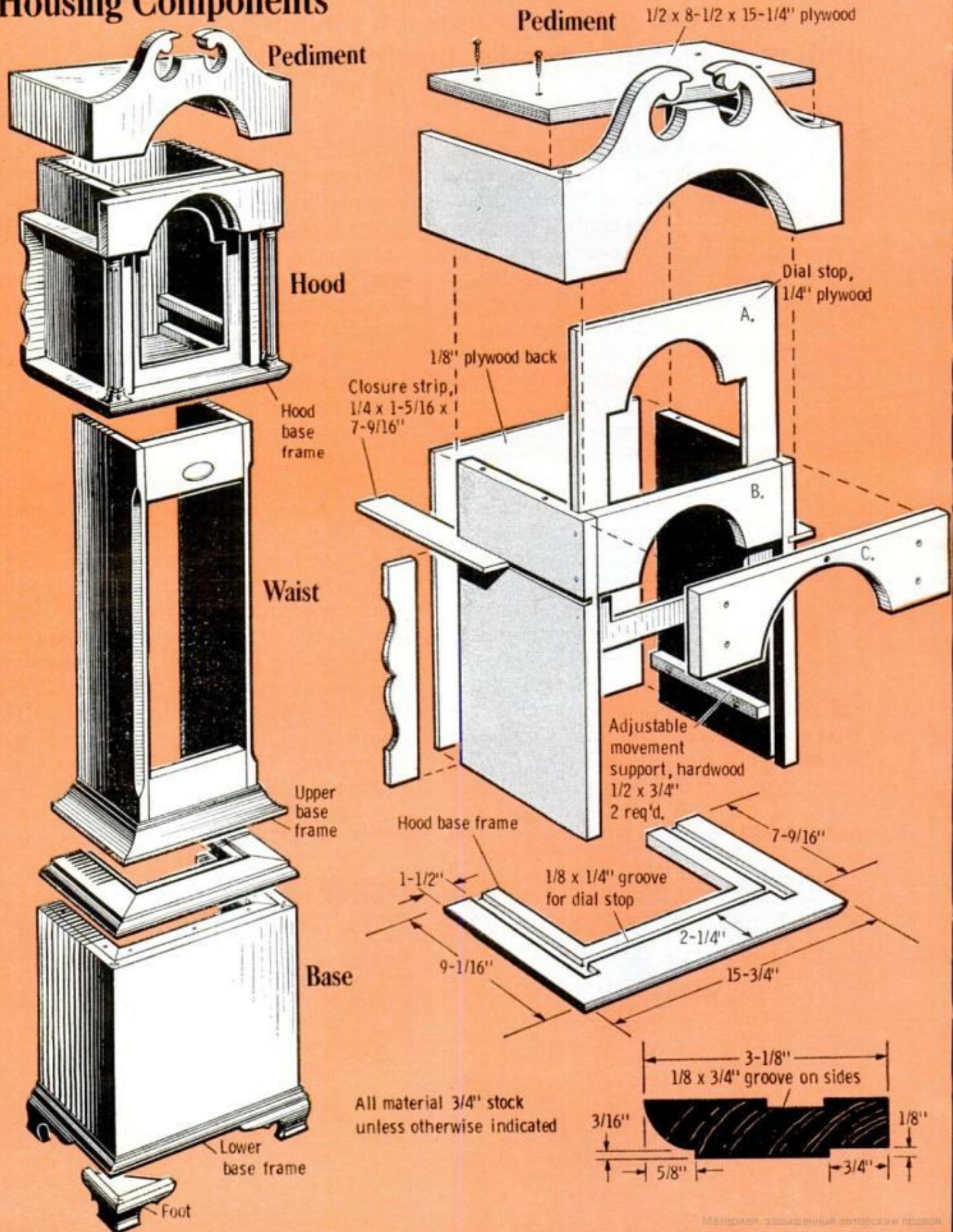

design. Mitered corners are splined. Notice that mitered cuts come to a blunt point. You leave about $\frac{1}{32}$ in. as a bearing against the ripping fence then sand to a corner after joining.

Photos show how the waist, or column, is assembled. The inlaid eagle is a

marquetry assembled from several woods, also sold by Craftsman Wood Service. It should be inlaid carefully to obtain as perfect a fit as possible. The depth of the recess receiving it should insure that the marquetry, when glued in, is slightly above the wood surface;

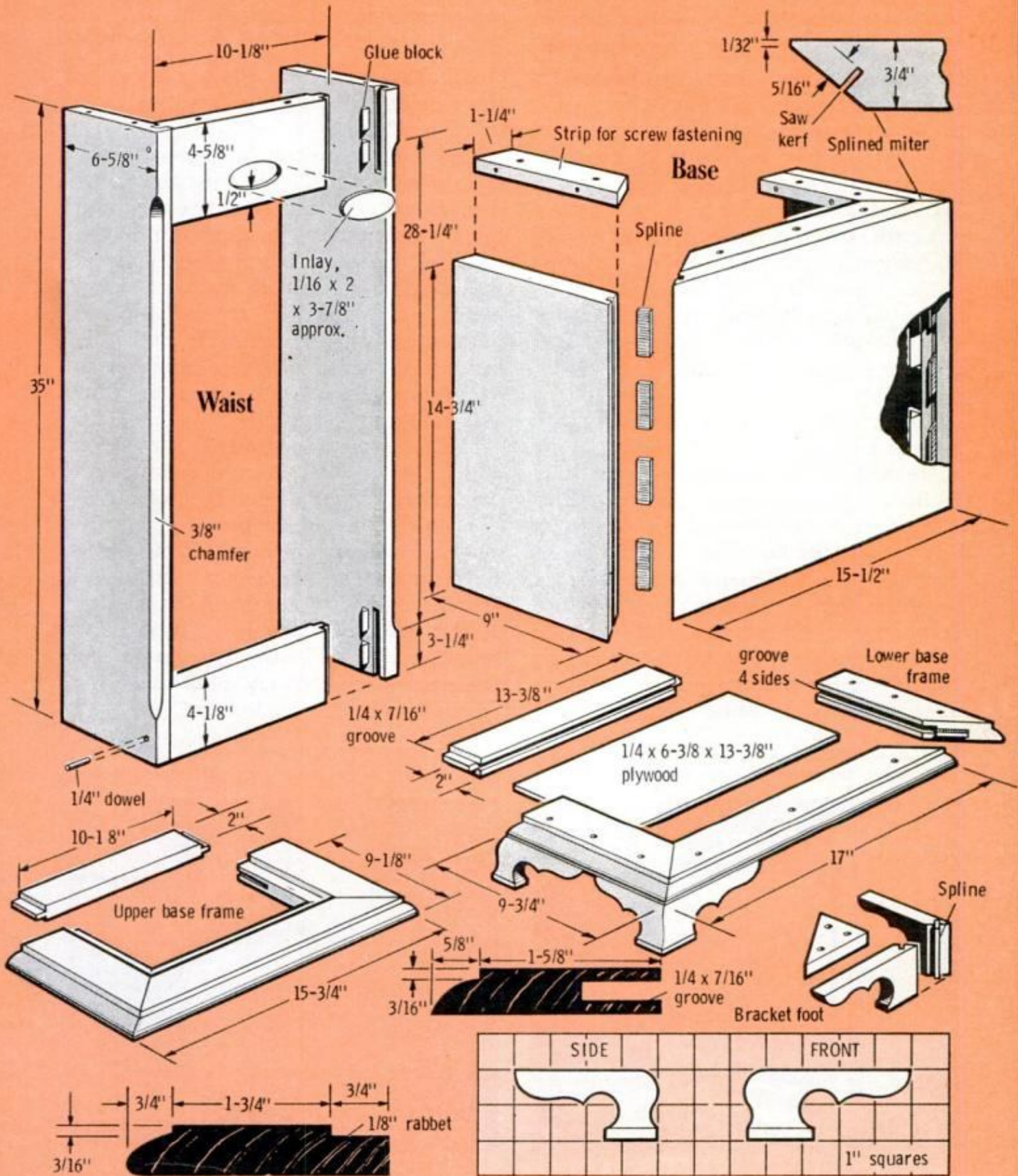

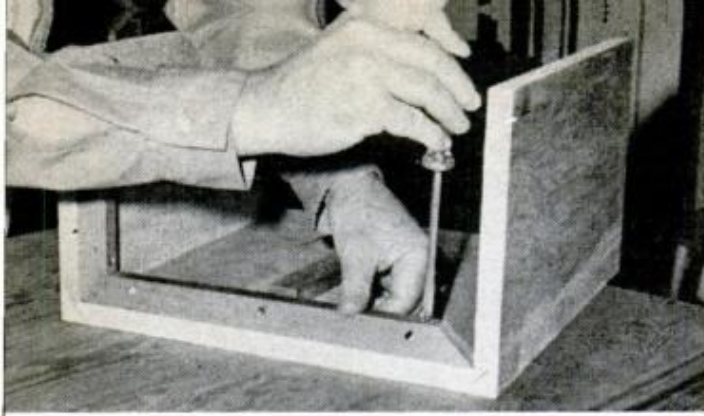

SCREW-FASTENING STRIPS are glued and screwed inside the three-sided base, flush with the top edge

it is then sanded perfectly flush. The joinery at top and bottom is by means of simple grooves and tenons, must be done accurately to insure a neat fit. Cross members and base miter joints are glue-blocked. Each joint, further strengthened with a 1/4-in. dowel will be concealed later by cove molding.

Use 1 1/2-in. No. 4 flathead screws to assemble. Be sure that the base is properly located on the lower frame and make a nonglue test assembly to check for fit.

The strips for screw fastening are attached to the inside of the box, flush with the top. The top frame of the base is then attached with screws.

Next, turn the assembly upside down and install the bracket feet. To make sure the case will stand level when assembled, shim a piece of 3/4-in. plywood level on your workbench, and place the assembled base on it. Then check the "stand" of the base with a level. If it is even slightly wobbly, remove stock

BASE IS COMPLETED when upper frame is attached with screws turned up through the fastening strips

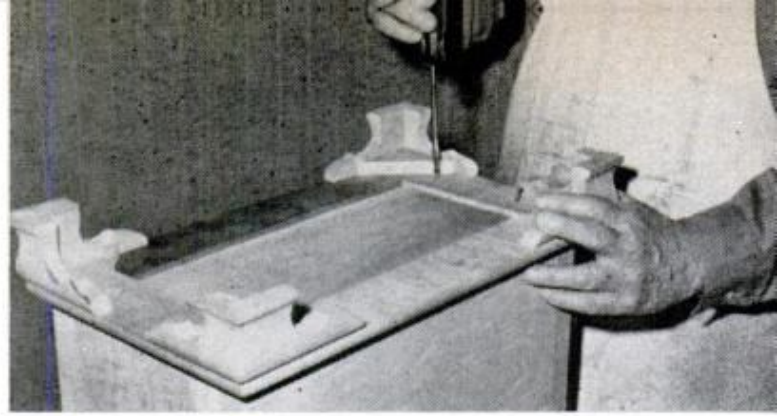
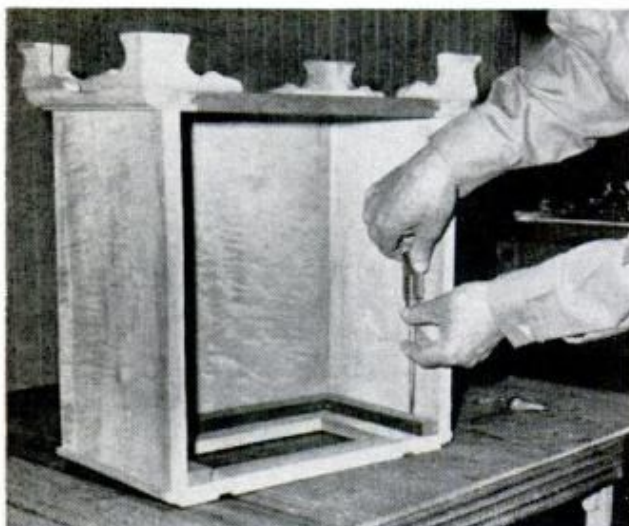

LOWER BASE FRAME is attached to the base with screws only in a preliminary non-glue trial assembly

from alternate feet with a rasp until the base stands perfectly level and firm on all four feet.

The waist now can be joined to the base in a trial fitting, leaving the joints dry. This dry run makes it easier and more workmanlike to disassemble the parts for finishing. It's also best to sand individual parts smooth as they are cut to size, and to "soften" (round) all corners slightly as you sand. Finishing stains and varnishes have a tendency to draw away from a sharp corner, thus leaving it unfinished.

The hood and pediment, shown on page 126, will be discussed in detail next month. They demand closer attention to detail and require having the clock movement on hand. Parts could be rough-cut to shape now, but leave ample waste for trimming to exact size.

This completes the basic unit. Next month we'll tackle the two doors and the decorative touches, plus the heart of the clock—the movement. ★★★

WAIST DROPS INTO PLACE in the edge rabbets that are ploughed in the frame parts before assembling

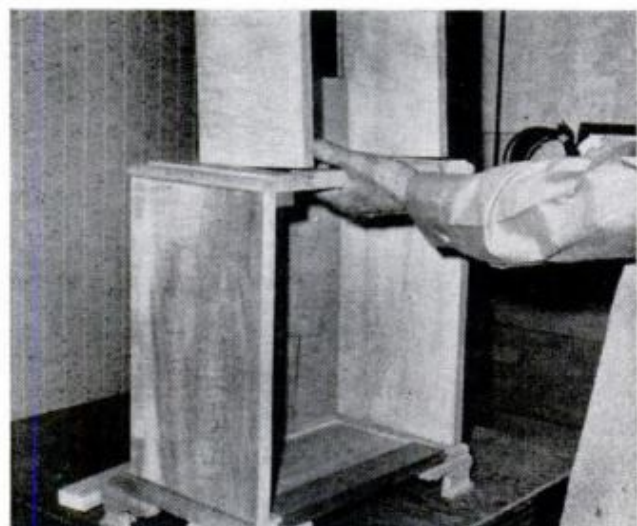

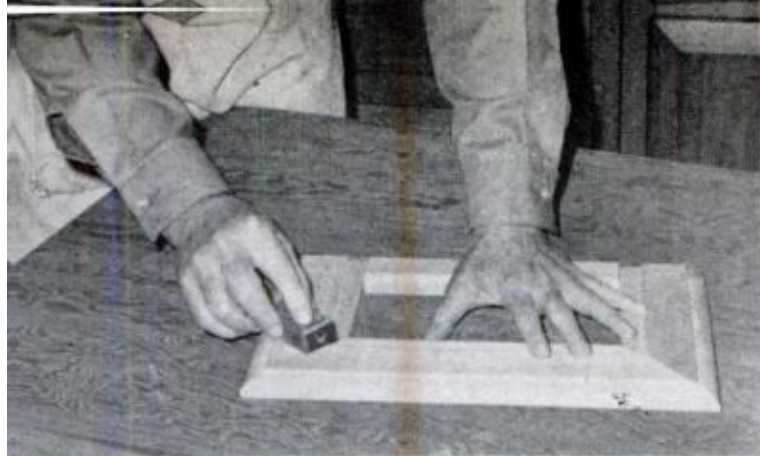

UPPER BASE FRAME is simply a hollow frame permitting weights to fall their required distance

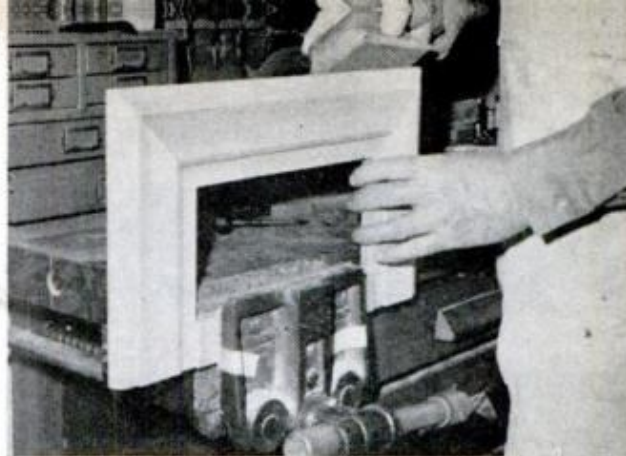

MOLDED EDGE of upper base frame is fully rounded with a block plane, then sanded to a uniform radius

Miter-Joint Assembly

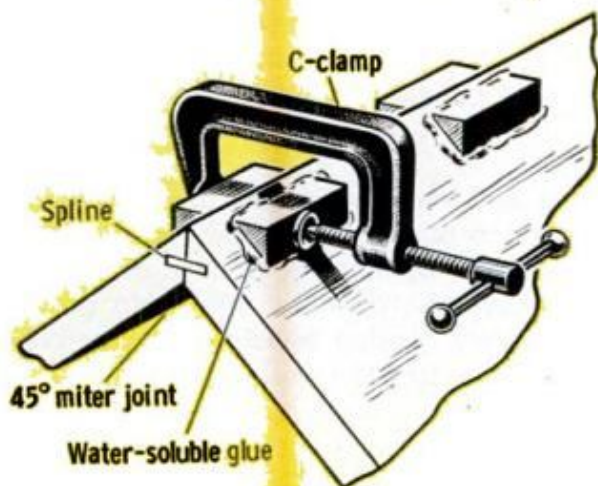

CLAMPING SPLINED MITERS. Triangular blocks are glued near the edges of the pieces to be joined. When dry, the joint is spread with glue and drawn tight with C-clamps. After glue in the joint has dried, the blocks are cut off with a sharp chisel. Use sandpaper to remove any glue that's left on workpiece

SCREWS DRIVEN UP through upper base frame hold the waist securely. Use nine equally spaced screws

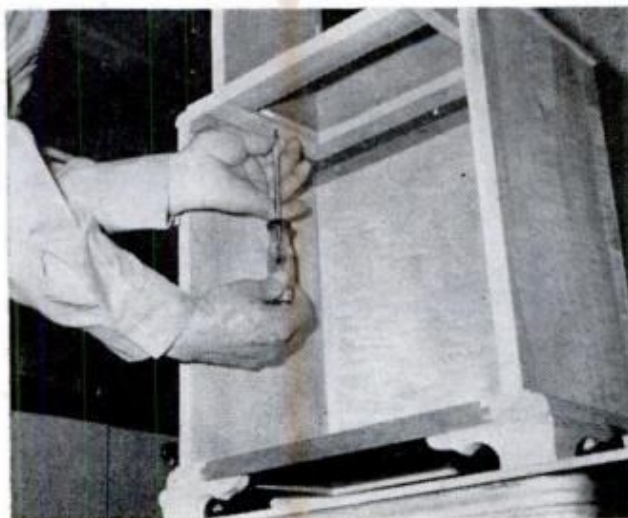

OCTOBER 1969

MATERIALS LIST

No. Reqd.	Size*	Use
HARDWOOD		
Base		
1	3/4x2 1/4x40"	Bracket feet
1	3/4x4x55"	Base frame (lower)
2	3/4x9x15"	Base sides
2	3/4x8x15"	Base front
Waist (column)		
2	3/4x7x36"	Sides
1	3/4x5x10 1/2"	Top rail
1	3/4x4 1/2x10 1/2"	lower rail
Hood		
1	3/4x3 1/2x36"	Hood base frame
2	3/4x8x17"	Sides
1	3/4x5x11 1/2"	Inner arch (B)
1	3/4x5x15"	Spacer (C)
1	3/4x9x16"	Pediment front
2	3/4x5x9 1/2"	Pediment sides
Cove Molding		
1	3/4x2 1/2x84"	Upper and lower
Arched Door		
2	5/8x1 1/2x12"	Stiles
1	5/8x1 1/2x11 1/2"	Bottom rail
1	5/8x5 1/2x11 1/2"	Top (arched) rail
Waist Door		
2	3/4x1 1/2x27"	Stiles
1	3/4x1 1/2x10"	Bottom rail
1	3/4x5x8"	Top rail
Miscellaneous Hardwood		
2	1/4x1 1/2x12 1/4"	Scrolled ornaments
2	1/4x1 1/2x8"	Closure strips
2	1/2x1x6"	Movement seat cleats
1	3/8x3/4x12"	Retaining strip
2	3/4x12" dowel	Pilaster
PLYWOOD		
1	1/2x9x16"	Hood top
1	1/2x11x14"	Chime-rod bracket support
1	1/2x6x11 1/2"	Movement seat
1	1/4x12x17"	Hood dial stop (A)
1	1/4x7x14"	Base
1	1/8x24x48"	Backing
1	1/8x12x36"	Backing

HARDWARE

2 each brass capitals and bases for pilaster; 1 pediment ornament with 2" ball; 1 brass pull, 3/8"; 1 brass pull, 5/8"; 1 pr. 1 1/2" loose-pin hinges; 22-ga. brass for arched door hinges; clock movement and dial.

MISCELLANEOUS

1 2x37/8" marquetry inlay (eagle); 1 arched glass panel to suit hood door; 1 rectangular glass panel to suit waist door; assorted flat and roundhead screws; white glue, stain, lacquer, sandpaper.

*Pieces are listed slightly oversize in width and length to allow for finish trimming. Several pieces included in this list are not shown in Part 1. Additional detailed drawings will appear in Part 2 next month.

129

PM's exclusive preview of

PATEXPO '69

WORLD'S BIGGEST INVENTORS SHOW

On these and the following six pages, PM brings you a behind-the-scenes look at some of the more than 10,000 exciting new ideas to be unveiled later this month at the huge New York Coliseum

By SHELDON M. GALLAGER

INVENTORS FROM ALL OVER the United States and 24 foreign countries are about to gather at Patexpo '69—short for Patent Exposition—to display their latest creations. To bring you the exciting highlights of this important annual event, PM editors studied hundreds of entries in advance by special arrangement with the show's sponsor, the International New Products Center at 680 Fifth Avenue, New York, N.Y. 10019. The show—largest of its kind in the world—will be held at New York's giant Coliseum October 9-12. Exhibit hours are 11:00 a.m. to 8:00 p.m. weekdays and noon to 8:00 p.m. on Saturday and Sunday. Tickets are \$2.50 each.

CRATES BECOME CABINS in this clever scheme proposed by William Field of Royal Oak, Mich. Large shipping crates would be made with sloping tops, as in the photo below. Instead of being discarded after use, the crates could be stacked together with

doors and windows added to form cabins, sheds and other small structures. The idea would save millions of dollars of waste a year, says the inventor, and help provide desperately needed housing in underprivileged regions of the world.

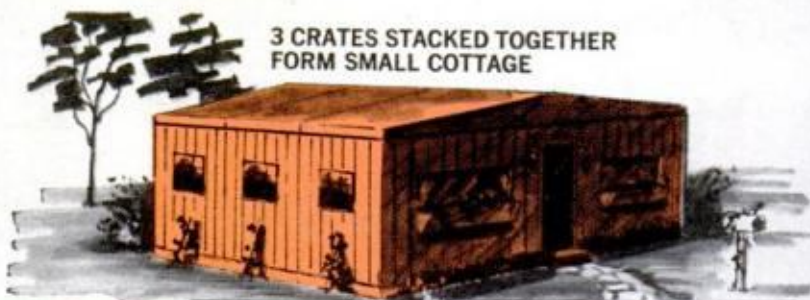
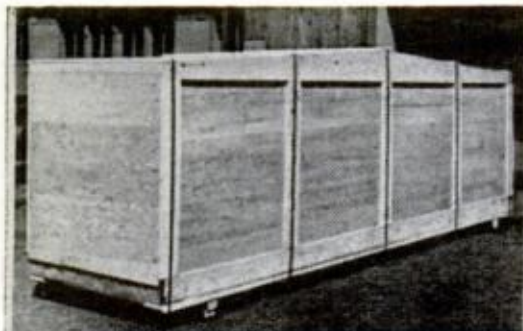

3 CRATES STACKED TOGETHER FORM SMALL COTTAGE

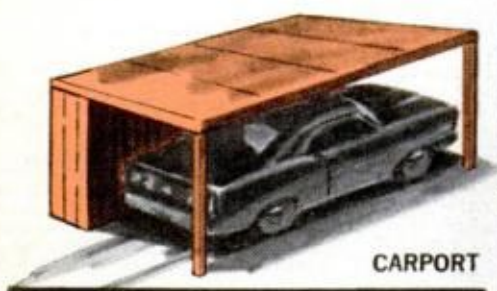

CARPORT

STORAGE SHED



VACATION CABIN OR BOAT-HOUSE

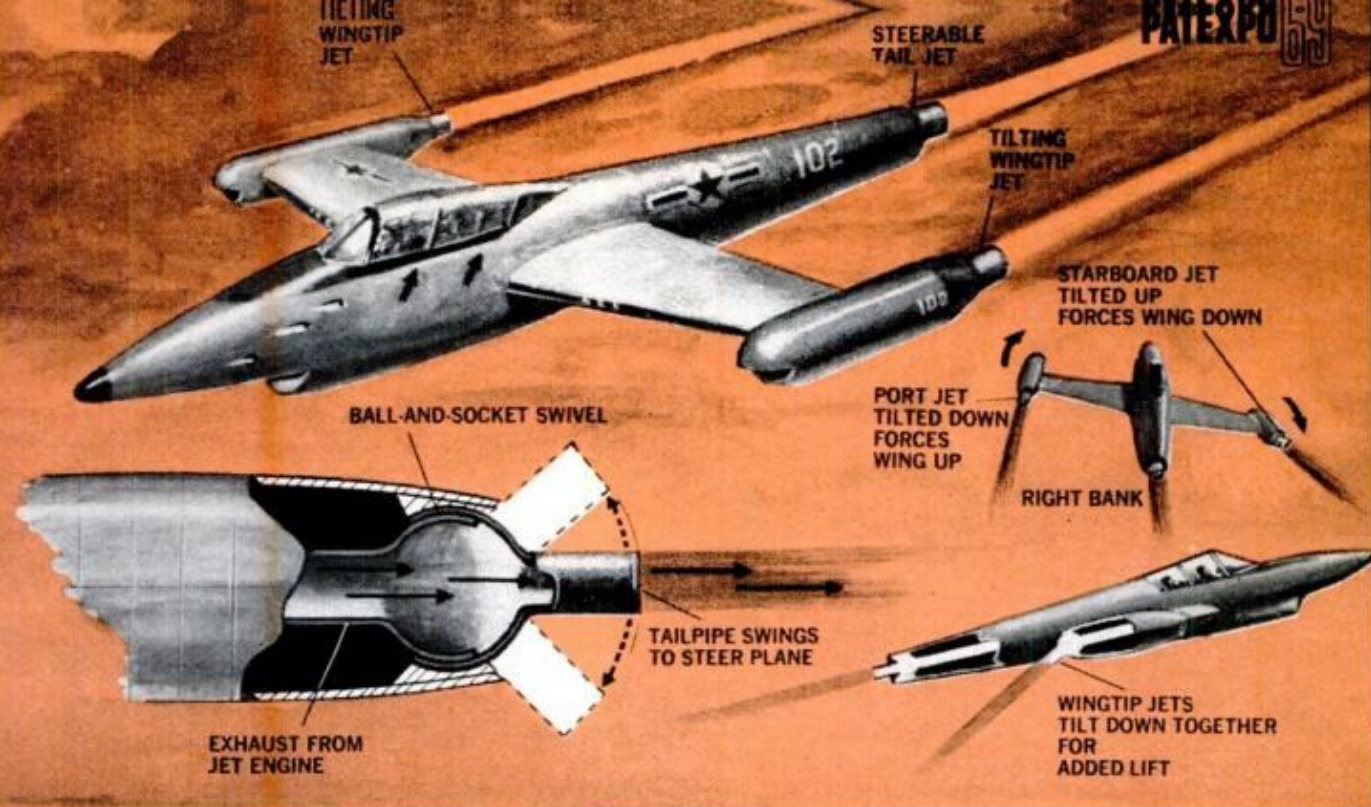

TAILLESS FIGHTER uses steerable jets to maneuver with instead of conventional control surfaces. The tail jet moves up and down and sideways for climbing, diving and turning. The wingtip jets can be used to-

gether for added lift or tilted in opposite directions to serve as ailerons for banking. Object: faster, more precise maneuvering in combat with less chance of failure. Sam Fatouras of Chicago is the inventor.

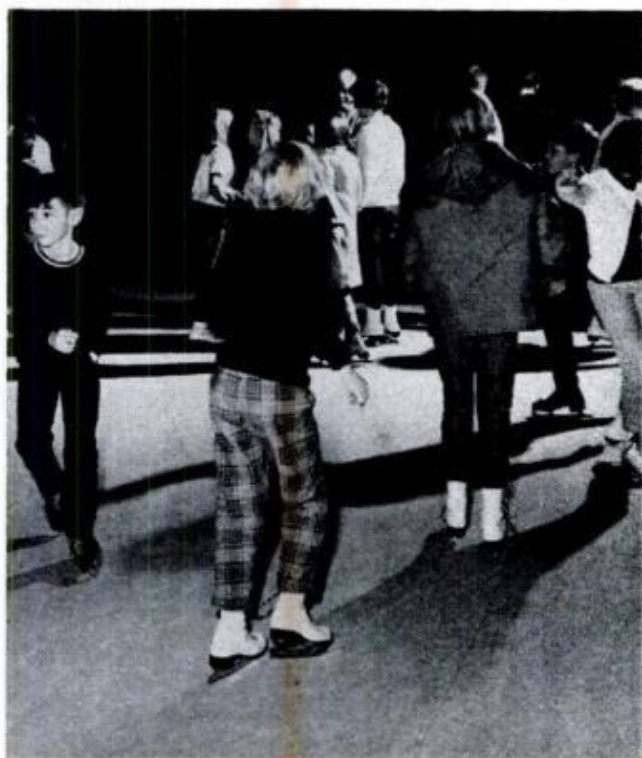

THAT'S NOT ICE they're skating on—it's plastic. Vinyl Plastics, Inc., of Sheboygan, Wis., has devised a system of lightweight plastic panels you can put down over any flat surface—a cellar floor or porch deck—to make an instant, year-round skating rink. The 3 x 8-foot panels are joined with special clips that hold them firmly together.



COLLAPSIBLE GUIDE POST can be run over with no damage to either it or your car. The spring-mounted plastic post is designed for areas that need markers but not a restraining rail. It saves lives, claims inventor Josef Hausegger of Steiermark, Austria, because cars striking it at high speed don't bounce off to hit other cars nearby.

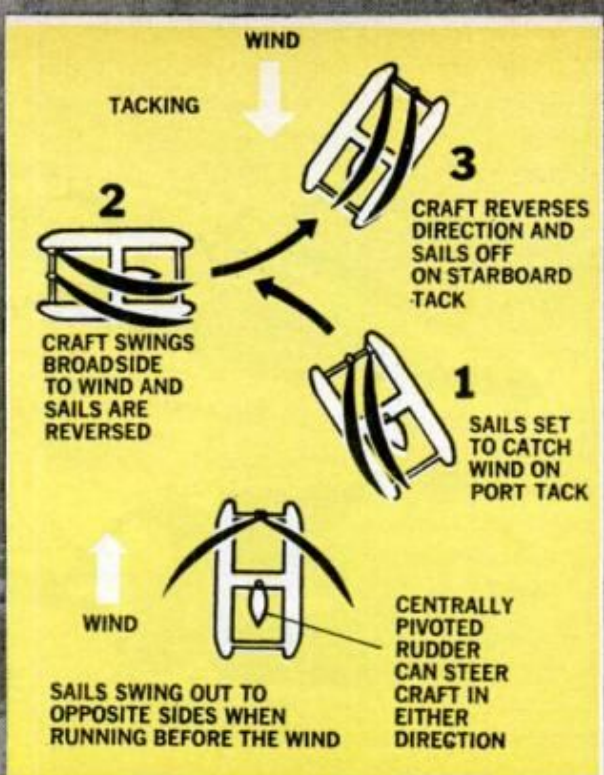
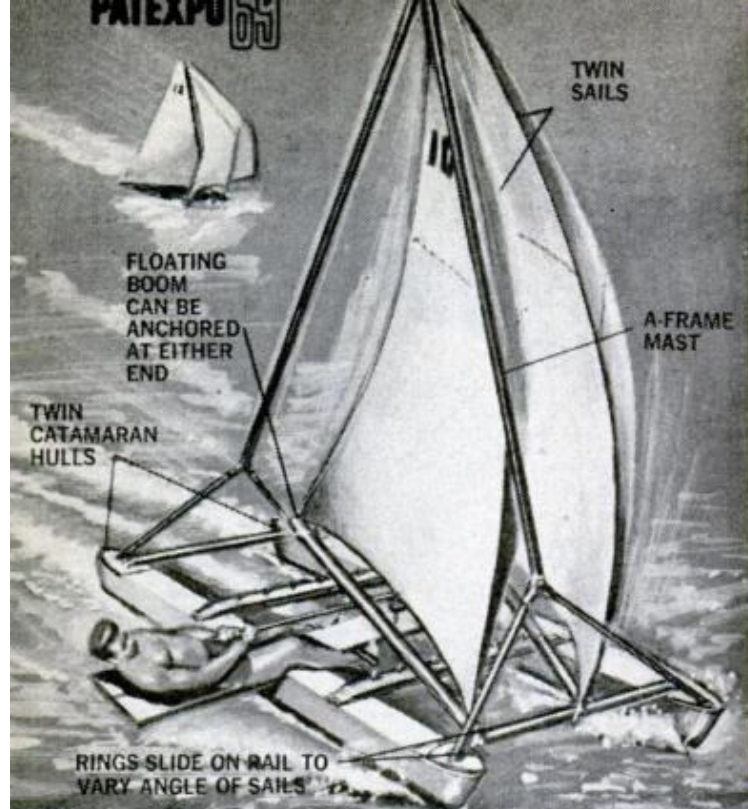

TWIN-SAIL CATAMARAN never has to turn around—it can sail in either direction. The booms are attached by sliding rings to a crossbar at each end of the boat. To go one way, you pull the booms in at one end and let them out at the other. To go the op-

posite way, you merely pull in the free ends and let out the anchored ends, reversing the sails. Advantages: Dangerous jibe turns are eliminated and you don't have to keep switching sides in the boat. Inventor is Friedrich Lucht of Bremerhaven, West Germany.

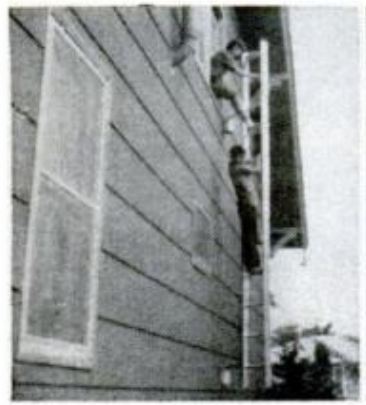

ESCAPE LADDER is hinged to the side of the house in this tricky burglar-proof arrangement by Virgil Teach of Portland, Ore. In a fire, the ladder is unlocked and swung over to the window. When not in use, it's too far from the window for prowlers to use, and the lock can be released only from the window.

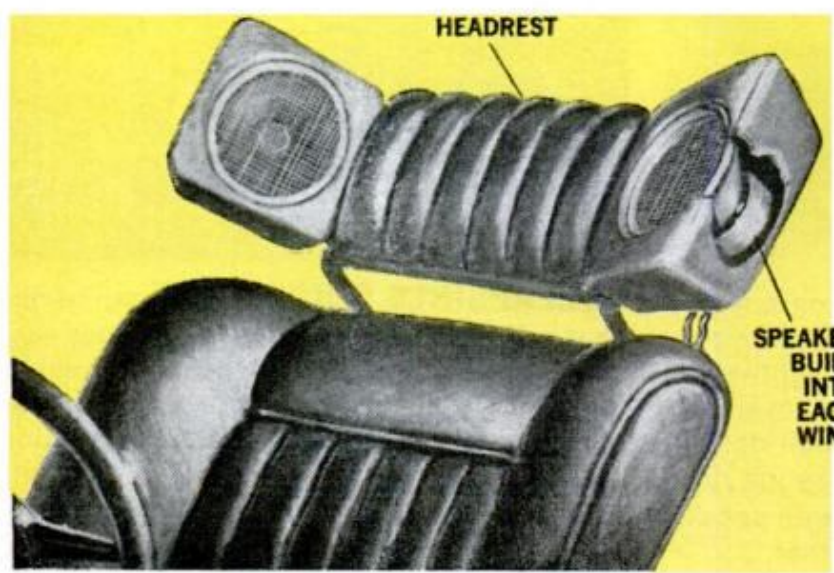

BUILT-IN SPEAKERS in this novel headrest for cars surround you with stereo music on long trips. The wraparound shape with the right and left channels fed to opposite ears gives you a stereo effect similar to that of headphones. You can also hook the speakers to a mobile CB or ham set for improved shortwave listening. Spartan Products of Madison Heights, Mich., came up with the idea.

MECHANIZED HAND TRUCK

makes it possible for one man to move a 600-pound load up or down stairs all by himself. Two pairs of small rollers ride on a motor-driven chain between the hand truck's wheels. As each pair moves downward on the chain, it catches on the lip of a step and lifts the hand truck up. As the rollers swing around the pulley at the bottom, they lever the truck's wheels up and onto the step. At the same time, the second pair of rollers catches on the next higher step and the process is repeated. For going down stairs, the battery-powered motor is reversed. The hand truck was developed by Escalera, Inc., of Yuba City, Calif.

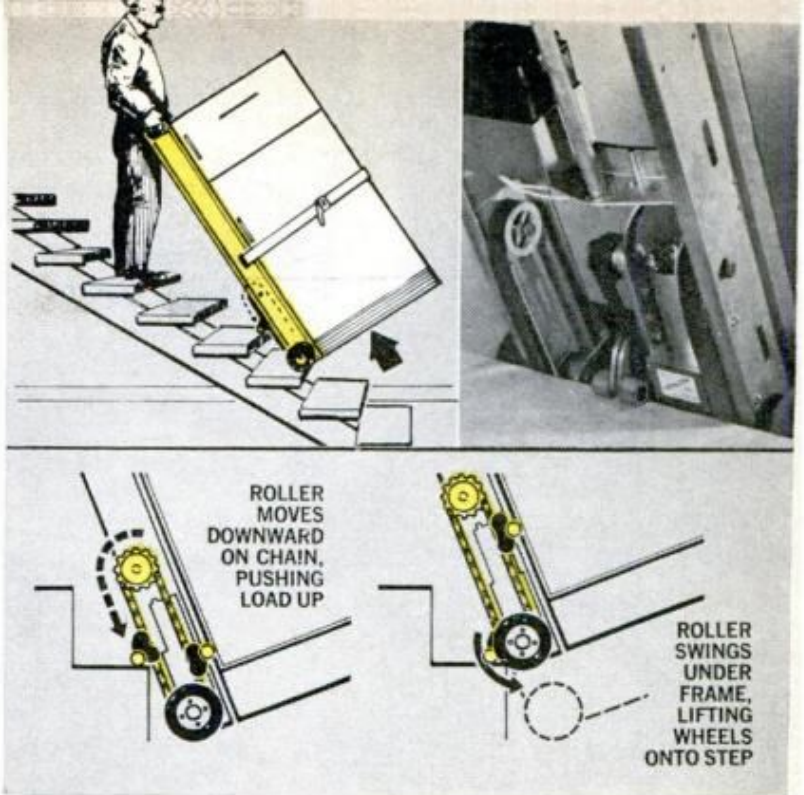

TIRE TELLTALE warns you at a glance if your pressure is low. The indicator, invented by S. M. Ellis of Shorne, England, has a spring-loaded plunger inside. So long as air pressure is adequate, it holds the plunger in the outward position so you can see its colored tip. If the pressure falls, the spring forces the plunger inward, indicating that the tire is soft.



STEP-ON SKI BINDINGS let you put your skis on and take them off without even bending over. You just press down and spring-loaded latches snap into sockets built into the boots. To get out, you push your ski

pole tip into a projecting tab. This retracts the springs, releasing each ski. For safety, the latches also release automatically under a preset pressure if you fall. Henry Glass of Chicago is the inventor.

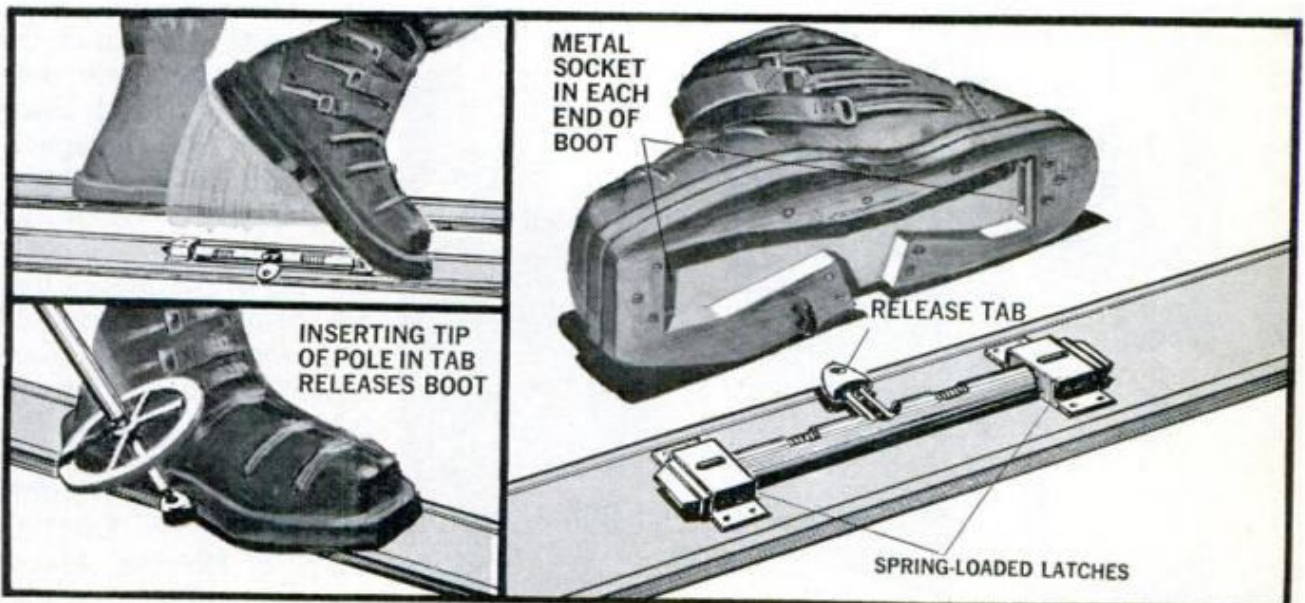



ARM MOVES UP AND DOWN, CHANGING CAPACITANCE TO CONTROL TRANSMITTER FREQUENCY

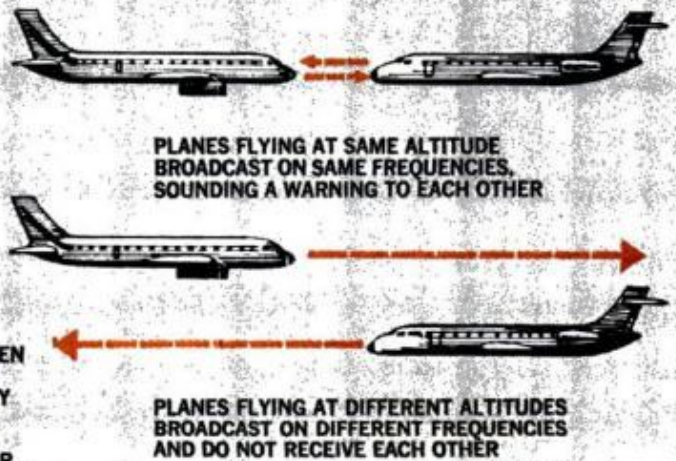
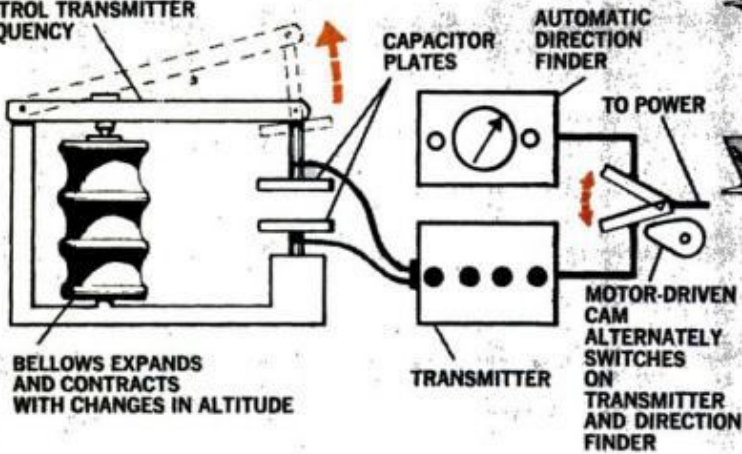

PLANES FLYING AT SAME ALTITUDE BROADCAST ON SAME FREQUENCIES, SOUNDING A WARNING TO EACH OTHER

PLANES FLYING AT DIFFERENT ALTITUDES BROADCAST ON DIFFERENT FREQUENCIES AND DO NOT RECEIVE EACH OTHER

AIRLINERS WOULDN'T COLLIDE with this ingenious warning system devised by Angelo Boudouris of Sylvania, Ohio. Each airliner sends out a signal that varies in frequency according to the plane's altitude. Its direction finder is also controlled by altitude so it receives only the frequency for a par-

ticular elevation. Two planes flying at different altitudes would be on different frequencies and would not hear each other. But the minute they approached the same altitude, they would pick up each other's warning signal. Frequency is controlled by an altimeter-like bellows as shown in the diagram.



PORTABLE BAR can be set up in three minutes before a party, then taken apart and stored away afterward to save space. Made of tough, plastic-impregnated, water-resistant cardboard, it consists entirely of flat pieces that are bent and interlocked to provide strength. When assembled, it can support 200 pounds on top and another 40 pounds on an inside glass and bottle shelf. Plastic Coating Corp. of Holyoke, Mass., designed the fold-up bar.

WAVE ACTION does the work for you in this handy bilge pump invented by Robert Kafka of Maitland, Fla. The pump piston is driven by a ball float that bobs up and down with the motion of the waves. This moves a diaphragm up and down, forcing water through a hose against a second diaphragm in the boat. As the second diaphragm moves up and down, it draws bilge water in through a one-way valve that opens only inward and expels it through another one-way valve that opens only outward. The nice thing about the idea is that, in an emergency, the rougher it is, the harder the pump works—automatically.

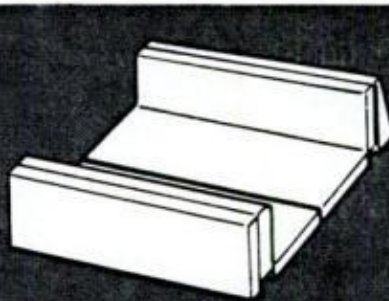
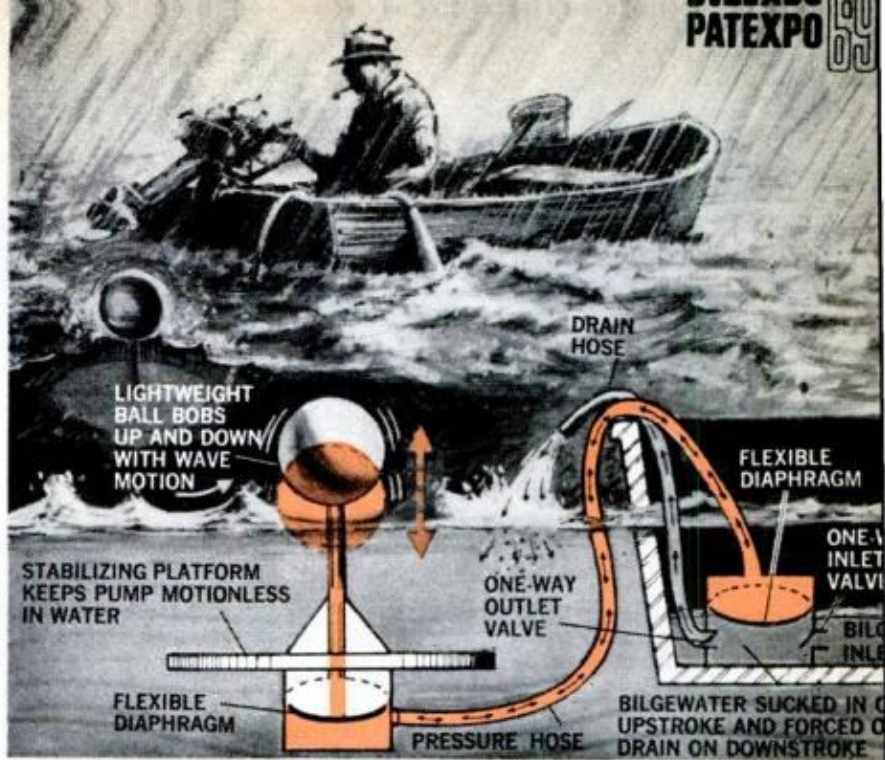

PADDED PLAY AREA FOR KIDS



CAMP BED

CONVERTIBLE PAD for a station wagon can be used in three different ways. Invented by R. O. Dunaway of San Pedro, Calif., it has six hinged sections with one of them wedge-shaped. With the end sections folded up, it

makes a safe, cushioned play area for children. Folded as shown in the photo, it becomes an extra seat. Laid out flat, it's a mattress for sleeping with the wedge-shaped section at the end making a pillow.

ONE WRENCH does the jobs of a whole set with this adjustable open-end design. Turning a five-sided plate pivoted at the end gives you a choice of five different jaw openings. A similar rotating plate in the opposite end provides another series of openings so the wrench can handle 10 different nut sizes. A spring-loaded ball snaps into the appropriate detent hole to lock each plate at the desired setting. Inventor is R. D. Allred of Toledo, Ohio.

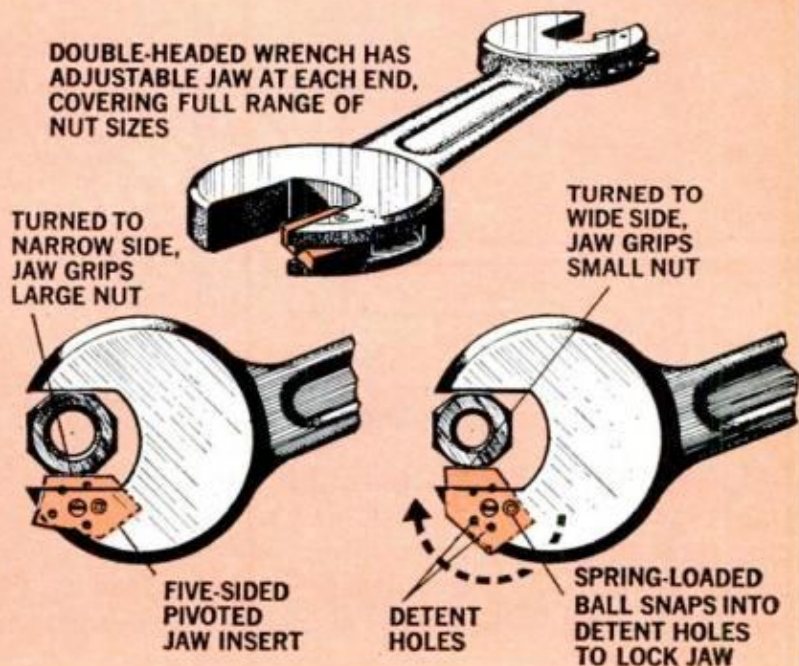

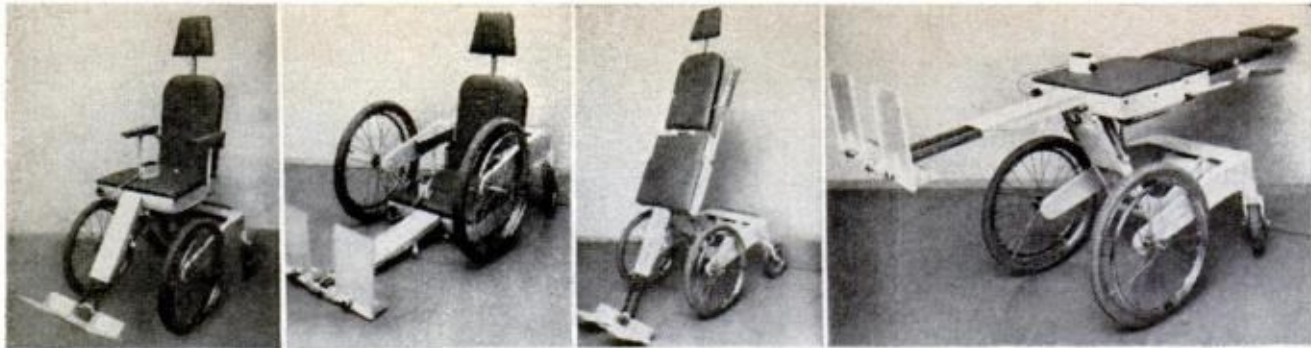

QUICK-CHANGE WHEELCHAIR turns itself into a variety of shapes to help handicapped persons maneuver more easily. Electrically controlled, it can squat to let its owner pick something off the floor or stand

up straight to make getting in and out simpler. It can also be straightened out flat for taking a snooze. The chair is the invention of the Redev Rehabilitation Development Co. of Helsingborg, Sweden.

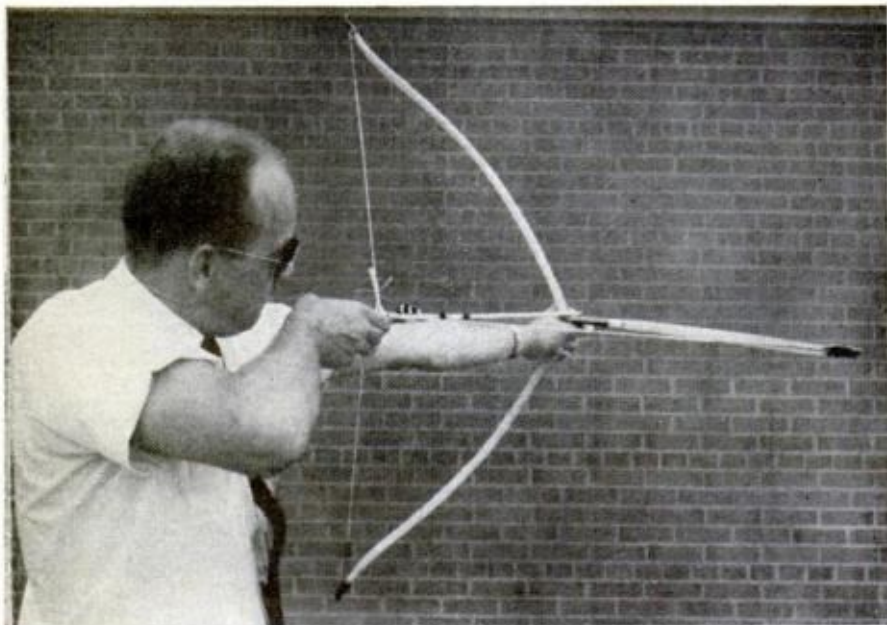

THREE-ARMED BOW lets you see your target clearly with nothing to get in the way. The Y-shaped design, invented by Raymond Gage of Dearborn Heights, Mich., also holds the arrow securely in the crotch.

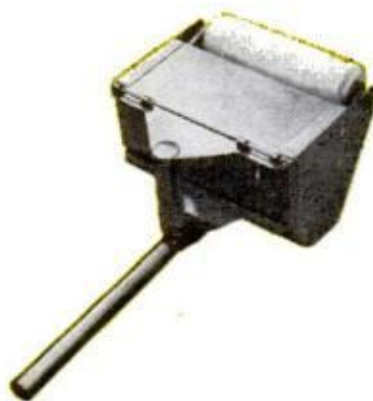
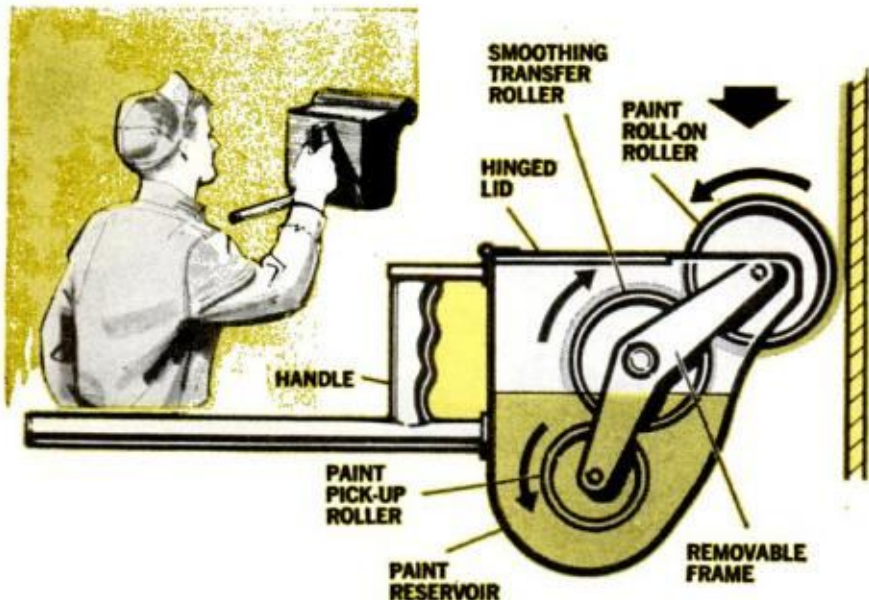

SELF-FEEDING PAINT ROLLER lets you cover a lot of area fast without stopping to refill it every few strokes. Paint is fed continuously from a reservoir by two lower rollers that pick it up and

smooth it out so just the right amount goes on the nap-covered top roller. The entire roller assembly is removable for cleaning. Elvin R. Munn of St. Louis, Mo., invented the work-saving device.

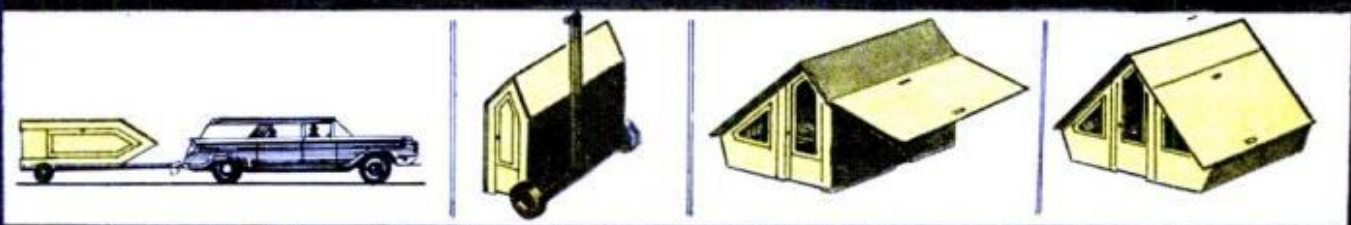
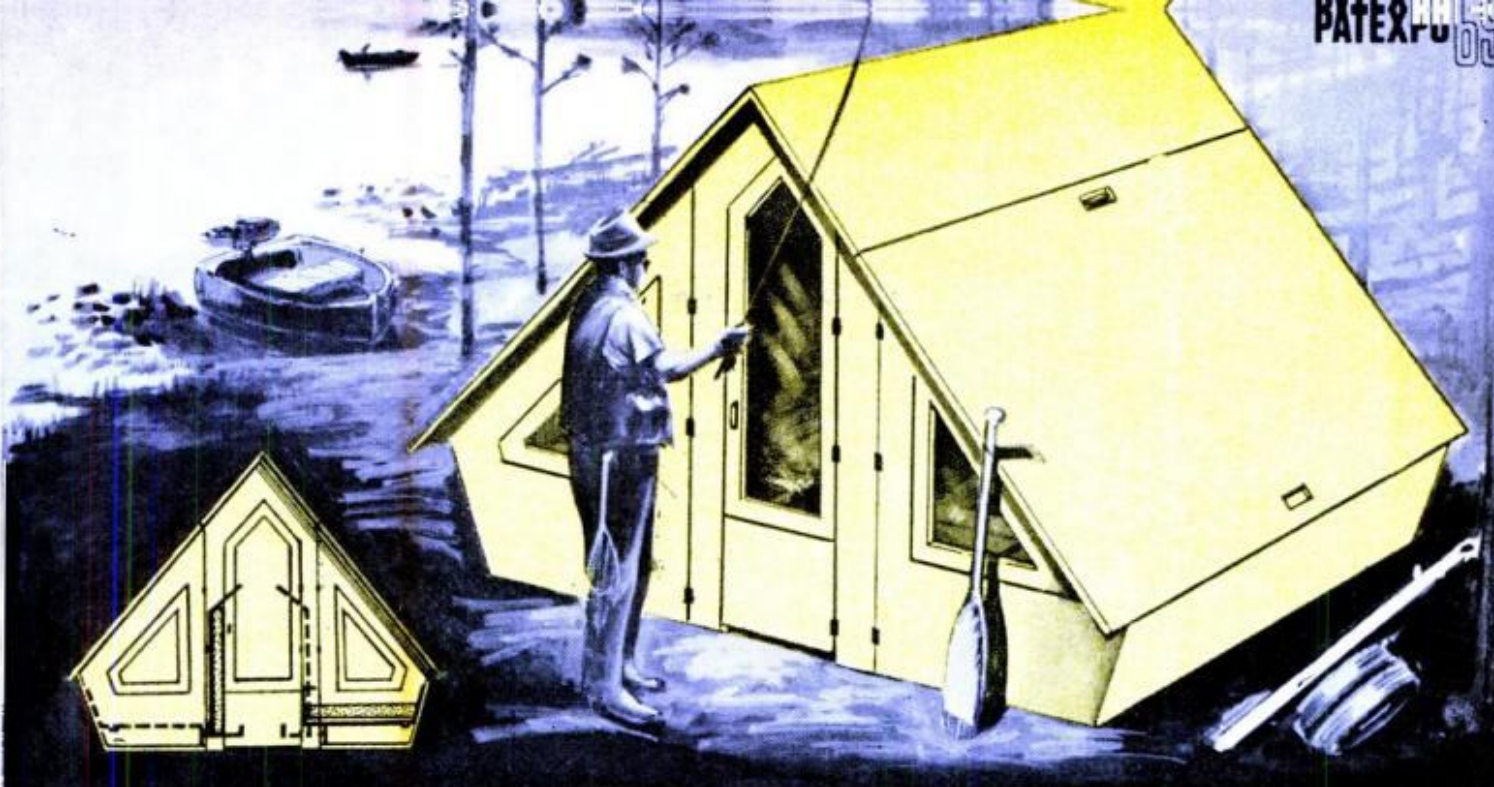

COLLAPSIBLE VACATION CABIN can be towed right along with you wherever you go. At the campsite, you stand the unit upright, remove the wheels and fold out hinged side panels to form a shelter for two. Cush-

ioned panels swing down inside to make seat-bunks. Invented by Henry Glass of Chicago, the sturdy metal structure is storm and animal-proof and can be left erected for use as a semipermanent weekend cabin.

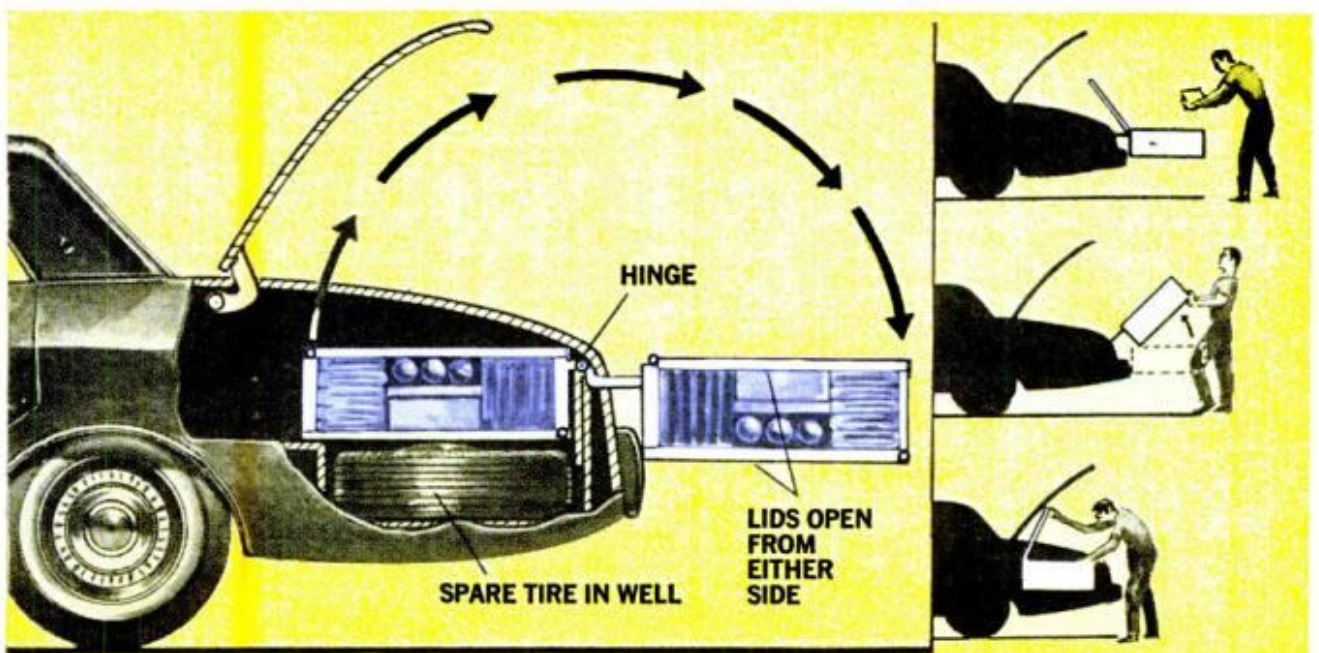

SWING-OUT LUGGAGE CARRIER makes it easy to pack and unpack your car trunk and lets you get at the spare tire quickly if you need it on a trip. De-

signed by J. D. Fernicola of Centreville, Md., the hinged compartment has lids on both sides so you can reach the contents with the carrier in either position.

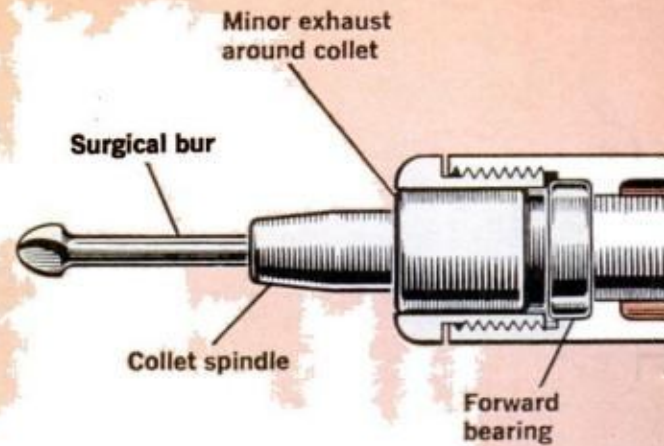

FINGER-TIP THROTTLE (left) gives surgeon precise control. Brake stops drill in two seconds

MECHANICS OF MEDICINE:

A 200-mph Surgical Drill, The Steady Beep of a Heart Monitor and an Electronic Voice Box

By ARTHUR FREESE

YOUR DENTIST'S high-speed drill has been converted to serious life-and-death business. In 1957, a young Pittsburgh oral surgeon traveled to a major dental convention in Chicago. There he saw a new high-speed air-driven dental drill—and a new technique of modern surgery had been born, for the instrument filled his thoughts all the way home. As Dr. Robert M. Hall told me—after buying one of these used drills the following year, he began to experiment with it, practicing on bones from an anatomy laboratory and on extracted teeth. He soon learned the dental drill was just that—a dental drill—and unsuitable even for oral surgery.

Hall began to move beyond dentistry

as he worked with the drill, finally turning to industry for parts he needed. He spent time and money devising a new air drill until he was no longer a dentist but an inventor, promoter, manufacturer and salesman, all in one. He located manufacturers to supply his air turbines—so tiny their bearings were the size of pinheads—some 50 separate parts are packed into his air drill which is little more than 5 inches long and $\frac{3}{4}$ of an inch in diameter; it weighs only 6 ounces.

The air drill is operated by a fingertip throttle at speeds of 100,000 rpm and has brakes that will stop it in one to two seconds. The air passes through the first turbine, then over a stator which redirects it through the second

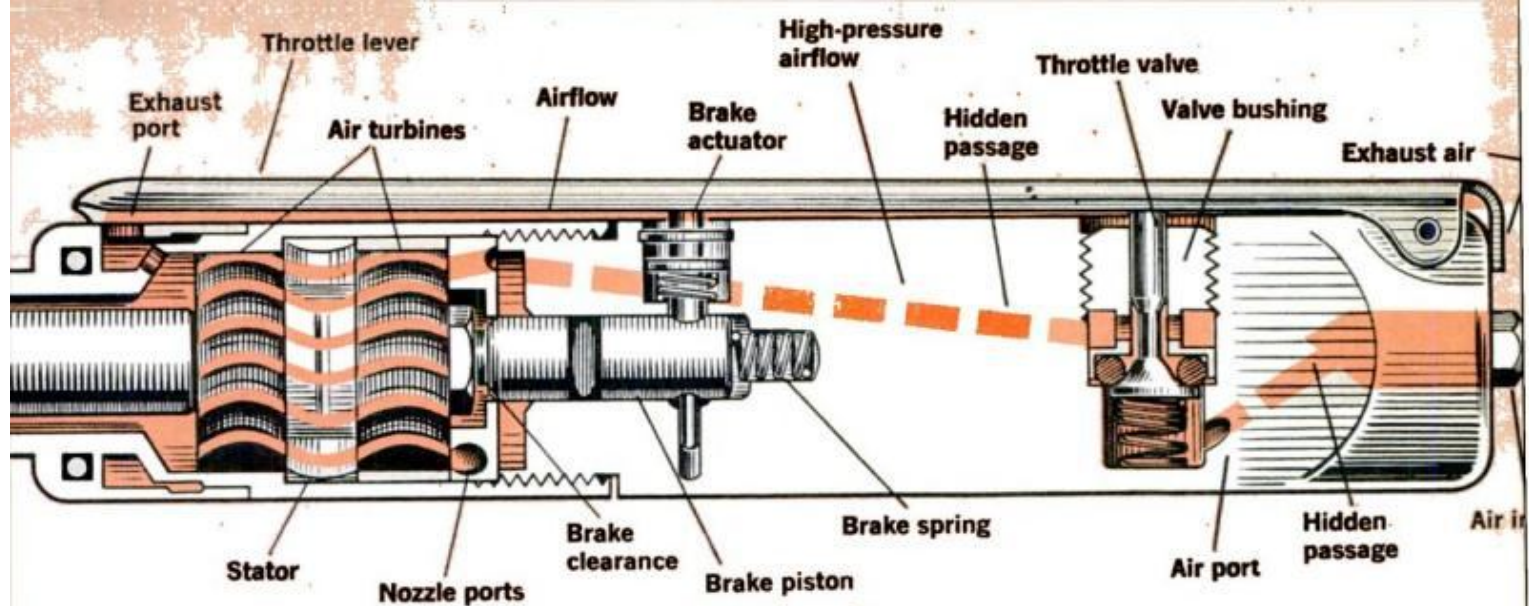

HALL AIR DRILL directs air through turbine, then over stator which redirects it through a second turbine. This ups torque 80 percent, or 20 times that of dental air drill. Its tiny turbines whirl at 200 mph

turbine, increasing the torque some 80 percent. The combination gives the Hall Air Drill a torque some 20 times that of the dental air turbine high-speed drill; it can be sterilized repeatedly by autoclaving (heating in a moist atmosphere at 275°F. for a half hour) without damage; its tiny turbines whirl at 200 mph and a circular race containing a full set of their bearings is about the size of a bird shot.

Dry nitrogen is the best gas-power source and has to be 99.995-percent vaporfree, although breathing-grade compressed air of the same purity can also be used. The operating pressure is 90 to 110 psi. The air drill itself is of stainless steel and anodized aluminum with attachments of titanium and tubing of autoclavable neoprene. It utilizes drill burrs of high-speed steel, tungsten carbide and diamond, ground to tolerances up to 1/5000 inch.

The day of the hammer and chisel in bone surgery has passed—over 10,000 surgeons in more than 50 countries are now using the Hall Air Drill. Estimated to reduce surgery time as much as 80 percent, it's being used for more than 500 different operations, ranging from delicate sculpturing of heart valves and spinal bones to "wiping away" the bony growth of bunions.

With its speed, the burrs need only touch bone to take it off cleanly, without trauma. Bone grafts can be prepared with accuracy and precision, practically as a dentist does an inlay, using this instrument in place of the damaging hammer and chisel method, which necessarily produced only the roughest fit.

Healing is quicker and less painful, for the air drill can cut through bone

PRECISE CONTROL of Hall drill is demonstrated as it removes shell of egg without damaging membrane

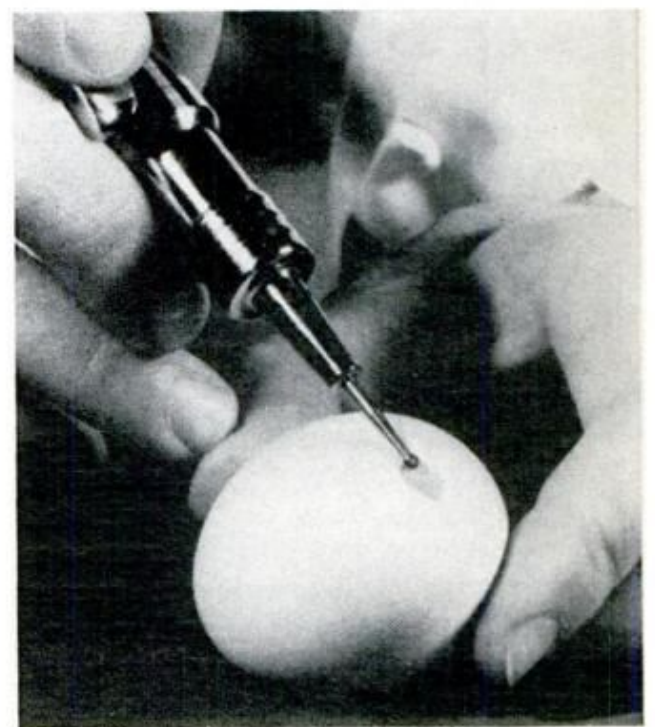



BEDSIDE MONITOR for victims of heart disease keeps constant record of patient's heartbeat, blood pressure and respiration. Electrocardiogram is displayed on oscilloscope. Meter (at nurse's right) calculates heartbeats per minute. Movement of meter pointer above or below set limits automatically triggers an alarm. Audible "beep" signal also indicates the heart-beat rate and eliminates need for nurse to constantly watch the scope. Each patient in a modern hospital's coronary-care unit has a bedside monitor. Two electrodes that are attached to the body carry bioelectric stimuli to the monitor

CENTRAL STATION is slave unit that lets a nurse monitor four bedside units. By selecting a patient's channel, she can get waveform reading of heartbeat on the scope. Meters duplicate those on the bedside units. A red indicator button (top button next to each meter) lights when the heart rate exceeds preset limits of the meter. An audio alarm also signals this condition. Electrocardiogram recordings are made at the central station. When heart-rate alarm goes on, recording begins automatically, provides ECG for study by patient's doctor



or cartilage with the ease of a sharp scalpel slicing through soft tissue. Furthermore, there is little danger of injury to soft tissues which are simply pushed aside.

Coronary care unit

"I felt as if I were in the control room of a space ship to Mars." Elliott Gray spoke to me of a visit to his brother in a new type of lifesaving hospital facility. "There was this steady, eerie 'beep . . . beep . . . beep'; and those things that looked like space-age TV sets with orange-colored screens with moving lines dancing up and down all across their faces (there were six or seven other patients in the

room). Then my brother's lines suddenly jumped up and down as he laughed and I felt like calling for a nurse who seemed unconcerned and, barely glanced at the screens."

This was the coronary care unit (CCU) of a large modern hospital, the latest method of caring for the victims of heart attacks. This new facility permits closer scientific individual monitoring of numerous patients at the same time than the old-time nurse-by-the-bedside ever could achieve for her one patient. Modern electronics can even warn of trouble before it starts.

Fundamentally, the heart is nothing but a powerful, muscular pump. It stimulates itself to contract (beat) to

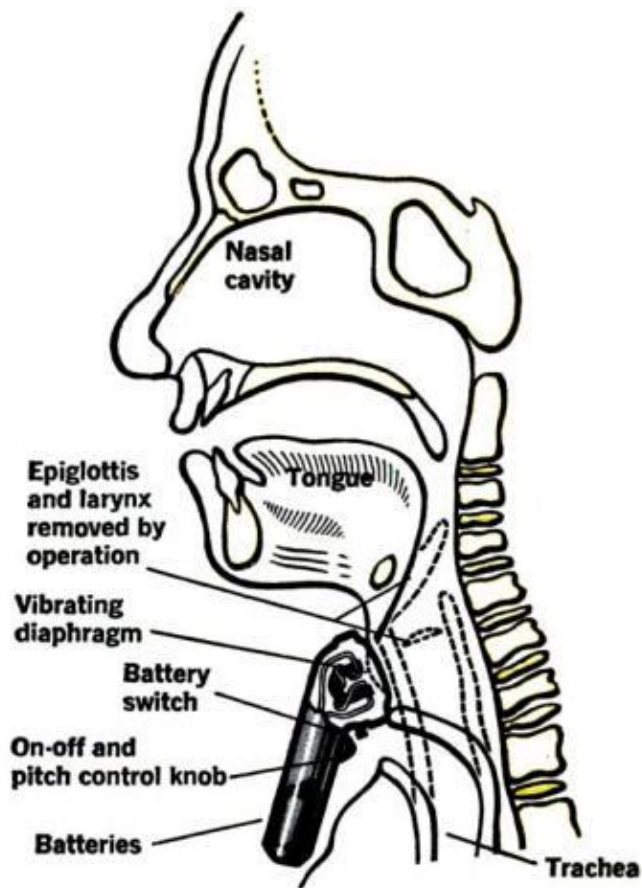

ELECTRONIC LARYNX is simple vibrating device that makes speech possible for those whose larynx has been removed (usually because of cancer.) Pressed against neck, the electrolarynx's vibrating diaphragm substitutes for the vibrations of vocal cords. Components (left) are vibrating transducer, mercury batteries and two transistors—an amplifier and an oscillator

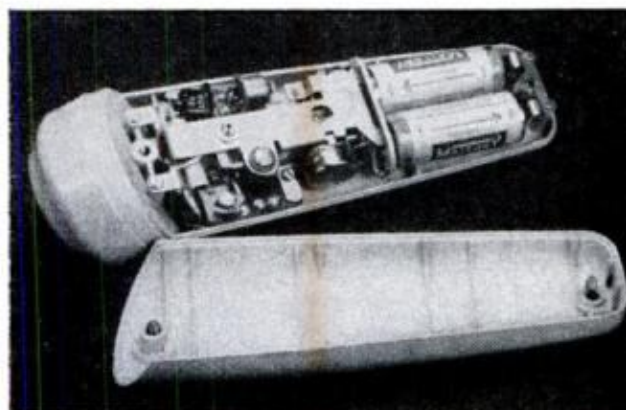

squeeze the blood out into the vessels under sufficient pressure (blood pressure) to reach and supply the most remote body tissues. These bioelectric currents, produced when a muscle contracts, can be picked up by electrodes properly placed on special areas of the skin.

Monitoring systems pick up certain body functions (bioelectric stimuli, blood pressure, respiration rate and others) and convert them into electrical signals which are then processed electronically to produce a meaningful output on various display devices. This output can appear as an electrocardiogram wave, either on a sheet of paper in your doctor's office or the oscillo-

scope of the CCU, or the meter reading on Honeywell's new Patient Monitoring Unit, or as some form of alarm—a light or a sound. The orange screen shows the electrocardiogram. Blood pressure can also be shown as a waveform and recorded by inserting a catheter directly into an artery or vein, or even the heart itself, then converting the pressure energy into an electrical analog for electronic processing. Beeps occur each time the wave on the screen shoots upward—by measuring the number of these "blips" or sharp peaks per minute, Honeywell's monitor calculates the heartbeats per minute. This rate appears on an adjoining

(Please turn to page 206)

THIS IS THE YEAR of acquisitions. Many big names in the outdoor recreation business are entering the snowmobile market in grand style. Starcraft, big in boats and recreation vehicles, is in the business as is Glasstron, now broadening its line after a hurried entry last year. Mercury is also firming up its product after a one-model start last year, and Wheel Horse has entered the field via its purchase of Sno-Flite.

Attesting to this snowballing market, recent figures show that 285,000 snowmobiles were sold last year.

It's a cinch more than that will be

sold in the year ahead. This is the year you can take advantage of new refinements in popular snowmobile lines. Prices are about the same as last year, so you'll get extra value for your dollar.

Ski-Doo this year has started a five-model "personality line." The smallest model, called the 12/3, is a full-sized machine with a 300-cc, 12-hp Rotax engine. It runs on a 15-in. track and has a suggested price of \$695. The next larger machine is the Olympique, what Ski-Doo calls the sporty machine with 15-in. track and an 18 or 24-hp engine. Suggested prices range from \$825 to \$945. Electric start is optional, starting

'70 A Sensational Year

**Big money, big names,
big technical improvements all go to
make them a big deal this fall**

By DAN FALES



SNO-JET has four new snowmobile series with 15 power choices from 12.5 to 35 hp. Prices go from \$699 to \$1349, plus freight from Quebec, Canada.

with the popular Nordic series. This 18-in. track machine comes with a 24 or 35-hp engine. The electric-start feature is standard on the higher horsepower model, which retails at a suggested \$1345.

The T'NT (Track and Trail) is the high-performance model on either 15 or 18-in. track. Engines range from 22 to 40-hp. Cost runs from \$875 to \$1345.

The Invader is Ski-Doo's big family or sportsman machine. This twin-15-in.-track snowmobile can climb through soft mountain snow and over difficult terrain. It has



SKI-DADDLER has a new series this year called the Mark models. This new AMF design is available in four models

Coming Up for Snowmobiles



ARCTIC CAT has eight models in its Panther line. Price runs from \$895 to \$1595, horsepower from 14 to 55, while 75 is available on a special order



JOHNSON'S SKEE-HORSE comes in two basic 25-hp models. This Light-Trac model sports a 15½-in. track while the Wide-Trac model has one of 20½-in.



SKI-DOO has 15 models in five series this year with horsepower running from 12 to 40. Prices go from \$695 to \$1645. Ski-Doo has race models, too



KIEKHAEFER MERCURY has seven models for '70 including this 25-hp machine with electric start. Other Merc snowmobiles include 22 and 20-hp models



EVINRUDE'S SKEETER is available in three types of machines, all with 25-hp engines. Track widths are either 15½ or 20½ in. Prices \$1025 to \$1395



WHEEL HORSE is just entering the snowmobile market with the six-model line called Safari. Wheel Horse bought the Canadian firm of Sno-Flite last April



MOTOR SKI, a subsidiary of Giffen Industries, is offering five snowmobiles in its 1970 line with a wide range of motors running from 298 to 634 cc

a 35-hp engine and costs about \$1645.

Ski-Doo also has the Blizzard—a limited-edition machine for registered racers only.

Adding four new models to its line, Kiekhaefer Mercury has seven models for 1970. The Mercury machines are available in three basic powers—25, 22

MASSEY-FERGUSON SKI WHIZ is available in three models with 18½, 22 and 29-hp engines. These machines are built with a very low center of gravity



and 20 hp. The 250 series has 437-cc, 25-hp Kiekhaefer engines with capacitor discharge ignition; comes with manual start as standard and electric start and reverse as optional. Machines have dual tuned exhaust systems with sealed mufflers and run on 17-in. tracks.

The Mercury 220 series has 399-cc, 22-hp Kiekhaefer engines with capacitor-discharge ignitions. Electric start and reverse are optional. This series is really the same as the 250 except for a lower horsepower engine and a sprocket reduction ratio of 13 to 29 instead of 16 to 29. The price is lower, too.

The Mercury 200, a smaller and less expensive version of other Mercury machines, has a 20-hp engine, 15½-in. track, 4½-in. ski width and a Salisbury variable-speed, torque-sensing clutch.

New designs of top Mercury models include six-inch-wide skis, four-leaf springs, redesigned rubber tread and direct reversing with no gearbox.

Wheel Horse entered the snowmobile

RUPP SNO-SPORT snowmobiles with aluminum chassis come in five engine classes ranging from 18 to 36 hp and with tracks either 15½ or 17½ in. wide



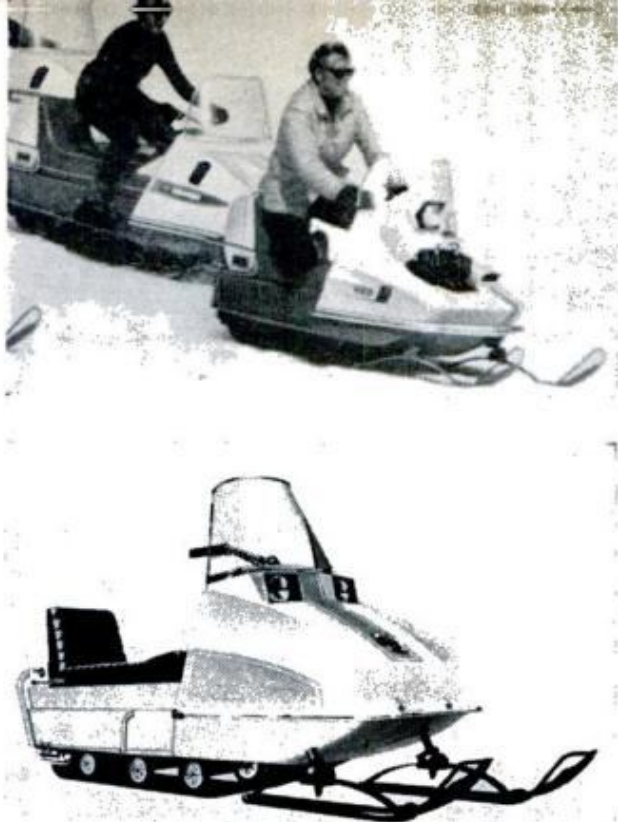

POLARIS, left, has 17 different types of snowmobiles this year. These go from the mini, 150-cc machine called Playmate up to the big 30-in.-track Voyager



STARCRAFT, above, is entering the snowmobile business this year with nine models from 15 to 31 hp. Suggested prices run from \$750 to \$1260

FOX TRAC has 10 different snowmobile models which range in horsepower from 15.5 to 55. These machines are available on either 15 or 18-in. tracks

market with its purchase of the Sno-Flite snowmobile company last April. This famous power-equipment maker has named its machine Safari. Six models range from 295 to 440cc and from 18 to 30 hp. All have 15-in. tread except the 20-hp model with 22-in. tread. Prices are \$845 for the Safari 295 (18-hp); \$995 for Safari 309 (20-hp); \$1195 for the 309W (wide track); \$1065 for the 335 (23-hp); \$1125 for the 339 (26-hp); \$1195 for the 440 (30-hp).

Evinrude's snowmobiles for 1970 all
(Please turn to page 236)



ALLOUETTE has nine different machines available, running from the large 26-hp, 18-in.-track machine down to a more modest 14-hp, 15-in.-track version

YAMAHA is offering three basic snowmobile models. The machines have 24, 27 and 36-hp models with 15 and 18-in. tracks, cost from \$895 to \$1075

SCORPION is presenting five models with 14 engine options in its new Mark series. Sizes of 275 to 800 cc are available. Tracks are 15, 18 and 28 inches



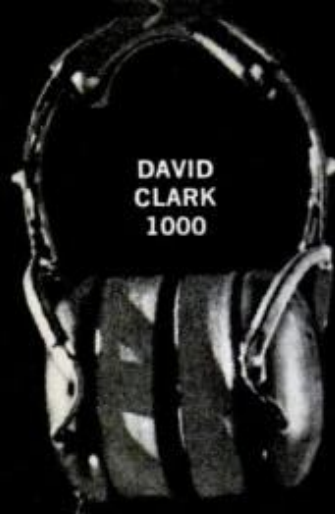

DAVID
CLARK
1000



DAVID
CLARK
300



SENNHEISER
HD-414



SUPEREX
ST-PRO-B

WIDE RANGE of stereo headphones gives you many types to choose from, all the way from under \$10 to almost \$100. Some of most popular models are shown on these pages. Prices are: Telex Encore, \$9.95; David Clark 300, \$19; AKG-Norelco K-20, \$19.95; Realistic Custom Pro, \$21.95; Koss K-6, \$26.50; Pioneer SE-30, \$29.95; Sennheiser HD-414, \$29.95; Superex ST-Pro-B, \$50; Clark 1000, \$85; and Koss ESP-6, \$95



REALISTIC
CUSTOM PRO



INDIVIDUAL VOLUME CONTROLS on some earphones let you adjust the sound level separately for each ear to provide a balanced stereo effect. Some models also incorporate tone controls. These Model H-876 headphones sell for \$19.95 from Allied

FOR TOPS IN HI-FI LISTENING:

Now It's Back

They went out with cat-whisker radios only to return as one of today's biggest-selling hi-fi accessories. Here's why they're back in style

By HANS FANTEL

Photos by Robert D. Borst

EARPHONES HAVE BEEN as extinct as dinosaurs for nearly half a century since the first loudspeakers made their appearance in the 1920s. Yet suddenly they're back in style. Sales are jumping so fast that many audio dealers consider them the hottest thing in hi-fi sound.

What accounts for the amazing revival of these

TELEX
ENCOREKOSS
ELECTRO-
STATIC
ESP-6KOSS
K-6AKG-
NORELCO
K-20PIONEER
SE-30

to Earphones Yet!

ancient relics? Basically, there are three reasons: They sound good, sell cheap and give you something hard to come by these days — instant privacy. Today's earphones — or headsets, as they're often called — are as different from their ancestors as modern solid-state stereo FM receivers are from early crystal radios. Earphones now rival the fidelity of the best loudspeakers, yet the price of a good pair is only a fraction of the cost of a good speaker. With many excellent models selling for around \$30 or less,

they offer fine sound at a real bargain.

As for instant privacy, just try it. Slip on a pair of earphones and you are whisked magically away from all the petty distractions of our bustling, noisy life. Gone is the rumble of the air conditioner or furnace, the clatter in the kitchen, the annoying chatter of someone talking on the telephone. You feel removed from the scene — alone with the music.

The privacy works both ways. It also makes life peaceful for others in your

home. You can crank up your Tijuana Brass loud and sassy without anybody yelling "Turn that darn thing down!" Great orchestral climaxes can roll out with their full vibrant power while everyone else is sleeping. The music is yours alone.

The first time you put on a stereo headset, it can be startling. Because the sound is piped directly to your ears, it skips the acoustic quirks of your living room. Problems like speaker placement and proper stereo listening location are automatically bypassed. The music reaches you exactly as it was recorded in the studio or concert hall. The effect is uncanny—you feel as if the whole concert stage is right in your head.

While you can use headphones for monaural listening, they are at their best on stereo recordings and broadcasts. Because each earpiece plays one stereo channel, the relationship between the two channels is always the same no matter where you sit or how you move around. The right channel is always on the right and the left on the left, and both sources are always the same distance from your ears.

Early earphones were nothing but primitive telephone receivers—and sounded that way. Today's designs are like miniature high-fidelity speakers. Each earpiece consists of a coil suspended in a magnetic field, connected to the output of the amplifier. The signal from the amplifier changes the magnetic attraction and repulsion between the coil and magnet, so the coil bounces back and forth in rhythm with the musical waveform. Attached to the coil is a plastic diaphragm—the cone—which pushes on the surrounding air to transmit audible sound vibrations to the ear.

The moving parts—coil and cone—must be carefully designed for minimum inertia. If they are sluggish to move, they can't keep up with the nearly 20,000 back-and-forth trips per second that spell out the top frequencies of the musical spectrum. A slow-moving cone would jiggle out of

CONVENTIONAL SINGLE-CONE EARPHONE

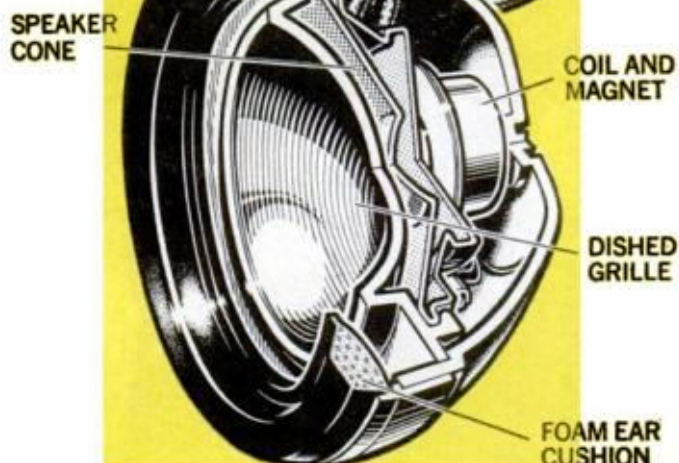

Technical Art by Peter Trojan



step with the musical waveforms and thus cause distortion. Moreover, the cone must be free from any resonance of its own. Otherwise, it might rattle like a window pane when a certain note is struck. Ideally, it should respond evenly to all the notes within the musical range.

While most earphones are similar in basic design, there are some interesting departures. Two manufacturers, Superex and Sharpe, put two separate coil-and-cone units into each earpiece in some of their models. One unit handles the low range; the other specializes in treble. The idea is to duplicate in earphones the separate functions

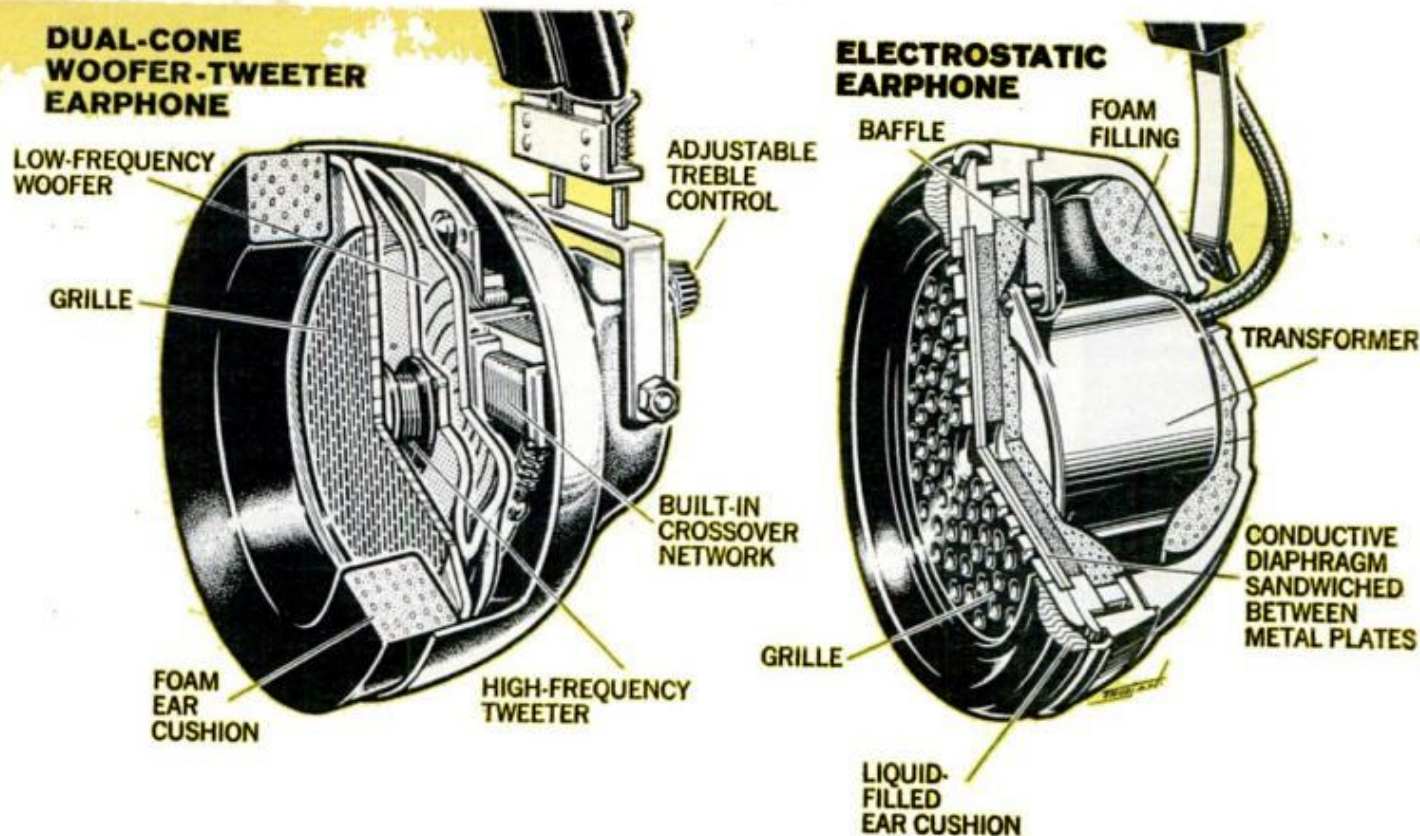

THREE BASIC TYPES of earphones are shown here. Most common is single-cone design on opposite page, consisting of a miniature coil-and-magnet speaker about 3 inches in diameter. Tiny speaker is able to deliver good sound because it feeds vibrations directly to ear and has to move only a small air volume. Dual-cone model above contains separate woofer and tweeter, designed to divide high and low frequencies for more efficient reproduction. Most radical departure is Koss's electrostatic design at right. Instead of a conventional coil and cone, it has a conductively coated plastic diaphragm stretched between two electrically charged metal plates. Diaphragm moves back and forth as the electrostatic attraction between the plates varies according to changes in the musical signal. This produces matching sound vibrations carried to the ear



that woofer and tweeter perform in loudspeakers.

One of the latest innovations in earphone design is an entirely new principle recently introduced by Koss. Instead of the magnet, coil and cone system, their Model ESP-6 has a thin, conductive diaphragm stretched between two electrically charged metal plates. Variations in the musical signal cause the diaphragm to be attracted first to one plate and then the other. It thus moves rapidly back and forth between the plates, creating sound vibrations that duplicate the musical signal.

Because the diaphragm is thin and light, it responds quickly and faith-

fully to changes in the signal. Also, the driving force is applied evenly over its entire surface so it never flaps or buckles in its rapid reverses. That's why extremely low distortion is claimed for this unique design.

Competition is keen. Nearly a dozen manufacturers are now making high-quality stereo headsets, foremost among them Koss, Telex, Superex, Pioneer, AKG-Norelco, Clark, Sharpe and Sennheiser. Big mail-order houses like Allied, Lafayette and Radio Shack also market headsets under their own brand names. Prices range from \$9.95 for the Telex Encore up to \$95 for the Koss ESP-6 electrostatic model, with many

BUYING GUIDE TO STEREO HEADPHONES

MANUFACTURER	APPROX. PRICE RANGE OF MODELS	MANUFACTURERS' ADDRESSES
AKG-Norelco	\$19.95-\$39.95	North American Philips Co., 100 E. 42nd St., New York, N. Y. 10017
Allied Radio	\$11.95-\$34.50	Allied Radio, 100 N. Western Ave., Chicago, Ill. 60680
Beyer	\$85.00*	Gotham Audio Corp., 2 W. 46th St., New York, N. Y. 10036
David Clark	\$19.00-\$85.00	David Clark, Inc., 300 Franklin St., Worcester, Mass. 01601
Jensen	\$24.95*	Jensen Mfg. Div., 5655 W. 73rd St., Chicago, Ill. 60638
Koss Electronics	\$24.95-\$95.00	Koss Electronics, Inc., 2277 N. 31st St., Milwaukee, Wis. 53208
Lafayette Radio	\$7.95-\$29.95	Lafayette Radio, 111 Jericho Turnpike, Syosset, N. Y. 11791
Pioneer Electronics	\$19.95-\$49.50	Pioneer Electronics, 140 Smith St., Farmingdale, N. Y. 11735
Realistic	\$11.95-\$21.95	Radio Shack, 730 Commonwealth Ave., Boston, Mass. 02215
Sennheiser Electronics	\$29.95*	Sennheiser Electronics Co., 500 Fifth Ave., New York, N. Y. 10036
Sharpe Instruments	\$19.95-\$100.00	Sharpe Instruments, Inc., 955 Maryvale Drive, Buffalo, N. Y. 14225
Sony/Superscope	\$27.50-\$29.50	Sony/Superscope, Inc., 8150 Vineland Ave., Sun Valley, Calif. 91352
Superex Electronics	\$19.95-\$50.00	Superex Electronics Corp., 4-6 Radford Place, Yonkers, N. Y. 10701
Telex	\$9.95-\$60.00	Telex Corp., 9600 Aldrich Ave. South, Minneapolis, Minn. 55420

*Only one model available.



CHAIRSIDE CONTROLS let you plug in headphones and adjust volume and balance without leaving your seat. Models above are (clockwise from lower left): Realistic, Superex, Koss T-5, Koss T-10, Allied and (at center) Heathkit. Other accessories are impedance-matching transformer (lower center) and dual-jack adapter cord



excellent models clustering in the \$20 to \$30 bracket.

Many listeners are amazed at the full bass obtained from earphones because of their extremely small size. Ordinary loudspeakers have to be fairly large for adequate bass response because they must push a large volume of air to project bass energy into a room-size listening space. But the "listening space" to be filled by earphones is only the tiny air volume between the phones and your eardrums. With earphones fitting snugly over the ears, this small air space is sealed off and represents what engineers call a "closed system." This provides a practically loss-free transfer of the low-frequency energy between earphone and eardrum—something like hollering down a tube. Under such conditions, a small sound generator can produce whumping big bass.

Just like loudspeakers, stereo headsets often have their own individual tone coloration. Some sound crisp and brilliant, others more mellow and velvety. Before you buy one for your own use, compare different makes and models just as if you were buying a pair of speakers. Clarity is the most important factor to judge by. Make sure the sound doesn't blur, even at full volume. Try to pick out the individual instruments in the or-

(Please turn to page 208)



The 'Shark' thrives on New York's trash piles

Without even a mild burp, the "Shark" recently demonstrated its ability to chew up such solid castoffs as old refrigerators, appliances and furniture. The \$25,000 German-built garbage truck was tested by the New York City Sanitation Dept.



In you go, head down

New automobiles may soon be shipped from the factory hanging nose down in a special rail car that saves space and speeds the job of loading and unloading. Developed jointly by General Motors and the Southern Pacific, the Vert-A-Pac car is designed especially for compacts that are short enough to be stood on end. The sides of the car swing down to form ramps. As each automobile rolls onto a ramp, its wheels drop into wells and hooks engage the underframe, automatically locking it in place. The ramp is then swung back up by a fork-lift truck. The vertical stacking arrangement accommodates 30 small automobiles compared to the 8 to 15 carried on a conventional rail transporter.

OCTOBER 1969



Husky road-and-railer

The Unimog, built by Mercedes-Benz, is a road and rail machine that can shunt 300-ton loads when it's on railroad tracks.



Buccaneer's halo

Humidity in the air caused this unusual cloud halo to form around a Royal Navy Buccaneer during a high-speed, low-level pass near the plane's carrier, the HMS Eagle.

151



Helicopter with an escalator

All that the passengers have to do is hold on in order to ride this "escalator to the sky." A powered ladder on the Chinook helicopter, moving five feet per second, can lift or lower 20 men in four minutes.

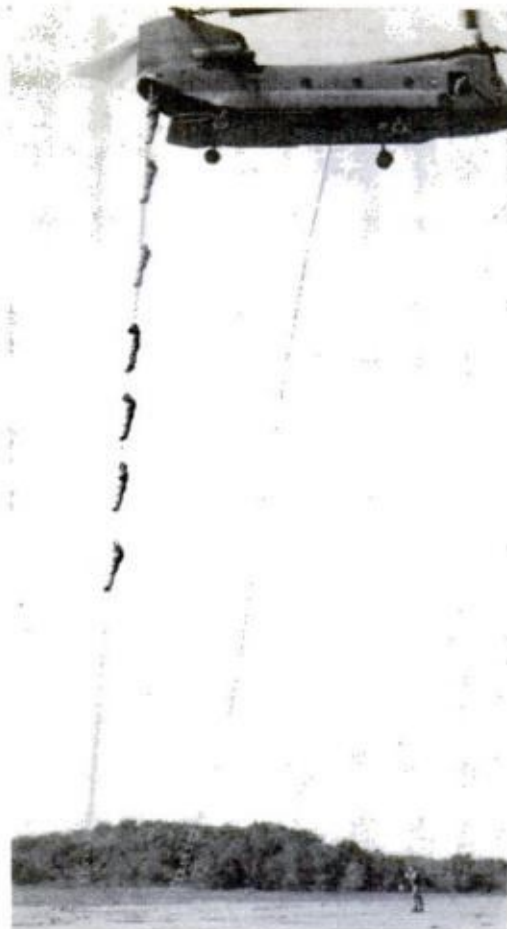

Mobile greenhouse

Walter Finch of England has found that his parked car, heated by the sun, is a perfect greenhouse for starting vegetables, flowers.



Lock-on parking ticket

Yokohama police make it impossible for a motorist to throw away a parking ticket. They lock it in place on his car.

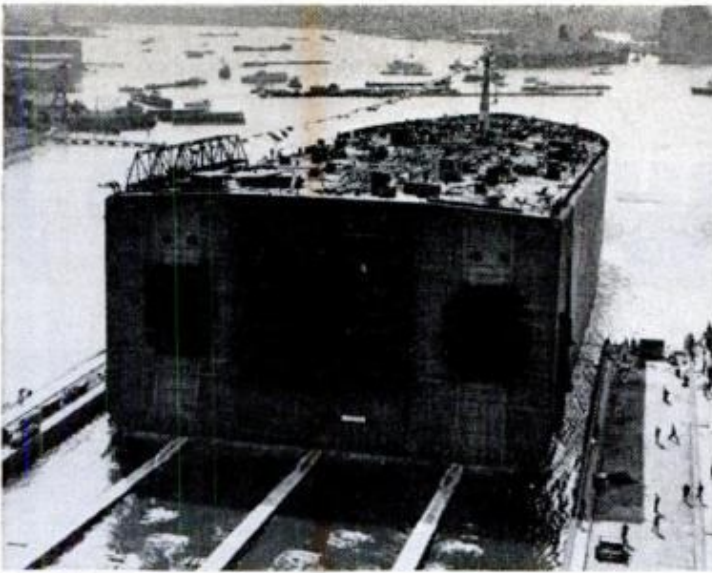

Two-piece ship is welded together while afloat

Lacking space to assemble the 1066-foot-long *Melania*, the N.D.S.M. shipyard in Amsterdam built it in halves, floated the halves (upper left) and welded it together in the water (upper right). The tricky job of aligning the separate halves was accomplished by ballasting each of them, then adding a U-shaped "tunnel" under the hull to hold the alignment.

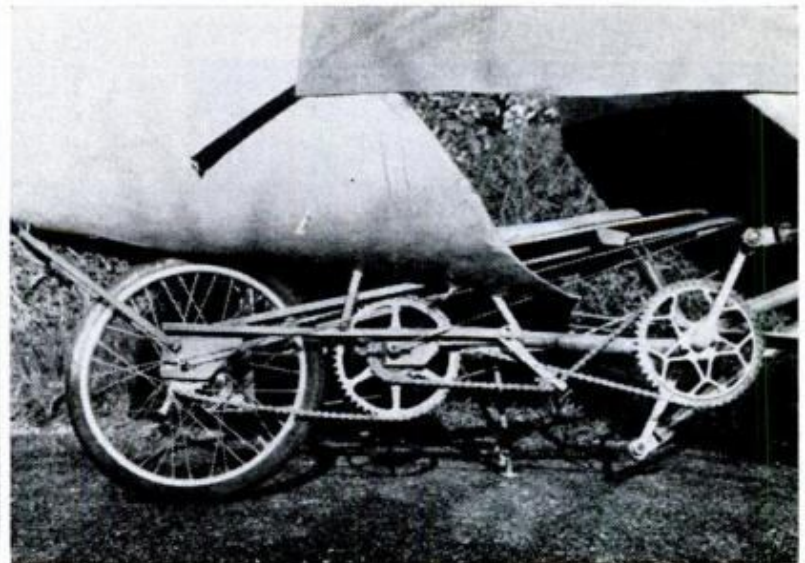

Speedy, two-wheeled egg

W. G. Lydiard, British aircraft engineer, has designed a plastic-enclosed bicycle that's driven 6 mph faster than standard bikes through a chain and pull-rod system.

HOW TO STOP A

When your engine continues running after you turn off the ignition, you have to follow a checklist that includes accurate timing and carburetor adjustments to stop it.

By MORT SCHULTZ

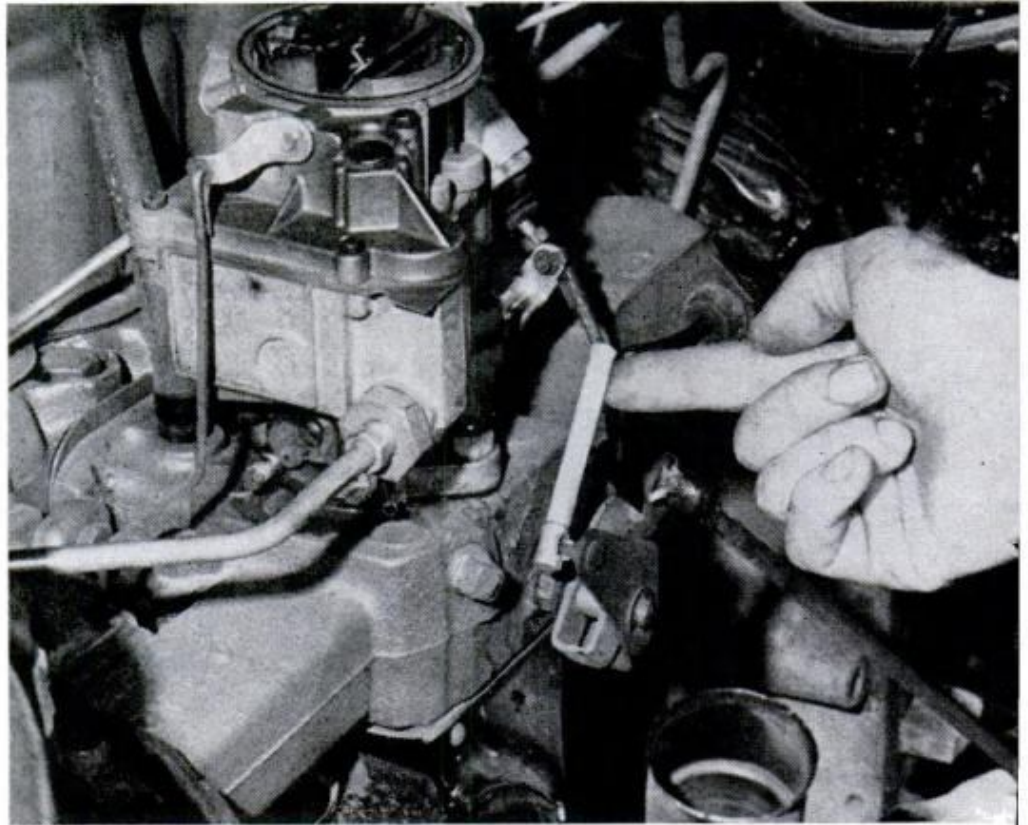

EXCESSIVE FUEL getting into cylinders contributes to dieseling. Check that the linkage is not keeping the throttle plate open wider than it should be

EXCESSIVE HEAT also contributes to dieseling. Periodic lubrication of the manifold-heat-control valve will keep it free and keep temperature down



MILLIONS OF OWNERS of '68 and '69 cars are asking why their engines keep running after they turn off the ignition. The condition, called after-running, dieseling, run-on or self-ignition, occurs when combustion-chamber temperature gets hot enough to ignite fuel which has flowed into the cylinders.

Dieseling is common in newer cars because of the calibrations that have to be maintained with new anti-air-pollution hardware. Exhaust-emission systems require strict compliance with tight idle-speed and ignition-timing adjustments. Unfortunately, a slight variation from specs results in a situation conducive to dieseling.

Late-model engines operate on lean

DIESELING ENGINE

fuel mixtures so automakers can keep noxious emissions within allowable limits. A lean mixture contributes to rough idling. To prevent it, the "curb" idle speed has to be set pretty high—600 to 700 rpm is normal in '68 and '69 cars.

Don't confuse curb-idle speed with fast-idle speed. The latter is the idle setting for a cold engine with the choke closed. The fast-idle screw is positioned on the high step of the fast-idle cam to allow faster warmup. The specification is about double the curb-idle speed, which is idle rpm with the engine warm and choke open.

However, a curb-idle rpm of 600 to 700 is high. To permit it, the carburetor throttle plate is open fairly wide. This gives fuel more of a chance to flow through the carburetor idle system and into the cylinders. Dieseling occurs when the engine's shut off and this raw fuel is ignited inside the cylinders.

No spark is needed to ignite this fuel. Cylinder temperatures are high enough to do it: A lean fuel mixture burns faster than a rich fuel mixture. To compensate for this, ignition timing of 1968 and 1969 cars has been retarded more than ever, and burning of the fuel mixture proceeds well into the power stroke. Since the fuel mixture burns late, the removal of combustion-chamber heat through the exhaust stream is also retarded, and temperatures get hot enough inside cylinders to cause after-running.

To control dieseling, either the fuel flow into the cylinders or the heat (or both) has to be kept at a pitch where it can do no harm. The throttle-plate setting and the adjustment of ignition timing play the most significant roles. However, there are other factors to consider.

For example, if you keep your foot on the gas pedal as you turn off the ignition, you contribute to dieseling by keeping the throttle plate open more than it should be.

An obstruction might be holding the

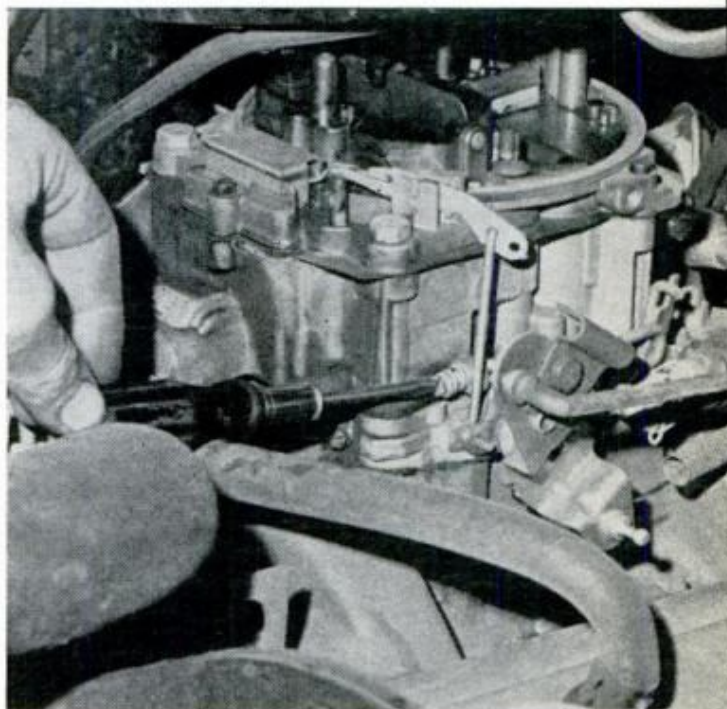

CARBURETOR ADJUSTMENTS include fast-idle setting that's right on specification. Turn the fast-idle screw until tachometer reads the correct engine rpm

IDLE-STOP SOLENOID on some newer cars operates a plunger that retracts to allow the complete closing of the throttle when the ignition is turned off

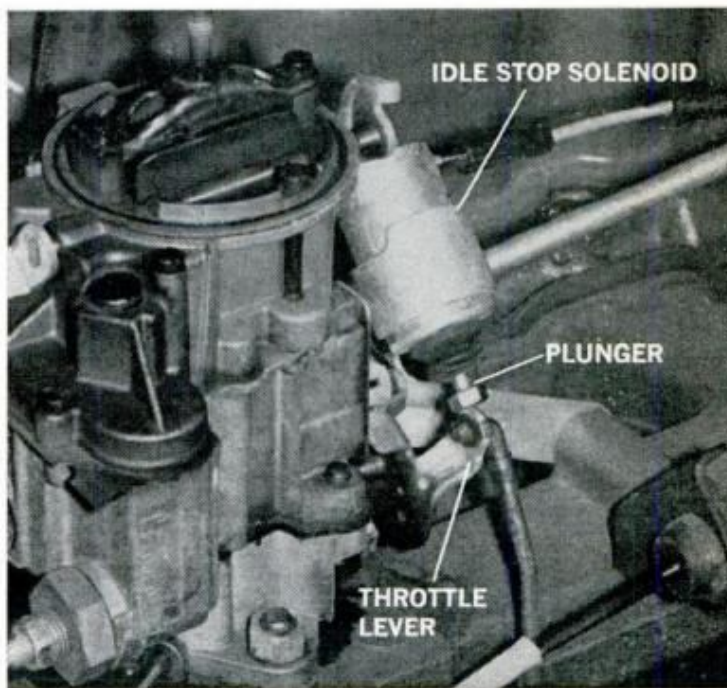

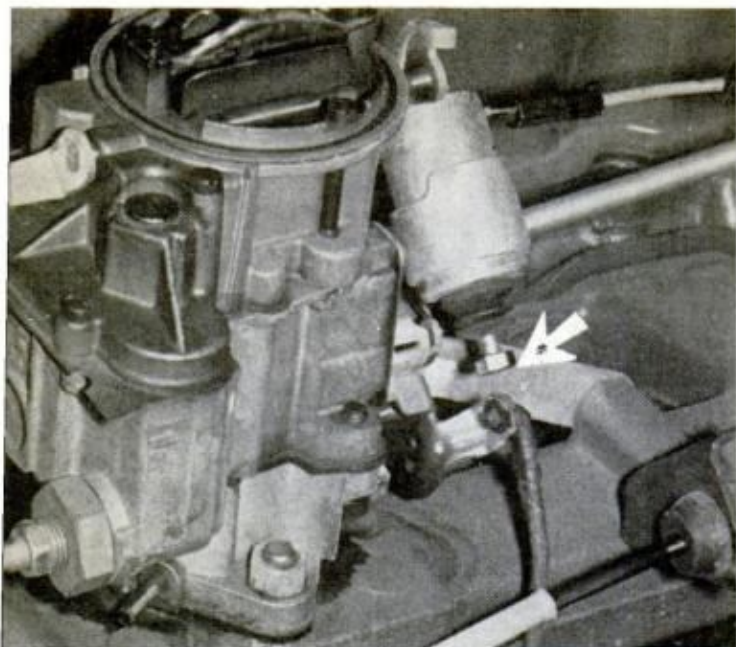

PLUNGER of the idle-stop solenoid remains in a fixed position just as long as the engine is running. Throttle linkage only comes in contact at idle

throttle plate open. Check that the throttle linkage is not binding or damaged.

Check the manifold-heat-control valve. If it is stuck, hot exhaust gases will be trapped and engine temperature will rise. Find this valve beneath the exhaust manifold and test its operation by jiggling the counterweight. If the valve is stuck, tap it with a hammer and lubricate with manifold-heat-control-valve lubricant. If the valve can't be freed, replace it.

As mentioned, what you have to do most times to stop dieseling is to assure correct curb-idle speed and proper ignition timing. Check these when dieseling occurs and set to specifications given in the manual. On most 1968 and 1969 cars, these specs are also on a label attached to the top of the radiator or grille.

In setting curb-idle speed, note that the idle-mixture adjusting screws on your carburetor probably have plastic caps on them. These caps (one if you have a one-barrel carburetor) control richness of fuel mixture by limiting travel of the screws.

Although specifications vary from car to car, the curb-idle adjustment is pretty much the same. Warm up the engine to normal operating temperature, making sure that the choke is released. Cars with manual transmission are placed in neutral; those with automatic transmissions, in drive. Set the handbrake firmly.

Hook up an engine tachometer and turn the idle-speed screw until you get the rpm reading for your engine. Turn

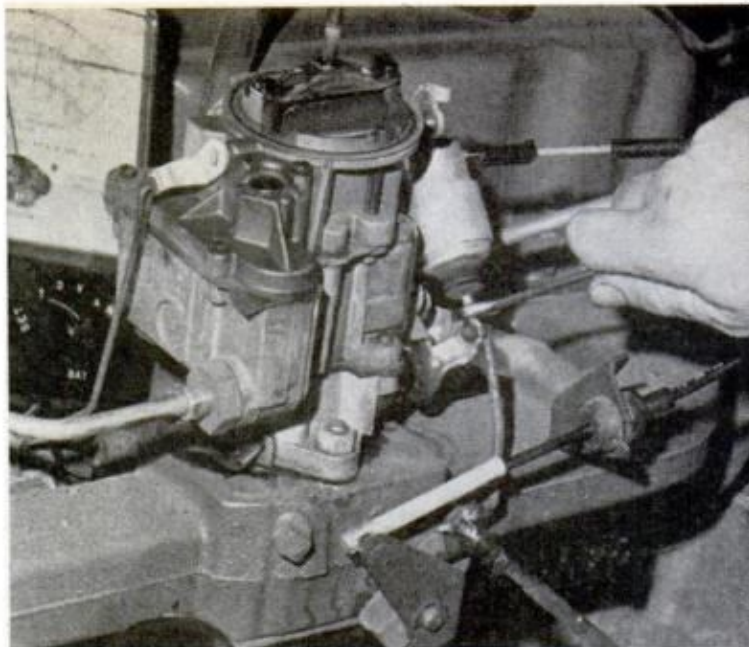

IDLE SPEED of engine equipped with idle-stop solenoid is adjusted by turning the plunger against or away from the throttle linkage to get right rpm

the idle mixture screw until the tachometer shows the highest rpm you can get.

Now, skip back to the idle-speed screw and readjust until the tach again shows the correct rpm reading for your engine.

If you're lucky, you will have an innovation on your carburetor known as an idle-stop solenoid. This provides for immediate and full closing of the throttle valve as soon as the ignition is shut off.

Automakers claim after-running will not occur if idle speed and timing are kept properly adjusted. However, this solenoid assures that dieseling won't occur even if they do go out of adjustment.

In operation, the plunger of the idle-stop solenoid holds itself against the throttle-plate lever while the engine idles. This keeps the throttle valve open. But as soon as ignition is turned off, cutting current to the solenoid, the plunger retracts and the throttle valve snaps shut.

Checking the function of the idle-stop solenoid is easy. Warm up the engine and let it idle. Look at the solenoid's plunger. It should be resting against the throttle-plate lever. Now, shut the engine off and watch the plunger. You should see it retract to allow the throttle valve to close. Failure of the plunger to act this way means that the solenoid is defective. There is no idle adjusting screw on a carburetor that has an idle-stop solenoid. Idle is set by adjusting the position of the solenoid plunger.

Idle the engine and turn the plunger

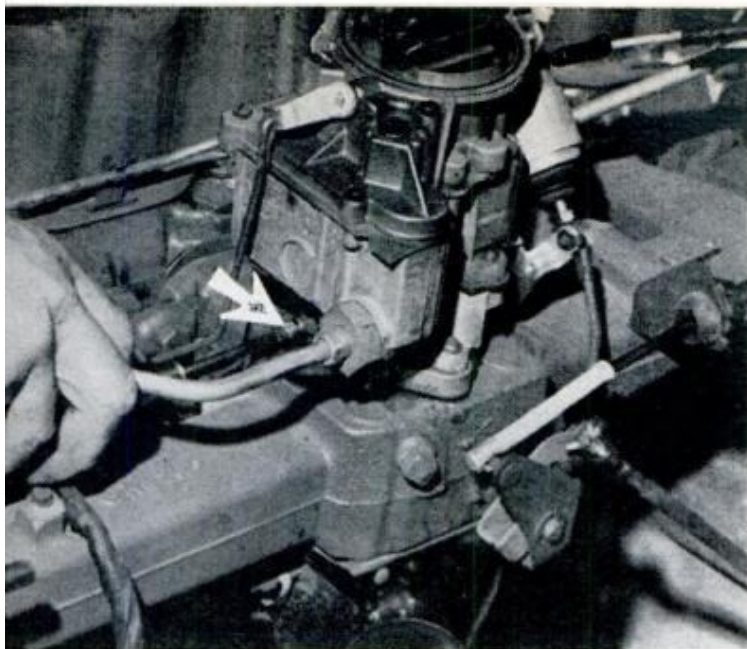

IDLE-MIXTURE SCREW on carburetor is adjusted as part of curb-idle speed setting. Newer cars have a built-in stop to prevent too rich an adjustment

until the tachometer records the curb-idle rpm specification for your engine. Other than this, setting idle on your car is done the same as described before.

Timing—that other critical adjustment—is done with a timing light. Disconnect the spark-advance unit vacuum line and run the engine at idle.

Timed pulses of the timing light will make the timing mark on the crankshaft pulley or vibration damper appear stationary if the correct mark is in alignment with the pointer. If the mark is not aligned, loosen the distributor and turn it against rotor rotation to retard timing. Tighten the distributor housing and recheck.

If dieseling should strike your engine, you should stop it immediately to prevent undue strain on parts. If the car's equipped with a manual transmission, "stall" the engine by engaging the brake, and releasing the clutch. If the car has an automatic transmission, engage the brake and put the transmission selector lever into drive.

Dieseling, incidentally, is not the same as detonation or preignition. These are far more serious, since either can ruin pistons and rings.

Detonation is the uncontrolled burning of the fuel mixture at the time of or immediately after ignition. Combustion is so rapid that rising pressure causes shock waves to reverberate through the cylinder and they produce an audible noise.

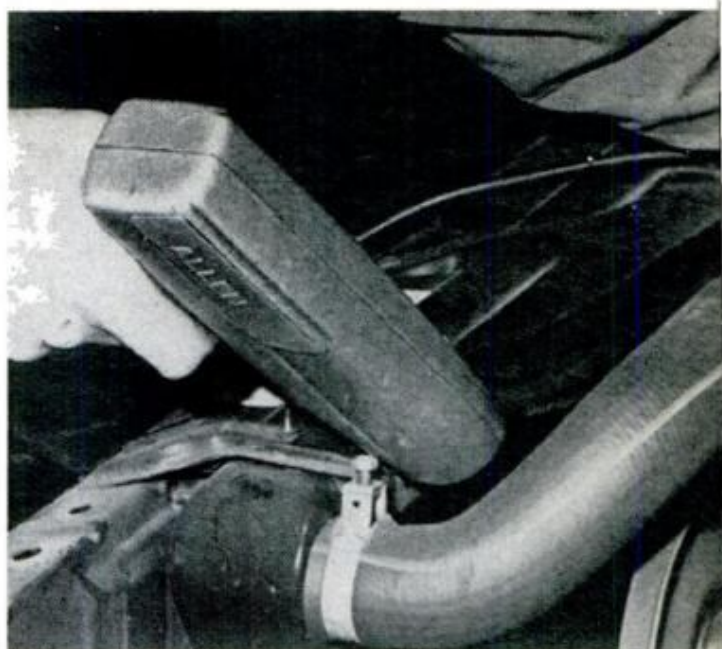

ENGINE TIMING with exhaust emission controls must be accurate. Timing light, shown here aimed down at timing marks on pulley, gives best reading

Detonation results from using a poor grade of fuel, having the carburetor set for an excessively lean fuel mixture and having ignition timing overadvanced. If switching gasolines, and adjusting timing and carburetion don't help, the cause is carbon particles on a piston or the cylinder head. They produce "hot" spots which are igniting the fuel. A carbon-and-valve job is the solution.

Preignition is igniting of the fuel mixture before normal ignition takes place. This occurs when the piston is still in its compression stroke. It causes extremely high combustion chamber temperatures—in fact, hot enough to burn a hole right in the top of a piston.

Preignition is caused by combustion chamber deposits, combustion chamber "hot" spots resulting from poor heat dissipation by the surrounding cooling jackets and use of wrong heat-range sparkplugs.

Preignition, like detonation, causes engine knock or ping. However, it's difficult to tell which one is causing the noise. For this reason, the procedure to follow when you start hearing noise from inside the engine should be the same:

- Switch to a better grade of gas, and set carburetion and ignition timing.
- Check sparkplug condition and the heat range.
- If the condition doesn't clear up, clean out the engine deposits by doing a carbon-and-valve job. ★★★

NEW IN

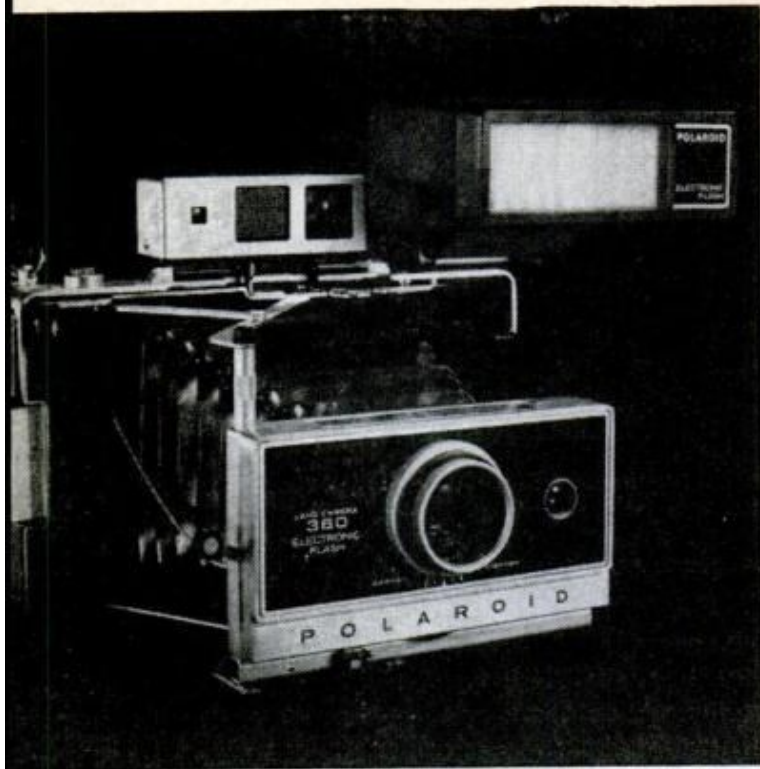

FIRST ELECTRONIC-FLASH POLAROID is this new Model 360 with a clever brightness control. The flash clips to the top of the camera and is interlocked with the focusing bar so its light intensity varies automatically with subject distance. As shown in the drawings, tiny louvers open wide on distant shots, then close as you focus on nearer objects to reduce the flash's brilliance. For recharging, the flash fits onto a small plug-in charger shown at upper right. For natural-light shots, there's also an electric-eye exposure control. A timer on the back (photo on facing page) tells you when film is developed so you don't have to bother counting. The camera takes color or black-and-white, sells for \$199.95.

ADDING SOUND TO SLIDES is easy with this accessory tape-recording unit designed to sit on top of Kodak Carousel projectors. Each slide fits

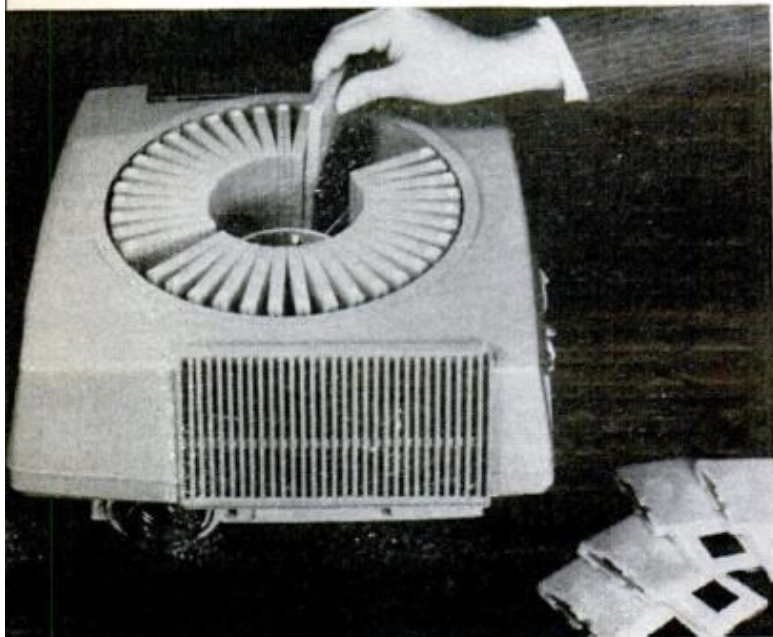

158

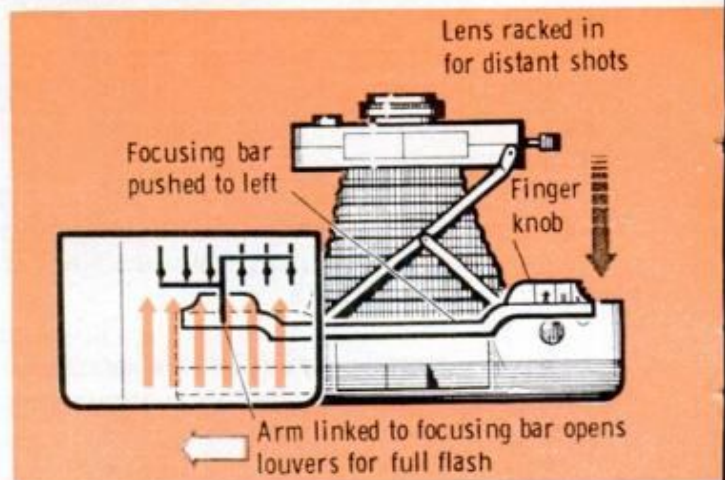
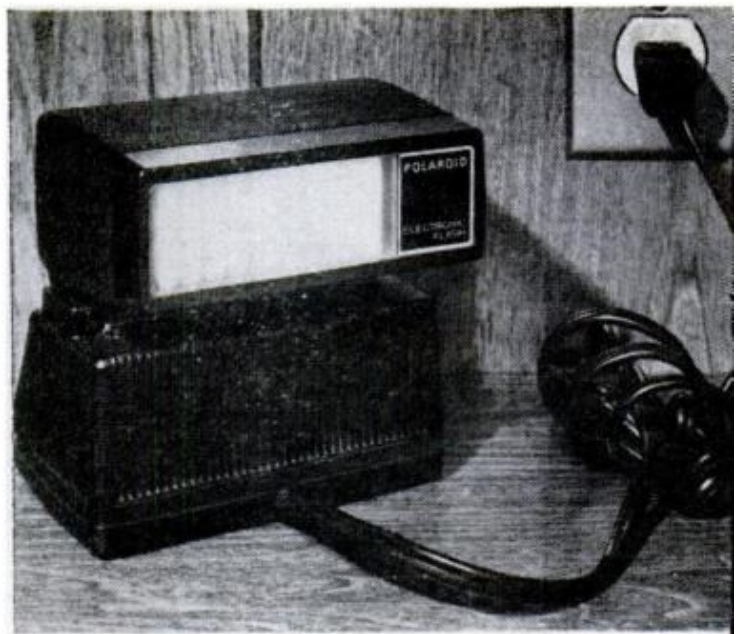

into a plastic holder that also contains a miniature tape cassette. The cassettes ride in the upper rotary tray, while the slides hang down into the conventional projector tray underneath. As each slide is projected, up to a minute of home-recorded commentary plays automatically. The new attachment, developed by The Kalart Co., Inc., Plainville, Conn., will sell for \$325.



POPULAR MECHANICS

PHOTOGRAPHY

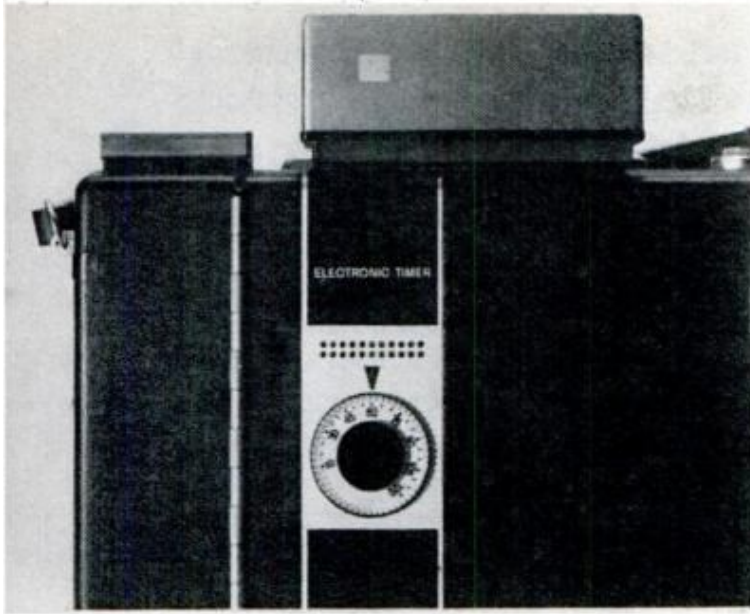

IT TAKES ONLY 15 MINUTES to recharge nickel cadmium batteries used in Honeywell flashguns with the Rapid Charger below—an overnight job before. Battery clip (at right in upper photo) is removed from the gun and inserted in top of the charger (lower photo). With a spare clip, you can have unlimited flashes, using one as other is charging. Charger can be used with Honeywell Strobonar 700 and 770 guns and sells for \$39.95.

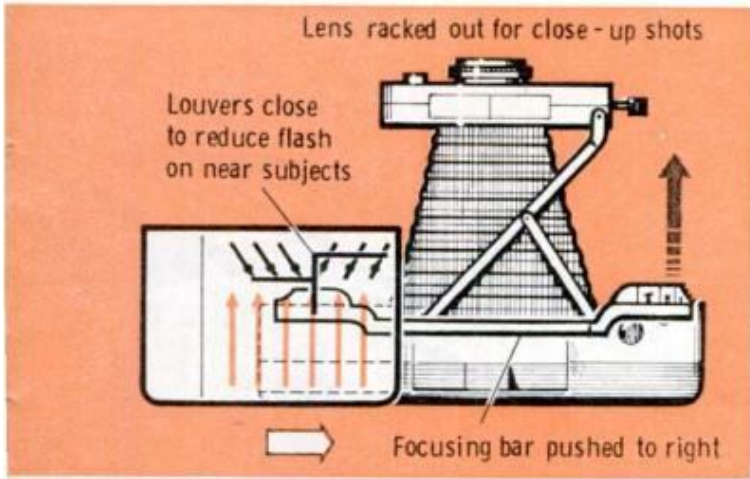

NEW CARTRIDGE-LOADING movie projectors from Kodak take the fuss out of threading and rewinding Super-8 film. You just drop in a cartridge and the film threads by itself onto the takeup reel, then rewinds automatically

back into the cartridge. Cartridges (left, below) come in 50 and 100-foot sizes. Two Instamatic projectors are the M105 at right for Super-8 film at \$139.50 and M109 at left for either Super-8 or regular 8 film at \$159.50.

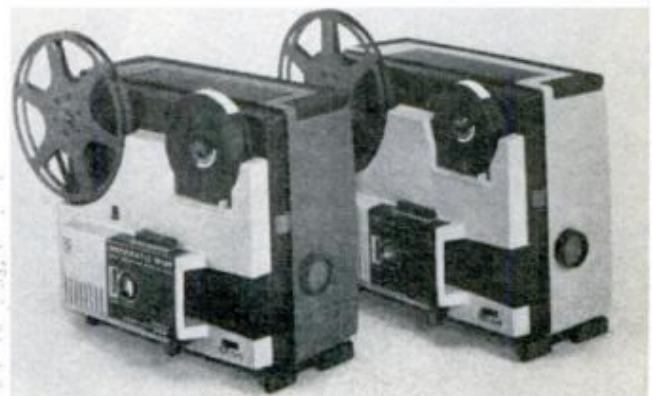
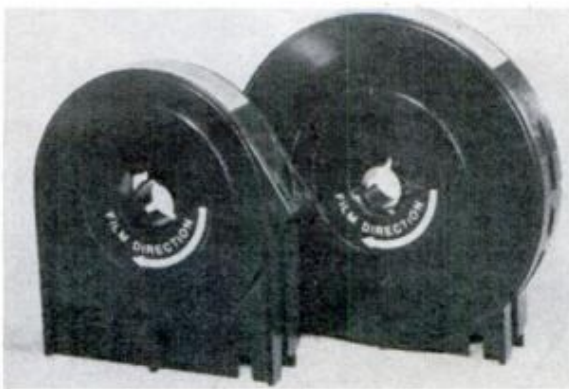

ZOOM YOUR WAY TO BIGGER,

Handy variable-range zoom lenses, now available at moderate prices, can replace half a dozen separate lenses. Here's what they do and how to shop for one

By PHIL GERACI

Technical Art for PM by Fred Wolff

IT'S THE START of the big game and the players are lined up for the kickoff. You back off on your lens to get a full view of the field. As the ball sails through the air, you quickly switch to a medium-range focal length to pick up the receiver as he makes the catch.

Finally, you zoom in real close for a dramatic shot of the runner as he goes down under a mass of tacklers.

In the space of a few seconds, you've made three separate pictures, all at different focal lengths, all showing different types of action and all shot from the

SECRET OF A ZOOM lies in a set of movable lens elements that slide back and forth, as shown in this cutaway view. As these move backward, they increase the focal length, enlarging the image on the film to give you dramatic close-ups. Moving them forward decreases the focal length, making the image smaller but including more of the scene in your picture. At the same time, the "focus compensator" lens also moves back and forth slightly to keep the image sharp so you don't have to refocus. Drawing is patterned after Vivitar lens, typical of many high-quality, moderate-priced zooms now available

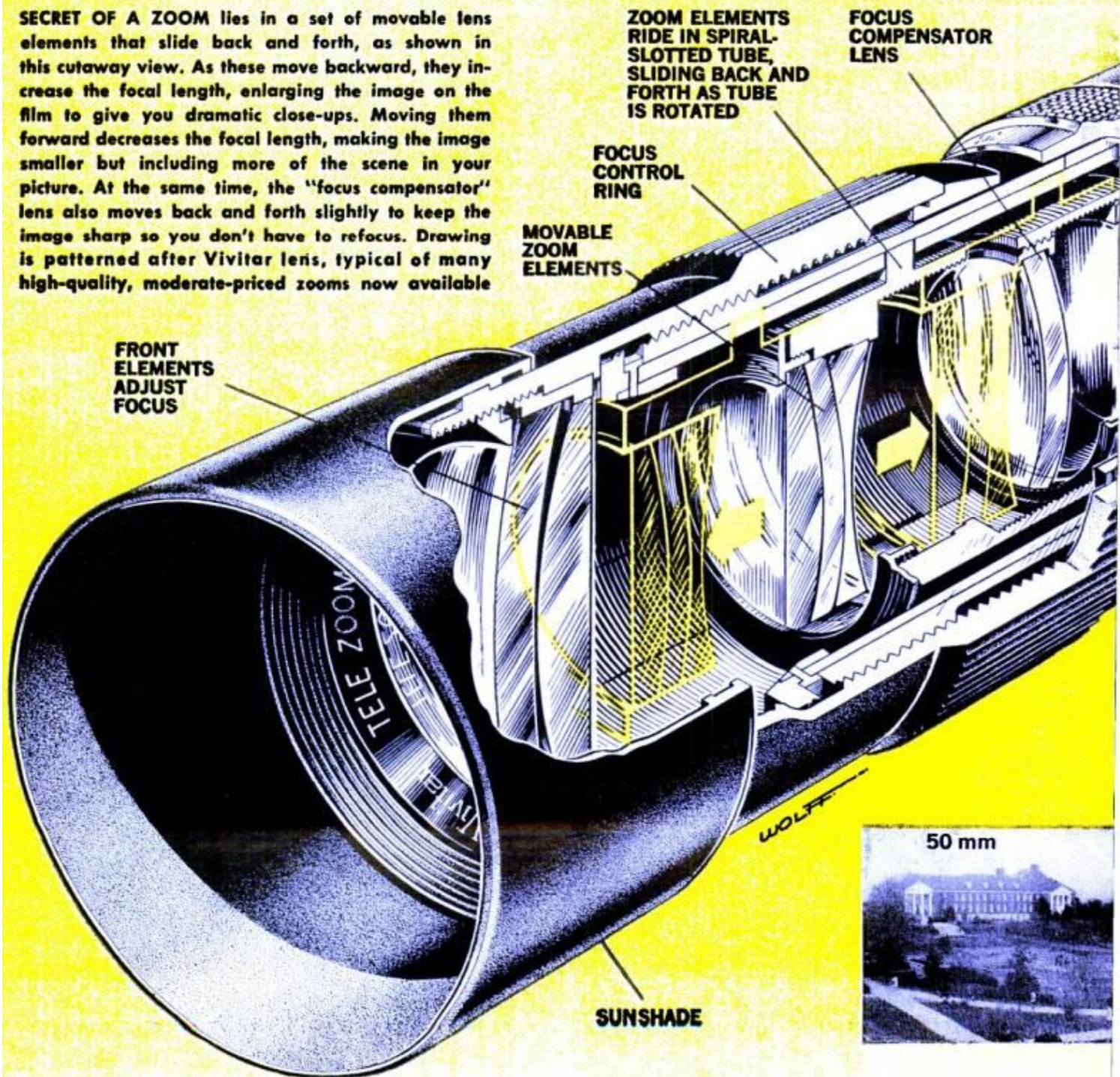

BETTER PICTURES

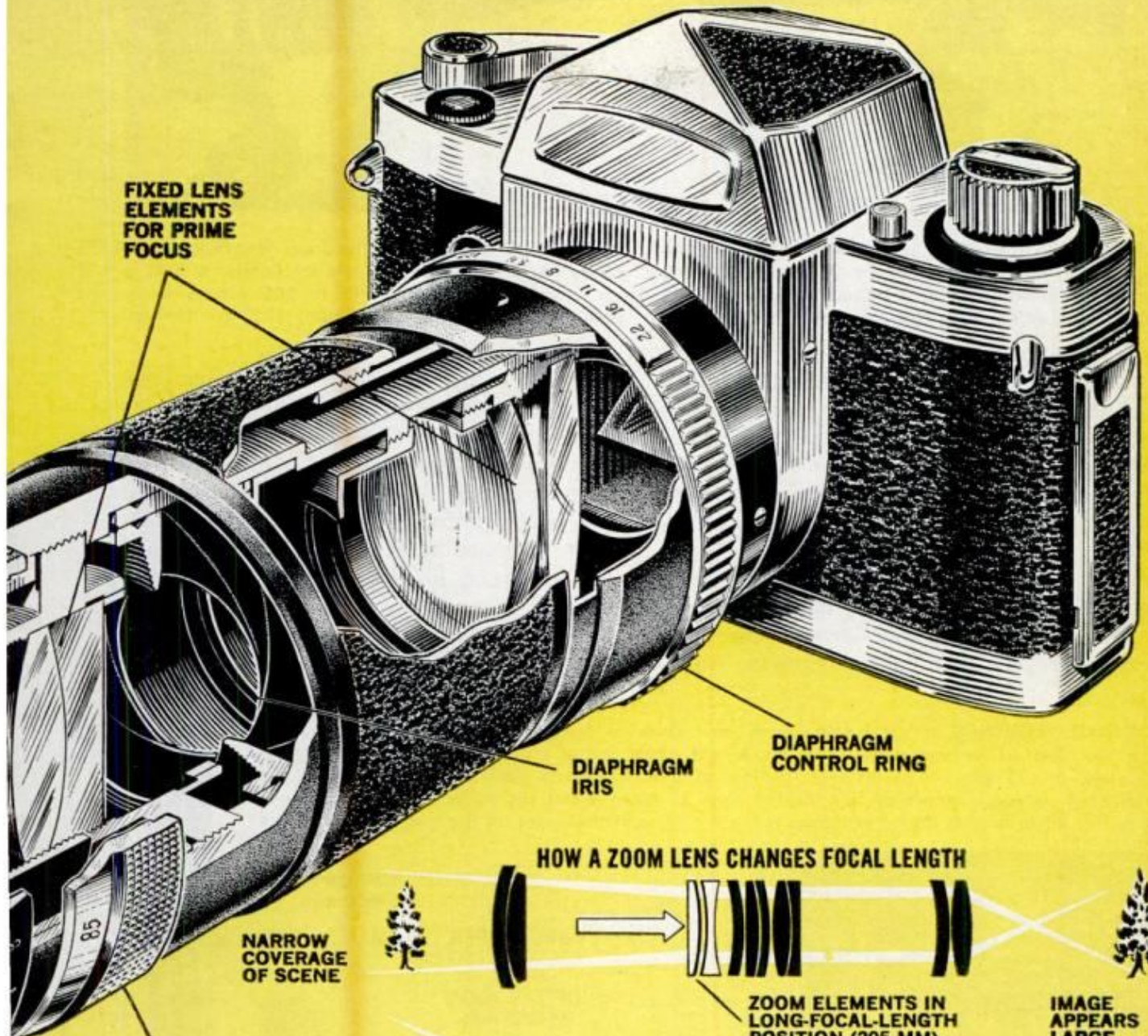

HOW A ZOOM LENS CHANGES FOCAL LENGTH

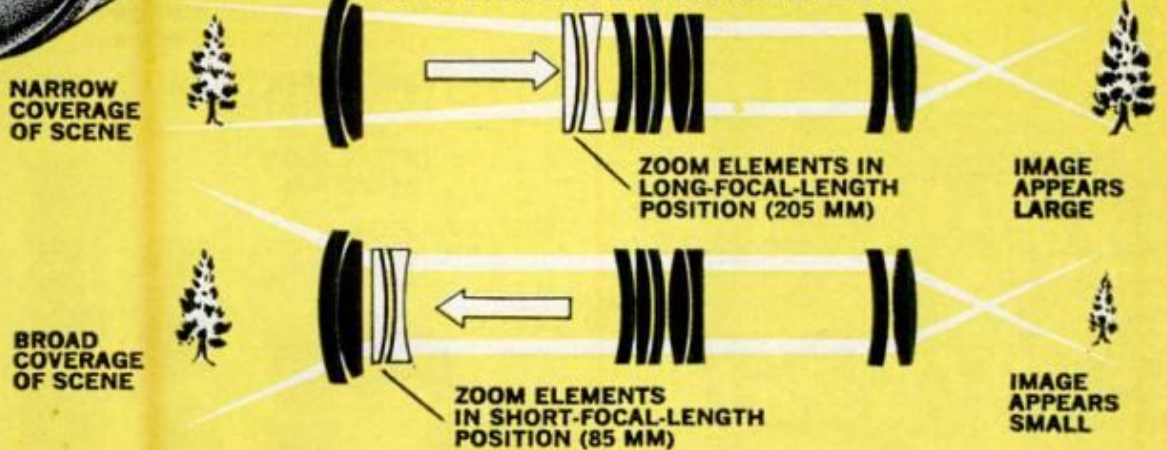

PROGRESSIVE PICTURES below show how a building looks at different focal lengths from the same distance. At far left is view seen with normal 50-mm lens. Image is magnified as you zoom from 85 to 205 mm





PISTOL-GRIP DESIGN helps balance lens's weight, is preferred by some zoom users. This 85 to 210-mm Sun has handy trigger-controlled shutter release, sells for \$149.95 from Spiratone in Flushing, N.Y.



TURNING A RING varies the focal length on most zoom lenses. This Vivitar, sold by Ponder & Best in Los Angeles, zooms from 85 to 205 mm. Price is about \$195 for automatic model, \$152 for manual

same spot in the stands. This is the kind of fun and excitement you can have with a zoom lens on a 35-mm single-lens reflex camera. You not only can switch rapidly from one focal length to another, but you don't have to worry about refocusing, either. Once you've focused on your subject, a zoom lens lets you vary the size of the image without affecting its sharpness.

Until recently, zoom lenses were expensive toys for wealthy camera buffs.

Now this is no longer true. There are several selling for less than \$100 and dozens to choose from in the \$100 to \$200 range. In many cases, the price of a zoom is little more than that of a comparable telephoto lens of fixed focal length. With a single zoom, you can have the equivalent of half a dozen fixed lenses at a fraction of the cost.

Surprisingly, zoom lenses are not new in principle. "Variable telephoto" lenses,

FOOTBALL SEQUENCE at left below shows how zooming can help you shoot different types of action. Shot at top was made at 85 mm to get whole line of players at kickoff. Tighter middle view, at 135 mm, shows receiver starting runback. In bottom shot, camera zooms in close at 205 mm to catch runner as he's tackled. Row of zoom lenses shows typical range of sizes, from tiny 43 to 86-mm shorty at left to tall giant at right that goes all the way up to 600 mm

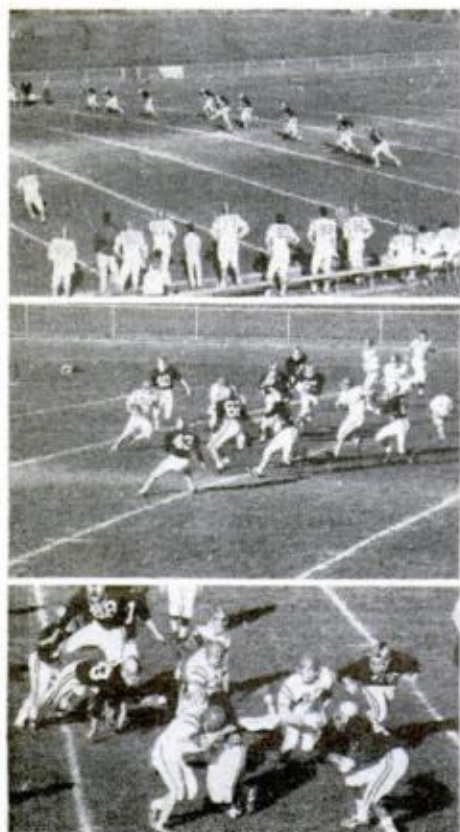

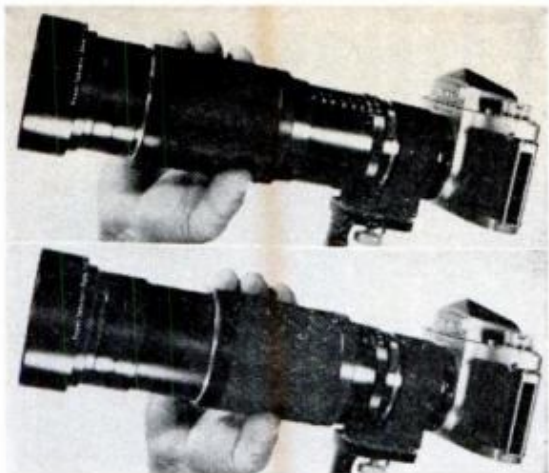

UNUSUAL TWO-IN-ONE CONTROL uses a single collar to adjust both focus and zoom range on this Super Takumar lens sold by Honeywell. Sliding collar back and forth varies focal length from 70 to 150 mm. At same time, you turn collar to focus. Price is \$395

as they used to be called, have been around since the early days of moviemaking. Though crude, they offered a simple substitute for the more cumbersome "dolly" technique where the entire camera must be moved to change image size. Spurred on by the need for variable TV-camera lenses, the zoom has now become a versatile aid for the still photographer as well, making a perfect companion for the single-lens reflex.

For SLR owners, zooms mean less weight in the gadget bag, and quicker camera operation. It's much faster to zoom than to change lenses. You can make your image fill the film frame from virtually any distance and thus reduce the amount of enlargement needed later, giving you greater sharpness and less grain. You can zero in on any portion of the scene you want, cropping out distracting details and composing your picture to good proportions right in the viewfinder.

A zoom lens works because it is able to change its focal length at will. Focal length is determined by the lens-to-film distance when the lens is focused at infinity. The longer the focal length, the larger the image on the film. In a conventional fixed-length telephoto, most of the lens elements are stationary, producing an image of fixed size on the film. The only elements that move are

(Please turn to page 210)

OCTOBER 1969

Medium-Range Zooms (70-250 mm)

Brand	Zoom Range (mm)	Speed	Cameras	Price
Super Takumar Zoom	70-150	f/4.5	Most SLRs	\$395.00
Accura Diamatic Zoom	70-230	f/4.5	Most SLRs	On request
Auto Tamron	70-220	f/4	Most SLRs	249.95
Proxitel Zoom	70-230	f/4.5	Most SLRs	On request
Auto Komura Zoom	75-150	f/4.5	Most SLRs	199.50
Auto Yashinon Zoom	75-230	f/4.5	Most SLRs	199.95
Yashinon-R	75-230	f/4.5	Most SLRs	179.95
Auto-Yashinon/DX Zoom	80-160	f/4	Most SLRs	229.95
Auto Zoom Rokkor	80-160	f/3.5	Minolta	329.50
Petri Zoom	80-200	f/4.5	Petri	298.50
Schneider Auto-Variogon	80-240	f/4	Most SLRs	551.00
Schneider Tele-Variogon	80-240	f/4	Most SLRs	400.00
Auto Rokunar Zoom	80-250	f/3.8	Most SLRs	269.50
Bushnell	80-250	f/3.8	Most SLRs	285.00
Auto Tamron	80-250	f/3.8	Most SLRs	299.95
Vivitar Zoom	85-205	f/3.8	Most SLRs	194.95
Caspeco	85-210	f/4.8	Most SLRs	80.00
Sun Auto Zoom	85-210	f/4.8	Most SLRs	149.95
Alpa Enna Zoom	85-250		Alpa	299.00
Auto-Nikkor Zoom	85-250	f/4	Nikon Nikkormat Nikkorex	515.00
Enna Telezoom	85-250	f/4	Most SLRs	249.50
Topcor Auto Zoom	87-205	f/4.7	Topcon	334.00
Super Yashinon R Zoom	90-190	f/5.8	Most SLRs	129.95
Rikenon	90-190	f/5.3	Most SLRs	155.95
Auto Soligor	90-230	f/4.5	Most SLRs	269.50
Soligor	90-230	f/4.5	Most SLRs	169.50
Rokunar	95-205	f/5.6	Most SLRs	179.50
Bushnell	95-250	f/5.6	Most SLRs	159.50
Canon FL Zoom	100-200	f/5.6	Canon	199.95
Caspeco	100-200	f/5.6	Most SLRs	100.00
Kaligar	100-200	f/5.6	Most SLRs	99.50
Zoom Rokkor	100-200	f/5.6	Minolta	184.50
Soligor Zoom	100-200	f/5.6	Most SLRs	139.95
Telesar	100-200	f/5.6	Most SLRs	109.50
Zuiko	100-200	f/5	Olympus Pen	199.95

Short Zooms (36-135 mm)

Brand	Zoom Range (mm)	Speed	Cameras	Price
Voigtlander Zoomar	36-82	f/2.8	Most SLRs	\$300.00
Vario-Sonnar	40-120	f/2.8	Contarex	648.00
Auto-Nikkor Zoom	43-86	f/3.5	Nikon Nikkormat Nikkorex	179.50
Schneider Auto-Variogon	45-100	f/2.8	Most SLRs	436.00
V-Hexanon	47-100	f/3.5	Konica	199.95
Zuiko Auto Zoom	50-90	f/3.5	Olympus Pen	159.95
Auto-Zoom Rokkor	50-100	f/3.5	Minolta	249.95
Rokunar	55-90	f/4	Most SLRs	150.00
Canon FL Zoom	55-135	f/3.5	Canon	278.50

Long Zooms (160-600 mm)

Brand	Zoom Range (mm)	Speed	Cameras	Price
Auto-Zoom Rokkor	160-500	f/8	Minolta	\$749.50
Rokunar	200-400	f/6.3	Most SLRs	199.50
Auto-Nikkor Zoom	200-600	f/9.5	Nikon Nikkormat Nikkorex	515.00

Specialty Zooms (extreme ranges)

Brand	Zoom Range (mm)	Speed	Cameras	Price
Auto-Nikkor Zoom	50-300	f/4.5	Nikon Nikkormat Nikkorex	\$720.00
V-Hexanon	58-400	f/4	Konica	On request
Canon FL Zoom	85-300	f/5	Canon	548.50

163

Weekend 'Thinwall'

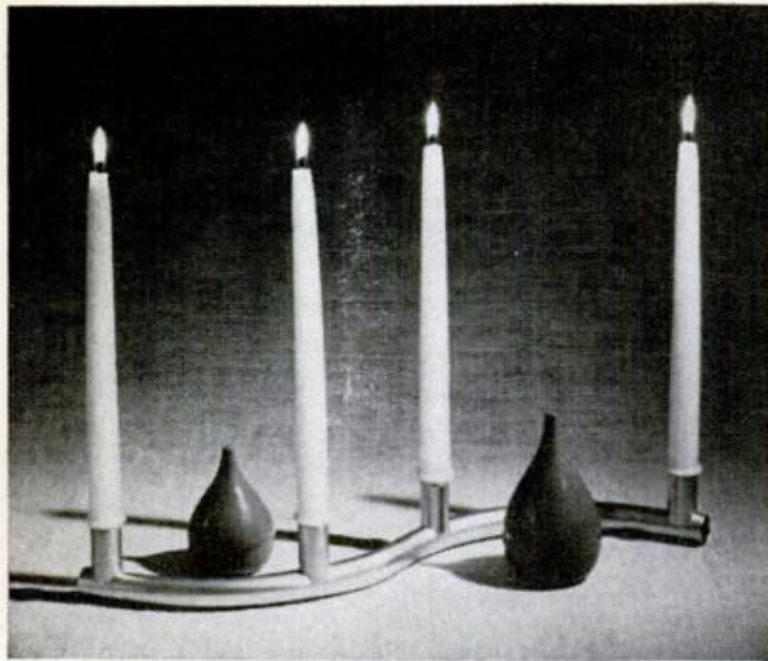

TWO CANDLEHOLDERS



HOLLOW SQUARE

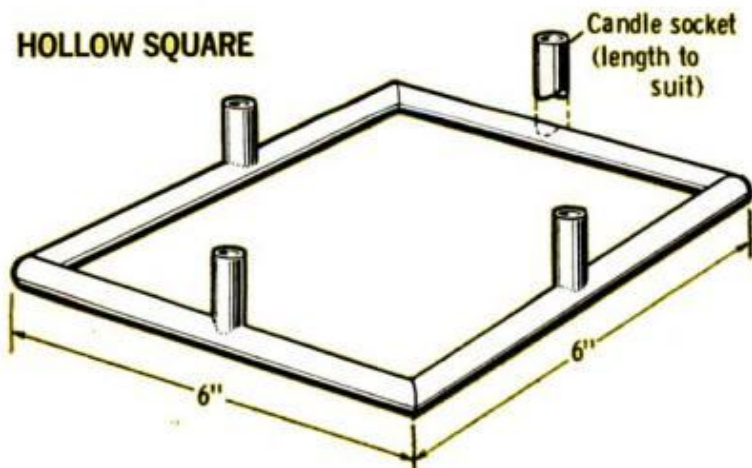

DOUBLE-BENDER

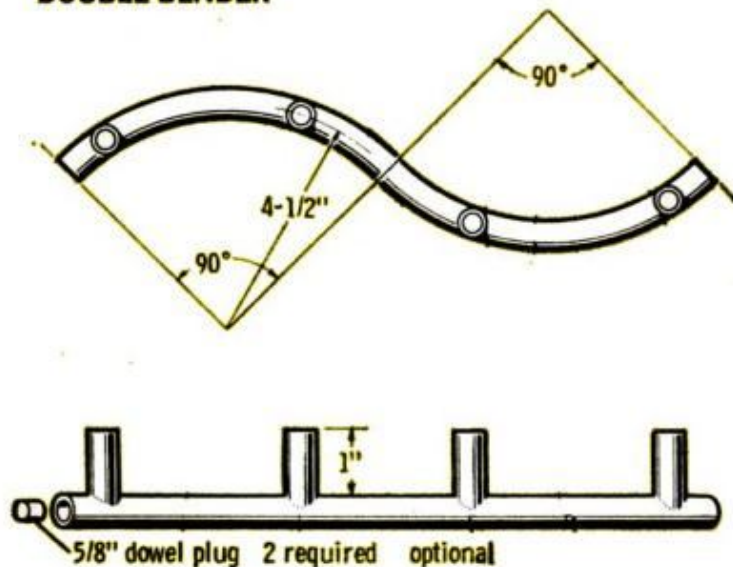

By R. S. HEDIN

IT'S NOT ALWAYS necessary to spend a lot of money and time to turn out good-looking, functional projects in your shop. Using thinwall steel conduit (the type that is used in electrical work), any of these projects can be built and finished in a single weekend.

Sold in 10-ft. lengths, thinwall conduit is zinc-plated steel tubing with an inside diameter of $\frac{5}{8}$ in. and a wall thickness of about .040 in. (hence the label, thin-wall). Low in cost, about 10 cents per foot, it is extremely ductile and can be bent easily without crimping.

Except for the hickey (conduit bender), you probably already have the tools you need for working with thinwall. Lacking a hickey, you can rent one for a day and knock out all your bending work in one session. But, if you want to add one to your toolbox, Sears offers one for about \$8. You supply a length of pipe for the handle.

Though no special skills are

POPULAR MECHANICS

Projects

needed, these four projects do require some knowledge of the basic techniques for working with thinwall. Here's a quick rundown on what you should know about handling thinwall conduit.

● **Cutting.** Use a fine-toothed hacksaw to cut parts and rough out joints. For square cuts, a tubing cutter gives an almost perfect cut. Cutting goes best (when using a hacksaw) if the work is clamped in a miterbox as shown on page 167. To insure tight joints, dress all cuts with a smooth file.

● **Bending.** Since the bend radius is $4\frac{1}{2}$ in. at the center of the tubing, you need approximately $7\frac{1}{16}$ in. around the bend to make a bend of 90° . Using this information, bends can be made with



HOSE CART

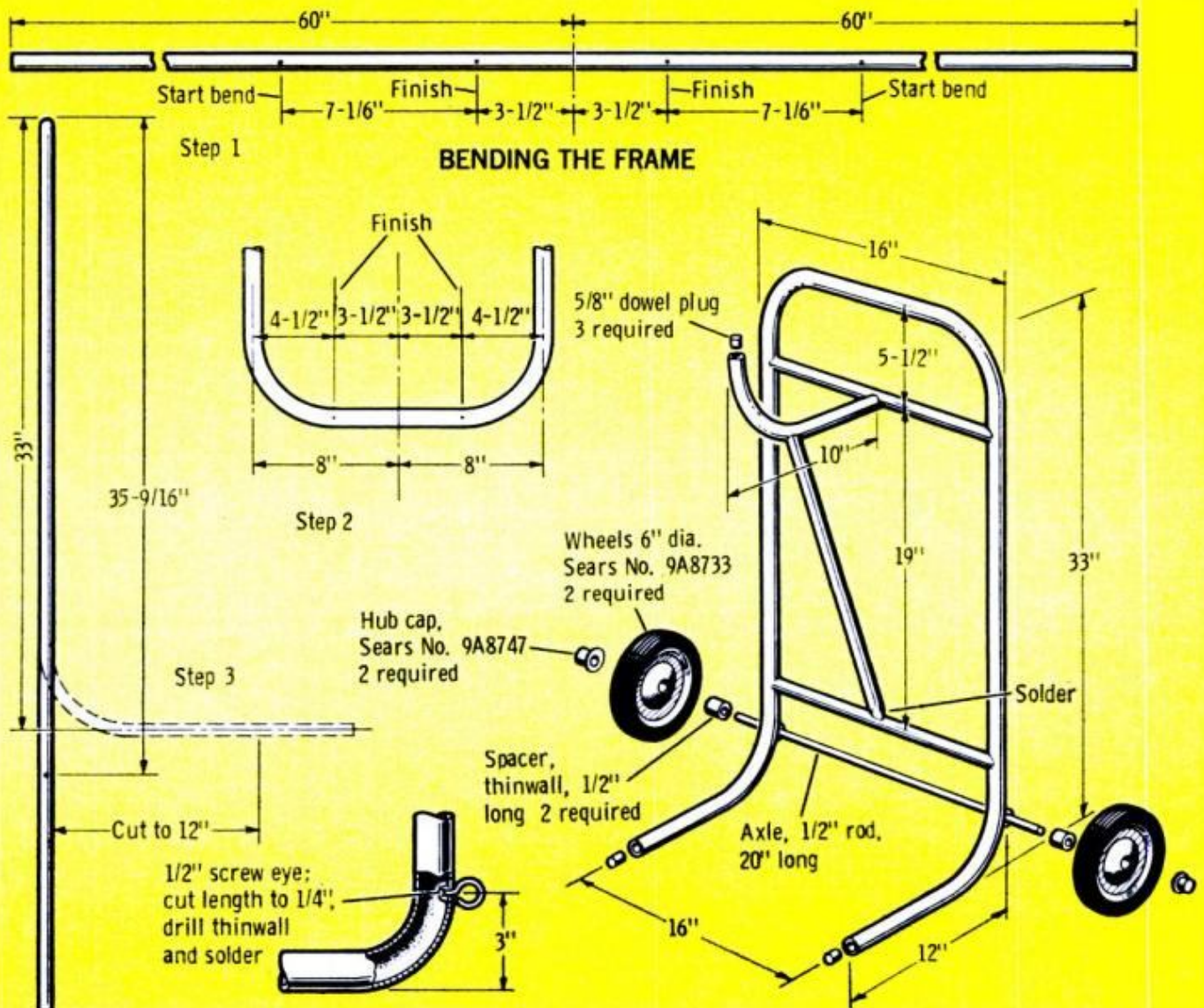



GOOSENECK LAMP

some degree of accuracy. Bends of up to 180° (or more) can be made by slipping the hickey along the curve, but this takes a little practice. Don't be discouraged if the first attempt is somewhat less than perfect. When making a 90° bend, always check the finished work with a square.

● **Soldering.** All soldering is done with silver solder. Sold locally, this is a silver alloy—about 45 percent silver—with a melting point of about 1125° F. It flows freely at 1145° F. A special flux is used in silver soldering; it comes in wet paste form and sells for about 75 cents per half-pound. It is thinned with water and applied with a brush.

Before soldering, file off the zinc coating on the joint surface. Next, put a light coating of flux on both surfaces and position the pieces. (Note: Flux *must* be between the mating surfaces).

With the torch turned full-on, heat the joint all around until the water in the flux evaporates and the flux turns

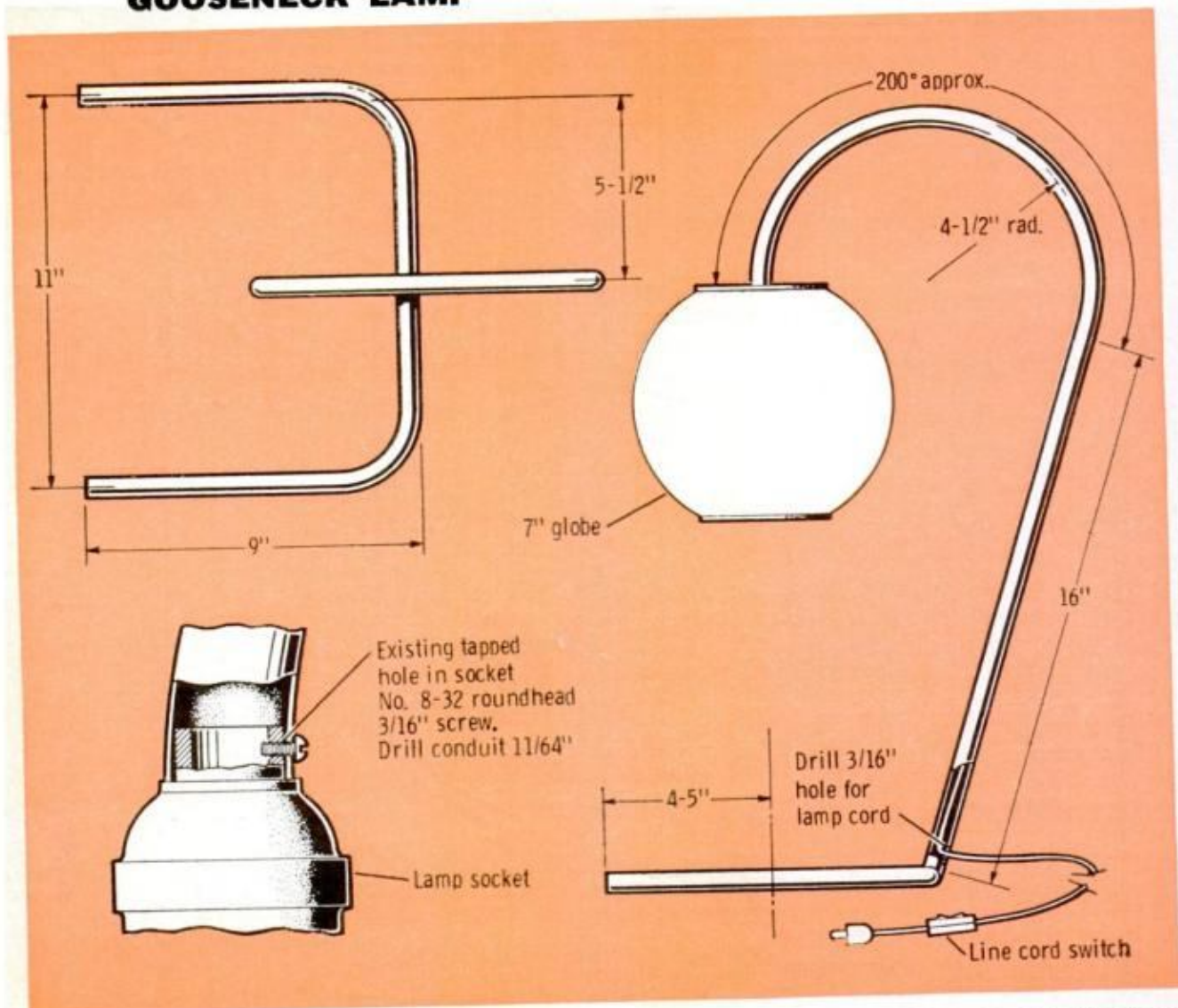

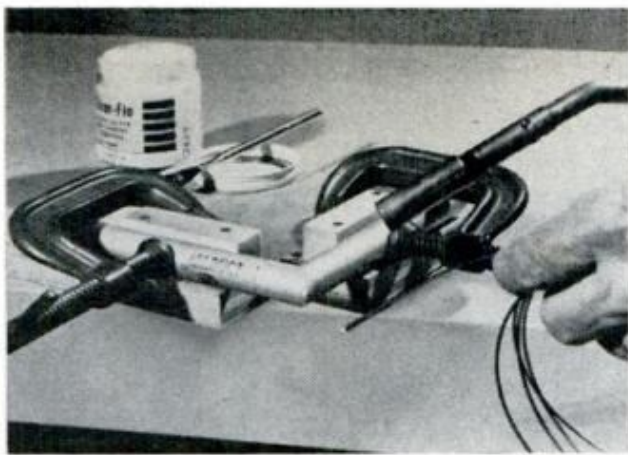

SIMPLE WOOD JIG holds the work securely, is built with space between the blocks to prevent scorching

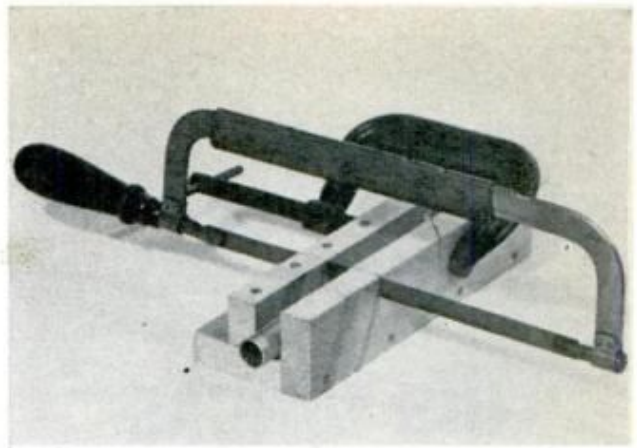

DO ALL CUTTING with a 32-tooth hacksaw. Miterbox will assure craftsmanlike square and miter cuts



TO MAKE BUTT JOINT, the tubing is rough-sawn to shape, filed to fit conduit and then silver-soldered

white. After that, concentrate the heat equally on both parts, keeping the flame pointed at one spot until the flux melts. At this point the tubing will be near a dull red color. Apply the solder wire to the joint, letting the work—not the torch—melt the solder.

After melting a small amount of solder, work the torch around the joint and the solder will follow. When the solder stops flowing, apply more solder and continue on around. If you start at the top of the joint, gravity will work for you in pulling the solder around. However, in a good close-fitting joint, solder will actually run uphill.

Next, let the joint cool and remove the flux with a wire brush or water. When finished, a good joint will have a fillet of solder at the junction of the surfaces.

Tips: If this is your first crack at soldering, make a couple of test joints to get the feel of it. Do your soldering in a well ventilated area and avoid breathing the flux fumes.

All of the projects shown were prepared for painting by wirebrushing and sanding to remove loose plating and flux. To finish, I chose spray-can paint for a professional-looking job that requires a minimum of effort. ★ ★ ★

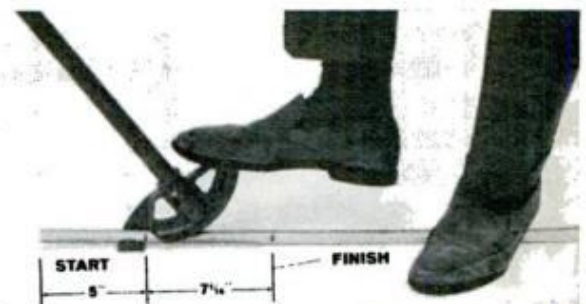

HICKEY IS PLACED on bend-start mark (top), and pressure applied. At finish mark bend is 90°. To bend 180°, pipe passes handle, must be straightened

Instant Cement Fills Cracks For Good



BOLT EMBEDDED in slab with Quik-Rok is permanently held. As it sets, cement expands, develops strength

AS IT BEGINS TO SET, 15 minutes after mixing, the cement can be smoothed with a trowel or knife

TO FILL CRACKS in concrete slab, wet the crack and dribble in cement, smooth off excess as it sets

AS IT COMES from the package, Preco Chemical Corp.'s new patching cement, Quik-Rok, looks much the same as portland cement. When it is mixed as recommended with water, it looks like gray plaster of paris. But it is neither.

It's an expanding, nonportland hydraulic cement, one of the latest developments in cement technology. The difference is that ordinary portland cement shrinks slightly as it sets. An expanding cement expands slightly and hardens without shrinking. When it is poured into a recess that restricts its expansion—a hole, for example—it prestresses itself as it hydrates (combines with the water) and develops a very high compressive strength. A 1/2-in.-dia. bolt embedded in a hole in concrete with expanding cement, for example will snap before it pulls out.

Quik-Rok hydrates rapidly, setting firm in 15 minutes, hardening in an hour and curing to full strength in 5 days (compared to 28 days curing time for portland cement). This rapid chemical reaction

generates considerable exothermic heat. Immediately after its initial set, a large pour heats enough to give off a slight amount of steam.

Mixing proportions aren't critical. While the ideal consistency is about that of pancake batter; the recommended mix for the average job is 2½ parts cement to 1 part water. But a thicker, puttylike mix also cures satisfactorily, and for many repairs the thicker mix is easier to apply and finish. Mixed either way, the working life of the mix is about the same—very short. Don't mix more cement than you can use in 10 minutes.

For maximum strength, apply Quik-Rok at least 1/2-in. thick. However, it can be used to fill hairline cracks provided they are first well-wetted. Having a high degree of weather and heat resistance, it is virtually an all-purpose cement.

Packaged in 1, 5, 25 and 50-lb. containers, Quik-Rok is sold through builders' supply firms and hardware stores. A one-lb. box costs 89 cents. ★★★

HINTS FROM READERS

Lathe drill gauge

Here's a simple depth gauge that serves as a great aid when drilling in the lathe. To make it, you need a hose clamp, binding post and length of rod. Mount post atop the clamp with a flathead screw and bend the rod at right angles to reach the drill's chuck jaws when in the post. With large drills, turn the rod so it rests in the drill's flute.—*Peter Legon*

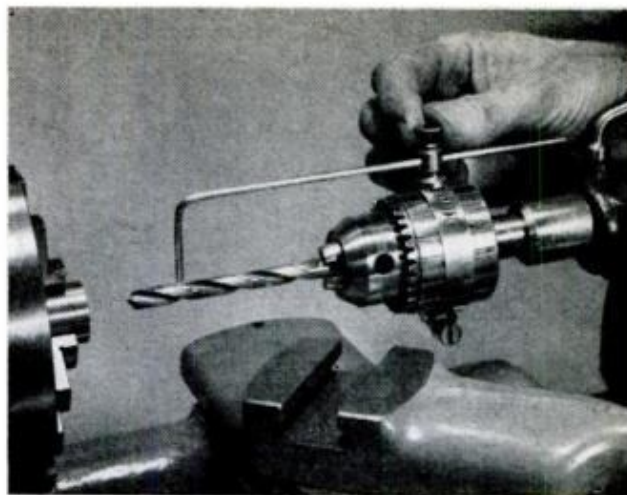

Battery cable-clamp puller

A corroded battery cable-clamp can be easily removed from the terminal with this puller. Drill and tap a short length of $\frac{1}{4}$ x1-in. flat steel to receive two carriage bolts spaced to fit the clamp, plus a centered capscrew. Allow the boltheads to grip the clamp's lower face and tighten the capscrew to lift off the clamp.

—*C. W. Woodson*



Saving late tomatoes

If your plants are heavy with green tomatoes when the first frost threatens, you can still bring them to delicious ripeness and color. To do it, simply pull the plants up by the roots and suspend them upside down from a line stretched in your basement. In a few weeks the green tomatoes will turn red and boast vine-fresh sweetness.—*G.E. Hendrickson*

Lathe dog for large work

Large-diameter work can be turned between centers using a homemade lathe dog. First, bend a thin steel bar around the work to make a snug fit, then give the ends a sharp, straight-up bend to act as driving tail. Drill the ends for a clamp screw to hold dog securely, fasten a bolt with two nuts through the faceplate slot for driving dog and work.—*C.W. Woodson*

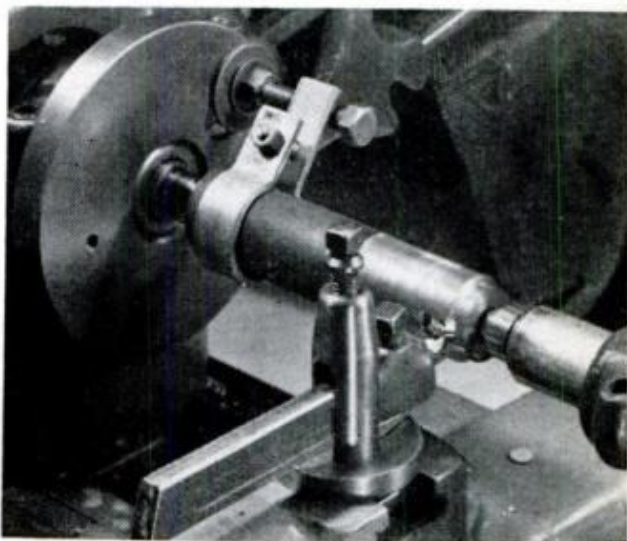

Lagscrew vise helper

To keep pipe from turning in a smooth-jawed vise when threading or cutting, you can use four lagscrews as shown at right. As you tighten the vise, the sharp screw threads bite into the pipe and hold it fast while you cut. One word of caution though: If using soft pipe, go easy on the muscle.—*Victor H. Lamoy*

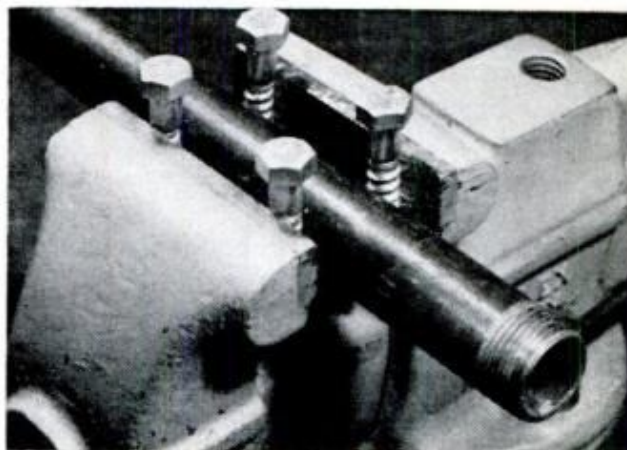

Which Insulation

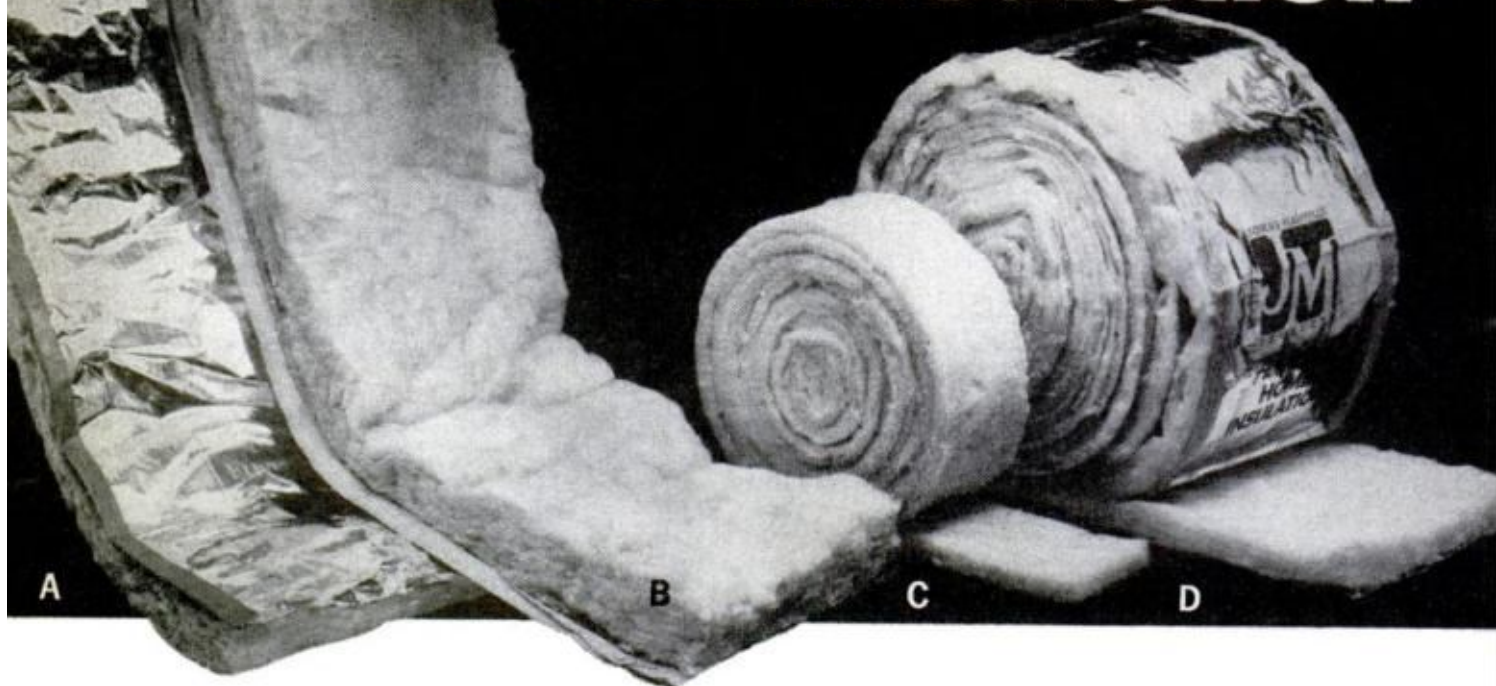

AVAILABLE IN GREAT VARIETY, insulations most often used are shown above: A, blanket; B, batt; C, sill sealer; D, roll; E, blown-in; F, pouring, and G, rigid. Text and art tell how and where to use them

There's a type for every job and, once installed, insulation pays for itself by cutting both heating and cooling costs

IF YOUR HOME is hot in the summer and chilly in the winter, it's a pretty safe bet that the house is underinsulated and you're throwing money away. Happily, you can still do something about it. And, if you are planning an attic renovation or addition, you can avoid the same problems in those areas.

All materials used in home construction offer some resistance to heat transfer from the warm side to the cold side. But, if you add a material with a high degree of resistance to heat transfer, comfort will be greatly increased—while fuel and air-conditioning bills go down. That's what insulation is all about.

Of four basic types—blanket, batt, loose and rigid—insulation is inexpensive and easy to install. In most cases you can handle the job yourself.

Blankets and batts are probably most commonly used and can be either mineral wool or fiberglass. The minimum recommended thicknesses are 4 and 2-in. for ceilings and walls respectively. Available with and without vapor barrier facings (which will be discussed later in this

article), it's safe to say that the thicker the material, the more efficient the job.

The job at hand usually dictates which type is best suited. Where wall insulation is wanted in an existing house for example, the smartest move is to call in a pro (and his equipment) for a "blown-in" installation. Blankets or batts would require the tearing down and rebuilding



STAPLING FLANGES are lapped over studs, provide vapor barrier. Notice loose insulation around jamb

Should You Use?

By BURT MURPHY



of entire walls to get the stuff in place.

Insulating between joists in a crawlspace or attic is a homeowner's task. Blankets or batts can be used in both areas or loose fill simply can be poured between joists in the attic.

On any new work such as an attic renovation or addition, where the framing members are fully exposed, consult the chart on the following page for the best choice of insulating material.

Unlike the insulating materials mentioned above, the rigid fiberboard type is installed over, not between, studs. Manufactured in standardized building sheet sizes, it comes smooth one side for finish painting.



UNSUPPORTED AREAS, such as a crawlspace, are insulated with batts held by galvanized screen wire

The most often used perimeter insulation is Styrofoam. Of varying thickness, it is installed around the perimeter (forms) as shown on page 174 before the slab is poured. It should also be used in heated crawlspaces that serve as return plenums.

About vapor barriers

Most materials used in house construction are permeable to water vapor. Thus, water vapor generated in the air by dishwashers, showers, baths and the like, can travel through the walls and condense in the attic, eaves or crawlspace. This causes damage to exterior and interior finishes (blistering paint) and, sometimes, decay.

To prevent this, the house should be skinned with a water-resistant material (vapor-barrier) on the *warm* side of all exterior walls and between attic floor insulation and heated rooms below.

Most commercially available insulations now come with a vapor barrier on one or both sides. With these (excepting foil-faced types), the insulation is installed with the stapling flange on the face of studs. Blankets or batts lacking a vapor barrier are installed between studs and then covered with a vapor barrier such as 6-mil polyethylene or asphalt-saturated paper.

When insulation is blown-in in an existing home, paint coatings cannot be considered as a substitute for membrane

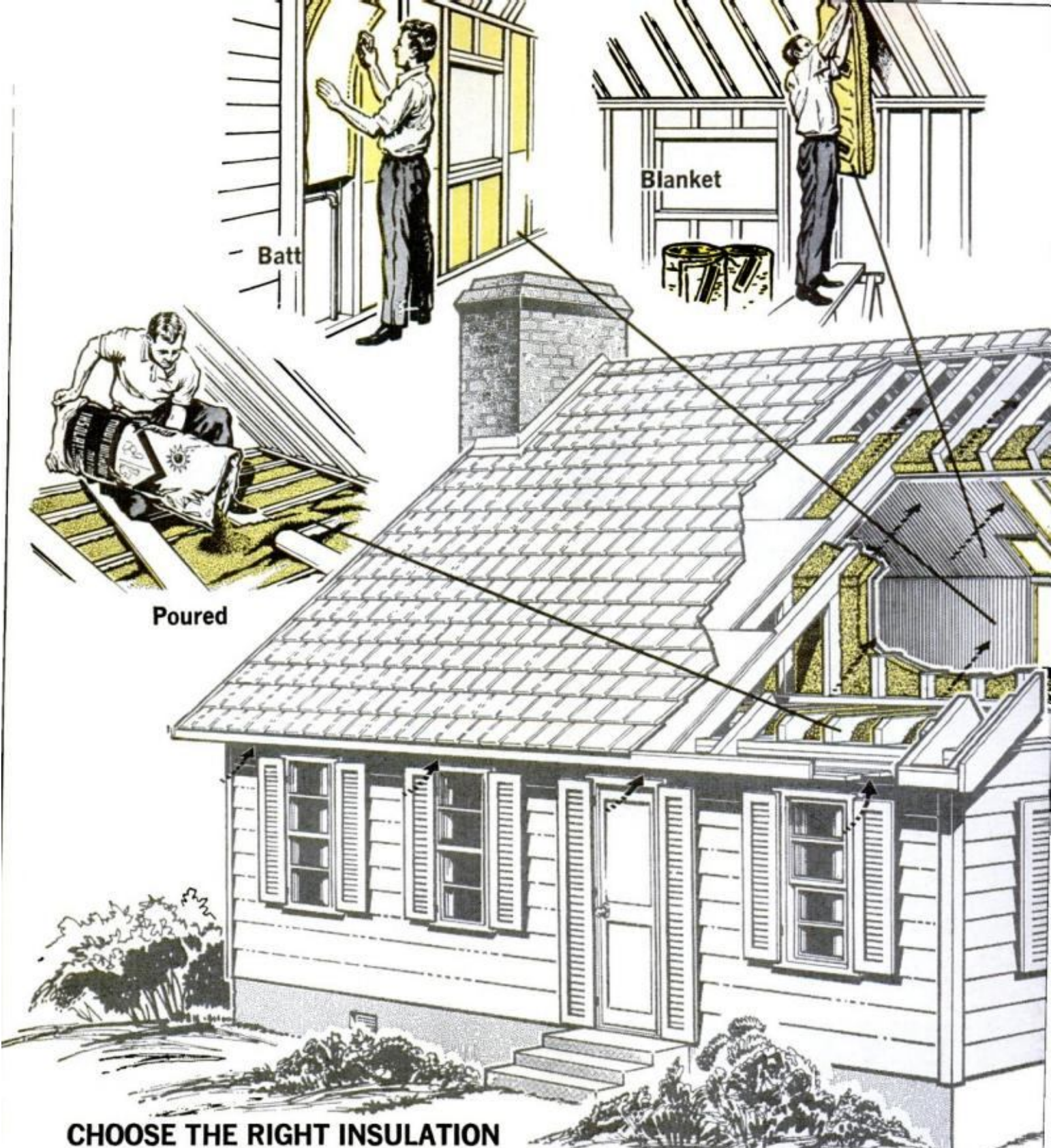

CHOOSE THE RIGHT INSULATION

Fully insulated and vented, house gives greater comfort, costs less to heat and cool. Note that wherever used, insulation (shown in yellow) is placed between heated and unheated areas. Vent in crawl space is installed when that area is unheated. If heated, perimeter of foundation wall is insulated as shown.

TYPE OF INSULATION	WALLS	CEILING	FLOOR	FOUNDATION	ATTIC	SLAB	BASEMENT WALLS
Blankets, batts	✓	✓	✓		✓		✓
Poured					✓***		
Blown-in*	✓	✓**					
Sill sealer				✓			
Rigid (Fiberboard)	✓	✓	✓		✓		✓
Rigid (Perimeter)				✓***		✓	

*Existing house

**Floor of unheated attic

***Heated crawl space

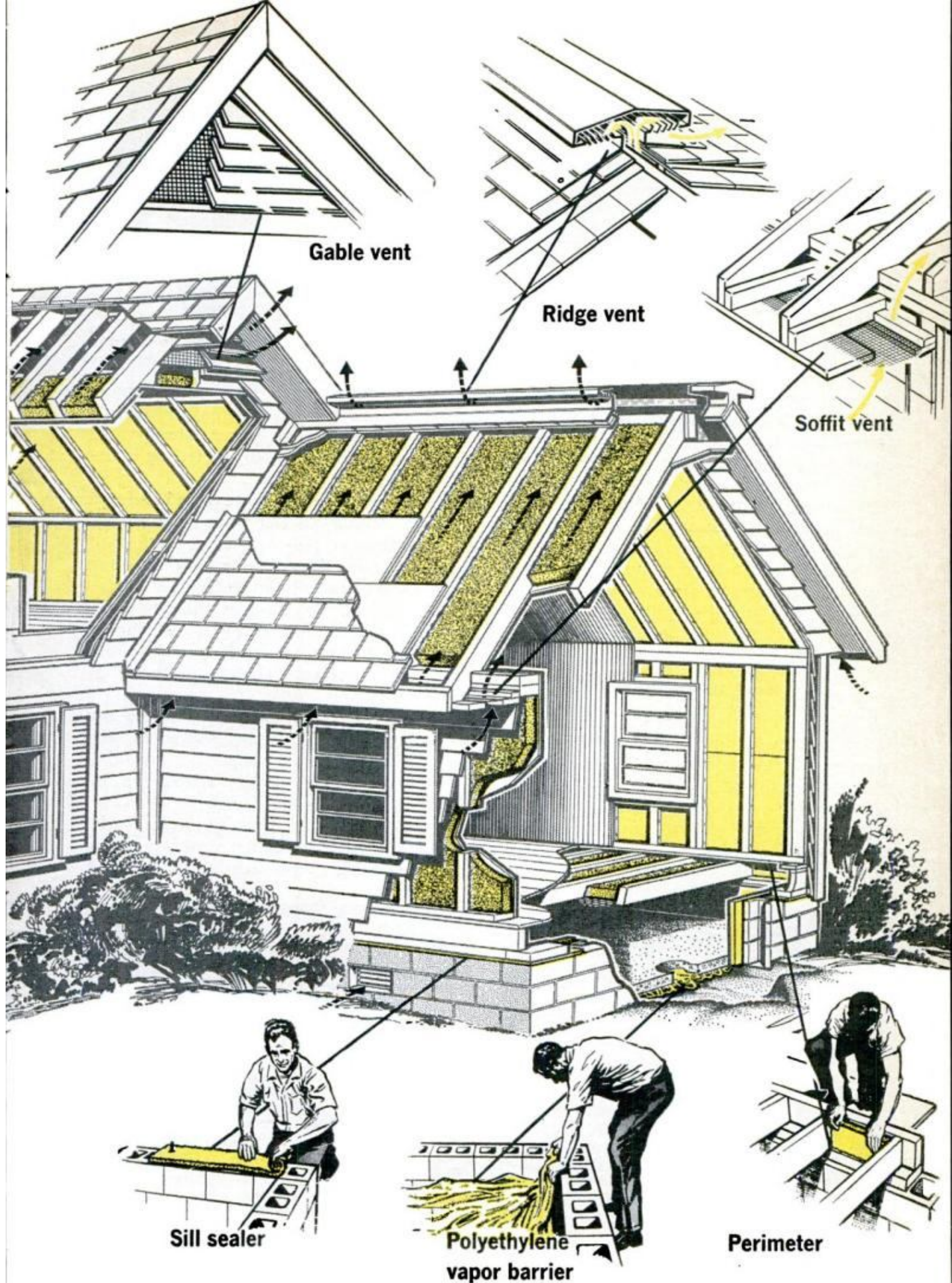

Gable vent

Ridge vent

Soffit vent

Sill sealer

**Polyethylene
vapor barrier**

Perimeter

Technical Art Created Specially for PM by Peter Trojan



VERMICULITE ATTIC INSULATION used to beef up inadequate insulation is poured between joists

types of vapor barriers. But one coat of aluminum primer followed by two decorator coats is quite effective. In drywall construction, paint coats can be applied to the back surface before installation.

Adequate ventilation is equally important. Until recently it was thought that venting a house caused wasted heat. But, with today's improved insulations, year-round fixed venting gives definite advantages. Used in the attic, it removes extreme heat in the summer and excess moisture from below in the winter.

How to insulate

No special tools are needed to install insulation. A stapler loaded with 5/16-in. staples, a large shears or utility knife and a ruler complete the toolkit. When insulating between ceiling joists, start at the outside-wall top plate and work across the room. Be sure the insulation doesn't block ventilation at the plate.



BLOWN-IN installation requires special knowledge and equipment, is a chore best left to the pros

In an attic where a finished ceiling is in place, batts or blankets may be laid in from above. Keep the vapor barrier face down and tightly butt the batts, or blankets, where they meet.

Joists over a crawlspace are insulated with the vapor-barrier side face up. If a vapor-barrier paper is used instead of 15-lb. felt over the subfloor, you can save dollars and use insulation without a vapor-barrier facing. To support the blankets, use well-nailed chicken wire as shown in the photo or, rustproof wire laced in boot fashion around roofing nails set at intervals in the joists.

Basement walls can be insulated by fastening 2x2-in. furring strips to the wall to simulate framing and blankets installed between, or the strips can be faced with insulation board.

Whether installing insulation on walls or ceiling, leave space for ventilation between sheathing and insulation. ★★★



FOIL-FACED insulations are stapled to stud sides to provide air space between foil and back of wall



SLAB HOUSE construction calls for rigid insulation placed around perimeter. Notice vapor barrier

POPULAR MECHANICS

HINTS FROM READERS

Basket prevents fan accidents

A plastic clothes basket, placed over an electric fan, will keep youngsters (and pets) from reaching the whirring blades. For extra safety, mount the setup on a piece of plywood and secure the basket with screws and pipe-strap hold-downs. Then the youngsters will not be able to move or tip the basket.—*Ken Patterson*

Easier-to-use mason line

Tired of untying and tying knots every time I had to move my mason's string when laying out my patio, I hit on this idea. By fitting the end of the line with a wire terminal, I can simply slip it on or off nails tacked in the stakes. I found the best terminals for this application were those that grip small, insulated wires firmly.—*Daniel Bousha*

Clenched fist saves a dime

I am farsighted and don't always have my eyeglasses handy. Thus, if I have to look up a number at a telephone pay station, I'm hurting. To make the numbers stand out clearly, an optometrist told me to clench a fist and peep through the hole between thumb and index finger. Make the hole small as possible, and hold your fist close to the eye.—*Stephen Stresnic*

Easy way to chamfer a cut bolt

If you've ever cut a bolt you know that gripping the bolt in one hand, while you file burrs on the cut with the other, is not a pleasant chore. Next time try this: Run a nut on the bolt, then clamp the nut in your vise. Using a wrench, rotate the bolt slowly as you file. With a little practice, you'll have a uniform conical chamfer every time.—*Robert Beck*

Heat sink aids grinding

A heat sink is the answer when shaping hardened tool steel. I found that out when shaping special cutters for my table saw molding cutterhead. A ¼ or ½-in. piece of aluminum scrap is so efficient that even a high-speed grinder will not overheat the cutting edge. If you use a small bench grinder, secure tool to the aluminum block with a small C-clamp.

—*Frank Greenwald*

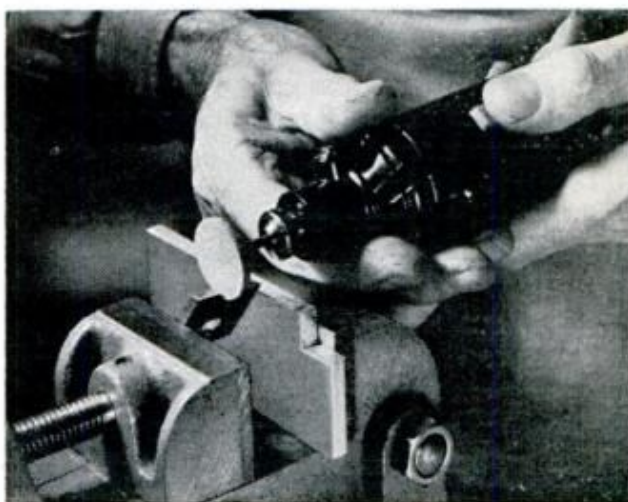
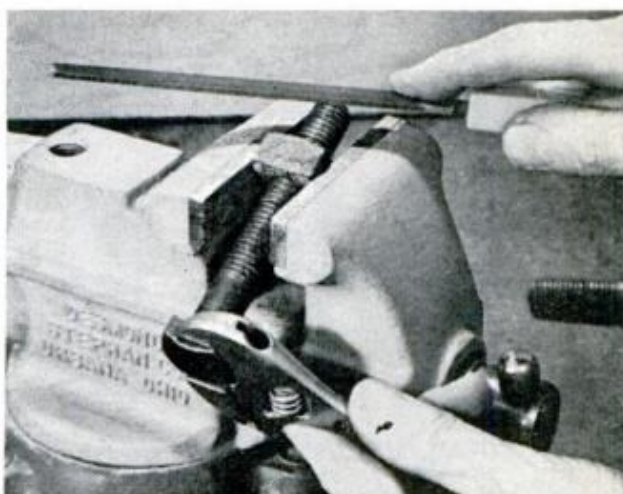
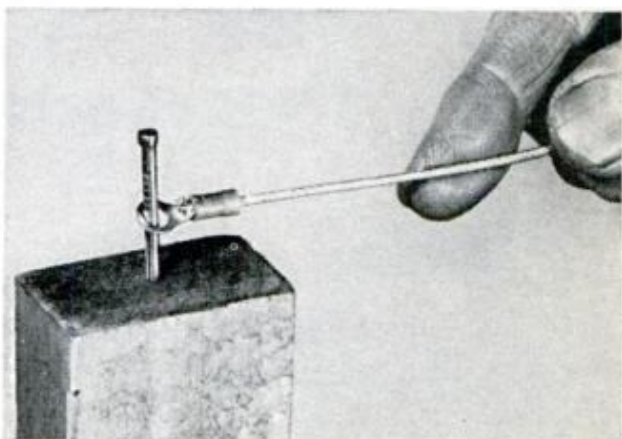
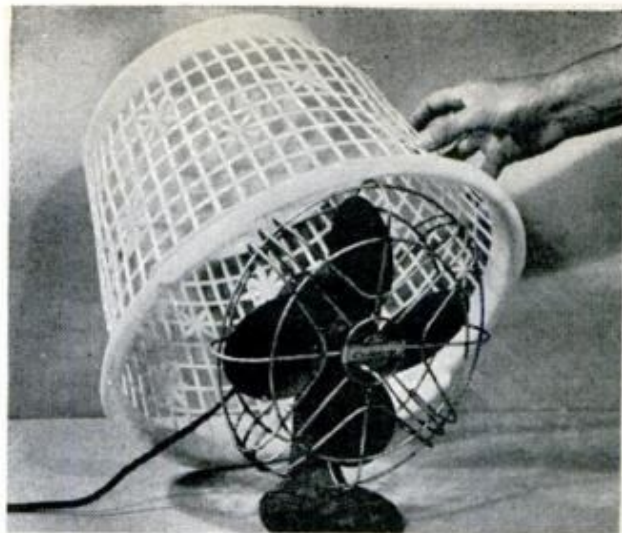

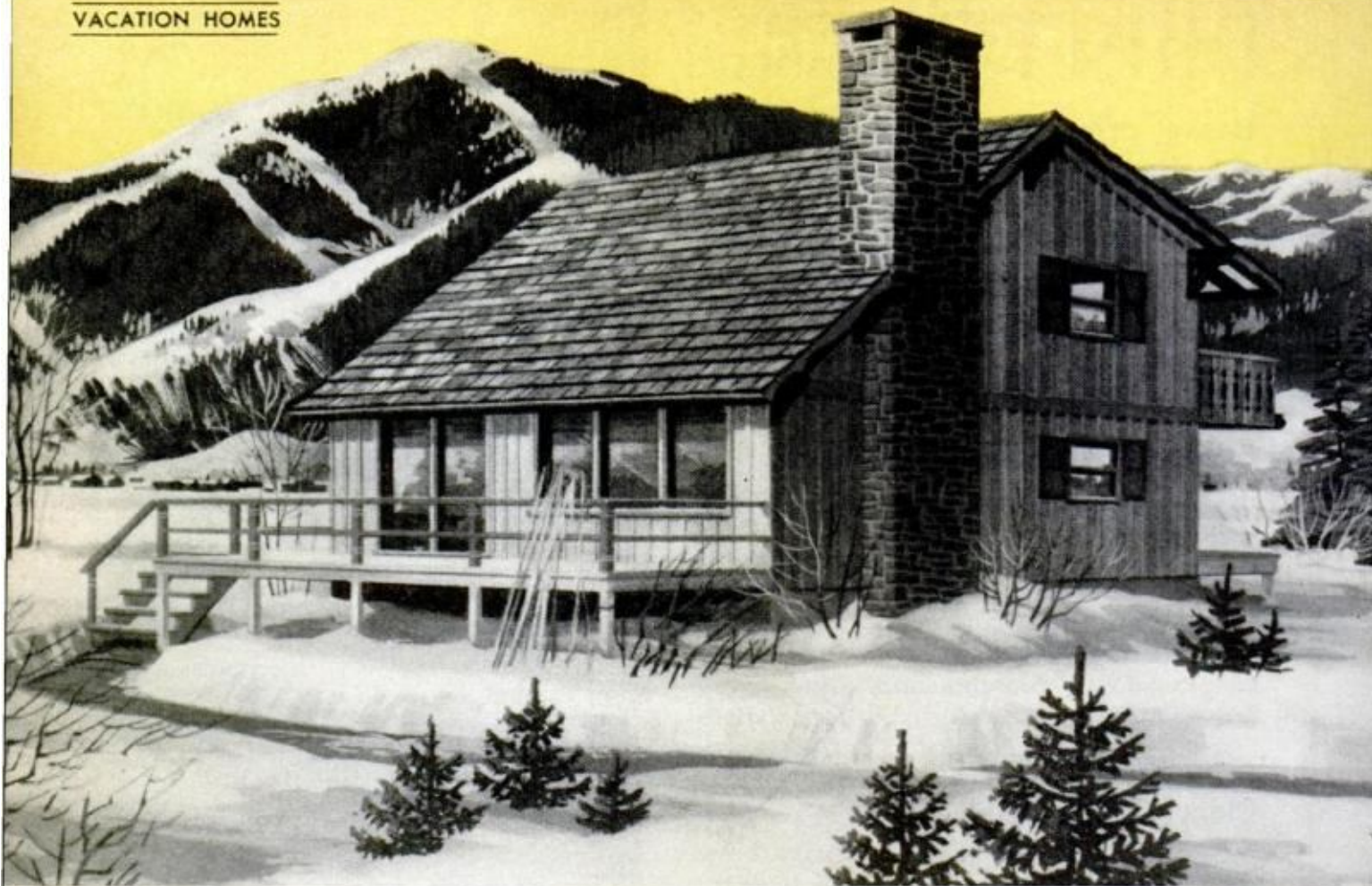

All-Season 'Ski Lodges'

Tucked away in wooded back country or along water frontage these four vacation dream homes let you live the good life

WHETHER IT SERVES as a hide-away for a weekend of skiing or as a year-round haven where you can enjoy boating and fishing too, nothing promises to pay you such big dividends in pure pleasure as a second home.

You'll find a home away from home is really a risk-free investment in the good life. It means periodic relief from tensions and frustrations of the work week. It adds new dimensions to vacation living for the whole family. And it may be the perfect answer to the housing needs of your retirement years.

Be it a rugged ski lodge or a sophisticated beach house you're dreaming of, each of the four vacation homes pictured here lets you save money several ways. First you may have a contractor erect the structural shell and then finish off the rest at your leisure. Or you can build all or most of the house yourself.

The plans for these homes give you, or your builder, everything you need to do the job and do it right. Being drawn for the do-it-yourself builder, they are more complete than those normally produced for professional contractors.

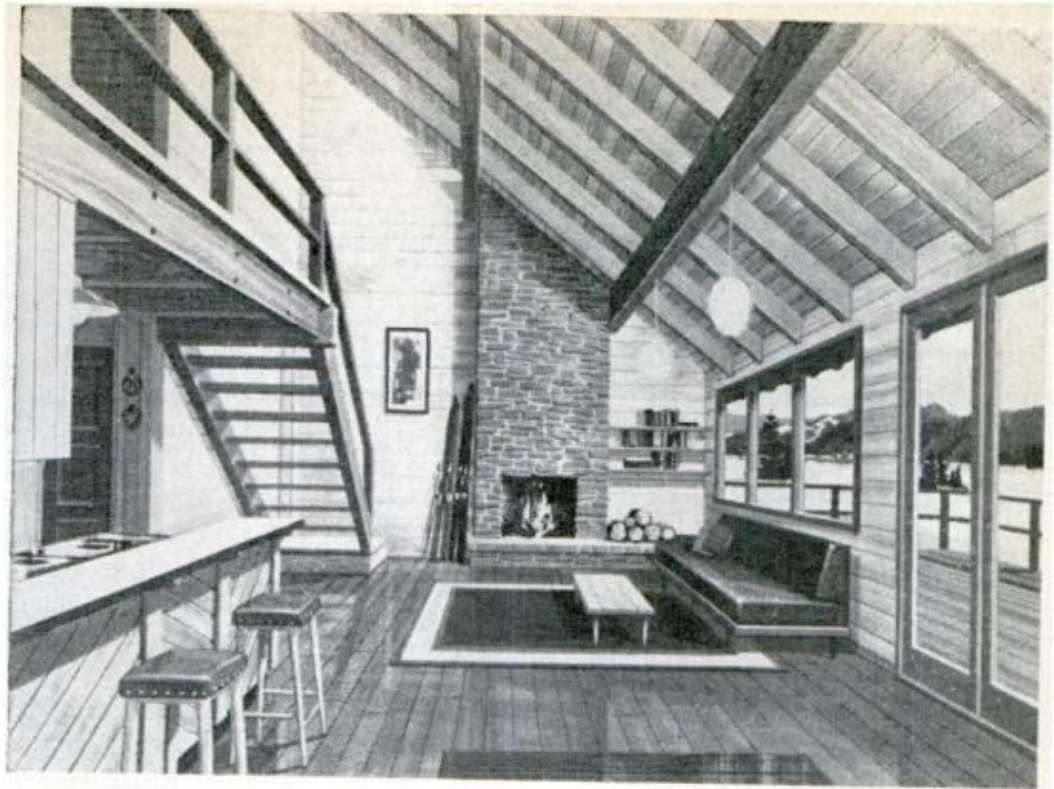

FEATURING AN OPEN STAIRWAY which leads to a second-level balcony from where one can look out at the vaulted ceiling of a spacious living room, this charming ski lodge has a lot going for it, despite limited floor area. Both levels have roomy decks which run the width of the dwelling. A window wall across the front brings a panoramic view inside and helps create a cheery feeling on gloomy winter days. A built-in eating bar, tucked under the balcony, is part of U-shaped kitchen. This home makes a delightful family-size ski lodge for high, open country. Specify plan No. 5 when ordering



ALTHOUGH THERE ARE ONLY 660 square feet on the first floor and 332 on the second, there are three roomy bedrooms, bath, U-shaped kitchen and spacious living room. There's ample storage, too

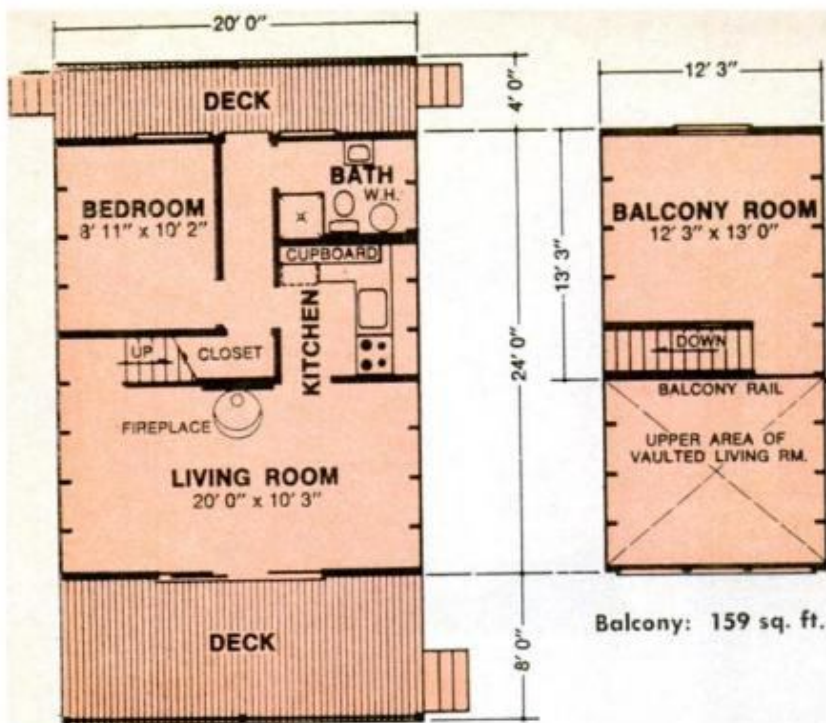

Main floor plan: 480 sq. ft.

Classic Design for a Low-Budget A-Frame

SKILLFULLY DETAILED, this version of the once radically different A-frame has been worked out to give you maximum living space and convenience on a minimum building budget. The plans call for a slightly elevated structure with a dramatic glass outlook to bring the whole view inside of the house. The living area is centered around a prefab fireplace and the kitchen area is close by. The plan is laid out for one bedroom down and a spacious sleeping loft up. Texture One-Eleven plywood (panels with deep grooves) is applied with the texture face down to provide a handsome ceiling effect. Both front and back doors are protected and provided with good deck space. Loft overlooks the living room with vaulted ceiling. Closet makes full use of space under stairs. Specify plan APA-112 when ordering.

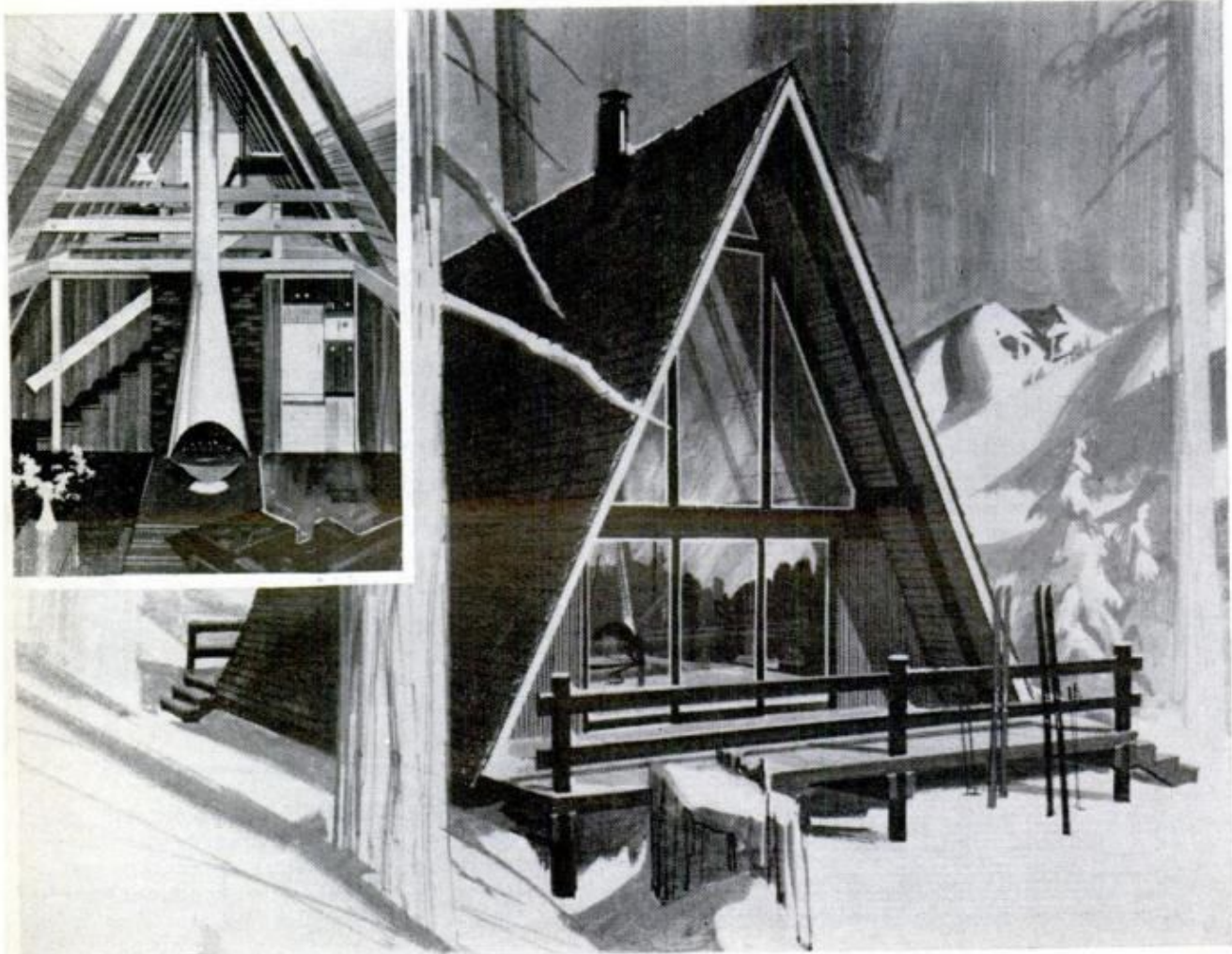

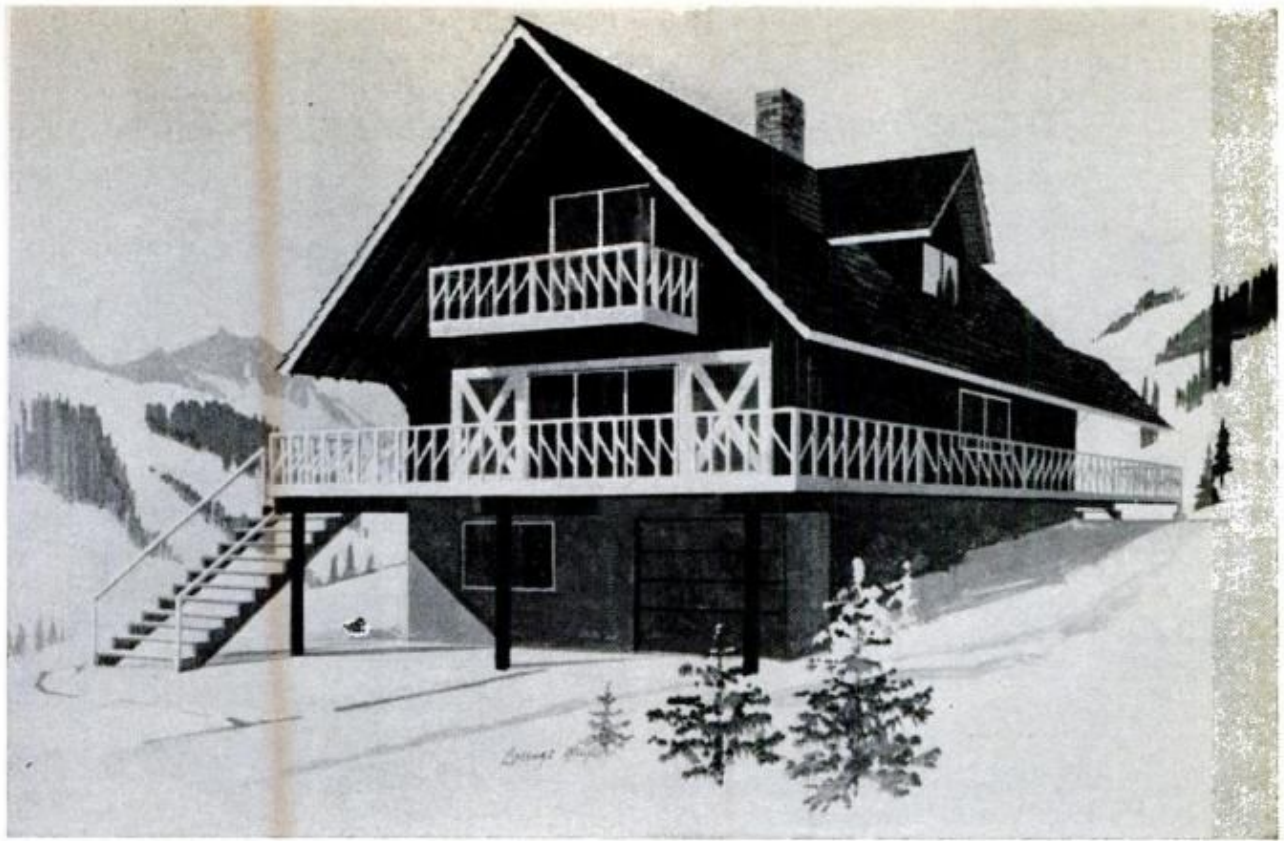

Classic Chalet for the High Country

A BIG DECK and generous roof overhangs give this handsome two-story ski lodge the look of a classic chalet. It gives you one bedroom and bath down, two bedrooms and bath up. The massive fireplace and raised hearth combine with open stairs and exposed beams to create an atmosphere of hearty open-handed living that's in tune with winter. Specify plan APA-103-A.

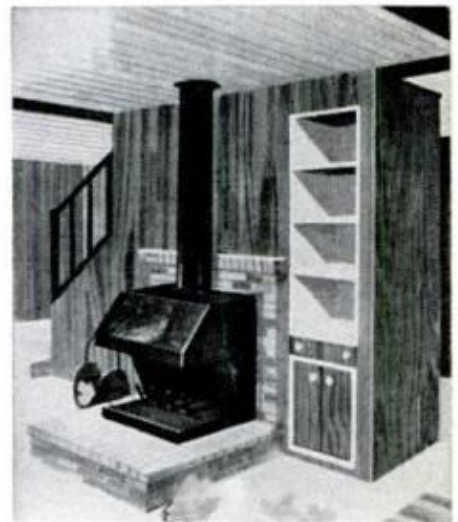

BUILT-IN CABINET becomes part of stair wall if house has no basement

ALTERNATE PLAN APA-103-B (with basement) gives you a garage with laundry and storage space beneath the main structure

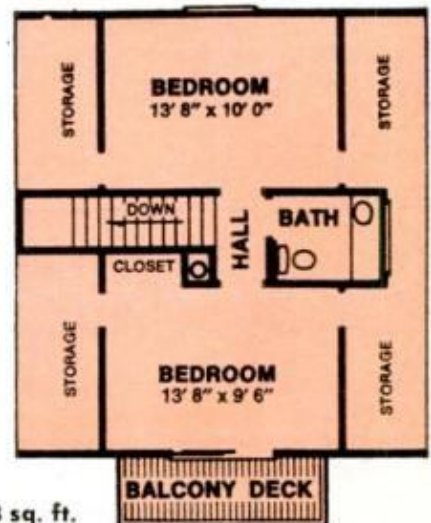
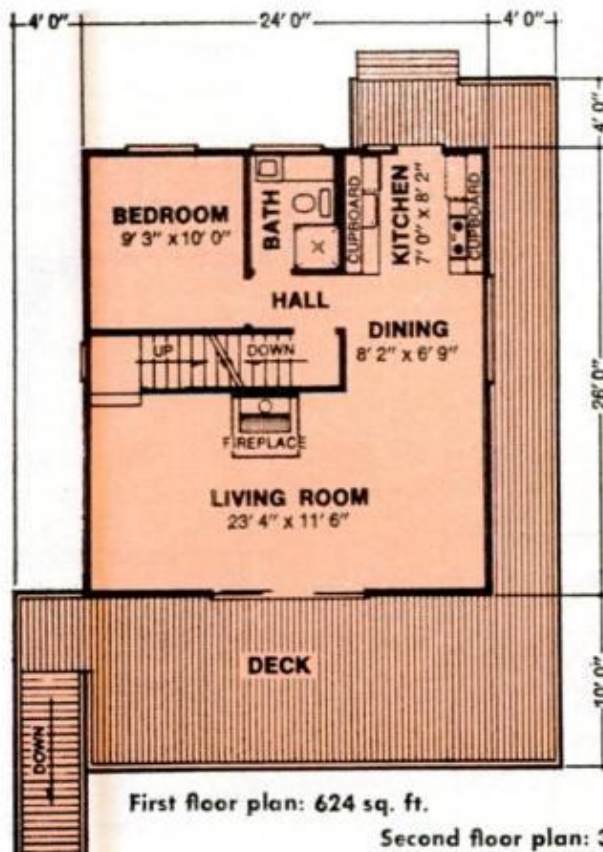

Wraparound Decks and Generous Overhang

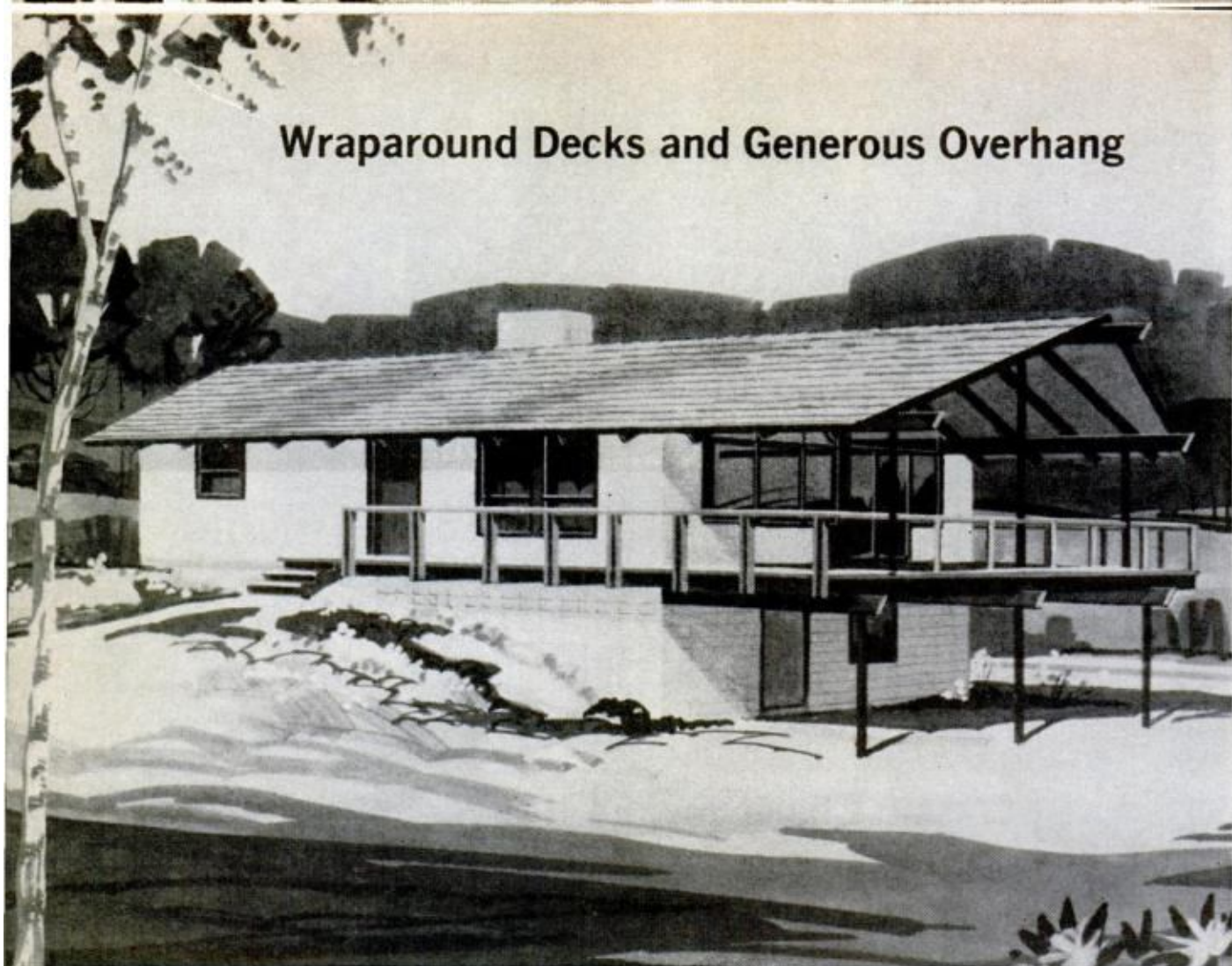

SURROUNDED on three sides by a protected deck to add outdoor living space to its 864 sq. ft. of floor space, this compact ski lodge is perhaps the most popular style of vacation home in America today. It has an excellent traffic pattern in that one can enter the house at three points off the deck, and has an abundance of storage in its foundation area. Its elevated front deck provides shelter for a car or boat.

An L-shaped kitchen merges with the dining area, and an open-end fireplace provides the cozy warmth one needs after a day's run on the slopes. The foundation plan is ideally suited to a sloping site. To obtain blueprints for this ski lodge, specify plan No. 772-1.

HOW TO ORDER PLANS

Plans for any of the four homes can be ordered for \$25 each, or \$35 for four sets of the same plan, from Home Building Plan Service, 2235 N.E. Sandy Blvd., Portland, Ore. 97232. As a rule four sets of plans are needed for permits, financing, cost estimates and construction.

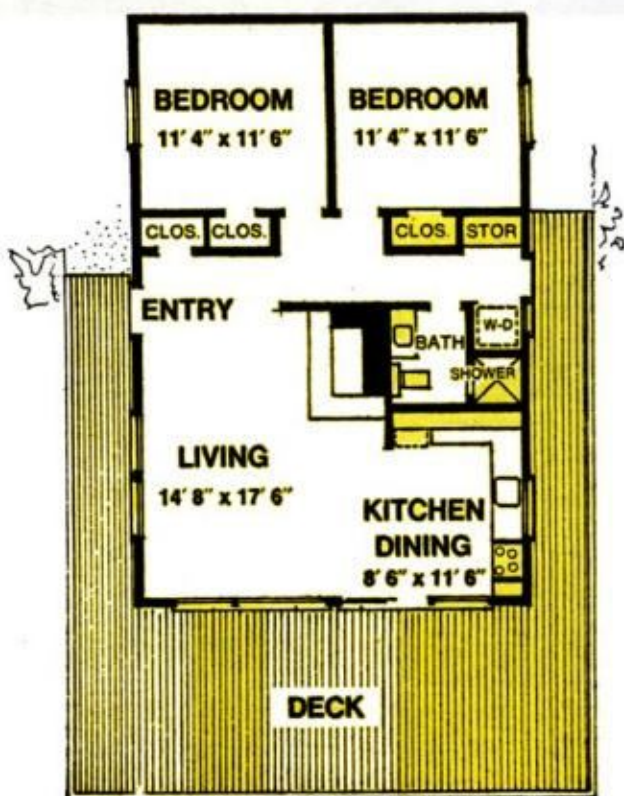

Width: 24 ft.

Depth: 36 ft.

Floor area: 864 sq. ft.

POPULAR MECHANICS

NOW: A VACATION HOME IN 3 HOURS

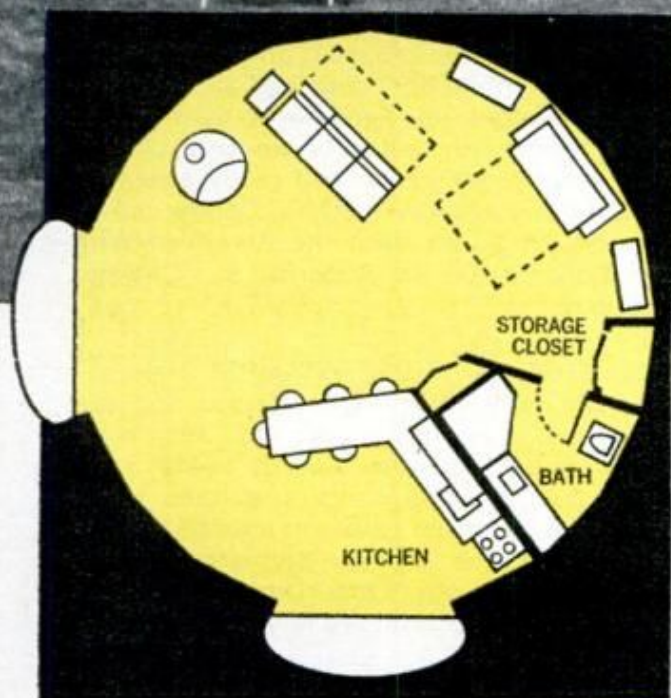

DESIGNED TO FILL the gap between the tent and the second home, the portable O'Dome shown above is a brightly colored, ellipsoid-shaped building of laminated fiberboard that can be erected in three hours by two people.

Selling for \$2650, it boasts 530 sq. ft. of unobstructed living space (see floor plan left) with room to sleep six comfortably. Weighing less than 1200 lbs., the home can be disassembled and stacked in a space approximately 3x5x16 ft.—small enough to be hauled on a boat trailer.

Lightweight but rugged, each of 18 wall panels snap together in a continuous pattern. Patented strips connect the pie-shaped panels and seal out moisture. The panels, in white, yellow, blue and green, can be ordered in any combination to mix or match as you choose.

Installation is easy. The first panel is anchored and shaped until others are joined to it; the rest assume proper shape and remain erect during assembly. For information, write Tension Structures, Inc., Box 217, Ann Arbor, Mich. 48107.



PANEL IS RAISED, held in place by tension. With all up, basic unit is 9 ft. high, 26 ft. in diameter

EXCITING NEW PRODUCTS

By CATHERINE BILSKI

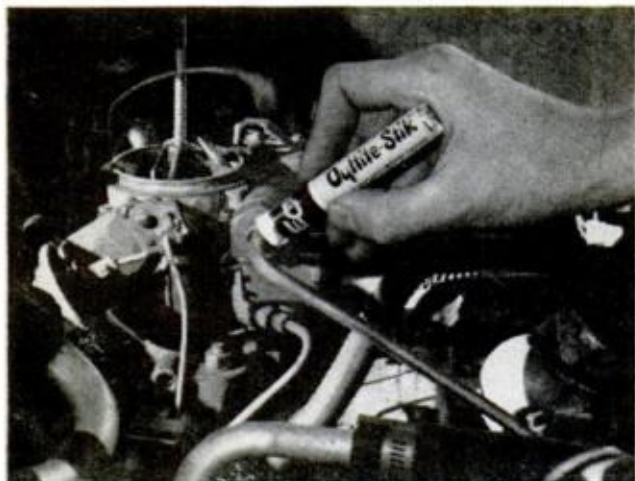

WANT TO STOP OIL LEAKS and eliminate messy stains and spots on driveways or garage floors? Oyltite-Stik seals leaks of oil, kerosene, gasoline, battery acids, grease, and so on. According to the manufacturer you just apply Oyltite-Stik to the leak and it stops instantly. No need to drain the system. Priced at \$2 a tube from Ed Cholakian Enterprises, Inc., 8125 Lankershim Blvd., North Hollywood, Calif. 91605.

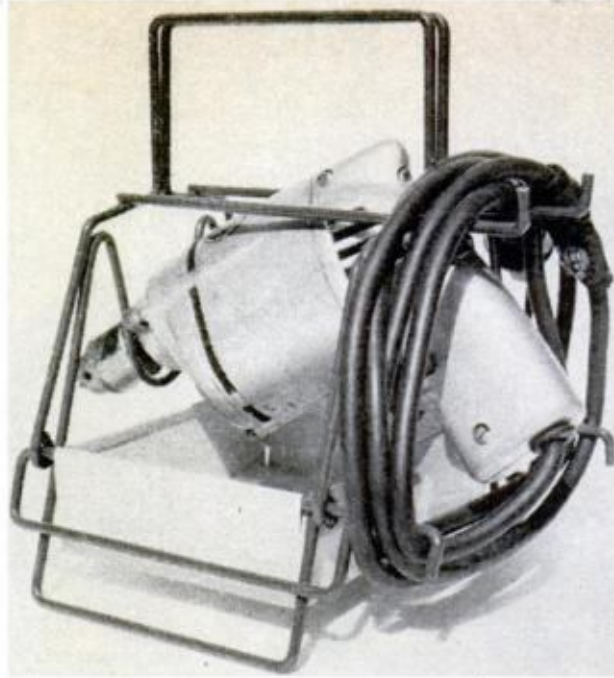

HERE'S A HANDY CADDY for toting and storing your often abused portable electric drill. The combination case and rack is sturdily constructed, yet lightweight so it can be carried easily from shop to worksite. A storage tray provides space and ready access to drill bits and small wrenches. Caddy can be acquired for \$4.95 from the American Wire-case Corp., 2208 W. Superior St., Chicago, Ill. 60612.



HATE LICKING THOSE STAMPS? Here's a dispenser that will moisten stamps and seal letters, too. The Jiffy Mailer No. 395, made of high-impact styrene plastic, holds a roll of 100 to 500 stamps. Its automatic moistener has a leakproof reservoir and a stainless-steel seal keeps stamps dry until needed. Costs \$3.95 from Lora Dumas, 13292-C Yockey St. No. 14, Garden Grove, Calif.

GET THAT OUTDOOR FIRE GOING in minutes with Char-Lighter, an electric lighter that makes charcoal cooking clean, quick, simple, safe and eliminates lighting fluids, matches—even kindling. Just plug it into any household outlet and place directly on charcoal or briquets. It can also be used to fry eggs and boil water. Priced at \$5.94 postpaid from Flintridge Products Co., 4032 Hampstead Rd., Pasadena, Calif.



NOW YOU CAN APPLY masking tape the way professional painters do. Tape-On is designed to apply the tape to woodwork, wallbase, windows, carpeting, whatever. It can save work on any edging job, and there's no worry about annoying drips, roller splatter or seepage. It also eliminates costly and time-consuming cleanups. Retail for \$8.95 and manufactured by Tape-On Corp., 143 W. Market, Akron, Ohio 44303.

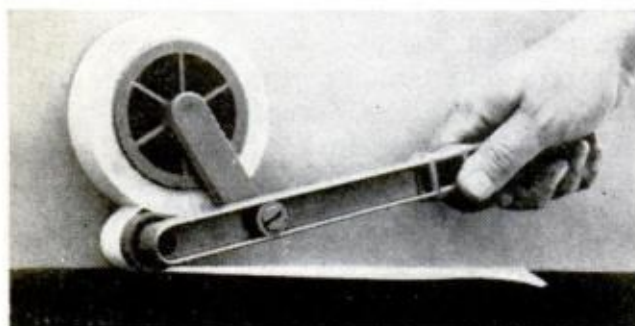

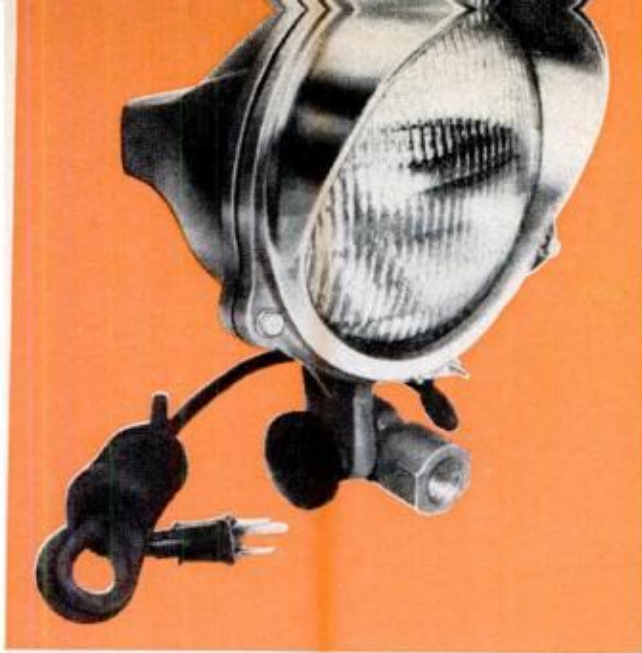

EXTRA LIGHT FOR WORK AREAS, swimming pools, tennis courts, and so on can be yours with a new line of quartz-iodine, prefocused sealed-beam lights. The lights have a life rating in excess of 4000 hours and produce 40 percent more light per rating. Available in 500 and 1000 watts and furnished with a 15-ft. cord and two-prong polarized plug. Made by Generac Corp., Box 8, Waukesha, Wis. 53186.

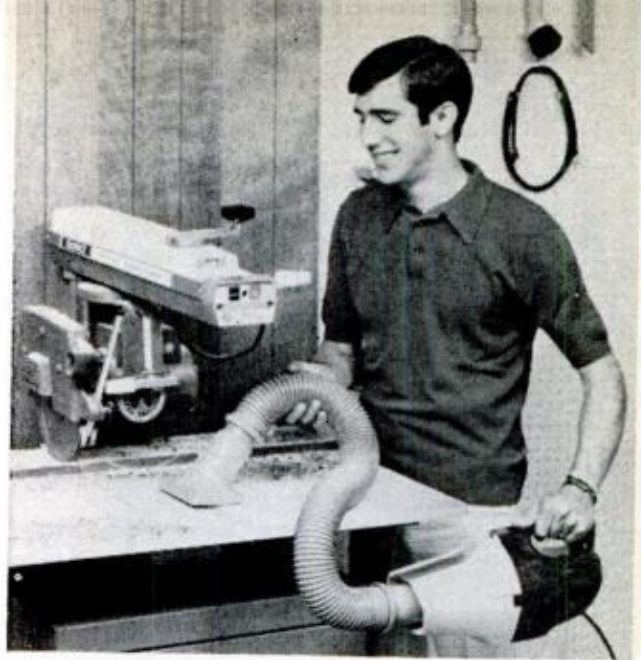

DOUBLE PICKUP POWER is promised in this new portable vacuum unit designed to clean hard-to-reach areas. Called "The Hippo," the unit features an adapter for use of standard 1 1/4-in. accessories, or you can order special accessories for special jobs. An 18-ft. cord covers lots of ground, making it ideal for home, shop, garage, or even outdoor use. Retailed at \$39.95 by Shop-Vac, Corp., 1 Industrial Rd., Wood-Ridge, N.J.



LOW-COST PROTECTION can be yours with this combination burglar-fire alarm. It's completely self-contained, needs no wiring or special installation, provides 24-hour unattended protection. Instructions and batteries included. Only \$4.95, it's made by Protect-Alarm, Dept. PM, 1746 N. Orange Dr., Hollywood, Calif.

"INSTANT" CLOTHESLINE is easy to assemble and set up. Made of high-quality coated aluminum, it goes up quickly when needed, comes down just as quickly, is easily stored. Called "Rigidrig," it's available in single (\$23.95) and double (\$39.95) units. Made by Rigidrig, 250 W. Main St., Evansville, Wis. 53536.

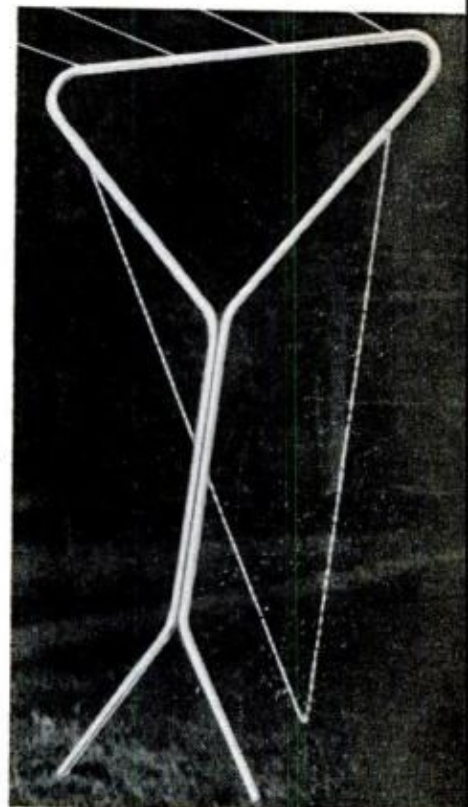

FIX CRACKS FOR GOOD with Krack-Kote wall and ceiling repair kit. Permanently repairs cracks because it bridges instead of fills them. Tuffglass fabric embeds in mastic coat to produce noncracking joint. Trial kit costs \$3.99, economy kit, \$6.99, both post-paid from Collectors Unlimited, Dept. K-183, Box 268, Fair Lawn, N.J.



How to Install a Wall Safe

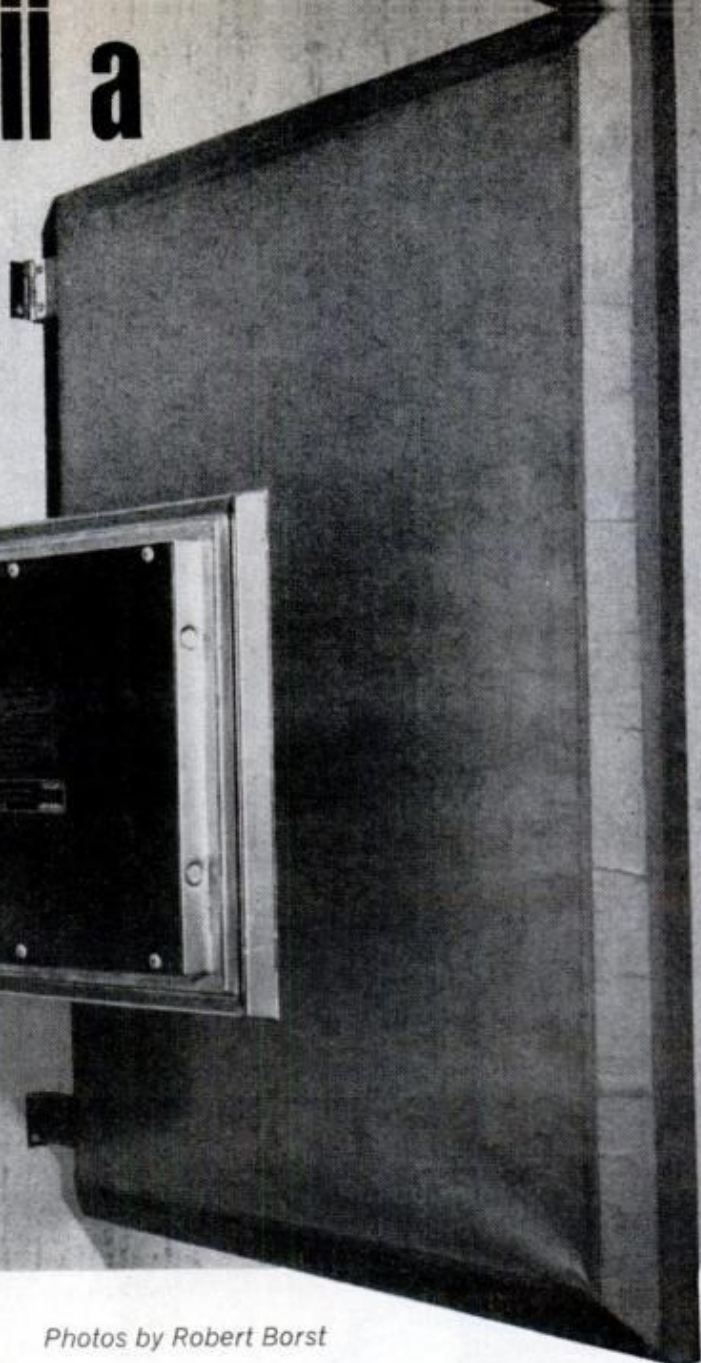

Photos by Robert Borst

Without a home safe to go with your bank safety-deposit box, you are only half safe in protecting your valuables

By WAYNE C. LECKEY, Home and Shop Editor

EVER STOP TO THINK what a job it would be to replace your birth certificate, insurance policies, deeds, bonds and other vital records should you have a fire? What about jewelry and money?

With such valuables kept safe from both fire and theft in your own "safe-deposit box" in a wall of your home, you'll not only have the peace of mind of knowing they're secure, but the convenience of having them always at hand—not just during banking hours.

As pointed out by the Safe Manufacturers National Assn., a home safe provides several



PICTURE HINGED TO WALL conceals safe from view, thus permits use of convenient location

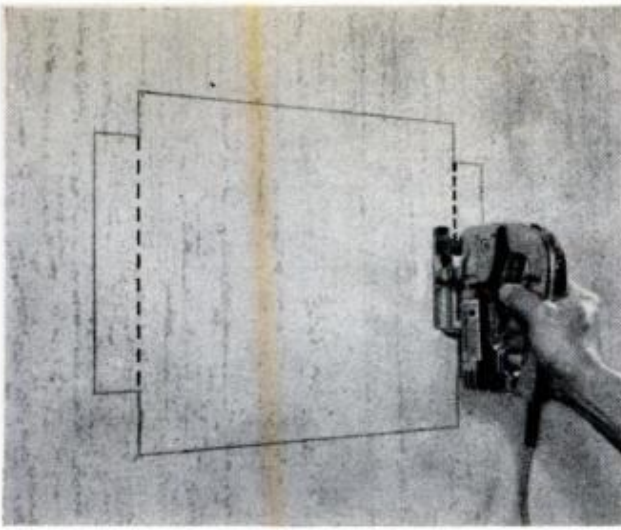

1 **SABRE SAW** makes quick work of sawing through plaster to cut 13 x 14½-in. opening

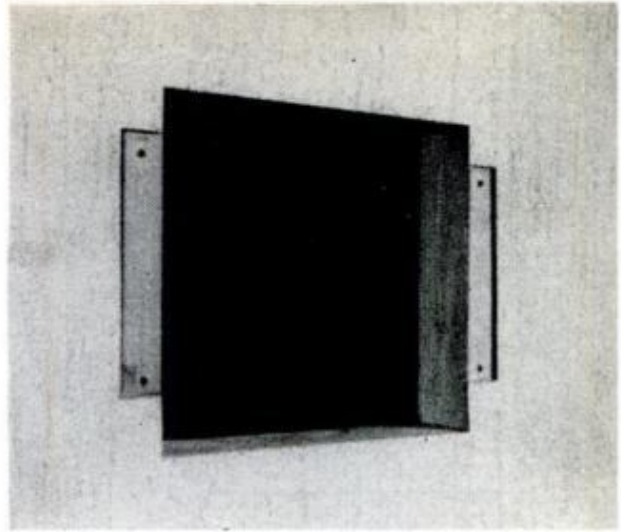

2 **RECESSES ARE CUT** in plaster over studs to accommodate safe's bolting flanges at sides

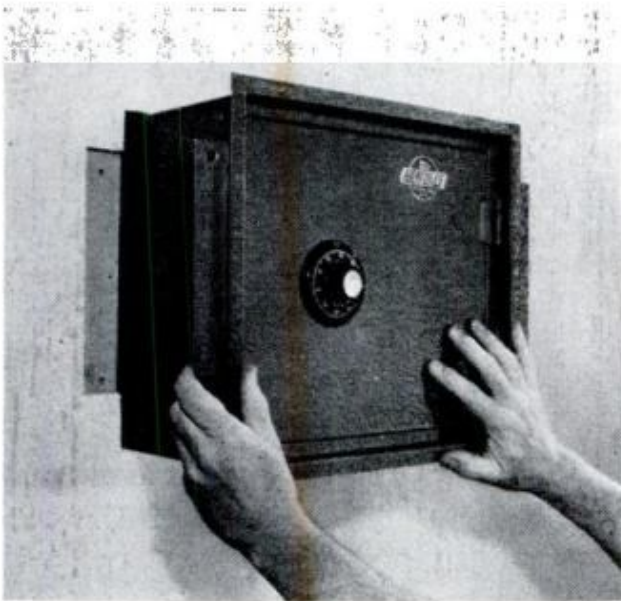

3 **SAFE IS SHOVED** in opening until flanges are seated. Pilot holes for bolts are made in studs

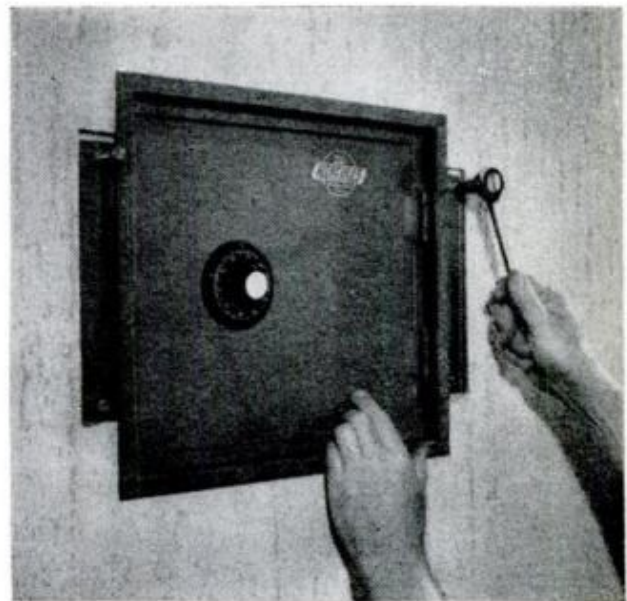

4 **FOUR LAGSCREWS** (¼ x 2-in.) anchor safe. Flange recesses are filled to hide screw heads

National Assn., a home safe provides several advantages for the homeowner:

- **Security.** Should a fire destroy his home, he knows that his family records will be protected.
- **Convenience.** The home safe is a general, single-source repository for all records and valuables.
- **Protection.** The danger of theft is minimized since the amateur burglar is generally prevented from entering the safe.
- **Accessibility.** Daily access to the safe enables the homeowner to protect important incoming receipts and records on the day of arrival.
- **Job protection.** Many businessmen take work home nights and weekends. Many times, one-of-a-kind records travel home in the briefcase. To assure their protec-

tion, the executive can store these company records in the home safe for added security.

- **Jewelry safety.** For the home without a money safe designed to hold valuables other than records and documents, the home safe is a stop-gap security measure until infrequently used jewelry is returned to the bank vault.

The Meilink Hercules vault shown here is designed to fit flush in the wall even though it has a three-tumbler combination lock. Thus the safe can be concealed by a wall picture or mirror, and only you know where it is. Inside it measures 9½ in. high, 11 in. wide and 8⅜ in. deep, roomy enough to hold all your documents and valuables. It weighs 80 lbs., costs about \$50 f.o.b. A thinner one is

FRAMING THE OPENING

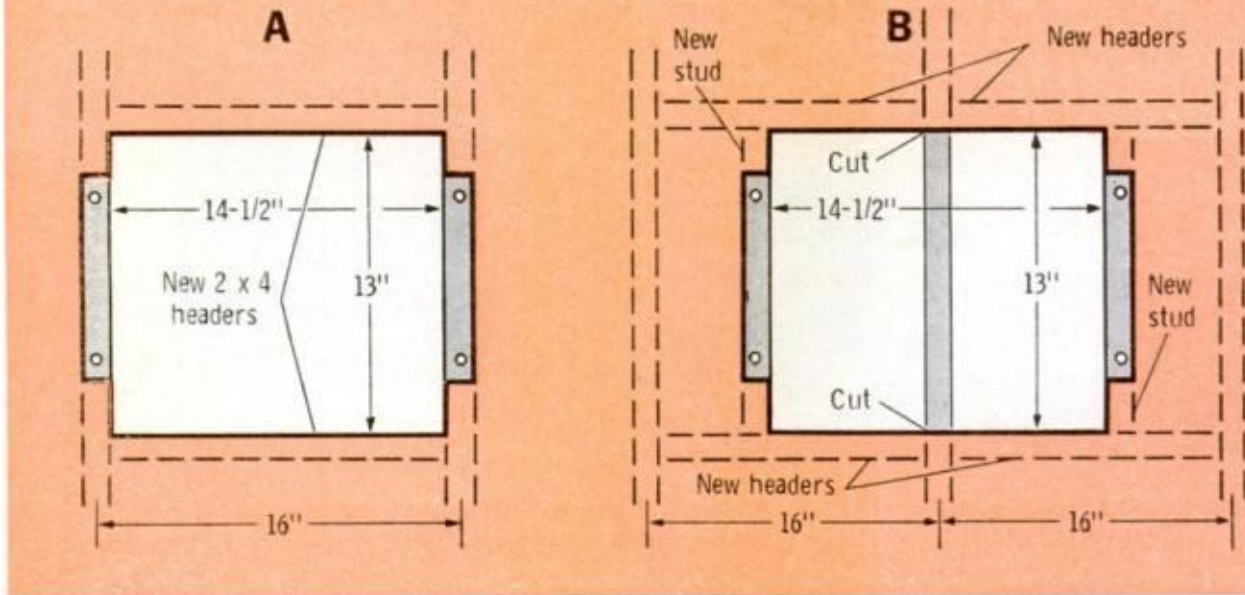

only 4³/₈ in. deep and weighs 60 pounds.

It's double-steel walls are thoroughly insulated to withstand a temperature up to 1700°F. for a period of one hour. Two ½-in. steel operating bolts on one side of the door, plus two stationary bolts on the hinge side, provide added security. Inside, there is a shelf and a flock lining.

The safe's four-number combination lock is registered at the factory. Should you forget or lose the combination, the factory will disclose it only to the registered owner of the safe.

Installation is made on an inside wall, preferably one which is backed by a closet. This way the safe can stick through the wall without protruding into another room. The least installation work is required when the safe is located between two existing studs as shown in detail A above. Here you need only add a 2x4 header at top and bottom of the opening.

Where you wish to center the safe on a wall, you may find the opening straddles a

stud as shown in Detail B. When this happens, the stud must be sawed off even with the opening and new fill-in studs installed along each side for bolting the safe. These are cut to wedge and glue in place between headers, then nails are driven through the plaster or drywall, as the case may be, to provide a rigid framework.

Hidden studs in the wall can be located by tapping the wall lightly and noting a solid sound. Since most studs are located 16 in. on centers, and since the safe is made to fit between two studs, you simply cut the plaster away between the studs. A sabre saw is a handy tool to use for cutting through plaster or drywall, although a handsaw will let you pass through both sides of the wall at one time. Try to keep sawing at right angles to the wall so that both openings will be the same size. This is particularly important when making the horizontal cuts; the studs will guide you when making the vertical ones.

A sharp chisel is used to chop away the plaster when cutting the recesses. The plaster or drywall, incidentally, should be a minimum of ½ in. thick to bring the safe's tumbler flush with the wall.

The safe is bolted to the studs with four lagscrews inserted through flanges welded to each side and recesses are made in the plaster over the studs to accommodate the flanges. Once the bolts are in place, the recesses are patched with a spackling compound or filled in with pieces of drywall, to make the bolt heads inaccessible. The patched areas are then painted.

★★★

HOME SAFE MANUFACTURERS

Diebold Inc.
828 Mulberry Rd. S.E.
Canton, Ohio.

Gary Safe Co.
306 9th Ave.
City of Industry, Calif.

Meilink Steel Safe Co.
Oakwood & Dawson Aves.
Toledo, Ohio.

Mosler Safe Co.
1561 Grand Blvd.
Hamilton, Ohio.

Protectall Safes
1957 Grand Blvd.
Hamilton, Ohio.

Murphy Mfg. Co.
128 E. Main
Louisville, Ky.

Schwab Safe Co., Inc.
Lafayette, Ind. 47902

York Safe Lock Co
818 Mulberry Rd., S.E.
Canton, Ohio.

Make This Hinged Fixture for Your Radial Saw

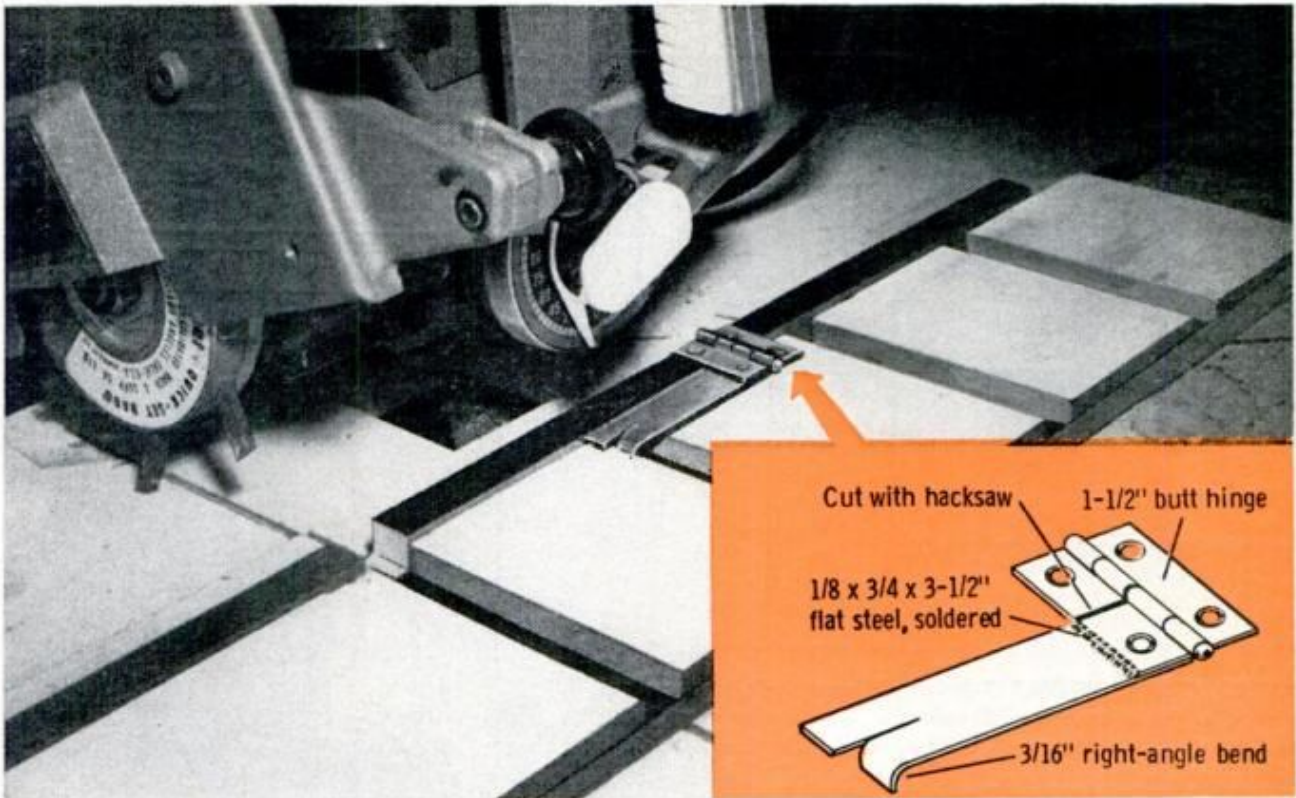

No radial-arm saw should be without this combination dado spacer and cutoff stop. It's the handiest thing for insuring equal spacing of shelf dadoes and cutting pieces to duplicate length. Permanently attached to the top of the wood fence, it's set to the desired spacing by sliding the fence in its slot. It flips over when not in use; if in the way when you're sawing 2-in. stock, turn the fence end for end.

When measuring for the first dado, the fixture is set against the end of the work, not the table. Otherwise the slight arc of

the pivoting fixture is enough to throw off the measurement.

The fixture is made from a 1½-in. loose-pin butt hinge. One leaf is hacksawed as shown and a metal arm is soldered to it. The end of the arm also is hacksawed and bent down to produce a lip. The hinge is screwed to the fence so the fixture overhangs the edge. This lets it drop down into the dado or against the saw table for cutoff work. When it's flipped back, 1-in. stock can still pass under it freely.—William Waggoner

Pencil eraser starts nut

If you are faced with starting a nut on the end of a bolt in a counterbored hole, you can do it with a pencil eraser. Hold it so it positions the nut squarely on the bolt and turn the pencil as you bear down. Friction will turn the nut. Once the nut catches hold, you can draw it up tight by jamming a screwdriver against the nut and the side of the hole and turning the bolt head with a second screwdriver. Ordinarily a regular nut driver is used to engage the nut but this special tool is not always at hand. In place of a pencil, a piece of double-backed tape on the end of a dowel would do.—Walter E. Burton



Solving home problems

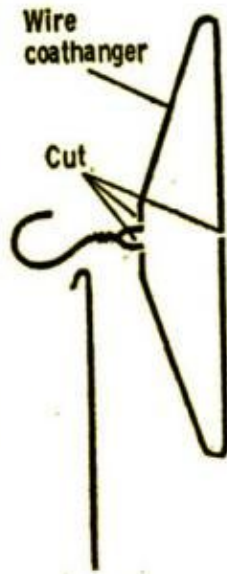

POTTED PLANTS WON'T TIP in a strong wind when set around a patio or grave if you use wire anchors cut from coathangers. Hook over pot, push wire in ground.—*J. H. Lewis*

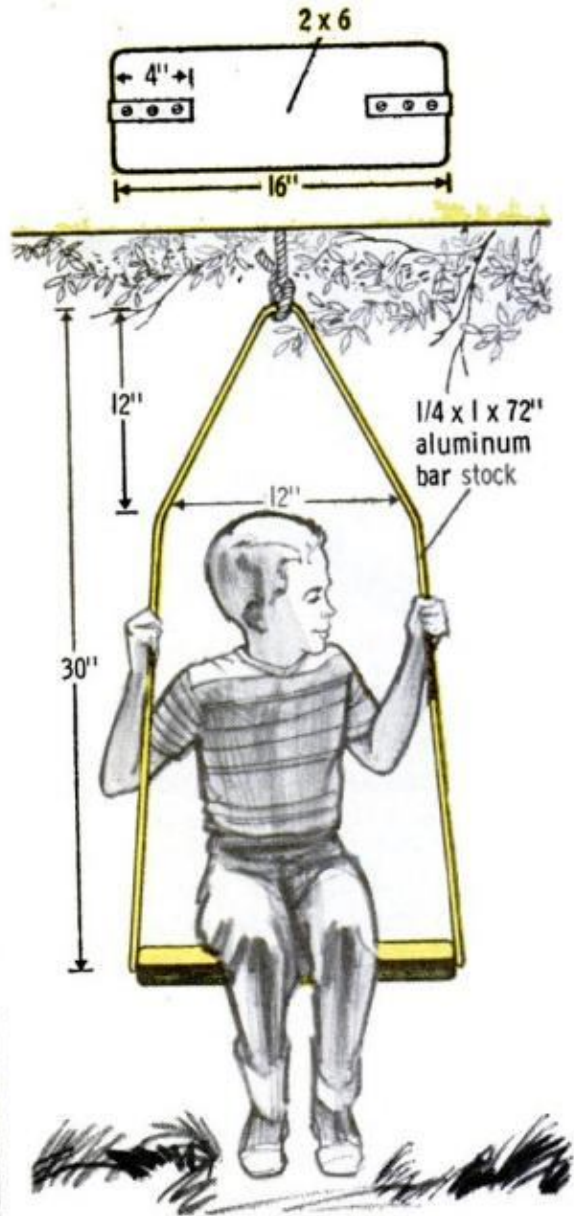

LIKE A TIRE SWING, this one-rope adaptation is more fun than two-rope one. Bend yoke from aluminum and add wood seat.—*Harold Miglin*

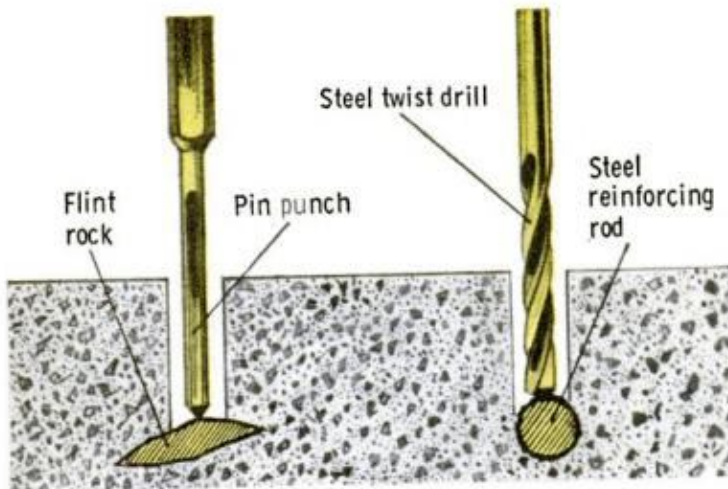

NEXT TIME FLINT ROCK IS IN PATH of your masonry drill, stop drilling and use drift pin to break it. If you hit steel reinforcing rod, switch to twist drill.—*George B. Domenico*

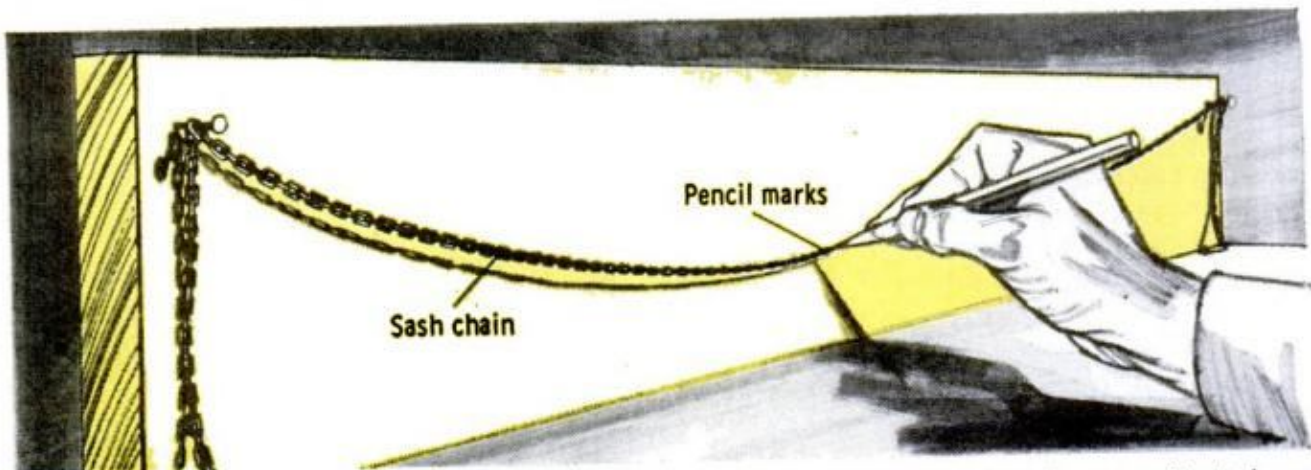

LENGTH OF SASH CHAIN makes simple compass for drawing large arc. Suspend chain by two nails, let hang free and make a dot every four or five links. Then connect dots to form unbroken line.—*Victor H. Lamoy*



TO REACH HORNET'S NEST under eave attach strap hinge and spray can to pole. String to hinge runs spray.—*B. R. Alexander*

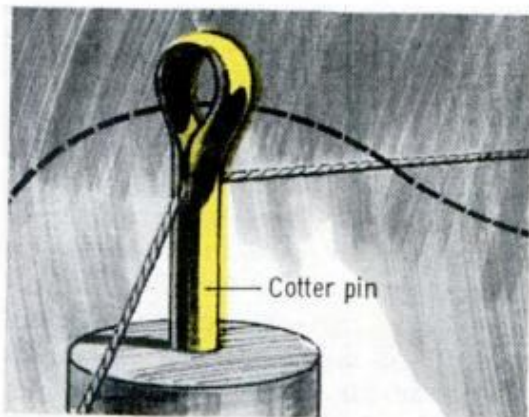

QUICK-RELEASE STRING HOLDER is a cotter pin in end of stake. String wedges between pin, quick yank pulls it free.—*Daniel Bousha*

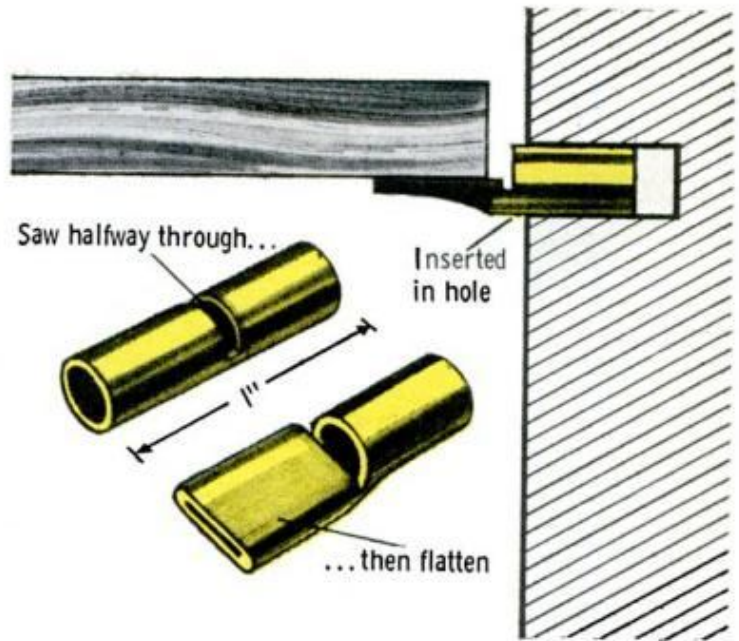

YOU CAN MAKE SHELF SUPPORTS by the dozen if you cut $\frac{1}{4}$ -in. tubing in 1-in. lengths, saw halfway through and flatten with hammer. Round end is stuck in blind hole.—*Daniel Bousha*

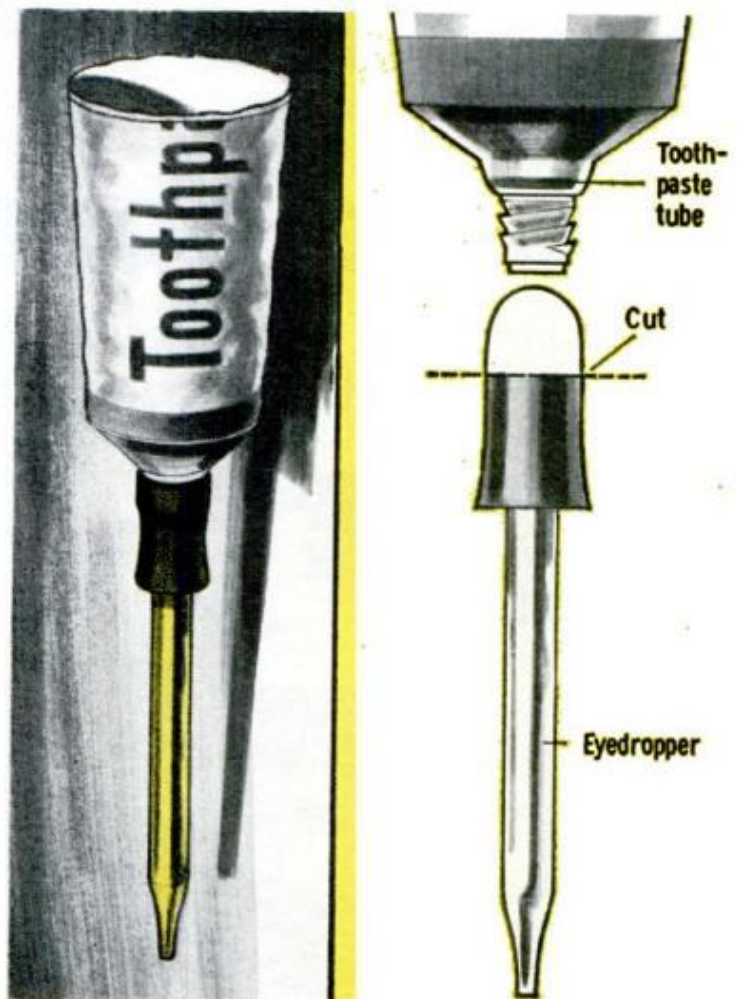

TO FILL SMALL-MOUTH BOTTLE, eyedropper and empty toothpaste tube make perfect funnel. Cut rubber end off dropper and force it over threaded end of tube.—*Joseph Braunstein*



CLEARING THE AIR in winter is a problem. Opening a window gives chilly blasts and causes heat loss

Update Your Heating

A fresh-air intake that you can install yourself makes stuffy air a thing of the past.

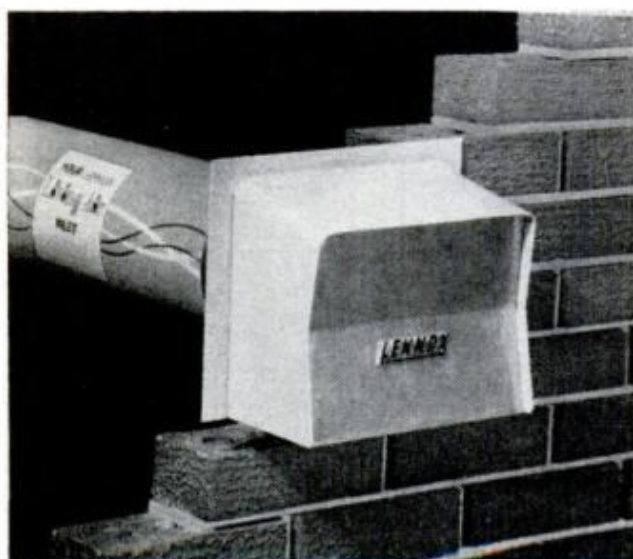

FRESH-AIR UNIT comes complete with bug screen and a damper that's located in the 6-in. round pipe.

IF YOUR HOME is equipped with a ducted central heating system and you are just plain tired of opening windows and living with drafts every time you want fresh air, you're in luck. New from the Lennox Corp. is a fresh-air intake that installs quickly and inexpensively. And, happily, it makes the which-window-to-use game a thing of the past.

Called Living Air Inlet, the unit draws fresh (outdoor) air into the system and pipes it directly into the inlet or return-air side of the warm-air system. A manually operated damper lets you adjust the flow of outside air to suit your comfort. All outside air is filtered and conditioned (heated or cooled) before it enters the living areas of the home.

Construction techniques in the past produced houses that were pretty leaky. Windows were loose in their frames; weatherstripping was expensive, thus not widely used, and installation of adequate vapor barriers was practically unknown. Additionally, walls, ceilings and floors were comparatively porous, so outside air could move through the home by infiltration. In effect, there was enough "leakage" to keep the inside air satisfactorily fresh.

Today's construction methods have changed the picture. Windows and doors are factory-tight; well-designed weatherstrips are universal; and modern insulation, if properly installed, provides an airtight vapor barrier. Thus, to replace stale air, you must open windows. And that means drafts and loss of heat which costs you money.

A fresh-air inlet solves those problems by bringing fresh air into your heating/cooling unit. Additionally, through the constant supply of outdoor air, a slight positive pressure is created in the home. The maker claims this tends to counteract normal infiltration.

The beauty of the unit is that its use is not restricted to new construction. A 6-

in.-diameter hole is required to install the intake through an exterior wall to the outside. Then, you simply caulk all around the pipe in order to prevent rain seepage and connect the pipe to the nearest return-air duct (or drop) in your warm-air heating system.

Lennox recommends that warm-air furnace blowers should be set to operate constantly, rather than be controlled by the "on-off" operation that is usually used. With the fan operating constantly you will receive full-time benefits from your warm-air furnace when combined with the fresh-air inlet.

Keep in mind that outside air can only be effectively introduced into your home if you have a ducted central heating system. A nonducted system (radiators, for example) cannot carry outside fresh air at all. Radiators simply heat air within each room; there is no mixing of the air drawn because it is not drawn back from all of the rooms to one central point for filtering.

Price for all this luxury is under \$10 if you install the intake yourself. For buying information, contact the certified Lennox dealer nearest you. He's listed in the Yellow Pages. ★★★

System With Fresh Air

HOW SYSTEM WORKS

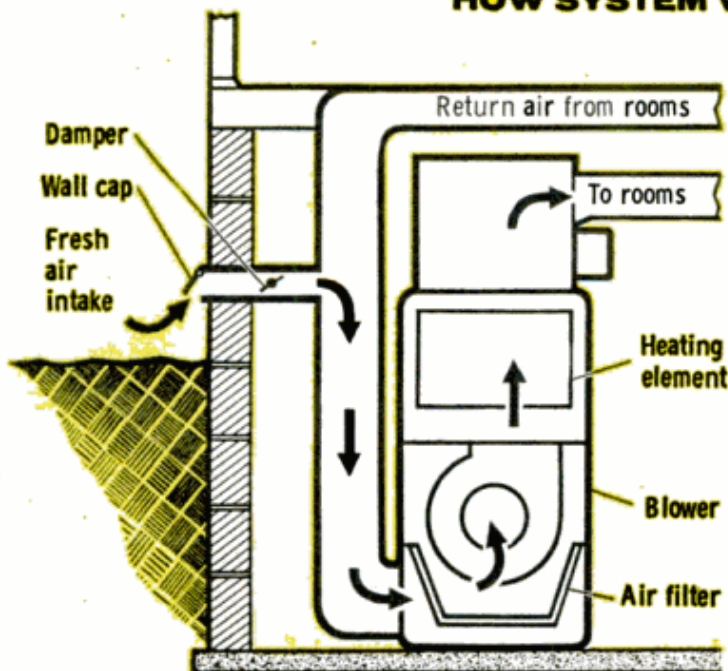

Positive pressure created combats infiltration, eliminates drafts through walls

◀ Fresh air is introduced directly into return duct, filtered clean, conditioned and ducted to living area

New tools you should know about



Do-everything cutting tool

Here's a tool that handles like a conventional plane or file and boasts a 10-sq.-in. cutting surface. Dubbed Versaplane, it will cut hard and soft wood, brass, zinc and other alloys; bevel glass and marble, and sharpen axes, scythes and mower blades. At hardware stores, \$9. Made by Great Neck Saw Mfrs., Mineola, N.Y. 11502.

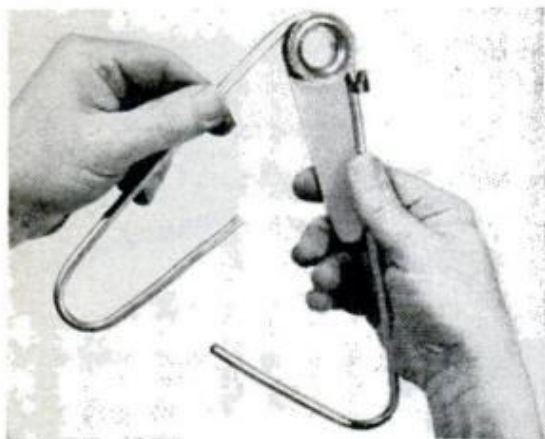

Low-cost tubing bender

Fast and easy to use without kinking is the Tube Bender 541A. Tubing up to 5/16 in. in diameter is simply slipped under the bender's flange and bent around the circle. For right-hand bends, the procedure is reversed. Sold through hardware stores for \$1.65. Kastar, Inc., Station Rd., Bellport, N.Y. 11713.

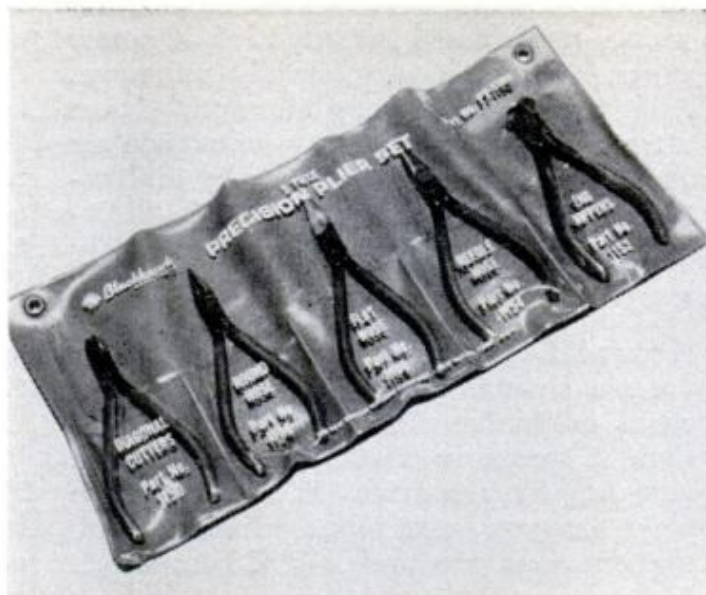

Midget plier set for close-in work

Five-piece electrical plier assortment (above) consists of diagonal cutter, end nippers, and needle, flat and round-nose pliers. The 4½-in.-long pliers of high-grade alloy steel are drop-forged, heat-treated and fitted with oil and chemical-resistant vinyl grips. Plier set No. PT-1160 in the Blackhawk line is priced at \$19.50. New Britain Machine Co., New Britain, Conn., is the maker.

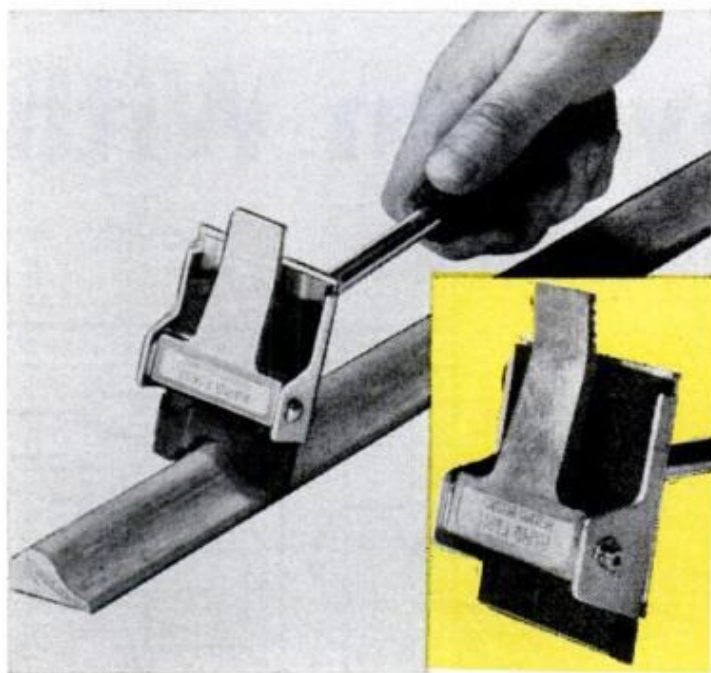

Scraper features form-fitting cutters

Paint can be easily scraped from contours such as window frames, boat hulls and moldings with this tool called Rapid-Form, which has tempered steel blades fitted into its adjustable head. You simply release the clamp-lock, position the blades against the form to be scraped and relock the blades. Priced at \$7.95, it's made by Crystal Metal Products Co., Inc., Philadelphia, Pa. 19134.

HINTS FROM READERS



Hook saves drill

When working with an electric drill on a stepladder, it's easy to knock the tool off and cause expensive damage. To prevent this from happening, I fastened an ordinary coat hook to the ladder to serve as a tool hook. If you add an extra hook, other power tools can be hung with a short piece of string or wire.—Ken Patterson



No-cost nail carrier

Here's a versatile nail carrier that can be toted right to the job, even when working on a ladder. To make it, cut two half-gallon milk cartons as shown above, then simply staple the tops together. The carrier can be hung over the rung of a ladder, or placed on the floor or bench where you are working.

—Ken Patterson

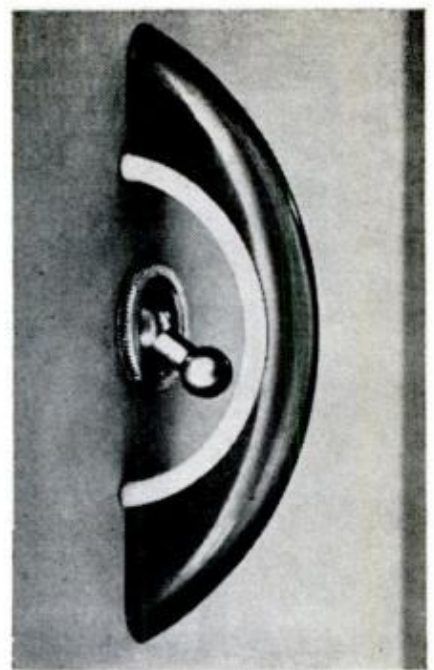

Toggle-switch safety

An exposed toggle switch is subject to damage and breakage and, if accidentally flicked on, can cause injury by a power tool. To minimize these hazards, I installed a drawer pull over the switch. This requires reaching under the handle to push the switch, but the pull now takes the brunt of any blows.—Allen Wilks

NEXT MONTH IN SHOP AND CRAFTS

BUILD A CHRISTMAS GREETING FOR YOUR LAWN. Designed especially for our readers, it's motorized and gaily decorated with three lovable Disney characters. Sure to draw raves from the neighbors, it may even cop a prize in an outdoor decorating contest. Complete plans, including Project-A-Plan slides which make it a snap to copy the art, are in the November issue.

WOODTURNING FUN FOR BEGINNERS. Here's the answer for the man who wants to try his hand at woodturning without investing a lot of money. Using a low-cost lathe, you can experience the same enjoyment that you would get working with a more expensive tool. Packed with useful woodturning information and tips, this article will help experienced, as well as beginning, lathe buffs. In *PM* next month.

WHAT YOU SHOULD KNOW ABOUT HOME BURGLAR ALARMS. High, low and middle-income families have one thing in common: they are all fair game for burglars. However, you can do something about protecting your family and property. Here's a round-up of foolproof systems available for burglarproofing your home and how to install them—in the November issue of *PM*.

HOW TO ANTIQUE YOUR OWN BEAMS. If you like the look but not the price of hand-hewn beams, why not add the ancient art of adzing to your woodworking skills? Using a "homemade" adz, you can turn out finished beams that will match those that you've seen in restored Early American homes. Learn more about this fascinating woodworking technique in *PM* next month.

How to 'Plane' On a Lathe

The number of tricks you can perform on a machine lathe seems endless. Here's another you can add to your bag

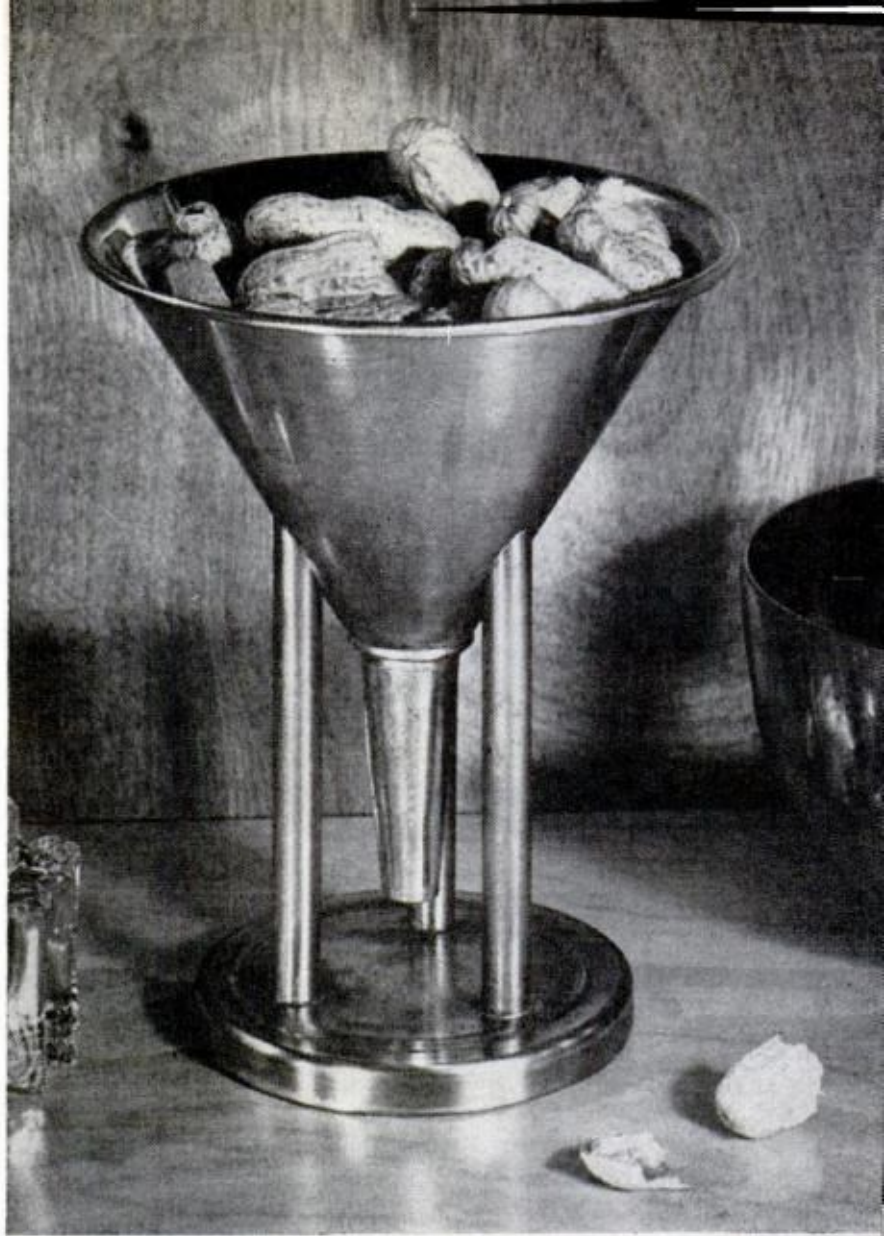

By **WALTER E. BURTON**
Technical Art by Fred Wolff

NOVEL DISH has conically planed legs. Text gives technique

YOU DON'T HAVE TO OWN a planer, shaper and milling machine to do flat and conic surfacing. Using a machine lathe and the proper techniques you can:

- "Plane" a flat surface on a chunk of steel.
- Square up a block or bar, or simply reduce its thickness.
- Convert a rod into a gouge-like tool.
- Shape a rod end to fit the contour of a cone.

To machine a flat surface, the workpiece is clamped in a chuck or bolted to a faceplate, and the tool cross-fed. Depth of cut is determined by carriage movement or by the compound slide while the carriage remains stationary.

Often, when a rectangular or nonround area is to be machined, the cutting action is intermittent. The tool shaves a chip, then traverses empty space until it con-

tacts the workpiece again. Because of this intermittent action, a too-deep bite by the cutting tool puts excessive stress on the work, chuck or holder, and bit. A must in such work is to maintain a keen cutting edge and to keep the feed gradual. For cutting steel, use a tool that is ground to produce an effective shearing action.

Nonround workpieces, such as a rectangular steel block, are generally clamped in independent four-jaw chucks. If necessary, jaws can be reversed to accommodate the work and reduce jaw overhang.

A flat surface (for example, a block to be squared-up when toward the chuck or faceplate) can be leveled by one of three methods: 1. Placed against chuck or faceplate surface with jaws or clamping devices tightened to prevent an edge from moving away from the surface; 2. Rested against jaw steps that are equidistant

from the chuck face; 3. Positioned with the aid of round rods, or rectangular bars of uniform thickness, used as shims. As you tighten the chuck jaws, keep the workpieces in good contact with shims, then tap shims endwise and remove before starting.

When the surface to be machined is reasonably flat, but thickness varies or the opposite surface is not suited for leveling, the block can be positioned with the help of a dial indicator or by the method shown in the bottom photo at right. With the compound slide set at about a 30° angle to the lathe axis, the micrometer scale on the compound screw is used for checking positions of the four corners of the outer surface. The tool bit is run forward until it stops against the workpiece face near one corner and a scale reading is made. Then, the bit is retracted and the workpiece turned to bring the second corner into alignment with the bit for a second scale reading.

Continue adjusting the block until all four corners are within a few thousandths of being in the same plane. Done this way, only a small amount of material need be machined off to produce a true, smooth surface.

Surfacing a block may consist of feeding the tool with the cross-slide screw all the way from the outermost edge, or corner, to the center. There are also jobs in which the area to be machined lies near the outer periphery of the chuck or faceplate. In such cases, the setup must be made so the work is positioned where the bit engages it without striking the chuck jaws or any other part of the workpiece.

To square round stock, as in making a socket-wrench handle, the tool must contact only the end to be squared. If you are machining two of the surfaces, the rod end being squared must be shimmed to compensate for metal removed from the other two surfaces. The rod has to be positioned so opposite surfaces will be parallel, unless you want to provide relief (as for a punch) because the same setup can be used to produce triangular, hexagonal or even nonsymmetrical sections. This setup can also be used for cutting side openings in tubular pieces.

Straight edges can be machined on small pieces clamped in a chuck or faceplate fixture. They must be held firmly and in proper alignment with respect to

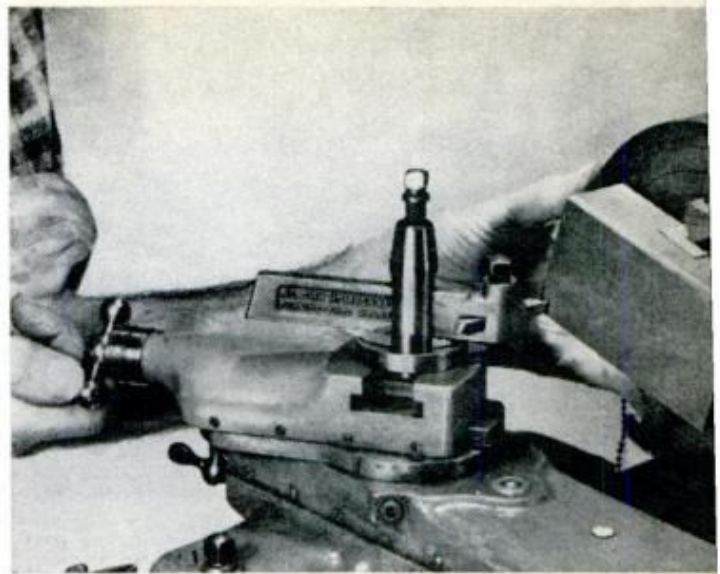

MICROMETER SCALE used on compound slide is angled at about 30° to check alignment of block being machined to reduce thickness, true up the surface

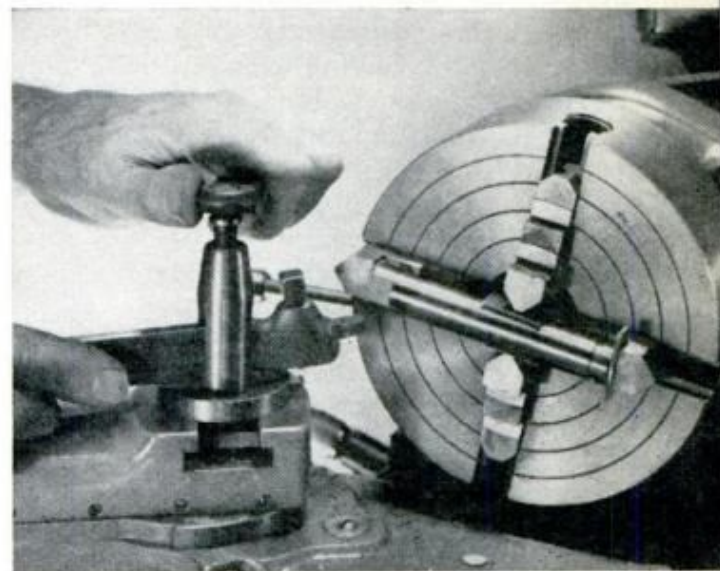

MACHINING A FLAT END of $\frac{1}{2}$ -in. steel rod, slightly curved margin is usually not objectionable. Below, workholder is used when planing small work

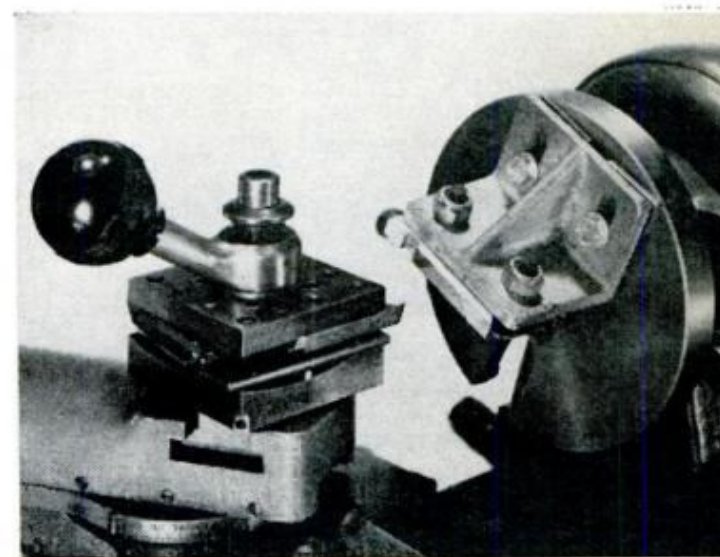



JIG FOR MACHINING ROD ENDS is of scrap cast iron. Hole drilled to accommodate rod snugly is fitted with two brass setscrews to hold the work securely

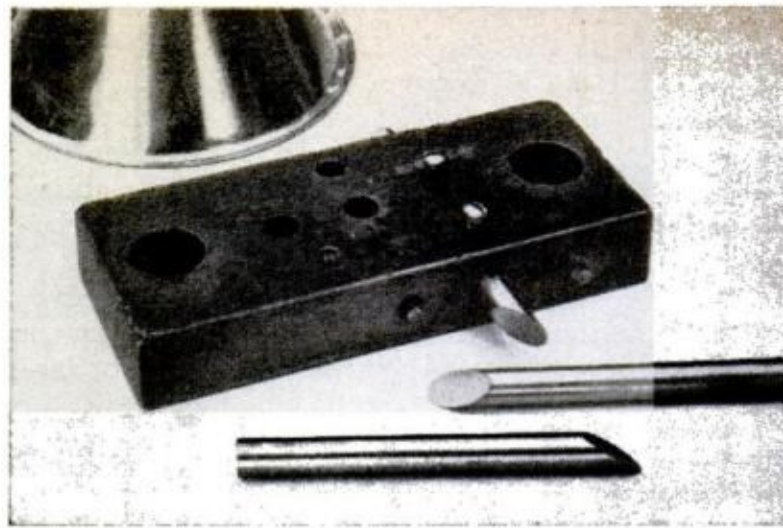

TO SHAPE END OF ROD to fit cone of 66° angle (funnel side), compound is set at 33° to lathe axis. Hole for tailstock center must be drilled accurately

amount of tool travel and the edge bevel.

The photo at the bottom of page 195 shows a setup improvised from a small angle bracket (salvaged from a junkbox) and a faceplate having a dogtail slot. The bracket happened to have a clamping arrangement that operated somewhat like vise jaws under the squeeze of two bolts. It also was not quite square—less than 90° —and required shimming.

Cutting the ends of short rods or tubes

to precision angles is easy when the workpiece is mounted securely in a chuck or faceplate fixture so that it projects at the required angle. To make a cut, the lathe tool is moved gradually crosswise with the cross-feed screw.

The fixture shown in the middle photo on page 197 is a scrap bar of steel clamped firmly in the four-jaw chuck. A hole was drilled at the desired angle near one end of the bar and a $\frac{1}{4}$ -20 setscrew installed

TYPICAL SETUP FOR PLANING CONIC SURFACE ON ROD

Imaginary cone segment generated by machined surface

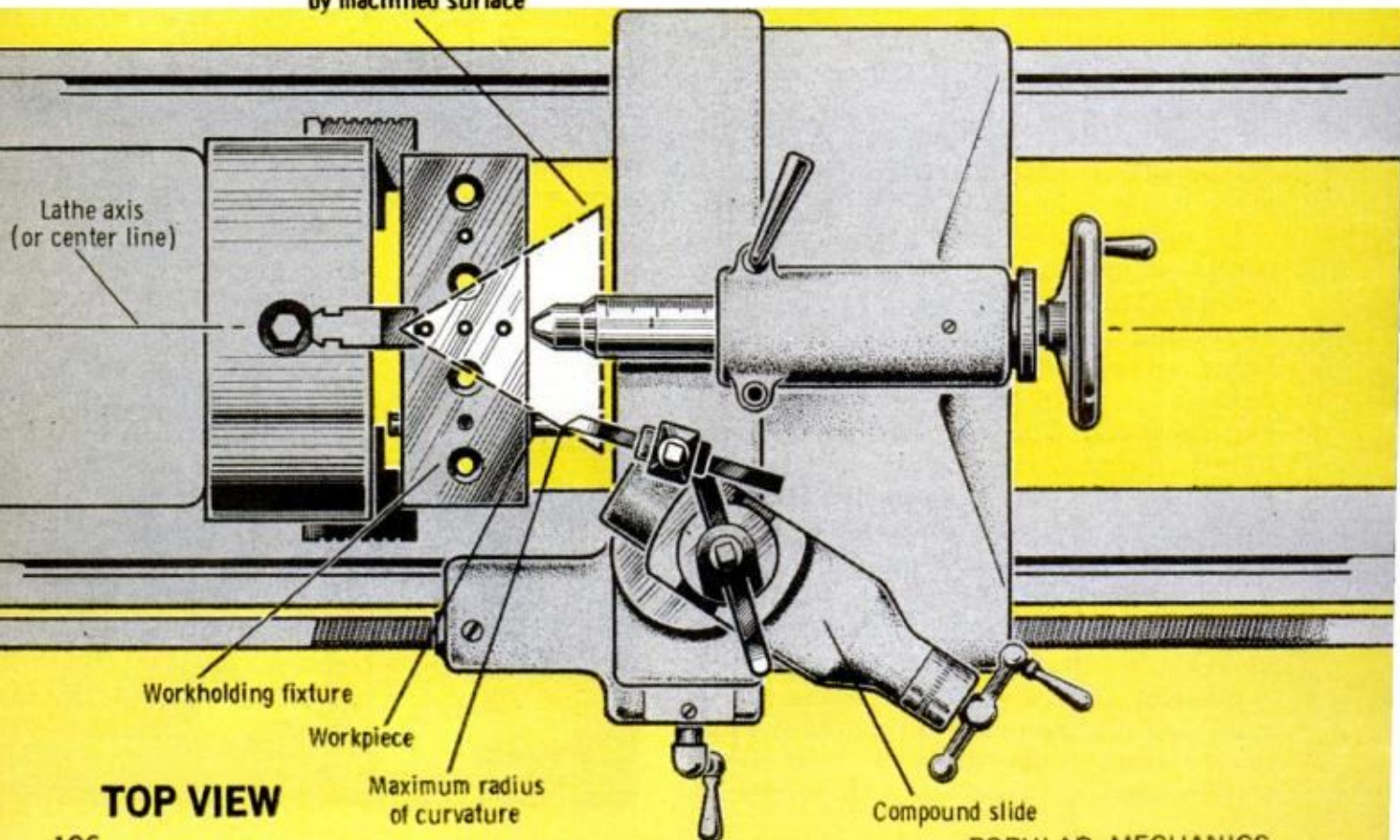

TOP VIEW

to lock the piece to be machined. This bar also has a similar hole at a right angle to the first hole, for holding a rod whose end is to be machined square—that is, 90° with respect to rod axis. The same setscrew serves both holes.

Using a little imagination, it would not be difficult to make a fixture that could be adjusted for producing a wide range of angles on rod or tube ends. For example, if the workholding bar (see photos at top of facing page) were round instead of rectangular in cross section, it could be rotated to vary the angle. Here the jaw bite would be less at the ends. Normally, the workpiece would be clamped in a hole drilled at a right angle to the bar axis, but you can compound things further by angling the hole outward and rotating the bar to an angular position.

Conical surfaces

For machining a flat surface on the end of a rod or other piece, the cutting tool moved straight across the lathe bed by means of the cross-feed screw. But, if you set the compound slide at an angle and use it to control feed, the resulting surface is a segment of a conical surface.

The piece of maple wood shown in the chuck (top, right) is a good example of conical planing. The V-notch has been cut near one end by compound-slide movement. The outermost concave surface of the V was formed with the tool right-side up and operating at the front of the lathe. The convex, or second half, of the V was cut with the tool inverted and operating at the back of the lathe. (You'll notice that some of the other end of the piece is cut away during the second step.)

Of what use is such a stunt? A number of V-cut blocks could be glued together, side by side, to produce a novel molding or panel. If you want an even more pronounced surface curvature, simply cut the notch nearer to the chuck center.

The ability to produce conical surfaces by controlling tool movement with the compound slide on a workpiece located offcenter in relation to lathe axis, can be put to use to shape a rod end to make a special chisel or gouge.

To produce the novelty nut or candy dish shown in the lead photo, three metal rods were machined so that their ends fit neatly against the outside of a tin-plated funnel. You may never need a funnel

(Please turn to page 246)

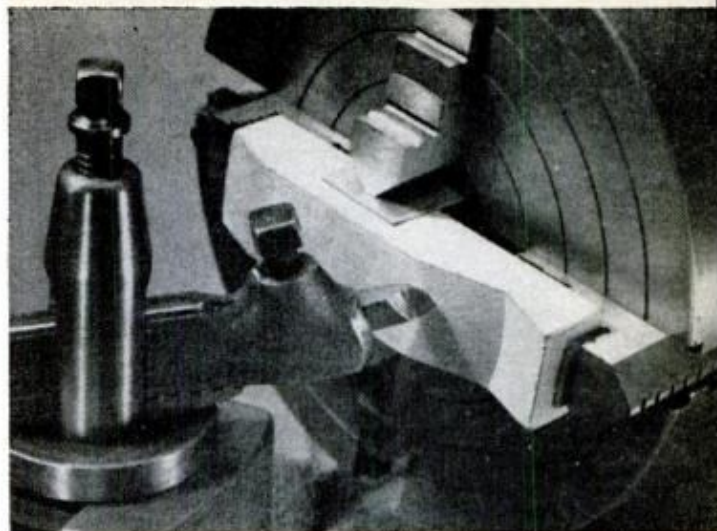

COMPOUND SLIDE can be used to produce concave or convex surfaces depending on the position. Block of maple is shown mounted in the back position

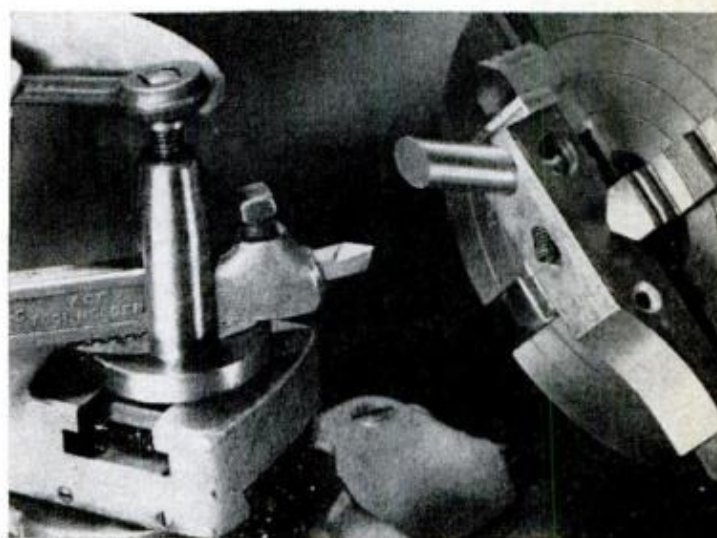

MOUNTED AT AN ANGLE to chuck or faceplate, end of rod is machined flat and diagonal. Here, end slope depends on angle of hole drilled in holding block

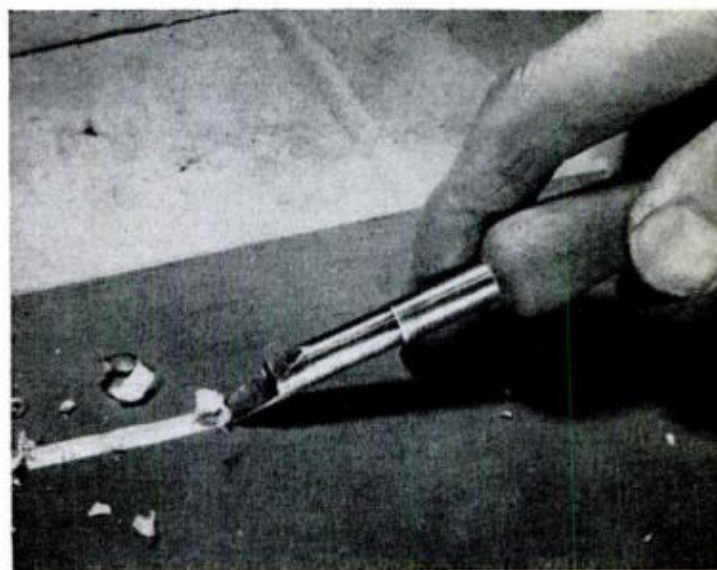

CUTTING EDGE OF GOUGE was formed with compound slide set at about 15° angle to lathe axis. Radius of swing was approximately 3/8-in. minimum

DENT PULLER FROM PIPE PARTS

Here's how it works: You first solder a flathead nail or screw to the center of the dented area to serve as a stud. Then you place the puller over the stud and tighten it with a setscrew. To pull out the dent you simply turn the nut on the end of the bolt. When the dent's gone, you unsolder the stud.

Besides pulling dents, the puller will be handy for extracting pins, small gears and wheel hubs.

A soldered nail or screw will usually do the trick when the dent is in light metal. However, on heavier metal you may find it necessary to braze the stud to keep it from pulling free since the tool exerts considerable pull.

I used a 1-in. pipe cap for the base of the puller and bored out the threads, although you really don't have to do this. Then I drilled and tapped the cap for a $\frac{3}{8}$ -in. pipe nipple $3\frac{1}{4}$ in. long. "Windows" are required in opposite sides of the cap to reach the setscrew that locks the puller to the stud. To cut the oval-shape windows, I first drilled two small holes and reamed them to $\frac{5}{8}$ in. Then I cut away the metal web between the holes and filed the sharp edges smooth with a rattle file.

To cut the narrow slot in the side of the nipple, I drilled a row of overlapping holes for a distance of $1\frac{1}{8}$ in. to accept a $\frac{6}{32}$ machine screw and then filed out the slot with a small rattle file. The slot is located $\frac{3}{8}$ in. from the pipe threads.

Next I drilled a No. 27 hole $1\frac{1}{4}$ -in. deep into the end of the hex bolt. Then I drilled a second hole at right angles ($1\frac{1}{2}$ in. from the bolthead) and tapped it for the $\frac{6}{32}$ stud-locking screw.

When the pipe-cap rim is too far from the dent, and pulling tends to form an outward bulge, a large washer, or other metal plate with a hole of suitable size in it, can be interposed to concentrate the force in the dent area.

For pulling hubs and pins, the bolt head can be modified as required—perhaps fitted with a chuck that will grip less roughly than a setscrew. ★★★

POPULAR MECHANICS



By WALTER E. BURTON

NINE TIMES OUT OF TEN you can hammer out a dent in metal from the back, but there's always that one time when you can't. Such is the case when you bash in the side of a metal container, the pump on a garden sprayer or other sealed receptacle. When this happens, the job requires a puller, such as this one made primarily of pipe fittings and a hex-head bolt.

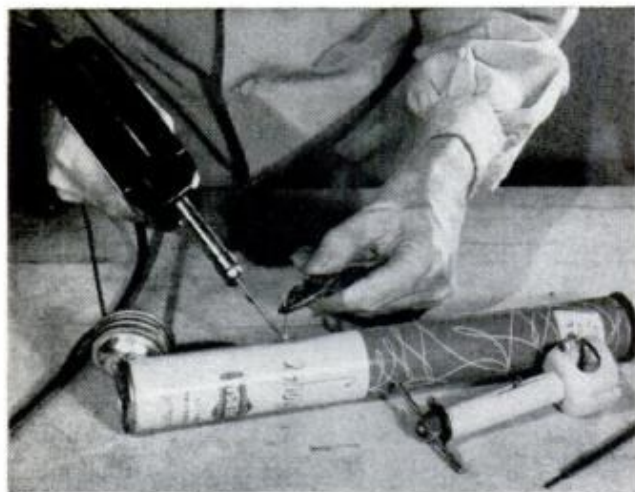

NAIL STUD soldered to dent is "handle" for puller. Flat end of puller works on round surface; saddle from a bent washer placed over the stud is better

HINTS FROM READERS

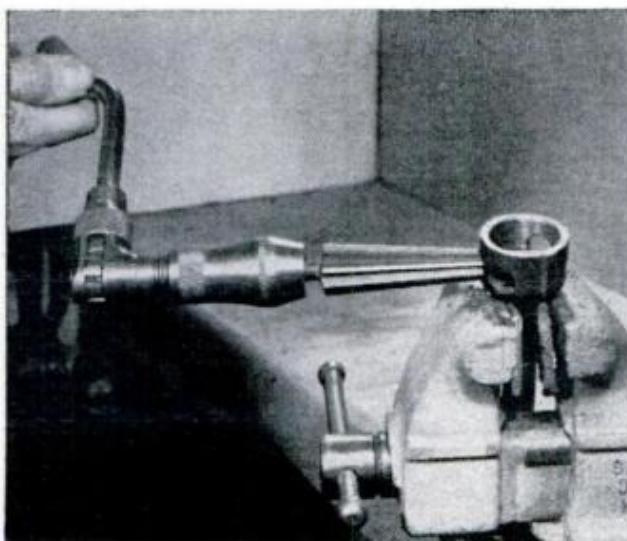
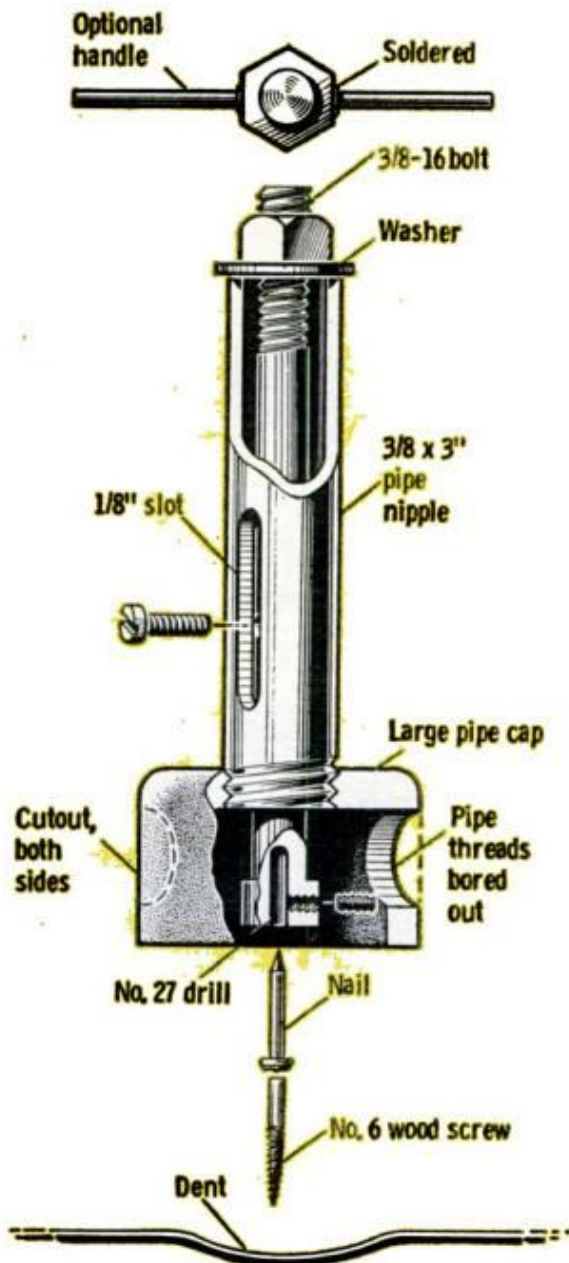

"WINDOWS" IN PIPE CAP are formed on each side by enlarging pair of holes with reamer, then cutting away remaining web. File is used for final shaping

OCTOBER 1969

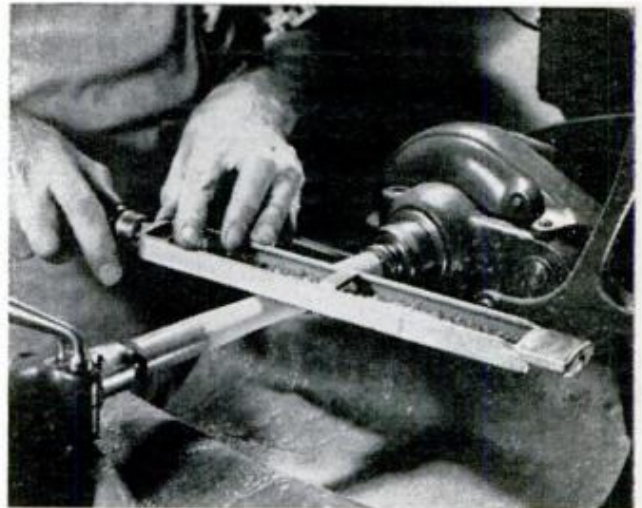

Rasp shaves turning quickly

On occasion I use my metal lathe as a wood lathe and, when the turning might be a simple cylindrical shape, I have found that a rasp, such as a Surform or a Versaplane, provides a fast-cutting "chisel" for roughing-down the work. With no regular toolrest to support the tool, I hold the rasp like a file in conventional lathe filing, being careful to keep dangling shirt sleeves out of the work. When the turning is brought down to rough size, I switch to a coarse-tooth file, then finish with sandpaper. It's a good idea to cover the ways of the lathe to catch the chips and dust.

—Walter E. Burton

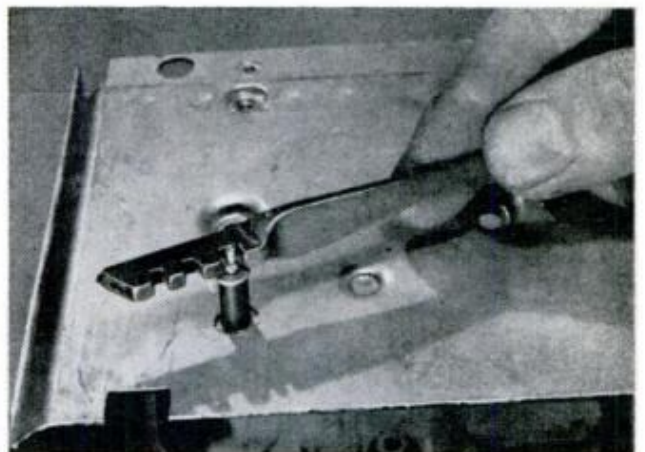

Glass cutter serves as wrench

You might not think of your glass cutter as a wrench, but it will serve in a pinch when you are faced with tightening a tiny nut. Just pick the notch that fits the nut and use the cutter like a regular open-end wrench. It won't mark up the nut like pliers do.—Ken Murray

199

You Can Build a Lightweight

Got pressing problems? Here's a 5-ton rig you can build in a couple of hours.

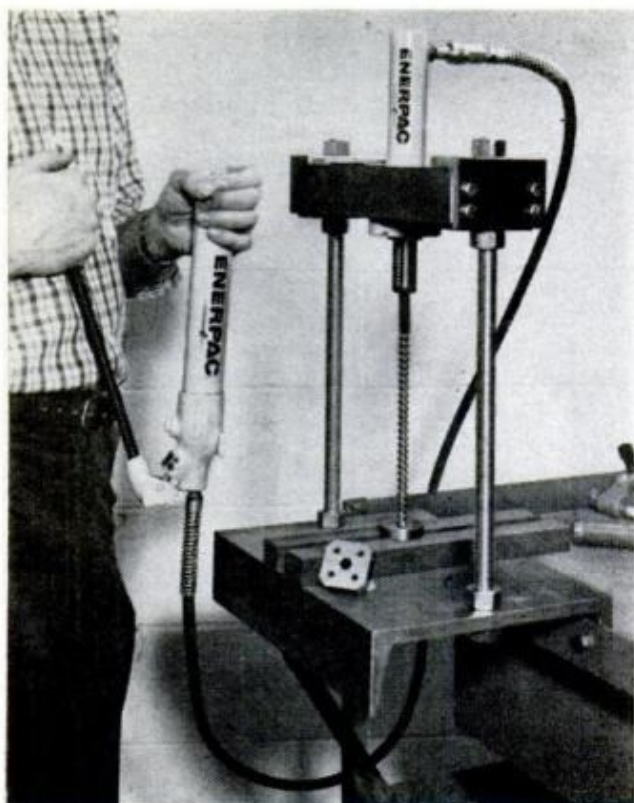
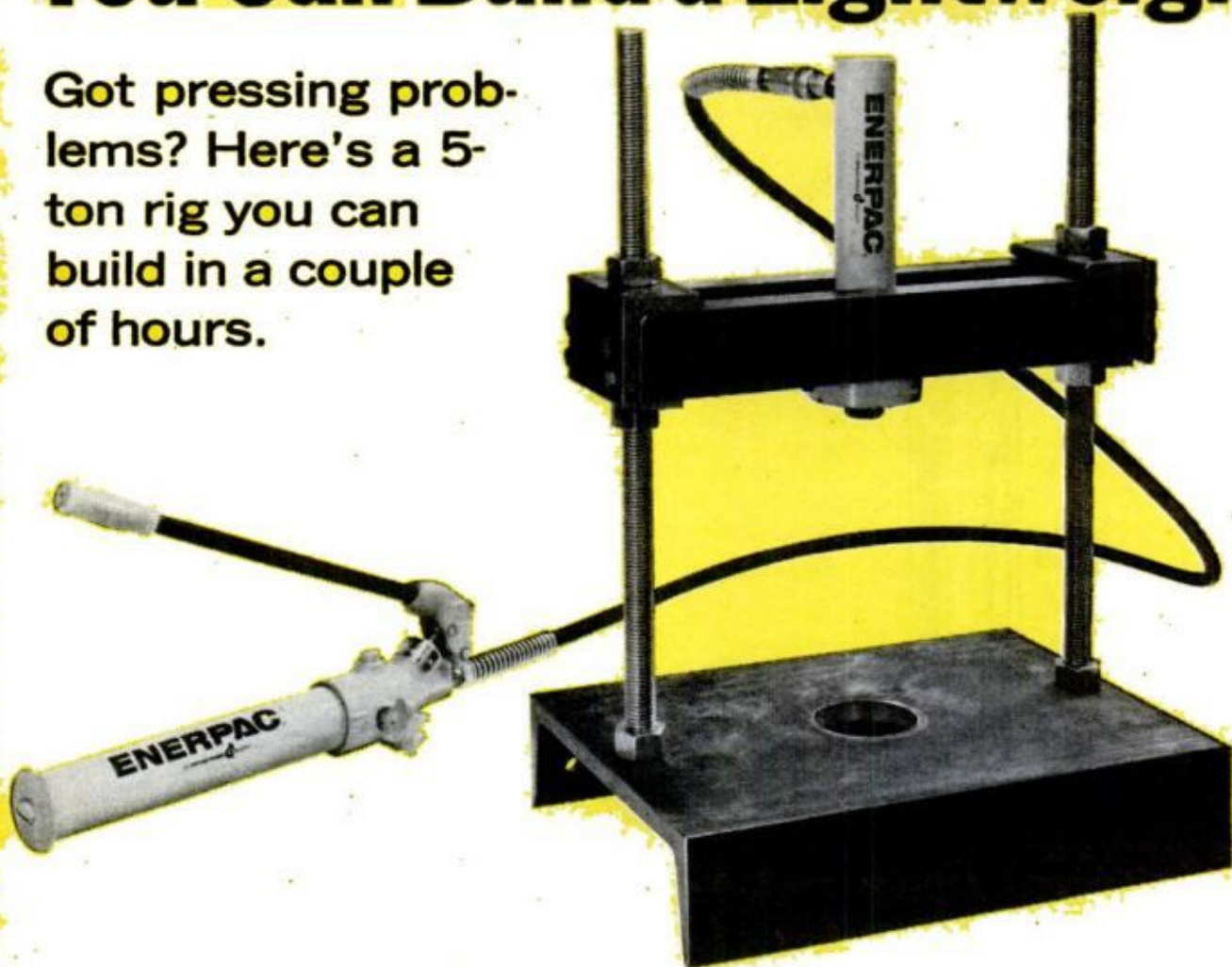

TO CUT HEX HOLE, opening is adjusted to fit broach. Press forces the tool through part being worked

FULLY ADJUSTABLE, this press can be built quickly to handle home or professional workshop pressing problems such as bending, aligning, laminating, deep-drawing, and more. Though surprisingly light in weight when assembled, about 50 lbs., it gives full versatility of use with up to five tons of force.

The muscle of the unit is the Enerpac S-150 hydraulic set. Priced at \$89 including the mounting flange, the tool delivers the flexibility and ease of handling usually found in more expensive presses. The steel components which complete the set-up, can be bought locally and will up your cash outlay another \$15.

Built-in versatility

Since the steel press header can be adjusted up or down on the threaded rods, the press can be quickly adapted to suit the size and shape of the workpiece to be pressed. The opening (daylight) can be altered to suit the job at hand. (Daylight

Press for Heavyweight Jobs

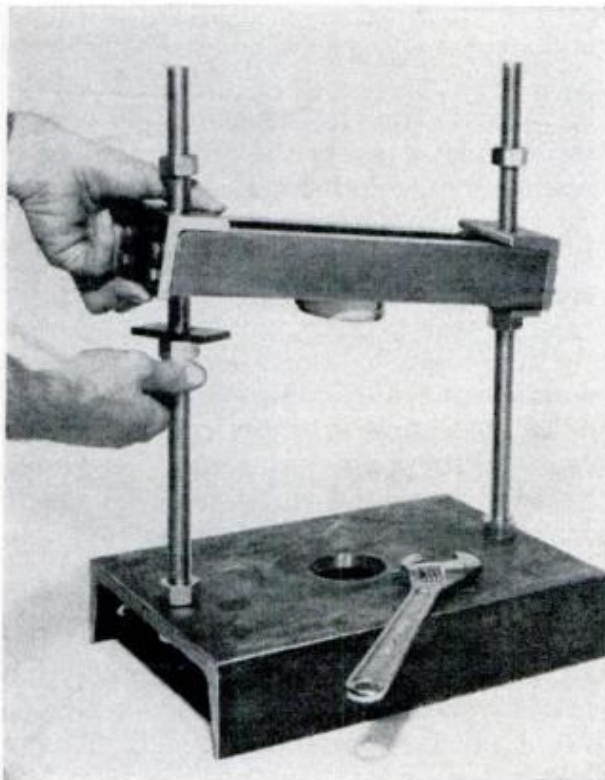
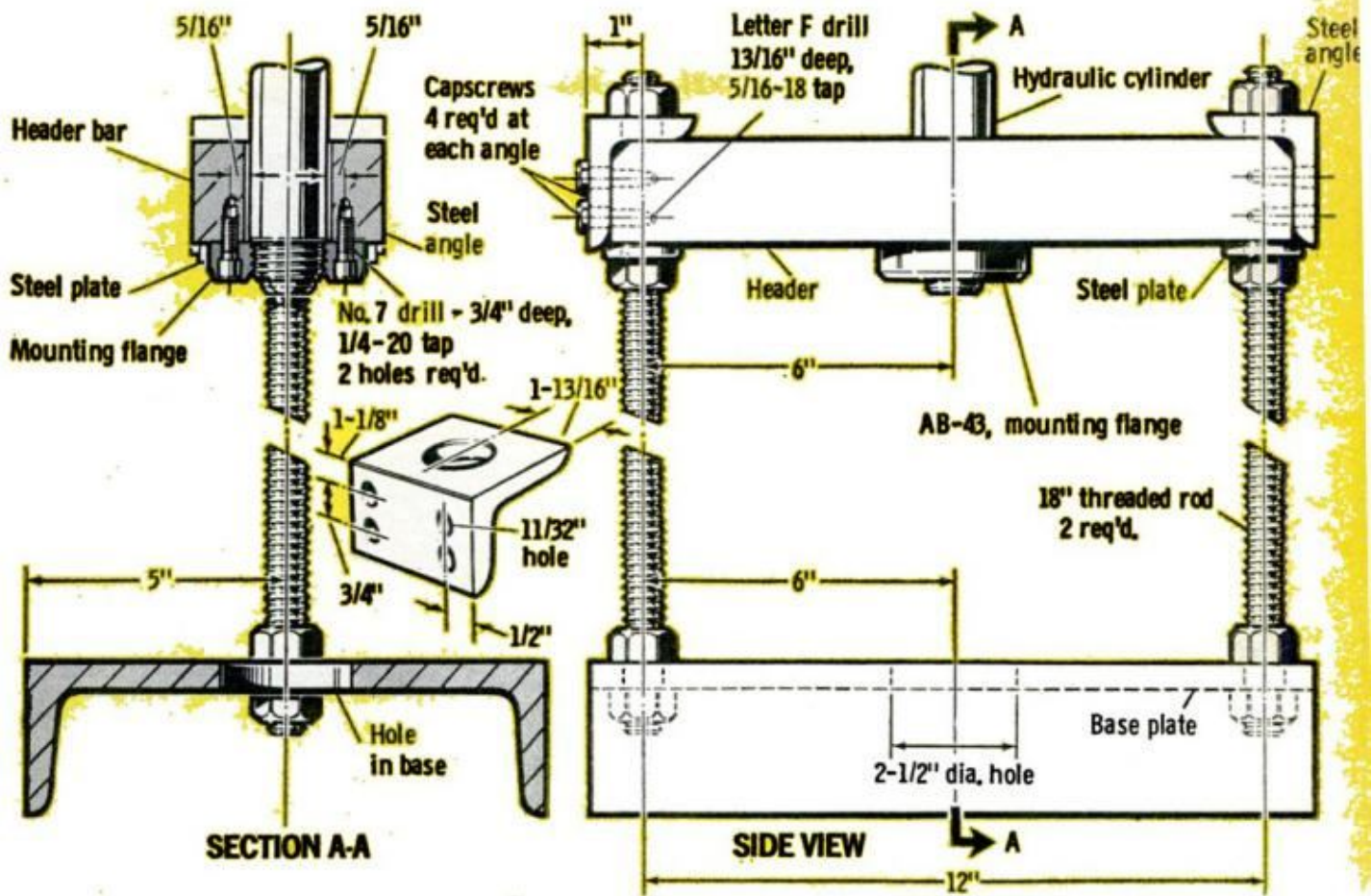

THREADED ROD determines maximum opening. If large opening requirements are expected, use longer lengths
OCTOBER 1969

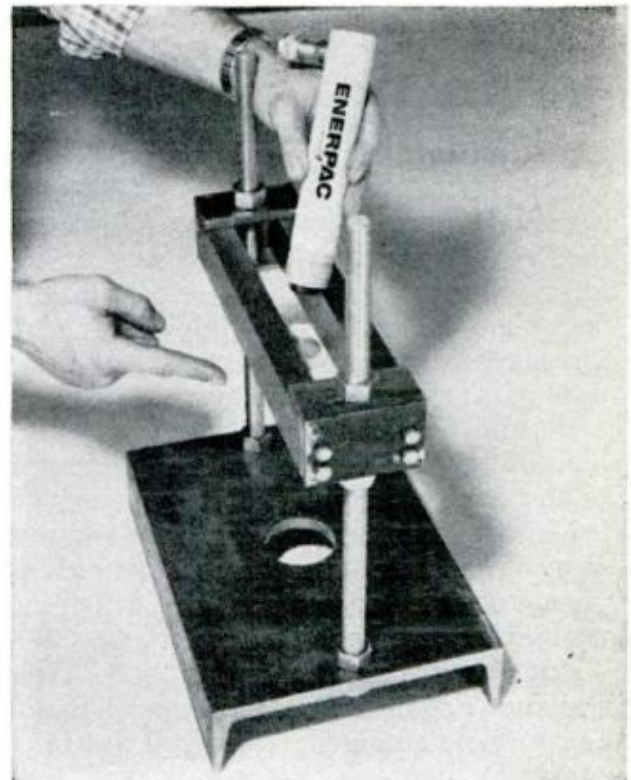

MOUNTING FLANGE bolted to header, receives the threaded end of cylinder, securely holds it in place

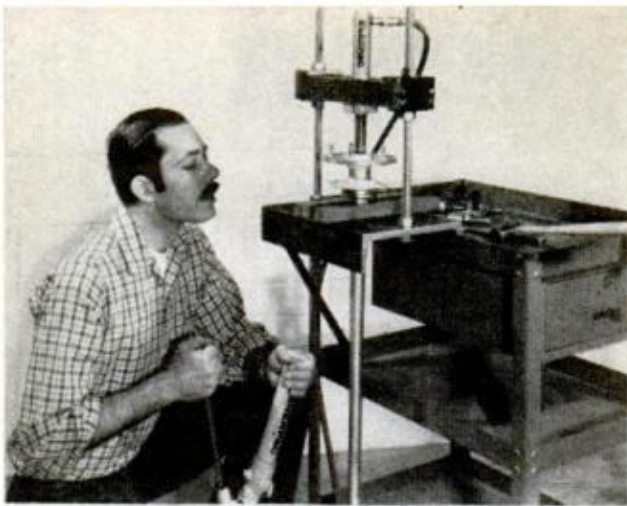

PRESSING AXLE BEARING is easy and fast. Hydraulic-control characteristics insure smooth pressing job

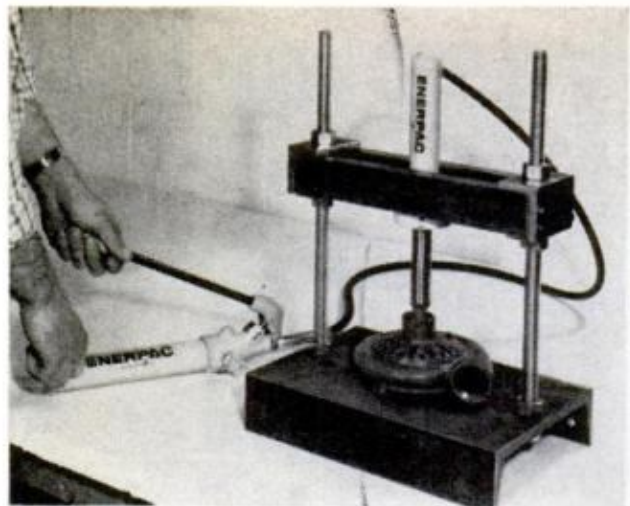

NEW BEARING being pressed in, pushes out old bearing through hole in base plate in the same operation

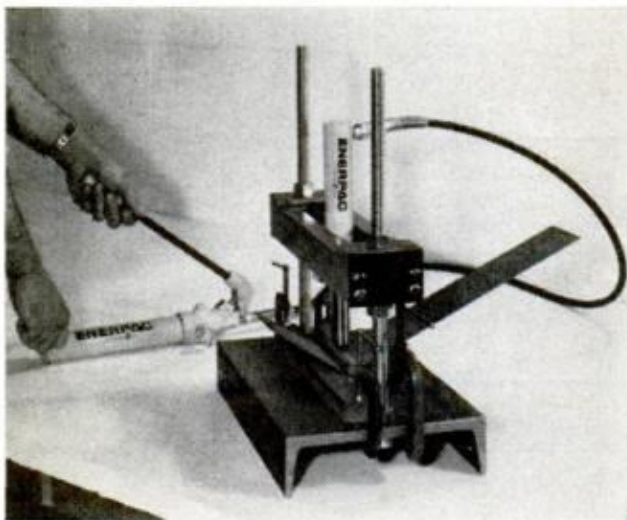

SMOOTH 90° BEND is made with reduced opening. Clamped steel acts as female die, bar serves as mate

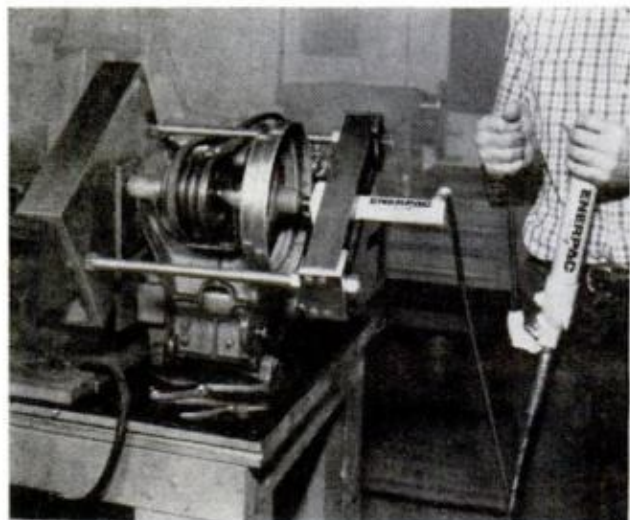

USED HORIZONTALLY and adjusted to its full opening, press handles unwieldy part such as lathe pulley

opening is measured from the press base plate to the plunger end cap of the hydraulic cylinder.)

For example, equipped with 18-in. rods the press shown is adjustable from a 12½-in. maximum, down to a ⅝-in. minimum opening. Horizontal daylight is 10¾ in. Thus, by having on hand several pairs of rods of varying lengths, you will have a wide selection of daylight openings.

Another good feature is the 2½-in. hole in the base plate which lets you put extra-long pieces through the base if necessary. The hole can also be used for push-through operations or, when not wanted, covered with a steel plate.

But you are not limited to the shape or size shown. The hole can be made smaller, or its shape changed, when you are fabricating the press or to suit a particular job.

The five-ton hydraulic cylinder (similar to a jack) has an 0 to 5¼-in. stroke,

or plunger travel. This gives the operator the choice of using the full travel or adjusting the header down close to the work to use only a fraction of the cylinder stroke to contact and press. The latter technique is recommended for operations where speed is important.

There may be times—awkward-shaped workpiece for example—when this method of operation is undesirable. Here, because of the long cylinder stroke, you can be away from the work, but still reach it for your pressing cycle.

The hydraulic cylinder

Of spring-return design, the cylinder pulls back the plunger to a completely retracted position when the load-release valve on the pump is opened. This releases the press load on the part being worked and retracts the plunger out of the way. The action is good and makes

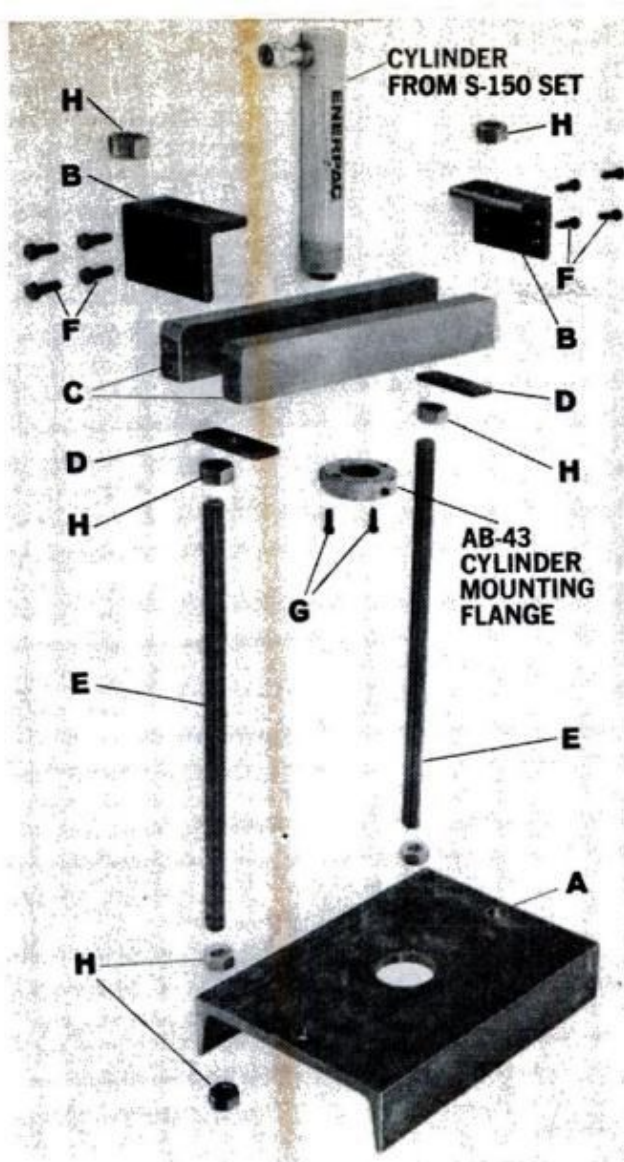

STEEL PRESS COMPONENTS drilled and ready to assemble (above). Materials list identifies the parts

for fast, easy removal and insertion of parts to be worked.

The basic Enerpac unit consists of a hydraulic hand pump, high-pressure flexible hydraulic hose and the five-ton hydraulic-spring-return cylinder. It operates simply by turning the load-release valve clockwise and actuating the pump handle. The pump transmits hydraulic oil from the pump reservoir into the cylinder. The cylinder then converts pressure applied by the pump into forces several hundred times greater than the force at the pump. To release the press load on the part being worked, the load-release valve is turned counterclockwise, permitting the oil to drain back to the cylinder-pump reservoir.

Built-in bonus

Being light in weight (12 lbs.), the S-150 can be removed quickly from the press and toted to work that cannot be moved. Thus, you can use it for on-the-spot force applications such as prying, bending, jacking or pushing.

For buying information about the Enerpac hydraulic unit, write to Enerpac Div., Applied Power Ind. Inc., Dept. 901, Butler, Wis., 53007. The steel component parts for the frame are available at local steel warehouses. Make certain the steel you buy meets the specifications given for full five-ton-capacity strength.

—Harry Wicks, Workshop Editor

MATERIALS LIST

Key	Pieces	Description	Length	Size & Specifications
A	1	Steel channel (for press base plate)	14"	10" x 25 lb./ft.
B	2	Steel angles (for header ends)	3 1/2"	2 x 2 1/2 x 3/8"
C	2	Steel bars (for headers)	13 1/4"	1 x 2" (cold finish)
D	2	Steel plates (for header supports)	3"	1/4 x 1 1/4" (cold finish)
E	2	Threaded steel support rods (posts on press)	18" (optional)	3/4-10nc
F	8	Hex head capscrews (for header angles)	1"	3/16-18nc
G	2	Socket head capscrews (for mounting AB-43 flange)	3/4"	1/4-20nc
H	8	Hex nuts (for header, base & rod assembly)	—	3/4-10nc
—	1	Enerpac S-150 set (pump, hose and cylinder)	—	5-ton capacity
—	1	Enerpac AB-43 cylinder flange (for mounting cylinder to press)	—	—

ANNOUNCING: The Handiest Tool in Your Shop!

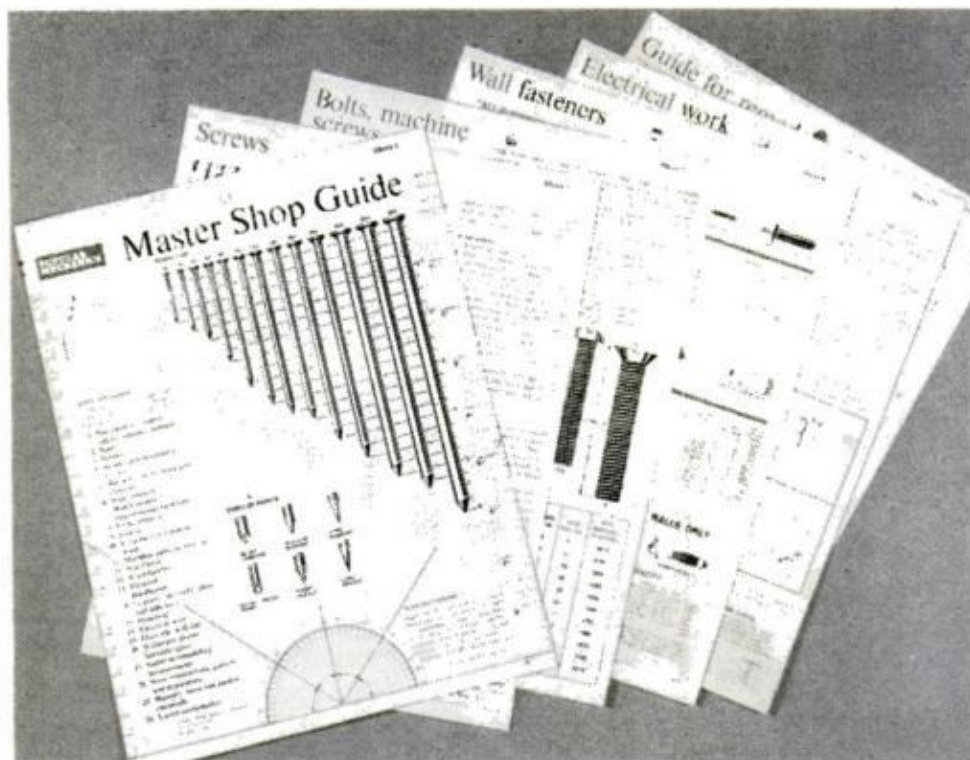

PARTIAL LIST OF CONTENTS

Nails of all types
Screws
Sheet-metal screws
Bolts and washers
Wall fasteners
Drills
Abrasives
Lumber
Moldings
Wood joints
Wood finishes
Plywood
Hardboard
Gypsum drywall
Glues and adhesives
Plumbing
Electrical work
Floor and wall tile
Wallpaper
Plastic laminate
Glass
Remodeling
Stair construction
Gutters
Masonry
Useful mathematics
Ruler
Drawing compass
45° triangle
Protractor

WE KNOW YOU'LL AGREE when you see the *Popular Mechanics Master Shop Guide*. We've printed all the aspects of shop know-how and home maintenance on 12 heavy plastic-coated cards that you can hang right above your bench. Here's everything you need to know about choosing and using nails, screws, bolts, wall fasteners, drills and abrasives. Here are all the basic facts on lumber, plywood, hardboard, glues, adhesives, hardwoods and wood finishes. The most-used plumbing and electrical fittings are illustrated, with tips on where and how to use them. Want to know how many floor tile or wall tile you'll need, or how many rolls of wallpaper? Easy-to-read charts show you at a glance. Remodeling? All the recommended measurements for doors, windows, kitchen cabinets, closets, even furniture of various types, are listed. You'll find complete information on the right chemical to use to knock out specific lawn and garden weeds and diseases; gutter and downspout repairs; many other subjects. The first card alone, in addition to an exact-size nail guide, includes a ruler, centimeter rule, protractor, 45° triangle, and a big compass that permits you to draw precise circles up to 19½ in. in diameter! Fifty-six charts and scores of drawings give you the essence of all how-to information, right at your fingertips. No shop is complete without the *Master Shop Guide*.

To order THE POPULAR MECHANICS MASTER SHOP GUIDE fill out coupon and mail to
POPULAR MECHANICS, Dept. 5G, 575 Lexington Ave., New York, N.Y. 10022.

Enclosed is my check or money order for \$3.95. Please send my *Popular Mechanics Master Guide* to me at the following address:

Name _____
 Address _____
 City _____ State _____ Zip _____

"I'd walk a mile for a Camel."

This message is strictly for smokers who never tasted a Camel cigarette. Camel smokers, you know what we mean. You other guys, start walking.

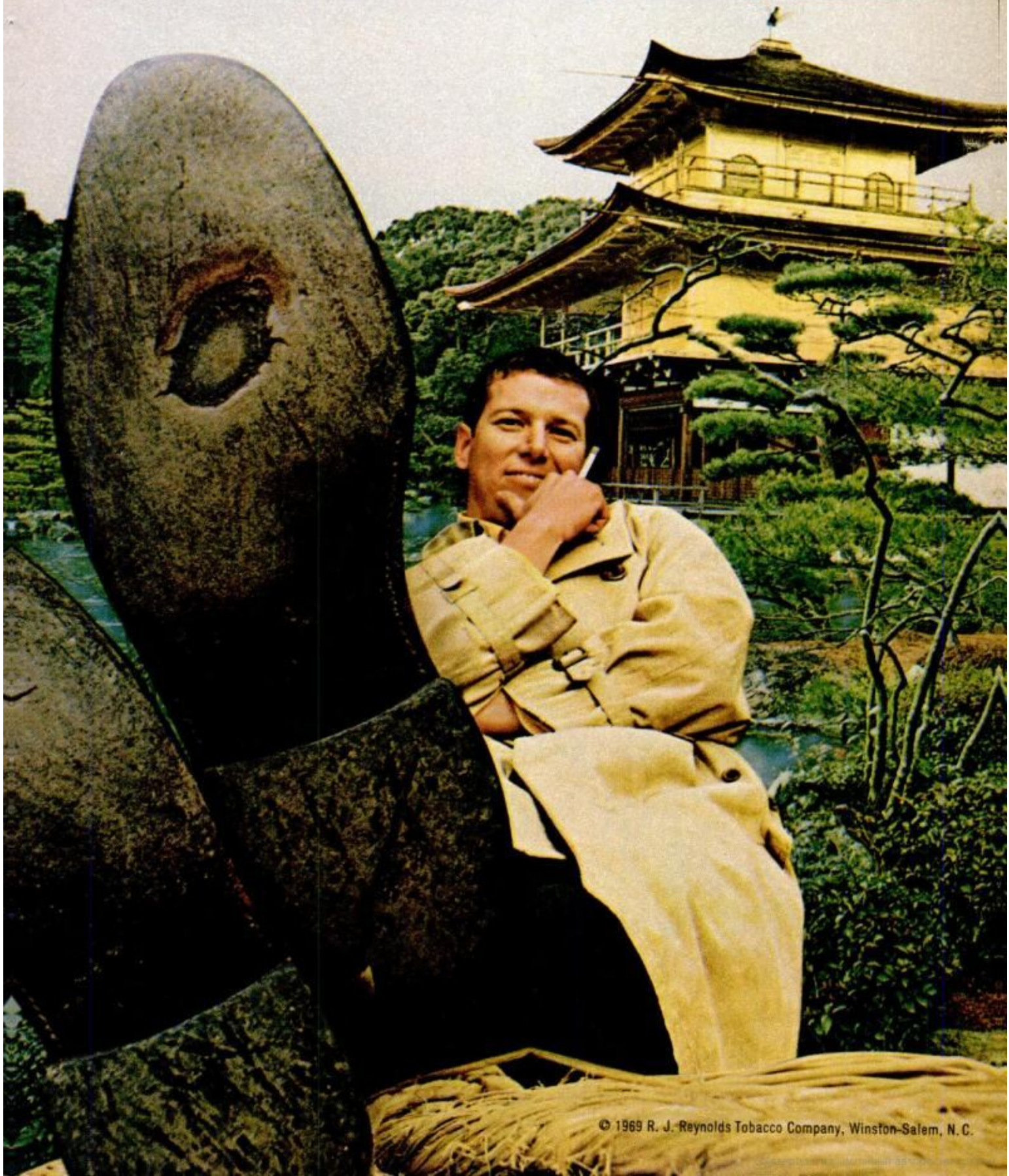

(Continued from page 141)

meter which sounds an alarm or flashes a light if the rate becomes too fast or slow, or with each premature or delayed beat.

An orange-colored screen is used because it's said to be highly visible in a well-lighted room. Honeywell's new system incorporates a photoelectric cell in the front of the unit: this automatically varies the intensity of the oscilloscope in relation to the light in the room to maintain best visibility. The oscilloscope is actually a cathode-ray tube identical with your TV picture tube.

The nurses' seeming disregard for the screens arises from the fact that it's easy to hear a change in the rhythm of the beeps. The experienced nurse can even pick out one particular patient's beeps from the seven or eight, or more, sounding away—and respond immediately to the slightest variation.

... some can speak with an electronic larynx only two days after a laryngectomy.

In the United States some 3000 successful laryngectomies (operations for removal of the larynx or voice box) are performed every year, virtually all due to cancer of this organ (9 or 10 men to every woman,) but occasionally to war injuries and hunting or auto accidents. A year ago, there were some 25,000 laryngectomees—those who've undergone laryngectomies—in America. The operation seals off the lungs from the throat and mouth, making ordinary speech impossible. The person breathes through a small hole, "stoma," created in the base of the neck. Dr. Hayes Martin, one of the world's great surgeons in this field, points out that today's doctor can confidently assure his patient of reasonably adequate speech following this surgery. Two methods are available—"esophageal speech" in which the individual swallows air and, with what amounts to a controlled belch, uses it for speech, and the electronic larynx.

Dr. Martin tells how Gilbert Wright, son of the author-minister, Harold Bell Wright, noticed that he could convert the buzzing sound of his electric razor, as he held it against his neck, into speech. Wright developed a battery-powered buzzing device, the Sonovox, which was originally used in motion-picture cartoons for producing human voice effects from nonhuman objects. In 1942, Wright

utilized it to produce the first workable electronic larynx.

Success of the electronic larynx lies in the fact that it can be used as you speak. If somehow you were able to listen, during speech, to the air as it leaves your vocal cords you would hear only a buzzing sound. Words and sounds of speech are produced by changes in the shape of the resonant cavities that make up your vocal tract—throat, mouth and nose. Speech is made possible not by the flow of air from your lungs but by its vibration—the vocal cords are there to set the air vibrating. Pressed against the neck, vibrations of the electronic larynx are transmitted through the soft tissues to make the air in throat and mouth vibrate. Then, using mouth, throat, tongue, lips and teeth as in normal speech, the laryngectomee can speak once more.

So natural is this process, that some can speak with an electronic larynx only two days after a laryngectomy. Esophageal speech, however, usually takes months to learn and there is doubt as to how many can learn it successfully. For those who cannot, the electronic larynx has made recommunication with the world possible. It has also made immediate speech possible following surgery—until esophageal speech can be learned.

The Bell System's electronic larynx is deceptively simple, with little that can go wrong. Designed by Bell Telephone Labs and produced by Western Electric, it is distributed by local Bell companies and sold on a nonprofit basis. About six inches long, beige in color, and tapered with its head offset at a 70° angle, it could almost be taken for a electric razor.

The device comes high-pitched for women and low for men. Fingertip control allows variation of pitch to produce more natural inflection and emphasis. It is said to provide a 97 percent sentence intelligibility, even allow some to sing simple tunes. Its speech volume is about that at normal conversational level. The principle is that of a small vibrating driver or transducer (actually a modified telephone receiver.) On the head is a button the size of a 50-cent piece and ¼ inch thick. This is cemented to a diaphragm like that in your telephone receiver but producing much stronger vibrations, for little power is needed to move your eardrum.

The artificial larynx utilizes two commercial mercury batteries and a pair of power transistors. In normal conversational use the batteries can last weeks, even months. While sound leakage produces a background buzz during use, some experienced users have learned to eliminate it during their speech. ★★ ★

What makes a snowmobile great?

Polaris Knows



Say it in one word. Performance. A get-up-and-go snowmobile that turns any stretch of snow into an open highway. One word, but a dozen design refinements in the '70 Polaris make it happen. Like powerful twin-cylinder Star engines, new Drift-Skipper suspension, Polaratone muffler, and dependable electric start. These are just a few of the pace-setting innovations in the 1970 Polaris. Take a test drive. You won't risk anything but temptation. Polaris Industries, Roseau, Minnesota. A Textron Division.

TAME A POLARIS ON THE PONDEROSA

Win a trip for two to the Ponderosa Ranch of "Bonanza" TV fame. Register at your Polaris dealer.

BACK TO EARPHONES YET!

(Continued from page 150)

chestra. Watch for the presence of bass, even in soft passages. The low notes shouldn't drop out.

Listen for crispness in the sound of such instruments as harpsichord, guitar and percussion. Nobody wants to hear a soggy drum. And watch for the telltale mark of inferior design: high-frequency distortion. Violins, for example, should sound silky and smooth—not like chalk scraping on a blackboard.

As with loudspeakers, frequency response figures listed in the catalogs are not always meaningful. Some manufacturers claim an upper response of 30,000 cycles and a lower limit of 10 cycles—a range far greater than that of any high-quality loudspeaker system. The fact is, it isn't really too important whether the range goes above 17,000 cycles because beyond that point sounds become too high for the human ear to hear anyway.

As for the low end, few earphones put out much effective bass below 50 cycles, no matter what the specs say. Few speakers do much good in that range either. The best way to check the bass performance of any model is to listen to a test record with test tones in the 30 to 50-cycle range.

What really counts, though, is not the ability to reach extreme highs and lows, but the balance and clarity of the sound spectrum from about 50 to 12,000 cycles. The best test for this is listening to a good, clear recording of a full symphonic score.

Aside from sound quality, comfort is the main factor in picking your earphones. You should be able to wear your headset as easily as a comfortable hat. Weight, of course, is important, and such designs as the AKG-Norelco, Sennheiser and Telex Encore are outstanding for lightness.

More important than weight, however, is proper fit. Even the heavier models don't become burdensome if they fit comfortably on head and ears. The headband is rarely a problem because it's either flexible or adjustable. Earpieces, however, have fixed dimensions, so make sure they don't squeeze or pinch your ears. They should fit *around* the ears, not ride on top of them. Otherwise, you don't get a tight air seal and lose bass response. Some ear cushions are liquid-filled so that they mold themselves to the contour of your head. Others rely on foam material for a firm sound seal.

Some models have separate volume and/or tone controls right on the headset. While they are not a necessity, some listeners may find it convenient to be able to make loudness and tone adjustments

without having to get up and fiddle with the controls on the amplifier.

Connecting up your earphones is a simple job, but the procedure may vary slightly depending on the type of headset you buy and the kind of arrangement you want. Headphones come in a variety of impedance ratings, all the way from 8 ohms up to 50,000 or more. Impedance is a measure of electrical resistance. Ideally, the impedance of your headphones should match the impedance of your amplifier's output, although this is not a must in all cases. You can connect high-impedance phones to a low-impedance source with no trouble. Do not, however, attempt the reverse. Connecting low-impedance phones to a high-impedance source will result in loss of volume and distortion.

Modern amplifiers and receivers usually have front-panel stereo phone jacks that make it easy to plug in a headset without doing any wiring. In most cases, these jacks represent a low impedance and thus will accept either low or high-impedance phones. Follow the directions supplied with your particular headset for any special wiring instructions. Should you find you have a serious impedance mismatch between your headphones and your amplifier's output, it's possible to get a small matching transformer that will solve the problem. Some earphone makers, like Superex, can provide matching transformers in a variety of impedances to suit any situation.

Chairside control desirable

One handy headphone accessory is a remote chairside control. Available in a variety of makes and models, this is basically a small box connected to your set by a 15 or 20-foot multi-conductor cable. It provides two earphone jacks and controls for adjusting balance and volume without getting out of your chair. There's also a switch for selecting speakers or phones.

Chairside controls not only offer the convenience of remote switching, but they also make it easy to connect headphones to a set that does not have a front-panel jack. They attach to the speaker terminals at the rear of the set and contain the necessary built-in electronics to provide a proper impedance match. Prices range from under \$10 to \$20 or \$30 for fancier models. For the kit-builder, Heathkit has a model that sells unassembled for \$7.95.

The sudden popularity of earphones may have something to do with the tensions of modern life. In a world full of noise, turmoil and distraction, they provide an island of private, personalized enjoyment. As one grateful music fan puts it, "They're my instant escape hatch." ★ ★ ★

Dodge



For the Smart Swinger... the Dart Swinger.

If you're a swinger who thinks your budget can't swing a new car this year . . . take a look at the new Dart Swinger. Our lowest priced two-door hardtop. Swinger's big and roomy inside for that big-car ride. With all-vinyl seats that carry six of the gang around in style. And new, larger standard engines. A mini-fuel 198-cu.-in. Six and a maxi-power 318-cu.-in. V8. Dart Swinger. One low-priced compact that doesn't slight you on looks, comfort, or extras. See Dart Swinger soon.



If you won't
take small
for an answer . . .

you could be
**DODGE
MATERIAL.**



ZOOM TO BIGGER PICTURES

(Continued from page 163)

those that adjust the focus, usually the front set.

In a zoom, there is an additional set of movable lens elements positioned between the front and rear sets. The fixed elements provide what is known as the "prime" or basic focal length, usually about midway in the zoom range. In an 85 to 205-mm zoom, for instance, the prime focal length is generally 135 mm. Shifting the movable zoom elements backward or forward has the effect of increasing or decreasing this basic focal length. As the focal length changes, the image on the film grows or shrinks accordingly.

To keep the image in focus, there is still another movable lens called the "focus compensator." This shifts back and forth along with the zoom elements but at a different rate, automatically keeping the image in focus as it changes in size.

Because zoom lenses are complicated, they are admittedly not perfect in all respects. They may not be as sharp at every focal length as a fixed telephoto lens designed for a single focal length. Usually, there are three or four points along the scale where the image is sharpest, with somewhat less crispness in between. You can find these points by shooting the same subject at different focal lengths on a test roll of film. While differences in sharpness are generally slight, knowing your best focal lengths can be helpful on critical shots.

While zoom lenses are designed to stay in focus throughout their range, it's a good idea to keep rechecking your image to be sure it's as sharp as possible. In some cases, it may be necessary to "touch up" the focus after you've zoomed.

Shoot fast, hold steady

For most of your shooting, other factors will affect the quality of your image more than lens sharpness. Camera motion, for example. If you zoom much beyond 200 mm, you'd better use a tripod, or camera shake, due to mirror bounce or your own unsteadiness, will be agonizingly evident. The reason is simply that magnifying the image has the effect of also magnifying the slightest bit of motion until it becomes a streaky blur. To avoid this, use as high a shutter speed as possible and hold the camera very steady.

Closing the lens opening down several stops, say from $f/4$ to $f/8$, will usually increase not only the actual sharpness of the lens but also its *apparent* sharpness because of the increase in depth of field—more of your picture will be in focus

than with a shallow depth of field. One advantage of higher-priced zooms is that they tend to be "faster"—they require less light than slower lenses. This means you can shoot at a higher shutter speed and smaller lens opening.

Zoom speeds range all the way from an extremely fast $f/2.8$ to a slow $f/9.5$. In the past, slow lenses were a disadvantage because they forced you to shoot at a large lens opening and slow shutter speed, compounding the problems of camera shake and shallow depth of field. Modern fast films give you so much speed, however, that they generally let you shoot at both a small lens opening and a good shutter speed even with a slow lens. This is one reason why today's moderate-priced, moderate-speed zoom lenses can be such a good buy.

Medium-range zoom is best

What type of zoom you select depends on the kind of shooting you want to do. You'll note from the accompanying chart that zoom lenses provide different ranges of focal lengths. Some start at a very short length, almost a wide angle, and go to the equivalent of a moderate telephoto, say 135 mm. Others start at about 70 or 80 mm and go on up to 200 or 250 mm—a fairly long telephoto. Very long zooms start at 200 mm or so and go on up to a whopping 500 or 600 mm. Only a few specialty zooms cover a full range of focal lengths from short to long, and these are very expensive.

A medium-range zoom is the best choice for all-around shooting. Since you probably already have a standard 50 or 55-mm lens on your camera, a zoom that starts at around 70 mm and goes to 200 mm or higher will give you a good range of focal lengths for sporting events, scenic views, photographing boats at a distance, picking faces out of a crowd and similar shots.

Be sure the lens you buy will fit your camera. Some are made only for a particular make of SLR. Most zooms, however, are designed to fit a variety of makes by means of interchangeable adapter rings. Automatic zooms—those that stop down by themselves as you press the shutter release—generally run \$20 to \$50 more than equivalent nonautomatic models and are well worth the extra cost.

One handy accessory you may want to consider is a converter. This is a small supplementary lens that, when combined with a zoom or telephoto lens, doubles its effective range. It doesn't provide the quality of a true telephoto lens, but it's a way of getting a lot of added range at relatively little cost. ★★

When your car is worth caring for...
Pennzoil is worth asking for.



Turn any car into the toughest car in town

Whether your baby is a 'Vette or a VW, you can have her humming like a little atom-smasher, every part doing its job with laser-beam cleanness. Just grab onto the fat new '68 MOTOR's AUTO REPAIR MANUAL.

Brand New 1968 Edition Now Available

Shrewd racing mechanics bank on MOTOR's AUTO REPAIR MANUAL to give them every last fact about the cars they're handling and to make the most of their car sense. Whatever it takes to get top performance, from a simple carb adjustment to a complete tune-up, MOTOR's brand-new 1968 Manual gives you the know-how of a pit pro.

225,000 Repair Facts for 2,300 Car Models

The new 1968 Edition has more than 1,196 double-size pages featuring 55,000 specs and 365 quick-check spec charts, 225,000 service and repair facts, and over 3,200 "this-is-how" photos and diagrams. They get you into the guts of 2,300 domestic models—Standards, Compacts, and Intermediates—including all the hot '68's, plus the Volkswagens.

Detailed Trouble-Shooter Section, plus trouble-shooting information throughout, helps you to pinpoint 4,200 car troubles. Then you're shown exactly how to quickly fix almost any part of these cars made in America from 1962 to 1968: Toronado, Mustang, Barracuda, Bronco, Jeep,



Chevy II, Pontiac, Thunderbird, Buick, Imperial, Cadillac, Marlin, Continental, Dart, Ford, Mercury, Chevelle, Chevrolet, Chrysler, Plymouth, Rambler, Dodge, Oldsmobile, Buick Special, Comet, Corvair, American, Olds F-85, Falcon, Ford Fairlane, Lancer, Tempest, Corvette, Riviera, Firebird, Camaro, Valiant, Cougar, International Scout, Eldorado—even Montego, Javelin, Torino. They're all included—plus Volkswagen. And you get tune-up and front-end alignment specifications for all cars built from 1941 thru 1961.

And all this information is authoritative. It comes from the car manufacturers themselves. MOTOR's editors distill more than 300 official factory manuals and hundreds of service bulletins to make sure your auto repair questions are answered, your service problems are solved. That's why over 5 million men who care about cars—auto buffs, beginner and professional mechanics, students—have bought MOTOR's Manual, making it the all-time best seller in the field.

If you really want to keep your machine mean, we'd like you to make a test run with the new '68 MOTOR's AUTO REPAIR MANUAL.

10-Day Free Home Trial

Just fill in and mail the coupon on this page, and we'll send you a hot-off-the-press copy of the new '68 MOTOR's Manual to look over and use, free, for ten days. Then, if you're satisfied, simply pay \$9.95 plus a few cents handling. Otherwise, return the book and owe nothing. MOTOR Book Dept., 250 West 55th Street, New York, N. Y. 10019.

SAME 10-DAY FREE TRIAL ON MOTOR's Auto Engines & Electrical Systems.



Ideal basic book for enthusiasts, students, engineers, mechanics. Explains engines and electrical systems thoroughly, showing exactly how and why they work. Over 600 pages, 1,300 illustrations. Only \$8.95.

**MOTOR BOOK DEPT., Desk 910
250 W. 55th St., N.Y., N.Y. 10019**

Please send me the book(s) checked below, for 10-day free examination. If I decide to keep them, I will remit payment as indicated.

MOTOR's Auto Repair Manual, \$9.95, for which I will remit \$2.00 in ten days, \$3.00 monthly for two months, and a final payment of \$1.95 (plus delivery charges and sales tax, if any).

MOTOR's Auto Engines & Electrical Systems, \$8.95, for which I will remit \$3.00 in ten days, \$2.00 monthly for two months, and a final payment of \$1.95 (plus delivery charges and sales tax, if any).

Print Name _____ Age _____

Address _____

City _____ State _____ Zip Code _____

SAVE MONEY! Check here if you are including payment in full for book(s) ordered, in which case we pay postage. Same 10-day trial applies; you can return book(s) for prompt, full refund. New York State residents please add 2 percent sales tax; New York City residents 5 percent.

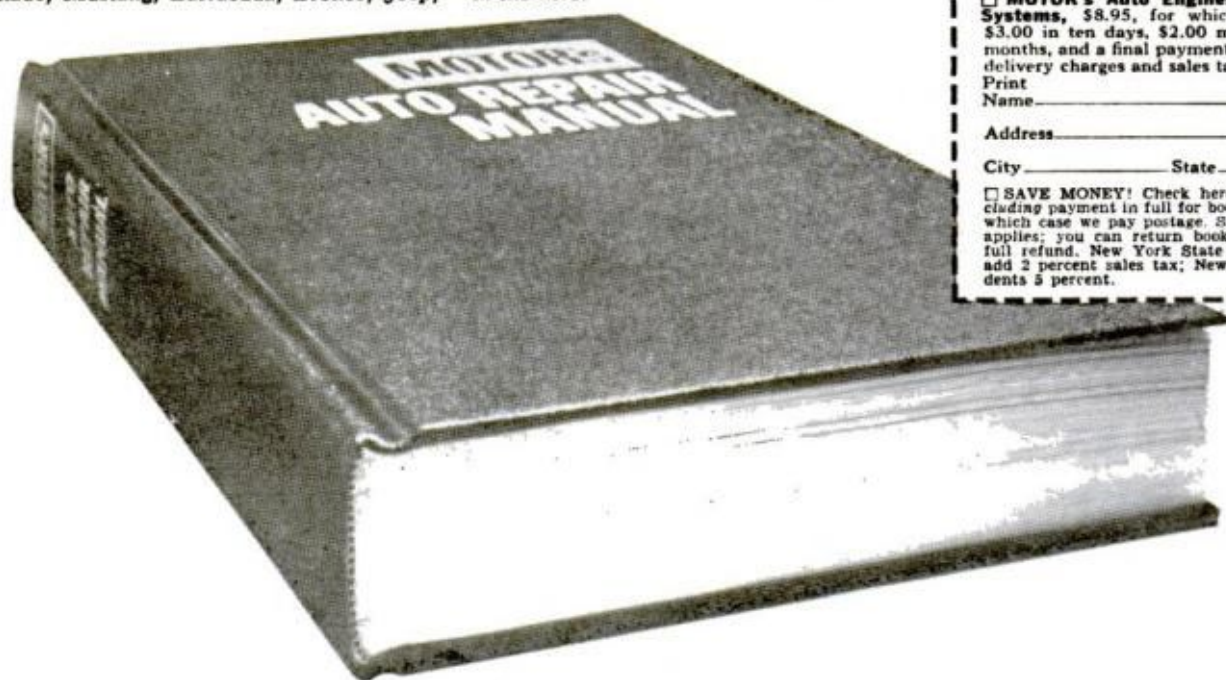

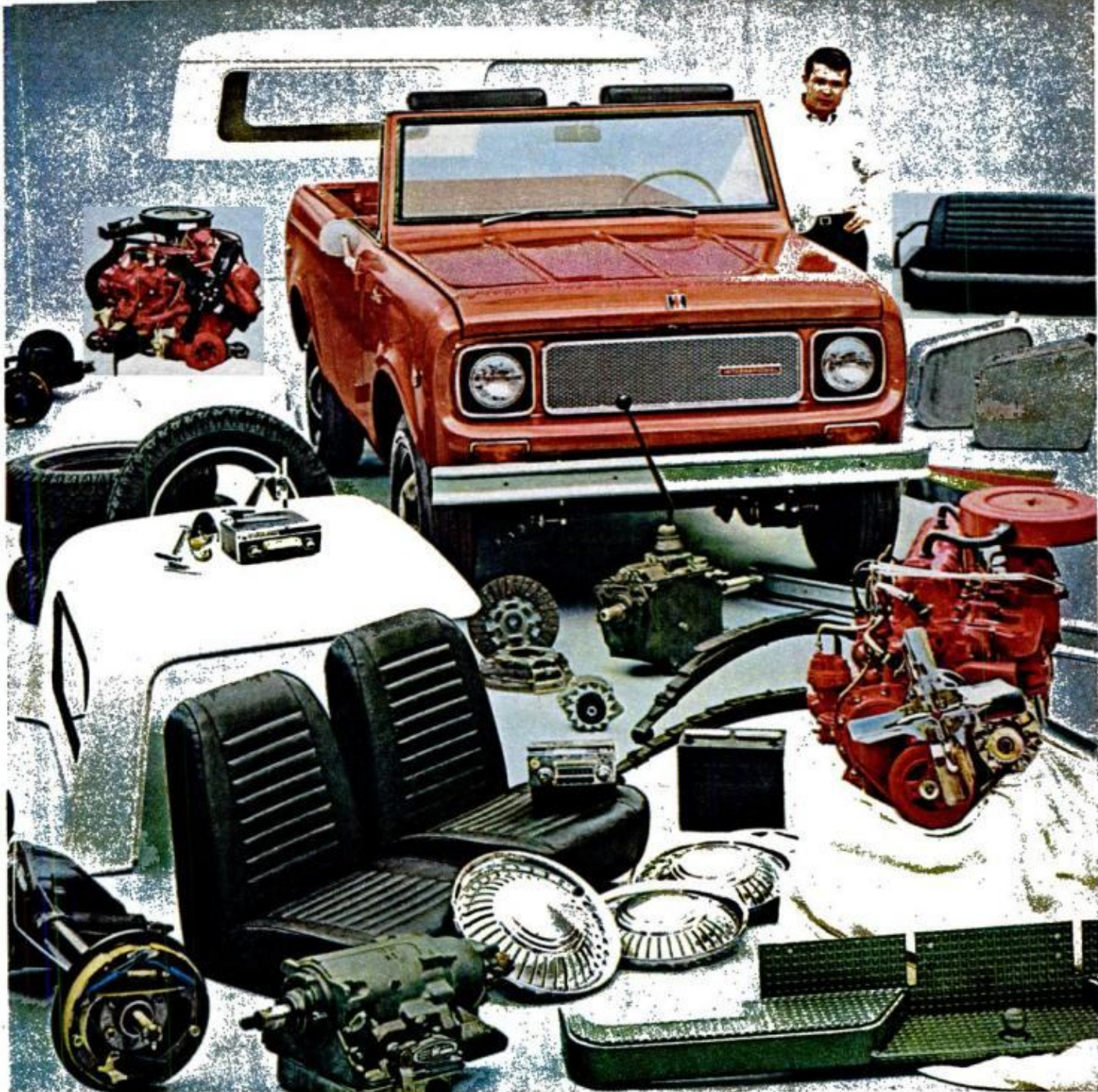

The do-it-yourself Scout.

See what you can do with all the power, performance and pizzazz options we offer you

People are using the SCOUT® so many different ways we figure they ought to be able to get 'em any way they want 'em.

So we offer you more engines, transmissions, rear axles, seating arrangements, and unusual accessories than anybody else in the class.

You can option yourself into any kind of SCOUT from a sassy little runabout to a gutsy beast that'll take off straight up . . .

. . . from a stick shift that's sync-ed in all three gears to a four-on-the-floor to a smooth automatic . . .

. . . from a stripped-down workhorse to

a jazzy creampuff with color-keyed interiors, bucket seats, padding all over and even a stereo tape deck.

Two-wheel drive if you're the conservative type, all-wheel drive if you're not.

We'll start you off with 100 rugged inches of wheelbase . . . and from there on your SCOUT is the most exciting do-it-yourself project you ever tackled.

Your INTERNATIONAL SCOUT Dealer has all the tools and a good price.

IH INTERNATIONAL HARVESTER
 COMPANY CHICAGO, ILLINOIS 60611

FIX your appliances,
car,
house,

SAVE

on home improvements,
air conditioning,
power tools and more

WITH THIS

FREE \$3.49
VALUE
GIFT VOLUME

Just look back over the past few years and figure how much you have spent on repairs for your home, your car, your appliances. Wouldn't you like to keep these high-priced repair fees for yourself? Well, now you can.

As a reader of *Popular Mechanics* the chances are that you already have a considerable degree of skill with tools. Nevertheless, you may have hesitated to tackle more complicated repairs, improvements or hobby projects.

Now, however, this FREE Book—packed with the combined skill and know-how of 257 *Popular Mechanics* expert editors, consultants and designers—can put a professional edge on your do-it-yourself skills.

The most difficult jobs will soon become easy

Before you know it, you'll be able to fix car engine troubles... transform unfinished attic space into an extra bedroom... catch more fish using homemade lures... learn "tricks-of-the-trade" in handling power tools... save hundreds of dollars when buying and servicing appliances.

These are just a few of more than 6,000 exciting "how-to" ideas, plans, and valuable projects you'll find in **POPULAR MECHANICS DO-IT-YOURSELF ENCYCLOPEDIA**. You'll learn how to get more professional-looking results than ever before in your carpentry, metalwork, plumbing, masonry, electrical wiring, electronics, hi-fi, stereo, car repair, painting, decorating... PLUS exciting new ways to help you get more fun out of your hobbies, sports, vacations. Experts lead you step-by-step through every project you select. Without question, here is the most helpful, reliable, "how-to-do-it" guide you've ever seen—and Volume 1—a \$3.49 value—is yours ENTIRELY FREE!

You risk nothing on this FREE Book offer!

As soon as your gift book comes, browse through it—try some of the exciting ideas—use some of the money-saving tips. We're sure you'll get so much valuable help from this book, you'll want to see the other volumes as they are published. You can see future volumes without risk—on a 14-day FREE TRIAL basis. But this first volume is yours as an outright gift—whether you buy one, two, five, the whole set, or none at all. But please hurry. Our supply of gift volumes is definitely limited. To be sure of getting your copy FREE, mail the coupon today.

Here is a brief glimpse of all your FREE Volume brings you:

- Fix 8 common car engine problems and save garage fees
- Save money air conditioning your entire home
- Cure a wet basement and save \$200 to \$2,000 under what professionals charge
- Burglarproof your home with special power alarm
- Professional tips for expert sanding
- Learn arc welding basics in 6 hours of easy practice
- How to save on band saw blade costs by making your own
- Build a gas-fired barbecue for more back-yard fun

PLUS much, much more

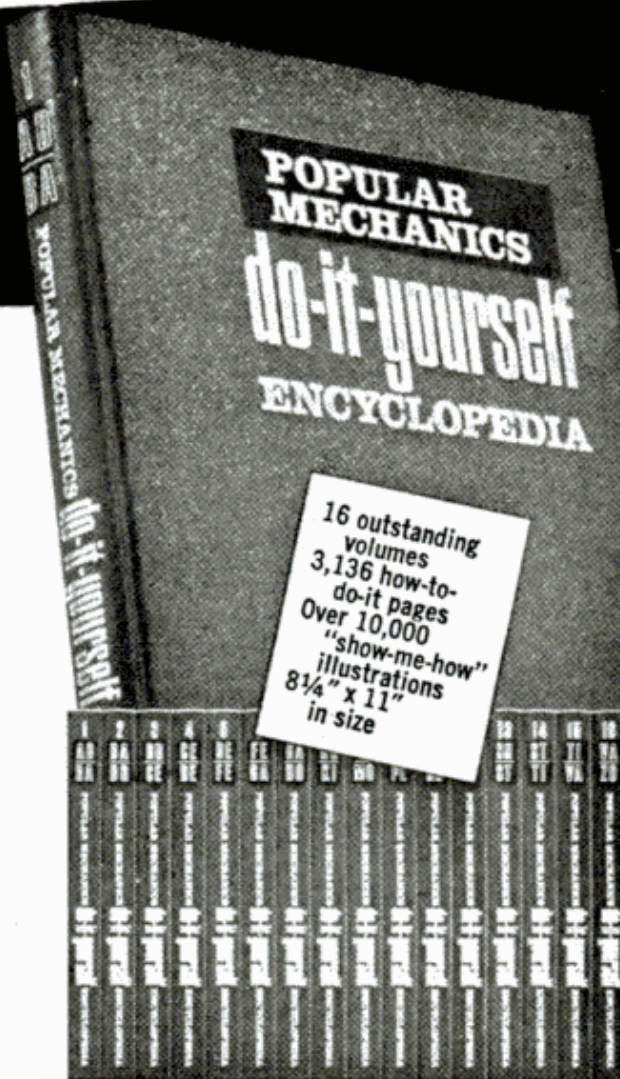

16 outstanding volumes
3,136 how-to-do-it pages
Over 10,000 "show-me-how" illustrations
8 1/4" x 11" in size

MAIL COUPON TODAY!

Popular Mechanics Book Division, Dept. 910
250 West 55th Street, New York, N.Y. 10019

Please send me, ENTIRELY FREE of any charge, my complimentary copy of Volume One of the all-new, illustrated **POPULAR MECHANICS DO-IT-YOURSELF ENCYCLOPEDIA**. I am not obligated to buy anything—now or later.

I understand I will be entitled to receive additional volumes for my FREE EXAMINATION as they are published each month. After examining each volume FREE for 14 days, I will either return it and owe nothing—or keep it and remit low subscriber price of only \$3.49 a volume, plus a few cents for shipping.

I reserve the right to cancel any time I wish—even immediately after receiving my FREE Volume 1—without obligation. Whatever I decide, Volume 1 is mine to keep FREE.

Name _____
(Please Print)

Address _____

City _____

State _____ Zip

Signature _____

The 62 caliber shocker.



The "Core-Lokt" bullet you see here was a precise 30 caliber when it left the muzzle of the rifle. It suddenly mushroomed to 62 caliber when it hit its big-game target.

The effect was exactly what you'd expect from a 62 caliber slug. The animal dropped in its tracks. No long trailing. No chance of losing it.

Take another look at the picture. Note how the jacket and core held together. The controlled expansion of "Core-Lokt" bullets assures deep penetration, excellent mushrooming, but no fragmentation.

That's why, in a caliber suitable to the size of the game, any well-placed "Core-Lokt" will mean knockout wallop.

We load "Core-Lokt" bullets into a wide variety of Remington and Peters big-game cartridges. They're also available to handloaders.

We hope you'll use them on your next hunting trip. Partly because we want to do business with you. But mostly because we want you to be sure you get what you go after.

Remington® DU PONT® PETERS®

More big game has been dropped with "Core-Lokt" — and we mean dropped — than with any other bullet.

Remington, Peters and Core-Lokt are Reg. U. S. Pat. Off. by Remington Arms Company, Inc., Bridgeport, Conn. 06602. In Canada: Remington Arms of Canada Limited, Toronto, Canada.





GM

MARK OF EXCELLENCE

Chevrolet put it all together.
Solid gentlemanly comfort without
bombast. Sailplane silence.

Computer-selected coil springs for
a ride that glides.

Yet Monte Carlo's handling leaves
you feeling like anything but a fifth
wheel. A taut 116" wheelbase and a
track five feet wide go where pointed.
Precisely.

And powerfully: a 350-cubic-inch
V8 is basic. (Order on up to a 454.)

Standard is an instrument panel

with the rare look of hand-rubbed
burled elm.

And Astro Ventilation.

Even power disc brakes, fiberglass-
belted tires and higher intensity head-
lights.

Nothing's missing.

Nothing except the fat you find on
fat cars at fat prices.

Monte Carlo.

The only car in its field. Period.

Putting you first, keeps us first.



On The Move.

**A group picture of all the cars in
Monte Carlo's field.**

Next Month in Popular Mechanics

How We Built a House for \$7500

A 29-foot living room with fireplace and glass doors to the patio; three bedrooms, two complete baths, 90 square feet of closet space and airconditioning—how do you get all that for \$7500 today? You build it yourself. The Robert Hunt family of Cicero, Ind., did—and they have the receipts to prove that you can do it, too.

How to Catch a Hippopotamus

. . . or an elephant or a zebra or a buffalo. Game wardens in South Africa's Kruger National Park do it every day. All you need is a helicopter or a bulldozer, a crossbow, a quiver of tranquilizing darts and a steady aim. It also helps to take a tranquilizer yourself.

Build a Christmas Greeting for Your Lawn

Designed especially for *PM* readers, this Christmas greeter is motorized and decorated with Disney characters. Complete plans, including Project-a-Plan slides (which make it a snap to copy the art), are in the November issue.

Oceangoing Drive-In

There's a new type of cargo vessel—the roll on/roll off container ship—that handles almost anything that can be pushed, pulled or driven aboard. The odd-shaped and oversized cargo that won't fit in containers (buses, bulldozers, steamshovels and the like) is rolled aboard over stern ramps while overhead cranes load the container cargo.

Jetting Down Montana's Mighty Missouri

Shallows, rapids and steamboats were all part of *PM*'s test of Glastron's new 17-foot Berkeley jet boat.

Bring Life to Those Forgotten Snapshots: Make a Montage

Mounting a whole collection of prints on a background panel is a handsome way to display photos that usually get stored away in a bureau drawer.

Tune In Shortwave on That Transistor Portable

This handy, home-built antenna selector can pull in shortwave on a small transistor portable as well as improve reception on expensive multiband receivers. It also lets you control a tape recorder and external speaker.

What we go through to be Number One



Look down a velocity stack of a winning race engine and you'll most likely find Firebird® Racing Gasoline . . . the Number One choice of the men who race. Because PURE wins more races, sets more records, than *all* other brands combined.

PURE makes more racing gasoline than anyone else in the

world. That's why PURE knows how to make a powerful gasoline for you. It's called PURE Firebird Super . . . from the Number One name in racing!



UNION 76

Pure Oil Division

THE '70 CARS

(Continued from page 106)

around regarding warranties. Some of the hanky-panky brought to light was and is shocking. Yet the industry considers such investigations as being the devil's work, a threat to America's free enterprise system.

To see what sort of reaction I'd get more than anything else, I once said to a high-ranking auto executive, moaning about what he termed "government interference," "The Government is going to save you guys from yourselves." You can imagine how the already ruffled feathers flew. Yet it's true; if the auto industry pursues a narrow, self-serving path, an aroused public is going to flatten it. Cars are no longer a private concern. They are a public one. And the public, however haphazardly, expresses its concern through government. It doesn't take any great insight to see a day—and soon—when a team of government inspectors will be resident in every auto plant. 'Twould be a damn shame, too, because the industry's resilience, imagination and energy would be lost.

In an interview published last February, GM chairman James M. Roche said that by 1980 there would be 115 million cars and 25 million trucks on U.S. roads and highways. If Roche is correct, where in God's name are we going to put them? What are they going to look like? How big will they be? We can't—just can't—continue to plunder our countryside and resources just so all of us can have the dubious pleasure of crawling along bumper-to-bumper. A line must be drawn somewhere, and if the industry doesn't draw it soon, the government will.

Discuss this sort of thing with industry officials and they'll say, yes, we're concerned. But on the other hand, the forecast is of ever-spiraling production figures. This, to my mind, is doublethink.

Yet it would be unfair not to point out that this remarkable, uniquely American phenomenon—the auto industry—is coping with, and groping to solve, problems that often seem to defy solution, or at the very least are staggering.

For one thing there's the industry's size. It's so big its channels of communication, both within and without, are clogged. A good idea seemingly takes forever to surface. There are so many cooks working on the broth that individuality, however brilliant, is lost. With this loss comes an unwillingness to experiment and truly innovate.

Keep in mind, too, that unlike, say, the Army, which can operate its sprawling

bureaucracy at a loss, the auto industry must make a profit. Billions and billions, to say nothing of the national economy, are at stake. Obviously, rash actions, genuine deviations from the beaten path have no place in such a prodigious undertaking. The cards *have* to be played close to the vest.

All of which helps to explain why your new 1970 Zipper really isn't very different (or even better) than, say, your 1968 Zipper.

But the rub—again—is that the good gray minds that run the auto industry *know*, for example, that they're putting their "mark of quality" on a certain percentage of defective cars. Does this apparent (and very real) contradiction give anyone pause? Not on your life. Does the fact that last year's fender, called new at the time, is used again this year and is also called new bother any of them? Apparently not.

My plea, then, is for a lot more straight talk out of Detroit. I think the public would respond favorably. We are not so childish that we can't be told the truth. Besides, we're a sporting people, more than willing to give the other fellow a chance. The industry could, I feel, save itself and beat off government predators simply by leveling with us—its customers—and itself.

Is that so hard, gentlemen? ★★★

THE REALLY NEW ONES

(Continued from page 108)

a fancy SE version. The Challenger offers a number of safety features—reinforced doors, a sort of built-in roll cage for the hardtop, a new energy-absorbing steering column, beefed-up door hinges and locks. Standard engines are a 225-CID Six, a 318-CID 2-bbl. V8. For the R/T, a 383-CID 4-bbl. V8 is standard. Optional on the R/T are Chrysler's muscle engines—the 440-CID and 426-CID "Hemi" V8s. There are three transmissions—a standard three-speed or optional four-speed, both floor-mounted, or an automatic, either console or column-mounted. Driving the Challenger can be either a pleasure or work, depending upon whether you get it in a mild or brute version. But in any event, the heads will turn when this one goes by.

PLYMOUTH: New here is the Barracuda and a little jewel called the Valiant Duster. The Barracuda, available either as a two-door hardtop or a convertible, is a sports/specialty car that's aimed squarely at Mustang and Camaro. And it's an all-

(Please turn to page 220)



**EARN
HIGH
WAGES**
as a **HEAVY
EQUIPMENT
OPERATOR**

Train your way to high pay in the booming construction industry! Learn the skills you need to qualify, by actual field training on machines like the ones used by the industry. Huge training grounds in North Carolina, a million dollars worth of school-owned diesel-engined machines, experienced instructors, full 220-hour and 440-hour courses. National, the original school of heavy equipment operation, is a recognized leader. Member American Road Builders Assn., Services and Supply Division. Associate Member A.G.C. Full-time Job Advisory and Counseling Director on staff. VA approved. For men ages 17 to 56. Train Now-Pay Later plan... other payment plans also available. Write TODAY for FREE catalog and FREE copy of school newspaper reporting news of National School graduates. Accredited member NATTS.

**NATIONAL SCHOOL
OF HEAVY EQUIPMENT OPERATION, Dept. D-32**
P. O. Box 8529, Moores Chapel Road, Charlotte, N. C. 28201

Please send me FREE illustrated school catalog and complete information. I understand there's no obligation.

Name _____ Age _____

Address _____ Phone _____

City _____ State _____ Zip Code _____

**If you like to
work on cars,
why not get
paid for it?**

Home study training makes the difference between a hobby and a big money job. Trained auto mechanics are in greater demand than ever before. And when you're in demand, you do the choosing. You choose where you work and what you work on.

You can have the same choice. Our program lets you prepare to become a mechanic at home, in your spare time. This program gets you ready for the big money. Write today.

ITT Technical Institute
1340 S. Michigan Avenue, Chicago, Ill. 60650 • Dept. 163-109

Please send FREE information on your program for Automotive Training.

Name _____ Age _____

Address _____ Married Single

City _____ State _____ Zip _____

Approved for Veterans Training
ITT TECHNICAL INSTITUTE
An educational service of
International Telephone & Telegraph Corporation **ITT**

SPARE TIME CASH! SELLS ON SIGHT!

SELL new lifetime, Golden Metal Social Security Plates in spare time for **BIG PROFITS**. Millions waiting to buy. No investment or obligation whatsoever. SEND FOR FREE SAMPLE AND COMPLETE SALES KIT NOW!
RUSSELL PRODUCTS CO.
P. O. BOX 286 -PMA, PULASKI, TENN. 38478

locksmithing and key making

PRACTICAL UP-TO-DATE COURSE — ONLY \$6.95



Teaches you how to pick locks, de-code, make master keys, repair, install, service, etc. New self-instruction lessons for every handyman, homeowner, carpenter, mechanic, service station operator, fix-it shop, hardware dealer, gunsmith. 53 easy illustrated lessons. Full price only \$6.95, postpaid. Satisfaction or refund guaranteed. Mail order today!

NELSON-HALL CO., Dept. KR-2
325 W. Jackson Blvd., Chicago 60606

TREASURE

Find buried gold, silver, coins, treasures.
5 Powerful models.
Write for free catalog



RELCO DEPT. D-3
BOX 10839, HOUSTON, TEX. 77018 **\$19.95 UP**

travel the SHORT way

avoid wrong turns — save time, money and frustration with



... at leading stores everywhere!

AIRWAY COMPASS, Mexico, Indiana 46958



Solves Repair Problems

Durham's fills cracks and holes in plaster, wood and tile. Won't shrink or fall out. Economical, easy to use. Big 4-lb. can, only \$1.80 at lumber, paint, and hardware dealers, or shipped direct postpaid in U. S. for \$2.25. Money-back guarantee. Order now. Donald Durham Co., Box 804, Des Moines, Iowa 50304

LASER

LASER PISTOL—\$1.00. How to build. **PHASER PISTOL—\$1.00.** You have seen it on TV, now build your own—SAFE, loads of fun.

Add 25¢ each course for postage. **BACK TO SCHOOL SALE.** Over 200 science projects. Order our new catalogue now—only 25¢. **Roy Davis Laboratories, Dept. PM, 118 West Adams St., Jacksonville, Florida 32202.**

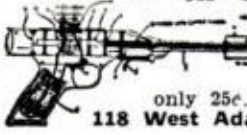

ROTARY FILES



U.S. Surplus High Speed Milling Files going fast. New, in G.I. Packs. Hardened steel, for filing, milling, routing, drilling—any work in light metal or wood. Use in 1/4 in. drill, etc. Range in size from 1/4 to 1 inch wide. Get these most useful tools now.

16 tool set—government cost \$109 \$ 9.00 to you!
36 tool set—government cost \$265 \$15.00 to you!
100% GUARANTEED. WE PAY POSTAGE. A LIFETIME BUY!!

THE SURPLUS CENTER
LANCASTER, TEXAS 75146

Top Tool Values From

See the broad selection of fine tools by Black & Decker and other quality manufacturers now being featured at True Value and V&S Hardware Stores.



OVER 2900
FRANCHISED
HARDWARE
STORES IN
46 STATES



COTTER & COMPANY • 100% DEALER OWNED
GENERAL OFFICES IN CHICAGO, ILLINOIS 60614

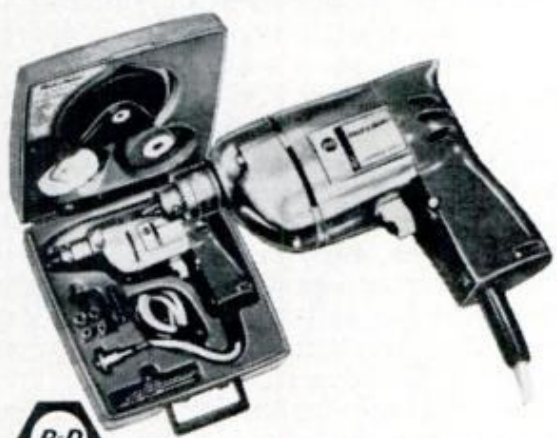

B-D **VARIABLE SPEED 1/4" DRILL KIT**
New 0-2250 rpm, 1/2 HP drill locks trigger at selected speed. 31 pcs. in custom case. 7021. **24.88**



B-D **POWERFUL 1 HP CIRCULAR SAW**
With 7 1/4" combination blade, bevel/depth adjustments. Appr. for 6 1/2" or 7 1/4" blades. 7301. **24.88**



B-D **DUAL-ACTION FINISHING SANDER**
Deluxe 1/4 HP. Orbital action for fast material removal, straight line for fine sand. U240. **24.88**



TRU-TEST
SAVE \$22 ON SOCKET WRENCH AND TOOL SET
78-piece set includes nine 1/4", seven 3/8" and ten 1/2" diameter socket wrenches with all attachments, plus hack saw set, hex key set, chisel set and many other tools in sturdy metal box. Total cost if purchased separately: \$62.56. T3778 **39.99**



TRU-TEST **HAMMERS**
Hickory handles stay tight forever. Polished steel heads. Regular style or with ripper claw. Your Choice **3.48**

TRU-TEST **SCREWDRIVER SET**
8-piece set, a size and style for every need. With blister-proof handles. Extra power and turning strength . . . **2.99**

For more tool values, see the special Black & Decker insert. Then shop your nearby True Value or V&S Hardware Store.

You're Never Out of a Job

With a Sparetime

BUSINESS OF YOUR OWN



Turn your spare hours into extra dollars this proven, practical way—start your own money-making sharpening business! No selling or canvassing, no experience needed . . . you do it all automatically with the Foley Saw Filer or Mower Sharpener.

Earn \$300 to \$600 an Hour in Sparetime



Hundreds of people like yourself are making cash like this—\$20 to \$30 a week—right now in spare time. "My spare time saw filing business has made me \$952 these first ten months"—says R. T. Chapman. Many have built a complete sharpening service with year-around profits. You can, too, simply by following, the sure, easy Foley plan.

No Experience or Training Needed

You can sharpen combination (rip and crosscut) circular saws, hand saws, band saws, crosscut circular saws—and do a perfect job every time without experience or special training. The precision Foley Filer does it for you automatically! A complete repair shop in one machine! Set up in basement or garage, work your own hours in your own way and earn big sparetime profits.



Husband and Wife Have Going Business

Here's the story from Dick and Jo Ann Koester after being in business 10 months: "We have acquired another Foley Saw Filer and for the past two months we have been in full-time operation. As we live in a small town of 150 population in farm area we use our truck to pick up saws in five nearby towns. With a family to support and plans for building to our house we had to pick up business fast and already sharpen an average of 15-20 saws a day. Business for the future looks even better as good machine filing is our best advertising."

Free Booklet Tells How

Free Book "Money Making Facts" shows just how you can start at home in spare time and sharpen hand, band and circular saws with the Foley Saw Filer. Small investment—time payments if desired. Get this booklet—study it! Send coupon today. No salesman will call on you.



**FOLEY MFG. CO., 1016-9 Foley Bldg.
Minneapolis, Minn. 55418**

Send free book "Money Making Facts" and Time Payment Plan

Name _____

Address _____

City _____ State _____ Zip Code _____

THE '70 CARS

(Continued from page 217)

new car; don't let the "Barracuda" tag fool you. It's offered in three series—the base Barracuda, the plush Gran Coupe, the all-out 'Cuda. Thanks largely to a unique grille and bumper arrangement, it's a startling looking car, about as "tomorrow" as anything coming out of Detroit these days. Although similar in many respects to Dodge's Challenger—including the engine and transmission lineup—Chrysler's stylists have managed to make it look different. For one thing, it's almost five inches shorter overall, a fact that somehow makes it more . . . oh, *personal*. Again, driving the Barracuda can be pleasing or a chore. It can even be fun. The car handles quite well, although nothing out of the ordinary in either intent or results.

The Duster is something of an enigma. Plymouth didn't bill it as an all-new car, yet by Detroit standards it's as new as anything herein described. True, the Valiant line still includes the four-door sedan, carried over pretty much as is (or was) from '69. And true, the Duster and its companion Duster 340 carry the Valiant label. Yet the latter is a far different breed of cat than the four-door. It's a nifty looking little thing, its two-door coupe styling being "new from the ground up." For real. Coupled with its great looks is what Plymouth promises will be "economy-budget prices" (not announced as this is being written). If it *does* manage to keep the price down, the Duster could be the sales sleeper of the year. Standard engine in the Duster is a new 198-CID Six. The options include a 225-CID Six and a 318-CID V8. Standard in the Duster 340 is—give up?—a 340-CID 4-bbl. V8, a package bound to make the car big news with the younger muscle-car set. The car is unabashed fun to drive and, like I said, it could be the sleeper of the year. ★★

THE NEW INTERMEDIATES

(Continued from page 114)

trim styling and a wider choice of inside trim colors. Although the 112-in. (coupe and convertible) and 116-in. (sedan) wheelbases are carried over, overall length and front and rear track are up fractions, overall width a fraction down. The hot SS 396 is available only as a coupe or convertible. Standard engines include a 250-CID Six, a 307-CID V8. The options—all V8s—include a 350-CID 2- or 4-bbl., a 396-CID, 400-CID and new 454-CID. There are two manual transmissions—a column-mounted three-speed and a

console-mounted four-speed—and two automatics.

In all, a broad, appealing line.

DODGE: Coronet is the overall name here, although five series of cars are offered—the Coronet Deluxe, 440, 500, R/T, Super Bee. Biggest styling change has overall body length up nearly three inches. There's also a new split grille set behind a new twin-loop bumper. Front fenders are new. In back there's a new deck lid, new tail-light arrangement, new bumper. The base Coronet DeLuxe is available as a two-door coupe, four-door sedan, two-seat wagon. The 440 is offered as a two-door coupe or hardtop, a four-door sedan, two or three-seat wagons. Same with the 500, except a convertible replaces the coupe. The R/T comes as a two-door hardtop and convertible, the Super Bee as a two-door coupe or hardtop. In the Deluxe and 440, standard engines are a 225-CID Six, a 318-CID V8 (this V8 is standard in the 500). The Super Bee gets a 383-CID V8 as standard, the R/T a big 440-CID V8. There are engine options throughout, including the formidable 426-CID Hemi V8. There's a new floor or column-mounted three-speed manual transmission, in addition to a manual four-speed and an automatic.

Dodge did well with these cars last year, taking about 12 percent of the intermediate market. This year should be a winner, too; it's a good looking, snappy line.

FORD: Offered here are the Fairlane 500 and the Torino series—base, GT, Brougham, Cobra. Overall length is up five inches, wheelbase an inch. The hood is longer, slopes more, and rooflines are lower. There are a couple of new grilles. Around back there's a new taillight setup and new backup lamps. Inside is a new three-point lap and seat-belt arrangement, new dash panel, steering wheel. Optional inside are "upbeat interiors," whatever that might mean. The Fairlane is offered as a two-door hardtop, four-door sedan, wagon. The base Torino adds a four-door hardtop. The GT is offered as a two-door hardtop and convertible, the Brougham a two or four-door hardtop and wagon, the Cobra as a two-door hardtop. Standard engine on everything except the GT and Cobra is a 250-CID Six. Standard on the GT is a 302-CID V8. Standard on the Cobra is a 429-CID V8. Other engines available are two 351-CID V8s, one a 2-bbl., the other a 4-bbl. (not in the Cobra, however), and four versions of the 429, ranging from merely snarling to out-and-out nasty. Transmissions include three and four-speed manuals and an automatic.

There's a lot to like here. A bit gim-

(Please turn to page 222)

EASY MASK® Pat. No. 3,032,181
PAINTING TAPE

The Only Masking Tape
That IS A DROPCLOTH™



Easy-Mask, the *only* one-piece paper-tape combination

- Protects carpet, woodwork, tile, linoleum.
- Catches spills, splatters, drops, mist.
- 4 ideal sizes: (4" x 60', 4" x 120', 6" x 60', 6" x 120'). Available at leading paint, hardware and building supply stores.

Easy-Mask puts pleasure into painting!



DAUBERT CHEMICAL CO.
CONSUMER PRODUCTS DIVISION
Oak Brook, Illinois 60521 312/582-1000



**NEW
TURNER
Tornado
TORCH**

***World's hottest
propane torch!***

***Completes jobs faster...easier.
Guaranteed 100 years.***

At your hardware dealer now

HOW TO GET UP TO \$150 MORE FOR YOUR CAR AT TRADE-IN TIME!

FOLLOW THESE FOUR "FROM THE DEALER" TIPS AND PUT UP TO \$150 IN YOUR POCKET AT TRADE IN TIME.

1. Wash and wax your car. Use a brand name polish or wax, it pays.
2. Have your local car wash steam clean your engine, wheels and wheel wells.
3. Vacuum and shampoo interior and trunk. Wash down spare tire.
4. **REFINISH YOUR VINYL ROOF WITH NEW FINISH-R AUTO TOP REVINYLIZER, (DEALERS DO)!**

FINISH-R actually bonds a better than new polymer acrylic "vinyl" finish to your old, grey, dull top. It gives you the deep color and sheen that you have always wanted.

WARNING

With your car and vinyl top looking this good, you may forget all about that new car for a while. Don't worry. The FINISH-R application lasts up to one full year, so you will be able to save more in '71 too!

SEND FOR YOUR FINISH-R KIT TODAY!

Only \$995

(N.Y. State residents—please include local tax—we pay postage and handling)

P.C.A. Sales
P.O. Box 29
Staten Island, N.Y. 10314

**POPULAR
MECHANICS
PRODUCT FEATURE**

Please send me _____ FINISH-R Kits at \$9.95 each.

Enclosed is my check or money order for \$ _____

My car top color is: _____

NAME _____

ADDRESS _____

CITY _____ STATE _____ ZIP _____

THE '70 CARS

(Continued from page 221)

micky in spots, but the overall line is smashing.

MERCURY: Two series here—Montego and Cyclone. In the Montego there's a base model, an MX and Brougham; in the Cyclone, a base, GT and Spoiler. Wheelbase is up an inch, overall length almost four. Tread is wider fore and aft. The hood is longer, rooflines lower. There are new grilles, a new bumper, new rear-end treatment. Inside are new two or three-spoke steering wheels and a new instrument cluster, plus several trim touches. You can get the base Montego as a two-door hardtop or a four-door sedan. Same with the MX, except add a wagon. The Brougham is available as either a two or four-door hardtop, a four-door sedan and wagon. The Cyclone series comes only as a two-door hardtop. Base engine on everything except the Cyclone series is a 250-CID Six. Standard on the Cyclone is a 429-CID V8, on the GT a 351-CID 2-bbl. V8, on the Spoiler a muscle version of the 429. Other engine options include a 302-CID V8, a 351 4-bbl. and an even more muscular 429, available only on two-door hardtops. There's a three or four-speed manual transmission on tap, as well as an automatic.

Here again there's a lot to like from in front. Add Mercury's long option list and you can come up with just about anything you might want.

OLDSMOBILE: Available here are the F-85, the Cutlass, Cutlass Supreme, 4-4-2 and Vista Cruiser wagons. The base F-85 is a sports coupe; the Cutlass a sports coupe, two or four-door hardtop, four-door sedan, convertible and two-seat wagon; the Supreme a four-door sedan, two or four-door hardtop and convertible; the 4-4-2 a sports coupe, two-door hardtop and convertible. In addition there are special "S" dress-up options for the Cutlass, an "SX" (I don't know what it means either) option for the Supreme Holiday Coupe and convertible. The Vista Cruiser wagons are either two or three-seat. There are new grilles, fenders, doors, rear quarter panels, taillights, bumpers front and back. There's a new instrument panel inside along with a lot of "wood grain" facing. Engines include a 250-CID Six, either 2-bbl. or 4-bbl. 350-CID V8s, and—for the 4-4-2—a big 455-CID V8. Transmissions include manual three and four-speeds and an automatic.

As always, the Olds line has a nicely finished look about it.

PLYMOUTH: There are five series here—Belvedere, Satellite, Sport Satellite, Road

Runner and GTX. You'll notice new front and rear bumpers, a new grille, new rear-deck lid, new taillights, a new instrument panel, some new hood gimmickry and new stripe treatment. The Belvedere comes as a two-door coupe, four-door sedan, two-seat wagon. In the Satellite there's a two-door hardtop, a four-door sedan, a convertible and two or three-seat wagons. Same with the Sports Satellite, only no convertible. The Road Runner is a two-door coupe or hardtop and convertible, the GTX strictly a two-door hardtop. Engines start off with a 225-CID Six and go up through 318, 383, 426 and 440-CID V8s. Transmissions are a manual three or four-speed and an automatic.

You'll be interested to know you can get Plymouth's intermediates in any one of 18 colors including—brace yourself—"Vitamin C, Tor-red, Lime-light, In-violet and Lemon Twist." We're in more trouble than I thought.

PONTIAC: Four cars here—Tempest, LeMans, LeMans Sport and GTO. Pontiac's split grille theme has been retained, albeit slightly restyled via a new bumper and parking and side marker-light arrangement. There's not much new inside, primarily a reshuffled instrument panel and some trim touches. You can get the Tempest as a two-door coupe or four-door sedan. With the LeMans add a two-door and four-door hardtop and a two-seat wagon. In the LeMans Sport, drop the four-door sedan and add a convertible. The GTO is either a two-door hardtop or a convertible. The line's standard engine is a 250-CID Six. Optional are 350 and 400-CID V8s, the latter in 2-bbl. and 4-bbl. versions and available only with an automatic transmission. Standard in the GTO is a 400-CID V8 with a 360-hp, 455-CID V8 the option. The OHC Six has been dropped. Transmissions include a three or four-speed manual and two automatics.

There's not too much that's new here, granted, but Pontiac says it's placing a lot of its effort on improving quality. Let's hear it for Pontiac! ★★

THE PERSONAL CARS

(Continued from page 118)

side, things are pretty much carried over. There's only one engine for the Riviera—a 455-CID, 4-bbl. V8. The car is (as always) a two-door hardtop and the transmission is automatic.

I'm not a Riviera buff per se, but I like this one.

CHEVROLET: Corvette and Camaro are the action here. The Corvette is the same *(Please turn to page 224)*

TAX SEASON IS COMING!

LEARN TAX PREPARATION WITH H&R BLOCK

EARN UP TO \$700 PER MONTH

Here's your opportunity to learn tax preparation in your spare time from H & R Block, America's largest tax service. Join the ranks of successful H & R Block graduates who occupy a respected position in the tax preparation field. Earn up to \$700 a month as a tax preparer during tax season. No previous training or education required. Ideal for retired people and/or men and women seeking full or part time income. Job opportunities available for qualified graduates. Low tuition costs includes all supplies you need for this complete home study course. Send for free information today. No salesman will call.

H&R BLOCK Inc.

301-109

TAX TRAINING INSTITUTE

4410 Main Street Kansas City, Mo. 64111

Yes, please send me without obligation full details on your home study course for income tax preparation.

Name _____

Address _____

City _____ State _____ Zip _____

New windows that don't need paint!

Nor putty, nor storm windows . . . that won't warp, rust, dent, corrode nor need scraping, or repairing.

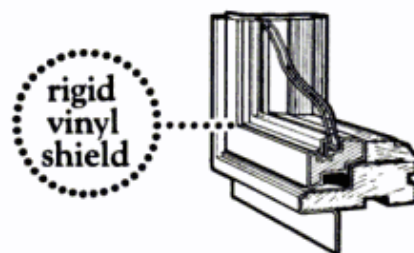

Get FREE Booklet on New Andersen Perma-Shield® Windows

Andersen Corporation
Bayport, Minnesota 55003

Name _____

Address _____

City _____

State _____ Zip _____

Andersen Windowalls™

Only the rich can afford poor windows

PM-109

THE '70 CARS

(Continued from page 223)

coupe and convertible it was last year, which is to say pretty spiffy. There are no real changes outside and strictly minor ones inside. Power is various versions of two V8s—350 and 427-CID engines. There's a manual three-speed, a manual four-speed and an automatic. A nice car, but not for the timid or indiscreet. Camaro, too, is carried over as is. It'll be an all-new car after the first of the year, so Chevy let it ride. It comes as a coupe or convertible in both base and SS versions. There's all sorts of dress-up stuff available, too. In engines there are 230 and 250 CID Sixes, 307, 350 and 396 CID V8s. In transmissions there are two manual three-speeds, a manual four-speed, and three automatics, not all of which are available in all models.

Again, a nice car. I look forward to seeing the new one.

DODGE: Charger is the name of this game. There's a new lower-priced model called—oddly enough—Charger, the Charger 500 and Charger R/T. The Charger Daytona is strictly a race car being built in limited numbers (although, as pointed out earlier, anybody can buy one if a dealer has one to sell). In all series the car is a two-door hardtop coupe. Styling changes are mostly up front and involve a new loop bumper and minor ornamentation touches. The new bumper, by the way, can be color-keyed in hues tabbed "Hemi Orange, Plum Crazy, Banana." Heaven save us! A 225-CID Six or 318-CID V8 are standard on the base Charger and the Charger 500. On the R/T, the standard engine is a 440-CID V8. Optional at the top end of the line is the 426-CID Hemi V8. Transmissions include a three or four-speed manual and an automatic.

Again, it's what it was last time around—a bit brutish, but a head-turner.

FORD: Two cars here—Mustang and Thunderbird. The Mustang has been re-vamped fore and aft, up front via a new grille and fender treatment, in back via a new taillight arrangement. The changes, however, are minor. The car is available as a two-door hardtop coupe, a fastback and a convertible. There's a base Mustang, a dressy Grandé, two muscle versions—the Boss and Mach 1. In engines there are two Sixes—200 and 250-CID—2-bbl. and 4-bbl. 302-CID V8s, 2-bbl. and 4-bbl., 351-CID V8s, two 4-bbl. 428-CID V8s, and an all-out 429-CID V8. Transmissions are a three and four-speed manual and an automatic. The T-bird, on the other hand, has been extensively restyled up front. You'll notice

a brand-new nose appearing at the end of a longer (five-inch-plus) hood. The grille, bumper and headlight setup are new. The car is available as a two-door hardtop, a two or four-door landau. There's only one engine—a 360-hp, 429-CID V8. The transmission is automatic.

Ford went easy with both the Mustang and T-bird this year (despite the latter's new nose job), meaning there are no surprises, just the usual nice and/or elegant touches.

MERCURY: Here we have the Cougar in three series—base, XR-7, Eliminator. The Cougar and XR-7 are available as two-door hardtops or convertibles, the Eliminator only as a two-door hardtop. Styling changes are minor, centering mainly around a new grille and new ornamentation. Inside are new trim schemes, new high-back bucket seats, new two and three-spoke steering wheels. The Eliminator features front and rear spoilers. Engines include 351-CID 2-bbl. and 4-bbl. V8s, a Boss 302-CID 4-bbl., 428-CID and 429-CID V8s. There's a three or four-speed manual transmission and an automatic.

I liked the Cougar when it was first introduced. I still do.

OLDSMOBILE: They've redone the front end of the Toronado, giving it a new grille, new bumper, new headlight arrangement. There's also a new rear-deck lid, new taillight assembly, new rear quarter-panels. Inside there's a new instrument panel and new trim throughout. Here, styling touches really are refinements—a pushbutton ash tray, for example, and rearranged airconditioning outlets. Power is a 455-CID 4-bbl. V8, the transmission automatic.

I've put a lot of miles on the front-drive Toronado, all soothing and comfortable.

PONTIAC: Again, two cars—the Firebird and Grand Prix, both carried over pretty much intact. The Grand Prix was new last year, the Firebird will be after the first of the year. There's really not much to report about either car. The Firebird comes as a two-door coupe and convertible, the Grand Prix as a two-door hardtop coupe. The Grand Prix is powered by 400-CID 2-bbl. and 4-bbl. V8s or a 455-CID 4-bbl. V8. Transmissions are a three-speed manual and an automatic. Firebird power includes a 250-CID Six, 2-bbl. and 4-bbl. 350-CID V8s, two 400-CID V8s (2-bbl., 4-bbl.), a 428-CID 4-bbl. V8, and a 455-CID 4-bbl. V8. Transmissions are a three or four-speed manual and an automatic.

As mentioned earlier, Pontiac is making an effort on the workmanship front, which has to be some of the best news of the year. ★★★

GO with the best!



BEAUTIFUL

Distinctive styling and design refinements make the all-new Big "A" the one to go with. Nine beautiful models with sleek, graceful lines . . . flawless construction and finish. And Alouette is first with safety features. New emergency kit with spare plug, drive belt, pull cord, light bulb. New permanently mounted instrument dashboard eliminates short circuits. New caster and camber steering banks skis for safer turning. New one-piece steel underbody welded to steel chassis for maximum strength and safety. New safety-design seat and backrest for non-slip support. Good reasons to go Alouette.

EXCITING

The powerful Big "A" is a top performer in every way . . . and you can trust the rugged, sure-footed Alouette anywhere. Low center of gravity and wider track skis give better traction and stability. Alouette's new variable speed, cam-operated torque converter transmission is electronically dynamically balanced for safe, smoothly controlled power. From the lively 277 c.c. to the luxury widetrack

Big Bird and new high-performance competition models, Alouette is way out front. So if it's exciting action you want, go with the best. Go see your Alouette dealer.

1970
Alouette[®]
The Reliable One

FEATHERWEIGHT CORPORATION, MONTREAL, CANADA

new breed of scat

The Bobcat, from Evinrude



*Evinrude driver takes the Bobcat
over a test jump.
(Leave this to the "pros" — it's tricky.)*

the performance-plus snowmobile

Most "performance" snowmobiles are stripped-down, single-purpose speed machines.

The Evinrude Bobcat is a high performance *trail* machine. A world of difference.

Bobcat is designed for speed — *plus*. 50 mph speed in flat country. With

power in reserve for hill climbing and high altitude running; and for powering through deep powder and soft, sticky snow.

The secret is the Bobcat engine — a 25 hp Evinrude twin with enormous 437 cc displacement.

An engine big and powerful enough

so the whole machine can be made as strong and tough as it needs to be for high speed cross-country running.

With enough performance left over to take a little luxury along.

Man can't live on speed alone.

Write for catalog. Evinrude Motors, 4077 N. 27th St., Milwaukee, Wis. 53216

the trailblazers, from **EVINRUDE**  **first in outboards**
Div. of Outboard Marine Corporation

EVINRUDE



power for the
performance generation

Evinrude moves into the '70's — with motors so advanced they couldn't be built (or even believed) a few years ago.

Motors like the new loop-charged Triumph "60" — with aimed, angled fuel ports and flat-top pistons. With a power-tuned exhaust that *adds power* instead of subtracting it. And new piston rings that *use* compression pressure instead of fighting it.*

*Patent applied for.

De-luxe push-button motors that can change direction *without using neutral*. Electric power shifting that *uses no current* in forward gear.

Motors with lower units designed by computers. With anti-pollution fuel systems that *re-cycle and re-burn fuel* that used to go out the exhaust.

There are new 50 mph mini-V-4's — dramatically shorter and smaller — the

quickest, strongest Evinrude ever built. High performance motors that sit so low on the boat and run so quietly you scarcely know they're there.

There are *New Generation* Evinrudes for every generation — from the tiny 20 lb. Mate to the mighty 115 hp Starflite V-4.

Coming soon. Watch for your Evinrude dealer's announcement.

EVINRUDE  **first in outboards**
Div. of Outboard Marine Corporation

EVINRUDE MOTORS
4107 N. 27th St.
Milwaukee, Wisconsin 53216

FREE PREVIEW — Please send me your new 1970 catalog.

NAME _____

ADDRESS _____

CITY _____ STATE _____ ZIP CODE _____

Take it
from people
who know,
ski-doo is the one
with the
winning
personality!



Last winter, Ski-Doo won more races than all other snowmobiles combined. And set a world speed record doing it!
If a snowmobile can take on all competitors in every class and win race after race, it has to be good. But being good on the track isn't good enough. Once again, we've gone all out, so you can go one better on the trail, too.
Better performance. Ski-Doo has more dependable power for climbing, towing, funning around. Better ride. Smoother over the bumps. More stable in the turns. And no snowmobile is so light-footed — over deep, deep snow. Better selection. For 1970, we offer five Ski-Doo series, each with a totally different personality. If it's luxury you're after, we have it. If it's economy, we have a Ski-Doo so low-priced, many people are buying two.
If you want the number one choice in snowmobiles, in high fashion winter sportswear and accessories, see your Ski-Doo dealer. He'll show you the 1970 reasons why you go one better when you go Ski-Doo.

go one better
go **ski-doo**
North America's number one snowmobile



*T.M. Bombardier Ltd.

A Firestone truck tire priced as low as a car tire.

The Transport nylon cord truck tire. Everything you're looking for in a pickup or light-truck tire. With a low price that'll make you money.

It features a rugged Shock-Fortified nylon cord body for extra strength. Higher ply ratings for more load capacity. Exclusive Sup-R-Tuf rubber for long, long mileage. And a non-skid tread for sure starts and safe stops.

Our low-cost Transport truck tire. Long run, short money. Get it at your nearby Firestone Dealer or Store.

Sup-R-Tuf®. Transport®

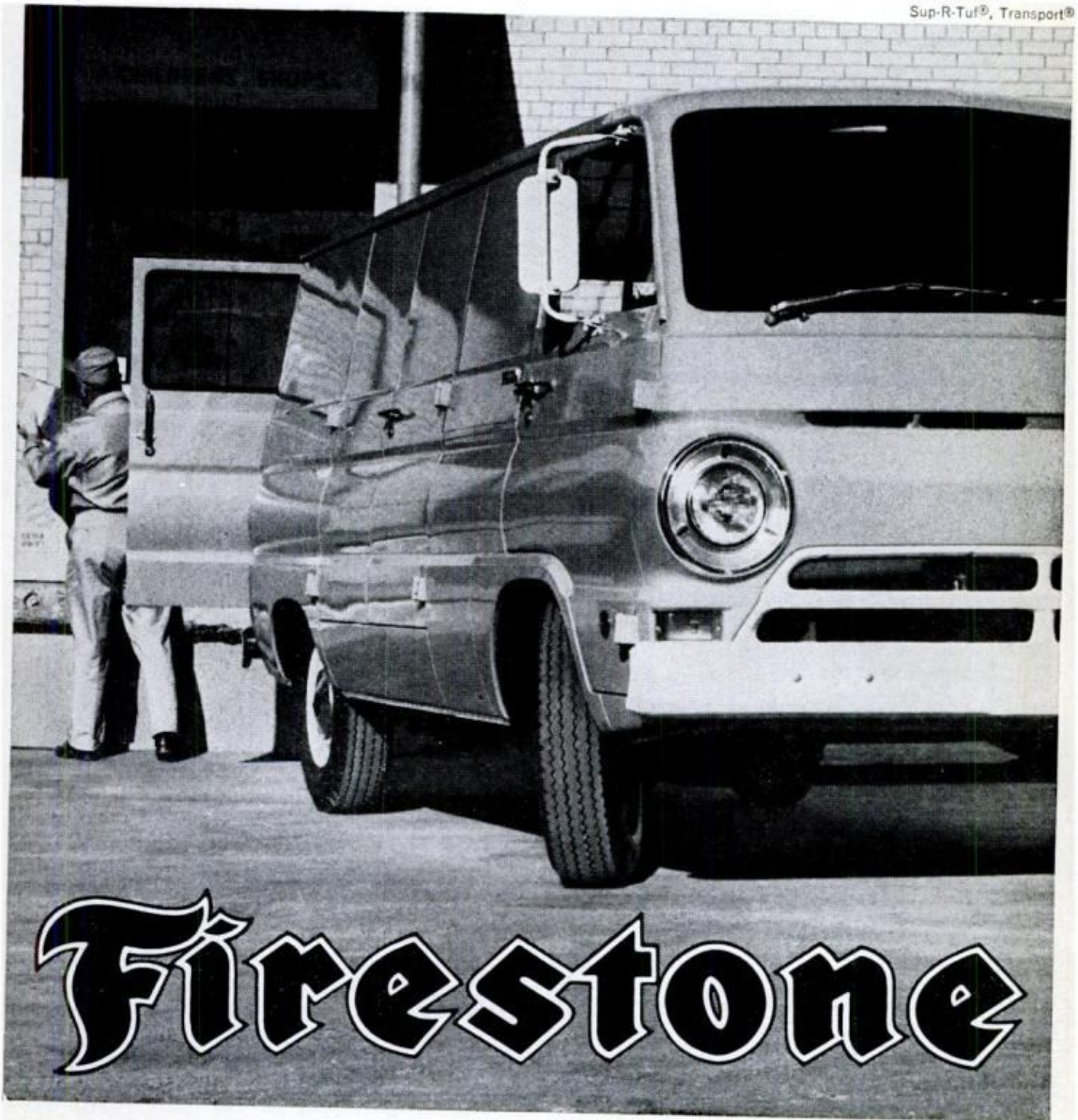

PRACTICAL PICTORIAL GUIDE TO MECHANISMS AND MACHINES

By S. S. Palestrant

Every kind of mechanical motion or holding device is fully illustrated and explained.

A complete reference book. Contains 4000 photos and illustrations.

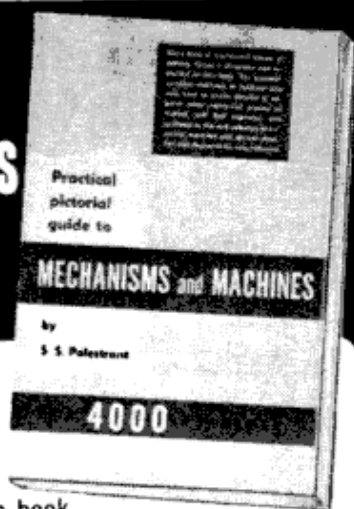

#502 \$5.95

PARTIAL CONTENTS —

Electrical System

Magnetic Fields
Electron Theory of Electricity
Amperage and Voltage
Resistance
Circuit Breaker
Regulators
Wiring Circuit for Regulators
Wiring Diagram—Voltage Regulator
Single-Loop DC Motor
Generator System
Vacuum Switch Control—Solenoid
Two-Circuit Distributor
Two-Circuit System, V-12 Engine
Wiring Diagram

Electrical Wiring and Equipment

Demand Loads for Household Ranges
Overcurrent Problems
Overhead Electrical Service
Fire Protection Equipment
Fire Alarm Systems
Fire Detecting Systems

Gears, Bearings and Joints

Meshing Gears
Ball Bearings
Tapered Roller Bearing
Three-Speed Selective Gear System
Universal Joint
Final Drive Gears
Spring Shackles

Braking Devices

External Contracting Brake
Internal Expanding Brake
Disk Brake
Braking Devices—Braking Action

Air Conditioning and Refrigeration

Electrical Ratings
Condensation
Compressed Air Temperature Chart
Voltage Amplification Principles
Heat Pump Operation

Power Sources

Internal Combustion Engine
External Combustion Engine
Fuel Injection Principles
The Two-Cylinder Engine
Piston Pin Arrangements
Fuel-Air Ratio
Metering Rod Circuit
Power Jet
Carburetor
Vacuum Stepup Circuit
Accelerator Circuit
View of four-Cylinder Engine
Radial Engine Gear Trains
Diesel Engines
Atomic Power Plants
Fuel Injector
Governors
Rotor Pump
Gear-Type Oil Pump

More Great Reference & Self-Improvement Books:

500	Key To A Successful Business.....	\$2.95
501	The Engineers' Illustrated Thesaurus.....	5.95
503	Electrical Engineer.....	7.95
511	The Key To Basic Electronics.....	4.00
512	The Key To Advanced Electronics.....	4.00
513	Engineer's Handbook.....	5.95
1512	Be Your Own Carpenter.....	2.95
1514	Be Your Own Plumber.....	2.95
3118	Mechanical Drawing Self Taught.....	2.00
3148	Inventor's Guidebook.....	2.00
3161	Motorboat Owner's Handbook.....	2.00
3162	How To Repair Your Car.....	2.00
3164	Home Repairs Made Easy.....	2.00

ORDER BOOKS BY NUMBER • MONEY-BACK GUARANTEE—No C.O.D.'s

KEY PUBLISHING CO. | 817 Broadway
New York, N.Y. 10003

Please rush books checked below, I enclose

\$ _____ in payment.

500 501 502 503 511 512 513
 1512 1514 3118 3148 3161 3162 3164

Name _____

Address _____

City _____ State _____ Zip _____

Dept. PM-1089

THE '70 CARS

(Continued from page 230)

Marquis lineup is the same as the Monterey except the wagon is called Colony Park. In the Marquis Brougham you can get a four-door sedan, a two or four-door hardtop. A 390-CID 2-bbl. V8 is standard in the Monterey, Monterey Custom, base Marauder and Colony Park wagon. The Marquis and Marquis Brougham feature a 429-CID 2-bbl. V8, the X-100 a 429 4-bbl. Transmissions are a three-speed manual and an automatic. As pointed out in *The Luxury Cars*, page 123, these cars are becoming more Lincolnesque as the years go by. And I guess that's not bad.

OLDSMOBILE: The hand of the stylist has been stayed on the 1970 Delta 88s. There are new grilles, a new headlight arrangement. There's a new rear bumper. Inside there's a new steering wheel and new decor themes accented via wood-grain appliques. The car comes as either a base Delta 88, a Custom or Royale. The base model is available as a four-door sedan, two or four-door hardtop, a convertible. Same for the Custom, only no convertible. The Royale is strictly a two-door hardtop. There are three V8 engines—a standard 350-CID 2-bbl. and a 455-CID 2-bbl. and 4-bbl. You get a manual three-speed as standard transmission, with an automatic as the option. Optional on the shift lever of all 88s is a fingertip control for the windshield washer/wiper. You needn't take your eyes off the road to turn it on. A good idea on a nice line of cars.

PLYMOUTH: Four series of cars here—Fury I, II and III, Sport Fury. All have been slightly restyled front and rear, mainly via grilles and bumpers. Fury I and II are available as a two-door coupe, a four-door sedan. Fury III comes as two-two-door hardtops, a four-door sedan and hardtop, a convertible. Same with the Sport Fury, only there's no convertible. New this year is a Sport Fury GT replacing the VIP. It comes only as a two-door hardtop. In addition, there are three wagons—Suburban, Custom Suburban and Sport Suburban, all available as either two or three-seaters. Engines include a 225-CID Six, a 318-CID V8, two 383-CID V8s (2-bbl., 4-bbl.), two 440-CID V8s, a 4-bbl. and a three 2-bbl. Transmissions are a manual three-speed and automatic.

These are big, generous offerings, well worth a look if you're interested in a family-size car.

PONTIAC: You'll notice big changes up front in these cars. There's a new grille, new hood and fenders, a new bumper. Things have been redone in back, too, but

(Please turn to page 234)



If you're not working with tools coated with TEFLON-S*



you're working much too hard.

The friction-free magic of TEFLON-S means handsaws don't bind, putty knives don't drag, pruning shears don't gum up, snow shovels don't let ice and snow build up and power saw blades last longer and cut cleaner. They all clean up like a snap, and resist rusting.

TEFLON-S lends the same ease to grass clippers, anvil pruners, hedge trimmers, wall scrapers—and who knows what next?

When you see the TEFLON-S Quality Seal on a tool you know that the coating definitely contributes to its performance, and that the coating meets Du Pont's tough standards. You can have confidence in it even before you use it.

Look for the TEFLON-S seal on tools in your hardware store.

*Reg. U.S. Pat. Off. for Du Pont's non-stick finishes.



Better things for better living... through chemistry





3 easy ways to bore holes faster

1. Irwin Speedbor "88" for all electric drills. Bores faster in any wood at any angle. Sizes $\frac{1}{4}$ " to $\frac{3}{8}$ ", \$.85 each. $\frac{3}{8}$ " to 1", \$1.95 each. $1\frac{1}{8}$ " to $1\frac{1}{2}$ ", \$1.50 each.

2. Irwin No. 22 Micro-Dial expansive bit. Fits all hand braces. Just dial your size. Bores 35 standard holes, $\frac{7}{8}$ " to 3". Only \$5.00. No. 21 small size bores 19 standard holes, $\frac{3}{8}$ " to $1\frac{3}{4}$ ". Only \$4.50.

3. Irwin 62T Solid Center hand brace type. Only 16 turns to bore 1" holes through 1" wood. Double-cutter boring action. Sizes $\frac{1}{4}$ " to $1\frac{1}{2}$ ". As low as \$1.45 each. **EVERY IRWIN BIT** made of high analysis tool steel, heat tempered, machine-sharpened and highly polished, too. Buy from your independent hardware, building supply or lumber dealer.

Strait-Line Chalk Line Reel Box
only \$1.35 for 50 ft. size

New and improved Irwin self-chalking design. Durable aluminum alloy box. Practically damage-proof. Fits pocket or hand. 50 ft. and 100 ft. sizes.



IRWIN every bit as good as the name
at Wilmington, Ohio, since 1885

LAW FREE BOOK THE LAW TRAINED MAN

Write today for a FREE copy of illustrated law book, "THE LAW TRAINED MAN," which shows how to earn the professional Bachelor of Laws (LL.B.) degree through home study of the famous Blackstone Law Course. All necessary books and lessons provided. Moderate cost; convenient monthly terms. Write for FREE law training book today.

Blackstone School of Law, 307 N. Michigan Ave.
Founded 1890 Dept. 57, Chicago, Illinois 60601

REAL ESTATE BE A BROKER

PAYS BIG! SEND FOR BIG FREE CATALOG NOW! Graduates report making substantial incomes. Operate your own business quickly. Men, Women, all ages, learn easily. Course covers Sales, Appraising, Loans, Mortgages, & related subjects. **STUDY AT HOME** or in class-rooms in leading cities. **Diploma Awarded. Write Today for FREE Book!** Accredited Member National Home Study Council, (Est. 1936) G. I. Approved.

WEAVER SCHOOL OF REAL ESTATE
3521-P Broadway Kansas City, Mo. 64111

75 POWER TELESCOPE \$498

NEW 3 in one telescopes, 3 variable 25X 45X-75X magnification. Brass bound, 25 power for ultra bright images 45 & 75 power for long range. Guaranteed to bring distant stars, moons, objects, sports 75 times closer. Most powerful scope anywhere at this amazing-low price. 5 sections. Opens 36" closes 1 ft.; contains 4 ground & polished lenses. Can also be used as powerful microscope. American made. Mass production enables us to offer telescope complete including case \$4.98 post paid. Money back guarantee.

CRITERION CO., Dept. PBM-55, 331 Church St., Hartford, Conn. 06101

LEARN MEAT CUTTING



Train quickly in 8 short weeks at Toledo for a bright future with security in vital meat business. Big pay, full-time jobs — **HAVE A PROFITABLE MARKET OF YOUR OWN!** Time payment plan available. Diploma given. Job help. Thousands of successful graduates. **OUR 46th YEAR!** Send now for big new illustrated FREE

catalog. No obligation. G.I. Approved.
NATIONAL SCHOOL OF MEAT CUTTING
Dept. 50Z, Toledo, Ohio 43604

THE '70 CARS

(Continued from page 232)

not as radically. Inside is a new instrument panel, all-new trim schemes. There's a new type of inside door pull on the Bonneville. Cars in the line are the Catalina (a fancy trim option on the Catalina is called the Ventura), the Executive and the Bonneville. The Catalina is available as a four-door sedan, a two or four-door hardtop, a convertible and a two or three-seat wagon. Same with the Executive, but no convertible. The Bonneville adds a convertible, but drops a two-seat wagon. Engines include a 350-CID 2-bbl. V8, a 400-CID 2-bbl. or 4-bbl. V8, a 4-bbl. 455-CID V8. There's a manual three-speed transmission and an automatic.

My personal jury is still out on the revised front ends of these cars, but see what you think. ★ ★ ★

THE LUXURY CARS

(Continued from page 123)

new front end—new grille, bumper, hood. Around back there are new, vertically-mounted backup lamps, one feature of which is that although white, they glow red when unlit. Otherwise, changes are oh-so-slight, the main one being a new rocker panel. The Electra 225 is offered in a base and Custom series. The base model is available as a two or four-door hardtop or a four-door sedan. The Custom offers the same models, but with the addition of a convertible. There's one engine—a 455-CID 4-bbl. V8. A three-speed automatic is the only available transmission. Of all the big cars I've driven, this one somehow "feels" best. For comfort, the Electra is hard to beat.

CHRYSLER: The Imperial was an all-new car last year, and a handsome one at that. They've left it pretty much as is (or was) for '70, adding only slight changes up front with a new grille and minor trim and



BUICK ELECTRA 225 offers somewhat wider, lower look thanks to new grille, hood, wraparound bumper



LINCOLN CONTINENTAL MARK III remains pretty much the same as when first introduced in mid-1968

ornamentation shifts and additions. The car is offered in two series—the Crown and the LeBaron, both available only as two and four-door hardtops. A 440-CID 4-bbl. V8 is the only engine offered and the transmission is an automatic. I said in these pages last year that I thought the new Imperial was finally competitive with Cadillac and Lincoln in appearance. Apparently buyers agreed; the car did very well, giving Imperial one of its best years. All things being equal, it should do well this year, too. It's an impressive car.

LINCOLN: There are two cars here—the Continental and the Continental Mark III. The Continental has been extensively restyled, particularly up front where you'll notice a new grille, fenders, hood, headlight treatment, ornamentation. Wheelbase is up an inch and front and rear track have been widened. In addition, there's new body-on-frame construction, a new front suspension, new rear suspension. The car is offered in a single series as either a two-door hardtop or a four-door sedan. There's only one engine—the 460-CID V8 introduced last year, the same engine that powers the Mark III. The transmission, of course, is automatic. The Mark III is essentially the same car as when introduced in mid-1968. There are new wheel covers, new bumper reflectors, a new power-operated sun roof, new concealed windshield wipers. The car is available only as a two-door hardtop.

OLDSMOBILE: New for '70 on the Olds 98 is a grille, hood, front bumper, rear bumper, taillight arrangement, some accent molding and striping. In general, however, the car looks very much like it did last year, which is to say, elegant. It's available as a convertible, a two-door hardtop coupe, two four-door sedans and two four-door hardtops. Featured in the top-end models is a 60/40 powered seating arrangement. The one available engine is a 455-CID 4-bbl. V8 and the transmission is an automatic. In common with most cars in the luxury category, power disc brakes and power steering are standard. ★★

GOVT. SURPLUS AND OTHER BARGAINS SAVE UP TO 90%



MOTORIZED TRANSFER PUMP

High volume. Delivers up to 700 GPH @ 35 PSI. 1 1/2" pipe ports. Exc. for pumping water & oil base insecticides, transferring diesel fuel, gas, kerosene & solvents. 1/4 HP motor will operate 24 or 12V DC. Tested prior to shipment. Shpg. wt. 17 lbs. Approx GOVT COST \$135. NOW \$24.50 (Stk. #1243).



ELECTRIC GEAR MOTOR

Heavy duty, all ball bearing const. Rated approx. 3 H.P. @ 24 V.D.C. Turns 400 RPM no load on 12 V.D.C. 750 RPM on 24 V.D.C. Contains magnetic clutch. 1 1/4" dia. Like NEW. Tested prior to ship. Approx. GOVT COST \$250. Shpg. wt. 40 lbs. \$27.50 (Stk. #2410)



ELECTRIC UTILITY PUMP

Output up to 300 gal. per hr. @ 18 PSI. Exc. for water, fuel, insecticides, etc. Aluminum construction. Runs on 12 or 24 V.D.C. Explosion-proof motor. Inlet & outlet ports are 1/2" pipe. Shpg. wt. 8 lbs. \$14.50 (Stk. #2480A).



NEW! BIG! 1969 CATALOG

Send 25¢ for amazing catalog with 1000's of bargains in hydraulics; electrical, marine, automotive items, etc. Order from ad. All prices FOB Culver City. 50% deposit required for COD. Cal. res. add 5% sales tax. Include zip. Satisfying world-wide customers since 1945.

AIRBORNE SALES CO. Dept. PM1069
8501 Stellar Dr., Box 2727 • Culver City, Calif. 90230

U.S. Bureau of Labor Statistics predicts shortage of 50,000 civil engineering technicians (surveyors, etc.) by 1975. Send for FREE "SURVEYING CAREER KIT." No salesman will call.

LEARN SURVEYING AT HOME

NAME _____ AGE _____
ADDRESS _____
CITY _____ STATE _____ ZIP _____

NORTH AMERICAN SCHOOL OF SURVEYING & MAPPING
4500 Campus Drive • Dept. 4170, Newport, Calif. 92660

ALL 3 FREE!



This is TOP GUN

A new kind of hunting garment that gives you the kind of comfort and convenience you've dreamed about... available only from AMERICAN FIELD dealers. We'll send your dealer's name and valuable booklet, "Camping Tents & Tips"... send 10¢ to

HETRICK, Dept. PM-C, Statesville, N. C. 28677

LAFAYETTE RADIO ELECTRONICS FREE!

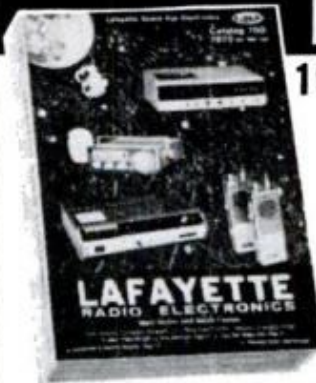

1970 CATALOG 700
496 Pages

BETTER THAN EVER

Stereo Hi-Fi • Citizens Band • Ham Gear • Tape Recorders • Test Equipment • TV and Radio Tubes and Parts • Cameras • Auto Accessories • Musical Instruments • Tools • Books

LAFAYETTE Radio ELECTRONICS
Dept. 15109 P.O. Box 10
Syosset, L.I., N.Y. 11791

Send me the FREE 1970 catalog 700 15109

Name _____
Address _____
City _____
State _____ Zip _____

'70 SNOWMOBILES

(Continued from page 145)

have 125-hp engines, including the Skeeter models and a Bobcat. Skeeter models include the 15½-in. tread for \$1025, a 20½-in. with reverse for \$1275, a 20½-in. with reverse and electric-start for \$1395. The 15½-in.-track Bobcat goes for \$995.

Sno-Jet, a division of Glastron Boat Co., has four new snowmobile series with 15 choices from 12.5 to 35 hp. Heading the line with 15½-in. tracks is the Super Sport with optional electric-start and power ranging from 22 to 35 hp—hot machines that can be used in competition. Jet-Flite, the lowest-power model, has a 12.5-hp engine, sells for about \$699 f.o.b. Quebec. Other models run from the Star-Jet (15 to 19 hp) through the Super Sport to the 18½-in.-track Super-Jet. Sno-Jet's prices range from \$699 to \$1349.

Bolens has four models of the Sprint snowmobile. On 15½-in. tracks, they are available with 297, 315, 340 and 399-cc engines. Model TW-400 has electric-start.

Rupp Manufacturing, Inc. has eight models. Four 15½-in.-track "S" machines have engines of 293 cc (18 hp) to 438 cc (30 hp). Four "WT" models with 17½-in. tracks have electric-start and engines rated at 436 cc (30 hp) and 634 cc (38 hp).

Yamaha has three models—two for the road, one for the racetrack. The small SL 338 has a 24-hp engine on a 15-in. track; the SL 396 a 27-hp engine and 18-in. track, the racing SS 396 a 36-hp engine on a 15-in. track.

Polaris, in its 14th year of building snowmobiles, has a raft of options. You can choose from 17 engines ranging from 150 to 792 cc. You can get a new rigid-frame suspension called Drift Skipper, a new all-rubber track, quieter muffler, redesigned Torque-O-Matic transmission.

Mini-snowmobile of the Polaris line is the Playmate, which weighs 215 lbs., has engines ranging from 150 to 175 cc. Suggested prices are \$575 to \$695.

In its regular line, Polaris has the family-type Mustang with engines of 398 to 744 cc and priced at \$1245 to \$1595. The sporty, lightweight Charger has engines of 293 to 488 cc and prices from \$845 to \$1195. The workhorse Voyager has a 30-in. track and standard 488-cc engine. High-performance machines make up the TX series with engines of 291 to 792 cc.

Arctic Cat has a nine-model, 17-in.-track Panther series, starting with the 290-lb., 14-hp P-246. It uses a torsion-spring and slide-rail suspension system.

Panther models are rated at 20, 25, 27, 33, 40, 55 and 75 hp. Electric-start kits are available for all models except

the P-246. Model prices range from \$895 for P-216 to \$1595 for the 55-hp P-760.

An all-new 2-hp snowmobile called Light-Trac heads the Johnson Skee-Horse entries. Priced at \$995, it has a 437-cc, 25-hp engine, 15½-in. steel-cleat track and a variable-speed, torque-sensing drive.

Two other Johnson Skee-Horse models are the 20½-in. Wide-Trac with a 25-hp engine priced at \$1275 (\$1395 with electric-start) and the Challenger, available with 15½-in. track and 12, 17, 19 or 23 hp.

Montgomery Ward has two models, one a normal-sized Model 370 with a 369-cc engine, coil-spring suspension and 18-in. track. This black and orange machine weighs 382 lbs. and sells for about \$999 or, with electric-start, about \$1149.

For the kids, Ward's has the Mini 99, a 125-pounder with a 99-cc JLO (4½-hp) engine with speed up to 16 mph. It's priced around \$389.

There are five models in the Motor-Ski line made by Industries Bouchard Inc. of Canada, a subsidiary of the U.S. company, Giffen Industries. One is the 295-cc, 15-in.-track Cadet. Others have engines sized from 300 to 634 cc. Most of the primary drive systems have a cam clutch.

Scorpion tops off the horsepower rating with an 800-cc engine on its Mark II Stinger, a 15-in.-track machine also available with 293, 340, 399, 438, 493 and 634-cc engines. Other machines in the Mark series have 15, 18 and 23-in. tracks.

Fox Trac snowmobiles have substantially increased available cc rating—from 227 to 760. The Fox Trac Special has a 15-in. track and 15.5-hp. motor; the Futura series goes from 20.5 to 26 hp. The Centura line, on 18-in. tracks, has engines rated at 23.5 to 28 hp; the Spoiler series, 15 or 18-in. tracks, 26 to 55 hp.

The AMF Ski-Daddler Mark series of snowmobiles looks like it was designed by an aerodynamic engineer. For the novice, there's the Mark IV, a 19½-hp machine on a 15-in. track; for the family, the Mark V, 27 hp, 18-in. track; for the sportsman, the Mark VI, 36 hp, 15-in. track; for racers, the Mark XX, in limited production.

Massey-Ferguson's Ski Whiz has the lowest center of gravity in the business. Three models include the 18.5-hp 300 S, the 22-hp 350 SS and 29-hp 500 SST, all on 15½ in. tracks.

Alouette offers nine machines topped by the 29-hp Competition GTO. Others in the XL series range from the 26-hp Big Bird (electric-start) to the 14-hp XL 20 which runs on a 15-in. track.

Homelite has 11 models ranging from a 9-hp unit for \$555 to a 28-hp electric-start machine for \$1465. ★ ★ ★

BOSS CAT

with a competition record of performance and durability

WINNER OF THE BIG ONES

Canadian National Kawartha Cup
Championship

World Championship Snowmobile Derby
at Eagle River, Wis.

Winnipeg to St. Paul cross-country
International 500

Arctic Cat has the stuff to win. The advanced design and precision engineering

that forged this proud race record is built into every Arctic Cat. Like the traction-grabbing torsion spring/slide rail suspension system that powers you smoothly over all terrain and snow conditions. And the forward mounted engine and all-aluminum chassis that lowers the center of gravity for unparalleled stability.

So, whether you race or not, the competition record says Arctic Cat is *the* choice of the sportsman who demands a fast, tough and all-day comfortable machine.

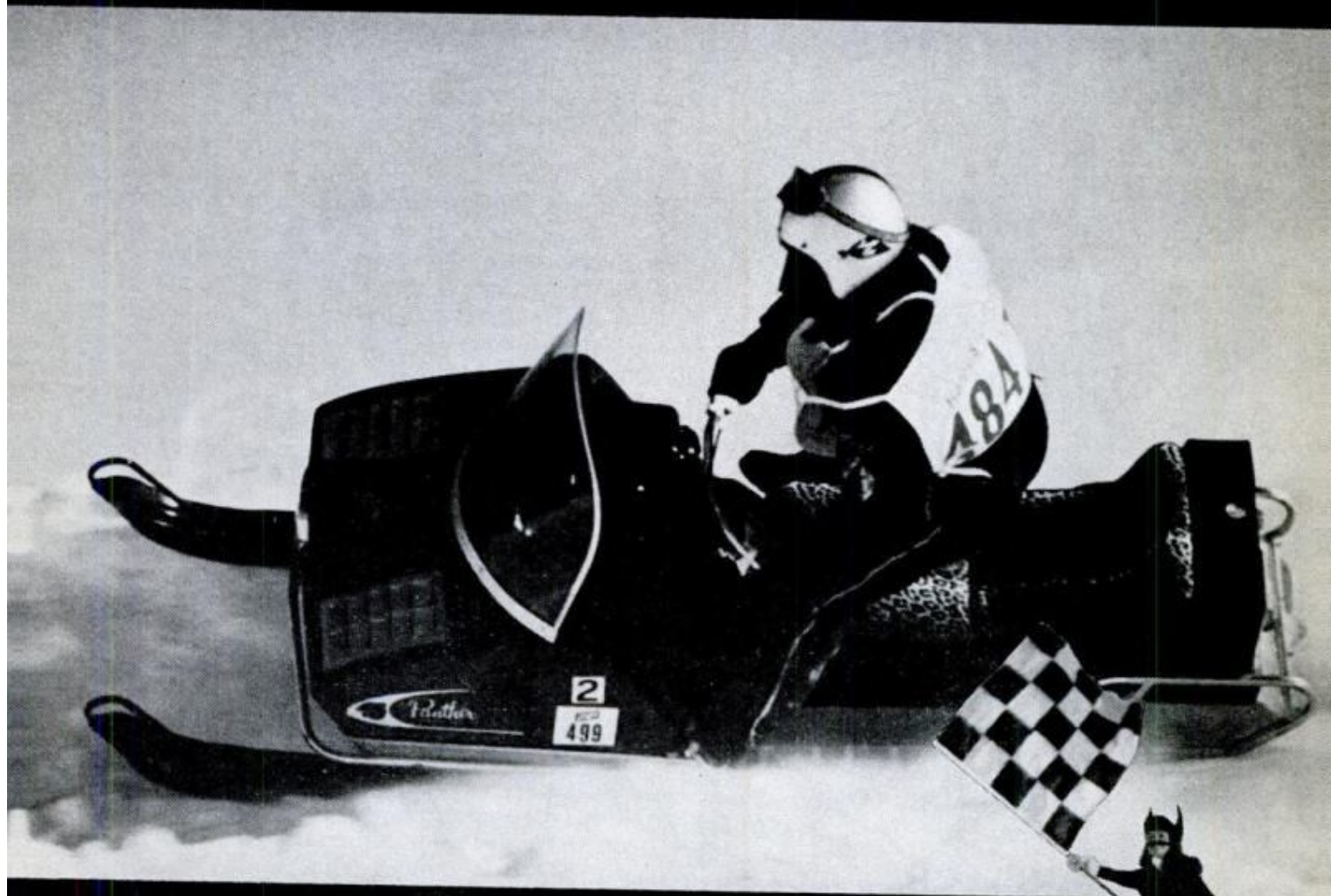

ARCTIC Cat[®] 70

ARCTIC ENTERPRISES, INC., Thief River Falls, Minnesota

Maybe the cigarette you should switch to is a cigar.



Tall n' Slim.
The first 100mm. low-nicotine cigar.
Available in regular or menthol.
With a charcoal filter. And smooth,
mild enjoyable taste.

Tall n' Slim.
The cigar
for cigarette smokers.

United States Tobacco Company, 630 Fifth Avenue, New York, N.Y. 10020

LANDINGS ON A CARRIER

(Continued from page 99)

down to stay on the glide path and moving laterally to maintain alignment with the landing area center line. An automatic throttle keeps the plane's airspeed steady.

From approximately a third of a mile aft of the ship to touchdown, a factor known as deck motion compensation is employed to synchronize the aircraft with the projected landing point aboard the carrier; in other words, the plane begins to "follow the deck" as it rises and falls, pitches and rolls.

Compensating for deck motion in manual landings is just about impossible—and is, in fact, discouraged—because neither the pilot nor personnel aboard ship can react quickly enough to keep the plane "in tune" with the landing point. As a result, flight deck motion has probably caused more accidents—and more aborted landing attempts—than any other factor in the carrier landing process.

But if the pilot cannot react to the pitching, rolling flight deck, the AWCLS can. Its commands are issued with such lightning-fast precision that the plane can respond in microseconds to deck motion. It is because of these high-speed commands, especially during the 12.5 seconds that the deck motion compensation factor is employed, that an aircraft coming in for an automatic landing buffets steadily. NACIS engineers are the first to admit that indoctrinating experienced aviators to expect a rougher ride than usual is one of the major problems in introducing the system to the fleet. But they also believe that about all that is necessary to get even the most skeptical carrier pilot to accept the system is to let him experience just one automatic landing.

In combat, the new system will surely save lives. The returning pilot, who may be weary from a tough mission or even wounded, will know that all he has to do to make a safe carrier landing is flip a switch, take his hands from the controls, and relax. ★★★

Tasmanian devils in research

The Tasmanian devil, long fought as a pest, may provide important clues in the battle against cancer and heart disease.

Scientists at the University of Tasmania have established that the devil has characteristics which make it ideal for research into these diseases.

Those that have died in captivity have all died of cancer, and though the blood of the devil clots more readily than that of humans, none has died of heart disease.

The Mystik tear-out, tape-up tape chart.

TAPE	DESCRIPTION	USES
Mystik® Colored Plastic-Coated Cloth Tape	comes in 18 colors; won't stretch out of shape.	mark tools; color-code storage containers, luggage, etc; decorate; mat pictures; make a cloth backing for sandpaper.
Mystik Masking Tape	thin, yet flexible.	protect baseboards, woodwork and glass panes, or make straight lines when painting; make reference marks on saw tables; tape pieces together to make duplicate cuts accurately.
Mystik Double-Faced Tape	has high-tack adhesive on both sides.	make a tack hammer; mount signs, charts and photos; secure shelf paper; tape on a non-skid surface when working with glass; hold small parts; hold down carpets, rugs, vinyl floor tiles.
Mystik Plastic Electrical Tape	UL listed; has a dielectric strength over 8,000 volts; gives better insulation than friction or rubber tapes; stretches to irregular surfaces.	repair frayed appliance cords; insulate electrical splice; make a non-slip grip for hammers, chisels and files; protect plumbing from scratches.
Mystik Colored Plastic Tape	comes in 9 popular colors; tear resistant; flexible, conforms to irregular surfaces.	mend garden hose, plastic swimming pools, inflatable plastic toys and colored vinyl upholstery.
Mystik Clear Plastic Tape	tear resistant, waterproof and shrinkproof; won't yellow or dry out.	mend plastic shower curtains vinyl upholstery or anything that needs a strong, clear tape.
Mystik Package Sealing Tape	self-sticking; high tensile strength; meets Post Office requirements.	seal cartons and wrap packages with ease.
Mystik Flexstron® Tape	reinforced in both directions with fiber glass.	band heavy cartons; strap pipes, dowels, lumber, etc.



Free. From the makers of Elmer's, Mystik and Krylon: a guide to gluing, taping and spray painting. Mail a stamped, self-addressed envelope to: Borden Inc./Chemical Div., 350 Madison Ave., N.Y., N.Y. 10017.



**MY SPARE TIME HOBBY
MAKES ME
\$500 an hour
CASH PROFIT**

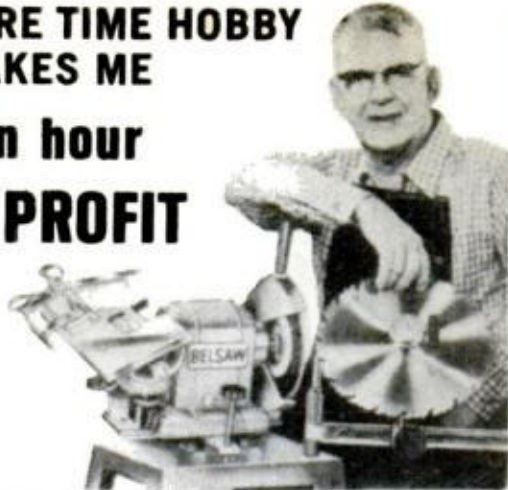

START YOUR OWN SPARE TIME BUSINESS
You can turn your spare time into Big Cash Profits with your own **COMPLETE SHARPENING SHOP**... Grind saws, knives, scissors, skates, lawn mower blades... all cutting edges. Your Own Cash Business with no inventory... right at home... no experience needed. **FREE BOOK** tells how you can start your own spare time business while you are still working at your regular job. Low Cost—time payments.



FREE BOOK

Just Mail Coupon—No Salesman Will Call

BELSAW SHARP-ALL CO., 710T Field Bldg., Kansas City, Mo. 64111
Send Free Book, "LIFETIME SECURITY." No obligation.

Name _____
Address _____
City _____ State _____ Zip _____

**Men Wanted NOW
TO TRAIN AS CLAIMS ADJUSTERS**

Former U.S. Army mechanic and service station attendant **EDWARD D. PAIGE** is now employed as staff adjuster by Free State Adjusters, in Virginia. "Your I.A.S. Home Study Course, in my opinion, is the best that can be obtained. Also, the Resident Training I received, gave me a good working knowledge and understanding of the claim adjusting business."



You can earn top money in this fast moving, action packed field. Insurance Investigators are urgently needed to settle claims worth billions of dollars annually. The tremendous increase of auto accidents alone have doubled the need of qualified adjusters. **INSURANCE ADJUSTERS SCHOOLS** lets you train at home in your spare time, followed by Resident Training at school owned facilities at **MIAMI BEACH, FLA.** or **LAS VEGAS, NEVADA.** Nationwide employment assistance. Don't Delay! Write for **FREE** information today!

Accredited Member N.H.S.C.

APPROVED FOR VETERANS UNDER NEW GI BILL

INSURANCE ADJUSTERS SCHOOLS DEPT. PM3
1901 N.W. 7 Street, Miami, Fla. 33125

Please Print

Name.....
Address.....
City.....State.....Zip.....
Age.....Phone.....

MOLDS

for making
Ornamental Concrete
Items...



Book about Aluminum Molds with prices and production trade secrets direct from world's largest mold manufacturer.

SEND
\$2.00

CONCRETE MACHINERY COMPANY, INC.

P. O. BOX 99 • HICKORY 2, N. C. 28601

ELECTRIC ARC WELDER \$9.99!



NATIONALLY ADVERTISED \$18.95 VALUE!—NOW 1/2 PRICE! WELDS—BRAZES—SOLDERS—CUTS—ALL METALS! Plugs into ANY 110 volt socket. **MAKE—REPAIR 1001 items for CAR—HOME—BUSINESS.** Lifetime **BURNOUT GUARANTEE** 10 day money back trial (if retnd). **HEAVY DUTY** Design—Does \$85.00 welder work. No experience needed—**FREE WELDING LESSONS!** (cash, ck, M.O.) and pay postman \$7.99 COD postage or send \$9.99 plus \$1.00 postage for paid del. in U.S.A. **COMPLETE READY TO USE**—Includes **BIG** pack steel, Brazing, Solder, Carbon "touch" rods. **ELECTROFLAME ARC TORCH!** OFFER LIMITED—Order **TODAY!** **MIDWAY WELDER Dept. EPM-10 Kearney, Nebr. 68847**

SEND ONLY \$2.00

Dept. PM, Post Office Box 8748, Kansas City, Missouri 64114

ENROLL—EARN YOUR DEGREE

of Bachelor of Bible Philosophy (B.Ph.B.), Master of Bible Philosophy (M.Ph.B.), Graduate of Bible Philosophy (G.Ph.B.), Doctor of Metaphysics (Ms.D.), or Doctor of Divinity (D.D.). Chartered by State, Correspondence Courses only. Please write for **FREE BOOKLET.**

AMERICAN BIBLE INSTITUTE

Dept. PM, Post Office Box 8748, Kansas City, Missouri 64114

**I-N-V-E-N-T-O-R-S
WE NEED INVENTIONS**

Sell your invention for cash—need money for Patent?—Are technical problems holding you back? Universal Inventions has helped inventors all over the world—just like yourself—why not you? Inventions provide the magic spring-board to sudden riches. **REMEMBER,** we either sell your invention or pay you a cash bonus. Write for details. **UNIVERSAL INVENTIONS, Dept. 13, Marion, Ohio**

Print Your Own

Cards, Stationery, Advertising, Circulars, labels, photo and movie titles, church work, tags, greeting, sympathy, prayer cards, etc. Save money. Pays for itself in a short time.

Own a Printing Business

Good Profit. Raised printing like engraving too. Have home shop. We supply everything. Direct from factory, only. Easily followed rules. Write now for free details. **KELSEY PRESSES E-37 Meriden, Conn. 06450**

110-120 VOLT A.C. LIGHT PLANTS—60 CYCLES

Fanbelt driven from pickup or small gas engine. Operates saws, drills, pumps, freezers, T.V. X1000 Watts—Needs No Battery. Now \$70.00. 1500 Watts—8 and 12 volt vehicles. Now \$60.00. 3000 Watts—12 volt vehicles only. Now \$99.50. *Guaranteed.* Check or Money Order.

VIRDEN PERMA-BILT, Box 7066 P.M., Amarillo, Texas 79109

NEW RUBBER STAMP BUSINESS PAYS BEGINNERS ^{UP} TO \$16.50 AN HR.

**START AT HOME
IN SPARE TIME**
with Table Top Machine!

We Help Finance You
... at less than bank rates!

The multi-million dollar Rubber Stamp business—once controlled by a few big companies—is now being taken over by small operators—one in each community throughout the United States. Men and Women who have this inexpensive machine can turn out huge quantities of Rubber Stamps with special wording that buyers once were forced to buy from big cities. Material costing only 27c makes a stamp that sells for \$2.75. The machine that does the work is simple and easy to operate and it turns out as many as six Rubber Stamps at a time, each with different wording such as names, addresses, notices, stock numbers, prices and other "copy" needed by offices, factories and individuals. Working full capacity, it can earn as much as **\$33.00 an hour for the operator!** Now you can get into the big-pay business yourself, with your own home as headquarters. You don't need experience. We supply everything, including complete instructions and eight ways to get business coming in fast. **We even help finance your start.** Start making up to \$16.50 an hour from the very beginning. Cash in on the profitable Rubber Stamp business in your community, right away. We'll mail full particulars FREE and no salesman will call. Be first in your locality. Rush coupon today or send your name on postcard to:

RUBBER STAMP DIV., Dept. R-2-LS
1512 JARVIS AVENUE • CHICAGO, ILL. 60626



RUBBER STAMP DIV.
1512 Jarvis Ave., Dept. R-2-LS
Chicago, Illinois 60626

FREE!

Please rush full particulars about your financing plan and the little machine that can get me started in the profitable Rubber Stamp business at home in spare time. Everything you send me is FREE and no salesman will call.

NAME

ADDRESS

CITY STATE Zip Code

Precisely tapered claws make it easy to pull even headless nails.



The hammer with the handle that packs its own punch

...thanks to **TRUE TEMPER** engineering.

Fiberglass handle adds flex action to your swing, more drive to each stroke.

Epoxy-bonded filaments of unidirectional glass fibers deliver punch all their own. Head is permanently bonded to handle.

Grip is cushioned for comfort, won't slip wet or dry — even in a gloved hand!

TRUE TEMPER Fiberglass-Handled Hammer — 16 ounce. (#FG16)

TRUE TEMPER Steel-Handled Rocket® Hammer. With all the quality features! Strong tubular steel handle. 16 ounces. (#A16R)

TRUE TEMPER Hand Sledge. Perfect for all-purpose use, lightweight. Ideal for use anywhere nail-pulling claws are not needed. Nonslip grip. 3 pound. (#403H)

"You'll be glad you bought the best!" **TRUE TEMPER**

The smokeless tobaccos.

They aren't lit, puffed or inhaled. They're too good to smoke.



Put a pinch between gum and cheek, and enjoy it. Without even chewing. The smokeless tobaccos are too good to smoke. You get all the satisfaction of prime aged tobaccos. They cost less, too. Sure beats smoking!



Straight



Wintergreen



Raspberry

For information on how to use smokeless tobaccos, please write:
United States Tobacco Company, Dept. PM, 630 Fifth Ave., New York, N.Y. 10020.

Big Profits in UPHOLSTERY Get Your Share... FAST!

EARN BIG MONEY **3** NEW EASY WAYS



FREE Deluxe Illustrated Book and Sample Lesson Pages

1. Be your own boss, make up to 85% profit.
2. Start earning right away at home in spare-time—keep furniture you make, or sell for hundreds of dollars.
3. Today's home and office upholstery, re-upholstery, slipcover boom make it easy to take your pick of big-pay jobs.

LEARN FAST—EARN FAST

You get expert instructions, plus all tools, new wooden frames, materials, fabrics, business tips, wholesale privileges, decorating magic AT NO EXTRA CHARGE. FREE Book, sample lesson pages show you how—no obligation—no salesman. Write TODAY.



Tools, Equip., Frames, Materials, Fabrics, Supplies yours with course.

UPHOLSTERY TRADES SCHOOL

Division of Singer Communications Corporation
Dept. 5110-109 Little Falls, New Jersey 07424
(N. J. State Approved. Accredited Member National Home Study Council. Vet Approved.)

MAIL COUPON TODAY

Upholstery Trades School, Dept 5110-109
Division of Singer Communications Corporation
Little Falls, New Jersey 07424

ESTABLISHED 1939

Please send me FREE book, "Your New Way to a Successful Career," and FREE sample lesson pages. No obligation—no salesman will call.

Name

Address

City State Zip

ALL FAMOUS BRANDS! **FARM TRUCK AUTO** **AT LESS THAN WHOLESALE**

TIRES! SAVINGS NEVER LESS THAN 50% up to 70% OFF REG. PRICE!
HEADQUARTERS for ALL SPORT CAR TIRE SIZES
FREE • SEND FOR YOUR FREE CATALOG • FREE!

RELIABLE TIRE DIST., 1111 Chestnut St., Camden, N. J.

MAKE MONEY!

REPAIR HYDRAULIC JACKS



Earn while you learn at home. Millions of jacks in gas and auto service stations, trucking firms, body shops, riggers, factories and farms need servicing... most of which you can learn to repair. We show you HOW. Start spare time in your basement or garage. Big opportunity for mechanics. ACT NOW!

Write for Folder P10 and Free Bonus Offer

Hydraulic Jack Repair Manual Co., Inc.

G. P. O. BOX 3 • STATEN ISLAND, N. Y. 10314



"Buy auto air conditioning now? You're kidding."

"When you can save \$200 or more - why not? Write Comfy-Kit, Box 8585, Dallas, Tex."



FREE!

Learn how you can buy used engines \$15 up, new engines \$30 with FREE confidential list and coupons when you order your plans

BUILD THIS MINI-BIKE!

Plans reveal step by step details!

BUILD A RACING KART!

Build frame for less than \$10!



RUSH \$2 for plans (indicate type) or send 25¢ for circular describing plans
PLANS, Box 517, Omaha, Nebr. 68101



Luckily, it can't sting

One hundred times larger than life, this model bee is used for lectures in the Museum of Natural History, Bremen, Germany.

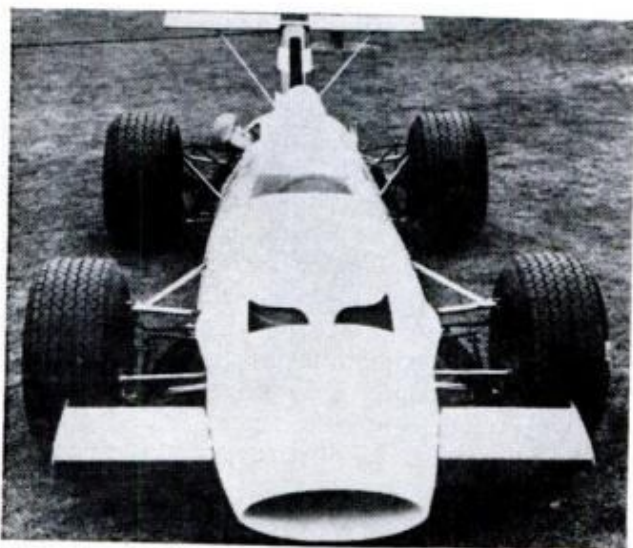

Colt F2C

The Colt F2C is a new racing car developed by Mitsubishi for Japan Auto Federation Grand Prix racing. Its 240-hp engine moves it along at a top speed of more than 174 mph.



Typing by voice

"Speech"—actually a modified Morse code—is picked up by throat microphone and translated into signals that come out as messages on this voice-operated typewriter.

Before it was a snowmobile it was a championship motorcycle.

Our machine tore up the world's biggest tracks. Won top-competition races right and left. Then we dropped that engine in a beautifully-engineered snowmobile.

Shazaam!

A snowmobile without equal. With a 338 or 396cc performance-proven, 5-port power engine. With Autolube, our automatic oil injection system. With a big disc brake that stops you even in wet snow. And with rabbit-quick, ball joint steering. (In case you want to chase snowshoe rabbits.)

Everything you want and need in a snowmobile.

Just add snow.

YAMAHA 

It's a better machine

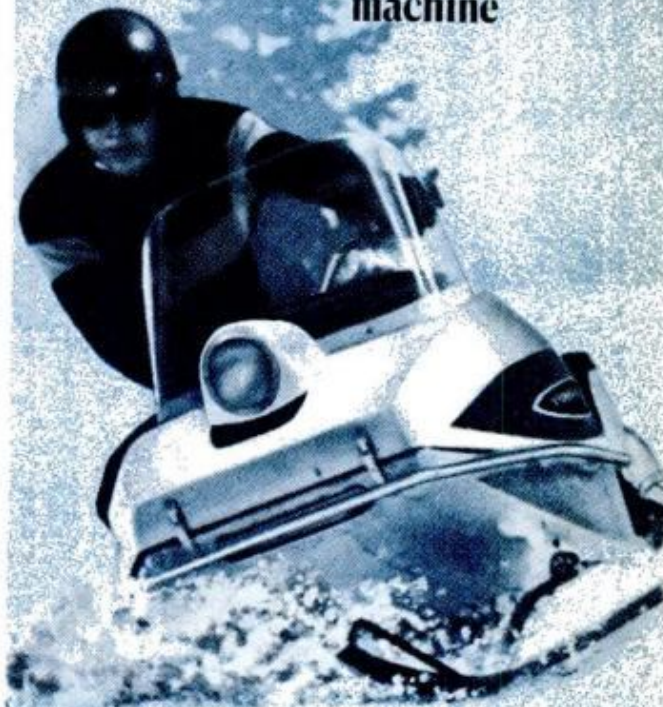

The SL 396. One of three new snowmobiles. Yamaha International Corp. P.O. Box 54540, L.A., Calif. 90054 Canadian Distributor: Fred Deeley, Ltd., Vancouver, B.C.

SUPER-POWERED FOR ANY JOB

**Grinds!
Carves!
Drills!
Polishes!
Deburrs!
Sands!
Sharpens!
Engraves!
Routs!**



DREMEL MOTO-TOOL

Now you can handle any home, shop, craft or hobby job faster and easier than ever before. Super-powered, 30,000 rpm Moto-Tool belts out twice the power of previous models. Virtually stallproof, even when bearing down. It's compact, lightweight—has a tough, shock-proof Lexan housing. There's a choice of three Moto-Tool models from \$22.95 to \$39.95. Complete kits with storage case and 34 accessories from \$32.95 to \$49.95.

See your dealer or write for free power tool catalog. And 160-page "Dremel Handbook of Hobbies, Crafts and Projects." Only \$1.45.

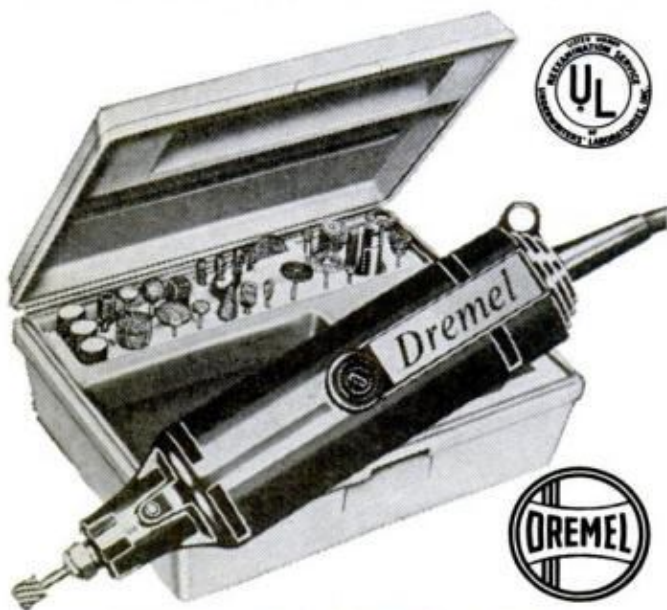

DREMEL MFG. CO.
Dept. 119-K, Racine, Wis. 53401

INSTANT FIRE EXTINGUISHER

(Continued from page 95)

solenoid valve on a tank of Freon, shooting the gas out under pressure to kill the fire—all in a fraction of a second. Electricity for the system can be furnished by battery, such as in a car or boat, or by ordinary current in home installations.

In addition to protecting racing drivers, this remarkable flame-detection system is now going to war. One serious problem in Vietnam has been the loss of expensive vehicles and their personnel to a new enemy weapon: shaped charges. Incorporating these charges, land mines or shells with collapsing noses are designed to lay against the side or bottom of a vehicle where they burn, just like an acetylene torch, right through five or more inches of armor. Typically, these land mines pierce the bottom of a tank or personnel carrier, rupturing gas tanks and spraying fiery gasoline all over the inside.

The government asked Pyrotec to develop a suppression system that would protect both vehicle and personnel. The containers of Freon were supercharged with nitrogen to a pressure of nearly a thousand pounds to produce an extra-fast discharge. A special valve also was devised—a diaphragm with a blank cartridge behind it. When the optical sensor sees a flame, its electrical signal fires the cartridge to blow out this cover and dump the gas with a speed, from detection to discharge, of 7 to 15 milliseconds.

To test the new device, one personnel carrier's bottom was pierced with a land mine fitted with a shaped charge. When the observers entered the vehicle after the explosion, the walls were completely wet with liquid gasoline, yet there had been no fire. Human hair, taped in various areas inside the carrier, was unburned. Another carrier, blasted in the same way, burned for two days.

Even our mighty aircraft carrier, the *John F. Kennedy*, a floating city of 5000 men and nearly five acres of flight deck, utilizes this system to protect her magazines and other critical areas. All military and commercial helicopters are protected by this system. In these choppers, it is located right under the rotor in the engine compartment.

This optical system also protects many commercial jet airliners. In these planes, the device is placed between the engine and the housing around it—a space filled with pipes, tubing, valves, wire and other equipment. The detectors are aimed at all areas where the presence of a fire would mean trouble. In jets, however, the system is not automatic because a false

alarm would actuate the system and kill the engine. This might cause a crash under certain circumstances. Instead, the pilot gets a signal from the system and must decide whether it is a false alarm or not.

In boats with inboard engines, as in racing cars, one of the greatest fears is fire. If the engine compartment of a boat is not adequately ventilated, or if there is a gas leak and gas vapors accumulate, starting the engine can set off an explosion followed by fire. An optical detection system can prevent the fire.

These automatic fire-detection systems are also being used in so-called "glove boxes" where radioactive materials are handled by means of special gloves fitted into sealed containers. An automatic system is essential here because it's impossible to open these boxes with their "hot" contents to get at a fire. The new system is so sensitive it works even when

The next area to be protected will probably be you—your car, your boat, your home.

separated from the same by the four-foot-thick zinc bromide or leaded glass window needed to shield workers from the dangerous material inside.

The next area to be protected will probably be you—your car, your boat, your business or your home. While the system is still fairly expensive, it may well go down in price as wider use makes possible quantity production. As of now, it's available in three models from Formula 1 Enterprises, Inc., 37 W. 57th St., New York, N.Y. 10019. System 1, priced at \$600, is completely automatic and can be switched on and off repeatedly. While primarily designed to protect the cockpit of a racing car, it is used by antique car buffs to safeguard the engine compartment of irreplaceable classic cars. The same unit could also be used in a boat or the furnace room in a home.

System 2, slightly lower in price at \$550, is the same as System 1 except that its Freon-release valve is designed only for one-time use—once it's triggered, all the gas is expended at one crack. System 3, the least expensive, is designed for manual operation and does not have the optical infrared sensing mechanism. You press a button to fire the extinguisher yourself as needed. While this doesn't have the automatic protection feature, it still gives you the rapid snuffing out action of the Freon gas. The price for this version is \$200. ★★★

RADIAL ARM SAW KIT—for under \$100...



Buy direct from factory, assemble yourself. Incl. 1/2 h.p. G.E. motor, easy to follow instructions, all parts, nuts and bolts. Guar. for life pat. pend. radial arm track; twice the usual bearings for extra rigidity, greater precision. Rips 24", crosscuts 12"; belt brake. \$99. complete, freight col. Kit less motor (any standard 1/2 h.p. or larger will do) \$84.85. With opt'l G.E. motor developing 1 h.p. \$108.65. Money back guaranteed by one of world's largest manufacturers of bench power tools.

MAIL COUPON FOR ILLUSTRATED BROCHURE

American Machine & Tool Co.
Dept. PMOR, Royersford, Pennsylvania 19468

Please send me without obligation your free illustrated brochure containing full information on the PermaTrak radial arm saw kit. Also send free reprints of feature articles by editors of Popular Mechanics, Workbench and Family Handyman. NO SALESMAN IS TO CALL.

NAME _____

ADDRESS _____

CITY _____ STATE _____ ZIP _____

Carpenter's Secret Makes Ugly Nail Holes Vanish.

(Mr. W. C. B., Norristown, Pa.)

Repair ugly nail holes like professional carpenters do with PLASTIC WOOD. Handles like putty. Hardens like wood. Plane it. Sandpaper it. Varnish or paint it for perfect finish. Get PLASTIC WOOD in tube or can. Walnut, oak, mahogany or natural color. At all hardware outlets.

GENUINE
PLASTIC WOOD®



CELLULOSE FIBRE FILLER

Learn at home to become a
GAME WARDEN,
FOREST RANGER, RECREATION OFFICER,
FISH-WILDLIFE MGR., PARK OFFICER

FREE Career Kit shows how to qualify at home in spare time. 500,000 new jobs open. Excellent pay - Lifetime security - Many other benefits. H.S. Diploma not required. Approved under GI Bill. Write Forestry & Conservation, 2000 P Street, N.W., Washington, D.C. 20036. Dept. 21-10N.



NEW **DYNAMIC** MARK 88
80 AMP **INDUSTRIAL TRANSFORMER ARC WELDER**

IDEAL GIFT — EDUCATIONAL, ENJOYABLE, PROFITABLE

WELD, BRAZE,
CUT, SOLDER, HEAT
STEEL, BRASS, ALUMINUM,
AND MOST OTHER METALS.

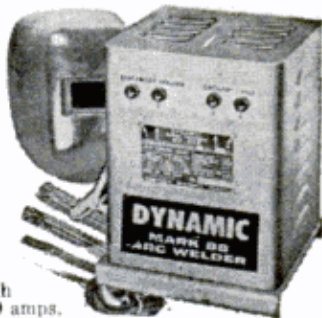

Build and repair anything of metal. Save time & money with this **BRAND NEW, PROFESSIONAL ARC WELDER!** Rugged metal cabinet, baked Hammerloid finish. Ideal for home, shop, farm and industrial use. **POWERFUL** glass insulated transformer welds most metals up to 1/2" cross-section or multi-pass weld, with 1/8" rods. 4 heat settings 20 to 80 amps. Operates on 110 Volt AC line fused for 30 amps. Complete with fibre glass helmet, electrode holder, ground clamp and cables, solder, assorted rods and simplified welding manual. **DOUBLE PROTECTION GUARANTEE.** 10 day money back trial plus full 5-yr. warranty. If inoperative return prepaid, we will repair or replace without charge & reship collect. **ORDER TODAY. Complete ready to weld. Only \$59.50 F.O.B. SEND ONLY \$6.00.** Pay balance plus C.O.D. & delivery charges or write for easy "PAY AS YOU WELD" Low Down Payment Plan. Welder details FREE.

DYNAMIC WELDER CO.

1808 SO. FEDERAL ST.
Dept. D2-K
CHICAGO, ILL. 60616

BIG NEED FOR SYSTEMS MEN
... LEARN AT HOME IN SPARE TIME



Every company, large & small, needs a Systems Man. As a Systems Man, you'll work with management... help them make vital decisions... make a prestige salary... and enjoy your work, too! You'll supervise **CHARTING, PROCEDURE PLANNING, FORMS DESIGN, OFFICE LAYOUT, COMPUTER PROGRAMMING, DATA PROCESSING, etc.** Big demand — see high salary positions in "help wanted" sections of your newspaper. You need no previous experience or special training... easy home-study plan guides you toward success, prestige, good salary in exciting, respected field. High school education required. Send for Free Booklet, "OPPORTUNITIES IN SYSTEMS."
North American Institute of Systems & Procedures
4401 BIRCH ST., DEPT. 4170, NEWPORT, CALIF. 92660



HEARING AIDS
2/3 OFF DEALER PRICES

LARGEST SELECTION of tiny, all-in-the-ear, behind the ear, eyeglass and pocket models. **FREE HOME TRIAL.** No obligation. Money back guarantee. No down payment. Easy terms. No salesmen or dealers. Order direct, save 65%. Write for free catalog. **PRESTIGE,** Dept. D-34 Box 10947, Houston, Tex. 77018.



POLICE - FIRE - EMERGENCY - CAR RADIO \$9.99

Works with regular CAR RADIO and **ANY** car. **YENNA!** NO special wiring or installation. Mounts **UNDER DASH** in 5 minutes in **ANY CAR OR TRUCK.** Panel switches **INSTANTLY** from **REGULAR** to **POLICE-FIRE-EMERGENCY** radio **CALLS**—Receives **ALL** stations in your **AREA** within range. Size only 2"x3 1/2"—Two-tone steel cabinet. (Cash, Ck, M.O.) and pay **SEND ONLY \$2.00** postman \$7.95 plus COD post or send \$9.99 for ppd Del in USA. **COMPLETE** ready to clip in your **CAR** with all parts & instructions. One year parts and service **Warranty**—10 day money back trial (if retdn). **AMAZING OFFER** good only by mail and from: **WESTERN RADIO Dept. BPM-10 Kearney, Nebr. 68847**



SNOWMOBILES / SAVE 20%

Buy **DIRECT** at **FACTORY PRICES**—Save dealer profit. Have fun this winter! 6 Models from 12-24 HP in 15" and 18" track width. '69 styling, performance. Welded steel chassis, Fiberglass body. 10% down, E-Z terms. Free, inspection money back guarantee. Free delivery. Free color catalog. Write: **LUGER INDUSTRIES, DEPT. BS-109** 1300 E. Cliff Road Burnsville, Minnesota 55378



HOW TO 'PLANE' ON A LATHE

(Continued from page 197)

novelty of this type, but the project illustrates the ability you have to machine unusual surfaces—in this case, conical ones.

To cut them, a lathe bit ground somewhat like a parting tool was clamped in a boring-tool holder mounted in the regular toolpost. The compound slide was adjusted to move at an angle parallel to the funnel side (the funnel itself serving as the setup gauge).

To reduce machining time, the rods were first beveled with a hacksaw to approximate the angle of compound movement. Because of the intermittent action, compound feed was gradual—about .015 in. between passes.

After trimming ends to the desired curvature, the opposite ends were trimmed to uniform length and tinned for soldering.

A similar setup can be used to make special-purpose gouges. Here, the compound slide is usually more nearly parallel to the lathe axis (about 15°), and the distance between rod and lathe axis is reduced in order to produce greater concavity.

Safety tips

In intermittent machining, even with rather slow spindle speeds, the red-hot chips are likely to zing off with considerable force. So it's a must for the operator to wear a face shield or, at least, safety goggles; keep his shirt buttoned at the neck and protect hands and arms to avoid the possibility of entanglement with moving parts. A transparent plastic shield can be mounted on the toolholder or other part to intercept flying chips.

Special effort should be made to mount work and tools so firmly they cannot become unseated. Tools should *never* be permitted to take oversize bites. The operator and any onlookers should maintain safe distances whenever the lathe is in operation.

Never permit the lathe slide or tool mount to be so loose or sloppy that the tool tends to hog-in when making a cut.

As a rule of thumb, tools can be ground to the same angles as for conventional turning of the same materials. Increased rake might make a tool cut with a smoother shearing action, but might also increase hogging-in tendencies if there is any excessive play or looseness. And because of the setup's unbalanced nature when heavy fixtures are mounted off-center on faceplates, counter-balancing weights may be advisable. ★★★

TOM McCAHILL SAYS:

"There's no mystery to making money if you can repair these things"

The greatest detectives in history would be hard pressed to track down somebody to fix a bum toaster or dishwasher these days. It's funny: you have no trouble finding any number of so-called experts who'll fix a leaky pipe or a home run through the picture window. But electrical appliance repairmen are still as scarce as hippies in bathtubs.

If you're lucky enough to get a repairman to come from across town, he'll eventually have your bum dishwasher humming again like bees at a picnic. He'll also present you with an oversized bill. That's where the picnic ends.

If you're in the market for more money you don't need to be a super-sleuth to find it. Look for clues in your own hacienda. If you're typical, you own a couple dozen appliances, counting your wife's hair dryer, power tools and usual plug-ins like air conditioners, toasters, refrigerators, freezers, fry pans, and on and on. A lot of men like yourself have built rewarding full-time businesses after starting part-time earning \$5 and more an hour fixing broken appliances. Others have found full-time jobs as Service Technicians. And when you hit Social Security years, think how great it would be to pick up a little extra cash doing as much Appliance Repair as you cared to do.

The Appliance Division of the National Radio Institute in Washington, D.C., has a great low-cost, home-study course covering every type of Appliance repair in detail—from toasters and irons to air conditioners, refrigeration equipment and one-lung gas engines. There's a section on farm and commercial appliances, too, if you're interested in a big payoff, for when major appliances go kaput, they're as useful as moose antlers on a mouse.

To get technical know-how, NRI starts you with basic principles of electricity. You can gain ex-



perience through actual practice, using an Appliance Tester included in the low cost of training. It's the same kind of tester a professional would use while charging you six bucks an hour. With the tester and a few basic hand tools, you can be repairing Appliances long before you finish the course. All you need for a shop is a corner of your basement or a card table left up between poker games.

You'll be amazed at how easy NRI has made this course. Lessons are bite-size and loaded with photos and drawings so you see how each appliance comes apart—and goes together again. Men who felt they were as handy as icemen in the Arctic have nothing but praise for this great training.

The coupon below will get you a free NRI catalog with all the facts. There on it's up to you. No salesman is going to bother you. Do yourself a favor and mail the coupon today . . . tomorrow morning, for sure.

Tom McCahill

TOM McCAHILL

NATIONAL RADIO INSTITUTE, APPLIANCE DIVISION
3939 Wisconsin Avenue, Washington, D.C. 20016

APPROVED UNDER NEW GI BILL
If you served since January 31, 1953 or
are in service, check GI line below.

600-109

OK—I want to see for myself. Send me the free book on Professional Appliance Servicing. No salesman will call.

Name.....Age.....

Address.....

City..... State..... Zip Code.....

Accredited Member National Home Study Council.

Check for facts on new GI Bill.

NEW IN ELECTRONICS

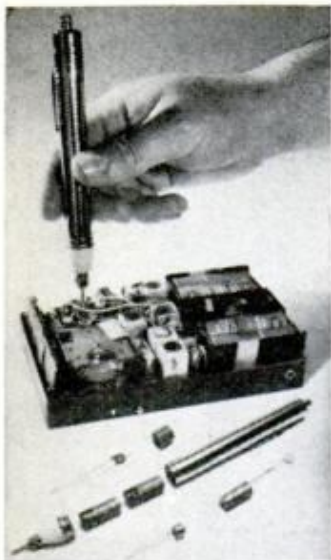

POCKET-SIZED PROBE at left injects a test signal into any RF and IF radio or TV circuit so you can track down faulty parts. By moving the probe from stage to stage until the signal can't be heard, you can pinpoint source of trouble. Probe comes as a kit for \$5.95. Eico Electronic Instrument Co., 283 Malta St., Brooklyn, N.Y.

YOU GET INSTANT WEATHER REPORTS on the midget, single-channel radio at right. Press a button and on comes the official U.S. Weather Bureau forecast, broadcast 24 hours a day on 162.55 MHz. In 3-in. walnut-grained cube, battery-powered transistor receiver has a telescoping antenna, sells for \$14.95 from Radio Shack, Boston.

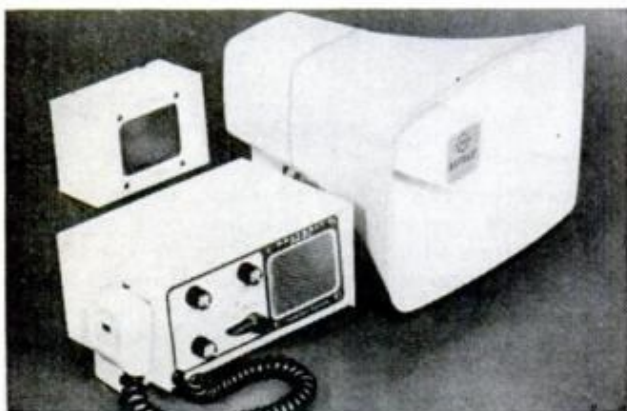
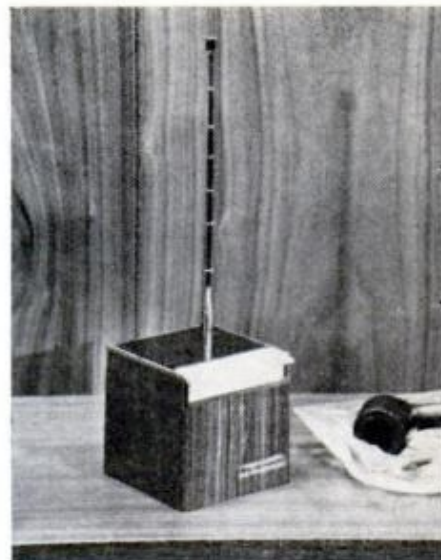

VERSATILE FOGHORN-HAILER for boats can be switched to perform any of five different functions. It serves as a foghorn, a regular boat horn, a loud hailer for calling to neighboring boats and an amplified listener for picking up other boats' calls. With an extension speaker, it's also an intercom. Sold as a kit for \$84.95. Heath Co., Benton Harbor, Mich.

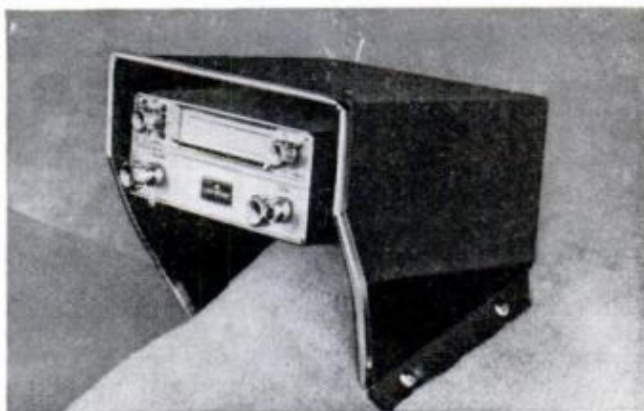

STEREO FLOOR MOUNT makes it easy to install a cartridge tape unit in cars where there's no space in or under the dash. It straddles the transmission hump, putting the machine within close reach of either driver or passenger, and is designed to accept all makes of tape units. Price is \$9.95 from K & R Enterprises, 7242 Sepulveda Blvd., Van Nuys, Calif.



CASSETTE RECORDERS are getting fancier every day. This swank Ampex, in addition to playing its own tapes, has inputs for adding a phonograph, AM/FM tuner or second recorder. It's priced at \$219.95, including stereo speakers. Another model incorporates a built-in AM/FM stereo receiver for \$259.95. Ampex Corp., 2201 Estes Ave., Elk Grove Village, Ill.

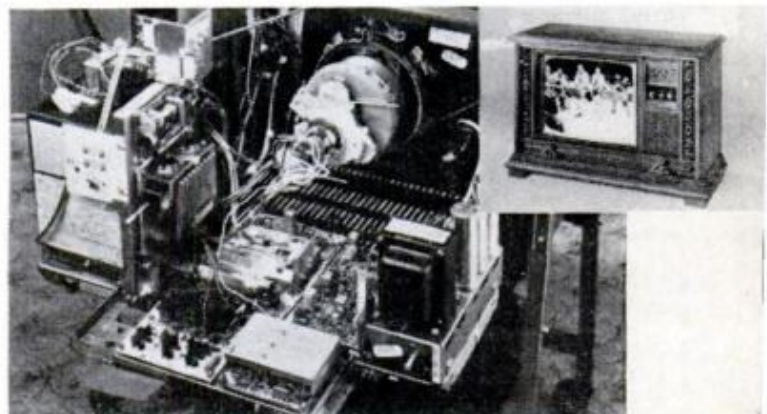

PULL-OUT TV CHASSIS is designed for fast, easy servicing in Motorola's new line of Quasar color sets for 1970. All parts slide out like a drawer, and plug-in subassemblies can be removed and replaced quickly without any wiring. Prices start at \$499.95 for 20-in. models and at \$599.95 for 23-in. sets. Motorola, Inc., 9401 W. Grand Ave., Franklin Park, Ill.

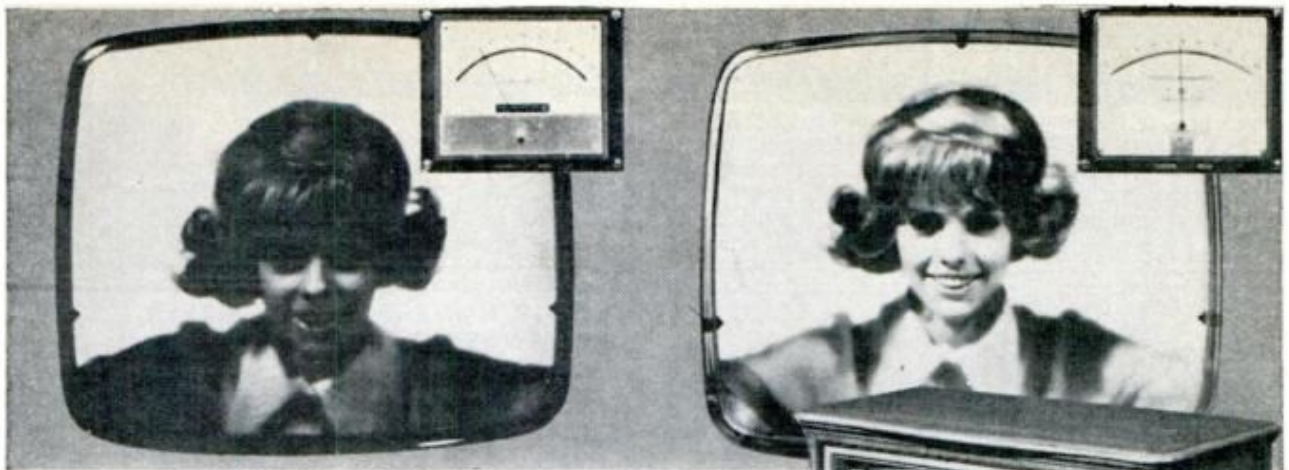

TWICE AS BRIGHT as previous types, Zenith's new 23-in. color TV tube at upper right measures 49.5 foot lamberts in tests compared to only 22.8 for a conventional tube at left. The added brightness is achieved by enlarging the electron beams to excite more area of the screen's phosphor dots. A black mask around the dots absorbs reflections, making it possible to use clear glass. In conventional tubes, only about half of each phosphor dot is excited, and dark glass is needed to absorb stray light, reducing picture brightness. TV sets using the new color tube range from \$629.95 to \$950.

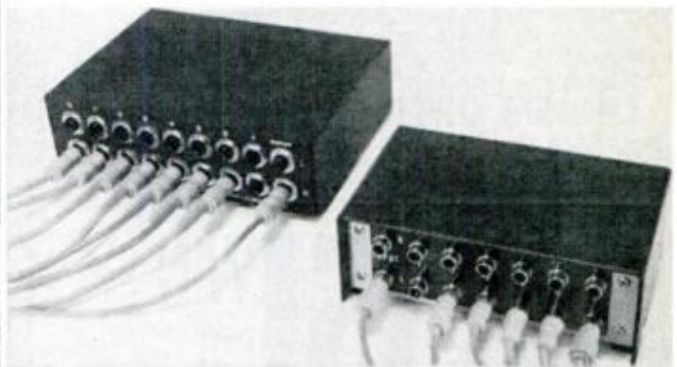
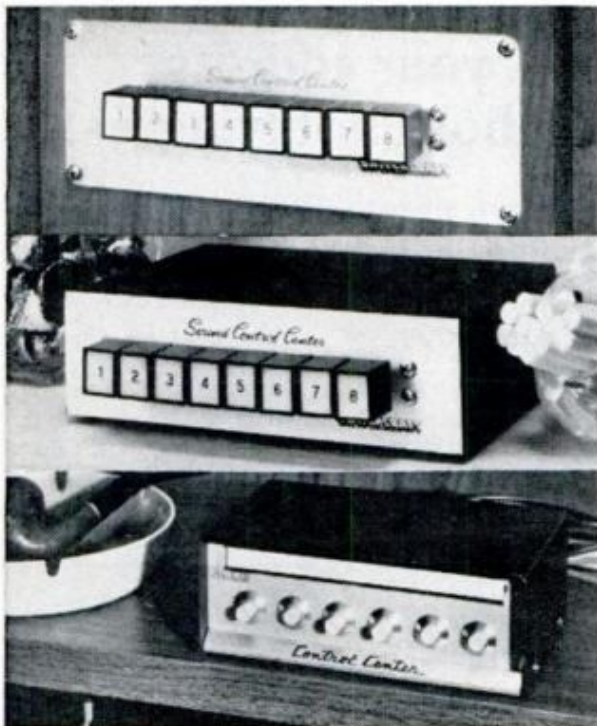

PUSHBUTTON SPEAKER SELECTORS are becoming a popular hi-fi accessory. One at lower left controls up to six pairs of stereo speakers throughout the house. It's \$26.95 from Alco Electronic Products, North Andover, Mass. Upper model handles eight pairs of speakers, can be wall-mounted with an adapter plate. It's \$49.50 from Switchcraft, 5555 N. Elston Ave., Chicago. Both controls can also be used for switching inputs into an amplifier.

POP-UP TV SCREEN is the newest feature on a solid-state portable to be sold soon by Panasonic. For easy carrying, the 5-in. screen folds down into the case, making a compact package weighing less than 15 pounds. The battery-powered portable includes an AM/FM radio and a telescoping antenna. A 115-volt adapter lets you run the set at home on house current and recharge batteries at same time. Price to be announced later.



Train for top jobs, top earnings, in PHOTOGRAPHY

NYI trains you for the best jobs—or your own successful business. Learn by doing at home, quickly, easily the individualized NYI way. Low cost. No experience or expensive equipment needed. Earn while you learn. Easy pay plan. Approved for Veterans, Student Loans. Approved by N.Y. State Ed. Dept. Accredited member Natl. Home Study Council. FREE color career book. No salesman will call. RESIDENT TRAINING in all profitable phases of photography and Creative Motion Picture Course. Our 60th year.

NEW YORK INSTITUTE OF PHOTOGRAPHY • 10 West 33 St., New York, N.Y. 10001, Dept. 49-10



XPLORER MOTOR HOME DODGE POWERED PASSENGER CAR SIZE

Self-contained—Running Water—Permanent Double Bed—Furnace—LP Gas Stove—Refrigerator—Dinette—Closet—Bathroom—Sleeps up to six.

Original aerodynamic design by Frank. Excellent for long and short trips. Will go into a 7' garage.—Low center of gravity for safety and excellent roadability. See your Dodge Dealer or write today.

XPLORER MOTOR HOMES, INC.
P.O. Box 70-PM2, Brown City, Michigan 48416

TO YOUR OWN DOCTOR'S PRESCRIPTION



EYEGLASSES BY MAIL AT GREAT SAVINGS!

Mail orders filled by licensed optician from **\$9.95**

(Including single vision lenses, frame and case).

Doctor's prescription will be filled by a skilled, approved and licensed optician or your own prescription duplicated. Lenses are ground and manufactured to U.S. optical standards. Choose from complete catalog of men's, women's and children's glasses. Bifocals, trifocals, sunglasses or SAFETY HARDENED LENSES at low additional cost. We guarantee accuracy, perfect fit.

SEND FOR YOUR FREE CATALOG TODAY
PRISM OPTICAL INC.

Dept. PM-10 136 Liberty St., New York 6, N. Y.

WRIST ROCKET

AMERICA'S Pat. HARDEST U.S. HITTING SLING

Range 225 yd. - 232 fps

Matched spare rubbers and pouch assembly, \$1.00.

Write **WRIST ROCKET®** \$3.00 Post Pd. 2654 44th Ave. Columbus, Nebr. 68601 **PM** No C.O.D.'s



Don't change your address without notifying us!

To insure uninterrupted service on your **Popular Mechanics** subscription, please notify us at least six weeks before you move.

1. Attach your address label from a recent issue in the space provided below... (If label not available, be sure to give us your old address, including Zip Code)
2. Print your name and new address below (be sure to include your Zip Code).

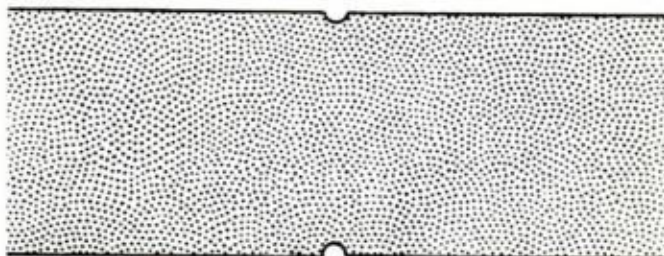

3. Mail entire notice to: **Subscription Service Dept. Bex No. 646 New York, N. Y. 10019**

Name _____ **Please Print**

New Address _____

City _____

State _____ Zip Code _____

ARE RACE HORSES MONEYMAKING'S MACHINES? GET UP TO \$151 WIN A RACE DAY

SENSATIONAL—space age—scientific, yet so easy to use. All purchasers get facts. Over 4 years checkable Big Win Pencliff results. Over THREE THOUSAND Big Win Pencliff Payoffs to \$2 stakes incl. \$89, \$105, \$160. Big Pencliff Track Wins—\$2 on all predictions in the 9 races incl. \$87, \$108, \$151 clear net profit on the day. Obviously payoffs and profits every day are not ALL BIG, but PENCLIFF shows a magnificent 28% aver. approx. win with a GRAND percent of real big 'uns. 30 day money back guarantee. Learn how an accident on the inventor's yacht, his 25 years horse race knowledge, the aid of 12 other expert Handicappers, and a giant I. B. M. computer all led to the invention of amazing PENCLIFF.

R.H.P. CO. Box 5715-PME2, Carmel, Calif. 93921.
Tear out this ad NOW and mail with name, address, & zip.

\$\$ TREASURE \$\$



New revolutionary analytical transistorized metal detector will distinguish a gold bar from a tin can. No more unnecessary digging for tin cans, nails, bottle caps, etc. Also features push button tuning, automatic tuning, loudspeaker. Negligible ground pickup. Greatest detection range, etc. Many models — free catalog.

GARDINER ELECTRONICS CO.

Dept. 8, 4729 No. 7th Ave., Phoenix, Ariz. 85013

LEARNING COLOR TV, COMMUNICATIONS, ELECTRONICS IS FAST, EASY, FASCINATING WITH NRI



ALL THIS IS YOURS — from Achievement Kit to Color TV set you build yourself — when you enroll for the NRI TV-Radio Servicing course. Other courses are equally complete. Unique training methods, "bite-size" texts, many personal services have kept NRI the 55-year leader in its field.

ACT NOW—STEP UP TO HIGHER PAY, A BRIGHTER FUTURE EARN \$5 TO \$7 AN HOUR SOON AFTER YOU ENROLL

Regardless of your educational background, you CAN learn Color Television Servicing, Communications or Industrial Electronics at home in your spare time the NRI way. NRI has spent millions of dollars in simplifying, organizing, dramatizing home study methods in this fast growing field—reaching new heights of perfection in education-at-home to make Electronics subjects easy to grasp, entertaining and practical. The NRI learn-by-doing way trains your hands as well as your head.

BE A SKILLED TECHNICIAN IN AMERICA'S FASTEST GROWING INDUSTRY

The NRI color catalog, sent to you free and without obligation, tells you how you can qualify quickly to be a part of the fast growing Electronic Age. It tells you about NRI home study plans to fit every interest, every need in Color TV Servicing, Communications, Industrial Electronics. You can learn to be your own boss in your own TV-Radio Servicing business, or make \$5 to \$7 an hour spare time fixing sets. Or you can get into the fascinating field of broadcasting-communications. Or be a part of the Electronics "revolution" in business and industry; learn to understand computers or take part in rocket and space programs. Electronics is growing so fast, it is expected to be America's number-one industry in a few short years. Even now, engineering jobs are being offered to men without college degrees.

CASH IN ON THE COLOR TV BOOM

Color Television is just one of the money-making "boom" markets in the field of Electronics. TV technicians are in demand now to keep growing

millions of color sets in working order. NRI prepares you with actual on-the-job experience by including in its Color TV course a custom-designed set totally engineered for training purposes. You learn by doing, demonstrating things you read about in "bite-size" texts as you build and work with professional equipment (not "hobby" kits). Electronics comes alive in a fascinating way. In Color TV, the end product is your own high quality set, yours to keep for years of viewing pleasure.

TRAIN AT HOME WITH THE LEADER

Opportunities are endless for the well-prepared man. Discover the ease and excitement of training at home with America's leading school of its kind—NRI. Mail the postage-free insert card today for the new NRI color catalog. No obligation. No salesman will call on you. NATIONAL RADIO INSTITUTE, Electronics Division, Washington, D.C. 20016.



APPROVED UNDER GI BILL If you served since January 31, 1955, or are in service, check GI line on postage-free card.

Mail insert card for
**your FREE NRI
color CATALOG**
No salesman will call



THE TUB FIXER

EASY WAY TO PUT
NEAT, WATERTIGHT
SEALS AROUND
TUBS, SINKS,
SHOWER STALLS.
KWIK-SEAL STAYS
FLEXIBLE. RESISTS
MILDEW. ODORLESS.
BRIGHT WHITE. MONEY
BACK GUARANTEE.



DAP Inc., Dayton, Ohio 45401 / SUBSIDIARY OF Plough, Inc.
Also available in Canada

Heating and cooling technicians have it made.

If your job is not a great job, it's the wrong job. Now is the time for you to have it made. As a trained technician. A technician that makes big money in a big field. A field that grows each year.

Find out if heating and cooling is for you. Our program lets you prepare for this rewarding career at home in your spare time. A program that gets you ready for the big money. Write today.

ITT Technical Institute

1340 S. Michigan Avenue, Chicago, Ill. 60605 • Dept. 163-109A

Please send me FREE information on your program for a career in Air Conditioning, Heating & Refrigeration.

Name _____ Age _____

Address _____ Married

City _____ State _____ Zip _____ Single

ITT TECHNICAL INSTITUTE **ITT**
An educational service of
International Telephone and Telegraph Corporation

THE '70 CARS

THE FAVORITE FAMILY CARS

(Continued from page 122)

lengthened three inches, the rear end shortened four, tending to give both the Monaco and Polara a longer, lower look. Actually, however, the car is an inch shorter overall. The rear track has been widened three inches. There are new bumpers front and rear and grilles have been slightly restyled. You can get a base Polara as either a two or four-door hardtop, a convertible, a four-door sedan or a two or three-seat wagon; a Polara Custom as a two or four-door hardtop and a four-door sedan; the Monaco same as the Polara less the convertible. Engine lineup for the big Dodge includes a 318-CID V8, a 383 2-bbl. V8, a 440 4-bbl. with either single or dual exhaust. In transmissions there's a new three-speed manual and an automatic. Again this year Dodge is going to go it alone with Super-Lite, an auxiliary light option available only on the Polara and Monaco.

FORD: There are six series offered here—the base Custom, Custom 500, Galaxie 500, XL, LTD, and LTD Brougham. The base Custom can be either a four-door sedan or a Ranch Wagon. Same with the Custom 500 except there's another wagon featuring dual-facing rear seats. The Galaxie comes as a four-door sedan or hardtop, a sport roof or formal two-door hardtop and two wagons. The XL is only a two-door hardtop or convertible. In the LTD, you can get a two or four-door hardtop, a four-door sedan and two Country Squire wagons. The fancier LTD Brougham is available as either a two or four-door hardtop or a four-door sedan.

Styling changes are slight throughout the line with most of the emphasis being placed on new ornamentation and new exterior colors. The XL and LTD have new grilles, and the Brougham, of course, is a new series. Engines include the 240 Six and 302, 351, 390 and 429 V8s, the latter in both 2 and 4-bbl. Transmissions include three and four-speed manuals and an automatic.

MERCURY: Here we have the Monterey, Monterey Custom, Marauder and Marauder X-100, Marquis and Marquis Brougham. All have new grilles, rearranged rear ends, revised ornamentation overall. In general, however, styling changes are slight. You can get the Monterey as a four-door sedan, a two or four-door hardtop, a convertible and a wagon. Same with the Monterey Custom, but no convertible. Both Marauders come only as two-door hardtops. The

(Please turn to page 232)



IT'S ALMOST LIKE PRINTING YOUR OWN MONEY!

9¢ WORTH OF RAW MATERIAL *becomes* **\$125** in less than 60 seconds—and ANYONE can LEARN to do it in a FEW SHORT HOURS!

Since 1922, Warner has enabled thousands of men and women to establish a business of their own—to reap the benefits of their own labor and have the personal satisfaction, and independence, that comes with operating a business of their own.

Now, a revolutionary new machine makes it possible for an Independent Business Man with no "PULL" . . . No Big Money to Invest . . . and, No Experience — to start a business of his own, at home in his spare time. Here's what J. H. of Pennsylvania says:

\$7,280.00 for 1 to 1½ hours work an evening in my spare time—and without advertising. When I start to advertise I will have my own full-time business. Right now I am using the extra income to give my family the luxuries my present job does not afford.

Now you can get into this highly lucrative business, and use your own home as headquarters. No experience needed because we supply everything. The new Warner Success Program, "Engraving as a Profitable Business," is now ready for you. We will send you a FREE illustrated brochure and no salesman will call. Send no money — just your name and address on the coupon or on a postcard. Be the first in your locality to cash in on this ground floor opportunity.

**Warner Electric Co., Dept. E-2-LS
1512 Jarvis Ave., Chicago, Ill. 60626**

Engraving Division, Dept. E-2-LS SEND NO MONEY
1512 Jarvis Ave., Chicago, Ill. 60626

Please rush your free illustrated brochure to:

Name _____

Address _____

City, State, Zip _____



3½" x 9¼"

Let's Do LEATHERCRAFT! HERE'S A GENUINE LEATHER BILLFOLD KIT AS A STARTER

WORTH \$5.00 AFTER YOU ASSEMBLE AND LACE!

ONLY **50¢** with coupon below

ONLY 50¢ IF YOU ACT NOW!

Tandy
LEATHER COMPANY
A TANDY CORPORATION COMPANY

1001 Foch, Dept. HP, Fort Worth, Texas, 76107

Yes, send me your embossed billfold kit and 112-page catalog. I'm sending 50¢ as full payment. (Limit one per family.)

NAME _____

ADDRESS _____

CITY _____ STATE _____ ZIP _____

ONLY 50¢ IF YOU ACT NOW!

Get all the features of expensive billfolds... hidden money pocket, four-unit card case and two side pockets. Handsome design already embossed. Kit complete. Easy 'n fun to assemble and lace. You'll also receive a 112-page Leathercraft catalog and easy-to-follow instructional manual. **Order yours today!**



JET CHRONOGRAPH with Day-Date Calendar Band

Tells time, measures distance, registers speed, and serves as a stop watch. Outer revolving ring serves as an elapsed time recorder for parking, sports, conferences, etc. Luminous hands and figures are clearly legible in the dark. Matching Day-Date expansion band. It looks impressive on your wrist or makes an ideal gift on any occasion. Comes direct to you from Switzerland for only \$12.95 ea. Add \$1.—for registered airmail. Send money order, bank check or personal check. No COD's please!

PROTIL WATCH SA,
Dept. PM-1069, Gartenstrasse 10,
8002 ZURICH/Switzerland



The Easy
Way to
Build



BEAUTIFUL CLOCKS

Send 25¢ for 48-page catalog of easy patterns, fine clock movements, dials and hardwood kits.

CRAFT PRODUCTS
ELMHURST (1) ILL. 60126

BELSAW PLANER · MOLDER · SAW!

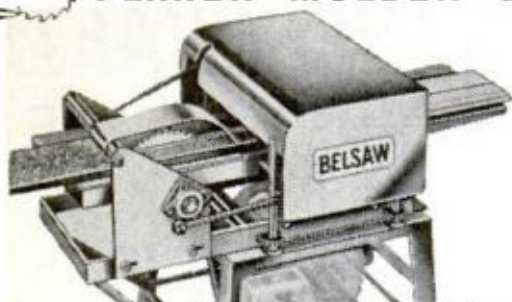

Now you can use this ONE power-feed shop to turn rough lumber into moldings, trim, flooring, furniture . . . ALL popular patterns. RIP . . . PLANE . . . MOLD . . . separately or all at once with a one HP motor. Use 3 to 5 HP for high speed output. Low Cost . . . You can own this power tool for only \$30.00 down.

Send Postcard Today . . . No Salesman Will Call
BELSAW POWER TOOLS, 900T Field Bldg., Kansas City, Mo. 64111

HEAVY DUTY BALL-BEARING PUMP



IRRIGATE • DRAIN • SPRAY • CIRCULATE • All-metal, rust-proof XB. Stainless shaft. Use ¼ HP or larger. 1 HP for up to 5,200 GPH 60' high or 3,000 GPH from 25' well. 1¼" inlet. 1" outlet. For belt or direct drives \$12.95

Type P won't rust or clog. Bronze bearing. Hundreds of thousands in use. Up to 2,400 GPH, 1" inlet, ¾" outlet. \$8.95

P'pd. cash with order. MONEY BACK GUARANTEE.
LABAWCO, Box 2, Belle Mead, N.J. 08502

LOOSENS RUSTED NUTS, BOLTS, PARTS



LIQUID WRENCH

AT HARDWARE & AUTO STORES

BE YOUR OWN BOSS!

A SPACE AS SMALL AS 10" X 13" CAN
MAKE YOU INDEPENDENT
in the high profit (low investment) rubber stamp field. Increase your income; full or part time basis. Deal direct with manufacturer offering lowest prices on professional SIMPLE-X presses & supplies, plus valuable aid. For FREE full facts write

CUSTOM MFRS.
406PM E. Elm, Springfield, Mo. 65801



HOLD IT!

the glue that never lets go!

write for FREE
glue and caulk
selector guides

WILHOLD

WILHOLD GLUES, INC.
8707 Millergrove Dr., Santa Fe Springs, Cal. 90670



HIP POCKET WORKSHOP



11 tools including screw driver, bottle opener, corkscrew, file, can opener, scissors, saw, many others. All combined in this Swiss type Pocket Knife that closes to a neat compact 3¼". \$4.50 Postpaid. Send Check, Cash or Money Order—No C.O.D.'s

KNIGHT SALES
P.O. Box 97
Tallman, New York 10982

BUILD THE POPULAR MECHANICS MINI-BIKE



FROM 26-IN. BICYCLE FRAME

—with VARIABLE SPEED TRANSMISSION, as featured in June '67 issue. Step-by-Step plans, photos show you how. PLANS, \$2.50, refundable with order for wheels, engines, clutches, kits at Discount Prices. Order Plans, or send 25c for Catalog, today!

SAVE \$50 to \$150
GILLIOM MFG. CO. Dept. PM-10 St. Charles, Mo. 63301

IS THERE A CHEMIST IN THE HOUSE???

Only \$4.00 Plus \$1.00 p.p. Will bring 49 "PLUS" individual, assorted, items of standard quality laboratory apparatus: glassware, porcelain, rubber, plastic, etc., etc. Value? 2 to 3 times our offer. None dangerous. No junk. One surprise item. Pyrex Advanced Student Assort. @ \$10 plus \$2 p.p.



HARRY ROSS Scientific & Lab. Projects
61-D Reade St. N.Y. 7, N.Y.



REPOWER with a 6 or V-8. H.D. ADAPTORS for using Car, Compact and some Truck engines. "State year & model. Jeep or Scout." Want fast action? Give us FULL INFORMATION. Send \$25.00 Dep. and we will ship correct kit, bal. COD. Send full amount for prepaid shipment. Wire, phone or write today. Details FREE

HOOSIER MACHINE PRODUCTS CO.

312 S. E. 6th St., Phone 276-3442, Pendleton, Oregon 97801

PERMANENT MATCH

AMAZING INVENTION SELLS LIKE MAD!

Lights up to 15,000 times. Pull this ingenious metal wonder out of its case, strike on side, and presto!—it's lit. Amazes everyone who sees it. MAKE BIG PROFITS. Show to friends, fellow-workers, in stores, offices, taverns, factories. Sells on sight for \$1.00. Order at low wholesale prices ONLY \$4.90 per doz.; \$14.25 for 3 doz.; \$49.20 for 12 doz. (2 samples \$1.00). Display cards available for big store sales. Catalog of 100 other fast sellers inc'd free! Lakeside Company, Dept. PP-105, 6800 N. Campbell Ave.; Chicago, Ill. 60645.



106 ^{Pc.} PROFESSIONAL SOCKET WRENCH & TOOL SET

DO ANY JOB • FASTER • BETTER • EASIER!

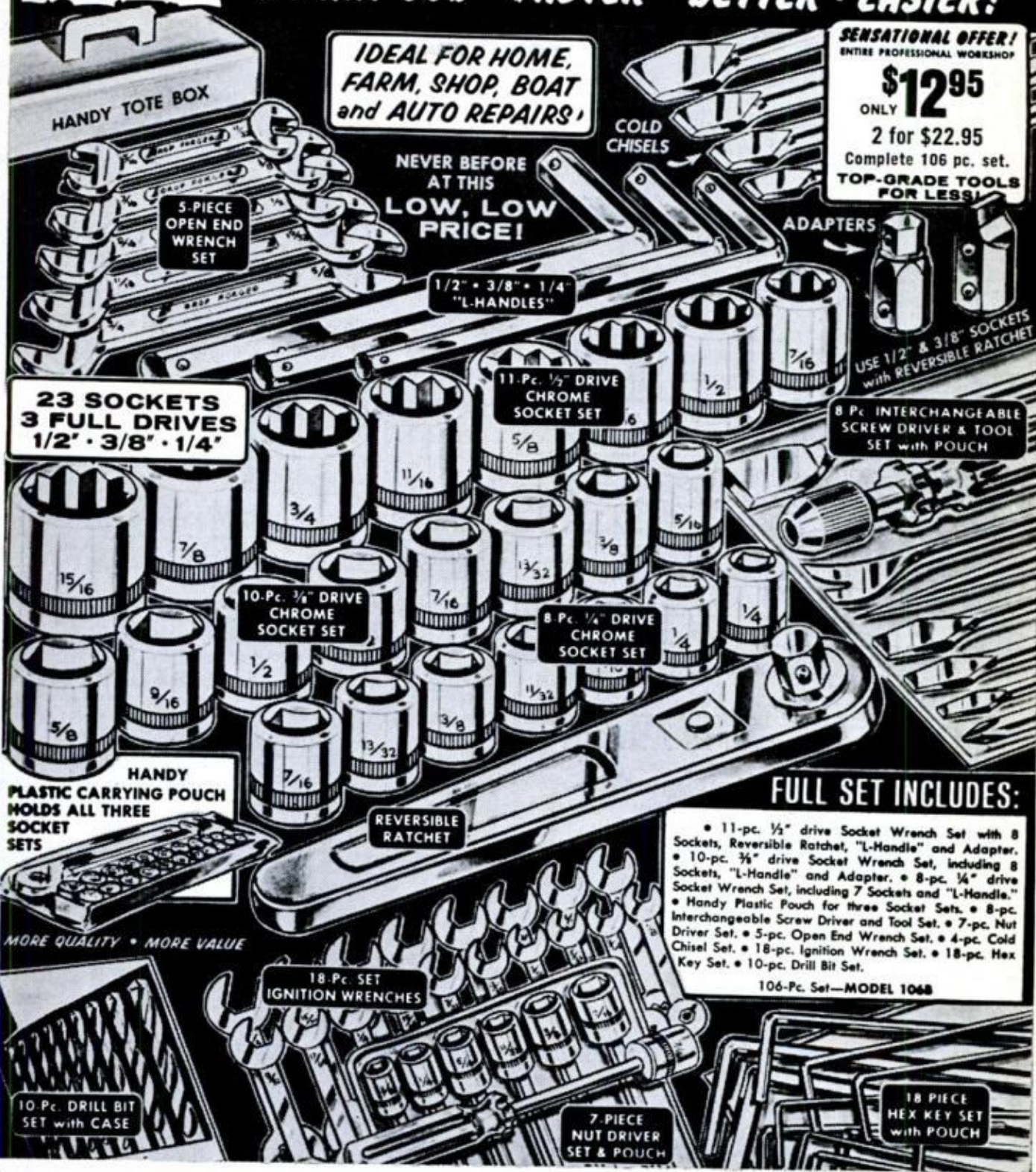

HANDY TOTE BOX

IDEAL FOR HOME, FARM, SHOP, BOAT and AUTO REPAIRS!

SENSATIONAL OFFER!
ENTIRE PROFESSIONAL WORKSHOP
\$12.95
ONLY
2 for \$22.95
Complete 106 pc. set.
TOP-GRADE TOOLS FOR LESS!

5-PIECE OPEN END WRENCH SET

NEVER BEFORE AT THIS LOW, LOW PRICE!

COLD CHISELS

ADAPTERS

1/2" • 3/8" • 1/4" "L-HANDLES"

USE 1/2" & 3/8" SOCKETS with REVERSIBLE RATCHET

23 SOCKETS
3 FULL DRIVES
1/2" • 3/8" • 1/4"

11-Pc. 1/2" DRIVE CHROME SOCKET SET

8-Pc. INTERCHANGEABLE SCREW DRIVER & TOOL SET with POUCH

10-Pc. 3/8" DRIVE CHROME SOCKET SET

8-Pc. 1/4" DRIVE CHROME SOCKET SET

HANDY PLASTIC CARRYING POUCH HOLDS ALL THREE SOCKET SETS

REVERSIBLE RATCHET

FULL SET INCLUDES:

- 11-pc. 1/2" drive Socket Wrench Set with 8 Sockets, Reversible Ratchet, "L-Handle" and Adapter.
- 10-pc. 3/8" drive Socket Wrench Set, including 8 Sockets, "L-Handle" and Adapter.
- 8-pc. 1/4" drive Socket Wrench Set, including 7 Sockets and "L-Handle."
- Handy Plastic Pouch for three Socket Sets.
- 8-pc. Interchangeable Screw Driver and Tool Set.
- 5-pc. Open End Wrench Set.
- 7-pc. Nut Driver Set.
- 18-pc. Ignition Wrench Set.
- 18-pc. Hex Key Set.
- 10-pc. Drill Bit Set.

106-Pc. Set—MODEL 1068

MORE QUALITY • MORE VALUE

18-Pc. SET IGNITION WRENCHES

10-Pc. DRILL BIT SET with CASE

7-PIECE NUT DRIVER SET & POUCH

18-PIECE HEX KEY SET with POUCH

106 WAYS TO SAVE BIG MONEY YEAR AFTER YEAR!

Home handyman, amateur mechanic, or just plain tinkerer — here's your chance to get a whole workshop of professional quality hand tools . . . in their own handy tote box — all at an unbeatable low price! Equip yourself with this tremendously versatile, amazingly complete outfit . . . and you're ready for just about any repair job that comes along!

JAY NORRIS CORP.,

Dept. ME-4, 31 Hanse Ave., Freeport, N.Y. 11520

MONEY BACK IF NOT DELIGHTED

JAY NORRIS CORP., Dept. ME-4, 31 Hanse Ave., Freeport, N.Y. 11520

Please rush me the following 106-PC. Professional Socket Wrench Tool Sets:

- 1 Set for \$12.95 2 Sets for \$22.95

I enclose 25% deposit—send C.O.D.

Enclosed is check. money order.

Charge Diners Club Am. Express

BankAmericard Master Charge

Account # _____

Signature _____

Name _____

(Print) _____

Address _____

City _____

State _____ Zip _____

ADD 10% for pstg., handling and ins.

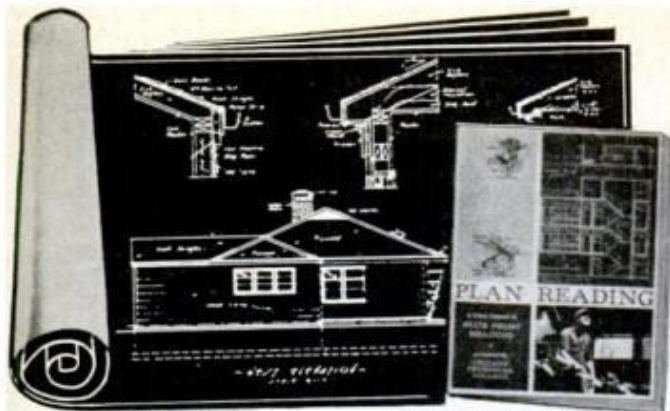

These FREE BLUEPRINTS CAN START YOU TO BIG SUCCESS IN BUILDING CONSTRUCTION

In all fifty states, men who have sent for these free blue prints are today enjoying big success as foremen, estimators, or building contractors, and so can you. Learn to read blueprints; master all the practical details of construction in your spare time, at home. Prepare for a big-pay job in building, or start your own profitable contracting business. Mail the coupon today and cash in on the booming building business. Approved for veterans. Accredited member, N.H.S.C.

CHICAGO TECHNICAL COLLEGE

N207 Tech Bldg., 2000 S. Michigan
Chicago, Illinois 60616

Please mail me FREE trial lesson, blueprints.

Name _____ Age _____

Address _____

City _____ State _____ Zip _____

Occupation _____

New G.I. Bill! Veterans check here

FREE Trial Lesson in DRAFTING

Learn Drafting at home, in your spare time. Just a few hours weekly can prepare you for a good job and better pay. Send for FREE Trial Lesson today. Dept. DH, 2000 S. Michigan Ave., Chicago, Ill. 60616

CHICAGO TECHNICAL COLLEGE

Now! Use your Bank Americard

5000° OXYGEN WELDING TORCH

\$34.95 New portable SOLIDOX welding torch goes anywhere. Only 4 lbs. Burns amazing solid oxygen pellets & propane. Flame exceeds 5000°F. Braze weld, silver solder, melt 1/4" steel. Complete kit: torch, pellets, propane, glasses, braze rods, lighter, etc. Ideal for shops, hobby, metal repair. Professional results. Low-cost SOLIDOX pellets available by mail. SOLIDOX is simple and safe. Money-back guarantee. Only \$34.95 ppd.

SEND ONLY \$5.00

Write for free brochure.

pay postman \$29.95 plus postage on delivery.

Cleanweld Products Co., PM-10 Box 1061, South Gate, Calif. 90280

Fox Mini Bike

DO IT YOURSELF OR FULLY ASSEMBLED

from \$99⁵⁰



SEND \$1 FOR BIG CATALOG Shows new line of the world's finest MINI-BIKES (street and trail models), plus Go Kart (R), parts, accessories and plans. Amazingly low prices! There's a Fox MINI-BIKE for everyone from age 10 to adults.

EXTRA BONUS Catalog shows radios, watches, walki-talkies, cameras, musical instruments, tools, appliances and many other items you can buy at practically wholesale prices. Free \$1 coupon.

FOX CORP., Box 797PM, Janesville, Wis. 53545

ENJOY YOUR OWN BUSINESS

Start earning at once—No special experience required

A SHOP IN ITSELF
AUTOMATIC FOOLPROOF

STAND-ALL Model 7

Sharpens & Retoots Hand Saws 3 point through 16 point. **SHARPENS—BAND SAWS—HACK SAWS—WOOD AND METAL CUTTING SAWS** with straight back and identical tooth profile.

CROWNS—adjusts to any standard crown.

HOOKS—5° to 21°
BEVELS—0° to 30°

SMITH-NIELSEN EQUIPMENT CO.

P-109

Mfg. of Saw Grinders—Distributor of Complete Saw Shop Equip.
Box 2505 Terminal Annex, Spokane, Washington 99220 FA 8-6680

YOU CAN FIND HIDDEN TREASURE AND RELICS

New professional metal locator out performs other models.

Guaranteed to detect gold, silver, coins, relics. Light weight and fully transistorized. Comes ready to operate.

ONLY **2995**



Order now for immediate shipment or write for a free illustrated brochure. \$5.00 deposit for C.O.D. orders.

Dart Electronics
Box 361-PM, Huntsville, Texas 77340

RON RIEDER, PRESIDENT OF AMERICAN UNIFAX, SAYS:



"Selling's a cinch with the new American Unifax line. Our people report profits as high as \$300 per week, even in their spare time!"

THERE'S virtually no limit to the amount of money you can make in the Direct Selling field—provided you have the right product. About a year and a half ago, my company introduced a product called COPYFAX. Within a few short months, COPYFAX made Direct Selling history.

COPYFAX is a fully patented "breakthrough" product that is rapidly taking over the multi-million-dollar carbon paper market. Made from incredibly tough DuPont Mylar® and a liquid ink similar to that used by printers, COPYFAX makes carbon paper as obsolete as high-button shoes and buggy whips. COPYFAX can't be torn. It won't smudge, smear, curl, or wrinkle. Carbon paper is ready for the wastebasket after 5 to 10 uses. COPYFAX is still going strong after 100 . . . 150 . . . even 200 uses!

Wide-awake Direct Sellers have been cashing in BIG with COPYFAX. A Florida housewife, who had never sold a thing, spent "maybe 5 minutes" in her local newspaper office and nailed down a \$785 sale—including a juicy \$215 profit for herself. A Connecticut bank manager racks up spare-time profits of over \$275 per week selling COPYFAX via mail order. A California businessman reports that the sales volume of his 14-year-old company QUADRUPLED two months after he started handling COPYFAX.

Sensational? You bet—COPYFAX is the kind of product that makes selling a cinch. And now COPYFAX is being joined by two NEW American Unifax products, each one as fantastic a money-maker as COPYFAX itself!

The first is the American Unifax Typing Ribbon—made of the same DuPont Mylar and special solvent ink used in COPYFAX. This miracle ribbon converts *any* typewriter—old or new, manual or electric, standard or portable—into a prestige "Executive" machine that produces a sharp, crisp, smearproof image almost impossible to distinguish from fine printing! Installs instantly, without special spools or adapters. What's more, *the ink never touches the keys*, ending forever the messy, time-consuming job of typewriter cleaning!

"Corrections so neat that only your typewriter knows you made a mistake!" Say those 12 words to any typist, any steno, any secretary, and you'll have made another convert to new American Unifax Correction Paper with miracle M-E-K! Ordinary correction paper employs a powdered-chalk coating—often requires several strikes to blank out the error, several more to insert the correction. American Unifax Correction Paper employs a snow-white, total-release solvent ink—one strike and the error disappears, one more and the correction appears . . . like magic! No eraser crumbs, no chalk dust, no paint spatters! Every typist loves it—and so does her boss—because corrections made with this amazing paper are virtually undetectable!

There you have it—three great American Unifax products that guarantee you fast, easy, high-profit sales—and repeat sales—in offices, factories, stores, schools, churches, private homes—wherever there are typewriters!

Now is the time for YOU to join the big swing to American Unifax. No special experience or big cash investment is necessary. And under the terms of our new Exclusive Distributorship Program you can stake out a Protected Sales Territory for yourself just as big as you can handle—start enjoying profits as high as \$300 per week part-time, much more full-time! But hurry—territories are assigned to qualified individuals on a first-come, first-served basis. Mail the coupon TODAY!

AMERICAN UNIFAX, INC. Dept. P-109
95 Madison Ave., New York, N.Y. 10016

The new American Unifax product line sounds good to me—tell me how I can get in on the ground floor!

FREE and without obligation, send me complete information on the American Unifax Direct Selling Program.

I enclose \$9.00. Send me 1 pack of COPYFAX, 1 Typing Ribbon, and 1 pack of Correction Paper (total retail value \$12.40), plus complete information. If you wish, specify make and model typewriter:

Name _____

Address _____

City _____ State _____ Zip _____



AMERICAN UNIFAX

Dept. P-109 95 Madison Ave., New York, New York 10016

OCTOBER 1969

255

AFTER ONE HOUR'S WORK

*Your Typewriter
is now like new!
I'll send a bill
for the \$25.*



This Can Be YOU Sooner Than You Think!

BECOME A TYPEWRITER MAINTENANCE EXPERT

Quickly—Easily—At Home without risk!



Earn \$50 for 2 hours in your spare time, get a big pay position with a future or, start your own business.

There is a critical shortage of technicians to keep America's 30 million typewriters in repair. Now, regardless of age, education, or present job, you can enter this big-paying field by training in the Office Equipment Industry's only Approved Home Study Course.

Learn fast, and earn money while learning. Diagrams, photos, clear lessons, professional tools, plus benchwork assignments on actual typewriter that we give you, make learning easy.

Send name today for **FREE BOOKLET** telling of your opportunities in this profitable vocation. Full information, no obligation. No salesman will call. (VA Approved.)

MAIL COUPON FOR FREE BOOKLET

Typewriter Repair School, Dept. 3110-109
Little Falls, N. J. 07424

Please rush Booklet entirely FREE. No obligation. No salesman is to call.

Name _____

Address _____

City _____ State _____ Zip _____

COASTAL®

ZIPPIDI-DO

ALL-PURPOSE CUTTING AND SANDING DISC

*Zippidi-Do
even cuts a file*

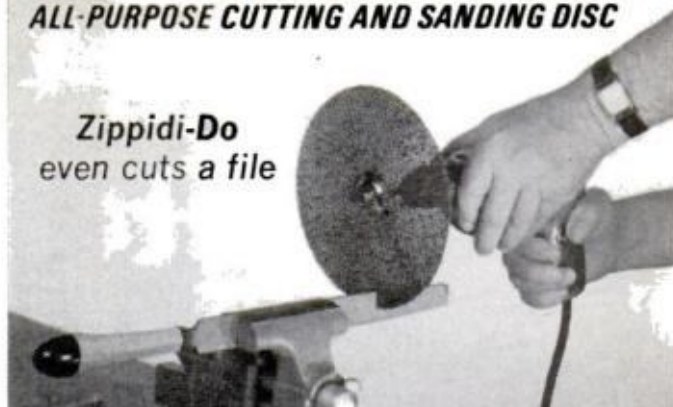

The most versatile power tool accessory... ever!

You can cut through ceramic tile, fiberglass, brick, slate, stone, all metals... even a hard file in minutes with the Zippidi-Do cutting and sanding disc. Silicon carbide grains embedded in nylon mesh give it amazing cutting ability. And the Zippidi-Do makes a great sanding and shaping disc for use on old paint, rust, wood, tile, all metals. The Zippidi-Do can be used with any electric drill or flexible shaft. It wears and wears and never clogs.

Complete kit contains Zippidi-Do disc, molded backing disc, arbor and flanges... only \$4.00 at hardware stores and depts. Coastal Abrasive and Tool Co., Inc., Trumbull, Conn. 06611.

LAKEFRONT LANDS FOR SALE

IN ONTARIO, CANADA—ONE OF THE WORLD'S BEAUTY SPOTS

Booming Ontario, land of a quarter million lakes, Canada's wealthiest province, welcomes visitors, settlers and investors. A country of four distinct seasons—Gentle Springs, lush, warm Summers, breathtaking Falls, and Invigorating Winters.

Accessible by fine 4-lane toll-free roads, radiating into the land, right from U.S. Border. Friendly people to welcome YOU! U.S. citizens may buy, build and sell real estate in Canada, under the same conditions as Canadian citizens. You are not obliged to live on any property you own or carry out any improvements.

HERE ARE A FEW OF HUNDREDS OF PROPERTIES AVAILABLE:

- 35 Acres in mineral-rich Huffman Township on Shore of Rice Lake. \$1003.
- 115 Wooded acres in Westmeath Township—Great deer country. \$1763.
- 21 Acres lying along lazy Spanish River in Sheddon Township on Lake Huron. \$1460.
- 50 Acres in rugged Strong Township—crystal streams bulge with fighting trout. \$1365.
- Building lot right in town, close to stores, school and all facilities at Larder Lake. \$174.
- 80 Acre Farmland Retreat in Cane Township with good roads and services. \$1278.

There are many, many more properties available at similar prices on Lakes, Rivers, and Streams of interest to sportsmen, farmers, and investors. Write for a descriptive booklet, together with very detailed maps and complete descriptions. Sold on monthly terms. Please remit \$2.00 to cover maps, postage, packaging. (Refundable)

Municipal Tax Land Disposal Agency, 36 Shelly St., Georgetown, Ontario, Canada. Attn: Henry G. Janssen. Cables: MUNTAX.



BIG

YACHT-SMART
Sail Rig
DACRON
from
\$112



FALL SAVINGS NOW

FOLBOT

TRAVEL CRAFT
fits in every
home or car

FOR YOUR SPORT AND FAMILY FUN

and
RECORD FISHING

GENUINE Folbot RECREATION for just ONE small investment, WITHOUT the continuous burdens of complicated 'big rig' operation. You GO CAREFREE anytime with COMPACT Folbot . . . rocky streams, lakes, marsh, surf & open sea. Superior non-sinkable designs provide SAFEST low gravity center, balanced low & high seating, substantial construction, protective decks & EXCLUSIVE swivel-back COMFORT. ALL within your reach. In handy Folbot YOU GLIDE smoother, faster & NOISELESS with paddles, oars, or sails and ride softly w. 1 to 10 HP. motors. Many styles & sizes from 1 to 4 seaters, FOLDING or rigid PORTABLE come in PREFAB KIT, or expertly FACTORY BUILT

Just a few Dollars start
YOU right away. From

ONLY \$19 NOW

for **BASIC KIT**

16 feet long

'CAYAT'
car top
YACHT.



©

NEW
Fabulous
16 foot
\$115

Factory BUILT

FREE
ACTION CATALOG

STARTLING
FACTS & FIGURES
Mail coupon or address

to: **FOLBOT CORP.**
Dept. PM1069, Charleston, S. C. 29405

Name _____

Address _____

City _____ State _____

It only tastes expensive



Popular price



DEFENDER OF WOMEN!

Instantly Stops Attacker

Assailants run screaming when sprayed in face with DEFENDER. When you're in danger, simply press top. Temporarily leaves attackers helpless. Dyes skin identifying attacker for police. Effective up to 15 ft. Lip-Stick size-hides easily in palm of hand. Women buy on sight. Amazing profit!
SAMPLES for TRIAL Sample offer sent to all who send name at once. Postcard will do, **SEND NO MONEY**. Just your name.
KRISTEE CO., Dept. 676, Akron, Ohio 44308

LEARN TO BE A SKILLED LOCKSMITH

Professional Key Machine yours to keep!

Be your own boss. Earn steady, year-around income in your spare time at home. BELSAW INSTITUTE lessons show you how to make keys, open and repair locks on homes, cars, business buildings. Accredited Member NHSC. Approved for Veterans. All tools and supplies furnished including the \$125 Key Machine. Write for FREE BOOK. No salesman will call.

BELSAW INSTITUTE / 100T Field Bldg.
Kansas City, Mo. 64111

the
minute
menders

from the
fix 'n' fasten
people

THERMOGRIP® Electric Glue Gun

for neat, permanent gluing



IN A MINUTE . . . a permanent bond with no clamping or waiting. Hot-melt glue bonds wood, leather, canvas, fabric and most materials. Popular kit includes gun and sealer sticks. Regular price, \$7.95. At hardware and department stores.

ONLY THERMOGRIP has automatic "Drip-Chek" valve...instant start and stop of glue flow!

No wrenches
or other tools
needed.

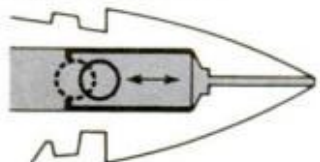

USM Corporation

Consumer Products Division

Reading, Pa. 19601

Now Annoying Squeaky Hinges Can Be Sprayed Quiet.

One sw-o-o-sh is all it takes to get rid of the nerve-wracking squeak of a stubborn hinge when you apply new 3-IN-ONE Oil Spray. Lubricates. Cleans. Polishes. Prevents rust and tarnish. Get 3-IN-ONE can or new aerosol spray at all hardware stores.



3-IN-ONE®

HOUSEHOLD OIL

LICKITY SPLITTER

Splits Big Profits from
toughest woods— Ends
Splitting Drudgery
with 18 ton
hydraulic power!

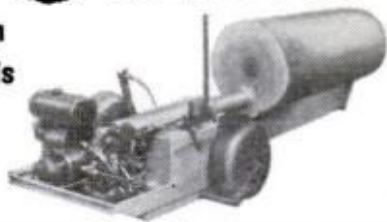

7 H.P. trailer unit squats under power to load logs without dead lift. Has 2 speeds, auto-shift, auto-stroke. 26" ram travel splits logs up to 34", any diameter — with extended frame and adjustable wedge splits up to 60". **NEW LOW COST** Economy model for farmers and small wood lots. Also ask about the 60L Series for logs up to 8½ ft. long—Details free.

Piqua Engineering Inc., Dept. P, Box 605, Piqua, Ohio

make your own Gems 39.50
F.O.B.

The Gem Maker comes complete with all necessary equipment, including a super-charged diamond blade for sawing, and all the wheels for grinding, shaping and polishing; also complete instructions. The complete equipment as shown, less motor and belt for only \$39.50. f.o.b., Burlington, Wisconsin. Write today for information and literature.

B&I MANUFACTURING CO.
Dept. P, Burlington, Wis. 53105



HOW TO GET RICH

Secret Mail Order business brings cash by mail. Pyramid profits. No investment. Start at home in spare time. Write for full details and Free Book.

MAIL ORDER ASSOCIATES, INC.

Dept. 2, Montvale, New Jersey 07645



ALVA ALLEN Power Punch Presses

1 to 100 Ton Capacity

Complete line of Punch Presses in hundreds of different style and model combinations. Write for FREE literature on presses and complete line of punch Press accessories as—Feeds, Punch Units, Dies, etc.

Alva Allen Industries, Dept. PM, Clinton, Mo. 64735



"I Earn Two Incomes Now"

Says **JOHN BENNIE, Pittsburgh, Pennsylvania**

"Thanks to your wonderful training, I have been able to earn \$20 to \$25 extra each and every week doing little locksmith jobs at home and after work at my regular job. This is the best trade a man can take up."

Be a LOCKSMITH

Train at HOME—Earn While You Learn. Add 50%-100% to YOUR INCOME with easy spare time earnings. Cash in on the nation-wide shortage—trained locksmiths in great demand! Quickly step into a big pay opportunity job or start a high-profit shop of your own.

Earn Extra Money RIGHT AWAY! All Master Locksmiths Special Tools, Equipment and Supplies Furnished FREE for use with course.

Age, education, minor physical handicaps don't matter in this growing trade. You can quickly qualify as a skilled locksmith. It's like a fascinating hobby. Study at home as little as one hour a week. Gain practical experience through complete well-illustrated lessons. Do real jobs on car locks, house locks, padlocks and safe locks, under the guidance of experts. FREE Illustrated Book, write now.

LOCKSMITHING INSTITUTE,

(Div. of Singer Communications Corp.)

Dept. 1110-109 • Little Falls, New Jersey 07424

306 pieces of professional equipment

FREE for use with course.

Professional Equipment includes
LOCKS—PICKS—PARTS—KEYS
SPECIAL TOOLS & SUPPLIES
all FREE for use with course.

Accredited, Nat'l Home Study Council.

Only school of its kind. Licensed by State of New Jersey. Approved for Veterans.

MAIL COUPON NOW

LOCKSMITHING INSTITUTE, Dept. 1110-109 Little Falls, New Jersey 07424

Please send FREE Illustrated Book—"Your Big Opportunities in Locksmithing," complete Equipment folder and sample lesson pages—FREE of all obligation—(no salesman will call).

Name _____

Address _____

City _____ State _____ Zip _____

Your Opportunities in Locksmithing

WORK WITH METAL

on precision
UNIMAT

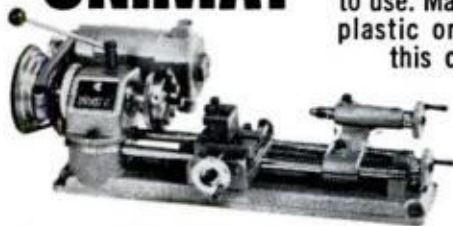

It's a lathe, miller, borer, drill press and grinder—extremely accurate, a pleasure to use. Make your own metal, plastic or wood parts with this complete bench-top machine shop. Only \$139.50.

Send for free literature today to American Edelstaal, Inc.
Dept. BJ9, 350 Broadway, New York.

SAVE ON WOOD

Imported & Domestic



CABINET HARDWARE—VENEERS—TOOLS

EVERYTHING for the Wood Shop

SEND FOR CATALOG NOW!

OVER 1500 ITEMS at MONEY SAVING PRICES! Finest domestic and imported hardwoods . . . all dimensions. Hardwood veneers. Power tools at discount prices. Hardware, lamp parts, upholstery supplies, mosaic tile. Hard to find inlays, bandings, etc. Get new catalog . . . send name, address and enclose 35¢ to pay postage, handling.

CRAFTSMAN WOOD SERVICE CO. Dept. A-109
2729 S. MARY ST., CHICAGO, ILL. 60608

BE YOUR OWN MAN— OPERATE HEAVY EQUIPMENT

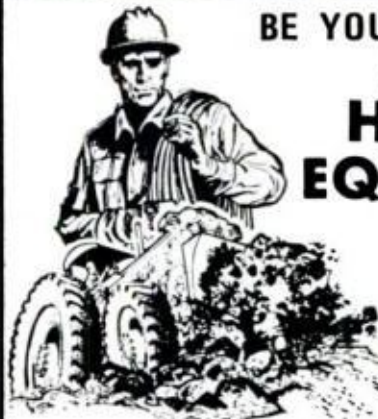

- BULLDOZERS
- DRAG LINES
- SCRAPERS
- CLAM SHELLS
- BACK HOES
- GRADERS

Train NOW to operate earth-moving equipment. The Construction Business is Booming! Earn top money in this fast moving, action-packed field! Keep present job and train at home in your spare time followed by Resident Training in the actual operation of heavy earth-moving equipment under project conditions at our facilities near MIAMI, FLA. Excellent employment assistance.

Member American Road Builders' Assn.

CONTRACTORS: Information about our trained Operators available upon request

UNIVERSAL HEAVY CONSTRUCTION SCHOOLS

Dept. PM2- 1901 N.W. 7 STREET, MIAMI, FLORIDA 33125

Name

Address

City State Zip

Age Phone

The Man Who Made Bentleys



AT THE WHEEL of a 1922 Bentley is W. O. Bentley, founder of the firm

IT'S JUST 50 YEARS since Bentley Motors Ltd. was founded (on Jan. 19, 1919, to be exact). In the years between 1921 and 1931 the company produced a total of only 3062 cars, but it was enough to start an empire and a mystique that still flourishes. In 1931, mainly because of Britain's nationwide "slump," the firm went into liquidation; Rolls-Royce bought it out and made it a subsidiary company. But the mystique survived, and today an aura of almost fanatical devotion surrounds the company's founder and the cars.

W. O. Bentley retired many years ago and now lives in a small cottage in Shamley Green, Surrey, England. Alert and healthy at 80, he lives quietly with his wife and two dachshunds. "I don't do much motoring," he says. "If I do, I'm driven by somebody."

It's a long time since the glorious days of the 1920s when the dark green racing Bentleys dominated the racetracks of the world and became famous for their raucous exhaust noise and their daredevil drivers—the "Bentley Boys." W.O. himself last competed in a race in 1922.

Today the Bentley memory is kept alive by the official Bentley Drivers Club, which has a worldwide membership of well over 2000. Owned by club members are more than 1000 vintage Bentleys.

Once described as the most brilliant designer of cars that England ever produced, W.O. Bentley is now, says one acquaintance, "probably Britain's most unrewarded man." Having lost practically all his money in his firm's crash, he now lives on a pension of \$1200 a year.

—Jon McCaughey

1922 BENTLEY, owned by Cyril Wadsworth (left), stands beside W. O. and new Bentley produced by Rolls-Royce



What Weldwood® hath joined together, let no man put asunder.

When you glue something to something else with a Weldwood glue, you can be sure it'll stay stuck.

For example, Weldwood White Glue keeps things around the house and shop glued together. Weldwood Contact Cement bonds instantly, on contact. Without clamps. If you're building cabinets, our Plastic-Resin Glue will make wood joints stronger than the wood itself.

Then there's Weldwood Waterproof Exterior Resorcinol Glue. It's so strong it

holds boats together. Heavy-duty glue? Sure. Weldwood Panel and Construction Adhesive for bonding panels. Or our Big Stick™ Construction Adhesive that sticks big jobs together like dry walls and styrofoam at a budget price.

So whatever kind of job you've got to do, stick with Weldwood Adhesives. You'll never get stuck. (If you'll pardon the pun.)



U.S. Plywood

A Division of U.S. Plywood-Champion Papers Inc.
777 Third Avenue, New York, N.Y. 10017



SUPERIOR QUALITY • SOLD ONLY BY MAIL

Hard-to-Find TOOLS



A.—GENUINE DIAMOND GLASS CUTTER

Now you can easily cut any glass or mirror up to 1/4" thick. Requires little skill. Head swivels or locks rigid. Outlasts dozens of ordinary cutters. \$6.50 ppd. (2 for \$11.95)

TOOL FINDS OF THE MONTH

B.—SILVER-TIN SOLDER

melts at only 430°F. O.K. for soldering iron or gun. 5 times stronger than ordinary solders. Stays bright. Joins all metals. 1/16" dia. x 5 ft., with flux. \$1.95 ppd.



C.—TUNGSTEN CARBIDE HACKSAW BLADE

Super-hard round blade cuts virtually all those hard materials regular blades can't cut. Easily cuts hardened steel, glass, marble, stone, brick, tile, toughest alloys. Cuts in any direction—straight or curved. Blade reverses for double life. Fits any standard



hacksaw frame. \$2.50 ea. ppd. (6 or more \$2.25 ea. ppd.)

MONEY BACK GUARANTEE ON ALL ORDERS

D.—FINEST RUST REMOVER MADE

Attacks only rust. Harmless to metals, wood, cloth, plastic, plating, normal skin, etc. Non-flammable, odorless, safe. Concentrated—8 oz. makes 10 qts. Easy—just soak rusted articles, rust vanishes. 8 oz. bottle \$2.50 ppd.



E.—SMALL STAINLESS STEEL WIRE BRUSH—



Removes rust, dirt, fast. But .005" x 1/2" bristles don't scratch. Safely removes hot sticky sawdust, metal chips, from saws, drills, etc. Saves burned, cut fingers. Cleans files, rasps. 2 for \$1.95 ppd.

F.—MINIATURE HOLE CUTTER SET

makes neat, accurate holes in sheet steel, brass, wood, plastics, cardboard, paper. FAST. High speed steel cutters 1/4", 5/16", 3/8", 7/16", 1/2", 9/16", 5/8" dia. Arbor fits 1/4" electric drill. Set \$13.60 ppd.



ORDERS SHIPPED SAME DAY

G.—VERSATILE POSITIONER

holds objects at just-right angles for difficult soldering or gluing. 6 ball joints for complete adjustability in all directions, at all angles, leaving your hands free to make the joint. Nickel plated. Cross-Bar about 5 1/4" long. Heavy, painted base. \$5.95 ppd. Replacement clamps 10¢ ea.

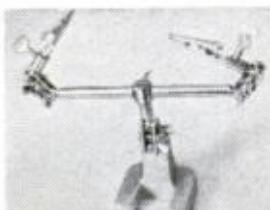

FULLY ILLUSTRATED CATALOG 25¢ (Free with order)

BROOKSTONE CO.

10924-A River Road, Worthington, Mass. 01098

The Brookstone Co., 10924-A River Rd., Worthington, Mass. 01098

A B C D E F G 25¢ Catalog

Enclosed Find _____ Cash, Check, M.O.

Name _____

Address _____

City _____

State _____ Zip _____

HEAVY DUTY WELDER



Does work of \$85.00 welder yet costs only **1895** POST PAID

Fits ordinary 110V outlet Not one • but 3 welding heats

Weld, braze, solder or cut most anything made of metal. No experience necessary. Follow simple instructions. Uses standard 1/8" rods to weld iron, steel, brass, bronze, aluminum, other metals. Repair cars, farm implements, appliances, toys. Make campers, trailers boats. Pays for itself quickly. Comes complete with mask, \$2.00 pack of rods, flux, etc. NOTHING ELSE TO BUY.

3 WELDING HEATS . . . Not just one as with other low cost models. "High" for tough jobs, "Medium" or "Regular" for lighter work. 3 heat feature saves you money. New HEAVY DUTY circuit gives more welding potential than ever before. Approved for homes, garages, factories, shops. Has power boost circuit for industrial uses. Raises heat to 4 TIMES that needed to melt toughest iron. No other welder has all three fine features.

FREE! Automatic arc striker now makes welding easy, even for beginners. Just plug welder into ordinary 110V outlet, touch automatic arc striker and start welding. You can't buy this important new Wel-Dex invention but it's yours free if you order from this ad.

10 day MONEY BACK TRIAL. Guaranteed against burnout. SEND \$2.00 and pay \$16.95 plus small C.O.D. when delivered or \$18.95 for postpaid shipment. Phone (713) 682-5811 for C.O.D.

WEL-DEX MFG. CO., Dept. W-10, Box 10776, Houston, Texas 77018

MAN-SIZE DOES TOUGH JOBS OTHERS CAN'T!



Clears 16" snow. Mows 2 to 3 acres/hour. Handles bigger garden implements. More power with 14 hp, all-gear-drive, extra size and traction. Your best buy! Free catalog.

ECONOMY TRACTOR

1005 K-10 Anoka Avenue, Waukesha, Wisconsin

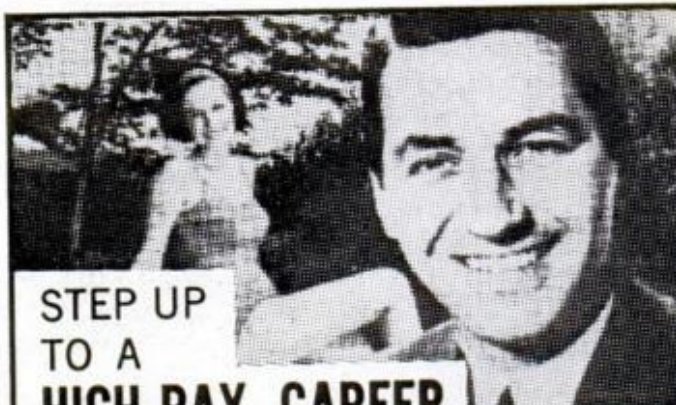

STEP UP TO A HIGH-PAY CAREER IN MOTEL MANAGEMENT

NOW—regardless of your age or present occupation you can qualify for high-pay positions in the fast-growing motel industry. New motels must have trained managers, assistant managers, restaurant managers, etc. AMS is the ONLY management training program developed and supervised by one of America's largest motel chains. It's program is practical, simplified and designed for rapid completion in spare time. Does not interfere with present job. National placement assistance too! Join the many AMS graduates now enjoying happiness and security in glamorous motels throughout the nation. Mail the success coupon below for information on how you may also enjoy big opportunities and rich rewards in motel management.

MAIL THIS SUCCESS COUPON NOW

AMERICAN MOTEL SCHOOL A-1

105-107 Campbell Ave., SW
Roanoke, Virginia 24011

Name _____ Age _____

Address _____ Phone _____

City _____ State _____ Zip _____

Master Mechanic Everlite Battery Charger
DON'T BUY BATTERIES
SAVE \$ - RECHARGE THEM

Over and over up to 15 times or more

- By far the best
- Charges 6 batteries at once
- Charges 3 times faster
- Charges all types of batteries.

Only Everlite charges tiny hearing aid batteries as well as big lantern batteries.

Only Everlite charges flashlight, toys, radio, telephone, hearing aid, cameras—yes, even mercury cells. Save money and have the convenience of fresh batteries. Simple, safe, foolproof and unbelievably efficient. Plugs into any 115 volt outlet. Free battery tester included. Guaranteed for one year.

2 MODELS—The Everlite #75 for all Dry Cell Batteries up to 12 volts.Send

\$6.95

plus \$.65 for shipping.

\$8.95

plus \$.75 for shipping.

The Everlite #76 for all Dry Cell Batteries plus a special charge for Car Batteries to assure fast starts on cold mornings.Send



"Copy any Contour Instantly"



NEW IMPROVED
Contour Copy

Copies exact outline of any object!

Save dollars—save material. Can pay for itself on one job. The perfect tool for fitting in against door casings, bath fixtures, moldings, pipes, sinks, masonry, etc. A real boon to pattern makers, sheet metal mechanics, tool makers, body men, linoleum and floor tile men, etc. **EASY TO USE**—Just push the gauge leaves against any contour and lock. A perfect template every time. Works against any surface or material.



TEMPLATES

DOOR CASINGS



Made of hardened aluminum alloy.

Size 1#—4¼" x 4¼"

\$6.90

plus \$.65 for shipping.

Will retain its accuracy forever.

Size #2—7½" x 4¼"

\$9.90

plus \$.75 for shipping.

EVERLITE * **World's THRIFTIEST Light Plants**

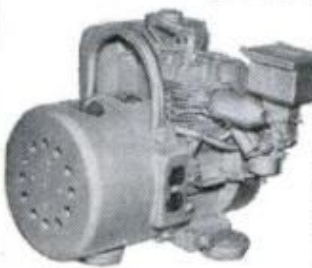

THE CHAMPION \$149.50

The Champion—1200 watts 115 volts AC for only \$149.50

Unbelievable but true—Brand new production methods now make possible world's finest design in a service free alternator light plant at this unprecedented price. Plant puts out a steady 1200 watts of 115 volt AC power to run power tools, oil burners, pumps, TV, or anything that requires up to 1200 watts. Powered by a rugged 3 HP, 4 cycle, easy start gas engine with 1 year factory warranty. Complete with carry handle and shock mounts. Why fool with short life 2 cycle plants when you can buy this rugged top quality machine at our factory price.

Item #1265 **\$149.50**
 wt. 65 lbs.

2¾ h.p. Clinton—39.95

Model 400, rugged 4 cycle model. Alum. Block, castiron cylinder Rope start—¾" std. shaft.

Item 1107 **39.95**

2 for **78.95**

3½ h.p. Clinton—44.50

A big engine with big power. Model 404, 4 cycle, rope start, ¾" std. shaft, industrial ball bearing engine.

Item 404 **44.50**

2 for **87.50**

Remember these engines are absolutely perfect and standard and under factory warranty. Money back guarantee. Order now while stocks are complete. Factories—we buy new engines.



STANDARD DIAL PHONES WITH BELL

Bell System late model dial phones same as used by all telephone companies. Ideal as extensions on any system. Easy to connect. Several may be connected on one line. Easily modified for private inter-com system. Cost \$40.00 new—guaranteed excellent condition.



ITEM 855 NC. Wt. 8 lbs. **\$8.95**

All Prices FOB Factory—10 Day Money-Back Guarantee

Briggs & Stratton — Clinton
New Gas Engine Sale



Clinton 2½ hp. Md. 500—Re-coil starter Std. 5/8" shaft w. keyway—ready to go. Reg. price \$59.50 Special (item 1002)

\$39.95

2 for **\$78.95**
 6 for **\$229.50**



Briggs & Stratton 2¾ hp. Md. 81100 ratch-et start, ¾" shaft. Sturdy 4 cycle engine. Reg. price \$69.50 Spec Item #1518

\$39.50

2 for **\$78.95**
 6 for **\$229.50**

\$69.95

5¾ hp.

Briggs

&

Stratton

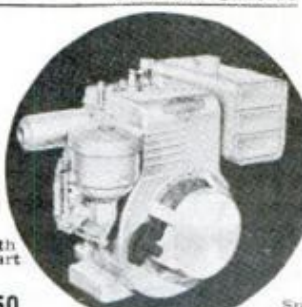

Same engine with 12 v. elec. start and battery charging. (Item #1571) **\$99.50**

Remember these engines are absolutely perfect and standard and under factory warranty. Money back guarantee. Order now while stocks are complete. Factories—we buy new engines.

TRUCK OR BOAT WINCH 2000

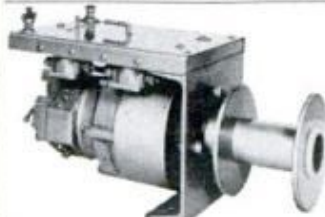

A powerful, compact winch which installs easily even in limited space. Works with any 12, 24 or 32 volt system. Reverses under power—positive brake holds load. Drip proof cover. Remote control if desired. Drum holds 100 ft. of ¼" cable. Speed 30 ft. per minute. A terrific winch at an economy price. Item 1263

Wt. 55# **\$69.50**

MASTER MECHANICS MFG. CO. Dept. A-109

Send orders to nearest office. Box A, Burlington, Wis. Box 65, Sarasota, Fla.

Introducing: Elmer's improvements on the nail and screw.



Elmer's® new Heavy Grip® Cement does what nails and screws can't.

It installs things like towel bars and brackets to tile, metal, concrete, brick, plastic. Just about anything.

And it's so strong that parts need no support while Heavy Grip is setting.

Elmer's Panel Fast® eliminates nails and screws. You can install any kind of paneling with it. You can even reposition a panel while Panel Fast is setting.

And, if a stud or furring strip is set back too far, Panel Fast will fill in the gap.

These improvements are brought to you by the makers of Elmer's® Glue-All, America's favorite glue.

Free. A guide to gluing, taping and spray painting. Mail a stamped, self-addressed envelope to: Borden Inc/Chemical Division, Dept. B-2, 350 Madison Ave., N.Y., N.Y. 10017.



INVENTORS

INVENTIONS—NEW PRODUCTS—IDEAS DEVELOPED & PREPARED

For Commercial Appeal & Sales

DESIGN—MARKETING—PATENT RESEARCH—DRAWINGS

DIRECTOR: *United States Patent Office former Patent Examiner
United States Dept. of Army former Patent Adviser
Member: United States Council Int'l Chamber Commerce
Second Decade of Reliable Service to*

INVENTORS—MANUFACTURERS—ATTORNEYS

FREE CONSULTATION

THE RAYMOND LEE ORGANIZATION

230-Z Park Ave., New York 10017 (212-MU 6-8500)

SEND FREE "INVENTION RECORD" Form & "IMPORTANT PATENT INFORMATION"

Name _____

Address _____

City _____ State _____ Zip _____

The Grabber

... the tool that allows you to truly do-it-yourself! The GRABBER allows you to hold, position, and line up just about everything. No handyman should be without one. Tough, versatile, self adjusting made of high tensile alloys.

101 Uses

- Repair walls
- Hold paneling
- Furniture Clamps
- Automotive repairs

**LIMITED OFFER
only \$3.95**



Please send me (no.) _____ GILSON GRABBERS at \$3.95 each. Money back guarantee.

GILSON PRODUCTS

3888 Vly Road, Schenectady, New York 12309

2,000

wood CATALOG & MANUAL

Hard-to-find PRODUCTS
for easier...better woodworking!

Discover! Enjoy! Benefit from newest products and ideas in Constantine's big picture-packed Manual. Wood headquarters since 1812. Largest selection of world's most beautiful cabinet lumber, veneers, plywood, inlays, moldings. Woods in natural color. Tool bargains. Furn. hdwe. Finishing & upholstery supplies. Fabulous glue that needs no clamps! Instructions. Everything. Unsurpassed values. Send 25¢ now for your copy. **TEAR OUT AD.**



ALBERT CONSTANTINE AND SON, INC.

2050 Eastchester Rd., Bronx N.Y. 10461 Dept. P-5

Enclosed 25¢ for new Constantine Catalog-Manual

NAME _____

ADDRESS _____

BUILD YOUR OWN CAMPER SAVE UP TO 50%

Complete, easy to follow plans, instructions, materials list.

Camper Plans	\$3.95
Travel Trailer	\$3.95
Pickup Cover	\$2.00
CONVERSION PLANS:	
Econoline Type Van	\$2.95
Passenger Bus or Delivery Van	\$2.95
Satisfaction Guaranteed	



VIKING CAMPER SUPPLY, INC.

99-BP Glenwood Ave.,

Minneapolis, Minn. 55403

Please send _____ for

which I enclose \$ _____

NAME _____

ADDRESS _____

CITY _____

STATE _____ ZIP _____

EQUIPMENT CATALOG \$1.00

Refundable on First Order.
Send Dime for Details.
Save 50% on Camper Kit.
All items from catalog to
build \$1,795. Camper. 8',
10', 10'6" or Chassis Unit.



NEW PRICE SHOES

SAY
"the END"
to
\$15 to \$30
SHOES



2 PAIR
FOR
\$14⁹⁵

Take Your Choice in Cordovan, Black or Olive Brown of 4 Styles

WE CARRY ALL THESE SIZES

Oxfords, Loafers, Monk Strap, and Wing Tips

	5 1/2	6	6 1/2	7	7 1/2	8	8 1/2	9	9 1/2	10	10 1/2	11	12	13
A														
B														
C														
D														
E														
EEE														

You'll be shocked when you see our shoes

After what you've paid for shoes, you'll wonder how any such price as ours can be. Well, you get top quality uppers, good lifetime laces, life-of-the-shoe PVC sole and heels, flexible support shank in the arch, gentle foam heel cushions, superior gentleman's detailing. The works! Even the new luxury linings.

leather, scoff at scuffs, keep better shape. Why spend even one dollar more for shoes? Here's something NEW. Here's something PROVEN.

Please note. At the price we sell shoes, we are not allowed to mention the famous brand name of this new shoe material. Suffice it to say it looks like top grain leather, performs even better. Why pay higher and higher prices? Get in on this astounding low price. Send in now:

SOONER OR LATER you'll be wearing The New Price Shoes

Today's new man-made shoe materials beat the price out of

TWO PAIRS FOR \$14.95

CASH IN NOW on these Extraordinary SAVINGS

The day of the high priced shoe is over. Folks are paying many dollars less than ever before, thanks to the miracle new "polymeric" shoe materials. This is no "cheap imitation" shoe. It's the real thing: the New Price Shoe that looks and feels and wears as well as any shoe you have ever worn, yet costs a fraction of the price.

AS ADVERTISED IN
Life Magazine
The New York Times
Wall Street Journal
National Observer
Look Magazine

SEE IT YOURSELF USE THIS COUPON

We will be proud to send them to you for On Approval At Home Inspection.

Haband Company
PATERSON, NEW JERSEY 07508

TWO PAIRS FOR \$14.95

HABAND COMPANY
265 North 9th Street
PATERSON, N. J. 07508

O.K. Gentlemen, Send me on Approval, the two pairs of Shoes specified at right. My remittance

of \$..... is enclosed herewith.

Name

Street

City & State

ZIP CODE

COLOR & STYLE	HOW MANY	WHAT SIZE
Black Oxfords		
Brown Oxfords		
Cordovan Oxfords		
Black Loafers		
Cordovan Loafers		
Black Wing Tips		
Brown Wing Tips		
Black Monk Strap		

PM-2

Haband, operating by U.S. Mail since 1925



You can make money in

WATCH REPAIR

Learn at home the low cost Sweazey Way

Watch repairing pays up to \$6 an hour, part time watch makers report on survey. Unique and modern Sweazey home study System starts you making repairs right away on Swiss and American watches. Professionally prepared training. No previous experience needed. Special tools provided for practice. Diploma Awarded. Free sample lesson and opportunity book give all facts. Write today. No obligation.

CHICAGO SCHOOL OF WATCHMAKING
Dept. 1109 Fox River Grove, Illinois 60021

FREE BOOK and SAMPLE LESSON

CHICAGO SCHOOL OF WATCHMAKING
Dept. 1109, Fox River Grove, Illinois 60021
Please rush **FREE BOOK** and Sample Home Study Lesson.

Name _____ Age _____

Address _____

City _____ State _____ Zip _____

New Saw And Tool Maintenance SCHOOL

Starts you in profitable business

Be your own boss, regardless of age, in a highly profitable service business. Every manufacturer, carpenter, handyman, and hardware store in your town can be your customer. A steady year-round business. We help you set up your own business and will finance you.

Factory Training School

Complete instruction-packed 5 day course in the factory teaches you all about famous Foley sharpening equipment. Proven program and 40 years' experience assures you of success.

For further information and booklet write:

FOLEY SAW and TOOL SCHOOL
Dept. PMMA • 3300 N. E. 5th Street
Minneapolis, Minnesota 55418

FREE BOOKLET
Get the complete facts about this new training school in fact-filled booklet - Write today!

MAKE EXTRA MONEY IN YOUR SPARE TIME

LEARN PROFESSIONAL "PLEXIGLAS" SIGN MAKING!

\$13.75 brings you over 120 ACRYLIC LETTERS AND FREE INSTRUCTIONS. Send your remittance to:

DAYTONA PLASTIX

Box 6161, Daytona Beach, Florida 32022.

MAGIC MAIL PLAN

that comes with this Little Machine CAN MAKE YOU \$1200 AN HOUR

The machine is turning out a job that will bring operator \$2.58, by mail. Material cost, only 11c



Write today for free facts about the newest and most fascinating of all new home operated businesses. For the first time, a simplified machine brings the fabulous profits of Plastic Sealing and Plastic Laminating within reach of the small operator. Anyone can learn to operate it with a few minutes practice. Then—with our **MAGIC MAIL PLAN**—can get mail orders pouring in daily with cash in every envelope.

No Canvassing or Selling

Fill orders at home in spare time to start. Then expand to full time business. We even supply circulars to bring back cash and orders. Rush name for all the facts you need to start. A postcard will do. No charge.

WARNER ELECTRIC CO., Dept. L-2-LS
1512 Jarvis, Chicago, Ill. 60626

Career in ELECTRONICS?

Career training at home the new easy way with RCA Institutes. Lab work with first lesson. Easy payment plans. Send for free 64-page book.

RCA Institutes, Inc. Dept. PM-09
320 W. 31 St., N.Y., N.Y. 10001



BASEMENT TOILET FLUSHES UP



TO OVERHEAD SEWER OR SEPTIC TANK. NO DIGGING UP FLOORS. INSTALLS EASY. Write **McPHERSON, INC., BOX 15133, TAMPA, FLORIDA 33614**

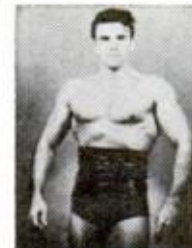

"Sta-Trim" WAIST BELT!!!

Designed for the person desiring a trimmer waistline appearance... Ruggedly constructed non-porous belt covers the entire waist area, and causes it to perspire with the slightest exertion. Exercise program and instructions included. Send waist size and \$3.98 to **"STA-TRIM," Suite 1204-PM-4 28 E. Jackson Blvd., Chicago, Ill. 60604**

MECHANICAL PENCIL CALCULATOR.



Math-Wiz mech. pencil calculator gives answers automatically to addition, subtraction, multiplication, division and square root problems. 6 1/2" x 1/2" gold anodized sturdy aluminum casing. Practical and useful gift. \$3.50 ppd. (No C.O.D.) **Jack Weiser, dept. 1, 1417 S. Fairfax Ave., Los Angeles, Calif. 90019**

HOW YOU CAN BECOME RICH!

FREE! Revolutionary New wealth-building secrets! You can become a Money-Making Success... **FAST!** Write today for your free copy of "How To Become Rich"!

Success International, Box 2447-CI, Livonia, Mich. 48151

Dr. Grabow VIKING



A dozen pipes in one! Interchangeable bowls make Dr. Grabow's Viking an entire collection of fine pipes. Extra bowls are only \$1.50 and available everywhere.

LOOKS COOLER... SMOKES COOLER

\$2⁹⁵
DeLuxe

INTERCHANGEABLE
BRIAR BOWLS



NICOTINE TRAP

For FREE informative booklet, write VIKING PIPES, P. O. Box 21888, Greensboro, N. C. 27420

RIDE THE NEW COLT.

\$99.95 complete

It's got everything—for less!



The high-performance minibike you've been waiting for, with the style, safety, and comfort of much higher-priced models. Rugged 2½ HP "Tecumseh" engine, automotive drum-type brakes, premium nylon tires on wide base wheels. (3.5 HP Colt just \$109.95) Perfect for campus, errands, or fun. Send for the new COLT brochure now!

\$99.95. Not a kit! Direct Builder-to-You Price!

COLT MINIBIKES

3307 South Lawndale
Chicago, Illinois 60623

Rush me your brochure on the COLT stable of minibikes.

NAME _____

ADDRESS _____

CITY _____

STATE _____

ZIP _____

10M

TREASURE & COIN DETECTOR 10-DAY FREE TRIAL

New circuit guaranteed to give at least twice the detection ability of any detector in this price range or return in 10 days for refund. Find buried gold, silver, coins, treasure. More power for more depth. Not a "probe" type but a fully electronic 1969 model detector. Uses ordinary 9V battery, weighs 2 pounds, fully transistorized. Powerful loudspeaker gives loud, clear signal when object is detected. **NOTHING ELSE TO BUY.** Complete, ready to operate.



29⁹⁵
POST PAID

Send \$29.95 check, cash or M.O. for postpaid shipment or \$3.00 and pay postman \$26.95 plus small C.O.D. when delivered.

U. S. Pat. Pend.

VIKING DETECTORS

Dept. V-2, Box 10880
Houston, Texas 77018

SURE SQUARE



Sturdy aluminum, locates 90° cuts to your mark as it clamps instantly to stock up to 12" wide, eliminating creep under vibration. Free Literature—10 day trial privilege **ONLY \$12.50** + \$1 pstg. & ins. (Pa. + 75c S.T.)

Saw Guide as shown in Dec. & Feb. ('69) Popular Mechanics
INDEPENDENCE SPECIALTIES, Box 2987, Phila., Pa. 19126

PROFIT IN YOUR SPARE TIME

SMALL ENGINE REPAIR PAYS BIG!

Outboard • Powermower • Chain Saw • Tractor

MAKE EXTRA MONEY — or fix your own engines and SAVE! Illustrated, easy-to-learn Home Study Course qualifies you as expert. Approved for Veterans. Write today!



LINCOLN TECHNICAL INSTITUTE
SUITE 10-E, 472 MARKET ST., NEWARK, N.J. 07105

HANDEE®

the most versatile tool in your workshop



Cut, carve, sand, grind, drill, engrave, polish, clean. Complete line of accessories, including: Drill Press, Bench Holder, Tool Post Adapter, Foot Speed Control, No. 7001 Drill Set (No. 61 thru No. 80) and No. 38A Drill Chuck for model builders. Fully guaranteed against defects in material and workmanship.

No. 6000 Handee with ½" collet, ⅜" collet, and wrench **\$28.50**

No. 6009 Handee with 7 accessories **\$29.50**

No. 6010 Handee with 45 accessories and case **\$39.50**

Free micro-oiler with each Handee ordered on coupon below. (\$1.00 value)

See your Handee Dealer or Order direct

CHICAGO WHEEL & MFG. CO.
Dept. PM-10, 1101 W. Monroe St., Chicago, Ill. 60607

Enclosed is payment for set No. (add 60¢ to cost of each set for postage and handling).

Please send me Handee catalog.

NAME _____

STREET _____

CITY _____ STATE _____ ZIP _____

FANTASTIC VALUES WITH THIS COUPON

AMERICAN MACHINE & TOOL CO., Dept. P M09, Royersford, Pa. 19468

Please send me the units checked. Payment in full enclosed \$.....
or \$3 deposit each item enclosed, balance C.O.D. I MUST BE FULLY
SATISFIED OR WILL RETURN UNIT WITHIN 10 DAYS FOR FULL REFUND.
No questions asked.

- 8" Power Saw at \$14.95
 Standard Rip Fence at \$3.50
 Long Rip Fence at \$4.50
 Precision Ball Bearing Spindle at \$5.00
 Jointer Planer at \$19.95
 Drill Press at \$29.95
- Belt Sander at \$14.95
 Disc sander attach. at \$7.95
 Mitre Gauge for sander at \$1.95
 Lathe at \$14.95
 Face Plate at \$2.50
 Turning Chisels at \$4.95
- G.E. Motor \$18.80 (with other item) \$24.85 (purchased separately)

NAME

ADDRESS

CITY STATE ZIP

SAVE AS MUCH AS...
80% WITH
QUALITY 
POWER TOOLS

DIRECT FACTORY OFFER AND REVOLUTIONARY PATENTS decrease costs, increase efficiency. Full scale power tools of heavy duty 100% cast iron and steel. Streamlined design reduces weight, cuts material and production costs. Special patents provide added efficiency, accuracy, savings. Parts made, assembled, tested, packed right in our own factories shipped direct... save store profits.

ENDORSED BY AMERICA'S TOP MAGAZINES... Here is what the editors say:

"A good bit of sound—imaginative—engineering." Popular Science; "(saw) boasts many features of bigger brothers." Popular Mechanics; "Amazingly versatile." Workbench; "Highly substantial construction, sturdy enough for production line use." Industrial Woodworking. And Workbench awarded these tools their coveted "Work Tested" Seal.

UNCONDITIONAL 10-DAY MONEY BACK GUARANTEE
You must be fully satisfied. If not, return in 10 days, freight collect. Money promptly refunded in full.

OVER A MILLION USERS confirm their precision, versatility and rugged performance.

***10-YEAR FULL SERVICE GUARANTEE...** Any part or parts of any AMCO power tool (except motor) which may become inoperative for any reason within ten years after the purchase date will be repaired or replaced by the factory without cost to the purchaser. Your only cost: for postage.

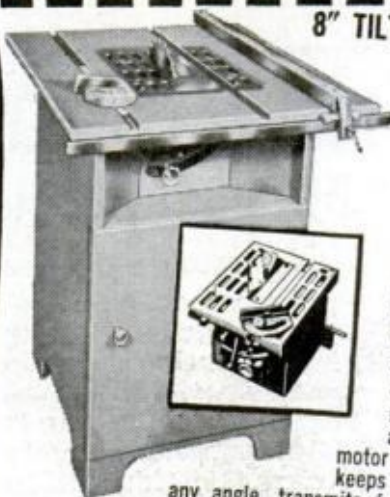

8" TILT ARBOR POWER SAW

DOES WORK OF \$75 BENCH SAW as is. Converts easily to equal any \$300 floor model cabinet units! Crosscuts, rips, mitres, cuts compound angles, dadoes, makes coves and mouldings.

\$14.95 f.o.b. factory. Wt. 25 lbs. Includes completely assembled cast iron and steel 8" saw with ground cast iron table... less blade. **RIP FENCE**, if desired, for easier work alignment, \$3.50 add'l.

PRECISION BALL BEARING SPINDLE for Commercial Service, \$5.00 add'l.

SAW BLADE TILTS... TABLE STAYS LEVEL

Locks securely at any angle up to 50°, raises, lowers 0"-2 3/4". Patented tilt mechanism, accurate etched scale. Patented motor mount takes std. 3/4 h.p. or larger motor, keeps belt tight, assures perfect alignment at any angle, transmits full power. Takes std. blade, saw insert removes to take dadoe heads, cutters, etc. (not incl.). Accurate mitre gauge assembly. Ground spindle. Enclosed steel base. "Compo" bearings. Std. size (for bench saw) \$3.50; larger fence (for cabinet base, as ill'd.) \$4.50.

FREE CABINET BASE PLANS Use as portable bench saw as received (inset photo) or transform easily and inexpensively into floor model (as shown) guar. to do work of floor models costing \$300. **FREE plans**... all you'll need are a sheet of 3/4" plywood and 3-4 hours. Use your AMCO saw for cutting. Plans provide 27" x 24" work surface, 33" height, tool storage compartment.

10-YEAR FULL SERVICE GUARANTEE*

6" SWING 3-FOOT LATHE



Optional faceplate for turning bowls, trays, lamp bases, rosettes, etc. \$2.50. **\$14.95** f.o.b. factory Wt. 14 lbs.

Set of 3 high speed turning chisels, \$4.95 add'l.
DOES THE WORK OF \$40 UNITS... with same precision and speed. Turns wood, plastic. Sturdy cast iron with tubular steel bed. Ball thrust cup center, spur center, T-rest assembly, lever action tail stock, 2-speed pulley. Fits any motor.

10-YEAR FULL SERVICE GUARANTEE*

PRECISION 4" x 36" BELT SANDER

f.o.b. factory. Wt. 15 lbs.

\$14.95 + Disc Sander attachment incl. disc bracket, ground cast table (tilts 0-45°): \$7.95 add'l.

DOES WORK OF \$50 SANDERS... The world's most talented belt sander. Heavy cast sander incl. 4" x 36" sanding belt, V-pulley drive, multi-purpose drive spindle. Changes from horizontal to vertical sanding in secs. Uses 1/2 hp or larger motor.

10-YEAR FULL SERVICE GUARANTEE*



FULL 22" LONG, 4 1/8" JOINTER-PLANER

\$19.95

f.o.b. factory. Wt.: 19 lbs. Complete as shown.

100% precision ground cast iron and steel.

DOES THE WORK OF \$60 UNITS... Professional power planing at a hand tool price. Make faster, more accurate joints, rabbetts, at a hand tool price. Make faster, more accurate joints, rabbetts, bevels for windows, doors, drawers, square tapered legs—Adjustable precision ground cast iron tables. Patent-pending design holds knife to table clearances at any depth. Rabbett depth 3/8". Fence adjustable 0°-50°. Hardened, ground hi-speed steel knives. Dual cutter guards. Balanced cutter head.

10-YEAR FULL SERVICE GUARANTEE*

32" RADIAL DRILL PRESS

All cast iron and steel
f.o.b. factory **\$29.95**
Wt. 30 lbs.
1/2" cap.
Jacob's chuck incl.

DOES WORK OF \$90 UNITS... and much more. Industrial quality precision unit with all standard features, many extras. Head raises, lowers. Depth of throat up to 16". Pre-set to any angle for on-or-off table drilling, even horizontal drilling. **10-YEAR FULL SERVICE GUARANTEE.***

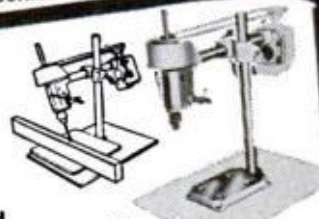

BRAND NEW  **MOTOR**

DEVELOPING FULL 1 HP... **\$18.80**

F.O.B. FACTORY / FOR ANY OF ABOVE MACHINES. WT. 17 LBS. PURCHASED SEPARATELY, \$24.85

STRANGE as it seems ELSIE HIX



THE ORIGIN OF THE MODERN DAY UMBRELLA WAS A SUNSHADE, USED BY NOBILITY IN ANCIENT EGYPT



TODAY, A CHILD IN GRADE SCHOOL CAN AVERAGE ONLY ABOUT 3 MINUTES A DAY WITH THE SCHOOL ENCYCLOPEDIA



BRITANNICA JUNIOR—

THE FIRST MAJOR ENCYCLOPEDIA FOR CHILDREN IS AVAILABLE **FREE** OF EXTRA COST WITH THE NEW EDITION OF ENCYCLOPAEDIA BRITANNICA

COLOR TV, IN A CRUDE STATE, WAS DEMONSTRATED IN 1928 ...NEARLY 8 YEARS BEFORE TV BROADCASTING BEGAN



NEW EDITION

ENCYCLOPAEDIA BRITANNICA

available direct from the publisher on **Book a Month Payment Plan** you get all volumes now... pay later!



Plus Britannica Junior **FREE** of extra cost

YES—THE LATEST EDITION OF Britannica, the greatest treasury of knowledge ever published, is now available on a remarkable Cooperative Offer.

You may obtain the latest edition of Britannica Junior, *free of extra cost*, when you choose this new Encyclopaedia Britannica. The two complete sets will be placed in your home NOW...you pay *later* on convenient budget terms. *It's as easy as buying a book a month.*

Britannica Junior is written, illustrated and indexed especially for children in grade school... easy to read and understand, rich in picture interest and carefully matched to school subjects. It'll help your children get a head start in school and it leads right into Encyclopaedia Britannica.

Thousands of Subjects of Practical Value. The new edition of Britannica has special articles on household budgets, interior decorating, medicine, health, home remodeling, child care, adolescent problems, and many more. A 70-page section provides complete, up-to-date records on all sports. It's an astounding collection of useful information that can save you many dollars.

New Edition is Profusely Illustrated. The new Encyclopaedia Britannica offers over 22,000 magnificent illustrations — thousands in brilliant color. But it does not merely show "attractive pictures," it's the work of 10,400 of the world's great authorities.

Essential For Homework. For students, Britannica is indispensable. It is the finest, most com-

plete reference published in America. Its use develops active, alert minds that bring success in school and later life.

Free Preview Booklet. If you'd like to learn how your family can get Britannica Junior, free of extra cost, with Encyclopaedia Britannica on our Cooperative Offer and a Free Preview Booklet —simply mail the attached postage-free card now.

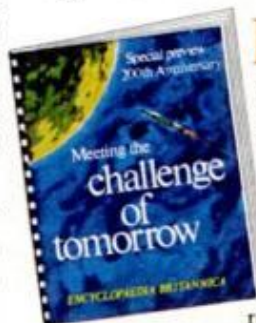

FREE! Mail card now for Special New **Preview Booklet** and complete details on this remarkable offer.

If card is detached, write to Encyclopaedia Britannica, Dept. 481 Z, 425 N. Michigan Ave., Chicago, Ill. 60611.



**If other beers
took as much time
and care to brew,
would they taste
as good as
Budweiser?**

**(That's an
interesting
question.)**